

## RA4M3 Group

User's Manual: Hardware

### 32-Bit MCU

Renesas Advanced (RA) Family  
Renesas RA4 Series

## RA4M3 Group

User's Manual: Hardware

瑞萨电子高级(RA)系列32位MCU

Renesas RA4 Series

All information contained in these materials, including products and product specifications, represents information on the product at the time of publication and is subject to change by Renesas Electronics Corp. without notice. Please review the latest information published by Renesas Electronics Corp. through various means, including the Renesas Electronics Corp. website (<http://www.renesas.com>).

这些材料中包含的所有信息，包括产品和产品规格，均代表发布时的产品信息，瑞萨电子公司如有更改，恕不另行通知。请查看瑞萨电子公司通过各种方式发布的最新信息，包括瑞萨电子公司网站(<http://www.renesas.com>)。

RA生态工作室

## Notice

1. Descriptions of circuits, software and other related information in this document are provided only to illustrate the operation of semiconductor products and application examples. You are fully responsible for the incorporation or any other use of the circuits, software, and information in the design of your product or system. Renesas Electronics disclaims any and all liability for any losses and damages incurred by you or third parties arising from the use of these circuits, software, or information.
2. Renesas Electronics hereby expressly disclaims any warranties against and liability for infringement or any other claims involving patents, copyrights, or other intellectual property rights of third parties, by or arising from the use of Renesas Electronics products or technical information described in this document, including but not limited to, the product data, drawings, charts, programs, algorithms, and application examples.
3. No license, express, implied or otherwise, is granted hereby under any patents, copyrights or other intellectual property rights of Renesas Electronics or others.
4. You shall not alter, modify, copy, or reverse engineer any Renesas Electronics product, whether in whole or in part. Renesas Electronics disclaims any and all liability for any losses or damages incurred by you or third parties arising from such alteration, modification, copying or reverse engineering.
5. Renesas Electronics products are classified according to the following two quality grades: "Standard" and "High Quality". The intended applications for each Renesas Electronics product depends on the product's quality grade, as indicated below.

"Standard": Computers; office equipment; communications equipment; test and measurement equipment; audio and visual equipment; home electronic appliances; machine tools; personal electronic equipment; industrial robots; etc.

"High Quality": Transportation equipment (automobiles, trains, ships, etc.); traffic control (traffic lights); large-scale communication equipment; key financial terminal systems; safety control equipment; etc.

- Unless expressly designated as a high reliability product or a product for harsh environments in a Renesas Electronics data sheet or other Renesas Electronics document, Renesas Electronics products are not intended or authorized for use in products or systems that may pose a direct threat to human life or bodily injury (artificial life support devices or systems; surgical implantations; etc.), or may cause serious property damage (space system; undersea repeaters; nuclear power control systems; aircraft control systems; key plant systems; military equipment; etc.). Renesas Electronics disclaims any and all liability for any damages or losses incurred by you or any third parties arising from the use of any Renesas Electronics product that is inconsistent with any Renesas Electronics data sheet, user's manual or other Renesas Electronics document.
6. When using Renesas Electronics products, refer to the latest product information (data sheets, user's manuals, application notes, "General Notes for Handling and Using Semiconductor Devices" in the reliability handbook, etc.), and ensure that usage conditions are within the ranges specified by Renesas Electronics with respect to maximum ratings, operating power supply voltage range, heat dissipation characteristics, installation, etc. Renesas Electronics disclaims any and all liability for any malfunctions, failure or accident arising out of the use of Renesas Electronics products outside of such specified ranges.
  7. Although Renesas Electronics endeavors to improve the quality and reliability of Renesas Electronics products, semiconductor products have specific characteristics, such as the occurrence of failure at a certain rate and malfunctions under certain use conditions. Unless designated as a high reliability product or a product for harsh environments in a Renesas Electronics data sheet or other Renesas Electronics document, Renesas Electronics products are not subject to radiation resistance design. You are responsible for implementing safety measures to guard against the possibility of bodily injury, injury or damage caused by fire, and/or danger to the public in the event of a failure or malfunction of Renesas Electronics products, such as safety design for hardware and software, including but not limited to redundancy, fire control and malfunction prevention, appropriate treatment for aging degradation or any other appropriate measures. Because the evaluation of microcomputer software alone is very difficult and impractical, you are responsible for evaluating the safety of the final products or systems manufactured by you.
  8. Please contact a Renesas Electronics sales office for details as to environmental matters such as the environmental compatibility of each Renesas Electronics product. You are responsible for carefully and sufficiently investigating applicable laws and regulations that regulate the inclusion or use of controlled substances, including without limitation, the EU RoHS Directive, and using Renesas Electronics products in compliance with all these applicable laws and regulations. Renesas Electronics disclaims any and all liability for damages or losses occurring as a result of your noncompliance with applicable laws and regulations.
  9. Renesas Electronics products and technologies shall not be used for or incorporated into any products or systems whose manufacture, use, or sale is prohibited under any applicable domestic or foreign laws or regulations. You shall comply with any applicable export control laws and regulations promulgated and administered by the governments of any countries asserting jurisdiction over the parties or transactions.
  10. It is the responsibility of the buyer or distributor of Renesas Electronics products, or any other party who distributes, disposes of, or otherwise sells or transfers the product to a third party, to notify such third party in advance of the contents and conditions set forth in this document.
  11. This document shall not be reprinted, reproduced or duplicated in any form, in whole or in part, without prior written consent of Renesas Electronics.
  12. Please contact a Renesas Electronics sales office if you have any questions regarding the information contained in this document or Renesas Electronics products.

(Note1) "Renesas Electronics" as used in this document means Renesas Electronics Corporation and also includes its directly or indirectly controlled subsidiaries.

(Note2) "Renesas Electronics product(s)" means any product developed or manufactured by or for Renesas Electronics.

(Rev.4.0-1 November 2017)

## Corporate Headquarters

TOYOSU FORESIA, 3-2-24 Toyosu,  
Koto-ku, Tokyo 135-0061, Japan

[www.renesas.com](http://www.renesas.com)

## Trademarks

Renesas and the Renesas logo are trademarks of Renesas Electronics Corporation. All trademarks and registered trademarks are the property of their respective owners.

## Notice

1. 本文档中对电路、软件和其他相关信息的描述仅用于说明半导体产品的操作和应用示例。您对在您的产品或系统设计中使用或以任何其他方式使用电路、软件和信息负全部责任。对于您或第三方因使用这些电路、软件或信息而遭受的任何损失和损害，瑞萨电子不承担任何责任。

2. 瑞萨电子特此明确声明，对于因使用本文档中描述的瑞萨电子产品或技术信息（包括但不限于产品数据、图纸、图表、程序、算法和应用示例。

3. 瑞萨电子或其他方的任何专利、版权或其他知识产权在此未授予任何明示、暗示或其他许可。

4. 您不得全部或部分更改、修改、复制或反向工程任何瑞萨电子产品。对于您或第三方因此类更改、修改、复制或反向工程而遭受的任何损失或损害，瑞萨电子不承担任何责任。

5. 瑞萨电子产品根据以下两个质量等级进行分类：“标准”和“高质量”。每个瑞萨电子产品的预期应用取决于产品的质量等级，如下所示。

“标准”：计算机；办公用品;通讯设备；测试和测量设备；视听设备；家用电器；机械工具;个人电子设备；工业机器人；等等

“高品质”：运输设备（汽车、火车、轮船等）；交通管制（红绿灯）；大型通讯设备；关键金融终端系统；安全控制设备；除非在瑞萨电子数据表或其他瑞萨电子文档中明确指定为高可靠性产品或适用于恶劣环境的产品，否则瑞萨电子产品不得用于或授权用于可能对人类构成直接威胁的产品或系统生命或身体伤害（人工生命支持设备或系统；外科植入物等），或可能造成严重财产损失（空间系统；海底中继器；核电控制系统；飞机控制系统；关键工厂系统；军事装备等）。对于您或任何第三方因使用与任何瑞萨电子数据表、用户手册或其他瑞萨电子文档不一致的任何瑞萨电子产品而导致的任何损害或损失，瑞萨电子不承担任何责任。

6. 使用瑞萨电子产品时，请参阅最新的产品信息（数据表、用户手册、应用说明、“通用说明”处理和使用半导体器件“在可靠性手册等），并确保使用条件在规定的范围内  
瑞萨电子关于最大额定值、工作电源电压范围、散热特性、安装等方面的信息。瑞萨电子不对因在上述规定范围之外使用瑞萨电子产品而引起的任何故障、故障或事故承担任何责任。

7. 尽管瑞萨电子努力提高瑞萨电子产品的质量和可靠性，但半导体产品具有特定的特性，例如以一定的速度发生故障以及在特定使用条件下发生故障。除非在瑞萨电子数据表或其他瑞萨电子文档中指定为高可靠性产品或适用于恶劣环境的产品，否则瑞萨电子产品不得用于或授权用于可能对人类构成直接威胁的产品或系统生命或身体伤害（人工生命支持设备或系统；外科植入物等），或可能造成严重财产损失（空间系统；海底中继器；核电控制系统；飞机控制系统；关键工厂系统；军事装备等）。对于您或任何第三方因使用与任何瑞萨电子数据表、用户手册或其他瑞萨电子文档不一致的任何瑞萨电子产品而导致的任何损害或损失，瑞萨电子不承担任何责任。

8. 请联系瑞萨电子销售办事处了解有关环境问题的详细信息，例如每个瑞萨电子的环境兼容性  
电子产品。您有责任仔细、充分地调查适用于管制物质的包含或使用的法律和法规，包括但不限于欧盟RoHS指令，并按照所有这些适用的法律和法规使用瑞萨电子产品。瑞萨电子对因您不遵守适用法律和法规而造成的损害或损失不承担任何责任。

9.瑞萨电子的产品和技术不得用于或整合到任何适用的国内或国外法律或法规禁止制造、使用或销售的产品或系统中。您应遵守对各方或交易主张管辖权的任何国家/地区的政府颁布和管理的任何适用的出口管制法律和法规。10.瑞萨电子产品的购买者或分销商，或将产品分销、处置或以其他方式出售或转让给第三方的任何其他方，有责任提前通知该第三方有关内容和条件本文件中规定。11.未经瑞萨电子事先书面同意，不得以任何形式全部或部分翻印、复制或复制本文档。12.如果您对本文档中包含的信息或瑞萨电子产品有任何疑问，请联系瑞萨电子销售办事处。

(Note1) 本文档中使用的“瑞萨电子”是指瑞萨电子公司，还包括其直接或间接控制的子公司。

(Note2) “瑞萨电子产品”是指由瑞萨电子开发或制造或为瑞萨电子开发或制造的任何产品。

(Rev.4.0-1 November 2017)

## 公司总部

TOYOSU FORESIA, 3-2-24 Toyosu,  
日本东京都江东区135-0061

[www.renesas.com](http://www.renesas.com)

## Trademarks

瑞萨电子和瑞萨电子标识是瑞萨电子的商标  
电子公司。所有商标和注册商标均为其各自所有者的财产。

## 联系信息

有关产品、技术、文档的最新版本或离您最近的销售办事处的更多信息，请访问：[www.renesas.com](http://www.renesas.com)联系方式。



## General Precautions in the Handling of Microprocessing Unit and Microcontroller Unit Products

The following usage notes are applicable to all Microprocessing unit and Microcontroller unit products from Renesas. For detailed usage notes on the products covered by this document, refer to the relevant sections of the document as well as any technical updates that have been issued for the products.

### 1. Precaution against Electrostatic Discharge (ESD)

A strong electrical field, when exposed to a CMOS device, can cause destruction of the gate oxide and ultimately degrade the device operation. Steps must be taken to stop the generation of static electricity as much as possible, and quickly dissipate it when it occurs. Environmental control must be adequate. When it is dry, a humidifier should be used. This is recommended to avoid using insulators that can easily build up static electricity.

Semiconductor devices must be stored and transported in an anti-static container, static shielding bag or conductive material. All test and measurement tools including work benches and floors must be grounded. The operator must also be grounded using a wrist strap. Semiconductor devices must not be touched with bare hands. Similar precautions must be taken for printed circuit boards with mounted semiconductor devices.

### 2. Processing at power-on

The state of the product is undefined at the time when power is supplied. The states of internal circuits in the LSI are indeterminate and the states of register settings and pins are undefined at the time when power is supplied. In a finished product where the reset signal is applied to the external reset pin, the states of pins are not guaranteed from the time when power is supplied until the reset process is completed. In a similar way, the states of pins in a product that is reset by an on-chip power-on reset function are not guaranteed from the time when power is supplied until the power reaches the level at which resetting is specified.

### 3. Input of signal during power-off state

Do not input signals or an I/O pull-up power supply while the device is powered off. The current injection that results from input of such a signal or I/O pull-up power supply may cause malfunction and the abnormal current that passes in the device at this time may cause degradation of internal elements. Follow the guideline for input signal during power-off state as described in your product documentation.

### 4. Handling of unused pins

Handle unused pins in accordance with the directions given under handling of unused pins in the manual. The input pins of CMOS products are generally in the high-impedance state. In operation with an unused pin in the open-circuit state, extra electromagnetic noise is induced in the vicinity of the LSI, an associated shoot-through current flows internally, and malfunctions occur due to the false recognition of the pin state as an input signal become possible.

### 5. Clock signals

After applying a reset, only release the reset line after the operating clock signal becomes stable. When switching the clock signal during program execution, wait until the target clock signal is stabilized. When the clock signal is generated with an external resonator or from an external oscillator during a reset, ensure that the reset line is only released after full stabilization of the clock signal. Additionally, when switching to a clock signal produced with an external resonator or by an external oscillator while program execution is in progress, wait until the target clock signal is stable.

### 6. Voltage application waveform at input pin

Waveform distortion due to input noise or a reflected wave may cause malfunction. If the input of the CMOS device stays in the area between  $V_{IL}$  (Max.) and  $V_{IH}$  (Min.) due to noise, for example, the device may malfunction. Take care to prevent chattering noise from entering the device when the input level is fixed, and also in the transition period when the input level passes through the area between  $V_{IL}$  (Max.) and  $V_{IH}$  (Min.).

### 7. Prohibition of access to reserved addresses

Access to reserved addresses is prohibited. The reserved addresses are provided for possible future expansion of functions. Do not access these addresses as the correct operation of the LSI is not guaranteed.

### 8. Differences between products

Before changing from one product to another, for example to a product with a different part number, confirm that the change will not lead to problems. The characteristics of a microprocessing unit or microcontroller unit products in the same group but having a different part number might differ in terms of internal memory capacity, layout pattern, and other factors, which can affect the ranges of electrical characteristics, such as characteristic values, operating margins, immunity to noise, and amount of radiated noise. When changing to a product with a different part number, implement a system-evaluation test for the given product.

## 处理微处理单元和微控制器的一般注意事项 单位产品

以下使用说明适用于瑞萨的所有微处理单元和微控制器单元产品。有关详细的使用说明本文档所涵盖的产品，请参阅文档的相关部分以及为产品发布的任何技术更新。

### 1. 防止静电放电(ESD)

当暴露于CMOS器件时，强电场会导致栅极氧化物的破坏并最终降低器件的运行性能。脚步必须采取措施，尽可能停止静电的产生，并在出现时迅速消散。环境控制必须足够的。干燥时，应使用加湿器。建议避免使用容易产生静电的绝缘体。

半导体器件必须在防静电电容器、静电屏蔽袋或导电材料中储存和运输。所有测试和包括工作台和地板在内的测量工具必须接地。操作员还必须使用腕带接地。半导体不得赤手触摸设备。对于安装有半导体器件的印刷电路板，必须采取类似的预防措施。

### 2. 上电处理

通电时产品的状态是不确定的。LSI内部电路的状态是不确定的，通电时寄存器设置和引脚未定义。在将复位信号施加到外部复位的成品中管脚，从通电到复位过程完成，管脚的状态不能保证。以类似的方式，引脚的状态在通过片内上电复位功能复位的产品中，从供电时间到供电达到指定重置的级别。

### 3. 断电状态下的信号输入

请勿在设备断电时输入信号或IO上拉电源。输入此类信号或IO导致的电流注入上拉电源可能会导致故障，此时通过设备的异常电流可能会导致内部退化元素。请按照产品文档中所述的电源关闭状态下的输入信号指南进行操作。

### 4. 处理未使用的引脚

按照手册中未使用引脚处理中给出的说明处理未使用的引脚。CMOS产品的输入引脚是一般处于高阻状态。在开路状态下使用未使用的引脚操作时，会在附近感应出额外的电磁噪声LSI，相关的直通电流在内部流动，并且由于将引脚状态错误识别为输入信号而发生故障成为可能。

### 5. 时钟信号

应用复位后，只有在工作时钟信号稳定后才释放复位线。在程序中切换时钟信号时执行，等待目标时钟信号稳定。当时钟信号由外部谐振器或外部振荡器产生时在复位期间，确保只有在时钟信号完全稳定后才释放复位线。此外，当切换到时钟信号时在程序执行过程中由外部谐振器或外部振荡器产生，等待目标时钟信号稳定。

### 6. 输入引脚的电压施加波形

由于输入噪声或反射波导致的波形失真可能会导致故障。如果CMOS器件的输入保持在 $V_{IL}$ 之间的区域(Max.)和 $V_{IH}$ (Min.)由于噪音，例如，设备可能发生故障。小心，以防止颤动的噪音进入设备时，输入电平是固定的，并且在输入电平通过 $V_{IL}$ (Max.)和 $V_{IH}$ (Min.)之间的区域时的过渡期间也是如此。

### 7. 禁止访问保留地址

禁止访问保留地址。保留地址是为将来可能的功能扩展提供的。不要访问这些不能保证LSI的正确操作。

### 8. 产品之间的差异

在从一种产品更改为另一种产品之前，例如更改为具有不同部件号的产品，请确认更改不会导致问题。同一组中的微处理单元或微控制器单元产品的特性，但具有不同的部件号，其特性可能会有所不同内部存储器容量，布局模式和其他因素，这些因素会影响电气特性的范围，例如特性值，工作裕度、抗噪声能力和辐射噪声量。当更改为具有不同部件号的产品时，实施系统-给定产品的评估测试。

# Preface

## 1. About this document

This manual is generally organized into an overview of the product, descriptions of the CPU, system control functions, peripheral functions, electrical characteristics, and usage notes. This manual describes the product specification of the microcontroller (MCU) superset. Depending on your product, some pins, registers, or functions might not exist. Address space that store unavailable registers are reserved.

## 2. Audience

This manual is written for system designers who are designing and programming applications using the Renesas Microcontroller. The user is expected to have basic knowledge of electrical circuits, logic circuits, and the MCU.

## 3. Renesas Publications

Renesas provides the following documents. Before using any of these documents, visit [www.renesas.com](http://www.renesas.com) for the most up-to-date version of the document.

| Component               | Document Type                    | Description  |
|-------------------------|----------------------------------|--|
| Microcontrollers        | Data sheet                       | Features, overview, and electrical characteristics of the MCU  |
|                         | User's Manual: Hardware          | MCU specifications such as pin assignments, memory maps, peripheral functions, electrical characteristics, timing diagrams, and operation descriptions   |
|                         | Application Notes                | Technical notes, board design guidelines, and software migration information   |
|                         | Technical Update (TU)            | Preliminary reports on product specifications such as restriction and errata   |
| Software                | User's Manual: Software          | API reference and programming information  |
|                         | Application Notes                | Project files, guidelines for software programming, and application examples to develop embedded software applications   |
| Tools & Kits, Solutions | User's Manual: Development Tools | User's manual and quick start guide for developing embedded software applications with Development Kits (DK), Starter Kits (SK), Promotion Kits (PK), Product Examples (PE), and Application Examples (AE) |
|                         | User's Manual: Software          |  |
|                         | Quick Start Guide                |  |
|                         | Application Notes                | Project files, guidelines for software programming, and application examples to develop embedded software applications   |

# Preface

## 1. 关于本文档

本手册一般由产品概述、CPU说明、系统控制功能、外围功能、电气特性和使用说明组成。本手册描述了微控制器(MCU)超集的产品规格。根据您的产品,某些引脚、寄存器或功能可能不存在。保留存储不可用寄存器的地址空间。

## 2. Audience

本手册是为使用瑞萨微控制器设计和编程应用程序的系统设计人员编写的。要求用户具备电路、逻辑电路和MCU的基本知识。

## 3. Renesas Publications

瑞萨电子提供以下文件。在使用任何这些文档之前,请访问[www.renesas.com](http://www.renesas.com)以获取该文档的最新版本。

| Component        | 文件类型                    | Description   |
|------------------|-------------------------|---|
| Microcontrollers | 数据表                     | MCU的特性、概述和电气特性  |
|                  | User's Manual: Hardware | MCU规范,例如引脚分配、存储器映射、外设功能、电气特性、时序图和操作描述                             |
|                  | 应用笔记                    | 技术说明、电路板设计指南和软件迁移信息   |
|                  | 技术更新(TU)                | 限制、勘误等产品规格的初步报告   |
| Software         | User's Manual: Software | API参考和编程信息  |
|                  | 应用笔记                    | 用于开发嵌入式软件应用程序的项目文件、软件编程指南和应用程序示例                                  |
| 工具和套件 解决方案       | 用户手册: 开发工具              | 使用开发套件(DK)、入门套件(SK)、促销套件(PK)、产品示例(PE)和应用程序开发嵌入式软件应用程序的用户手册和快速入门指南 |
|                  | User's Manual: Software |   |
|                  | 快速入门指南                  | Examples (AE)   |
|                  | 应用笔记                    | 用于开发嵌入式软件应用程序的项目文件、软件编程指南和应用程序示例                                  |

## 4. Numbering Notation

The following numbering notation is used throughout this manual:

| Example | Description   |
|---------|---|
| 011b    | Binary number. For example, the binary equivalent of the number 3 is 011b.  |
| 0x1F    | Hexadecimal number. For example, the hexadecimal equivalent of the number 31 is described 0x1F. In some cases, a hexadecimal number is shown with the suffix "h". |
| 1234    | Decimal number. A decimal number is followed by this symbol only when the possibility of confusion exists. Decimal numbers are generally shown without a suffix.  |

## 5. Typographic Notation

The following typographic notation is used throughout this manual:

| Example            | Description  |
|--------------------|--|
| WDT.WDTRCR.RSTIRQS | Periods separated a function module symbol (WDT), register symbol (WDTRCR), and bit field symbol (RSTIRQS).                          |
| WDT.WDTRCR         | A period separated a function module symbol (WDT) and register symbol (WDTRCR).  |
| WDTRCR.RSTIRQS     | A period separated a register symbol (WDTRCR) and bit field symbol (RSTIRQS).  |
| CKS[3:0]           | Numbers in brackets expresses a bit number. For example, CKS[3:0] occupies bits 3 to 0 of the WDT Control Register (WDTCR) register. |

## 6. Unit and Unit Prefix

The following units and unit prefixes are sometimes misleading. Those unit prefixes are described throughout this manual with the following meaning:

| Symbol | Name         | Description  |
|--------|--------------|--|
| b      | Binary Digit | Single 0 or 1  |
| B      | Byte         | This unit is generally used for memory specification of the MCU and address space.   |
| k      | kilo-        | 1000 = 10 <sup>3</sup> . k is also used to denote 1024 (2 <sup>10</sup> ) but this unit prefix is used to denote 1000 (10 <sup>3</sup> ) throughout this manual. |
| K      | Kilo-        | 1024 = 2 <sup>10</sup> . This unit prefix is used to denote 1024 (2 <sup>10</sup> ) not 1000 (10 <sup>3</sup> ) throughout this manual.                          |

## 7. Special Terms

The following terms have special meanings.

| Term | Description   |
|------|---|
| NC   | Not connected pin. NC means that pin is not connected to the MCU. |
| Hi-Z | High impedance.   |

## 4. 编号符号

本手册通篇使用以下编号符号：

| Example | Description   |
|---------|---|
| 011b    | 二进制数。例如，数字3的二进制等价物是011b。                              |
| 0x1F    | 十六进制数。例如，数字31的十六进制等效项被描述为0x1F。在某些情况下，显示的十六进制数带有后缀“h”。 |
| 1234    | 十进制数。仅当存在混淆的可能性时，才在十进制数后面加上此符号。十进制数字通常不带后缀。           |

## 5. 排版符号

本手册通篇使用以下印刷符号：

| Example            | Description  |
|--------------------|--|
| WDT.WDTRCR.RSTIRQS | 句点分隔功能模块符号(WDT)、寄存器符号(WDTRCR)和位域符号(RSTIRQS)。       |
| WDT.WDTRCR         | 句点分隔功能模块符号(WDT)和寄存器符号(WDTRCR)。                     |
| WDTRCR.RSTIRQS     | 一个句点分隔寄存器符号(WDTRCR)和位域符号(RSTIRQS)。                 |
| CKS[3:0]           | 括号中的数字表示一个位数。例如，CKS[3:0]占用WDT的3到0位控制寄存器(WDTCR)寄存器。 |

## 6. 单位和单位前缀

以下单位和单位前缀有时会产生误导。这些单位前缀在本手册中进行了描述，含义如下：

| Symbol | Name  | Description  |
|--------|-------|--|
| b      | 二进制数字 | 单个0或1  |
| B      | Byte  | 该单元一般用于MCU的内存规范和地址空间。  |
| k      | kilo- | 1000=10 <sup>3</sup> 。k也用于表示1024(2 <sup>10</sup> )，但在本手册中，此单位前缀用于表示1000(10 <sup>3</sup> )。 |
| K      | Kilo- | 1024=2 <sup>10</sup> 。在本手册中，该单位前缀用于表示1024(2 <sup>10</sup> )而不是1000(10 <sup>3</sup> )。      |

## 7. 特别条款

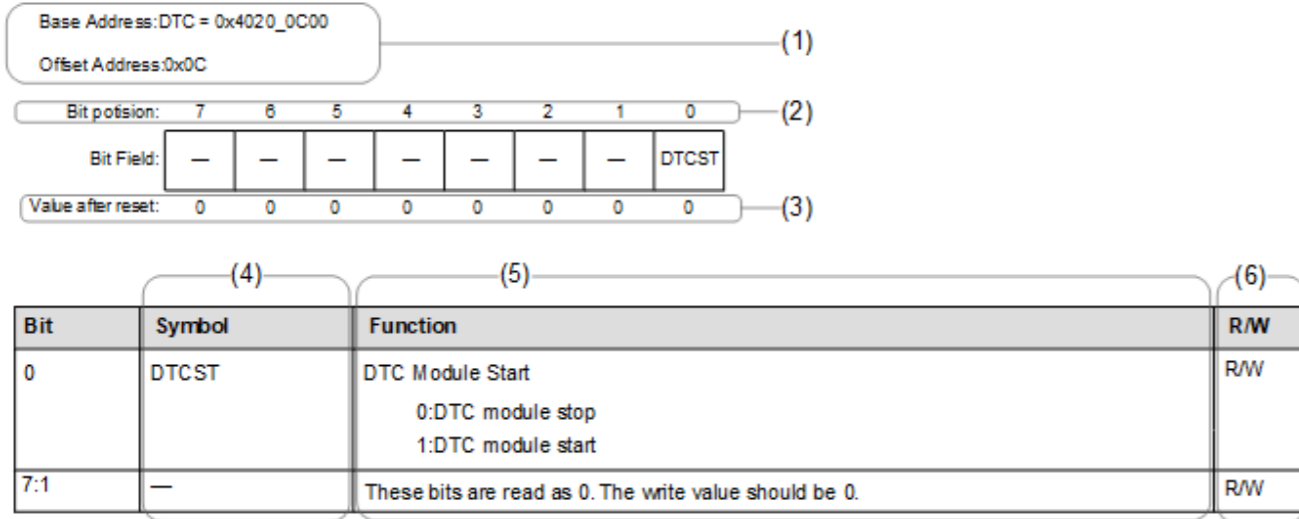
以下术语具有特殊含义。

| Term | Description           |
|------|-----------------------|
| NC   | 未连接引脚。NC表示该引脚未连接到MCU。 |
| Hi-Z | 高阻抗。                  |

## 8. Register Description

Each register description includes both a register diagram that shows the bit assignments and a register bit table that describes the content of each bit. The example of symbols used in these tables are described in the sections that follow. The following is an example of a register description and associated bit field definition.

### XX.XX DTCST : DTC Module Start Register



#### (1) Function module symbol, register symbol, and address assignment

Function module symbol, register symbol, and address assignment of this register are generally expressed. Base Address and Offset Address mean DTC Module Start Register (DTCST) of Data Transfer Controller (DTC) is assigned to address 0x4020\_0C00.

#### (2) Bit number

This number indicates the bit number. This bits are shown in order from bits 31 to 0 for 32-bit register, from bits 15 to 0 for 16-bit register, and from bits 7 to 0 for 8-bit register.

#### (3) Value after reset

This symbol or number indicate the value of each bit after a hard reset. The value is shown in binary unless specified otherwise.

- 0: Indicates that the value is 0 after a reset.
- 1: Indicates that the value is 1 after a reset.
- x: Indicates that the value is undefined after a reset.

#### (4) Symbol

Symbol indicates the short name of bit field. Reserved bit is expressed with a —.

#### (5) Function

Function indicates the full name of the bit field and enumerated values.

#### (6) R/W

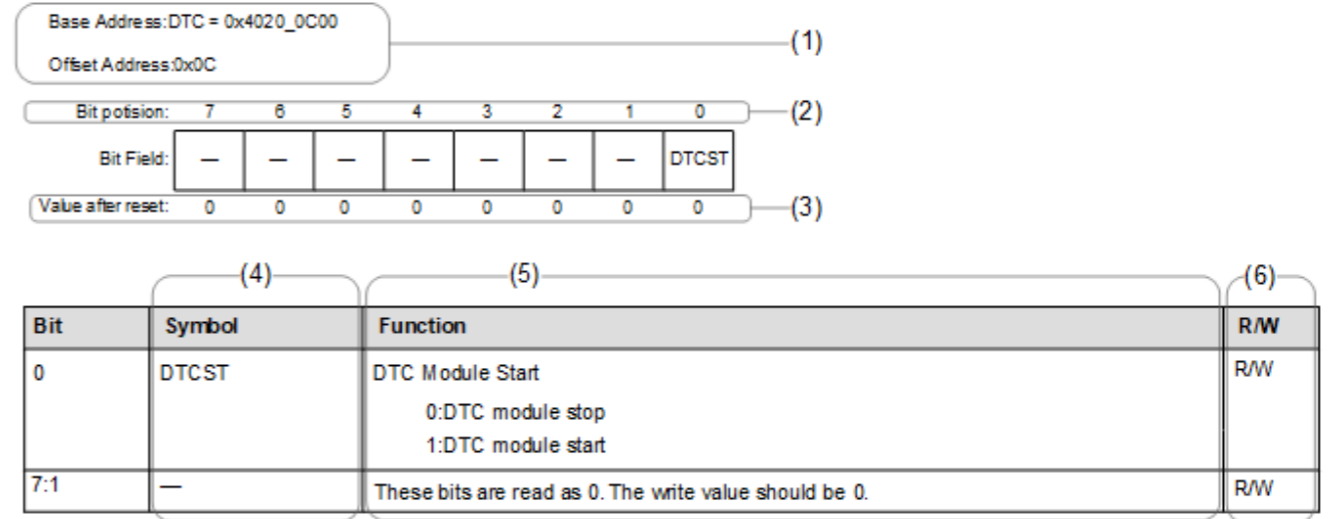
The R/W column indicates access type whether the bit field is readable or writable.

- R/W: The bit field is readable and writable.
- R: The bit field is readable only. Writing to this bit field has no effect.
- W: The bit field is writable only. The read value is the same as after a reset unless specified otherwise.

## 8. 注册说明

每个寄存器描述都包括一个显示位分配的寄存器图和一个描述每个位内容的寄存器位表。这些表中使用的符号示例将在以下部分中描述。以下是寄存器描述和相关位字段定义的示例。

### XX.XX DTCST : DTC Module Start Register



#### (1) 功能模块符号、寄存器符号、地址分配

一般表示该寄存器的功能模块符号、寄存器符号、地址分配。基地址和偏移地址意味着数据传输控制器(DTC)的DTC模块起始寄存器(DTCST)分配到地址0x4020\_0C00。

#### (2) 位号

该数字表示位数。对于32位寄存器，这些位按位31到0、16位寄存器从位15到0、8位寄存器从位7到0的顺序显示。

#### (3) 复位后的值

该符号或数字表示硬复位后每个位的值。除非另有说明，否则该值以二进制显示。

- 0: 表示复位后值为0。
- 1: 表示复位后值为1。
- x: 表示复位后该值未定义。

#### (4) Symbol

符号表示位域的简称。保留位用—表示。

#### (5) Function

函数表示位域的全称和枚举值。

#### (6) R/W

RW列指示位字段是可读还是可写的访问类型。

- RW: 位域可读可写。
- R: 位域是只读的。写入该位域无效。
- W: 位域只可写。除非另有说明，否则读取的值与复位后的值相同。



## 9. Abbreviations

Abbreviations used in this document are shown in the following table.

| Abbreviation | Description                                 |
|--------------|---|
| AES          | Advanced Encryption Standard                |
| AHB          | Advanced High-performance Bus               |
| AHB-AP       | AHB Access Port                             |
| APB          | Advanced Peripheral Bus                     |
| ARC          | Alleged RC                                  |
| ATB          | Advanced Trace Bus                          |
| BCD          | Binary Coded Decimal                        |
| BSDL         | Boundary Scan Description Language          |
| DES          | Data Encryption Standard                    |
| DSA          | Digital Signature Algorithm                 |
| ETB          | Embedded Trace Buffer                       |
| ETM          | Embedded Trace Macrocell                    |
| FLL          | Frequency Locked Loop                       |
| FPU          | Floating Point Unit                         |
| HMI          | Human Machine Interface                     |
| IrDA         | Infrared Data Association                   |
| LSB          | Least Significant Bit                       |
| MSB          | Most Significant Bit                        |
| NVIC         | Nested Vector Interrupt Controller          |
| PC           | Program Counter                             |
| PFS          | Port Function Select                        |
| PLL          | Phase Locked Loop                           |
| POR          | Power-on reset                              |
| PWM          | Pulse Width Modulation                      |
| RSA          | Rivest Shamir Adleman                       |
| SHA          | Secure Hash Algorithm                       |
| S/H          | Sample and Hold                             |
| SP           | Stack Pointer                               |
| SWD          | Serial Wire Debug                           |
| SW-DP        | Serial Wire-Debug Port                      |
| TRNG         | True Random Number Generator                |
| UART         | Universal Asynchronous Receiver/Transmitter |
| VCO          | Voltage Controlled Oscillator               |

## 9. Abbreviations

本文中使用的缩写如下表所示。

| Abbreviation | Description           |
|--------------|-----------------------|
| AES          | 高级加密标准                |
| AHB          | 先进的高性能总线              |
| AHB-AP       | AHB访问端口               |
| APB          | 先进的外围总线               |
| ARC          | Alleged RC            |
| ATB          | 高级跟踪总线                |
| BCD          | 二进制编码的十进制             |
| BSDL         | 边界扫描描述语言              |
| DES          | 数据加密标准                |
| DSA          | 数字签名算法                |
| ETB          | 嵌入式跟踪缓冲区              |
| ETM          | 嵌入式跟踪宏单元              |
| FLL          | 锁频环                   |
| FPU          | 浮点单元                  |
| HMI          | 人机接口                  |
| IrDA         | 红外数据协会                |
| LSB          | 最低有效位                 |
| MSB          | 最高有效位                 |
| NVIC         | 嵌套向量中断控制器             |
| PC           | 程序计数器                 |
| PFS          | 端口功能选择                |
| PLL          | 锁相环                   |
| POR          | Power-on reset        |
| PWM          | 脉冲宽度调制                |
| RSA          | Rivest Shamir Adleman |
| SHA          | 安全哈希算法                |
| S/H          | 采样和保持                 |
| SP           | 堆栈指针                  |
| SWD          | 串口线调试                 |
| SW-DP        | 串行线调试端口               |
| TRNG         | 真随机数发生器               |
| UART         | 通用异步收发器               |
| VCO          | 压控振荡器                 |

## 10. Proprietary Notice

All text, graphics, photographs, trademarks, logos, artwork and computer code, collectively known as content, contained in this document is owned, controlled or licensed by or to Renesas, and is protected by trade dress, copyright, patent and trademark laws, and other intellectual property rights and unfair competition laws. Except as expressly provided herein, no part of this document or content may be copied, reproduced, republished, posted, publicly displayed, encoded, translated, transmitted or distributed in any other medium for publication or distribution or for any commercial enterprise, without prior written consent from Renesas.

Arm® and Cortex® are registered trademarks of Arm Limited. CoreSight™ is a trademark of Arm Limited.

CoreMark® is a registered trademark of the Embedded Microprocessor Benchmark Consortium.

Other brands and names mentioned in this document may be the trademarks or registered trademarks of their respective holders.

## 11. Feedback on the product

If you have any comments or suggestions about this product, go to [Contact Us](#).

## 10. 所有权声明

本文档中包含的所有文本、图形、照片、商标、徽标、艺术品和计算机代码（统称为内容）均归瑞萨电子所有、控制或许可，并受商业外观、版权、专利和商标法的保护，以及其他知识产权和不正当竞争法。除非在此明确规定，否则未经事先书面同意，不得将本文档或内容的任何部分复制、复制、再版、张贴、公开展示、编码、翻译、传输或分发到任何其他媒体中以供出版或分发或用于任何商业企业瑞萨电子的同意。

Arm®和Cortex®是Arm Limited的注册商标。CoreSight™是Arm Limited的商标。

CoreMark®是嵌入式微处理器基准联盟的注册商标。

本文档中提及的其他品牌和名称可能是其各自所有者的商标或注册商标。

## 11. 产品反馈

如果您对本产品有任何意见或建议，请前往联系我们。

RA生态工作室

# Contents

|  |           |
|--|-----------|
| <b>Features</b> .....  | <b>51</b> |
| <b>1. Overview</b> .....   | <b>52</b> |
| 1.1 Function Outline .....                                       | 52        |
| 1.2 Block Diagram .....  | 57        |
| 1.3 Part Numbering .....   | 57        |
| 1.4 Function Comparison .....                                    | 59        |
| 1.5 Pin Functions.....   | 60        |
| 1.6 Pin Assignments.....   | 64        |
| 1.7 Pin Lists .....  | 66        |
| <b>2. CPU</b> .....  | <b>70</b> |
| 2.1 Overview.....  | 70        |
| 2.1.1 CPU .....  | 70        |
| 2.1.2 Debug .....  | 70        |
| 2.1.3 Operating Frequency .....                                  | 71        |
| 2.1.4 Block Diagram .....  | 71        |
| 2.2 Implementation Options.....                                  | 72        |
| 2.3 Trace Interface.....   | 73        |
| 2.4 JTAG/SWD Interface .....                                     | 73        |
| 2.5 Security Attribution for Memory .....                        | 74        |
| 2.6 Debug Function .....   | 74        |
| 2.6.1 Debugger connectivity .....                                | 74        |
| 2.6.2 Emulator Connection .....                                  | 75        |
| 2.6.3 Self-Hosted Debug Function.....                            | 76        |
| 2.6.4 Effect of Debug Function .....                             | 76        |
| 2.7 Programmers Model .....                                      | 76        |
| 2.7.1 Address Spaces.....  | 76        |
| 2.7.2 Peripheral Address Map .....                               | 77        |
| 2.7.3 CoreSight ROM Table .....                                  | 77        |
| 2.7.4 DBGREG Module .....  | 79        |
| 2.7.5 OCDREG Module .....  | 81        |
| 2.7.6 CPUDSAR : CPU Debug Security Attribution Register .....    | 83        |
| 2.7.7 Processing on Error response generated by CPU access ..... | 83        |
| 2.8 CoreSight Cross Trigger Interface (CTI).....                 | 85        |
| 2.9 CoreSight ATB Funnel.....                                    | 86        |
| 2.10 Break Point Unit.....                                       | 87        |
| 2.11 CoreSight Time Stamp Generator .....                        | 87        |
| 2.12 SysTick Timer .....   | 87        |

# Contents

|                                       |           |
|---------------------------------------|-----------|
| <b>Features</b> .....                 | <b>51</b> |
| <b>1. Overview</b> .....              | <b>52</b> |
| 1.1 功能概要.....                         | 52        |
| 1.2 框图.....                           | 57        |
| 1.3 零件编号.....                         | 57        |
| 1.4 功能比较.....                         | 59        |
| 1.5 Pin Functions.....                | 60        |
| 1.6 Pin Assignments.....              | 64        |
| 1.7 Pin Lists .....                   | 66        |
| <b>2. CPU</b> .....                   | <b>70</b> |
| 2.1 Overview.....                     | 70        |
| 2.1.1 CPU .....                       | 70        |
| 2.1.2 Debug .....                     | 70        |
| 2.1.3 工作频率.....                       | 71        |
| 2.1.4 框图.....                         | 71        |
| 2.2 Implementation Options.....       | 72        |
| 2.3 Trace Interface.....              | 73        |
| 2.4 JTAG/SWD Interface .....          | 73        |
| 2.5 内存的安全归属.....                      | 74        |
| 2.6 调试功能.....                         | 74        |
| 2.6.1 调试器连接.....                      | 74        |
| 2.6.2 仿真器连接.....                      | 75        |
| 2.6.3 Self-Hosted Debug Function..... | 76        |
| 2.6.4 调试功能的作用.....                    | 76        |
| 2.7 Programmers Model .....           | 76        |
| 2.7.1 Address Spaces.....             | 76        |
| 2.7.2 外设地址映射.....                     | 77        |
| 2.7.3 CoreSight ROM Table .....       | 77        |
| 2.7.4 DBGREG Module .....             | 79        |
| 2.7.5 OCDREG Module .....             | 81        |
| 2.7.6 CPUDSAR: CPU调试安全属性寄存器.....      | 83        |
| 2.7.7 处理CPU访问产生的错误响应.....             | 83        |
| 2.8 CoreSight交叉触发接口(CTI).....         | 85        |
| 2.9 CoreSight ATB Funnel.....         | 86        |
| 2.10 断点单元.....                        | 87        |
| 2.11 CoreSight时间戳生成器.....             | 87        |
| 2.12 SysTick Timer .....              | 87        |

|           |  |            |
|-----------|--|------------|
| 2.13      | OCD Emulator Connection .....  | 87         |
| 2.13.1    | DBGEN .....  | 88         |
| 2.13.2    | Restrictions on Connecting an OCD emulator .....                       | 88         |
| 2.14      | References .....   | 89         |
| <b>3.</b> | <b>Operating Modes .....</b>   | <b>90</b>  |
| 3.1       | Overview .....   | 90         |
| 3.2       | Details of Operating Modes .....                                       | 90         |
| 3.2.1     | Single-Chip Mode .....   | 90         |
| 3.2.2     | SCI Boot Mode .....  | 90         |
| 3.2.3     | USB Boot Mode .....  | 90         |
| 3.3       | Operating Modes Transitions .....                                      | 90         |
| 3.3.1     | Operating Mode Transitions as Determined by the Mode-Setting Pin ..... | 90         |
| <b>4.</b> | <b>Address Space .....</b>   | <b>92</b>  |
| 4.1       | Address Space .....  | 92         |
| 4.2       | External Address Space .....   | 93         |
| <b>5.</b> | <b>Resets .....</b>  | <b>94</b>  |
| 5.1       | Overview .....   | 94         |
| 5.2       | Register Descriptions .....  | 99         |
| 5.2.1     | RSTSAR : Reset Security Attribution Register .....                     | 99         |
| 5.2.2     | RSTSR0 : Reset Status Register 0 .....                                 | 100        |
| 5.2.3     | RSTSR1 : Reset Status Register 1 .....                                 | 102        |
| 5.2.4     | RSTSR2 : Reset Status Register 2 .....                                 | 104        |
| 5.3       | Operation .....  | 105        |
| 5.3.1     | RES Pin Reset .....  | 105        |
| 5.3.2     | Power-On Reset .....   | 105        |
| 5.3.3     | Voltage Monitor Reset .....  | 106        |
| 5.3.4     | Deep Software Standby Reset .....                                      | 107        |
| 5.3.5     | Independent Watchdog Timer Reset .....                                 | 108        |
| 5.3.6     | Watchdog Timer Reset .....   | 108        |
| 5.3.7     | Software Reset .....   | 108        |
| 5.3.8     | Determination of Cold/Warm Start .....                                 | 108        |
| 5.3.9     | Determination of Reset Generation Source .....                         | 109        |
| <b>6.</b> | <b>Option-Setting Memory .....</b>                                     | <b>110</b> |
| 6.1       | Overview .....   | 110        |
| 6.2       | Register Descriptions .....  | 111        |
| 6.2.1     | OFS0 : Option Function Select Register 0 .....                         | 111        |
| 6.2.2     | SAS : Startup Area Setting Register .....                              | 114        |
| 6.2.3     | OFS1, OFS1_SEC, OFS1_SEL : Option Function Select Register 1 .....     | 115        |
| 6.2.4     | BANKSEL, BANKSEL_SEC, BANKSEL_SEL : Bank Select Register .....         | 116        |

|           |  |            |
|-----------|--|------------|
| 2.13      | OCD仿真器连接 .....                                 | 87         |
| 2.13.1    | DBGEN .....                                    | 88         |
| 2.13.2    | 连接OCD模拟器的限制 .....                              | 88         |
| 2.14      | References .....                               | 89         |
| <b>3.</b> | <b>操作模式 .....</b>                              | <b>90</b>  |
| 3.1       | Overview .....                                 | 90         |
| 3.2       | 操作模式的详细信息 .....                                | 90         |
| 3.2.1     | Single-Chip Mode .....                         | 90         |
| 3.2.2     | SCI启动模式 .....                                  | 90         |
| 3.2.3     | USB启动模式 .....                                  | 90         |
| 3.3       | 操作模式转换 .....                                   | 90         |
| 3.3.1     | 由模式设置引脚确定的工作模式转换 .....                         | 90         |
| <b>4.</b> | <b>Address Space .....</b>                     | <b>92</b>  |
| 4.1       | 地址空间 .....                                     | 92         |
| 4.2       | 外部地址空间 .....                                   | 93         |
| <b>5.</b> | <b>Resets .....</b>                            | <b>94</b>  |
| 5.1       | Overview .....                                 | 94         |
| 5.2       | 寄存器说明 .....                                    | 99         |
| 5.2.1     | RSTSAR: 重置安全属性寄存器 .....                        | 99         |
| 5.2.2     | RSTSR0: 复位状态寄存器0 .....                         | 100        |
| 5.2.3     | RSTSR1: 复位状态寄存器1 .....                         | 102        |
| 5.2.4     | RSTSR2: 复位状态寄存器2 .....                         | 104        |
| 5.3       | Operation .....                                | 105        |
| 5.3.1     | RES引脚复位 .....                                  | 105        |
| 5.3.2     | Power-On Reset .....                           | 105        |
| 5.3.3     | 电压监控器复位 .....                                  | 106        |
| 5.3.4     | 深度软件待机复位 .....                                 | 107        |
| 5.3.5     | 独立看门狗定时器复位 .....                               | 108        |
| 5.3.6     | 看门狗定时器复位 .....                                 | 108        |
| 5.3.7     | 软件复位 .....                                     | 108        |
| 5.3.8     | 冷暖启动的确定 .....                                  | 108        |
| 5.3.9     | 复位产生源的确定 .....                                 | 109        |
| <b>6.</b> | <b>Option-Setting Memory .....</b>             | <b>110</b> |
| 6.1       | Overview .....                                 | 110        |
| 6.2       | 寄存器说明 .....                                    | 111        |
| 6.2.1     | OFS0: 选项功能选择寄存器0 .....                         | 111        |
| 6.2.2     | SAS: 启动区设置寄存器 .....                            | 114        |
| 6.2.3     | OFS1、OFS1_SEC、OFS1_SEL: 选项功能选择寄存器1 .....       | 115        |
| 6.2.4     | BANKSEL、BANKSEL_SEC、BANKSEL_SEL: 银行选择寄存器 ..... | 116        |



|           |  |            |
|-----------|--|------------|
| 6.2.5     | BPS, BPS_SEC, BPS_SEL : Block Protect Setting Register .....                           | 118        |
| 6.2.6     | PBPS, PBPS_SEC : Permanent Block Protect Setting Register .....                        | 119        |
| 6.3       | Setting Option-Setting Memory .....  | 120        |
| 6.3.1     | Allocation of Data in Option-Setting Memory .....                                      | 120        |
| 6.3.2     | Setting Data for Programming Option-Setting Memory .....                               | 120        |
| 6.3.3     | Security attribution of option-setting memory .....                                    | 120        |
| 6.3.4     | Timing of the Setting Value .....  | 121        |
| 6.4       | Usage Notes .....  | 121        |
| 6.4.1     | Data for Programming Reserved Areas and Reserved Bits in the Option-Setting Memory ... | 121        |
| <b>7.</b> | <b>Low Voltage Detection (LVD) .....</b>   | <b>122</b> |
| 7.1       | Overview .....   | 122        |
| 7.2       | Register Descriptions .....  | 124        |
| 7.2.1     | LVDSAR : Low Voltage Detection Security Attribution Register .....                     | 124        |
| 7.2.2     | LVD1CMPCR : Voltage Monitoring 1 Comparator Control Register .....                     | 124        |
| 7.2.3     | LVD2CMPCR : Voltage Monitoring 2 Comparator Control Register .....                     | 125        |
| 7.2.4     | LVD1CR0 : Voltage Monitor 1 Circuit Control Register 0 .....                           | 126        |
| 7.2.5     | LVD2CR0 : Voltage Monitor 2 Circuit Control Register 0 .....                           | 127        |
| 7.2.6     | LVD1CR1 : Voltage Monitor 1 Circuit Control Register .....                             | 128        |
| 7.2.7     | LVD1SR : Voltage Monitor 1 Circuit Status Register .....                               | 129        |
| 7.2.8     | LVD2CR1 : Voltage Monitor 2 Circuit Control Register 1 .....                           | 129        |
| 7.2.9     | LVD2SR : Voltage Monitor 2 Circuit Status Register .....                               | 130        |
| 7.3       | VCC Input Voltage Monitor .....  | 130        |
| 7.3.1     | Monitoring Vdet0 .....   | 130        |
| 7.3.2     | Monitoring Vdet1 .....   | 130        |
| 7.3.3     | Monitoring Vdet2 .....   | 131        |
| 7.4       | Reset from Voltage Monitor 0 .....   | 131        |
| 7.5       | Interrupt and Reset from Voltage Monitor 1 .....                                       | 132        |
| 7.6       | Interrupt and Reset from Voltage Monitor 2 .....                                       | 135        |
| 7.7       | Event Link Controller (ELC) Output .....   | 137        |
| 7.7.1     | Interrupt Handling and Event Linking .....   | 138        |
| <b>8.</b> | <b>Clock Generation Circuit .....</b>  | <b>139</b> |
| 8.1       | Overview .....   | 139        |
| 8.2       | Register Descriptions .....  | 143        |
| 8.2.1     | CGFSAR : Clock Generation Function Security Attribute Register .....                   | 143        |
| 8.2.2     | SCKDIVCR : System Clock Division Control Register .....                                | 145        |
| 8.2.3     | SCKSCR : System Clock Source Control Register .....                                    | 147        |
| 8.2.4     | PLLCCR : PLL Clock Control Register .....  | 148        |
| 8.2.5     | PLLCR : PLL Control Register .....   | 149        |
| 8.2.6     | PLL2CCR : PLL2 Clock Control Register .....  | 149        |

|           |                                   |            |
|-----------|-----------------------------------|------------|
| 6.2.5     | BPS BPS_SEC BPS_SEL:块保护设置寄存器..... | 118        |
| 6.2.6     | PBPS PBPS_SEC:永久块保护设置寄存器.....     | 119        |
| 6.3       | 设置选项设置记忆.....                     | 120        |
| 6.3.1     | 选项设置内存中的数据分配.....                 | 120        |
| 6.3.2     | 编程选项设置存储器的设置数据.....               | 120        |
| 6.3.3     | 选项设置内存的安全属性.....                  | 120        |
| 6.3.4     | 设定值的时机.....                       | 121        |
| 6.4       | Usage Notes .....                 | 121        |
| 6.4.1     | 用于编程选项设置存储器中的保留区域和保留位的数据...121    |            |
| <b>7.</b> | <b>低电压检测(LVD).....</b>            | <b>122</b> |
| 7.1       | Overview.....                     | 122        |
| 7.2       | 寄存器说明.....                        | 124        |
| 7.2.1     | LVDSAR:低电压检测安全属性寄存器.....          | 124        |
| 7.2.2     | LVD1CMPCR:电压监控1比较器控制寄存器.....      | 124        |
| 7.2.3     | LVD2CMPCR:电压监测2比较器控制寄存器.....      | 125        |
| 7.2.4     | LVD1CR0:电压监视器1电路控制寄存器0.....       | 126        |
| 7.2.5     | LVD2CR0:电压监视器2电路控制寄存器0.....       | 127        |
| 7.2.6     | LVD1CR1:电压监视器1电路控制寄存器.....        | 128        |
| 7.2.7     | LVD1SR:电压监视器1电路状态寄存器.....         | 129        |
| 7.2.8     | LVD2CR1:电压监视器2电路控制寄存器1.....       | 129        |
| 7.2.9     | LVD2SR:电压监视器2电路状态寄存器.....         | 130        |
| 7.3       | VCC输入电压监视器.....                   | 130        |
| 7.3.1     | Monitoring Vdet0.....             | 130        |
| 7.3.2     | Monitoring Vdet1.....             | 130        |
| 7.3.3     | Monitoring Vdet2.....             | 131        |
| 7.4       | 从电压监视器复位0.....                    | 131        |
| 7.5       | 电压监视器1的中断和复位.....                 | 132        |
| 7.6       | 电压监视器2的中断和复位.....                 | 135        |
| 7.7       | 事件链接控制器(ELC)输出.....               | 137        |
| 7.7.1     | 中断处理和事件链接.....                    | 138        |
| <b>8.</b> | <b>时钟产生电路.....</b>                | <b>139</b> |
| 8.1       | Overview.....                     | 139        |
| 8.2       | 寄存器说明.....                        | 143        |
| 8.2.1     | CGFSAR:时钟生成功能安全属性寄存器.....         | 143        |
| 8.2.2     | SCKDIVCR:系统时钟分频控制寄存器.....         | 145        |
| 8.2.3     | SCKSCR:系统时钟源控制寄存器.....            | 147        |
| 8.2.4     | PLLCCR:PLL时钟控制寄存器.....            | 148        |
| 8.2.5     | PLLCR:PLL Control Register.....   | 149        |
| 8.2.6     | PLL2CCR:PLL2时钟控制寄存器.....          | 149        |

|        |   |     |
|--------|---|-----|
| 8.2.7  | PLL2CR : PLL2 Control Register                                  | 150 |
| 8.2.8  | MOSCCR : Main Clock Oscillator Control Register                 | 151 |
| 8.2.9  | SOSCCR : Sub-Clock Oscillator Control Register                  | 152 |
| 8.2.10 | LOCOCR : Low-Speed On-Chip Oscillator Control Register          | 153 |
| 8.2.11 | HOCOOCR : High-Speed On-Chip Oscillator Control Register        | 154 |
| 8.2.12 | MOCOOCR : Middle-Speed On-Chip Oscillator Control Register      | 155 |
| 8.2.13 | FLLCR1 : FLL Control Register1                                  | 155 |
| 8.2.14 | FLLCR2 : FLL Control Register2                                  | 157 |
| 8.2.15 | OSCSF : Oscillation Stabilization Flag Register                 | 157 |
| 8.2.16 | OSTDCR : Oscillation Stop Detection Control Register            | 159 |
| 8.2.17 | OSTDSR : Oscillation Stop Detection Status Register             | 160 |
| 8.2.18 | MOSCWTCR : Main Clock Oscillator Wait Control Register          | 160 |
| 8.2.19 | MOMCR : Main Clock Oscillator Mode Oscillation Control Register | 161 |
| 8.2.20 | SOMCR : Sub-Clock Oscillator Mode Control Register              | 162 |
| 8.2.21 | CKOCR : Clock Out Control Register                              | 162 |
| 8.2.22 | LOCOUTCR : LOCO User Trimming Control Register                  | 163 |
| 8.2.23 | MOCOUTCR : MOCO User Trimming Control Register                  | 164 |
| 8.2.24 | HOCOUTCR : HOCO User Trimming Control Register                  | 165 |
| 8.2.25 | USBCKDIVCR : USB Clock Division Control Register                | 165 |
| 8.2.26 | USBCKCR : USB Clock Control Register                            | 166 |
| 8.2.27 | TRCKCR : Trace Clock Control Register                           | 167 |
| 8.3    | Main Clock Oscillator   | 167 |
| 8.3.1  | Connecting a Crystal Resonator                                  | 167 |
| 8.3.2  | External Clock Input  | 168 |
| 8.3.3  | Notes on External Clock Input                                   | 168 |
| 8.4    | Sub-Clock Oscillator  | 168 |
| 8.4.1  | Connecting a 32.768-kHz Crystal Resonator                       | 169 |
| 8.4.2  | Pin Handling When the Sub-Clock Oscillator Is Not Used          | 169 |
| 8.5    | Oscillation Stop Detection Function                             | 170 |
| 8.5.1  | Oscillation Stop Detection and Operation after Detection        | 170 |
| 8.5.2  | Oscillation Stop Detection Interrupts                           | 171 |
| 8.6    | PLL Circuit   | 172 |
| 8.7    | Internal Clock  | 172 |
| 8.7.1  | System Clock (ICLK)   | 172 |
| 8.7.2  | Peripheral Module Clock (PCLKA, PCLKB, PCLKC, PCLKD)            | 173 |
| 8.7.3  | FlashIF Clock (FCLK)  | 173 |
| 8.7.4  | USB Clock (USBCLK)  | 174 |
| 8.7.5  | CAN Clock (CANMCLK)   | 174 |
| 8.7.6  | CAC Clock (CACCLK)  | 174 |
| 8.7.7  | RTC-Dedicated Clock (RTCSCLK, RTCLCLK)                          | 174 |

|        |  |     |
|--------|--|-----|
| 8.2.7  | PLL2CR : PLL2 Control Register         | 150 |
| 8.2.8  | MOSCCR:主时钟振荡器控制寄存器                     | 151 |
| 8.2.9  | SOSCCR:副时钟振荡器控制寄存器                     | 152 |
| 8.2.10 | LOCOCR:低速片上振荡器控制寄存器                    | 153 |
| 8.2.11 | HOCOOCR:高速片上振荡器控制寄存器                   | 154 |
| 8.2.12 | MOCOOCR:中速片上振荡器控制寄存器                   | 155 |
| 8.2.13 | FLLCR1 : FLL Control Register1         | 155 |
| 8.2.14 | FLLCR2 : FLL Control Register2         | 157 |
| 8.2.15 | OSCSF:振荡稳定标志寄存器                        | 157 |
| 8.2.16 | OSTDCR:振荡停止检测控制寄存器                     | 159 |
| 8.2.17 | OSTDSR:振荡停止检测状态寄存器                     | 160 |
| 8.2.18 | MOSCWTCR:主时钟振荡器等待控制寄存器                 | 160 |
| 8.2.19 | MOMCR:主时钟振荡器模式振荡控制寄存器                  | 161 |
| 8.2.20 | SOMCR:副时钟振荡器模式控制寄存器                    | 162 |
| 8.2.21 | CKOCR:时钟输出控制寄存器                        | 162 |
| 8.2.22 | LOCOUTCR:LOCO用户微调控制寄存器                 | 163 |
| 8.2.23 | MOCOUTCR:MOCO用户微调控制寄存器                 | 164 |
| 8.2.24 | HOCOUTCR:HOCO用户微调控制寄存器                 | 165 |
| 8.2.25 | USBCKDIVCR:USB时钟分频控制寄存器                | 165 |
| 8.2.26 | USBCKCR:USB时钟控制寄存器                     | 166 |
| 8.2.27 | TRCKCR:跟踪时钟控制寄存器                       | 167 |
| 8.3    | 主时钟振荡器                                 | 167 |
| 8.3.1  | 连接晶体谐振器                                | 167 |
| 8.3.2  | 外部时钟输入                                 | 168 |
| 8.3.3  | 外部时钟输入注意事项                             | 168 |
| 8.4    | Sub-Clock Oscillator                   | 168 |
| 8.4.1  | 连接32.768-kHz晶体谐振器                      | 169 |
| 8.4.2  | 不使用副时钟振荡器时的引脚处理                        | 169 |
| 8.5    | 振荡停止检测功能                               | 170 |
| 8.5.1  | 振荡停止检测和检测后的操作                          | 170 |
| 8.5.2  | 振荡停止检测中断                               | 171 |
| 8.6    | PLL Circuit                            | 172 |
| 8.7    | Internal Clock                         | 172 |
| 8.7.1  | 系统时钟(ICLK)                             | 172 |
| 8.7.2  | 外设模块时钟(PCLKA、PCLKB、PCLKC、PCLKD)        | 173 |
| 8.7.3  | FlashIF Clock (FCLK)                   | 173 |
| 8.7.4  | USB时钟(USBCLK)                          | 174 |
| 8.7.5  | CAN时钟(CANMCLK)                         | 174 |
| 8.7.6  | CAC时钟(CACCLK)                          | 174 |
| 8.7.7  | RTC-Dedicated Clock (RTCSCLK, RTCLCLK) | 174 |

|            |  |            |
|------------|--|------------|
| 8.7.8      | IWDT-Dedicated Clock (IWDTCLK)                                       | 174        |
| 8.7.9      | AGT-Dedicated Clock (AGTSCLK, AGTLCLK)                               | 174        |
| 8.7.10     | SysTick Timer-Dedicated Clock (SYSTICCLK)                            | 174        |
| 8.7.11     | External Pin Output Clock (CLKOUT)                                   | 174        |
| 8.7.12     | JTAG Clock (JTAGTCK)   | 175        |
| 8.8        | Usage Notes  | 175        |
| 8.8.1      | Notes on Clock Generation Circuit                                    | 175        |
| 8.8.2      | Notes on Resonator   | 175        |
| 8.8.3      | Notes on Board Design  | 175        |
| 8.8.4      | Notes on Resonator Connect Pin                                       | 176        |
| 8.8.5      | Notes on Using Sub-Clock Oscillator                                  | 176        |
| <b>9.</b>  | <b>Clock Frequency Accuracy Measurement Circuit (CAC)</b>            | <b>177</b> |
| 9.1        | Overview   | 177        |
| 9.2        | Register Descriptions  | 178        |
| 9.2.1      | CACR0 : CAC Control Register 0                                       | 178        |
| 9.2.2      | CACR1 : CAC Control Register 1                                       | 179        |
| 9.2.3      | CACR2 : CAC Control Register 2                                       | 179        |
| 9.2.4      | CAICR : CAC Interrupt Control Register                               | 180        |
| 9.2.5      | CASTR : CAC Status Register  | 181        |
| 9.2.6      | CAULVR : CAC Upper-Limit Value Setting Register                      | 182        |
| 9.2.7      | CALLVR : CAC Lower-Limit Value Setting Register                      | 183        |
| 9.2.8      | CACNTBR : CAC Counter Buffer Register                                | 183        |
| 9.3        | Operation  | 183        |
| 9.3.1      | Measuring Clock Frequency  | 183        |
| 9.3.2      | Digital Filtering of Signals on CACREF Pin                           | 185        |
| 9.4        | Interrupt Requests   | 185        |
| 9.5        | Usage Notes  | 185        |
| 9.5.1      | Settings for the Module-Stop Function                                | 185        |
| <b>10.</b> | <b>Low Power Modes</b>   | <b>186</b> |
| 10.1       | Overview   | 186        |
| 10.2       | Register Descriptions  | 190        |
| 10.2.1     | LPMSAR : Low Power Mode Security Attribution Register                | 190        |
| 10.2.2     | DPFSAR : Deep Standby Interrupt Factor Security Attribution Register | 191        |
| 10.2.3     | SBYCR : Standby Control Register                                     | 193        |
| 10.2.4     | MSTPCRA : Module Stop Control Register A                             | 193        |
| 10.2.5     | MSTPCRB : Module Stop Control Register B                             | 194        |
| 10.2.6     | MSTPCRC : Module Stop Control Register C                             | 196        |
| 10.2.7     | MSTPCRD : Module Stop Control Register D                             | 197        |
| 10.2.8     | MSTPCRE : Module Stop Control Register E                             | 198        |

|            |   |            |
|------------|---|------------|
| 8.7.8      | IWDT-Dedicated Clock (IWDTCLK)            | 174        |
| 8.7.9      | AGT-Dedicated Clock (AGTSCLK, AGTLCLK)    | 174        |
| 8.7.10     | SysTick Timer-Dedicated Clock (SYSTICCLK) | 174        |
| 8.7.11     | 外部引脚输出时钟 (CLKOUT)                         | 174        |
| 8.7.12     | JTAG Clock (JTAGTCK)                      | 175        |
| 8.8        | Usage Notes                               | 175        |
| 8.8.1      | 时钟产生电路的注意事项                               | 175        |
| 8.8.2      | 谐振器注意事项                                   | 175        |
| 8.8.3      | 电路板设计注意事项                                 | 175        |
| 8.8.4      | 谐振器连接引脚注意事项                               | 176        |
| 8.8.5      | 使用副时钟振荡器的注意事项                             | 176        |
| <b>9.</b>  | <b>时钟频率精度测量电路(CAC)</b>                    | <b>177</b> |
| 9.1        | Overview                                  | 177        |
| 9.2        | 寄存器说明                                     | 178        |
| 9.2.1      | CACR0: CAC控制寄存器0                          | 178        |
| 9.2.2      | CACR1: CAC控制寄存器1                          | 179        |
| 9.2.3      | CACR2: CAC控制寄存器2                          | 179        |
| 9.2.4      | CAICR: CAC中断控制寄存器                         | 180        |
| 9.2.5      | CASTR: CAC状态寄存器                           | 181        |
| 9.2.6      | CAULVR: CAC上限值设置寄存器                       | 182        |
| 9.2.7      | CALLVR: CAC下限值设置寄存器                       | 183        |
| 9.2.8      | CACNTBR: CAC计数器缓冲寄存器                      | 183        |
| 9.3        | Operation                                 | 183        |
| 9.3.1      | 测量时钟频率                                    | 183        |
| 9.3.2      | CACREF引脚上的信号数字滤波                          | 185        |
| 9.4        | Interrupt Requests                        | 185        |
| 9.5        | Usage Notes                               | 185        |
| 9.5.1      | 模块停止功能的设置                                 | 185        |
| <b>10.</b> | <b>低功耗模式</b>                              | <b>186</b> |
| 10.1       | Overview                                  | 186        |
| 10.2       | 寄存器说明                                     | 190        |
| 10.2.1     | LPMSAR: 低功耗模式安全属性寄存器                      | 190        |
| 10.2.2     | DPFSAR: 深度待机中断因素安全属性寄存器                   | 191        |
| 10.2.3     | SBYCR: 待机控制寄存器                            | 193        |
| 10.2.4     | MSTPCRA: 模块停止控制寄存器A                       | 193        |
| 10.2.5     | MSTPCRB: 模块停止控制寄存器B                       | 194        |
| 10.2.6     | MSTPCRC: 模块停止控制寄存器C                       | 196        |
| 10.2.7     | MSTPCRD: 模块停止控制寄存器D                       | 197        |
| 10.2.8     | MSPCRE: 模块停止控制寄存器E                        | 198        |

|         |   |     |
|---------|---|-----|
| 10.2.9  | OPCCR : Operating Power Control Register              | 199 |
| 10.2.10 | SOPCCR : Sub Operating Power Control Register         | 200 |
| 10.2.11 | SNZCR : Snooze Control Register                       | 202 |
| 10.2.12 | SNZEDCR0 : Snooze End Control Register 0              | 203 |
| 10.2.13 | SNZEDCR1 : Snooze End Control Register 1              | 204 |
| 10.2.14 | SNZREQCR0 : Snooze Request Control Register 0         | 205 |
| 10.2.15 | SNZREQCR1 : Snooze Request Control Register 1         | 207 |
| 10.2.16 | DPSBYCR : Deep Standby Control Register               | 207 |
| 10.2.17 | DPSWCR : Deep Standby Wait Control Register           | 209 |
| 10.2.18 | DPSIER0 : Deep Standby Interrupt Enable Register 0    | 209 |
| 10.2.19 | DPSIER1 : Deep Standby Interrupt Enable Register 1    | 210 |
| 10.2.20 | DPSIER2 : Deep Standby Interrupt Enable Register 2    | 211 |
| 10.2.21 | DPSIER3 : Deep Standby Interrupt Enable Register 3    | 212 |
| 10.2.22 | DPSIFR0 : Deep Standby Interrupt Flag Register 0      | 212 |
| 10.2.23 | DPSIFR1 : Deep Standby Interrupt Flag Register 1      | 214 |
| 10.2.24 | DPSIFR2 : Deep Standby Interrupt Flag Register 2      | 215 |
| 10.2.25 | DPSIFR3 : Deep Standby Interrupt Flag Register 3      | 216 |
| 10.2.26 | DPSIEGR0 : Deep Standby Interrupt Edge Register 0     | 217 |
| 10.2.27 | DPSIEGR1 : Deep Standby Interrupt Edge Register 1     | 218 |
| 10.2.28 | DPSIEGR2 : Deep Standby Interrupt Edge Register 2     | 219 |
| 10.2.29 | SYOCDRCR : System Control OCD Control Register        | 220 |
| 10.3    | Reducing Power Consumption by Switching Clock Signals | 220 |
| 10.4    | Module-Stop Function                                  | 221 |
| 10.5    | Function for Lower Operating Power Consumption        | 221 |
| 10.5.1  | Setting Operating Power Control Mode                  | 221 |
| 10.6    | Sleep Mode  | 222 |
| 10.6.1  | Transitioning to Sleep Mode                           | 222 |
| 10.6.2  | Canceling Sleep Mode                                  | 222 |
| 10.7    | Software Standby Mode                                 | 223 |
| 10.7.1  | Transitioning to Software Standby Mode                | 223 |
| 10.7.2  | Canceling Software Standby Mode                       | 224 |
| 10.7.3  | Example of Software Standby Mode Application          | 225 |
| 10.8    | Snooze Mode   | 226 |
| 10.8.1  | Transition to Snooze Mode                             | 226 |
| 10.8.2  | Canceling Snooze Mode                                 | 226 |
| 10.8.3  | Returning from Snooze Mode to Software Standby Mode   | 227 |
| 10.8.4  | Snooze Operation Example                              | 228 |
| 10.9    | Deep Software Standby Mode                            | 231 |
| 10.9.1  | Transitioning to Deep Software Standby Mode           | 231 |
| 10.9.2  | Cancelling Deep Software Standby Mode                 | 232 |

|         |                        |     |
|---------|------------------------|-----|
| 10.2.9  | OPCCR: 工作电源控制寄存器       | 199 |
| 10.2.10 | SOPCCR: 副操作功率控制寄存器     | 200 |
| 10.2.11 | SNZCR: 贪睡控制寄存器         | 202 |
| 10.2.12 | SNZEDCR0: 贪睡结束控制寄存器0   | 203 |
| 10.2.13 | SNZEDCR1: 贪睡结束控制寄存器1   | 204 |
| 10.2.14 | SNZREQCR0: 贪睡请求控制寄存器0  | 205 |
| 10.2.15 | SNZREQCR1: 贪睡请求控制寄存器1  | 207 |
| 10.2.16 | DPSBYCR: 深度待机控制寄存器     | 207 |
| 10.2.17 | DPSWCR: 深度待机等待控制寄存器    | 209 |
| 10.2.18 | DPSIER0: 深度待机中断使能寄存器0  | 209 |
| 10.2.19 | DPSIER1: 深度待机中断使能寄存器1  | 210 |
| 10.2.20 | DPSIER2: 深度待机中断使能寄存器2  | 211 |
| 10.2.21 | DPSIER3: 深度待机中断使能寄存器3  | 212 |
| 10.2.22 | DPSIFR0: 深度待机中断标志寄存器0  | 212 |
| 10.2.23 | DPSIFR1: 深度待机中断标志寄存器1  | 214 |
| 10.2.24 | DPSIFR2: 深度待机中断标志寄存器2  | 215 |
| 10.2.25 | DPSIFR3: 深度待机中断标志寄存器3  | 216 |
| 10.2.26 | DPSIEGR0: 深度待机中断边沿寄存器0 | 217 |
| 10.2.27 | DPSIEGR1: 深度待机中断边沿寄存器1 | 218 |
| 10.2.28 | DPSIEGR2: 深度待机中断边沿寄存器2 | 219 |
| 10.2.29 | SOOCDRCR: 系统控制OCD控制寄存器 | 220 |
| 10.3    | 通过切换时钟信号降低功耗           | 220 |
| 10.4    | Module-Stop Function   | 221 |
| 10.5    | 降低运行功耗的功能              | 221 |
| 10.5.1  | 设置工作电源控制模式             | 221 |
| 10.6    | 睡眠模式                   | 222 |
| 10.6.1  | 转换到睡眠模式                | 222 |
| 10.6.2  | 取消睡眠模式                 | 222 |
| 10.7    | 软件待机模式                 | 223 |
| 10.7.1  | 转换到软件待机模式              | 223 |
| 10.7.2  | 取消软件待机模式               | 224 |
| 10.7.3  | 软件待机模式应用示例             | 225 |
| 10.8    | 贪睡模式                   | 226 |
| 10.8.1  | 过渡到贪睡模式                | 226 |
| 10.8.2  | 取消贪睡模式                 | 226 |
| 10.8.3  | 从贪睡模式返回到软件待机模式         | 227 |
| 10.8.4  | 贪睡操作示例                 | 228 |
| 10.9    | 深度软件待机模式               | 231 |
| 10.9.1  | 过渡到深度软件待机模式            | 231 |
| 10.9.2  | 取消深度软件待机模式             | 232 |



|            |   |            |
|------------|---|------------|
| 10.9.3     | Pin States when Deep Software Standby mode is Canceled                        | 233        |
| 10.9.4     | Example of Deep Software Standby Mode Application                             | 233        |
| 10.9.5     | Usage Flow for Deep Software Standby Mode                                     | 234        |
| 10.10      | Usage Notes   | 235        |
| 10.10.1    | Register Access   | 235        |
| 10.10.2    | I/O Port pin states   | 237        |
| 10.10.3    | Module-Stop State of DTC, DMAC  | 237        |
| 10.10.4    | Internal Interrupt Sources  | 237        |
| 10.10.5    | Input Buffer Control by DIRQnE Bit  | 237        |
| 10.10.6    | Transitioning to Low Power Modes  | 237        |
| 10.10.7    | Timing of WFI Instruction   | 237        |
| 10.10.8    | Writing to the WDT/IWDT Registers by DTC or DMAC in Sleep Mode or Snooze Mode | 238        |
| 10.10.9    | Oscillators in Snooze Mode  | 238        |
| 10.10.1    | Snooze Mode Entry by RXD0 Falling Edge  | 238        |
| 0          |   |            |
| 10.10.1    | Using UART of SCIO in Snooze Mode   | 238        |
| 1          |   |            |
| 10.10.1    | Conditions of A/D Conversion Start in Snooze Mode                             | 238        |
| 2          |   |            |
| 10.10.1    | Conditions of CTSU in Snooze Mode   | 238        |
| 3          |   |            |
| 10.10.1    | ELC Events in Snooze Mode   | 238        |
| 4          |   |            |
| 10.10.1    | Module-Stop Bit Write Timing  | 239        |
| 5          |   |            |
| <b>11.</b> | <b>Battery Backup Function</b>  | <b>240</b> |
| 11.1       | Overview  | 240        |
| 11.1.1     | Features of Battery Backup Function   | 240        |
| 11.1.2     | Battery Power Supply Switch   | 240        |
| 11.1.3     | Backup Registers  | 240        |
| 11.1.4     | Time Capture Pin Detection  | 240        |
| 11.2       | Register Descriptions   | 241        |
| 11.2.1     | BBFSAR : Battery Backup Function Security Attribute Register                  | 242        |
| 11.2.2     | VBATTMNSCLR : Battery Backup Voltage Monitor Function Select Register         | 243        |
| 11.2.3     | VBATTMONR : Battery Backup Voltage Monitor Register                           | 244        |
| 11.2.4     | VBTBERR : VBATT Backup Enable Register  | 244        |
| 11.2.5     | VBTBKR[n] : VBATT Backup Register (n = 0 to 127)                              | 245        |
| 11.2.6     | VBTICTLR : VBATT Input Control Register                                       | 246        |
| 11.3       | Operation   | 246        |
| 11.3.1     | Battery Backup Function   | 246        |
| 11.3.2     | VBATT Battery Power Supply Switch Usage                                       | 248        |

|            |                                   |            |
|------------|-----------------------------------|------------|
| 10.9.3     | 取消深度软件待机模式时的引脚状态                  | 233        |
| 10.9.4     | 深度软件待机模式应用示例                      | 233        |
| 10.9.5     | 深度软件待机模式的使用流程                     | 234        |
| 10.10      | Usage Notes                       | 235        |
| 10.10.1    | Register Access                   | 235        |
| 10.10.2    | IO端口引脚状态                          | 237        |
| 10.10.3    | DTC、DMAC的模块停止状态                   | 237        |
| 10.10.4    | 内部中断源                             | 237        |
| 10.10.5    | DIRQnE位的输入缓冲器控制                   | 237        |
| 10.10.6    | 转换到低功耗模式                          | 237        |
| 10.10.7    | WFI指令的时序                          | 237        |
| 10.10.8    | 在睡眠模式或贪睡模式下通过DTC或DMAC写入WDTIWDT寄存器 | 238        |
| 10.10.9    | 贪睡模式下的振荡器                         | 238        |
| 10.10.1    | 通过RXD0下降沿进入贪睡模式                   | 238        |
| 0          |                                   |            |
| 10.10.1    | 在贪睡模式下使用SCIO的UART                 | 238        |
| 1          |                                   |            |
| 10.10.1    | 贪睡模式下AD转换开始的条件                    | 238        |
| 2          |                                   |            |
| 10.10.1    | CTSU处于贪睡模式的条件                     | 238        |
| 3          |                                   |            |
| 10.10.1    | 贪睡模式下的ELC事件                       | 238        |
| 4          |                                   |            |
| 10.10.1    | 模块停止位写时序                          | 239        |
| 5          |                                   |            |
| <b>11.</b> | <b>电池备份功能</b>                     | <b>240</b> |
| 11.1       | Overview                          | 240        |
| 11.1.1     | 电池备份功能的特点                         | 240        |
| 11.1.2     | 电池电源开关                            | 240        |
| 11.1.3     | Backup Registers                  | 240        |
| 11.1.4     | 时间捕捉引脚检测                          | 240        |
| 11.2       | 寄存器说明                             | 241        |
| 11.2.1     | BBFSAR: 电池备份功能安全属性寄存器             | 242        |
| 11.2.2     | VBATTMNSCLR: 电池备用电压监控功能选择寄存器      | 243        |
| 11.2.3     | VBATTMONR: 电池备用电压监控寄存器            | 244        |
| 11.2.4     | VBTBERR: VBATT备份使能寄存器             | 244        |
| 11.2.5     | VBTBKR[n]: VBATT备份寄存器(n=0到127)    | 245        |
| 11.2.6     | VBTICTLR: VBATT输入控制寄存器            | 246        |
| 11.3       | Operation                         | 246        |
| 11.3.1     | 电池备份功能                            | 246        |
| 11.3.2     | VBATT电池电源开关使用                     | 248        |

|            |   |            |
|------------|---|------------|
| 11.3.3     | VBATT Backup Register Usage.....  | 248        |
| 11.4       | Usage Notes.....  | 248        |
| <b>12.</b> | <b>Register Write Protection .....</b>                                    | <b>249</b> |
| 12.1       | Overview.....   | 249        |
| 12.2       | Register Descriptions .....   | 249        |
| 12.2.1     | PRCR : Protect Register.....  | 249        |
| <b>13.</b> | <b>Interrupt Controller Unit (ICU).....</b>                               | <b>251</b> |
| 13.1       | Overview.....   | 251        |
| 13.2       | Register Descriptions .....   | 252        |
| 13.2.1     | ICUSARA : Interrupt Controller Unit Security Attribution Register A ..... | 253        |
| 13.2.2     | ICUSARB : Interrupt Controller Unit Security Attribution Register B ..... | 253        |
| 13.2.3     | ICUSARC : Interrupt Controller Unit Security Attribution Register C ..... | 254        |
| 13.2.4     | ICUSARD : Interrupt Controller Unit Security Attribution Register D ..... | 255        |
| 13.2.5     | ICUSARE : Interrupt Controller Unit Security Attribution Register E ..... | 255        |
| 13.2.6     | ICUSARF : Interrupt Controller Unit Security Attribution Register F.....  | 256        |
| 13.2.7     | ICUSARG : Interrupt Controller Unit Security Attribution Register G.....  | 257        |
| 13.2.8     | ICUSARH : Interrupt Controller Unit Security Attribution Register H.....  | 257        |
| 13.2.9     | ICUSARI : Interrupt Controller Unit Security Attribution Register I ..... | 258        |
| 13.2.10    | IRQCRi : IRQ Control Register (i = 0 to 15).....                          | 258        |
| 13.2.11    | NMISR : Non-Maskable Interrupt Status Register .....                      | 260        |
| 13.2.12    | NMIER : Non-Maskable Interrupt Enable Register .....                      | 262        |
| 13.2.13    | NMICLR : Non-Maskable Interrupt Status Clear Register .....               | 264        |
| 13.2.14    | NMICR : NMI Pin Interrupt Control Register.....                           | 266        |
| 13.2.15    | IELSRn : ICU Event Link Setting Register n (n = 0 to 95).....             | 267        |
| 13.2.16    | DELSRn : DMAC Event Link Setting Register n (n = 0 to 7) .....            | 268        |
| 13.2.17    | SELSR0 : SYS Event Link Setting Register .....                            | 269        |
| 13.2.18    | WUPEN0 : Wake Up Interrupt Enable Register 0.....                         | 270        |
| 13.2.19    | WUPEN1 : Wake Up interrupt enable register 1.....                         | 272        |
| 13.3       | Vector Table.....   | 272        |
| 13.3.1     | Interrupt Vector Table.....   | 272        |
| 13.3.2     | Event Number .....  | 275        |
| 13.4       | Interrupt Operation .....   | 282        |
| 13.4.1     | Detecting Interrupts .....  | 282        |
| 13.5       | Interrupt setting procedure .....   | 283        |
| 13.5.1     | Enabling Interrupt Requests .....   | 283        |
| 13.5.2     | Disabling Interrupt Requests .....  | 283        |
| 13.5.3     | Polling for interrupts.....   | 283        |
| 13.5.4     | Selecting Interrupt Request Destinations .....                            | 283        |
| 13.5.5     | Digital Filter.....   | 285        |

|            |                                      |            |
|------------|--------------------------------------|------------|
| 11.3.3     | VBATT备份寄存器的使用.....                   | 248        |
| 11.4       | Usage Notes.....                     | 248        |
| <b>12.</b> | <b>寄存器写保护.....</b>                   | <b>249</b> |
| 12.1       | Overview.....                        | 249        |
| 12.2       | 寄存器说明.....                           | 249        |
| 12.2.1     | PRCR : Protect Register.....         | 249        |
| <b>13.</b> | <b>中断控制器单元(ICU).....</b>             | <b>251</b> |
| 13.1       | Overview.....                        | 251        |
| 13.2       | 寄存器说明.....                           | 252        |
| 13.2.1     | ICUSARA: 中断控制器单元安全属性寄存器A.....        | 253        |
| 13.2.2     | ICUSARB:中断控制器单元安全属性寄存器B.....         | 253        |
| 13.2.3     | ICUUSARC: 中断控制器单元安全属性寄存器C.....       | 254        |
| 13.2.4     | ICUSARD:中断控制器单元安全属性寄存器D.....         | 255        |
| 13.2.5     | ICUSARE: 中断控制器单元安全属性寄存器E.....        | 255        |
| 13.2.6     | ICUSARF: 中断控制器单元安全属性寄存器F.....        | 256        |
| 13.2.7     | ICUSARG: 中断控制器单元安全属性寄存器G.....        | 257        |
| 13.2.8     | ICUSARH: 中断控制器单元安全属性寄存器H.....        | 257        |
| 13.2.9     | ICUSARI: 中断控制器单元安全属性寄存器I.....        | 258        |
| 13.2.10    | IRQCRi: IRQ控制寄存器 (i=0到15) .....      | 258        |
| 13.2.11    | NMISR: 不可屏蔽中断状态寄存器.....              | 260        |
| 13.2.12    | NMIER: 不可屏蔽中断使能寄存器.....              | 262        |
| 13.2.13    | NMICLR: 不可屏蔽中断状态清除寄存器.....           | 264        |
| 13.2.14    | NMICR: NMI引脚中断控制寄存器.....             | 266        |
| 13.2.15    | IELSRn:ICU事件链接设置寄存器n(n=0到95).....    | 267        |
| 13.2.16    | DELSRn: DMAC事件链接设置寄存器n (n=0到7) ..... | 268        |
| 13.2.17    | SELSR0: SYS事件链接设置寄存器.....            | 269        |
| 13.2.18    | WUPEN0: 唤醒中断使能寄存器0.....              | 270        |
| 13.2.19    | WUPEN1: 唤醒中断使能寄存器1.....              | 272        |
| 13.3       | Vector Table.....                    | 272        |
| 13.3.1     | 中断向量表.....                           | 272        |
| 13.3.2     | Event Number .....                   | 275        |
| 13.4       | 中断操作.....                            | 282        |
| 13.4.1     | 检测中断.....                            | 282        |
| 13.5       | 中断设置程序.....                          | 283        |
| 13.5.1     | 启用中断请求.....                          | 283        |
| 13.5.2     | 禁用中断请求.....                          | 283        |
| 13.5.3     | 轮询中断.....                            | 283        |
| 13.5.4     | 选择中断请求目标.....                        | 283        |
| 13.5.5     | Digital Filter.....                  | 285        |

RA生态工作室

|            |   |            |
|------------|---|------------|
| 13.5.6     | External Pin Interrupts .....   | 286        |
| 13.6       | Non-Maskable Interrupt Operation .....  | 286        |
| 13.6.1     | Correspondence to TrustZone-M by NMI .....  | 287        |
| 13.7       | Return from Low Power Modes .....   | 288        |
| 13.7.1     | Return from Sleep Mode.....   | 288        |
| 13.7.2     | Return from Software Standby Mode .....   | 289        |
| 13.7.3     | Return from Snooze Mode.....  | 289        |
| 13.8       | Using the WFI Instruction with Non-Maskable Interrupts .....                            | 289        |
| 13.9       | Reference .....   | 289        |
| <b>14.</b> | <b>Buses.....</b>   | <b>290</b> |
| 14.1       | Overview.....   | 290        |
| 14.2       | Description of Buses.....   | 291        |
| 14.2.1     | Arbitration .....   | 291        |
| 14.2.2     | Parallel Operation .....  | 291        |
| 14.2.3     | Restrictions .....  | 292        |
| 14.3       | Register Descriptions .....   | 292        |
| 14.3.1     | BUSSARA : BUS Security Attribution Register A .....                                     | 292        |
| 14.3.2     | BUSSARB : BUS Security Attribution Register B .....                                     | 293        |
| 14.3.3     | BUSSCNT<slave> : Slave Bus Control Register (<slave> = FHBIU, FLBIU, S0BIU, EQBIU)..... | 294        |
| 14.3.4     | BUSSCNT<slave> : Slave Bus Control Register (<slave> = PSBIU, PLBIU, PHBIU).....        | 294        |
| 14.3.5     | BUSnERRADD : BUS Error Address Register (n = 1 to 3).....                               | 295        |
| 14.3.6     | BUSnERRRW : BUS Error Read Write Register (n = 1 to 3).....                             | 295        |
| 14.3.7     | BTZFnERRADD : BUS TZF Error Address Register (n = 1 to 3).....                          | 296        |
| 14.3.8     | BTZFnERRRW : BUS TZF Error Read Write Register (n = 1 to 3) .....                       | 297        |
| 14.3.9     | BUSnERRSTAT : BUS Error Status Register n (n = 1 to 3).....                             | 297        |
| 14.3.10    | DMACDTCERRSTAT : DMAC/DTC Error Status Register .....                                   | 299        |
| 14.3.11    | BUSnERRCLR : BUS Error Clear Register n (n = 1 to 3).....                               | 299        |
| 14.3.12    | DMACDTCERRCLR : DMAC/DTC Error Clear Register .....                                     | 300        |
| 14.4       | Bus Error Monitoring Section.....   | 300        |
| 14.4.1     | Bus Error Types .....   | 300        |
| 14.4.2     | Operations When a Bus Error Occurs .....  | 300        |
| 14.4.3     | Conditions Leading to Illegal Address Access Errors .....                               | 302        |
| 14.4.4     | Time-out.....   | 303        |
| 14.5       | References .....  | 303        |
| 14.6       | Cache .....   | 303        |
| 14.6.1     | Overview .....  | 303        |
| 14.6.2     | Register Description .....  | 305        |
| 14.6.3     | Operation .....   | 310        |
| 14.6.4     | Usage Notes .....   | 314        |

|            |  |            |
|------------|--|------------|
| 13.5.6     | 外部引脚中断.....  | 286        |
| 13.6       | 不可屏蔽中断操作.....  | 286        |
| 13.6.1     | NMI与TrustZone-M的通信.....  | 287        |
| 13.7       | 从低功耗模式返回.....  | 288        |
| 13.7.1     | 从睡眠模式返回.....   | 288        |
| 13.7.2     | 从软件待机模式返回.....   | 289        |
| 13.7.3     | 从贪睡模式返回.....   | 289        |
| 13.8       | 将WFI指令与不可屏蔽中断一起使用.....   | 289        |
| 13.9       | Reference .....  | 289        |
| <b>14.</b> | <b>Buses.....</b>  | <b>290</b> |
| 14.1       | Overview.....  | 290        |
| 14.2       | 巴士说明.....  | 291        |
| 14.2.1     | Arbitration .....  | 291        |
| 14.2.2     | 并行操作.....  | 291        |
| 14.2.3     | Restrictions .....   | 292        |
| 14.3       | 寄存器说明.....   | 292        |
| 14.3.1     | BUSSARA:BUS安全属性寄存器A.....   | 292        |
| 14.3.2     | BUSSARB:BUS安全属性寄存器B.....   | 293        |
| 14.3.3     | BUSSCNT<slave>: 从总线控制寄存器 (<slave>=FHBIU、FLBIU、S0BIU、EQBIU) ..... | 294        |
| 14.3.4     | BUSSCNT<slave>:从总线控制寄存器(<slave>=PSBIU PLBIU PHBIU).....          | 294        |
| 14.3.5     | BUSnERRADD:BUS错误地址寄存器 (n=1到3) .....                              | 295        |
| 14.3.6     | BUSnERRRW: 总线错误读写寄存器 (n=1到3) .....                               | 295        |
| 14.3.7     | BTZFnERRADD:BUS TZF错误地址寄存器 (n=1到3) .....                         | 296        |
| 14.3.8     | BTZFnERRRW:BUS TZF错误读写寄存器 (n=1到3) .....                          | 297        |
| 14.3.9     | BUSnERRSTAT:BUS错误状态寄存器n(n=1到3).....                              | 297        |
| 14.3.10    | DMACDTCERRSTAT: DMACDTC错误状态寄存器.....                              | 299        |
| 14.3.11    | BUSnERRCLR: BUS错误清除寄存器n (n=1到3) .....                            | 299        |
| 14.3.12    | DMACDTCERRCLR: DMACDTC错误清除寄存器.....                               | 300        |
| 14.4       | 总线错误监控部分.....  | 300        |
| 14.4.1     | 总线错误类型.....  | 300        |
| 14.4.2     | 发生总线错误时的操作.....  | 300        |
| 14.4.3     | 导致非法地址访问错误的条件.....   | 302        |
| 14.4.4     | Time-out.....  | 303        |
| 14.5       | References .....   | 303        |
| 14.6       | Cache .....  | 303        |
| 14.6.1     | Overview .....   | 303        |
| 14.6.2     | 寄存器说明.....   | 305        |
| 14.6.3     | Operation .....  | 310        |
| 14.6.4     | 使用说明.....  | 314        |

|   |            |
|---|------------|
| <b>15. Memory Protection Unit (MPU)</b> .....                       | <b>315</b> |
| 15.1 Overview.....  | 315        |
| 15.2 Arm MPU.....   | 315        |
| 15.3 Bus Master MPU.....  | 315        |
| 15.3.1 Register Descriptions.....                                   | 316        |
| 15.3.2 Operation.....   | 324        |
| 15.4 References.....  | 327        |
| <b>16. DMA Controller (DMAC)</b> .....                              | <b>328</b> |
| 16.1 Overview.....  | 328        |
| 16.2 Register Descriptions.....                                     | 330        |
| 16.2.1 DMACSAR : DMAC Controller Security Attribution Register..... | 330        |
| 16.2.2 DMSAR : DMA Source Address Register.....                     | 330        |
| 16.2.3 DMSRR : DMA Source Reload Address Register.....              | 331        |
| 16.2.4 DMDAR : DMA Destination Address Register.....                | 331        |
| 16.2.5 DMDRR : DMA Destination Reload Address Register.....         | 332        |
| 16.2.6 DMCRA : DMA Transfer Count Register.....                     | 332        |
| 16.2.7 DMCRB : DMA Block Transfer Count Register.....               | 333        |
| 16.2.8 DMTMD : DMA Transfer Mode Register.....                      | 334        |
| 16.2.9 DMINT : DMA Interrupt Setting Register.....                  | 335        |
| 16.2.10 DMAMD : DMA Address Mode Register.....                      | 337        |
| 16.2.11 DMOFR : DMA Offset Register.....                            | 339        |
| 16.2.12 DMCNT : DMA Transfer Enable Register.....                   | 340        |
| 16.2.13 DMREQ : DMA Software Start Register.....                    | 340        |
| 16.2.14 DMSTS : DMA Status Register.....                            | 341        |
| 16.2.15 DMSBS : DMA Source Buffer Size Register.....                | 343        |
| 16.2.16 DMDBS : DMA Destination Buffer Size Register.....           | 344        |
| 16.2.17 DMAST : DMA Module Activation Register.....                 | 345        |
| 16.2.18 DMECHR : DMAC Error Channel Register.....                   | 345        |
| 16.3 Operation.....   | 347        |
| 16.3.1 Transfer Mode.....   | 347        |
| 16.3.2 Extended Repeat Area Function.....                           | 356        |
| 16.3.3 Free-running Function.....                                   | 358        |
| 16.3.4 Address Update Function using Offset.....                    | 359        |
| 16.3.5 Address Update Function in Repeat-Block Transfer Mode.....   | 364        |
| 16.3.6 Example of Using Repeat-Block Transfer Mode.....             | 366        |
| 16.3.7 Activation Sources.....                                      | 369        |
| 16.3.8 Operation Timing.....  | 369        |
| 16.3.9 DMAC Execution Cycles.....                                   | 370        |
| 16.3.10 Activating the DMAC.....                                    | 371        |
| 16.3.11 Starting DMA Transfer.....                                  | 373        |

|  |            |
|--|------------|
| <b>15. 内存保护单元(MPU)</b> .....             | <b>315</b> |
| 15.1 Overview.....                       | 315        |
| 15.2 Arm MPU.....                        | 315        |
| 15.3 总线主控MPU.....                        | 315        |
| 15.3.1 Register Descriptions.....        | 316        |
| 15.3.2 Operation.....                    | 324        |
| 15.4 References.....                     | 327        |
| <b>16. DMA Controller (DMAC)</b> .....   | <b>328</b> |
| 16.1 Overview.....                       | 328        |
| 16.2 寄存器说明.....                          | 330        |
| 16.2.1 DMACSAR: DMAC控制器安全属性寄存器.....      | 330        |
| 16.2.2 DMSAR: DMA源地址寄存器.....             | 330        |
| 16.2.3 DMSRR:DMA源重载地址寄存器.....            | 331        |
| 16.2.4 DMDAR: DMA目标地址寄存器.....            | 331        |
| 16.2.5 DMDRR:DMA目标重载地址寄存器.....           | 332        |
| 16.2.6 DMCRA: DMA传输计数寄存器.....            | 332        |
| 16.2.7 DMCRB:DMA块传输计数寄存器.....            | 333        |
| 16.2.8 DMTMD:DMA传输模式寄存器.....             | 334        |
| 16.2.9 DMINT: DMA中断设置寄存器.....            | 335        |
| 16.2.10DMAMD: DMA地址模式寄存器.....            | 337        |
| 16.2.11 DMOFR : DMA Offset Register..... | 339        |
| 16.2.12DMCNT: DMA传输使能寄存器.....            | 340        |
| 16.2.13DMREQ: DMA软件启动寄存器.....            | 340        |
| 16.2.14 DMSTS : DMA Status Register..... | 341        |
| 16.2.15DMSBS: DMA源缓冲区大小寄存器.....          | 343        |
| 16.2.16DMDBS: DMA目标缓冲区大小寄存器.....         | 344        |
| 16.2.17DMAST: DMA模块激活寄存器.....            | 345        |
| 16.2.18DMECHR: DMAC错误通道寄存器.....          | 345        |
| 16.3 Operation.....                      | 347        |
| 16.3.1 Transfer Mode.....                | 347        |
| 16.3.2 扩展的重复区域功能.....                    | 356        |
| 16.3.3 Free-running Function.....        | 358        |
| 16.3.4 使用偏移量的地址更新功能.....                 | 359        |
| 16.3.5 重复块传输模式中的地址更新功能.....              | 364        |
| 16.3.6 使用重复块传输模式的示例.....                 | 366        |
| 16.3.7 激活源.....                          | 369        |
| 16.3.8 操作时间.....                         | 369        |
| 16.3.9 DMAC Execution Cycles.....        | 370        |
| 16.3.10激活DMAC.....                       | 371        |
| 16.3.11开始DMA传输.....                      | 373        |

RA生态工作室



|            |  |            |
|------------|--|------------|
| 16.3.12    | Registers during DMA Transfer  | 373        |
| 16.3.13    | Channel Priority   | 374        |
| 16.3.14    | Channel Security   | 374        |
| 16.3.15    | Master TrustZone Filter in DMAC  | 375        |
| 16.4       | Ending DMA Transfer  | 376        |
| 16.4.1     | Transfer End by Completion of Specified Total Number of Transfer Operations                          | 376        |
| 16.4.2     | Transfer End by Repeat Size End Interrupt  | 376        |
| 16.4.3     | Transfer End by Interrupt on Extended Repeat Area Overflow   | 377        |
| 16.5       | Processing on DMA Transfer Error   | 377        |
| 16.5.1     | Processing on NMI handler  | 377        |
| 16.5.2     | Processing on Error response detection interrupt request (DMA_TRANSERR) handler                      | 380        |
| 16.6       | Interrupts   | 386        |
| 16.6.1     | Transfer End Interrupt   | 386        |
| 16.6.2     | Transfer Error Interrupt   | 388        |
| 16.7       | Event Link   | 389        |
| 16.8       | Low-Power Consumption Function   | 389        |
| 16.9       | Usage Notes  | 389        |
| 16.9.1     | Access to the Registers during DMA Transfer  | 389        |
| 16.9.2     | DMA Transfer to Reserved Areas   | 390        |
| 16.9.3     | Setting of DMAC Event Link Setting Register of the Interrupt Controller Unit (ICU.DELSRn n = 0 to 7) | 390        |
| 16.9.4     | Suspending or Restarting DMAC Activation   | 390        |
| 16.9.5     | Precautions for Resuming DMA Transfer  | 390        |
| <b>17.</b> | <b>Data Transfer Controller (DTC)</b>  | <b>392</b> |
| 17.1       | Overview   | 392        |
| 17.2       | Register Descriptions  | 393        |
| 17.2.1     | DTCSAR : DTC Controller Security Attribution Register  | 394        |
| 17.2.2     | MRA : DTC Mode Register A  | 394        |
| 17.2.3     | MRB : DTC Mode Register B  | 395        |
| 17.2.4     | SAR : DTC Transfer Source Register   | 396        |
| 17.2.5     | DAR : DTC Transfer Destination Register  | 396        |
| 17.2.6     | CRA : DTC Transfer Count Register A  | 397        |
| 17.2.7     | CRB : DTC Transfer Count Register B  | 397        |
| 17.2.8     | DTCCR : DTC Control Register   | 398        |
| 17.2.9     | DTCCR_SEC : DTC Control Register for secure Region   | 398        |
| 17.2.10    | DTCVBR : DTC Vector Base Register  | 399        |
| 17.2.11    | DTCVBR_SEC : DTC Vector Base Register for secure Region  | 399        |
| 17.2.12    | DTCST : DTC Module Start Register  | 399        |
| 17.2.13    | DTCSTS : DTC Status Register   | 400        |
| 17.2.14    | DTEVR : DTC Error Vector Register  | 401        |

|            |  |            |
|------------|--|------------|
| 16.3.12    | DMA传输期间的寄存器                                | 373        |
| 16.3.13    | 通道优先级                                      | 374        |
| 16.3.14    | 通道安全                                       | 374        |
| 16.3.15    | DMAC中的主TrustZone过滤器                        | 375        |
| 16.4       | 结束DMA传输                                    | 376        |
| 16.4.1     | 完成指定的传输操作总数后传输结束                           | 376        |
| 16.4.2     | 通过重复大小结束中断传输结束                             | 376        |
| 16.4.3     | 扩展重复区域溢出时通过中断传输结束                          | 377        |
| 16.5       | 处理DMA传输错误                                  | 377        |
| 16.5.1     | NMI处理程序上的处理                                | 377        |
| 16.5.2     | 错误响应检测中断请求 (DMA_TRANSERR) 处理程序的处理          | 380        |
| 16.6       | Interrupts                                 | 386        |
| 16.6.1     | 传输结束中断                                     | 386        |
| 16.6.2     | 传输错误中断                                     | 388        |
| 16.7       | Event Link                                 | 389        |
| 16.8       | Low-Power Consumption Function             | 389        |
| 16.9       | Usage Notes                                | 389        |
| 16.9.1     | 在DMA传输期间访问寄存器                              | 389        |
| 16.9.2     | DMA传输到保留区域                                 | 390        |
| 16.9.3     | 中断控制器单元的DMAC事件链接设置寄存器的设置 (ICU.DELSRnn=0至7) | 390        |
| 16.9.4     | 暂停或重新启动DMAC激活                              | 390        |
| 16.9.5     | 恢复DMA传输的注意事项                               | 390        |
| <b>17.</b> | <b>数据传输控制器(DTC)</b>                        | <b>392</b> |
| 17.1       | Overview                                   | 392        |
| 17.2       | 寄存器说明                                      | 393        |
| 17.2.1     | DTCSAR: DTC控制器安全属性寄存器                      | 394        |
| 17.2.2     | MRA: DTC模式寄存器A                             | 394        |
| 17.2.3     | MRB: DTC模式寄存器B                             | 395        |
| 17.2.4     | SAR: DTC传输源寄存器                             | 396        |
| 17.2.5     | DAR: DTC传输目的地寄存器                           | 396        |
| 17.2.6     | CRA: DTC传输计数寄存器A                           | 397        |
| 17.2.7     | CRB: DTC传输计数寄存器B                           | 397        |
| 17.2.8     | DTCCR : DTC Control Register               | 398        |
| 17.2.9     | DTCCR_SEC: 安全区域的DTC控制寄存器                   | 398        |
| 17.2.10    | DTCVBR: DTC向量基址寄存器                         | 399        |
| 17.2.11    | DTCVBR_SEC: 安全区域的DTC向量基址寄存器                | 399        |
| 17.2.12    | DTCST: DTC模块启动寄存器                          | 399        |
| 17.2.13    | DTCSTS: DTC状态寄存器                           | 400        |
| 17.2.14    | DTEVR: DTC错误向量寄存器                          | 401        |

|            |   |            |
|------------|---|------------|
| 17.3       | Activation Sources  | 402        |
| 17.3.1     | Allocating Transfer Information and DTC Vector Table                            | 402        |
| 17.4       | Operation   | 404        |
| 17.4.1     | Transfer Information Read Skip Function   | 406        |
| 17.4.2     | Transfer Information Write-Back Skip Function                                   | 406        |
| 17.4.3     | Normal Transfer Mode  | 407        |
| 17.4.4     | Repeat Transfer Mode  | 408        |
| 17.4.5     | Block Transfer Mode   | 409        |
| 17.4.6     | Chain Transfer  | 410        |
| 17.4.7     | Operation Timing  | 411        |
| 17.4.8     | Execution Cycles of DTC   | 413        |
| 17.4.9     | DTC Bus Mastership Release Timing   | 414        |
| 17.4.10    | Vector Security   | 414        |
| 17.4.11    | Master TrustZone Filter in DTC  | 414        |
| 17.5       | DTC Setting Procedure   | 414        |
| 17.6       | Examples of DTC Usage   | 415        |
| 17.6.1     | Normal Transfer   | 415        |
| 17.6.2     | Chain transfer  | 416        |
| 17.6.3     | Chain Transfer when Counter = 0   | 417        |
| 17.7       | Processing on DTC Transfer Error  | 419        |
| 17.7.1     | Processing on NMI handler   | 420        |
| 17.7.2     | Processing on Error response detection interrupt request (DMA_TRANSERR) handler | 424        |
| 17.8       | Interrupt   | 429        |
| 17.8.1     | Interrupt Request of Transfer End   | 429        |
| 17.8.2     | Interrupt Request of Transfer Error   | 429        |
| 17.9       | Event Link  | 430        |
| 17.10      | Low Power Consumption Function  | 430        |
| 17.11      | Usage Notes   | 431        |
| 17.11.1    | Transfer Information Start Address  | 431        |
| <b>18.</b> | <b>Event Link Controller (ELC)</b>  | <b>432</b> |
| 18.1       | Overview  | 432        |
| 18.2       | Register Descriptions   | 433        |
| 18.2.1     | ELCR : Event Link Controller Register   | 433        |
| 18.2.2     | ELSEGRn : Event Link Software Event Generation Register n (n = 0, 1)            | 434        |
| 18.2.3     | ELSRn : Event Link Setting Register n (n = 0 to 18)                             | 435        |
| 18.2.4     | ELCSARA : Event Link Controller Security Attribution Register A                 | 440        |
| 18.2.5     | ELCSARB : Event Link Controller Security Attribution Register B                 | 441        |
| 18.2.6     | ELCSARC : Event Link Controller Security Attribution Register C                 | 441        |
| 18.3       | Operation   | 442        |
| 18.3.1     | Relation between Interrupt Handling and Event Linking                           | 442        |

|            |                                   |            |
|------------|-----------------------------------|------------|
| 17.3       | Activation Sources                | 402        |
| 17.3.1     | 分配传输信息和DTC向量表                     | 402        |
| 17.4       | Operation                         | 404        |
| 17.4.1     | 传输信息读取跳过功能                        | 406        |
| 17.4.2     | 传输信息回写跳过功能                        | 406        |
| 17.4.3     | 正常传输模式                            | 407        |
| 17.4.4     | 重复传输模式                            | 408        |
| 17.4.5     | 块传输模式                             | 409        |
| 17.4.6     | 链转移                               | 410        |
| 17.4.7     | 操作时间                              | 411        |
| 17.4.8     | DTC的执行周期                          | 413        |
| 17.4.9     | DTC总线主控释放时序                       | 414        |
| 17.4.10    | Vector Security                   | 414        |
| 17.4.11    | DTC中的主TrustZone过滤器                | 414        |
| 17.5       | DTC设置程序                           | 414        |
| 17.6       | DTC使用示例                           | 415        |
| 17.6.1     | Normal Transfer                   | 415        |
| 17.6.2     | 链转移                               | 416        |
| 17.6.3     | 计数器=0时的链转移                        | 417        |
| 17.7       | DTC传输错误的处理                        | 419        |
| 17.7.1     | NMI处理程序上的处理                       | 420        |
| 17.7.2     | 错误响应检测中断请求 (DMA_TRANSERR) 处理程序的处理 | 424        |
| 17.8       | Interrupt                         | 429        |
| 17.8.1     | 传输结束的中断请求                         | 429        |
| 17.8.2     | 传输错误的中断请求                         | 429        |
| 17.9       | Event Link                        | 430        |
| 17.10      | 低功耗功能                             | 430        |
| 17.11      | Usage Notes                       | 431        |
| 17.11.1    | 传输信息起始地址                          | 431        |
| <b>18.</b> | <b>事件链接控制器(ELC)</b>               | <b>432</b> |
| 18.1       | Overview                          | 432        |
| 18.2       | 寄存器说明                             | 433        |
| 18.2.1     | ELCR: 事件链接控制器寄存器                  | 433        |
| 18.2.2     | ELSEGRn:事件链接软件事件生成寄存器n(n=0 1)     | 434        |
| 18.2.3     | ELSRn: 事件链接设置寄存器n (n=0到18)        | 435        |
| 18.2.4     | ELCSARA: 事件链接控制器安全属性寄存器A          | 440        |
| 18.2.5     | ELCSARB: 事件链接控制器安全属性寄存器B          | 441        |
| 18.2.6     | ELCSARC:事件链接控制器安全属性寄存器C           | 441        |
| 18.3       | Operation                         | 442        |
| 18.3.1     | 中断处理和事件链接的关系                      | 442        |

|            |   |            |
|------------|---|------------|
| 18.3.2     | Linking Events .....  | 442        |
| 18.3.3     | Example of Procedure for Linking Events.....  | 442        |
| 18.4       | Usage Notes .....   | 443        |
| 18.4.1     | Linking DMAC/DTC Transfer End Signals as Events .....   | 443        |
| 18.4.2     | Setting Clocks .....  | 443        |
| 18.4.3     | Module-Stop Function Setting .....  | 443        |
| 18.4.4     | ELC Delay Time.....   | 443        |
| <b>19.</b> | <b>I/O Ports.....</b>   | <b>444</b> |
| 19.1       | Overview.....   | 444        |
| 19.2       | Register Descriptions .....   | 445        |
| 19.2.1     | PCNTR1/PODR/PDR : Port Control Register 1 .....   | 445        |
| 19.2.2     | PCNTR2/EIDR/PIDR : Port Control Register 2.....   | 446        |
| 19.2.3     | PCNTR3/PORR/POSR : Port Control Register 3 .....  | 447        |
| 19.2.4     | PCNTR4/EORR/EOSR : Port Control Register 4 .....  | 448        |
| 19.2.5     | PmnPFS/PmnPFS_HA/PmnPFS_BY : Port mn Pin Function Select Register (m = 0 to 8, n = 00 to 15)..... | 449        |
| 19.2.6     | PWPR : Write-Protect Register.....  | 451        |
| 19.2.7     | PWPRS : Write-Protect Register for Secure.....  | 452        |
| 19.2.8     | PmSAR : Port Security Attribution register (m = 0 to 8).....                                      | 452        |
| 19.3       | Operation.....  | 453        |
| 19.3.1     | General I/O Ports .....   | 453        |
| 19.3.2     | Port Function Select .....  | 453        |
| 19.3.3     | Port Group Function for ELC .....   | 454        |
| 19.4       | Handling of Unused Pins .....   | 455        |
| 19.5       | Usage Notes.....  | 456        |
| 19.5.1     | Procedure for Specifying the Pin Functions.....   | 456        |
| 19.5.2     | Procedure for Using Port Group Input .....  | 456        |
| 19.5.3     | Port Output Data Register (PODR) Summary .....  | 457        |
| 19.5.4     | Notes on Using Analog Functions .....   | 457        |
| 19.5.5     | I/O Buffer Specification .....  | 457        |
| 19.6       | Peripheral Select Settings for Each Product .....   | 458        |
| <b>20.</b> | <b>Port Output Enable for GPT (POEG).....</b>   | <b>465</b> |
| 20.1       | Overview.....   | 465        |
| 20.2       | Register Descriptions .....   | 467        |
| 20.2.1     | POEGGn : POEG Group n Setting Register (n = A to D) .....   | 467        |
| 20.3       | Output-Disable Control Operation .....  | 468        |
| 20.3.1     | Pin Input Level Detection Operation .....   | 468        |
| 20.3.2     | Output-Disable Requests from the GPT .....  | 469        |
| 20.3.3     | Output-Disable Control Using Detection of Stopped Oscillation.....                                | 469        |
| 20.3.4     | Output-Disable Control Using Registers .....  | 469        |

|            |  |            |
|------------|--|------------|
| 18.3.2     | 链接事件.....  | 442        |
| 18.3.3     | 链接事件的过程示例.....   | 442        |
| 18.4       | Usage Notes .....  | 443        |
| 18.4.1     | 将DMACDTC传输结束信号链接为事件.....   | 443        |
| 18.4.2     | Setting Clocks .....   | 443        |
| 18.4.3     | 模块停止功能设置.....  | 443        |
| 18.4.4     | ELC Delay Time.....  | 443        |
| <b>19.</b> | <b>I/O Ports.....</b>  | <b>444</b> |
| 19.1       | Overview.....  | 444        |
| 19.2       | 寄存器说明.....   | 445        |
| 19.2.1     | PCNTR1PODRPDR: 端口控制寄存器1.....                                     | 445        |
| 19.2.2     | PCNTR2EIDRPIDR: 端口控制寄存器2.....                                    | 446        |
| 19.2.3     | PCNTR3PORRPOSR: 端口控制寄存器3.....                                    | 447        |
| 19.2.4     | PCNTR4EORREOSR: 端口控制寄存器4.....                                    | 448        |
| 19.2.5     | PmnPFS_PmnPFS_HA_PmnPFS_BY: 端口mn引脚功能选择寄存器 (m=0到8, n=00到15) ..... | 449        |
| 19.2.6     | PWPR : Write-Protect Register.....                               | 451        |
| 19.2.7     | PWPRS: 用于安全的写保护寄存器.....  | 452        |
| 19.2.8     | PmSAR: 端口安全属性寄存器 (m=0到8) .....                                   | 452        |
| 19.3       | Operation.....   | 453        |
| 19.3.1     | General I/O Ports .....  | 453        |
| 19.3.2     | 端口功能选择.....  | 453        |
| 19.3.3     | ELC的端口组功能.....   | 454        |
| 19.4       | 未使用引脚的处理.....  | 455        |
| 19.5       | Usage Notes.....   | 456        |
| 19.5.1     | 指定引脚功能的过程.....   | 456        |
| 19.5.2     | 使用端口组输入的过程.....  | 456        |
| 19.5.3     | 端口输出数据寄存器(PODR)汇总.....   | 457        |
| 19.5.4     | 使用模拟功能的注意事项.....   | 457        |
| 19.5.5     | IO缓冲器规范.....   | 457        |
| 19.6       | 每个产品的外设选择设置.....   | 458        |
| <b>20.</b> | <b>GPT(POEG)端口输出使能.....</b>                                      | <b>465</b> |
| 20.1       | Overview.....  | 465        |
| 20.2       | 寄存器说明.....   | 467        |
| 20.2.1     | POEGGn:POEG组n设置寄存器(n=A到D).....                                   | 467        |
| 20.3       | 输出禁用控制操作.....  | 468        |
| 20.3.1     | 引脚输入电平检测操作.....  | 468        |
| 20.3.2     | 来自GPT的输出禁用请求.....  | 469        |
| 20.3.3     | 使用停止振荡检测的输出禁用控制.....   | 469        |
| 20.3.4     | 使用寄存器的输出禁用控制.....  | 469        |

|            |  |            |
|------------|--|------------|
| 20.3.5     | Release from Output-Disable .....  | 469        |
| 20.4       | Interrupt Sources .....  | 470        |
| 20.5       | External Trigger Output to the GPT .....   | 470        |
| 20.6       | Usage Notes .....  | 471        |
| 20.6.1     | Transition to Software Standby Mode .....  | 471        |
| 20.6.2     | Specifying Pins Associated with the GPT .....  | 471        |
| <b>21.</b> | <b>General PWM Timer (GPT) .....</b>   | <b>472</b> |
| 21.1       | Overview .....   | 472        |
| 21.2       | Register Descriptions .....  | 475        |
| 21.2.1     | GTWP : General PWM Timer Write-Protection Register .....   | 475        |
| 21.2.2     | GTSTR : General PWM Timer Software Start Register .....  | 477        |
| 21.2.3     | GTSTP : General PWM Timer Software Stop Register .....   | 478        |
| 21.2.4     | GTCLR : General PWM Timer Software Clear Register .....  | 478        |
| 21.2.5     | GTSSR : General PWM Timer Start Source Select Register .....   | 479        |
| 21.2.6     | GTPSR : General PWM Timer Stop Source Select Register .....  | 482        |
| 21.2.7     | GTCSR : General PWM Timer Clear Source Select Register .....   | 485        |
| 21.2.8     | GTUPSR : General PWM Timer Up Count Source Select Register .....                                       | 488        |
| 21.2.9     | GTDNSR : General PWM Timer Down Count Source Select Register .....                                     | 491        |
| 21.2.10    | GTICASR : General PWM Timer Input Capture Source Select Register A .....                               | 495        |
| 21.2.11    | GTICBSR : General PWM Timer Input Capture Source Select Register B .....                               | 498        |
| 21.2.12    | GTCR : General PWM Timer Control Register .....  | 501        |
| 21.2.13    | GTUDDTYC : General PWM Timer Count Direction and Duty Setting Register .....                           | 503        |
| 21.2.14    | GTIOR : General PWM Timer I/O Control Register .....   | 505        |
| 21.2.15    | GTINTAD : General PWM Timer Interrupt Output Setting Register .....                                    | 509        |
| 21.2.16    | GTST : General PWM Timer Status Register .....   | 510        |
| 21.2.17    | GTBER : General PWM Timer Buffer Enable Register .....   | 514        |
| 21.2.18    | GTCNT : General PWM Timer Counter .....  | 515        |
| 21.2.19    | GTCCRn : General PWM Timer Compare Capture Register n (n = A to F) .....                               | 515        |
| 21.2.20    | GTPR : General PWM Timer Cycle Setting Register .....  | 516        |
| 21.2.21    | GTPBR : General PWM Timer Cycle Setting Buffer Register .....  | 516        |
| 21.2.22    | GTDTCR : General PWM Timer Dead Time Control Register .....  | 517        |
| 21.2.23    | GTDVU : General PWM Timer Dead Time Value Register U .....   | 517        |
| 21.2.24    | GTICLF : General PWM Timer Inter Channel Logical Operation Function Setting Register ..                | 518        |
| 21.2.25    | GTPC : General PWM Timer Period Count Register .....   | 519        |
| 21.2.26    | GTSECSR : General PWM Timer Operation Enable Bit Simultaneous Control Channel<br>Select Register ..... | 521        |
| 21.2.27    | GTSECR : General PWM Timer Operation Enable Bit Simultaneous Control Register .....                    | 522        |
| 21.2.28    | OPSCR : Output Phase Switching Control Register .....  | 523        |
| 21.3       | Operation .....  | 526        |
| 21.3.1     | Basic Operation .....  | 526        |

|            |  |            |
|------------|--|------------|
| 20.3.5     | 从输出禁用释放 .....                              | 469        |
| 20.4       | Interrupt Sources .....                    | 470        |
| 20.5       | 到GPT的外部触发输出 .....                          | 470        |
| 20.6       | Usage Notes .....                          | 471        |
| 20.6.1     | 过渡到软件待机模式 .....                            | 471        |
| 20.6.2     | 指定与GPT关联的引脚 .....                          | 471        |
| <b>21.</b> | <b>通用PWM定时器 (GPT) .....</b>                | <b>472</b> |
| 21.1       | Overview .....                             | 472        |
| 21.2       | 寄存器说明 .....                                | 475        |
| 21.2.1     | GTWP:通用PWM定时器写保护寄存器 .....                  | 475        |
| 21.2.2     | GTSTR: 通用PWM定时器软件启动寄存器 .....               | 477        |
| 21.2.3     | GTSTP: 通用PWM定时器软件停止寄存器 .....               | 478        |
| 21.2.4     | GTCLR: 通用PWM定时器软件清零寄存器 .....               | 478        |
| 21.2.5     | GTSSR: 通用PWM定时器启动源选择寄存器 .....              | 479        |
| 21.2.6     | GTPSR: 通用PWM定时器停止源选择寄存器 .....              | 482        |
| 21.2.7     | GTCSR: 通用PWM定时器清零源选择寄存器 .....              | 485        |
| 21.2.8     | GTUPSR: 通用PWM定时器向上计数源选择寄存器 .....           | 488        |
| 21.2.9     | GTDNSR: 通用PWM定时器递减计数源选择寄存器 .....           | 491        |
| 21.2.10    | GTICASR: 通用PWM定时器输入捕捉源选择寄存器A .....         | 495        |
| 21.2.11    | GTICBSR: 通用PWM定时器输入捕捉源选择寄存器B .....         | 498        |
| 21.2.12    | GTCR: 通用PWM定时器控制寄存器 .....                  | 501        |
| 21.2.13    | GTUDDTYC: 通用PWM定时器计数方向和占空比设置寄存器 .....      | 503        |
| 21.2.14    | GTIOR: 通用PWM定时器IO控制寄存器 .....               | 505        |
| 21.2.15    | GTINTAD: 通用PWM定时器中断输出设置寄存器 .....           | 509        |
| 21.2.16    | GTST: 通用PWM定时器状态寄存器 .....                  | 510        |
| 21.2.17    | GTBER: 通用PWM定时器缓冲器使能寄存器 .....              | 514        |
| 21.2.18    | GTCNT: 通用PWM定时器计数器 .....                   | 515        |
| 21.2.19    | GTCCRn: 通用PWM定时器比较捕捉寄存器n (n=A到F) .....     | 515        |
| 21.2.20    | GTPR: 通用PWM定时器周期设置寄存器 .....                | 516        |
| 21.2.21    | GTPBR: 通用PWM定时器周期设置缓冲寄存器 .....             | 516        |
| 21.2.22    | GTDTCR: 通用PWM定时器死区控制寄存器 .....              | 517        |
| 21.2.23    | GTDVU: 通用PWM定时器死区值寄存器U .....               | 517        |
| 21.2.24    | GTICLF: 通用PWM定时器通道间逻辑运算功能设置寄存器 ..          | 518        |
| 21.2.25    | GTPC: 通用PWM定时器周期计数寄存器 .....                | 519        |
| 21.2.26    | GTSECSR: 通用PWM定时器操作使能位同时控制通道<br>选择注册 ..... | 521        |
| 21.2.27    | GTSECR: 通用PWM定时器操作使能位同时控制寄存器 .....         | 522        |
| 21.2.28    | OPSCR: 输出相位切换控制寄存器 .....                   | 523        |
| 21.3       | Operation .....                            | 526        |
| 21.3.1     | 基本操作 .....                                 | 526        |

|            |  |            |
|------------|--|------------|
| 21.3.2     | Buffer Operation.....  | 534        |
| 21.3.3     | PWM Output Operating Mode .....                                  | 540        |
| 21.3.4     | Automatic Dead Time Setting Function .....                       | 550        |
| 21.3.5     | Count Direction Changing Function .....                          | 554        |
| 21.3.6     | Function of Output Duty 0% and 100% .....                        | 554        |
| 21.3.7     | Hardware Count Start/Count Stop and Clear Operation.....         | 556        |
| 21.3.8     | Synchronized Operation .....                                     | 561        |
| 21.3.9     | PWM Output Operation Examples.....                               | 565        |
| 21.3.10    | Period Count Function .....                                      | 571        |
| 21.3.11    | Phase Counting Function .....                                    | 572        |
| 21.3.12    | Output Phase Switching (GPT_OPS).....                            | 582        |
| 21.3.13    | Inter Channel Logical Operation Function .....                   | 589        |
| 21.4       | Interrupt Sources .....  | 591        |
| 21.4.1     | Interrupt Sources .....  | 591        |
| 21.4.2     | DMAC and DTC Activation .....                                    | 593        |
| 21.5       | Operations Linked by ELC.....                                    | 593        |
| 21.5.1     | Event Signal Output to ELC.....                                  | 593        |
| 21.5.2     | Event Signal Inputs from ELC.....                                | 593        |
| 21.6       | Noise Filter Function.....                                       | 593        |
| 21.7       | Protection Function.....   | 594        |
| 21.7.1     | Write-Protection for Registers.....                              | 594        |
| 21.7.2     | Disabling of Buffer Operation.....                               | 594        |
| 21.7.3     | GTIOcNm Pin Output Negate Control (n = 0 to 7, m = A, B).....    | 596        |
| 21.8       | Initialization Method of Output Pins .....                       | 597        |
| 21.8.1     | Pin Settings after Reset .....                                   | 597        |
| 21.8.2     | Pin Initialization Due to Error during Operation .....           | 598        |
| 21.9       | Usage Notes.....   | 598        |
| 21.9.1     | Module-Stop Function Setting .....                               | 598        |
| 21.9.2     | GTCCRn Settings during Compare Match Operation (n = A to F)..... | 598        |
| 21.9.3     | Setting Range for GTCNT Counter.....                             | 599        |
| 21.9.4     | Starting and Stopping the GTCNT Counter .....                    | 599        |
| 21.9.5     | Priority Order of Each Event .....                               | 600        |
| <b>22.</b> | <b>Low Power Asynchronous General Purpose Timer (AGT).....</b>   | <b>601</b> |
| 22.1       | Overview.....  | 601        |
| 22.2       | Register Descriptions .....                                      | 603        |
| 22.2.1     | AGT : AGT Counter Register.....                                  | 603        |
| 22.2.2     | AGTCMA : AGT Compare Match A Register.....                       | 603        |
| 22.2.3     | AGTCMB : AGT Compare Match B Register.....                       | 604        |
| 22.2.4     | AGTCR : AGT Control Register.....                                | 604        |
| 22.2.5     | AGTMR1 : AGT Mode Register 1 .....                               | 606        |

|            |                                       |            |
|------------|---------------------------------------|------------|
| 21.3.2     | Buffer Operation.....                 | 534        |
| 21.3.3     | PWM输出工作模式.....                        | 540        |
| 21.3.4     | 自动死区时间设置功能.....                       | 550        |
| 21.3.5     | 计数方向改变功能.....                         | 554        |
| 21.3.6     | 输出占空比0%和100%的功能.....                  | 554        |
| 21.3.7     | 硬件计数开始计数停止和清除操作.....                  | 556        |
| 21.3.8     | 同步操作.....                             | 561        |
| 21.3.9     | PWM输出操作示例.....                        | 565        |
| 21.3.10    | 周期计数功能.....                           | 571        |
| 21.3.11    | 相位计数功能.....                           | 572        |
| 21.3.12    | 输出相位切换(GPT_OPS).....                  | 582        |
| 21.3.13    | 通道间逻辑运算函数.....                        | 589        |
| 21.4       | Interrupt Sources .....               | 591        |
| 21.4.1     | 中断源.....                              | 591        |
| 21.4.2     | DMAC和DTC激活.....                       | 593        |
| 21.5       | 由ELC链接的操作.....                        | 593        |
| 21.5.1     | 事件信号输出到ELC.....                       | 593        |
| 21.5.2     | 来自ELC的事件信号输入.....                     | 593        |
| 21.6       | 噪声过滤功能.....                           | 593        |
| 21.7       | Protection Function.....              | 594        |
| 21.7.1     | Write-Protection for Registers.....   | 594        |
| 21.7.2     | 禁用缓冲区操作.....                          | 594        |
| 21.7.3     | GTIOcNm引脚输出否定控制 (n=0至7, m=A, B) ..... | 596        |
| 21.8       | 输出管脚的初始化方法.....                       | 597        |
| 21.8.1     | 复位后的引脚设置.....                         | 597        |
| 21.8.2     | 由于操作过程中的错误而导致的引脚初始化.....              | 598        |
| 21.9       | Usage Notes.....                      | 598        |
| 21.9.1     | 模块停止功能设置.....                         | 598        |
| 21.9.2     | 比较匹配操作期间的GTCCRn设置 (n=A到F) .....       | 598        |
| 21.9.3     | GTCNT计数器的设置范围.....                    | 599        |
| 21.9.4     | 启动和停止GTCNT计数器.....                    | 599        |
| 21.9.5     | 每个事件的优先顺序.....                        | 600        |
| <b>22.</b> | <b>低功耗异步通用定时器 (AGT) .....</b>         | <b>601</b> |
| 22.1       | Overview.....                         | 601        |
| 22.2       | 寄存器说明.....                            | 603        |
| 22.2.1     | AGT : AGT Counter Register.....       | 603        |
| 22.2.2     | AGTCMA:AGT比较匹配A寄存器.....               | 603        |
| 22.2.3     | AGTCMB: AGT比较匹配B寄存器.....              | 604        |
| 22.2.4     | AGTCR : AGT Control Register.....     | 604        |
| 22.2.5     | AGTMR1: AGT模式寄存器1 .....               | 606        |

|                                 |   |            |
|---------------------------------|---|------------|
| 22.2.6                          | AGTMR2 : AGT Mode Register 2 .....  | 606        |
| 22.2.7                          | AGTIOC : AGT I/O Control Register .....                                   | 608        |
| 22.2.8                          | AGTISR : AGT Event Pin Select Register .....                              | 609        |
| 22.2.9                          | AGTCMSR : AGT Compare Match Function Select Register.....                 | 610        |
| 22.2.10                         | AGTIOSEL : AGT Pin Select Register .....                                  | 610        |
| 22.3                            | Operation.....  | 611        |
| 22.3.1                          | Reload Register and Counter Rewrite Operation .....                       | 611        |
| 22.3.2                          | Reload Register and AGT Compare Match A/B Register Rewrite Operation..... | 613        |
| 22.3.3                          | Timer Mode.....   | 614        |
| 22.3.4                          | Pulse Output Mode .....   | 615        |
| 22.3.5                          | Event Counter Mode.....   | 616        |
| 22.3.6                          | Pulse Width Measurement Mode.....   | 617        |
| 22.3.7                          | Pulse Period Measurement Mode .....                                       | 618        |
| 22.3.8                          | Compare Match function.....   | 619        |
| 22.3.9                          | Output Settings for Each Mode.....  | 620        |
| 22.3.10                         | Standby Mode.....   | 621        |
| 22.3.11                         | Interrupt Sources .....   | 622        |
| 22.3.12                         | Event Signal Output to ELC.....   | 622        |
| 22.4                            | Usage Notes.....  | 623        |
| 22.4.1                          | Count Operation Start and Stop Control.....                               | 623        |
| 22.4.2                          | Access to Counter Register .....  | 623        |
| 22.4.3                          | When Changing Mode .....  | 623        |
| 22.4.4                          | Output pin setting.....   | 623        |
| 22.4.5                          | Digital Filter.....   | 623        |
| 22.4.6                          | How to Calculate Event Number, Pulse Width, and Pulse Period .....        | 623        |
| 22.4.7                          | When Count is Forcibly Stopped by TSTOP Bit .....                         | 624        |
| 22.4.8                          | When Selecting AGTn (n = 0, 2, 4) Underflow as the Count Source.....      | 624        |
| 22.4.9                          | Module-stop function .....  | 624        |
| 22.4.10                         | When Switching Source Clock.....  | 624        |
| <b>23. Realtime Clock (RTC)</b> | .....   | <b>625</b> |
| 23.1                            | Overview.....   | 625        |
| 23.2                            | Register Descriptions .....   | 626        |
| 23.2.1                          | R64CNT : 64-Hz Counter .....  | 627        |
| 23.2.2                          | RSECCNT : Second Counter (in Calendar Count Mode).....                    | 627        |
| 23.2.3                          | RMINCNT : Minute Counter (in Calendar Count Mode) .....                   | 628        |
| 23.2.4                          | RHRCNT : Hour Counter (in Calendar Count Mode).....                       | 628        |
| 23.2.5                          | RWKCNT : Day-of-Week Counter (in Calendar Count Mode).....                | 629        |
| 23.2.6                          | BCNTn : Binary Counter n (n = 0 to 3) (in Binary Count Mode).....         | 629        |
| 23.2.7                          | RDAYCNT : Day Counter.....  | 629        |
| 23.2.8                          | RMONCNT : Month Counter.....  | 630        |

|                      |   |            |
|----------------------|---|------------|
| 22.2.6               | AGTMR2: AGT模式寄存器2.....                  | 606        |
| 22.2.7               | AGTIOC : AGT I/O Control Register ..... | 608        |
| 22.2.8               | AGTISR:AGT事件引脚选择寄存器.....                | 609        |
| 22.2.9               | AGTCMSR:AGT比较匹配功能选择寄存器.....             | 610        |
| 22.2.10              | AGTIOSEL: AGT引脚选择寄存器.....               | 610        |
| 22.3                 | Operation.....                          | 611        |
| 22.3.1               | 重载寄存器和计数器重写操作.....                      | 611        |
| 22.3.2               | 重载寄存器和AGT比较匹配AB寄存器重写操作.....             | 613        |
| 22.3.3               | Timer Mode.....                         | 614        |
| 22.3.4               | 脉冲输出模式.....                             | 615        |
| 22.3.5               | 事件计数器模式.....                            | 616        |
| 22.3.6               | 脉冲宽度测量模式.....                           | 617        |
| 22.3.7               | 脉冲周期测量模式.....                           | 618        |
| 22.3.8               | 比较匹配功能.....                             | 619        |
| 22.3.9               | 每种模式的输出设置.....                          | 620        |
| 22.3.10              | Standby Mode.....                       | 621        |
| 22.3.11              | 中断源.....                                | 622        |
| 22.3.12              | 事件信号输出到ELC.....                         | 622        |
| 22.4                 | Usage Notes.....                        | 623        |
| 22.4.1               | 计数操作启动和停止控制.....                        | 623        |
| 22.4.2               | 访问计数器寄存器.....                           | 623        |
| 22.4.3               | 更改模式时.....                              | 623        |
| 22.4.4               | 输出引脚设置.....                             | 623        |
| 22.4.5               | Digital Filter.....                     | 623        |
| 22.4.6               | 如何计算事件数、脉冲宽度和脉冲周期.....                  | 623        |
| 22.4.7               | 当计数被TSTOP位强制停止时.....                    | 624        |
| 22.4.8               | 选择AGTN (n=0, 2, 4) 下流作为计数源.....         | 624        |
| 22.4.9               | Module-stop function .....              | 624        |
| 22.4.10              | 切换源时钟时.....                             | 624        |
| <b>23. 实时时钟(RTC)</b> | .....                                   | <b>625</b> |
| 23.1                 | Overview.....                           | 625        |
| 23.2                 | 寄存器说明.....                              | 626        |
| 23.2.1               | R64CNT : 64-Hz Counter .....            | 627        |
| 23.2.2               | RSECCNT: 秒计数器 (日历计数模式) .....            | 627        |
| 23.2.3               | RMINCNT: 分钟计数器 (在日历计数模式下) .....         | 628        |
| 23.2.4               | RHRCNT: 小时计数器 (在日历计数模式下) .....          | 628        |
| 23.2.5               | RWKCNT:星期计数器 (在日历计数模式下) .....           | 629        |
| 23.2.6               | BCNTn:二进制计数器n (n=0到3) (在二进制计数模式下) ..... | 629        |
| 23.2.7               | RDAYCNT : Day Counter.....              | 629        |
| 23.2.8               | RMONCNT : Month Counter.....            | 630        |

|         |   |     |
|---------|---|-----|
| 23.2.9  | RYRCNT : Year Counter   | 630 |
| 23.2.10 | RSECAR : Second Alarm Register (in Calendar Count Mode)                             | 631 |
| 23.2.11 | RMINAR : Minute Alarm Register (in Calendar Count Mode)                             | 632 |
| 23.2.12 | RHRAR : Hour Alarm Register (in Calendar Count Mode)                                | 632 |
| 23.2.13 | RWKAR : Day-of-Week Alarm Register (in Calendar Count Mode)                         | 633 |
| 23.2.14 | BCNTnAR : Binary Counter n Alarm Register (n = 0 to 3) (in Binary Count Mode)       | 634 |
| 23.2.15 | RDAYAR : Date Alarm Register (in Calendar Count Mode)                               | 634 |
| 23.2.16 | RMONAR : Month Alarm Register (in Calendar Count Mode)                              | 635 |
| 23.2.17 | RYRAR : Year Alarm Register (in Calendar Count Mode)                                | 635 |
| 23.2.18 | RYRAREN : Year Alarm Enable Register (in Calendar Count Mode)                       | 636 |
| 23.2.19 | BCNTnAER : Binary Counter n Alarm Enable Register (n = 0, 1) (in Binary Count Mode) | 636 |
| 23.2.20 | BCNT2AER : Binary Counter 2 Alarm Enable Register (in Binary Count Mode)            | 637 |
| 23.2.21 | BCNT3AER : Binary Counter 3 Alarm Enable Register (in Binary Count Mode)            | 637 |
| 23.2.22 | RCR1 : RTC Control Register 1   | 638 |
| 23.2.23 | RCR2 : RTC Control Register 2 (in Calendar Count Mode)                              | 639 |
| 23.2.24 | RCR2 : RTC Control Register 2 (in Binary Count Mode)                                | 641 |
| 23.2.25 | RCR4 : RTC Control Register 4   | 642 |
| 23.2.26 | RFRL : Frequency Register L   | 642 |
| 23.2.27 | RFRH : Frequency Register H   | 643 |
| 23.2.28 | RADJ : Time Error Adjustment Register   | 643 |
| 23.2.29 | RTCCRn : Time Capture Control Register n (n = 0 to 2)                               | 644 |
| 23.2.30 | RSECCPn : Second Capture Register n (n = 0 to 2) (in Calendar Count Mode)           | 645 |
| 23.2.31 | RMINCPn : Minute Capture Register n (n = 0 to 2) (in Calendar Count Mode)           | 646 |
| 23.2.32 | RHRCPn : Hour Capture Register n (n = 0 to 2) (in Calendar Count Mode)              | 646 |
| 23.2.33 | RDAYCPn : Date Capture Register n (n = 0 to 2) (in Calendar Count Mode)             | 647 |
| 23.2.34 | RMONCPn : Month Capture Register n (n = 0 to 2) (in Calendar Count Mode)            | 647 |
| 23.2.35 | BCNTnCPm : BCNTn Capture Register m (n= 0 to 3, m = 0 to 2) (in Binary Count Mode)  | 648 |
| 23.3    | Operation   | 648 |
| 23.3.1  | Outline of Initial Settings of Registers after Power On                             | 648 |
| 23.3.2  | Clock and Count Mode Setting Procedure  | 648 |
| 23.3.3  | Setting the Time  | 649 |
| 23.3.4  | 30-Second Adjustment  | 650 |
| 23.3.5  | Reading 64-Hz Counter and Time  | 651 |
| 23.3.6  | Alarm Function  | 653 |
| 23.3.7  | Procedure for Disabling Alarm Interrupt   | 654 |
| 23.3.8  | Time Error Adjustment Function  | 654 |
| 23.3.9  | Capturing the time  | 656 |
| 23.4    | Interrupt Sources   | 657 |
| 23.5    | Event Link Output   | 658 |
| 23.5.1  | Interrupt Handling and Event Linking  | 659 |

|         |   |     |
|---------|---|-----|
| 23.2.9  | RYRCNT : Year Counter                             | 630 |
| 23.2.10 | RSCAR : 第二个闹钟寄存器 (在日历计数模式下)                       | 631 |
| 23.2.11 | RMINAR : 分钟报警寄存器 (在日历计数模式下)                       | 632 |
| 23.2.12 | RHRAR : 小时报警寄存器 (在日历计数模式下)                        | 632 |
| 23.2.13 | RWKAR : 星期报警寄存器 (在日历计数模式下)                        | 633 |
| 23.2.14 | BCNTnAR : 二进制计数器n报警寄存器 (n=0到3) (在二进制计数模式中)        | 634 |
| 23.2.15 | RDAYAR : 日期报警寄存器 (在日历计数模式下)                       | 634 |
| 23.2.16 | RMONAR : 月报警寄存器 (在日历计数模式下)                        | 635 |
| 23.2.17 | RYRAR : 年报警寄存器 (在日历计数模式下)                         | 635 |
| 23.2.18 | RYRAREN : 年闹钟启用寄存器 (在日历计数模式下)                     | 636 |
| 23.2.19 | BCNTnAER : 二进制计数器n报警使能寄存器(n=0 1) (在二进制计数模式下)      | 636 |
| 23.2.20 | BCNT2AER : 二进制计数器2报警使能寄存器 (在二进制计数模式下)             | 637 |
| 23.2.21 | BCNT3AER : 二进制计数器3报警使能寄存器 (在二进制计数模式下)             | 637 |
| 23.2.22 | RCR1 : RTC控制寄存器1                                  | 638 |
| 23.2.23 | RCR2 : RTC控制寄存器2 (在日历计数模式下)                       | 639 |
| 23.2.24 | RCR2 : RTC控制寄存器2 (在二进制计数模式下)                      | 641 |
| 23.2.25 | RCR4 : RTC控制寄存器4                                  | 642 |
| 23.2.26 | RFRL : 频率寄存器L                                     | 642 |
| 23.2.27 | RFRH : 频率寄存器H                                     | 643 |
| 23.2.28 | RADJ : 时间误差调整寄存器                                  | 643 |
| 23.2.29 | RTCCRn : 时间捕捉控制寄存器n (n=0到2)                       | 644 |
| 23.2.30 | RSCCPn : 第二个捕捉寄存器n (n=0到2) (在日历计数模式中)             | 645 |
| 23.2.31 | RMINCPn : 分钟捕捉寄存器n (n=0到2) (在日历计数模式下)             | 646 |
| 23.2.32 | RHRCPn : 小时捕捉寄存器n (n=0到2) (在日历计数模式下)              | 646 |
| 23.2.33 | RDAYCPn : 日期捕捉寄存器n (n=0到2) (在日历计数模式中)             | 647 |
| 23.2.34 | RMONCPn : 月份捕捉寄存器n (n=0到2) (在日历计数模式下)             | 647 |
| 23.2.35 | BCNTnCPm : BCNTn捕捉寄存器m (n=0到3, m=0到2) (在二进制计数模式下) | 648 |
| 23.3    | Operation   | 648 |
| 23.3.1  | 上电后寄存器的初始设置概述                                     | 648 |
| 23.3.2  | 时钟和计数模式设置过程                                       | 648 |
| 23.3.3  | 设置时间  | 649 |
| 23.3.4  | 30-Second Adjustment                              | 650 |
| 23.3.5  | 读取64-Hz计数器和时间                                     | 651 |
| 23.3.6  | Alarm Function                                    | 653 |
| 23.3.7  | 禁用警报中断的步骤   | 654 |
| 23.3.8  | 时间误差调整功能  | 654 |
| 23.3.9  | 捕捉时间  | 656 |
| 23.4    | Interrupt Sources                                 | 657 |
| 23.5    | 事件链接输出  | 658 |
| 23.5.1  | 中断处理和事件链接   | 659 |

|            |   |            |
|------------|---|------------|
| 23.6       | Usage Notes.....  | 659        |
| 23.6.1     | Register Writing during Counting.....   | 659        |
| 23.6.2     | Use of Periodic Interrupts.....   | 659        |
| 23.6.3     | RTCOUT (1-Hz/64-Hz) Clock Output.....   | 660        |
| 23.6.4     | Transitions to Low Power Modes after Setting Registers.....                         | 660        |
| 23.6.5     | Notes on Writing to and Reading from Registers.....                                 | 660        |
| 23.6.6     | Changing the Count Mode.....  | 660        |
| 23.6.7     | Initialization Procedure When the RTC Is Not to Be Used.....                        | 660        |
| 23.6.8     | When Switching Source Clock.....  | 661        |
| <b>24.</b> | <b>Watchdog Timer (WDT).....</b>  | <b>662</b> |
| 24.1       | Overview.....   | 662        |
| 24.2       | Register Descriptions.....  | 663        |
| 24.2.1     | WDTRR : WDT Refresh Register.....   | 663        |
| 24.2.2     | WDTCR : WDT Control Register.....   | 664        |
| 24.2.3     | WDTSR : WDT Status Register.....  | 666        |
| 24.2.4     | WDTRCR : WDT Reset Control Register.....  | 667        |
| 24.2.5     | WDTCSPTPR : WDT Count Stop Control Register.....                                    | 668        |
| 24.2.6     | Option Function Select Register 0 (OFS0).....                                       | 668        |
| 24.3       | Operation.....  | 668        |
| 24.3.1     | Count Operation in each Start Mode.....   | 668        |
| 24.3.2     | Controlling Writes to the WDTCR, WDTRCR, and WDTCSPTPR Registers.....               | 671        |
| 24.3.3     | Refresh Operation.....  | 672        |
| 24.3.4     | Status Flags.....   | 673        |
| 24.3.5     | Reset Output.....   | 673        |
| 24.3.6     | Interrupt Sources.....  | 673        |
| 24.3.7     | Reading the Down-Counter Value.....   | 674        |
| 24.3.8     | Association between Option Function Select Register 0 (OFS0) and WDT Registers..... | 674        |
| 24.4       | Output to the Event Link Controller (ELC).....                                      | 675        |
| 24.5       | Usage Notes.....  | 675        |
| 24.5.1     | ICU Event Link Setting Register n (IELSRn) Setting.....                             | 675        |
| <b>25.</b> | <b>Independent Watchdog Timer (IWDT).....</b>                                       | <b>676</b> |
| 25.1       | Overview.....   | 676        |
| 25.2       | Register Descriptions.....  | 677        |
| 25.2.1     | IWDTRR : IWDT Refresh Register.....   | 677        |
| 25.2.2     | IWDTSR : IWDT Status Register.....  | 678        |
| 25.2.3     | OFS0 : Option Function Select Register 0.....                                       | 679        |
| 25.3       | Operation.....  | 681        |
| 25.3.1     | Auto Start Mode.....  | 681        |
| 25.3.2     | Refresh Operation.....  | 682        |

|            |                                       |            |
|------------|---------------------------------------|------------|
| 23.6       | Usage Notes.....                      | 659        |
| 23.6.1     | 计数期间的寄存器写入.....                       | 659        |
| 23.6.2     | 使用周期性中断.....                          | 659        |
| 23.6.3     | RTCOUT (1-Hz/64-Hz) Clock Output..... | 660        |
| 23.6.4     | 设置寄存器后转换到低功耗模式.....                   | 660        |
| 23.6.5     | 写入和读取寄存器的注意事项.....                    | 660        |
| 23.6.6     | 更改计数模式.....                           | 660        |
| 23.6.7     | 不使用RTC时的初始化程序.....                    | 660        |
| 23.6.8     | 切换源时钟时.....                           | 661        |
| <b>24.</b> | <b>看门狗定时器(WDT).....</b>               | <b>662</b> |
| 24.1       | Overview.....                         | 662        |
| 24.2       | 寄存器说明.....                            | 663        |
| 24.2.1     | WDTRR:WDT刷新寄存器.....                   | 663        |
| 24.2.2     | WDTCR:WDT控制寄存器.....                   | 664        |
| 24.2.3     | WDTSR : WDT Status Register.....      | 666        |
| 24.2.4     | WDTRCR:WDT复位控制寄存器.....                | 667        |
| 24.2.5     | WDTCSPTPR:WDT计数停止控制寄存器.....           | 668        |
| 24.2.6     | 选项功能选择寄存器0(OFS0).....                 | 668        |
| 24.3       | Operation.....                        | 668        |
| 24.3.1     | 每种启动模式下的计数操作.....                     | 668        |
| 24.3.2     | 控制对WDTCR、WDTRCR和WDTCSPTPR寄存器的写入.....  | 671        |
| 24.3.3     | 刷新操作.....                             | 672        |
| 24.3.4     | Status Flags.....                     | 673        |
| 24.3.5     | Reset Output.....                     | 673        |
| 24.3.6     | 中断源.....                              | 673        |
| 24.3.7     | 读取递减计数器值.....                         | 674        |
| 24.3.8     | 选项功能选择寄存器0(OFS0)和WDT寄存器之间的关联.....     | 674        |
| 24.4       | 输出到事件链接控制器(ELC).....                  | 675        |
| 24.5       | Usage Notes.....                      | 675        |
| 24.5.1     | ICU事件链接设置寄存器n(IELSRn)设置.....          | 675        |
| <b>25.</b> | <b>独立看门狗定时器 (IWDT).....</b>           | <b>676</b> |
| 25.1       | Overview.....                         | 676        |
| 25.2       | 寄存器说明.....                            | 677        |
| 25.2.1     | IWDTRR: IWDT刷新寄存器.....                | 677        |
| 25.2.2     | IWDTSR : IWDT Status Register.....    | 678        |
| 25.2.3     | OFS0: 选项功能选择寄存器0.....                 | 679        |
| 25.3       | Operation.....                        | 681        |
| 25.3.1     | 自动启动模式.....                           | 681        |
| 25.3.2     | 刷新操作.....                             | 682        |



|            |   |            |
|------------|---|------------|
| 25.3.3     | Status Flags.....   | 683        |
| 25.3.4     | Reset Output.....   | 684        |
| 25.3.5     | Interrupt Sources .....   | 684        |
| 25.3.6     | Reading the Down-Counter Value .....  | 684        |
| 25.4       | Output to the Event Link Controller (ELC).....                              | 684        |
| 25.5       | Usage Notes.....  | 685        |
| 25.5.1     | Refresh Operations.....   | 685        |
| 25.5.2     | Clock Division Ratio Setting.....   | 685        |
| 25.5.3     | Constraints on the ICU Event Link Setting Register n (IELSRn) Setting ..... | 685        |
| <b>26.</b> | <b>USB 2.0 Full-Speed Module (USBFS) .....</b>                              | <b>686</b> |
| 26.1       | Overview.....   | 686        |
| 26.2       | Register Descriptions .....   | 687        |
| 26.2.1     | SYSCFG : System Configuration Control Register.....                         | 687        |
| 26.2.2     | SYSSTS0 : System Configuration Status Register 0.....                       | 689        |
| 26.2.3     | DVSTCTR0 : Device State Control Register 0 .....                            | 690        |
| 26.2.4     | CFIFO/CFIFOL : CFIFO Port Register .....                                    | 692        |
| 26.2.5     | DnFIFO/DnFIFOL : DnFIFO Port Register (n = 0, 1).....                       | 693        |
| 26.2.6     | CFIFOSEL : CFIFO Port Select Register .....                                 | 695        |
| 26.2.7     | DnFIFOSEL : DnFIFO Port Select Register (n = 0, 1).....                     | 696        |
| 26.2.8     | CFIFOCTR : CFIFO Port Control Register .....                                | 698        |
| 26.2.9     | DnFIFOCTR : DnFIFO Port Control Register (n = 0, 1).....                    | 699        |
| 26.2.10    | INTENB0 : Interrupt Enable Register 0.....                                  | 701        |
| 26.2.11    | INTENB1 : Interrupt Enable Register 1.....                                  | 702        |
| 26.2.12    | BRDYENB : BRDY Interrupt Enable Register .....                              | 703        |
| 26.2.13    | NRDYENB : NRDY Interrupt Enable Register .....                              | 704        |
| 26.2.14    | BEMPENB : BEMP Interrupt Enable Register .....                              | 705        |
| 26.2.15    | SOFCFG : SOF Output Configuration Register.....                             | 706        |
| 26.2.16    | INTSTS0 : Interrupt Status Register 0 .....                                 | 706        |
| 26.2.17    | INTSTS1 : Interrupt Status Register 1 .....                                 | 709        |
| 26.2.18    | BRDYSTS : BRDY Interrupt Status Register .....                              | 711        |
| 26.2.19    | NRDYSTS : NRDY Interrupt Status Register .....                              | 712        |
| 26.2.20    | BEMPSTS : BEMP Interrupt Status Register .....                              | 713        |
| 26.2.21    | FRMNUM : Frame Number Register .....  | 714        |
| 26.2.22    | DVCHGR : Device State Change Register.....                                  | 715        |
| 26.2.23    | USBADDR : USB Address Register .....  | 715        |
| 26.2.24    | USBREQ : USB Request Type Register.....                                     | 716        |
| 26.2.25    | USBVAL : USB Request Value Register.....                                    | 717        |
| 26.2.26    | USBINDX : USB Request Index Register .....                                  | 717        |
| 26.2.27    | USBLENG : USB Request Length Register .....                                 | 718        |
| 26.2.28    | DCPCFG : DCP Configuration Register .....                                   | 718        |

|            |                                       |            |
|------------|---------------------------------------|------------|
| 25.3.3     | Status Flags.....                     | 683        |
| 25.3.4     | Reset Output.....                     | 684        |
| 25.3.5     | 中断源.....                              | 684        |
| 25.3.6     | 读取递减计数器值.....                         | 684        |
| 25.4       | 输出到事件链接控制器(ELC).....                  | 684        |
| 25.5       | Usage Notes.....                      | 685        |
| 25.5.1     | Refresh Operations.....               | 685        |
| 25.5.2     | 时钟分频比设置.....                          | 685        |
| 25.5.3     | ICU事件链接设置寄存器n(IELSRn)设置的约束.....       | 685        |
| <b>26.</b> | <b>USB2.0全速模块(USBFS).....</b>         | <b>686</b> |
| 26.1       | Overview.....                         | 686        |
| 26.2       | 寄存器说明.....                            | 687        |
| 26.2.1     | SYSCFG: 系统配置控制寄存器.....                | 687        |
| 26.2.2     | SYSSTS0: 系统配置状态寄存器0.....              | 689        |
| 26.2.3     | DVSTCTR0:设备状态控制寄存器0.....              | 690        |
| 26.2.4     | CFIFO/CFIFOL:CFIFO端口寄存器.....          | 692        |
| 26.2.5     | DnFIFODnFIFOL:DnFIFO端口寄存器(n=0 1)..... | 693        |
| 26.2.6     | CFIFOSEL: CFIFO端口选择寄存器.....           | 695        |
| 26.2.7     | DnFIFOSEL:DnFIFO端口选择寄存器(n=0 1).....   | 696        |
| 26.2.8     | CFIFOCTR:CFIFO端口控制寄存器.....            | 698        |
| 26.2.9     | DnFIFOCTR:DnFIFO端口控制寄存器(n=0 1).....   | 699        |
| 26.2.10    | INTENB0: 中断允许寄存器0.....                | 701        |
| 26.2.11    | INTENB1: 中断允许寄存器1.....                | 702        |
| 26.2.12    | BRDYENB: BRDY中断允许寄存器.....             | 703        |
| 26.2.13    | NRDYENB: NRDY中断允许寄存器.....             | 704        |
| 26.2.14    | BEMPENB: BEMP中断使能寄存器.....             | 705        |
| 26.2.15    | SOFCFG: SOF输出配置寄存器.....               | 706        |
| 26.2.16    | INTSTS0: 中断状态寄存器0.....                | 706        |
| 26.2.17    | INTSTS1: 中断状态寄存器1.....                | 709        |
| 26.2.18    | BRDYSTS: BRDY中断状态寄存器.....             | 711        |
| 26.2.19    | NRDYSTS: NRDY中断状态寄存器.....             | 712        |
| 26.2.20    | BEMPSTS: BEMP中断状态寄存器.....             | 713        |
| 26.2.21    | FRMNUM: 帧号寄存器.....                    | 714        |
| 26.2.22    | DVCHGR: 设备状态变化寄存器.....                | 715        |
| 26.2.23    | USBADDR: USB地址寄存器.....                | 715        |
| 26.2.24    | USBREQ: USB请求类型寄存器.....               | 716        |
| 26.2.25    | USBVAL: USB请求值寄存器.....                | 717        |
| 26.2.26    | USBINDX: USB请求索引寄存器.....              | 717        |
| 26.2.27    | USBLENG: USB请求长度寄存器.....              | 718        |
| 26.2.28    | DCPCFG: DCP配置寄存器.....                 | 718        |

|  |  |     |
|--|--|-----|
| 26.2.29  | DCPMAXP : DCP Maximum Packet Size Register .....                                   | 719 |
| 26.2.30  | DCPCTR : DCP Control Register .....  | 720 |
| 26.2.31  | PIPESEL : Pipe Window Select Register .....  | 723 |
| 26.2.32  | PIPECFG : Pipe Configuration Register .....  | 723 |
| 26.2.33  | PIPEMAXP : Pipe Maximum Packet Size Register .....                                 | 725 |
| 26.2.34  | PIPEPERI : Pipe Cycle Control Register .....                                       | 726 |
| 26.2.35  | PIPEnCTR : PIPEn Control Registers (n = 1 to 5).....                               | 727 |
| 26.2.36  | PIPEnCTR : PIPEn Control Registers (n = 6 to 9).....                               | 731 |
| 26.2.37  | PIPEnTRE : PIPEn Transaction Counter Enable Register (n = 1 to 5).....             | 733 |
| 26.2.38  | PIPEnTRN : PIPEn Transaction Counter Register (n = 1 to 5).....                    | 734 |
| 26.2.39  | BCCTRL1 : Battery Charging Control Register 1 .....                                | 735 |
| 26.2.40  | BCCTRL2 : Battery Charging Control Register 2 .....                                | 736 |
| 26.2.41  | DEVADDn : Device Address n Configuration Register (n = 0 to 5).....                | 737 |
| 26.2.42  | PHYSECTRL : PHY Single-ended Receiver Control Register .....                       | 738 |
| 26.2.43  | DPUSR0R : Deep Software Standby USB Transceiver Control/Pin Monitor Register ..... | 738 |
| 26.2.44  | DPUSR1R : Deep Software Standby USB Suspend/Resume Interrupt Register.....         | 739 |
| 26.3   | Operation.....   | 741 |
| 26.3.1   | System Control .....   | 741 |
| 26.3.2   | Interrupts.....  | 751 |
| 26.3.3   | Interrupt Descriptions.....  | 755 |
| 26.3.4   | Pipe Control.....  | 764 |
| 26.3.5   | FIFO Buffer .....  | 768 |
| 26.3.6   | FIFO Buffer Clearing.....  | 769 |
| 26.3.7   | FIFO Port Functions .....  | 769 |
| 26.3.8   | DMA Transfers (D0FIFO and D1FIFO Ports) .....                                      | 770 |
| 26.3.9   | Control Transfers Using the DCP .....  | 771 |
| 26.3.10  | Bulk Transfers (Pipes 1 to 5) .....  | 773 |
| 26.3.11  | Interrupt Transfers (Pipes 6 to 9).....  | 773 |
| 26.3.12  | Isochronous Transfers (Pipes 1 and 2).....   | 773 |
| 26.3.13  | SOF Interpolation Function.....  | 780 |
| 26.3.14  | Pipe Schedule.....   | 781 |
| 26.3.15  | Battery Charging Detection Processing.....   | 782 |
| 26.4   | Usage Notes.....   | 786 |
| 26.4.1   | Settings for the Module-Stop State.....  | 786 |
| 26.4.2   | Clearing the Interrupt Status Register on Exiting Software Standby Mode .....      | 786 |
| 26.4.3   | Clearing the Interrupt Status Register after Setting Up the Port Function .....    | 786 |
| <b>27. Serial Communications Interface (SCI) .....</b> | <b>788</b>   |     |
| 27.1   | Overview.....  | 788 |
| 27.2   | Register Descriptions .....  | 793 |
| 27.2.1   | RSR : Receive Shift Register.....  | 793 |

|                             |   |     |
|-----------------------------|---|-----|
| 26.2.29                     | DCPMAXP: DCP最大数据包大小寄存器.....             | 719 |
| 26.2.30                     | DCPCTR: DCP控制寄存器.....                   | 720 |
| 26.2.31                     | PIPESEL: 管道窗口选择寄存器.....                 | 723 |
| 26.2.32                     | PIPECFG: 管道配置寄存器.....                   | 723 |
| 26.2.33                     | PIPEMAXP: 管道最大数据包大小寄存器.....             | 725 |
| 26.2.34                     | PIPEPERI: 管道循环控制寄存器.....                | 726 |
| 26.2.35                     | PIPEnCTR: PIPEn控制寄存器 (n=1到5) .....      | 727 |
| 26.2.36                     | PIPEnCTR: PIPEn控制寄存器 (n=6到9) .....      | 731 |
| 26.2.37                     | PIPEnTRE: PIPEn事务计数器使能寄存器 (n=1到5) ..... | 733 |
| 26.2.38                     | PIPEnTRN: PIPEn事务计数器寄存器 (n=1到5) .....   | 734 |
| 26.2.39                     | BCCTRL1: 电池充电控制寄存器1.....                | 735 |
| 26.2.40                     | BCCTRL2: 电池充电控制寄存器2.....                | 736 |
| 26.2.41                     | DEVADDn: 器件地址n配置寄存器 (n=0到5) .....       | 737 |
| 26.2.42                     | PHYSECTRL: PHY单端接收器控制寄存器.....           | 738 |
| 26.2.43                     | DPUSR0R: 深度软件待机USB收发器控制引脚监控寄存器.....     | 738 |
| 26.2.44                     | DPUSR1R:深度软件待机USB挂起恢复中断寄存器.....         | 739 |
| 26.3                        | Operation.....                          | 741 |
| 26.3.1                      | 系统控制.....                               | 741 |
| 26.3.2                      | Interrupts.....                         | 751 |
| 26.3.3                      | Interrupt Descriptions.....             | 755 |
| 26.3.4                      | 管道控制.....                               | 764 |
| 26.3.5                      | FIFO Buffer .....                       | 768 |
| 26.3.6                      | FIFO Buffer Clearing.....               | 769 |
| 26.3.7                      | FIFO端口功能.....                           | 769 |
| 26.3.8                      | DMA传输 (D0FIFO和D1FIFO端口) .....           | 770 |
| 26.3.9                      | 使用DCP进行控制传输.....                        | 771 |
| 26.3.10                     | 批量传输 (管道1到5) .....                      | 773 |
| 26.3.11                     | 中断传输 (管道6到9) .....                      | 773 |
| 26.3.12                     | 同步传输 (管道1和2) .....                      | 773 |
| 26.3.13                     | SOF插值函数.....                            | 780 |
| 26.3.14                     | Pipe Schedule.....                      | 781 |
| 26.3.15                     | 电池充电检测处理.....                           | 782 |
| 26.4                        | Usage Notes.....                        | 786 |
| 26.4.1                      | 模块停止状态的设置.....                          | 786 |
| 26.4.2                      | 退出软件待机模式时清除中断状态寄存器.....                 | 786 |
| 26.4.3                      | 设置端口功能后清除中断状态寄存器.....                   | 786 |
| <b>27. 串行通信接口(SCI).....</b> | <b>788</b>                              |     |
| 27.1                        | Overview.....                           | 788 |
| 27.2                        | 寄存器说明.....                              | 793 |
| 27.2.1                      | RSR:接收移位寄存器.....                        | 793 |

|         |   |     |
|---------|---|-----|
| 27.2.2  | RDR : Receive Data Register .....   | 793 |
| 27.2.3  | RDRHL : Receive Data Register for Non-Manchester mode (MMR.MANEN = 0).....  | 793 |
| 27.2.4  | RDRHL_MAN : Receive Data Register for Manchester mode (MMR.MANEN = 1) .....   | 794 |
| 27.2.5  | FRDRHL/FRDRH/FRDRL : Receive FIFO Data Register .....   | 794 |
| 27.2.6  | TDR : Transmit Data Register.....   | 796 |
| 27.2.7  | TDRHL : Transmit Data Register for Non-Manchester mode (MMR.MANEN = 0).....   | 796 |
| 27.2.8  | TDRHL_MAN : Transmit Data Register for Manchester mode (MMR.MANEN = 1).....   | 797 |
| 27.2.9  | FTDRHL/FTDRH/FTDRL : Transmit FIFO Data Register.....   | 798 |
| 27.2.10 | TSR : Transmit Shift Register .....   | 798 |
| 27.2.11 | SMR : Serial Mode Register for Non-Smart Card Interface Mode (SCMR.SMIF = 0).....   | 799 |
| 27.2.12 | SMR_SMCI : Serial Mode Register for Smart Card Interface Mode (SCMR.SMIF = 1).....  | 800 |
| 27.2.13 | SCR : Serial Control Register for Non-Smart Card Interface Mode (SCMR.SMIF = 0).....  | 802 |
| 27.2.14 | SCR_SMCI : Serial Control Register for Smart Card Interface Mode (SCMR.SMIF = 1).....   | 804 |
| 27.2.15 | SSR : Serial Status Register for Non-Smart Card Interface and Non-FIFO Mode<br>(SCMR.SMIF = 0, FCR.FM = 0, and MMR.MANEN = 0).....  | 805 |
| 27.2.16 | SSR_FIFO : Serial Status Register for Non-Smart Card Interface and FIFO Mode<br>(SCMR.SMIF = 0, FCR.FM = 1, and MMR.MANEN = 0)..... | 807 |
| 27.2.17 | SSR_SMCI : Serial Status Register for Smart Card Interface Mode (SCMR.SMIF = 1, and<br>MMR.MANEN = 0).....                          | 810 |
| 27.2.18 | SSR_MANC : Serial Status Register for Manchester Mode (SCMR.SMIF = 0, and<br>MMR.MANEN = 1).....                                    | 812 |
| 27.2.19 | SCMR : Smart Card Mode Register .....   | 815 |
| 27.2.20 | BRR : Bit Rate Register .....   | 817 |
| 27.2.21 | MDDR : Modulation Duty Register.....  | 826 |
| 27.2.22 | SEMR : Serial Extended Mode Register.....   | 829 |
| 27.2.23 | SNFR : Noise Filter Setting Register .....  | 832 |
| 27.2.24 | SIMR1 : IIC Mode Register 1 .....   | 833 |
| 27.2.25 | SIMR2 : IIC Mode Register 2 .....   | 833 |
| 27.2.26 | SIMR3 : IIC Mode Register 3.....  | 834 |
| 27.2.27 | SISR : IIC Status Register .....  | 836 |
| 27.2.28 | SPMR : SPI Mode Register .....  | 837 |
| 27.2.29 | FCR : FIFO Control Register .....   | 838 |
| 27.2.30 | FDR : FIFO Data Count Register.....   | 839 |
| 27.2.31 | LSR : Line Status Register .....  | 840 |
| 27.2.32 | CDR : Compare Match Data Register .....   | 841 |
| 27.2.33 | DCCR : Data Compare Match Control Register .....  | 841 |
| 27.2.34 | SPTR : Serial Port Register .....   | 843 |
| 27.2.35 | ACTR : Adjustment Communication Timing Register .....   | 845 |
| 27.2.36 | MMR : Manchester Mode Register .....  | 846 |
| 27.2.37 | TMPR : Transmit Manchester Preface Setting Register .....   | 847 |
| 27.2.38 | RMPR : Receive Manchester Preface Setting Register .....  | 848 |

|         |  |     |
|---------|--|-----|
| 27.2.2  | RDR: 接收数据寄存器.....  | 793 |
| 27.2.3  | RDRHL:非曼彻斯特模式的接收数据寄存器(MMR.MANEN=0).....  | 793 |
| 27.2.4  | RDRHL_MAN: 曼彻斯特模式的接收数据寄存器 (MMR.MANEN=1) .....  | 794 |
| 27.2.5  | FRDRHLFRDRHFRDRL: 接收FIFO数据寄存器.....   | 794 |
| 27.2.6  | TDR:发送数据寄存器.....   | 796 |
| 27.2.7  | TDRHL: 非曼彻斯特模式的发送数据寄存器 (MMR.MANEN=0) .....   | 796 |
| 27.2.8  | TDRHL_MAN: 曼彻斯特模式的发送数据寄存器 (MMR.MANEN=1) .....  | 797 |
| 27.2.9  | FTDRHLFTDRHFTDRL:发送FIFO数据寄存器.....  | 798 |
| 27.2.10 | TSR: 发送移位寄存器.....  | 798 |
| 27.2.11 | SMR: 非智能卡接口模式的串行模式寄存器 (SCMR.SMIF=0) .....  | 799 |
| 27.2.12 | SMR_SMCI: 智能卡接口模式的串行模式寄存器 (SCMR.SMIF=1) .....  | 800 |
| 27.2.13 | SCR: 非智能卡接口模式的串行控制寄存器 (SCMR.SMIF=0) .....  | 802 |
| 27.2.14 | SCR_SMCI: 智能卡接口模式的串行控制寄存器 (SCMR.SMIF=1) .....  | 804 |
| 27.2.15 | SSR: 非智能卡接口和非FIFO模式的串行状态寄存器<br>(SCMR.SMIF = 0, FCR.FM = 0, and MMR.MANEN = 0).....     | 805 |
| 27.2.16 | SSR_FIFO: 非智能卡接口和FIFO模式的串行状态寄存器<br>(SCMR.SMIF = 0, FCR.FM = 1, and MMR.MANEN = 0)..... | 807 |
| 27.2.17 | SSR_SMCI: 智能卡接口模式的串行状态寄存器 (SCMR.SMIF=1, 并且<br>MMR.MANEN = 0).....                      | 810 |
| 27.2.18 | SSR_MANC: 曼彻斯特模式的串行状态寄存器 (SCMR.SMIF=0, 并且<br>MMR.MANEN = 1).....                       | 812 |
| 27.2.19 | SCMR: 智能卡模式寄存器.....  | 815 |
| 27.2.20 | BRR: 比特率寄存器.....   | 817 |
| 27.2.21 | MDDR: 调制占空比寄存器.....  | 826 |
| 27.2.22 | SEMR: 串行扩展模式寄存器.....   | 829 |
| 27.2.23 | SNFR: 噪声滤波器设置寄存器.....  | 832 |
| 27.2.24 | SIMR1: IIC模式寄存器1.....  | 833 |
| 27.2.25 | SIMR2: IIC模式寄存器2.....  | 833 |
| 27.2.26 | SIMR3: IIC模式寄存器3.....  | 834 |
| 27.2.27 | SISR: IIC状态寄存器.....  | 836 |
| 27.2.28 | SPMR: SPI模式寄存器.....  | 837 |
| 27.2.29 | FCR: FIFO控制寄存器.....  | 838 |
| 27.2.30 | FDR: FIFO数据计数寄存器.....  | 839 |
| 27.2.31 | LSR: 线路状态寄存器.....  | 840 |
| 27.2.32 | CDR: 比较匹配数据寄存器.....  | 841 |
| 27.2.33 | DCCR: 数据比较匹配控制寄存器.....   | 841 |
| 27.2.34 | SPTR: 串行端口寄存器.....   | 843 |
| 27.2.35 | ACTR: 调整通信时序寄存器.....   | 845 |
| 27.2.36 | MMR: 曼彻斯特模式寄存器.....  | 846 |
| 27.2.37 | TMPR: 发送曼彻斯特前言设置寄存器.....   | 847 |
| 27.2.38 | RMPR: 接收曼彻斯特前言设置寄存器.....   | 848 |

RA生态工作室

|  |     |  |     |
|--|-----|--|-----|
| 27.2.39 MESR : Manchester Extended Error Status Register .....                     | 849 | 27.2.39MESR: 曼彻斯特扩展错误状态寄存器.....                  | 849 |
| 27.2.40 MECR : Manchester Extended Error Control Register .....                    | 850 | 27.2.40MECR: 曼彻斯特扩展错误控制寄存器.....                  | 850 |
| 27.2.41 ESMER : Extended Serial Module Enable Register .....                       | 851 | 27.2.41ESMER: 扩展串行模块使能寄存器.....                   | 851 |
| 27.2.42 CR0 : Control Register 0.....  | 852 | 27.2.42CR0: 控制寄存器0.....                          | 852 |
| 27.2.43 CR1 : Control Register 1.....  | 852 | 27.2.43CR1: 控制寄存器1.....                          | 852 |
| 27.2.44 CR2 : Control Register 2.....  | 853 | 27.2.44CR2: 控制寄存器2.....                          | 853 |
| 27.2.45 CR3 : Control Register 3.....  | 854 | 27.2.45CR3: 控制寄存器3.....                          | 854 |
| 27.2.46 PCR : Port Control Register.....   | 854 | 27.2.46PCR: 端口控制寄存器.....                         | 854 |
| 27.2.47 ICR : Interrupt Control Register .....                                     | 855 | 27.2.47ICR: 中断控制寄存器.....                         | 855 |
| 27.2.48 STR : Status Register .....  | 855 | 27.2.48STR: 状态寄存器.....                           | 855 |
| 27.2.49 STCR : Status Clear Register.....  | 856 | 27.2.49STCR: 状态清除寄存器.....                        | 856 |
| 27.2.50 CF0DR : Control Field 0 Data Register .....                                | 856 | 27.2.50CF0DR: 控制字段0数据寄存器.....                    | 856 |
| 27.2.51 CF0CR : Control Field 0 Compare Enable Register .....                      | 857 | 27.2.51CF0CR: 控制字段0比较使能寄存器.....                  | 857 |
| 27.2.52 CF0RR : Control Field 0 Receive Data Register .....                        | 857 | 27.2.52CF0RR: 控制字段0接收数据寄存器.....                  | 857 |
| 27.2.53 PCF1DR : Primary Control Field 1 Data Register.....                        | 858 | 27.2.53PCF1DR: 主控制字段1数据寄存器.....                  | 858 |
| 27.2.54 SCF1DR : Secondary Control Field 1 Data Register.....                      | 858 | 27.2.54SCF1DR: 辅助控制字段1数据寄存器.....                 | 858 |
| 27.2.55 CF1CR : Control Field 1 Compare Enable Register .....                      | 858 | 27.2.55CF1CR: 控制字段1比较使能寄存器.....                  | 858 |
| 27.2.56 CF1RR : Control Field 1 Receive Data Register .....                        | 859 | 27.2.56CF1RR: 控制字段1接收数据寄存器.....                  | 859 |
| 27.2.57 TCR : Timer Control Register .....   | 859 | 27.2.57TCR: 定时器控制寄存器.....                        | 859 |
| 27.2.58 TMR : Timer Mode Register.....   | 859 | 27.2.58TMR: 定时器模式寄存器.....                        | 859 |
| 27.2.59 TPRES : Timer Prescaler Register.....                                      | 860 | 27.2.59 TPRES : Timer Prescaler Register.....    | 860 |
| 27.2.60 TCNT : Timer Count Register .....  | 860 | 27.2.60TCNT: 定时器计数寄存器.....                       | 860 |
| 27.3 Operation in Asynchronous Mode .....  | 860 | 27.3 异步模式下的操作.....                               | 860 |
| 27.3.1 Serial Data Transfer Format .....   | 861 | 27.3.1 串行数据传输格式.....                             | 861 |
| 27.3.2 Receive Data Sampling Timing and Reception Margin in Asynchronous Mode..... | 862 | 27.3.2 异步模式下的接收数据采样时序和接收裕度.....                  | 862 |
| 27.3.3 Clock.....  | 863 | 27.3.3 Clock.....                                | 863 |
| 27.3.4 Double-Speed Operation and Frequency of 6 Times the Bit Rate.....           | 864 | 27.3.4 双倍速操作和6倍比特率的频率.....                       | 864 |
| 27.3.5 CTS and RTS Functions .....   | 864 | 27.3.5 CTS and RTS Functions .....               | 864 |
| 27.3.6 Address Match (Receive Data Match Detection) Function .....                 | 864 | 27.3.6 地址匹配 (接收数据匹配检测) 功能.....                   | 864 |
| 27.3.7 SCI Initialization in Asynchronous Mode .....                               | 867 | 27.3.7 异步模式下的SCI初始化.....                         | 867 |
| 27.3.8 Serial Data Transmission in Asynchronous Mode .....                         | 869 | 27.3.8 异步模式下的串行数据传输.....                         | 869 |
| 27.3.9 Serial Data Reception in Asynchronous Mode .....                            | 874 | 27.3.9 异步模式下的串行数据接收.....                         | 874 |
| 27.3.10 The function of adjust receive sampling timing (Asynchronous Mode).....    | 887 | 27.3.10调整接收采样定时功能 (异步模式) .....                   | 887 |
| 27.3.11 The function of adjust transmit timing (Asynchronous Mode).....            | 891 | 27.3.11调整发送时间的功能 (异步模式) .....                    | 891 |
| 27.4 Multi-Processor Communication Function.....                                   | 896 | 27.4 Multi-Processor Communication Function..... | 896 |
| 27.4.1 Multi-Processor Serial Data Transmission.....                               | 897 | 27.4.1 多处理器串行数据传输.....                           | 897 |
| 27.4.2 Multi-Processor Serial Data Reception.....                                  | 900 | 27.4.2 多处理器串行数据接收.....                           | 900 |
| 27.5 Operation in Manchester mode .....  | 905 | 27.5 曼彻斯特模式下的操作.....                             | 905 |
| 27.5.1 Frame Format .....  | 906 | 27.5.1 帧格式.....                                  | 906 |
| 27.5.2 Clock.....  | 910 | 27.5.2 Clock.....                                | 910 |

|         |   |     |
|---------|---|-----|
| 27.5.3  | Initialization of the SCI in Manchester Mode                                  | 910 |
| 27.5.4  | Double-speed operation  | 911 |
| 27.5.5  | CTS and RTS functions   | 911 |
| 27.5.6  | Serial data transmission in Manchester mode                                   | 912 |
| 27.5.7  | Serial Data Reception in Manchester Mode                                      | 915 |
| 27.5.8  | Operation When Multi-Processor Bit Is Used                                    | 918 |
| 27.5.9  | Receive Retiming  | 919 |
| 27.5.10 | Polarity Setting for Manchester Code  | 920 |
| 27.5.11 | Errors in Manchester Mode   | 920 |
| 27.6    | Operation in Clock Synchronous Mode   | 925 |
| 27.6.1  | Clock   | 925 |
| 27.6.2  | CTS and RTS Functions   | 925 |
| 27.6.3  | SCI Initialization in Clock Synchronous Mode                                  | 926 |
| 27.6.4  | Serial Data Transmission in Clock Synchronous Mode                            | 927 |
| 27.6.5  | Serial Data Reception in Clock Synchronous Mode                               | 931 |
| 27.6.6  | Simultaneous Serial Data Transmission and Reception in Clock Synchronous Mode | 936 |
| 27.7    | Operation in Smart Card Interface Mode  | 939 |
| 27.7.1  | Example Connection  | 939 |
| 27.7.2  | Data Format (Except in Block Transfer Mode)                                   | 939 |
| 27.7.3  | Block Transfer Mode   | 941 |
| 27.7.4  | Receive Data Sampling Timing and Reception Margin                             | 941 |
| 27.7.5  | SCI Initialization (Smart Card Interface Mode)                                | 942 |
| 27.7.6  | Serial Data Transmission (Except in Block Transfer Mode)                      | 943 |
| 27.7.7  | Serial Data Reception (Except in Block Transfer Mode)                         | 945 |
| 27.7.8  | Clock Output Control  | 947 |
| 27.8    | Operation in Simple IIC Mode  | 948 |
| 27.8.1  | Generation of Start, Restart, and Stop Conditions                             | 949 |
| 27.8.2  | Clock Synchronization   | 950 |
| 27.8.3  | SDAn Output Delay   | 951 |
| 27.8.4  | SCI Initialization in Simple IIC Mode   | 951 |
| 27.8.5  | Operation in Master Transmission in Simple IIC Mode                           | 952 |
| 27.8.6  | Master Reception in Simple IIC Mode   | 955 |
| 27.9    | Operation in Simple SPI Mode  | 956 |
| 27.9.1  | States of Pins in Master and Slave Modes                                      | 957 |
| 27.9.2  | SS Function in Master Mode  | 958 |
| 27.9.3  | SS Function in Slave Mode   | 958 |
| 27.9.4  | Relationship between Clock and Transmit/Receive Data                          | 958 |
| 27.9.5  | SCI Initialization in Simple SPI Mode   | 959 |
| 27.9.6  | Transmission and Reception of Serial Data in Simple SPI Mode                  | 959 |
| 27.10   | Bit Rate Modulation Function  | 959 |

|         |                        |     |
|---------|------------------------|-----|
| 27.5.3  | 曼彻斯特模式下SCI的初始化         | 910 |
| 27.5.4  | Double-speed operation | 911 |
| 27.5.5  | CTS和RTS功能              | 911 |
| 27.5.6  | 曼彻斯特模式下的串行数据传输         | 912 |
| 27.5.7  | 曼彻斯特模式下的串行数据接收         | 915 |
| 27.5.8  | 使用多处理器位时的操作            | 918 |
| 27.5.9  | Receive Retiming       | 919 |
| 27.5.10 | 曼彻斯特码的极性设置             | 920 |
| 27.5.11 | 曼彻斯特模式中的错误             | 920 |
| 27.6    | 时钟同步模式下的操作             | 925 |
| 27.6.1  | Clock                  | 925 |
| 27.6.2  | CTS and RTS Functions  | 925 |
| 27.6.3  | 时钟同步模式下的SCI初始化         | 926 |
| 27.6.4  | 时钟同步模式下的串行数据传输         | 927 |
| 27.6.5  | 时钟同步模式下的串行数据接收         | 931 |
| 27.6.6  | 在时钟同步模式下同时发送和接收串行数据    | 936 |
| 27.7    | 智能卡接口模式下的操作            | 939 |
| 27.7.1  | Example Connection     | 939 |
| 27.7.2  | 数据格式（块传输模式除外）          | 939 |
| 27.7.3  | 块传输模式                  | 941 |
| 27.7.4  | 接收数据采样时序和接收裕量          | 941 |
| 27.7.5  | SCI初始化（智能卡接口模式）        | 942 |
| 27.7.6  | 串行数据传输（块传输模式除外）        | 943 |
| 27.7.7  | 串行数据接收（块传输模式除外）        | 945 |
| 27.7.8  | 时钟输出控制                 | 947 |
| 27.8    | 简单IIC模式下的操作            | 948 |
| 27.8.1  | 启动、重新启动和停止条件的生成        | 949 |
| 27.8.2  | 时钟同步                   | 950 |
| 27.8.3  | SDAn输出延迟               | 951 |
| 27.8.4  | 简单IIC模式下的SCI初始化        | 951 |
| 27.8.5  | 简单IIC模式下的主传输操作         | 952 |
| 27.8.6  | 简单IIC模式下的主接收           | 955 |
| 27.9    | 简单SPI模式下的操作            | 956 |
| 27.9.1  | 主模式和从模式下的引脚状态          | 957 |
| 27.9.2  | 主模式下的SS功能              | 958 |
| 27.9.3  | 从模式下的SS功能              | 958 |
| 27.9.4  | 时钟与发送接收数据的关系           | 958 |
| 27.9.5  | 简单SPI模式下的SCI初始化        | 959 |
| 27.9.6  | 简单SPI模式下串行数据的发送和接收     | 959 |
| 27.10   | 比特率调制功能                | 959 |

|         |  |     |
|---------|--|-----|
| 27.11   | Extended Serial Mode Control Section: Description of Operation                               | 960 |
| 27.11.1 | Serial Transfer Protocol   | 960 |
| 27.11.2 | Transmitting a Start Frame   | 961 |
| 27.11.3 | Receiving a Start Frame  | 964 |
| 27.11.4 | Detection of Bus Collisions  | 970 |
| 27.11.5 | Digital Filter for Input on the RXDXn (n = 1, 2) Pin   | 971 |
| 27.11.6 | Bit Rate Measurement   | 972 |
| 27.11.7 | Selectable Timing for Sampling Data Received through RXDXn (n = 1, 2)                        | 973 |
| 27.11.8 | Timer  | 973 |
| 27.12   | Interrupt Sources  | 975 |
| 27.12.1 | Buffer Operation for SCIn_TXI and SCIn_RXI Interrupts (non-FIFO selected)                    | 975 |
| 27.12.2 | Buffer Operation for SCIn_TXI and SCIn_RXI Interrupts (FIFO selected)                        | 975 |
| 27.12.3 | Interrupts in Asynchronous, Manchester, Clock Synchronous, and Simple SPI Modes              | 976 |
| 27.12.4 | Interrupts in Smart Card Interface Mode  | 977 |
| 27.12.5 | Interrupts in Simple IIC Mode  | 978 |
| 27.12.6 | Interrupt Requests from the Extended Serial Mode Control Section                             | 979 |
| 27.13   | Event Linking  | 979 |
| 27.14   | Address Non-match Event Output (SCIO_DCUF)   | 980 |
| 27.15   | Noise Cancellation Function  | 980 |
| 27.16   | Usage Notes  | 981 |
| 27.16.1 | Settings for the Module-Stop Function  | 981 |
| 27.16.2 | SCI Operation during Low Power State   | 981 |
| 27.16.3 | Break Detection and Processing   | 986 |
| 27.16.4 | Mark State and Production of Breaks  | 987 |
| 27.16.5 | Receive Error Flags and Transmit Operation in Clock Synchronous Mode and Simple SPI Mode     | 987 |
| 27.16.6 | Restrictions on Clock Synchronous Transmission in Clock Synchronous Mode and Simple SPI Mode | 987 |
| 27.16.7 | Restrictions on Using DTC or DMAC  | 988 |
| 27.16.8 | Notes on Starting Transfer   | 989 |
| 27.16.9 | External Clock Input in Clock Synchronous Mode and Simple SPI Mode                           | 989 |
| 27.16.1 | Limitations on Simple SPI Mode   | 989 |
| 0       |  |     |
| 27.16.1 | Notes on Transmitt Enable bit (SCR.TE)   | 990 |
| 1       |  |     |
| 27.16.1 | Limitation 1 on Usage of the Extended Serial Mode Control Section                            | 990 |
| 2       |  |     |
| 27.16.1 | Limitation 2 on Usage of the Extended Serial Mode Control Section                            | 990 |
| 3       |  |     |
| 27.16.1 | Note on Stopping Reception When Using the RTS Function in Asynchronous Mode                  | 991 |
| 4       |  |     |
| 28.     | I2C Bus Interface (IIC)  | 992 |

|         |                                    |     |
|---------|------------------------------------|-----|
| 27.11   | 扩展串行模式控制部分：操作说明                    | 960 |
| 27.11.1 | 串行传输协议                             | 960 |
| 27.11.2 | 发送起始帧                              | 961 |
| 27.11.3 | 接收起始帧                              | 964 |
| 27.11.4 | 总线碰撞检测                             | 970 |
| 27.11.5 | RXDXn(n=1 2)引脚上的输入数字滤波器            | 971 |
| 27.11.6 | 比特率测量                              | 972 |
| 27.11.7 | 对通过RXDXn(n=1 2)接收到的数据进行采样的可选时序     | 973 |
| 27.11.8 | Timer                              | 973 |
| 27.12   | Interrupt Sources                  | 975 |
| 27.12.1 | SCIn_TXI和SCIn_RXI中断的缓冲区操作（选择非FIFO） | 975 |
| 27.12.2 | SCIn_TXI和SCIn_RXI中断的缓冲区操作（选择FIFO）  | 975 |
| 27.12.3 | 异步、曼彻斯特、时钟同步和简单SPI模式下的中断           | 976 |
| 27.12.4 | 智能卡接口模式中的中断                        | 977 |
| 27.12.5 | 简单IIC模式下的中断                        | 978 |
| 27.12.6 | 来自扩展串行模式控制部分的中断请求                  | 979 |
| 27.13   | Event Linking                      | 979 |
| 27.14   | 地址不匹配事件输出(SCIO_DCUF)               | 980 |
| 27.15   | 降噪功能                               | 980 |
| 27.16   | Usage Notes                        | 981 |
| 27.16.1 | 模块停止功能的设置                          | 981 |
| 27.16.2 | 低功耗状态下的SCI操作                       | 981 |
| 27.16.3 | 断线检测和处理                            | 986 |
| 27.16.4 | 标记状态和中断的产生                         | 987 |
| 27.16.5 | 时钟同步模式和简单SPI下的接收错误标志和发送操作 Mode     | 987 |
| 27.16.6 | 时钟同步模式和简单时钟同步传输的限制 SPI模式           | 987 |
| 27.16.7 | 使用DTC或DMAC的限制                      | 988 |
| 27.16.8 | 开始传输注意事项                           | 989 |
| 27.16.9 | 时钟同步模式和简单SPI模式下的外部时钟输入             | 989 |
| 27.16.1 | 简单SPI模式的限制                         | 989 |
| 0       |                                    |     |
| 27.16.1 | 发送使能位(SCR.TE)的注意事项                 | 990 |
| 1       |                                    |     |
| 27.16.1 | 使用扩展串行模式控制部分的限制1                   | 990 |
| 2       |                                    |     |
| 27.16.1 | 使用扩展串行模式控制部分的限制2                   | 990 |
| 3       |                                    |     |
| 27.16.1 | 在异步模式下使用RTS功能时停止接收的注意事项            | 991 |
| 4       |                                    |     |
| 28.     | I2C总线接口(IIC)                       | 992 |

|         |   |      |
|---------|---|------|
| 28.1    | Overview  | 992  |
| 28.2    | Register Descriptions                                     | 994  |
| 28.2.1  | ICCR1 : I <sup>2</sup> C Bus Control Register 1           | 994  |
| 28.2.2  | ICCR2 : I <sup>2</sup> C Bus Control Register 2           | 996  |
| 28.2.3  | ICMR1 : I <sup>2</sup> C Bus Mode Register 1              | 999  |
| 28.2.4  | ICMR2 : I <sup>2</sup> C Bus Mode Register 2              | 1000 |
| 28.2.5  | ICMR3 : I <sup>2</sup> C Bus Mode Register 3              | 1001 |
| 28.2.6  | ICFER : I <sup>2</sup> C Bus Function Enable Register     | 1003 |
| 28.2.7  | ICSER : I <sup>2</sup> C Bus Status Enable Register       | 1004 |
| 28.2.8  | ICIER : I <sup>2</sup> C Bus Interrupt Enable Register    | 1006 |
| 28.2.9  | ICSR1 : I <sup>2</sup> C Bus Status Register 1            | 1007 |
| 28.2.10 | ICSR2 : I <sup>2</sup> C Bus Status Register 2            | 1009 |
| 28.2.11 | ICWUR : I <sup>2</sup> C Bus Wakeup Unit Register         | 1012 |
| 28.2.12 | ICWUR2 : I <sup>2</sup> C Bus Wakeup Unit Register 2      | 1013 |
| 28.2.13 | SARLy : Slave Address Register Ly (y = 0 to 2)            | 1015 |
| 28.2.14 | SARUy : Slave Address Register Uy (y = 0 to 2)            | 1015 |
| 28.2.15 | ICBRL : I <sup>2</sup> C Bus Bit Rate Low-Level Register  | 1016 |
| 28.2.16 | ICBRH : I <sup>2</sup> C Bus Bit Rate High-Level Register | 1016 |
| 28.2.17 | ICDRT : I <sup>2</sup> C Bus Transmit Data Register       | 1018 |
| 28.2.18 | ICDRR : I <sup>2</sup> C Bus Receive Data Register        | 1018 |
| 28.2.19 | ICDRS : I <sup>2</sup> C Bus Shift Register               | 1018 |
| 28.3    | Operation   | 1018 |
| 28.3.1  | Communication Data Format                                 | 1018 |
| 28.3.2  | Initial Settings  | 1019 |
| 28.3.3  | Master Transmit Operation                                 | 1020 |
| 28.3.4  | Master Receive Operation                                  | 1024 |
| 28.3.5  | Slave Transmit Operation                                  | 1029 |
| 28.3.6  | Slave Receive Operation                                   | 1031 |
| 28.4    | SCL Synchronization Circuit                               | 1033 |
| 28.5    | SDA Output Delay Function                                 | 1034 |
| 28.6    | Digital Noise Filter Circuits                             | 1035 |
| 28.7    | Address Match Detection                                   | 1036 |
| 28.7.1  | Slave-Address Match Detection                             | 1036 |
| 28.7.2  | Detection of General Call Address                         | 1039 |
| 28.7.3  | Device-ID Address Detection                               | 1040 |
| 28.7.4  | Host Address Detection                                    | 1041 |
| 28.8    | Wakeup Function   | 1042 |
| 28.8.1  | Normal Wakeup Mode 1                                      | 1043 |

|         |                             |      |
|---------|-----------------------------|------|
| 28.1    | Overview                    | 992  |
| 28.2    | 寄存器说明                       | 994  |
| 28.2.1  | ICCR1:I2C总线控制寄存器1           | 994  |
| 28.2.2  | ICCR2:I2C总线控制寄存器2           | 996  |
| 28.2.3  | ICMR1: I2C总线模式寄存器1          | 999  |
| 28.2.4  | ICMR2: I2C总线模式寄存器2          | 1000 |
| 28.2.5  | ICMR3:I2C总线模式寄存器3           | 1001 |
| 28.2.6  | ICFER:I2C总线功能使能寄存器          | 1003 |
| 28.2.7  | ICSER:I2C总线状态使能寄存器          | 1004 |
| 28.2.8  | ICIER:I2C总线中断使能寄存器          | 1006 |
| 28.2.9  | ICSR1:I2C总线状态寄存器1           | 1007 |
| 28.2.10 | ICSR2: I2C总线状态寄存器2          | 1009 |
| 28.2.11 | ICWUR: I2C总线唤醒单元寄存器         | 1012 |
| 28.2.12 | ICWUR2: I2C总线唤醒单元寄存器2       | 1013 |
| 28.2.13 | SARLy: 从地址寄存器Ly (y=0到2)     | 1015 |
| 28.2.14 | SARUy: 从地址寄存器Uy (y=0到2)     | 1015 |
| 28.2.15 | ICBRL: I2C总线比特率低电平寄存器       | 1016 |
| 28.2.16 | ICBRH: I2C总线比特率高电平寄存器       | 1016 |
| 28.2.17 | ICDRT: I2C总线发送数据寄存器         | 1018 |
| 28.2.18 | ICDRR: I2C总线接收数据寄存器         | 1018 |
| 28.2.19 | ICDRS: I2C总线移位寄存器           | 1018 |
| 28.3    | Operation                   | 1018 |
| 28.3.1  | 通讯数据格式                      | 1018 |
| 28.3.2  | 初始设置                        | 1019 |
| 28.3.3  | 主发送操作                       | 1020 |
| 28.3.4  | 主接收操作                       | 1024 |
| 28.3.5  | 从机发送操作                      | 1029 |
| 28.3.6  | 从机接收操作                      | 1031 |
| 28.4    | SCL Synchronization Circuit | 1033 |
| 28.5    | SDA输出延迟功能                   | 1034 |
| 28.6    | 数字噪声滤波器电路                   | 1035 |
| 28.7    | 地址匹配检测                      | 1036 |
| 28.7.1  | 从地址匹配检测                     | 1036 |
| 28.7.2  | 广播呼叫地址的检测                   | 1039 |
| 28.7.3  | Device-ID Address Detection | 1040 |
| 28.7.4  | 主机地址检测                      | 1041 |
| 28.8    | Wakeup Function             | 1042 |
| 28.8.1  | 正常唤醒模式1                     | 1043 |

|   |  |             |
|---|--|-------------|
| 28.8.2  | Normal Wakeup Mode 2   | 1046        |
| 28.8.3  | Command Recovery Mode and EEP Response Mode (Special Wakeup Modes)         | 1048        |
| 28.9  | Automatic Low-Hold Function for SCL  | 1051        |
| 28.9.1  | Function to Prevent Wrong Transmission of Transmit Data                    | 1051        |
| 28.9.2  | NACK Reception Transfer Suspension Function                                | 1052        |
| 28.9.3  | Function to Prevent Failure to Receive Data                                | 1053        |
| 28.10   | Arbitration-Lost Detection Functions                                       | 1054        |
| 28.10.1   | Master Arbitration-Lost Detection (MALE Bit)                               | 1054        |
| 28.10.2   | Function to Detect Loss of Arbitration during NACK Transmission (NALE Bit) | 1056        |
| 28.10.3   | Slave Arbitration-Lost Detection (SALE Bit)                                | 1057        |
| 28.11   | Start, Restart, and Stop Condition Issuing Function                        | 1058        |
| 28.11.1   | Issuing a Start Condition  | 1058        |
| 28.11.2   | Issuing a Restart Condition  | 1058        |
| 28.11.3   | Issuing a Stop Condition   | 1060        |
| 28.12   | Bus Hanging  | 1060        |
| 28.12.1   | Timeout Function   | 1060        |
| 28.12.2   | Extra SCL Clock Cycle Output Function                                      | 1061        |
| 28.12.3   | IIC Reset and Internal Reset   | 1062        |
| 28.13   | SMBus Operation  | 1062        |
| 28.13.1   | SMBus Timeout Measurement  | 1063        |
| 28.13.2   | Packet Error Code (PEC)  | 1064        |
| 28.13.3   | SMBus Host Notification Protocol (Notify ARP Master Command)               | 1064        |
| 28.14   | Interrupt Sources  | 1064        |
| 28.14.1   | Buffer Operation for IICn_TXI and IICn_RXI Interrupts                      | 1065        |
| 28.15   | State of Registers When Issuing Each Condition                             | 1065        |
| 28.16   | Event Link Output  | 1066        |
| 28.16.1   | Interrupt Handling and Event Linking                                       | 1066        |
| 28.17   | Usage Notes  | 1067        |
| 28.17.1   | Settings for the Module-Stop Function                                      | 1067        |
| 28.17.2   | Notes on Starting Transfer   | 1067        |
| <b>29. Controller Area Network (CAN) Module</b> |  | <b>1068</b> |
| 29.1  | Overview   | 1068        |
| 29.2  | Register Descriptions  | 1070        |
| 29.2.1  | CTLR : Control Register  | 1070        |
| 29.2.2  | BCR : Bit Configuration Register   | 1073        |
| 29.2.3  | MKR[k] : Mask Register k (k = 0 to 7)                                      | 1075        |
| 29.2.4  | FIDCRk : FIFO Received ID Compare Register k (k = 0, 1)                    | 1075        |
| 29.2.5  | MKIVLR : Mask Invalid Register   | 1076        |
| 29.2.6  | Mailbox Registers  | 1077        |
| 29.2.7  | MIER : Mailbox Interrupt Enable Register                                   | 1080        |

|                          |                              |             |
|--------------------------|------------------------------|-------------|
| 28.8.2                   | 正常唤醒模式2                      | 1046        |
| 28.8.3                   | 命令恢复模式和EEP响应模式 (特殊唤醒模式)      | 1048        |
| 28.9                     | SCL的自动低保持功能                  | 1051        |
| 28.9.1                   | 防止传输数据错误传输的功能                | 1051        |
| 28.9.2                   | NACK接收传输暂停功能                 | 1052        |
| 28.9.3                   | 防止数据接收失败的功能                  | 1053        |
| 28.10                    | 仲裁丢失检测函数                     | 1054        |
| 28.10.1                  | 主仲裁丢失检测 (MALE位)              | 1054        |
| 28.10.2                  | 在NACK传输期间检测仲裁丢失的功能 (NALE位)   | 1056        |
| 28.10.3                  | 从设备仲裁丢失检测 (SALE位)            | 1057        |
| 28.11                    | 启动、重启和停止条件发出函数               | 1058        |
| 28.11.1                  | 发出开始条件                       | 1058        |
| 28.11.2                  | 发出重启条件                       | 1058        |
| 28.11.3                  | 发出停止条件                       | 1060        |
| 28.12                    | Bus Hanging                  | 1060        |
| 28.12.1                  | 超时功能                         | 1060        |
| 28.12.2                  | 额外SCL时钟周期输出功能                | 1061        |
| 28.12.3                  | IIC复位和内部复位                   | 1062        |
| 28.13                    | SMBus Operation              | 1062        |
| 28.13.1                  | SMBus超时测量                    | 1063        |
| 28.13.2                  | 数据包错误代码(PEC)                 | 1064        |
| 28.13.3                  | SMBus主机通知协议 (通知ARP主机命令)      | 1064        |
| 28.14                    | Interrupt Sources            | 1064        |
| 28.14.1                  | IICn_TXI和IICn_RXI中断的缓冲器操作    | 1065        |
| 28.15                    | 发出每个条件时的寄存器状态                | 1065        |
| 28.16                    | 事件链接输出                       | 1066        |
| 28.16.1                  | 中断处理和事件链接                    | 1066        |
| 28.17                    | Usage Notes                  | 1067        |
| 28.17.1                  | 模块停止功能的设置                    | 1067        |
| 28.17.2                  | 开始传输注意事项                     | 1067        |
| <b>29. 控制器局域网(CAN)模块</b> |                              | <b>1068</b> |
| 29.1                     | Overview                     | 1068        |
| 29.2                     | 寄存器说明                        | 1070        |
| 29.2.1                   | CTLR:控制寄存器                   | 1070        |
| 29.2.2                   | BCR: 位配置寄存器                  | 1073        |
| 29.2.3                   | MKR[k]: 屏蔽寄存器k (k=0到7)       | 1075        |
| 29.2.4                   | FIDCRk:FIFO接收ID比较寄存器k(k=0 1) | 1075        |
| 29.2.5                   | MKIVLR: 屏蔽无效寄存器              | 1076        |
| 29.2.6                   | 邮箱寄存器                        | 1077        |
| 29.2.7                   | MIER:邮箱中断使能寄存器               | 1080        |



|   |   |      |
|---|---|------|
| 29.2.8  | MIER_FIFO : Mailbox Interrupt Enable Register for FIFO Mailbox Mode ..... | 1080 |
| 29.2.9  | MCTL_TX[j] : Message Control Register for Transmit (j = 0 to 31).....     | 1081 |
| 29.2.10   | MCTL_RX[j] : Message Control Register for Receive (j = 0 to 31).....      | 1083 |
| 29.2.11   | RFPCR : Receive FIFO Control Register.....                                | 1085 |
| 29.2.12   | RFPCR : Receive FIFO Pointer Control Register.....                        | 1087 |
| 29.2.13   | TFCR : Transmit FIFO Control Register.....                                | 1088 |
| 29.2.14   | TFPCR : Transmit FIFO Pointer Control Register.....                       | 1089 |
| 29.2.15   | STR : Status Register.....  | 1090 |
| 29.2.16   | MSMR : Mailbox Search Mode Register.....                                  | 1092 |
| 29.2.17   | MSSR : Mailbox Search Status Register.....                                | 1092 |
| 29.2.18   | CSSR : Channel Search Support Register.....                               | 1093 |
| 29.2.19   | AFSR : Acceptance Filter Support Register.....                            | 1094 |
| 29.2.20   | EIER : Error Interrupt Enable Register.....                               | 1095 |
| 29.2.21   | EIFR : Error Interrupt Factor Judge Register.....                         | 1096 |
| 29.2.22   | RECR : Receive Error Count Register.....                                  | 1098 |
| 29.2.23   | TECR : Transmit Error Count Register.....                                 | 1099 |
| 29.2.24   | ECSR : Error Code Store Register.....                                     | 1099 |
| 29.2.25   | TSR : Time Stamp Register.....  | 1100 |
| 29.2.26   | TCR : Test Control Register.....  | 1101 |
| 29.3  | Operation Modes.....  | 1102 |
| 29.3.1  | CAN Reset Mode.....   | 1103 |
| 29.3.2  | CAN Halt Mode.....  | 1104 |
| 29.3.3  | CAN Sleep Mode.....   | 1105 |
| 29.3.4  | CAN Operation Mode (Excluding Bus-Off State).....                         | 1105 |
| 29.3.5  | CAN Operation Mode (Bus-Off State).....                                   | 1106 |
| 29.4  | Data Transfer Rate Configuration.....                                     | 1106 |
| 29.4.1  | Clock Setting.....  | 1106 |
| 29.4.2  | Bit Timing Setting.....   | 1107 |
| 29.4.3  | Data Transfer Rate.....   | 1107 |
| 29.5  | Mailbox and Mask Register Structure.....                                  | 1107 |
| 29.6  | Acceptance Filtering and Masking Functions.....                           | 1109 |
| 29.7  | Reception and Transmission.....   | 1111 |
| 29.7.1  | Reception.....  | 1111 |
| 29.7.2  | Transmission.....   | 1113 |
| 29.8  | Interrupts.....   | 1114 |
| 29.9  | Usage Notes.....  | 1115 |
| 29.9.1  | Settings for the Module-Stop State.....                                   | 1115 |
| 29.9.2  | Settings for the Operating Clock.....                                     | 1115 |
| <b>30. Serial Peripheral Interface (SPI).....</b> | <b>1116</b>   |      |
| 30.1  | Overview.....   | 1116 |

|                             |   |      |
|-----------------------------|---|------|
| 29.2.8                      | MIER_FIFO:FIFO邮箱模式的邮箱中断使能寄存器.....       | 1080 |
| 29.2.9                      | MCTL_TX[j]: 用于发送的消息控制寄存器 (j=0到31) ..... | 1081 |
| 29.2.10                     | MCTL_RX[j]: 用于接收的消息控制寄存器 (j=0到31) ..... | 1083 |
| 29.2.11                     | RFPCR: 接收FIFO控制寄存器.....                 | 1085 |
| 29.2.12                     | RFPCR: 接收FIFO指针控制寄存器.....               | 1087 |
| 29.2.13                     | TFCR: 发送FIFO控制寄存器.....                  | 1088 |
| 29.2.14                     | TFPCR: 发送FIFO指针控制寄存器.....               | 1089 |
| 29.2.15                     | STR: 状态寄存器.....                         | 1090 |
| 29.2.16                     | MSMR: 邮箱搜索模式寄存器.....                    | 1092 |
| 29.2.17                     | MSSR: 邮箱搜索状态寄存器.....                    | 1092 |
| 29.2.18                     | CSSR: 频道搜索支持寄存器.....                    | 1093 |
| 29.2.19                     | AFSR: 接受过滤器支持寄存器.....                   | 1094 |
| 29.2.20                     | EIER: 错误中断使能寄存器.....                    | 1095 |
| 29.2.21                     | EIFR: 错误中断因素判断寄存器.....                  | 1096 |
| 29.2.22                     | RECR: 接收错误计数寄存器.....                    | 1098 |
| 29.2.23                     | TECR: 发送错误计数寄存器.....                    | 1099 |
| 29.2.24                     | ECSR: 错误代码存储寄存器.....                    | 1099 |
| 29.2.25                     | TSR: 时间戳寄存器.....                        | 1100 |
| 29.2.26                     | TCR: 测试控制寄存器.....                       | 1101 |
| 29.3                        | 操作模式.....                               | 1102 |
| 29.3.1                      | CAN复位模式.....                            | 1103 |
| 29.3.2                      | CAN暂停模式.....                            | 1104 |
| 29.3.3                      | CAN睡眠模式.....                            | 1105 |
| 29.3.4                      | CAN操作模式 (不包括总线关闭状态) .....               | 1105 |
| 29.3.5                      | CAN操作模式 (总线关闭状态) .....                  | 1106 |
| 29.4                        | 数据传输率配置.....                            | 1106 |
| 29.4.1                      | 时钟设置.....                               | 1106 |
| 29.4.2                      | 位时序设置.....                              | 1107 |
| 29.4.3                      | 数据传输率.....                              | 1107 |
| 29.5                        | 邮箱和掩码寄存器结构.....                         | 1107 |
| 29.6                        | 接受过滤和屏蔽功能.....                          | 1109 |
| 29.7                        | 接收和发送.....                              | 1111 |
| 29.7.1                      | Reception.....                          | 1111 |
| 29.7.2                      | Transmission.....                       | 1113 |
| 29.8                        | Interrupts.....                         | 1114 |
| 29.9                        | Usage Notes.....                        | 1115 |
| 29.9.1                      | 模块停止状态的设置.....                          | 1115 |
| 29.9.2                      | 工作时钟设置.....                             | 1115 |
| <b>30. 串行外设接口(SPI).....</b> | <b>1116</b>                             |      |
| 30.1                        | Overview.....                           | 1116 |

|         |   |      |
|---------|---|------|
| 30.2    | Register Descriptions .....                                       | 1119 |
| 30.2.1  | SPCR : SPI Control Register .....                                 | 1119 |
| 30.2.2  | SSLP : SPI Slave Select Polarity Register .....                   | 1120 |
| 30.2.3  | SPPCR : SPI Pin Control Register .....                            | 1121 |
| 30.2.4  | SPSR : SPI Status Register .....                                  | 1122 |
| 30.2.5  | SPDR/SPDR_HA/SPDR_BY : SPI Data Register .....                    | 1125 |
| 30.2.6  | SPSCR : SPI Sequence Control Register .....                       | 1128 |
| 30.2.7  | SPSSR : SPI Sequence Status Register .....                        | 1129 |
| 30.2.8  | SPBR : SPI Bit Rate Register .....                                | 1130 |
| 30.2.9  | SPDCR : SPI Data Control Register .....                           | 1130 |
| 30.2.10 | SPCKD : SPI Clock Delay Register .....                            | 1132 |
| 30.2.11 | SSLND : SPI Slave Select Negation Delay Register .....            | 1132 |
| 30.2.12 | SPND : SPI Next-Access Delay Register .....                       | 1133 |
| 30.2.13 | SPCR2 : SPI Control Register 2 .....                              | 1133 |
| 30.2.14 | SPCMDm : SPI Command Register m (m = 0 to 7) .....                | 1135 |
| 30.2.15 | SPDCR2 : SPI Data Control Register 2 .....                        | 1137 |
| 30.2.16 | SPCR3 : SPI Control Register 3 .....                              | 1138 |
| 30.3    | Operation .....   | 1139 |
| 30.3.1  | Overview of SPI Operation .....                                   | 1139 |
| 30.3.2  | Controlling the SPI Pins .....                                    | 1140 |
| 30.3.3  | SPI System Configuration Examples .....                           | 1142 |
| 30.3.4  | Data Formats .....  | 1147 |
| 30.3.5  | Transfer Formats .....  | 1158 |
| 30.3.6  | Data Transfer Modes .....   | 1160 |
| 30.3.7  | Transmit Buffer Empty and Receive Buffer Full Interrupts .....    | 1162 |
| 30.3.8  | Communication End Interrupt .....                                 | 1164 |
| 30.3.9  | Error Detection .....   | 1170 |
| 30.3.10 | Initializing the SPI .....  | 1175 |
| 30.3.11 | SPI Operation .....   | 1176 |
| 30.3.12 | Clock Synchronous Operation .....                                 | 1190 |
| 30.3.13 | Loopback Mode .....   | 1196 |
| 30.3.14 | Self-Diagnosis of Parity Bit Function .....                       | 1197 |
| 30.3.15 | Interrupt Sources .....   | 1198 |
| 30.4    | Event Link Controller Event Output .....                          | 1199 |
| 30.4.1  | Receive Buffer Full Event Output .....                            | 1199 |
| 30.4.2  | Transmit Buffer Empty Event Output .....                          | 1199 |
| 30.4.3  | Mode-Fault, Underrun, Overrun, or Parity Error Event Output ..... | 1200 |
| 30.4.4  | SPI Idle Event Output .....                                       | 1200 |
| 30.4.5  | Communication End Event Output .....                              | 1200 |
| 30.5    | Usage Notes .....   | 1202 |

|         |                                      |      |
|---------|--------------------------------------|------|
| 30.2    | 寄存器说明 .....                          | 1119 |
| 30.2.1  | SPCR: SPI控制寄存器 .....                 | 1119 |
| 30.2.2  | SSLP: SPI从机选择极性寄存器 .....             | 1120 |
| 30.2.3  | SPPCR: SPI引脚控制寄存器 .....              | 1121 |
| 30.2.4  | SPSR: SPI状态寄存器 .....                 | 1122 |
| 30.2.5  | SPDR/SPDR_HA/SPDR_BY: SPI数据寄存器 ..... | 1125 |
| 30.2.6  | SPSCR: SPI序列控制寄存器 .....              | 1128 |
| 30.2.7  | SPSSR: SPI序列状态寄存器 .....              | 1129 |
| 30.2.8  | SPBR: SPI比特率寄存器 .....                | 1130 |
| 30.2.9  | SPDCR: SPI数据控制寄存器 .....              | 1130 |
| 30.2.10 | SPCKD: SPI时钟延迟寄存器 .....              | 1132 |
| 30.2.11 | SSLND: SPI从机选择取反延迟寄存器 .....          | 1132 |
| 30.2.12 | SPND: SPI下一次访问延迟寄存器 .....            | 1133 |
| 30.2.13 | SPCR2: SPI控制寄存器2 .....               | 1133 |
| 30.2.14 | SPCMDm: SPI命令寄存器m (m=0到7) .....      | 1135 |
| 30.2.15 | SPDCR2: SPI数据控制寄存器2 .....            | 1137 |
| 30.2.16 | SPCR3: SPI控制寄存器3 .....               | 1138 |
| 30.3    | Operation .....                      | 1139 |
| 30.3.1  | SPI操作概述 .....                        | 1139 |
| 30.3.2  | 控制SPI引脚 .....                        | 1140 |
| 30.3.3  | SPI系统配置示例 .....                      | 1142 |
| 30.3.4  | 数据格式 .....                           | 1147 |
| 30.3.5  | 传输格式 .....                           | 1158 |
| 30.3.6  | 数据传输模式 .....                         | 1160 |
| 30.3.7  | 发送缓冲区空和接收缓冲区满中断 .....                | 1162 |
| 30.3.8  | 通讯结束中断 .....                         | 1164 |
| 30.3.9  | 错误检测 .....                           | 1170 |
| 30.3.10 | 初始化SPI .....                         | 1175 |
| 30.3.11 | SPI操作 .....                          | 1176 |
| 30.3.12 | 时钟同步操作 .....                         | 1190 |
| 30.3.13 | Loopback Mode .....                  | 1196 |
| 30.3.14 | 奇偶校验位功能自诊断 .....                     | 1197 |
| 30.3.15 | 中断源 .....                            | 1198 |
| 30.4    | 事件链接控制器事件输出 .....                    | 1199 |
| 30.4.1  | 接收缓冲区满事件输出 .....                     | 1199 |
| 30.4.2  | 发送缓冲区空事件输出 .....                     | 1199 |
| 30.4.3  | 模式故障、欠载、溢出或奇偶校验错误事件输出 .....          | 1200 |
| 30.4.4  | SPI空闲事件输出 .....                      | 1200 |
| 30.4.5  | 通讯结束事件输出 .....                       | 1200 |
| 30.5    | Usage Notes .....                    | 1202 |

|            |  |             |
|------------|--|-------------|
| 30.5.1     | Settings for the Module-Stop State   | 1202        |
| 30.5.2     | Constraint on Low-Power Functions  | 1202        |
| 30.5.3     | Constraints on Starting Transfer   | 1202        |
| 30.5.4     | Constraints on Mode-Fault, Underrun, Overrun, or Parity Error Event Output | 1202        |
| 30.5.5     | Constraints on the SPSR.SPRF and SPSR.SPTEF Flags                          | 1202        |
| <b>31.</b> | <b>Quad Serial Peripheral Interface (QSPI)</b>                             | <b>1203</b> |
| 31.1       | Overview   | 1203        |
| 31.2       | Register Descriptions  | 1204        |
| 31.2.1     | SFMSMD : Transfer Mode Control Register                                    | 1204        |
| 31.2.2     | SFMSSC : Chip Selection Control Register                                   | 1205        |
| 31.2.3     | SFMSKC : Clock Control Register  | 1206        |
| 31.2.4     | SFMSST : Status Register   | 1208        |
| 31.2.5     | SFMCOM : Communication Port Register                                       | 1209        |
| 31.2.6     | SFMCMD : Communication Mode Control Register                               | 1209        |
| 31.2.7     | SFMCST : Communication Status Register                                     | 1210        |
| 31.2.8     | SFMSIC : Instruction Code Register   | 1210        |
| 31.2.9     | SFMSAC : Address Mode Control Register                                     | 1211        |
| 31.2.10    | SFMSDC : Dummy Cycle Control Register                                      | 1211        |
| 31.2.11    | SFMSPC : SPI Protocol Control Register                                     | 1212        |
| 31.2.12    | SFMPPMD : Port Control Register  | 1213        |
| 31.2.13    | SFMCNT1 : External QSPI Address Register                                   | 1213        |
| 31.3       | Memory Map   | 1214        |
| 31.3.1     | External Bus Space   | 1214        |
| 31.3.2     | Address Width of the SPI Space and SPI Bus                                 | 1214        |
| 31.4       | SPI Bus  | 1215        |
| 31.4.1     | SPI Protocol   | 1215        |
| 31.4.2     | SPI Mode   | 1218        |
| 31.5       | SPI Bus Timing Adjustment  | 1219        |
| 31.5.1     | SPI Bus Reference Cycles   | 1219        |
| 31.5.2     | QSPCLK Signal Duty Ratio   | 1220        |
| 31.5.3     | Minimum High-Level Width for the QSSL Signal                               | 1221        |
| 31.5.4     | QSSL Signal Setup Time   | 1221        |
| 31.5.5     | QSSL Signal Hold Time  | 1222        |
| 31.5.6     | Hold Time of the Serial Data Output Enable                                 | 1222        |
| 31.5.7     | Setup Time for Serial Data Output  | 1223        |
| 31.5.8     | Hold Time for Serial Data Output   | 1223        |
| 31.5.9     | Serial Data Receiving Latency  | 1224        |
| 31.6       | SPI Instruction Set Used for Serial Flash Memory Access                    | 1225        |
| 31.6.1     | SPI Instructions That Are Automatically Generated                          | 1225        |
| 31.6.2     | Standard Read Instruction  | 1226        |

|            |                           |             |
|------------|---------------------------|-------------|
| 30.5.1     | 模块停止状态的设置                 | 1202        |
| 30.5.2     | 对低功耗功能的限制                 | 1202        |
| 30.5.3     | 开始传输的限制                   | 1202        |
| 30.5.4     | 模式故障、欠载、溢出或奇偶校验错误事件输出的约束  | 1202        |
| 30.5.5     | SPSR.SPRF和SPSR.SPTEF标志的约束 | 1202        |
| <b>31.</b> | <b>四路串行外设接口(QSPI)</b>     | <b>1203</b> |
| 31.1       | Overview                  | 1203        |
| 31.2       | 寄存器说明                     | 1204        |
| 31.2.1     | SFMSMD: 传输模式控制寄存器         | 1204        |
| 31.2.2     | SFMSSC: 芯片选择控制寄存器         | 1205        |
| 31.2.3     | SFMSKC: 时钟控制寄存器           | 1206        |
| 31.2.4     | SFMSST : Status Register  | 1208        |
| 31.2.5     | SFMCOM: 通信端口寄存器           | 1209        |
| 31.2.6     | SFMCMD: 通信模式控制寄存器         | 1209        |
| 31.2.7     | SFMCST: 通信状态寄存器           | 1210        |
| 31.2.8     | SMSIC: 指令代码寄存器            | 1210        |
| 31.2.9     | SFMSAC: 地址模式控制寄存器         | 1211        |
| 31.2.10    | SFMSDC: 虚拟周期控制寄存器         | 1211        |
| 31.2.11    | SFMSPC: SPI协议控制寄存器        | 1212        |
| 31.2.12    | SFMPPMD: 端口控制寄存器          | 1213        |
| 31.2.13    | SFMCNT1: 外部QSPI地址寄存器      | 1213        |
| 31.3       | Memory Map                | 1214        |
| 31.3.1     | 外部总线空间                    | 1214        |
| 31.3.2     | SPI空间和SPI总线的地址宽度          | 1214        |
| 31.4       | SPI Bus                   | 1215        |
| 31.4.1     | SPI Protocol              | 1215        |
| 31.4.2     | SPI模式                     | 1218        |
| 31.5       | SPI总线时序调整                 | 1219        |
| 31.5.1     | SPI总线参考周期                 | 1219        |
| 31.5.2     | QSPCLK信号占空比               | 1220        |
| 31.5.3     | QSSL信号的最小高电平宽度            | 1221        |
| 31.5.4     | QSSL信号建立时间                | 1221        |
| 31.5.5     | QSSL信号保持时间                | 1222        |
| 31.5.6     | 串行数据输出使能的保持时间             | 1222        |
| 31.5.7     | 串行数据输出的建立时间               | 1223        |
| 31.5.8     | 串行数据输出的保持时间               | 1223        |
| 31.5.9     | 串行数据接收延迟                  | 1224        |
| 31.6       | 用于串行闪存访问的SPI指令集           | 1225        |
| 31.6.1     | 自动生成的SPI指令                | 1225        |
| 31.6.2     | 标准阅读说明                    | 1226        |

|            |  |             |
|------------|--|-------------|
| 31.6.3     | Fast Read Instruction.....   | 1226        |
| 31.6.4     | Fast Read Dual Output Instruction .....                            | 1227        |
| 31.6.5     | Fast Read Dual I/O Instruction .....                               | 1229        |
| 31.6.6     | Fast Read Quad Output Instruction .....                            | 1230        |
| 31.6.7     | Fast Read Quad I/O Instruction .....                               | 1231        |
| 31.6.8     | Enter 4-Byte Mode Instruction .....                                | 1232        |
| 31.6.9     | Exit 4-Byte Mode Instruction.....                                  | 1233        |
| 31.6.10    | Write Enable Instruction.....                                      | 1233        |
| 31.7       | SPI Bus Cycle Arrangement.....                                     | 1234        |
| 31.7.1     | Serial Flash Memory Read Based on Individual Conversion.....       | 1234        |
| 31.7.2     | Serial Flash Memory Read Using the Prefetch Function .....         | 1234        |
| 31.7.3     | Halt of Prefetching .....  | 1235        |
| 31.7.4     | Direct Specification of Prefetch Destination.....                  | 1235        |
| 31.7.5     | Prefetch State Polling .....                                       | 1235        |
| 31.7.6     | SPI Bus Cycle Extension Function .....                             | 1236        |
| 31.8       | XIP Control .....  | 1236        |
| 31.8.1     | Setting XIP Mode.....  | 1237        |
| 31.8.2     | Releasing the XIP Mode .....                                       | 1238        |
| 31.9       | QIO2 and QIO3 Pin States .....                                     | 1239        |
| 31.10      | Direct Communication Mode .....                                    | 1240        |
| 31.10.1    | About Direct Communication .....                                   | 1240        |
| 31.10.2    | Using Direct Communication Mode .....                              | 1240        |
| 31.10.3    | Generating the SPI Bus Cycle during Direct Communication.....      | 1240        |
| 31.11      | Interrupts .....   | 1244        |
| 31.12      | Usage Note.....  | 1244        |
| 31.12.1    | Settings for the Module-Stop Function .....                        | 1244        |
| 31.12.2    | Procedure for Changing Settings in Multiple Control Registers..... | 1244        |
| <b>32.</b> | <b>Serial Sound Interface Enhanced (SSIE).....</b>                 | <b>1246</b> |
| 32.1       | Overview.....  | 1246        |
| 32.2       | Features .....   | 1246        |
| 32.3       | Block Diagram .....  | 1247        |
| 32.4       | Register Descriptions .....  | 1250        |
| 32.4.1     | SSICR : Control Register.....                                      | 1250        |
| 32.4.2     | SSISR : Status Register .....                                      | 1260        |
| 32.4.3     | SSIFCR : FIFO Control Register .....                               | 1271        |
| 32.4.4     | SSIFSR : FIFO Status Register .....                                | 1277        |
| 32.4.5     | SSIFTDR : Transmit FIFO Data Register .....                        | 1280        |
| 32.4.6     | SSIFRDR : Receive FIFO Data Register.....                          | 1283        |
| 32.4.7     | SSIOFR : Audio Format Register .....                               | 1285        |
| 32.4.8     | SSISCR : Status Control Register .....                             | 1288        |

|            |                               |             |
|------------|-------------------------------|-------------|
| 31.6.3     | 快速阅读说明.....                   | 1226        |
| 31.6.4     | 快速读取双输出指令.....                | 1227        |
| 31.6.5     | 快速读取双IO指令.....                | 1229        |
| 31.6.6     | 快速读取四路输出指令.....               | 1230        |
| 31.6.7     | 快速读取四线IO指令.....               | 1231        |
| 31.6.8     | 进入4字节模式指令.....                | 1232        |
| 31.6.9     | 退出4字节模式指令.....                | 1233        |
| 31.6.10    | 写使能指令.....                    | 1233        |
| 31.7       | SPI总线周期安排.....                | 1234        |
| 31.7.1     | 基于单独转换的串行闪存读取.....            | 1234        |
| 31.7.2     | 使用预取功能读取串行闪存存储器.....          | 1234        |
| 31.7.3     | 停止预取.....                     | 1235        |
| 31.7.4     | 预取目的地的直接指定.....               | 1235        |
| 31.7.5     | 预取状态轮询.....                   | 1235        |
| 31.7.6     | SPI总线周期扩展功能.....              | 1236        |
| 31.8       | XIP Control .....             | 1236        |
| 31.8.1     | Setting XIP Mode.....         | 1237        |
| 31.8.2     | 释放XIP模式.....                  | 1238        |
| 31.9       | QIO2和QIO3引脚状态.....            | 1239        |
| 31.10      | 直接通信方式.....                   | 1240        |
| 31.10.1    | 关于直接通信.....                   | 1240        |
| 31.10.2    | 使用直接通信模式.....                 | 1240        |
| 31.10.3    | 在直接通信期间生成SPI总线周期.....         | 1240        |
| 31.11      | Interrupts .....              | 1244        |
| 31.12      | Usage Note.....               | 1244        |
| 31.12.1    | 模块停止功能的设置.....                | 1244        |
| 31.12.2    | 更改多个控制寄存器中的设置的步骤.....         | 1244        |
| <b>32.</b> | <b>增强型串行声音接口(SSIE).....</b>   | <b>1246</b> |
| 32.1       | Overview.....                 | 1246        |
| 32.2       | Features .....                | 1246        |
| 32.3       | 框图.....                       | 1247        |
| 32.4       | 寄存器说明.....                    | 1250        |
| 32.4.1     | SSICR : Control Register..... | 1250        |
| 32.4.2     | SSISR: 状态寄存器.....             | 1260        |
| 32.4.3     | SSIFCR:FIFO控制寄存器.....         | 1271        |
| 32.4.4     | SSIFSR:FIFO状态寄存器.....         | 1277        |
| 32.4.5     | SSIFTDR: 发送FIFO数据寄存器.....     | 1280        |
| 32.4.6     | SSIFRDR: 接收FIFO数据寄存器.....     | 1283        |
| 32.4.7     | SSIOFR:音频格式寄存器.....           | 1285        |
| 32.4.8     | SSISCR: 状态控制寄存器.....          | 1288        |

|            |  |             |
|------------|--|-------------|
| 32.5       | Communication Formats .....                    | 1289        |
| 32.5.1     | I2S Format .....                               | 1290        |
| 32.5.2     | Monaural Format .....                          | 1290        |
| 32.5.3     | TDM Format.....                                | 1292        |
| 32.6       | Communication Modes.....                       | 1293        |
| 32.6.1     | Slave-mode Communication.....                  | 1293        |
| 32.6.2     | Master-mode Communication.....                 | 1293        |
| 32.6.3     | Transmission.....                              | 1294        |
| 32.6.4     | Reception.....                                 | 1294        |
| 32.6.5     | Transmission and Reception .....               | 1294        |
| 32.7       | Operation.....                                 | 1294        |
| 32.7.1     | Idle State.....                                | 1294        |
| 32.7.2     | Communication States.....                      | 1296        |
| 32.8       | Communication Operation.....                   | 1300        |
| 32.8.1     | Start Communication .....                      | 1300        |
| 32.8.2     | Transmission.....                              | 1301        |
| 32.8.3     | Reception.....                                 | 1302        |
| 32.8.4     | Transmission and Reception .....               | 1303        |
| 32.8.5     | Halt Communication .....                       | 1303        |
| 32.8.6     | Error Handling.....                            | 1304        |
| 32.8.7     | Resume Communication .....                     | 1305        |
| 32.9       | Interrupts .....                               | 1306        |
| 32.9.1     | SSIE0_SSIF Interrupt .....                     | 1307        |
| 32.9.2     | SSIE0_SSITXI Interrupt.....                    | 1308        |
| 32.9.3     | SSIE0_SSIRXI Interrupt .....                   | 1308        |
| 32.10      | Software Resets .....                          | 1308        |
| 32.10.1    | Software Reset Procedure.....                  | 1308        |
| 32.11      | Notes .....                                    | 1309        |
| 32.11.1    | Notes for Slave-mode Communication .....       | 1309        |
| 32.11.2    | Notes for Master-mode Communication .....      | 1310        |
| 32.11.3    | Notes for Communication Flow.....              | 1310        |
| 32.11.4    | Write Access Restriction .....                 | 1311        |
| <b>33.</b> | <b>SD/MMC Host Interface (SDHI).....</b>       | <b>1313</b> |
| 33.1       | Overview.....                                  | 1313        |
| 33.2       | Register Descriptions .....                    | 1314        |
| 33.2.1     | SD_CMD : Command Type Register .....           | 1314        |
| 33.2.2     | SD_ARG : SD Command Argument Register .....    | 1315        |
| 33.2.3     | SD_ARG1 : SD Command Argument Register 1 ..... | 1316        |
| 33.2.4     | SD_STOP : Data Stop Register.....              | 1316        |
| 33.2.5     | SD_SECCNT : Block Count Register .....         | 1317        |

|            |                                |             |
|------------|--------------------------------|-------------|
| 32.5       | 通讯格式.....                      | 1289        |
| 32.5.1     | I2S Format .....               | 1290        |
| 32.5.2     | Monaural Format .....          | 1290        |
| 32.5.3     | TDM Format.....                | 1292        |
| 32.6       | Communication Modes.....       | 1293        |
| 32.6.1     | Slave-mode Communication.....  | 1293        |
| 32.6.2     | Master-mode Communication..... | 1293        |
| 32.6.3     | Transmission.....              | 1294        |
| 32.6.4     | Reception.....                 | 1294        |
| 32.6.5     | 传输和接收.....                     | 1294        |
| 32.7       | Operation.....                 | 1294        |
| 32.7.1     | Idle State.....                | 1294        |
| 32.7.2     | Communication States.....      | 1296        |
| 32.8       | Communication Operation.....   | 1300        |
| 32.8.1     | 开始沟通.....                      | 1300        |
| 32.8.2     | Transmission.....              | 1301        |
| 32.8.3     | Reception.....                 | 1302        |
| 32.8.4     | 传输和接收.....                     | 1303        |
| 32.8.5     | 停止通信.....                      | 1303        |
| 32.8.6     | Error Handling.....            | 1304        |
| 32.8.7     | 恢复沟通.....                      | 1305        |
| 32.9       | Interrupts .....               | 1306        |
| 32.9.1     | SSIE0_SSIF Interrupt .....     | 1307        |
| 32.9.2     | SSIE0_SSITXI Interrupt.....    | 1308        |
| 32.9.3     | SSIE0_SSIRXI Interrupt .....   | 1308        |
| 32.10      | 软件复位.....                      | 1308        |
| 32.10.1    | 软件复位程序.....                    | 1308        |
| 32.11      | Notes .....                    | 1309        |
| 32.11.1    | 从模式通信的注意事项.....                | 1309        |
| 32.11.2    | 主模式通信注意事项.....                 | 1310        |
| 32.11.3    | 通信流程注意事项.....                  | 1310        |
| 32.11.4    | 写访问限制.....                     | 1311        |
| <b>33.</b> | <b>SDMMC主机接口(SDHI).....</b>    | <b>1313</b> |
| 33.1       | Overview.....                  | 1313        |
| 33.2       | 寄存器说明.....                     | 1314        |
| 33.2.1     | SD_CMD: 命令类型寄存器.....           | 1314        |
| 33.2.2     | SD_ARG:SD命令参数寄存器.....          | 1315        |
| 33.2.3     | SD_ARG1:SD命令参数寄存器1.....        | 1316        |
| 33.2.4     | SD_STOP: 数据停止寄存器.....          | 1316        |
| 33.2.5     | SD_SECCNT: 块计数寄存器.....         | 1317        |

|         |   |      |
|---------|---|------|
| 33.2.6  | SD_RSPi : SD Card Response Register i (i = 10, 32, 54)  | 1318 |
| 33.2.7  | SD_RSPj : SD Card Response Register j (j = 1, 3, 5)     | 1318 |
| 33.2.8  | SD_RSP76 : SD Card Response Register 76                 | 1318 |
| 33.2.9  | SD_RSP7 : SD Card Response Register 7                   | 1319 |
| 33.2.10 | SD_INFO1 : SD Card Interrupt Flag Register 1            | 1319 |
| 33.2.11 | SD_INFO2 : SD Card Interrupt Flag Register 2            | 1322 |
| 33.2.12 | SD_INFO1_MASK : SD INFO1 Interrupt Mask Register        | 1326 |
| 33.2.13 | SD_INFO2_MASK : SD INFO2 Interrupt Mask Register        | 1327 |
| 33.2.14 | SD_CLK_CTRL : SD Clock Control Register                 | 1328 |
| 33.2.15 | SD_SIZE : Transfer Data Length Register                 | 1329 |
| 33.2.16 | SD_OPTION : SD Card Access Control Option Register      | 1330 |
| 33.2.17 | SD_ERR_STS1 : SD Error Status Register 1                | 1331 |
| 33.2.18 | SD_ERR_STS2 : SD Error Status Register 2                | 1332 |
| 33.2.19 | SD_BUF0 : SD Buffer Register                            | 1333 |
| 33.2.20 | SDIO_MODE : SDIO Mode Control Register                  | 1334 |
| 33.2.21 | SDIO_INFO1 : SDIO Interrupt Flag Register               | 1335 |
| 33.2.22 | SDIO_INFO1_MASK : SDIO INFO1 Interrupt Mask Register    | 1336 |
| 33.2.23 | SD_DMAEN : DMA Mode Enable Register                     | 1337 |
| 33.2.24 | SOFT_RST : Software Reset Register                      | 1338 |
| 33.2.25 | SDIF_MODE : SD Interface Mode Setting Register          | 1338 |
| 33.2.26 | EXT_SWAP : Swap Control Register                        | 1339 |
| 33.3    | Operation   | 1339 |
| 33.3.1  | SD/MMC Interface  | 1339 |
| 33.3.2  | Card Detect/Write Protect                               | 1341 |
| 33.3.3  | Interrupt Request and DMA Transfer Request              | 1343 |
| 33.3.4  | Communication Errors and Timeouts                       | 1344 |
| 33.3.5  | Command without Data Transfer (SD/MMC)                  | 1345 |
| 33.3.6  | Single Block Read (SD/MMC)                              | 1347 |
| 33.3.7  | Single Block Write (SD/MMC)                             | 1349 |
| 33.3.8  | Multiple Block Read (SD/MMC)                            | 1350 |
| 33.3.9  | Multiple Block Write (SD/MMC Using Internal Timer)      | 1352 |
| 33.3.10 | Multiple Block Write (MMC using external timer)         | 1354 |
| 33.3.11 | IO_RW_DIRECT Command (SD: CMD52)                        | 1356 |
| 33.3.12 | IO_RW_EXTENDED Command (SD: CMD53/Multiple Block Read)  | 1356 |
| 33.3.13 | IO_RW_EXTENDED Command (SD: CMD53/Multiple Block Write) | 1358 |
| 33.3.14 | DMA Transfer (SD/MMC)                                   | 1360 |
| 33.3.15 | Example of SD_CMD Register Setting                      | 1362 |
| 33.4    | Usage Notes   | 1366 |
| 33.4.1  | SD_BUF Illegal Write Access (SD/MMC)                    | 1366 |
| 33.4.2  | Block Number Constraint for Multiple Block Read (SD)    | 1366 |

|         |                                   |      |
|---------|-----------------------------------|------|
| 33.2.6  | SD_RSPi:SD卡响应寄存器i(i=10 32 54)     | 1318 |
| 33.2.7  | SD_RSPj:SD卡响应寄存器j(j=1 3 5)        | 1318 |
| 33.2.8  | SD_RSP76:SD卡响应寄存器76               | 1318 |
| 33.2.9  | SD_RSP7:SD卡响应寄存器7                 | 1319 |
| 33.2.10 | SD_INFO1: SD卡中断标志寄存器1             | 1319 |
| 33.2.11 | SD_INFO2: SD卡中断标志寄存器2             | 1322 |
| 33.2.12 | SD_INFO1_MASK: SDINFO1中断屏蔽寄存器     | 1326 |
| 33.2.13 | SD_INFO2_MASK: SDINFO2中断屏蔽寄存器     | 1327 |
| 33.2.14 | SD_CLK_CTRL: SD时钟控制寄存器            | 1328 |
| 33.2.15 | SD_SIZE: 传输数据长度寄存器                | 1329 |
| 33.2.16 | SD_OPTION: SD卡访问控制选项寄存器           | 1330 |
| 33.2.17 | SD_ERR_STS1: SD错误状态寄存器1           | 1331 |
| 33.2.18 | SD_ERR_STS2: SD错误状态寄存器2           | 1332 |
| 33.2.19 | SD_BUF0: SD Buffer Register       | 1333 |
| 33.2.20 | SDIO_MODE: SDIO模式控制寄存器            | 1334 |
| 33.2.21 | SDIO_INFO1: SDIO中断标志寄存器           | 1335 |
| 33.2.22 | SDIO_INFO1_MASK: SDIOINFO1中断屏蔽寄存器 | 1336 |
| 33.2.23 | SD_DMAEN: DMA模式使能寄存器              | 1337 |
| 33.2.24 | SOFT_RST: 软件复位寄存器                 | 1338 |
| 33.2.25 | SDIF_MODE: SD接口模式设置寄存器            | 1338 |
| 33.2.26 | EXT_SWAP: 交换控制寄存器                 | 1339 |
| 33.3    | Operation                         | 1339 |
| 33.3.1  | SD/MMC Interface                  | 1339 |
| 33.3.2  | Card Detect/Write Protect         | 1341 |
| 33.3.3  | 中断请求和DMA传输请求                      | 1343 |
| 33.3.4  | 通信错误和超时                           | 1344 |
| 33.3.5  | 不带数据传输的命令(SDMMC)                  | 1345 |
| 33.3.6  | 单块读取(SDMMC)                       | 1347 |
| 33.3.7  | 单块写入(SDMMC)                       | 1349 |
| 33.3.8  | 多块读取(SDMMC)                       | 1350 |
| 33.3.9  | 多块写入(使用内部定时器的SDMMC)               | 1352 |
| 33.3.10 | 多块写入(MMC使用外部定时器)                  | 1354 |
| 33.3.11 | IO_RW_DIRECT Command (SD: CMD52)  | 1356 |
| 33.3.12 | IO_RW_EXTENDED命令(SD: CMD53多块读取)   | 1356 |
| 33.3.13 | IO_RW_EXTENDED命令(SD: CMD53多块写入)   | 1358 |
| 33.3.14 | DMA Transfer (SD/MMC)             | 1360 |
| 33.3.15 | SD_CMD寄存器设置示例                     | 1362 |
| 33.4    | Usage Notes                       | 1366 |
| 33.4.1  | SD_BUF非法写访问(SDMMC)                | 1366 |
| 33.4.2  | 多块读取(SD)的块号约束                     | 1366 |

RA生态工作室

|            |   |             |
|------------|---|-------------|
| 33.4.3     | Automatic Control of SD/MMC Clock Output (SD/MMC)           | 1366        |
| 33.4.4     | Control of the C52PUB Setting for Multiple Block Write (SD) | 1367        |
| 33.4.5     | Notes on SD_CLK_CTRL Register Settings (SD/MMC)             | 1367        |
| 33.4.6     | Specification Limitations                                   | 1367        |
| 33.4.7     | STP Bit Setting during Multiple Block Read (SD/MMC)         | 1367        |
| 33.4.8     | Register Setting Notes                                      | 1368        |
| <b>34.</b> | <b>Cyclic Redundancy Check (CRC) Calculator</b>             | <b>1369</b> |
| 34.1       | Overview  | 1369        |
| 34.2       | Register Descriptions                                       | 1369        |
| 34.2.1     | CRCCR0 : CRC Control Register 0                             | 1370        |
| 34.2.2     | CRCDIR/CRCDIR_BY : CRC Data Input Register                  | 1370        |
| 34.2.3     | CRCDOR/CRCDOR_HA/CRCDOR_BY : CRC Data Output Register       | 1371        |
| 34.3       | Operation   | 1371        |
| 34.3.1     | Basic Operation   | 1371        |
| 34.4       | Usage Notes   | 1374        |
| 34.4.1     | Settings for the Module-Stop State                          | 1374        |
| 34.4.2     | Note on Transmission  | 1374        |
| <b>35.</b> | <b>Boundary Scan</b>  | <b>1376</b> |
| 35.1       | Overview  | 1376        |
| 35.2       | Register Descriptions                                       | 1376        |
| 35.2.1     | JTIR : Instruction Register                                 | 1377        |
| 35.2.2     | JTIDR : ID Code Register                                    | 1377        |
| 35.2.3     | JTBPR : Bypass Register                                     | 1378        |
| 35.2.4     | JTBSR : Boundary Scan Register                              | 1378        |
| 35.3       | Operation   | 1378        |
| 35.3.1     | TAP Controller  | 1378        |
| 35.3.2     | Commands  | 1379        |
| 35.4       | Usage Notes   | 1380        |
| <b>36.</b> | <b>Secure Cryptographic Engine (SCE9)</b>                   | <b>1382</b> |
| 36.1       | Overview  | 1382        |
| 36.2       | Operation   | 1383        |
| 36.2.1     | Encryption Engine   | 1383        |
| 36.2.2     | Encryption and Decryption                                   | 1384        |
| 36.3       | Usage Notes   | 1385        |
| 36.3.1     | Software Standby Mode                                       | 1385        |
| 36.3.2     | Module-Stop Function Setting                                | 1385        |
| <b>37.</b> | <b>12-Bit A/D Converter (ADC12)</b>                         | <b>1386</b> |
| 37.1       | Overview  | 1386        |
| 37.2       | Register Descriptions                                       | 1391        |

|            |  |             |
|------------|--|-------------|
| 33.4.3     | SDMMC时钟输出(SDMMC)的自动控制                  | 1366        |
| 33.4.4     | 控制多块写入(SD)的C52PUB设置                    | 1367        |
| 33.4.5     | SD_CLK_CTRL寄存器设置(SDMMC)的注意事项           | 1367        |
| 33.4.6     | 规格限制                                   | 1367        |
| 33.4.7     | 多块读取期间的STP位设置(SDMMC)                   | 1367        |
| 33.4.8     | 注册设置注意事项                               | 1368        |
| <b>34.</b> | <b>循环冗余校验(CRC)计算器</b>                  | <b>1369</b> |
| 34.1       | Overview                               | 1369        |
| 34.2       | 寄存器说明                                  | 1369        |
| 34.2.1     | CRCCR0: CRC控制寄存器0                      | 1370        |
| 34.2.2     | CRCDIR/CRCDIR_BY: CRC数据输入寄存器           | 1370        |
| 34.2.3     | CRCDOR/CRCDOR_HA/CRCDOR_BY: CRC数据输出寄存器 | 1371        |
| 34.3       | Operation                              | 1371        |
| 34.3.1     | 基本操作                                   | 1371        |
| 34.4       | Usage Notes                            | 1374        |
| 34.4.1     | 模块停止状态的设置                              | 1374        |
| 34.4.2     | 传输注意事项                                 | 1374        |
| <b>35.</b> | <b>边界扫描</b>                            | <b>1376</b> |
| 35.1       | Overview                               | 1376        |
| 35.2       | 寄存器说明                                  | 1376        |
| 35.2.1     | JTIR: 指令寄存器                            | 1377        |
| 35.2.2     | JTIDR: ID代码寄存器                         | 1377        |
| 35.2.3     | JTBPR: 旁路寄存器                           | 1378        |
| 35.2.4     | JTBSR: 边界扫描寄存器                         | 1378        |
| 35.3       | Operation                              | 1378        |
| 35.3.1     | TAP Controller                         | 1378        |
| 35.3.2     | Commands                               | 1379        |
| 35.4       | Usage Notes                            | 1380        |
| <b>36.</b> | <b>安全加密引擎(SCE9)</b>                    | <b>1382</b> |
| 36.1       | Overview                               | 1382        |
| 36.2       | Operation                              | 1383        |
| 36.2.1     | Encryption Engine                      | 1383        |
| 36.2.2     | 加密和解密                                  | 1384        |
| 36.3       | Usage Notes                            | 1385        |
| 36.3.1     | 软件待机模式                                 | 1385        |
| 36.3.2     | 模块停止功能设置                               | 1385        |
| <b>37.</b> | <b>12-Bit A/D Converter (ADC12)</b>    | <b>1386</b> |
| 37.1       | Overview                               | 1386        |
| 37.2       | 寄存器说明                                  | 1391        |

|         |  |      |
|---------|--|------|
| 37.2.1  | ADDRn : A/D Data Registers n   | 1391 |
| 37.2.2  | ADDBLDR : A/D Data Duplexing Register  | 1392 |
| 37.2.3  | ADDBLDRn : A/D Data Duplexing Register n (n = A, B)  | 1393 |
| 37.2.4  | ADTSDR : A/D Temperature Sensor Data Register  | 1394 |
| 37.2.5  | ADOCDR : A/D Internal Reference Voltage Data Register  | 1396 |
| 37.2.6  | ADRD : A/D Self-Diagnosis Data Register  | 1397 |
| 37.2.7  | ADCSR : A/D Control Register   | 1398 |
| 37.2.8  | ADANSA0 : A/D Channel Select Register A0   | 1401 |
| 37.2.9  | ADANSA1 : A/D Channel Select Register A1   | 1401 |
| 37.2.10 | ADANSB0 : A/D Channel Select Register B0   | 1402 |
| 37.2.11 | ADANSB1 : A/D Channel Select Register B1   | 1403 |
| 37.2.12 | ADADS0 : A/D-Converted Value Addition/Average Channel Select Register 0                          | 1403 |
| 37.2.13 | ADADS1 : A/D-Converted Value Addition/Average Channel Select Register 1                          | 1404 |
| 37.2.14 | ADADC : A/D-Converted Value Addition/Average Count Select Register                               | 1405 |
| 37.2.15 | ADCER : A/D Control Extended Register  | 1406 |
| 37.2.16 | ADSTRGR : A/D Conversion Start Trigger Select Register   | 1407 |
| 37.2.17 | ADEXICR : A/D Conversion Extended Input Control Registers  | 1409 |
| 37.2.18 | ADSSTRn/ADSSTRL/ADSSTRT/ADSSTRO : A/D Sampling State Register                                    | 1410 |
| 37.2.19 | ADDISCR : A/D Disconnection Detection Control Register   | 1411 |
| 37.2.20 | ADGSPCR : A/D Group Scan Priority Control Register   | 1412 |
| 37.2.21 | ADCMPCR : A/D Compare Function Control Register  | 1413 |
| 37.2.22 | ADCMPSR0 : A/D Compare Function Window A Channel Select Register 0                               | 1415 |
| 37.2.23 | ADCMPSR1 : A/D Compare Function Window A Channel Select Register 1                               | 1415 |
| 37.2.24 | ADCMPSER : A/D Compare Function Window A Extended Input Select Register                          | 1416 |
| 37.2.25 | ADCMPLR0 : A/D Compare Function Window A Comparison Condition Setting Register 0                 | 1416 |
| 37.2.26 | ADCMPLR1 : A/D Compare Function Window A Comparison Condition Setting Register 1                 | 1417 |
| 37.2.27 | ADCMPLER : A/D Compare Function Window A Extended Input Comparison Condition Setting Register    | 1418 |
| 37.2.28 | ADCMPSRn : A/D Compare Function Window A Lower-Side/Upper-Side Level Setting Register (n = 0, 1) | 1419 |
| 37.2.29 | ADWINnLB : A/D Compare Function Window B Lower-Side/Upper-Side Level Setting Register (n = L, U) | 1421 |
| 37.2.30 | ADCMPSR0 : A/D Compare Function Window A Channel Status Register 0                               | 1422 |
| 37.2.31 | ADCMPSR1 : A/D Compare Function Window A Channel Status Register 1                               | 1423 |
| 37.2.32 | ADCMPSER : A/D Compare Function Window A Extended Input Channel Status Register                  | 1423 |
| 37.2.33 | ADCMPSRn : A/D Compare Function Window B Channel Select Register                                 | 1424 |
| 37.2.34 | ADCMPSRn : A/D Compare Function Window B Status Register   | 1426 |
| 37.2.35 | ADWINMON : A/D Compare Function Window A/B Status Monitor Register                               | 1427 |
| 37.2.36 | ADBUFEN : A/D Data Buffer Enable Register  | 1428 |
| 37.2.37 | ADBUFPTR : A/D Data Buffer Pointer Register  | 1428 |
| 37.2.38 | ADBUFn : A/D Data Buffer Registers n (n = 0 to 15)   | 1429 |

|         |  |      |
|---------|--|------|
| 37.2.1  | ADDRn:AD数据寄存器n   | 1391 |
| 37.2.2  | ADDBLDR:AD数据双工寄存器  | 1392 |
| 37.2.3  | ADDBLDRn:AD数据双工寄存器n(n=A B)                                     | 1393 |
| 37.2.4  | ATSDR:AD温度传感器数据寄存器   | 1394 |
| 37.2.5  | ADocDR:AD内部参考电压数据寄存器   | 1396 |
| 37.2.6  | ADRD:AD自诊断数据寄存器  | 1397 |
| 37.2.7  | ADCSR: AD控制寄存器   | 1398 |
| 37.2.8  | ADANSA0:AD通道选择寄存器A0  | 1401 |
| 37.2.9  | ADANSA1:AD通道选择寄存器A1  | 1401 |
| 37.2.10 | ADANSB0: AD通道选择寄存器B0   | 1402 |
| 37.2.11 | ADANSB1: AD通道选择寄存器B1   | 1403 |
| 37.2.12 | ADADS0: AD转换值加法平均通道选择寄存器0                                      | 1403 |
| 37.2.13 | ADADS1: D转换值加法平均通道选择寄存器1                                       | 1404 |
| 37.2.14 | ADADC: D转换值加法平均计数选择寄存器   | 1405 |
| 37.2.15 | ADCER: AD控制扩展寄存器   | 1406 |
| 37.2.16 | ADSTRGR: AD转换开始触发选择寄存器   | 1407 |
| 37.2.17 | ADEXICR: AD转换扩展输入控制寄存器   | 1409 |
| 37.2.18 | ADSSTRnADSSTRLADSSTRTADSSTRO: AD采样状态寄存器                        | 1410 |
| 37.2.19 | ADDISCR: AD断线检测控制寄存器   | 1411 |
| 37.2.20 | ADGSPCR: AD组扫描优先级控制寄存器   | 1412 |
| 37.2.21 | ADCMPCR: AD比较功能控制寄存器   | 1413 |
| 37.2.22 | ADCMPSR0:AD比较功能窗口A通道选择寄存器0                                     | 1415 |
| 37.2.23 | ADCMPSR1:AD比较功能窗口A通道选择寄存器1                                     | 1415 |
| 37.2.24 | ADCMPSER: AD比较功能窗口A扩展输入选择寄存器                                   | 1416 |
| 37.2.25 | ADCMPLR0:AD比较功能窗口A比较条件设置寄存器0                                   | 1416 |
| 37.2.26 | ADCMPLR1: AD比较功能窗口A比较条件设置寄存器1                                  | 1417 |
| 37.2.27 | ADCMPLER: AD比较功能窗口A扩展输入比较条件设置寄存器                               | 1418 |
| 37.2.28 | ADCMPSRn:AD比较功能窗口ALower-SideUpper-Side电平设置 Register (n = 0, 1) | 1419 |
| 37.2.29 | ADWINnLB:AD比较功能窗口BLower-SideUpper-Side电平设置 Register (n = L, U) | 1421 |
| 37.2.30 | ADCMPSR0:AD比较功能窗口A通道状态寄存器0                                     | 1422 |
| 37.2.31 | ADCMPSR1:AD比较功能窗口A通道状态寄存器1                                     | 1423 |
| 37.2.32 | ADCMPSER: AD比较功能窗口A扩展输入通道状态寄存器                                 | 1423 |
| 37.2.33 | ADCMPSRn: AD比较功能窗口B通道选择寄存器                                     | 1424 |
| 37.2.34 | ADCMPSRn: AD比较功能窗口B状态寄存器                                       | 1426 |
| 37.2.35 | ADWINMON:AD比较功能窗口AB状态监控寄存器                                     | 1427 |
| 37.2.36 | ADBUFEN: AD数据缓冲器使能寄存器  | 1428 |
| 37.2.37 | ADBUFPTR: AD数据缓冲区指针寄存器   | 1428 |
| 37.2.38 | ADBUFn: AD数据缓冲寄存器n (n=0到15)                                    | 1429 |



|            |  |             |
|------------|--|-------------|
| 37.3       | Operation  | 1430        |
| 37.3.1     | Scanning Operation   | 1430        |
| 37.3.2     | Single Scan Mode   | 1431        |
| 37.3.3     | Continuous Scan Mode   | 1436        |
| 37.3.4     | Group Scan Mode  | 1439        |
| 37.3.5     | Interleaved operation  | 1448        |
| 37.3.6     | Compare Function for Windows A and B   | 1452        |
| 37.3.7     | Analog Input Sampling and Scan Conversion Time                               | 1456        |
| 37.3.8     | Usage Example of A/D Data Register Automatic Clearing Function               | 1458        |
| 37.3.9     | A/D-Converted Value Addition/Average Mode                                    | 1459        |
| 37.3.10    | Disconnection Detection Assist Function                                      | 1459        |
| 37.3.11    | Starting A/D Conversion with an Asynchronous Trigger                         | 1461        |
| 37.3.12    | Starting A/D Conversion with a Synchronous Trigger from a Peripheral Module  | 1462        |
| 37.3.13    | Using Data Buffers   | 1462        |
| 37.4       | Interrupt Sources and DTC, DMAC Transfer Requests                            | 1463        |
| 37.4.1     | Interrupt Requests   | 1463        |
| 37.5       | Event Link Function  | 1464        |
| 37.5.1     | Event Output to the ELC  | 1464        |
| 37.5.2     | ADC12 Operation through an Event from the ELC                                | 1464        |
| 37.6       | Usage Notes  | 1465        |
| 37.6.1     | Constraints on Setting the Registers   | 1465        |
| 37.6.2     | Constraints on Reading the Data Registers                                    | 1465        |
| 37.6.3     | Constraints on Stopping A/D Conversion                                       | 1465        |
| 37.6.4     | A/D Conversion Restart and Termination Timing                                | 1467        |
| 37.6.5     | Constraints on Scan End Interrupt Handling                                   | 1467        |
| 37.6.6     | Settings for the Module-Stop Function  | 1467        |
| 37.6.7     | Notes on Entering the Low-Power States                                       | 1467        |
| 37.6.8     | Error in Absolute Accuracy When Disconnection Detection Assistance Is in Use | 1467        |
| 37.6.9     | Constraints on Operating Modes and Status Bits                               | 1467        |
| 37.6.10    | Notes on Board Design  | 1468        |
| 37.6.11    | Constraints on Noise Prevention  | 1468        |
| 37.6.12    | Port Settings When Using the ADC12 Input                                     | 1468        |
| 37.6.13    | Notes on Canceling Software Standby Mode                                     | 1468        |
| 37.6.14    | Calculation for sampling time  | 1469        |
| <b>38.</b> | <b>12-Bit D/A Converter (DAC12)</b>  | <b>1470</b> |
| 38.1       | Overview   | 1470        |
| 38.2       | Register Descriptions  | 1471        |
| 38.2.1     | DADRn : D/A Data Register n (n = 0, 1)                                       | 1471        |
| 38.2.2     | DACR : D/A Control Register  | 1471        |
| 38.2.3     | DADPR : DADRn Format Select Register   | 1473        |

|            |   |             |
|------------|---|-------------|
| 37.3       | Operation                                 | 1430        |
| 37.3.1     | 扫描操作                                      | 1430        |
| 37.3.2     | 单次扫描模式                                    | 1431        |
| 37.3.3     | 连续扫描模式                                    | 1436        |
| 37.3.4     | 组扫描模式                                     | 1439        |
| 37.3.5     | Interleaved operation                     | 1448        |
| 37.3.6     | 比较WindowsA和B的功能                           | 1452        |
| 37.3.7     | 模拟输入采样和扫描转换时间                             | 1456        |
| 37.3.8     | AD数据寄存器自动清零功能的使用示例                        | 1458        |
| 37.3.9     | A/D-Converted Value Addition/Average Mode | 1459        |
| 37.3.10    | 断线检测辅助功能                                  | 1459        |
| 37.3.11    | 使用异步触发启动AD转换                              | 1461        |
| 37.3.12    | 使用来自外设模块的同步触发启动AD转换                       | 1462        |
| 37.3.13    | 使用数据缓冲区                                   | 1462        |
| 37.4       | 中断源和DTC、DMAC传输请求                          | 1463        |
| 37.4.1     | 中断请求                                      | 1463        |
| 37.5       | 事件链接功能                                    | 1464        |
| 37.5.1     | 事件输出到ELC                                  | 1464        |
| 37.5.2     | ADC12通过来自ELC的事件进行操作                       | 1464        |
| 37.6       | Usage Notes                               | 1465        |
| 37.6.1     | 设置寄存器的限制                                  | 1465        |
| 37.6.2     | 读取数据寄存器的限制                                | 1465        |
| 37.6.3     | 停止AD转换的限制                                 | 1465        |
| 37.6.4     | AD转换重启和终止时序                               | 1467        |
| 37.6.5     | 扫描结束中断处理的限制                               | 1467        |
| 37.6.6     | 模块停止功能的设置                                 | 1467        |
| 37.6.7     | 进入低功耗状态的注意事项                              | 1467        |
| 37.6.8     | 使用断线检测辅助时的绝对精度错误                          | 1467        |
| 37.6.9     | 操作模式和状态位的限制                               | 1467        |
| 37.6.10    | 电路板设计注意事项                                 | 1468        |
| 37.6.11    | 噪声预防的限制                                   | 1468        |
| 37.6.12    | 使用ADC12输入时的端口设置                           | 1468        |
| 37.6.13    | 关于取消软件待机模式的注意事项                           | 1468        |
| 37.6.14    | 采样时间的计算                                   | 1469        |
| <b>38.</b> | <b>12-Bit D/A Converter (DAC12)</b>       | <b>1470</b> |
| 38.1       | Overview                                  | 1470        |
| 38.2       | 寄存器说明                                     | 1471        |
| 38.2.1     | DADRn:DA数据寄存器n(n=0 1)                     | 1471        |
| 38.2.2     | DACR : D/A Control Register               | 1471        |
| 38.2.3     | DADPR:DADRn格式选择寄存器                        | 1473        |

|            |  |             |
|------------|--|-------------|
| 38.2.4     | DAADSCR : D/A A/D Synchronous Start Control Register.....                                      | 1473        |
| 38.2.5     | DAAMPCR : D/A Output Amplifier Control Register .....  | 1474        |
| 38.2.6     | DAASWCR : D/A Amplifier Stabilization Wait Control Register .....                              | 1474        |
| 38.2.7     | DAADUSR : D/A A/D Synchronous Unit Select Register .....                                       | 1475        |
| 38.3       | Operation.....   | 1475        |
| 38.3.1     | Reducing Interference between D/A and A/D Conversion.....                                      | 1476        |
| 38.4       | Event Link Operation Setting Procedure .....   | 1478        |
| 38.4.1     | DA0 Event Link Operation Setting Procedure .....   | 1478        |
| 38.4.2     | DA1 Event Link Operation Setting Procedure .....   | 1478        |
| 38.5       | Usage Notes on Event Link Operation .....  | 1478        |
| 38.6       | Usage Notes.....   | 1478        |
| 38.6.1     | Settings for the Module-Stop Function .....  | 1478        |
| 38.6.2     | DAC12 Operation in the Module-Stop State.....  | 1478        |
| 38.6.3     | DAC12 Operation in Software Standby Mode .....   | 1479        |
| 38.6.4     | Constraint on Entering Deep Software Standby Mode .....  | 1479        |
| 38.6.5     | Initialization Procedure with the Output Amplifier .....                                       | 1479        |
| 38.6.6     | Constraint on Usage When Interference Reduction between D/A and A/D Conversion Is Enabled..... | 1479        |
| <b>39.</b> | <b>Temperature Sensor (TSN) .....</b>  | <b>1480</b> |
| 39.1       | Overview.....  | 1480        |
| 39.2       | Register Descriptions .....  | 1481        |
| 39.2.1     | TSCR : Temperature Sensor Control Register .....   | 1481        |
| 39.2.2     | TSCDR : Temperature Sensor Calibration Data Register.....                                      | 1481        |
| 39.3       | Using the Temperature Sensor.....  | 1482        |
| 39.3.1     | Preparation for Using the Temperature Sensor .....   | 1482        |
| 39.3.2     | Procedures for Using the Temperature Sensor .....  | 1482        |
| 39.4       | Usage Notes.....   | 1484        |
| 39.4.1     | Settings for the Module-Stop Function .....  | 1484        |
| <b>40.</b> | <b>Capacitive Touch Sensing Unit (CTSUS).....</b>  | <b>1485</b> |
| 40.1       | Overview.....  | 1485        |
| 40.2       | Register Descriptions .....  | 1487        |
| 40.2.1     | CTSUCR0 : CTSU Control Register 0 .....  | 1487        |
| 40.2.2     | CTSUCR1 : CTSU Control Register 1 .....  | 1489        |
| 40.2.3     | CTSUSDPRS : CTSU Synchronous Noise Reduction Setting Register.....                             | 1490        |
| 40.2.4     | CTSUSST : CTSU Sensor Stabilization Wait Control Register .....                                | 1491        |
| 40.2.5     | CTSUSMCH0 : CTSU Measurement Channel Register 0 .....  | 1491        |
| 40.2.6     | CTSUSMCH1 : CTSU Measurement Channel Register 1 .....  | 1492        |
| 40.2.7     | CTSUSCHAC0 : CTSU Channel Enable Control Register 0 .....                                      | 1492        |
| 40.2.8     | CTSUSCHAC1 : CTSU Channel Enable Control Register 1 .....                                      | 1493        |
| 40.2.9     | CTSUSCHAC2 : CTSU Channel Enable Control Register 2 .....                                      | 1493        |

|            |                                   |             |
|------------|-----------------------------------|-------------|
| 38.2.4     | DAADSCR:DAAD同步启动控制寄存器.....        | 1473        |
| 38.2.5     | DAAMPCR:DA输出放大器控制寄存器.....         | 1474        |
| 38.2.6     | DAASWCR:DA放大器稳定等待控制寄存器.....       | 1474        |
| 38.2.7     | DAADUSR:DAAD同步单元选择寄存器.....        | 1475        |
| 38.3       | Operation.....                    | 1475        |
| 38.3.1     | 减少DA和AD转换之间的干扰.....               | 1476        |
| 38.4       | 事件链接操作设置程序.....                   | 1478        |
| 38.4.1     | DA0事件链接操作设置步骤.....                | 1478        |
| 38.4.2     | DA1事件链接操作设置步骤.....                | 1478        |
| 38.5       | 事件链接操作的使用说明.....                  | 1478        |
| 38.6       | Usage Notes.....                  | 1478        |
| 38.6.1     | 模块停止功能的设置.....                    | 1478        |
| 38.6.2     | DAC12在模块停止状态下的操作.....             | 1478        |
| 38.6.3     | DAC12在软件待机模式下的操作.....             | 1479        |
| 38.6.4     | 进入深度软件待机模式的限制.....                | 1479        |
| 38.6.5     | 使用输出放大器的初始化程序.....                | 1479        |
| 38.6.6     | DA和AD转换之间的干扰减少时的使用限制 Enabled..... | 1479        |
| <b>39.</b> | <b>温度传感器(TSN).....</b>            | <b>1480</b> |
| 39.1       | Overview.....                     | 1480        |
| 39.2       | 寄存器说明.....                        | 1481        |
| 39.2.1     | TSCR: 温度传感器控制寄存器.....             | 1481        |
| 39.2.2     | TSCDR: 温度传感器校准数据寄存器.....          | 1481        |
| 39.3       | 使用温度传感器.....                      | 1482        |
| 39.3.1     | 使用温度传感器的准备工作.....                 | 1482        |
| 39.3.2     | 使用温度传感器的步骤.....                   | 1482        |
| 39.4       | Usage Notes.....                  | 1484        |
| 39.4.1     | 模块停止功能的设置.....                    | 1484        |
| <b>40.</b> | <b>电容式触摸感应单元(CTSUS).....</b>      | <b>1485</b> |
| 40.1       | Overview.....                     | 1485        |
| 40.2       | 寄存器说明.....                        | 1487        |
| 40.2.1     | CTSUCR0:CTSUS控制寄存器0.....          | 1487        |
| 40.2.2     | CTSUCR1: CTSUS控制寄存器1.....         | 1489        |
| 40.2.3     | CTSUSDPRS:CTSUS同步降噪设置寄存器.....     | 1490        |
| 40.2.4     | CTSUSST:CTSUS传感器稳定等待控制寄存器.....    | 1491        |
| 40.2.5     | CTSUSCH0:CTSUS测量通道寄存器0.....       | 1491        |
| 40.2.6     | CTSUSCH1:CTSUS测量通道寄存器1.....       | 1492        |
| 40.2.7     | CTSUSCHAC0:CTSUS通道使能控制寄存器0.....   | 1492        |
| 40.2.8     | CTSUSCHAC1:CTSUS通道使能控制寄存器1.....   | 1493        |
| 40.2.9     | CTSUSCHAC2:CTSUS通道使能控制寄存器2.....   | 1493        |

|            |   |             |
|------------|---|-------------|
| 40.2.10    | CTSUCHTRC0 : CTSU Channel Transmit/Receive Control Register 0 .....               | 1493        |
| 40.2.11    | CTSUCHTRC1 : CTSU Channel Transmit/Receive Control Register 1 .....               | 1494        |
| 40.2.12    | CTSUCHTRC2 : CTSU Channel Transmit/Receive Control Register 2 .....               | 1494        |
| 40.2.13    | CTSUDCLKC : CTSU High-Pass Noise Reduction Control Register .....                 | 1495        |
| 40.2.14    | CTSUST : CTSU Status Register .....   | 1495        |
| 40.2.15    | CTSUSSC : CTSU High-Pass Noise Reduction Spectrum Diffusion Control Register..... | 1496        |
| 40.2.16    | CTSUSO0 : CTSU Sensor Offset Register 0.....                                      | 1497        |
| 40.2.17    | CTSUSO1 : CTSU Sensor Offset Register 1.....                                      | 1498        |
| 40.2.18    | CTSUSC : CTSU Sensor Counter .....  | 1500        |
| 40.2.19    | CTSURC : CTSU Reference Counter.....  | 1500        |
| 40.2.20    | CTSUERRS : CTSU Error Status Register.....  | 1501        |
| 40.2.21    | CTSUTRMR : CTSU Reference Current Calibration Register.....                       | 1502        |
| 40.3       | Operation.....  | 1502        |
| 40.3.1     | Principles of Measurement Operation .....   | 1502        |
| 40.3.2     | Measurement Modes .....   | 1504        |
| 40.3.3     | Parameters Common to Multiple Modes .....   | 1513        |
| 40.4       | Usage Notes.....  | 1515        |
| 40.4.1     | Measurement Result Data (CTSUSC and CTSURC Counters) .....                        | 1515        |
| 40.4.2     | Constraint on Software Trigger .....  | 1515        |
| 40.4.3     | Constraints on External Triggers .....  | 1516        |
| 40.4.4     | Constraints on Forced Stops .....   | 1516        |
| 40.4.5     | TSCAP Pin.....  | 1516        |
| 40.4.6     | Constraints on Measurement Operation (CTSUCR0.CTSUSTRT Bit = 1).....              | 1516        |
| <b>41.</b> | <b>Data Operation Circuit (DOC) .....</b>   | <b>1517</b> |
| 41.1       | Overview.....   | 1517        |
| 41.2       | DOC Register Descriptions .....   | 1517        |
| 41.2.1     | DOCR : DOC Control Register .....   | 1517        |
| 41.2.2     | DODIR : DOC Data Input Register .....   | 1518        |
| 41.2.3     | DODSR : DOC Data Setting Register.....  | 1519        |
| 41.3       | Operation.....  | 1519        |
| 41.3.1     | Data Comparison Mode.....   | 1519        |
| 41.3.2     | Data Addition Mode .....  | 1519        |
| 41.3.3     | Data Subtraction Mode .....   | 1520        |
| 41.4       | Interrupt Source .....  | 1520        |
| 41.5       | Output of an Event Signal to the Event Link Controller (ELC).....                 | 1521        |
| 41.6       | Usage Notes.....  | 1521        |
| 41.6.1     | Settings for the Module-Stop State .....  | 1521        |
| <b>42.</b> | <b>SRAM .....</b>   | <b>1522</b> |
| 42.1       | Overview.....   | 1522        |

|            |                                     |             |
|------------|-------------------------------------|-------------|
| 40.2.10    | CTSUHTRC0: CTSU通道发送接收控制寄存器0.....    | 1493        |
| 40.2.11    | CTSUCHTRC1: CTSU通道发送接收控制寄存器1.....   | 1494        |
| 40.2.12    | CTSUCHTRC2: CTSU通道发送接收控制寄存器2.....   | 1494        |
| 40.2.13    | CTSUDCLKC: CTSU高通降噪控制寄存器.....       | 1495        |
| 40.2.14    | CTSUST: CTSU状态寄存器.....              | 1495        |
| 40.2.15    | CTSUSSC: CTSU高通降噪频谱扩散控制寄存器.....     | 1496        |
| 40.2.16    | CTSUSO0: CTSU传感器偏移寄存器0.....         | 1497        |
| 40.2.17    | CTSUSO1: CTSU传感器偏移寄存器1.....         | 1498        |
| 40.2.18    | CTSUSC: CTSU传感器计数器.....             | 1500        |
| 40.2.19    | CTSURC: CTSU Reference Counter..... | 1500        |
| 40.2.20    | CTSUERRS: CTSU错误状态寄存器.....          | 1501        |
| 40.2.21    | CTSUTRMR: CTSU参考电流校准寄存器.....        | 1502        |
| 40.3       | Operation.....                      | 1502        |
| 40.3.1     | 测量操作原理.....                         | 1502        |
| 40.3.2     | 测量模式.....                           | 1504        |
| 40.3.3     | 多种模式共有的参数.....                      | 1513        |
| 40.4       | Usage Notes.....                    | 1515        |
| 40.4.1     | 测量结果数据 (CTSUSC和CTSURC计数器) .....     | 1515        |
| 40.4.2     | 软件触发的约束.....                        | 1515        |
| 40.4.3     | 外部触发器的约束.....                       | 1516        |
| 40.4.4     | 强制停止的限制.....                        | 1516        |
| 40.4.5     | TSCAP Pin.....                      | 1516        |
| 40.4.6     | 测量操作的约束 (CTSUCR0.CTSUSTRT位=1) ..... | 1516        |
| <b>41.</b> | <b>数据运算电路(DOC).....</b>             | <b>1517</b> |
| 41.1       | Overview.....                       | 1517        |
| 41.2       | DOC寄存器说明.....                       | 1517        |
| 41.2.1     | DOCR:DOC控制寄存器.....                  | 1517        |
| 41.2.2     | DODIR:DOC数据输入寄存器.....               | 1518        |
| 41.2.3     | DODSR:DOC数据设置寄存器.....               | 1519        |
| 41.3       | Operation.....                      | 1519        |
| 41.3.1     | 数据比较模式.....                         | 1519        |
| 41.3.2     | 数据添加模式.....                         | 1519        |
| 41.3.3     | 数据减法模式.....                         | 1520        |
| 41.4       | Interrupt Source .....              | 1520        |
| 41.5       | 将事件信号输出到事件链接控制器(ELC).....           | 1521        |
| 41.6       | Usage Notes.....                    | 1521        |
| 41.6.1     | 模块停止状态的设置.....                      | 1521        |
| <b>42.</b> | <b>SRAM .....</b>                   | <b>1522</b> |
| 42.1       | Overview.....                       | 1522        |

|            |  |             |
|------------|--|-------------|
| 42.2       | Register Descriptions .....  | 1522        |
| 42.2.1     | SRAMSAR : SRAM Security Attribution Register .....                   | 1522        |
| 42.2.2     | PARIOAD : SRAM Parity Error Operation After Detection Register ..... | 1523        |
| 42.2.3     | SRAMPRCR : SRAM Protection Register .....                            | 1524        |
| 42.2.4     | SRAMWTSC : SRAM Wait State Control Register .....                    | 1524        |
| 42.2.5     | SRAMPRCR2 : SRAM Protection Register 2 .....                         | 1525        |
| 42.2.6     | ECCMODE : ECC Operating Mode Control Register .....                  | 1525        |
| 42.2.7     | ECC2STS : ECC 2-Bit Error Status Register.....                       | 1526        |
| 42.2.8     | ECC1STSEN : ECC 1-Bit Error Information Update Enable Register ..... | 1526        |
| 42.2.9     | ECC1STS : ECC 1-Bit Error Status Register.....                       | 1527        |
| 42.2.10    | ECCPRCR : ECC Protection Register .....                              | 1527        |
| 42.2.11    | ECCPRCR2 : ECC Protection Register 2 .....                           | 1528        |
| 42.2.12    | ECCETST : ECC Test Control Register .....                            | 1529        |
| 42.2.13    | ECCOAD : SRAM ECC Error Operation After Detection Register .....     | 1529        |
| 42.3       | Operation.....   | 1530        |
| 42.3.1     | Module Stop Function.....  | 1530        |
| 42.3.2     | Correction of ECC errors .....                                       | 1530        |
| 42.3.3     | ECC Error Interrupt Function .....                                   | 1530        |
| 42.3.4     | ECC Decoder Testing .....  | 1531        |
| 42.3.5     | Parity Calculation Function .....                                    | 1532        |
| 42.3.6     | TrustZone Filter function .....                                      | 1533        |
| 42.3.7     | Interrupt Source .....   | 1534        |
| 42.3.8     | Wait state .....   | 1534        |
| 42.3.9     | Access Cycle .....   | 1535        |
| 42.3.10    | ECC encode specification.....  | 1536        |
| <b>43.</b> | <b>Standby SRAM.....</b>   | <b>1537</b> |
| 43.1       | Overview.....  | 1537        |
| 43.2       | Register Descriptions .....  | 1537        |
| 43.2.1     | STBRAMSAR : Standby RAM memory Security Attribution Register.....    | 1537        |
| 43.3       | Operation.....   | 1538        |
| 43.3.1     | Data Retention.....  | 1538        |
| 43.3.2     | Setting for the Module-stop Function .....                           | 1538        |
| 43.3.3     | Parity Calculation Function .....                                    | 1538        |
| 43.3.4     | TrustZone Filter function .....                                      | 1539        |
| 43.3.5     | Access Cycle .....   | 1539        |
| 43.4       | Usage Notes.....   | 1539        |
| 43.4.1     | Instruction Fetch from the Standby SRAM Area.....                    | 1539        |
| <b>44.</b> | <b>Flash Memory .....</b>  | <b>1540</b> |
| 44.1       | Overview.....  | 1540        |

|            |   |             |
|------------|---|-------------|
| 42.2       | 寄存器说明.....                              | 1522        |
| 42.2.1     | SRAMSAR: SRAM安全属性寄存器.....               | 1522        |
| 42.2.2     | PARIOAD:检测寄存器后的SRAM奇偶校验错误操作.....        | 1523        |
| 42.2.3     | SRAMPRCR:SRAM保护寄存器.....                 | 1524        |
| 42.2.4     | SRAMWTSC:SRAM等待状态控制寄存器.....             | 1524        |
| 42.2.5     | SRAMPRCR2:SRAM保护寄存器2.....               | 1525        |
| 42.2.6     | ECCMODE:ECC操作模式控制寄存器.....               | 1525        |
| 42.2.7     | ECC2STS: ECC2位错误状态寄存器.....              | 1526        |
| 42.2.8     | ECC1STSEN:ECC1位错误信息更新使能寄存器.....         | 1526        |
| 42.2.9     | ECC1STS: ECC1位错误状态寄存器.....              | 1527        |
| 42.2.10    | ECCPRCR : ECC Protection Register ..... | 1527        |
| 42.2.11    | ECPCRR2: ECC保护寄存器2.....                 | 1528        |
| 42.2.12    | ECCETST: ECC测试控制寄存器.....                | 1529        |
| 42.2.13    | ECCOAD: 检测寄存器后的SRAMECC错误操作.....         | 1529        |
| 42.3       | Operation.....                          | 1530        |
| 42.3.1     | 模块停止功能.....                             | 1530        |
| 42.3.2     | ECC错误的更正.....                           | 1530        |
| 42.3.3     | ECC错误中断功能.....                          | 1530        |
| 42.3.4     | ECC解码器测试.....                           | 1531        |
| 42.3.5     | 奇偶校验计算函数.....                           | 1532        |
| 42.3.6     | TrustZone Filter function .....         | 1533        |
| 42.3.7     | 中断源.....                                | 1534        |
| 42.3.8     | Wait state .....                        | 1534        |
| 42.3.9     | 访问周期.....                               | 1535        |
| 42.3.10    | ECC encode specification.....           | 1536        |
| <b>43.</b> | <b>Standby SRAM.....</b>                | <b>1537</b> |
| 43.1       | Overview.....                           | 1537        |
| 43.2       | 寄存器说明.....                              | 1537        |
| 43.2.1     | STBRAMSAR:备用RAM内存安全属性寄存器.....           | 1537        |
| 43.3       | Operation.....                          | 1538        |
| 43.3.1     | Data Retention.....                     | 1538        |
| 43.3.2     | 模块停止功能的设置.....                          | 1538        |
| 43.3.3     | 奇偶校验计算函数.....                           | 1538        |
| 43.3.4     | TrustZone Filter function .....         | 1539        |
| 43.3.5     | 访问周期.....                               | 1539        |
| 43.4       | Usage Notes.....                        | 1539        |
| 43.4.1     | 从备用SRAM区域取指令.....                       | 1539        |
| <b>44.</b> | <b>闪存.....</b>                          | <b>1540</b> |
| 44.1       | Overview.....                           | 1540        |

RA生态工作室

|         |  |      |
|---------|--|------|
| 44.2    | Structure of Memory .....  | 1542 |
| 44.3    | Address Space .....  | 1544 |
| 44.4    | Register Descriptions .....  | 1544 |
| 44.4.1  | FCACHEE : Flash Cache Enable Register .....                            | 1544 |
| 44.4.2  | FCACHEIV : Flash Cache Invalidate Register .....                       | 1544 |
| 44.4.3  | FLWT : Flash Wait Cycle Register .....                                 | 1545 |
| 44.4.4  | FSAR : Flash Security Attribution Register .....                       | 1545 |
| 44.4.5  | UIDRn : Unique ID Registers n (n = 0 to 3) .....                       | 1546 |
| 44.4.6  | PNRn : Part Numbering Register n (n = 0 to 3) .....                    | 1546 |
| 44.4.7  | MCUVER : MCU Version Register .....                                    | 1547 |
| 44.4.8  | FWEPROR : Flash P/E Protect Register .....                             | 1547 |
| 44.4.9  | FASTAT : Flash Access Status Register .....                            | 1548 |
| 44.4.10 | FAEINT : Flash Access Error Interrupt Enable Register .....            | 1549 |
| 44.4.11 | FRDYIE : Flash Ready Interrupt Enable Register .....                   | 1550 |
| 44.4.12 | FSADDR : FACI Command Start Address Register .....                     | 1550 |
| 44.4.13 | FEADDR : FACI Command End Address Register .....                       | 1551 |
| 44.4.14 | FMEPROT : Flash P/E Mode Entry Protection Register .....               | 1551 |
| 44.4.15 | FBPROT0 : Flash Block Protection Register .....                        | 1552 |
| 44.4.16 | FBPROT1 : Flash Block Protection for Secure Register .....             | 1553 |
| 44.4.17 | FSTATR : Flash Status Register .....                                   | 1553 |
| 44.4.18 | FENTRYR : Flash P/E Mode Entry Register .....                          | 1557 |
| 44.4.19 | FSUINTR : Flash Sequencer Setup Initialization Register .....          | 1558 |
| 44.4.20 | FCMDR : FACI Command Register .....                                    | 1559 |
| 44.4.21 | FBCCNT : Blank Check Control Register .....                            | 1559 |
| 44.4.22 | FBCSTAT : Blank Check Status Register .....                            | 1560 |
| 44.4.23 | FPSADDR : Data Flash Programming Start Address Register .....          | 1560 |
| 44.4.24 | FSUASMON : Flash Startup Area Select Monitor Register .....            | 1561 |
| 44.4.25 | FCPSR : Flash Sequencer Processing Switching Register .....            | 1561 |
| 44.4.26 | FPCKAR : Flash Sequencer Processing Clock Notification Register .....  | 1562 |
| 44.4.27 | FSUACR : Flash Startup Area Control Register .....                     | 1562 |
| 44.4.28 | FCKMHZ : Data Flash Access Frequency Register .....                    | 1563 |
| 44.5    | Flash Cache .....  | 1563 |
| 44.5.1  | Feature of flash cache .....   | 1563 |
| 44.6    | Operating Modes Associated with Flash Memory .....                     | 1565 |
| 44.7    | Overview of Functions .....  | 1566 |
| 44.8    | Operating Modes of the Flash Sequencer .....                           | 1567 |
| 44.9    | FACI Commands .....  | 1568 |
| 44.9.1  | List of FACI Commands .....  | 1568 |
| 44.9.2  | Relationship between the Flash Sequencer State and FACI Commands ..... | 1569 |
| 44.9.3  | Usage of FACI Commands .....   | 1571 |

|         |                                    |      |
|---------|------------------------------------|------|
| 44.2    | 内存结构.....                          | 1542 |
| 44.3    | 地址空间.....                          | 1544 |
| 44.4    | 寄存器说明.....                         | 1544 |
| 44.4.1  | FCACHEE: FlashCache使能寄存器.....      | 1544 |
| 44.4.2  | FCACHEIV: 闪存缓存无效寄存器.....           | 1544 |
| 44.4.3  | FLWT: 闪存等待周期寄存器.....               | 1545 |
| 44.4.4  | FSAR:Flash安全属性寄存器.....             | 1545 |
| 44.4.5  | UIDRn: 唯一ID寄存器n (n=0到3) .....      | 1546 |
| 44.4.6  | PNRn: 零件编号寄存器n (n=0到3) .....       | 1546 |
| 44.4.7  | MCUVER : MCU Version Register..... | 1547 |
| 44.4.8  | FWEPROR:FlashPE保护寄存器.....          | 1547 |
| 44.4.9  | FASTAT: 闪存访问状态寄存器.....             | 1548 |
| 44.4.10 | FAEINT: 闪存访问错误中断使能寄存器.....         | 1549 |
| 44.4.11 | FRDYIE: 闪存就绪中断使能寄存器.....           | 1550 |
| 44.4.12 | FSADDR: FACI命令起始地址寄存器.....         | 1550 |
| 44.4.13 | FEADDR: FACI命令结束地址寄存器.....         | 1551 |
| 44.4.14 | FMEPROT: FlashPE模式进入保护寄存器.....     | 1551 |
| 44.4.15 | FBPROT0: 闪存块保护寄存器.....             | 1552 |
| 44.4.16 | FBPROT1: 安全寄存器的闪存块保护.....          | 1553 |
| 44.4.17 | FSTATR: 闪存状态寄存器.....               | 1553 |
| 44.4.18 | FENTRYR: FlashPE模式进入寄存器.....       | 1557 |
| 44.4.19 | FSUINTR: 闪存定序器设置初始化寄存器.....        | 1558 |
| 44.4.20 | FCMDR: FACI命令寄存器.....              | 1559 |
| 44.4.21 | FBCCNT: 空白检查控制寄存器.....             | 1559 |
| 44.4.22 | FBCSTAT: 空白检查状态寄存器.....            | 1560 |
| 44.4.23 | FPSADDR: 数据闪存编程起始地址寄存器.....        | 1560 |
| 44.4.24 | FSUASMON: Flash启动区域选择监控寄存器.....    | 1561 |
| 44.4.25 | FCPSR: Flash定序器处理切换寄存器.....        | 1561 |
| 44.4.26 | FPCKAR: 闪存定序器处理时钟通知寄存器.....        | 1562 |
| 44.4.27 | FSUACR: 闪存启动区控制寄存器.....            | 1562 |
| 44.4.28 | FCKMHZ: 数据闪存访问频率寄存器.....           | 1563 |
| 44.5    | 闪存.....                            | 1563 |
| 44.5.1  | 闪存缓存的特点.....                       | 1563 |
| 44.6    | 与闪存相关的操作模式.....                    | 1565 |
| 44.7    | 功能概述.....                          | 1566 |
| 44.8    | FlashSequencer的操作模式.....           | 1567 |
| 44.9    | FACI命令.....                        | 1568 |
| 44.9.1  | FACI命令列表.....                      | 1568 |
| 44.9.2  | Flash排序器状态和FACI命令之间的关系.....        | 1569 |
| 44.9.3  | FACI命令的使用.....                     | 1571 |

|   |             |
|---|-------------|
| 44.10 Suspend Operation.....                          | 1588        |
| 44.11 Protection Function.....                        | 1589        |
| 44.11.1 Software Protection .....                     | 1589        |
| 44.11.2 Error Protection.....                         | 1591        |
| 44.11.3 Start-Up Program Protection .....             | 1593        |
| 44.11.4 Block Swap Function .....                     | 1597        |
| 44.12 Security Function.....                          | 1598        |
| 44.12.1 Security Flag for Startup Area Select .....   | 1599        |
| 44.12.2 Permanent Block Protect Setting.....          | 1599        |
| 44.12.3 Flash Memory Protection for TrustZone .....   | 1600        |
| 44.13 Boot Mode .....                                 | 1608        |
| 44.13.1 Boot Mode (for the SCI Interface).....        | 1609        |
| 44.13.2 Boot Mode (for the USB Interface) .....       | 1610        |
| 44.14 Using the Serial Programmer for Rewriting ..... | 1611        |
| 44.14.1 Environments for Serial Programming.....      | 1611        |
| 44.15 Programming through Self-Programming.....       | 1612        |
| 44.15.1 Overview .....                                | 1612        |
| 44.15.2 Background Operation .....                    | 1612        |
| 44.16 Reading Flash Memory .....                      | 1612        |
| 44.16.1 Reading Code Flash Memory .....               | 1612        |
| 44.16.2 Reading Data Flash Memory .....               | 1612        |
| 44.16.3 Access Cycle .....                            | 1613        |
| 44.17 Usage Notes.....                                | 1613        |
| <b>45. Internal Voltage Regulator .....</b>           | <b>1616</b> |
| 45.1 Overview.....                                    | 1616        |
| 45.2 Operation.....                                   | 1616        |
| <b>46. Security Features .....</b>                    | <b>1617</b> |
| 46.1 Features .....                                   | 1617        |
| 46.2 Arm TrustZone Security .....                     | 1617        |
| 46.2.1 Arm TrustZone Technology.....                  | 1617        |
| 46.2.2 Memory Security Attribution.....               | 1617        |
| 46.2.3 Peripheral Security Attribution .....          | 1619        |
| 46.2.4 Flash Sequencer Security Attribution .....     | 1619        |
| 46.2.5 Address Space Security Attribution .....       | 1620        |
| 46.2.6 TrustZone Access Error .....                   | 1620        |
| 46.3 Device Lifecycle Management.....                 | 1621        |
| 46.3.1 Changing the Lifecycle State .....             | 1622        |
| 46.3.2 Debug access level.....                        | 1623        |
| 46.3.3 Serial Programming .....                       | 1623        |

|                                      |             |
|--------------------------------------|-------------|
| 44.10 Suspend Operation.....         | 1588        |
| 44.11 Protection Function.....       | 1589        |
| 44.11.1软件保护.....                     | 1589        |
| 44.11.2 Error Protection.....        | 1591        |
| 44.11.3启动程序保护.....                   | 1593        |
| 44.11.4块交换功能.....                    | 1597        |
| 44.12 Security Function.....         | 1598        |
| 44.12.1启动区域选择的安全标志.....              | 1599        |
| 44.12.2永久块保护设置.....                  | 1599        |
| 44.12.3TrustZone的闪存保护.....           | 1600        |
| 44.13引导模式.....                       | 1608        |
| 44.13.1引导模式（用于SCI接口）.....            | 1609        |
| 44.13.2引导模式（用于USB接口）.....            | 1610        |
| 44.14使用串行编程器进行改写.....                | 1611        |
| 44.14.1串行编程环境.....                   | 1611        |
| 44.15通过自编程进行编程.....                  | 1612        |
| 44.15.1 Overview .....               | 1612        |
| 44.15.2 Background Operation .....   | 1612        |
| 44.16读取闪存.....                       | 1612        |
| 44.16.1读取代码闪存.....                   | 1612        |
| 44.16.2读取数据闪存.....                   | 1612        |
| 44.16.3访问周期.....                     | 1613        |
| 44.17 Usage Notes.....               | 1613        |
| <b>45. 内部稳压器.....</b>                | <b>1616</b> |
| 45.1 Overview.....                   | 1616        |
| 45.2 Operation.....                  | 1616        |
| <b>46. 安全功能.....</b>                 | <b>1617</b> |
| 46.1 Features .....                  | 1617        |
| 46.2 ArmTrustZone安全.....             | 1617        |
| 46.2.1 Arm TrustZone Technology..... | 1617        |
| 46.2.2 内存安全归属.....                   | 1617        |
| 46.2.3 外设安全归属.....                   | 1619        |
| 46.2.4 FlashSequencer安全归属.....       | 1619        |
| 46.2.5 地址空间安全归属.....                 | 1620        |
| 46.2.6 TrustZone Access Error .....  | 1620        |
| 46.3 设备生命周期管理.....                   | 1621        |
| 46.3.1 更改生命周期状态.....                 | 1622        |
| 46.3.2 调试访问级别.....                   | 1623        |
| 46.3.3 串行编程.....                     | 1623        |

|            |  |             |
|------------|--|-------------|
| 46.3.4     | Lifecycle changing example.....                                    | 1623        |
| 46.3.5     | Failure analysis.....  | 1623        |
| 46.4       | Key Injection.....   | 1624        |
| 46.5       | Register Description.....  | 1626        |
| 46.5.1     | PSARB : Peripheral Security Attribution Register B.....            | 1626        |
| 46.5.2     | PSARC : Peripheral Security Attribution Register C.....            | 1627        |
| 46.5.3     | PSARD : Peripheral Security Attribution Register D.....            | 1628        |
| 46.5.4     | PSARE : Peripheral Security Attribution Register E.....            | 1629        |
| 46.5.5     | MSSAR : Module Stop Security Attribution Register.....             | 1631        |
| 46.5.6     | CFSAMONA : Code Flash Security Attribution Monitor Register A..... | 1631        |
| 46.5.7     | CFSAMONB : Code Flash Security Attribution Monitor Register B..... | 1632        |
| 46.5.8     | DFSAMON : Data Flash Security Attribution Monitor Register.....    | 1632        |
| 46.5.9     | SSAMONA : SRAM Security Attribution Monitor Register A.....        | 1632        |
| 46.5.10    | SSAMONB : SRAM Security Attribution Monitor Register B.....        | 1633        |
| 46.5.11    | DLMMON : Device Lifecycle Management State Monitor Register.....   | 1633        |
| 46.5.12    | TZFSAR : TrustZone Filter Security Attribution Register.....       | 1634        |
| 46.5.13    | TZFOAD : TrustZone Filter Operation After Detection Register.....  | 1634        |
| 46.5.14    | TZFPT : TrustZone Filter Protect Register.....                     | 1635        |
| 46.6       | Usage Notes.....   | 1635        |
| 46.6.1     | Restrictions on setting the security attribution.....              | 1635        |
| 46.6.2     | SAU setting.....   | 1636        |
| 46.6.3     | Non-secure exception during the setting of FACL registers.....     | 1636        |
| 46.6.4     | FCU interrupt usage.....   | 1636        |
| <b>47.</b> | <b>Electrical Characteristics.....</b>                             | <b>1637</b> |
| 47.1       | Absolute Maximum Ratings.....                                      | 1637        |
| 47.2       | DC Characteristics.....  | 1638        |
| 47.2.1     | Tj/Ta Definition.....  | 1638        |
| 47.2.2     | I/O VIH, VIL.....  | 1638        |
| 47.2.3     | I/O IOH, IOL.....  | 1640        |
| 47.2.4     | I/O VOH, VOL, and Other Characteristics.....                       | 1641        |
| 47.2.5     | Operating and Standby Current.....                                 | 1642        |
| 47.2.6     | VCC Rise and Fall Gradient and Ripple Frequency.....               | 1646        |
| 47.2.7     | Thermal Characteristics.....                                       | 1646        |
| 47.3       | AC Characteristics.....  | 1650        |
| 47.3.1     | Frequency.....   | 1650        |
| 47.3.2     | Clock Timing.....  | 1651        |
| 47.3.3     | Reset Timing.....  | 1653        |
| 47.3.4     | Wakeup Timing.....   | 1654        |
| 47.3.5     | NMI and IRQ Noise Filter.....                                      | 1657        |
| 47.3.6     | I/O Ports, POEG, GPT, AGT, and ADC12 Trigger Timing.....           | 1658        |

|            |  |             |
|------------|--|-------------|
| 46.3.4     | 生命周期更改示例.....                          | 1623        |
| 46.3.5     | Failure analysis.....                  | 1623        |
| 46.4       | Key Injection.....                     | 1624        |
| 46.5       | 寄存器说明.....                             | 1626        |
| 46.5.1     | PSARB: 外设安全属性寄存器B.....                 | 1626        |
| 46.5.2     | PSARC: 外设安全属性寄存器C.....                 | 1627        |
| 46.5.3     | PSARD: 外设安全属性寄存器D.....                 | 1628        |
| 46.5.4     | PSARE: 外设安全属性寄存器E.....                 | 1629        |
| 46.5.5     | MSSAR: 模块停止安全属性寄存器.....                | 1631        |
| 46.5.6     | CFSAMONA:代码闪存安全属性监控寄存器A.....           | 1631        |
| 46.5.7     | CFSAMONB:代码闪存安全属性监控寄存器B.....           | 1632        |
| 46.5.8     | DFSAMON:数据闪存安全属性监控寄存器.....             | 1632        |
| 46.5.9     | SSAMONA:SRAM安全属性监控寄存器A.....            | 1632        |
| 46.5.10    | SSAMONB: SRAM安全属性监控寄存器B.....           | 1633        |
| 46.5.11    | DLMMON:设备生命周期管理状态监控寄存器.....            | 1633        |
| 46.5.12    | TZFSAR: TrustZone过滤器安全属性寄存器.....       | 1634        |
| 46.5.13    | TZFOAD: 检测寄存器后的TrustZone过滤器操作.....     | 1634        |
| 46.5.14    | TZFPT: TrustZone过滤器保护寄存器.....          | 1635        |
| 46.6       | Usage Notes.....                       | 1635        |
| 46.6.1     | 设置安全属性的限制.....                         | 1635        |
| 46.6.2     | SAU setting.....                       | 1636        |
| 46.6.3     | FACL寄存器设置过程中的非安全异常.....                | 1636        |
| 46.6.4     | FCU中断使用.....                           | 1636        |
| <b>47.</b> | <b>Electrical Characteristics.....</b> | <b>1637</b> |
| 47.1       | 绝对最大额定值.....                           | 1637        |
| 47.2       | DC Characteristics.....                | 1638        |
| 47.2.1     | Tj/Ta Definition.....                  | 1638        |
| 47.2.2     | I/O VIH, VIL.....                      | 1638        |
| 47.2.3     | I/O IOH, IOL.....                      | 1640        |
| 47.2.4     | IOVOH、VOL和其他特性.....                    | 1641        |
| 47.2.5     | 工作和待机电流.....                           | 1642        |
| 47.2.6     | VCC上升和下降梯度和纹波频率.....                   | 1646        |
| 47.2.7     | Thermal Characteristics.....           | 1646        |
| 47.3       | AC Characteristics.....                | 1650        |
| 47.3.1     | Frequency.....                         | 1650        |
| 47.3.2     | 时钟时序.....                              | 1651        |
| 47.3.3     | Reset Timing.....                      | 1653        |
| 47.3.4     | 唤醒时间.....                              | 1654        |
| 47.3.5     | NMI和IRQ噪声滤波器.....                      | 1657        |
| 47.3.6     | IO端口、POEG、GPT、AGT和ADC12触发时序.....       | 1658        |

|                         |   |             |
|-------------------------|---|-------------|
| 47.3.7                  | CAC Timing.....                                 | 1660        |
| 47.3.8                  | SCI Timing.....                                 | 1661        |
| 47.3.9                  | SPI Timing.....                                 | 1667        |
| 47.3.10                 | QSPI Timing.....                                | 1671        |
| 47.3.11                 | IIC Timing.....                                 | 1673        |
| 47.3.12                 | SSIE Timing.....                                | 1676        |
| 47.3.13                 | SD/MMC Host Interface Timing.....               | 1678        |
| 47.4                    | USB Characteristics.....                        | 1679        |
| 47.4.1                  | USBFS Timing.....                               | 1679        |
| 47.5                    | ADC12 Characteristics.....                      | 1681        |
| 47.6                    | DAC12 Characteristics.....                      | 1685        |
| 47.7                    | TSN Characteristics.....                        | 1685        |
| 47.8                    | OSC Stop Detect Characteristics.....            | 1685        |
| 47.9                    | POR and LVD Characteristics.....                | 1686        |
| 47.10                   | VBATT Characteristics.....                      | 1689        |
| 47.11                   | CTSU Characteristics.....                       | 1690        |
| 47.12                   | Flash Memory Characteristics.....               | 1690        |
| 47.12.1                 | Code Flash Memory Characteristics.....          | 1690        |
| 47.12.2                 | Data Flash Memory Characteristics.....          | 1692        |
| 47.12.3                 | Option Setting Memory Characteristics.....      | 1693        |
| 47.13                   | Boundary Scan.....                              | 1693        |
| 47.14                   | Joint European Test Action Group (JTAG).....    | 1695        |
| 47.15                   | Serial Wire Debug (SWD).....                    | 1696        |
| 47.16                   | Embedded Trace Macro Interface (ETM).....       | 1697        |
| <b>Appendix 1.</b>      | <b>Port States in Each Processing Mode.....</b> | <b>1699</b> |
| <b>Appendix 2.</b>      | <b>Package Dimensions.....</b>                  | <b>1700</b> |
| <b>Appendix 3.</b>      | <b>I/O Registers.....</b>                       | <b>1703</b> |
| 3.1                     | Peripheral Base Addresses.....                  | 1703        |
| 3.2                     | Access Cycles.....                              | 1705        |
| <b>Revision History</b> | <b>.....</b>                                    | <b>1708</b> |

|                    |                            |             |
|--------------------|----------------------------|-------------|
| 47.3.7             | CAC Timing.....            | 1660        |
| 47.3.8             | SCI时序.....                 | 1661        |
| 47.3.9             | SPI时序.....                 | 1667        |
| 47.3.10            | QSPI Timing.....           | 1671        |
| 47.3.11            | IIC Timing.....            | 1673        |
| 47.3.12            | SSIE Timing.....           | 1676        |
| 47.3.13            | SDMMC主机接口时序.....           | 1678        |
| 47.4               | USB特性.....                 | 1679        |
| 47.4.1             | USBFS Timing.....          | 1679        |
| 47.5               | ADC12 Characteristics..... | 1681        |
| 47.6               | DAC12 Characteristics..... | 1685        |
| 47.7               | TSN Characteristics.....   | 1685        |
| 47.8               | OSC停止检测特性.....             | 1685        |
| 47.9               | POR和LVD特性.....             | 1686        |
| 47.10              | VBATT Characteristics..... | 1689        |
| 47.11              | CTSU Characteristics.....  | 1690        |
| 47.12              | 闪存特性.....                  | 1690        |
| 47.12.1            | 代码闪存特性.....                | 1690        |
| 47.12.2            | 数据闪存特性.....                | 1692        |
| 47.12.3            | 选项设置内存特性.....              | 1693        |
| 47.13              | Boundary Scan.....         | 1693        |
| 47.14              | 欧洲联合测试行动组(JTAG).....       | 1695        |
| 47.15              | 串行线调试(SWD).....            | 1696        |
| 47.16              | 嵌入式跟踪宏接口(ETM).....         | 1697        |
| <b>Appendix 1.</b> | <b>每种处理模式下的端口状态.....</b>   | <b>1699</b> |
| <b>Appendix 2.</b> | <b>封装尺寸.....</b>           | <b>1700</b> |
| <b>Appendix 3.</b> | <b>I/O Registers.....</b>  | <b>1703</b> |
| 3.1                | 外设基地址.....                 | 1703        |
| 3.2                | 访问周期.....                  | 1705        |
| <b>修订记录</b>        | <b>.....</b>               | <b>1708</b> |

RA生态工作室



Leading-performance 100 MHz Arm Cortex-M33 core, up to 1 MB code flash memory with background and SWAP operation, 8 KB Data flash memory, and 128 KB SRAM with Parity/ECC. High-integration with USB 2.0 Full-Speed, SDHI, Quad SPI, and advanced analog. Integrated Secure Crypto Engine with cryptography accelerators, key management support, tamper detection and power analysis resistance in concert with Arm TrustZone for integrated secure element functionality.

## Features

- **Arm® Cortex®-M33 Core**
  - Armv8-M architecture with the main extension
  - Maximum operating frequency: 100 MHz
  - Arm Memory Protection Unit (Arm MPU)
    - Protected Memory System Architecture (PMSAv8)
    - Secure MPU (MPU\_S): 8 regions
    - Non-secure MPU (MPU\_NS): 8 regions
  - SysTick timer
    - Embeds two SysTick timers: Secure and Non-secure instance
    - Driven by LOCO or system clock
  - CoreSight™ ETM-M33
- **Memory**
  - Up to 1-MB code flash memory
  - 8-KB data flash memory (100,000 program/erase (P/E) cycles)
  - 128-KB SRAM
- **Connectivity**
  - Serial Communications Interface (SCI) × 6
    - Asynchronous interfaces
    - 8-bit clock synchronous interface
    - Smart card interface
    - Simple IIC
    - Simple SPI
    - Manchester coding (SCI3, SCI4)
  - I<sup>2</sup>C bus interface (IIC) × 2
  - Serial Peripheral Interface (SPI)
  - Quad Serial Peripheral Interface (QSPI)
  - USB 2.0 Full-Speed Module (USBFS)
  - Control Area Network module (CAN) × 2
  - SD/MMC Host Interface (SDHI)
  - Serial Sound Interface Enhanced (SSIE)
- **Analog**
  - 12-bit A/D Converter (ADC12) × 2
  - 12-bit D/A Converter (DAC12) × 2
  - Temperature Sensor (TSN)
- **Timers**
  - General PWM Timer 32-bit (GPT32) × 4
  - General PWM Timer 16-bit (GPT16) × 4
  - Low Power Asynchronous General Purpose Timer (AGT) × 6
- **Security and Encryption**
  - Secure Crypto Engine 9
    - Symmetric algorithms: AES
    - Asymmetric algorithms: RSA, ECC, and DSA
    - Hash-value generation: SHA224, SHA256, GHASH
    - 128-bit unique ID
  - Arm® TrustZone®
    - Up to three regions for the code flash
    - Up to two regions for the data flash
    - Up to three regions for the SRAM
    - Individual secure or non-secure security attribution for each peripheral
  - Device lifecycle management
  - Pin function
    - Up to three tamper pins
    - Secure pin multiplexing
- **System and Power Management**
  - Low power modes
  - Battery backup function (VBATT)
  - Realtime Clock (RTC) with calendar and VBATT support
  - Event Link Controller (ELC)
  - Data Transfer Controller (DTC)
  - DMA Controller (DMAC) × 8
  - Power-on reset
  - Low Voltage Detection (LVD) with voltage settings
  - Watchdog Timer (WDT)

- Independent Watchdog Timer (IWDT)
- **Human Machine Interface (HMI)**
  - Capacitive Touch Sensing Unit (CTSU)
- **Multiple Clock Sources**
  - Main clock oscillator (MOSC) (8 to 24 MHz)
  - Sub-clock oscillator (SOSC) (32.768 kHz)
  - High-speed on-chip oscillator (HOCO) (16/18/20 MHz)
  - Middle-speed on-chip oscillator (MOCO) (8 MHz)
  - Low-speed on-chip oscillator (LOCO) (32.768 kHz)
  - IWDT-dedicated on-chip oscillator (15 kHz)
  - Clock trim function for HOCO/MOCO/LOCO
  - PLL/PLL2
  - Clock out support
- **General-Purpose I/O Ports**
  - 5-V tolerance, open drain, input pull-up, switchable driving ability
- **Operating Voltage**
  - VCC: 2.7 to 3.6 V
- **Operating Temperature and Packages**
  - Ta = -40°C to +105°C
    - 144-pin LQFP (20 mm × 20 mm, 0.5 mm pitch)
    - 100-pin LQFP (14 mm × 14 mm, 0.5 mm pitch)
    - 64-pin LQFP (10 mm × 10 mm, 0.5 mm pitch)

性能领先的100MHzArmCortex-M33内核、高达1MB的具有后台和SWAP操作的代码闪存、8KB数据闪存和具有奇偶校验ECC的128KBSRAM。与USB2.0全速、SDHI、QuadSPI和高级模拟的高度集成。具有加密加速器的集成安全加密引擎、密钥管理支持、篡改检测和电源分析抗性与ArmTrustZone相结合，可实现集成安全元件功能。

## Features

- **Arm®Cortex®-M33内核**
  - 带有主扩展的Armv8-M架构●最大工作频率: 100MHz●Arm内存保护单元 (ArmMPU)
  - 受保护的内存系统架构(PMSAv8) 安全MPU(MPU\_S): 8个区域 非安全MPU(MPU\_NS): 8个区域●Sy sTick计时器
  - 嵌入两个SysTick计时器: 安全和非安全实例 由LOCO或系统时钟驱动●CoreSight ETM-M33
- **Memory**
  - 高达1-MB代码闪存●8-KB数据闪存 (100 000次程序擦除(PE)周期) ●128-KBSRAM
- **Connectivity**
  - 串行通信接口(SCI)×6-异步接口-8位时钟同步接口-智能卡接口-简单IIC-简单SPI-曼彻斯特编码(SCI3 SCI4)●I2C总线接口(IIC)×2●串行外设接口(SPI)●四路串行外设接口(QSPI)●USB2.0全速模块(USBFS)●控制局域网模块(CAN)×2●SDMMC主机接口(SDHI)●增强型串行声音接口(SSIE)
- **Analog**
  - 12位模数转换器(ADC12)×2●12位模数转换器(DAC12)×2●温度传感器(TSN)
- **Timers**
  - 通用PWM定时器32位(GPT32)×4●通用PWM定时器16位(GPT16)×4●低功耗异步通用定时器(AGT)×6
- **安全和加密●安全加密引擎9**
  - 对称算法: AES 非对称算法: RSA、ECC和DSA 哈希值生成: SHA224、SHA256、GHASH 128位唯一ID●Arm®TrustZone®
  - 代码闪存最多三个区域 数据闪存最多两个区域 SRAM最多三个区域 每个外围设备的单独安全或非安全安全属性●设备生命周期管理●引脚功能
  - 最多三个防篡改引脚 安全引脚复用
- **系统和电源管理●低功耗模式●电池备份功能(VBATT)**
  - 支持日历和VBATT的实时时钟(RTC)●事件链接控制器(ELC)●数据传输控制器(DTC)●DMA控制器(DMAC)×8●上电复位●具有电压设置的低电压检测(LVD)●看门狗定时器(WDT)

- 独立看门狗定时器 (IWDT)
- **人机界面(HMI)●电容式触摸感应单元(CTSU)**
- **多个时钟源**
  - 主时钟振荡器 (MOSC) (8至24MHz) ●副时钟振荡器 (SOSC) (32.768kHz) ●高速片上振荡器 (HOCO) (16/18/20MHz) ●中速片上振荡器(MOCO)(8MHz)●低速片上振荡器(LOCO)(32.768kHz)●IWDT专用片上振荡器(15kHz)●HOCOMOCOLOCO的时钟微调功能●PLLPLL2●时钟输出支持
- **General-Purpose I/O Ports**
  - 5V容差、开漏、输入上拉、可切换驱动能力
- **工作电压●VCC: 2.7至3.6V**
- **工作温度和封装●Ta=-40°Cto+105°C**
  - 144-pin LQFP (20 mm × 20 mm, 0.5 mm pitch)
  - 100-pin LQFP (14 mm × 14 mm, 0.5 mm pitch)
  - 64-pin LQFP (10 mm × 10 mm, 0.5 mm pitch)

## 1. Overview

The MCU integrates multiple series of software- and pin-compatible Arm®-based 32-bit cores that share a common set of Renesas peripherals to facilitate design scalability and efficient platform-based product development.

The MCU in this series incorporates a high-performance Arm Cortex®-M33 core running up to 100 MHz with the following features:

- Up to 1 MB code flash memory
- 128 KB SRAM
- Quad Serial Peripheral Interface (QSPI)
- USBFS, SD/MMC Host Interface
- Capacitive Touch Sensing Unit (CTSUS)
- Analog peripherals
- Security and safety features

### 1.1 Function Outline

Table 1.1 Arm core

| Feature             | Functional description  |
|---------------------|---|
| Arm Cortex-M33 core | <ul style="list-style-type: none"> <li>● Maximum operating frequency: up to 100 MHz</li> <li>● Arm Cortex-M33 core: <ul style="list-style-type: none"> <li>– Armv8-M architecture with security extension</li> <li>– Revision: r0p4-00rel0</li> </ul> </li> <li>● Arm Memory Protection Unit (Arm MPU) <ul style="list-style-type: none"> <li>– Protected Memory System Architecture (PMSAv8)</li> <li>– Secure MPU (MPU_S): 8 regions</li> <li>– Non-secure MPU (MPU_NS): 8 regions</li> </ul> </li> <li>● SysTick timer <ul style="list-style-type: none"> <li>– Embeds two SysTick timers: Secure and Non-secure instance</li> <li>– Driven by SysTick timer clock (SYSTICCLK) or system clock (ICLK)</li> </ul> </li> <li>● CoreSight™ ETM-M33</li> </ul> |

Table 1.2 Memory

| Feature               | Functional description   |
|-----------------------|--|
| Code flash memory     | Maximum 1 MB of code flash memory.<br>See <a href="#">section 44, Flash Memory</a> .   |
| Data flash memory     | 8 KB of data flash memory.<br>See <a href="#">section 44, Flash Memory</a> .   |
| Option-setting memory | The option-setting memory determines the state of the MCU after a reset.<br>See <a href="#">section 6, Option-Setting Memory</a> . |
| SRAM                  | On-chip high-speed SRAM with either parity bit or Error Correction Code (ECC).<br>See <a href="#">section 42, SRAM</a> .           |

Table 1.3 System (1 of 2)

|                 | Functional description  |
|-----------------|---|
| Operating modes | Two operating modes: <ul style="list-style-type: none"> <li>● Single-chip mode</li> <li>● SCI/USB boot mode</li> </ul> See <a href="#">section 3, Operating Modes</a> . |
| Resets          | The MCU provides 14 resets.<br>See <a href="#">section 5, Resets</a> .  |

## 1. Overview

MCU集成了多个系列的软件和基于Arm®引脚兼容的32位内核，这些内核共享一组通用的瑞萨外围设备可促进设计可扩展性和高效的基于平台的产品开发。

该系列中的MCU包含一个运行频率高达100MHz的高性能ArmCortex®-M33内核，具有以下特性：

- 高达1MB的代码闪存
- 128 KB SRAM
- 四路串行外设接口(QSPI)
- USBFS、SDMMC主机接口
- 电容式触控感应单元(CTSUS)
- 模拟外设
- 安全和安全功能

### 1.1 功能概要

Table 1.1 臂芯

| Feature         | 功能说明  |
|-----------------|---|
| ArmCortex-M33内核 | <ul style="list-style-type: none"> <li>● 最大工作频率：高达100MHz</li> <li>● Arm Cortex-M33 core: <ul style="list-style-type: none"> <li>– 带有安全扩展的Armv8-M架构</li> <li>– Revision: r0p4-00rel0</li> </ul> </li> <li>● Arm内存保护单元 (ArmMPU) <ul style="list-style-type: none"> <li>– 受保护的内存系统架构(PMSAv8)</li> <li>– 安全MPU(MPU_S): 8个区域</li> <li>– Non-secure MPU (MPU_NS): 8 regions</li> </ul> </li> <li>● SysTick timer <ul style="list-style-type: none"> <li>– 嵌入两个SysTick计时器：安全和非安全实例</li> <li>– 由SysTick定时器时钟(SYSTICCLK)或系统时钟(ICLK)驱动</li> </ul> </li> <li>● CoreSight™ ETM-M33</li> </ul> |

Table 1.2 Memory

| Feature               | 功能说明                                       |
|-----------------------|--|
| 代码闪存                  | 最大1MB代码闪存。<br>请参见第44节，闪存。                  |
| 数据闪存                  | 8KB数据闪存。请参见第44节，闪存。                        |
| Option-setting memory | 选项设置存储器确定复位后MCU的状态。<br>请参见第6节，选项设置内存。      |
| SRAM                  | 具有奇偶校验位或纠错码(ECC)的片上高速SRAM。<br>参见第42节，SRAM。 |

Table 1.3 系统(1of2)

|        | 功能说明  |
|--------|---|
| 操作模式   | 两种操作模式：● <ul style="list-style-type: none"> <li>● SCI/USB启动模式</li> </ul> 请参见第3节，操作模式。 |
| Resets | MCU提供14次复位。<br>请参见第5节，重置。   |

Table 1.3 System (2 of 2)

| Feature  | Functional description  |
|--|---|
| Low Voltage Detection (LVD)                        | The Low Voltage Detection (LVD) module monitors the voltage level input to the VCC pin. The detection level can be selected by register settings. The LVD module consists of three separate voltage level detectors (LVD0, LVD1, LVD2). LVD0, LVD1, and LVD2 measure the voltage level input to the VCC pin. LVD registers allow your application to configure detection of VCC changes at various voltage thresholds.<br>See <a href="#">section 7, Low Voltage Detection (LVD)</a> .  |
| Clocks   | <ul style="list-style-type: none"> <li>• Main clock oscillator (MOSC)</li> <li>• Sub-clock oscillator (SOSC)</li> <li>• High-speed on-chip oscillator (HOCO)</li> <li>• Middle-speed on-chip oscillator (MOCO)</li> <li>• Low-speed on-chip oscillator (LOCO)</li> <li>• IWDG-dedicated on-chip oscillator</li> <li>• PLL/PLL2</li> <li>• Clock out support</li> </ul> See <a href="#">section 8, Clock Generation Circuit</a> .  |
| Clock Frequency Accuracy Measurement Circuit (CAC) | The Clock Frequency Accuracy Measurement Circuit (CAC) counts pulses of the clock to be measured (measurement target clock) within the time generated by the clock selected as the measurement reference (measurement reference clock), and determines the accuracy depending on whether the number of pulses is within the allowable range. When measurement is complete or the number of pulses within the time generated by the measurement reference clock is not within the allowable range, an interrupt request is generated.<br>See <a href="#">section 9, Clock Frequency Accuracy Measurement Circuit (CAC)</a> . |
| Interrupt Controller Unit (ICU)                    | The Interrupt Controller Unit (ICU) controls which event signals are linked to the Nested Vector Interrupt Controller (NVIC), the DMA Controller (DMAC), and the Data Transfer Controller (DTC) modules. The ICU also controls non-maskable interrupts.<br>See <a href="#">section 13, Interrupt Controller Unit (ICU)</a> .  |
| Low power modes                                    | Power consumption can be reduced in multiple ways, including setting clock dividers, stopping modules, selecting power control mode in normal operation, and transitioning to low power modes.<br>See <a href="#">section 10, Low Power Modes</a> .   |
| Battery backup function                            | A battery backup function is provided for partial powering by a battery. The battery-powered area includes the RTC, SOSC, backup memory, and switch between VCC and VBATT.<br>See <a href="#">section 11, Battery Backup Function</a> .   |
| Register write protection                          | The register write protection function protects important registers from being overwritten due to software errors. The registers to be protected are set with the Protect Register (PRCR).<br>See <a href="#">section 12, Register Write Protection</a> .   |
| Memory Protection Unit (MPU)                       | The MCU has one Memory Protection Unit (MPU).<br>See <a href="#">section 15, Memory Protection Unit (MPU)</a> .   |

Table 1.4 Event link

| Feature                     | Functional description  |
|-----------------------------|---|
| Event Link Controller (ELC) | The Event Link Controller (ELC) uses the event requests generated by various peripheral modules as source signals to connect them to different modules, allowing direct link between the modules without CPU intervention.<br>See <a href="#">section 18, Event Link Controller (ELC)</a> . |

Table 1.5 Direct memory access

| Feature                        | Functional description   |
|--------------------------------|--|
| Data Transfer Controller (DTC) | A Data Transfer Controller (DTC) module is provided for transferring data when activated by an interrupt request.<br>See <a href="#">section 17, Data Transfer Controller (DTC)</a> .  |
| DMA Controller (DMAC)          | The MCU includes an 8-channel direct memory access controller (DMAC) that can transfer data without intervention from the CPU. When a DMA transfer request is generated, the DMAC transfers data stored at the transfer source address to the transfer destination address.<br>See <a href="#">section 16, DMA Controller (DMAC)</a> . |

Table 1.3 系统(2之2)

| Feature         | 功能说明  |
|-----------------|---|
| 低电压检测(LVD)      | 低电压检测(LVD)模块监控输入到VCC引脚的电压电平。检测等级可以通过寄存器设置来选择。LVD模块由三个独立的电压电平检测器(LVD0、LVD1、LVD2)组成。LVD0、LVD1和LVD2测量输入到VCC引脚的电压电平。LVD寄存器允许您的应用程序配置在各种电压阈值下检测VCC变化。请参见第7节, 低电压检测(LVD)。   |
| Clocks          | <ul style="list-style-type: none"> <li>• 主时钟振荡器(MOSC)</li> <li>• Sub-clock oscillator (SOSC)</li> <li>• High-speed on-chip oscillator (HOCO)</li> <li>• Middle-speed on-chip oscillator (MOCO)</li> <li>• Low-speed on-chip oscillator (LOCO)</li> <li>• IWDG-dedicated on-chip oscillator</li> <li>• PLL/PLL2</li> <li>• 打卡支持</li> </ul> 请参见第8节, 时钟生成电路。 |
| 时钟频率精度测量电路(CAC) | 时钟频率精度测量电路(CAC)在被选为测量基准的时钟(测量基准时钟)产生的时间内对要测量的时钟(测量目标时钟)的脉冲进行计数,并根据脉冲数在允许范围内。当测量完成或测量参考时钟产生的时间内的脉冲数不在允许范围内时,将产生中断请求。请参见第9节, 时钟频率精度测量电路(CAC)。   |
| 中断控制器单元(ICU)    | 中断控制器单元(ICU)控制哪些事件信号链接到嵌套向量中断控制器(NVIC)、DMA控制器(DMAC)和数据传输控制器(DTC)模块。ICU还控制不可屏蔽的中断。请参见第13节, 中断控制器单元(ICU)。   |
| 低功耗模式           | 可以通过多种方式降低功耗,包括设置时钟分频器、停止模块、在正常操作中选择电源控制模式以及转换到低功耗模式。请参见第10节, 低功耗模式。  |
| 电池备份功能          | 提供电池备份功能,由电池部分供电。电池供电区域包括RTC、SOSC、备份存储器以及VCC和VBATT之间的切换。请参见第11节, 电池备份功能。  |
| 寄存器写保护          | 寄存器写保护功能可保护重要寄存器不因软件错误而被覆盖。要保护的寄存器由保护寄存器(PRCR)设置。请参见第12节, 寄存器写保护。   |
| 内存保护单元(MPU)     | MCU有一个内存保护单元(MPU)。<br>请参见第15节, 内存保护单元(MPU)。   |

Table 1.4 活动链接

| Feature      | 功能说明   |
|--------------|--|
| 事件链接控制器(ELC) | EventLinkController(ELC)使用各种外围模块产生的事件请求作为源信号,将它们连接到不同的模块,允许模块之间直接链接,无需CPU干预。请参见第18节, 事件链接控制器(ELC)。 |

Table 1.5 直接内存访问

| Feature               | 功能说明   |
|-----------------------|--|
| 数据传输控制器(DTC)          | 数据传输控制器(DTC)模块用于在被中断请求激活时传输数据。请参见第17节, 数据传输控制器(DTC)。   |
| DMA Controller (DMAC) | MCU包括一个8通道直接内存访问控制器(DMAC),无需CPU干预即可传输数据。当产生DMA传输请求时,DMAC将存储在传输源地址的数据传输到传输目标地址。请参见第16节, DMA控制器(DMAC)。 |



Table 1.6 External bus interface

| Feature        | Functional description   |
|----------------|--|
| External buses | <ul style="list-style-type: none"> <li>QSPI area (EQBIU): Connected to the QSPI (external device interface)</li> </ul> |

Table 1.7 Timers

| Feature  | Functional description   |
|--|--|
| General PWM Timer (GPT)                            | The General PWM Timer (GPT) is a 32-bit timer with GPT32 × 4 channels and a 16-bit timer with GPT16 × 4 channels. PWM waveforms can be generated by controlling the up-counter, down-counter, or the up- and down-counter. In addition, PWM waveforms can be generated for controlling brushless DC motors. The GPT can also be used as a general-purpose timer. See <a href="#">section 21, General PWM Timer (GPT)</a> .   |
| Port Output Enable for GPT (POEG)                  | The Port Output Enable (POEG) function can place the General PWM Timer (GPT) output pins in the output disable state. See <a href="#">section 20, Port Output Enable for GPT (POEG)</a> .  |
| Low power Asynchronous General Purpose Timer (AGT) | The low power Asynchronous General Purpose Timer (AGT) is a 16-bit timer that can be used for pulse output, external pulse width or period measurement, and counting external events. This timer consists of a reload register and a down counter. The reload register and the down counter are allocated to the same address, and can be accessed with the AGT register. See <a href="#">section 22, Low Power Asynchronous General Purpose Timer (AGT)</a> .   |
| Realtime Clock (RTC)                               | The realtime clock (RTC) has two counting modes, calendar count mode and binary count mode, that are used by switching register settings. For calendar count mode, the RTC has a 100-year calendar from 2000 to 2099 and automatically adjusts dates for leap years. For binary count mode, the RTC counts seconds and retains the information as a serial value. Binary count mode can be used for calendars other than the Gregorian (Western) calendar. See <a href="#">section 23, Realtime Clock (RTC)</a> .  |
| Watchdog Timer (WDT)                               | The Watchdog Timer (WDT) is a 14-bit down counter that can be used to reset the MCU when the counter underflows because the system has run out of control and is unable to refresh the WDT. In addition, the WDT can be used to generate a non-maskable interrupt or an underflow interrupt. See <a href="#">section 24, Watchdog Timer (WDT)</a> .  |
| Independent Watchdog Timer (IWDT)                  | The Independent Watchdog Timer (IWDT) consists of a 14-bit down counter that must be serviced periodically to prevent counter underflow. The IWDT provides functionality to reset the MCU or to generate a non-maskable interrupt or an underflow interrupt. Because the timer operates with an independent, dedicated clock source, it is particularly useful in returning the MCU to a known state as a fail-safe mechanism when the system runs out of control. The IWDT can be triggered automatically by a reset, underflow, refresh error, or a refresh of the count value in the registers. See <a href="#">section 25, Independent Watchdog Timer (IWDT)</a> . |

Table 1.8 Communication interfaces (1 of 2)

| Feature                               | Functional description   |
|---------------------------------------|--|
| Serial Communications Interface (SCI) | <p>The Serial Communications Interface (SCI) × 6 channels have asynchronous and synchronous serial interfaces:</p> <ul style="list-style-type: none"> <li>Asynchronous interfaces (UART and Asynchronous Communications Interface Adapter (ACIA))</li> <li>8-bit clock synchronous interface</li> <li>Simple IIC (master-only)</li> <li>Simple SPI</li> <li>Smart card interface</li> <li>Manchester interface</li> <li>Extended Serial interface</li> </ul> <p>The smart card interface complies with the ISO/IEC 7816-3 standard for electronic signals and transmission protocol. SCIn (n = 0, 3, 4, 9) has FIFO buffers to enable continuous and full-duplex communication, and the data transfer speed can be configured independently using an on-chip baud rate generator. See <a href="#">section 27, Serial Communications Interface (SCI)</a>.</p> |
| I <sup>2</sup> C bus interface (IIC)  | The I <sup>2</sup> C bus interface (IIC) has 2 channels. The IIC module conforms with and provides a subset of the NXP I <sup>2</sup> C (Inter-Integrated Circuit) bus interface functions. See <a href="#">section 28, I2C Bus Interface (IIC)</a> .  |

Table 1.6 外部总线接口

| Feature | 功能说明   |
|---------|--|
| 外部总线    | <ul style="list-style-type: none"> <li>QSPI区 (EQBIU) : 连接到QSPI (外部设备接口)</li> </ul> |

Table 1.7 Timers

| Feature           | 功能说明   |
|-------------------|--|
| 通用PWM定时器(GPT)     | 通用PWM定时器(GPT)是一个具有GPT32×4通道的32位定时器和一个具有GPT16×4通道。PWM波形可以通过控制加计数器、减计数器或加减计数器来产生。此外,可以生成PWM波形来控制无刷直流电机。GPT也可以用作通用定时器。请参见第21节,通用PWM定时器(GPT)。  |
| GPT(POEG)的端口输出使能  | 端口输出启用(POEG)功能可以将通用PWM定时器(GPT)输出引脚置于输出禁用状态,请参见第20节,GPT端口输出启用(POEG)。  |
| 低功耗异步通用目的定时器(AGT) | 低功耗异步通用定时器(AGT)是一个16位定时器,可用于脉冲输出、外部脉冲宽度或周期测量以及外部事件计数。该定时器由一个重载寄存器和一个递减计数器组成。重载寄存器和递减计数器分配到同一个地址,可以通过AGT寄存器访问。请参见第22节,低功耗异步通用定时器(AGT)。  |
| 实时时钟(RTC)         | 实时时钟(RTC)有两种计数模式,日历计数模式和二进制计数模式,通过切换寄存器设置使用。对于日历计数模式,RTC有一个从2000年到2099年的100年日历,并自动调整闰年的日期。对于二进制计数模式,RTC会计算秒数并将信息保留为序列值。二进制计数模式可用于公历(西方)以外的日历。请参阅第23节,实时时钟(RTC)。                              |
| 看门狗定时器(WDT)       | 看门狗定时器(WDT)是一个14位递减计数器,可用于在计数器下溢时复位MCU,因为系统已失控且无法刷新WDT。此外,WDT可用于产生不可屏蔽中断或下溢中断。请参见第24节,看门狗定时器(WDT)。   |
| 独立看门狗定时器(IWDT)    | 独立看门狗定时器(IWDT)包含一个14位递减计数器,必须定期对其进行服务以防止计数器下溢。IWDT提供复位MCU或生成不可屏蔽中断或下溢中断的功能。由于定时器使用独立的专用时钟源运行,因此当系统失控时,它在将MCU作为故障安全机制返回到已知状态时特别有用。IWDT可以通过复位、下溢、刷新错误或寄存器中的计数值的刷新来自动触发。请参见第25节,独立看门狗定时器(IWDT)。 |

Table 1.8 通信接口 (2个中的1个)

| Feature      | 功能说明  |
|--------------|---|
| 串行通信接口(SCI)  | <p>串行通信接口(SCI)×6通道具有异步和同步串行接口: ●</p> <p>异步接口 (UART和异步通信接口适配器(ACIA))</p> <ul style="list-style-type: none"> <li>8位时钟同步接口</li> <li>Simple IIC (master-only)</li> <li>简单的SPI</li> <li>智能卡接口</li> <li>曼彻斯特界面</li> <li>扩展串行接口</li> </ul> <p>智能卡接口符合ISO/IEC7816-3电子信号和传输协议标准。SCIn(n=0 3 4 9)具有FIFO缓冲区以实现连续和全双工通信,并且可以使用片上波特率发生器独立配置数据传输速度。参见第27节,串行通信接口(SCI)。</p> |
| I2C总线接口(IIC) | I2C总线接口(IIC)有2个通道。IIC模块符合并提供NXP I2C (内部集成电路) 总线接口功能的子集。请参见第28节,I2C总线接口(IIC)。  |

Table 1.8 Communication interfaces (2 of 2)

| Feature                                 | Functional description   |
|---|--|
| Serial Peripheral Interface (SPI)       | The Serial Peripheral Interface (SPI) provides high-speed full-duplex synchronous serial communications with multiple processors and peripheral devices.<br>See <a href="#">section 30, Serial Peripheral Interface (SPI)</a> .  |
| Control Area Network (CAN)              | The Controller Area Network (CAN) module uses a message-based protocol to receive and transmit data between multiple slaves and masters in electromagnetically noisy applications. The module complies with the ISO 11898-1 (CAN 2.0A/CAN 2.0B) standard and supports up to 32 mailboxes, which can be configured for transmission or reception in normal mailbox and FIFO modes. Both standard (11-bit) and extended (29-bit) messaging formats are supported. The CAN module requires an additional external CAN transceiver.<br>See <a href="#">section 29, Controller Area Network (CAN) Module</a> .  |
| USB 2.0 Full-Speed module (USBFS)       | The USB 2.0 Full-Speed module (USBFS) can operate as a host controller or device controller. The module supports full-speed and low-speed (host controller only) transfer as defined in Universal Serial Bus Specification 2.0. The module has an internal USB transceiver and supports all of the transfer types defined in Universal Serial Bus Specification 2.0. The USB has buffer memory for data transfer, providing a maximum of 10 pipes. Pipes 1 to 9 can be assigned any endpoint number based on the peripheral devices used for communication or based on your system.<br>See <a href="#">section 26, USB 2.0 Full-Speed Module (USBFS)</a> .   |
| Quad Serial Peripheral Interface (QSPI) | The Quad Serial Peripheral Interface (QSPI) is a memory controller for connecting a serial ROM (nonvolatile memory such as a serial flash memory, serial EEPROM, or serial FeRAM) that has an SPI-compatible interface.<br>See <a href="#">section 31, Quad Serial Peripheral Interface (QSPI)</a> .   |
| Serial Sound Interface Enhanced (SSIE)  | The Serial Sound Interface Enhanced (SSIE) peripheral provides functionality to interface with digital audio devices for transmitting I <sup>2</sup> S/Monaural/TDM audio data over a serial bus. The SSIE supports an audio clock frequency of up to 50 MHz, and can be operated as a slave or master receiver, transmitter, or transceiver to suit various applications. The SSIE includes 32-stage FIFO buffers in the receiver and transmitter, and supports interrupts and DMA-driven data reception and transmission.<br>See <a href="#">section 32, Serial Sound Interface Enhanced (SSIE)</a> .  |
| SD/MMC Host Interface (SDHI)            | The SDHI and MultiMediaCard (MMC) interface module provides the functionality required to connect a variety of external memory cards to the MCU. The SDHI supports both 1- and 4-bit buses for connecting memory cards that support SD, SDHC, and SDXC formats. When developing host devices that are compliant with the SD Specifications, you must comply with the SD Host/Ancillary Product License Agreement (SD HALA). The MMC interface supports 1-bit, 4-bit, and 8-bit MMC buses that provide eMMC 4.51 (JEDEC Standard JESD 84-B451) device access. This interface also provides backward compatibility and supports high-speed SDR transfer modes.<br>See <a href="#">section 33, SD/MMC Host Interface (SDHI)</a> . |

Table 1.9 Analog

|                              | Functional description   |
|------------------------------|--|
| 12-bit A/D Converter (ADC12) | A 12-bit successive approximation A/D converter is provided. Up to 22 analog input channels are selectable. Temperature sensor output and internal reference voltage are selectable for conversion.<br>See <a href="#">section 37, 12-Bit A/D Converter (ADC12)</a> .  |
| 12-bit D/A Converter (DAC12) | A 12-bit D/A converter (DAC12) is provided.<br>See <a href="#">section 38, 12-Bit D/A Converter (DAC12)</a> .  |
| Temperature Sensor (TSN)     | The on-chip Temperature Sensor (TSN) determines and monitors the die temperature for reliable operation of the device. The sensor outputs a voltage directly proportional to the die temperature, and the relationship between the die temperature and the output voltage is fairly linear. The output voltage is provided to the ADC12 for conversion and can be further used by the end application.<br>See <a href="#">section 39, Temperature Sensor (TSN)</a> . |

Table 1.8 通信接口 (2个中的2个)

| Feature           | 功能说明   |
|-------------------|--|
| 串行外设接口(SPI)       | 串行外设接口(SPI)提供与多个处理器和外围设备的高速全双工同步串行通信。请参阅第30节, 串行外设接口(SPI)。   |
| 控制区域网络(CAN)       | 控制器局域网(CAN)模块使用基于消息的协议在电磁噪声应用中的多个从机和主机之间接收和传输数据。该模块符合ISO11898-1(CAN2.0A/CAN2.0B)标准, 最多支持32个邮箱, 可配置为普通邮箱和FIFO模式下的发送或接收。支持标准(11位)和扩展(29位)消息格式。CAN模块需要额外的外部CAN收发器。请参阅第29节, 控制器局域网(CAN)模块。   |
| USB2.0全速模块(USBFS) | USB2.0全速模块(USBFS)可以作为主机控制器或设备控制器运行。该模块支持全速和低速(仅限主机控制器)传输, 如通用串行总线规范2.0。该模块有一个内部USB收发器, 支持通用串行总线规范2.0中定义的所有传输类型。USB具有用于数据传输的缓冲存储器, 最多可提供10个管道。可以根据用于通信的外围设备或根据您的系统为管道1到9分配任何端点编号。请参阅第26节, USB2.0全速模块(USBFS)。                          |
| 四路串行外设接口(QSPI)    | QuadSerialPeripheralInterface(QSPI)是一种存储器控制器, 用于连接具有SPI兼容接口的串行ROM(非易失性存储器, 例如串行闪存、串行EEPROM或串行FeRAM)。请参见第31节, 四通道串行外设接口(QSPI)。  |
| 增强型串行声音接口(SSIE)   | 增强型串行声音接口(SSIE)外设提供与数字音频设备接口的功能, 用于通过串行总线传输I <sup>2</sup> S单声道TDM音频数据。SSIE支持高达50MHz的音频时钟频率, 并可作为从属或主接收器、发送器或收发器运行, 以适应各种应用。SSIE在接收器和发送器中包含32级FIFO缓冲区, 并支持中断和DMA驱动的数据接收和发送。请参阅第32节, 增强的串行声音接口(SSIE)。                                  |
| SDMMC主机接口(SDHI)   | SDHI和多媒体卡(MMC)接口模块提供将各种外部存储卡连接到MCU所需的功能。SDHI支持1位和4位总线, 用于连接支持SD、SDHC和SDXC格式的存储卡。在开发符合SD规范的主机设备时, 您必须遵守SD主机辅助产品许可协议(SDHALA)。MMC接口支持提供eMMC4.51(JEDEC标准JESD84-B451)器件访问的1位、4位和8位MMC总线。该接口还提供向后兼容性并支持高速SDR传输模式。请参阅第33节, SDMMC主机接口(SDHI)。 |

Table 1.9 Analog

|                              | 功能说明   |
|------------------------------|--|
| 12-bit A/D Converter (ADC12) | 提供了一个12位逐次逼近模数转换器。最多可选择22个模拟输入通道。可选择温度传感器输出和内部参考电压进行转换。请参见第37节, 12位AD转换器(ADC12)。   |
| 12-bit D/A Converter (DAC12) | 提供了一个12位DA转换器(DAC12)。请参阅第38节, 12位DA转换器(DAC12)。   |
| 温度传感器(TSN)                   | 片上温度传感器(TSN)确定并监控芯片温度, 以确保器件可靠运行。传感器输出与管芯温度成正比的电压, 管芯温度与输出电压之间的关系相当线性。输出电压被提供给ADC12进行转换, 并且可以被最终应用进一步使用。请参见第39节, 温度传感器(TSN)。 |

Table 1.10 Human machine interfaces

| Feature                               | Functional description  |
|---------------------------------------|---|
| Capacitive Touch Sensing Unit (CTSUS) | The Capacitive Touch Sensing Unit (CTSUS) measures the electrostatic capacitance of the touch sensor. Changes in the electrostatic capacitance are determined by software that enables the CTSUS to detect whether a finger is in contact with the touch sensor. The electrode surface of the touch sensor is usually enclosed with an electrical conductor so that a finger does not come into direct contact with the electrode.<br>See <a href="#">section 40, Capacitive Touch Sensing Unit (CTSUS)</a> . |

Table 1.11 Data processing

| Feature                                  | Functional description  |
|--|---|
| Cyclic Redundancy Check (CRC) calculator | The Cyclic Redundancy Check (CRC) calculator generates CRC codes to detect errors in the data. The bit order of CRC calculation results can be switched for LSB-first or MSB-first communication. Additionally, various CRC-generation polynomials are available.<br>See <a href="#">section 34, Cyclic Redundancy Check (CRC) Calculator</a> . |
| Data Operation Circuit (DOC)             | The Data Operation Circuit (DOC) compares, adds, and subtracts 16-bit data. When a selected condition applies, 16-bit data is compared and an interrupt can be generated.<br>See <a href="#">section 41, Data Operation Circuit (DOC)</a> .   |

Table 1.12 Security

| Feature                       | Functional description   |
|-------------------------------|--|
| Security function             | <ul style="list-style-type: none"> <li>• ARMv8-M TrustZone security</li> <li>• Device lifecycle management</li> <li>• Debug access level</li> <li>• Key injection</li> <li>• Secure pin multiplexing</li> </ul>  |
| Secure Crypto Engine 9 (SCE9) | <ul style="list-style-type: none"> <li>• Symmetric algorithms: AES</li> <li>• Asymmetric algorithms: RSA, ECC, and DSA</li> <li>• Hash-value generation: SHA224, SHA256, GHASH</li> <li>• 128-bit unique ID.</li> </ul> See <a href="#">section 36, Secure Cryptographic Engine (SCE9)</a> . |

Table 1.10 人机界面

| Feature          | 功能说明  |
|------------------|---|
| 电容式触控感应单元(CTSUS) | 电容式触摸传感单元(CTSUS)测量触摸传感器的静电电容。静电电容的变化由软件确定，该软件使CTSUS能够检测手指是否与触摸传感器接触。触摸传感器的电极表面通常被电导体包围，因此手指不会直接接触电极。请参阅第40节，电容式触摸传感单元(CTSUS)。 |

Table 1.11 数据处理

| Feature        | 功能说明  |
|----------------|---|
| 循环冗余校验(CRC)计算器 | 循环冗余校验(CRC)计算器生成CRC代码以检测数据中的错误。CRC计算结果的位顺序可以切换为LSB-first或MSB-first通信。此外，还可以使用各种CRC生成多项式。请参阅第34节，循环冗余校验(CRC)计算器。 |
| 数据运算电路(DOC)    | 数据运算电路(DOC)对16位数据进行比较、加法和减法。当适用选定条件时，比较16位数据并可以生成中断。请参阅第41节，数据操作电路(DOC)。  |

Table 1.12 Security

| Feature       | 功能说明  |
|---------------|---|
| 安全功能          | <ul style="list-style-type: none"> <li>• ARMv8-M TrustZone security</li> <li>• 设备生命周期管理</li> <li>• 调试访问级别</li> <li>• 密钥注入</li> <li>• 安全引脚复用</li> </ul>  |
| 安全加密引擎9(SCE9) | <ul style="list-style-type: none"> <li>• Symmetric algorithms: AES</li> <li>• 非对称算法: RSA、ECC和DSA</li> <li>• Hash-value generation: SHA224, SHA256, GHASH</li> <li>• 128位唯一标识。请参阅第36节，安全加密引擎(SCE9)。</li> </ul> |

### 1.2 Block Diagram

Figure 1.1 shows a block diagram of the MCU superset. Some individual devices within the group have a subset of the features.

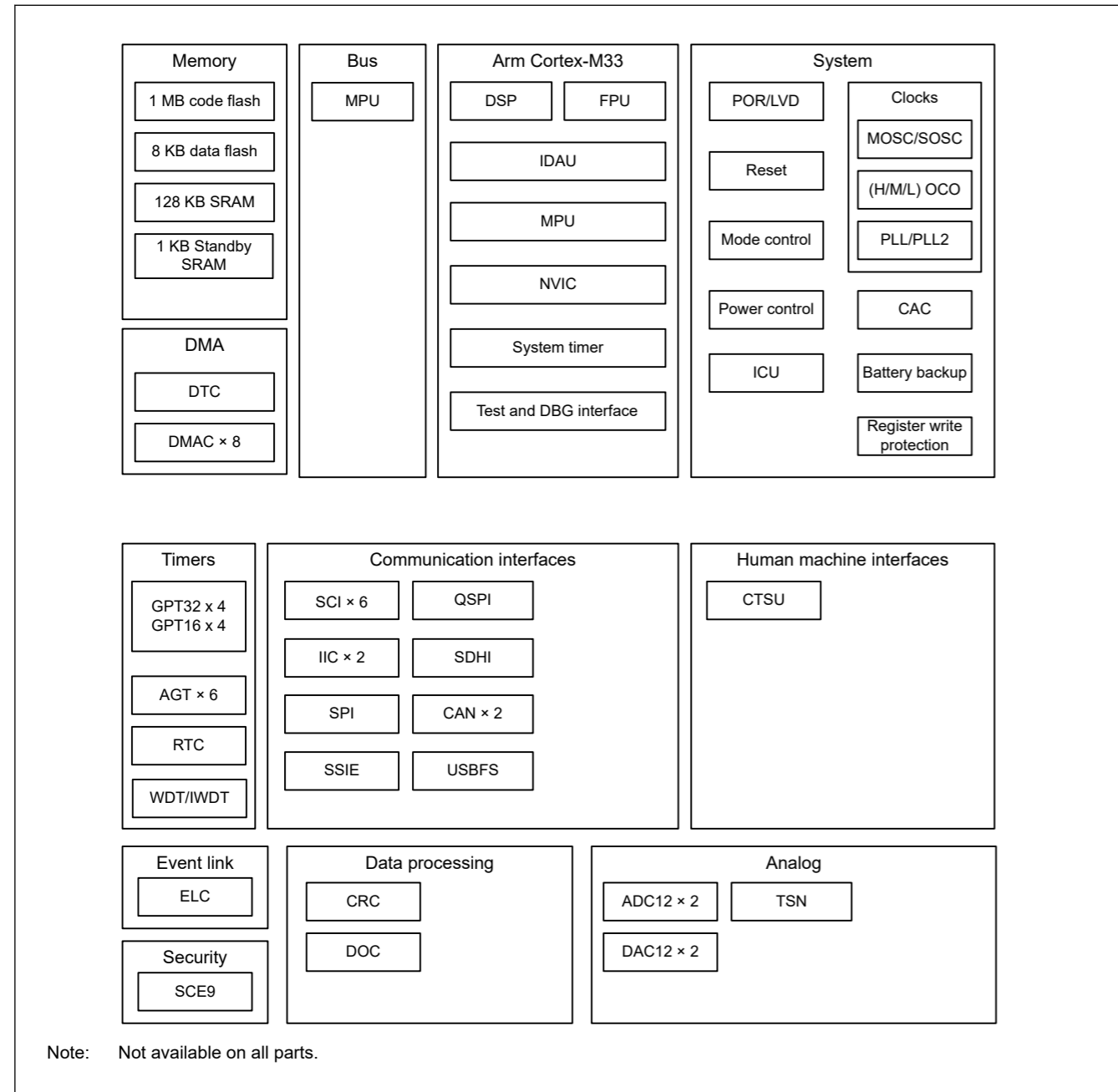


Figure 1.1 Block diagram

### 1.3 Part Numbering

Figure 1.2 shows the product part number information, including memory capacity and package type. Table 1.13 shows a list of products.

### 1.2 框图

图1.1显示了MCU超集的框图。组内的某些单独设备具有部分功能。

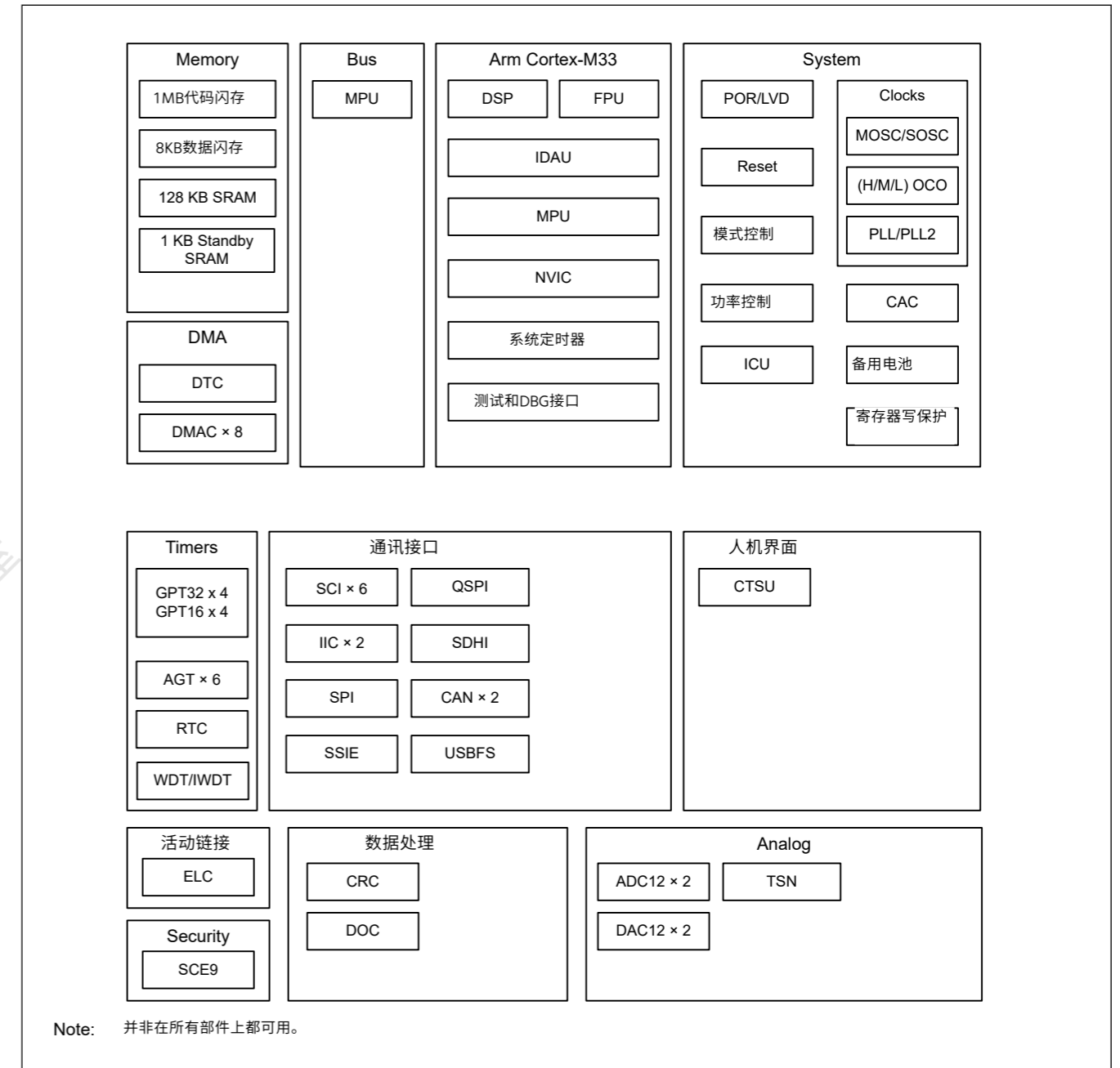


Figure 1.1 框图

### 1.3 零件编号

图1.2显示了产品部件号信息，包括内存容量和封装类型。表1.13显示了产品列表。

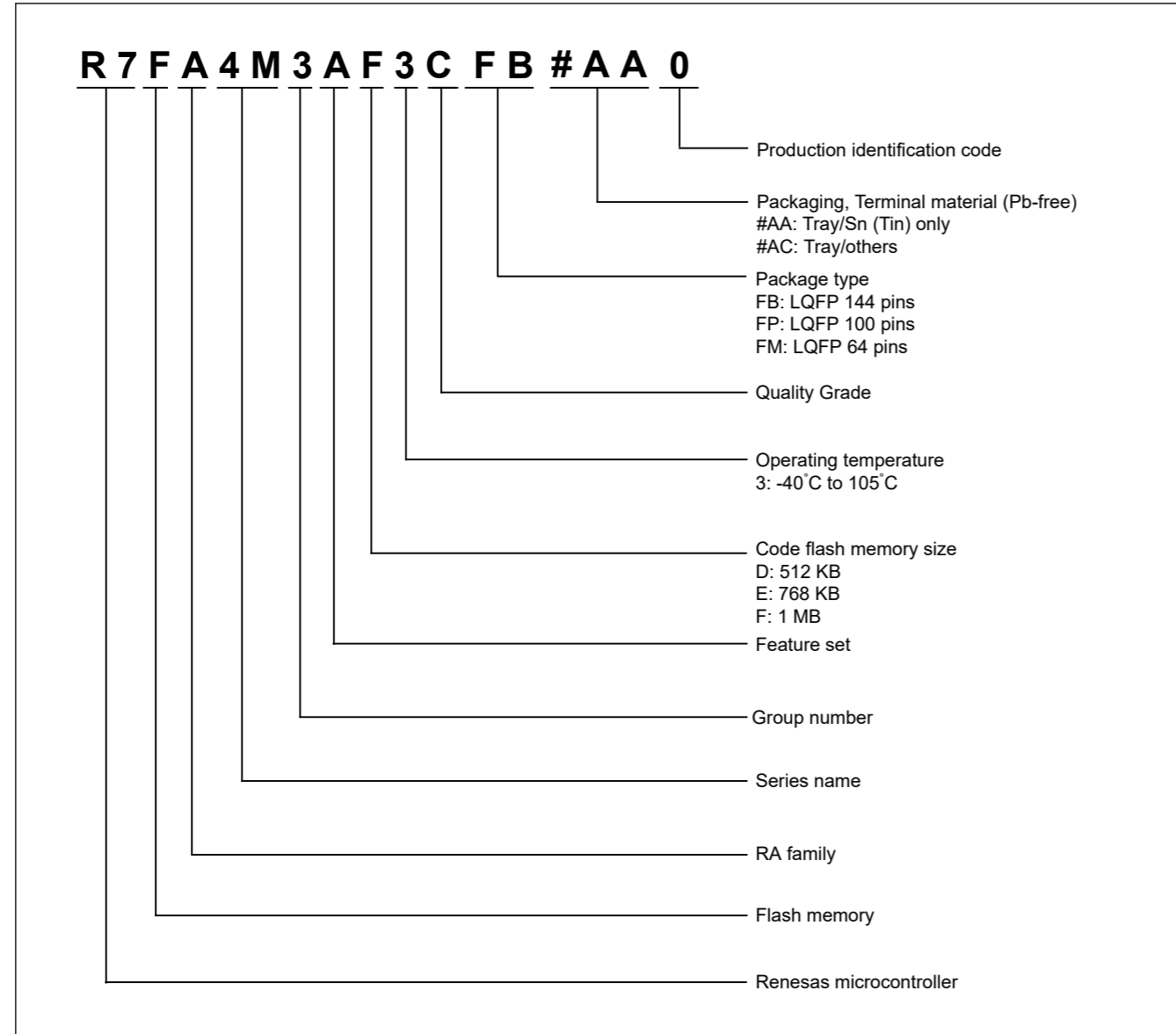


Figure 1.2 Part numbering scheme

Table 1.13 Product list

| Product part number | Package code | Code flash | Data flash | SRAM   | Operating temperature |
|---------------------|--------------|------------|------------|--------|-----------------------|
| R7FA4M3AF3CFB       | PLQP0144KA-B | 1 MB       | 8 KB       | 128 KB | -40 to +105°C         |
| R7FA4M3AF3CFP       | PLQP0100KB-B |            |            |        |                       |
| R7FA4M3AF3CFM       | PLQP0064KB-C |            |            |        |                       |
| R7FA4M3AE3CFB       | PLQP0144KA-B | 768 KB     | 8 KB       | 128 KB | -40 to +105°C         |
| R7FA4M3AE3CFP       | PLQP0100KB-B |            |            |        |                       |
| R7FA4M3AE3CFM       | PLQP0064KB-C |            |            |        |                       |
| R7FA4M3AD3CFB       | PLQP0144KA-B | 512 KB     | 8 KB       | 128 KB | -40 to +105°C         |

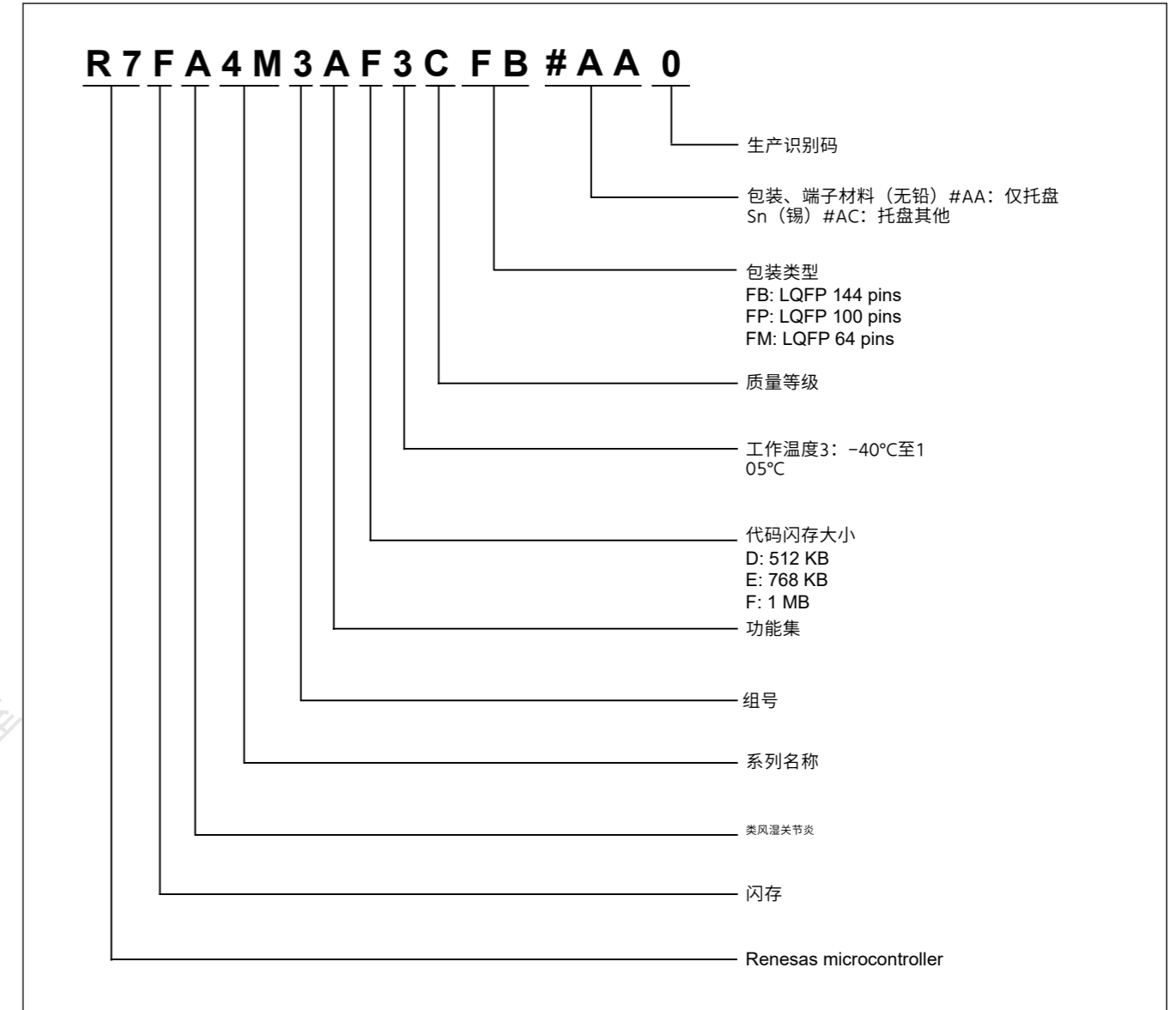


Figure 1.2 零件编号方案

Table 1.13 产品列表

| 产品部件号         | 包装代码         | 代码闪存   | 数据闪存 | SRAM   | 工作温度          |
|---------------|--------------|--------|------|--------|---------------|
| R7FA4M3AF3CFB | PLQP0144KA-B | 1 MB   | 8 KB | 128 KB | -40 to +105°C |
| R7FA4M3AF3CFP | PLQP0100KB-B |        |      |        |               |
| R7FA4M3AF3CFM | PLQP0064KB-C |        |      |        |               |
| R7FA4M3AE3CFB | PLQP0144KA-B | 768 KB | 8 KB | 128 KB | -40 to +105°C |
| R7FA4M3AE3CFP | PLQP0100KB-B |        |      |        |               |
| R7FA4M3AE3CFM | PLQP0064KB-C |        |      |        |               |
| R7FA4M3AD3CFB | PLQP0144KA-B | 512 KB | 8 KB | 128 KB | -40 to +105°C |



## 1.4 Function Comparison

Table 1.14 Function Comparison

| Parts number      | R7FA4M3AF3CFB<br>R7FA4M3AE3CFB<br>R7FA4M3AD3CFB | R7FA4M3AF3CFP<br>R7FA4M3AE3CFP    | R7FA4M3AF3CFM<br>R7FA4M3AE3CFM                    |   |
|-------------------|---|-----------------------------------|---|---|
| Pin count         | 144   | 100                               | 64  |   |
| Package           | LQFP  |                                   |   |   |
| Code flash memory | 1 MB<br>768 KB<br>512 KB                        | 1 MB<br>768 KB                    |   |   |
| Data flash memory | 8 KB  |                                   |   |   |
| SRAM              | 128 KB  |                                   |   |   |
|                   | Parity  | 64 KB                             |   |   |
|                   | ECC   | 64 KB                             |   |   |
| Standby SRAM      | 1 KB  |                                   |   |   |
| DMA               | DTC   | Yes                               |   |   |
|                   | DMAC  | 8                                 |   |   |
| System            | CPU clock                                       | 100 MHz (max.)                    |   |   |
|                   | CPU clock sources                               | MOSC, SOSC, HOCO, MOCO, LOCO, PLL |   |   |
|                   | CAC   | Yes                               |   |   |
|                   | WDT/IWDT  | Yes                               |   |   |
|                   | Backup register                                 | 128 B                             |   |   |
| Communication     | SCI   | 6                                 |   |   |
|                   | IIC   | 2                                 |   |   |
|                   | SPI   | 1                                 |   |   |
|                   | CAN   | 2                                 |   |   |
|                   | USBFS   | Yes                               |   |   |
|                   | QSPI  | Yes                               |   |   |
|                   | SSIE  | Yes                               | No  |   |
|                   | SDHI/MMC  | Yes                               | No  |   |
| Timers            | GPT32*1   | 4                                 |   |   |
|                   | GPT16*1   | 4                                 |   |   |
|                   | AGT*1   | 6                                 |   |   |
|                   | RTC   | Yes                               |   |   |
| Analog            | ADC12   | Unit 0: 12<br>Unit 1: 10          | Unit 0: 11<br>Unit 1: 9<br>Unit 0: 7<br>Unit 1: 4 |   |
|                   | DAC12   | 2                                 |   |   |
|                   | TSN   | Yes                               |   |   |
| HMI               | CTSUS   | 20                                | 12  | 7 |
| Data processing   | CRC   | Yes                               |   |   |
|                   | DOC   | Yes                               |   |   |
| Event control     | ELC   | Yes                               |   |   |
| Security          | SCE9, TrustZone, and Lifecycle management       |                                   |   |   |

Note 1. Available pins depend on the Pin count, about details see [section 1.7. Pin Lists](#).

## 1.4 功能比较

Table 1.14 功能比较

| 零件编号          | R7FA4M3AF3CFB<br>R7FA4M3AE3CFB<br>R7FA4M3AD3CFB | R7FA4M3AF3CFP<br>R7FA4M3AE3CFP    | R7FA4M3AF3CFM<br>R7FA4M3AE3CFM                    |   |
|---------------|---|-----------------------------------|---|---|
| 针数            | 144   | 100                               | 64  |   |
| Package       | LQFP  |                                   |   |   |
| 代码闪存          | 1 MB<br>768 KB<br>512 KB                        | 1 MB<br>768 KB                    |   |   |
| 数据闪存          | 8 KB  |                                   |   |   |
| SRAM          | 128 KB  |                                   |   |   |
|               | Parity  | 64 KB                             |   |   |
|               | ECC   | 64 KB                             |   |   |
| Standby SRAM  | 1 KB  |                                   |   |   |
| DMA           | DTC   | Yes                               |   |   |
|               | DMAC  | 8                                 |   |   |
| System        | 中央处理器时钟   | 100 MHz (max.)                    |   |   |
|               | CPU时钟源  | MOSC, SOSC, HOCO, MOCO, LOCO, PLL |   |   |
|               | CAC   | Yes                               |   |   |
|               | WDT/IWDT  | Yes                               |   |   |
|               | 备份寄存器   | 128 B                             |   |   |
| Communication | SCI   | 6                                 |   |   |
|               | IIC   | 2                                 |   |   |
|               | SPI   | 1                                 |   |   |
|               | CAN   | 2                                 |   |   |
|               | USBFS   | Yes                               |   |   |
|               | QSPI  | Yes                               |   |   |
|               | SSIE  | Yes                               | No  |   |
|               | SDHI/MMC  | Yes                               | No  |   |
| Timers        | GPT32*1   | 4                                 |   |   |
|               | GPT16*1   | 4                                 |   |   |
|               | AGT*1   | 6                                 |   |   |
|               | RTC   | Yes                               |   |   |
| Analog        | ADC12   | Unit 0: 12<br>Unit 1: 10          | Unit 0: 11<br>Unit 1: 9<br>Unit 0: 7<br>Unit 1: 4 |   |
|               | DAC12   | 2                                 |   |   |
|               | TSN   | Yes                               |   |   |
| HMI           | CTSUS   | 20                                | 12  | 7 |
| 数据处理          | CRC   | Yes                               |   |   |
|               | DOC   | Yes                               |   |   |
| 事件控制          | ELC   | Yes                               |   |   |
| Security      | SCE9、TrustZone和生命周期管理                           |                                   |   |   |

注1.可用管脚取决于管脚数，详情见1.7节。引脚列表。

## 1.5 Pin Functions

Table 1.15 Pin functions (1 of 4)

| Function               | Signal           | I/O    | Description  |
|------------------------|------------------|--------|--|
| Power supply           | VCC              | Input  | Power supply pin. Connect it to the system power supply. Connect this pin to VSS by a 0.1- $\mu$ F capacitor. The capacitor should be placed close to the pin. |
|                        | VCL/VCL0         | I/O    | Connect this pin to the VSS pin by the smoothing capacitor used to stabilize the internal power supply. Place the capacitor close to the pin.                  |
|                        | VSS              | Input  | Ground pin. Connect it to the system power supply (0 V).   |
|                        | VBATT            | Input  | Battery Backup power pin   |
| Clock                  | XTAL             | Output | Pins for a crystal resonator. An external clock signal can be input through the EXTAL pin.   |
|                        | EXTAL            | Input  |  |
|                        | XCIN             | Input  | Input/output pins for the sub-clock oscillator. Connect a crystal resonator between XCOUT and XCIN.  |
|                        | XCOUT            | Output |  |
|                        | CLKOUT           | Output | Clock output pin   |
| Operating mode control | MD               | Input  | Pin for setting the operating mode. The signal level on this pin must not be changed during operation mode transition on release from the reset state.         |
| System control         | RES              | Input  | Reset signal input pin. The MCU enters the reset state when this signal goes low.  |
| CAC                    | CACREF           | Input  | Measurement reference clock input pin  |
| On-chip emulator       | TMS              | I/O    | On-chip emulator or boundary scan pins   |
|                        | TDI              | Input  |  |
|                        | TCK              | Input  |  |
|                        | TDO              | Output |  |
|                        | TCLK             | Output | Output clock for synchronization with the trace data   |
|                        | TDATA0 to TDATA3 | Output | Trace data output  |
|                        | SWO              | Output | Serial wire trace output pin   |
|                        | SWDIO            | I/O    | Serial wire debug data input/output pin  |
|                        | SWCLK            | Input  | Serial wire clock pin  |
| Interrupt              | NMI              | Input  | Non-maskable interrupt request pin   |
|                        | IRQn             | Input  | Maskable interrupt request pins  |
|                        | IRQn-DS          | Input  | Maskable interrupt request pins that can also be used in Deep Software Standby mode  |

## 1.5 引脚功能

Table 1.15 引脚功能(1of4)

| Function         | Signal           | I/O    | Description   |
|------------------|------------------|--------|---|
| 电源               | VCC              | Input  | 电源引脚。将其连接到系统电源。通过一个0.1 $\mu$ F电容将此引脚连接到VSS。电容应靠近引脚放置。 |
|                  | VCL/VCL0         | I/O    | 通过用于稳定内部电源的平滑电容器将此引脚连接到VSS引脚。将电容器靠近引脚放置。              |
|                  | VSS              | Input  | 接地引脚。将其连接到系统电源(0V)。                                   |
|                  | VBATT            | Input  | 电池备用电源引脚  |
| Clock            | XTAL             | Output | 晶体谐振器的引脚。外部时钟信号可以通过EXTAL引脚输入。                         |
|                  | EXTAL            | Input  |   |
|                  | XCIN             | Input  | 副时钟振荡器的输入输出引脚。在XCOUT和XCIN之间连接一个晶体谐振器。                 |
|                  | XCOUT            | Output |   |
|                  | CLKOUT           | Output | 时钟输出引脚  |
| 操作模式控制           | MD               | Input  | 用于设置操作模式的引脚。在从复位状态释放的操作模式转换期间，不得更改此引脚上的信号电平。          |
| 系统控制             | RES              | Input  | 复位信号输入引脚。当该信号变低时，MCU进入复位状态。                           |
| CAC              | CACREF           | Input  | 测量参考时钟输入引脚  |
| On-chip emulator | TMS              | I/O    | 片上仿真器或边界扫描引脚  |
|                  | TDI              | Input  |   |
|                  | TCK              | Input  |   |
|                  | TDO              | Output |   |
|                  | TCLK             | Output | 用于与跟踪数据同步的输出时钟  |
|                  | TDATA0 to TDATA3 | Output | 跟踪数据输出  |
|                  | SWO              | Output | 串行线迹输出引脚  |
|                  | SWDIO            | I/O    | 串行线调试数据输入输出引脚   |
|                  | SWCLK            | Input  | 串行线时钟引脚   |
| Interrupt        | NMI              | Input  | 不可屏蔽中断请求引脚  |
|                  | IRQn             | Input  | 可屏蔽中断请求引脚   |
|                  | IRQn-DS          | Input  | 可屏蔽中断请求引脚，也可用于Deep软件待机模式                              |

Table 1.15 Pin functions (2 of 4)

| Function | Signal                             | I/O    | Description   |
|----------|------------------------------------|--------|---|
| GPT      | GTETRGA, GTETRGB, GTETRGC, GTETRGD | Input  | External trigger input pins   |
|          | GTIOCnA, GTIOCnB                   | I/O    | Input capture, output compare, or PWM output pins   |
|          | GTIU                               | Input  | Hall sensor input pin U   |
|          | GTIV                               | Input  | Hall sensor input pin V   |
|          | GTIW                               | Input  | Hall sensor input pin W   |
|          | GTOUUP                             | Output | 3-phase PWM output for BLDC motor control (positive U phase)  |
|          | GTOULO                             | Output | 3-phase PWM output for BLDC motor control (negative U phase)  |
|          | GTOVUP                             | Output | 3-phase PWM output for BLDC motor control (positive V phase)  |
|          | GTOVLO                             | Output | 3-phase PWM output for BLDC motor control (negative V phase)  |
|          | GTOVUP                             | Output | 3-phase PWM output for BLDC motor control (positive W phase)  |
|          | GTOVLO                             | Output | 3-phase PWM output for BLDC motor control (negative W phase)  |
|          | AGT                                | AGTEEn | Input   |
| AGTIOn   |                                    | I/O    | External event input and pulse output pins  |
| AGTOAn   |                                    | Output | Pulse output pins   |
| AGTOAn   |                                    | Output | Output compare match A output pins  |
| AGTOBn   |                                    | Output | Output compare match B output pins  |
| RTC      | RTCOUT                             | Output | Output pin for 1-Hz or 64-Hz clock  |
|          | RTClCn                             | Input  | Time capture event input pins   |
| SCI      | SCKn                               | I/O    | Input/output pins for the clock (clock synchronous mode)  |
|          | RXDn                               | Input  | Input pins for received data (asynchronous mode/clock synchronous mode)   |
|          | TXDn                               | Output | Output pins for transmitted data (asynchronous mode/clock synchronous mode)   |
|          | CTS <sub>n</sub> _RTS <sub>n</sub> | I/O    | Input/output pins for controlling the start of transmission and reception (asynchronous mode/clock synchronous mode), active-low. |
|          | CTS <sub>n</sub>                   | Input  | Input for the start of transmission.  |
|          | SCLn                               | I/O    | Input/output pins for the IIC clock (simple IIC mode)   |
|          | SDAn                               | I/O    | Input/output pins for the IIC data (simple IIC mode)  |
|          | SCKn                               | I/O    | Input/output pins for the clock (simple SPI mode)   |
|          | MISO <sub>n</sub>                  | I/O    | Input/output pins for slave transmission of data (simple SPI mode)  |
|          | MOSI <sub>n</sub>                  | I/O    | Input/output pins for master transmission of data (simple SPI mode)   |
|          | SS <sub>n</sub>                    | Input  | Chip-select input pins (simple SPI mode), active-low  |
|          | RXDX <sub>n</sub>                  | Input  | Input pins for received data (Extended Serial Mode)   |
|          | TXDX <sub>n</sub>                  | Output | Output pins for transmitted data (Extended Serial Mode)   |
|          | SIOX <sub>n</sub>                  | I/O    | Input/output pins for received or transmitted data (Extended Serial Mode)   |
| IIC      | SCLn                               | I/O    | Input/output pins for the clock   |
|          | SDAn                               | I/O    | Input/output pins for data  |

Table 1.15 引脚功能(2of4)

| Function           | Signal                             | I/O    | Description                             |
|--------------------|------------------------------------|--------|---|
| GPT                | GTETRGA, GTETRGB, GTETRGC, GTETRGD | Input  | 外部触发输入引脚                                |
|                    | GTIOCnA, GTIOCnB                   | I/O    | 输入捕捉、输出比较或PWM输出引脚                       |
|                    | GTIU                               | Input  | 霍尔传感器输入引脚U                              |
|                    | GTIV                               | Input  | 霍尔传感器输入引脚V                              |
|                    | GTIW                               | Input  | 霍尔传感器输入引脚W                              |
|                    | GTOUUP                             | Output | 用于BLDC电机控制的3相PWM输出 (正U相)                |
|                    | GTOULO                             | Output | 用于BLDC电机控制的3相PWM输出 (负U相)                |
|                    | GTOVUP                             | Output | 用于BLDC电机控制的3相PWM输出 (正V相)                |
|                    | GTOVLO                             | Output | 用于BLDC电机控制的3相PWM输出 (负V相)                |
|                    | GTOVUP                             | Output | 用于BLDC电机控制的3相PWM输出 (正W相)                |
|                    | GTOVLO                             | Output | 用于BLDC电机控制的3相PWM输出 (负W相)                |
|                    | AGT                                | AGTEEn | Input                                   |
| AGTIO <sub>n</sub> |                                    | I/O    | 外部事件输入和脉冲输出引脚                           |
| AGTO <sub>n</sub>  |                                    | Output | 脉冲输出引脚                                  |
| AGTOA <sub>n</sub> |                                    | Output | 输出比较匹配A输出引脚                             |
| AGTOB <sub>n</sub> |                                    | Output | 输出比较匹配B输出引脚                             |
| RTC                | RTCOUT                             | Output | 用于1Hz或64Hz时钟的输出引脚                       |
|                    | RTClC <sub>n</sub>                 | Input  | 时间捕捉事件输入引脚                              |
| SCI                | SCK <sub>n</sub>                   | I/O    | 时钟输入输出引脚 (时钟同步模式)                       |
|                    | RXD <sub>n</sub>                   | Input  | 接收数据的输入引脚 (异步模式时钟同步模式)                  |
|                    | TXD <sub>n</sub>                   | Output | 传输数据的输出引脚 (异步模式时钟同步模式)                  |
|                    | CTS <sub>n</sub> _RTS <sub>n</sub> | I/O    | 输入输出引脚用于控制发送和接收的开始 (异步模式时钟同步模式), 低电平有效。 |
|                    | CTS <sub>n</sub>                   | Input  | 开始传输的输入。                                |
|                    | SCL <sub>n</sub>                   | I/O    | IIC时钟的输入输出引脚 (简单IIC模式)                  |
|                    | SDA <sub>n</sub>                   | I/O    | IIC数据的输入输出引脚 (简单IIC模式)                  |
|                    | SCK <sub>n</sub>                   | I/O    | 时钟输入输出引脚 (简单SPI模式)                      |
|                    | MISO <sub>n</sub>                  | I/O    | 用于从机传输数据的输入输出引脚 (简单SPI模式)               |
|                    | MOSI <sub>n</sub>                  | I/O    | 输入输出引脚用于主数据传输 (简单SPI模式)                 |
|                    | SS <sub>n</sub>                    | Input  | 片选输入引脚 (简单SPI模式), 低电平有效                 |
|                    | RXDX <sub>n</sub>                  | Input  | 接收数据的输入引脚 (扩展串行模式)                      |
|                    | TXDX <sub>n</sub>                  | Output | 传输数据的输出引脚 (扩展串行模式)                      |
|                    | SIOX <sub>n</sub>                  | I/O    | 用于接收或传输数据的输入输出引脚 (扩展串行 Mode)            |
| IIC                | SCL <sub>n</sub>                   | I/O    | 时钟的输入输出引脚                               |
|                    | SDA <sub>n</sub>                   | I/O    | 数据输入输出引脚                                |

Table 1.15 Pin functions (3 of 4)

| Function | Signal                         | I/O    | Description  |
|----------|--------------------------------|--------|--|
| SPI      | RSPCKA                         | I/O    | Clock input/output pin   |
|          | MOSIA                          | I/O    | Input or output pins for data output from the master   |
|          | MISOA                          | I/O    | Input or output pins for data output from the slave  |
|          | SSLA0                          | I/O    | Input or output pin for slave selection  |
|          | SSLA1 to SSLA3                 | Output | Output pins for slave selection  |
| CAN      | CRXn                           | Input  | Receive data   |
|          | CTXn                           | Output | Transmit data  |
| USBFS    | VCC_USB                        | Input  | Power supply pin   |
|          | VSS_USB                        | Input  | Ground pin   |
|          | USB_DP                         | I/O    | D+ pin of the USB on-chip transceiver. Connect this pin to the D+ pin of the USB bus.  |
|          | USB_DM                         | I/O    | D- pin of the USB on-chip transceiver. Connect this pin to the D- pin of the USB bus.  |
|          | USB_VBUS                       | Input  | USB cable connection monitor pin. Connect this pin to VBUS of the USB bus. The VBUS pin status (connected or disconnected) can be detected when the USB module is operating as a function controller.  |
|          | USB_EXICEN                     | Output | Low-power control signal for external power supply (OTG) chip  |
|          | USB_VBUSEN                     | Output | VBUS (5 V) supply enable signal for external power supply chip   |
|          | USB_OVRCURA, USB_OVRCURB       | Input  | Connect the external overcurrent detection signals to these pins. Connect the VBUS comparator signals to these pins when the OTG power supply chip is connected.   |
|          | USB_OVRCURA-DS, USB_OVRCURB-DS | Input  | Overcurrent pins for USBFS that can also be used in Deep Software Standby mode. Connect the external overcurrent detection signals to these pins. Connect the VBUS comparator signals to these pins when the OTG power supply chip is connected. |
|          | USB_ID                         | Input  | Connect the MicroAB connector ID input signal to this pin during operation in OTG mode   |
| QSPI     | QSPCLK                         | Output | QSPI clock output pin  |
|          | QSSL                           | Output | QSPI slave output pin  |
|          | QIO0 to QIO3                   | I/O    | Data0 to Data3   |
| SSIE     | SSIBCK0                        | I/O    | SSIE serial bit clock pins   |
|          | SSILRCK0/SSIFS0                | I/O    | LR clock/frame synchronization pins  |
|          | SSITXD0                        | Output | Serial data output pin   |
|          | SSIRXD0                        | Input  | Serial data input pin  |
|          | SSIDATA0                       | I/O    | Serial data input/output pins  |
|          | AUDIO_CLK                      | Input  | External clock pin for audio (input oversampling clock)  |
| SDHI/MMC | SD0CLK                         | Output | SD clock output pins   |
|          | SD0CMD                         | I/O    | Command output pin and response input signal pins  |
|          | SD0DAT0 to SD0DAT7             | I/O    | SD and MMC data bus pins   |
|          | SD0CD                          | Input  | SD card detection pins   |
|          | SD0WP                          | Input  | SD write-protect signals   |

Table 1.15 引脚功能(3of4)

| Function | Signal                         | I/O    | Description  |
|----------|--------------------------------|--------|--|
| SPI      | RSPCKA                         | I/O    | 时钟输入输出引脚   |
|          | MOSIA                          | I/O    | 用于从主机输出数据的输入或输出引脚  |
|          | MISOA                          | I/O    | 从机数据输出的输入或输出引脚   |
|          | SSLA0                          | I/O    | 从机选择的输入或输出引脚   |
|          | SSLA1 to SSLA3                 | Output | 从机选择的输出引脚  |
| CAN      | CRXn                           | Input  | 接收数据   |
|          | CTXn                           | Output | 传输数据   |
| USBFS    | VCC_USB                        | Input  | 电源引脚   |
|          | VSS_USB                        | Input  | 接地引脚   |
|          | USB_DP                         | I/O    | USB片上收发器的D+引脚。将此引脚连接到USB总线的D+引脚。   |
|          | USB_DM                         | I/O    | USB片上收发器的Dpin。将此引脚连接到USB总线的Dpin。   |
|          | USB_VBUS                       | Input  | USB电缆连接监视器引脚。将此引脚连接到USB总线的VBUS。当USB模块作为功能控制器运行时，可以检测VBUS引脚状态（连接或断开）。             |
|          | USB_EXICEN                     | Output | 用于外部电源(OTG)芯片的低功耗控制信号  |
|          | USB_VBUSEN                     | Output | VBUS(5V)为外部供电芯片供电使能信号  |
|          | USB_OVRCURA, USB_OVRCURB       | Input  | 将外部过电流检测信号连接到这些引脚。连接OTG电源芯片时，将VBUS比较器信号连接到这些引脚。                                  |
|          | USB_OVRCURA-DS, USB_OVRCURB-DS | Input  | 也可在DeepSoftware中使用的USBFS过流引脚待机模式。将外部过电流检测信号连接到这些引脚。连接OTG电源芯片时，将VBUS比较器信号连接到这些引脚。 |
|          | USB_ID                         | Input  | 在OTG模式下运行期间，将MicroAB连接器ID输入信号连接到此引脚  |
| QSPI     | QSPCLK                         | Output | QSPI时钟输出引脚   |
|          | QSSL                           | Output | QSPI从机输出引脚   |
|          | QIO0 to QIO3                   | I/O    | Data0 to Data3   |
| SSIE     | SSIBCK0                        | I/O    | SSIE串行位时钟引脚  |
|          | SSILRCK0/SSIFS0                | I/O    | LR时钟帧同步管脚  |
|          | SSITXD0                        | Output | 串行数据输出引脚   |
|          | SSIRXD0                        | Input  | 串行数据输入引脚   |
|          | SSIDATA0                       | I/O    | 串行数据输入输出引脚   |
|          | AUDIO_CLK                      | Input  | 音频外部时钟引脚（输入过采样时钟）  |
| SDHI/MMC | SD0CLK                         | Output | SD时钟输出引脚   |
|          | SD0CMD                         | I/O    | 命令输出引脚和响应输入信号引脚  |
|          | SD0DAT0 to SD0DAT7             | I/O    | SD和MMC数据总线引脚   |
|          | SD0CD                          | Input  | SD卡检测引脚  |
|          | SD0WP                          | Input  | SD write-protect signals   |

Table 1.15 Pin functions (4 of 4)

| Function            | Signal | I/O    | Description  |
|---------------------|--------|--------|--|
| Analog power supply | AVCC0  | Input  | Analog voltage supply pin. This is used as the analog power supply for the respective modules. Supply this pin with the same voltage as the VCC pin.         |
|                     | AVSS0  | Input  | Analog ground pin. This is used as the analog ground for the respective modules. Supply this pin with the same voltage as the VSS pin.                       |
|                     | VREFH0 | Input  | Analog reference voltage supply pin for the ADC12 (unit 0). Connect this pin to AVCC0 when not using the ADC12 (unit 0).                                     |
|                     | VREFL0 | Input  | Analog reference ground pin for the ADC12. Connect this pin to AVSS0 when not using the ADC12 (unit 0).  |
|                     | VREFH  | Input  | Analog reference voltage supply pin for the ADC12 (unit 1) and D/A Converter. Connect this pin to AVCC0 when not using the ADC12 (unit 1) and D/A Converter. |
|                     | VREFL  | Input  | Analog reference ground pin for the ADC12 and D/A Converter. Connect this pin to AVSS0 when not using the ADC12 (unit 1) and D/A Converter.                  |
| ADC12               | ANmn   | Input  | Input pins for the analog signals to be processed by the A/D converter.<br>(m: ADC unit number, n: pin number)   |
|                     | ADTRGm | Input  | Input pins for the external trigger signals that start the A/D conversion, active-low.   |
| DAC12               | DAn    | Output | Output pins for the analog signals processed by the D/A converter.   |
| CTSU                | TSn    | Input  | Capacitive touch detection pins (touch pins)   |
|                     | TSCAP  | I/O    | Secondary power supply pin for the touch driver  |
| I/O ports           | Pmn    | I/O    | General-purpose input/output pins<br>(m: port number, n: pin number)   |
|                     | P200   | Input  | General-purpose input pin  |

Table 1.15 引脚功能 (4个, 共4个)

| Function  | Signal | I/O    | Description   |
|-----------|--------|--------|---|
| 模拟电源      | AVCC0  | Input  | 模拟电压电源引脚。这用作各个模块的模拟电源。为该引脚提供与VCC引脚相同的电压。                            |
|           | AVSS0  | Input  | 模拟接地引脚。这用作各个模块的模拟地。为该引脚提供与VSS引脚相同的电压。                               |
|           | VREFH0 | Input  | ADC12 (单元0) 的模拟参考电压电源引脚。不使用ADC12 (单元0) 时, 将此引脚连接到AVCC0。             |
|           | VREFL0 | Input  | ADC12的模拟参考接地引脚。将此引脚连接到不使用ADC12 (单元0) 时的AVSS0。                       |
|           | VREFH  | Input  | ADC12 (单元1) 和DA的模拟参考电压电源引脚转换器。不使用ADC12 (单元1) 和DA转换器时, 将此引脚连接到AVCC0。 |
|           | VREFL  | Input  | ADC12和DA转换器的模拟参考接地引脚。不使用ADC12 (单元1) 时将此引脚连接到AVSS0, 并且D/A Converter。 |
| ADC12     | ANmn   | Input  | AD转换器要处理的模拟信号的输入引脚。(m: ADC单元编号, n: 引脚编号)                            |
|           | ADTRGm | Input  | 用于启动AD转换的外部触发信号的输入引脚, 低电平有效。  |
| DAC12     | DAn    | Output | 由数模转换器处理的模拟信号的输出引脚。   |
| CTSU      | TSn    | Input  | 电容式触摸检测引脚 (触摸引脚)  |
|           | TSCAP  | I/O    | 触摸驱动器的辅助电源引脚  |
| I/O ports | Pmn    | I/O    | 通用输入输出引脚 (m: 端口号, n: 引脚号)   |
|           | P200   | Input  | 通用输入引脚  |

### 1.6 Pin Assignments

The following figures show the pin assignments from the top view.

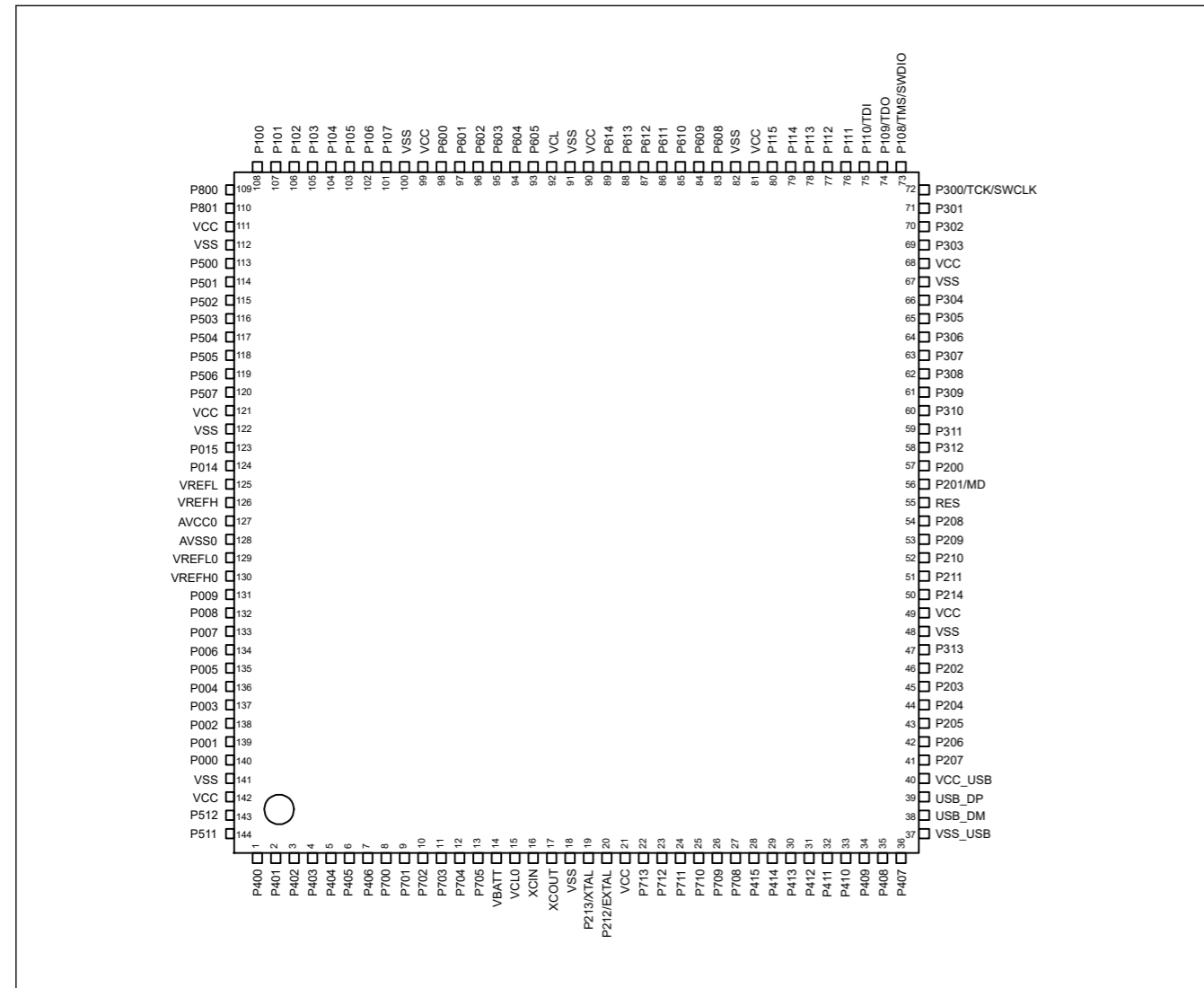


Figure 1.3 Pin assignment for LQFP 144-pin

### 1.6 引脚分配

下图从顶视图显示了引脚分配。

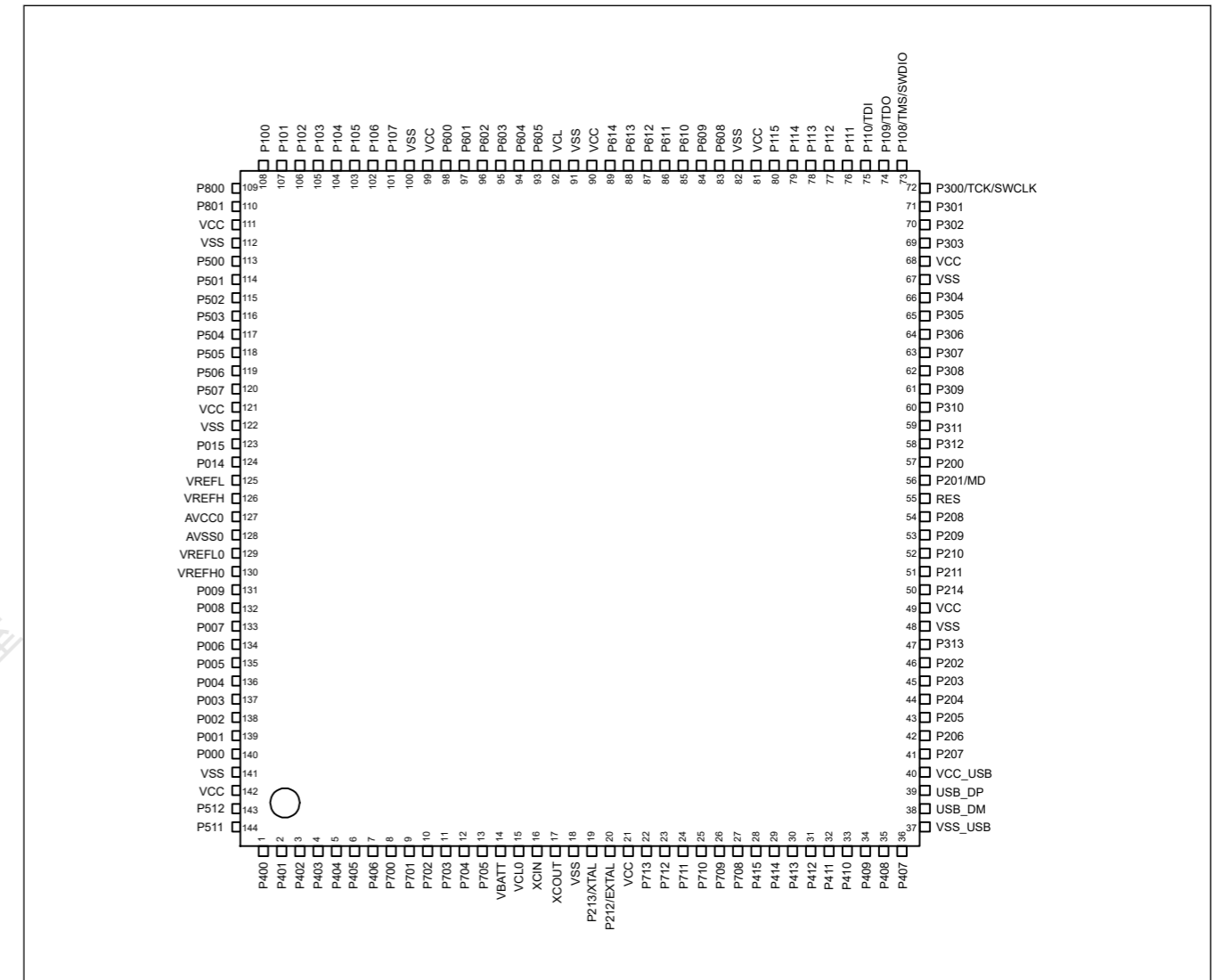


Figure 1.3 LQFP144引脚的引脚分配





1.7 Pin Lists

Table 1.16 Pin list (1 of 4)

| LPOFP144 | LPOFP100 | LPOFP64 | Power, System, Clock, Debug, CAC | I/O ports | Ex. Interrupt | SCI/IIC/SPI/CAN/USBFS/QSPI/SSIE/SDHI/MMC  | GPT/AGT/RTC                                 | ADC12/DAC12 | CTSU  |
|----------|----------|---------|----------------------------------|-----------|---------------|---|---|-------------|-------|
| 1        | 1        | 1       | —                                | P400      | IRQ0          | SCK4/SCL0_A/AUDIO_CLK   | GTIOC6A/AGTIO1                              | ADTRG1      | —     |
| 2        | 2        | 2       | —                                | P401      | IRQ5-DS       | CTS4_RTS4/SS4/SDA0_A/CTX0   | GTETRGA/GTIOC6B                             | —           | —     |
| 3        | 3        | 3       | CACREF                           | P402      | IRQ4-DS       | CTS4/CRX0/AUDIO_CLK   | AGTIO0/AGTIO1/AGTIO2/AGTIO3/RTICIC0         | —           | —     |
| 4        | 4        | —       | —                                | P403      | IRQ14-DS      | SSIBCK0_A   | GTIOC3A/AGTIO0/AGTIO1/AGTIO2/AGTIO3/RTICIC1 | —           | —     |
| 5        | 5        | —       | —                                | P404      | IRQ15-DS      | SSILRCK0/SSIFS0_A   | GTIOC3B/AGTIO0/AGTIO1/AGTIO2/AGTIO3/RTICIC2 | —           | —     |
| 6        | 6        | —       | —                                | P405      | —             | SSITXD0_A   | GTIOC1A                                     | —           | —     |
| 7        | 7        | —       | —                                | P406      | —             | SSLA3_C/SSIRXD0_A   | GTIOC1B/AGTO5                               | —           | —     |
| 8        | —        | —       | —                                | P700      | —             | MISOA_C   | GTIOC5A/AGTO4                               | —           | —     |
| 9        | —        | —       | —                                | P701      | —             | MOSIA_C   | GTIOC5B/AGTO3                               | —           | —     |
| 10       | —        | —       | —                                | P702      | —             | RSPCKA_C  | GTIOC6A/AGTO2                               | —           | —     |
| 11       | —        | —       | —                                | P703      | —             | SSLA0_C   | GTIOC6B/AGTO1                               | —           | —     |
| 12       | —        | —       | —                                | P704      | —             | SSLA1_C/CTX0  | AGTO0                                       | —           | —     |
| 13       | —        | —       | —                                | P705      | —             | CTS3/SSLA2_C/CRX0   | AGTIO0                                      | —           | —     |
| 14       | 8        | 4       | VBATT                            | —         | —             | —   | —   | —           | —     |
| 15       | 9        | 5       | VCL0                             | —         | —             | —   | —   | —           | —     |
| 16       | 10       | 6       | XCIN                             | —         | —             | —   | —   | —           | —     |
| 17       | 11       | 7       | XCOUT                            | —         | —             | —   | —   | —           | —     |
| 18       | 12       | 8       | VSS                              | —         | —             | —   | —   | —           | —     |
| 19       | 13       | 9       | XTAL                             | P213      | IRQ2          | TXD1/MOSI1/SDA1/TXD1/SIOX1  | GTETRGC/GTIOC0A/AGTEE2                      | ADTRG1      | —     |
| 20       | 14       | 10      | EXTAL                            | P212      | IRQ3          | RXD1/MISO1/SCL1/RXD1  | GTETRGD/GTIOC0B/AGTEE1                      | —           | —     |
| 21       | 15       | 11      | VCC                              | —         | —             | —   | —   | —           | —     |
| 22       | —        | —       | —                                | P713      | —             | —   | GTIOC2A/AGTOA0                              | —           | TS17  |
| 23       | —        | —       | —                                | P712      | —             | —   | GTIOC2B/AGTOB0                              | —           | TS16  |
| 24       | —        | —       | —                                | P711      | —             | CTS1_RTS1/SS1   | AGTEE0                                      | —           | TS15  |
| 25       | —        | —       | —                                | P710      | —             | SCK1  | —   | —           | TS14  |
| 26       | —        | —       | —                                | P709      | IRQ10         | TXD1/MOSI1/SDA1/TXD1/SIOX1  | —   | —           | TS13  |
| 27       | 16       | —       | CACREF                           | P708      | IRQ11         | RXD1/MISO1/SCL1/RXD1/AUDIO_CLK  | —   | —           | TS12  |
| 28       | 17       | —       | —                                | P415      | IRQ8          | USB_VBUSEN/SD0CD  | GTIOC0A/AGTIO4                              | —           | TS11  |
| 29       | 18       | —       | —                                | P414      | IRQ9          | CTS0/SD0WP  | GTIOC0B/AGTIO5                              | —           | TS10  |
| 30       | 19       | —       | —                                | P413      | —             | CTS0_RTS0/SSL0/SD0CLK_A   | GTOUUP/AGTEE3                               | —           | TS09  |
| 31       | 20       | —       | —                                | P412      | —             | SCK0/CTS3/SD0CMD_A  | GTOULO/AGTEE1                               | —           | TS08  |
| 32       | 21       | 12      | —                                | P411      | IRQ4          | TXD0/MOSI0/SDA0/CTS3_RTS3/SS3/SD0DAT0_A   | GTOVUP/AGTOA1                               | —           | TS07  |
| 33       | 22       | 13      | —                                | P410      | IRQ5          | RXD0/MISO0/SCL0/SCK3/SD0DAT1_A  | GTOVLO/AGTOB1                               | —           | TS06  |
| 34       | 23       | 14      | —                                | P409      | IRQ6          | TXD3/MOSI3/SDA3/USB_EXICEN  | GTOUUP/AGTOA2                               | —           | TS05  |
| 35       | 24       | 15      | —                                | P408      | IRQ7          | CTS4/RXD3/MISO3/SCL3/SCL0_B/USB_ID  | GTOWLO/GTIOC6B/AGTOB2                       | —           | TS04  |
| 36       | 25       | 16      | —                                | P407      | —             | CTS4_RTS4/SS4/SDA0_B/SSLA3_A/USB_VBUS   | GTIOC6A/AGTIO0/RTCOUT                       | ADTRG0      | TS03  |
| 37       | 26       | 17      | VSS_USB                          | —         | —             | —   | —   | —           | —     |
| 38       | 27       | 18      | USB_DM                           | —         | —             | —   | —   | —           | —     |
| 39       | 28       | 19      | USB_DP                           | —         | —             | —   | —   | —           | —     |
| 40       | 29       | 20      | VCC_USB                          | —         | —             | —   | —   | —           | —     |
| 41       | 30       | 21      | —                                | P207      | —             | TXD4/MOSI4/SDA4/SSLA2_A/QSSL  | —   | —           | TSCAP |
| 42       | 31       | 22      | —                                | P206      | IRQ0-DS       | RXD4/MISO4/SCL4/CTS9/SDA1_B/SSLA1_A/USB_VBUSEN/SSIDATA0_C/SD0DAT2_A                     | GTIU  | —           | TS02  |
| 43       | 32       | 23      | CLKOUT                           | P205      | IRQ1-DS       | TXD4/MOSI4/SDA4/CTS9_RTS9/SS9/SCL1_B/SSLA0_A/USB_OVRCURA-DS/SSILRCK0/SSIFS0_C/SD0DAT3_A | GTIV/GTIOC4A/AGTO1                          | —           | TS01  |
| 44       | —        | —       | CACREF                           | P204      | —             | SCK4/SCK9/RSPCKA_A/USB_OVRCURB-DS/SSIBCK0_C/SD0DAT4_A                                   | GTIW/GTIOC4B/AGTIO1                         | —           | TS00  |

1.7 引脚列表

Table 1.16 引脚列表 (4个中的1个)

| LPOFP144 | LPOFP100 | LPOFP64 | 电源、系统、时钟、调试、CAC | I/O ports | 前任. 打断   | SCI/IIC/SPI/CAN/USBFS/QSPI/SSIE/SDHI/MMC  | GPT/AGT/RTC                                 | ADC12/DAC12 | CTSU  |
|----------|----------|---------|-----------------|-----------|----------|---|---|-------------|-------|
| 1        | 1        | 1       | —               | P400      | IRQ0     | SCK4/SCL0_A/AUDIO_CLK   | GTIOC6A/AGTIO1                              | ADTRG1      | —     |
| 2        | 2        | 2       | —               | P401      | IRQ5-DS  | CTS4_RTS4/SS4/SDA0_A/CTX0   | GTETRGA/GTIOC6B                             | —           | —     |
| 3        | 3        | 3       | CACREF          | P402      | IRQ4-DS  | CTS4/CRX0/AUDIO_CLK   | AGTIO0/AGTIO1/AGTIO2/AGTIO3/RTICIC0         | —           | —     |
| 4        | 4        | —       | —               | P403      | IRQ14-DS | SSIBCK0_A   | GTIOC3A/AGTIO0/AGTIO1/AGTIO2/AGTIO3/RTICIC1 | —           | —     |
| 5        | 5        | —       | —               | P404      | IRQ15-DS | SSILRCK0/SSIFS0_A   | GTIOC3B/AGTIO0/AGTIO1/AGTIO2/AGTIO3/RTICIC2 | —           | —     |
| 6        | 6        | —       | —               | P405      | —        | SSITXD0_A   | GTIOC1A                                     | —           | —     |
| 7        | 7        | —       | —               | P406      | —        | SSLA3_C/SSIRXD0_A   | GTIOC1B/AGTO5                               | —           | —     |
| 8        | —        | —       | —               | P700      | —        | MISOA_C   | GTIOC5A/AGTO4                               | —           | —     |
| 9        | —        | —       | —               | P701      | —        | MOSIA_C   | GTIOC5B/AGTO3                               | —           | —     |
| 10       | —        | —       | —               | P702      | —        | RSPCKA_C  | GTIOC6A/AGTO2                               | —           | —     |
| 11       | —        | —       | —               | P703      | —        | SSLA0_C   | GTIOC6B/AGTO1                               | —           | —     |
| 12       | —        | —       | —               | P704      | —        | SSLA1_C/CTX0  | AGTO0                                       | —           | —     |
| 13       | —        | —       | —               | P705      | —        | CTS3/SSLA2_C/CRX0   | AGTIO0                                      | —           | —     |
| 14       | 8        | 4       | VBATT           | —         | —        | —   | —   | —           | —     |
| 15       | 9        | 5       | VCL0            | —         | —        | —   | —   | —           | —     |
| 16       | 10       | 6       | XCIN            | —         | —        | —   | —   | —           | —     |
| 17       | 11       | 7       | XCOUT           | —         | —        | —   | —   | —           | —     |
| 18       | 12       | 8       | VSS             | —         | —        | —   | —   | —           | —     |
| 19       | 13       | 9       | XTAL            | P213      | IRQ2     | TXD1/MOSI1/SDA1/TXD1/SIOX1  | GTETRGC/GTIOC0A/AGTEE2                      | ADTRG1      | —     |
| 20       | 14       | 10      | EXTAL           | P212      | IRQ3     | RXD1/MISO1/SCL1/RXD1  | GTETRGD/GTIOC0B/AGTEE1                      | —           | —     |
| 21       | 15       | 11      | VCC             | —         | —        | —   | —   | —           | —     |
| 22       | —        | —       | —               | P713      | —        | —   | GTIOC2A/AGTOA0                              | —           | TS17  |
| 23       | —        | —       | —               | P712      | —        | —   | GTIOC2B/AGTOB0                              | —           | TS16  |
| 24       | —        | —       | —               | P711      | —        | CTS1_RTS1/SS1   | AGTEE0                                      | —           | TS15  |
| 25       | —        | —       | —               | P710      | —        | SCK1  | —   | —           | TS14  |
| 26       | —        | —       | —               | P709      | IRQ10    | TXD1/MOSI1/SDA1/TXD1/SIOX1  | —   | —           | TS13  |
| 27       | 16       | —       | CACREF          | P708      | IRQ11    | RXD1/MISO1/SCL1/RXD1/AUDIO_CLK  | —   | —           | TS12  |
| 28       | 17       | —       | —               | P415      | IRQ8     | USB_VBUSEN/SD0CD  | GTIOC0A/AGTIO4                              | —           | TS11  |
| 29       | 18       | —       | —               | P414      | IRQ9     | CTS0/SD0WP  | GTIOC0B/AGTIO5                              | —           | TS10  |
| 30       | 19       | —       | —               | P413      | —        | CTS0_RTS0/SSL0/SD0CLK_A   | GTOUUP/AGTEE3                               | —           | TS09  |
| 31       | 20       | —       | —               | P412      | —        | SCK0/CTS3/SD0CMD_A  | GTOULO/AGTEE1                               | —           | TS08  |
| 32       | 21       | 12      | —               | P411      | IRQ4     | TXD0/MOSI0/SDA0/CTS3_RTS3/SS3/SD0DAT0_A   | GTOVUP/AGTOA1                               | —           | TS07  |
| 33       | 22       | 13      | —               | P410      | IRQ5     | RXD0/MISO0/SCL0/SCK3/SD0DAT1_A  | GTOVLO/AGTOB1                               | —           | TS06  |
| 34       | 23       | 14      | —               | P409      | IRQ6     | TXD3/MOSI3/SDA3/USB_EXICEN  | GTOUUP/AGTOA2                               | —           | TS05  |
| 35       | 24       | 15      | —               | P408      | IRQ7     | CTS4/RXD3/MISO3/SCL3/SCL0_B/USB_ID  | GTOWLO/GTIOC6B/AGTOB2                       | —           | TS04  |
| 36       | 25       | 16      | —               | P407      | —        | CTS4_RTS4/SS4/SDA0_B/SSLA3_A/USB_VBUS   | GTIOC6A/AGTIO0/RTCOUT                       | ADTRG0      | TS03  |
| 37       | 26       | 17      | VSS_USB         | —         | —        | —   | —   | —           | —     |
| 38       | 27       | 18      | USB_DM          | —         | —        | —   | —   | —           | —     |
| 39       | 28       | 19      | USB_DP          | —         | —        | —   | —   | —           | —     |
| 40       | 29       | 20      | VCC_USB         | —         | —        | —   | —   | —           | —     |
| 41       | 30       | 21      | —               | P207      | —        | TXD4/MOSI4/SDA4/SSLA2_A/QSSL  | —   | —           | TSCAP |
| 42       | 31       | 22      | —               | P206      | IRQ0-DS  | RXD4/MISO4/SCL4/CTS9/SDA1_B/SSLA1_A/USB_VBUSEN/SSIDATA0_C/SD0DAT2_A                     | GTIU  | —           | TS02  |
| 43       | 32       | 23      | CLKOUT          | P205      | IRQ1-DS  | TXD4/MOSI4/SDA4/CTS9_RTS9/SS9/SCL1_B/SSLA0_A/USB_OVRCURA-DS/SSILRCK0/SSIFS0_C/SD0DAT3_A | GTIV/GTIOC4A/AGTO1                          | —           | TS01  |
| 44       | —        | —       | CACREF          | P204      | —        | SCK4/SCK9/RSPCKA_A/USB_OVRCURB-DS/SSIBCK0_C/SD0DAT4_A                                   | GTIW/GTIOC4B/AGTIO1                         | —           | TS00  |



Table 1.16 Pin list (2 of 4)

| LPQFP144 | LPQFP100 | LPQFP64 | Power, System, Clock, Debug, CAC | I/O ports | Ex. Interrupt | SCI/IIC/SPI/CAN/USBFS/QSPI/SSIE/SDHI/MMC               | GPT/AGT/RTC           | ADC12/DAC12 | CTSU |
|----------|----------|---------|----------------------------------|-----------|---------------|--|-----------------------|-------------|------|
| 45       | —        | —       | —                                | P203      | IRQ2-DS       | CTS2_RTS2/SS2/TXD9/MOSI9/SDA9/MOSIA_A/CTX0/SD0DAT5_A   | GTIOC5A/AGTOA3        | —           | TS18 |
| 46       | —        | —       | —                                | P202      | IRQ3-DS       | SCK2/RXD9/MISO9/SCL9/MISOA_A/CRX0/SD0DAT6_A            | GTIOC5B/AGTOB3        | —           | TS19 |
| 47       | —        | —       | —                                | P313      | —             | SD0DAT7_A  | —                     | —           | —    |
| 48       | —        | —       | VSS                              | —         | —             | —  | —                     | —           | —    |
| 49       | —        | —       | VCC                              | —         | —             | —  | —                     | —           | —    |
| 50       | 33       | —       | TCLK                             | P214      | —             | QSPCLK/SD0CLK_B  | GTIU/AGTO5            | —           | —    |
| 51       | 34       | —       | TDATA0                           | P211      | —             | QIO0/SD0CMD_B  | GTIV/AGTOA5           | —           | —    |
| 52       | 35       | —       | TDATA1                           | P210      | —             | QIO1/SD0CD   | GTIW/AGTOB5           | —           | —    |
| 53       | 36       | —       | TDATA2                           | P209      | —             | QIO2/SD0WP   | GTOVUP/AGTEE5         | —           | —    |
| 54       | 37       | 24      | TDATA3                           | P208      | —             | QIO3/SD0DAT0_B   | GTOVLO                | —           | —    |
| 55       | 38       | 25      | RES                              | —         | —             | —  | —                     | —           | —    |
| 56       | 39       | 26      | MD                               | P201      | —             | —  | —                     | —           | —    |
| 57       | 40       | 27      | —                                | P200      | NMI           | —  | —                     | —           | —    |
| 58       | —        | —       | —                                | P312      | —             | CTS3_RTS3/SS3  | AGTOA1                | —           | —    |
| 59       | —        | —       | —                                | P311      | —             | SCK3   | AGTOB1                | —           | —    |
| 60       | —        | —       | —                                | P310      | —             | TXD3/MOSI3/SDA3/QIO3                                   | AGTEE1                | —           | —    |
| 61       | —        | —       | —                                | P309      | —             | RXD3/MISO3/SCL3/QIO2                                   | AGTOA4                | —           | —    |
| 62       | —        | —       | —                                | P308      | —             | CTS3/QIO1  | AGTOB4                | —           | —    |
| 63       | 41       | —       | —                                | P307      | —             | QIO0   | GTOUUP_D/AGTEE4       | —           | —    |
| 64       | 42       | —       | —                                | P306      | —             | QSSL   | GTOULO_D/AGTOA2       | —           | —    |
| 65       | 43       | —       | —                                | P305      | IRQ8          | QSPCLK   | GTOVUP/AGTOB2         | —           | —    |
| 66       | 44       | 28      | —                                | P304      | IRQ9          | —  | GTOVLO/GTIOC7A/AGTEE2 | —           | —    |
| 67       | 45       | —       | VSS                              | —         | —             | —  | —                     | —           | —    |
| 68       | 46       | —       | VCC                              | —         | —             | —  | —                     | —           | —    |
| 69       | 47       | 29      | —                                | P303      | —             | CTS9   | GTIOC7B               | —           | —    |
| 70       | 48       | 30      | —                                | P302      | IRQ5          | TXD2/MOSI2/SDA2/TXD2/SIOX2/SSLA3_B                     | GTOUUP/GTIOC4A        | —           | —    |
| 71       | 49       | 31      | —                                | P301      | IRQ6          | RXD2/MISO2/SCL2/RXD2/CTS9_RTS9/SS9/SSLA2_B             | GTOULO/GTIOC4B/AGTIO0 | —           | —    |
| 72       | 50       | 32      | TCK/SWCLK                        | P300      | —             | SSLA1_B  | GTOUUP/GTIOC0A        | —           | —    |
| 73       | 51       | 33      | TMS/SWDIO                        | P108      | —             | CTS9_RTS9/SS9/SSLA0_B                                  | GTOULO/GTIOC0B/AGTOA3 | —           | —    |
| 74       | 52       | 34      | TDO/SWO/CLKOUT                   | P109      | —             | TXD9/MOSI9/SDA9/MOSIA_B/CTX1                           | GTOVUP/GTIOC1A/AGTOB3 | —           | —    |
| 75       | 53       | 35      | TDI                              | P110      | IRQ3          | CTS2_RTS2/SS2/RXD9/MISO9/SCL9/MISOA_B/CRX1             | GTOVLO/GTIOC1B/AGTEE3 | —           | —    |
| 76       | 54       | 36      | —                                | P111      | IRQ4          | SCK2/SCK9/RSPCKA_B                                     | GTIOC3A/AGTOA5        | —           | —    |
| 77       | 55       | 37      | —                                | P112      | —             | TXD2/MOSI2/SDA2/TXD2/SIOX2/SCK1/SSLA0_B/QSSL/SSIBCK0_B | GTIOC3B/AGTOB5        | —           | —    |
| 78       | 56       | 38      | —                                | P113      | —             | RXD2/MISO2/SCL2/RXD2/SSILRCK0/SSIFS0_B                 | GTIOC2A/AGTEE5        | —           | —    |
| 79       | 57       | —       | —                                | P114      | —             | CTS9/SSIRXD0_B   | GTIOC2B/AGTIO5        | —           | —    |
| 80       | 58       | —       | —                                | P115      | —             | SSITXD0_B  | GTIOC4A               | —           | —    |
| 81       | —        | —       | VCC                              | —         | —             | —  | —                     | —           | —    |
| 82       | —        | —       | VSS                              | —         | —             | —  | —                     | —           | —    |
| 83       | 59       | —       | —                                | P608      | —             | —  | GTIOC4B               | —           | —    |
| 84       | 60       | —       | —                                | P609      | —             | CTX1   | GTIOC5A/AGTO5         | —           | —    |
| 85       | 61       | —       | —                                | P610      | —             | CRX1   | GTIOC5B/AGTO4         | —           | —    |
| 86       | —        | —       | CACREF/CLKOUT                    | P611      | —             | —  | AGTO3                 | —           | —    |
| 87       | —        | —       | —                                | P612      | —             | —  | AGTO2                 | —           | —    |
| 88       | —        | —       | —                                | P613      | —             | —  | AGTO1                 | —           | —    |
| 89       | —        | —       | —                                | P614      | —             | —  | AGTO0                 | —           | —    |
| 90       | 62       | 39      | VCC                              | —         | —             | —  | —                     | —           | —    |
| 91       | 63       | 40      | VSS                              | —         | —             | —  | —                     | —           | —    |
| 92       | 64       | 41      | VCL                              | —         | —             | —  | —                     | —           | —    |

Table 1.16 引脚列表 (2个, 共4个)

| LPQFP144 | LPQFP100 | LPQFP64 | 电源、系统、时钟、调试、CAC | I/O ports | 前任。打断   | SCI/IIC/SPI/CAN/USBFS/QSPI/SSIE/SDHI/MMC               | GPT/AGT/RTC           | ADC12/DAC12 | CTSU |
|----------|----------|---------|-----------------|-----------|---------|--|-----------------------|-------------|------|
| 45       | —        | —       | —               | P203      | IRQ2-DS | CTS2_RTS2/SS2/TXD9/MOSI9/SDA9/MOSIA_A/CTX0/SD0DAT5_A   | GTIOC5A/AGTOA3        | —           | TS18 |
| 46       | —        | —       | —               | P202      | IRQ3-DS | SCK2/RXD9/MISO9/SCL9/MISOA_A/CRX0/SD0DAT6_A            | GTIOC5B/AGTOB3        | —           | TS19 |
| 47       | —        | —       | —               | P313      | —       | SD0DAT7_A  | —                     | —           | —    |
| 48       | —        | —       | VSS             | —         | —       | —  | —                     | —           | —    |
| 49       | —        | —       | VCC             | —         | —       | —  | —                     | —           | —    |
| 50       | 33       | —       | TCLK            | P214      | —       | QSPCLK/SD0CLK_B  | GTIU/AGTO5            | —           | —    |
| 51       | 34       | —       | TDATA0          | P211      | —       | QIO0/SD0CMD_B  | GTIV/AGTOA5           | —           | —    |
| 52       | 35       | —       | TDATA1          | P210      | —       | QIO1/SD0CD   | GTIW/AGTOB5           | —           | —    |
| 53       | 36       | —       | TDATA2          | P209      | —       | QIO2/SD0WP   | GTOVUP/AGTEE5         | —           | —    |
| 54       | 37       | 24      | TDATA3          | P208      | —       | QIO3/SD0DAT0_B   | GTOVLO                | —           | —    |
| 55       | 38       | 25      | RES             | —         | —       | —  | —                     | —           | —    |
| 56       | 39       | 26      | MD              | P201      | —       | —  | —                     | —           | —    |
| 57       | 40       | 27      | —               | P200      | NMI     | —  | —                     | —           | —    |
| 58       | —        | —       | —               | P312      | —       | CTS3_RTS3/SS3  | AGTOA1                | —           | —    |
| 59       | —        | —       | —               | P311      | —       | SCK3   | AGTOB1                | —           | —    |
| 60       | —        | —       | —               | P310      | —       | TXD3/MOSI3/SDA3/QIO3                                   | AGTEE1                | —           | —    |
| 61       | —        | —       | —               | P309      | —       | RXD3/MISO3/SCL3/QIO2                                   | AGTOA4                | —           | —    |
| 62       | —        | —       | —               | P308      | —       | CTS3/QIO1  | AGTOB4                | —           | —    |
| 63       | 41       | —       | —               | P307      | —       | QIO0   | GTOUUP_D/AGTEE4       | —           | —    |
| 64       | 42       | —       | —               | P306      | —       | QSSL   | GTOULO_D/AGTOA2       | —           | —    |
| 65       | 43       | —       | —               | P305      | IRQ8    | QSPCLK   | GTOVUP/AGTOB2         | —           | —    |
| 66       | 44       | 28      | —               | P304      | IRQ9    | —  | GTOVLO/GTIOC7A/AGTEE2 | —           | —    |
| 67       | 45       | —       | VSS             | —         | —       | —  | —                     | —           | —    |
| 68       | 46       | —       | VCC             | —         | —       | —  | —                     | —           | —    |
| 69       | 47       | 29      | —               | P303      | —       | CTS9   | GTIOC7B               | —           | —    |
| 70       | 48       | 30      | —               | P302      | IRQ5    | TXD2/MOSI2/SDA2/TXD2/SIOX2/SSLA3_B                     | GTOUUP/GTIOC4A        | —           | —    |
| 71       | 49       | 31      | —               | P301      | IRQ6    | RXD2/MISO2/SCL2/RXD2/CTS9_RTS9/SS9/SSLA2_B             | GTOULO/GTIOC4B/AGTIO0 | —           | —    |
| 72       | 50       | 32      | TCK/SWCLK       | P300      | —       | SSLA1_B  | GTOUUP/GTIOC0A        | —           | —    |
| 73       | 51       | 33      | TMS/SWDIO       | P108      | —       | CTS9_RTS9/SS9/SSLA0_B                                  | GTOULO/GTIOC0B/AGTOA3 | —           | —    |
| 74       | 52       | 34      | TDO/SWO/CLKOUT  | P109      | —       | TXD9/MOSI9/SDA9/MOSIA_B/CTX1                           | GTOVUP/GTIOC1A/AGTOB3 | —           | —    |
| 75       | 53       | 35      | TDI             | P110      | IRQ3    | CTS2_RTS2/SS2/RXD9/MISO9/SCL9/MISOA_B/CRX1             | GTOVLO/GTIOC1B/AGTEE3 | —           | —    |
| 76       | 54       | 36      | —               | P111      | IRQ4    | SCK2/SCK9/RSPCKA_B                                     | GTIOC3A/AGTOA5        | —           | —    |
| 77       | 55       | 37      | —               | P112      | —       | TXD2/MOSI2/SDA2/TXD2/SIOX2/SCK1/SSLA0_B/QSSL/SSIBCK0_B | GTIOC3B/AGTOB5        | —           | —    |
| 78       | 56       | 38      | —               | P113      | —       | RXD2/MISO2/SCL2/RXD2/SSILRCK0/SSIFS0_B                 | GTIOC2A/AGTEE5        | —           | —    |
| 79       | 57       | —       | —               | P114      | —       | CTS9/SSIRXD0_B   | GTIOC2B/AGTIO5        | —           | —    |
| 80       | 58       | —       | —               | P115      | —       | SSITXD0_B  | GTIOC4A               | —           | —    |
| 81       | —        | —       | VCC             | —         | —       | —  | —                     | —           | —    |
| 82       | —        | —       | VSS             | —         | —       | —  | —                     | —           | —    |
| 83       | 59       | —       | —               | P608      | —       | —  | GTIOC4B               | —           | —    |
| 84       | 60       | —       | —               | P609      | —       | CTX1   | GTIOC5A/AGTO5         | —           | —    |
| 85       | 61       | —       | —               | P610      | —       | CRX1   | GTIOC5B/AGTO4         | —           | —    |
| 86       | —        | —       | CACREF/CLKOUT   | P611      | —       | —  | AGTO3                 | —           | —    |
| 87       | —        | —       | —               | P612      | —       | —  | AGTO2                 | —           | —    |
| 88       | —        | —       | —               | P613      | —       | —  | AGTO1                 | —           | —    |
| 89       | —        | —       | —               | P614      | —       | —  | AGTO0                 | —           | —    |
| 90       | 62       | 39      | VCC             | —         | —       | —  | —                     | —           | —    |
| 91       | 63       | 40      | VSS             | —         | —       | —  | —                     | —           | —    |
| 92       | 64       | 41      | VCL             | —         | —       | —  | —                     | —           | —    |

Table 1.16 Pin list (3 of 4)

| LPQFP144 | LPQFP100 | LPQFP64 | Power, System, Clock, Debug, CAC | I/O ports | Ex. Interrupt | SCI/IIC/SPI/CAN/USBFS/QSPI/SSIE/SDHI/MMC | GPT/AGT/RTC            | ADC12/DAC12 | CTSU |
|----------|----------|---------|----------------------------------|-----------|---------------|--|------------------------|-------------|------|
| 93       | —        | —       | —                                | P605      | —             | —  | AGTO4                  | —           | —    |
| 94       | —        | —       | —                                | P604      | —             | CTS9                                     | AGTEE4                 | —           | —    |
| 95       | —        | —       | —                                | P603      | —             | CTS9_RTS9/SS9                            | GTIOC7A/AGTIO4         | —           | —    |
| 96       | 65       | —       | —                                | P602      | —             | TXD9/MOSI9/SDA9                          | GTIOC7B/AGTO3          | —           | —    |
| 97       | 66       | —       | —                                | P601      | —             | RXD9/MISO9/SCL9                          | GTIOC6A/AGTEE3         | —           | —    |
| 98       | 67       | —       | CACREF/CLKOUT                    | P600      | —             | SCK9                                     | GTIOC6B/AGTIO3         | —           | —    |
| 99       | —        | —       | VCC                              | —         | —             | —  | —                      | —           | —    |
| 100      | —        | —       | VSS                              | —         | —             | —  | —                      | —           | —    |
| 101      | 68       | —       | —                                | P107      | —             | —  | AGTOA0                 | —           | —    |
| 102      | 69       | 42      | —                                | P106      | —             | —  | AGTOB0                 | —           | —    |
| 103      | 70       | 43      | —                                | P105      | IRQ0          | —  | GTETRG/AGTIOC1A/AGTO2  | —           | —    |
| 104      | 71       | 44      | —                                | P104      | IRQ1          | QIO2                                     | GTETRGB/GTIOC1B/AGTEE2 | —           | —    |
| 105      | 72       | 45      | —                                | P103      | —             | CTS0_RTS0/SS0/CTX0/QIO3                  | GTOWUP/GTIOC2A/AGTIO2  | —           | —    |
| 106      | 73       | 46      | —                                | P102      | —             | SCK0/CRX0/QIO0                           | GTOWLO/GTIOC2B/AGTO0   | ADTRG0      | —    |
| 107      | 74       | 47      | —                                | P101      | IRQ1          | TXD0/MOSI0/SDA0/CTS1_RTS1/SS1/QIO1       | GTETRGB/GTIOC5A/AGTEE0 | —           | —    |
| 108      | 75       | 48      | —                                | P100      | IRQ2          | RXD0/MISO0/SCL0/SCK1/QSPCLK              | GTETRG/AGTIOC5B/AGTIO0 | —           | —    |
| 109      | —        | —       | —                                | P800      | —             | CTS0                                     | AGTOA4                 | —           | —    |
| 110      | —        | —       | —                                | P801      | —             | —  | AGTOB4                 | —           | —    |
| 111      | —        | —       | VCC                              | —         | —             | —  | —                      | —           | —    |
| 112      | —        | —       | VSS                              | —         | —             | —  | —                      | —           | —    |
| 113      | 76       | 49      | CACREF                           | P500      | —             | USB_VBUSEN/QSPCLK                        | GTIU/AGTOA0            | AN116       | —    |
| 114      | 77       | —       | —                                | P501      | IRQ11         | USB_OVRCURB/QSSL                         | GTIV/AGTOB0            | AN117       | —    |
| 115      | 78       | —       | —                                | P502      | IRQ12         | USB_OVRCURB/QIO0                         | GTIV/AGTOA2            | AN118       | —    |
| 116      | 79       | —       | —                                | P503      | —             | USB_EXICEN/QIO1                          | GTETRG/AGTOB2          | AN119       | —    |
| 117      | 80       | —       | —                                | P504      | —             | USB_ID/QIO2                              | GTETRGD/AGTOA3         | AN120       | —    |
| 118      | 81       | —       | —                                | P505      | IRQ14         | QIO3                                     | AGTOB3                 | AN121       | —    |
| 119      | —        | —       | —                                | P506      | IRQ15         | —  | —                      | AN122       | —    |
| 120      | —        | —       | —                                | P507      | —             | —  | —                      | —           | —    |
| 121      | 82       | 50      | VCC                              | —         | —             | —  | —                      | —           | —    |
| 122      | 83       | 51      | VSS                              | —         | —             | —  | —                      | —           | —    |
| 123      | 84       | 52      | —                                | P015      | IRQ13         | —  | —                      | AN013/DA1   | —    |
| 124      | 85       | 53      | —                                | P014      | —             | —  | —                      | AN012/DA0   | —    |
| 125      | 86       | 54      | VREFL                            | —         | —             | —  | —                      | —           | —    |
| 126      | 87       | 55      | VREFH                            | —         | —             | —  | —                      | —           | —    |
| 127      | 88       | 56      | AVCC0                            | —         | —             | —  | —                      | —           | —    |
| 128      | 89       | 57      | AVSS0                            | —         | —             | —  | —                      | —           | —    |
| 129      | 90       | 58      | VREFL0                           | —         | —             | —  | —                      | —           | —    |
| 130      | 91       | 59      | VREFH0                           | —         | —             | —  | —                      | —           | —    |
| 131      | —        | —       | —                                | P009      | IRQ13-DS      | —  | —                      | AN009       | —    |
| 132      | 92       | —       | —                                | P008      | IRQ12-DS      | —  | —                      | AN008       | —    |
| 133      | 93       | —       | —                                | P007      | —             | —  | —                      | AN007       | —    |
| 134      | 94       | —       | —                                | P006      | IRQ11-DS      | —  | —                      | AN006       | —    |
| 135      | 95       | —       | —                                | P005      | IRQ10-DS      | —  | —                      | AN005       | —    |
| 136      | 96       | 60      | —                                | P004      | IRQ9-DS       | —  | —                      | AN004       | —    |
| 137      | 97       | 61      | —                                | P003      | —             | —  | —                      | AN003       | —    |
| 138      | 98       | 62      | —                                | P002      | IRQ8-DS       | —  | —                      | AN002/AN102 | —    |
| 139      | 99       | 63      | —                                | P001      | IRQ7-DS       | —  | —                      | AN001/AN101 | —    |
| 140      | 100      | 64      | —                                | P000      | IRQ6-DS       | —  | —                      | AN000/AN100 | —    |
| 141      | —        | —       | VSS                              | —         | —             | —  | —                      | —           | —    |

Table 1.16 引脚列表 (4个中的3个)

| LPQFP144 | LPQFP100 | LPQFP64 | 电源、系统、时钟、调试、CAC | I/O ports | 前任。打断    | SCI/IIC/SPI/CAN/USBFS/QSPI/SSIE/SDHI/MMC | GPT/AGT/RTC            | ADC12/DAC12 | CTSU |
|----------|----------|---------|-----------------|-----------|----------|--|------------------------|-------------|------|
| 93       | —        | —       | —               | P605      | —        | —  | AGTO4                  | —           | —    |
| 94       | —        | —       | —               | P604      | —        | CTS9                                     | AGTEE4                 | —           | —    |
| 95       | —        | —       | —               | P603      | —        | CTS9_RTS9/SS9                            | GTIOC7A/AGTIO4         | —           | —    |
| 96       | 65       | —       | —               | P602      | —        | TXD9/MOSI9/SDA9                          | GTIOC7B/AGTO3          | —           | —    |
| 97       | 66       | —       | —               | P601      | —        | RXD9/MISO9/SCL9                          | GTIOC6A/AGTEE3         | —           | —    |
| 98       | 67       | —       | CACREF/CLKOUT   | P600      | —        | SCK9                                     | GTIOC6B/AGTIO3         | —           | —    |
| 99       | —        | —       | VCC             | —         | —        | —  | —                      | —           | —    |
| 100      | —        | —       | VSS             | —         | —        | —  | —                      | —           | —    |
| 101      | 68       | —       | —               | P107      | —        | —  | AGTOA0                 | —           | —    |
| 102      | 69       | 42      | —               | P106      | —        | —  | AGTOB0                 | —           | —    |
| 103      | 70       | 43      | —               | P105      | IRQ0     | —  | GTETRG/AGTIOC1A/AGTO2  | —           | —    |
| 104      | 71       | 44      | —               | P104      | IRQ1     | QIO2                                     | GTETRGB/GTIOC1B/AGTEE2 | —           | —    |
| 105      | 72       | 45      | —               | P103      | —        | CTS0_RTS0/SS0/CTX0/QIO3                  | GTOWUP/GTIOC2A/AGTIO2  | —           | —    |
| 106      | 73       | 46      | —               | P102      | —        | SCK0/CRX0/QIO0                           | GTOWLO/GTIOC2B/AGTO0   | ADTRG0      | —    |
| 107      | 74       | 47      | —               | P101      | IRQ1     | TXD0/MOSI0/SDA0/CTS1_RTS1/SS1/QIO1       | GTETRGB/GTIOC5A/AGTEE0 | —           | —    |
| 108      | 75       | 48      | —               | P100      | IRQ2     | RXD0/MISO0/SCL0/SCK1/QSPCLK              | GTETRG/AGTIOC5B/AGTIO0 | —           | —    |
| 109      | —        | —       | —               | P800      | —        | CTS0                                     | AGTOA4                 | —           | —    |
| 110      | —        | —       | —               | P801      | —        | —  | AGTOB4                 | —           | —    |
| 111      | —        | —       | VCC             | —         | —        | —  | —                      | —           | —    |
| 112      | —        | —       | VSS             | —         | —        | —  | —                      | —           | —    |
| 113      | 76       | 49      | CACREF          | P500      | —        | USB_VBUSEN/QSPCLK                        | GTIU/AGTOA0            | AN116       | —    |
| 114      | 77       | —       | —               | P501      | IRQ11    | USB_OVRCURB/QSSL                         | GTIV/AGTOB0            | AN117       | —    |
| 115      | 78       | —       | —               | P502      | IRQ12    | USB_OVRCURB/QIO0                         | GTIV/AGTOA2            | AN118       | —    |
| 116      | 79       | —       | —               | P503      | —        | USB_EXICEN/QIO1                          | GTETRG/AGTOB2          | AN119       | —    |
| 117      | 80       | —       | —               | P504      | —        | USB_ID/QIO2                              | GTETRGD/AGTOA3         | AN120       | —    |
| 118      | 81       | —       | —               | P505      | IRQ14    | QIO3                                     | AGTOB3                 | AN121       | —    |
| 119      | —        | —       | —               | P506      | IRQ15    | —  | —                      | AN122       | —    |
| 120      | —        | —       | —               | P507      | —        | —  | —                      | —           | —    |
| 121      | 82       | 50      | VCC             | —         | —        | —  | —                      | —           | —    |
| 122      | 83       | 51      | VSS             | —         | —        | —  | —                      | —           | —    |
| 123      | 84       | 52      | —               | P015      | IRQ13    | —  | —                      | AN013/DA1   | —    |
| 124      | 85       | 53      | —               | P014      | —        | —  | —                      | AN012/DA0   | —    |
| 125      | 86       | 54      | VREFL           | —         | —        | —  | —                      | —           | —    |
| 126      | 87       | 55      | VREFH           | —         | —        | —  | —                      | —           | —    |
| 127      | 88       | 56      | AVCC0           | —         | —        | —  | —                      | —           | —    |
| 128      | 89       | 57      | AVSS0           | —         | —        | —  | —                      | —           | —    |
| 129      | 90       | 58      | VREFL0          | —         | —        | —  | —                      | —           | —    |
| 130      | 91       | 59      | VREFH0          | —         | —        | —  | —                      | —           | —    |
| 131      | —        | —       | —               | P009      | IRQ13-DS | —  | —                      | AN009       | —    |
| 132      | 92       | —       | —               | P008      | IRQ12-DS | —  | —                      | AN008       | —    |
| 133      | 93       | —       | —               | P007      | —        | —  | —                      | AN007       | —    |
| 134      | 94       | —       | —               | P006      | IRQ11-DS | —  | —                      | AN006       | —    |
| 135      | 95       | —       | —               | P005      | IRQ10-DS | —  | —                      | AN005       | —    |
| 136      | 96       | 60      | —               | P004      | IRQ9-DS  | —  | —                      | AN004       | —    |
| 137      | 97       | 61      | —               | P003      | —        | —  | —                      | AN003       | —    |
| 138      | 98       | 62      | —               | P002      | IRQ8-DS  | —  | —                      | AN002/AN102 | —    |
| 139      | 99       | 63      | —               | P001      | IRQ7-DS  | —  | —                      | AN001/AN101 | —    |
| 140      | 100      | 64      | —               | P000      | IRQ6-DS  | —  | —                      | AN000/AN100 | —    |
| 141      | —        | —       | VSS             | —         | —        | —  | —                      | —           | —    |

Table 1.16 Pin list (4 of 4)

| LPQFP144 | LPQFP100 | LPQFP64 | Power, System, Clock, Debug, CAC | I/O ports | Ex. Interrupt | SCI/IIC/SPI/CAN/USBFS/QSPI/SSIE/SDHI/MMC | GPT/AGT/RTC | ADC12/DAC12 | CTSU |
|----------|----------|---------|----------------------------------|-----------|---------------|--|-------------|-------------|------|
| 142      | —        | —       | VCC                              | —         | —             | —  | —           | —           | —    |
| 143      | —        | —       | —                                | P512      | IRQ14         | TXD4/MOSI4/SDA4/SCL1_A/CTX1              | GTIOC0A     | —           | —    |
| 144      | —        | —       | —                                | P511      | IRQ15         | RXD4/MISO4/SCL4/SDA1_A/CRX1              | GTIOC0B     | —           | —    |

Note: Several pin names have the added suffix of \_A, \_B, and \_C. The suffix can be ignored when assigning functionality.

Table 1.16 引脚列表 (4个, 共4个)

| LPQFP144 | LPQFP100 | LPQFP64 | 电源、系统、时钟、调试、CAC | I/O ports | 前任。打断 | SCI/IIC/SPI/CAN/USBFS/QSPI/SSIE/SDHI/MMC | GPT/AGT/RTC | ADC12/DAC12 | CTSU |
|----------|----------|---------|-----------------|-----------|-------|--|-------------|-------------|------|
| 142      | —        | —       | VCC             | —         | —     | —  | —           | —           | —    |
| 143      | —        | —       | —               | P512      | IRQ14 | TXD4/MOSI4/SDA4/SCL1_A/CTX1              | GTIOC0A     | —           | —    |
| 144      | —        | —       | —               | P511      | IRQ15 | RXD4/MISO4/SCL4/SDA1_A/CRX1              | GTIOC0B     | —           | —    |

Note: 几个引脚名称添加了\_A、\_B和\_C的后缀。分配功能时可以忽略后缀。

## 2. CPU

The MCU is based on the Arm® Cortex®-M33 core.

### 2.1 Overview

#### 2.1.1 CPU

- Arm Cortex-M33
  - Revision: r0p4-00rel1
  - Armv8-M architecture profile
  - Single Precision Floating-Point Unit compliant with the ANSI/IEEE Std 754-2008
- SAU (Security Attribution Unit): 0 region
- IDAU (Implementation Defined Attribution Unit): 8 regions
  - Code flash (secure/non-secure callable/non-secure)
  - Data Flash (secure/non-secure)
  - SRAM0 (secure/non-secure callable/non-secure)
- Memory Protection Unit (MPU)
  - Armv8 Protected Memory System Architecture (PMSAv8)
  - Secure MPU (MPU\_S): 8 regions
  - Non-secure MPU (MPU\_NS): 8 regions
- SysTick timer
  - Two SysTick timers: Secure and Non-secure instance
  - Driven by SysTick timer clock (SYSTICCLK) or system clock (ICLK)

See reference 1. and reference 2. in [section 2.14. References](#) for details.

#### 2.1.2 Debug

- Arm® CoreSight™ ETM-M33
  - Revision: r0p2-00rel0
  - ARM ETM Architecture version 4.2
- Instrumentation Trace Macrocell (ITM)
- Data Watchpoint and Trace Unit (DWT)
  - 4 comparators for watchpoints and triggers
- Breakpoint Unit (BPU)
  - Breakpoint function is available.
    - 8 instruction comparators
    - 0 literal comparators
- Time Stamp Generator (TSG)
  - Time stamp for ETM and ITM
  - Driven by CPU clock
- Debug Register Module (DBGREG)
  - Reset control
  - Halt control
- Debug Access Port (DAP)

## 2. CPU

MCU基于Arm®Cortex®-M33内核。

### 2.1 Overview

#### 2.1.1 CPU

- Arm Cortex-M33
  - Revision: r0p4-00rel1
  - Armv8-M架构配置文件
  - 符合ANSIIEEEStd754-2008的单精度浮点单元
- SAU（安全归属单元）：0地区
- IDAU（实施定义的归因单元）：8个地区
  - 代码闪存（安全非安全可调用非安全）
  - 数据闪存（安全非安全）
  - SRAM0 (secure/non-secure callable/non-secure)
- 内存保护单元（MPU）
  - Armv8保护内存系统架构(PMSAv8)
  - 安全MPU(MPU\_S)：8个区域
  - Non-secure MPU (MPU\_NS): 8 regions
- SysTick timer
  - 两个Systick计时器：安全和非安全实例
  - 由SysTick定时器时钟(SYSTICCLK)或系统时钟(ICLK)驱动

请参阅第2.14节中的参考1和参考2。详情参考。

#### 2.1.2 Debug

- Arm® CoreSight™ ETM-M33
  - Revision: r0p2-00rel0
  - ARMETM架构版本4.2
- 仪器跟踪宏单元(ITM)
- 数据观察点和跟踪单元(DWT)
  - 4个用于观察点和触发器的比较器
- Breakpoint Unit (BPU)
  - 断点功能可用。
    - 8 instruction comparators
    - 0 literal comparators
- 时间戳生成器(TSG)
  - ETM和ITM的时间戳
  - 由CPU时钟驱动
- 调试寄存器模块（DBGREG）
  - 重置控制
  - 停止控制
- 调试访问端口(DAP)

- JTAG Debug Port (JTAG-DP)
- Serial Wire Debug Port (SW-DP)
- Cortex-M33 Trace Port Interface Unit (TPIU)
  - 4 bits TPIU formatter output
  - Serial Wire Output
- Cross Trigger Interface (CTI)
- Embedded Trace Buffer (ETB)
  - CoreSight Trace Memory Controller with ETB configuration
  - Buffer size: 2 KB

See reference 1. and reference 2. in [section 2.14. References](#) for details.

### 2.1.3 Operating Frequency

The operating frequencies for the MCU are as follows:

- CPU: maximum 100 MHz
- 4-bit TPIU trace interface: maximum 50 MHz
- Serial Write Output (SWO) trace interface: maximum 50 MHz
- Joint Test Action Group (JTAG) interface: maximum 25 MHz
- Serial Wire Data (SWD) interface: maximum 25 MHz

### 2.1.4 Block Diagram

[Figure 2.1](#) shows a block diagram of the Cortex-M33 core.

- JTAG调试端口(JTAG-DP)
- 串行线调试端口(SW-DP)
- Cortex-M33跟踪端口接口单元(TPIU)
  - 4位TPIU格式化输出
  - 串行线输出
- 交叉触发接口(CTI)
- 嵌入式跟踪缓冲区(ETB)
  - 具有ETB配置的CoreSight跟踪内存控制器
  - Buffer size: 2 KB

请参阅第2.14节中的参考1和参考2。详情参考。

### 2.1.3 工作频率

MCU的工作频率如下：

- CPU: maximum 100 MHz
- 4位TPIU跟踪接口：最大50MHz
- 串行写输出(SWO)跟踪接口：最大50MHz
- 联合测试行动组(JTAG)接口：最大25MHz
- 串行线数据(SWD)接口：最大25MHz

### 2.1.4 框图

图2.1显示了Cortex-M33内核的框图。

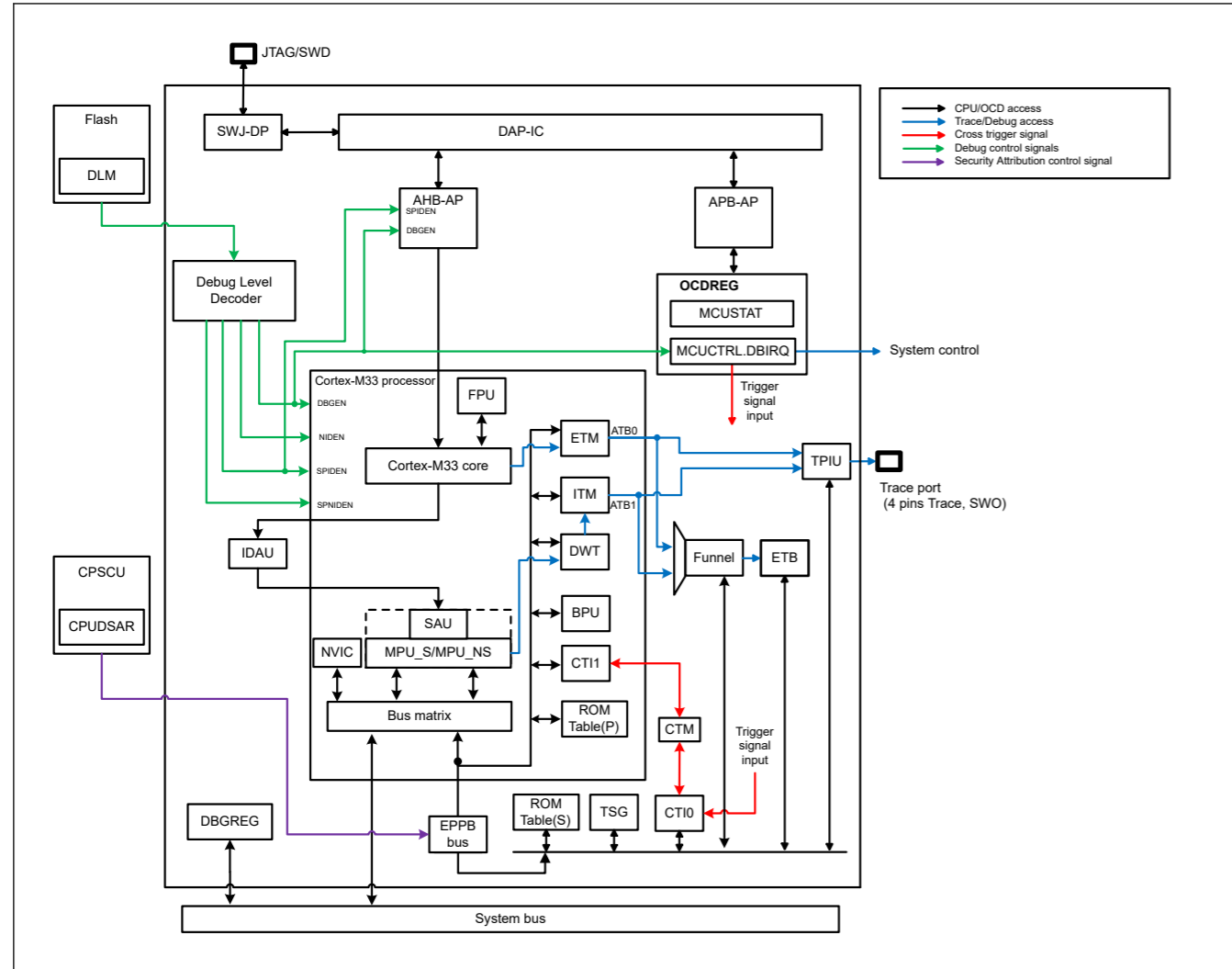


Figure 2.1 Cortex-M33 block diagram

2.2 Implementation Options

Table 2.1 shows the implementation options of the MCU.

Table 2.1 Implementation options (1 of 2)

| Option                                       | Implementation  |
|--|---|
| SAU  | Not included  |
| IDAU   | Included, 8 regions   |
| MPU  | Included, 8 regions for Secure and 8 regions for Non-secure   |
| BPU  | Included  |
| Cross Trigger Interface (CTI)                | Included  |
| DWT  | Included  |
| Number of Wakeup Interrupt Controllers (WIC) | Not included<br>ICU can wake up CPU instead of WIC. See section 13, Interrupt Controller Unit (ICU) for details.    |
| TPIU   | Included <ul style="list-style-type: none"> <li>4 bits TPIU formatter output</li> <li>Serial Wire Output</li> </ul> |
| FPU  | Included  |
| DSP  | Included  |

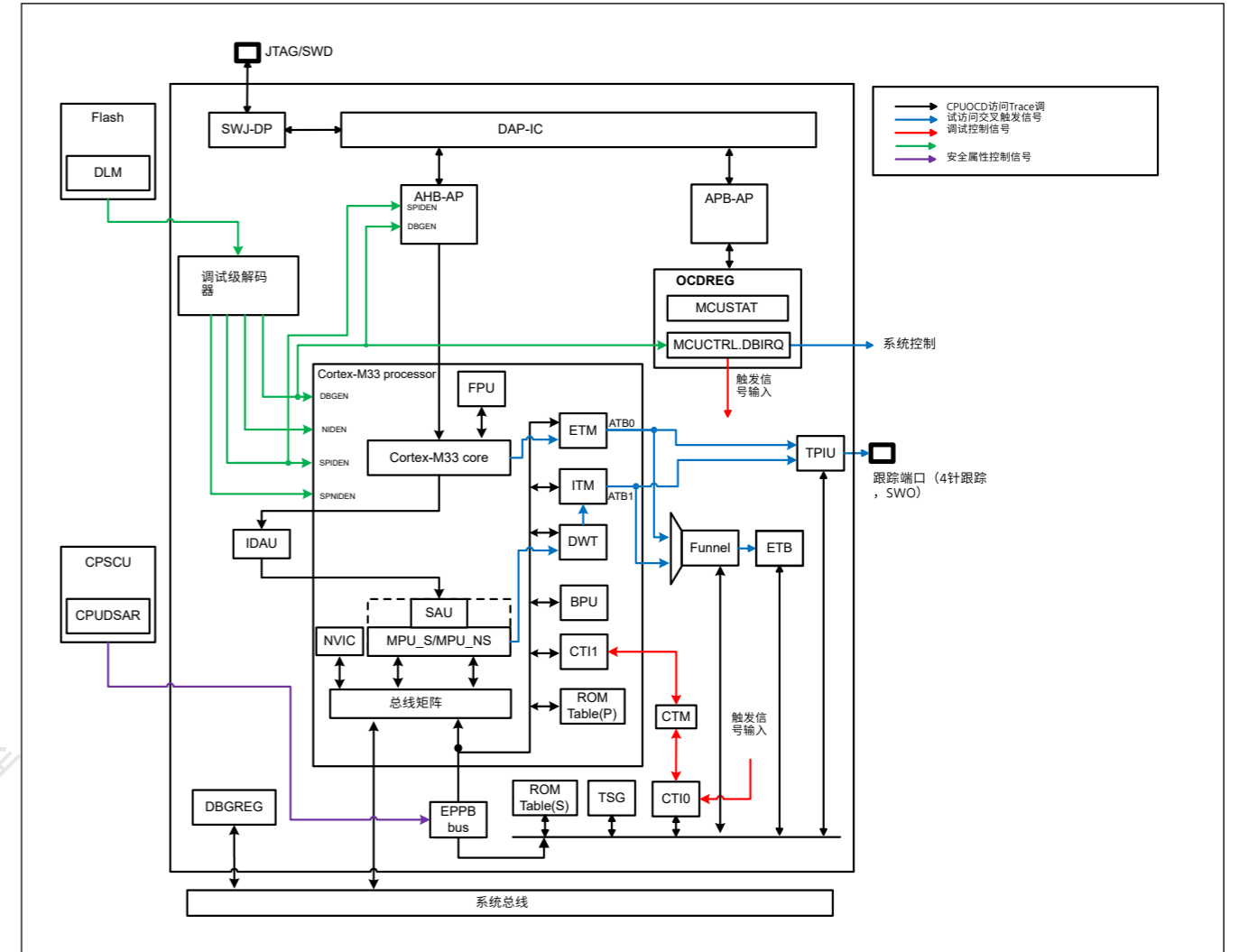


Figure 2.1 Cortex-M33框图

2.2 实施选项

表2.1显示了MCU的实现选项。

Table 2.1 实施选项 (2个中的1个)

| Option          | Implementation  |
|-----------------|---|
| SAU             | 不包含   |
| IDAU            | 包括, 8个地区  |
| MPU             | 包括, 8个安全区域和8个非安全区域  |
| BPU             | Included  |
| 交叉触发接口(CTI)     | Included  |
| DWT             | Included  |
| 唤醒中断控制器(WIC)的数量 | 不包含<br>ICU可以唤醒CPU而不是WIC。有关详细信息, 请参见第13节, 中断控制器单元(ICU)。                                |
| TPIU            | Included <ul style="list-style-type: none"> <li>4位TPIU格式化输出</li> <li>串行线输出</li> </ul> |
| FPU             | Included  |
| DSP             | Included  |

Table 2.1 Implementation options (2 of 2)

| Option                            | Implementation   |
|-----------------------------------|--|
| Embedded Trace Macrocell (ETM)    | Included   |
| Sleep mode power saving           | Sleep mode and other low power modes are supported. For more details, see <a href="#">section 10, Low Power Modes</a> .<br>Note: SCB.SCR.SLEEPDEEP is ignored.   |
| Interrupts                        | 98   |
| Priority bits                     | 4 bits (16 levels)   |
| Endianness                        | Little-endian  |
| Memory features                   | Cacheable attribute is utilized in the MCU. See <a href="#">section 14, Buses</a> for the detail.  |
| SysTick                           | Included   |
| SYST_CALIB register (0x4000_0147) | Bit [31] = 0 Reference clock provided<br>Bit [30] = 1 TERMS value is inexact<br>Bits [29:24] = 0x00 Reserved<br>Bits [23:0] = 0x000147 TERM: (32768 × 10 ms) - 1/32.768 kHz<br>= 326.66 decimal<br>= 327 with skew<br>= 0x000147 |
| Event input/output                | Not implemented  |
| Global exclusive monitor          | Not implemented  |
| System reset request output       | The SYSRESETREQ bit in Application Interrupt and Reset Control Register causes a CPU reset   |

## 2.3 Trace Interface

A Trace Port Interface Unit (TPIU) and Serial Wire Output (SWO) provide trace output. [Table 2.2](#) shows the MCU pins for the function. These pins are multiplexed with other functions.

Table 2.2 Trace function pins

| Name    | I/O    | Function   | When not in use |
|---------|--------|--|-----------------|
| TCLK    | Output | Trace clock                                      | Open            |
| TDATA0  | Output | Trace data output 0                              | Open            |
| TDATA1  | Output | Trace data output 1                              | Open            |
| TDATA2  | Output | Trace data output 2                              | Open            |
| TDATA3  | Output | Trace data output 3                              | Open            |
| TDO/SWO | Output | Serial wire output multiplexed with JTAG TDO pin | Open            |

## 2.4 JTAG/SWD Interface

[Table 2.3](#) shows the JTAG/SWD pins.

Table 2.3 JTAG/SWD pins

| Name      | I/O    | Function   | When not in use |
|-----------|--------|--|-----------------|
| TDI       | Input  | JTAG TDI pin                                     | Pull-up         |
| TDO/SWO   | Output | JTAG TDO pin multiplexed with serial wire output | Open            |
| TCK/SWCLK | Input  | JTAG clock pin<br>Serial wire clock pin          | Pull-up         |
| TMS/SWDIO | I/O    | JTAG TMS pin<br>Serial wire data I/O pin         | Pull-up         |

Table 2.1 实施选项 (2个中的2个)

| Option                            | Implementation   |
|-----------------------------------|--|
| 嵌入式跟踪宏单元(ETM)                     | Included   |
| 睡眠模式省电                            | 支持睡眠模式和其他低功耗模式。有关详细信息，请参阅第10节，低电源模式。<br>Note: SCB.SCR.SLEEPDEEP被忽略。  |
| Interrupts                        | 98   |
| 优先位                               | 4 bits (16 levels)   |
| Endianness                        | Little-endian  |
| 记忆功能                              | 可缓存属性在MCU中使用。有关详细信息，请参阅第14节，总线。  |
| SysTick                           | Included   |
| SYST_CALIB register (0x4000_0147) | Bit [31] = 0 提供参考时钟<br>Bit [30] = 1 TERMS值不准确<br>Bits [29:24] = 0x00 Reserved<br>Bits [23:0] = 0x000147 TERM:(32768×10ms)132.768kHz=326.66十进制=327withskew=0x000147 |
| Event input/output                | 未实现  |
| 全球独家监控                            | 未实现  |
| 系统复位请求输出                          | 应用程序中断和复位控制寄存器中的SYSRESETREQ位导致CPU复位  |

## 2.3 跟踪接口

跟踪端口接口单元(TPIU)和串行线输出(SWO)提供跟踪输出。表2.2显示了该功能的MCU引脚。这些引脚与其他功能复用。

Table 2.2 跟踪功能引脚

| Name    | I/O    | Function          | 不使用时 |
|---------|--------|-------------------|------|
| TCLK    | Output | 跟踪时钟              | Open |
| TDATA0  | Output | 跟踪数据输出0           | Open |
| TDATA1  | Output | 跟踪数据输出1           | Open |
| TDATA2  | Output | 跟踪数据输出2           | Open |
| TDATA3  | Output | 跟踪数据输出3           | Open |
| TDO/SWO | Output | 串行线输出与JTAGTDO引脚复用 | Open |

## 2.4 JTAG/SWD Interface

表2.3显示了JTAG/SWD引脚。

Table 2.3 JTAG/SWD pins

| Name      | I/O    | Function                   | 不使用时    |
|-----------|--------|----------------------------|---------|
| TDI       | Input  | JTAG TDI pin               | Pull-up |
| TDO/SWO   | Output | JTAGTDO引脚与串行线输出复用          | Open    |
| TCK/SWCLK | Input  | JTAG时钟引脚<br>串行线时钟引脚        | Pull-up |
| TMS/SWDIO | I/O    | JTAG TMS pin<br>串行线数据I/O引脚 | Pull-up |



## 2.5 Security Attribution for Memory

In this MCU, SAU is not implemented and IDAU performs region definition for memory. IDAU divides the memory into 8 different areas as shown in Figure 2.2.

The code flash, the data flash, and the SRAM are divided into Secure (S), Non-secure (NS) and Non-secure callable (NSC) regions. These memory security attributions are set into the nonvolatile memory by the serial programming command when the device lifecycle is in SSD state. These memory security attributions are loaded into the IDAU and the memory controller before application execution. These memory security attributions cannot be updated by application but can read through the dedicated registers.

Note: When configuring, the memory regions should satisfy the setting condition of minimum address unit shown in Table 2.4.

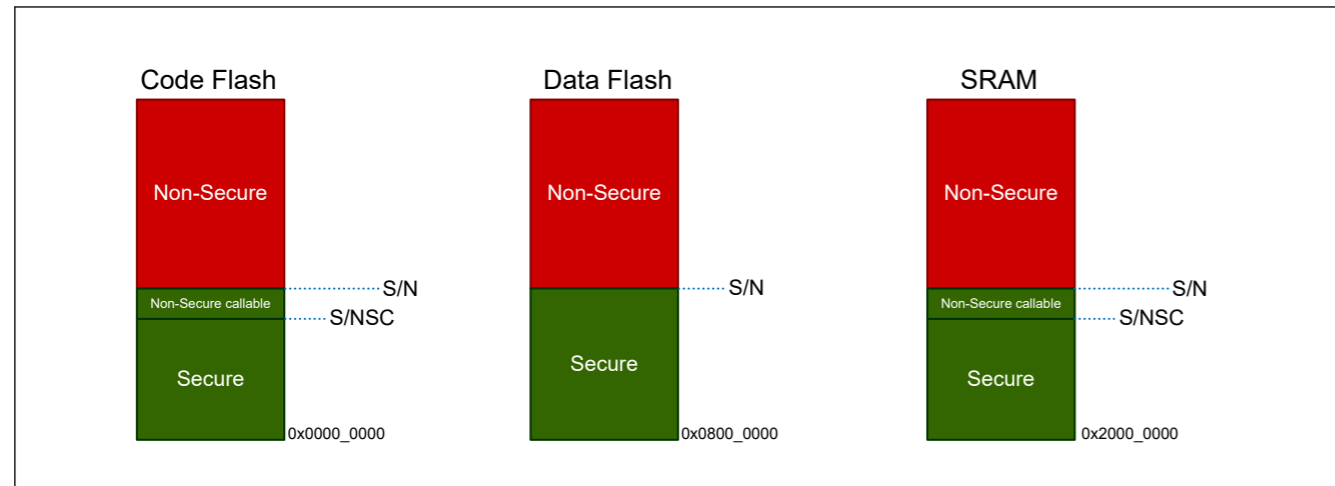


Figure 2.2 Memory partitioning

Table 2.4 S/NS and S/NSC boundary list

| Boundary | Code flash | Data flash | SRAM |
|----------|------------|------------|------|
| S/NS     | 32 KB      | 1 KB       | 8 KB |
| S/NSC    | 1 KB       | —          | 1 KB |

Each region has its dedicated ID as follows. For more details, see section 46.2.2. Memory Security Attribution.

| Region ID | Description                    |
|-----------|--------------------------------|
| 0x0D      | Non-secure SRAM                |
| 0x0E      | Non-secure callable SRAM       |
| 0x0F      | Secure SRAM                    |
| 0x09      | Non-secure data flash          |
| 0x0B      | Secure data flash              |
| 0x05      | Non-secure code flash          |
| 0x06      | Non-secure callable code flash |
| 0x07      | Secure code flash              |

## 2.6 Debug Function

### 2.6.1 Debugger connectivity

In this MCU, debug function is considered in three levels, DBG0, DBG1, DBG2. At DBG0, no debug function is available. DBG1 level is defined as non-secure debug in ARMv-8 and the debugger can only access defined non-secure debug accessible regions. DBG2 level is defined as secure debug in ARMv-8 and at this level, nonsecure and secure debug function is enabled and can be accessible from the debugger.

## 2.5 内存安全归属

在这个MCU中，没有实现SAU，而IDAU为内存执行区域定义。IDAU将内存划分为8个不同的区域，如图2.2所示。

代码闪存、数据闪存和SRAM分为安全(S)、非安全(NS)和非安全可调用(NSC)区域。当设备生命周期处于SSD状态时，这些内存安全属性由串行编程命令设置到非易失性内存中。这些内存安全属性在应用程序执行之前被加载到IDAU和内存控制器中。这些内存安全属性不能由应用程序更新，但可以通过专用寄存器读取。

Note: 配置时，内存区域应满足表2.4所示的最小地址单元设置条件。

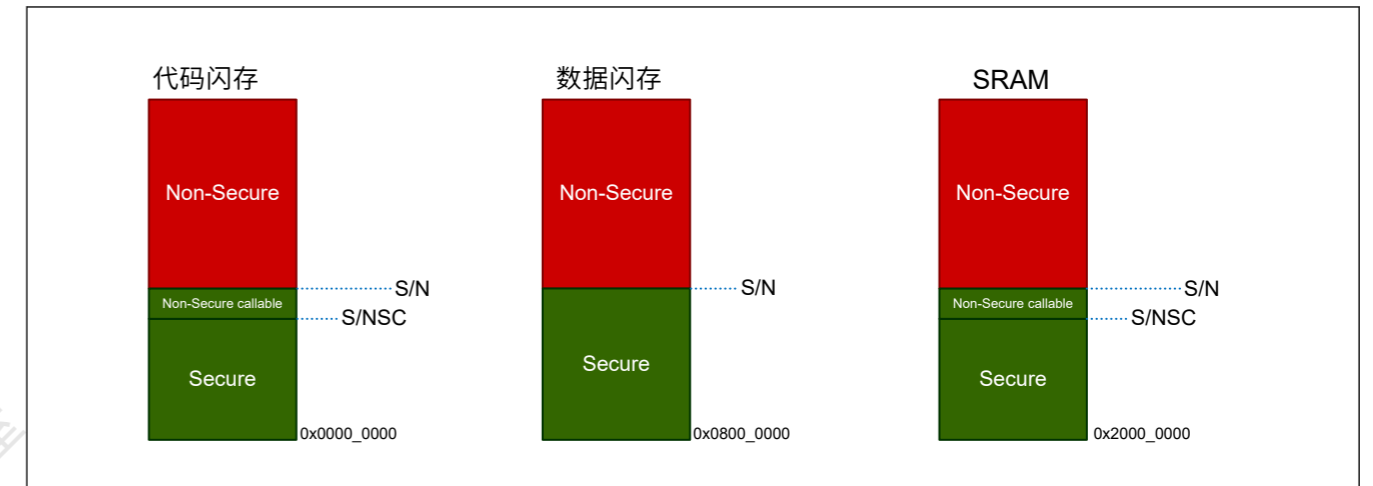


Figure 2.2 内存分区

Table 2.4 SNS和SNSC边界列表

| Boundary | 代码闪存  | 数据闪存 | SRAM |
|----------|-------|------|------|
| S/NS     | 32 KB | 1 KB | 8 KB |
| S/NSC    | 1 KB  | —    | 1 KB |

每个区域都有其专用ID，如下所示。有关详细信息，请参阅第46.2.2节。内存安全归属。

| 区域编号 | Description              |
|------|--------------------------|
| 0x0D | Non-secure SRAM          |
| 0x0E | Non-secure callable SRAM |
| 0x0F | Secure SRAM              |
| 0x09 | 非安全数据闪存                  |
| 0x0B | 安全数据闪存                   |
| 0x05 | 非安全代码闪存                  |
| 0x06 | 非安全可调用代码闪存               |
| 0x07 | 安全代码闪存                   |

## 2.6 调试功能

### 2.6.1 调试器连接

在本单片机中，调试功能分为三个层次，DBG0、DBG1、DBG2。在DBG0，没有调试功能可用。DBG1级别在ARMv-8中定义为非安全调试，调试器只能访问已定义的非安全调试可访问区域。DBG2级别在ARMv-8中定义为安全调试，在此级别，启用了非安全和安全调试功能，并且可以从调试器访问。



Debug level is determined by the Device Lifecycle Management (DLM) state of the product.

See Figure 2.1 for debugger accessible regions.

Table 2.5 shows the CPU debug function and conditions.

Table 2.5 CPU debug function and conditions

| Condition     |           |             | Permitted debug function                    |
|---------------|-----------|-------------|---|
| OCD connect*1 | DLM State | Debug level | Description                                 |
| Connected     | CM        | DBG2        | All debug functions are available           |
| Connected     | SSD       | DBG2        | All debug functions are available           |
| Connected     | NSECSD    | DBG1        | Only Non-secure debug function is available |
| Connected     | DPL       | DBG0        | Debugger connection is not available        |
| Connected     | LCK_DBG   | DBG0        | Debugger connection is not available        |
| Connected     | LCK_BOOT  | DBG0        | Debugger connection is not available        |
| Connected     | RMA_REQ   | DBG0        | Debugger connection is not available        |
| Connected     | RMA_ACK   | DBG2        | All debug functions are available           |

Note 1. OCD connect is determined by the CDBGPWUPREQ bit output in the SWJ-DP register. The bit can only be written by the OCD. However, the level of the bit can be confirmed by reading the DBGSTR.CDBGPWUPREQ bit.

## 2.6.2 Emulator Connection

Renesas provides the emulator which supports both debugging using SWD or JTAG communication and serial programming using SCI communication. This emulator makes it easy to switch between debug-ging and serial programming.

Table 2.6 shows the pinout of 10 pin or 20 pin socket pinouts when using this emulator. The pinout of SWD and JTAG is ARM standard, and MD, TXD, RXD pins are added for the serial programming using SCI communication.

The serial programming interface must be used to program the TrustZone IDAU boundary register settings.

It is recommended to connect P300/SWCLK/TCK and P201/MD pins using wired OR circuit on the board to use both debugging and serial programming.

Table 2.6 Pin assign for emulator

| Pin No.          | SWD                                 | JTAG                              | Serial Programming using SCI |
|------------------|-------------------------------------|-----------------------------------|------------------------------|
| 1                | VCC                                 | VCC                               | VCC                          |
| 2                | P108/SWDIO                          | P108/TMS                          | NC                           |
| 4                | P300/SWCLK<br>Wired OR with P201/MD | P300/TCK<br>Wired OR with P201/MD | P201/MD                      |
| 6                | P109/SWO/TXD9                       | P109/SWO/TXD9                     | P109/TXD9                    |
| 8                | P110/RXD9                           | P110/TDI/RXD9                     | P110/RXD9                    |
| 9                | GNDdetect                           | GNDdetect                         | GNDdetect                    |
| 10               | nRESET                              | nRESET                            | nRESET                       |
| 12               | P214/TCLK                           | P214/TCLK                         | NC                           |
| 14               | P211/TDATA[0]                       | P211/TDATA[0]                     | NC                           |
| 16               | P210/TDATA[1]                       | P210/TDATA[1]                     | NC                           |
| 18               | P209/TDATA[2]                       | P209/TDATA[2]                     | NC                           |
| 20               | P208/TDATA[3]                       | P208/TDATA[3]                     | NC                           |
| 3, 5, 15, 17, 19 | GND                                 | GND                               | GND                          |
| 7                | NC                                  | NC                                | NC                           |
| 11, 13           | NC                                  | NC                                | NC                           |

调试级别由产品的设备生命周期管理(DLM)状态确定。

有关调试器可访问区域，请参见图2.1。

表2.5显示了CPU调试功能和条件。

Table 2.5 CPU调试功能及条件

| Condition |           |      | 允许的调试功能     |
|-----------|-----------|------|-------------|
| 强迫症连接*1   | DLM State | 调试级别 | Description |
| Connected | CM        | DBG2 | 所有调试功能均可用   |
| Connected | SSD       | DBG2 | 所有调试功能均可用   |
| Connected | NSECSD    | DBG1 | 只有非安全调试功能可用 |
| Connected | DPL       | DBG0 | 调试器连接不可用    |
| Connected | LCK_DBG   | DBG0 | 调试器连接不可用    |
| Connected | LCK_BOOT  | DBG0 | 调试器连接不可用    |
| Connected | RMA_REQ   | DBG0 | 调试器连接不可用    |
| Connected | RMA_ACK   | DBG2 | 所有调试功能均可用   |

注1.OCD连接由SWJ-DP寄存器中的CDBGPWUPREQ位输出决定。该位只能由OCD写入。但是，可以通过读取DBGSTR.CDBGPWUPREQ位来确认该位的电平。

## 2.6.2 仿真器连接

瑞萨电子提供的仿真器支持使用SWD或JTAG通信进行调试和使用SCI通信进行串行编程。该仿真器可以轻松地在调试和串行编程之间切换。

表2.6显示了使用该仿真器时10针或20针插座的引脚排列。SWD和JTAG的管脚是ARM标准，并增加了MD、TXD、RXD引脚用于使用SCI通信的串行编程。

必须使用串行编程接口对TrustZoneIDAU边界寄存器设置进行编程。

建议使用板上的有线或电路连接P300SWCLKTCK和P201MD引脚，以同时使用调试和串行编程。

Table 2.6 为模拟器分配引脚

| 针号               | SWD                      | JTAG                   | 使用SCI进行串行编程 |
|------------------|--------------------------|------------------------|-------------|
| 1                | VCC                      | VCC                    | VCC         |
| 2                | P108/SWDIO               | P108/TMS               | NC          |
| 4                | P300/SWCLK<br>有线或带P201MD | P300/TCK<br>有线或带P201MD | P201/MD     |
| 6                | P109/SWO/TXD9            | P109/SWO/TXD9          | P109/TXD9   |
| 8                | P110/RXD9                | P110/TDI/RXD9          | P110/RXD9   |
| 9                | GNDdetect                | GNDdetect              | GNDdetect   |
| 10               | nRESET                   | nRESET                 | nRESET      |
| 12               | P214/TCLK                | P214/TCLK              | NC          |
| 14               | P211/TDATA[0]            | P211/TDATA[0]          | NC          |
| 16               | P210/TDATA[1]            | P210/TDATA[1]          | NC          |
| 18               | P209/TDATA[2]            | P209/TDATA[2]          | NC          |
| 20               | P208/TDATA[3]            | P208/TDATA[3]          | NC          |
| 3, 5, 15, 17, 19 | GND                      | GND                    | GND         |
| 7                | NC                       | NC                     | NC          |
| 11, 13           | NC                       | NC                     | NC          |

### 2.6.3 Self-Hosted Debug Function

As described in [section 2.7.6. CPUDSAR : CPU Debug Security Attribution Register](#), at the initial setting access from the CPU in non-secure state to CoreSight debug components is protected, that is, the non-secure access to Coresight debug components from the self-hosted debugger is not allowed when the debug level is DBG2 at the initial setting. Therefore, you must set CPUDSAR.CPUDSA0 to 1 to enable the full self-hosted debug function.

Note: There is no restriction for the self-hosted debug function while the CPU is in the secure state.

### 2.6.4 Effect of Debug Function

The debug function effects inside and outside of CPU.

#### 2.6.4.1 Low power mode

All CoreSight debug components can store the register settings even when the CPU enters Software Standby, Snooze or Deep Software Standby mode. However, AHB-AP cannot respond to On-Chip Debug (OCD) access in these low power modes. The OCD must wait for cancellation of the low power mode to access the CoreSight debug components. To request low power mode cancellation, the OCD can set the DBIRQ bit in the MCUCTRL register. For details, see [section 2.7.5.2. MCUCTRL : MCU Control Register](#).

#### 2.6.4.2 Reset

In OCD mode, some resets depend on the CPU status and the DBGSTOPPCR register setting.

**Table 2.7 Reset or interrupt and mode setting**

| Reset or interrupt name                    | Control in On-Chip Debug (OCD) mode |                               |
|--|-------------------------------------|-------------------------------|
|  | OCD break mode                      | OCD run mode                  |
| RES pin reset                              | Same as user mode                   |                               |
| Power-on reset                             | Same as user mode                   |                               |
| Independent watchdog timer reset/interrupt | Does not occur*1                    | Depends on DBGSTOPPCR setting |
| Watchdog timer reset/interrupt             | Does not occur*1                    | Depends on DBGSTOPPCR setting |
| Voltage monitor 0 reset                    | Depends on DBGSTOPPCR setting       |                               |
| Voltage monitor 1 reset/interrupt          | Depends on DBGSTOPPCR setting       |                               |
| Voltage monitor 2 reset/interrupt          | Depends on DBGSTOPPCR setting       |                               |
| SRAM parity error reset/interrupt          | Depends on DBGSTOPPCR setting       |                               |
| SRAM ECC error reset/interrupt             | Depends on DBGSTOPPCR setting       |                               |
| Cache parity error reset/interrupt         | Depends on DBGSTOPPCR setting       |                               |
| Bus master MPU error reset/interrupt       | Same as user mode                   |                               |
| Deep software standby reset                | Same as user mode                   |                               |
| Software reset                             | Same as user mode                   |                               |

Note: In OCD break mode, the CPU is halted. In OCD run mode, the CPU is in OCD mode and the CPU is not halted.

Note 1. The IWDT and WDT always stop in this mode.

## 2.7 Programmers Model

### 2.7.1 Address Spaces

The MCU debug system includes two CoreSight Access Ports (AP):

- AHB-AP, which is connected to the CPU bus matrix and has the same access to the system address space as the CPU
- APB-AP, which has a dedicated address space (OCD address space) and is connected to the OCDREG registers.

[Figure 2.3](#) shows a block diagram of the AP connection and address spaces.

### 2.6.3 自托管调试功能

如第2.7.6节所述。CPUDSAR: CPUDebugSecurityAttributionRegister, 在初始设置时从对CoreSight调试组件处于非安全状态的CPU受到保护, 即当初始设置的调试级别为DBG2时, 不允许自托管调试器对Coresight调试组件的非安全访问。因此, 您必须将CPUDSAR.CPUDSA0设置为1以启用完全自托管调试功能。

Note: 当CPU处于安全状态时, 自托管调试功能没有限制。

### 2.6.4 调试功能的效果

调试功能影响CPU内部和外部。

#### 2.6.4.1 低功耗模式

即使CPU进入软件待机、贪睡或深度软件待机模式, 所有CoreSight调试组件都可以存储寄存器设置。但是, AHB-AP在这些低功耗模式下无法响应片上调试(OCD)访问。OCD必须等待取消低功耗模式才能访问CoreSight调试组件。要请求取消低功耗模式, OCD可以设置MCUCTRL寄存器中的DBIRQ位。详见2.7.5.2节。MCUCTRL: MCU控制寄存器。

#### 2.6.4.2 Reset

在OCD模式下, 一些复位取决于CPU状态和DBGSTOPPCR寄存器设置。

**Table 2.7 复位或中断和模式设置**

| 重置或中断名称                        | 片上调试(OCD)模式下的控制 |                 |
|--------------------------------|-----------------|-----------------|
|                                | 强迫症休息模式         | 强迫症运行模式         |
| RES引脚复位                        | 与用户模式相同         |                 |
| Power-on reset                 | 与用户模式相同         |                 |
| 独立看门狗定时器复位中断                   | 不发生*1           | 取决于DBGSTOPPCR设置 |
| 看门狗定时器复位中断                     | 不发生*1           | 取决于DBGSTOPPCR设置 |
| 电压监控器0复位                       | 取决于DBGSTOPPCR设置 |                 |
| 电压监视器1复位中断                     | 取决于DBGSTOPPCR设置 |                 |
| 电压监视器2复位中断                     | 取决于DBGSTOPPCR设置 |                 |
| SRAM奇偶校验错误复位中断                 | 取决于DBGSTOPPCR设置 |                 |
| SRAM ECC error reset/interrupt | 取决于DBGSTOPPCR设置 |                 |
| 缓存奇偶校验错误复位中断                   | 取决于DBGSTOPPCR设置 |                 |
| 总线主控MPU错误复位中断                  | 与用户模式相同         |                 |
| 深度软件待机复位                       | 与用户模式相同         |                 |
| 软件复位                           | 与用户模式相同         |                 |

Note: 在OCD中断模式下, CPU停止。在OCD运行模式下, CPU处于OCD模式并且CPU不会停止。

注1.IWDT和WDT在此模式下始终停止。

## 2.7 程序员模型

### 2.7.1 地址空间

MCU调试系统包括两个CoreSight访问端口(AP):

- AHB-AP, 与CPU总线矩阵相连, 与CPU具有相同的系统地址空间访问权限
- APB-AP, 具有专用的地址空间 (OCD地址空间) 并连接到OCDREG寄存器。

图2.3显示了AP连接和地址空间的框图。

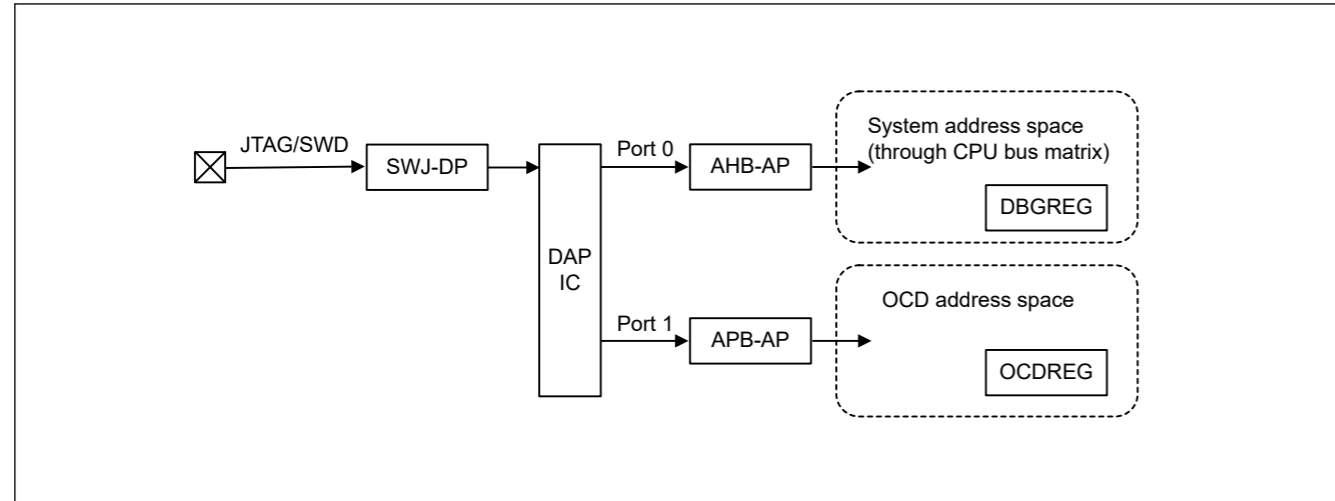


Figure 2.3 JTAG/SWD authentication block diagram

For debugging purposes, there are two register modules, DBGREG and OCDREG. DBGREG is located in the system address space and can be accessed from the OCD emulator, the CPU, and other bus masters in the MCU. OCDREG is located in the OCD address space and can only be accessed from the OCD tool. The CPU and other bus masters cannot access OCDREG.

### 2.7.2 Peripheral Address Map

In system address space, the Cortex-M33 core has a Private Peripheral Bus (PPB) which can be accessed only from CPU and OCD emulator. The PPB is expanded from the original implementation of the Cortex-M33 core for this MCU. Table 2.8 shows the address map of the MCU.

Table 2.8 Peripheral address map

| Component name       | Start address | End address | Note  |
|----------------------|---------------|-------------|---|
| ITM                  | 0xE000_0000   | 0xE000_0FFF | See reference 2. in <a href="#">section 2.14. References</a>  |
| DWT                  | 0xE000_1000   | 0xE000_1FFF | See reference 2. in <a href="#">section 2.14. References</a>  |
| BPU                  | 0xE000_2000   | 0xE000_2FFF | See reference 2. in <a href="#">section 2.14. References</a>  |
| Secure SCS/SCS       | 0xE000_E000   | 0xE000_EFFF | See reference 1. in <a href="#">section 2.14. References</a>  |
| Non-Secure SCS       | 0xE002_E000   | 0xE002_EFFF | See reference 2. in <a href="#">section 2.14. References</a>  |
| TPIU                 | 0xE004_0000   | 0xE004_0FFF | See reference 3. in <a href="#">section 2.14. References</a>  |
| ETM                  | 0xE004_1000   | 0xE004_1FFF | See reference 1. in <a href="#">section 2.14. References</a>  |
| CTI1                 | 0xE004_2000   | 0xE004_2FFF | See reference 2. in <a href="#">section 2.14. References</a>  |
| CTI0                 | 0xE004_4000   | 0xE004_4FFF | See reference 4. in <a href="#">section 2.14. References</a>  |
| ATB Funnel           | 0xE004_7000   | 0xE004_7FFF | See <a href="#">section 2.9. CoreSight ATB Funnel</a> and reference 4. in <a href="#">section 2.14. References</a>            |
| ETB                  | 0xE004_8000   | 0xE004_8FFF | See reference 4. in <a href="#">section 2.14. References</a>  |
| Time Stamp Generator | 0xE004_9000   | 0xE004_9FFF | See <a href="#">section 2.11. CoreSight Time Stamp Generator</a> and reference 4. in <a href="#">section 2.14. References</a> |
| System ROM Table     | 0xE00F_E000   | 0xE00F_EFFF | See reference 3. in <a href="#">section 2.14. References</a>  |
| Processor ROM Table  | 0xE00F_F000   | 0xE00F_FFFF | See reference 2. in <a href="#">section 2.14. References</a>  |

### 2.7.3 CoreSight ROM Table

The MCU contains two CoreSight ROM Tables, the processor and system ROM Tables. The Processor ROM Table contains entries which hold a list of debug components inside the processor. The System ROM Table contains entries of Processor ROM Table and others debug components outside the processor.

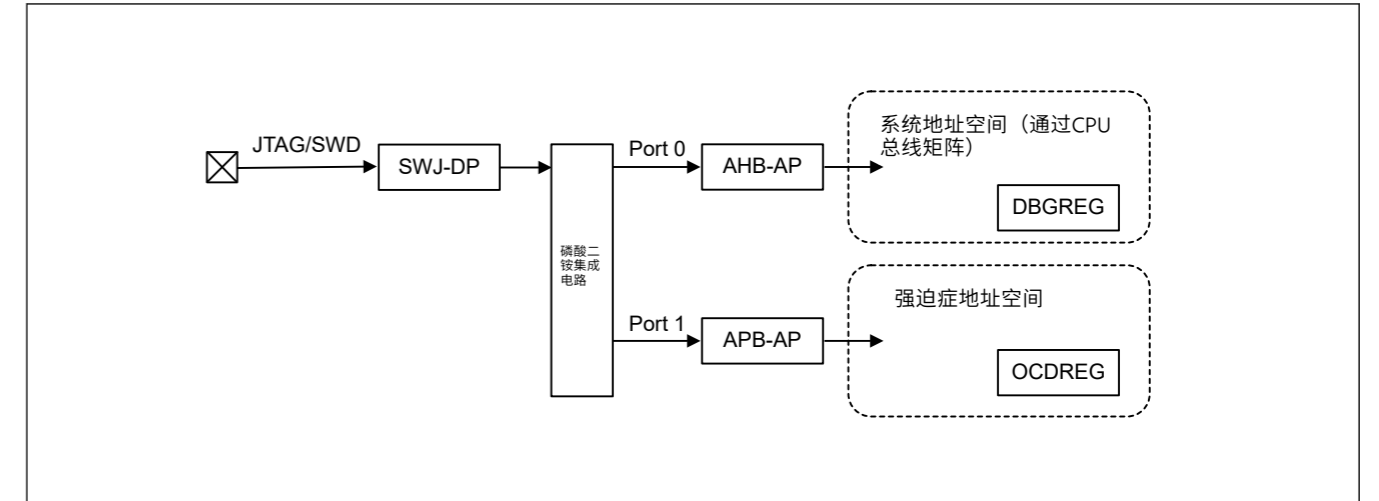


Figure 2.3 JTAG/SWD认证框图

出于调试目的，有两个寄存器模块，DBGREG和OCDREG。DBGREG位于系统地址空间中，可以从OCD仿真器、CPU和MCU中的其他总线主控器访问。OCDREG位于OCD地址空间，只能从OCD工具访问。CPU和其他总线主机无法访问OCDREG。

### 2.7.2 外设地址映射

在系统地址空间中，Cortex-M33内核有一个专用外设总线(PPB)，只能从CPU和OCD仿真器访问。PPB是从该MCU的Cortex-M33内核的原始实现扩展而来的。表2.8显示了MCU的地址映射。

Table 2.8 外设地址图

| 组件名称           | 起始地址        | 结束地址        | Note   |
|----------------|-------------|-------------|--|
| ITM            | 0xE000_0000 | 0xE000_0FFF | 请参阅第2.14节中的参考2。参考                                |
| DWT            | 0xE000_1000 | 0xE000_1FFF | 请参阅第2.14节中的参考2。参考                                |
| BPU            | 0xE000_2000 | 0xE000_2FFF | 请参阅第2.14节中的参考2。参考                                |
| Secure SCS/SCS | 0xE000_E000 | 0xE000_EFFF | 请参阅第2.14节中的参考1。参考                                |
| Non-Secure SCS | 0xE002_E000 | 0xE002_EFFF | 请参阅第2.14节中的参考2。参考                                |
| TPIU           | 0xE004_0000 | 0xE004_0FFF | 请参见第2.14节中的参考3。参考                                |
| ETM            | 0xE004_1000 | 0xE004_1FFF | 请参阅第2.14节中的参考1。参考                                |
| CTI1           | 0xE004_2000 | 0xE004_2FFF | 请参阅第2.14节中的参考2。参考                                |
| CTI0           | 0xE004_4000 | 0xE004_4FFF | 参见第2.14节中的参考4。参考                                 |
| ATB Funnel     | 0xE004_7000 | 0xE004_7FFF | 请参阅第2.9节。CoreSight ATB漏斗和参考4.在第2.14节中。References |
| ETB            | 0xE004_8000 | 0xE004_8FFF | 参见第2.14节中的参考4。参考                                 |
| 时间戳生成器         | 0xE004_9000 | 0xE004_9FFF | 请参阅第2.11节。CoreSight时间戳生成器和第2.14节中的参考4。参考         |
| 系统ROM表         | 0xE00F_E000 | 0xE00F_EFFF | 请参见第2.14节中的参考3。参考                                |
| 处理器ROM表        | 0xE00F_F000 | 0xE00F_FFFF | 请参阅第2.14节中的参考2。参考                                |

### 2.7.3 CoreSightROM表

MCU包含两个CoreSightROM表，即处理器和系统ROM表。处理器ROM表包含保存处理器内部调试组件列表的条目。系统ROM表包含处理器ROM表和处理器外部的其他调试组件的条目。

### 2.7.3.1 ROM entries

ROM entries hold a list of components in the system. OCD emulator can use the ROM entries to determine which components are implemented in a system.

Table 2.9 and Table 2.10 show the System ROM entries and Processor ROM entries. See reference 5. in section 2.14. References for details.

**Table 2.9 System ROM entries**

| # | Address     | Access size | R/W | Value      | Target module pointer |
|---|-------------|-------------|-----|------------|-----------------------|
| 0 | 0xE00F_E000 | 32 bits     | R   | 0xFFF46003 | CTI0                  |
| 1 | 0xE00F_E004 | 32 bits     | R   | 0xFFF49003 | Funnel                |
| 2 | 0xE00F_E008 | 32 bits     | R   | 0xFFF4A003 | ETB                   |
| 3 | 0xE00F_E00C | 32 bits     | R   | 0xFFF4B003 | TSG                   |
| 4 | 0xE00F_E010 | 32 bits     | R   | 0xFFF42003 | TPIU                  |
| 5 | 0xE00F_E014 | 32 bits     | R   | 0x00001003 | Processor ROM table   |
| 6 | 0xE00F_E018 | 32 bits     | R   | 0x00000000 | End of entries        |

**Table 2.10 Processor ROM Entries**

| # | Address     | Access size | R/W | Value      | Target module pointer |
|---|-------------|-------------|-----|------------|-----------------------|
| 0 | 0xE00F_F000 | 32 bits     | R   | 0xFFF0F003 | SCS                   |
| 1 | 0xE00F_F004 | 32 bits     | R   | 0xFFF02003 | DWT                   |
| 2 | 0xE00F_F008 | 32 bits     | R   | 0xFFF03003 | BPU                   |
| 3 | 0xE00F_F00C | 32 bits     | R   | 0xFFF01003 | ITM                   |
| 4 | 0xE00F_F014 | 32 bits     | R   | 0xFFF42003 | ETM                   |
| 5 | 0xE00F_F018 | 32 bits     | R   | 0xFFF43003 | CTI1                  |
| 6 | 0xE00F_F020 | 32 bits     | R   | 0x00000000 | End of entries        |

### 2.7.3.2 CoreSight component registers

The CoreSight ROM Table lists the CoreSight component registers defined in the Arm CoreSight architecture.

Table 2.11 shows the registers. See reference 5. in section 2.14. References for details of each register.

**Table 2.11 CoreSight component registers in the CoreSight ROM Table**

| Name | Address     | Access size | R/W | Initial value |
|------|-------------|-------------|-----|---------------|
| PID4 | 0xE00F_EFD0 | 32 bits     | R   | 0x00000004    |
| PID5 | 0xE00F_EFD4 | 32 bits     | R   | 0x00000000    |
| PID6 | 0xE00F_EFD8 | 32 bits     | R   | 0x00000000    |
| PID7 | 0xE00F_EFDC | 32 bits     | R   | 0x00000000    |
| PID0 | 0xE00F_EFE0 | 32 bits     | R   | 0x00000031    |
| PID1 | 0xE00F_EFE4 | 32 bits     | R   | 0x00000030    |
| PID2 | 0xE00F_EFE8 | 32 bits     | R   | 0x0000000A    |
| PID3 | 0xE00F_EFEC | 32 bits     | R   | 0x00000000    |
| CID0 | 0xE00F_EFF0 | 32 bits     | R   | 0x0000000D    |
| CID1 | 0xE00F_EFF4 | 32 bits     | R   | 0x00000010    |
| CID2 | 0xE00F_EFF8 | 32 bits     | R   | 0x00000005    |
| CID3 | 0xE00F_EFFC | 32 bits     | R   | 0x000000B1    |

### 2.7.3.1 ROM条目

ROM条目保存系统中的组件列表。OCD仿真器可以使用ROM条目来确定系统中实现了哪些组件。

表2.9和表2.10显示了系统ROM条目和处理器ROM条目。请参阅第2.14节中的参考5。详情参考。

**Table 2.9 系统ROM条目**

| # | Address     | 访问大小    | R/W | Value      | 目标模块指针  |
|---|-------------|---------|-----|------------|---------|
| 0 | 0xE00F_E000 | 32 bits | R   | 0xFFF46003 | CTI0    |
| 1 | 0xE00F_E004 | 32 bits | R   | 0xFFF49003 | Funnel  |
| 2 | 0xE00F_E008 | 32 bits | R   | 0xFFF4A003 | ETB     |
| 3 | 0xE00F_E00C | 32 bits | R   | 0xFFF4B003 | TSG     |
| 4 | 0xE00F_E010 | 32 bits | R   | 0xFFF42003 | TPIU    |
| 5 | 0xE00F_E014 | 32 bits | R   | 0x00001003 | 处理器ROM表 |
| 6 | 0xE00F_E018 | 32 bits | R   | 0x00000000 | 条目结束    |

**Table 2.10 处理器ROM条目**

| # | Address     | 访问大小    | R/W | Value      | 目标模块指针 |
|---|-------------|---------|-----|------------|--------|
| 0 | 0xE00F_F000 | 32 bits | R   | 0xFFF0F003 | SCS    |
| 1 | 0xE00F_F004 | 32 bits | R   | 0xFFF02003 | DWT    |
| 2 | 0xE00F_F008 | 32 bits | R   | 0xFFF03003 | BPU    |
| 3 | 0xE00F_F00C | 32 bits | R   | 0xFFF01003 | ITM    |
| 4 | 0xE00F_F014 | 32 bits | R   | 0xFFF42003 | ETM    |
| 5 | 0xE00F_F018 | 32 bits | R   | 0xFFF43003 | CTI1   |
| 6 | 0xE00F_F020 | 32 bits | R   | 0x00000000 | 条目结束   |

### 2.7.3.2 CoreSight组件寄存器

CoreSightROM表列出了ArmCoreSight架构中定义的CoreSight组件寄存器。

表2.11显示了寄存器。请参阅第2.14节中的参考5。每个寄存器的详细信息参考。

**Table 2.11 CoreSightROM表中的CoreSight组件寄存器**

| Name | Address     | 访问大小    | R/W | 初始值        |
|------|-------------|---------|-----|------------|
| PID4 | 0xE00F_EFD0 | 32 bits | R   | 0x00000004 |
| PID5 | 0xE00F_EFD4 | 32 bits | R   | 0x00000000 |
| PID6 | 0xE00F_EFD8 | 32 bits | R   | 0x00000000 |
| PID7 | 0xE00F_EFDC | 32 bits | R   | 0x00000000 |
| PID0 | 0xE00F_EFE0 | 32 bits | R   | 0x00000031 |
| PID1 | 0xE00F_EFE4 | 32 bits | R   | 0x00000030 |
| PID2 | 0xE00F_EFE8 | 32 bits | R   | 0x0000000A |
| PID3 | 0xE00F_EFEC | 32 bits | R   | 0x00000000 |
| CID0 | 0xE00F_EFF0 | 32 bits | R   | 0x0000000D |
| CID1 | 0xE00F_EFF4 | 32 bits | R   | 0x00000010 |
| CID2 | 0xE00F_EFF8 | 32 bits | R   | 0x00000005 |
| CID3 | 0xE00F_EFFC | 32 bits | R   | 0x000000B1 |



### 2.7.4 DBGREG Module

The DBGREG module controls the debug functionalities and is implemented as a CoreSight-compliant component.

Table 2.12 shows the DBGREG registers other than the CoreSight component registers.

Table 2.12 Non-CoreSight DBGREG registers

| Name                        | DAP port | Address     | Access size | R/W |
|-----------------------------|----------|-------------|-------------|-----|
| Debug Status Register       | Port 0   | 0x4001_B000 | 32 bits     | R   |
| Debug Stop Control Register | Port 0   | 0x4001_B010 | 32 bits     | R/W |

#### 2.7.4.1 DBGSTR : Debug Status Register

Base address: DBG = 0x4001\_B000

Offset address: 0x00

|                    |    |    |                |                |    |    |    |    |    |    |    |    |    |    |    |    |
|--------------------|----|----|----------------|----------------|----|----|----|----|----|----|----|----|----|----|----|----|
| Bit position:      | 31 | 30 | 29             | 28             | 27 | 26 | 25 | 24 | 23 | 22 | 21 | 20 | 19 | 18 | 17 | 16 |
| Bit field:         | —  | —  | CDBG PWRU PACK | CDBG PWRU PREQ | —  | —  | —  | —  | —  | —  | —  | —  | —  | —  | —  | —  |
| Value after reset: | 0  | 0  | 0              | 0              | 0  | 0  | 0  | 0  | 0  | 0  | 0  | 0  | 0  | 0  | 0  | 0  |
| Bit position:      | 15 | 14 | 13             | 12             | 11 | 10 | 9  | 8  | 7  | 6  | 5  | 4  | 3  | 2  | 1  | 0  |
| Bit field:         | —  | —  | —              | —              | —  | —  | —  | —  | —  | —  | —  | —  | —  | —  | —  | —  |
| Value after reset: | 0  | 0  | 0              | 0              | 0  | 0  | 0  | 0  | 0  | 0  | 0  | 0  | 0  | 0  | 0  | 0  |

| Bit   | Symbol       | Function   | R/W |
|-------|--------------|--|-----|
| 27:0  | —            | These bits are read as 0.  | R   |
| 28    | CDBGPWRUPREQ | Debug power-up request<br>0: OCD is not requesting debug power up<br>1: OCD is requesting debug power up                 | R   |
| 29    | CDBGPWRUPACK | Debug power-up acknowledge<br>0: Debug power-up request is not acknowledged<br>1: Debug power-up request is acknowledged | R   |
| 31:30 | —            | These bits are read as 0.  | R   |

The DBGSTR register is a status register which indicates the state of the debug power-up request to the MCU from the emulator.

#### 2.7.4.2 DBGSTOPCR : Debug Stop Control Register

Base address: DBG = 0x4001\_B000

Offset address: 0x10

|                    |               |    |    |    |    |    |                |               |    |    |    |    |    |               |               |               |
|--------------------|---------------|----|----|----|----|----|----------------|---------------|----|----|----|----|----|---------------|---------------|---------------|
| Bit position:      | 31            | 30 | 29 | 28 | 27 | 26 | 25             | 24            | 23 | 22 | 21 | 20 | 19 | 18            | 17            | 16            |
| Bit field:         | DBGS TOP_CPER | —  | —  | —  | —  | —  | DBGS TOP_RECCR | DBGS TOP_RPER | —  | —  | —  | —  | —  | DBGS TOP_LVD2 | DBGS TOP_LVD1 | DBGS TOP_LVD0 |
| Value after reset: | 0             | 0  | 0  | 0  | 0  | 0  | 0              | 0             | 0  | 0  | 0  | 0  | 0  | 0             | 0             | 0             |
| Bit position:      | 15            | 14 | 13 | 12 | 11 | 10 | 9              | 8             | 7  | 6  | 5  | 4  | 3  | 2             | 1             | 0             |
| Bit field:         | —             | —  | —  | —  | —  | —  | —              | —             | —  | —  | —  | —  | —  | —             | DBGS TOP_WDT  | DBGS TOP_IWDT |
| Value after reset: | 0             | 0  | 0  | 0  | 0  | 0  | 0              | 0             | 0  | 0  | 0  | 0  | 0  | 0             | 1             | 1             |

### 2.7.4 DBGREG Module

DBGREG模块控制调试功能并被实现为符合CoreSight的组件。

表2.12显示了除CoreSight组件寄存器之外的DBGREG寄存器。

Table 2.12 Non-CoreSight DBGREG registers

| Name      | 端口     | Address     | 访问大小    | R/W |
|-----------|--------|-------------|---------|-----|
| 调试状态寄存器   | Port 0 | 0x4001_B000 | 32 bits | R   |
| 调试停止控制寄存器 | Port 0 | 0x4001_B010 | 32 bits | R/W |

#### 2.7.4.1 DBGSTR: 调试状态寄存器

Base address: DBG = 0x4001\_B000

Offset address: 0x00

|               |    |    |                |                |    |    |    |    |    |    |    |    |    |    |    |    |
|---------------|----|----|----------------|----------------|----|----|----|----|----|----|----|----|----|----|----|----|
| Bit position: | 31 | 30 | 29             | 28             | 27 | 26 | 25 | 24 | 23 | 22 | 21 | 20 | 19 | 18 | 17 | 16 |
| Bit field:    | —  | —  | CDBG PWRU PACK | CDBG PWRU PREQ | —  | —  | —  | —  | —  | —  | —  | —  | —  | —  | —  | —  |
| 重置后的值:        | 0  | 0  | 0              | 0              | 0  | 0  | 0  | 0  | 0  | 0  | 0  | 0  | 0  | 0  | 0  | 0  |
| Bit position: | 15 | 14 | 13             | 12             | 11 | 10 | 9  | 8  | 7  | 6  | 5  | 4  | 3  | 2  | 1  | 0  |
| Bit field:    | —  | —  | —              | —              | —  | —  | —  | —  | —  | —  | —  | —  | —  | —  | —  | —  |
| 重置后的值:        | 0  | 0  | 0              | 0              | 0  | 0  | 0  | 0  | 0  | 0  | 0  | 0  | 0  | 0  | 0  | 0  |

| Bit   | Symbol       | Function                            | R/W |
|-------|--------------|-------------------------------------|-----|
| 27:0  | —            | 这些位读为0。                             | R   |
| 28    | CDBGPWRUPREQ | 调试上电请求<br>0: OCD不请求调试上电1: OCD请求调试上电 | R   |
| 29    | CDBGPWRUPACK | 调试上电确认<br>0: 未确认调试上电请求1: 确认调试上电请求   | R   |
| 31:30 | —            | 这些位读为0。                             | R   |

DBGSTR寄存器是一个状态寄存器，它指示从仿真器到MCU的调试上电请求的状态。

#### 2.7.4.2 DBGSTOPCR:调试停止控制寄存器

Base address: DBG = 0x4001\_B000

Offset address: 0x10

|               |               |    |    |    |    |    |                |               |    |    |    |    |    |               |               |               |
|---------------|---------------|----|----|----|----|----|----------------|---------------|----|----|----|----|----|---------------|---------------|---------------|
| Bit position: | 31            | 30 | 29 | 28 | 27 | 26 | 25             | 24            | 23 | 22 | 21 | 20 | 19 | 18            | 17            | 16            |
| Bit field:    | DBGS TOP_CPER | —  | —  | —  | —  | —  | DBGS TOP_RECCR | DBGS TOP_RPER | —  | —  | —  | —  | —  | DBGS TOP_LVD2 | DBGS TOP_LVD1 | DBGS TOP_LVD0 |
| 重置后的值:        | 0             | 0  | 0  | 0  | 0  | 0  | 0              | 0             | 0  | 0  | 0  | 0  | 0  | 0             | 0             | 0             |
| Bit position: | 15            | 14 | 13 | 12 | 11 | 10 | 9              | 8             | 7  | 6  | 5  | 4  | 3  | 2             | 1             | 0             |
| Bit field:    | —             | —  | —  | —  | —  | —  | —              | —             | —  | —  | —  | —  | —  | —             | DBGS TOP_WDT  | DBGS TOP_IWDT |
| 重置后的值:        | 0             | 0  | 0  | 0  | 0  | 0  | 0              | 0             | 0  | 0  | 0  | 0  | 0  | 0             | 1             | 1             |

| Bit   | Symbol        | Function   | R/W |
|-------|---------------|--|-----|
| 0     | DBGSTOP_IWDT  | Mask bit for IWDT reset/interrupt<br>0: Enable IWDT reset/interrupt<br>1: Mask IWDT reset/interrupt and stop IWDT count when CPU is in OCD break mode        | R/W |
| 1     | DBGSTOP_WDT   | Mask bit for WDT reset/interrupt<br>0: Enable WDT reset/interrupt<br>1: Mask WDT reset/interrupt and stop WDT count when CPU is in OCD break mode            | R/W |
| 15:2  | —             | These bits are read as 0. The write value should be 0.   | R/W |
| 16    | DBGSTOP_LVD0  | Mask bit for LVD0 reset<br>0: Enable LVD0 reset<br>1: Mask LVD0 reset  | R/W |
| 17    | DBGSTOP_LVD1  | Mask bit for LVD1 reset/interrupt<br>0: Enable LVD1 reset/interrupt<br>1: Mask LVD1 reset/interrupt  | R/W |
| 18    | DBGSTOP_LVD2  | Mask bit for LVD2 reset/interrupt<br>0: Enable LVD2 reset/interrupt<br>1: Mask LVD2 reset/interrupt  | R/W |
| 23:19 | —             | These bits are read as 0. The write value should be 0.   | R/W |
| 24    | DBGSTOP_RPER  | Mask bit for SRAM parity error reset/interrupt<br>0: Enable SRAM parity error reset/interrupt<br>1: Mask SRAM parity error reset/interrupt                   | R/W |
| 25    | DBGSTOP_RECCR | Mask bit for SRAM ECC error reset/interrupt<br>0: Enable SRAM ECC error reset/interrupt<br>1: Mask SRAM ECC error reset/interrupt                            | R/W |
| 30:26 | —             | These bits are read as 0. The write value should be 0.   | R/W |
| 31    | DBGSTOP_CPER  | Mask bit for Cache SRAM parity error reset/interrupt<br>0: Enable Cache SRAM parity error reset/interrupt<br>1: Mask Cache SRAM parity error reset/interrupt | R/W |

The Debug Stop Control Register (DBGSTOPCR) specifies the functional stop in OCD mode. All bits in the register are regarded as 0 when the MCU is not in OCD mode.

### 2.7.4.3 DBGREG CoreSight component registers

The DBGREG module provides the CoreSight component registers defined in the Arm CoreSight architecture.

Table 2.13 shows the registers. See reference 4. in section 2.14. References for details of each register.

Table 2.13 DBGREG CoreSight component registers

| Name | Address     | Access size | R/W | Initial value |
|------|-------------|-------------|-----|---------------|
| PID4 | 0x4001_BFD0 | 32 bits     | R   | 0x00000004    |
| PID5 | 0x4001_BFD4 | 32 bits     | R   | 0x00000000    |
| PID6 | 0x4001_BFD8 | 32 bits     | R   | 0x00000000    |
| PID7 | 0x4001_BFDC | 32 bits     | R   | 0x00000000    |
| PID0 | 0x4001_BFE0 | 32 bits     | R   | 0x00000005    |
| PID1 | 0x4001_BFE4 | 32 bits     | R   | 0x00000030    |
| PID2 | 0x4001_BFE8 | 32 bits     | R   | 0x0000000A    |
| PID3 | 0x4001_BFEC | 32 bits     | R   | 0x00000000    |
| CID0 | 0x4001_BFF0 | 32 bits     | R   | 0x0000000D    |
| CID1 | 0x4001_BFF4 | 32 bits     | R   | 0x000000F0    |
| CID2 | 0x4001_BFF8 | 32 bits     | R   | 0x00000005    |
| CID3 | 0x4001_BFFC | 32 bits     | R   | 0x000000B1    |

| Bit   | Symbol        | Function  | R/W |
|-------|---------------|---|-----|
| 0     | DBGSTOP_IWDT  | IWDT复位中断屏蔽位<br>0: 使能IWDT复位中断1: 在CPU处于OCD中断模式时屏蔽IWDT复位中断并停止IWDT计数            | R/W |
| 1     | DBGSTOP_WDT   | WDT复位中断屏蔽位<br>0: 使能WDT复位中断1: 在CPU处于OCD中断模式时屏蔽WDT复位中断并停止WDT计数                | R/W |
| 15:2  | —             | 这些位被读取为0。写入值应为0。  | R/W |
| 16    | DBGSTOP_LVD0  | LVD0复位屏蔽位<br>0: 启用LVD0复位1: 屏蔽LVD0复位   | R/W |
| 17    | DBGSTOP_LVD1  | LVD1复位中断的屏蔽位<br>0: 使能LVD1复位中断1: 屏蔽LVD1复位中断                                  | R/W |
| 18    | DBGSTOP_LVD2  | LVD2复位中断的屏蔽位<br>0: 使能LVD2复位中断1: 屏蔽LVD2复位中断                                  | R/W |
| 23:19 | —             | 这些位被读取为0。写入值应为0。  | R/W |
| 24    | DBGSTOP_RPER  | SRAM奇偶校验错误复位中断的屏蔽位<br>0: 使能SRAM奇偶校验错误复位中断1: 屏蔽SRAM奇偶校验错误复位中断                | R/W |
| 25    | DBGSTOP_RECCR | SRAMECC错误复位中断的屏蔽位<br>0: 使能SRAMECC错误复位中断1: 屏蔽SRAMECC错误复位中断                   | R/W |
| 30:26 | —             | 这些位被读取为0。写入值应为0。  | R/W |
| 31    | DBGSTOP_CPER  | CacheSRAM奇偶校验错误复位中断的屏蔽位<br>0: 使能CacheSRAM奇偶校验错误复位中断1: 屏蔽CacheSRAM奇偶校验错误复位中断 | R/W |

调试停止控制寄存器(DBGSTOPCR)指定OCD模式下的功能停止。当MCU不处于OCD模式时，寄存器中的所有位都被视为0。

### 2.7.4.3 DBGREG CoreSight组件寄存器

DBGREG模块提供在Arm CoreSight架构中定义的CoreSight组件寄存器。

表2.13显示了寄存器。参见第2.14节中的参考4。每个寄存器的详细信息参考。

Table 2.13 DBGREG CoreSight组件寄存器

| Name | Address     | 访问大小    | R/W | 初始值        |
|------|-------------|---------|-----|------------|
| PID4 | 0x4001_BFD0 | 32 bits | R   | 0x00000004 |
| PID5 | 0x4001_BFD4 | 32 bits | R   | 0x00000000 |
| PID6 | 0x4001_BFD8 | 32 bits | R   | 0x00000000 |
| PID7 | 0x4001_BFDC | 32 bits | R   | 0x00000000 |
| PID0 | 0x4001_BFE0 | 32 bits | R   | 0x00000005 |
| PID1 | 0x4001_BFE4 | 32 bits | R   | 0x00000030 |
| PID2 | 0x4001_BFE8 | 32 bits | R   | 0x0000000A |
| PID3 | 0x4001_BFEC | 32 bits | R   | 0x00000000 |
| CID0 | 0x4001_BFF0 | 32 bits | R   | 0x0000000D |
| CID1 | 0x4001_BFF4 | 32 bits | R   | 0x000000F0 |
| CID2 | 0x4001_BFF8 | 32 bits | R   | 0x00000005 |
| CID3 | 0x4001_BFFC | 32 bits | R   | 0x000000B1 |

### 2.7.5 OCDREG Module

The OCDREG module are only accessible by the On-Chip Debug (OCD) emulator. OCDREG is implemented as a CoreSight-compliant component.

Table 2.14 lists the OCDREG registers.

Table 2.14 OCDREG registers

| Name                 | DAP port | Address               | Access size | R/W |
|----------------------|----------|-----------------------|-------------|-----|
| MCU Status Register  | MCUSTAT  | Port 1<br>0x8000_0400 | 32 bits     | R   |
| MCU Control Register | MCUCTRL  | Port 1<br>0x8000_0410 | 32 bits     | R/W |

Note: OCDREG is located in the dedicated OCD address space. This address map is independent from the system address map.

#### 2.7.5.1 MCUSTAT : MCU Status Register

Base address: CPU\_OCD = 0x8000\_0000

Offset address: 0x400

|                    |    |    |                  |                  |                  |    |    |    |    |    |    |    |    |                    |                  |    |
|--------------------|----|----|------------------|------------------|------------------|----|----|----|----|----|----|----|----|--------------------|------------------|----|
| Bit position:      | 31 | 30 | 29               | 28               | 27               | 26 | 25 | 24 | 23 | 22 | 21 | 20 | 19 | 18                 | 17               | 16 |
| Bit field:         | —  | —  | —                | —                | —                | —  | —  | —  | —  | —  | —  | —  | —  | —                  | —                | —  |
| Value after reset: | 0  | 0  | 0                | 0                | 0                | 0  | 0  | 0  | 0  | 0  | 0  | 0  | 0  | 0                  | 0                | 0  |
| Bit position:      | 15 | 14 | 13               | 12               | 11               | 10 | 9  | 8  | 7  | 6  | 5  | 4  | 3  | 2                  | 1                | 0  |
| Bit field:         | —  | —  | SECD<br>BG       | DBGF<br>UNCEN    | BOOT<br>MD       | —  | —  | —  | —  | —  | —  | —  | —  | CPUS<br>TOPC<br>LK | CPUS<br>LEEP     | —  |
| Value after reset: | 0  | 0  | 1/0 <sup>1</sup> | 1/0 <sup>1</sup> | 1/0 <sup>1</sup> | 0  | 0  | 1  | 0  | 0  | 0  | 0  | 0  | 1/0 <sup>1</sup>   | 1/0 <sup>1</sup> | 0  |

| Bit   | Symbol     | Function  | R/W |
|-------|------------|---|-----|
| 0     | —          | These bits are read as 0.   | R   |
| 1     | CPUSLEEP   | Sleep mode status<br>This bit is unpredictable when the MCU is in Software Standby mode, Snooze mode, or Deep Software Standby mode.<br>0: CPU is not in Sleep mode<br>1: CPU in Sleep mode | R   |
| 2     | CPUSTOPCLK | CPU clock status<br>This bit is unpredictable when the MCU is in Deep Software Standby mode.<br>0: CPU clock is not stopped.<br>1: CPU clock is stopped.                                    | R   |
| 7:3   | —          | These bits are read as 0.   | R   |
| 8     | —          | These bits are read as 1.   | R   |
| 10:9  | —          | These bits are read as 0.   | R   |
| 11    | BOOTMD     | Boot mode status<br>0: Device is not in Boot mode<br>1: Device is in Boot mode  | R   |
| 12    | DBGFUNCEN  | Debugger status<br>0: Debugger connection is not available<br>1: Debugger function is enabled   | R   |
| 13    | SECDBG     | Secure Debug status<br>0: Secure Debug is not available<br>1: Secure Debug is available   | R   |
| 31:14 | —          | These bits are read as 0.   | R   |

Note 1. Depends on the MCU status.

### 2.7.5 OCDREG Module

OCDREG模块只能由片上调试(OCD)仿真器访问。OCDREG被实现为CoreSight-compliant component.

表2.14列出了OCDREG寄存器。

Table 2.14 OCDREG registers

| Name     | 端口      | Address               | 访问大小    | R/W |
|----------|---------|-----------------------|---------|-----|
| MCU状态寄存器 | MCUSTAT | Port 1<br>0x8000_0400 | 32 bits | R   |
| MCU控制寄存器 | MCUCTRL | Port 1<br>0x8000_0410 | 32 bits | R/W |

Note: OCDREG位于专用的OCD地址空间中。该地址映射独立于系统地址映射。

#### 2.7.5.1 MCUSTAT: MCU状态寄存器

Base address: CPU\_OCD = 0x8000\_0000

Offset address: 0x400

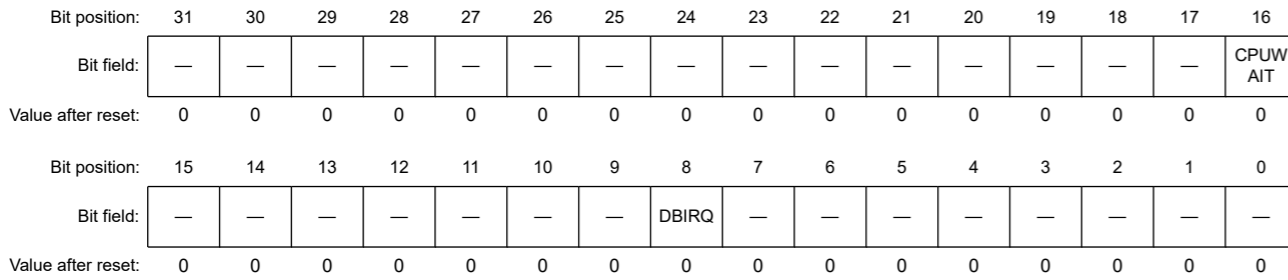
|               |    |    |                  |                  |                  |    |    |    |    |    |    |    |    |    |    |    |
|---------------|----|----|------------------|------------------|------------------|----|----|----|----|----|----|----|----|----|----|----|
| Bit position: | 31 | 30 | 29               | 28               | 27               | 26 | 25 | 24 | 23 | 22 | 21 | 20 | 19 | 18 | 17 | 16 |
| Bit field:    | —  | —  | —                | —                | —                | —  | —  | —  | —  | —  | —  | —  | —  | —  | —  | —  |
| 重置后的值:        | 0  | 0  | 0                | 0                | 0                | 0  | 0  | 0  | 0  | 0  | 0  | 0  | 0  | 0  | 0  | 0  |
| Bit position: | 15 | 14 | 13               | 12               | 11               | 10 | 9  | 8  | 7  | 6  | 5  | 4  | 3  | 2  | 1  | 0  |
| Bit field:    | —  | —  | SECD<br>BG       | DBGF<br>UNCEN    | BOOT<br>MD       | —  | —  | —  | —  | —  | —  | —  | —  | —  | —  | —  |
| 重置后的值:        | 0  | 0  | 1/0 <sup>1</sup> | 1/0 <sup>1</sup> | 1/0 <sup>1</sup> | 0  | 0  | 1  | 0  | 0  | 0  | 0  | 0  | 0  | 0  | 0  |

| Bit   | Symbol     | Function   | R/W |
|-------|------------|--|-----|
| 0     | —          | 这些位读为0。  | R   |
| 1     | CPUSLEEP   | 睡眠模式状态<br>当MCU处于软件待机模式、贪睡模式或深度软件待机模式。<br>0: CPU不处于休眠模式1: CPU处于休眠模式 | R   |
| 2     | CPUSTOPCLK | CPU时钟状态<br>当MCU处于深度软件待机模式时, 该位是不可预测的。<br>0: CPU时钟不停止。1: CPU时钟停止。   | R   |
| 7:3   | —          | 这些位读为0。  | R   |
| 8     | —          | 这些位读为1。  | R   |
| 10:9  | —          | 这些位读为0。  | R   |
| 11    | BOOTMD     | 引导模式状态<br>0: 设备未处于引导模式1: 设备处于引导模式                                  | R   |
| 12    | DBGFUNCEN  | 调试器状态<br>0: 调试器连接不可用1: 调试器功能启用                                     | R   |
| 13    | SECDBG     | 安全调试状态<br>0: 安全调试不可用1: 安全调试可用                                      | R   |
| 31:14 | —          | 这些位读为0。  | R   |

注1.取决于MCU状态。

### 2.7.5.2 MCUCTRL : MCU Control Register

Base address: CPU\_OCD = 0x8000\_0000  
Offset address: 0x410



| Bit   | Symbol               | Function  | R/W |
|-------|----------------------|---|-----|
| 7:0   | —                    | These bits are read as 0. The write value should be 0.  | R/W |
| 8     | DBIRQ <sup>2</sup>   | Debug Interrupt Request<br>Writing 1 to the bit wakes up the MCU from low power mode. The condition can be cleared by writing 0 to the DBIRQ bit.<br>0: Debug interrupt not requested<br>1: Debug interrupt requested | R/W |
| 15:9  | —                    | These bits are read as 0. The write value should be 0.  | R/W |
| 16    | CPUWAIT <sup>2</sup> | CPU Wait Setting<br>Write 1 to assert CPUWAIT, write 0 to deassert CPUWAIT <sup>1</sup> .<br>0: Clear CPUWAIT to low<br>1: Set CPUWAIT to high  | R/W |
| 31:17 | —                    | These bits are read as 0. The write value should be 0.  | R/W |

Note 1. CPUWAIT is used to prevent the processor from executing code immediately after reset.  
Note 2. Access (R/W) to bit is valid only when Debug Level is DBG1 or DBG2.

### 2.7.5.3 OCDREG CoreSight component registers

The OCDREG module provides the CoreSight component registers defined in the Arm CoreSight architecture.

Table 2.15 shows the registers. See reference 4. in section 2.14. References for details of each register.

Table 2.15 OCDREG CoreSight component registers

| Name | Address     | Access size | R/W | Initial value |
|------|-------------|-------------|-----|---------------|
| PID4 | 0x8000_0FD0 | 32 bits     | R   | 0x00000004    |
| PID5 | 0x8000_0FD4 | 32 bits     | R   | 0x00000000    |
| PID6 | 0x8000_0FD8 | 32 bits     | R   | 0x00000000    |
| PID7 | 0x8000_0FDC | 32 bits     | R   | 0x00000000    |
| PID0 | 0x8000_0FE0 | 32 bits     | R   | 0x00000004    |
| PID1 | 0x8000_0FE4 | 32 bits     | R   | 0x00000030    |
| PID2 | 0x8000_0FE8 | 32 bits     | R   | 0x0000000A    |
| PID3 | 0x8000_0FEC | 32 bits     | R   | 0x00000000    |
| CID0 | 0x8000_0FF0 | 32 bits     | R   | 0x0000000D    |
| CID1 | 0x8000_0FF4 | 32 bits     | R   | 0x000000F0    |
| CID2 | 0x8000_0FF8 | 32 bits     | R   | 0x00000005    |
| CID3 | 0x8000_0FFC | 32 bits     | R   | 0x000000B1    |

### 2.7.5.2 MCUCTRL:MCU控制寄存器

Base address: CPU\_OCD = 0x8000\_0000  
Offset address: 0x410



| Bit   | Symbol               | Function  | R/W |
|-------|----------------------|---|-----|
| 7:0   | —                    | 这些位被读取为0。写入值应为0。  | R/W |
| 8     | DBIRQ <sup>2</sup>   | 调试中断请求<br>向该位写入1将MCU从低功耗模式唤醒。可以通过将0写入DBIRQ位来清除该条件。<br>0: 未请求调试中断1: 请求调试中断 | R/W |
| 15:9  | —                    | 这些位被读取为0。写入值应为0。  | R/W |
| 16    | CPUWAIT <sup>2</sup> | CPU等待设置<br>写1来断言CPUWAIT，写0到甜点CPUWAIT*1。<br>0: 清除CPUWAIT为低1: 设置CPUWAIT为高   | R/W |
| 31:17 | —                    | 这些位被读取为0。写入值应为0。  | R/W |

注1.CPUWAIT用于防止处理器在复位后立即执行代码。  
注2.只有当DebugLevel为DBG1或DBG2时，对位的访问(RW)才有效。

### 2.7.5.3 OCDREGCoreSight组件寄存器

OCDREG模块提供在ArmCoreSight架构中定义的CoreSight组件寄存器。

表2.15显示了寄存器。参见第2.14节中的参考4。每个寄存器的详细信息参考。

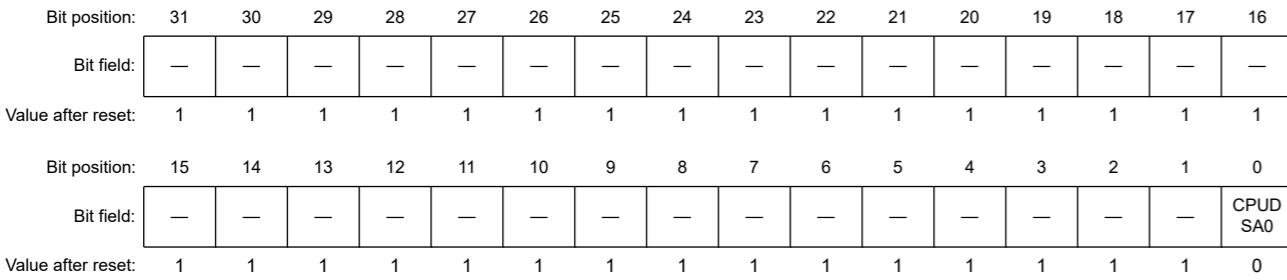
Table 2.15 OCDREGCoreSight组件寄存器

| Name | Address     | 访问大小    | R/W | 初始值        |
|------|-------------|---------|-----|------------|
| PID4 | 0x8000_0FD0 | 32 bits | R   | 0x00000004 |
| PID5 | 0x8000_0FD4 | 32 bits | R   | 0x00000000 |
| PID6 | 0x8000_0FD8 | 32 bits | R   | 0x00000000 |
| PID7 | 0x8000_0FDC | 32 bits | R   | 0x00000000 |
| PID0 | 0x8000_0FE0 | 32 bits | R   | 0x00000004 |
| PID1 | 0x8000_0FE4 | 32 bits | R   | 0x00000030 |
| PID2 | 0x8000_0FE8 | 32 bits | R   | 0x0000000A |
| PID3 | 0x8000_0FEC | 32 bits | R   | 0x00000000 |
| CID0 | 0x8000_0FF0 | 32 bits | R   | 0x0000000D |
| CID1 | 0x8000_0FF4 | 32 bits | R   | 0x000000F0 |
| CID2 | 0x8000_0FF8 | 32 bits | R   | 0x00000005 |
| CID3 | 0x8000_0FFC | 32 bits | R   | 0x000000B1 |



### 2.7.6 CPUDSAR : CPU Debug Security Attribution Register

Base address: CPSCU = 0x4000\_8000  
Offset address: 0x1B0



| Bit  | Symbol  | Function   | R/W |
|------|---------|--|-----|
| 0    | CPUDSA0 | CPU Debug Security Attribution 0<br>0: Secure<br>1: Non-secure | R/W |
| 31:1 | —       | These bits are read as 1. The write value should be 1.         | R/W |

Note: Only secure access can write to this register. Both secure access and non-secure read access are allowed. Non-secure write access is denied, and no TrustZone access error is generated.  
Note: This register is write-protected by PRCR register.

When Debug level of the MCU is DBG2, by guarding entire EPPB bus, the non-secure access from CPU to debug related components is completely controlled by the current value of the CPUDSA0 bit. Since this bit is modifiable only when CPU is in secure state, user must be aware of the CPUDSAR register before using Coresight debug components.

#### CPUDSA0 bit (CPU Debug Security Attribution 0)

Security attributes of register for accessing the debug component of the CPU.

- 0: Debug component can only be accessed with secure access.
- 1: There is no restriction on accessing the debug component.

### 2.7.7 Processing on Error response generated by CPU access

In addition to the specific-error detection specification of the Arm Cortex-M33 processor, this MCU also provides additional error information which is described in section 14, Buses.

This section describes how to handle the additional error information with no conflict to that of the Arm Cortex-M33 processor.

Table 2.16 shows error detection modules, which are also described in section 14, Buses. These error detection modules not only provide error information on the bus module, but also notify the processor to trigger the exception handler.

Table 2.16

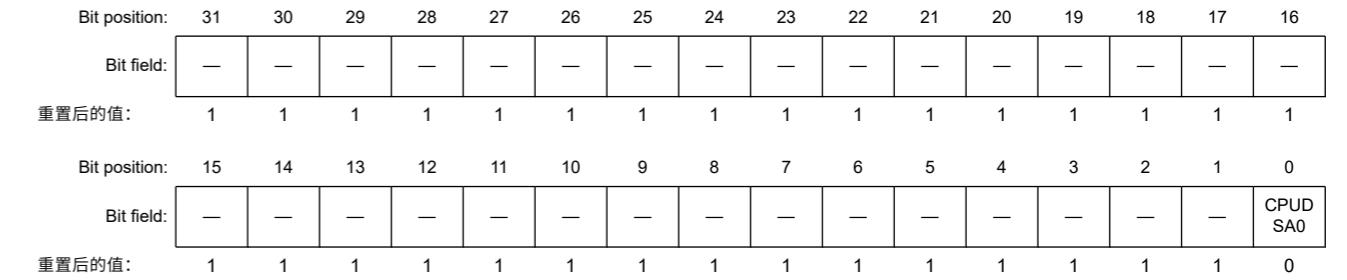
|                              | NMI/RESET request | Interrupt                   | Bus error status register | Error address register<br>Error RW register |
|------------------------------|-------------------|-----------------------------|---------------------------|---|
| Slave TZF                    | NMISR.TZFST       | Bus Fault*1<br>(Hard Fault) | BUS.BUSnERRSTAT.STERRSTAT | BUS.BTZFnERRADD<br>BUS.BTZFnERRRW           |
| Slave bus error              | —                 | Bus Fault                   | BUS.BUSnERRSTAT.SLERRSTAT | BUS.BUSnERRADD<br>BUS.BUSnERRRW             |
| Illegal address access error | —                 | Bus Fault                   | BUS.BUSnERRSTAT.ILERRSTAT | BUS.BUSnERRADD<br>BUS.BUSnERRRW             |

Note 1. A Bus Fault can be treated as HardFault. ARM® Cortex®-M33 Device Generic User Guide in the References section 2.14. References

To prevent unexpected operation, when handling the exception, additional operation should be added into exception routing. BusFault when occurred by error detected as shown in Table 2.16:

### 2.7.6 CPUDSAR:CPU调试安全属性寄存器

Base address: CPSCU = 0x4000\_8000  
Offset address: 0x1B0



| Bit  | Symbol  | Function                                 | R/W |
|------|---------|--|-----|
| 0    | CPUDSA0 | CPU调试安全属性0<br>0: Secure<br>1: Non-secure | R/W |
| 31:1 | —       | 这些位被读取为1。写入值应为1。                         | R/W |

Note: 只有安全访问才能写入该寄存器。允许安全访问和非安全读取访问。拒绝非安全写入访问，并且不会生成TrustZone访问错误。  
Note: 该寄存器由PRCR寄存器写保护。

当MCU的Debug级别为DBG2时，通过保护整个EPPB总线，CPU对调试相关组件的非安全访问完全由CPUDSA0位的当前值控制。由于该位仅在CPU处于安全状态时才可修改，因此用户在使用Coresight调试组件之前必须了解CPUDSAR寄存器。

#### CPUDSA0位 (CPU调试安全属性0)

用于访问CPU调试组件的寄存器的安全属性。

- 0: 只能通过安全访问访问调试组件。
- 1: 对调试组件的访问没有限制。

### 2.7.7 CPU访问产生的错误响应的处理

除了ArmCortex-M33处理器的特定错误检测规范外，此MCU还提供第14节“总线”中描述的其他错误信息。

本节介绍如何处理与ArmCortex-M33处理器不冲突的附加错误信息。

表2.16显示了错误检测模块，这些模块也在第14节“总线”中进行了描述。这些错误检测模块不仅提供总线模块上的错误信息，还通知处理器触发异常处理程序。

Table 2.16

|           | NMI/RESET request | Interrupt              | 总线错误状态寄存器                 | 错误地址寄存器<br>错误RW寄存器                |
|-----------|-------------------|------------------------|---------------------------|-----------------------------------|
| Slave TZF | NMISR.TZFST       | 总线故障*1<br>(Hard Fault) | BUS.BUSnERRSTAT.STERRSTAT | BUS.BTZFnERRADD<br>BUS.BTZFnERRRW |
| 从站总线错误    | —                 | 总线故障                   | BUS.BUSnERRSTAT.SLERRSTAT | BUS.BUSnERRADD<br>BUS.BUSnERRRW   |
| 非法地址访问错误  | —                 | 总线故障                   | BUS.BUSnERRSTAT.ILERRSTAT | BUS.BUSnERRADD<br>BUS.BUSnERRRW   |

注1.总线故障可被视为硬故障。参考第2.14节中的ARM®Cortex®-M33设备通用用户指南。References

为防止意外操作，在处理异常时，应在异常路由中增加额外的操作。检测到错误发生时的BusFault，如表2.16所示：

- See section 14, Buses for the error information in the corresponding register
- Clear the data in cache for the error address
- Clear the Error Status register in the bus module
- Service exception handling with Arm-guided operation

For a Bus Fault that is not detected in the Renesas-specific error detection module (occurred inside the Arm Cortex-M33 core), see the *ARM® Cortex®-M33 Device Generic User Guide* to handle this case.

In the system bus specification, there is a specific case for Slave TrustZone Filter, that is, if an error is selected to generate an NMI, then before the processor handles the Bus Fault exception, NMI with higher priority takes the exception first. Therefore, use the BusFault handler and not NMI handler to handle this error. In other words, the NMI status should be cleared but the error status bit should not be cleared to ensure that BusFault captures all the error information.

Figure 2.4 and Figure 2.5 show the recommended flows for NMI handler and BusFault handler for the errors described in Table 2.16.

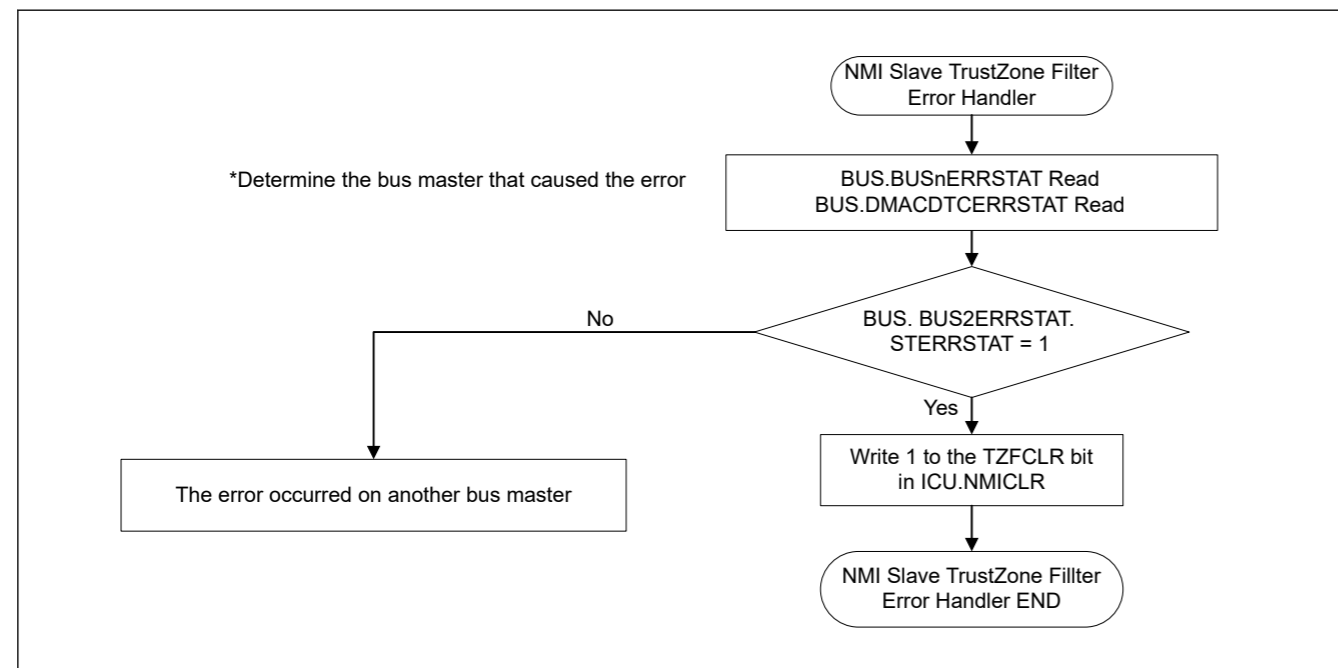


Figure 2.4 NMI handling flowchart

- 相应寄存器中的错误信息见第14节，总线
- 清除缓存中错误地址的数据
- 清除总线模块中的错误状态寄存器
- 服务异常处理，手臂引导操作

对于未在Renesas特定错误检测模块中检测到的总线故障（发生在ArmCortex-M33内核中），请参阅ARM®Cortex®-M33DeviceGenericUserGuide来处理这种情况。

在系统总线规范中，SlaveTrustZoneFilter有一个具体的案例，即如果选择了错误产生NMI，那么在处理器处理BusFault异常之前，优先级较高的NMI先处理该异常。因此，使用BusFault处理程序而不是NMI处理程序来处理此错误。换言之，应清除NMI状态但不应清除错误状态位，以确保BusFault捕获所有错误信息。

图2.4和图2.5显示了NMI处理程序和BusFault处理程序的推荐流程，用于处理中描述的错误 Table 2.16.

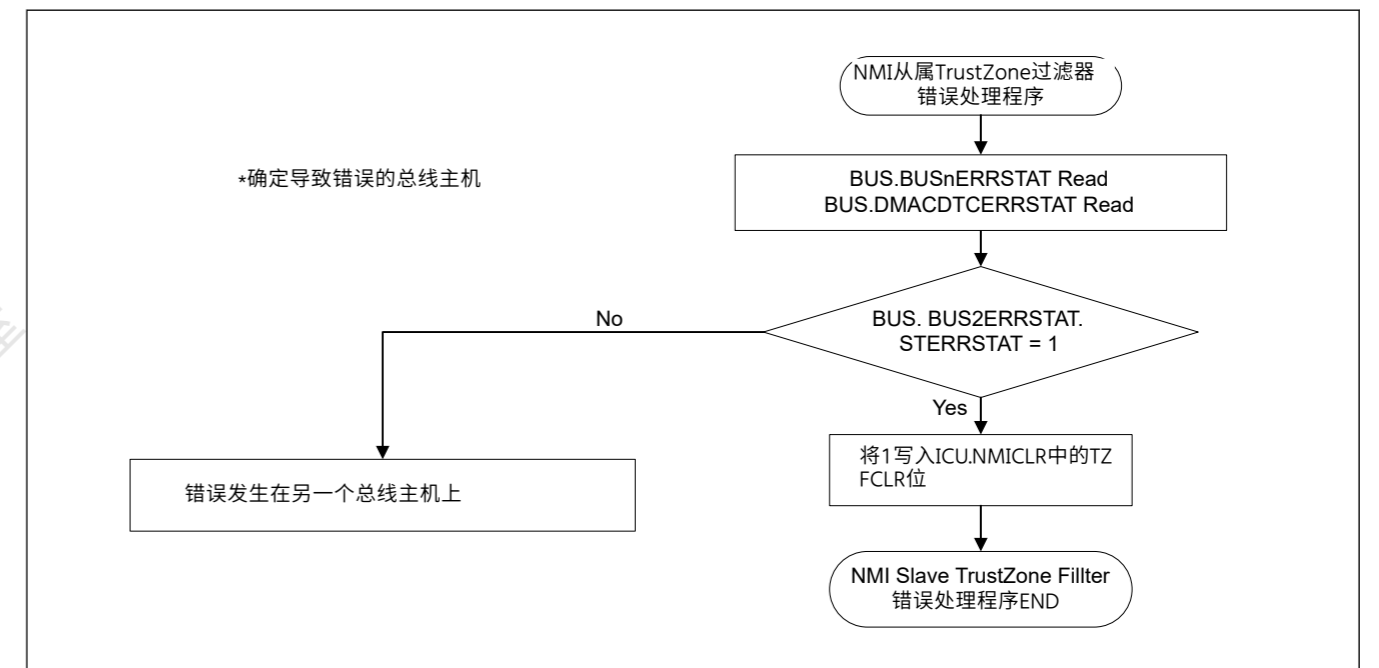


Figure 2.4 NMI处理流程图

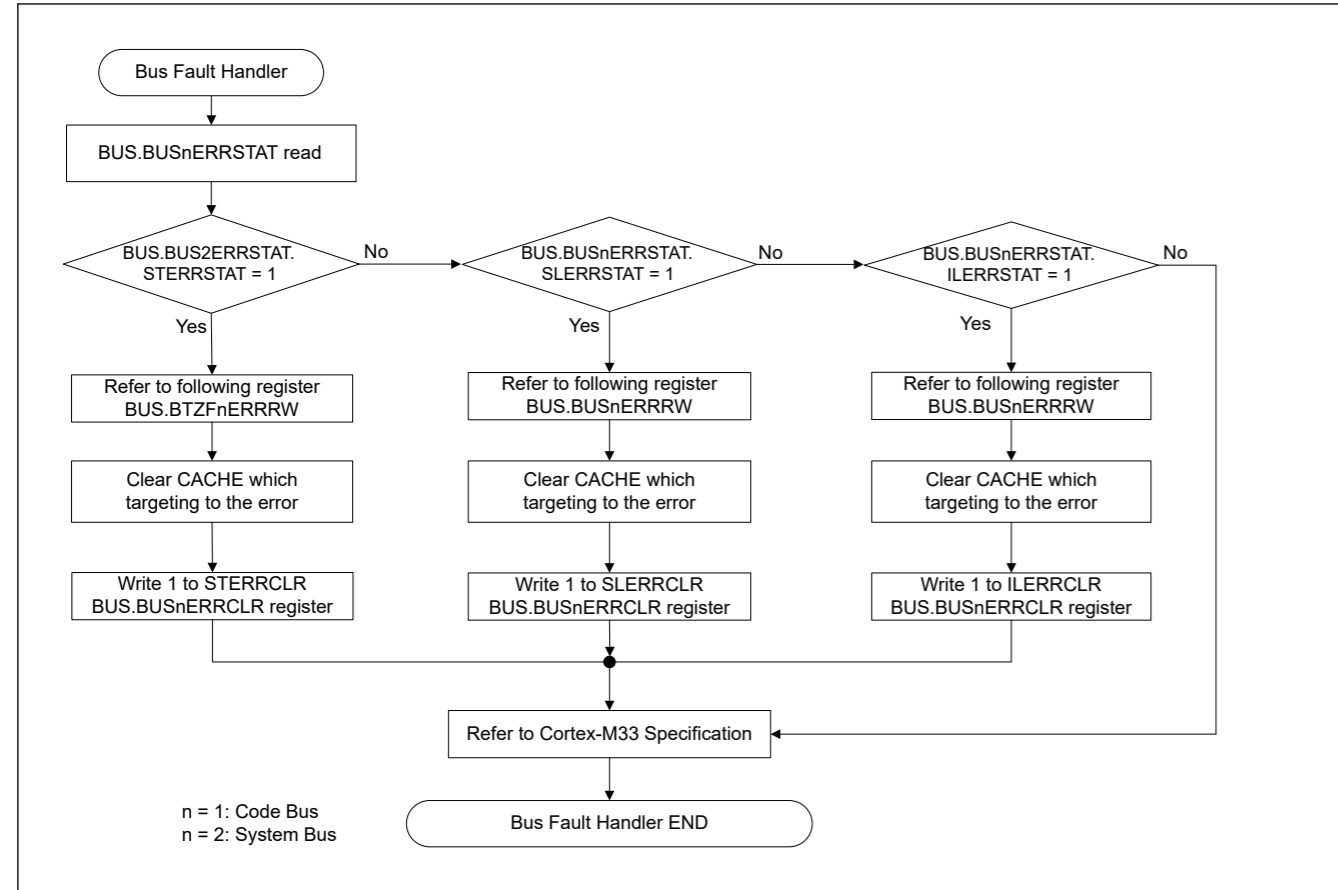


Figure 2.5 BusFault interrupt handling flowchart

## 2.8 CoreSight Cross Trigger Interface (CTI)

As shown in Figure 2.6, the input and output of a Cross Trigger Interface (CTI) interact with each other through four CTM channels. Input of a CTI can be used to trigger the output of another CTI using the four CTM channels.

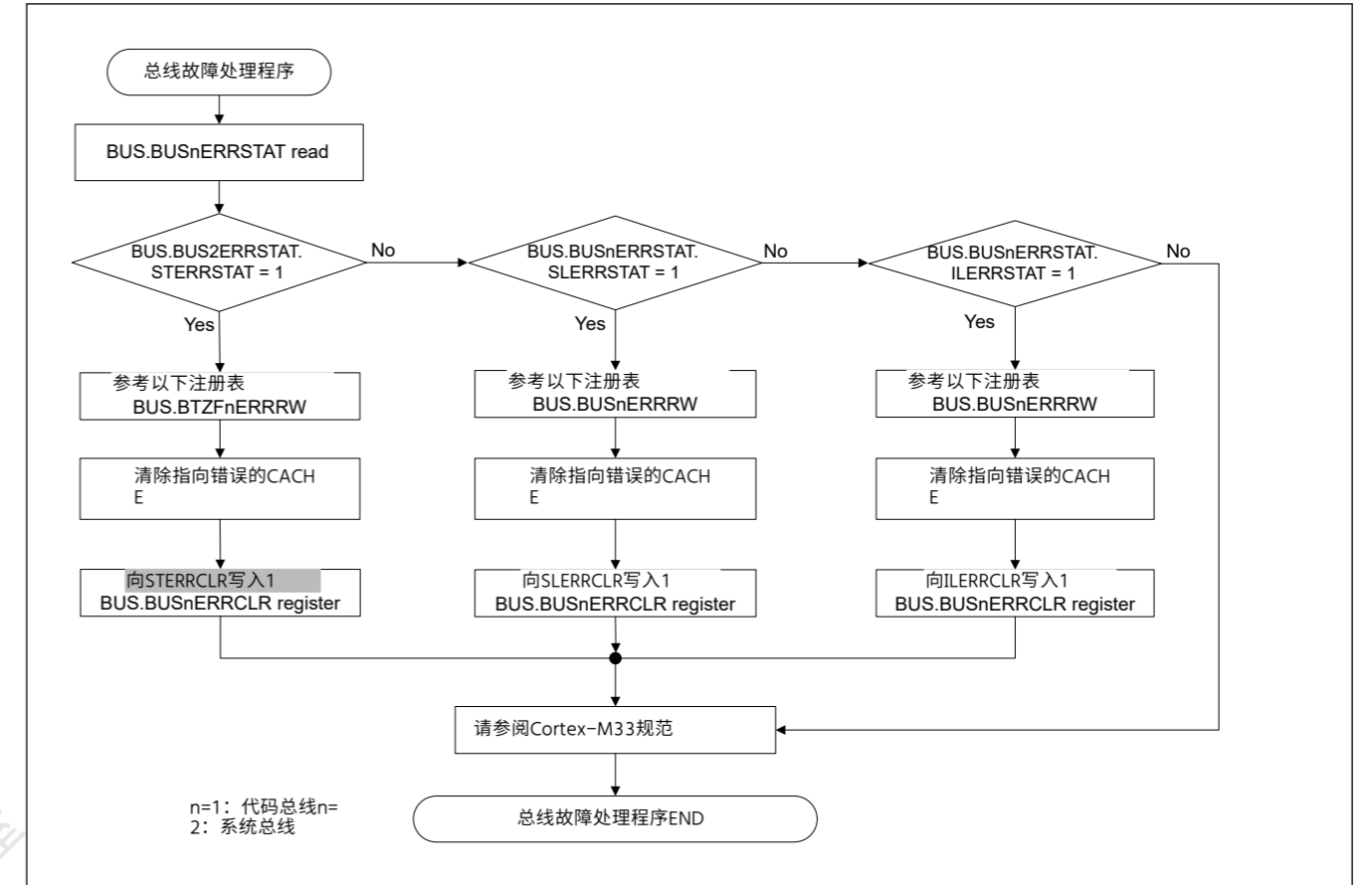


Figure 2.5 BusFault中断处理流程图

## 2.8 CoreSight交叉触发接口(CTI)

如图2.6所示，交叉触发接口（CTI）的输入和输出通过四个CTM通道相互交互。一个CTI的输入可用于使用四个CTM通道触发另一个CTI的输出。

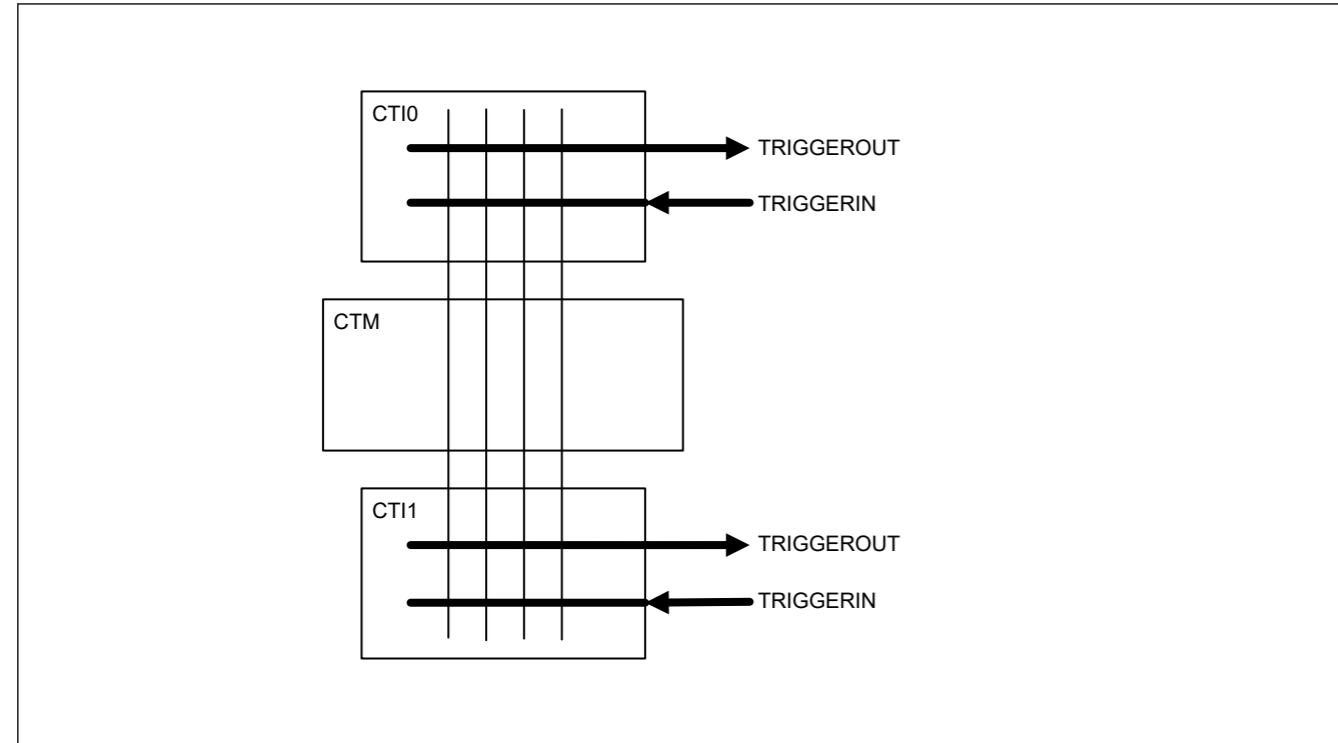


Figure 2.6 CTI System

Debug Interrupt Request (DBGIRQ) is controlled by MCUCTRL register in OCDREG module.

Table 2.17 CTI Trigger signals

| Number of CTI channel | CTITRIGIN |                         | CTITRIGOUT |                                |
|-----------------------|-----------|-------------------------|------------|--------------------------------|
| CTI0 (Debug common)   | 0         | ACQCOMP                 | 0          | —                              |
|                       | 1         | FULL                    | 1          | —                              |
|                       | 2         | DBIRQ                   | 2          | ETB FLUSHIN                    |
|                       | 3         | —                       | 3          | ETB TRIGIN                     |
|                       | 4         | —                       | 4          | —                              |
|                       | 5         | —                       | 5          | —                              |
|                       | 6         | —                       | 6          | —                              |
|                       | 7         | —                       | 7          | —                              |
| CTI1 (CPU)            | 0         | Processor Halted        | 0          | Processor debug request        |
|                       | 1         | DWT Comparator Output 0 | 1          | Processor Restart              |
|                       | 2         | DWT Comparator Output 1 | 2          | CTIIRQ[0] (Connected to IRQ96) |
|                       | 3         | DWT Comparator Output 2 | 3          | CTIIRQ[1] (Connected to IRQ97) |
|                       | 4         | ETM Event Output 0      | 4          | ETM Event Input 0              |
|                       | 5         | ETM Event Output 1      | 5          | ETM Event Input 1              |
|                       | 6         | —                       | 6          | ETM Event Input 2              |
|                       | 7         | —                       | 7          | ETM Event Input 3              |

### 2.9 CoreSight ATB Funnel

There is one CoreSight ATB funnel in the MCU. The funnel has two ATB slaves and one ATB master, and it selects the debug trace source from ETM and ITM to ETB. Figure 2.7 shows the CoreSight ATB connection in the MCU.

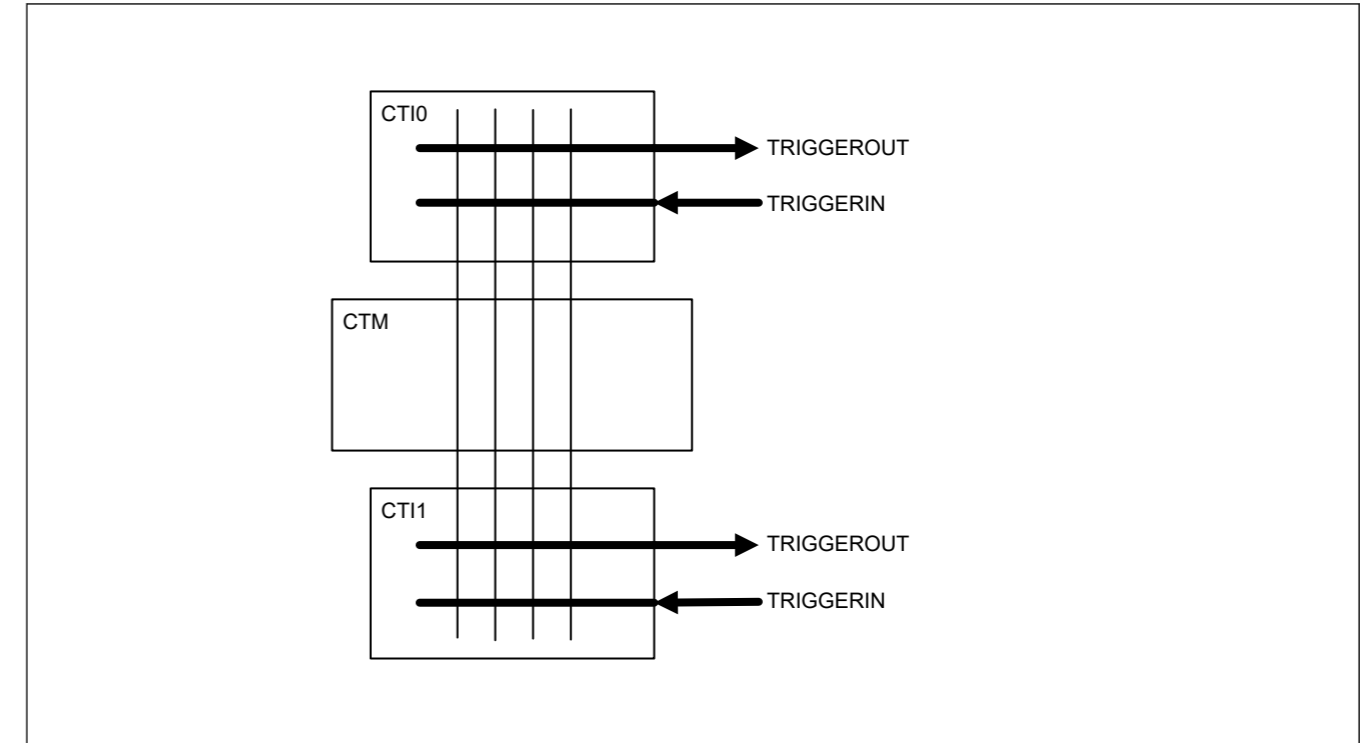


Figure 2.6 CTI System

调试中断请求(DBGIRQ)由OCDREG模块中的MCUCTRL寄存器控制。

Table 2.17 CTI触发信号

| CTI通道数              | CTITRIGIN |           | CTITRIGOUT |                                |
|---------------------|-----------|-----------|------------|--------------------------------|
| CTI0 (Debug common) | 0         | ACQCOMP   | 0          | —                              |
|                     | 1         | FULL      | 1          | —                              |
|                     | 2         | DBIRQ     | 2          | ETB FLUSHIN                    |
|                     | 3         | —         | 3          | ETB TRIGIN                     |
|                     | 4         | —         | 4          | —                              |
|                     | 5         | —         | 5          | —                              |
|                     | 6         | —         | 6          | —                              |
|                     | 7         | —         | 7          | —                              |
| CTI1 (CPU)          | 0         | 处理器停止     | 0          | 处理器调试请求                        |
|                     | 1         | DWT比较器输出0 | 1          | 处理器重启                          |
|                     | 2         | DWT比较器输出1 | 2          | CTIIRQ[0] (Connected to IRQ96) |
|                     | 3         | DWT比较器输出2 | 3          | CTIIRQ[1] (Connected to IRQ97) |
|                     | 4         | ETM事件输出0  | 4          | ETM事件输入0                       |
|                     | 5         | ETM事件输出1  | 5          | ETM事件输入1                       |
|                     | 6         | —         | 6          | ETM事件输入2                       |
|                     | 7         | —         | 7          | ETM事件输入3                       |

### 2.9 CoreSight ATB Funnel

MCU中有一个CoreSight ATB漏斗。漏斗有两个ATB从站和一个ATB主站，它选择从ETM和ITM到ETB的调试跟踪源。图2.7显示了MCU中的CoreSight ATB连接。

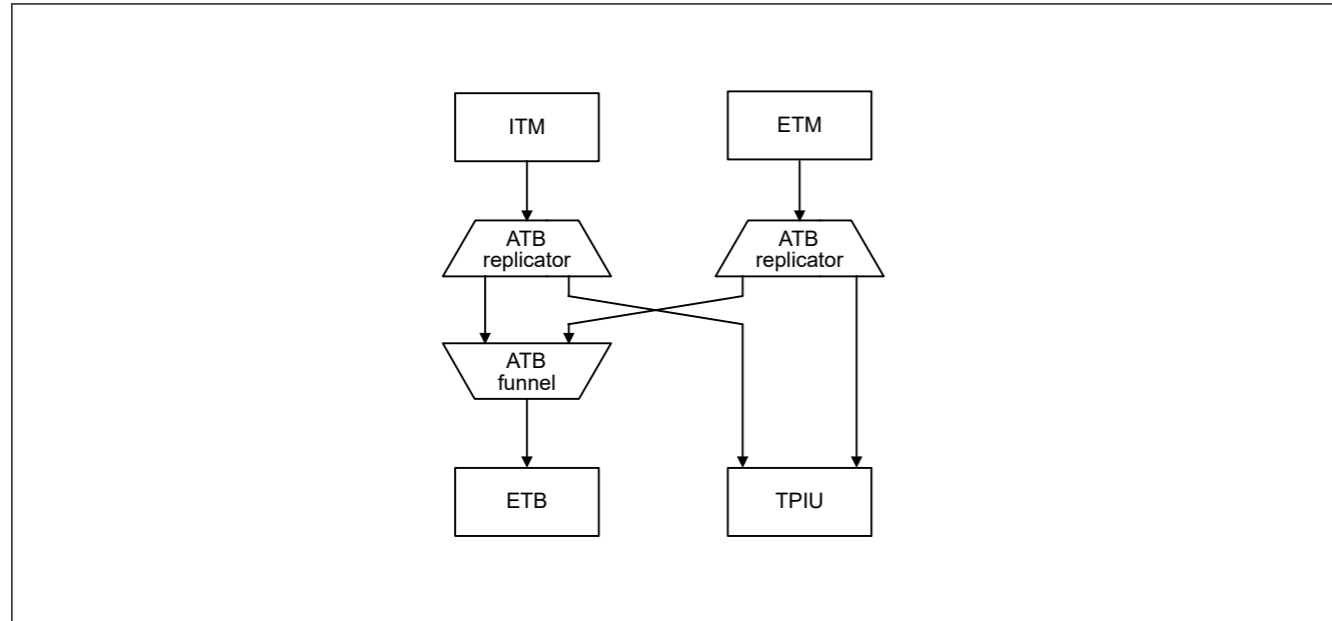


Figure 2.7 CoreSight ATB connection

Table 2.18 shows the ATB slave connection for the funnel.

Table 2.18 ATB slave connection

| ATB slave number | Connected trace source |
|------------------|------------------------|
| #0               | ITM                    |
| #1               | ETM                    |

See reference 4. in [section 2.14. References](#) for details of the ATB and funnel.

## 2.10 Break Point Unit

The MCU has Break Point Unit. See BreakPoint unit chapter of reference 1. in [section 2.14. References](#) for details about register description of this module.

## 2.11 CoreSight Time Stamp Generator

A CoreSight Time Stamp Generator provides a CPU clock-based timestamp to ITM and ETM. The timestamp is generated by a 64-bit counter. See reference 4. in [section 2.14. References](#) for details.

## 2.12 SysTick Timer

The MCU has SysTick timer that provides two 24-bit down counters, non-secure and secure counters. The timer can select SysTick timer clock (SYSTICCLK) or System clock (ICLK).

See [section 8, Clock Generation Circuit](#) and reference 1. in [section 2.14. References](#) for details.

Note: SysTick timer counter operation is enabled by signal synchronized with CPU clock. Therefore, the counter might not operate correctly if the CPU clock is slower than the SysTick timer clock. In other words, clock setting must satisfy the following: CPU clock  $\geq$  Systick clock (LOCO: 32.768 kHz).

## 2.13 OCD Emulator Connection

In this product, the MCU confirms the access permission for Non-secure debug and Non-secure chip resources by checking Debug level is DBG1 or higher. For full access permission for debug and chip resources, Secure debug level DBG2 is required.

Figure 2.8 shows a block diagram of SWD authentication mechanism.

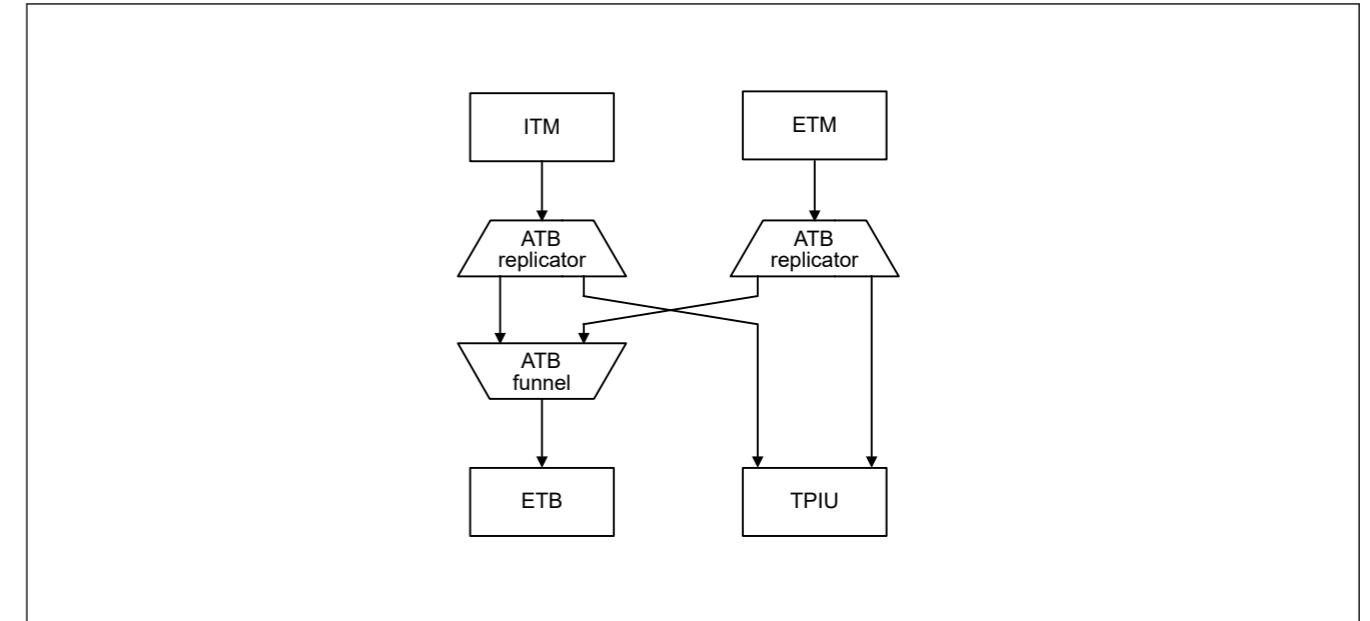


Figure 2.7 CoreSight ATB connection

表2.18显示了漏斗的ATB从属连接。

Table 2.18 ATB从机连接

| ATB从机号 | 连接的跟踪源 |
|--------|--------|
| #0     | ITM    |
| #1     | ETM    |

参见第2.14节中的参考4。有关ATB和漏斗详细信息的参考资料。

## 2.10 断点单元

MCU有断点单元。请参阅第2.14节中参考文献1的断点单元章节。关于该模块的寄存器描述的详细信息参考。

## 2.11 CoreSight时间戳生成器

CoreSight时间戳生成器为ITM和ETM提供基于CPU时钟的时间戳。时间戳由64位计数器生成。参见第2.14节中的参考4。详情参考。

## 2.12 SysTick Timer

MCU具有SysTick定时器，提供两个24位递减计数器、非安全计数器和安全计数器。定时器可以选择SysTick定时器时钟(SYSTICCLK)或系统时钟(ICLK)。

请参见第8节，时钟生成电路和第2.14节中的参考1。详情参考。

Note: SysTick定时器计数器操作由与CPU时钟同步的信号启用。因此，如果CPU时钟比SysTick定时器时钟慢，计数器可能无法正确运行。换言之，时钟设置必须满足以下条件：CPU时钟 $\geq$ Systick时钟（LOCO：32.768kHz）。

## 2.13 OCD模拟器连接

本产品中，MCU通过勾选确认非安全调试和非安全芯片资源的访问权限调试级别为DBG1或更高。对于调试和芯片资源的完全访问权限，需要安全调试级别DBG2。

图2.8显示了SWD认证机制的框图。



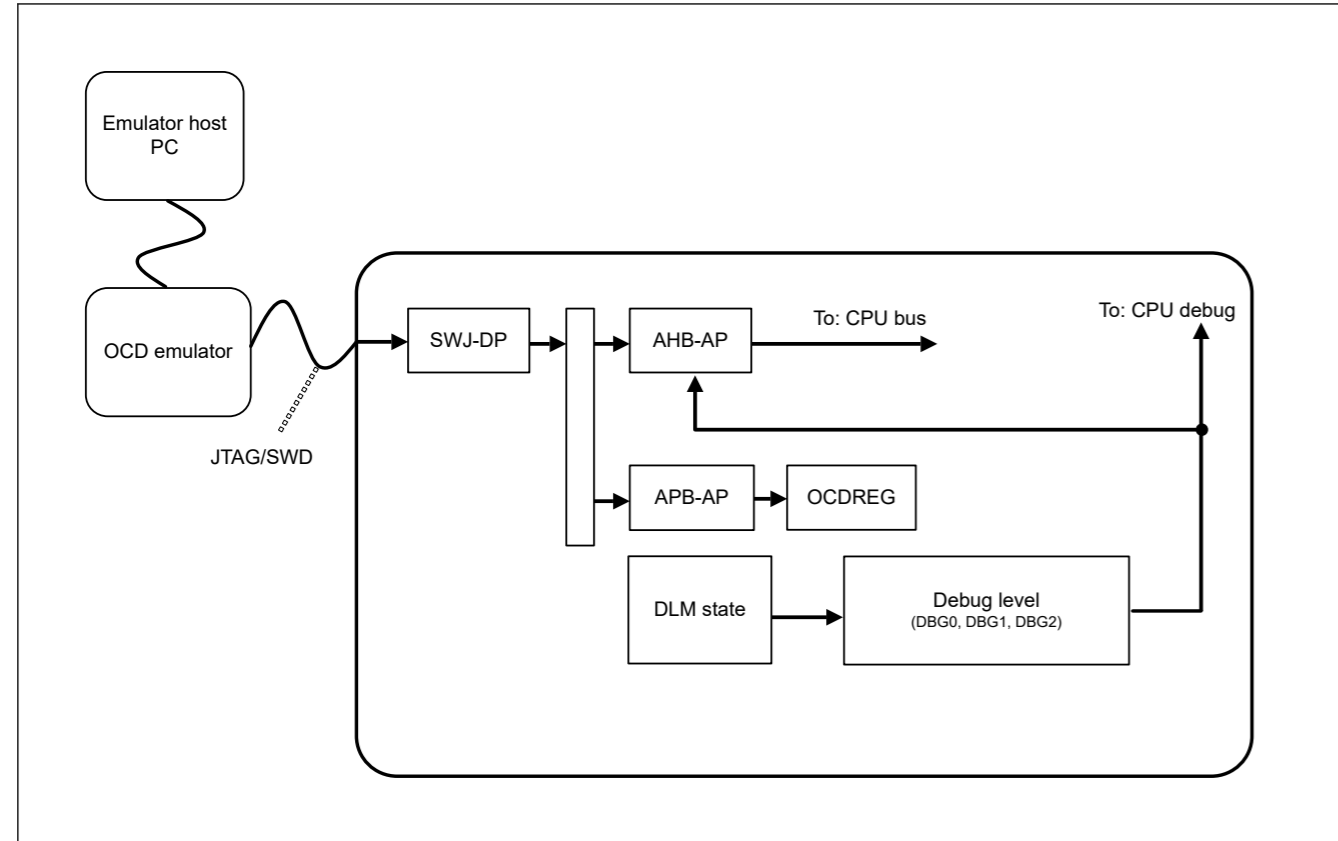


Figure 2.8 SWD Authentication mechanism block diagram

Three levels of debug capability are available, DBG0, DBG1, and DBG2, which correspond to the Device Level Management (DLM) states. When debug level is DBG0, access to debug components and system bus from OCD emulator is not permitted. When debug level is DBG1 or DBG2, the corresponding non-secure or secure debug components and system bus can be accessed from the OCD emulator. See Table 2.5 for more information about debug levels.

2.13.1 DBGEN

After the OCD emulator gets access permission, the OCD emulator must set the DBGEN bit in the System Control OCD Control Register (SYOCDRCR). In addition, the OCD emulator must clear the DBGEN bit before disconnecting it. See section 10, Low Power Modes for details.

2.13.2 Restrictions on Connecting an OCD emulator

This section describes the restrictions on emulator access.

2.13.2.1 Starting connection while in low power mode

When starting a JTAG/SWD connection from an OCD emulator, the MCU must be in Normal or Sleep mode. If the MCU is in Software Standby, Snooze, or Deep Software Standby mode, the OCD emulator can cause the MCU to hang.

2.13.2.2 Changing low power mode while in OCD mode

When the MCU is in OCD mode, the low power mode can be changed. However, system bus access from AHB-AP is prohibited in Software Standby, Snooze or Deep Software Standby mode. Only SWJ-DP, APB-AP, and OCDREG can be accessed from the OCD emulator in these modes. Table 2.19 shows the restrictions.

Table 2.19 Restrictions by mode (1 of 2)

| Active mode | Start OCD emulator connection | Change low power mode | Access AHB-AP and system bus | Access APB-AP and OCDREG |
|-------------|-------------------------------|-----------------------|------------------------------|--------------------------|
| Normal      | Yes                           | Yes                   | Yes                          | Yes                      |

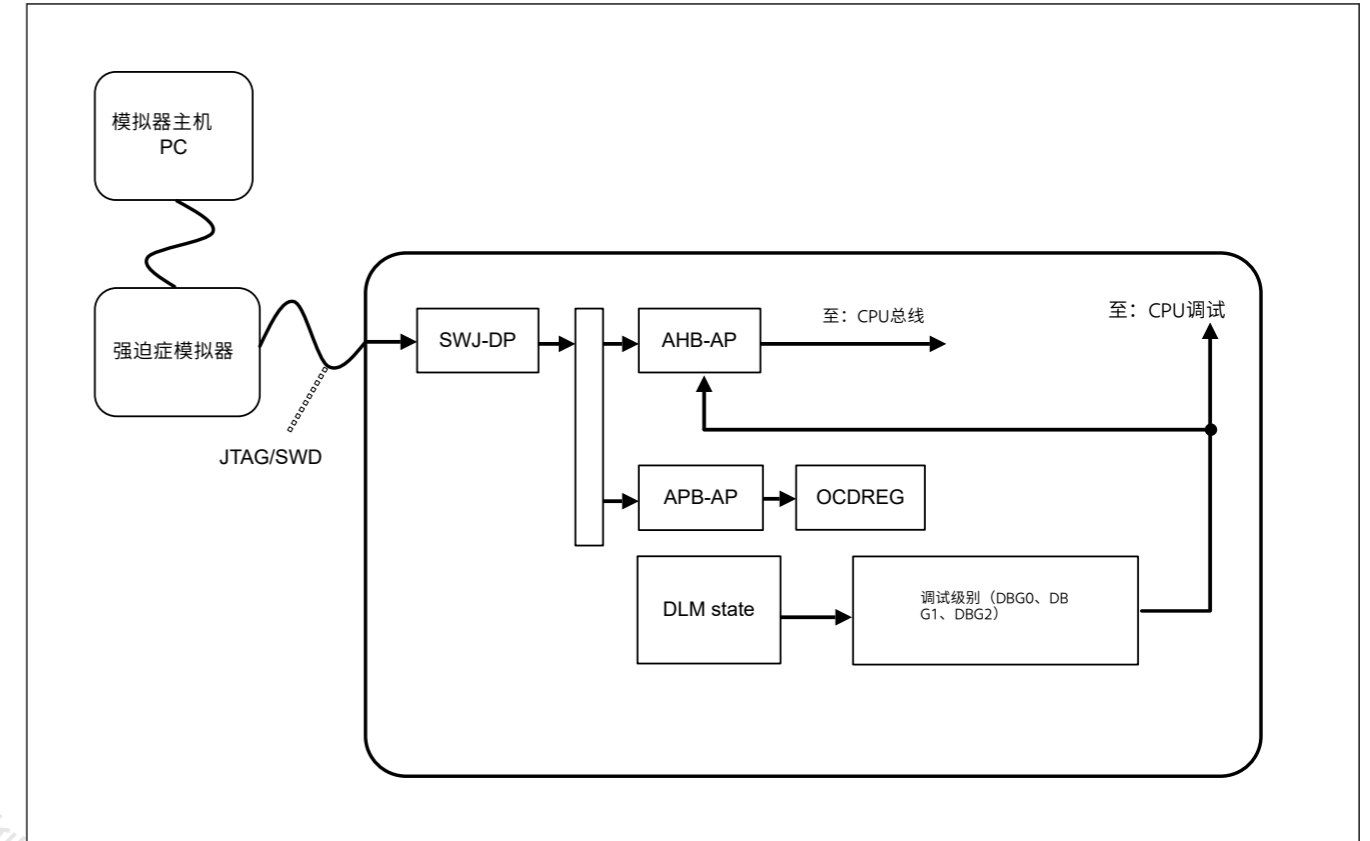


Figure 2.8 SWD认证机制框图

提供三个级别的调试能力，DBG0、DBG1和DBG2，它们对应于DeviceLevel管理(DLM)状态。当调试级别为DBG0时，不允许从OCD仿真器访问调试组件和系统总线。当调试级别为DBG1或DBG2时，可以从OCD仿真器访问相应的非安全或安全调试组件和系统总线。有关调试级别的更多信息，请参见表2.5。

2.13.1 DBGEN

OCD模拟器获得访问权限后，OCD模拟器必须设置SystemControlOCD中的DBGEN位控制寄存器(SYOCDRCR)。此外，OCD仿真器必须在断开连接之前清除DBGEN位。有关详细信息，请参见第10节，低功耗模式。

2.13.2 连接强迫症模拟器的限制

本节介绍对仿真器访问的限制。

2.13.2.1 在低功耗模式下开始连接

从OCD仿真器启动JTAGSWD连接时，MCU必须处于正常或睡眠模式。如果MCU处于软件待机、贪睡或深度软件待机模式，OCD仿真器可能会导致MCU挂起。

2.13.2.2 在OCD模式下更改低功耗模式

当MCU处于OCD模式时，可以更改低功耗模式。但是，在软件待机、贪睡或深度软件待机模式下，禁止从AHB-AP访问系统总线。在这些模式下，只能从OCD仿真器访问SWJ-DP、APB-AP和OCDREG。表2.19显示了这些限制。

Table 2.19 模式限制(1of2)

| 主动模式   | 启动强迫症模拟器连接 | 更改低功耗模式 | 访问AHB-AP和系统总线 | 访问APB-AP和OCDREG |
|--------|------------|---------|---------------|-----------------|
| Normal | Yes        | Yes     | Yes           | Yes             |

Table 2.19 Restrictions by mode (2 of 2)

| Active mode           | Start OCD emulator connection | Change low power mode | Access AHB-AP and system bus | Access APB-AP and OCDREG |
|-----------------------|-------------------------------|-----------------------|------------------------------|--------------------------|
| Sleep                 | Yes                           | Yes                   | Yes                          | Yes                      |
| Software Standby      | No                            | Yes                   | No                           | Yes                      |
| Snooze                | No                            | Yes                   | No                           | Yes                      |
| Deep Software Standby | No                            | Yes                   | No                           | Yes                      |

If system bus access is required in Software Standby, Snooze, or Deep Software Standby mode, set the MCUCTRL.DBIRQ bit in OCDREG to wake up the MCU from the low power modes. Simultaneously, by asserting the MCUCTRL.DBIRQ bit in OCDREG, the OCD emulator can wake up the MCU without starting CPU execution by using a CPU break.

### 2.13.2.3 Connecting sequence and JTAG/SWD authentication

1. Connect the OCD debugger to the MCU through the JTAG or SWD interface.
2. Set up SWJ-DP to access DAP bus.  
In the setup, the OCD emulator must assert CDBGPWRUPREQ in the SWJDP Control Status Register, and then wait until CSDBGPWRUPACK in the same register is asserted.
3. Set the APB-AP to access OCDREG. This APB-AP is connected to DAP bus port 1.
4. Set MCUCTRL.CPUWAIT = 1.
5. Confirm the debug capability of device by reading MCUSTAT:
  - If Debug function is prohibited, this device is not able to debug.
  - If Debug function is enabled and secure debug is not available, only non-secure debug is available.
  - If Debug function is enabled and secure debug is available, full debug functions are available.

If Debug function is available, set debug-related register then clear MCUCTRL.CPUWAIT = 0.

6. Set up the AHB-AP to access the system address space. The AHB-AP is connected to DAP bus port 0.
7. Set SYOCDCLR.DBGEN to 1.
8. Start accessing the CPU debug resources using the AHB-AP.

Note: Debug level is determined by the current DLM state of product.

## 2.14 References

1. ARM®v8-M Architecture Reference Manual (ARM DDI 0553B.a)
2. ARM® Cortex®-M33 Processor Technical Reference Manual (ARM 100230)
3. ARM® Cortex®-M33 Device Generic User Guide (ARM 100235)
4. ARM® CoreSight™ SoC-400 Technical Reference Manual (ARM DDI 0480G)
5. ARM® CoreSight™ Architecture Specification (ARM IHI 0029E)

Table 2.19 模式限制(2of2)

| 主动模式   | 启动强迫模拟器连接 | 更改低功耗模式 | 访问AHB-AP和系统总线 | 访问APB-AP和OCDREG |
|--------|-----------|---------|---------------|-----------------|
| Sleep  | Yes       | Yes     | Yes           | Yes             |
| 软件待机   | No        | Yes     | No            | Yes             |
| Snooze | No        | Yes     | No            | Yes             |
| 深度软件待机 | No        | Yes     | No            | Yes             |

如果在软件待机、贪睡或深度软件待机模式下需要系统总线访问，则设置OCDREG中的MCUCTRL.DBIRQ位以将MCU从低功耗模式中唤醒。同时，通过置位OCDREG中的MCUCTRL.DBIRQ位，OCD仿真器可以在不使用CPU中断启动CPU执行的情况下唤醒MCU。

### 2.13.2.3 连接顺序和JTAG/SWD认证

- 1.通过JTAG或SWD接口将OCD调试器连接到MCU。
- 2.设置SWJ-DP访问DAP总线。  
在设置中，OCD仿真器必须在SWJDP中声明CDBGPWRUPREQ。控制状态寄存器，然后等待同一寄存器中的CSDBGPWRUPACK被断言。
- 3.将APB-AP设置为访问OCDREG。此APB-AP连接到DAP总线端口1。
4. Set MCUCTRL.CPUWAIT = 1.
- 5.通过读取MCUSTAT确认设备的调试能力：
  - 如果Debug功能被禁止，则本设备无法调试。
  - 如果启用了Debug功能且没有安全调试，则只能进行非安全调试。
  - 如果启用了Debug功能并且可以使用安全调试，则可以使用完整的调试功能。

如果Debug功能可用，设置调试相关寄存器然后清除MCUCTRL.CPUWAIT=0。

- 6.设置AHB-AP访问系统地址空间。AHB-AP连接到DAP总线端口0。
- 7.将SYOCDCLR.DBGEN设置为1。
- 8.开始使用AHB-AP访问CPU调试资源。

Note: 调试级别由产品的当前DLM状态决定。

## 2.14 References

- 1.ARM®v8-M架构参考手册 (ARMDDI0553B.a)
- 2.ARM®Cortex®-M33处理器技术参考手册 (ARM100230)
- 3.ARM®Cortex®-M33设备通用用户指南(ARM100235)
- 4.ARM®CoreSight SoC-400技术参考手册 (ARMDDI0480G)
- 5.ARM®CoreSight 架构规范 (ARMIHI0029E)



## 3. Operating Modes

### 3.1 Overview

Table 3.1 shows the selection of operating modes by the mode-setting pin. For details, see [section 3.2. Details of Operating Modes](#). Operation starts with the on-chip flash memory enabled, regardless of the mode in which operation started.

Table 3.1 Selection of operating modes by the mode-setting pin

| Mode-setting pin (MD) | Operating mode      | On-chip Flash |
|-----------------------|---------------------|---------------|
| 1                     | Single-chip mode    | Enable        |
| 0                     | SCI / USB boot mode | Enable        |

### 3.2 Details of Operating Modes

#### 3.2.1 Single-Chip Mode

In single-chip mode, all I/O pins are available for use as input or output port, inputs or outputs for peripheral functions, or as interrupt inputs.

When a reset is released while the MD pin is high, the MCU starts in single-chip mode and the on-chip flash is enabled.

#### 3.2.2 SCI Boot Mode

In this mode, the on-chip flash memory programming routine (SCI boot program), stored in the boot area within the MCU, is used. The on-chip flash, including code flash memory and data flash memory, can be modified from outside the MCU by using a universal asynchronous receiver/transmitter (UART) SCI. For details, see [section 44, Flash Memory](#). The MCU starts in SCI boot mode if the MD pin is held low on release from the reset state.

#### 3.2.3 USB Boot Mode

In this mode, the on-chip flash memory programming routine (USB boot program), stored in the boot area within the MCU, is used. The on-chip flash, including code flash memory and data flash memory, can be modified from outside the MCU by using USB. For details, see [section 44, Flash Memory](#). The MCU starts in USB boot mode if the MD pin is held low on release from the reset state.

## 3.3 Operating Modes Transitions

### 3.3.1 Operating Mode Transitions as Determined by the Mode-Setting Pin

Figure 3.1 shows operating mode transitions determined by the MD pin settings.

## 3. 操作模式

### 3.1 Overview

表3.1显示了通过模式设置引脚选择的工作模式。有关详细信息，请参阅第3.2节。经营详情模式。无论操作以何种模式开始，操作都会从启用片上闪存开始。

Table 3.1 通过模式设置引脚选择工作模式

| Mode-setting pin (MD) | 操作模式             | On-chip Flash |
|-----------------------|------------------|---------------|
| 1                     | Single-chip mode | Enable        |
| 0                     | SCI/USB启动模式      | Enable        |

### 3.2 操作模式的详细信息

#### 3.2.1 Single-Chip Mode

在单片机模式下，所有IO引脚都可用作输入或输出端口、外围功能的输入或输出，或用作中断输入。

当MD引脚为高电平时释放复位时，MCU以单芯片模式启动，并启用片上闪存。

#### 3.2.2 SCI启动模式

在这种模式下，使用存储在MCU引导区域中的片上闪存编程例程（SCI引导程序）。片上闪存，包括代码闪存和数据闪存，可以通过使用通用异步接收发送器(UART)SCI从MCU外部进行修改。有关详细信息，请参阅第44节，闪存。如果MD引脚在从复位状态释放时保持低电平，则MCU以SCI启动模式启动。

#### 3.2.3 USB启动模式

在这种模式下，使用存储在MCU引导区域中的片上闪存编程例程（USB引导程序）。片上闪存，包括代码闪存和数据闪存，可以通过USB从MCU外部进行修改。有关详细信息，请参阅第44节，闪存。如果MD引脚在从复位状态释放时保持低电平，则MCU在USB引导模式下启动。

## 3.3 操作模式转换

### 3.3.1 由模式设置引脚确定的操作模式转换

图3.1显示了由MD引脚设置确定的操作模式转换。

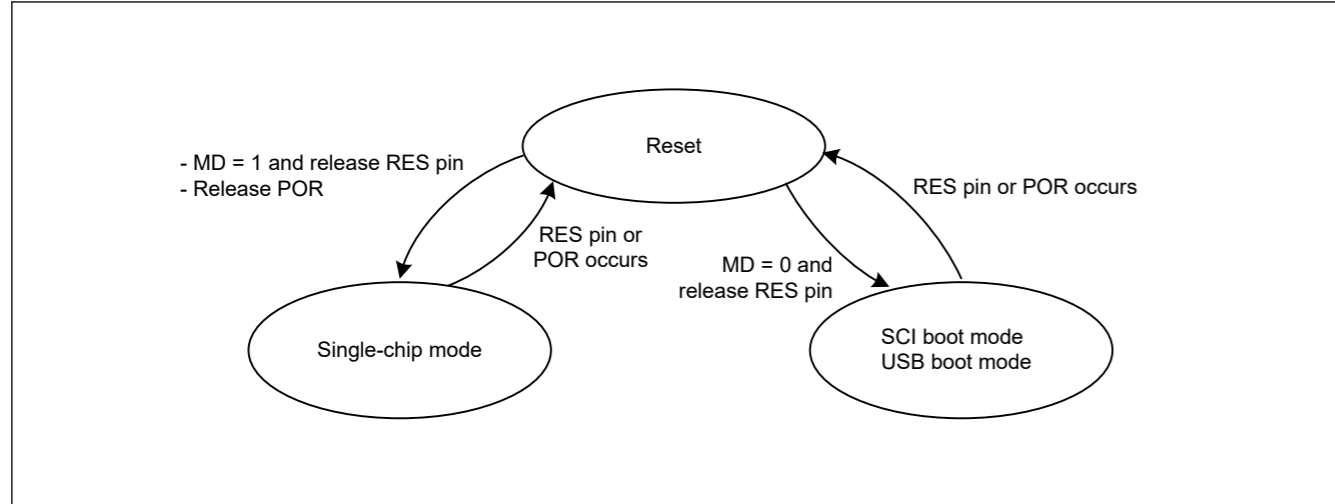


Figure 3.1 Mode-setting pin level and operating mode

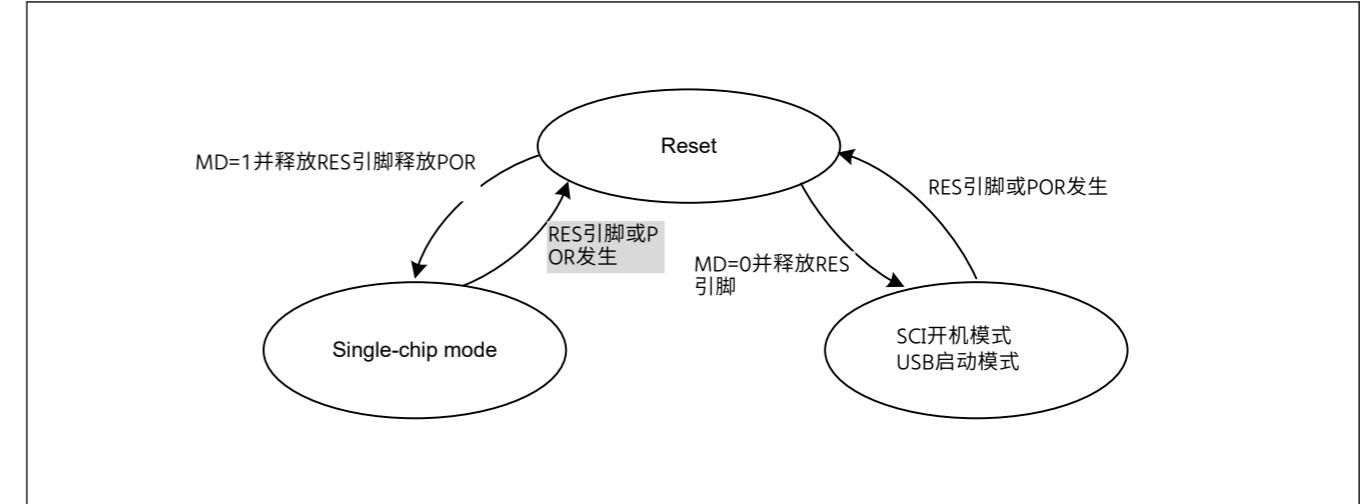


Figure 3.1 模式设置引脚电平和操作模式

RA生态工作室

## 4. Address Space

### 4.1 Address Space

The MCU supports a 4-GB linear address space ranging from 0x0000\_0000 to 0xFFFF\_FFFF that can contain both program and data. Figure 4.1 shows the memory map.

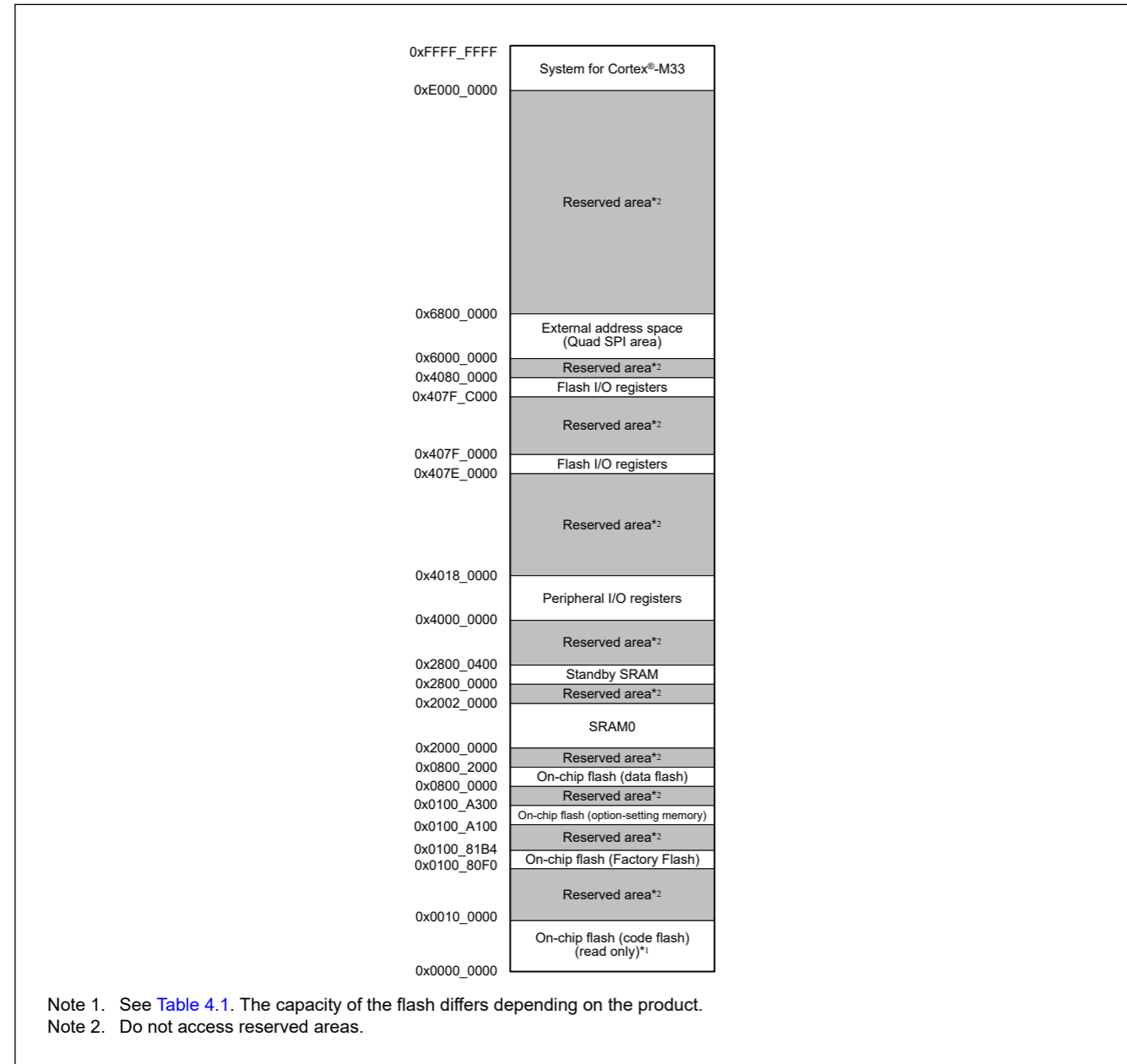


Figure 4.1 Memory map

Table 4.1 Capacity of the code flash memory, data flash memory, and SRAM0

| Code flash memory |                           | Data flash memory |                           | SRAM0    |                           |
|-------------------|---------------------------|-------------------|---------------------------|----------|---------------------------|
| Capacity          | Address                   | Capacity          | Address                   | Capacity | Address                   |
| 1 MB              | 0x0000_0000 - 0x000F_FFFF | 8 KB              | 0x0800_0000 - 0x0800_1FFF | 128 KB   | 0x2000_0000 - 0x2001_FFFF |
| 768 KB            | 0x0000_0000 - 0x000B_FFFF |                   |                           |          |                           |
| 512 KB            | 0x0000_0000 - 0x0007_FFFF |                   |                           |          |                           |

## 4. 地址空间

### 4.1 地址空间

MCU支持4-GB线性地址空间，范围从0x0000\_0000到0xFFFF\_FFFF，可以同时包含程序和数据。图4.1显示了内存映射。

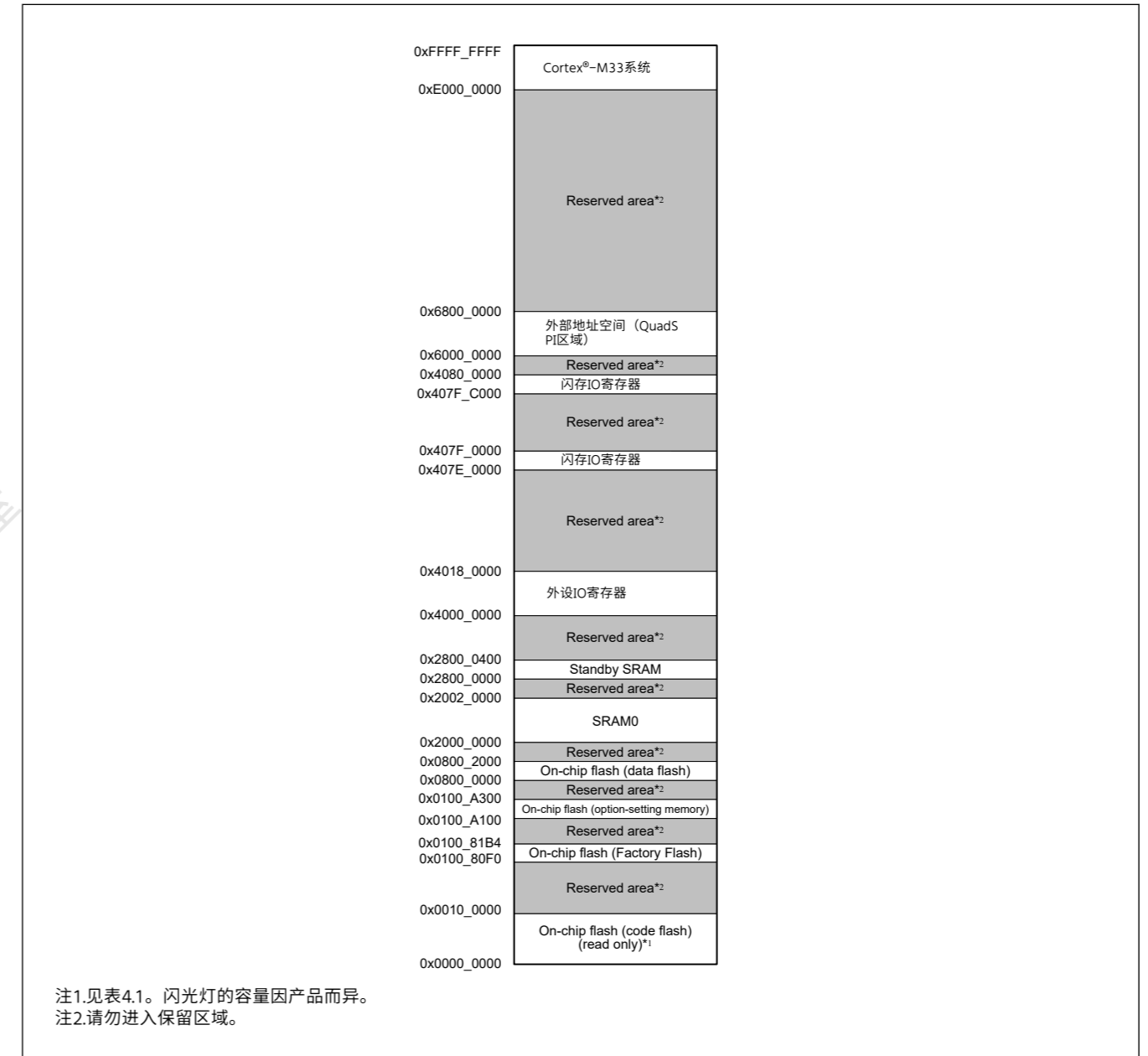


Figure 4.1 内存映射

Table 4.1 代码闪存、数据闪存和SRAM0的容量

| 代码闪存     |                           | 数据闪存     |                           | SRAM0    |                           |
|----------|---------------------------|----------|---------------------------|----------|---------------------------|
| Capacity | Address                   | Capacity | Address                   | Capacity | Address                   |
| 1 MB     | 0x0000_0000 - 0x000F_FFFF | 8 KB     | 0x0800_0000 - 0x0800_1FFF | 128 KB   | 0x2000_0000 - 0x2001_FFFF |
| 768 KB   | 0x0000_0000 - 0x000B_FFFF |          |                           |          |                           |
| 512 KB   | 0x0000_0000 - 0x0007_FFFF |          |                           |          |                           |

### 4.2 External Address Space

The external address space is Quad SPI area and is divided into two areas, QSPI I/O registers and external SPI device space. Figure 4.2 shows the address ranges associated with the Quad SPI area.

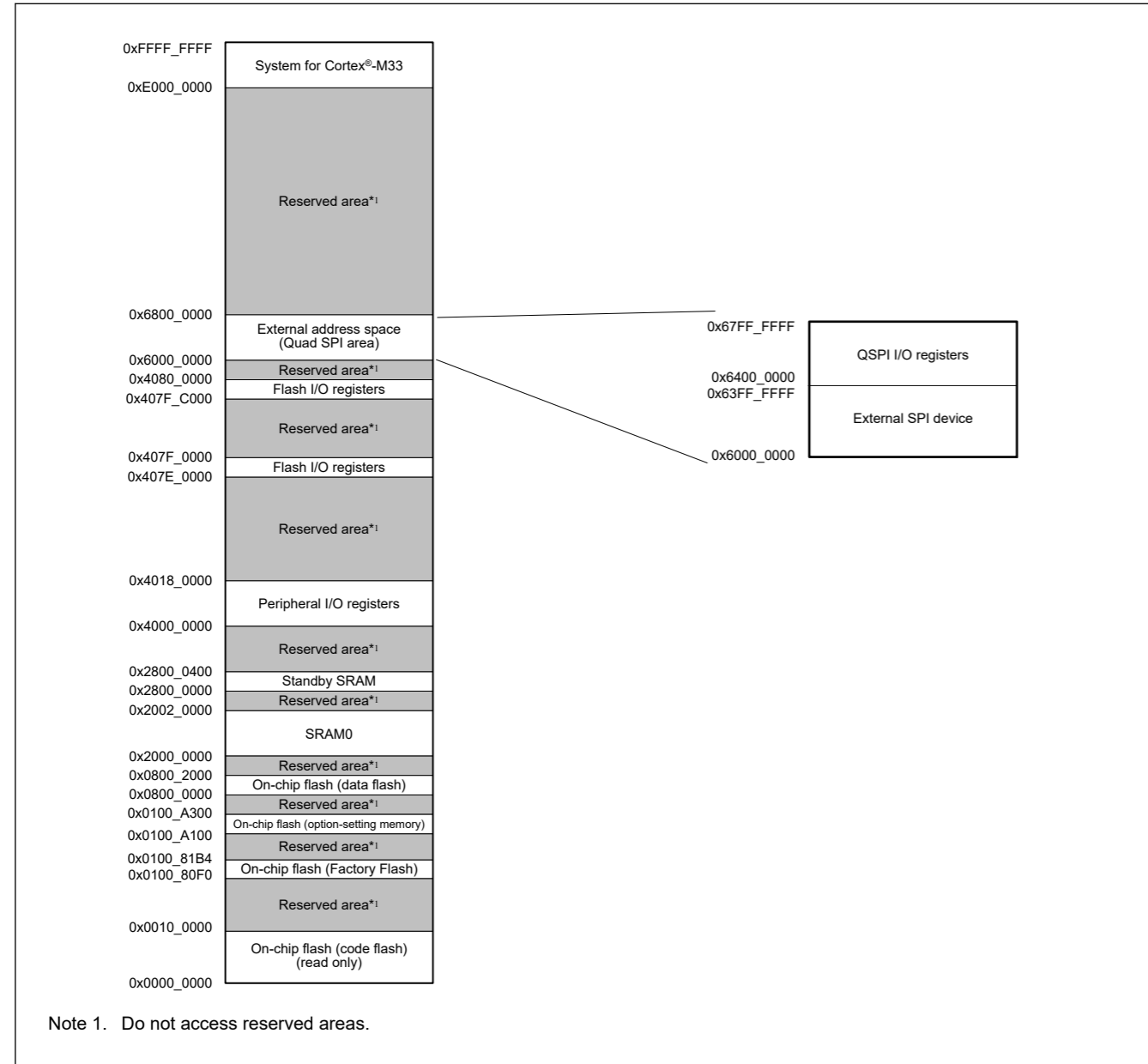


Figure 4.2 Association between external address spaces

### 4.2 外部地址空间

外部地址空间为QuadSPI区域，分为两个区域，QSPIIO寄存器和外部SPI设备空间。图4.2显示了与QuadSPI区域相关的地址范围。

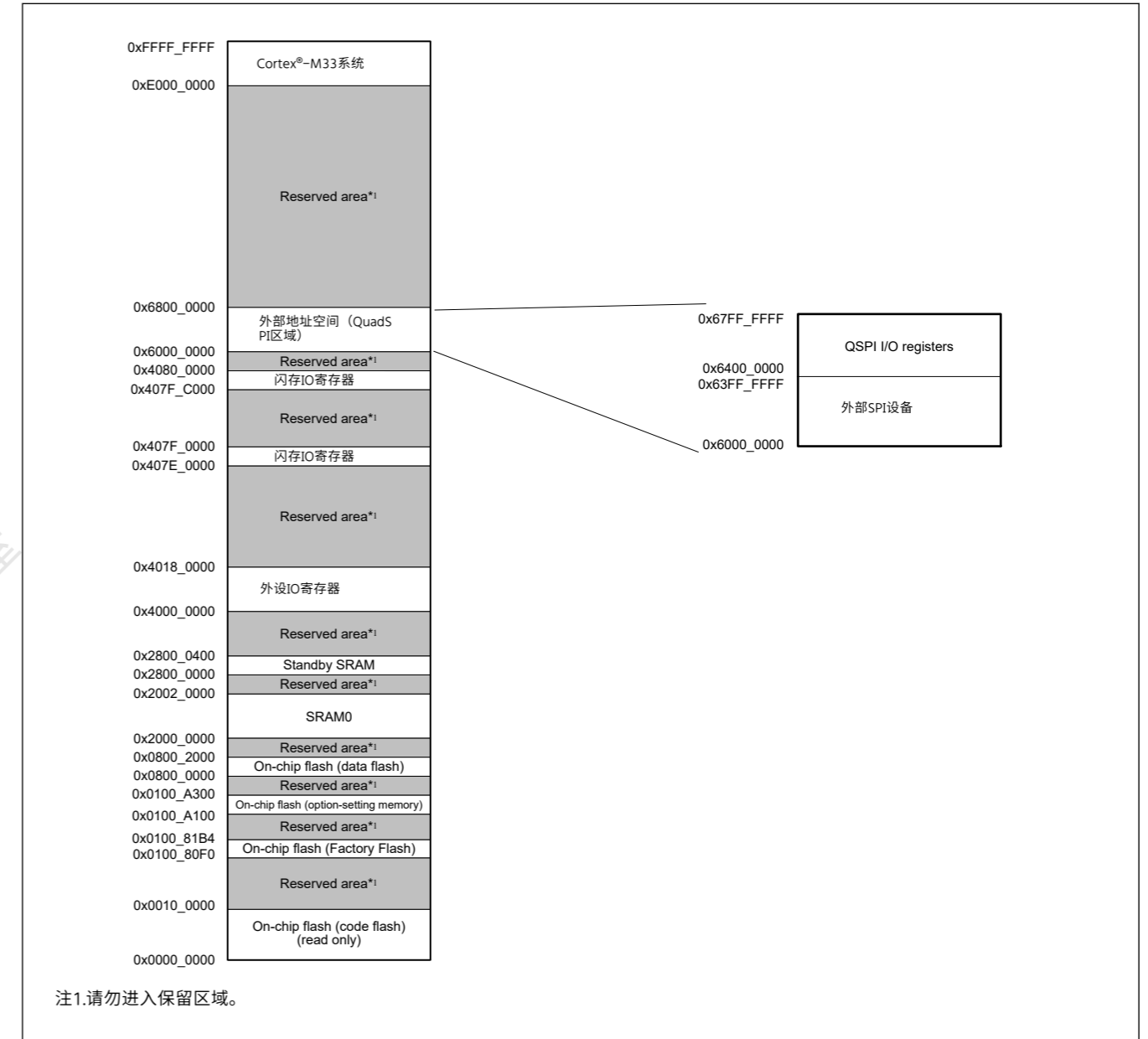


Figure 4.2 外部地址空间之间的关联

## 5. Resets

### 5.1 Overview

The MCU provides 14 resets.

Table 5.1 lists the reset names and sources.

**Table 5.1 Reset names and sources**

| Reset name                       | Source  |
|----------------------------------|---|
| RES pin reset                    | Voltage input to the RES pin is driven low                      |
| Power-on reset                   | VCC rise (voltage detection $V_{POR}$ ) <sup>*1</sup>           |
| Independent watchdog timer reset | IWDT underflow or refresh error                                 |
| Watchdog timer reset             | WDT underflow or refresh error                                  |
| Voltage monitor 0 reset          | VCC fall (voltage detection $V_{det0}$ ) <sup>*1</sup>          |
| Voltage monitor 1 reset          | VCC fall (voltage detection $V_{det1}$ ) <sup>*1</sup>          |
| Voltage monitor 2 reset          | VCC fall (voltage detection $V_{det2}$ ) <sup>*1</sup>          |
| SRAM parity error reset          | SRAM parity error detection                                     |
| SRAM ECC error reset             | SRAM ECC error detection  |
| Bus master MPU error reset       | Bus master MPU error detection                                  |
| TrustZone error reset            | TrustZone error detection                                       |
| Cache Parity error reset         | Cache Parity error detection                                    |
| Deep software standby reset      | Deep software standby mode is canceled by an interrupt          |
| Software reset                   | Register setting (use the software reset bit AIRCR.SYSRESETREQ) |

Note 1. For details on the voltages to be monitored ( $V_{POR}$ ,  $V_{det0}$ ,  $V_{det1}$ , and  $V_{det2}$ ), see section 7, Low Voltage Detection (LVD) and section 47, Electrical Characteristics.

The internal state and pins are initialized by a reset. Table 5.2 and Table 5.3 list the targets initialized by resets.

**Table 5.2 Reset detect flags initialized by each reset source (1 of 4)**

| Flag to be initialized                                       | Reset source  |                |                         |                                  |                      |                         |                         |                |
|--|---------------|----------------|-------------------------|----------------------------------|----------------------|-------------------------|-------------------------|----------------|
|  | RES pin reset | Power-on reset | Voltage monitor 0 reset | Independent watchdog timer reset | Watchdog timer reset | Voltage monitor 1 reset | Voltage monitor 2 reset | Software reset |
| Power-On Reset Detect Flag (RSTSR0.PORF)                     | ✓             | —              | —                       | —                                | —                    | —                       | —                       | —              |
| Voltage Monitor 0 Reset Detect Flag (RSTSR0.LVD0RF)          | ✓             | ✓              | —                       | —                                | —                    | —                       | —                       | —              |
| Independent Watchdog Timer Reset Detect Flag (RSTSR1.IWDTRF) | ✓             | ✓              | ✓                       | —                                | —                    | —                       | —                       | —              |
| Watchdog Timer Reset Detect Flag (RSTSR1.WDTRF)              | ✓             | ✓              | ✓                       | —                                | —                    | —                       | —                       | —              |
| Voltage Monitor 1 Reset Detect Flag (RSTSR0.LVD1RF)          | ✓             | ✓              | ✓                       | —                                | —                    | —                       | —                       | —              |
| Voltage Monitor 2 Reset Detect Flag (RSTSR0.LVD2RF)          | ✓             | ✓              | ✓                       | —                                | —                    | —                       | —                       | —              |

## 5. Resets

### 5.1 Overview

MCU提供14次复位。

表5.1列出了复位名称和来源。

**Table 5.1 重置名称和来源**

| 重置名称           | Source                          |
|----------------|---------------------------------|
| RES引脚复位        | 输入到RES引脚的电压被驱动为低电平              |
| Power-on reset | VCC上升（电压检测VPOR）*1               |
| 独立看门狗定时器复位     | IWDT下溢或刷新错误                     |
| 看门狗定时器复位       | WDT下溢或刷新错误                      |
| 电压监控器0复位       | VCC下降（电压检测Vdet0）*1              |
| 电压监视器1复位       | VCC下降（电压检测Vdet1）*1              |
| 电压监视器2复位       | VCC下降（电压检测Vdet2）*1              |
| SRAM奇偶校验错误复位   | SRAM奇偶校验错误检测                    |
| SRAMECC错误复位    | SRAMECC错误检测                     |
| 总线主控MPU错误复位    | 总线主控MPU错误检测                     |
| TrustZone错误重置  | TrustZone错误检测                   |
| 缓存奇偶校验错误重置     | 缓存奇偶校验错误检测                      |
| 深度软件待机复位       | 深度软件待机模式被中断取消                   |
| 软件复位           | 寄存器设置（使用软件复位位AIRCR.SYSRESETREQ） |

注1.有关要监控的电压（VPOR、Vdet0、Vdet1和Vdet2）的详细信息，请参阅第7节，低电压检测(LVD)和第47节，电气特性。

内部状态和引脚由复位初始化。表5.2和表5.3列出了由复位初始化的目标。

**Table 5.2 由每个复位源初始化的复位检测标志（4个中的1个）**

| 要初始化的标志                                | 重置源     |                |          |            |          |          |          |      |
|--|---------|----------------|----------|------------|----------|----------|----------|------|
|  | RES引脚复位 | Power-on reset | 电压监控器0复位 | 独立看门狗定时器复位 | 看门狗定时器复位 | 电压监视器1复位 | 电压监视器2复位 | 软件复位 |
| 上电复位检测标志(RSTSR0.PORF)                  | ✓       | —              | —        | —          | —        | —        | —        | —    |
| 电压监视器0复位检测标志(RSTSR0.LVD0RF)            | ✓       | ✓              | —        | —          | —        | —        | —        | —    |
| Independent看门狗定时器复位检测标志(RSTSR1.IWDTRF) | ✓       | ✓              | ✓        | —          | —        | —        | —        | —    |
| 看门狗定时器复位检测标志(RSTSR1.WDTRF)             | ✓       | ✓              | ✓        | —          | —        | —        | —        | —    |
| 电压监视器1复位检测标志(RSTSR0.LVD1RF)            | ✓       | ✓              | ✓        | —          | —        | —        | —        | —    |
| 电压监视器2复位检测标志(RSTSR0.LVD2RF)            | ✓       | ✓              | ✓        | —          | —        | —        | —        | —    |

Table 5.2 Reset detect flags initialized by each reset source (2 of 4)

| Flag to be initialized                                   | Reset source  |                |                         |                                  |                      |                         |                         |                |
|--|---------------|----------------|-------------------------|----------------------------------|----------------------|-------------------------|-------------------------|----------------|
|  | RES pin reset | Power-on reset | Voltage monitor 0 reset | Independent watchdog timer reset | Watchdog timer reset | Voltage monitor 1 reset | Voltage monitor 2 reset | Software reset |
| Software Reset Detect Flag (RSTSR1.SWRF)                 | ✓             | ✓              | ✓                       | —                                | —                    | —                       | —                       | —              |
| SRAM Parity Error Reset Detect Flag (RSTSR1.RPERF)       | ✓             | ✓              | ✓                       | —                                | —                    | —                       | —                       | —              |
| SRAM ECC Error Reset Detect Flag (RSTSR1.REERF)          | ✓             | ✓              | ✓                       | —                                | —                    | —                       | —                       | —              |
| Bus Master MPU Error Reset Detect Flag (RSTSR1.BUSMRF)   | ✓             | ✓              | ✓                       | —                                | —                    | —                       | —                       | —              |
| TrustZone Error Reset Detect Flag (RSTSR1.TZERF)         | ✓             | ✓              | ✓                       | —                                | —                    | —                       | —                       | —              |
| Cache Parity Reset Detect Flag (RSTSR1.CPERF)            | ✓             | ✓              | ✓                       | —                                | —                    | —                       | —                       | —              |
| Deep Software Standby Reset Detect Flag (RSTSR0.DPSRSTF) | ✓             | ✓              | ✓                       | —                                | —                    | —                       | —                       | —              |
| Cold Start/Warm Start Determination Flag (RSTSR2.CWSF)   | —             | ✓              | —                       | —                                | —                    | —                       | —                       | —              |

Table 5.2 Reset detect flags initialized by each reset source (3 of 4)

| Flag to be initialized                                       | Reset source            |                      |                            |                       |                          |                             |                |  |
|--|-------------------------|----------------------|----------------------------|-----------------------|--------------------------|-----------------------------|----------------|--|
|  | SRAM parity error reset | SRAM ECC error reset | Bus master MPU error reset | TrustZone reset error | Cache Parity error reset | Deep Software Standby reset |                |  |
|  |                         |                      |                            |                       |                          | DEEPCUT[0] = 0              | DEEPCUT[0] = 1 |  |
| Power-On Reset Detect Flag (RSTSR0.PORF)                     | —                       | —                    | —                          | —                     | —                        | —                           | —              |  |
| Voltage Monitor 0 Reset Detect Flag (RSTSR0.LVD0RF)          | —                       | —                    | —                          | —                     | —                        | —                           | —              |  |
| Independent Watchdog Timer Reset Detect Flag (RSTSR1.IWDTRF) | —                       | —                    | —                          | —                     | —                        | ✓                           | ✓              |  |
| Watchdog Timer Reset Detect Flag (RSTSR1.WDTRF)              | —                       | —                    | —                          | —                     | —                        | ✓                           | ✓              |  |
| Voltage Monitor 1 Reset Detect Flag (RSTSR0.LVD1RF)          | —                       | —                    | —                          | —                     | —                        | —                           | —              |  |
| Voltage Monitor 2 Reset Detect Flag (RSTSR0.LVD2RF)          | —                       | —                    | —                          | —                     | —                        | —                           | —              |  |
| Software Reset Detect Flag (RSTSR1.SWRF)                     | —                       | —                    | —                          | —                     | —                        | ✓                           | ✓              |  |
| SRAM Parity Error Reset Detect Flag (RSTSR1.RPERF)           | —                       | —                    | —                          | —                     | —                        | ✓                           | ✓              |  |
| SRAM ECC Error Reset Detect Flag (RSTSR1.REERF)              | —                       | —                    | —                          | —                     | —                        | ✓                           | ✓              |  |

Table 5.2 由每个复位源初始化的复位检测标志 (4个中的2个)

| 要初始化的标志                         | 重置源     |                |          |            |          |          |          |      |
|---------------------------------|---------|----------------|----------|------------|----------|----------|----------|------|
|                                 | RES引脚复位 | Power-on reset | 电压监控器0复位 | 独立看门狗定时器复位 | 看门狗定时器复位 | 电压监视器1复位 | 电压监视器2复位 | 软件复位 |
| 软件复位检测标志(RSTSR1.SWRF)           | ✓       | ✓              | ✓        | —          | —        | —        | —        | —    |
| SRAM奇偶校验错误复位检测标志 (RSTSR1.RPERF) | ✓       | ✓              | ✓        | —          | —        | —        | —        | —    |
| SRAMECC错误复位检测标志(RSTSR1.REERF)   | ✓       | ✓              | ✓        | —          | —        | —        | —        | —    |
| 总线主控MPU错误复位检测标志(RSTSR1.BUSMRF)  | ✓       | ✓              | ✓        | —          | —        | —        | —        | —    |
| TrustZone错误重置检测标志(RSTSR1.TZERF) | ✓       | ✓              | ✓        | —          | —        | —        | —        | —    |
| 高速缓存奇偶校验复位检测标志(RSTSR1.CPERF)    | ✓       | ✓              | ✓        | —          | —        | —        | —        | —    |
| 深度软件待机复位检测标志(RSTSR0.DPRSTF)     | ✓       | ✓              | ✓        | —          | —        | —        | —        | —    |
| 冷启动热启动确定标志(RSTSR2.CWSF)         | —       | ✓              | —        | —          | —        | —        | —        | —    |

Table 5.2 由每个复位源初始化的复位检测标志 (4个中的3个)

| 要初始化的标志                         | 重置源          |              |             |               |            |                |                |  |
|---------------------------------|--------------|--------------|-------------|---------------|------------|----------------|----------------|--|
|                                 | SRAM奇偶校验错误复位 | SRAM ECC错误复位 | 总线主控MPU错误复位 | TrustZone重置错误 | 缓存奇偶校验错误重置 | 深度软件待机复位       |                |  |
|                                 |              |              |             |               |            | DEEPCUT[0] = 0 | DEEPCUT[0] = 1 |  |
| 上电复位检测标志(RSTSR0.PORF)           | —            | —            | —           | —             | —          | —              | —              |  |
| 电压监控器0复位检测标志 (RSTSR0.LVD0RF)    | —            | —            | —           | —             | —          | —              | —              |  |
| 独立看门狗定时器复位检测标志(RSTSR1.IWDTRF)   | —            | —            | —           | —             | —          | ✓              | ✓              |  |
| 看门狗定时器复位检测标志 (RSTSR1.WDTRF)     | —            | —            | —           | —             | —          | ✓              | ✓              |  |
| 电压监视器1复位检测标志 (RSTSR0.LVD1RF)    | —            | —            | —           | —             | —          | —              | —              |  |
| 电压监视器2复位检测标志 (RSTSR0.LVD2RF)    | —            | —            | —           | —             | —          | —              | —              |  |
| 软件复位检测标志(RSTSR1.SWRF)           | —            | —            | —           | —             | —          | ✓              | ✓              |  |
| SRAM奇偶校验错误复位检测标志 (RSTSR1.RPERF) | —            | —            | —           | —             | —          | ✓              | ✓              |  |
| SRAMECC错误复位检测标志 (RSTSR1.REERF)  | —            | —            | —           | —             | —          | ✓              | ✓              |  |



Table 5.2 Reset detect flags initialized by each reset source (4 of 4)

| Flag to be initialized                                   | Reset source            |                      |                            |                       |                          |                             |                |
|--|-------------------------|----------------------|----------------------------|-----------------------|--------------------------|-----------------------------|----------------|
|  | SRAM parity error reset | SRAM ECC error reset | Bus master MPU error reset | TrustZone reset error | Cache Parity error reset | Deep Software Standby reset |                |
|  |                         |                      |                            |                       |                          | DEEPCUT[0] = 0              | DEEPCUT[0] = 1 |
| Bus Master MPU Error Reset Detect Flag (RSTSR1.BUSMRF)   | —                       | —                    | —                          | —                     | —                        | ✓                           | ✓              |
| TrustZone Error Reset Detect Flag (RSTSR1.TZERF)         | —                       | —                    | —                          | —                     | —                        | ✓                           | ✓              |
| Cache Parity Reset Detect Flag (RSTSR1.CPERF)            | —                       | —                    | —                          | —                     | —                        | ✓                           | ✓              |
| Deep Software Standby Reset Detect Flag (RSTSR0.DPSRSTF) | —                       | —                    | —                          | —                     | —                        | —                           | —              |
| Cold Start/Warm Start Determination Flag (RSTSR2.CWSF)   | —                       | —                    | —                          | —                     | —                        | —                           | —              |

Note: ✓ : Initialized to 0  
 — : Not initialized

Table 5.3 Module-related registers initialized by each reset source (1 of 4)

| Registers to be initialized                 | Reset source                         | Reset source  |                 |                         |                                  |                      |                         |                         |                |
|---|--------------------------------------|---------------|-----------------|-------------------------|----------------------------------|----------------------|-------------------------|-------------------------|----------------|
|   |                                      | RES pin reset | Power-on reset  | Voltage monitor 0 reset | Independent watchdog timer reset | Watchdog timer reset | Voltage monitor 1 reset | Voltage monitor 2 reset | Software reset |
| Independent watchdog timer registers        | IWDTRR, IWDTSR                       | ✓             | ✓               | ✓                       | ✓                                | ✓                    | ✓                       | ✓                       | ✓              |
| Watchdog timer registers                    | WDTRR, WDTCR, WDTSR, WDTRCR, WDCSTPR | ✓             | ✓               | ✓                       | ✓                                | ✓                    | ✓                       | ✓                       | ✓              |
| Voltage monitor function 1 registers        | LVD1CR0,LVD1CMP CR                   | ✓             | ✓               | ✓                       | ✓                                | ✓                    | —                       | —                       | —              |
|   | LVD1CR1/LVD1SR                       | ✓             | ✓               | ✓                       | ✓                                | ✓                    | —                       | —                       | —              |
| Voltage monitor function 2 registers        | LVD2CR0, LVD2CMPCR                   | ✓             | ✓               | ✓                       | ✓                                | ✓                    | —                       | —                       | —              |
|   | LVD2CR1/LVD2SR                       | ✓             | ✓               | ✓                       | ✓                                | ✓                    | —                       | —                       | —              |
| SOSC register                               | SOSCCR                               | —             | ✓ <sup>*1</sup> | —                       | —                                | —                    | —                       | —                       | —              |
|   | SOMCR                                | —             | —               | —                       | —                                | —                    | —                       | —                       | —              |
| LOCO registers                              | LOCOCR                               | ✓             | ✓               | ✓                       | ✓                                | ✓                    | ✓                       | ✓                       | ✓              |
|   | LOCOUTCR                             | —             | ✓               | ✓                       | —                                | —                    | ✓                       | ✓                       | —              |
| MOSC register                               | MOMCR                                | ✓             | ✓               | ✓                       | ✓                                | ✓                    | ✓                       | ✓                       | ✓              |
| Realtime Clock (RTC) register <sup>*2</sup> |                                      | —             | —               | —                       | —                                | —                    | —                       | —                       | —              |
| AGTn registers (n = 0 to 3)                 |                                      | —             | ✓               | ✓                       | —                                | —                    | ✓                       | ✓                       | —              |
| AGTn registers (n = 4, 5)                   |                                      | ✓             | ✓               | ✓                       | ✓                                | ✓                    | ✓                       | ✓                       | ✓              |
| USBFS registers                             | Except DPUSR0R, DPUSR1R              | ✓             | ✓               | ✓                       | ✓                                | ✓                    | ✓                       | ✓                       | ✓              |
|   | DPUSR0R, DPUSR1R                     | ✓             | ✓               | ✓                       | ✓                                | ✓                    | ✓                       | ✓                       | ✓              |

Table 5.2 由每个复位源初始化的复位检测标志 (4个中的4个)

| 要初始化的标志                         | 重置源          |              |              |               |            |                |                |
|---------------------------------|--------------|--------------|--------------|---------------|------------|----------------|----------------|
|                                 | SRAM奇偶校验错误复位 | SRAM ECC错误复位 | 总线主控 MPU错误复位 | TrustZone重置错误 | 缓存奇偶校验错误重置 | 深度软件待机复位       |                |
|                                 |              |              |              |               |            | DEEPCUT[0] = 0 | DEEPCUT[0] = 1 |
| 总线主控MPU错误复位检测标志(RSTSR1.BUSMRF)  | —            | —            | —            | —             | —          | ✓              | ✓              |
| TrustZone错误复位检测标志(RSTSR1.TZERF) | —            | —            | —            | —             | —          | ✓              | ✓              |
| 高速缓存奇偶校验复位检测标志(RSTSR1.CPERF)    | —            | —            | —            | —             | —          | ✓              | ✓              |
| 深度软件待机复位检测标志(RSTSR0.DPRSTF)     | —            | —            | —            | —             | —          | —              | —              |
| 冷启动热启动确定标志(RSTSR2.CWSF)         | —            | —            | —            | —             | —          | —              | —              |

Note: — :初始化为0—未初始化

Table 5.3 由每个复位源初始化的模块相关寄存器 (4个中的1个)

| 待初始化的寄存器                  | Reset source                         | 重置源     |                 |          |            |          |          |          |      |
|---------------------------|--------------------------------------|---------|-----------------|----------|------------|----------|----------|----------|------|
|                           |                                      | RES引脚复位 | Power-on reset  | 电压监控器0复位 | 独立看门狗定时器复位 | 看门狗定时器复位 | 电压监视器1复位 | 电压监视器2复位 | 软件复位 |
| 独立的看门狗定时器寄存器              | IWDTRR, IWDTSR                       | ✓       | ✓               | ✓        | ✓          | ✓        | ✓        | ✓        | ✓    |
| 看门狗定时器寄存器                 | WDTRR, WDTCR, WDTSR, WDTRCR, WDCSTPR | ✓       | ✓               | ✓        | ✓          | ✓        | ✓        | ✓        | ✓    |
| 电压监控功能1个寄存器               | LVD1CR0,LVD1CMP CR                   | ✓       | ✓               | ✓        | ✓          | ✓        | —        | —        | —    |
|                           | LVD1CR1/LVD1SR                       | ✓       | ✓               | ✓        | ✓          | ✓        | —        | —        | —    |
| 电压监控功能2个寄存器               | LVD2CR0, LVD2CMPCR                   | ✓       | ✓               | ✓        | ✓          | ✓        | —        | —        | —    |
|                           | LVD2CR1/LVD2SR                       | ✓       | ✓               | ✓        | ✓          | ✓        | —        | —        | —    |
| SOSC register             | SOSCCR                               | —       | ✓ <sup>*1</sup> | —        | —          | —        | —        | —        | —    |
|                           | SOMCR                                | —       | —               | —        | —          | —        | —        | —        | —    |
| LOCO寄存器                   | LOCOCR                               | ✓       | ✓               | ✓        | ✓          | ✓        | ✓        | ✓        | ✓    |
|                           | LOCOUTCR                             | —       | ✓               | ✓        | —          | —        | ✓        | ✓        | —    |
| MOSC register             | MOMCR                                | ✓       | ✓               | ✓        | ✓          | ✓        | ✓        | ✓        | ✓    |
| 实时时钟(RTC)寄存器*2            |                                      | —       | —               | —        | —          | —        | —        | —        | —    |
| AGTn寄存器 (n=0到3)           |                                      | —       | ✓               | ✓        | —          | —        | ✓        | ✓        | —    |
| AGTn registers (n = 4, 5) |                                      | ✓       | ✓               | ✓        | ✓          | ✓        | ✓        | ✓        | ✓    |
| USBFS registers           | Except DPUSR0R, DPUSR1R              | ✓       | ✓               | ✓        | ✓          | ✓        | ✓        | ✓        | ✓    |
|                           | DPUSR0R, DPUSR1R                     | ✓       | ✓               | ✓        | ✓          | ✓        | ✓        | ✓        | ✓    |



Table 5.3 Module-related registers initialized by each reset source (2 of 4)

| Registers to be initialized                               |  | Reset source  |                |                         |                                  |                      |                         |                         |                |
|---|--|---------------|----------------|-------------------------|----------------------------------|----------------------|-------------------------|-------------------------|----------------|
|   |  | RES pin reset | Power-on reset | Voltage monitor 0 reset | Independent watchdog timer reset | Watchdog timer reset | Voltage monitor 1 reset | Voltage monitor 2 reset | Software reset |
| Bus, MPU and TrustZone error registers*4                  | BUS_ERROR_ADDR, ESS Register, BUS_ERROR_STAT, US Register  | ✓             | ✓              | ✓                       | ✓                                | ✓                    | ✓                       | ✓                       | ✓              |
| Pin states (except XCIN/XCOUT pin)                        |  | ✓             | ✓              | ✓                       | ✓                                | ✓                    | ✓                       | ✓                       | ✓              |
| Pin states (XCIN/XCOUT pin)                               |  | —             | —              | —                       | —                                | —                    | —                       | —                       | —              |
| Low-power function registers                              | DPSBYCR, DPSIER0 to DPSIER3, DPSIFR0 to DPSIFR3, DPSIEGR0 to DPSIEGR2  | ✓             | ✓              | ✓                       | ✓                                | ✓                    | ✓                       | ✓                       | ✓              |
|   | SYOCDRCR   | —             | ✓              | —                       | —                                | —                    | —                       | —                       | —              |
| Security Attribute Registers                              | CPUDSAR, RSTSAR, LVDSAR, CGFSAR, LPMSAR, DPFSAR, BBFSAR, ICUSARx, BUSSARA, BUSSARB, CSAR, MMPUSARA, MMPUSARB, DMACSAR, DTCSAR, ELCSARA, ELCSARB, ELCSARC, PmSAR, SRAMSAR, STBRAMSAR, FSAR, PSARB, PSARC, PSARD, PSARE, MSSAR, TZFSAR | ✓*5           | ✓              | ✓*5                     | ✓*5                              | ✓*5                  | ✓*5                     | ✓*5                     | ✓*5            |
| Battery backup register                                   | VBTKRn, VBTICTLR   | —             | —              | —                       | —                                | —                    | —                       | —                       | —              |
|   | VBTKBER  | —             | ✓              | —                       | —                                | —                    | —                       | —                       | —              |
| Registers other than those shown, CPU, and internal state |  | ✓             | ✓              | ✓                       | ✓                                | ✓                    | ✓                       | ✓                       | ✓              |

Table 5.3 Module-related registers initialized by each reset source (3 of 4)

| Registers to be initialized          |  | Reset source            |                      |                            |                       |                          |                             |                 |
|--------------------------------------|--|-------------------------|----------------------|----------------------------|-----------------------|--------------------------|-----------------------------|-----------------|
|                                      |  | SRAM parity error reset | SRAM ECC error reset | Bus master MPU error reset | TrustZone error reset | Cache Parity error reset | Deep Software Standby reset |                 |
|                                      |  |                         |                      |                            |                       |                          | DEEPCU T[0] = 0             | DEEPCU T[0] = 1 |
| Independent watchdog timer registers | IWDTRR, IWDTSR                         | ✓                       | ✓                    | ✓                          | ✓                     | ✓                        | ✓                           | ✓               |
| Watchdog timer registers             | WDTRR, WDTCR, WDTSR, WDTRCR, WDTCSNTPR | ✓                       | ✓                    | ✓                          | ✓                     | ✓                        | ✓                           | ✓               |
| Voltage monitor function 1 registers | LVD1CR0, LVD1CMPCR                     | —                       | —                    | —                          | —                     | —                        | —                           | —               |
|                                      | LVD1CR1 / LVD1SR                       | —                       | —                    | —                          | —                     | —                        | ✓                           | ✓               |

Table 5.3 由每个复位源初始化的模块相关寄存器 (4个中的2个)

| 待初始化的寄存器                |  | 重置源     |                |          |            |          |          |          |      |
|-------------------------|--|---------|----------------|----------|------------|----------|----------|----------|------|
|                         |  | RES引脚复位 | Power-on reset | 电压监控器0复位 | 独立看门狗定时器复位 | 看门狗定时器复位 | 电压监视器1复位 | 电压监视器2复位 | 软件复位 |
| 总线、MPU和TrustZone错误寄存器*4 | BUS_ERROR_ADDR, S寄存器, BUS_ERROR_STAT, 美国注册   | ✓       | ✓              | ✓        | ✓          | ✓        | ✓        | ✓        | ✓    |
| 引脚状态 (XCIN/XCOUT引脚除外)   |  | ✓       | ✓              | ✓        | ✓          | ✓        | ✓        | ✓        | ✓    |
| 引脚状态 (XCIN/XCOUT引脚)     |  | —       | —              | —        | —          | —        | —        | —        | —    |
| 低功耗功能寄存器                | DPSBYCR, DPSIER0 to DPSIER3, DPSIFR0 to DPSIFR3, DPSIEGR0 to DPSIEGR2  | ✓       | ✓              | ✓        | ✓          | ✓        | ✓        | ✓        | ✓    |
|                         | SYOCDRCR   | —       | ✓              | —        | —          | —        | —        | —        | —    |
| 安全属性 Registers          | CPUDSAR, RSTSAR, LVDSAR, CGFSAR, LPMSAR, DPFSAR, BBFSAR, ICUSARx, BUSSARA, BUSSARB, CSAR, MMPUSARA, MMPUSARB, DMACSAR, DTCSAR, ELCSARA, ELCSARB, ELCSARC, PmSAR, SRAMSAR, STBRAMSAR, FSAR, PSARB, PSARC, PSARD, PSARE, MSSAR, TZFSAR | ✓*5     | ✓              | ✓*5      | ✓*5        | ✓*5      | ✓*5      | ✓*5      | ✓*5  |
| 电池备份寄存器                 | VBTKRn, VBTICTLR   | —       | —              | —        | —          | —        | —        | —        | —    |
|                         | VBTKBER  | —       | ✓              | —        | —          | —        | —        | —        | —    |
| 未显示的寄存器、CPU和内部状态        |  | ✓       | ✓              | ✓        | ✓          | ✓        | ✓        | ✓        | ✓    |

Table 5.3 由每个复位源初始化的模块相关寄存器 (4个中的3个)

| 待初始化的寄存器     |  | 重置源          |             |              |               |            |                 |                 |
|--------------|--|--------------|-------------|--------------|---------------|------------|-----------------|-----------------|
|              |  | SRAM奇偶校验错误复位 | SRAMECC错误复位 | 总线主控 MPU错误复位 | TrustZone错误重置 | 缓存奇偶校验错误重置 | 深度软件待机复位        |                 |
|              |  |              |             |              |               |            | DEEPCU T[0] = 0 | DEEPCU T[0] = 1 |
| 独立的看门狗定时器寄存器 | IWDTRR, IWDTSR                         | ✓            | ✓           | ✓            | ✓             | ✓          | ✓               | ✓               |
| 看门狗定时器寄存器    | WDTRR, WDTCR, WDTSR, WDTRCR, WDTCSNTPR | ✓            | ✓           | ✓            | ✓             | ✓          | ✓               | ✓               |
| 电压监控功能1个寄存器  | LVD1CR0, LVD1CMPCR                     | —            | —           | —            | —             | —          | —               | —               |
|              | LVD1CR1 / LVD1SR                       | —            | —           | —            | —             | —          | ✓               | ✓               |

Table 5.3 Module-related registers initialized by each reset source (4 of 4)

| Registers to be initialized                               |  | Reset source            |                      |                            |                       |                          |                             |                 |
|---|--|-------------------------|----------------------|----------------------------|-----------------------|--------------------------|-----------------------------|-----------------|
|   |  | SRAM parity error reset | SRAM ECC error reset | Bus master MPU error reset | TrustZone error reset | Cache Parity error reset | Deep Software Standby reset |                 |
|   |  |                         |                      |                            |                       |                          | DEEPCU T[0] = 0             | DEEPCU T[0] = 1 |
| Voltage monitor function 2 registers                      | LVD2CR0, LVD2CMPCR   | —                       | —                    | —                          | —                     | —                        | —                           | —               |
|   | LVD2CR1/LVD2SR   | —                       | —                    | —                          | —                     | —                        | ✓                           | ✓               |
| SOSC register   | SOSCCR   | —                       | —                    | —                          | —                     | —                        | —                           | —               |
|   | SOMCR  | —                       | —                    | —                          | —                     | —                        | —                           | —               |
| LOCO registers  | LOCOCR   | ✓                       | ✓                    | ✓                          | ✓                     | ✓                        | ✓                           | ✓               |
|   | LOCOUTCR   | —                       | —                    | —                          | —                     | —                        | —                           | ✓               |
| MOSC register   | MOMCR  | ✓                       | ✓                    | ✓                          | ✓                     | ✓                        | —                           | —               |
| Realtime Clock (RTC) register*2                           |  | —                       | —                    | —                          | —                     | —                        | —                           | —               |
| AGTn registers (n = 0 to 3)                               |  | —                       | —                    | —                          | —                     | —                        | —                           | ✓               |
| AGTn registers (n = 4,5)                                  |  | ✓                       | ✓                    | ✓                          | ✓                     | ✓                        | ✓                           | ✓               |
| USBFS registers   | Except DPUSR0R, DPUSR1R  | ✓                       | ✓                    | ✓                          | ✓                     | ✓                        | ✓                           | ✓               |
|   | DPUSR0R, DPUSR1R   | ✓                       | ✓                    | ✓                          | ✓                     | ✓                        | —                           | ✓               |
| Bus, MPU and TrustZone error registers*4                  | BUS_ERROR_ADDRES Register<br>BUS_ERROR_STATUS Register   | ✓                       | ✓                    | —                          | —                     | —                        | ✓                           | ✓               |
| Pin states (except XCIN/XCOUT pin)                        |  | ✓                       | ✓                    | ✓                          | ✓                     | ✓                        | *3                          | *3              |
| Pin states (XCIN/XCOUT pin)                               |  | —                       | —                    | —                          | —                     | —                        | —                           | —               |
| Low-power function registers                              | DPSBYCR, DPSIER0 to DPSIER3, DPSIFR0 to DPSIFR3, DPSIEGR0 to DPSIEGR2  | ✓                       | ✓                    | ✓                          | ✓                     | ✓                        | —                           | —               |
|   | SYOCDR   | —                       | —                    | —                          | —                     | —                        | —                           | —               |
| Security Attribute Registers                              | CPUDSAR, RSTSAR, LVDSAR, CGFSAR, LPMSAR, DPFSAR, BBFSAR, ICUSARx, BUSSARA, BUSSARB, CSAR, MMPUSARA, MMPUSARB, DMACSAR, DTCSAR, ELCSARA, ELCSARB, ELCSARC, PmSAR, SRAMSAR, STBRAMSAR, FSAR, PSARB, PSARC, PSARD, PSARE, MSSAR, TZFSAR | ✓*5                     | ✓*5                  | ✓*5                        | ✓*5                   | ✓*5                      | ✓*6                         | ✓*6             |
| Battery backup register                                   | VBTKRn, VBTICTLR   | —                       | —                    | —                          | —                     | —                        | —                           | —               |
|   | VBTBER   | —                       | —                    | —                          | —                     | —                        | —                           | —               |
| Registers other than those shown, CPU, and internal state |  | ✓                       | ✓                    | ✓                          | ✓                     | ✓                        | ✓                           | ✓               |

Note: ✓ : Initialized  
— : Not initialized

Note 1. For the initial value of each register, see section 8, Clock Generation Circuit.

Table 5.3 由每个复位源初始化的模块相关寄存器 (4个, 共4个)

| 待初始化的寄存器                 |  | 重置源          |             |              |               |            |                 |                 |
|--------------------------|--|--------------|-------------|--------------|---------------|------------|-----------------|-----------------|
|                          |  | SRAM奇偶校验错误复位 | SRAMECC错误复位 | 总线主控 MPU错误复位 | TrustZone错误重置 | 缓存奇偶校验错误重置 | 深度软件待机复位        |                 |
|                          |  |              |             |              |               |            | DEEPCU T[0] = 0 | DEEPCU T[0] = 1 |
| 电压监控功能2个寄存器              | LVD2CR0, LVD2CMPCR   | —            | —           | —            | —             | —          | —               | —               |
|                          | LVD2CR1/LVD2SR   | —            | —           | —            | —             | —          | ✓               | ✓               |
| SOSC register            | SOSCCR   | —            | —           | —            | —             | —          | —               | —               |
|                          | SOMCR  | —            | —           | —            | —             | —          | —               | —               |
| LOCO寄存器                  | LOCOCR   | ✓            | ✓           | ✓            | ✓             | ✓          | ✓               | ✓               |
|                          | LOCOUTCR   | —            | —           | —            | —             | —          | —               | ✓               |
| MOSC register            | MOMCR  | ✓            | ✓           | ✓            | ✓             | ✓          | —               | —               |
| 实时时钟(RTC)寄存器*2           |  | —            | —           | —            | —             | —          | —               | —               |
| AGTn寄存器 (n=0到3)          |  | —            | —           | —            | —             | —          | —               | ✓               |
| AGTn registers (n = 4,5) |  | ✓            | ✓           | ✓            | ✓             | ✓          | ✓               | ✓               |
| USBFS registers          | Except DPUSR0R, DPUSR1R  | ✓            | ✓           | ✓            | ✓             | ✓          | ✓               | ✓               |
|                          | DPUSR0R, DPUSR1R   | ✓            | ✓           | ✓            | ✓             | ✓          | —               | ✓               |
| 总线、MPU和TrustZone错误寄存器*4  | BUS_ERROR_ADDRES Register<br>BUS_ERROR_STATUS Register   | ✓            | ✓           | —            | —             | —          | ✓               | ✓               |
| 引脚状态 (XCIN/XCOUT引脚除外)    |  | ✓            | ✓           | ✓            | ✓             | ✓          | *3              | *3              |
| 引脚状态 (XCIN/XCOUT引脚)      |  | —            | —           | —            | —             | —          | —               | —               |
| 低功耗功能寄存器                 | DPSBYCR, DPSIER0 to DPSIER3, DPSIFR0 to DPSIFR3, DPSIEGR0 to DPSIEGR2  | ✓            | ✓           | ✓            | ✓             | ✓          | —               | —               |
|                          | SYOCDR   | —            | —           | —            | —             | —          | —               | —               |
| 安全属性 Registers           | CPUDSAR, RSTSAR, LVDSAR, CGFSAR, LPMSAR, DPFSAR, BBFSAR, ICUSARx, BUSSARA, BUSSARB, CSAR, MMPUSARA, MMPUSARB, DMACSAR, DTCSAR, ELCSARA, ELCSARB, ELCSARC, PmSAR, SRAMSAR, STBRAMSAR, FSAR, PSARB, PSARC, PSARD, PSARE, MSSAR, TZFSAR | ✓*5          | ✓*5         | ✓*5          | ✓*5           | ✓*5        | ✓*6             | ✓*6             |
| 电池备份寄存器                  | VBTKRn, VBTICTLR   | —            | —           | —            | —             | —          | —               | —               |
|                          | VBTBER   | —            | —           | —            | —             | —          | —               | —               |
| 未显示的寄存器、CPU和内部状态         |  | ✓            | ✓           | ✓            | ✓             | ✓          | ✓               | ✓               |

Note: — : 已初始化—未初始化

注1.关于各寄存器的初始值, 请参阅第8节“时钟生成电路”。

- Note 2. The RTC has a software reset. Some control bits are not initialized by all types of resets. For details on the target bits, see [section 23, Realtime Clock \(RTC\)](#).
- Note 3. Depends on the setting of DPSBYCR.IOKEEP.
- Note 4. Some control bits are not initialized by all types of resets. For details on the target bits, see [section 14, Buses](#).
- Note 5. Reset does not occur while the debugger is connected (DBGSTR.CDBGWRUPREQ = 1) even if On-chip debugger is disabled (SYOCDRCR.DBGEN = 0).
- Note 6. Reset does not occur while On-chip debugger is enabled (SYOCDRCR.DBGEN = 1).

The RTC is not initialized by any reset source. SOSC and LOCO can be selected as the clock sources of the RTC.

[Table 5.4](#) and [Table 5.5](#) show the states of SOSC and LOCO when a reset occurs.

**Table 5.4 States of SOSC when a reset occurs**

|      |                   | Reset source  |   |
|------|-------------------|---|---|
|      |                   | POR   | Other   |
| SOSC | Enable or disable | Initialized to enable   | Continue with the state that was selected before the reset occurred |
|      | Drive capability  | Continue with the state that was selected before the reset occurred |   |

**Table 5.5 States of LOCO when a reset occurs**

|      |                        | Reset source  |   |
|------|------------------------|---|---|
|      |                        | POR, LVD0, LVD1, LVD2, Deep Software Standby (DEEPCUT[0] = 1)         | Other   |
| LOCO | Enable or disable      | Initialized to enable   |   |
|      | Oscillation accuracy*1 | Initialized to accuracy before trimming by power-on (accuracy: ± 10%) | Continue with the accuracy that was trimmed by LOCOUTCR |

Note 1. The LOCO User Trimming Control Register (LOCOUTCR) is reset by POR, LVD0, LVD1, LVD2, and Deep Software Standby (DEEPCUT[0] = 1) resets, returning the LOCO to the default oscillation accuracy. This can affect RTC accuracy if the RTC uses the LOCO (with a user trimming value in LOCOUTCR) as the RTC source clock. To restore the pre-reset LOCO oscillation accuracy, reload the required trimming value into LOCOUTCR after any of these resets.

When a reset is released, reset exception handling starts.

[Table 5.6](#) lists the pin related to the reset function.

**Table 5.6 Pin related to reset**

| Pin name | I/O   | Function  |
|----------|-------|-----------|
| RES      | Input | Reset pin |

## 5.2 Register Descriptions

### 5.2.1 RSTSAR : Reset Security Attribution Register

Base address: SYSC = 0x4001\_E000

Offset address: 0x3C4

|                    |    |    |    |    |    |    |    |    |    |    |    |    |    |    |          |          |          |
|--------------------|----|----|----|----|----|----|----|----|----|----|----|----|----|----|----------|----------|----------|
| Bit position:      | 31 | 30 | 29 | 28 | 27 | 26 | 25 | 24 | 23 | 22 | 21 | 20 | 19 | 18 | 17       | 16       |          |
| Bit field:         | —  | —  | —  | —  | —  | —  | —  | —  | —  | —  | —  | —  | —  | —  | —        | —        |          |
| Value after reset: | 1  | 1  | 1  | 1  | 1  | 1  | 1  | 1  | 1  | 1  | 1  | 1  | 1  | 1  | 1        | 1        |          |
| Bit position:      | 15 | 14 | 13 | 12 | 11 | 10 | 9  | 8  | 7  | 6  | 5  | 4  | 3  | 2  | 1        | 0        |          |
| Bit field:         | —  | —  | —  | —  | —  | —  | —  | —  | —  | —  | —  | —  | —  | —  | NONS EC2 | NONS EC1 | NONS EC0 |
| Value after reset: | 1  | 1  | 1  | 1  | 1  | 1  | 1  | 1  | 1  | 1  | 1  | 1  | 1  | 1  | 1        | 1        | 1        |

注2.RTC具有软件复位功能。某些控制位并非由所有类型的复位初始化。有关目标位的详细信息，请参见第23节，实时时钟(RTC)。

注3.取决于DPSBYCR.IOKEEP的设置。

注4.并非所有类型的复位都会初始化一些控制位。有关目标位的详细信息，请参阅第14节，总线

注5.连接调试器(DBGSTR.CDBGWRUPREQ=1)时不会发生复位，即使禁用片上调试器(SYOCDRCR.DBGEN=0)。

注6.启用片上调试器(SYOCDRCR.DBGEN=1)时不会发生复位。

RTC不会被任何复位源初始化。可选择SOSC和LOCO作为RTC的时钟源。

表5.4和表5.5显示了复位发生时SOSC和LOCO的状态。

**Table 5.4 发生复位时SOSC的状态**

|      |       | 重置源             |                 |
|------|-------|-----------------|-----------------|
|      |       | POR             | Other           |
| SOSC | 启用或禁用 | 初始化为启用          | 继续使用重置发生之前选择的状态 |
|      | 驱动能力  | 继续使用重置发生之前选择的状态 |                 |

**Table 5.5 发生复位时的LOCO状态**

|      |        | 重置源                                     |                     |
|------|--------|---|---------------------|
|      |        | POR、LVD0、LVD1、LVD2、深软件待机 (DEEPCUT[0]=1) | Other               |
| LOCO | 启用或禁用  | 初始化为启用                                  |                     |
|      | 振荡精度*1 | 上电微调前初始化为精度 (精度: ±10%)                  | 继续使用被修剪的精度 LOCOUTCR |

注1.LOCO用户微调控制寄存器(LOCOUTCR)由POR、LVD0、LVD1、LVD2和深度软件待机复位 (DEEPCUT[0]=1)复位，将LOCO返回到默认振荡精度。如果RTC使用LOCO (在LOCOUTCR中具有用户修整值)作为RTC源时钟，这可能会影响RTC精度。要恢复预复位的LOCO振荡精度，请在任何这些复位后将所需的微调值重新加载到LOCOUTCR。

当一个复位被释放时，复位异常处理开始。

表5.6列出了与复位功能相关的引脚。

**Table 5.6 复位相关引脚**

| 引脚名称 | I/O   | Function |
|------|-------|----------|
| RES  | Input | 复位引脚     |

## 5.2 注册说明

### 5.2.1 RSTSAR: 重置安全属性寄存器

Base address: SYSC = 0x4001\_E000

Offset address: 0x3C4

|               |    |    |    |    |    |    |    |    |    |    |    |    |    |    |          |          |          |
|---------------|----|----|----|----|----|----|----|----|----|----|----|----|----|----|----------|----------|----------|
| Bit position: | 31 | 30 | 29 | 28 | 27 | 26 | 25 | 24 | 23 | 22 | 21 | 20 | 19 | 18 | 17       | 16       |          |
| Bit field:    | —  | —  | —  | —  | —  | —  | —  | —  | —  | —  | —  | —  | —  | —  | —        | —        |          |
| 重置后的值:        | 1  | 1  | 1  | 1  | 1  | 1  | 1  | 1  | 1  | 1  | 1  | 1  | 1  | 1  | 1        | 1        |          |
| Bit position: | 15 | 14 | 13 | 12 | 11 | 10 | 9  | 8  | 7  | 6  | 5  | 4  | 3  | 2  | 1        | 0        |          |
| Bit field:    | —  | —  | —  | —  | —  | —  | —  | —  | —  | —  | —  | —  | —  | —  | NONS EC2 | NONS EC1 | NONS EC0 |
| 重置后的值:        | 1  | 1  | 1  | 1  | 1  | 1  | 1  | 1  | 1  | 1  | 1  | 1  | 1  | 1  | 1        | 1        | 1        |

| Bit  | Symbol  | Function   | R/W |
|------|---------|--|-----|
| 0    | NONSEC0 | Non Secure Attribute bit 0<br>Target register: Reset Status Register 0<br>0: Secure<br>1: Non Secure | R/W |
| 1    | NONSEC1 | Non Secure Attribute bit 1<br>Target register: Reset Status Register 1<br>0: Secure<br>1: Non Secure | R/W |
| 2    | NONSEC2 | Non Secure Attribute bit 2<br>Target register: Reset Status Register 2<br>0: Secure<br>1: Non Secure | R/W |
| 31:3 | —       | These bits are read as 1. The write value should be 1.   | R/W |

Note: Only secure access can write to this register. Both secure access and Non-secure read access are allowed but Non-secure write access is not allowed and TrustZone access error is not generated.

Note: This register is write-protected by PRCR register.

#### NONSEC0 bit (Non Secure Attribute bit 0)

This bit controls the security attribute of RSTSR0.

#### NONSEC1 bit (Non Secure Attribute bit 1)

This bit controls the security attribute of RSTSR1.

#### NONSEC2 bit (Non Secure Attribute bit 2)

This bit controls the security attribute of RSTSR2.

### 5.2.2 RSTSR0 : Reset Status Register 0

Base address: SYSC = 0x4001\_E000

Offset address: 0x410

| Bit position: | 7           | 6 | 5 | 4 | 3          | 2          | 1          | 0    |
|---------------|-------------|---|---|---|------------|------------|------------|------|
| Bit field:    | DPSR<br>STF | — | — | — | LVD2R<br>F | LVD1R<br>F | LVD0R<br>F | PORF |

Value after reset: x<sup>1</sup> 0 0 0 x<sup>1</sup> x<sup>1</sup> x<sup>1</sup> x<sup>1</sup>

| Bit | Symbol  | Function   | R/W              |
|-----|---------|--|------------------|
| 0   | PORF    | Power-On Reset Detect Flag<br>0: Power-on reset not detected<br>1: Power-on reset detected   | R/W <sup>2</sup> |
| 1   | LVD0RF  | Voltage Monitor 0 Reset Detect Flag<br>0: Voltage monitor 0 reset not detected<br>1: Voltage monitor 0 reset detected  | R/W <sup>2</sup> |
| 2   | LVD1RF  | Voltage Monitor 1 Reset Detect Flag<br>0: Voltage monitor 1 reset not detected<br>1: Voltage monitor 1 reset detected  | R/W <sup>2</sup> |
| 3   | LVD2RF  | Voltage Monitor 2 Reset Detect Flag<br>0: Voltage monitor 2 reset not detected<br>1: Voltage monitor 2 reset detected  | R/W <sup>2</sup> |
| 6:4 | —       | These bits are read as 0. The write value should be 0.   | R/W              |
| 7   | DPSRSTF | Deep Software Standby Reset Flag<br>0: Deep software standby mode cancellation not requested by an interrupt.<br>1: Deep software standby mode cancellation requested by an interrupt. | R/W <sup>2</sup> |

Note: If the security attribution is configured as secure:

- Secure access and Non-secure read access are allowed

| Bit  | Symbol  | Function                                      | R/W |
|------|---------|---|-----|
| 0    | NONSEC0 | 非安全属性位0<br>目标寄存器: 复位状态寄存器0<br>0: 安全1: 不<br>安全 | R/W |
| 1    | NONSEC1 | 非安全属性位1<br>目标寄存器: 复位状态寄存器1<br>0: 安全1: 不<br>安全 | R/W |
| 2    | NONSEC2 | 非安全属性位2<br>目标寄存器: 复位状态寄存器2<br>0: 安全1: 不<br>安全 | R/W |
| 31:3 | —       | 这些位被读取为1。写入值应为1。                              | R/W |

Note: 只有安全访问才能写入该寄存器。允许安全访问和非安全读取访问, 但不允许非安全写入访问, 并且不会生成TrustZone访问错误。

Note: 该寄存器由PRCR寄存器写保护。

#### NONSEC0位 (非安全属性位0)

该位控制RSTSR0的安全属性。

#### NONSEC1位 (非安全属性位1)

该位控制RSTSR1的安全属性。

#### NONSEC2位 (非安全属性位2)

该位控制RSTSR2的安全属性。

### 5.2.2 RSTSR0: 复位状态寄存器0

Base address: SYSC = 0x4001\_E000

Offset address: 0x410

| Bit position: | 7           | 6 | 5 | 4 | 3          | 2          | 1          | 0    |
|---------------|-------------|---|---|---|------------|------------|------------|------|
| Bit field:    | DPSR<br>STF | — | — | — | LVD2R<br>F | LVD1R<br>F | LVD0R<br>F | PORF |

重置后的值: x<sup>1</sup> 0 0 0 x<sup>1</sup> x<sup>1</sup> x<sup>1</sup> x<sup>1</sup>

| Bit | Symbol  | Function   | R/W              |
|-----|---------|--|------------------|
| 0   | PORF    | 上电复位检测标志<br>0: 未检测到上电复位1: 检测到上电复位                    | R/W <sup>2</sup> |
| 1   | LVD0RF  | 电压监视器0复位检测标志<br>0: 未检测到电压监控器0复位1: 检测到电压监控器0复位        | R/W <sup>2</sup> |
| 2   | LVD1RF  | 电压监视器1复位检测标志<br>0: 未检测到电压监控器1复位1: 检测到电压监控器1复位        | R/W <sup>2</sup> |
| 3   | LVD2RF  | 电压监视器2复位检测标志<br>0: 未检测到电压监控器2复位1: 检测到电压监控器2复位        | R/W <sup>2</sup> |
| 6:4 | —       | 这些位被读取为0。写入值应为0。                                     | R/W              |
| 7   | DPSRSTF | 深度软件待机复位标志<br>0: 中断未请求深度软件待机模式取消。1: 中断请求的深度软件待机模式取消。 | R/W <sup>2</sup> |

Note: 如果安全属性配置为安全: ●  
允许安全访问和非安全读取访问

- Non-secure write access is ignored, and TrustZone access error is not generated.
- If the security attribution is configured as Non-secure:
- Secure and Non-secure access are allowed.

Note 1. The value after reset depends on the reset source.

Note 2. The register is cleared when a reset source listed in Table 5.2 occurs or when 0 is written to clear a flag. Bits other than the flag that is cleared should be set to 1.

#### PORF flag (Power-On Reset Detect Flag)

The PORF flag indicates that a power-on reset occurred.

[Setting condition]

- When a power-on reset occurs.

[Clearing conditions]

- When a reset listed in Table 5.2 occurs
- When PORF is read as 1 and then 0 is written to PORF

#### LVD0RF flag (Voltage Monitor 0 Reset Detect Flag)

The LVD0RF flag indicates that the VCC voltage fell below  $V_{det0}$ .

[Setting condition]

- When a voltage monitor 0 reset occurs.

[Clearing conditions]

- When a reset listed in Table 5.2 occurs
- When LVD0RF is read as 1 and then 0 is written to LVD0RF.

#### LVD1RF flag (Voltage Monitor 1 Reset Detect Flag)

The LVD1RF flag indicates that the VCC voltage fell below  $V_{det1}$ .

[Setting condition]

- When a voltage monitor 1 reset occurs.

[Clearing conditions]

- When a reset listed in Table 5.2 occurs
- When LVD1RF is read as 1 and then 0 is written to LVD1RF

#### LVD2RF flag (Voltage Monitor 2 Reset Detect Flag)

The LVD2RF flag indicates that the VCC voltage fell below  $V_{det2}$ .

[Setting condition]

- When a voltage monitor 2 reset occurs.

[Clearing conditions]

- When a reset listed in Table 5.2 occurs
- When LVD2RF is read as 1 and then 0 is written to LVD2RF

#### DPSRSTF flag (Deep Software Standby Reset Flag)

The DPSRSTF flag indicates that deep software standby mode has been canceled by an external or internal interrupt and that an internal reset (deep software standby reset) occurred when the exception from Deep Software Standby Mode occur.

[Setting condition]

- When deep software standby mode is cancelled by an external or an internal interrupt. For details, see section 10, Low Power Modes.

[Clearing conditions]

- 忽略非安全写入访问，不会生成TrustZone访问错误。
- 如果安全属性配置为非安全：●
- 允许安全和非安全访问。

注1.复位后的值取决于复位源。

注2.当表5.2中列出的复位源发生或写入0以清除标志时，该寄存器被清除。清除标志以外的位应设置为1。

#### PORF标志（上电复位检测标志）

PORF标志表示发生了上电复位。

[Setting condition]

- 发生上电复位时。

[Clearing conditions]

- 发生表5.2中列出的复位时
- 当PORF读为1，然后将0写入PORF

#### LVD0RF标志（电压监视器0复位检测标志）

LVD0RF标志表示VCC电压低于 $V_{det0}$ 。

[Setting condition]

- 发生电压监视器0复位时。

[Clearing conditions]

- 发生表5.2中列出的复位时
- 当LVD0RF被读为1，然后0被写入LVD0RF。

#### LVD1RF标志（电压监视器1复位检测标志）

LVD1RF标志表示VCC电压低于 $V_{det1}$ 。

[Setting condition]

- 发生电压监视器1复位时。

[Clearing conditions]

- 发生表5.2中列出的复位时
- 当LVD1RF被读为1，然后0被写入LVD1RF

#### LVD2RF标志（电压监视器2复位检测标志）

LVD2RF标志表示VCC电压低于 $V_{det2}$ 。

[Setting condition]

- 发生电压监视器2复位时。

[Clearing conditions]

- 发生表5.2中列出的复位时
- 当LVD2RF被读为1，然后0被写入LVD2RF

#### DPSRSTF标志（深度软件待机复位标志）

DPSRSTF标志表示深度软件待机模式已被外部或内部中断取消，并且当深度软件待机模式发生异常时发生内部复位（深度软件待机复位）。

[Setting condition]

- 当深度软件待机模式被外部或内部中断取消时。有关详细信息，请参阅第10节，低功耗模式。

[Clearing conditions]



- When a reset listed in Table 5.2 occurs.
- When DPSRSTF is read as 1 and then 0 is written to DPSRSTF

### 5.2.3 RSTSR1 : Reset Status Register 1

Base address: SYSC = 0x4001\_E000

Offset address: 0x0C0

|                    |                |    |                |    |                |    |                |                |   |   |   |   |   |                |                |                |
|--------------------|----------------|----|----------------|----|----------------|----|----------------|----------------|---|---|---|---|---|----------------|----------------|----------------|
| Bit position:      | 15             | 14 | 13             | 12 | 11             | 10 | 9              | 8              | 7 | 6 | 5 | 4 | 3 | 2              | 1              | 0              |
| Bit field:         | CPERF          | —  | TZERF          | —  | BUSMRF         | —  | REERF          | RPERF          | — | — | — | — | — | SWRF           | WDTRF          | IWDTRF         |
| Value after reset: | x <sup>1</sup> | 0  | x <sup>1</sup> | 0  | x <sup>1</sup> | 0  | x <sup>1</sup> | x <sup>1</sup> | 0 | 0 | 0 | 0 | 0 | x <sup>1</sup> | x <sup>1</sup> | x <sup>1</sup> |

| Bit | Symbol | Function   | R/W              |
|-----|--------|--|------------------|
| 0   | IWDTRF | Independent Watchdog Timer Reset Detect Flag<br>0: Independent watchdog timer reset not detected<br>1: Independent watchdog timer reset detected | R/W <sup>2</sup> |
| 1   | WDTRF  | Watchdog Timer Reset Detect Flag<br>0: Watchdog timer reset not detected<br>1: Watchdog timer reset detected                                     | R/W <sup>2</sup> |
| 2   | SWRF   | Software Reset Detect Flag<br>0: Software reset not detected<br>1: Software reset detected   | R/W <sup>2</sup> |
| 7:3 | —      | These bits are read as 0. The write value should be 0.   | R/W              |
| 8   | RPERF  | SRAM Parity Error Reset Detect Flag<br>0: SRAM parity error reset not detected<br>1: SRAM parity error reset detected                            | R/W <sup>2</sup> |
| 9   | REERF  | SRAM ECC Error Reset Detect Flag<br>0: SRAM ECC error reset not detected<br>1: SRAM ECC error reset detected                                     | R/W <sup>2</sup> |
| 10  | —      | This bit is read as 0. The write value should be 0.  | R/W              |
| 11  | BUSMRF | Bus Master MPU Error Reset Detect Flag<br>0: Bus master MPU error reset not detected<br>1: Bus master MPU error reset detected                   | R/W <sup>2</sup> |
| 12  | —      | This bit is read as 0. The write value should be 0.  | R/W              |
| 13  | TZERF  | TrustZone Error Reset Detect Flag<br>0: TrustZone error reset not detected.<br>1: TrustZone error reset detected.                                | R/W <sup>2</sup> |
| 14  | —      | This bit is read as 0. The write value should be 0.  | R/W              |
| 15  | CPERF  | Cache Parity Error Reset Detect Flag<br>0: Cache Parity error reset not detected.<br>1: Cache Parity error reset detected.                       | R/W <sup>2</sup> |

Note: If the security attribution is configured as secure:

- Secure access and Non-secure read access are allowed
  - Non-secure write access is ignored, and TrustZone access error is not generated.
- If the security attribution is configured as Non-secure:
- Secure and Non-secure access are allowed.

Note 1. The value after reset depends on the reset source.

Note 2. Only 0 can be written to clear the flag. The flag must be cleared by writing 0 after 1 is read.

#### IWDTRF flag (Independent Watchdog Timer Reset Detect Flag)

The IWDTRF flag indicates that an independent watchdog timer reset occurs.

[Setting condition]

- When an independent watchdog timer reset occurs.

- 发生表5.2中列出的复位时。
- DPSRSTF被读为1，然后0被写入DPSRSTF

### 5.2.3 RSTSR1：复位状态寄存器1

Base address: SYSC = 0x4001\_E000

Offset address: 0x0C0

|               |                |    |                |    |                |    |                |                |   |   |   |   |   |   |                |                |                |
|---------------|----------------|----|----------------|----|----------------|----|----------------|----------------|---|---|---|---|---|---|----------------|----------------|----------------|
| Bit position: | 15             | 14 | 13             | 12 | 11             | 10 | 9              | 8              | 7 | 6 | 5 | 4 | 3 | 2 | 1              | 0              |                |
| Bit field:    | CPERF          | —  | TZERF          | —  | BUSMRF         | —  | REERF          | RPERF          | — | — | — | — | — | — | SWRF           | WDTRF          | IWDTRF         |
| 重置后的值:        | x <sup>1</sup> | 0  | x <sup>1</sup> | 0  | x <sup>1</sup> | 0  | x <sup>1</sup> | x <sup>1</sup> | 0 | 0 | 0 | 0 | 0 | 0 | x <sup>1</sup> | x <sup>1</sup> | x <sup>1</sup> |

| Bit | Symbol | Function   | R/W              |
|-----|--------|--|------------------|
| 0   | IWDTRF | 独立看门狗定时器复位检测标志<br>0: 未检测到独立看门狗定时器复位1: 检测到独立看门狗定时器复位            | R/W <sup>2</sup> |
| 1   | WDTRF  | 看门狗定时器复位检测标志<br>0: 未检测到看门狗定时器复位1: 检测到看门狗定时器复位                  | R/W <sup>2</sup> |
| 2   | SWRF   | 软件复位检测标志<br>0: 未检测到软件复位1: 检测到软件复位                              | R/W <sup>2</sup> |
| 7:3 | —      | 这些位被读取为0。写入值应为0。   | R/W              |
| 8   | RPERF  | SRAM奇偶校验错误复位检测标志<br>0: 未检测到SRAM奇偶校验错误复位1: 检测到SRAM奇偶校验错误复位      | R/W <sup>2</sup> |
| 9   | REERF  | SRAMECC错误复位检测标志<br>0: 未检测到SRAMECC错误复位1: 检测到SRAMECC错误复位         | R/W <sup>2</sup> |
| 10  | —      | 该位读取为0。写入值应为0。   | R/W              |
| 11  | BUSMRF | 总线主控MPU错误复位检测标志<br>0: 未检测到总线主控MPU错误复位1: 检测到总线主控MPU错误复位         | R/W <sup>2</sup> |
| 12  | —      | 该位读取为0。写入值应为0。   | R/W              |
| 13  | TZERF  | TrustZone错误复位检测标志<br>0: 未检测到TrustZone错误复位。1: 检测到TrustZone错误复位。 | R/W <sup>2</sup> |
| 14  | —      | 该位读取为0。写入值应为0。   | R/W              |
| 15  | CPERF  | 高速缓存奇偶校验错误复位检测标志<br>0: 未检测到缓存奇偶校验错误复位。1: 检测到缓存奇偶校验错误复位。        | R/W <sup>2</sup> |

Note: 如果安全属性配置为安全: ●

- 允许安全访问和非安全读取访问
  - 忽略非安全写入访问，不会生成TrustZone访问错误。
- 如果安全属性配置为非安全: ●
- 允许安全和非安全访问。

注1.复位后的值取决于复位源。

注2.只能写入0来清除标志。该标志必须在读取1后写入0来清除。

#### IWDTRF标志（独立看门狗定时器复位检测标志）

IWDTRF标志指示发生了独立的看门狗定时器复位。

[Setting condition]

- 发生独立看门狗定时器复位时。

[Clearing conditions]

- When a reset listed in [Table 5.2](#) occurs
- When 1 is read and then 0 is written to IWDTRF.

#### WDTRF flag (Watchdog Timer Reset Detect Flag)

The WDTRF flag indicates that a watchdog timer reset occurs.

[Setting condition]

- When a watchdog timer reset [Table 5.2](#) occurs.

[Clearing conditions]

- When a reset listed in occurs
- When 1 is read and then 0 is written WDTRF.

#### SWRF flag (Software Reset Detect Flag)

The SWRF flag indicates that a software reset occurs.

[Setting condition]

- When a software reset occurs.

[Clearing conditions]

- When a reset listed in [Table 5.2](#) occurs
- When 1 is read and then 0 is written to SWRF.

#### RPERF flag (SRAM Parity Error Reset Detect Flag)

The RPERF flag indicates that an SRAM parity error reset occurs.

[Setting condition]

- When an SRAM parity error reset occurs.

[Clearing conditions]

- When a reset listed in [Table 5.2](#) occurs
- When 1 is read as 1 and then 0 is written to RPERF.

#### REERF flag (SRAM ECC Error Reset Detect Flag)

The REERF flag indicates that an SRAM ECC error reset occurs.

[Setting condition]

- When an SRAM ECC error reset occurs.

[Clearing conditions]

- When a reset listed in [Table 5.2](#) occurs
- When 1 is read as 1 and then 0 is written to REERF.

#### BUSMRF flag (Bus Master MPU Error Reset Detect Flag)

The BUSMRF flag indicates that a bus master MPU error reset occurs.

[Setting condition]

- When a bus master MPU error reset occurs.

[Clearing conditions]

- When a reset listed in [Table 5.2](#) occurs
- When 1 is read and then 0 is written to BUSMRF.

[Clearing conditions]

- 发生表5.2中列出的复位时
- 读取1，然后将0写入IWDTRF。

#### WDTRF标志（看门狗定时器复位检测标志）

WDTRF标志指示发生了看门狗定时器复位。

[Setting condition]

- 当看门狗定时器复位表5.2发生时。

[Clearing conditions]

- 发生复位时
- 读取1后写入0时WDTRF。

#### SWRF标志（软件复位检测标志）

SWRF标志表示发生了软件复位。

[Setting condition]

- 发生软件复位时。

[Clearing conditions]

- 发生表5.2中列出的复位时
- 读取1，然后将0写入SWRF。

#### RPERF标志（SRAM奇偶校验错误复位检测标志）

RPERF标志表示发生SRAM奇偶校验错误复位。

[Setting condition]

- SRAM奇偶校验错误复位发生时。

[Clearing conditions]

- 发生表5.2中列出的复位时
- 当1被读为1，然后0被写入RPERF。

#### REERF标志（SRAMECC错误复位检测标志）

REERF标志表示发生了SRAMECC错误复位。

[Setting condition]

- SRAMECC错误复位发生时。

[Clearing conditions]

- 发生表5.2中列出的复位时
- 当1被读为1，然后0被写入REERF。

#### BUSMRF标志（总线主控MPU错误复位检测标志）

BUSMRF标志指示发生总线主控MPU错误复位。

[Setting condition]

- 发生总线主控MPU错误复位时。

[Clearing conditions]

- 发生表5.2中列出的复位时
- 读取1，然后将0写入BUSMRF。



**TZERF flag (TrustZone Error Reset Detect Flag)**

The TZERF flag indicates that a TrustZone error reset has occurred.

[Setting condition]

- When a TrustZone error reset occurs.

[Clearing conditions]

- When a reset listed in Table 5.2 occurs
- When 1 is read then and 0 is written to TZERF.

**CPERF flag (Cache Parity Error Reset Detect Flag)**

The CPERF flag indicates that a Cache Parity error reset has occurred.

[Setting condition]

- When a Cache Parity error reset occurs.

[Clearing conditions]

- When a reset listed in Table 5.2 occurs
- When 1 is read then and 0 is written to CPERF.

**5.2.4 RSTSR2 : Reset Status Register 2**

Base address: SYSC = 0x4001\_E000

Offset address: 0x411

|                    |   |   |   |   |   |   |   |                |
|--------------------|---|---|---|---|---|---|---|----------------|
| Bit position:      | 7 | 6 | 5 | 4 | 3 | 2 | 1 | 0              |
| Bit field:         | — | — | — | — | — | — | — | CWSF           |
| Value after reset: | 0 | 0 | 0 | 0 | 0 | 0 | 0 | x <sup>1</sup> |

| Bit | Symbol | Function   | R/W              |
|-----|--------|--|------------------|
| 0   | CWSF   | Cold/Warm Start Determination Flag<br>0: Cold start<br>1: Warm start | R/W <sup>2</sup> |
| 7:1 | —      | These bits are read as 0. The write value should be 0.               | R/W              |

Note: If the security attribution is configured as secure:

- Secure access and Non-secure read access are allowed
- Non-secure write access is ignored, and TrustZone access error is not generated.

If the security attribution is configured as Non-secure:

- Secure and Non-secure access are allowed.

Note 1. The value after reset depends on the reset source.

Note 2. Only 1 can be written to set the flag.

RSTSR2 determines whether a power-on reset caused the reset processing (cold start) or a reset signal input during operation caused the reset processing (warm start).

**CWSF flag (Cold/Warm Start Determination Flag)**

The CWSF flag indicates the type of reset processing, either cold start or warm start. The determines whether a power-on reset caused the reset processing (cold start) or a reset signal input during operation caused the reset processing (warm start).

CWSF flag is initialized by a power-on reset. It is not initialized by a reset signal generated by the RES pin.

[Setting condition]

- When 1 is written by software. Writing 0 to CWSF does not set it to 0.

[Clearing condition]

- When a reset listed in Table 5.2 occurs.

**TZERF标志 (TrustZone错误复位检测标志)**

TZERF标志指示发生了TrustZone错误重置。

[Setting condition]

- 发生TrustZone错误重置时。

[Clearing conditions]

- 发生表5.2中列出的复位时
- 读取1并将0写入TZERF。

**CPERF标志 (高速缓存奇偶校验错误复位检测标志)**

CPERF标志表示发生了缓存奇偶校验错误重置。

[Setting condition]

- 发生CacheParity错误复位时。

[Clearing conditions]

- 发生表5.2中列出的复位时
- 读取1并将0写入CPERF。

**5.2.4 RSTSR2: 复位状态寄存器2**

Base address: SYSC = 0x4001\_E000

Offset address: 0x411

|               |   |   |   |   |   |   |   |                |
|---------------|---|---|---|---|---|---|---|----------------|
| Bit position: | 7 | 6 | 5 | 4 | 3 | 2 | 1 | 0              |
| Bit field:    | — | — | — | — | — | — | — | CWSF           |
| 重置后的值:        | 0 | 0 | 0 | 0 | 0 | 0 | 0 | x <sup>1</sup> |

| Bit | Symbol | Function                    | R/W              |
|-----|--------|-----------------------------|------------------|
| 0   | CWSF   | 冷暖启动确定标志<br>0: 冷启动1:<br>热启动 | R/W <sup>2</sup> |
| 7:1 | —      | 这些位被读取为0。写入值应为0。            | R/W              |

Note: 如果安全属性配置为安全: ●

- 允许安全访问和非安全读取访问
- 忽略非安全写入访问, 不会生成TrustZone访问错误。

如果安全属性配置为非安全: ●

- 允许安全和非安全访问。

注1.复位后的值取决于复位源。

注2.只能写入1来设置标志。

RSTSR2判断是上电复位导致复位处理 (冷启动) 还是操作期间输入的复位信号导致复位处理 (热启动)。

**CWSF标志 (冷暖启动确定标志)**

CWSF标志指示复位处理的类型, 冷启动或热启动。确定是上电复位导致复位处理 (冷启动) 还是操作期间输入的复位信号导致复位处理 (热启动)。CWSF标志由上电复位初始化。它不会被RES引脚产生的复位信号初始化。

[Setting condition]

- 软件写入1时。将0写入CWSF不会将其设置为0。

[Clearing condition]

- 发生表5.2中列出的复位时。

## 5.3 Operation

### 5.3.1 RES Pin Reset

The RES pin generates this reset. When the RES pin is driven low, all the processing in progress is aborted and the MCU enters a reset state. To successfully reset the MCU, the RES pin must be held low for the power supply stabilization time specified at power-on.

When the RES pin is driven high from low, the internal reset is canceled after the post-RES cancellation wait time ( $t_{RESWT}$ ) elapses. The CPU then starts the reset exception handling.

For details, see [section 47, Electrical Characteristics](#).

### 5.3.2 Power-On Reset

The power-on reset (POR) is an internal reset generated by the power-on reset circuit. A power-on reset is generated under the following conditions.

1. If the RES pin is in a high level state when power is supplied
2. If the RES pin is in a high level state when VCC is below  $V_{POR}$

After VCC exceeds  $V_{POR}$  and the specified power-on reset time ( $t_{POR}$ ) elapses, the CPU starts the reset exception handling. The power-on reset time is a stabilization period of the external power supply and the MCU circuit.

After a power-on reset is generated, the PORF flag in the RSTSR0 is set to 1. The PORF flag is initialized by the RES pin reset. When VCC falls below  $V_{POR}$ , a power-on reset state is occurred.

[Figure 5.1](#) shows example of operations during a power-on reset.

## 5.3 Operation

### 5.3.1 RES引脚复位

RES引脚产生此复位。当RES引脚被驱动为低电平时，所有正在进行的处理都被中止，MCU进入复位状态。要成功复位MCU，RES引脚必须在上电时指定的电源稳定时间内保持低电平。

当RES引脚从低电平驱动为高电平时，内部复位会在RES取消后等待时间( $t_{RESWT}$ )过去后取消。CPU然后开始复位异常处理。

有关详细信息，请参见第47节，电气特性。

### 5.3.2 Power-On Reset

上电复位（POR）是由上电复位电路产生的内部复位。在以下条件下会产生上电复位。

- 1.如果RES引脚在供电时处于高电平状态
- 2.如果VCC低于VPOR时RES管脚处于高电平状态

在VCC超过VPOR并且经过指定的上电复位时间( $t_{POR}$ )后，CPU开始复位异常处理。上电复位时间是外部电源和MCU电路的稳定期。

上电复位产生后，RSTSR0中的PORF标志设置为1。PORF标志由RES引脚复位初始化。当VCC低于VPOR时，会发生上电复位状态。

图5.1显示了上电复位期间的操作示例。

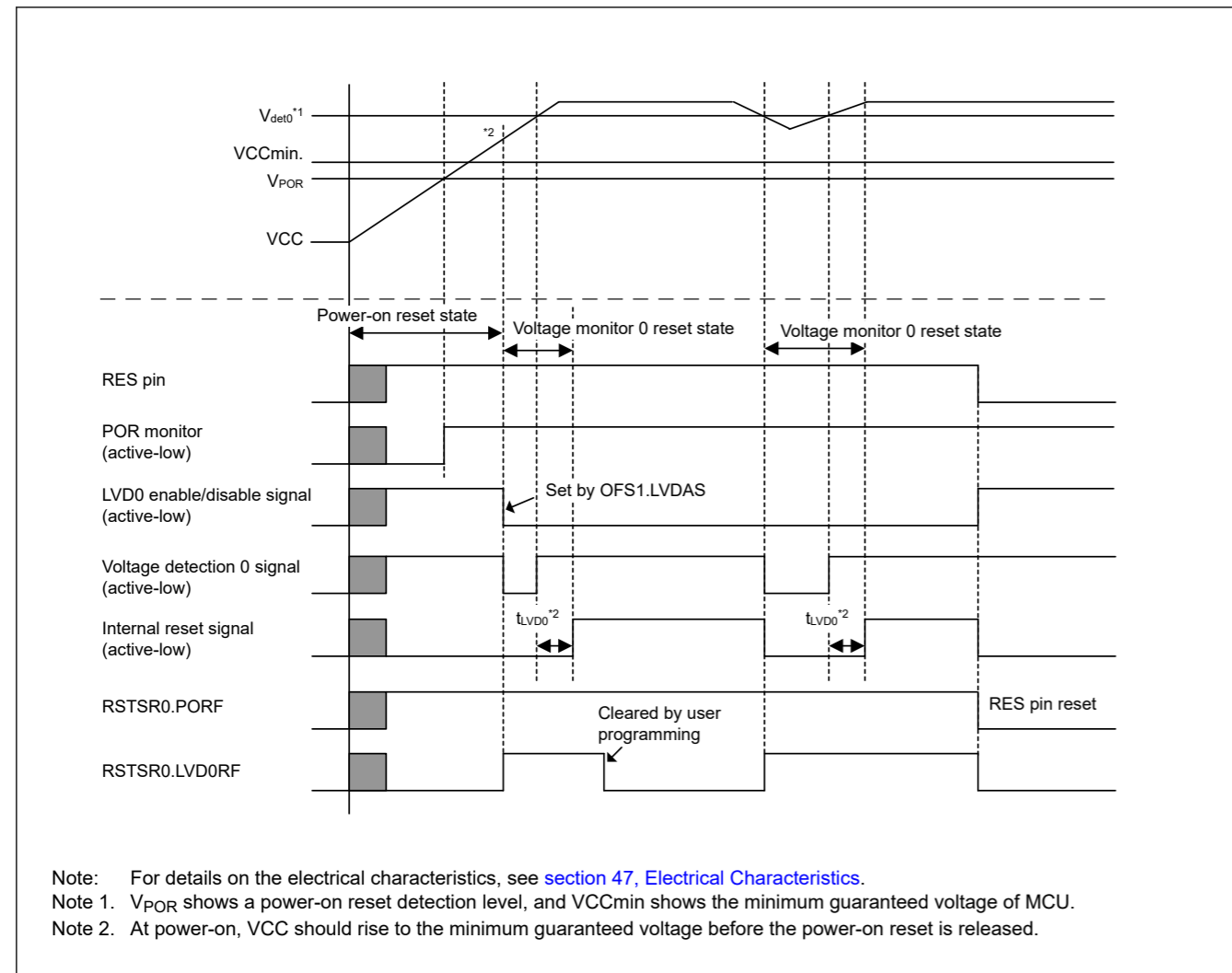


Figure 5.1 Example of operations during a power-on reset

### 5.3.3 Voltage Monitor Reset

The voltage monitor  $i$  ( $i = 0, 1, 2$ ) reset is an internal reset generated by the voltage monitor  $i$  circuit. If the Voltage Detection 0 Circuit Start (LVDAS) bit in the Option Function Select Register 1 (OFS1) is 0 (voltage monitor 0 reset is enabled after a reset) and VCC falls below  $V_{det0}$ , the RSTSR0.LVD0RF flag becomes 1 and the voltage detection circuit generates voltage monitor 0 reset. Clear the OFS1.LVDAS bit to 0 if the voltage monitor 0 reset is to be used. After VCC exceeds  $V_{det0}$  and the voltage monitor 0 reset time ( $t_{LVD0}$ ) elapses, the internal reset is canceled and the CPU starts the reset exception handling.

When the Voltage Monitor 1 Interrupt/Reset Enable bit (RIE) is set to 1 (enabling generation of a reset or interrupt by the voltage detection circuit) and the Voltage Monitor 1 Circuit Mode Select bit (RI) is set to 1 (selecting generation of a reset in response to detection of a low voltage) in Voltage Monitor 1 Circuit Control Register 0 (LVD1CR0), the RSTSR0.LVD1RF flag is set to 1 and the voltage detection circuit generates a voltage monitor 1 reset if VCC falls to or below  $V_{det1}$ .

Likewise, when the Voltage Monitor 2 Interrupt/Reset Enable bit (RIE) is set to 1 (enabling generation of a reset or interrupt by the voltage detection circuit) and the Voltage Monitor 2 Circuit Mode Select bit (RI) is set to 1 (selecting generation of a reset in response to detection of a low voltage) in Voltage Monitor 2 Circuit Control Register 0 (LVD2CR0), the RSTSR0.LVD2RF flag is set to 1 and the voltage detection circuit generates a voltage monitor 2 reset if VCC falls to or below  $V_{det2}$ .

Similarly, timing for release from the voltage monitor 1 reset state is selectable with the Voltage Monitor 1 Reset Negate Select bit (RN) in the LVD1CR0. When the LVD1CR0.RN bit is 0 and VCC falls to or below  $V_{det1}$ , the CPU is released from the internal reset state and starts reset exception handling when the LVD1 reset time ( $t_{LVD1}$ ) elapses after VCC rises

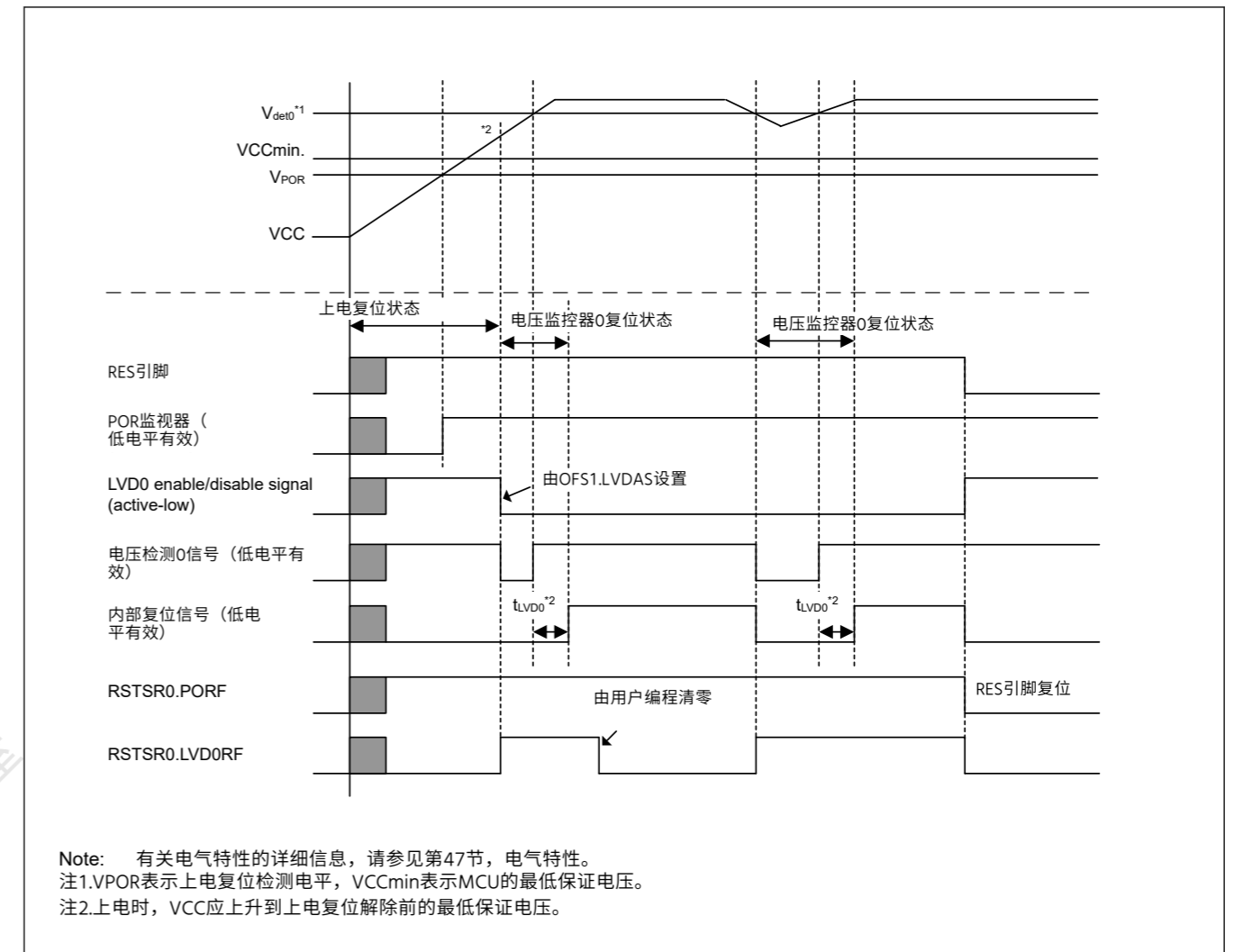


Figure 5.1 上电复位时的动作示例

### 5.3.3 电压监视器复位

电压监视器( $i=0, 1, 2$ )复位是由电压监视器 $i$ 电路产生的内部复位。如果电压选项功能选择寄存器1(OFS1)中的检测0电路启动(LVDAS)位为0(复位后使能电压监视器0复位)且VCC低于 $V_{det0}$ 时, RSTSR0.LVD0RF标志变为1, 电压检测电路生成电压监视器0复位。如果要使用电压监视器0复位, 则将OFS1.LVDAS位清零。在VCC超过 $V_{det0}$ 并且经过电压监视器0复位时间( $t_{LVD0}$ )后, 内部复位被取消, CPU开始复位异常处理。

当电压监视器1中断复位允许位(RIE)设置为1(允许电压检测电路产生复位或中断)且电压监视器1电路模式选择位(RI)设置为1(选择产生电压监视器1电路控制寄存器0(LVD1CR0)中的低电压检测复位响应), RSTSR0.LVD1RF标志设置为1, 如果VCC降至或低于 $V_{det1}$ , 电压检测电路将产生电压监视器1复位 $det1$ 。

同样, 当电压监视器2中断复位使能位(RIE)设置为1(允许电压检测电路产生复位或中断)并且电压监视器2电路模式选择位(RI)设置为1(选择在电压监视器2电路控制寄存器0(LVD2CR0)中响应检测到低电压产生复位), RSTSR0.LVD2RF标志设置为1, 如果VCC下降到或电压检测电路产生电压监视器2复位低于 $V_{det2}$ 。

类似地, 从电压监视器1复位状态释放的时间可以通过LVD1CR0中的电压监视器1复位否定选择位(RN)来选择。当LVD1CR0.RN位为0且VCC下降到或低于 $V_{det1}$ 时, CPU从内部复位状态中释放并在VCC上升后经过LVD1复位时间( $t_{LVD1}$ )时开始复位异常处理。

above  $V_{det1}$ . When the LVD1CR0.RN bit is 1 and VCC falls to or below  $V_{det1}$ , the CPU is released from the internal reset state and starts reset exception handling when the LVD1 reset time ( $t_{LVD1}$ ) elapses.

Likewise, timing for release from the voltage monitor 2 reset state is selectable by setting the Voltage Monitor 2 Reset Negate Select bit (RN) in the LDV2CR0 register.

Detection levels  $V_{det1}$  and  $V_{det2}$  can be changed in the Voltage Monitoring Comparator Control Register (LVD1CMPCR/LVD2CMPCR).

Figure 5.2 shows example of operations during voltage monitor 1 and 2 resets. For details on the voltage monitor 1 reset and voltage monitor 2 reset, see [section 7, Low Voltage Detection \(LVD\)](#).

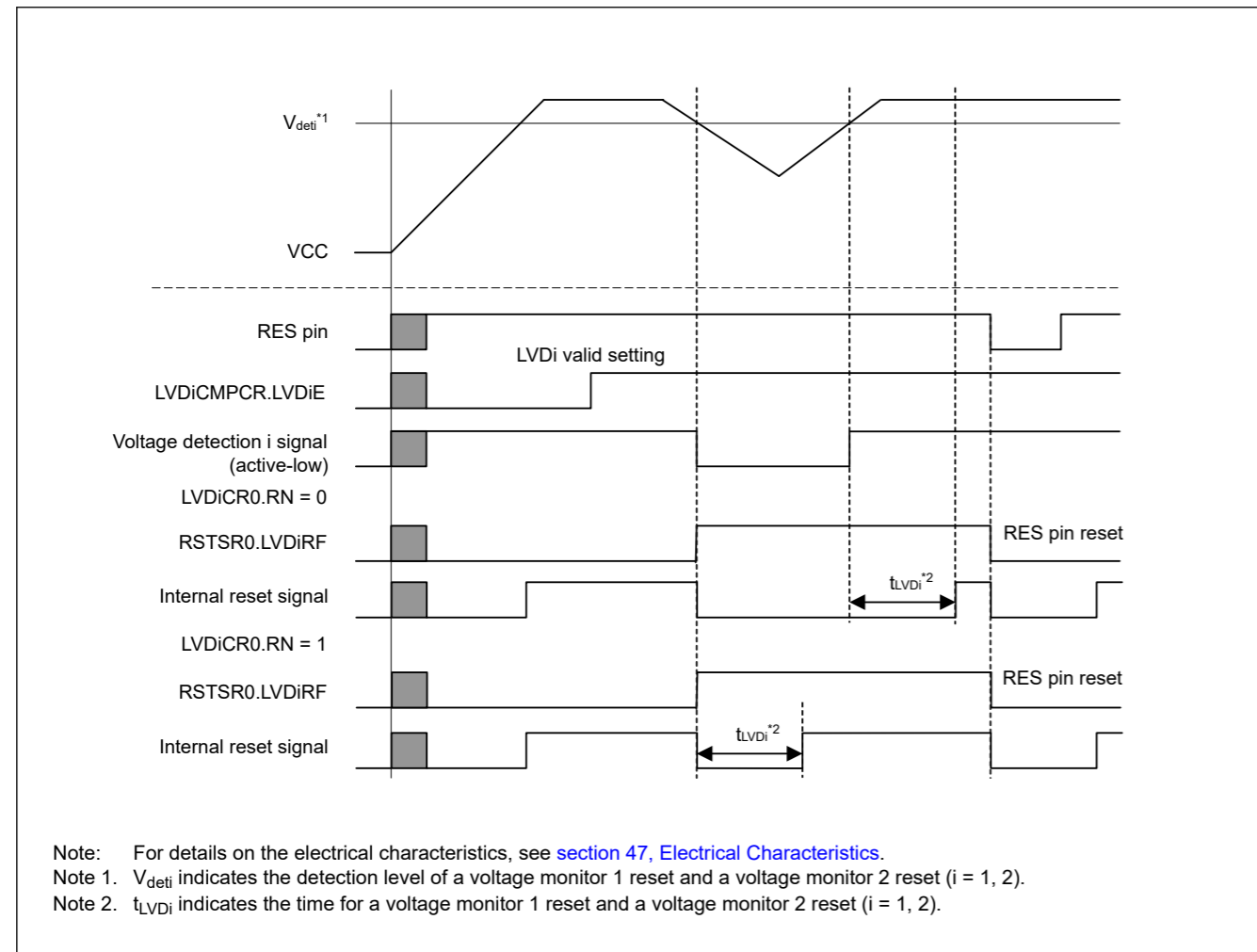


Figure 5.2 Example of operations during voltage monitor 1 and voltage monitor 2 resets

### 5.3.4 Deep Software Standby Reset

This is an internal reset generated when deep software standby mode is canceled by an interrupt.

When a deep software standby mode cancellation source is generated, a deep software standby reset is generated. The deep software standby reset is canceled after  $t_{DSBY}$  (return time after deep software standby mode cancellation) has elapsed. At the same time, deep software standby mode is also canceled.

When  $t_{DSBYWT}$  (wait time after deep software standby mode cancellation) has elapsed after deep software standby mode has been canceled, the internal reset is canceled and the CPU starts the reset exception handling.

For details of the deep software standby reset, see [section 10, Low Power Modes](#).

高于 $V_{det1}$ 。当LVD1CR0.RN位为1且VCC下降到或低于 $V_{det1}$ 时，CPU会从内部复位状态中释放，并在LVD1复位时间( $t_{LVD1}$ )过去后开始复位异常处理。

同样，从电压监视器2复位状态释放的时间可通过设置电压监视器2复位来选择LDV2CR0寄存器中的取反选择位(RN)。

检测电平 $V_{det1}$ 和 $V_{det2}$ 可以在电压监控比较器控制寄存器(LVD1CMPCR/LVD2CMPCR)。

图5.2显示了电压监视器1和2复位期间的操作示例。有关电压监视器1复位和电压监视器2复位的详细信息，请参见第7节，低电压检测(LVD)。

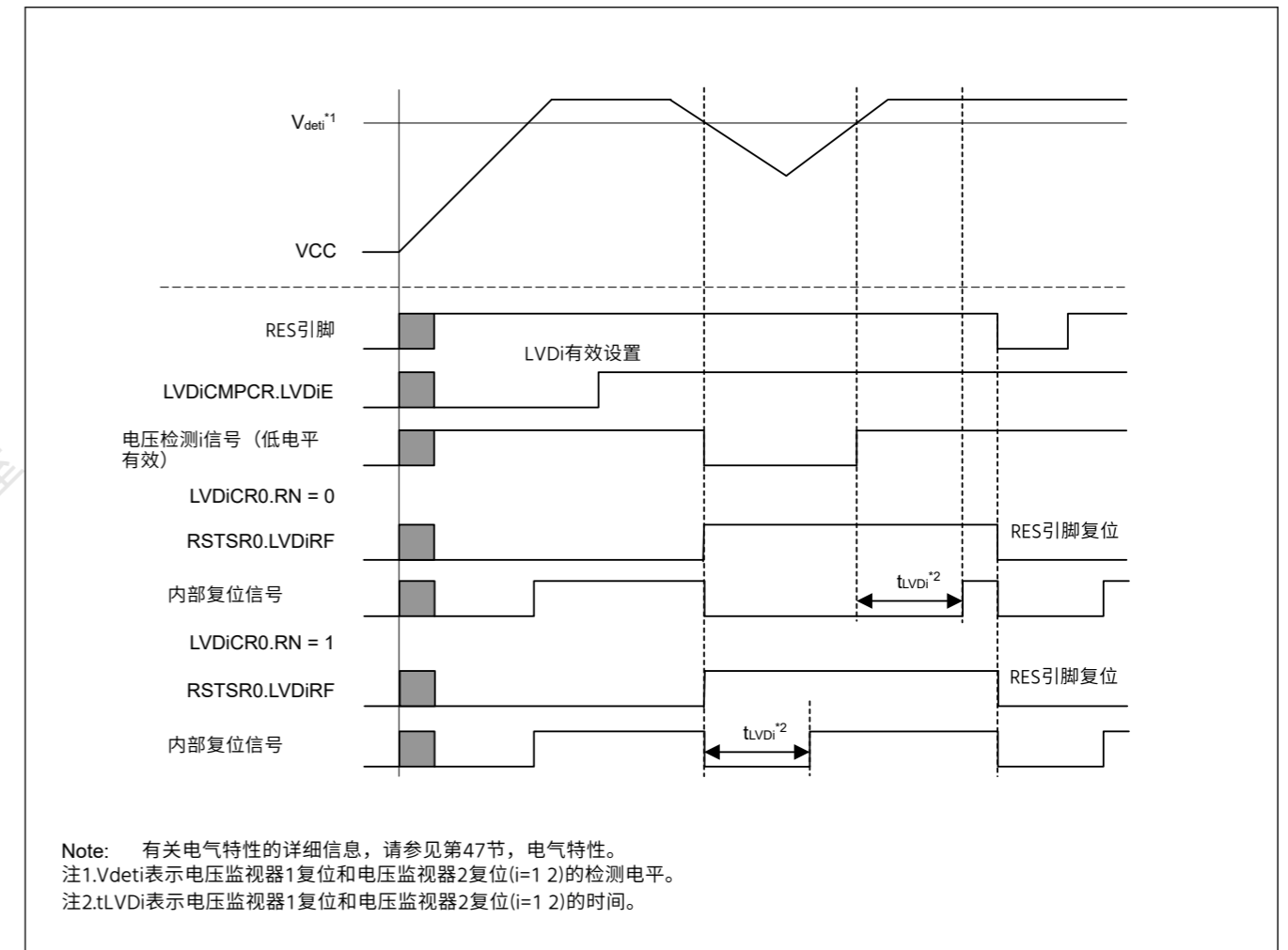


Figure 5.2 电压监视器1和电压监视器2复位期间的操作示例

### 5.3.4 深度软件待机复位

这是当深度软件待机模式被中断取消时产生的内部复位。

当产生深度软件待机模式取消源时，将产生深度软件待机复位。在经过 $t_{DSBY}$ （深度软件待机模式取消后的返回时间）后，深度软件待机复位被取消。同时，深度软件待机模式也被取消。

在深度软件待机模式取消后经过 $t_{DSBYWT}$ （深度软件待机模式取消后的等待时间）时，内部复位被取消，CPU开始复位异常处理。

有关深度软件待机复位的详细信息，请参见第10节，低功耗模式。



### 5.3.5 Independent Watchdog Timer Reset

The independent watchdog timer reset is an internal reset generated from the Independent Watchdog Timer (IWDT). Output of the reset from the IWDT can be selected in the Option Function Select Register 0 (OFS0).

When output of the independent watchdog timer reset is selected, the reset is generated if the IWDT underflows, or if data is written when refresh operation is disabled. When the internal reset time ( $t_{RESW2}$ ) elapses after the independent watchdog timer reset is generated, the internal reset is canceled and the CPU starts the reset exception handling.

For details on the independent watchdog timer reset, see [section 25, Independent Watchdog Timer \(IWDT\)](#).

### 5.3.6 Watchdog Timer Reset

The watchdog timer reset is an internal reset generated from the Watchdog Timer (WDT). Output of the reset from the WDT can be selected in the WDT Reset Control Register (WDTRCR) or Option Function Select register 0 (OFS0).

When output of the watchdog timer reset is selected, a watchdog timer reset is generated if the WDT underflows, or if data is written when refresh operation is disabled. When the internal reset time ( $t_{RESW2}$ ) elapses after the watchdog timer reset is generated, the internal reset is canceled and the CPU starts the reset exception handling.

For details on the watchdog timer reset, see [section 24, Watchdog Timer \(WDT\)](#).

### 5.3.7 Software Reset

The software reset is an internal reset generated by a software setting of the SYSRESETREQ bit in the AIRCR register in the Arm core. When the SYSRESETREQ bit is set to 1, a software reset is generated. When the internal reset time ( $t_{RESW2}$ ) elapses after the software reset is generated, the internal reset is canceled and the CPU starts the reset exception handling.

For details on the SYSRESETREQ bit, see the *ARM® Cortex®-M33 Technical Reference Manual*.

### 5.3.8 Determination of Cold/Warm Start

Read the CWSF flag in RSTSR2 to determine the cause of reset processing. This flag indicates whether a power-on reset caused the reset processing (cold start) or a reset signal input during operation caused the reset processing (warm start).

The CWSF flag is set to 0 when a power-on reset occurs (cold start), otherwise the flag is not set to 0. The flag is set to 1 when 1 is written to it through software. It is not set to 0 even on writing 0 to it.

[Figure 5.3](#) shows an example of cold/warm start determination operation.

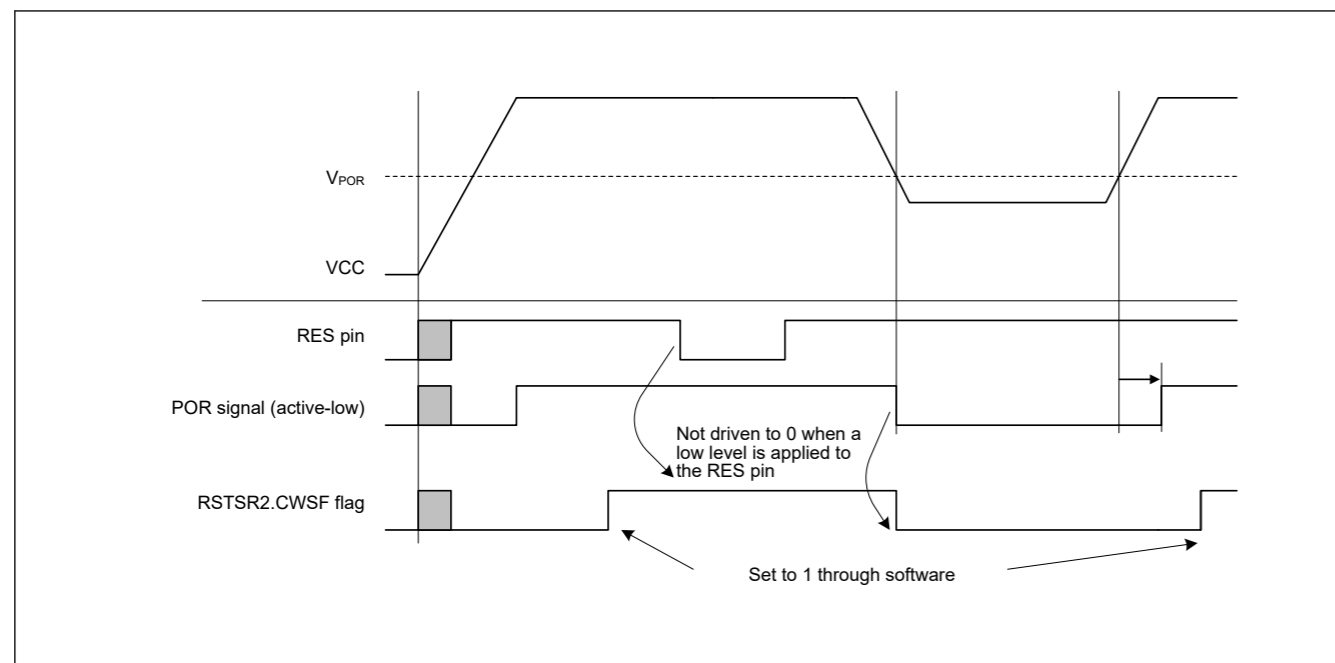


Figure 5.3 Example of cold/warm start determination operation

### 5.3.5 独立看门狗定时器复位

独立看门狗定时器复位是由独立看门狗定时器 (IWDT) 产生的内部复位。可以在选项功能选择寄存器0(OFS0)中选择IWDT的复位输出。

When output of the independent watchdog timer reset is selected, the reset is generated if the IWDT underflows or if data is written when refresh operation is disabled. 当独立看门狗定时器复位产生后经过内部复位时间( $t_{RESW2}$ )时, 内部复位被取消, CPU开始复位异常处理。

有关独立看门狗定时器复位的详细信息, 请参见第25节, 独立看门狗定时器(IWDT)。

### 5.3.6 看门狗定时器复位

看门狗定时器复位是由看门狗定时器(WDT)产生的内部复位。WDT的复位输出可以在WDT复位控制寄存器(WDTRCR)或选项功能选择寄存器0(OFS0)中选择。

选择看门狗定时器复位输出时, 如果WDT下溢, 或者在禁止刷新操作时写入数据, 则会产生看门狗定时器复位。在产生看门狗定时器复位后经过内部复位时间( $t_{RESW2}$ )时, 内部复位被取消, CPU开始复位异常处理。

有关看门狗定时器复位的详细信息, 请参见第24节, 看门狗定时器(WDT)。

### 5.3.7 软件复位

软件复位是通过软件设置Arm内核的AIRCR寄存器中的SYSRESETREQ位产生的内部复位。当SYSRESETREQ位设置为1时, 会产生软件复位。当软件复位产生后经过内部复位时间( $t_{RESW2}$ )时, 内部复位被取消, CPU开始复位异常处理。

有关SYSRESETREQ位的详细信息, 请参阅ARM®Cortex®-M33技术参考手册。

### 5.3.8 冷暖启动的测定

读取RSTSR2中的CWSF标志以确定复位处理的原因。该标志指示是上电复位导致复位处理 (冷启动) 还是操作期间输入的复位信号导致复位处理 (热启动)。

当发生上电复位 (冷启动) 时, CWSF标志设置为0, 否则该标志不设置为0。当通过软件向其写入1时, 该标志设置为1。即使向其写入0, 它也不会设置为0。

图5.3显示了冷暖启动确定操作的示例。

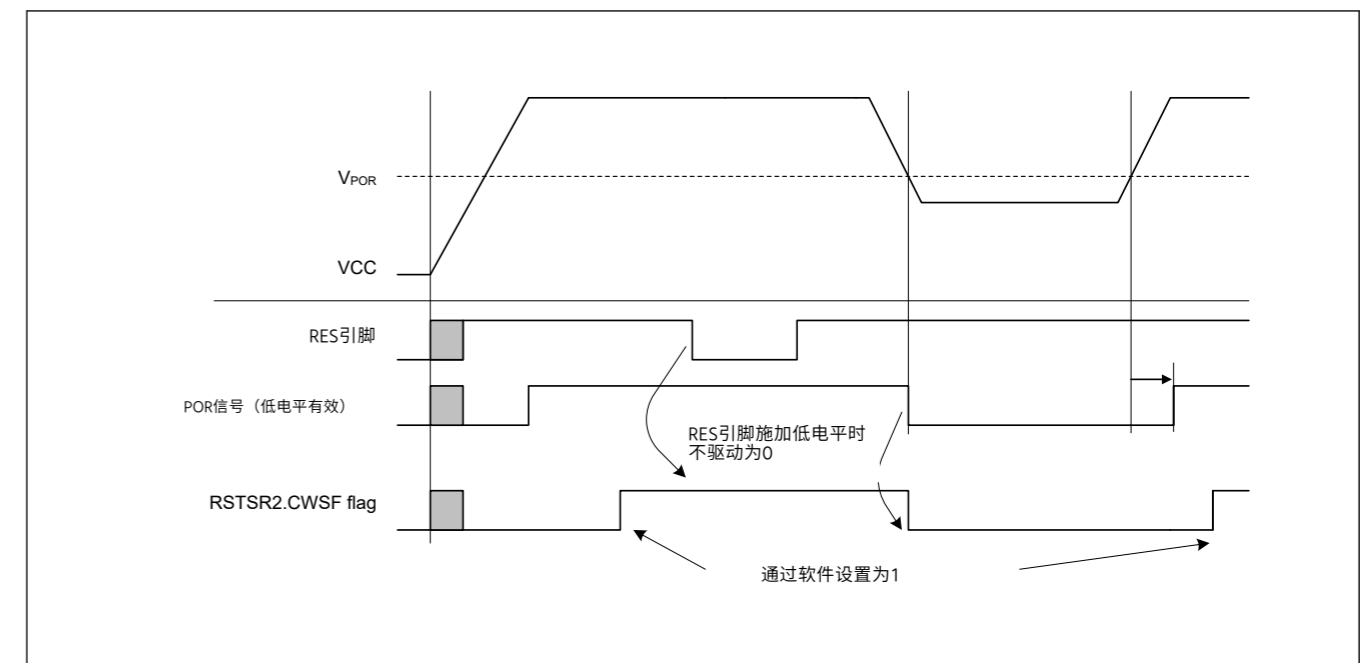


Figure 5.3 冷暖启动判定动作示例

### 5.3.9 Determination of Reset Generation Source

Read RSTSR0 and RSTSR1 to determine which reset executes the reset exception handling.

Figure 5.4 shows an example of the flow to identify a reset generation source. The reset flag must be written with 0 after it is read as 1.

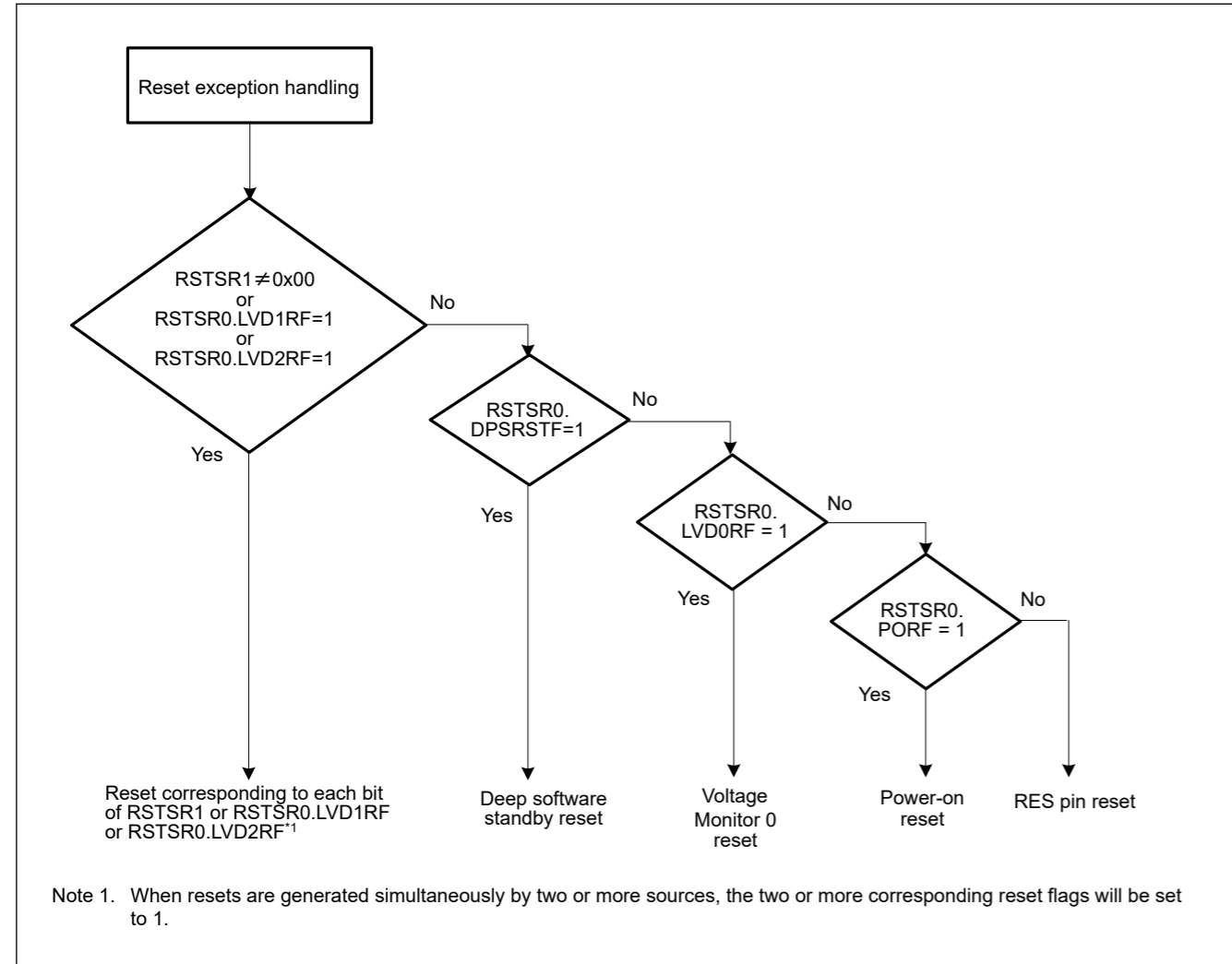


Figure 5.4 Example of reset generation source determination flow

### 5.3.9 复位产生源的确定

读取RSTSR0和RSTSR1以确定哪个复位执行复位异常处理。

图5.4显示了识别复位产生源的流程示例。复位标志读为1后必须写为0。

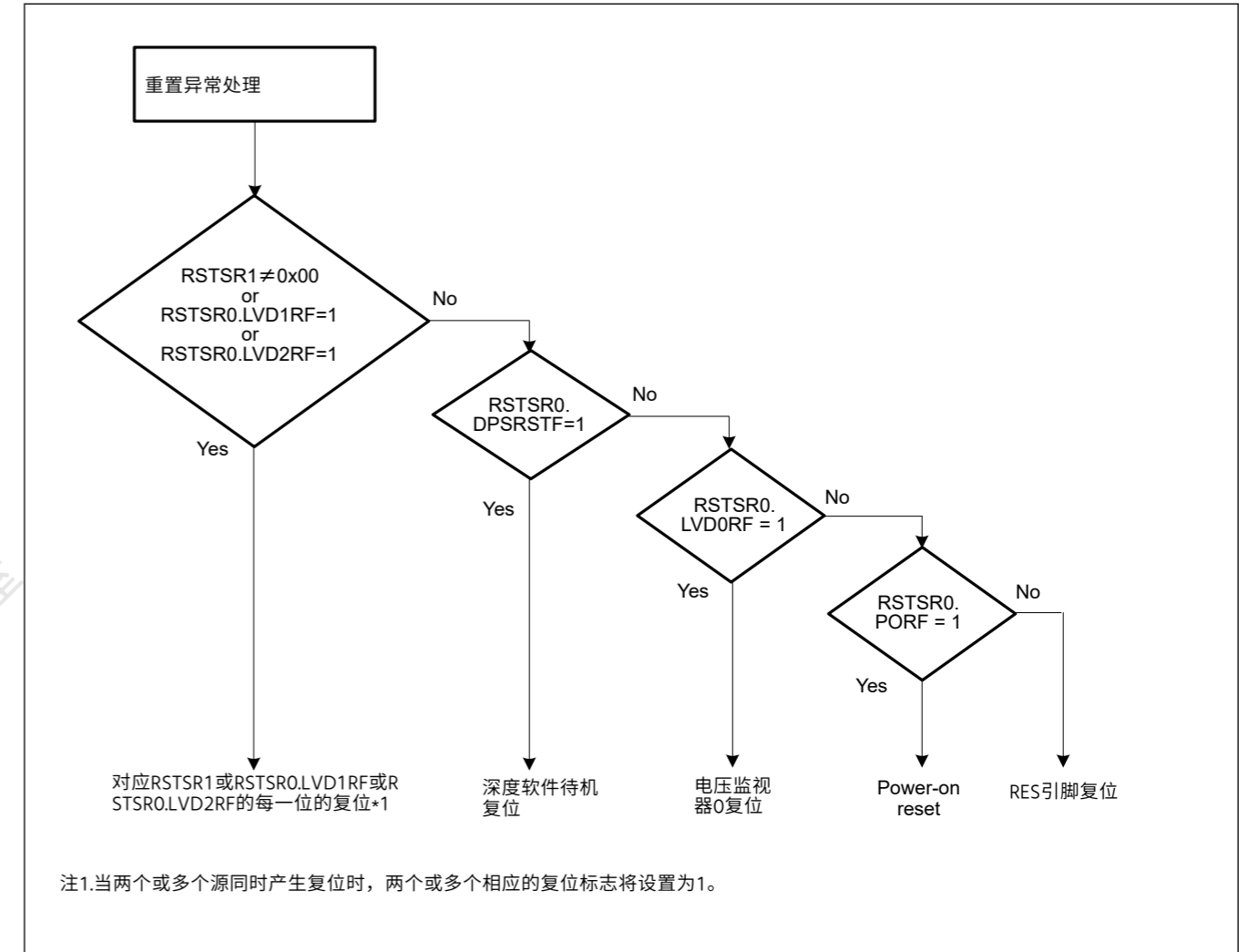


Figure 5.4 复位产生源确定流程示例

## 6. Option-Setting Memory

### 6.1 Overview

The option-setting memory determines the state of the MCU after a reset. The option-setting memory is allocated to the configuration setting area of the flash memory.

Figure 6.1 shows the option-setting memory area. The option-setting memory area has secure region. Table 6.1 shows the programming condition of the option-setting memory area.

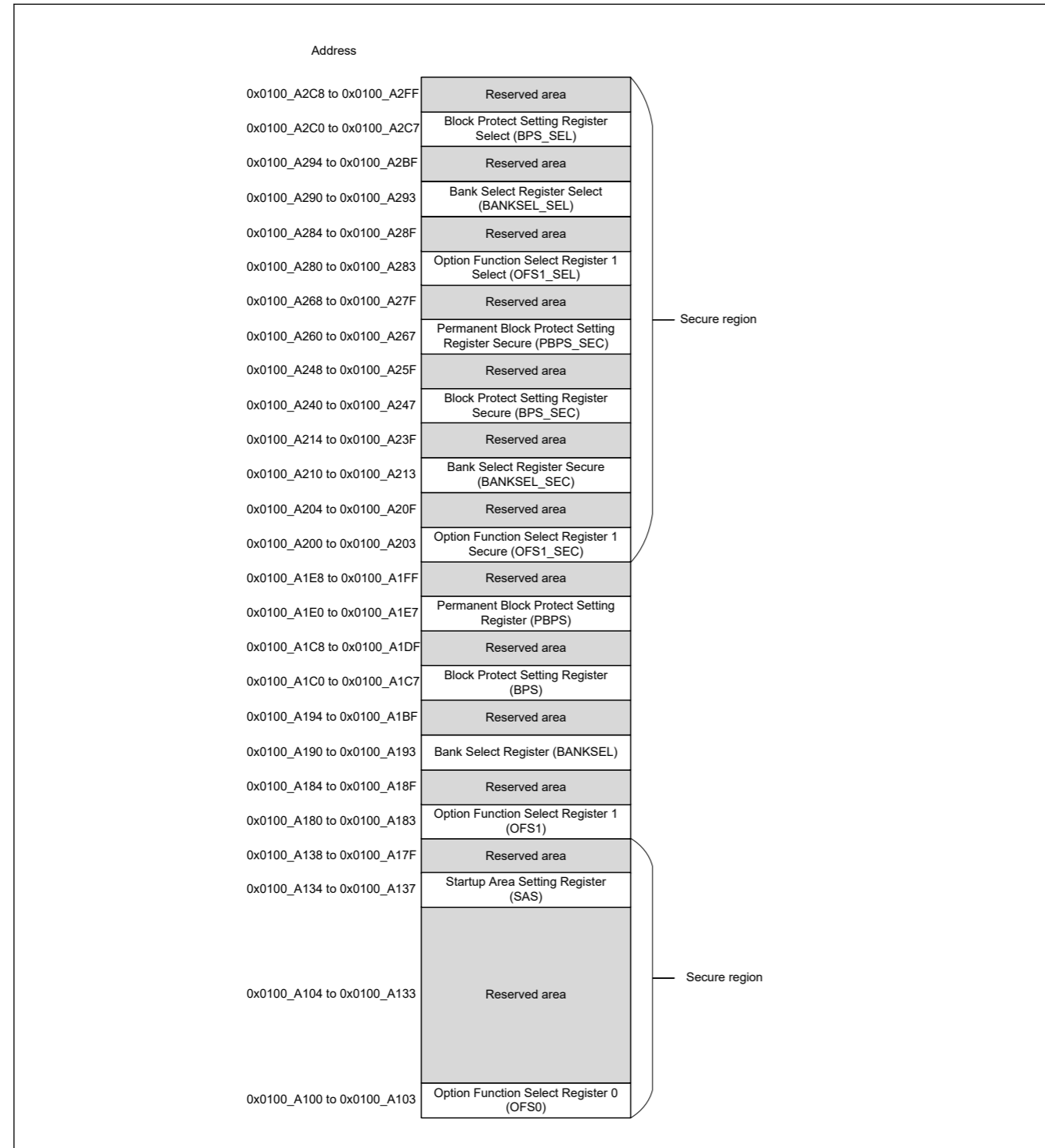


Figure 6.1 Option-setting memory area

## 6. Option-Setting Memory

### 6.1 Overview

选项设置存储器确定复位后MCU的状态。选项设置内存分配给闪存配置设置区域。

图6.1显示了选项设置存储区。选项设置内存区域具有安全区域。表6.1显示了选项设置存储区的编程条件。

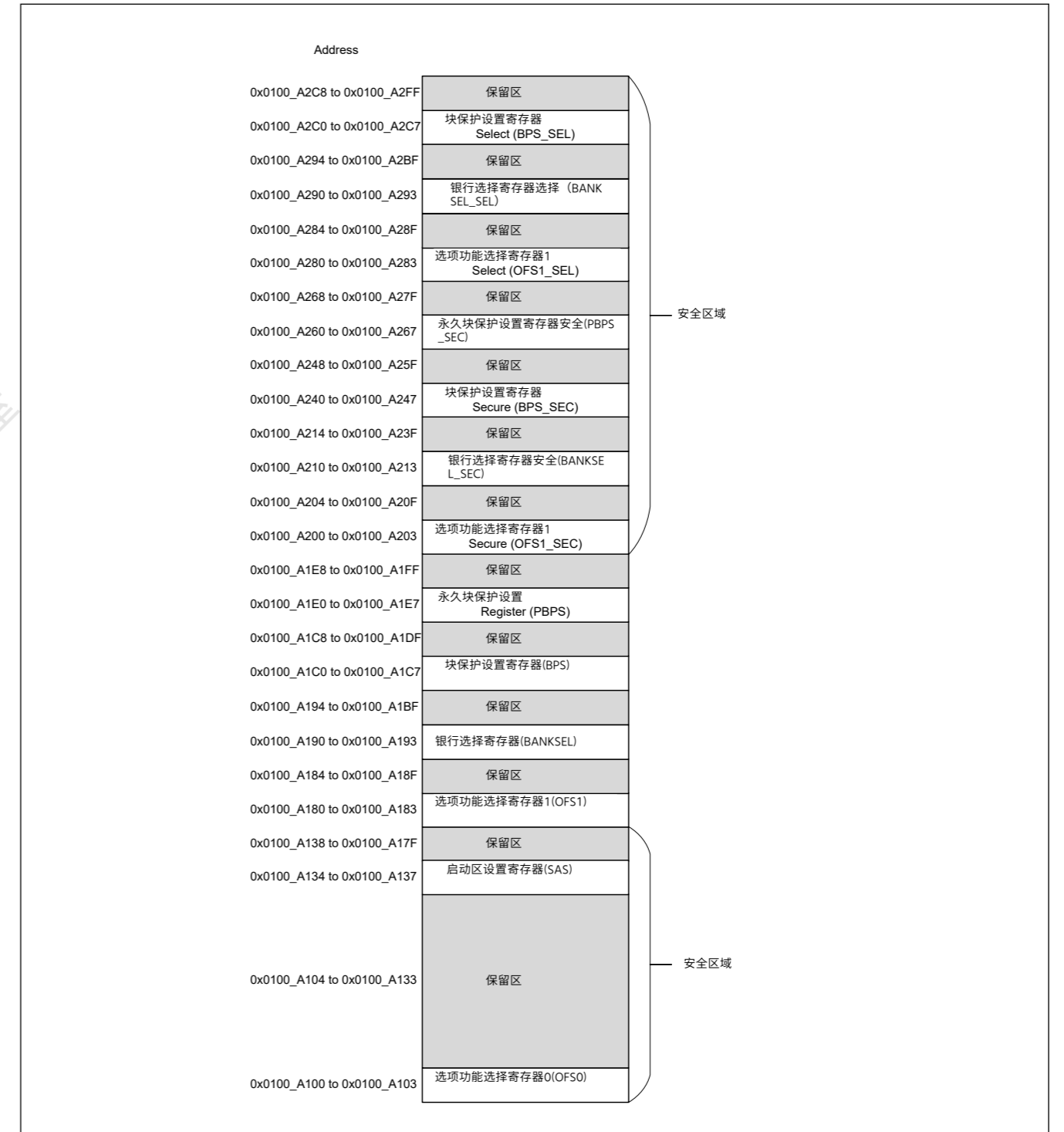


Figure 6.1 选项设置存储区



Table 6.1 The programming condition of the option-setting memory area

|               | Self programming  | Serial programming   | Programming by the on-chip debugger                               |
|---------------|---|--|---|
| Secure region | Programming commands issued by secure access.               | Programming commands issued when the device life cycle is SSD.           | Programming commands issued when the debug level is DBG2.         |
| Other region  | Programming commands issued by secure or non-secure access. | Programming commands issued when the device life cycle is SSD or NSECSD. | Programming commands issued when the debug level is DBG2 or DBG1. |

6.2 Register Descriptions

6.2.1 OFS0 : Option Function Select Register 0

Address: 0x0100\_A100

|               |    |            |    |             |              |              |             |    |    |              |          |    |    |    |    |    |
|---------------|----|------------|----|-------------|--------------|--------------|-------------|----|----|--------------|----------|----|----|----|----|----|
| Bit position: | 31 | 30         | 29 | 28          | 27           | 26           | 25          | 24 | 23 | 22           | 21       | 20 | 19 | 18 | 17 | 16 |
| Bit field:    | —  | WDTS TPCTL | —  | WDTR STIRQS | WDTRPSS[1:0] | WDTRPES[1:0] | WDTCKS[3:0] |    |    | WDTTOPS[1:0] | WDTS TRT | —  |    |    |    |    |

Value after reset: User setting\*1

|               |    |             |    |              |              |              |              |   |   |               |           |   |   |   |   |   |
|---------------|----|-------------|----|--------------|--------------|--------------|--------------|---|---|---------------|-----------|---|---|---|---|---|
| Bit position: | 15 | 14          | 13 | 12           | 11           | 10           | 9            | 8 | 7 | 6             | 5         | 4 | 3 | 2 | 1 | 0 |
| Bit field:    | —  | IWDT STPCTL | —  | IWDT RSTIRQS | IWDRPSS[1:0] | IWDRPES[1:0] | IWDTCKS[3:0] |   |   | IWDTTOPS[1:0] | IWDT STRT | — |   |   |   |   |

Value after reset: User setting\*1

| Bit   | Symbol        | Function  | R/W |
|-------|---------------|---|-----|
| 0     | —             | When read, this bit returns the written value. The write value should be 1.   | R   |
| 1     | IWDTSTRT      | IWDT Start Mode Select<br>0: Automatically activate IWDT after a reset (auto start mode)<br>1: Disable IWDT after a reset   | R   |
| 3:2   | IWDTTOPS[1:0] | IWDT Timeout Period Select<br>0 0: 128 cycles (0x007F)<br>0 1: 512 cycles (0x01FF)<br>1 0: 1024 cycles (0x03FF)<br>1 1: 2048 cycles (0x07FF)                                | R   |
| 7:4   | IWDTCKS[3:0]  | IWDT-Dedicated Clock Frequency Division Ratio Select<br>0x0: × 1<br>0x2: × 1/16<br>0x3: × 1/32<br>0x4: × 1/64<br>0xF: × 1/128<br>0x5: × 1/256<br>Others: Setting prohibited | R   |
| 9:8   | IWDRPES[1:0]  | IWDT Window End Position Select<br>0 0: 75%<br>0 1: 50%<br>1 0: 25%<br>1 1: 0% (no window end position setting)   | R   |
| 11:10 | IWDRPSS[1:0]  | IWDT Window Start Position Select<br>0 0: 25%<br>0 1: 50%<br>1 0: 75%<br>1 1: 100% (no window start position setting)   | R   |
| 12    | IWDRSTRIRQS   | IWDT Reset Interrupt Request Select<br>0: Enable non-maskable interrupt request or interrupt request<br>1: Enable reset   | R   |

Table 6.1 选项设置存储区的编程条件

|      | 自编程                | 串行编程                       | 通过片上调试器进行编程             |
|------|--------------------|----------------------------|-------------------------|
| 安全区域 | 安全访问发出的编程命令。       | 设备生命周期为SSD时发出的编程命令。        | 调试级别为DBG2时发出的编程命令。      |
| 其他地区 | 通过安全或非安全访问发出的编程命令。 | 设备生命周期为SSD或NSECSD时发出的编程命令。 | 调试级别为DBG2或DBG1时发出的编程命令。 |

6.2 注册说明

6.2.1 OFS0: 选项功能选择寄存器0

Address: 0x0100\_A100

|               |    |            |    |             |              |              |             |    |    |              |          |    |    |    |    |    |
|---------------|----|------------|----|-------------|--------------|--------------|-------------|----|----|--------------|----------|----|----|----|----|----|
| Bit position: | 31 | 30         | 29 | 28          | 27           | 26           | 25          | 24 | 23 | 22           | 21       | 20 | 19 | 18 | 17 | 16 |
| Bit field:    | —  | WDTS TPCTL | —  | WDTR STIRQS | WDTRPSS[1:0] | WDTRPES[1:0] | WDTCKS[3:0] |    |    | WDTTOPS[1:0] | WDTS TRT | —  |    |    |    |    |

重置后的值: 用户设置\*1

|               |    |             |    |              |              |              |              |   |   |               |           |   |   |   |   |   |
|---------------|----|-------------|----|--------------|--------------|--------------|--------------|---|---|---------------|-----------|---|---|---|---|---|
| Bit position: | 15 | 14          | 13 | 12           | 11           | 10           | 9            | 8 | 7 | 6             | 5         | 4 | 3 | 2 | 1 | 0 |
| Bit field:    | —  | IWDT STPCTL | —  | IWDT RSTIRQS | IWDRPSS[1:0] | IWDRPES[1:0] | IWDTCKS[3:0] |   |   | IWDTTOPS[1:0] | IWDT STRT | — |   |   |   |   |

重置后的值: 用户设置\*1

| Bit   | Symbol        | Function   | R/W |
|-------|---------------|--|-----|
| 0     | —             | 读取时, 该位返回写入的值。写入值应为1。  | R   |
| 1     | IWDTSTRT      | IWDT启动模式选择<br>0: 复位后自动激活IWDT (自动启动模式) 1: 复位后禁用IWDT   | R   |
| 3:2   | IWDTTOPS[1:0] | IWDT超时周期选择<br>0 0: 128 cycles (0x007F)<br>0 1: 512 cycles (0x01FF)<br>1 0: 1024 cycles (0x03FF)<br>1 1: 2048 cycles (0x07FF) | R   |
| 7:4   | IWDTCKS[3:0]  | IWDT-专用时钟分频比选择<br>0x0: × 1<br>0x2: × 1/16<br>0x3: × 1/32<br>0x4: × 1/64<br>0xF: × 1/128<br>0x5: × 1/256<br>Others: 禁止设定      | R   |
| 9:8   | IWDRPES[1:0]  | IWDT窗口结束位置选择<br>00: 75%01: 50%10: 25%11: 0% (无窗口结束位置设置)  | R   |
| 11:10 | IWDRPSS[1:0]  | IWDT窗口起始位置选择<br>00: 25%01: 50%10: 75%11: 100% (无窗口起始位置设置)  | R   |
| 12    | IWDRSTRIRQS   | IWDT复位中断请求选择<br>0: 使能不可屏蔽中断请求或中断请求1: 使能复位  | R   |

| Bit   | Symbol       | Function   | R/W |
|-------|--------------|--|-----|
| 13    | —            | When read, this bit returns the written value. The write value should be 1.  | R   |
| 14    | IWDTSTPCTL   | IWDT Stop Control<br>0: Continue counting<br>1: Stop counting when in Sleep, Snooze, or Software Standby mode  | R   |
| 16:15 | —            | When read, these bits return the written value. The write value should be 1.   | R   |
| 17    | WDTSTRT      | WDT Start Mode Select<br>0: Automatically activate WDT after a reset (auto start mode)<br>1: Stop WDT after a reset (register start mode)  | R   |
| 19:18 | WDTTOPS[1:0] | WDT Timeout Period Select<br>0 0: 1024 cycles (0x03FF)<br>0 1: 4096 cycles (0x0FFF)<br>1 0: 8192 cycles (0x1FFF)<br>1 1: 16384 cycles (0x3FFF)   | R   |
| 23:20 | WDTCKS[3:0]  | WDT Clock Frequency Division Ratio Select<br>0x1: PCLKB divided by 4<br>0x4: PCLKB divided by 64<br>0xF: PCLKB divided by 128<br>0x6: PCLKB divided by 512<br>0x7: PCLKB divided by 2048<br>0x8: PCLKB divided by 8192<br>Others: Setting prohibited | R   |
| 25:24 | WDRPES[1:0]  | WDT Window End Position Select<br>0 0: 75%<br>0 1: 50%<br>1 0: 25%<br>1 1: 0% (no window end position setting)   | R   |
| 27:26 | WDRPSS[1:0]  | WDT Window Start Position Select<br>0 0: 25%<br>0 1: 50%<br>1 0: 75%<br>1 1: 100% (no window start position setting)   | R   |
| 28    | WDRSTIRQS    | WDT Reset Interrupt Request Select<br>0: Enable non-maskable interrupt request or interrupt request<br>1: Reset  | R   |
| 29    | —            | When read, these bits return the written value. The write value should be 1.   | R   |
| 30    | WDTSTPCTL    | WDT Stop Control<br>0: Continue counting<br>1: Stop counting when entering Sleep mode  | R   |
| 31    | —            | When read, these bits return the written value. The write value should be 1.   | R   |

Note 1. The value in a blank product is 0xFFFFFFFF. It is set to the value written by your application.

#### IWDTSTRT bit (IWDT Start Mode Select)

The IWDTSTRT bit selects the mode in which the IWDT is activated after a reset (stopped state or activated state).

#### IWDTTOPS[1:0] bits (IWDT Timeout Period Select)

The IWDTTOPS[1:0] bits specify the timeout period, that is, the time it takes for the down counter to underflow, as 128, 512, 1024, or 2048 cycles of the frequency-divided clock set in the IWDTCKS[3:0] bits. The number of clock cycles that the IWDT takes to underflow after a refresh operation is determined by the combination of the IWDTCKS[3:0] and IWDTTOPS[1:0] bits.

For details, see [section 25, Independent Watchdog Timer \(IWDT\)](#).

#### IWDTCKS[3:0] bits (IWDT-Dedicated Clock Frequency Division Ratio Select)

The IWDTCKS[3:0] bits specify the division ratio of the prescaler for dividing the frequency of the clock for the IWDT as 1/1, 1/16, 1/32, 1/64, 1/128, and 1/256. Using this setting combined with the IWDTTOPS[1:0] bits setting, the IWDT counting period can be set from 128 to 524288 IWDT clock cycles.

| Bit   | Symbol       | Function   | R/W |
|-------|--------------|--|-----|
| 13    | —            | 读取时，该位返回写入的值。写入值应为1。   | R   |
| 14    | IWDTSTPCTL   | IWDT停止控制<br>0: 继续计数1: 在休眠、贪睡或软件待机模式下停止计数   | R   |
| 16:15 | —            | 读取时，这些位返回写入的值。写入值应为1。  | R   |
| 17    | WDTSTRT      | WDT启动模式选择<br>0: 复位后自动激活WDT (自动启动模式) 1: 复位后停止WDT (寄存器启动模式)  | R   |
| 19:18 | WDTTOPS[1:0] | WDT超时周期选择<br>0 0: 1024 cycles (0x03FF)<br>0 1: 4096 cycles (0x0FFF)<br>1 0: 8192 cycles (0x1FFF)<br>1 1: 16384 cycles (0x3FFF) | R   |
| 23:20 | WDTCKS[3:0]  | WDT时钟分频比选择<br>0x1: PCLKB4分频0x4: PCLKB64分频0xF: PCLKB128分频<br>0x6: PCLKB512分频0x7: PCLKB2048分频0x8: PCLKB8192分频<br>Others: 禁止设定    | R   |
| 25:24 | WDRPES[1:0]  | WDT窗口结束位置选择<br>00: 75%01: 50%10: 25%11: 0% (无窗口结束位置设置)   | R   |
| 27:26 | WDRPSS[1:0]  | WDT窗口起始位置选择<br>00: 25%01: 50%10: 75%11: 100% (无窗口起始位置设置)   | R   |
| 28    | WDRSTIRQS    | WDT复位中断请求选择<br>0: 使能不可屏蔽中断请求或中断请求1: 复位   | R   |
| 29    | —            | 读取时，这些位返回写入的值。写入值应为1。  | R   |
| 30    | WDTSTPCTL    | WDT停止控制<br>0: 继续计数1: 进入休眠模式时停止计数   | R   |
| 31    | —            | 读取时，这些位返回写入的值。写入值应为1。  | R   |

注1.空白产品中的值为0xFFFFFFFF。它设置为您的应用程序写入的值。

#### IWDTSTRT位 (IWDT启动模式选择)

IWDTSTRT位选择复位后激活IWDT的模式 (停止状态或激活状态)。

#### IWDTTOPS[1:0]位 (IWDT超时周期选择)

IWDTTOPS[1:0]位指定超时周期，即递减计数器下溢所需的时间，为IWDTCKS[3]中设置的分频时钟的128、512、1024或2048个周期：0]位。刷新操作后IWDT下溢所需的时钟周期数由IWDTCKS[3:0]和IWDTTOPS[1:0]位的组合决定。

有关详细信息，请参见第25节，独立看门狗定时器(IWDT)。

#### IWDTCKS[3:0]位 (IWDT专用时钟分频比选择)

IWDTCKS[3:0]位指定用于将IWDT的时钟频率分频为11、116、132、164、1128和1256的预分频器的分频比。将此设置与IWDTTOPS[1:0]位设置，IWDT计数周期可以设置为128到524288个IWDT时钟周期。

For details, see [section 25, Independent Watchdog Timer \(IWDTRPES\)](#).

#### IWDTRPES[1:0] bits (IWDTRPES Window End Position Select)

The IWDTRPES[1:0] bits specify the position where the window for the down counter ends as 0%, 25%, 50%, or 75% of the count value. The value of the window end position must be smaller than the value of the window start position, otherwise only the value for the window start position is valid.

The counter values associated with the settings for the start and end positions of the window in the IWDTRPSS[1:0] and IWDTRPES[1:0] bits vary with the setting in the IWDTTOPS[1:0] bits.

For details, see [section 25, Independent Watchdog Timer \(IWDTRPSS\)](#).

#### IWDTRPSS[1:0] bits (IWDTRPSS Window Start Position Select)

The IWDTRPSS[1:0] bits specify the position where the window for the down counter starts as 25%, 50%, 75%, or 100% of the counted value. The point at which counting starts is 100% and the point at which an underflow occurs is 0%. The interval between the window starts and ends positions becomes the period in which a refresh is possible. Refresh is not possible outside this period.

For details, see [section 25, Independent Watchdog Timer \(IWDTRSTIRQS\)](#).

#### IWDTRSTIRQS bit (IWDTRSTIRQS Reset Interrupt Request Select)

The IWDTRSTIRQS bit selects the operation on an underflow of the down counter or generation of a refresh error. The operation is selectable to an independent watchdog timer reset, a non-maskable interrupt request, or an interrupt request.

For details, see [section 25, Independent Watchdog Timer \(IWDTRPSS\)](#).

#### IWDTRPCTL bit (IWDTRPCTL Stop Control)

The IWDTRPCTL bit specifies whether to stop counting when entering Sleep mode, Snooze mode, or Software Standby mode.

For details, see [section 25, Independent Watchdog Timer \(IWDTRPSS\)](#).

#### WDTSTRT bit (WDTSTRT Start Mode Select)

The WDTSTRT bit selects the mode in which the WDT is activated after a reset (stopped state or activated in auto start mode). When WDT is activated in auto start mode, the OFS0 register setting for the WDT is valid.

#### WDTTOPS[1:0] bits (WDTTOPS Timeout Period Select)

The WDTTOPS[1:0] bits specify the timeout period, that is, the time it takes for the down counter to underflow as 1024, 4096, 8192, or 16384 cycles of the frequency-divided clock set in the WDTCKS[3:0] bits. The number of PCLKB cycles that takes to underflow after a refresh operation is determined by a combination of the WDTCKS[3:0] and WDTTOPS[1:0] bits.

For details, see [section 24, Watchdog Timer \(WDT\)](#).

#### WDTCKS[3:0] bits (WDTCKS Clock Frequency Division Ratio Select)

The WDTCKS[3:0] bits specify the division ratio of the prescaler for dividing the frequency of PCLKB as 1/4, 1/64, 1/128, 1/512, 1/2048, and 1/8192. Using this setting combined with the WDTTOPS[1:0] bits setting, the WDT counting period can be set from 4096 to 134217728 PCLKB cycles.

For details, see [section 24, Watchdog Timer \(WDT\)](#).

#### WDRPES[1:0] bits (WDRPES Window End Position Select)

The WDRPES[1:0] bits specify the position where the window on the down counter ends as 0%, 25%, 50%, or 75% of the counted value. The value of the window end position must be smaller than the value of the window start position, otherwise only the value for the window start position is valid.

The counter values associated with the settings for the start and end positions of the window in the WDRPSS[1:0] and WDRPES[1:0] bits vary with the setting of the WDTTOPS[1:0] bits.

For details, see [section 24, Watchdog Timer \(WDT\)](#).

有关详细信息，请参见第25节，独立看门狗定时器(IWDTRPES)。

#### IWDTRPES[1:0]位 (IWDTRPES窗口结束位置选择)

IWDTRPES[1:0]位指定递减计数器窗口结束的位置为计数值的0%、25%、50%或75%。窗口结束位置的值必须小于窗口开始位置的值，否则只有窗口开始位置的值有效。

与IWDTRPSS[1:0]中窗口的开始和结束位置的设置相关的计数器值和IWDTRPES[1:0]位随IWDTTOPS[1:0]位的设置而变化。

有关详细信息，请参见第25节，独立看门狗定时器(IWDTRPSS)。

#### IWDTRPSS[1:0]位 (IWDTRPSS窗口起始位置选择)

IWDTRPSS[1:0]位指定递减计数器窗口的起始位置为计数值的25%、50%、75%或100%。计数开始点为100%，下溢发生点为0%。窗口开始位置和结束位置之间的间隔成为可以刷新的时间段。在此期间之外无法刷新。

有关详细信息，请参见第25节，独立看门狗定时器(IWDTRSTIRQS)。

#### IWDTRSTIRQS位 (IWDTRSTIRQS复位中断请求选择)

IWDTRSTIRQS位选择在递减计数器下溢或产生刷新错误时的操作。该操作可选择独立看门狗定时器复位、不可屏蔽中断请求或中断请求。

有关详细信息，请参见第25节，独立看门狗定时器(IWDTRPSS)。

#### IWDTRPCTL位 (IWDTRPCTL停止控制)

IWDTRPCTL位指定在进入休眠模式、贪睡模式或软件待机模式时是否停止计数。

有关详细信息，请参见第25节，独立看门狗定时器(IWDTRPSS)。

#### WDTSTRT位 (WDTSTRT启动模式选择)

WDTSTRT位选择WDT在复位后激活的模式（停止状态或在自动启动模式下激活）。当WDT在自动启动模式下激活时，WDT的OFS0寄存器设置有效。

#### WDTTOPS[1:0]位 (WDTTOPS超时周期选择)

WDTTOPS[1:0]位指定超时周期，即在WDTCKS[3:0]中设置的分频时钟的1024、4096、8192或16384个周期时，递减计数器下溢所需的时间。刷新操作后下溢的PCLKB周期数由WDTCKS[3:0]和WDTTOPS[1:0]位的组合决定。

有关详细信息，请参见第24节，看门狗定时器(WDT)。

#### WDTCKS[3:0]位 (WDTCKS时钟分频比选择)

WDTCKS[3:0]位指定用于分频PCLKB的预分频器的分频比为14、164、1128、1512、12048和18192。将此设置与WDTTOPS[1:0]位设置，WDT计数周期可以设置为4096到134217728个PCLKB周期。

有关详细信息，请参见第24节，看门狗定时器(WDT)。

#### WDRPES[1:0]位 (WDRPES窗口结束位置选择)

WDRPES[1:0]位指定递减计数器上窗口结束的位置为计数值的0%、25%、50%或75%。窗口结束位置的值必须小于窗口开始位置的值，否则只有窗口开始位置的值有效。

与WDRPSS[1:0]中窗口的开始和结束位置设置相关的计数器值和WDRPES[1:0]位随WDTTOPS[1:0]位的设置而变化。

有关详细信息，请参见第24节，看门狗定时器(WDT)。

**WDTRPSS[1:0] bits (WDT Window Start Position Select)**

The WDTRPSS[1:0] bits specify the position where the window for the down counter starts as 25%, 50%, 75%, or 100% of the counted value. The point at which counting starts is 100% and the point at which an underflow occurs is 0%. The interval between the positions where the window starts and ends becomes the period in which a refresh is possible.

Refresh is not possible outside this period.

For details, see [section 24, Watchdog Timer \(WDT\)](#).

**WDRSTIRQS bit (WDT Reset Interrupt Request Select)**

The WDRSTIRQS bit selects the operation on an underflow of the down-counter or generation of a refresh error. The operation is selectable to a watchdog timer reset, a non-maskable interrupt request, or an interrupt request.

For details, see [section 24, Watchdog Timer \(WDT\)](#).

**WDTSTPCTL bit (WDT Stop Control)**

The WDTSTPCTL bit specifies whether to stop counting when entering Sleep mode.

For details, see [section 24, Watchdog Timer \(WDT\)](#).

**6.2.2 SAS : Startup Area Setting Register**

Address: 0x0100\_A134

|                    |              |    |    |    |    |    |    |    |    |    |    |    |    |    |    |    |
|--------------------|--------------|----|----|----|----|----|----|----|----|----|----|----|----|----|----|----|
| Bit position:      | 31           | 30 | 29 | 28 | 27 | 26 | 25 | 24 | 23 | 22 | 21 | 20 | 19 | 18 | 17 | 16 |
| Bit field:         | BTFLG        | —  | —  | —  | —  | —  | —  | —  | —  | —  | —  | —  | —  | —  | —  | —  |
| Value after reset: | User setting |    |    |    |    |    |    |    |    |    |    |    |    |    |    |    |
| Bit position:      | 15           | 14 | 13 | 12 | 11 | 10 | 9  | 8  | 7  | 6  | 5  | 4  | 3  | 2  | 1  | 0  |
| Bit field:         | FSPR         | —  | —  | —  | —  | —  | —  | —  | —  | —  | —  | —  | —  | —  | —  | —  |
| Value after reset: | User setting |    |    |    |    |    |    |    |    |    |    |    |    |    |    |    |

| Bit   | Symbol | Function   | R/W |
|-------|--------|--|-----|
| 14:0  | —      | When read, these bits return the written value. The write value should be 1.   | R   |
| 15    | FSPR   | Protection of Startup Area Select Function<br>This bit controls the programming of the write/erase protection for the Startup Area Select flag (SAS.BTFLG), and the temporary boot swap control. When this bit is set to 0, it cannot be changed to 1.<br>0: Executing the configuration setting command for programming the Startup Area Select flag (SAS.BTFLG) is invalid.<br>1: Executing the configuration setting command for programming the Startup Area Select flag (SAS.BTFLG) is valid. | R   |
| 30:16 | —      | When read, these bits return the written value. The write value should be 1.   | R   |
| 31    | BTFLG  | Startup Area Select Flag<br>This bit specifies whether the address of the startup area is exchanged for the boot swap function or not.<br>0: First 8-KB area (0x0000_0000 to 0x0000_1FFF) and second 8-KB area (0x0000_2000 to 0x0000_3FFF) are exchanged.<br>1: First 8-KB area (0x0000_0000 to 0x0000_1FFF) and second 8-KB area (0x0000_2000 to 0x0000_3FFF) are not exchanged.   | R   |

**WDTRPSS[1:0]位 (WDT窗口起始位置选择)**

WDTRPSS[1:0]位指定递减计数器窗口的起始位置为计数值的25%、50%、75%或100%。计数开始点为100%，下溢发生点为0%。窗口开始和结束位置之间的间隔成为可以刷新的时间段。

在此期间之外无法刷新。

有关详细信息，请参见第24节，看门狗定时器(WDT)。

**WDRSTIRQS位 (WDT复位中断请求选择)**

WDRSTIRQS位选择在递减计数器下溢或产生刷新错误时的操作。该操作可选择看门狗定时器复位、不可屏蔽中断请求或中断请求。

有关详细信息，请参见第24节，看门狗定时器(WDT)。

**WDTSTPCTL位 (WDT停止控制)**

WDTSTPCTL位指定进入休眠模式时是否停止计数。

有关详细信息，请参见第24节，看门狗定时器(WDT)。

**6.2.2 SAS: 启动区设置寄存器**

Address: 0x0100\_A134

|               |       |    |    |    |    |    |    |    |    |    |    |    |    |    |    |    |
|---------------|-------|----|----|----|----|----|----|----|----|----|----|----|----|----|----|----|
| Bit position: | 31    | 30 | 29 | 28 | 27 | 26 | 25 | 24 | 23 | 22 | 21 | 20 | 19 | 18 | 17 | 16 |
| Bit field:    | BTFLG | —  | —  | —  | —  | —  | —  | —  | —  | —  | —  | —  | —  | —  | —  | —  |
| 重置后的值:        | 用户设置  |    |    |    |    |    |    |    |    |    |    |    |    |    |    |    |
| Bit position: | 15    | 14 | 13 | 12 | 11 | 10 | 9  | 8  | 7  | 6  | 5  | 4  | 3  | 2  | 1  | 0  |
| Bit field:    | FSPR  | —  | —  | —  | —  | —  | —  | —  | —  | —  | —  | —  | —  | —  | —  | —  |
| 重置后的值:        | 用户设置  |    |    |    |    |    |    |    |    |    |    |    |    |    |    |    |

| Bit   | Symbol | Function  | R/W |
|-------|--------|---|-----|
| 14:0  | —      | 读取时，这些位返回写入的值。写入值应为1。   | R   |
| 15    | FSPR   | 保护启动区选择功能<br>该位控制启动区域选择标志(SAS.BTFLG)的写擦除保护的编程，以及临时引导交换控制。当该位设置为0时，不能更改为1。<br>0: 执行用于编程启动区域选择标志 (SAS.BTFLG) 的配置设置命令无效。<br>1: 执行用于编程启动区域选择标志 (SAS.BTFLG) 的配置设置命令有效。   | R   |
| 30:16 | —      | 读取时，这些位返回写入的值。写入值应为1。   | R   |
| 31    | BTFLG  | 启动区选择标志<br>该位指定是否将启动区域的地址交换为引导交换功能。<br>0: 交换第一个8-KB区域 (0x0000_0000到0x0000_1FFF) 和第二个8-KB区域 (0x0000_2000到0x0000_3FFF)。<br>1: 第一个8-KB区域 (0x0000_0000到0x0000_1FFF) 和第二个8-KB区域 (0x0000_2000到0x0000_3FFF) 不交换。 | R   |



## 6.2.3 OFS1, OFS1\_SEC, OFS1\_SEL : Option Function Select Register 1

Address: OFS1: 0x0100\_A180  
OFS1\_SEC: 0x0100\_A200  
OFS1\_SEL: 0x0100\_A280

|                    |                             |    |    |    |    |               |        |    |    |    |    |    |    |        |            |    |
|--------------------|-----------------------------|----|----|----|----|---------------|--------|----|----|----|----|----|----|--------|------------|----|
| Bit position:      | 31                          | 30 | 29 | 28 | 27 | 26            | 25     | 24 | 23 | 22 | 21 | 20 | 19 | 18     | 17         | 16 |
| Bit field:         | —                           | —  | —  | —  | —  | —             | —      | —  | —  | —  | —  | —  | —  | —      | —          | —  |
| Value after reset: | The value set by the user*1 |    |    |    |    |               |        |    |    |    |    |    |    |        |            |    |
| Bit position:      | 15                          | 14 | 13 | 12 | 11 | 10            | 9      | 8  | 7  | 6  | 5  | 4  | 3  | 2      | 1          | 0  |
| Bit field:         | —                           | —  | —  | —  | —  | HOCOFRQ0[1:0] | HOCOEN | —  | —  | —  | —  | —  | —  | LVDA S | VDSEL[1:0] | —  |
| Value after reset: | The value set by the user*1 |    |    |    |    |               |        |    |    |    |    |    |    |        |            |    |

| Bit   | Symbol        | Function   | R/W |
|-------|---------------|--|-----|
| 1:0   | VDSEL[1:0]    | Voltage Detection 0 Level Select<br>0 0: Setting prohibited<br>0 1: Select 2.94 V<br>1 0: Select 2.87 V<br>1 1: Select 2.80 V            | R   |
| 2     | LVDAS         | Voltage Detection 0 Circuit Start<br>0: Enable voltage monitor 0 reset after a reset<br>1: Disable voltage monitor 0 reset after a reset | R   |
| 7:3   | —             | When read, these bits return the written value. The write value should be 1.   | R   |
| 8     | HOCOEN        | HOCO Oscillation Enable<br>0: Enable HOCO oscillation after a reset<br>1: Disable HOCO oscillation after a reset                         | R   |
| 10:9  | HOCOFRQ0[1:0] | HOCO Frequency Setting 0<br>0 0: 16 MHz<br>0 1: 18 MHz<br>1 0: 20 MHz<br>1 1: Setting prohibited   | R   |
| 31:11 | —             | When read, these bits return the written value. The write value should be 1.   | R   |

Note 1. The value in a blank product is 0xFFFFFFFF. It is set to the value written by your application.

Only secure developer can program OFS1\_SEC and OFS1\_SEL registers. OFS1\_SEC register is for secure developer, and OFS1 register is for non-secure developer. The applied setting value is determined by the setting value of the corresponding bit in OFS1\_SEL register. For details, see [section 6.3.3. Security attribution of option-setting memory](#).

**VDSEL[1:0] bits (Voltage Detection 0 Level Select)**

The VDSEL[1:0] bits select the voltage detection level of the voltage detection 0 circuit.

**LVDAS bits (Voltage Detection 0 Circuit Start)**

The LVDAS bit selects whether the voltage monitor 0 reset is enabled or disabled after a reset.

**HOCOEN bit (HOCO Oscillation Enable)**

The HOCOEN bit selects whether the HOCO oscillation is enabled or disabled after a reset. Setting this bit to 0 allows the HOCO oscillation to start before the CPU starts operation, which reduces the wait time for oscillation stabilization.

Note: When the HOCOEN bit is set to 0, the system clock source is not switched to HOCO. The system clock source is only switched to HOCO by setting the Clock Source Select bits (SCKSCR.CKSEL[2:0]). To use the HOCO clock, you must set the OFS1.HOCOFRQ0 bit to an optimum value.

**HOCOFRQ0[1:0] bits (HOCO Frequency Setting 0)**

The HOCOFRQ0[1:0] bits specify the HOCO frequency after a reset as 16, 18, or 20 MHz.

## 6.2.3 OFS1、OFS1\_SEC、OFS1\_SEL：选项功能选择寄存器1

Address: OFS1: 0x0100\_A180  
OFS1\_SEC: 0x0100\_A200  
OFS1\_SEL: 0x0100\_A280

|               |          |    |    |    |    |               |        |    |    |    |    |    |    |    |        |            |
|---------------|----------|----|----|----|----|---------------|--------|----|----|----|----|----|----|----|--------|------------|
| Bit position: | 31       | 30 | 29 | 28 | 27 | 26            | 25     | 24 | 23 | 22 | 21 | 20 | 19 | 18 | 17     | 16         |
| Bit field:    | —        | —  | —  | —  | —  | —             | —      | —  | —  | —  | —  | —  | —  | —  | —      | —          |
| 重置后的值:        | 用户设置的值*1 |    |    |    |    |               |        |    |    |    |    |    |    |    |        |            |
| Bit position: | 15       | 14 | 13 | 12 | 11 | 10            | 9      | 8  | 7  | 6  | 5  | 4  | 3  | 2  | 1      | 0          |
| Bit field:    | —        | —  | —  | —  | —  | HOCOFRQ0[1:0] | HOCOEN | —  | —  | —  | —  | —  | —  | —  | LVDA S | VDSEL[1:0] |
| 重置后的值:        | 用户设置的值*1 |    |    |    |    |               |        |    |    |    |    |    |    |    |        |            |

| Bit   | Symbol        | Function   | R/W |
|-------|---------------|--|-----|
| 1:0   | VDSEL[1:0]    | 电压检测0电平选择<br>00: 禁止设置01: 选择2.94V10: 选择2.87V11: 选择2.80V | R   |
| 2     | LVDAS         | 电压检测0电路启动<br>0: 启用电压监控0复位后复位1: 禁用电压监控0复位后复位            | R   |
| 7:3   | —             | 读取时，这些位返回写入的值。写入值应为1。                                  | R   |
| 8     | HOCOEN        | HOCO振荡使能<br>0: 复位后启用HOCO振荡1: 复位后禁用HOCO振荡               | R   |
| 10:9  | HOCOFRQ0[1:0] | HOCO频率设定0<br>00: 16MHz01: 18MHz10: 20MHz11: 禁止设置       | R   |
| 31:11 | —             | 读取时，这些位返回写入的值。写入值应为1。                                  | R   |

注1.空白产品中的值为0xFFFFFFFF。它设置为您的应用程序写入的值。

只有安全的开发人员才能对OFS1\_SEC和OFS1\_SEL寄存器进行编程。OFS1\_SEC寄存器用于安全开发者，OFS1寄存器用于非安全开发者。应用的设置值由OFS1\_SEL寄存器中相应位的设置值决定。详见6.3.3节。选项设置内存的安全属性。

**VDSEL[1:0]位（电压检测0电平选择）**

VDSEL[1:0]位选择电压检测0电路的电压检测电平。

**LVDAS位（电压检测0电路启动）**

LVDAS位选择在复位后是启用还是禁用电压监视器0复位。

**HOCOEN位（HOCO振荡使能）**

HOCOEN位选择在复位后是启用还是禁用HOCO振荡。将此位设置为0允许在CPU开始运行之前启动HOCO振荡，减少了振荡稳定的等待时间。

Note: 当HOCOEN位设置为0时，系统时钟源不切换到HOCO。系统时钟源只能通过设置时钟源选择位(SCKSCR.CKSEL[2:0])切换到HOCO。要使用HOCO时钟，您必须将OFS1.HOCOFRQ0位设置为最佳值。

**HOCOFRQ0[1:0]位（HOCO频率设置0）**

HOCOFRQ0[1:0]位指定复位后的HOCO频率为16、18或20MHz。





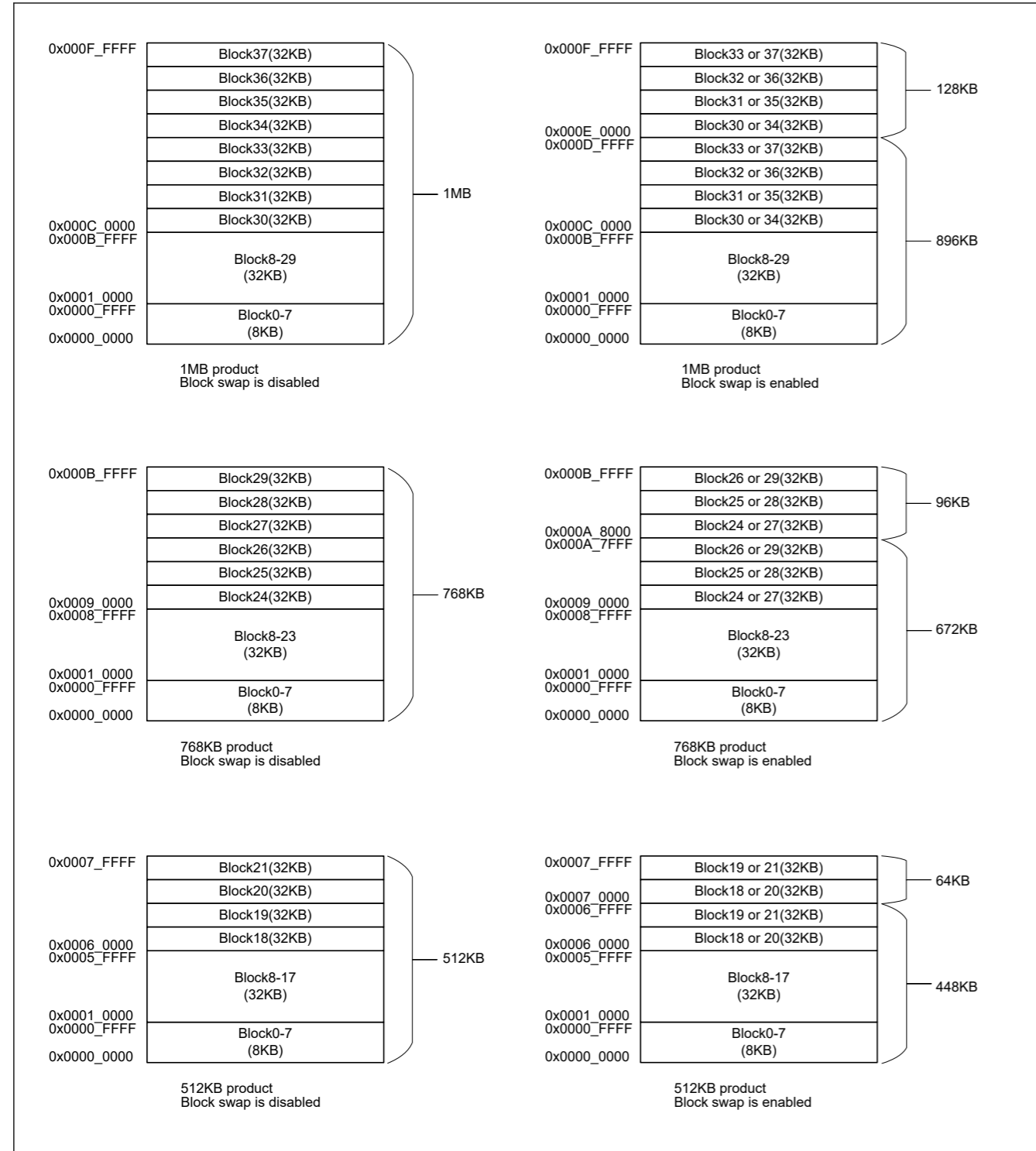


Figure 6.2 Mapping of the flash memory

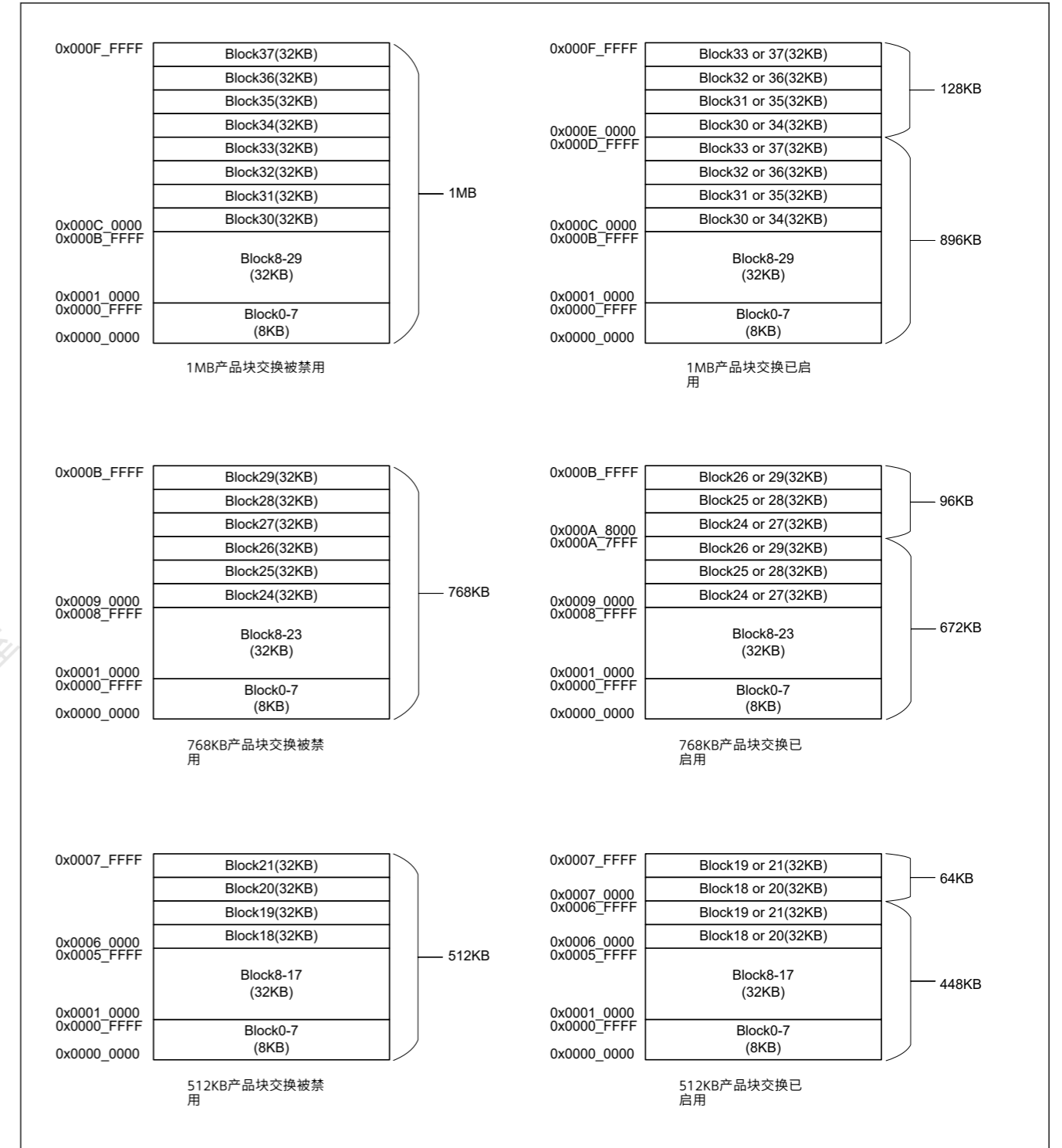


Figure 6.2 闪存映射

Table 6.2 Specification of BLCKSWP bits for each product

|                | BLCKSWP bits | Select 0 / 1   |
|----------------|--------------|--|
| 1 MB product   | BLCKSWP[0]   | 1 : Block30 start address is 0x000C_0000. Block34 start address is 0x000E_0000.<br>0 : Block30 start address is 0x000E_0000. Block34 start address is 0x000C_0000. |
|                | BLCKSWP[1]   | 1 : Block31 start address is 0x000C_8000. Block35 start address is 0x000E_8000.<br>0 : Block31 start address is 0x000E_8000. Block35 start address is 0x000C_8000. |
|                | BLCKSWP[2]   | 1 : Block32 start address is 0x000D_0000. Block36 start address is 0x000F_0000.<br>0 : Block32 start address is 0x000F_0000. Block36 start address is 0x000D_0000. |
|                | BLCKSWP[3]   | 1 : Block33 start address is 0x000D_8000. Block37 start address is 0x000F_8000.<br>0 : Block33 start address is 0x000F_8000. Block37 start address is 0x000D_8000. |
| 768 KB product | BLCKSWP[0]   | 1 : Block24 start address is 0x0009_0000. Block27 start address is 0x000A_8000.<br>0 : Block24 start address is 0x000A_8000. Block27 start address is 0x0009_0000. |
|                | BLCKSWP[1]   | 1 : Block25 start address is 0x0009_8000. Block28 start address is 0x000B_0000.<br>0 : Block25 start address is 0x000B_0000. Block28 start address is 0x0009_8000. |
|                | BLCKSWP[2]   | 1 : Block26 start address is 0x000A_0000. Block29 start address is 0x000B_8000.<br>0 : Block26 start address is 0x000B_8000. Block29 start address is 0x000A_0000. |
| 512 KB product | BLCKSWP[0]   | 1 : Block18 start address is 0x0006_0000. Block20 start address is 0x0007_0000.<br>0 : Block18 start address is 0x0007_0000. Block20 start address is 0x0006_0000. |
|                | BLCKSWP[1]   | 1 : Block19 start address is 0x0006_8000. Block21 start address is 0x0007_8000.<br>0 : Block19 start address is 0x0007_8000. Block21 start address is 0x0006_8000. |

## 6.2.5 BPS, BPS\_SEC, BPS\_SEL : Block Protect Setting Register

address:

BPS: 0x0100\_A1C0, 0x0100\_A1C4  
 BPS\_SEC: 0x0100\_A240, 0x0100\_A244  
 BPS\_SEL: 0x0100\_A2C0, 0x0100\_A2C4

Bit position: 31

0

Bit field:

Value after reset:

User setting\*1

Note 1. The value in a blank product is 0xFFFFFFFF. It is set to the value written by your application.

Only secure developer can program BPS\_SEC and BPS\_SEL registers. BPS\_SEC register is for secure developer, and BPS register is for non-secure developer. The applied setting value is determined by the setting value of the corresponding bit in BPS\_SEL register. For details, see [section 6.3.3. Security attribution of option-setting memory](#).

The BPS and BPS\_SEC registers invalidate the programming and erasure to the code flash memory. When the bit of this register is set to 0, the programming and erasure to the corresponding block are invalid. [Figure 6.3](#) shows the code flash block structure of each product. [Figure 6.4](#) shows the relationship between the bit of register and the block number. Unused bits are reserved and should be set to 1.

Table 6.2 各产品的BLCKSWP位规格

|                | BLCKSWP bits | Select 0 / 1   |
|----------------|--------------|--|
| 1 MB product   | BLCKSWP[0]   | 1: Block30起始地址为0x000C_0000。Block34起始地址为0x000E_0000。0: Block30起始地址为0x000E_0000。Block34起始地址为0x000C_0000。 |
|                | BLCKSWP[1]   | 1: Block31起始地址为0x000C_8000。Block35起始地址为0x000E_8000。0: Block31起始地址为0x000E_8000。Block35起始地址为0x000C_8000。 |
|                | BLCKSWP[2]   | 1: Block32起始地址为0x000D_0000。Block36起始地址为0x000F_0000。0: Block32起始地址为0x000F_0000。Block36起始地址为0x000D_0000。 |
|                | BLCKSWP[3]   | 1: Block33起始地址为0x000D_8000。Block37起始地址为0x000F_8000。0: Block33起始地址为0x000F_8000。Block37起始地址为0x000D_8000。 |
| 768 KB product | BLCKSWP[0]   | 1: Block24起始地址为0x0009_0000。Block27起始地址为0x000A_8000。0: Block24起始地址为0x000A_8000。Block27起始地址为0x0009_0000。 |
|                | BLCKSWP[1]   | 1: Block25起始地址为0x0009_8000。Block28起始地址为0x000B_0000。0: Block25起始地址为0x000B_0000。Block28起始地址为0x0009_8000。 |
|                | BLCKSWP[2]   | 1: Block26起始地址为0x000A_0000。Block29起始地址为0x000B_8000。0: Block26起始地址为0x000B_8000。Block29起始地址为0x000A_0000。 |
| 512 KB product | BLCKSWP[0]   | 1: Block18起始地址为0x0006_0000。Block20起始地址为0x0007_0000。0: Block18起始地址为0x0007_0000。Block20起始地址为0x0006_0000。 |
|                | BLCKSWP[1]   | 1: Block19起始地址为0x0006_8000。Block21起始地址为0x0007_8000。0: Block19起始地址为0x0007_8000。Block21起始地址为0x0006_8000。 |

## 6.2.5 BPS、BPS\_SEC、BPS\_SEL：块保护设置寄存器

address:

BPS: 0x0100\_A1C0, 0x0100\_A1C4  
 BPS\_SEC: 0x0100\_A240, 0x0100\_A244  
 BPS\_SEL: 0x0100\_A2C0, 0x0100\_A2C4

Bit position: 31

0

Bit field:

重置后的值:

用户设置\*1

注1.空白产品中的值为0xFFFFFFFF。它设置为您的应用程序写入的值。

只有安全的开发人员才能对BPS\_SEC和BPS\_SEL寄存器进行编程。BPS\_SEC寄存器用于安全开发者，BPS寄存器用于非安全开发者。应用的设置值由BPS\_SEL寄存器中相应位的设置值决定。详见6.3.3节。选项设置内存的安全属性。

BPS和BPS\_SEC寄存器使对代码闪存的编程和擦除无效。当该寄存器的位设置为0时，对相应块的编程和擦除无效。图6.3显示了每个产品的代码闪存块结构。图6.4显示了寄存器的位和块号之间的关系。未使用的位被保留，应设置为1。



Table 6.3 The relationship between the bit of PBPS, PBPS\_SEC and bit of BPS, BPS\_SEC

| The bit of applied PBPS | The bit of applied BPS | Content   |
|-------------------------|------------------------|---|
| 1                       | 1                      | Programming and erasure to the corresponding block is valid.  |
| 1                       | 0                      | Programming and erasure to the corresponding block is invalid. This protection can be canceled by FBPROT0 or FBPROT1 registers. |
| 0                       | 1                      | Can not set this condition  |
| 0                       | 0                      | Programming and erasure to the corresponding block is invalid permanently   |

### 6.3 Setting Option-Setting Memory

#### 6.3.1 Allocation of Data in Option-Setting Memory

Programming data is allocated to the addresses in the option-setting memory shown in Figure 6.1. The allocated data is used by tools such as a flash programming software or an on-chip debugger.

Note: Programming formats vary depending on the compiler. See the compiler manual for details.

#### 6.3.2 Setting Data for Programming Option-Setting Memory

Allocating data according to the procedure described in section 6.3.1. Allocation of Data in Option-Setting Memory, alone does not actually write the data to the option-setting memory. You must also follow one of the actions described in this section.

##### (1) Changing the option-setting memory by self-programming

Use the configuration setting command to write data to the option-setting memory in the configuration setting area.

The option-setting memory does not support background operations (BGO). When write the option-setting memory, jump to SRAM after copying writing software to SRAM.

For details of the configuration setting command, see section 44, Flash Memory.

##### (2) Debugging through an OCD or programming by a flash writer

This procedure depends on the tool in use, see the tool manual for details.

The MCU provides two setting procedures:

- Read the data allocated as described in section 6.3.1. Allocation of Data in Option-Setting Memory, from an object file or Motorola S-format file generated by the compiler, and write the data to the MCU
- Use the GUI interface of the tool to program the same data as allocated in section 6.3.1. Allocation of Data in Option-Setting Memory.

#### 6.3.3 Security attribution of option-setting memory

Some functionality has 3 registers for non-secure (FUNC NAME), and secure (FUNC NAME\_SEC), and security attribution (FUNC NAME\_SEL). Only secure developer can set the registers for secure and security attribution. As shown in Figure 6.5, when the bit of security attribution register is set to 0, the corresponding bit of secure register is applied. When the bit of security attribution register is set to 1, the corresponding bit of non-secure register is applied.

For example, if the secure developer wants to configure LVD of OFS1 as secure, HOCO of OFS1 as non-secure, the secure developer needs to set OFS1\_SEL as follows.

OFS1\_SEL = 0xFFFF\_FFF8

By this setting, LVDAS and VDSEL[1:0] values of OFS1\_SEC and HOCOFRQ0[1:0] and HOCOEN values of OFS1 are applied to MCU. The reserved bits of the security attribution register (FUNC NAME\_SEL) should be set to 1.

Table 6.3 PBPS、PBPS\_SEC的位与BPS、BPS\_SEC的位的关系

| 应用PBPS的位 | 应用BPS的点滴 | Content                                   |
|----------|----------|---|
| 1        | 1        | 对相应块的编程和擦除是有效的。                           |
| 1        | 0        | 对相应块的编程和擦除无效。该保护可以通过FBPROT0或FBPROT1寄存器取消。 |
| 0        | 1        | 不能设置这个条件                                  |
| 0        | 0        | 对相应块的编程和擦除永久无效                            |

### 6.3 设置选项设置内存

#### 6.3.1 选项设置内存中的数据分配

编程数据被分配到图6.1所示的选项设置存储器中的地址。分配的数据由闪存编程软件或片上调试器等工具使用。

Note: 编程格式因编译器而异。有关详细信息，请参阅编译器手册。

#### 6.3.2 编程选项设置存储器的设置数据

根据第6.3.1节中描述的程序分配数据。选项设置内存中的数据分配，单独并不实际将数据写入选项设置内存。您还必须遵循本节中描述的操作之一。

##### (1) 通过自编程更改选项设置存储器

使用配置设置命令将数据写入配置设置区的选项设置内存。

选项设置内存不支持后台操作(BGO)。写入选项设置内存时，跳转到将写入软件复制到SRAM后的SRAM。

有关配置设置命令的详细信息，请参见第44节，闪存。

##### (2) 通过OCD进行调试或通过闪存写入器进行编程

此过程取决于所使用的工具，详细信息请参见工具手册。

MCU提供两种设置程序：

- 读取第6.3.1节所述分配的数据。在选项设置内存中分配数据，从编译器生成的目标文件或摩托罗拉S格式文件，并将数据写入MCU
- 使用工具的GUI界面对6.3.1节分配的相同数据进行编程。OptionSetting内存中的数据分配。

#### 6.3.3 选项设置内存的安全属性

某些功能具有3个用于非安全(FUNCNAME)、安全(FUNCNAME\_SEC)和安全属性(FUNCNAME\_SEL)的寄存器。只有安全的开发人员才能设置安全和安全属性的寄存器。如图6.5所示，当安全属性寄存器的位设置为0时，应用安全寄存器的相应位。当安全属性寄存器的位设置为1时，应用非安全寄存器的相应位。

例如，如果安全开发者要将OFS1的LVD配置为安全，将OFS1的HOCO配置为非安全，则安全开发者需要如下设置OFS1\_SEL。

OFS1\_SEL = 0xFFFF\_FFF8

通过此设置，OFS1\_SEC和HOCOFRQ0[1:0]的LVDAS和VDSEL[1:0]值以及OFS1的HOCOEN值将应用于MCU。安全属性寄存器(FUNCNAME\_SEL)的保留位应设置为1。

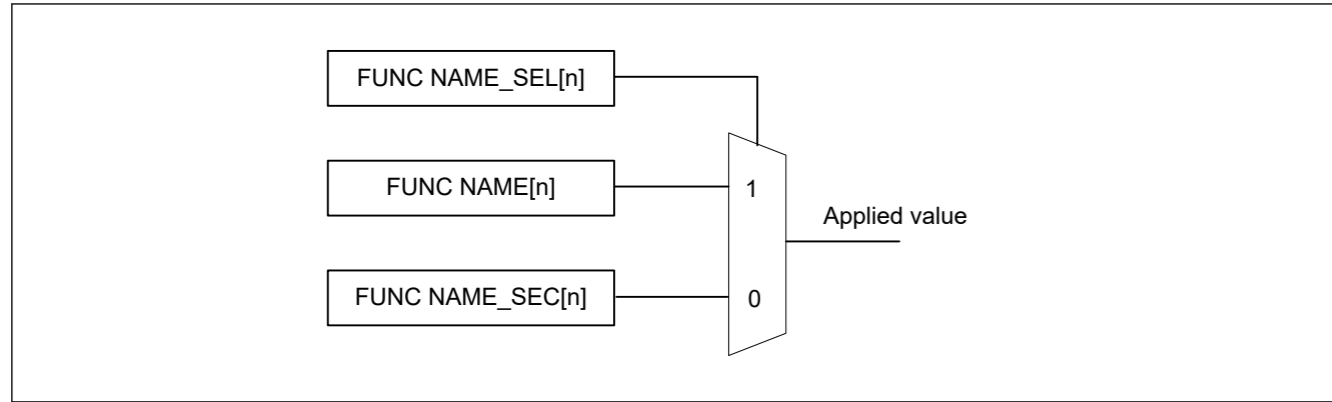


Figure 6.5 Selection of applied value

### 6.3.4 Timing of the Setting Value

For SAS, BPS, BPS\_SEC, PBPS, and PBPS\_SEC registers, the setting value of the related startup area and block protection is applied immediately after programming. For other registers, the setting value is applied after the MCU is reset.

In case the programming using the serial programming mode in customer's factory, be careful that the block protection for secure user is applied after MCU is reset. Because initial value of the security attribution registers of block protection (BPS\_SEL) is 1 (non-secure), the block protection setting for secure developer (BPS\_SEC/PBPS\_SEC) is not applied until MCU is reset even if the corresponding bit of BPS\_SEL is programmed to 0 (secure).

## 6.4 Usage Notes

### 6.4.1 Data for Programming Reserved Areas and Reserved Bits in the Option-Setting Memory

When reserved areas and reserved bits in the option-setting memory are within the scope of programming, write 1 to all bits of reserved areas and all reserved bits. If 0 is written to these bits, normal operation cannot be guaranteed.

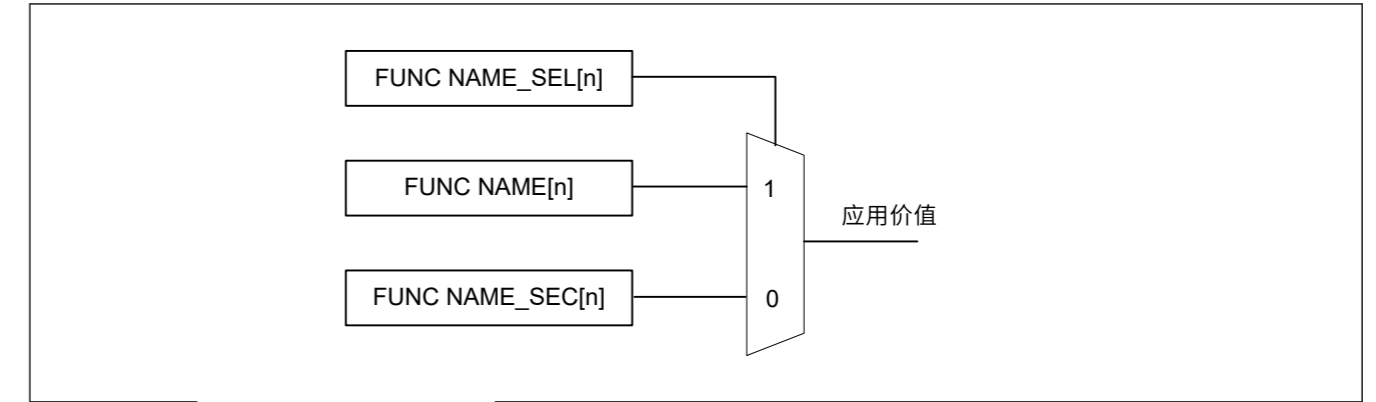


Figure 6.5 应用值的选择

### 6.3.4 设定值的时机

对于SAS、BPS、BPS\_SEC、PBPS和PBPS\_SEC寄存器，编程后立即应用相关启动区域和块保护的设置值。对于其他寄存器，设置值在MCU复位后应用。

如果在客户工厂使用串行编程模式进行编程，请注意在MCU复位后应用安全用户的块保护。由于块保护(BPS\_SEL)的安全属性寄存器的初始值为1（非安全），因此即使BPS\_SEL的相应位被编程为0（安全）。

## 6.4 使用说明

### 6.4.1 用于编程选项设置中的保留区域和保留位的数据 Memory

当期权设置内存中的保留区域和保留位在编程范围内时，将1写入保留区域和所有保留位的所有位。如果将0写入这些位，则无法保证正常操作。



## 7. Low Voltage Detection (LVD)

### 7.1 Overview

The Low Voltage Detection (LVD) module monitors the voltage level input to the VCC pin. The detection level can be selected by register settings. The LVD module consists of three separate voltage level detectors (LVD0, LVD1, LVD2). LVD0, LVD1, and LVD2 measure the voltage level input to the VCC pin. LVD registers allow your application to configure detection of VCC changes at various voltage thresholds.

Voltage monitor registers are used to configure the LVD to trigger an interrupt, event link output, or reset when the thresholds are crossed.

Table 7.1 lists the LVD specifications. Figure 7.1 shows a block diagram of the voltage monitor 0 reset generation circuit. Figure 7.2 shows a block diagram of the voltage monitor 1 interrupt and reset circuit, and Figure 7.3 shows a block diagram of the voltage monitor 2 interrupt and reset circuit.

Table 7.1 LVD specifications

| Parameter                      |                                      | Voltage monitor 0   | Voltage monitor 1  | Voltage monitor 2   |
|--------------------------------|--------------------------------------|---|--|---|
| Means for setting up operation |                                      | OFS1 register   | Registers  | Registers   |
| Target for monitoring          |                                      | VCC pin input voltage   | VCC pin input voltage  | VCC pin input voltage   |
| Monitored voltage              |                                      | $V_{det0}$  | $V_{det1}$   | $V_{det2}$  |
| Detected event                 |                                      | Voltage falls past $V_{det0}$   | Voltage rises or falls past $V_{det1}$   | Voltage rises or falls past $V_{det2}$  |
| Detection voltage              |                                      | Selectable from 3 different levels in the OFS1.VDSEL[1:0] bits                        | Selectable from 3 different levels in the LVD1CMPCR.LVD1LVL[4:0] bits  | Selectable from 3 different levels in the LVD2CMPCR.LVD2LVL[2:0] bits   |
| Monitoring flag                |                                      | None  | LVD1SR.MON flag: Monitors whether voltage is higher or lower than $V_{det1}$   | LVD2SR.MON flag: Monitors whether voltage is higher or lower than $V_{det2}$  |
|                                |                                      |   | LVD1SR.DET flag: $V_{det1}$ passage detection  | LVD2SR.DET flag: $V_{det2}$ passage detection   |
| Process on voltage detection   | Reset                                | Voltage monitor 0 reset   | Voltage monitor 1 reset  | Voltage monitor 2 reset   |
|                                |                                      | Reset when $V_{det0} > VCC$<br>CPU restart after specified time with $VCC > V_{det0}$ | Reset when $V_{det1} > VCC$<br>CPU restart timing selectable: after specified time with $VCC > V_{det1}$ or $V_{det1} > VCC$ | Reset when $V_{det2} > VCC$<br>CPU restart timing selectable: after specified time with either $VCC > V_{det2}$ or $V_{det2} > VCC$ |
|                                | Interrupt                            | No interrupt  | Voltage monitor 1 interrupt  | Voltage monitor 2 interrupt   |
|                                |                                      |   | Non-maskable or maskable interrupt selectable  | Non-maskable or maskable interrupt selectable   |
|                                |                                      |   | Interrupt request issued when $V_{det1} > VCC$ and $VCC > V_{det1}$ or either  | Interrupt request issued when $V_{det2} > VCC$ and $VCC > V_{det2}$ or either   |
| Digital filter                 | Switching between enable and disable | No digital filter function  | Available  | Available   |
|                                | Sampling time                        | —   | $1/n$ LOCO frequency $\times 2$ (n: 2, 4, 8, 16)   | $1/n$ LOCO frequency $\times 2$ (n: 2, 4, 8, 16)  |
| Event link function            |                                      | None  | Available<br>Output of event signals on detection of $V_{det1}$ crossings  | Available<br>Output of event signals on detection of $V_{det2}$ crossings   |
| TrustZone Filter               |                                      | —   | Security attribution can be set for each registers   |   |

## 7. 低电压检测(LVD)

### 7.1 Overview

低电压检测(LVD)模块监控输入到VCC引脚的电压电平。检测等级可以通过寄存器设置来选择。LVD模块由三个独立的电压电平检测器(LVD0、LVD1、LVD2)组成。LVD0、LVD1和LVD2测量输入到VCC引脚的电压电平。LVD寄存器允许您的应用程序配置在各种电压阈值下检测VCC变化。

电压监控寄存器用于配置LVD，以在超过阈值时触发中断、事件链接输出或复位。

表7.1列出了LVD规格。图7.1显示了电压监视器0复位产生电路的框图。图7.2显示了电压监视器1中断和复位电路的框图，图7.3显示了电压监视器2中断和复位电路的框图。

Table 7.1 LVD specifications

| Parameter        |            | 电压监视器0  | 电压监视器1  | 电压监视器2  |
|------------------|------------|---|---|---|
| 设置操作的方法          |            | OFS1 register   | Registers   | Registers   |
| 监测目标             |            | VCC引脚输入电压   | VCC引脚输入电压   | VCC引脚输入电压   |
| 监控电压             |            | $V_{det0}$  | $V_{det1}$  | $V_{det2}$  |
| 检测到的事件           |            | 电压下降超过 $V_{det0}$                                       | 电压上升或下降超过 $V_{det1}$  | 电压上升或下降超过 $V_{det2}$  |
| 检测电压             |            | 可从OFS1.VDSEL[1:0]位的3个不同级别中选择                            | 可从LVD1CMPCR.LVD1LVL[4:0]位中的3个不同级别中选择  | 可从LVD2CMPCR.LVD2LVL[2:0]位中的3个不同级别中选择  |
| 监控标志             |            | None  | LVD1SR.MON标志: 监控电压是高于还是低于 $V_{det1}$  | LVD2SR.MON标志: 监控电压是高于还是低于 $V_{det2}$  |
|                  |            |   | LVD1SR.DET标志: $V_{det1}$ 通过检测   | LVD2SR.DET标志: $V_{det2}$ 通过检测   |
| 电压检测流程           | Reset      | 电压监视器0复位  | 电压监视器1复位  | 电压监视器2复位  |
|                  |            | 当 $V_{det0} > VCC$ 时复位<br>CPU在 $VCC > V_{det0}$ 指定时间后重启 | 当 $V_{det1} > VCC$ 时复位<br>CPU重启时间可选: 在 $VCC > V_{det1}$ 或 $V_{det1} > VCC$ 的指定时间后 | 当 $V_{det2} > VCC$ 时复位<br>CPU重启时间可选: 在 $VCC > V_{det2}$ 或 $V_{det2} > VCC$ 的指定时间后 |
|                  | Interrupt  | 无中断   | 电压监视器1中断  | 电压监视器2中断  |
|                  |            |   | 可选择不可屏蔽或可屏蔽中断   | 可选择不可屏蔽或可屏蔽中断   |
|                  |            |   | 当 $V_{det1} >$ 时发出中断请求<br>$VCC$ 和 $VCC > V_{det1}$ 或                              | 当 $V_{det2} > VCC$ 和 $VCC > V_{det2}$ 或任一<br>时发出中断请求                              |
| 数字滤波器            | 在启用和禁用之间切换 | 无数字滤波功能   | Available   | Available   |
|                  | 采样时间       | —   | $1/n$ LOCO频率 $\times 2$ (n:2 4 8 16)  | $1/n$ LOCO频率 $\times 2$ (n:2 4 8 16)  |
| 事件链接功能           |            | None  | Available<br>在检测到 $V_{det1}$ 交叉点时输出事件信号   | Available<br>在检测到 $V_{det2}$ 交叉点时输出事件信号   |
| TrustZone Filter |            | —   | 可以为每个寄存器设置安全属性  |   |



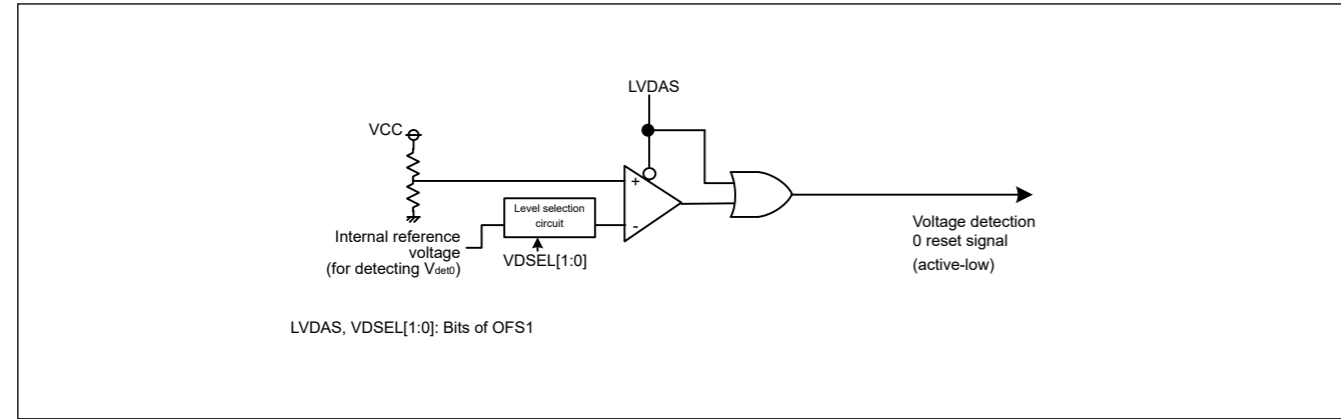


Figure 7.1 Block diagram of voltage monitor 0 reset generation circuit

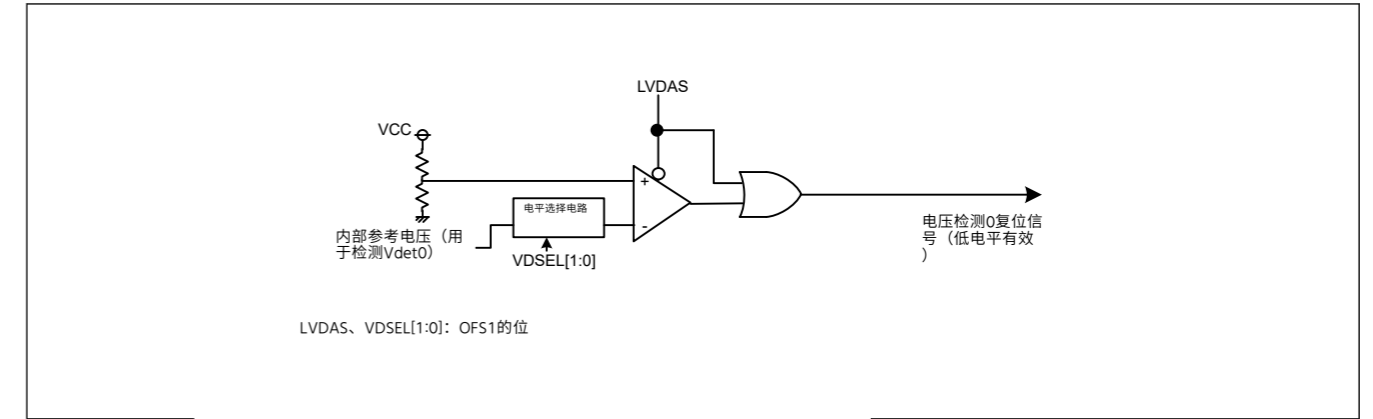


Figure 7.1 电压监视器0复位产生电路框图

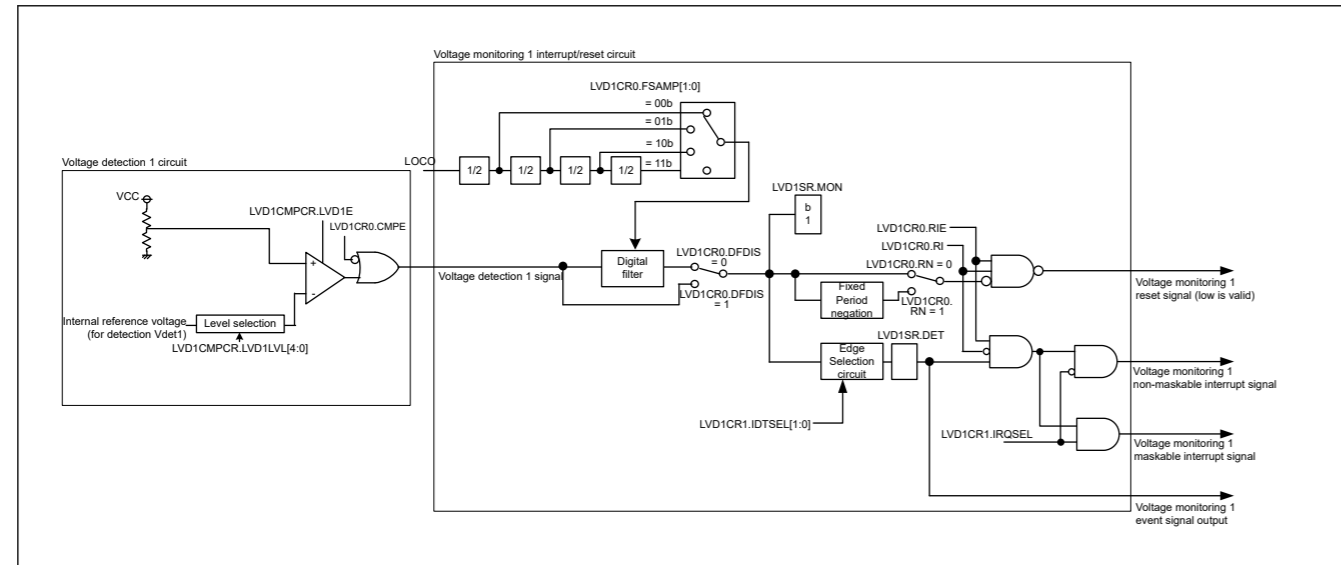


Figure 7.2 Block diagram of voltage monitor 1 interrupt and reset circuit

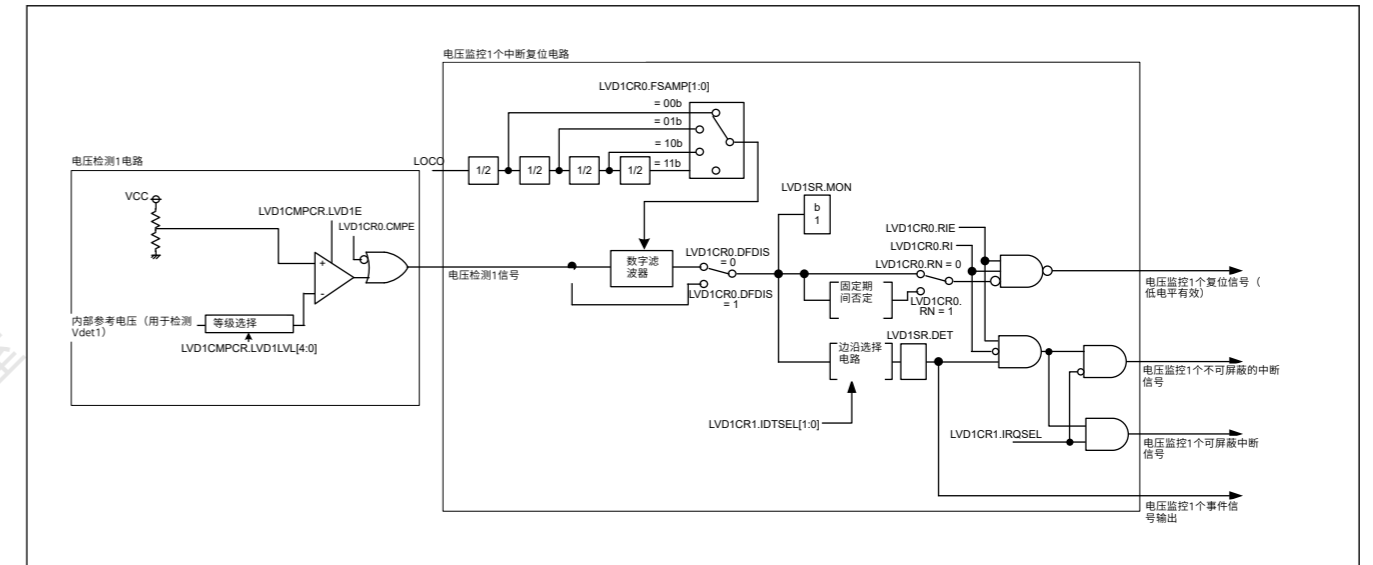


Figure 7.2 电压监视器1中断和复位电路框图

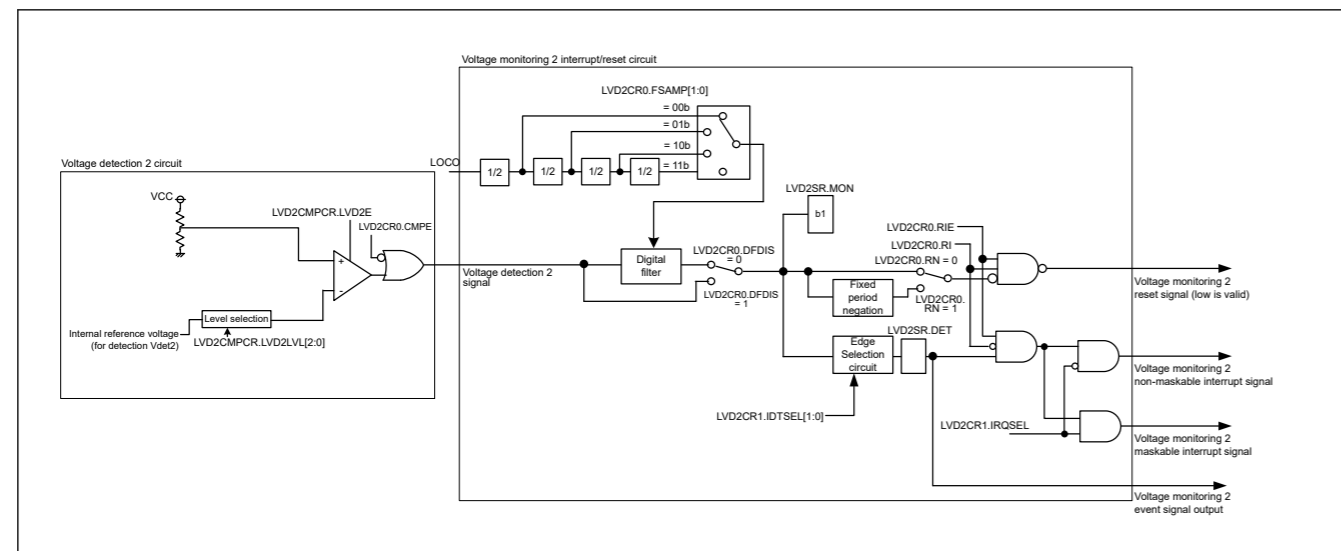


Figure 7.3 Block diagram of voltage monitor 2 interrupt and reset circuit

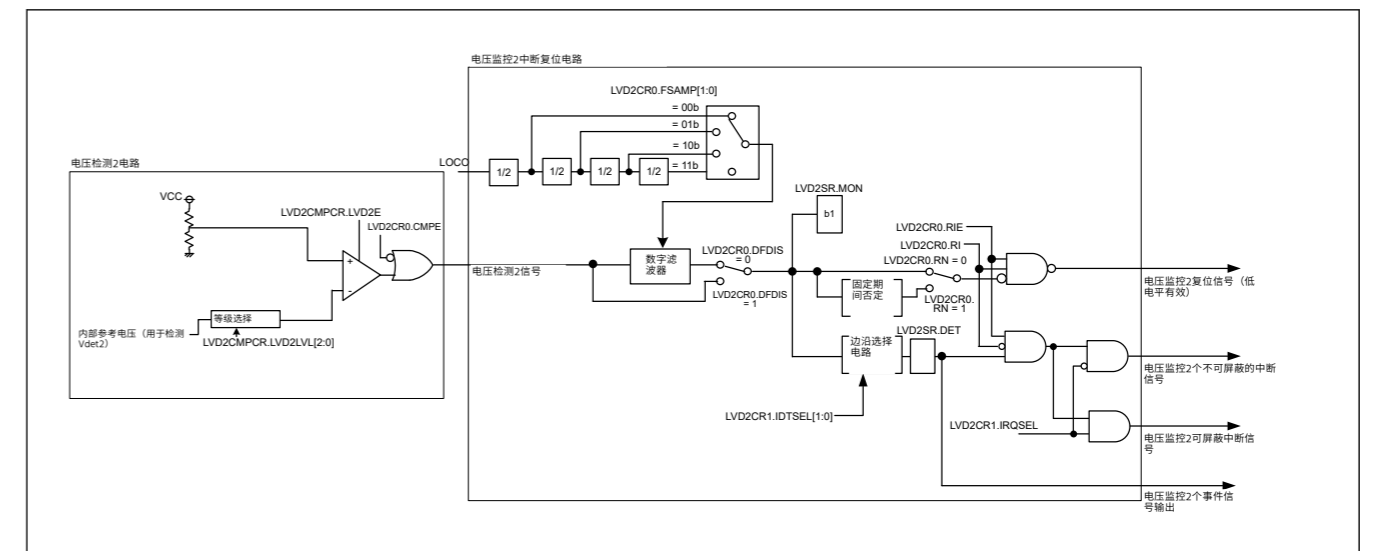


Figure 7.3 电压监视器2中断和复位电路框图

7.2 Register Descriptions

7.2.1 LVDSAR : Low Voltage Detection Security Attribution Register

Base address: SYSC = 0x4001\_E000  
Offset address: 0x3CC

|                    |    |    |    |    |    |    |    |    |    |    |    |    |    |    |             |             |
|--------------------|----|----|----|----|----|----|----|----|----|----|----|----|----|----|-------------|-------------|
| Bit position:      | 31 | 30 | 29 | 28 | 27 | 26 | 25 | 24 | 23 | 22 | 21 | 20 | 19 | 18 | 17          | 16          |
| Bit field:         | —  | —  | —  | —  | —  | —  | —  | —  | —  | —  | —  | —  | —  | —  | —           | —           |
| Value after reset: | 1  | 1  | 1  | 1  | 1  | 1  | 1  | 1  | 1  | 1  | 1  | 1  | 1  | 1  | 1           | 1           |
| Bit position:      | 15 | 14 | 13 | 12 | 11 | 10 | 9  | 8  | 7  | 6  | 5  | 4  | 3  | 2  | 1           | 0           |
| Bit field:         | —  | —  | —  | —  | —  | —  | —  | —  | —  | —  | —  | —  | —  | —  | NONS<br>EC1 | NONS<br>EC0 |
| Value after reset: | 1  | 1  | 1  | 1  | 1  | 1  | 1  | 1  | 1  | 1  | 1  | 1  | 1  | 1  | 1           | 1           |

| Bit  | Symbol  | Function  | R/W |
|------|---------|---|-----|
| 0    | NONSEC0 | Non Secure Attribute bit 0<br>Target register: registers for LVD1<br>0: Secure<br>1: Non Secure | R/W |
| 1    | NONSEC1 | Non Secure Attribute bit 1<br>Target register: registers for LVD2<br>0: Secure<br>1: Non Secure | R/W |
| 31:2 | —       | These bits are read as 1. The write value must be 1 when it is possible to write.               | R/W |

Note: Only secure access can write to this register. Both secure access and Non-secure read access are allowed but Non-secure write access is not allowed and TrustZone access error is not generated.  
Note: This register is write-protected by PRCR register.

The LVDSAR register controls the secure attribute of LVD registers.

**NONSEC0 bit (Non Secure Attribute bit 0)**

This bit controls the security attribute of LVD1CMPCR, LVD1CR0, LVD1CR1, LVD1SR.

**NONSEC1 bit (Non Secure Attribute bit 1)**

This bit controls the security attribute of LVD2CMPCR, LVD2CR0, LVD2CR1, LVD2SR.

7.2.2 LVD1CMPCR : Voltage Monitoring 1 Comparator Control Register

Base address: SYSC = 0x4001\_E000  
Offset address: 0x417

|                    |       |   |   |              |   |   |   |   |
|--------------------|-------|---|---|--------------|---|---|---|---|
| Bit position:      | 7     | 6 | 5 | 4            | 3 | 2 | 1 | 0 |
| Bit field:         | LVD1E | — | — | LVD1LVL[4:0] |   |   |   | — |
| Value after reset: | 0     | 0 | 0 | 1            | 0 | 0 | 1 | 1 |

| Bit | Symbol       | Function  | R/W |
|-----|--------------|---|-----|
| 4:0 | LVD1LVL[4:0] | Voltage Detection 1 Level Select (Standard voltage during drop in voltage)<br>0x11: 2.99 V (Vdet1_11)<br>0x12: 2.92 V (Vdet1_12)<br>0x13: 2.85 V (Vdet1_13)<br>Others: Setting prohibited | R/W |
| 6:5 | —            | These bits are read as 0. The write value should be 0.  | R/W |

7.2 注册说明

7.2.1 LVDSAR: 低电压检测安全属性寄存器

Base address: SYSC = 0x4001\_E000  
Offset address: 0x3CC

|               |    |    |    |    |    |    |    |    |    |    |    |    |    |    |             |             |
|---------------|----|----|----|----|----|----|----|----|----|----|----|----|----|----|-------------|-------------|
| Bit position: | 31 | 30 | 29 | 28 | 27 | 26 | 25 | 24 | 23 | 22 | 21 | 20 | 19 | 18 | 17          | 16          |
| Bit field:    | —  | —  | —  | —  | —  | —  | —  | —  | —  | —  | —  | —  | —  | —  | —           | —           |
| 重置后的值:        | 1  | 1  | 1  | 1  | 1  | 1  | 1  | 1  | 1  | 1  | 1  | 1  | 1  | 1  | 1           | 1           |
| Bit position: | 15 | 14 | 13 | 12 | 11 | 10 | 9  | 8  | 7  | 6  | 5  | 4  | 3  | 2  | 1           | 0           |
| Bit field:    | —  | —  | —  | —  | —  | —  | —  | —  | —  | —  | —  | —  | —  | —  | NONS<br>EC1 | NONS<br>EC0 |
| 重置后的值:        | 1  | 1  | 1  | 1  | 1  | 1  | 1  | 1  | 1  | 1  | 1  | 1  | 1  | 1  | 1           | 1           |

| Bit  | Symbol  | Function                                   | R/W |
|------|---------|--|-----|
| 0    | NONSEC0 | 非安全属性位0<br>目标寄存器: LVD1的寄存器<br>0: 安全 1: 不安全 | R/W |
| 1    | NONSEC1 | 非安全属性位1<br>目标寄存器: LVD2的寄存器<br>0: 安全 1: 不安全 | R/W |
| 31:2 | —       | 这些位被读取为1。当可以写入时, 写入值必须为1。                  | R/W |

Note: 只有安全访问才能写入该寄存器。允许安全访问和非安全读取访问, 但不允许非安全写入访问, 并且不会生成TrustZone访问错误。  
Note: 该寄存器由PRCR寄存器写保护。

LVDSAR寄存器控制LVD寄存器的安全属性。

**NONSEC0位 (非安全属性位0)**

该位控制LVD1CMPCR、LVD1CR0、LVD1CR1、LVD1SR的安全属性。

**NONSEC1位 (非安全属性位1)**

该位控制LVD2CMPCR、LVD2CR0、LVD2CR1、LVD2SR的安全属性。

7.2.2 LVD1CMPCR:电压监测1比较器控制寄存器

Base address: SYSC = 0x4001\_E000  
Offset address: 0x417

|               |       |   |   |              |   |   |   |   |
|---------------|-------|---|---|--------------|---|---|---|---|
| Bit position: | 7     | 6 | 5 | 4            | 3 | 2 | 1 | 0 |
| Bit field:    | LVD1E | — | — | LVD1LVL[4:0] |   |   |   | — |
| 重置后的值:        | 0     | 0 | 0 | 1            | 0 | 0 | 1 | 1 |

| Bit | Symbol       | Function  | R/W |
|-----|--------------|---|-----|
| 4:0 | LVD1LVL[4:0] | 电压检测1电平选择 (电压下降时的标准电压)<br>0x11: 2.99 V (Vdet1_11)<br>0x12: 2.92 V (Vdet1_12)<br>0x13: 2.85 V (Vdet1_13)<br>其他: 禁止设置 | R/W |
| 6:5 | —            | 这些位被读取为0。写入值应为0。  | R/W |

| Bit | Symbol | Function  | R/W |
|-----|--------|---|-----|
| 7   | LVD1E  | Voltage Detection 1 Enable<br>0: Voltage detection 1 circuit disabled<br>1: Voltage detection 1 circuit enabled | R/W |

Note: If the security attribution is configured as secure:

- Secure access and Non-secure read access are allowed
- Non-secure write access is ignored, and TrustZone access error is not generated.

If the security attribution is configured as Non-secure:

- Secure and Non-secure access are allowed.

Note: Set the PRCR.PRC3 bit to 1 (write enabled) before rewriting this register.

The LVD1CMPCR.LVD1LVL can be changed only if the LVD1CMPCR.LVD1E and LVD2CMPCR.LVD2E bits are both 0. The voltage detection circuits 1 and 2 should not be set at the same voltage detection level.

Please do not change LVD1CMPCR.LVD1LVL and LVD1CMPCR.LVD1E at the same time.

#### LVD1E bit (Voltage Detection 1 Enable)

When using voltage detection 1 interrupt/reset or the LVD1SR.MON bit, set the LVD1E bit to 1. The voltage detection 1 circuit starts once td(E-A) passes after the LVD1E bit value is changed from 0 to 1. When using the voltage detection 1 circuit in deep software standby mode, do not set the DPSBYCR.DEEPCUT[1:0] bits to 11b.

### 7.2.3 LVD2CMPCR : Voltage Monitoring 2 Comparator Control Register

Base address: SYSC = 0x4001\_E000

Offset address: 0x418

| Bit position:      | 7     | 6 | 5 | 4 | 3 | 2            | 1 | 0 |
|--------------------|-------|---|---|---|---|--------------|---|---|
| Bit field:         | LVD2E | — | — | — | — | LVD2LVL[2:0] |   |   |
| Value after reset: | 0     | 0 | 0 | 0 | 0 | 1            | 1 | 1 |

| Bit | Symbol       | Function  | R/W |
|-----|--------------|---|-----|
| 2:0 | LVD2LVL[2:0] | Voltage Detection 2 Level Select (Standard voltage during drop in voltage)<br>1 0 1: 2.99 V (Vdet2_5)<br>1 1 0: 2.92 V (Vdet2_6)<br>1 1 1: 2.85 V (Vdet2_7)<br>Others: Setting prohibited | R/W |
| 6:3 | —            | These bits are read as 0. The write value should be 0.  | R/W |
| 7   | LVD2E        | Voltage Detection 2 Enable<br>0: Voltage detection 2 circuit disabled<br>1: Voltage detection 2 circuit enabled   | R/W |

Note: If the security attribution is configured as secure:

- Secure access and Non-secure read access are allowed
- Non-secure write access is ignored, and TrustZone access error is not generated.

If the security attribution is configured as Non-secure:

- Secure and Non-secure access are allowed.

Note: Set the PRCR.PRC3 bit to 1 (write enabled) before rewriting this register.

The LVD2CMPCR.LVD2LVL can be changed only if the LVD1CMPCR.LVD1E and LVD2CMPCR.LVD2E bits are both 0. The voltage detection circuits 1 and 2 should not be set at the same voltage detection level.

Do not change LVD2CMPCR.LVD2LVL and LVD2CMPCR.LVD2E at the same time.

#### LVD2E bit (Voltage Detection 2 Enable)

When using voltage detection 2 interrupt/reset or the LVD2SR.MON bit, set the LVD2E bit to 1. The voltage detection 2 circuit starts once td(E-A) passes after the LVD2E bit value is changed from 0 to 1. When using the voltage detection 2 circuit in deep software standby mode, do not set the DPSBYCR.DEEPCUT[1:0] bits to 11b.

| Bit | Symbol | Function                            | R/W |
|-----|--------|-------------------------------------|-----|
| 7   | LVD1E  | 电压检测1使能<br>0: 电压检测1电路无效1: 电压检测1电路有效 | R/W |

Note: 如果安全属性配置为安全: ●

- 允许安全访问和非安全读取访问
- 忽略非安全写入访问, 不会生成TrustZone访问错误。

如果安全属性配置为非安全: ●

- 允许安全和非安全访问。

Note: 在重写该寄存器之前将PRCR.PRC3位设置为1 (允许写入)。

LVD1CMPCR.LVD1LVL只有在LVD1CMPCR.LVD1E和LVD2CMPCR.LVD2E位均为0时才能更改。电压检测电路1和2不应设置为相同的电压检测电平。

请不要同时更改LVD1CMPCR.LVD1LVL和LVD1CMPCR.LVD1E。

#### LVD1E位 (电压检测1使能)

使用电压检测1中断复位或LVD1SR.MON位时, 将LVD1E位设置为1。LVD1E位值从0变为1后, 一旦经过td(E-A), 电压检测1电路就会启动。使用电压检测时1电路处于深度软件待机模式, 请勿将DPSBYCR.DEEPCUT[1:0]位设置为11b。

### 7.2.3 LVD2CMPCR:电压监测2比较器控制寄存器

Base address: SYSC = 0x4001\_E000

Offset address: 0x418

| Bit position: | 7     | 6 | 5 | 4 | 3 | 2            | 1 | 0 |
|---------------|-------|---|---|---|---|--------------|---|---|
| Bit field:    | LVD2E | — | — | — | — | LVD2LVL[2:0] |   |   |
| 重置后的值:        | 0     | 0 | 0 | 0 | 0 | 1            | 1 | 1 |

| Bit | Symbol       | Function  | R/W |
|-----|--------------|---|-----|
| 2:0 | LVD2LVL[2:0] | 电压检测2电平选择 (电压下降时的标准电压)<br>1 0 1: 2.99 V (Vdet2_5)<br>1 1 0: 2.92 V (Vdet2_6)<br>1 1 1: 2.85 V (Vdet2_7)<br>其他: 禁止设置 | R/W |
| 6:3 | —            | 这些位被读取为0。写入值应为0。  | R/W |
| 7   | LVD2E        | 电压检测2使能<br>0: 电压检测2电路无效1: 电压检测2电路有效   | R/W |

Note: 如果安全属性配置为安全: ●

- 允许安全访问和非安全读取访问
- 忽略非安全写入访问, 不会生成TrustZone访问错误。

如果安全属性配置为非安全: ●

- 允许安全和非安全访问。

Note: 在重写该寄存器之前将PRCR.PRC3位设置为1 (允许写入)。

LVD2CMPCR.LVD2LVL只有在LVD1CMPCR.LVD1E和LVD2CMPCR.LVD2E位均为0时才能更改。电压检测电路1和2不应设置为相同的电压检测电平。

不要同时更改LVD2CMPCR.LVD2LVL和LVD2CMPCR.LVD2E。

#### LVD2E位 (电压检测2使能)

使用电压检测2中断复位或LVD2SR.MON位时, 将LVD2E位设置为1。LVD2E位值从0变为1后, 一旦经过td(E-A), 电压检测2电路就会启动。使用电压检测时2电路处于深度软件待机模式, 请勿将DPSBYCR.DEEPCUT[1:0]位设置为11b。

## 7.2.4 LVD1CR0 : Voltage Monitor 1 Circuit Control Register 0

Base address: SYSC = 0x4001\_E000

Offset address: 0x41A

|                    |    |    |            |   |      |       |     |   |
|--------------------|----|----|------------|---|------|-------|-----|---|
| Bit position:      | 7  | 6  | 5          | 4 | 3    | 2     | 1   | 0 |
| Bit field:         | RN | RI | FSAMP[1:0] | — | CMPE | DFDIS | RIE |   |
| Value after reset: | 1  | 0  | 0          | 0 | x    | 0     | 1   | 0 |

| Bit | Symbol     | Function   | R/W |
|-----|------------|--|-----|
| 0   | RIE        | Voltage Monitor 1 Interrupt/Reset Enable<br>0: Disable<br>1: Enable  | R/W |
| 1   | DFDIS      | Voltage monitor 1 Digital Filter Disabled Mode Select<br>0: Enable the digital filter<br>1: Disable the digital filter   | R/W |
| 2   | CMPE       | Voltage Monitor 1 Circuit Comparison Result Output Enable<br>0: Disable voltage monitor 1 circuit comparison result output<br>1: Enable voltage monitor 1 circuit comparison result output                           | R/W |
| 3   | —          | The read value is undefined. The write value should be 1.  | R/W |
| 5:4 | FSAMP[1:0] | Sampling Clock Select<br>00: 1/2 LOCO frequency<br>01: 1/4 LOCO frequency<br>10: 1/8 LOCO frequency<br>11: 1/16 LOCO frequency   | R/W |
| 6   | RI         | Voltage Monitor 1 Circuit Mode Select<br>0: Generate voltage monitor 1 interrupt on $V_{det1}$ crossing<br>1: Enable voltage monitor 1 reset when the voltage falls to and below $V_{det1}$                          | R/W |
| 7   | RN         | Voltage Monitor 1 Reset Negate Select<br>0: Negate after a stabilization time ( $t_{LVD1}$ ) when $VCC > V_{det1}$ is detected<br>1: Negate after a stabilization time ( $t_{LVD1}$ ) on assertion of the LVD1 reset | R/W |

Note: If the security attribution is configured as secure:

- Secure access and Non-secure read access are allowed
  - Non-secure write access is ignored, and TrustZone access error is not generated.
- If the security attribution is configured as Non-secure:
- Secure and Non-secure access are allowed.

Note: Set the PRCR.PRC3 bit to 1 (write enabled) before rewriting this register.

**RIE bit (Voltage Monitor 1 Interrupt/Reset Enable)**

The RIE bit enables or disables voltage monitor 1 interrupt/reset. Ensure that neither a voltage monitor 1 interrupt nor a voltage monitor 1 reset is generated during programming or erasure of the flash memory.

**DFDIS bit (Voltage monitor 1 Digital Filter Disabled Mode Select)**

The DFDIS bit disables the digital filter circuit. Set the LOCOCR.LCSTP bit to 0 (the LOCO operates) when this bit is 0(enabled). Set this bit to 1 (disabled) when using the voltage monitor 1 circuit in Software Standby mode or in Deep Software Standby mode.

**CMPE bit (Voltage Monitor 1 Circuit Comparison Result Output Enable)**

The CMPE bit enables or disables voltage monitor 1 circuit comparison result output. Set the CMPE bit to 1 after the voltage detection 1 circuit enables and stabilization time ( $t_{d(E-A)}$ ) elapses. When stopping the voltage detection 1 circuit, disable the voltage detection 1 circuit after setting the CMPE bit is 0.

**FSAMP[1:0] bits (Sampling Clock Select)**

The FSAMP[1:0] bits can be rewritten only when the LVD1CR0.DFDIS bit is 1 (digital filter circuit disabled). Do not rewrite these bits if the LVD1CR0.DFDIS bit is 0 (digital filter circuit enabled).

## 7.2.4 LVD1CR0: 电压监视器1电路控制寄存器0

Base address: SYSC = 0x4001\_E000

Offset address: 0x41A

|               |    |    |            |   |      |       |     |   |
|---------------|----|----|------------|---|------|-------|-----|---|
| Bit position: | 7  | 6  | 5          | 4 | 3    | 2     | 1   | 0 |
| Bit field:    | RN | RI | FSAMP[1:0] | — | CMPE | DFDIS | RIE |   |
| 重置后的值:        | 1  | 0  | 0          | 0 | x    | 0     | 1   | 0 |

| Bit | Symbol     | Function  | R/W |
|-----|------------|---|-----|
| 0   | RIE        | 电压监视器1中断复位使能<br>0: 禁用1<br>1: 启用   | R/W |
| 1   | DFDIS      | 电压监视器1数字滤波器禁用模式选择<br>0: 启用数字滤波器1: 禁用数字滤波器   | R/W |
| 2   | CMPE       | 电压监视器1电路比较结果输出使能<br>0: 禁止电压监视1电路比较结果输出1: 使能电压监视1电路比较结果输出  | R/W |
| 3   | —          | 读取值未定义。写入值应为1。  | R/W |
| 5:4 | FSAMP[1:0] | 采样时钟选择<br>00:12LOCO频率01:14LOCO频率10:18LOCO频率11:16LOCO频率  | R/W |
| 6   | RI         | 电压监视器1电路模式选择<br>0: 在 $V_{det1}$ 交叉时产生电压监视器1中断1: 当电压下降到或低于 $V_{det1}$ 时使能电压监视器1复位                    | R/W |
| 7   | RN         | 电压监视器1复位否定选择<br>0: 在检测到 $VCC > V_{det1}$ 时在稳定时间( $t_{LVD1}$ )后取反1: 在LVD1复位有效时在稳定时间( $t_{LVD1}$ )后取反 | R/W |

Note: 如果安全属性配置为安全: ●

- 允许安全访问和非安全读取访问
  - 忽略非安全写入访问, 不会生成TrustZone访问错误。
- 如果安全属性配置为非安全: ●
- 允许安全和非安全访问。

Note: 在重写该寄存器之前将PRCR.PRC3位设置为1 (允许写入)。

**RIE位 (电压监视器1中断复位使能)**

RIE位启用或禁用电压监视器1中断复位。确保在对闪存进行编程或擦除期间, 既不会产生电压监视器1中断, 也不会产生电压监视器1复位。

**DFDIS位 (电压监视器1数字滤波器禁用模式选择)**

DFDIS位禁用数字滤波器电路。当该位为0 (启用) 时, 将LOCOCR.LCSTP位设置为0 (LOCO运行)。在软件待机模式或深度软件待机模式下使用电压监视器1电路时, 将此位设置为1 (禁用)。

**CMPE位 (电压监视器1电路比较结果输出使能)**

CMPE位启用或禁用电压监视器1电路比较结果输出。在电压检测1电路使能并经过稳定时间( $t_{d(E-A)}$ )后, 将CMPE位设置为1。停止电压检测1电路时, 将CMPE位设置为0后禁用电压检测1电路。

**FSAMP[1:0]位 (采样时钟选择)**

只有当LVD1CR0.DFDIS位为1 (数字滤波器电路禁用) 时, FSAMP[1:0]位才能被重写。如果LVD1CR0.DFDIS位为0 (启用数字滤波器电路), 请勿重写这些位。



**RI bit (Voltage Monitor 1 Circuit Mode Select)**

When the RI bit is 1 (voltage monitor 1 reset selected), transition to Deep Software Standby mode cannot be made. In this case, transition to Software Standby mode is made. To enter Deep Software Standby mode, set the RI bit to 0 (voltage monitor 1 interrupt selected).

**RN bit (Voltage Monitor 1 Reset Negate Select)**

If the RN bit is set to 1 (negation follows a stabilization time on assertion of the LVD1 reset signal), set the LOCOCR.LCSTP bit to 0 (the LOCO operates). In addition, for a transition to Software Standby or Deep Software Standby mode, the only possible value for the RN bit is 0 (negation follows stabilization time when  $VCC > V_{det1}$  is detected). Do not set the RN bit to 1 when this is the case.

**7.2.5 LVD2CR0 : Voltage Monitor 2 Circuit Control Register 0**

Base address: SYSC = 0x4001\_E000

Offset address: 0x41B

|                    |    |    |            |   |      |       |     |   |
|--------------------|----|----|------------|---|------|-------|-----|---|
| Bit position:      | 7  | 6  | 5          | 4 | 3    | 2     | 1   | 0 |
| Bit field:         | RN | RI | FSAMP[1:0] | — | CMPE | DFDIS | RIE |   |
| Value after reset: | 1  | 0  | 0          | 0 | x    | 0     | 1   | 0 |

| Bit | Symbol     | Function   | R/W |
|-----|------------|--|-----|
| 0   | RIE        | Voltage Monitor 2 Interrupt/Reset Enable<br>0: Disable<br>1: Enable  | R/W |
| 1   | DFDIS      | Voltage monitor 2 Digital Filter Disabled Mode Select<br>0: Enable the digital filter<br>1: Disable the digital filter   | R/W |
| 2   | CMPE       | Voltage Monitor 2 Circuit Comparison Result Output Enable<br>0: Disable voltage monitor 2 circuit comparison result output<br>1: Enable voltage monitor 2 circuit comparison result output                           | R/W |
| 3   | —          | The read value is undefined. The write value should be 1.  | R/W |
| 5:4 | FSAMP[1:0] | Sampling Clock Select<br>00: 1/2 LOCO frequency<br>01: 1/4 LOCO frequency<br>10: 1/8 LOCO frequency<br>11: 1/16 LOCO frequency   | R/W |
| 6   | RI         | Voltage Monitor 2 Circuit Mode Select<br>0: Generate voltage monitor 2 interrupt on $V_{det2}$ crossing<br>1: Enable voltage monitor 2 reset when the voltage falls to and below $V_{det2}$                          | R/W |
| 7   | RN         | Voltage Monitor 2 Reset Negate Select<br>0: Negate after a stabilization time ( $t_{LVD2}$ ) when $VCC > V_{det2}$ is detected<br>1: Negate after a stabilization time ( $t_{LVD2}$ ) on assertion of the LVD2 reset | R/W |

Note: If the security attribution is configured as secure:

- Secure access and Non-secure read access are allowed
- Non-secure write access is ignored, and TrustZone access error is not generated.

If the security attribution is configured as Non-secure:

- Secure and Non-secure access are allowed.

Note: Set the PRCR.PRC3 bit to 1 (write enabled) before rewriting this register.

**RIE bit (Voltage Monitor 2 Interrupt/Reset Enable)**

The RIE bit enables or disables the voltage monitor 2 interrupt/reset. Ensure that neither a voltage monitor 2 interrupt nor a voltage monitor 2 reset is generated during programming or erasure of the flash memory.

**RI位 (电压监视器1电路模式选择)**

当RI位为1 (选择电压监视器1复位) 时, 无法转换到深度软件待机模式。在这种情况下, 将转换到软件待机模式。要进入深度软件待机模式, 请将RI位设置为0 (选择电压监视器1中断)。

**RN位 (电压监视器1复位否定选择)**

如果RN位设置为1 (否定遵循LVD1复位信号断言的稳定时间), 设置 LOCOCR.LCSTP位为0 (LOCO运行)。此外, 为了转换到软件待机或深度软件待机模式, RN位的唯一可能值为0 (当检测到 $VCC > V_{det1}$ 时, 取反跟随稳定时间)。在这种情况下, 请勿将RN位设置为1。

**7.2.5 LVD2CR0: 电压监视器2电路控制寄存器0**

Base address: SYSC = 0x4001\_E000

Offset address: 0x41B

|               |    |    |            |   |      |       |     |   |
|---------------|----|----|------------|---|------|-------|-----|---|
| Bit position: | 7  | 6  | 5          | 4 | 3    | 2     | 1   | 0 |
| Bit field:    | RN | RI | FSAMP[1:0] | — | CMPE | DFDIS | RIE |   |
| 重置后的值:        | 1  | 0  | 0          | 0 | x    | 0     | 1   | 0 |

| Bit | Symbol     | Function  | R/W |
|-----|------------|---|-----|
| 0   | RIE        | 电压监视器2中断复位使能<br>0: 禁用1<br>1: 启用   | R/W |
| 1   | DFDIS      | 电压监视器2数字滤波器禁用模式选择<br>0: 启用数字滤波器1: 禁用数字滤波器   | R/W |
| 2   | CMPE       | 电压监视器2电路比较结果输出使能<br>0: 禁止电压监视2电路比较结果输出1: 使能电压监视2电路比较结果输出  | R/W |
| 3   | —          | 读取值未定义。写入值应为1。  | R/W |
| 5:4 | FSAMP[1:0] | 采样时钟选择<br>00:12LOCO频率01:14LOC<br>0频率10:18LOCO频率11:1<br>16LOCO频率                                     | R/W |
| 6   | RI         | 电压监视器2电路模式选择<br>0: 在 $V_{det2}$ 交叉时产生电压监视器2中断1: 当电压下降到或低于 $V_{det2}$ 时使能电压监视器2复位                    | R/W |
| 7   | RN         | 电压监视器2复位否定选择<br>0: 在检测到 $VCC > V_{det2}$ 时在稳定时间( $t_{LVD2}$ )后取反1: 在LVD2复位有效时在稳定时间( $t_{LVD2}$ )后取反 | R/W |

Note: 如果安全属性配置为安全: ●

- 允许安全访问和非安全读取访问
- 忽略非安全写入访问, 不会生成TrustZone访问错误。

如果安全属性配置为非安全: ●

- 允许安全和非安全访问。

Note: 在重写该寄存器之前将PRCR.PRC3位设置为1 (允许写入)。

**RIE位 (电压监视器2中断复位使能)**

RIE位启用或禁用电压监视器2中断复位。确保在对闪存进行编程或擦除期间, 既不会产生电压监视器2中断, 也不会产生电压监视器2复位。

**DFDIS bit (Voltage monitor 2 Digital Filter Disabled Mode Select)**

The DFDIS bit disables the digital filter circuit. Set the LOCOCR.LCSTP bit to 0 (the LOCO operates) when this bit is 0 (digital filter enabled). Set this bit to 1 (digital filter disabled) when using the voltage monitor 2 circuit in Software Standby mode or in Deep Software Standby mode.

**CMPE bit (Voltage Monitor 2 Circuit Comparison Result Output Enable)**

The CMPE bit enables or disables voltage monitor 2 circuit comparison result output. Set the CMPE bit to 1 after the voltage detection 2 circuit enables and stabilization time ( $t_{d(E-A)}$ ) elapses. When stopping the voltage detection 2 circuit, disable the voltage detection 2 circuit after setting the CMPE bit is 0.

**FSAMP[1:0] bits (Sampling Clock Select)**

The FSAMP[1:0] bits can be rewritten only when the LVD2CR0.DFDIS bit is 1 (digital filter circuit disabled). Do not rewrite these bits if the LVD2CR0.DFDIS bit is 0 (digital filter circuit enabled).

**RI bit (Voltage Monitor 2 Circuit Mode Select)**

When the RI bit is 1 (voltage monitor 2 reset selected), transition to Deep Software Standby mode cannot be made. In this case, transition to Software Standby mode is made. To enter Deep Software Standby mode, set the RI bit to 0 (voltage monitor 2 interrupt selected).

**RN bit (Voltage Monitor 2 Reset Negate Select)**

If the RN bit is set to 1 (negating LVD2 reset in a specified time after its assertion), set the LOCOCR.LCSTP bit to 0 (the LOCO operates). Additionally, for a transition to Software Standby or Deep Software Standby mode, the only possible value for the RN bit is 0 (negation follows a stabilization time when  $VCC > V_{det2}$  is detected). Do not set the RN bit to 1 (negation follows a stabilization time after assertion of the LVD2 reset signal) when this is the case.

**7.2.6 LVD1CR1 : Voltage Monitor 1 Circuit Control Register**

Base address: SYSC = 0x4001\_E000

Offset address: 0x0E0

|                    |   |   |   |   |   |        |             |   |
|--------------------|---|---|---|---|---|--------|-------------|---|
| Bit position:      | 7 | 6 | 5 | 4 | 3 | 2      | 1           | 0 |
| Bit field:         | — | — | — | — | — | IRQSEL | IDTSEL[1:0] |   |
| Value after reset: | 0 | 0 | 0 | 0 | 0 | 0      | 0           | 1 |

| Bit | Symbol      | Function   | R/W |
|-----|-------------|--|-----|
| 1:0 | IDTSEL[1:0] | Voltage Monitor 1 Interrupt Generation Condition Select<br>0 0: When $VCC \geq V_{det1}$ (rise) is detected<br>0 1: When $VCC < V_{det1}$ (fall) is detected<br>1 0: When fall and rise are detected<br>1 1: Settings prohibited | R/W |
| 2   | IRQSEL      | Voltage Monitor 1 Interrupt Type Select<br>0: Non-maskable interrupt<br>1: Maskable interrupt*1  | R/W |
| 7:3 | —           | These bits are read as 0. The write value should be 0.   | R/W |

Note: If the security attribution is configured as secure:

- Secure access and Non-secure read access are allowed
- Non-secure write access is ignored, and TrustZone access error is not generated.

If the security attribution is configured as Non-secure:

- Secure and Non-secure access are allowed.

Note: Set the PRCR.PRC3 bit to 1 (writing enabled) before rewriting this register.

Note 1. When enabling maskable interrupts, do not change the NMIER.LVD1EN bit value in the ICU from the reset state.

**DFDIS位 (电压监视器2数字滤波器禁用模式选择)**

DFDIS位禁用数字滤波器电路。当该位为0 (启用数字滤波器) 时, 将LOCOCR.LCSTP位设置为0 (LOCO运行)。在软件待机模式或深度软件待机模式下使用电压监视器2电路时, 将此位设置为1 (禁用数字滤波器)。

**CMPE位 (电压监视器2电路比较结果输出使能)**

CMPE位启用或禁用电压监视器2电路比较结果输出。在电压检测2电路使能且稳定时间( $t_{d(E-A)}$ )过后, 将CMPE位设置为1。停止电压检测2电路时, 将CMPE位设置为0后禁用电压检测2电路。

**FSAMP[1:0]位 (采样时钟选择)**

只有当LVD2CR0.DFDIS位为1 (数字滤波器电路禁用) 时, FSAMP[1:0]位才能被重写。如果LVD2CR0.DFDIS位为0 (启用数字滤波器电路), 请勿重写这些位。

**RI位 (电压监视器2电路模式选择)**

当RI位为1 (选择电压监视器2复位) 时, 无法转换到深度软件待机模式。在这种情况下, 将转换到软件待机模式。要进入深度软件待机模式, 请将RI位设置为0 (选择电压监视器2中断)。

**RN位 (电压监视器2复位否定选择)**

如果RN位设置为1 (在其断言后的指定时间内否定LVD2复位), 则将LOCOCR.LCSTP位设置为0 (LOCO运行)。此外, 为了转换到软件待机或深度软件待机模式, RN位的唯一可能值为0 (当检测到 $VCC > V_{det2}$ 时, 取反遵循稳定时间)。在这种情况下, 请勿将RN位设置为1 (在LVD2复位信号置位后的稳定时间之后取反)。

**7.2.6 LVD1CR1: 电压监视器1电路控制寄存器**

Base address: SYSC = 0x4001\_E000

Offset address: 0x0E0

|               |   |   |   |   |   |        |             |   |
|---------------|---|---|---|---|---|--------|-------------|---|
| Bit position: | 7 | 6 | 5 | 4 | 3 | 2      | 1           | 0 |
| Bit field:    | — | — | — | — | — | IRQSEL | IDTSEL[1:0] |   |
| 重置后的值:        | 0 | 0 | 0 | 0 | 0 | 0      | 0           | 1 |

| Bit | Symbol      | Function   | R/W |
|-----|-------------|--|-----|
| 1:0 | IDTSEL[1:0] | 电压监视器1中断发生条件选择<br>00: 检测到 $VCC \geq V_{det1}$ (上升) 时<br>01: 检测到 $VCC < V_{det1}$ (下降) 时<br>10: 检测到下降和上升时<br>11: 禁止设置 | R/W |
| 2   | IRQSEL      | 电压监视器1中断类型选择<br>0: Non-maskable interrupt<br>1: Maskable interrupt*1   | R/W |
| 7:3 | —           | 这些位被读取为0。写入值应为0。   | R/W |

Note: 如果安全属性配置为安全: ●

- 允许安全访问和非安全读取访问
- 忽略非安全写入访问, 不会生成TrustZone访问错误。

如果安全属性配置为非安全: ●

- 允许安全和非安全访问。

Note: 在重写该寄存器之前将PRCR.PRC3位设置为1 (允许写入)。

注1.当使能可屏蔽中断时, 不要从复位状态更改ICU中的NMIER.LVD1EN位值。



## 7.2.7 LVD1SR : Voltage Monitor 1 Circuit Status Register

Base address: SYSC = 0x4001\_E000

Offset address: 0x0E1

|                    |   |   |   |   |   |   |     |     |
|--------------------|---|---|---|---|---|---|-----|-----|
| Bit position:      | 7 | 6 | 5 | 4 | 3 | 2 | 1   | 0   |
| Bit field:         | — | — | — | — | — | — | MON | DET |
| Value after reset: | 0 | 0 | 0 | 0 | 0 | 0 | 1   | 0   |

| Bit | Symbol | Function   | R/W               |
|-----|--------|--|-------------------|
| 0   | DET    | Voltage Monitor 1 Voltage Variation Detection Flag<br>0: Not detected<br>1: V <sub>det1</sub> crossing is detected   | R/W <sup>*1</sup> |
| 1   | MON    | Voltage Monitor 1 Signal Monitor Flag<br>0: VCC < V <sub>det1</sub><br>1: VCC ≥ V <sub>det1</sub> or MON is disabled | R                 |
| 7:2 | —      | These bits are read as 0. The write value should be 0.   | R/W               |

Note: If the security attribution is configured as secure:

- Secure access and Non-secure read access are allowed
  - Non-secure write access is ignored, and TrustZone access error is not generated.
- If the security attribution is configured as Non-secure:
- Secure and Non-secure access are allowed.

Note: Set the PRCR.PRC3 bit to 1 (write enabled) before rewriting this register.

Note 1. Only 0 can be written to this bit. After writing 0 to this bit, 2 system clock cycles are required for the bit to be read as 0.

**DET flag (Voltage Monitor 1 Voltage Variation Detection Flag)**

The DET flag is enabled when the LVD1CMPCR.LVD1E bit is 1 (voltage detection 1 circuit enabled) and the LVD1CR0.CMPE bit is 1 (voltage monitor 1 circuit comparison result output enabled).

When detecting V<sub>det1</sub>, set the DET flag to 0 after setting LVD1CR0.RIE is 0 (disabled). When setting LVD1CR0.RIE bit to 1 (enabled) after setting it to 0, wait for 2 or more PCLKB cycles which have elapsed.

**MON flag (Voltage Monitor 1 Signal Monitor Flag)**

The MON flag is enabled when the LVD1CMPCR.LVD1E bit is 1 (voltage detection 1 circuit enabled) and the LVD1CR0.CMPE bit is 1 (voltage monitor 1 circuit comparison result output enabled).

## 7.2.8 LVD2CR1 : Voltage Monitor 2 Circuit Control Register 1

Base address: SYSC = 0x4001\_E000

Offset address: 0x0E2

|                    |   |   |   |   |   |        |             |   |
|--------------------|---|---|---|---|---|--------|-------------|---|
| Bit position:      | 7 | 6 | 5 | 4 | 3 | 2      | 1           | 0 |
| Bit field:         | — | — | — | — | — | IRQSEL | IDTSEL[1:0] |   |
| Value after reset: | 0 | 0 | 0 | 0 | 0 | 0      | 0           | 1 |

| Bit | Symbol      | Function  | R/W |
|-----|-------------|---|-----|
| 1:0 | IDTSEL[1:0] | Voltage Monitor 2 Interrupt Generation Condition Select<br>0 0: When VCC ≥ V <sub>det2</sub> (rise) is detected<br>0 1: When VCC < V <sub>det2</sub> (fall) is detected<br>1 0: When fall and rise are detected<br>1 1: Settings prohibited | R/W |
| 2   | IRQSEL      | Voltage Monitor 2 Interrupt Type Select<br>0: Non-maskable interrupt<br>1: Maskable interrupt <sup>*1</sup>   | R/W |

## 7.2.7 LVD1SR:电压监视器1 电路状态寄存器

Base address: SYSC = 0x4001\_E000

Offset address: 0x0E1

|               |   |   |   |   |   |   |     |     |
|---------------|---|---|---|---|---|---|-----|-----|
| Bit position: | 7 | 6 | 5 | 4 | 3 | 2 | 1   | 0   |
| Bit field:    | — | — | — | — | — | — | MON | DET |
| 重置后的值:        | 0 | 0 | 0 | 0 | 0 | 0 | 1   | 0   |

| Bit | Symbol | Function  | R/W               |
|-----|--------|---|-------------------|
| 0   | DET    | 电压监视器1电压变化检测标志<br>0: 未检测到1: 检测到V <sub>det1</sub> 交叉                               | R/W <sup>*1</sup> |
| 1   | MON    | 电压监视器1信号监视器标志<br>0: VCC < V <sub>det1</sub><br>1: VCC ≥ V <sub>det1</sub> 或MON被禁用 | R                 |
| 7:2 | —      | 这些位被读取为0。写入值应为0。  | R/W               |

Note: 如果安全属性配置为安全: ●

- 允许安全访问和非安全读取访问
  - 忽略非安全写入访问, 不会生成TrustZone访问错误。
- 如果安全属性配置为非安全: ●
- 允许安全和非安全访问。

Note: 在重写该寄存器之前将PRCR.PRC3位设置为1 (允许写入)。

注1.该位只能写入0。向该位写入0后, 需要2个系统时钟周期才能将该位读为0。

**DET标志 (电压监视器1电压变化检测标志)**

当LVD1CMPCR.LVD1E位为1 (使能电压检测1电路) 且 LVD1CR0.CMPE位为1 (电压监视器1电路比较结果输出使能)。

检测V<sub>det1</sub>时, 将LVD1CR0.RIE设置为0 (禁用) 后, 将DET标志设置为0。在将LVD1CR0.RIE位设置为0后将其设置为1 (启用) 时, 等待2个或更多PCLKB周期已过去。

**MON标志 (电压监控1信号监控标志)**

当LVD1CMPCR.LVD1E位为1 (使能电压检测1电路) 且 LVD1CR0.CMPE位为1 (电压监视器1电路比较结果输出使能)。

## 7.2.8 LVD2CR1: 电压监视器2电路控制寄存器1

Base address: SYSC = 0x4001\_E000

Offset address: 0x0E2

|               |   |   |   |   |   |        |             |   |
|---------------|---|---|---|---|---|--------|-------------|---|
| Bit position: | 7 | 6 | 5 | 4 | 3 | 2      | 1           | 0 |
| Bit field:    | — | — | — | — | — | IRQSEL | IDTSEL[1:0] |   |
| 重置后的值:        | 0 | 0 | 0 | 0 | 0 | 0      | 0           | 1 |

| Bit | Symbol      | Function  | R/W |
|-----|-------------|---|-----|
| 1:0 | IDTSEL[1:0] | 电压监视器2中断发生条件选择<br>00: 检测到VCC ≥ V <sub>det2</sub> (上升) 时<br>01: 检测到VCC < V <sub>det2</sub> (下降) 时<br>10: 检测到下降和上升时<br>11: 禁止设置 | R/W |
| 2   | IRQSEL      | 电压监视器2中断类型选择<br>0: Non-maskable interrupt<br>1: Maskable interrupt <sup>*1</sup>  | R/W |

| Bit | Symbol | Function   | R/W |
|-----|--------|--|-----|
| 7:3 | —      | These bits are read as 0. The write value should be 0. | R/W |

Note: If the security attribution is configured as secure:

- Secure access and Non-secure read access are allowed
- Non-secure write access is ignored, and TrustZone access error is not generated.

If the security attribution is configured as Non-secure:

- Secure and Non-secure access are allowed.

Note: Set the PRCR.PRC3 bit to 1 (writing enabled) before rewriting this register.

Note 1. When enabling maskable interrupts, do not change the NMIER.LVD2EN bit value in the ICU from the reset state.

### 7.2.9 LVD2SR : Voltage Monitor 2 Circuit Status Register

Base address: SYSC = 0x4001\_E000

Offset address: 0x0E3

| Bit position:      | 7 | 6 | 5 | 4 | 3 | 2 | 1   | 0   |
|--------------------|---|---|---|---|---|---|-----|-----|
| Bit field:         | — | — | — | — | — | — | MON | DET |
| Value after reset: | 0 | 0 | 0 | 0 | 0 | 0 | 1   | 0   |

| Bit | Symbol | Function  | R/W              |
|-----|--------|---|------------------|
| 0   | DET    | Voltage Monitor 2 Voltage Variation Detection Flag<br>0: Not detected<br>1: $V_{det2}$ crossing is detected | R/W <sup>1</sup> |
| 1   | MON    | Voltage Monitor 2 Signal Monitor Flag<br>0: $VCC < V_{det2}$<br>1: $VCC \geq V_{det2}$ or MON is disabled   | R                |
| 7:2 | —      | These bits are read as 0. The write value should be 0.  | R/W              |

Note: If the security attribution is configured as secure:

- Secure access and Non-secure read access are allowed
- Non-secure write access is ignored, and TrustZone access error is not generated.

If the security attribution is configured as Non-secure:

- Secure and Non-secure access are allowed.

Note: Set the PRCR.PRC3 bit to 1 (write enabled) before rewriting this register.

Note 1. Only 0 can be written to this bit. After writing 0 to this bit, 2 system clock cycles are required for the bit to be read as 0.

#### DET flag (Voltage Monitor 2 Voltage Variation Detection Flag)

The DET flag is enabled when the LVD2CMPCR.LVD2E bit is 1 (voltage detection 2 circuit enabled) and the LVD2CR0.CMPE bit is 1 (voltage monitor 2 circuit comparison result output enabled).

Set the DET flag to 0 after setting LVD2CR0.RIE is 0 (disabled). When setting LVD2CR0.RIE bit to 1 (enabled) after setting it to 0, wait for 2 or more PCLKB cycles which have elapsed.

#### MON flag (Voltage Monitor 2 Signal Monitor Flag)

The MON flag is enabled when the LVD2CMPCR.LVD2E bit is 1 (voltage detection 2 circuit enabled) and the LVD2CR0.CMPE bit is 1 (voltage monitor 2 circuit comparison result output enabled).

## 7.3 VCC Input Voltage Monitor

### 7.3.1 Monitoring $V_{det0}$

The comparison results from voltage monitor 0 are not available for reading.

### 7.3.2 Monitoring $V_{det1}$

Table 7.2 shows the procedures to set up monitoring against  $V_{det1}$ . After the settings are complete, the comparison results from voltage monitor 1 can be monitored with the LVD1SR.MON flag.

| Bit | Symbol | Function         | R/W |
|-----|--------|------------------|-----|
| 7:3 | —      | 这些位被读取为0。写入值应为0。 | R/W |

Note: 如果安全属性配置为安全: ●

- 允许安全访问和非安全读取访问
- 忽略非安全写入访问, 不会生成TrustZone访问错误。

如果安全属性配置为非安全: ●

- 允许安全和非安全访问。

Note: 在重写该寄存器之前将PRCR.PRC3位设置为1 (允许写入)。

注1.当启用可屏蔽中断时, 不要从复位状态更改ICU中的NMIER.LVD2EN位值。

### 7.2.9 LVD2SR: 电压监视器2电路状态寄存器

Base address: SYSC = 0x4001\_E000

Offset address: 0x0E3

| Bit position: | 7 | 6 | 5 | 4 | 3 | 2 | 1   | 0   |
|---------------|---|---|---|---|---|---|-----|-----|
| Bit field:    | — | — | — | — | — | — | MON | DET |
| 重置后的值:        | 0 | 0 | 0 | 0 | 0 | 0 | 1   | 0   |

| Bit | Symbol | Function  | R/W              |
|-----|--------|---|------------------|
| 0   | DET    | 电压监视器2电压变化检测标志<br>0: 未检测到1: 检测到 $V_{det2}$ 交叉                       | R/W <sup>1</sup> |
| 1   | MON    | 电压监视器2信号监视器标志<br>0: $VCC < V_{det2}$ 1: $VCC \geq V_{det2}$ 或MON被禁用 | R                |
| 7:2 | —      | 这些位被读取为0。写入值应为0。  | R/W              |

Note: 如果安全属性配置为安全: ●

- 允许安全访问和非安全读取访问
- 忽略非安全写入访问, 不会生成TrustZone访问错误。

如果安全属性配置为非安全: ●

- 允许安全和非安全访问。

Note: 在重写该寄存器之前将PRCR.PRC3位设置为1 (允许写入)。

注1.该位只能写入0。向该位写入0后, 需要2个系统时钟周期才能将该位读为0。

#### DET标志 (电压监视器2电压变化检测标志)

当LVD2CMPCR.LVD2E位为1 (使能电压检测2电路) 且 LVD2CR0.CMPE位为1 (电压监视器2电路比较结果输出使能)。

设置LVD2CR0.RIE为0 (禁用) 后, 将DET标志设置为0。在将LVD2CR0.RIE位设置为0后将其设置为1 (启用) 时, 等待2个或更多PCLKB周期已过去。

#### MON标志 (电压监视器2信号监视器标志)

当LVD2CMPCR.LVD2E位为1 (电压检测2电路使能) 且 LVD2CR0.CMPE位为1 (电压监视器2电路比较结果输出使能)。

## 7.3 VCC输入电压监视器

### 7.3.1 Monitoring $V_{det0}$

电压监视器0的比较结果不可读取。

### 7.3.2 Monitoring $V_{det1}$

表7.2显示了针对 $V_{det1}$ 设置监控的程序。设置完成后, 电压监视器1的比较结果可以通过LVD1SR.MON标志进行监视。

Table 7.2 Procedures to set up monitoring against  $V_{det1}$ 

| Step                                       | Monitoring the comparison results from voltage monitor 1  |
|--|---|
| Setting up the voltage detection 1 circuit | 1 Set LVD1CMPCR.LVD1E = 0 to disable voltage detection 1 before writing to the LVD1CMPCR.LVD1LVL[4:0] bits.   |
|  | 2 Select the detection voltage in the LVD1CMPCR.LVD1LVL[4:0] bits.  |
|  | 3 Set LVD1CMPCR.LVD1E = 1 to enable the voltage detection 1 circuit.  |
|  | 4 Wait for at least $t_{d(E-A)}$ for the LVD1 operation stabilization time after LVD1 is enabled.*1   |
| Setting the digital filter*2               | 5 Select the sampling clock for the digital filter in the LVD1CR0.FSAMP[1:0] bits.  |
|  | 6 Set LVD1CR0.DFDIS = 0 to enable the digital filter.   |
|  | 7 Wait for at least $2n + 3$ cycles of the LOCO, where $n = 2, 4, 8, \text{ or } 16$ , and the sampling clock for the digital filter is the LOCO frequency-divided by $n$ . |
| Enabling output                            | 8 Set LVD1CR0.CMPE = 1 to enable output of the comparison results from voltage monitor 1.   |

Note 1. Steps 5 to 7 can be performed during the wait time of step 4. For details of  $t_{d(E-A)}$ , see section 47, Electrical Characteristics.

Note 2. Steps 5 to 7 are not required if the digital filter is not in use.

### 7.3.3 Monitoring $V_{det2}$

Table 7.3 shows the procedures to set up monitoring against  $V_{det2}$ . After the settings are complete, the comparison results from voltage monitor 2 can be monitored in the LVD2SR.MON flag.

Table 7.3 Procedures to set up monitoring against  $V_{det2}$ 

| Step                                       | Monitoring the results of comparison by voltage monitor 2   |
|--|---|
| Setting up the voltage detection 2 circuit | 1 Set LVD2CMPCR.LVD2E = 0 to disable voltage detection 2 before writing to the LVD2CMPCR.LVD2LVL[2:0] bits.   |
|  | 2 Select the detection voltage in the LVD2CMPCR.LVD2LVL[2:0] bits.  |
|  | 3 Set LVD2CMPCR.LVD2E = 1 to enable the voltage detection 2 circuit.  |
|  | 4 Wait for at least $t_{d(E-A)}$ for the LVD2 operation stabilization time after LVD2 is enabled.*1   |
| Setting the digital filter*2               | 5 Select the sampling clock for the digital filter in the LVD2CR0.FSAMP[1:0] bits.  |
|  | 6 Set LVD2CR0.DFDIS = 0 to enable the digital filter.   |
|  | 7 Wait for at least $2n + 3$ cycles of the LOCO, where $n = 2, 4, 8, \text{ or } 16$ , and the sampling clock for the digital filter is the LOCO frequency-divided by $n$ . |
| Enabling output                            | 8 Set LVD2CR0.CMPE = 1 to enable output of the comparison results from voltage monitor 2.   |

Note 1. Steps 5 to 7 can be performed during the wait time of step 4. For details of  $t_{d(E-A)}$ , see section 47, Electrical Characteristics.

Note 2. Steps 5 to 7 are not required if the digital filter is not in use.

### 7.4 Reset from Voltage Monitor 0

When using the reset from voltage monitor 0, clear the OFS1.LVDAS bit to 0 to enable the voltage monitor 0 reset after a reset. However, at boot mode, the reset from voltage monitor 0 is disabled regardless of the value of the OFS1.LVDAS bit.

Figure 7.4 shows an example of operations for a voltage monitor 0 reset.

Table 7.2 针对 $V_{det1}$ 设置监控的程序

| Step      | 从电压监视器1监视比较结果   |
|-----------|---|
| 设置电压检测1电路 | 1 设置LVD1CMPCR.LVD1E=0以在写入之前禁用电压检测1 LVD1CMPCR.LVD1LVL[4:0] bits.       |
|           | 2 在LVD1CMPCR.LVD1LVL[4:0]位中选择检测电压。                                    |
|           | 3 设置LVD1CMPCR.LVD1E=1以启用电压检测1电路。                                      |
|           | 4 启用LVD1后, 至少等待 $t_{d(E-A)}$ 的LVD1操作稳定时间。*1                           |
| 设置数字滤波器*2 | 5 在LVD1CR0.FSAMP[1:0]位中选择数字滤波器的采样时钟。                                  |
|           | 6 设置LVD1CR0.DFDIS=0以启用数字滤波器。  |
|           | 7 等待至少 $2n+3$ 个LOCO周期, 其中 $n=2、4、8$ 或 $16$ , 数字滤波器的采样时钟是LOCO分频的 $n$ 。 |
| 启用输出      | 8 设置LVD1CR0.CMPE=1以启用电压监视器1的比较结果输出。                                   |

注1.可以在步骤4的等待时间内执行步骤5至7。有关 $t_{d(E-A)}$ 的详细信息, 请参阅第47节, 电气特性。

注2.如果不使用数字滤波器, 则不需要步骤5至7。

### 7.3.3 Monitoring $V_{det2}$

表7.3显示了针对 $V_{det2}$ 设置监控的程序。设置完成后, 可以在LVD2SR.MON标志中监控电压监视器2的比较结果。

Table 7.3 针对 $V_{det2}$ 设置监控的程序

| Step      | 通过电压监视器2监视比较结果  |
|-----------|---|
| 设置电压检测2电路 | 1 设置LVD2CMPCR.LVD2E=0以在写入之前禁用电压检测2 LVD2CMPCR.LVD2LVL[2:0] bits.       |
|           | 2 在LVD2CMPCR.LVD2LVL[2:0]位中选择检测电压。                                    |
|           | 3 设置LVD2CMPCR.LVD2E=1以启用电压检测2电路。                                      |
|           | 4 启用LVD2后, 至少等待 $t_{d(E-A)}$ 的LVD2操作稳定时间。*1                           |
| 设置数字滤波器*2 | 5 在LVD2CR0.FSAMP[1:0]位中选择数字滤波器的采样时钟。                                  |
|           | 6 设置LVD2CR0.DFDIS=0以启用数字滤波器。  |
|           | 7 等待至少 $2n+3$ 个LOCO周期, 其中 $n=2、4、8$ 或 $16$ , 数字滤波器的采样时钟是LOCO分频的 $n$ 。 |
| 启用输出      | 8 设置LVD2CR0.CMPE=1以启用电压监视器2的比较结果输出。                                   |

注1.可以在步骤4的等待时间内执行步骤5至7。有关 $t_{d(E-A)}$ 的详细信息, 请参阅第47节, 电气特性。

注2.如果不使用数字滤波器, 则不需要步骤5至7。

### 7.4 从电压监视器复位0

使用电压监视器0复位时, 将OFS1.LVDAS位清零以在复位后启用电压监视器0复位。但是, 在引导模式下, 无论OFS1.LVDAS位的值如何, 都禁止从电压监视器0进行的复位。

图7.4显示了电压监视器0复位的操作示例。

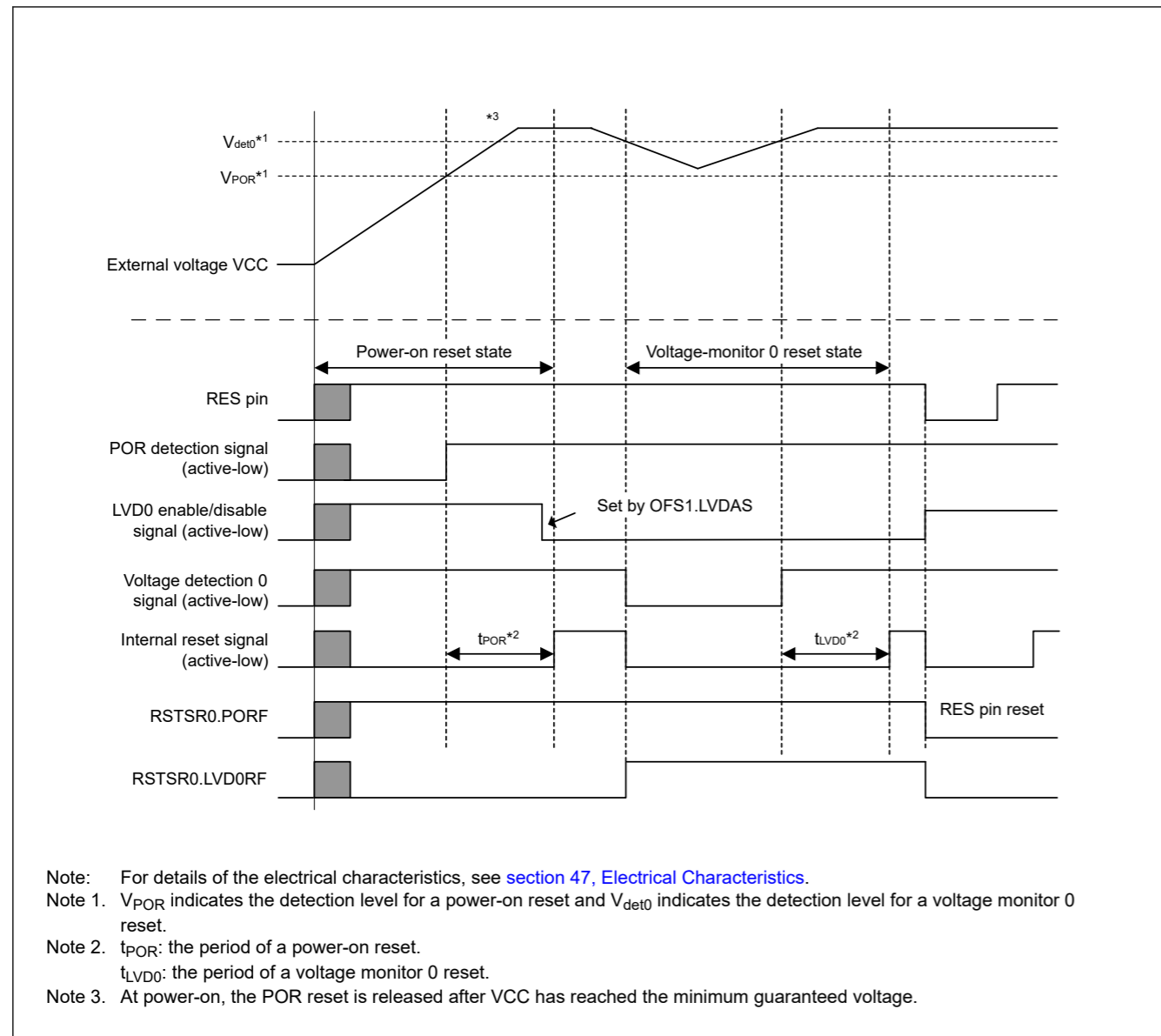


Figure 7.4 Example of voltage monitor 0 reset operation

## 7.5 Interrupt and Reset from Voltage Monitor 1

An interrupt or reset can be generated in response to the comparison results from the voltage monitor 1 circuit.

[Table 7.4](#) shows the procedures for setting bits related to the voltage monitor 1 interrupt/reset so that voltage monitoring occurs. [Table 7.5](#) shows the procedures for setting bits related to the voltage monitor 1 interrupt/reset so that voltage monitoring stops. [Figure 7.5](#) shows an example of operations for a voltage monitor 1 interrupt. For the operation of the voltage monitor 1 reset, see [Figure 5.2](#) in [section 5, Resets](#).

When using the voltage monitor 1 circuit in Software Standby mode or Deep Software Standby mode, set up the circuit using the procedures in this section.

### (1) Setting in Software Standby mode

- Disable the digital filter ( $LVD1CR0.DFDIS = 1$ ).
- When  $VCC > V_{det1}$  is detected, negate the voltage monitor 1 reset signal ( $LVD1CR0.RN = 0$ ) following a stabilization time.

### (2) Settings in Deep Software Standby mode

- Disable the digital filter ( $LVD1CR0.DFDIS = 1$ ).

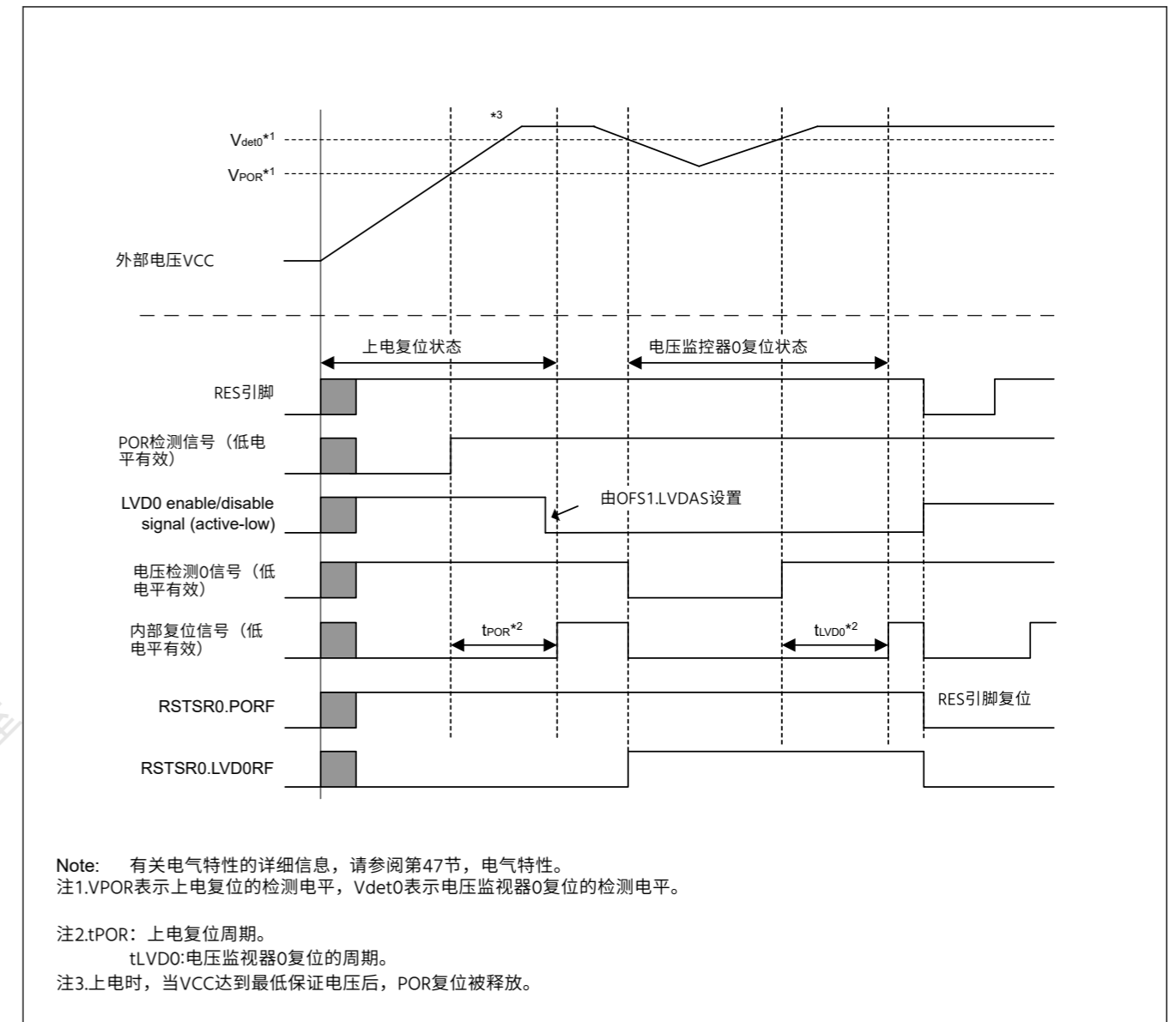


Figure 7.4 电压监视器0复位操作示例

## 7.5 电压监视器1的中断和复位

响应电压监视器1电路的比较结果, 可以产生中断或复位。

[表7.4](#)显示了设置与电压监控1中断复位相关的位以进行电压监控的过程。[表7.5](#)显示了设置与电压监控1中断复位相关的位以停止电压监控的步骤。[图7.5](#)显示了电压监视器1中断的操作示例。有关电压监视器1复位的操作, 请参见第5节“复位”中的[图5.2](#)。

在软件待机模式或深度软件待机模式下使用电压监视器1电路时, 请使用本节中的步骤设置电路。

### (1) 在软件待机模式下设置

- 禁用数字滤波器 ( $LVD1CR0.DFDIS=1$ )。
- 当检测到 $VCC > V_{det1}$ 时, 在经过一段稳定时间后将电压监视器1复位信号( $LVD1CR0.RN=0$ )取反。

### (2) 深度软件待机模式中的设置

- 禁用数字滤波器 ( $LVD1CR0.DFDIS=1$ )。



- Enable the voltage monitor 1 interrupt (LVD1CR0.RI = 0). If the voltage monitor 1 reset is enabled (LVD1CR0.RI = 1), a transition to Deep Software Standby mode is not possible, and the operation transitions to Software Standby mode instead.
- When the DPSBYCR.DEEPCUT[1:0] bits are 11b, the voltage monitor 1 circuit stops. To use the voltage monitor 1 circuit in Deep Software Standby mode, set the DPSBYCR.DEEPCUT[1:0] bits to a value other than 11b.

**Table 7.4 Procedures for setting bits related to voltage monitor 1 interrupt and voltage monitor 1 reset so that voltage monitoring occurs**

| Step  | Voltage monitor 1 interrupt (voltage monitor 1 ELC event output) | Voltage monitor 1 reset  |
|---|--|--|
| Setting up the voltage detection 1 circuit          | 1  | Set LVD1CMPCR.LVD1E = 0 to disable voltage detection 1 before writing to the LVD1CMPCR register.   |
|   | 2  | Select the detection voltage in the LVD1CMPCR.LVD1LVL[4:0] bits.   |
|   | 3  | Set LVD1CMPCR.LVD1E = 1 to enable the voltage detection 1 circuit.   |
|   | 4  | Wait for at least $t_{d(E-A)}$ for the LVD1 operation stabilization time after LVD1 is enabled.*1  |
| Setting the digital filter*3                        | 5  | Select the sampling clock for the digital filter in the LVD1CR0.FSAMP[1:0] bits.   |
|   | 6  | Set LVD1CR0.DFDIS = 0 to enable the digital filter.  |
|   | 7  | Wait for at least $2n + 3$ LOCO cycles, where $n = 2, 4, 8,$ or $16,$ and the sampling clock for the digital filter is the LOCO frequency-divided by $n$ .*4                               |
| Setting up the voltage monitor 1 interrupt or reset | 8  | Set LVD1CR0.RI = 0 to select the voltage monitor 1 interrupt.<br>● Set LVD1CR0.RI = 1 to select the voltage monitor 1 reset.<br>● Select the type of reset negation in the LVD1CR0.RN bit. |
|   | 9  | ● Select the interrupt request condition in the LVD1CR1.IDTSEL[1:0] bits.<br>● Select the interrupt type in the LVD1CR1.IRQSEL bit.  |
| Enabling output                                     | 10   | Set LVD1SR.DET = 0.  |
|   | 11   | Set LVD1CR0.RIE = 1 to enable the voltage monitor 1 interrupt or reset.*2  |
|   | 12   | Set LVD1CR0.CMPE = 1 to enable output of the comparison results from voltage monitor 1.  |

Note 1. Steps 5 to 11 can be performed during the wait time in step 4. For details on  $t_{d(E-A)}$ , see [section 47, Electrical Characteristics](#).

Note 2. Step 11 is not required if only the ELC event signal is to be output.

Note 3. Steps 5 to 7 are not required if the digital filter is not in use.

Note 4. Steps 8 to 11 can be performed during the wait time of step 7.

**Table 7.5 Procedures for setting bits related to voltage monitor 1 interrupt and voltage monitor 1 reset so that voltage monitoring stops**

| Step                                     | Voltage monitor 1 interrupt (voltage monitor 1 ELC event output), voltage monitor 1 reset |   |
|--|---|---|
| Stopping the enabling output             | 1   | Set LVD1CR0.CMPE = 0 to disable output of the comparison results from voltage monitor 1.  |
|  | 2   | Wait for at least $2n + 3$ cycles of the LOCO, where $n = 2, 4, 8,$ or $16,$ and the sampling clock for the digital filter is the LOCO frequency-divided by $n$ .*2 |
|  | 3   | Set LVD1CR0.RIE = 0 to disable the voltage monitor 1 interrupt or reset.*1  |
| Stopping the digital filter              | 4   | Set LVD1CR0.DFDIS = 1 to disable the digital filter.*2 *3   |
| Stopping the voltage detection 1 circuit | 5   | Set LVD1CMPCR.LVD1E = 0 to disable the voltage detection 1 circuit.   |

Note 1. Step 3 is not required if only the ELC event signal is to be output.

Note 2. Steps 2 and 4 are not required if the digital filter is not in use.

Note 3. To disable the digital filter from its enabled state and then re-enable it, disable it and wait for at least 2 LOCO clock cycles before re-enabling it.

If the voltage monitor 1 interrupt or reset setting is to be made again after it is used and stopped once, you can omit the following steps in the procedures for stopping and setting, depending on the conditions:

- Setting the voltage detection 1 circuit is not required if the settings for the circuit do not change.

●启用电压监视器1中断(LVD1CR0.RI=0)。如果使能电压监视器1复位(LVD1CR0.RI=1)，则无法转换到深度软件待机模式，而是将操作转换到软件待机模式。

●当DPSBYCR.DEEPCUT[1:0]位为11b时，电压监视器1电路停止。要在深度软件待机模式下使用电压监视器1电路，请将DPSBYCR.DEEPCUT[1:0]位设置为11b以外的值。

**Table 7.4 设置与电压监视器1中断和电压监视器1相关的位以进行电压监控的步骤**

| Step          | 电压监视器1中断 (电压监视器1 ELC event output) | 电压监视器1复位  |
|---------------|------------------------------------|---|
| 设置电压检测1电路     | 1                                  | 设置LVD1CMPCR.LVD1E=0以在写入LVD1CMPCR寄存器之前禁用电压检测1。   |
|               | 2                                  | 在LVD1CMPCR.LVD1LVL[4:0]位中选择检测电压。  |
|               | 3                                  | 设置LVD1CMPCR.LVD1E=1以启用电压检测1电路。  |
|               | 4                                  | 启用LVD1后，至少等待 $t_{d(E-A)}$ 的LVD1操作稳定时间。*1  |
| 设置数字滤波器*3     | 5                                  | 在LVD1CR0.FSAMP[1:0]位中选择数字滤波器的采样时钟。  |
|               | 6                                  | 设置LVD1CR0.DFDIS=0以启用数字滤波器。  |
|               | 7                                  | 等待至少 $2n+3$ 个LOCO周期，其中 $n=2、4、8$ 或 $16$ ，并且数字滤波器的采样时钟是LOCO频率除以 $n$ 。*4                    |
| 设置电压监视器1中断或复位 | 8                                  | 设置LVD1CR0.RI=0以选择电压监视器1中断。<br>● 设置LVD1CR0.RI=1以选择电压监视器1复位。<br>● 选择复位否定的类型 LVD1CR0.RN bit. |
|               | 9                                  | ● 选择中断请求条件 LVD1CR1.IDTSEL[1:0] bits.<br>● 选择中断类型 LVD1CR1.IRQSEL bit.                      |
| 启用输出          | 10                                 | Set LVD1SR.DET = 0.   |
|               | 11                                 | 设置LVD1CR0.RIE=1以启用电压监视器1中断或复位。*2  |
|               | 12                                 | 设置LVD1CR0.CMPE=1以使能电压监视器1的比较结果输出。   |

注1.步骤5至11可以在步骤4的等待时间内执行。有关 $t_{d(E-A)}$ 的详细信息，请参阅第47节，电气特性。

注2.如果只输出ELC事件信号，则不需要步骤11。

注3.如果不使用数字滤波器，则不需要步骤5至7。

注4.步骤7的等待时间内可以执行步骤8至11。

**Table 7.5 设置与电压监视器1中断和电压监视器1相关的位以使电压监控停止的步骤**

| Step      | 电压监视器1中断 (电压监视器1 ELC事件输出)，电压监视器1复位 |   |
|-----------|------------------------------------|---|
| 停止使能输出    | 1                                  | 设置LVD1CR0.CMPE=0以禁用电压监视器1的比较结果输出。                                   |
|           | 2                                  | 等待至少 $2n+3$ 个LOCO周期，其中 $n=2、4、8$ 或 $16$ ，数字滤波器的采样时钟是LOCO分频的 $n$ 。*2 |
|           | 3                                  | 设置LVD1CR0.RIE=0以禁用电压监视器1中断或复位。*1                                    |
| 停止数字滤波器   | 4                                  | 设置LVD1CR0.DFDIS=1以禁用数字滤波器。*2*3                                      |
| 停止电压检测1电路 | 5                                  | 设置LVD1CMPCR.LVD1E=0以禁用电压检测1电路。                                      |

注1.如果只输出ELC事件信号，则不需要步骤3。

注2.如果不使用数字滤波器，则不需要步骤2和4。

注3.要从启用状态禁用数字滤波器然后重新启用它，请禁用它并等待至少2个LOCO时钟周期，然后再重新启用它。

如果电压监视器1在使用和停止一次后再次进行中断或复位设置，可根据情况省略停止和设置过程中的以下步骤：

- 如果电路的设置不变，则不需要设置电压检测1电路。

- Setting the digital filter is not required if the settings for the circuit do not change.
- Setting the voltage monitor 1 interrupt or reset is not required if the settings for the voltage monitor 1 interrupt or voltage monitor 1 reset do not change.

Figure 7.5 shows an example of the voltage monitor 1 interrupt operation.

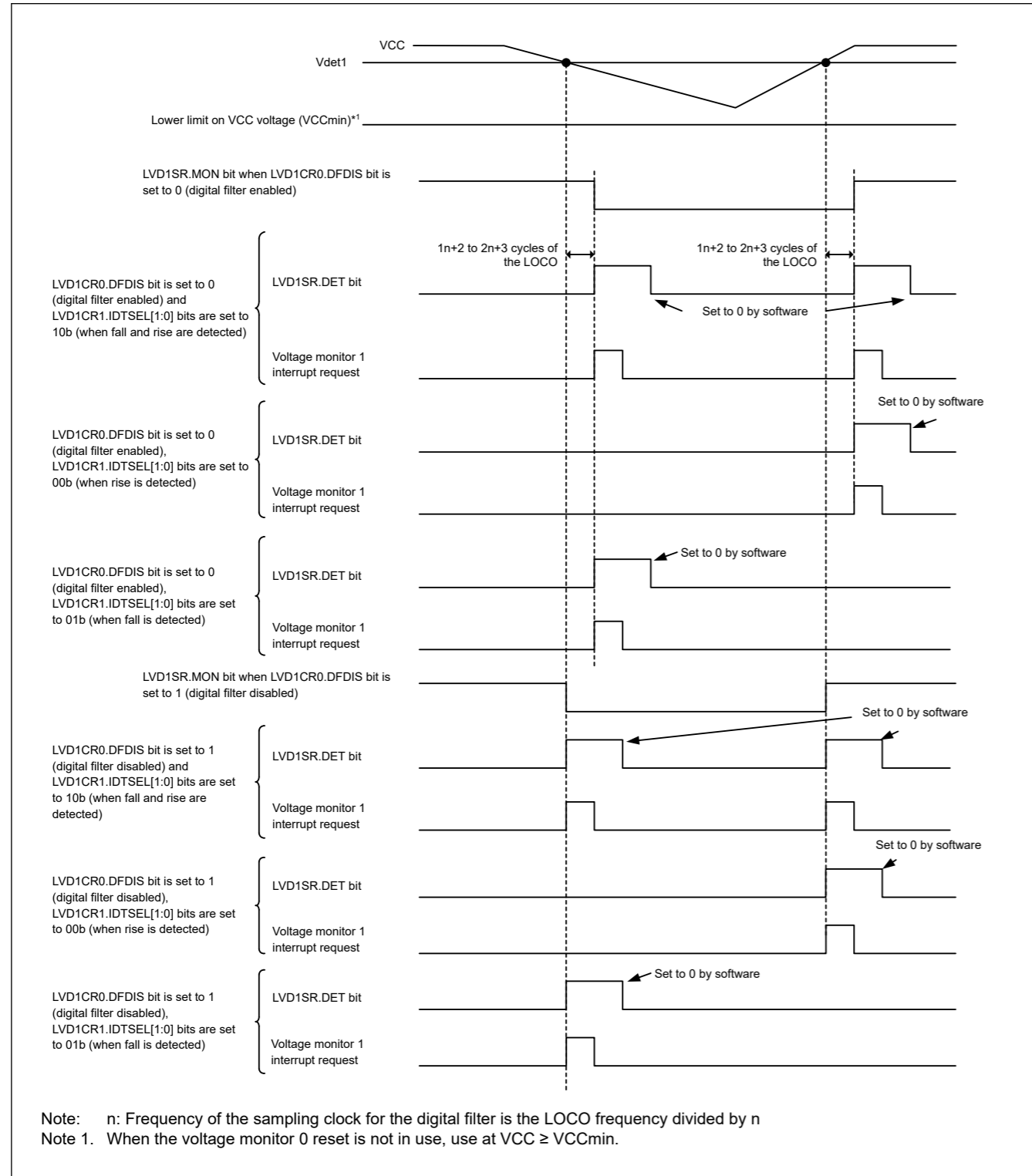


Figure 7.5 Example of voltage monitor 1 interrupt operation

- 如果电路的设置不变，则不需要设置数字滤波器。
- 如果电压监视器1中断或电压监视器1复位的设置没有改变，则不需要设置电压监视器1中断或复位。

图7.5显示了电压监视器1中断操作的示例。

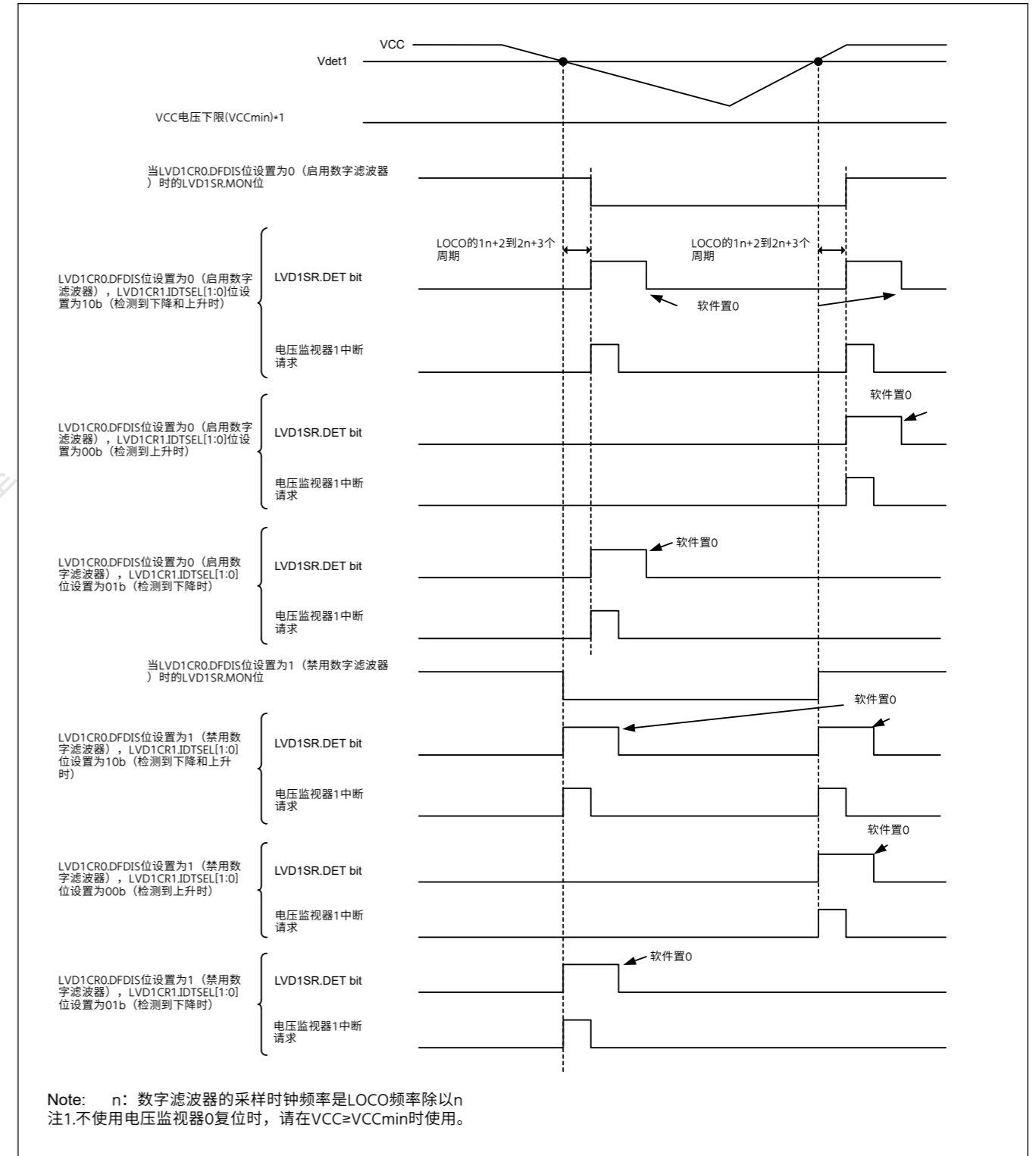


Figure 7.5 电压监视器1中断操作示例



## 7.6 Interrupt and Reset from Voltage Monitor 2

An interrupt or reset can be generated in response to the comparison results from the voltage monitor 2 circuit.

Table 7.6 shows the procedures for setting bits related to the voltage monitor 2 interrupt/reset so that voltage monitoring occurs. Table 7.7 shows the procedures for setting bits related to the voltage monitor 2 interrupt/reset so that voltage monitoring stops. Figure 7.6 shows an example of operations for a voltage monitor 2 interrupt. For the operation of the voltage monitor 2 reset, see Figure 5.2 in section 5, Resets.

When using the voltage monitor 2 circuit in Software Standby mode or Deep Software Standby mode, set up the circuit with the following procedures.

### (1) Setting in Software Standby mode

- Disable the digital filter (LVD2CR0.DFDIS = 1)
- When  $V_{CC} > V_{det2}$  is detected, negate the voltage monitor 2 reset signal (LVD2CR0.RN = 0) following a LVD2 stabilization time.

### (2) Settings in Deep Software Standby mode

- Disable the digital filter (LVD2CR0.DFDIS = 1).
- Enable the voltage monitor 2 interrupt (LVD2CR0.RI = 0). If the voltage monitor 2 reset is enabled (LVD2CR0.RI = 1), a transition to Deep Software Standby mode is not possible, and the operation transitions to Software Standby mode instead.
- When the DPSBYCR.DEEPCUT[1:0] bits are 11b, the voltage monitor 2 circuit stops. To use the voltage monitor 2 circuit in Deep Software Standby mode, set the DPSBYCR.DEEPCUT[1:0] bits to a value other than 11b.

**Table 7.6 Procedures for setting bits related to voltage monitor 2 interrupt and voltage monitor 2 reset so that voltage monitoring occurs**

| Step  | Voltage monitor 2 interrupt (voltage monitor 2 ELC event output) | Voltage monitor 2 reset  |
|---|--|--|
| 2 circuit   | 1  | Set LVD2CMPCR.LVD2E = 0 to disable voltage detection 2 before writing to the LVD2CMPCR register.   |
|   | 2  | Select the detection voltage in the LVD2CMPCR.LVD2LVL[2:0] bits.   |
|   | 3  | Set LVD2CMPCR.LVD2E = 1 to enable the voltage detection 2 circuit.   |
|   | 4  | Wait for at least $t_{d(E-A)}$ for the LVD2 operation stabilization time after LVD2 is enabled.*1  |
| Setting the digital filter*3                        | 5  | Select the sampling clock for the digital filter in the LVD2CR0.FSAMP[1:0] bits.   |
|   | 6  | Set LVD2CR0.DFDIS = 0 to enable the digital filter.  |
|   | 7  | Wait for at least $2n + 3$ LOCO cycles, where $n = 2, 4, 8,$ or $16$ , and the sampling clock for the digital filter is the LOCO frequency-divided by $n$ .*4                              |
| Setting up the voltage monitor 2 interrupt or reset | 8  | Set LVD2CR0.RI = 0 to select the voltage monitor 2 interrupt.<br>● Set LVD2CR0.RI = 1 to select the voltage monitor 2 reset.<br>● Select the type of reset negation in the LVD2CR0.RN bit. |
|   | 9  | ● Select the interrupt request condition in the LVD2CR1.IDTSEL[1:0] bits.<br>● Select the interrupt type in the LVD2CR1.IRQSEL bit.  |
| Enabling output                                     | 10   | Set LVD2SR.DET = 0.  |
|   | 11   | Set LVD2CR0.RIE = 1 to enable the voltage monitor 2 interrupt or reset.*2  |
|   | 12   | Set LVD2CR0.CMPE = 1 to enable output of the comparison results from voltage monitor 2.  |

Note 1. Steps 5 to 11 can be performed during the wait time in step 4. For details on  $t_{d(E-A)}$ , see section 47, Electrical Characteristics.

Note 2. Step 11 is not required if only the ELC event signal is to be output.

Note 3. Steps 5 to 7 are not required if the digital filter is not in use.

Note 4. Steps 8 to 11 can be performed during the wait time of step 7.

## 7.6 电压监视器2的中断和复位

响应电压监视器2电路的比较结果，可以产生中断或复位。

表7.6显示了设置与电压监视器2中断复位相关的位以进行电压监视的过程。表7.7显示了设置与电压监视器2中断复位相关的位以停止电压监视的步骤。图7.6显示了电压监视器2中断的操作示例。有关电压监视器2复位的操作，请参见第5节“复位”中的图5.2。

在软件待机模式或深度软件待机模式下使用电压监视器2电路时，请按照以下步骤设置电路。

### (1) 在软件待机模式下设置

- 禁用数字滤波器(LVD2CR0.DFDIS=1)
- 当检测到 $V_{CC} > V_{det2}$ 时，在LVD2稳定时间后取消电压监视器2复位信号(LVD2CR0.RN=0)。

### (2) 深度软件待机模式中的设置

- 禁用数字滤波器 (LVD2CR0.DFDIS=1)。
- 启用电压监视器2中断(LVD2CR0.RI=0)。如果启用电压监视器2复位(LVD2CR0.RI=1)，则无法转换到深度软件待机模式，而是将操作转换到软件待机模式。
- 当DPSBYCR.DEEPCUT[1:0]位为11b时，电压监视器2电路停止。要在深度软件待机模式下使用电压监视器2电路，请将DPSBYCR.DEEPCUT[1:0]位设置为11b以外的值。

**Table 7.6 设置与电压监视器2中断和电压监视器2相关的位以进行电压监视的步骤**

| Step          | 电压监视器2中断 (电压监视器2 ELC event output) | 电压监视器2复位  |
|---------------|------------------------------------|---|
| 2 circuit     | 1                                  | 在写入LVD2CMPCR寄存器之前，设置LVD2CMPCR.LVD2E=0以禁用电压检测2。  |
|               | 2                                  | 在LVD2CMPCR.LVD2LVL[2:0]位中选择检测电压。  |
|               | 3                                  | 设置LVD2CMPCR.LVD2E=1以启用电压检测2电路。  |
|               | 4                                  | 启用LVD2后，至少等待 $t_{d(E-A)}$ 的LVD2操作稳定时间。*1  |
| 设置数字滤波器*3     | 5                                  | 在LVD2CR0.FSAMP[1:0]位中选择数字滤波器的采样时钟。  |
|               | 6                                  | 设置LVD2CR0.DFDIS=0以启用数字滤波器。  |
|               | 7                                  | 等待至少 $2n+3$ 个LOCO周期，其中 $n=2、4、8$ 或 $16$ ，并且数字滤波器的采样时钟是LOCO频率除以 $n$ 。*4                    |
| 设置电压监视器2中断或复位 | 8                                  | 设置LVD2CR0.RI=0以选择电压监视器2中断。<br>● 设置LVD2CR0.RI=1以选择电压监视器2复位。<br>● 选择复位否定的类型 LVD2CR0.RN bit. |
|               | 9                                  | ● 选择中断请求条件 LVD2CR1.IDTSEL[1:0] bits.<br>● 选择中断类型 LVD2CR1.IRQSEL bit.                      |
| 启用输出          | 10                                 | Set LVD2SR.DET = 0.   |
|               | 11                                 | 设置LVD2CR0.RIE=1以启用电压监视器2中断或复位。*2  |
|               | 12                                 | 设置LVD2CR0.CMPE=1以使能电压监视器2的比较结果输出。   |

注1.步骤5至11可以在步骤4的等待时间内执行。有关 $t_{d(E-A)}$ 的详细信息，请参阅第47节，电气特性。

注2.如果只输出ELC事件信号，则不需要步骤11。

注3.如果不使用数字滤波器，则不需要步骤5至7。

注4.步骤7的等待时间内可以执行步骤8至11。

**Table 7.7 Procedures for setting bits related to voltage monitor 2 interrupt and voltage monitor 2 reset so that voltage monitoring stops**

| Step                                     | Voltage monitor 2 interrupt (voltage monitor 2 ELC event output), voltage monitor 2 reset |  |
|--|---|--|
| Settings to stop enabling output         | 1   | Set LVD2CR0.CMPE = 0 to disable output of the comparison results from voltage monitor 2.   |
|  | 2   | Wait for at least $2n + 3$ cycles of the LOCO, where $n = 2, 4, 8,$ or $16,$ and the sampling clock for the digital filter is the LOCO frequency-divided by $n$ . *2 |
|  | 3   | Set LVD2CR0.RIE = 0 to disable the voltage monitor 2 interrupt or reset. *1  |
| Stopping the digital filter              | 4   | Set LVD2CR0.DFDIS = 1 to disable the digital filter. *2 *3   |
| Stopping the voltage detection 2 circuit | 5   | Set LVD2CMPCR.LVD2E = 0 to disable the voltage detection 2 circuit.  |

Note 1. Step 3 is not required if only the ELC event signal is to be output.

Note 2. Steps 2 and 4 are not required if the digital filter is not in use.

Note 3. To disable the digital filter from its enabled state and then re-enable it, disable it and wait for at least 2 LOCO clock cycles before re-enabling it.

If the voltage monitor 2 interrupt or reset setting is to be made again after it is used and stopped once, you can omit the following steps in the procedures for stopping and setting, depending on the conditions:

- Setting the voltage detection 2 is not required if the settings for the circuit do not change.
- Setting the digital filter is not required if the settings for the circuit do not change.
- Setting the voltage monitor 2 interrupt or reset is not required if the settings for the voltage monitor 2 interrupt or voltage monitor 2 reset do not change.

**Table 7.7 设置与电压监控器2中断和电压监控器2相关的位以使电压监控器停止的步骤**

| Step      | 电压监控器2中断（电压监控器2ELC事件输出），电压监控器2复位 |   |
|-----------|----------------------------------|---|
| 停止启用输出的设置 | 1                                | 设置LVD2CR0.CMPE=0以禁用电压监视器2的比较结果输出。                                   |
|           | 2                                | 等待至少 $2n+3$ 个LOCO周期，其中 $n=2、4、8$ 或 $16$ ，数字滤波器的采样时钟是LOCO分频的 $n$ 。*2 |
|           | 3                                | 设置LVD2CR0.RIE=0以禁用电压监视器2中断或复位。*1                                    |
| 停止数字滤波器   | 4                                | 设置LVD2CR0.DFDIS=1以禁用数字滤波器。*2*3                                      |
| 停止电压检测2电路 | 5                                | 设置LVD2CMPCR.LVD2E=0以禁用电压检测2电路。                                      |

注1.如果只输出ELC事件信号，则不需要步骤3。

注2.如果不使用数字滤波器，则不需要步骤2和4。

注3.要从启用状态禁用数字滤波器然后重新启用它，请禁用它并等待至少2个LOCO时钟周期，然后再重新启用它。

如果电压监视器2的中断或复位设置在使用和停止一次后再次进行，可以根据情况省略停止和设置过程中的以下步骤：

- 如果电路的设置不变，则不需要设置电压检测2。
- 如果电路的设置不变，则不需要设置数字滤波器。
- 如果电压监视器2中断或电压监视器2复位的设置没有改变，则不需要设置电压监视器2中断或复位。

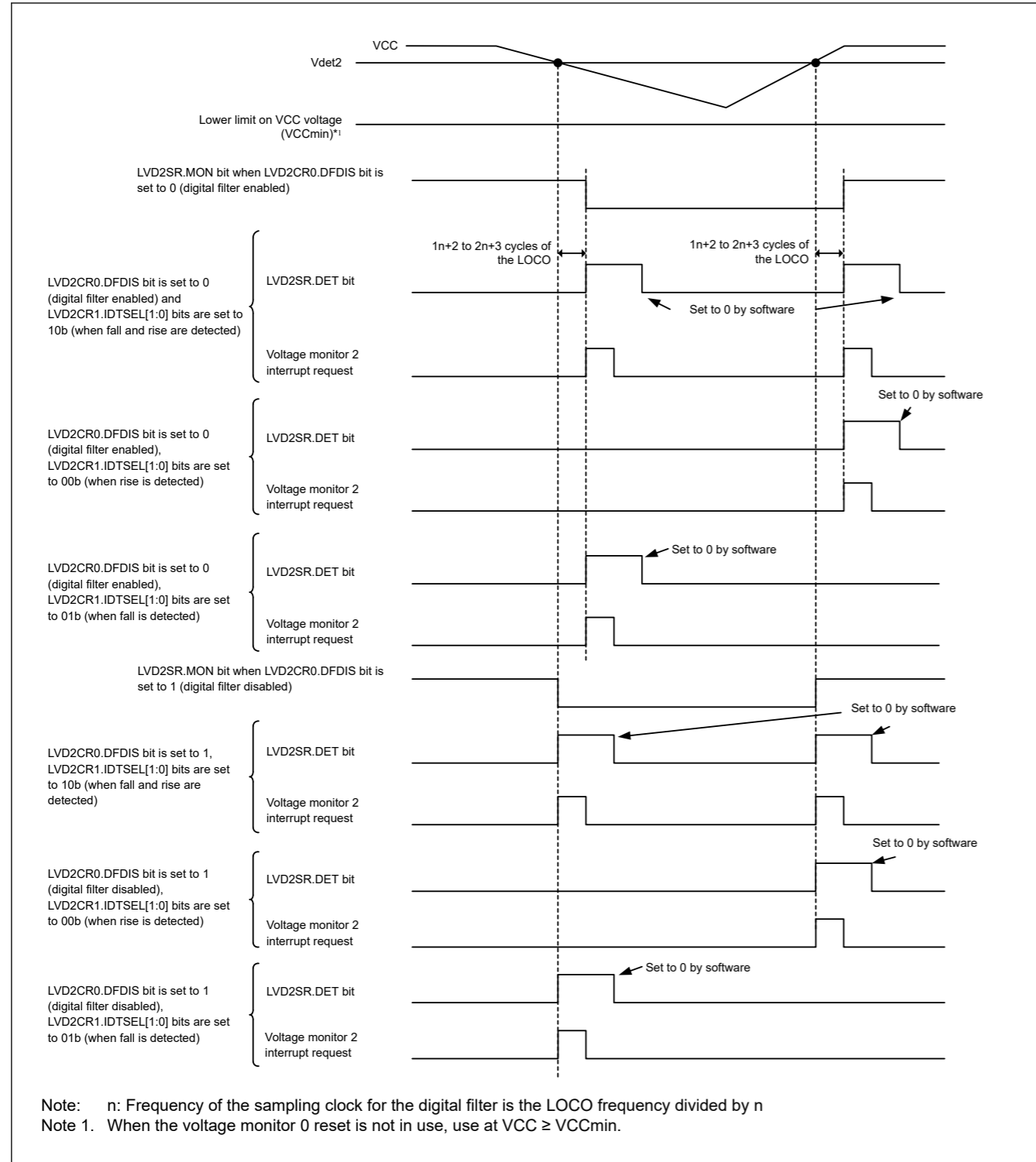


Figure 7.6 Example of voltage monitor 2 interrupt operation

### 7.7 Event Link Controller (ELC) Output

The LVD can output the event signals to the Event Link Controller (ELC).

#### (1) $V_{det1}$ Crossing Detection Event

The LVD outputs the event signal when it detects that the voltage has passed the  $V_{det1}$  voltage while both the voltage detection 1 circuit and the voltage monitor 1 circuit comparison result output are enabled.

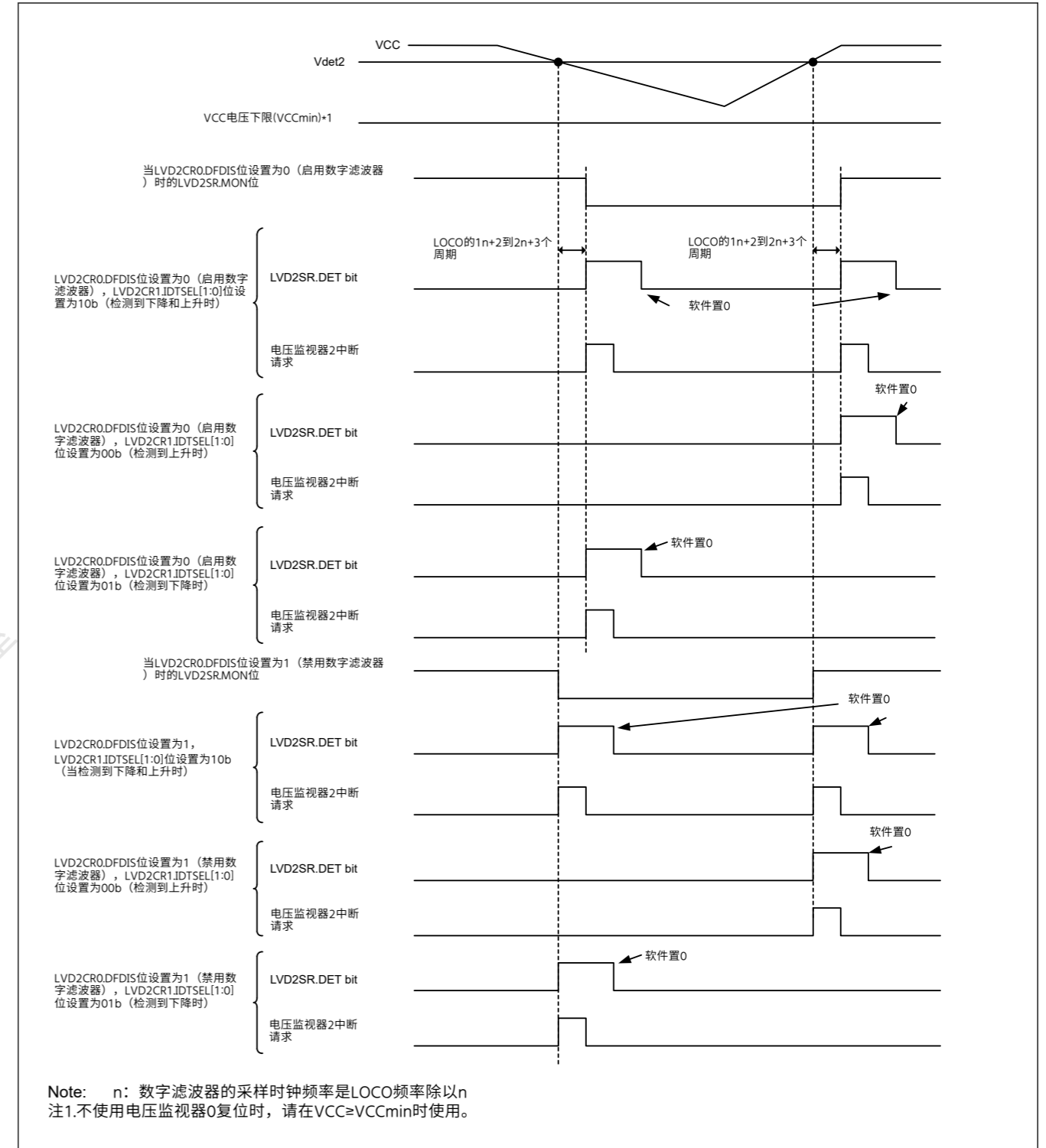


Figure 7.6 电压监视器2中断操作示例

### 7.7 事件链接控制器(ELC)输出

LVD可以将事件信号输出到事件链接控制器(ELC)。

#### (1) $V_{det1}$ 交叉检测事件

当电压检测1电路和电压监视器1电路比较结果输出都启用时, LVD检测到电压已超过 $V_{det1}$ 电压时输出事件信号。

## (2) $V_{det2}$ Crossing Detection Event

The LVD outputs the event signal when it detects that the voltage has passed the  $V_{det2}$  voltage while both the voltage detection 2 circuit and the voltage monitor 2 circuit comparison result output are enabled.

When enabling the event link output function of the LVD, you must enable the LVD before enabling the LVD event link function of the ELC. To stop the event link output function of the LVD, you must stop the LVD before disabling the LVD event link function of the ELC.

### 7.7.1 Interrupt Handling and Event Linking

The LVD provides bits to separately enable or disable the voltage monitor 1 and 2 interrupts. When an interrupt source is generated and the interrupt is enabled by the interrupt enable bit, the interrupt signal is output to the CPU.

In contrast, as soon as an interrupt source is generated, an event link signal is output as the event signal to the other module through the ELC, regardless of the state of the interrupt enable bit.

It is possible to output voltage monitor 1 and 2 interrupts in Software Standby and Deep Software Standby modes. The event signals for the ELC in Software Standby and Deep Software Standby modes are output as follows:

- When a  $V_{det1}$  or  $V_{det2}$  passage events is detected in Software Standby mode, event signals are not generated for the ELC because the clock is not supplied in Software Standby mode. Because the  $V_{det1}$  and  $V_{det2}$  passage detection flags are saved, when the clock supply resumes after returning from Software Standby mode, the event signals for the ELC are output based on the state of the  $V_{det1}$  and  $V_{det2}$  detection flags.
- When a  $V_{det1}$  or  $V_{det2}$  passage events are detected in Deep Software Standby mode, event signals are not generated for the ELC.

## (2) $V_{det2}$ 交叉检测事件

当电压检测2电路和电压监测器2电路比较结果输出都启用时，LVD检测到电压已超过 $V_{det2}$ 电压时输出事件信号。

使能LVD的事件链接输出功能时，必须先使能LVD，再使能ELC的LVD事件链接功能。要停止LVD的事件链接输出功能，必须先停止LVD，然后再禁用ELC的LVD事件链接功能。

### 7.7.1 中断处理和事件链接

LVD提供位来分别启用或禁用电压监视器1和2中断。当产生中断源并通过中断使能位使能中断时，将中断信号输出到CPU。

相反，一旦产生中断源，无论中断使能位的状态如何，都会通过ELC将事件链接信号作为事件信号输出到其他模块。

在软件待机和深度软件待机模式下，可以输出电压监视器1和2中断。软件待机和深度软件待机模式下ELC的事件信号输出如下：

- 当在软件待机模式下检测到 $V_{det1}$ 或 $V_{det2}$ 通过事件时，不会为ELC，因为在软件待机模式下不提供时钟。因为保存了 $V_{det1}$ 和 $V_{det2}$ 通过检测标志，所以当从软件待机模式恢复后时钟供应恢复时，ELC的事件信号将根据 $V_{det1}$ 和 $V_{det2}$ 检测标志的状态输出。
- 当在深度软件待机模式下检测到 $V_{det1}$ 或 $V_{det2}$ 通过事件时，不会为ELC生成事件信号。

## 8. Clock Generation Circuit

### 8.1 Overview

The MCU provides a clock generation circuit. Table 8.1 and Table 8.2 list the clock generation circuit specifications. Figure 8.1 show a block diagram, and Table 8.3 lists the I/O pins.

**Table 8.1 Clock generation circuit specifications for the clock sources**

| Clock source                                 | Description                              | Specification  |
|--|--|--|
| Main clock oscillator (MOSC)                 | Resonator frequency                      | 8 MHz to 24 MHz<br>8, 10, 16, 20, 24 MHz (USB boot mode) |
|  | External clock input frequency           | Up to 24 MHz   |
|  | External resonator or additional circuit | ceramic resonator, crystal                               |
|  | Connection pins                          | EXTAL, XTAL  |
|  | Drive capability switching               | Available  |
|  | Oscillation stop detection function      | Available  |
| Sub-clock oscillator (SOSC)                  | Resonator frequency                      | 32.768 kHz   |
|  | External resonator or additional circuit | crystal resonator  |
|  | Connection pins                          | XCIN, XCOUT  |
|  | Drive capability switching               | Available  |
| PLL circuit                                  | Input clock source                       | MOSC, HOCO   |
|  | Input pulse frequency division ratio     | Selectable from 1, 2, and 3                              |
|  | Input frequency                          | 8 MHz to 24 MHz  |
|  | Frequency multiplication ratio           | Selectable from 10 to 30 (0.5 steps)                     |
|  | Output pulse frequency division ratio    | Unavailable  |
|  | PLL Output frequency                     | 100 MHz to 200 MHz                                       |
| PLL2 circuit                                 | Input clock source                       | MOSC, HOCO   |
|  | Input pulse frequency division ratio     | Selectable from 1, 2, and 3                              |
|  | Input frequency                          | 8 MHz to 24 MHz  |
|  | Frequency multiplication ratio           | Selectable from 10 to 30 (0.5 steps)                     |
|  | Output pulse frequency division ratio    | Unavailable  |
|  | PLL Output frequency                     | 120 MHz to 240 MHz                                       |
|  | PLL2-LDO stop function                   | Unavailable  |
| High-speed on-chip oscillator (HOCO)         | Oscillation frequency                    | 16/18/20 MHz   |
|  | FLL function                             | Available  |
|  | User trimming                            | Available  |
| Middle-speed on-chip oscillator (MOCO)       | Oscillation frequency                    | 8 MHz  |
|  | User trimming                            | Available  |
| Low-speed on-chip oscillator (LOCO)          | Oscillation frequency                    | 32.768 kHz   |
|  | User trimming                            | Available  |
| IWDT-dedicated on-chip oscillator (IWDTLOCO) | Oscillation frequency                    | 15 kHz   |
|  | User trimming                            | Unavailable  |
| External clock input for JTAG (TCK)          | Input clock frequency                    | Up to 25 MHz   |
| External clock input for SWD (SWCLK)         | Input clock frequency                    | Up to 25 MHz   |

## 8. 时钟产生电路

### 8.1 Overview

MCU提供时钟生成电路。表8.1和表8.2列出了时钟生成电路规格。图8.1显示了框图，表8.3列出了IO引脚。

**Table 8.1 时钟源的时钟生成电路规格**

| 时钟源  | Description  | Specification                            |
|--|--------------|--|
| 主时钟振荡器(MOSC)                                 | 谐振器频率        | 8MHz至24MHz<br>8、10、16、20、24MHz (USB引导模式) |
|  | 外部时钟输入频率     | 高达24MHz                                  |
|  | 外部谐振器或附加电路   | 陶瓷谐振器, 晶体                                |
|  | 连接引脚         | EXTAL, XTAL                              |
|  | 驱动能力切换       | Available                                |
|  | 振荡停止检测功能     | Available                                |
| Sub-clock oscillator (SOSC)                  | 谐振器频率        | 32.768 kHz                               |
|  | 外部谐振器或附加电路   | 晶体谐振器                                    |
|  | 连接引脚         | XCIN, XCOUT                              |
|  | 驱动能力切换       | Available                                |
| PLL circuit                                  | 输入时钟源        | MOSC, HOCO                               |
|  | 输入脉冲分频比      | 可从1、2和3中选择                               |
|  | 输入频率         | 8 MHz to 24 MHz                          |
|  | 倍频比          | 可选择10至30 (0.5步)                          |
|  | 输出脉冲分频比      | Unavailable                              |
|  | 锁相环输出频率      | 100 MHz to 200 MHz                       |
| PLL2 circuit                                 | 输入时钟源        | MOSC, HOCO                               |
|  | 输入脉冲分频比      | 可从1、2和3中选择                               |
|  | 输入频率         | 8 MHz to 24 MHz                          |
|  | 倍频比          | 可选择10至30 (0.5步)                          |
|  | 输出脉冲分频比      | Unavailable                              |
|  | 锁相环输出频率      | 120 MHz to 240 MHz                       |
|  | PLL2-LDO停止功能 | Unavailable                              |
| High-speed on-chip oscillator (HOCO)         | 振荡频率         | 16/18/20 MHz                             |
|  | FLL function | Available                                |
|  | 用户修剪         | Available                                |
| Middle-speed on-chip oscillator (MOCO)       | 振荡频率         | 8 MHz                                    |
|  | 用户修剪         | Available                                |
| Low-speed on-chip oscillator (LOCO)          | 振荡频率         | 32.768 kHz                               |
|  | 用户修剪         | Available                                |
| IWDT-dedicated on-chip oscillator (IWDTLOCO) | 振荡频率         | 15 kHz                                   |
|  | 用户修剪         | Unavailable                              |
| JTAG(TCK)的外部时钟输入                             | 输入时钟频率       | 高达25MHz                                  |
| SWD的外部时钟输入(SWCLK)                            | 输入时钟频率       | 高达25MHz                                  |



Table 8.2 Clock generation circuit specifications for the internal clocks

| Item                              | Clock source                  | Clock supply  | Specification  |
|-----------------------------------|-------------------------------|---|--|
| System clock (ICLK)               | MOSC/SOSC/HOCO/MOCO/ LOCO/PLL | CPU, DTC, DMAC, Flash, RAM  | Up to 100 MHz<br>Division ratios: 1/2/4/8/16/32/64                             |
| Peripheral module clock A (PCLKA) | MOSC/SOSC/HOCO/MOCO/ LOCO/PLL | Peripheral modules (QSPI, SCI, SPI, CRC, DOC, ADC12, DAC12, SCE9, GPT bus clock)  | Up to 100 MHz<br>Division ratio: 1/2/4/8/16/32/64                              |
| Peripheral module clock B (PCLKB) | MOSC/SOSC/HOCO/MOCO/ LOCO/PLL | Peripheral modules (CAC, ELC, I/O ports, POEG, RTC, WDT, IWDT, AGT, IIC, CAN, USBFS, SSIE, SDHI, TSN, CTSU, Standby SRAM) | Up to 50 MHz<br>Division ratio: 1/2/4/8/16/32/64                               |
| Peripheral module clock C (PCLKC) | MOSC/SOSC/HOCO/MOCO/ LOCO/PLL | Peripheral module (ADC12 conversion clock)  | Up to 50 MHz<br>Division ratio: 1/2/4/8/16/32/64                               |
| Peripheral module clock D (PCLKD) | MOSC/SOSC/HOCO/MOCO/ LOCO/PLL | Peripheral module(GPT count clock)  | Up to 100 MHz<br>Division ratio: 1/2/4/8/16/32/64                              |
| FlashIF clock (FCLK)              | MOSC/SOSC/HOCO/MOCO/ LOCO/PLL | FlashIF   | 4 MHz to 50 MHz(P/E)<br>Up to 50 MHz(read)<br>Division ratio: 1/2/4/8/16/32/64 |
| USB clock (USBCLK)                | PLL/PLL2                      | USBFS   | 48 MHz<br>Division ratio: 3/4/5  |
| CAN clock (CANMCLK)               | MOSC                          | CAN   | 8 MHz to 24 MHz  |
| AGT clock (AGTSCLK)               | SOSC                          | AGT   | 32.768 kHz   |
| AGT clock (AGTLCLK)               | LOCO                          | AGT   | 32.768 kHz   |
| CAC Main clock (CACMCLK)          | MOSC                          | CAC   | Up to 24 MHz   |
| CAC Sub clock (CACSCCLK)          | SOSC                          | CAC   | 32.768 kHz   |
| CAC LOCO clock (CACLCLK)          | LOCO                          | CAC   | 32.768 kHz   |
| CAC MOCO clock (CACMOCLK)         | MOCO                          | CAC   | 8 MHz  |
| CAC HOCO clock (CACHCLK)          | HOCO                          | CAC   | 16/18/20 MHz   |
| CAC IWDTLOCO clock (CACILCLK)     | IWDTLOCO                      | CAC   | 15 kHz   |
| RTC clock (RTCCLK)                | SOSC/LOCO                     | RTC   | 32.768 kHz   |
| IWDT clock (IWDTCLK)              | IWDTLOCO                      | IWDT  | 15 kHz   |
| SysTick timer clock (SYSTICCLK)   | LOCO                          | SysTick timer   | 32.768 kHz   |
| JTAG clock (JTAGTCK)              | TCK                           | JTAG  | Up to 25 MHz   |
| Serial wire clock (SWCLK)         | SWCLK                         | OCD   | Up to 25 MHz   |
| Trace clock (TRCLK)               | MOSC/SOSC/HOCO/MOCO/ LOCO/PLL | CPU-OCD   | Up to 50 MHz, Division ratio: 1/2/4  |
| TCLK pin output (TCLK)            | 1/2 TRCLK                     | TCLK pin  | Up to 25 MHz   |
| Clock/buzzer output (CLKOUT)      | MOSC/SOSC/LOCO/MOCO/ HOCO     | CLKOUT pin  | Up to 60 MHz<br>Division ratios: 1/2/4/8/16/32/64/128                          |

Note: Restrictions on setting clock frequency:  $ICLK \geq PCLKA \geq PCLKB, PCLKD \geq PCLKA \geq PCLKB$   
 $ICLK \geq FCLK$   
 Restrictions on clock frequency ratio: (N: integer, and up to 64)  
 $ICLK:FCLK = N:1, ICLK:PCLKA = N:1, ICLK:PCLKB = N:1, ICLK:PCLKC = N:1$  or  $1:N, ICLK:PCLKD = N:1$  or  $1:N, ICLK:TRCLK = N:1$  or  $1:N$   
 If the A/D converter is enabled, the clock frequency ratio is constrained as follows:  
 $PCLKA:PCLKC = 1:1$  or  $2:1$  or  $4:1$  or  $8:1$  or  $1:2$  or  $1:4$   
 Note: Restrictions on the minimum FCLK frequency 4MHz when P/E.  
 Note: The multiplication of PLL and PLL2 should be set to be within the output frequency range of PLL and PLL2, taking the frequency of HOCO into consideration when not using the FLL function.  
 Note: Clocks have a permissible frequency range (See Table 8.2).

Table 8.2 内部时钟的时钟生成电路规格

| Item                         | 时钟源                           | 时钟电源   | Specification  |
|------------------------------|-------------------------------|--|--|
| 系统时钟(ICLK)                   | MOSC/SOSC/HOCO/MOCO/ LOCO/PLL | CPU、DTC、DMAC、闪存、RAM  | 高达100MHz<br>Division ratios: 1/2/4/8/16/32/64                  |
| 外设模块时钟A(PCLKA)               | MOSC/SOSC/HOCO/MOCO/ LOCO/PLL | 外围模块 (QSPI, SCI, SPI, CRC, DOC, ADC12, DAC12, SCE9, GPT bus clock)                                     | 高达100MHz<br>Division ratio: 1/2/4/8/16/32/64                   |
| 外设模块时钟B(PCLKB)               | MOSC/SOSC/HOCO/MOCO/ LOCO/PLL | 外围模块 (CAC, ELC, IO端口, POEG, RTC, WDT, IWDT, AGT, IIC, CAN, USBFS, SSIE, SDHI, TSN, CTSU, Standby SRAM) | 高达50MHz<br>Division ratio: 1/2/4/8/16/32/64                    |
| 外设模块时钟C(PCLKC)               | MOSC/SOSC/HOCO/MOCO/ LOCO/PLL | 外设模块 (ADC12转换时钟)   | 高达50MHz<br>Division ratio: 1/2/4/8/16/32/64                    |
| 外设模块时钟D(PCLKD)               | MOSC/SOSC/HOCO/MOCO/ LOCO/PLL | 外设模块 (GPT计数时钟)   | 高达100MHz<br>Division ratio: 1/2/4/8/16/32/64                   |
| FlashIF clock (FCLK)         | MOSC/SOSC/HOCO/MOCO/ LOCO/PLL | FlashIF  | 4MHz至50MHz(PE)高达50MHz (读取)<br>Division ratio: 1/2/4/8/16/32/64 |
| USB时钟(USBCLK)                | PLL/PLL2                      | USBFS  | 48 MHz<br>Division ratio: 3/4/5                                |
| CAN时钟(CANMCLK)               | MOSC                          | CAN  | 8 MHz to 24 MHz  |
| AGT clock (AGTSCLK)          | SOSC                          | AGT  | 32.768 kHz   |
| AGT clock (AGTLCLK)          | LOCO                          | AGT  | 32.768 kHz   |
| CAC主时钟(CACMCLK)              | MOSC                          | CAC  | 高达24MHz  |
| CAC副时钟(CACSCCLK)             | SOSC                          | CAC  | 32.768 kHz   |
| CACLOCO时钟(CACLCLK)           | LOCO                          | CAC  | 32.768 kHz   |
| CACMOCO时钟(CACMOCLK)          | MOCO                          | CAC  | 8 MHz  |
| CACHOCO时钟(CACHCLK)           | HOCO                          | CAC  | 16/18/20 MHz   |
| CACIWDTLOCO时钟(CACILCLK)      | IWDTLOCO                      | CAC  | 15 kHz   |
| RTC clock (RTCCLK)           | SOSC/LOCO                     | RTC  | 32.768 kHz   |
| IWDT clock (IWDTCLK)         | IWDTLOCO                      | IWDT   | 15 kHz   |
| SysTick定时器时钟(SYSTICCLK)      | LOCO                          | SysTick timer  | 32.768 kHz   |
| JTAG clock (JTAGTCK)         | TCK                           | JTAG   | 高达25MHz  |
| 串行线时钟(SWCLK)                 | SWCLK                         | OCD  | 高达25MHz  |
| 跟踪时钟(TRCLK)                  | MOSC/SOSC/HOCO/MOCO/ LOCO/PLL | CPU-OCD  | 高达50MHz, 分频比: 124  |
| TCLK引脚输出(TCLK)               | 1/2 TRCLK                     | TCLK pin   | 高达25MHz  |
| Clock/buzzer output (CLKOUT) | MOSC/SOSC/LOCO/MOCO/ HOCO     | CLKOUT pin   | 高达60MHz<br>Division ratios: 1/2/4/8/16/32/64/128               |

Note: 设置时钟频率的限制:  $ICLK \geq PCLKA \geq PCLKB, PCLKD \geq PCLKA \geq PCLKB$   
 $ICLK \geq FCLK$   
 时钟频率比的限制: (N: 整数, 最大为64)  
 $ICLK:FCLK = N:1, ICLK:PCLKA = N:1, ICLK:PCLKB = N:1, ICLK:PCLKC = N:1$  or  $1:N, ICLK:PCLKD = N:1$  or  $1:N, ICLK:TRCLK = N:1$  or  $1:N$   
 如果启用了AD转换器, 则时钟频率比受到如下限制:  
 $PCLKA:PCLKC = 1:1$  or  $2:1$  or  $4:1$  or  $8:1$  or  $1:2$  or  $1:4$   
 Note: PE时对最小FCLK频率4MHz的限制。  
 Note: PLL和PLL2的倍频应设置在PLL和PLL2的输出频率范围内, 取频率为不使用FLL功能时考虑HOCO。  
 Note: 时钟有一个允许的频率范围 (见表8.2)。



Flash memory and SRAM also have a permissible operating frequency range in each wait cycle setting. (See [section 42, SRAM](#), [section 44, Flash Memory](#))  
Those clock frequency ranges must be satisfied even if the HOCO has its maximum or minimum frequency when not using FLL function. (See [section 47, Electrical Characteristics](#)).

闪存和SRAM在每个等待周期设置中也有一个允许的工作频率范围。（参见第42节，SRAM，第44节，闪存）即使HOCO在不使用FLL功能时具有其最大或最小频率，也必须满足这些时钟频率范围。（见第47节，电气特性）。

RA生态工作室

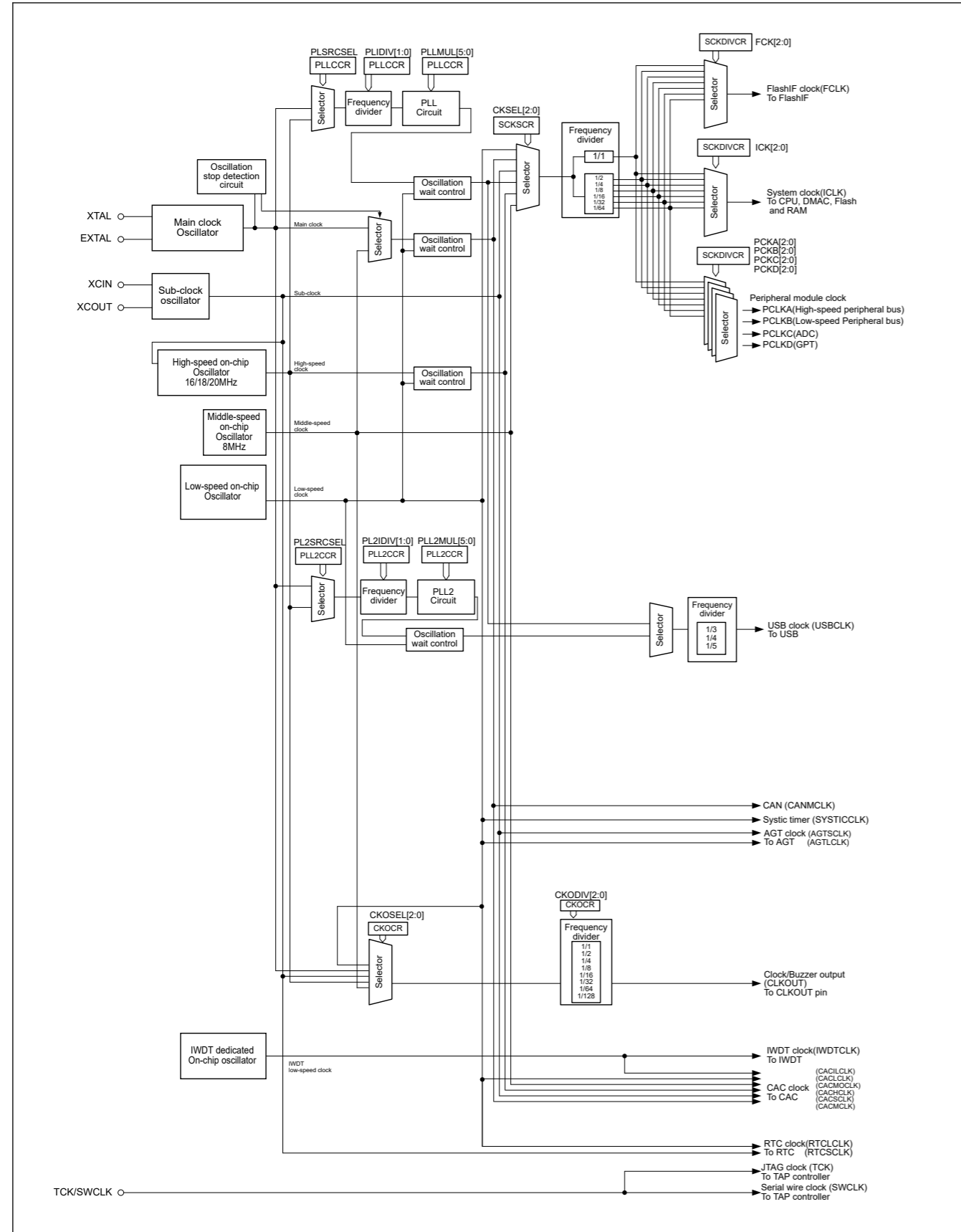


Figure 8.1 Clock generation circuit block diagram

Table 8.3 lists the input/output pins of the clock generation circuit.

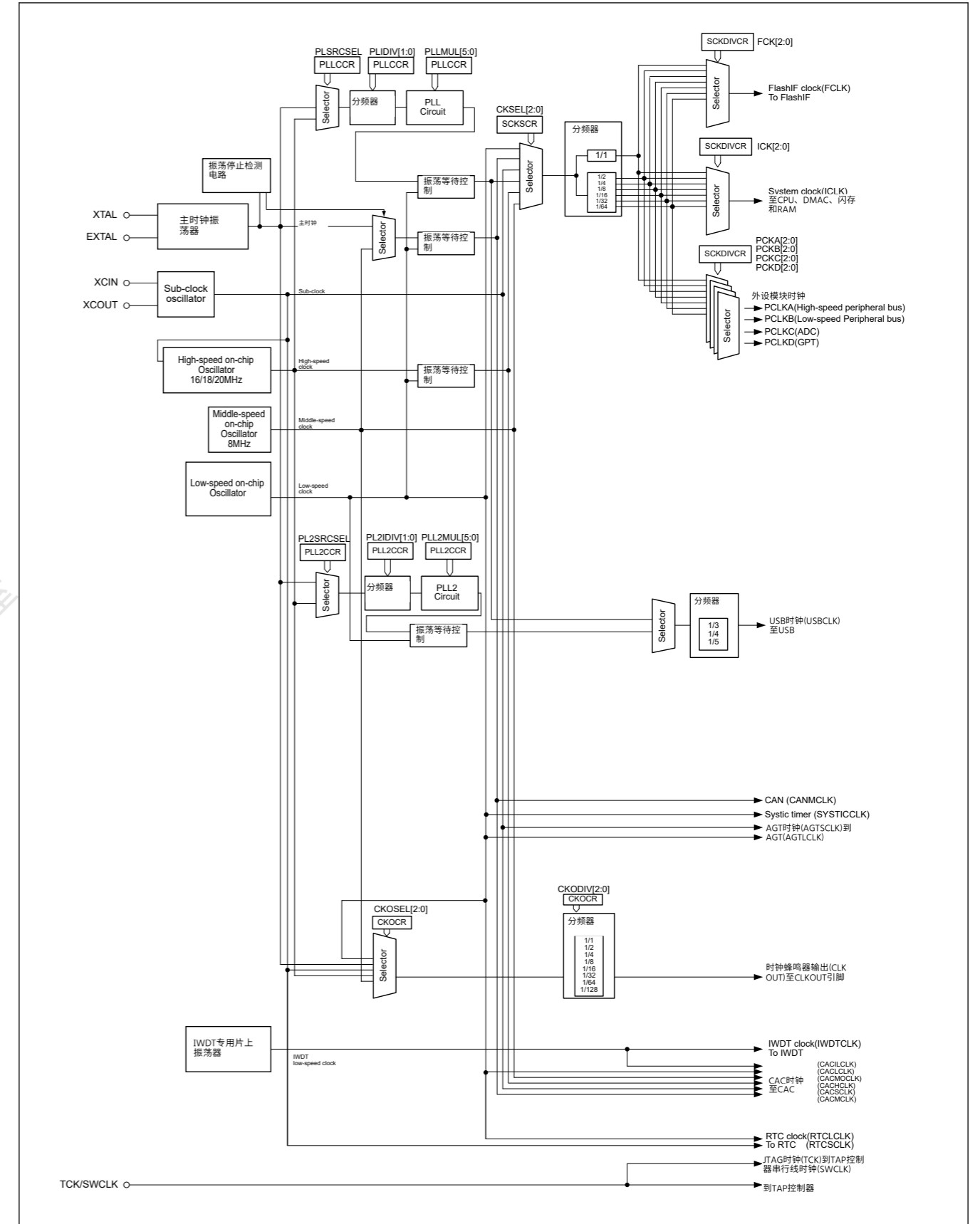


Figure 8.1 时钟产生电路框图

表8.3列出了时钟生成电路的输入输出引脚。

Table 8.3 Input/Output Pins of Clock Generation Circuit

| Pin name  | I/O    | Description  |
|-----------|--------|--|
| XTAL      | Output | These pins are used to connect a ceramic resonator or crystal resonator. The EXTAL pin can also be used to input an external clock. For details, see <a href="#">section 8.3.2. External Clock Input</a> . |
| EXTAL     | Input  |  |
| XCIN      | Input  | These pins are used to connect a 32.768-kHz crystal resonator  |
| XCOU      | Output |  |
| TCK/SWCLK | Input  | This pin is used to input the clock for the JTAG/SWD   |
| CLKOUT    | Output | This pin is used to output the CLKOUT/BUZZER clock   |

## 8.2 Register Descriptions

### 8.2.1 CGFSAR : Clock Generation Function Security Attribute Register

Base address: SYSC = 0x4001\_E000

Offset address: 0x3C0

|                    |    |    |    |    |           |    |           |           |           |           |           |           |           |           |    |           |
|--------------------|----|----|----|----|-----------|----|-----------|-----------|-----------|-----------|-----------|-----------|-----------|-----------|----|-----------|
| Bit position:      | 31 | 30 | 29 | 28 | 27        | 26 | 25        | 24        | 23        | 22        | 21        | 20        | 19        | 18        | 17 | 16        |
| Bit field:         | —  | —  | —  | —  | —         | —  | —         | —         | —         | —         | —         | —         | —         | —         | —  | NONS EC16 |
| Value after reset: | 1  | 1  | 1  | 1  | 1         | 1  | 1         | 1         | 1         | 1         | 1         | 1         | 1         | 1         | 1  | 1         |
| Bit position:      | 15 | 14 | 13 | 12 | 11        | 10 | 9         | 8         | 7         | 6         | 5         | 4         | 3         | 2         | 1  | 0         |
| Bit field:         | —  | —  | —  | —  | NONS EC11 | —  | NONS EC09 | NONS EC08 | NONS EC07 | NONS EC06 | NONS EC05 | NONS EC04 | NONS EC03 | NONS EC02 | —  | NONS EC00 |
| Value after reset: | 1  | 1  | 1  | 1  | 1         | 1  | 1         | 1         | 1         | 1         | 1         | 1         | 1         | 1         | 1  | 1         |

| Bit | Symbol     | Function   | R/W |
|-----|------------|--|-----|
| 0   | NONSEC00*1 | Non Secure Attribute bit 00<br>Target register: SCKDIVCR, SCKSCR<br>Target factor: system clock control<br>0: Secure<br>1: Non Secure  | R/W |
| 1   | —          | This bit is read as 1. The write value should be 1.  | R/W |
| 2   | NONSEC02*1 | Non Secure Attribute bit 02<br>Target register: HOCOOCR, FLLCR1, FLLCR2, HOCOUTCR<br>Target factor: HOCO<br>0: Secure<br>1: Non Secure | R/W |
| 3   | NONSEC03*1 | Non Secure Attribute bit 03<br>Target register: MOCOOCR, MOCOUTCR<br>Target factor: MOCO<br>0: Secure<br>1: Non Secure                 | R/W |
| 4   | NONSEC04   | Non Secure Attribute bit 04<br>Target register: LOCOOCR, LOCOUTCR<br>Target factor: LOCO<br>0: Secure<br>1: Non Secure                 | R/W |
| 5   | NONSEC05   | Non Secure Attribute bit 05<br>Target register: MOSCCR, MOSCWTCR, MOMCR<br>Target factor: MOSC<br>0: Secure<br>1: Non Secure           | R/W |

Table 8.3 时钟产生电路的输入输出引脚

| 引脚名称      | I/O    | Description  |
|-----------|--------|--|
| XTAL      | Output | 这些引脚用于连接陶瓷谐振器或晶体谐振器。EXTAL引脚也可用于输入外部时钟。详见8.3.2节。外部时钟输入。 |
| EXTAL     | Input  |  |
| XCIN      | Input  | 这些引脚用于连接32.768-kHz晶体谐振器                                |
| XCOU      | Output |  |
| TCK/SWCLK | Input  | 该引脚用于输入JTAGSWD的时钟                                      |
| CLKOUT    | Output | 该引脚用于输出CLKOUTBUZZER时钟                                  |

## 8.2 注册说明

### 8.2.1 CGFSAR:时钟生成功能安全属性寄存器

Base address: SYSC = 0x4001\_E000

Offset address: 0x3C0

|               |    |    |    |    |           |    |           |           |           |           |           |           |           |           |    |           |
|---------------|----|----|----|----|-----------|----|-----------|-----------|-----------|-----------|-----------|-----------|-----------|-----------|----|-----------|
| Bit position: | 31 | 30 | 29 | 28 | 27        | 26 | 25        | 24        | 23        | 22        | 21        | 20        | 19        | 18        | 17 | 16        |
| Bit field:    | —  | —  | —  | —  | —         | —  | —         | —         | —         | —         | —         | —         | —         | —         | —  | NONS EC16 |
| 重置后的值:        | 1  | 1  | 1  | 1  | 1         | 1  | 1         | 1         | 1         | 1         | 1         | 1         | 1         | 1         | 1  | 1         |
| Bit position: | 15 | 14 | 13 | 12 | 11        | 10 | 9         | 8         | 7         | 6         | 5         | 4         | 3         | 2         | 1  | 0         |
| Bit field:    | —  | —  | —  | —  | NONS EC11 | —  | NONS EC09 | NONS EC08 | NONS EC07 | NONS EC06 | NONS EC05 | NONS EC04 | NONS EC03 | NONS EC02 | —  | NONS EC00 |
| 重置后的值:        | 1  | 1  | 1  | 1  | 1         | 1  | 1         | 1         | 1         | 1         | 1         | 1         | 1         | 1         | 1  | 1         |

| Bit | Symbol     | Function   | R/W |
|-----|------------|--|-----|
| 0   | NONSEC00*1 | 非安全属性位00<br>Target register: SCKDIVCR, SCKSCR<br>目标因素: 系统时钟控制<br>0: 安全1: 不安全                         | R/W |
| 1   | —          | 该位读取为1。写入值应为1。   | R/W |
| 2   | NONSEC02*1 | 非安全属性位02<br>Target register: HOCOOCR, FLLCR1, FLLCR2, HOCOUTCR<br>Target factor: HOCO<br>0: 安全1: 不安全 | R/W |
| 3   | NONSEC03*1 | 非安全属性位03<br>Target register: MOCOOCR, MOCOUTCR<br>Target factor: MOCO<br>0: 安全1: 不安全                 | R/W |
| 4   | NONSEC04   | 非安全属性位04<br>Target register: LOCOOCR, LOCOUTCR<br>目标因素: LOCO<br>0: 安全1: 不安全                          | R/W |
| 5   | NONSEC05   | 非安全属性位05<br>Target register: MOSCCR, MOSCWTCR, MOMCR<br>Target factor: MOSC<br>0: 安全1: 不安全           | R/W |

| Bit   | Symbol     | Function  | R/W |
|-------|------------|---|-----|
| 6     | NONSEC06   | Non Secure Attribute bit 06<br>Target register: OSTDCR, OSTDSR<br>Target factor: oscillation stop detection control<br>0: Secure<br>1: Non Secure | R/W |
| 7     | NONSEC07   | Non Secure Attribute bit 07<br>Target register: SOSCCR, SOMCR<br>Target factor: SOSC<br>0: Secure<br>1: Non Secure                                | R/W |
| 8     | NONSEC08*1 | Non Secure Attribute bit 08<br>Target register: PLLCCR, PLLCR<br>Target factor: PLL<br>0: Secure<br>1: Non Secure                                 | R/W |
| 9     | NONSEC09   | Non Secure Attribute bit 09<br>Target register: PLL2CCR, PLL2CR<br>Target factor: PLL2<br>0: Secure<br>1: Non Secure                              | R/W |
| 10    | —          | This bit is read as 1. The write value should be 1.   | R/W |
| 11    | NONSEC11   | Non Secure Attribute bit 11<br>Target register: CKOCR<br>Target factor: CLKOUT control<br>0: Secure<br>1: Non Secure                              | R/W |
| 15:12 | —          | These bits are read as 1. The write value should be 1.  | R/W |
| 16    | NONSEC16   | Non Secure Attribute bit 16<br>Target register: USBCKDIVCR, USBCKCR<br>Target factor: USBCLK<br>0: Secure<br>1: Non Secure                        | R/W |
| 17    | —          | This bit is read as 1. The write value should be 1.   | R/W |
| 18    | —          | This bit is read as 1. The write value should be 1.   | R/W |
| 19    | —          | This bit is read as 1. The write value should be 1.   | R/W |
| 20    | —          | This bit is read as 1. The write value should be 1.   | R/W |
| 31:21 | —          | These bits are read as 1. The write value should be 1.  | R/W |

Note: Only secure access can write to this register. Both secure access and Non-secure read access are allowed but Non-secure write access is not allowed and TrustZone access error is not generated.

Note: This register is write-protected by PRCR register.

Note 1. It is recommended that these bits are configured as Non Secure when the device life cycle is NSECSD (DLMMON.DLMMON[3:0] = 0011b). See [section 46.6.1. Restrictions on setting the security attribution](#) for the details.

CGFSAR register controls the secure attribute of Clock Generation Function registers.

#### NONSEC00 bit (Non Secure Attribute bit 00)

This bit controls the security attribute of SCKDIVCR, SCKSCR.

#### NONSEC02 bit (Non Secure Attribute bit 02)

This bit controls the security attribute of HOCOVR, FLLCR1, FLLCR2, HOCOUTCR.

#### NONSEC03 bit (Non Secure Attribute bit 03)

This bit controls the security attribute of MOCOVR, MOCOUTCR.

#### NONSEC04 bit (Non Secure Attribute bit 04)

This bit controls the security attribute of LOCOVR, LOCOUTCR.

| Bit   | Symbol     | Function   | R/W |
|-------|------------|--|-----|
| 6     | NONSEC06   | 非安全属性位06<br>Target register: OSTDCR, OSTDSR<br>目标因素: 振荡停止检测控制<br>0: 安全1: 不安全             | R/W |
| 7     | NONSEC07   | 非安全属性位07<br>Target register: SOSCCR, SOMCR<br>Target factor: SOSC<br>0: 安全1: 不安全         | R/W |
| 8     | NONSEC08*1 | 非安全属性位08<br>Target register: PLLCCR, PLLCR<br>Target factor: PLL<br>0: 安全1: 不安全          | R/W |
| 9     | NONSEC09   | 非安全属性位09<br>Target register: PLL2CCR, PLL2CR<br>Target factor: PLL2<br>0: 安全1: 不安全       | R/W |
| 10    | —          | 该位读取为1。写入值应为1。   | R/W |
| 11    | NONSEC11   | 非安全属性位11<br>Target register: CKOCR<br>目标因素: CLKOUT控制<br>0: 安全1: 不安全                      | R/W |
| 15:12 | —          | 这些位被读取为1。写入值应为1。   | R/W |
| 16    | NONSEC16   | 非安全属性位16<br>Target register: USBCKDIVCR, USBCKCR<br>Target factor: USBCLK<br>0: 安全1: 不安全 | R/W |
| 17    | —          | 该位读取为1。写入值应为1。   | R/W |
| 18    | —          | 该位读取为1。写入值应为1。   | R/W |
| 19    | —          | 该位读取为1。写入值应为1。   | R/W |
| 20    | —          | 该位读取为1。写入值应为1。   | R/W |
| 31:21 | —          | 这些位被读取为1。写入值应为1。   | R/W |

Note: 只有安全访问才能写入该寄存器。允许安全访问和非安全读取访问，但不允许非安全写入访问，并且不会生成TrustZone访问错误。

Note: 该寄存器由PRCR寄存器写保护。

注1.当器件生命周期为NSECSD(DLMMON.DLMMON[3:0]=0011b)时，建议将这些位配置为非安全。请参见第46.6.1节。设置详细信息的安全属性的限制。

CGFSAR寄存器控制时钟生成功能寄存器的安全属性。

#### NONSEC00位 (非安全属性位00)

该位控制SCKDIVCR、SCKSCR的安全属性。

#### NONSEC02位 (非安全属性位02)

该位控制HOCOVR、FLLCR1、FLLCR2、HOCOUTCR的安全属性。

#### NONSEC03位 (非安全属性位03)

该位控制MOCOVR、MOCOUTCR的安全属性。

#### NONSEC04位 (非安全属性位04)

该位控制LOCOVR、LOCOUTCR的安全属性。

**NONSEC05 bit (Non Secure Attribute bit 05)**

This bit controls the security attribute of MOSCCR, MOSCWTCR, MOMCR.

**NONSEC06 bit (Non Secure Attribute bit 06)**

This bit controls the security attribute of OSTDCR, OSTDSR.

**NONSEC07 bit (Non Secure Attribute bit 07)**

This bit controls the security attribute of SOSCCR, SOMCR.

**NONSEC08 bit (Non Secure Attribute bit 08)**

This bit controls the security attribute of PLLCCR, PLLCR.

**NONSEC09 bit (Non Secure Attribute bit 09)**

This bit controls the security attribute of PLL2CCR, PLL2CR.

**NONSEC11 bit (Non Secure Attribute bit 11)**

This bit controls the security attribute of CKOCR.

**NONSEC16 bit (Non Secure Attribute bit 16)**

This bit controls the security attribute of USBCKDIVCR, USBCKCR.

**8.2.2 SCKDIVCR : System Clock Division Control Register**

Base address: SYSC = 0x4001\_E000

Offset address: 0x020

|                    |    |           |    |    |    |           |    |    |    |           |    |    |    |           |    |    |
|--------------------|----|-----------|----|----|----|-----------|----|----|----|-----------|----|----|----|-----------|----|----|
| Bit position:      | 31 | 30        | 29 | 28 | 27 | 26        | 25 | 24 | 23 | 22        | 21 | 20 | 19 | 18        | 17 | 16 |
| Bit field:         | —  | FCK[2:0]  |    |    | —  | ICK[2:0]  |    |    | —  | —         | —  | —  | —  | RSV       |    |    |
| Value after reset: | 0  | 0         | 1  | 0  | 0  | 0         | 1  | 0  | 0  | 0         | 0  | 0  | 0  | 0         | 1  | 0  |
| Bit position:      | 15 | 14        | 13 | 12 | 11 | 10        | 9  | 8  | 7  | 6         | 5  | 4  | 3  | 2         | 1  | 0  |
| Bit field:         | —  | PCKA[2:0] |    |    | —  | PCKB[2:0] |    |    | —  | PCKC[2:0] |    |    | —  | PCKD[2:0] |    |    |
| Value after reset: | 0  | 0         | 1  | 0  | 0  | 0         | 1  | 0  | 0  | 0         | 1  | 0  | 0  | 0         | 1  | 0  |

| Bit | Symbol                 | Function   | R/W |
|-----|------------------------|--|-----|
| 2:0 | PCKD[2:0] <sup>3</sup> | Peripheral Module Clock D (PCLKD) Select<br>0 0 0: × 1/1<br>0 0 1: × 1/2<br>0 1 0: × 1/4<br>0 1 1: × 1/8<br>1 0 0: × 1/16<br>1 0 1: × 1/32<br>1 1 0: × 1/64<br>Others: Setting prohibited. | R/W |
| 3   | —                      | This bit is read as 0. The write value should be 0.  | R/W |
| 6:4 | PCKC[2:0] <sup>3</sup> | Peripheral Module Clock C (PCLKC) Select<br>0 0 0: × 1/1<br>0 0 1: × 1/2<br>0 1 0: × 1/4<br>0 1 1: × 1/8<br>1 0 0: × 1/16<br>1 0 1: × 1/32<br>1 1 0: × 1/64<br>Others: Setting prohibited. | R/W |
| 7   | —                      | This bit is read as 0. The write value should be 0.  | R/W |

**NONSEC05位 (非安全属性位05)**

该位控制MOSCCR、MOSCWTCR、MOMCR的安全属性。

**NONSEC06位 (非安全属性位06)**

该位控制OSTDCR、OSTDSR的安全属性。

**NONSEC07位 (非安全属性位07)**

该位控制SOSCCR、SOMCR的安全属性。

**NONSEC08位 (非安全属性位08)**

该位控制PLLCCR、PLLCR的安全属性。

**NONSEC09位 (非安全属性位09)**

该位控制PLL2CCR、PLL2CR的安全属性。

**NONSEC11位 (非安全属性位11)**

该位控制CKOCR的安全属性。

**NONSEC16位 (非安全属性位16)**

该位控制USBCKDIVCR、USBCKCR的安全属性。

**8.2.2 SCKDIVCR:系统时钟分频控制寄存器**

Base address: SYSC = 0x4001\_E000

Offset address: 0x020

|               |    |           |    |    |    |           |    |    |    |           |    |    |    |           |    |    |
|---------------|----|-----------|----|----|----|-----------|----|----|----|-----------|----|----|----|-----------|----|----|
| Bit position: | 31 | 30        | 29 | 28 | 27 | 26        | 25 | 24 | 23 | 22        | 21 | 20 | 19 | 18        | 17 | 16 |
| Bit field:    | —  | FCK[2:0]  |    |    | —  | ICK[2:0]  |    |    | —  | —         | —  | —  | —  | RSV       |    |    |
| 重置后的值:        | 0  | 0         | 1  | 0  | 0  | 0         | 1  | 0  | 0  | 0         | 0  | 0  | 0  | 0         | 1  | 0  |
| Bit position: | 15 | 14        | 13 | 12 | 11 | 10        | 9  | 8  | 7  | 6         | 5  | 4  | 3  | 2         | 1  | 0  |
| Bit field:    | —  | PCKA[2:0] |    |    | —  | PCKB[2:0] |    |    | —  | PCKC[2:0] |    |    | —  | PCKD[2:0] |    |    |
| 重置后的值:        | 0  | 0         | 1  | 0  | 0  | 0         | 1  | 0  | 0  | 0         | 1  | 0  | 0  | 0         | 1  | 0  |

| Bit | Symbol                 | Function   | R/W |
|-----|------------------------|--|-----|
| 2:0 | PCKD[2:0] <sup>3</sup> | 外设模块时钟D(PCLKD)选择<br>0 0 0: × 1/1<br>0 0 1: × 1/2<br>0 1 0: × 1/4<br>0 1 1: × 1/8<br>1 0 0: × 1/16<br>1 0 1: × 1/32<br>1 1 0: × 1/64<br>其他: 禁止设置。 | R/W |
| 3   | —                      | 该位读取为0。写入值应为0。   | R/W |
| 6:4 | PCKC[2:0] <sup>3</sup> | 外设模块时钟C(PCLKC)选择<br>0 0 0: × 1/1<br>0 0 1: × 1/2<br>0 1 0: × 1/4<br>0 1 1: × 1/8<br>1 0 0: × 1/16<br>1 0 1: × 1/32<br>1 1 0: × 1/64<br>其他: 禁止设置。 | R/W |
| 7   | —                      | 该位读取为0。写入值应为0。   | R/W |

| Bit   | Symbol                        | Function   | R/W |
|-------|-------------------------------|--|-----|
| 10:8  | PCKB[2:0] <sup>2</sup>        | Peripheral Module Clock B (PCLKB) Select<br>0 0 0: × 1/1<br>0 0 1: × 1/2<br>0 1 0: × 1/4<br>0 1 1: × 1/8<br>1 0 0: × 1/16<br>1 0 1: × 1/32<br>1 1 0: × 1/64<br>Others: Setting prohibited.                 | R/W |
| 11    | —                             | This bit is read as 0. The write value should be 0.  | R/W |
| 14:12 | PCKA[2:0] <sup>2</sup>        | Peripheral Module Clock A (PCKA) Select<br>0 0 0: × 1/1<br>0 0 1: × 1/2<br>0 1 0: × 1/4<br>0 1 1: × 1/8<br>1 0 0: × 1/16<br>1 0 1: × 1/32<br>1 1 0: × 1/64<br>Others: Setting prohibited.                  | R/W |
| 15    | —                             | This bit is read as 0. The write value should be 0.  | R/W |
| 18:16 | RSV                           | Reserved. Set these bits to the same value as PCKB[2:0].<br>0 0 0: × 1/1<br>0 0 1: × 1/2<br>0 1 0: × 1/4<br>0 1 1: × 1/8<br>1 0 0: × 1/16<br>1 0 1: × 1/32<br>1 1 0: × 1/64<br>Others: Settings prohibited | R/W |
| 23:19 | —                             | These bits are read as 0. The write value should be 0.   | R/W |
| 26:24 | ICK[2:0] <sup>1*2*3*4*5</sup> | System Clock (ICK) Select<br>0 0 0: × 1/1<br>0 0 1: × 1/2<br>0 1 0: × 1/4<br>0 1 1: × 1/8<br>1 0 0: × 1/16<br>1 0 1: × 1/32<br>1 1 0: × 1/64<br>Others: Setting prohibited.                                | R/W |
| 27    | —                             | This bit is read as 0. The write value should be 0.  | R/W |
| 30:28 | FCK[2:0] <sup>1</sup>         | FlashIF Clock (FCLK) Select<br>0 0 0: × 1/1<br>0 0 1: × 1/2<br>0 1 0: × 1/4<br>0 1 1: × 1/8<br>1 0 0: × 1/16<br>1 0 1: × 1/32<br>1 1 0: × 1/64<br>Others: Setting prohibited.                              | R/W |
| 31    | —                             | This bit is read as 0. The write value should be 0.  | R/W |

Note: If the security attribution is configured as secure:

- Secure access and Non-secure read access are allowed
- Non-secure write access is ignored, and TrustZone access error is not generated.

If the security attribution is configured as Non-secure:

- Secure and Non-secure access are allowed.

Note: Set the PRCR.PRC0 bit to 1 (write enabled) before rewriting this register.

Note 1. The following relation is required between the frequencies of the system clock (ICK) and the FlashIF clock (FCLK).

$$ICK:FCLK=N:1 \text{ (N: integer)}$$

Note 2. The following relation is required between the frequencies of the system clock (ICK) and the peripheral module clocks (PCKA, PCKB)

$$ICK:PCKA = N:1, ICK:PCKB = N:1 \text{ (N: integer)}$$

| Bit   | Symbol                        | Function  | R/W |
|-------|-------------------------------|---|-----|
| 10:8  | PCKB[2:0] <sup>2</sup>        | 外设模块时钟B(PCLKB)选择<br>0 0 0: × 1/1<br>0 0 1: × 1/2<br>0 1 0: × 1/4<br>0 1 1: × 1/8<br>1 0 0: × 1/16<br>1 0 1: × 1/32<br>1 1 0: × 1/64<br>其他: 禁止设置。          | R/W |
| 11    | —                             | 该位读取为0。写入值应为0。  | R/W |
| 14:12 | PCKA[2:0] <sup>2</sup>        | 外设模块时钟A(PCKA)选择<br>0 0 0: × 1/1<br>0 0 1: × 1/2<br>0 1 0: × 1/4<br>0 1 1: × 1/8<br>1 0 0: × 1/16<br>1 0 1: × 1/32<br>1 1 0: × 1/64<br>其他: 禁止设置。           | R/W |
| 15    | —                             | 该位读取为0。写入值应为0。  | R/W |
| 18:16 | RSV                           | 预订的。将这些位设置为与PCKB[2:0]相同的值。<br>0 0 0: × 1/1<br>0 0 1: × 1/2<br>0 1 0: × 1/4<br>0 1 1: × 1/8<br>1 0 0: × 1/16<br>1 0 1: × 1/32<br>1 1 0: × 1/64<br>其他: 禁止设置 | R/W |
| 23:19 | —                             | 这些位被读取为0。写入值应为0。  | R/W |
| 26:24 | ICK[2:0] <sup>1*2*3*4*5</sup> | 系统时钟(ICK)选择<br>0 0 0: × 1/1<br>0 0 1: × 1/2<br>0 1 0: × 1/4<br>0 1 1: × 1/8<br>1 0 0: × 1/16<br>1 0 1: × 1/32<br>1 1 0: × 1/64<br>其他: 禁止设置。               | R/W |
| 27    | —                             | 该位读取为0。写入值应为0。  | R/W |
| 30:28 | FCK[2:0] <sup>1</sup>         | FlashIF时钟(FCLK)选择<br>0 0 0: × 1/1<br>0 0 1: × 1/2<br>0 1 0: × 1/4<br>0 1 1: × 1/8<br>1 0 0: × 1/16<br>1 0 1: × 1/32<br>1 1 0: × 1/64<br>其他: 禁止设置。         | R/W |
| 31    | —                             | 该位读取为0。写入值应为0。  | R/W |

Note: 如果安全属性配置为安全: ●

- 允许安全访问和非安全读取访问
- 忽略非安全写入访问, 不会生成TrustZone访问错误。

如果安全属性配置为非安全: ●

- 允许安全和非安全访问。

Note: 在重写此寄存器之前将PRCR.PRC0位设置为1 (允许写入)。

注1.系统时钟(ICK)和FlashIF时钟(FCLK)的频率之间需要以下关系。

$$ICK:FCLK=N:1 \text{ (N: integer)}$$

注2.系统时钟(ICK)和外围模块时钟(PCKA, PCKB)

$$ICK:PCKA = N:1, ICK:PCKB = N:1 \text{ (N: integer)}$$



Note 3. The following relation is required between the frequencies of the system clock (ICLK) and the peripheral module clocks (PCLKC, PCLKD):

$$\text{ICLK}:\text{PCLKC},\text{PCLKD} = \text{N}:1\text{or}1:\text{N} \quad (\text{N: integer})$$

Note 4. Selecting the division-by-1 to ICLK is prohibited when SCKSCR.CKSEL[2:0] bits select the system clock source faster than 100 MHz.

Note 5. The frequency of the system clock (ICLK) is limited to the flash wait cycle register (FLWT). See [section 44, Flash Memory](#).

SCKDIVCR selects the frequencies of the system clock (ICLK), peripheral module clock (PCLKA, PCLKB, PCLKC, PCLKD), FlashIF clock (FCLK).

### 8.2.3 SCKSCR : System Clock Source Control Register

Base address: SYSC = 0x4001\_E000

Offset address: 0x026

|                    |   |   |   |   |   |            |   |   |
|--------------------|---|---|---|---|---|------------|---|---|
| Bit position:      | 7 | 6 | 5 | 4 | 3 | 2          | 1 | 0 |
| Bit field:         | — | — | — | — | — | CKSEL[2:0] |   |   |
| Value after reset: | 0 | 0 | 0 | 0 | 0 | 0          | 0 | 1 |

| Bit | Symbol     | Function  | R/W |
|-----|------------|---|-----|
| 2:0 | CKSEL[2:0] | Clock Source Select<br>0 0 0: HOCO<br>0 0 1: MOCO<br>0 1 0: LOCO<br>0 1 1: Main clock oscillator (MOSC)<br>1 0 0: Sub-clock oscillator (SOSC)<br>1 0 1: PLL<br>1 1 0: Setting prohibited<br>1 1 1: Setting prohibited | R/W |
| 7:3 | —          | These bits are read as 0. The write value should be 0.  | R/W |

Note: Set the PRCR.PRC0 bit to 1 (write enabled) before rewriting this register.

Note: If the security attribution is configured as secure:

- Secure access and Non-secure read access are allowed
  - Non-secure write access is ignored, and TrustZone access error is not generated.
- If the security attribution is configured as Non-secure:
- Secure and Non-secure access are allowed.

The SCKSCR register selects the clock source for the system clock.

#### CKSEL[2:0] bits (Clock Source Select)

The CKSEL[2:0] bits select the source for the following modules:

- System clock (ICLK)
- Peripheral module clocks (PCLKA, PCLKB, PCLKC, and PCLKD)
- FlashIF clock (FCLK)

The bits select from one of the following sources:

- Low-speed on-chip oscillator (LOCO)
- Middle-speed on-chip oscillator (MOCO)
- High-speed on-chip oscillator (HOCO)
- Main clock oscillator (MOSC)
- Sub-clock oscillator (SOSC)
- PLL

The operating state of each clock source is controlled not only by the clock oscillation enable settings but also by the operating modes of the product. Some clock sources might be forcibly stopped depending on the product operating mode being used.

注3.系统时钟(ICLK)和外围模块时钟(PCLKC

PCLKD):

$$\text{ICLK}:\text{PCLKC},\text{PCLKD} = \text{N}:1\text{or}1:\text{N} \quad (\text{N: integer})$$

注4.当SCKSCR.CKSEL[2:0]位选择快于100的系统时钟源时,禁止选择对ICLK进行1分频MHz.

注5.系统时钟(ICLK)的频率仅限于闪存等待周期寄存器(FLWT)。请参见第44节,闪存。

SCKDIVCR选择系统时钟 (ICLK)、外围模块时钟 (PCLKA、PCLKB、PCLKC、PCLKD)、FlashIF clock (FCLK)。

### 8.2.3 SCKSCR:系统时钟源控制寄存器

Base address: SYSC = 0x4001\_E000

Offset address: 0x026

|               |   |   |   |   |   |            |   |   |
|---------------|---|---|---|---|---|------------|---|---|
| Bit position: | 7 | 6 | 5 | 4 | 3 | 2          | 1 | 0 |
| Bit field:    | — | — | — | — | — | CKSEL[2:0] |   |   |
| 重置后的值:        | 0 | 0 | 0 | 0 | 0 | 0          | 0 | 1 |

| Bit | Symbol     | Function  | R/W |
|-----|------------|---|-----|
| 2:0 | CKSEL[2:0] | 时钟源选择<br>000: HOCO001: MOCO010: LOC<br>0011: 主时钟振荡器 (MOSC) 100<br>: 副时钟振荡器 (SOSC) 101: PLL<br>110: 禁止设置111:禁止设定 | R/W |
| 7:3 | —          | 这些位被读取为0。写入值应为0。  | R/W |

Note: 在重写此寄存器之前将PRCR.PRC0位设置为1 (允许写入)。

Note: 如果安全属性配置为安全: ●

- 允许安全访问和非安全读取访问
  - 忽略非安全写入访问,不会生成TrustZone访问错误。
- 如果安全属性配置为非安全: ●
- 允许安全和非安全访问。

SCKSCR寄存器选择系统时钟的时钟源。

#### CKSEL[2:0]位 (时钟源选择)

CKSEL[2:0]位选择以下模块的源:

- 系统时钟 (ICLK)
- 外设模块时钟 (PCLKA、PCLKB、PCLKC和PCLKD)
- FlashIF clock (FCLK)

这些位从以下来源之一中选择:

- Low-speed on-chip oscillator (LOCO)
- Middle-speed on-chip oscillator (MOCO)
- High-speed on-chip oscillator (HOCO)
- 主时钟振荡器 (MOSC)
- Sub-clock oscillator (SOSC)
- PLL

每个时钟源的工作状态不仅由时钟振荡使能设置控制,还由产品的工作模式控制。根据所使用的产品操作模式,某些时钟源可能会被强制停止。

Check the operation state of clock sources in each product operating mode, and do not select the clock source to be stopped in SCKSCR. The clock sources should be switched when there are no occurring internal asynchronous interrupt. For details, see [section 10, Low Power Modes](#).

### 8.2.4 PLLCCR : PLL Clock Control Register

Base address: SYSC = 0x4001\_E000

Offset address: 0x028

|                    |    |    |             |    |    |    |   |   |   |   |          |   |   |             |   |   |
|--------------------|----|----|-------------|----|----|----|---|---|---|---|----------|---|---|-------------|---|---|
| Bit position:      | 15 | 14 | 13          | 12 | 11 | 10 | 9 | 8 | 7 | 6 | 5        | 4 | 3 | 2           | 1 | 0 |
| Bit field:         | —  | —  | PLLMUL[5:0] |    |    |    |   | — | — | — | PLSRCSEL | — | — | PLIDIV[1:0] |   |   |
| Value after reset: | 0  | 0  | 0           | 1  | 0  | 0  | 1 | 1 | 0 | 0 | 0        | 0 | 0 | 0           | 0 | 0 |

| Bit   | Symbol                    | Function  | R/W |
|-------|---------------------------|---|-----|
| 1:0   | PLIDIV[1:0] <sup>*1</sup> | PLL Input Frequency Division Ratio Select<br>0 0: /1<br>0 1: /2<br>1 0: /3<br>Others: Setting prohibited.   | R/W |
| 3:2   | —                         | These bits are read as 0. The write value should be 0.  | R/W |
| 4     | PLSRCSEL                  | PLL Clock Source Select<br>0: Main clock oscillator<br>1: HOCO <sup>*3</sup>  | R/W |
| 7:5   | —                         | These bits are read as 0. The write value should be 0.  | R/W |
| 13:8  | PLLMUL[5:0] <sup>*2</sup> | PLL Frequency Multiplication Factor Select<br>0x13: × 10.0 (value after reset)<br>0x14: × 10.5<br>0x15: × 11.0<br>⋮<br>0x1C: × 14.5<br>0x1D: × 15.0<br>0x1E: × 15.5<br>⋮<br>0x3A: × 29.5<br>0x3B: × 30.0<br>Others: Setting prohibited. | R/W |
| 15:14 | —                         | These bits are read as 0. The write value should be 0.  | R/W |

Note: If the security attribution is configured as secure:

- Secure access and Non-secure read access are allowed
- Non-secure write access is ignored, and TrustZone access error is not generated.

If the security attribution is configured as Non-secure:

- Secure and Non-secure access are allowed.

Note: Set the PRCR.PRC0 bit to 1 (write enabled) before rewriting this register.

Note 1. PLIDIV[1:0] should be set so that the frequency of PLL input signal is within the range of [section 8.1. Overview](#).

Note 2. PLLMUL[5:0] should be set so that the frequency of PLL output signal is within the range of [section 8.1. Overview](#).

Note 3. The FLL function must be enabled when using USBCLK.

The PLLCCR register sets the operation of the PLL circuit.

Writing to the PLLCCR is prohibited when the PLLCR.PLLSTP bit is 0 (the PLL operates).

#### PLIDIV[1:0] bits (PLL Input Frequency Division Ratio Select)

These bits select the frequency division ratio of the PLL clock source.

#### PLSRCSEL bit (PLL Clock Source Select)

This bit selects the clock source for the PLL.

#### PLLMUL[5:0] bits (PLL Frequency Multiplication Factor Select)

These bits select the frequency multiplication factor of the PLL circuit.

检查各产品工作模式下时钟源的运行状态，不要在SCKSCR中选择要停止的时钟源。当没有发生内部异步中断时，应切换时钟源。有关详细信息，请参阅第10节，低功耗模式。

### 8.2.4 PLLCCR:PLL时钟控制寄存器

Base address: SYSC = 0x4001\_E000

Offset address: 0x028

|               |    |    |             |    |    |    |   |   |   |   |          |   |   |             |   |   |
|---------------|----|----|-------------|----|----|----|---|---|---|---|----------|---|---|-------------|---|---|
| Bit position: | 15 | 14 | 13          | 12 | 11 | 10 | 9 | 8 | 7 | 6 | 5        | 4 | 3 | 2           | 1 | 0 |
| Bit field:    | —  | —  | PLLMUL[5:0] |    |    |    |   | — | — | — | PLSRCSEL | — | — | PLIDIV[1:0] |   |   |
| 重置后的值:        | 0  | 0  | 0           | 1  | 0  | 0  | 1 | 1 | 0 | 0 | 0        | 0 | 0 | 0           | 0 | 0 |

| Bit   | Symbol                    | Function   | R/W |
|-------|---------------------------|--|-----|
| 1:0   | PLIDIV[1:0] <sup>*1</sup> | PLL输入分频比选择<br>0 0: /1<br>0 1: /2<br>1 0: /3<br>其他: 禁止设置。   | R/W |
| 3:2   | —                         | 这些位被读取为0。写入值应为0。   | R/W |
| 4     | PLSRCSEL                  | PLL时钟源选择<br>0: 主时钟振荡器1: H<br>OCO*3   | R/W |
| 7:5   | —                         | 这些位被读取为0。写入值应为0。   | R/W |
| 13:8  | PLLMUL[5:0] <sup>*2</sup> | PLL倍频因子选择<br>0x13: × 10.0 (value after reset)<br>0x14: × 10.5<br>0x15: × 11.0<br>⋮<br>0x1C: × 14.5<br>0x1D: × 15.0<br>0x1E: × 15.5<br>⋮<br>0x3A: × 29.5<br>0x3B: × 30.0<br>其他: 禁止设置。 | R/W |
| 15:14 | —                         | 这些位被读取为0。写入值应为0。   | R/W |

Note: 如果安全属性配置为安全: ●

- 允许安全访问和非安全读取访问
- 忽略非安全写入访问，不会生成TrustZone访问错误。

如果安全属性配置为非安全: ●

- 允许安全和非安全访问。

Note: 在重写此寄存器之前将PRCR.PRC0位设置为1（允许写入）。  
注1.应设置PLIDIV[1:0]，使PLL输入信号的频率在8.1节的范围内。概述。  
注2.PLLMUL[5:0]应设置为使PLL输出信号的频率在8.1节的范围内。概述。  
注3.使用USBCLK时必须使能FLL功能。

PLLCCR寄存器设置PLL电路的操作。

当PLLCR.PLLSTP位为0（PLL工作）时，禁止写入PLLCCR。

#### PLIDIV[1:0]位（PLL输入分频比选择）

这些位选择PLL时钟源的分频比。

#### PLSRCSEL位（PLL时钟源选择）

该位选择PLL的时钟源。

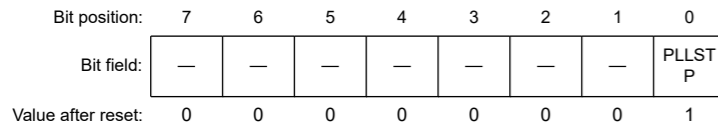
#### PLLMUL[5:0]位（PLL倍频因子选择）

这些位选择PLL电路的倍频因子。

## 8.2.5 PLLCR : PLL Control Register

Base address: SYSC = 0x4001\_E000

Offset address: 0x02A



| Bit | Symbol | Function  | R/W |
|-----|--------|---|-----|
| 0   | PLLSTP | PLL Stop Control<br>0: PLL is operating<br>1: PLL is stopped. | R/W |
| 7:1 | —      | These bits are read as 0. The write value should be 0.        | R/W |

Note: If the security attribution is configured as secure:

- Secure access and Non-secure read access are allowed
- Non-secure write access is ignored, and TrustZone access error is not generated.

If the security attribution is configured as Non-secure:

- Secure and Non-secure access are allowed.

Note: Set the PRCR.PRC0 bit to 1 (write enabled) before rewriting this register.

The PLLCR register controls the operation of the PLL circuit.

**PLLSTP bit (PLL Stop Control)**

This bit runs or stops the PLL circuit.

If the main clock oscillator is to be selected as the clock source for the PLL by the PLLCCR.PLSRCSEL bit, the Main Clock Oscillator Wait Control Register (MOSCWTCR) must be set.

After the PLLSTP bit setting is changed to run the PLL, only use the PLL clock after confirming that the OSCSF.PLLSF bit is set to 1. That is, a fixed time for stabilization is required after starting the PLL operation. A fixed time is also required for oscillation to stop after stopping the PLL operation. Additionally, apply the following limitations when starting and stopping the PLL operation by the PLLSTP bit:

- After stopping the PLL, confirm that the OSCSF.PLLSF bit is 0 before restarting the PLL.
- Confirm that the PLL is operating and that the OSCSF.PLLSF bit is 1 before stopping the PLL.
- Regardless of whether the PLL clock is selected as the system clock, confirm that the OSCSF.PLLSF is set to 1 before executing a WFI instruction to place the MCU in Software Standby or Deep Software Standby mode after operating the PLL.
- When transitioning to Software Standby or Deep Software Standby mode after stopping the PLL, confirm that the OSCSF.PLLSF bit is cleared to 0 before executing a WFI instruction.

Writing 1 to the PLLSTP bit is prohibited when SCKSCR.CKSEL[2:0] = 101 (system clock source = PLL).

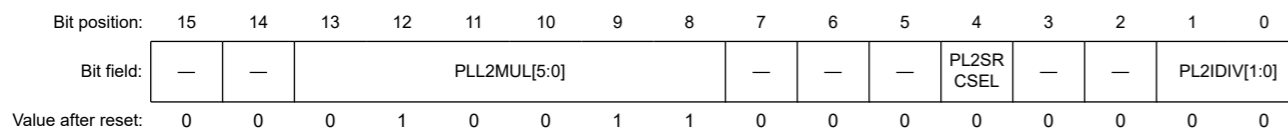
Confirm the following conditions before writing 0 to PLLSTP:

- When PLL source clock = MOSC: MOSCCR.MOSTP = 0 (MOSC is enabled)
- When PLL source clock = HOCO: HOCOCR.HCSTP = 0 (HOCO is enabled).

## 8.2.6 PLL2CCR : PLL2 Clock Control Register

Base address: SYSC = 0x4001\_E000

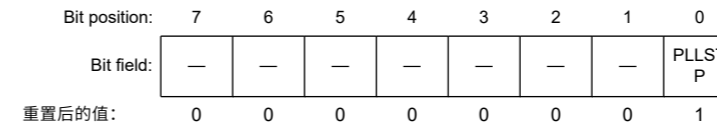
Offset address: 0x048



## 8.2.5 PLLCR:PLL控制寄存器

Base address: SYSC = 0x4001\_E000

Offset address: 0x02A



| Bit | Symbol | Function                           | R/W |
|-----|--------|------------------------------------|-----|
| 0   | PLLSTP | PLL停止控制<br>0: PLL正在运行<br>1: PLL停止。 | R/W |
| 7:1 | —      | 这些位被读取为0。写入值应为0。                   | R/W |

Note: 如果安全属性配置为安全: ●

- 允许安全访问和非安全读取访问
- 忽略非安全写入访问, 不会生成TrustZone访问错误。

如果安全属性配置为非安全: ●

- 允许安全和非安全访问。

Note: 在重写此寄存器之前将PRCR.PRC0位设置为1 (允许写入)。

PLLCR寄存器控制PLL电路的操作。

**PLLSTP位 (PLL停止控制)**

该位运行或停止PLL电路。

如果通过PLLCCR.PLSRCSEL位选择主时钟振荡器作为PLL的时钟源, 则Main必须设置时钟振荡器等待控制寄存器(MOSCWTCR)。

更改PLLSTP位设置以运行PLL后, 只有在确认OSCSF.PLLSF位设置为1后才能使用PLL时钟。即, 启动PLL操作后需要固定的稳定时间。在停止PLL操作后, 振荡停止也需要一段固定的时间。此外, 在通过PLLSTP位启动和停止PLL操作时应用以下限制:

- 停止PLL后, 请确认OSCSF.PLLSF位为0, 然后再重新启动PLL。
- 在停止PLL之前, 确认PLL正在运行并且OSCSF.PLLSF位为1。
- 无论是否选择PLL时钟作为系统时钟, 在执行WFI指令之前, 请确认OSCSF.PLLSF设置为1, 以便在操作PLL后将MCU置于软件待机或深度软件待机模式。
- 在停止PLL后转换到软件待机或深度软件待机模式时, 请确认OSCSF.PLLSF位在执行WFI指令之前被清除为0。

当SCKSCR.CKSEL[2:0]=101 (系统时钟源=PLL) 时, 禁止向PLLSTP位写入1。

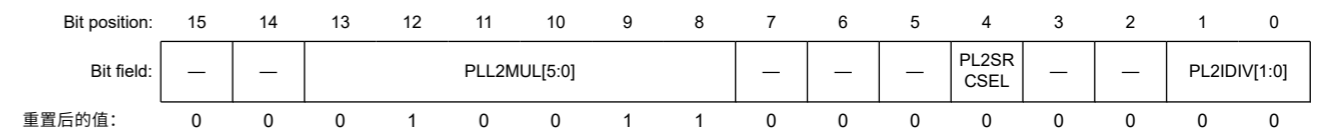
在将0写入PLLSTP之前, 请确认以下条件:

- 当PLL源时钟=MOSC时: MOSCCR.MOSTP=0 (启用MOSC)
- 当PLL源时钟=HOCO时: HOCOCR.HCSTP=0 (启用HOCO)。

## 8.2.6 PLL2CCR:PLL2时钟控制寄存器

Base address: SYSC = 0x4001\_E000

Offset address: 0x048



| Bit   | Symbol                     | Function   | R/W |
|-------|----------------------------|--|-----|
| 1:0   | PL2IDIV[1:0] <sup>*1</sup> | PLL2 Input Frequency Division Ratio Select<br>0 0: /1 (value after reset)<br>0 1: /2<br>1 0: /3<br>Others: Setting prohibited.   | R/W |
| 3:2   | —                          | These bits are read as 0. The write value should be 0.   | R/W |
| 4     | PL2SRCSEL                  | PLL2 Clock Source Select<br>0: Main clock oscillator<br>1: HOCO <sup>*3</sup>  | R/W |
| 7:5   | —                          | These bits are read as 0. The write value should be 0.   | R/W |
| 13:8  | PLL2MUL[5:0] <sup>*2</sup> | PLL2 Frequency Multiplication Factor Select<br>0x13: × 10.0 (value after reset)<br>0x14: × 10.5<br>0x15: × 11.0<br>⋮<br>0x1C: × 14.5<br>0x1D: × 15.0<br>0x1E: × 15.5<br>⋮<br>0x3A: × 29.5<br>0x3B: × 30.0<br>Others: Setting prohibited. | R/W |
| 15:14 | —                          | These bits are read as 0. The write value should be 0.   | R/W |

Note: If the security attribution is configured as secure:

- Secure access and Non-secure read access are allowed
- Non-secure write access is ignored, and TrustZone access error is not generated.

If the security attribution is configured as Non-secure:

- Secure and Non-secure access are allowed.

Note: Set the PRCR.PRC0 bit to 1 (write enabled) before rewriting this register.

Note 1. PL2IDIV[1:0] should be set so that the frequency of PLL2 input signal is within the range of [section 8.1. Overview](#).

Note 2. PLL2MUL[5:0] should be set so that the frequency of PLL2 output signal is within the range of [section 8.1. Overview](#).

Note 3. The FLL function must be enabled when using USBCLK.

The PLL2CCR register sets the operation of the PLL2 circuit.

Writing to the PLL2CCR register is prohibited when the PLL2CR.PLL2STP bit is 0 (the PLL2 operates).

#### PL2IDIV[1:0] bits (PLL2 Input Frequency Division Ratio Select)

These bits select the frequency division ratio of the PLL2 clock source.

#### PL2SRCSEL bit (PLL2 Clock Source Select)

This bit selects the clock source for the PLL2.

#### PLL2MUL[5:0] bits (PLL2 Frequency Multiplication Factor Select)

These bits select the frequency multiplication factor of the PLL2 circuit.

### 8.2.7 PLL2CR : PLL2 Control Register

Base address: SYSC = 0x4001\_E000

Offset address: 0x04A

| Bit position:      | 7 | 6 | 5 | 4 | 3 | 2 | 1 | 0           |
|--------------------|---|---|---|---|---|---|---|-------------|
| Bit field:         | — | — | — | — | — | — | — | PLL2S<br>TP |
| Value after reset: | 0 | 0 | 0 | 0 | 0 | 0 | 0 | 1           |

| Bit   | Symbol                     | Function  | R/W |
|-------|----------------------------|---|-----|
| 1:0   | PL2IDIV[1:0] <sup>*1</sup> | PLL2输入分频比选择<br>0 0: /1 (value after reset)<br>0 1: /2<br>1 0: /3<br>其他: 禁止设置。   | R/W |
| 3:2   | —                          | 这些位被读取为0。写入值应为0。  | R/W |
| 4     | PL2SRCSEL                  | PLL2时钟源选择<br>0: 主时钟振荡器1: H<br>OCO*3   | R/W |
| 7:5   | —                          | 这些位被读取为0。写入值应为0。  | R/W |
| 13:8  | PLL2MUL[5:0] <sup>*2</sup> | PLL2倍频因子选择<br>0x13: × 10.0 (value after reset)<br>0x14: × 10.5<br>0x15: × 11.0<br>⋮<br>0x1C: × 14.5<br>0x1D: × 15.0<br>0x1E: × 15.5<br>⋮<br>0x3A: × 29.5<br>0x3B: × 30.0<br>其他: 禁止设置。 | R/W |
| 15:14 | —                          | 这些位被读取为0。写入值应为0。  | R/W |

Note: 如果安全属性配置为安全: ●

- 允许安全访问和非安全读取访问
- 忽略非安全写入访问, 不会生成TrustZone访问错误。

如果安全属性配置为非安全: ●

- 允许安全和非安全访问。

Note: 在重写此寄存器之前将PRCR.PRC0位设置为1 (允许写入)。

注1.应设置PL2IDIV[1:0], 使PLL2输入信号的频率在8.1节的范围内。概述。

注2.PLL2MUL[5:0]应设置为使PLL2输出信号的频率在8.1节的范围内。概述。

注3.使用USBCLK时必须使能FLL功能。

PLL2CCR寄存器设置PLL2电路的操作。

当PLL2CR.PLL2STP位为0 (PLL2工作) 时, 禁止写入PLL2CCR寄存器。

#### PL2IDIV[1:0]位 (PLL2输入分频比选择)

这些位选择PLL2时钟源的分频比。

#### PL2SRCSEL位 (PLL2时钟源选择)

该位选择PLL2的时钟源。

#### PLL2MUL[5:0]位 (PLL2倍频因子选择)

这些位选择PLL2电路的倍频因子。

### 8.2.7 PLL2CR: PLL2控制寄存器

Base address: SYSC = 0x4001\_E000

Offset address: 0x04A

| Bit position: | 7 | 6 | 5 | 4 | 3 | 2 | 1 | 0           |
|---------------|---|---|---|---|---|---|---|-------------|
| Bit field:    | — | — | — | — | — | — | — | PLL2S<br>TP |
| 重置后的值:        | 0 | 0 | 0 | 0 | 0 | 0 | 0 | 1           |



| Bit | Symbol  | Function   | R/W |
|-----|---------|--|-----|
| 0   | PLL2STP | PLL2 Stop Control<br>0: PLL2 is operating<br>1: PLL2 is stopped. | R/W |
| 7:1 | —       | These bits are read as 0. The write value should be 0.           | R/W |

Note: If the security attribution is configured as secure:

- Secure access and Non-secure read access are allowed
  - Non-secure write access is ignored, and TrustZone access error is not generated.
- If the security attribution is configured as Non-secure:
- Secure and Non-secure access are allowed.

Note: Set the PRCR.PRC0 bit to 1 (write enabled) before rewriting this register.

The PLL2CR register controls the operation of the PLL2 circuit.

### PLL2STP bit (PLL2 Stop Control)

This bit runs or stops the PLL2 circuit.

If the main clock oscillator is to be selected as the clock source for the PLL2 by the PLL2CCR.PL2SRCSEL bit, the Main Clock Oscillator Wait Control Register (MOSCWTCR) must be set.

After the PLL2STP bit setting is changed to run the PLL2, only use the PLL2 clock after confirming that the OSCSF.PLL2SF bit is set to 1. That is, a fixed time for stabilization is required after starting the PLL2 operation. A fixed time is also required for oscillation to stop after stopping the PLL2 operation. Additionally, apply the following limitations when starting and stopping the PLL2 operation by the PLL2STP bit:

- After stopping the PLL2, confirm that the OSCSF.PLL2SF bit is 0 before restarting the PLL2.
- Confirm that the PLL2 is operating and that the OSCSF.PLL2SF bit is 1 before stopping the PLL2.
- Confirm that the OSCSF.PLL2SF bit is set to 1 before executing a WFI instruction to place the MCU in Software Standby or Deep Software Standby mode after operating the PLL2.
- When transitioning to Software Standby or Deep Software Standby mode after stopping the PLL2, confirm that the OSCSF.PLL2SF bit is cleared to 0 before executing a WFI instruction.

Confirm the following conditions before writing 0 to PLL2STP:

- When the PLL2 source clock = MOSC: MOSCCR.MOSTP = 0 (MOSC is enabled)
- When the PLL2 source clock = HOCO: HOCO.CHCSTP = 0 (HOCO is enabled).

### 8.2.8 MOSCCR : Main Clock Oscillator Control Register

Base address: SYSC = 0x4001\_E000

Offset address: 0x032

| Bit position:      | 7 | 6 | 5 | 4 | 3 | 2 | 1 | 0     |
|--------------------|---|---|---|---|---|---|---|-------|
| Bit field:         | — | — | — | — | — | — | — | MOSTP |
| Value after reset: | 0 | 0 | 0 | 0 | 0 | 0 | 0 | 1     |

| Bit | Symbol | Function  | R/W |
|-----|--------|---|-----|
| 0   | MOSTP  | Main Clock Oscillator Stop<br>0: Operate the main clock oscillator*1<br>1: Stop the main clock oscillator | R/W |
| 7:1 | —      | These bits are read as 0. The write value should be 0.  | R/W |

Note: Set the PRCR.PRC0 bit to 1 (write enabled) before rewriting this register.

Note: If the security attribution is configured as secure:

- Secure access and Non-secure read access are allowed
  - Non-secure write access is ignored, and TrustZone access error is not generated.
- If the security attribution is configured as Non-secure:
- Secure and Non-secure access are allowed.

Note 1. MOMCR register must be set before setting MOSTP to 0.

| Bit | Symbol  | Function                             | R/W |
|-----|---------|--------------------------------------|-----|
| 0   | PLL2STP | PLL2停止控制<br>0: PLL2正在运行1:<br>PLL2停止。 | R/W |
| 7:1 | —       | 这些位被读取为0。写入值应为0。                     | R/W |

Note: 如果安全属性配置为安全: ●

- 允许安全访问和非安全读取访问
  - 忽略非安全写入访问, 不会生成TrustZone访问错误。
- 如果安全属性配置为非安全: ●
- 允许安全和非安全访问。

Note: 在重写此寄存器之前将PRCR.PRC0位设置为1 (允许写入)。

PLL2CR寄存器控制PLL2电路的操作。

### PLL2STP位 (PLL2停止控制)

该位运行或停止PLL2电路。

如果要通过PLL2CCR.PL2SRCSEL位选择主时钟振荡器作为PLL2的时钟源, 则Main必须设置时钟振荡器等待控制寄存器(MOSCWTCR)。

更改PLL2STP位设置运行PLL2后, 确认

OSCSF.PLL2SF位设置为1。也就是说, 在启动PLL2操作后需要一个固定的稳定时间。在停止PLL2操作后, 振荡停止也需要一个固定的时间。此外, 在通过PLL2STP位启动和停止PLL2操作时应用以下限制:

- 停止PLL2后, 确认OSCSF.PLL2SF位为0, 再重启PLL2。
- 在停止PLL2之前, 确认PLL2正在运行并且OSCSF.PLL2SF位为1。
- 在操作PLL2后, 在执行WFI指令以将MCU置于软件待机或深度软件待机模式之前, 确认OSCSF.PLL2SF位设置为1。
- 在停止PLL2后转换到软件待机或深度软件待机模式时, 请确认OSCSF.PLL2SF位在执行WFI指令之前被清除为0。

在将0写入PLL2STP之前, 请确认以下条件:

- 当PLL2源时钟=MOSC时: MOSCCR.MOSTP=0 (启用MOSC)
- 当PLL2源时钟=HOCO时: HOCO.CHCSTP=0 (启用HOCO)。

### 8.2.8 MOSCCR:主时钟振荡器控制寄存器

Base address: SYSC = 0x4001\_E000

Offset address: 0x032

| Bit position: | 7 | 6 | 5 | 4 | 3 | 2 | 1 | 0     |
|---------------|---|---|---|---|---|---|---|-------|
| Bit field:    | — | — | — | — | — | — | — | MOSTP |
| 重置后的值:        | 0 | 0 | 0 | 0 | 0 | 0 | 0 | 1     |

| Bit | Symbol | Function                                | R/W |
|-----|--------|---|-----|
| 0   | MOSTP  | 主时钟振荡器停止<br>0:运行主时钟振荡器*1<br>1: 停止主时钟振荡器 | R/W |
| 7:1 | —      | 这些位被读取为0。写入值应为0。                        | R/W |

Note: 在重写此寄存器之前将PRCR.PRC0位设置为1 (允许写入)。

Note: 如果安全属性配置为安全: ●

- 允许安全访问和非安全读取访问
  - 忽略非安全写入访问, 不会生成TrustZone访问错误。
- 如果安全属性配置为非安全: ●
- 允许安全和非安全访问。

注1.在将MOSTP设置为0之前, 必须设置MOMCR寄存器。

The MOSCCR register controls the main clock oscillator.

### MOSTP bit (Main Clock Oscillator Stop)

The MOSTP bit starts or stops the main clock oscillator.

When changing the value of the MOSTP bit, execute subsequent instructions only after reading the bit to check that the value is updated.

When using the main clock, the Main Clock Oscillator Mode Oscillation Control Register (MOMCR) and the Main Clock Oscillator Wait Control Register (MOSCWTCR) must be set before setting MOSTP to 0. After setting the MOSTP bit to 0, confirm that the OSCSF.MOSCSF bit is set to 1 before using the main clock oscillator.

A fixed stabilization wait time is required after setting the main clock oscillator to start operation. A fixed wait time is also required for oscillation to stop after stopping the main clock oscillator.

The following restrictions apply when starting and stopping operation:

- After stopping the main clock oscillator, confirm that the OSCSF.MOSCSF bit is 0 before restarting the main clock oscillator
- Confirm that the main clock oscillator operates and that the OSCSF.MOSCSF bit is 1 before stopping the main clock oscillator
- Regardless of whether the main clock oscillator is selected as the system clock, confirm that the OSCSF.MOSCSF bit is set to 1 before executing a WFI instruction to place the MCU in Software Standby or Deep Software Standby mode.
- When a transition to Software Standby or Deep Software Standby mode is to follow the setting to stop the main clock oscillator, confirm that the OSCSF.MOSCSF bit is set to 0 before executing the WFI instruction.

Writing 1 to MOSTP is prohibited under the following condition:

- SCKSCR.CKSEL[2:0] = 011b (system clock source = MOSC).
- PLLCCR.PLSRCSEL = 0 (PLL source clock = MOSC) and SCKSCR.CKSEL[2:0] = 101b (system clock source = PLL)
- PLLCCR.PLSRCSEL = 0 (PLL source clock = MOSC) and PLLCR.PLLSTP = 0 (PLL is operating)
- PLL2CCR.PL2SRCSEL = 0 (PLL2 source clock = MOSC) and PLL2CR.PLL2STP = 0 (PLL2 is operating)

### 8.2.9 SOSCCR : Sub-Clock Oscillator Control Register

Base address: SYSC = 0x4001\_E000

Offset address: 0x480

|                    |   |   |   |   |   |   |   |       |
|--------------------|---|---|---|---|---|---|---|-------|
| Bit position:      | 7 | 6 | 5 | 4 | 3 | 2 | 1 | 0     |
| Bit field:         | — | — | — | — | — | — | — | SOSTP |
| Value after reset: | 0 | 0 | 0 | 0 | 0 | 0 | 0 | 0     |

| Bit | Symbol | Function   | R/W |
|-----|--------|--|-----|
| 0   | SOSTP  | Sub Clock Oscillator Stop<br>0: Operate the sub-clock oscillator*1<br>1: Stop the sub-clock oscillator | R/W |
| 7:1 | —      | These bits are read as 0. The write value should be 0.   | R/W |

Note: Set the PRCR.PRC0 bit to 1 (write enabled) before rewriting this register.

Note: If the security attribution is configured as secure:

- Secure access and Non-secure read access are allowed
- Non-secure write access is ignored, and TrustZone access error is not generated.

If the security attribution is configured as Non-secure:

- Secure and Non-secure access are allowed.

Note 1. The SOMCR register must be set before setting SOSTP to 0.

The SOSCCR register controls the sub-clock oscillator.

MOSCCR寄存器控制主时钟振荡器。

### MOSTP位（主时钟振荡器停止）

MOSTP位启动或停止主时钟振荡器。

更改MOSTP位的值时，仅在读取该位后执行后续指令以检查该值是否已更新。

使用主时钟时，必须先设置主时钟振荡器模式振荡控制寄存器(MOMCR)和主时钟振荡器等待控制寄存器(MOSCWTCR)，然后再将MOSTP设置为0。将MOSTP位设置为0后，确认OSCSF。MOSCSF位在使用主时钟振荡器之前设置为1。

设置主时钟振荡器开始工作后，需要一个固定的稳定等待时间。停止主时钟振荡器后，振荡停止也需要一个固定的等待时间。

启动和停止操作时适用以下限制：

- 停止主时钟振荡器后，请确认OSCSF.MOSCSF位为0，然后再重新启动主时钟振荡器
- 在停止主时钟振荡器之前，确认主时钟振荡器工作并且OSCSF.MOSCSF位为1
- 无论是否选择主时钟振荡器作为系统时钟，在执行WFI指令之前确认OSCSF.MOSCSF位设置为1，将MCU置于软件待机或深度软件待机模式。
- 当转换到软件待机或深度软件待机模式是按照设置停止主时钟振荡器时，在执行WFI指令之前确认OSCSF.MOSCSF位设置为0。

在以下情况下禁止向MOSTP写入1：

- SCKSCR.CKSEL[2:0]=011b（系统时钟源=MOSC）。
- PLLCCR.PLSRCSEL=0（PLL源时钟=MOSC）和SCKSCR.CKSEL[2:0]=101b（系统时钟源=PLL）
- PLLCCR.PLSRCSEL=0（PLL源时钟=MOSC）和PLLCR.PLLSTP=0（PLL正在运行）
- PLL2CCR.PL2SRCSEL=0（PLL2源时钟=MOSC）和PLL2CR.PLL2STP=0（PLL2正在运行）

### 8.2.9 SOSCCR：副时钟振荡器控制寄存器

Base address: SYSC = 0x4001\_E000

Offset address: 0x480

|               |   |   |   |   |   |   |   |       |
|---------------|---|---|---|---|---|---|---|-------|
| Bit position: | 7 | 6 | 5 | 4 | 3 | 2 | 1 | 0     |
| Bit field:    | — | — | — | — | — | — | — | SOSTP |
| 重置后的值:        | 0 | 0 | 0 | 0 | 0 | 0 | 0 | 0     |

| Bit | Symbol | Function                                 | R/W |
|-----|--------|--|-----|
| 0   | SOSTP  | 副时钟振荡器停止<br>0: 运行副时钟振荡器*1<br>1: 停止副时钟振荡器 | R/W |
| 7:1 | —      | 这些位被读取为0。写入值应为0。                         | R/W |

Note: 在重写此寄存器之前将PRCR.PRC0位设置为1（允许写入）。

Note: 如果安全属性配置为安全：●

- 允许安全访问和非安全读取访问
- 忽略非安全写入访问，不会生成TrustZone访问错误。

如果安全属性配置为非安全：●

- 允许安全和非安全访问。

注1.在将SOSTP设置为0之前，必须设置SOMCR寄存器。

SOSCCR寄存器控制副时钟振荡器。



**SOSTP bit (Sub Clock Oscillator Stop)**

The SOSTP bit starts or stops the sub-clock oscillator. When changing the value of the SOSTP bit, only execute subsequent instructions after reading the bit to check that the value is updated. Use the SOSTP bit when using the sub-clock oscillator as the source for a peripheral module, for example the RTC. When using the sub-clock oscillator, set the Sub-Clock Oscillator Mode Control Register (SOMCR) before setting SOSTP to 0.

The following restrictions apply when starting and stopping the operation:

- After stopping the sub-clock oscillator, allow a stop interval of at least 5 SOSC clock cycles before restarting it
- After setting the SOSTP bit to 0, use the sub-clock only after the sub-clock oscillation stabilization time ( $t_{SUBOSCWT}$ ) has elapsed.
- Regardless of whether the sub-clock oscillator is selected as the system clock, confirm that the sub-clock oscillation is stable before executing a WFI instruction to place the MCU in Software Standby or Deep Software Standby mode
- When a transition to Software Standby or Deep Software Standby mode is to follow the setting to stop the sub-clock oscillator, wait for at least 3 SOSC clock cycles before executing the WFI instruction.

Writing 1 to SOSTP is prohibited under the following condition:

- SCKSCR.CKSEL[2:0] = 100b (system clock source = SOSC).

**8.2.10 LOCOCR : Low-Speed On-Chip Oscillator Control Register**

Base address: SYSC = 0x4001\_E000

Offset address: 0x490

|                    |   |   |   |   |   |   |   |       |
|--------------------|---|---|---|---|---|---|---|-------|
| Bit position:      | 7 | 6 | 5 | 4 | 3 | 2 | 1 | 0     |
| Bit field:         | — | — | — | — | — | — | — | LCSTP |
| Value after reset: | 0 | 0 | 0 | 0 | 0 | 0 | 0 | 0     |

| Bit | Symbol | Function   | R/W |
|-----|--------|--|-----|
| 0   | LCSTP  | LOCO Stop<br>0: Operate the LOCO clock<br>1: Stop the LOCO clock | R/W |
| 7:1 | —      | These bits are read as 0. The write value should be 0.           | R/W |

Note: Set the PRCR.PRC0 bit to 1 (write enabled) before rewriting this register.

Note: If the security attribution is configured as secure:

- Secure access and Non-secure read access are allowed
  - Non-secure write access is ignored, and TrustZone access error is not generated.
- If the security attribution is configured as Non-secure:
- Secure and Non-secure access are allowed.

The LOCOCR register controls the LOCO clock.

**LCSTP bit (LOCO Stop)**

The LCSTP bit starts or stops the LOCO clock.

After setting the LCSTP bit to 0 to start the LOCO clock, only use the clock after the LOCO clock-oscillation stabilization wait time ( $t_{LOCOWT}$ ) elapses. A fixed stabilization wait time is required after setting the LOCO clock to start operation. A fixed wait time is also required after setting the LOCO clock to stop.

The following restrictions apply when starting and stopping operation:

- After stopping the LOCO clock, allow a stop interval of at least 5 LOCO clock cycles before restarting it
- Confirm that LOCO oscillation is stable before stopping the LOCO clock
- Regardless of whether the LOCO is selected as the system clock, confirm that LOCO oscillation is stable before executing a WFI instruction to place the MCU in Software Standby or Deep Software Standby mode
- When a transition to Software Standby or Deep Software Standby mode is to follow the setting to stop the LOCO clock, wait for at least 3 LOCO cycles before executing the WFI instruction.

**SONTP位 (副时钟振荡器停止)**

SONTP位启动或停止副时钟振荡器。更改SONTP位的值时，仅在读取该位后执行后续指令以检查该值是否已更新。当使用副时钟振荡器作为外围模块（例如RTC）的源时，使用SONTP位。使用副时钟振荡器时，请先设置副时钟振荡器模式控制寄存器(SOMCR)，然后再将SOSTP设置为0。

启动和停止操作时适用以下限制：

- 子时钟振荡器停止后，在重新启动之前允许至少5个SOSC时钟周期的停止间隔
- 将SOSTP位设置为0后，仅在副时钟振荡稳定时间( $t_{SUBOSCWT}$ )过去后使用副时钟。
- 无论是否选择副时钟振荡器作为系统时钟，在执行WFI指令之前确认副时钟振荡稳定，将MCU置于软件待机或深度软件待机模式
- 当根据设置转换到软件待机或深度软件待机模式以停止副时钟振荡器时，请等待至少3个SOSC时钟周期，然后再执行WFI指令。

在以下情况下禁止向SONTP写入1：

- SCKSCR.CKSEL[2:0]=100b（系统时钟源=SOSC）。

**8.2.10 LOCOCR：低速片上振荡器控制寄存器**

Base address: SYSC = 0x4001\_E000

Offset address: 0x490

|               |   |   |   |   |   |   |   |       |
|---------------|---|---|---|---|---|---|---|-------|
| Bit position: | 7 | 6 | 5 | 4 | 3 | 2 | 1 | 0     |
| Bit field:    | — | — | — | — | — | — | — | LCSTP |
| 重置后的值:        | 0 | 0 | 0 | 0 | 0 | 0 | 0 | 0     |

| Bit | Symbol | Function                      | R/W |
|-----|--------|-------------------------------|-----|
| 0   | LCSTP  | 机车站<br>0: 运行LOCO时钟1: 停止LOCO时钟 | R/W |
| 7:1 | —      | 这些位被读取为0。写入值应为0。              | R/W |

Note: 在重写此寄存器之前将PRCR.PRC0位设置为1（允许写入）。

Note: 如果安全属性配置为安全：●

- 允许安全访问和非安全读取访问
  - 忽略非安全写入访问，不会生成TrustZone访问错误。
- 如果安全属性配置为非安全：●
- 允许安全和非安全访问。

LOCOCR寄存器控制LOCO时钟。

**LCSTP bit (LOCO Stop)**

LCSTP位启动或停止LOCO时钟。

将LCSTP位设置为0以启动LOCO时钟后，仅在LOCO时钟振荡稳定等待时间( $t_{LOCOWT}$ )过去后使用时钟。设置LOCO时钟开始运行后，需要一个固定的稳定等待时间。将LOCO时钟设置为停止后，还需要一个固定的等待时间。

启动和停止操作时适用以下限制：

- 停止LOCO时钟后，在重新启动之前允许至少5个LOCO时钟周期的停止间隔
- 在停止LOCO时钟之前确认LOCO振荡稳定
- 无论是否选择LOCO作为系统时钟，在执行WFI指令将MCU置于软件待机或深度软件待机模式之前，请确认LOCO振荡稳定
- 当转换到软件待机或深度软件待机模式是按照设置停止LOCO时钟时，在执行WFI指令之前至少等待3个LOCO周期。

Writing 1 to LCSTP is prohibited under the following condition:

- SCKSCR.CKSEL[2:0] = 010b (system clock source = LOCO).

Because the LOCO clock measures the wait time for other oscillators, it continues to oscillate while measuring this time, regardless of the setting in LOCOCR.LCSTP. As a result, the LOCO clock might be unintentionally supplied even when the LCSTP is set to stop.

### 8.2.11 HOCOCCR : High-Speed On-Chip Oscillator Control Register

Base address: SYSC = 0x4001\_E000

Offset address: 0x036

|                    |   |   |   |   |   |   |   |                   |
|--------------------|---|---|---|---|---|---|---|-------------------|
| Bit position:      | 7 | 6 | 5 | 4 | 3 | 2 | 1 | 0                 |
| Bit field:         | — | — | — | — | — | — | — | HCSTP             |
| Value after reset: | 0 | 0 | 0 | 0 | 0 | 0 | 0 | 0/1 <sup>11</sup> |

| Bit | Symbol | Function  | R/W |
|-----|--------|---|-----|
| 0   | HCSTP  | HOCO Stop<br>0: Operate the HOCO clock *2<br>1: Stop the HOCO clock | R/W |
| 7:1 | —      | These bits are read as 0. The write value should be 0.              | R/W |

Note: Set the PRCR.PRC0 bit to 1 (write enabled) before rewriting this register.

Note: If the security attribution is configured as secure:

- Secure access and Non-secure read access are allowed
- Non-secure write access is ignored, and TrustZone access error is not generated.

If the security attribution is configured as Non-secure:

- Secure and Non-secure access are allowed.

Note 1. The HCSTP bit value after a reset is 0 when the OFS1.HOCOEN bit is 0. It is 1 when the OFS1.HOCOEN bit is 1.

Note 2. If you are using the HOCO (HCSTP = 0), set the OFS1.HOCOFREQ[1:0] bit to an optimum value.

The HOCOCCR register controls the HOCO clock.

#### HCSTP bit (HOCO Stop)

The HCSTP bit starts or stops the HOCO clock.

After setting the HCSTP bit to 0 to start the HOCO clock, confirm that the OSCSF.HOCOSF is set to 1 before using the clock. When OFS1.HOCOEN is set to 0, confirm that OSCSF.HOCOSF is also set to 1 before using the HOCO clock. A fixed stabilization wait time is required after setting the HOCO clock to start operation. A fixed wait time is also required after setting the HOCO clock to stop.

The following limitations apply when starting and stopping operation:

- After stopping the HOCO clock, confirm that the OSCSF.HOCOSF is 0 before restarting the HOCO clock.
- Confirm that the HOCO clock operates and that the OSCSF.HOCOSF is 1 before stopping the HOCO clock.
- Regardless of whether the HOCO clock is selected as the system clock, confirm that the OSCSF.HOCOSF is set to 1 before executing a WFI instruction to place the MCU in Software Standby or Deep Software Standby mode after setting HOCO operation with the HCSTP bit.
- When a transition to Software Standby or Deep Software Standby mode is to follow the setting of the HOCO clock to stop, confirm that the OSCSF.HOCOSF is set to 0 after setting the HOCO clock and before executing the WFI instruction.

Writing 1 to HCSTP is prohibited under the following conditions:

- SCKSCR.CKSEL[2:0] = 000b (system clock source = HOCO).
- PLLCCR.PLSRCSEL = 1 (PLL source clock = HOCO) and SCKSCR.CKSEL[2:0] = 101b (system clock source = PLL)
- PLLCCR.PLSRCSEL = 1 (PLL source clock = HOCO) and PLLCR.PLLSTP = 0 (PLL is operating)

在以下情况下禁止向LCSTP写入1:

- SCKSCR.CKSEL[2:0]=010b (系统时钟源=LOCO)。

因为LOCO时钟测量其他振荡器的等待时间,所以无论LOCOCR.LCSTP中的设置如何,它都会在测量该时间时继续振荡。因此,即使LCSTP设置为停止,也可能无意中提供LOCO时钟。

### 8.2.11 HOCOCCR:高速片上振荡器控制寄存器

Base address: SYSC = 0x4001\_E000

Offset address: 0x036

|               |   |   |   |   |   |   |   |                   |
|---------------|---|---|---|---|---|---|---|-------------------|
| Bit position: | 7 | 6 | 5 | 4 | 3 | 2 | 1 | 0                 |
| Bit field:    | — | — | — | — | — | — | — | HCSTP             |
| 重置后的值:        | 0 | 0 | 0 | 0 | 0 | 0 | 0 | 0/1 <sup>11</sup> |

| Bit | Symbol | Function                                  | R/W |
|-----|--------|---|-----|
| 0   | HCSTP  | HOCO Stop<br>0: 运行HOCO时钟*2<br>1: 停止HOCO时钟 | R/W |
| 7:1 | —      | 这些位被读取为0。写入值应为0。                          | R/W |

Note: 在重写此寄存器之前将PRCR.PRC0位设置为1 (允许写入)。

Note: 如果安全属性配置为安全: ●

- 允许安全访问和非安全读取访问
- 忽略非安全写入访问,不会生成TrustZone访问错误。

如果安全属性配置为非安全: ●

- 允许安全和非安全访问。

注1.OFS1.HOCOEN位为0时复位后的HCSTP位值为0。OFS1.HOCOEN位为1时为1。

注2.如果您使用HOCO(HCSTP=0),请将OFS1.HOCOFREQ[1:0]位设置为最佳值。

HOCOCCR寄存器控制HOCO时钟。

#### HCSTP bit (HOCO Stop)

HCSTP位启动或停止HOCO时钟。

将HCSTP位设置为0以启动HOCO时钟后,在使用时钟之前确认OSCSF.HOCOSF设置为1。当OFS1.HOCOEN设置为0时,请在使用HOCO时钟之前确认OSCSF.HOCOSF也设置为1。设置HOCO时钟开始运行后,需要一个固定的稳定等待时间。将HOCO时钟设置为停止后,还需要一个固定的等待时间。

启动和停止操作时适用以下限制:

- 停止HOCO时钟后,确认OSCSF.HOCOSF为0,再重新启动HOCO时钟。
- 在停止HOCO时钟之前,请确认HOCO时钟运行并且OSCSF.HOCOSF为1。
- 无论是否选择HOCO时钟作为系统时钟,确认OSCSF.HOCOSF设置为1  
在使用HCSTP位设置HOCO操作后,执行WFI指令以将MCU置于软件待机或深度软件待机模式之前。
- 当转换到软件待机或深度软件待机模式是跟随HOCO时钟的设置停止时,在设置HOCO时钟之后和执行WFI指令之前确认OSCSF.HOCOSF设置为0。

在以下情况下禁止向HCSTP写入1:

- SCKSCR.CKSEL[2:0]=000b (系统时钟源=HOCO)。
- PLLCCR.PLSRCSEL=1 (PLL源时钟=HOCO) 和SCKSCR.CKSEL[2:0]=101b (系统时钟源=PLL)
- PLLCCR.PLSRCSEL=1 (PLL源时钟=HOCO) 和PLLCR.PLLSTP=0 (PLL正在运行)

- PLL2CCR.PLL2SRCSEL = 1 (PLL2 source clock = HOCO) and PLL2CR.PLL2STP = 0 (PLL2 is operating)

### 8.2.12 MOCOCCR : Middle-Speed On-Chip Oscillator Control Register

Base address: SYSC = 0x4001\_E000

Offset address: 0x038

|                    |   |   |   |   |   |   |   |       |
|--------------------|---|---|---|---|---|---|---|-------|
| Bit position:      | 7 | 6 | 5 | 4 | 3 | 2 | 1 | 0     |
| Bit field:         | — | — | — | — | — | — | — | MCSTP |
| Value after reset: | 0 | 0 | 0 | 0 | 0 | 0 | 0 | 0     |

| Bit | Symbol | Function  | R/W |
|-----|--------|---|-----|
| 0   | MCSTP  | MOCO Stop<br>0: MOCO clock is operating<br>1: MOCO clock is stopped | R/W |
| 7:1 | —      | These bits are read as 0. The write value should be 0.              | R/W |

Note: Set the PRCR.PRC0 bit to 1 (write enabled) before rewriting this register.

Note: If the security attribution is configured as secure:

- Secure access and Non-secure read access are allowed
- Non-secure write access is ignored, and TrustZone access error is not generated.

If the security attribution is configured as Non-secure:

- Secure and Non-secure access are allowed.

The MOCOCCR register controls the MOCO clock.

#### MCSTP bit (MOCO Stop)

The MCSTP bit starts or stops the MOCO clock.

After setting MCSTP to 0, use the MOCO clock only after the MOCO clock oscillation stabilization time ( $t_{MOCOWT}$ ) elapses. A fixed stabilization wait time is required after setting the MOCO clock to start operation. A fixed wait time is also required for oscillation to stop after setting the MOCO clock to stop operation.

The following restrictions apply when starting and stopping the oscillator:

- After stopping the MOCO clock, allow a stop interval of at least 5 MOCO clock cycles before restarting it
- Confirm that MOCO clock oscillation is stable before stopping the MOCO clock
- Regardless of whether the MOCO clock is selected as the system clock, confirm that MOCO clock oscillation is stable before executing a WFI instruction to place the MCU in Software Standby or Deep Software Standby mode
- When a transition to Software Standby or Deep Software Standby mode is to follow the setting to stop the MOCO clock, wait for at least 3 MOCO clock cycles before executing the WFI instruction.

Writing 1 to MCSTP is prohibited under the following condition:

- SCKSCR.CKSEL[2:0] = 001b (system clock source = MOCO).

Writing 1 to the MCSTP bit (stopping the MOCO) is prohibited if oscillation stop detection is enabled in the Oscillation Stop Detection Control Register (OSTDCR.OSTDE).

### 8.2.13 FLLCR1 : FLL Control Register1

Base address: SYSC = 0x4001\_E000

Offset address: 0x039

|                    |   |   |   |   |   |   |   |       |
|--------------------|---|---|---|---|---|---|---|-------|
| Bit position:      | 7 | 6 | 5 | 4 | 3 | 2 | 1 | 0     |
| Bit field:         | — | — | — | — | — | — | — | FLLCN |
| Value after reset: | 0 | 0 | 0 | 0 | 0 | 0 | 0 | 0     |

- PLL2CCR.PLL2SRCSEL=1 (PLL2源时钟=HOCO) 和PLL2CR.PLL2STP=0 (PLL2正在运行)

### 8.2.12 MOCOCCR:中速片上振荡器控制寄存器

Base address: SYSC = 0x4001\_E000

Offset address: 0x038

|               |   |   |   |   |   |   |   |       |
|---------------|---|---|---|---|---|---|---|-------|
| Bit position: | 7 | 6 | 5 | 4 | 3 | 2 | 1 | 0     |
| Bit field:    | — | — | — | — | — | — | — | MCSTP |
| 重置后的值:        | 0 | 0 | 0 | 0 | 0 | 0 | 0 | 0     |

| Bit | Symbol | Function                                | R/W |
|-----|--------|---|-----|
| 0   | MCSTP  | MOCO Stop<br>0: MOCO时钟运行<br>1: MOCO时钟停止 | R/W |
| 7:1 | —      | 这些位被读取为0。写入值应为0。                        | R/W |

Note: 在重写此寄存器之前将PRCR.PRC0位设置为1 (允许写入)。

Note: 如果安全属性配置为安全:

- 允许安全访问和非安全读取访问
- 忽略非安全写入访问, 不会生成TrustZone访问错误。

如果安全属性配置为非安全:

- 允许安全和非安全访问。

MOCOCCR寄存器控制MOCO时钟。

#### MCSTP bit (MOCO Stop)

MCSTP位启动或停止MOCO时钟。

将MCSTP设置为0后, 仅在MOCO时钟振荡稳定时间( $t_{MOCOWT}$ )过去后使用MOCO时钟。设置MOCO时钟开始运行后, 需要一个固定的稳定等待时间。在将MOCO时钟设置为停止操作后, 振荡停止也需要一个固定的等待时间。

启动和停止振荡器时适用以下限制:

- 停止MOCO时钟后, 在重新启动之前允许至少5个MOCO时钟周期的停止间隔
- 确认MOCO时钟振荡稳定后再停止MOCO时钟
- 无论是否选择MOCO时钟作为系统时钟, 在执行WFI指令将MCU置于软件待机或深度软件待机模式之前, 请确认MOCO时钟振荡稳定
- 当按照设置转换到软件待机或深度软件待机模式以停止MOCO时钟时, 请等待至少3个MOCO时钟周期, 然后再执行WFI指令。

在以下情况下禁止向MCSTP写入1:

- SCKSCR.CKSEL[2:0]=001b (系统时钟源=MOCO)。

如果在Oscillation中使能了振荡停止检测, 则禁止向MCSTP位写入1 (停止MOCO) 停止检测控制寄存器(OSTDCR.OSTDE)。

### 8.2.13 FLLCR1 : FLL Control Register1

Base address: SYSC = 0x4001\_E000

Offset address: 0x039

|               |   |   |   |   |   |   |   |       |
|---------------|---|---|---|---|---|---|---|-------|
| Bit position: | 7 | 6 | 5 | 4 | 3 | 2 | 1 | 0     |
| Bit field:    | — | — | — | — | — | — | — | FLLCN |
| 重置后的值:        | 0 | 0 | 0 | 0 | 0 | 0 | 0 | 0     |



| Bit | Symbol | Function   | R/W |
|-----|--------|--|-----|
| 0   | FLLCN  | FLL Enable<br>0: FLL function is disabled<br>1: FLL function is enabled. | R/W |
| 7:1 | —      | These bits are read as 0. The write value should be 0.                   | R/W |

Note: If the security attribution is configured as secure:

- Secure access and Non-secure read access are allowed
- Non-secure write access is ignored, and TrustZone access error is not generated.

If the security attribution is configured as Non-secure:

- Secure and Non-secure access are allowed.

Note: HOCO must be stopped (HOCO.CR.HCSTP = 1) before FLLCN.FLLCN is modified.

Note: SOSC must be operating with stabilization while FLL is enabled (FLLCN.FLLCN = 1).

Note: Set the PRCR.PRC0 bit to 1 (write enabled) before rewriting this register.

The FLLCN register controls the FLL function of the HOCO.

#### FLLCN bit (FLL Enable)

This bit enables or disables the FLL function of the HOCO.

If FLL is enabled, the frequency accuracy is guaranteed after FLL is stabilized. The FLL stabilization can be checked by the CAC frequency measurement, but it must be executed after HOCO stabilization.

In addition, you must disable FLL by setting the FLLCN bit to 0 before transitioning to Software Standby mode.

Table 8.4 show an example flow of the FLL setting for each case.

Table 8.4 FLL setting flow

| Step   | Operation  |
|--|--|
| After reset release/deep software standby cancellation | 1 Start (After reset release / deep software standby cancellation)   |
|  | 2 FLL setting (FLLCN.FLLCNTL)  |
|  | 3 Enable FLL (FLLCN.FLLCN = 1)<br>Note: SOSC must be running with the oscillation stabilization.   |
|  | 4 Enable HOCO (HOCO.CR.HCSTP = 0)  |
|  | 5 Wait for the FLL stabilization ( $t_{FLLWT}$ )   |
|  | 6 Check the HOCO stabilization (OSCSF.HOCOSF = 1)  |
|  | 7 End (HOCO can be used.)  |
| Software standby transition/cancellation               | 1 Start (FLL is being used.)   |
|  | 2 Stop HOCO (HOCO.CR.HCSTP = 1)<br>Note: If HOCO is used as the system clock or the PLL reference clock, these clock source must be changed to another clock before HOCO is stopped. |
|  | 3 Disable FLL (FLLCN.FLLCN = 0)  |
|  | 4 WFI instruction  |
|  | 5 Software standby mode  |
|  | 6 Software standby cancellation  |
|  | 7 Enable FLL (FLLCN.FLLCN = 1)   |
|  | 8 Enable HOCO (HOCO.CR.HCSTP = 0)  |
|  | 9 Wait for the FLL stabilization ( $t_{FLLWT}$ )   |
|  | 10 Check the HOCO stabilization (OSCSF.HOCOSF = 1)   |
|  | 11 End (HOCO can be used.)   |

| Bit | Symbol | Function                                | R/W |
|-----|--------|---|-----|
| 0   | FLLCN  | FLL Enable<br>0: 禁用FLL功能<br>1: 启用FLL功能。 | R/W |
| 7:1 | —      | 这些位被读取为0。写入值应为0。                        | R/W |

Note: 如果安全属性配置为安全: ●

允许安全访问和非安全读取访问

- 忽略非安全写入访问, 不会生成TrustZone访问错误。

如果安全属性配置为非安全: ●

允许安全和非安全访问。

Note: 在修改FLLCN.FLLCN之前, 必须停止HOCO (HOCO.CR.HCSTP=1)。

Note: SOSC必须在启用FLL时稳定运行(FLLCN.FLLCN=1)。

Note: 在重写此寄存器之前将PRCR.PRC0位设置为1 (允许写入)。

FLLCN寄存器控制HOCO的FLL功能。

#### FLLCN bit (FLL Enable)

该位启用或禁用HOCO的FLL功能。

如果启用FLL, 则在FLL稳定后, 频率精度得到保证。FLL稳定性可以通过CAC频率测量, 但必须在HOCO稳定后执行。

此外, 在转换到软件待机模式之前, 您必须通过将FLLCN位设置为0来禁用FLL。

表8.4显示了每种情况下FLL设置的示例流程。

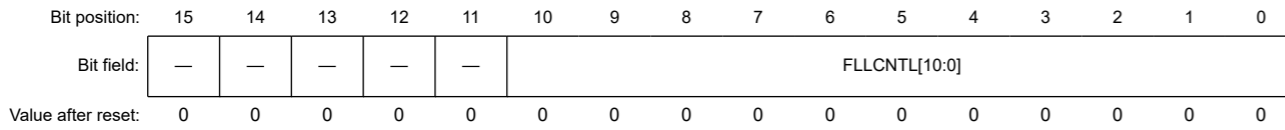
Table 8.4 FLL设置流程

| Step          | Operation   |
|---------------|---|
| 复位后释放深度软件待机取消 | 1 启动 (复位后释放深度软件待机取消)  |
|               | 2 FLL setting (FLLCN.FLLCNTL)   |
|               | 3 Enable FLL (FLLCN.FLLCN = 1)<br>Note: SOSC必须在振荡稳定的情况下运行。                                |
|               | 4 Enable HOCO (HOCO.CR.HCSTP = 0)   |
|               | 5 等待FLL稳定( $t_{FLLWT}$ )  |
|               | 6 检查HOCO稳定性(OSCSF.HOCOSF=1)   |
|               | 7 结束 (可以使用HOCO。)  |
| 软件待机转换取消      | 1 开始 (正在使用FLL。)   |
|               | 2 Stop HOCO (HOCO.CR.HCSTP = 1)<br>Note: 如果HOCO用作系统时钟或PLL参考时钟, 则这些时钟源必须在HOCO停止之前更改为另一个时钟。 |
|               | 3 Disable FLL (FLLCN.FLLCN = 0)   |
|               | 4 WFI instruction   |
|               | 5 软件待机模式  |
|               | 6 软件待机取消  |
|               | 7 Enable FLL (FLLCN.FLLCN = 1)  |
|               | 8 Enable HOCO (HOCO.CR.HCSTP = 0)   |
|               | 9 等待FLL稳定( $t_{FLLWT}$ )  |
|               | 10 检查HOCO稳定性(OSCSF.HOCOSF=1)  |
|               | 11 结束 (可以使用HOCO。)   |

## 8.2.14 FLLCR2 : FLL Control Register2

Base address: SYSC = 0x4001\_E000

Offset address: 0x03A



| Bit   | Symbol        | Function  | R/W |
|-------|---------------|---|-----|
| 10:0  | FLLCNTL[10:0] | FLL Multiplication Control<br>When OFS1.HOCOFRQ[1:0] is 00b (16MHz), these bits must be set to 0x1E9.<br>When OFS1.HOCOFRQ[1:0] is 01b (18MHz), these bits must be set to 0x226.<br>When OFS1.HOCOFRQ[1:0] is 10b (20MHz), these bits must be set to 0x263.<br>Other settings are prohibited. | R/W |
| 15:11 | —             | These bits are read as 0. The write value should be 0.  | R/W |

Note: If the security attribution is configured as secure:

- Secure access and Non-secure read access are allowed
- Non-secure write access is ignored, and TrustZone access error is not generated.

If the security attribution is configured as Non-secure:

- Secure and Non-secure access are allowed.

Note: Set the PRCR.PRC0 bit to 1 (write enabled) before rewriting this register.

The FLLCR2 register controls the FLL function of the HOCO.

**FLLCNTL[10:0] bits (FLL Multiplication Control)**

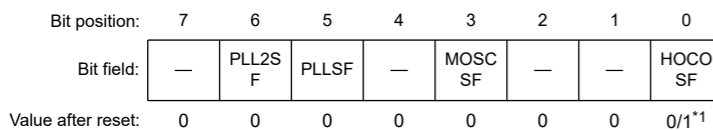
These bits select the multiplication ratio of the FLL reference clock.

These bits must be set before FLL is enabled (FLLCR1.FLLEN=1).

## 8.2.15 OSCSF : Oscillation Stabilization Flag Register

Base address: SYSC = 0x4001\_E000

Offset address: 0x03C

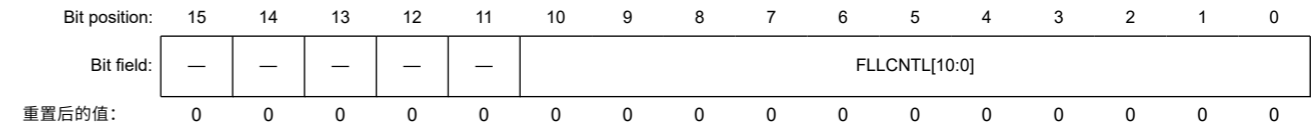


| Bit | Symbol | Function   | R/W |
|-----|--------|--|-----|
| 0   | HOCOSF | HOCO Clock Oscillation Stabilization Flag<br>0: The HOCO clock is stopped or is not yet stable<br>1: The HOCO clock is stable, so is available for use as the system clock                                     | R   |
| 2:1 | —      | These bits are read as 0.  | R   |
| 3   | MOSCSF | Main Clock Oscillation Stabilization Flag<br>0: The main clock oscillator is stopped (MOSTP = 1) or is not yet stable*2<br>1: The main clock oscillator is stable, so is available for use as the system clock | R   |
| 4   | —      | This bit is read as 0.   | R   |
| 5   | PLLSF  | PLL Clock Oscillation Stabilization Flag<br>0: The PLL clock is stopped, or oscillation of the PLL clock is not stable yet<br>1: The PLL clock is stable, so is available for use as the system clock          | R   |
| 6   | PLL2SF | PLL2 Clock Oscillation Stabilization Flag<br>0: The PLL2 clock is stopped, or oscillation of the PLL2 clock is not stable yet<br>1: The PLL2 clock is stable   | R   |
| 7   | —      | These bits are read as 0.  | R   |

## 8.2.14 FLLCR2 : FLL Control Register2

Base address: SYSC = 0x4001\_E000

Offset address: 0x03A



| Bit   | Symbol        | Function   | R/W |
|-------|---------------|--|-----|
| 10:0  | FLLCNTL[10:0] | FLL乘法控制<br>当OFS1.HOCOFRQ[1:0]为00b(16MHz)时, 这些位必须设置为0x1E9。当OFS1.HOCOFRQ[1:0]为01b(18MHz)时, 这些位必须设置为0x226。当OFS1.HOCOFRQ[1:0]为10b(20MHz)时, 这些位必须设置为0x263。<br>禁止其他设置。 | R/W |
| 15:11 | —             | 这些位被读取为0。写入值应为0。   | R/W |

Note: 如果安全属性配置为安全: ●  
允许安全访问和非安全读取访问  
● 忽略非安全写入访问, 不会生成TrustZone访问错误。  
如果安全属性配置为非安全: ●  
允许安全和非安全访问。

Note: 在重写此寄存器之前将PRCR.PRC0位设置为1 (允许写入)。

FLLCR2寄存器控制HOCO的FLL功能。

**FLLCNTL[10:0]位 (FLL乘法控制)**

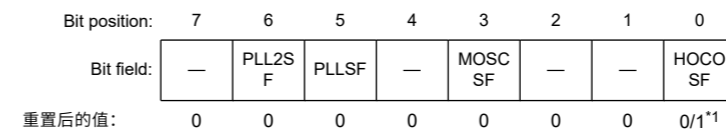
这些位选择FLL参考时钟的倍频比。

这些位必须在启用FLL之前设置(FLLCR1.FLLEN=1)。

## 8.2.15 OSCSF:振荡稳定标志寄存器

Base address: SYSC = 0x4001\_E000

Offset address: 0x03C



| Bit | Symbol | Function   | R/W |
|-----|--------|--|-----|
| 0   | HOCOSF | HOCO时钟振荡稳定标志<br>0: HOCO时钟停止或尚未稳定1: HOCO时钟稳定, 可用作系统时钟                 | R   |
| 2:1 | —      | 这些位读为0。  | R   |
| 3   | MOSCSF | 主时钟振荡稳定标志<br>0: 主时钟振荡器停止 (MOSTP=1) 或尚未稳定*2<br>1: 主时钟振荡器稳定, 可作为系统时钟使用 | R   |
| 4   | —      | 该位读为0。   | R   |
| 5   | PLLSF  | PLL时钟振荡稳定标志<br>0: PLL时钟停止, 或PLL时钟振荡尚未稳定1: PLL时钟稳定, 可用作系统时钟           | R   |
| 6   | PLL2SF | PLL2时钟振荡稳定标志<br>0: PLL2时钟停止, 或PLL2时钟振荡尚未稳定1: PLL2时钟稳定                | R   |
| 7   | —      | 这些位读为0。  | R   |

Note 1. The value after reset depends on the OFS1.HOCOEN setting.

When OFS1.HOCOEN = 1 (disable HOCO), the value after reset of HOCOSF is 0.

When OFS1.HOCOEN = 0 (enable HOCO), the HOCOSF value is set to 0 immediately after reset is released, and the HOCOSF value is set to 1 after the HOCO oscillation stabilization wait time elapses.

Note 2. This is true when an appropriate value is set in the Wait Control register for the main clock oscillator. If the wait time value is not sufficient, the oscillation stabilization flag is set to 1 and supply of the clock signal to the internal circuits starts before oscillation is stable.

This register is not controlled by CGFSAR register.

The OSCSF register contains flags to indicate the operating status of the counters in the oscillation stabilization wait circuits for the individual oscillators. After oscillation starts, these counters measure the wait time until each oscillator output clock is supplied to the internal circuits. An overflow of a counter indicates that the clock supply is stable and available for the associated circuit.

#### HOCOSF flag (HOCO Clock Oscillation Stabilization Flag)

The HOCOSF flag indicates the operating status of the counter that measures the wait time for the high-speed clock oscillator (HOCO). When OFS1.HOCOEN is set to 0, confirm that OSCSF.HOCOSF is set to 1 before using the HOCO clock.

[Setting condition]

- When the HOCO clock is stopped and the HOCOCCR.HCSTP bit is set to 0, and then the HOCO oscillation stabilization time is counted by the LOCO clock and supply of the HOCO clock within the MCU is started. For the HOCO oscillation stabilization time, see [section 47, Electrical Characteristics](#).

[Clearing condition]

- When the HOCO clock is operating and then is deactivated because the HOCOCCR.HCSTP bit is set to 1.

#### MOSCSF flag (Main Clock Oscillation Stabilization Flag)

The MOSCSF flag indicates the operating status of the counter that measures the wait time for the main clock oscillator.

[Setting condition]

- When the main clock oscillator is stopped and the MOSCCR.MOSTP bit is set to 0, and then the number of LOCO clock cycles corresponding to the setting of the MOSCWTCR register is counted and supply of the main clock within the MCU is started.

[Clearing condition]

- When the main clock oscillator is operating and then is deactivated because the MOSCCR.MOSTP bit is set to 1.

#### PLLSF flag (PLL Clock Oscillation Stabilization Flag)

The PLLSF flag indicates the operating state of the counter that measures the wait time of the PLL.

[Setting condition]

- When the PLL is stopped and the PLLCR.PLLSTP bit is set to 0, and then the PLL oscillation stabilization time is counted by the LOCO clock and supply of the PLL clock within the MCU is started. If oscillation by the PLL clock source is not stable when the PLLCR.PLLSTP bit is set to 0, counting of the LOCO cycles continues even after the PLL clock source oscillation is stabilized. For the PLL oscillation stabilization time, see [section 47, Electrical Characteristics](#).

[Clearing condition]

- When the PLL is operating and then is deactivated because the PLLCR.PLLSTP bit is set to 1.

#### PLL2SF flag (PLL2 Clock Oscillation Stabilization Flag)

The PLL2SF flag indicates the operating state of the counter that measures the wait time of the PLL2.

[Setting condition]

- When the PLL2 is stopped and the PLL2CR.PLL2STP bit is set to 0, and then the PLL2 oscillation stabilization time is counted by the LOCO clock and supply of the PLL2 clock within the MCU is started. If oscillation by the PLL2 clock source is not stable when the PLL2CR.PLL2STP bit is set to 0, counting of the LOCO cycles continues even after the

注1.复位后的值取决于OFS1.HOCOEN的设置。

当OFS1.HOCOEN=1（禁用HOCO）时，HOCOSF复位后的值为0。

当OFS1.HOCOEN=0（启用HOCO）时，释放复位后立即将HOCOSF值设置为0，并在经过HOCO振荡稳定等待时间后将HOCOSF值设置为1。

注2.当主时钟振荡器的等待控制寄存器中设置了适当的值时，这是正确的。如果等待时间值不够，则将振荡稳定标志设置为1，并在振荡稳定之前开始向内部电路提供时钟信号。

该寄存器不受CGFSAR寄存器控制。

OSCSF寄存器包含用于指示各个振荡器的振荡稳定等待电路中的计数器的操作状态的标志。振荡开始后，这些计数器测量等待时间，直到每个振荡器输出时钟被提供给内部电路。计数器溢出表明时钟供应稳定并可用于相关电路。

#### HOCOSF标志（HOCO时钟振荡稳定标志）

HOCOSF标志指示测量高速时钟振荡器(HOCO)等待时间的计数器的操作状态。当OFS1.HOCOEN设置为0时，请在使用HOCO时钟之前确认OSCSF.HOCOSF设置为1。

[Setting condition]

- 当HOCO时钟停止并且HOCOCCR.HCSTP位设置为0时，然后通过LOCO时钟计算HOCO振荡稳定时间并开始提供MCU内的HOCO时钟。关于HOCO振荡稳定时间，请参见第47节，电气特性。

[Clearing condition]

- HOCO时钟正在运行，然后由于HOCOCCR.HCSTP位设置为1而被停用。

#### MOSCSF标志（主时钟振荡稳定标志）

MOSCSF标志指示测量主时钟振荡器等待时间的计数器的操作状态。

[Setting condition]

- 当主时钟振荡器停止并且MOSCCR.MOSTP位设置为0，然后LOCO的个数与MOSCWTCR寄存器的设置相对应的时钟周期被计数，并开始提供MCU内的主时钟。

[Clearing condition]

- 当主时钟振荡器正在运行，然后因为MOSCCR.MOSTP位被设置为1而被禁用时。

#### PLLSF标志（PLL时钟振荡稳定标志）

PLLSF标志指示测量PLL等待时间的计数器的操作状态。

[Setting condition]

- 当PLL停止并且PLLCR.PLLSTP位设置为0时，然后PLL振荡稳定时间由LOCO时钟计数并开始提供MCU内的PLL时钟。如果当PLLCR.PLLSTP位设置为0时PLL时钟源的振荡不稳定，即使PLL时钟源振荡稳定后，LOCO周期的计数也会继续。关于PLL振荡稳定时间，请参见第47节，电气特性。

[Clearing condition]

- 当PLL正在运行然后因为PLLCR.PLLSTP位设置为1而被禁用时。

#### PLL2SF标志（PLL2时钟振荡稳定标志）

PLL2SF标志指示测量PLL2等待时间的计数器的操作状态。

[Setting condition]

- 当PLL2停止并且PLL2CR.PLL2STP位设置为0时，然后PLL2振荡稳定时间由LOCO时钟计数并开始提供MCU内的PLL2时钟。如果在PLL2CR.PLL2STP位设置为0时PLL2时钟源的振荡不稳定，即使在



PLL2 clock source oscillation is stabilized. For the PLL2 oscillation stabilization time, see [section 47, Electrical Characteristics](#).

[Clearing condition]

- When the PLL2 is operating and then is deactivated because the PLL2CR.PLL2STP bit is set to 1.

### 8.2.16 OSTDCR : Oscillation Stop Detection Control Register

Base address: SYSC = 0x4001\_E000

Offset address: 0x040

|                    |           |   |   |   |   |   |   |            |
|--------------------|-----------|---|---|---|---|---|---|------------|
| Bit position:      | 7         | 6 | 5 | 4 | 3 | 2 | 1 | 0          |
| Bit field:         | OSTD<br>E | — | — | — | — | — | — | OSTDI<br>E |
| Value after reset: | 0         | 0 | 0 | 0 | 0 | 0 | 0 | 0          |

| Bit | Symbol | Function  | R/W |
|-----|--------|---|-----|
| 0   | OSTDIE | Oscillation Stop Detection Interrupt Enable<br>0: Disable oscillation stop detection interrupt (do not notify the POEG)<br>1: Enable oscillation stop detection interrupt (notify the POEG) | R/W |
| 6:1 | —      | These bits are read as 0. The write value should be 0.  | R/W |
| 7   | OSTDE  | Oscillation Stop Detection Function Enable<br>0: Disable oscillation stop detection function<br>1: Enable oscillation stop detection function   | R/W |

Note: Set the PRCR.PRC0 bit to 1 (write enabled) before rewriting this register.

Note: If the security attribution is configured as secure:

- Secure access and Non-secure read access are allowed
  - Non-secure write access is ignored, and TrustZone access error is not generated.
- If the security attribution is configured as Non-secure:
- Secure and Non-secure access are allowed.

The OSTDCR register controls the oscillation stop detection function.

#### OSTDIE bit (Oscillation Stop Detection Interrupt Enable)

The OSTDIE bit enables the oscillation stop detection function interrupt. It also controls whether oscillation stop detection is reported to the POEG.

If the Oscillation Stop Detection flag in the Oscillation Stop Detection Status Register (OSTDSR.OSTDF) requires clearing, set the OSTDIE bit to 0 before clearing OSTDF. Wait for at least 2 PCLKB cycles before setting the OSTDIE bit to 1. By reading the I/O register whose access cycle number is defined by PCLKB, it is possible to secure waiting time of 2 or more cycles of PCLKB.

#### OSTDE bit (Oscillation Stop Detection Function Enable)

The OSTDE bit enables the oscillation stop detection function.

When the OSTDE bit is 1 (enabled), the MOCO stop bit (MOCOCR.MCSTP) is set to 0 and the MOCO operation starts. The MOCO clock cannot be stopped while the oscillation stop detection function is enabled. Writing 1 to the MOCOCR.MCSTP bit (MOCO stopped) is invalid.

When the Oscillation Stop Detection flag in the Oscillation Stop Detection Status Register (OSTDSR.OSTDF) is 1 (main clock oscillation stop detected), writing 0 to the OSTDE bit is invalid.

The OSTDE bit must be set to 0 before transitioning to Software Standby or Deep Software Standby mode. To transition to Software Standby or Deep Software Standby mode, first set the OSTDE bit to 0, then execute the WFI instruction.

The following restrictions apply when using the oscillation stop detection function:

In low-speed mode, selecting division by 1, 2, 4, 8 for ICLK, FCLK, PCLKA, PCLKB, PCLKC, and PCLKD is prohibited.

PLL2时钟源振荡稳定。有关PLL2振荡稳定时间，请参见第47节，电气特性。

[Clearing condition]

- 当PLL2正在运行，然后因为PLL2CR.PLL2STP位设置为1而被停用时。

### 8.2.16 OSTDCR:振荡停止检测控制寄存器

Base address: SYSC = 0x4001\_E000

Offset address: 0x040

|               |           |   |   |   |   |   |   |            |
|---------------|-----------|---|---|---|---|---|---|------------|
| Bit position: | 7         | 6 | 5 | 4 | 3 | 2 | 1 | 0          |
| Bit field:    | OSTD<br>E | — | — | — | — | — | — | OSTDI<br>E |
| 重置后的值:        | 0         | 0 | 0 | 0 | 0 | 0 | 0 | 0          |

| Bit | Symbol | Function  | R/W |
|-----|--------|---|-----|
| 0   | OSTDIE | 振荡停止检测中断使能<br>0: 禁止振荡停止检测中断（不通知POEG）<br>1: 使能振荡停止检测中断（通知POEG） | R/W |
| 6:1 | —      | 这些位被读取为0。写入值应为0。  | R/W |
| 7   | OSTDE  | 振荡停止检测功能启用<br>0: 禁用振荡停止检测功能<br>1: 启用振荡停止检测功能                  | R/W |

Note: 在重写此寄存器之前将PRCR.PRC0位设置为1（允许写入）。

Note: 如果安全属性配置为安全：●

- 允许安全访问和非安全读取访问
  - 忽略非安全写入访问，不会生成TrustZone访问错误。
- 如果安全属性配置为非安全：●
- 允许安全和非安全访问。

OSTDCR寄存器控制振荡停止检测功能。

#### OSTDIE位（振荡停止检测中断使能）

OSTDIE位使能振荡停止检测功能中断。它还控制是否将振荡停止检测报告给POEG。

如果振荡停止检测状态寄存器(OSTDSR.OSTDF)中的振荡停止检测标志需要清零，则在清零OSTDF之前将OSTDIE位设置为0。在将OSTDIE位设置为1之前等待至少2个PCLKB周期。通过读取访问周期数由PCLKB定义的IO寄存器，可以确保2个或更多PCLKB周期的等待时间。

#### OSTDE位（振荡停止检测功能使能）

OSTDE位使能振荡停止检测功能。

当OSTDE位为1（使能）时，MOCO停止位（MOCOCR.MCSTP）设置为0，MOCO操作开始。MOCO时钟在振荡停止检测功能启用时不能停止。将1写入MOCOCR.MCSTP位（MOCO停止）无效。

当振荡停止检测状态寄存器(OSTDSR.OSTDF)中的振荡停止检测标志为1（检测到主时钟振荡停止）时，向OSTDE位写入0无效。

在转换到软件待机或深度软件待机模式之前，必须将OSTDE位设置为0。过渡到软件待机或深度软件待机模式，首先将OSTDE位设置为0，然后执行WFI指令。

使用振荡停止检测功能时有以下限制：

在低速模式下，禁止为ICLK、FCLK、PCLKA、PCLKB、PCLKC和PCLKD选择1、2、4、8分频。

## 8.2.17 OSTDSR : Oscillation Stop Detection Status Register

Base address: SYSC = 0x4001\_E000

Offset address: 0x041

|                    |   |   |   |   |   |   |   |       |
|--------------------|---|---|---|---|---|---|---|-------|
| Bit position:      | 7 | 6 | 5 | 4 | 3 | 2 | 1 | 0     |
| Bit field:         | — | — | — | — | — | — | — | OSTDF |
| Value after reset: | 0 | 0 | 0 | 0 | 0 | 0 | 0 | 0     |

| Bit | Symbol | Function  | R/W              |
|-----|--------|---|------------------|
| 0   | OSTDF  | Oscillation Stop Detection Flag<br>0: Main clock oscillation stop not detected<br>1: Main clock oscillation stop detected | R/W <sup>1</sup> |
| 7:1 | —      | These bits are read as 0. The write value should be 0.  | R/W              |

Note: Set the PRCR.PRC0 bit to 1 (write enabled) before rewriting this register.

Note: If the security attribution is configured as secure:

- Secure access and Non-secure read access are allowed
  - Non-secure write access is ignored, and TrustZone access error is not generated.
- If the security attribution is configured as Non-secure:
- Secure and Non-secure access are allowed.

Note 1. This bit can only be set to 0. This bit is cleared to 0 by writing 0 after reading it as 1.

The OSTDSR register indicates the stop detection status of the main clock oscillator.

**OSTDF flag (Oscillation Stop Detection Flag)**

The OSTDF flag indicates the main clock oscillator status. When this flag is 1, it indicates that the main clock oscillation stop was detected. After this stop is detected, the OSTDF flag is not set to 0 even when the main clock oscillation is restarted. The OSTDF bit is cleared to 0 by writing 0 after reading it as 1.

At least 3 ICLK cycles of wait time are required between writing 0 to OSTDF and reading it as 0. If the OSTDF flag is set to 0 when the main clock oscillation is stopped, the OSTDF flag becomes 0 then returns to 1.

The OSTDF flag cannot be set to 0 under the following conditions:

- SCKSCR.CKSEL[2:0] = 011b (system clock source = MOSC).
- PLLCCR.PLSRCSEL = 0 (PLL source clock = MOSC) and SCKSCR.CKSEL[2:0] = 101b (System clock source = PLL)

The OSTDF flag must be set to 0 after switching the clock source to sources other than the main clock oscillator and PLL.

[Setting condition]

- The main clock oscillator is stopped when OSTDCR.OSTDE = 1 (oscillation stop detection function enabled).

[Clearing condition]

- 1 is read and then 0 is written when the SCKSCR.CKSEL[2:0] bits are neither 011b (system clock is MOSC) nor 101b (system clock is PLL) and PLLCCR.PLSRCSEL bit is not 0 (PLL source clock is MOSC).

## 8.2.18 MOSCWTCR : Main Clock Oscillator Wait Control Register

Base address: SYSC = 0x4001\_E000

Offset address: 0x0A2

|                    |   |   |   |   |           |   |   |   |
|--------------------|---|---|---|---|-----------|---|---|---|
| Bit position:      | 7 | 6 | 5 | 4 | 3         | 2 | 1 | 0 |
| Bit field:         | — | — | — | — | MSTS[3:0] |   |   |   |
| Value after reset: | 0 | 0 | 0 | 0 | 0         | 1 | 0 | 1 |

## 8.2.17 OSTDSR: 振荡停止检测状态寄存器

Base address: SYSC = 0x4001\_E000

Offset address: 0x041

|               |   |   |   |   |   |   |   |       |
|---------------|---|---|---|---|---|---|---|-------|
| Bit position: | 7 | 6 | 5 | 4 | 3 | 2 | 1 | 0     |
| Bit field:    | — | — | — | — | — | — | — | OSTDF |
| 重置后的值:        | 0 | 0 | 0 | 0 | 0 | 0 | 0 | 0     |

| Bit | Symbol | Function                                    | R/W              |
|-----|--------|---|------------------|
| 0   | OSTDF  | 振荡停止检测标志<br>0: 未检测到主时钟振荡停止<br>1: 检测到主时钟振荡停止 | R/W <sup>1</sup> |
| 7:1 | —      | 这些位被读取为0。写入值应为0。                            | R/W              |

Note: 在重写此寄存器之前将PRCR.PRC0位设置为1（允许写入）。

Note: 如果安全属性配置为安全: ●

- 允许安全访问和非安全读取访问
  - 忽略非安全写入访问，不会生成TrustZone访问错误。
- 如果安全属性配置为非安全: ●
- 允许安全和非安全访问。

注1.该位只能设置为0。读为1后写入0清除该位为0。

OSTDSR寄存器指示主时钟振荡器的停止检测状态。

**OSTDF标志（振荡停止检测标志）**

OSTDF标志指示主时钟振荡器状态。该标志为1时，表示检测到主时钟振荡停止。检测到此停止后，即使重新启动主时钟振荡，OSTDF标志也不会设置为0。OSTDF位在读为1后写入0清零。

从向OSTDF写入0到将其读取为0之间至少需要3个ICLK周期的等待时间。如果在主时钟振荡停止时将OSTDF标志设置为0，则OSTDF标志变为0然后返回1。

在以下情况下，OSTDF标志不能设置为0:

- SCKSCR.CKSEL[2:0]=011b（系统时钟源=MOSC）。
- PLLCCR.PLSRCSEL=0（PLL源时钟=MOSC）和SCKSCR.CKSEL[2:0]=101b（系统时钟源=PLL）

将时钟源切换到主时钟振荡器和PLL以外的源后，必须将OSTDF标志设置为0。

[Setting condition]

- 当OSTDCR.OSTDE=1（振荡停止检测功能使能）时，主时钟振荡器停止。

[Clearing condition]

- 当SCKSCR.CKSEL[2:0]位既不是011b（系统时钟为MOSC）也不是101b（系统时钟为PLL）且PLLCCR.PLSRCSEL位不为0（PLL源时钟为MOSC）。

## 8.2.18 MOSCWTCR:主时钟振荡器等待控制寄存器

Base address: SYSC = 0x4001\_E000

Offset address: 0x0A2

|               |   |   |   |   |           |   |   |   |
|---------------|---|---|---|---|-----------|---|---|---|
| Bit position: | 7 | 6 | 5 | 4 | 3         | 2 | 1 | 0 |
| Bit field:    | — | — | — | — | MSTS[3:0] |   |   |   |
| 重置后的值:        | 0 | 0 | 0 | 0 | 0         | 1 | 0 | 1 |

| Bit | Symbol    | Function  | R/W |
|-----|-----------|---|-----|
| 3:0 | MSTS[3:0] | Main Clock Oscillator Wait Time Setting<br>0x0: Wait time = 3 cycles (11.4 μs)<br>0x1: Wait time = 35 cycles (133.5 μs)<br>0x2: Wait time = 67 cycles (255.6 μs)<br>0x3: Wait time = 131 cycles (499.7 μs)<br>0x4: Wait time = 259 cycles (988.0 μs)<br>0x5: Wait time = 547 cycles (2086.6 μs)<br>0x6: Wait time = 1059 cycles (4039.8 μs)<br>0x7: Wait time = 2147 cycles (8190.2 μs)<br>0x8: Wait time = 4291 cycles (16368.9 μs)<br>0x9: Wait time = 8163 cycles (31139.4 μs)<br>Others: Setting prohibited | R/W |
| 7:4 | —         | These bits are read as 0. The write value should be 0.  | R/W |

Note: Set the PRCR.PRC0 bit to 1 (write enabled) before rewriting this register.  
 Note: If the security attribution is configured as secure:  
 • Secure access and Non-secure read access are allowed  
 • Non-secure write access is ignored, and TrustZone access error is not generated.  
 If the security attribution is configured as Non-secure:  
 • Secure and Non-secure access are allowed.

**MSTS[3:0] bits (Main Clock Oscillator Wait Time Setting)**

The MSTS[3:0] bits specify the oscillation stabilization wait time for the main clock oscillator.  
 Set the main clock oscillation stabilization time to a period longer than or equal to the stabilization time recommended by the oscillator manufacturer. When the main clock is input externally, set these bits to 0x0 because the oscillation stabilization time is not required.  
 The wait time set in these bits is counted using: 1 cycle (μs) = 1/(fLOCO[MHz] × 8) = 1/(0.032768 × 8) = 3.81 (μs) (min.)  
 The LOCO clock automatically oscillates when necessary, regardless of the value of the LOCO.LCSTP bit. After the specified wait time elapses, supply of the main clock starts internally in the MCU, and the OSCSF.MOSCSF flag is set to 1. If the specified wait time is short, supply of the main clock starts before oscillation of the clock becomes stable.  
 Only rewrite the MOSCWTCR register when the MOSCCR.MOSTP bit is 1 and the OSCSF.MOSCSF flag is 0. Do not rewrite this register under any other conditions.

**8.2.19 MOMCR : Main Clock Oscillator Mode Oscillation Control Register**

Base address: SYSC = 0x4001\_E000  
 Offset address: 0x413

|                    |   |           |            |   |   |   |   |   |
|--------------------|---|-----------|------------|---|---|---|---|---|
| Bit position:      | 7 | 6         | 5          | 4 | 3 | 2 | 1 | 0 |
| Bit field:         | — | MOSE<br>L | MODRV[1:0] | — | — | — | — | — |
| Value after reset: | 0 | 0         | 0          | 0 | 0 | 0 | 0 | 0 |

| Bit | Symbol     | Function   | R/W |
|-----|------------|--|-----|
| 3:0 | —          | These bits are read as 0. The write value should be 0.   | R/W |
| 5:4 | MODRV[1:0] | Main Clock Oscillator Drive Capability 0 Switching<br>0 0: 20 MHz to 24 MHz<br>0 1: 16 MHz to 20 MHz<br>1 0: 8 MHz to 16 MHz<br>1 1: 8 MHz | R/W |
| 6   | MOSEL      | Main Clock Oscillator Switching<br>0: Resonator<br>1: External clock input   | R/W |
| 7   | —          | These bits are read as 0. The write value should be 0.   | R/W |

Note: If the security attribution is configured as secure:  
 • Secure access and Non-secure read access are allowed  
 • Non-secure write access is ignored, and TrustZone access error is not generated.

| Bit | Symbol    | Function  | R/W |
|-----|-----------|---|-----|
| 3:0 | MSTS[3:0] | 主时钟振荡器等待时间设置<br>0x0: 等待时间=3个周期(11.4μs)0x1: 等待时间=35个周期(133.5μs)0x2: 等待时间=67个周期(255.6μs)0x3: 等待时间=131个周期(499.7μs)0x4: 等待时间=259周期(988.0μs)0x5: 等待时间=547个周期(2086.6μs)0x6: 等待时间=1059个周期(4039.8μs)0x7: 等待时间=2147个周期(8190.2μs)0x8: 等待时间=4291个周期(16368.9μs)0x9: 等待时间=8163个周期(31139.4μs)<br>其他: 禁止设置 | R/W |
| 7:4 | —         | 这些位被读取为0。写入值应为0。  | R/W |

Note: 在重写此寄存器之前将PRCR.PRC0位设置为1（允许写入）。  
 Note: 如果安全属性配置为安全: ●  
 允许安全访问和非安全读取访问  
 • 忽略非安全写入访问, 不会生成TrustZone访问错误。  
 如果安全属性配置为非安全: ●  
 允许安全和非安全访问。

**MSTS[3:0]位（主时钟振荡器等待时间设置）**

MSTS[3:0]位指定主时钟振荡器的振荡稳定等待时间。  
 将主时钟振荡稳定时间设置为大于或等于振荡器制造商推荐的稳定时间。当主时钟从外部输入时, 将这些位设置为0x0, 因为不需要振荡稳定时间。  
 这些位中设置的等待时间使用以下公式计算: 1个周期(μs)=1/(fLOCO[MHz]×8)=1(0.032768×8)=3.81(μs)(min.)  
 无论LOCO.LCSTP位的值如何, LOCO时钟都会在必要时自动振荡。经过指定的等待时间后, MCU内部开始提供主时钟, 并将OSCSF.MOSCSF标志设置为1。如果指定的等待时间短, 则在时钟振荡稳定之前开始提供主时钟。  
 仅当MOSCCR.MOSTP位为1且OSCSF.MOSCSF标志为0时才重写MOSCWTCR寄存器。在任何其他情况下请勿重写此寄存器。

**8.2.19 MOMCR: 主时钟振荡器模式振荡控制寄存器**

Base address: SYSC = 0x4001\_E000  
 Offset address: 0x413

|               |   |           |            |   |   |   |   |   |
|---------------|---|-----------|------------|---|---|---|---|---|
| Bit position: | 7 | 6         | 5          | 4 | 3 | 2 | 1 | 0 |
| Bit field:    | — | MOSE<br>L | MODRV[1:0] | — | — | — | — | — |
| 重置后的值:        | 0 | 0         | 0          | 0 | 0 | 0 | 0 | 0 |

| Bit | Symbol     | Function  | R/W |
|-----|------------|---|-----|
| 3:0 | —          | 这些位被读取为0。写入值应为0。  | R/W |
| 5:4 | MODRV[1:0] | 主时钟振荡器驱动能力0开关<br>0 0: 20 MHz to 24 MHz<br>0 1: 16 MHz to 20 MHz<br>1 0: 8 MHz to 16 MHz<br>1 1: 8 MHz | R/W |
| 6   | MOSEL      | 主时钟振荡器切换<br>0: 谐振器1: 外部时钟输入   | R/W |
| 7   | —          | 这些位被读取为0。写入值应为0。  | R/W |

Note: 如果安全属性配置为安全: ●  
 允许安全访问和非安全读取访问  
 • 忽略非安全写入访问, 不会生成TrustZone访问错误。

If the security attribution is configured as Non-secure:

- Secure and Non-secure access are allowed.

Note: The EXTAL/XTAL pins are also used as ports. In the initial state, the pin is set as a port.

Note: The MOSTP bit must be 1 (MOSC is stopped) before changing this register.

Note: Set the PRCR.PRC0 bit to 1 (write enabled) before rewriting this register.

### MODRV[1:0] bit (Main Clock Oscillator Drive Capability 0 Switching)

The MODRV[1:0] bit switches the drive capability of the main clock oscillator.

### MOSEL bit (Main Clock Oscillator Switching)

The MOSEL bit switches the source for the main clock oscillator.

## 8.2.20 SOMCR : Sub-Clock Oscillator Mode Control Register

Base address: SYSC = 0x4001\_E000

Offset address: 0x481

|                    |   |   |   |   |   |   |       |   |
|--------------------|---|---|---|---|---|---|-------|---|
| Bit position:      | 7 | 6 | 5 | 4 | 3 | 2 | 1     | 0 |
| Bit field:         | — | — | — | — | — | — | SODRV | — |
| Value after reset: | 0 | 0 | 0 | 0 | 0 | 0 | 0     | 0 |

| Bit | Symbol | Function   | R/W |
|-----|--------|--|-----|
| 0   | —      | These bits are read as 0. The write value should be 0.                   | R/W |
| 1   | SODRV  | Sub-Clock Oscillator Drive Capability Switching<br>0: Standard<br>1: Low | R/W |
| 7:2 | —      | These bits are read as 0. The write value should be 0.                   | R/W |

Note: If the security attribution is configured as secure:

- Secure access and Non-secure read access are allowed
- Non-secure write access is ignored, and TrustZone access error is not generated.

If the security attribution is configured as Non-secure:

- Secure and Non-secure access are allowed.

Note: Set the PRCR.PRC0 bit to 1 (write enabled) before rewriting this register.

The SOMCR register must be modified when SOSCCR.SOSTP is 1 (SOSC is stopped).

### SODRV bits (Sub-Clock Oscillator Drive Capability Switching)

The SODRV bits switch the drive capability of the sub-clock oscillator. SODRV is undefined at the first Power up, but value after reset of SOSCCR.SOSTP is 0 (SOSC is operated). And therefore, please set the SOSC as follows when the first Power up:

- Set the SOSCCR.SOSTP to 1 (SOSC is stopped)
- Set this bit to a value corresponding to the using capacitor.
- Clear the SOSCCR.SOSTP to 0 (SOSC is operated)

## 8.2.21 CKOCR : Clock Out Control Register

Base address: SYSC = 0x4001\_E000

Offset address: 0x03E

|                    |       |             |   |   |   |   |             |   |
|--------------------|-------|-------------|---|---|---|---|-------------|---|
| Bit position:      | 7     | 6           | 5 | 4 | 3 | 2 | 1           | 0 |
| Bit field:         | CKOEN | CKODIV[2:0] | — | — | — | — | CKOSEL[2:0] | — |
| Value after reset: | 0     | 0           | 0 | 0 | 0 | 0 | 0           | 0 |

如果安全属性配置为非安全: ●

允许安全和非安全访问。

Note: EXTAL/XTAL引脚也用作端口。在初始状态下,该引脚被设置为一个端口。

Note: 在更改此寄存器之前, MOSTP位必须为1 (MOSC停止)。

Note: 在重写此寄存器之前将PRCR.PRC0位设置为1 (允许写入)。

### MODRV[1:0]位 (主时钟振荡器驱动能力0切换)

MODRV[1:0]位切换主时钟振荡器的驱动能力。

### MOSEL位 (主时钟振荡器切换)

MOSEL位切换主时钟振荡器的源。

## 8.2.20 SOMCR: 副时钟振荡器模式控制寄存器

Base address: SYSC = 0x4001\_E000

Offset address: 0x481

|               |   |   |   |   |   |   |       |   |
|---------------|---|---|---|---|---|---|-------|---|
| Bit position: | 7 | 6 | 5 | 4 | 3 | 2 | 1     | 0 |
| Bit field:    | — | — | — | — | — | — | SODRV | — |
| 重置后的值:        | 0 | 0 | 0 | 0 | 0 | 0 | 0     | 0 |

| Bit | Symbol | Function                     | R/W |
|-----|--------|------------------------------|-----|
| 0   | —      | 这些位被读取为0。写入值应为0。             | R/W |
| 1   | SODRV  | 副时钟振荡器驱动能力切换<br>0: 标准1:<br>低 | R/W |
| 7:2 | —      | 这些位被读取为0。写入值应为0。             | R/W |

Note: 如果安全属性配置为安全: ●

允许安全访问和非安全读取访问

- 忽略非安全写入访问, 不会生成TrustZone访问错误。

如果安全属性配置为非安全: ●

允许安全和非安全访问。

Note: 在重写此寄存器之前将PRCR.PRC0位设置为1 (允许写入)。

当SOSCCR.SOSTP为1 (SOSC停止) 时, 必须修改SOMCR寄存器。

### SODRV位 (副时钟振荡器驱动能力切换)

SODRV位切换副时钟振荡器的驱动能力。首次上电时SODRV未定义, 但SOSCCR.SOSTP复位后的值为0 (SOSC运行)。因此, 请在第一次上电时将SOSC设置如下:

- 将SOSCCR.SOSTP设置为1 (SOSC停止)
- 将此位设置为与使用电容相对应的值。
- 清除SOSCCR.SOSTP为0 (SOSC操作)

## 8.2.21 CKOCR: 时钟输出控制寄存器

Base address: SYSC = 0x4001\_E000

Offset address: 0x03E

|               |       |             |   |   |   |   |             |   |
|---------------|-------|-------------|---|---|---|---|-------------|---|
| Bit position: | 7     | 6           | 5 | 4 | 3 | 2 | 1           | 0 |
| Bit field:    | CKOEN | CKODIV[2:0] | — | — | — | — | CKOSEL[2:0] | — |
| 重置后的值:        | 0     | 0           | 0 | 0 | 0 | 0 | 0           | 0 |



| Bit | Symbol      | Function   | R/W |
|-----|-------------|--|-----|
| 2:0 | CKOSEL[2:0] | Clock Out Source Select<br>0 0 0: HOCO<br>0 0 1: MOCO<br>0 1 0: LOCO<br>0 1 1: MOSC<br>1 0 0: SOSC<br>1 0 1: Setting prohibited<br>Others: Setting prohibited              | R/W |
| 3   | —           | This bit is read as 0. The write value should be 0.  | R/W |
| 6:4 | CKODIV[2:0] | Clock Output Frequency Division Ratio<br>0 0 0: × 1/1<br>0 0 1: × 1/2<br>0 1 0: × 1/4<br>0 1 1: × 1/8<br>1 0 0: × 1/16<br>1 0 1: × 1/32<br>1 1 0: × 1/64<br>1 1 1: × 1/128 | R/W |
| 7   | CKOEN       | Clock Out Enable<br>0: Disable clock out<br>1: Enable clock out  | R/W |

Note: Set the PRCR.PRC0 bit to 1 (write enabled) before rewriting this register.

Note: If the security attribution is configured as secure:

- Secure access and Non-secure read access are allowed
- Non-secure write access is ignored, and TrustZone access error is not generated.

If the security attribution is configured as Non-secure:

- Secure and Non-secure access are allowed.

#### CKOSEL[2:0] bits (Clock Out Source Select)

The CKOSEL[2:0] bits select the source of the clock to be output from the CLKOUT pin. When changing the clock source, set the CKOEN bit to 0.

#### CKODIV[2:0] bits (Clock Output Frequency Division Ratio)

The CKODIV[2:0] bits specify the clock division ratio. Set the CKOEN bit to 0 when changing the division ratio.

#### CKOEN bit (Clock Out Enable)

The CKOEN bit enables output from the CLKOUT pin.

When this bit is set to 1, the selected clock is output. When this bit is set to 0, low is output. When changing this bit, confirm that the clock out source clock selected in the CKOSEL[2:0] bits is stable. Otherwise, a glitch might be generated in the output.

Clear this bit before entering Software Standby or Deep Software Standby mode if the selecting clock out source clock is stopped in that mode.

### 8.2.22 LOCOUTCR : LOCO User Trimming Control Register

Base address: SYSC = 0x4001\_E000

Offset address: 0x492

| Bit position:      | 7             | 6 | 5 | 4 | 3 | 2 | 1 | 0 |
|--------------------|---------------|---|---|---|---|---|---|---|
| Bit field:         | LOCOUTRM[7:0] |   |   |   |   |   |   |   |
| Value after reset: | 0             | 0 | 0 | 0 | 0 | 0 | 0 | 0 |

| Bit | Symbol      | Function   | R/W |
|-----|-------------|--|-----|
| 2:0 | CKOSEL[2:0] | 时钟输出源选择<br>000: HOCO001: MOC<br>0010: LOCO011: MOS<br>C100: SOSC101: 禁止设置<br><br>其他: 禁止设置  | R/W |
| 3   | —           | 该位读取为0。写入值应为0。   | R/W |
| 6:4 | CKODIV[2:0] | 时钟输出分频比<br>0 0 0: × 1/1<br>0 0 1: × 1/2<br>0 1 0: × 1/4<br>0 1 1: × 1/8<br>1 0 0: × 1/16<br>1 0 1: × 1/32<br>1 1 0: × 1/64<br>1 1 1: × 1/128 | R/W |
| 7   | CKOEN       | 时钟输出使能<br>0: 禁用时钟输出1<br>: 启用时钟输出   | R/W |

Note: 在重写此寄存器之前将PRCR.PRC0位设置为1（允许写入）。

Note: 如果安全属性配置为安全: ●

- 允许安全访问和非安全读取访问
- 忽略非安全写入访问，不会生成TrustZone访问错误。

如果安全属性配置为非安全: ●

- 允许安全和非安全访问。

#### CKOSEL[2:0]位 (时钟输出源选择)

CKOSEL[2:0]位选择从CLKOUT引脚输出的时钟源。更改时钟源时，将CKOEN位设置为0。

#### CKODIV[2:0]位 (时钟输出分频比)

CKODIV[2:0]位指定时钟分频比。更改分频比时将CKOEN位设置为0。

#### CKOEN位 (时钟输出使能)

CKOEN位使能CLKOUT引脚的输出。

当该位设置为1时，输出选定的时钟。当该位设置为0时，输出低电平。更改此位时，请确认CKOSEL[2:0]位中选择的时钟输出源时钟稳定。否则，可能会在输出中产生故障。

如果选择时钟输出源时钟在该模式下停止，则在进入软件待机或深度软件待机模式之前清零该位。

### 8.2.22 LOCOUTCR:LOCO用户微调控制寄存器

Base address: SYSC = 0x4001\_E000

Offset address: 0x492

| Bit position: | 7             | 6 | 5 | 4 | 3 | 2 | 1 | 0 |
|---------------|---------------|---|---|---|---|---|---|---|
| Bit field:    | LOCOUTRM[7:0] |   |   |   |   |   |   |   |
| 重置后的值:        | 0             | 0 | 0 | 0 | 0 | 0 | 0 | 0 |



| Bit | Symbol        | Function  | R/W |
|-----|---------------|---|-----|
| 7:0 | LOCOUTRM[7:0] | LOCO User Trimming<br>0x80: -128<br>0x81: -127<br>⋮<br>0xFF: -1<br>0x00: Center Code<br>0x01: +1<br>⋮<br>0x7E: +126<br>0x7F: +127 | R/W |

Note: If the security attribution is configured as secure:

- Secure access and Non-secure read access are allowed
- Non-secure write access is ignored, and TrustZone access error is not generated.

If the security attribution is configured as Non-secure:

- Secure and Non-secure access are allowed.

Note: Set the PRCR.PRC0 bit to 1 (write enabled) before rewriting this register.

The LOCOUTCR register is added to the original LOCO trimming data.

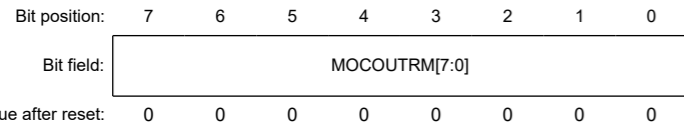
MCU operation is not guaranteed when LOCOUTCR is set to a value that causes the LOCO frequency to be outside of the specification range. When LOCOUTCR is modified, the frequency stabilization time corresponds to the frequency stabilization time at the start of MCU operation. When the ratio of the LOCO frequency and the other oscillation frequency is an integer value, changing the LOCOUTCR value is prohibited.

Changing LOCOUTCR during RTC operation is prohibited.

### 8.2.23 MOCOUTCR : MOCO User Trimming Control Register

Base address: SYSC = 0x4001\_E000

Offset address: 0x061



| Bit | Symbol        | Function  | R/W |
|-----|---------------|---|-----|
| 7:0 | MOCOUTRM[7:0] | MOCO User Trimming<br>0x80: -128<br>0x81: -127<br>⋮<br>0xFF: -1<br>0x00: Center Code<br>0x01: +1<br>⋮<br>0x7E: +126<br>0x7F: +127 | R/W |

Note: If the security attribution is configured as secure:

- Secure access and Non-secure read access are allowed
- Non-secure write access is ignored, and TrustZone access error is not generated.

If the security attribution is configured as Non-secure:

- Secure and Non-secure access are allowed.

Note: Set the PRCR.PRC0 bit to 1 (write enabled) before rewriting this register.

The MOCOUTCR register is added to the original MOCO trimming data.

MCU operation is not guaranteed when MOCOUTCR is set to a value that causes the MOCO frequency to be outside of the specification range. When MOCOUTCR is modified, the frequency stabilization wait time corresponds to the frequency stabilization wait time at the start of the MCU operation. When the ratio of the MOCO frequency and the other oscillation frequency is an integer value, changing the MOCOUTCR value is prohibited.

| Bit | Symbol        | Function  | R/W |
|-----|---------------|---|-----|
| 7:0 | LOCOUTRM[7:0] | LOCO用户修整<br>0x80: -1280x81:<br>-127 0xFF: -10x00<br>: 中心代码0x01: +<br>1 0x7E: +1260x7F<br>: +127 | R/W |

Note: 如果安全属性配置为安全: ●

- 允许安全访问和非安全读取访问
- 忽略非安全写入访问, 不会生成TrustZone访问错误。

如果安全属性配置为非安全: ●

- 允许安全和非安全访问。

Note: 在重写此寄存器之前将PRCR.PRC0位设置为1 (允许写入)。

LOCOUTCR寄存器被添加到原始LOCO修整数据中。

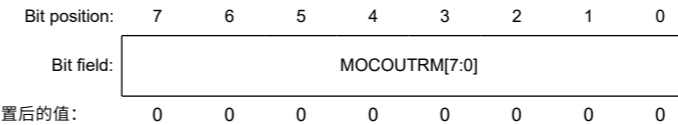
当LOCOUTCR设置为导致LOCO频率超出规范范围的值时, MCU操作无法保证。修改LOCOUTCR时, 频率稳定时间对应于MCU工作开始时的频率稳定时间。当LOCO频率与其他振荡频率之比为整数值时, 禁止更改LOCOUTCR值。

禁止在RTC操作期间更改LOCOUTCR。

### 8.2.23 MOCOUTCR:MOCO用户微调控制寄存器

Base address: SYSC = 0x4001\_E000

Offset address: 0x061



| Bit | Symbol        | Function  | R/W |
|-----|---------------|---|-----|
| 7:0 | MOCOUTRM[7:0] | MOCO用户修整<br>0x80: -1280x81:<br>-127 0xFF: -10x00<br>: 中心代码0x01: +<br>1 0x7E: +1260x7F<br>: +127 | R/W |

Note: 如果安全属性配置为安全: ●

- 允许安全访问和非安全读取访问
- 忽略非安全写入访问, 不会生成TrustZone访问错误。

如果安全属性配置为非安全: ●

- 允许安全和非安全访问。

Note: 在重写此寄存器之前将PRCR.PRC0位设置为1 (允许写入)。

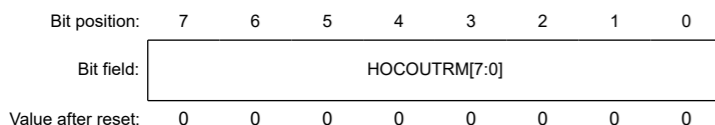
MOCOUTCR寄存器被添加到原始MOCO修整数据中。

当MOCOUTCR设置为导致MOCO频率超出规格范围的值时, 无法保证MCU操作。修改MOCOUTCR时, 稳频等待时间对应MCU开始工作时的稳频等待时间。当MOCO频率与其他振荡频率之比为整数值时, 禁止更改MOCOUTCR值。

## 8.2.24 HOCOUTCR : HOCO User Trimming Control Register

Base address: SYSC = 0x4001\_E000

Offset address: 0x062



| Bit | Symbol        | Function  | R/W |
|-----|---------------|---|-----|
| 7:0 | HOCOUTRM[7:0] | HOCO User Trimming<br>0x80: -128<br>0x81: -127<br>⋮<br>0xFF: -1<br>0x00: Center Code<br>0x01: +1<br>⋮<br>0x7E: +126<br>0x7F: +127 | R/W |

Note: If the security attribution is configured as secure:

- Secure access and Non-secure read access are allowed
- Non-secure write access is ignored, and TrustZone access error is not generated.

If the security attribution is configured as Non-secure:

- Secure and Non-secure access are allowed.

Note: Set the PRCR.PRC0 bit to 1 (write enabled) before rewriting this register.

The HOCOUTCR register is added to the original HOCO trimming data.

MCU operation is not guaranteed when HOCOUTCR is set to a value that causes the HOCO frequency to be outside of the specification range. When HOCOUTCR is modified, the frequency stabilization wait time corresponds to the frequency stabilization wait time at the start of the MCU operation.

These bits must be 0x00 when FLL is enabled (FLLCR1.FLLEN = 1).

## 8.2.25 USBCKDIVCR : USB Clock Division Control Register

Base address: SYSC = 0x4001\_E000

Offset address: 0x06C



| Bit | Symbol        | Function   | R/W |
|-----|---------------|--|-----|
| 2:0 | USBCKDIV[2:0] | USB Clock (USBCLK) Division Select<br>0 1 0: /4<br>1 0 1: /3<br>1 1 0: /5<br>Others: Setting prohibited. | R/W |
| 7:3 | —             | These bits are read as 0. The write value should be 0.   | R/W |

Note: If the security attribution is configured as secure:

- Secure access and Non-secure read access are allowed
- Non-secure write access is ignored, and TrustZone access error is not generated.

If the security attribution is configured as Non-secure:

- Secure and Non-secure access are allowed.

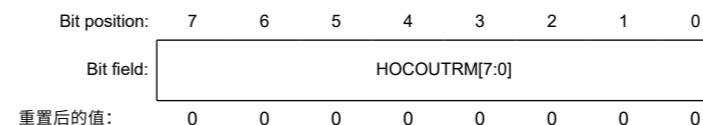
Note: Set the PRCR.PRC0 bit to 1 (write enabled) before rewriting this register.

The USBCKDIVCR register controls the USB clock.

## 8.2.24 HOCOUTCR:HOCO用户微调控制寄存器

Base address: SYSC = 0x4001\_E000

Offset address: 0x062



| Bit | Symbol        | Function  | R/W |
|-----|---------------|---|-----|
| 7:0 | HOCOUTRM[7:0] | HOCO用户修整<br>0x80: -128<br>0x81: -127<br>0xFF: -1<br>0x00: 中心代码<br>0x01: +1<br>⋮<br>0x7E: +126<br>0x7F: +127 | R/W |

Note: 如果安全属性配置为安全: ●

- 允许安全访问和非安全读取访问
- 忽略非安全写入访问, 不会生成TrustZone访问错误。

如果安全属性配置为非安全: ●

- 允许安全和非安全访问。

Note: 在重写此寄存器之前将PRCR.PRC0位设置为1 (允许写入)。

HOCOUTCR寄存器被添加到原始HOCO修整数据中。

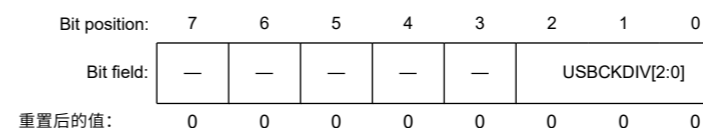
当HOCOUTCR设置为导致HOCO频率超出规范范围的值时, MCU操作无法保证。修改HOCOUTCR时, 稳频等待时间对应MCU运行开始时的稳频等待时间。

当FLL使能时 (FLLCR1.FLLEN=1), 这些位必须为0x00。

## 8.2.25 USBCKDIVCR:USB时钟分频控制寄存器

Base address: SYSC = 0x4001\_E000

Offset address: 0x06C



| Bit | Symbol        | Function  | R/W |
|-----|---------------|---|-----|
| 2:0 | USBCKDIV[2:0] | USB时钟(USBCLK)分频选择<br>0 1 0: /4<br>1 0 1: /3<br>1 1 0: /5<br>其他: 禁止设置。 | R/W |
| 7:3 | —             | 这些位被读取为0。写入值应为0。  | R/W |

Note: 如果安全属性配置为安全: ●

- 允许安全访问和非安全读取访问
- 忽略非安全写入访问, 不会生成TrustZone访问错误。

如果安全属性配置为非安全: ●

- 允许安全和非安全访问。

Note: 在重写此寄存器之前将PRCR.PRC0位设置为1 (允许写入)。

USBCKDIVCR寄存器控制USB时钟。

**USBCKDIV[2:0] bits (USB Clock (USBCLK) Division Select)**

These bits select the frequency of the USB clock (USBCLK) and must be modified when USBCKCR.USBCKSRDY = 1.

**8.2.26 USBCKCR : USB Clock Control Register**

Base address: SYSC = 0x4001\_E000

Offset address: 0x074

|                    |                   |                   |   |   |   |               |   |   |
|--------------------|-------------------|-------------------|---|---|---|---------------|---|---|
| Bit position:      | 7                 | 6                 | 5 | 4 | 3 | 2             | 1 | 0 |
| Bit field:         | USBC<br>KSRD<br>Y | USBC<br>KSRE<br>Q | — | — | — | USBCKSEL[2:0] |   |   |
| Value after reset: | 0                 | 0                 | 0 | 0 | 0 | 0             | 0 | 1 |

| Bit | Symbol        | Function  | R/W |
|-----|---------------|---|-----|
| 2:0 | USBCKSEL[2:0] | USB Clock (USBCLK) Source Select<br>1 0 1: PLL<br>1 1 0: PLL2<br>Others: Setting prohibited.      | R/W |
| 5:3 | —             | These bits are read as 0. The write value should be 0.  | R/W |
| 6   | USBCKSREQ     | USB Clock (USBCLK) Switching Request<br>0: No request<br>1: Request switching.                    | R/W |
| 7   | USBCKSRDY     | USB Clock (USBCLK) Switching Ready state flag<br>0: Impossible to Switch<br>1: Possible to Switch | R   |

Note: If the security attribution is configured as secure:

- Secure access and Non-secure read access are allowed
- Non-secure write access is ignored, and TrustZone access error is not generated.

If the security attribution is configured as Non-secure:

- Secure and Non-secure access are allowed.

Note: Set the PRCR.PRC0 bit to 1 (write enabled) before rewriting this register.

The USBCKCR register controls the USB clock.

When switching the clock source, ensure that the clock before the switch and the clock after the switch generate stable output. To change the set value of USBCKDIVCR.USBCKDIV[2:0] and USBCKSEL[2:0], use the following procedure:

- Write 1 to USBCKSREQ.
- Poll until USBCKSRDY is read as 1. While USBCKSRDY = 1, no clock is output to USBCLK.
- Write to USBCKDIVCR.USBCKDIV[2:0] and USBCKSEL[2:0].
- Write 0 to USBCKSREQ.
- Poll until USBCKSRDY is read as 0.
- When USBCKSRDY becomes 0, USBCLK starts to output. Clock switching is complete.

When transitioning to Software Standby or Deep Software Standby mode, do not execute the WFI instruction while performing clock switching. That is, do not execute the WFI instruction when USBCKSREQ = 1 and USBCKSRDY = 0, or when USBCKSREQ = 0 and USBCKSRDY = 1.

**USBCKSEL[2:0] bits (USB Clock (USBCLK) Source Select)**

These bits select the clock source of the USB clock (USBCLK) and must be modified when USBCKCR.USBCKSRDY = 1.

**USBCKSREQ bit (USB Clock (USBCLK) Switching Request)**

This bit selects the USBCLK switching request.

**USBCKSRDY flag (USB Clock (USBCLK) Switching Ready state flag)**

This flag indicates the state of switching ready for the USBCLK. When USBCKSRDY = 1, no clock is output to USBCLK.

**USBCKDIV[2:0]位 (USB时钟(USBCLK)分频选择)**

这些位选择USB时钟(USBCLK)的频率,并且必须在USBCKCR.USBCKSRDY=1时进行修改。

**8.2.26 USBCKCR:USB时钟控制寄存器**

Base address: SYSC = 0x4001\_E000

Offset address: 0x074

|               |                   |                   |   |   |   |               |   |   |
|---------------|-------------------|-------------------|---|---|---|---------------|---|---|
| Bit position: | 7                 | 6                 | 5 | 4 | 3 | 2             | 1 | 0 |
| Bit field:    | USBC<br>KSRD<br>Y | USBC<br>KSRE<br>Q | — | — | — | USBCKSEL[2:0] |   |   |
| 重置后的值:        | 0                 | 0                 | 0 | 0 | 0 | 0             | 0 | 1 |

| Bit | Symbol        | Function   | R/W |
|-----|---------------|--|-----|
| 2:0 | USBCKSEL[2:0] | USB时钟(USBCLK)源选择<br>1 0 1: PLL<br>1 1 0: PLL2<br>其他: 禁止设置。 | R/W |
| 5:3 | —             | 这些位被读取为0。写入值应为0。   | R/W |
| 6   | USBCKSREQ     | USB时钟(USBCLK)切换请求<br>0: 无请求1: 请求切换。                        | R/W |
| 7   | USBCKSRDY     | USB时钟(USBCLK)切换就绪状态标志<br>0: 不能切换1: 可以切换                    | R   |

Note: 如果安全属性配置为安全: ●

- 允许安全访问和非安全读取访问
- 忽略非安全写入访问,不会生成TrustZone访问错误。

如果安全属性配置为非安全: ●

- 允许安全和非安全访问。

Note: 在重写此寄存器之前将PRCR.PRC0位设置为1(允许写入)。

USBCKCR寄存器控制USB时钟。

切换时钟源时,确保切换前的时钟和切换后的时钟产生稳定的输出。要更改USBCKDIVCR.USBCKDIV[2:0]和USBCKSEL[2:0]的设置值,请使用以下过程:

- 将1写入USBCKSREQ。
- 轮询直到USBCKSRDY被读取为1。当USBCKSRDY=1时,没有时钟输出到USBCLK。
- 写入USBCKDIVCR.USBCKDIV[2:0]和USBCKSEL[2:0]。
- 将0写入USBCKSREQ。
- 轮询直到USBCKSRDY被读取为0。
- 当USBCKSRDY变为0时,USBCLK开始输出。时钟切换完成。

当转换到软件待机或深度软件待机模式时,不要在执行时钟切换时执行WFI指令。即USBCKSREQ=1且USBCKSRDY=0时,或USBCKSREQ=0且USBCKSRDY=1时不执行WFI指令。

**USBCKSEL[2:0]位 (USB时钟(USBCLK)源选择)**

这些位选择USB时钟(USBCLK)的时钟源,并且必须在USBCKCR.USBCKSRDY=1时进行修改。

**USBCKSREQ位 (USB时钟(USBCLK)切换请求)**

该位选择USBCLK切换请求。

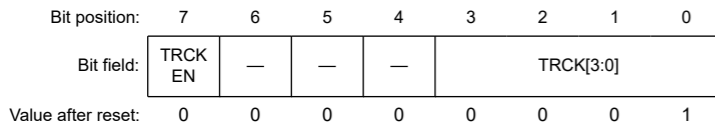
**USBCKSRDY标志 (USB时钟(USBCLK)切换就绪状态标志)**

该标志指示USBCLK的切换就绪状态。当USBCKSRDY=1时,没有时钟输出到USBCLK。

## 8.2.27 TRCKCR : Trace Clock Control Register

Base address: SYSC = 0x4001\_E000

Offset address: 0x03F



| Bit | Symbol    | Function  | R/W |
|-----|-----------|---|-----|
| 3:0 | TRCK[3:0] | Trace Clock operating frequency select<br>0x0: /1<br>0x1: /2 (value after reset)<br>0x2: /4<br>Others: Setting prohibited | R/W |
| 6:4 | —         | These bits are read as 0. The write value should be 0.  | R/W |
| 7   | TRCKEN    | Trace Clock operating Enable<br>0: Stop<br>1: Operation enable  | R/W |

Note: Set the PRCR.PRC0 bit to 1 (write enabled) before rewriting this register.

Trace Clock Control Register controls switching the trace clock.

TRCKCR can be written only when the debugger is connected (DBGSTR.CDBGPWRUPREQ = 1).

When the debugger is not connected, it is not necessary to change TRCK[3:0] even if the TRCLK frequency is higher than the maximum value of the specification.

Change the TRCLK frequency in the state of TRCKEN = 0.

Factor of the initialization of TRCKCR register is all resets.

## 8.3 Main Clock Oscillator

To supply the clock signal to the main clock oscillator, use one of the following ways:

- Connect an oscillator
- Connect the input of an external clock signal.

## 8.3.1 Connecting a Crystal Resonator

Figure 8.2 shows an example of connecting a crystal resonator. A damping resistor (Rd) can be added, if required.

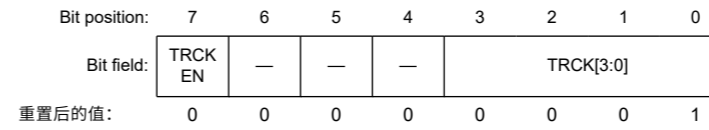
Because the resistor values vary according to the resonator and the oscillation drive capability, use values recommended by the resonator manufacturer. If the manufacturer recommends using an external feedback resistor (Rf), insert an Rf between EXTAL and XTAL by following the instructions.

When connecting a resonator to supply the clock, the frequency of the resonator must be in the frequency range of the resonator for the main clock oscillator as described in Table 8.1.

## 8.2.27 TRCKCR: 跟踪时钟控制寄存器

Base address: SYSC = 0x4001\_E000

Offset address: 0x03F



| Bit | Symbol    | Function  | R/W |
|-----|-----------|---|-----|
| 3:0 | TRCK[3:0] | 跟踪时钟工作频率选择<br>0x0: /1<br>0x1: /2 (value after reset)<br>0x2: /4<br>其他: 禁止设置 | R/W |
| 6:4 | —         | 这些位被读取为0。写入值应为0。  | R/W |
| 7   | TRCKEN    | 跟踪时钟操作使能<br>0: 停止1: 运行使能  | R/W |

Note: 在重写此寄存器之前将PRCR.PRC0位设置为1（允许写入）。

跟踪时钟控制寄存器控制跟踪时钟的切换。

TRCKCR只能在调试器连接时写入(DBGSTR.CDBGPWRUPREQ=1)。

未连接调试器时，即使TRCLK频率高于规范的最大值，也无需更改TRCK[3:0]。

在TRCKEN=0的状态下改变TRCLK频率。

TRCKCR寄存器初始化的因素是所有的复位。

## 8.3 主时钟振荡器

要将时钟信号提供给主时钟振荡器，请使用以下方法之一：

- 连接振荡器
- 连接外部时钟信号的输入。

## 8.3.1 连接晶体谐振器

图8.2显示了连接晶体谐振器的示例。如果需要，可以添加一个阻尼电阻器(Rd)。

由于电阻值因谐振器和振荡驱动能力而异，请使用谐振器制造商推荐的值。如果制造商建议使用外部反馈电阻器(Rf)，请按照说明在EXTAL和XTAL之间插入一个Rf。

连接谐振器以提供时钟时，谐振器的频率必须在表8.1中所述的主时钟振荡器的谐振器频率范围内。

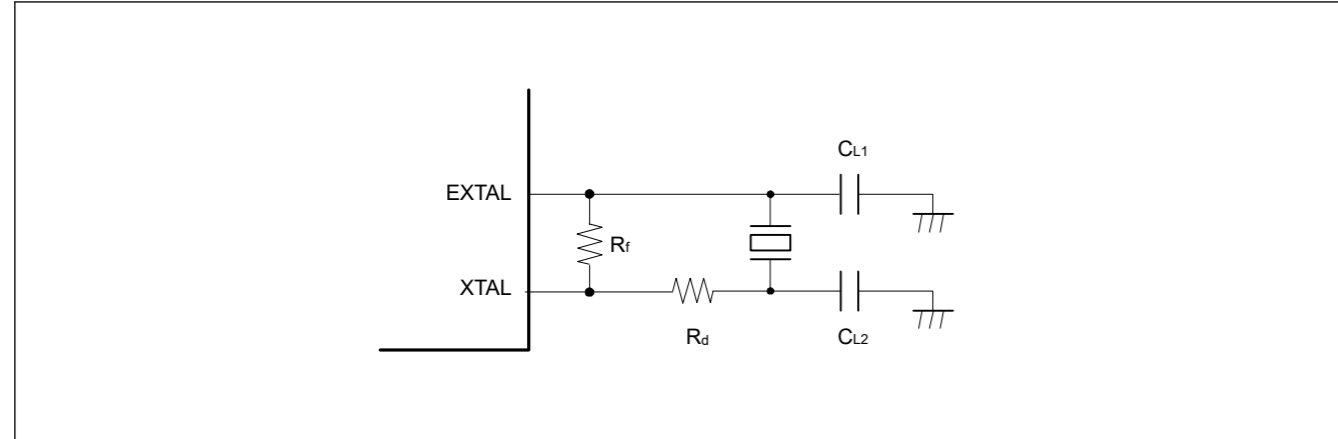


Figure 8.2 Example of crystal resonator connection

Figure 8.3 shows an equivalent circuit of the crystal resonator.

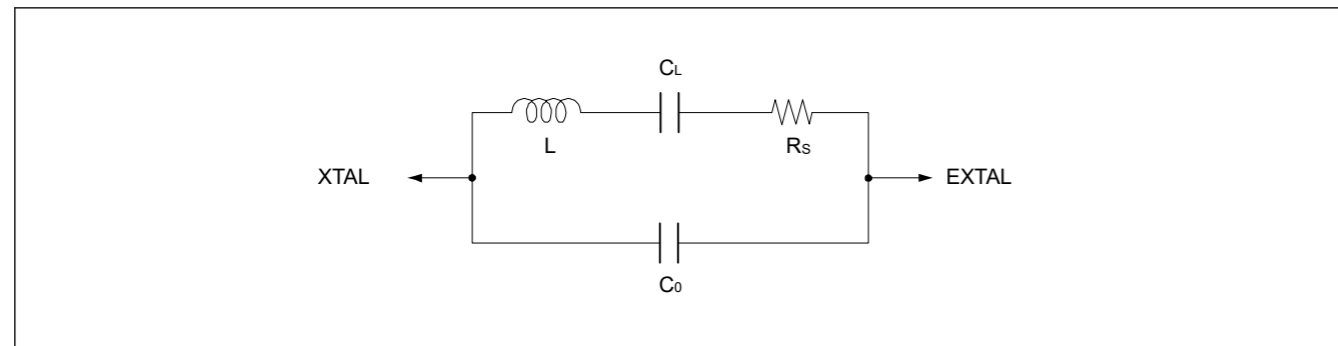


Figure 8.3 Equivalent circuit of the crystal resonator

### 8.3.2 External Clock Input

Figure 8.4 shows an example of connecting an external clock input. To operate the oscillator with an external clock signal, set the MOMCR.MOSEL bit to 1. The XTAL pin becomes high impedance.

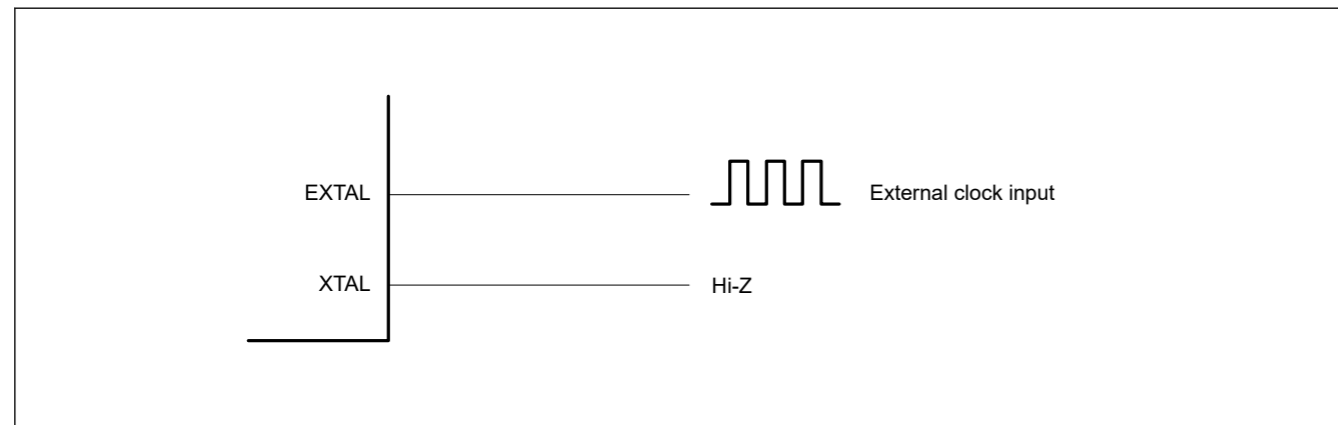


Figure 8.4 Equivalent circuit for external clock

### 8.3.3 Notes on External Clock Input

The frequency of the external clock input can only be changed when the main clock oscillator is stopped. Do not change the frequency of the external clock input when the setting of the Main Clock Oscillator Stop bit (MOSCCR.MOSTP) is 0.

### 8.4 Sub-Clock Oscillator

The only way of supplying a clock signal to the sub-clock oscillator is by connecting a crystal oscillator.

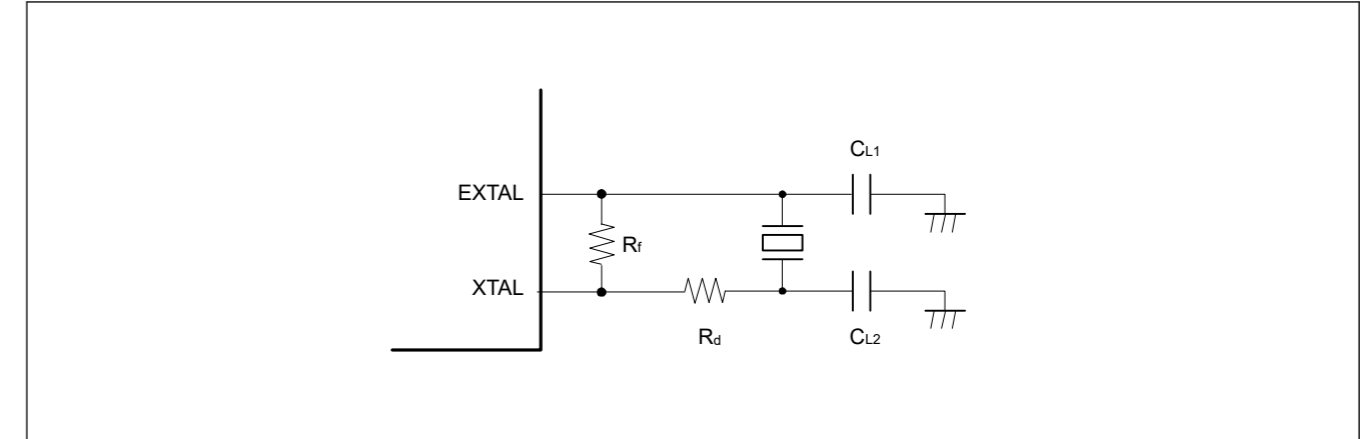


Figure 8.2 晶体谐振器连接示例

图8.3显示了晶体谐振器的等效电路。

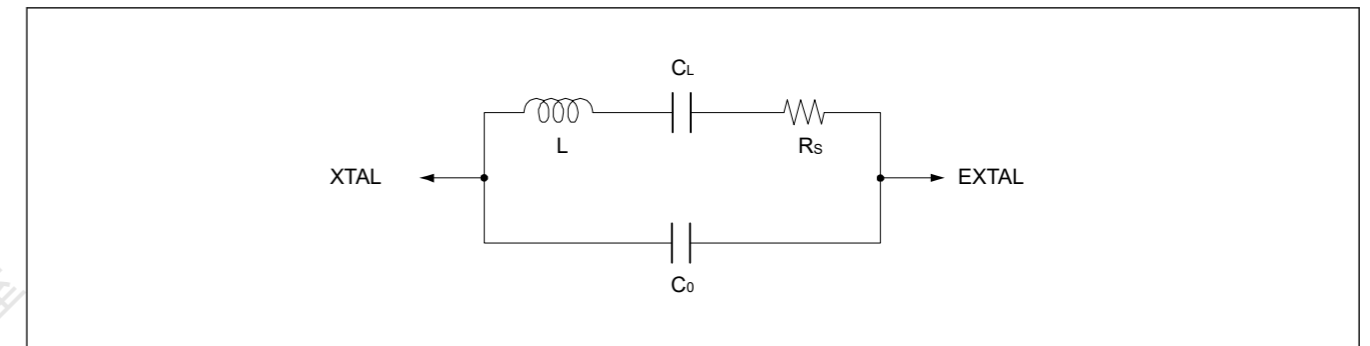


Figure 8.3 晶体谐振器的等效电路

### 8.3.2 外部时钟输入

图8.4显示了连接外部时钟输入的示例。要使用外部时钟信号操作振荡器，请将MOMCR.MOSEL位设置为1。XTAL引脚变为高阻抗。

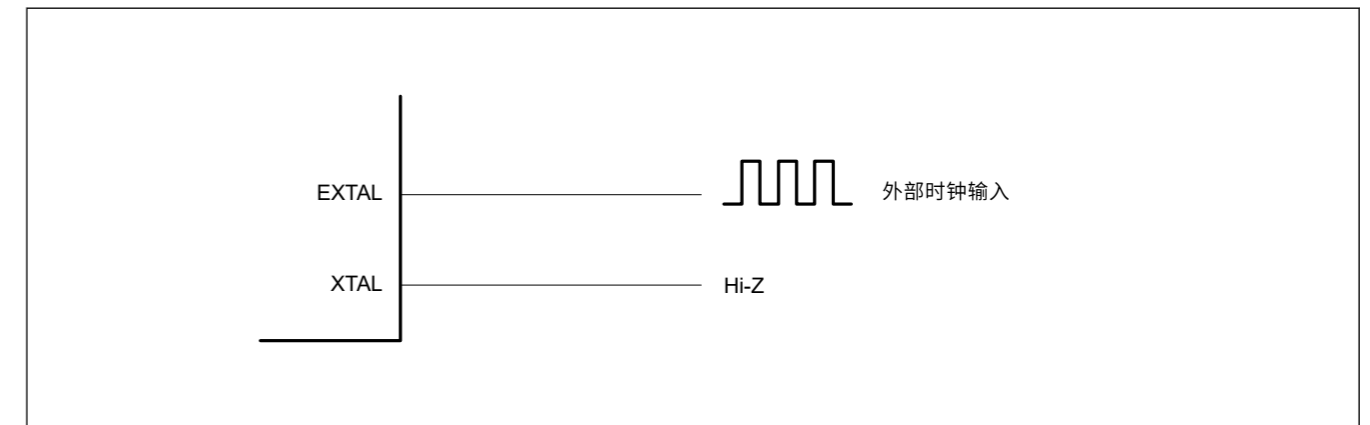


Figure 8.4 外部时钟等效电路

### 8.3.3 外部时钟输入注意事项

外部时钟输入的频率只有在主时钟振荡器停止时才能改变。当主时钟振荡器停止位(MOSCCR.MOSTP)设置为0时，请勿更改外部时钟输入的频率。

### 8.4 Sub-Clock Oscillator

向副时钟振荡器提供时钟信号的唯一方法是连接晶体振荡器。



### 8.4.1 Connecting a 32.768-kHz Crystal Resonator

To supply a clock to the sub-clock oscillator, connect a 32.768-kHz crystal resonator as shown in Figure 8.5. A damping resistor ( $R_d$ ) can be added, if necessary. Because the resistor values vary according to the resonator and the oscillation drive capability, use values recommended by the resonator manufacturer. If the resonator manufacturer recommends the use of an external feedback resistor ( $R_f$ ), insert an  $R_f$  between XCIN and XCOU by following the instructions. When connecting a resonator to supply the clock, the frequency of the resonator must be in the frequency range of the resonator for the sub-clock oscillator as described in Table 8.1.

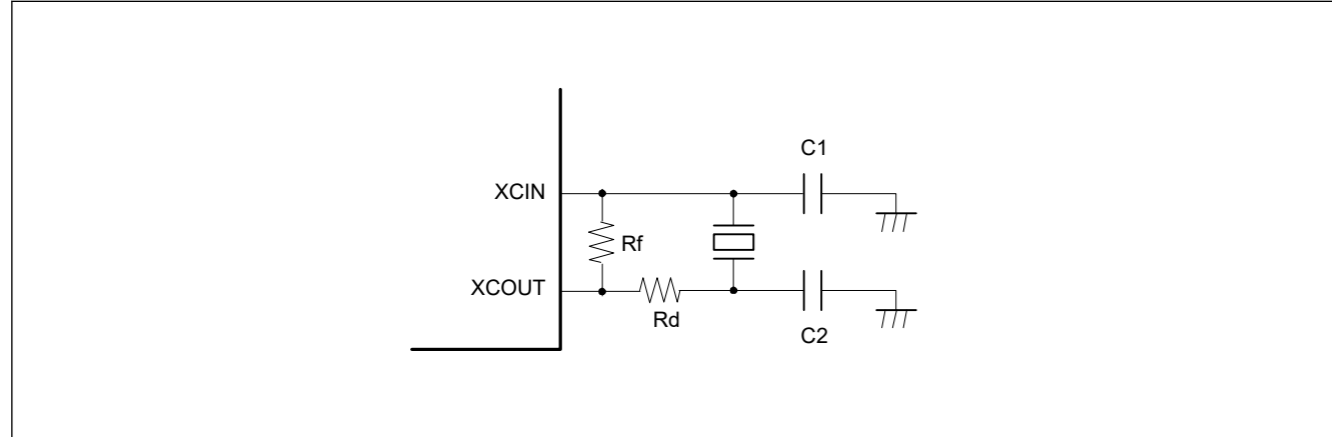


Figure 8.5 Connection example of 32.768-kHz crystal resonator

Figure 8.6 shows an equivalent circuit for the 32.768-kHz crystal resonator.

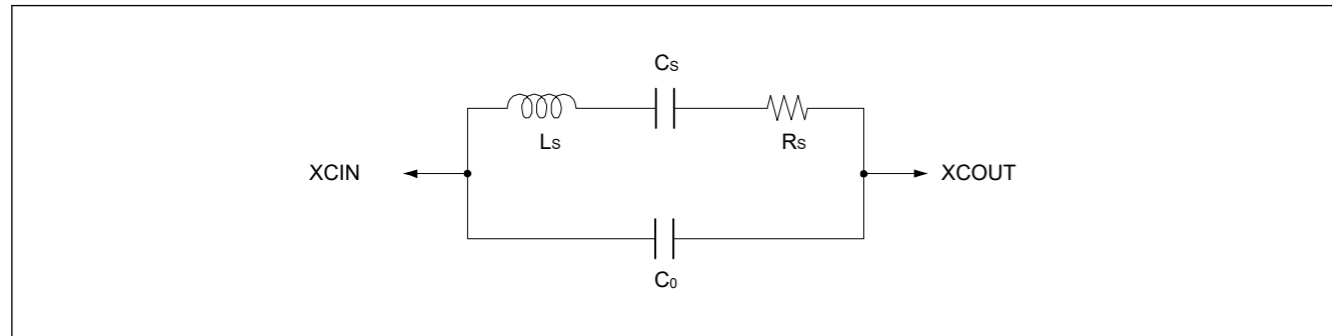


Figure 8.6 Equivalent circuit for the 32.768-kHz crystal resonator

### 8.4.2 Pin Handling When the Sub-Clock Oscillator Is Not Used

When the sub-clock oscillator is not in use, connect the XCIN pin to VSS through a resistor (to pull VSS down) and leave the XCOU pin open as shown in Figure 8.7. In addition, if an oscillator is not connected, set the Sub-Clock Oscillator Stop bit (SOSCCR.SOSTP) to 1 to stop the oscillator.

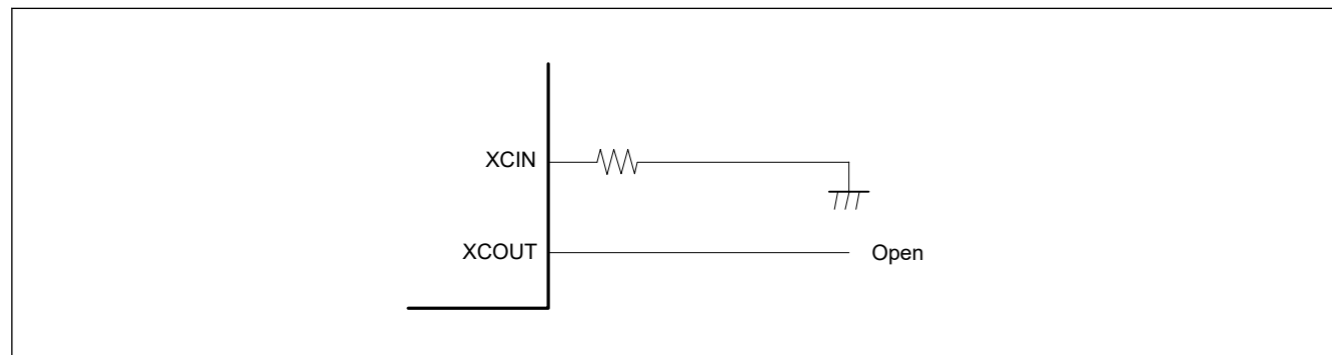


Figure 8.7 Pin handling when the sub-clock oscillator is not used

### 8.4.1 连接32.768kHz晶体谐振器

要为副时钟振荡器提供时钟，请连接一个32.768-kHz晶体谐振器，如图8.5所示。如有必要，可以添加阻尼电阻器( $R_d$ )。由于电阻值因谐振器和振荡驱动能力而异，请使用谐振器制造商推荐的值。如果谐振器制造商建议使用外部反馈电阻器( $R_f$ )，请按照说明在XCIN和XCOU之间插入一个 $R_f$ 。连接谐振器以提供时钟时，谐振器的频率必须在表8.1中所述的副时钟振荡器的谐振器频率范围内。

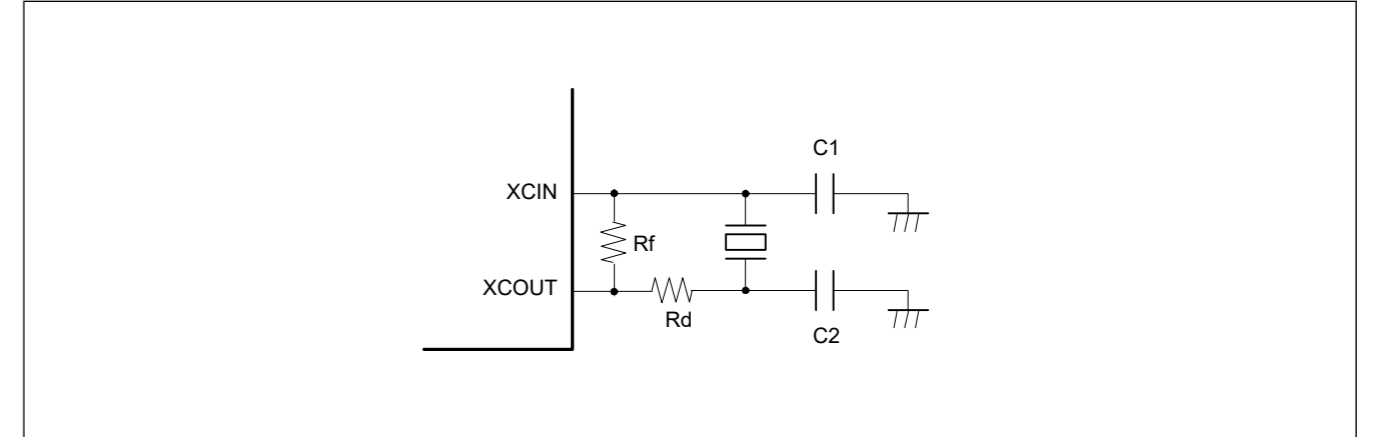


Figure 8.5 32.768-kHz晶体谐振器的连接示例

图8.6显示了32.768kHz晶体谐振器的等效电路。

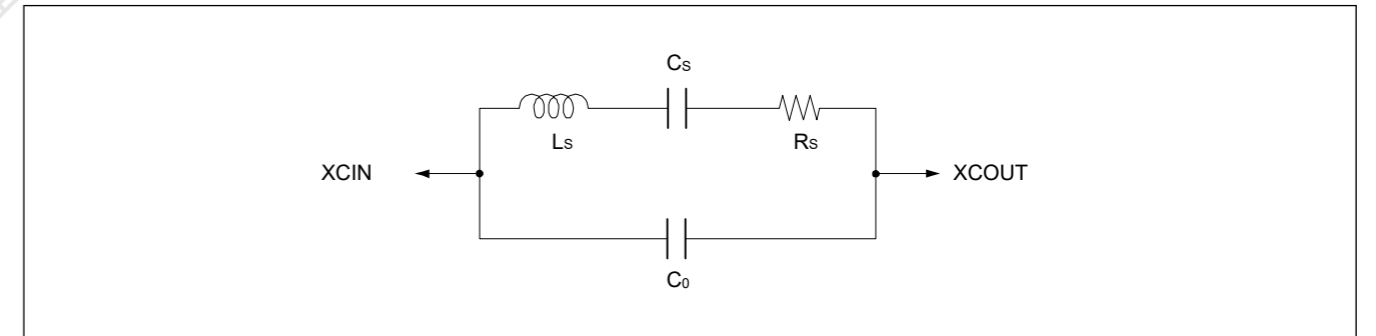


Figure 8.6 32.768kHz晶体谐振器的等效电路

### 8.4.2 不使用副时钟振荡器时的引脚处理

不使用副时钟振荡器时，通过一个电阻将XCIN引脚连接到VSS（将VSS下拉），并使XCOU引脚保持开路，如图8.7所示。此外，如果未连接振荡器，请将副时钟振荡器停止位(SOSCCR.SOSTP)设置为1以停止振荡器。

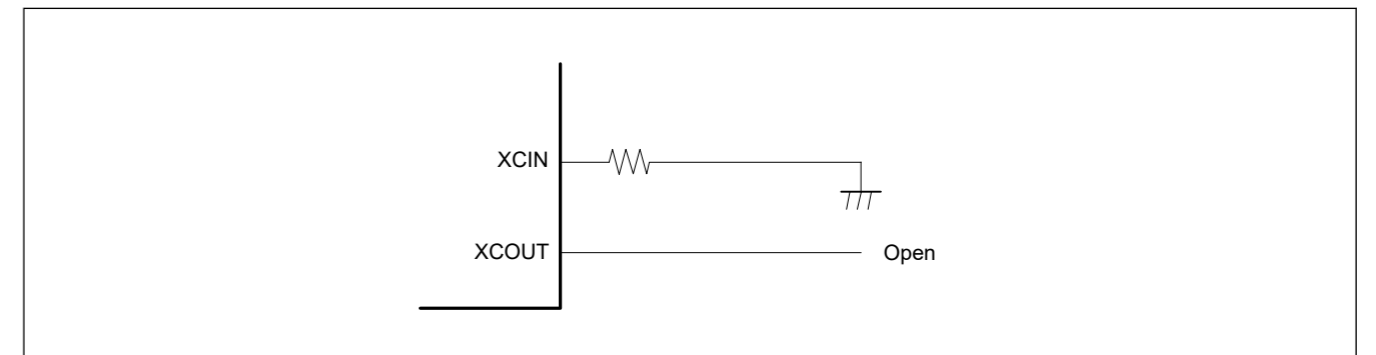


Figure 8.7 不使用副时钟振荡器时的引脚处理

## 8.5 Oscillation Stop Detection Function

### 8.5.1 Oscillation Stop Detection and Operation after Detection

The oscillation stop detection function detects the main clock oscillator stop. When oscillation stop is detected, the system clock switches as follows:

- If an oscillation stop is detected with  $SCKSCR.CKSEL[2:0] = 011b$  (system clock source = MOSC), the system clock source switches to the MOCO clock.
- If an oscillation stop is detected with  $PLLCCR.PLSRCSEL = 0$  (PLL source clock = MOSC) and  $SCKSCR.CKSEL[2:0] = 101b$  (system clock source = PLL), PLL clock remains the system clock source. However, the frequency becomes a free-running oscillation frequency.

An oscillation stop detection interrupt request can be generated when an oscillation stop is detected. In addition, the General PWM Timer (GPT) output can be forced to a high-impedance state on detection.

The main clock oscillation stop is detected when the input clock remains at 0 or 1 for a certain period, for example, when a malfunction occurs in the main clock oscillator. See [section 47, Electrical Characteristics](#).

Switching between the main clock oscillator and the MOCO clock or between the PLL clock and PLL free-running clock is controlled by the Oscillation Stop Detection Flag (OSTDSR.OSTDF).

OSTDF controls the switched clock as follows:

- When  $SCKSCR.CKSEL[2:0] = 011b$  (system clock source = MOSC):
  - When OSTDF changes from 0 to 1, the clock source switches to the MOCO clock.
  - When OSTDF changes from 1 to 0, the clock source switches back to MOSC.
- When  $PLLCCR.PLSRCSEL = 0$  (PLL source clock = MOSC) and  $SCKSCR.CKSEL[2:0] = 101b$  (System clock source = PLL):
  - When OSTDF changes 0 to 1, the clock source switches to the PLL free-running oscillation clock.
  - When OSTDF changes 1 to 0, the clock source switches back to PLL.

To switch the clock source to the main clock or PLL clock again after the oscillation stop detection, set the  $CKSEL[2:0]$  bits to a clock source other than the main clock or PLL clock and clear the OSTDF flag to 0. Also, check that the OSTDF flag is not 1, then set the  $CKSEL[2:0]$  bits to the main clock or PLL clock after the specified oscillation stabilization time elapses.

After a reset release, the main clock oscillator is stopped and the oscillation stop detection function is disabled. To enable the oscillation stop detection function, activate the main clock oscillator and write 1 to the oscillation stop detection function enable bit (OSTDCR.OSTDE) after a specified oscillation stabilization time elapses.

The oscillation stop detection function detects when the main clock is stopped by an external cause. Therefore, the oscillation stop detection function must be disabled before the main clock oscillator is stopped by software or a transition is made to Software Standby or Deep Software Standby mode.

The oscillation stop detection function switches all clocks that can be selected as the MOSC clock except CLKOUT to the MOCO (when system clock is MOSC) or PLL free-running (when system clock is PLL).

The system clock (ICKL) frequency during the MOCO (when system clock is MOSC) or PLL free-running (when system clock is PLL) operation is specified by the MOCO oscillation frequency and the division ratio set by the system clock select bits ( $SCKDIVCR.ICK[2:0]$ )

## 8.5 振荡停止检测功能

### 8.5.1 振荡停止检测和检测后操作

振荡停止检测功能检测主时钟振荡器停止。当检测到振荡停止时，系统时钟切换如下：

- 如果通过 $SCKSCR.CKSEL[2:0]=011b$ （系统时钟源=MOSC）检测到振荡停止，则系统时钟源切换到MOCO时钟。
- 如果在 $PLLCCR.PLSRCSEL=0$ （PLL源时钟=MOSC）的情况下检测到振荡停止并且 $SCKSCR.CKSEL[2:0]=101b$ （系统时钟源=PLL），PLL时钟仍然是系统时钟源。然而，该频率变为自由运行的振荡频率。

当检测到振荡停止时，可以产生一个振荡停止检测中断请求。此外，一般PWM定时器(GPT)输出可在检测时强制为高阻抗状态。

当输入时钟保持在0或1一段时间，例如，当主时钟振荡器发生故障时，检测到主时钟振荡停止。参见第47节，电气特性。

主时钟振荡器和MOCO时钟之间或PLL时钟和PLL自由运行时钟之间的切换由振荡停止检测标志(OSTDSR.OSTDF)控制。

OSTDF控制切换时钟如下：

- 当 $SCKSCR.CKSEL[2:0]=011b$ 时（系统时钟源=MOSC）：
  - 当OSTDF从0变为1时，时钟源切换到MOCO时钟。
  - 当OSTDF从1变为0时，时钟源切换回MOSC。
- 当 $PLLCCR.PLSRCSEL=0$ （PLL源时钟=MOSC）且 $SCKSCR.CKSEL[2:0]=101b$ （系统时钟源=PLL）时：
  - 当OSTDF由0变为1时，时钟源切换到PLL自由运行振荡时钟。
  - 当OSTDF由1变为0时，时钟源切换回PLL。

要在检测到振荡停止后再次将时钟源切换为主时钟或PLL时钟，请将 $CKSEL[2:0]$ 位设置为主时钟或PLL时钟以外的时钟源，并将OSTDF标志清零。此外，检查OSTDF标志不为1，然后在指定的振荡稳定时间过去后将 $CKSEL[2:0]$ 位设置为主时钟或PLL时钟。

复位释放后，主时钟振荡器停止，振荡停止检测功能被禁用。要启用振荡停止检测功能，激活主时钟振荡器并在经过指定的振荡稳定时间后将1写入振荡停止检测功能使能位(OSTDCR.OSTDE)。

振荡停止检测功能检测主时钟何时因外部原因停止。因此，必须在软件停止主时钟振荡器或转换到软件待机或深度软件待机模式之前禁用振荡停止检测功能。

振荡停止检测功能将除CLKOUT之外的所有可选择作为MOSC时钟的时钟切换到MOCO（系统时钟为MOSC时）或PLL自由运行（系统时钟为PLL时）。

MOCO（系统时钟为MOSC时）或PLL自由运行（系统时钟为PLL时）操作期间的系统时钟（ICKL）频率由MOCO振荡频率和系统时钟选择位（ $SCKDIVCR$ ）设置的分频比指定。 $ICK[2:0]$

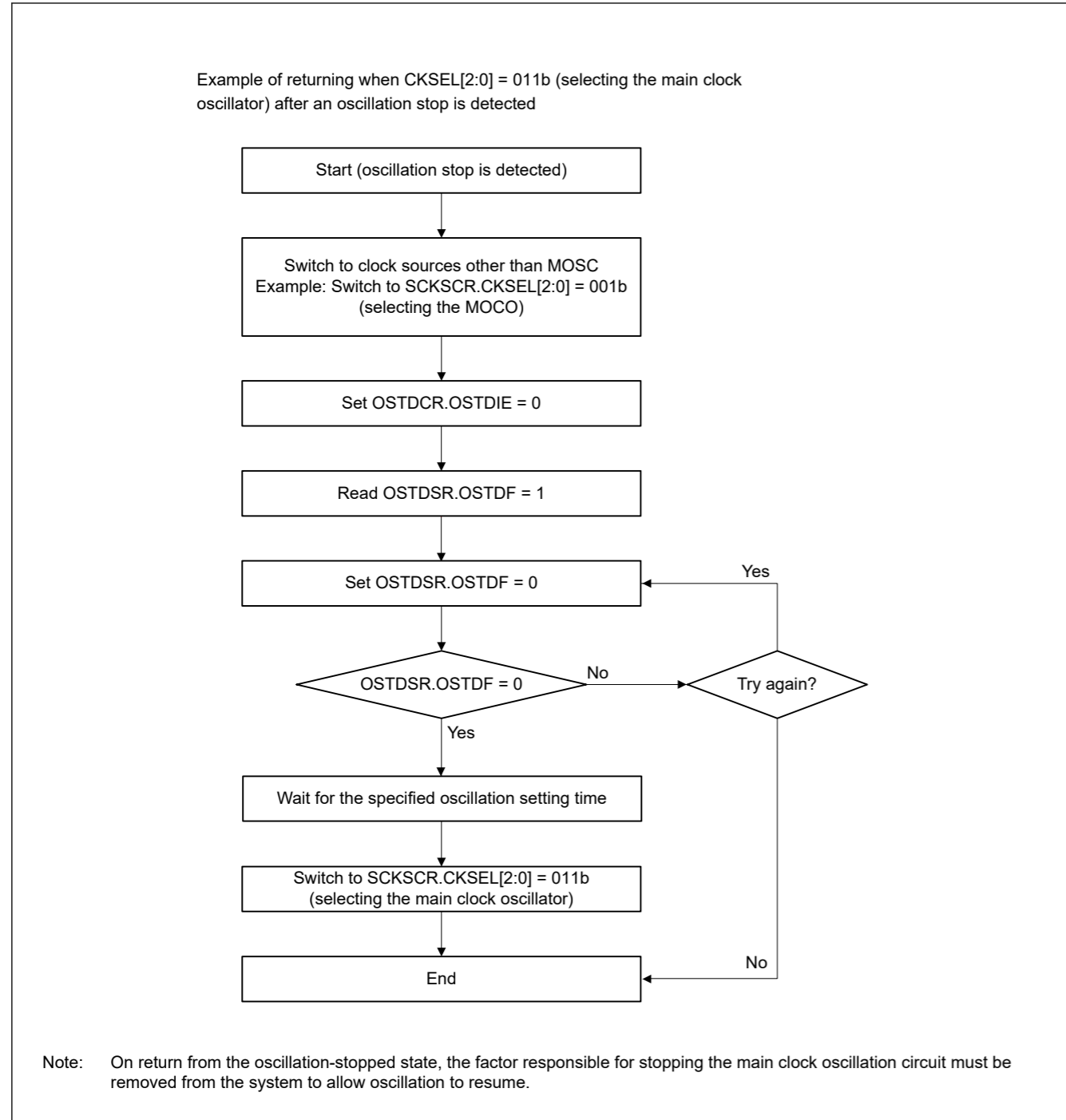


Figure 8.8 Flow of recovery on detection of oscillator stop

### 8.5.2 Oscillation Stop Detection Interrupts

An oscillation stop detection interrupt (MOSC\_STOP) is generated when the Oscillation Stop Detection Flag (OSTDSR.OSTDF) is 1 and the Oscillation Stop Detection Interrupt Enable bit in the Oscillation Stop Detection Control Register (OSTDCR.OSTDIE) is 1 (enabled). The Port Output Enable for GPT (POEG) is notified of the main clock oscillator stop. On receiving the notification, the POEG sets the Oscillation Stop Detection Flag in the POEG Group n Setting Register (POEGGn.OSTPF) to 1 (n = A, B, C, D).

After the oscillation stop is detected, wait at least 10 PCLKB clock cycles before writing to the POEGGn.OSTPF flag. When the OSTDSR.OSTDF flag requires clearing, do so after clearing the Oscillation Stop Detection Interrupt Enable bit in the Oscillation Stop Detection Control Register (OSTDCR.OSTDIE). Wait at least 2 PCLKB clock cycles before setting the OSTDCR.OSTDIE bit to 1 again. A longer PCLKB wait time might be required, depending on the number of cycles required to read a given I/O register.

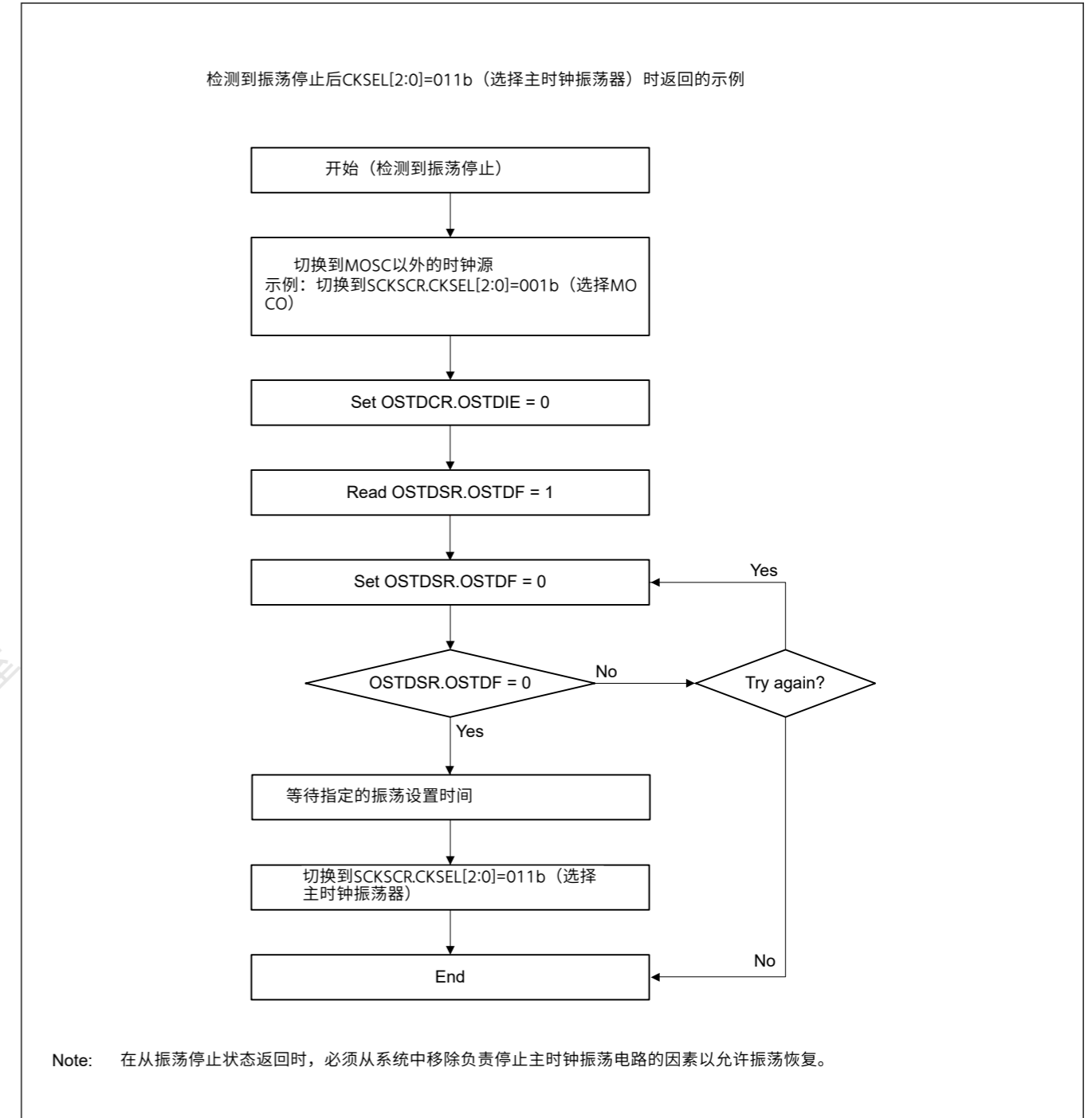


Figure 8.8 检测到振荡器停止时的恢复流程

### 8.5.2 振荡停止检测中断

当振荡停止检测标志(OSTDSR.OSTDF)为1且振荡停止检测控制寄存器(OSTDCR.OSTDIE)中的振荡停止检测中断使能位为1 (使能) 时, 将产生一个振荡停止检测中断(MOSC\_STOP)。GPT端口输出使能(POEG)被通知主时钟振荡器停止。收到通知后, POEG将POEG组n设置寄存器(POEGGn.OSTPF)中的振荡停止检测标志设置为1(n=A B C D)。

检测到振荡停止后, 至少等待10个PCLKB时钟周期, 然后再写入POEGGn.OSTPF标志。当需要清除OSTDSR.OSTDF标志时, 请在清除振荡停止检测控制寄存器(OSTDCR.OSTDIE)中的振荡停止检测中断使能位后执行此操作。至少等待2个PCLKB时钟周期, 然后再将OSTDCR.OSTDIE位设置为1。可能需要更长的PCLKB等待时间, 具体取决于读取给定IO寄存器所需的周期数。

The oscillation stop detection interrupt is a non-maskable interrupt. Because non-maskable interrupts are disabled in the initial state after a reset release, enable non-maskable interrupts through software before using oscillation stop detection interrupts. For details, see [section 13, Interrupt Controller Unit \(ICU\)](#).

## 8.6 PLL Circuit

The PLL circuit has a function to multiply the frequency from the oscillator.

## 8.7 Internal Clock

Clock sources for the internal clock signals include:

- Main clock
- Sub-clock
- HOCO clock
- MOCO clock
- LOCO clock
- PLL clock
- PLL2 clock
- IWDT-dedicated clock
- JTAG clock

The following internal clocks are produced from these sources.

- Operating clock of the CPU, DMAC, DTC, Flash, and RAM: System clock (ICLK)
- Operating clocks of peripheral modules: Peripheral module clocks (PCLKA, PCLKB, PCLKC, PCLKD)
- Operating clock of the FlashIF: FlashIF clock (FCLK)
- Operating clock for the USBFS clock (USBCLK)
- Operating clock for the CAN: CAN clock (CANMCLK)
- Operating clocks for the CAC: CAC clock (CACCLK)
- Operating clock for the RTC: RTC-dedicated LOCO clock (RTCLCLK)
- Operating clock for the RTC: RTC-dedicated sub clock (RTCSCLK)
- Operating clock for the IWDT: IWDT-dedicated clock (IWDTCLK)
- Operating clock for the AGT: AGT-dedicated LOCO clock (AGTLCLK)
- Operating clock for the AGT: AGT-dedicated sub clock (AGTSCLK)
- Operating clock for the Systick Timer: Systick Timer-dedicated clock (SYSTICCLK)
- Clock for external pin output: Clock/Buzzer output clock (CLKOUT)
- Operating clock for the JTAG: JTAG clock (JTAGTCK)

For details on the registers used to set the frequencies of the internal clocks, see [section 8.7.1. System Clock \(ICLK\)](#) to [section 8.7.12. JTAG Clock \(JTAGTCK\)](#)

If the value of any of these bits is changed, subsequent operation is at the frequency determined by the new value.

### 8.7.1 System Clock (ICLK)

The system clock (ICLK) is the operating clock of the CPU, DMAC, DTC, Flash, and SRAM.

The ICLK frequency is specified by the ICK[2:0] bits in SCKDIVCR, the CKSEL[2:0] bits in SCKSCR, the PLLMUL[5:0], and PLIDIV[1:0] bits in PLLCCR, and the HOCOFREQ[1:0] bits in OFS1.

When the ICLK clock source is switched, the duration of the ICLK clock cycle becomes longer during the clock source transition period. See [Figure 8.9](#) and [Figure 8.10](#).

振荡停止检测中断是一个不可屏蔽的中断。由于不可屏蔽中断在复位释放后的初始状态下被禁用，因此在使用振荡停止检测中断之前，请通过软件启用不可屏蔽中断。有关详细信息，请参阅第13节，中断控制器单元(ICU)。

## 8.6 PLL Circuit

PLL电路具有倍增振荡器频率的功能。

## 8.7 内部时钟

内部时钟信号的时钟源包括：

- 主时钟
- Sub-clock
- HOCO clock
- MOCO clock
- LOCO时钟
- PLL clock
- PLL2 clock
- IWDT-dedicated clock
- JTAG clock

以下内部时钟由这些源产生。

- CPU、DMAC、DTC、Flash、RAM的工作时钟：系统时钟 (ICLK)
- 外设模块工作时钟：外设模块时钟 (PCLKA、PCLKB、PCLKC、PCLKD)
- FlashIF的工作时钟：FlashIF时钟 (FCLK)
- USBFS时钟 (USBCLK) 的工作时钟
- CAN的工作时钟：CAN时钟(CANMCLK)
- CAC的工作时钟：CAC时钟(CACCLK)
- RTC的工作时钟：RTC专用的LOCO时钟(RTCLCLK)
- RTC的工作时钟：RTC专用子时钟(RTCSCLK)
- IWDT的工作时钟：IWDT专用时钟 (IWDTCLK)
- AGT的工作时钟：AGT专用的LOCO时钟(AGTLCLK)
- AGT的工作时钟：AGT专用子时钟(AGTSCLK)
- SystickTimer的工作时钟：SystickTimer专用时钟(SYSTICCLK)
- 外部引脚输出时钟：时钟蜂鸣器输出时钟 (CLKOUT)
- JTAG的工作时钟：JTAG时钟 (JTAGTCK)

有关用于设置内部时钟频率的寄存器的详细信息，请参见第8.7.1节。系统时钟(ICLK)参见第8.7.12节。JTAG时钟(JTAGTCK)

如果这些位中的任何一个的值发生变化，则后续操作将以新值确定的频率进行。

### 8.7.1 系统时钟(ICLK)

系统时钟(ICLK)是CPU、DMAC、DTC、Flash和SRAM的工作时钟。

ICLK频率由SCKDIVCR中的ICK[2:0]位、SCKSCR中的CKSEL[2:0]位、PLLCCR中的PLLMUL[5:0]和PLIDIV[1:0]位以及HOCOFREQ指定OFS1中的[1:0]位。

当ICLK时钟源切换时，ICLK时钟周期的持续时间在时钟源转换期间变长。请参见图8.9和图8.10。



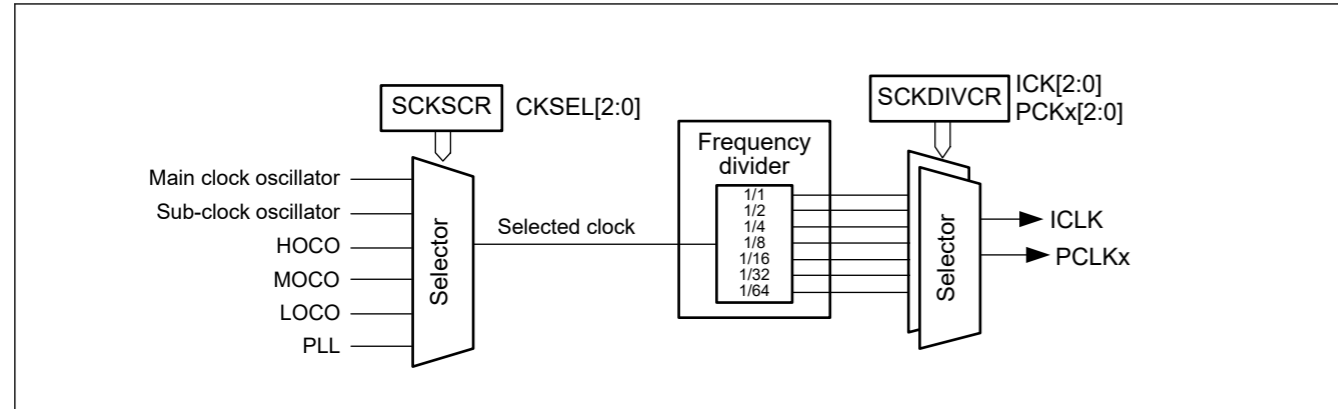


Figure 8.9 Block diagram of clock source selector

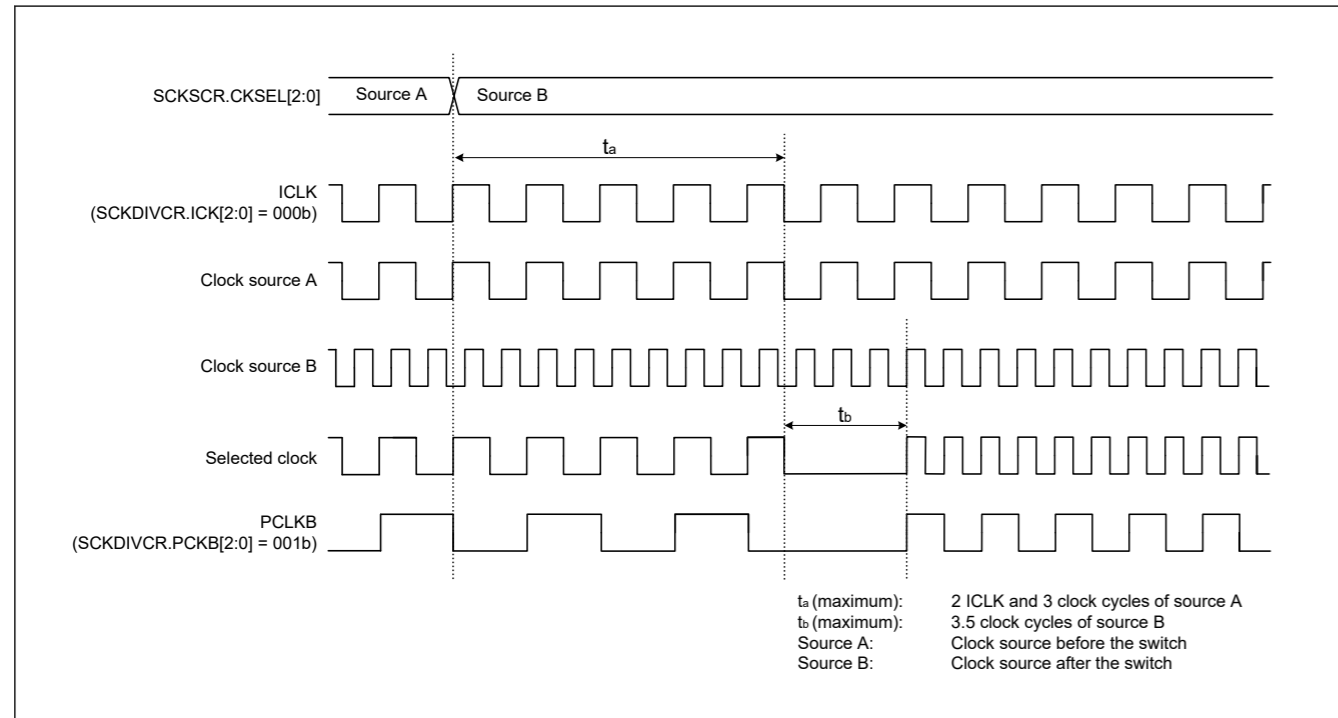


Figure 8.10 Timing of clock source switching

### 8.7.2 Peripheral Module Clock (PCLKA, PCLKB, PCLKC, PCLKD)

The peripheral module clocks (PCLKA, PCLKB, PCLKC, PCLKD) are the operating clocks for the peripheral modules.

The frequency of the given clock is specified in the following bits:

- PCKA[2:0], PCKB[2:0], PCKC[2:0], PCKD[2:0] bits in SCKDIVCR
- CKSEL[2:0] bits in SCKSCR
- PLLMUL[5:0] and PLIDIV[1:0] bits in PLLCCR
- HOCOFRQ0[1:0] bits in OFS1.

When the clock source of the peripheral module clock is switched, the duration of the peripheral module clock cycle becomes longer during the clock source transition period. See Figure 8.9 and Figure 8.10.

### 8.7.3 FlashIF Clock (FCLK)

The flash interface clock (FCLK) is the operating clock for the flash memory interface. In addition to reading from the data flash, FCLK is used for the programming and erasure of the code flash and data flash.

The FCLK frequency is specified in the following bits:

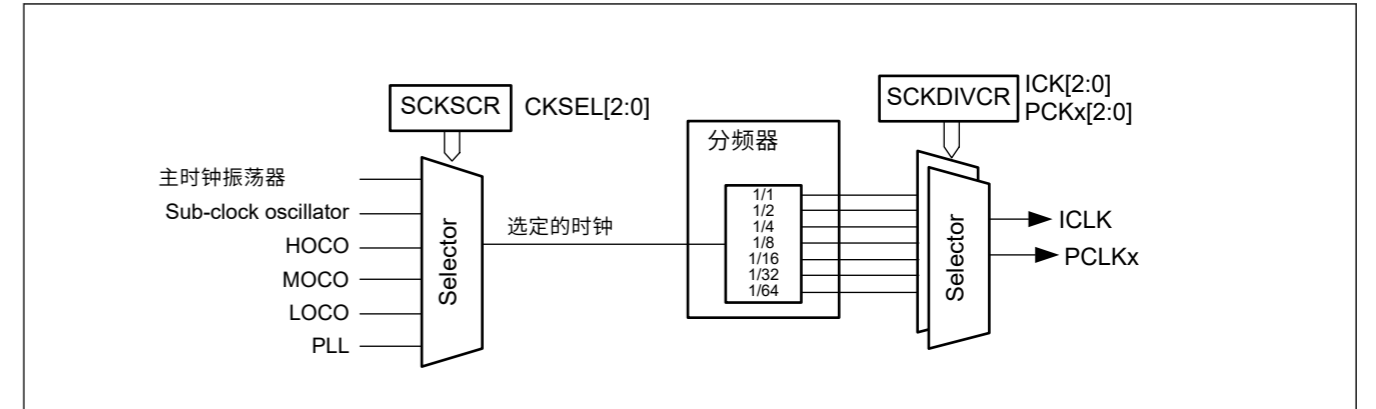


Figure 8.9 时钟源选择器框图

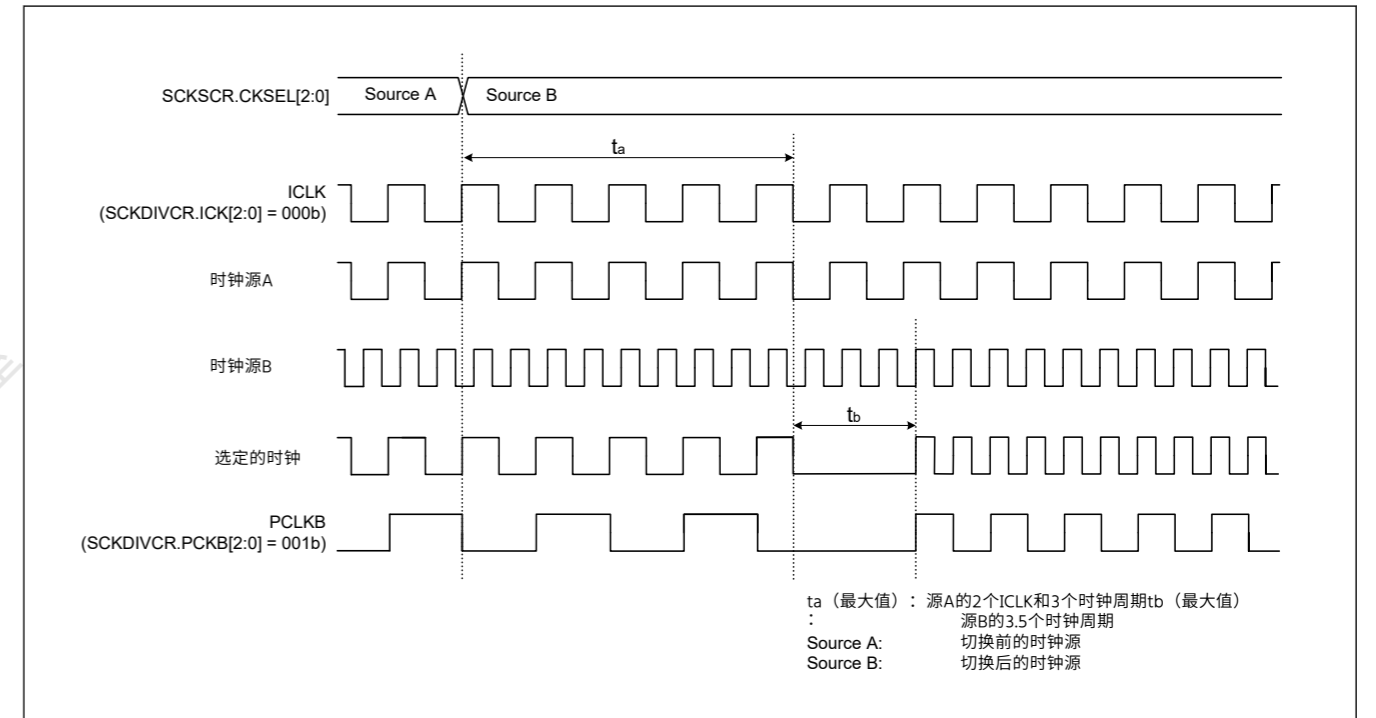


Figure 8.10 时钟源切换时序

### 8.7.2 外设模块时钟 (PCLKA、PCLKB、PCLKC、PCLKD)

外围模块时钟 (PCLKA、PCLKB、PCLKC、PCLKD) 是外围模块的工作时钟。

给定时钟的频率在以下位中指定：

- SCKDIVCR中的PCKA[2:0]、PCKB[2:0]、PCKC[2:0]、PCKD[2:0]位
- SCKSCR中的CKSEL[2:0]位
- PLLCCR中的PLLMUL[5:0]和PLIDIV[1:0]位
- OFS1中的HOCOFRQ0[1:0]位。

当外围模块时钟的时钟源切换时，外围模块时钟周期的持续时间在时钟源转换期间会变长。请参见图8.9和图8.10。

### 8.7.3 FlashIF Clock (FCLK)

闪存接口时钟(FCLK)是闪存接口的工作时钟。除了从数据闪存读取外，FCLK还用于代码闪存和数据闪存的编程和擦除。

FCLK频率在以下位中指定：



- FCK[2:0] bits in SCKDIVCR
- CKSEL[2:0] bits in SCKSCR
- PLLMUL[5:0] and PLIDIV[1:0] bits in PLLCCR
- HOCOFRQ0[1:0] bits in OFS1.

#### 8.7.4 USB Clock (USBCLK)

The USB clock (USBCLK) is the operating clock for the USBFS module.

A 48-MHz clock must be supplied to the USB module. When the USB module is used, setting must be made so that USBCLK is 48 MHz.

The USBCLK frequency is specified in the following bits:

- USBCKSEL[2:0] bits in USBCKCR
- USBCKDIV[2:0] bits in USBCKDIVCR
- PLLMUL[5:0] and PLIDIV[1:0] bits in PLLCCR
- PLL2MUL[5:0] and PL2IDIV[1:0] bits in PLL2CCR.

#### 8.7.5 CAN Clock (CANMCLK)

The CAN clock, CANMCLK, is the operating clock for the CAN module. CANMCLK is generated by the main clock oscillator.

#### 8.7.6 CAC Clock (CACCLK)

The CAC clock, CACCLK, is the operating clock for the CAC. CACCLK is generated by the following oscillators:

- Main clock oscillator
- Sub-clock oscillator
- High-speed clock oscillator (HOCO)
- Middle-speed clock oscillator (MOCO)
- Low-speed on-chip oscillator (LOCO)
- IWDT-dedicated on-chip oscillator. (IWDTLOCO)

#### 8.7.7 RTC-Dedicated Clock (RTCSCLK, RTCLCLK)

The RTC-dedicated clock (RTCSCLK, RTCLCLK) is the operating clock for the RTC.

RTCSCLK is generated by the sub-clock oscillator, and RTCLCLK is generated by the LOCO clock.

#### 8.7.8 IWDT-Dedicated Clock (IWDTCLK)

The IWDT-dedicated clock (IWDTCLK) is the operating clock for the IWDT. IWDTCLK is internally generated by the IWDT-dedicated on-chip oscillator.

#### 8.7.9 AGT-Dedicated Clock (AGTSCLK, AGTLCLK)

The AGT-dedicated clocks (AGTSCLK and AGTLCLK) are the operating clocks for the AGT. AGTSCLK is generated by the sub-clock oscillator, and AGTLCLK is generated by the LOCO clock.

#### 8.7.10 SysTick Timer-Dedicated Clock (SYSTICCLK)

The SysTick timer-dedicated clock, SYSTICCLK, is the operating clock for the SYSTICCLK. SYSTICCLK is generated by the LOCO clock.

#### 8.7.11 External Pin Output Clock (CLKOUT)

- SCKDIVCR中的FCK[2:0]位
- SCKSCR中的CKSEL[2:0]位
- PLLCCR中的PLLMUL[5:0]和PLIDIV[1:0]位
- OFS1中的HOCOFRQ0[1:0]位。

#### 8.7.4 USB时钟(USBCLK)

USB时钟(USBCLK)是USBFS模块的工作时钟。

必须为USB模块提供48-MHz时钟。使用USB模块时，必须进行设置，以便USBCLK is 48 MHz。

USBCLK频率在以下位中指定：

- USBCKCR中的USBCKSEL[2:0]位
- USBCKDIVCR中的USBCKDIV[2:0]位
- PLLCCR中的PLLMUL[5:0]和PLIDIV[1:0]位
- PLL2CCR中的PLL2MUL[5:0]和PL2IDIV[1:0]位。

#### 8.7.5 CAN时钟(CANMCLK)

CAN时钟CANMCLK是CAN模块的工作时钟。CANMCLK由主时钟振荡器产生。

#### 8.7.6 CAC时钟(CACCLK)

CAC时钟CACCLK是CAC的工作时钟。CACCLK由以下振荡器产生：

- 主时钟振荡器
- Sub-clock oscillator
- 高速时钟振荡器 (HOCO)
- 中速时钟振荡器 (MOCO)
- Low-speed on-chip oscillator (LOCO)
- IWDT-dedicated on-chip oscillator. (IWDTLOCO)

#### 8.7.7 RTC-Dedicated Clock (RTCSCLK, RTCLCLK)

RTC专用时钟 (RTCSCLK、RTCLCLK) 是RTC的工作时钟。

RTCSCLK由副时钟振荡器产生，RTCLCLK由LOCO时钟产生。

#### 8.7.8 IWDT-Dedicated Clock (IWDTCLK)

IWDT专用时钟(IWDTCLK)是IWDT的工作时钟。IWDTCLK由内部产生IWDT-dedicated on-chip oscillator。

#### 8.7.9 AGT-Dedicated Clock (AGTSCLK, AGTLCLK)

AGT专用时钟 (AGTSCLK和AGTLCLK) 是AGT的工作时钟。AGTSCLK由副时钟振荡器产生，AGTLCLK由LOCO时钟产生。

#### 8.7.10 SysTick Timer-Dedicated Clock (SYSTICCLK)

SysTick定时器专用时钟SYSTICCLK是SYSTICCLK的工作时钟。SYSTICCLK由LOCO时钟生成。

#### 8.7.11 外部引脚输出时钟(CLKOUT)

The CLKOUT is output externally from the CLKOUT pin for the clock or buzzer output. CLKOUT is output to the CLKOUT pin when CKOCR.CKOEN is set to 1. Only change the value in the CKODIV[2:0] or CKOSEL[2:0] bits in CKOCR when the CKOCR.CKOEN bit is 0.

The CLKOUT clock frequency is specified in the following bits:

- CKODIV[2:0] or CKOSEL[2:0] in CKOCR
- HOCOFRQ0[1:0] bit in OFS1

### 8.7.12 JTAG Clock (JTAGTCK)

The JTAG clock (JTAGTCK) is the clock for the JTAG.

JTAGTCK is generated by the JTAG external clock (TCK).

## 8.8 Usage Notes

### 8.8.1 Notes on Clock Generation Circuit

The frequency of the following clocks supplied to each module changes according to the setting of the SCKDIVCR register:

- System clock (ICLK)
- Peripheral module clocks (PCLKA, PCLKB, PCLKC, and PCLKD)
- FlashIF clock (FCLK)

Each frequency must meet the following conditions:

- Each frequency must be selected within the operation-guaranteed range of the operating frequency (f) specified in the AC characteristics. See [section 47, Electrical Characteristics](#).
- The system clock, peripheral module clock must be set according to [Table 8.2](#).

To ensure correct processing after the clock frequency changes, first write to the relevant Clock Control register to change the frequency, then read the value from the register, and finally perform the subsequent processing.

### 8.8.2 Notes on Resonator

Because various resonator characteristics relate closely to your board design, adequate evaluation is required before use. See the resonator connection example in [Figure 8.5](#). The circuit constants for the resonator depend on the resonator to be used and the stray capacitance of the mounting circuit. Therefore, consult the resonator manufacturer when determining the circuit constants. The voltage to be applied between the resonator pins must be within the absolute maximum rating.

### 8.8.3 Notes on Board Design

When using a crystal resonator, place the resonator and its load capacitors as close to the XTAL and EXTAL pins as possible. Other signal lines should be routed away from the oscillation circuit as shown in [Figure 8.11](#) to prevent electromagnetic induction from interfering with correct oscillation. [Figure 8.11](#) shows the case which the main clock oscillator is used. In case of sub-clock oscillator, it is also same as [Figure 8.11](#).

CLKOUT从CLKOUT引脚外部输出，用于时钟或蜂鸣器输出。CLKOUT被输出到CKOCR.CKOEN设置为1时的CLKOUT引脚。仅更改CKODIV[2:0]或CKOSEL[2:0]位中的值CKOCR.CKOEN位为0时的CKOCR。

CLKOUT时钟频率在以下位中指定：

- CKOCR中的CKODIV[2:0]或CKOSEL[2:0]
- OFS1中的HOCOFRQ0[1:0]位

### 8.7.12 JTAG Clock (JTAGTCK)

JTAG时钟(JTAGTCK)是JTAG的时钟。

JTAGTCK由JTAG外部时钟(TCK)生成。

## 8.8 使用说明

### 8.8.1 时钟产生电路注意事项

提供给每个模块的以下时钟的频率根据SCKDIVCR寄存器的设置而变化：

- 系统时钟 (ICLK)
- 外设模块时钟 (PCLKA、PCLKB、PCLKC和PCLKD)
- FlashIF clock (FCLK)

每个频率必须满足以下条件：

- 各频率必须在交流特性规定的工作频率(f)的工作保证范围内选择。参见第47节，电气特性。
- 系统时钟、外围模块时钟必须按照表8.2设置。

为保证时钟频率变化后的正确处理，首先写入相关的ClockControl寄存器改变频率，然后从寄存器中读取值，最后进行后续处理。

### 8.8.2 谐振器注意事项

由于各种谐振器特性与您的电路板设计密切相关，因此在使用前需要进行充分评估。请参见图8.5中的谐振器连接示例。谐振器的电路常数取决于要使用的谐振器和安装电路的杂散电容。因此，在确定电路常数时，请咨询谐振器制造商。施加在谐振器引脚之间的电压必须在绝对最大额定值范围内。

### 8.8.3 电路板设计注意事项

使用晶体谐振器时，将谐振器及其负载电容尽可能靠近XTAL和EXTAL引脚。其他信号线应远离振荡电路，如图8.11所示，以防止电磁感应干扰正确的振荡。图8.11显示了使用主时钟振荡器的情况。如果是副时钟振荡器，也与图8.11相同。

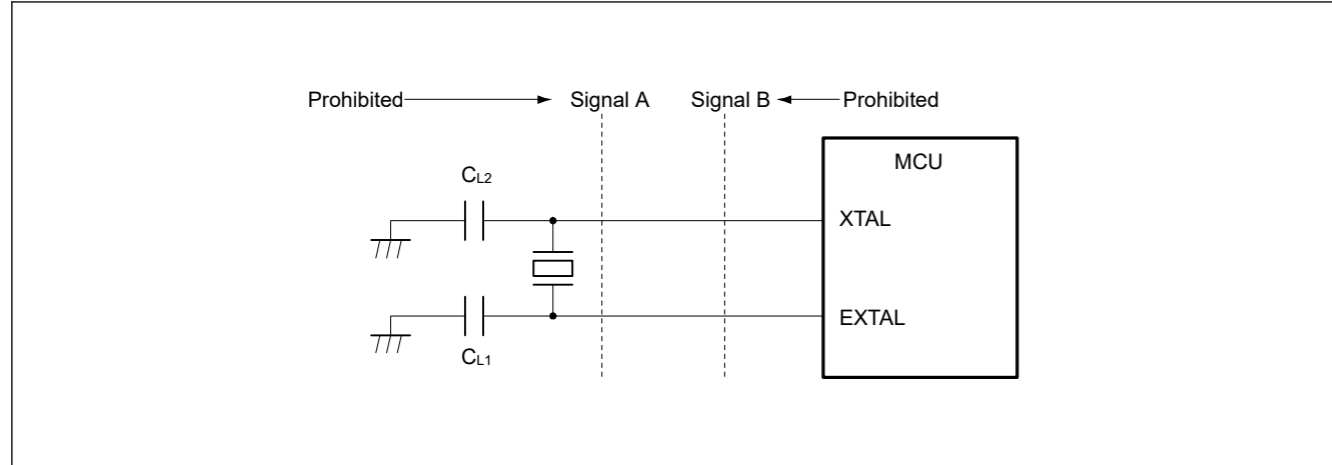


Figure 8.11 Signal routing in board design for oscillation circuit

#### 8.8.4 Notes on Resonator Connect Pin

When the main clock is not used, the EXTAL and XTAL pins can be used as general ports. When these pins are used as general ports, the main clock must be stopped (MOSCCR.MOSTP bit should be set to 1).

#### 8.8.5 Notes on Using Sub-Clock Oscillator

The output of the P212 (EXTAL), P213 (XTAL), and P705 pins may affect the oscillation by the sub-clock oscillator.

If the sub-clock oscillator is used, implement board design so as not to affect the oscillation. Renesas strongly recommends setting the DSCR[1:0] bits to 00b or 01b when using the P212 (EXTAL), P213 (XTAL), and P705 as output pins and using the sub-clock oscillator.

In addition, when using the sub-clock oscillator in middle drive capability (SOMCR.SODRV1 = 1), Renesas recommends setting the DSCR[1:0] bits to 00b when using the P212 (EXTAL), P213 (XTAL), and P705 as output pins and using the sub-clock oscillator.

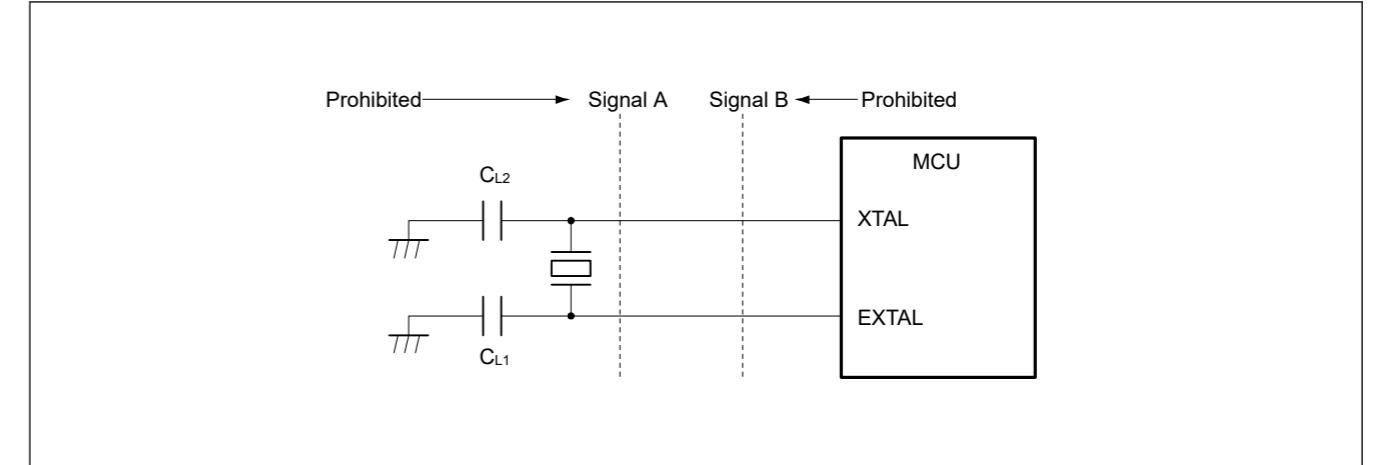


Figure 8.11 振荡电路板设计中的信号路由

#### 8.8.4 谐振器连接引脚注意事项

当不使用主时钟时，EXTAL和XTAL引脚可用作通用端口。当这些引脚用作通用端口时，必须停止主时钟（MOSCCR.MOSTP位应设置为1）。

#### 8.8.5 使用副时钟振荡器的注意事项

P212(EXTAL)、P213(XTAL)和P705引脚的输出可能会影响副时钟振荡器的振荡。

如果使用副时钟振荡器，请在不影响振荡的情况下进行板卡设计。当使用P212(EXTAL)、P213(XTAL)和P705作为输出引脚并使用副时钟振荡器时，瑞萨强烈建议将DSCR[1:0]位设置为00b或01b。

此外，当在中间驱动能力中使用副时钟振荡器(SOMCR.SODRV1=1)时，瑞萨建议在使用P212(EXTAL)、P213(XTAL)和P705时将DSCR[1:0]位设置为00b作为输出引脚并使用副时钟振荡器。

## 9. Clock Frequency Accuracy Measurement Circuit (CAC)

### 9.1 Overview

The Clock Frequency Accuracy Measurement Circuit (CAC) counts pulses of the clock to be measured (measurement target clock) within the time generated by the clock selected as the measurement reference (measurement reference clock), and determines the accuracy depending on whether the number of pulses is within the allowable range. When measurement is complete or the number of pulses within the time generated by the measurement reference clock is not within the allowable range, an interrupt request is generated.

Table 9.1 lists the CAC specifications, Figure 9.1 shows the CAC block diagram, and Table 9.2 lists the CAC I/O pin.

**Table 9.1 CAC specifications**

| Parameter                    | Specifications   |
|------------------------------|--|
| Measurement target clocks    | Frequency can be measured for: <ul style="list-style-type: none"> <li>• Main clock oscillator</li> <li>• Sub-clock oscillator</li> <li>• HOCO clock</li> <li>• MOCO clock</li> <li>• LOCO clock</li> <li>• Peripheral module clock B (PCLKB)</li> <li>• IWDT-dedicated clock</li> </ul>  |
| Measurement reference clocks | Frequency can be referenced to: <ul style="list-style-type: none"> <li>• External clock input to the CACREF pin</li> <li>• Main clock oscillator</li> <li>• Sub-clock oscillator</li> <li>• HOCO clock</li> <li>• MOCO clock</li> <li>• LOCO clock</li> <li>• Peripheral module clock B (PCLKB)</li> <li>• IWDT-dedicated clock</li> </ul> |
| Selectable function          | Digital filter   |
| Interrupt sources            | <ul style="list-style-type: none"> <li>• Measurement end</li> <li>• Frequency error</li> <li>• Overflow</li> </ul>   |
| Module-stop function         | Module-stop state can be set to reduce power consumption   |
| TrustZone Filter             | Security attribution can be set  |

## 9. 时钟频率精度测量电路(CAC)

### 9.1 Overview

时钟频率精度测量电路(CAC)在被选为测量基准的时钟(测量基准时钟)产生的时间内对要测量的时钟(测量目标时钟)的脉冲进行计数,并根据脉冲数在允许范围内。当测量完成或测量参考时钟产生的时间内的脉冲数不在允许范围内时,将产生中断请求。

表9.1列出了CAC规格,图9.1显示了CAC框图,表9.2列出了CACIO引脚。

**Table 9.1 CAC规格**

| Parameter            | Specifications   |
|----------------------|--|
| 测量目标时钟               | 可以测量频率: ● <ul style="list-style-type: none"> <li>• 主时钟振荡器</li> <li>• Sub-clock oscillator</li> <li>• HOCO clock</li> <li>• MOCO clock</li> <li>• 机车时钟</li> <li>• 外设模块时钟B(PCLKB)</li> <li>• IWDT-dedicated clock</li> </ul>                           |
| 测量参考时钟               | 频率可参考: ● <ul style="list-style-type: none"> <li>• CACREF引脚的外部时钟输入</li> <li>• 主时钟振荡器</li> <li>• Sub-clock oscillator</li> <li>• HOCO clock</li> <li>• MOCO clock</li> <li>• 机车时钟</li> <li>• 外设模块时钟B(PCLKB)</li> <li>• IWDT-dedicated clock</li> </ul> |
| 可选择的功能               | 数字滤波器  |
| 中断源                  | <ul style="list-style-type: none"> <li>• 测量结束</li> <li>• 频率误差</li> <li>• Overflow</li> </ul>   |
| Module-stop function | 可设置模块停止状态以降低功耗   |
| TrustZone Filter     | 可设置安全属性  |

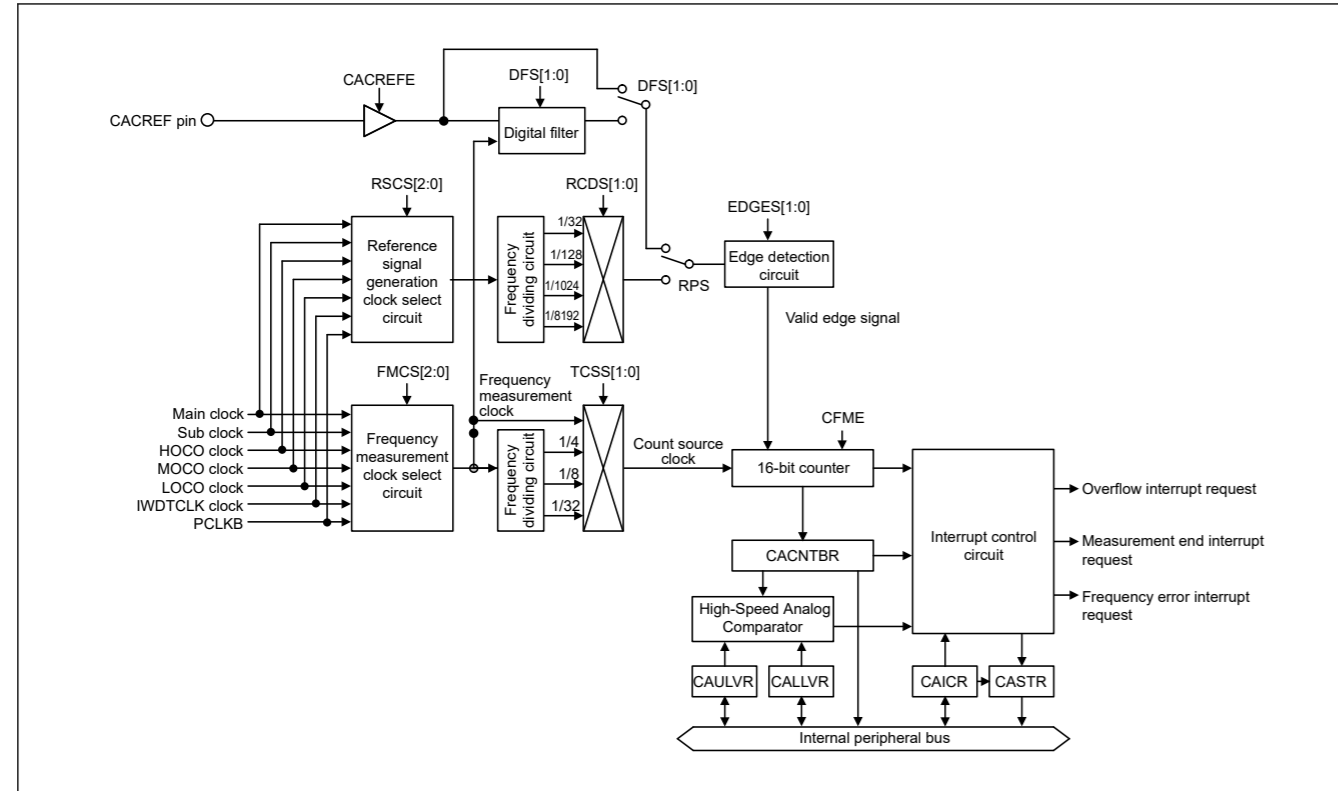


Figure 9.1 CAC block diagram

Table 9.2 CAC I/O pin

| Function | Pin name | I/O   | Description                           |
|----------|----------|-------|---------------------------------------|
| CAC      | CACREF   | Input | Measurement reference clock input pin |

## 9.2 Register Descriptions

### 9.2.1 CACR0 : CAC Control Register 0

Base address: CAC = 0x4008\_3600

Offset address: 0x00

Bit position: 7 6 5 4 3 2 1 0

| Bit field | 7 | 6 | 5 | 4 | 3 | 2 | 1 | 0    |
|-----------|---|---|---|---|---|---|---|------|
|           | — | — | — | — | — | — | — | CFME |

Value after reset: 0 0 0 0 0 0 0 0 0

| Bit | Symbol | Function  | R/W |
|-----|--------|---|-----|
| 0   | CFME   | Clock Frequency Measurement Enable<br>0: Disable<br>1: Enable | R/W |
| 7:1 | —      | These bits are read as 0. The write value should be 0.        | R/W |

#### CFME bit (Clock Frequency Measurement Enable)

The CFME bit enables clock frequency measurement. Changes made to this bit are not immediately reflected to the internal circuit. Read the bit to confirm that the change has been reflected.

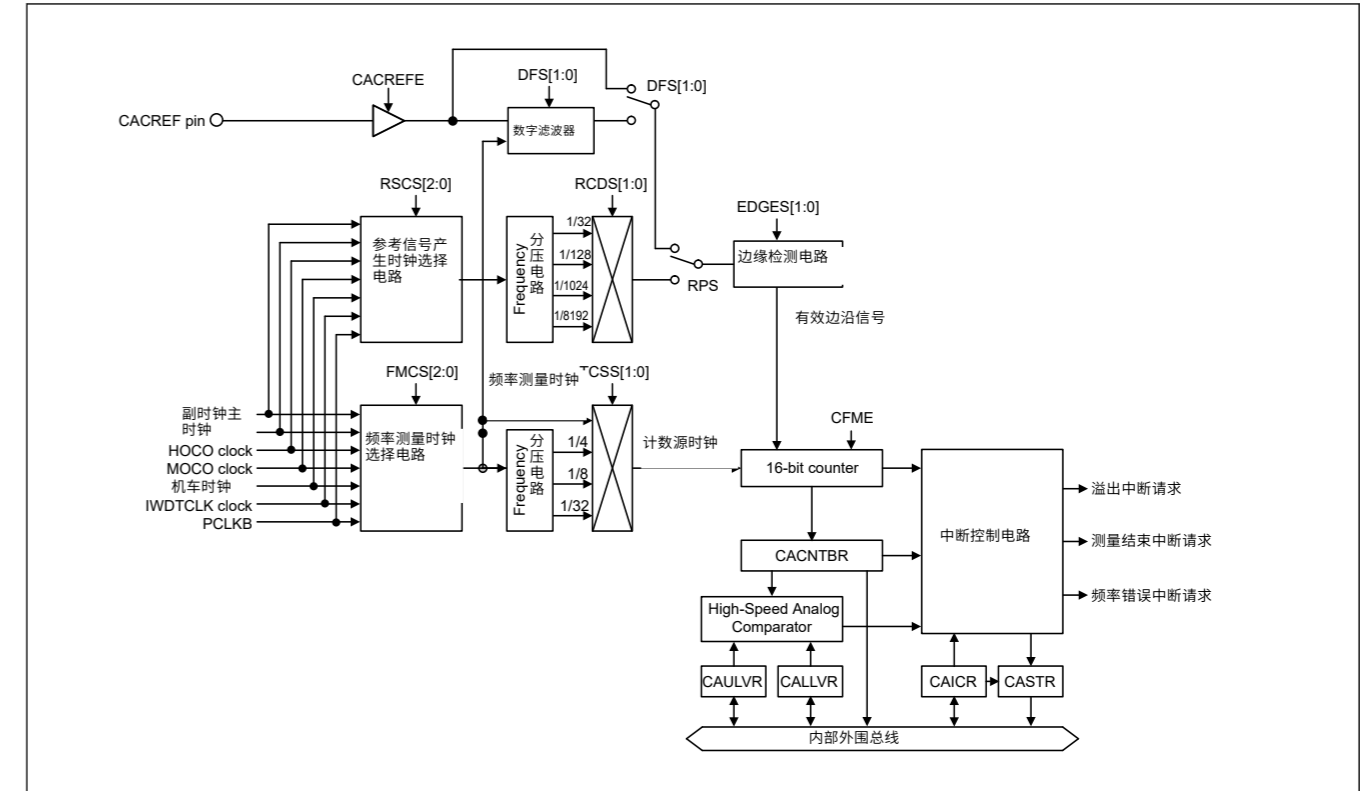


Figure 9.1 CAC框图

Table 9.2 CACIO引脚

| Function | 引脚名称   | I/O   | Description |
|----------|--------|-------|-------------|
| CAC      | CACREF | Input | 测量参考时钟输入引脚  |

## 9.2 注册说明

### 9.2.1 CACR0:CAC控制寄存器0

Base address: CAC = 0x4008\_3600

Offset address: 0x00

Bit position: 7 6 5 4 3 2 1 0

| Bit field | 7 | 6 | 5 | 4 | 3 | 2 | 1 | 0    |
|-----------|---|---|---|---|---|---|---|------|
|           | — | — | — | — | — | — | — | CFME |

重置后的值: 0 0 0 0 0 0 0 0 0

| Bit | Symbol | Function                   | R/W |
|-----|--------|----------------------------|-----|
| 0   | CFME   | 时钟频率测量启用<br>0: 禁用<br>1: 启用 | R/W |
| 7:1 | —      | 这些位被读取为0。写入值应为0。           | R/W |

#### CFME位 (时钟频率测量使能)

CFME位使能时钟频率测量。对该位所做的更改不会立即反映到内部电路。读取该位以确认更改已反映。



## 9.2.2 CACR1 : CAC Control Register 1

Base address: CAC = 0x4008\_3600

Offset address: 0x01

|                    |            |   |           |   |           |   |             |   |
|--------------------|------------|---|-----------|---|-----------|---|-------------|---|
| Bit position:      | 7          | 6 | 5         | 4 | 3         | 2 | 1           | 0 |
| Bit field:         | EDGES[1:0] |   | TCSS[1:0] |   | FMCS[2:0] |   | CACR<br>EFE |   |
| Value after reset: | 0          | 0 | 0         | 0 | 0         | 0 | 0           | 0 |

| Bit | Symbol     | Function  | R/W |
|-----|------------|---|-----|
| 0   | CACREFE    | CACREF Pin Input Enable<br>0: Disable<br>1: Enable  | R/W |
| 3:1 | FMCS[2:0]  | Measurement Target Clock Select<br>0 0 0: Main clock oscillator<br>0 0 1: Sub-clock oscillator<br>0 1 0: HOCO clock<br>0 1 1: MOCO clock<br>1 0 0: LOCO clock<br>1 0 1: Peripheral module clock B (PCLKB)<br>1 1 0: IWDT-dedicated clock<br>1 1 1: Setting prohibited | R/W |
| 5:4 | TCSS[1:0]  | Timer Count Clock Source Select<br>0 0: No division<br>0 1: × 1/4 clock<br>1 0: × 1/8 clock<br>1 1: × 1/32 clock  | R/W |
| 7:6 | EDGES[1:0] | Valid Edge Select<br>0 0: Rising edge<br>0 1: Falling edge<br>1 0: Both rising and falling edges<br>1 1: Setting prohibited   | R/W |

Note: Set the CACR1 register when the CACR0.CFME bit is 0.

**CACREFE bit (CACREF Pin Input Enable)**

The CACREFE bit enables the CACREF pin input.

**FMCS[2:0] bits (Measurement Target Clock Select)**

The FMCS[2:0] bits select the measurement target clock whose frequency is to be measured.

**TCSS[1:0] bits (Timer Count Clock Source Select)**

The TCSS[1:0] bits select the division ratio of the measurement target clock.

**EDGES[1:0] bits (Valid Edge Select)**

The EDGES[1:0] bits select the valid edge for the reference signal.

## 9.2.3 CACR2 : CAC Control Register 2

Base address: CAC = 0x4008\_3600

Offset address: 0x02

|                    |          |   |           |   |           |   |     |   |
|--------------------|----------|---|-----------|---|-----------|---|-----|---|
| Bit position:      | 7        | 6 | 5         | 4 | 3         | 2 | 1   | 0 |
| Bit field:         | DFS[1:0] |   | RCDS[1:0] |   | RSCS[2:0] |   | RPS |   |
| Value after reset: | 0        | 0 | 0         | 0 | 0         | 0 | 0   | 0 |

## 9.2.2 CACR1: CAC控制寄存器1

Base address: CAC = 0x4008\_3600

Offset address: 0x01

|               |            |   |           |   |           |   |             |   |
|---------------|------------|---|-----------|---|-----------|---|-------------|---|
| Bit position: | 7          | 6 | 5         | 4 | 3         | 2 | 1           | 0 |
| Bit field:    | EDGES[1:0] |   | TCSS[1:0] |   | FMCS[2:0] |   | CACR<br>EFE |   |
| 重置后的值:        | 0          | 0 | 0         | 0 | 0         | 0 | 0           | 0 |

| Bit | Symbol     | Function  | R/W |
|-----|------------|---|-----|
| 0   | CACREFE    | CACREF引脚输入使能<br>0: 禁用<br>1: 启用  | R/W |
| 3:1 | FMCS[2:0]  | 测量目标时钟选择<br>000: 主时钟振荡器001: 副时钟振荡器010: HOCO时钟011: MOCO时钟100: LOCO时钟101: 外设模块时钟B(PCLKB)110: IWDT-专用时钟111: 禁止设置 | R/W |
| 5:4 | TCSS[1:0]  | 定时器计数时钟源选择<br>00: 不分频01: ×14个时钟10: ×18个时钟11: ×32个时钟   | R/W |
| 7:6 | EDGES[1:0] | 有效边沿选择<br>00: 上升沿01: 下降沿10: 上升沿和下降沿11: 禁止设置   | R/W |

Note: 当CACR0.CFME位为0时设置CACR1寄存器。

**CACREFE位 (CACREF引脚输入使能)**

CACREFE位使能CACREF引脚输入。

**FMCS[2:0]位 (测量目标时钟选择)**

FMCS[2:0]位选择要测量其频率的测量目标时钟。

**TCSS[1:0]位 (定时器计数时钟源选择)**

TCSS[1:0]位选择测量目标时钟的分频比。

**EDGES[1:0]位 (有效边沿选择)**

EDGES[1:0]位选择参考信号的有效边沿。

## 9.2.3 CACR2: CAC控制寄存器2

Base address: CAC = 0x4008\_3600

Offset address: 0x02

|               |          |   |           |   |           |   |     |   |
|---------------|----------|---|-----------|---|-----------|---|-----|---|
| Bit position: | 7        | 6 | 5         | 4 | 3         | 2 | 1   | 0 |
| Bit field:    | DFS[1:0] |   | RCDS[1:0] |   | RSCS[2:0] |   | RPS |   |
| 重置后的值:        | 0        | 0 | 0         | 0 | 0         | 0 | 0   | 0 |

| Bit | Symbol    | Function   | R/W |
|-----|-----------|--|-----|
| 0   | RPS       | Reference Signal Select<br>0: CACREF pin input<br>1: Internal clock (internally generated signal)  | R/W |
| 3:1 | RSCS[2:0] | Measurement Reference Clock Select<br>0 0 0: Main clock oscillator<br>0 0 1: Sub-clock oscillator<br>0 1 0: HOCO clock<br>0 1 1: MOCO clock<br>1 0 0: LOCO clock<br>1 0 1: Peripheral module clock B (PCLKB)<br>1 1 0: IWDt-dedicated clock<br>1 1 1: Setting prohibited   | R/W |
| 5:4 | RCDS[1:0] | Measurement Reference Clock Frequency Division Ratio Select<br>0 0: × 1/32 clock<br>0 1: × 1/128 clock<br>1 0: × 1/1024 clock<br>1 1: × 1/8192 clock   | R/W |
| 7:6 | DFS[1:0]  | Digital Filter Select<br>0 0: Disable digital filtering<br>0 1: Use sampling clock for the digital filter as the frequency measuring clock<br>1 0: Use sampling clock for the digital filter as the frequency measuring clock divided by 4<br>1 1: Use sampling clock for the digital filter as the frequency measuring clock divided by 16. | R/W |

Note: Set the CACR2 register when the CACR0.CFME bit is 0.

**RPS bit (Reference Signal Select)**

The RPS bit selects whether to use the CACREF pin input or an internal clock (internally generated signal) as the reference signal.

**RSCS[2:0] bits (Measurement Reference Clock Select)**

The RSCS[2:0] bits select the reference clock for measurement.

**RCDS[1:0] bits (Measurement Reference Clock Frequency Division Ratio Select)**

The RCDS[1:0] bits select the frequency-divisor of the reference clock for measurement when an internal reference clock is selected. When RPS = 0 (CACREF pin is used as the reference clock source), the reference clock is not divided.

**DFS[1:0] bits (Digital Filter Select)**

The DFS[1:0] bits enable or disable the digital filter and selects its sampling clock.

**9.2.4 CAICR : CAC Interrupt Control Register**

Base address: CAC = 0x4008\_3600

Offset address: 0x03

|                    |   |            |             |             |   |       |            |            |
|--------------------|---|------------|-------------|-------------|---|-------|------------|------------|
| Bit position:      | 7 | 6          | 5           | 4           | 3 | 2     | 1          | 0          |
| Bit field:         | — | OVFF<br>CL | MEND<br>FCL | FERR<br>FCL | — | OVFIE | MEND<br>IE | FERRI<br>E |
| Value after reset: | 0 | 0          | 0           | 0           | 0 | 0     | 0          | 0          |

| Bit | Symbol | Function  | R/W |
|-----|--------|---|-----|
| 0   | FERRIE | Frequency Error Interrupt Request Enable<br>0: Disable<br>1: Enable | R/W |

| Bit | Symbol    | Function  | R/W |
|-----|-----------|---|-----|
| 0   | RPS       | 参考信号选择<br>0: CACREF引脚输入1: 内部时钟 (内部产生的信号)  | R/W |
| 3:1 | RSCS[2:0] | 测量参考时钟选择<br>000: 主时钟振荡器001: 副时钟振荡器010: HOCO时钟011: MOCO时钟100: LOC O时钟101: 外设模块时钟B(PCLKB)110: I WDT-专用时钟111: 禁止设置 | R/W |
| 5:4 | RCDS[1:0] | 测量参考时钟分频比选择<br>0 0: × 1/32 clock<br>0 1: × 1/128 clock<br>1 0: × 1/1024 clock<br>1 1: × 1/8192 clock            | R/W |
| 7:6 | DFS[1:0]  | 数字滤波器选择<br>00: 关闭数字滤波01: 使用数字滤波器的采样时钟作为测频时钟10: 使用数字滤波器的采样时钟作为测频时钟的4分频<br><br>11: 使用数字滤波器的采样时钟作为频率测量时钟除以16。      | R/W |

Note: 当CACR0.CFME位为0时设置CACR2寄存器。

**RPS位 (参考信号选择)**

RPS位选择是使用CACREF引脚输入还是使用内部时钟 (内部产生的信号) 作为参考信号。

**RSCS[2:0]位 (测量参考时钟选择)**

RSCS[2:0]位选择用于测量的参考时钟。

**RCDS[1:0]位 (测量参考时钟分频比选择)**

The RCDS[1:0] bits select the frequency-divisor of the reference clock for measurement when an internal reference clock is selected. 当RPS=0 (CACREF引脚用作参考时钟源) 时, 参考时钟不分频。

**DFS[1:0]位 (数字滤波器选择)**

DFS[1:0]位启用或禁用数字滤波器并选择其采样时钟。

**9.2.4 CAICR: CAC中断控制寄存器**

Base address: CAC = 0x4008\_3600

Offset address: 0x03

|               |   |            |             |             |   |       |            |            |
|---------------|---|------------|-------------|-------------|---|-------|------------|------------|
| Bit position: | 7 | 6          | 5           | 4           | 3 | 2     | 1          | 0          |
| Bit field:    | — | OVFF<br>CL | MEND<br>FCL | FERR<br>FCL | — | OVFIE | MEND<br>IE | FERRI<br>E |
| 重置后的值:        | 0 | 0          | 0           | 0           | 0 | 0     | 0          | 0          |

| Bit | Symbol | Function                     | R/W |
|-----|--------|------------------------------|-----|
| 0   | FERRIE | 频率错误中断请求使能<br>0: 禁用<br>1: 启用 | R/W |

| Bit | Symbol  | Function  | R/W |
|-----|---------|---|-----|
| 1   | MENDIE  | Measurement End Interrupt Request Enable<br>0: Disable<br>1: Enable | R/W |
| 2   | OVFIE   | Overflow Interrupt Request Enable<br>0: Disable<br>1: Enable        | R/W |
| 3   | —       | This bit is read as 0. The write value should be 0.                 | R/W |
| 4   | FERRFCL | FERRF Clear<br>0: No effect<br>1: The CASTR.FERRF flag is cleared   | W   |
| 5   | MENDFCL | MENDF Clear<br>0: No effect<br>1: The CASTR.MENDF flag is cleared   | W   |
| 6   | OVFFCL  | OVFF Clear<br>0: No effect<br>1: The CASTR.OVFF flag is cleared.    | W   |
| 7   | —       | This bit is read as 0. The write value should be 0.                 | R/W |

**FERRIE bit (Frequency Error Interrupt Request Enable)**

The FERRIE bit enables or disables the frequency error interrupt request.

**MENDIE bit (Measurement End Interrupt Request Enable)**

The MENDIE bit enables or disables the measurement end interrupt request.

**OVFIE bit (Overflow Interrupt Request Enable)**

The OVFIE bit enables or disables the overflow interrupt request.

**FERRFCL bit (FERRF Clear)**

Setting the FERRFCL bit to 1 clears the CASTR.FERRF flag.

**MENDFCL bit (MENDF Clear)**

Setting the MENDFCL bit to 1 clears the CASTR.MENDF flag.

**OVFFCL bit (OVFF Clear)**

Setting the OVFFCL bit to 1 clears the CASTR.OVFF flag.

**9.2.5 CASTR : CAC Status Register**

Base address: CAC = 0x4008\_3600

Offset address: 0x04

|                    |   |   |   |   |   |      |           |           |
|--------------------|---|---|---|---|---|------|-----------|-----------|
| Bit position:      | 7 | 6 | 5 | 4 | 3 | 2    | 1         | 0         |
| Bit field:         | — | — | — | — | — | OVFF | MEND<br>F | FERR<br>F |
| Value after reset: | 0 | 0 | 0 | 0 | 0 | 0    | 0         | 0         |

| Bit | Symbol | Function  | R/W |
|-----|--------|---|-----|
| 0   | FERRF  | Frequency Error Flag<br>0: Clock frequency is within the allowable range<br>1: Clock frequency has deviated beyond the allowable range (frequency error). | R   |
| 1   | MENDF  | Measurement End Flag<br>0: Measurement is in progress<br>1: Measurement ended   | R   |

| Bit | Symbol  | Function                               | R/W |
|-----|---------|--|-----|
| 1   | MENDIE  | 测量结束中断请求使能<br>0: 禁用1<br>: 启用           | R/W |
| 2   | OVFIE   | 溢出中断请求使能<br>0: 禁用1<br>: 启用             | R/W |
| 3   | —       | 该位读取为0。写入值应为0。                         | R/W |
| 4   | FERRFCL | FERRF Clear<br>0: 无效1: 清除CASTR.FERRF标志 | W   |
| 5   | MENDFCL | MENDF Clear<br>0: 无效1: 清除CASTR.MENDF标志 | W   |
| 6   | OVFFCL  | OVFF Clear<br>0: 无效1: 清除CASTR.OVFF标志。  | W   |
| 7   | —       | 该位读取为0。写入值应为0。                         | R/W |

**FERRIE位 (频率错误中断请求使能)**

FERRIE位启用或禁用频率错误中断请求。

**MENDIE位 (测量结束中断请求使能)**

MENDIE位启用或禁用测量结束中断请求。

**OVFIE位 (溢出中断请求使能)**

OVFIE位启用或禁用溢出中断请求。

**FERRFCL bit (FERRF Clear)**

将FERRFCL位设置为1会清除CASTR.FERRF标志。

**MENDFCL bit (MENDF Clear)**

将MENDFCL位设置为1会清除CASTR.MENDF标志。

**OVFFCL bit (OVFF Clear)**

将OVFFCL位设置为1会清除CASTR.OVFF标志。

**9.2.5 CASTR:CAC状态寄存器**

Base address: CAC = 0x4008\_3600

Offset address: 0x04

|               |   |   |   |   |   |      |           |           |
|---------------|---|---|---|---|---|------|-----------|-----------|
| Bit position: | 7 | 6 | 5 | 4 | 3 | 2    | 1         | 0         |
| Bit field:    | — | — | — | — | — | OVFF | MEND<br>F | FERR<br>F |
| 重置后的值:        | 0 | 0 | 0 | 0 | 0 | 0    | 0         | 0         |

| Bit | Symbol | Function                                     | R/W |
|-----|--------|--|-----|
| 0   | FERRF  | 频率错误标志<br>0: 时钟频率在允许范围内1: 时钟频率偏离允许范围 (频率误差)。 | R   |
| 1   | MENDF  | 测量结束标志<br>0: 测量中1: 测量结束                      | R   |

| Bit | Symbol | Function  | R/W |
|-----|--------|---|-----|
| 2   | OVFF   | Overflow Flag<br>0: Counter has not overflowed<br>1: Counter overflowed | R   |
| 7:3 | —      | These bits are read as 0.   | R   |

**FERRF flag (Frequency Error Flag)**

The FERRF flag indicates a deviation of the clock frequency from the set value (frequency error).

[Setting condition]

- The clock frequency is outside the allowable range defined in the CAULVR and CALLVR registers.

[Clearing condition]

- 1 is written to the FERRFCL bit.

**MENDF flag (Measurement End Flag)**

The MENDF flag indicates the end of measurement.

[Setting condition]

- Measurement ends.

[Clearing condition]

- 1 is written to the MENDFCL bit.

**OVFF flag (Overflow Flag)**

The OVFF flag indicates that the counter overflowed.

[Setting condition]

- The counter overflows.

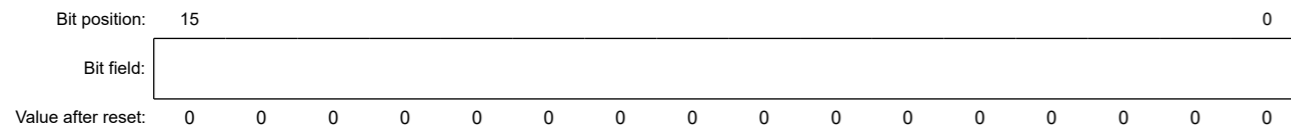
[Clearing condition]

- 1 is written to the CAICR.OVFFCL bit.

**9.2.6 CAULVR : CAC Upper-Limit Value Setting Register**

Base address: CAC = 0x4008\_3600

Offset address: 0x06



| Bit  | Symbol | Function   | R/W |
|------|--------|--|-----|
| 15:0 | n/a    | The Upper Value of the Allowable Range<br>The CAULVR register is a 16-bit read/write register that specifies the upper value of the allowable range. When the counter value exceeds the value specified in this register, a frequency error is detected. Write to this register when the CACR0.CFME bit is 0.<br>The counter value stored in CACNTBR can vary depending on the difference between the phases of the digital filter and edge-detection circuit, and the signal on the CACREF pin. Ensure that this setting allows an adequate margin. | R/W |

| Bit | Symbol | Function                   | R/W |
|-----|--------|----------------------------|-----|
| 2   | OVFF   | 溢出标志<br>0: 计数器未溢出 1: 计数器溢出 | R   |
| 7:3 | —      | 这些位读为0。                    | R   |

**FERRF标志 (频率错误标志)**

FERRF标志表示时钟频率与设定值的偏差 (频率误差)。

[Setting condition]

- 时钟频率超出CAULVR和CALLVR寄存器中定义的允许范围。

[Clearing condition]

- 1写入FERRFCL位。

**MENDF标志 (测量结束标志)**

MENDF标志表示测量结束。

[Setting condition]

- 测量结束。

[Clearing condition]

- 1写入MENDFCL位。

**OVFF flag (Overflow Flag)**

OVFF标志表示计数器溢出。

[Setting condition]

- 计数器溢出。

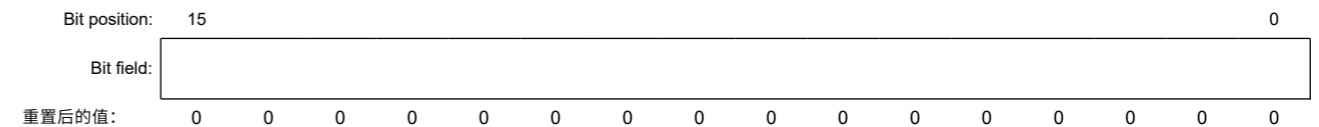
[Clearing condition]

- 1写入CAICR.OVFFCL位。

**9.2.6 CAULVR:CAC上限值设置寄存器**

Base address: CAC = 0x4008\_3600

Offset address: 0x06

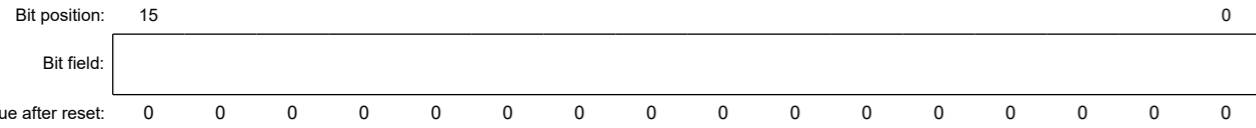


| Bit  | Symbol | Function  | R/W |
|------|--------|---|-----|
| 15:0 | n/a    | 允许范围的上限值<br>CAULVR寄存器是一个16位读写寄存器，用于指定允许范围的上限值。当计数器值超过此寄存器中指定的值时，检测到频率错误。当CACR0.CFME位为0时写入该寄存器。存储在CACNTBR中的计数器值会根据数字滤波器和边沿检测电路的相位差以及CACREF引脚上的信号而变化。确保此设置允许有足够的余量。 | R/W |

9.2.7 CALLVR : CAC Lower-Limit Value Setting Register

Base address: CAC = 0x4008\_3600

Offset address: 0x08

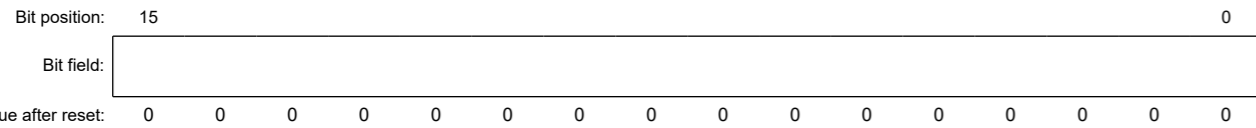


| Bit  | Symbol | Function   | R/W |
|------|--------|--|-----|
| 15:0 | n/a    | The Lower Value of the Allowable Range<br>The CALLVR register is a 16-bit read/write register that specifies the lower value of the allowable range. When the counter value falls below the value specified in this register, a frequency error is detected. Write to this register when the CACR0.CFME bit is 0.<br>The counter value stored in CACNTBR can vary depending on the difference between the phases of the digital filter and edge-detection circuit, and the signal on the CACREF pin. Ensure that this setting allows an adequate margin. | R/W |

9.2.8 CACNTBR : CAC Counter Buffer Register

Base address: CAC = 0x4008\_3600

Offset address: 0x0A



| Bit  | Symbol | Function  | R/W |
|------|--------|---|-----|
| 15:0 | n/a    | The Measurement Result<br>The CACNTBR register is a 16-bit read-only register that stores the measurement result. | R   |

9.3 Operation

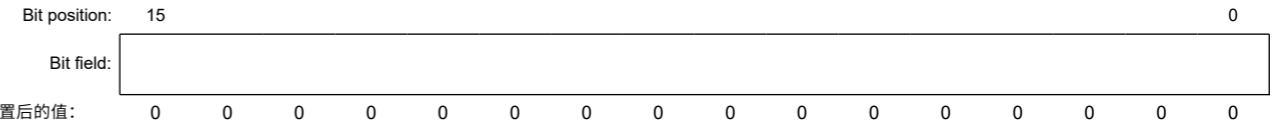
9.3.1 Measuring Clock Frequency

The CAC measures the clock frequency using the CACREF pin input or an internal clock as a reference. Figure 9.2 shows an operating example of the CAC.

9.2.7 CALLVR:CAC下限值设置寄存器

Base address: CAC = 0x4008\_3600

Offset address: 0x08

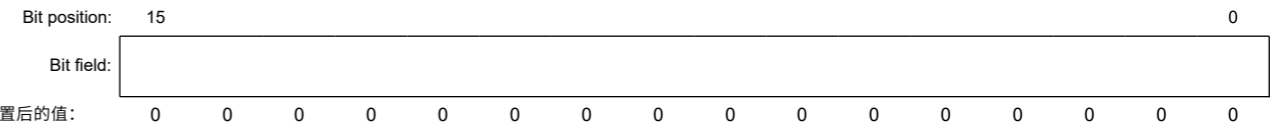


| Bit  | Symbol | Function  | R/W |
|------|--------|---|-----|
| 15:0 | n/a    | 允许范围的下限值<br>CALLVR寄存器是一个16位读写寄存器，用于指定允许范围的下限值。当计数器值低于此寄存器中指定的值时，检测到频率错误。当CACR0.CFME位为0时写入该寄存器。存储在CACNTBR中的计数器值会根据数字滤波器和边沿检测电路的相位差以及CACREF引脚上的信号而变化。确保此设置允许有足够的余量。 | R/W |

9.2.8 CACNTBR:CAC计数器缓冲寄存器

Base address: CAC = 0x4008\_3600

Offset address: 0x0A



| Bit  | Symbol | Function                                | R/W |
|------|--------|---|-----|
| 15:0 | n/a    | 测量结果<br>CACNTBR寄存器是一个16位只读寄存器，用于存储测量结果。 | R   |

9.3 Operation

9.3.1 测量时钟频率

CAC使用CACREF引脚输入或内部时钟作为参考来测量时钟频率。图9.2显示了CAC的操作示例。



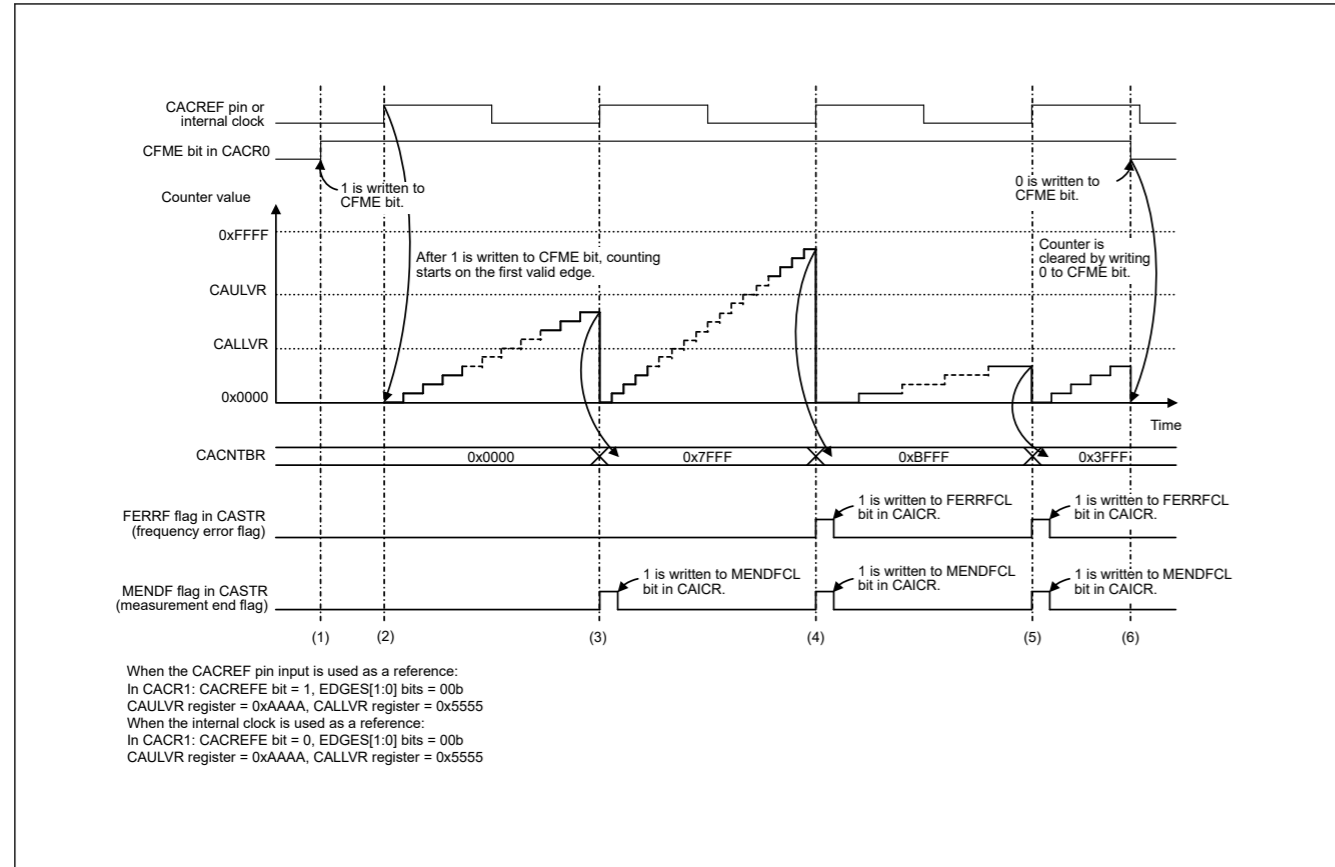


Figure 9.2 CAC operating example

The events in Figure 9.2 are:

- When the CACREF pin input is used as reference (CACR1.CACREFE = 1), frequency measurement is enabled by writing 1 to the CACR0.CFME bit while the CACR2.RPS bit is set to 0 and the CACR1.CACREFE bit is set to 1. When the internal clock is used as reference (CACR1.CACREFE = 0), frequency measurement is enabled by writing 1 to the CACR0.CFME bit while the CACR2.RPS bit is set to 1.
- When the CACREF pin input is used as reference, after 1 is written to the CFME bit, the timer starts up-counting if the valid edge selected by the CACR1.EDGES[1:0] bits (rising edge (CACR1.EDGES[1:0] = 00b) in Figure 9.2) is input from the CACREF pin. When the internal clock is used as reference, after 1 is written to the CFME bit, the timer starts up-counting if the valid edge selected by the CACR1.EDGES[1:0] bits (rising edge (CACR1.EDGES[1:0] = 00b) in Figure 9.2) is input based on the clock source selected by the CACR2.RSCS[2:0] bits.
- When the next valid edge is input, the counter value is transferred to CACNTBR and compared with the values in CAULVR and CALLVR. If both  $CACNTBR \leq CAULVR$  and  $CACNTBR \geq CALLVR$  are true, only the MENDF flag in CASTR is set to 1, because the clock frequency is correct. If the MENDIE bit in CAICR is 1, a measurement end interrupt is generated.
- When the next valid edge is input, the counter value is transferred to CACNTBR and compared with the values in CAULVR and CALLVR. If  $CACNTBR > CAULVR$ , the FERRF flag in CASTR is set to 1, because the clock frequency is erroneous. If the FERRIE bit in CAICR is 1, a frequency error interrupt is generated. The MENDF flag in CASTR is set to 1 at the end of measurement. If the MENDIE bit in CAICR is 1, a measurement end interrupt is generated.
- When the next valid edge is input, the counter value is transferred to CACNTBR and compared with the values in CAULVR and CALLVR. If  $CACNTBR < CALLVR$ , the FERRF flag in CASTR is set to 1, because the clock frequency is erroneous. If the FERRIE bit in CAICR is 1, a frequency error interrupt is generated. The MENDF flag in CASTR is set to 1 at the end of measurement. If the MENDIE bit in CAICR is 1, a measurement end interrupt is generated.
- When the CFME bit in CACR0 is 1, the counter value is transferred to CACNTBR and compared with the values in CAULVR and CALLVR every time a valid edge is input. Writing 0 to the CFME bit in CACR0 clears the counter and stops up-counting.

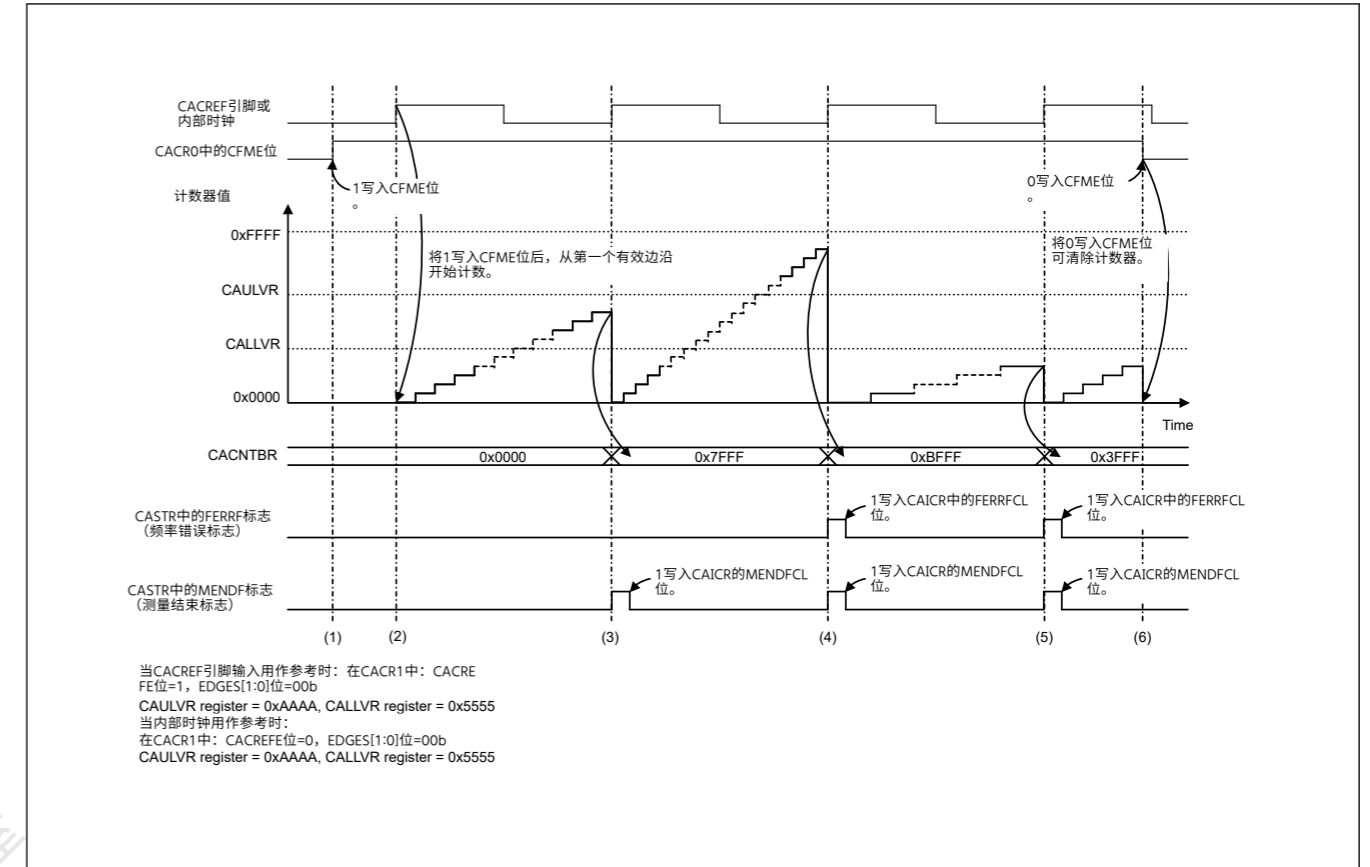


Figure 9.2 CAC操作示例

图9.2中的事件是:

- 当CACREF引脚输入用作参考时 (CACR1.CACREFE=1), 频率测量通过以下方式启用  
将1写入CACR0.CFME位, 同时将CACR2.RPS位设置为0, 并将CACR1.CACREFE位设置为1。当内部时钟用作参考时 (CACR1.CACREFE=0), 频率测量通过以下方式启用将1写入CACR0.CFME位, 同时CACR2.RPS位设置为1。
- 当CACREF引脚输入用作参考时, 向CFME位写入1后, 如果CACR1.EDGES[1:0]位选择的有效沿 (上升沿 (CACR1.EDGES[1:0]=00b)在图9.2中)从CACREF引脚输入。当内部时钟用作参考时, CFME位写入1后, 如果CACR1.EDGES[1:0]位选择的有效沿 (上升沿 (CACR1.EDGES[1:0]=00b)在图9.2中)根据CACR2.RSCS[2:0]位选择的时钟源输入。
- 当输入下一个有效边沿时, 计数器值被传送到CACNTBR并与中的值进行比较  
CAULVR和CALLVR。如果 $CACNTBR \leq CAULVR$ 和 $CACNTBR \geq CALLVR$ 都为真, 则只有MENDF标志  
CASTR设置为1, 因为时钟频率正确。如果CAICR中的MENDIE位为1, 则产生测量结束中断。
- 当输入下一个有效边沿时, 计数器值被传送到CACNTBR并与中的值进行比较  
CAULVR和CALLVR。如果 $CACNTBR > CAULVR$ , 则CASTR中的FERRF标志设置为1, 因为时钟频率错误。如果CAICR中的FERRIE位为1, 则产生频率错误中断。CASTR中的MENDF标志在测量结束时设置为1。如果CAICR中的MENDIE位为1, 则产生测量结束中断。
- 当输入下一个有效边沿时, 计数器值被传送到CACNTBR并与中的值进行比较  
CAULVR和CALLVR。如果 $CACNTBR < CALLVR$ , 则CASTR中的FERRF标志设置为1, 因为时钟频率错误。如果CAICR中的FERRIE位为1, 则产生频率错误中断。CASTR中的MENDF标志在测量结束时设置为1。如果CAICR中的MENDIE位为1, 则产生测量结束中断。
- 当CACR0中的CFME位为1时, 每次输入有效边沿时, 计数器值被传送到CACNTBR并与CAULVR和CALLVR中的值进行比较。向CACR0中的CFME位写入0将清除计数器并停止向上计数。

### 9.3.2 Digital Filtering of Signals on CACREF Pin

The CACREF pin has a digital filter, and levels on the CACREF pin are transmitted to the internal circuitry after three consecutive matches in the selected sampling interval. The same level continues to be transmitted internally until the level on the pin has three consecutive matches again. Enabling or disabling of the digital filter and its sampling clock are selectable.

The counter value transferred to CACNTBR might be in error by up to 1 cycle of the sampling clock because of the difference between the phases of the digital filter and the signal input to the CACREF pin. When a frequency dividing clock is selected as a count source clock, the counter value error is obtained using the following formula:

$$\text{Counter value error} = (1 \text{ cycle of the count source clock}) / (1 \text{ cycle of the sampling clock})$$

## 9.4 Interrupt Requests

The CAC generates three types of interrupt requests:

- Frequency error interrupt
- Measurement end interrupt
- Overflow interrupt

When an interrupt source is generated, the associated status flag is set to 1. Table 9.3 provides information on the CAC interrupt requests.

**Table 9.3 CAC interrupt requests**

| Interrupt request         | Interrupt enable bit | Status flag | Interrupt sources   |
|---------------------------|----------------------|-------------|---|
| Frequency error interrupt | CAICR.FERRIE         | CASTR.FERRF | The result of comparing CACNTBR with CAULVR and CALLVR is either CACNTBR > CAULVR or CACNTBR < CALLVR   |
| Measurement end interrupt | CAICR.MENDIE         | CASTR.MENDF | <ul style="list-style-type: none"> <li>● Valid edge is input from the CACREF pin or internal clock</li> <li>● Measurement end interrupt does not occur at the first valid edge after writing 1 to the CACR0.CFME bit</li> </ul> |
| Overflow interrupt        | CAICR.OVFIE          | CASTR.OVFF  | Counter overflows   |

## 9.5 Usage Notes

### 9.5.1 Settings for the Module-Stop Function

The Module Stop Control Register C (MSTPCRC) can enable or disable CAC operation. The CAC module is initially stopped after reset. Releasing the module-stop state enables access to the registers. For details, see [section 10, Low Power Modes](#).

### 9.3.2 CACREF引脚上的信号数字滤波

CACREF引脚有一个数字滤波器，CACREF引脚上的电平在选定的采样间隔内连续三个匹配后传输到内部电路。同一电平继续在内部传输，直到引脚上的电平再次连续匹配三个。可选择启用或禁用数字滤波器及其采样时钟。

由于数字滤波器的相位和输入到CACREF引脚的信号之间的差异，传输到CACNTBR的计数器值可能会出现最多1个采样时钟周期的错误。When a frequency dividing clock is selected as a count source clock the counter value error is obtained using the following formula:

$$\text{计数器值误差} = (\text{计数源时钟的1个周期}) / (\text{采样时钟的1个周期})$$

## 9.4 中断请求

CAC产生三种类型的中断请求：

- 频率错误中断
- 测量结束中断
- 溢出中断

产生中断源时，相关状态标志设置为1。表9.3提供了有关CAC中断请求的信息。

**Table 9.3 CAC中断请求**

| 中断请求   | 中断使能位        | 状态标志        | 中断源  |
|--------|--------------|-------------|--|
| 频率错误中断 | CAICR.FERRIE | CASTR.FERRF | CACNTBR与CAULVR和CALLVR比较的结果是CACNTBR>CAULVR或CACNTBR<CALLVR   |
| 测量结束中断 | CAICR.MENDIE | CASTR.MENDF | <ul style="list-style-type: none"> <li>● 有效边沿从CACREF引脚或内部时钟输入</li> <li>● 将1写入CACR0.CFME位后，在第一个有效边沿不发生测量结束中断</li> </ul> |
| 溢出中断   | CAICR.OVFIE  | CASTR.OVFF  | 计数器溢出  |

## 9.5 使用说明

### 9.5.1 模块停止功能的设置

模块停止控制寄存器C(MSTPCRC)可以启用或禁用CAC操作。CAC模块在复位后最初停止。释放模块停止状态可以访问寄存器。有关详细信息，请参阅第10节，低功耗模式。

## 10. Low Power Modes

### 10.1 Overview

The MCU has several functions for reducing power consumption, such as setting clock dividers, stopping modules, selecting power control mode in Normal mode, and transitioning to low power modes.

Table 10.1 lists the specifications of the low power mode functions. Table 10.2 lists the conditions to transition to low power modes, the states of the CPU and peripheral modules, and the method for canceling each mode. After a reset, the MCU enters the program execution state, but only the DTC, DMAC and SRAM operate.

**Table 10.1 Specifications of the low power mode functions**

| Item  | Specification   |
|---|---|
| Reducing power consumption by switching clock signals | The frequency division ratio can be selected independently for the system clock (ICLK), peripheral module clocks (PCLKA, PCLKB, PCLKC, PCLKD), and flash interface clock (FCLK). *1   |
| Module stop   | Functions can be stopped independently for each peripheral module   |
| Low-power modes                                       | <ul style="list-style-type: none"> <li>Sleep mode</li> <li>Software Standby mode</li> <li>Snooze mode</li> <li>Deep Software Standby mode</li> </ul>  |
| Power control modes                                   | <ul style="list-style-type: none"> <li>Power consumption can be reduced in Normal and Sleep modes by selecting an appropriate operating power control mode according to the operating frequency.</li> <li>Three operating power control modes are available:               <ul style="list-style-type: none"> <li>High-speed mode</li> <li>Low-speed mode</li> <li>Subosc-speed mode</li> </ul> </li> </ul> |
| TrustZone Filter                                      | Security attribution can be set for each registers  |

Note 1. For details, see section 8, Clock Generation Circuit

**Table 10.2 Operating conditions of each low power mode (1 of 2)**

| Item                                     | Sleep mode                                       | Software Standby mode  | Snooze mode  | Deep Software Standby mode                                       |
|--|--|--|--|--|
| Transition condition                     | WFI instruction while SBYCR.SSBY = 0             | WFI instruction while SBYCR.SSBY = 1 and DPSBYCR.DPSBY = 0       | Snooze request trigger in Software Standby mode. SNZCR.SNZE=1.   | WFI instruction while SBYCR.SSBY = 1 and DPSBYCR.DPSBY = 1       |
| Canceling method                         | All interrupts. Any reset available in the mode. | Interrupts shown in Table 10.3. Any reset available in the mode. | Interrupts shown in Table 10.3. Any reset available in the mode. | Interrupts shown in Table 10.3. Any reset available in the mode. |
| State after cancellation by an interrupt | Program execution state (interrupt processing)   | Program execution state (interrupt processing)                   | Program execution state (interrupt processing)                   | Reset state  |
| State after cancellation by a reset      | Reset state                                      | Reset state  | Reset state  | Reset state  |
| Main clock oscillator                    | Selectable                                       | Stop   | Selectable*5   | Stop   |
| Sub-clock oscillator                     | Selectable                                       | Selectable   | Selectable   | Selectable   |
| High-speed on-chip oscillator            | Selectable                                       | Stop   | Selectable   | Stop   |
| Middle-speed on-chip oscillator          | Selectable                                       | Stop   | Selectable   | Stop   |
| Low-speed on-chip oscillator             | Selectable                                       | Selectable   | Selectable   | Selectable*8   |
| IWDT-dedicated on-chip oscillator        | Selectable*1                                     | Selectable*1   | Selectable*1   | Stop   |
| PLL                                      | Selectable                                       | Stop   | Selectable*5   | Stop   |
| PLL2                                     | Selectable                                       | Stop   | Selectable*5   | Stop   |
| Oscillation stop detection function      | Selectable                                       | Operation prohibited   | Operation prohibited   | Operation prohibited   |
| Clock/buzzer output function             | Selectable                                       | Selectable*2   | Selectable   | Stop (Undefined)   |
| CPU                                      | Stop (Retained)                                  | Stop (Retained)  | Stop (Retained)  | Stop (Undefined)   |

## 10. 低功耗模式

### 10.1 Overview

MCU具有多种降低功耗的功能，例如设置时钟分频器、停止模块、在正常模式下选择电源控制模式以及转换到低功耗模式。

表10.1列出了低功耗模式功能的规格。表10.2列出了转换到低功耗模式的条件、CPU和外围模块的状态以及取消每种模式的方法。复位后，MCU进入程序执行状态，但只有DTC、DMAC和SRAM运行。

**Table 10.1 低功耗模式功能的规格**

| Item             | Specification   |
|------------------|---|
| 通过切换时钟信号降低功耗     | 分频比可以为系统时钟 (ICLK)、外围模块时钟 (PCLKA、PCLKB、PCLKC、PCLKD) 和闪存接口时钟 (FCLK) 独立选择。*1   |
| 模块停止             | 每个外围模块可以独立停止功能  |
| Low-power modes  | <ul style="list-style-type: none"> <li>睡眠模式</li> <li>软件待机模式</li> <li>贪睡模式</li> <li>深度软件待机模式</li> </ul>  |
| 电源控制模式           | <ul style="list-style-type: none"> <li>根据工作频率选择合适的工作功率控制模式，可以降低正常和睡眠模式下的功耗。</li> <li>提供三种工作功率控制模式：               <ul style="list-style-type: none"> <li>High-speed mode</li> <li>Low-speed mode</li> <li>Subosc-speed mode</li> </ul> </li> </ul> |
| TrustZone Filter | 可以为每个寄存器设置安全属性  |

注1.详见第8节，时钟产生电路

**Table 10.2 每种低功耗模式的运行条件 (2个中的1个)**

| Item                              | 睡眠模式                   | 软件待机模式                                       | 贪睡模式                          | 深度软件待机模式                                     |
|-----------------------------------|------------------------|--|-------------------------------|--|
| 过渡条件                              | WFI指令同时 SBYCR.SSBY = 0 | WFI指令同时 SBYCR.SSBY = 1 and DPSBYCR.DPSBY = 0 | 软件待机模式下的贪睡请求触发。 SNZCR.SNZE=1. | WFI指令同时 SBYCR.SSBY = 1 and DPSBYCR.DPSBY = 1 |
| 取消方法                              | 所有中断。该模式下可用的任何复位。      | 中断如表10.3所示。该模式下可用的任何复位。                      | 中断如表10.3所示。该模式下可用的任何复位。       | 中断如表10.3所示。该模式下可用的任何复位。                      |
| 中断取消后的状态                          | 程序执行状态 (中断处理)          | 程序执行状态 (中断处理)                                | 程序执行状态 (中断处理)                 | 重置状态   |
| 通过复位取消后的状态                        | 重置状态                   | 重置状态   | 重置状态                          | 重置状态   |
| 主时钟振荡器                            | Selectable             | Stop   | Selectable*5                  | Stop   |
| Sub-clock oscillator              | Selectable             | Selectable                                   | Selectable                    | Selectable                                   |
| High-speed on-chip oscillator     | Selectable             | Stop   | Selectable                    | Stop   |
| Middle-speed on-chip oscillator   | Selectable             | Stop   | Selectable                    | Stop   |
| Low-speed on-chip oscillator      | Selectable             | Selectable                                   | Selectable                    | Selectable*8                                 |
| IWDT-dedicated on-chip oscillator | Selectable*1           | Selectable*1                                 | Selectable*1                  | Stop   |
| PLL                               | Selectable             | Stop   | Selectable*5                  | Stop   |
| PLL2                              | Selectable             | Stop   | Selectable*5                  | Stop   |
| 振荡停止检测功能                          | Selectable             | 禁止操作   | 禁止操作                          | 禁止操作   |
| 时钟蜂鸣器输出功能                         | Selectable             | Selectable*2                                 | Selectable                    | Stop (Undefined)                             |
| CPU                               | Stop (Retained)        | Stop (Retained)                              | Stop (Retained)               | Stop (Undefined)                             |



Table 10.2 Operating conditions of each low power mode (2 of 2)

| Item   | Sleep mode               | Software Standby mode                                     | Snooze mode   | Deep Software Standby mode  |
|--|--------------------------|---|---|---|
| SRAMn (n = 0)  | Selectable               | Stop (Retained)   | Selectable  | Stop (Undefined)  |
| Standby SRAM   | Selectable               | Stop (Retained)   | Selectable  | Stop (Retained/Undefined) <sup>9</sup>  |
| Flash memory   | Operating                | Stop (Retained)   | Stop (Retained)   | Stop (Retained)   |
| DMA Controller (DMAC)                                  | Selectable               | Stop (Retained)   | Operation prohibited  | Stop (Undefined)  |
| Data Transfer Controller (DTC)                         | Selectable               | Stop (Retained)   | Selectable  | Stop (Undefined)  |
| USB 2.0 Full-Speed (USBFsn, n = 0)                     | Selectable               | Stop (Retained). Detection of USB resumption is possible. | Operation prohibited. Detection of USB resumption is possible.  | Stop (Retained/Undefined). Detection of USB resumption is possible. <sup>10</sup> |
| Watchdog Timer (WDT)                                   | Selectable <sup>11</sup> | Stop (Retained)   | Stop (Retained)   | Stop (Undefined)  |
| Independent Watchdog Timer (IWDT)                      | Selectable <sup>11</sup> | Selectable <sup>11</sup>                                  | Selectable <sup>11</sup>  | Stop (Undefined)  |
| Realtime clock (RTC)                                   | Selectable               | Selectable  | Selectable  | Selectable <sup>11</sup>  |
| Asynchronous General Purpose Timer (AGTn (n = 0 to 3)) | Selectable               | Selectable <sup>3</sup>                                   | Selectable <sup>3</sup>   | Selectable <sup>3</sup>   |
| Asynchronous General Purpose Timer (AGTn (n = 4 to 5)) | Selectable               | Selectable <sup>14</sup>                                  | Selectable <sup>14</sup>  | Stop (Undefined)  |
| 12-Bit A/D Converter (ADC12)                           | Selectable               | Stop (Retained)   | Selectable <sup>15</sup>  | Stop (Undefined)  |
| 12-Bit D/A Converter (DAC12)                           | Selectable               | Stop (Retained)   | Selectable  | Stop (Undefined)  |
| Capacitive Touch Sensing Unit (CTSU)                   | Selectable               | Stop (Retained)   | Selectable  | Stop (Undefined)  |
| Data Operation Circuit (DOC)                           | Selectable               | Stop (Retained)   | Selectable  | Stop (Undefined)  |
| Serial Communications Interface (SCI0)                 | Selectable               | Stop (Retained)   | Selectable (RXD0 falling edge is available, to enter snooze mode) (only in asynchronous mode). <sup>6</sup> | Stop (Undefined)  |
| Serial Communications Interface (SCIn (n = 1 to 4, 9)) | Selectable               | Stop (Retained)   | Operation prohibited  | Stop (Undefined)  |
| I2C Bus Interface (IIC0)                               | Selectable               | Selectable <sup>4</sup>                                   | Selectable <sup>4</sup><br>Only wakeup interrupt is available.  | Stop (Undefined)  |
| I2C Bus Interface (IIC1)                               | Selectable               | Stop (Retained)   | Operation prohibited  | Stop (Undefined)  |
| Event Link Controller (ELC)                            | Selectable               | Stop (Retained)   | Selectable <sup>7</sup>   | Stop (Undefined)  |
| IRQn (n = 0 to 15) pin interrupt                       | Selectable               | Selectable  | Selectable  | Stop (Undefined)  |
| NMI, IRQn-DS (n = 0 to 15) pin interrupt               | Selectable               | Selectable  | Selectable  | Selectable  |
| Low voltage detection (LVD)                            | Selectable               | Selectable  | Selectable  | Selectable <sup>12</sup>  |
| Power-on reset circuit                                 | Operating                | Operating   | Operating   | Operating <sup>13</sup>   |
| Other peripheral modules                               | Selectable               | Stop (Retained)   | Operation prohibited  | Stop (Undefined)  |
| I/O Ports  | Operating                | Retained  | Operating   | Retained  |

Note: Selectable means that operating or not operating can be selected by the control registers.  
 Stop (Retained) means that the contents of the internal registers are retained but the operations are suspended.  
 Operation prohibited means that the function must be stopped before entering Software Standby mode.  
 Stop (Undefined) means that the contents of the internal registers are undefined and power to the internal circuit is cut off.  
 All modules whose module-stop bits are 0 start as soon as PCLKs are supplied after entering Snooze mode. In order to avoid increase in power consumption in Snooze mode, module-stop bit of modules which are unnecessary in Snooze mode must be set to 1 before entering Software Standby mode.

Note 1. In IWDT-dedicated on-chip oscillator and IWDT, operating or stopping is selected by setting the IWDT Stop Control bit (IWDTSTPCTL) in Option Function Select register 0 (OFS0) in IWDT auto start mode. In WDT, operating or stopping is selected by setting the WDT Stop Control bit (WDTSTPCTL) in Option Function Select Register 0 (OFS0) in WDT auto start mode. Power consumption can be reduced in Normal and Sleep modes by selecting an appropriate operating power control mode according to the operating frequency.

Table 10.2 每种低功耗模式的操作条件 (2个中的2个)

| Item                               | 睡眠模式                     | 软件待机模式                      | 贪睡模式                                 | 深度软件待机模式  |
|------------------------------------|--------------------------|-----------------------------|--------------------------------------|---|
| SRAMn (n = 0)                      | Selectable               | Stop (Retained)             | Selectable                           | Stop (Undefined)                                    |
| Standby SRAM                       | Selectable               | Stop (Retained)             | Selectable                           | Stop (Retained/Undefined) <sup>9</sup>              |
| 闪存                                 | Operating                | Stop (Retained)             | Stop (Retained)                      | Stop (Retained)                                     |
| DMA Controller (DMAC)              | Selectable               | Stop (Retained)             | 禁止操作                                 | Stop (Undefined)                                    |
| 数据传输控制器(DTC)                       | Selectable               | Stop (Retained)             | Selectable                           | Stop (Undefined)                                    |
| USB 2.0 Full-Speed (USBFsn, n = 0) | Selectable               | Stop (Retained). 可以检测USB恢复。 | 禁止操作。可以检测USB恢复。                      | Stop (Retained/Undefined). 可以检测USB恢复。 <sup>10</sup> |
| 看门狗定时器(WDT)                        | Selectable <sup>11</sup> | Stop (Retained)             | Stop (Retained)                      | Stop (Undefined)                                    |
| 独立看门狗定时器 (IWDT)                    | Selectable <sup>11</sup> | Selectable <sup>11</sup>    | Selectable <sup>11</sup>             | Stop (Undefined)                                    |
| 实时时钟(RTC)                          | Selectable               | Selectable                  | Selectable                           | Selectable <sup>11</sup>                            |
| 异步通用定时器 (AGTn (n =0到3))            | Selectable               | Selectable <sup>3</sup>     | Selectable <sup>3</sup>              | Selectable <sup>3</sup>                             |
| 异步通用定时器 (AGTn (n =4到5))            | Selectable               | Selectable <sup>14</sup>    | Selectable <sup>14</sup>             | Stop (Undefined)                                    |
| 12-Bit A/D Converter (ADC12)       | Selectable               | Stop (Retained)             | Selectable <sup>15</sup>             | Stop (Undefined)                                    |
| 12-Bit D/A Converter (DAC12)       | Selectable               | Stop (Retained)             | Selectable                           | Stop (Undefined)                                    |
| 电容式触控感应单元(CTSU)                    | Selectable               | Stop (Retained)             | Selectable                           | Stop (Undefined)                                    |
| 数据运算电路(DOC)                        | Selectable               | Stop (Retained)             | Selectable                           | Stop (Undefined)                                    |
| 串行通信接口(SCI0)                       | Selectable               | Stop (Retained)             | 可选 (RXD0下降沿可用, 进入贪睡模式) (仅在异步模式下)。*6  | Stop (Undefined)                                    |
| 串行通信接口(SCIn(n=1to4 9))             | Selectable               | Stop (Retained)             | 禁止操作                                 | Stop (Undefined)                                    |
| I2C总线接口(IIC0)                      | Selectable               | Selectable <sup>4</sup>     | Selectable <sup>4</sup><br>只有唤醒中断可用。 | Stop (Undefined)                                    |
| I2C总线接口(IIC1)                      | Selectable               | Stop (Retained)             | 禁止操作                                 | Stop (Undefined)                                    |
| 事件链接控制器(ELC)                       | Selectable               | Stop (Retained)             | Selectable <sup>7</sup>              | Stop (Undefined)                                    |
| IRQn(n=0to15)引脚中断                  | Selectable               | Selectable                  | Selectable                           | Stop (Undefined)                                    |
| NMI IRQn-DS(n=0to15)引脚中断           | Selectable               | Selectable                  | Selectable                           | Selectable  |
| 低电压检测(LVD)                         | Selectable               | Selectable                  | Selectable                           | Selectable <sup>12</sup>                            |
| 上电复位电路                             | Operating                | Operating                   | Operating                            | Operating <sup>13</sup>                             |
| 其他外围模块                             | Selectable               | Stop (Retained)             | 禁止操作                                 | Stop (Undefined)                                    |
| I/O Ports                          | Operating                | Retained                    | Operating                            | Retained  |

Note: 可选择的意思是可以通过控制寄存器来选择操作或不操作。  
 停止 (Retained) 表示内部寄存器的内容被保留但操作被暂停。  
 禁止操作意味着在进入软件待机模式之前必须停止该功能。  
 停止 (未定义) 表示内部寄存器的内容未定义, 内部电路的电源被切断。  
 进入贪睡模式后, 一旦提供PCLK, 所有模块停止位为0的模块都会启动。为了避免贪睡模式下的功耗增加, 在进入软件待机模式之前, 必须将在贪睡模式下不需要的模块的模块停止位设置为1。

注1.在IWDT专用内部振荡器和IWDT中, 通过设置IWDT停止控制位来选择操作或停止 (IWDTSTPCTL)在IWDT自动启动模式下选项功能选择寄存器0(OFS0)。在WDT中, 通过在WDT自动启动模式下设置选项功能选择寄存器0(OFS0)中的WDT停止控制位(WDTSTPCTL)来选择操作或停止。通过选择适当的操作功率控制, 可以在正常和睡眠模式下降低功耗模式根据工作频率。

- Note 2. Stopped when the clock output source select bits (CKOCR.CKOSEL[2:0]) are set to a value other than 010b (LOCO) and 100b (SOSC).
- Note 3. AGT0/AGT2 operation is possible when 100b (AGTLCLK) or 110b (AGTSCLK) is selected by the AGT0/2.AGTMR1.TCK[2:0] bits. AGT1/AGT3 operation is possible when 100b (AGTLCLK), 110b (AGTSCLK) or 101b (Underflow event signal from AGT0/AGT2) is selected by the AGT1/3.AGTMR1.TCK[2:0] bits. When 100b (AGTLCLK) is selected by AGTn.AGTMR1.TCK[2:0] bits (n = 0, 1, 2, 3), the DPSBYCR.DEEPCUT[1:0] bits must set to 00b before entering Deep Software Standby mode.
- Note 4. IIC0 wakeup interrupt is available.
- Note 5. When using SCI0 in Snooze mode, MOSCCR.MOSTP and PLLCR.PLLSTP and PLL2CR.PLL2STP bits must be 1.
- Note 6. Serial communication modes of SCI0 is only in asynchronous mode.
- Note 7. Event lists the restrictions described in [section 10.10.14. ELC Events in Snooze Mode](#).
- Note 8. If the DPSBYCR.DEEPCUT[1:0] bits are 00b, the oscillator status is the same as before entering Deep Software Standby mode. When the DPSBYCR.DEEPCUT[1:0] bits are not 00b, the oscillator stops when the MCU enters Deep Software Standby mode.
- Note 9. If the DPSBYCR.DEEPCUT[1:0] bits are 00b, data in the Standby SRAM is retained in Deep Software Standby mode. When the DPSBYCR.DEEPCUT[1:0] bits are not 00b, data in the Standby SRAM is undefined in Deep Software Standby mode.
- Note 10. If the DPSBYCR.DEEPCUT[1:0] bits are 00b, the values of the USB resume detection circuit registers are retained and detection of USB resumption is enabled, and the values of other registers are undefined in Deep Software Standby mode. When the DPSBYCR.DEEPCUT[1:0] bits are not 00b, the values of all registers are undefined in Deep Software Standby mode.
- Note 11. When the RCR4.RCKSEL bit set to 1 (LOCO), the DPSBYCR.DEEPCUT[1:0] bits must set to 00b before entering Deep Software Standby mode.
- Note 12. When using LVD in Deep Software Standby mode, DPSBYCR.DEEPCUT[1:0] bits must be 00b or 01b before entering Deep Software Standby mode.
- Note 13. When the MCU enters Deep Software Standby mode with the DPSBYCR.DEEPCUT[1:0] bits set to 11b, the LVD circuit stops and the low-power function of the power-on reset circuit is enabled.
- Note 14. AGT4 operation is possible when 100b (AGTLCLK) or 110b (AGTSCLK) is selected by the AGT4.AGTMR1.TCK[2:0] bits. AGT5 operation is possible when 100b (AGTLCLK), 110b (AGTSCLK) or 101 (Underflow event signal from AGT4) is selected by the AGT5.AGTMR1.TCK[2:0] bits.
- Note 15. When using the 12-bit A/D Converter in Snooze mode, the ADCMPCR.CMPAE and ADCMPCR.CMPBE bits must be 1.

**Table 10.3 Interrupt Source for canceling Snooze, Software Standby and Deep Software Standby Modes (1 of 2)**

| Interrupt source     | Name                          | Software Standby Mode | Snooze Mode                      | Deep Software Standby Mode |
|----------------------|-------------------------------|-----------------------|----------------------------------|----------------------------|
| NMI                  |                               | Yes                   | Yes                              | Yes                        |
| Port                 | PORT_IRQn<br>(n = 0 to 15)    | Yes                   | Yes                              | No                         |
|                      | PORT_IRQn-DS<br>(n = 0 to 15) | Yes                   | Yes                              | Yes                        |
| LVD                  | LVD_LVD1                      | Yes                   | Yes                              | Yes                        |
|                      | LVD_LVD2                      | Yes                   | Yes                              | Yes                        |
| IWDT                 | IWDT_NMIUNDF                  | Yes                   | Yes                              | No                         |
| USBFS0               | USBFS0_USBR                   | Yes                   | Yes                              | Yes                        |
| RTC                  | RTC_ALM                       | Yes                   | Yes                              | Yes                        |
|                      | RTC_PRD                       | Yes                   | Yes                              | Yes                        |
| AGT1                 | AGT1_AGTI                     | Yes                   | Yes <sup>*3</sup>                | Yes                        |
|                      | AGT1_AGTCMAI                  | Yes                   | Yes                              | No                         |
|                      | AGT1_AGTCMBI                  | Yes                   | Yes                              | No                         |
| AGT3                 | AGT3_AGTI                     | Yes                   | Yes <sup>*3</sup>                | Yes                        |
|                      | AGT3_AGTCMAI                  | Yes                   | Yes                              | No                         |
|                      | AGT3_AGTCMBI                  | Yes                   | Yes                              | No                         |
| IIC0                 | IIC0_WUI                      | Yes                   | Yes                              | No                         |
| ADC12n<br>(n = 0, 1) | ADC12n_WCMPPM                 | No                    | Yes with SELSR0 <sup>*1 *3</sup> | No                         |
|                      | ADC12n_WCMPUM                 | No                    | Yes with SELSR0 <sup>*1 *3</sup> | No                         |
| SCI0                 | SCI0_AM                       | No                    | Yes with SELSR0 <sup>*1 *2</sup> | No                         |
|                      | SCI0_RXI_OR_ERI               | No                    | Yes with SELSR0 <sup>*1 *2</sup> | No                         |
| DTC                  | DTC_COMPLETE                  | No                    | Yes with SELSR0 <sup>*1 *3</sup> | No                         |
| DOC                  | DOC_DOPCI                     | No                    | Yes with SELSR0 <sup>*1</sup>    | No                         |

- 注2.当时钟输出源选择位(CKOCR.CKOSEL[2:0])设置为010b(LOCO)和100b(SOSC)以外的值时停止。
- 注3.当AGT02.AGTMR1.TCK[2:0]位选择100b(AGTLCLK)或110b(AGTSCLK)时, AGT0可以进行AGT2操作。当AGT13.AGTMR1.TCK[2:0]位选择100b(AGTLCLK)、110b(AGTSCLK)或101b(来自AGT0AGT2的下溢事件信号)时, AGT1AGT3操作是可能的。当AGTn.AGTMR1.TCK[2:0]位(n=0 1 2 3)选择100b(AGTLCLK)时, DPSBYCR.DEEPCUT[1:0]位必须在进入深度软件待机之前设置为00b模式。
- 注4.IIC0唤醒中断可用。
- 注5.在贪睡模式下使用SCI0时, MOSCCR.MOSTP和PLLCR.PLLSTP和PLL2CR.PLL2STP位必须为1。
- 注6.SCI0的串行通信模式仅在异步模式下。
- 注7.事件列出了10.10.14节中描述的限制。贪睡模式下的ELC事件。
- 注8.如果DPSBYCR.DEEPCUT[1:0]位为00b, 则振荡器状态与进入深度软件待机模式前相同。当DPSBYCR.DEEPCUT[1:0]位不为00b时, 当MCU进入深度软件待机模式时振荡器停止。
- 注9.如果DPSBYCR.DEEPCUT[1:0]位为00b, 则待机SRAM中的数据在深度软件待机模式下保留。当。。。的时候DPSBYCR.DEEPCUT[1:0]位不是00b, 在深度软件待机模式下, 待机SRAM中的数据未定义。
- 注10.如果DPSBYCR.DEEPCUT[1:0]位为00b, 则USB恢复检测电路寄存器的值被保留并检测USB恢复使能, 并且在深度软件待机模式下其他寄存器的值未定义。当。。。的时候DPSBYCR.DEEPCUT[1:0]位不是00b, 在深度软件待机模式下所有寄存器的值都是未定义的。
- 注11.当RCR4.RCKSEL位设置为1(LOCO)时, DPSBYCR.DEEPCUT[1:0]位必须在进入深度软件之前设置为00b待机模式。
- 注12.在深度软件待机模式下使用LVD时, DPSBYCR.DEEPCUT[1:0]位在进入深度之前必须为00b或01b软件待机模式。
- 注13.当MCU进入深度软件待机模式且DPSBYCR.DEEPCUT[1:0]位设置为11b时, LVD电路停止并启用上电复位电路的低功耗功能。
- 注14.当AGT4.AGTMR1.TCK[2:0]位选择100b(AGTLCLK)或110b(AGTSCLK)时, 可以进行AGT4操作。当AGT5.AGTMR1.TCK[2:0]位选择100b(AGTLCLK)、110b(AGTSCLK)或101(来自AGT4的下溢事件信号)时, 可以进行AGT5操作。
- 注15.在贪睡模式下使用12位AD转换器时, ADCMPCR.CMPAE和ADCMPCR.CMPBE位必须为1。

**Table 10.3 用于取消贪睡、软件待机和深度软件待机模式的中断源 (1 of 2)**

| 中断源                  | Name                          | 软件待机模式 | 贪睡模式              | 深度软件待机模式 |
|----------------------|-------------------------------|--------|-------------------|----------|
| NMI                  |                               | Yes    | Yes               | Yes      |
| Port                 | PORT_IRQn<br>(n = 0 to 15)    | Yes    | Yes               | No       |
|                      | PORT_IRQn-DS<br>(n = 0 to 15) | Yes    | Yes               | Yes      |
| LVD                  | LVD_LVD1                      | Yes    | Yes               | Yes      |
|                      | LVD_LVD2                      | Yes    | Yes               | Yes      |
| IWDT                 | IWDT_NMIUNDF                  | Yes    | Yes               | No       |
| USBFS0               | USBFS0_USBR                   | Yes    | Yes               | Yes      |
| RTC                  | RTC_ALM                       | Yes    | Yes               | Yes      |
|                      | RTC_PRD                       | Yes    | Yes               | Yes      |
| AGT1                 | AGT1_AGTI                     | Yes    | Yes <sup>*3</sup> | Yes      |
|                      | AGT1_AGTCMAI                  | Yes    | Yes               | No       |
|                      | AGT1_AGTCMBI                  | Yes    | Yes               | No       |
| AGT3                 | AGT3_AGTI                     | Yes    | Yes <sup>*3</sup> | Yes      |
|                      | AGT3_AGTCMAI                  | Yes    | Yes               | No       |
|                      | AGT3_AGTCMBI                  | Yes    | Yes               | No       |
| IIC0                 | IIC0_WUI                      | Yes    | Yes               | No       |
| ADC12n<br>(n = 0, 1) | ADC12n_WCMPPM                 | No     | 是SELSR0*1*3       | No       |
|                      | ADC12n_WCMPUM                 | No     | 是SELSR0*1*3       | No       |
| SCI0                 | SCI0_AM                       | No     | 是SELSR0*1*2       | No       |
|                      | SCI0_RXI_OR_ERI               | No     | 是SELSR0*1*2       | No       |
| DTC                  | DTC_COMPLETE                  | No     | 是SELSR0*1*3       | No       |
| DOC                  | DOC_DOPCI                     | No     | 是SELSR0*1         | No       |



Table 10.3 Interrupt Source for canceling Snooze, Software Standby and Deep Software Standby Modes (2 of 2)

| Interrupt source | Name          | Software Standby Mode | Snooze Mode       | Deep Software Standby Mode |
|------------------|---------------|-----------------------|-------------------|----------------------------|
| CTSUSU           | CTSUSU_CTSUFN | No                    | Yes with SELSR0*1 | No                         |

Note 1. To use the interrupt request as a trigger for exiting the Snooze mode, the request must be selected in SELSR0. See section 13, Interrupt Controller Unit (ICU) for the setting of SELSR0. When a trigger selected in SELSR0 occurs after executing WFI instruction and during the transition from Normal mode to Software Standby mode, the request might or might not be accepted, depending on the timing of the occurrence.

Note 2. Only one of either SCIO\_AM or SCIO\_RXI\_OR\_ERI can be set.

Note 3. The event which is enabled by the SNZEDCRn must not be used.

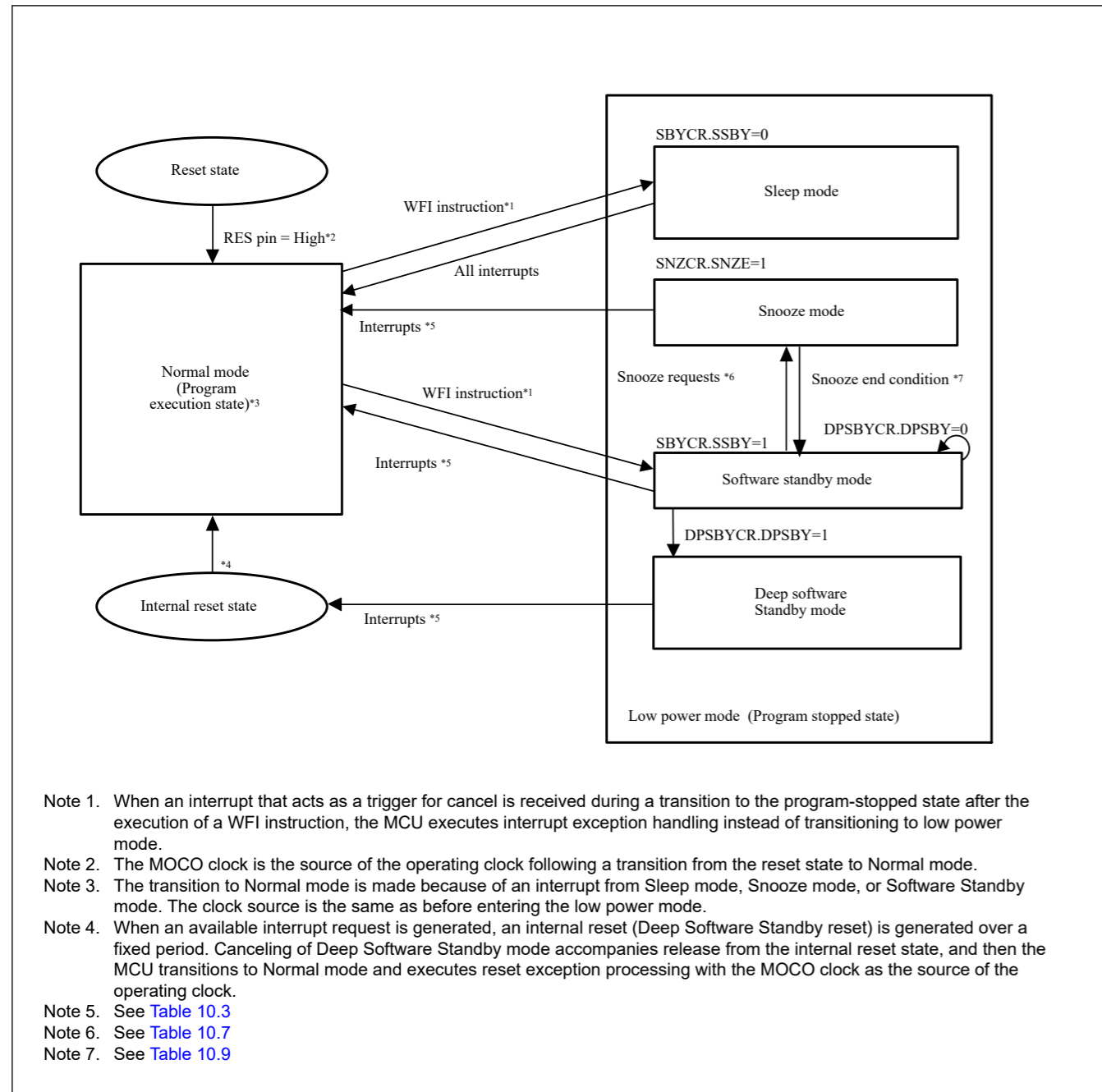


Figure 10.1 Mode Transitions

- Note 1. When an interrupt that acts as a trigger for cancel is received during a transition to the program-stopped state after the execution of a WFI instruction, the MCU executes interrupt exception handling instead of transitioning to low power mode.
- Note 2. The MOCO clock is the source of the operating clock following a transition from the reset state to Normal mode.
- Note 3. The transition to Normal mode is made because of an interrupt from Sleep mode, Snooze mode, or Software Standby mode. The clock source is the same as before entering the low power mode.
- Note 4. When an available interrupt request is generated, an internal reset (Deep Software Standby reset) is generated over a fixed period. Canceling of Deep Software Standby mode accompanies release from the internal reset state, and then the MCU transitions to Normal mode and executes reset exception processing with the MOCO clock as the source of the operating clock.
- Note 5. See Table 10.3
- Note 6. See Table 10.7
- Note 7. See Table 10.9

Table 10.3 用于取消贪睡、软件待机和深度软件待机模式的中断源(2of2)

| 中断源    | Name          | 软件待机模式 | 贪睡模式      | 深度软件待机模式 |
|--------|---------------|--------|-----------|----------|
| CTSUSU | CTSUSU_CTSUFN | No     | 是SELSR0*1 | No       |

注1.要将中断请求用作退出贪睡模式的触发器，必须在SELSR0中选择该请求。见第13节，用于设置SELSR0的中断控制器单元(ICU)。当SELSR0中选择的触发发生在执行WFI指令之后以及从正常模式到软件待机模式的转换期间，请求可能会或可能不会被接受，具体取决于发生的时间。

注2.只能设置SCIO\_AM或SCIO\_RXI\_OR\_ERI之一。

注3.不得使用由SNZEDCRn启用的事件。

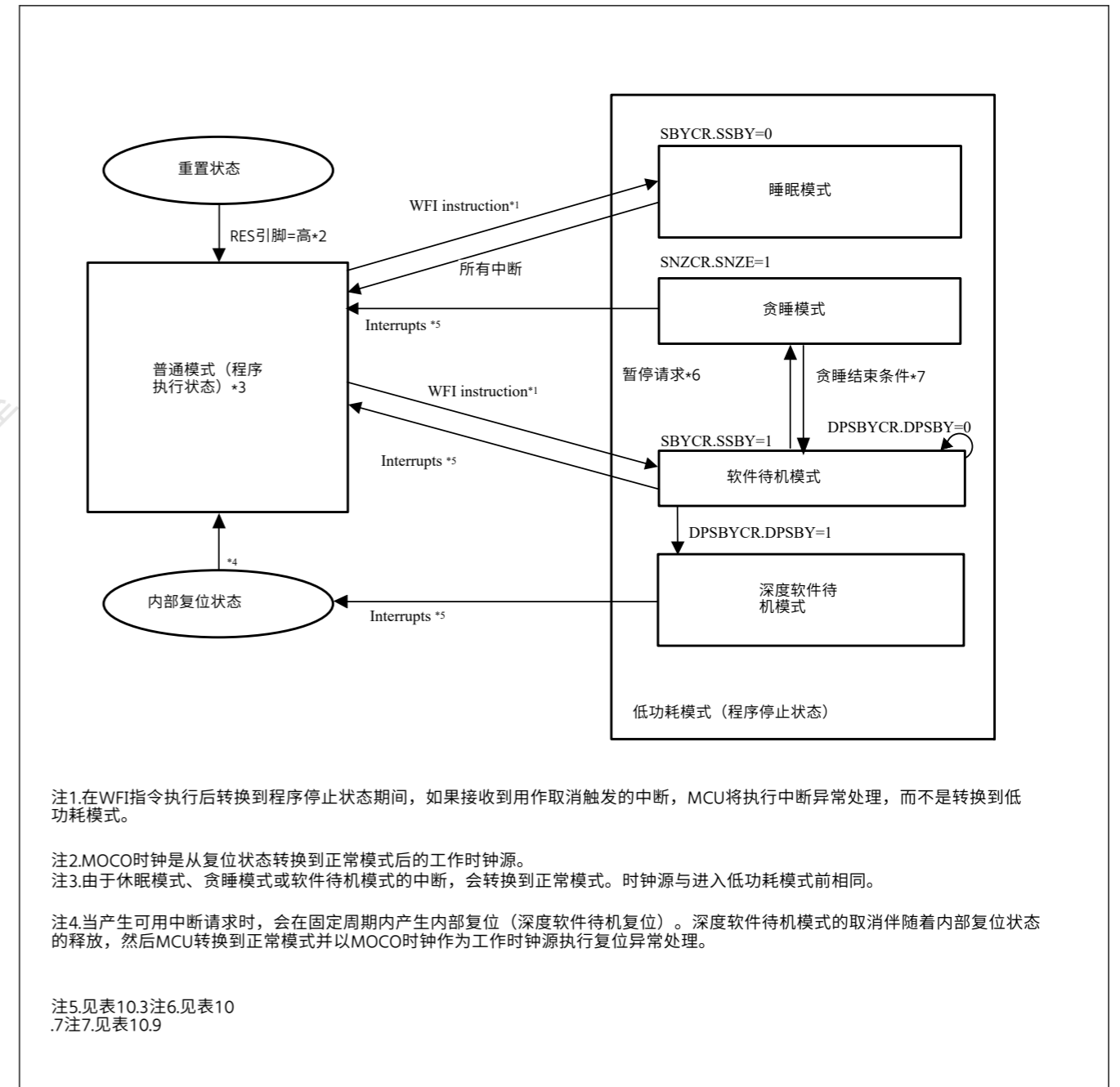


Figure 10.1 模式转换

- 注1.在WFI指令执行后转换到程序停止状态期间，如果接收到用作取消触发的中断，MCU将执行中断异常处理，而不是转换到低功耗模式。
- 注2.MOCO时钟是从复位状态转换到正常模式后的工作时钟源。
- 注3.由于休眠模式、贪睡模式或软件待机模式的中断，会转换到正常模式。时钟源与进入低功耗模式前相同。
- 注4.当产生可用中断请求时，会在固定周期内产生内部复位（深度软件待机复位）。深度软件待机模式的取消伴随着内部复位状态的释放，然后MCU转换到正常模式并以MOCO时钟作为工作时钟源执行复位异常处理。
- 注5.见表10.3注6.见表10.7注7.见表10.9

## 10.2 Register Descriptions

## 10.2.1 LPMSAR : Low Power Mode Security Attribution Register

Base address: SYSC = 0x4001\_E000

Offset address: 0x3C8

|                    |    |    |    |    |    |    |             |             |    |    |    |             |    |             |    |             |
|--------------------|----|----|----|----|----|----|-------------|-------------|----|----|----|-------------|----|-------------|----|-------------|
| Bit position:      | 31 | 30 | 29 | 28 | 27 | 26 | 25          | 24          | 23 | 22 | 21 | 20          | 19 | 18          | 17 | 16          |
| Bit field:         | —  | —  | —  | —  | —  | —  | —           | —           | —  | —  | —  | —           | —  | —           | —  | —           |
| Value after reset: | 1  | 1  | 1  | 1  | 1  | 1  | 1           | 1           | 1  | 1  | 1  | 1           | 1  | 1           | 1  | 1           |
| Bit position:      | 15 | 14 | 13 | 12 | 11 | 10 | 9           | 8           | 7  | 6  | 5  | 4           | 3  | 2           | 1  | 0           |
| Bit field:         | —  | —  | —  | —  | —  | —  | NONS<br>EC9 | NONS<br>EC8 | —  | —  | —  | NONS<br>EC4 | —  | NONS<br>EC2 | —  | NONS<br>EC0 |
| Value after reset: | 1  | 1  | 1  | 1  | 1  | 1  | 1           | 1           | 1  | 1  | 1  | 1           | 1  | 1           | 1  | 1           |

| Bit   | Symbol    | Function  | R/W |
|-------|-----------|---|-----|
| 0     | NONSEC0*1 | Non Secure Attribute bit 0<br>Target register: OPCCR, SOPCCR<br>0: Secure<br>1: Non Secure              | R/W |
| 1     | —         | This bit is read as 1. The write value should be 1.   | R/W |
| 2     | NONSEC2   | Non Secure Attribute bit 2<br>Target register: SBYCR<br>0: Secure<br>1: Non Secure                      | R/W |
| 3     | —         | This bit is read as 1. The write value should be 1.   | R/W |
| 4     | NONSEC4   | Non Secure Attribute bit 4<br>Target register: SNZCR, SNZEDCRn, SNZREQCRn<br>0: Secure<br>1: Non Secure | R/W |
| 7:5   | —         | These bits are read as 1. The write value should be 1.  | R/W |
| 8     | NONSEC8   | Non Secure Attribute bit 8<br>Target register: DPSBYCR<br>0: Secure<br>1: Non Secure                    | R/W |
| 9     | NONSEC9   | Non Secure Attribute bit 9<br>Target register: DPSWCR<br>0: Secure<br>1: Non Secure                     | R/W |
| 31:10 | —         | These bits are read as 1. The write value should be 1.  | R/W |

Note: Only secure access can write to this register. Both secure access and Non-secure read access are allowed but Non-secure write access is not allowed and TrustZone access error is not generated.

Note: This register is write-protected by PRCR register.

Note 1. It is recommended that these bits are configured as Non Secure when the device life cycle is NSECSD (DLMMON.DLMMON[3:0]=0011b). See [section 46.6.1. Restrictions on setting the security attribution](#) for the details.

The LPMSAR register controls the secure attribute of Low Power Mode registers.

**NONSEC0 bit (Non Secure Attribute bit 0)**

This bit controls the security attribute of OPCCR, SOPCCR.

**NONSEC2 bit (Non Secure Attribute bit 2)**

This bit controls the security attribute of SBYCR.

**NONSEC4 bit (Non Secure Attribute bit 4)**

This bit controls the security attribute of SNZCR, SNZEDCRn, SNZREQCRn

## 10.2 注册说明

## 10.2.1 LPMSAR: 低功耗模式安全属性寄存器

Base address: SYSC = 0x4001\_E000

Offset address: 0x3C8

|               |    |    |    |    |    |    |             |             |    |    |    |             |    |             |    |             |
|---------------|----|----|----|----|----|----|-------------|-------------|----|----|----|-------------|----|-------------|----|-------------|
| Bit position: | 31 | 30 | 29 | 28 | 27 | 26 | 25          | 24          | 23 | 22 | 21 | 20          | 19 | 18          | 17 | 16          |
| Bit field:    | —  | —  | —  | —  | —  | —  | —           | —           | —  | —  | —  | —           | —  | —           | —  | —           |
| 重置后的值:        | 1  | 1  | 1  | 1  | 1  | 1  | 1           | 1           | 1  | 1  | 1  | 1           | 1  | 1           | 1  | 1           |
| Bit position: | 15 | 14 | 13 | 12 | 11 | 10 | 9           | 8           | 7  | 6  | 5  | 4           | 3  | 2           | 1  | 0           |
| Bit field:    | —  | —  | —  | —  | —  | —  | NONS<br>EC9 | NONS<br>EC8 | —  | —  | —  | NONS<br>EC4 | —  | NONS<br>EC2 | —  | NONS<br>EC0 |
| 重置后的值:        | 1  | 1  | 1  | 1  | 1  | 1  | 1           | 1           | 1  | 1  | 1  | 1           | 1  | 1           | 1  | 1           |

| Bit   | Symbol    | Function   | R/W |
|-------|-----------|--|-----|
| 0     | NONSEC0*1 | 非安全属性位0<br>Target register: OPCCR, SOPCCR<br>0: 安全 1: 不安全              | R/W |
| 1     | —         | 该位读取为1。写入值应为1。   | R/W |
| 2     | NONSEC2   | 非安全属性位2<br>Target register: SBYCR<br>0: 安全 1: 不安全                      | R/W |
| 3     | —         | 该位读取为1。写入值应为1。   | R/W |
| 4     | NONSEC4   | 非安全属性位4<br>Target register: SNZCR, SNZEDCRn, SNZREQCRn<br>0: 安全 1: 不安全 | R/W |
| 7:5   | —         | 这些位被读取为1。写入值应为1。   | R/W |
| 8     | NONSEC8   | 非安全属性位8目标寄存器<br>: DPSBYCR<br>0: 安全 1: 不安全                              | R/W |
| 9     | NONSEC9   | 非安全属性位9目标寄存器<br>: DPSWCR<br>0: 安全 1: 不安全                               | R/W |
| 31:10 | —         | 这些位被读取为1。写入值应为1。   | R/W |

Note: 只有安全访问才能写入该寄存器。允许安全访问和非安全读取访问，但不允许非安全写入访问，并且不会生成TrustZone访问错误。

Note: 该寄存器由PRCR寄存器写保护。

注1.当设备生命周期为NSECSD时，建议将这些位配置为非安全 (DLMMON.DLMMON[3:0]=0011b)。请参见第46.6.1节。设置详细信息的安全属性的限制。

LPMSAR寄存器控制低功耗模式寄存器的安全属性。

**NONSEC0位 (非安全属性位0)**

该位控制OPCCR的安全属性SOPCCR。

**NONSEC2位 (非安全属性位2)**

该位控制SBYCR的安全属性。

**NONSEC4位 (非安全属性位4)**

该位控制SNZCR、SNZEDCRn、SNZREQCRn的安全属性



| Bit   | Symbol  | Function   | R/W |
|-------|---------|--|-----|
| 25    | —       | This bit is read as 1. The write value should be 1.  | R/W |
| 26    | DPFSA26 | Deep Standby Interrupt Factor Security Attribute bit 26<br>Target register: DPSIER3.b2, DPSIFR3.b2<br>Target factor : AGT1 Underflow<br>0: Secure<br>1: Non Secure | R/W |
| 27    | DPFSA27 | Deep Standby Interrupt Factor Security Attribute bit 27<br>Target register: DPSIER3.b3, DPSIFR3.b3<br>Target factor : AGT3 Underflow<br>0: Secure<br>1: Non Secure | R/W |
| 31:28 | —       | These bits are read as 1. The write value should be 1.   | R/W |

Note: Only secure access can write to this register. Both secure access and Non-secure read access are allowed but Non-secure write access is not allowed and TrustZone access error is not generated.

Note: This register is write-protected by PRCR register.

The DPFSA register controls the secure attribute of Deep Standby Interrupt Factor control registers.

#### DPFSA0 to DPFSA7 bit (Deep Standby Interrupt Factor Security Attribute bit n (n = 0 to 7))

This bit controls the security attribute of DPSIER0.bn, DPSIFR0.bn, DPSIEGR0.bn (n = 0 to 7).

Target factor is IRQn-DS Pin (n = 0 to 7).

#### DPFSA8 to DPFSA15 bit (Deep Standby Interrupt Factor Security Attribute bit n (n = 8 to 15))

This bit controls the security attribute of DPSIER1.bn, DPSIFR1.bn, DPSIEGR1.bn (n = 0 to 7).

Target factor is IRQn-DS Pin (n = 8 to 15)

#### DPFSA16 bit (Deep Standby Interrupt Factor Security Attribute bit 16)

This bit controls the security attribute of DPSIER2.b0, DPSIFR2.b0, DPSIEGR2.b0.

Target factor is LVD1.

#### DPFSA17 bits (Deep Standby Interrupt Factor Security Attribute bit 17)

This bit controls the security attribute of DPSIER2.b1, DPSIFR2.b1, DPSIEGR2.b1.

Target factor is LVD2.

#### DPFSA18 bit (Deep Standby Interrupt Factor Security Attribute bit 18)

This bit controls the security attribute of DPSIER2.b2, DPSIFR2.b2.

Target factor is RTC Interval.

#### DPFSA19 bit (Deep Standby Interrupt Factor Security Attribute bit 19)

This bit controls the security attribute of DPSIER2.b3, DPSIFR2.b3.

Target factor is RTC Alarm.

#### DPFSA20 bit (Deep Standby Interrupt Factor Security Attribute bit 20)

This bit controls the security attribute of DPSIER2.b4, DPSIFR2.b4, DPSIEGR2.b4.

Target factor is NMI Pin.

#### DPFSA24 bit (Deep Standby Interrupt Factor Security Attribute bit 24)

This bit controls the security attribute of DPSIER3.b0, DPSIFR3.b0.

Target factor is USBFS0 Suspend/Resume.

#### DPFSA26 bit (Deep Standby Interrupt Factor Security Attribute bit 26)

This bit controls the security attribute of DPSIER3.b2, DPSIFR3.b2.

Target factor is AGT1 Underflow.

| Bit   | Symbol  | Function  | R/W |
|-------|---------|---|-----|
| 25    | —       | 该位读取为1。写入值应为1。  | R/W |
| 26    | DPFSA26 | 深度待机中断因素安全属性位26<br>Target register: DPSIER3.b2, DPSIFR3.b2<br>目标因素: AGT1下溢<br>0: 安全<br>1: 不安全 | R/W |
| 27    | DPFSA27 | 深度待机中断因素安全属性位27<br>Target register: DPSIER3.b3, DPSIFR3.b3<br>目标因素: AGT3下溢<br>0: 安全<br>1: 不安全 | R/W |
| 31:28 | —       | 这些位被读取为1。写入值应为1。  | R/W |

Note: 只有安全访问才能写入该寄存器。允许安全访问和非安全读取访问，但不允许非安全写入访问，并且不会生成TrustZone访问错误。

Note: 该寄存器由PRCR寄存器写保护。

DPFSA寄存器控制深度待机中断因子控制寄存器的安全属性。

#### DPFSA0至DPFSA7位（深度待机中断因素安全属性位n（n=0至7））

该位控制DPSIER0.bn DPSIFR0.bn DPSIEGR0.bn(n=0to7)的安全属性。

目标因子是IRQn-DS引脚（n=0到7）。

#### DPFSA8至DPFSA15位（深度待机中断因素安全属性位n（n=8至15））

该位控制DPSIER1.bn DPSIFR1.bn DPSIEGR1.bn(n=0to7)的安全属性。

目标因子是IRQn-DS引脚（n=8到15）

#### DPFSA16位（深度待机中断因素安全属性位16）

该位控制DPSIER2.b0、DPSIFR2.b0、DPSIEGR2.b0的安全属性。

目标因子是LVD1。

#### DPFSA17位（深度待机中断因素安全属性位17）

该位控制DPSIER2.b1、DPSIFR2.b1、DPSIEGR2.b1的安全属性。

目标因子是LVD2。

#### DPFSA18位（深度待机中断因素安全属性位18）

该位控制DPSIER2.b2、DPSIFR2.b2的安全属性。

目标因素是RTC间隔。

#### DPFSA19位（深度待机中断因素安全属性位19）

该位控制DPSIER2.b3、DPSIFR2.b3的安全属性。

目标因素是RTC警报。

#### DPFSA20位（深度待机中断因素安全属性位20）

该位控制DPSIER2.b4、DPSIFR2.b4、DPSIEGR2.b4的安全属性。

目标因素是NMI引脚。

#### DPFSA24位（深度待机中断因素安全属性位24）

该位控制DPSIER3.b0、DPSIFR3.b0的安全属性。

目标因素是USBFS0暂停恢复。

#### DPFSA26位（深度待机中断因素安全属性位26）

该位控制DPSIER3.b2、DPSIFR3.b2的安全属性。

目标因子是AGT1下溢。



**DPFSA27 bit (Deep Standby Interrupt Factor Security Attribute bit 27)**

This bit controls the security attribute of DPSIER3.b3, DPSIFR3.b3.

Target factor is AGT3 Underflow.

**10.2.3 SBYCR : Standby Control Register**

Base address: SYSC = 0x4001\_E000

Offset address: 0x00C

|                    |      |    |    |    |    |    |   |   |   |   |   |   |   |   |   |   |
|--------------------|------|----|----|----|----|----|---|---|---|---|---|---|---|---|---|---|
| Bit position:      | 15   | 14 | 13 | 12 | 11 | 10 | 9 | 8 | 7 | 6 | 5 | 4 | 3 | 2 | 1 | 0 |
| Bit field:         | SSBY | —  | —  | —  | —  | —  | — | — | — | — | — | — | — | — | — | — |
| Value after reset: | 0    | 1  | 0  | 0  | 0  | 0  | 0 | 0 | 0 | 0 | 0 | 0 | 0 | 0 | 0 | 0 |

| Bit  | Symbol | Function   | R/W |
|------|--------|--|-----|
| 14:0 | —      | These bits are read as reset value. The write value should be reset value  | R/W |
| 15   | SSBY   | Software Standby Mode Select<br>0: Sleep mode<br>1: Software Standby mode. | R/W |

- Note: If the security attribution is configured as secure:
- Secure access and Non-secure read access are allowed
  - Non-secure write access is ignored, and TrustZone access error is not generated.
- If the security attribution is configured as Non-secure:
- Secure and Non-secure access are allowed.

Note: Set the PRCR.PRC1 bit to 1 (write enabled) before rewriting this register.

**SSBY bit (Software Standby Mode Select)**

The SSBY bit specifies the transition destination after a WFI instruction is executed.

When the SSBY bit is set to 1, the MCU enters Software Standby mode after execution of a WFI instruction. When the MCU returns to Normal mode from Software Standby mode by an interrupt, the SSBY bit remains 1. The SSBY bit can be cleared by writing 0 to it.

While the OSTDCR.OSTDE bit is 1, setting of the SSBY bit is ignored. Even if SSBY bit is 1, the MCU enters Sleep mode on execution of a WFI instruction.

While the FENTRYR.FENTRY0 bit is 1 setting of the SSBY bit is ignored. Even if SSBY bit is 1, the MCU enters Sleep mode on execution of a WFI instruction.

**10.2.4 MSTPCRA : Module Stop Control Register A**

Base address: MSTP = 0x4008\_4000

Offset address: 0x000

|                    |    |    |    |    |    |    |    |    |         |          |    |    |    |    |    |         |
|--------------------|----|----|----|----|----|----|----|----|---------|----------|----|----|----|----|----|---------|
| Bit position:      | 31 | 30 | 29 | 28 | 27 | 26 | 25 | 24 | 23      | 22       | 21 | 20 | 19 | 18 | 17 | 16      |
| Bit field:         | —  | —  | —  | —  | —  | —  | —  | —  | —       | MSTP A22 | —  | —  | —  | —  | —  | —       |
| Value after reset: | 1  | 1  | 1  | 1  | 1  | 1  | 1  | 1  | 1       | 0        | 1  | 1  | 1  | 1  | 1  | 1       |
| Bit position:      | 15 | 14 | 13 | 12 | 11 | 10 | 9  | 8  | 7       | 6        | 5  | 4  | 3  | 2  | 1  | 0       |
| Bit field:         | —  | —  | —  | —  | —  | —  | —  | —  | MSTP A7 | —        | —  | —  | —  | —  | —  | MSTP A0 |
| Value after reset: | 1  | 1  | 1  | 1  | 1  | 1  | 1  | 1  | 0       | 1        | 1  | 1  | 1  | 1  | 1  | 0       |

**DPFSA27位 (深度待机中断因素安全属性位27)**

该位控制DPSIER3.b3、DPSIFR3.b3的安全属性。

目标因子是AGT3下溢。

**10.2.3 SBYCR: 待机控制寄存器**

Base address: SYSC = 0x4001\_E000

Offset address: 0x00C

|               |      |    |    |    |    |    |   |   |   |   |   |   |   |   |   |   |
|---------------|------|----|----|----|----|----|---|---|---|---|---|---|---|---|---|---|
| Bit position: | 15   | 14 | 13 | 12 | 11 | 10 | 9 | 8 | 7 | 6 | 5 | 4 | 3 | 2 | 1 | 0 |
| Bit field:    | SSBY | —  | —  | —  | —  | —  | — | — | — | — | — | — | — | — | — | — |
| 重置后的值:        | 0    | 1  | 0  | 0  | 0  | 0  | 0 | 0 | 0 | 0 | 0 | 0 | 0 | 0 | 0 | 0 |

| Bit  | Symbol | Function                      | R/W |
|------|--------|-------------------------------|-----|
| 14:0 | —      | 这些位被读取为复位值。写入值应为复位值           | R/W |
| 15   | SSBY   | 软件待机模式选择<br>0: 休眠模式1: 软件待机模式。 | R/W |

- Note: 如果安全属性配置为安全: ●
- 允许安全访问和非安全读取访问
  - 忽略非安全写入访问, 不会生成TrustZone访问错误。
- 如果安全属性配置为非安全: ●
- 允许安全和非安全访问。

Note: 在重写该寄存器之前将PRCR.PRC1位设置为1 (允许写入)。

**SSBY位 (软件待机模式选择)**

SSBY位指定执行WFI指令后的转移目标。

当SSBY位设置为1时, MCU在执行WFI指令后进入软件待机模式。当。。。的时候 MCU通过中断从软件待机模式返回到正常模式, SSBY位保持为1。SSBY位可以通过向其写入0来清除。

当OSTDCR.OSTDE位为1时, 忽略SSBY位的设置。即使SSBY位为1, MCU也会在执行WFI指令时进入休眠模式。

当FENTRYR.FENTRY0位为1时, SSBY位的设置被忽略。即使SSBY位为1, MCU也会在执行WFI指令时进入休眠模式。

**10.2.4 MSTPCRA:模块停止控制寄存器A**

Base address: MSTP = 0x4008\_4000

Offset address: 0x000

|               |    |    |    |    |    |    |    |    |         |          |    |    |    |    |    |         |
|---------------|----|----|----|----|----|----|----|----|---------|----------|----|----|----|----|----|---------|
| Bit position: | 31 | 30 | 29 | 28 | 27 | 26 | 25 | 24 | 23      | 22       | 21 | 20 | 19 | 18 | 17 | 16      |
| Bit field:    | —  | —  | —  | —  | —  | —  | —  | —  | —       | MSTP A22 | —  | —  | —  | —  | —  | —       |
| 重置后的值:        | 1  | 1  | 1  | 1  | 1  | 1  | 1  | 1  | 1       | 0        | 1  | 1  | 1  | 1  | 1  | 1       |
| Bit position: | 15 | 14 | 13 | 12 | 11 | 10 | 9  | 8  | 7       | 6        | 5  | 4  | 3  | 2  | 1  | 0       |
| Bit field:    | —  | —  | —  | —  | —  | —  | —  | —  | MSTP A7 | —        | —  | —  | —  | —  | —  | MSTP A0 |
| 重置后的值:        | 1  | 1  | 1  | 1  | 1  | 1  | 1  | 1  | 0       | 1        | 1  | 1  | 1  | 1  | 1  | 0       |



| Bit   | Symbol  | Function   | R/W |
|-------|---------|--|-----|
| 0     | MSTPA0  | SRAM0 Module Stop<br>Target module: SRAM0<br>0: Cancel the module-stop state<br>1: Enter the module-stop state   | R/W |
| 6:1   | —       | These bits are read as 1. The write value should be 1.   | R/W |
| 7     | MSTPA7  | Standby SRAM Module Stop<br>Target module: Standby SRAM<br>0: Cancel the module-stop state<br>1: Enter the module-stop state                           | R/W |
| 21:8  | —       | These bits are read as 1. The write value should be 1.   | R/W |
| 22    | MSTPA22 | DMA Controller/Data Transfer Controller Module Stop*1<br>Target module: DTC, DMAC<br>0: Cancel the module-stop state<br>1: Enter the module-stop state | R/W |
| 31:23 | —       | These bits are read as 1. The write value should be 1.   | R/W |

Note: If the security attribution is configured as secure:

- Secure access and Non-secure read access are allowed
- Non-secure write access is ignored, and TrustZone access error is not generated.

If the security attribution is configured as Non-secure:

- Secure and Non-secure access are allowed.

Note 1. When rewriting the MSTPA22 bit from 0 to 1, disable the DMAC and DTC before setting the MSTPA22 bit.

### 10.2.5 MSTPCRB : Module Stop Control Register B

Base address: MSTP = 0x4008\_4000

Offset address: 0x004

|                    |          |          |          |          |          |    |         |         |    |          |    |    |          |         |         |    |
|--------------------|----------|----------|----------|----------|----------|----|---------|---------|----|----------|----|----|----------|---------|---------|----|
| Bit position:      | 31       | 30       | 29       | 28       | 27       | 26 | 25      | 24      | 23 | 22       | 21 | 20 | 19       | 18      | 17      | 16 |
| Bit field:         | MSTP B31 | MSTP B30 | MSTP B29 | MSTP B28 | MSTP B27 | —  | —       | —       | —  | MSTP B22 | —  | —  | MSTP B19 | —       | —       | —  |
| Value after reset: | 1        | 1        | 1        | 1        | 1        | 1  | 1       | 1       | 1  | 1        | 1  | 1  | 1        | 1       | 1       | 1  |
| Bit position:      | 15       | 14       | 13       | 12       | 11       | 10 | 9       | 8       | 7  | 6        | 5  | 4  | 3        | 2       | 1       | 0  |
| Bit field:         | —        | —        | —        | —        | MSTP B11 | —  | MSTP B9 | MSTP B8 | —  | MSTP B6  | —  | —  | —        | MSTP B2 | MSTP B1 | —  |
| Value after reset: | 1        | 1        | 1        | 1        | 1        | 1  | 1       | 1       | 1  | 1        | 1  | 1  | 1        | 1       | 1       | 1  |

| Bit | Symbol | Function   | R/W |
|-----|--------|--|-----|
| 0   | —      | This bit is read as 1. The write value should be 1.  | R/W |
| 1   | MSTPB1 | Controller Area Network 1 Module Stop*1<br>Target module: CAN1<br>0: Cancel the module-stop state<br>1: Enter the module-stop state      | R/W |
| 2   | MSTPB2 | Controller Area Network 0 Module Stop*1<br>Target module: CAN0<br>0: Cancel the module-stop state<br>1: Enter the module-stop state      | R/W |
| 5:3 | —      | These bits are read as 1. The write value should be 1.   | R/W |
| 6   | MSTPB6 | Quad Serial Peripheral Interface Module Stop<br>Target module: QSPI<br>0: Cancel the module-stop state<br>1: Enter the module-stop state | R/W |
| 7   | —      | This bit is read as 1. The write value should be 1.  | R/W |

| Bit   | Symbol  | Function  | R/W |
|-------|---------|---|-----|
| 0     | MSTPA0  | SRAM0模块停止<br>Target module: SRAM0<br>0: 取消模块停止状态1: 进入模块停止状态               | R/W |
| 6:1   | —       | 这些位被读取为1。写入值应为1。  | R/W |
| 7     | MSTPA7  | 待机SRAM模块停止<br>目标模块: 备用SRAM<br>0: 取消模块停止状态1: 进入模块停止状态                      | R/W |
| 21:8  | —       | 这些位被读取为1。写入值应为1。  | R/W |
| 22    | MSTPA22 | DMA控制器数据传输控制器模块停止*1<br>Target module: DTC, DMAC<br>0: 取消模块停止状态1: 进入模块停止状态 | R/W |
| 31:23 | —       | 这些位被读取为1。写入值应为1。  | R/W |

Note: 如果安全属性配置为安全: ●

- 允许安全访问和非安全读取访问
- 忽略非安全写入访问, 不会生成TrustZone访问错误。

如果安全属性配置为非安全: ●

- 允许安全和非安全访问。

注1.将MSTPA22位从0改写为1时, 在设置MSTPA22位之前禁用DMAC和DTC。

### 10.2.5 MSTPCRB:模块停止控制寄存器B

Base address: MSTP = 0x4008\_4000

Offset address: 0x004

|               |          |          |          |          |          |    |         |         |    |          |    |    |          |         |         |    |
|---------------|----------|----------|----------|----------|----------|----|---------|---------|----|----------|----|----|----------|---------|---------|----|
| Bit position: | 31       | 30       | 29       | 28       | 27       | 26 | 25      | 24      | 23 | 22       | 21 | 20 | 19       | 18      | 17      | 16 |
| Bit field:    | MSTP B31 | MSTP B30 | MSTP B29 | MSTP B28 | MSTP B27 | —  | —       | —       | —  | MSTP B22 | —  | —  | MSTP B19 | —       | —       | —  |
| 重置后的值:        | 1        | 1        | 1        | 1        | 1        | 1  | 1       | 1       | 1  | 1        | 1  | 1  | 1        | 1       | 1       | 1  |
| Bit position: | 15       | 14       | 13       | 12       | 11       | 10 | 9       | 8       | 7  | 6        | 5  | 4  | 3        | 2       | 1       | 0  |
| Bit field:    | —        | —        | —        | —        | MSTP B11 | —  | MSTP B9 | MSTP B8 | —  | MSTP B6  | —  | —  | —        | MSTP B2 | MSTP B1 | —  |
| 重置后的值:        | 1        | 1        | 1        | 1        | 1        | 1  | 1       | 1       | 1  | 1        | 1  | 1  | 1        | 1       | 1       | 1  |

| Bit | Symbol | Function   | R/W |
|-----|--------|--|-----|
| 0   | —      | 该位读取为1。写入值应为1。   | R/W |
| 1   | MSTPB1 | 控制器局域网1模块停止*1<br>Target module: CAN1<br>0: 取消模块停止状态1: 进入模块停止状态 | R/W |
| 2   | MSTPB2 | 控制器局域网0模块停止*1<br>Target module: CAN0<br>0: 取消模块停止状态1: 进入模块停止状态 | R/W |
| 5:3 | —      | 这些位被读取为1。写入值应为1。   | R/W |
| 6   | MSTPB6 | 四路串行外围接口模块停止<br>Target module: QSPI<br>0: 取消模块停止状态1: 进入模块停止状态  | R/W |
| 7   | —      | 该位读取为1。写入值应为1。   | R/W |

| Bit   | Symbol  | Function  | R/W |
|-------|---------|---|-----|
| 8     | MSTPB8  | I <sup>2</sup> C Bus Interface 1 Module Stop<br>Target module: IIC1<br>0: Cancel the module-stop state<br>1: Enter the module-stop state            | R/W |
| 9     | MSTPB9  | I <sup>2</sup> C Bus Interface 0 Module Stop<br>Target module: IIC0<br>0: Cancel the module-stop state<br>1: Enter the module-stop state            | R/W |
| 10    | —       | This bit is read as 1. The write value should be 1.   | R/W |
| 11    | MSTPB11 | Universal Serial Bus 2.0 FS Interface 0 Module Stop*2<br>Target module: USBFS0<br>0: Cancel the module-stop state<br>1: Enter the module-stop state | R/W |
| 12    | —       | This bit is read as 1. The write value should be 1.   | R/W |
| 18:13 | —       | These bits are read as 1. The write value should be 1.  | R/W |
| 19    | MSTPB19 | Serial Peripheral Interface 0 Module Stop<br>Target module: SPI0<br>0: Cancel the module-stop state<br>1: Enter the module-stop state               | R/W |
| 21:20 | —       | These bits are read as 1. The write value should be 1.  | R/W |
| 22    | MSTPB22 | Serial Communication Interface 9 Module Stop<br>Target module: SCI9<br>0: Cancel the module-stop state<br>1: Enter the module-stop state            | R/W |
| 26:23 | —       | These bits are read as 1. The write value should be 1.  | R/W |
| 27    | MSTPB27 | Serial Communication Interface 4 Module Stop<br>Target module: SCI4<br>0: Cancel the module-stop state<br>1: Enter the module-stop state            | R/W |
| 28    | MSTPB28 | Serial Communication Interface 3 Module Stop<br>Target module: SCI3<br>0: Cancel the module-stop state<br>1: Enter the module-stop state            | R/W |
| 29    | MSTPB29 | Serial Communication Interface 2 Module Stop<br>Target module: SCI2<br>0: Cancel the module-stop state<br>1: Enter the module-stop state            | R/W |
| 30    | MSTPB30 | Serial Communication Interface 1 Module Stop<br>Target module: SCI1<br>0: Cancel the module-stop state<br>1: Enter the module-stop state            | R/W |
| 31    | MSTPB31 | Serial Communication Interface 0 Module Stop<br>Target module: SCI0<br>0: Cancel the module-stop state<br>1: Enter the module-stop state            | R/W |

Note: If the security attribution is configured as secure:

- Secure access and Non-secure read access are allowed
- Non-secure write access is ignored, and TrustZone access error is not generated.

If the security attribution is configured as Non-secure:

- Secure and Non-secure access are allowed.

Note 1. The MSTPBi bit must be written while the oscillation of the clock controlled by this bit is stabilized. For entering Software Standby mode after writing the MSTPBi bit, wait for two CAN clock (CANMCLK) cycles after writing, and then execute a WFI instruction (i = 1 to 2).

Note 2. The MSTPBi bit must be written while the oscillation of the clock controlled by this bit is stabilized. For entering Software Standby mode after writing the MSTPBi bit, wait for two USB clock (USBCLK) cycles after writing, and then execute a WFI instruction (i = 11).

| Bit   | Symbol  | Function  | R/W |
|-------|---------|---|-----|
| 8     | MSTPB8  | I2C总线接口1模块停止<br>Target module: IIC1<br>0: 取消模块停止状态1: 进入模块停止状态           | R/W |
| 9     | MSTPB9  | I2C总线接口0模块停止<br>Target module: IIC0<br>0: 取消模块停止状态1: 进入模块停止状态           | R/W |
| 10    | —       | 该位读取为1。写入值应为1。  | R/W |
| 11    | MSTPB11 | 通用串行总线2.0FS接口0模块停止*2<br>Target module: USBFS0<br>0: 取消模块停止状态1: 进入模块停止状态 | R/W |
| 12    | —       | 该位读取为1。写入值应为1。  | R/W |
| 18:13 | —       | 这些位被读取为1。写入值应为1。  | R/W |
| 19    | MSTPB19 | 串行外设接口0模块停止<br>Target module: SPI0<br>0: 取消模块停止状态1: 进入模块停止状态            | R/W |
| 21:20 | —       | 这些位被读取为1。写入值应为1。  | R/W |
| 22    | MSTPB22 | 串行通讯接口9模块停止<br>Target module: SCI9<br>0: 取消模块停止状态1: 进入模块停止状态            | R/W |
| 26:23 | —       | 这些位被读取为1。写入值应为1。  | R/W |
| 27    | MSTPB27 | 串行通讯接口4模块停止<br>Target module: SCI4<br>0: 取消模块停止状态1: 进入模块停止状态            | R/W |
| 28    | MSTPB28 | 串行通讯接口3模块停止<br>Target module: SCI3<br>0: 取消模块停止状态1: 进入模块停止状态            | R/W |
| 29    | MSTPB29 | 串行通讯接口2模块停止<br>Target module: SCI2<br>0: 取消模块停止状态1: 进入模块停止状态            | R/W |
| 30    | MSTPB30 | 串行通讯接口1模块停止<br>Target module: SCI1<br>0: 取消模块停止状态1: 进入模块停止状态            | R/W |
| 31    | MSTPB31 | 串行通讯接口0模块停止<br>Target module: SCI0<br>0: 取消模块停止状态1: 进入模块停止状态            | R/W |

Note: 如果安全属性配置为安全: ●

- 允许安全访问和非安全读取访问
- 忽略非安全写入访问, 不会生成TrustZone访问错误。

如果安全属性配置为非安全: ●

- 允许安全和非安全访问。

注1.MSTPBi位必须在由该位控制的时钟振荡稳定时写入。进入软件待机模式写入MSTPBi位后, 写入后等待两个CAN时钟 (CANMCLK) 周期, 然后执行WFI指令 (i=1到2)。

注2.MSTPBi位必须在由该位控制的时钟振荡稳定时写入。要在写入MSTPBi位后进入软件待机模式, 写入后等待两个USB时钟(USBCLK)周期, 然后执行WFI指令(i=11)。

## 10.2.6 MSTPCRC : Module Stop Control Register C

Base address: MSTP = 0x4008\_4000

Offset address: 0x008

|                    |          |          |          |          |    |    |    |         |    |    |    |    |         |    |         |         |
|--------------------|----------|----------|----------|----------|----|----|----|---------|----|----|----|----|---------|----|---------|---------|
| Bit position:      | 31       | 30       | 29       | 28       | 27 | 26 | 25 | 24      | 23 | 22 | 21 | 20 | 19      | 18 | 17      | 16      |
| Bit field:         | MSTP C31 | —        | —        | —        | —  | —  | —  | —       | —  | —  | —  | —  | —       | —  | —       | —       |
| Value after reset: | 1        | 1        | 1        | 1        | 1  | 1  | 1  | 1       | 1  | 1  | 1  | 1  | 1       | 1  | 1       | 1       |
| Bit position:      | 15       | 14       | 13       | 12       | 11 | 10 | 9  | 8       | 7  | 6  | 5  | 4  | 3       | 2  | 1       | 0       |
| Bit field:         | —        | MSTP C14 | MSTP C13 | MSTP C12 | —  | —  | —  | MSTP C8 | —  | —  | —  | —  | MSTP C3 | —  | MSTP C1 | MSTP C0 |
| Value after reset: | 1        | 1        | 1        | 1        | 1  | 1  | 1  | 1       | 1  | 1  | 1  | 1  | 1       | 1  | 1       | 1       |

| Bit   | Symbol  | Function   | R/W |
|-------|---------|--|-----|
| 0     | MSTPC0  | Clock Frequency Accuracy Measurement Circuit Module Stop*1<br>Target module: CAC<br>0: Cancel the module-stop state<br>1: Enter the module-stop state    | R/W |
| 1     | MSTPC1  | Cyclic Redundancy Check Calculator Module Stop<br>Target module: CRC<br>0: Cancel the module-stop state<br>1: Enter the module-stop state                | R/W |
| 2     | —       | This bit is read as 1. The write value should be 1.  | R/W |
| 3     | MSTPC3  | Capacitive Touch Sensing Unit Module Stop<br>Target module: CTSU<br>0: Cancel the module-stop state<br>1: Enter the module-stop state                    | R/W |
| 7:4   | —       | These bits are read as 1. The write value should be 1.   | R/W |
| 8     | MSTPC8  | Serial Sound Interface Enhanced Module Stop<br>Target module: SSIE<br>0: Cancel the module-stop state<br>1: Enter the module-stop state                  | R/W |
| 11:9  | —       | These bits are read as 1. The write value should be 1.   | R/W |
| 12    | MSTPC12 | Secure Digital HOST IF / Multi Media Card 0 Module Stop<br>Target module: SDHI/MMC0<br>0: Cancel the module-stop state<br>1: Enter the module-stop state | R/W |
| 13    | MSTPC13 | Data Operation Circuit Module Stop<br>Target module: DOC<br>0: Cancel the module-stop state<br>1: Enter the module-stop state                            | R/W |
| 14    | MSTPC14 | Event Link Controller Module Stop<br>Target module: ELC<br>0: Cancel the module-stop state<br>1: Enter the module-stop state                             | R/W |
| 30:15 | —       | These bits are read as 1. The write value should be 1.   | R/W |
| 31    | MSTPC31 | SCE9 Module Stop<br>Target module: SCE9<br>0: Cancel the module-stop state<br>1: Enter the module-stop state   | R/W |

Note: If the security attribution is configured as secure:

- Secure access and Non-secure read access are allowed
- Non-secure write access is ignored, and TrustZone access error is not generated.

If the security attribution is configured as Non-secure:

- Secure and Non-secure access are allowed.

## 10.2.6 MSTPCRC:模块停止控制寄存器C

Base address: MSTP = 0x4008\_4000

Offset address: 0x008

|               |          |          |          |          |    |    |    |         |    |    |    |    |         |    |         |         |
|---------------|----------|----------|----------|----------|----|----|----|---------|----|----|----|----|---------|----|---------|---------|
| Bit position: | 31       | 30       | 29       | 28       | 27 | 26 | 25 | 24      | 23 | 22 | 21 | 20 | 19      | 18 | 17      | 16      |
| Bit field:    | MSTP C31 | —        | —        | —        | —  | —  | —  | —       | —  | —  | —  | —  | —       | —  | —       | —       |
| 重置后的值:        | 1        | 1        | 1        | 1        | 1  | 1  | 1  | 1       | 1  | 1  | 1  | 1  | 1       | 1  | 1       | 1       |
| Bit position: | 15       | 14       | 13       | 12       | 11 | 10 | 9  | 8       | 7  | 6  | 5  | 4  | 3       | 2  | 1       | 0       |
| Bit field:    | —        | MSTP C14 | MSTP C13 | MSTP C12 | —  | —  | —  | MSTP C8 | —  | —  | —  | —  | MSTP C3 | —  | MSTP C1 | MSTP C0 |
| 重置后的值:        | 1        | 1        | 1        | 1        | 1  | 1  | 1  | 1       | 1  | 1  | 1  | 1  | 1       | 1  | 1       | 1       |

| Bit   | Symbol  | Function   | R/W |
|-------|---------|--|-----|
| 0     | MSTPC0  | 时钟频率精度测量电路模块停止*1<br>目标模块: CAC<br>0: 取消模块停止状态1: 进入模块停止状态                            | R/W |
| 1     | MSTPC1  | 循环冗余校验计算器模块停止<br>Target module: CRC<br>0: 取消模块停止状态1: 进入模块停止状态                      | R/W |
| 2     | —       | 该位读取为1。写入值应为1。   | R/W |
| 3     | MSTPC3  | 电容式触摸感应单元模块停止<br>Target module: CTSU<br>0: 取消模块停止状态1: 进入模块停止状态                     | R/W |
| 7:4   | —       | 这些位被读取为1。写入值应为1。   | R/W |
| 8     | MSTPC8  | 串行声音接口增强模块停止<br>Target module: SSIE<br>0: 取消模块停止状态1: 进入模块停止状态                      | R/W |
| 11:9  | —       | 这些位被读取为1。写入值应为1。   | R/W |
| 12    | MSTPC12 | SecureDigitalHOSTIF多媒体卡0模块停止<br>Target module: SDHI/MMC0<br>0: 取消模块停止状态1: 进入模块停止状态 | R/W |
| 13    | MSTPC13 | 数据运算电路模块停止<br>目标模块: DOC<br>0: 取消模块停止状态1: 进入模块停止状态                                  | R/W |
| 14    | MSTPC14 | 事件链接控制器模块停止<br>Target module: ELC<br>0: 取消模块停止状态1: 进入模块停止状态                        | R/W |
| 30:15 | —       | 这些位被读取为1。写入值应为1。   | R/W |
| 31    | MSTPC31 | SCE9模块停止<br>Target module: SCE9<br>0: 取消模块停止状态1: 进入模块停止状态                          | R/W |

Note: 如果安全属性配置为安全: ●

- 允许安全访问和非安全读取访问
- 忽略非安全写入访问, 不会生成TrustZone访问错误。

如果安全属性配置为非安全: ●

- 允许安全和非安全访问。

Note 1. The MSTPC0 bit must be written while the oscillation of the clock to be controlled by this bit is stable. To enter Software Standby mode after writing this bit, wait for 2 cycles of the slowest clock from the clocks output by the oscillators, then execute a WFI instruction.

10.2.7 MSTPCRD : Module Stop Control Register D

Base address: MSTP = 0x4008\_4000

Offset address: 0x00C

|                    |          |          |          |          |          |    |    |    |    |          |    |          |         |         |         |          |
|--------------------|----------|----------|----------|----------|----------|----|----|----|----|----------|----|----------|---------|---------|---------|----------|
| Bit position:      | 31       | 30       | 29       | 28       | 27       | 26 | 25 | 24 | 23 | 22       | 21 | 20       | 19      | 18      | 17      | 16       |
| Bit field:         | —        | —        | —        | —        | —        | —  | —  | —  | —  | MSTP D22 | —  | MSTP D20 | —       | —       | —       | MSTP D16 |
| Value after reset: | 1        | 1        | 1        | 1        | 1        | 1  | 1  | 1  | 1  | 1        | 1  | 1        | 1       | 1       | 1       | 1        |
| Bit position:      | 15       | 14       | 13       | 12       | 11       | 10 | 9  | 8  | 7  | 6        | 5  | 4        | 3       | 2       | 1       | 0        |
| Bit field:         | MSTP D15 | MSTP D14 | MSTP D13 | MSTP D12 | MSTP D11 | —  | —  | —  | —  | —        | —  | —        | MSTP D3 | MSTP D2 | MSTP D1 | MSTP D0  |
| Value after reset: | 1        | 1        | 1        | 1        | 1        | 1  | 1  | 1  | 1  | 1        | 1  | 1        | 1       | 1       | 1       | 1        |

| Bit  | Symbol  | Function   | R/W |
|------|---------|--|-----|
| 0    | MSTPD0  | Low Power Asynchronous General Purpose Timer 3 Module Stop <sup>*3</sup><br>Target module: AGT3<br>0: Cancel the module-stop state<br>1: Enter the module-stop state | R/W |
| 1    | MSTPD1  | Low Power Asynchronous General Purpose Timer 2 Module Stop <sup>*4</sup><br>Target module: AGT2<br>0: Cancel the module-stop state<br>1: Enter the module-stop state | R/W |
| 2    | MSTPD2  | Low Power Asynchronous General Purpose Timer 1 Module Stop <sup>*1</sup><br>Target module: AGT1<br>0: Cancel the module-stop state<br>1: Enter the module-stop state | R/W |
| 3    | MSTPD3  | Low Power Asynchronous General Purpose Timer 0 Module Stop <sup>*2</sup><br>Target module: AGT0<br>0: Cancel the module-stop state<br>1: Enter the module-stop state | R/W |
| 10:4 | —       | These bits are read as 1. The write value should be 1.   | R/W |
| 11   | MSTPD11 | Port Output Enable for GPT 3 Module Stop<br>Target module: POEG3<br>0: Cancel the module-stop state<br>1: Enter the module-stop state                                | R/W |
| 12   | MSTPD12 | Port Output Enable for GPT 2 Module Stop<br>Target module:POEG2<br>0: Cancel the module-stop state<br>1: Enter the module-stop state                                 | R/W |
| 13   | MSTPD13 | Port Output Enable for GPT 1 Module Stop<br>Target module: POEG1<br>0: Cancel the module-stop state<br>1: Enter the module-stop state                                | R/W |
| 14   | MSTPD14 | Port Output Enable for GPT 0 Module Stop<br>Target module: POEG0<br>0: Cancel the module-stop state<br>1: Enter the module-stop state                                | R/W |
| 15   | MSTPD15 | 12-bit A/D Converter 1 Module Stop<br>Target module: ADC121<br>0: Cancel the module-stop state<br>1: Enter the module-stop state                                     | R/W |

注1.MSTPC0位必须在位控制的时钟振荡稳定时写入。要在写入该位后进入软件待机模式，请等待振荡器输出时钟中最慢时钟的2个周期，然后执行WFI指令。

10.2.7 MSTPCRD:模块停止控制寄存器D

Base address: MSTP = 0x4008\_4000

Offset address: 0x00C

|               |          |          |          |          |          |    |    |    |    |          |    |          |    |    |         |          |         |         |
|---------------|----------|----------|----------|----------|----------|----|----|----|----|----------|----|----------|----|----|---------|----------|---------|---------|
| Bit position: | 31       | 30       | 29       | 28       | 27       | 26 | 25 | 24 | 23 | 22       | 21 | 20       | 19 | 18 | 17      | 16       |         |         |
| Bit field:    | —        | —        | —        | —        | —        | —  | —  | —  | —  | MSTP D22 | —  | MSTP D20 | —  | —  | —       | MSTP D16 |         |         |
| 重置后的值:        | 1        | 1        | 1        | 1        | 1        | 1  | 1  | 1  | 1  | 1        | 1  | 1        | 1  | 1  | 1       | 1        |         |         |
| Bit position: | 15       | 14       | 13       | 12       | 11       | 10 | 9  | 8  | 7  | 6        | 5  | 4        | 3  | 2  | 1       | 0        |         |         |
| Bit field:    | MSTP D15 | MSTP D14 | MSTP D13 | MSTP D12 | MSTP D11 | —  | —  | —  | —  | —        | —  | —        | —  | —  | MSTP D3 | MSTP D2  | MSTP D1 | MSTP D0 |
| 重置后的值:        | 1        | 1        | 1        | 1        | 1        | 1  | 1  | 1  | 1  | 1        | 1  | 1        | 1  | 1  | 1       | 1        | 1       | 1       |

| Bit  | Symbol  | Function   | R/W |
|------|---------|--|-----|
| 0    | MSTPD0  | 低功耗异步通用定时器3模块停止*3<br>Target module: AGT3<br>0: 取消模块停止状态1: 进入模块停止状态 | R/W |
| 1    | MSTPD1  | 低功耗异步通用定时器2模块停止*4<br>Target module: AGT2<br>0: 取消模块停止状态1: 进入模块停止状态 | R/W |
| 2    | MSTPD2  | 低功耗异步通用定时器1模块停止*1<br>Target module: AGT1<br>0: 取消模块停止状态1: 进入模块停止状态 | R/W |
| 3    | MSTPD3  | 低功耗异步通用定时器0模块停止*2<br>Target module: AGT0<br>0: 取消模块停止状态1: 进入模块停止状态 | R/W |
| 10:4 | —       | 这些位被读取为1。写入值应为1。   | R/W |
| 11   | MSTPD11 | GPT3模块停止的端口输出启用<br>Target module: POEG3<br>0: 取消模块停止状态1: 进入模块停止状态  | R/W |
| 12   | MSTPD12 | GPT2模块停止的端口输出启用<br>Target module:POEG2<br>0: 取消模块停止状态1: 进入模块停止状态   | R/W |
| 13   | MSTPD13 | GPT1模块停止的端口输出使能<br>Target module: POEG1<br>0: 取消模块停止状态1: 进入模块停止状态  | R/W |
| 14   | MSTPD14 | GPT0模块停止的端口输出使能<br>Target module: POEG0<br>0: 取消模块停止状态1: 进入模块停止状态  | R/W |
| 15   | MSTPD15 | 12位AD转换器1模块停止目标模块: ADC121<br>0: 取消模块停止状态1: 进入模块停止状态                | R/W |



| Bit   | Symbol  | Function   | R/W |
|-------|---------|--|-----|
| 16    | MSTPD16 | 12-bit A/D Converter 0 Module Stop<br>Target module: ADC120<br>0: Cancel the module-stop state<br>1: Enter the module-stop state         | R/W |
| 19:17 | —       | These bits are read as 1. The write value should be 1.   | R/W |
| 20    | MSTPD20 | 12-bit D/A Converter Module Stop<br>Target module: DAC12<br>0: Cancel the module-stop state<br>1: Enter the module-stop state            | R/W |
| 21    | —       | This bit is read as 1. The write value should be 1.  | R/W |
| 22    | MSTPD22 | Temperature Sensor Module Stop<br>Target module: Temperature Sensor<br>0: Cancel the module-stop state<br>1: Enter the module-stop state | R/W |
| 31:23 | —       | These bits are read as 1. The write value should be 1.   | R/W |

Note: If the security attribution is configured as secure:

- Secure access and Non-secure read access are allowed
- Non-secure write access is ignored, and TrustZone access error is not generated.

If the security attribution is configured as Non-secure:

- Secure and Non-secure access are allowed.

- Note 1. When the count source is sub-clock oscillator or LOCO, AGT1 counting does not stop even if MSTPD2 is set to 1. If the count source is the sub-clock oscillator or LOCO, this bit must be set to 1 except when accessing the AGT1 registers.
- Note 2. When the count source is sub-clock oscillator or LOCO, AGT0 counting does not stop even if MSTPD3 is set to 1. If the count source is the sub-clock oscillator or LOCO, this bit must be set to 1 except when accessing the AGT0 registers.
- Note 3. When the count source is sub-clock oscillator or LOCO, AGT3 counting doesn't stop even if MSTPD0 is set to 1. If the count source is the sub-clock oscillator or LOCO, this bit must be set to 1 except when accessing the AGT3 registers.
- Note 4. When the count source is sub-clock oscillator or LOCO, AGT2 counting doesn't stop even if MSTPD1 is set to 1. If the count source is the sub-clock oscillator or LOCO, this bit must be set to 1 except when accessing the AGT2 registers.

### 10.2.8 MSTPCRE : Module Stop Control Register E

Base address: MSTP = 0x4008\_4000

Offset address: 0x010

|                    |          |          |          |          |          |          |          |          |    |    |    |    |    |    |    |    |
|--------------------|----------|----------|----------|----------|----------|----------|----------|----------|----|----|----|----|----|----|----|----|
| Bit position:      | 31       | 30       | 29       | 28       | 27       | 26       | 25       | 24       | 23 | 22 | 21 | 20 | 19 | 18 | 17 | 16 |
| Bit field:         | MSTP E31 | MSTP E30 | MSTP E29 | MSTP E28 | MSTP E27 | MSTP E26 | MSTP E25 | MSTP E24 | —  | —  | —  | —  | —  | —  | —  | —  |
| Value after reset: | 1        | 1        | 1        | 1        | 1        | 1        | 1        | 1        | 1  | 1  | 1  | 1  | 1  | 1  | 1  | 1  |
| Bit position:      | 15       | 14       | 13       | 12       | 11       | 10       | 9        | 8        | 7  | 6  | 5  | 4  | 3  | 2  | 1  | 0  |
| Bit field:         | MSTP E15 | MSTP E14 | —        | —        | —        | —        | —        | —        | —  | —  | —  | —  | —  | —  | —  | —  |
| Value after reset: | 1        | 1        | 1        | 1        | 1        | 1        | 1        | 1        | 1  | 1  | 1  | 1  | 1  | 1  | 1  | 1  |

| Bit   | Symbol  | Function   | R/W |
|-------|---------|--|-----|
| 13:0  | —       | These bits are read as 1. The write value should be 1.   | R/W |
| 14    | MSTPE14 | Low Power Asynchronous General Purpose Timer 5 Module Stop*1<br>Target module: AGT5<br>0: Cancel the module-stop state<br>1: Enter the module-stop state | R/W |
| 15    | MSTPE15 | Low Power Asynchronous General Purpose Timer 4 Module Stop*2<br>Target module: AGT4<br>0: Cancel the module-stop state<br>1: Enter the module-stop state | R/W |
| 23:16 | —       | These bits are read as 1. The write value should be 1.   | R/W |

| Bit   | Symbol  | Function   | R/W |
|-------|---------|--|-----|
| 16    | MSTPD16 | 12位AD转换器0模块停止目标模块 : ADC120<br>0: 取消模块停止状态1: 进入模块停止状态 | R/W |
| 19:17 | —       | 这些位被读取为1。写入值应为1。                                     | R/W |
| 20    | MSTPD20 | 12位DA转换器模块停止目标模块 : DAC12<br>0: 取消模块停止状态1: 进入模块停止状态   | R/W |
| 21    | —       | 该位读取为1。写入值应为1。                                       | R/W |
| 22    | MSTPD22 | 温度传感器模块停止<br>目标模块: 温度传感器<br>0: 取消模块停止状态1: 进入模块停止状态   | R/W |
| 31:23 | —       | 这些位被读取为1。写入值应为1。                                     | R/W |

Note: 如果安全属性配置为安全: ●  
允许安全访问和非安全读取访问

- 忽略非安全写入访问, 不会生成TrustZone访问错误。

如果安全属性配置为非安全: ●  
允许安全和非安全访问。

- 注1.当计数源为副时钟振荡器或LOCO时, 即使MSTPD2设置为1, AGT1计数也不会停止。如果计数源为副时钟振荡器或LOCO, 该位必须设置为1, 除非访问AGT1寄存器。
- 注2.当计数源为副时钟振荡器或LOCO时, 即使MSTPD3设置为1, AGT0计数也不会停止。如果计数源为副时钟振荡器或LOCO, 该位必须设置为1, 除非访问AGT0寄存器。
- 注3.当计数源为副时钟振荡器或LOCO时, 即使MSTPD0设置为1, AGT3计数也不会停止。如果计数源为副时钟振荡器或LOCO, 该位必须设置为1, 除非访问AGT3寄存器。
- 注4.当计数源为副时钟振荡器或LOCO时, 即使MSTPD1设置为1, AGT2计数也不会停止。如果计数源为副时钟振荡器或LOCO, 该位必须设置为1, 除非访问AGT2寄存器。

### 10.2.8 MSPCRE:模块停止控制寄存器E

Base address: MSTP = 0x4008\_4000

Offset address: 0x010

|               |          |          |          |          |          |          |          |          |    |    |    |    |    |    |    |    |
|---------------|----------|----------|----------|----------|----------|----------|----------|----------|----|----|----|----|----|----|----|----|
| Bit position: | 31       | 30       | 29       | 28       | 27       | 26       | 25       | 24       | 23 | 22 | 21 | 20 | 19 | 18 | 17 | 16 |
| Bit field:    | MSTP E31 | MSTP E30 | MSTP E29 | MSTP E28 | MSTP E27 | MSTP E26 | MSTP E25 | MSTP E24 | —  | —  | —  | —  | —  | —  | —  | —  |
| 重置后的值:        | 1        | 1        | 1        | 1        | 1        | 1        | 1        | 1        | 1  | 1  | 1  | 1  | 1  | 1  | 1  | 1  |
| Bit position: | 15       | 14       | 13       | 12       | 11       | 10       | 9        | 8        | 7  | 6  | 5  | 4  | 3  | 2  | 1  | 0  |
| Bit field:    | MSTP E15 | MSTP E14 | —        | —        | —        | —        | —        | —        | —  | —  | —  | —  | —  | —  | —  | —  |
| 重置后的值:        | 1        | 1        | 1        | 1        | 1        | 1        | 1        | 1        | 1  | 1  | 1  | 1  | 1  | 1  | 1  | 1  |

| Bit   | Symbol  | Function   | R/W |
|-------|---------|--|-----|
| 13:0  | —       | 这些位被读取为1。写入值应为1。   | R/W |
| 14    | MSTPE14 | 低功耗异步通用定时器5模块停止*1<br>Target module: AGT5<br>0: 取消模块停止状态1: 进入模块停止状态 | R/W |
| 15    | MSTPE15 | 低功耗异步通用定时器4模块停止*2<br>Target module: AGT4<br>0: 取消模块停止状态1: 进入模块停止状态 | R/W |
| 23:16 | —       | 这些位被读取为1。写入值应为1。   | R/W |



| Bit | Symbol  | Function   | R/W |
|-----|---------|--|-----|
| 24  | MSTPE24 | GPT7 Module Stop<br>Target module: GPT7<br>0: Cancel the module-stop state<br>1: Enter the module-stop state | R/W |
| 25  | MSTPE25 | GPT6 Module Stop<br>Target module: GPT6<br>0: Cancel the module-stop state<br>1: Enter the module-stop state | R/W |
| 26  | MSTPE26 | GPT5 Module Stop<br>Target module: GPT5<br>0: Cancel the module-stop state<br>1: Enter the module-stop state | R/W |
| 27  | MSTPE27 | GPT4 Module Stop<br>Target module: GPT4<br>0: Cancel the module-stop state<br>1: Enter the module-stop state | R/W |
| 28  | MSTPE28 | GPT3 Module Stop<br>Target module: GPT3<br>0: Cancel the module-stop state<br>1: Enter the module-stop state | R/W |
| 29  | MSTPE29 | GPT2 Module Stop<br>Target module: GPT2<br>0: Cancel the module-stop state<br>1: Enter the module-stop state | R/W |
| 30  | MSTPE30 | GPT1 Module Stop<br>Target module: GPT1<br>0: Cancel the module-stop state<br>1: Enter the module-stop state | R/W |
| 31  | MSTPE31 | GPT0 Module Stop<br>Target module: GPT0<br>0: Cancel the module-stop state<br>1: Enter the module-stop state | R/W |

Note: If the security attribution is configured as secure:

- Secure access and Non-secure read access are allowed
- Non-secure write access is ignored, and TrustZone access error is not generated.

If the security attribution is configured as Non-secure:

- Secure and Non-secure access are allowed.

Note 1. When the count source is sub-clock oscillator or LOCO, AGT5 counting does not stop even if MSTPE14 is set to 1. If the count source is the sub-clock oscillator or LOCO, this bit must be set to 1 except when accessing the AGT5 registers.

Note 2. When the count source is sub-clock oscillator or LOCO, AGT4 counting does not stop even if MSTPE15 is set to 1. If the count source is the sub-clock oscillator or LOCO, this bit must be set to 1 except when accessing the AGT4 registers.

### 10.2.9 OPCCR : Operating Power Control Register

Base address: SYSC = 0x4001\_E000

Offset address: 0x0A0

| Bit position:      | 7 | 6 | 5 | 4           | 3 | 2 | 1         | 0 |
|--------------------|---|---|---|-------------|---|---|-----------|---|
| Bit field:         | — | — | — | OPCM<br>TSF | — | — | OPCM[1:0] |   |
| Value after reset: | 0 | 0 | 0 | 0           | 0 | 0 | 0         | 0 |

| Bit | Symbol    | Function   | R/W |
|-----|-----------|--|-----|
| 1:0 | OPCM[1:0] | Operating Power Control Mode Select<br>0 0: High-speed mode<br>0 1: Setting prohibited<br>1 0: Setting prohibited<br>1 1: Low-speed mode | R/W |

| Bit | Symbol  | Function  | R/W |
|-----|---------|---|-----|
| 24  | MSTPE24 | GPT7模块停止<br>Target module: GPT7<br>0: 取消模块停止状态1: 进入模块停止状态 | R/W |
| 25  | MSTPE25 | GPT6模块停止<br>Target module: GPT6<br>0: 取消模块停止状态1: 进入模块停止状态 | R/W |
| 26  | MSTPE26 | GPT5模块停止<br>Target module: GPT5<br>0: 取消模块停止状态1: 进入模块停止状态 | R/W |
| 27  | MSTPE27 | GPT4模块停止<br>Target module: GPT4<br>0: 取消模块停止状态1: 进入模块停止状态 | R/W |
| 28  | MSTPE28 | GPT3模块停止<br>Target module: GPT3<br>0: 取消模块停止状态1: 进入模块停止状态 | R/W |
| 29  | MSTPE29 | GPT2模块停止<br>Target module: GPT2<br>0: 取消模块停止状态1: 进入模块停止状态 | R/W |
| 30  | MSTPE30 | GPT1模块停止<br>Target module: GPT1<br>0: 取消模块停止状态1: 进入模块停止状态 | R/W |
| 31  | MSTPE31 | GPT0模块停止<br>Target module: GPT0<br>0: 取消模块停止状态1: 进入模块停止状态 | R/W |

Note: 如果安全属性配置为安全: ●

- 允许安全访问和非安全读取访问
- 忽略非安全写入访问, 不会生成TrustZone访问错误。

如果安全属性配置为非安全: ●

- 允许安全和非安全访问。

注1.当计数源为副时钟振荡器或LOCO时, 即使MSTPE14设置为1, AGT5计数也不会停止。如果计数源为副时钟振荡器或LOCO, 该位必须设置为1, 除非当访问AGT5寄存器。

注2.当计数源为副时钟振荡器或LOCO时, 即使MSTPE15设置为1, AGT4计数也不会停止。如果计数源为副时钟振荡器或LOCO, 该位必须设置为1, 除非当访问AGT4寄存器。

### 10.2.9 OPCCR:工作电源控制寄存器

Base address: SYSC = 0x4001\_E000

Offset address: 0x0A0

| Bit position: | 7 | 6 | 5 | 4           | 3 | 2 | 1         | 0 |
|---------------|---|---|---|-------------|---|---|-----------|---|
| Bit field:    | — | — | — | OPCM<br>TSF | — | — | OPCM[1:0] |   |
| 重置后的值:        | 0 | 0 | 0 | 0           | 0 | 0 | 0         | 0 |

| Bit | Symbol    | Function   | R/W |
|-----|-----------|--|-----|
| 1:0 | OPCM[1:0] | 工作电源控制模式选择<br>00: 高速模式01: 禁止设定10: 禁止设定1<br>1: 低速模式 | R/W |

| Bit | Symbol  | Function   | R/W |
|-----|---------|--|-----|
| 3:2 | —       | These bits are read as 0. The write value should be 0.   | R/W |
| 4   | OPCMTSF | Operating Power Control Mode Transition Status Flag<br>0: Transition completed<br>1: During transition | R   |
| 7:5 | —       | These bits are read as 0. The write value should be 0.   | R/W |

Note: If the security attribution is configured as secure:

- Secure access and Non-secure read access are allowed
- Non-secure write access is ignored, and TrustZone access error is not generated.

If the security attribution is configured as Non-secure:

- Secure and Non-secure access are allowed.

Note: Set the PRCR.PRC1 bit to 1 (write enabled) before rewriting this register.

The OPCCR register is used to reduce power consumption in Normal and Sleep modes by specifying a lower operating frequency. For the procedure to change the operating power control modes, see [section 10.5. Function for Lower Operating Power Consumption](#).

When transitioning from Software Standby mode to Normal or Snooze mode, the settings in the OPCCR.OPCM[1:0] and SOPCCR.SOPCM bits are as follows, regardless of their settings before entering Software Standby mode:

- OPCCR.OPCM[1:0] = 00b (High-speed mode)
- SOPCCR.SOPCM = 0b (not Subosc-speed mode).

If Software Standby mode is canceled before the transition to Software Standby completes, the OPCCR.OPCM[1:0] and SOPCCR.SOPCM bits retain their settings from before the WFI instruction is executed. If this causes any problem, set the MCU to High-speed mode during the exception handling procedure when canceling Software Standby mode.

#### OPCM[1:0] bits (Operating Power Control Mode Select)

The OPCM[1:0] bits select the operating power control mode in Normal and Sleep modes. [Table 10.4](#) shows the relationship between the operating power control modes and the OPCM[1:0] and SOPCM settings.

#### OPCMTSF flag (Operating Power Control Mode Transition Status Flag)

The OPCMTSF flag indicates the switching control state when the operating power control mode is switched. This flag becomes 1 when the OPCM bit is written, and 0 when mode transition completes. Read this flag and confirm that it is 0 before proceeding.

#### 10.2.10 SOPCCR : Sub Operating Power Control Register

Base address: SYSC = 0x4001\_E000

Offset address: 0x0AA

| Bit position:      | 7 | 6 | 5 | 4            | 3 | 2 | 1 | 0         |
|--------------------|---|---|---|--------------|---|---|---|-----------|
| Bit field:         | — | — | — | SOPC<br>MTSF | — | — | — | SOPC<br>M |
| Value after reset: | 0 | 0 | 0 | 0            | 0 | 0 | 0 | 0         |

| Bit | Symbol   | Function   | R/W |
|-----|----------|--|-----|
| 0   | SOPCM    | Sub Operating Power Control Mode Select<br>0: Other than Subosc-speed mode<br>1: Subosc-speed mode     | R/W |
| 3:1 | —        | These bits are read as 0. The write value should be 0.   | R/W |
| 4   | SOPCMTSF | Operating Power Control Mode Transition Status Flag<br>0: Transition completed<br>1: During transition | R   |
| 7:5 | —        | These bits are read as 0. The write value should be 0.   | R/W |

Note: If the security attribution is configured as secure:

- Secure access and Non-secure read access are allowed

| Bit | Symbol  | Function                        | R/W |
|-----|---------|---------------------------------|-----|
| 3:2 | —       | 这些位被读取为0。写入值应为0。                | R/W |
| 4   | OPCMTSF | 工作电源控制模式转换状态标志<br>0: 转换完成1: 转换中 | R   |
| 7:5 | —       | 这些位被读取为0。写入值应为0。                | R/W |

Note: 如果安全属性配置为安全: ●

- 允许安全访问和非安全读取访问
- 忽略非安全写入访问, 不会生成TrustZone访问错误。

如果安全属性配置为非安全: ●

- 允许安全和非安全访问。

Note: 在重写该寄存器之前将PRCR.PRC1位设置为1 (允许写入)。

OPCCR寄存器用于通过指定较低的工作频率来降低正常和休眠模式下的功耗。有关更改运行功率控制模式的步骤, 请参阅第10.5节。降低运行功耗的功能。

当从软件待机模式转换到正常或贪睡模式时, OPCCR.OPCM[1:0]中的设置和SOPCCR.SOPCM位如下, 无论它们在进入软件待机模式之前的设置如何:

- OPCCR.OPCM[1:0] = 00b (High-speed mode)
- SOPCCR.SOPCM = 0b (not Subosc-speed mode).

如果在转换到软件待机完成之前取消软件待机模式, 则OPCCR.OPCM[1:0]和SOPCCR.SOPCM位保留其在执行WFI指令之前的设置。如果这导致任何问题, 请设置取消软件待机模式时, MCU在异常处理过程中进入高速模式。

#### OPCM[1:0]位 (工作电源控制模式选择)

OPCM[1:0]位选择正常和休眠模式下的工作功率控制模式。表10.4显示了工作功率控制模式与OPCM[1:0]和SOPCM设置之间的关系。

#### OPCMTSF标志 (工作电源控制模式转换状态标志)

OPCMTSF标志指示切换操作功率控制模式时的切换控制状态。该标志在OPCM位被写入时变为1, 在模式转换完成时变为0。阅读此标志并确认其为0, 然后再继续。

#### 10.2.10 SOPCCR:副操作功率控制寄存器

Base address: SYSC = 0x4001\_E000

Offset address: 0x0AA

| Bit position: | 7 | 6 | 5 | 4            | 3 | 2 | 1 | 0         |
|---------------|---|---|---|--------------|---|---|---|-----------|
| Bit field:    | — | — | — | SOPC<br>MTSF | — | — | — | SOPC<br>M |
| 重置后的值:        | 0 | 0 | 0 | 0            | 0 | 0 | 0 | 0         |

| Bit | Symbol   | Function                                    | R/W |
|-----|----------|---|-----|
| 0   | SOPCM    | 副工作功率控制模式选择<br>0: Subosc速度模式以外1: Subosc速度模式 | R/W |
| 3:1 | —        | 这些位被读取为0。写入值应为0。                            | R/W |
| 4   | SOPCMTSF | 工作电源控制模式转换状态标志<br>0: 转换完成1: 转换中             | R   |
| 7:5 | —        | 这些位被读取为0。写入值应为0。                            | R/W |

Note: 如果安全属性配置为安全: ●

- 允许安全访问和非安全读取访问

- Non-secure write access is ignored, and TrustZone access error is not generated.
- If the security attribution is configured as Non-secure:
- Secure and Non-secure access are allowed.

Note: Set the PRCR.PRC1 bit to 1 (write enabled) before rewriting this register.

The SOPCCR register is used to reduce power consumption in Normal mode and Sleep mode. Setting this register initiates entry to and exit from Subosc-speed mode. Subosc-speed mode is available only when using the sub-clock oscillator or LOCO without dividing the frequency.

For the procedure to change operating power control modes, see [section 10.5. Function for Lower Operating Power Consumption](#).

#### SOPCM bit (Sub Operating Power Control Mode Select)

The SOPCM bit selects the operating power control mode in Normal and Sleep modes. Setting this bit to 1 allows transition to Subosc-speed mode. Setting this bit to 0 allows a return to the operating mode (operating mode set by OPCCR.OPCM[1:0]) that was active before the transition to Subosc-speed mode.

When transitioning from Software Standby mode to Normal mode or Snooze mode, the OPCCR.OPCM[1:0] and SOPCCR.SOPCM settings are as follows, regardless of their settings before entering Software Standby mode:

- OPCCR.OPCM[1:0] = 00b (High-speed mode)
- SOPCCR.SOPCM = 0b (not Subosc-speed mode)

If Software Standby mode is canceled before the transition to Software Standby completes, the OPCCR.OPCM[1:0] and SOPCCR.SOPCM bits retain their settings from before the WFI instruction is executed. If this causes any problem, set the MCU to High-speed mode during the exception handling procedure when canceling Software Standby mode.

[Table 10.4](#) shows the relationship between the operating power control modes, the OPCM[1:0], and SOPCM bits settings.

#### SOPCMTSF flag (Operating Power Control Mode Transition Status Flag)

The SOPCMTSF flag indicates the switching control state when the operating power control mode is switched to or from Subosc-speed mode. This flag becomes 1 when the SOPCM bit is written, and 0 when mode transition completes. Read this flag and confirm that it is 0 before proceeding.

[Table 10.4](#) shows each operating power control mode.

**Table 10.4 Operating power control mode**

| Operating power control mode | OPCM[1:0] bits | SOPCM bit | Power consumption |
|------------------------------|----------------|-----------|-------------------|
| High-speed mode              | 00b            | 0         | High              |
| Low-speed mode               | 11b            | 0         | ↓                 |
| Subosc-speed mode            | xxb            | 1         | Low               |

For details about the operating frequency range, see [section 47, Electrical Characteristics](#).

Each operating power control mode is described below.

- High-speed mode  
After a reset cancellation, the MCU is activated in this mode.
- Low-speed mode  
The following constraints apply in low-speed mode:
  - Programming and erasure operations for the flash memory are prohibited
  - Using the PLL or PLL2 is prohibited. See [section 10.10.1. Register Access](#)

In this mode, lower power consumption is possible than in High-speed mode when the same operation is performed under the same conditions, such as operating frequency.

- Subosc-speed mode  
The following constraints apply in Subosc-speed mode:
  - Programming and erasure operations for the flash memory are prohibited
  - Reading of the data flash is prohibited
  - Using MOSC, PLL, PLL2, MOCO, or HOCO is prohibited. See [section 10.10.1. Register Access](#)

- 忽略非安全写入访问，不会生成TrustZone访问错误。
- 如果安全属性配置为非安全：●
- 允许安全和非安全访问。

Note: 在重写该寄存器之前将PRCR.PRC1位设置为1（允许写入）。

SOPCCR寄存器用于降低正常模式和休眠模式下的功耗。设置该寄存器启动进入和退出Subosc速度模式。Subosc速度模式仅在使用副时钟振荡器或LOCO而不分频时可用。

有关更改操作功率控制模式的步骤，请参阅第10.5节。降低操作功率的功能 [Consumption](#)。

#### SOPCM位（副工作功率控制模式选择）

SOPCM位选择正常和休眠模式下的工作功率控制模式。将此位设置为1允许转换到Subosc速度模式。将此位设置为0允许返回到转换到Subosc速度模式之前处于活动状态的操作模式（由OPCCR.OPCM[1:0]设置的操作模式）。

当从软件待机模式转换到正常模式或贪睡模式时，OPCCR.OPCM[1:0]和 SOPCCR.SOPCM设置如下，无论其进入软件待机模式前的设置如何：

- OPCCR.OPCM[1:0] = 00b (High-speed mode)
- SOPCCR.SOPCM = 0b (not Subosc-speed mode)

如果在转换到软件待机完成之前取消软件待机模式，则OPCCR.OPCM[1:0]和 SOPCCR.SOPCM位保留其在执行WFI指令之前的设置。如果这导致任何问题，请设置取消软件待机模式时，MCU在异常处理过程中进入高速模式。

表10.4显示了工作功率控制模式、OPCM[1:0]和SOPCM位设置之间的关系。

#### SOPCMTSF标志（工作电源控制模式转换状态标志）

SOPCMTSF标志指示当操作功率控制模式切换到或从切换控制状态 Subosc速度模式。写入SOPCM位时该标志变为1，模式转换完成时变为0。阅读此标志并确认其为0，然后再继续。

表10.4显示了每种工作功率控制模式。

**Table 10.4 工作功率控制方式**

| 工作功率控制方式          | OPCM[1:0] bits | SOPCM bit | 能量消耗 |
|-------------------|----------------|-----------|------|
| High-speed mode   | 00b            | 0         | High |
| Low-speed mode    | 11b            | 0         | ↓    |
| Subosc-speed mode | xxb            | 1         | Low  |

有关工作频率范围的详细信息，请参阅第47节，电气特性。

下面描述每种操作功率控制模式。

- High-speed mode  
复位取消后，MCU在此模式下激活。
- Low-speed mode  
以下约束适用于低速模式：
  - 禁止对闪存进行编程和擦除操作
  - 禁止使用PLL或PLL2。请参阅第10.10.1节。注册访问

在这种模式下，如果在相同的条件下（例如工作频率）执行相同的操作，则可能比高速模式下的功耗更低。

- Subosc-speed mode  
以下约束适用于Subosc速度模式：
  - 禁止对闪存进行编程和擦除操作
  - 禁止读取数据闪存
  - 禁止使用MOSC、PLL、PLL2、MOCO或HOCO。请参阅第10.10.1节。注册访问



- Using the divided clock for ICK or FCK is prohibited. See [section 10.10.1. Register Access](#)
- Using the oscillation stop detection function of the main clock oscillator is prohibited.

In this mode, lower power consumption is possible than in low-speed mode when the same operation is performed under the same conditions, such as operating frequency.

### 10.2.11 SNZCR : Snooze Control Register

Base address: SYSC = 0x4001\_E000

Offset address: 0x092

|                    |      |   |   |   |   |   |           |           |
|--------------------|------|---|---|---|---|---|-----------|-----------|
| Bit position:      | 7    | 6 | 5 | 4 | 3 | 2 | 1         | 0         |
| Bit field:         | SNZE | — | — | — | — | — | SNZD TCEN | RXDR EQEN |
| Value after reset: | 0    | 0 | 0 | 0 | 0 | 0 | 0         | 0         |

| Bit | Symbol   | Function   | R/W |
|-----|----------|--|-----|
| 0   | RXDREQEN | RXD0 Snooze Request Enable<br>0: Ignore RXD0 falling edge in Software Standby mode<br>1: Detect RXD0 falling edge in Software Standby mode | R/W |
| 1   | SNZDTCEN | DTC Enable in Snooze mode<br>0: Disable DTC operation<br>1: Enable DTC operation   | R/W |
| 6:2 | —        | These bits are read as 0. The write value should be 0.   | R/W |
| 7   | SNZE     | Snooze mode Enable<br>0: Disable Snooze mode<br>1: Enable Snooze mode  | R/W |

Note: If the security attribution is configured as secure:

- Secure access and Non-secure read access are allowed
- Non-secure write access is ignored, and TrustZone access error is not generated.

If the security attribution is configured as Non-secure:

- Secure and Non-secure access are allowed.

Note: Set the PRCR.PRC1 bit to 1 (write enabled) before rewriting this register.

#### RXDREQEN bit (RXD0 Snooze Request Enable)

The RXDREQEN bit specifies whether to detect a falling edge of the RXD0 pin in Software Standby mode. This bit can be used only when SCIO is operating in asynchronous mode. To detect a falling edge of the RXD0 pin, set this bit before entering Software Standby mode. When this bit is set to 1, a falling edge of the RXD0 pin in Software Standby mode causes the MCU to enter Snooze mode.

#### SNZDTCEN bit (DTC Enable in Snooze mode)

The SNZDTCEN bit specifies whether to use the DTC and SRAM in Snooze mode. To use the DTC and SRAM in Snooze mode, set this bit to 1 before entering Software Standby mode. When this bit is set to 1, the DTC can be activated by setting IELSRn register.

#### SNZE bit (Snooze mode Enable)

The SNZE bit specifies whether to enable a transition from Software Standby mode to Snooze mode. To use Snooze mode, set this bit to 1 before entering Software Standby mode. When this bit is set to 1, a trigger as shown in [Table 10.7](#) in Software Standby mode causes the MCU to enter Snooze mode. After the MCU transitions from Software Standby mode or Snooze mode to Normal operating mode, set 0 to the SNZE bit once then set it before re-entering Software Standby mode. For details, see [section 10.8. Snooze Mode](#).

禁止将分频时钟用于ICK或FCK。请参阅第10.10.1节。注册访问  
禁止使用主时钟振荡器的振荡停止检测功能。

在这种模式下，当在相同的条件下（例如工作频率）执行相同的操作时，可以比低速模式更低的功耗。

### 10.2.11 SNZCR: 贪睡控制寄存器

Base address: SYSC = 0x4001\_E000

Offset address: 0x092

|               |      |   |   |   |   |   |           |           |
|---------------|------|---|---|---|---|---|-----------|-----------|
| Bit position: | 7    | 6 | 5 | 4 | 3 | 2 | 1         | 0         |
| Bit field:    | SNZE | — | — | — | — | — | SNZD TCEN | RXDR EQEN |
| 重置后的值:        | 0    | 0 | 0 | 0 | 0 | 0 | 0         | 0         |

| Bit | Symbol   | Function  | R/W |
|-----|----------|---|-----|
| 0   | RXDREQEN | RXD0贪睡请求启用<br>0: 在软件待机模式下忽略RXD0下降沿 1: 在软件待机模式下检测RXD0下降沿 | R/W |
| 1   | SNZDTCEN | 在贪睡模式下启用DTC<br>0: 禁用DTC操作 1: 启用DTC操作                    | R/W |
| 6:2 | —        | 这些位被读取为0。写入值应为0。  | R/W |
| 7   | SNZE     | 贪睡模式启用<br>0: 禁用贪睡模式 1: 启用贪睡模式                           | R/W |

Note: 如果安全属性配置为安全: ●

- 允许安全访问和非安全读取访问
- 忽略非安全写入访问，不会生成TrustZone访问错误。

如果安全属性配置为非安全: ●

- 允许安全和非安全访问。

Note: 在重写该寄存器之前将PRCR.PRC1位设置为1（允许写入）。

#### RXDREQEN位 (RXD0贪睡请求使能)

RXDREQEN位指定在软件待机模式下是否检测RXD0引脚的下降沿。该位只能在SCIO工作在异步模式时使用。要检测RXD0引脚的下降沿，请在进入软件待机模式之前设置该位。当该位设置为1时，软件待机模式下RXD0引脚的下降沿会导致MCU进入贪睡模式。

#### SNZDTCEN位 (在贪睡模式下启用DTC)

SNZDTCEN位指定是否在贪睡模式下使用DTC和SRAM。要在贪睡模式下使用DTC和SRAM，请在进入软件待机模式之前将此位设置为1。当该位设置为1时，可以通过设置IELSRn寄存器来激活DTC。

#### SNZE位 (贪睡模式启用)

SNZE位指定是否启用从软件待机模式到贪睡模式的转换。要使用贪睡模式，请在进入软件待机模式之前将此位设置为1。当该位设置为1时，软件待机模式下如表10.7所示的触发会导致MCU进入贪睡模式。MCU从软件待机模式转换后或

贪睡模式到正常工作模式，将SNZE位设置为0一次，然后在重新进入软件待机模式之前将其设置。

有关详细信息，请参阅第10.8节。贪睡模式。

## 10.2.12 SNZEDCR0 : Snooze End Control Register 0

Base address: SYSC = 0x4001\_E000

Offset address: 0x094

|                    |               |              |              |              |              |              |             |              |
|--------------------|---------------|--------------|--------------|--------------|--------------|--------------|-------------|--------------|
| Bit position:      | 7             | 6            | 5            | 4            | 3            | 2            | 1           | 0            |
| Bit field:         | SCI0U<br>MTED | AD1U<br>MTED | AD1M<br>ATED | AD0U<br>MTED | AD0M<br>ATED | DTCN<br>ZRED | DTCZ<br>RED | AGTU<br>NFED |
| Value after reset: | 0             | 0            | 0            | 0            | 0            | 0            | 0           | 0            |

| Bit | Symbol    | Function  | R/W |
|-----|-----------|---|-----|
| 0   | AGTUNFED  | AGT1 Underflow Snooze End Enable<br>0: Disable the snooze end request<br>1: Enable the snooze end request                       | R/W |
| 1   | DTCZRED   | Last DTC Transmission Completion Snooze End Enable<br>0: Disable the snooze end request<br>1: Enable the snooze end request     | R/W |
| 2   | DTCNZRED  | Not Last DTC Transmission Completion Snooze End Enable<br>0: Disable the snooze end request<br>1: Enable the snooze end request | R/W |
| 3   | AD0MATED  | ADC120 Compare Match Snooze End Enable<br>0: Disable the snooze end request<br>1: Enable the snooze end request                 | R/W |
| 4   | AD0UMTED  | ADC120 Compare Mismatch Snooze End Enable<br>0: Disable the snooze end request<br>1: Enable the snooze end request              | R/W |
| 5   | AD1MATED  | ADC121 Compare Match Snooze End Enable<br>0: Disable the snooze end request<br>1: Enable the snooze end request                 | R/W |
| 6   | AD1UMTED  | ADC121 Compare Mismatch Snooze End Enable<br>0: Disable the snooze end request<br>1: Enable the snooze end request              | R/W |
| 7   | SCI0UMTED | SCI0 Address Mismatch Snooze End Enable<br>0: Disable the snooze end request<br>1: Enable the snooze end request                | R/W |

Note: If the security attribution is configured as secure:

- Secure access and Non-secure read access are allowed
- Non-secure write access is ignored, and TrustZone access error is not generated.

If the security attribution is configured as Non-secure:

- Secure and Non-secure access are allowed.

Note: Set the PRCR.PRC1 bit to 1 (write enabled) before rewriting this register.

The SNZEDCR0 register controls the condition of switching from Snooze mode to Software Standby mode. In order to use a trigger shown in Table 10.8 as a condition to switch from Snooze mode to Software Standby mode, the corresponding bit in the SNZEDCR0 register must be set to 1.

The event that is used to return from snooze mode to normal operating mode as shown in Table 10.3 must not be enabled in the SNZEDCR0 register.

**AGTUNFED bit (AGT1 Underflow Snooze End Enable)**

The AGTUNFED bit specifies whether to enable a transition from Snooze mode to Software Standby mode on an AGT1 underflow. For details on the trigger conditions, see section 22, Low Power Asynchronous General Purpose Timer (AGT).

**DTCZRED bit (Last DTC Transmission Completion Snooze End Enable)**

The DTCZRED bit specifies whether to enable a transition from Snooze mode to Software Standby mode on completion of the last DTC transmission, that is, when CRA or CRB registers in the DTC is 0. For details on the trigger conditions, see section 17, Data Transfer Controller (DTC).

## 10.2.12 SNZEDCR0: 贪睡结束控制寄存器0

Base address: SYSC = 0x4001\_E000

Offset address: 0x094

|               |               |              |              |              |              |              |             |              |
|---------------|---------------|--------------|--------------|--------------|--------------|--------------|-------------|--------------|
| Bit position: | 7             | 6            | 5            | 4            | 3            | 2            | 1           | 0            |
| Bit field:    | SCI0U<br>MTED | AD1U<br>MTED | AD1M<br>ATED | AD0U<br>MTED | AD0M<br>ATED | DTCN<br>ZRED | DTCZ<br>RED | AGTU<br>NFED |
| 重置后的值:        | 0             | 0            | 0            | 0            | 0            | 0            | 0           | 0            |

| Bit | Symbol    | Function  | R/W |
|-----|-----------|---|-----|
| 0   | AGTUNFED  | AGT1下溢贪睡结束使能<br>0: 禁用贪睡结束请求<br>1: 启用贪睡结束请求        | R/W |
| 1   | DTCZRED   | 上次DTC传输完成贪睡结束启用<br>0: 禁用贪睡结束请求<br>1: 启用贪睡结束请求     | R/W |
| 2   | DTCNZRED  | 不是最后一个DTC传输完成贪睡结束启用<br>0: 禁用贪睡结束请求<br>1: 启用贪睡结束请求 | R/W |
| 3   | AD0MATED  | ADC120比较匹配贪睡结束使能<br>0: 禁用贪睡结束请求<br>1: 启用贪睡结束请求    | R/W |
| 4   | AD0UMTED  | ADC120比较失配贪睡结束使能<br>0: 禁用贪睡结束请求<br>1: 启用贪睡结束请求    | R/W |
| 5   | AD1MATED  | ADC121比较匹配贪睡结束使能<br>0: 禁用贪睡结束请求<br>1: 启用贪睡结束请求    | R/W |
| 6   | AD1UMTED  | ADC121比较失配贪睡结束使能<br>0: 禁用贪睡结束请求<br>1: 启用贪睡结束请求    | R/W |
| 7   | SCI0UMTED | SCI0地址不匹配贪睡结束使能<br>0: 禁用贪睡结束请求<br>1: 启用贪睡结束请求     | R/W |

Note: 如果安全属性配置为安全: ●

- 允许安全访问和非安全读取访问
- 忽略非安全写入访问, 不会生成TrustZone访问错误。

如果安全属性配置为非安全: ●

- 允许安全和非安全访问。

Note: 在重写该寄存器之前将PRCR.PRC1位设置为1 (允许写入)。

SNZEDCR0寄存器控制从贪睡模式切换到软件待机模式的条件。为了使用表10.8中所示的触发作为从贪睡模式切换到软件待机模式的条件, 必须将SNZEDCR0寄存器中的相应位设置为1。

不得在SNZEDCR0寄存器中启用用于从贪睡模式返回到正常操作模式的事件, 如表10.3所示。

**AGTUNFED位 (AGT1下溢贪睡结束使能)**

AGTUNFED位指定是否在AGT1下溢时启用从贪睡模式到软件待机模式的转换。有关触发条件的详细信息, 请参见第22节, 低功耗异步通用定时器(AGT)。

**DTCZRED位 (最后一个DTC传输完成贪睡结束使能)**

DTCZRED位指定是否在最后一次DTC传输完成时, 即当DTC中的CRA或CRB寄存器为0时启用从贪睡模式到软件待机模式的转换。有关触发条件的详细信息, 请参见第17节, 数据传输控制器(DTC)。



**DTCNZRED bit (Not Last DTC Transmission Completion Snooze End Enable)**

The DTCNZRED bit specifies whether to enable a transition from Snooze mode to Software Standby mode on completion of each DTC transmission, that is, when CRA or CRB registers in the DTC is not 0. For details on the trigger conditions, see [section 17, Data Transfer Controller \(DTC\)](#).

**AD0MATED bit (ADC120 Compare Match Snooze End Enable)**

The AD0MATED bit specifies whether to enable a transition from Snooze mode to Software Standby mode on an AD0 event when a conversion result matches the expected data. For details on the trigger conditions, see [section 37, 12-Bit A/D Converter \(ADC12\)](#).

**AD0UMTED bit (ADC120 Compare Mismatch Snooze End Enable)**

The AD0UMTED bit specifies whether to enable a transition from Snooze mode to Software Standby mode on an AD0 event when the conversion result does not match the expected data. For details on the trigger conditions, see [section 37, 12-Bit A/D Converter \(ADC12\)](#).

**AD1MATED bit (ADC121 Compare Match Snooze End Enable)**

The AD1MATED bit specifies whether to enable a transition from Snooze mode to Software Standby mode on an ADC121 event when a conversion result matches the expected data. For details on the trigger conditions, see [section 37, 12-Bit A/D Converter \(ADC12\)](#).

**AD1UMTED bit (ADC121 Compare Mismatch Snooze End Enable)**

The AD1UMTED bit specifies whether to enable a transition from Snooze mode to Software Standby mode on an ADC121 event when the conversion result does not match the expected data. For details on the trigger conditions, see [section 37, 12-Bit A/D Converter \(ADC12\)](#).

**SCI0UMTED bit (SCI0 Address Mismatch Snooze End Enable)**

The SCI0UMTED bit specifies whether to enable a transition from Snooze mode to Software Standby mode on an SCI0 event when an address received in Software Standby mode does not match the expected data. For details on the trigger conditions, see [section 27, Serial Communications Interface \(SCI\)](#). Only set this bit to 1 when SCI0 operates in asynchronous mode.

**10.2.13 SNZEDCR1 : Snooze End Control Register 1**

Base address: SYSC = 0x4001\_E000

Offset address: 0x095

|                    |   |   |   |   |   |   |   |            |
|--------------------|---|---|---|---|---|---|---|------------|
| Bit position:      | 7 | 6 | 5 | 4 | 3 | 2 | 1 | 0          |
| Bit field:         | — | — | — | — | — | — | — | AGT3 UNFED |
| Value after reset: | 0 | 0 | 0 | 0 | 0 | 0 | 0 | 0          |

| Bit | Symbol    | Function  | R/W |
|-----|-----------|---|-----|
| 0   | AGT3UNFED | AGT3 underflow Snooze End Enable<br>0: Disable the Snooze End request<br>1: Enable the Snooze End request | R/W |
| 7:1 | —         | These bits are read as 0. The write value should be 0.  | R/W |

Note: If the security attribution is configured as secure:

- Secure access and Non-secure read access are allowed
- Non-secure write access is ignored, and TrustZone access error is not generated.

If the security attribution is configured as Non-secure:

- Secure and Non-secure access are allowed.

Note: Set the PRCR.PRC1 bit to 1 (write enabled) before rewriting this register.

The SNZEDCR1 register controls the condition of switching from Snooze mode to Software Standby mode. In order to use a trigger shown in [Table 10.8](#) as a condition to switch from Snooze mode to Software Standby mode, the corresponding bit in the SNZEDCR1 register must be set to 1.

**DTCNZRED位 (非最后一个DTC传输完成贪睡结束使能)**

DTCNZRED位指定是否在每次DTC传输完成时启用从贪睡模式到软件待机模式的转换，即当DTC中的CRA或CRB寄存器不为0时。有关触发条件的详细信息，请参见第17节，数据传输控制器(DTC)。

**AD0MATED位 (ADC120比较匹配暂停结束使能)**

AD0MATED位指定当转换结果与预期数据匹配时，是否在发生AD0事件时启用从贪睡模式到软件待机模式的转换。有关触发条件的详细信息，请参阅第37节，12位AD转换器(ADC12)。

**AD0UMTED位 (ADC120比较不匹配贪睡结束使能)**

AD0UMTED位指定当转换结果与预期数据不匹配时，是否在发生AD0事件时启用从贪睡模式到软件待机模式的转换。有关触发条件的详细信息，请参阅第37节，12位AD转换器(ADC12)。

**AD1MATED位 (ADC121比较匹配暂停结束使能)**

AD1MATED位指定当转换结果与预期数据匹配时，是否在发生ADC121事件时启用从贪睡模式到软件待机模式的转换。有关触发条件的详细信息，请参阅第37节，12位AD转换器(ADC12)。

**AD1UMTED位 (ADC121比较不匹配贪睡结束使能)**

AD1UMTED位指定当转换结果与预期数据不匹配时，是否在发生ADC121事件时启用从贪睡模式到软件待机模式的转换。有关触发条件的详细信息，请参阅第37节，12位AD转换器(ADC12)。

**SCI0UMTED位 (SCI0地址不匹配贪睡结束使能)**

SCI0UMTED位指定当在软件待机模式下接收到的地址与预期数据不匹配时，是否在发生SCI0事件时启用从贪睡模式到软件待机模式的转换。有关触发条件的详细信息，请参阅第27节，串行通信接口(SCI)。仅当SCI0在异步模式下工作时将该位设置为1。

**10.2.13 SNZEDCR1: 贪睡结束控制寄存器1**

Base address: SYSC = 0x4001\_E000

Offset address: 0x095

|               |   |   |   |   |   |   |   |            |
|---------------|---|---|---|---|---|---|---|------------|
| Bit position: | 7 | 6 | 5 | 4 | 3 | 2 | 1 | 0          |
| Bit field:    | — | — | — | — | — | — | — | AGT3 UNFED |
| 重置后的值:        | 0 | 0 | 0 | 0 | 0 | 0 | 0 | 0          |

| Bit | Symbol    | Function                               | R/W |
|-----|-----------|--|-----|
| 0   | AGT3UNFED | AGT3下溢贪睡结束使能<br>0: 禁用贪睡结束请求1: 启用贪睡结束请求 | R/W |
| 7:1 | —         | 这些位被读取为0。写入值应为0。                       | R/W |

Note: 如果安全属性配置为安全: ●

- 允许安全访问和非安全读取访问
- 忽略非安全写入访问，不会生成TrustZone访问错误。

如果安全属性配置为非安全: ●

- 允许安全和非安全访问。

Note: 在重写该寄存器之前将PRCR.PRC1位设置为1 (允许写入)。

SNZEDCR1寄存器控制从贪睡模式切换到软件待机模式的条件。为了使用表10.8中所示的触发作为从贪睡模式切换到软件待机模式的条件，必须将SNZEDCR1寄存器中的相应位设置为1。

The event that is used to return from Snooze mode to normal operating mode as shown in Table 10.3 must not be enabled in the SNZEDCR1 register.

#### AGT3UNFED bit (AGT3 underflow Snooze End Enable)

The AGT3UNFED bit specifies whether to enable a transition from Snooze mode to Software Standby mode by an underflow of the AGT3. For the detail of the condition of the trigger, see section 22, Low Power Asynchronous General Purpose Timer (AGT).

#### 10.2.14 SNZREQCR0 : Snooze Request Control Register 0

Base address: SYSC = 0x4001\_E000

Offset address: 0x098

|                    |                    |                    |                    |                    |                    |                    |                    |                    |                   |                   |                   |                   |                   |                   |                   |                   |
|--------------------|--------------------|--------------------|--------------------|--------------------|--------------------|--------------------|--------------------|--------------------|-------------------|-------------------|-------------------|-------------------|-------------------|-------------------|-------------------|-------------------|
| Bit position:      | 31                 | 30                 | 29                 | 28                 | 27                 | 26                 | 25                 | 24                 | 23                | 22                | 21                | 20                | 19                | 18                | 17                | 16                |
| Bit field:         | —                  | SNZR<br>EQEN<br>30 | SNZR<br>EQEN<br>29 | SNZR<br>EQEN<br>28 | —                  | —                  | SNZR<br>EQEN<br>25 | SNZR<br>EQEN<br>24 | —                 | —                 | —                 | —                 | —                 | —                 | —                 | —                 |
| Value after reset: | 0                  | 0                  | 0                  | 0                  | 0                  | 0                  | 0                  | 0                  | 0                 | 0                 | 0                 | 0                 | 0                 | 0                 | 0                 | 0                 |
| Bit position:      | 15                 | 14                 | 13                 | 12                 | 11                 | 10                 | 9                  | 8                  | 7                 | 6                 | 5                 | 4                 | 3                 | 2                 | 1                 | 0                 |
| Bit field:         | SNZR<br>EQEN<br>15 | SNZR<br>EQEN<br>14 | SNZR<br>EQEN<br>13 | SNZR<br>EQEN<br>12 | SNZR<br>EQEN<br>11 | SNZR<br>EQEN<br>10 | SNZR<br>EQEN<br>9  | SNZR<br>EQEN<br>8  | SNZR<br>EQEN<br>7 | SNZR<br>EQEN<br>6 | SNZR<br>EQEN<br>5 | SNZR<br>EQEN<br>4 | SNZR<br>EQEN<br>3 | SNZR<br>EQEN<br>2 | SNZR<br>EQEN<br>1 | SNZR<br>EQEN<br>0 |
| Value after reset: | 0                  | 0                  | 0                  | 0                  | 0                  | 0                  | 0                  | 0                  | 0                 | 0                 | 0                 | 0                 | 0                 | 0                 | 0                 | 0                 |

| Bit | Symbol    | Function  | R/W |
|-----|-----------|---|-----|
| 0   | SNZREQEN0 | Enable IRQ0 pin snooze request<br>0: Disable the snooze request<br>1: Enable the snooze request | R/W |
| 1   | SNZREQEN1 | Enable IRQ1 pin snooze request<br>0: Disable the snooze request<br>1: Enable the snooze request | R/W |
| 2   | SNZREQEN2 | Enable IRQ2 pin snooze request<br>0: Disable the snooze request<br>1: Enable the snooze request | R/W |
| 3   | SNZREQEN3 | Enable IRQ3 pin snooze request<br>0: Disable the snooze request<br>1: Enable the snooze request | R/W |
| 4   | SNZREQEN4 | Enable IRQ4 pin snooze request<br>0: Disable the snooze request<br>1: Enable the snooze request | R/W |
| 5   | SNZREQEN5 | Enable IRQ5 pin snooze request<br>0: Disable the snooze request<br>1: Enable the snooze request | R/W |
| 6   | SNZREQEN6 | Enable IRQ6 pin snooze request<br>0: Disable the snooze request<br>1: Enable the snooze request | R/W |
| 7   | SNZREQEN7 | Enable IRQ7 pin snooze request<br>0: Disable the snooze request<br>1: Enable the snooze request | R/W |
| 8   | SNZREQEN8 | Enable IRQ8 pin snooze request<br>0: Disable the snooze request<br>1: Enable the snooze request | R/W |
| 9   | SNZREQEN9 | Enable IRQ9 pin snooze request<br>0: Disable the snooze request<br>1: Enable the snooze request | R/W |

不得在SNZEDCR1寄存器中启用用于从贪睡模式返回到正常操作模式的事件，如表10.3所示。

#### AGT3UNFED位 (AGT3下溢贪睡结束使能)

AGT3UNFED位指定是否通过AGT3的下溢来使能从贪睡模式到软件待机模式的转换。有关触发条件的详细信息，请参见第22节，低功耗异步通用定时器(AGT)。

#### 10.2.14 SNZREQCR0:贪睡请求控制寄存器0

Base address: SYSC = 0x4001\_E000

Offset address: 0x098

|               |                    |                    |                    |                    |                    |                    |                    |                    |                   |                   |                   |                   |                   |                   |                   |                   |
|---------------|--------------------|--------------------|--------------------|--------------------|--------------------|--------------------|--------------------|--------------------|-------------------|-------------------|-------------------|-------------------|-------------------|-------------------|-------------------|-------------------|
| Bit position: | 31                 | 30                 | 29                 | 28                 | 27                 | 26                 | 25                 | 24                 | 23                | 22                | 21                | 20                | 19                | 18                | 17                | 16                |
| Bit field:    | —                  | SNZR<br>EQEN<br>30 | SNZR<br>EQEN<br>29 | SNZR<br>EQEN<br>28 | —                  | —                  | SNZR<br>EQEN<br>25 | SNZR<br>EQEN<br>24 | —                 | —                 | —                 | —                 | —                 | —                 | —                 | —                 |
| 重置后的值:        | 0                  | 0                  | 0                  | 0                  | 0                  | 0                  | 0                  | 0                  | 0                 | 0                 | 0                 | 0                 | 0                 | 0                 | 0                 | 0                 |
| Bit position: | 15                 | 14                 | 13                 | 12                 | 11                 | 10                 | 9                  | 8                  | 7                 | 6                 | 5                 | 4                 | 3                 | 2                 | 1                 | 0                 |
| Bit field:    | SNZR<br>EQEN<br>15 | SNZR<br>EQEN<br>14 | SNZR<br>EQEN<br>13 | SNZR<br>EQEN<br>12 | SNZR<br>EQEN<br>11 | SNZR<br>EQEN<br>10 | SNZR<br>EQEN<br>9  | SNZR<br>EQEN<br>8  | SNZR<br>EQEN<br>7 | SNZR<br>EQEN<br>6 | SNZR<br>EQEN<br>5 | SNZR<br>EQEN<br>4 | SNZR<br>EQEN<br>3 | SNZR<br>EQEN<br>2 | SNZR<br>EQEN<br>1 | SNZR<br>EQEN<br>0 |
| 重置后的值:        | 0                  | 0                  | 0                  | 0                  | 0                  | 0                  | 0                  | 0                  | 0                 | 0                 | 0                 | 0                 | 0                 | 0                 | 0                 | 0                 |

| Bit | Symbol    | Function                           | R/W |
|-----|-----------|------------------------------------|-----|
| 0   | SNZREQEN0 | 启用IRQ0引脚贪睡请求<br>0: 禁用贪睡请求1: 启用贪睡请求 | R/W |
| 1   | SNZREQEN1 | 启用IRQ1引脚贪睡请求<br>0: 禁用贪睡请求1: 启用贪睡请求 | R/W |
| 2   | SNZREQEN2 | 启用IRQ2引脚贪睡请求<br>0: 禁用贪睡请求1: 启用贪睡请求 | R/W |
| 3   | SNZREQEN3 | 启用IRQ3引脚贪睡请求<br>0: 禁用贪睡请求1: 启用贪睡请求 | R/W |
| 4   | SNZREQEN4 | 启用IRQ4引脚贪睡请求<br>0: 禁用贪睡请求1: 启用贪睡请求 | R/W |
| 5   | SNZREQEN5 | 启用IRQ5引脚贪睡请求<br>0: 禁用贪睡请求1: 启用贪睡请求 | R/W |
| 6   | SNZREQEN6 | 启用IRQ6引脚贪睡请求<br>0: 禁用贪睡请求1: 启用贪睡请求 | R/W |
| 7   | SNZREQEN7 | 启用IRQ7引脚贪睡请求<br>0: 禁用贪睡请求1: 启用贪睡请求 | R/W |
| 8   | SNZREQEN8 | 启用IRQ8引脚贪睡请求<br>0: 禁用贪睡请求1: 启用贪睡请求 | R/W |
| 9   | SNZREQEN9 | 启用IRQ9引脚贪睡请求<br>0: 禁用贪睡请求1: 启用贪睡请求 | R/W |

| Bit   | Symbol     | Function  | R/W |
|-------|------------|---|-----|
| 10    | SNZREQEN10 | Enable IRQ10 pin snooze request<br>0: Disable the snooze request<br>1: Enable the snooze request            | R/W |
| 11    | SNZREQEN11 | Enable IRQ11 pin snooze request<br>0: Disable the snooze request<br>1: Enable the snooze request            | R/W |
| 12    | SNZREQEN12 | Enable IRQ12 pin snooze request<br>0: Disable the snooze request<br>1: Enable the snooze request            | R/W |
| 13    | SNZREQEN13 | Enable IRQ13 pin snooze request<br>0: Disable the snooze request<br>1: Enable the snooze request            | R/W |
| 14    | SNZREQEN14 | Enable IRQ14 pin snooze request<br>0: Disable the snooze request<br>1: Enable the snooze request            | R/W |
| 15    | SNZREQEN15 | Enable IRQ15 pin snooze request<br>0: Disable the snooze request<br>1: Enable the snooze request            | R/W |
| 23:16 | —          | These bits are read as 0. The write value should be 0.  | R/W |
| 24    | SNZREQEN24 | Enable RTC alarm snooze request<br>0: Disable the snooze request<br>1: Enable the snooze request            | R/W |
| 25    | SNZREQEN25 | Enable RTC period snooze request<br>0: Disable the snooze request<br>1: Enable the snooze request           | R/W |
| 27:26 | —          | These bits are read as 0. The write value should be 0.  | R/W |
| 28    | SNZREQEN28 | Enable AGT1 underflow snooze request<br>0: Disable the snooze request<br>1: Enable the snooze request       | R/W |
| 29    | SNZREQEN29 | Enable AGT1 compare match A snooze request<br>0: Disable the snooze request<br>1: Enable the snooze request | R/W |
| 30    | SNZREQEN30 | Enable AGT1 compare match B snooze request<br>0: Disable the snooze request<br>1: Enable the snooze request | R/W |
| 31    | —          | This bit is read as 0. The write value should be 0.   | R/W |

Note: If the security attribution is configured as secure:

- Secure access and Non-secure read access are allowed
  - Non-secure write access is ignored, and TrustZone access error is not generated.
- If the security attribution is configured as Non-secure:
- Secure and Non-secure access are allowed.

Note: Set the PRCR.PRC1 bit to 1 (write enabled) before rewriting this register.

The SNZREQCR0 register controls which trigger causes the MCU to switch from Software Standby mode to Snooze mode. If a trigger is selected as a request to cancel Software Standby mode by setting the WUPENn register, see [section 13, Interrupt Controller Unit \(ICU\)](#), the MCU enters Normal mode when the trigger is generated while the associated bit of the SNZREQCR0 is 1. The setting of the WUPENn register always has higher priority than the setting of the SNZREQCR0 register. For details, see [section 10.8. Snooze Mode](#) and [section 13, Interrupt Controller Unit \(ICU\)](#).

| Bit   | Symbol     | Function                              | R/W |
|-------|------------|---------------------------------------|-----|
| 10    | SNZREQEN10 | 启用IRQ10引脚贪睡请求<br>0: 禁用贪睡请求1: 启用贪睡请求   | R/W |
| 11    | SNZREQEN11 | 启用IRQ11引脚贪睡请求<br>0: 禁用贪睡请求1: 启用贪睡请求   | R/W |
| 12    | SNZREQEN12 | 启用IRQ12引脚贪睡请求<br>0: 禁用贪睡请求1: 启用贪睡请求   | R/W |
| 13    | SNZREQEN13 | 启用IRQ13引脚贪睡请求<br>0: 禁用贪睡请求1: 启用贪睡请求   | R/W |
| 14    | SNZREQEN14 | 启用IRQ14引脚贪睡请求<br>0: 禁用贪睡请求1: 启用贪睡请求   | R/W |
| 15    | SNZREQEN15 | 启用IRQ15引脚贪睡请求<br>0: 禁用贪睡请求1: 启用贪睡请求   | R/W |
| 23:16 | —          | 这些位被读取为0。写入值应为0。                      | R/W |
| 24    | SNZREQEN24 | 启用RTC闹钟暂停请求<br>0: 禁用贪睡请求1: 启用贪睡请求     | R/W |
| 25    | SNZREQEN25 | 启用RTC周期暂停请求<br>0: 禁用贪睡请求1: 启用贪睡请求     | R/W |
| 27:26 | —          | 这些位被读取为0。写入值应为0。                      | R/W |
| 28    | SNZREQEN28 | 启用AGT1下溢暂停请求<br>0: 禁用贪睡请求1: 启用贪睡请求    | R/W |
| 29    | SNZREQEN29 | 启用AGT1比较匹配贪睡请求<br>0: 禁用贪睡请求1: 启用贪睡请求  | R/W |
| 30    | SNZREQEN30 | 启用AGT1比较匹配B贪睡请求<br>0: 禁用贪睡请求1: 启用贪睡请求 | R/W |
| 31    | —          | 该位读取为0。写入值应为0。                        | R/W |

Note: 如果安全属性配置为安全: ●

- 允许安全访问和非安全读取访问
  - 忽略非安全写入访问, 不会生成TrustZone访问错误。
- 如果安全属性配置为非安全: ●
- 允许安全和非安全访问。

Note: 在重写该寄存器之前将PRCR.PRC1位设置为1 (允许写入)。

SNZREQCR0寄存器控制哪个触发器导致MCU从软件待机模式切换到贪睡模式。如果通过设置WUPENn寄存器选择触发作为取消软件待机模式的请求, 请参见第13节, 中断控制器单元 (ICU), 当触发产生时MCU进入正常模式, 而相关位SNZREQCR0为1。WUPENn寄存器的设置总是比SNZREQCR0寄存器的设置具有更高的优先级。有关详细信息, 请参阅第10.8节。贪睡模式和第13节, 中断控制器单元(ICU)。

## 10.2.15 SNZREQCR1 : Snooze Request Control Register 1

Base address: SYSC = 0x4001\_E000

Offset address: 0x088

|                    |    |    |    |    |    |    |    |    |    |    |    |    |    |    |           |           |           |
|--------------------|----|----|----|----|----|----|----|----|----|----|----|----|----|----|-----------|-----------|-----------|
| Bit position:      | 31 | 30 | 29 | 28 | 27 | 26 | 25 | 24 | 23 | 22 | 21 | 20 | 19 | 18 | 17        | 16        |           |
| Bit field:         | —  | —  | —  | —  | —  | —  | —  | —  | —  | —  | —  | —  | —  | —  | —         | —         |           |
| Value after reset: | 0  | 0  | 0  | 0  | 0  | 0  | 0  | 0  | 0  | 0  | 0  | 0  | 0  | 0  | 0         | 0         |           |
| Bit position:      | 15 | 14 | 13 | 12 | 11 | 10 | 9  | 8  | 7  | 6  | 5  | 4  | 3  | 2  | 1         | 0         |           |
| Bit field:         | —  | —  | —  | —  | —  | —  | —  | —  | —  | —  | —  | —  | —  | —  | SNZREQEN2 | SNZREQEN1 | SNZREQEN0 |
| Value after reset: | 0  | 0  | 0  | 0  | 0  | 0  | 0  | 0  | 0  | 0  | 0  | 0  | 0  | 0  | 0         | 0         | 0         |

| Bit  | Symbol    | Function  | R/W |
|------|-----------|---|-----|
| 0    | SNZREQEN0 | Enable AGT3 underflow snooze request<br>0: Disable the snooze request<br>1: Enable the snooze request       | R/W |
| 1    | SNZREQEN1 | Enable AGT3 compare match A snooze request<br>0: Disable the snooze request<br>1: Enable the snooze request | R/W |
| 2    | SNZREQEN2 | Enable AGT3 compare match B snooze request<br>0: Disable the snooze request<br>1: Enable the snooze request | R/W |
| 31:3 | —         | These bits are read as 0. The write value should be 0.  | R/W |

Note: If the security attribution is configured as secure:

- Secure access and Non-secure read access are allowed
- Non-secure write access is ignored, and TrustZone access error is not generated.

If the security attribution is configured as Non-secure:

- Secure and Non-secure access are allowed.

Note: Set the PRCR.PRC1 bit to 1 (write enabled) before rewriting this register.

The SNZREQCR1 register controls which trigger causes the MCU to switch from Software Standby mode to Snooze mode. If a trigger is selected as a request to cancel Software Standby mode by setting the WUPENn register, see [section 13, Interrupt Controller Unit \(ICU\)](#), the MCU enters Normal mode when the trigger is generated while the associated bit of the SNZREQCR1 is 1. The setting of the WUPENn register always has higher priority than the setting of the SNZREQCR1 register. For details, see [section 10.8. Snooze Mode](#) and [section 13, Interrupt Controller Unit \(ICU\)](#).

## 10.2.16 DPSBYCR : Deep Standby Control Register

Base address: SYSC = 0x4001\_E000

Offset address: 0x400

|                    |       |        |   |   |   |   |   |              |
|--------------------|-------|--------|---|---|---|---|---|--------------|
| Bit position:      | 7     | 6      | 5 | 4 | 3 | 2 | 1 | 0            |
| Bit field:         | DPSBY | IOKEEP | — | — | — | — | — | DEEPCUT[1:0] |
| Value after reset: | 0     | 0      | 0 | 0 | 0 | 0 | 0 | 1            |

## 10.2.15 SNZREQCR1: 贪睡请求控制寄存器1

Base address: SYSC = 0x4001\_E000

Offset address: 0x088

|               |    |    |    |    |    |    |    |    |    |    |    |    |    |    |           |           |           |
|---------------|----|----|----|----|----|----|----|----|----|----|----|----|----|----|-----------|-----------|-----------|
| Bit position: | 31 | 30 | 29 | 28 | 27 | 26 | 25 | 24 | 23 | 22 | 21 | 20 | 19 | 18 | 17        | 16        |           |
| Bit field:    | —  | —  | —  | —  | —  | —  | —  | —  | —  | —  | —  | —  | —  | —  | —         | —         |           |
| 重置后的值:        | 0  | 0  | 0  | 0  | 0  | 0  | 0  | 0  | 0  | 0  | 0  | 0  | 0  | 0  | 0         | 0         |           |
| Bit position: | 15 | 14 | 13 | 12 | 11 | 10 | 9  | 8  | 7  | 6  | 5  | 4  | 3  | 2  | 1         | 0         |           |
| Bit field:    | —  | —  | —  | —  | —  | —  | —  | —  | —  | —  | —  | —  | —  | —  | SNZREQEN2 | SNZREQEN1 | SNZREQEN0 |
| 重置后的值:        | 0  | 0  | 0  | 0  | 0  | 0  | 0  | 0  | 0  | 0  | 0  | 0  | 0  | 0  | 0         | 0         | 0         |

| Bit  | Symbol    | Function                              | R/W |
|------|-----------|---------------------------------------|-----|
| 0    | SNZREQEN0 | 启用AGT3下溢暂停请求<br>0: 禁用贪睡请求1: 启用贪睡请求    | R/W |
| 1    | SNZREQEN1 | 启用AGT3比较匹配A贪睡请求<br>0: 禁用贪睡请求1: 启用贪睡请求 | R/W |
| 2    | SNZREQEN2 | 启用AGT3比较匹配B贪睡请求<br>0: 禁用贪睡请求1: 启用贪睡请求 | R/W |
| 31:3 | —         | 这些位被读取为0。写入值应为0。                      | R/W |

Note: 如果安全属性配置为安全: ●

- 允许安全访问和非安全读取访问
- 忽略非安全写入访问, 不会生成TrustZone访问错误。

如果安全属性配置为非安全: ●

- 允许安全和非安全访问。

Note: 在重写该寄存器之前将PRCR.PRC1位设置为1 (允许写入)。

SNZREQCR1寄存器控制哪个触发器导致MCU从软件待机模式切换到贪睡模式。如果通过设置WUPENn寄存器选择触发作为取消软件待机模式的请求, 请参见第13节, 中断控制器单元 (ICU), 当触发产生时MCU进入正常模式, 而相关位SNZREQCR1为1。WUPENn寄存器的设置总是比SNZREQCR1寄存器的设置具有更高的优先级。有关详细信息, 请参阅第10.8节。贪睡模式和第13节, 中断控制器单元(ICU)。

## 10.2.16 DPSBYCR: 深度待机控制寄存器

Base address: SYSC = 0x4001\_E000

Offset address: 0x400

|               |       |        |   |   |   |   |   |              |
|---------------|-------|--------|---|---|---|---|---|--------------|
| Bit position: | 7     | 6      | 5 | 4 | 3 | 2 | 1 | 0            |
| Bit field:    | DPSBY | IOKEEP | — | — | — | — | — | DEEPCUT[1:0] |
| 重置后的值:        | 0     | 0      | 0 | 0 | 0 | 0 | 0 | 1            |



| Bit | Symbol       | Function  | R/W |
|-----|--------------|---|-----|
| 1:0 | DEEPCUT[1:0] | Power-Supply Control<br>0 0: Power to the standby RAM, Low-speed on-chip oscillator, AGTn (n = 0 to 3), and USBFS resume detecting unit is supplied in Deep Software Standby mode.<br>0 1: Power to the standby RAM, Low-speed on-chip oscillator, AGT, and USBFS resume detecting unit is not supplied in Deep Software Standby mode.<br>1 0: Setting prohibited<br>1 1: Power to the standby RAM, Low-speed on-chip oscillator, AGT, and USBFS resume detecting unit is not supplied in Deep Software Standby mode. In addition, LVD is disabled and the low power function in a power-on reset circuit is enabled. | R/W |
| 5:2 | —            | These bits are read as 0. The write value should be 0.  | R/W |
| 6   | IOKEEP       | I/O Port Rentention<br>0: When the Deep Software Standby mode is canceled, the I/O ports are in the reset state.<br>1: When the Deep Software Standby mode is canceled, the I/O ports are in the same state as in the Deep Software Standby mode.   | R/W |
| 7   | DPSBY        | Deep Software Standby<br>0: Sleep mode (SBYCR.SSBY=0)<br>/ Software Standby mode (SBYCR.SSBY=1)<br>1: Sleep mode (SBYCR.SSBY=0)<br>/ Deep Software Standby mode (SBYCR.SSBY=1)  | R/W |

Note: If the security attribution is configured as secure:

- Secure access and Non-secure read access are allowed
- Non-secure write access is ignored, and TrustZone access error is not generated.

If the security attribution is configured as Non-secure:

- Secure and Non-secure access are allowed.

Note: Set the PRCR.PRC1 bit to 1 (write enabled) before rewriting this register.

The DPSBYCR register controls the Deep Software Standby mode.

DPSBYCR is not initialized by the internal reset signal that is the source to cancel the Deep Software Standby mode. For details, see [section 5, Resets](#).

#### DEEPCUT[1:0] bit (Power-Supply Control)

The DEEPCUT[1:0] bits control the internal power supply to the standby RAM, Low-speed on-chip oscillator, AGT, and USBFS resume detecting unit in Deep Software Standby mode. In addition, these bits control the state of LVD and power-on reset circuit in Deep Software Standby mode.

When a USBFS suspend/resume interrupt is used as a Deep Software Standby mode Cancelling source, the DEEPCUT[1:0] bits must be set to 00b.

When an LVD interrupt is used in Deep Software Standby mode, the DEEPCUT[1:0] bits must be set to 00b or 01b.

For lower power consumption, set the DEEPCUT[1:0] bits to 11b so that the LVD is stopped and the low power consumption function of the power-on reset circuit is enabled.

Regardless of the DEEPCUT [1: 0] bit setting, during deep software standby mode, internal power supply to SRAM other than standby SRAM is stopped.

When a deep standby mode is used, set DPSWCR.WTSTS bits depending on the value of DEEPCUT[1] before entering Deep Software Standby mode.

#### IOKEEP bit (I/O Port Rentention)

In Deep Software Standby mode, I/O ports keep the same states as in the Software Standby mode. The IOKEEP bit specifies whether to reset the state of the I/O ports or not when the Deep Software Standby mode is canceled.

#### DPSBY bit (Deep Software Standby)

The DPSBY bit controls transitions to Deep Software Standby mode.

When the WFI instruction is executed while SBYCR.SSBY bit and DPSBYCR.DPSBY bit are both 1, the MCU enters Deep Software Standby mode through Software Standby mode.

The DPSBY bit remains 1 when Deep Software Standby mode is canceled by certain pins which are sources of external pin interrupts (NMI, IRQ0-DS to IRQ15-DS) or a peripheral interrupt (RTC alarm, RTC interval, USB suspend/resume, voltage monitor 1, or voltage monitor 2). Write 0 to this bit to clear it.

| Bit | Symbol       | Function  | R/W |
|-----|--------------|---|-----|
| 1:0 | DEEPCUT[1:0] | Power-Supply Control<br>00: 在深度软件待机模式下, 为待机RAM、低速片上振荡器、AGTn (n=0至3) 和USB FS恢复检测单元供电。<br>01: 在深度软件待机模式下, 不为待机RAM、低速片上振荡器、AGT和USBFS恢复检测单元供电。<br>10: 禁止设置11: 给待机RAM、低速内部振荡器、AGT和USBFS供电<br><br>在深度软件待机模式下不提供恢复检测单元。此外, LVD被禁用, 上电复位电路中的低功耗功能被启用。 | R/W |
| 5:2 | —            | 这些位被读取为0。写入值应为0。  | R/W |
| 6   | IOKEEP       | I/O Port Rentention<br>0: 取消深度软件待机模式时, IO口处于复位状态。<br>1: 当深度软件待机模式取消时, IO端口处于与深度软件待机模式相同的状态。   | R/W |
| 7   | DPSBY        | 深度软件待机<br>0: 休眠模式 (SBYCR.SSBY=0)<br>软件待机模式(SBYCR.SSBY=1)<br>1: 休眠模式 (SBYCR.SSBY=0)<br>深度软件待机模式(SBYCR.SSBY=1)  | R/W |

Note: 如果安全属性配置为安全: ●  
允许安全访问和非安全读取访问  
● 忽略非安全写入访问, 不会生成TrustZone访问错误。  
如果安全属性配置为非安全: ●  
允许安全和非安全访问。

Note: 在重写该寄存器之前将PRCR.PRC1位设置为1 (允许写入)。

DPSBYCR寄存器控制深度软件待机模式。

DPSBYCR不会由作为取消深度软件待机模式的源的内部复位信号初始化。有关详细信息, 请参阅第5节, 重置。

#### DEEPCUT[1:0] bit (Power-Supply Control)

DEEPCUT[1:0]位控制待机RAM、低速片上振荡器、AGT和USBFS在深度软件待机模式下恢复检测单元。此外, 这些位控制LVD的状态和深度软件待机模式下的上电复位电路。

当USBFS挂起恢复中断用作深度软件待机模式取消源时, DEEPCUT[1:0]位必须设置为00b。

在深度软件待机模式下使用LVD中断时, DEEPCUT[1:0]位必须设置为00b或01b。

为降低功耗, 将DEEPCUT[1:0]位设置为11b, 使LVD停止并启用上电复位电路的低功耗功能。

无论DEEPCUT[1:0]位设置如何, 在深度软件待机模式下, 除待机SRAM之外的SRAM内部电源都会停止。

当使用深度待机模式时, 在进入之前根据DEEPCUT[1]的值设置DPSWCR.WTSTS位深度软件待机模式。

#### IOKEEP位 (IO端口保留)

在深度软件待机模式下, IO端口保持与软件待机模式相同的状态。IOKEEP位指定当深度软件待机模式被取消时是否复位IO端口的状态。

#### DPSBY位 (深度软件待机)

DPSBY位控制向深度软件待机模式的转换。

当SBYCR.SSBY位和DPSBYCR.DPSBY位均为1时执行WFI指令, MCU进入深度软件待机模式到软件待机模式。

当某些引脚取消深度软件待机模式时, DPSBY位保持为1, 这些引脚是外部引脚中断 (NMI、IRQ0-DS至IRQ15-D S) 或外设中断 (RTC警报、RTC间隔、USB暂停恢复、电压监控器) 的来源1, 或电压监视器2)。向该位写入0以清除它。



The DPSBY bit setting is invalid when OFS0.IWDTSTPCTL bit is 0 (counting continues) regardless of the setting in OFS0.IWDTSTRT bit. In that case, even when SBYCR.SSBY bit is 1 and the DPSBY bit is 1, the transition after the execution of a WFI instruction is to Software Standby mode.

The setting of the DPSBY bit is invalid when voltage monitor 1 reset is enabled (LVD1CR0.RI = 1) or when a voltage monitor 2 reset is enabled (LVD2CR0.RI = 1). In this case, even when the SBYCR.SSBY bit is 1 and the DPSBY bit is 1, the transition after the execution of a WFI instruction is to Software Standby mode.

### 10.2.17 DPSWCR : Deep Standby Wait Control Register

Base address: SYSC = 0x4001\_E000

Offset address: 0x401

|                    |   |   |            |   |   |   |   |   |
|--------------------|---|---|------------|---|---|---|---|---|
| Bit position:      | 7 | 6 | 5          | 4 | 3 | 2 | 1 | 0 |
| Bit field:         | — | — | WTSTS[5:0] |   |   |   |   |   |
| Value after reset: | 0 | 0 | 0          | 1 | 1 | 0 | 0 | 1 |

| Bit | Symbol     | Function  | R/W |
|-----|------------|---|-----|
| 5:0 | WTSTS[5:0] | Deep Software Wait Standby Time Setting Bit<br>0x0E: Wait cycle for fast recovery<br>0x19: Wait cycle for slow recovery<br>Others: Setting prohibited | R/W |
| 7:6 | —          | These bits are read as 0. The write value should be 0.  | R/W |

Note: If the security attribution is configured as secure:

- Secure access and Non-secure read access are allowed
- Non-secure write access is ignored, and TrustZone access error is not generated.

If the security attribution is configured as Non-secure:

- Secure and Non-secure access are allowed.

Note: Set the PRCR.PRC1 bit to 1 (write enabled) before rewriting this register.

The DPSWCR register sets the wait stabilization time when a Deep Software Standby mode is canceled by certain pins that are the sources of external pin interrupts or a peripheral interrupt such as RTC alarm, RTC interval, and USB suspend/resume.

During a wait stabilization period set in this register, a Deep Software Standby reset occurs, and the MCU is initialized.

The DPSWCR register is not initialized with the internal reset signal by the cancellation of the Deep Software Standby mode. For details, see [section 5, Resets](#).

When a deep standby mode is used, set DPSWCR.WTSTS bits according to the value of DPSBYCR.DEEPCUT[1] before entering Deep Software Standby mode.

When DPSBYCR.DEEPCUT[1]=0, you can set DPSWCR.WTSTS to the wait cycle for fast recovery.

When DPSBYCR.DEEPCUT[1]=1, you must set DPSWCR.WTSTS to the wait cycle for slow recovery.

### 10.2.18 DPSIER0 : Deep Standby Interrupt Enable Register 0

Base address: SYSC = 0x4001\_E000

Offset address: 0x402

|                    |            |            |            |            |            |            |            |            |
|--------------------|------------|------------|------------|------------|------------|------------|------------|------------|
| Bit position:      | 7          | 6          | 5          | 4          | 3          | 2          | 1          | 0          |
| Bit field:         | DIRQ7<br>E | DIRQ6<br>E | DIRQ5<br>E | DIRQ4<br>E | DIRQ3<br>E | DIRQ2<br>E | DIRQ1<br>E | DIRQ0<br>E |
| Value after reset: | 0          | 0          | 0          | 0          | 0          | 0          | 0          | 0          |

| Bit | Symbol | Function  | R/W |
|-----|--------|---|-----|
| 0   | DIRQ0E | IRQ0-DS Pin Enable<br>0: Cancelling Deep Software Standby mode is disabled<br>1: Cancelling Deep Software Standby mode is enabled | R/W |

无论OFS0.IWDTSTRT位的设置如何，当OFS0.IWDTSTPCL位为0（继续计数）时，DPSBY位设置无效。在这种情况下，即使SBYCR.SSBY位为1且DPSBY位为1，在执行WFI指令后转换为软件待机模式。

当使能电压监视器1复位(LVD1CR0.RI=1)或使能电压监视器2复位(LVD2CR0.RI=1)时，DPSBY位的设置无效。在这种情况下，即使SBYCR.SSBY位为1且DPSBY位为1，在执行WFI指令后转换为软件待机模式。

### 10.2.17 DPSWCR：深度待机等待控制寄存器

Base address: SYSC = 0x4001\_E000

Offset address: 0x401

|               |   |   |            |   |   |   |   |   |
|---------------|---|---|------------|---|---|---|---|---|
| Bit position: | 7 | 6 | 5          | 4 | 3 | 2 | 1 | 0 |
| Bit field:    | — | — | WTSTS[5:0] |   |   |   |   |   |
| 重置后的值:        | 0 | 0 | 0          | 1 | 1 | 0 | 0 | 1 |

| Bit | Symbol     | Function   | R/W |
|-----|------------|--|-----|
| 5:0 | WTSTS[5:0] | 深度软件等待待机时间设置位<br>0x0E: 快速恢复的等待周期0x19:<br>慢速恢复的等待周期<br>其他: 禁止设置 | R/W |
| 7:6 | —          | 这些位被读取为0。写入值应为0。   | R/W |

Note: 如果安全属性配置为安全：●

- 允许安全访问和非安全读取访问
- 忽略非安全写入访问，不会生成TrustZone访问错误。

如果安全属性配置为非安全：●

- 允许安全和非安全访问。

Note: 在重写该寄存器之前将PRCR.PRC1位设置为1（允许写入）。

DPSWCR寄存器设置当某个引脚取消深度软件待机模式时的等待稳定时间，这些引脚是外部引脚中断或外设中断（如RTC警报、RTC间隔和USB挂起恢复）的源。

在此寄存器中设置的等待稳定期间，会发生深度软件待机复位，并且初始化MCU。

通过取消深度软件待机模式，DPSWCR寄存器不会使用内部复位信号进行初始化。有关详细信息，请参阅第5节，重置。

当使用深度待机模式时，在进入深度软件待机模式之前，根据DPSBYCR.DEEPCUT[1]的值设置DPSWCR.WTSTS位。

当DPSBYCR.DEEPCUT[1]=0时，可以设置DPSWCR.WTSTS为等待周期，以便快速恢复。

当DPSBYCR.DEEPCUT[1]=1时，必须将DPSWCR.WTSTS设置为等待周期，以便缓慢恢复。

### 10.2.18 DPSIER0：深度待机中断使能寄存器0

Base address: SYSC = 0x4001\_E000

Offset address: 0x402

|               |            |            |            |            |            |            |            |            |
|---------------|------------|------------|------------|------------|------------|------------|------------|------------|
| Bit position: | 7          | 6          | 5          | 4          | 3          | 2          | 1          | 0          |
| Bit field:    | DIRQ7<br>E | DIRQ6<br>E | DIRQ5<br>E | DIRQ4<br>E | DIRQ3<br>E | DIRQ2<br>E | DIRQ1<br>E | DIRQ0<br>E |
| 重置后的值:        | 0          | 0          | 0          | 0          | 0          | 0          | 0          | 0          |

| Bit | Symbol | Function  | R/W |
|-----|--------|---|-----|
| 0   | DIRQ0E | IRQ0-DS引脚使能<br>0: 禁用取消深度软件待机模式1: 启用取消深度软件待<br>机模式 | R/W |

| Bit | Symbol | Function  | R/W |
|-----|--------|---|-----|
| 1   | DIRQ1E | IRQ1-DS Pin Enable<br>0: Cancelling Deep Software Standby mode is disabled<br>1: Cancelling Deep Software Standby mode is enabled | R/W |
| 2   | DIRQ2E | IRQ2-DS Pin Enable<br>0: Cancelling Deep Software Standby mode is disabled<br>1: Cancelling Deep Software Standby mode is enabled | R/W |
| 3   | DIRQ3E | IRQ3-DS Pin Enable<br>0: Cancelling Deep Software Standby mode is disabled<br>1: Cancelling Deep Software Standby mode is enabled | R/W |
| 4   | DIRQ4E | IRQ4-DS Pin Enable<br>0: Cancelling Deep Software Standby mode is disabled<br>1: Cancelling Deep Software Standby mode is enabled | R/W |
| 5   | DIRQ5E | IRQ5-DS Pin Enable<br>0: Cancelling Deep Software Standby mode is disabled<br>1: Cancelling Deep Software Standby mode is enabled | R/W |
| 6   | DIRQ6E | IRQ6-DS Pin Enable<br>0: Cancelling Deep Software Standby mode is disabled<br>1: Cancelling Deep Software Standby mode is enabled | R/W |
| 7   | DIRQ7E | IRQ7-DS Pin Enable<br>0: Cancelling Deep Software Standby mode is disabled<br>1: Cancelling Deep Software Standby mode is enabled | R/W |

Note: If the security attribution is configured as secure:

- Secure access and Non-secure read access are allowed.
- Non-secure write access is ignored, and TrustZone access error is not generated.

If the security attribution is configured as Non-secure:

- Secure and Non-secure access are allowed.

Note: Set the PRCR.PRC1 bit to 1 (write enabled) before rewriting this register.

DPSIER0 is not initialized by the internal reset signal used as Deep Software Standby mode Cancelling source. For details, see [section 5, Resets](#).

After the setting of DPSIER0 is modified, an edge may be internally generated depending on the state of the pin, resulting in DPSIFR0 being set to 1. Therefore, DPSIFR0 should be cleared to 0 before entering Deep Software Standby mode.

### 10.2.19 DPSIER1 : Deep Standby Interrupt Enable Register 1

Base address: SYSC = 0x4001\_E000

Offset address: 0x403

Bit position: 7 6 5 4 3 2 1 0

| Bit field:         | DIRQ1<br>5E | DIRQ1<br>4E | DIRQ1<br>3E | DIRQ1<br>2E | DIRQ1<br>1E | DIRQ0<br>0E | DIRQ9<br>E | DIRQ8<br>E |
|--------------------|-------------|-------------|-------------|-------------|-------------|-------------|------------|------------|
| Value after reset: | 0           | 0           | 0           | 0           | 0           | 0           | 0          | 0          |

| Bit | Symbol  | Function   | R/W |
|-----|---------|--|-----|
| 0   | DIRQ8E  | IRQ8-DS Pin Enable<br>0: Cancelling Deep Software Standby mode is disabled<br>1: Cancelling Deep Software Standby mode is enabled  | R/W |
| 1   | DIRQ9E  | IRQ9-DS Pin Enable<br>0: Cancelling Deep Software Standby mode is disabled<br>1: Cancelling Deep Software Standby mode is enabled  | R/W |
| 2   | DIRQ10E | IRQ10-DS Pin Enable<br>0: Cancelling Deep Software Standby mode is disabled<br>1: Cancelling Deep Software Standby mode is enabled | R/W |
| 3   | DIRQ11E | IRQ11-DS Pin Enable<br>0: Cancelling Deep Software Standby mode is disabled<br>1: Cancelling Deep Software Standby mode is enabled | R/W |

| Bit | Symbol | Function                                      | R/W |
|-----|--------|---|-----|
| 1   | DIRQ1E | IRQ1-DS引脚使能<br>0: 禁用取消深度软件待机模式1: 启用取消深度软件待机模式 | R/W |
| 2   | DIRQ2E | IRQ2-DS引脚使能<br>0: 禁用取消深度软件待机模式1: 启用取消深度软件待机模式 | R/W |
| 3   | DIRQ3E | IRQ3-DS引脚使能<br>0: 禁用取消深度软件待机模式1: 启用取消深度软件待机模式 | R/W |
| 4   | DIRQ4E | IRQ4-DS引脚使能<br>0: 禁用取消深度软件待机模式1: 启用取消深度软件待机模式 | R/W |
| 5   | DIRQ5E | IRQ5-DS引脚使能<br>0: 禁用取消深度软件待机模式1: 启用取消深度软件待机模式 | R/W |
| 6   | DIRQ6E | IRQ6-DS引脚使能<br>0: 禁用取消深度软件待机模式1: 启用取消深度软件待机模式 | R/W |
| 7   | DIRQ7E | IRQ7-DS引脚使能<br>0: 禁用取消深度软件待机模式1: 启用取消深度软件待机模式 | R/W |

Note: 如果安全属性配置为安全: ●

- 允许安全访问和非安全读取访问。
- 忽略非安全写入访问, 不会生成TrustZone访问错误。

如果安全属性配置为非安全: ●

- 允许安全和非安全访问。

Note: 在重写该寄存器之前将PRCR.PRC1位设置为1 (允许写入)。

DPSIER0未被用作深度软件待机模式取消源的内部复位信号初始化。有关详细信息, 请参阅第5节, 重置。

修改DPSIER0的设置后, 可能会在内部产生一个边沿, 具体取决于引脚的状态, 导致DPSIFR0被设置为1。因此, 在进入深度软件待机模式之前, 应将DPSIFR0清零。

### 10.2.19 DPSIER1: 深度待机中断使能寄存器1

Base address: SYSC = 0x4001\_E000

Offset address: 0x403

Bit position: 7 6 5 4 3 2 1 0

| Bit field: | DIRQ1<br>5E | DIRQ1<br>4E | DIRQ1<br>3E | DIRQ1<br>2E | DIRQ1<br>1E | DIRQ0<br>0E | DIRQ9<br>E | DIRQ8<br>E |
|------------|-------------|-------------|-------------|-------------|-------------|-------------|------------|------------|
| 重置后的值:     | 0           | 0           | 0           | 0           | 0           | 0           | 0          | 0          |

| Bit | Symbol  | Function                                       | R/W |
|-----|---------|--|-----|
| 0   | DIRQ8E  | IRQ8-DS引脚使能<br>0: 禁用取消深度软件待机模式1: 启用取消深度软件待机模式  | R/W |
| 1   | DIRQ9E  | IRQ9-DS引脚使能<br>0: 禁用取消深度软件待机模式1: 启用取消深度软件待机模式  | R/W |
| 2   | DIRQ10E | IRQ10-DS引脚使能<br>0: 禁用取消深度软件待机模式1: 启用取消深度软件待机模式 | R/W |
| 3   | DIRQ11E | IRQ11-DS引脚使能<br>0: 禁用取消深度软件待机模式1: 启用取消深度软件待机模式 | R/W |

| Bit | Symbol  | Function   | R/W |
|-----|---------|--|-----|
| 4   | DIRQ12E | IRQ12-DS Pin Enable<br>0: Cancelling Deep Software Standby mode is disabled<br>1: Cancelling Deep Software Standby mode is enabled | R/W |
| 5   | DIRQ13E | IRQ13-DS Pin Enable<br>0: Cancelling Deep Software Standby mode is disabled<br>1: Cancelling Deep Software Standby mode is enabled | R/W |
| 6   | DIRQ14E | IRQ14-DS Pin Enable<br>0: Cancelling Deep Software Standby mode is disabled<br>1: Cancelling Deep Software Standby mode is enabled | R/W |
| 7   | DIRQ15E | IRQ15-DS Pin Enable<br>0: Cancelling Deep Software Standby mode is disabled<br>1: Cancelling Deep Software Standby mode is enabled | R/W |

Note: If the security attribution is configured as secure:

- Secure access and Non-secure read access are allowed
- Non-secure write access is ignored, and TrustZone access error is not generated.

If the security attribution is configured as Non-secure:

- Secure and Non-secure access are allowed.

Note: Set the PRCR.PRC1 bit to 1 (write enabled) before rewriting this register.

DPSIER1 is not initialized by the internal reset signal used as Deep Software Standby mode Cancelling source. For details, see [section 5, Resets](#).

After the setting of DPSIER1 is modified, an edge may be internally generated depending on the state of the pin, resulting in DPSIFR1 being set to 1. Therefore, DPSIFR1 should be cleared to 0 before entering Deep Software Standby mode.

### 10.2.20 DPSIER2 : Deep Standby Interrupt Enable Register 2

Base address: SYSC = 0x4001\_E000

Offset address: 0x404

| Bit position:      | 7 | 6 | 5 | 4         | 3           | 2          | 1           | 0           |
|--------------------|---|---|---|-----------|-------------|------------|-------------|-------------|
| Bit field:         | — | — | — | DNMI<br>E | DRTC<br>AIE | DRTC<br>IE | DLVD2<br>IE | DLVD1<br>IE |
| Value after reset: | 0 | 0 | 0 | 0         | 0           | 0          | 0           | 0           |

| Bit | Symbol  | Function  | R/W              |
|-----|---------|---|------------------|
| 0   | DLVD1IE | LVD1 Deep Standby Cancel Signal Enable<br>0: Cancelling Deep Software Standby mode is disabled<br>1: Cancelling Deep Software Standby mode is enabled                   | R/W              |
| 1   | DLVD2IE | LVD2 Deep Standby Cancel Signal Enable<br>0: Cancelling Deep Software Standby mode is disabled<br>1: Cancelling Deep Software Standby mode is enabled                   | R/W              |
| 2   | DRTCIE  | RTC Interval interrupt Deep Standby Cancel Signal Enable<br>0: Cancelling Deep Software Standby mode is disabled<br>1: Cancelling Deep Software Standby mode is enabled | R/W              |
| 3   | DRTCAIE | RTC Alarm interrupt Deep Standby Cancel Signal Enable<br>0: Cancelling Deep Software Standby mode is disabled<br>1: Cancelling Deep Software Standby mode is enabled    | R/W              |
| 4   | DNMIE   | NMI Pin Enable<br>0: Cancelling Deep Software Standby mode is disabled<br>1: Cancelling Deep Software Standby mode is enabled   | R/W <sup>1</sup> |
| 7:5 | —       | These bits are read as 0. The write value should be 0.  | R/W              |

Note: If the security attribution is configured as secure:

- Secure access and Non-secure read access are allowed
- Non-secure write access is ignored, and TrustZone access error is not generated.

If the security attribution is configured as Non-secure:

- Secure and Non-secure access are allowed.

Note: Set the PRCR.PRC1 bit to 1 (write enabled) before rewriting this register.

| Bit | Symbol  | Function                                       | R/W |
|-----|---------|--|-----|
| 4   | DIRQ12E | IRQ12-DS引脚使能<br>0: 禁用取消深度软件待机模式1: 启用取消深度软件待机模式 | R/W |
| 5   | DIRQ13E | IRQ13-DS引脚使能<br>0: 禁用取消深度软件待机模式1: 启用取消深度软件待机模式 | R/W |
| 6   | DIRQ14E | IRQ14-DS引脚使能<br>0: 禁用取消深度软件待机模式1: 启用取消深度软件待机模式 | R/W |
| 7   | DIRQ15E | IRQ15-DS引脚使能<br>0: 禁用取消深度软件待机模式1: 启用取消深度软件待机模式 | R/W |

Note: 如果安全属性配置为安全: ●

允许安全访问和非安全读取访问

- 忽略非安全写入访问, 不会生成TrustZone访问错误。

如果安全属性配置为非安全: ●

允许安全和非安全访问。

Note: 在重写该寄存器之前将PRCR.PRC1位设置为1 (允许写入)。

DPSIER1未被用作深度软件待机模式取消源的内部复位信号初始化。有关详细信息, 请参阅第5节, 重置。

修改DPSIER1的设置后, 可能会在内部产生一个边沿, 具体取决于引脚的状态, 导致DPSIFR1被设置为1。因此, 在进入深度软件待机模式之前, 应将DPSIFR1清零。

### 10.2.20 DPSIER2: 深度待机中断使能寄存器2

Base address: SYSC = 0x4001\_E000

Offset address: 0x404

| Bit position: | 7 | 6 | 5 | 4         | 3           | 2          | 1           | 0           |
|---------------|---|---|---|-----------|-------------|------------|-------------|-------------|
| Bit field:    | — | — | — | DNMI<br>E | DRTC<br>AIE | DRTC<br>IE | DLVD2<br>IE | DLVD1<br>IE |
| 重置后的值:        | 0 | 0 | 0 | 0         | 0           | 0          | 0           | 0           |

| Bit | Symbol  | Function  | R/W              |
|-----|---------|---|------------------|
| 0   | DLVD1IE | LVD1深度待机取消信号使能<br>0: 禁用取消深度软件待机模式1: 启用取消深度软件待机模式    | R/W              |
| 1   | DLVD2IE | LVD2深度待机取消信号使能<br>0: 禁用取消深度软件待机模式1: 启用取消深度软件待机模式    | R/W              |
| 2   | DRTCIE  | RTC间隔中断深度待机取消信号使能<br>0: 禁用取消深度软件待机模式1: 启用取消深度软件待机模式 | R/W              |
| 3   | DRTCAIE | RTC闹钟中断深度待机取消信号使能<br>0: 禁用取消深度软件待机模式1: 启用取消深度软件待机模式 | R/W              |
| 4   | DNMIE   | NMI引脚使能<br>0: 禁用取消深度软件待机模式1: 启用取消深度软件待机模式           | R/W <sup>1</sup> |
| 7:5 | —       | 这些位被读取为0。写入值应为0。                                    | R/W              |

Note: 如果安全属性配置为安全: ●

允许安全访问和非安全读取访问

- 忽略非安全写入访问, 不会生成TrustZone访问错误。

如果安全属性配置为非安全: ●

允许安全和非安全访问。

Note: 在重写该寄存器之前将PRCR.PRC1位设置为1 (允许写入)。



Note 1. 1 can be written only once. Once 1 is written to this bit, subsequent write accesses are disabled.

DPSIER2 is not initialized by the internal reset signal used as Deep Software Standby mode Cancelling source. For details, see [section 5, Resets](#).

After the setting of DPSIER2 is modified, an edge may be internally generated depending on the state of the pin, resulting in DPSIFR2 being set to 1. Therefore, DPSIFR2 should be cleared to 0 before entering Deep Software Standby mode.

### 10.2.21 DPSIER3 : Deep Standby Interrupt Enable Register 3

Base address: SYSC = 0x4001\_E000

Offset address: 0x405

|                    |   |   |   |   |             |             |   |               |
|--------------------|---|---|---|---|-------------|-------------|---|---------------|
| Bit position:      | 7 | 6 | 5 | 4 | 3           | 2           | 1 | 0             |
| Bit field:         | — | — | — | — | DAGT<br>3IE | DAGT<br>1IE | — | DUSB<br>FS0IE |
| Value after reset: | 0 | 0 | 0 | 0 | 0           | 0           | 0 | 0             |

| Bit | Symbol    | Function   | R/W |
|-----|-----------|--|-----|
| 0   | DUSBFS0IE | USBFS0 Suspend/Resume Deep Standby Cancel Signal Enable<br>0: Cancelling deep standby mode is disabled<br>1: Cancelling deep standby mode is enabled | R/W |
| 1   | —         | This bit is read as 0. The write value should be 0.  | R/W |
| 2   | DAGT1IE   | AGT1 Underflow Deep Standby Cancel Signal Enable<br>0: Cancelling deep standby mode is disabled<br>1: Cancelling deep standby mode is enabled        | R/W |
| 3   | DAGT3IE   | AGT3 Underflow Deep Standby Cancel Signal Enable<br>0: Cancelling deep standby mode is disabled<br>1: Cancelling deep standby mode is enabled        | R/W |
| 7:4 | —         | These bits are read as 0. The write value should be 0.   | R/W |

Note: If the security attribution is configured as secure:

- Secure access and Non-secure read access are allowed
  - Non-secure write access is ignored, and TrustZone access error is not generated.
- If the security attribution is configured as Non-secure:
- Secure and Non-secure access are allowed.

Note: Set the PRCR.PRC1 bit to 1 (write enabled) before rewriting this register.

DPSIER3 is not initialized by the internal reset signal used as Deep Software Standby mode Cancelling source. For details, see [section 5, Resets](#).

After the setting of DPSIER3 is modified, an edge may be internally generated depending on the state of the pin, resulting in DPSIFR3 being set to 1. Therefore, DPSIFR3 should be cleared to 0 before entering Deep Software Standby mode.

### 10.2.22 DPSIFR0 : Deep Standby Interrupt Flag Register 0

Base address: SYSC = 0x4001\_E000

Offset address: 0x406

|                    |            |            |            |            |            |            |            |            |
|--------------------|------------|------------|------------|------------|------------|------------|------------|------------|
| Bit position:      | 7          | 6          | 5          | 4          | 3          | 2          | 1          | 0          |
| Bit field:         | DIRQ7<br>F | DIRQ6<br>F | DIRQ5<br>F | DIRQ4<br>F | DIRQ3<br>F | DIRQ2<br>F | DIRQ1<br>F | DIRQ0<br>F |
| Value after reset: | 0          | 0          | 0          | 0          | 0          | 0          | 0          | 0          |

| Bit | Symbol | Function   | R/W |
|-----|--------|--|-----|
| 0   | DIRQ0F | IRQ0-DS Pin Deep Standby Cancel Flag<br>0: The cancel request is not generated<br>1: The cancel request is generated | R/W |

注1.1只能写一次。一旦向该位写入1，随后的写访问将被禁用。

DPSIER2未被用作深度软件待机模式取消源的内部复位信号初始化。有关详细信息，请参阅第5节，重置。

修改DPSIER2的设置后，可能会根据引脚的状态在内部产生一个边沿，从而导致DPSIFR2被设置为1。因此，在进入深度软件待机模式之前，应将DPSIFR2清除为0。

### 10.2.21 DPSIER3：深度待机中断使能寄存器3

Base address: SYSC = 0x4001\_E000

Offset address: 0x405

|               |   |   |   |   |             |             |   |               |
|---------------|---|---|---|---|-------------|-------------|---|---------------|
| Bit position: | 7 | 6 | 5 | 4 | 3           | 2           | 1 | 0             |
| Bit field:    | — | — | — | — | DAGT<br>3IE | DAGT<br>1IE | — | DUSB<br>FS0IE |
| 重置后的值:        | 0 | 0 | 0 | 0 | 0           | 0           | 0 | 0             |

| Bit | Symbol    | Function   | R/W |
|-----|-----------|--|-----|
| 0   | DUSBFS0IE | USBFS0暂停恢复深度待机取消信号使能<br>0: 禁用取消深度待机模式1: 启用取消深度待机模式 | R/W |
| 1   | —         | 该位读取为0。写入值应为0。                                     | R/W |
| 2   | DAGT1IE   | AGT1下溢深度待机取消信号使能<br>0: 禁用取消深度待机模式1: 启用取消深度待机模式     | R/W |
| 3   | DAGT3IE   | AGT3下溢深度待机取消信号使能<br>0: 禁用取消深度待机模式1: 启用取消深度待机模式     | R/W |
| 7:4 | —         | 这些位被读取为0。写入值应为0。                                   | R/W |

Note: 如果安全属性配置为安全: ●

- 允许安全访问和非安全读取访问
  - 忽略非安全写入访问，不会生成TrustZone访问错误。
- 如果安全属性配置为非安全: ●
- 允许安全和非安全访问。

Note: 在重写该寄存器之前将PRCR.PRC1位设置为1（允许写入）。

DPSIER3未被用作深度软件待机模式取消源的内部复位信号初始化。有关详细信息，请参阅第5节，重置。

修改DPSIER3的设置后，根据引脚的状态，可能会在内部产生一个边沿，导致DPSIFR3被设置为1。因此，在进入深度软件待机模式之前，应将DPSIFR3清零。

### 10.2.22 DPSIFR0：深度待机中断标志寄存器0

Base address: SYSC = 0x4001\_E000

Offset address: 0x406

|               |            |            |            |            |            |            |            |            |
|---------------|------------|------------|------------|------------|------------|------------|------------|------------|
| Bit position: | 7          | 6          | 5          | 4          | 3          | 2          | 1          | 0          |
| Bit field:    | DIRQ7<br>F | DIRQ6<br>F | DIRQ5<br>F | DIRQ4<br>F | DIRQ3<br>F | DIRQ2<br>F | DIRQ1<br>F | DIRQ0<br>F |
| 重置后的值:        | 0          | 0          | 0          | 0          | 0          | 0          | 0          | 0          |

| Bit | Symbol | Function                                 | R/W |
|-----|--------|--|-----|
| 0   | DIRQ0F | IRQ0-DS引脚深度待机取消标志<br>0: 不产生取消请求1: 产生取消请求 | R/W |

| Bit | Symbol | Function   | R/W |
|-----|--------|--|-----|
| 1   | DIRQ1F | IRQ1-DS Pin Deep Standby Cancel Flag<br>0: The cancel request is not generated<br>1: The cancel request is generated | R/W |
| 2   | DIRQ2F | IRQ2-DS Pin Deep Standby Cancel Flag<br>0: The cancel request is not generated<br>1: The cancel request is generated | R/W |
| 3   | DIRQ3F | IRQ3-DS Pin Deep Standby Cancel Flag<br>0: The cancel request is not generated<br>1: The cancel request is generated | R/W |
| 4   | DIRQ4F | IRQ4-DS Pin Deep Standby Cancel Flag<br>0: The cancel request is not generated<br>1: The cancel request is generated | R/W |
| 5   | DIRQ5F | IRQ5-DS Pin Deep Standby Cancel Flag<br>0: The cancel request is not generated<br>1: The cancel request is generated | R/W |
| 6   | DIRQ6F | IRQ6-DS Pin Deep Standby Cancel Flag<br>0: The cancel request is not generated<br>1: The cancel request is generated | R/W |
| 7   | DIRQ7F | IRQ7-DS Pin Deep Standby Cancel Flag<br>0: The cancel request is not generated<br>1: The cancel request is generated | R/W |

Note: If the security attribution is configured as secure:

- Secure access and Non-secure read access are allowed
- Non-secure write access is ignored, and TrustZone access error is not generated.

If the security attribution is configured as Non-secure:

- Secure and Non-secure access are allowed.

Note: Writing 0 clears the flag. Writing 1 is ignored.

Note: Set the PRCR.PRC1 bit to 1 (write enabled) before rewriting this register.

Each flag is set to 1 when a cancel request specified by DPSIEGR0 is generated.

Each flag may be set to 1 when a cancel request is generated in any mode (not only in Deep Software Standby mode) or when the setting of DPSIER0 is modified. Therefore, a transition to Deep Software Standby mode should be made after DPSIFR0 is cleared to 0x00.

To clear DPSIFR0 to 0x00 after modifying DPSIER0, wait for at least 6 PCLKB cycles, read DPSIFR0, and then write 0 to DPSIFR0. Six or more PCLKB cycles can be secured, for example, by reading DPSIER0.

DPSIFR0 is not initialized by the internal reset signal used as Deep Software Standby mode Cancelling source. To clear DPSIFR0 to 0x00 after modifying DPSIER0, wait for at least 6 PCLKB cycles, read DPSIFR0, and then write 0 to DPSIFR0. Six or more PCLKB cycles can be secured, for example, by reading DPSIER0. For details, see [section 5, Resets](#).

#### DIRQnF flag (IRQn-DS Pin Deep Standby Cancel Flag) (n = 0 to 7)

The DIRQnF flag indicates that a cancel request by the IRQn-DS pin has been generated.

[Setting condition]

A cancel request by the IRQn-DS pin specified by DPSIEGR0 is generated.

[Clearing condition]

Writing 0 to each flag after 1 is read.

| Bit | Symbol | Function                                     | R/W |
|-----|--------|--|-----|
| 1   | DIRQ1F | IRQ1-DS引脚深度待机取消标志<br>0: 不产生取消请求1: 产生取消请求     | R/W |
| 2   | DIRQ2F | IRQ2-DS引脚深度待机取消标志<br>0: 不产生取消请求1: 产生取消请求     | R/W |
| 3   | DIRQ3F | IRQ3-DS引脚深度待机取消标志<br>0: 不产生取消请求1: 产生取消请求     | R/W |
| 4   | DIRQ4F | IRQ4-DS引脚深度待机取消标志<br>0: 不产生取消请求<br>1: 生成取消请求 | R/W |
| 5   | DIRQ5F | IRQ5-DS引脚深度待机取消标志<br>0: 不产生取消请求1: 产生取消请求     | R/W |
| 6   | DIRQ6F | IRQ6-DS引脚深度待机取消标志<br>0: 不产生取消请求1: 产生取消请求     | R/W |
| 7   | DIRQ7F | IRQ7-DS引脚深度待机取消标志<br>0: 不产生取消请求1: 产生取消请求     | R/W |

Note: 如果安全属性配置为安全: ●

- 允许安全访问和非安全读取访问
- 忽略非安全写入访问, 不会生成TrustZone访问错误。

如果安全属性配置为非安全: ●

- 允许安全和非安全访问。

Note: 写入0清除标志。写入1被忽略。

Note: 在重写该寄存器之前将PRCR.PRC1位设置为1 (允许写入)。

当生成由DPSIEGR0指定的取消请求时, 每个标志都设置为1。

当在任何模式下 (不仅在深度软件待机模式下) 生成取消请求或修改DPSIER0的设置时, 每个标志都可以设置为1。因此, 应在DPSIFR0清零后转换到深度软件待机模式。

要在修改DPSIER0后将DPSIFR0清为0x00, 请等待至少6个PCLKB周期, 读取DPSIFR0, 然后将0写入DPSIFR0。例如, 可以通过读取DPSIER0来确保六个或更多PCLKB周期。

DPSIFR0不被用作深度软件待机模式取消源的内部复位信号初始化。清除修改DPSIER0后DPSIFR0到0x00, 等待至少6个PCLKB周期, 读取DPSIFR0, 然后写入0到DPSIFR0。例如, 可以通过读取DPSIER0来确保六个或更多PCLKB周期。有关详细信息, 请参阅第5节, 重置。

#### DIRQnF标志 (IRQn-DS引脚深度待机取消标志) (n=0至7)

DIRQnF标志表示已生成IRQn-DS引脚的取消请求。

[Setting condition]

由DPSIEGR0指定的IRQn-DS引脚产生一个取消请求。

[Clearing condition]

读取1后将0写入每个标志。



## 10.2.23 DPSIFR1 : Deep Standby Interrupt Flag Register 1

Base address: SYSC = 0x4001\_E000

Offset address: 0x407

|                    |             |             |             |             |             |             |            |            |
|--------------------|-------------|-------------|-------------|-------------|-------------|-------------|------------|------------|
| Bit position:      | 7           | 6           | 5           | 4           | 3           | 2           | 1          | 0          |
| Bit field:         | DIRQ1<br>5F | DIRQ1<br>4F | DIRQ1<br>3F | DIRQ1<br>2F | DIRQ1<br>1F | DIRQ1<br>0F | DIRQ9<br>F | DIRQ8<br>F |
| Value after reset: | 0           | 0           | 0           | 0           | 0           | 0           | 0          | 0          |

| Bit | Symbol  | Function  | R/W |
|-----|---------|---|-----|
| 0   | DIRQ8F  | IRQ8-DS Pin Deep Standby Cancel Flag<br>0: The cancel request is not generated<br>1: The cancel request is generated  | R/W |
| 1   | DIRQ9F  | IRQ9-DS Pin Deep Standby Cancel Flag<br>0: The cancel request is not generated<br>1: The cancel request is generated  | R/W |
| 2   | DIRQ10F | IRQ10-DS Pin Deep Standby Cancel Flag<br>0: The cancel request is not generated<br>1: The cancel request is generated | R/W |
| 3   | DIRQ11F | IRQ11-DS Pin Deep Standby Cancel Flag<br>0: The cancel request is not generated<br>1: The cancel request is generated | R/W |
| 4   | DIRQ12F | IRQ12-DS Pin Deep Standby Cancel Flag<br>0: The cancel request is not generated<br>1: The cancel request is generated | R/W |
| 5   | DIRQ13F | IRQ13-DS Pin Deep Standby Cancel Flag<br>0: The cancel request is not generated<br>1: The cancel request is generated | R/W |
| 6   | DIRQ14F | IRQ14-DS Pin Deep Standby Cancel Flag<br>0: The cancel request is not generated<br>1: The cancel request is generated | R/W |
| 7   | DIRQ15F | IRQ15-DS Pin Deep Standby Cancel Flag<br>0: The cancel request is not generated<br>1: The cancel request is generated | R/W |

Note: If the security attribution is configured as secure:

- Secure access and Non-secure read access are allowed
- Non-secure write access is ignored, and TrustZone access error is not generated.

If the security attribution is configured as Non-secure:

- Secure and Non-secure access are allowed.

Note: Writing 0 clears the flag. Writing 1 is ignored.

Note: Set the PRCR.PRC1 bit to 1 (write enabled) before rewriting this register.

Each flag is set to 1 when a cancel request specified by DPSIEGR1 is generated.

Each flag may be set to 1 when a cancel request is generated in any mode (not only in Deep Software Standby mode) or when the setting of DPSIER1 is modified. Therefore, a transition to Deep Software Standby mode should be made after DPSIFR1 is cleared to 0x00.

To clear DPSIFR1 to 0x00 after modifying DPSIER1, wait for at least 6 PCLKB cycles, read DPSIFR1, and then write 0 to DPSIFR1. Six or more PCLKB cycles can be secured, for example, by reading DPSIER1.

DPSIFR1 is not initialized by the internal reset signal used as Deep Software Standby mode Cancelling source. For details, see [section 5, Resets](#).

**DIRQnF flag (IRQn-DS Pin Deep Standby Cancel Flag) (n = 8 to 15)**

The DIRQnF flag indicates that a cancel request by the IRQn-DS pin has been generated.

[Setting condition]

A cancel request by the IRQn-DS pin specified by DPSIEGR1 is generated.

## 10.2.23 DPSIFR1：深度待机中断标志寄存器1

Base address: SYSC = 0x4001\_E000

Offset address: 0x407

|               |             |             |             |             |             |             |            |            |
|---------------|-------------|-------------|-------------|-------------|-------------|-------------|------------|------------|
| Bit position: | 7           | 6           | 5           | 4           | 3           | 2           | 1          | 0          |
| Bit field:    | DIRQ1<br>5F | DIRQ1<br>4F | DIRQ1<br>3F | DIRQ1<br>2F | DIRQ1<br>1F | DIRQ1<br>0F | DIRQ9<br>F | DIRQ8<br>F |
| 重置后的值:        | 0           | 0           | 0           | 0           | 0           | 0           | 0          | 0          |

| Bit | Symbol  | Function                                  | R/W |
|-----|---------|---|-----|
| 0   | DIRQ8F  | IRQ8-DS引脚深度待机取消标志<br>0: 不产生取消请求1: 产生取消请求  | R/W |
| 1   | DIRQ9F  | IRQ9-DS引脚深度待机取消标志<br>0: 不产生取消请求1: 产生取消请求  | R/W |
| 2   | DIRQ10F | IRQ10-DS引脚深度待机取消标志<br>0: 不产生取消请求1: 产生取消请求 | R/W |
| 3   | DIRQ11F | IRQ11-DS引脚深度待机取消标志<br>0: 不产生取消请求1: 产生取消请求 | R/W |
| 4   | DIRQ12F | IRQ12-DS引脚深度待机取消标志<br>0: 不产生取消请求1: 产生取消请求 | R/W |
| 5   | DIRQ13F | IRQ13-DS引脚深度待机取消标志<br>0: 不产生取消请求1: 产生取消请求 | R/W |
| 6   | DIRQ14F | IRQ14-DS引脚深度待机取消标志<br>0: 不产生取消请求1: 产生取消请求 | R/W |
| 7   | DIRQ15F | IRQ15-DS引脚深度待机取消标志<br>0: 不产生取消请求1: 产生取消请求 | R/W |

Note: 如果安全属性配置为安全: ●

- 允许安全访问和非安全读取访问
- 忽略非安全写入访问, 不会生成TrustZone访问错误。

如果安全属性配置为非安全: ●

- 允许安全和非安全访问。

Note: 写入0清除标志。写入1被忽略。

Note: 在重写该寄存器之前将PRCR.PRC1位设置为1 (允许写入)。

当生成由DPSIEGR1指定的取消请求时, 每个标志都设置为1。

当在任何模式下 (不仅在深度软件待机模式下) 生成取消请求或修改DPSIER1的设置时, 每个标志都可以设置为1。因此, 应在DPSIFR1被清除为0x00后转换到深度软件待机模式。

修改DPSIER1后要清除DPSIFR1为0x00, 至少等待6个PCLKB周期, 读取DPSIFR1, 然后将0写入DPSIFR1。例如, 可以通过读取DPSIER1来确保六个或更多PCLKB周期。

DPSIFR1未被用作深度软件待机模式取消源的内部复位信号初始化。有关详细信息, 请参阅第5节, 重置。

**DIRQnF标志 (IRQn-DS引脚深度待机取消标志) (n=8到15)**

DIRQnF标志表示已生成IRQn-DS引脚的取消请求。

[Setting condition]

由DPSIEGR1指定的IRQn-DS引脚产生取消请求。

[Clearing condition]

Writing 0 to each flag after 1 is read.

## 10.2.24 DPSIFR2 : Deep Standby Interrupt Flag Register 2

Base address: SYSC = 0x4001\_E000

Offset address: 0x408

|                    |   |   |   |       |          |          |          |          |
|--------------------|---|---|---|-------|----------|----------|----------|----------|
| Bit position:      | 7 | 6 | 5 | 4     | 3        | 2        | 1        | 0        |
| Bit field:         | — | — | — | DNMIF | DRTC AIF | DRTC IIF | DLVD2 IF | DLVD1 IF |
| Value after reset: | 0 | 0 | 0 | 0     | 0        | 0        | 0        | 0        |

| Bit | Symbol   | Function  | R/W |
|-----|----------|---|-----|
| 0   | DLVD1IF  | LVD1 Deep Standby Cancel Flag<br>0: The cancel request is not generated<br>1: The cancel request is generated                   | R/W |
| 1   | DLVD2IF  | LVD2 Deep Standby Cancel Flag<br>0: The cancel request is not generated<br>1: The cancel request is generated                   | R/W |
| 2   | DRTC IIF | RTC Interval Interrupt Deep Standby Cancel Flag<br>0: The cancel request is not generated<br>1: The cancel request is generated | R/W |
| 3   | DRTCAIF  | RTC Alarm Interrupt Deep Standby Cancel Flag<br>0: The cancel request is not generated<br>1: The cancel request is generated    | R/W |
| 4   | DNMIF    | NMI Pin Deep Standby Cancel Flag<br>0: The cancel request is not generated<br>1: The cancel request is generated                | R/W |
| 7:5 | —        | These bits are read as 0. The write value should be 0.  | R/W |

Note: If the security attribution is configured as secure:

- Secure access and Non-secure read access are allowed
- Non-secure write access is ignored, and TrustZone access error is not generated.

If the security attribution is configured as Non-secure:

- Secure and Non-secure access are allowed.

Note: Writing 0 clears the flag. Writing 1 is ignored.

Note: Set the PRCR.PRC1 bit to 1 (write enabled) before rewriting this register.

Each flag is set to 1 when a cancel request specified by DPSIEGR2 is generated.

Each flag may be set to 1 when a cancel request is generated in any mode (not only in Deep Software Standby mode) or when the setting of DPSIER2 is modified. Therefore, a transition to Deep Software Standby mode should be made after DPSIFR2 is cleared to 0x00.

To clear DPSIFR2 to 0x00 after modifying DPSIER2, wait for at least 6 PCLKB cycles, read DPSIFR2, and then write 0 to DPSIFR2. Six or more PCLKB cycles can be secured, for example, by reading DPSIER2.

DPSIFR2 is not initialized by the internal reset signal used as Deep Software Standby mode Cancelling source. For details, see [section 5, Resets](#).

**DLVDmIF flag (LVDm Deep Standby Cancel Flag) (m = 1 to 2)**

The DLVDmIF flag indicates that a cancel request by the voltage monitor m signal has been generated.

[Setting condition]

A cancel request is generated by the voltage monitor m signal that is selected in DPSIEGR2.

[Clearing condition]

Writing 0 to each flag after 1 is read.

[Clearing condition]

读取1后将0写入每个标志。

## 10.2.24 DPSIFR2: 深度待机中断标志寄存器2

Base address: SYSC = 0x4001\_E000

Offset address: 0x408

|               |   |   |   |       |          |          |          |          |
|---------------|---|---|---|-------|----------|----------|----------|----------|
| Bit position: | 7 | 6 | 5 | 4     | 3        | 2        | 1        | 0        |
| Bit field:    | — | — | — | DNMIF | DRTC AIF | DRTC IIF | DLVD2 IF | DLVD1 IF |
| 重置后的值:        | 0 | 0 | 0 | 0     | 0        | 0        | 0        | 0        |

| Bit | Symbol   | Function                               | R/W |
|-----|----------|--|-----|
| 0   | DLVD1IF  | LVD1深度待机取消标志<br>0: 不产生取消请求1: 产生取消请求    | R/W |
| 1   | DLVD2IF  | LVD2深度待机取消标志<br>0: 不产生取消请求1: 产生取消请求    | R/W |
| 2   | DRTC IIF | RTC间隔中断深度待机取消标志<br>0: 不产生取消请求1: 产生取消请求 | R/W |
| 3   | DRTCAIF  | RTC警报中断深度待机取消标志<br>0: 不产生取消请求1: 产生取消请求 | R/W |
| 4   | DNMIF    | NMI引脚深度待机取消标志<br>0: 不产生取消请求1: 产生取消请求   | R/W |
| 7:5 | —        | 这些位被读取为0。写入值应为0。                       | R/W |

Note: 如果安全属性配置为安全: ●

- 允许安全访问和非安全读取访问
- 忽略非安全写入访问, 不会生成TrustZone访问错误。

如果安全属性配置为非安全: ●

- 允许安全和非安全访问。

Note: 写入0清除标志。写入1被忽略。

Note: 在重写该寄存器之前将PRCR.PRC1位设置为1 (允许写入)。

当生成由DPSIEGR2指定的取消请求时, 每个标志都设置为1。

当在任何模式下 (不仅在深度软件待机模式下) 生成取消请求或修改DPSIER2的设置时, 每个标志都可以设置为1。因此, 应在DPSIFR2清零为0x00后转换到深度软件待机模式。

要在修改DPSIER2后将DPSIFR2清为0x00, 请等待至少6个PCLKB周期, 读取DPSIFR2, 然后将0写入DPSIFR2。例如, 可以通过读取DPSIER2来确保六个或更多PCLKB周期。

DPSIFR2未被用作深度软件待机模式取消源的内部复位信号初始化。有关详细信息, 请参阅第5节, 重置。

**DLVDmIF标志 (LVDm深度待机取消标志) (m=1到2)**

DLVDmIF标志表示电压监视器m信号的取消请求已经产生。

[Setting condition]

取消请求由DPSIEGR2中选择的电压监视器m信号生成。

[Clearing condition]

读取1后将0写入每个标志。

**DRTCIF flag (RTC Interval Interrupt Deep Standby Cancel Flag)**

This flag indicates that a cancel request by the RTC interval interrupt signal has been generated.

[Setting condition]

A cancel request by the RTC interval interrupt signal is generated

[Clearing condition]

Writing 0 to each flag after 1 is read.

**DRTCAIF flag (RTC Alarm Interrupt Deep Standby Cancel Flag)**

This flag indicates that a cancel request by the RTC alarm interrupt signal has been generated.

[Setting condition]

A cancel request by the RTC alarm interrupt signal is generated

[Clearing condition]

Writing 0 to each flag after 1 is read.

**DNMIF flag (NMI Pin Deep Standby Cancel Flag)**

This flag indicates that a cancel request by the NMI pin has been generated.

[Setting condition]

A cancel request by the NMI pin specified by DPSIEGR2 is generated

[Clearing condition]

Writing 0 to each flag after 1 is read.

**10.2.25 DPSIFR3 : Deep Standby Interrupt Flag Register 3**

Base address: SYSC = 0x4001\_E000

Offset address: 0x409

|                    |   |   |   |   |             |             |   |               |
|--------------------|---|---|---|---|-------------|-------------|---|---------------|
| Bit position:      | 7 | 6 | 5 | 4 | 3           | 2           | 1 | 0             |
| Bit field:         | — | — | — | — | DAGT<br>3IF | DAGT<br>1IF | — | DUSB<br>FS0IF |
| Value after reset: | 0 | 0 | 0 | 0 | 0           | 0           | 0 | 0             |

| Bit | Symbol    | Function   | R/W |
|-----|-----------|--|-----|
| 0   | DUSBFS0IF | USBFS0 Suspend/Resume Deep Standby Cancel Flag<br>0: The cancel request is not generated.<br>1: The cancel request is generated. | R/W |
| 1   | —         | These bits are read as 0. The write value should be 0.   | R/W |
| 2   | DAGT1IF   | AGT1 Underflow Deep Standby Cancel Flag<br>0: The cancel request is not generated.<br>1: The cancel request is generated.        | R/W |
| 3   | DAGT3IF   | AGT3 Underflow Deep Standby Cancel Flag<br>0: The cancel request is not generated.<br>1: The cancel request is generated.        | R/W |
| 7:4 | —         | These bits are read as 0. The write value should be 0.   | R/W |

Note: If the security attribution is configured as secure:

- Secure access and Non-secure read access are allowed
- Non-secure write access is ignored, and TrustZone access error is not generated.

If the security attribution is configured as Non-secure:

- Secure and Non-secure access are allowed.

Note: Writing 0 clears the flag. Writing 1 is ignored.

Note: Set the PRCR.PRC1 bit to 1 (write enabled) before rewriting this register.

Each flag is set to 1 when the corresponding cancel request is generated.

**DRTCIF标志 (RTC间隔中断深度待机取消标志)**

该标志表示已经产生了RTC间隔中断信号的取消请求。

[Setting condition]

由RTC间隔中断信号产生一个取消请求

[Clearing condition]

读取1后将0写入每个标志。

**DRTCAIF标志 (RTC警报中断深度待机取消标志)**

该标志表示已经产生了RTC警报中断信号的取消请求。

[Setting condition]

由RTC报警中断信号产生一个取消请求

[Clearing condition]

读取1后将0写入每个标志。

**DNMIF标志 (NMI引脚深度待机取消标志)**

该标志表示已生成NMI引脚的取消请求。

[Setting condition]

由DPSIEGR2指定的NMI引脚生成取消请求

[Clearing condition]

读取1后将0写入每个标志。

**10.2.25 DPSIFR3：深度待机中断标志寄存器3**

Base address: SYSC = 0x4001\_E000

Offset address: 0x409

|               |   |   |   |   |             |             |   |               |
|---------------|---|---|---|---|-------------|-------------|---|---------------|
| Bit position: | 7 | 6 | 5 | 4 | 3           | 2           | 1 | 0             |
| Bit field:    | — | — | — | — | DAGT<br>3IF | DAGT<br>1IF | — | DUSB<br>FS0IF |
| 重置后的值:        | 0 | 0 | 0 | 0 | 0           | 0           | 0 | 0             |

| Bit | Symbol    | Function                                    | R/W |
|-----|-----------|---|-----|
| 0   | DUSBFS0IF | USBFS0暂停恢复深度待机取消标志<br>0: 不产生取消请求。1: 产生取消请求。 | R/W |
| 1   | —         | 这些位被读取为0。写入值应为0。                            | R/W |
| 2   | DAGT1IF   | AGT1下溢深度待机取消标志<br>0: 不产生取消请求。1: 产生取消请求。     | R/W |
| 3   | DAGT3IF   | AGT3下溢深度待机取消标志<br>0: 不产生取消请求。1: 产生取消请求。     | R/W |
| 7:4 | —         | 这些位被读取为0。写入值应为0。                            | R/W |

Note: 如果安全属性配置为安全: ●

- 允许安全访问和非安全读取访问
- 忽略非安全写入访问, 不会生成TrustZone访问错误。

如果安全属性配置为非安全: ●

- 允许安全和非安全访问。

Note: 写入0清除标志。写入1被忽略。

Note: 在重写该寄存器之前将PRCR.PRC1位设置为1 (允许写入)。

当生成相应的取消请求时, 每个标志都设置为1。

Each flag may be set to 1 when a cancel request is generated in any mode (not only in Deep Software Standby mode) or when the setting of DPSIER3 is modified. Therefore, a transition to Deep Software Standby mode should be made after DPSIFR3 is cleared to 0x00.

To clear DPSIFR3 to 0x00 after modifying DPSIER3, wait for at least 6 PCLKB cycles, read DPSIFR3, and then write 0 to DPSIFR3. Six or more PCLKB cycles can be secured, for example, by reading DPSIER3.

DPSIFR3 is not initialized by the internal reset signal used as Deep Software Standby mode Cancelling source. For details, see [section 5, Resets](#).

#### DUSBFS0IF flag (USBFS0 Suspend/Resume Deep Standby Cancel Flag)

The DUSBFS0IF flag is the flag for USBFS0 that indicates that a cancel request by the USBFS0 suspend/resume has been generated.

[Setting condition]

A cancel request by the USBFS0 suspend/resume is generated

[Clearing condition]

Writing 0 to each flag after 1 is read.

#### DAGT1IF flag (AGT1 Underflow Deep Standby Cancel Flag)

This flag indicates that a cancel request by the AGT1 underflow has been generated.

[Setting condition]

A cancel request by the AGT1 underflow is generated

[Clearing condition]

Writing 0 to each flag after 1 is read.

#### DAGT3IF flag (AGT3 Underflow Deep Standby Cancel Flag)

This flag indicates that a cancel request by the AGT3 underflow has been generated.

[Setting condition]

A cancel request by the AGT3 underflow is generated

[Clearing condition]

Writing 0 to each flag after 1 is read.

### 10.2.26 DPSIEGR0 : Deep Standby Interrupt Edge Register 0

Base address: SYSC = 0x4001\_E000

Offset address: 0x40A

|                    |             |             |             |             |             |             |             |             |
|--------------------|-------------|-------------|-------------|-------------|-------------|-------------|-------------|-------------|
| Bit position:      | 7           | 6           | 5           | 4           | 3           | 2           | 1           | 0           |
| Bit field:         | DIRQ7<br>EG | DIRQ6<br>EG | DIRQ5<br>EG | DIRQ4<br>EG | DIRQ3<br>EG | DIRQ2<br>EG | DIRQ1<br>EG | DIRQ0<br>EG |
| Value after reset: | 0           | 0           | 0           | 0           | 0           | 0           | 0           | 0           |

| Bit | Symbol  | Function   | R/W |
|-----|---------|--|-----|
| 0   | DIRQ0EG | IRQ0-DS Pin Edge Select<br>0: A cancel request is generated at a falling edge<br>1: A cancel request is generated at a rising edge | R/W |
| 1   | DIRQ1EG | IRQ1-DS Pin Edge Select<br>0: A cancel request is generated at a falling edge<br>1: A cancel request is generated at a rising edge | R/W |
| 2   | DIRQ2EG | IRQ2-DS Pin Edge Select<br>0: A cancel request is generated at a falling edge<br>1: A cancel request is generated at a rising edge | R/W |

当在任何模式下（不仅在深度软件待机模式下）生成取消请求或修改DPSIER3的设置时，每个标志都可以设置为1。因此，应在DPSIFR3被清除为0x00后转换到深度软件待机模式。

修改DPSIER3后要清除DPSIFR3为0x00，等待至少6个PCLKB周期，读取DPSIFR3，然后将0写入DPSIFR3。例如，可以通过读取DPSIER3来确保六个或更多PCLKB周期。

DPSIFR3未被用作深度软件待机模式取消源的内部复位信号初始化。有关详细信息，请参阅第5节，重置。

#### DUSBFS0IF标志 (USBFS0暂停恢复深度待机取消标志)

DUSBFS0IF标志是USBFS0的标志，指示USBFS0暂停恢复的取消请求已生成。

[Setting condition]

USBFS0暂停恢复的取消请求产生

[Clearing condition]

读取1后将0写入每个标志。

#### DAGT1IF标志 (AGT1下溢深度待机取消标志)

该标志表示已经产生了AGT1下溢的取消请求。

[Setting condition]

产生AGT1下溢的取消请求

[Clearing condition]

读取1后将0写入每个标志。

#### DAGT3IF标志 (AGT3下溢深度待机取消标志)

该标志表示已经产生了AGT3下溢的取消请求。

[Setting condition]

生成AGT3下溢的取消请求

[Clearing condition]

读取1后将0写入每个标志。

### 10.2.26 DPSIEGR0: 深度待机中断边沿寄存器0

Base address: SYSC = 0x4001\_E000

Offset address: 0x40A

|               |             |             |             |             |             |             |             |             |
|---------------|-------------|-------------|-------------|-------------|-------------|-------------|-------------|-------------|
| Bit position: | 7           | 6           | 5           | 4           | 3           | 2           | 1           | 0           |
| Bit field:    | DIRQ7<br>EG | DIRQ6<br>EG | DIRQ5<br>EG | DIRQ4<br>EG | DIRQ3<br>EG | DIRQ2<br>EG | DIRQ1<br>EG | DIRQ0<br>EG |
| 重置后的值:        | 0           | 0           | 0           | 0           | 0           | 0           | 0           | 0           |

| Bit | Symbol  | Function                                  | R/W |
|-----|---------|---|-----|
| 0   | DIRQ0EG | IRQ0-DS引脚边沿选择<br>0: 下降沿产生取消请求1: 上升沿产生取消请求 | R/W |
| 1   | DIRQ1EG | IRQ1-DS引脚边沿选择<br>0: 下降沿产生取消请求1: 上升沿产生取消请求 | R/W |
| 2   | DIRQ2EG | IRQ2-DS引脚边沿选择<br>0: 下降沿产生取消请求1: 上升沿产生取消请求 | R/W |



| Bit | Symbol  | Function   | R/W |
|-----|---------|--|-----|
| 3   | DIRQ3EG | IRQ3-DS Pin Edge Select<br>0: A cancel request is generated at a falling edge<br>1: A cancel request is generated at a rising edge | R/W |
| 4   | DIRQ4EG | IRQ4-DS Pin Edge Select<br>0: A cancel request is generated at a falling edge<br>1: A cancel request is generated at a rising edge | R/W |
| 5   | DIRQ5EG | IRQ5-DS Pin Edge Select<br>0: A cancel request is generated at a falling edge<br>1: A cancel request is generated at a rising edge | R/W |
| 6   | DIRQ6EG | IRQ6-DS Pin Edge Select<br>0: A cancel request is generated at a falling edge<br>1: A cancel request is generated at a rising edge | R/W |
| 7   | DIRQ7EG | IRQ7-DS Pin Edge Select<br>0: A cancel request is generated at a falling edge<br>1: A cancel request is generated at a rising edge | R/W |

Note: If the security attribution is configured as secure:

- Secure access and Non-secure read access are allowed
- Non-secure write access is ignored, and TrustZone access error is not generated.

If the security attribution is configured as Non-secure:

- Secure and Non-secure access are allowed.

Note: Set the PRCR.PRC1 bit to 1 (write enabled) before rewriting this register.

DPSIEGR0 is not initialized by the internal reset signal that is the source to cancel the Deep Software Standby mode. For details, see [section 5, Resets](#).

### 10.2.27 DPSIEGR1 : Deep Standby Interrupt Edge Register 1

Base address: SYSC = 0x4001\_E000

Offset address: 0x40B

| Bit position:      | 7            | 6            | 5            | 4            | 3            | 2            | 1           | 0           |
|--------------------|--------------|--------------|--------------|--------------|--------------|--------------|-------------|-------------|
| Bit field:         | DIRQ1<br>5EG | DIRQ1<br>4EG | DIRQ1<br>3EG | DIRQ1<br>2EG | DIRQ1<br>1EG | DIRQ1<br>0EG | DIRQ9<br>EG | DIRQ8<br>EG |
| Value after reset: | 0            | 0            | 0            | 0            | 0            | 0            | 0           | 0           |

| Bit | Symbol   | Function  | R/W |
|-----|----------|---|-----|
| 0   | DIRQ8EG  | IRQ8-DS Pin Edge Select<br>0: A cancel request is generated at a falling edge.<br>1: A cancel request is generated at a rising edge.  | R/W |
| 1   | DIRQ9EG  | IRQ9-DS Pin Edge Select<br>0: A cancel request is generated at a falling edge.<br>1: A cancel request is generated at a rising edge.  | R/W |
| 2   | DIRQ10EG | IRQ10-DS Pin Edge Select<br>0: A cancel request is generated at a falling edge.<br>1: A cancel request is generated at a rising edge  | R/W |
| 3   | DIRQ11EG | IRQ11-DS Pin Edge Select<br>0: A cancel request is generated at a falling edge.<br>1: A cancel request is generated at a rising edge. | R/W |
| 4   | DIRQ12EG | IRQ12-DS Pin Edge Select<br>0: A cancel request is generated at a falling edge.<br>1: A cancel request is generated at a rising edge. | R/W |
| 5   | DIRQ13EG | IRQ13-DS Pin Edge Select<br>0: A cancel request is generated at a falling edge.<br>1: A cancel request is generated at a rising edge. | R/W |

| Bit | Symbol  | Function                                  | R/W |
|-----|---------|---|-----|
| 3   | DIRQ3EG | IRQ3-DS引脚边沿选择<br>0: 下降沿产生取消请求1: 上升沿产生取消请求 | R/W |
| 4   | DIRQ4EG | IRQ4-DS引脚边沿选择<br>0: 下降沿产生取消请求1: 上升沿产生取消请求 | R/W |
| 5   | DIRQ5EG | IRQ5-DS引脚边沿选择<br>0: 下降沿产生取消请求1: 上升沿产生取消请求 | R/W |
| 6   | DIRQ6EG | IRQ6-DS引脚边沿选择<br>0: 下降沿产生取消请求1: 上升沿产生取消请求 | R/W |
| 7   | DIRQ7EG | IRQ7-DS引脚边沿选择<br>0: 下降沿产生取消请求1: 上升沿产生取消请求 | R/W |

Note: 如果安全属性配置为安全: ●

- 允许安全访问和非安全读取访问
- 忽略非安全写入访问, 不会生成TrustZone访问错误。

如果安全属性配置为非安全: ●

- 允许安全和非安全访问。

Note: 在重写该寄存器之前将PRCR.PRC1位设置为1 (允许写入)。

DPSIEGR0不会被作为取消深度软件待机模式的源的内部复位信号初始化。有关详细信息, 请参阅第5节, 重置。

### 10.2.27 DPSIEGR1: 深度待机中断边沿寄存器1

Base address: SYSC = 0x4001\_E000

Offset address: 0x40B

| Bit position: | 7            | 6            | 5            | 4            | 3            | 2            | 1           | 0           |
|---------------|--------------|--------------|--------------|--------------|--------------|--------------|-------------|-------------|
| Bit field:    | DIRQ1<br>5EG | DIRQ1<br>4EG | DIRQ1<br>3EG | DIRQ1<br>2EG | DIRQ1<br>1EG | DIRQ1<br>0EG | DIRQ9<br>EG | DIRQ8<br>EG |
| 重置后的值:        | 0            | 0            | 0            | 0            | 0            | 0            | 0           | 0           |

| Bit | Symbol   | Function                                       | R/W |
|-----|----------|--|-----|
| 0   | DIRQ8EG  | IRQ8-DS引脚边沿选择<br>0: 在下降沿产生取消请求。1: 在上升沿产生取消请求。  | R/W |
| 1   | DIRQ9EG  | IRQ9-DS引脚边沿选择<br>0: 在下降沿产生取消请求。1: 在上升沿产生取消请求。  | R/W |
| 2   | DIRQ10EG | IRQ10-DS引脚边沿选择<br>0: 在下降沿产生取消请求。1: 在上升沿产生取消请求。 | R/W |
| 3   | DIRQ11EG | IRQ11-DS引脚边沿选择<br>0: 在下降沿产生取消请求。1: 在上升沿产生取消请求。 | R/W |
| 4   | DIRQ12EG | IRQ12-DS引脚边沿选择<br>0: 在下降沿产生取消请求。1: 在上升沿产生取消请求。 | R/W |
| 5   | DIRQ13EG | IRQ13-DS引脚边沿选择<br>0: 在下降沿产生取消请求。1: 在上升沿产生取消请求。 | R/W |



| Bit | Symbol   | Function  | R/W |
|-----|----------|---|-----|
| 6   | DIRQ14EG | IRQ14-DS Pin Edge Select<br>0: A cancel request is generated at a falling edge.<br>1: A cancel request is generated at a rising edge. | R/W |
| 7   | DIRQ15EG | IRQ15-DS Pin Edge Select<br>0: A cancel request is generated at a falling edge.<br>1: A cancel request is generated at a rising edge. | R/W |

Note: If the security attribution is configured as secure:

- Secure access and Non-secure read access are allowed
- Non-secure write access is ignored, and TrustZone access error is not generated.

If the security attribution is configured as Non-secure:

- Secure and Non-secure access are allowed.

Note: Set the PRCR.PRC1 bit to 1 (write enabled) before rewriting this register.

DPSIEGR1 is not initialized by the internal reset signal that is the source to cancel the Deep Software Standby mode. For details, see [section 5, Resets](#).

### 10.2.28 DPSIEGR2 : Deep Standby Interrupt Edge Register 2

Base address: SYSC = 0x4001\_E000

Offset address: 0x40C

| Bit position:      | 7 | 6 | 5 | 4          | 3 | 2 | 1           | 0           |
|--------------------|---|---|---|------------|---|---|-------------|-------------|
| Bit field:         | — | — | — | DNMI<br>EG | — | — | DLVD2<br>EG | DLVD1<br>EG |
| Value after reset: | 0 | 0 | 0 | 0          | 0 | 0 | 0           | 0           |

| Bit | Symbol  | Function  | R/W |
|-----|---------|---|-----|
| 0   | DLVD1EG | LVD1 Edge Select<br>0: A cancel request is generated when $VCC < V_{det1}$ (fall) is detected<br>1: A cancel request is generated when $VCC \geq V_{det1}$ (rise) is detected | R/W |
| 1   | DLVD2EG | LVD2 Edge Select<br>0: A cancel request is generated when $VCC < V_{det2}$ (fall) is detected<br>1: A cancel request is generated when $VCC \geq V_{det2}$ (rise) is detected | R/W |
| 3:2 | —       | These bits are read as 0. The write value should be 0.  | R/W |
| 4   | DNMIEG  | NMI Pin Edge Select<br>0: A cancel request is generated at a falling edge<br>1: A cancel request is generated at a rising edge  | R/W |
| 7:5 | —       | These bits are read as 0. The write value should be 0.  | R/W |

Note: If the security attribution is configured as secure:

- Secure access and Non-secure read access are allowed
- Non-secure write access is ignored, and TrustZone access error is not generated.

If the security attribution is configured as Non-secure:

- Secure and Non-secure access are allowed.

Note: Set the PRCR.PRC1 bit to 1 (write enabled) before rewriting this register.

DPSIEGR2 is not initialized by the internal reset signal that is the source to cancel the Deep Software Standby mode. For details, see [section 5, Resets](#).

| Bit | Symbol   | Function                                       | R/W |
|-----|----------|--|-----|
| 6   | DIRQ14EG | IRQ14-DS引脚边沿选择<br>0: 在下降沿产生取消请求。1: 在上升沿产生取消请求。 | R/W |
| 7   | DIRQ15EG | IRQ15-DS引脚边沿选择<br>0: 在下降沿产生取消请求。1: 在上升沿产生取消请求。 | R/W |

Note: 如果安全属性配置为安全: ●

- 允许安全访问和非安全读取访问
- 忽略非安全写入访问, 不会生成TrustZone访问错误。

如果安全属性配置为非安全: ●

- 允许安全和非安全访问。

Note: 在重写该寄存器之前将PRCR.PRC1位设置为1 (允许写入)。

DPSIEGR1不会被作为取消深度软件待机模式的源的内部复位信号初始化。有关详细信息, 请参阅第5节, 重置。

### 10.2.28 DPSIEGR2: 深度待机中断边沿寄存器2

Base address: SYSC = 0x4001\_E000

Offset address: 0x40C

| Bit position: | 7 | 6 | 5 | 4          | 3 | 2 | 1           | 0           |
|---------------|---|---|---|------------|---|---|-------------|-------------|
| Bit field:    | — | — | — | DNMI<br>EG | — | — | DLVD2<br>EG | DLVD1<br>EG |
| 重置后的值:        | 0 | 0 | 0 | 0          | 0 | 0 | 0           | 0           |

| Bit | Symbol  | Function  | R/W |
|-----|---------|---|-----|
| 0   | DLVD1EG | LVD1边沿选择<br>0: 检测到 $VCC < V_{det1}$ (下降) 时产生取消请求<br>1: 检测到 $VCC \geq V_{det1}$ (上升) 时产生取消请求 | R/W |
| 1   | DLVD2EG | LVD2边沿选择<br>0: 检测到 $VCC < V_{det2}$ (下降) 时产生取消请求<br>1: 检测到 $VCC \geq V_{det2}$ (上升) 时产生取消请求 | R/W |
| 3:2 | —       | 这些位被读取为0。写入值应为0。  | R/W |
| 4   | DNMIEG  | NMI引脚边沿选择<br>0: 下降沿产生取消请求<br>1: 上升沿产生取消请求   | R/W |
| 7:5 | —       | 这些位被读取为0。写入值应为0。  | R/W |

Note: 如果安全属性配置为安全: ●

- 允许安全访问和非安全读取访问
- 忽略非安全写入访问, 不会生成TrustZone访问错误。

如果安全属性配置为非安全: ●

- 允许安全和非安全访问。

Note: 在重写该寄存器之前将PRCR.PRC1位设置为1 (允许写入)。

DPSIEGR2不会由作为取消深度软件待机模式的源的内部复位信号初始化。有关详细信息, 请参阅第5节, 重置。

## 10.2.29 SYOCDCCR : System Control OCD Control Register

Base address: SYSC = 0x4001\_E000

Offset address: 0x040E

|                    |       |   |   |   |   |   |   |       |
|--------------------|-------|---|---|---|---|---|---|-------|
| Bit position:      | 7     | 6 | 5 | 4 | 3 | 2 | 1 | 0     |
| Bit field:         | DBGEN | — | — | — | — | — | — | DOCDF |
| Value after reset: | 0     | 0 | 0 | 0 | 0 | 0 | 0 | x     |

| Bit | Symbol | Function  | R/W              |
|-----|--------|---|------------------|
| 0   | DOCDF  | Deep Software Standby OCD flag<br>0: DBIRQ is not generated<br>1: DBIRQ is generated  | R/W <sup>1</sup> |
| 6:1 | —      | These bits are read as 0. The write value should be 0.  | R/W              |
| 7   | DBGEN  | Debugger Enable bit<br>Set to 1 first in on-chip debug mode.<br>0: On-chip debugger is disabled<br>1: On-chip debugger is enabled | R/W              |

Note: Set the PRCR.PRC1 bit to 1 (write enabled) before rewriting this register.

Note 1. Writing 0 clears the flag. Writing 1 is ignored

This register is not controlled by any security attribute register (eg. LPMSAR, DPFSAR).

SYOCDCCR can be written when DBGSTR.CDBGWRUPREQ = 1 (the debugger is connected).

SYOCDCCR is not initialized by the internal reset signal that is the source to cancel the Deep Software Standby mode.

**DOCDF flag (Deep Software Standby OCD flag)**

DOCDF flag indicates that a cancel request of Deep Software Standby mode by the MCUCTRL.DBIRQ bit has been generated. DOCDF flag is set to 1 when a cancel request is generated. This flag may be set to 1 when a cancel request is generated in any mode (not only in Deep Software Standby mode). Therefore, a transition to Deep Software Standby mode must be made after DOCDF flag is cleared to 0.

[Setting condition]

- A cancel request by the MCUCTRL.DBIRQ is generated

[Clearing condition]

- Writing 0 to the flag after reading the bit as 1
- When DBGEN bit is 0

**DBGEN bit (Debugger Enable bit)**

The DBGEN bit enables the on-chip debug mode. This bit must be set to 1 first in the on-chip debugger mode.

[Setting condition]

- Writing 1 to the bit when the debugger is connected.

[Clearing condition]

- Power-on reset is generated
- Writing 0 to the bit.

Note: Certain restrictions apply in terms of the MCU states in which the DBGEN bit can be set to 1. For details, see [section 2.13.2. Restrictions on Connecting an OCD emulator.](#)

## 10.3 Reducing Power Consumption by Switching Clock Signals

The clock frequency changes when the SCKDIVCR register is set.

## 10.2.29 SOOCDCCR:系统控制OCD控制寄存器

Base address: SYSC = 0x4001\_E000

Offset address: 0x040E

|               |       |   |   |   |   |   |   |       |
|---------------|-------|---|---|---|---|---|---|-------|
| Bit position: | 7     | 6 | 5 | 4 | 3 | 2 | 1 | 0     |
| Bit field:    | DBGEN | — | — | — | — | — | — | DOCDF |
| 重置后的值:        | 0     | 0 | 0 | 0 | 0 | 0 | 0 | x     |

| Bit | Symbol | Function  | R/W              |
|-----|--------|---|------------------|
| 0   | DOCDF  | 深度软件待机OCD标志<br>0: 不产生DBIRQ1: 产生DBIRQ              | R/W <sup>1</sup> |
| 6:1 | —      | 这些位被读取为0。写入值应为0。                                  | R/W              |
| 7   | DBGEN  | 调试器使能位<br>在片上调试模式下首先设置为1。<br>0: 禁用片上调试器1: 启用片上调试器 | R/W              |

Note: 在重写该寄存器之前将PRCR.PRC1位设置为1（允许写入）。

注1.写入0清除标志。写1被忽略

该寄存器不受任何安全属性寄存器（例如LPMSAR、DPFSAR）的控制。

当DBGSTR.CDBGWRUPREQ=1（调试器已连接）时，可以写入SOOCDCCR。

SOOCDCCR不会由作为取消深度软件待机模式的源的内部复位信号初始化。

**DOCDF标志（深度软件待机OCD标志）**

DOCDF标志指示已通过MCUCTRL.DBIRQ位生成了深度软件待机模式的取消请求。生成取消请求时，DOCDF标志设置为1。当在任何模式下（不仅在深度软件待机模式下）生成取消请求时，此标志可能设置为1。因此，必须在DOCDF标志清零后切换到深度软件待机模式。

[Setting condition]

- MCUCTRL.DBIRQ产生取消请求

[Clearing condition]

- 读取位为1后向标志位写入0
- DBGEN位为0时

**DBGEN位（调试器启用位）**

DBGEN位使能片上调试模式。在片上调试器模式下，该位必须首先设置为1。

[Setting condition]

- 连接调试器时向该位写入1。

[Clearing condition]

- 产生上电复位
- 向该位写入0。

Note: 某些限制适用于可以将DBGEN位设置为1的MCU状态。有关详细信息，请参阅第2.13.2节。连接强迫症模拟器的限制。

## 10.3 通过切换时钟信号降低功耗

设置SCKDIVCR寄存器时，时钟频率会发生变化。

For information on module and clock associations, see [section 8.2.2. SCKDIVCR : System Clock Division Control Register](#).

## 10.4 Module-Stop Function

The module stop function can stop the clock supply set for each peripheral module.

When the MSTPmi bit (m = A to E, i = 31 to 0) in MSTPCRn (n = A to E) is set to 1, the specified module stops operating and enters the module-stop state, but the CPU continues to operate independently. Setting the MSTPmi bit to 0 cancels the module-stop state, allowing the module to resume operation at the end of the bus cycle.

After a reset is canceled, all modules other than the DMAC, DTC and SRAMn modules are placed in the module-stop state. Do not access the module while the corresponding MSTPmi bit is 1. Additionally, do not set 1 to the MSTPmi bit while the corresponding module is accessed.

## 10.5 Function for Lower Operating Power Consumption

By selecting an appropriate operating power consumption control mode according to the operating frequency, power consumption can be reduced in Normal mode and Sleep mode.

### 10.5.1 Setting Operating Power Control Mode

Ensure the operating condition such as the frequency range is always within the specified range before and after switching the operating power control modes.

This section provides example procedures for switching operating power control modes.

**Table 10.5 Available oscillators in each mode**

| Mode         | Oscillator |                               |                                 |                              |                       |                      |                                   |
|--------------|------------|-------------------------------|---------------------------------|------------------------------|-----------------------|----------------------|-----------------------------------|
|              | PLL, PLL2  | High-speed on-chip oscillator | Middle-speed on-chip oscillator | Low-speed on-chip oscillator | Main clock oscillator | Sub-clock oscillator | IWDT-dedicated on-chip oscillator |
| High-speed   | Available  | Available                     | Available                       | Available                    | Available             | Available            | Available                         |
| Low-speed    | N/A        | Available                     | Available                       | Available                    | Available             | Available            | Available                         |
| Subosc-speed | N/A        | N/A                           | N/A                             | Available                    | N/A                   | Available            | Available                         |

#### (1) Switching from a higher power mode to a lower power mode

Example 1: From High-speed mode to Low-speed mode:

(Operation begins in High-speed mode)

1. Change the oscillator to what is used in Low-speed mode. Set the frequency of each clock lower than the maximum operating frequency in Low-speed mode.
2. Turn off the oscillator that is not required in Low-speed mode.
3. Confirm that the OPCCR.OPCMTSF flag is 0 (indicates transition completed).
4. Set the OPCCR.OPCM[1:0] bits to 11b (Low-speed mode).
5. Confirm that OPCCR.OPCMTSF flag is 0 (indicates transition completed).

(Operation is now in Low-speed mode)

Example 2: From High-speed mode to Subosc-speed mode

(Operation begins in High-speed mode)

1. Switch the clock source to sub-clock oscillator. Turn off PLL, PLL2, HOCO, MOCO, LOCO and main oscillator.
2. Confirm that all clock sources other than the sub-clock oscillator are stopped.
3. Confirm that the SOPCCR.SOPCMTSF flag is 0 (indicates transition completed).
4. Set the SOPCCR.SOPCM bit to 1 (Subosc-speed mode).

有关模块和时钟关联的信息，请参见第8.2.2节。SCKDIVCR:系统时钟分频控制 Register。

## 10.4 Module-Stop Function

模块停止功能可以停止为每个外围模块设置的时钟供应。

当MSTPCRn(n=AtoE)中的MSTPmi位(m=AtoE i=31to0)设置为1时，指定模块停止运行并进入module-stop状态，但CPU继续运行独立。将MSTPmi位设置为0可取消模块停止状态，允许模块在总线周期结束时恢复运行。

取消复位后，除DMAC、DTC和SRAMn模块之外的所有模块都置于模块停止状态。相应的MSTPmi位为1时不要访问模块。另外，访问相应的模块时不要将MSTPmi位设置为1。

## 10.5 降低运行功耗的功能

通过根据工作频率选择合适的工作功耗控制模式，可以降低正常模式和睡眠模式下的功耗。

### 10.5.1 设置工作电源控制模式

确保在切换工作功率控制模式前后，频率范围等工作条件始终在规定范围内。

本节提供切换操作电源控制模式的示例程序。

**Table 10.5 每种模式下可用的振荡器**

| Mode         | Oscillator |                               |                                 |                              |           |                      |                                   |
|--------------|------------|-------------------------------|---------------------------------|------------------------------|-----------|----------------------|-----------------------------------|
|              | PLL, PLL2  | High-speed on-chip oscillator | Middle-speed on-chip oscillator | Low-speed on-chip oscillator | 主时钟振荡器    | Sub-clock oscillator | IWDT-dedicated on-chip oscillator |
| High-speed   | Available  | Available                     | Available                       | Available                    | Available | Available            | Available                         |
| Low-speed    | N/A        | Available                     | Available                       | Available                    | Available | Available            | Available                         |
| Subosc-speed | N/A        | N/A                           | N/A                             | Available                    | N/A       | Available            | Available                         |

#### (1) 从高功率模式切换到低功率模式

示例1：从高速模式到低速模式：

(以高速模式开始运行)

- 1.将振荡器更改为低速模式下使用的振荡器。将每个时钟的频率设置为低于低速模式下的最大工作频率。
- 2.关闭低速模式下不需要的振荡器。
- 3.确认OPCCR.OPCMTSF标志为0（表示转换完成）。
- 4.将OPCCR.OPCM[1:0]位设置为11b（低速模式）。
- 5.确认OPCCR.OPCMTSF标志为0（表示转换完成）。

(操作现在处于低速模式)

示例2：从高速模式到Subosc速度模式

(以高速模式开始运行)

- 1.将时钟源切换为副时钟振荡器。关闭PLL、PLL2、HOCO、MOCO、LOCO和主振荡器。
- 2.确认除副时钟振荡器之外的所有时钟源都已停止。
- 3.确认SOPCCR.SOPCMTSF标志为0（表示转换完成）。
- 4.将SOPCCR.SOPCM位设置为1（Subosc速度模式）。



5. Confirm that the SOPCCR.SOPCMTSF flag is 0 (indicates transition completed).

(Operation is now in Subosc-speed mode)

## (2) Switching from a lower power mode to a higher power mode

Example 1: From Subosc-speed mode to High-speed mode

(Operation begins in Subosc-speed mode)

1. Confirm that the SOPCCR.SOPCMTSF flag is 0 (indicates transition completed).
2. Set the SOPCCR.SOPCM bit to 0 (High-speed mode).
3. Confirm that the SOPCCR.SOPCMTSF flag is 0 (indicates transition completed).
4. Turn on the required oscillator in High-speed mode.
5. Set the frequency of each clock lower than the maximum operating frequency for High-speed mode.

(Operation is now in High-speed mode)

Example 2: From Low-speed mode to High-speed mode

(Operation begins in Low-speed mode)

1. Confirm that the OPCCR.OPCMTSF flag is 0 (indicates transition completed).
2. Set the OPCCR.OPCM[1:0] bits to 00b (High-speed mode).
3. Confirm that the OPCCR.OPCMTSF flag is 0 (indicates transition completed).
4. Turn on any required oscillator in High-speed mode.
5. Set the frequency of each clock lower than the maximum operating frequency for High-speed mode.

(Operation is now in High-speed mode)

## 10.6 Sleep Mode

### 10.6.1 Transitioning to Sleep Mode

When a WFI instruction is executed while SBYCR.SSBY bit is 0, the MCU enters Sleep mode. In this mode, the CPU stops operating but the contents of its internal registers are retained. Other peripheral functions do not stop. Available resets or interrupts in Sleep mode cause the MCU to cancel Sleep mode. All interrupt sources are available. If using an interrupt to cancel Sleep mode, you must set the associated IELSRn register before executing a WFI instruction. For details, see [section 13, Interrupt Controller Unit \(ICU\)](#).

Counting by IWDT stops when the MCU enters Sleep mode while the IWDT is in auto start mode and the OFS0.IWDTSTPCTL bit is 1 (IWDT stops in Sleep mode, Software Standby mode or Snooze mode).

Counting by IWDT continues when the MCU enters Sleep mode while the IWDT is in auto start mode and the OFS0.IWDTSTPCTL bit is 0 (IWDT does not stop in Sleep mode, Software Standby mode or Snooze mode).

Counting by WDT stops when the MCU enters Sleep mode while the WDT is in auto start mode and the OFS0.WDTSTPCTL bit is 1 (WDT stops in Sleep mode). Similarly, counting by WDT stops when the MCU enters Sleep mode while the WDT is in register start mode and the WDCSTPR.SLCSTP bit is 1 (WDT stops in Sleep mode).

Counting by WDT continues when the MCU enters Sleep mode while the WDT is in auto start mode and the OFS0.WDTSTPCTL bit is 0 (WDT does not stop in Sleep mode). Similarly, counting by WDT continues when the MCU enters Sleep mode while the WDT is in register start mode and the WDCSTPR.SLCSTP bit is 0 (WDT does not stop in Sleep mode).

### 10.6.2 Canceling Sleep Mode

Sleep mode is canceled by:

- An interrupt
- A RES pin reset

5.确认SOPCCR.SOPCMTSF标志为0 (表示转换完成)。  
(操作现在处于Subosc速度模式)

## (2) 从低功耗模式切换到高功耗模式

示例1: 从Subosc速度模式到高速模式

(以Subosc速度模式开始运行)

- 1.确认SOPCCR.SOPCMTSF标志为0 (表示转换完成)。
- 2.将SOPCCR.SOPCM位设置为0 (高速模式)。
- 3.确认SOPCCR.SOPCMTSF标志为0 (表示转换完成)。
- 4.在高速模式下打开所需的振荡器。
- 5.将每个时钟的频率设置为低于高速模式的最大工作频率。

(操作现在处于高速模式)

示例2: 从低速模式到高速模式

(以低速模式开始运行)

- 1.确认OPCCR.OPCMTSF标志为0 (表示转换完成)。
- 2.将OPCCR.OPCM[1:0]位设置为00b (高速模式)。
- 3.确认OPCCR.OPCMTSF标志为0 (表示转换完成)。
- 4.在高速模式下打开任何需要的振荡器。
- 5.将每个时钟的频率设置为低于高速模式的最大工作频率。

(操作现在处于高速模式)

## 10.6 睡眠模式

### 10.6.1 转换到睡眠模式

当SBYCR.SSBY位为0时执行WFI指令, MCU进入休眠模式。在这种模式下, CPU停止运行, 但其内部寄存器的内容被保留。其他外围功能不会停止。休眠模式下可用的复位或中断会导致MCU取消休眠模式。所有中断源均可用。如果使用中断取消休眠模式, 则必须在执行WFI指令之前设置相关的IELSRn寄存器。有关详细信息, 请参阅第13节, 中断控制器单元(ICU)。

当MCU进入休眠模式且IWDT处于自动启动模式且OFS0.IWDTSTPCTL位为1 (IWDT在休眠模式、软件待机模式或贪睡模式下停止)。

当MCU进入休眠模式且IWDT处于自动启动模式且OFS0.IWDTSTPCTL位为0 (IWDT在休眠模式、软件待机模式或贪睡模式下不停止) 时, IWDT继续计数。

当MCU进入休眠模式且WDT处于自动启动模式且OFS0.WDTSTPCTL位为1 (WDT在休眠模式下停止)。同样, 当MCU进入休眠模式且WDT处于寄存器启动模式且WDCSTPR.SLCSTP位为1 (WDT在休眠模式下停止) 时, WDT停止计数。

当MCU进入休眠模式且WDT处于自动启动模式且OFS0.WDTSTPCTL位为0 (WDT在休眠模式下不停止)。同样, 当MCU进入休眠模式且WDT处于寄存器启动模式且WDCSTPR.SLCSTP位为0 (休眠模式下WDT不会停止) 时, WDT继续计数。

### 10.6.2 取消睡眠模式

睡眠模式通过以下方式取消:

- 中断
- ARES引脚复位

- A power-on reset
- A voltage monitor reset
- An SRAM parity error reset
- An SRAM ECC error reset
- A bus master MPU error reset
- A TrustZone error reset
- A reset caused by an IWDT or a WDT underflow

The operations are as follows:

1. Canceling by an interrupt  
When an available interrupt request is generated, Sleep mode is canceled and the MCU starts the interrupt handling.
2. Canceling by RES pin reset  
When the RES pin is driven low, the MCU enters the reset state. Be sure to keep the RES pin low for the time period specified in [section 47, Electrical Characteristics](#). When the RES pin is driven high after the specified time period, the CPU starts the reset exception handling.
3. Canceling by IWDT reset
  - Sleep mode is canceled by an internal reset generated by an IWDT underflow and the MCU starts the reset exception handling. However, IWDT stops in Sleep mode and an internal reset for canceling Sleep mode is not generated in the following conditions:
    - OFS0.IWDTSTRT = 0 and OFS0.IWDTSTPCTL = 1.
4. Canceling by WDT reset  
Sleep mode is canceled by an internal reset generated by a WDT underflow and the MCU starts the reset exception handling. However, WDT stops in Sleep mode even when counting in Normal mode and an internal reset for canceling Sleep mode is not generated in the following conditions:
  - OFS0.WDTSTRT = 0 (auto start mode) and OFS0.WDTSTPCTL = 1
  - OFS0.WDTSTRT = 1 (register start mode) and WDTDCSTPR.SLCSTP = 1.
5. Canceling by other resets available in Sleep mode  
Sleep mode is canceled by other resets and the MCU starts the reset exception handling.

Note: For details on proper setting of the interrupts, see [section 13, Interrupt Controller Unit \(ICU\)](#).

## 10.7 Software Standby Mode

### 10.7.1 Transitioning to Software Standby Mode

When a WFI instruction is executed while SBYCR.SSBY bit is 1 and DPSBYCR.DPSBY bit is 0, the MCU enters Software Standby mode. In this mode, the CPU, most of the on-chip peripheral functions and the oscillators stop. However, the contents of the CPU internal registers and SRAM data, the states of on-chip peripheral functions and the I/O ports are retained. Software Standby mode allows significant reduction in power consumption because most of the oscillators stops in this mode. [Table 10.2](#) shows the status of each on-chip peripheral functions and oscillators. Available resets or interrupts in Software Standby mode make the MCU to cancel Software Standby mode. See [Table 10.3](#) for available interrupt sources and [section 13.2.18. WUPEN0 : Wake Up Interrupt Enable Register 0](#), [section 13.2.19. WUPEN1 : Wake Up interrupt enable register 1](#) for information on waking up the MCU from Software Standby mode. If using an interrupt to cancel an interrupt, you must set the associated IELSRn register before executing a WFI instruction. For details, see [section 13, Interrupt Controller Unit \(ICU\)](#).

Clear DMAST.DMST bit and DTCST.DTCST bit to 0 before executing WFI instruction except when using DTC in Snooze mode. If DTC is required in Snooze mode, set DTCST.DTCST bit to 1 before executing a WFI instruction.

Counting by the IWDT stops if the MCU enters Software Standby mode while the IWDT is in auto start mode and the OFS0.IWDTSTPCTL bit is 1 (IWDT stops in Sleep, Software Standby or Snooze mode).

Counting by the IWDT continues if the MCU enters Software Standby mode while the IWDT is in auto start mode and the OFS0.IWDTSTPCTL bit is 0 (IWDT does not stop in Sleep, Software Standby or Snooze mode).

- A power-on reset
- 电压监视器复位
- SRAM奇偶校验错误复位
- SRAMECC错误复位
- 总线主控MPU错误复位
- TrustZone错误重置
- IWDT或WDT下溢引起的复位

操作如下:

- 1.中断取消  
当产生可用的中断请求时, 休眠模式被取消, MCU开始中断处理。
- 2.通过RES引脚复位取消  
当RES引脚驱动为低电平时, MCU进入复位状态。请务必在第47节“电气特性”中指定的时间段内保持RES引脚为低电平。当RES引脚在指定时间后被驱动为高电平时, CPU开始复位异常处理。
- 3.IWDT复位取消
  - 休眠模式由IWDT下溢产生的内部复位取消, MCU开始复位异常处理。但是, IWDT在休眠模式下停止, 并且在以下情况下不会产生用于取消休眠模式的内部复位:
    - OFS0.IWDTSTRT = 0 and OFS0.IWDTSTPCTL = 1.
- 4.WDT复位取消  
睡眠模式由WDT下溢产生的内部复位取消, MCU启动复位异常处理。但是, 即使在正常模式下计数, WDT也会在休眠模式下停止, 并且在以下情况下不会产生用于取消休眠模式的内部复位:
  - OFS0.WDTSTRT=0 (自动启动模式) 和OFS0.WDTSTPCTL=1
  - OFS0.WDTSTRT=1 (寄存器启动模式) 和WDTDCSTPR.SLCSTP=1。
- 5.通过睡眠模式下可用的其他复位取消  
休眠模式被其他复位取消, MCU开始复位异常处理。

Note: 有关正确设置中断的详细信息, 请参阅第13节, 中断控制器单元(ICU)。

## 10.7 软件待机模式

### 10.7.1 过渡到软件待机模式

当SBYCR.SSBY位为1且DPSBYCR.DPSBY位为0时执行WFI指令, MCU进入软件待机模式。在这种模式下, CPU、大部分片上外围功能和振荡器停止。但是, CPU内部寄存器和SRAM数据的内容、片上外围功能的状态和IO端口的状态会被保留。软件待机模式可显著降低功耗, 因为大多数振荡器在此模式下停止。表10.2显示了每个片上外围功能和振荡器的状态。软件待机模式下可用的复位或中断使MCU取消软件待机模式。有关可用的中断源, 请参见表10.3和第13.2.18节。WUPEN0: 唤醒中断使能寄存器0, 第13.2.19节。WUPEN1: 唤醒中断使能寄存器1, 用于将MCU从软件待机模式唤醒的信息。如果使用中断取消中断, 则必须在执行WFI指令之前设置相关的IELSRn寄存器。有关详细信息, 请参阅第13节, 中断控制器单元(ICU)。

在执行WFI指令之前将DMAST.DMST位和DTCST.DTCST位清除为0, 除非在贪睡模式下使用DTC。如果在贪睡模式下需要DTC, 请在执行WFI指令之前将DTCST.DTCST位设置为1。

如果MCU进入软件待机模式, 而IWDT处于自动启动模式并且OFS0.IWDTSTPCTL位为1 (IWDT在休眠、软件待机或贪睡模式下停止)。

如果MCU进入软件待机模式, 而IWDT处于自动启动模式并且OFS0.IWDTSTPCTL位为0 (IWDT在休眠、软件待机或贪睡模式下不停止)。



WDT stops counting when the MCU enters Software Standby mode because the PCLKB stops.

Do not enter Software Standby mode while OSTDCR.OSTDE = 1 (oscillation stop detection function is enabled). To enter Software Standby mode, execute a WFI instruction after disabling the oscillation stop detection function (OSTDCR.OSTDE = 0). In case of executing WFI instruction while OSTDCR.OSTDE = 1, the MCU enters Sleep mode even if SBYCR.SSBY = 1.

Do not enter Software Standby mode while the flash memory is programming or erasing. To enter Software Standby mode, execute a WFI instruction after programming or erasing procedure completes.

Table 10.6 shows the setting of the related control bits and the modes to enter after executing WFI instruction.

**Table 10.6 Bit settings that affect modes when executing a WFI instruction**

|                                    |   | SBYCR.SSBY and PSBYCR.DPSBY bit settings |                        |                        |                        |
|------------------------------------|---|--|------------------------|------------------------|------------------------|
|                                    |   | SSBY = 0,<br>DPSBY = 0                   | SSBY = 0,<br>DPSBY = 1 | SSBY = 1,<br>DPSBY = 0 | SSBY = 1,<br>DPSBY = 1 |
| OSTDCR.OSTDE                       | 0 | Sleep                                    | Sleep                  | Software Standby       | Deep Software Standby  |
|                                    | 1 |  |                        | Sleep                  | Sleep                  |
| FENTRYR.FENTRYC<br>FENTRYR.FENTRYD | 0 | Sleep                                    | Sleep                  | Software Standby       | Deep Software Standby  |
|                                    | 1 |  |                        | Sleep                  | Sleep                  |
| OFS0.IWDTSTPCTL                    | 0 | Sleep                                    | Sleep                  | Software Standby       | Software Standby       |
|                                    | 1 |  |                        |                        | Deep Software Standby  |
| LVD1CR0.RI                         | 0 | Sleep                                    | Sleep                  | Software Standby       | Deep Software Standby  |
|                                    | 1 |  |                        |                        | Software Standby       |
| LVD2CR0.RI                         | 0 | Sleep                                    | Sleep                  | Software Standby       | Deep Software Standby  |
|                                    | 1 |  |                        |                        | Software Standby       |

### 10.7.2 Canceling Software Standby Mode

Software Standby mode is canceled by:

- An available interrupt shown in Table 10.3
- A RES pin reset
- A power-on reset
- A voltage monitor reset
- A reset caused by an IWDTC underflow.

On exiting Software Standby mode, the oscillators that operate before the transition to the mode restart. After all the oscillators are stabilized, the MCU returns to Normal mode from Software Standby mode. See section 13.2.18. WUPEN0 : Wake Up Interrupt Enable Register 0, section 13.2.19. WUPEN1 : Wake Up interrupt enable register 1 for information on how to wake up the MCU from Software Standby mode.

You can cancel Software Standby mode in any of the following ways:

1. Canceling by an interrupt  
When an available interrupt request (see Table 10.3) is generated, an oscillator that operates before the transition to Software Standby mode restarts. After all the oscillators are stabilized, the MCU returns to Normal mode from Software Standby mode and starts the interrupt handling.
2. Canceling by a RES pin reset  
When the RES pin is driven low, the MCU enters the reset state, and the oscillators whose default status is operating, start the oscillation. Be sure to keep the RES pin low for the time period specified in section 47, Electrical Characteristics. When the RES pin is driven high after the specified time period, the CPU starts the reset exception handling.
3. Canceling by a power-on reset  
Software Standby mode is canceled by a power-on reset and the MCU starts the reset exception handling.
4. Canceling by a voltage monitor reset

当MCU进入软件待机模式时，WDT停止计数，因为PCLKB停止。

OSTDCR.OSTDE=1时不要进入软件待机模式（振荡停止检测功能启用）。要进入软件待机模式，请在禁用振荡停止检测功能(OSTDCR.OSTDE=0)后执行WFI指令。如果在OSTDCR.OSTDE=1时执行WFI指令，即使SBYCR.SSBY=1，MCU也会进入休眠模式。

闪存正在编程或擦除时，请勿进入软件待机模式。要进入软件待机模式，请在编程或擦除过程完成后执行WFI指令。

表10.6显示了相关控制位的设置以及执行WFI指令后进入的模式。

**Table 10.6 执行WFI指令时影响模式的位设置**

|                                    |   | SBYCR.SSBY和PSBYCR.DPSBY位设置 |                        |                        |                        |
|------------------------------------|---|----------------------------|------------------------|------------------------|------------------------|
|                                    |   | SSBY = 0,<br>DPSBY = 0     | SSBY = 0,<br>DPSBY = 1 | SSBY = 1,<br>DPSBY = 0 | SSBY = 1,<br>DPSBY = 1 |
| OSTDCR.OSTDE                       | 0 | Sleep                      | Sleep                  | 软件待机                   | 深度软件待机                 |
|                                    | 1 |                            |                        | Sleep                  | Sleep                  |
| FENTRYR.FENTRYC<br>FENTRYR.FENTRYD | 0 | Sleep                      | Sleep                  | 软件待机                   | 深度软件待机                 |
|                                    | 1 |                            |                        | Sleep                  | Sleep                  |
| OFS0.IWDTSTPCTL                    | 0 | Sleep                      | Sleep                  | 软件待机                   | 软件待机                   |
|                                    | 1 |                            |                        |                        | 深度软件待机                 |
| LVD1CR0.RI                         | 0 | Sleep                      | Sleep                  | 软件待机                   | 深度软件待机                 |
|                                    | 1 |                            |                        |                        | 软件待机                   |
| LVD2CR0.RI                         | 0 | Sleep                      | Sleep                  | 软件待机                   | 深度软件待机                 |
|                                    | 1 |                            |                        |                        | 软件待机                   |

### 10.7.2 取消软件待机模式

软件待机模式通过以下方式取消：

- 可用中断如表10.3所示
- ARES引脚复位
  - A power-on reset
- 电压监视器复位
- IWDTC下溢引起的复位。

在退出软件待机模式时，在转换到模式之前工作的振荡器会重新启动。在所有振荡器稳定后，MCU从软件待机模式返回到正常模式。请参阅第13.2.18节。WUPEN0：唤醒中断使能寄存器0，第13.2.19节。WUPEN1：唤醒中断使能寄存器1，用于了解如何将MCU从软件待机模式唤醒。

您可以通过以下任一方式取消软件待机模式：

- 1.中断取消  
当一个可用的中断请求（见表10.3）产生时，一个振荡器在转换到软件待机模式重新启动。在所有振荡器稳定后，MCU从软件返回到正常模式待机模式并启动中断处理。
- 2.通过RES引脚复位取消  
当RES引脚驱动为低电平时，MCU进入复位状态，默认状态为工作的振荡器开始振荡。请务必在第47节“电气特性”中指定的时间段内保持RES引脚为低电平。当RES引脚在指定时间后被驱动为高电平时，CPU开始复位异常处理。
- 3.上电复位取消  
软件待机模式通过上电复位取消，MCU启动复位异常处理。
- 4.通过电压监视器复位取消

Software Standby mode is canceled by a voltage monitor reset from the voltage detection circuit and the MCU starts the reset exception handling.

5. Canceling by IWDT reset

Software Standby mode is canceled by an internal reset generated by an IWDT underflow and the MCU starts the reset exception handling. However, IWDT stops in Software Standby mode and an internal reset for canceling Software Standby mode is not generated in the following condition:

- OFS0.IWDTSTRT = 0 and OFS0.IWDTSTPCTL = 1.

10.7.3 Example of Software Standby Mode Application

Figure 10.2 shows an example of entry to Software Standby mode on detection of a falling edge of the IRQn pin, and exit from Software Standby mode by a rising edge of the IRQn pin.

In this example, an IRQn pin interrupt is accepted with the IRQCRi.IRQMD[1:0] bits of the ICU set to 00b (falling edge) in Normal operating mode, and the IRQCRi.IRQMD[1:0] bits are set to 01b (rising edge). After that, the SBYCR.SSBY bit is set to 1 and a WFI instruction is executed. As a result, entry to Software Standby mode completes and exit from Software Standby mode is initiated by a rising edge of the IRQn pin.

Setting the ICU is also required to exit Software Standby mode. For details, see section 13, Interrupt Controller Unit (ICU). The oscillation stabilization time in Figure 10.2 is specified in section 47, Electrical Characteristics.

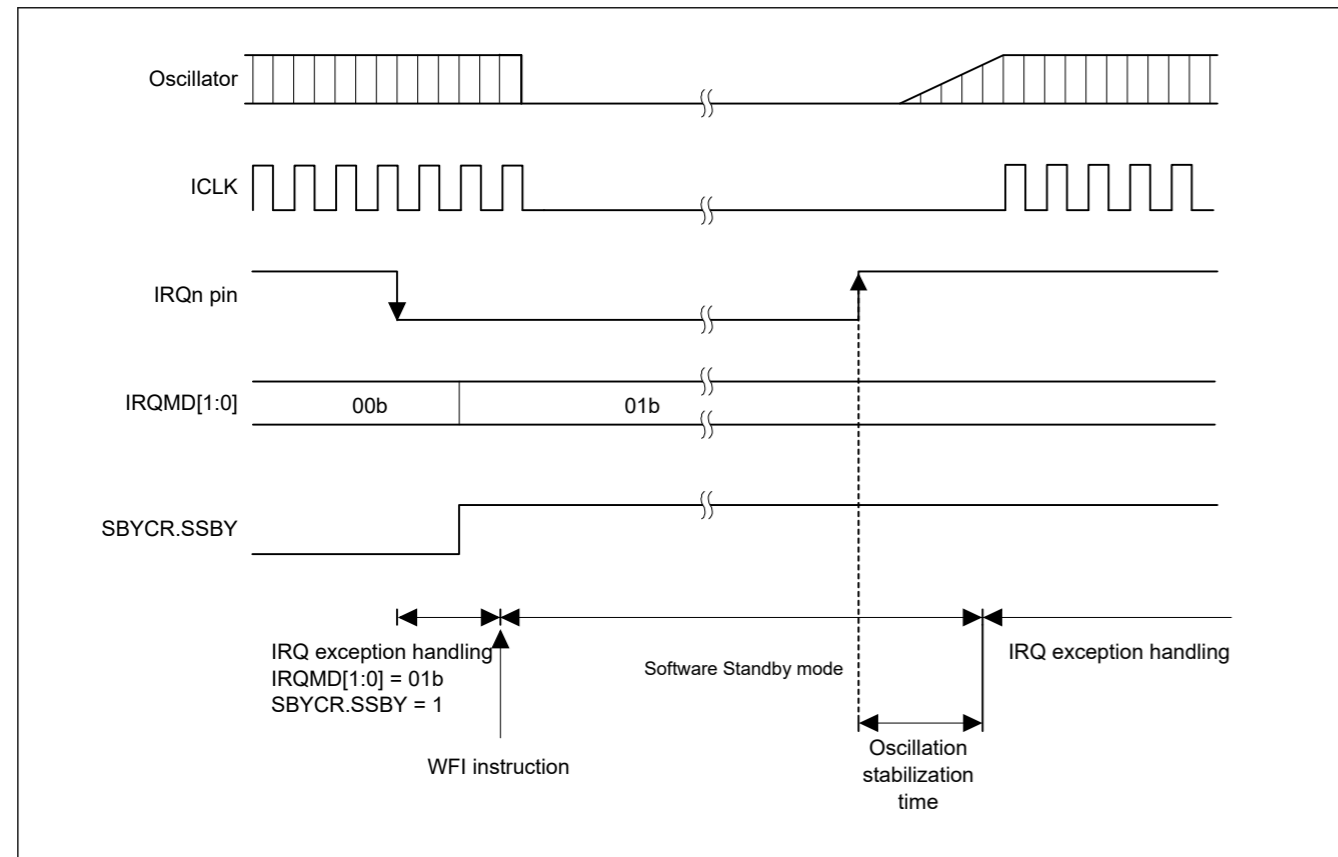


Figure 10.2 Example of Software Standby mode application

软件待机模式通过电压检测电路的电压监视器复位取消，MCU开始复位异常处理。

5.IWDT复位取消

软件待机模式由IWDT下溢产生的内部复位取消，MCU开始复位异常处理。但是，IWDT在软件待机模式下停止，并且在以下情况下不会产生用于取消软件待机模式的内部复位：

- OFS0.IWDTSTRT = 0 and OFS0.IWDTSTPCTL = 1.

10.7.3 软件待机模式应用示例

图10.2显示了在检测到IRQn引脚的下降沿进入软件待机模式并在IRQn引脚的上升沿退出软件待机模式的示例。

在此示例中，IRQn引脚中断被接受，ICU的IRQCRi.IRQMD[1:0]位在正常操作模式下设置为00b（下降沿），并且IRQCRi.IRQMD[1:0]位设置为01b（上升沿）。之后，SBYCR.SSBY位设置为1并执行WFI指令。因此，软件待机模式的进入完成，软件待机模式的退出由IRQn引脚的上升沿启动。

退出软件待机模式也需要设置ICU。有关详细信息，请参阅第13节，中断控制器单元(ICU)。图10.2中的振荡稳定时间在第47节“电气特性”中指定。

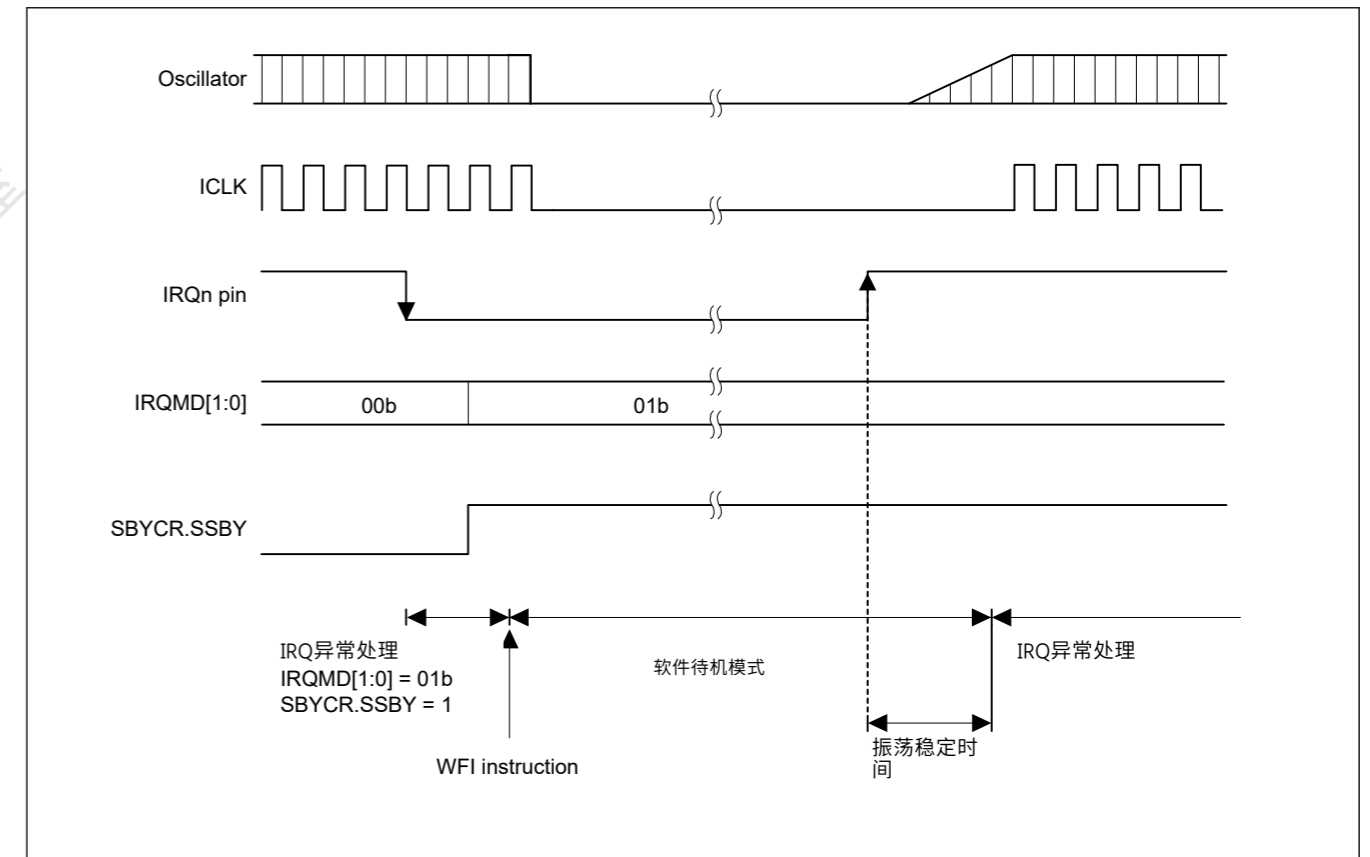


Figure 10.2 软件待机模式应用示例

10.8 Snooze Mode

10.8.1 Transition to Snooze Mode

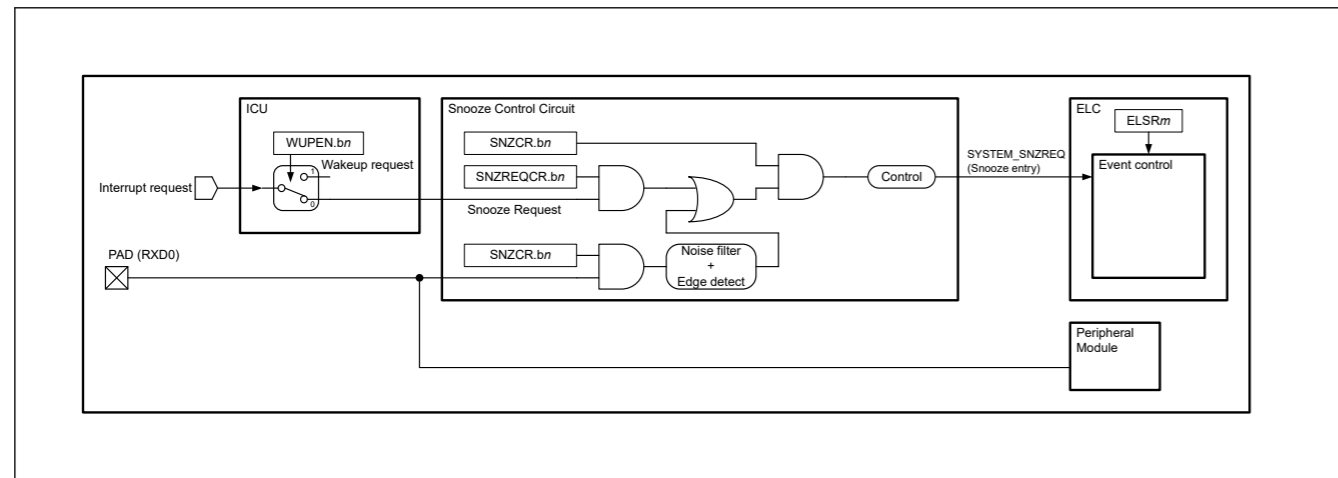


Figure 10.3 Snooze mode entry configuration

When the snooze control circuit accepts an available snooze request in Software Standby mode, the MCU transfers to Snooze mode. In this mode, some peripheral modules operate without waking the CPU. The peripheral modules that can operate in Snooze mode are shown in Table 10.2. Also, DTC operation in Snooze mode can be selected by the setting of SNZCR.SNZDTCEN bit.

Table 10.7 shows the Snooze requests that switch the MCU from Software Standby mode to Snooze mode. To use the listed Snooze requests as a trigger to switch to Snooze mode, the corresponding SNZREQENn bit of the SNZREQCRn register or RXDREQEN bit of SNZCR register must be set before entering Software Standby mode.

Table 10.7 Available snooze requests to switch to Snooze mode

| Snooze request          | Control Register |                         |
|-------------------------|------------------|-------------------------|
|                         | Register         | Bit <sup>1</sup> *3     |
| PORT_IRQn (n = 0 to 15) | SNZREQCR0        | SNZREQENn (n = 0 to 15) |
| RTC_ALM                 | SNZREQCR0        | SNZREQEN24              |
| RTC_PRD                 | SNZREQCR0        | SNZREQEN25              |
| AGT1_AGTI               | SNZREQCR0        | SNZREQEN28              |
| AGT1_AGTCMAI            | SNZREQCR0        | SNZREQEN29              |
| AGT1_AGTCMBI            | SNZREQCR0        | SNZREQEN30              |
| AGT3_AGTI               | SNZREQCR1        | SNZREQEN0               |
| AGT3_AGTCMAI            | SNZREQCR1        | SNZREQEN1               |
| AGT3_AGTCMBI            | SNZREQCR1        | SNZREQEN2               |
| RXD0 falling edge       | SNZCR            | RXDREQEN <sup>2</sup>   |

- Note 1. Do not enable multiple snooze requests at the same time.
- Note 2. Do not set the RXDREQEN bit to 1 except in asynchronous mode.
- Note 3. When AGT1 is used for Snooze request factor, Snooze end factor is not allowed to set AGT3 (only AGT1).  
When AGT3 is used for Snooze request factor, Snooze end factor is not allowed to set AGT1 (only AGT3).

Clear the DMAST.DMST and DTCST.DTCST bits to 0 before executing a WFI instruction, except when using the DTC in Snooze mode. If the DTC is required in Snooze mode, set the DTCST.DTCST bit to 1 before executing a WFI instruction.

10.8.2 Canceling Snooze Mode

Snooze mode is canceled by an interrupt request that is available in Software Standby mode or a reset. Table 10.3 shows the requests that can be used to exit each mode. After canceling the Snooze mode, the MCU enters Normal operating mode and proceeds with exception processing for the given interrupt or reset. The action triggered by the interrupt requests, selected in

10.8 贪睡模式

10.8.1 过渡到贪睡模式

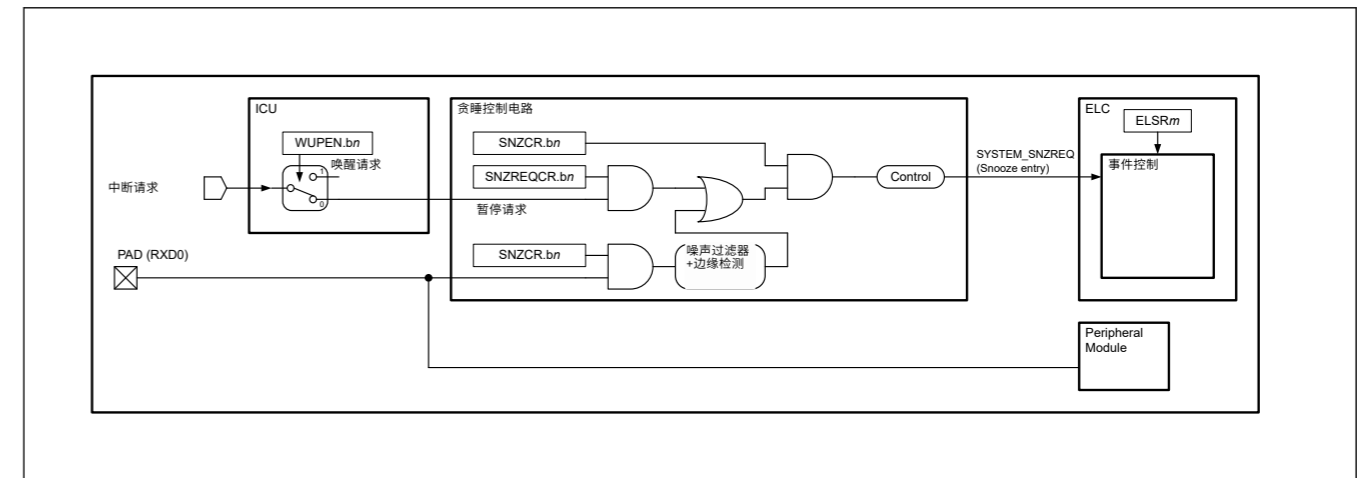


Figure 10.3 贪睡模式进入配置

当贪睡控制电路在软件待机模式下接受一个可用的贪睡请求时，MCU转移到贪睡模式。在这种模式下，一些外围模块在不唤醒CPU的情况下运行。可在贪睡模式下运行的外围模块如表10.2所示。此外，可以通过设置SNZCR.SNZDTCEN位来选择贪睡模式下的DTC操作。

表10.7显示了将MCU从软件待机模式切换到贪睡模式的贪睡请求。要将列出的贪睡请求用作切换到贪睡模式的触发器，SNZREQCRn寄存器的相应SNZREQENn位或在进入软件待机模式之前，必须设置SNZCR寄存器的RXDREQEN位。

Table 10.7 可用的贪睡请求以切换到贪睡模式

| Snooze request          | Control Register |                         |
|-------------------------|------------------|-------------------------|
|                         | Register         | Bit <sup>1</sup> *3     |
| PORT_IRQn (n = 0 to 15) | SNZREQCR0        | SNZREQENn (n = 0 to 15) |
| RTC_ALM                 | SNZREQCR0        | SNZREQEN24              |
| RTC_PRD                 | SNZREQCR0        | SNZREQEN25              |
| AGT1_AGTI               | SNZREQCR0        | SNZREQEN28              |
| AGT1_AGTCMAI            | SNZREQCR0        | SNZREQEN29              |
| AGT1_AGTCMBI            | SNZREQCR0        | SNZREQEN30              |
| AGT3_AGTI               | SNZREQCR1        | SNZREQEN0               |
| AGT3_AGTCMAI            | SNZREQCR1        | SNZREQEN1               |
| AGT3_AGTCMBI            | SNZREQCR1        | SNZREQEN2               |
| RXD0下降沿                 | SNZCR            | RXDREQEN <sup>2</sup>   |

- 注意1.不要同时启用多个贪睡请求。
- 注2.除异步模式外，请勿将RXDREQEN位设置为1。
- 注3.当AGT1用于贪睡请求因子时，贪睡结束因子不允许设置AGT3（仅AGT1）。  
当AGT3用于Snooze request factor时，Snooze end factor 不允许设置AGT1（仅AGT3）。

在执行WFI指令之前将DMAST.DMST和DTCST.DTCST位清零，除非在贪睡模式下使用DTC。如果在贪睡模式下需要DTC，请在执行WFI指令之前将DTCST.DTCST位设置为1。

10.8.2 取消贪睡模式

贪睡模式由软件待机模式下可用的中断请求或复位取消。表10.3显示了可用于退出每种模式的请求。取消贪睡模式后，MCU进入正常工作模式并继续对给定中断或复位进行异常处理。中断请求触发的动作，在

SELSR0, cancels Snooze mode. Interrupt canceling Snooze mode must be selected in IELSRn to link to the NVIC for the corresponding interrupt handling. See section 13, Interrupt Controller Unit (ICU) for information on SELSR0 and IELSRn registers.

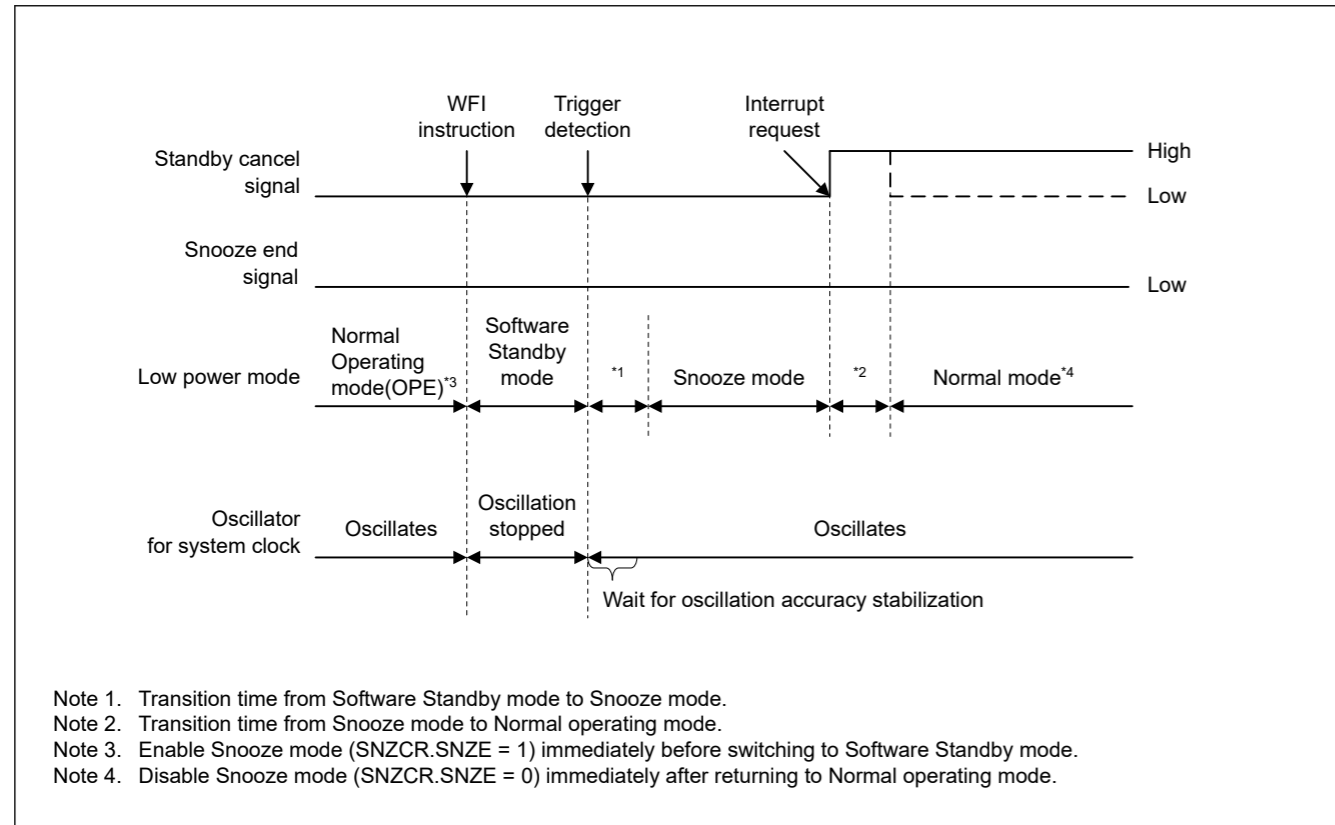


Figure 10.4 Canceling of Snooze mode when an interrupt request signal is generated

### 10.8.3 Returning from Snooze Mode to Software Standby Mode

Table 10.8 shows the snooze end request that can be used as triggers to return to Software Standby mode. The snooze end requests are available only in Snooze mode. If the requests are generated when the MCU is not in Snooze mode, they are ignored. When multiple requests are selected, each of the requests invokes transition to Software Standby mode from Snooze mode.

Table 10.9 shows the snooze end conditions that consist of the snooze end requests and the conditions of the peripheral modules. The CTSU, SCIO, ADC12n (n = 0, 1), and DTC modules can keep the MCU in Snooze mode until they complete the operation. However, an AGTn (n = 1, 3) underflow as a trigger to return to Software Standby mode cancels Snooze mode without waiting for the completion of SCIO operation.

Figure 10.5 shows the timing diagram for the transition from Snooze mode to Software Standby mode. This mode transition occurs according to which snooze end requests are set in the SNZEDCR0 register. A snooze request is cleared automatically after returning to Software Standby mode.

Table 10.8 Available snooze end requests (triggers to return to Software Standby mode) (1 of 2)

| Peripheral Module | Snooze end request                                  | Enable/Disable Control |          |
|-------------------|---|------------------------|----------|
|                   |   | Register               | Symbol   |
| AGT1              | AGT1 underflow (AGT1_AGTI)                          | SNZEDCR0               | AGTUNFED |
| DTC               | Last DTC transmission completion (DTC_COMPLETE)     | SNZEDCR0               | DTCZRED  |
| DTC               | Not Last DTC Transmission Completion (DTC_TRANSFER) | SNZEDCR0               | DTCNZRED |
| ADC120            | Window A/B compare match (ADC120_WCMPPM)            | SNZEDCR0               | ADOMATED |
| ADC120            | Window A/B compare mismatch (ADC120_WCMPUM)         | SNZEDCR0               | ADOUMTED |

SELSR0, 取消贪睡模式。必须在IELSRn中选择中断取消贪睡模式以链接到NVIC以进行相应的中断处理。有关SELSR0和IELSRn寄存器的信息, 请参见第13节, 中断控制器单元(ICU)。

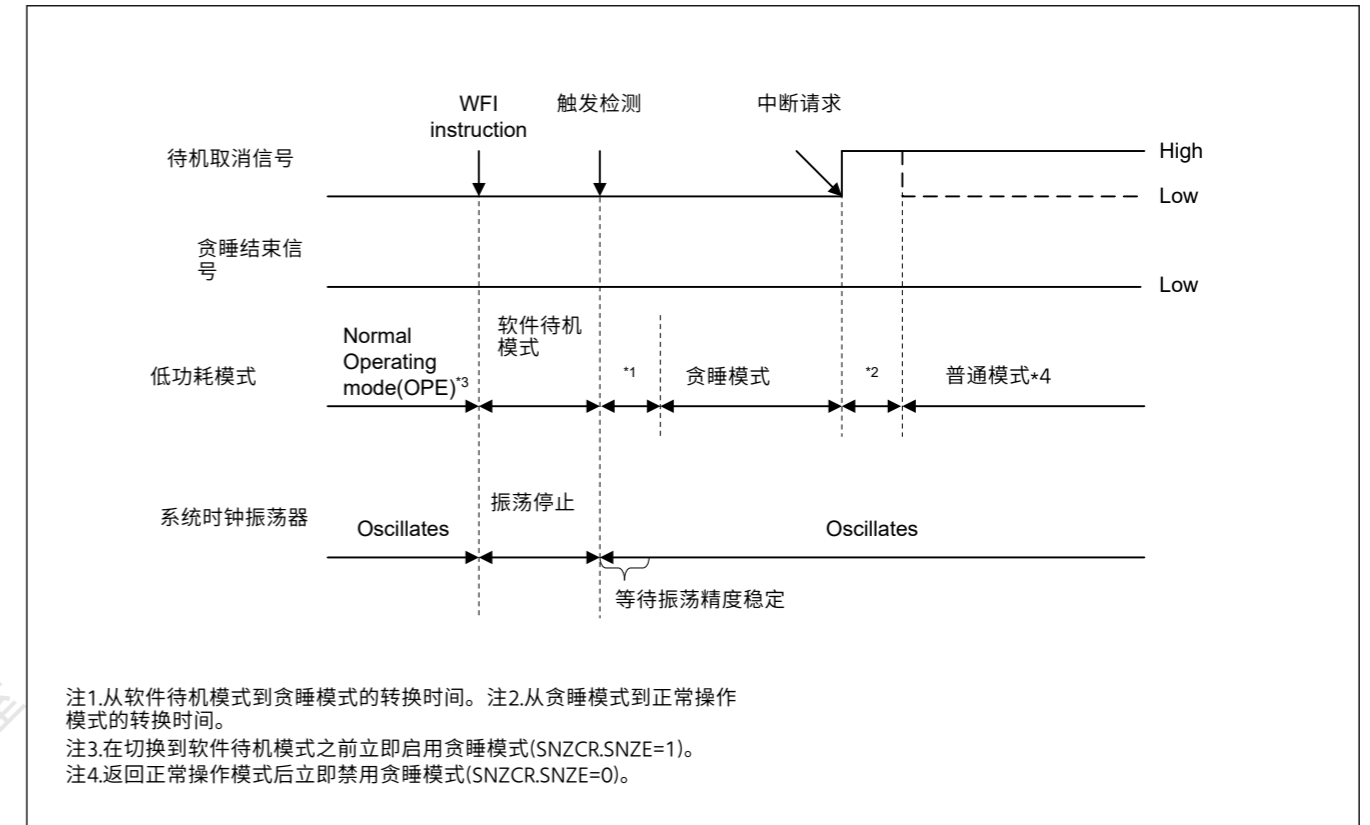


Figure 10.4 产生中断请求信号时取消贪睡模式

### 10.8.3 从贪睡模式返回到软件待机模式

表10.8显示了可用作返回到软件待机模式的触发器的贪睡结束请求。贪睡结束请求仅在贪睡模式下可用。如果请求是在MCU未处于贪睡模式时生成的, 则它们将被忽略。选择多个请求时, 每个请求都会从贪睡模式转移到软件待机模式。

表10.9显示了贪睡结束条件, 包括贪睡结束请求和外围模块的条件。CTSU、SCIO、ADC12n(n=0 1)和DTC模块可以使MCU保持在贪睡模式, 直到它们完成操作。但是, AGTn(n=1 3)下溢作为返回软件待机模式的触发器会取消贪睡模式, 而无需等待SCIO操作完成。

图10.5显示了从贪睡模式转换到软件待机模式的时序图。该模式转换根据SNZEDCR0寄存器中设置的贪睡结束请求发生。返回软件待机模式后, 贪睡请求会自动清除。

Table 10.8 可用的暂停结束请求 (触发返回到软件待机模式) (1 of 2)

| Peripheral Module | 暂停结束请求                      | Enable/Disable Control |          |
|-------------------|-----------------------------|------------------------|----------|
|                   |                             | Register               | Symbol   |
| AGT1              | AGT1 underflow (AGT1_AGTI)  | SNZEDCR0               | AGTUNFED |
| DTC               | 上次DTC传输完成(DTC_COMPLETE)     | SNZEDCR0               | DTCZRED  |
| DTC               | 不是最后一个DTC传输完成(DTC_TRANSFER) | SNZEDCR0               | DTCNZRED |
| ADC120            | 窗口AB比较匹配(ADC120_WCMPPM)     | SNZEDCR0               | ADOMATED |
| ADC120            | 窗口AB比较不匹配(ADC120_WCMPUM)    | SNZEDCR0               | ADOUMTED |



Table 10.8 Available snooze end requests (triggers to return to Software Standby mode) (2 of 2)

| Peripheral Module | Snooze end request                            | Enable/Disable Control |           |
|-------------------|---|------------------------|-----------|
|                   |   | Register               | Symbol    |
| ADC121            | Window A/B compare match (ADC121_WCMPPM)      | SNZEDCR0               | AD1MATED  |
| ADC121            | Window A/B compare mismatch (ADC121_WCMPPUM)  | SNZEDCR0               | AD1UMTED  |
| SCI0              | SCI0 address mismatch (SCI0_DCUF)             | SNZEDCR0               | SCI0UMTED |
| AGT3              | Underflow or measurement complete (AGT3_AGTI) | SNZEDCR1               | AGT3UNFED |

Table 10.9 Snooze end conditions

| Operating module when a snooze end request occurs | Snooze end request   |   |
|---|--|---|
|   | AGT1/AGT3 underflow  | Other than AGT1/AGT3 underflow  |
| DTC   | The MCU transfers to the Software Standby mode after all of the modules listed in this table complete operation. | The MCU transfers to the Software Standby mode after all of the modules listed to the left of this column complete the operation. |
| ADC12n  |  |   |
| CTSUS   |  |   |
| SCI0  | The MCU transfers to the Software Standby mode immediately after the snooze end request is generated.            |   |
| Other than specified                              | The MCU transfers to the Software Standby mode immediately after a snooze end request is generated.              |   |

Note: If the DTC is used to activate the ADC12n, CTSU, or SCI, the MCU transitions to Software Standby mode immediately after a snooze end request is generated.

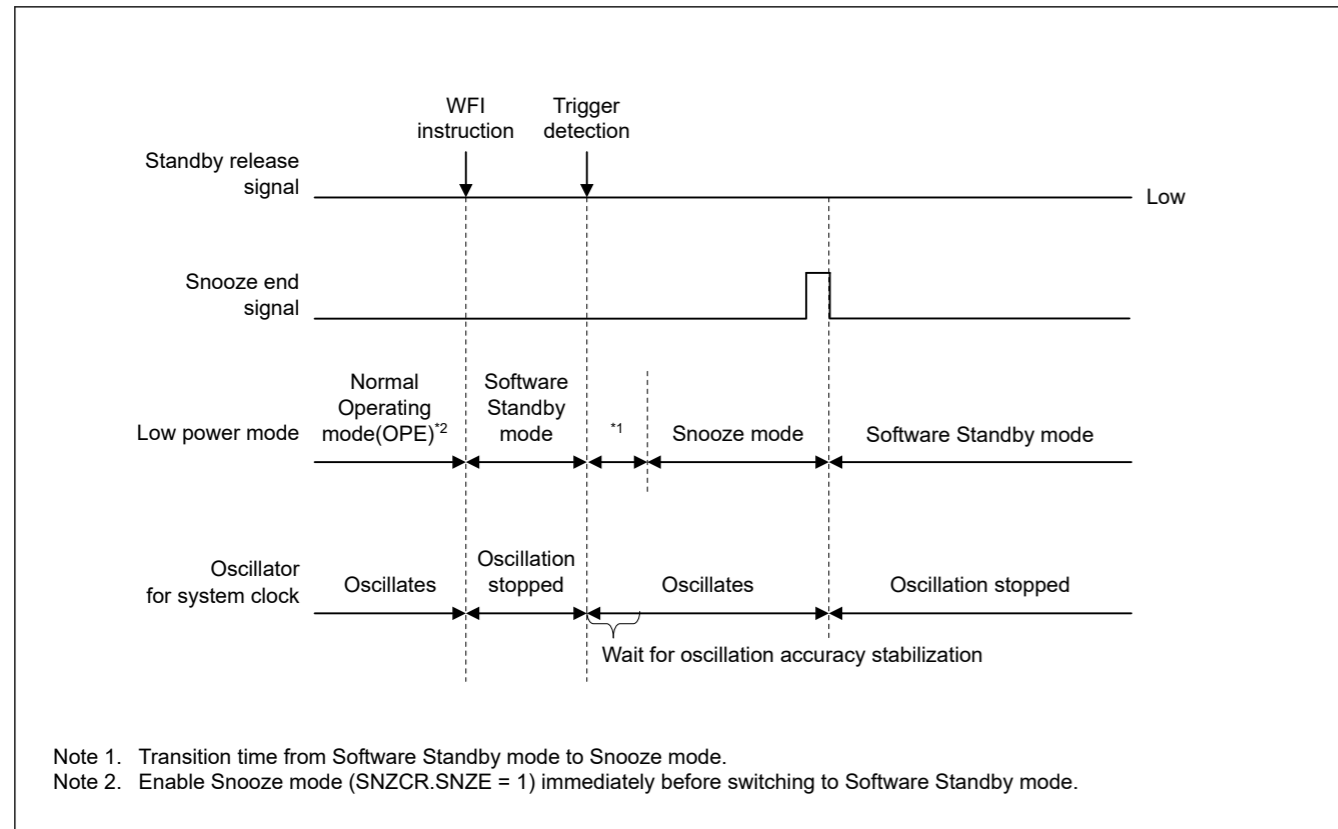


Figure 10.5 Canceling of Snooze mode when an interrupt request signal is not generated

10.8.4 Snooze Operation Example

Figure 10.6 shows an example setting for using ELC in Snooze mode.

Table 10.8 可用的暂停结束请求（触发返回到软件待机模式）（2个中的2个）

| Peripheral Module | 暂停结束请求                    | Enable/Disable Control |           |
|-------------------|---------------------------|------------------------|-----------|
|                   |                           | Register               | Symbol    |
| ADC121            | 窗口AB比较匹配(ADC121_WCMPPM)   | SNZEDCR0               | AD1MATED  |
| ADC121            | 窗口AB比较不匹配(ADC121_WCMPPUM) | SNZEDCR0               | AD1UMTED  |
| SCI0              | SCI0地址不匹配(SCI0_DCUF)      | SNZEDCR0               | SCI0UMTED |
| AGT3              | 下溢或测量完成(AGT3_AGTI)        | SNZEDCR1               | AGT3UNFED |

Table 10.9 暂停结束条件

| 发生贪睡结束请求时的操作模块 | 暂停结束请求                         |                                 |
|----------------|--------------------------------|---------------------------------|
|                | AGT1/AGT3 underflow            | 除了AGT1/AGT3下溢                   |
| DTC            | 在此表中列出的所有模块完成操作后，MCU将进入软件待机模式。 | 在此列左侧列出的所有模块完成操作后，MCU将进入软件待机模式。 |
| ADC12n         |                                |                                 |
| CTSUS          |                                |                                 |
| SCI0           | 产生贪睡结束请求后，MCU立即进入软件待机模式。       |                                 |
| 指定以外的          | 产生贪睡结束请求后，MCU立即转入软件待机模式。       |                                 |

Note: 如果DTC用于激活ADC12n、CTSUS或SCI，则MCU在产生贪睡结束请求后立即转换到软件待机模式。

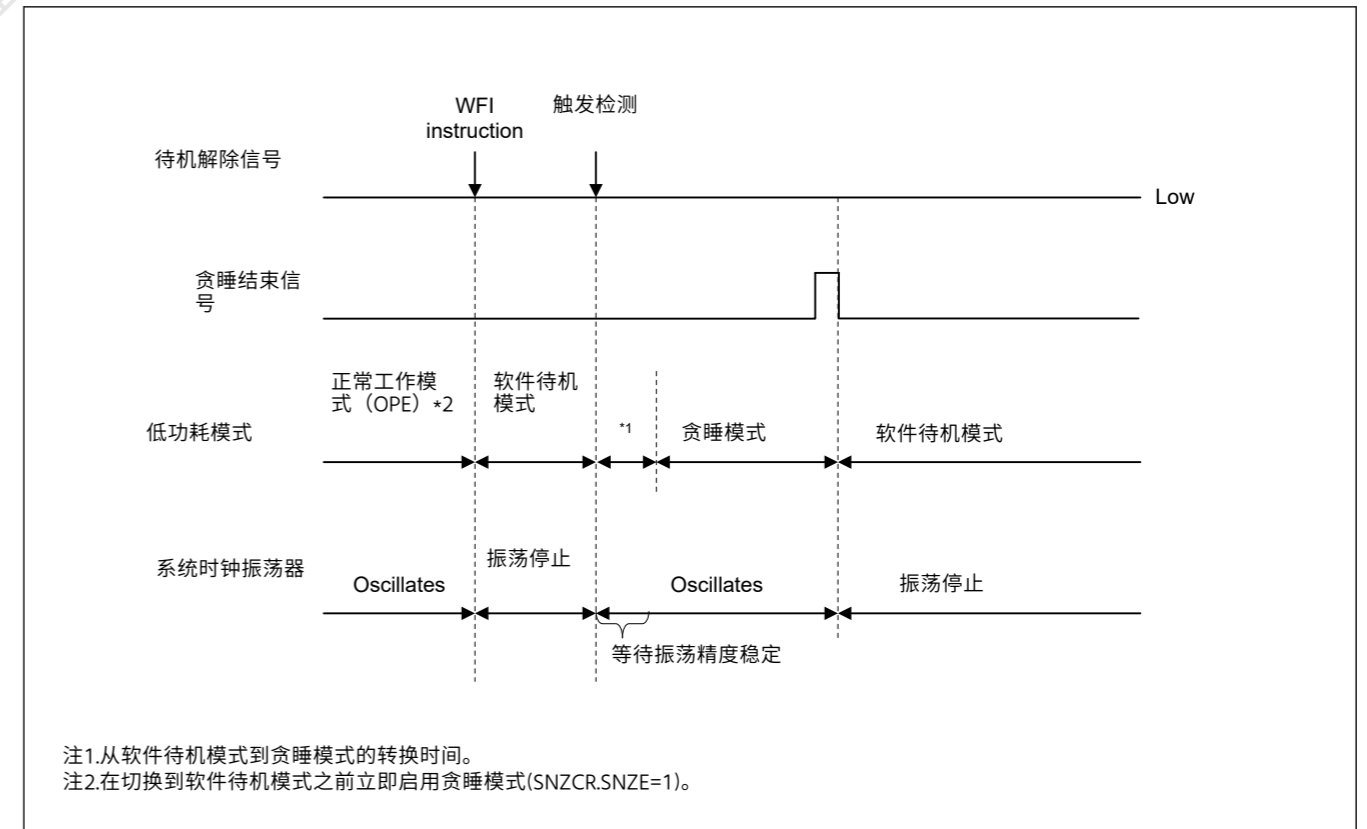


Figure 10.5 未产生中断请求信号时取消贪睡模式

10.8.4 贪睡操作示例

图10.6显示了在贪睡模式下使用ELC的示例设置。



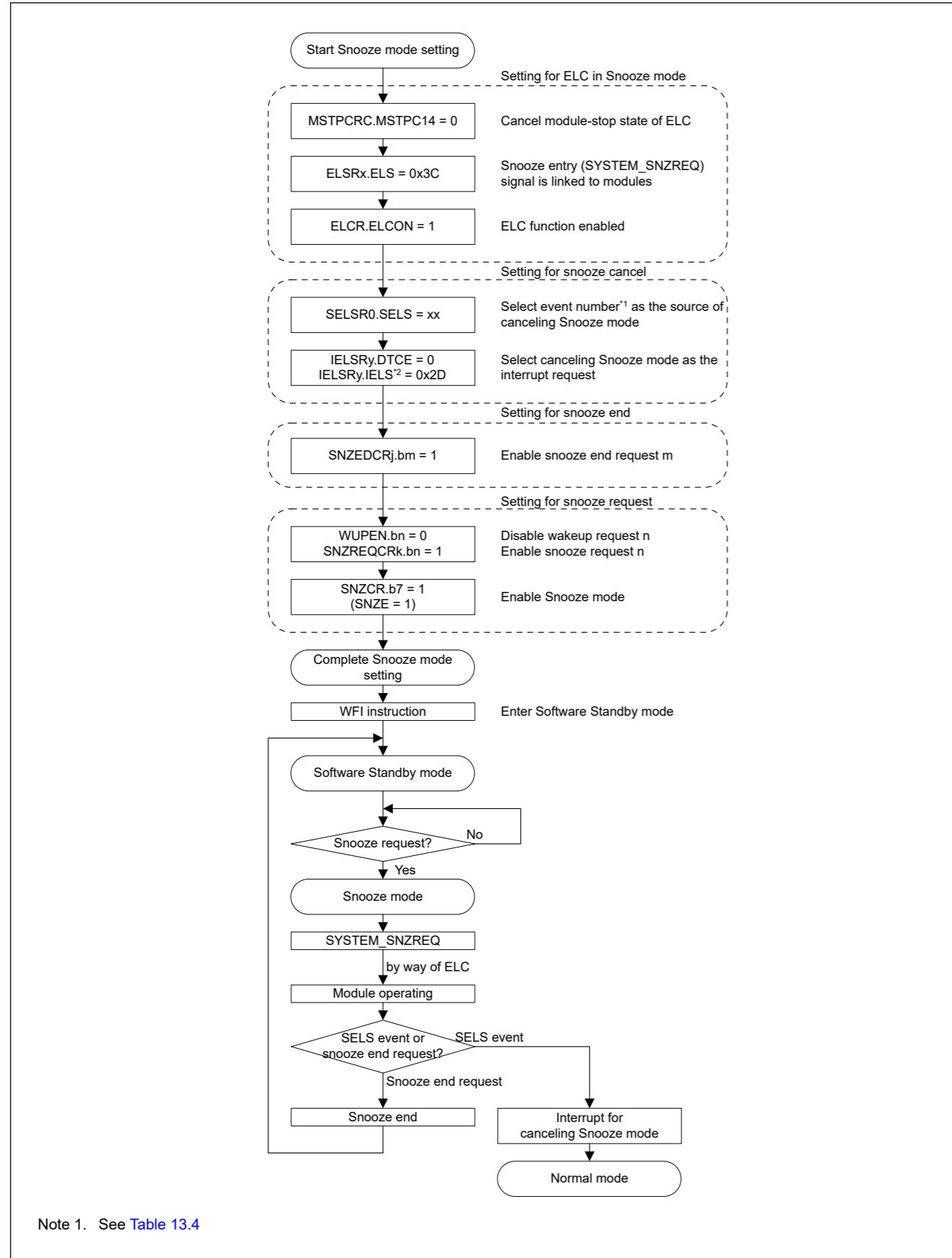


Figure 10.6 Setting example of using ELC in Snooze mode

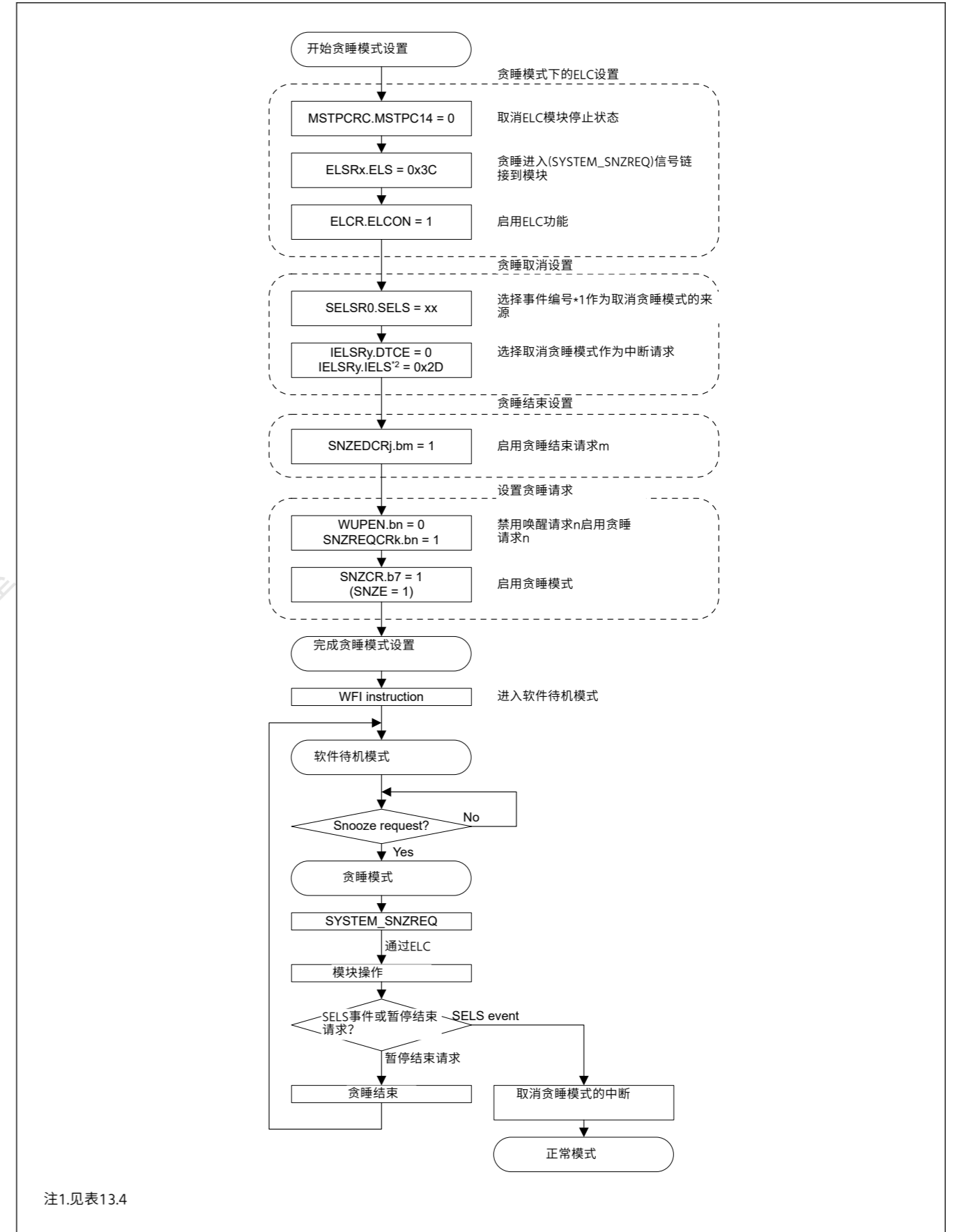


Figure 10.6 在贪睡模式下使用ELC的设置示例

The MCU can transmit and receive data in SCI0 asynchronous mode without CPU intervention. When using the SCI0 in Snooze mode, use either High-speed mode or Low-speed mode.

Do not use Subosc-speed mode. Table 10.10 shows the maximum transfer rate of SCI0 in Snooze mode.

**Table 10.10 HOCO:  $\pm 1.4\%$  ( $T_a = -20^\circ$  to  $105^\circ\text{C}$ ) (Unit: bps)**

| Maximum division ratio of ICLK, PCLKA, PCLKB, PCLKC, PCLKD, FCLK, and TRCLK | HOCO frequency        |        |        |                   |        |        |
|---|-----------------------|--------|--------|-------------------|--------|--------|
|   | LOCO is not operating |        |        | LOCO is operating |        |        |
|   | 16 MHz                | 18 MHz | 20 MHz | 16 MHz            | 18 MHz | 20 MHz |
| 1   | 2400                  |        |        | 4800              |        |        |
| 2   |                       |        |        |                   |        |        |
| 4   |                       |        |        |                   |        |        |
| 8   |                       |        |        |                   |        |        |
| 16  |                       |        |        |                   |        |        |
| 32  | 1200                  |        |        | 2400              |        |        |
| 64  |                       |        |        |                   |        |        |

When using SCI0 in Snooze mode, use the following setting: BGDM = 0, ABCS = 0, ABCSE = 0. See section 27, [Serial Communications Interface \(SCI\)](#) for information on these bits.

Figure 10.7 shows a setting example for using SCI0 in Snooze mode entry.

MCU可以在SCI0异步模式下发送和接收数据，无需CPU干预。在使用SCI0时贪睡模式，使用高速模式或低速模式。

不要使用Subosc速度模式。表10.10显示了Snooze模式下SCI0的最大传输速率。

**Table 10.10 HOCO:  $\pm 1.4\%$  ( $T_a = -20^\circ$  to  $105^\circ\text{C}$ ) (Unit: bps)**

| ICLK, PCLKA, PCLKB, PCLKC<br>的最大分频比,<br>PCLKD, FCLK, and TRCLK | HOCO frequency |        |        |          |        |        |
|--|----------------|--------|--------|----------|--------|--------|
|  | LOCO没有运行       |        |        | LOCO正在运营 |        |        |
|  | 16 MHz         | 18 MHz | 20 MHz | 16 MHz   | 18 MHz | 20 MHz |
| 1  | 2400           |        |        | 4800     |        |        |
| 2  |                |        |        |          |        |        |
| 4  |                |        |        |          |        |        |
| 8  |                |        |        |          |        |        |
| 16   |                |        |        |          |        |        |
| 32   | 1200           |        |        | 2400     |        |        |
| 64   |                |        |        |          |        |        |

在贪睡模式下使用SCI0时，使用以下设置：BGDM=0，ABCS=0，ABCSE=0。参见第27节，串行通信接口(SCI)以获取有关这些位的信息。

图10.7显示了在贪睡模式进入中使用SCI0的设置示例。

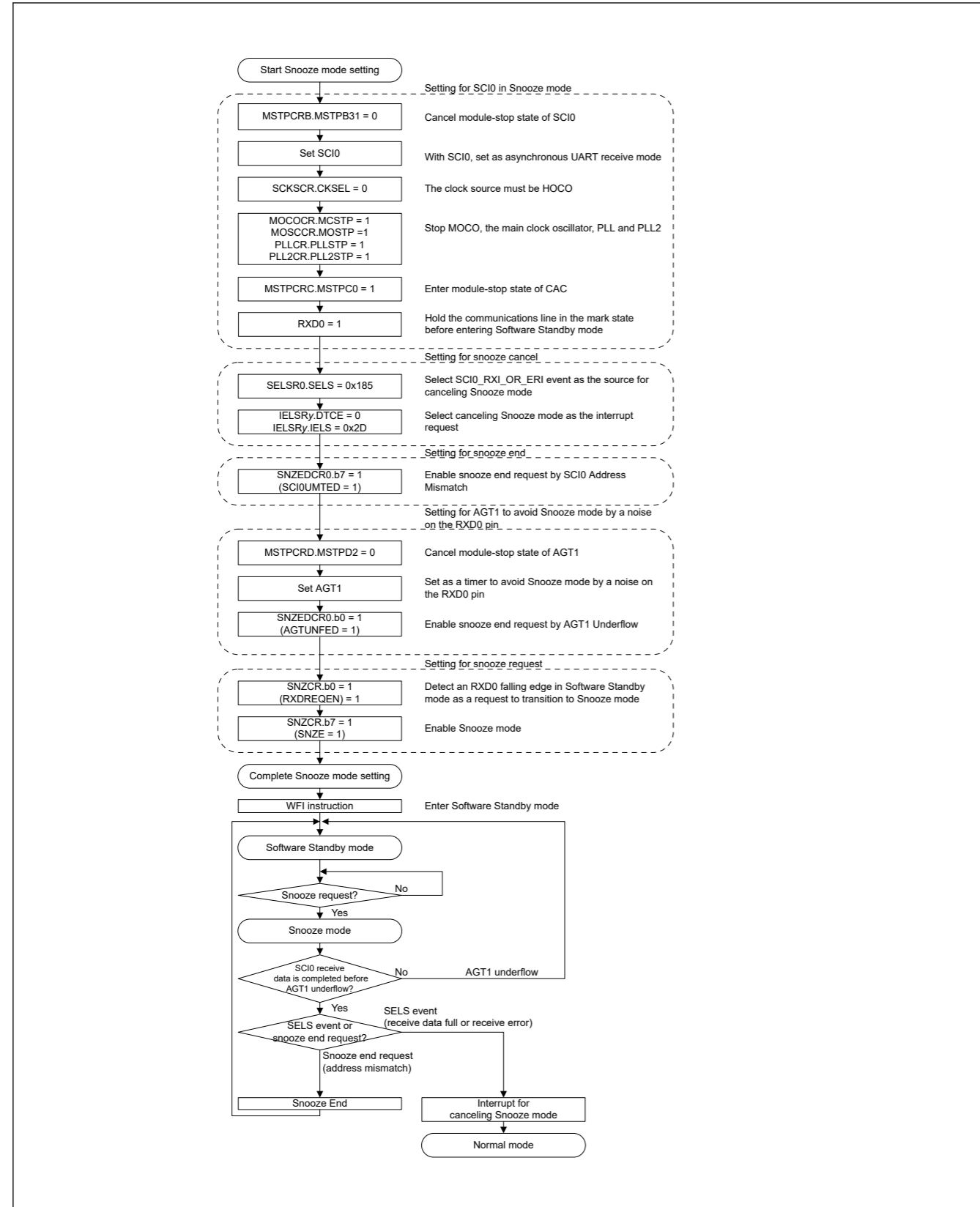


Figure 10.7 Setting example of using SCI0 in Snooze mode entry

10.9 Deep Software Standby Mode

10.9.1 Transitioning to Deep Software Standby Mode

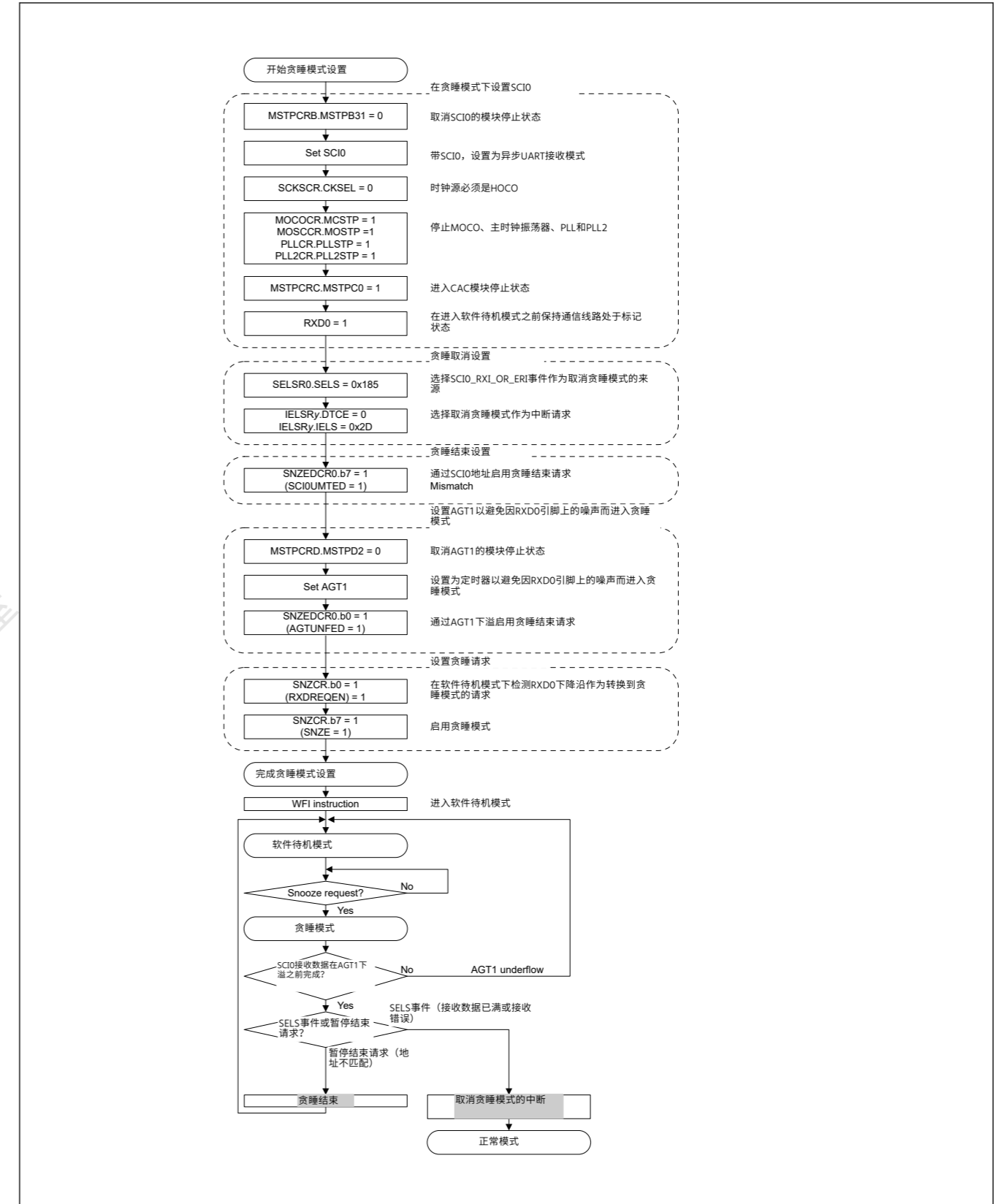


Figure 10.7 在Snooze模式进入使用SCI0的设置示例

10.9 深度软件待机模式

10.9.1 过渡到深度软件待机模式

When a WFI instruction is executed with the SBYCR.SSBY and DPSBYCR.DPSBY bits set to 1, the MCU enters Deep Software Standby mode. See [Table 10.6](#) for the setting of the related control bits. In this mode, the CPU, on-chip peripheral functions (except for RTC alarm, RTC interval, and USB suspend/resume detecting unit), SRAM (except for standby RAM), and all oscillators (except for Sub-clock oscillator and Low-speed on-chip oscillator) are stopped. Also because the internal power supply to these modules is stopped, power consumption is remarkably reduced. The contents of all CPU registers and internal peripheral modules (except for RTC alarm, RTC interval, and USB suspend/resume detecting unit) become undefined.

Data in the standby SRAM are preserved if the setting of the DEEPCUT[1:0] bits are 00b. If the setting of the DEEPCUT[1:0] bits are 01b, the internal power supply to the standby SRAM and the USB resume detecting unit is cut off, reducing power consumption. Data in the standby SRAM becomes undefined at this time. If the setting of the DEEPCUT[1:0] bits are 11b, the internal power supply to the standby SRAM, and the USB resume detecting unit is cut off, the LVD is stopped, and the low-power-consumption function of the power-on reset circuit is enabled, so power consumption is further reduced. For details, see [section 47, Electrical Characteristics](#).

When the MCU enters Deep Software Standby mode while the IWDTC is in auto start mode and the OFS0.IWDTCSTPCTL bit is 1, power supply to the IWDTC-dedicated clock and the IWDTC is cut off, and counting by the IWDTC stops.

When OFS0.IWDTCSTPCTL bit is 0, the MCU enters Software Standby mode instead of Deep Software Standby mode, regardless of the setting of OFS0.IWDTCSTRT bit or DPSBYCR.DPSBY bit. If OFS0.IWDTCSTPCTL bit is 0 while OFS0.IWDTCSTRT bit is 0 (auto start mode), IWDTC-dedicated clock and IWDTC continues the operation.

When LVD1CR0.RI = 1 (voltage monitor 1 reset selected) or LVD2CR0.RI = 1 (voltage monitor 2 reset selected), the MCU enters Software Standby mode instead of Deep Software Standby mode. The I/O port states are the same as in Software Standby mode.

Note: Conditions on the DTC, DMAC, and IWDTC for transitioning to Software Standby mode should be met before the WFI instruction is executed. For details, see [section 10.7. Software Standby Mode](#).

### 10.9.2 Cancelling Deep Software Standby Mode

Deep Software Standby mode is canceled by:

- An interrupt shown in [Table 10.3](#)
- A RES pin reset
- A power-on reset
- A voltage monitor 0 reset.

#### (1) Cancelling by an interrupt

Cancelling by interrupts is controlled by DPSIERn (n = 0 to 3) and DPSIFRn (n = 0 to 3). When a Deep Software Standby Cancelling interrupt is generated, the corresponding flag in DPSIFRn is set to 1. If the interrupt is enabled in DPSIERn, Deep Software Standby mode is canceled. Rising edge or falling edge can be selected by DPSIEGRn (n = 0 to 2). The interrupts for which an edge can be selected are the NMI, IRQn\_DS (n = 0 to 15), voltage monitor 1, and voltage monitor 2 interrupts. When a Deep Software Standby mode canceling request occurs, the internal power is supplied and MOCO starts oscillating, and an internal reset (Deep Software Standby reset) is generated for the entire MCU.

The stable MOCO clock is supplied to the entire MCU and Deep Software Standby reset is canceled. The MCU starts reset exception handling.

When Deep Software Standby mode is canceled by an external interrupt pin or internal interrupt signal, the RSTSR0.DPSRSTF flag is set to 1.

#### (2) Cancelling by RES pin reset

When the RES pin is driven low, the MCU cancels Deep Software Standby mode and enters the reset state. Keep the RES pin low for the time specified in [section 47, Electrical Characteristics](#). When RES pin is driven high after the specified time period, the CPU starts the reset exception handling.

#### (3) Cancelling by a power-on reset

Deep Software Standby mode is canceled by a power-on reset and the MCU starts the reset exception handling.

当在SBYCR.SSBY和DPSBYCR.DPSBY位设置为1的情况下执行WFI指令时，MCU进入Deep软件待机模式。相关控制位的设置见表10.6。在此模式下，CPU、片上外围功能（RTC闹钟、RTC间隔和USB暂停恢复检测单元除外）、SRAM（备用RAM除外）和所有振荡器（副时钟振荡器和Low-速度片上振荡器）停止。此外，由于这些模块的内部电源停止，功耗显著降低。所有CPU寄存器和内部外围模块（RTC警报、RTC间隔和USB暂停恢复检测单元除外）的内容变为未定义。

如果DEEPCUT[1:0]位的设置为00b，则保留备用SRAM中的数据。如果DEEPCUT[1:0]位设置为01b，则内部对待机SRAM和USB恢复检测单元的供电被切断，从而降低功耗。此时备用SRAM中的数据变为未定义。如果DEEPCUT[1:0]位设置为11b，则内部对待机SRAM的供电，以及USB恢复检测单元被切断，LVD停止，电源的低功耗功能-on复位电路使能，因此功耗进一步降低。有关详细信息，请参见第47节，电气特性。

当MCU在IWDTC处于自动启动模式且OFS0.IWDTCSTPCTL位为1时进入深度软件待机模式时，IWDTC专用时钟和IWDTC的电源被切断，IWDTC的计数停止。

当OFS0.IWDTCSTPCTL位为0时，MCU进入软件待机模式而不是深度软件待机模式，无论OFS0.IWDTCSTRT位或DPSBYCR.DPSBY位如何设置。如果OFS0.IWDTCSTPCTL位为0而OFS0.IWDTCSTRT位为0（自动启动模式），IWDTC专用时钟和IWDTC继续运行。

当LVD1CR0.RI=1（选择电压监视器1复位）或LVD2CR0.RI=1（选择电压监视器2复位）时，MCU进入软件待机模式而不是深度软件待机模式。IO端口状态与软件待机模式相同。

Note: 在执行WFI指令之前，应满足DTC、DMAC和IWDTC转换到软件待机模式的条件。有关详细信息，请参阅第10.7节。软件待机模式。

### 10.9.2 取消深度软件待机模式

深度软件待机模式通过以下方式取消：

- 表10.3所示的中断
- ARES引脚复位
- A power-on reset
- 电压监视器0复位。

#### (1) 通过中断取消

中断取消由DPSIERn(n=0到3)和DPSIFRn(n=0到3)控制。深度软件待机时产生取消中断时，DPSIFRn中的相应标志置1。如果在DPSIERn中使能中断，深度软件待机模式被取消。上升沿或下降沿可以通过DPSIEGRn(n=0到2)选择。可以选择边沿的中断是NMI、IRQn\_DS (n=0到15)、电压监视器1和电压监视器2中断。当产生深度软件待机模式取消请求时，内部电源被提供，MOCO开始振荡，并为整个MCU产生内部复位（深度软件待机复位）。

为整个MCU提供稳定的MOCO时钟，并取消深度软件待机复位。MCU开始复位异常处理。

当深度软件待机模式被外部中断引脚或内部中断信号取消时，RSTSR0.DPSRSTF标志设置为1。

#### (2) 通过RES引脚复位取消

当RES引脚驱动为低电平时，MCU取消深度软件待机模式并进入复位状态。在第47节“电气特性”中指定的时间内保持RES引脚为低电平。当RES引脚在指定时间段后被驱动为高电平时，CPU开始复位异常处理。

#### (3) 通过上电复位取消

深度软件待机模式通过上电复位取消，MCU启动复位异常处理。

#### (4) Cancelling by a voltage monitor 0 reset

Deep Software Standby mode is canceled by a voltage monitor 0 reset from the voltage detection circuit and the MCU starts the reset exception handling.

#### 10.9.3 Pin States when Deep Software Standby mode is Canceled

In Deep Software Standby mode, the I/O ports retain the same states from Software Standby mode. The MCU is initialized by an internal reset generated when Deep Software Standby mode is canceled, and reset exception handling starts immediately. The DPSBYCR.IOKEEP bit setting determines whether to initialize the I/O ports or to retain the I/O ports states for Software Standby mode. The following is the state of the I/O ports for each bit setting:

- When the DPSBYCR.IOKEEP bit = 0  
I/O ports are initialized by an internal reset generated when Deep Software Standby mode is canceled.
- When the DPSBYCR.IOKEEP bit = 1  
Although the MCU is initialized by an internal reset generated when Deep Software Standby mode is canceled, the I/O ports retain their states from Software Standby mode regardless of the MCU internal state. The I/O ports states remain unchanged from Software Standby mode even when settings are made to the I/O ports or peripheral modules. The retained I/O ports states are released by clearing the DPSBYCR.IOKEEP bit to 0, and the MCU operates according to the internal state. The DPSBYCR.IOKEEP bit is not initialized by any internal reset generated when Deep Software Standby mode is canceled.

#### 10.9.4 Example of Deep Software Standby Mode Application

##### (1) Entering and exiting Deep Software Standby mode

Figure 10.8 shows an example where a transition to Deep Software Standby mode is made at the falling edge of the IRQn\_DS pin, and exiting Deep Software Standby mode is made at the rising edge of the IRQn\_DS pin. In this example, an IRQn interrupt is accepted with the IRQCRi.IRQMD[1:0] bits of the ICU set to 00b (falling edge). After the DPSIEGRy.DIRQnEG (y = 0 or 1, n = 0 to 15) bit is set to 1 (rising edge) and the SBYCR.SSBY bit and DPSBYCR.DPSBY bit are both set to 1, the WFI instruction is executed. As a result, the MCU transitions to Deep Software Standby mode. Deep Software Standby mode is then canceled on the rising edge of the IRQn\_DS pin.

#### (4) 通过电压监视器取消0复位

深度软件待机模式通过电压检测电路的电压监视器0复位取消，MCU开始复位异常处理。

#### 10.9.3 取消深度软件待机模式时的引脚状态

在深度软件待机模式下，IO端口保持与软件待机模式相同的状态。MCU通过取消深度软件待机模式时产生的内部复位进行初始化，并立即开始复位异常处理。DPSBYCR.IOKEEP位设置确定是初始化IO端口还是保留软件待机模式下的IO端口状态。以下是每个位设置的IO端口状态：

- 当DPSBYCR.IOKEEP位=0时  
IO端口由取消深度软件待机模式时产生的内部复位进行初始化。
- 当DPSBYCR.IOKEEP位=1时  
虽然MCU由取消深度软件待机模式时产生的内部复位来初始化，但无论MCU内部状态如何，IO端口仍会保持软件待机模式下的状态。即使对IO端口或外围模块进行了设置，IO端口状态在软件待机模式下也保持不变。通过将DPSBYCR.IOKEEP位清0来释放保留的IO端口状态，MCU根据内部状态运行。DPSBYCR.IOKEEP位不会被取消深度软件待机模式时产生的任何内部复位初始化。

#### 10.9.4 深度软件待机模式应用示例

##### (1) 进入和退出深度软件待机模式

图10.8显示了一个示例，在该示例的下降沿转换到深度软件待机模式。IRQn\_DS引脚，并在IRQn\_DS引脚的上升沿退出深度软件待机模式。在这个例子中，一个将ICU的IRQCRi.IRQMD[1:0]位设置为00b（下降沿）接受IRQn中断。之后DPSIEGRy.DIRQnEG（y=0或1，n=0到15）位设置为1（上升沿）并且SBYCR.SSBY位和DPSBYCR.DPSBY位都设置为1，执行WFI指令。因此，MCU过渡到DeepSoftware待机模式。然后在IRQn\_DS引脚的上升沿取消深度软件待机模式。



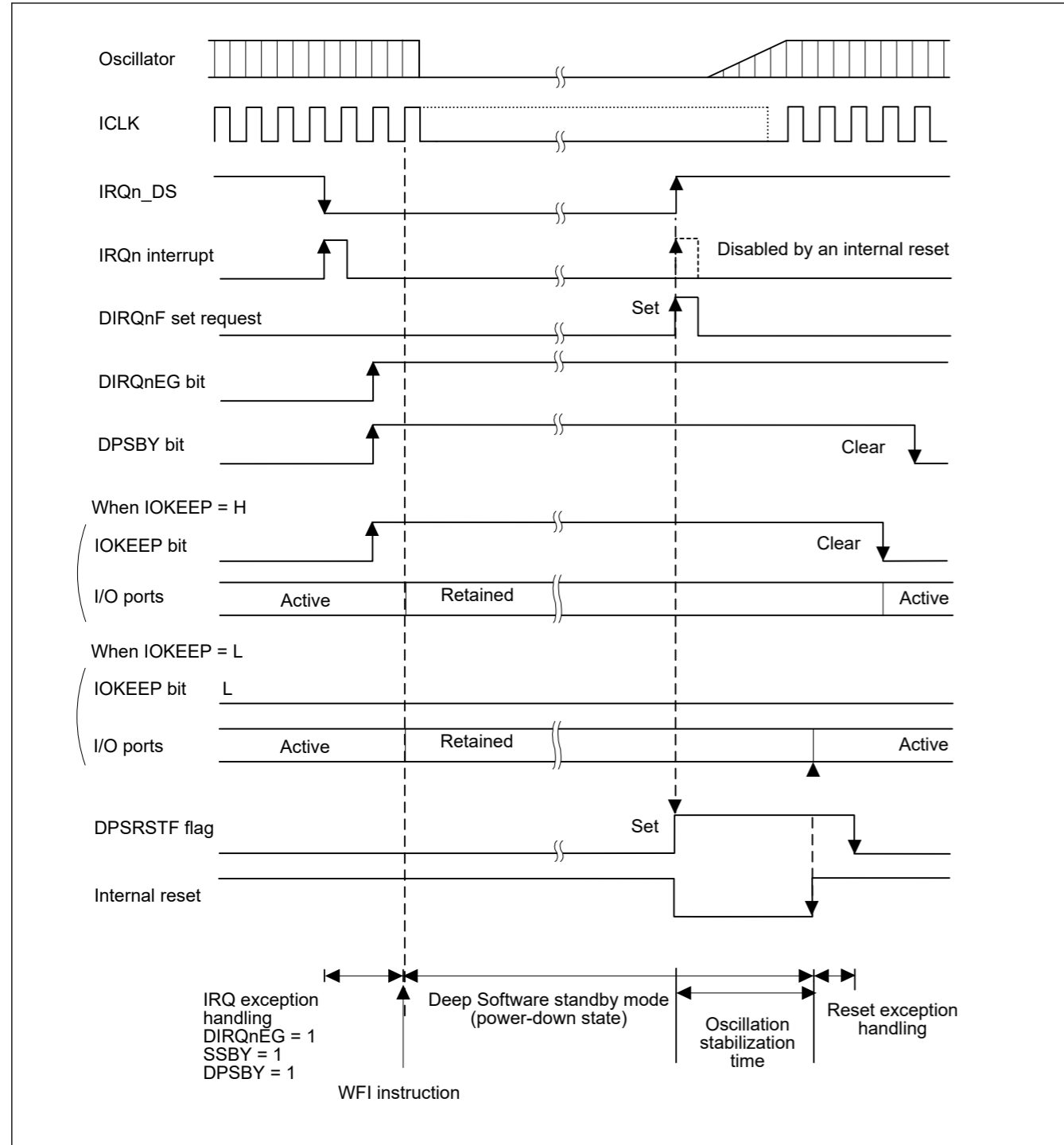


Figure 10.8 Example of Deep Software Standby Mode Application

### 10.9.5 Usage Flow for Deep Software Standby Mode

Figure 10.9 shows an example flow for using Deep Software Standby mode.

In this example, the RSTSR0.DPSRSTF flag of the reset function is read after the reset exception handling to determine whether a reset was generated by the RES pin or by the cancellation of Deep Software Standby mode.

For a reset by the RES pin, the MCU transitions to Deep Software Standby mode after the required register settings are made.

For a reset by cancellation of Deep Software Standby mode, the DPSBYCR.IOKEEP bit is cleared to 0 after the I/O port settings are made.

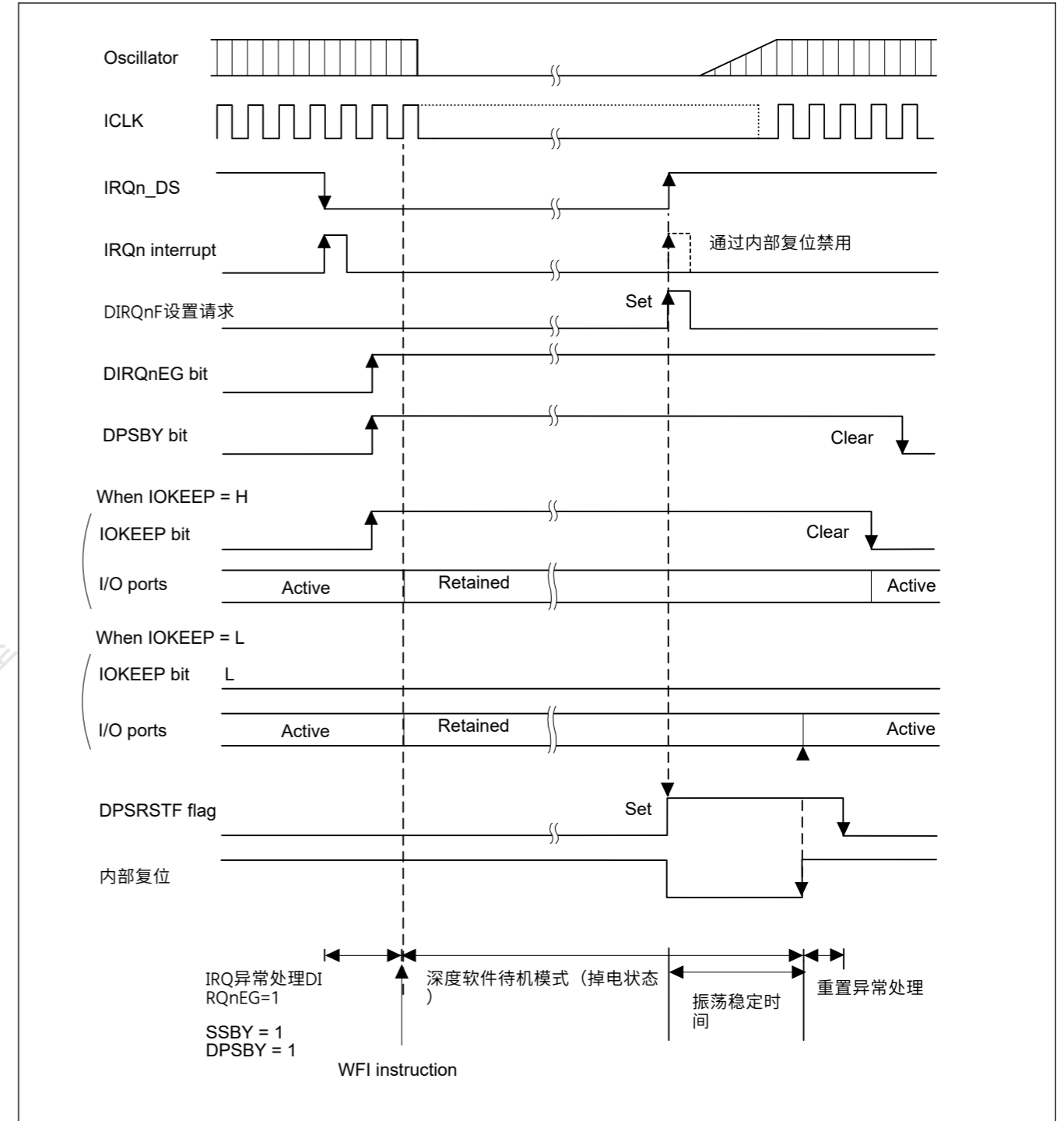


Figure 10.8 深度软件待机模式应用示例

### 10.9.5 深度软件待机模式的使用流程

图10.9显示了使用深度软件待机模式的示例流程。

在本例中，复位功能的RSTSR0.DPRSTF标志在复位异常处理后被读取，以确定复位是由RES引脚产生还是由深度软件待机模式的取消产生。

对于通过RES引脚进行的复位，在进行所需的寄存器设置后，MCU会转换到深度软件待机模式。

对于通过取消深度软件待机模式进行的复位，在IO端口设置完成后DPSBYCR.IOKEEP位被清零。

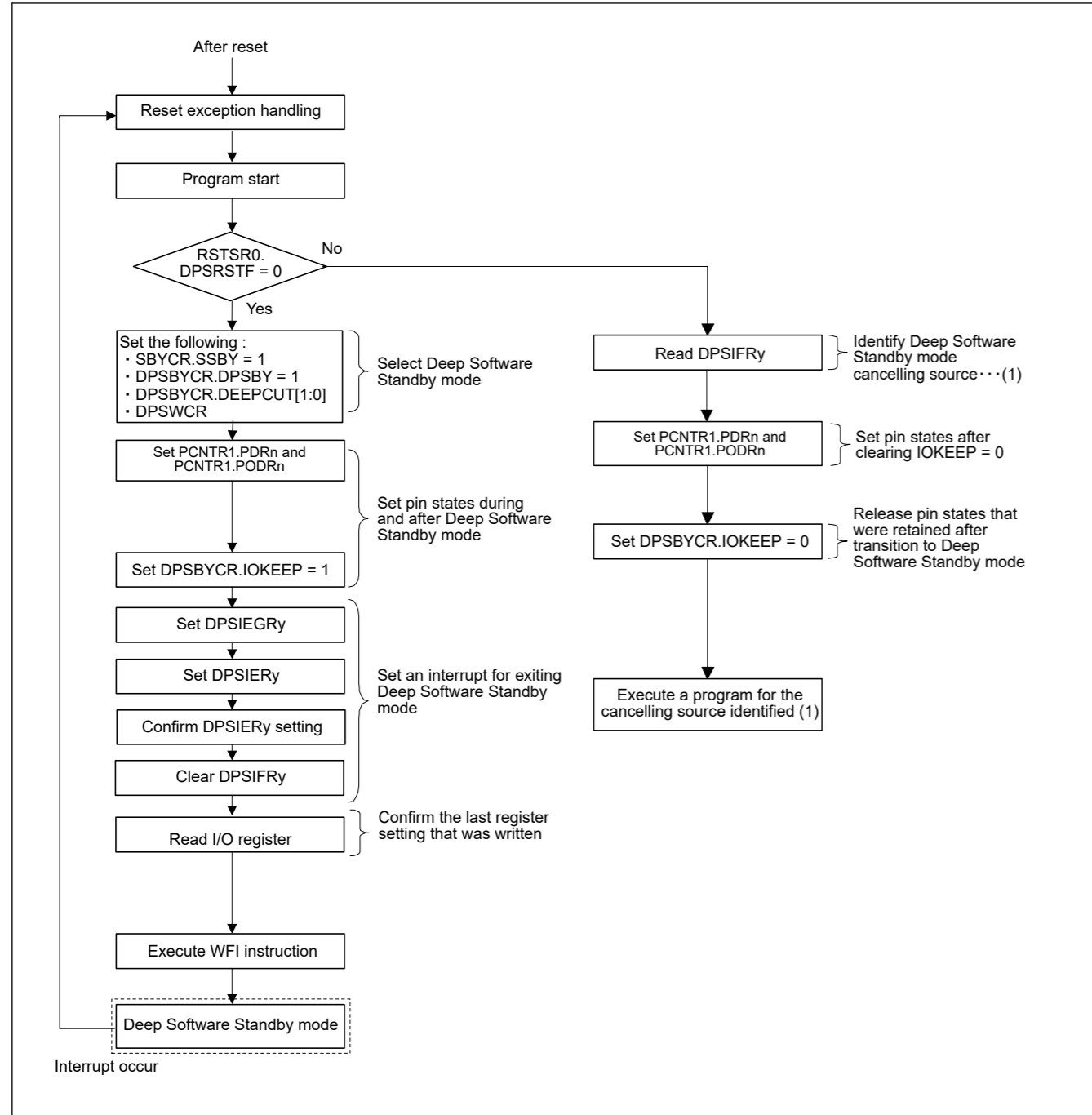


Figure 10.9 Example flow for using Deep Software Standby mode

10.10 Usage Notes

10.10.1 Register Access

(1) Invalid register write accesses during specific modes or transitions

Do not write to registers under any of the conditions listed in this section.

[Registers]

- All registers with a peripheral name of SYSTEM.

[Conditions]

- OPCCR.OPCMTSF = 1 or SOPCCR.SOPCMTSF = 1 (during transition of the operating power control mode)

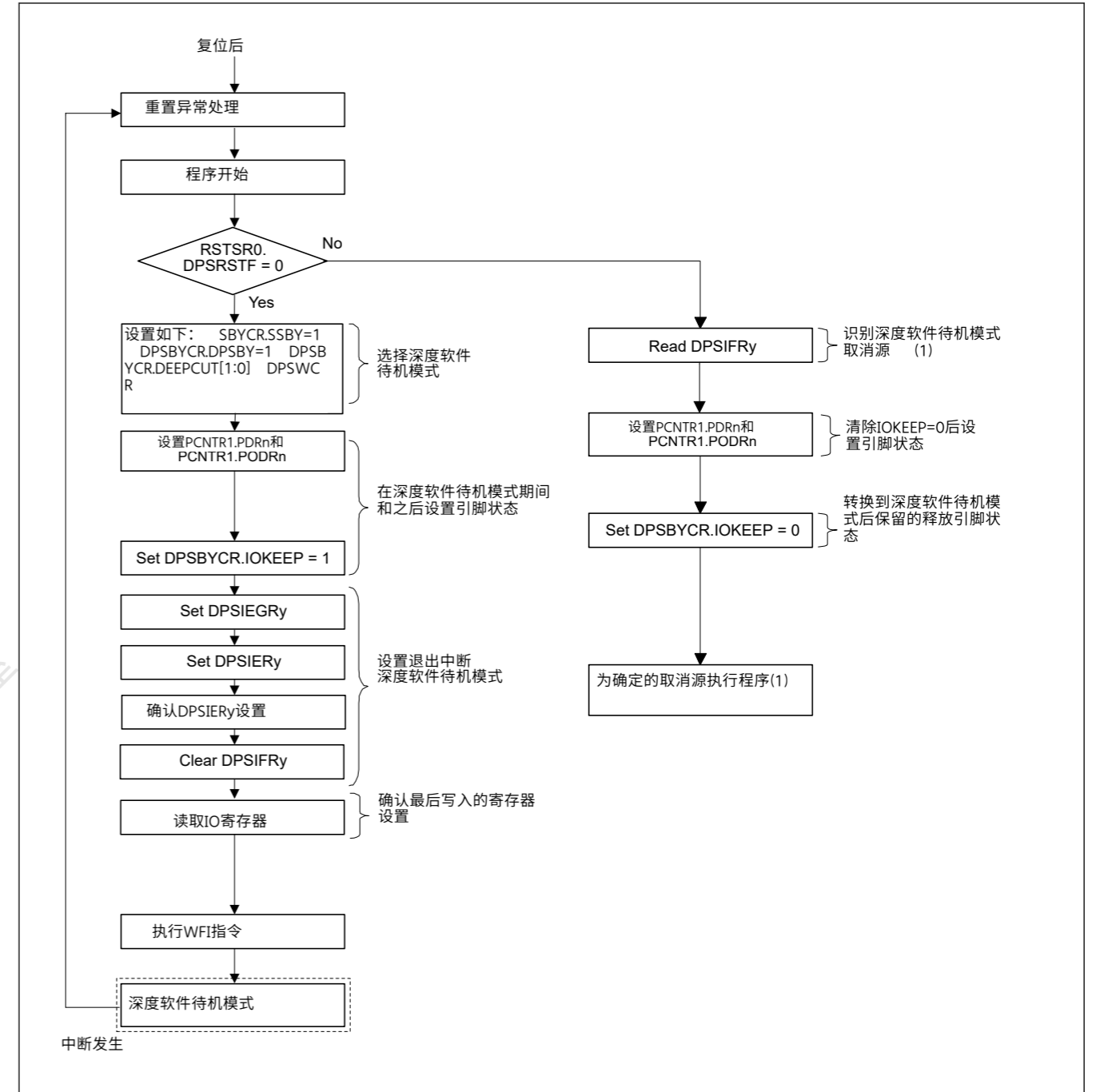


Figure 10.9 使用深度软件待机模式的示例流程

10.10 使用说明

10.10.1 注册访问

(1) 特定模式或转换期间的无效寄存器写访问

不要在本节列出的任何条件下写入寄存器。

[Registers]

- 外设名称为SYSTEM的所有寄存器。

[Conditions]

- OPCCR.OPCMTSF=1或SOPCCR.SOPCMTSF=1 (在工作功率控制模式转换期间)

- During the time period from executing a WFI instruction to returning to Normal mode
- FENTRYR.FENTRY0 = 1 or FENTRYR.FENTRYD = 1 (flash P/E mode, data flash P/E mode)

### (2) Valid setting for the clock-related registers

Table 10.11 and Table 10.12 show the valid settings of the clock-related registers in each operating power control mode. Do not write any value other than the valid setting. Each register has certain prohibited settings under conditions other than those related to the operating power control modes. See section 8, [Clock Generation Circuit](#) for another condition of each register.

Table 10.11 Valid settings for the clock-related registers (1)

| Mode         | Valid settings  |  |                           |                           |                              |                              |                              |                              |                              |
|--------------|---|--|---------------------------|---------------------------|------------------------------|------------------------------|------------------------------|------------------------------|------------------------------|
|              | SCKSCR.CKSEL[2:0]<br>CKOCR.<br>CKOSEL[2:0]  | SCKDIVC<br>R.<br>FCK[2:0]<br>ICK[2:0]  | PLLCR.<br>PLLSTP          | PLL2CR.<br>PLL2STP        | HOCOVR.<br>HCSTP             | MOCOVR.<br>MCSTP             | LOCOVR.<br>LCSTP             | MOSCCR.<br>MOSTP             | SOSCCR.<br>SOSTP             |
| High-speed   | 000b (HOCO)<br>001b (MOCO)<br>010b (LOCO)<br>011b (Main clock)<br>100b (Sub clock)<br>101b (PLL) ** | 000b (1/1)<br>001b (1/2)<br>010b (1/4)<br>011b (1/8)<br>100b<br>(1/16)<br>101b | 0 (operating)<br>1 (stop) | 0 (operating)<br>1 (stop) | 0 (operating)<br>1 (stopped) | 0 (operating)<br>1 (stopped) | 0 (operating)<br>1 (stopped) | 0 (operating)<br>1 (stopped) | 0 (operating)<br>1 (stopped) |
| Low-speed    | 000b (HOCO)<br>001b (MOCO)<br>010b (LOCO)<br>011b (Main clock)<br>100b (Sub clock)                  | 000b (1/1)<br>001b (1/2)<br>010b (1/4)<br>011b (1/8)<br>100b<br>(1/16)<br>101b | 1 (stop)                  | 1 (stop)                  |                              |                              |                              |                              |                              |
| Subosc-speed | 010b (LOCO)<br>100b (SOSC)  | 000b (1/1)   | 1 (stop)                  | 1 (stop)                  | 1 (stopped)                  | 1 (stopped)                  | 0 (operating)<br>1 (stopped) | 1 (stopped)                  | 0 (operating)<br>1 (stopped) |

Note 1. SCKSCR.CKSEL[2:0] only

Table 10.12 Valid settings for the clock-related registers (2)

| Operating oscillator              | Valid settings |                 |
|-----------------------------------|----------------|-----------------|
|                                   | SOPCCR.SOPCM   | OPCCR.OPCM[1:0] |
| PLL, PLL2                         | 0              | 00b             |
| High-speed on-chip oscillator     | 0              | 00b, 11b        |
| Middle-speed on-chip oscillator   |                |                 |
| Main clock oscillator             |                |                 |
| Low-speed on-chip oscillator      | 0, 1           | 00b, 11b        |
| Sub-clock oscillator              |                |                 |
| IWDT-dedicated on-chip oscillator |                |                 |

### (3) Invalid register write accesses in subosc-speed mode

Do not write to registers under the listed condition in this section.

[Registers]

- SCKSCR, OPCCR.

[Condition]

- SOPCCR.SOPCM = 1 (Subosc-speed mode).

### (4) Invalid register write accesses by the DTC or DMAC

Do not write to registers listed in this section by the DTC or DMAC.

[Registers]

- MSTPCRA, MSTPCRB, MSTPCRC, MSTPCRD, MSTPCRE

- 从执行WFI指令到返回Normal模式的时间段内
- FENTRYR.FENTRY0=1或FENTRYR.FENTRYD=1 (闪存PE模式, 数据闪存PE模式)

### (2) 时钟相关寄存器的有效设置

表10.11和表10.12显示了每种工作电源控制模式下时钟相关寄存器的有效设置。请勿写入有效设置以外的任何值。每个寄存器在与工作功率控制模式相关的条件下都有某些禁止设置。有关每个寄存器的另一个条件, 请参见第8节, 时钟生成电路。

Table 10.11 时钟相关寄存器的有效设置(1)

| Mode         | 有效设置  |  |                           |                           |                              |                              |                              |                              |                              |
|--------------|---|--|---------------------------|---------------------------|------------------------------|------------------------------|------------------------------|------------------------------|------------------------------|
|              | SCKSCR.CKSEL[2:0]<br>CKOCR.<br>CKOSEL[2:0]  | SCKDIVC<br>R.<br>FCK[2:0]<br>ICK[2:0]  | PLLCR.<br>PLLSTP          | PLL2CR.<br>PLL2STP        | HOCOVR.<br>HCSTP             | MOCOVR.<br>MCSTP             | LOCOVR.<br>LCSTP             | MOSCCR.<br>MOSTP             | SOSCCR.<br>SOSTP             |
| High-speed   | 000b (HOCO)<br>001b (MOCO)<br>010b (LOCO)<br>011b (Main clock)<br>100b (Sub clock)<br>101b (PLL) ** | 000b (1/1)<br>001b (1/2)<br>010b (1/4)<br>011b (1/8)<br>100b<br>(1/16)<br>101b | 0 (operating)<br>1 (stop) | 0 (operating)<br>1 (stop) | 0 (operating)<br>1 (stopped) | 0 (operating)<br>1 (stopped) | 0 (operating)<br>1 (stopped) | 0 (operating)<br>1 (stopped) | 0 (operating)<br>1 (stopped) |
| Low-speed    | 000b (HOCO)<br>001b (MOCO)<br>010b (LOCO)<br>011b (Main clock)<br>100b (Sub clock)                  | 000b (1/1)<br>001b (1/2)<br>010b (1/4)<br>011b (1/8)<br>100b<br>(1/16)<br>101b | 1 (stop)                  | 1 (stop)                  |                              |                              |                              |                              |                              |
| Subosc-speed | 010b (LOCO)<br>100b (SOSC)  | 000b (1/1)   | 1 (stop)                  | 1 (stop)                  | 1 (stopped)                  | 1 (stopped)                  | 0 (operating)<br>1 (stopped) | 1 (stopped)                  | 0 (operating)<br>1 (stopped) |

注1.仅SCKSCR.CKSEL[2:0]

Table 10.12 时钟相关寄存器的有效设置(2)

| 操作振荡器                             | 有效设置         |                 |
|-----------------------------------|--------------|-----------------|
|                                   | SOPCCR.SOPCM | OPCCR.OPCM[1:0] |
| PLL, PLL2                         | 0            | 00b             |
| High-speed on-chip oscillator     | 0            | 00b, 11b        |
| Middle-speed on-chip oscillator   |              |                 |
| 主时钟振荡器                            |              |                 |
| Low-speed on-chip oscillator      | 0, 1         | 00b, 11b        |
| Sub-clock oscillator              |              |                 |
| IWDT-dedicated on-chip oscillator |              |                 |

### (3) subosc-speed模式下的无效寄存器写访问

不要在本节列出的条件下写入寄存器。

[Registers]

- SCKSCR, OPCCR.

[Condition]

- SOPCCR.SOPCM = 1 (Subosc-speed mode).

### (4) DTC或DMAC的无效寄存器写访问

不要写入DTC或DMAC在本节中列出的寄存器。

[Registers]

- MSTPCRA, MSTPCRB, MSTPCRC, MSTPCRD, MSTPCRE

### (5) Invalid register write accesses in Snooze mode

Do not write to registers listed in this section in Snooze mode. They must be set before entering Software Standby mode.

[Registers]

- SNZCR, SNZEDCRn, SNZREQCRn.

### (6) Invalid write access to FLWT.FLWT[2:0]

Do not write any value other than 000b to the FLWT.FLWT[2:0] bits under the listed condition.

[Conditions]

- SOPCCR.SOPCM = 1 (Subosc-speed mode)

### (7) Invalid write access when PRCR.PRC1 is 0

Do not write to registers listed in this section when the PRCR.PRC1 bit is 0.

[Registers]

- SBYCR, SNZCR, SNZEDCRn, SNZREQCRn, OPCCR, SOPCCR, DPSBYCR, DPSWCR, DPSIERn, DPSIFRn, DPSIGRn, SYOCDRCR

### (8) Invalid write access when when PRCR.PRC4 bit is 0

Do not write to registers listed in this section when the PRCR.PRC4 bit is 0.

[Registers]

- LPMSAR, DPFSAR

## 10.10.2 I/O Port pin states

The I/O port pin states in Software Standby mode, Deep Software Standby and Snooze mode, unless modifying in Snooze mode, are the same before entering the modes. Therefore, power consumption is not reduced while the output signals are held high.

## 10.10.3 Module-Stop State of DTC, DMAC

Before writing 1 to MSTPCRA.MSTPA22, clear the DMAST.DMST bit of the DMAC and the DTCST.DTCST bit of the DTC to 0. For details, see [section 16, DMA Controller \(DMAC\)](#) and [section 17, Data Transfer Controller \(DTC\)](#).

## 10.10.4 Internal Interrupt Sources

Interrupts do not operate in the module-stop state. If setting the module-stop bit while an interrupt request is generated, a CPU interrupt source or a DTC or DMAC startup source cannot be cleared. Always disable the associated interrupts before setting the module-stop bits.

## 10.10.5 Input Buffer Control by DIRQnE Bit

Setting the DPSIERy.DIRQnE (y = 0 or 1, n = 0 to 15) bit to 1 enables the associated input buffer of the IRQ0-DS to IRQ15-DS pins. Although inputs to these pins are sent to the DPSIFRy.DIRQnF (y = 0 or 1, n = 0 to 15) bits, they are not sent to the interrupt controller (ICU), peripheral modules, and I/O ports.

## 10.10.6 Transitioning to Low Power Modes

Because the MCU does not support wakeup by events, do not enter the low power modes such as Sleep mode, Software Standby mode or Deep Software Standby Mode by executing a WFE instruction. Also, do not set the SLEEPDEEP bit of the System Control Register in the Cortex-M33 core because the MCU does not support low power modes by SLEEPDEEP.

## 10.10.7 Timing of WFI Instruction

It is possible for the WFI instruction to be executed before I/O register write is completed, in which case operation might not be as intended. This can happen if the WFI is placed immediately after a write to an I/O register. To avoid this problem, read back the register that was written to confirm that the write completed.

### (5) 贪睡模式下的无效寄存器写访问

不要在贪睡模式下写入本节中列出的寄存器。必须在进入软件待机模式之前设置它们。

[Registers]

- SNZCR, SNZEDCRn, SNZREQCRn.

### (6) 对FLWT.FLWT[2:0]的写入访问无效

在所列条件下, 请勿将000b以外的任何值写入FLWT.FLWT[2:0]位。

[Conditions]

- SOPCCR.SOPCM = 1 (Subosc-speed mode)

### (7) 当PRCR.PRC1为0时, 写入访问无效

当PRCR.PRC1位为0时, 不要写入本节中列出的寄存器。

[Registers]

- SBYCR, SNZCR, SNZEDCRn, SNZREQCRn, OPCCR, SOPCCR, DPSBYCR, DPSWCR, DPSIERn, DPSIFRn, DPSIGRn, SYOCDRCR

### (8) 当PRCR.PRC4位为0时, 写访问无效

当PRCR.PRC4位为0时, 不要写入本节中列出的寄存器。

[Registers]

- LPMSAR, DPFSAR

## 10.10.2 IO端口引脚状态

软件待机模式、深度软件待机和贪睡模式下的IO端口引脚状态, 除非在贪睡模式下进行修改, 否则在进入这些模式之前是相同的。因此, 当输出信号保持为高时, 功耗不会降低。

## 10.10.3 DTC、DMAC的模块停止状态

在将1写入MSTPCRAM.MSTPA22之前, 清除DMAC的DMAST.DMST位和DTCST.DTCST位DTC为0。有关详细信息, 请参阅第16节, DMA控制器(DMAC)和第17节, 数据传输控制器(DTC)。

## 10.10.4 内部中断源

中断不会在模块停止状态下运行。如果在产生中断请求时设置模块停止位, 则无法清除CPU中断源或DTC或DMAC启动源。在设置模块停止位之前, 始终禁用相关的中断。

## 10.10.5 通过DIRQnE位控制输入缓冲器

将DPSIERy.DIRQnE (y=0或1, n=0至15) 位设置为1可使IRQ0-DS的相关输入缓冲器IRQ15-DS引脚。尽管这些引脚的输入被发送到DPSIFRy.DIRQnF (y=0或1, n=0到15) 位, 但它们不会被发送到中断控制器(ICU)、外设模块和IO端口。

## 10.10.6 过渡到低功耗模式

由于MCU不支持事件唤醒, 请勿进入睡眠模式、软件等低功耗模式待机模式或深度软件待机模式通过执行WFE指令。此外, 不要设置Cortex-M33内核中系统控制寄存器的SLEEPDEEP位, 因为MCU不支持SLEEPDEEP的低功耗模式。

## 10.10.7 WFI指令的时间安排

WFI指令可能在IO寄存器写入完成之前执行, 在这种情况下操作可能不会按预期进行。如果在写入IO寄存器后立即放置WFI, 则会发生这种情况。为避免此问题, 请回读已写入的寄存器以确认写入已完成。



### 10.10.8 Writing to the WDT/IWDT Registers by DTC or DMAC in Sleep Mode or Snooze Mode

Do not write to the WDT or IWDT registers by the DTC or DMAC while WDT or IWDT is stopped after entering Sleep mode or Snooze mode.

### 10.10.9 Oscillators in Snooze Mode

Oscillators that stop on entering Software Standby mode automatically restart when a trigger for switching to Snooze mode is generated. The MCU does not enter Snooze mode until all the oscillators stabilize. If in Snooze mode, you must disable oscillators that are not required in Snooze mode before entering Software Standby mode. Otherwise, the transition from Software Standby mode to Snooze mode takes longer.

### 10.10.10 Snooze Mode Entry by RXD0 Falling Edge

When the SNZCR.RXDREQEN bit is 1, the falling edge of RXD0 pin is used to switch MCU from Software Standby mode to Snooze mode when using UART of SCIO in Snooze mode. In this case an interrupt such as SCIO\_ERI, SCIO\_RXI or an address mismatch event is used as the source for canceling Snooze mode. However noise on the RXD0 pin might cause the MCU to transfer from Software Standby mode to Snooze mode unexpectedly. In this case if the MCU does not receive RXD0 data after the noise, an interrupt such as SCIO\_ERI or SCIO\_RXI, or an address mismatch event is not generated and the MCU stays in Snooze mode. This can be avoided by using AGTn (n = 1, 3) underflow interrupt to return to Software Standby mode or Normal mode unless otherwise UART receive data is completed before AGTn (n = 1, 3) underflow. However, do not use the AGTn (n = 1, 3) underflow as a source to return to Software Standby mode during an UART communication. This causes the UART to stop the operation in a half-finished state.

### 10.10.11 Using UART of SCIO in Snooze Mode

When using UART in Snooze mode, ensure that the snooze request (RXD0 falling edge) does not conflict with the wakeup requests set by the WUPEN register, otherwise UART cannot be guaranteed.

When using UART in Snooze mode, the following conditions must be satisfied:

- The clock source must be HOCO
- MOCO, PLL, PLL2, and the main clock oscillator must be stopped before entering Software Standby mode
- The RXD0 pin must be kept high before entering Software Standby mode
- A transition to Software Standby mode must not occur during an SCIO communication
- The MSTPCRC.MSTPC0 bit must be 1 before entering Software Standby mode.

### 10.10.12 Conditions of A/D Conversion Start in Snooze Mode

ADC120 can only be triggered by the ELC in Snooze mode. Do not use software trigger or ADTRGn (n = 0, 1) pin.

### 10.10.13 Conditions of CTSU in Snooze Mode

The CTSU can only be started by the ELC in Snooze mode.

### 10.10.14 ELC Events in Snooze Mode

This section lists available ELC events in Snooze mode. Do not use any other events. If starting peripheral modules for the first time after entering Snooze mode, the Event Link Setting Register (ELSRn) must set a Snooze mode entry event (SYSTEM\_SNZREQ) as the trigger.

- Snooze mode entry (SYSTEM\_SNZREQ)
- DTC transfer end (DTC\_DTCEND)
- ADC120 window A/B compare match (ADC120\_WCMPPM)
- ADC120 window A/B compare mismatch (ADC120\_WCMPUM)
- ADC121 window A/B compare match (ADC121\_WCMPPM)
- ADC121 window A/B compare mismatch (ADC121\_WCMPUM)

### 10.10.8 在睡眠模式或贪睡模式下通过DTC或DMAC写入WDT/IWDT寄存器 Mode

当WDT或IWDT在进入休眠模式或贪睡模式后停止时，请勿通过DTC或DMAC写入WDT或IWDT寄存器。

### 10.10.9 贪睡模式下的振荡器

进入软件待机模式时停止的振荡器会在生成切换到贪睡模式的触发器时自动重新启动。在所有振荡器稳定之前，MCU不会进入贪睡模式。如果处于贪睡模式，您必须在进入软件待机模式之前禁用贪睡模式中不需要的振荡器。否则，从软件待机模式到贪睡模式的转换需要更长的时间。

### 10.10.10 通过RXD0下降沿进入贪睡模式

当SNZCR.RXDREQEN位为1时，在贪睡模式下使用SCIO的UART时，RXD0引脚的下降沿用于将MCU从软件待机模式切换到贪睡模式。在这种情况下，中断如SCIO\_ERI、SCIO\_RXI或地址不匹配事件被用作取消贪睡模式的源。然而，RXD0引脚上的噪声可能会导致MCU意外地从软件待机模式转换到贪睡模式。在这种情况下，如果MCU没有收到

噪声后的RXD0数据，如SCIO\_ERI或SCIO\_RXI等中断，或地址不匹配事件不产生，MCU保持在贪睡模式。这可以通过使用AGTn(n=1 3)下溢中断返回到软件待机模式或正常模式来避免，除非在AGTn(n=1 3)下溢之前完成UART接收数据。但是，不要使用AGTn(n=1 3)下溢作为UART通信期间返回软件待机模式的源。这会导致UART在半完成状态下停止操作。

### 10.10.11 在贪睡模式下使用SCIO的UART

在Snooze模式下使用UART时，确保Snooze请求（RXD0下降沿）与WUPEN寄存器设置的唤醒请求不冲突，否则无法保证UART。

在Snooze模式下使用UART时，必须满足以下条件：

- 时钟源必须是HOCO
- MOCO、PLL、PLL2和主时钟振荡器必须在进入软件待机模式之前停止
- 进入软件待机模式前，RXD0引脚必须保持高电平
- 在SCIO通信期间不得转换到软件待机模式
- MSTPCRC.MSTPC0位必须为1才能进入软件待机模式。

### 10.10.12 贪睡模式下AD转换开始的条件

ADC120只能由ELC在贪睡模式下触发。不要使用软件触发或ADTRGn(n=0 1)引脚。

### 10.10.13 CTSU在贪睡模式下的情况

CTSU只能由ELC在贪睡模式下启动。

### 10.10.14 贪睡模式下的ELC事件

本节列出了贪睡模式下可用的ELC事件。不要使用任何其他事件。如果进入贪睡模式后第一次启动外围模块，事件链接设置寄存器（ELSRn）必须设置贪睡模式进入事件（SYSTEM\_SNZREQ）作为触发器。

- 贪睡模式条目(SYSTEM\_SNZREQ)
- DTC传输结束 (DTC\_DTCEND)
- ADC120窗口AB比较匹配(ADC120\_WCMPPM)
- ADC120窗口AB比较不匹配(ADC120\_WCMPUM)
- ADC121窗口AB比较匹配(ADC121\_WCMPPM)
- ADC121窗口AB比较不匹配(ADC121\_WCMPUM)



- Data operation circuit interrupt (DOC\_DOPCI).

#### 10.10.15 Module-Stop Bit Write Timing

It is possible that access to I/O register may be executed before the corresponding module-stop bit write completed. In this case, access to I/O register may not proceed as intended. To avoid this issue, before accessing I/O register, read back the module-stop bit that was written to confirm that the write completed.

- 数据操作电路中断（DOC\_DOPCI）。

#### 10.10.15 模块停止位写时序

在相应的模块停止位写入完成之前，可能会执行对IO寄存器的访问。在这种情况下，对IO寄存器的访问可能不会按预期进行。为避免此问题，在访问IO寄存器之前，请回读已写入的模块停止位以确认写入已完成。

RA生态工作室

## 11. Battery Backup Function

### 11.1 Overview

The MCU provides a battery backup function that maintains partial battery powering in the event of a power loss. Switching between VCC and VBATT, the battery-powered area includes RTC, SOSC, and backup memory.

During normal operation, the battery-powered area is powered by the main power supply, the VCC pin. When a VCC voltage drop is detected, the power source switches to the dedicated battery backup power pin, the VBATT pin. When the voltage rises again, the power source switches back from VBATT to VCC.

#### 11.1.1 Features of Battery Backup Function

The features include:

- Battery power supply switch
- Backup registers
- Time capture pin detection

#### 11.1.2 Battery Power Supply Switch

When the voltage applied to the VCC pin drops, this feature switches the power supply from the VCC pin to the VBATT pin. When the voltage rises, it switches the power supply from the VBATT pin back to the VCC pin.

#### 11.1.3 Backup Registers

The battery-powered area provides 128-byte backup registers. These registers retain data when power is supplied from the VBATT pin even when the VCC pin is in the power-off state.

#### 11.1.4 Time Capture Pin Detection

The RTC detects input level changes on the time capture pin. For more information, see [section 23, Realtime Clock \(RTC\)](#).

**Note:** When  $VCC < V_{DET\_BATT}$  and  $> (VBATT + 0.6 V)$ , the injected current flows from the VCC to the VBATT pin through an internal diode. If the power supply battery connected to the VBATT pin cannot support this current injection, for example if the battery is not rechargeable, Renesas strongly recommends that you connect through a low-voltage threshold diode between the power supply battery and the VBATT pin.

**Note:** You must enable voltage monitor 0 reset to use the battery backup function. The voltage monitor 0 level must be higher than the VBATT switch level.

[Figure 11.1](#) shows the configuration of the battery backup function.

## 11. 电池备份功能

### 11.1 Overview

MCU提供电池备份功能，可在断电时保持部分电池供电。在VCC和VBATT之间切换，电池供电区域包括RTC、SOSC和备份存储器。

在正常工作期间，电池供电区域由主电源VCC引脚供电。当检测到VCC电压下降时，电源切换到专用电池备用电源引脚VBATT引脚。当电压再次上升时，电源从VBATT切换回VCC。

#### 11.1.1 电池备份功能的特点

特点包括：

- 电池供电开关
- 备份寄存器
- 时间捕捉引脚检测

#### 11.1.2 电池电源开关

当施加到VCC引脚的电压下降时，此功能将电源从VCC引脚切换到VBATT引脚。当电压上升时，它将电源从VBATT引脚切换回VCC引脚。

#### 11.1.3 备份寄存器

电池供电区提供128字节的备份寄存器。这些寄存器在供电时保留数据VBATT引脚即使在VCC引脚处于断电状态时。

#### 11.1.4 时间捕捉引脚检测

RTC检测时间捕捉引脚上的输入电平变化。有关详细信息，请参阅第23节，实时时钟(RTC)。

**Note:** 当 $VCC < V_{DET\_BATT}$ 且 $> (VBATT + 0.6V)$ 时，注入电流通过内部二极管从VCC流向VBATT引脚。如果连接到VBATT引脚的电源电池不能支持这种电流注入，例如，如果电池不可充电，瑞萨强烈建议您通过电源电池和VBATT引脚之间的低压阈值二极管进行连接。

**Note:** 您必须启用电压监视器0复位才能使用电池备份功能。电压监视器0电平必须高于VBATT开关电平。

图11.1显示了电池备份功能的配置。

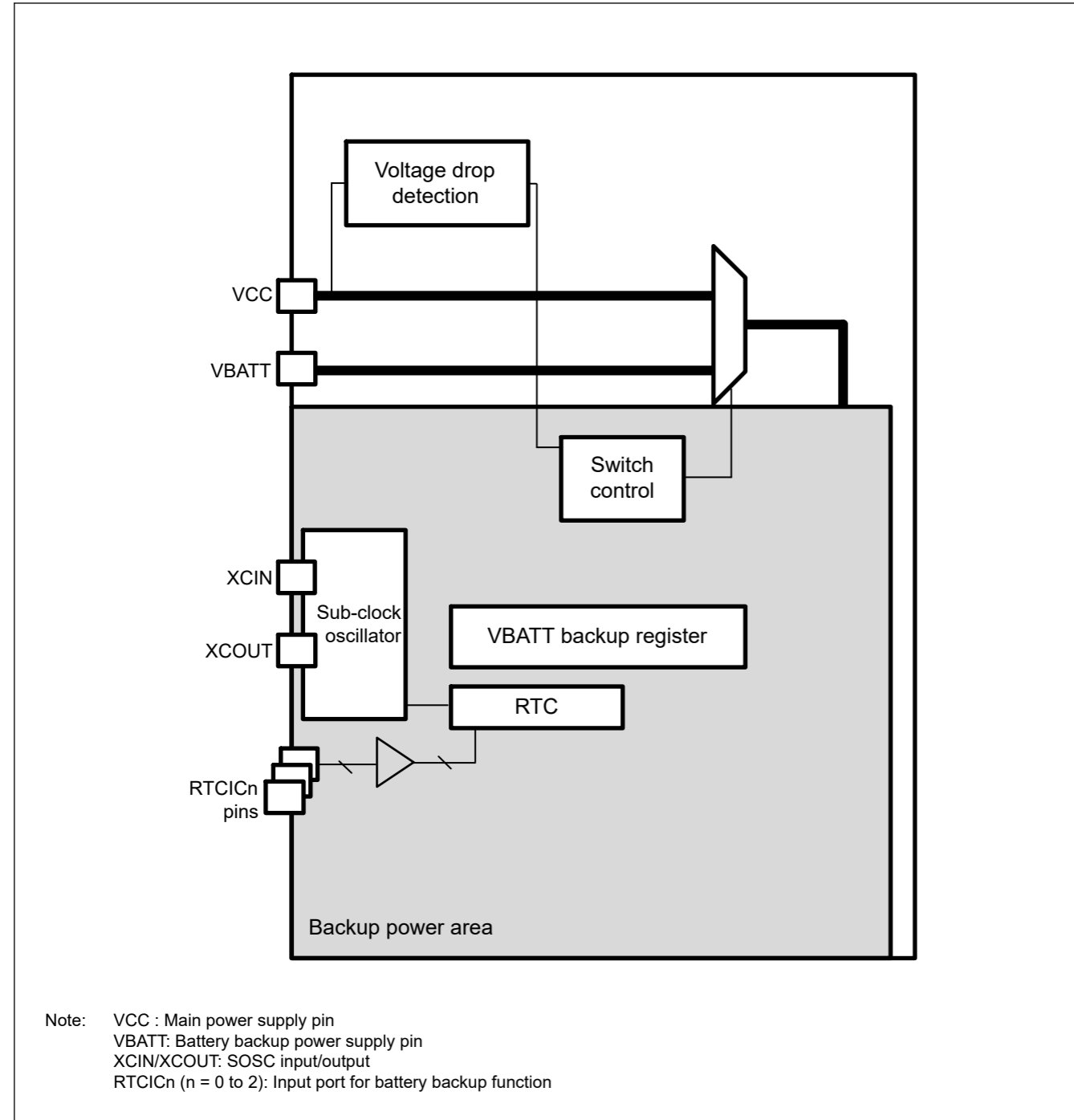


Figure 11.1 Configuration of the battery backup function

11.2 Register Descriptions

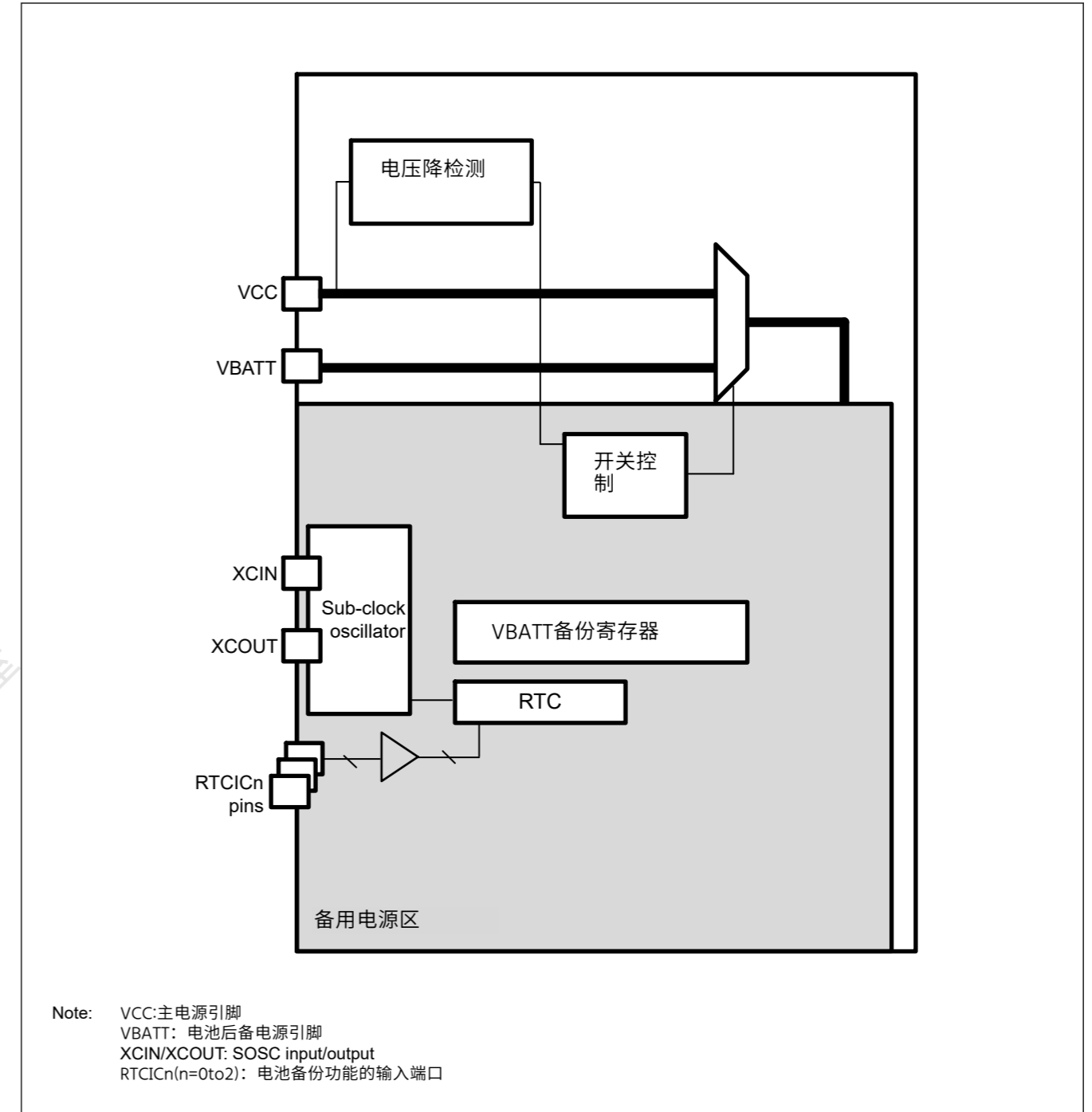


Figure 11.1 电池备份功能的配置

11.2 注册说明

11.2.1 BBFSAR : Battery Backup Function Security Attribute Register

Base address: SYSC = 0x4001\_E000

Offset address: 0x3D0

|                    |    |    |    |    |    |    |    |    |              |              |              |              |              |              |              |              |
|--------------------|----|----|----|----|----|----|----|----|--------------|--------------|--------------|--------------|--------------|--------------|--------------|--------------|
| Bit position:      | 31 | 30 | 29 | 28 | 27 | 26 | 25 | 24 | 23           | 22           | 21           | 20           | 19           | 18           | 17           | 16           |
| Bit field:         | —  | —  | —  | —  | —  | —  | —  | —  | NONS<br>EC23 | NONS<br>EC22 | NONS<br>EC21 | NONS<br>EC20 | NONS<br>EC19 | NONS<br>EC18 | NONS<br>EC17 | NONS<br>EC16 |
| Value after reset: | 0  | 0  | 0  | 0  | 0  | 0  | 0  | 0  | 0            | 0            | 0            | 0            | 0            | 0            | 0            | 0            |
| Bit position:      | 15 | 14 | 13 | 12 | 11 | 10 | 9  | 8  | 7            | 6            | 5            | 4            | 3            | 2            | 1            | 0            |
| Bit field:         | —  | —  | —  | —  | —  | —  | —  | —  | —            | —            | —            | —            | —            | NONS<br>EC2  | NONS<br>EC1  | NONS<br>EC0  |
| Value after reset: | 1  | 1  | 1  | 1  | 1  | 1  | 1  | 1  | 1            | 1            | 1            | 1            | 1            | 1            | 1            | 1            |

| Bit  | Symbol   | Function  | R/W |
|------|----------|---|-----|
| 0    | NONSEC0  | Non Secure Attribute bit 0<br>Target register: VBATTMNSLR<br>0: Secure<br>1: Non Secure               | R/W |
| 1    | NONSEC1  | Non Secure Attribute bit 1<br>Target register: VBTBER<br>0: Secure<br>1: Non Secure                   | R/W |
| 2    | NONSEC2  | Non Secure Attribute bit 2<br>Target register: VBTICTLR<br>0: Secure<br>1: Non Secure                 | R/W |
| 15:3 | —        | These bits are read as 1. The write value should be 1.  | R/W |
| 16   | NONSEC16 | Non Secure Attribute bit 16<br>Target register: VBTBKRn (n = 0 to 15)<br>0: Secure<br>1: Non Secure   | R/W |
| 17   | NONSEC17 | Non Secure Attribute bit 17<br>Target register: VBTBKRn (n = 16 to 31)<br>0: Secure<br>1: Non Secure  | R/W |
| 18   | NONSEC18 | Non Secure Attribute bit 18<br>Target register: VBTBKRn (n = 32 to 47)<br>0: Secure<br>1: Non Secure  | R/W |
| 19   | NONSEC19 | Non Secure Attribute bit 19<br>Target register: VBTBKRn (n = 48 to 63)<br>0: Secure<br>1: Non Secure  | R/W |
| 20   | NONSEC20 | Non Secure Attribute bit 20<br>Target register: VBTBKRn (n = 64 to 79)<br>0: Secure<br>1: Non Secure  | R/W |
| 21   | NONSEC21 | Non Secure Attribute bit 21<br>Target register: VBTBKRn (n = 80 to 95)<br>0: Secure<br>1: Non Secure  | R/W |
| 22   | NONSEC22 | Non Secure Attribute bit 22<br>Target register: VBTBKRn (n = 96 to 111)<br>0: Secure<br>1: Non Secure | R/W |

11.2.1 BBFSAR: 电池备份功能安全属性寄存器

Base address: SYSC = 0x4001\_E000

Offset address: 0x3D0

|               |    |    |    |    |    |    |    |    |              |              |              |              |              |              |              |              |             |
|---------------|----|----|----|----|----|----|----|----|--------------|--------------|--------------|--------------|--------------|--------------|--------------|--------------|-------------|
| Bit position: | 31 | 30 | 29 | 28 | 27 | 26 | 25 | 24 | 23           | 22           | 21           | 20           | 19           | 18           | 17           | 16           |             |
| Bit field:    | —  | —  | —  | —  | —  | —  | —  | —  | NONS<br>EC23 | NONS<br>EC22 | NONS<br>EC21 | NONS<br>EC20 | NONS<br>EC19 | NONS<br>EC18 | NONS<br>EC17 | NONS<br>EC16 |             |
| 重置后的值:        | 0  | 0  | 0  | 0  | 0  | 0  | 0  | 0  | 0            | 0            | 0            | 0            | 0            | 0            | 0            | 0            |             |
| Bit position: | 15 | 14 | 13 | 12 | 11 | 10 | 9  | 8  | 7            | 6            | 5            | 4            | 3            | 2            | 1            | 0            |             |
| Bit field:    | —  | —  | —  | —  | —  | —  | —  | —  | —            | —            | —            | —            | —            | —            | NONS<br>EC2  | NONS<br>EC1  | NONS<br>EC0 |
| 重置后的值:        | 1  | 1  | 1  | 1  | 1  | 1  | 1  | 1  | 1            | 1            | 1            | 1            | 1            | 1            | 1            | 1            |             |

| Bit  | Symbol   | Function  | R/W |
|------|----------|---|-----|
| 0    | NONSEC0  | 非安全属性位0<br>Target register: VBATTMNSLR<br>0: 安全1: 不<br>安全 | R/W |
| 1    | NONSEC1  | 非安全属性位1目标寄存<br>器: VBTBER<br>0: 安全1: 不<br>安全               | R/W |
| 2    | NONSEC2  | 非安全属性位2目标寄存器<br>: VBTICTLR<br>0: 安全1: 不<br>安全             | R/W |
| 15:3 | —        | 这些位被读取为1。写入值应为1。  | R/W |
| 16   | NONSEC16 | 非安全属性位16<br>目标寄存器: VBTBKRn (n=0到15)<br>0: 安全1: 不<br>安全    | R/W |
| 17   | NONSEC17 | 非安全属性位17<br>目标寄存器: VBTBKRn (n=16至31)<br>0: 安全1: 不<br>安全   | R/W |
| 18   | NONSEC18 | 非安全属性位18<br>目标寄存器: VBTBKRn (n=32到47)<br>0: 安全1: 不<br>安全   | R/W |
| 19   | NONSEC19 | 非安全属性位19<br>目标寄存器: VBTBKRn (n=48到63)<br>0: 安全1: 不<br>安全   | R/W |
| 20   | NONSEC20 | 非安全属性位20<br>目标寄存器: VBTBKRn (n=64到79)<br>0: 安全1: 不<br>安全   | R/W |
| 21   | NONSEC21 | 非安全属性位21<br>目标寄存器: VBTBKRn (n=80到95)<br>0: 安全1: 不<br>安全   | R/W |
| 22   | NONSEC22 | 非安全属性位22<br>目标寄存器: VBTBKRn (n=96至111)<br>0: 安全1: 不<br>安全  | R/W |

| Bit   | Symbol   | Function   | R/W |
|-------|----------|--|-----|
| 23    | NONSEC23 | Non Secure Attribute bit 23<br>Target register: VBTBKRn (n = 112 to 127)<br>0: Secure<br>1: Non Secure | R/W |
| 31:24 | —        | These bits are read as 0. The write value should be 0.   | R/W |

Note: Only secure access can write to this register. Both secure access and Non-secure read access are allowed but Non-secure write access is not allowed and TrustZone access error is not generated.

Note: This register is write-protected by PRCR register.

The BBFSAR register controls the secure attribute of the battery backup function registers.

#### NONSEC0 bit (Non Secure Attribute bit 0)

This bit controls the security attribute of VBATTMNSLR.

#### NONSEC1 bit (Non Secure Attribute bit 1)

This bit controls the security attribute of VBTBER.

#### NONSEC2 bit (Non Secure Attribute bit 2)

This bit controls the security attribute of VBTICTLR.

#### NONSEC16 bit (Non Secure Attribute bit 16)

This bit controls the security attribute of VBTBKRn (n = 0 to 15).

#### NONSEC17 bit (Non Secure Attribute bit 17)

This bit controls the security attribute of VBTBKRn (n = 16 to 31).

#### NONSEC18 bit (Non Secure Attribute bit 18)

This bit controls the security attribute of VBTBKRn (n = 32 to 47).

#### NONSEC19 bit (Non Secure Attribute bit 19)

This bit controls the security attribute of VBTBKRn (n = 48 to 63).

#### NONSEC20 bit (Non Secure Attribute bit 20)

This bit controls the security attribute of VBTBKRn (n = 64 to 79).

#### NONSEC21 bit (Non Secure Attribute bit 21)

This bit controls the security attribute of VBTBKRn (n = 80 to 95).

#### NONSEC22 bit (Non Secure Attribute bit 22)

This bit controls the security attribute of VBTBKRn (n = 96 to 111).

#### NONSEC23 bit (Non Secure Attribute bit 23)

This bit controls the security attribute of VBTBKRn (n = 112 to 127).

### 11.2.2 VBATTMNSLR : Battery Backup Voltage Monitor Function Select Register

Base address: SYSC = 0x4001\_E000

Offset address: 0x41D

|                    |   |   |   |   |   |   |   |                |
|--------------------|---|---|---|---|---|---|---|----------------|
| Bit position:      | 7 | 6 | 5 | 4 | 3 | 2 | 1 | 0              |
| Bit field:         | — | — | — | — | — | — | — | VBATT<br>MNSLR |
| Value after reset: | 0 | 0 | 0 | 0 | 0 | 0 | 0 | 0              |

| Bit   | Symbol   | Function   | R/W |
|-------|----------|--|-----|
| 23    | NONSEC23 | 非安全属性位23<br>目标寄存器: VBTBKRn (n=112至127)<br>0: 安全 1: 不安全 | R/W |
| 31:24 | —        | 这些位被读取为0。写入值应为0。                                       | R/W |

Note: 只有安全访问才能写入该寄存器。允许安全访问和非安全读取访问，但不允许非安全写入访问，并且不会生成TrustZone访问错误。

Note: 该寄存器由PRCR寄存器写保护。

BBFSAR寄存器控制电池备份功能寄存器的安全属性。

#### NONSEC0位 (非安全属性位0)

该位控制VBATTMNSLR的安全属性。

#### NONSEC1位 (非安全属性位1)

该位控制VBTBER的安全属性。

#### NONSEC2位 (非安全属性位2)

该位控制VBTICTLR的安全属性。

#### NONSEC16位 (非安全属性位16)

该位控制VBTBKRn (n=0到15) 的安全属性。

#### NONSEC17位 (非安全属性位17)

该位控制VBTBKRn (n=16到31) 的安全属性。

#### NONSEC18位 (非安全属性位18)

该位控制VBTBKRn (n=32到47) 的安全属性。

#### NONSEC19位 (非安全属性位19)

该位控制VBTBKRn (n=48到63) 的安全属性。

#### NONSEC20位 (非安全属性位20)

该位控制VBTBKRn (n=64到79) 的安全属性。

#### NONSEC21位 (非安全属性位21)

该位控制VBTBKRn (n=80到95) 的安全属性。

#### NONSEC22位 (非安全属性位22)

该位控制VBTBKRn (n=96到111) 的安全属性。

#### NONSEC23位 (非安全属性位23)

该位控制VBTBKRn (n=112到127) 的安全属性。

### 11.2.2 VBATTMNSLR: 电池备用电压监控功能选择寄存器

Base address: SYSC = 0x4001\_E000

Offset address: 0x41D

|               |   |   |   |   |   |   |   |                |
|---------------|---|---|---|---|---|---|---|----------------|
| Bit position: | 7 | 6 | 5 | 4 | 3 | 2 | 1 | 0              |
| Bit field:    | — | — | — | — | — | — | — | VBATT<br>MNSLR |
| 重置后的值:        | 0 | 0 | 0 | 0 | 0 | 0 | 0 | 0              |



| Bit | Symbol     | Function  | R/W |
|-----|------------|---|-----|
| 0   | VBATTMNSEL | VBATT Low Voltage Detect Function Select Bit<br>0: Disables VBATT low voltage detect function<br>1: Enables VBATT low voltage detect function | R/W |
| 7:1 | —          | These bits are read as 0. The write value should be 0.  | R/W |

Note: If the security attribution is configured as secure:

- Secure access and Non-secure read access are allowed
  - Non-secure write access is ignored, and TrustZone access error is not generated.
- If the security attribution is configured as Non-secure:
- Secure and Non-secure access are allowed.

Note: Set the PRCR.PRC3 bit to 1 (write enabled) before rewriting this register.

VBATTMNSELR is the register which controls VBATT low voltage detect function.

This register is initialized by all reset sources including deep software standby reset.

### VBATTMNSEL bit (VBATT Low Voltage Detect Function Select Bit)

Select VBATT low voltage detect function

Consumption current increases while VBATTMNSEL = 1. So, after monitoring the VBATT voltage level, clear VBATTMNSEL to 0 in order to reduce power consumption of VBATT power supply.

### 11.2.3 VBATTMONR : Battery Backup Voltage Monitor Register

Base address: SYSC = 0x4001\_E000

Offset address: 0x41E

| Bit position:      | 7 | 6 | 5 | 4 | 3 | 2 | 1 | 0         |
|--------------------|---|---|---|---|---|---|---|-----------|
| Bit field:         | — | — | — | — | — | — | — | VBATT MON |
| Value after reset: | 0 | 0 | 0 | 0 | 0 | 0 | 0 | 0         |

| Bit | Symbol   | Function  | R/W |
|-----|----------|---|-----|
| 0   | VBATTMON | VBATT Voltage Monitor Bit<br>Check VBATT voltage level<br>0 can be read when VBATT Low Voltage Detect Function Select Bit is 0.<br>0: VBATT ≥ Vbattldet*1<br>1: VBATT < Vbattldet | R   |
| 7:1 | —        | These bits are read as 0.   | R   |

Note 1. Vbattldet is VBATT low voltage detection level. For more details, see [section 47, Electrical Characteristics](#).

VBATTMONR is the register that can check VBATT voltage level when VBATTMNSELR.VBATTMNSEL = 1 and also VCC is supplied.

This register is initialized by all reset sources including deep software standby reset.

### VBATTMON bit (VBATT Voltage Monitor Bit)

Monitor VBATT voltage level

### 11.2.4 VBTBER : VBATT Backup Enable Register

Base address: SYSC = 0x4001\_E000

Offset address: 0x4C0

| Bit position:      | 7 | 6 | 5 | 4 | 3    | 2 | 1 | 0 |
|--------------------|---|---|---|---|------|---|---|---|
| Bit field:         | — | — | — | — | VBAE | — | — | — |
| Value after reset: | 0 | 0 | 0 | 0 | 1    | 0 | 0 | 0 |

| Bit | Symbol     | Function  | R/W |
|-----|------------|---|-----|
| 0   | VBATTMNSEL | VBATT低电压检测功能选择位<br>0: 禁用VBATT低电压检测功能<br>1: 启用VBATT低电压检测功能 | R/W |
| 7:1 | —          | 这些位被读取为0。写入值应为0。  | R/W |

Note: 如果安全属性配置为安全: ●

- 允许安全访问和非安全读取访问
  - 忽略非安全写入访问, 不会生成TrustZone访问错误。
- 如果安全属性配置为非安全: ●
- 允许安全和非安全访问。

Note: 在重写该寄存器之前将PRCR.PRC3位设置为1 (允许写入)。

VBATTMNSELR是控制VBATT低电压检测功能的寄存器。

该寄存器由所有复位源初始化, 包括深度软件待机复位。

### VBATTMNSEL位 (VBATT低电压检测功能选择位)

选择VBATT低电压检测功能

VBATTMNSEL=1时消耗电流增加。因此, 在监测VBATT电压电平后, 清除VBATTMNSEL为0以降低VBATT电源的功耗。

### 11.2.3 VBATTMONR: 电池备用电压监控寄存器

Base address: SYSC = 0x4001\_E000

Offset address: 0x41E

| Bit position: | 7 | 6 | 5 | 4 | 3 | 2 | 1 | 0         |
|---------------|---|---|---|---|---|---|---|-----------|
| Bit field:    | — | — | — | — | — | — | — | VBATT MON |
| 重置后的值:        | 0 | 0 | 0 | 0 | 0 | 0 | 0 | 0         |

| Bit | Symbol   | Function  | R/W |
|-----|----------|---|-----|
| 0   | VBATTMON | VBATT电压监控位检查当VBATT低电压检测功能选择位为0时, 可以读取VBATT电压电平。<br>0: VBATT ≥ Vbattldet*1<br>1: VBATT < Vbattldet | R   |
| 7:1 | —        | 这些位读为0。   | R   |

注1.Vbattldet为VBATT低电压检测电平。有关详细信息, 请参阅第47节, 电气特性。

VBATTMONR是当VBATTMNSELR.VBATTMNSEL=1时可以检查VBATT电压电平的寄存器。提供VCC。

该寄存器由所有复位源初始化, 包括深度软件待机复位。

### VBATTMON位 (VBATT电压监控位)

监控VBATT电压电平

### 11.2.4 VBTBER: VBATT备份使能寄存器

Base address: SYSC = 0x4001\_E000

Offset address: 0x4C0

| Bit position: | 7 | 6 | 5 | 4 | 3    | 2 | 1 | 0 |
|---------------|---|---|---|---|------|---|---|---|
| Bit field:    | — | — | — | — | VBAE | — | — | — |
| 重置后的值:        | 0 | 0 | 0 | 0 | 1    | 0 | 0 | 0 |

| Bit | Symbol | Function   | R/W |
|-----|--------|--|-----|
| 2:0 | —      | These bits are read as 0. The write value should be 0.   | R/W |
| 3   | VBAE   | VBATT backup register access enable bit<br>0: Disable to access VBTBKR<br>1: Enable to access VBTBKR | R/W |
| 7:4 | —      | These bits are read as 0. The write value should be 0.   | R/W |

Note: If the security attribution is configured as secure:

- Secure access and Non-secure read access are allowed
- Non-secure write access is ignored, and TrustZone access error is not generated.

If the security attribution is configured as Non-secure:

- Secure and Non-secure access are allowed.

Note: Set the PRCR.PRC1 bit to 1 (write enabled) before rewriting this register.

#### VBAE bit (VBATT backup register access enable bit)

You must write 1 to VBAE before accessing VBTBKR and you must write 0 to VBAE after finishing all access (write or read) to VBTBKR. If you do not write 0 to VBAE, the data of VBTBKR is not kept in VBATT mode.

To access VBTBKR, wait for at least 500 ns after writing 1 to VBAE, and then access VBTBKR.

Before entering the deep software standby mode, you must write 0 to VBAE.

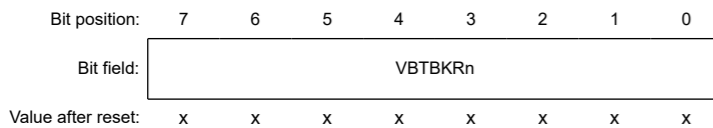
To enter the deep software standby mode, wait for at least 250 ns after writing 0 to VBAE, then enter the deep software standby mode.

If you do not use VBTBKR, you should change VBAE to 0 to reduce power consumption of VBTBKR.

#### 11.2.5 VBTBKR[n] : VBATT Backup Register (n = 0 to 127)

Base address: SYSC = 0x4001\_E000

Offset address: 0x500 + 0x001 × n



| Bit | Symbol  | Function  | R/W |
|-----|---------|---|-----|
| 7:0 | VBTBKRn | VBATT Backup Register<br>The value of this register is retained even in VBATT mode.<br>This register is not initialized by any reset sources. | R/W |

Note: If the security attribution is configured as Secure,

- Secure access is allowed,
- Non-secure access is ignored, but TrustZone access error is not generated.

If the security attribution is configured as Non-secure,

- Secure and Non-secure access are allowed.

Note: Set the PRCR.PRC1 bit to 1 (write enabled) before rewriting this register.

Table 11.1 VBATT Backup Register (1 of 2)

| Address                    | Symbol                    |
|----------------------------|---------------------------|
| 0x4001_E500 to 0x4001_E50F | VBTBKR[0] to VBTBKR[15]   |
| 0x4001_E510 to 0x4001_E51F | VBTBKR[16] to VBTBKR[31]  |
| 0x4001_E520 to 0x4001_E52F | VBTBKR[32] to VBTBKR[47]  |
| 0x4001_E530 to 0x4001_E53F | VBTBKR[48] to VBTBKR[63]  |
| 0x4001_E540 to 0x4001_E54F | VBTBKR[64] to VBTBKR[79]  |
| 0x4001_E550 to 0x4001_E55F | VBTBKR[80] to VBTBKR[95]  |
| 0x4001_E560 to 0x4001_E56F | VBTBKR[96] to VBTBKR[111] |

| Bit | Symbol | Function                                      | R/W |
|-----|--------|---|-----|
| 2:0 | —      | 这些位被读取为0。写入值应为0。                              | R/W |
| 3   | VBAE   | VBATT备份寄存器访问使能位<br>0: 禁止访问VBTBKR1: 允许访问VBTBKR | R/W |
| 7:4 | —      | 这些位被读取为0。写入值应为0。                              | R/W |

Note: 如果安全属性配置为安全: ●

- 允许安全访问和非安全读取访问
- 忽略非安全写入访问, 不会生成TrustZone访问错误。

如果安全属性配置为非安全: ●

- 允许安全和非安全访问。

Note: 在重写该寄存器之前将PRCR.PRC1位设置为1 (允许写入)。

#### VBAE位 (VBATT备份寄存器访问使能位)

在访问VBTBKR之前必须向VBAE写入1, 在完成对VBTBKR的所有访问 (写入或读取) 后必须向VBAE写入0。如果不向VBAE写入0, 则VBTBKR的数据不会在VBATT模式下保存。

要访问VBTBKR, 请在向VBAE写入1后等待至少500ns, 然后再访问VBTBKR。

在进入深度软件待机模式之前, 必须将0写入VBAE。

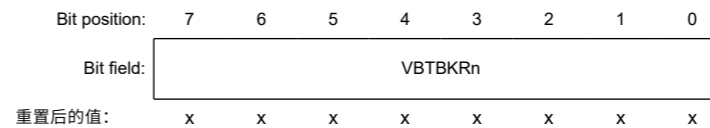
要进入深度软件待机模式, 在将0写入VBAE后至少等待250ns, 然后进入深度软件待机模式。

如果不使用VBTBKR, 则应将VBAE更改为0, 以降低VBTBKR的功耗。

#### 11.2.5 VBTBKR[n]:VBATT备份寄存器(n=0to127)

Base address: SYSC = 0x4001\_E000

Offset address: 0x500 + 0x001 × n



| Bit | Symbol  | Function  | R/W |
|-----|---------|---|-----|
| 7:0 | VBTBKRn | VBATT备份寄存器<br>即使在VBATT模式下, 该寄存器的值也会保留。<br>该寄存器不被任何复位源初始化。 | R/W |

Note: 如果安全属性配置为安全, ●

- 允许安全访问,
- 忽略非安全访问, 但不会生成TrustZone访问错误。

如果安全属性配置为非安全, ●

- 允许安全和非安全访问。

Note: 在重写该寄存器之前将PRCR.PRC1位设置为1 (允许写入)。

Table 11.1 VBATT备份寄存器(1of2)

| Address                    | Symbol                    |
|----------------------------|---------------------------|
| 0x4001_E500 to 0x4001_E50F | VBTBKR[0] to VBTBKR[15]   |
| 0x4001_E510 to 0x4001_E51F | VBTBKR[16] to VBTBKR[31]  |
| 0x4001_E520 to 0x4001_E52F | VBTBKR[32] to VBTBKR[47]  |
| 0x4001_E530 to 0x4001_E53F | VBTBKR[48] to VBTBKR[63]  |
| 0x4001_E540 to 0x4001_E54F | VBTBKR[64] to VBTBKR[79]  |
| 0x4001_E550 to 0x4001_E55F | VBTBKR[80] to VBTBKR[95]  |
| 0x4001_E560 to 0x4001_E56F | VBTBKR[96] to VBTBKR[111] |

Table 11.1 VBATT Backup Register (2 of 2)

| Address                    | Symbol                     |
|----------------------------|----------------------------|
| 0x4001_E570 to 0x4001_E57F | VBTBKR[112] to VBTBKR[127] |

### 11.2.6 VBTICTLR : VBATT Input Control Register

Base address: SYSC = 0x4001\_E000

Offset address: 0x4BB

| Bit position:      | 7 | 6 | 5 | 4 | 3 | 2            | 1            | 0            |
|--------------------|---|---|---|---|---|--------------|--------------|--------------|
| Bit field:         | — | — | — | — | — | VCH2I<br>NEN | VCH1I<br>NEN | VCH0I<br>NEN |
| Value after reset: | 0 | 0 | 0 | 0 | 0 | x            | x            | x            |

| Bit | Symbol   | Function  | R/W |
|-----|----------|---|-----|
| 0   | VCH0INEN | VBATT CH0 Input Enable<br>0: RTCIC0 input disable<br>1: RTCIC0 input enable | R/W |
| 1   | VCH1INEN | VBATT CH1 Input Enable<br>0: RTCIC1 input disable<br>1: RTCIC1 input enable | R/W |
| 2   | VCH2INEN | VBATT CH2 Input Enable<br>0: RTCIC2 input disable<br>1: RTCIC2 input enable | R/W |
| 7:3 | —        | These bits are read as 0. The write value should be 0.                      | R/W |

Note: If the security attribution is configured as secure:

- Secure access and Non-secure read access are allowed
- Non-secure write access is ignored, and TrustZone access error is not generated.

If the security attribution is configured as Non-secure:

- Secure and Non-secure access are allowed.

Note: Set the PRCR.PRC1 bit to 1 (write enabled) before rewriting this register.

VBTICTLR is the register that can select VBATT I/O direction as input. This register is not initialized by any reset.

#### VCHnINEN bits (VBATT CHn Input Enable Bits) (n = 0 to 2)

The VCHnINEN bit enables the input direction on the associated VBATT channel.

## 11.3 Operation

### 11.3.1 Battery Backup Function

When the voltage on the VCC pin drops, power can be supplied to the RTC and sub-clock oscillator from the VBATT pin. When a drop of power supply from VCC pin is detected, the power connection switches from VCC pin to the VBATT pin. The power supply from the VCC pin is resumed when the voltage on the VCC pin exceeds  $V_{DET\ BATT}$ . This power supply change does not affect the RTC operation.

You must enable voltage monitor 0 reset to use the battery backup function. The RTC supports time capture detection, triggered by a change of the time capture pin input level.

The VBATT pin supplies power to the following modules:

- RTC
- Sub-clock oscillator (including XCIN and XCOU pins)
- VBATT Backup Register

Table 11.2 shows the operating states in VBATT mode.

Table 11.1 VBATT备份寄存器(2of2)

| Address                    | Symbol                     |
|----------------------------|----------------------------|
| 0x4001_E570 to 0x4001_E57F | VBTBKR[112] to VBTBKR[127] |

### 11.2.6 VBTICTLR:VBATT输入控制寄存器

Base address: SYSC = 0x4001\_E000

Offset address: 0x4BB

| Bit position: | 7 | 6 | 5 | 4 | 3 | 2            | 1            | 0            |
|---------------|---|---|---|---|---|--------------|--------------|--------------|
| Bit field:    | — | — | — | — | — | VCH2I<br>NEN | VCH1I<br>NEN | VCH0I<br>NEN |
| 重置后的值:        | 0 | 0 | 0 | 0 | 0 | x            | x            | x            |

| Bit | Symbol   | Function                                       | R/W |
|-----|----------|--|-----|
| 0   | VCH0INEN | VBATTCH0输入使能<br>0: RTCIC0输入禁止1: R<br>TCIC0输入使能 | R/W |
| 1   | VCH1INEN | VBATTCH1输入使能<br>0: RTCIC1输入禁止1: R<br>TCIC1输入使能 | R/W |
| 2   | VCH2INEN | VBATTCH2输入使能<br>0: RTCIC2输入禁止1: R<br>TCIC2输入使能 | R/W |
| 7:3 | —        | 这些位被读取为0。写入值应为0。                               | R/W |

Note: 如果安全属性配置为安全: ●

- 允许安全访问和非安全读取访问
- 忽略非安全写入访问, 不会生成TrustZone访问错误。

如果安全属性配置为非安全: ●

- 允许安全和非安全访问。

Note: 在重写该寄存器之前将PRCR.PRC1位设置为1 (允许写入)。

VBTICTLR是可以选择VBATTIO方向作为输入的寄存器。该寄存器不会被任何复位初始化。

#### VCHnINEN位 (VBATTCHn输入使能位) (n=0到2)

VCHnINEN位使能相关VBATT通道上的输入方向。

## 11.3 Operation

### 11.3.1 电池备份功能

当VCC引脚上的电压下降时, 可以从VBATT引脚为RTC和副时钟振荡器供电。当检测到来自VCC引脚的电源下降时, 电源连接从VCC引脚切换到VBATT引脚。当VCC引脚上的电压超过 $V_{DET\ BATT}$ 时, 重新从VCC引脚供电。此电源更改不会影响RTC操作。

您必须启用电压监视器0复位才能使用电池备份功能。RTC支持时间捕捉检测, 由时间捕捉引脚输入电平的变化触发。

VBATT引脚为以下模块供电:

- RTC
- 副时钟振荡器 (包括XCIN和XCOU引脚)
- VBATT备份寄存器

表11.2显示了VBATT模式下的操作状态。

Table 11.2 Operating States in VBATT Mode

| Operating state                          | VBATT Mode  |
|--|---|
| Transition condition                     | Detection of VCC voltage drop   |
| Canceling method other than reset        | Detection of VCC voltage rise   |
| State after cancellation by an interrupt | —   |
| State after cancellation by a reset      | —   |
| Main clock oscillator                    | Stop  |
| Sub-clock oscillator                     | Operating   |
| High-speed on-chip oscillator            | Stop  |
| Middle-speed on-chip oscillator          | Stop  |
| Low-speed on-chip oscillator             | Stop  |
| IWDT-dedicated on-chip oscillator        | Stop  |
| PLL                                      | Stop  |
| PLL2                                     | Stop  |
| CPU                                      | Stop (Undefined)  |
| SRAM (ECC RAM included)                  | Stop (Undefined)  |
| Standby SRAM                             | Stop (Undefined)  |
| VBATT Backup Register                    | Stop (Retained)   |
| Flash memory                             | Stop (Retained)   |
| Realtime clock (RTC)                     | Selectable when selecting clock which is operating as the count source.         |
| AGTn (n = 0 to 3)                        | Stop (Undefined)  |
| Low voltage detection circuit (LVD)      | Stop  |
| Power-on reset circuit                   | Stop  |
| Other Peripheral modules                 | Stop (Undefined)  |
| I/O ports                                | RTCICn ports (n = 0 to 2): Operating<br>All ports not specified here: Undefined |

Note: Selectable means that operating or stopped is selectable in the control registers. Some modules are also controlled by the associated module-stop bit.

Note: Stop (retained) means that the contents of the internal registers are retained but the operations are suspended.

Note: Stop (undefined) means that the contents of the internal registers are undefined and power to the internal circuit is cut off.

Figure 11.2 shows switching sequence of Battery backup function.

Table 11.2 VBATT模式下的操作状态

| 运行状态                              | VBATT Mode                               |
|-----------------------------------|--|
| 过渡条件                              | 检测VCC电压降                                 |
| 复位以外的取消方法                         | 检测VCC电压上升                                |
| 中断取消后的状态                          | —  |
| 通过复位取消后的状态                        | —  |
| 主时钟振荡器                            | Stop                                     |
| Sub-clock oscillator              | Operating                                |
| High-speed on-chip oscillator     | Stop                                     |
| Middle-speed on-chip oscillator   | Stop                                     |
| Low-speed on-chip oscillator      | Stop                                     |
| IWDT-dedicated on-chip oscillator | Stop                                     |
| PLL                               | Stop                                     |
| PLL2                              | Stop                                     |
| CPU                               | Stop (Undefined)                         |
| SRAM (ECC RAM included)           | Stop (Undefined)                         |
| Standby SRAM                      | Stop (Undefined)                         |
| VBATT备份寄存器                        | Stop (Retained)                          |
| 闪存                                | Stop (Retained)                          |
| 实时时钟(RTC)                         | 选择用作计数源的时钟时可选择。                          |
| AGTn (n = 0 to 3)                 | Stop (Undefined)                         |
| 低电压检测电路 (LVD)                     | Stop                                     |
| 上电复位电路                            | Stop                                     |
| 其他外围模块                            | Stop (Undefined)                         |
| I/O ports                         | RTCICn端口 (n=0到2) : 工作<br>此处未指定的所有端口: 未定义 |

Note: 可选意味着在控制寄存器中可以选择操作或停止。一些模块也由相关的模块停止位控制。

Note: 停止 (retained) 是指内部寄存器的内容被保留但操作被暂停。

Note: 停止 (未定义) 表示内部寄存器的内容未定义, 内部电路的电源被切断。

图11.2显示了电池备份功能的切换顺序。

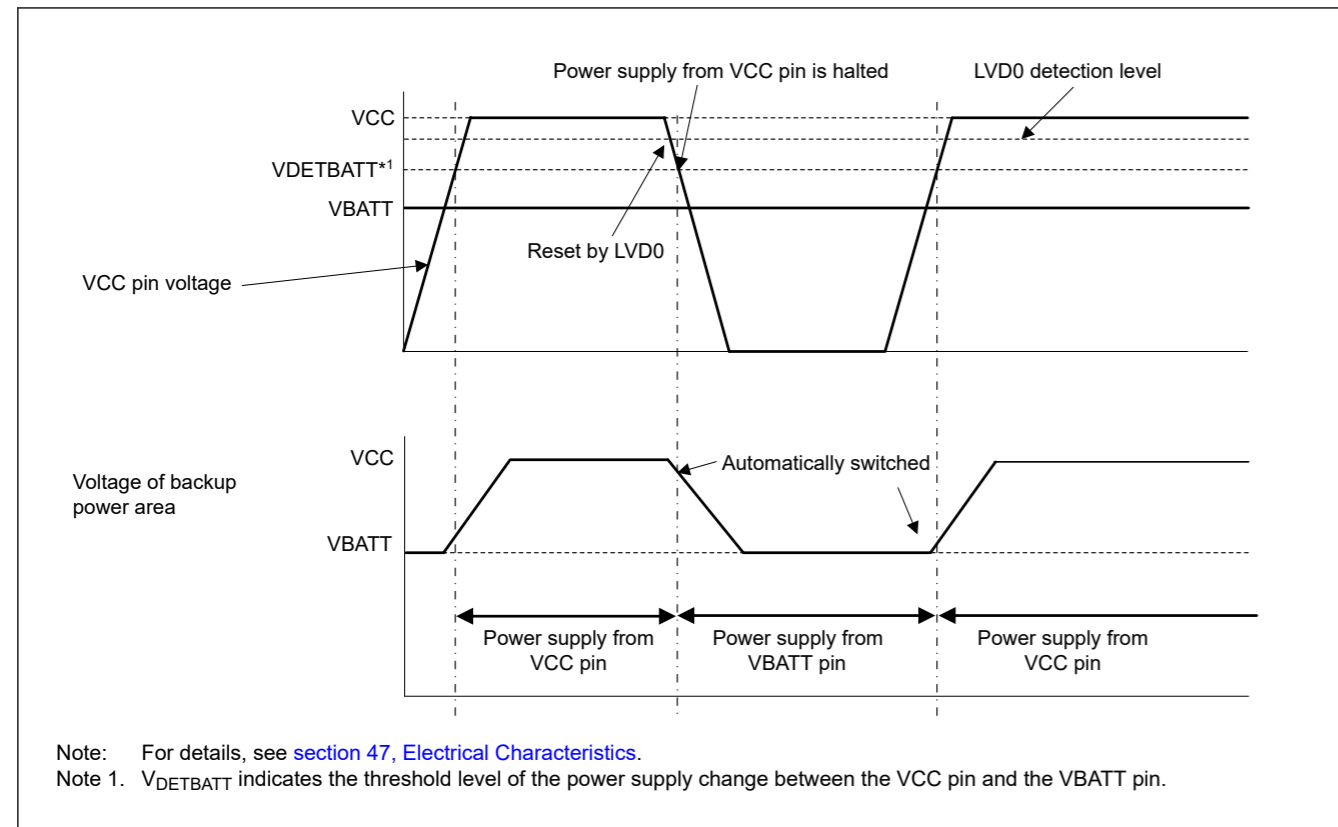


Figure 11.2 Switching sequence of Battery backup function.

### 11.3.2 VBATT Battery Power Supply Switch Usage

The battery power supply switch can switch the power supply from the VCC pin to the VBATT pin when the voltage being applied to the VCC pin drops. When the voltage rises, this switch changes the power supply from the VBATT pin to the VCC pin.

Note: The battery backup function should be used after the voltage monitor 0 reset is enabled (OFS1.LVDAS bit is 0). Voltage monitor 0 level should be higher than VBATT switch level.

### 11.3.3 VBATT Backup Register Usage

Use the VBATT backup registers VBTBKRn, where n = 0 to 127, to store or restore data with an 8-bit read or write operation.

## 11.4 Usage Notes

- Operation of the sub-clock oscillator and RTC are not guaranteed when the voltage level on VBATT is lower than the guaranteed operation range. Initialize the RTC when the VBATT pin falls below the guaranteed operating voltage and then powers up again.
- A reset generated while writing to registers described in this section might destroy the register value.
- When VCC is higher than  $V_{DET BATT}$ , the VCC pin and VBATT pin are separated. When VCC is lower than  $V_{DET BATT}$  and the switch is connected to the VBATT pin, and if the voltage on VBATT drops lower than  $(VCC - 0.6 V)$ , current might flow into the VBATT pin through the parasitic diode between the VCC and VBATT pins.
- During RTC operation using the voltage from the VBATT pin and the I/O ports within the backup, the power supply area can only be used as time capture event input pins for the RTC.

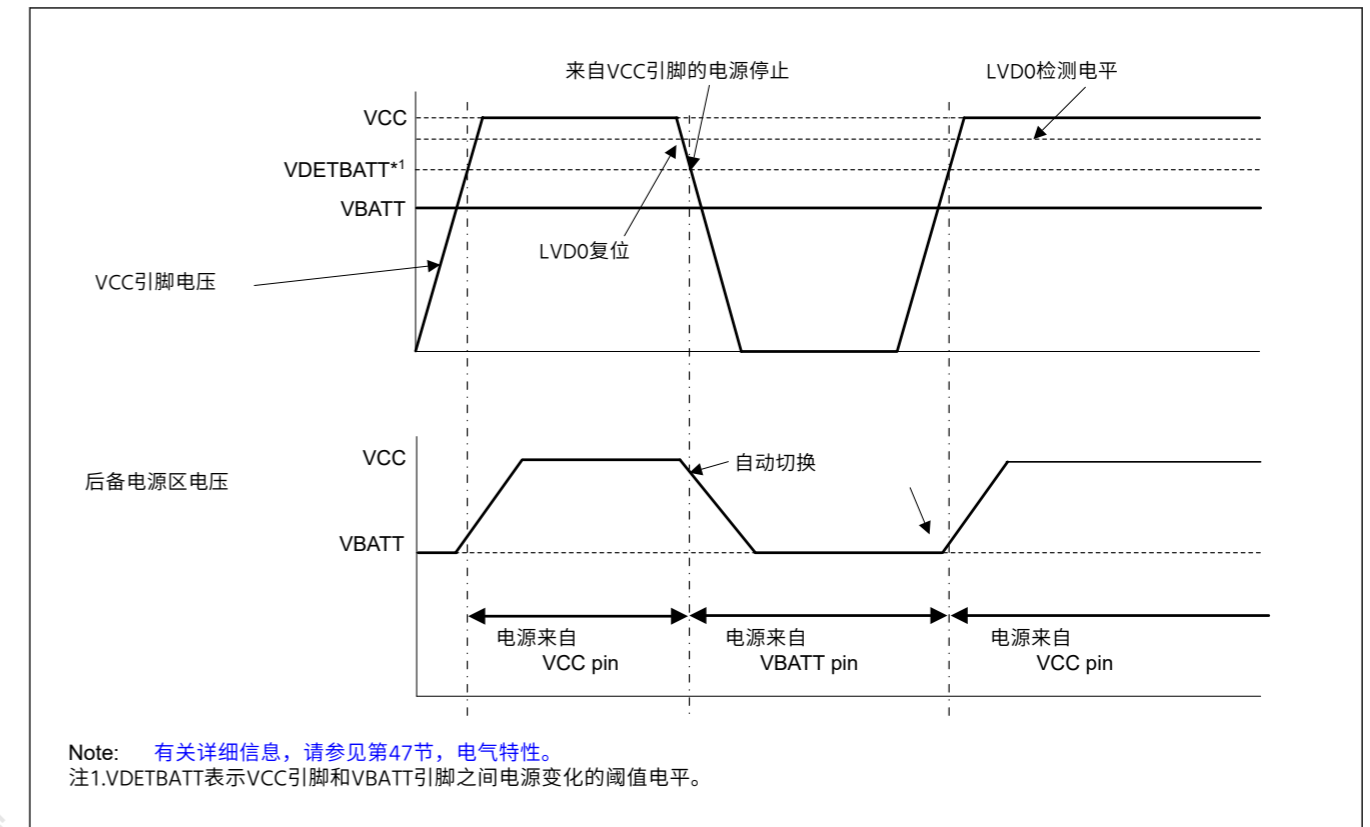


Figure 11.2 电池备份功能的切换顺序。

### 11.3.2 VBATT电池电源开关使用

当施加到VCC引脚的电压下降时，电池电源开关可以将电源从VCC引脚切换到VBATT引脚。当电压上升时，该开关将电源从VBATT引脚切换到VCC引脚。

Note: 电池备份功能应在电压监视器0复位使能（OFS1.LVDAS位为0）后使用。电压监视器0电平应高于VBATT开关电平。

### 11.3.3 VBATT备份寄存器使用

使用VBATT备份寄存器VBTBKRn，其中n=0到127，通过8位读取或写入操作来存储或恢复数据。

## 11.4 使用说明

- 当VBATT上的电压电平低于保证工作范围时，不保证副时钟振荡器和RTC的工作。当VBATT引脚低于保证工作电压时初始化RTC，然后再次上电。
- 写入本节中描述的寄存器时产生的复位可能会破坏寄存器值。
- 当VCC高于 $V_{DET BATT}$ 时，VCC管脚和VBATT管脚是分开的。当VCC低于 $V_{DET BATT}$ 且开关连接到VBATT引脚时，如果VBATT上的电压低于 $(VCC - 0.6V)$ ，电流可能会通过VCC和VBATT引脚之间的寄生二极管流入VBATT引脚。
- RTC操作期间，使用来自VBATT引脚和备份内部IO端口的电压，电源区域只能用作RTC的时间捕捉事件输入引脚。



## 12. Register Write Protection

### 12.1 Overview

The register write protection function protects important registers from being overwritten due to software errors. The registers to be protected are set with the Protect Register (PRCR).

Table 12.1 lists the association between the bits in the PRCR register and the registers to be protected.

**Table 12.1 Association between the bits in the PRCR register and registers to be protected**

| PRCR bit | Register to be protected  |
|----------|---|
| PRC0     | <ul style="list-style-type: none"> <li>Registers related to the clock generation circuit: SCKDIVCR, SCKSCR, PLLCCR, PLLCR, MOSCCR, HOCOGR, MOCOGR, FLLCR1, FLLCR2, CKOCR, TRCKCR, OSTDCR, OSTDSR, PLL2CCR, PLL2CR, MOCOUTCR, HOCOUTCR, USBCKDIVCR, USBCKCR, MOSCWTCR, MOMCR, SOSCCR, SOMCR, LOCOGR, LOCOUTCR</li> </ul>           |
| PRC1     | <ul style="list-style-type: none"> <li>Registers related to the low power modes: SBYCR, SNZCR, SNZEDCR0, SNZEDCR1, SNZREQCR0, SNZREQCR1, OPCCR, SOPCCR, DPSBYCR, DPSWCR, DPSIER0-3, DPSIFR0-3, DPSIEGR0-2, SYOCDRCR</li> <li>Register related to the battery backup function: VBTBER, VBTICTLR, VBTBKRn (n = 0 to 127)</li> </ul> |
| PRC3     | <ul style="list-style-type: none"> <li>Registers related to the LVD: LVD1CR1, LVD1SR, LVD2CR1, LVD2SR, LVD1CMPCR, LVD2CMPCR, LVD1CR0, LVD2CR0, VBATTMNSLR</li> </ul>  |
| PRC4     | <ul style="list-style-type: none"> <li>Registers related to the security function: CGFSAR, RSTSAR, LPMSAR, LVDSAR, BBFSAR, DPFSAR, CSAR, SRAMSAR, STBRAMSAR, DTCSAR, DMACSAR, ICUSARx, BUSSARx, MMPUSARx, TZFSAR, CPUDSAR, FSAR, PSARx, MSSAR, PmSAR, ELCSARx</li> </ul>  |

### 12.2 Register Descriptions

#### 12.2.1 PRCR : Protect Register

Base address: SYSC = 0x4001\_E000

Offset address: 0x3FE

|                    |            |    |    |    |    |    |   |   |   |   |      |      |   |      |      |   |
|--------------------|------------|----|----|----|----|----|---|---|---|---|------|------|---|------|------|---|
| Bit position:      | 15         | 14 | 13 | 12 | 11 | 10 | 9 | 8 | 7 | 6 | 5    | 4    | 3 | 2    | 1    | 0 |
| Bit field:         | PRKEY[7:0] |    |    |    |    |    |   | — | — | — | PRC4 | PRC3 | — | PRC1 | PRC0 |   |
| Value after reset: | 0          | 0  | 0  | 0  | 0  | 0  | 0 | 0 | 0 | 0 | 0    | 0    | 0 | 0    | 0    | 0 |

| Bit | Symbol | Function   | R/W |
|-----|--------|--|-----|
| 0   | PRC0   | Enable writing to the registers related to the clock generation circuit<br>0: Disable writes<br>1: Enable writes                         | R/W |
| 1   | PRC1   | Enable writing to the registers related to the low power modes, and the battery backup function<br>0: Disable writes<br>1: Enable writes | R/W |
| 2   | —      | This bit is read as 0. The write value should be 0.  | R/W |
| 3   | PRC3   | Enable writing to the registers related to the LVD<br>0: Disable writes<br>1: Enable writes  | R/W |
| 4   | PRC4   | Enables writing to the registers related to the security function<br>0: Disable writes<br>1: Enable writes                               | R/W |
| 7:5 | —      | These bits are read as 0. The write value should be 0.   | R/W |

## 12. 寄存器写保护

### 12.1 Overview

寄存器写保护功能可保护重要寄存器不因软件错误而被覆盖。要保护的寄存器由保护寄存器(PRCR)设置。

表12.1列出了PRCR寄存器中的位与要保护的寄存器之间的关联。

**Table 12.1 PRCR寄存器中的位与要保护的寄存器之间的关联**

| PRCR bit | 注册受保护   |
|----------|---|
| PRC0     | <ul style="list-style-type: none"> <li>与时钟产生电路相关的寄存器: SCKDIVCR, SCKSCR, PLLCCR, PLLCR, MOSCCR, HOCOGR, MOCOGR, FLLCR1, FLLCR2, CKOCR, TRCKCR, OSTDCR, OSTDSR, PLL2CCR, PLL2CR, MOCOUTCR, HOCOUTCR, USBCKDIVCR, USBCKCR, MOSCWTCR, MOMCR, SOSCCR, SOMCR, LOCOGR, LOCOUTCR</li> </ul> |
| PRC1     | <ul style="list-style-type: none"> <li>与低功耗模式相关的寄存器: SBYCR, SNZCR, SNZEDCR0, SNZEDCR1, SNZREQCR0, SNZREQCR1, OPCCR, SOPCCR, DPSBYCR, DPSWCR, DPSIER0-3, DPSIFR0-3, DPSIEGR0-2, SYOCDRCR</li> <li>与电池备份功能相关的寄存器: VBTBER, VBTICTLR, VBTBKRn(n=0to127)</li> </ul>                      |
| PRC3     | <ul style="list-style-type: none"> <li>与LVD相关的寄存器: LVD1CR1, LVD1SR, LVD2CR1, LVD2SR, LVD1CMPCR, LVD2CMPCR, LVD1CR0, LVD2CR0, VBATTMNSLR</li> </ul>  |
| PRC4     | <ul style="list-style-type: none"> <li>与安全功能相关的寄存器: CGFSAR, RSTSAR, LPMSAR, LVDSAR, BBFSAR, DPFSAR, CSAR, SRAMSAR, STBRAMSAR, DTCSAR, DMACSAR, ICUSARx, BUSSARx, MMPUSARx, TZFSAR, CPUDSAR, FSAR, PSARx, MSSAR, PmSAR, ELCSARx</li> </ul>   |

### 12.2 注册说明

#### 12.2.1 PRCR:保护寄存器

Base address: SYSC = 0x4001\_E000

Offset address: 0x3FE

|               |            |    |    |    |    |    |   |   |   |   |      |      |   |      |      |   |
|---------------|------------|----|----|----|----|----|---|---|---|---|------|------|---|------|------|---|
| Bit position: | 15         | 14 | 13 | 12 | 11 | 10 | 9 | 8 | 7 | 6 | 5    | 4    | 3 | 2    | 1    | 0 |
| Bit field:    | PRKEY[7:0] |    |    |    |    |    |   | — | — | — | PRC4 | PRC3 | — | PRC1 | PRC0 |   |
| 重置后的值:        | 0          | 0  | 0  | 0  | 0  | 0  | 0 | 0 | 0 | 0 | 0    | 0    | 0 | 0    | 0    | 0 |

| Bit | Symbol | Function  | R/W |
|-----|--------|---|-----|
| 0   | PRC0   | 允许写入与时钟生成电路相关的寄存器<br>0: 禁用写入1:<br>启用写入          | R/W |
| 1   | PRC1   | 允许写入与低功耗模式相关的寄存器, 以及电池备份功能<br>0: 禁用写入1:<br>启用写入 | R/W |
| 2   | —      | 该位读取为0。写入值应为0。                                  | R/W |
| 3   | PRC3   | 允许写入与LVD相关的寄存器<br>0: 禁用写入1:<br>启用写入             | R/W |
| 4   | PRC4   | 允许写入与安全功能相关的寄存器<br>0: 禁用写入1:<br>启用写入            | R/W |
| 7:5 | —      | 这些位被读取为0。写入值应为0。                                | R/W |

| Bit  | Symbol     | Function   | R/W |
|------|------------|--|-----|
| 15:8 | PRKEY[7:0] | PRC Key Code<br>These bits control the write access to the PRCR register. To modify the PRCR register, write 0xA5 to the upper 8 bits and the target value to the lower 8 bits as a 16-bit unit. | W   |

**PRCn bits (Protect bit n) (n = 0, 1, 3, 4)**

The PRCn bits enable or disable writing to the protected registers listed in [Table 12.1](#). Setting the PRCn bits to 1 or 0 enables or disables writing, respectively.

The register controlled by PRC4 may not reflect the PRC4 change when PRCR and its controlled registers are continuously written access. Avoid continuous write access or read the PRCR after PRC4 change, and then write access the PRC4-controlled register.

| Bit  | Symbol     | Function   | R/W |
|------|------------|--|-----|
| 15:8 | PRKEY[7:0] | 中华人民共和国密钥代码<br>这些位控制对PRCR寄存器的写访问。修改PRCR寄存器，将0xA5写入高8位，将目标值写入低8位，以16位为单位。 | W   |

**PRCn位（保护位n）（n=0、1、3、4）**

PRCn位启用或禁用对表12.1中列出的受保护寄存器的写入。将PRCn位设置为1或0分别启用或禁用写入。

当PRCR及其受控寄存器连续写入访问时，PRC4控制的寄存器可能无法反映PRC4的变化。避免连续写访问或在PRC4更改后读取PRCR，然后再写访问PRC4控制的寄存器。

## 13. Interrupt Controller Unit (ICU)

### 13.1 Overview

The Interrupt Controller Unit (ICU) controls which event signals are linked to the Nested Vector Interrupt Controller (NVIC), the DMA Controller (DMAC), and the Data Transfer Controller (DTC) modules. The ICU also controls non-maskable interrupts.

Table 13.1 lists the ICU specifications, Figure 13.1 shows a block diagram, and Table 13.2 lists the I/O pins.

**Table 13.1 ICU specifications**

| Parameter                             |   | Description   |
|---------------------------------------|---|---|
| Maskable interrupts                   | Peripheral function interrupts  | <ul style="list-style-type: none"> <li>Interrupts from peripheral modules</li> <li>Number of sources: 223 (select factor within event list numbers 32 to 511)</li> </ul>  |
|                                       | External pin interrupts   | <ul style="list-style-type: none"> <li>Interrupt detection on low level<sup>*4</sup>, falling edge, rising edge, rising and falling edges. One of these detection methods can be set for each source</li> <li>Digital filter function supported</li> <li>16 sources, with interrupts from IRQi (i = 0 to 15) pins.</li> </ul> |
|                                       | Interrupt requests to CPU (NVIC)  | <ul style="list-style-type: none"> <li>96 interrupt requests are output to NVIC.</li> </ul>   |
|                                       | DMAC control  | <ul style="list-style-type: none"> <li>The DMAC can be activated using interrupt sources<sup>*1</sup></li> <li>The target interrupt source can be selected individually for every DMAC channels.</li> </ul>   |
|                                       | DTC control   | <ul style="list-style-type: none"> <li>The DTC can be activated using interrupt sources<sup>*1</sup></li> <li>The method for selecting an interrupt source is the same as that of the interrupt request to NVIC.</li> </ul>   |
| Non-maskable interrupts <sup>*2</sup> | NMI pin interrupt   | <ul style="list-style-type: none"> <li>Interrupt from the NMI pin</li> <li>Interrupt detection on falling edge or rising edge</li> <li>Digital filter function supported</li> </ul>   |
|                                       | WDT underflow/refresh error <sup>*3</sup>   | Interrupt on an underflow of the down-counter or occurrence of a refresh error  |
|                                       | IWDT underflow/refresh error <sup>*3</sup>  | Interrupt on an underflow of the down-counter or occurrence of a refresh error  |
|                                       | Low voltage detection 1 <sup>*3</sup>   | Voltage monitor 1 interrupt of the voltage monitor 1 circuit (LVD_LVD1)   |
|                                       | Low voltage detection 2 <sup>*3</sup>   | Voltage monitor 2 interrupt of the voltage monitor 2 circuit (LVD_LVD2)   |
|                                       | RPEST <sup>*5</sup>   | Interrupt on SRAM parity error  |
|                                       | RECCST <sup>*5</sup>  | Interrupt on SRAM ECC error   |
|                                       | TZFST <sup>*5</sup>   | TrustZone Filter error.   |
|                                       | CPEST <sup>*5</sup>   | Cache RAM Parity error.   |
|                                       | Oscillation stop detection interrupt <sup>*3</sup>  | Interrupt on detecting that the main oscillation has stopped  |
|                                       | Bus master MPU error <sup>*5</sup>  | Interrupt on MPU bus master error   |
| Low power modes                       | <ul style="list-style-type: none"> <li>Sleep mode: return is initiated by non-maskable interrupts or any other interrupt source</li> <li>Software Standby mode: return is initiated by non-maskable interrupts. Interrupt can be selected in the WUPEN register.</li> <li>Snooze mode: return is initiated by non-maskable interrupts. Interrupt can be selected in the SELSR0 and WUPEN registers.</li> </ul> <p>See section 13.2.17. SELSR0 : SYS Event Link Setting Register and section 13.2.18. WUPEN0 : Wake Up Interrupt Enable Register 0, section 13.2.19. WUPEN1 : Wake Up interrupt enable register 1.</p> |   |
| TrustZone Filter                      | Available   |   |

Note 1. For the DMAC and DTC activation sources, see Table 13.4.

Note 2. Non-maskable interrupts can be enabled only once after a reset release.

Note 3. These non-maskable interrupts can also be used as maskable interrupts. When used as maskable interrupts, do not change the value of the NMIER register from the reset state. To enable voltage monitor 1 and voltage monitor 2 interrupts, set the LVD1CR1.IRQSEL and LVD2CR1.IRQSEL bits to 1.

## 13. 中断控制器单元(ICU)

### 13.1 Overview

中断控制器单元(ICU)控制哪些事件信号链接到嵌套向量中断控制器(NVIC)、DMA控制器(DMAC)和数据传输控制器(DTC)模块。ICU还控制不可屏蔽的中断。

表13.1列出了ICU规格，图13.1显示了框图，表13.2列出了IO引脚。

**Table 13.1 ICU规格**

| Parameter                             |  | Description   |
|---------------------------------------|--|---|
| Maskable interrupts                   | 外设功能中断   | <ul style="list-style-type: none"> <li>来自外围模块的中断</li> <li>源数：223（在事件列表编号32到511中选择因子）</li> </ul>   |
|                                       | 外部引脚中断   | <ul style="list-style-type: none"> <li>低电平中断检测<sup>*4</sup>、下降沿、上升沿、上升沿和下降沿。可以为每个来源设置其中一种检测方法</li> <li>支持数字滤波功能</li> <li>16个源，来自IRQi (i=0到15) 引脚的中断。</li> </ul> |
|                                       | 对CPU的中断请求(NVIC)  | <ul style="list-style-type: none"> <li>96个中断请求输出到NVIC。</li> </ul>   |
|                                       | DMAC control   | <ul style="list-style-type: none"> <li>可以使用中断源激活DMAC<sup>*1</sup></li> <li>可以为每个DMAC通道单独选择目标中断源。</li> </ul>   |
|                                       | DTC control  | <ul style="list-style-type: none"> <li>可以使用中断源激活DTC<sup>*1</sup></li> <li>中断源的选择方法与中断请求相同</li> <li>NVIC.</li> </ul>   |
| Non-maskable interrupts <sup>*2</sup> | NMI引脚中断  | <ul style="list-style-type: none"> <li>来自NMI引脚的中断</li> <li>下降沿或上升沿中断检测</li> <li>支持数字滤波功能</li> </ul>   |
|                                       | WDT underflow/refresh error <sup>*3</sup>  | 递减计数器下溢或发生刷新错误时中断   |
|                                       | IWDT underflow/refresh error <sup>*3</sup>   | 递减计数器下溢或发生刷新错误时中断   |
|                                       | 低电压检测1 <sup>*3</sup>   | 电压监视器1电路的电压监视器1中断(LVD_LVD1)   |
|                                       | 低电压检测2 <sup>*3</sup>   | 电压监视器2电路的电压监视器2中断(LVD_LVD2)   |
|                                       | RPEST <sup>*5</sup>  | SRAM奇偶校验错误中断  |
|                                       | RECCST <sup>*5</sup>   | SRAMECC错误中断   |
|                                       | TZFST <sup>*5</sup>  | TrustZone过滤器错误。   |
|                                       | CPEST <sup>*5</sup>  | 高速缓存RAM奇偶校验错误。  |
|                                       | 振荡停止检测中断 <sup>*3</sup>   | 检测到主振荡停止时中断   |
|                                       | 总线主控MPU错误 <sup>*5</sup>  | MPU总线主机错误中断   |
| 低功耗模式                                 | <ul style="list-style-type: none"> <li>睡眠模式：返回由不可屏蔽中断或任何其他中断源启动</li> <li>软件待机模式：返回由不可屏蔽的中断启动。可以在WUPEN寄存器中选择中断。</li> <li>贪睡模式：返回由不可屏蔽的中断发起。中断可以在 SELSR0和WUPEN寄存器。</li> </ul> <p>请参阅第13.2.17节。SELSR0：SYS事件链接设置寄存器和第13.2.18节。WUPEN0：唤醒中断使能寄存器0，第13.2.19节。WUPEN1：唤醒中断使能寄存器1。</p> |   |
| TrustZone Filter                      | Available  |   |

注1.对于DMAC和DTC激活源，请参见表13.4。

注2.不可屏蔽中断只能在复位释放后启用一次。

注3：这些不可屏蔽中断也可以用作可屏蔽中断。当用作可屏蔽中断时，不要从复位状态更改NMIER寄存器的值。要启用电压监视器1和电压监视器2中断，请将LVD1CR1.IRQSEL和LVD2CR1.IRQSEL位设置为1。

Note 4. Low level: interrupt detection is not canceled if you do not clear it after a detection.  
 Note 5. These non-maskable interrupt sources cannot be recovered if the request source clock is stopped during low power mode.

Figure 13.1 shows the ICU block diagram.

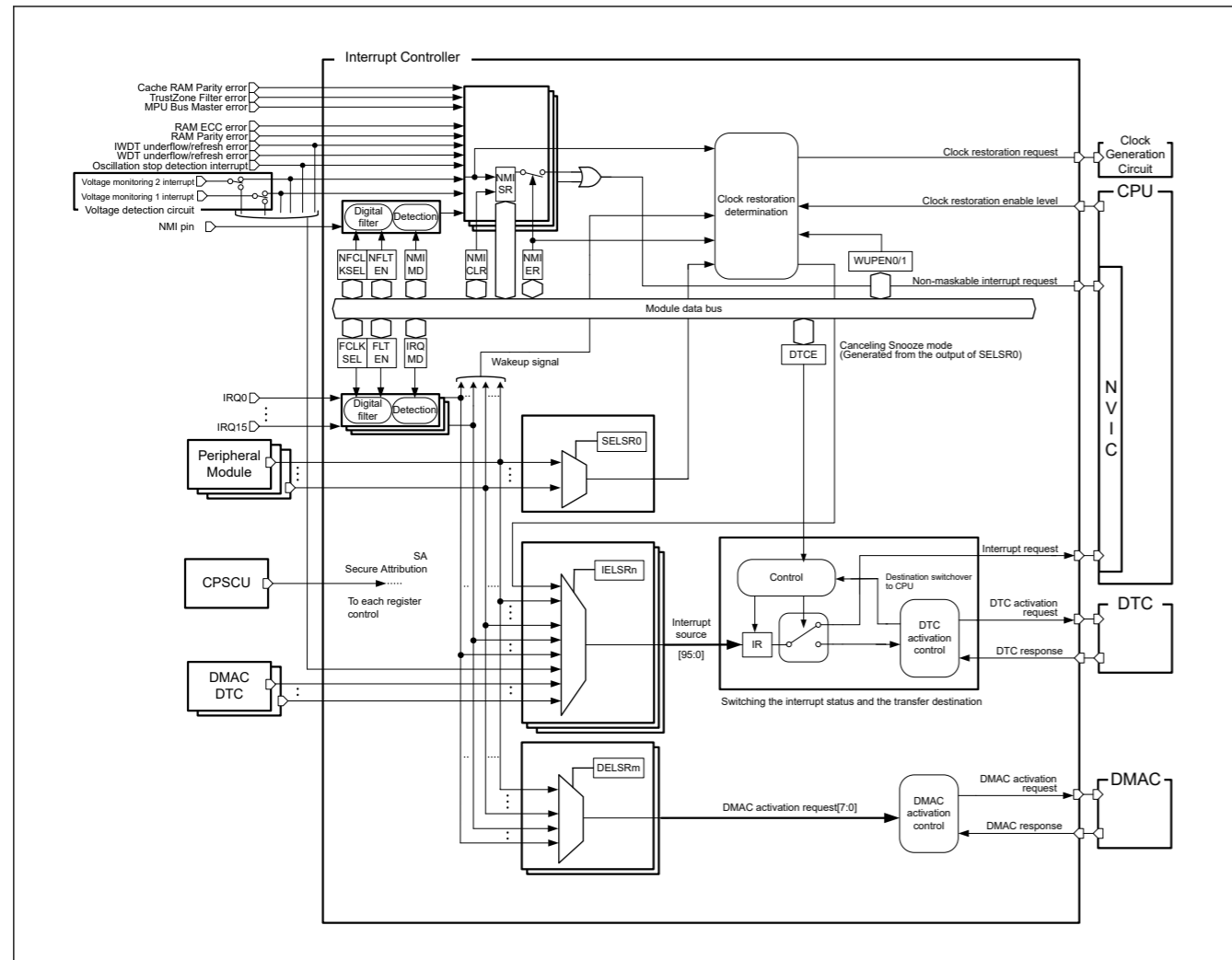


Figure 13.1 ICU block diagram

Table 13.2 lists the ICU input/output pins.

Table 13.2 ICU I/O pins

| Pin name                       | I/O   | Description                        |
|--------------------------------|-------|------------------------------------|
| NMI                            | Input | Non-maskable interrupt request pin |
| IRQ <sub>i</sub> (i = 0 to 15) | Input | External interrupt request pins    |

### 13.2 Register Descriptions

This chapter does not describe the Arm® NVIC internal registers. For information about these registers, see ARM Limited., ARM® Cortex®-M33 Processor Technical Reference Manual (ARM 100230).

注4.低电平: 检测后不清除中断检测不取消。  
 注5.如果请求源时钟在低功耗模式下停止, 这些不可屏蔽的中断源将无法恢复。

图13.1显示了ICU框图。

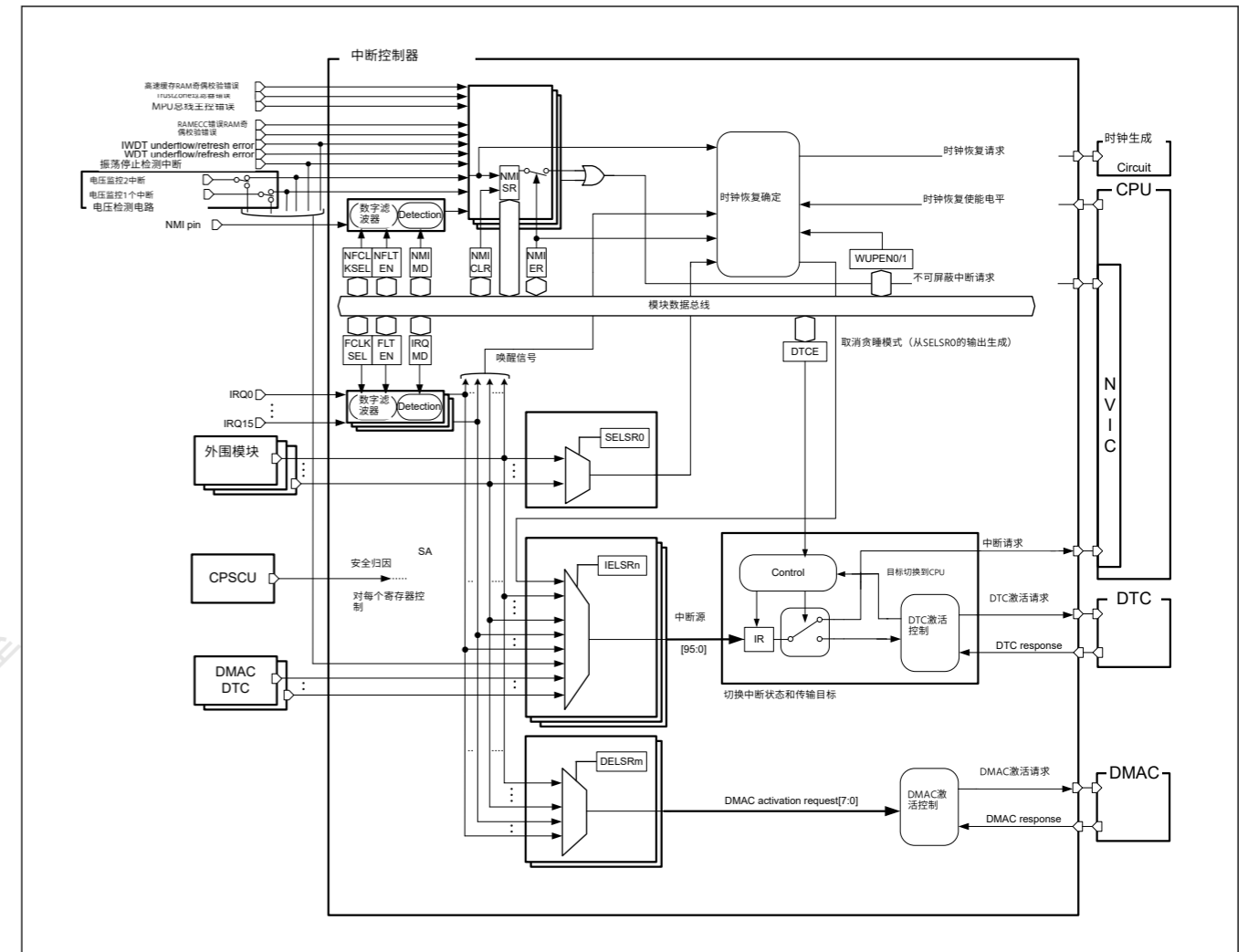


Figure 13.1 ICU框图

表13.2列出了ICU输入输出引脚。

Table 13.2 ICU I/O引脚

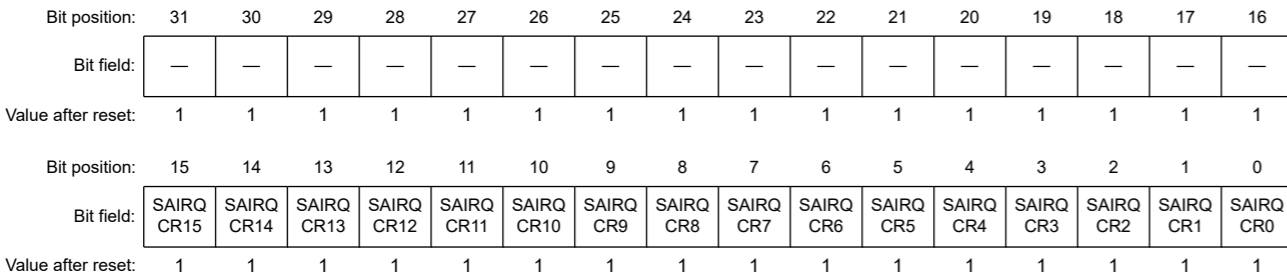
| 引脚名称                           | I/O   | Description |
|--------------------------------|-------|-------------|
| NMI                            | Input | 不可屏蔽中断请求引脚  |
| IRQ <sub>i</sub> (i = 0 to 15) | Input | 外部中断请求引脚    |

### 13.2 注册说明

本章不介绍Arm®NVIC内部寄存器。有关这些寄存器的信息, 请参阅ARM Limited. ARM®Cortex®-M33处理器技术参考手册(ARM100230)。

13.2.1 ICUSARA : Interrupt Controller Unit Security Attribution Register A

Base address: CPSCU = 0x4000\_8000  
Offset address: 0x40



| Bit   | Symbol                | Function   | R/W |
|-------|-----------------------|--|-----|
| 15:0  | SAIRQCR15 to SAIRQCR0 | Security attributes of registers for the IRQCRn register<br>0: Secure<br>1: Non-secure | R/W |
| 31:16 | —                     | These bits are read as 1. The write value should be 1.                                 | R/W |

Note: Only secure access can write to this register. Both secure access and Non-secure read access are allowed but Non-secure write access is not allowed and TrustZone access error is not generated.  
Note: This register is write-protected by PRCR register.

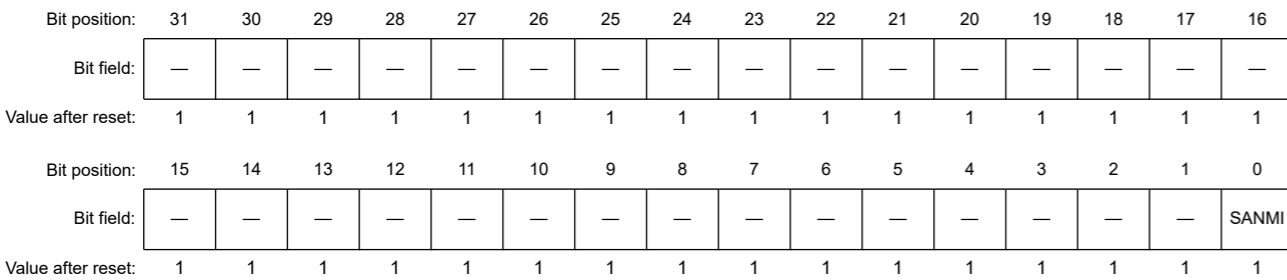
SAIRQCRn bits (Security attributes of registers for the IRQCRn register)

The target registers are as follows:

- IRQCR0 to IRQCR15 registers
- WUPEN0.IRQWUPEN[15:0] bits

13.2.2 ICUSARB : Interrupt Controller Unit Security Attribution Register B

Base address: CPSCU = 0x4000\_8000  
Offset address: 0x44



| Bit  | Symbol | Function   | R/W |
|------|--------|--|-----|
| 0    | SANMI  | Security attributes of registers for nonmaskable interrupt<br>0: Secure<br>1: Non-secure | R/W |
| 31:1 | —      | These bits are read as 1. The write value should be 1.                                   | R/W |

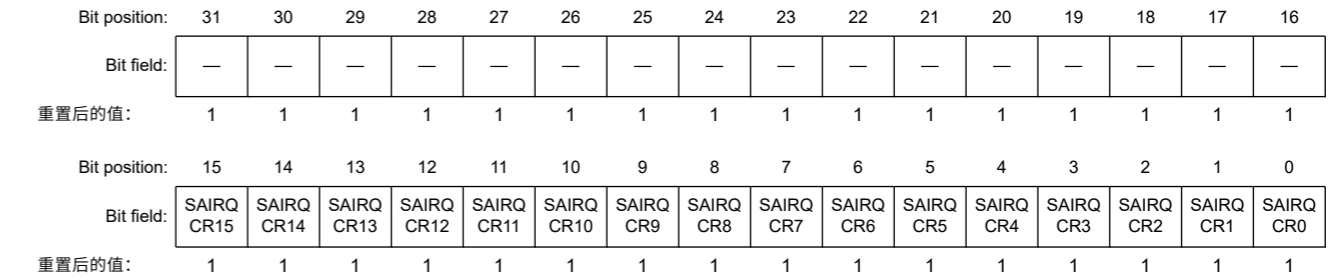
Note: Only secure access can write to this register. Both secure access and Non-secure read access are allowed but Non-secure write access is not allowed and TrustZone access error is not generated.  
Note: This register is write-protected by PRCR register.

SANMI bit (Security attributes of registers for nonmaskable interrupt)

Security attributes of registers for non-maskable interrupt. The target registers are as follows:

13.2.1 ICUSARA:中断控制器单元安全属性寄存器A

Base address: CPSCU = 0x4000\_8000  
Offset address: 0x40



| Bit   | Symbol                | Function  | R/W |
|-------|-----------------------|---|-----|
| 15:0  | SAIRQCR15 to SAIRQCR0 | IRQCRn寄存器的寄存器安全属性<br>0: Secure<br>1: Non-secure | R/W |
| 31:16 | —                     | 这些位被读取为1。写入值应为1。                                | R/W |

Note: 只有安全访问才能写入该寄存器。允许安全访问和非安全读取访问，但不允许非安全写入访问，并且不会生成TrustZone访问错误。  
Note: 该寄存器由PRCR寄存器写保护。

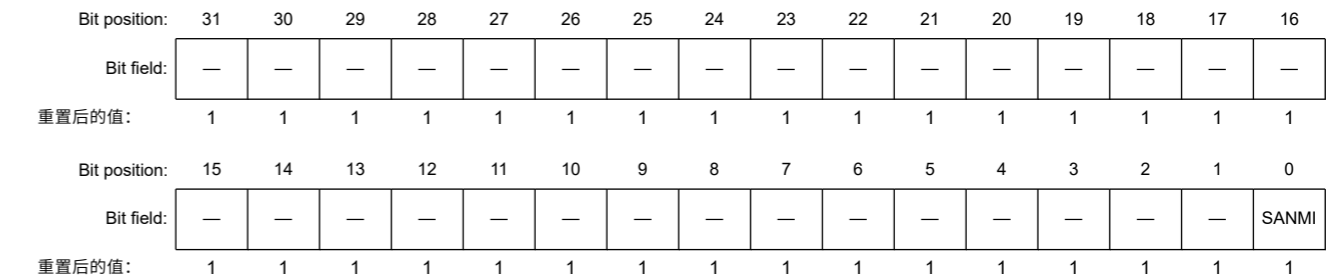
SAIRQCRn位 (IRQCRn寄存器的寄存器安全属性)

目标寄存器如下:

- SAIRQCR0到SAIRQCR15寄存器
- WUPEN0.IRQWUPEN[15:0] bits

13.2.2 ICUSARB:中断控制器单元安全属性寄存器B

Base address: CPSCU = 0x4000\_8000  
Offset address: 0x44



| Bit  | Symbol | Function                                     | R/W |
|------|--------|--|-----|
| 0    | SANMI  | 不可屏蔽中断寄存器的安全属性<br>0: Secure<br>1: Non-secure | R/W |
| 31:1 | —      | 这些位被读取为1。写入值应为1。                             | R/W |

Note: 只有安全访问才能写入该寄存器。允许安全访问和非安全读取访问，但不允许非安全写入访问，并且不会生成TrustZone访问错误。  
Note: 该寄存器由PRCR寄存器写保护。

SANMI位 (不可屏蔽中断的寄存器的安全属性)

不可屏蔽中断的寄存器的安全属性。目标寄存器如下:



- NMIER
- NMICLR
- NMICR

The value of AIRCR.BFHFNMINs bit [13] in Application Interrupt and Reset Control Register of ARM CPU should be the same as the value of security attribution. The initial values of AIRCR.BFHFNMINs and the SANMI bits are different. AIRCR.BFHFNMINs is secure and SANMI is non-secure. Polarity has the same meaning so program these to match.

Note: Only one of Secure and Non-Secure can set security attribution for non-maskable interrupt-related registers. If you program the Secure attribute as secure, it always goes to the Secure interrupt handler. To release any of the non-maskable interrupt sources to the non-secure user, write a function to execute a nonsecure program from the interrupt handler for Secure.

### 13.2.3 ICUSARC : Interrupt Controller Unit Security Attribution Register C

Base address: CPSCU = 0x4000\_8000

Offset address: 0x48

|                    |    |    |    |    |    |    |    |    |          |          |          |          |          |          |          |          |
|--------------------|----|----|----|----|----|----|----|----|----------|----------|----------|----------|----------|----------|----------|----------|
| Bit position:      | 31 | 30 | 29 | 28 | 27 | 26 | 25 | 24 | 23       | 22       | 21       | 20       | 19       | 18       | 17       | 16       |
| Bit field:         | —  | —  | —  | —  | —  | —  | —  | —  | —        | —        | —        | —        | —        | —        | —        | —        |
| Value after reset: | 1  | 1  | 1  | 1  | 1  | 1  | 1  | 1  | 1        | 1        | 1        | 1        | 1        | 1        | 1        | 1        |
| Bit position:      | 15 | 14 | 13 | 12 | 11 | 10 | 9  | 8  | 7        | 6        | 5        | 4        | 3        | 2        | 1        | 0        |
| Bit field:         | —  | —  | —  | —  | —  | —  | —  | —  | SADM AC7 | SADM AC6 | SADM AC5 | SADM AC4 | SADM AC3 | SADM AC2 | SADM AC1 | SADM AC0 |
| Value after reset: | 1  | 1  | 1  | 1  | 1  | 1  | 1  | 1  | 1        | 1        | 1        | 1        | 1        | 1        | 1        | 1        |

| Bit  | Symbol             | Function  | R/W |
|------|--------------------|---|-----|
| 7:0  | SADMAC7 to SADMAC0 | Security attributes of registers for DMAC channel<br>0: Secure<br>1: Non-secure | R/W |
| 31:8 | —                  | These bits are read as 1. The write value should be 1.                          | R/W |

Note: Only secure access can write to this register. Both secure access and Non-secure read access are allowed but Non-secure write access is not allowed and TrustZone access error is not generated.

Note: This register is write-protected by PRCR register.

#### SADMACn bits (Security attributes of registers for DMAC channel)

Security attributes of registers for DMAC channel. This register is referred to as the security attribute of the ICU and DMAC registers.

The controlled ICU register is:

- DELSRn

The controlled DMAC registers are:

- DMACn.DMSAR
- DMACn.DMSRR
- DMACn.DMDAR
- DMACn.DMDRR
- DMACn.DMCRA
- DMACn.DMCRB
- DMACn.DMTMD
- DMACn.DMINT
- DMACn.DMAMD

- NMIER
- NMICLR
- NMICR

ARMCPU的应用中断和复位控制寄存器AIRCR.BFHFNMINsbit[13]的值应与安全属性的值相同。AIRCR.BFHFNMINs和SANMI位的初始值不同。AIRCR.BFHFNMINs是安全的，而SANMI是不安全的。极性具有相同的含义，因此请对它们进行编程以匹配。

Note: 只有Secure和Non-Secure之一可以为不可屏蔽的中断相关寄存器设置安全属性。如果您将Secure属性编程为安全，则它始终会转到Secure中断处理程序。要将任何不可屏蔽的中断源释放给非安全用户，请编写一个函数以从Secure的中断处理程序执行非安全程序。

### 13.2.3 ICUSARC:中断控制器单元安全属性寄存器C

Base address: CPSCU = 0x4000\_8000

Offset address: 0x48

|               |    |    |    |    |    |    |    |    |          |          |          |          |          |          |          |          |
|---------------|----|----|----|----|----|----|----|----|----------|----------|----------|----------|----------|----------|----------|----------|
| Bit position: | 31 | 30 | 29 | 28 | 27 | 26 | 25 | 24 | 23       | 22       | 21       | 20       | 19       | 18       | 17       | 16       |
| Bit field:    | —  | —  | —  | —  | —  | —  | —  | —  | —        | —        | —        | —        | —        | —        | —        | —        |
| 重置后的值:        | 1  | 1  | 1  | 1  | 1  | 1  | 1  | 1  | 1        | 1        | 1        | 1        | 1        | 1        | 1        | 1        |
| Bit position: | 15 | 14 | 13 | 12 | 11 | 10 | 9  | 8  | 7        | 6        | 5        | 4        | 3        | 2        | 1        | 0        |
| Bit field:    | —  | —  | —  | —  | —  | —  | —  | —  | SADM AC7 | SADM AC6 | SADM AC5 | SADM AC4 | SADM AC3 | SADM AC2 | SADM AC1 | SADM AC0 |
| 重置后的值:        | 1  | 1  | 1  | 1  | 1  | 1  | 1  | 1  | 1        | 1        | 1        | 1        | 1        | 1        | 1        | 1        |

| Bit  | Symbol             | Function                                     | R/W |
|------|--------------------|--|-----|
| 7:0  | SADMAC7 to SADMAC0 | DMAC通道寄存器的安全属性<br>0: Secure<br>1: Non-secure | R/W |
| 31:8 | —                  | 这些位被读取为1。写入值应为1。                             | R/W |

Note: 只有安全访问才能写入该寄存器。允许安全访问和非安全读取访问，但不允许非安全写入访问，并且不会生成TrustZone访问错误。

Note: 该寄存器由PRCR寄存器写保护。

#### SADMACn位 (DMAC通道寄存器的安全属性)

DMAC通道寄存器的安全属性。该寄存器被称为ICU的安全属性和DMAC registers.

受控ICU寄存器为:

- DELSRn

受控的DMAC寄存器是:

- DMACn.DMSAR
- DMACn.DMSRR
- DMACn.DMDAR
- DMACn.DMDRR
- DMACn.DMCRA
- DMACn.DMCRB
- DMACn.DMTMD
- DMACn.DMINT
- DMACn.DMAMD

- DMACn.DMOFR
- DMACn.DMCNT
- DMACn.DMREQ
- DMACn.DMSTS
- DMACn.DMSBS
- DMACn.DMDBS

For details on DMAC registers, see [section 16, DMA Controller \(DMAC\)](#).

### 13.2.4 ICUSARD : Interrupt Controller Unit Security Attribution Register D

Base address: CPSCU = 0x4000\_8000

Offset address: 0x4C

|                    |    |    |    |    |    |    |    |    |    |    |    |    |    |    |    |          |
|--------------------|----|----|----|----|----|----|----|----|----|----|----|----|----|----|----|----------|
| Bit position:      | 31 | 30 | 29 | 28 | 27 | 26 | 25 | 24 | 23 | 22 | 21 | 20 | 19 | 18 | 17 | 16       |
| Bit field:         | —  | —  | —  | —  | —  | —  | —  | —  | —  | —  | —  | —  | —  | —  | —  | —        |
| Value after reset: | 1  | 1  | 1  | 1  | 1  | 1  | 1  | 1  | 1  | 1  | 1  | 1  | 1  | 1  | 1  | 1        |
| Bit position:      | 15 | 14 | 13 | 12 | 11 | 10 | 9  | 8  | 7  | 6  | 5  | 4  | 3  | 2  | 1  | 0        |
| Bit field:         | —  | —  | —  | —  | —  | —  | —  | —  | —  | —  | —  | —  | —  | —  | —  | SASELSR0 |
| Value after reset: | 1  | 1  | 1  | 1  | 1  | 1  | 1  | 1  | 1  | 1  | 1  | 1  | 1  | 1  | 1  | 1        |

| Bit  | Symbol   | Function  | R/W |
|------|----------|---|-----|
| 0    | SASELSR0 | Security attributes of registers for SELSR0<br>0: Secure<br>1: Non-secure | R/W |
| 31:1 | —        | These bits are read as 1. The write value should be 1.                    | R/W |

Note: Only secure access can write to this register. Both secure access and Non-secure read access are allowed but Non-secure write access is not allowed and TrustZone access error is not generated.

Note: This register is write-protected by PRCR register.

### 13.2.5 ICUSARE : Interrupt Controller Unit Security Attribution Register E

Base address: CPSCU = 0x4000\_8000

Offset address: 0x50

|                    |            |               |               |               |               |    |               |               |    |    |    |    |             |             |    |             |
|--------------------|------------|---------------|---------------|---------------|---------------|----|---------------|---------------|----|----|----|----|-------------|-------------|----|-------------|
| Bit position:      | 31         | 30            | 29            | 28            | 27            | 26 | 25            | 24            | 23 | 22 | 21 | 20 | 19          | 18          | 17 | 16          |
| Bit field:         | SAIIC0 WUP | SAAG T1CB WUP | SAAG T1CA WUP | SAAG T1UD WUP | SAUS BFS0 WUP | —  | SART CPRD WUP | SART CALM WUP | —  | —  | —  | —  | SALV D2WU P | SALV D1WU P | —  | SAIW DTWU P |
| Value after reset: | 1          | 1             | 1             | 1             | 1             | 1  | 1             | 1             | 1  | 1  | 1  | 1  | 1           | 1           | 1  | 1           |
| Bit position:      | 15         | 14            | 13            | 12            | 11            | 10 | 9             | 8             | 7  | 6  | 5  | 4  | 3           | 2           | 1  | 0           |
| Bit field:         | —          | —             | —             | —             | —             | —  | —             | —             | —  | —  | —  | —  | —           | —           | —  | —           |
| Value after reset: | 1          | 1             | 1             | 1             | 1             | 1  | 1             | 1             | 1  | 1  | 1  | 1  | 1           | 1           | 1  | 1           |

| Bit  | Symbol    | Function  | R/W |
|------|-----------|---|-----|
| 15:0 | —         | These bits are read as 1. The write value should be 1.                        | R/W |
| 16   | SAIWDTWUP | Security attributes of registers for WUPEN0.b16<br>0: Secure<br>1: Non-secure | R/W |

- DMACn.DMOFR
- DMACn.DMCNT
- DMACn.DMREQ
- DMACn.DMSTS
- DMACn.DMSBS
- DMACn.DMDBS

有关DMAC寄存器的详细信息，请参见第16节，DMA控制器(DMAC)。

### 13.2.4 ICUSARD:中断控制器单元安全属性寄存器D

Base address: CPSCU = 0x4000\_8000

Offset address: 0x4C

|               |    |    |    |    |    |    |    |    |    |    |    |    |    |    |    |          |
|---------------|----|----|----|----|----|----|----|----|----|----|----|----|----|----|----|----------|
| Bit position: | 31 | 30 | 29 | 28 | 27 | 26 | 25 | 24 | 23 | 22 | 21 | 20 | 19 | 18 | 17 | 16       |
| Bit field:    | —  | —  | —  | —  | —  | —  | —  | —  | —  | —  | —  | —  | —  | —  | —  | —        |
| 重置后的值:        | 1  | 1  | 1  | 1  | 1  | 1  | 1  | 1  | 1  | 1  | 1  | 1  | 1  | 1  | 1  | 1        |
| Bit position: | 15 | 14 | 13 | 12 | 11 | 10 | 9  | 8  | 7  | 6  | 5  | 4  | 3  | 2  | 1  | 0        |
| Bit field:    | —  | —  | —  | —  | —  | —  | —  | —  | —  | —  | —  | —  | —  | —  | —  | SASELSR0 |
| 重置后的值:        | 1  | 1  | 1  | 1  | 1  | 1  | 1  | 1  | 1  | 1  | 1  | 1  | 1  | 1  | 1  | 1        |

| Bit  | Symbol   | Function                                     | R/W |
|------|----------|--|-----|
| 0    | SASELSR0 | SELSR0寄存器的安全属性<br>0: Secure<br>1: Non-secure | R/W |
| 31:1 | —        | 这些位被读取为1。写入值应为1。                             | R/W |

Note: 只有安全访问才能写入该寄存器。允许安全访问和非安全读取访问，但不允许非安全写入访问，并且不会生成TrustZone访问错误。

Note: 该寄存器由PRCR寄存器写保护。

### 13.2.5 ICUSARE:中断控制器单元安全属性寄存器E

Base address: CPSCU = 0x4000\_8000

Offset address: 0x50

|               |            |               |               |               |               |    |               |          |    |    |    |    |             |             |    |             |
|---------------|------------|---------------|---------------|---------------|---------------|----|---------------|----------|----|----|----|----|-------------|-------------|----|-------------|
| Bit position: | 31         | 30            | 29            | 28            | 27            | 26 | 25            | 24       | 23 | 22 | 21 | 20 | 19          | 18          | 17 | 16          |
| Bit field:    | SAIIC0 WUP | SAAG T1CB WUP | SAAG T1CA WUP | SAAG T1UD WUP | SAUS BFS0 WUP | —  | SART CPRD WUP | 萨特冷静 WUP | —  | —  | —  | —  | SALV D2WU P | SALV D1WU P | —  | SAIW DTWU P |
| 重置后的值:        | 1          | 1             | 1             | 1             | 1             | 1  | 1             | 1        | 1  | 1  | 1  | 1  | 1           | 1           | 1  | 1           |
| Bit position: | 15         | 14            | 13            | 12            | 11            | 10 | 9             | 8        | 7  | 6  | 5  | 4  | 3           | 2           | 1  | 0           |
| Bit field:    | —          | —             | —             | —             | —             | —  | —             | —        | —  | —  | —  | —  | —           | —           | —  | —           |
| 重置后的值:        | 1          | 1             | 1             | 1             | 1             | 1  | 1             | 1        | 1  | 1  | 1  | 1  | 1           | 1           | 1  | 1           |

| Bit  | Symbol    | Function   | R/W |
|------|-----------|--|-----|
| 15:0 | —         | 这些位被读取为1。写入值应为1。                                 | R/W |
| 16   | SAIWDTWUP | WUPEN0.b16寄存器的安全属性<br>0: Secure<br>1: Non-secure | R/W |

| Bit   | Symbol      | Function  | R/W |
|-------|-------------|---|-----|
| 17    | —           | This bit is read as 1. The write value should be 1.                           | R/W |
| 18    | SALVD1WUP   | Security attributes of registers for WUPEN0.b18<br>0: Secure<br>1: Non-secure | R/W |
| 19    | SALVD2WUP   | Security attributes of registers for WUPEN0.b19<br>0: Secure<br>1: Non-secure | R/W |
| 23:20 | —           | These bits are read as 1. The write value should be 1.                        | R/W |
| 24    | SARTCALMWUP | Security attributes of registers for WUPEN0.b24<br>0: Secure<br>1: Non-secure | R/W |
| 25    | SARTCPRDWUP | Security attributes of registers for WUPEN0.b25<br>0: Secure<br>1: Non-secure | R/W |
| 26    | —           | These bits are read as 1. The write value should be 1.                        | R/W |
| 27    | SAUSBFS0WUP | Security attributes of registers for WUPEN0.b27<br>0: Secure<br>1: Non-secure | R/W |
| 28    | SAAGT1UDWUP | Security attributes of registers for WUPEN0.b28<br>0: Secure<br>1: Non-secure | R/W |
| 29    | SAAGT1CAWUP | Security attributes of registers for WUPEN0.b29<br>0: Secure<br>1: Non-secure | R/W |
| 30    | SAAGT1CBWUP | Security attributes of registers for WUPEN0.b30<br>0: Secure<br>1: Non-secure | R/W |
| 31    | SAIC0WUP    | Security attributes of registers for WUPEN0.b31<br>0: Secure<br>1: Non-secure | R/W |

Note: Only secure access can write to this register. Both secure access and Non-secure read access are allowed but Non-secure write access is not allowed and TrustZone access error is not generated.

Note: This register is write-protected by PRCR register.

### 13.2.6 ICUSARF : Interrupt Controller Unit Security Attribution Register F

Base address: CPSCU = 0x4000\_8000

Offset address: 0x54

|                    |    |    |    |    |    |    |    |    |    |    |    |    |    |    |               |               |               |
|--------------------|----|----|----|----|----|----|----|----|----|----|----|----|----|----|---------------|---------------|---------------|
| Bit position:      | 31 | 30 | 29 | 28 | 27 | 26 | 25 | 24 | 23 | 22 | 21 | 20 | 19 | 18 | 17            | 16            |               |
| Bit field:         | —  | —  | —  | —  | —  | —  | —  | —  | —  | —  | —  | —  | —  | —  | —             | —             |               |
| Value after reset: | 1  | 1  | 1  | 1  | 1  | 1  | 1  | 1  | 1  | 1  | 1  | 1  | 1  | 1  | 1             | 1             |               |
| Bit position:      | 15 | 14 | 13 | 12 | 11 | 10 | 9  | 8  | 7  | 6  | 5  | 4  | 3  | 2  | 1             | 0             |               |
| Bit field:         | —  | —  | —  | —  | —  | —  | —  | —  | —  | —  | —  | —  | —  | —  | SAAG T3CB WUP | SAAG T3CA WUP | SAAG T3UD WUP |
| Value after reset: | 1  | 1  | 1  | 1  | 1  | 1  | 1  | 1  | 1  | 1  | 1  | 1  | 1  | 1  | 1             | 1             |               |

| Bit | Symbol      | Function   | R/W |
|-----|-------------|--|-----|
| 0   | SAAGT3UDWUP | Security attributes of registers for WUPEN1.b0<br>0: Secure<br>1: Non-secure | R/W |

| Bit   | Symbol      | Function   | R/W |
|-------|-------------|--|-----|
| 17    | —           | 该位读取为1。写入值应为1。                                   | R/W |
| 18    | SALVD1WUP   | WUPEN0.b18寄存器的安全属性<br>0: Secure<br>1: Non-secure | R/W |
| 19    | SALVD2WUP   | WUPEN0.b19寄存器的安全属性<br>0: Secure<br>1: Non-secure | R/W |
| 23:20 | —           | 这些位被读取为1。写入值应为1。                                 | R/W |
| 24    | SARTCALMWUP | WUPEN0.b24寄存器的安全属性<br>0: Secure<br>1: Non-secure | R/W |
| 25    | SARTCPRDWUP | WUPEN0.b25寄存器的安全属性<br>0: Secure<br>1: Non-secure | R/W |
| 26    | —           | 这些位被读取为1。写入值应为1。                                 | R/W |
| 27    | SAUSBFS0WUP | WUPEN0.b27寄存器的安全属性<br>0: Secure<br>1: Non-secure | R/W |
| 28    | SAAGT1UDWUP | WUPEN0.b28寄存器的安全属性<br>0: Secure<br>1: Non-secure | R/W |
| 29    | SAAGT1CAWUP | WUPEN0.b29寄存器的安全属性<br>0: Secure<br>1: Non-secure | R/W |
| 30    | SAAGT1CBWUP | WUPEN0.b30寄存器的安全属性<br>0: Secure<br>1: Non-secure | R/W |
| 31    | SAIC0WUP    | WUPEN0.b31寄存器的安全属性<br>0: Secure<br>1: Non-secure | R/W |

Note: 只有安全访问才能写入该寄存器。允许安全访问和非安全读取访问，但不允许非安全写入访问，并且不会生成TrustZone访问错误。

Note: 该寄存器由PRCR寄存器写保护。

### 13.2.6 ICUSARF:中断控制器单元安全属性寄存器F

Base address: CPSCU = 0x4000\_8000

Offset address: 0x54

|               |    |    |    |    |    |    |    |    |    |    |    |    |    |    |               |               |               |
|---------------|----|----|----|----|----|----|----|----|----|----|----|----|----|----|---------------|---------------|---------------|
| Bit position: | 31 | 30 | 29 | 28 | 27 | 26 | 25 | 24 | 23 | 22 | 21 | 20 | 19 | 18 | 17            | 16            |               |
| Bit field:    | —  | —  | —  | —  | —  | —  | —  | —  | —  | —  | —  | —  | —  | —  | —             | —             |               |
| 重置后的值:        | 1  | 1  | 1  | 1  | 1  | 1  | 1  | 1  | 1  | 1  | 1  | 1  | 1  | 1  | 1             | 1             |               |
| Bit position: | 15 | 14 | 13 | 12 | 11 | 10 | 9  | 8  | 7  | 6  | 5  | 4  | 3  | 2  | 1             | 0             |               |
| Bit field:    | —  | —  | —  | —  | —  | —  | —  | —  | —  | —  | —  | —  | —  | —  | SAAG T3CB WUP | SAAG T3CA WUP | SAAG T3UD WUP |
| 重置后的值:        | 1  | 1  | 1  | 1  | 1  | 1  | 1  | 1  | 1  | 1  | 1  | 1  | 1  | 1  | 1             | 1             |               |

| Bit | Symbol      | Function  | R/W |
|-----|-------------|---|-----|
| 0   | SAAGT3UDWUP | WUPEN1.b0寄存器的安全属性<br>0: Secure<br>1: Non-secure | R/W |

| Bit  | Symbol      | Function   | R/W |
|------|-------------|--|-----|
| 1    | SAAGT3CAWUP | Security attributes of registers for WUPEN1.b1<br>0: Secure<br>1: Non-secure | R/W |
| 2    | SAAGT3CBWUP | Security attributes of registers for WUPEN1.b2<br>0: Secure<br>1: Non-secure | R/W |
| 31:3 | —           | These bits are read as 1. The write value should be 1.                       | R/W |

Note: Only secure access can write to this register. Both secure access and Non-secure read access are allowed but Non-secure write access is not allowed and TrustZone access error is not generated.

Note: This register is write-protected by PRCR register.

### 13.2.7 ICUSARG : Interrupt Controller Unit Security Attribution Register G

Base address: CPSCU = 0x4000\_8000

Offset address: 0x70

| Bit position:      | 31         | 30         | 29         | 28         | 27         | 26         | 25         | 24         | 23         | 22         | 21         | 20         | 19         | 18         | 17         | 16         |
|--------------------|------------|------------|------------|------------|------------|------------|------------|------------|------------|------------|------------|------------|------------|------------|------------|------------|
| Bit field:         | SAIEL SR31 | SAIEL SR30 | SAIEL SR29 | SAIEL SR28 | SAIEL SR27 | SAIEL SR26 | SAIEL SR25 | SAIEL SR24 | SAIEL SR23 | SAIEL SR22 | SAIEL SR21 | SAIEL SR20 | SAIEL SR19 | SAIEL SR18 | SAIEL SR17 | SAIEL SR16 |
| Value after reset: | 1          | 1          | 1          | 1          | 1          | 1          | 1          | 1          | 1          | 1          | 1          | 1          | 1          | 1          | 1          | 1          |
| Bit position:      | 15         | 14         | 13         | 12         | 11         | 10         | 9          | 8          | 7          | 6          | 5          | 4          | 3          | 2          | 1          | 0          |
| Bit field:         | SAIEL SR15 | SAIEL SR14 | SAIEL SR13 | SAIEL SR12 | SAIEL SR11 | SAIEL SR10 | SAIEL SR9  | SAIEL SR8  | SAIEL SR7  | SAIEL SR6  | SAIEL SR5  | SAIEL SR4  | SAIEL SR3  | SAIEL SR2  | SAIEL SR1  | SAIEL SR0  |
| Value after reset: | 1          | 1          | 1          | 1          | 1          | 1          | 1          | 1          | 1          | 1          | 1          | 1          | 1          | 1          | 1          | 1          |

| Bit  | Symbol                | Function   | R/W |
|------|-----------------------|--|-----|
| 31:0 | SAIELSR31 to SAIELSR0 | Security attributes of registers for IELSR31 to IELSR0<br>0: Secure<br>1: Non-secure | R/W |

Note: Only secure access can write to this register. Both secure access and Non-secure read access are allowed but Non-secure write access is not allowed and TrustZone access error is not generated.

Note: This register is write-protected by PRCR register.

#### SAIELSRn bits (Security attributes of registers for IELSR31 to IELSR0)

The Secure Attribute managed within the Arm CPU NVIC must match the security attribution of IELSEn ( n = 0 to 31 ). NVIC internal registers are in NVIC\_ITNS0[31:0]. The initial values of NVIC\_ITNS0 and ICUSARG are different. NVIC\_ITNS0 is secure and ICUSARG is non-secure. Polarity has the same meaning so program these to match.

### 13.2.8 ICUSARH : Interrupt Controller Unit Security Attribution Register H

Base address: CPSCU = 0x4000\_8000

Offset address: 0x74

| Bit position:      | 31         | 30         | 29         | 28         | 27         | 26         | 25         | 24         | 23         | 22         | 21         | 20         | 19         | 18         | 17         | 16         |
|--------------------|------------|------------|------------|------------|------------|------------|------------|------------|------------|------------|------------|------------|------------|------------|------------|------------|
| Bit field:         | SAIEL SR63 | SAIEL SR62 | SAIEL SR61 | SAIEL SR60 | SAIEL SR59 | SAIEL SR58 | SAIEL SR57 | SAIEL SR56 | SAIEL SR55 | SAIEL SR54 | SAIEL SR53 | SAIEL SR52 | SAIEL SR51 | SAIEL SR50 | SAIEL SR49 | SAIEL SR48 |
| Value after reset: | 1          | 1          | 1          | 1          | 1          | 1          | 1          | 1          | 1          | 1          | 1          | 1          | 1          | 1          | 1          | 1          |
| Bit position:      | 15         | 14         | 13         | 12         | 11         | 10         | 9          | 8          | 7          | 6          | 5          | 4          | 3          | 2          | 1          | 0          |
| Bit field:         | SAIEL SR47 | SAIEL SR46 | SAIEL SR45 | SAIEL SR44 | SAIEL SR43 | SAIEL SR42 | SAIEL SR41 | SAIEL SR40 | SAIEL SR39 | SAIEL SR38 | SAIEL SR37 | SAIEL SR36 | SAIEL SR35 | SAIEL SR34 | SAIEL SR33 | SAIEL SR32 |
| Value after reset: | 1          | 1          | 1          | 1          | 1          | 1          | 1          | 1          | 1          | 1          | 1          | 1          | 1          | 1          | 1          | 1          |

| Bit  | Symbol      | Function  | R/W |
|------|-------------|---|-----|
| 1    | SAAGT3CAWUP | WUPEN1.b1寄存器的安全属性<br>0: Secure<br>1: Non-secure | R/W |
| 2    | SAAGT3CBWUP | WUPEN1.b2寄存器的安全属性<br>0: Secure<br>1: Non-secure | R/W |
| 31:3 | —           | 这些位被读取为1。写入值应为1。                                | R/W |

Note: 只有安全访问才能写入该寄存器。允许安全访问和非安全读取访问，但不允许非安全写入访问，并且不会生成TrustZone访问错误。

Note: 该寄存器由PRCR寄存器写保护。

### 13.2.7 ICUSARG:中断控制器单元安全属性寄存器G

Base address: CPSCU = 0x4000\_8000

Offset address: 0x70

| Bit position: | 31         | 30         | 29         | 28         | 27         | 26         | 25         | 24         | 23         | 22         | 21         | 20         | 19         | 18         | 17         | 16         |
|---------------|------------|------------|------------|------------|------------|------------|------------|------------|------------|------------|------------|------------|------------|------------|------------|------------|
| Bit field:    | SAIEL SR31 | SAIEL SR30 | SAIEL SR29 | SAIEL SR28 | SAIEL SR27 | SAIEL SR26 | SAIEL SR25 | SAIEL SR24 | SAIEL SR23 | SAIEL SR22 | SAIEL SR21 | SAIEL SR20 | SAIEL SR19 | SAIEL SR18 | SAIEL SR17 | SAIEL SR16 |
| 重置后的值:        | 1          | 1          | 1          | 1          | 1          | 1          | 1          | 1          | 1          | 1          | 1          | 1          | 1          | 1          | 1          | 1          |
| Bit position: | 15         | 14         | 13         | 12         | 11         | 10         | 9          | 8          | 7          | 6          | 5          | 4          | 3          | 2          | 1          | 0          |
| Bit field:    | SAIEL SR15 | SAIEL SR14 | SAIEL SR13 | SAIEL SR12 | SAIEL SR11 | SAIEL SR10 | SAIEL SR9  | SAIEL SR8  | SAIEL SR7  | SAIEL SR6  | SAIEL SR5  | SAIEL SR4  | SAIEL SR3  | SAIEL SR2  | SAIEL SR1  | SAIEL SR0  |
| 重置后的值:        | 1          | 1          | 1          | 1          | 1          | 1          | 1          | 1          | 1          | 1          | 1          | 1          | 1          | 1          | 1          | 1          |

| Bit  | Symbol                | Function   | R/W |
|------|-----------------------|--|-----|
| 31:0 | SAIELSR31 to SAIELSR0 | IELSR31到IELSR0寄存器的安全属性<br>0: Secure<br>1: Non-secure | R/W |

Note: 只有安全访问才能写入该寄存器。允许安全访问和非安全读取访问，但不允许非安全写入访问，并且不会生成TrustZone访问错误。

Note: 该寄存器由PRCR寄存器写保护。

#### SAIELSRn位 (IELSR31至IELSR0寄存器的安全属性)

ArmCPUNVIC中管理的安全属性必须与IELSEn的安全属性匹配 (n=0到31)。NVIC内部寄存器位于NVIC\_ITNS0[31:0]。NVIC\_ITNS0和ICUSARG的初始值不同。NVIC\_ITNS0是安全的，而ICUSARG是不安全的。极性具有相同的含义，因此请对它们进行编程以匹配。

### 13.2.8 ICUSARH: 中断控制器单元安全属性寄存器H

Base address: CPSCU = 0x4000\_8000

Offset address: 0x74

| Bit position: | 31         | 30         | 29         | 28         | 27         | 26         | 25         | 24         | 23         | 22         | 21         | 20         | 19         | 18         | 17         | 16         |
|---------------|------------|------------|------------|------------|------------|------------|------------|------------|------------|------------|------------|------------|------------|------------|------------|------------|
| Bit field:    | SAIEL SR63 | SAIEL SR62 | SAIEL SR61 | SAIEL SR60 | SAIEL SR59 | SAIEL SR58 | SAIEL SR57 | SAIEL SR56 | SAIEL SR55 | SAIEL SR54 | SAIEL SR53 | SAIEL SR52 | SAIEL SR51 | SAIEL SR50 | SAIEL SR49 | SAIEL SR48 |
| 重置后的值:        | 1          | 1          | 1          | 1          | 1          | 1          | 1          | 1          | 1          | 1          | 1          | 1          | 1          | 1          | 1          | 1          |
| Bit position: | 15         | 14         | 13         | 12         | 11         | 10         | 9          | 8          | 7          | 6          | 5          | 4          | 3          | 2          | 1          | 0          |
| Bit field:    | SAIEL SR47 | SAIEL SR46 | SAIEL SR45 | SAIEL SR44 | SAIEL SR43 | SAIEL SR42 | SAIEL SR41 | SAIEL SR40 | SAIEL SR39 | SAIEL SR38 | SAIEL SR37 | SAIEL SR36 | SAIEL SR35 | SAIEL SR34 | SAIEL SR33 | SAIEL SR32 |
| 重置后的值:        | 1          | 1          | 1          | 1          | 1          | 1          | 1          | 1          | 1          | 1          | 1          | 1          | 1          | 1          | 1          | 1          |

| Bit  | Symbol                 | Function  | R/W |
|------|------------------------|---|-----|
| 31:0 | SAIELSR63 to SAIELSR32 | Security attributes of registers for IELSR63 to IELSR32<br>0: Secure<br>1: Non-secure | R/W |

Note: Only secure access can write to this register. Both secure access and Non-secure read access are allowed but Non-secure write access is not allowed and TrustZone access error is not generated.

Note: This register is write-protected by PRCR register.

**SAIELSRn bits (Security attributes of registers for IELSR63 to IELSR32)**

The Secure Attribute managed within the ARM CPU NVIC must match the security attribution of IELSEn ( n = 32 to 63 ). NVIC internal registers are in NVIC\_ITNS1[31:0]. The initial values of NVIC\_ITNS1 and ICUSARH are different. NVIC\_ITNS1 is secure and ICUSARH is non-secure. Polarity has the same meaning so program these to match.

**13.2.9 ICUSARI : Interrupt Controller Unit Security Attribution Register I**

Base address: CPSCU = 0x4000\_8000

Offset address: 0x78

|                    |            |            |            |            |            |            |            |            |            |            |            |            |            |            |            |            |
|--------------------|------------|------------|------------|------------|------------|------------|------------|------------|------------|------------|------------|------------|------------|------------|------------|------------|
| Bit position:      | 31         | 30         | 29         | 28         | 27         | 26         | 25         | 24         | 23         | 22         | 21         | 20         | 19         | 18         | 17         | 16         |
| Bit field:         | SAIEL SR95 | SAIEL SR94 | SAIEL SR93 | SAIEL SR92 | SAIEL SR91 | SAIEL SR90 | SAIEL SR89 | SAIEL SR88 | SAIEL SR87 | SAIEL SR86 | SAIEL SR85 | SAIEL SR84 | SAIEL SR83 | SAIEL SR82 | SAIEL SR81 | SAIEL SR80 |
| Value after reset: | 1          | 1          | 1          | 1          | 1          | 1          | 1          | 1          | 1          | 1          | 1          | 1          | 1          | 1          | 1          | 1          |
| Bit position:      | 15         | 14         | 13         | 12         | 11         | 10         | 9          | 8          | 7          | 6          | 5          | 4          | 3          | 2          | 1          | 0          |
| Bit field:         | SAIEL SR79 | SAIEL SR78 | SAIEL SR77 | SAIEL SR76 | SAIEL SR75 | SAIEL SR74 | SAIEL SR73 | SAIEL SR72 | SAIEL SR71 | SAIEL SR70 | SAIEL SR69 | SAIEL SR68 | SAIEL SR67 | SAIEL SR66 | SAIEL SR65 | SAIEL SR64 |
| Value after reset: | 1          | 1          | 1          | 1          | 1          | 1          | 1          | 1          | 1          | 1          | 1          | 1          | 1          | 1          | 1          | 1          |

| Bit  | Symbol                 | Function  | R/W |
|------|------------------------|---|-----|
| 31:0 | SAIELSR95 to SAIELSR64 | Security attributes of registers for IELSR95 to IELSR64<br>0: Secure<br>1: Non-secure | R/W |

Note: Only secure access can write to this register. Both secure access and Non-secure read access are allowed but Non-secure write access is not allowed and TrustZone access error is not generated.

Note: This register is write-protected by PRCR register.

**SAIELSRn bits (Security attributes of registers for IELSR95 to IELSR64)**

The Secure Attribute managed within the ARM CPU NVIC must match the security attribution of IELSEn ( n = 64 to 95 ). NVIC internal registers are in NVIC\_ITNS2[31:0]. The initial values of NVIC\_ITNS2 and ICUSARI are different. NVIC\_ITNS2 is secure and ICUSARI is non-secure. Polarity has the same meaning so program these to match.

**13.2.10 IRQCRi : IRQ Control Register (i = 0 to 15)**

Base address: ICU = 0x4000\_6000

Offset address: 0x000 + 0x1 × i

|                    |       |   |              |   |   |   |            |   |
|--------------------|-------|---|--------------|---|---|---|------------|---|
| Bit position:      | 7     | 6 | 5            | 4 | 3 | 2 | 1          | 0 |
| Bit field:         | FLTEN | — | FCLKSEL[1:0] | — | — | — | IRQMD[1:0] | — |
| Value after reset: | 0     | 0 | 0            | 0 | 0 | 0 | 0          | 0 |

| Bit  | Symbol                 | Function  | R/W |
|------|------------------------|---|-----|
| 31:0 | SAIELSR63 to SAIELSR32 | IELSR63到IELSR32寄存器的安全属性<br>0: Secure<br>1: Non-secure | R/W |

Note: 只有安全访问才能写入该寄存器。允许安全访问和非安全读取访问，但不允许非安全写入访问，并且不会生成TrustZone访问错误。

Note: 该寄存器由PRCR寄存器写保护。

**SAIELSRn位 (IELSR63至IELSR32寄存器的安全属性)**

在ARMCPUNVIC中管理的安全属性必须与IELSEn的安全属性匹配 (n=32到63)。NVIC内部寄存器位于NVIC\_ITNS1[31:0]中。NVIC\_ITNS1和ICUSARH的初始值不同。NVIC\_ITNS1是安全的，而ICUSARH是不安全的。极性具有相同的含义，因此请对它们进行编程以匹配。

**13.2.9 ICUSARI:中断控制器单元安全属性寄存器I**

Base address: CPSCU = 0x4000\_8000

Offset address: 0x78

|               |            |            |            |            |            |            |            |            |            |            |            |            |            |            |            |            |
|---------------|------------|------------|------------|------------|------------|------------|------------|------------|------------|------------|------------|------------|------------|------------|------------|------------|
| Bit position: | 31         | 30         | 29         | 28         | 27         | 26         | 25         | 24         | 23         | 22         | 21         | 20         | 19         | 18         | 17         | 16         |
| Bit field:    | SAIEL SR95 | SAIEL SR94 | SAIEL SR93 | SAIEL SR92 | SAIEL SR91 | SAIEL SR90 | SAIEL SR89 | SAIEL SR88 | SAIEL SR87 | SAIEL SR86 | SAIEL SR85 | SAIEL SR84 | SAIEL SR83 | SAIEL SR82 | SAIEL SR81 | SAIEL SR80 |
| 重置后的值:        | 1          | 1          | 1          | 1          | 1          | 1          | 1          | 1          | 1          | 1          | 1          | 1          | 1          | 1          | 1          | 1          |
| Bit position: | 15         | 14         | 13         | 12         | 11         | 10         | 9          | 8          | 7          | 6          | 5          | 4          | 3          | 2          | 1          | 0          |
| Bit field:    | SAIEL SR79 | SAIEL SR78 | SAIEL SR77 | SAIEL SR76 | SAIEL SR75 | SAIEL SR74 | SAIEL SR73 | SAIEL SR72 | SAIEL SR71 | SAIEL SR70 | SAIEL SR69 | SAIEL SR68 | SAIEL SR67 | SAIEL SR66 | SAIEL SR65 | SAIEL SR64 |
| 重置后的值:        | 1          | 1          | 1          | 1          | 1          | 1          | 1          | 1          | 1          | 1          | 1          | 1          | 1          | 1          | 1          | 1          |

| Bit  | Symbol                 | Function  | R/W |
|------|------------------------|---|-----|
| 31:0 | SAIELSR95 to SAIELSR64 | IELSR95到IELSR64寄存器的安全属性<br>0: Secure<br>1: Non-secure | R/W |

Note: 只有安全访问才能写入该寄存器。允许安全访问和非安全读取访问，但不允许非安全写入访问，并且不会生成TrustZone访问错误。

Note: 该寄存器由PRCR寄存器写保护。

**SAIELSRn位 (IELSR95至IELSR64寄存器的安全属性)**

ARMCPUNVIC中管理的安全属性必须与IELSEn的安全属性相匹配 (n=64到95)。NVIC内部寄存器位于NVIC\_ITNS2[31:0]中。NVIC\_ITNS2和ICUSARI的初始值不同。NVIC\_ITNS2是安全的，而ICUSARI是不安全的。极性具有相同的含义，因此请对它们进行编程以匹配。

**13.2.10 IRQCRi:IRQ控制寄存器(i=0到15)**

Base address: ICU = 0x4000\_6000

Offset address: 0x000 + 0x1 × i

|               |       |   |              |   |   |   |            |   |
|---------------|-------|---|--------------|---|---|---|------------|---|
| Bit position: | 7     | 6 | 5            | 4 | 3 | 2 | 1          | 0 |
| Bit field:    | FLTEN | — | FCLKSEL[1:0] | — | — | — | IRQMD[1:0] | — |
| 重置后的值:        | 0     | 0 | 0            | 0 | 0 | 0 | 0          | 0 |



| Bit | Symbol       | Function  | R/W |
|-----|--------------|---|-----|
| 1:0 | IRQMD[1:0]   | IRQi Detection Sense Select<br>0 0: Falling edge<br>0 1: Rising edge<br>1 0: Rising and falling edges<br>1 1: Low level | R/W |
| 3:2 | —            | These bits are read as 0. The write value should be 0.  | R/W |
| 5:4 | FCLKSEL[1:0] | IRQi Digital Filter Sampling Clock Select<br>0 0: PCLKB<br>0 1: PCLKB/8<br>1 0: PCLKB/32<br>1 1: PCLKB/64               | R/W |
| 6   | —            | This bit is read as 0. The write value should be 0.   | R/W |
| 7   | FLTEN        | IRQi Digital Filter Enable<br>0: Digital filter is disabled<br>1: Digital filter is enabled.                            | R/W |

Note: If the security attribution is configured as secure:

- Secure access and Non-secure read access are allowed
- Non-secure write access is ignored, and TrustZone access error is not generated.

If the security attribution is configured as Non-secure:

- Secure and Non-secure access are allowed.

IRQCRi register changes must satisfy the following conditions:

- For a CPU interrupt or DTC trigger:  
Change the IRQCRi register value before setting the target IELSRn register (n = 0 to 95).  
You can change the register values only when the value of the target IELSRn register is 0x0000.
- For a DMAC trigger:  
Change the IRQCRi register value before setting the target DELSRn register (n = 0 to 7).  
You can change the register values only when the value of the target DELSRn register is 0x0000.
- For a wakeup enable signal:  
Change the IRQCRi register setting before setting the target WUPEN.IRQWUPEN[n] (n = 0 to 15). You can only change the register values when the target WUPEN.IRQWUPEN[n] is 0.

#### IRQMD[1:0] bits (IRQi Detection Sense Select)

The IRQMD[1:0] bits set the detection sensing method for the IRQi external pin interrupt sources. For more information about the settings, see [section 13.5.6. External Pin Interrupts](#).

#### FCLKSEL[1:0] bits (IRQi Digital Filter Sampling Clock Select)

The FCLKSEL[1:0] bits select the digital filter sampling clock for the IRQi external pin interrupt request pins, selectable to:

- PCLKB (every cycle)
- PCLKB/8 (once every 8 cycles)
- PCLKB/32 (once every 32 cycles)
- PCLKB/64 (once every 64 cycles)

For details of the digital filter, see [section 13.5.5. Digital Filter](#).

#### FLTEN bit (IRQi Digital Filter Enable)

The FLTEN bit enables the digital filter used for the IRQi external pin interrupt sources. The digital filter is enabled when the IRQCRi.FLTEN bit is 1 and disabled when the IRQCRi.FLTEN bit is 0. The IRQi pin level is sampled at the clock cycle specified in the IRQCRi.FCLKSEL[1:0] bits. When the sampled level matches three times, the output level from the digital filter changes. For details of the digital filter, see [section 13.5.5. Digital Filter](#).

| Bit | Symbol       | Function  | R/W |
|-----|--------------|---|-----|
| 1:0 | IRQMD[1:0]   | IRQi检测检测选择<br>00: 下降沿01: 上升沿10:<br>上升沿和下降沿11: 低电平                               | R/W |
| 3:2 | —            | 这些位被读取为0。写入值应为0。  | R/W |
| 5:4 | FCLKSEL[1:0] | IRQi数字滤波器采样时钟选择<br>0 0: PCLKB<br>0 1: PCLKB/8<br>1 0: PCLKB/32<br>1 1: PCLKB/64 | R/W |
| 6   | —            | 该位读取为0。写入值应为0。  | R/W |
| 7   | FLTEN        | IRQi数字滤波器启用<br>0: 禁用数字滤波器1: 启用数字滤波器。  | R/W |

Note: 如果安全属性配置为安全: ●  
允许安全访问和非安全读取访问  
● 忽略非安全写入访问, 不会生成TrustZone访问错误。  
如果安全属性配置为非安全: ●  
允许安全和非安全访问。

IRQCRi寄存器变更必须满足以下条件:

- 对于CPU中断或DTC触发:  
在设置目标IELSRn寄存器 (n=0到95) 之前更改IRQCRi寄存器值。  
仅当目标IELSRn寄存器的值为0x0000时才能更改寄存器值。
- 对于DMAC trigger:  
在设置目标DELSRn寄存器 (n=0到7) 之前更改IRQCRi寄存器值。  
只有当目标DELSRn寄存器的值为0x0000时, 才能更改寄存器值。
- 对于唤醒使能信号:  
在设置目标WUPEN.IRQWUPEN[n] (n=0到15) 之前更改IRQCRi寄存器设置。当目标WUPEN.IRQWUPEN[n]为0时, 您只能更改寄存器值。

#### IRQMD[1:0]位 (IRQi检测检测选择)

IRQMD[1:0]位设置IRQi外部引脚中断源的检测检测方法。有关设置的更多信息, 请参阅第13.5.6节。外部引脚中断。

#### FCLKSEL[1:0]位 (IRQi数字滤波器采样时钟选择)

FCLKSEL[1:0]位选择IRQi外部引脚中断请求引脚的数字滤波器采样时钟, 可选择:

- PCLKB (every cycle)
- PCLKB/8 (once every 8 cycles)
- PCLKB/32 (once every 32 cycles)
- PCLKB/64 (once every 64 cycles)

关于数字滤波器的详细信息, 请参阅13.5.5节。数字滤波器。

#### FLTEN位 (IRQi数字滤波器使能)

FLTEN位使能用于IRQi外部引脚中断源的数字滤波器。数字滤波器在IRQCRi.FLTEN位为1时启用, 在IRQCRi.FLTEN位为0时禁用。IRQi引脚电平在IRQCRi.FCLKSEL[1:0]位指定的时钟周期内采样。当采样电平匹配3次时, 数字滤波器的输出电平会发生变化。关于数字滤波器的详细信息, 请参阅13.5.5节。数字滤波器。

## 13.2.11 NMISR : Non-Maskable Interrupt Status Register

Base address: ICU = 0x4000\_6000

Offset address: 0x140

|                    |           |    |       |    |            |    |            |           |       |           |   |   |            |            |           |            |
|--------------------|-----------|----|-------|----|------------|----|------------|-----------|-------|-----------|---|---|------------|------------|-----------|------------|
| Bit position:      | 15        | 14 | 13    | 12 | 11         | 10 | 9          | 8         | 7     | 6         | 5 | 4 | 3          | 2          | 1         | 0          |
| Bit field:         | CPES<br>T | —  | TZFST | —  | BUSM<br>ST | —  | RECC<br>ST | RPES<br>T | NMIST | OSTS<br>T | — | — | LVD2S<br>T | LVD1S<br>T | WDTS<br>T | IWDT<br>ST |
| Value after reset: | 0         | 0  | 0     | 0  | 0          | 0  | 0          | 0         | 0     | 0         | 0 | 0 | 0          | 0          | 0         | 0          |

| Bit | Symbol | Function   | R/W |
|-----|--------|--|-----|
| 0   | IWDTST | IWDT Underflow/Refresh Error Status Flag<br>0: Interrupt not requested<br>1: Interrupt requested   | R   |
| 1   | WDTST  | WDT Underflow/Refresh Error Status Flag<br>0: Interrupt not requested<br>1: Interrupt requested  | R   |
| 2   | LVD1ST | Voltage Monitor 1 Interrupt Status Flag<br>0: Interrupt not requested<br>1: Interrupt requested  | R   |
| 3   | LVD2ST | Voltage Monitor 2 Interrupt Status Flag<br>0: Interrupt not requested<br>1: Interrupt requested  | R   |
| 5:4 | —      | These bits are read as 0.  | R   |
| 6   | OSTST  | Oscillation Stop Detection Interrupt Status Flag<br>0: Interrupt not requested for main oscillation stop<br>1: Interrupt requested for main oscillation stop | R   |
| 7   | NMIST  | NMI Status Flag<br>0: Interrupt not requested<br>1: Interrupt requested  | R   |
| 8   | RPEST  | SRAM Parity Error Interrupt Status Flag<br>0: Interrupt not requested<br>1: Interrupt requested  | R   |
| 9   | RECCST | SRAM ECC Error Interrupt Status Flag<br>0: Interrupt not requested<br>1: Interrupt requested   | R   |
| 10  | —      | This bit is read as 0.   | R   |
| 11  | BUSMST | MPU Bus Master Error Interrupt Status Flag<br>0: Interrupt not requested<br>1: Interrupt requested   | R   |
| 12  | —      | This bit is read as 0.   | R   |
| 13  | TZFST  | TrustZone Filter Error Status Flag<br>0: Interrupt not requested<br>1: Interrupt requested   | R   |
| 14  | —      | This bit is read as 0.   | R   |
| 15  | CPEST  | Cache RAM Parity Error Status Flag<br>0: Interrupt not requested<br>1: Interrupt requested   | R   |

The NMISR register monitors the status of non-maskable interrupt sources. Writes to the NMISR register are ignored. The setting in the Non-Maskable Interrupt Enable Register (NMIER) does not affect the status flags in this register. Before the end of the non-maskable interrupt handler, check that all of the bits in this register are set to 0 to confirm that no other NMI requests are generated during handler processing.

## 13.2.11 NMISR: 不可屏蔽中断状态寄存器

Base address: ICU = 0x4000\_6000

Offset address: 0x140

|               |           |    |       |    |            |    |            |           |       |           |   |   |            |            |           |            |
|---------------|-----------|----|-------|----|------------|----|------------|-----------|-------|-----------|---|---|------------|------------|-----------|------------|
| Bit position: | 15        | 14 | 13    | 12 | 11         | 10 | 9          | 8         | 7     | 6         | 5 | 4 | 3          | 2          | 1         | 0          |
| Bit field:    | CPES<br>T | —  | TZFST | —  | BUSM<br>ST | —  | RECC<br>ST | RPES<br>T | NMIST | OSTS<br>T | — | — | LVD2S<br>T | LVD1S<br>T | WDTS<br>T | IWDT<br>ST |
| 重置后的值:        | 0         | 0  | 0     | 0  | 0          | 0  | 0          | 0         | 0     | 0         | 0 | 0 | 0          | 0          | 0         | 0          |

| Bit | Symbol | Function  | R/W |
|-----|--------|---|-----|
| 0   | IWDTST | IWDT下溢刷新错误状态标志<br>0: 未请求中断1: 请求中<br>断           | R   |
| 1   | WDTST  | WDT下溢刷新错误状态标志<br>0: 未请求中断1: 请求中<br>断            | R   |
| 2   | LVD1ST | 电压监视器1中断状态标志<br>0: 未请求中断1: 请求中<br>断             | R   |
| 3   | LVD2ST | 电压监视器2中断状态标志<br>0: 未请求中断1: 请求中<br>断             | R   |
| 5:4 | —      | 这些位读为0。   | R   |
| 6   | OSTST  | 振荡停止检测中断状态标志<br>0: 主振荡停止时不请求中断1: 主振荡停止时请求<br>中断 | R   |
| 7   | NMIST  | NMI状态标志<br>0: 未请求中断1: 请求中<br>断                  | R   |
| 8   | RPEST  | SRAM奇偶校验错误中断状态标志<br>0: 未请求中断1: 请求中<br>断         | R   |
| 9   | RECCST | SRAMECC错误中断状态标志<br>0: 未请求中断1: 请求中<br>断          | R   |
| 10  | —      | 该位读为0。  | R   |
| 11  | BUSMST | MPU总线主机错误中断状态标志<br>0: 未请求中断1: 请求中<br>断          | R   |
| 12  | —      | 该位读为0。  | R   |
| 13  | TZFST  | TrustZone过滤器错误状态标志<br>0: 未请求中断1: 请求中<br>断       | R   |
| 14  | —      | 该位读为0。  | R   |
| 15  | CPEST  | 高速缓存RAM奇偶校验错误状态标志<br>0: 未请求中断1: 请求中<br>断        | R   |

NMISR寄存器监视不可屏蔽中断源的状态。忽略对NMISR寄存器的写入。不可屏蔽中断使能寄存器(NMIER)中的设置不会影响该寄存器中的状态标志。在不可屏蔽中断处理程序结束之前，检查该寄存器中的所有位是否都设置为0，以确认在处理程序处理期间没有产生其他NMI请求。

**IWDST flag (IWDT Underflow/Refresh Error Status Flag)**

The IWDST flag indicates an IWDT underflow/refresh error interrupt request. It is read-only and cleared by the NMICLR.IWDTCCLR bit.

[Setting condition]

When the IWDT underflow/refresh error interrupt is generated and this interrupt source is enabled.

[Clearing condition]

When 1 is written to the NMICLR.IWDTCCLR bit.

**WDTST flag (WDT Underflow/Refresh Error Status Flag)**

The WDTST flag indicates a WDT underflow/refresh error interrupt request. It is read-only and cleared by the NMICLR.WDTCLR bit.

[Setting condition]

When the WDT underflow/refresh error interrupt is generated.

[Clearing condition]

When 1 is written to the NMICLR.WDTCLR bit.

**LVD1ST flag (Voltage Monitor 1 Interrupt Status Flag)**

The LVD1ST flag indicates a request for voltage monitor 1 interrupt. It is read-only and cleared by the NMICLR.LVD1CLR bit.

[Setting condition]

When the voltage monitor 1 interrupt is generated and this interrupt source is enabled.

[Clearing condition]

When 1 is written to the NMICLR.LVD1CLR bit.

**LVD2ST flag (Voltage Monitor 2 Interrupt Status Flag)**

The LVD2ST flag indicates a request for voltage monitor 2 interrupt. It is read-only and cleared by the NMICLR.LVD2CLR bit.

[Setting condition]

When the voltage monitor 2 interrupt is generated and this interrupt source is enabled.

[Clearing condition]

When 1 is written to the NMICLR.LVD2CLR bit.

**OSTST flag (Oscillation Stop Detection Interrupt Status Flag)**

The OSTST flag indicates an oscillation stop detection interrupt request. It is read-only and cleared by the NMICLR.OSTCLR bit.

[Setting condition]

When the main oscillation stop detection interrupt is generated.

[Clearing condition]

When 1 is written to the NMICLR.OSTCLR bit.

**NMIST flag (NMI Status Flag)**

The NMIST flag indicates an NMI pin interrupt request. It is read-only and cleared by the NMICLR.NMISTCLR bit.

[Setting condition]

When an edge specified by the NMICR.NMIMD bit is input to the NMI pin.

[Clearing condition]

When 1 is written to the NMICLR.NMISTCLR bit.

**IWDST标志 (IWDT下溢刷新错误状态标志)**

IWDST标志指示IWDT下溢刷新错误中断请求。它是只读的并由NMICLR.IWDTCCLR位清除。

[Setting condition]

当IWDT下溢刷新错误中断产生并且该中断源被使能时。

[Clearing condition]

当1写入NMICLR.IWDTCCLR位时。

**WDTST标志 (WDT下溢刷新错误状态标志)**

WDTST标志指示WDT下溢刷新错误中断请求。它是只读的并由NMICLR.WDTCLR位清除。

[Setting condition]

当产生WDT下溢刷新错误中断时。

[Clearing condition]

当1写入NMICLR.WDTCLR位时。

**LVD1ST标志 (电压监视器1中断状态标志)**

LVD1ST标志指示电压监视器1中断请求。它是只读的，由NMICLR.LVD1CLR位清零。

[Setting condition]

当电压监视器1中断产生并且该中断源被使能时。

[Clearing condition]

当1写入NMICLR.LVD1CLR位时。

**LVD2ST标志 (电压监视器2中断状态标志)**

LVD2ST标志指示电压监视器2中断请求。它是只读的，由NMICLR.LVD2CLR位清零。

[Setting condition]

当电压监视器2中断产生并且该中断源被使能时。

[Clearing condition]

当1写入NMICLR.LVD2CLR位时。

**OSTST标志 (振荡停止检测中断状态标志)**

OSTST标志表示振荡停止检测中断请求。它是只读的并由NMICLR.OSTCLR位清除。

[Setting condition]

当产生主振荡停止检测中断时。

[Clearing condition]

当1写入NMICLR.OSTCLR位时。

**NMIST标志 (NMI状态标志)**

NMIST标志指示NMI引脚中断请求。它是只读的，由NMICLR.NMISTCLR位清零。

[Setting condition]

当NMICR.NMIMD位指定的边沿输入到NMI引脚时。

[Clearing condition]

当1写入NMICLR.NMISTCLR位时。

**RPEST flag (SRAM Parity Error Interrupt Status Flag)**

The RPEST flag indicates an SRAM parity error interrupt request.

[Setting condition]

When an interrupt is generated in response to an SRAM parity error.

[Clearing condition]

When 1 is written to the NMICLR.RPECLR bit.

**RECCST flag (SRAM ECC Error Interrupt Status Flag)**

The RECCST flag indicates an SRAM ECC error interrupt request.

[Setting condition]

When an interrupt is generated in response to an SRAM ECC error.

[Clearing condition]

When 1 is written to the NMICLR.RECCCLR bit.

**BUSMST flag (MPU Bus Master Error Interrupt Status Flag)**

The BUSMST flag indicates a bus master error interrupt request.

[Setting condition]

When an interrupt is generated in response to a bus master error.

[Clearing condition]

When 1 is written to the NMICLR.BUSMCLR bit.

**TZFST flag (TrustZone Filter Error Status Flag)**

This flag indicates the TrustZone Filter error interrupt request.

[Setting condition]

When an interrupt is generated in response to a TrustZone Filter error

[Clearing condition]

When 1 is written to the NMICLR.TZFCLR bit

**CPEST flag (Cache RAM Parity Error Status Flag)**

This flag indicates the Cache RAM Parity error interrupt request.

[Setting condition]

When an interrupt is generated in response to an Cache RAM Parity error

[Clearing condition]

When 1 is written to the NMICLR.CPECLR bit

**13.2.12 NMIER : Non-Maskable Interrupt Enable Register**

Base address: ICU = 0x4000\_6000

Offset address: 0x120

| Bit position:      | 15        | 14 | 13        | 12 | 11         | 10 | 9          | 8         | 7         | 6         | 5 | 4 | 3          | 2          | 1         | 0          |
|--------------------|-----------|----|-----------|----|------------|----|------------|-----------|-----------|-----------|---|---|------------|------------|-----------|------------|
| Bit field:         | CPEE<br>N | —  | TZFE<br>N | —  | BUSM<br>EN | —  | RECC<br>EN | RPEE<br>N | NMIE<br>N | OSTE<br>N | — | — | LVD2E<br>N | LVD1E<br>N | WDTE<br>N | IWDT<br>EN |
| Value after reset: | 0         | 0  | 0         | 0  | 0          | 0  | 0          | 0         | 0         | 0         | 0 | 0 | 0          | 0          | 0         | 0          |

**RPEST标志 (SRAM奇偶校验错误中断状态标志)**

RPEST标志指示SRAM奇偶校验错误中断请求。

[Setting condition]

当响应SRAM奇偶校验错误而产生中断时。

[Clearing condition]

当1写入NMICLR.RPECLR位时。

**RECCST标志 (SRAMECC错误中断状态标志)**

RECCST标志指示SRAMECC错误中断请求。

[Setting condition]

当响应SRAMECC错误而产生中断时。

[Clearing condition]

当1写入NMICLR.RECCCLR位时。

**BUSMST标志 (MPU总线主机错误中断状态标志)**

BUSMST标志指示总线主机错误中断请求。

[Setting condition]

当响应总线主机错误而产生中断时。

[Clearing condition]

当1写入NMICLR.BUSMCLR位时。

**TZFST标志 (TrustZone过滤器错误状态标志)**

该标志指示TrustZoneFilter错误中断请求。

[Setting condition]

当响应TrustZone过滤器错误而生成中断时

[Clearing condition]

当1写入NMICLR.TZFCLR位时

**CPEST标志 (高速缓存RAM奇偶校验错误状态标志)**

该标志指示缓存RAM奇偶校验错误中断请求。

[Setting condition]

当响应高速缓存RAM奇偶校验错误而产生中断时

[Clearing condition]

当1写入NMICLR.CPECLR位时

**13.2.12 NMIER:不可屏蔽中断使能寄存器**

Base address: ICU = 0x4000\_6000

Offset address: 0x120

| Bit position: | 15        | 14 | 13        | 12 | 11         | 10 | 9          | 8         | 7         | 6         | 5 | 4 | 3          | 2          | 1         | 0          |
|---------------|-----------|----|-----------|----|------------|----|------------|-----------|-----------|-----------|---|---|------------|------------|-----------|------------|
| Bit field:    | CPEE<br>N | —  | TZFE<br>N | —  | BUSM<br>EN | —  | RECC<br>EN | RPEE<br>N | NMIE<br>N | OSTE<br>N | — | — | LVD2E<br>N | LVD1E<br>N | WDTE<br>N | IWDT<br>EN |
| 重置后的值:        | 0         | 0  | 0         | 0  | 0          | 0  | 0          | 0         | 0         | 0         | 0 | 0 | 0          | 0          | 0         | 0          |



| Bit | Symbol | Function  | R/W                 |
|-----|--------|---|---------------------|
| 0   | IWDTEN | IWDT Underflow/Refresh Error Interrupt Enable<br>0: Disabled<br>1: Enabled. | R/W <sup>1</sup> *2 |
| 1   | WDTEN  | WDT Underflow/Refresh Error Interrupt Enable<br>0: Disabled<br>1: Enabled   | R/W <sup>1</sup> *2 |
| 2   | LVD1EN | Voltage monitor 1 Interrupt Enable<br>0: Disabled<br>1: Enabled             | R/W <sup>1</sup> *2 |
| 3   | LVD2EN | Voltage monitor 2 Interrupt Enable<br>0: Disabled<br>1: Enabled             | R/W <sup>1</sup> *2 |
| 5:4 | —      | These bits are read as 0. The write value should be 0.                      | R/W                 |
| 6   | OSTEN  | Oscillation Stop Detection Interrupt Enable<br>0: Disabled<br>1: Enabled    | R/W <sup>1</sup> *2 |
| 7   | NMIEN  | NMI Pin Interrupt Enable<br>0: Disabled<br>1: Enabled                       | R/W <sup>1</sup>    |
| 8   | RPEEN  | SRAM Parity Error Interrupt Enable<br>0: Disabled<br>1: Enabled             | R/W <sup>1</sup>    |
| 9   | RECCEN | SRAM ECC Error Interrupt Enable<br>0: Disabled<br>1: Enabled                | R/W <sup>1</sup>    |
| 10  | —      | This bit is read as 0. The write value should be 0.                         | R/W                 |
| 11  | BUSMEN | MPU Bus Master Error Interrupt Enable<br>0: Disabled<br>1: Enabled          | R/W <sup>1</sup>    |
| 12  | —      | This bit is read as 0. The write value should be 0.                         | R/W                 |
| 13  | TZFEN  | TrustZone Filter Error Interrupt Enable<br>0: Disabled<br>1: Enabled        | R/W <sup>1</sup>    |
| 14  | —      | This bit is read as 0. The write value should be 0.                         | R/W                 |
| 15  | CPEEN  | Cache RAM Parity Error Interrupt Enable<br>0: Disabled<br>1: Enabled        | R/W <sup>1</sup>    |

Note: If the security attribution is configured as secure:

- Secure access and Non-secure read access are allowed
- Non-secure write access is ignored, and TrustZone access error is not generated.

If the security attribution is configured as Non-secure:

- Secure and Non-secure access are allowed.

Note 1. You can write 1 to this bit only once after reset. Subsequent write accesses are invalid. Writing 0 to this bit is invalid.

Note 2. Do not write 1 to this bit when the source is used as an event signal.

#### IWDTEN bit (IWDT Underflow/Refresh Error Interrupt Enable)

The IWDTEN bit enables IWDT underflow/refresh error interrupt as an NMI trigger.

#### WDTEN bit (WDT Underflow/Refresh Error Interrupt Enable)

The WDTEN bit enables WDT underflow/refresh error interrupt as an NMI trigger.

#### LVD1EN bit (Voltage monitor 1 Interrupt Enable)

The LVD1EN bit enables voltage monitor 1 interrupt as an NMI trigger.

| Bit | Symbol | Function                            | R/W                 |
|-----|--------|-------------------------------------|---------------------|
| 0   | IWDTEN | IWDT下溢刷新错误中断 使能<br>0: 禁用1:<br>启用。   | R/W <sup>1</sup> *2 |
| 1   | WDTEN  | WDT下溢刷新错误中断 使能<br>0: 禁用1:<br>启用     | R/W <sup>1</sup> *2 |
| 2   | LVD1EN | 电压监视器1中断使能<br>0: 禁用1:<br>启用         | R/W <sup>1</sup> *2 |
| 3   | LVD2EN | 电压监视器2中断使能<br>0: 禁用1:<br>启用         | R/W <sup>1</sup> *2 |
| 5:4 | —      | 这些位被读取为0。写入值应为0。                    | R/W                 |
| 6   | OSTEN  | 振荡停止检测中断使能<br>0: 禁用1:<br>启用         | R/W <sup>1</sup> *2 |
| 7   | NMIEN  | NMI引脚中断使能<br>0: 禁用1:<br>启用          | R/W <sup>1</sup>    |
| 8   | RPEEN  | SRAM奇偶校验错误中断使能<br>0: 禁用1:<br>启用     | R/W <sup>1</sup>    |
| 9   | RECCEN | SRAMECC错误中断使能<br>0: 禁用1:<br>启用      | R/W <sup>1</sup>    |
| 10  | —      | 该位读取为0。写入值应为0。                      | R/W                 |
| 11  | BUSMEN | MPU总线主机错误中断使能<br>0: 禁用1:<br>启用      | R/W <sup>1</sup>    |
| 12  | —      | 该位读取为0。写入值应为0。                      | R/W                 |
| 13  | TZFEN  | TrustZone过滤器错误中断启用<br>0: 禁用1:<br>启用 | R/W <sup>1</sup>    |
| 14  | —      | 该位读取为0。写入值应为0。                      | R/W                 |
| 15  | CPEEN  | 高速缓存RAM奇偶校验错误中断使能<br>0: 禁用1:<br>启用  | R/W <sup>1</sup>    |

Note: 如果安全属性配置为安全: ●

允许安全访问和非安全读取访问

- 忽略非安全写入访问, 不会生成TrustZone访问错误。

如果安全属性配置为非安全: ●

允许安全和非安全访问。

注1.复位后您只能向该位写入1一次。随后的写访问无效。向该位写入0无效。

注2.当源用作事件信号时, 请勿向该位写入1。

#### IWDTEN位 (IWDT下溢刷新错误中断 允许)

IWDTEN位使能IWDT下溢刷新错误中断 作为NMI触发。

#### WDTEN位 (WDT下溢刷新错误中断 允许)

WDTEN位使能WDT下溢刷新错误中断 作为NMI触发。

#### LVD1EN位 (电压监视器1中断允许)

LVD1EN位使能电压监视器1中断作为NMI触发。



**LVD2EN bit (Voltage monitor 2 Interrupt Enable)**

The LVD2EN bit enables voltage monitor 2 interrupt as an NMI trigger.

**OSTEN bit (Oscillation Stop Detection Interrupt Enable)**

The OSTEN bit enables main oscillation stop detection interrupt as an NMI trigger.

**NMIEN bit (NMI Pin Interrupt Enable)**

The NMIEN bit enables NMI pin interrupt as an NMI trigger.

**RPEEN bit (SRAM Parity Error Interrupt Enable)**

The RPEEN bit enables SRAM parity error interrupt as an NMI trigger.

**RECCEN bit (SRAM ECC Error Interrupt Enable)**

The RECCEN bit enables SRAM ECC error interrupt as an NMI trigger.

**BUSMEN bit (MPU Bus Master Error Interrupt Enable)**

The BUSMEN bit enables bus master error interrupt as an NMI trigger.

**TZFEN bit (TrustZone Filter Error Interrupt Enable)**

TZFEN bit enables the TrustZone Filter error interrupt as an NMI trigger.

**CPEEN bit (Cache RAM Parity Error Interrupt Enable)**

CPEEN bit enables the Cache RAM Parity error interrupt as an NMI trigger.

**13.2.13 NMICLR : Non-Maskable Interrupt Status Clear Register**

Base address: ICU = 0x4000\_6000

Offset address: 0x130

|                    |         |    |         |    |          |    |          |         |         |         |   |   |          |          |         |          |
|--------------------|---------|----|---------|----|----------|----|----------|---------|---------|---------|---|---|----------|----------|---------|----------|
| Bit position:      | 15      | 14 | 13      | 12 | 11       | 10 | 9        | 8       | 7       | 6       | 5 | 4 | 3        | 2        | 1       | 0        |
| Bit field:         | CPEC LR | —  | TZFCL R | —  | BUSM CLR | —  | RECC CLR | RPEC LR | NMICL R | OSTC LR | — | — | LVD2C LR | LVD1C LR | WDTC LR | IWDT CLR |
| Value after reset: | 0       | 0  | 0       | 0  | 0        | 0  | 0        | 0       | 0       | 0       | 0 | 0 | 0        | 0        | 0       | 0        |

| Bit | Symbol  | Function  | R/W              |
|-----|---------|---|------------------|
| 0   | IWDTCLR | IWDT Clear<br>0: No effect<br>1: Clear the NMISR.IWDTST flag  | R/W <sup>1</sup> |
| 1   | WDTCLR  | WDT Clear<br>0: No effect<br>1: Clear the NMISR.WDTST flag    | R/W <sup>1</sup> |
| 2   | LVD1CLR | LVD1 Clear<br>0: No effect<br>1: Clear the NMISR.LVD1ST flag  | R/W <sup>1</sup> |
| 3   | LVD2CLR | LVD2 Clear<br>0: No effect<br>1: Clear the NMISR.LVD2ST flag. | R/W <sup>1</sup> |
| 5:4 | —       | These bits are read as 0. The write value should be 0.        | R/W              |
| 6   | OSTCLR  | OST Clear<br>0: No effect<br>1: Clear the NMISR.OSTST flag    | R/W <sup>1</sup> |
| 7   | NMICLR  | NMI Clear<br>0: No effect<br>1: Clear the NMISR.NMIST flag    | R/W <sup>1</sup> |

**LVD2EN位 (电压监视器2中断允许)**

LVD2EN位使能电压监视器2中断作为NMI触发。

**OSTEN位 (振荡停止检测中断使能)**

OSTEN位使能主振荡停止检测中断作为NMI触发。

**NMIEN位 (NMI引脚中断允许)**

NMIEN位使能NMI引脚中断作为NMI触发器。

**RPEEN位 (SRAM奇偶校验错误中断使能)**

RPEEN位启用SRAM奇偶校验错误中断作为NMI触发器。

**RECCEN位 (SRAMECC错误中断允许)**

RECCEN位启用SRAMECC错误中断作为NMI触发器。

**BUSMEN位 (MPU总线主机错误中断允许)**

BUSMEN位使能总线主机错误中断作为NMI触发器。

**TZFEN位 (TrustZone过滤器错误中断使能)**

TZFEN位启用TrustZone过滤器错误中断作为NMI触发器。

**CPEEN位 (高速缓存RAM奇偶校验错误中断使能)**

CPEEN位启用缓存RAM奇偶校验错误中断作为NMI触发器。

**13.2.13 NMICLR:不可屏蔽中断状态清除寄存器**

Base address: ICU = 0x4000\_6000

Offset address: 0x130

|               |         |    |         |    |          |    |          |         |         |         |   |   |          |          |         |          |
|---------------|---------|----|---------|----|----------|----|----------|---------|---------|---------|---|---|----------|----------|---------|----------|
| Bit position: | 15      | 14 | 13      | 12 | 11       | 10 | 9        | 8       | 7       | 6       | 5 | 4 | 3        | 2        | 1       | 0        |
| Bit field:    | CPEC LR | —  | TZFCL R | —  | BUSM CLR | —  | RECC CLR | RPEC LR | NMICL R | OSTC LR | — | — | LVD2C LR | LVD1C LR | WDTC LR | IWDT CLR |
| 重置后的值:        | 0       | 0  | 0       | 0  | 0        | 0  | 0        | 0       | 0       | 0       | 0 | 0 | 0        | 0        | 0       | 0        |

| Bit | Symbol  | Function                               | R/W              |
|-----|---------|--|------------------|
| 0   | IWDTCLR | IWDT Clear<br>0: 无效1: 清除NMISR.IWDTST标志 | R/W <sup>1</sup> |
| 1   | WDTCLR  | WDT Clear<br>0: 无效1: 清除NMISR.WDTST标志   | R/W <sup>1</sup> |
| 2   | LVD1CLR | LVD1 Clear<br>0: 无效1: 清除NMISRLVD1ST标志  | R/W <sup>1</sup> |
| 3   | LVD2CLR | LVD2 Clear<br>0: 无效1: 清除NMISRLVD2ST标志。 | R/W <sup>1</sup> |
| 5:4 | —       | 这些位被读取为0。写入值应为0。                       | R/W              |
| 6   | OSTCLR  | 原声清除<br>0: 无效1: 清除NMISR.OSTST标志        | R/W <sup>1</sup> |
| 7   | NMICLR  | NMI Clear<br>0: 无效1: 清除NMISR.NMIST标志   | R/W <sup>1</sup> |

| Bit | Symbol  | Function   | R/W              |
|-----|---------|--|------------------|
| 8   | RPECLR  | SRAM Parity Error Clear<br>0: No effect<br>1: Clear the NMISR.RPEST flag       | R/W <sup>1</sup> |
| 9   | RECCCLR | SRAM ECC Error Clear<br>0: No effect<br>1: Clear the NMISR.RECCST flag         | R/W <sup>1</sup> |
| 10  | —       | This bit is read as 0. The write value should be 0.                            | R/W              |
| 11  | BUSMCLR | Bus Master Error Clear<br>0: No effect<br>1: Clear the NMISR.BUSMST flag       | R/W <sup>1</sup> |
| 12  | —       | This bit is read as 0. The write value should be 0.                            | R/W              |
| 13  | TZFCLR  | TrustZone Filter Error Clear<br>0: No effect<br>1: Clear the NMISR.TZFCLR flag | R/W <sup>1</sup> |
| 14  | —       | This bit is read as 0. The write value should be 0.                            | R/W              |
| 15  | CPECLR  | Cache RAM Parity Error Clear<br>0: No effect<br>1: Clear the NMISR.CPECLR flag | R/W <sup>1</sup> |

Note: If the security attribution is configured as secure:

- Secure access and Non-secure read access are allowed.
  - Non-secure write access is ignored, and TrustZone access error is not generated.
- If the security attribution is configured as Non-secure:
- Secure and Non-secure access are allowed.

Note 1. Only write 1 to this bit.

#### IWDTCLR bit (IWDT Clear)

Writing 1 to the IWDTCLR bit clears the NMISR.IWDTST flag. This bit is read as 0.

#### WDTCLR bit (WDT Clear)

Writing 1 to the WDTCLR bit clears the NMISR.WDTST flag. This bit is read as 0.

#### LVD1CLR bit (LVD1 Clear)

Writing 1 to the LVD1CLR bit clears the NMISR.LVD1ST flag. This bit is read as 0.

#### LVD2CLR bit (LVD2 Clear)

Writing 1 to the LVD2CLR bit clears the NMISR.LVD2ST flag. This bit is read as 0.

#### OSTCLR bit (OST Clear)

Writing 1 to the OSTCLR bit clears the NMISR.OSTST flag. This bit is read as 0.

#### NMICLR bit (NMI Clear)

Writing 1 to the NMICLR bit clears the NMISR.NMIST flag. This bit is read as 0.

#### RPECLR bit (SRAM Parity Error Clear)

Writing 1 to the RPECLR bit clears the NMISR.RPEST flag. This bit is read as 0.

#### RECCCLR bit (SRAM ECC Error Clear)

Writing 1 to the RECCCLR bit clears the NMISR.RECCST flag. This bit is read as 0.

#### BUSMCLR bit (Bus Master Error Clear)

Writing 1 to the BUSMCLR bit clears the NMISR.BUSMST flag. This bit is read as 0.

#### TZFCLR bit (TrustZone Filter Error Clear)

Writing 1 to the TZFCLR bit clears the NMISR.TZFST flag. This bit is read as 0.

| Bit | Symbol  | Function                                     | R/W              |
|-----|---------|--|------------------|
| 8   | RPECLR  | SRAM奇偶校验错误清除<br>0: 无效1: 清除NMISR.RPEST标志      | R/W <sup>1</sup> |
| 9   | RECCCLR | SRAMECC错误清除<br>0: 无效1: 清除NMISR.RECCST标志      | R/W <sup>1</sup> |
| 10  | —       | 该位读取为0。写入值应为0。                               | R/W              |
| 11  | BUSMCLR | 总线主机错误清除<br>0: 无效1: 清除NMISR.BUSMST标志         | R/W <sup>1</sup> |
| 12  | —       | 该位读取为0。写入值应为0。                               | R/W              |
| 13  | TZFCLR  | TrustZone过滤器错误清除<br>0: 无效1: 清除NMISR.TZFCLR标志 | R/W <sup>1</sup> |
| 14  | —       | 该位读取为0。写入值应为0。                               | R/W              |
| 15  | CPECLR  | 高速缓存RAM奇偶校验错误清除<br>0: 无效1: 清除NMISR.CPECLR标志  | R/W <sup>1</sup> |

Note: 如果安全属性配置为安全: ●

- 允许安全访问和非安全读取访问。
  - 忽略非安全写入访问, 不会生成TrustZone访问错误。
- 如果安全属性配置为非安全: ●
- 允许安全和非安全访问。

注1.仅向该位写入1。

#### IWDTCLR bit (IWDT Clear)

将1写入IWDTCLR位会清除NMISR.IWDTST标志。该位读为0。

#### WDTCLR bit (WDT Clear)

将1写入WDTCLR位会清除NMISR.WDTST标志。该位读为0。

#### LVD1CLR bit (LVD1 Clear)

将1写入LVD1CLR位会清除NMISR.LVD1ST标志。该位读为0。

#### LVD2CLR bit (LVD2 Clear)

将1写入LVD2CLR位会清除NMISR.LVD2ST标志。该位读为0。

#### OSTCLR bit (OST Clear)

将1写入OSTCLR位会清除NMISR.OSTST标志。该位读为0。

#### NMICLR bit (NMI Clear)

将1写入NMICLR位会清除NMISR.NMIST标志。该位读为0。

#### RPECLR位 (SRAM奇偶校验错误清除)

将1写入RPECLR位会清除NMISR.RPEST标志。该位读为0。

#### RECCCLR位 (SRAMECC错误清除)

将1写入RECCCLR位会清除NMISR.RECCST标志。该位读为0。

#### BUSMCLR位 (总线主机错误清除)

将1写入BUSMCLR位会清除NMISR.BUSMST标志。该位读为0。

#### TZFCLR位 (TrustZone过滤器错误清除)

将1写入TZFCLR位会清除NMISR.TZFST标志。该位读为0。

**CPECLR bit (Cache RAM Parity Error Clear)**

Writing 1 to the CPECLR bit clears the NMISR.CPEST flag. This bit is read as 0.

**13.2.14 NMICR : NMI Pin Interrupt Control Register**

Base address: ICU = 0x4000\_6000

Offset address: 0x100

|                    |            |   |               |   |   |   |   |           |
|--------------------|------------|---|---------------|---|---|---|---|-----------|
| Bit position:      | 7          | 6 | 5             | 4 | 3 | 2 | 1 | 0         |
| Bit field:         | NFLTE<br>N | — | NFCLKSEL[1:0] | — | — | — | — | NMIM<br>D |
| Value after reset: | 0          | 0 | 0             | 0 | 0 | 0 | 0 | 0         |

| Bit | Symbol        | Function   | R/W |
|-----|---------------|--|-----|
| 0   | NMIMD         | NMI Detection Set<br>0: Falling edge<br>1: Rising edge   | R/W |
| 3:1 | —             | These bits are read as 0. The write value should be 0.   | R/W |
| 5:4 | NFCLKSEL[1:0] | NMI Digital Filter Sampling Clock Select<br>0 0: PCLKB<br>0 1: PCLKB/8<br>1 0: PCLKB/32<br>1 1: PCLKB/64 | R/W |
| 6   | —             | This bit is read as 0. The write value should be 0.  | R/W |
| 7   | NFLTEN        | NMI Digital Filter Enable<br>0: Disabled<br>1: Enabled   | R/W |

Note: If the security attribution is configured as secure:

- Secure access and Non-secure read access are allowed
- Non-secure write access is ignored, and TrustZone access error is not generated.

If the security attribution is configured as Non-secure:

- Secure and Non-secure access are allowed.

Change the NMICR register settings before enabling NMI pin interrupts, that is, before setting NMIER.NMIEN to 1.

**NMIMD bit (NMI Detection Set)**

The NMIMD bit selects the detection sensing method for the NMI pin interrupts.

**NFCLKSEL[1:0] bits (NMI Digital Filter Sampling Clock Select)**

The NFCLKSEL[1:0] bits select the digital filter sampling clock for the NMI pin interrupts, selectable to:

- PCLKB (every cycle)
- PCLKB/8 (once every eight cycles)
- PCLKB/32 (once every 32 cycles)
- PCLKB/64 (once every 64 cycles)

For details of the digital filter, see [section 13.5.5. Digital Filter](#).

**NFLTEN bit (NMI Digital Filter Enable)**

The NFLTEN bit enables the digital filter used for NMI pin interrupts. The filter is enabled when NFLTEN is 1, and disabled when NFLTEN is 0. The NMI pin level is sampled at the clock cycle specified in NFCLKSEL[1:0]. When the sampled level matches three times, the output level from the digital filter changes. For details of the digital filter, see [section 13.5.5. Digital Filter](#).

**CPECLR位 (高速缓存RAM奇偶校验错误清除)**

将1写入CPECLR位会清除NMISR.CPEST标志。该位读为0。

**13.2.14 NMICR:NMI引脚中断控制寄存器**

Base address: ICU = 0x4000\_6000

Offset address: 0x100

|               |            |   |               |   |   |   |   |           |
|---------------|------------|---|---------------|---|---|---|---|-----------|
| Bit position: | 7          | 6 | 5             | 4 | 3 | 2 | 1 | 0         |
| Bit field:    | NFLTE<br>N | — | NFCLKSEL[1:0] | — | — | — | — | NMIM<br>D |
| 重置后的值:        | 0          | 0 | 0             | 0 | 0 | 0 | 0 | 0         |

| Bit | Symbol        | Function   | R/W |
|-----|---------------|--|-----|
| 0   | NMIMD         | NMI检测集<br>0: 下降沿1:<br>上升沿  | R/W |
| 3:1 | —             | 这些位被读取为0。写入值应为0。   | R/W |
| 5:4 | NFCLKSEL[1:0] | NMI数字滤波器采样时钟选择<br>0 0: PCLKB<br>0 1: PCLKB/8<br>1 0: PCLKB/32<br>1 1: PCLKB/64 | R/W |
| 6   | —             | 该位读取为0。写入值应为0。   | R/W |
| 7   | NFLTEN        | NMI数字滤波器启用<br>0: 禁用1:<br>启用  | R/W |

Note: 如果安全属性配置为安全: ●

- 允许安全访问和非安全读取访问
- 忽略非安全写入访问, 不会生成TrustZone访问错误。

如果安全属性配置为非安全: ●

- 允许安全和非安全访问。

在启用NMI引脚中断之前更改NMICR寄存器设置, 即将NMIER.NMIEN设置为1。

**NMIMD位 (NMI检测集)**

NMIMD位选择NMI引脚中断的检测检测方法。

**NFCLKSEL[1:0]位 (NMI数字滤波器采样时钟选择)**

NFCLKSEL[1:0]位选择用于NMI引脚中断的数字滤波器采样时钟, 可选择:

- PCLKB (every cycle)
- PCLKB8 (每八个周期一次)
- PCLKB/32 (once every 32 cycles)
- PCLKB/64 (once every 64 cycles)

关于数字滤波器的详细信息, 请参阅13.5.5节。数字滤波器。

**NFLTEN位 (NMI数字滤波器使能)**

NFLTEN位使能用于NMI引脚中断的数字滤波器。滤波器在NFLTEN为1时启用, 在NFLTEN为0时禁用。NMI引脚电平在NFCLKSEL[1:0]中指定的时钟周期进行采样。当采样电平匹配3次时, 数字滤波器的输出电平会发生变化。关于数字滤波器的详细信息, 请参阅13.5.5节。数字滤波器。

## 13.2.15 IELSRn : ICU Event Link Setting Register n (n = 0 to 95)

Base address: ICU = 0x4000\_6000

Offset address: 0x300 + 0x4 × n

|                    |    |    |    |    |    |    |    |           |    |    |    |    |    |    |    |    |   |   |
|--------------------|----|----|----|----|----|----|----|-----------|----|----|----|----|----|----|----|----|---|---|
| Bit position:      | 31 | 30 | 29 | 28 | 27 | 26 | 25 | 24        | 23 | 22 | 21 | 20 | 19 | 18 | 17 | 16 |   |   |
| Bit field:         | —  | —  | —  | —  | —  | —  | —  | DTCE      | —  | —  | —  | —  | —  | —  | —  | IR |   |   |
| Value after reset: | 0  | 0  | 0  | 0  | 0  | 0  | 0  | 0         | 0  | 0  | 0  | 0  | 0  | 0  | 0  | 0  |   |   |
| Bit position:      | 15 | 14 | 13 | 12 | 11 | 10 | 9  | 8         | 7  | 6  | 5  | 4  | 3  | 2  | 1  | 0  |   |   |
| Bit field:         | —  | —  | —  | —  | —  | —  | —  | IELS[8:0] |    |    |    |    |    |    |    |    | — | — |
| Value after reset: | 0  | 0  | 0  | 0  | 0  | 0  | 0  | 0         | 0  | 0  | 0  | 0  | 0  | 0  | 0  | 0  |   |   |

| Bit   | Symbol    | Function  | R/W              |
|-------|-----------|---|------------------|
| 8:0   | IELS[8:0] | ICU Event Link Select<br>0x00: Disable interrupts to the associated NVIC or DTC module<br>Others: Event signal number to be linked. For details, see <a href="#">section 13.3.2. Event Number</a> . | R/W              |
| 15:9  | —         | These bits are read as 0. The write value should be 0.  | R/W              |
| 16    | IR        | Interrupt Status Flag<br>0: No interrupt request generated.<br>1: An interrupt request is generated.  | R/W <sup>1</sup> |
| 23:17 | —         | These bits are read as 0. The write value should be 0.  | R/W              |
| 24    | DTCE      | DTC Activation Enable<br>0: DTC activation is disabled.<br>1: DTC activation is enabled.  | R/W              |
| 31:25 | —         | These bits are read as 0. The write value should be 0.  | R/W              |

Note: If the security attribution is configured as secure:

- Secure access and Non-secure read access are allowed
  - Non-secure write access is ignored, and TrustZone access error is not generated.
- If the security attribution is configured as Non-secure:
- Secure and Non-secure access are allowed.

Note: This register requires halfword or word access.

Note 1. Writing 1 to the IR flag is prohibited.

The IELSRn register selects the IRQi source used by the NVIC. For details, see [xref to Table 13.3](#). IELSRn corresponds to the NVIC IRQ input source number, where n = 0 to 95.

**IELS[8:0] bits (ICU Event Link Select)**

The IELS[8:0] bits link an event signal to the associated NVIC or DTC module. Event options are classified into 8 groups (groups 0 to 7). For details, see [Table 13.3](#) and [Table 13.4](#).

**IR flag (Interrupt Status Flag)**

The IR status flag indicates an individual interrupt request from the event specified in IELS[8:0].

[Setting condition]

When an interrupt request is received from the associated peripheral module or IRQi pin.

[Clearing condition]

- The IR flag is cleared to 0 by writing 0.
- At the time other than the final transfer transfer end in DTC transfer during DTCE = 1, IR flag repeat set and cleared by Hardware.

When DTC transfer except last transfer is completed (DTCE bit is changed from 1 to 0).

During DTCE = 1, write 0 to IR register is prohibited.

In the case of level detection, clear of the IR flag should follow the steps below.

## 13.2.15 IELSRn:ICU事件链接设置寄存器n(n=0到95)

Base address: ICU = 0x4000\_6000

Offset address: 0x300 + 0x4 × n

|               |    |    |    |    |    |    |    |           |    |    |    |    |    |    |    |    |   |   |
|---------------|----|----|----|----|----|----|----|-----------|----|----|----|----|----|----|----|----|---|---|
| Bit position: | 31 | 30 | 29 | 28 | 27 | 26 | 25 | 24        | 23 | 22 | 21 | 20 | 19 | 18 | 17 | 16 |   |   |
| Bit field:    | —  | —  | —  | —  | —  | —  | —  | DTCE      | —  | —  | —  | —  | —  | —  | —  | IR |   |   |
| 重置后的值:        | 0  | 0  | 0  | 0  | 0  | 0  | 0  | 0         | 0  | 0  | 0  | 0  | 0  | 0  | 0  | 0  |   |   |
| Bit position: | 15 | 14 | 13 | 12 | 11 | 10 | 9  | 8         | 7  | 6  | 5  | 4  | 3  | 2  | 1  | 0  |   |   |
| Bit field:    | —  | —  | —  | —  | —  | —  | —  | IELS[8:0] |    |    |    |    |    |    |    |    | — | — |
| 重置后的值:        | 0  | 0  | 0  | 0  | 0  | 0  | 0  | 0         | 0  | 0  | 0  | 0  | 0  | 0  | 0  | 0  |   |   |

| Bit   | Symbol    | Function   | R/W              |
|-------|-----------|--|------------------|
| 8:0   | IELS[8:0] | ICU事件链接选择<br>0x00: 禁用相关NVIC或DTC模块的中断<br>其他: 要链接的事件信号编号。详见13.3.2节。事件编号。 | R/W              |
| 15:9  | —         | 这些位被读取为0。写入值应为0。   | R/W              |
| 16    | IR        | 中断状态标志<br>0: 不产生中断请求。1: 产生中断请求。  | R/W <sup>1</sup> |
| 23:17 | —         | 这些位被读取为0。写入值应为0。   | R/W              |
| 24    | DTCE      | DTC激活启用<br>0: 禁用DTC激活。1: 启用DTC激活。                                      | R/W              |
| 31:25 | —         | 这些位被读取为0。写入值应为0。   | R/W              |

Note: 如果安全属性配置为安全: ●

- 允许安全访问和非安全读取访问
  - 忽略非安全写入访问, 不会生成TrustZone访问错误。
- 如果安全属性配置为非安全: ●
- 允许安全和非安全访问。

Note: 该寄存器需要半字或字访问。

注1.禁止向IR标志写入1。

IELSRn寄存器选择NVIC使用的IRQi源。有关详细信息, 请参阅表13.3的外部参照。IELSRn对应于NVICIRQ输入源编号, 其中n=0到95。

**IELS[8:0]位 (ICU事件链接选择)**

IELS[8:0]位将事件信号链接到相关的NVIC或DTC模块。事件选项分为8组 (组0到7)。详见表13.3和表13.4。

**IR标志 (中断状态标志)**

IR状态标志指示来自IELS[8:0]中指定事件的单个中断请求。

[Setting condition]

当从相关外设模块或IRQi引脚接收到中断请求时。

[Clearing condition]

- IR标志通过写入0清除为0。
- 在DTCE=1期间DTC传输中最后传输传输结束以外的时间, IR标志由硬件重复设置和清除。

完成最后一次传输以外的DTC传输时 (DTCE位从1变为0)。

在DTCE=1期间, 禁止向IR寄存器写入0。

在电平检测的情况下, 清除IR标志应遵循以下步骤。



1. Negate the input interrupt signal.
2. Read access the peripheral once and wait for 2 clock cycles of the target module clock.
3. Clear the IR flag by writing 0.

**DTCE bit (DTC Activation Enable)**

When the DTCE bit is set to 1, the associated event is selected as the source for DTC activation.

[Setting condition]

- When 1 is written to the DTCE bit.

[Clearing condition]

- When the specified number of transfers is complete. For chain transfers, when the specified number of transfers for the last chain transfer is complete.
- When 0 is written to the DTCE bit.

Note: Error during DTC transfer

If an error response occurs during DTC transfer, the DTC notifies the ICU that an error has occurred. ICU clears all bits of the target IELSRn (n = 0 to 95). IELSRn that is not the target is not cleared.

Note: DTC transfer error in snooze mode

When an error occurs in DTC transfer in Snooze mode, ICU issues a wakeup request. However, interrupt requests are not issued automatically. See section 17, Data Transfer Controller (DTC) for how to set the interrupt when a DTC error occurs.

**13.2.16 DELSRn : DMAC Event Link Setting Register n (n = 0 to 7)**

Base address: ICU = 0x4000\_6000

Offset address: 0x280 + 0x4 × n

|                    |    |    |    |    |    |    |    |           |    |    |    |    |    |    |    |    |   |   |
|--------------------|----|----|----|----|----|----|----|-----------|----|----|----|----|----|----|----|----|---|---|
| Bit position:      | 31 | 30 | 29 | 28 | 27 | 26 | 25 | 24        | 23 | 22 | 21 | 20 | 19 | 18 | 17 | 16 |   |   |
| Bit field:         | —  | —  | —  | —  | —  | —  | —  | —         | —  | —  | —  | —  | —  | —  | —  | IR |   |   |
| Value after reset: | 0  | 0  | 0  | 0  | 0  | 0  | 0  | 0         | 0  | 0  | 0  | 0  | 0  | 0  | 0  | 0  |   |   |
| Bit position:      | 15 | 14 | 13 | 12 | 11 | 10 | 9  | 8         | 7  | 6  | 5  | 4  | 3  | 2  | 1  | 0  |   |   |
| Bit field:         | —  | —  | —  | —  | —  | —  | —  | DELS[8:0] |    |    |    |    |    |    |    |    | — | — |
| Value after reset: | 0  | 0  | 0  | 0  | 0  | 0  | 0  | 0         | 0  | 0  | 0  | 0  | 0  | 0  | 0  | 0  |   |   |

| Bit   | Symbol    | Function   | R/W              |
|-------|-----------|--|------------------|
| 8:0   | DELS[8:0] | DMAC Event Link Select<br>0x00: Disable interrupts to the associated DMAC module<br>Others: Event signal number to be linked. For details, see Table 13.4. | R/W              |
| 15:9  | —         | These bits are read as 0. The write value should be 0.   | R/W              |
| 16    | IR        | DMAC Activation Request Status flag<br>0: No DMAC activation request occurred<br>1: DMAC activation request occurred.                                      | R/W <sup>1</sup> |
| 31:17 | —         | These bits are read as 0. The write value should be 0.   | R/W              |

- Note: If the security attribution is configured as secure:
- Secure access and Non-secure read access are allowed
  - Non-secure write access is ignored, and TrustZone access error is not generated.
- If the security attribution is configured as Non-secure:
- Secure and Non-secure access are allowed.

Note 1. Writing 1 to the IR flag is prohibited.

- 1.取反输入中断信号。
- 2.对外设进行一次读取访问，并等待目标模块时钟的2个时钟周期。
- 3.写0清除IR标志。

**DTCE位 (DTC激活使能)**

当DTCE位设置为1时，相关事件被选为DTC激活源。

[Setting condition]

- 当1写入DTCE位时。

[Clearing condition]

- 当指定数量的传输完成时。对于链式转移，当最后一次链式转移的指定转移次数完成时。
- 当0写入DTCE位时。

Note: DTC传输期间出错

如果在DTC传输期间发生错误响应，则DTC会通知ICU发生了错误。ICU清除目标IELSRn(n=0到95)的所有位。不是目标的IELSRn不会被清除。

Note: 贪睡模式下的DTC传输错误

当贪睡模式下的DTC传输发生错误时，ICU会发出唤醒请求。但是，不会自动发出中断请求。有关如何在发生DTC错误时设置中断，请参见第17节，数据传输控制器(DTC)。

**13.2.16 DELSRn: DMAC事件链接设置寄存器n (n=0到7)**

Base address: ICU = 0x4000\_6000

Offset address: 0x280 + 0x4 × n

|               |    |    |    |    |    |    |    |           |    |    |    |    |    |    |    |    |   |   |
|---------------|----|----|----|----|----|----|----|-----------|----|----|----|----|----|----|----|----|---|---|
| Bit position: | 31 | 30 | 29 | 28 | 27 | 26 | 25 | 24        | 23 | 22 | 21 | 20 | 19 | 18 | 17 | 16 |   |   |
| Bit field:    | —  | —  | —  | —  | —  | —  | —  | —         | —  | —  | —  | —  | —  | —  | —  | IR |   |   |
| 重置后的值:        | 0  | 0  | 0  | 0  | 0  | 0  | 0  | 0         | 0  | 0  | 0  | 0  | 0  | 0  | 0  | 0  |   |   |
| Bit position: | 15 | 14 | 13 | 12 | 11 | 10 | 9  | 8         | 7  | 6  | 5  | 4  | 3  | 2  | 1  | 0  |   |   |
| Bit field:    | —  | —  | —  | —  | —  | —  | —  | DELS[8:0] |    |    |    |    |    |    |    |    | — | — |
| 重置后的值:        | 0  | 0  | 0  | 0  | 0  | 0  | 0  | 0         | 0  | 0  | 0  | 0  | 0  | 0  | 0  | 0  |   |   |

| Bit   | Symbol    | Function   | R/W              |
|-------|-----------|--|------------------|
| 8:0   | DELS[8:0] | DMAC事件链接选择<br>0x00: 禁用相关DMAC模块的中断<br>其他: 要链接的事件信号编号。详见表13.4。 | R/W              |
| 15:9  | —         | 这些位被读取为0。写入值应为0。   | R/W              |
| 16    | IR        | DMAC激活请求状态标志<br>0: 未发生DMAC激活请求1: 发生DMAC激活请求。                 | R/W <sup>1</sup> |
| 31:17 | —         | 这些位被读取为0。写入值应为0。   | R/W              |

- Note: 如果安全属性配置为安全: ●
- 允许安全访问和非安全读取访问
  - 忽略非安全写入访问，不会生成TrustZone访问错误。
- 如果安全属性配置为非安全: ●
- 允许安全和非安全访问。

注1.禁止向IR标志写入1。



**DELS[8:0] bit (DMAC Event Link Select)**

The DELS[8:0] bits link an event signal to the associated DMAC module. Do not set the same event number in multiple DELSRn registers.

**IR flag (DMAC Activation Request Status flag)**

The IR flag is the status flag of a DMAC activation request. This flag is associated with the DELS[8:0] bits of this register.

[Setting condition]

- The flag is set to 1 when a DMAC activation request is generated from the associated peripheral module or IRQi pin.

[Clearing conditions]

- When 0 is written to the flag
- At the start of a DMA transfer after the DMAC activation request is issued.

Note: The IR flag is automatically cleared after completion of DMA transfer, so do not write 0 unless an abort occurs. DMA transfer operation when 0 is written cannot be guaranteed.

Note: Error during DMAC transfer

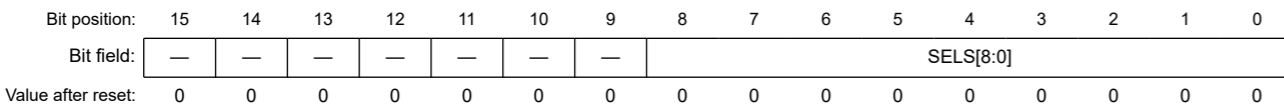
If an error response occurs during DMAC transfer, the DMAC notifies the ICU that an error has occurred.

The ICU clears all bits of the target channel of DELSRn (n = 0 to 7). DELSRn that is not the target channel is not cleared.

**13.2.17 SELSR0 : SYS Event Link Setting Register**

Base address: ICU = 0x4000\_6000

Offset address: 0x200



| Bit  | Symbol    | Function  | R/W |
|------|-----------|---|-----|
| 8:0  | SELS[8:0] | SYS Event Link Select<br>0x00: Disable event output to the associated low-power mode module<br>Others: Event signal number to be linked. For details, see Table 13.4. | R/W |
| 15:9 | —         | These bits are read as 0. The write value should be 0.  | R/W |

Note: If the security attribution is configured as secure:

- Secure access and Non-secure read access are allowed
- Non-secure write access is ignored, and TrustZone access error is not generated.

If the security attribution is configured as Non-secure:

- Secure and Non-secure access are allowed.

The SELSR0 register selects the events that wake up the CPU from Snooze mode. You can use only the events listed in Table 13.4 checked as “Canceling Snooze mode using SELSR0”. Events specified in this register are defined as ICU\_SNZCANCEL in Table 13.4. When ICU\_SNZCANCEL is selected in the IELSRn.IELS[8:0] bits, the SELSR0 event interrupt occurs.

**Caution:** For security attribution added to parts related to a series of actions, make sure to match all security attribution so that security holes cannot be created.

**About security attribution to be matched**

- Event source to be set to SELSR0.
- SELSR0
- IELSRn (n = 0 to 95) to receive event No. 45 (ICU\_SNZCANCEL).
- NVIC internal registers from the CPU of the three specified interrupts.
- Interrupt Handler.

**DELS[8:0]位 (DMAC事件链接选择)**

DELS[8:0]位将事件信号链接到相关的DMAC模块。不要在多个中设置相同的事件编号 DELSRn registers.

**IR标志 (DMAC激活请求状态标志)**

IR标志是DMAC激活请求的状态标志。该标志与该寄存器的DELS[8:0]位相关联。

[Setting condition]

- 当相关外设模块或IRQi引脚产生DMAC激活请求时，该标志设置为1。

[Clearing conditions]

- 标志写入0时
- 在发出DMAC激活请求后开始DMA传输。

Note: IR标志在DMA传输完成后自动清除，因此除非发生中止，否则不要写0。无法保证写入0时的DMA传输操作。

Note: DMAC传输期间出错

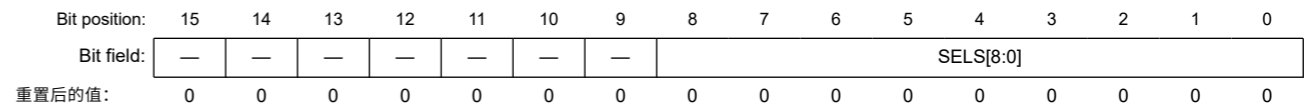
如果在DMAC传输期间发生错误响应，则DMAC会通知ICU发生了错误。

ICU清除DELSRn (n=0到7) 的目标通道的所有位。不是目标通道的DELSRn不会被清除。

**13.2.17 SELSR0: SYS事件链接设置寄存器**

Base address: ICU = 0x4000\_6000

Offset address: 0x200



| Bit  | Symbol    | Function  | R/W |
|------|-----------|---|-----|
| 8:0  | SELS[8:0] | SYS事件链接选择<br>0x00: 禁用到相关低功耗模式模块的事件输出<br>其他: 要链接的事件信号编号。详见表13.4。 | R/W |
| 15:9 | —         | 这些位被读取为0。写入值应为0。  | R/W |

Note: 如果安全属性配置为安全: ●

- 允许安全访问和非安全读取访问
- 忽略非安全写入访问，不会生成TrustZone访问错误。

如果安全属性配置为非安全: ●

- 允许安全和非安全访问。

SELSR0寄存器选择将CPU从贪睡模式唤醒的事件。您只能使用中列出的事件表13.4选中“使用SELSR0取消贪睡模式”。该寄存器中指定的事件定义为ICU\_SNZCANCEL在表13.4中。在IELSRn.IELS[8:0]位中选择ICU\_SNZCANCEL时，将发生SELSR0事件中断。

**Caution:** 对于添加到与一系列动作相关的部分的安全属性，请确保匹配所有的安全属性，以免造成安全漏洞。

**关于要匹配的安全属性●**

- 事件源设置为SELSR0。
- SELSR0
- IELSRn(n=0到95)接收事件编号45(ICU\_SNZCANCEL)。
- NVIC内部寄存器来自CPU的三个指定中断。
- 中断处理程序。

## 13.2.18 WUPEN0 : Wake Up Interrupt Enable Register 0

Base address: ICU = 0x4000\_6000

Offset address: 0x1A0

|                    |                |             |             |             |             |    |             |             |    |    |    |    |           |           |    |           |
|--------------------|----------------|-------------|-------------|-------------|-------------|----|-------------|-------------|----|----|----|----|-----------|-----------|----|-----------|
| Bit position:      | 31             | 30          | 29          | 28          | 27          | 26 | 25          | 24          | 23 | 22 | 21 | 20 | 19        | 18        | 17 | 16        |
| Bit field:         | IIC0WUPEN      | AGT1CBWUPEN | AGT1CAWUPEN | AGT1UDWUPEN | USBFS0WUPEN | —  | RTCPRDWUPEN | RTCALMWUPEN | —  | —  | —  | —  | LVD2WUPEN | LVD1WUPEN | —  | IWDTWUPEN |
| Value after reset: | 0              | 0           | 0           | 0           | 0           | 0  | 0           | 0           | 0  | 0  | 0  | 0  | 0         | 0         | 0  | 0         |
| Bit position:      | 15             | 14          | 13          | 12          | 11          | 10 | 9           | 8           | 7  | 6  | 5  | 4  | 3         | 2         | 1  | 0         |
| Bit field:         | IRQWUPEN[15:0] |             |             |             |             |    |             |             |    |    |    |    |           |           |    |           |
| Value after reset: | 0              | 0           | 0           | 0           | 0           | 0  | 0           | 0           | 0  | 0  | 0  | 0  | 0         | 0         | 0  | 0         |

| Bit   | Symbol         | Function  | R/W |
|-------|----------------|---|-----|
| 15:0  | IRQWUPEN[15:0] | IRQn Interrupt Software Standby/Snooze Mode Returns Enable bit<br>0: Software Standby/Snooze Mode returns by IRQn interrupt is disabled<br>1: Software Standby/Snooze Mode returns by IRQn interrupt is enabled*1   | R/W |
| 16    | IWDTWUPEN      | IWDT Interrupt Software Standby/Snooze Mode Returns Enable bit<br>0: Software Standby/Snooze Mode returns by IWDT interrupt is disabled<br>1: Software Standby/Snooze Mode returns by IWDT interrupt is enabled   | R/W |
| 17    | —              | This bit is read as 0. The write value should be 0.   | R/W |
| 18    | LVD1WUPEN      | LVD1 Interrupt Software Standby/Snooze Mode Returns Enable bit<br>0: Software Standby/Snooze Mode returns by LVD1 interrupt is disabled<br>1: Software Standby/Snooze Mode returns by LVD1 interrupt is enabled   | R/W |
| 19    | LVD2WUPEN      | LVD2 Interrupt Software Standby/Snooze Mode Returns Enable bit<br>0: Software Standby/Snooze Mode returns by LVD2 interrupt is disabled<br>1: Software Standby/Snooze Mode returns by LVD2 interrupt is enabled   | R/W |
| 23:20 | —              | These bits are read as 0. The write value should be 0.  | R/W |
| 24    | RTCALMWUPEN    | RTC Alarm Interrupt Software Standby/Snooze Mode Returns Enable bit<br>0: Software Standby/Snooze Mode returns by RTC alarm interrupt is disabled<br>1: Software Standby/Snooze Mode returns by RTC alarm interrupt is enabled                                  | R/W |
| 25    | RTCPRDWUPEN    | RTC Period Interrupt Software Standby/Snooze Mode Returns Enable bit<br>0: Software Standby/Snooze Mode returns by RTC period interrupt is disabled<br>1: Software Standby/Snooze Mode returns by RTC period interrupt is enabled                               | R/W |
| 26    | —              | This bit is read as 0. The write value should be 0.   | R/W |
| 27    | USBFS0WUPEN    | USBFS0 Interrupt Software Standby/Snooze Mode Returns Enable bit<br>0: Software Standby/Snooze Mode returns by USBFS0 interrupt is disabled<br>1: Software Standby/Snooze Mode returns by USBFS0 interrupt is enabled   | R/W |
| 28    | AGT1UDWUPEN    | AGT1 Underflow Interrupt Software Standby/Snooze Mode Returns Enable bit<br>0: Software Standby/Snooze Mode returns by AGT1 underflow interrupt is disabled<br>1: Software Standby/Snooze Mode returns by AGT1 underflow interrupt is enabled                   | R/W |
| 29    | AGT1CAWUPEN    | AGT1 Compare Match A Interrupt Software Standby/Snooze Mode Returns Enable bit<br>0: Software Standby/Snooze Mode returns by AGT1 compare match A interrupt is disabled<br>1: Software Standby/Snooze Mode returns by AGT1 compare match A interrupt is enabled | R/W |
| 30    | AGT1CBWUPEN    | AGT1 Compare Match B Interrupt Software Standby/Snooze Mode Returns Enable bit<br>0: Software Standby/Snooze Mode returns by AGT1 compare match B interrupt is disabled<br>1: Software Standby/Snooze Mode returns by AGT1 compare match B interrupt is enabled | R/W |

## 13.2.18 WUPEN0:唤醒中断使能寄存器0

Base address: ICU = 0x4000\_6000

Offset address: 0x1A0

|               |                |             |             |             |             |    |             |             |    |    |    |    |           |           |    |           |
|---------------|----------------|-------------|-------------|-------------|-------------|----|-------------|-------------|----|----|----|----|-----------|-----------|----|-----------|
| Bit position: | 31             | 30          | 29          | 28          | 27          | 26 | 25          | 24          | 23 | 22 | 21 | 20 | 19        | 18        | 17 | 16        |
| Bit field:    | IIC0WUPEN      | AGT1CBWUPEN | AGT1CAWUPEN | AGT1UDWUPEN | USBFS0WUPEN | —  | RTCPRDWUPEN | RTCALMWUPEN | —  | —  | —  | —  | LVD2WUPEN | LVD1WUPEN | —  | IWDTWUPEN |
| 重置后的值:        | 0              | 0           | 0           | 0           | 0           | 0  | 0           | 0           | 0  | 0  | 0  | 0  | 0         | 0         | 0  | 0         |
| Bit position: | 15             | 14          | 13          | 12          | 11          | 10 | 9           | 8           | 7  | 6  | 5  | 4  | 3         | 2         | 1  | 0         |
| Bit field:    | IRQWUPEN[15:0] |             |             |             |             |    |             |             |    |    |    |    |           |           |    |           |
| 重置后的值:        | 0              | 0           | 0           | 0           | 0           | 0  | 0           | 0           | 0  | 0  | 0  | 0  | 0         | 0         | 0  | 0         |

| Bit   | Symbol         | Function   | R/W |
|-------|----------------|--|-----|
| 15:0  | IRQWUPEN[15:0] | IRQn中断软件待机贪睡模式返回使能位<br>0: 禁用IRQn中断返回软件待机贪睡模式*1<br>1: 启用IRQn中断返回软件待机贪睡模式*1              | R/W |
| 16    | IWDTWUPEN      | IWDT中断软件待机贪睡模式返回使能位<br>0: 禁止通过IWDT中断返回软件待机贪睡模式*1<br>1: 使能通过IWDT中断返回软件待机贪睡模式            | R/W |
| 17    | —              | 该位读取为0。写入值应为0。   | R/W |
| 18    | LVD1WUPEN      | LVD1中断软件待机贪睡模式返回使能位<br>0: 禁用LVD1中断返回软件待机贪睡模式*1<br>1: 启用LVD1中断返回软件待机贪睡模式                | R/W |
| 19    | LVD2WUPEN      | LVD2中断软件待机贪睡模式返回使能位<br>0: 禁用LVD2中断返回软件待机贪睡模式*1<br>1: 启用LVD2中断返回软件待机贪睡模式                | R/W |
| 23:20 | —              | 这些位被读取为0。写入值应为0。   | R/W |
| 24    | RTCALMWUPEN    | RTC闹钟中断软件待机贪睡模式返回使能位<br>0: 禁用RTC闹钟中断返回软件待机贪睡模式*1<br>1: 启用RTC闹钟中断返回软件待机贪睡模式             | R/W |
| 25    | RTCPRDWUPEN    | RTC周期中断软件待机贪睡模式返回使能位<br>0: 禁用RTC周期中断返回软件待机贪睡模式*1<br>1: 启用RTC周期中断返回软件待机贪睡模式             | R/W |
| 26    | —              | 该位读取为0。写入值应为0。   | R/W |
| 27    | USBFS0WUPEN    | USBFS0中断软件待机贪睡模式返回使能位<br>0: 禁用USBFS0中断返回软件待机贪睡模式*1<br>1: 启用USBFS0中断返回软件待机贪睡模式          | R/W |
| 28    | AGT1UDWUPEN    | AGT1下溢中断软件待机贪睡模式返回使能位<br>0: 禁用AGT1下溢中断返回软件待机贪睡模式*1<br>1: 启用AGT1下溢中断返回软件待机贪睡模式          | R/W |
| 29    | AGT1CAWUPEN    | AGT1比较匹配A中断软件待机贪睡模式返回使能位<br>0: 软件待机贪睡模式由AGT1比较匹配返回A中断被禁用<br>1: 软件待机贪睡模式由AGT1比较匹配返回启用中断 | R/W |
| 30    | AGT1CBWUPEN    | AGT1比较匹配B中断软件待机贪睡模式返回使能位<br>0: 软件待机贪睡模式由AGT1比较匹配B中断被禁用返回<br>1: 软件待机贪睡模式由AGT1比较匹配B中断启用  | R/W |

| Bit | Symbol    | Function  | R/W |
|-----|-----------|---|-----|
| 31  | IIC0WUPEN | IIC0 Address Match Interrupt Software Standby/Snooze Mode Returns Enable bit<br>0: Software Standby/Snooze Mode returns by IIC0 address match interrupt is disabled<br>1: Software Standby/Snooze Mode returns by IIC0 address match interrupt is enabled | R/W |

Note: If the security attribution is configured as secure:

- Secure access and Non-secure read access are allowed
- Non-secure write access is ignored, and TrustZone access error is not generated.

If the security attribution is configured as Non-secure:

- Secure and Non-secure access are allowed.

Note 1. Description is a description of each bit.

#### IRQWUPEN[15:0] bits (IRQn Interrupt Software Standby/Snooze Mode Returns Enable bit)

This bit is the enable bit to control the use of the IRQn pin as a Software standby return factor.

n = 0 to 15

#### IWDTWUPEN bit (IWDT Interrupt Software Standby/Snooze Mode Returns Enable bit)

This bit is the enable bit to control the use of the IWDT interrupt as an Software standby return factor.

#### LVD1WUPEN bit (LVD1 Interrupt Software Standby/Snooze Mode Returns Enable bit)

This bit is the enable bit to control the use of the LVD1 interrupt as an Software standby return factor.

#### LVD2WUPEN bit (LVD2 Interrupt Software Standby/Snooze Mode Returns Enable bit)

This bit is the enable bit to control the use of the LVD2 interrupt as an Software standby return factor.

#### RTCALMWUPEN bit (RTC Alarm Interrupt Software Standby/Snooze Mode Returns Enable bit)

This bit is the enable bit to control the use of the RTC alarm interrupt as an Software standby return factor.

#### RTCPRDWUPEN bit (RTC Period Interrupt Software Standby/Snooze Mode Returns Enable bit)

This bit is the enable bit to control the use of the RTC period interrupt as an Software standby return factor.

#### USBFS0WUPEN bit (USBFS0 Interrupt Software Standby/Snooze Mode Returns Enable bit)

This bit is the enable bit to control the use of the USBFS0 interrupt as an Software standby return factor.

#### AGT1UDWUPEN bit (AGT1 Underflow Interrupt Software Standby/Snooze Mode Returns Enable bit)

This bit is the enable bit to control the use of the AGT1 underflow interrupt as an Software standby return factor.

#### AGT1CAWUPEN bit (AGT1 Compare Match A Interrupt Software Standby/Snooze Mode Returns Enable bit)

This bit is the enable bit to control the use of the AGT1 compare match A interrupt as an Software standby return factor.

#### AGT1CBWUPEN bit (AGT1 Compare Match B Interrupt Software Standby/Snooze Mode Returns Enable bit)

This bit is the enable bit to control the use of the AGT1 compare match B interrupt as an Software standby return factor.

#### IIC0WUPEN bit (IIC0 Address Match Interrupt Software Standby/Snooze Mode Returns Enable bit)

This bit is the enable bit to control the use of the IIC0 interrupt as an Software standby return factor.

Note: The security attribution of this register is set for each wakeup event.  
To avoid the occurrence of a security hole, the target event of a wakeup and the security attribution added to this bit must match.

| Bit | Symbol    | Function   | R/W |
|-----|-----------|--|-----|
| 31  | IIC0WUPEN | IIC0地址匹配中断软件待机贪睡模式返回使能位<br>0: 软件待机贪睡模式由IIC0地址匹配中断返回被禁用<br>1: 软件待机贪睡模式由IIC0地址匹配中断返回使能 | R/W |

Note: 如果安全属性配置为安全: ●  
允许安全访问和非安全读取访问  
● 忽略非安全写入访问, 不会生成TrustZone访问错误。  
如果安全属性配置为非安全: ●  
允许安全和非安全访问。

注1.描述是对每个位的描述。

#### IRQWUPEN[15:0]位 (IRQn中断软件待机贪睡模式返回使能位)

该位是控制使用IRQn引脚作为软件待机返回因子的使能位。

n = 0 to 15

#### IWDTWUPEN位 (IWDT中断软件待机贪睡模式返回使能位)

该位是控制使用IWDT中断作为软件待机返回因素的使能位。

#### LVD1WUPEN位 (LVD1中断软件待机贪睡模式返回使能位)

该位是控制使用LVD1中断作为软件待机返回因素的使能位。

#### LVD2WUPEN位 (LVD2中断软件待机贪睡模式返回使能位)

该位是控制使用LVD2中断作为软件待机返回因素的使能位。

#### RTCALMWUPEN位 (RTC闹钟中断软件待机贪睡模式返回使能位)

该位是控制使用RTC闹钟中断作为软件待机返回因素的使能位。

#### RTCPRDWUPEN位 (RTC周期中断软件待机贪睡模式返回使能位)

该位是控制使用RTC周期中断作为软件待机返回因素的使能位。

#### USBFS0WUPEN位 (USBFS0中断软件待机贪睡模式返回使能位)

该位是控制使用USBFS0中断作为软件待机返回因子的使能位。

#### AGT1UDWUPEN位 (AGT1下溢中断软件待机贪睡模式返回使能位)

该位是控制使用AGT1下溢中断作为软件待机返回因素的使能位。

#### AGT1CAWUPEN位 (AGT1比较匹配A中断软件待机贪睡模式返回使能位)

该位是控制使用AGT1比较匹配A中断作为软件待机返回因素的使能位。

#### AGT1CBWUPEN位 (AGT1比较匹配B中断软件待机贪睡模式返回使能位)

该位是控制使用AGT1比较匹配B中断作为软件待机返回因素的使能位。

#### IIC0WUPEN位 (IIC0地址匹配中断软件待机贪睡模式返回使能位)

该位是控制使用IIC0中断作为软件待机返回因素的使能位。

Note: 该寄存器的安全属性为每个唤醒事件设置。  
为了避免安全漏洞的发生, 唤醒的目标事件和添加到该位的安全属性必须匹配。



## 13.2.19 WUPEN1 : Wake Up interrupt enable register 1

Base address: ICU = 0x4000\_6000

Offset address: 0x1A4

|                    |    |    |    |    |    |    |    |    |    |    |    |    |    |    |                     |                     |                     |
|--------------------|----|----|----|----|----|----|----|----|----|----|----|----|----|----|---------------------|---------------------|---------------------|
| Bit position:      | 31 | 30 | 29 | 28 | 27 | 26 | 25 | 24 | 23 | 22 | 21 | 20 | 19 | 18 | 17                  | 16                  |                     |
| Bit field:         | —  | —  | —  | —  | —  | —  | —  | —  | —  | —  | —  | —  | —  | —  | —                   | —                   |                     |
| Value after reset: | 0  | 0  | 0  | 0  | 0  | 0  | 0  | 0  | 0  | 0  | 0  | 0  | 0  | 0  | 0                   | 0                   |                     |
| Bit position:      | 15 | 14 | 13 | 12 | 11 | 10 | 9  | 8  | 7  | 6  | 5  | 4  | 3  | 2  | 1                   | 0                   |                     |
| Bit field:         | —  | —  | —  | —  | —  | —  | —  | —  | —  | —  | —  | —  | —  | —  | AGT3<br>CBWU<br>PEN | AGT3<br>CAWU<br>PEN | AGT3<br>UDWU<br>PEN |
| Value after reset: | 0  | 0  | 0  | 0  | 0  | 0  | 0  | 0  | 0  | 0  | 0  | 0  | 0  | 0  | 0                   | 0                   | 0                   |

| Bit  | Symbol      | Function   | R/W            |
|------|-------------|--|----------------|
| 0    | AGT3UDWUPEN | AGT3 Underflow Interrupt Software Standby Return Enable bit<br>0: Software standby returns by AGT3 underflow interrupt is disabled<br>1: Software standby returns by AGT3 underflow interrupt is enabled                   | R/W            |
| 1    | AGT3CAWUPEN | AGT3 Compare Match A Interrupt Software Standby Return Enable bit<br>0: Software standby returns by AGT3 compare match A interrupt is disabled<br>1: Software standby returns by AGT3 compare match A interrupt is enabled | R/W            |
| 2    | AGT3CBWUPEN | AGT3 Compare Match B Interrupt Software Standby Return Enable bit<br>0: Software standby returns by AGT3 compare match B interrupt is disabled<br>1: Software standby returns by AGT3 compare match B interrupt is enabled | R/W            |
| 31:3 | —           | These bits are read as 0. The write value should be 0.   | R <sup>1</sup> |

Note: If the security attribution is configured as secure:

- Secure access and Non-secure read access are allowed
- Non-secure write access is ignored, and TrustZone access error is not generated.

If the security attribution is configured as Non-secure:

- Secure and Non-secure access are allowed.

Note 1. This bit is read only

**AGT3UDWUPEN bit (AGT3 Underflow Interrupt Software Standby Return Enable bit)**

This bit is the enable bit to control the use of the AGT3 underflow interrupt as an Software standby return factor.

**AGT3CAWUPEN bit (AGT3 Compare Match A Interrupt Software Standby Return Enable bit)**

This bit is the enable bit to control the use of the AGT3 compare match A interrupt as an Software standby return factor.

**AGT3CBWUPEN bit (AGT3 Compare Match B Interrupt Software Standby Return Enable bit)**

This bit is the enable bit to control the use of the AGT3 compare match B interrupt as an Software standby return factor.

Note: The security attribution of this register is set for each wakeup event.  
To avoid the occurrence of a security hole, the target event of a wakeup and the security attribution added to this bit must match.

## 13.3 Vector Table

The ICU detects maskable and non-maskable interrupts. Interrupt priorities are set up in the Arm NVIC. For information about these registers, see [section 13.9. Reference](#).

## 13.3.1 Interrupt Vector Table

[Table 13.3](#) describes the interrupt vector table. The interrupt vector addresses conform to the NVIC specifications.

## 13.2.19 WUPEN1: 唤醒中断使能寄存器1

Base address: ICU = 0x4000\_6000

Offset address: 0x1A4

|               |    |    |    |    |    |    |    |    |    |    |    |    |    |    |    |                     |                     |                     |
|---------------|----|----|----|----|----|----|----|----|----|----|----|----|----|----|----|---------------------|---------------------|---------------------|
| Bit position: | 31 | 30 | 29 | 28 | 27 | 26 | 25 | 24 | 23 | 22 | 21 | 20 | 19 | 18 | 17 | 16                  |                     |                     |
| Bit field:    | —  | —  | —  | —  | —  | —  | —  | —  | —  | —  | —  | —  | —  | —  | —  | —                   |                     |                     |
| 重置后的值:        | 0  | 0  | 0  | 0  | 0  | 0  | 0  | 0  | 0  | 0  | 0  | 0  | 0  | 0  | 0  | 0                   |                     |                     |
| Bit position: | 15 | 14 | 13 | 12 | 11 | 10 | 9  | 8  | 7  | 6  | 5  | 4  | 3  | 2  | 1  | 0                   |                     |                     |
| Bit field:    | —  | —  | —  | —  | —  | —  | —  | —  | —  | —  | —  | —  | —  | —  | —  | AGT3<br>CBWU<br>PEN | AGT3<br>CAWU<br>PEN | AGT3<br>UDWU<br>PEN |
| 重置后的值:        | 0  | 0  | 0  | 0  | 0  | 0  | 0  | 0  | 0  | 0  | 0  | 0  | 0  | 0  | 0  | 0                   | 0                   | 0                   |

| Bit  | Symbol      | Function   | R/W            |
|------|-------------|--|----------------|
| 0    | AGT3UDWUPEN | AGT3下溢中断软件待机返回使能位<br>0: 禁用AGT3下溢中断返回软件待机1: 启用AGT3下溢中断返回软件待机              | R/W            |
| 1    | AGT3CAWUPEN | AGT3比较匹配A中断软件待机返回使能位<br>0: 通过AGT3比较匹配A中断禁用软件待机返回1: 通过AGT3比较匹配A中断启用软件待机返回 | R/W            |
| 2    | AGT3CBWUPEN | AGT3比较匹配B中断软件待机返回使能位<br>0: 禁用AGT3比较匹配B中断返回软件待机1: 启用AGT3比较匹配B中断返回软件待机     | R/W            |
| 31:3 | —           | 这些位被读取为0。写入值应为0。   | R <sup>1</sup> |

Note: 如果安全属性配置为安全: ●  
允许安全访问和非安全读取访问  
● 忽略非安全写入访问, 不会生成TrustZone访问错误。  
如果安全属性配置为非安全: ●  
允许安全和非安全访问。

注1.该位是只读的

**AGT3UDWUPEN位 (AGT3下溢中断软件待机返回使能位)**

该位是控制使用AGT3下溢中断作为软件待机返回因子的使能位。

**AGT3CAWUPEN位 (AGT3比较匹配A中断软件待机返回使能位)**

该位是控制使用AGT3比较匹配A中断作为软件待机返回因子的使能位。

**AGT3CBWUPEN位 (AGT3比较匹配B中断软件待机返回使能位)**

该位是控制使用AGT3比较匹配B中断作为软件待机返回因素的使能位。

Note: 该寄存器的安全属性为每个唤醒事件设置。  
为了避免安全漏洞的发生, 唤醒的目标事件和添加到该位的安全属性必须匹配。

## 13.3 向量表

ICU检测可屏蔽和不可屏蔽中断。中断优先级在ArmNVIC中设置。有关这些寄存器的信息, 请参阅第13.9节。参考。

## 13.3.1 中断向量表

[表13.3](#)描述了中断向量表。中断向量地址符合NVIC规范。

Table 13.3 Interrupt vector table (1 of 3)

| Exception number | IRQ number | Vector offset | Source      | Description  |
|------------------|------------|---------------|-------------|--|
| 0                | —          | 0x000         | Arm         | Initial stack pointer                                |
| 1                | —          | 0x004         | Arm         | Initial program counter (reset vector)               |
| 2                | —          | 0x008         | Arm         | Non-Maskable Interrupt (NMI)                         |
| 3                | —          | 0x00C         | Arm         | Hard Fault   |
| 4                | —          | 0x010         | Arm         | MemManage fault                                      |
| 5                | —          | 0x014         | Arm         | BusFault   |
| 6                | —          | 0x018         | Arm         | UsageFault   |
| 7                | —          | 0x01C         | Arm         | SecureFault  |
| 8                | —          | 0x020         | Arm         | Reserved   |
| 9                | —          | 0x024         | Arm         | Reserved   |
| 10               | —          | 0x028         | Arm         | Reserved   |
| 11               | —          | 0x02C         | Arm         | Supervisor Call (SVCall)                             |
| 12               | —          | 0x030         | Arm         | DebugMonitor   |
| 13               | —          | 0x034         | Arm         | Reserved   |
| 14               | —          | 0x038         | Arm         | Pendable request for system service (PendableSrvReq) |
| 15               | —          | 0x03C         | Arm         | System Tick Timer (SysTick)                          |
| 16               | 0          | 0x040         | ICU.IELSR0  | Event selected in the ICU.IELSR0 register            |
| 17               | 1          | 0x044         | ICU.IELSR1  | Event selected in the ICU.IELSR1 register            |
| 18               | 2          | 0x048         | ICU.IELSR2  | Event selected in the ICU.IELSR2 register            |
| 19               | 3          | 0x04C         | ICU.IELSR3  | Event selected in the ICU.IELSR3 register            |
| 20               | 4          | 0x050         | ICU.IELSR4  | Event selected in the ICU.IELSR4 register            |
| 21               | 5          | 0x054         | ICU.IELSR5  | Event selected in the ICU.IELSR5 register            |
| 22               | 6          | 0x058         | ICU.IELSR6  | Event selected in the ICU.IELSR6 register            |
| 23               | 7          | 0x05C         | ICU.IELSR7  | Event selected in the ICU.IELSR7 register            |
| 24               | 8          | 0x060         | ICU.IELSR8  | Event selected in the ICU.IELSR8 register            |
| 25               | 9          | 0x064         | ICU.IELSR9  | Event selected in the ICU.IELSR9 register            |
| 26               | 10         | 0x068         | ICU.IELSR10 | Event selected in the ICU.IELSR10 register           |
| 27               | 11         | 0x06C         | ICU.IELSR11 | Event selected in the ICU.IELSR11 register           |
| 28               | 12         | 0x070         | ICU.IELSR12 | Event selected in the ICU.IELSR12 register           |
| 29               | 13         | 0x074         | ICU.IELSR13 | Event selected in the ICU.IELSR13 register           |
| 30               | 14         | 0x078         | ICU.IELSR14 | Event selected in the ICU.IELSR14 register           |
| 31               | 15         | 0x07C         | ICU.IELSR15 | Event selected in the ICU.IELSR15 register           |
| 32               | 16         | 0x080         | ICU.IELSR16 | Event selected in the ICU.IELSR16 register           |
| 33               | 17         | 0x084         | ICU.IELSR17 | Event selected in the ICU.IELSR17 register           |
| 34               | 18         | 0x088         | ICU.IELSR18 | Event selected in the ICU.IELSR18 register           |
| 35               | 19         | 0x08C         | ICU.IELSR19 | Event selected in the ICU.IELSR19 register           |
| 36               | 20         | 0x090         | ICU.IELSR20 | Event selected in the ICU.IELSR20 register           |
| 37               | 21         | 0x094         | ICU.IELSR21 | Event selected in the ICU.IELSR21 register           |
| 38               | 22         | 0x098         | ICU.IELSR22 | Event selected in the ICU.IELSR22 register           |
| 39               | 23         | 0x09C         | ICU.IELSR23 | Event selected in the ICU.IELSR23 register           |
| 40               | 24         | 0x0A0         | ICU.IELSR24 | Event selected in the ICU.IELSR24 register           |

Table 13.3 中断向量表(1of3)

| 异常编号 | IRQ number | 矢量偏移  | Source      | Description                  |
|------|------------|-------|-------------|------------------------------|
| 0    | —          | 0x000 | Arm         | 初始堆栈指针                       |
| 1    | —          | 0x004 | Arm         | 初始程序计数器 (复位向量)               |
| 2    | —          | 0x008 | Arm         | Non-Maskable Interrupt (NMI) |
| 3    | —          | 0x00C | Arm         | 硬故障                          |
| 4    | —          | 0x010 | Arm         | MemManage fault              |
| 5    | —          | 0x014 | Arm         | BusFault                     |
| 6    | —          | 0x018 | Arm         | UsageFault                   |
| 7    | —          | 0x01C | Arm         | SecureFault                  |
| 8    | —          | 0x020 | Arm         | Reserved                     |
| 9    | —          | 0x024 | Arm         | Reserved                     |
| 10   | —          | 0x028 | Arm         | Reserved                     |
| 11   | —          | 0x02C | Arm         | 主管呼叫(SVCall)                 |
| 12   | —          | 0x030 | Arm         | DebugMonitor                 |
| 13   | —          | 0x034 | Arm         | Reserved                     |
| 14   | —          | 0x038 | Arm         | 系统服务的挂起请求(PendableSrvReq)    |
| 15   | —          | 0x03C | Arm         | 系统滴答计时器(SysTick)             |
| 16   | 0          | 0x040 | ICU.IELSR0  | 在ICU.IELSR0寄存器中选择的事件         |
| 17   | 1          | 0x044 | ICU.IELSR1  | 在ICU.IELSR1寄存器中选择的事件         |
| 18   | 2          | 0x048 | ICU.IELSR2  | 在ICU.IELSR2寄存器中选择的事件         |
| 19   | 3          | 0x04C | ICU.IELSR3  | 在ICU.IELSR3寄存器中选择的事件         |
| 20   | 4          | 0x050 | ICU.IELSR4  | 在ICU.IELSR4寄存器中选择的事件         |
| 21   | 5          | 0x054 | ICU.IELSR5  | 在ICU.IELSR5寄存器中选择的事件         |
| 22   | 6          | 0x058 | ICU.IELSR6  | 在ICU.IELSR6寄存器中选择的事件         |
| 23   | 7          | 0x05C | ICU.IELSR7  | 在ICU.IELSR7寄存器中选择的事件         |
| 24   | 8          | 0x060 | ICU.IELSR8  | 在ICU.IELSR8寄存器中选择的事件         |
| 25   | 9          | 0x064 | ICU.IELSR9  | 在ICU.IELSR9寄存器中选择的事件         |
| 26   | 10         | 0x068 | ICU.IELSR10 | 在ICU.IELSR10寄存器中选择的事件        |
| 27   | 11         | 0x06C | ICU.IELSR11 | 在ICU.IELSR11寄存器中选择的事件        |
| 28   | 12         | 0x070 | ICU.IELSR12 | 在ICU.IELSR12寄存器中选择的事件        |
| 29   | 13         | 0x074 | ICU.IELSR13 | 在ICU.IELSR13寄存器中选择的事件        |
| 30   | 14         | 0x078 | ICU.IELSR14 | 在ICU.IELSR14寄存器中选择的事件        |
| 31   | 15         | 0x07C | ICU.IELSR15 | 在ICU.IELSR15寄存器中选择的事件        |
| 32   | 16         | 0x080 | ICU.IELSR16 | 在ICU.IELSR16寄存器中选择的事件        |
| 33   | 17         | 0x084 | ICU.IELSR17 | 在ICU.IELSR17寄存器中选择的事件        |
| 34   | 18         | 0x088 | ICU.IELSR18 | 在ICU.IELSR18寄存器中选择的事件        |
| 35   | 19         | 0x08C | ICU.IELSR19 | 在ICU.IELSR19寄存器中选择的事件        |
| 36   | 20         | 0x090 | ICU.IELSR20 | 在ICU.IELSR20寄存器中选择的事件        |
| 37   | 21         | 0x094 | ICU.IELSR21 | 在ICU.IELSR21寄存器中选择的事件        |
| 38   | 22         | 0x098 | ICU.IELSR22 | 在ICU.IELSR22寄存器中选择的事件        |
| 39   | 23         | 0x09C | ICU.IELSR23 | 在ICU.IELSR23寄存器中选择的事件        |
| 40   | 24         | 0x0A0 | ICU.IELSR24 | 在ICU.IELSR24寄存器中选择的事件        |



Table 13.3 Interrupt vector table (2 of 3)

| Exception number | IRQ number | Vector offset | Source      | Description                                |
|------------------|------------|---------------|-------------|--|
| 41               | 25         | 0x0A4         | ICU.IELSR25 | Event selected in the ICU.IELSR25 register |
| 42               | 26         | 0x0A8         | ICU.IELSR26 | Event selected in the ICU.IELSR26 register |
| 43               | 27         | 0x0AC         | ICU.IELSR27 | Event selected in the ICU.IELSR27 register |
| 44               | 28         | 0x0B0         | ICU.IELSR28 | Event selected in the ICU.IELSR28 register |
| 45               | 29         | 0x0B4         | ICU.IELSR29 | Event selected in the ICU.IELSR29 register |
| 46               | 30         | 0x0B8         | ICU.IELSR30 | Event selected in the ICU.IELSR30 register |
| 47               | 31         | 0x0BC         | ICU.IELSR31 | Event selected in the ICU.IELSR31 register |
| 48               | 32         | 0x0C0         | ICU.IELSR32 | Event selected in the ICU.IELSR32 register |
| 49               | 33         | 0x0C4         | ICU.IELSR33 | Event selected in the ICU.IELSR33 register |
| 50               | 34         | 0x0C8         | ICU.IELSR34 | Event selected in the ICU.IELSR34 register |
| 51               | 35         | 0x0CC         | ICU.IELSR35 | Event selected in the ICU.IELSR35 register |
| 52               | 36         | 0x0D0         | ICU.IELSR36 | Event selected in the ICU.IELSR36 register |
| 53               | 37         | 0x0D4         | ICU.IELSR37 | Event selected in the ICU.IELSR37 register |
| 54               | 38         | 0x0D8         | ICU.IELSR38 | Event selected in the ICU.IELSR38 register |
| 55               | 39         | 0x0DC         | ICU.IELSR39 | Event selected in the ICU.IELSR39 register |
| 56               | 40         | 0x0E0         | ICU.IELSR40 | Event selected in the ICU.IELSR40 register |
| 57               | 41         | 0x0E4         | ICU.IELSR41 | Event selected in the ICU.IELSR41 register |
| 58               | 42         | 0x0E8         | ICU.IELSR42 | Event selected in the ICU.IELSR42 register |
| 59               | 43         | 0x0EC         | ICU.IELSR43 | Event selected in the ICU.IELSR43 register |
| 60               | 44         | 0x0F0         | ICU.IELSR44 | Event selected in the ICU.IELSR44 register |
| 61               | 45         | 0x0F4         | ICU.IELSR45 | Event selected in the ICU.IELSR45 register |
| 62               | 46         | 0x0F8         | ICU.IELSR46 | Event selected in the ICU.IELSR46 register |
| 63               | 47         | 0x0FC         | ICU.IELSR47 | Event selected in the ICU.IELSR47 register |
| 64               | 48         | 0x100         | ICU.IELSR48 | Event selected in the ICU.IELSR48 register |
| 65               | 49         | 0x104         | ICU.IELSR49 | Event selected in the ICU.IELSR49 register |
| 66               | 50         | 0x108         | ICU.IELSR50 | Event selected in the ICU.IELSR50 register |
| 67               | 51         | 0x10C         | ICU.IELSR51 | Event selected in the ICU.IELSR51 register |
| 68               | 52         | 0x110         | ICU.IELSR52 | Event selected in the ICU.IELSR52 register |
| 69               | 53         | 0x114         | ICU.IELSR53 | Event selected in the ICU.IELSR53 register |
| 70               | 54         | 0x118         | ICU.IELSR54 | Event selected in the ICU.IELSR54 register |
| 71               | 55         | 0x11C         | ICU.IELSR55 | Event selected in the ICU.IELSR55 register |
| 72               | 56         | 0x120         | ICU.IELSR56 | Event selected in the ICU.IELSR56 register |
| 73               | 57         | 0x124         | ICU.IELSR57 | Event selected in the ICU.IELSR57 register |
| 74               | 58         | 0x128         | ICU.IELSR58 | Event selected in the ICU.IELSR58 register |
| 75               | 59         | 0x12C         | ICU.IELSR59 | Event selected in the ICU.IELSR59 register |
| 76               | 60         | 0x130         | ICU.IELSR60 | Event selected in the ICU.IELSR60 register |
| 77               | 61         | 0x134         | ICU.IELSR61 | Event selected in the ICU.IELSR61 register |
| 78               | 62         | 0x138         | ICU.IELSR62 | Event selected in the ICU.IELSR62 register |
| 79               | 63         | 0x13C         | ICU.IELSR63 | Event selected in the ICU.IELSR63 register |
| 80               | 64         | 0x140         | ICU.IELSR64 | Event selected in the ICU.IELSR64 register |
| 81               | 65         | 0x144         | ICU.IELSR65 | Event selected in the ICU.IELSR65 register |

Table 13.3 中断向量表(2of3)

| 异常编号 | IRQ number | 矢量偏移  | Source      | Description           |
|------|------------|-------|-------------|-----------------------|
| 41   | 25         | 0x0A4 | ICU.IELSR25 | 在ICU.IELSR25寄存器中选择的事件 |
| 42   | 26         | 0x0A8 | ICU.IELSR26 | 在ICU.IELSR26寄存器中选择的事件 |
| 43   | 27         | 0x0AC | ICU.IELSR27 | 在ICU.IELSR27寄存器中选择的事件 |
| 44   | 28         | 0x0B0 | ICU.IELSR28 | 在ICU.IELSR28寄存器中选择的事件 |
| 45   | 29         | 0x0B4 | ICU.IELSR29 | 在ICU.IELSR29寄存器中选择的事件 |
| 46   | 30         | 0x0B8 | ICU.IELSR30 | 在ICU.IELSR30寄存器中选择的事件 |
| 47   | 31         | 0x0BC | ICU.IELSR31 | 在ICU.IELSR31寄存器中选择的事件 |
| 48   | 32         | 0x0C0 | ICU.IELSR32 | 在ICU.IELSR32寄存器中选择的事件 |
| 49   | 33         | 0x0C4 | ICU.IELSR33 | 在ICU.IELSR33寄存器中选择的事件 |
| 50   | 34         | 0x0C8 | ICU.IELSR34 | 在ICU.IELSR34寄存器中选择的事件 |
| 51   | 35         | 0x0CC | ICU.IELSR35 | 在ICU.IELSR35寄存器中选择的事件 |
| 52   | 36         | 0x0D0 | ICU.IELSR36 | 在ICU.IELSR36寄存器中选择的事件 |
| 53   | 37         | 0x0D4 | ICU.IELSR37 | 在ICU.IELSR37寄存器中选择的事件 |
| 54   | 38         | 0x0D8 | ICU.IELSR38 | 在ICU.IELSR38寄存器中选择的事件 |
| 55   | 39         | 0x0DC | ICU.IELSR39 | 在ICU.IELSR39寄存器中选择的事件 |
| 56   | 40         | 0x0E0 | ICU.IELSR40 | 在ICU.IELSR40寄存器中选择的事件 |
| 57   | 41         | 0x0E4 | ICU.IELSR41 | 在ICU.IELSR41寄存器中选择的事件 |
| 58   | 42         | 0x0E8 | ICU.IELSR42 | 在ICU.IELSR42寄存器中选择的事件 |
| 59   | 43         | 0x0EC | ICU.IELSR43 | 在ICU.IELSR43寄存器中选择的事件 |
| 60   | 44         | 0x0F0 | ICU.IELSR44 | 在ICU.IELSR44寄存器中选择的事件 |
| 61   | 45         | 0x0F4 | ICU.IELSR45 | 在ICU.IELSR45寄存器中选择的事件 |
| 62   | 46         | 0x0F8 | ICU.IELSR46 | 在ICU.IELSR46寄存器中选择的事件 |
| 63   | 47         | 0x0FC | ICU.IELSR47 | 在ICU.IELSR47寄存器中选择的事件 |
| 64   | 48         | 0x100 | ICU.IELSR48 | 在ICU.IELSR48寄存器中选择的事件 |
| 65   | 49         | 0x104 | ICU.IELSR49 | 在ICU.IELSR49寄存器中选择的事件 |
| 66   | 50         | 0x108 | ICU.IELSR50 | 在ICU.IELSR50寄存器中选择的事件 |
| 67   | 51         | 0x10C | ICU.IELSR51 | 在ICU.IELSR51寄存器中选择的事件 |
| 68   | 52         | 0x110 | ICU.IELSR52 | 在ICU.IELSR52寄存器中选择的事件 |
| 69   | 53         | 0x114 | ICU.IELSR53 | 在ICU.IELSR53寄存器中选择的事件 |
| 70   | 54         | 0x118 | ICU.IELSR54 | 在ICU.IELSR54寄存器中选择的事件 |
| 71   | 55         | 0x11C | ICU.IELSR55 | 在ICU.IELSR55寄存器中选择的事件 |
| 72   | 56         | 0x120 | ICU.IELSR56 | 在ICU.IELSR56寄存器中选择的事件 |
| 73   | 57         | 0x124 | ICU.IELSR57 | 在ICU.IELSR57寄存器中选择的事件 |
| 74   | 58         | 0x128 | ICU.IELSR58 | 在ICU.IELSR58寄存器中选择的事件 |
| 75   | 59         | 0x12C | ICU.IELSR59 | 在ICU.IELSR59寄存器中选择的事件 |
| 76   | 60         | 0x130 | ICU.IELSR60 | 在ICU.IELSR60寄存器中选择的事件 |
| 77   | 61         | 0x134 | ICU.IELSR61 | 在ICU.IELSR61寄存器中选择的事件 |
| 78   | 62         | 0x138 | ICU.IELSR62 | 在ICU.IELSR62寄存器中选择的事件 |
| 79   | 63         | 0x13C | ICU.IELSR63 | 在ICU.IELSR63寄存器中选择的事件 |
| 80   | 64         | 0x140 | ICU.IELSR64 | 在ICU.IELSR64寄存器中选择的事件 |
| 81   | 65         | 0x144 | ICU.IELSR65 | 在ICU.IELSR65寄存器中选择的事件 |

Table 13.3 Interrupt vector table (3 of 3)

| Exception number | IRQ number | Vector offset | Source      | Description                                |
|------------------|------------|---------------|-------------|--|
| 82               | 66         | 0x148         | ICU.IELSR66 | Event selected in the ICU.IELSR66 register |
| 83               | 67         | 0x14C         | ICU.IELSR67 | Event selected in the ICU.IELSR67 register |
| 84               | 68         | 0x150         | ICU.IELSR68 | Event selected in the ICU.IELSR68 register |
| 85               | 69         | 0x154         | ICU.IELSR69 | Event selected in the ICU.IELSR69 register |
| 86               | 70         | 0x158         | ICU.IELSR70 | Event selected in the ICU.IELSR70 register |
| 87               | 71         | 0x15C         | ICU.IELSR71 | Event selected in the ICU.IELSR71 register |
| 88               | 72         | 0x160         | ICU.IELSR72 | Event selected in the ICU.IELSR72 register |
| 89               | 73         | 0x164         | ICU.IELSR73 | Event selected in the ICU.IELSR73 register |
| 90               | 74         | 0x168         | ICU.IELSR74 | Event selected in the ICU.IELSR74 register |
| 91               | 75         | 0x16C         | ICU.IELSR75 | Event selected in the ICU.IELSR75 register |
| 92               | 76         | 0x170         | ICU.IELSR76 | Event selected in the ICU.IELSR76 register |
| 93               | 77         | 0x174         | ICU.IELSR77 | Event selected in the ICU.IELSR77 register |
| 94               | 78         | 0x178         | ICU.IELSR78 | Event selected in the ICU.IELSR78 register |
| 95               | 79         | 0x17C         | ICU.IELSR79 | Event selected in the ICU.IELSR79 register |
| 96               | 80         | 0x180         | ICU.IELSR80 | Event selected in the ICU.IELSR80 register |
| 97               | 81         | 0x184         | ICU.IELSR81 | Event selected in the ICU.IELSR81 register |
| 98               | 82         | 0x188         | ICU.IELSR82 | Event selected in the ICU.IELSR82 register |
| 99               | 83         | 0x18C         | ICU.IELSR83 | Event selected in the ICU.IELSR83 register |
| 100              | 84         | 0x190         | ICU.IELSR84 | Event selected in the ICU.IELSR84 register |
| 101              | 85         | 0x194         | ICU.IELSR85 | Event selected in the ICU.IELSR85 register |
| 102              | 86         | 0x198         | ICU.IELSR86 | Event selected in the ICU.IELSR86 register |
| 103              | 87         | 0x19C         | ICU.IELSR87 | Event selected in the ICU.IELSR87 register |
| 104              | 88         | 0x1A0         | ICU.IELSR88 | Event selected in the ICU.IELSR88 register |
| 105              | 89         | 0x1A4         | ICU.IELSR89 | Event selected in the ICU.IELSR89 register |
| 106              | 90         | 0x1A8         | ICU.IELSR90 | Event selected in the ICU.IELSR90 register |
| 107              | 91         | 0x1AC         | ICU.IELSR91 | Event selected in the ICU.IELSR91 register |
| 108              | 92         | 0x1B0         | ICU.IELSR92 | Event selected in the ICU.IELSR92 register |
| 109              | 93         | 0x1B4         | ICU.IELSR93 | Event selected in the ICU.IELSR93 register |
| 110              | 94         | 0x1B8         | ICU.IELSR94 | Event selected in the ICU.IELSR94 register |
| 111              | 95         | 0x1BC         | ICU.IELSR95 | Event selected in the ICU.IELSR95 register |

### 13.3.2 Event Number

The following table lists heading details for Table 13.4, which describes each event number.

| Heading                  | Description  |
|--------------------------|--|
| Interrupt request source | Name of the source generating the interrupt request                          |
| Name                     | Name of the interrupt  |
| Connect to NVIC          | "✓" indicates the interrupt can be used as a CPU interrupt                   |
| Invoke DTC               | "✓" indicates the interrupt can be used to request DTC activation            |
| Invoke DMAC              | "✓" indicates the interrupt can be used to request DMAC activation           |
| Canceling Snooze         | "✓" indicates the interrupt can be used to request a return from Snooze mode |

Table 13.3 中断向量表(3of3)

| 异常编号 | IRQ number | 矢量偏移  | Source      | Description           |
|------|------------|-------|-------------|-----------------------|
| 82   | 66         | 0x148 | ICU.IELSR66 | 在ICU.IELSR66寄存器中选择的事件 |
| 83   | 67         | 0x14C | ICU.IELSR67 | 在ICU.IELSR67寄存器中选择的事件 |
| 84   | 68         | 0x150 | ICU.IELSR68 | 在ICU.IELSR68寄存器中选择的事件 |
| 85   | 69         | 0x154 | ICU.IELSR69 | 在ICU.IELSR69寄存器中选择的事件 |
| 86   | 70         | 0x158 | ICU.IELSR70 | 在ICU.IELSR70寄存器中选择的事件 |
| 87   | 71         | 0x15C | ICU.IELSR71 | 在ICU.IELSR71寄存器中选择的事件 |
| 88   | 72         | 0x160 | ICU.IELSR72 | 在ICU.IELSR72寄存器中选择的事件 |
| 89   | 73         | 0x164 | ICU.IELSR73 | 在ICU.IELSR73寄存器中选择的事件 |
| 90   | 74         | 0x168 | ICU.IELSR74 | 在ICU.IELSR74寄存器中选择的事件 |
| 91   | 75         | 0x16C | ICU.IELSR75 | 在ICU.IELSR75寄存器中选择的事件 |
| 92   | 76         | 0x170 | ICU.IELSR76 | 在ICU.IELSR76寄存器中选择的事件 |
| 93   | 77         | 0x174 | ICU.IELSR77 | 在ICU.IELSR77寄存器中选择的事件 |
| 94   | 78         | 0x178 | ICU.IELSR78 | 在ICU.IELSR78寄存器中选择的事件 |
| 95   | 79         | 0x17C | ICU.IELSR79 | 在ICU.IELSR79寄存器中选择的事件 |
| 96   | 80         | 0x180 | ICU.IELSR80 | 在ICU.IELSR80寄存器中选择的事件 |
| 97   | 81         | 0x184 | ICU.IELSR81 | 在ICU.IELSR81寄存器中选择的事件 |
| 98   | 82         | 0x188 | ICU.IELSR82 | 在ICU.IELSR82寄存器中选择的事件 |
| 99   | 83         | 0x18C | ICU.IELSR83 | 在ICU.IELSR83寄存器中选择的事件 |
| 100  | 84         | 0x190 | ICU.IELSR84 | 在ICU.IELSR84寄存器中选择的事件 |
| 101  | 85         | 0x194 | ICU.IELSR85 | 在ICU.IELSR85寄存器中选择的事件 |
| 102  | 86         | 0x198 | ICU.IELSR86 | 在ICU.IELSR86寄存器中选择的事件 |
| 103  | 87         | 0x19C | ICU.IELSR87 | 在ICU.IELSR87寄存器中选择的事件 |
| 104  | 88         | 0x1A0 | ICU.IELSR88 | 在ICU.IELSR88寄存器中选择的事件 |
| 105  | 89         | 0x1A4 | ICU.IELSR89 | 在ICU.IELSR89寄存器中选择的事件 |
| 106  | 90         | 0x1A8 | ICU.IELSR90 | 在ICU.IELSR90寄存器中选择的事件 |
| 107  | 91         | 0x1AC | ICU.IELSR91 | 在ICU.IELSR91寄存器中选择的事件 |
| 108  | 92         | 0x1B0 | ICU.IELSR92 | 在ICU.IELSR92寄存器中选择的事件 |
| 109  | 93         | 0x1B4 | ICU.IELSR93 | 在ICU.IELSR93寄存器中选择的事件 |
| 110  | 94         | 0x1B8 | ICU.IELSR94 | 在ICU.IELSR94寄存器中选择的事件 |
| 111  | 95         | 0x1BC | ICU.IELSR95 | 在ICU.IELSR95寄存器中选择的事件 |

### 13.3.2 事件编号

下表列出了表13.4的标题详细信息，其中描述了每个事件编号。

| Heading     | Description          |
|-------------|----------------------|
| 中断请求源       | 产生中断请求的源名称           |
| Name        | 中断名称                 |
| 连接到NVIC     | " "表示该中断可以作为CPU中断使用  |
| Invoke DTC  | " "表示该中断可用于请求DTC激活   |
| Invoke DMAC | " "表示该中断可用于请求DMAC激活  |
| 取消贪睡        | " "表示该中断可用于请求从贪睡模式返回 |

| Heading                         | Description   |
|---------------------------------|---|
| Canceling Software Standby      | "✓" indicates the interrupt can be used to request a return from Software Standby mode      |
| Canceling Deep Software Standby | "✓" indicates the interrupt can be used to request a return from Deep Software Standby mode |

Table 13.4 Event table (1 of 7)

| Event number | Interrupt request source | Name          | IELSRn          |            | DELSRn      | Canceling Snooze | Canceling Software Standby | Canceling Deep Software Standby |
|--------------|--------------------------|---------------|-----------------|------------|-------------|------------------|----------------------------|---------------------------------|
|              |                          |               | Connect to NVIC | Invoke DTC | Invoke DMAC |                  |                            |                                 |
| 0x001        | Port                     | PORT_IRQ0     | ✓               | ✓          | ✓           | ✓                | ✓                          | ✓                               |
| 0x002        |                          | PORT_IRQ1     | ✓               | ✓          | ✓           | ✓                | ✓                          | ✓                               |
| 0x003        |                          | PORT_IRQ2     | ✓               | ✓          | ✓           | ✓                | ✓                          | ✓                               |
| 0x004        |                          | PORT_IRQ3     | ✓               | ✓          | ✓           | ✓                | ✓                          | ✓                               |
| 0x005        |                          | PORT_IRQ4     | ✓               | ✓          | ✓           | ✓                | ✓                          | ✓                               |
| 0x006        |                          | PORT_IRQ5     | ✓               | ✓          | ✓           | ✓                | ✓                          | ✓                               |
| 0x007        |                          | PORT_IRQ6     | ✓               | ✓          | ✓           | ✓                | ✓                          | ✓                               |
| 0x008        |                          | PORT_IRQ7     | ✓               | ✓          | ✓           | ✓                | ✓                          | ✓                               |
| 0x009        |                          | PORT_IRQ8     | ✓               | ✓          | ✓           | ✓                | ✓                          | ✓                               |
| 0x00A        |                          | PORT_IRQ9     | ✓               | ✓          | ✓           | ✓                | ✓                          | ✓                               |
| 0x00B        |                          | PORT_IRQ10    | ✓               | ✓          | ✓           | ✓                | ✓                          | ✓                               |
| 0x00C        |                          | PORT_IRQ11    | ✓               | ✓          | ✓           | ✓                | ✓                          | ✓                               |
| 0x00D        |                          | PORT_IRQ12    | ✓               | ✓          | ✓           | ✓                | ✓                          | ✓                               |
| 0x00E        |                          | PORT_IRQ13    | ✓               | ✓          | ✓           | ✓                | ✓                          | ✓                               |
| 0x00F        |                          | PORT_IRQ14    | ✓               | ✓          | ✓           | ✓                | ✓                          | ✓                               |
| 0x010        |                          | PORT_IRQ15    | ✓               | ✓          | ✓           | ✓                | ✓                          | ✓                               |
| 0x020        | DMAC0                    | DMAC0_INT     | ✓               | ✓          | —           | —                | —                          | —                               |
| 0x021        | DMAC1                    | DMAC1_INT     | ✓               | ✓          | —           | —                | —                          | —                               |
| 0x022        | DMAC2                    | DMAC2_INT     | ✓               | ✓          | —           | —                | —                          | —                               |
| 0x023        | DMAC3                    | DMAC3_INT     | ✓               | ✓          | —           | —                | —                          | —                               |
| 0x024        | DMAC4                    | DMAC4_INT     | ✓               | ✓          | —           | —                | —                          | —                               |
| 0x025        | DMAC5                    | DMAC5_INT     | ✓               | ✓          | —           | —                | —                          | —                               |
| 0x026        | DMAC6                    | DMAC6_INT     | ✓               | ✓          | —           | —                | —                          | —                               |
| 0x027        | DMAC7                    | DMAC7_INT     | ✓               | ✓          | —           | —                | —                          | —                               |
| 0x029        | DTC                      | DTC_COMPLETE  | ✓               | —          | —           | ✓ <sup>*3</sup>  | —                          | —                               |
| 0x02B        | DMAC/DTC                 | DMA_TRANSERR  | ✓               | —          | —           | ✓                | —                          | —                               |
| 0x02D        | ICU                      | ICU_SNZCANCEL | ✓               | —          | —           | ✓                | —                          | —                               |
| 0x030        | FCU                      | FCU_FIFERR    | ✓               | —          | —           | —                | —                          | —                               |
| 0x031        |                          | FCU_FRDY1     | ✓               | —          | —           | —                | —                          | —                               |
| 0x038        | LVD                      | LVD_LVD1      | ✓               | —          | —           | ✓                | ✓                          | ✓                               |
| 0x039        |                          | LVD_LVD2      | ✓               | —          | —           | ✓                | ✓                          | ✓                               |
| 0x03B        | MOSC                     | MOSC_STOP     | ✓               | —          | —           | —                | —                          | —                               |
| 0x03C        | LPW                      | SYSTEM_SNZREQ | —               | ✓          | —           | —                | —                          | —                               |
| 0x040        | AGT0                     | AGT0_AGTI     | ✓               | ✓          | ✓           | —                | —                          | —                               |
| 0x041        |                          | AGT0_AGTCMAI  | ✓               | ✓          | ✓           | —                | —                          | —                               |
| 0x042        |                          | AGT0_AGTCMBI  | ✓               | ✓          | ✓           | —                | —                          | —                               |

| Heading  | Description              |
|----------|--------------------------|
| 取消软件待机   | " "表示该中断可用于请求从软件待机模式返回   |
| 取消深度软件待机 | " "表示该中断可用于请求从深度软件待机模式返回 |

Table 13.4 事件表 (1个, 共7个)

| 事件编号  | 中断请求源    | Name          | IELSRn   |            | DELSRn      | Canceling Snooze | 取消软件待机 | 取消深度软件待机 |
|-------|----------|---------------|----------|------------|-------------|------------------|--------|----------|
|       |          |               | 连接至 NVIC | Invoke DTC | Invoke DMAC |                  |        |          |
| 0x001 | Port     | PORT_IRQ0     | ✓        | ✓          | ✓           | ✓                | ✓      | ✓        |
| 0x002 |          | PORT_IRQ1     | ✓        | ✓          | ✓           | ✓                | ✓      | ✓        |
| 0x003 |          | PORT_IRQ2     | ✓        | ✓          | ✓           | ✓                | ✓      | ✓        |
| 0x004 |          | PORT_IRQ3     | ✓        | ✓          | ✓           | ✓                | ✓      | ✓        |
| 0x005 |          | PORT_IRQ4     | ✓        | ✓          | ✓           | ✓                | ✓      | ✓        |
| 0x006 |          | PORT_IRQ5     | ✓        | ✓          | ✓           | ✓                | ✓      | ✓        |
| 0x007 |          | PORT_IRQ6     | ✓        | ✓          | ✓           | ✓                | ✓      | ✓        |
| 0x008 |          | PORT_IRQ7     | ✓        | ✓          | ✓           | ✓                | ✓      | ✓        |
| 0x009 |          | PORT_IRQ8     | ✓        | ✓          | ✓           | ✓                | ✓      | ✓        |
| 0x00A |          | PORT_IRQ9     | ✓        | ✓          | ✓           | ✓                | ✓      | ✓        |
| 0x00B |          | PORT_IRQ10    | ✓        | ✓          | ✓           | ✓                | ✓      | ✓        |
| 0x00C |          | PORT_IRQ11    | ✓        | ✓          | ✓           | ✓                | ✓      | ✓        |
| 0x00D |          | PORT_IRQ12    | ✓        | ✓          | ✓           | ✓                | ✓      | ✓        |
| 0x00E |          | PORT_IRQ13    | ✓        | ✓          | ✓           | ✓                | ✓      | ✓        |
| 0x00F |          | PORT_IRQ14    | ✓        | ✓          | ✓           | ✓                | ✓      | ✓        |
| 0x010 |          | PORT_IRQ15    | ✓        | ✓          | ✓           | ✓                | ✓      | ✓        |
| 0x020 | DMAC0    | DMAC0_INT     | ✓        | ✓          | —           | —                | —      | —        |
| 0x021 | DMAC1    | DMAC1_INT     | ✓        | ✓          | —           | —                | —      | —        |
| 0x022 | DMAC2    | DMAC2_INT     | ✓        | ✓          | —           | —                | —      | —        |
| 0x023 | DMAC3    | DMAC3_INT     | ✓        | ✓          | —           | —                | —      | —        |
| 0x024 | DMAC4    | DMAC4_INT     | ✓        | ✓          | —           | —                | —      | —        |
| 0x025 | DMAC5    | DMAC5_INT     | ✓        | ✓          | —           | —                | —      | —        |
| 0x026 | DMAC6    | DMAC6_INT     | ✓        | ✓          | —           | —                | —      | —        |
| 0x027 | DMAC7    | DMAC7_INT     | ✓        | ✓          | —           | —                | —      | —        |
| 0x029 | DTC      | DTC_COMPLETE  | ✓        | —          | —           | ✓ <sup>*3</sup>  | —      | —        |
| 0x02B | DMAC/DTC | DMA_TRANSERR  | ✓        | —          | —           | ✓                | —      | —        |
| 0x02D | ICU      | ICU_SNZCANCEL | ✓        | —          | —           | ✓                | —      | —        |
| 0x030 | FCU      | FCU_FIFERR    | ✓        | —          | —           | —                | —      | —        |
| 0x031 |          | FCU_FRDY1     | ✓        | —          | —           | —                | —      | —        |
| 0x038 | LVD      | LVD_LVD1      | ✓        | —          | —           | ✓                | ✓      | ✓        |
| 0x039 |          | LVD_LVD2      | ✓        | —          | —           | ✓                | ✓      | ✓        |
| 0x03B | MOSC     | MOSC_STOP     | ✓        | —          | —           | —                | —      | —        |
| 0x03C | LPW      | SYSTEM_SNZREQ | —        | ✓          | —           | —                | —      | —        |
| 0x040 | AGT0     | AGT0_AGTI     | ✓        | ✓          | ✓           | —                | —      | —        |
| 0x041 |          | AGT0_AGTCMAI  | ✓        | ✓          | ✓           | —                | —      | —        |
| 0x042 |          | AGT0_AGTCMBI  | ✓        | ✓          | ✓           | —                | —      | —        |

Table 13.4 Event table (2 of 7)

| Event number | Interrupt request source | Name                 | IELSRn          |            | DELSRn      | Canceling Snooze | Canceling Software Standby | Canceling Deep Software Standby |
|--------------|--------------------------|----------------------|-----------------|------------|-------------|------------------|----------------------------|---------------------------------|
|              |                          |                      | Connect to NVIC | Invoke DTC | Invoke DMAC |                  |                            |                                 |
| 0x043        | AGT1                     | AGT1_AGTI            | ✓               | ✓          | ✓           | ✓                | ✓                          | ✓                               |
| 0x044        |                          | AGT1_AGTCMAI         | ✓               | ✓          | ✓           | ✓                | ✓                          | —                               |
| 0x045        |                          | AGT1_AGTCMBI         | ✓               | ✓          | ✓           | ✓                | ✓                          | —                               |
| 0x046        | AGT2                     | AGT2_AGTI            | ✓               | ✓          | ✓           | —                | —                          | —                               |
| 0x047        |                          | AGT2_AGTCMAI         | ✓               | ✓          | ✓           | —                | —                          | —                               |
| 0x048        |                          | AGT2_AGTCMBI         | ✓               | ✓          | ✓           | —                | —                          | —                               |
| 0x049        | AGT3                     | AGT3_AGTI            | ✓               | ✓          | ✓           | ✓                | ✓                          | ✓                               |
| 0x04A        |                          | AGT3_AGTCMAI         | ✓               | ✓          | ✓           | ✓                | ✓                          | —                               |
| 0x04B        |                          | AGT3_AGTCMBI         | ✓               | ✓          | ✓           | ✓                | ✓                          | —                               |
| 0x04C        | AGT4                     | AGT4_AGTI            | ✓               | ✓          | ✓           | —                | —                          | —                               |
| 0x04D        |                          | AGT4_AGTCMAI         | ✓               | ✓          | ✓           | —                | —                          | —                               |
| 0x04E        |                          | AGT4_AGTCMBI         | ✓               | ✓          | ✓           | —                | —                          | —                               |
| 0x04F        | AGT5                     | AGT5_AGTI            | ✓               | ✓          | ✓           | —                | —                          | —                               |
| 0x050        |                          | AGT5_AGTCMAI         | ✓               | ✓          | ✓           | —                | —                          | —                               |
| 0x051        |                          | AGT5_AGTCMBI         | ✓               | ✓          | ✓           | —                | —                          | —                               |
| 0x052        | IWDT                     | IWDT_NMIUNDF         | ✓               | —          | —           | ✓                | ✓                          | —                               |
| 0x053        | WDT                      | WDT_NMIUNDF          | ✓               | —          | —           | —                | —                          | —                               |
| 0x054        | RTC                      | RTC_ALM              | ✓               | —          | —           | ✓                | ✓                          | ✓                               |
| 0x055        |                          | RTC_PRD              | ✓               | —          | —           | ✓                | ✓                          | ✓                               |
| 0x056        |                          | RTC_CUP              | ✓               | —          | —           | —                | —                          | —                               |
| 0x06B        | USBFS                    | USBFS0_D0FIFO        | ✓               | ✓          | ✓           | —                | —                          | —                               |
| 0x06C        |                          | USBFS0_D1FIFO        | ✓               | ✓          | ✓           | —                | —                          | —                               |
| 0x06D        |                          | USBFS0_USBI          | ✓               | —          | —           | —                | —                          | —                               |
| 0x06E        |                          | USBFS0_USBR          | ✓               | —          | —           | ✓                | ✓                          | ✓                               |
| 0x073        | IIC0                     | IIC0_RXI             | ✓               | ✓          | ✓           | —                | —                          | —                               |
| 0x074        |                          | IIC0_TXI             | ✓               | ✓          | ✓           | —                | —                          | —                               |
| 0x075        |                          | IIC0_TEI             | ✓               | —          | —           | —                | —                          | —                               |
| 0x076        |                          | IIC0_EEI             | ✓               | —          | —           | —                | —                          | —                               |
| 0x077        |                          | IIC0_WUI             | ✓               | —          | —           | ✓                | ✓                          | —                               |
| 0x078        | IIC1                     | IIC1_RXI             | ✓               | ✓          | ✓           | —                | —                          | —                               |
| 0x079        |                          | IIC1_TXI             | ✓               | ✓          | ✓           | —                | —                          | —                               |
| 0x07A        |                          | IIC1_TEI             | ✓               | —          | —           | —                | —                          | —                               |
| 0x07B        |                          | IIC1_EEI             | ✓               | —          | —           | —                | —                          | —                               |
| 0x082        | SDHI MMC                 | SDHI_MMC0_ACCS       | ✓               | —          | —           | —                | —                          | —                               |
| 0x083        |                          | SDHI_MMC0_SDIO       | ✓               | —          | —           | —                | —                          | —                               |
| 0x084        |                          | SDHI_MMC0_CARD       | ✓               | —          | —           | —                | —                          | —                               |
| 0x085        |                          | SDHI_MMC0_ODMSDBR EQ | —               | ✓          | ✓           | —                | —                          | —                               |

Table 13.4 事件表 (2个, 共7个)

| 事件编号  | 中断请求源    | Name                 | IELSRn   |            | DELSRn      | Canceling Snooze | 取消软件待机 | 取消深度软件待机 |
|-------|----------|----------------------|----------|------------|-------------|------------------|--------|----------|
|       |          |                      | 连接至 NVIC | Invoke DTC | Invoke DMAC |                  |        |          |
| 0x043 | AGT1     | AGT1_AGTI            | ✓        | ✓          | ✓           | ✓                | ✓      | ✓        |
| 0x044 |          | AGT1_AGTCMAI         | ✓        | ✓          | ✓           | ✓                | ✓      | —        |
| 0x045 |          | AGT1_AGTCMBI         | ✓        | ✓          | ✓           | ✓                | ✓      | —        |
| 0x046 | AGT2     | AGT2_AGTI            | ✓        | ✓          | ✓           | —                | —      | —        |
| 0x047 |          | AGT2_AGTCMAI         | ✓        | ✓          | ✓           | —                | —      | —        |
| 0x048 |          | AGT2_AGTCMBI         | ✓        | ✓          | ✓           | —                | —      | —        |
| 0x049 | AGT3     | AGT3_AGTI            | ✓        | ✓          | ✓           | ✓                | ✓      | ✓        |
| 0x04A |          | AGT3_AGTCMAI         | ✓        | ✓          | ✓           | ✓                | ✓      | —        |
| 0x04B |          | AGT3_AGTCMBI         | ✓        | ✓          | ✓           | ✓                | ✓      | —        |
| 0x04C | AGT4     | AGT4_AGTI            | ✓        | ✓          | ✓           | —                | —      | —        |
| 0x04D |          | AGT4_AGTCMAI         | ✓        | ✓          | ✓           | —                | —      | —        |
| 0x04E |          | AGT4_AGTCMBI         | ✓        | ✓          | ✓           | —                | —      | —        |
| 0x04F | AGT5     | AGT5_AGTI            | ✓        | ✓          | ✓           | —                | —      | —        |
| 0x050 |          | AGT5_AGTCMAI         | ✓        | ✓          | ✓           | —                | —      | —        |
| 0x051 |          | AGT5_AGTCMBI         | ✓        | ✓          | ✓           | —                | —      | —        |
| 0x052 | IWDT     | IWDT_NMIUNDF         | ✓        | —          | —           | ✓                | ✓      | —        |
| 0x053 | WDT      | WDT_NMIUNDF          | ✓        | —          | —           | —                | —      | —        |
| 0x054 | RTC      | RTC_ALM              | ✓        | —          | —           | ✓                | ✓      | ✓        |
| 0x055 |          | RTC_PRD              | ✓        | —          | —           | ✓                | ✓      | ✓        |
| 0x056 |          | RTC_CUP              | ✓        | —          | —           | —                | —      | —        |
| 0x06B | USBFS    | USBFS0_D0FIFO        | ✓        | ✓          | ✓           | —                | —      | —        |
| 0x06C |          | USBFS0_D1FIFO        | ✓        | ✓          | ✓           | —                | —      | —        |
| 0x06D |          | USBFS0_USBI          | ✓        | —          | —           | —                | —      | —        |
| 0x06E |          | USBFS0_USBR          | ✓        | —          | —           | ✓                | ✓      | ✓        |
| 0x073 | IIC0     | IIC0_RXI             | ✓        | ✓          | ✓           | —                | —      | —        |
| 0x074 |          | IIC0_TXI             | ✓        | ✓          | ✓           | —                | —      | —        |
| 0x075 |          | IIC0_TEI             | ✓        | —          | —           | —                | —      | —        |
| 0x076 |          | IIC0_EEI             | ✓        | —          | —           | —                | —      | —        |
| 0x077 |          | IIC0_WUI             | ✓        | —          | —           | ✓                | ✓      | —        |
| 0x078 | IIC1     | IIC1_RXI             | ✓        | ✓          | ✓           | —                | —      | —        |
| 0x079 |          | IIC1_TXI             | ✓        | ✓          | ✓           | —                | —      | —        |
| 0x07A |          | IIC1_TEI             | ✓        | —          | —           | —                | —      | —        |
| 0x07B |          | IIC1_EEI             | ✓        | —          | —           | —                | —      | —        |
| 0x082 | SDHI MMC | SDHI_MMC0_ACCS       | ✓        | —          | —           | —                | —      | —        |
| 0x083 |          | SDHI_MMC0_SDIO       | ✓        | —          | —           | —                | —      | —        |
| 0x084 |          | SDHI_MMC0_CARD       | ✓        | —          | —           | —                | —      | —        |
| 0x085 |          | SDHI_MMC0_ODMSDBR EQ | —        | ✓          | ✓           | —                | —      | —        |

Table 13.4 Event table (3 of 7)

| Event number | Interrupt request source | Name          | IELSRn          |                 | DELSRn          | Canceling Snooze | Canceling Software Standby | Canceling Deep Software Standby |
|--------------|--------------------------|---------------|-----------------|-----------------|-----------------|------------------|----------------------------|---------------------------------|
|              |                          |               | Connect to NVIC | Invoke DTC      | Invoke DMAC     |                  |                            |                                 |
| 0x08A        | SSI                      | SSI0_SSITXI   | ✓               | ✓               | ✓               | —                | —                          | —                               |
| 0x08B        |                          | SSI0_SSIRXI   | ✓               | ✓               | ✓               | —                | —                          | —                               |
| 0x08D        |                          | SSI0_SSIF     | ✓               | —               | —               | —                | —                          | —                               |
| 0x09A        | CTSU                     | CTSU_CTSUWR   | ✓               | ✓               | ✓               | —                | —                          | —                               |
| 0x09B        |                          | CTSU_CTSURD   | ✓               | ✓               | ✓               | —                | —                          | —                               |
| 0x09C        |                          | CTSU_CTSUFN   | ✓               | —               | —               | ✓ <sup>*3</sup>  | —                          | —                               |
| 0x09E        | CAC                      | CAC_FEERI     | ✓               | —               | —               | —                | —                          | —                               |
| 0x09F        |                          | CAC_MENDI     | ✓               | —               | —               | —                | —                          | —                               |
| 0x0A0        |                          | CAC_OVFI      | ✓               | —               | —               | —                | —                          | —                               |
| 0x0A1        | CAN0                     | CAN0_ERS      | ✓               | —               | —               | —                | —                          | —                               |
| 0x0A2        |                          | CAN0_RXF      | ✓               | —               | —               | —                | —                          | —                               |
| 0x0A3        |                          | CAN0_TXF      | ✓               | —               | —               | —                | —                          | —                               |
| 0x0A4        |                          | CAN0_RXM      | ✓               | —               | —               | —                | —                          | —                               |
| 0x0A5        |                          | CAN0_TXM      | ✓               | —               | —               | —                | —                          | —                               |
| 0x0A6        | CAN1                     | CAN1_ERS      | ✓               | —               | —               | —                | —                          | —                               |
| 0x0A7        |                          | CAN1_RXF      | ✓               | —               | —               | —                | —                          | —                               |
| 0x0A8        |                          | CAN1_TXF      | ✓               | —               | —               | —                | —                          | —                               |
| 0x0A9        |                          | CAN1_RXM      | ✓               | —               | —               | —                | —                          | —                               |
| 0x0AA        |                          | CAN1_TXM      | ✓               | —               | —               | —                | —                          | —                               |
| 0x0B1        | PORT                     | IOPORT_GROUP1 | ✓               | ✓ <sup>*1</sup> | ✓ <sup>*1</sup> | —                | —                          | —                               |
| 0x0B2        |                          | IOPORT_GROUP2 | ✓               | ✓ <sup>*1</sup> | ✓ <sup>*1</sup> | —                | —                          | —                               |
| 0x0B3        |                          | IOPORT_GROUP3 | ✓               | ✓ <sup>*1</sup> | ✓ <sup>*1</sup> | —                | —                          | —                               |
| 0x0B4        |                          | IOPORT_GROUP4 | ✓               | ✓ <sup>*1</sup> | ✓ <sup>*1</sup> | —                | —                          | —                               |
| 0x0B5        | ELC                      | ELC_SWEVT0    | ✓ <sup>*2</sup> | ✓               | —               | —                | —                          | —                               |
| 0x0B6        |                          | ELC_SWEVT1    | ✓ <sup>*2</sup> | ✓               | —               | —                | —                          | —                               |
| 0x0B7        | POEG                     | POEG_GROUPA   | ✓               | —               | —               | —                | —                          | —                               |
| 0x0B8        |                          | POEG_GROUPB   | ✓               | —               | —               | —                | —                          | —                               |
| 0x0B9        |                          | POEG_GROUPC   | ✓               | —               | —               | —                | —                          | —                               |
| 0x0BA        |                          | POEG_GROUPD   | ✓               | —               | —               | —                | —                          | —                               |
| 0x0C0        | GPT0                     | GPT0_CCMPA    | ✓               | ✓               | ✓               | —                | —                          | —                               |
| 0x0C1        |                          | GPT0_CCMPB    | ✓               | ✓               | ✓               | —                | —                          | —                               |
| 0x0C2        |                          | GPT0_CMPC     | ✓               | ✓               | ✓               | —                | —                          | —                               |
| 0x0C3        |                          | GPT0_CMPD     | ✓               | ✓               | ✓               | —                | —                          | —                               |
| 0x0C4        |                          | GPT0_CMPE     | ✓               | ✓               | ✓               | —                | —                          | —                               |
| 0x0C5        |                          | GPT0_CMPF     | ✓               | ✓               | ✓               | —                | —                          | —                               |
| 0x0C6        |                          | GPT0_OVF      | ✓               | ✓               | ✓               | —                | —                          | —                               |
| 0x0C7        |                          | GPT0_UDF      | ✓               | ✓               | ✓               | —                | —                          | —                               |
| 0x0C8        | GPT0_PC                  | ✓             | ✓               | ✓               | —               | —                | —                          |                                 |

Table 13.4 事件表 (3个, 共7个)

| 事件编号  | 中断请求源   | Name          | IELSRn          |                 | DELSRn          | Canceling Snooze | 取消软件待机 | 取消深度软件待机 |
|-------|---------|---------------|-----------------|-----------------|-----------------|------------------|--------|----------|
|       |         |               | 连接至 NVIC        | Invoke DTC      | Invoke DMAC     |                  |        |          |
| 0x08A | SSI     | SSI0_SSITXI   | ✓               | ✓               | ✓               | —                | —      | —        |
| 0x08B |         | SSI0_SSIRXI   | ✓               | ✓               | ✓               | —                | —      | —        |
| 0x08D |         | SSI0_SSIF     | ✓               | —               | —               | —                | —      | —        |
| 0x09A | CTSU    | CTSU_CTSUWR   | ✓               | ✓               | ✓               | —                | —      | —        |
| 0x09B |         | CTSU_CTSURD   | ✓               | ✓               | ✓               | —                | —      | —        |
| 0x09C |         | CTSU_CTSUFN   | ✓               | —               | —               | ✓ <sup>*3</sup>  | —      | —        |
| 0x09E | CAC     | CAC_FEERI     | ✓               | —               | —               | —                | —      | —        |
| 0x09F |         | CAC_MENDI     | ✓               | —               | —               | —                | —      | —        |
| 0x0A0 |         | CAC_OVFI      | ✓               | —               | —               | —                | —      | —        |
| 0x0A1 | CAN0    | CAN0_ERS      | ✓               | —               | —               | —                | —      | —        |
| 0x0A2 |         | CAN0_RXF      | ✓               | —               | —               | —                | —      | —        |
| 0x0A3 |         | CAN0_TXF      | ✓               | —               | —               | —                | —      | —        |
| 0x0A4 |         | CAN0_RXM      | ✓               | —               | —               | —                | —      | —        |
| 0x0A5 |         | CAN0_TXM      | ✓               | —               | —               | —                | —      | —        |
| 0x0A6 | CAN1    | CAN1_ERS      | ✓               | —               | —               | —                | —      | —        |
| 0x0A7 |         | CAN1_RXF      | ✓               | —               | —               | —                | —      | —        |
| 0x0A8 |         | CAN1_TXF      | ✓               | —               | —               | —                | —      | —        |
| 0x0A9 |         | CAN1_RXM      | ✓               | —               | —               | —                | —      | —        |
| 0x0AA |         | CAN1_TXM      | ✓               | —               | —               | —                | —      | —        |
| 0x0B1 | PORT    | IOPORT_GROUP1 | ✓               | ✓ <sup>*1</sup> | ✓ <sup>*1</sup> | —                | —      | —        |
| 0x0B2 |         | IOPORT_GROUP2 | ✓               | ✓ <sup>*1</sup> | ✓ <sup>*1</sup> | —                | —      | —        |
| 0x0B3 |         | IOPORT_GROUP3 | ✓               | ✓ <sup>*1</sup> | ✓ <sup>*1</sup> | —                | —      | —        |
| 0x0B4 |         | IOPORT_GROUP4 | ✓               | ✓ <sup>*1</sup> | ✓ <sup>*1</sup> | —                | —      | —        |
| 0x0B5 | ELC     | ELC_SWEVT0    | ✓ <sup>*2</sup> | ✓               | —               | —                | —      | —        |
| 0x0B6 |         | ELC_SWEVT1    | ✓ <sup>*2</sup> | ✓               | —               | —                | —      | —        |
| 0x0B7 | POEG    | POEG_GROUPA   | ✓               | —               | —               | —                | —      | —        |
| 0x0B8 |         | POEG_GROUPB   | ✓               | —               | —               | —                | —      | —        |
| 0x0B9 |         | POEG_GROUPC   | ✓               | —               | —               | —                | —      | —        |
| 0x0BA |         | POEG_GROUPD   | ✓               | —               | —               | —                | —      | —        |
| 0x0C0 | GPT0    | GPT0_CCMPA    | ✓               | ✓               | ✓               | —                | —      | —        |
| 0x0C1 |         | GPT0_CCMPB    | ✓               | ✓               | ✓               | —                | —      | —        |
| 0x0C2 |         | GPT0_CMPC     | ✓               | ✓               | ✓               | —                | —      | —        |
| 0x0C3 |         | GPT0_CMPD     | ✓               | ✓               | ✓               | —                | —      | —        |
| 0x0C4 |         | GPT0_CMPE     | ✓               | ✓               | ✓               | —                | —      | —        |
| 0x0C5 |         | GPT0_CMPF     | ✓               | ✓               | ✓               | —                | —      | —        |
| 0x0C6 |         | GPT0_OVF      | ✓               | ✓               | ✓               | —                | —      | —        |
| 0x0C7 |         | GPT0_UDF      | ✓               | ✓               | ✓               | —                | —      | —        |
| 0x0C8 | GPT0_PC | ✓             | ✓               | ✓               | —               | —                | —      |          |



Table 13.4 Event table (4 of 7)

| Event number | Interrupt request source | Name       | IELSRn          |            | DELSRn      | Canceling Snooze | Canceling Software Standby | Canceling Deep Software Standby |
|--------------|--------------------------|------------|-----------------|------------|-------------|------------------|----------------------------|---------------------------------|
|              |                          |            | Connect to NVIC | Invoke DTC | Invoke DMAC |                  |                            |                                 |
| 0x0C9        | GPT1                     | GPT1_CCMPA | ✓               | ✓          | ✓           | —                | —                          | —                               |
| 0x0CA        |                          | GPT1_CCMPB | ✓               | ✓          | ✓           | —                | —                          | —                               |
| 0x0CB        |                          | GPT1_CMPC  | ✓               | ✓          | ✓           | —                | —                          | —                               |
| 0x0CC        |                          | GPT1_CMPD  | ✓               | ✓          | ✓           | —                | —                          | —                               |
| 0x0CD        |                          | GPT1_CMPE  | ✓               | ✓          | ✓           | —                | —                          | —                               |
| 0x0CE        |                          | GPT1_CMPF  | ✓               | ✓          | ✓           | —                | —                          | —                               |
| 0x0CF        |                          | GPT1_OVF   | ✓               | ✓          | ✓           | —                | —                          | —                               |
| 0x0D0        |                          | GPT1_UDF   | ✓               | ✓          | ✓           | —                | —                          | —                               |
| 0x0D1        |                          | GPT1_PC    | ✓               | ✓          | ✓           | —                | —                          | —                               |
| 0x0D2        |                          | GPT2       | GPT2_CCMPA      | ✓          | ✓           | ✓                | —                          | —                               |
| 0x0D3        | GPT2_CCMPB               |            | ✓               | ✓          | ✓           | —                | —                          | —                               |
| 0x0D4        | GPT2_CMPC                |            | ✓               | ✓          | ✓           | —                | —                          | —                               |
| 0x0D5        | GPT2_CMPD                |            | ✓               | ✓          | ✓           | —                | —                          | —                               |
| 0x0D6        | GPT2_CMPE                |            | ✓               | ✓          | ✓           | —                | —                          | —                               |
| 0x0D7        | GPT2_CMPF                |            | ✓               | ✓          | ✓           | —                | —                          | —                               |
| 0x0D8        | GPT2_OVF                 |            | ✓               | ✓          | ✓           | —                | —                          | —                               |
| 0x0D9        | GPT2_UDF                 |            | ✓               | ✓          | ✓           | —                | —                          | —                               |
| 0x0DB        | GPT3                     | GPT3_CCMPA | ✓               | ✓          | ✓           | —                | —                          | —                               |
| 0x0DC        |                          | GPT3_CCMPB | ✓               | ✓          | ✓           | —                | —                          | —                               |
| 0x0DD        |                          | GPT3_CMPC  | ✓               | ✓          | ✓           | —                | —                          | —                               |
| 0x0DE        |                          | GPT3_CMPD  | ✓               | ✓          | ✓           | —                | —                          | —                               |
| 0x0DF        |                          | GPT3_CMPE  | ✓               | ✓          | ✓           | —                | —                          | —                               |
| 0x0E0        |                          | GPT3_CMPF  | ✓               | ✓          | ✓           | —                | —                          | —                               |
| 0x0E1        |                          | GPT3_OVF   | ✓               | ✓          | ✓           | —                | —                          | —                               |
| 0x0E2        | GPT3_UDF                 | ✓          | ✓               | ✓          | —           | —                | —                          |                                 |
| 0x0E4        | GPT4                     | GPT4_CCMPA | ✓               | ✓          | ✓           | —                | —                          | —                               |
| 0x0E5        |                          | GPT4_CCMPB | ✓               | ✓          | ✓           | —                | —                          | —                               |
| 0x0E6        |                          | GPT4_CMPC  | ✓               | ✓          | ✓           | —                | —                          | —                               |
| 0x0E7        |                          | GPT4_CMPD  | ✓               | ✓          | ✓           | —                | —                          | —                               |
| 0x0E8        |                          | GPT4_CMPE  | ✓               | ✓          | ✓           | —                | —                          | —                               |
| 0x0E9        |                          | GPT4_CMPF  | ✓               | ✓          | ✓           | —                | —                          | —                               |
| 0x0EA        |                          | GPT4_OVF   | ✓               | ✓          | ✓           | —                | —                          | —                               |
| 0x0EB        |                          | GPT4_UDF   | ✓               | ✓          | ✓           | —                | —                          | —                               |
| 0x0EC        |                          | GPT4_PC    | ✓               | ✓          | ✓           | —                | —                          | —                               |

Table 13.4 事件表 (4个, 共7个)

| 事件编号  | 中断请求源      | Name       | IELSRn     |            | DELSRn      | Canceling Snooze | 取消软件待机 | 取消深度软件待机 |
|-------|------------|------------|------------|------------|-------------|------------------|--------|----------|
|       |            |            | 连接至 NVIC   | Invoke DTC | Invoke DMAC |                  |        |          |
| 0x0C9 | GPT1       | GPT1_CCMPA | ✓          | ✓          | ✓           | —                | —      | —        |
| 0x0CA |            | GPT1_CCMPB | ✓          | ✓          | ✓           | —                | —      | —        |
| 0x0CB |            | GPT1_CMPC  | ✓          | ✓          | ✓           | —                | —      | —        |
| 0x0CC |            | GPT1_CMPD  | ✓          | ✓          | ✓           | —                | —      | —        |
| 0x0CD |            | GPT1_CMPE  | ✓          | ✓          | ✓           | —                | —      | —        |
| 0x0CE |            | GPT1_CMPF  | ✓          | ✓          | ✓           | —                | —      | —        |
| 0x0CF |            | GPT1_OVF   | ✓          | ✓          | ✓           | —                | —      | —        |
| 0x0D0 |            | GPT1_UDF   | ✓          | ✓          | ✓           | —                | —      | —        |
| 0x0D1 |            | GPT1_PC    | ✓          | ✓          | ✓           | —                | —      | —        |
| 0x0D2 |            | GPT2       | GPT2_CCMPA | ✓          | ✓           | ✓                | —      | —        |
| 0x0D3 | GPT2_CCMPB |            | ✓          | ✓          | ✓           | —                | —      | —        |
| 0x0D4 | GPT2_CMPC  |            | ✓          | ✓          | ✓           | —                | —      | —        |
| 0x0D5 | GPT2_CMPD  |            | ✓          | ✓          | ✓           | —                | —      | —        |
| 0x0D6 | GPT2_CMPE  |            | ✓          | ✓          | ✓           | —                | —      | —        |
| 0x0D7 | GPT2_CMPF  |            | ✓          | ✓          | ✓           | —                | —      | —        |
| 0x0D8 | GPT2_OVF   |            | ✓          | ✓          | ✓           | —                | —      | —        |
| 0x0D9 | GPT2_UDF   |            | ✓          | ✓          | ✓           | —                | —      | —        |
| 0x0DB | GPT3       | GPT3_CCMPA | ✓          | ✓          | ✓           | —                | —      | —        |
| 0x0DC |            | GPT3_CCMPB | ✓          | ✓          | ✓           | —                | —      | —        |
| 0x0DD |            | GPT3_CMPC  | ✓          | ✓          | ✓           | —                | —      | —        |
| 0x0DE |            | GPT3_CMPD  | ✓          | ✓          | ✓           | —                | —      | —        |
| 0x0DF |            | GPT3_CMPE  | ✓          | ✓          | ✓           | —                | —      | —        |
| 0x0E0 |            | GPT3_CMPF  | ✓          | ✓          | ✓           | —                | —      | —        |
| 0x0E1 |            | GPT3_OVF   | ✓          | ✓          | ✓           | —                | —      | —        |
| 0x0E2 | GPT3_UDF   | ✓          | ✓          | ✓          | —           | —                | —      |          |
| 0x0E4 | GPT4       | GPT4_CCMPA | ✓          | ✓          | ✓           | —                | —      | —        |
| 0x0E5 |            | GPT4_CCMPB | ✓          | ✓          | ✓           | —                | —      | —        |
| 0x0E6 |            | GPT4_CMPC  | ✓          | ✓          | ✓           | —                | —      | —        |
| 0x0E7 |            | GPT4_CMPD  | ✓          | ✓          | ✓           | —                | —      | —        |
| 0x0E8 |            | GPT4_CMPE  | ✓          | ✓          | ✓           | —                | —      | —        |
| 0x0E9 |            | GPT4_CMPF  | ✓          | ✓          | ✓           | —                | —      | —        |
| 0x0EA |            | GPT4_OVF   | ✓          | ✓          | ✓           | —                | —      | —        |
| 0x0EB |            | GPT4_UDF   | ✓          | ✓          | ✓           | —                | —      | —        |
| 0x0EC |            | GPT4_PC    | ✓          | ✓          | ✓           | —                | —      | —        |

Table 13.4 Event table (5 of 7)

| Event number | Interrupt request source | Name          | IELSRn          |            | DELSRn      | Canceling Snooze | Canceling Software Standby | Canceling Deep Software Standby |
|--------------|--------------------------|---------------|-----------------|------------|-------------|------------------|----------------------------|---------------------------------|
|              |                          |               | Connect to NVIC | Invoke DTC | Invoke DMAC |                  |                            |                                 |
| 0x0ED        | GPT5                     | GPT5_CCMPA    | ✓               | ✓          | ✓           | —                | —                          | —                               |
| 0x0EE        |                          | GPT5_CCMPB    | ✓               | ✓          | ✓           | —                | —                          | —                               |
| 0x0EF        |                          | GPT5_CMPC     | ✓               | ✓          | ✓           | —                | —                          | —                               |
| 0x0F0        |                          | GPT5_CMPD     | ✓               | ✓          | ✓           | —                | —                          | —                               |
| 0x0F1        |                          | GPT5_CMPE     | ✓               | ✓          | ✓           | —                | —                          | —                               |
| 0x0F2        |                          | GPT5_CMPF     | ✓               | ✓          | ✓           | —                | —                          | —                               |
| 0x0F3        |                          | GPT5_OVF      | ✓               | ✓          | ✓           | —                | —                          | —                               |
| 0x0F4        |                          | GPT5_UDF      | ✓               | ✓          | ✓           | —                | —                          | —                               |
| 0x0F5        |                          | GPT5_PC       | ✓               | ✓          | ✓           | —                | —                          | —                               |
| 0x0F6        |                          | GPT6          | GPT6_CCMPA      | ✓          | ✓           | ✓                | —                          | —                               |
| 0x0F7        | GPT6_CCMPB               |               | ✓               | ✓          | ✓           | —                | —                          | —                               |
| 0x0F8        | GPT6_CMPC                |               | ✓               | ✓          | ✓           | —                | —                          | —                               |
| 0x0F9        | GPT6_CMPD                |               | ✓               | ✓          | ✓           | —                | —                          | —                               |
| 0x0FA        | GPT6_CMPE                |               | ✓               | ✓          | ✓           | —                | —                          | —                               |
| 0x0FB        | GPT6_CMPF                |               | ✓               | ✓          | ✓           | —                | —                          | —                               |
| 0x0FC        | GPT6_OVF                 |               | ✓               | ✓          | ✓           | —                | —                          | —                               |
| 0x0FD        | GPT6_UDF                 |               | ✓               | ✓          | ✓           | —                | —                          | —                               |
| 0x0FE        | GPT6_PC                  |               | ✓               | ✓          | ✓           | —                | —                          | —                               |
| 0x0FF        | GPT7                     |               | GPT7_CCMPA      | ✓          | ✓           | ✓                | —                          | —                               |
| 0x100        |                          | GPT7_CCMPB    | ✓               | ✓          | ✓           | —                | —                          | —                               |
| 0x101        |                          | GPT7_CMPC     | ✓               | ✓          | ✓           | —                | —                          | —                               |
| 0x102        |                          | GPT7_CMPD     | ✓               | ✓          | ✓           | —                | —                          | —                               |
| 0x103        |                          | GPT7_CMPE     | ✓               | ✓          | ✓           | —                | —                          | —                               |
| 0x104        |                          | GPT7_CMPF     | ✓               | ✓          | ✓           | —                | —                          | —                               |
| 0x105        |                          | GPT7_OVF      | ✓               | ✓          | ✓           | —                | —                          | —                               |
| 0x106        |                          | GPT7_UDF      | ✓               | ✓          | ✓           | —                | —                          | —                               |
| 0x150        | GPT                      | GPT_UVWEDGE   | ✓               | —          | —           | —                | —                          | —                               |
| 0x160        | ADC120                   | ADC120_ADI    | ✓               | ✓          | ✓           | —                | —                          | —                               |
| 0x161        |                          | ADC120_GBADI  | ✓               | ✓          | ✓           | —                | —                          | —                               |
| 0x162        |                          | ADC120_CMPAI  | ✓               | —          | —           | —                | —                          | —                               |
| 0x163        |                          | ADC120_CMPBI  | ✓               | —          | —           | —                | —                          | —                               |
| 0x164        |                          | ADC120_WCMPPM | —               | ✓          | ✓           | ✓ <sup>*3</sup>  | —                          | —                               |
| 0x165        |                          | ADC120_WCMPUM | —               | ✓          | ✓           | ✓ <sup>*3</sup>  | —                          | —                               |
| 0x166        | ADC121                   | ADC121_ADII   | ✓               | ✓          | ✓           | —                | —                          | —                               |
| 0x167        |                          | ADC121_GBADI  | ✓               | ✓          | ✓           | —                | —                          | —                               |
| 0x168        |                          | ADC121_CMPAI  | ✓               | —          | —           | —                | —                          | —                               |
| 0x169        |                          | ADC121_CMPBI  | ✓               | —          | —           | —                | —                          | —                               |
| 0x16A        |                          | ADC121_WCMPPM | —               | ✓          | ✓           | ✓ <sup>*3</sup>  | —                          | —                               |
| 0x16B        |                          | ADC121_WCMPUM | —               | ✓          | ✓           | ✓ <sup>*3</sup>  | —                          | —                               |

Table 13.4 事件表 (5个, 共7个)

| 事件编号  | 中断请求源      | Name          | IELSRn     |            | DELSRn      | Canceling Snooze | 取消软件待机 | 取消深度软件待机 |
|-------|------------|---------------|------------|------------|-------------|------------------|--------|----------|
|       |            |               | 连接至 NVIC   | Invoke DTC | Invoke DMAC |                  |        |          |
| 0x0ED | GPT5       | GPT5_CCMPA    | ✓          | ✓          | ✓           | —                | —      | —        |
| 0x0EE |            | GPT5_CCMPB    | ✓          | ✓          | ✓           | —                | —      | —        |
| 0x0EF |            | GPT5_CMPC     | ✓          | ✓          | ✓           | —                | —      | —        |
| 0x0F0 |            | GPT5_CMPD     | ✓          | ✓          | ✓           | —                | —      | —        |
| 0x0F1 |            | GPT5_CMPE     | ✓          | ✓          | ✓           | —                | —      | —        |
| 0x0F2 |            | GPT5_CMPF     | ✓          | ✓          | ✓           | —                | —      | —        |
| 0x0F3 |            | GPT5_OVF      | ✓          | ✓          | ✓           | —                | —      | —        |
| 0x0F4 |            | GPT5_UDF      | ✓          | ✓          | ✓           | —                | —      | —        |
| 0x0F5 |            | GPT5_PC       | ✓          | ✓          | ✓           | —                | —      | —        |
| 0x0F6 |            | GPT6          | GPT6_CCMPA | ✓          | ✓           | ✓                | —      | —        |
| 0x0F7 | GPT6_CCMPB |               | ✓          | ✓          | ✓           | —                | —      | —        |
| 0x0F8 | GPT6_CMPC  |               | ✓          | ✓          | ✓           | —                | —      | —        |
| 0x0F9 | GPT6_CMPD  |               | ✓          | ✓          | ✓           | —                | —      | —        |
| 0x0FA | GPT6_CMPE  |               | ✓          | ✓          | ✓           | —                | —      | —        |
| 0x0FB | GPT6_CMPF  |               | ✓          | ✓          | ✓           | —                | —      | —        |
| 0x0FC | GPT6_OVF   |               | ✓          | ✓          | ✓           | —                | —      | —        |
| 0x0FD | GPT6_UDF   |               | ✓          | ✓          | ✓           | —                | —      | —        |
| 0x0FE | GPT6_PC    |               | ✓          | ✓          | ✓           | —                | —      | —        |
| 0x0FF | GPT7       |               | GPT7_CCMPA | ✓          | ✓           | ✓                | —      | —        |
| 0x100 |            | GPT7_CCMPB    | ✓          | ✓          | ✓           | —                | —      | —        |
| 0x101 |            | GPT7_CMPC     | ✓          | ✓          | ✓           | —                | —      | —        |
| 0x102 |            | GPT7_CMPD     | ✓          | ✓          | ✓           | —                | —      | —        |
| 0x103 |            | GPT7_CMPE     | ✓          | ✓          | ✓           | —                | —      | —        |
| 0x104 |            | GPT7_CMPF     | ✓          | ✓          | ✓           | —                | —      | —        |
| 0x105 |            | GPT7_OVF      | ✓          | ✓          | ✓           | —                | —      | —        |
| 0x106 |            | GPT7_UDF      | ✓          | ✓          | ✓           | —                | —      | —        |
| 0x150 | GPT        | GPT_UVWEDGE   | ✓          | —          | —           | —                | —      | —        |
| 0x160 | ADC120     | ADC120_ADI    | ✓          | ✓          | ✓           | —                | —      | —        |
| 0x161 |            | ADC120_GBADI  | ✓          | ✓          | ✓           | —                | —      | —        |
| 0x162 |            | ADC120_CMPAI  | ✓          | —          | —           | —                | —      | —        |
| 0x163 |            | ADC120_CMPBI  | ✓          | —          | —           | —                | —      | —        |
| 0x164 |            | ADC120_WCMPPM | —          | ✓          | ✓           | ✓ <sup>*3</sup>  | —      | —        |
| 0x165 |            | ADC120_WCMPUM | —          | ✓          | ✓           | ✓ <sup>*3</sup>  | —      | —        |
| 0x166 | ADC121     | ADC121_ADII   | ✓          | ✓          | ✓           | —                | —      | —        |
| 0x167 |            | ADC121_GBADI  | ✓          | ✓          | ✓           | —                | —      | —        |
| 0x168 |            | ADC121_CMPAI  | ✓          | —          | —           | —                | —      | —        |
| 0x169 |            | ADC121_CMPBI  | ✓          | —          | —           | —                | —      | —        |
| 0x16A |            | ADC121_WCMPPM | —          | ✓          | ✓           | ✓ <sup>*3</sup>  | —      | —        |
| 0x16B |            | ADC121_WCMPUM | —          | ✓          | ✓           | ✓ <sup>*3</sup>  | —      | —        |

Table 13.4 Event table (6 of 7)

| Event number | Interrupt request source | Name            | IELSRn          |            | DELSRn      | Canceling Snooze | Canceling Software Standby | Canceling Deep Software Standby |
|--------------|--------------------------|-----------------|-----------------|------------|-------------|------------------|----------------------------|---------------------------------|
|              |                          |                 | Connect to NVIC | Invoke DTC | Invoke DMAC |                  |                            |                                 |
| 0x180        | SCI0                     | SCI0_RXI        | ✓               | ✓          | ✓           | —                | —                          | —                               |
| 0x181        |                          | SCI0_TXI        | ✓               | ✓          | ✓           | —                | —                          | —                               |
| 0x182        |                          | SCI0_TEI        | ✓               | —          | —           | —                | —                          | —                               |
| 0x183        |                          | SCI0_ERI        | ✓               | —          | —           | —                | —                          | —                               |
| 0x184        |                          | SCI0_AM         | ✓               | —          | —           | ✓*3              | —                          | —                               |
| 0x185        |                          | SCI0_RXI_OR_ERI | —               | —          | —           | ✓*3              | —                          | —                               |
| 0x186        | SCI1                     | SCI1_RXI        | ✓               | ✓          | ✓           | —                | —                          | —                               |
| 0x187        |                          | SCI1_TXI        | ✓               | ✓          | ✓           | —                | —                          | —                               |
| 0x188        |                          | SCI1_TEI        | ✓               | —          | —           | —                | —                          | —                               |
| 0x189        |                          | SCI1_ERI        | ✓               | —          | —           | —                | —                          | —                               |
| 0x18C        | SCI2                     | SCI2_RXI        | ✓               | ✓          | ✓           | —                | —                          | —                               |
| 0x18D        |                          | SCI2_TXI        | ✓               | ✓          | ✓           | —                | —                          | —                               |
| 0x18E        |                          | SCI2_TEI        | ✓               | —          | —           | —                | —                          | —                               |
| 0x18F        |                          | SCI2_ERI        | ✓               | —          | —           | —                | —                          | —                               |
| 0x192        | SCI3                     | SCI3_RXI        | ✓               | ✓          | ✓           | —                | —                          | —                               |
| 0x193        |                          | SCI3_TXI        | ✓               | ✓          | ✓           | —                | —                          | —                               |
| 0x194        |                          | SCI3_TEI        | ✓               | —          | —           | —                | —                          | —                               |
| 0x195        |                          | SCI3_ERI        | ✓               | —          | —           | —                | —                          | —                               |
| 0x196        |                          | SCI3_AM         | ✓               | —          | —           | —                | —                          | —                               |
| 0x198        | SCI4                     | SCI4_RXI        | ✓               | ✓          | ✓           | —                | —                          | —                               |
| 0x199        |                          | SCI4_TXI        | ✓               | ✓          | ✓           | —                | —                          | —                               |
| 0x19A        |                          | SCI4_TEI        | ✓               | —          | —           | —                | —                          | —                               |
| 0x19B        |                          | SCI4_ERI        | ✓               | —          | —           | —                | —                          | —                               |
| 0x19C        |                          | SCI4_AM         | ✓               | —          | —           | —                | —                          | —                               |
| 0x1B6        | SCI9                     | SCI9_RXI        | ✓               | ✓          | ✓           | —                | —                          | —                               |
| 0x1B7        |                          | SCI9_TXI        | ✓               | ✓          | ✓           | —                | —                          | —                               |
| 0x1B8        |                          | SCI9_TEI        | ✓               | —          | —           | —                | —                          | —                               |
| 0x1B9        |                          | SCI9_ERI        | ✓               | —          | —           | —                | —                          | —                               |
| 0x1BA        |                          | SCI9_AM         | ✓               | —          | —           | —                | —                          | —                               |
| 0x1BC        | SCIX0                    | SCIX0_SCIX0     | ✓               | —          | —           | —                | —                          | —                               |
| 0x1BD        |                          | SCIX0_SCIX1     | ✓               | —          | —           | —                | —                          | —                               |
| 0x1BE        |                          | SCIX0_SCIX2     | ✓               | —          | —           | —                | —                          | —                               |
| 0x1BF        |                          | SCIX0_SCIX3     | ✓               | —          | —           | —                | —                          | —                               |
| 0x1C0        | SCIX1                    | SCIX1_SCIX0     | ✓               | —          | —           | —                | —                          | —                               |
| 0x1C1        |                          | SCIX1_SCIX1     | ✓               | —          | —           | —                | —                          | —                               |
| 0x1C2        |                          | SCIX1_SCIX2     | ✓               | —          | —           | —                | —                          | —                               |
| 0x1C3        |                          | SCIX1_SCIX3     | ✓               | —          | —           | —                | —                          | —                               |

Table 13.4 事件表 (6个, 共7个)

| 事件编号  | 中断请求源 | Name            | IELSRn   |            | DELSRn      | Canceling Snooze | 取消软件待机 | 取消深度软件待机 |
|-------|-------|-----------------|----------|------------|-------------|------------------|--------|----------|
|       |       |                 | 连接至 NVIC | Invoke DTC | Invoke DMAC |                  |        |          |
| 0x180 | SCI0  | SCI0_RXI        | ✓        | ✓          | ✓           | —                | —      | —        |
| 0x181 |       | SCI0_TXI        | ✓        | ✓          | ✓           | —                | —      | —        |
| 0x182 |       | SCI0_TEI        | ✓        | —          | —           | —                | —      | —        |
| 0x183 |       | SCI0_ERI        | ✓        | —          | —           | —                | —      | —        |
| 0x184 |       | SCI0_AM         | ✓        | —          | —           | ✓*3              | —      | —        |
| 0x185 |       | SCI0_RXI_OR_ERI | —        | —          | —           | ✓*3              | —      | —        |
| 0x186 | SCI1  | SCI1_RXI        | ✓        | ✓          | ✓           | —                | —      | —        |
| 0x187 |       | SCI1_TXI        | ✓        | ✓          | ✓           | —                | —      | —        |
| 0x188 |       | SCI1_TEI        | ✓        | —          | —           | —                | —      | —        |
| 0x189 |       | SCI1_ERI        | ✓        | —          | —           | —                | —      | —        |
| 0x18C | SCI2  | SCI2_RXI        | ✓        | ✓          | ✓           | —                | —      | —        |
| 0x18D |       | SCI2_TXI        | ✓        | ✓          | ✓           | —                | —      | —        |
| 0x18E |       | SCI2_TEI        | ✓        | —          | —           | —                | —      | —        |
| 0x18F |       | SCI2_ERI        | ✓        | —          | —           | —                | —      | —        |
| 0x192 | SCI3  | SCI3_RXI        | ✓        | ✓          | ✓           | —                | —      | —        |
| 0x193 |       | SCI3_TXI        | ✓        | ✓          | ✓           | —                | —      | —        |
| 0x194 |       | SCI3_TEI        | ✓        | —          | —           | —                | —      | —        |
| 0x195 |       | SCI3_ERI        | ✓        | —          | —           | —                | —      | —        |
| 0x196 |       | SCI3_AM         | ✓        | —          | —           | —                | —      | —        |
| 0x198 | SCI4  | SCI4_RXI        | ✓        | ✓          | ✓           | —                | —      | —        |
| 0x199 |       | SCI4_TXI        | ✓        | ✓          | ✓           | —                | —      | —        |
| 0x19A |       | SCI4_TEI        | ✓        | —          | —           | —                | —      | —        |
| 0x19B |       | SCI4_ERI        | ✓        | —          | —           | —                | —      | —        |
| 0x19C |       | SCI4_AM         | ✓        | —          | —           | —                | —      | —        |
| 0x1B6 | SCI9  | SCI9_RXI        | ✓        | ✓          | ✓           | —                | —      | —        |
| 0x1B7 |       | SCI9_TXI        | ✓        | ✓          | ✓           | —                | —      | —        |
| 0x1B8 |       | SCI9_TEI        | ✓        | —          | —           | —                | —      | —        |
| 0x1B9 |       | SCI9_ERI        | ✓        | —          | —           | —                | —      | —        |
| 0x1BA |       | SCI9_AM         | ✓        | —          | —           | —                | —      | —        |
| 0x1BC | SCIX0 | SCIX0_SCIX0     | ✓        | —          | —           | —                | —      | —        |
| 0x1BD |       | SCIX0_SCIX1     | ✓        | —          | —           | —                | —      | —        |
| 0x1BE |       | SCIX0_SCIX2     | ✓        | —          | —           | —                | —      | —        |
| 0x1BF |       | SCIX0_SCIX3     | ✓        | —          | —           | —                | —      | —        |
| 0x1C0 | SCIX1 | SCIX1_SCIX0     | ✓        | —          | —           | —                | —      | —        |
| 0x1C1 |       | SCIX1_SCIX1     | ✓        | —          | —           | —                | —      | —        |
| 0x1C2 |       | SCIX1_SCIX2     | ✓        | —          | —           | —                | —      | —        |
| 0x1C3 |       | SCIX1_SCIX3     | ✓        | —          | —           | —                | —      | —        |

Table 13.4 Event table (7 of 7)

| Event number | Interrupt request source | Name        | IELSRn          |            | DELSRn      | Canceling Snooze | Canceling Software Standby | Canceling Deep Software Standby |
|--------------|--------------------------|-------------|-----------------|------------|-------------|------------------|----------------------------|---------------------------------|
|              |                          |             | Connect to NVIC | Invoke DTC | Invoke DMAC |                  |                            |                                 |
| 0x1C4        | SPI0                     | SPI0_SPRI   | ✓               | ✓          | ✓           | —                | —                          | —                               |
| 0x1C5        |                          | SPI0_SPTI   | ✓               | ✓          | ✓           | —                | —                          | —                               |
| 0x1C6        |                          | SPI0_SPII   | ✓               | —          | —           | —                | —                          | —                               |
| 0x1C7        |                          | SPI0_SPEI   | ✓               | —          | —           | —                | —                          | —                               |
| 0x1C8        |                          | SPI0_SPCEND | ✓               | —          | —           | —                | —                          | —                               |
| 0x1DA        | QSPI                     | QSPI_INTR   | ✓               | —          | —           | —                | —                          | —                               |
| 0x1DB        | DOC                      | DOC_DOPCI   | ✓               | —          | —           | ✓ <sup>*3</sup>  | —                          | —                               |

Note 1. Only the first edge detection is valid.

Note 2. Only interrupts after DTC transfer are supported.

Note 3. Using SELSR0.

## 13.4 Interrupt Operation

The ICU performs the following functions:

- Detecting interrupts
- Enabling and disabling interrupts
- Selecting interrupt request destinations such as CPU interrupt, DTC activation, and DMAC activation.

### 13.4.1 Detecting Interrupts

The ICU selects an event source input from a peripheral function interrupt or an external pin interrupt with IELSRn.IELS[8:0].

The accepted interrupt source sets the IELSRn.IR to 1 and sends an interrupt request to the NVIC.

External pin interrupt requests are detected by either:

- Edges (falling edge, rising edge, or rising and falling edges)
- Level (low level) of the interrupt signal.

Set the IRQCRi.IRQMD[1:0] bits to select the detection mode for the IRQi pins. For interrupt sources associated with peripheral modules, see [Table 13.3](#) and [Table 13.4](#). Events must be accepted by the NVIC before an interrupt occurs and is accepted by the CPU.

Table 13.4 事件表 (7个中的7个)

| 事件编号  | 中断请求源 | Name        | IELSRn   |            | DELSRn      | Canceling Snooze | 取消软件待机 | 取消深度软件待机 |
|-------|-------|-------------|----------|------------|-------------|------------------|--------|----------|
|       |       |             | 连接至 NVIC | Invoke DTC | Invoke DMAC |                  |        |          |
| 0x1C4 | SPI0  | SPI0_SPRI   | ✓        | ✓          | ✓           | —                | —      | —        |
| 0x1C5 |       | SPI0_SPTI   | ✓        | ✓          | ✓           | —                | —      | —        |
| 0x1C6 |       | SPI0_SPII   | ✓        | —          | —           | —                | —      | —        |
| 0x1C7 |       | SPI0_SPEI   | ✓        | —          | —           | —                | —      | —        |
| 0x1C8 |       | SPI0_SPCEND | ✓        | —          | —           | —                | —      | —        |
| 0x1DA | QSPI  | QSPI_INTR   | ✓        | —          | —           | —                | —      | —        |
| 0x1DB | DOC   | DOC_DOPCI   | ✓        | —          | —           | ✓ <sup>*3</sup>  | —      | —        |

注1.只有第一个边缘检测有效。

注2.仅支持DTC传输后的中断。

注3.使用SELSR0。

## 13.4 中断操作

ICU执行以下功能：

- 检测中断
- 启用和禁用中断
- 选择中断请求目标，例如CPU中断、DTC激活和DMAC激活。

### 13.4.1 检测中断

ICU通过IELSRn.IELS[8:0]从外围功能中断或外部引脚中断选择事件源输入。

接受的中断源将IELSRn.IR设置为1，并向NVIC发送中断请求。

外部引脚中断请求通过以下任一方式检测：

- 边沿（下降沿、上升沿或上升沿和下降沿）
- 中断信号的电平（低电平）。

设置IRQCRi.IRQMD[1:0]位以选择IRQi引脚的检测模式。对于与外围模块相关的中断源，请参见表13.3和表13.4。事件必须在中断发生之前被NVIC接受并被CPU接受。

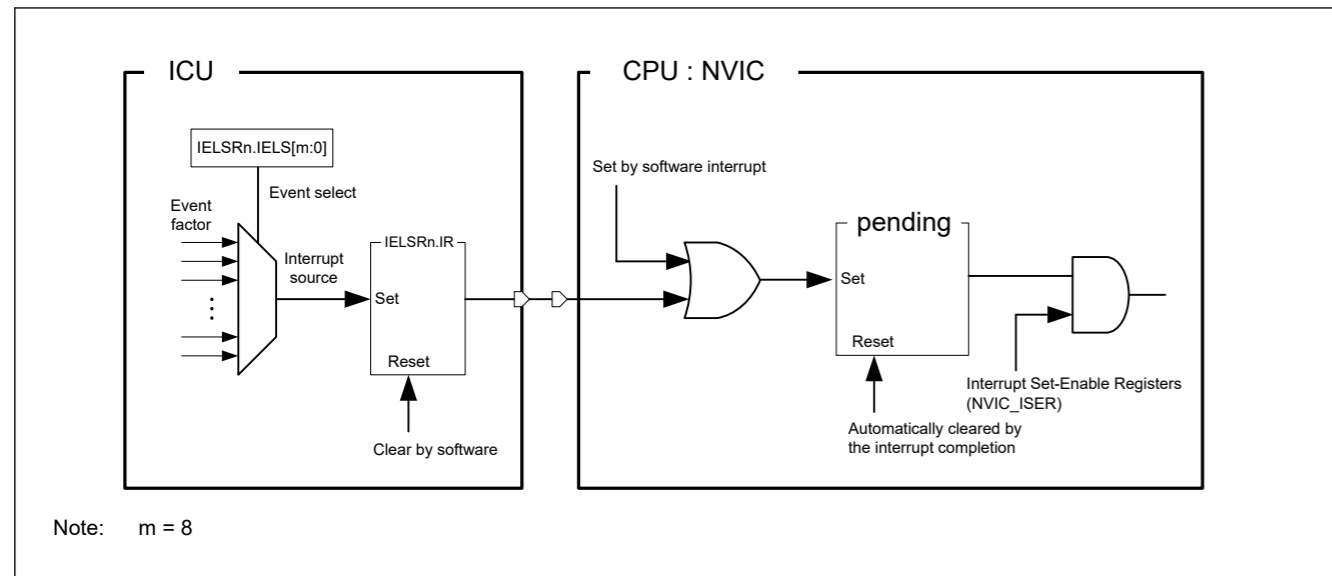


Figure 13.2 Interrupt path of the ICU and CPU (NVIC)

## 13.5 Interrupt setting procedure

### 13.5.1 Enabling Interrupt Requests

The procedure for enabling an interrupt request is as follows:

1. Set the Interrupt Set-Enable register (NVIC\_ISER).
2. Set the IELSRn.IELS[8:0] bits as the interrupt source.
3. Specify the operation settings for the event source, such as DMAC activation (DELSRn.DELS[8:0]), snooze mode cancellation (SELSR0.SELS[8:0]), software standby mode cancellation (WUPEN register setting).

### 13.5.2 Disabling Interrupt Requests

The procedure to disable the interrupt request is as follows:

1. Disable the operation settings for the event source, such as DMAC activation (DELSRn.DELS[8:0]), snooze mode cancellation (SELSR0.SELS[8:0]), software standby mode cancellation (WUPEN register setting).
2. Clear the interrupt source setting (IELSRn.IELS[8:0] = 0x00).
3. Clear the interrupt status flag (IELSRn.IR = 0).
4. Clear the interrupt Clear-Enable register (NVIC\_ICER) and interrupt Clear-Pending register (NVIC\_ICPR).

### 13.5.3 Polling for interrupts

The procedure for polling for interrupt requests is as follows:

1. Set the Interrupt Clear-Enable register (NVIC\_ICER).
2. Set the IELSRn.IELS[8:0] bits as the interrupt source.
3. Specify the operation settings for the event source, such as DMAC activation (DELSRn.DELS[8:0]), snooze mode cancellation (SELSR0.SELS[8:0]), software standby mode cancellation (WUPEN register setting).
4. Poll the interrupt Set-Pending register (NVIC\_ISPR).

### 13.5.4 Selecting Interrupt Request Destinations

The available destinations are fixed for each interrupt, as described in [Table 13.3](#), [Table 13.4](#).

The interrupt output destination, CPU, DMAC, or DTC can be independently selected for each interrupt source.

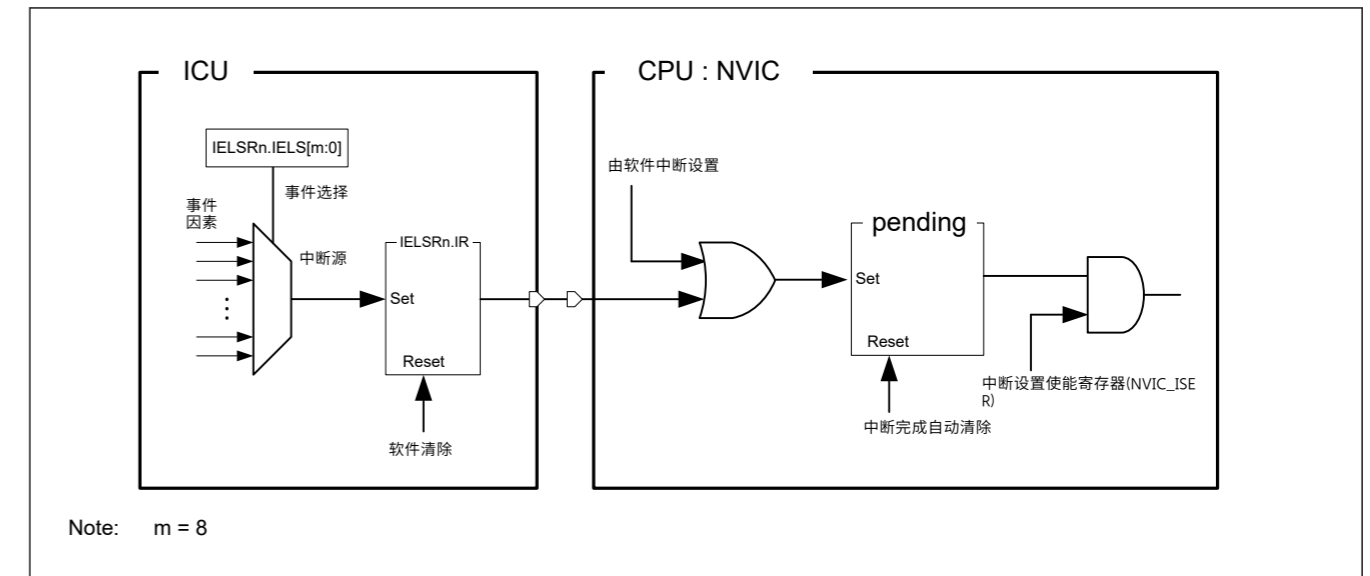


Figure 13.2 ICU和CPU(NVIC)的中断路径

## 13.5 中断设置程序

### 13.5.1 启用中断请求

使能中断请求的过程如下:

1. 设置中断设置使能寄存器(NVIC\_ISER)。
2. 将IELSRn.IELS[8:0]位设置为中断源。
3. 指定事件源的操作设置,例如DMAC激活 (DELSRn.DELS[8:0])、贪睡模式取消 (SELSR0.SELS[8:0])、软件待机模式取消 (WUPEN寄存器设置)。

### 13.5.2 禁用中断请求

禁用中断请求的过程如下:

1. 禁用事件源的操作设置,例如DMAC激活 (DELSRn.DELS[8:0])、贪睡模式取消 (SELSR0.SELS[8:0])、软件待机模式取消 (WUPEN寄存器设置)。
2. 清除中断源设置 (IELSRn.IELS[8:0]=0x00)。
3. 清除中断状态标志 (IELSRn.IR=0)。
4. 清除中断清除启用寄存器 (NVIC\_ICER) 和中断清除挂起寄存器 (NVIC\_ICPR)。

### 13.5.3 轮询中断

轮询中断请求的过程如下:

1. 设置中断清除启用寄存器(NVIC\_ICER)。
2. 将IELSRn.IELS[8:0]位设置为中断源。
3. 指定事件源的操作设置,例如DMAC激活 (DELSRn.DELS[8:0])、贪睡模式取消 (SELSR0.SELS[8:0])、软件待机模式取消 (WUPEN寄存器设置)。
4. 轮询中断设置挂起寄存器(NVIC\_ISPR)。

### 13.5.4 选择中断请求目标

每个中断的可用目的地都是固定的,如表13.3和表13.4中所述。

可以为每个中断源独立选择中断输出目标、CPU、DMAC或DTC。



Use an interrupt request destination setting that is indicated by a “✓” in the event list (see [section 13.3.2. Event Number](#)).

Note: Setting the same interrupt source for IELSRn and DELSRn is prohibited.

If the DMAC or DTC is selected as the destination for requests from an IRQi pin, you must set the IRQCRi.IRQMD[1:0] bits for that interrupt to select edge detection.

### 13.5.4.1 CPU interrupt request

When IELSRn.DTCE = 0, the event specified in the IELSRn register is output to the NVIC. Set the IELSRn.IELS[8:0] bits to the target event and set the IELSRn.DTCE bit to 0.

### 13.5.4.2 DTC activation

When IELSRn.DTCE = 1, the event specified in the IELSRn register is output to the DTC. Use the following procedure:

1. Set the IELSRn.IELS[8:0] bits to the target event and set the IELSRn.DTCE bit to 1.
2. Set the DTC Module Start bit (DTCST.DTCST) to 1.

Table 13.5 shows operation when the DTC is the interrupt request destination.

**Table 13.5 Operation when DTC becomes interrupt request destination**

| Interrupt request destination | DISEL*1 | Remaining transfer operations | Operation per request        | IR*2  | Interrupt request destination after transfer |
|-------------------------------|---------|-------------------------------|------------------------------|---|--|
| DTC*3                         | 1       | ≠ 0                           | DTC transfer → CPU interrupt | Cleared on interrupt acceptance by the CPU                                | DTC  |
|                               |         | = 0                           | DTC transfer → CPU interrupt | Cleared on interrupt acceptance by the CPU                                | CPU (IELSRn.DTCE bit is cleared)             |
|                               | 0       | ≠ 0                           | DTC transfer                 | Cleared at the start of DTC data transfer after reading DTC transfer data | DTC  |
|                               |         | = 0                           | DTC transfer → CPU interrupt | Cleared on interrupt acceptance by the CPU                                | CPU (IELSRn.DTCE bit is cleared)             |

Note 1. DTC.MRB.DISEL bit controls the interrupt generates timing from DTC to CPU.

Note 2. When the IELSRn.IR flag is 1, an interrupt request (DTC activation request) that occurs again is ignored.

Note 3. For chain transfers, DTC transfer continues until the last chain transfer ends. The DISEL bit state and the remaining transfer count determine whether a CPU interrupt occurs, the IELSRn.IR flag clear timing, and the interrupt request destination after transfer. See [Table 17.2 in section 17, Data Transfer Controller \(DTC\)](#).

Note: Error during DTC transfer

If an error response occurs during DTC transfer, the DTC notifies the ICU that an error has occurred. ICU clears all bits of the target IELSRn (n = 0 to 95). IELSRn that is not the target is not cleared.

Note: DTC transfer error in snooze mode

When an error occurs in DTC transfer in Snooze mode, ICU issues a Wake Up request. However, interrupt requests are not issued automatically. See [section 17, Data Transfer Controller \(DTC\)](#) chapter for information on how to set the interrupt when a DTC error occurs.

### 13.5.4.3 DMAC Activation

Events specified in the DELSRn registers are output to the DMAC.

To set the interrupt source for DMAC, use the following procedure:

1. Set the DELSRn.DELS[8:0] bits to the event to activate the DMAC.
2. When using interrupts to CPU, set the IELSRn.IELS bit to factor of DMAC interrupt and IELSRn.DTCE bit to 0.
3. Set the activation source for the target DMAC channel (DMACm.DMTMD.DCTG[1:0]) to 01b (interrupt module detection).
4. Set the DMAC transfer enable bit for the target DMAC channel (DMACm.DMCNT.DTE) to 1.

使用事件列表中由“ ”指示的中断请求目标设置（参见第13.3.2节。事件编号）。

Note: 禁止为IELSRn和DELSRn设置相同的中断源。

如果选择DMAC或DTC作为来自IRQi引脚的请求的目标，则必须设置IRQCRi.IRQMD[1:0]位以使该中断选择边沿检测。

### 13.5.4.1 CPU中断请求

当IELSRn.DTCE=0时，将IELSRn寄存器中指定的事件输出到NVIC。将IELSRn.IELS[8:0]位设置为目标事件，并将IELSRn.DTCE位设置为0。

### 13.5.4.2 DTC activation

当IELSRn.DTCE=1时，将IELSRn寄存器中指定的事件输出到DTC。使用以下过程：

- 1.将IELSRn.IELS[8:0]位设置为目标事件，并将IELSRn.DTCE位设置为1。
- 2.将DTC模块起始位(DTCST.DTCST)设置为1。

表13.5显示了DTC是中断请求目标时的操作。

**Table 13.5 DTC成为中断请求目标时的操作**

| 中断请求目的地 | DISEL*1 | 剩余的转移操作 | 按请求操作        | IR*2                     | 传输后的中断请求目的地          |
|---------|---------|---------|--------------|--------------------------|----------------------|
| DTC*3   | 1       | ≠ 0     | DTC传输→CPU中断  | CPU接受中断时清零               | DTC                  |
|         |         | = 0     | DTC传输→CPU中断  | CPU接受中断时清零               | CPU (IELSRn.DTCE位清零) |
|         | 0       | ≠ 0     | DTC transfer | 读取DTC传输数据后，在DTC数据传输开始时清零 | DTC                  |
|         |         | = 0     | DTC传输→CPU中断  | CPU接受中断时清零               | CPU (IELSRn.DTCE位清零) |

注1.DTC.MRB.DISEL位控制从DTC到CPU的中断产生时序。

注2.IELSRn.IR标志为1时，忽略再次发生的中断请求（DTC激活请求）。

注3.对于链式传输，DTC传输将持续到最后一个链式传输结束。DISEL位状态和剩余传输计数决定是否发生CPU中断、IELSRn.IR标志清除时序以及传输后的中断请求目的地。请参见第17节“数据传输控制器(DTC)”中的表17.2。

Note: DTC传输期间出错

如果在DTC传输期间发生错误响应，则DTC会通知ICU发生了错误。ICU清除目标IELSRn(n=0到95)的所有位。不是目标的IELSRn不会被清除。

Note: 贪睡模式下的DTC传输错误

当贪睡模式下的DTC传输发生错误时，ICU会发出唤醒请求。但是，不会自动发出中断请求。有关如何在发生DTC错误时设置中断的信息，请参见第17节，数据传输控制器(DTC)章节。

### 13.5.4.3 DMAC Activation

在DELSRn寄存器中指定的事件被输出到DMAC。

要为DMAC设置中断源，请使用以下过程：

- 1.将DELSRn.DELS[8:0]位设置为事件以激活DMAC。
- 2.当对CPU使用中断时，将IELSRn.IELS位设置为DMAC中断因素，并将IELSRn.DTCE位设置为0。
- 3.将目标DMAC通道 (DMACm.DMTMD.DCTG[1:0]) 的激活源设置为01b (中断模块检测)。
- 4.将目标DMAC通道(DMACm.DMCNT.DTE)的DMAC传输使能位设置为1。

5. Set the DMAC operation enable bit (DMAST.DMST) to 1.

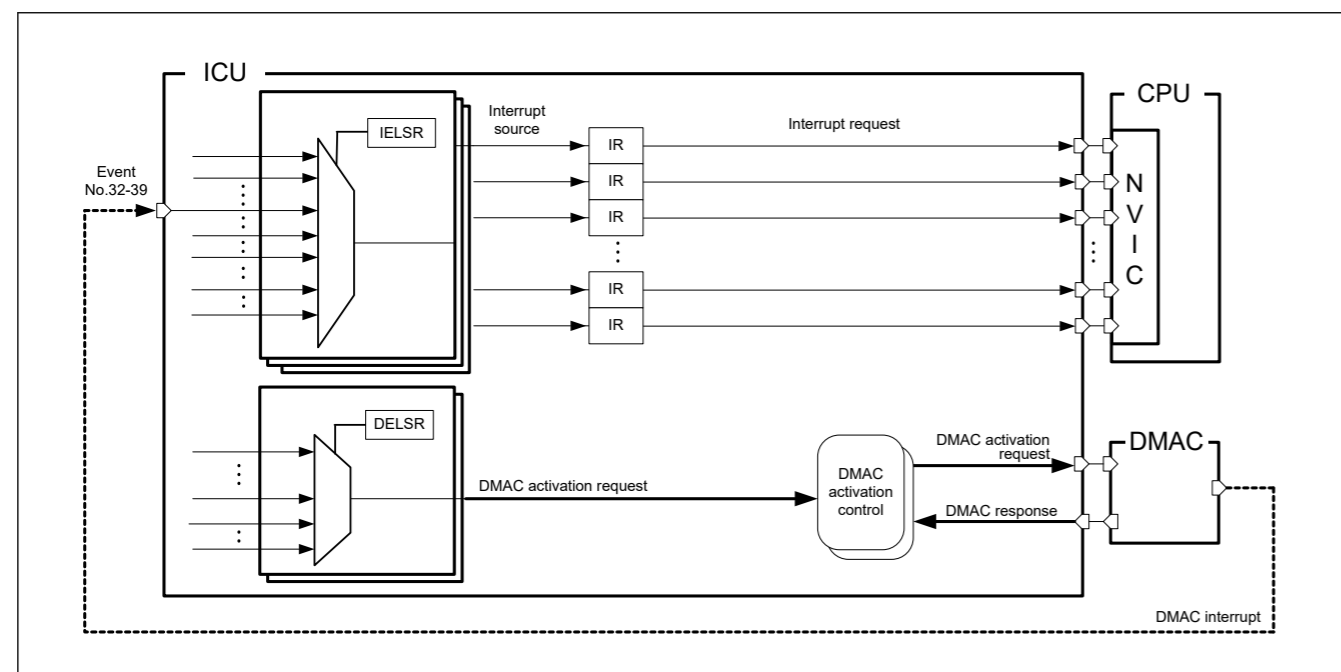


Figure 13.3 DMAC request trigger and interrupt path

Note: Error during DMAC transfer

If an error response occurs during DMAC transfer, the DMAC notifies the ICU that an error has occurred.

The ICU clears all bits of the target channel of DELSRn (n = 0 to 7). DELSRn that is not the target channel is not cleared.

### 13.5.5 Digital Filter

A digital filter function is provided for the external interrupt request pins IRQi, (i = 0 to 15) and the NMI pin interrupt. It samples input signals on the filter PCLKB sampling clock, and removes any signal with a pulse width less than 3 sampling cycles.

To use the digital filter for an IRQi pin:

1. Set the sampling clock cycle to PCLKB, PCLKB/8, PCLKB/32, or PCLKB/64 in the IRQCRi.FCLKSEL[1:0] bits (i = 0 to 15).
2. Set the IRQCRi.FLTEN bit (i = 0 to 15) to 1 (digital filter enabled).

To use the digital filter for an NMI pin:

1. Set the sampling clock cycle to PCLKB, PCLKB/8, PCLKB/32, or PCLKB/64 in the NMICR.NFCLKSEL[1:0] bits.
2. Set the NMICR.NFLTEN bit to 1 (digital filter enabled).

Figure 13.4 shows an example of digital filter operation.

- 5.将DMAC操作使能位(DMAST.DMST)设置为1。

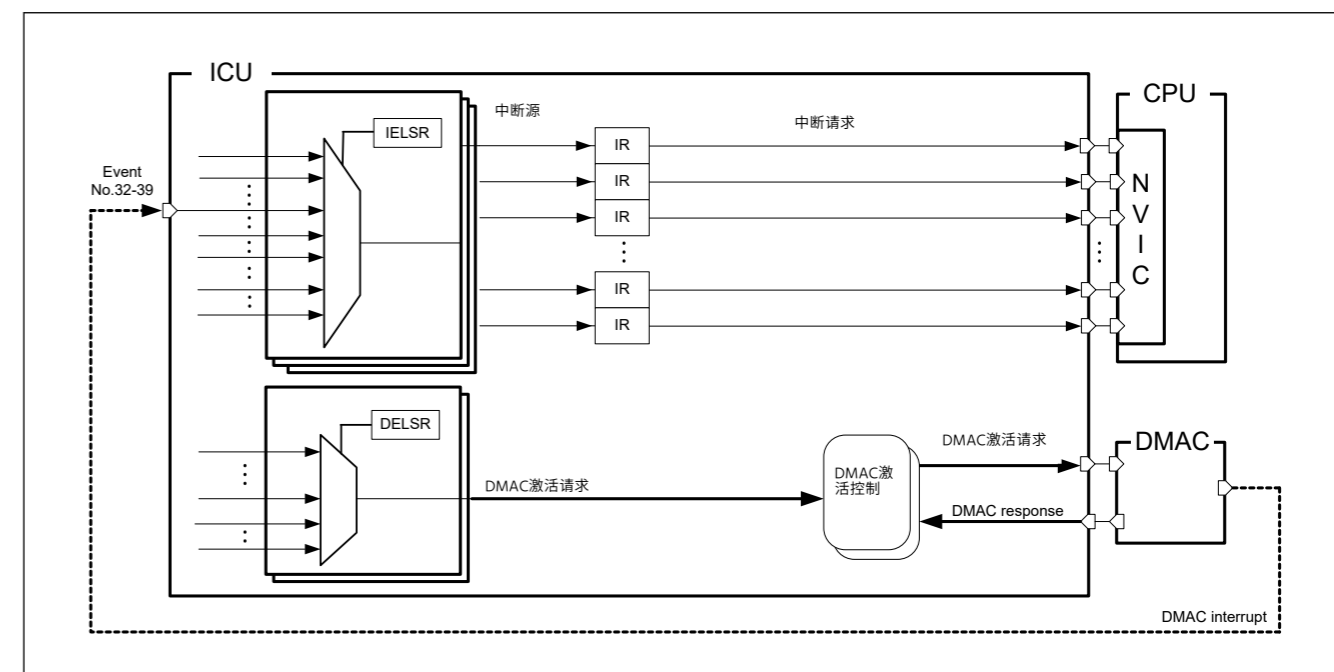


Figure 13.3 DMAC请求触发和中断路径

Note: DMAC传输期间出错

如果在DMAC传输期间发生错误响应, 则DMAC会通知ICU发生了错误。

ICU清除DELSRn (n=0到7) 的目标通道的所有位。不是目标通道的DELSRn不会被清除。

### 13.5.5 数字滤波器

为外部中断请求引脚IRQi (i=0到15) 和NMI引脚中断提供了数字过滤功能。它在滤波器PCLKB采样时钟上对输入信号进行采样, 并去除脉冲宽度小于3个采样周期的任何信号。

为IRQi引脚使用数字滤波器:

- 1.在IRQCRi.FCLKSEL[1:0]位 (i=0到15) 中将采样时钟周期设置为PCLKB、PCLKB8、PCLKB32或PCLKB64。
- 2.将IRQCRi.FLTEN位 (i=0到15) 设置为1 (启用数字滤波器)。

要将数字滤波器用于NMI引脚:

- 1.在NMICR.NFCLKSEL[1:0]位中将采样时钟周期设置为PCLKB、PCLKB8、PCLKB32或PCLKB64。
- 2.将NMICR.NFLTEN位设置为1 (启用数字滤波器)。

图13.4显示了数字滤波器操作的示例。

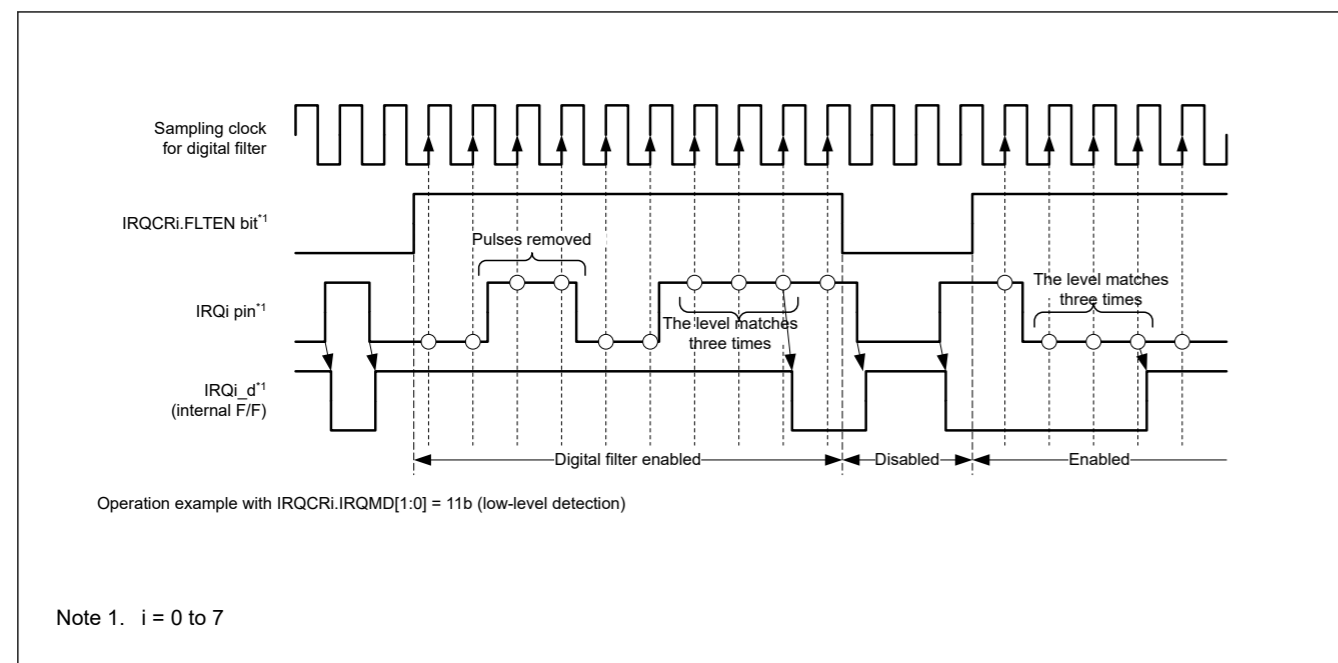


Figure 13.4 Digital filter operation example

Before entering Software Standby mode, disable the digital filters by clearing the IRQCRI.FLTEN and NMICR.NFLTEN bits. The ICU clock stops in Software Standby mode.

On exiting Software Standby, the circuit detects the edge by comparing the state before standby to the state after standby release. If the input changes during Software Standby, an incorrect edge might be detected. You can enable the digital filters again after exiting Software Standby mode.

### 13.5.6 External Pin Interrupts

To use external pin interrupts:

1. Configure I/O ports settings
2. Clear the IRQCRI.FLTEN bit ( $i = 0$  to 15) to 0 (digital filter disabled).
3. Set the IRQMD[1:0] bits of the given IRQCRI register ( $i = 0$  to 15) to select the senses of detection.
4. Set the FCLKSEL[1:0] bits, and the FLTEN bit of the IRQCRI register.
5. Select the IRQ pin as follows:
  - If the IRQ pin is to be used for CPU interrupt requests, set the IELSRn.IELS[8:0] bits and the IELSRn.DTCE bit to 0
  - If the IRQ pin is to be used for DTC activation, set the IELSRn.IELS[8:0] bits and the IELSRn.DTCE bit to 1.
  - If the IRQ pin is to be used for DMAC activation, set the DELSRn.DELS[8:0] bits.

### 13.6 Non-Maskable Interrupt Operation

The following sources can trigger a non-maskable interrupt:

- NMI pin interrupt
- Oscillation stop detection interrupt
- WDT underflow/refresh error interrupt
- IWDT underflow/refresh error interrupt
- Voltage monitor 1 interrupt
- Voltage monitor 2 interrupt
- SRAM parity error interrupt
- SRAM ECC error interrupt

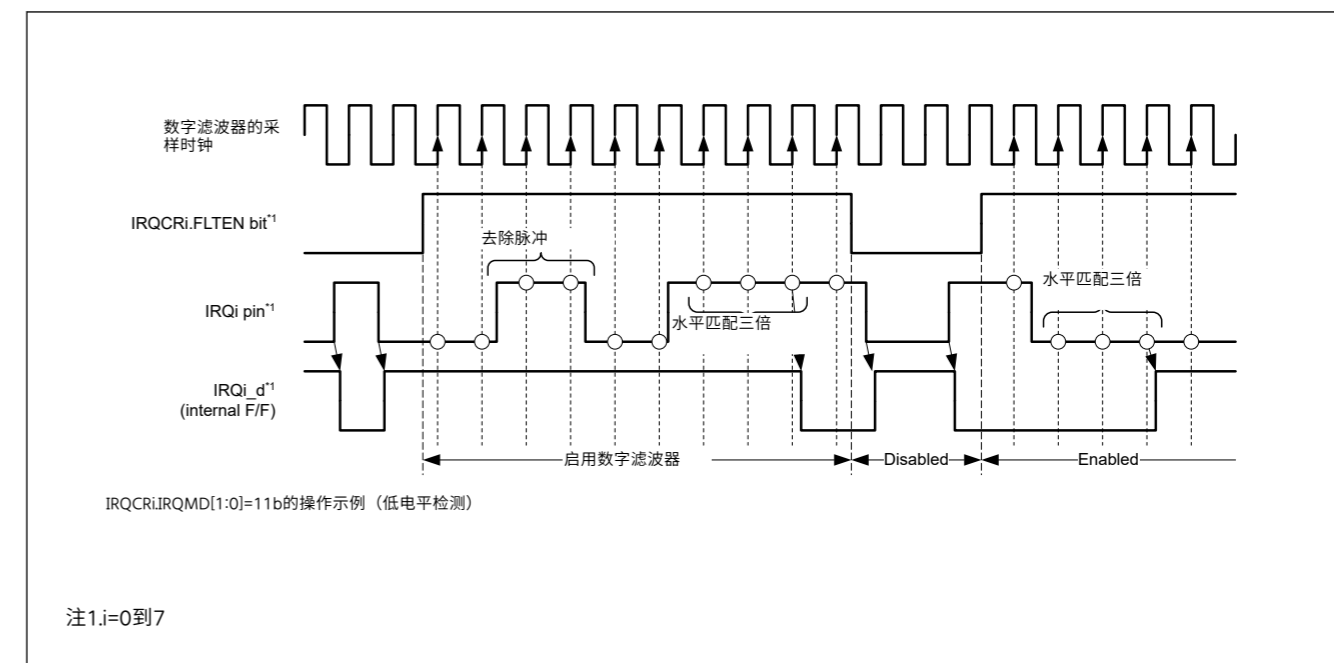


Figure 13.4 数字滤波器操作示例

在进入软件待机模式之前，通过清除IRQCRI.FLTEN和NMICR.NFLTEN位来禁用数字滤波器。ICU时钟在软件待机模式下停止。

在退出软件待机时，电路通过将待机前的状态与待机释放后的状态进行比较来检测边沿。如果在软件待机期间输入发生变化，则可能会检测到不正确的边沿。您可以在退出软件待机模式后再次启用数字滤波器。

### 13.5.6 外部引脚中断

要使用外部引脚中断：

- 1.配置IO端口设置
- 2.将IRQCRI.FLTEN位 ( $i=0$ 到15) 清零 (禁用数字滤波器)。
- 3.设置给定IRQCRI寄存器 ( $i=0$ 到15) 的IRQMD[1:0]位以选择检测的意义。
- 4.设置FCLKSEL[1:0]位和IRQCRI寄存器的FLTEN位。
- 5.选择IRQ引脚如下：
  - 如果IRQ引脚用于CPU中断请求，请将IELSRn.IELS[8:0]位和IELSRn.DTCE位设置为0
  - 如果IRQ引脚用于DTC激活，请将IELSRn.IELS[8:0]位和IELSRn.DTCE位设置为1。
  - 如果IRQ引脚用于激活DMAC，设置DELSRn.DELS[8:0]位。

### 13.6 不可屏蔽中断操作

以下源可以触发不可屏蔽中断：

- NMI引脚中断
- 振荡停止检测中断
- WDT下溢刷新错误中断
- IWDT下溢刷新错误中断
- 电压监控器1中断
- 电压监测器2中断
- SRAM奇偶校验错误中断
- SRAMECC错误中断

- MPU bus master error interrupt
- TrustZone filter error interrupt
- Cache RAM parity error interrupt.

Non-maskable interrupts can only be used with the CPU, not to activate the DTC or DMAC. Non-maskable interrupts take precedence over all other interrupts. The non-maskable interrupt states can be verified in the Non-Maskable Interrupt Status Register (NMISR). Confirm that all bits in the NMISR are 0 before returning from the NMI handler.

Non-maskable interrupts are disabled by default. To use non-maskable interrupts:

1. Clear the NMICR.NFLTEN bit to 0 (digital filter disabled).
2. Set the NMIMD bit, NFCLKSEL[1:0] bits, and NFLTEN bit of NMICR register.
3. Write 1 to the NMICLR.NMICLR bit to clear the NMISR.NMIST flag to 0.
4. Enable the non-maskable interrupt by writing 1 to the associated bit in the Non-Maskable Interrupt Enable Register (NMIER).

After 1 is written to the NMIER register, subsequent write access to the NMIEN bit in NMIER is ignored. An NMI interrupt cannot be disabled when enabled, except by a reset.

The secure attribution managed within the Application Interrupt and Reset Control Register (AIRCR) of the Arm CPU must match the security attribution of NMI.

The NMI secure of the CPU is changed by AIRCR.BFHFNMINs. It is managed by software developers who manage Secure program.

### 13.6.1 Correspondence to TrustZone-M by NMI

Although there is only one NMI per CPU, multiple factors can be set. This section describes the procedure for mixing Secure and NonSecure programs of NMI. When doing so, the NMI-related registers of the ICU are set to Secure.

NMI-related registers:

- NMIER
- NMICLR
- NMICR

Set "0" to ICUSARB.SANMI.

The value of AIRCR.BFHFNMINs[13] in the Application Interrupt and Reset Control Register of the ARM CPU must be the same as the value of security attribution. The initial values of AIRCR.BFHFNMINs and ICUSARB.SANMI are different.

AIRCR.BFHFNMINs is for secure and ICUSARB.SANMI is for non-secure. Polarity has the same meaning so program these to match.

If NMI is issued, jump to the NMI handler. When mixing secure and non-secure program, the NMI handler must branch according to the TrustZone-M rule. Figure 13.5 shows the flow.

- MPU总线主机错误中断
- TrustZone过滤器错误中断
- CacheRAM奇偶校验错误中断。

不可屏蔽中断只能用于CPU，不能激活DTC或DMAC。不可屏蔽中断优先于所有其他中断。不可屏蔽中断状态可以在不可屏蔽中断状态寄存器(NMISR)中验证。在从NMI处理程序返回之前，确认NMISR中的所有位都为0。

默认情况下禁用不可屏蔽中断。要使用不可屏蔽的中断：

- 1.将NMICR.NFLTEN位清为0（禁用数字滤波器）。
- 2.设置NMICR寄存器的NMIMD位、NFCLKSEL[1:0]位和NFLTEN位。
- 3.将1写入NMICLR.NMICLR位以将NMISR.NMIST标志清零。
- 4.通过将1写入不可屏蔽中断使能寄存器(NMIER)中的相关位来启用不可屏蔽中断。

将1写入NMIER寄存器后，随后对NMIER中的NMIEN位的写访问将被忽略。启用时不能禁用NMI中断，除非通过复位。

在ArmCPU的应用程序中断和复位控制寄存器(AIRCR)中管理的安全属性必须与NMI的安全属性相匹配。

CPU的NMI安全由AIRCR.BFHFNMINs更改。它由管理的软件开发人员管理安全程序。

### 13.6.1 NMI与TrustZone-M的通信

虽然每个CPU只有一个NMI，但可以设置多个因素。本节介绍混合程序NMI的安全和非安全程序。这样做时，ICU的NMI相关寄存器设置为Secure。

NMI-related registers:

- NMIER
- NMICLR
- NMICR

将"0"设置为ICUSARB.SANMI。

ARMCPU的应用中断和复位控制寄存器AIRCR.BFHFNMINs[13]的值必须与安全属性的值相同。AIRCR.BFHFNMINs和ICUSARB.SANMI的初始值不同。

AIRCR.BFHFNMINs用于安全，ICURASB.SANMI用于非安全。极性具有相同的含义，因此请对它们进行编程以匹配。

如果发出NMI，则跳转到NMI处理程序。当混合安全和非安全程序时，NMI处理程序必须根据TrustZone-M规则进行分支。图13.5显示了流程。



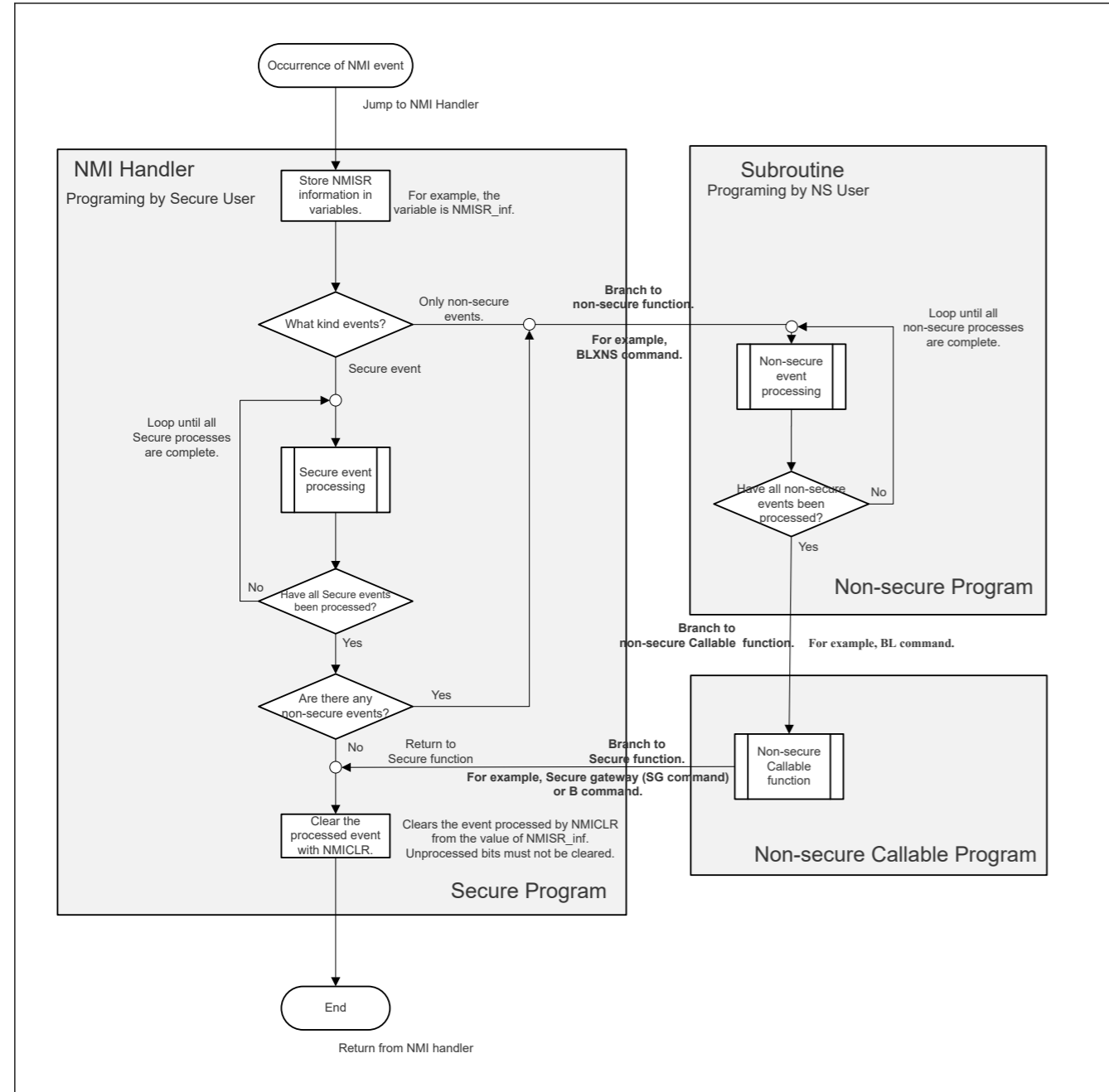


Figure 13.5 Correspondence to TrustZone-M by NMI

See the Arm documentation for details on how to move between secure and non-secure programs.

### 13.7 Return from Low Power Modes

Table 13.4 lists the interrupt sources you can use to exit Sleep, Snooze, or Software Standby mode. For more information, see section 10, Low Power Modes.

#### 13.7.1 Return from Sleep Mode

To return from Sleep mode in response to an interrupt:

##### non-maskable interrupt

- Use the NMIER register to enable the target interrupt request.

##### maskable interrupt

- Select the CPU as the interrupt request destination.

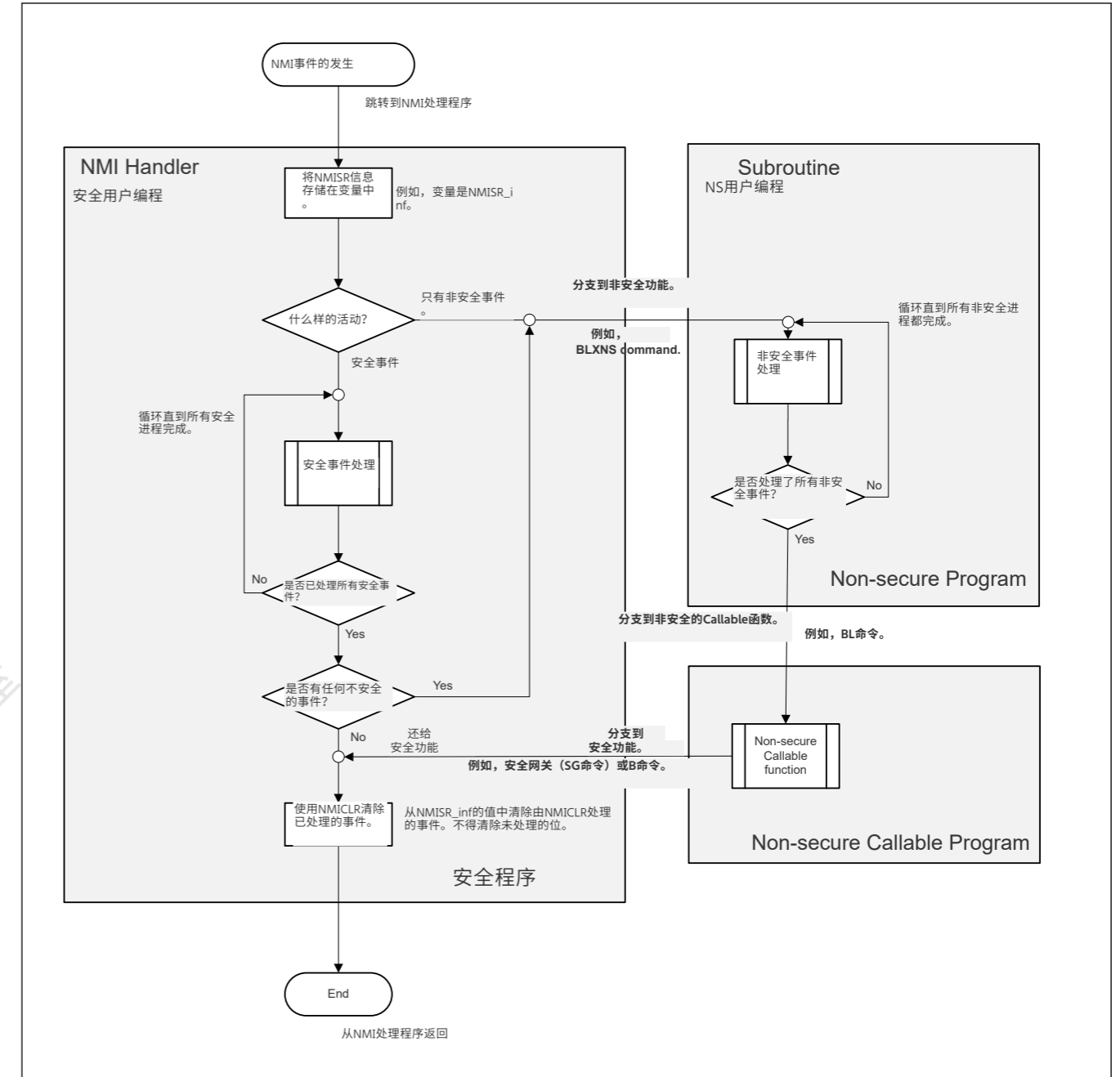


Figure 13.5 NMI与TrustZone-M的通信

有关如何在安全程序和非安全程序之间移动的信息，请参阅Arm文档。

### 13.7 从低功耗模式返回

表13.4列出了可用于退出睡眠、贪睡或软件待机模式的中断源。有关详细信息，请参阅第10节，低功耗模式。

#### 13.7.1 从睡眠模式返回

从睡眠模式返回以响应中断：

##### non-maskable interrupt

- 使用NMIER寄存器启用目标中断请求。

##### maskable interrupt

- 选择CPU作为中断请求目标。



- Enable the interrupt in the NVIC.

### 13.7.2 Return from Software Standby Mode

The ICU returns from Software Standby mode using a non-maskable interrupt or a maskable interrupt. For maskable interrupt of canceling source, see [Table 13.4](#).

To return from Software Standby mode:

1. Select the interrupt source that enables return from Software Standby:
  - For non-maskable interrupts, use the NMIER register to enable the target interrupt request
  - For maskable interrupts, use the WUPEN register to enable the target interrupt request.
2. Select the CPU as the interrupt request destination
3. Enable the interrupt in the NVIC.

Interrupt requests through the IRQn pins that do not satisfy these conditions are not detected while the clock is stopped in Software Standby mode.

Similarly, request for a non-maskable interrupt from a request source whose clock is stopped in Software Standby mode cannot be detected.

#### Transition to/from Software Standby mode

1. Before Software Standby mode is entered, disable the digital filter for the interrupt source as a return target (IRQCRI.FLTEN = 0, NMICR.NFLTEN = 0).
2. To use the digital filter again after returning from Software Standby mode, enable the digital filter (IRQCRI.FLTEN = 1, NMICR.NFLTEN = 1).

### 13.7.3 Return from Snooze Mode

The ICU can return to Normal mode from Snooze mode using the interrupts provided for this mode.

To return to Normal mode from Snooze mode:

1. Set the number of the required interrupt request in SELSR0.SELS[8:0]
2. Set the value 0x2D (ICU\_SNZCANCEL) in IELSRn.IELS[4:0] (n = 0 to 95).
3. Select the CPU as the interrupt request destination.
4. Enable the interrupt in the NVIC.

Interrupt requests through the non-maskable that do not satisfy the above conditions are not detected while the clock is stopped in snooze mode.

Note: In Snooze mode, a clock is supplied to the ICU. If an event selected in IELSRn is detected, the CPU acknowledges the interrupt after returning to Normal mode from Software Standby mode. If an event selected in DELSRn is detected, the DMAC can acknowledge the interrupt after returning to Normal mode from Software Standby mode.

### 13.8 Using the WFI Instruction with Non-Maskable Interrupts

Whenever a WFI instruction is executed, confirm that all status flags in the NMISR register are 0.

### 13.9 Reference

- ARM Limited., ARM<sup>®</sup> Cortex<sup>®</sup>-M33 Processor Technical Reference Manual (ARM 100230)

- 在NVIC中启用中断。

### 13.7.2 从软件待机模式返回

ICU使用不可屏蔽中断或可屏蔽中断从软件待机模式返回。取消源的可屏蔽中断见表13.4。

从软件待机模式返回:

- 1.选择允许从软件待机返回的中断源:
  - 对于不可屏蔽的中断,使用NMIER寄存器使能目标中断请求
  - 对于可屏蔽中断,使用WUPEN寄存器启用目标中断请求。
- 2.选择CPU作为中断请求目的地
- 3.在NVIC中启用中断。

不满足这些条件的通过IRQn引脚的中断请求在时钟停止时不会被检测到软件待机模式。

同样,无法检测到来自时钟在软件待机模式下停止的请求源的不可屏蔽中断请求。

#### 从软件待机模式转换

- 1.在进入软件待机模式之前,禁用作为返回目标的中断源的数字滤波器 (IRQCRI.FLTEN=0, NMICR.NFLTEN=0)。
- 2.要在从软件待机模式返回后再次使用数字滤波器,请启用数字滤波器 (IRQCRI.FLTEN=1, NMICR.NFLTEN=1)。

### 13.7.3 从贪睡模式返回

ICU可以使用为该模式提供的中断从贪睡模式返回到正常模式。

要从贪睡模式返回正常模式:

- 1.在SELSR0.SELS[8:0]中设置所需中断请求的数量
- 2.在IELSRn.IELS[4:0] (n=0到95) 中设置值0x2D(ICU\_SNZCANCEL)。
- 3.选择CPU作为中断请求目标。
- 4.在NVIC中启用中断。

当时钟在贪睡模式下停止时,不会检测到通过不可屏蔽的不满足上述条件的中断请求。

Note: 在贪睡模式下,向ICU提供时钟。如果检测到在IELSRn中选择的事件,CPU在从软件待机模式返回到正常模式后确认中断。如果检测到在DELSRn中选择的事件,则DMAC可以在从软件待机模式返回正常模式后确认中断。

### 13.8 将WFI指令与不可屏蔽中断一起使用

每当执行WFI指令时,请确认NMISR寄存器中的所有状态标志为0。

### 13.9 Reference

- ARMLimited. ARM<sup>®</sup>Cortex<sup>®</sup>-M33处理器技术参考手册(ARM100230)

## 14. Buses

### 14.1 Overview

The buses consists of 32 bits AHB bus matrix. [Table 14.1](#) lists the bus masters and bus slaves and [Figure 14.1](#) shows the bus configuration.

**Table 14.1 Bus Specifications**

| Classification | Bus Master/Slave name   | Bus I/F Max Freq | Sync Clock | Specifications  |
|----------------|-------------------------|------------------|------------|---|
| Bus Masters    | Code bus (Cortex-M33)   | 100 MHz          | ICLK       | Connected to the CPU Instruction Cache for instructions and operands  |
|                | System bus (Cortex-M33) | 100 MHz          | ICLK       | Connected to the CPU Data Cache for system  |
|                | DMAC / DTC              | 100 MHz          | ICLK       | Connected to the DMAC/DTC   |
| Bus Slaves     | FHBIU                   | 100 MHz          | ICLK       | Connected to Code Flash memory and Configuration area   |
|                | FLBIU                   | 50 MHz           | FCLK       | Connected to Data Flash memory, FACL  |
|                | SOBIU                   | 100 MHz          | ICLK       | Connected to SRAM0 (Standby RAM)  |
|                | PSBIU                   | 100 MHz          | ICLK       | Connected to peripheral system modules (DTC, DMAC, ICU, Flash, MPU, SRAM, Debug/Trace module, System controller and BUS controller) |
|                | PLBIU                   | 50 MHz           | PCLKB      | Connected to peripheral modules (CAC, ELC, I/O ports, POEG, RTC, WDT, IWDI, AGT, IIC, CAN, USBFS, SDHI, SSIE, TSN, and CTSU)        |
|                | PHBIU                   | 100 MHz          | PCLKA      | Connected to peripheral modules (GPT, SCI, SPI, CRC, DOC, ADC12, DAC12 and SCE9)  |
|                | EQBIU (QSPI area)       | 100 MHz          | PCLKA      | Connected to the QSPI (External Memory Interface)   |

Note: FHBIU: Flash High speed Bus Interface Unit.  
 FLBIU: Flash Low speed Bus Interface Unit.  
 SOBIU: SRAM0 Bus Interface Unit.  
 PSBIU: Peripheral System Bus Interface Unit.  
 PLBIU: Peripheral Low speed Bus Interface Unit.  
 PHBIU: Peripheral High speed Bus Interface Unit.  
 EQBIU: External memory interface Qspi Bus Interface Unit.

## 14. Buses

### 14.1 Overview

总线由32位AHB总线矩阵组成。表14.1列出了总线主机和总线从机，图14.1显示了总线配置。

**Table 14.1 总线规格**

| Classification | 总线主从名称            | Bus I/F 最大频率 | 同步时钟  | Specifications  |
|----------------|-------------------|--------------|-------|---|
| 巴士大师           | 代码总线(Cortex-M33)  | 100 MHz      | ICLK  | 连接到CPU指令缓存以获取指令和操作数   |
|                | 系统总线(Cortex-M33)  | 100 MHz      | ICLK  | 连接到系统的CPU数据缓存   |
|                | DMAC / DTC        | 100 MHz      | ICLK  | 连接到DMACDTC  |
| 总线从站           | FHBIU             | 100 MHz      | ICLK  | 连接到代码闪存和配置区   |
|                | FLBIU             | 50 MHz       | FCLK  | 连接到数据闪存, FACL   |
|                | SOBIU             | 100 MHz      | ICLK  | 连接到SRAM0 (备用RAM)  |
|                | PSBIU             | 100 MHz      | ICLK  | 连接到外围系统模块 (DTC、DMAC、ICU、闪存、MPU、SRAM、调试跟踪模块、系统控制器和BUS controller)              |
|                | PLBIU             | 50 MHz       | PCLKB | 连接到外围模块 (CAC、ELC、IO端口、POEG、RTC、WDT、IWDI、AGT、IIC、CAN、USBFS、SDHI、SSIE、TSN和CTSU) |
|                | PHBIU             | 100 MHz      | PCLKA | 连接到外围模块 (GPT、SCI、SPI、CRC、DOC、ADC12、DAC12 and SCE9)                            |
|                | EQBIU (QSPI area) | 100 MHz      | PCLKA | 连接到QSPI (外部存储器接口)   |

Note: FHBIU: 闪存高速总线接口单元。FLBIU: 闪存低速总线接口单元。  
 SOBIU: SRAM0总线接口单元。  
 PSBIU: 外围系统总线接口单元。  
 PLBIU: 外围低速总线接口单元。PHBIU: 外围高速总线接口单元。  
 EQBIU: 外部存储器接口Qspi总线接口单元。

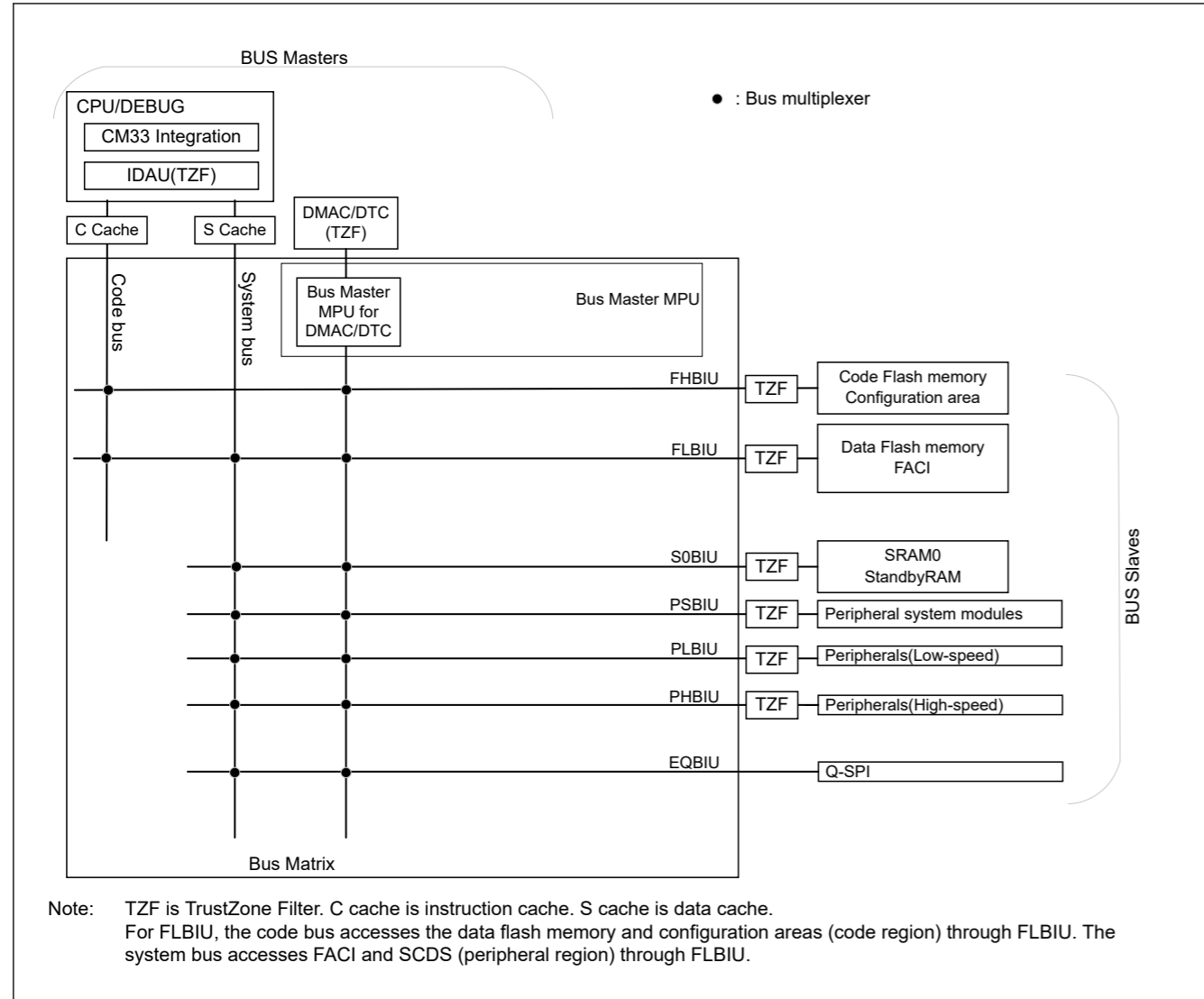


Figure 14.1 Bus Connection

## 14.2 Description of Buses

### 14.2.1 Arbitration

For arbitration between masters in each slave, fixed-priority and round-robin methods can be selected for each master. For details, see section 14.3.3. BUSSCNT<slave> : Slave Bus Control Register (<slave> = FHBIU, FLBIU, S0BIU, EQBIU), section 14.3.4. BUSSCNT<slave> : Slave Bus Control Register (<slave> = PSBIU, PLBIU, PHBIU).

### 14.2.2 Parallel Operation

Parallel operation is possible when different bus-master modules are requesting access to different slave modules. For example, if the CPU is fetching an instruction from Code Flash and an operand from SRAM0, the DMAC can handle transfer between a peripheral module.

Figure 14.2 shows an example of parallel operations. In this example, the CPU uses code bus and system bus for simultaneous access to FHBIU and S0BIU, respectively. Furthermore, the DMAC/DTC simultaneously accesses the peripheral bus during access to FHBIU and S0BIU by the CPU.

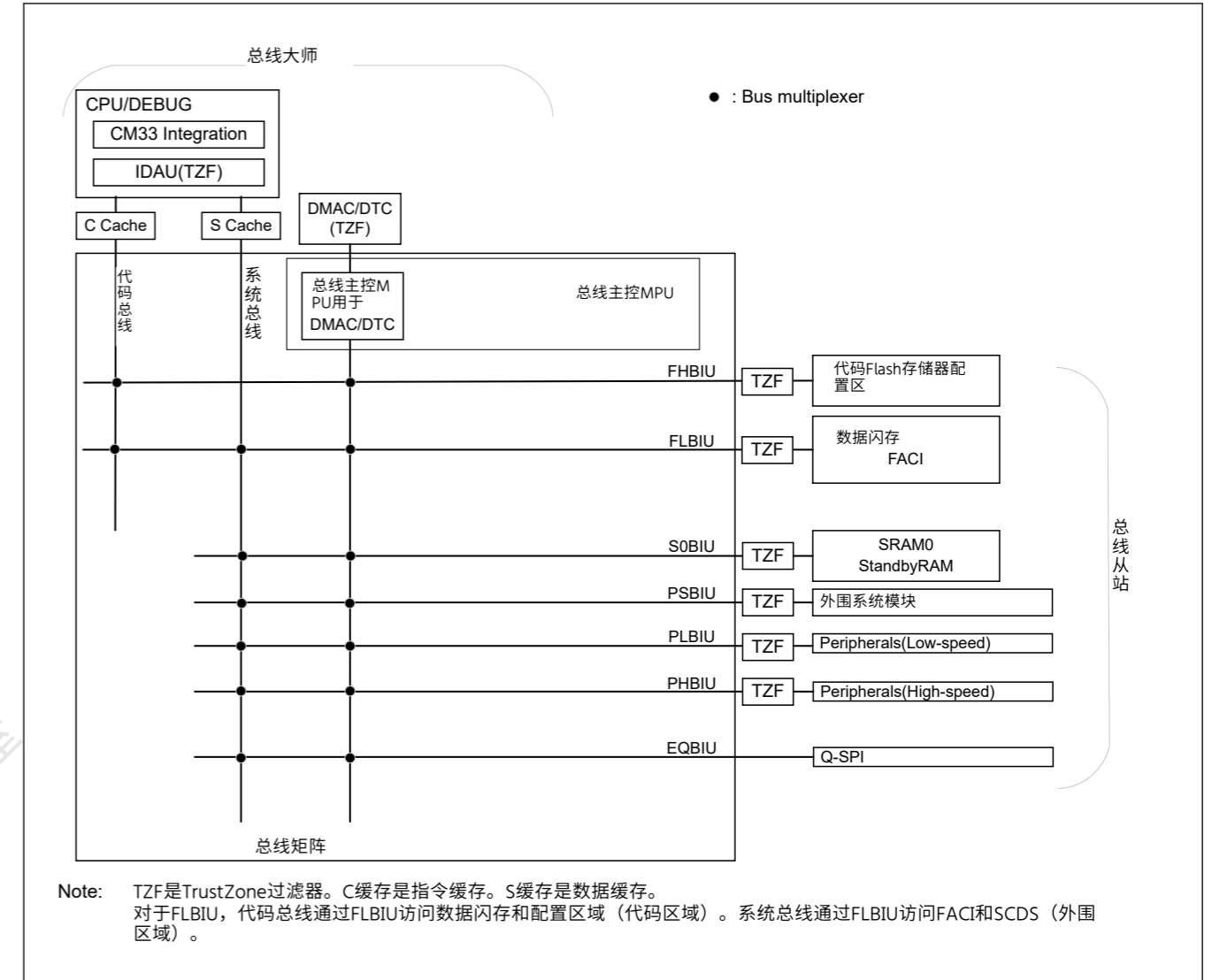


Figure 14.1 巴士连接

## 14.2 巴士的描述

### 14.2.1 Arbitration

对于每个从属设备中的主设备之间的仲裁，可以为每个主设备选择固定优先级和循环方法。详见14.3.3节。BUSSCNT<slave>：从总线控制寄存器（<slave>=FHBIU、FLBIU、S0BIU、EQBIU），第14.3.4节。BUSSCNT<slave>：从总线控制寄存器（<slave>=PSBIU、PLBIU、PHBIU）。

### 14.2.2 并行运行

当不同的总线主模块请求访问不同的从模块时，并行操作是可能的。例如，如果CPU从CodeFlash中获取指令并从SRAM0中获取操作数，则DMAC可以处理外设模块之间的传输。

图14.2显示了并行操作的示例。在本例中，CPU使用代码总线和系统总线分别同时访问FHBIU和S0BIU。此外，在CPU访问FHBIU和S0BIU期间，DMAC/DTC同时访问外围总线。

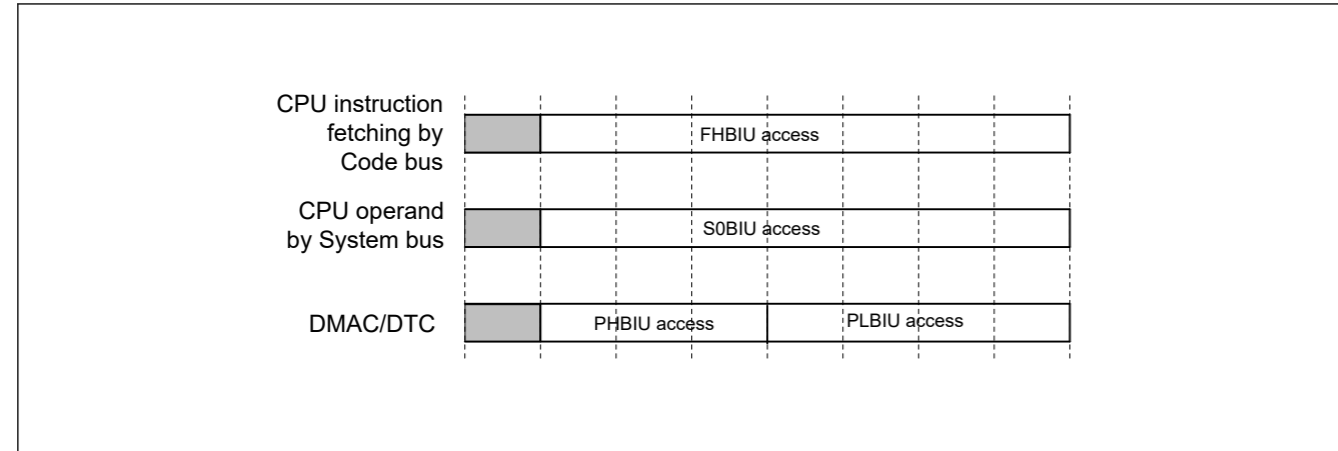


Figure 14.2 Example of Parallel Operations

### 14.2.3 Restrictions

#### (1) Restriction on Endian

Memory space must be little-endian in order to execute Cortex code.

#### (2) Bufferable write access

When CPU perform Bufferable Write access to PLBIU or PHBIU, if an STZF error occurs then the error response is invalidated. So there is no error flag will be set and no NMI / RESET request is generated.

When CPU perform Bufferable Write access to PHBIU, if a Slave BUS error occurs then the error response will become invalid and the error flag will not be set.

If error response is required, set the bus master to non-bufferable access.

#### (3) Access to reserved area of FLBIU and S0BIU

Access to the reserved area of FLBIU and S0BIU is prohibited. Operation is not guaranteed if accessed.

#### (4) Clock setting

The clock division ratio prohibits setting changes during bus access.

## 14.3 Register Descriptions

### 14.3.1 BUSSARA : BUS Security Attribution Register A

Base address: CPSCU = 0x4000\_8000

Offset address: 0x0100

|                    |    |    |    |    |    |    |    |    |    |    |    |    |    |    |    |         |
|--------------------|----|----|----|----|----|----|----|----|----|----|----|----|----|----|----|---------|
| Bit position:      | 31 | 30 | 29 | 28 | 27 | 26 | 25 | 24 | 23 | 22 | 21 | 20 | 19 | 18 | 17 | 16      |
| Bit field:         | —  | —  | —  | —  | —  | —  | —  | —  | —  | —  | —  | —  | —  | —  | —  | —       |
| Value after reset: | 1  | 1  | 1  | 1  | 1  | 1  | 1  | 1  | 1  | 1  | 1  | 1  | 1  | 1  | 1  | 1       |
| Bit position:      | 15 | 14 | 13 | 12 | 11 | 10 | 9  | 8  | 7  | 6  | 5  | 4  | 3  | 2  | 1  | 0       |
| Bit field:         | —  | —  | —  | —  | —  | —  | —  | —  | —  | —  | —  | —  | —  | —  | —  | BUSS A0 |
| Value after reset: | 1  | 1  | 1  | 1  | 1  | 1  | 1  | 1  | 1  | 1  | 1  | 1  | 1  | 1  | 1  | 1       |

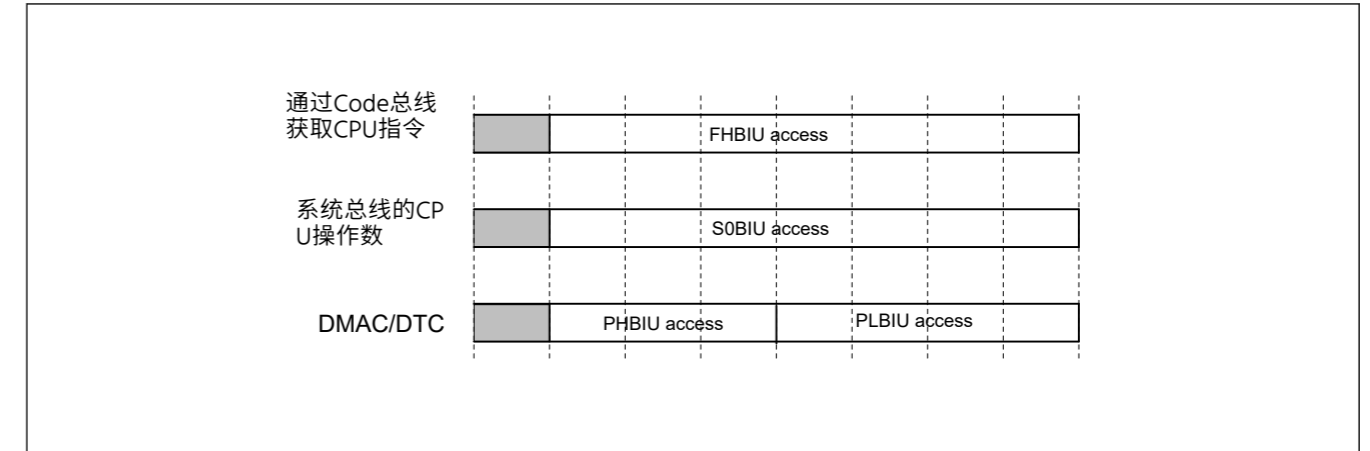


Figure 14.2 并行操作示例

### 14.2.3 Restrictions

#### (1) 对字节序的限制

为了执行Cortex代码，内存空间必须是little-endian。

#### (2) 可缓冲的写访问

当CPU对PLBIU或PHBIU执行BufferableWrite访问时，如果发生STZF错误，则错误响应无效。因此不会设置错误标志，也不会生成NMIRESET请求。

当CPU对PHBIU执行BufferableWrite访问时，如果发生SlaveBUS错误，则错误响应将变为无效且错误标志不会被设置。

如果需要错误响应，请将总线主机设置为非缓冲访问。

#### (3) 访问FLBIU和S0BIU的保留区

禁止访问FLBIU和S0BIU的保留区域。如果访问，则无法保证操作。

#### (4) 时钟设置

时钟分频比禁止在总线访问期间更改设置。

## 14.3 注册说明

### 14.3.1 BUSSARA:BUS安全属性寄存器A

Base address: CPSCU = 0x4000\_8000

Offset address: 0x0100

|               |    |    |    |    |    |    |    |    |    |    |    |    |    |    |    |         |
|---------------|----|----|----|----|----|----|----|----|----|----|----|----|----|----|----|---------|
| Bit position: | 31 | 30 | 29 | 28 | 27 | 26 | 25 | 24 | 23 | 22 | 21 | 20 | 19 | 18 | 17 | 16      |
| Bit field:    | —  | —  | —  | —  | —  | —  | —  | —  | —  | —  | —  | —  | —  | —  | —  | —       |
| 重置后的值:        | 1  | 1  | 1  | 1  | 1  | 1  | 1  | 1  | 1  | 1  | 1  | 1  | 1  | 1  | 1  | 1       |
| Bit position: | 15 | 14 | 13 | 12 | 11 | 10 | 9  | 8  | 7  | 6  | 5  | 4  | 3  | 2  | 1  | 0       |
| Bit field:    | —  | —  | —  | —  | —  | —  | —  | —  | —  | —  | —  | —  | —  | —  | —  | BUSS A0 |
| 重置后的值:        | 1  | 1  | 1  | 1  | 1  | 1  | 1  | 1  | 1  | 1  | 1  | 1  | 1  | 1  | 1  | 1       |

| Bit  | Symbol | Function  | R/W |
|------|--------|---|-----|
| 0    | BUSSA0 | BUS Security Attribution A0<br>0: Secure<br>1: Non-Secure | R/W |
| 31:1 | —      | These bits are read as 1.                                 | R   |

Note: Only secure access can write to this register. Both secure access and Non-secure read access are allowed but Non-secure write access is not allowed and TrustZone access error is not generated.

Note: This register is write-protected by PRCR register.

**BUSSA0 bit (BUS Security Attribution A0)**

The correspondence between register and BIU name is as follows

Connection (BUSSCNT<slave> = FHBIU/FLBIU/S0BIU/EQBIU/EOBIU/ECBIU)

Please see to [Figure 14.1](#) for connection between BIU and BUS

- BUSSCNTFHBIU
- BUSSCNTFLBIU
- BUSSCNTS0BIU
- BUSSCNTPSBIU
- BUSSCNTPLBIU
- BUSSCNTPHBIU
- BUSSCNTEQBIU

**14.3.2 BUSSARB : BUS Security Attribution Register B**

Base address: CPSCU = 0x4000\_8000

Offset address: 0x0104

|                    |    |    |    |    |    |    |    |    |    |    |    |    |    |    |    |         |
|--------------------|----|----|----|----|----|----|----|----|----|----|----|----|----|----|----|---------|
| Bit position:      | 31 | 30 | 29 | 28 | 27 | 26 | 25 | 24 | 23 | 22 | 21 | 20 | 19 | 18 | 17 | 16      |
| Bit field:         | —  | —  | —  | —  | —  | —  | —  | —  | —  | —  | —  | —  | —  | —  | —  | —       |
| Value after reset: | 1  | 1  | 1  | 1  | 1  | 1  | 1  | 1  | 1  | 1  | 1  | 1  | 1  | 1  | 1  | 1       |
| Bit position:      | 15 | 14 | 13 | 12 | 11 | 10 | 9  | 8  | 7  | 6  | 5  | 4  | 3  | 2  | 1  | 0       |
| Bit field:         | —  | —  | —  | —  | —  | —  | —  | —  | —  | —  | —  | —  | —  | —  | —  | BUSS B0 |
| Value after reset: | 1  | 1  | 1  | 1  | 1  | 1  | 1  | 1  | 1  | 1  | 1  | 1  | 1  | 1  | 1  | 1       |

| Bit  | Symbol | Function  | R/W |
|------|--------|---|-----|
| 0    | BUSSB0 | BUS Security Attribution B0<br>0: Secure<br>1: Non-Secure | R/W |
| 31:1 | —      | These bits are read as 1.                                 | R   |

Note: Only secure access can write to this register. Both secure access and Non-secure read access are allowed but Non-secure write access is not allowed and TrustZone access error is not generated.

Note: This register is write-protected by PRCR register.

**BUSSB0 bit (BUS Security Attribution B0)**

The BUSSB0 bit specifies the security attributes of registers for Bus Error Clear registers and DMAC/DTC Error Clear register.

BUS1ERRCLR: Code bus

BUS2ERRCLR: System bus

BUS3ERRCLR: DMAC/DTC

| Bit  | Symbol | Function                                | R/W |
|------|--------|---|-----|
| 0    | BUSSA0 | BUS安全属性A0<br>0: Secure<br>1: Non-Secure | R/W |
| 31:1 | —      | 这些位读为1。                                 | R   |

Note: 只有安全访问才能写入该寄存器。允许安全访问和非安全读取访问，但不允许非安全写入访问，并且不会生成TrustZone访问错误。

Note: 该寄存器由PRCR寄存器写保护。

**BUSSA0位 (BUS安全属性A0)**

寄存器和BIU名称的对应关系如下

Connection (BUSSCNT<slave> = FHBIU/FLBIU/S0BIU/EQBIU/EOBIU/ECBIU)

BIU和BUS的连接见图14.1

- BUSSCNTFHBIU
- BUSSCNTFLBIU
- BUSSCNTS0BIU
- BUSSCNTPSBIU
- BUSSCNTPLBIU
- BUSSCNTPHBIU
- BUSSCNTEQBIU

**14.3.2 BUSSARB:BUS安全属性寄存器B**

Base address: CPSCU = 0x4000\_8000

Offset address: 0x0104

|               |    |    |    |    |    |    |    |    |    |    |    |    |    |    |    |         |
|---------------|----|----|----|----|----|----|----|----|----|----|----|----|----|----|----|---------|
| Bit position: | 31 | 30 | 29 | 28 | 27 | 26 | 25 | 24 | 23 | 22 | 21 | 20 | 19 | 18 | 17 | 16      |
| Bit field:    | —  | —  | —  | —  | —  | —  | —  | —  | —  | —  | —  | —  | —  | —  | —  | —       |
| 重置后的值:        | 1  | 1  | 1  | 1  | 1  | 1  | 1  | 1  | 1  | 1  | 1  | 1  | 1  | 1  | 1  | 1       |
| Bit position: | 15 | 14 | 13 | 12 | 11 | 10 | 9  | 8  | 7  | 6  | 5  | 4  | 3  | 2  | 1  | 0       |
| Bit field:    | —  | —  | —  | —  | —  | —  | —  | —  | —  | —  | —  | —  | —  | —  | —  | BUSS B0 |
| 重置后的值:        | 1  | 1  | 1  | 1  | 1  | 1  | 1  | 1  | 1  | 1  | 1  | 1  | 1  | 1  | 1  | 1       |

| Bit  | Symbol | Function                                | R/W |
|------|--------|---|-----|
| 0    | BUSSB0 | BUS安全属性B0<br>0: Secure<br>1: Non-Secure | R/W |
| 31:1 | —      | 这些位读为1。                                 | R   |

Note: 只有安全访问才能写入该寄存器。允许安全访问和非安全读取访问，但不允许非安全写入访问，并且不会生成TrustZone访问错误。

Note: 该寄存器由PRCR寄存器写保护。

**BUSSB0位 (BUS安全属性B0)**

BUSSB0位指定总线错误清除寄存器和DMAC/DTC错误清除寄存器的安全属性。

BUS1ERRCLR: 代码总线

BUS2ERRCLR: 系统总线

BUS3ERRCLR: DMAC/DTC



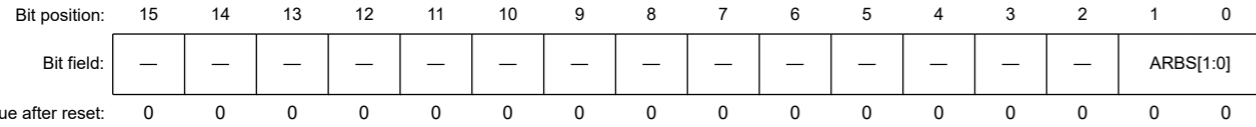
DMACDTCERRCLR: DMAC/DTC (Master-TZF)

See Figure 14.1 for connection of each BUS.

14.3.3 BUSSCNT<slave> : Slave Bus Control Register (<slave> = FHBIU, FLBIU, S0BIU, EQBIU)

Base address: BUS = 0x4000\_3000

Offset address: 0x1100 (BUSSCNTFHBIU)  
0x1104 (BUSSCNTFLBIU)  
0x1110 (BUSSCNTS0BIU)  
0x1140 (BUSSCNTEQBIU)



| Bit  | Symbol    | Function   | R/W |
|------|-----------|--|-----|
| 1:0  | ARBS[1:0] | Arbitration Select for two masters<br>Specify the priority between bus master.<br>> : Fixed Priority<br>↔: Round-Robin<br>0 0: DMAC/DTC > CPU<br>0 1: Setting prohibited<br>1 0: Setting prohibited<br>1 1: DMAC/DTC ↔ CPU | R/W |
| 15:2 | —         | These bits are read as 0. The write value should be 0.   | R/W |

- Note: If the security attribution is configured as secure:
- Secure access and Non-secure read access are allowed
  - Non-secure write access is ignored, and TrustZone access error is not generated.
- If the security attribution is configured as Non-secure:
- Secure and Non-secure access are allowed.
- Note:
- BUSSCNT<slave> : <slave> is bus interface unit name for Slave
  - The change is prohibited from initial value (0) to reserved bit. Operation when changing is not guaranteed.

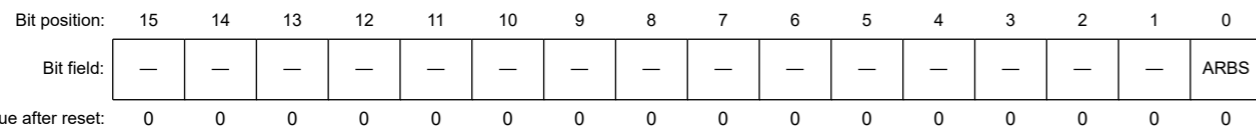
ARBS[1:0] bits (Arbitration Select for two masters)

The ARBS bits sets the arbitration method of each master.

14.3.4 BUSSCNT<slave> : Slave Bus Control Register (<slave> = PSBIU, PLBIU, PHBIU)

Base address: BUS = 0x4000\_3000

Offset address: 0x1120 (BUSSCNTPSBIU)  
0x1130 (BUSSCNTPLBIU)  
0x1134 (BUSSCNTPHBIU)



| Bit  | Symbol | Function   | R/W |
|------|--------|--|-----|
| 0    | ARBS   | Arbitration Select for two masters<br>Specify the priority between bus master.<br>> : Fixed Priority<br>↔: Round-Robin<br>0: DMAC/DTC > CPU<br>1: DMAC/DTC ↔ CPU | R/W |
| 15:1 | —      | These bits are read as 0. The write value should be 0.   | R/W |

- Note: If the security attribution is configured as secure:

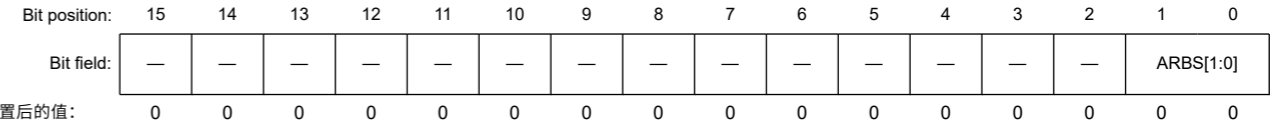
DMACDTCERRCLR: DMAC/DTC (Master-TZF)

每个BUS的连接请参见图14.1。

14.3.3 BUSSCNT<slave>:从总线控制寄存器(<slave>=FHBIU FLBIU S0BIU EQBIU)

Base address: BUS = 0x4000\_3000

Offset address: 0x1100 (BUSSCNTFHBIU)  
0x1104 (BUSSCNTFLBIU)  
0x1110 (BUSSCNTS0BIU)  
0x1140 (BUSSCNTEQBIU)



| Bit  | Symbol    | Function  | R/W |
|------|-----------|---|-----|
| 1:0  | ARBS[1:0] | 两个主机的仲裁选择<br>指定总线主机之间的优先级。>:固定优先级↔:循环<br>00: DMACDTC>CPU01<br>: 禁止设置10: 禁止设置<br>11: DMACDTC↔CPU | R/W |
| 15:2 | —         | 这些位被读取为0。写入值应为0。  | R/W |

- Note: 如果安全属性配置为安全: ●
- 允许安全访问和非安全读取访问
  - 忽略非安全写入访问, 不会生成TrustZone访问错误。
- 如果安全属性配置为非安全: ●
- 允许安全和非安全访问。
- Note:
- BUSSCNT<slave>:<slave>是Slave的总线接口单元名称
  - 禁止从初始值(0)更改为保留位。不保证更换时的操作。

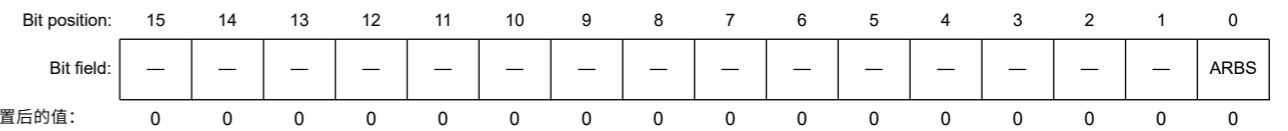
ARBS[1:0]位 (两个主机的仲裁选择)

ARBS位设置每个主机的仲裁方法。

14.3.4 BUSSCNT<slave>:从总线控制寄存器(<slave>=PSBIU PLBIU PHBIU)

Base address: BUS = 0x4000\_3000

Offset address: 0x1120 (BUSSCNTPSBIU)  
0x1130 (BUSSCNTPLBIU)  
0x1134 (BUSSCNTPHBIU)



| Bit  | Symbol | Function  | R/W |
|------|--------|---|-----|
| 0    | ARBS   | 两个主机的仲裁选择<br>指定总线主机之间的优先级。>:固定优先级↔:循环<br>0: DMAC/DTC > CPU<br>1: DMAC/DTC ↔ CPU | R/W |
| 15:1 | —      | 这些位被读取为0。写入值应为0。  | R/W |

- Note: 如果安全属性配置为安全:

- Secure access and Non-secure read access are allowed
- Non-secure write access is ignored, and TrustZone access error is not generated.

If the security attribution is configured as Non-secure:

- Secure and Non-secure access are allowed.

Note: • BUSSCNT<slave> : <slave> is bus interface unit name for Slave

- The change is prohibited from initial value (0) to reserved bit. Operation when changing is not guaranteed.

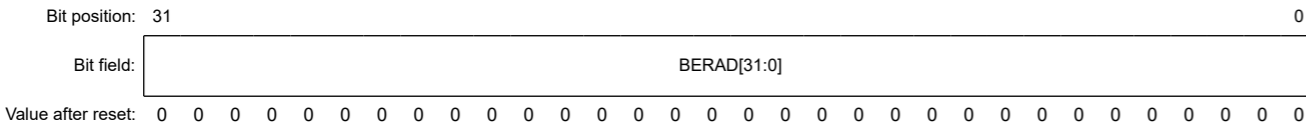
**ARBS bit (Arbitration Select for two masters)**

The ARBS bits sets the arbitration method of each master.

**14.3.5 BUSnERRADD : BUS Error Address Register (n = 1 to 3)**

Base address: BUS = 0x4000\_3000

Offset address: 0x1800 + 0x10 × (n - 1)



| Bit  | Symbol      | Function   | R/W |
|------|-------------|--|-----|
| 31:0 | BERAD[31:0] | Bus Error Address<br>When a bus error occurs, these bits store the error address | R   |

This register is cleared by reset other than MPU- and TZF-related resets which are Bus Master MPU Error Reset and TrustZone Filter Error Reset.

For detail of MPU related reset, see [section 5, Resets](#) and [section 15, Memory Protection Unit \(MPU\)](#).

The following bus errors correspond to the master bus:

BUS1ERRADD : Code bus

BUS2ERRADD : System bus

BUS3ERRADD : DMAC/DTC

**BERAD[31:0] bits (Bus Error Address)**

The BERAD[31:0] bits indicate the address when an error occurs on the associated bus. For detail of error that occurs by bus, see [section 14.3.9. BUSnERRSTAT : BUS Error Status Register n \(n = 1 to 3\)](#) and [section 14.4. Bus Error Monitoring Section](#).

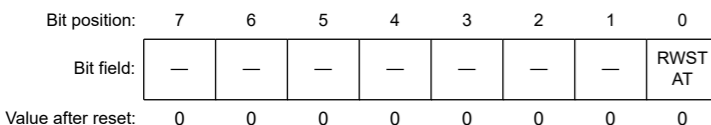
When an error occurs on the bus, the corresponding bit of ILERRSTAT, MMERRSTAT, SLERRSTAT in BUSnERRSTAT (n = 1 to 3) is set to 1, at the same time, the BERAD[31:0] bits store the address of the bus error access.

BERAD[31:0] bits are only valid when ILERRSTAT, MMERRSTAT, and SLERRSTAT in BUSnERRSTAT (n = 1 to 3) are set to 1.

**14.3.6 BUSnERRRW : BUS Error Read Write Register (n = 1 to 3)**

Base address: BUS = 0x4000\_3000

Offset address: 0x1804 + 0x10 × (n - 1)



- 允许安全访问和非安全读取访问
- 忽略非安全写入访问，不会生成TrustZone访问错误。

如果安全属性配置为非安全: ●

- 允许安全和非安全访问。

Note: • BUSSCNT<slave>:<slave>是Slave的总线接口单元名称

- 禁止从初始值(0)更改为保留位。不保证更换时的操作。

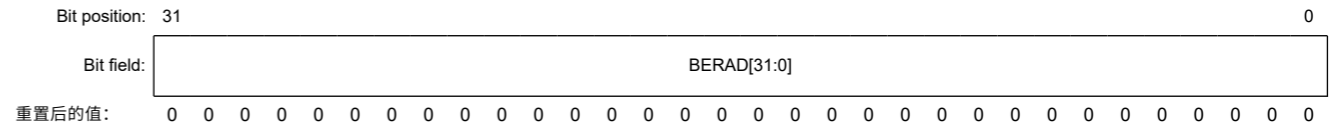
**ARBS位（两个主机的仲裁选择）**

ARBS位设置每个主机的仲裁方法。

**14.3.5 BUSnERRADD：总线错误地址寄存器（n=1到3）**

Base address: BUS = 0x4000\_3000

Offset address: 0x1800 + 0x10 × (n - 1)



| Bit  | Symbol      | Function                     | R/W |
|------|-------------|------------------------------|-----|
| 31:0 | BERAD[31:0] | 总线错误地址<br>当发生总线错误时，这些位存储错误地址 | R   |

该寄存器由除MPU和TZF相关的复位之外的复位清除，这些复位是总线主控MPU错误复位和TrustZone过滤器错误重置。

有关MPU相关复位的详细信息，请参阅[第5节，复位](#)和[第15节，内存保护单元\(MPU\)](#)。

以下总线错误对应于主总线：

BUS1ERRADD:代码总线

BUS2ERRADD:系统总线

BUS3ERRADD : DMAC/DTC

**BERAD[31:0]位（总线错误地址）**

BERAD[31:0]位指示相关总线上发生错误时的地址。关于总线发生错误的详细信息，请参阅[第14.3.9节。BUSnERRSTAT：总线错误状态寄存器n（n=1到3）](#)和[第14.4节。总线错误监控部分](#)。

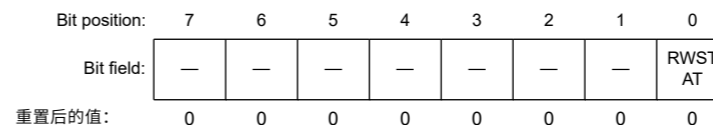
当总线发生错误时，BUSnERRSTAT（n=1~3）中ILERRSTAT、MMERRSTAT、SLERRSTAT的对应位置1，同时BERAD[31:0]位存储总线地址错误访问。

BERAD[31:0]位仅在BUSnERRSTAT（n=1至3）中的ILERRSTAT、MMERRSTAT和SLERRSTAT设置为1时有效。

**14.3.6 BUSnERRRW：总线错误读写寄存器（n=1到3）**

Base address: BUS = 0x4000\_3000

Offset address: 0x1804 + 0x10 × (n - 1)



| Bit | Symbol | Function   | R/W |
|-----|--------|--|-----|
| 0   | RWSTAT | Error Access Read/Write Status<br>The status at the time of the error<br>0: Read access<br>1: Write access | R   |
| 7:1 | —      | These bits are read as 0. The write value should be 0.   | R/W |

This register is cleared by reset other than MPU- and TZF-related resets which are Bus Master MPU Error Reset and TrustZone Filter Error Reset.

For detail of MPU related reset, see [section 5, Resets](#) and [section 15, Memory Protection Unit \(MPU\)](#).

The following bus errors correspond to the master bus:

- BUS1ERRRW : Code bus
- BUS2ERRRW : System bus
- BUS3ERRRW : DMAC/DTC

#### RWSTAT bit (Error Access Read/Write Status)

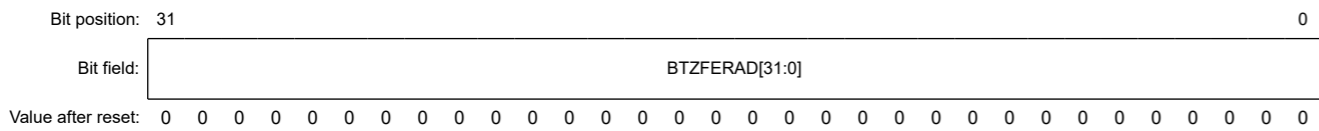
The RWSTAT bit indicates the access status, (write access or read access) when an error occurs on the associated bus. For detail of error that occurs by bus, see [section 14.3.9. BUSnERRSTAT : BUS Error Status Register n \(n = 1 to 3\)](#) and [section 14.4. Bus Error Monitoring Section](#).

When an error occurs on the bus, the corresponding bit of ILERRSTAT, MMERRSTAT, SLERRSTAT in BUSnERRSTAT (n = 1 to 3) is set to 1, at the same time, the RWSTAT bits store the read/write status of the bus error access.

RWSTAT bit is only valid when ILERRSTAT, MMERRSTAT, and SLERRSTAT in BUSnERRSTAT (n = 1 to 3) are set to 1.

#### 14.3.7 BTZFnERRADD : BUS TZF Error Address Register (n = 1 to 3)

Base address: BUS = 0x4000\_3000  
Offset address: 0x1900 + 0x10 × (n - 1)



| Bit  | Symbol         | Function  | R/W |
|------|----------------|---|-----|
| 31:0 | BTZFERAD[31:0] | Bus TrustZone Filter Error Address<br>When a bus error occurs, these bits store the error address | R   |

This register is cleared by reset other than MPU- and TZF-related resets which are Bus Master MPU Error Reset and TrustZone Filter Error Reset.

For detail of MPU related reset, see [section 5, Resets](#) and [section 15, Memory Protection Unit \(MPU\)](#).

The following bus errors correspond to the master bus:

- BTZF1ERRADD : Code bus
- BTZF2ERRADD : System bus
- BTZF3ERRADD : DMAC/DTC

See [Figure 14.1](#) for connection of each BUS.

#### BTZFERAD[31:0] bits (Bus TrustZone Filter Error Address)

The BTZFERAD[31:0] bits indicate the address, when an error occurs on the associated bus. For detail of error that occurs by bus, see [section 14.3.9. BUSnERRSTAT : BUS Error Status Register n \(n = 1 to 3\)](#) and [section 14.4. Bus Error Monitoring Section](#).

When an error occurs on the bus, the corresponding bit of STERRSTAT in BUSnERRSTAT (n = 1 to 3) is set to 1, at the same time, the BTZFERAD[31:0] bits store the address of the bus error access.

| Bit | Symbol | Function                           | R/W |
|-----|--------|------------------------------------|-----|
| 0   | RWSTAT | 错误访问读写状态<br>出错时的状态<br>0: 读访问1: 写访问 | R   |
| 7:1 | —      | 这些位被读取为0。写入值应为0。                   | R/W |

该寄存器由除MPU和TZF相关的复位之外的复位清除，这些复位是总线主控MPU错误复位和TrustZone过滤器错误重置。

有关MPU相关复位的详细信息，请参阅第5节，复位和第15节，内存保护单元(MPU)。

以下总线错误对应于主总线：

- BUS1ERRRW:代码总线
- BUS2ERRRW:系统总线
- BUS3ERRRW : DMAC/DTC

#### RWSTAT位（错误访问读写状态）

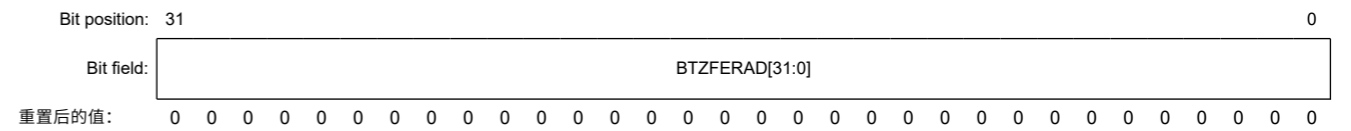
RWSTAT位指示相关总线上发生错误时的访问状态（写访问或读访问）。关于总线发生错误的详细信息，请参阅第14.3.9节。BUSnERRSTAT：总线错误状态寄存器n（n=1到3）和第14.4节。总线错误监控部分。

当总线发生错误时，BUSnERRSTAT（n=1~3）中ILERRSTAT、MMERRSTAT、SLERRSTAT的相应位设置为1，同时RWSTAT位存储总线错误访问的读写状态。

RWSTAT位仅在BUSnERRSTAT（n=1至3）中的ILERRSTAT、MMERRSTAT和SLERRSTAT设置为1时有效。

#### 14.3.7 BTZFnERRADD: BUSTZF错误地址寄存器(n=1to3)

Base address: BUS = 0x4000\_3000  
Offset address: 0x1900 + 0x10 × (n - 1)



| Bit  | Symbol         | Function                                 | R/W |
|------|----------------|--|-----|
| 31:0 | BTZFERAD[31:0] | 总线TrustZone过滤器错误地址<br>当发生总线错误时，这些位存储错误地址 | R   |

该寄存器由除MPU和TZF相关的复位之外的复位清除，这些复位是总线主控MPU错误复位和TrustZone过滤器错误重置。

有关MPU相关复位的详细信息，请参阅第5节，复位和第15节，内存保护单元(MPU)。

以下总线错误对应于主总线：

- BTZF1ERRADD:代码总线
- BTZF2ERRADD:系统总线
- BTZF3ERRADD : DMAC/DTC

每个BUS的连接请参见图14.1。

#### BTZFERAD[31:0]位（总线TrustZone过滤器错误地址）

当相关总线上发生错误时，BTZFERAD[31:0]位指示地址。关于总线发生错误的详细信息，请参阅第14.3.9节。BUSnERRSTAT：总线错误状态寄存器n（n=1到3）和第14.4节。总线错误监控部分。

当总线发生错误时，BUSnERRSTAT(n=1到3)中的STERRSTAT对应位设置为1，同时BTZFERAD[31:0]位存储总线错误访问的地址。

BTZFERAD[31:0] bits are only valid when STERRSTAT in BUSnERRSTAT (n = 1 to 3) is set to 1.

### 14.3.8 BTZFnERRRW : BUS TZF Error Read Write Register (n = 1 to 3)

Base address: BUS = 0x4000\_3000

Offset address: 0x1904 + 0x10 × (n - 1)

|                    |   |   |   |   |   |   |   |         |
|--------------------|---|---|---|---|---|---|---|---------|
| Bit position:      | 7 | 6 | 5 | 4 | 3 | 2 | 1 | 0       |
| Bit field:         | — | — | — | — | — | — | — | TRWSTAT |
| Value after reset: | 0 | 0 | 0 | 0 | 0 | 0 | 0 | 0       |

| Bit | Symbol  | Function  | R/W |
|-----|---------|---|-----|
| 0   | TRWSTAT | TrustZone filter error access Read/Write Status<br>The status at the time of the error<br>0: Read access<br>1: Write access | R   |
| 7:1 | —       | These bits are read as 0. The write value should be 0.  | R/W |

This register is cleared by reset other than MPU- and TZF-related resets which are Bus Master MPU Error Reset and TrustZone Filter Error Reset.

For detail of MPU related reset, see [section 5, Resets](#) and [section 15, Memory Protection Unit \(MPU\)](#).

The following bus errors correspond to the master bus:

BTZF1ERRRW : Code bus

BTZF2ERRRW : System bus

BTZF3ERRRW : DMAC/DTC

See [Figure 14.1](#) for connection of each BUS.

#### TRWSTAT bit (TrustZone filter error access Read/Write Status)

The TRWSTAT bit indicates the access status, (write access or read access), when an error occurs on the associated bus. For detail of error that occurs by bus, see [section 14.3.9. BUSnERRSTAT : BUS Error Status Register n \(n = 1 to 3\)](#) and [section 14.4. Bus Error Monitoring Section](#).

When an error occurs on the bus, the corresponding bit of STERRSTAT in BUSnERRSTAT (n = 1 to 3) is set to 1, at the same time, the TRWSTAT bits store the read/write status of the bus error access. The TRWSTAT bit is only valid when STERRSTAT in BUSnERRSTAT (n = 1 to 3) is set to 1.

### 14.3.9 BUSnERRSTAT : BUS Error Status Register n (n = 1 to 3)

Base address: BUS = 0x4000\_3000

Offset address: 0x1A00 + 0x10 × (n - 1)

|                    |   |   |   |           |           |   |           |           |
|--------------------|---|---|---|-----------|-----------|---|-----------|-----------|
| Bit position:      | 7 | 6 | 5 | 4         | 3         | 2 | 1         | 0         |
| Bit field:         | — | — | — | ILERRSTAT | MMERRSTAT | — | STERRSTAT | SLERRSTAT |
| Value after reset: | 0 | 0 | 0 | 0         | 0         | 0 | 0         | 0         |

| Bit | Symbol    | Function   | R/W |
|-----|-----------|--|-----|
| 0   | SLERRSTAT | Slave bus Error Status<br>0: No error occurred<br>1: Error occurred              | R   |
| 1   | STERRSTAT | Slave TrustZone filter Error Status<br>0: No error occurred<br>1: Error occurred | R   |

BTZFERAD[31:0]位仅在BUSnERRSTAT (n=1至3) 中的STERRSTAT设置为1时有效。

### 14.3.8 BTZFnERRRW: BUSTZF错误读写寄存器 (n=1到3)

Base address: BUS = 0x4000\_3000

Offset address: 0x1904 + 0x10 × (n - 1)

|               |   |   |   |   |   |   |   |         |
|---------------|---|---|---|---|---|---|---|---------|
| Bit position: | 7 | 6 | 5 | 4 | 3 | 2 | 1 | 0       |
| Bit field:    | — | — | — | — | — | — | — | TRWSTAT |
| 重置后的值:        | 0 | 0 | 0 | 0 | 0 | 0 | 0 | 0       |

| Bit | Symbol  | Function                                       | R/W |
|-----|---------|--|-----|
| 0   | TRWSTAT | TrustZone过滤器错误访问读写状态<br>出错时的状态<br>0: 读访问1: 写访问 | R   |
| 7:1 | —       | 这些位被读取为0。写入值应为0。                               | R/W |

该寄存器由除MPU和TZF相关的复位之外的复位清除，这些复位是总线主控MPU错误复位和TrustZone过滤器错误重置。

有关MPU相关复位的详细信息，请参阅第5节，复位和第15节，内存保护单元(MPU)。

以下总线错误对应于主总线：

BTZF1ERRRW:代码总线

BTZF2ERRRW:系统总线

BTZF3ERRRW : DMAC/DTC

每个BUS的连接请参见图14.1。

#### TRWSTAT位 (TrustZone过滤器错误访问读写状态)

当相关总线上发生错误时，TRWSTAT位指示访问状态（写访问或读访问）。关于总线发生错误的详细信息，请参阅第14.3.9节。BUSnERRSTAT: 总线错误状态寄存器n (n=1到3) 和第14.4节。总线错误监控部分。

当总线发生错误时，BUSnERRSTAT (n=1~3) 中STERRSTAT的对应位被置1，同时TRWSTAT位存储总线错误访问的读写状态。TRWSTAT位仅在BUSnERRSTAT (n=1至3) 中的STERRSTAT设置为1时有效。

### 14.3.9 BUSnERRSTAT:BUS错误状态寄存器n(n=1到3)

Base address: BUS = 0x4000\_3000

Offset address: 0x1A00 + 0x10 × (n - 1)

|               |   |   |   |           |           |   |           |           |
|---------------|---|---|---|-----------|-----------|---|-----------|-----------|
| Bit position: | 7 | 6 | 5 | 4         | 3         | 2 | 1         | 0         |
| Bit field:    | — | — | — | ILERRSTAT | MMERRSTAT | — | STERRSTAT | SLERRSTAT |
| 重置后的值:        | 0 | 0 | 0 | 0         | 0         | 0 | 0         | 0         |

| Bit | Symbol    | Function                              | R/W |
|-----|-----------|---------------------------------------|-----|
| 0   | SLERRSTAT | 从站总线错误状态<br>0: 未发生错误1: 发生错误           | R   |
| 1   | STERRSTAT | 从站TrustZone过滤器错误状态<br>0: 未发生错误1: 发生错误 | R   |



| Bit | Symbol    | Function   | R/W |
|-----|-----------|--|-----|
| 2   | —         | This bit is read as 0.   | R   |
| 3   | MMERRSTAT | Master MPU Error Status<br>0: No error occurred<br>1: Error occurred             | R   |
| 4   | ILERRSTAT | Illegal address access Error Status<br>0: No error occurred<br>1: Error occurred | R   |
| 7:5 | —         | These bits are read as 0.  | R   |

This register is cleared by reset other than MPU- and TZF-related resets which are Bus Master MPU Error Reset and TrustZone Filter Error Reset.

For detail of MPU related reset, see [section 5, Resets](#) and [section 15, Memory Protection Unit \(MPU\)](#).

The following bus errors correspond to the master bus:

BUS1ERRSTAT : Code bus

BUS2ERRSTAT : System bus

BUS3ERRSTAT : DMAC/DTC

See [Figure 14.1](#) for connection of each BUS

When an illegal access error, master MPU error, and slave bus error all occurred at the same time, the STAT bit is only valid in the following order of priority. The left side has higher priority.

Master MPU Error > Illegal access error, slave bus error

Note: Illegal access error and slave bus error do not occur at the same time.

Once ILERRSTAT, MMERRSTAT or SLERRSTAT is set, it cannot be cleared.

#### SLERRSTAT bit (Slave bus Error Status)

When slave error occurs by bus, BUSnERRSTAT.SLERRSTAT (n = 1 to 3) is set to 1. Clear condition is reset and set condition is when BUSnERRCLR.SLERRCLR (n = 1 to 3) is 1. Slave error is an error that occurs on a slave such as a timeout. For detail of slave error that occurs by bus, see [section 14.4. Bus Error Monitoring Section](#).

#### STERRSTAT bit (Slave TrustZone filter Error Status)

When slave TrustZone filter error occurs by bus, BUSnERRSTAT.STERRSTAT (n = 1 to 3) is set to 1. Clear condition is reset and set condition is when BUSnERRCLR.STERRCLR (n = 1 to 3) is 1. The STERRSTAT bit is not set when the debugger accesses the security area. For detail of slave TrustZone filter error that occurs by bus, see [section 46, Security Features](#).

#### MMERRSTAT bit (Master MPU Error Status)

When master MPU error occurs by bus, BUSnERRSTAT.MMERRSTAT (n = 1 to 3) is set to 1. Clear condition is reset and set condition is when BUSnERRCLR.MMERRCLR (n = 1 to 3) is 1. For detail of master MPU error that occurs by bus, see [section 15, Memory Protection Unit \(MPU\)](#).

Note: At master MPU error is occur in DMAC or DTC access, if error address value is not as master MPU area, illegal address access error or slave error is occurring before DMAC or DTC access. Decide the what error was happened by referring the error address value.

#### ILERRSTAT bit (Illegal address access Error Status)

When illegal address access error occurs by bus, BUSnERRSTAT.ILERRSTAT (n = 1 to 3) is set to 1. Clear condition is reset and set condition is when BUSnERRCLR.ILERRCLR (n = 1 to 3) is 1. For detail of illegal address access error that occurs by bus, see [section 14.4. Bus Error Monitoring Section](#).

| Bit | Symbol    | Function                      | R/W |
|-----|-----------|-------------------------------|-----|
| 2   | —         | 该位读为0。                        | R   |
| 3   | MMERRSTAT | 主控MPU错误状态<br>0: 未发生错误1: 发生错误  | R   |
| 4   | ILERRSTAT | 非法地址访问错误状态<br>0: 未发生错误1: 发生错误 | R   |
| 7:5 | —         | 这些位读为0。                       | R   |

该寄存器由除MPU和TZF相关的复位之外的复位清除，这些复位是总线主控MPU错误复位和TrustZone过滤器错误重置。

有关MPU相关复位的详细信息，请参阅第5节，复位和第15节，内存保护单元(MPU)。

以下总线错误对应于主总线：

BUS1ERRSTAT:代码总线

BUS2ERRSTAT:系统总线

BUS3ERRSTAT : DMAC/DTC

每个BUS的连接见图14.1

当非法访问错误、主MPU错误和从总线错误同时发生时，STAT位仅按以下优先级顺序有效。左侧优先级更高。

MasterMPUError>Illegalaccesserror slavebuserror

Note: 非法访问错误和从总线错误不会同时发生。

一旦ILERRSTAT、MMERRSTAT或SLERRSTAT被设置，就不能被清除。

#### SLERRSTAT位（从总线错误状态）

当总线发生从站错误时，BUSnERRSTAT.SLERRSTAT(n=1到3)设置为1。清除条件被复位，设置条件为BUSnERRCLR.SLERRCLR(n=1到3)为1。从站错误是发生在从属设备上，例如超时。关于总线发生的从站错误的详细信息，请参阅第14.4节。总线错误监控部分。

#### STERRSTAT位（从属TrustZone过滤器错误状态）

当总线发生从机TrustZone过滤器错误时，BUSnERRSTAT.STERRSTAT(n=1至3)设置为1。清除条件复位，设置条件为BUSnERRCLR.STERRCLR(n=1至3)为1。STERRSTAT位为调试器访问安全区域时不设置。有关总线发生的从属TrustZone过滤器错误的详细信息，请参阅第46节，安全功能。

#### MMERRSTAT位（主MPU错误状态）

当总线发生主MPU错误时，BUSnERRSTAT.MMERRSTAT(n=1至3)设置为1。清除条件复位，设置条件为BUSnERRCLR.MMERRCLR(n=1至3)为1。有关主MPU的详细信息总线发生的错误，请参阅第15节，内存保护单元(MPU)。

Note: 在访问DMAC或DTC时发生主MPU错误，如果错误地址值不是主MPU区域，则在访问DMAC或DTC之前发生非法地址访问错误或从站错误。通过参考错误地址值来确定发生了什么错误。

#### ILERRSTAT位（非法地址访问错误状态）

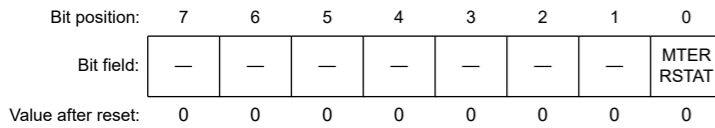
当总线发生非法地址访问错误时，BUSnERRSTAT.ILERRSTAT(n=1至3)设置为1。清除条件复位，设置条件为BUSnERRCLR.ILERRCLR(n=1至3)为1。有关非法地址的详细信息总线发生的地址访问错误，见14.4节。总线错误监控部分。



## 14.3.10 DMACDTCERRSTAT : DMAC/DTC Error Status Register

Base address: BUS = 0x4000\_3000

Offset address: 0x1A24



| Bit | Symbol    | Function  | R/W |
|-----|-----------|---|-----|
| 0   | MTERRSTAT | Master TrustZone Filter Error Status<br>0: No error occurred<br>1: Error occurred | R   |
| 7:1 | —         | These bits are read as 0.   | R   |

This register is cleared by reset other than MPU- and TZF-related resets which are Bus Master MPU Error Reset and TrustZone Filter Error Reset.

For detail of MPU related reset, see [section 5, Resets](#), [section 15, Memory Protection Unit \(MPU\)](#) and [section 46.2. Arm TrustZone Security](#).

**MTERRSTAT bit (Master TrustZone Filter Error Status)**

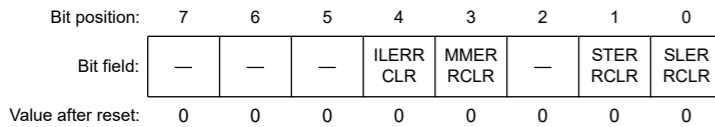
When a master TrustZone filter error occurs by DMAC or DTC, DMACDTCERRSTAT.MTERRSTAT is set to 1. Clear condition is reset and set condition is when DMACDTCERRCLR.MTERRCLR is 1.

For detail of master TrustZone filter error that occurs by DMAC or DTC, see [section 16, DMA Controller \(DMAC\)](#) and [section 17, Data Transfer Controller \(DTC\)](#)

## 14.3.11 BUSnERRCLR : BUS Error Clear Register n (n = 1 to 3)

Base address: BUS = 0x4000\_3000

Offset address: 0x1A08 + 0x10 × (n - 1)



| Bit | Symbol   | Function  | R/W              |
|-----|----------|---|------------------|
| 0   | SLERRCLR | Slave bus Error Clear<br>Writing 1 to the SLERRCLR bit clears the BUSnERRSTAT.SLERRSTAT (n = 1 to 3)              | R/W <sup>1</sup> |
| 1   | STERRCLR | Slave TrustZone filter Error Clear<br>Writing 1 to the STERRCLR bit clears the BUSnERRSTAT.STERRSTAT (n = 1 to 3) | R/W <sup>1</sup> |
| 2   | —        | This bit is read as 0. The write value should be 0.   | R/W              |
| 3   | MMERRCLR | Master MPU Error Clear<br>Writing 1 to the MMERRCLR bit clears the BUSnERRSTAT.MMERRSTAT (n = 1 to 3)             | R/W <sup>1</sup> |
| 4   | ILERRCLR | Illegal Address Access Error Clear<br>Writing 1 to the ILERRCLR bit clears the BUSnERRSTAT.ILERRSTAT (n = 1 to 3) | R/W <sup>1</sup> |
| 7:5 | —        | These bits are read as 0. The write value should be 0.  | R/W              |

Note: If the security attribution is configured as secure:

- Secure access and Non-secure read access are allowed
- Non-secure write access is ignored, and TrustZone access error is not generated.

If the security attribution is configured as Non-secure:

- Secure and Non-secure access are allowed.

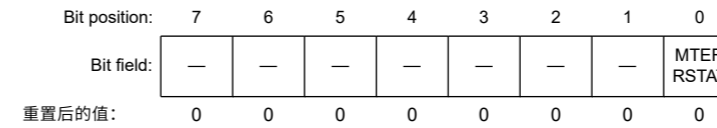
Note 1. Only 1 can be written to this bit. This bit is read as 0. Writing 0 to this bit has no effect.

The following bus errors correspond to the master bus:

## 14.3.10 DMACDTCERRSTAT: DMACDTC错误状态寄存器

Base address: BUS = 0x4000\_3000

Offset address: 0x1A24



| Bit | Symbol    | Function                                 | R/W |
|-----|-----------|--|-----|
| 0   | MTERRSTAT | 主TrustZone过滤器错误状态<br>0: 未发生错误<br>1: 发生错误 | R   |
| 7:1 | —         | 这些位读为0。                                  | R   |

该寄存器由除MPU和TZF相关的复位之外的复位清除，这些复位是总线主控MPU错误复位和TrustZone过滤器错误重置。

有关MPU相关复位的详细信息，请参阅第5节，复位，第15节，内存保护单元(MPU)和第46.2节。手臂TrustZone Security。

**MTERRSTAT位 (主TrustZone过滤器错误状态)**

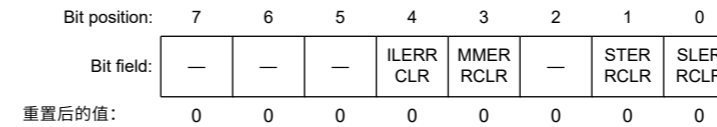
当DMAC或DTC发生主TrustZone过滤器错误时，DMACDTCERRSTAT.MTERRSTAT设置为1。清除条件复位，设置条件为DMACDTCERRCLR.MTERRCLR为1。

有关DMAC或DTC发生的主TrustZone过滤器错误的详细信息，请参阅第16节，DMA控制器(DMAC)和第17节，数据传输控制器(DTC)

## 14.3.11 BUSnERRCLR: 总线错误清除寄存器n (n=1到3)

Base address: BUS = 0x4000\_3000

Offset address: 0x1A08 + 0x10 × (n - 1)



| Bit | Symbol   | Function  | R/W              |
|-----|----------|---|------------------|
| 0   | SLERRCLR | 从总线错误清除<br>将1写入SLERRCLR位会清除BUSnERRSTAT.SLERRSTAT (n=1到3)            | R/W <sup>1</sup> |
| 1   | STERRCLR | 从站TrustZone过滤器错误清除<br>将1写入STERRCLR位会清除BUSnERRSTAT.STERRSTAT (n=1至3) | R/W <sup>1</sup> |
| 2   | —        | 该位读取为0。写入值应为0。  | R/W              |
| 3   | MMERRCLR | 主MPU错误清除<br>将1写入MMERRCLR位会清除BUSnERRSTAT.MMERRSTAT (n=1到3)           | R/W <sup>1</sup> |
| 4   | ILERRCLR | 非法地址访问错误清除<br>将1写入ILERRCLR位会清除BUSnERRSTAT.ILERRSTAT (n=1到3)         | R/W <sup>1</sup> |
| 7:5 | —        | 这些位被读取为0。写入值应为0。  | R/W              |

Note: 如果安全属性配置为安全: ●

- 允许安全访问和非安全读取访问
- 忽略非安全写入访问，不会生成TrustZone访问错误。

如果安全属性配置为非安全: ●

- 允许安全和非安全访问。

注1.该位只能写入1。该位被读取为0。向该位写入0无效。

以下总线错误对应于主总线:

BUS1ERRCLR : Code bus

BUS2ERRCLR : System bus

BUS3ERRCLR : DMAC/DTC

When writing 1 to BUSnERRCLR (n = 1 to 3), stop the bus access that causes an error in the corresponding bus master.

#### 14.3.12 DMACDTCERRCLR : DMAC/DTC Error Clear Register

Base address: BUS = 0x4000\_3000

Offset address: 0x1A2C

|                    |   |   |   |   |   |   |   |              |
|--------------------|---|---|---|---|---|---|---|--------------|
| Bit position:      | 7 | 6 | 5 | 4 | 3 | 2 | 1 | 0            |
| Bit field:         | — | — | — | — | — | — | — | MTER<br>RCLR |
| Value after reset: | 0 | 0 | 0 | 0 | 0 | 0 | 0 | 0            |

| Bit | Symbol   | Function   | R/W              |
|-----|----------|--|------------------|
| 0   | MTERRCLR | Master TrustZone filter Error Clear<br>Writing 1 to this bit clears the DMACDTCERRSTAT.MTERRSTAT flag. | R/W <sup>1</sup> |
| 7:1 | —        | This bit is read as 0. The write value should be 0.  | R/W              |

Note: If the security attribution is configured as secure:

- Secure access and Non-secure read access are allowed
  - Non-secure write access is ignored, and TrustZone access error is not generated.
- If the security attribution is configured as Non-secure:
- Secure and Non-secure access are allowed.

Note 1. Only 1 can be written to this bit. This bit is read as 0. Writing 0 to this bit has no effect.

When writing 1 to DMACDTCERRCLR, stop the bus access that causes an error in DMAC/DTC.

### 14.4 Bus Error Monitoring Section

The bus error monitoring system monitors each individual area, and when an error is detected, an error is returned to the requesting master IP using the AHB-Lite error response protocol.

#### 14.4.1 Bus Error Types

The following types of errors can occur on each bus:

- Illegal address access
- Bus master MPU error
- TrustZone Filter error
- Bus error transmitted from each slave IP

Table 14.2 lists the address ranges where access leads to illegal address access errors. The reserved area in the slave does not trigger an illegal address access error. For more information on the bus master MPU, see [section 15, Memory Protection Unit \(MPU\)](#).

#### 14.4.2 Operations When a Bus Error Occurs

When a bus error occurs, operation is not guaranteed and the error is returned to the requesting master IP.

Figure 14.3 shows operation from each error detection to user notification on the bus.

BUS1ERRCLR:代码总线

BUS2ERRCLR:系统总线

BUS3ERRCLR : DMAC/DTC

将1写入BUSnERRCLR (n=1至3)时, 停止导致相应总线主机出错的总线访问。

#### 14.3.12 DMACDTCERRCLR:DMACDTC错误清除寄存器

Base address: BUS = 0x4000\_3000

Offset address: 0x1A2C

|               |   |   |   |   |   |   |   |              |
|---------------|---|---|---|---|---|---|---|--------------|
| Bit position: | 7 | 6 | 5 | 4 | 3 | 2 | 1 | 0            |
| Bit field:    | — | — | — | — | — | — | — | MTER<br>RCLR |
| 重置后的值:        | 0 | 0 | 0 | 0 | 0 | 0 | 0 | 0            |

| Bit | Symbol   | Function  | R/W              |
|-----|----------|---|------------------|
| 0   | MTERRCLR | 主TrustZone过滤器错误清除<br>向该位写入1会清除DMACDTCERRSTAT.MTERRSTAT标志。 | R/W <sup>1</sup> |
| 7:1 | —        | 该位读取为0。写入值应为0。  | R/W              |

Note: 如果安全属性配置为安全: ●

- 允许安全访问和非安全读取访问
  - 忽略非安全写入访问, 不会生成TrustZone访问错误。
- 如果安全属性配置为非安全: ●
- 允许安全和非安全访问。

注1.该位只能写入1。该位被读取为0。向该位写入0无效。

向DMACDTCERRCLR写入1时, 停止导致DMACDTC错误的总线访问。

### 14.4 总线错误监控部分

总线错误监控系统监控每个单独的区域, 当检测到错误时, 使用AHB-Lite错误响应协议将错误返回给请求的主IP。

#### 14.4.1 总线错误类型

每条总线上都可能发生以下类型的错误:

- 非法地址访问
- 总线主控MPU错误
- TrustZone过滤器错误
- 从每个从IP传输的总线错误

表14.2列出了访问导致非法地址访问错误的地址范围。从机中的保留区域不会触发非法地址访问错误。有关总线主控MPU的更多信息, 请参阅第15节, 内存保护单元(MPU)。

#### 14.4.2 发生总线错误时的操作

当发生总线错误时, 无法保证操作, 错误会返回到请求的主IP。

图14.3显示了从每个错误检测到总线上的用户通知的操作。

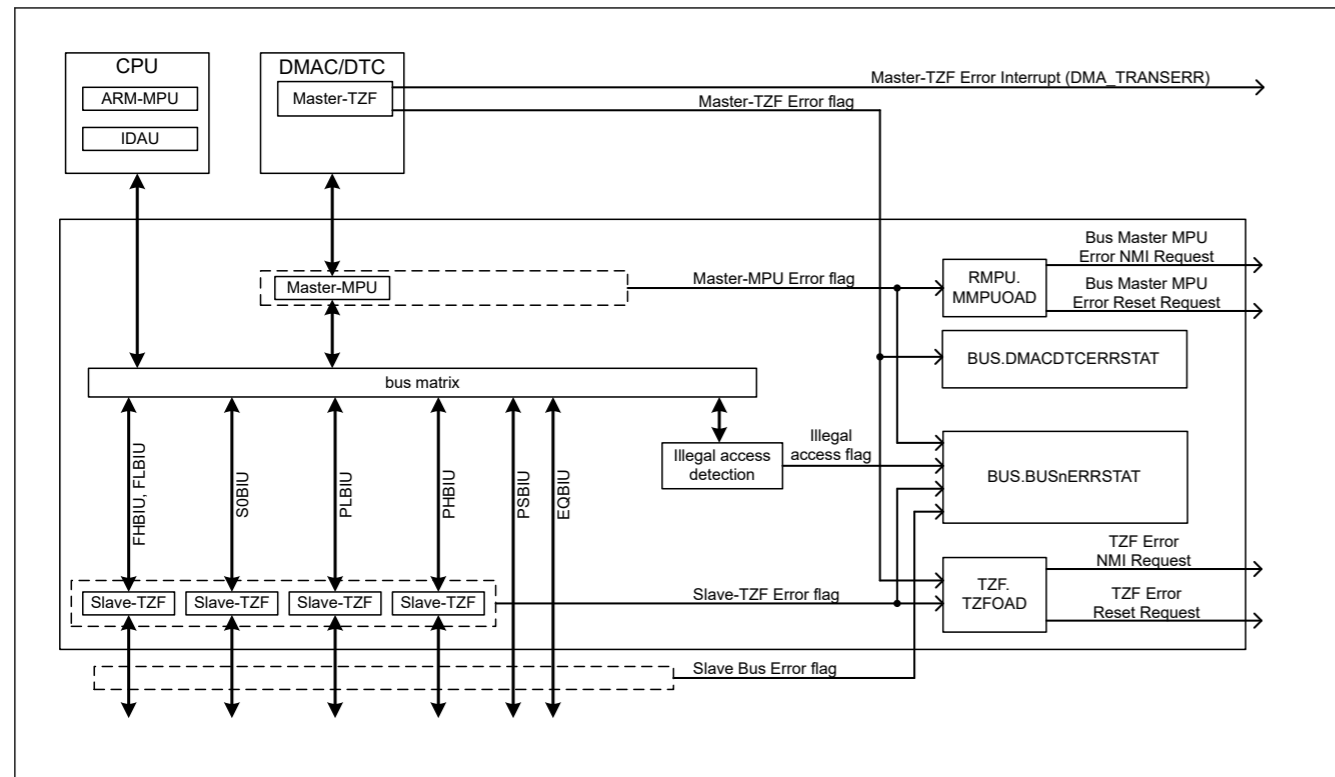


Figure 14.3 The operation from each error detection to user notification on the bus

### (1) Bus Master MPU Error

The bus master of DMAC/DTC has a master MPU for access control of the set address area. The CPU does not have a master MPU because it has an Arm MPU. When a bus master MPU error is detected, an Error response is returned to the master. At the same time, perform the following steps:

1. Store the address of the error in BUSnERRADD (n = 3).
2. Store the read/write information of the error in BUSnERRRW (n = 3).
3. Set 1 to MMERRSTAT bit of BUSnERRSTAT (n = 3).

An NMI request or a reset request is generated according to the MMPUOAD.OAD setting (see [section 15, Memory Protection Unit \(MPU\)](#)). Since BUSnERRADD (n = 3), BUSnERRRW (n = 3), and BUSnERRSTAT (n = 3) are held until reset other than MPU- and TZF-related resets or cleared by BUSnERRCLR (n = 3), they can be verified in the NMI handler or after reset.

An NMI request is generated only on the first bus master MPU error after a reset or clearing of BUSnERRSTAT.MMERRSTAT (n = 3) bit by BUSnERRCLR (n = 3).

### (2) Illegal Access Error

[section 14.4.3. Conditions Leading to Illegal Address Access Errors](#), describes illegal access errors. When an illegal access error is detected, an Error response is returned to the master. At the same time, perform the following steps:

1. Store the address of the error in BUSnERRADD (n = 1 to 3).
2. Store the read/write information of the error in BUSnERRRW (n = 1 to 3).
3. Set 1 to ILERRSTAT bit of BUSnERRSTAT (n = 1 to 3).

NMI request and reset request are not generated. Since BUSnERRADD (n = 1 to 3), BUSnERRRW (n = 1 to 3), BUSnERRSTAT (n = 1 to 3) are held until reset other than MPU- and TZF-related resets or cleared by BUSnERRCLR (n = 1 to 3), they can be confirmed in the Bus Fault handler or the interrupt handler.

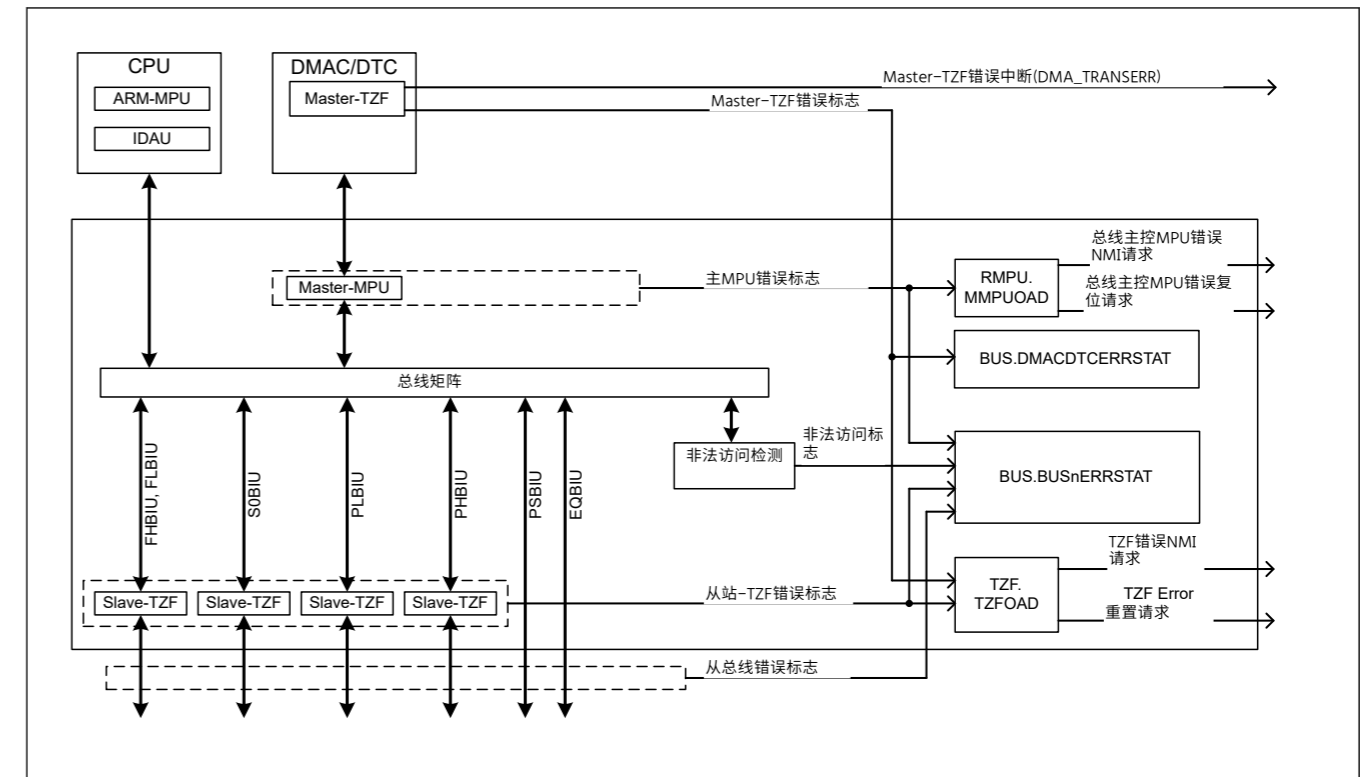


Figure 14.3 总线从每次错误检测到用户通知的操作

### (1) 总线主控MPU错误

DMACDTC的总线主控器有一个主控MPU，用于对设置的地址区域进行访问控制。CPU没有主MPU，因为它有一个ArmMPU。当检测到总线主控MPU错误时，会向主控返回错误响应。同时，执行以下步骤：

- 1.将错误地址存储在BUSnERRADD(n=3)中。
- 2.将错误的读写信息存入BUSnERRRW(n=3)。
- 3.将BUSnERRSTAT的MMERRSTAT位设置为1(n=3)。

根据MMPUOAD.OAD设置生成NMI请求或复位请求（参见第15节，内存保护单元（MPU））。由于BUSnERRADD(n=3)、BUSnERRRW(n=3)和BUSnERRSTAT(n=3)一直保持到除MPU和TZF相关复位之外的复位或被BUSnERRCLR(n=3)清除之前，它们可以在NMI中进行验证处理程序或重置后。

NMI请求仅在复位或清除后第一个总线主MPU错误时生成BUSnERRSTAT.MMERRSTAT(n=3)位由BUSnERRCLR(n=3)。

### (2) 非法访问错误

[第14.4.3节。导致非法地址访问错误的条件，描述非法访问错误。当检测到非法访问错误时，向主站返回错误响应。同时，执行以下步骤：](#)

- 1.将错误地址存储在BUSnERRADD (n=1到3) 中。
- 2.将错误的读写信息存入BUSnERRRW(n=1到3)。
- 3.将BUSnERRSTAT的ILERRSTAT位设置为1 (n=1到3) 。

不生成NMI请求和复位请求。由于BUSnERRADD (n=1到3)、BUSnERRRW (n=1到3)、BUSnERRSTAT(n=1到3)一直保持到除MPU和TZF相关的复位或被BUSnERRCLR(n=1到3)清除之前，它们可以在总线故障处理程序或中断处理程序中确认。

### (3) Master-TZF Error

As described in [section 46, Security Features](#), DMAC/DTC has Master-TZF errors. When a Master-TZF error is detected, 1 is set to MTERRSTAT bit of DMACDTCERRSTAT, and because the DMAC/DTC does not perform bus access, no bus error information is stored in BTZF3ERRADD and BTZF3ERRRW.

An NMI request or reset request is generated according to the setting of TZFOAD.OAD. See [section 16, DMA Controller \(DMAC\)](#), [section 17, Data Transfer Controller \(DTC\)](#) for details on Master-TZF errors. Because DMACDTCERRSTAT is held until reset other than MPU- and TZF-related resets or cleared by DMACDTCERRCLR, they can be verified in the NMI handler or after reset.

An NMI request is generated only on the first Master-TZF error after reset or clearing of the DMACDTCERRSTAT.MTERRSTAT bit by DMACDTCERRCLR.

### (4) Slave-TZF Error

As described in [section 46, Security Features](#), FHBIU (code flash), FLBIU (data flash), SOBIU (SRAM), PHBIU and PLBIU have Slave-TZF errors. When a Slave-TZF error is detected, perform the following steps:

1. Store the address of the error in BTZFnERRADD (n = 1 to 3).
2. Store the read/write information of the error in BTZFnERRRW (n = 1 to 3).
3. Set 1 to STERRSTAT bit of BUSnERRSTAT (n = 1 to 3).

NMI request or reset request is generated according to the setting in TZFOAD.OAD. Since BTZFnERRADD (n = 1 to 3), BTZFnERRRW (n = 1 to 3), and BUSnERRSTAT (n = 1 to 3) are held until reset other than MPU- and TZF-related resets or cleared by BUSnERRCLR (n = 1 to 3), they can be verified in the NMI handler or after reset.

An NMI request is generated only on the first Slave-TZF error after a reset or clearing of the BUSnERRSTAT.STERRSTAT (n = 1 to 3) bit by BUSnERRCLR (n = 1 to 3).

### (5) Slave Bus Error

Slave Bus Error occurs in the slave. When Slave Bus Error is detected, an Error response is returned to the master. At the same time, perform the following steps:

1. Store the address of the error in BUSnERRADD (n = 1 to 3)
2. Store the read/write information of the error in BUSnERRRW (n = 1 to 3)
3. Set 1 to SLERRSTAT bit of BUSnERRSTAT (n = 1 to 3).

An NMI request and reset request are not generated. Since BUSnERRADD (n = 1 to 3), BUSnERRRW (n = 1 to 3), and BUSnERRSTAT (n = 1 to 3) are held until reset other than MPU- and TZF-related resets or cleared by BUSnERRCLR (n = 1 to 3), they can be verified in the Bus Fault handler or interrupt handler. When a bus slave MPU error occurs, the error is returned to the requesting master IP and operation is not guaranteed.

## 14.4.3 Conditions Leading to Illegal Address Access Errors

[Table 14.2](#) lists the address spaces for each bus that trigger illegal address access errors.

**Table 14.2** Conditions leading to illegal address access errors (1 of 2)

| Address                    | Slave bus | Master bus |        |     |
|----------------------------|-----------|------------|--------|-----|
|                            |           | CPU        |        | DMA |
|                            |           | Code       | System |     |
| 0x0000_0000 to 0x01FF_FFFF | FHBIU     | —          |        | —   |
| 0x0200_0000 to 0x07FF_FFFF | Reserved  | E          |        | E   |
| 0x0800_0000 to 0x0803_FFFF | FLBIU     | —          |        | —   |
| 0x0804_0000 to 0x0FFF_FFFF | Reserved  | E          |        | E   |
| 0x1000_0000 to 0x100F_FFFF | Reserved  | —          |        | E   |
| 0x1010_0000 to 0x1FFF_FFFF | Reserved  | E          |        | E   |

### (3) Master-TZF Error

如第46节“安全特性”中所述，DMACDTC存在Master-TZF错误。当检测到Master-TZF错误时，将DMACDTCERRSTAT的MTERRSTAT位设置为1，并且由于DMACDTC不执行总线访问，因此BTZF3ERRADD和BTZF3ERRRW中不存储总线错误信息。

根据TZFOAD.OAD的设置生成NMI请求或复位请求。有关Master-TZF错误的详细信息，请参见第16节，DMA控制器(DMAC)，第17节，数据传输控制器(DTC)。因为除了MPU和TZF相关的复位或由DMACDTCERRCLR清除之外，DMACDTCERRSTAT一直保持到复位，所以可以在NMI处理程序中或在复位后对其进行验证。

NMI请求仅在复位或清除后第一个Master-TZF错误时生成DMACDTCERRCLR的DMACDTCERRSTAT.MTERRSTAT位。

### (4) Slave-TZF Error

如第46节所述，安全功能、FHBIU（代码闪存）、FLBIU（数据闪存）、SOBIU（SRAM）、PHBIU和PLBIU有Slave-TZF错误。当检测到Slave-TZF错误时，执行以下步骤：

- 1.将错误地址存储在BTZFnERRADD(n=1to3)中。
- 2.将错误的读写信息存入BTZFnERRRW(n=1to3)。
- 3.将BUSnERRSTAT的STERRSTAT位设置为1 (n=1至3)。

根据TZFOAD.OAD中的设置生成NMI请求或复位请求。由于BTZFnERRADD(n=1到3)、BTZFnERRRW(n=1到3)和BUSnERRSTAT(n=1到3)被保持到除MPU和TZF相关的复位或被BUSnERRCLR(n=1到3)清除之前，它们可以在NMI处理程序中或在重置后进行验证。

NMI请求仅在BUSnERRCLR (n=1至3) 复位或清除BUSnERRSTAT.STERRSTAT (n=1至3) 位后的第一个Slave-TZF错误时生成。

### (5) 从总线错误

从站总线错误发生在从站。当检测到从站总线错误时，将向主站返回错误响应。同时，执行以下步骤：

- 1.将错误的地址存储在BUSnERRADD(n=1to3)
- 2.将错误的读写信息存入BUSnERRRW(n=1to3)
- 3.将BUSnERRSTAT的SLERRSTAT位设置为1 (n=1至3)。

不会生成NMI请求和复位请求。由于BUSnERRADD(n=1到3)、BUSnERRRW(n=1到3)和BUSnERRSTAT(n=1到3)一直保持到除MPU和TZF相关复位之外的复位或被BUSnERRCLR(n=1到3)清除之前，它们可以在总线故障处理程序或中断处理程序中进行验证。当发生总线从MPU错误时，错误将返回到请求的主IP，并且无法保证操作。

## 14.4.3 导致非法地址访问错误的条件

[表14.2](#)列出了触发非法地址访问错误的每条总线的地址空间。

**Table 14.2** 导致非法地址访问错误的条件(1of2)

| Address                    | 从总线      | 主总线  |        |     |
|----------------------------|----------|------|--------|-----|
|                            |          | CPU  |        | DMA |
|                            |          | Code | System |     |
| 0x0000_0000 to 0x01FF_FFFF | FHBIU    | —    |        | —   |
| 0x0200_0000 to 0x07FF_FFFF | Reserved | E    |        | E   |
| 0x0800_0000 to 0x0803_FFFF | FLBIU    | —    |        | —   |
| 0x0804_0000 to 0x0FFF_FFFF | Reserved | E    |        | E   |
| 0x1000_0000 to 0x100F_FFFF | Reserved | —    |        | E   |
| 0x1010_0000 to 0x1FFF_FFFF | Reserved | E    |        | E   |



Table 14.2 Conditions leading to illegal address access errors (2 of 2)

| Address                    | Slave bus              | Master bus |        |     |
|----------------------------|------------------------|------------|--------|-----|
|                            |                        | CPU        |        | DMA |
|                            |                        | Code       | System |     |
| 0x2000_0000 to 0x2800_FFFF | S0BIU                  |            | —      | —   |
| 0x2801_0000 to 0x3FFF_FFFF | Reserved               |            | E      | E   |
| 0x4000_0000 to 0x4007_FFFF | PSBIU                  |            | —      | —   |
| 0x4008_0000 to 0x400F_FFFF | PLBIU                  |            | —      | —   |
| 0x4010_0000 to 0x4017_FFFF | PHBIU                  |            | —      | —   |
| 0x4018_0000 to 0x407D_FFFF | Reserved               |            | E      | E   |
| 0x407E_0000 to 0x407F_FFFF | FLBIU                  |            | —      | —   |
| 0x4080_0000 to 0x5FFF_FFFF | Reserved               |            | E      | E   |
| 0x6000_0000 to 0x67FF_FFFF | EQBIU                  |            | —      | —   |
| 0x6800_0000 to 0x87FF_FFFF | Reserved               |            | —      | —   |
| 0x8800_0000 to 0xDFFF_FFFF | Reserved               |            | E      | E   |
| 0xE000_0000 to 0xFFFF_FFFF | System for Cortex®-M33 |            |        | E   |

Note: "E": A bus error occurs.  
 " ": Transfer does not occur.  
 "—": A bus error has not occurred. Even if there has reserved area, a bus error has not occurred.  
 Do not access reserved area in FLBIU and S0BIU. If accessed, a slave TZF error might occur.

#### 14.4.4 Time-out

For some peripheral modules, a timeout error occurs with the module-stop function. When there is no response from the slave for a certain period of time, a timeout error is detected. A timeout error is returned to the requesting master IP using the AHB-Lite error response protocol.

### 14.5 References

1. ARM Limited, ARM v8-M Architecture Reference Manual (ARM DDI0553B.g)
2. ARM Limited, ARM Cortex-M33 Processor Technical Reference Manual Revision:r0p4 (ARM 100230\_0004\_00\_en)
3. ARM Limited, ARM AMBA 5 AHB Protocol Specification AHB5, AHB-Lite (ARM IHI 0033B.b)
4. ARM Limited, ARM AMBA AXI and ACE Protocol Specification AXI3, AXI4, and AXI4-Lite, ACE and ACE-Lite (ARM IHI 0022D)
5. ARM Limited, ARM AMBA APB Protocol Specification Version: 2.0 (ARM IHI 0024C)

### 14.6 Cache

#### 14.6.1 Overview

There are two types of caches:

- C-cache on code bus
- S-cache on system bus.

Table 14.3 lists the specifications of the cache, Figure 14.4 shows a block diagram of the cache, and Figure 14.5 shows the cache structure in details.

Table 14.3 Cache specifications (1 of 2)

| Parameter | C-cache | S-cache |
|-----------|---------|---------|
| Capacity  | 2 KB    | 2 KB    |

Table 14.2 导致非法地址访问错误的条件(2of2)

| Address                    | 从总线           | 主总线  |        |     |
|----------------------------|---------------|------|--------|-----|
|                            |               | CPU  |        | DMA |
|                            |               | Code | System |     |
| 0x2000_0000 to 0x2800_FFFF | S0BIU         |      | —      | —   |
| 0x2801_0000 to 0x3FFF_FFFF | Reserved      |      | E      | E   |
| 0x4000_0000 to 0x4007_FFFF | PSBIU         |      | —      | —   |
| 0x4008_0000 to 0x400F_FFFF | PLBIU         |      | —      | —   |
| 0x4010_0000 to 0x4017_FFFF | PHBIU         |      | —      | —   |
| 0x4018_0000 to 0x407D_FFFF | Reserved      |      | E      | E   |
| 0x407E_0000 to 0x407F_FFFF | FLBIU         |      | —      | —   |
| 0x4080_0000 to 0x5FFF_FFFF | Reserved      |      | E      | E   |
| 0x6000_0000 to 0x67FF_FFFF | EQBIU         |      | —      | —   |
| 0x6800_0000 to 0x87FF_FFFF | Reserved      |      | —      | —   |
| 0x8800_0000 to 0xDFFF_FFFF | Reserved      |      | E      | E   |
| 0xE000_0000 to 0xFFFF_FFFF | Cortex®-M33系统 |      |        | E   |

Note: "E": 发生总线错误。" ": 不发生传输。"—": 未发生总线错误。即使有保留区域, 也没有发生总线错误。不要访问FLBIU和S0BIU中的保留区域。如果访问, 可能会发生从属TZF错误。

#### 14.4.4 Time-out

对于某些外围模块, 模块停止功能会发生超时错误。当从机在一段时间内没有响应时, 检测到超时错误。使用AHB-Lite错误响应协议将超时错误返回给请求的主IP。

### 14.5 References

1. ARMLimited, ARMv8-M架构参考手册 (ARMDDI0553B.g)
2. ARMLimited, ARM Cortex-M33处理器技术参考手册修订版: r0p4 (ARM100230\_0004\_00\_en)
3. ARMLimited, ARM AMBA 5 AHB协议规范AHB5、AHB-Lite (ARM IHI0033B.b)
4. ARMLimited, ARM AMBA AXI和ACE协议规范AXI3、AXI4和AXI4-Lite、ACE和ACE-Lite (ARM IHI0022D)
5. ARMLimited, ARM AMBA APB协议规范版本: 2.0 (ARM IHI0024C)

### 14.6 Cache

#### 14.6.1 Overview

缓存有两种类型: ●代码总线上的C-cache ●系统总线上的S-cache。

表14.3列出了缓存的规格, 图14.4显示了缓存的框图, 图14.5详细显示了缓存结构。

Table 14.3 缓存规范(1of2)

| Parameter | C-cache | S-cache |
|-----------|---------|---------|
| Capacity  | 2 KB    | 2 KB    |



Table 14.3 Cache specifications (2 of 2)

| Parameter          | C-cache                          | S-cache  |
|--------------------|----------------------------------|--|
| Way                | 2-way set associative            | 2-way set associative  |
| Line size          | 32/64 bytes                      | 32/64 bytes  |
| Number of entry    | 32/16 entry/way                  | 32/16 entry/way  |
| Write way          | No write                         | Write-through, non-write allocate  |
| Replace way        | 2-way: LRU (least recently used) | 2-way: LRU (least recently used)   |
| Cache support area | 0x0000_0000 to 0x1FFF_FFFF       | 0x20000000 – 0xDFFFFFFF*1 except Standby SRAM area (0x2800_0000 to 0x2FFFF_FFFF) |

Note 1. Peripheral area 0x4000\_0000 to 0x5FFF\_FFFF must not have the cacheable attribution in the Arm MPU.

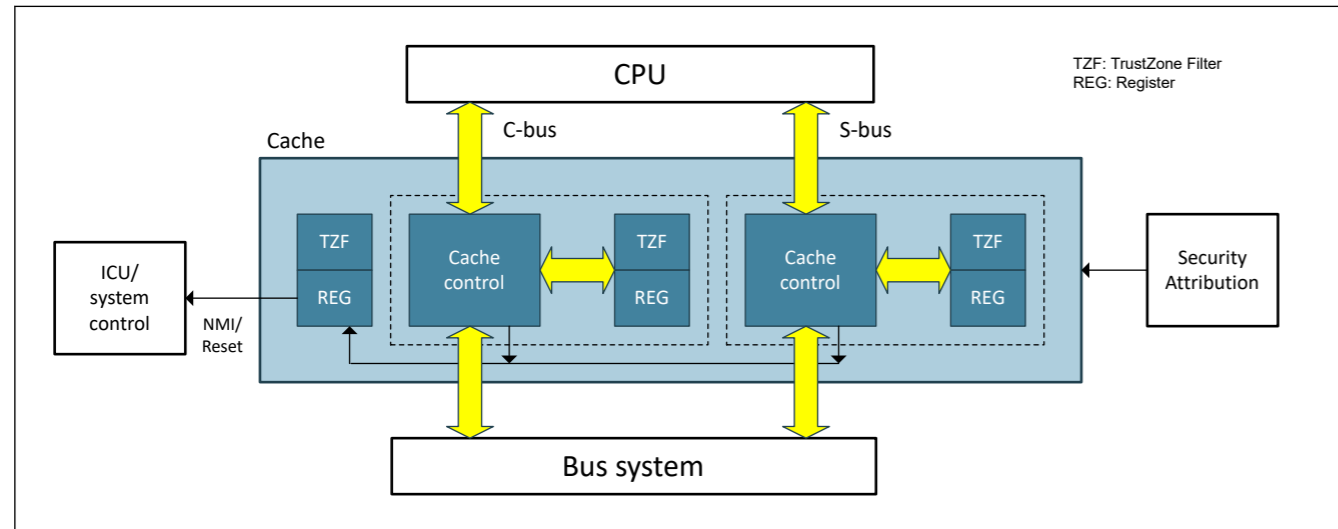


Figure 14.4 Cache block diagram

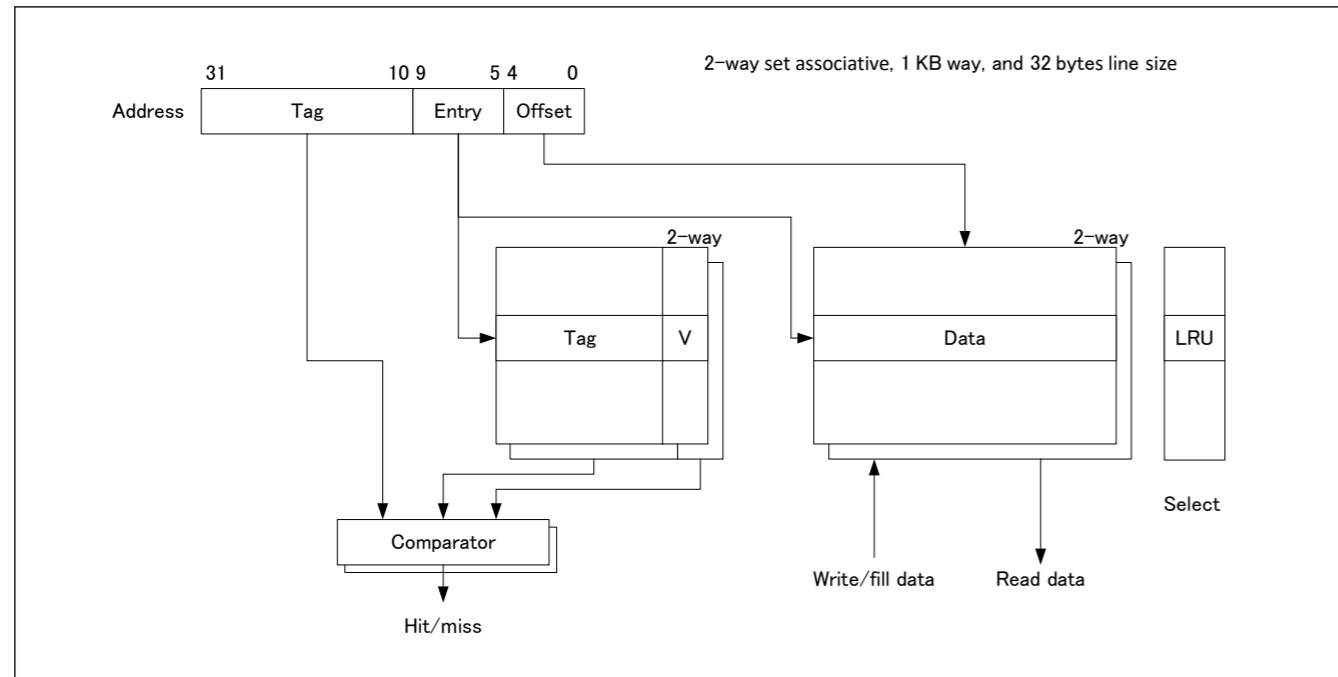


Figure 14.5 Cache structure for 2-way set associative of 2 KB capacity and 32 bytes line size

Table 14.3 缓存规范 (2个中的2个)

| Parameter | C-cache                          | S-cache  |
|-----------|----------------------------------|--|
| Way       | 2路组关联                            | 2路组关联  |
| 线条尺寸      | 32/64 bytes                      | 32/64 bytes  |
| 入境次数      | 32/16 entry/way                  | 32/16 entry/way  |
| 写法        | 不写                               | Write-through, non-write allocate                            |
| 更换方式      | 2-way: LRU (least recently used) | 2-way: LRU (least recently used)                             |
| 缓存支持区     | 0x0000_0000 to 0x1FFF_FFFF       | 0x20000000 0xDFFFFFFF*1除了待机SRAM区域 (0x2800_0000到0x2FFFF_FFFF) |

注1.外设区域0x4000\_0000到0x5FFF\_FFFF在ArmMPU中不得具有可缓存属性。

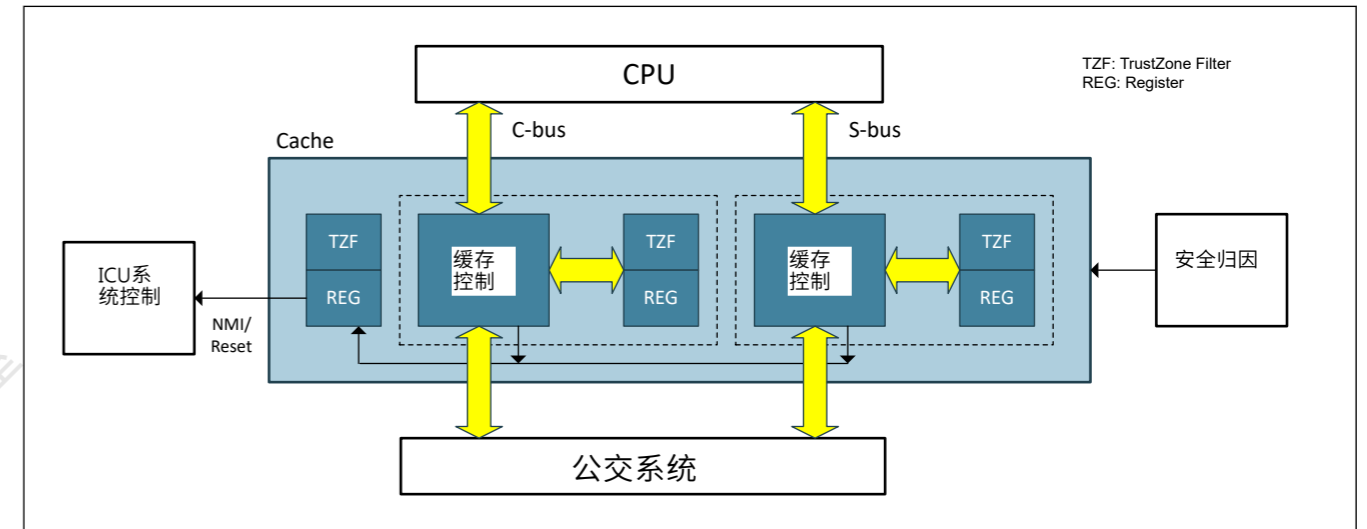


Figure 14.4 缓存框图

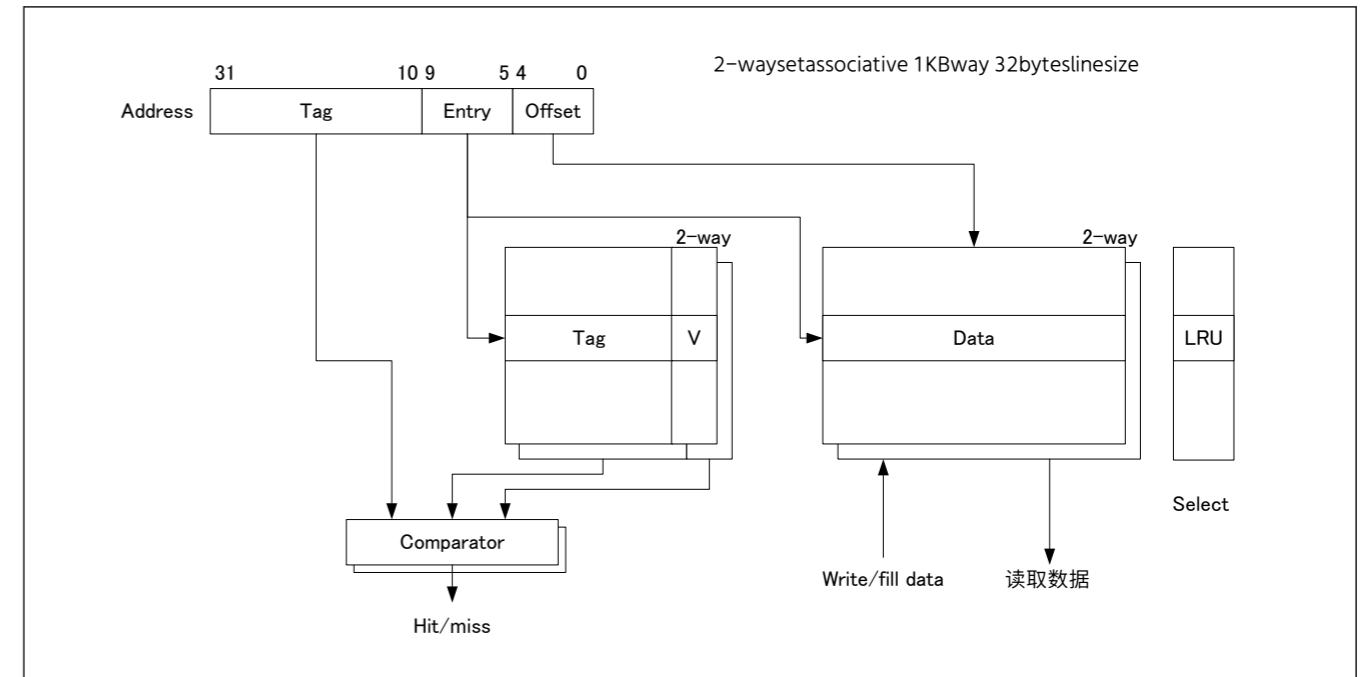


Figure 14.5 2KB容量和32字节行大小的2路组关联的缓存结构

## 14.6.2 Register Description

## 14.6.2.1 CSAR : Cache Security Attribution Register

Base address: CPSCU = 0x4000\_8000

Offset address: 0x000

|                    |    |    |    |    |    |    |    |    |    |    |    |    |    |              |              |             |
|--------------------|----|----|----|----|----|----|----|----|----|----|----|----|----|--------------|--------------|-------------|
| Bit position:      | 31 | 30 | 29 | 28 | 27 | 26 | 25 | 24 | 23 | 22 | 21 | 20 | 19 | 18           | 17           | 16          |
| Bit field:         | —  | —  | —  | —  | —  | —  | —  | —  | —  | —  | —  | —  | —  | —            | —            | —           |
| Value after reset: | 1  | 1  | 1  | 1  | 1  | 1  | 1  | 1  | 1  | 1  | 1  | 1  | 1  | 1            | 1            | 1           |
| Bit position:      | 15 | 14 | 13 | 12 | 11 | 10 | 9  | 8  | 7  | 6  | 5  | 4  | 3  | 2            | 1            | 0           |
| Bit field:         | —  | —  | —  | —  | —  | —  | —  | —  | —  | —  | —  | —  | —  | CACH<br>EESA | CACH<br>ELSA | CACH<br>ESA |
| Value after reset: | 1  | 1  | 1  | 1  | 1  | 1  | 1  | 1  | 1  | 1  | 1  | 1  | 1  | 1            | 1            | 1           |

| Bit  | Symbol   | Function  | R/W |
|------|----------|---|-----|
| 0    | CACHESA  | Security Attributes of Registers for Cache Control<br>0: Secure<br>1: Non-secure            | R/W |
| 1    | CACHELSA | Security Attributes of Registers for Cache Line Configuration<br>0: Secure<br>1: Non-secure | R/W |
| 2    | CACHEESA | Security Attributes of Registers for Cache Error<br>0: Secure<br>1: Non-secure              | R/W |
| 31:3 | —        | These bits are read as 1.   | R   |

Note: This register is write-protected by PRCR register.

**CACHESA bit (Security Attributes of Registers for Cache Control)**

The CACHESA bit indicates the security attributes of registers for cache control. The target registers are:

- CCACTL
- CCAFCT
- SCACTL
- SCAFCT.

**CACHELSA bit (Security Attributes of Registers for Cache Line Configuration)**

The CACHELSA bit indicates the security attributes of registers for cache line configuration. The target registers are:

- CCALCF
- SCALCF.

**CACHEESA bit (Security Attributes of Registers for Cache Error)**

The CACHEESA bit indicates the security attributes of registers for cache error.

- CAPOAD
- CAPRCR.

## 14.6.2 注册说明

## 14.6.2.1 CSAR:缓存安全属性寄存器

Base address: CPSCU = 0x4000\_8000

Offset address: 0x000

|               |    |    |    |    |    |    |    |    |    |    |    |    |    |    |              |              |             |
|---------------|----|----|----|----|----|----|----|----|----|----|----|----|----|----|--------------|--------------|-------------|
| Bit position: | 31 | 30 | 29 | 28 | 27 | 26 | 25 | 24 | 23 | 22 | 21 | 20 | 19 | 18 | 17           | 16           |             |
| Bit field:    | —  | —  | —  | —  | —  | —  | —  | —  | —  | —  | —  | —  | —  | —  | —            | —            |             |
| 重置后的值:        | 1  | 1  | 1  | 1  | 1  | 1  | 1  | 1  | 1  | 1  | 1  | 1  | 1  | 1  | 1            | 1            |             |
| Bit position: | 15 | 14 | 13 | 12 | 11 | 10 | 9  | 8  | 7  | 6  | 5  | 4  | 3  | 2  | 1            | 0            |             |
| Bit field:    | —  | —  | —  | —  | —  | —  | —  | —  | —  | —  | —  | —  | —  | —  | CACH<br>EESA | CACH<br>ELSA | CACH<br>ESA |
| 重置后的值:        | 1  | 1  | 1  | 1  | 1  | 1  | 1  | 1  | 1  | 1  | 1  | 1  | 1  | 1  | 1            | 1            |             |

| Bit  | Symbol   | Function                                    | R/W |
|------|----------|---|-----|
| 0    | CACHESA  | 缓存控制寄存器的安全属性<br>0: Secure<br>1: Non-secure  | R/W |
| 1    | CACHELSA | 缓存行配置寄存器的安全属性<br>0: Secure<br>1: Non-secure | R/W |
| 2    | CACHEESA | 缓存错误寄存器的安全属性<br>0: Secure<br>1: Non-secure  | R/W |
| 31:3 | —        | 这些位读为1。                                     | R   |

Note: 该寄存器由PRCR寄存器写保护。

**CACHESA位 (缓存控制寄存器的安全属性)**

CACHESA位指示用于缓存控制的寄存器的安全属性。目标寄存器是: ●CCACTL●CCAFCT●SCACTL●SCAFCT。

**CACHELSA位 (缓存线配置寄存器的安全属性)**

CACHELSA位指示用于高速缓存行配置的寄存器的安全属性。目标寄存器是: ●CCALCF●SCALCF。



**CACHEESA位 (缓存错误寄存器的安全属性)**

CACHEESA位指示缓存错误寄存器的安全属性。●CAPOAD●CAPRCR。

## 14.6.2.2 CCACTL : C-Cache Control Register

Base address: CACHE = 0x4000\_7000

Offset address: 0x000

|                    |    |  |   |
|--------------------|----|--|---|
| Bit position:      | 31 |  | 0 |
| Value after reset: |    |  |   |

| Bit  | Symbol | Function   | R/W |
|------|--------|--|-----|
| 0    | ENC    | C-Cache Enable<br>Set the C-cache enable:<br>0: Disable C-cache<br>1: Enable C-cache | R/W |
| 31:1 | —      | These bits are read as 0. The write value should be 0.                               | R   |

Note: If the security attribution is configured as secure:

- Secure access and Non-secure read access are allowed
- Non-secure write access is ignored, and TrustZone access error is not generated.

If the security attribution is configured as Non-secure:

- Secure and Non-secure access are allowed.

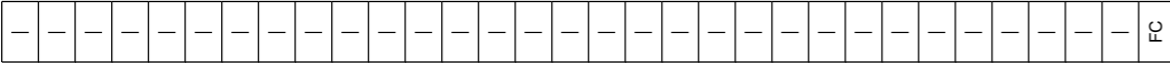

**ENC bit (C-Cache Enable)**

The ENC bit controls the cache enable of C-cache. When the ENC bit changes from 0 to 1, the Valid bit of C-cache is cleared.

## 14.6.2.3 CCAFCT : C-Cache Flush Control Register

Base address: CACHE = 0x4000\_7000

Offset address: 0x004

|                    |    |  |   |
|--------------------|----|--|---|
| Bit position:      | 31 |  | 0 |
| Value after reset: |    |  |   |

| Bit  | Symbol | Function  | R/W |
|------|--------|---|-----|
| 0    | FC     | C-Cache Flush<br>Set the C-cache line flush:<br>0: No action<br>1: C-cache line flush (all lines invalidated) | R/W |
| 31:1 | —      | These bits are read as 0. The write value should be 0.  | R   |

Note: If the security attribution is configured as secure:

- Secure access and Non-secure read access are allowed
- Non-secure write access is ignored, and TrustZone access error is not generated.

If the security attribution is configured as Non-secure:

- Secure and Non-secure access are allowed.

**FC bit (C-Cache Flush)**

The FC bit controls the cache flush of C-cache.

[Setting condition]

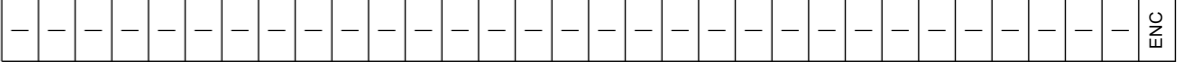
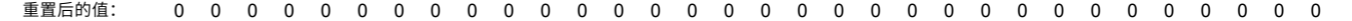
- When writing 1 to this bit.
- When setting CCACTL.ENC bit from "0" to "1".

[Clearing condition]

## 14.6.2.2 CCACTL:C-Cache控制寄存器

Base address: CACHE = 0x4000\_7000

Offset address: 0x000

|               |    |   |   |
|---------------|----|---|---|
| Bit position: | 31 |  | 0 |
| 重置后的值:        |    |  |   |

| Bit  | Symbol | Function   | R/W |
|------|--------|--|-----|
| 0    | ENC    | C-Cache Enable<br>设置C缓存启用:<br>0: 禁用C-cache<br>1: 启用C-cache | R/W |
| 31:1 | —      | 这些位被读取为0。写入值应为0。   | R   |

Note: 如果安全属性配置为安全: ●

- 允许安全访问和非安全读取访问
- 忽略非安全写入访问, 不会生成TrustZone访问错误。

如果安全属性配置为非安全: ●

- 允许安全和非安全访问。



**ENC bit (C-Cache Enable)**

ENC位控制C-cache的缓存使能。当ENC位从0变为1时, C-cache的Valid位被清除。

## 14.6.2.3 CCAFCT:C-Cache刷新控制寄存器

Base address: CACHE = 0x4000\_7000

Offset address: 0x004

|               |    |   |   |
|---------------|----|---|---|
| Bit position: | 31 |  | 0 |
| 重置后的值:        |    |  |   |

| Bit  | Symbol | Function  | R/W |
|------|--------|---|-----|
| 0    | FC     | C-Cache Flush<br>设置C-cache行刷新:<br>0: 无操作<br>1: C-cache行刷新 (所有行无效) | R/W |
| 31:1 | —      | 这些位被读取为0。写入值应为0。  | R   |

Note: 如果安全属性配置为安全: ●

- 允许安全访问和非安全读取访问
- 忽略非安全写入访问, 不会生成TrustZone访问错误。

如果安全属性配置为非安全: ●

- 允许安全和非安全访问。

**FC bit (C-Cache Flush)**

FC位控制C-cache的缓存刷新。

[Setting condition]

- 向该位写入1时。
- 将CCACTL.ENC位从"0"设置为"1"时。

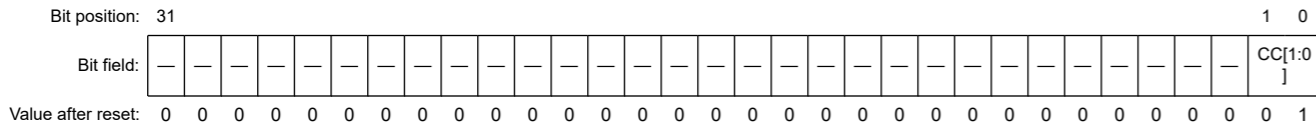
[Clearing condition]

- This bit is cleared automatically when cache flush is performed.

#### 14.6.2.4 CCALCF : C-Cache Line Configuration Register

Base address: CACHE = 0x4000\_7000

Offset address: 0x008



| Bit  | Symbol  | Function  | R/W |
|------|---------|---|-----|
| 1:0  | CC[1:0] | C-Cache Line Size<br>Set the C-cache line size:<br>0 0: Prohibited<br>0 1: Cache line size 32 bytes<br>1 0: Cache line size 64 bytes<br>1 1: Prohibited | R/W |
| 31:2 | —       | These bits are read as 0. The write value should be 0.  | R   |

Note: If the security attribution is configured as secure:

- Secure access and Non-secure read access are allowed
  - Non-secure write access is ignored, and TrustZone access error is not generated.
- If the security attribution is configured as Non-secure:
- Secure and Non-secure access are allowed.

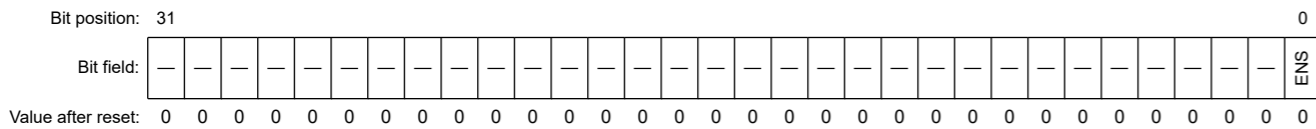
##### CC[1:0] bits (C-Cache Line Size)

The CC[1:0] bits control the cache line size of C-cache. This bit can be written when the CCACTL.ENC bit is 0. Otherwise, this bit cannot be written.

#### 14.6.2.5 SCACTL : S-Cache Control Register

Base address: CACHE = 0x4000\_7000

Offset address: 0x040



| Bit  | Symbol | Function   | R/W |
|------|--------|--|-----|
| 0    | ENS    | S-Cache Enable<br>Set the S-cache enable:<br>0: Disable S-cache<br>1: Enable S-cache | R/W |
| 31:1 | —      | These bits are read as 0. The write value should be 0.                               | R   |

Note: If the security attribution is configured as secure:

- Secure access and Non-secure read access are allowed
  - Non-secure write access is ignored, and TrustZone access error is not generated.
- If the security attribution is configured as Non-secure:
- Secure and Non-secure access are allowed.

##### ENS bit (S-Cache Enable)

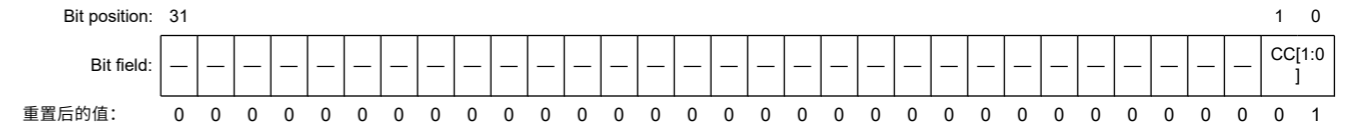
The ENS bit controls the cache enable of S-cache. When the ENS bit changes from 0 to 1, the Valid bit of S-cache is cleared.

- 执行缓存刷新时，该位自动清零。

#### 14.6.2.4 CCALCF:C-Cache行配置寄存器

Base address: CACHE = 0x4000\_7000

Offset address: 0x008



| Bit  | Symbol  | Function  | R/W |
|------|---------|---|-----|
| 1:0  | CC[1:0] | C-Cache行大小<br>设置C-cache行大小:<br>00: 禁止01: 缓存线大小32<br>字节10: 缓存线大小64字节1<br>1: 禁止 | R/W |
| 31:2 | —       | 这些位被读取为0。写入值应为0。  | R   |

Note: 如果安全属性配置为安全: ●

- 允许安全访问和非安全读取访问
  - 忽略非安全写入访问，不会生成TrustZone访问错误。
- 如果安全属性配置为非安全: ●
- 允许安全和非安全访问。

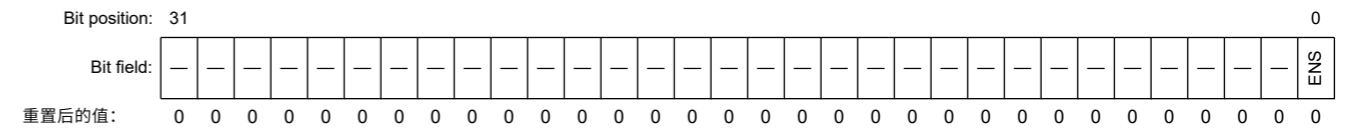
##### CC[1:0]位 (C-CacheLineSize)

CC[1:0]位控制C-cache的高速缓存行大小。当CACTL.ENC位为0时可以写入该位。否则，无法写入该位。

#### 14.6.2.5 SCACTL:S-Cache控制寄存器

Base address: CACHE = 0x4000\_7000

Offset address: 0x040



| Bit  | Symbol | Function   | R/W |
|------|--------|--|-----|
| 0    | ENS    | S-Cache Enable<br>设置S-cache启用:<br>0: 禁用S-cache1<br>: 启用S-cache | R/W |
| 31:1 | —      | 这些位被读取为0。写入值应为0。   | R   |

Note: 如果安全属性配置为安全: ●

- 允许安全访问和非安全读取访问
  - 忽略非安全写入访问，不会生成TrustZone访问错误。
- 如果安全属性配置为非安全: ●
- 允许安全和非安全访问。

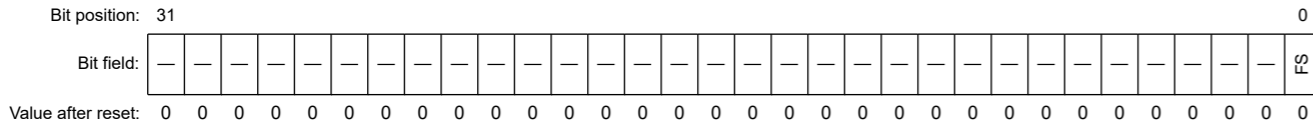
##### ENS位 (S-Cache启用)

ENS位控制S-cache的缓存使能。当ENS位从0变为1时，S-cache的Valid位被清除。

### 14.6.2.6 SCAFACT : S-Cache Flush Control Register

Base address: CACHE = 0x4000\_7000

Offset address: 0x044



| Bit  | Symbol | Function  | R/W |
|------|--------|---|-----|
| 0    | FS     | S-Cache Flush<br>Set the S-cache line flush:<br>0: No action<br>1: S-cache line flush (all lines invalidated) | R/W |
| 31:1 | —      | These bits are read as 0. The write value should be 0.  | R   |

Note: If the security attribution is configured as secure:

- Secure access and Non-secure read access are allowed
- Non-secure write access is ignored, and TrustZone access error is not generated.

If the security attribution is configured as Non-secure:

- Secure and Non-secure access are allowed.

#### FS bit (S-Cache Flush)

The FS bit controls the cache flush of S-cache.

[Setting condition]

When writing 1 to this bit.

When setting SCACTL.ENS bit from "0" to "1".

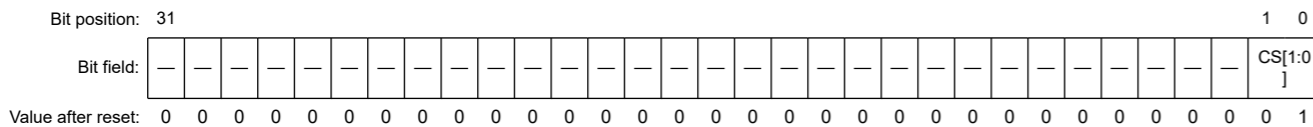
[Clearing condition]

This bit is cleared automatically when cache flush is performed.

### 14.6.2.7 SCALCF : S-Cache Line Configuration Register

Base address: CACHE = 0x4000\_7000

Offset address: 0x048



| Bit  | Symbol  | Function  | R/W |
|------|---------|---|-----|
| 1:0  | CS[1:0] | S-Cache Line Size<br>Set the S-cache line size:<br>00: Prohibited<br>01: Cache line size 32 bytes<br>10: Cache line size 64 bytes<br>11: Prohibited | R/W |
| 31:2 | —       | These bits are read as 0. The write value should be 0.  | R   |

Note: If the security attribution is configured as secure:

- Secure access and Non-secure read access are allowed
- Non-secure write access is ignored, and TrustZone access error is not generated.

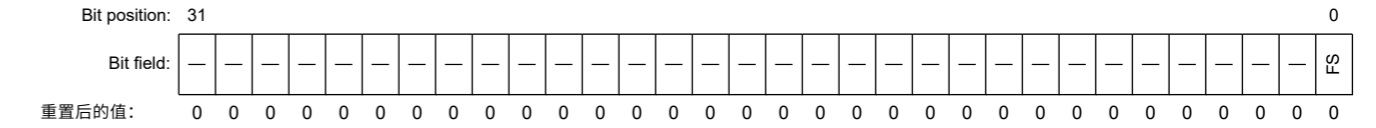
If the security attribution is configured as Non-secure:

- Secure and Non-secure access are allowed.

### 14.6.2.6 SCAFACT:S-Cache刷新控制寄存器

Base address: CACHE = 0x4000\_7000

Offset address: 0x044



| Bit  | Symbol | Function  | R/W |
|------|--------|---|-----|
| 0    | FS     | S-Cache Flush<br>设置S-cache行刷新:<br>0: 无操作1: S-cache行刷新 (所有行无效) | R/W |
| 31:1 | —      | 这些位被读取为0。写入值应为0。  | R   |

Note: 如果安全属性配置为安全: ●  
允许安全访问和非安全读取访问

- 忽略非安全写入访问, 不会生成TrustZone访问错误。

如果安全属性配置为非安全: ●  
允许安全和非安全访问。

#### FS bit (S-Cache Flush)

FS位控制S-cache的缓存刷新。

[Setting condition]

向该位写入1时。

将SCACTLENS位从“0”设置为“1”时。

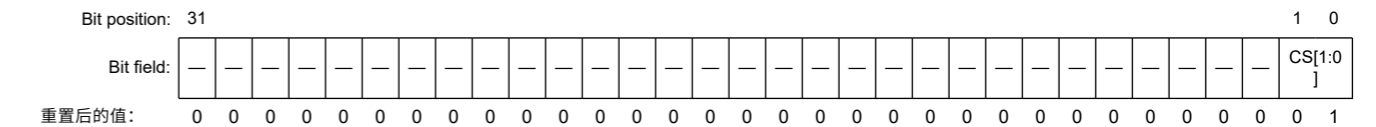
[Clearing condition]

执行缓存刷新时, 该位会自动清除。

### 14.6.2.7 SCALCF:S-Cache行配置寄存器

Base address: CACHE = 0x4000\_7000

Offset address: 0x048



| Bit  | Symbol  | Function  | R/W |
|------|---------|---|-----|
| 1:0  | CS[1:0] | S-Cache行大小<br>设置S-cache行大小:<br>00: 禁止01: 缓存线大小32字节<br>10: 缓存线大小64字节<br>11: 禁止 | R/W |
| 31:2 | —       | 这些位被读取为0。写入值应为0。  | R   |

Note: 如果安全属性配置为安全: ●  
允许安全访问和非安全读取访问

- 忽略非安全写入访问, 不会生成TrustZone访问错误。

如果安全属性配置为非安全: ●  
允许安全和非安全访问。



**CS[1:0] bits (S-Cache Line Size)**

The CS[1:0] bits control the cache line size of S-cache. This bit can be written when the SCACTL.ENS bit is 0. Otherwise, this bit cannot be written.

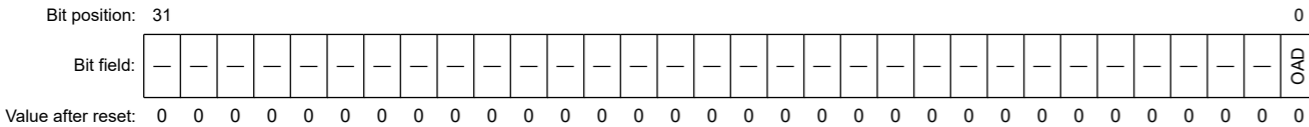
[Setting condition]

This bit can be written when the CACTL.ENS bit is 0. Otherwise, this bit cannot be written.

**14.6.2.8 CAPOAD : Cache Parity Error Operation After Detection Register**

Base address: CACHE = 0x4000\_7000

Offset address: 0x200



| Bit  | Symbol | Function  | R/W |
|------|--------|---|-----|
| 0    | OAD    | Operation after Detection<br>Select the operation after detection:<br>0: Non-maskable interrupt<br>1: Reset | R/W |
| 31:1 | —      | These bits are read as 0. The write value should be 0.  | R   |

Note: If the security attribution is configured as secure:  
 • Secure access and Non-secure read access are allowed  
 • Non-secure write access is ignored, and TrustZone access error is not generated.  
 If the security attribution is configured as Non-secure:  
 • Secure and Non-secure access are allowed.

**OAD bit (Operation after Detection)**

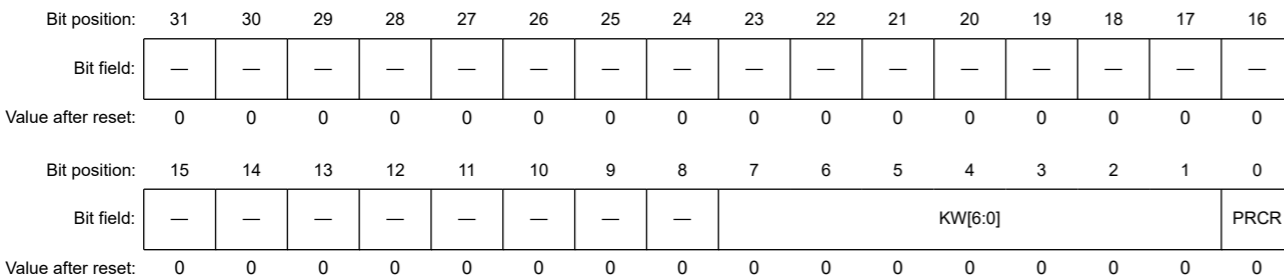
The OAD bit generates either a reset or a non-maskable interrupt when parity error is detected.

The protection register (CAPRCR) protects this register against writes. Modify the valid bit in the protection register (CAPRCR) to enable before writing to this bit. Do not write to CAPOAD while access to cache is in progress.

**14.6.2.9 CAPRCR : Cache Protection Register**

Base address: CACHE = 0x4000\_7000

Offset address: 0x204



| Bit | Symbol  | Function   | R/W |
|-----|---------|--|-----|
| 0   | PRCR    | Register Write Control<br>Set the register write control:<br>0: Disable writes to protected registers<br>1: Enable writes to protected registers | R/W |
| 7:1 | KW[6:0] | Write key code<br>These bits enable or disable writes to the PRCR bit.   | R/W |

**CS[1:0]位 (S-Cache行大小)**

CS[1:0]位控制S-cache的缓存线大小。当SCACTL.ENS位为0时可以写入该位。否则，无法写入该位。

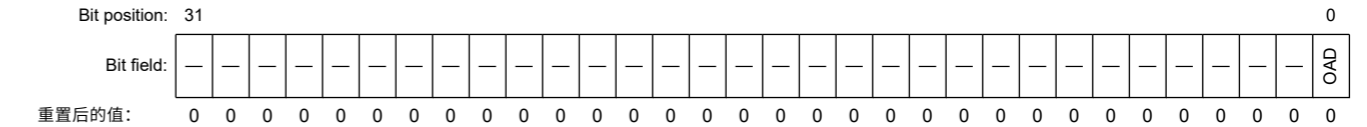
[Setting condition]

当CACTL.ENS位为0时可以写入该位。否则，无法写入该位。

**14.6.2.8 CAPOAD：检测寄存器后缓存奇偶校验错误操作**

Base address: CACHE = 0x4000\_7000

Offset address: 0x200



| Bit  | Symbol | Function                             | R/W |
|------|--------|--------------------------------------|-----|
| 0    | OAD    | 检测后的操作<br>检测后选择操作:<br>0: 不可屏蔽中断1: 复位 | R/W |
| 31:1 | —      | 这些位被读取为0。写入值应为0。                     | R   |

Note: 如果安全属性配置为安全: ●  
 允许安全访问和非安全读取访问  
 • 忽略非安全写入访问, 不会生成TrustZone访问错误。  
 如果安全属性配置为非安全: ●  
 允许安全和非安全访问。

**OAD位 (检测后的操作)**

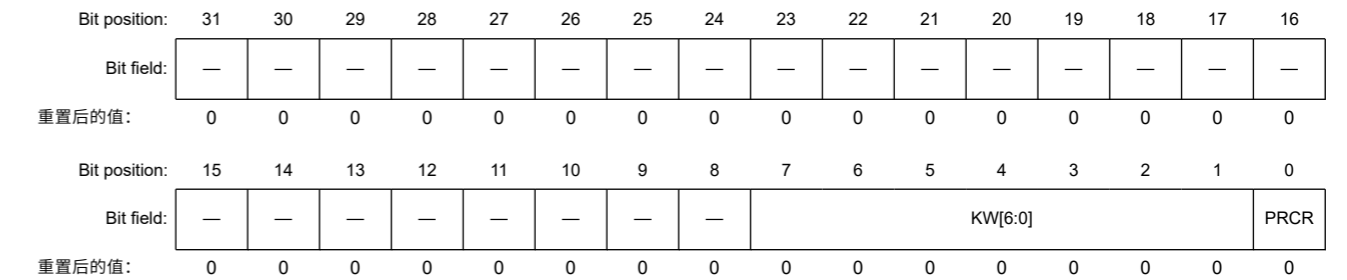
当检测到奇偶校验错误时, OAD位会产生复位或不可屏蔽中断。

保护寄存器(CAPRCR)保护该寄存器不被写入。在写入该位之前修改保护寄存器(CAPRCR)中的有效位以使用。在访问缓存的过程中不要写入CAPOAD。

**14.6.2.9 CAPRCR:缓存保护寄存器**

Base address: CACHE = 0x4000\_7000

Offset address: 0x204



| Bit | Symbol  | Function  | R/W |
|-----|---------|---|-----|
| 0   | PRCR    | 寄存器写控制<br>设置寄存器写控制:<br>0: 禁止写入受保护寄存器1: 允许写入受保护寄存器 | R/W |
| 7:1 | KW[6:0] | 编写关键代码<br>这些位启用或禁用对PRCR位的写入。                      | R/W |

| Bit  | Symbol | Function   | R/W |
|------|--------|--|-----|
| 31:8 | —      | These bits are read as 0. The write value should be 0. | R/W |

Note: If the security attribution is configured as secure:

- Secure access and Non-secure read access are allowed
- Non-secure write access is ignored, and TrustZone access error is not generated.

If the security attribution is configured as Non-secure:

- Secure and Non-secure access are allowed.

**PRCR bit (Register Write Control)**

The PRCR bit controls the write mode of the CAPOAD register. When this bit is set to 1, writing to the CAPOAD register is enabled. When writing to this bit, write 0x78 to the KW[6:0] bits simultaneously.

**KW[6:0] bits (Write key code)**

The KW[6:0] bits enable or disable writes to the PRCR bit. When writing to the PRCR bit, write 0x78 to the KW[6:0] bits simultaneously. When a value other than 0x78 is written to KW[6:0] bits, the PRCR bit is not updated. The KW[6:0] bits are always read as 0x00.

14.6.3 Operation

14.6.3.1 S-Cache

Figure 14.6 shows the access flow from CPU to S-cache.

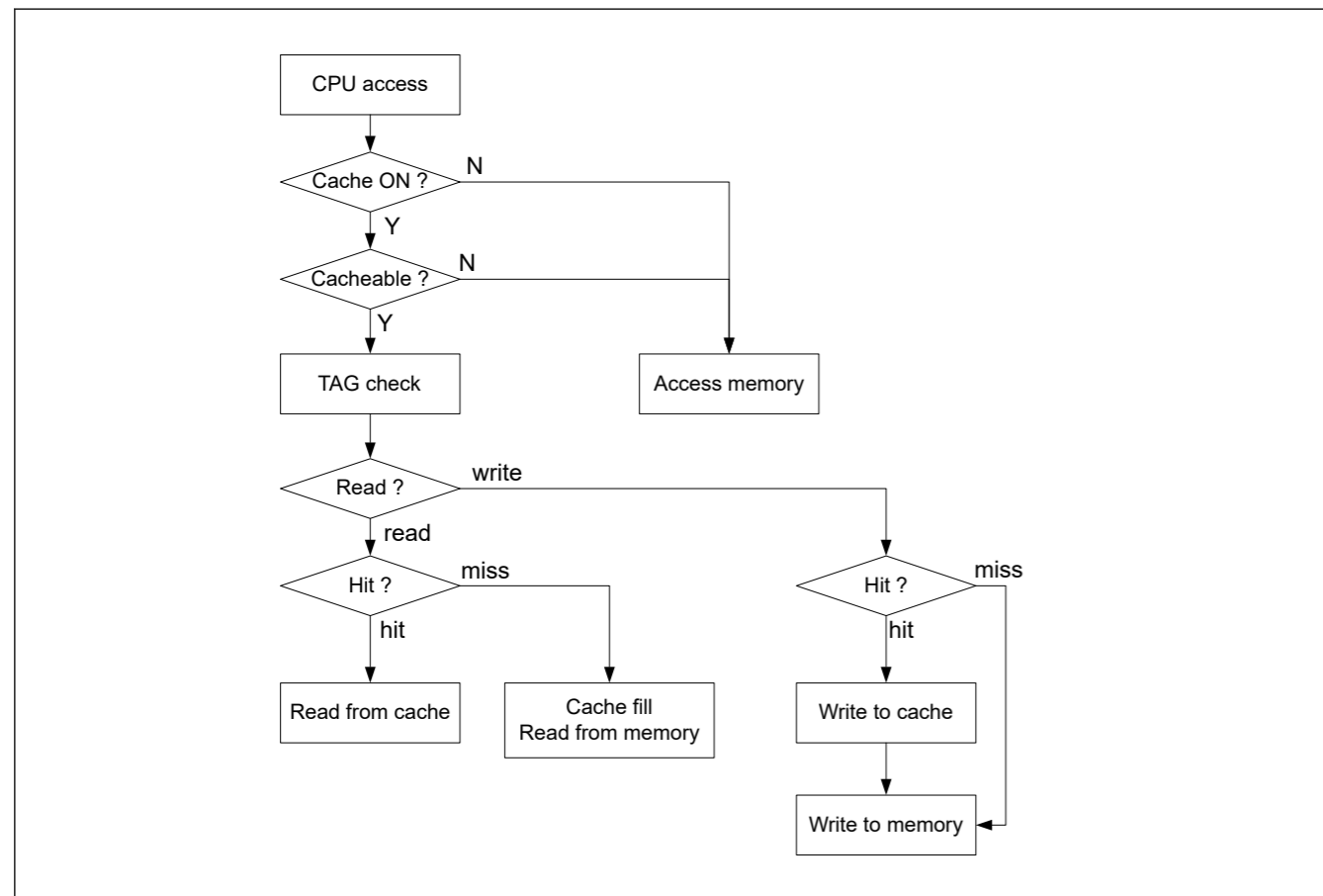


Figure 14.6 Access flow from CPU to S-cache

The cache function works when cache is enabled (CACTL.ENS = 1) and cacheable access is from CPU. The cache checks the address of CPU access request and request in cache tag, then determines whether the CPU access is a hit or a miss-hit.

| Bit  | Symbol | Function         | R/W |
|------|--------|------------------|-----|
| 31:8 | —      | 这些位被读取为0。写入值应为0。 | R/W |

Note: 如果安全属性配置为安全:

- 允许安全访问和非安全读取访问
- 忽略非安全写入访问, 不会生成TrustZone访问错误。

如果安全属性配置为非安全:

- 允许安全和非安全访问。

**PRCR位 (寄存器写控制)**

PRCR位控制CAPOAD寄存器的写模式。当该位设置为1时, 允许写入CAPOAD寄存器。写入该位时, 同时将0x78写入KW[6:0]位。

**KW[6:0]位 (写键码)**

KW[6:0]位启用或禁用对PRCR位的写入。写入PRCR位时, 同时将0x78写入KW[6:0]位。当将0x78以外的值写入KW[6:0]位时, PRCR位不会更新。KW[6:0]位总是被读取为0x00。

14.6.3 Operation

14.6.3.1 S-Cache

图14.6显示了从CPU到S-cache的访问流程。

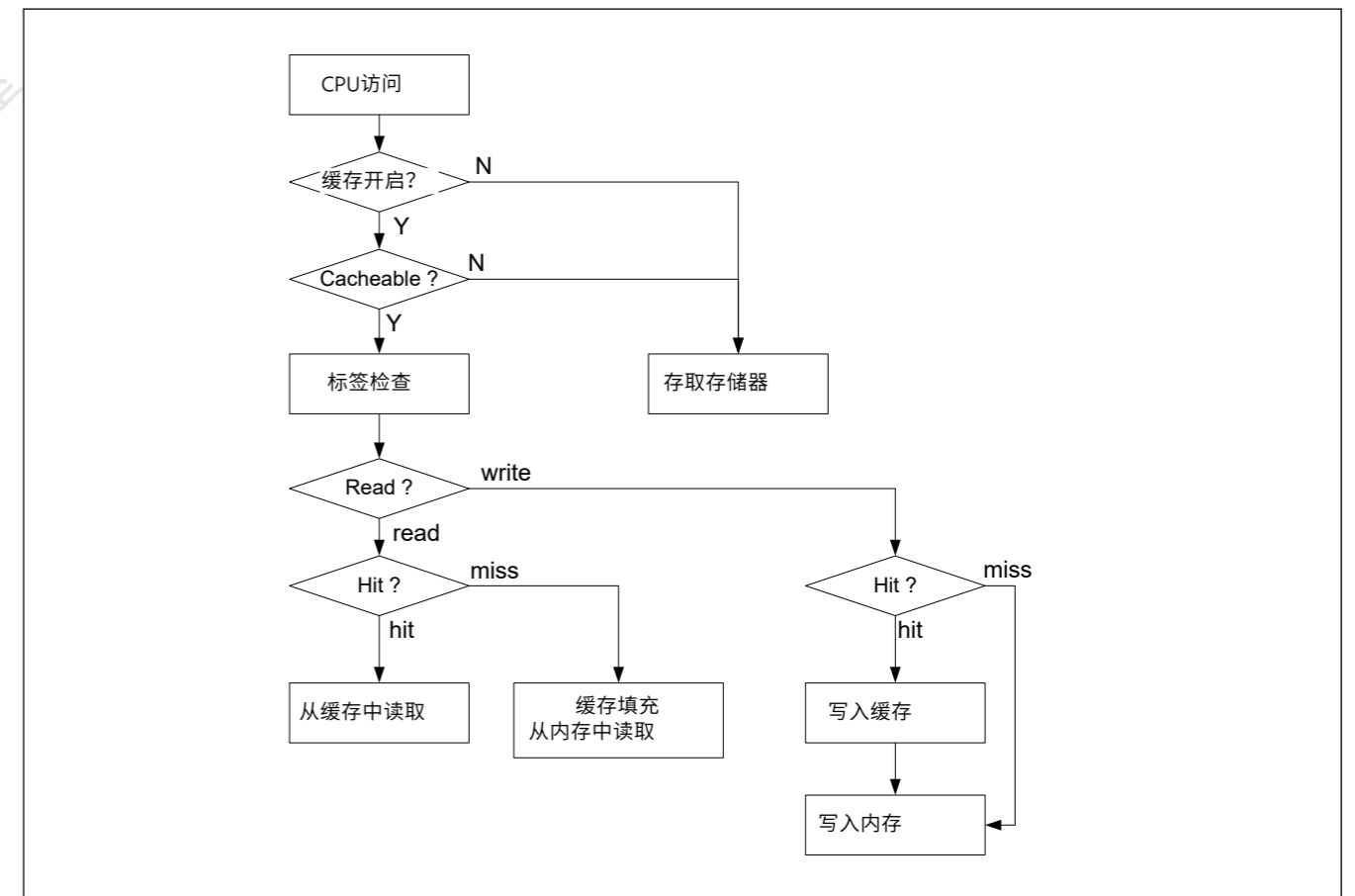


Figure 14.6 从CPU到S-cache的访问流程

缓存功能在启用缓存(CACTL.ENS=1)且可缓存访问来自CPU时起作用。缓存检查CPU访问请求的地址和缓存标签中的请求, 然后确定CPU访问是命中还是未命中。

**Read miss**

The cache reads one cache line data from memory and stores it into the cache data. The cache then returns the required data to CPU.

**Read hit**

The cache reads required data from the cache data and returns it to CPU. Access cycle then determines it is a hit because of the 0 wait cycle.

**Write miss**

The cache processes only a write cycle to memory. No affect to cache data.

**Write hit**

The cache processes both a write cycle to cache data and a write cycle to memory.

**14.6.3.2 C-Cache**

Figure 14.7 shows the access flow from CPU to C-cache.

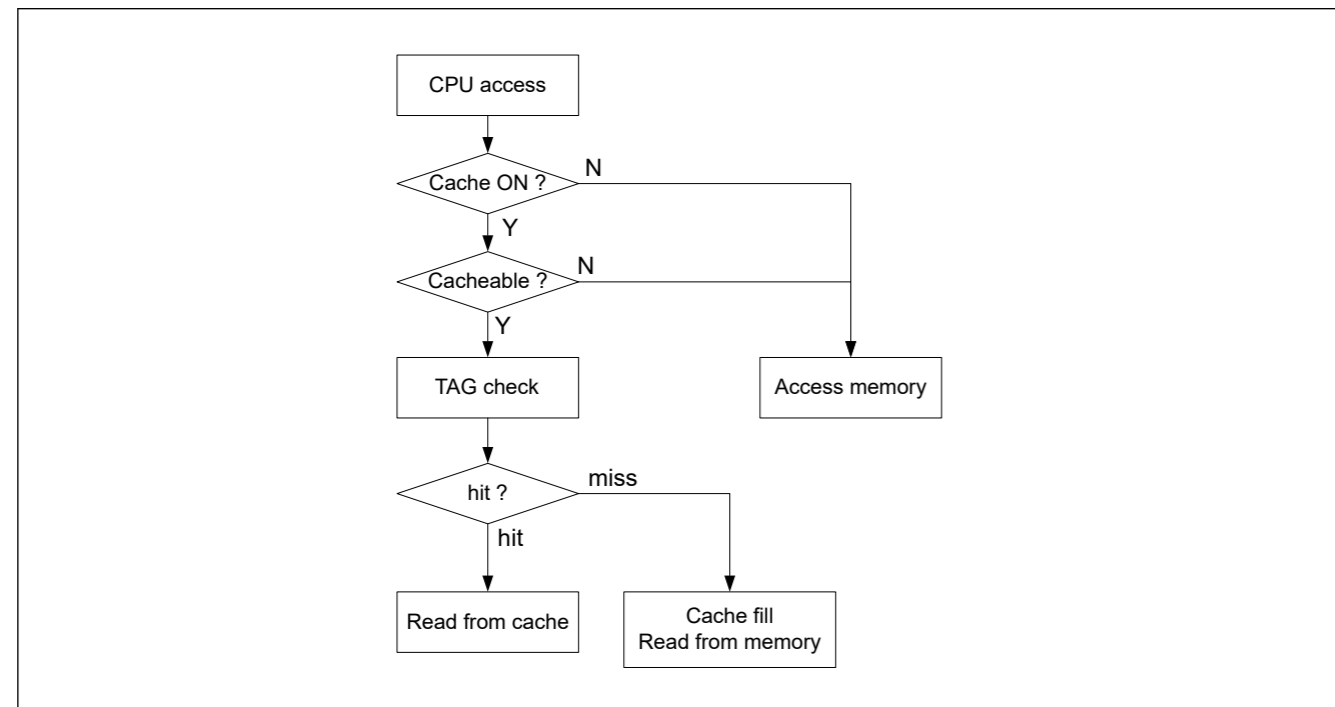


Figure 14.7 Access flow from CPU to C-cache

The cache function works when cache is enabled (CACTL.ENC = 1) and cacheable access is from CPU. The cache checks the address of CPU access request and request in cache tag, then determines whether the CPU access is a hit or a miss-hit.

**Read miss**

The cache reads one cache line data from memory and stores it into the cache data. The cache then returns the required data to CPU.

**Read hit**

The cache reads required data from the cache data and returns it to CPU. Access cycle then determines it is a hit because of the 0 wait cycle.

Because C-cache does not function in the ROM area of C-cache, therefore it operates in read-only access.

**14.6.3.3 Cache Flush**

The Valid bit is cleared with the CAFCT register. However, tag and cache data are not affected by the CAFCT register.

**读未读**

高速缓存从内存中读取一个高速缓存行数据并将其存储到高速缓存数据中。然后缓存将所需的数据返回给CPU。

**阅读命中**

缓存从缓存数据中读取需要的数据并返回给CPU。然后访问周期确定它是命中，因为等待周期为0。

**写小姐**

高速缓存仅处理对内存的写周期。不影响缓存数据。

**写命中**

高速缓存处理缓存数据的写周期和存储器的写周期。

**14.6.3.2 C-Cache**

图14.7显示了从CPU到C-cache的访问流程。

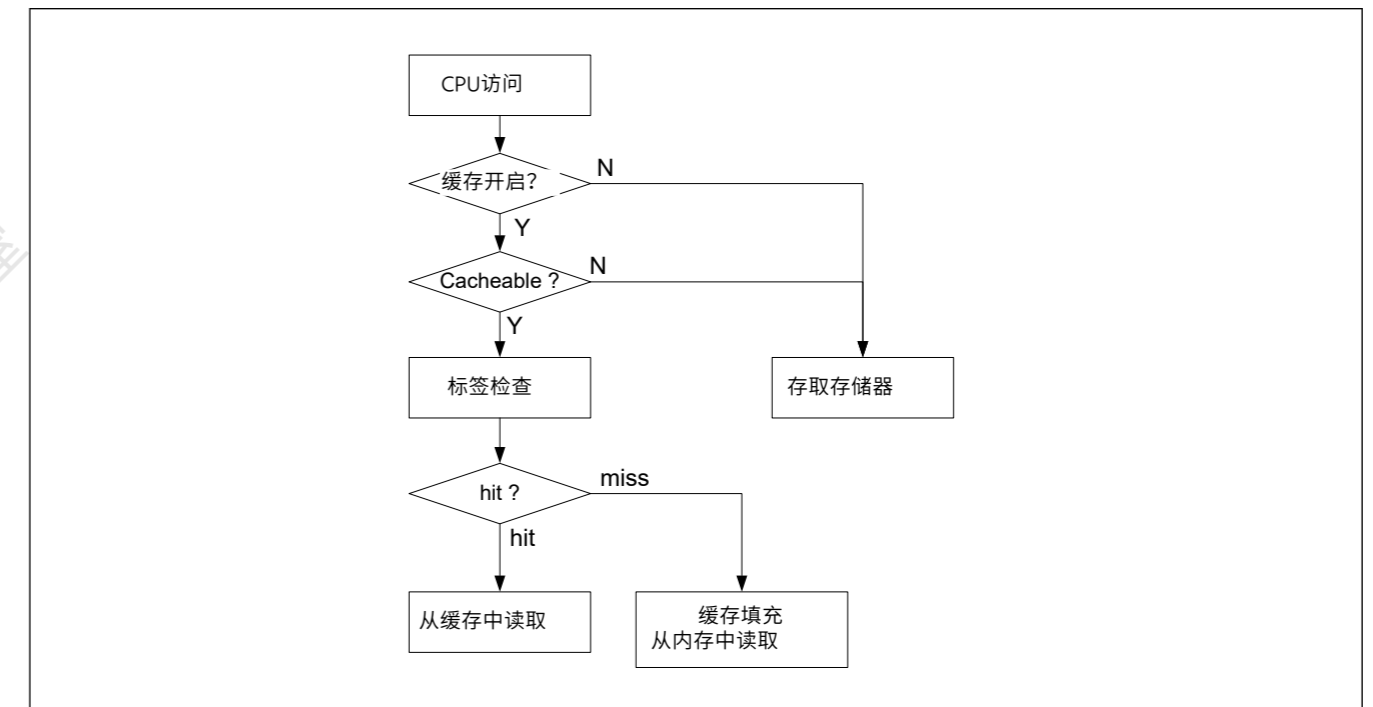


Figure 14.7 从CPU到C-cache的访问流程

缓存功能在启用缓存(CACTL.ENC=1)且可缓存访问来自CPU时起作用。缓存检查CPU访问请求的地址和缓存标签中的请求，然后确定CPU访问是命中还是未命中。

**读未读**

高速缓存从内存中读取一个高速缓存行数据并将其存储到高速缓存数据中。然后缓存将所需的数据返回给CPU。

**阅读命中**

缓存从缓存数据中读取需要的数据并返回给CPU。然后访问周期确定它是命中，因为等待周期为0。

由于C-cache在C-cache的ROM区域中不起作用，因此它以只读访问方式运行。

**14.6.3.3 缓存刷新**

有效位通过CAFCT寄存器清零。但是，标签和缓存数据不受 CAFCT寄存器的影响。

The valid bit is also cleared when CACTL is set from 0 to 1.

Note: After changing the cacheable attribute by the Arm MPU, clear the valid bit using the CAFCT register.

#### 14.6.3.4 LRU and Replace

The cache uses LRU (Least Recently Used) mechanism as the cache replacement algorithm. If a CPU access is determined as a hit or a miss-hit, the cache replaces cache data that is not the last restored. Additionally, the cache is tagged as the latest data in LRU of the cache data. Therefore even when the cache line in cache ways are full, the cache can replace cache data using LRU which shows older data.

The algorithm for a 2-way LRU shows which way, for example way 0 or way 1, is the latest stored.

#### 14.6.3.5 Parity Check

The cache has a parity check function for cache RAM that is stored as cache fill data. The cache has 4-bit parities for 32-bit data, that is when data is read, a parity bit is added to every 8-bit data of 32-bit data width. When the cache reads data with a hit status, it checks for parity errors. When a parity error occurs, a parity error notification is generated.

The cache reads 32-bit data even when the CPU requests a byte read or half-word read.

Note: A parity error might occur even though it is caused by a non validated-data byte of which the CPU does not request.

Parity error notification can be specified as a non-maskable interrupt or a reset request in the CAPOAD register. However, if the debug mode requests to suppress the parity error notification, then notification is not generated.

When a parity error occurs, the cache does not perform a cache flush and does not respond to the CPU with a bus error.

Parity errors often occur due to noise. To confirm whether the cause of the parity error is noise or corruption, see the flows for cache parity check in Figure 14.8 and Figure 14.9.

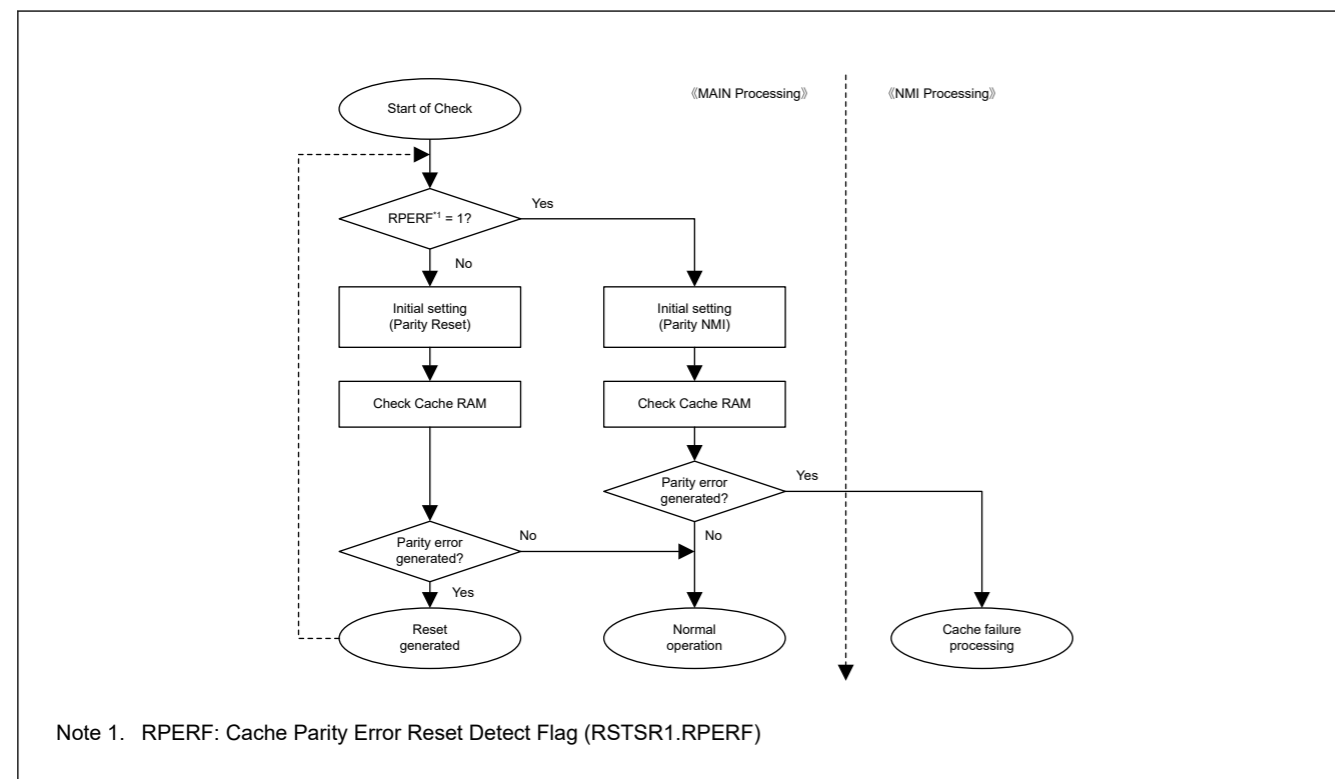


Figure 14.8 Flow of cache parity check when parity reset is enabled

当CACTL从0设置为1时，有效位也会被清除。

Note: 通过ArmMPU更改可缓存属性后，使用CAFCT寄存器清除有效位。

#### 14.6.3.4 LRU和替换

缓存使用LRU（最近最少使用）机制作为缓存替换算法。如果CPU访问被确定为命中或未命中，则缓存替换不是最后恢复的缓存数据。另外，缓存被标记为缓存数据的LRU中的最新数据。因此，即使缓存路中的缓存行已满，缓存也可以使用显示较旧数据的LRU替换缓存数据。

2路LRU的算法显示了最新存储的路，例如路0或路1。

#### 14.6.3.5 奇偶校验

高速缓存具有用于存储为高速缓存填充数据的高速缓存RAM的奇偶校验功能。高速缓存对于32位数据有4位奇偶校验，即在读取数据时，每32位数据宽度的8位数据添加一个奇偶校验位。当缓存读取具有命中状态的数据时，它会检查奇偶校验错误。当发生奇偶校验错误时，会生成奇偶校验错误通知。

即使CPU请求字节读取或半字读取，缓存也会读取32位数据。

Note: 即使奇偶校验错误是由CPU未请求的未经验证的数据字节引起的，也可能发生奇偶校验错误。

奇偶校验错误通知可以指定为不可屏蔽中断或CAPOAD寄存器中的复位请求。但是，如果调试模式请求抑制奇偶校验错误通知，则不会生成通知。

当发生奇偶校验错误时，缓存不会执行缓存刷新，也不会以总线错误响应CPU。

奇偶校验错误经常由于噪声而发生。要确认奇偶校验错误的原因是噪声还是损坏，请参见图14.8和图14.9中的缓存奇偶校验流程。

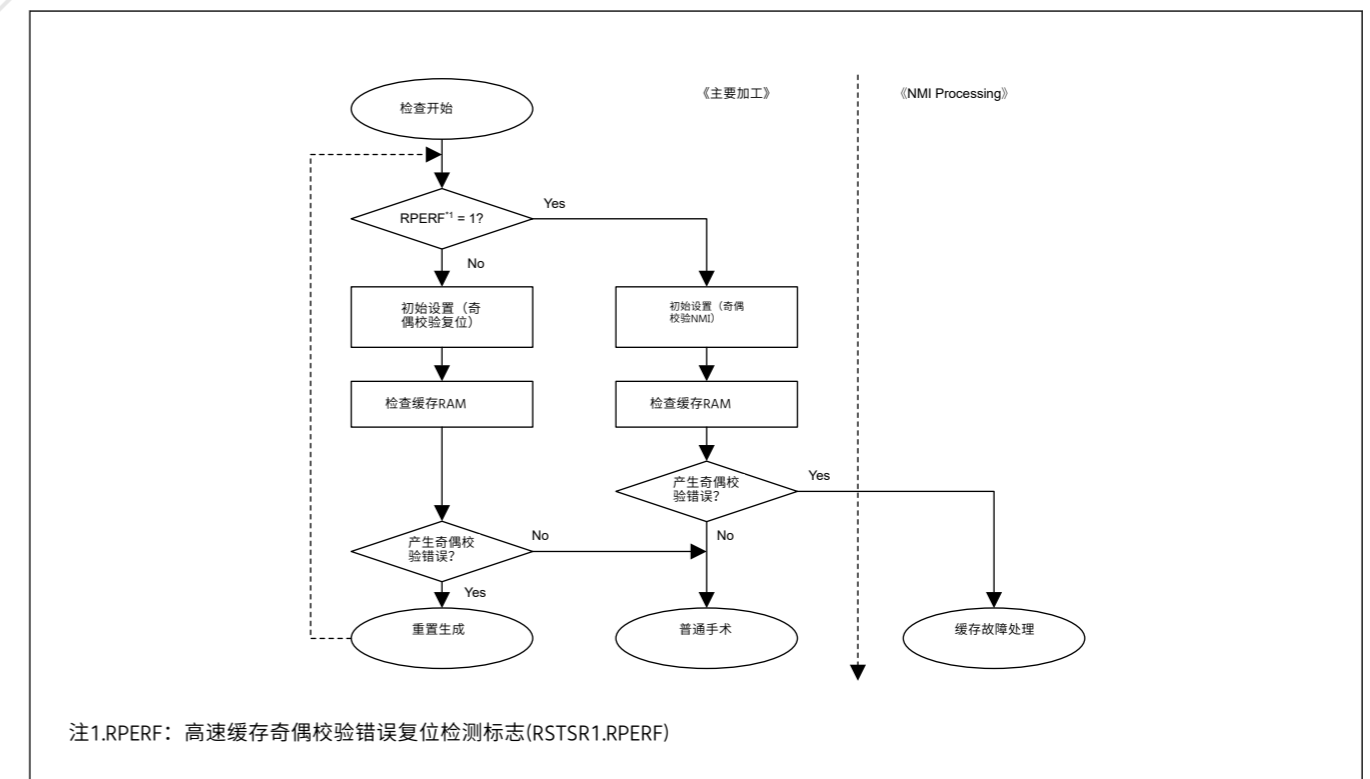


Figure 14.8 启用奇偶校验时的缓存奇偶校验流程

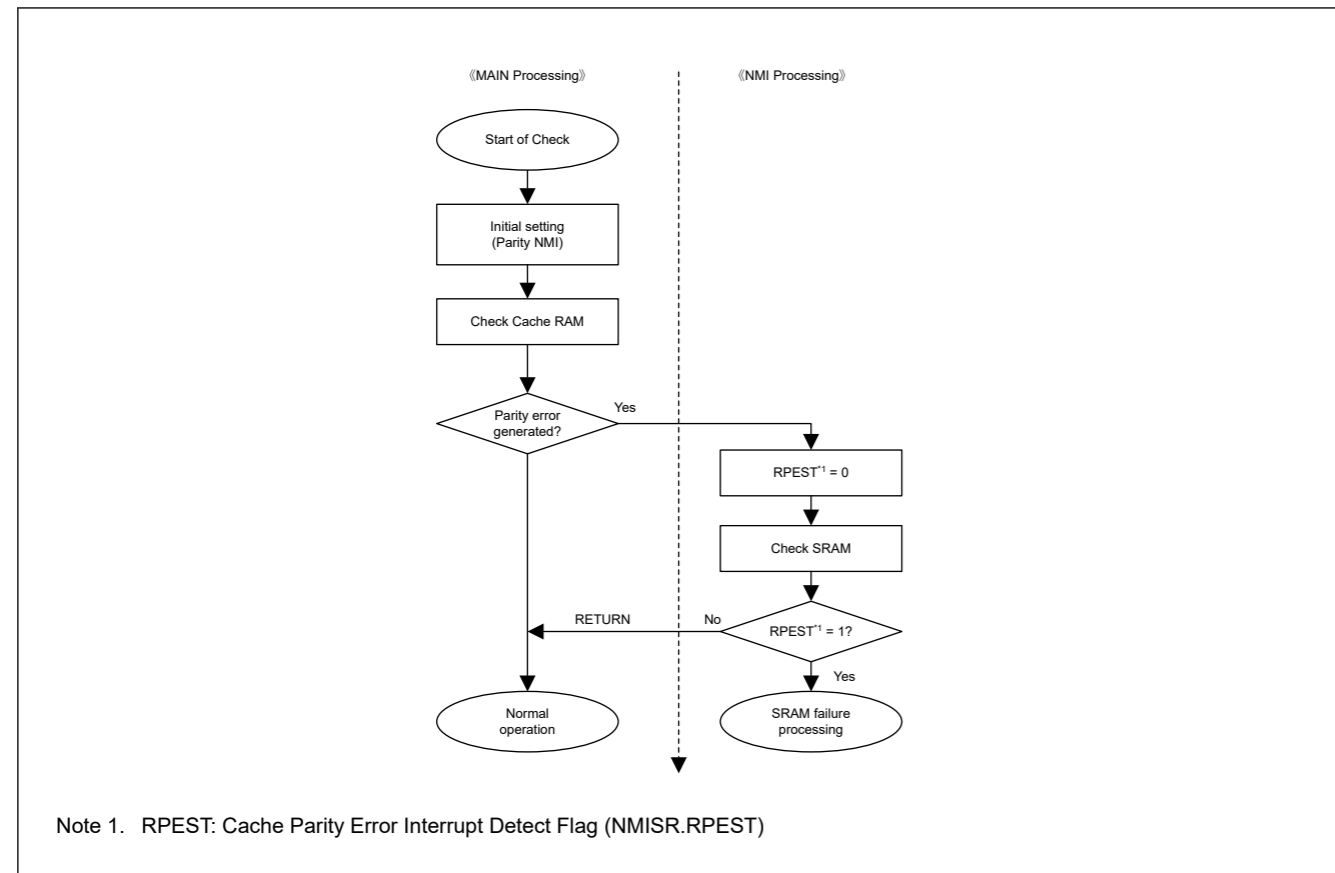


Figure 14.9 Flow of cache parity check when parity interrupt is enabled

#### 14.6.3.5.1 Cache RAM Check

Parity error of cache RAM occurs at a read access by CPU with a cache status of read-hit. With a read-hit status, some conditions are required before performing a cache RAM check. For S-cache check, execute the check program in flash memory. For C-cache check, execute the check program in SRAM or external memory.

##### (1) Cache RAM check flow

1. Flush all valid bits in cache to clear the cache enable bit.
2. Reserve a 2-KB work memory such as SRAM or external memory for S-cache. Because each cache in the MCU is a 2-way set associative with 1 KB RAM per way, a total of 2 KB is required for S-cache. The target address should not be used as reserved area.
3. Set the cache enable to 1.
4. Read data from the target word address of 2 KB using the CPU. The status of cache should be a read-miss with the result stored as cache fill data.
5. Read data in another cache way whose address is calculated by adding the address in step 4. with 1 KB address. The status of cache should be a read-miss with the result stored as cache fill data in another way. Cache RAM check for a write/read-hit status is now complete.
6. Write test data to the target word address in steps 4. and 5.. The status of cache in steps 4. and 5. should be a write-hit with the results written to the cache RAM.
7. Read from the target word address in steps 4. and 5. again. The status of cache in steps 4. and 5. should be a read-hit. Parity check for a word data is now complete.
8. Go to step 1. to continue parity check for different target addresses.

#### 14.6.3.6 Bus Error

The association from a bus slave to a bus error is described in the sections that follow.

##### In cache off

The cache returns a bus error to the CPU.

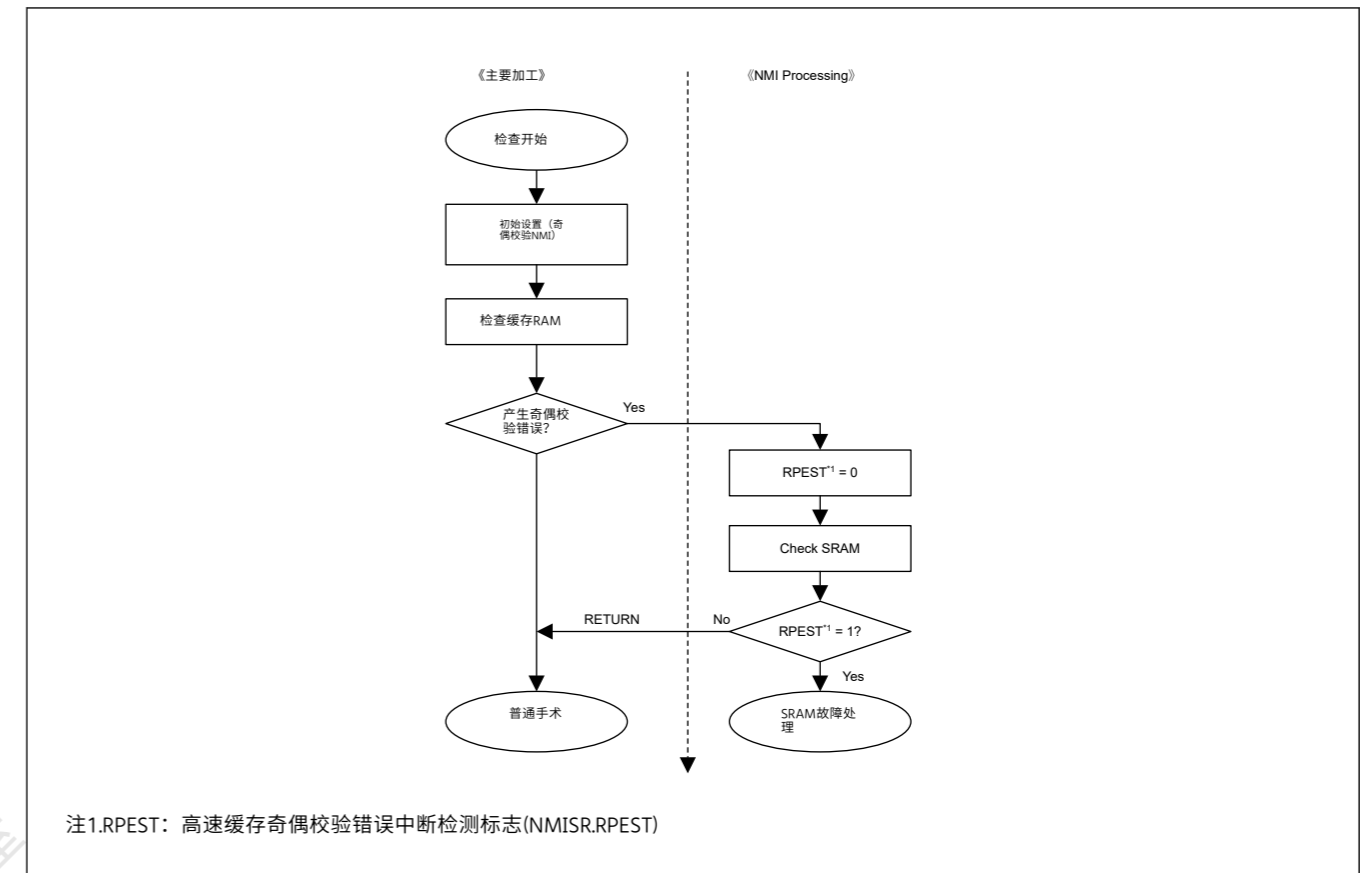


Figure 14.9 启用奇偶校验中断时的缓存奇偶校验流程

#### 14.6.3.5.1 缓存RAM检查

高速缓存RAM的奇偶校验错误发生在CPU读取访问时，高速缓存状态为read-hit。对于读取命中状态，在执行高速缓存RAM检查之前需要一些条件。对于S-cache检查，执行闪存中的检查程序。对于C-cache检查，在SRAM或外部存储器中执行检查程序。

##### (1) 缓存RAM检查流程

- 1.刷新缓存中的所有有效位以清除缓存启用位。
- 2.为S-cache预留2KB的工作存储器，例如SRAM或外部存储器。因为MCU中的每个缓存都是2way组，每路1KBRAM，所以S-cache总共需要2KB。目标地址不应用作保留区。
- 3.将缓存使能设置为1。
- 4.使用CPU从2KB的目标字地址读取数据。缓存的状态应该是读未命中，结果存储为缓存填充数据。
- 5.以另一种缓存方式读取数据，其地址是通过将步骤4中的地址与1KB地址相加计算出来的。缓存的状态应该是读未命中，结果以另一种方式存储为缓存填充数据。写读命中状态的高速缓存RAM检查现已完成。
- 6.在步骤4.和5.中将测试数据写入目标字地址。步骤4.和5.中的缓存状态应该是写入命中，结果写入缓存RAM。
- 7.再次从步骤4.和5.中的目标字地址读取。第4步和第5步中缓存的状态应该是读取命中。单词数据的奇偶校验现已完成。
- 8.转到步骤1.继续对不同的目标地址进行奇偶校验。

#### 14.6.3.6 总线错误

从总线从站到总线错误的关联将在后面的部分中描述。

##### 在缓存关闭

高速缓存将总线错误返回给CPU。



**For non-cacheable access**

The cache returns a bus error to the CPU.

**During read accesses for cache fill**

For the first data that corresponds to a CPU access request, the cache returns a bus error to the CPU. For other read data while filling the cache line, the cache cannot return a bus error to the CPU except for read data with early forwarding. The cache enable bit clears the cache line if the cache accepts a bus error response from the slave.

**For write-hit status**

The cache cannot return a bus error to the CPU because the cache enable bit does not clear the cache line.

**For write-miss status**

The cache cannot return a bus error to the CPU.

**14.6.3.7 Early Forwarding Function**

While filling data in the cache, if the address of the CPU read request and the address of the cache fill request are the same, the cache returns the data to CPU. Table 14.4 shows an example.

**Table 14.4 Example of early forwarding**

| Operation                   | Access sequence |             |             |      |             |      |      |      |   |             |
|-----------------------------|-----------------|-------------|-------------|------|-------------|------|------|------|---|-------------|
| Address of CPU read request | 0x04            | 0x08        | 0x0C        | 0x14 | →           | 0x10 | →    | →    | → |             |
| Address of cache fill       | 0x04            | 0x08        | 0x0C        | 0x10 | 0x14        | 0x18 | 0x1C | 0x00 | — |             |
| CPU access status           | Read (0x04)     | Read (0x08) | Read (0x0C) | —    | Read (0x14) | —    | —    | —    | — | Read (0x10) |

When the CPU requests read accesses and the addresses are 0x04, 0x08, 0x0C, 0x14 and 0x10 sequentially, the first read access to address 0x04 is of a miss-hit status and the cache starts to fill data into cache. The early forwarding function allows a return of read data to CPU when accesses are to addresses 0x08, 0x0C and 0x14 while the cache is filling the cache line. On the other hand, access to address 0x10 must wait for the completion of filling the cache line. The cache then returns data for address 0x10 when it finished filling the cache line.

**14.6.4 Usage Notes****14.6.4.1 Cache Line Configuration Register**

Writes to the Cache Line Configuration Register are allowed when the status is cache off (CACTL.ENS = 0 for S-cache, CACTL.ENC = 0 for C-cache).

**14.6.4.2 Coherency**

The coherency between the cache and the external memory / internal SRAM must be guaranteed by software.

When allocating shared memory between the CPU and a bus master such as DMAC in the cache support area, invalidate the cache data as necessary.

**对于不可缓存的访问**

高速缓存将总线错误返回给CPU。

**在缓存填充的读取访问期间**

对于与CPU访问请求对应的第一个数据，缓存将总线错误返回给CPU。对于其他在填充高速缓存行时读取的数据，除了提前转发的读取数据外，高速缓存不能向CPU返回总线错误。如果缓存接受来自设备的总线错误响应，缓存使能位清除缓存行。

**对于写命中状态**

高速缓存无法向CPU返回总线错误，因为高速缓存启用位不会清除高速缓存行。

**对于写未命中状态**

高速缓存不能将总线错误返回给CPU。

**14.6.3.7 提前转发功能**

在缓存中填充数据时，如果CPU读取请求的地址和缓存填充请求的地址相同，则缓存将数据返回给CPU。表14.4显示了一个示例。

**Table 14.4 提前转发示例**

| Operation | 访问顺序        |             |             |      |             |      |      |      |   |             |
|-----------|-------------|-------------|-------------|------|-------------|------|------|------|---|-------------|
| CPU读请求地址  | 0x04        | 0x08        | 0x0C        | 0x14 | →           | 0x10 | →    | →    | → |             |
| 缓存填充地址    | 0x04        | 0x08        | 0x0C        | 0x10 | 0x14        | 0x18 | 0x1C | 0x00 | — |             |
| CPU访问状态   | Read (0x04) | Read (0x08) | Read (0x0C) | —    | Read (0x14) | —    | —    | —    | — | Read (0x10) |

当CPU请求读访问，地址依次为0x04、0x08、0x0C、0x14和0x10时，对地址0x04的第一次读访问为未命中状态，缓存开始将数据填充到缓存中。早期转发功能允许在高速缓存填充高速缓存行时访问地址0x08、0x0C和0x14时将读取数据返回到CPU。另一方面，对地址0x10的访问必须等待缓存行的填充完成。然后，缓存在完成填充缓存行后返回地址0x10的数据。

**14.6.4 使用说明****14.6.4.1 高速缓存行配置寄存器**

当状态为高速缓存关闭时，允许写入高速缓存行配置寄存器（对于S-cache，CACTL.ENS=0，CACTL.ENC = 0 for C-cache）。

**14.6.4.2 Coherency**

高速缓存和外部存储器内部SRAM之间的一致性必须由软件来保证。

在高速缓存支持区域中，在CPU和DMAC等总线主控制器之间分配共享内存时，根据需要使高速缓存数据无效。

## 15. Memory Protection Unit (MPU)

### 15.1 Overview

The MCU has one Memory Protection Unit (MPU).

Table 15.1 lists the MPU specifications, and section 15.1. Overview shows the behavior on detection of each MPU error.

**Table 15.1 MPU specifications**

| Classification        | Module/Function      | Specifications  |
|-----------------------|----------------------|---|
| Illegal memory access | Arm® Cortex®-M33 CPU | <ul style="list-style-type: none"> <li>Arm CPU has a default memory map. If the CPU makes an illegal access, an exception interrupt occurs</li> <li>The MPU can change a default memory map.</li> </ul> |
| Memory protection     | Arm MPU              | Memory protection function for the CPU: <ul style="list-style-type: none"> <li>(8+8) region MPU with sub regions and background region for secure and non-secure.</li> </ul>                            |
|                       | Bus master MPU       | Memory protection function for each bus master except for the CPU: <ul style="list-style-type: none"> <li>DMAC/DTC: 8 regions</li> </ul>  |

**Table 15.2 Behavior on MPU error detection**

| MPU type       | Notification type  | Error Response by HRESP signal of AHB I/F | Bus Access on error detection   | Storing of error access information |
|----------------|--|---|---|-------------------------------------|
| Arm MPU        | <ul style="list-style-type: none"> <li>Hard fault</li> </ul>   | Not supported                             | <ul style="list-style-type: none"> <li>Does not correctly write access</li> <li>Does not correctly read access</li> </ul> | Stored in the Cortex-M33 processor  |
| Bus Master MPU | <ul style="list-style-type: none"> <li>Reset or Non-maskable interrupts</li> <li>Hard fault</li> </ul> | Supported                                 | <ul style="list-style-type: none"> <li>Write access ignore</li> <li>Read access is read as 0</li> </ul>                   | Stored                              |

For information on error access for the Arm MPU, see section 15.4. References. For information on error access for other MPUs, see section 14.3. Register Descriptions and section 14.4. Bus Error Monitoring Section in section 14, Buses.

### 15.2 Arm MPU

The Arm MCU monitors the addresses accessed by the CPU across the entire address space (0x0000\_0000 to 0xFFFF\_FFFF) and provides support for:

- (8 + 8) protected regions
- When memory regions overlap, the processor generates a fault if a core access hits the overlapping regions
- Setting access permissions to protected region (Read, Write, Execution)
- Export of memory attributes to the system.

Arm MPU mismatches and permission violations invoke the programmable-priority MemManage fault (Hard Fault) handler. For details, see reference 1., 3. and 4. in section 15.4. References.

### 15.3 Bus Master MPU

The bus master MPU monitors the addresses accessed by the bus masters in the entire address space (0x0000\_0000 to 0xFFFF\_FFFF). Access-control information can be set up to 8 regions in DMAC/DTC and monitor for access to each region is in accord with this information.

If access to a protected region is detected, the bus master MPU generates an internal reset or a non-maskable interrupt. For information on error access, see section 14.3. Register Descriptions and section 14.4. Bus Error Monitoring Section in section 14, Buses.

Table 15.3 lists the specifications of the bus master MPU.

## 15. 内存保护单元(MPU)

### 15.1 Overview

MCU有一个内存保护单元(MPU)。

表15.1列出了MPU规格和第15.1节。概述显示了检测每个MPU错误时的行为。

**Table 15.1 MPU specifications**

| Classification | Module/Function | Specifications  |
|----------------|-----------------|---|
| 非法内存访问         | Arm®皮质®-M33 CPU | <ul style="list-style-type: none"> <li>ArmCPU有一个默认的内存映射。如果CPU进行非法访问，则会发生异常中断</li> <li>MPU可以更改默认内存映射。</li> </ul> |
| 内存保护           | Arm MPU         | CPU的内存保护功能：●<br>(8+8)带有子区域和背景区域的区域MPU，用于安全和非安全。   |
|                | 总线主控MPU         | 除CPU外的每个总线主控的内存保护功能：●   |

**Table 15.2 MPU错误检测的行为**

| MPU type | 通知类型   | 错误响应 AHB的HRESP信号 I/F | 错误检测总线访问  | 存储错误访问信息                 |
|----------|--|----------------------|---|--------------------------|
| Arm MPU  | <ul style="list-style-type: none"> <li>硬故障</li> </ul>                    | 不支持                  | <ul style="list-style-type: none"> <li>没有正确的写访问</li> <li>未正确读取访问权限</li> </ul> | 存储在Cortex中 M33 processor |
| 总线主控MPU  | <ul style="list-style-type: none"> <li>复位或不可屏蔽中断</li> <li>硬故障</li> </ul> | Supported            | <ul style="list-style-type: none"> <li>写访问忽略</li> <li>读权限读为0</li> </ul>       | Stored                   |

有关ArmMPU错误访问的信息，请参阅第15.4节。参考。有关其他错误访问的信息MPU，见第14.3节。寄存器说明和第14.4节。第14节，总线中的总线错误监控部分。

### 15.2 Arm MPU

ArmMCU监控整个地址空间 (0x0000\_0000到0xFFFF\_FFFF) 中CPU访问的地址，并支持：

- (8+8)个保护区
- 当内存区域重叠时，如果核心访问命中重叠区域，处理器将产生故障
- 设置对受保护区域的访问权限（读、写、执行）
- 将内存属性导出到系统。

ArmMPU不匹配和权限违规调用可编程优先级MemManage故障（硬故障）处理程序。详见15.4节中的参考1.、3和4。参考。

### 15.3 总线主控MPU

总线主控MPU监控整个地址空间 (0x0000\_0000到0xFFFF\_FFFF) 中总线主控访问的地址。DMACDTC中最多可以设置8个区域的访问控制信息，每个区域的访问监控是否与该信息一致。

如果检测到对受保护区域的访问，总线主控MPU会产生内部复位或不可屏蔽中断。有关错误访问的信息，请参阅第14.3节。寄存器说明和第14.4节。第14节，总线中的总线错误监控部分。

表15.3列出了总线主控MPU的规格。

Table 15.3 Bus master MPU specifications

| Parameter   | Description   |
|---|---|
| Protected master groups   | • DMAC, DTC   |
| Protected regions   | 0x0000_0000 to 0xFFFF_FFFF                                |
| Number of regions   | • DMAC/DTC: 8 regions                                     |
| Address specification for individual regions                          | • Specifying start and end address for individual regions |
| Enable or disable setting for memory protection in individual regions | • Enabling or disabling setting for the associated region |
| Access-control settings for individual regions                        | • Permission for read and write                           |
| Operation on error detection  | • Reset or non-maskable interrupts                        |
| Register protection   | • Protecting registers from illegal writes                |
| TrustZone Filter  | • DMAC: Security attribution can be set for each regions  |

### 15.3.1 Register Descriptions

Bus access must be stopped before writing to MPU registers.

#### 15.3.1.1 MMPUSARA : Master Memory Protection Unit Security Attribution Register A

Base address: CPSCU = 0x4000\_8000

Offset address: 0x130

| Bit position:      | 31 | 30 | 29 | 28 | 27 | 26 | 25 | 24 | 23        | 22        | 21        | 20        | 19        | 18        | 17        | 16        |
|--------------------|----|----|----|----|----|----|----|----|-----------|-----------|-----------|-----------|-----------|-----------|-----------|-----------|
| Bit field:         | —  | —  | —  | —  | —  | —  | —  | —  | —         | —         | —         | —         | —         | —         | —         | —         |
| Value after reset: | 1  | 1  | 1  | 1  | 1  | 1  | 1  | 1  | 1         | 1         | 1         | 1         | 1         | 1         | 1         | 1         |
| Bit position:      | 15 | 14 | 13 | 12 | 11 | 10 | 9  | 8  | 7         | 6         | 5         | 4         | 3         | 2         | 1         | 0         |
| Bit field:         | —  | —  | —  | —  | —  | —  | —  | —  | MMPU ASA7 | MMPU ASA6 | MMPU ASA5 | MMPU ASA4 | MMPU ASA3 | MMPU ASA2 | MMPU ASA1 | MMPU ASA0 |
| Value after reset: | 1  | 1  | 1  | 1  | 1  | 1  | 1  | 1  | 1         | 1         | 1         | 1         | 1         | 1         | 1         | 1         |

| Bit  | Symbol   | Function  | R/W            |
|------|----------|---|----------------|
| 7:0  | MMPUASAn | MMPUA Security Attribution (n = 0 to 7)<br>0: Secure<br>1: Non-Secure | R/W            |
| 31:8 | —        | These bits are read as 1.   | R <sup>1</sup> |

Note: Only secure access can write to this register. Both secure access and Non-secure read access are allowed but Non-secure write access is not allowed and TrustZone access error is not generated.

Note: This register is write-protected by PRCR register.

Note 1. This bit is read only.

#### MMPUASAn bits (MMPUA Security Attribution (n = 0 to 7))

The MMPUASAn bits specify the security attributes of registers for the Bus Master MPU Region Setting register. The target registers are:

- MMPUSDMACn (n = 0 to 7)
- MMPUEDMACn (n = 0 to 7)
- MMPUACDMACn (n = 0 to 7)

Table 15.3 总线主控MPU规格

| Parameter        | Description                |
|------------------|----------------------------|
| 受保护的组            | • DMAC, DTC                |
| 保护区              | 0x0000_0000 to 0xFFFF_FFFF |
| 地区数量             | • DMAC/DTC: 8 regions      |
| 个别地区的地址规范        | • 指定各个区域的开始和结束地址           |
| 在各个区域启用或禁用内存保护设置 | • 启用或禁用关联区域的设置             |
| 各个区域的访问控制设置      | • 读写权限                     |
| 错误检测操作           | • 复位或不可屏蔽中断                |
| 注册保护             | • 保护寄存器免受非法写入              |
| TrustZone Filter | • DMAC: 可以为每个区域设置安全属性      |

### 15.3.1 注册说明

在写入MPU寄存器之前必须停止总线访问。

#### 15.3.1.1 MMPUSARA:主内存保护单元安全属性寄存器A

Base address: CPSCU = 0x4000\_8000

Offset address: 0x130

| Bit position: | 31 | 30 | 29 | 28 | 27 | 26 | 25 | 24 | 23        | 22        | 21        | 20        | 19        | 18        | 17        | 16        |
|---------------|----|----|----|----|----|----|----|----|-----------|-----------|-----------|-----------|-----------|-----------|-----------|-----------|
| Bit field:    | —  | —  | —  | —  | —  | —  | —  | —  | —         | —         | —         | —         | —         | —         | —         | —         |
| 重置后的值:        | 1  | 1  | 1  | 1  | 1  | 1  | 1  | 1  | 1         | 1         | 1         | 1         | 1         | 1         | 1         | 1         |
| Bit position: | 15 | 14 | 13 | 12 | 11 | 10 | 9  | 8  | 7         | 6         | 5         | 4         | 3         | 2         | 1         | 0         |
| Bit field:    | —  | —  | —  | —  | —  | —  | —  | —  | MMPU ASA7 | MMPU ASA6 | MMPU ASA5 | MMPU ASA4 | MMPU ASA3 | MMPU ASA2 | MMPU ASA1 | MMPU ASA0 |
| 重置后的值:        | 1  | 1  | 1  | 1  | 1  | 1  | 1  | 1  | 1         | 1         | 1         | 1         | 1         | 1         | 1         | 1         |

| Bit  | Symbol   | Function  | R/W            |
|------|----------|---|----------------|
| 7:0  | MMPUASAn | MMPUA安全属性 (n=0到7)<br>0: Secure<br>1: Non-Secure | R/W            |
| 31:8 | —        | 这些位读为1。   | R <sup>1</sup> |

Note: 只有安全访问才能写入该寄存器。允许安全访问和非安全读取访问，但不允许非安全写入访问，并且不会生成TrustZone访问错误。

Note: 该寄存器由PRCR寄存器写保护。

注1.该位是只读的。

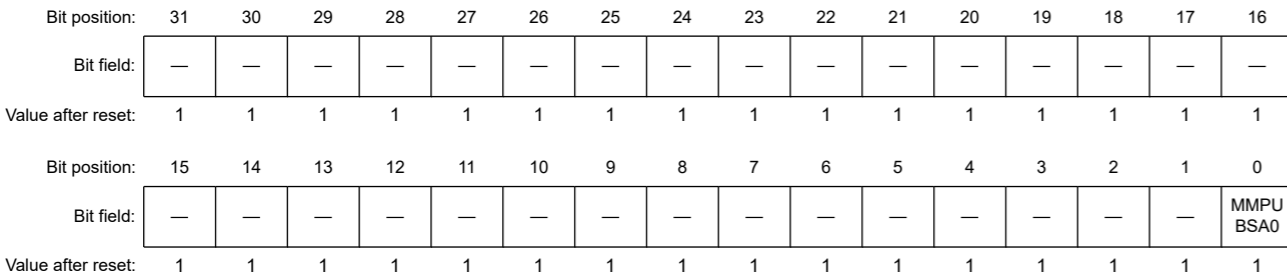
#### MMPUASAn位 (MMPUA安全属性 (n=0到7))

MMPUASAn位指定总线主控MPU区域设置寄存器的寄存器的安全属性。目标寄存器是:

- MMPUSDMACn (n = 0 to 7)
- MMPUEDMACn (n = 0 to 7)
- MMPUACDMACn (n = 0 to 7)

15.3.1.2 MMPUSARB : Master Memory Protection Unit Security Attribution Register B

Base address: CPSCU = 0x4000\_8000  
Offset address: 0x134



| Bit  | Symbol   | Function   | R/W            |
|------|----------|--|----------------|
| 0    | MMPUBSA0 | MMPUB Security Attribution<br>0: Secure<br>1: Non-Secure | R/W            |
| 31:1 | —        | These bits are read as 1.                                | R <sup>1</sup> |

Note: Only secure access can write to this register. Both secure access and Non-secure read access are allowed but Non-secure write access is not allowed and TrustZone access error is not generated.  
Note: This register is write-protected by PRCR register.  
Note 1. This bit is read-only.

MMPUBSA0 bit (MMPUB Security Attribution)

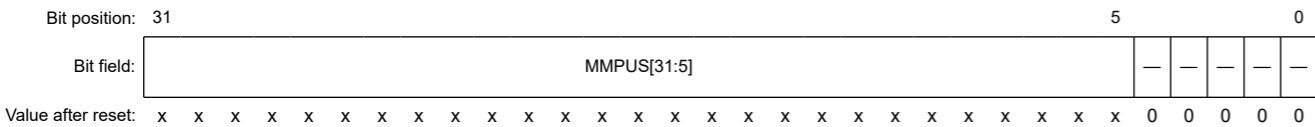
The MMPUBSA0 bit specifies the security attributes of registers for the Bus Master MPU Region Setting register, Protect register, and OAD register. The target registers are:

- MMPUENDMAC
- MMPUENPTDMAC
- MMPURPTDMAC
- MMPURPTDMAC\_SEC
- MMPUOAD
- MMPUOADPT

The Secure user provides a Secure API to Non-secure user for the modification of the MMPURPTDMAC value when MMPUBSA0 bit is set to 0 (Secure).

15.3.1.3 MMPUSDMACn : MPU Start Address Register for DMAC (n = 0 to 7)

Base address: RMPU = 0x4000\_0000  
Offset address: 0x0204 + 0x010 × n

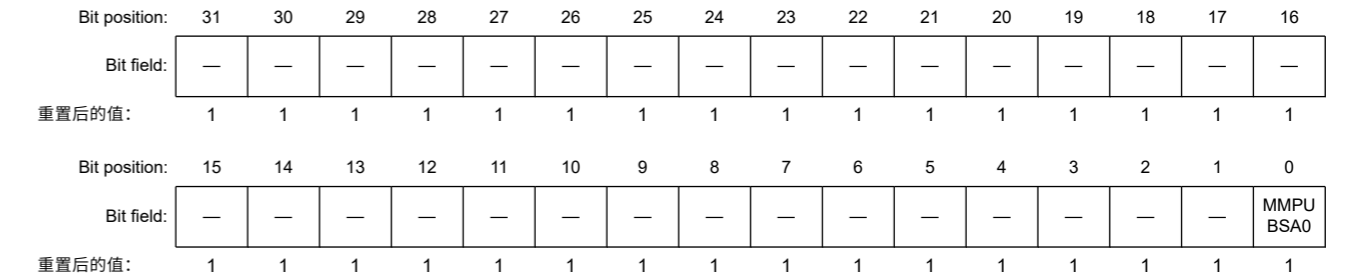


| Bit  | Symbol      | Function  | R/W |
|------|-------------|---|-----|
| 4:0  | —           | These bits are read as 0. The write value should be 0.  | R/W |
| 31:5 | MMPUS[31:5] | Region start address register<br>Address where the region starts, for use in region determination | R/W |

Note: If the security attribution is configured as secure:  
• Secure access and Non-secure read access are allowed

15.3.1.2 MMPUSARB:主存储器保护单元安全属性寄存器B

Base address: CPSCU = 0x4000\_8000  
Offset address: 0x134



| Bit  | Symbol   | Function                                | R/W            |
|------|----------|---|----------------|
| 0    | MMPUBSA0 | MMPUB安全归因<br>0: Secure<br>1: Non-Secure | R/W            |
| 31:1 | —        | 这些位读为1。                                 | R <sup>1</sup> |

Note: 只有安全访问才能写入该寄存器。允许安全访问和非安全读取访问，但不允许非安全写入访问，并且不会生成TrustZone访问错误。  
Note: 该寄存器由PRCR寄存器写保护。  
注1.该位是只读的。

MMPUBSA0位 (MMPUB安全属性)

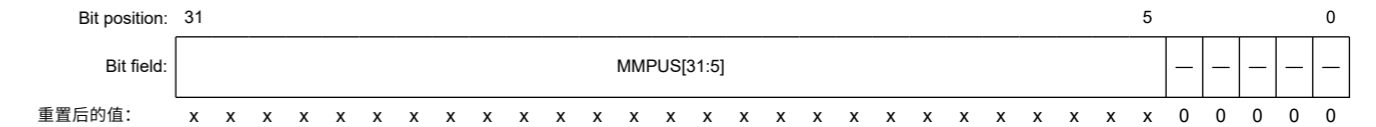
MMPUBSA0位指定总线主控MPU区域设置寄存器、保护寄存器和OAD寄存器的寄存器的安全属性。目标寄存器是:

- MMPUENDMAC
- MMPUENPTDMAC
- MMPURPTDMAC
- MMPURPTDMAC\_SEC
- MMPUOAD
- MMPUOADPT

安全用户向非安全用户提供一个安全API，用于在以下情况下修改MMPURPTDMAC值  
MMPUBSA0位设置为0 (安全)。

15.3.1.3 MMPUSDMACn: DMAC的MPU起始地址寄存器 (n=0到7)

Base address: RMPU = 0x4000\_0000  
Offset address: 0x0204 + 0x010 × n



| Bit  | Symbol      | Function                   | R/W |
|------|-------------|----------------------------|-----|
| 4:0  | —           | 这些位被读取为0。写入值应为0。           | R/W |
| 31:5 | MMPUS[31:5] | 区域起始地址寄存器<br>区域起始地址，用于区域确定 | R/W |

Note: 如果安全属性配置为安全: ●  
允许安全访问和非安全读取访问



- Non-secure write access is ignored, and TrustZone access error is not generated.
- If the security attribution is configured as Non-secure:
- Secure and Non-secure access are allowed.

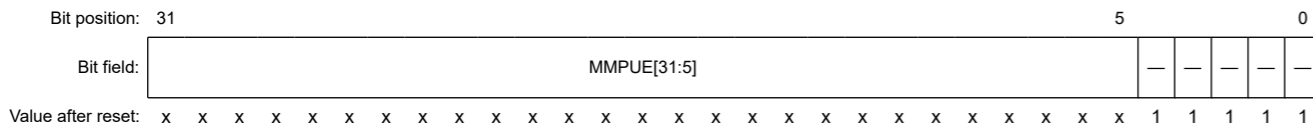
The MMPUSDMACn (n = 0 to 7) register specifies the start address where the region starts.

This register requires word access. Byte access and half word access is prohibited. When byte access and half word access is executed, operation is not guaranteed.

Regions set by MMPUSDMACn (n = 0 to 7), MMPUEDMACn (n = 0 to 7) and MMPUACDMACn (n = 0 to 7) registers, can be set for a secure access or a non-secure access with the MMPUSARA register. If the corresponding MMPUSARA.MMPUASAn (n = 0 to 7) bit is set to 1, only non-secure access is permitted for that region. On the other hand, if the corresponding MMPUSARA.MMPUASAn (n = 0 to 7) bit is set to 0, only secure access is permitted for that region.

### 15.3.1.4 MMPUEDMACn : MPU End Address Register for DMAC (n = 0 to 7)

Base address: RMPU = 0x4000\_0000  
Offset address: 0x0208 + 0x010 × n



| Bit  | Symbol      | Function   | R/W |
|------|-------------|--|-----|
| 4:0  | —           | These bits are read as 1. The write value should be 1.                                       | R/W |
| 31:5 | MMPUE[31:5] | Region end address register<br>Address where the region end, for use in region determination | R/W |

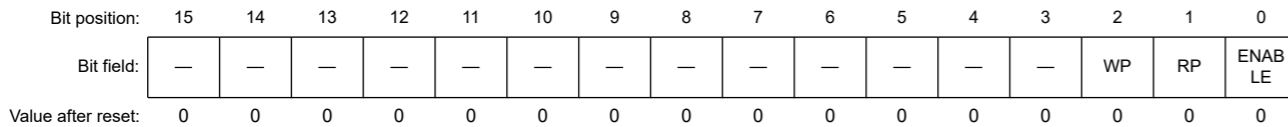
- Note: If the security attribution is configured as secure:
- Secure access and Non-secure read access are allowed
  - Non-secure write access is ignored, and TrustZone access error is not generated.
- If the security attribution is configured as Non-secure:
- Secure and Non-secure access are allowed.

The MMPUEDMAC (n = 0 to 7) register specifies the end address where the region ends.

This register requires word access. Byte access and half word access is prohibited. When byte access and half word access is executed, operation is not guaranteed.

### 15.3.1.5 MMPUACDMACn : MPU Access Control Register for DMAC (n = 0 to 7)

Base address: RMPU = 0x4000\_0000  
Offset address: 0x0200 + 0x010 × n



| Bit | Symbol | Function   | R/W |
|-----|--------|--|-----|
| 0   | ENABLE | Region enable<br>0: DMAC Region n unit is disabled<br>1: DMAC Region n unit is enabled | R/W |
| 1   | RP     | Read protection<br>0: Read permission<br>1: Read protection                            | R/W |
| 2   | WP     | Write protection<br>0: Write permission<br>1: Write protection                         | R/W |

- 忽略非安全写入访问，不会生成TrustZone访问错误。
- 如果安全属性配置为非安全：
- 允许安全和非安全访问。

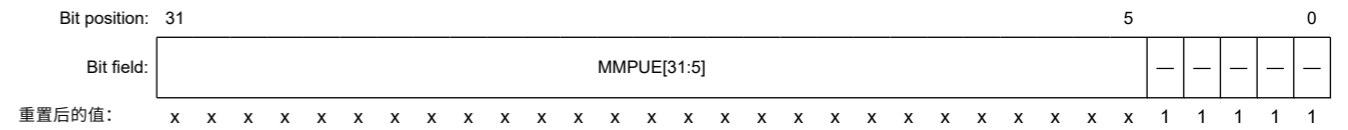
MMPUSDMACn (n=0到7) 寄存器指定区域开始的起始地址。

该寄存器需要字访问。禁止字节访问和半字访问。当执行字节访问和半字访问时，不能保证操作。

由MMPUSDMACn (n=0到7)、MMPUEDMACn (n=0到7)和MMPUACDMACn (n=0到7) 寄存器设置的区域可以通过MMPUSARA寄存器设置为安全访问或非安全访问。如果相应的MMPUSARA.MMPUASAn (n=0到7) 位设置为1，则该区域仅允许非安全访问。另一方面，如果相应的MMPUSARA.MMPUASAn(n=0到7)位设置为0，则仅允许对该区域进行安全访问。

### 15.3.1.4 MMPUEDMACn: DMAC的MPU结束地址寄存器 (n=0到7)

Base address: RMPU = 0x4000\_0000  
Offset address: 0x0208 + 0x010 × n



| Bit  | Symbol      | Function                    | R/W |
|------|-------------|-----------------------------|-----|
| 4:0  | —           | 这些位被读取为1。写入值应为1。            | R/W |
| 31:5 | MMPUE[31:5] | 区域结束地址寄存器<br>区域结束的地址，用于区域确定 | R/W |

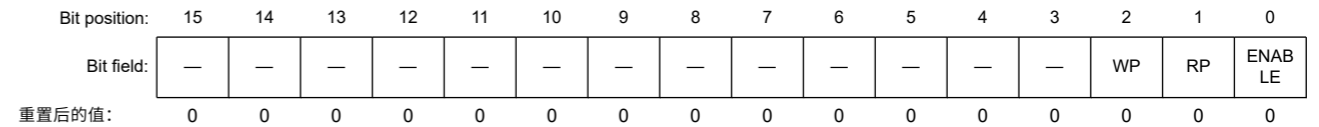
- Note: 如果安全属性配置为安全：
- 允许安全访问和非安全读取访问
  - 忽略非安全写入访问，不会生成TrustZone访问错误。
- 如果安全属性配置为非安全：
- 允许安全和非安全访问。

MMPUEDMAC (n=0到7) 寄存器指定区域结束的结束地址。

该寄存器需要字访问。禁止字节访问和半字访问。当执行字节访问和半字访问时，不能保证操作。

### 15.3.1.5 MMPUACDMACn: 用于DMAC的MPU访问控制寄存器 (n=0到7)

Base address: RMPU = 0x4000\_0000  
Offset address: 0x0200 + 0x010 × n



| Bit | Symbol | Function                             | R/W |
|-----|--------|--------------------------------------|-----|
| 0   | ENABLE | 区域启用<br>0: 禁用DMAC区域n单元1: 启用DMAC区域n单元 | R/W |
| 1   | RP     | 读保护<br>0: 读取权限1: 读取保护                | R/W |
| 2   | WP     | 写保护<br>0: 写权限1: 写保护                  | R/W |



| Bit  | Symbol | Function   | R/W |
|------|--------|--|-----|
| 15:3 | —      | These bits are read as 0. The write value should be 0. | R/W |

Note: If the security attribution is configured as secure:

- Secure access and Non-secure read access are allowed
- Non-secure write access is ignored, and TrustZone access error is not generated.

If the security attribution is configured as Non-secure:

- Secure and Non-secure access are allowed.

Region n unit sets the ENABLE bit, the RP bit, and the WP bit each.

**ENABLE bit (Region enable)**

The ENABLE bit controls the enable or disable of DMAC/DTC region n (n = 0 to 7) unit.

When the ENABLE bit is set to 1, the RP bit and the WP bit control access permission for read and write protection to MMPUSDMACn (n = 0 to 7) and MMPUEDMACn (n = 0 to 7).

When the ENABLE bit is set to 0, access to DMAC region n (n = 0 to 7) is the outside region.

**RP bit (Read protection)**

The RP bit enables or disables read protection of DMAC/DTC region n (n = 0 to 7).

When the ENABLE bit is set to 1, the RP bit is available.

**WP bit (Write protection)**

The WP bit enables or disables write protection of DMAC/DTC region n (n = 0 to 7).

When the ENABLE bit is set to 1, the WP bit is available.

Table 15.4 Function of Region Control Circuit for DMAC

| MMPUACDMACn (n = 0 to 7) |    |       | Access  | Region            | Output of DMAC Region n unit (n = 0 to 7) |
|--------------------------|----|-------|---------|-------------------|---|
| ENABLE                   | RP | WP    |         |                   |   |
| 0                        | —  | —     | Read    | —                 | Outside region                            |
|                          |    |       | Write   |                   | Outside region                            |
| 1                        | 0  | 0     | Read    | Inside            | Permitted region                          |
|                          |    |       |         | Outside           | Outside region                            |
|                          |    |       | Write   | Inside            | Permitted region                          |
|                          |    |       |         | Outside           | Outside region                            |
|                          | 0  | 1     | Read    | Inside            | Permitted region                          |
|                          |    |       |         | Outside           | Outside region                            |
|                          |    |       | Write   | Inside            | Protection region                         |
|                          |    |       |         | Outside           | Outside region                            |
|                          | 1  | 0     | Read    | Inside            | Protection region                         |
|                          |    |       |         | Outside           | Outside region                            |
|                          |    |       | Write   | Inside            | Permitted region                          |
|                          |    |       |         | Outside           | Outside region                            |
| 1                        | 1  | Read  | Inside  | Protection region |   |
|                          |    |       | Outside | Outside region    |   |
|                          |    | Write | Inside  | Protection region |   |
|                          |    |       | Outside | Outside region    |   |

Note: Each regions of DMAC / DTC are set for secure access and non-secure access by MMPUSARA register. In this case, Non-Secure regions in secure access and secure regions in Non-Secure access are outside regions.

| Bit  | Symbol | Function         | R/W |
|------|--------|------------------|-----|
| 15:3 | —      | 这些位被读取为0。写入值应为0。 | R/W |

Note: 如果安全属性配置为安全: ●

- 允许安全访问和非安全读取访问
- 忽略非安全写入访问, 不会生成TrustZone访问错误。

如果安全属性配置为非安全: ●

- 允许安全和非安全访问。

区域n单元分别设置ENABLE位、RP位和WP位。

**ENABLE位 (区域使能)**

ENABLE位控制DMACDTC区域n (n=0到7) 单元的启用或禁用。

当ENABLE位设置为1时, RP位和WP位控制读写保护的访问权限 MMPUSDMACn (n=0到7) 和MMPUEDMACn (n=0到7)。

当ENABLE位设置为0时, 访问DMAC区域n (n=0到7) 是外部区域。

**RP bit (Read protection)**

RP位启用或禁用DMACDTC区域n (n=0到7) 的读保护。

当ENABLE位设置为1时, RP位可用。

**WP bit (Write protection)**

WP位启用或禁用DMACDTC区域n (n=0到7) 的写保护。

当ENABLE位设置为1时, WP位可用。

Table 15.4 DMAC区域控制电路的功能

| MMPUACDMACn (n = 0 to 7) |    |       | Access  | Region  | DMAC区域n单元的输出 (n =0到7) |
|--------------------------|----|-------|---------|---------|-----------------------|
| ENABLE                   | RP | WP    |         |         |                       |
| 0                        | —  | —     | Read    | —       | 区域外                   |
|                          |    |       | Write   |         | 区域外                   |
| 1                        | 0  | 0     | Read    | Inside  | 许可区域                  |
|                          |    |       |         | Outside | 区域外                   |
|                          |    |       | Write   | Inside  | 许可区域                  |
|                          |    |       |         | Outside | 区域外                   |
|                          | 0  | 1     | Read    | Inside  | 许可区域                  |
|                          |    |       |         | Outside | 区域外                   |
|                          |    |       | Write   | Inside  | 保护区                   |
|                          |    |       |         | Outside | 区域外                   |
|                          | 1  | 0     | Read    | Inside  | 保护区                   |
|                          |    |       |         | Outside | 区域外                   |
|                          |    |       | Write   | Inside  | 许可区域                  |
|                          |    |       |         | Outside | 区域外                   |
| 1                        | 1  | Read  | Inside  | 保护区     |                       |
|                          |    |       | Outside | 区域外     |                       |
|                          |    | Write | Inside  | 保护区     |                       |
|                          |    |       | Outside | 区域外     |                       |

Note: DMACDTC的每个区域都通过MMPUSARA寄存器设置为安全访问和非安全访问。在这种情况下, 安全访问中的非安全区域和非安全访问中的安全区域是外部区域。

Table 15.5 Function of Master Control Circuit for DMAC

| MMPUENDMAC  | Output of DMAC Region 0 unit | Output of DMAC Region 1 unit | Output of DMAC Region 2-7 unit | Function of DMAC |
|-------------|------------------------------|------------------------------|--------------------------------|------------------|
| ENABLE      |                              |                              |                                |                  |
| 1           | Protected region             | Don't care                   | Don't care                     | Generate error   |
|             | Don't care                   | Protected region             | Don't care                     | Generate error   |
|             | Don't care                   | Don't care                   | Protected region               | Generate error   |
|             | Outside region               | Outside region               | Outside region                 | Generate error   |
| Other cases |                              |                              |                                | No error         |

A master MPU error occurs on the following conditions:

1. MMPUENDMAC.ENABLE = 1, and output of one or more Region n unit is protected region.
2. MMPUENDMAC.ENABLE = 1, and output of all Region n unit are outside region.

Other cases are handled as permitted region.

### 15.3.1.6 MMPUENDMAC : MPU Enable Register for DMAC

Base address: RMPU = 0x4000\_0000

Offset address: 0x0100

| Bit position:      | 15       | 14 | 13 | 12 | 11 | 10 | 9 | 8 | 7 | 6 | 5 | 4 | 3 | 2 | 1 | 0 |   |   |   |        |
|--------------------|----------|----|----|----|----|----|---|---|---|---|---|---|---|---|---|---|---|---|---|--------|
| Bit field:         | KEY[7:0] |    |    |    |    |    |   |   |   |   |   | — | — | — | — | — | — | — | — | ENABLE |
| Value after reset: | 0        | 0  | 0  | 0  | 0  | 0  | 0 | 0 | 0 | 0 | 0 | 0 | 0 | 0 | 0 | 0 | 0 | 0 | 0 |        |

| Bit  | Symbol   | Function   | R/W |
|------|----------|--|-----|
| 0    | ENABLE   | Bus Master MPU of DMAC enable<br>0: Bus Master MPU of DMAC is disabled.<br>1: Bus Master MPU of DMAC is enabled. | R/W |
| 7:1  | —        | These bits are read as 0. The write value should be 0.   | R/W |
| 15:8 | KEY[7:0] | Key Code<br>These bits enable or disable writes to the ENABLE bit.   | W   |

Note: If the security attribution is configured as secure:

- Secure access and Non-secure read access are allowed
  - Non-secure write access is ignored, and TrustZone access error is not generated.
- If the security attribution is configured as Non-secure:
- Secure and Non-secure access are allowed.

Note: It is necessary to write by half word access.

Byte write access is prohibited. When byte write access is executed, operation is not guaranteed.

#### ENABLE bit (Bus Master MPU of DMAC enable)

The ENABLE bit controls enable or disable of the bus master MPU function of each master group.

When the ENABLE bit is set to 1, MMPUACDMACn (n = 0 to 7) is valid. When the ENABLE bit is set to 0, MMPUACDMACn (n = 0 to 7) is invalid for all regions. The bus master MPU function sets the ENABLE bit of each master group. When the ENABLE bit is set, write 0xA5 in KEY[7:0] at the same time.

#### KEY[7:0] bits (Key Code)

The KEY[7:0] bits enable or disable writing to the ENABLE bit. When writing to the ENABLE bit, write 0xA5 in KEY[7:0] bits at the same time. When values other than 0xA5 are written to KEY[7:0] bits, the ENABLE bit is not updated. The KEY[7:0] bits are always read as 0x00.

Table 15.5 DMAC主控电路的功能

| MMPUENDMAC | DMAC区域0单元的输出 | DMAC区域1单元的输出 | DMAC区域2-7单元的输出 | DMAC的功能 |
|------------|--------------|--------------|----------------|---------|
| ENABLE     |              |              |                |         |
| 1          | 保护区          | Don't care   | Don't care     | 产生错误    |
|            | Don't care   | 保护区          | Don't care     | 产生错误    |
|            | Don't care   | Don't care   | 保护区            | 产生错误    |
|            | 区域外          | 区域外          | 区域外            | 产生错误    |
| 其他案例       |              |              |                | 没有错误    |

主控MPU错误发生在以下情况:

- 1.MMPUENDMAC.ENABLE=1, 一个或多个Regionn单元的输出为受保护区域。
- 2.MMPUENDMAC.ENABLE=1, 所有Regionn单元的输出都在Region外。

其他情况按许可区域处理。

### 15.3.1.6 MMPUENDMAC:DMAC的MPU使能寄存器

Base address: RMPU = 0x4000\_0000

Offset address: 0x0100

| Bit position: | 15       | 14 | 13 | 12 | 11 | 10 | 9 | 8 | 7 | 6 | 5 | 4 | 3 | 2 | 1 | 0 |   |   |   |        |
|---------------|----------|----|----|----|----|----|---|---|---|---|---|---|---|---|---|---|---|---|---|--------|
| Bit field:    | KEY[7:0] |    |    |    |    |    |   |   |   |   |   | — | — | — | — | — | — | — | — | ENABLE |
| 重置后的值:        | 0        | 0  | 0  | 0  | 0  | 0  | 0 | 0 | 0 | 0 | 0 | 0 | 0 | 0 | 0 | 0 | 0 | 0 | 0 |        |

| Bit  | Symbol   | Function   | R/W |
|------|----------|--|-----|
| 0    | ENABLE   | DMAC的总线主控MPU使能<br>0: DMAC的总线主控MPU禁用。1: DMA<br>C的总线主控MPU使能。 | R/W |
| 7:1  | —        | 这些位被读取为0。写入值应为0。   | R/W |
| 15:8 | KEY[7:0] | 关键代码<br>这些位启用或禁用对ENABLE位的写入。                               | W   |

Note: 如果安全属性配置为安全: ●

- 允许安全访问和非安全读取访问
  - 忽略非安全写入访问, 不会生成TrustZone访问错误。
- 如果安全属性配置为非安全: ●
- 允许安全和非安全访问。

Note: 必须通过半字访问写入。

禁止字节写访问。当执行字节写访问时, 不能保证操作。

#### ENABLE位 (DMAC的总线主控MPU使能)

ENABLE位控制每个主机组的总线主机MPU功能的启用或禁用。

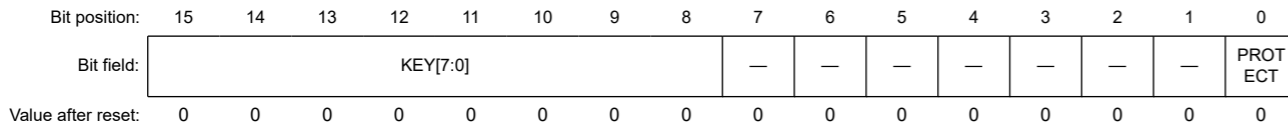
当ENABLE位设置为1时, MMPUACDMACn (n=0至7) 有效。当ENABLE位设置为0时, MMPUACDMACn(n=0至7)对所有地区都无效。总线主控MPU功能设置每个主控组的ENABLE位。当ENABLE位置位时, 同时在KEY[7:0]中写入0xA5。

#### KEY[7:0] bits (Key Code)

KEY[7:0]位启用或禁用对ENABLE位的写入。写入ENABLE位时, 将0xA5写入KEY[7:0]位。当0xA5以外的值写入KEY[7:0]位时, ENABLE位不会更新。KEY[7:0]位总是读为0x00。

15.3.1.7 MMPUENPTDMAC : MMPU Enable Protect Register for DMAC

Base address: RMPU = 0x4000\_0000  
Offset address: 0x0104



| Bit  | Symbol   | Function  | R/W |
|------|----------|---|-----|
| 0    | PROTECT  | Protection of register<br>0: MMPUENDMAC register writes are possible.<br>1: MMPUENDMAC register writes are protected. Read is possible. | R/W |
| 7:1  | —        | These bits are read as 0. The write value should be 0.  | R/W |
| 15:8 | KEY[7:0] | Key Code<br>These bits enable or disable writes to the PROTECT bit.   | W   |

Note: If the security attribution is configured as secure:  
 • Secure access and Non-secure read access are allowed  
 • Non-secure write access is ignored, and TrustZone access error is not generated.  
 If the security attribution is configured as Non-secure:  
 • Secure and Non-secure access are allowed.  
 Note: It is necessary to write by half word access.  
 Byte write access is prohibited. When byte write access is executed, operation is not guaranteed.

**PROTECT bit (Protection of register)**

The PROTECT bit enables or disables writes to the MMPUENDMAC register.  
 When writing to the PROTECT bit, write 0xA5 in KEY[7:0] at the same time.

**KEY[7:0] bits (Key Code)**

The KEY[7:0] bits enable or disable writes to the PROTECT bit. When writing to the PROTECT bit, write 0xA5 in KEY[7:0] at the same time. When values other than 0xA5 are written in KEY[7:0] bits, the PROTECT bit is not updated. The KEY[7:0] bits are always read as 0x00.

15.3.1.8 MMPURPTDMAC : MMPU Regions Protect Register for DMAC

Base address: RMPU = 0x4000\_0000  
Offset address: 0x0108

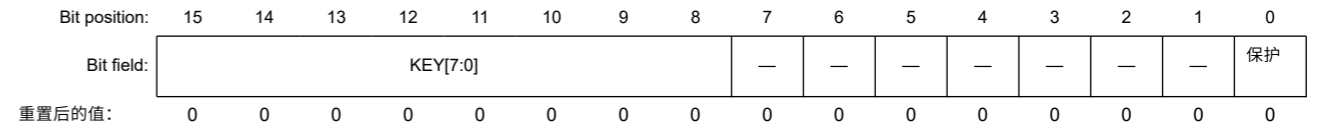


| Bit  | Symbol   | Function  | R/W |
|------|----------|---|-----|
| 0    | PROTECT  | Protection of register<br>0: Bus Master MPU register for DMAC writing is possible.<br>1: Bus Master MPU register for DMAC writing is protected. Read is possible. | R/W |
| 7:1  | —        | These bits are read as 0. The write value should be 0.  | R/W |
| 15:8 | KEY[7:0] | Key Code<br>These bits enable or disable writes to the PROTECT bit.   | W   |

Note: If the security attribution is configured as secure:  
 • Secure access and Non-secure read access are allowed  
 • Non-secure write access is ignored, and TrustZone access error is not generated.

15.3.1.7 MMPUENPTDMAC:MMPU启用DMAC的保护寄存器

Base address: RMPU = 0x4000\_0000  
Offset address: 0x0104



| Bit  | Symbol   | Function  | R/W |
|------|----------|---|-----|
| 0    | PROTECT  | 注册保护<br>0: 可以写入MMPUENDMAC寄存器。1: MMPUENDMAC寄存器写受保护。读取是可能的。 | R/W |
| 7:1  | —        | 这些位被读取为0。写入值应为0。  | R/W |
| 15:8 | KEY[7:0] | 关键代码<br>这些位启用或禁用对PROTECT位的写入。                             | W   |

Note: 如果安全属性配置为安全: ●  
 允许安全访问和非安全读取访问  
 • 忽略非安全写入访问, 不会生成TrustZone访问错误。  
 如果安全属性配置为非安全: ●  
 允许安全和非安全访问。  
 Note: 必须通过半字访问写入。  
 禁止字节写访问。当执行字节写访问时, 不能保证操作。

**PROTECT位 (寄存器保护)**

PROTECT位启用或禁用对MMPUENDMAC寄存器的写入。  
 写入PROTECT位时, 同时向KEY[7:0]写入0xA5。

**KEY[7:0] bits (Key Code)**

KEY[7:0]位启用或禁用对PROTECT位的写入。写入PROTECT位时, 将0xA5写入KEY[7:0]同时进行。当KEY[7:0]位中写入0xA5以外的值时, PROTECT位不会更新。KEY[7:0]位总是读为0x00。

15.3.1.8 MMPURPTDMAC:DMAC的MMPU区域保护寄存器

Base address: RMPU = 0x4000\_0000  
Offset address: 0x0108



| Bit  | Symbol   | Function   | R/W |
|------|----------|--|-----|
| 0    | PROTECT  | 注册保护<br>0: 可以进行DMAC写入的总线主控MPU寄存器。1: 用于DMAC写入的总线主控MPU寄存器受保护。读取是可能的。 | R/W |
| 7:1  | —        | 这些位被读取为0。写入值应为0。   | R/W |
| 15:8 | KEY[7:0] | 关键代码<br>这些位启用或禁用对PROTECT位的写入。                                      | W   |

Note: 如果安全属性配置为安全: ●  
 允许安全访问和非安全读取访问  
 • 忽略非安全写入访问, 不会生成TrustZone访问错误。

If the security attribution is configured as Non-secure:

- Secure and Non-secure access are allowed.

Note: It is necessary to write by half word access.

Byte write access is prohibited. When byte write access is executed, operation is not guaranteed.

**PROTECT bit (Protection of register)**

The PROTECT bit enables or disables writes to the associated registers to be protected.

MMPURPTDMAC.PROTECT controls the following registers:

- MMPUSDMACn (n = 0 to 7) of Non-Secure program
- MMPUEDMACn (n = 0 to 7) of Non-Secure program
- MMPUACDMACn (n = 0 to 7) of Non-Secure program

When writing to the PROTECT bit, write 0xA5 simultaneously to the KEY[7:0] bits, using halfword access.

**KEY[7:0] bits (Key Code)**

The KEY[7:0] bits enable or disable writes to the PROTECT bit. When writing to the PROTECT bit, write 0xA5 simultaneously to the KEY[7:0] bits. When other values are written, the PROTECT bit is not updated.

The KEY[7:0] bits always read as 0x00.

**15.3.1.9 MMPURPTDMAC\_SEC : MMPU Regions Protect register for DMAC Secure**

Base address: RMPU = 0x4000\_0000

Offset address: 0x010C



| Bit  | Symbol   | Function  | R/W |
|------|----------|---|-----|
| 0    | PROTECT  | Protection of register<br>0: Bus master MPU register for DMAC secure writes are possible.<br>1: Bus master MPU register for DMAC secure writes are protected. Read is possible. | R/W |
| 7:1  | —        | These bits are read as 0. The write value should be 0.  | R/W |
| 15:8 | KEY[7:0] | Key Code<br>These bits enable or disable writes to the PROTECT bit.   | W   |

Note: If the security attribution is configured as secure:

- Secure access and Non-secure read access are allowed
- Non-secure write access is ignored, and TrustZone access error is not generated.

If the security attribution is configured as Non-secure:

- Secure and Non-secure access are allowed.

Note: It is necessary to write by half word access.

Byte write access is prohibited. When byte write access is executed, operation is not guaranteed.

**PROTECT bit (Protection of register)**

The PROTECT bit enables or disables writes to the associated registers to be protected.

MMPURPTDMAC\_SEC.PROTECT controls the following registers:

- MMPUSDMACn (n = 0 to 7) of Secure program
- MMPUEDMACn (n = 0 to 7) of Secure program
- MMPUACDMACn (n = 0 to 7) of Secure program

When writing to the PROTECT bit, write 0xA5 simultaneously to the KEY[7:0] bits, using halfword access.

如果安全属性配置为非安全: ●

- 允许安全和非安全访问。

Note: 必须通过半字访问写入。

禁止字节写访问。当执行字节写访问时, 不能保证操作。

**PROTECT位 (寄存器保护)**

PROTECT位启用或禁用对要保护的相关寄存器的写入。

MMPURPTDMAC.PROTECT控制以下寄存器:

- 非安全程序的MMPUSDMACn(n=0到7)
- 非安全程序的MMPUEDMACn(n=0到7)
- 非安全程序的MMPUACDMACn(n=0到7)

写入PROTECT位时, 使用半字访问同时将0xA5写入KEY[7:0]位。

**KEY[7:0] bits (Key Code)**

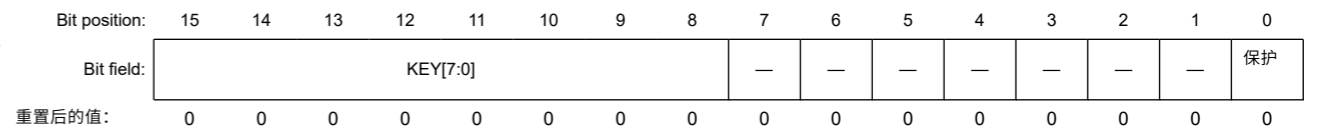
KEY[7:0]位启用或禁用对PROTECT位的写入。写入PROTECT位时, 同时将0xA5写入KEY[7:0]位。写入其他值时, PROTECT位不会更新。

KEY[7:0]位总是读为0x00。

**15.3.1.9 MMPURPTDMAC\_SEC: 用于DMACSecure的MMPU区域保护寄存器**

Base address: RMPU = 0x4000\_0000

Offset address: 0x010C



| Bit  | Symbol   | Function  | R/W |
|------|----------|---|-----|
| 0    | PROTECT  | 注册保护<br>0: 可以进行DMAC安全写入的总线主控MPU寄存器。1: 用于DMAC安全写入的总线主控MPU寄存器受到保护。读取是可能的。 | R/W |
| 7:1  | —        | 这些位被读取为0。写入值应为0。  | R/W |
| 15:8 | KEY[7:0] | 关键代码<br>这些位启用或禁用对PROTECT位的写入。   | W   |

Note: 如果安全属性配置为安全: ●

- 允许安全访问和非安全读取访问
- 忽略非安全写入访问, 不会生成TrustZone访问错误。

如果安全属性配置为非安全: ●

- 允许安全和非安全访问。

Note: 必须通过半字访问写入。

禁止字节写访问。当执行字节写访问时, 不能保证操作。

**PROTECT位 (寄存器保护)**

PROTECT位启用或禁用对要保护的相关寄存器的写入。

MMPURPTDMAC\_SEC.PROTECT控制以下寄存器:

- Secure程序的MMPUSDMACn(n=0到7)
- 安全程序的MMPUEDMACn(n=0到7)
- 安全程序的MMPUACDMACn(n=0到7)

写入PROTECT位时, 使用半字访问同时将0xA5写入KEY[7:0]位。



**KEY[7:0] bits (Key Code)**

The KEY[7:0] bits enable or disable writes to the PROTECT bit. When writing to the PROTECT bit, write 0xA5 simultaneously to the KEY[7:0] bits. When other values are written, the PROTECT bit is not updated.

The KEY[7:0] bits are always read as 0x00.

**15.3.1.10 MMPUOAD : MMPU Operation After Detection Register**

Base address: RMPU = 0x4000\_0000

Offset address: 0x0000

|                    |          |    |    |    |    |    |   |   |   |   |   |   |   |   |   |   |   |   |   |   |     |
|--------------------|----------|----|----|----|----|----|---|---|---|---|---|---|---|---|---|---|---|---|---|---|-----|
| Bit position:      | 15       | 14 | 13 | 12 | 11 | 10 | 9 | 8 | 7 | 6 | 5 | 4 | 3 | 2 | 1 | 0 |   |   |   |   |     |
| Bit field:         | KEY[7:0] |    |    |    |    |    |   |   |   |   |   |   | — | — | — | — | — | — | — | — | OAD |
| Value after reset: | 0        | 0  | 0  | 0  | 0  | 0  | 0 | 0 | 0 | 0 | 0 | 0 | 0 | 0 | 0 | 0 |   |   |   |   |     |

| Bit  | Symbol   | Function   | R/W |
|------|----------|--|-----|
| 0    | OAD      | Operation after detection<br>0: Non-maskable interrupt<br>1: Reset | R/W |
| 7:1  | —        | These bits are read as 0. The write value should be 0.             | R/W |
| 15:8 | KEY[7:0] | Key Code<br>This bit enables or disables writes to the OAD bit.    | W   |

Note: If the security attribution is configured as secure:

- Secure access and Non-secure read access are allowed
- Non-secure write access is ignored, and TrustZone access error is not generated.

If the security attribution is configured as Non-secure:

- Secure and Non-secure access are allowed.

Note: It is necessary to write by half word access.

Byte write access is prohibited. When byte write access is executed, operation is not guaranteed.

**OAD bit (Operation after detection)**

The OAD bit is specified to generate either reset or non-maskable interrupt when the access to the protect region is detected by the BUS Master MPU.

When writing to the OAD bit, write 0xA5 simultaneously to the KEY[7:0] bits using halfword access.

**KEY[7:0] bits (Key Code)**

The KEY[7:0] bits enable or disable writing to the OAD bit. When writing to the OAD bit, write 0xA5 simultaneously to the KEY[7:0] bits. When other values are written, the OAD bit is not updated.

The KEY[7:0] bits always read as 0x00.

**15.3.1.11 MMPUOADPT : MMPU Operation After Detection Protect Register**

Base address: RMPU = 0x4000\_0000

Offset address: 0x0004

|                    |          |    |    |    |    |    |   |   |   |   |   |   |   |   |   |   |   |   |   |   |         |
|--------------------|----------|----|----|----|----|----|---|---|---|---|---|---|---|---|---|---|---|---|---|---|---------|
| Bit position:      | 15       | 14 | 13 | 12 | 11 | 10 | 9 | 8 | 7 | 6 | 5 | 4 | 3 | 2 | 1 | 0 |   |   |   |   |         |
| Bit field:         | KEY[7:0] |    |    |    |    |    |   |   |   |   |   |   | — | — | — | — | — | — | — | — | PROTECT |
| Value after reset: | 0        | 0  | 0  | 0  | 0  | 0  | 0 | 0 | 0 | 0 | 0 | 0 | 0 | 0 | 0 | 0 |   |   |   |   |         |

**KEY[7:0] bits (Key Code)**

KEY[7:0]位启用或禁用对PROTECT位的写入。写入PROTECT位时，同时将0xA5写入KEY[7:0]位。写入其他值时，PROTECT位不会更新。

KEY[7:0]位总是读为0x00。

**15.3.1.10 MMPUOAD:检测后的MMPU操作寄存器**

Base address: RMPU = 0x4000\_0000

Offset address: 0x0000

|               |          |    |    |    |    |    |   |   |   |   |   |   |   |   |   |   |   |   |   |   |     |
|---------------|----------|----|----|----|----|----|---|---|---|---|---|---|---|---|---|---|---|---|---|---|-----|
| Bit position: | 15       | 14 | 13 | 12 | 11 | 10 | 9 | 8 | 7 | 6 | 5 | 4 | 3 | 2 | 1 | 0 |   |   |   |   |     |
| Bit field:    | KEY[7:0] |    |    |    |    |    |   |   |   |   |   |   | — | — | — | — | — | — | — | — | OAD |
| 重置后的值:        | 0        | 0  | 0  | 0  | 0  | 0  | 0 | 0 | 0 | 0 | 0 | 0 | 0 | 0 | 0 | 0 |   |   |   |   |     |

| Bit  | Symbol   | Function                 | R/W |
|------|----------|--------------------------|-----|
| 0    | OAD      | 检测后操作<br>0: 不可屏蔽中断1: 复位  | R/W |
| 7:1  | —        | 这些位被读取为0。写入值应为0。         | R/W |
| 15:8 | KEY[7:0] | 关键代码<br>该位启用或禁用对OAD位的写入。 | W   |

Note: 如果安全属性配置为安全: ●

- 允许安全访问和非安全读取访问
- 忽略非安全写入访问，不会生成TrustZone访问错误。

如果安全属性配置为非安全: ●

- 允许安全和非安全访问。

Note: 必须通过半字访问写入。

禁止字节写访问。当执行字节写访问时，不能保证操作。

**OAD位 (检测后的操作)**

当总线主控MPU检测到对保护区域的访问时，OAD位被指定为产生复位或不可屏蔽中断。

写入OAD位时，使用半字访问同时将0xA5写入KEY[7:0]位。

**KEY[7:0] bits (Key Code)**

KEY[7:0]位启用或禁用写入OAD位。写入OAD位时，同时将0xA5写入KEY[7:0]位。写入其他值时，不会更新OAD位。

KEY[7:0]位总是读为0x00。

**15.3.1.11 MMPUOADPT:检测保护寄存器后的MMPU操作**

Base address: RMPU = 0x4000\_0000

Offset address: 0x0004

|               |          |    |    |    |    |    |   |   |   |   |   |   |   |   |   |   |   |   |   |   |    |
|---------------|----------|----|----|----|----|----|---|---|---|---|---|---|---|---|---|---|---|---|---|---|----|
| Bit position: | 15       | 14 | 13 | 12 | 11 | 10 | 9 | 8 | 7 | 6 | 5 | 4 | 3 | 2 | 1 | 0 |   |   |   |   |    |
| Bit field:    | KEY[7:0] |    |    |    |    |    |   |   |   |   |   |   | — | — | — | — | — | — | — | — | 保护 |
| 重置后的值:        | 0        | 0  | 0  | 0  | 0  | 0  | 0 | 0 | 0 | 0 | 0 | 0 | 0 | 0 | 0 | 0 |   |   |   |   |    |



| Bit  | Symbol   | Function  | R/W |
|------|----------|---|-----|
| 0    | PROTECT  | Protection of register<br>0: MMPUOAD register writes are possible.<br>1: MMPUOAD register writes are protected. Read is possible. | R/W |
| 7:1  | —        | These bits are read as 0. The write value should be 0.  | R/W |
| 15:8 | KEY[7:0] | Key code<br>These bits enable or disable writes to the PROTECT bit.   | W   |

Note: If the security attribution is configured as secure:

- Secure access and Non-secure read access are allowed
- Non-secure write access is ignored, and TrustZone access error is not generated.

If the security attribution is configured as Non-secure:

- Secure and Non-secure access are allowed.

Note: It is necessary to write by half word access.  
Byte write access is prohibited. When byte write access is executed, operation is not guaranteed.

### PROTECT bit (Protection of register)

The PROTECT bit enables or disables writes to the associated registers to be protected.

MMPUOADPT.PROTECT controls the following register:

- MMPUOAD

When the PROTECT bit is set simultaneously, write 0xA5 to the KEY[7:0] bits using half word access.

### KEY[7:0] bits (Key code)

The KEY[7:0] bits enable or disable writes to the PROTECT bit. When writing to the PROTECT bit simultaneously, write 0xA5 to the KEY[7:0] bits. When other values are written to the KEY[7:0] bits, the PROTECT bit is not updated. The KEY[7:0] bits are always read as 0x00.

## 15.3.2 Operation

### 15.3.2.1 Memory protection

The bus master MPU monitors memory access using control settings made individually for the access control regions. If access to a protected region is detected, the bus master MPU generates a memory protection error.

Bus Master MPU can be set for up to 8 protection regions. It is protection region when set up of permission region and protection region overlaps. It is protection region when set up of two protection region overlaps.

Bus Master MPU has master groups of DMAC/DTC.

Memory protection checks the address of the bus which the master group unified. Therefore, all the access of a master group is detected by memory protection.

The region setting registers of the Bus Master MPU for DMAC/DTC can be set for secure access and Non-Secure access using the MMPUSARA register. Make secure access and Non-Secure access settings the same for each DMAC/DTC channel and the corresponding region setting registers of the Bus Master MPU.

Bus Master MPU is permission of all regions after reset. All region is protected by setting MMPUENDMAC.ENABLE=1.

Each region sets up a permission region on the protection region. If access to the protected region is detected, Bus Master MPU will generate an error.

Figure 15.1 shows the use case of a bus master MPU.

| Bit  | Symbol   | Function  | R/W |
|------|----------|---|-----|
| 0    | PROTECT  | 注册保护<br>0: MMPUOAD寄存器写入是可能的。1: MMPUOAD寄存器写受保护。读取是可能的。 | R/W |
| 7:1  | —        | 这些位被读取为0。写入值应为0。                                      | R/W |
| 15:8 | KEY[7:0] | 关键代码<br>这些位启用或禁用对PROTECT位的写入。                         | W   |

Note: 如果安全属性配置为安全: ●

- 允许安全访问和非安全读取访问
- 忽略非安全写入访问, 不会生成TrustZone访问错误。

如果安全属性配置为非安全: ●

- 允许安全和非安全访问。

Note: 必须通过半字访问写入。  
禁止字节写访问。当执行字节写访问时, 不能保证操作。

### PROTECT位 (寄存器保护)

PROTECT位启用或禁用对要保护的相关寄存器的写入。

MMPUOADPT.PROTECT控制以下寄存器:

- MMPUOAD

当PROTECT位同时置位时, 使用半字访问将0xA5写入KEY[7:0]位。

### KEY[7:0] bits (Key code)

KEY[7:0]位启用或禁用对PROTECT位的写入。同时写入PROTECT位时, 将0xA5写入KEY[7:0]位。当其他值写入KEY[7:0]位时, PROTECT位不会更新。KEY[7:0]位总是读为0x00。

## 15.3.2 Operation

### 15.3.2.1 内存保护

总线主控MPU使用为访问控制区域单独进行的控制设置来监视内存访问。如果检测到对受保护区域的访问, 则总线主控MPU会产生内存保护错误。

总线主控MPU最多可设置8个保护区域。许可区域与保护区域的设置重叠时为保护区域。两个保护区域重叠设置时为保护区域。

总线主控MPU具有DMACDTC主控组。

内存保护检查主组统一的总线地址。因此, 一个主组的所有访问都被内存保护检测到。

可以使用MMPUSARA寄存器为DMACDTC的总线主控MPU的区域设置寄存器设置安全访问和非安全访问。使每个DMACDTC通道和总线主控MPU的相应区域设置寄存器的安全访问和非安全访问设置相同。

BusMasterMPU是复位后所有区域的权限。通过设置MMPUENDMAC.ENABLE=1来保护所有区域。

每个区域在保护区域上设置一个权限区域。如果检测到对受保护区域的访问, 则总线主控MPU会产生错误。

图15.1显示了总线主控MPU的用例。

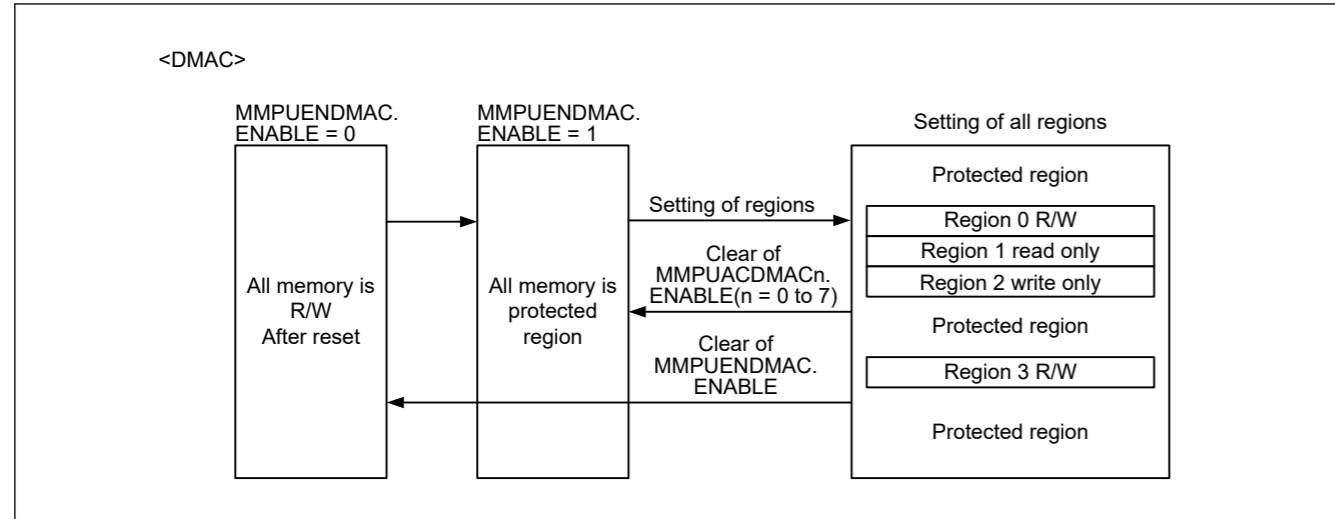


Figure 15.1 Use case of bus master MPU

Figure 15.2 shows the access permission or protection by the overlapping bus master MPU regions.

Access control for the overlapping regions is as follows:

- The region is handled as a protected region when output of one or more region units is a protected region
- The region is handled as a protected region when output of all region units is outside of the regions
- Other cases are handled as permitted regions.

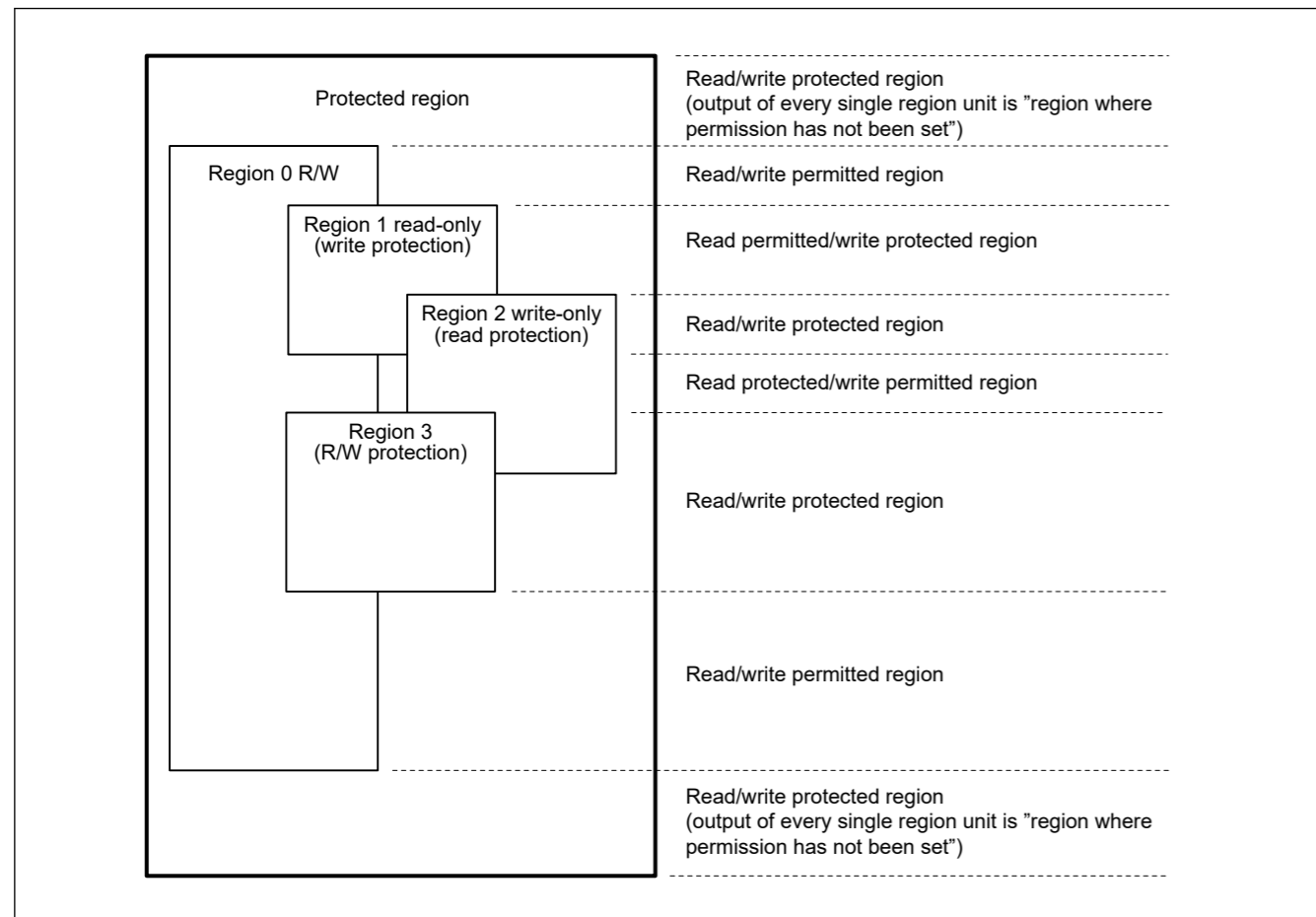


Figure 15.2 Access permission or protection by overlap of the bus master MPU regions

Figure 15.3 shows the register setting flow after reset. During this register setting, stop all bus masters except the CPU.

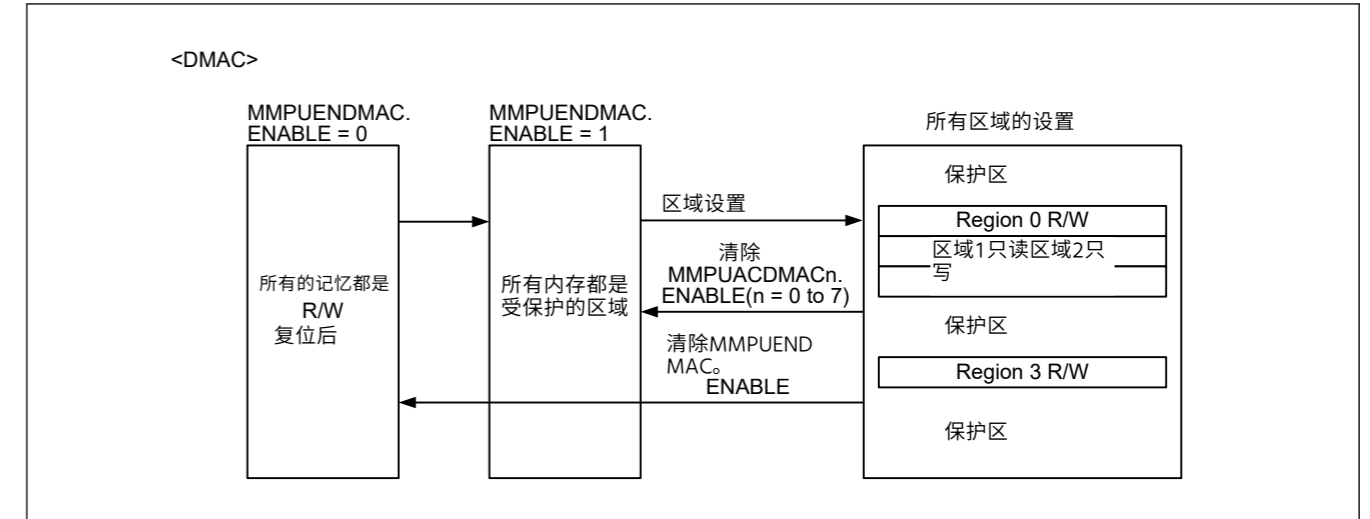


Figure 15.1 总线主控MPU用例

图15.2显示了重叠总线主控MPU区域的访问许可或保护。

重叠区域的访问控制如下：

- 当一个或多个区域单元的输出为受保护区域时，该区域被视为受保护区域
- 当所有区域单元的输出都在区域之外时，该区域被视为受保护区域
- 其他情况按许可区域处理。

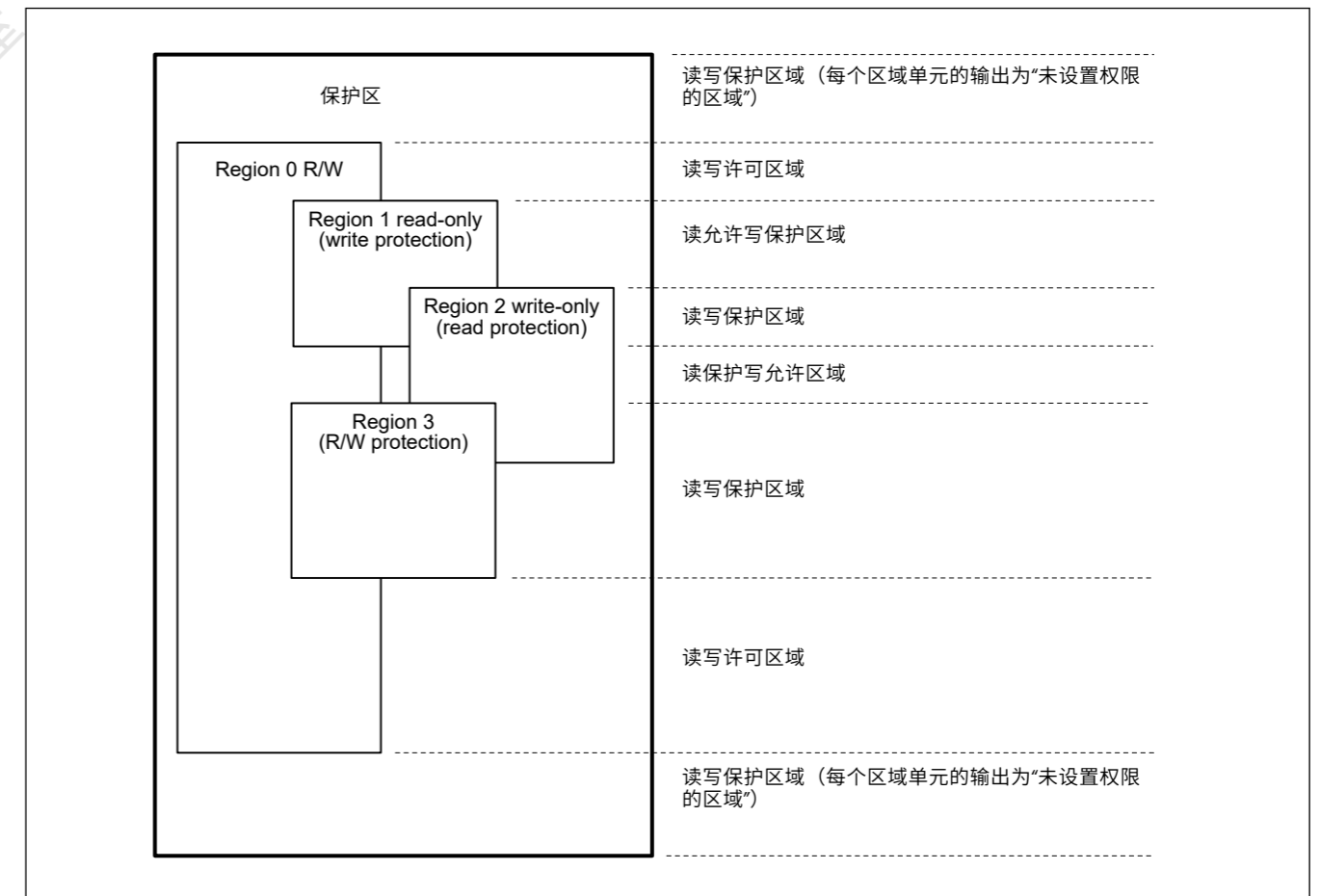


Figure 15.2 通过总线主控MPU区域的重叠访问许可或保护

图15.3显示了复位后的寄存器设置流程。在此寄存器设置期间，停止除CPU之外的所有总线主机。

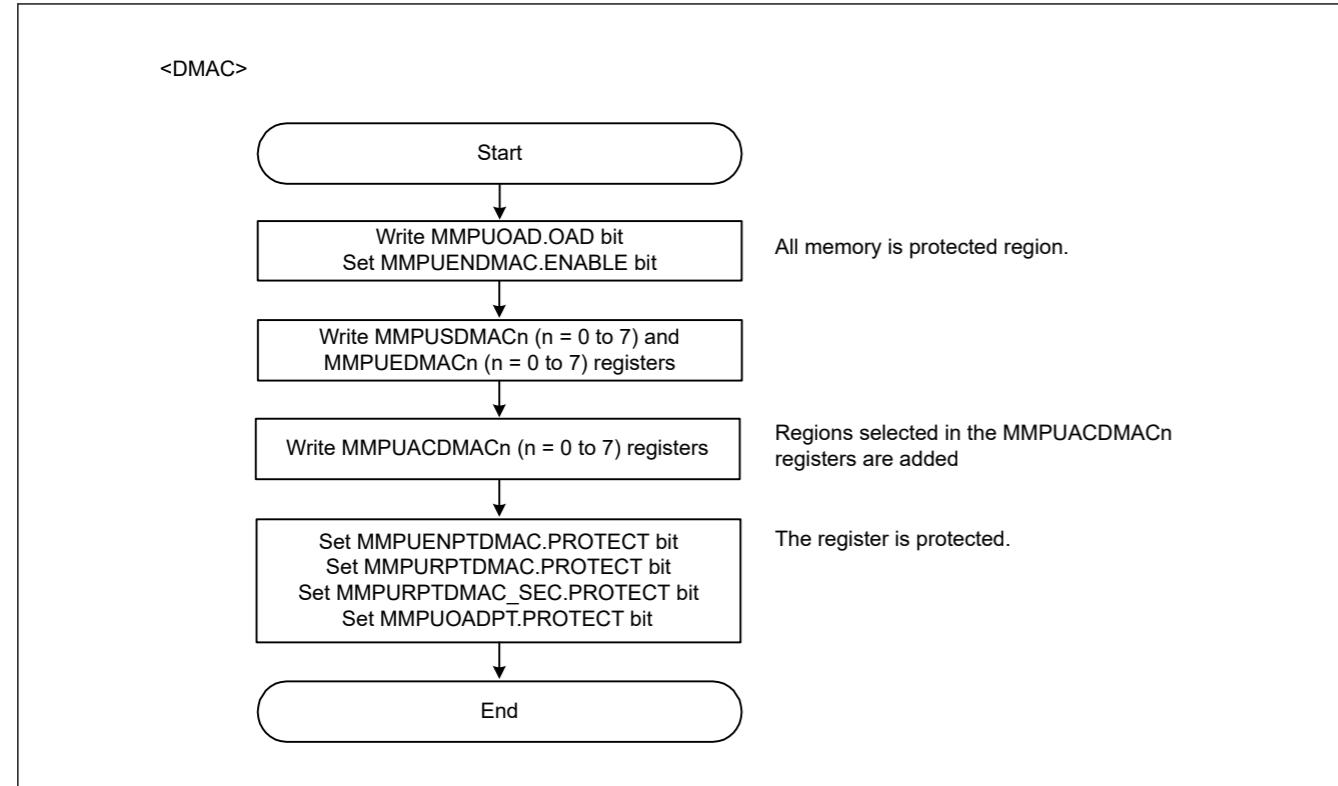


Figure 15.3 Register setting flow of bus master MPU after reset

Figure 15.4 shows the register setting flow for adding regions. During this register setting, stop all masters except the CPU.

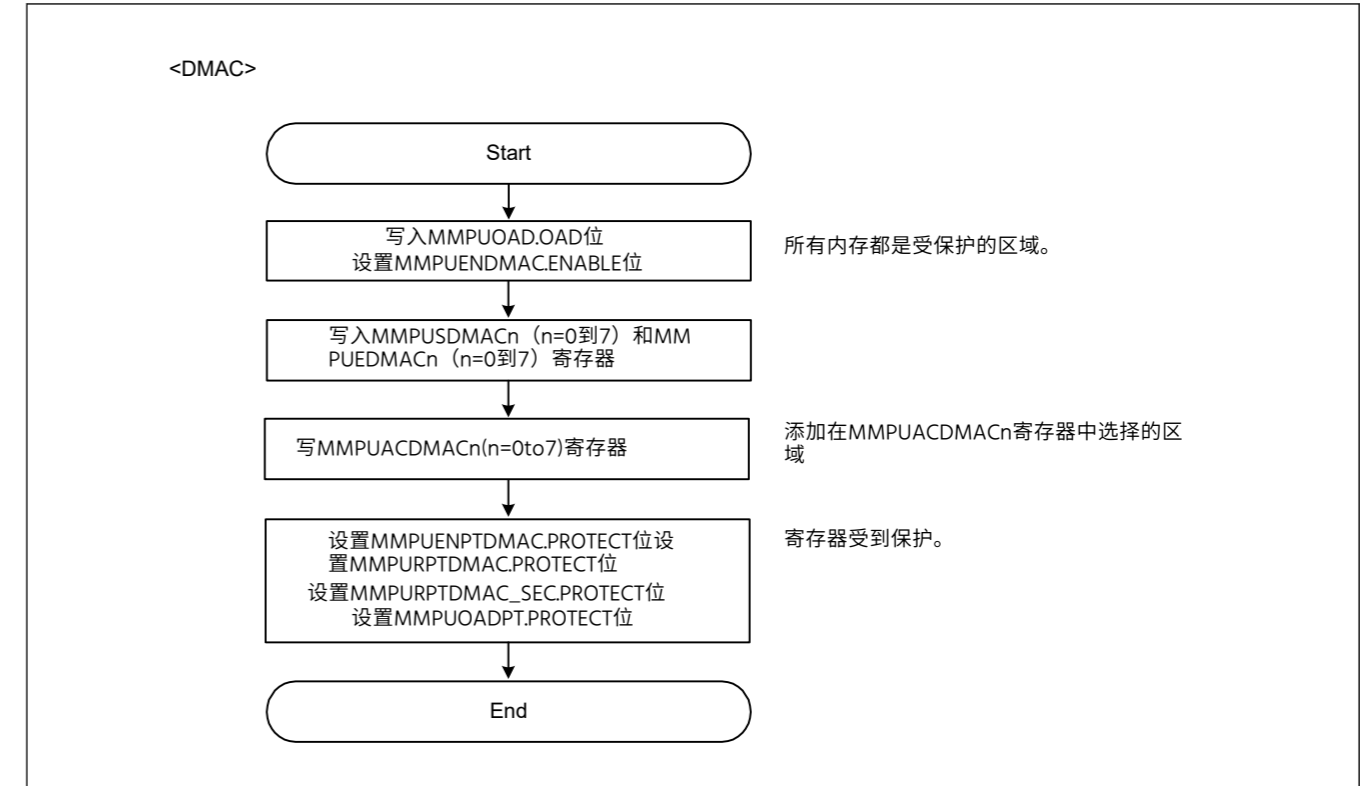


Figure 15.3 复位后总线主控MPU寄存器设置流程

图15.4显示了添加区域的寄存器设置流程。在此寄存器设置期间，停止除CPU之外的所有主机。

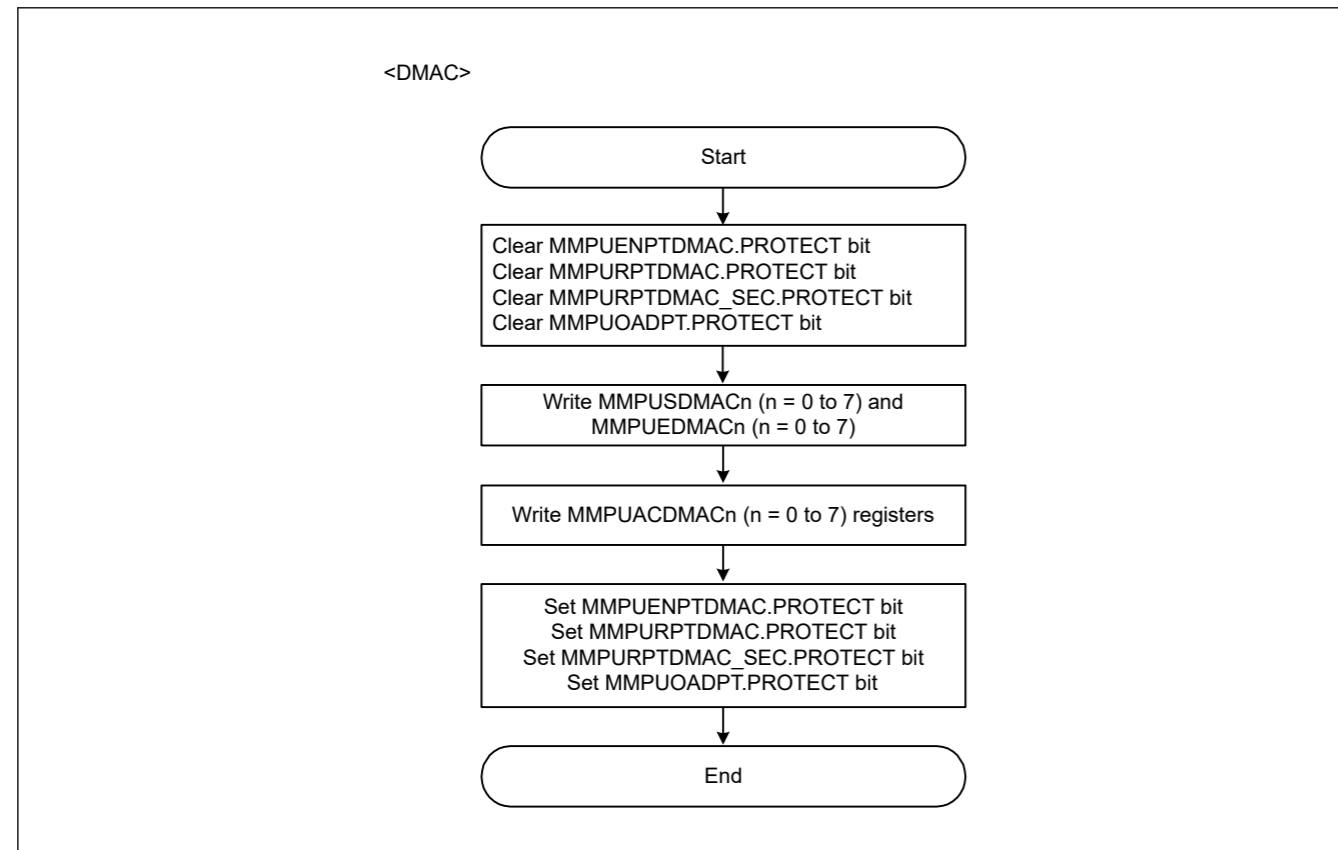


Figure 15.4 Register setting flow for region addition

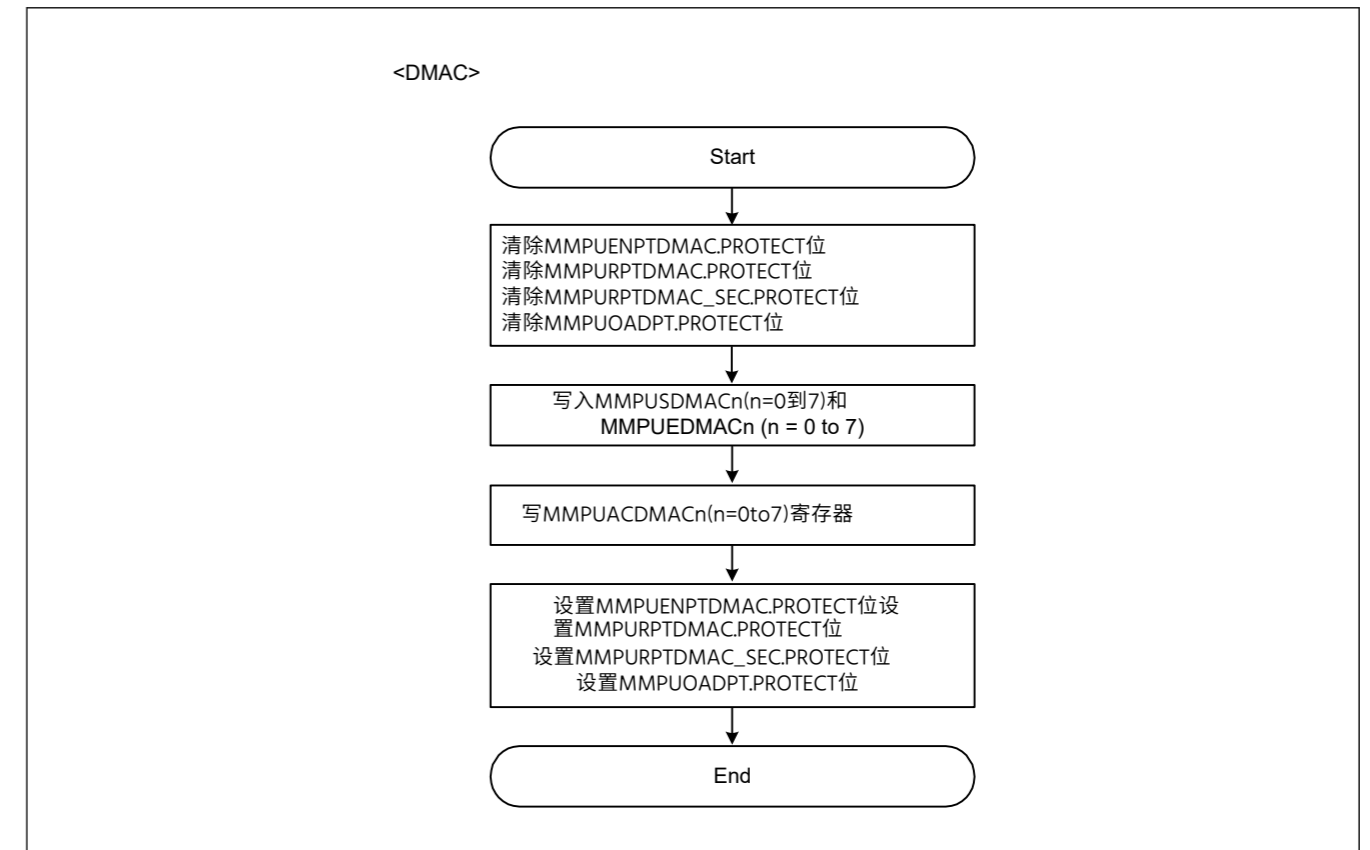


Figure 15.4 区域添加的注册设置流程

### 15.3.2.2 Protecting the registers

Registers related to the Bus Master MPU can be protected with the PROTECT bit in the MMPUENPTDMA, MMPURPTDMAC, MMPURPTDMAC\_SEC and MMPUOADPT registers.

**Table 15.6 PROTECT bit and Protected target registers**

| PROTECT bit             | Protect target registers   |
|-------------------------|--|
| MMPUENPTDMAC.PROTECT    | MMPUENDMAC   |
| MMPURPTDMAC.PROTECT     | The following registers set to Non-Secure by MMPUSARA.MMPUASAn (n = 0 to 7).<br>MMPUSDMACn (n = 0 to 7)<br>MMPUEDMACn (n = 0 to 7)<br>MMPUACDMACn (n = 0 to 7) |
| MMPURPTDMAC_SEC.PROTECT | The following registers set to Secure by MMPUSARA.MMPUASAn (n = 0 to 7).<br>MMPUSDMACn (n = 0 to 7)<br>MMPUEDMACn (n = 0 to 7)<br>MMPUACDMACn (n = 0 to 7)     |
| MMPUOADPT.PROTECT       | MMPUOAD  |

### 15.3.2.3 Memory protection error

If access to a protected region is detected, the bus master MPU generates an error. Set the OAD bit to select whether the error is reported as a non-maskable interrupt or a reset.

The non-maskable interrupt status is indicated in ICU.NMISR.BUSMST. For details, see [section 13, Interrupt Controller Unit \(ICU\)](#). The reset status is indicated in SYSTEM.RSTSR1.BUSMRF. For details, see [section 5, Resets](#).

## 15.4 References

1. *Arm®v8-M Architecture Reference Manual* (ARM DDI0553B.g)
2. *Arm®Cortex®-M33 Processor Technical Reference Manual* (ARM 100230\_0004\_00\_en)

### 15.3.2.2 保护寄存器

与总线主控MPU相关的寄存器可以通过MMPUENPTDMA中的PROTECT位进行保护，MMPURPTDMAC、MMPURPTDMAC\_SEC和MMPUOADPT寄存器。

**Table 15.6 PROTECT位和受保护的目標寄存器**

| 保护位                     | 保护目标寄存器   |
|-------------------------|---|
| MMPUENPTDMAC.PROTECT    | MMPUENDMAC  |
| MMPURPTDMAC.PROTECT     | 以下寄存器设置为非安全由<br>MMPUSARA.MMPUASAn (n = 0 to 7).<br>MMPUSDMACn (n = 0 to 7)<br>MMPUEDMACn (n = 0 to 7)<br>MMPUACDMACn (n = 0 to 7) |
| MMPURPTDMAC_SEC.PROTECT | 以下寄存器由MMPUSARA.MMPUASAn (n=0到7) 设置为Secure。<br>MMPUSDMACn (n=0到7) MMPUEDMACn (n=0到7)<br><br>MMPUACDMACn (n = 0 to 7)               |
| MMPUOADPT.PROTECT       | MMPUOAD   |

### 15.3.2.3 内存保护错误

如果检测到对受保护区域的访问，则总线主控MPU会产生错误。设置OAD位以选择将错误报告为不可屏蔽中断还是复位。

不可屏蔽中断状态在ICU.NMISR.BUSMST中指示。有关详细信息，请参阅第13节，中断控制器单位 (ICU)。复位状态在SYSTEM.RSTSR1.BUSMRF中指示。有关详细信息，请参阅第5节，重置。

## 15.4 References

1. *Arm®v8-M架构参考手册* (ARMDDI0553B.g)
2. *Arm®Cortex®-M33处理器技术参考手册* (ARM100230\_0004\_00\_en)

## 16. DMA Controller (DMAC)

### 16.1 Overview

The MCU includes an 8-channel direct memory access controller (DMAC) that can transfer data without intervention from the CPU. When a DMA transfer request is generated, the DMAC transfers data stored at the transfer source address to the transfer destination address.

Table 16.1 lists the DMAC specifications, and Figure 16.1 shows a block diagram of the DMAC.

**Table 16.1 DMAC specifications (1 of 2)**

| Item                              | Description  |   |
|-----------------------------------|--|---|
| Number of channels                | 8 channels (DMACn (n = 0 to 7))  |   |
| Transfer space                    | 4 GB<br>(0x00000000 to 0xFFFFFFFF excluding reserved areas)  |   |
| Maximum transfer volume           | 64 M data<br>(Maximum number of transfers in block transfer mode: 1,024 data × 65,536 blocks)  |   |
| DMAC activation source            | Selectable for each channel: <ul style="list-style-type: none"> <li>Software trigger</li> <li>Interrupt requests from peripheral modules or trigger from external interrupt input pins.*1</li> </ul> |   |
| Channel priority                  | Channel 0 > Channel 1 > Channel 2 > Channel 3... > Channel 7 (Channel 0: Highest)  |   |
| Transfer data                     | Single data  | Bit length: 8, 16, 32 bits  |
|                                   | Block size   | Number of data: 1 to 1,024  |
| Transfer mode                     | Normal transfer mode   | <ul style="list-style-type: none"> <li>One data transfer by one DMA transfer request</li> <li>Free running function (setting in which total number of data transfers is not specified) settable</li> </ul>  |
|                                   | Repeat transfer mode   | <ul style="list-style-type: none"> <li>One data transfer by one DMA transfer request</li> <li>Program returns to the transfer start address on completion of the repeat size of data transfer specified for the transfer source or destination.</li> <li>Maximum settable repeat size: 1,024</li> <li>Selectable free running function</li> </ul> |
|                                   | Repeat-block transfer mode   | <ul style="list-style-type: none"> <li>One block data transfer by one DMA transfer request</li> <li>Maximum settable block size: 1,024</li> <li>Block transfer can be repeated</li> <li>Maximum settable repeat size: 64K</li> <li>Selectable free running function</li> </ul>  |
|                                   | Block transfer mode  | <ul style="list-style-type: none"> <li>One block data transfer by one DMA transfer request</li> <li>Maximum settable block size: 1,024 data</li> <li>Selectable free running function</li> </ul>  |
| Selective functions               | Extended repeat area function  | <ul style="list-style-type: none"> <li>Function in which data can be transferred by repeating the address values in the specified range with the upper bit values in the transfer address register fixed</li> <li>Area of 2 bytes to 128 Mbytes separately settable as extended repeat area for transfer source and destination</li> </ul>        |
| Processing on DMAC transfer error |  | <ul style="list-style-type: none"> <li>When the DMAC transfer error occurs, it is stop the transfer that caused the error channel</li> <li>Request to clear the register for activation request of DMAC error channel to ICU</li> </ul>   |
| Interrupt (DMACn_INT)             | Transfer end interrupt   | Generated on completion of transferring data volume specified by the transfer counter.  |
|                                   | Transfer escape end interrupt  | <ul style="list-style-type: none"> <li>Generated when the repeat size of data transfer is completed.</li> <li>Generated when the source address extended repeat area overflows.</li> <li>Generated when the destination address extended repeat area overflows.</li> </ul>  |
| Interrupt (DMA_TRANSE RR)         | Error response detection interrupt   | <ul style="list-style-type: none"> <li>Generated when the DMAC transfer error occurs</li> </ul>   |
| Event link activation (DMACn_INT) |  | An event link request is generated after each data transfer (for block transfer, after each block is transferred).  |

## 16. DMA Controller (DMAC)

### 16.1 Overview

MCU包括一个8通道直接内存访问控制器(DMAC)，无需CPU干预即可传输数据。当产生DMA传输请求时，DMAC将存储在传输源地址的数据传输到传输目标地址。

表16.1列出了DMAC规范，图16.1显示了DMAC的框图。

**Table 16.1 DMAC规格(1of2)**

| Item                      | Description  |   |
|---------------------------|--|---|
| 通道数                       | 8个通道 (DMACn (n=0到7) )  |   |
| 转移空间                      | 4GB (0x00000000到0xFFFFFFFF不包括保留区域)   |   |
| 最大传输量                     | 64M数据 (块传输模式下的最大传输数: 1 024数据×65 536块)  |   |
| DMAC激活源                   | 每个通道可选择: ●<br>软件触发 <ul style="list-style-type: none"> <li>来自外围模块的 interrupt 请求或来自外部中断输入引脚的触发。*1</li> </ul> |   |
| 通道优先级                     | Channel 0 > Channel 1 > Channel 2 > Channel 3... > Channel 7 (Channel 0: Highest)                          |   |
| 传输数据                      | 单一数据   | 位长: 8、16、32位  |
|                           | 块大小  | 数据数量: 1至1 024   |
| 传输模式                      | 正常传输模式   | <ul style="list-style-type: none"> <li>1个DMA传输请求1个数据传输</li> <li>自由运行功能 (不指定数据传输总数的设置) 可设置</li> </ul>  |
|                           | 重复传输模式   | <ul style="list-style-type: none"> <li>1个DMA传输请求1个数据传输</li> <li>为传输源或目标指定的重复数据传输大小完成后, 程序返回传输起始地址。</li> <li>最大可设置重复大小: 1 024</li> <li>可选择的自由运行功能</li> </ul> |
|                           | 重复块传输模式  | <ul style="list-style-type: none"> <li>1个DMA传输请求的1个块数据传输</li> <li>最大可设置块大小: 1 024</li> <li>块传输可以重复</li> <li>最大可设置重复大小: 64K</li> <li>可选择的自由运行功能</li> </ul>   |
|                           | 块传输模式  | <ul style="list-style-type: none"> <li>1个DMA传输请求的1个块数据传输</li> <li>最大可设置块大小: 1 024个数据</li> <li>可选择的自由运行功能</li> </ul>   |
| 选择性功能                     | 扩展重复区域功能   | <ul style="list-style-type: none"> <li>可以通过重复指定范围内的地址值来传输数据的功能, 其中传输地址寄存器中的高位值是固定的</li> <li>2字节至128兆字节的区域可单独设置为传输源和目标的扩展重复区域</li> </ul>                     |
| 处理DMAC传输错误                |  | <ul style="list-style-type: none"> <li>当发生DMAC传输错误时, 是停止传输导致错误通道</li> <li>请求清除寄存器以激活对ICU的DMAC错误通道的请求</li> </ul>   |
| Interrupt (DMACn_INT)     | 传输结束中断   | 在传输计数器指定的传输数据量完成时生成。  |
|                           | 传输转义结束中断   | <ul style="list-style-type: none"> <li>数据传输的重复大小完成时生成。</li> <li>当源地址扩展重复区溢出时产生。</li> <li>当目标地址扩展重复区溢出时产生。</li> </ul>  |
| Interrupt (DMA_TRANSE RR) | 错误响应检测中断   | <ul style="list-style-type: none"> <li>发生DMAC传输错误时生成</li> </ul>   |
| 事件链接激活(DMACn_INT)         |  | 每次数据传输后都会生成一个事件链接请求 (对于块传输, 在每个块传输后)。   |



Table 16.1 DMAC specifications (2 of 2)

| Item                                 | Description  |
|--------------------------------------|--|
| Master TrustZone Filter              | TrustZone violation area of Flash and SRAM is detected before a non-secure channel access the bus. |
| Power consumption reduction function | Module-stop state can be set.  |
| TrustZone Filter                     | Security attribution can be set for each channels  |

Note: Security attribution Register of DMAC channel is described in ICU.ICUSRAC

Note 1. For details on DMAC activation sources, see Table 13.4 in section 13, Interrupt Controller Unit (ICU).

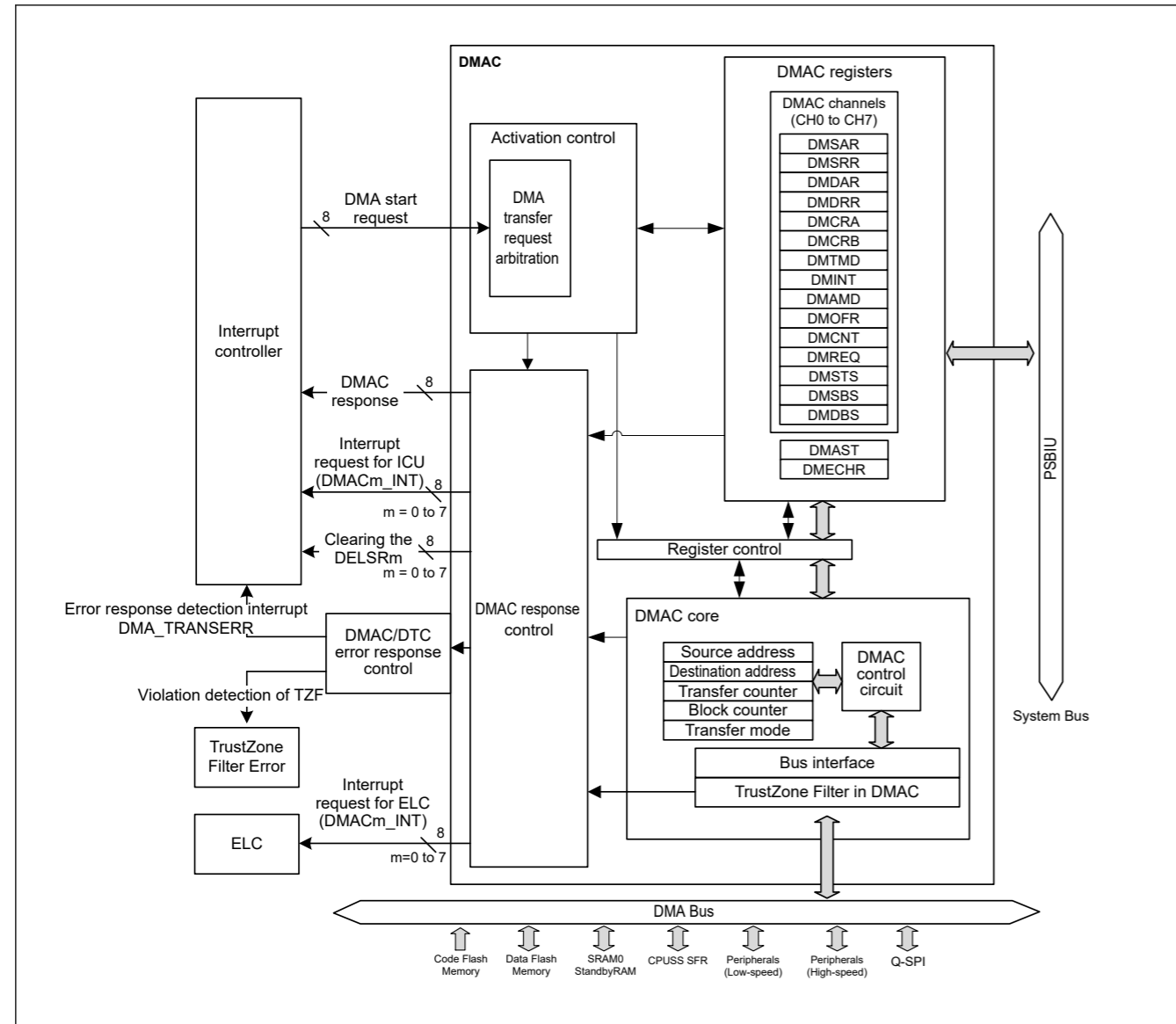


Figure 16.1 Block Diagram of DMAC

Table 16.1 DMAC规范 (2个中的2个)

| Item             | Description                              |
|------------------|--|
| 主信任区过滤器          | 在非安全通道访问总线之前检测到Flash和SRAM的TrustZone违规区域。 |
| 功耗降低功能           | 可设置模块停止状态。                               |
| TrustZone Filter | 可以为每个通道设置安全属性                            |

Note: ICU.ICUSRAC中描述了DMAC通道的安全属性寄存器

注1.有关DMAC激活源的详细信息, 请参见第13节“中断控制器单元(ICU)”中的表13.4。

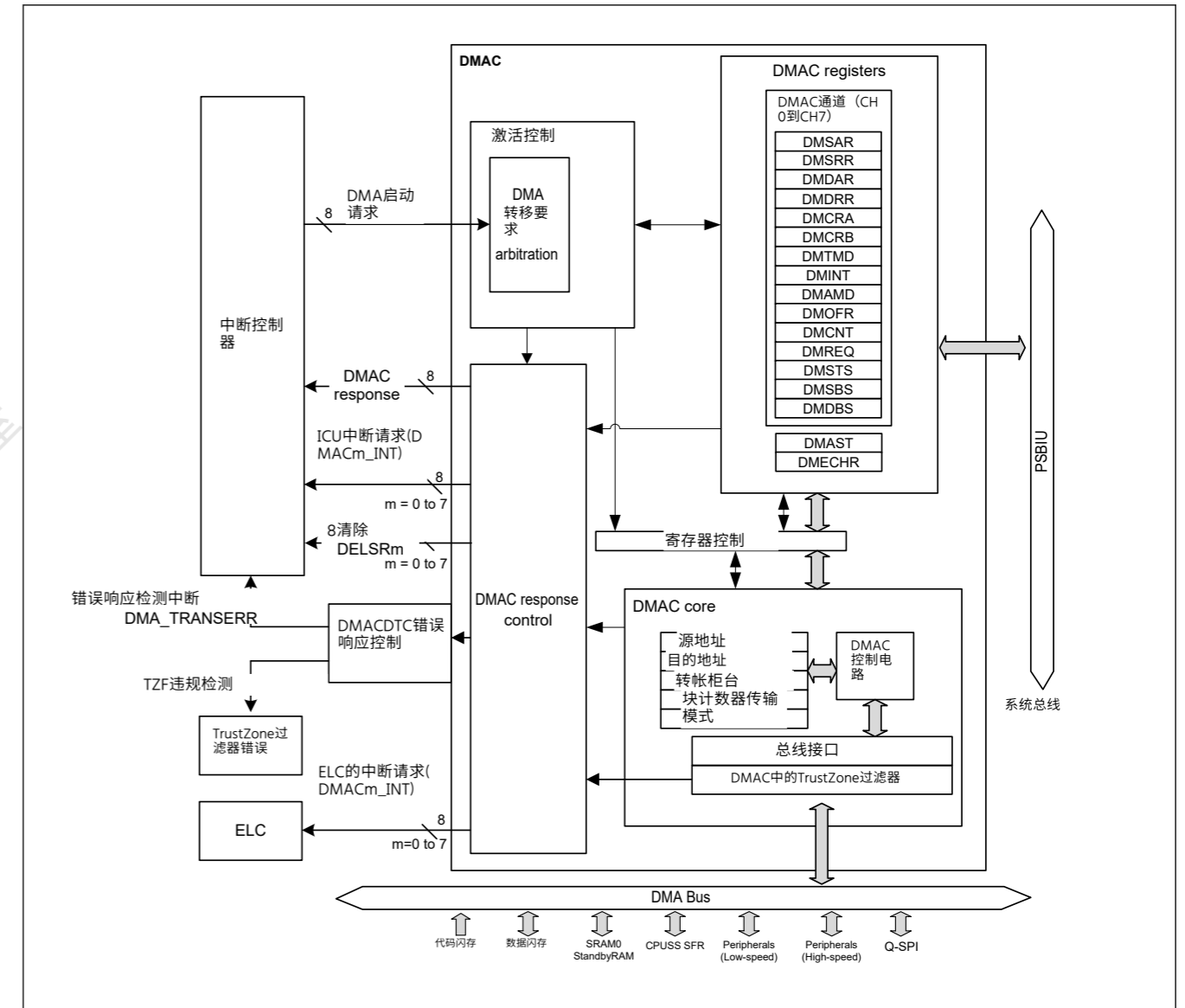


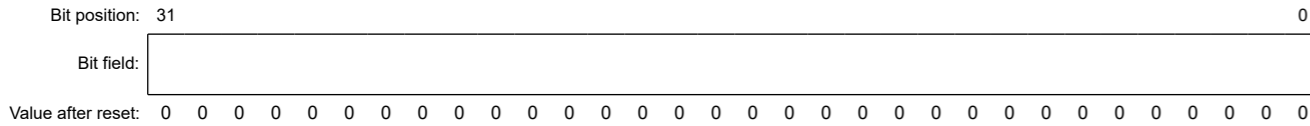
Figure 16.1 DMAC框图



## 16.2.3 DMSRR : DMA Source Reload Address Register

Base address:  $DMACn = 0x4000\_5000 + 0x0040 \times n$  (n = 0 to 7)

Offset address: 0x20



| Bit  | Symbol | Function   | R/W |
|------|--------|--|-----|
| 31:0 | n/a    | Specifies the transfer source reload address 0000 0000h to FFFF FFFFh (4 Gbytes) | R/W |

Note: If the security attribution is configured as secure:

- Secure access and Non-secure read access are allowed
- Non-secure write access is ignored, and TrustZone access error is not generated.

If the security attribution is configured as Non-secure:

- Secure and Non-secure access are allowed.

Set DMSRR while DMAC activation is disabled (DMAST.DMST = 0) or DMA transfer is disabled (DMCNT.DTE = 0).

DMSRR is initial value of DMSAR. In repeat-block transfer mode, DMSAR reloads value of DMSRR after specified transfer finished.

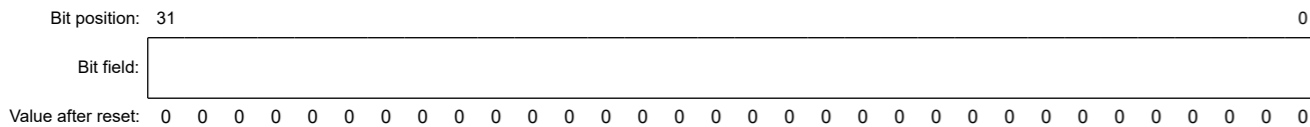
In normal transfer mode, repeat transfer mode and block transfer mode, DMSRR is not used. The setting is invalid.

Note: Address alignment in this register must match the Transfer Data Size value selected in the DMTMD.SZ bit.

## 16.2.4 DMDAR : DMA Destination Address Register

Base address:  $DMACn = 0x4000\_5000 + 0x0040 \times n$  (n = 0 to 7)

Offset address: 0x04



| Bit  | Symbol | Function   | R/W |
|------|--------|--|-----|
| 31:0 | n/a    | Specifies the transfer destination start address setting range is 0x00000000 to 0xFFFFFFFF (4 Gbytes). | R/W |

Note: If the security attribution is configured as secure:

- Secure access and Non-secure read access are allowed
- Non-secure write access is ignored, and TrustZone access error is not generated.

If the security attribution is configured as Non-secure:

- Secure and Non-secure access are allowed.

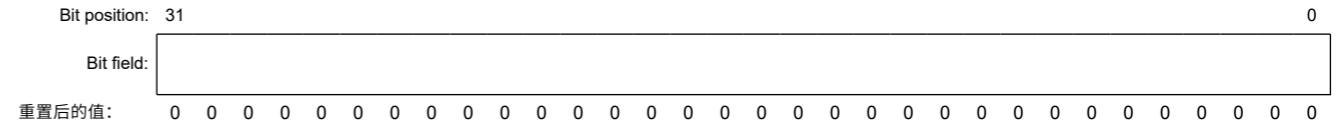
Set DMDAR while DMAC activation is disabled (the DMAST.DMST bit = 0) or DMA transfer is disabled (the DMCNT.DTE bit = 0).

Note: Address alignment in this register must match the Transfer Data Size value selected in the DMTMD.SZ bit.

## 16.2.3 DMSRR:DMA源重载地址寄存器

Base address:  $DMACn = 0x4000\_5000 + 0x0040 \times n$  (n = 0 to 7)

Offset address: 0x20



| Bit  | Symbol | Function                          | R/W |
|------|--------|-----------------------------------|-----|
| 31:0 | n/a    | 指定传输源重载地址00000000h到FFFFFFFFh(4GB) | R/W |

Note: 如果安全属性配置为安全: ●

- 允许安全访问和非安全读取访问
- 忽略非安全写入访问, 不会生成TrustZone访问错误。

如果安全属性配置为非安全: ●

- 允许安全和非安全访问。

在禁用DMAC激活(DMAST.DMST=0)或禁用DMA传输(DMCNT.DTE=0)时设置DMSRR。

DMSRR是DMSAR的初始值。在重复块传输模式下, DMSAR在指定传输完成后重新加载DMSRR的值。

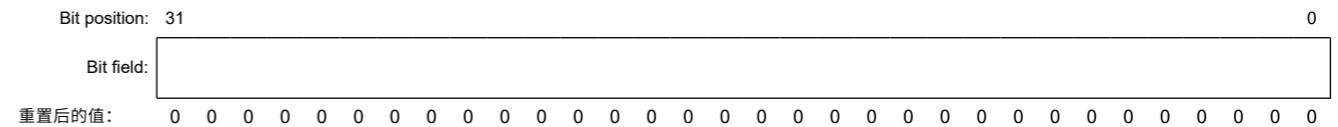
在正常传输模式、重复传输模式和块传输模式下, 不使用DMSRR。设置无效。

Note: 该寄存器中的地址对齐必须与在DMTMD.SZ位中选择的传输数据大小值相匹配。

## 16.2.4 DMDAR:DMA目标地址寄存器

Base address:  $DMACn = 0x4000\_5000 + 0x0040 \times n$  (n = 0 to 7)

Offset address: 0x04



| Bit  | Symbol | Function                                    | R/W |
|------|--------|---|-----|
| 31:0 | n/a    | 指定传输目标起始地址设置范围为0x00000000到0xFFFF FFFF(4GB)。 | R/W |

Note: 如果安全属性配置为安全: ●

- 允许安全访问和非安全读取访问
- 忽略非安全写入访问, 不会生成TrustZone访问错误。

如果安全属性配置为非安全: ●

- 允许安全和非安全访问。

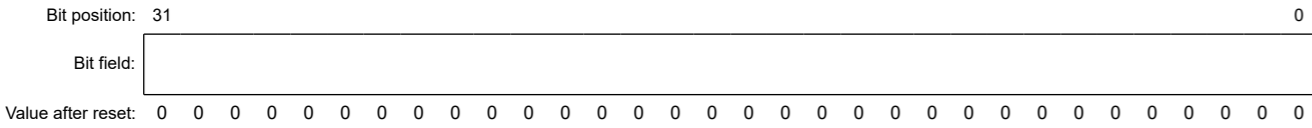
在禁用DMAC激活 (DMAST.DMST位=0) 或禁用DMA传输 ( DMCNT.DTE bit = 0).

Note: 该寄存器中的地址对齐必须与在DMTMD.SZ位中选择的传输数据大小值相匹配。

### 16.2.5 DMDRR : DMA Destination Reload Address Register

Base address: DMACn = 0x4000\_5000 + 0x0040 × n (n = 0 to 7)

Offset address: 0x24



| Bit  | Symbol | Function  | R/W |
|------|--------|---|-----|
| 31:0 | n/a    | Specifies the transfer destination reload address 0000 0000h to FFFF FFFFh (4 Gbytes) | R/W |

Note: If the security attribution is configured as secure:

- Secure access and Non-secure read access are allowed
- Non-secure write access is ignored, and TrustZone access error is not generated.

If the security attribution is configured as Non-secure:

- Secure and Non-secure access are allowed.

Set DMDRR while DMAC activation is disabled (the DMAST.DMST bit = 0) or DMA transfer is disabled (the DMCNT.DTE bit = 0).

DMDRR is initial value of DMDAR. In repeat-block transfer mode, DMDAR reloads value of DMDRR after specified transfer finished.

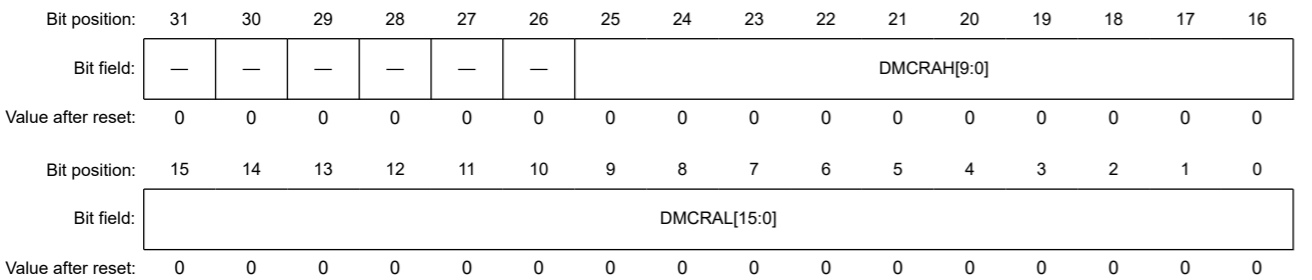
In normal transfer mode, repeat transfer mode and block transfer mode, DMDRR is not used. The setting is invalid.

Note: Address alignment in this register must match the Transfer Data Size value selected in the DMTMD.SZ bit.

### 16.2.6 DMCRA : DMA Transfer Count Register

Base address: DMACn = 0x4000\_5000 + 0x0040 × n (n = 0 to 7)

Offset address: 0x08



| Bit   | Symbol       | Function   | R/W |
|-------|--------------|--|-----|
| 15:0  | DMCRAL[15:0] | Lower bits of transfer count<br>Specifies the number of transfer operations. | R/W |
| 25:16 | DMCRAH[9:0]  | Upper bits of transfer count<br>Specifies the number of transfer operations. | R/W |
| 31:26 | —            | These bits are read as 0. The write value should be 0.                       | R/W |

Note: If the security attribution is configured as secure:

- Secure access and Non-secure read access are allowed
- Non-secure write access is ignored, and TrustZone access error is not generated.

If the security attribution is configured as Non-secure:

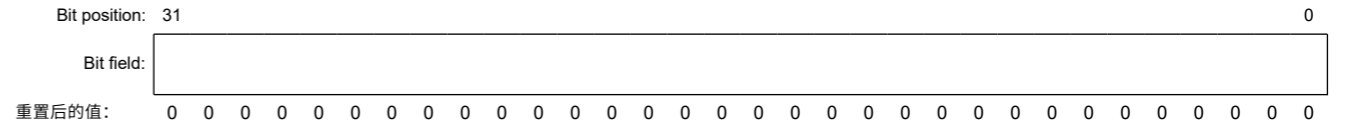
- Secure and Non-secure access are allowed.

Set the same value for DMCRAH and DMCRAL in repeat transfer mode and block transfer mode. Bits 15 to 10 are fixed to 0 in repeat transfer mode and block transfer mode.

### 16.2.5 DMDRR:DMA目标重载地址寄存器

Base address: DMACn = 0x4000\_5000 + 0x0040 × n (n = 0 to 7)

Offset address: 0x24



| Bit  | Symbol | Function                          | R/W |
|------|--------|-----------------------------------|-----|
| 31:0 | n/a    | 指定传输目标重载地址00000000h至FFFFFFFh(4GB) | R/W |

Note: 如果安全属性配置为安全: ●

- 允许安全访问和非安全读取访问
- 忽略非安全写入访问, 不会生成TrustZone访问错误。

如果安全属性配置为非安全: ●

- 允许安全和非安全访问。

在禁用DMAC激活 (DMAST.DMST位=0) 或禁用DMA传输 (DMCNT.DTE bit = 0).

DMDRR是DMDAR的初始值。在重复块传输模式下, DMDAR在指定传输完成后重新加载DMDRR的值。

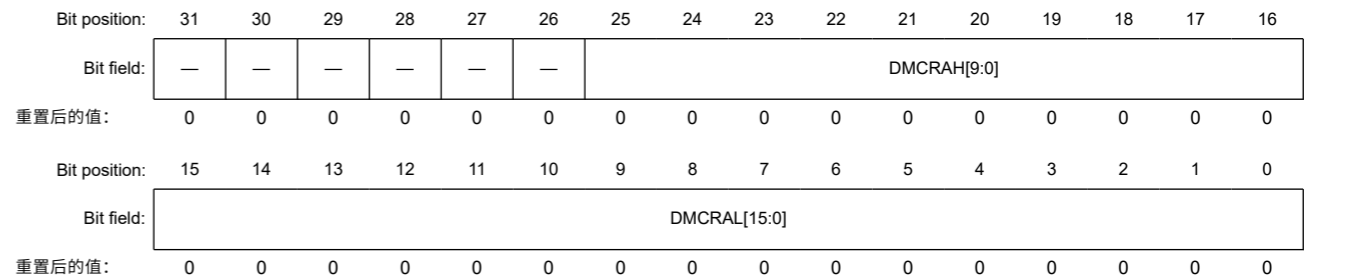
在正常传输模式、重复传输模式和块传输模式下, 不使用DMDRR。设置无效。

Note: 该寄存器中的地址对齐必须与在DMTMD.SZ位中选择的传输数据大小值相匹配。

### 16.2.6 DMCRA:DMA传输计数寄存器

Base address: DMACn = 0x4000\_5000 + 0x0040 × n (n = 0 to 7)

Offset address: 0x08



| Bit   | Symbol       | Function              | R/W |
|-------|--------------|-----------------------|-----|
| 15:0  | DMCRAL[15:0] | 传输计数的低位<br>指定传输操作的数量。 | R/W |
| 25:16 | DMCRAH[9:0]  | 传输计数的高位<br>指定传输操作的数量。 | R/W |
| 31:26 | —            | 这些位被读取为0。写入值应为0。      | R/W |

Note: 如果安全属性配置为安全: ●

- 允许安全访问和非安全读取访问
- 忽略非安全写入访问, 不会生成TrustZone访问错误。

如果安全属性配置为非安全: ●

- 允许安全和非安全访问。

在重复传输模式和块传输模式下, 为DMCRAH和DMCRAL设置相同的值。在重复传输模式和块传输模式中, 位15到10固定为0。

(1) Normal Transfer Mode (DMTMD.MD[1:0] = 00b)

DMCRAL functions as a 16-bit transfer counter.

The number of transfer operations is one when the setting is 0x0001, and 65,535 when it is 0xFFFF. The value is decremented by one each time data is transferred.

When the setting is 0x0000, no specific number of transfer operations is set; data transfer is performed with the transfer counter stopped (free running function).

Free running function is not selected by DMTMD.TKP bit in normal transfer mode.

DMCRAH is not used in normal transfer mode. Write 0x0000 to DMCRAH.

(2) Repeat Transfer Mode (DMTMD.MD[1:0] = 01b)

DMCRAH specifies the repeat size and DMCRAL functions as a 10-bit transfer counter.

The number of transfer operations is one when the setting is 0x001, 1,023 when it is 0x3FF, and 1,024 when it is 0x000. In repeat transfer mode, a value in the range of 0x000 to 0x3FF (1 to 1,024) can be set for DMCRAH and DMCRAL.

Setting bits 15 to 10 in DMCRAL is invalid. Write 0 to these bits.

The value in DMCRAL is decremented by one each time data is transferred until it reaches 0x000, at which the value in DMCRAH is loaded into DMCRAL.

(3) Block Transfer Mode (DMTMD.MD[1:0] = 10b)

DMCRAH specifies the block size and DMCRAL functions as a 10-bit block size counter.

The block size is one when the setting is 0x001, 1,023 when it is 0x3FF, and 1,024 when it is 0x000. In block transfer mode, a value in the range of 0x000 to 0x3FF can be set for DMCRAH and DMCRAL.

Setting bits 15 to 10 in DMCRAL is invalid. Write 0 to these bits.

The value in DMCRAL is decremented by one each time data is transferred until it reaches 0x000, at which the value in DMCRAH is loaded into DMCRAL.

(4) Repeat-Block Transfer Mode (DMTMD.MD[1:0] = 11b)

DMCRAH specifies the block size and DMCRAL functions as a 10-bit block size counter.

The block size is one when the setting is 001h, 1023 when it is 3FFh, and 1024 when it is 000h. In repeat-block transfer mode, a value in the range of 000h to 3FFh can be set for DMCRAH and DMCRAL.

Setting bits 15 to 10 in DMCRAL is invalid. Write 0 to these bits.

The value in DMCRAL is decremented by one each time data is transferred until it reaches 000h, at which the value in DMCRAH is loaded into DMCRAL.

16.2.7 DMCRB : DMA Block Transfer Count Register

Base address: DMACn = 0x4000\_5000 + 0x0040 × n (n = 0 to 7)

Offset address: 0x0C

|                    |              |    |    |    |    |    |    |    |    |    |    |    |    |    |    |    |
|--------------------|--------------|----|----|----|----|----|----|----|----|----|----|----|----|----|----|----|
| Bit position:      | 31           | 30 | 29 | 28 | 27 | 26 | 25 | 24 | 23 | 22 | 21 | 20 | 19 | 18 | 17 | 16 |
| Bit field:         | DMCRBH[15:0] |    |    |    |    |    |    |    |    |    |    |    |    |    |    |    |
| Value after reset: | 0            | 0  | 0  | 0  | 0  | 0  | 0  | 0  | 0  | 0  | 0  | 0  | 0  | 0  | 0  | 0  |
| Bit position:      | 15           | 14 | 13 | 12 | 11 | 10 | 9  | 8  | 7  | 6  | 5  | 4  | 3  | 2  | 1  | 0  |
| Bit field:         | DMCRBL[15:0] |    |    |    |    |    |    |    |    |    |    |    |    |    |    |    |
| Value after reset: | 0            | 0  | 0  | 0  | 0  | 0  | 0  | 0  | 0  | 0  | 0  | 0  | 0  | 0  | 0  | 0  |

(1) 正常传输模式 (DMTMD.MD[1:0]=00b)

DMCRAL用作16位传输计数器。

设置为0x0001时传输操作数为1，设置为0xFFFF时为65 535。每次传输数据时，该值减一。

设置为0x0000时，不设置具体的传输操作次数；在传输计数器停止的情况下执行数据传输（自由运行功能）。

在正常传输模式下，DMTMD.TKP位不选择自由运行功能。

DMCRAH不用于正常传输模式。将0x0000写入DMCRAH。

(2) 重复传输模式(DMTMD.MD[1:0]=01b)

DMCRAH指定重复大小，DMCRAL用作10位传输计数器。

设置为0x001时传输操作数为1，设置为0x3FF时为1 023，设置为0x000时为1 024。在重复传输模式下，可以为DMCRAH和DMCRAL设置0x000到0x3FF（1到1 024）范围内的值。

在DMCRAL中设置位15至10无效。将0写入这些位。

每次传输数据时，DMCRAL中的值减1，直到到达0x000，此时DMCRAL中的值DMCRAH被加载到DMCRAL中。

(3) 块传输模式 (DMTMD.MD[1:0]=10b)

DMCRAH指定块大小，DMCRAL用作10位块大小计数器。

设置为0x001时块大小为1，设置为0x3FF时为1 023，设置为0x000时为1 024。在块传输模式下，可以为DMCRAH和DMCRAL设置0x000到0x3FF范围内的值。

在DMCRAL中设置位15至10无效。将0写入这些位。

每次传输数据时，DMCRAL中的值减1，直到到达0x000，此时DMCRAL中的值DMCRAH被加载到DMCRAL中。

(4) 重复块传输模式(DMTMD.MD[1:0]=11b)

DMCRAH指定块大小，DMCRAL用作10位块大小计数器。

设置为001h时块大小为1，设置为3FFh时为1023，设置为000h时为1024。在重复块传输模式下，可以为DMCRAH和DMCRAL设置000h到3FFh范围内的值。

在DMCRAL中设置位15至10无效。将0写入这些位。

每次传输数据时，DMCRAL中的值减1，直到达到000h，此时DMCRAL中的值DMCRAH被加载到DMCRAL中。

16.2.7 DMCRB:DMA块传输计数寄存器

Base address: DMACn = 0x4000\_5000 + 0x0040 × n (n = 0 to 7)

Offset address: 0x0C

|               |              |    |    |    |    |    |    |    |    |    |    |    |    |    |    |    |
|---------------|--------------|----|----|----|----|----|----|----|----|----|----|----|----|----|----|----|
| Bit position: | 31           | 30 | 29 | 28 | 27 | 26 | 25 | 24 | 23 | 22 | 21 | 20 | 19 | 18 | 17 | 16 |
| Bit field:    | DMCRBH[15:0] |    |    |    |    |    |    |    |    |    |    |    |    |    |    |    |
| 重置后的值:        | 0            | 0  | 0  | 0  | 0  | 0  | 0  | 0  | 0  | 0  | 0  | 0  | 0  | 0  | 0  | 0  |
| Bit position: | 15           | 14 | 13 | 12 | 11 | 10 | 9  | 8  | 7  | 6  | 5  | 4  | 3  | 2  | 1  | 0  |
| Bit field:    | DMCRBL[15:0] |    |    |    |    |    |    |    |    |    |    |    |    |    |    |    |
| 重置后的值:        | 0            | 0  | 0  | 0  | 0  | 0  | 0  | 0  | 0  | 0  | 0  | 0  | 0  | 0  | 0  | 0  |



| Bit   | Symbol       | Function   | R/W |
|-------|--------------|--|-----|
| 15:0  | DMCRBL[15:0] | Functions as a number of block, repeat or repeat-block transfer counter. 0001h to FFFFh (1 to 65,535) 0000h (65,536)   | R/W |
| 31:16 | DMCRBH[15:0] | Specifies the number of block, repeat or repeat-block transfer operations. 0001h to FFFFh (1 to 65,535) 0000h (65,536) | R/W |

Note: If the security attribution is configured as secure:

- Secure access and Non-secure read access are allowed
  - Non-secure write access is ignored, and TrustZone access error is not generated.
- If the security attribution is configured as Non-secure:
- Secure and Non-secure access are allowed.

Set the same value for DMCRBH and DMCRBL in repeat transfer mode, block transfer mode and repeat-block transfer mode.

DMCRBH specifies the number of block, repeat and repeat-block transfer operations, and DMCRBL functions as a 16-bit the number of block counter in block, repeat, repeat-block transfer mode, respectively.

The number of transfer operations is one when the setting is 0001h, 65,535 when it is FFFFh, and 65,536 when it is 0000h.

In repeat transfer mode, the value is decremented by one when the final data of one repeat size is transferred.

In block transfer mode and repeat-block transfer mode, the value is decremented by one when the final data of one block size is transferred.

In normal transfer mode, DMCRB is not used. The setting is invalid.

When DMTMD.TKP is 1 and final data of one repeat size or one block size is transferred, DMCRBL reloads value of DMCRBH automatically.

### 16.2.8 DMTMD : DMA Transfer Mode Register

Base address: DMACn = 0x4000\_5000 + 0x0040 × n (n = 0 to 7)

Offset address: 0x10

| Bit position:      | 15      | 14       | 13 | 12  | 11      | 10 | 9 | 8 | 7 | 6 | 5 | 4 | 3 | 2 | 1         | 0 |
|--------------------|---------|----------|----|-----|---------|----|---|---|---|---|---|---|---|---|-----------|---|
| Bit field:         | MD[1:0] | DTS[1:0] | —  | TKP | SZ[1:0] | —  | — | — | — | — | — | — | — | — | DCTG[1:0] | — |
| Value after reset: | 0       | 0        | 0  | 0   | 0       | 0  | 0 | 0 | 0 | 0 | 0 | 0 | 0 | 0 | 0         | 0 |

| Bit | Symbol    | Function  | R/W |
|-----|-----------|---|-----|
| 1:0 | DCTG[1:0] | Transfer Request Source Select<br>0 0: Software request<br>0 1: Hardware request*1<br>1 0: Setting prohibited<br>1 1: Setting prohibited  | R/W |
| 7:2 | —         | These bits are read as 0. The write value should be 0.  | R/W |
| 9:8 | SZ[1:0]   | Transfer Data Size Select<br>0 0: 8 bits<br>0 1: 16 bits<br>1 0: 32 bits<br>1 1: Setting prohibited   | R/W |
| 10  | TKP       | Transfer Keeping<br>0: Transfer is stopped by completion of specified total number of transfer operations.<br>1: Transfer is not stopped by completion of specified total number of transfer operations. (free-running) | R/W |
| 11  | —         | These bits are read as 0. The write value should be 0.  | R/W |

| Bit   | Symbol       | Function   | R/W |
|-------|--------------|--|-----|
| 15:0  | DMCRBL[15:0] | 用作多个块、重复或重复块传输计数器。0001h至FFFFh(1至65 535)0000h(65 536) | R/W |
| 31:16 | DMCRBH[15:0] | 指定块、重复或重复块传输操作的数量。0001h至FFFFh(1至65 535)0000h(65 536) | R/W |

Note: 如果安全属性配置为安全: ●

- 允许安全访问和非安全读取访问
  - 忽略非安全写入访问, 不会生成TrustZone访问错误。
- 如果安全属性配置为非安全: ●
- 允许安全和非安全访问。

在重复传输模式、块传输模式和重复块传输模式中, 将DMCRBH和DMCRBL设置为相同的值。

DMCRBH指定块、重复和重复块传输操作的数量, DMCRBL分别用作块、重复、重复块传输模式下的16位块计数器。

设置为0001h时传输操作数为1, 设置为FFFFh时为65 535, 设置为0000h时为65 536。

在重复传输模式下, 当传输一个重复大小的最终数据时, 该值减一。

在块传输模式和重复块传输模式中, 当传输一个块大小的最终数据时, 该值减一。

在正常传输模式下, 不使用DMCRB。设置无效。

当DMTMD.TKP为1并且传输一个重复大小或一个块大小的最终数据时, DMCRBL重新加载值DMCRBH automatically.

### 16.2.8 DMTMD:DMA传输模式寄存器

Base address: DMACn = 0x4000\_5000 + 0x0040 × n (n = 0 to 7)

Offset address: 0x10

| Bit position: | 15      | 14       | 13 | 12  | 11      | 10 | 9 | 8 | 7 | 6 | 5 | 4 | 3 | 2 | 1         | 0 |
|---------------|---------|----------|----|-----|---------|----|---|---|---|---|---|---|---|---|-----------|---|
| Bit field:    | MD[1:0] | DTS[1:0] | —  | TKP | SZ[1:0] | —  | — | — | — | — | — | — | — | — | DCTG[1:0] | — |
| 重置后的值:        | 0       | 0        | 0  | 0   | 0       | 0  | 0 | 0 | 0 | 0 | 0 | 0 | 0 | 0 | 0         | 0 |

| Bit | Symbol    | Function   | R/W |
|-----|-----------|--|-----|
| 1:0 | DCTG[1:0] | 传输请求源选择<br>00: 软件请求01: 硬件请求*1<br>10: 禁止设置11: 禁止设置        | R/W |
| 7:2 | —         | 这些位被读取为0。写入值应为0。   | R/W |
| 9:8 | SZ[1:0]   | 传输数据大小选择<br>00: 8位01: 16位10: 32位11: 禁止设置                 | R/W |
| 10  | TKP       | 转让保管<br>0: 完成指定的传输操作总数后停止传输。1: 完成指定的传输操作总数后传输不会停止。(自由奔跑) | R/W |
| 11  | —         | 这些位被读取为0。写入值应为0。   | R/W |

| Bit   | Symbol   | Function  | R/W |
|-------|----------|---|-----|
| 13:12 | DTS[1:0] | Repeat Area Select<br>0 0: The destination is specified as the repeat area or block area<br>0 1: The source is specified as the repeat area or block area<br>1 0: The repeat area or block area is not specified<br>1 1: Setting prohibited | R/W |
| 15:14 | MD[1:0]  | Transfer Mode Select<br>0 0: Normal transfer<br>0 1: Repeat transfer<br>1 0: Block transfer<br>1 1: Repeat-block transfer   | R/W |

Note: If the security attribution is configured as secure:

- Secure access and Non-secure read access are allowed
- Non-secure write access is ignored, and TrustZone access error is not generated.

If the security attribution is configured as Non-secure:

- Secure and Non-secure access are allowed.

Note 1. To select the DMAC activation source, use the DELSRn registers of the ICU. For details on DMAC activation sources, see Table 13.4 in section 13, Interrupt Controller Unit (ICU).

### DTS[1:0] bits (Repeat Area Select)

DTS[1:0] select either the source or destination as the repeat area in repeat or block transfer mode. In normal or repeat-block transfer mode, setting these bits is invalid.

### TKP bits (Transfer Keeping)

TKP selects either stopping transfer or keeping transfer by completion of specified total number of transfer operations in repeat, block or repeat-block transfer mode. In normal transfer mode, setting these bits is invalid.

## 16.2.9 DMINT : DMA Interrupt Setting Register

Base address:  $\text{DMACn} = 0x4000\_5000 + 0x0040 \times n$  (n = 0 to 7)

Offset address: 0x13

| Bit position:      | 7 | 6 | 5 | 4    | 3    | 2     | 1     | 0     |
|--------------------|---|---|---|------|------|-------|-------|-------|
| Bit field:         | — | — | — | DTIE | ESIE | RPTIE | SARIE | DARIE |
| Value after reset: | 0 | 0 | 0 | 0    | 0    | 0     | 0     | 0     |

| Bit | Symbol | Function  | R/W |
|-----|--------|---|-----|
| 0   | DARIE  | Destination Address Extended Repeat Area Overflow Interrupt Enable<br>0: Disables an interrupt request for an extended repeat area overflow on the destination address<br>1: Enables an interrupt request for an extended repeat area overflow on the destination address | R/W |
| 1   | SARIE  | Source Address Extended Repeat Area Overflow Interrupt Enable<br>0: Disables an interrupt request for an extended repeat area overflow on the source address<br>1: Enables an interrupt request for an extended repeat area overflow on the source address                | R/W |
| 2   | RPTIE  | Repeat Size End Interrupt Enable<br>0: Disables the repeat size end interrupt request<br>1: Enables the repeat size end interrupt request   | R/W |
| 3   | ESIE   | Transfer Escape End Interrupt Enable<br>0: Disables the transfer escape end interrupt request<br>1: Enables the transfer escape end interrupt request   | R/W |
| 4   | DTIE   | Transfer End Interrupt Enable<br>0: Disables the transfer end interrupt request<br>1: Enables the transfer end interrupt request  | R/W |
| 7:5 | —      | These bits are read as 0. The write value should be 0.  | R/W |

| Bit   | Symbol   | Function   | R/W |
|-------|----------|--|-----|
| 13:12 | DTS[1:0] | 重复区域选择<br>00: 目标指定为重复区域或块区域01: 源指定为重复区域或块区域10: 不指定重复区域或块区域11: 设置禁止 | R/W |
| 15:14 | MD[1:0]  | 传输模式选择<br>00: 正常传输01: 重复传输10: 块传输11: 重复块传输                         | R/W |

Note: 如果安全属性配置为安全: ●  
允许安全访问和非安全读取访问  
● 忽略非安全写入访问, 不会生成TrustZone访问错误。  
如果安全属性配置为非安全: ●  
允许安全和非安全访问。

注1.要选择DMAC激活源, 请使用ICU的DELSRn寄存器。有关DMAC激活源的详细信息, 请参见第13节“中断控制器单元(ICU)”中的表13.4。

### DTS[1:0]位 (重复区域选择)

DTS[1:0]在重复或块传输模式中选择源或目标作为重复区域。在正常或重复块传输模式下, 设置这些位无效。

### TKP bits (Transfer Keeping)

TKP通过在重复、块或重复块传输模式下完成指定的传输操作总数来选择停止传输或保持传输。在正常传输模式下, 设置这些位无效。

## 16.2.9 DMINT:DMA中断设置寄存器

Base address:  $\text{DMACn} = 0x4000\_5000 + 0x0040 \times n$  (n = 0 to 7)

Offset address: 0x13

| Bit position: | 7 | 6 | 5 | 4    | 3    | 2     | 1     | 0     |
|---------------|---|---|---|------|------|-------|-------|-------|
| Bit field:    | — | — | — | DTIE | ESIE | RPTIE | SARIE | DARIE |
| 重置后的值:        | 0 | 0 | 0 | 0    | 0    | 0     | 0     | 0     |

| Bit | Symbol | Function  | R/W |
|-----|--------|---|-----|
| 0   | DARIE  | 目标地址扩展重复区溢出中断使能<br>0: 禁用目标地址上扩展重复区域溢出的中断请求<br>1: 使能目标地址上扩展重复区域溢出的中断请求 | R/W |
| 1   | SARIE  | 源地址扩展重复区溢出中断使能<br>0: 禁用源地址上扩展重复区域溢出的中断请求<br>1: 使能源地址上扩展重复区域溢出的中断请求    | R/W |
| 2   | RPTIE  | 重复大小结束中断使能<br>0: 禁用重复大小结束中断请求1: 启用重复大小结束中断请求                          | R/W |
| 3   | ESIE   | 传输转义结束中断使能<br>0: 禁用传输转义结束中断请求1: 启用传输转义结束中断请求                          | R/W |
| 4   | DTIE   | 传输结束中断使能<br>0: 禁止传输结束中断请求1: 允许传输结束中断请求                                | R/W |
| 7:5 | —      | 这些位被读取为0。写入值应为0。  | R/W |

Note: If the security attribution is configured as secure:

- Secure access and Non-secure read access are allowed
  - Non-secure write access is ignored, and TrustZone access error is not generated.
- If the security attribution is configured as Non-secure:
- Secure and Non-secure access are allowed.

#### DARIE bit (Destination Address Extended Repeat Area Overflow Interrupt Enable)

When an extended repeat area overflow on the destination address occurs while DARIE bit is set to 1, the DMCNT.DTE bit is cleared to 0. At the same time, the DMSTS.ESIF flag is set to 1 to indicate that an interrupt by an extended repeat area overflow on the destination address is requested.

When block transfer mode is used with the extended repeat area function, an interrupt is requested after completion of a 1-block size transfer. When setting 1 in the DMCNT.DTE bit of the channel for which a transfer has been stopped, the transfer is resumed from the state when the transfer is stopped.

When the extended repeat area is not specified for the destination address, this bit is ignored.

When set to repeat-block transfer mode, do not use this bit.

#### SARIE bit (Source Address Extended Repeat Area Overflow Interrupt Enable)

When an extended repeat area overflow on the source address occurs while SARIE bit is set to 1, the DMCNT.DTE bit is cleared to 0. At the same time, the DMSTS.ESIF flag is set to 1 to indicate that an interrupt by an extended repeat area overflow on the source address is requested.

When block transfer mode is used with the extended repeat area function, an interrupt is requested after completion of a 1-block size transfer. When setting 1 in the DMCNT.DTE bit of the channel for which a transfer has been stopped, the transfer is resumed from the state when the transfer is stopped.

When the extended repeat area is not specified for the source address, this bit is ignored.

When set to repeat-block transfer mode, do not use this bit.

#### RPTIE bit (Repeat Size End Interrupt Enable)

When RPTIE bit is set to 1 in repeat transfer mode, the DMCNT.DTE bit is cleared to 0 after completion of a 1-repeat size data transfer. At the same time, the DMSTS.ESIF flag is set to 1 to indicate that the repeat size end interrupt request has been generated. The repeat size end interrupt request can be generated even when the DMTMD.DTS[1:0] bits are 10b (= repeat area or block area is not specified).

When this bit is set to 1 in block transfer mode, the DMCNT.DTE bit is cleared to 0 after completion of a 1-block data transfer in the same way as repeat transfer mode. At the same time, the DMSTS.ESIF flag is set to 1 to indicate that the repeat size end interrupt request has been generated. The repeat size end interrupt request can be generated even when the DMTMD.DTS[1:0] bits are 10b (= repeat area or block area is not specified).

When set to repeat-block transfer mode, do not use this bit.

#### ESIE bit (Transfer Escape End Interrupt Enable)

ESIE bit enables or disables the transfer escape end interrupt requests (repeat size end interrupt request and extended repeat area overflow interrupt request) that are generated during DMA transfer.

The transfer escape end interrupt is generated when the DMSTS.ESIF flag is set to 1 with this bit set to 1. The transfer escape end interrupt is cleared by clearing this bit or the DMSTS.ESIF flag to 0.

#### DTIE bit (Transfer End Interrupt Enable)

DTIE bit enables or disables the transfer end interrupt request to be generated on completion of a specified number of data transfers.

The transfer end interrupt is generated when the DMSTS.DTIF flag is set to 1 with this bit set to 1. The transfer end interrupt is cleared by clearing this bit or the DMSTS.DTIF flag to 0.

Note: 如果安全属性配置为安全: ●

- 允许安全访问和非安全读取访问
  - 忽略非安全写入访问, 不会生成TrustZone访问错误。
- 如果安全属性配置为非安全: ●
- 允许安全和非安全访问。

#### DARIE位 (目标地址扩展重复区域溢出中断允许)

当DARIE位设置为1时目标地址发生扩展重复区域溢出时, DMCNT.DTE位清零。同时, DMSTS.ESIF标志设置为1, 表示由请求目标地址上的扩展重复区域溢出。

当块传输模式与扩展重复区域功能一起使用时, 在完成1块大小的传输后请求中断。将停止传输的通道的DMCNT.DTE位设置为1时, 将从停止传输时的状态恢复传输。

当没有为目标地址指定扩展重复区域时, 该位被忽略。

当设置为重复块传输模式时, 不要使用该位。

#### SARIE位 (源地址扩展重复区域溢出中断使能)

当SARIE位设置为1时源地址发生扩展重复区域溢出时, DMCNT.DTE位清零。同时, DMSTS.ESIF标志设置为1, 表示由请求源地址上的扩展重复区域溢出。

当块传输模式与扩展重复区域功能一起使用时, 在完成1块大小的传输后请求中断。将停止传输的通道的DMCNT.DTE位设置为1时, 将从停止传输时的状态恢复传输。

当源地址没有指定扩展重复区域时, 该位被忽略。

当设置为重复块传输模式时, 不要使用该位。

#### RPTIE位 (重复大小结束中断允许)

当RPTIE位在重复传输模式下设置为1时, DMCNT.DTE位在完成1次重复大小的数据传输后被清除为0。同时, 将DMSTS.ESIF标志设置为1, 表示已产生重复大小结束中断请求。即使DMTMD.DTS[1:0]位为10b (=未指定重复区域或块区域), 也可以生成重复大小结束中断请求。

当该位在块传输模式下设置为1时, DMCNT.DTE位在完成1块数据传输后清零, 方法与重复传输模式相同。同时, 将DMSTS.ESIF标志设置为1, 表示已产生重复大小结束中断请求。即使DMTMD.DTS[1:0]位为10b (=未指定重复区域或块区域), 也可以生成重复大小结束中断请求。

当设置为重复块传输模式时, 不要使用该位。

#### ESIE位 (传输转义结束中断使能)

ESIE位启用或禁用在DMA传输期间产生的传输转义结束中断请求 (重复大小结束中断请求和扩展重复区域溢出中断请求)。

当DMSTS.ESIF标志设置为1且该位设置为1时, 将产生传输退出结束中断。通过清除该位或DMSTS.ESIF标志为0来清除传输退出结束中断。

#### DTIE位 (传输结束中断允许)

DTIE位启用或禁用在完成指定数量的数据传输时生成的传输结束中断请求。

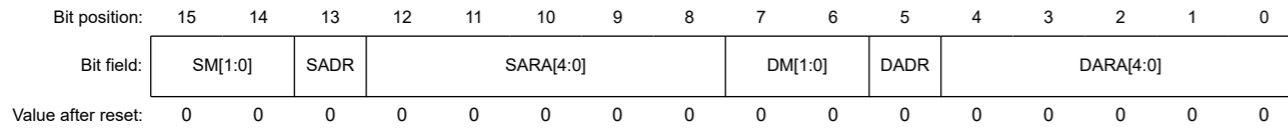
当DMSTS.DTIF标志设置为1且该位设置为1时, 将产生传输结束中断。通过清除该位或DMSTS.DTIF标志为0来清除传输结束中断。



## 16.2.10 DMAMD : DMA Address Mode Register

Base address: DMACn = 0x4000\_5000 + 0x0040 × n (n = 0 to 7)

Offset address: 0x14



| Bit   | Symbol    | Function   | R/W |
|-------|-----------|--|-----|
| 4:0   | DARA[4:0] | Destination Address Extended Repeat Area<br>Specifies the extended repeat area on the destination address. For details on the settings, see Table 16.2.                            | R/W |
| 5     | DADR      | Destination Address Update Select After Reload<br>0: Only reloading<br>1: Add index after reloading  | R/W |
| 7:6   | DM[1:0]   | Destination Address Update Mode<br>0 0: Destination address is fixed<br>0 1: Offset addition<br>1 0: Destination address is incremented<br>1 1: Destination address is decremented | R/W |
| 12:8  | SARA[4:0] | Source Address Extended Repeat Area<br>Specifies the extended repeat area on the source address. For details on the settings, see Table 16.2.                                      | R/W |
| 13    | SADR      | Source Address Update Select After Reload<br>0: Only reloading<br>1: Add index after reloading   | R/W |
| 15:14 | SM[1:0]   | Source Address Update Mode<br>0 0: Source address is fixed<br>0 1: Offset addition<br>1 0: Source address is incremented<br>1 1: Source address is decremented                     | R/W |

Note: If the security attribution is configured as secure:

- Secure access and Non-secure read access are allowed
- Non-secure write access is ignored, and TrustZone access error is not generated.

If the security attribution is configured as Non-secure:

- Secure and Non-secure access are allowed.

**DARA[4:0] bits (Destination Address Extended Repeat Area)**

DARA[4:0] bits specify the extended repeat area on the destination address. The extended repeat area function is realized by updating the specified lower address bits with the remaining upper address bits fixed. The size of the extended repeat area can be any power of two between 2 bytes and 128 Mbytes.

When the lower address overflows the extended repeat area by address increment, the start address of the extended repeat area is set. Similarly, when the lower address underflows the extended repeat area by address decrement, the end address of the extended repeat area is set.

When the repeat area or block area is specified as a transfer destination, do not specify the extended repeat area on the destination address. When repeat transfer or block transfer is selected, and when DMTMD.DTS[1:0] = 00b (the transfer destination is specified as the repeat area or block area), write 00000b in the DARA[4:0] bits.

In repeat-block transfer mode, write 00000b in the DARA[4:0] bits.

An interrupt can be requested when an overflow or underflow occurs in the extended repeat area with the DMINT.DARIE bit set to 1. Table 16.2 lists the settings and the corresponding extended repeat areas.

**DADR bits (Destination Address Update Select After Reload)**

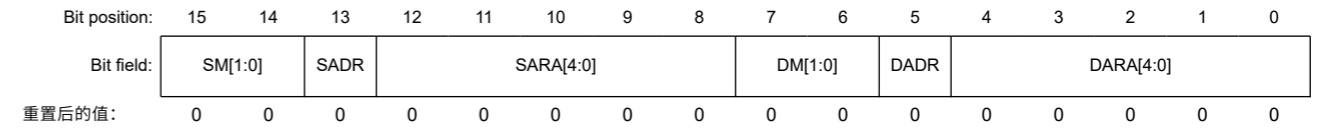
In repeat-block transfer mode, this bit specifies the behavior of DMDAR after reloading DMDRR.

When this bit is set to 1, an index value ((DMDBSH-DMDBSL) × DataSize) is added to DMDAR after reloading DMDRR.

## 16.2.10 DMAMD:DMA地址模式寄存器

Base address: DMACn = 0x4000\_5000 + 0x0040 × n (n = 0 to 7)

Offset address: 0x14



| Bit   | Symbol    | Function  | R/W |
|-------|-----------|---|-----|
| 4:0   | DARA[4:0] | 目标地址扩展重复区域<br>指定目标地址上的扩展重复区域。有关设置的详细信息，请参见表16.2。                | R/W |
| 5     | DADR      | 重新加载后目标地址更新选择<br>0: 仅重新加载<br>1: 重新加载后添加索引                       | R/W |
| 7:6   | DM[1:0]   | 目的地址更新模式<br>00: 目标地址固定<br>01: 偏移量加法<br>10: 目标地址递增<br>11: 目标地址递减 | R/W |
| 12:8  | SARA[4:0] | 源地址扩展重复区<br>指定源地址上的扩展重复区域。有关设置的详细信息，请参阅 Table 16.2.             | R/W |
| 13    | SADR      | 重新加载后源地址更新选择<br>0: 仅重新加载<br>1: 重新加载后添加索引                        | R/W |
| 15:14 | SM[1:0]   | 源地址更新模式<br>00: 源地址固定<br>01: 偏移量加法<br>10: 源地址递增<br>11: 源地址递减     | R/W |

Note: 如果安全属性配置为安全: ●

- 允许安全访问和非安全读取访问
- 忽略非安全写入访问，不会生成TrustZone访问错误。

如果安全属性配置为非安全: ●

- 允许安全和非安全访问。

**DARA[4:0]位 (目标地址扩展重复区)**

DARA[4:0]位指定目标地址上的扩展重复区域。扩展重复区功能是通过更新指定的低地址位来实现的，剩余的高地址位是固定的。扩展重复区域的大小可以是2字节到128MB之间的任意2次幂。

当低位地址以地址增量溢出扩展重复区域时，设置扩展重复区域的起始地址。类似地，当低位地址通过地址减量使扩展重复区域下溢时，设置扩展重复区域的结束地址。

将重复区域或块区域指定为传输目标时，请勿在目标地址上指定扩展重复区域。When repeat transfer or block transfer is selected and when DMTMD.DTS[1:0] = 00b (the transfer destination is specified as the repeat area or block area) write 00000b in the DARA[4:0] bits.

在重复块传输模式下，将00000b写入DARA[4:0]位。

当DMINT.DARIE位设置为1的扩展重复区域发生上溢或下溢时，可以请求中断。表16.2列出了设置和相应的扩展重复区域。

**DADR位 (重载后目标地址更新选择)**

在重复块传输模式下，该位指定重新加载DMDRR后DMDAR的行为。

当该位设置为1时，在重新加载DMDRR后将索引值((DMDBSH-DMDBSL)×DataSize)添加到DMDAR。

When this bit is set to 0, DMDAR only reloads DMDRR. This behavior is described in Table 16.13.

In normal, repeat or block transfer mode, this bit is ignored.

#### DM[1:0] bits (Destination Address Update Mode)

DM[1:0] bits select the mode of updating the destination address.

When increment is selected and the DMTMD.SZ[1:0] bits are set to 00b, 01b, and 10b, the destination address is incremented by 1, 2, and 4, respectively.

When decrement is selected and the DMTMD.SZ[1:0] bits are set to 00b, 01b, and 10b, the destination address is decremented by 1, 2, and 4, respectively.

When offset addition is selected, the offset specified by the DMOFR register is added to the address.

#### SARA[4:0] bits (Source Address Extended Repeat Area)

SARA[4:0] bits specify the extended repeat area on the source address. The extended repeat area function is realized by updating the specified lower address bits with the remaining upper address bits fixed. The size of the extended repeat area can be any power of two between 2 bytes and 128 Mbytes.

When the lower address overflows the extended repeat area by address increment, the start address of the extended repeat area is set. Similarly, when the lower address underflows the extended repeat area by address decrement, the end address of the extended repeat area is set.

When the repeat area or block area is specified as a transfer source, do not specify the extended repeat area on the source address. When repeat transfer or block transfer is selected, and when DMTMD.DTS[1:0] = 01b (the transfer source is specified as the repeat area or block area), write 00000b in the SARA[4:0] bits.

In repeat-block transfer mode, write 00000b in the SARA[4:0] bits.

An interrupt can be requested when an overflow or underflow occurs in the extended repeat area with the DMINT.SARIE bit set to 1. Table 16.2 lists the settings and the corresponding extended repeat areas.

#### SADR bits (Source Address Update Select After Reload)

In repeat-block transfer mode, this bit specifies the behavior of DMSAR after reloading DMSRR.

When this bit is set to 1, an index value  $((DMSBSH - DMSBSL) \times DataSize)$  is added to DMSAR after reloading DMSRR.

When this bit is set to 0, DMSAR only reloads DMSRR. This behavior is described in Table 16.12.

In normal, repeat or block transfer mode, this bit is ignored.

#### SM[1:0] bits (Source Address Update Mode)

SM[1:0] bits select the mode of updating the source address.

When increment is selected and the DMTMD.SZ[1:0] bits are set to 00b, 01b, and 10b, the source address is incremented by 1, 2, and 4, respectively.

When decrement is selected and the DMTMD.SZ[1:0] bits are set to 00b, 01b, and 10b, the source address is decremented by 1, 2, and 4, respectively.

When offset addition is selected, the offset specified by the DMOFR register is added to the address.

Table 16.2 SARA[4:0] or DARA[4:0] Settings and Corresponding Repeat Areas (1 of 2)

| SARA[4:0] or DARA[4:0] Settings and Corresponding Repeat Areas | Extended Repeat Area  |
|--|---|
| 00000b   | Not specified   |
| 00001b   | 2 bytes specified as extended repeat area by the lower 1 bit of the address   |
| 00010b   | 4 bytes specified as extended repeat area by the lower 2 bits of the address  |
| 00011b   | 8 bytes specified as extended repeat area by the lower 3 bits of the address  |
| 00100b   | 16 bytes specified as extended repeat area by the lower 4 bits of the address |
| 00101b   | 32 bytes specified as extended repeat area by the lower 5 bits of the address |
| 00110b   | 64 bytes specified as extended repeat area by the lower 6 bits of the address |

当该位设置为0时，DMDAR仅重新加载DMDRR。表16.13中描述了这种行为。

在正常、重复或块传输模式下，该位被忽略。

#### DM[1:0]位 (目标地址更新模式)

DM[1:0]位选择更新目标地址的模式。

When increment is selected and the DMTMD.SZ[1:0] bits are set to 00b, 01b, and 10b, the destination address is incremented by 1, 2, and 4, respectively.

When decrement is selected and the DMTMD.SZ[1:0] bits are set to 00b, 01b, and 10b, the destination address is decremented by 1, 2, and 4, respectively.

选择偏移添加后，将DMOFR寄存器指定的偏移添加到地址中。

#### SARA[4:0]位 (源地址扩展重复区)

SARA[4:0]位指定源地址上的扩展重复区域。扩展重复区功能是通过更新指定的低地址位来实现的，剩余的高地址位是固定的。扩展重复区域的大小可以是2字节到128MB之间的任意2次幂。

当低位地址以地址增量溢出扩展重复区域时，设置扩展重复区域的起始地址。类似地，当低位地址通过地址减量使扩展重复区域下溢时，设置扩展重复区域的结束地址。

当重复区域或块区域被指定为传输源时，不要在源地址上指定扩展重复区域。When repeat transfer or block transfer is selected and when DMTMD.DTS[1:0] = 01b (the transfer source is specified as the repeat area or block area) write 00000b in the SARA[4:0] bits.

在重复块传输模式下，将00000b写入SARA[4:0]位。

当DMINT.SARIE位设置为1的扩展重复区域发生上溢或下溢时，可以请求中断。表16.2列出了设置和相应的扩展重复区域。

#### SADR位 (重载后源地址更新选择)

在重复块传输模式下，该位指定重新加载DMSRR后DMSAR的行为。

当该位设置为1时，在重新加载DMSRR后将索引值 $((DMSBSH - DMSBSL) \times DataSize)$ 添加到DMSAR。

当该位设置为0时，DMSAR仅重新加载DMSRR。这种行为在表16.12中描述。

在正常、重复或块传输模式下，该位被忽略。

#### SM[1:0]位 (源地址更新模式)

SM[1:0]位选择更新源地址的模式。

When increment is selected and the DMTMD.SZ[1:0] bits are set to 00b, 01b, and 10b, the source address is incremented by 1, 2, and 4, respectively.

When decrement is selected and the DMTMD.SZ[1:0] bits are set to 00b, 01b, and 10b, the source address is decremented by 1, 2, and 4, respectively.

选择偏移添加后，将DMOFR寄存器指定的偏移添加到地址中。

Table 16.2 SARA[4:0]或DARA[4:0]设置和对应的重复区域(1 of 2)

| SARA[4:0]或DARA[4:0]设置和对应的重复区域 | 扩展重复区域                 |
|-------------------------------|------------------------|
| 00000b                        | 未指定                    |
| 00001b                        | 由地址的低1位指定为扩展重复区域的2个字节  |
| 00010b                        | 由地址的低2位指定为扩展重复区域的4个字节  |
| 00011b                        | 由地址的低3位指定为扩展重复区域的8个字节  |
| 00100b                        | 由地址的低4位指定为扩展重复区域的16个字节 |
| 00101b                        | 由地址的低5位指定为扩展重复区域的32个字节 |
| 00110b                        | 由地址的低6位指定为扩展重复区域的64个字节 |



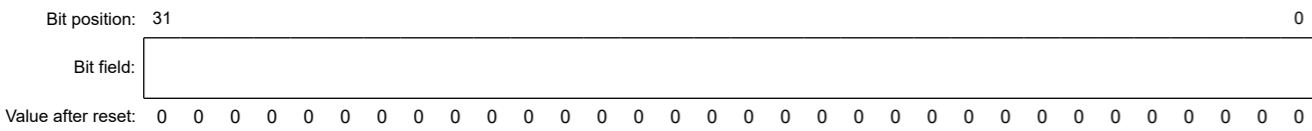
Table 16.2 SARA[4:0] or DARA[4:0] Settings and Corresponding Repeat Areas (2 of 2)

| SARA[4:0] or DARA[4:0] Settings and Corresponding Repeat Areas | Extended Repeat Area   |
|--|--|
| 00111b   | 128 bytes specified as extended repeat area by the lower 7 bits of the address   |
| 01000b   | 256 bytes specified as extended repeat area by the lower 8 bits of the address   |
| 01001b   | 512 bytes specified as extended repeat area by the lower 9 bits of the address   |
| 01010b   | 1 Kbyte specified as extended repeat area by the lower 10 bits of the address    |
| 01011b   | 2 Kbytes specified as extended repeat area by the lower 11 bits of the address   |
| 01100b   | 4 Kbytes specified as extended repeat area by the lower 12 bits of the address   |
| 01101b   | 8 Kbytes specified as extended repeat area by the lower 13 bits of the address   |
| 01110b   | 16 Kbytes specified as extended repeat area by the lower 14 bits of the address  |
| 01111b   | 32 Kbytes specified as extended repeat area by the lower 15 bits of the address  |
| 10000b   | 64 Kbytes specified as extended repeat area by the lower 16 bits of the address  |
| 10001b   | 128 Kbytes specified as extended repeat area by the lower 17 bits of the address |
| 10010b   | 256 Kbytes specified as extended repeat area by the lower 18 bits of the address |
| 10011b   | 512 Kbytes specified as extended repeat area by the lower 19 bits of the address |
| 10100b   | 1 Mbyte specified as extended repeat area by the lower 20 bits of the address    |
| 10101b   | 2 Mbytes specified as extended repeat area by the lower 21 bits of the address   |
| 10110b   | 4 Mbytes specified as extended repeat area by the lower 22 bits of the address   |
| 10111b   | 8 Mbytes specified as extended repeat area by the lower 23 bits of the address   |
| 11000b   | 16 Mbytes specified as extended repeat area by the lower 24 bits of the address  |
| 11001b   | 32 Mbytes specified as extended repeat area by the lower 25 bits of the address  |
| 11010b   | 64 Mbytes specified as extended repeat area by the lower 26 bits of the address  |
| 11011b   | 128 Mbytes specified as extended repeat area by the lower 27 bits of the address |
| 11100b to 11111b   | Setting prohibited.  |

## 16.2.11 DMOFR : DMA Offset Register

Base address: DMACn = 0x4000\_5000 + 0x0040 × n (n = 0 to 7)

Offset address: 0x18



| Bit  | Symbol | Function  | R/W |
|------|--------|---|-----|
| 31:0 | n/a    | Specifies the offset when offset addition is selected as the address update mode for transfer source or destination<br>0x00000000 to 0x00FFFFFF (0 bytes to (16 M – 1) bytes)<br>0xFF000000 to 0xFFFFFFFF (–16 Mbytes to –1 byte) | R/W |

Note: If the security attribution is configured as secure:

- Secure access and Non-secure read access are allowed
- Non-secure write access is ignored, and TrustZone access error is not generated.

If the security attribution is configured as Non-secure:

- Secure and Non-secure access are allowed.

Write to this register while the DMAC operation is stopped or DMA transfer is disabled (not during data transfer).

Setting bits 31 to 25 is invalid; a value of bit 24 is extended to bits 31 to 25. Reading DMOFR returns the extended value.

In repeat-block transfer mode, the offset is not specified by DMOFR when offset addition is selected, write 0 to DMOFR.

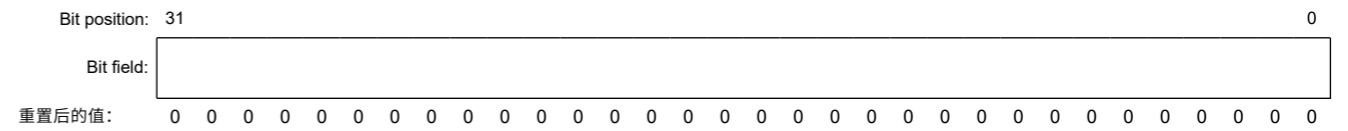
Table 16.2 SARA[4:0]或DARA[4:0]设置和对应的重复区域(2of2)

| SARA[4:0]或DARA[4:0]设置和对应的重复区域 | 扩展重复区域                  |
|-------------------------------|-------------------------|
| 00111b                        | 由地址的低7位指定为扩展重复区域的128个字节 |
| 01000b                        | 由地址的低8位指定为扩展重复区域的256个字节 |
| 01001b                        | 由地址的低9位指定为扩展重复区域的512个字节 |
| 01010b                        | 1KB由地址的低10位指定为扩展重复区域    |
| 01011b                        | 2KB由地址的低11位指定为扩展重复区域    |
| 01100b                        | 由地址的低12位指定为扩展重复区域的4KB   |
| 01101b                        | 8KB由地址的低13位指定为扩展重复区域    |
| 01110b                        | 16KB由地址的低14位指定为扩展重复区域   |
| 01111b                        | 32KB由地址的低15位指定为扩展重复区域   |
| 10000b                        | 64KB由地址的低16位指定为扩展重复区域   |
| 10001b                        | 128KB由地址的低17位指定为扩展重复区域  |
| 10010b                        | 256KB由地址的低18位指定为扩展重复区域  |
| 10011b                        | 512KB由地址的低19位指定为扩展重复区域  |
| 10100b                        | 1MB由地址的低20位指定为扩展重复区域    |
| 10101b                        | 2MB由地址的低21位指定为扩展重复区域    |
| 10110b                        | 4MB由地址的低22位指定为扩展重复区域    |
| 10111b                        | 8MB由地址的低23位指定为扩展重复区域    |
| 11000b                        | 16MB由地址的低24位指定为扩展重复区域   |
| 11001b                        | 32MB由地址的低25位指定为扩展重复区域   |
| 11010b                        | 64MB由地址的低26位指定为扩展重复区域   |
| 11011b                        | 128MB由地址的低27位指定为扩展重复区域  |
| 11100b to 11111b              | 禁止设置。                   |

## 16.2.11 DMOFR:DMA偏移寄存器

Base address: DMACn = 0x4000\_5000 + 0x0040 × n (n = 0 to 7)

Offset address: 0x18



| Bit  | Symbol | Function  | R/W |
|------|--------|---|-----|
| 31:0 | n/a    | Specifies the offset when offset addition is selected as the address update mode for transfer source or destination 0x00000000 to 0x00FFFFFF (0 bytes to (16 M – 1) bytes) 0xFF000000 to 0xFFFFFFFF (–16 Mbytes to –1 byte) | R/W |

Note: 如果安全属性配置为安全: ●

- 允许安全访问和非安全读取访问
- 忽略非安全写入访问, 不会生成TrustZone访问错误。

如果安全属性配置为非安全: ●

- 允许安全和非安全访问。

在DMAC操作停止或禁用DMA传输时(不是在数据传输期间)写入该寄存器。

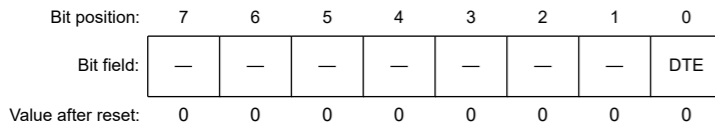
设置位31到25无效;位24的值扩展到到31到25。读取DMOFR将返回扩展值。

In repeat-block transfer mode the offset is not specified by DMOFR when offset addition is selected write 0 to DMOFR.

## 16.2.12 DMCNT : DMA Transfer Enable Register

Base address: DMACn = 0x4000\_5000 + 0x0040 × n (n = 0 to 7)

Offset address: 0x1C



| Bit | Symbol | Function   | R/W |
|-----|--------|--|-----|
| 0   | DTE    | DMA Transfer Enable<br>0: Disables DMA transfer<br>1: Enables DMA transfer | R/W |
| 7:1 | —      | These bits are read as 0. The write value should be 0.                     | R/W |

Note: If the security attribution is configured as secure:

- Secure access and Non-secure read access are allowed
  - Non-secure write access is ignored, and TrustZone access error is not generated.
- If the security attribution is configured as Non-secure:
- Secure and Non-secure access are allowed.

**DTE bit (DMA Transfer Enable)**

When the DMAST.DMST bit is set to 1 (DMAC activation is enabled) and this bit is set to 1 (DMA transfer is enabled), DMA transfer can be started for the corresponding channel.

[Setting condition]

- When 1 is written to this bit.

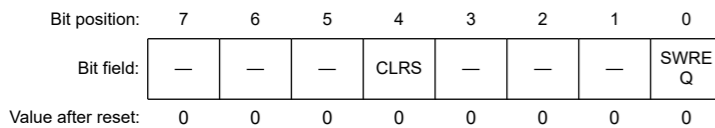
[Clearing conditions]

- When 0 is written to this bit.
- When the specified total volume of data transfer is completed.
- When DMA transfer is stopped by the repeat size end interrupt.
- When DMA transfer is stopped by the extended repeat area overflow interrupt.
- When DMA transfer is stopped by the access error occurs. Refer to [section 16.5. Processing on DMA Transfer Error](#).

## 16.2.13 DMREQ : DMA Software Start Register

Base address: DMACn = 0x4000\_5000 + 0x0040 × n (n = 0 to 7)

Offset address: 0x1D

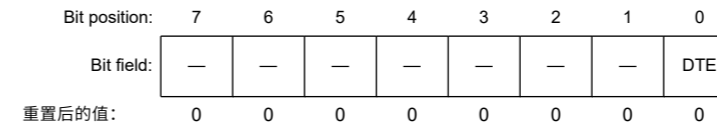


| Bit | Symbol | Function   | R/W |
|-----|--------|--|-----|
| 0   | SWREQ  | DMA Software Start<br>0: DMA transfer is not requested<br>1: DMA transfer is requested   | R/W |
| 3:1 | —      | These bits are read as 0. The write value should be 0.   | R/W |
| 4   | CLRS   | DMA Software Start Bit Auto Clear Select<br>0: SWREQ bit is cleared after DMA transfer is started by software<br>1: SWREQ bit is not cleared after DMA transfer is started by software | R/W |
| 7:5 | —      | These bits are read as 0. The write value should be 0.   | R/W |

## 16.2.12 DMCNT: DMA传输使能寄存器

Base address: DMACn = 0x4000\_5000 + 0x0040 × n (n = 0 to 7)

Offset address: 0x1C



| Bit | Symbol | Function                        | R/W |
|-----|--------|---------------------------------|-----|
| 0   | DTE    | DMA传输使能<br>0: 禁用DMA传输1: 启用DMA传输 | R/W |
| 7:1 | —      | 这些位被读取为0。写入值应为0。                | R/W |

Note: 如果安全属性配置为安全: ●

- 允许安全访问和非安全读取访问
  - 忽略非安全写入访问, 不会生成TrustZone访问错误。
- 如果安全属性配置为非安全: ●
- 允许安全和非安全访问。

**DTE位 (DMA传输使能)**

当DMAST.DMST位设置为1 (启用DMAC激活) 并且该位设置为1 (启用DMA传输) 时, 可以为相应的通道启动DMA传输。

[Setting condition]

- 向该位写入1时。

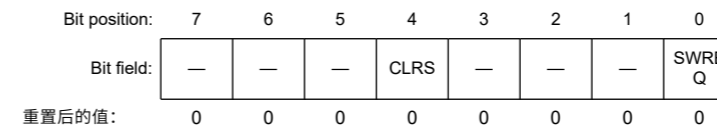
[Clearing conditions]

- 当0写入该位时。
- 当指定的总数据传输量完成时。
- 当DMA传输因重复大小结束中断而停止时。
- 当DMA传输因扩展重复区域溢出中断而停止时。
- DMA传输因访问错误而停止时。请参阅第16.5节。处理DMA传输错误。

## 16.2.13 DMREQ:DMA软件启动寄存器

Base address: DMACn = 0x4000\_5000 + 0x0040 × n (n = 0 to 7)

Offset address: 0x1D



| Bit | Symbol | Function  | R/W |
|-----|--------|---|-----|
| 0   | SWREQ  | DMA软件启动<br>0: 不请求DMA传输1: 请求DMA传输                              | R/W |
| 3:1 | —      | 这些位被读取为0。写入值应为0。  | R/W |
| 4   | CLRS   | DMA软件起始位自动清除选择<br>0: 软件启动DMA传输后SWREQ位清零1: 软件启动DMA传输后SWREQ位不清零 | R/W |
| 7:5 | —      | 这些位被读取为0。写入值应为0。  | R/W |

Note: If the security attribution is configured as secure:

- Secure access and Non-secure read access are allowed
  - Non-secure write access is ignored, and TrustZone access error is not generated.
- If the security attribution is configured as Non-secure:
- Secure and Non-secure access are allowed.

### SWREQ bit (DMA Software Start)

When 1 is written to SWREQ bit, a DMA transfer request is generated. After DMA transfer is started in response to the request, this bit is cleared to 0 if the CLRS bit is set to 0. This bit is not cleared to 0 while the CLRS bit is set to 1. In this case, a DMA transfer request can be issued again after completion of a transfer.

Note that, however, setting this bit is valid and DMA transfer by software is enabled only when the DMTMD.DCTG[1:0] bits are set to 00b (DMAC activation source is software).

Setting this bit is invalid when the DMTMD.DCTG[1:0] bits are set to a value other than 00b.

To start DMA transfer by software with the CLRS bit being 0, ensure that the SWREQ bit is 0, and then write 1 to the SWREQ bit.

[Setting condition]

- When 1 is written to this bit.

[Clearing conditions]

- When a DMA transfer request by software is accepted and DMA transfer is started while the CLRS bit is set to 0 (the SWREQ bit is cleared after DMA transfer is started by software).
- When 0 is written to this bit.

### CLRS bit (DMA Software Start Bit Auto Clear Select)

CLRS bit specifies whether to clear the SWREQ bit to 0 after DMA transfer is started in response to the DMA transfer request generated by setting the SWREQ bit to 1. With this bit set to 0, the SWREQ bit is cleared to 0 after DMA transfer is started. With this bit set to 1, the SWREQ bit is not cleared to 0. In this case, a DMA transfer request can be issued again after completion of a transfer.

#### 16.2.14 DMSTS : DMA Status Register

Base address: DMACn = 0x4000\_5000 + 0x0040 × n (n = 0 to 7)

Offset address: 0x1E

|                    |     |   |   |      |   |   |   |      |
|--------------------|-----|---|---|------|---|---|---|------|
| Bit position:      | 7   | 6 | 5 | 4    | 3 | 2 | 1 | 0    |
| Bit field:         | ACT | — | — | DTIF | — | — | — | ESIF |
| Value after reset: | 0   | 0 | 0 | 0    | 0 | 0 | 0 | 0    |

| Bit | Symbol | Function   | R/W              |
|-----|--------|--|------------------|
| 0   | ESIF   | Transfer Escape End Interrupt Flag<br>0: A transfer escape end interrupt has not been generated<br>1: A transfer escape end interrupt has been generated | R/W <sup>1</sup> |
| 3:1 | —      | These bits are read as 0. The write value should be 0.   | R                |
| 4   | DTIF   | Transfer End Interrupt Flag<br>0: A transfer end interrupt has not been generated<br>1: A transfer end interrupt has been generated                      | R/W <sup>1</sup> |
| 6:5 | —      | These bits are read as 0. The write value should be 0.   | R                |
| 7   | ACT    | DMAC Active Flag<br>0: DMAC is in the idle state<br>1: DMAC is operating   | R                |

Note: If the security attribution is configured as secure:

- Secure access and Non-secure read access are allowed
  - Non-secure write access is ignored, and TrustZone access error is not generated.
- If the security attribution is configured as Non-secure:

Note: 如果安全属性配置为安全: ●

- 允许安全访问和非安全读取访问
  - 忽略非安全写入访问, 不会生成TrustZone访问错误。
- 如果安全属性配置为非安全: ●
- 允许安全和非安全访问。

### SWREQ位 (DMA软件启动)

当SWREQ位写入1时, 会产生DMA传输请求。响应请求启动DMA传输后, 如果CLRS位设置为0, 则该位清零。当CLRS位设置为1时, 该位不清零。在这种情况下, DMA传输请求转让完成后可再次发行。

但是请注意, 设置该位有效, 并且仅当DMTMD.DCTG[1:0]位设置为00b (DMAC激活源为软件) 时, 才启用软件进行的DMA传输。

当DMTMD.DCTG[1:0]位设置为00b以外的值时, 设置该位无效。

软件启动DMA传输时CLRS位为0, 确保SWREQ位为0, 然后将1写入SWREQ bit。

[Setting condition]

- 向该位写入1时。

[Clearing conditions]

- 当CLRS位设置为0 (软件启动DMA传输后SWREQ位清零) 时, 接受软件的DMA传输请求并启动DMA传输。
- 当0写入该位时。

### CLRS位 (DMA软件起始位自动清除选择)

CLRS位指定在DMA传输开始后是否将SWREQ位清除为0, 以响应通过将SWREQ位设置为1产生的DMA传输请求。当该位设置为0时, 在DMA传输完成后SWREQ位被清除为0开始了。该位设置为1时, SWREQ位不会被清除为0。在这种情况下, 可以在传输完成后再次发出DMA传输请求。

#### 16.2.14 DMSTS:DMA状态寄存器

Base address: DMACn = 0x4000\_5000 + 0x0040 × n (n = 0 to 7)

Offset address: 0x1E

|               |     |   |   |      |   |   |   |      |
|---------------|-----|---|---|------|---|---|---|------|
| Bit position: | 7   | 6 | 5 | 4    | 3 | 2 | 1 | 0    |
| Bit field:    | ACT | — | — | DTIF | — | — | — | ESIF |
| 重置后的值:        | 0   | 0 | 0 | 0    | 0 | 0 | 0 | 0    |

| Bit | Symbol | Function                                   | R/W              |
|-----|--------|--|------------------|
| 0   | ESIF   | 传输转义结束中断标志<br>0: 未产生传输转义结束中断1: 已产生传输转义结束中断 | R/W <sup>1</sup> |
| 3:1 | —      | 这些位被读取为0。写入值应为0。                           | R                |
| 4   | DTIF   | 传输结束中断标志<br>0: 未产生传输结束中断1: 已产生传输结束中断       | R/W <sup>1</sup> |
| 6:5 | —      | 这些位被读取为0。写入值应为0。                           | R                |
| 7   | ACT    | DMAC活动标志<br>0: DMAC处于空闲状态1: DMAC正在运行       | R                |

Note: 如果安全属性配置为安全: ●

- 允许安全访问和非安全读取访问
  - 忽略非安全写入访问, 不会生成TrustZone访问错误。
- 如果安全属性配置为非安全:

- Secure and Non-secure access are allowed.

Note 1. Only 0 can be written to clear the flag.

### ESIF flag (Transfer Escape End Interrupt Flag)

This flag indicates that the transfer escape end interrupt has been generated.

[Setting conditions]

- When 1-repeat size data transfer is completed in repeat transfer mode with the DMINT.RPTIE bit set to 1.
- When 1-block data transfer is completed in block transfer mode with the DMINT.RPTIE bit set to 1.
- When an extended repeat area overflow on the source address occurs while the DMINT.SARIE bit is set to 1 and the DMAMD.SARA[4:0] bits are set to a value other than 00000b (extended repeat area is specified on the transfer source address)
- When an extended repeat area overflow on the destination address occurs while the DMINT.DARIE bit is set to 1 and the DMAMD.DARA[4:0] bits are set to a value other than 00000b (extended repeat area is specified on the transfer destination address)

[Clearing conditions]

- When 0 is written to this bit.
- When 1 is written to the DMCNT.DTE bit.

### DTIF flag (Transfer End Interrupt Flag)

This flag indicates that the transfer end interrupt has been generated.

[Setting conditions]

- When the specified number of unit-transfers are completed in normal transfer mode (the value of DMCRAL becoming 0 on completion of transfer)
- When the specified number of repeat transfer operations are completed in repeat transfer mode (the value of DMCRLB becoming 0 on completion of transfer with DMTMD.TKP = 0 or the value of DMCRLB reloading DMCRLB with DMTMD.TKP = 1)
- When the specified number of blocks have been transferred in block transfer mode (the value of DMCRLB becoming 0 on completion of transfer with DMTMD.TKP = 0 or the value of DMCRLB reloading DMCRLB with DMTMD.TKP = 1)

[Clearing conditions]

- When 0 is written to this bit
- When 1 is written to the DMCNT.DTE bit

### ACT flag (DMAC Active Flag)

This flag indicates whether the DMAC is in the idle or active state.

[Setting condition]

- When the DMAC starts data transfer operation

[Clearing condition]

- When data transfer in response to one transfer request is completed

- 允许安全和非安全访问。

注1.只能写入0来清除标志。

### ESIF标志 (传输转义结束中断标志)

该标志表明传输转义结束中断已经产生。

[Setting conditions]

- 当DMINT.RPTIE位设置为1在重复传输模式下完成1次重复大小的数据传输时。
- 当DMINT.RPTIE位设置为1在块传输模式下完成1块数据传输时。
- 当DMINT.SARIE位设置为1且DMAMD.SARA[4:0]位设置为00000b以外的值时，当源地址发生扩展重复区域溢出时（扩展重复区域在传输时指定源地址）
- 当DMINT.DARIE位设置为1且DMAMD.DARA[4:0]位设置为00000b以外的值时，当目标地址发生扩展重复区域溢出时（扩展重复区域在传输时指定目的地址）

[Clearing conditions]

- 当0写入该位时。
- 当1写入DMCNT.DTE位时。

### DTIF标志 (传输结束中断标志)

该标志表示已产生传输结束中断。

[Setting conditions]

- 在正常传输模式下完成指定数量的unit-transfer时（传输完成时DMCRAL的值变为0）
- 在重复传输模式下完成指定次数的重复传输操作时（DMCRBL的值在DMTMD.TKP=0的传输完成时变为0或DMCRBL的值在DMTMD.TKP=1时重新加载DMCRBL）
- 在块传输模式下已经传输了指定数量的块时（DMCRBL的值在传输完成时变为0且DMTMD.TKP=0或DMCRBL的值在DMTMD.TKP=1时重新加载DMCRBL）

[Clearing conditions]

- 当0写入该位时
- 当1写入DMCNT.DTE位时

### ACT标志 (DMAC活动标志)

该标志指示DMAC是处于空闲状态还是活动状态。

[Setting condition]

- DMAC开始数据传输操作时

[Clearing condition]

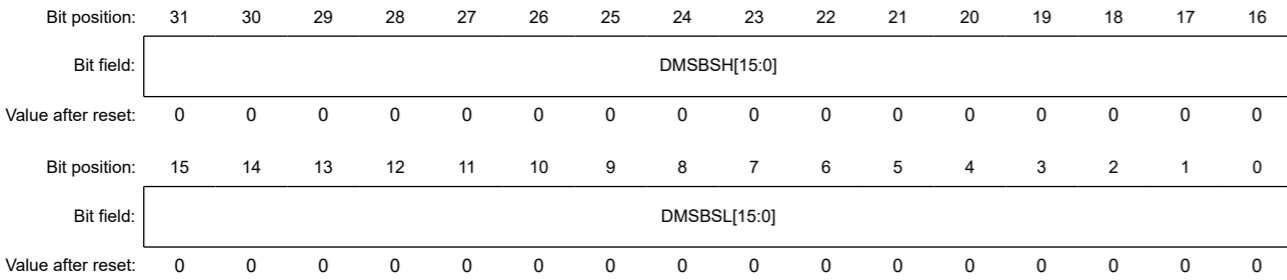
- 当响应一个传输请求的数据传输完成时



16.2.15 DMSBS : DMA Source Buffer Size Register

Base address: DMACn = 0x4000\_5000 + 0x0040 × n (n = 0 to 7)

Offset address: 0x28



| Bit   | Symbol       | Function   | R/W |
|-------|--------------|--|-----|
| 15:0  | DMSBSL[15:0] | Functions as data transfer counter in repeat-block transfer mode<br>See Table 16.3 for available settings. | R/W |
| 31:16 | DMSBSH[15:0] | Specifies the repeat-area size in repeat-block transfer mode<br>See Table 16.3 for available settings.     | R/W |

Note: If the security attribution is configured as secure:  
 • Secure access and Non-secure read access are allowed  
 • Non-secure write access is ignored, and TrustZone access error is not generated.  
 If the security attribution is configured as Non-secure:  
 • Secure and Non-secure access are allowed.

Set the same value for DMSBSH and DMSBSL in repeat-block transfer mode. Write 00000000h to DMSBS in normal, repeat and block transfer mode.

DMSBSH specifies buffer size and DMSBSL functions as a 16-bit buffer size counter in repeat-block transfer mode. In repeat-block transfer mode, source repeat area is specified by DMSBSH.

When address update mode is incremented address or decremented address, this register means the numbers of data of whole buffer. When address update mode is offset addition, this register means the numbers of data of an individual buffer. In offset addition, setting DMSBSH and DMSBSL to 0x0000 is prohibited. When final data of one buffer size is transferred, DMSBSL reloads value of DMSBSH. When address update mode is fixed address, this register is ignored. Table 16.3 shows the setting values of DMA Source Buffer Size Register corresponding to Transfer Data Size in Source Address Update Mode.

Table 16.3 Available setting for DMSBS register in repeat-block transfer mode

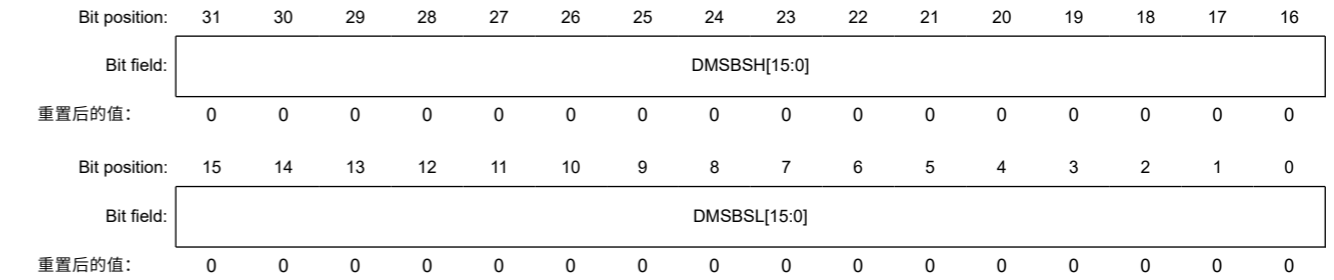
| Source Address Update Mode (DMAMD.SM)                   | Transfer Data Size (DMTMD.SZ) | Available Setting for DMSBSH and DMSBSL bits       |
|---|-------------------------------|--|
| Source address is fixed (SM = 00b)                      | Don't care                    | 0x0000 (DMSBS is not used)                         |
| Offset addition (SM = 01b)                              | 8 bits (SZ = 00b)             | 0x0001 to 0xFFFF (1 to 65535)                      |
|   | 16 bits (SZ = 01b)            | 0x0001h to 0x7FFF (1 to 32767)                     |
|   | 32 bits (SZ = 10b)            | 0x0001 to 0x3FFF (1 to 16383)                      |
| Source address is incremented or decremented (SM = 1xb) | Don't care                    | 0x0000 (infinite)<br>0x0001 to 0xFFFF (1 to 65535) |

In normal, repeat and block transfer mode, DMSBS is not used. The setting is invalid.

16.2.15 DMSBS:DMA源缓冲区大小寄存器

Base address: DMACn = 0x4000\_5000 + 0x0040 × n (n = 0 to 7)

Offset address: 0x28



| Bit   | Symbol       | Function                                | R/W |
|-------|--------------|---|-----|
| 15:0  | DMSBSL[15:0] | 在重复块传输模式中用作数据传输计数器<br>有关可用设置, 请参见表16.3。 | R/W |
| 31:16 | DMSBSH[15:0] | 指定重复块传输模式下的重复区域大小<br>有关可用设置, 请参见表16.3。  | R/W |

Note: 如果安全属性配置为安全: ●  
 允许安全访问和非安全读取访问  
 • 忽略非安全写入访问, 不会生成TrustZone访问错误。  
 如果安全属性配置为非安全: ●  
 允许安全和非安全访问。

在重复块传输模式下为DMSBSH和DMSBSL设置相同的值。在正常、重复和块传输模式下将00000000h写入DMSBS。

DMSBSH指定缓冲区大小, DMSBSL用作重复块传输模式下的16位缓冲区大小计数器。在重复块传输模式下, 源重复区域由DMSBSH指定。

当地址更新模式为递增地址或递减地址时, 该寄存器表示整个缓冲区的数据个数。当地址更新模式为偏移加法时, 该寄存器表示单个缓冲区的数据个数。此外, 禁止将DMSBSH和DMSBSL设置为0x0000。当传输一个缓冲区大小的最终数据时, DMSBSL重新加载DMSBSH的值。当地址更新模式为固定地址时, 该寄存器被忽略。表16.3显示了与源地址更新模式下的传输数据大小相对应的DMA源缓冲区大小寄存器的设置值。

Table 16.3 重复块传输模式下DMSBS寄存器的可用设置

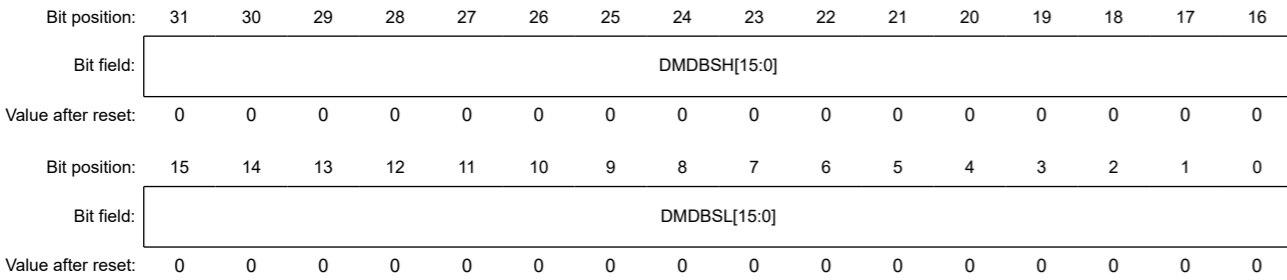
| 源地址更新模式(DMAMD.SM) | 传输数据大小(DMTMD.SZ)   | DMSBSH的可用设置和DMSBSL bits                            |
|-------------------|--------------------|--|
| 源地址是固定的 (SM=00b)  | 不在乎                | 0x0000 (未使用DMSBS)                                  |
| 偏移量加法(SM=01b)     | 8 bits (SZ = 00b)  | 0x0001 to 0xFFFF (1 to 65535)                      |
|                   | 16 bits (SZ = 01b) | 0x0001h to 0x7FFF (1 to 32767)                     |
|                   | 32 bits (SZ = 10b) | 0x0001 to 0x3FFF (1 to 16383)                      |
| 源地址递增或递减(SM=1xb)  | 不在乎                | 0x0000 (infinite)<br>0x0001 to 0xFFFF (1 to 65535) |

在正常、重复和块传输模式下, 不使用DMSBS。设置无效。



16.2.16 DMDBS : DMA Destination Buffer Size Register

Base address: DMACn = 0x4000\_5000 + 0x0040 × n (n = 0 to 7)  
 Offset address: 0x2C



| Bit   | Symbol       | Function   | R/W |
|-------|--------------|--|-----|
| 15:0  | DMDBSL[15:0] | Functions as data transfer counter in repeat-block transfer mode<br>See Table 16.4 for available settings. | R/W |
| 31:16 | DMDBSH[15:0] | Specifies the repeat-area size in repeat-block transfer mode<br>See Table 16.4 for available settings.     | R/W |

Note: If the security attribution is configured as secure:  
 • Secure access and Non-secure read access are allowed  
 • Non-secure write access is ignored, and TrustZone access error is not generated.  
 If the security attribution is configured as Non-secure:  
 • Secure and Non-secure access are allowed.

Set the same value for DMDBSH and DMDBSL in repeat-block transfer mode. Write 00000000h to DMDBS in normal, repeat and block transfer mode.

DMDBSH specifies buffer size and DMDBSL functions as a 16-bit buffer size counter in repeat-block transfer mode. In repeat-block transfer mode, destination repeat area is specified by DMDBSH.

When address update mode is incremented address or decremented address, this register means the numbers of data of whole buffer. When address update mode is offset addition, this register means the numbers of data of an individual buffer. In offset addition, setting DMDBSH and DMDBSL to 0x0000 is prohibited. When final data of one buffer size is transferred, DMDBSL reloads value of DMDBSH. When address update mode is fixed address, this register is ignored.

Table 16.4 shows the setting values of Destination Buffer Size Register corresponding to Transfer Data Size in Destination Address Update Mode.

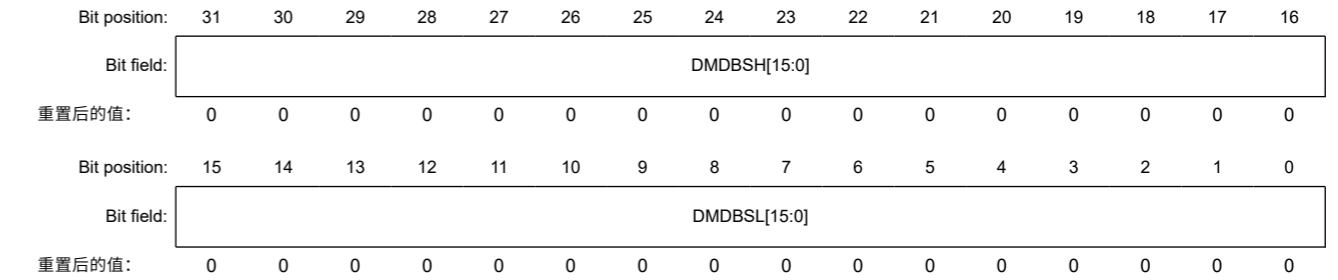
Table 16.4 Available setting for DMDBS register in repeat-block transfer mode

| Destination Address Update Mode (DMAMD.DM)                   | Transfer Data Size (DMTMD.SZ) | Available Setting for DMDBSH and DMDBSL bits       |
|--|-------------------------------|--|
| Destination address is fixed (DM = 00b)                      | Don't care                    | 0x0000 (DMDBS is not used)                         |
| Offset addition (DM = 01b)                                   | 8 bits (SZ = 00b)             | 0x0001 to 0xFFFF (1 to 65535)                      |
|  | 16 bits (SZ = 01b)            | 0x0001 to 0x7FFF (1 to 32767)                      |
|  | 32 bits (SZ = 10b)            | 0x0001 to 0x3FFF (1 to 16383)                      |
| Destination address is incremented or decremented (DM = 1xb) | Don't care                    | 0x0000 (infinite)<br>0x0001 to 0xFFFF (1 to 65535) |

In normal, repeat and block transfer mode, DMDBS is not used. The setting is invalid.

16.2.16 DMDBS:DMA目标缓冲区大小寄存器

Base address: DMACn = 0x4000\_5000 + 0x0040 × n (n = 0 to 7)  
 Offset address: 0x2C



| Bit   | Symbol       | Function                               | R/W |
|-------|--------------|--|-----|
| 15:0  | DMDBSL[15:0] | 在重复块传输模式中用作数据传输计数器<br>有关可用设置，请参见表16.4。 | R/W |
| 31:16 | DMDBSH[15:0] | 指定重复块传输模式下的重复区域大小<br>有关可用设置，请参见表16.4。  | R/W |

Note: 如果安全属性配置为安全: ●  
 允许安全访问和非安全读取访问  
 • 忽略非安全写入访问，不会生成TrustZone访问错误。  
 如果安全属性配置为非安全: ●  
 允许安全和非安全访问。

在重复块传输模式下为DMDBSH和DMDBSL设置相同的值。在正常、重复和块传输模式下将00000000h写入DMDBS。

DMDBSH指定缓冲区大小，DMDBSL用作重复块传输模式下的16位缓冲区大小计数器。在重复块传输模式中，目标重复区域由DMDBSH指定。

当地址更新模式为递增地址或递减地址时，该寄存器表示整个缓冲区的数据个数。当地址更新模式为偏移加法时，该寄存器表示单个缓冲区的数据个数。此外，禁止将DMDBSH和DMDBSL设置为0x0000。当传输一个缓冲区大小的最终数据时，DMDBSL重新加载DMDBSH的值。当地址更新模式为固定地址时，该寄存器被忽略。表16.4显示了与Destination中的TransferDataSize对应的DestinationBufferSizeRegister的设置值

地址更新模式。

Table 16.4 重复块传输模式下DMDBS寄存器的可用设置

| 目标地址更新模式(DMAMD.DM) | 传输数据大小(DMTMD.SZ)   | DMDBSH的可用设置和DMDBSL bits                            |
|--------------------|--------------------|--|
| 目标地址是固定的 (DM=00b)  | 不在乎                | 0x0000 (未使用DMDBS)                                  |
| 偏移量加法(DM=01b)      | 8 bits (SZ = 00b)  | 0x0001 to 0xFFFF (1 to 65535)                      |
|                    | 16 bits (SZ = 01b) | 0x0001 to 0x7FFF (1 to 32767)                      |
|                    | 32 bits (SZ = 10b) | 0x0001 to 0x3FFF (1 to 16383)                      |
| 目标地址递增或递减(DM=1xb)  | 不在乎                | 0x0000 (infinite)<br>0x0001 to 0xFFFF (1 to 65535) |

在正常、重复和块传输模式下，不使用DMDBS。设置无效。

## 16.2.17 DMAST : DMA Module Activation Register

Base address: DMA = 0x4000\_5200

Offset address: 0x00

|                    |   |   |   |   |   |   |   |      |
|--------------------|---|---|---|---|---|---|---|------|
| Bit position:      | 7 | 6 | 5 | 4 | 3 | 2 | 1 | 0    |
| Bit field:         | — | — | — | — | — | — | — | DMST |
| Value after reset: | 0 | 0 | 0 | 0 | 0 | 0 | 0 | 0    |

| Bit | Symbol | Function   | R/W |
|-----|--------|--|-----|
| 0   | DMST   | DMAC Operation Enable<br>0: DMAC activation is disabled<br>1: DMAC activation is enabled | R/W |
| 7:1 | —      | These bits are read as 0. The write value should be 0.                                   | R/W |

Note: If the security attribution is configured as secure:

- Secure access and Non-secure read access are allowed
  - Non-secure write access is ignored, and TrustZone access error is not generated.
- If the security attribution is configured as Non-secure:
- Secure and Non-secure access are allowed.

**DMST bit (DMAC Operation Enable)**

Setting the DMAST.DMST to 1 enables DMAC activation for all channels. When the DMST bit is set to 1 (DMAC activation is enabled), and 1 is written to the DMCNT.DTE bit (DMA transfer is enabled) for multiple channels, all of the associated channels can be placed in the transfer request ready state at the same time.

When the DMST bit clears to 0 during DMA transfer, DMA transfer is suspended after the current data transfer associated with a single transfer request completes. To resume DMA transfer, set the DMST bit to 1 again.

[Setting condition]

- When 1 is written to this bit

[Clearing condition]

- When 0 is written to this bit

## 16.2.18 DMECHR : DMAC Error Channel Register

Base address: DMA = 0x4000\_5200

Offset address: 0x40

|                    |    |    |    |    |    |    |    |           |    |    |    |    |    |    |    |         |
|--------------------|----|----|----|----|----|----|----|-----------|----|----|----|----|----|----|----|---------|
| Bit position:      | 31 | 30 | 29 | 28 | 27 | 26 | 25 | 24        | 23 | 22 | 21 | 20 | 19 | 18 | 17 | 16      |
| Bit field:         | —  | —  | —  | —  | —  | —  | —  | —         | —  | —  | —  | —  | —  | —  | —  | DMES TA |
| Value after reset: | 0  | 0  | 0  | 0  | 0  | 0  | 0  | 0         | 0  | 0  | 0  | 0  | 0  | 0  | 0  | 0       |
| Bit position:      | 15 | 14 | 13 | 12 | 11 | 10 | 9  | 8         | 7  | 6  | 5  | 4  | 3  | 2  | 1  | 0       |
| Bit field:         | —  | —  | —  | —  | —  | —  | —  | DMEC HSAM | —  | —  | —  | —  | —  | —  | —  | DMECH   |
| Value after reset: | 0  | 0  | 0  | 0  | 0  | 0  | 0  | 0         | 0  | 0  | 0  | 0  | 0  | 0  | 0  | 0       |

## 16.2.17 DMAST:DMA模块激活寄存器

Base address: DMA = 0x4000\_5200

Offset address: 0x00

|               |   |   |   |   |   |   |   |      |
|---------------|---|---|---|---|---|---|---|------|
| Bit position: | 7 | 6 | 5 | 4 | 3 | 2 | 1 | 0    |
| Bit field:    | — | — | — | — | — | — | — | DMST |
| 重置后的值:        | 0 | 0 | 0 | 0 | 0 | 0 | 0 | 0    |

| Bit | Symbol | Function                               | R/W |
|-----|--------|--|-----|
| 0   | DMST   | DMAC操作使能<br>0: 禁用DMAC激活<br>1: 启用DMAC激活 | R/W |
| 7:1 | —      | 这些位被读取为0。写入值应为0。                       | R/W |

Note: 如果安全属性配置为安全: ●

- 允许安全访问和非安全读取访问
  - 忽略非安全写入访问, 不会生成TrustZone访问错误。
- 如果安全属性配置为非安全: ●
- 允许安全和非安全访问。

**DMST位 (DMAC操作使能)**

将DMAST.DMST设置为1会启用所有通道的DMAC激活。当DMST位设置为1 (启用DMAC激活), 并将1写入多个通道的DMCNT.DTE位 (启用DMA传输) 时, 所有相关联的通道都可以置于传输请求就绪状态同时。

当DMA传输期间DMST位清除为0时, 在与单个传输请求相关的当前数据传输完成后, DMA传输将暂停。要恢复DMA传输, 请将DMST位再次设置为1。

[Setting condition]

- 向该位写入1时

[Clearing condition]

- 当0写入该位时

## 16.2.18 DMECHR:DMAC错误通道寄存器

Base address: DMA = 0x4000\_5200

Offset address: 0x40

|               |    |    |    |    |    |    |    |           |    |    |    |    |    |    |    |         |
|---------------|----|----|----|----|----|----|----|-----------|----|----|----|----|----|----|----|---------|
| Bit position: | 31 | 30 | 29 | 28 | 27 | 26 | 25 | 24        | 23 | 22 | 21 | 20 | 19 | 18 | 17 | 16      |
| Bit field:    | —  | —  | —  | —  | —  | —  | —  | —         | —  | —  | —  | —  | —  | —  | —  | DMES TA |
| 重置后的值:        | 0  | 0  | 0  | 0  | 0  | 0  | 0  | 0         | 0  | 0  | 0  | 0  | 0  | 0  | 0  | 0       |
| Bit position: | 15 | 14 | 13 | 12 | 11 | 10 | 9  | 8         | 7  | 6  | 5  | 4  | 3  | 2  | 1  | 0       |
| Bit field:    | —  | —  | —  | —  | —  | —  | —  | DMEC HSAM | —  | —  | —  | —  | —  | —  | —  | DMECH   |
| 重置后的值:        | 0  | 0  | 0  | 0  | 0  | 0  | 0  | 0         | 0  | 0  | 0  | 0  | 0  | 0  | 0  | 0       |

| Bit   | Symbol   | Function  | R/W              |
|-------|----------|---|------------------|
| 2:0   | DMECH    | DMAC Error channel<br>Indicates the channel number causing the error<br>0 0 0: Error occurred on Channel 0<br>0 0 1: Error occurred on Channel 1<br>0 1 0: Error occurred on Channel 2<br>⋮<br>1 1 1: Error occurred on Channel 7 | R                |
| 7:3   | —        | These bits are read as 0. The write value should be 0.  | R                |
| 8     | DMECHSAM | DMAC Error channel Security Attribution Monitor<br>Indicates the security attribution of a channel causing the error<br>0: secure channel<br>1: non-secure channel  | R                |
| 15:9  | —        | These bits are read as 0. The write value should be 0.  | R                |
| 16    | DMESTA   | DMAC Error Status<br>0: No DMA transfer error occurred<br>1: DMA transfer error occurred  | R/W <sup>1</sup> |
| 31:17 | —        | These bits are read as 0. The write value should be 0.  | R                |

Note 1. Writing to DMESTA depends on the value of DMECHSAM

#### DMECH[2:0] bit (DMAC Error channel)

When a transfer error due to DMA transfer occurs, it stores the channel of DMAC that was violated.

When reset was selected in MPU.MMPUOAD.OAD and TZF.TZFOAD.OAD, Since this register is also reset. Please select NMI when you want to debug the program.

[Set condition]

- When the DMAC transfer error occurs and DMESTA = 0.

[Clearing condition]

- When 1 is written to DMESTA.

#### DMECHSAM bit (DMAC Error channel Security Attribution Monitor)

When a transfer error due to DMA transfer occurs, it indicates the security attribution of the violating DMAC channel.

When reset was selected in MPU.MMPUOAD.OAD and TZF.TZFOAD.OAD, Since this register is also reset. Please select NMI when you want to debug the program.

[Set condition]

- When the DMAC transfer error occurs and DMESTA = 0.

[Clearing condition]

- When 1 is written to DMESTA.

#### DMESTA bit (DMAC Error Status)

Indicates whether or not a DMA transfer error occurred.

DMECH, DMECHSAM, DMESTA are cleared by writing 1 to DMESTA. Writing 0 to DMESTA is ignored.

When reset was selected in MPU.MMPUOAD.OAD and TZF.TZFOAD.OAD, Since this register is also reset. Please select NMI when you want to debug the program.

[Set condition]

- When the DMAC transfer error occurs.

[Clearing condition]

- When 1 is written to DMESTA.

| Bit   | Symbol   | Function  | R/W              |
|-------|----------|---|------------------|
| 2:0   | DMECH    | DMAC错误通道<br>指示导致错误的通道号<br>000: 通道0发生错误001: 通道1发生错误010: 通道2发生错误<br>⋮<br>111: 通道7发生错误 | R                |
| 7:3   | —        | 这些位被读取为0。写入值应为0。  | R                |
| 8     | DMECHSAM | DMAC错误通道安全归因监视器<br>指示导致错误的通道的安全属性<br>0: 安全通道1: 非安全通道                                | R                |
| 15:9  | —        | 这些位被读取为0。写入值应为0。  | R                |
| 16    | DMESTA   | DMAC错误状态<br>0: 未发生DMA传输错误1: 发生DMA传输错误   | R/W <sup>1</sup> |
| 31:17 | —        | 这些位被读取为0。写入值应为0。  | R                |

注1.写入DMESTA取决于DMECHSAM的值

#### DMECH[2:0]位 (DMAC错误通道)

当由于DMA传输而发生传输错误时，它会存储违反的DMAC通道。

当在MPU.MMPUOAD.OAD和TZF.TZFOAD.OAD中选择了复位时，由于该寄存器也被复位。请选择NMI当你想调试程序时。

[Set condition]

- 发生DMAC传输错误且DMESTA=0时。

[Clearing condition]

- 当1被写入DMESTA时。

#### DMECHSAM位 (DMAC错误通道安全属性监视器)

当由于DMA传输而发生传输错误时，表明违规DMAC通道的安全属性。

当在MPU.MMPUOAD.OAD和TZF.TZFOAD.OAD中选择了复位时，由于该寄存器也被复位。请选择NMI当你想调试程序时。

[Set condition]

- 发生DMAC传输错误且DMESTA=0时。

[Clearing condition]

- 当1被写入DMESTA时。

#### DMESTA位 (DMAC错误状态)

指示是否发生DMA传输错误。

DMECH、DMECHSAM、DMESTA通过向DMESTA写入1清零。将0写入DMESTA将被忽略。

当在MPU.MMPUOAD.OAD和TZF.TZFOAD.OAD中选择了复位时，由于该寄存器也被复位。请选择NMI当你想调试程序时。

[Set condition]

- 发生DMAC传输错误时。

[Clearing condition]

- 当1被写入DMESTA时。

Note: When DMECHSAM = 1, it can be cleared in the secure state and non-secure state. DMECHSAM = 0, it can not be cleared in the non-secure state.

### 16.3 Operation

#### 16.3.1 Transfer Mode

##### 16.3.1.1 Normal Transfer Mode

In normal transfer mode, one data is transferred by one transfer request. A maximum of 65535 can be set as the number of transfer operations using the DMCRAL register. When these bits are set to 0x0000, no specific number of transfer operations is set; data transfer is performed with the transfer counter stopped (free running function). Setting DMCRB register is invalid in normal transfer mode. Except in free running function, a transfer end interrupt request can be generated after completion of the specified number of transfer operations.

Table 16.5 summarizes the register update operation in normal transfer mode, and Figure 16.2 shows the operation in normal transfer mode.

Table 16.5 Register Update Operation in Normal Transfer Mode

| Register | Function                     | Update Operation after Completion of a Transfer by One Transfer Request |
|----------|------------------------------|---|
| DMSAR    | Transfer source address      | Increment/decrement/fixd/offset addition                                |
| DMDAR    | Transfer destination address | Increment/decrement/fixd/offset addition                                |
| DMCRAL   | Transfer count               | Decrementd by one/not updated (in free running function)                |
| DMCRAH   | —                            | Not updated (Not used in normal transfer mode)                          |
| DMCRB    | —                            | Not updated (Not used in normal transfer mode)                          |

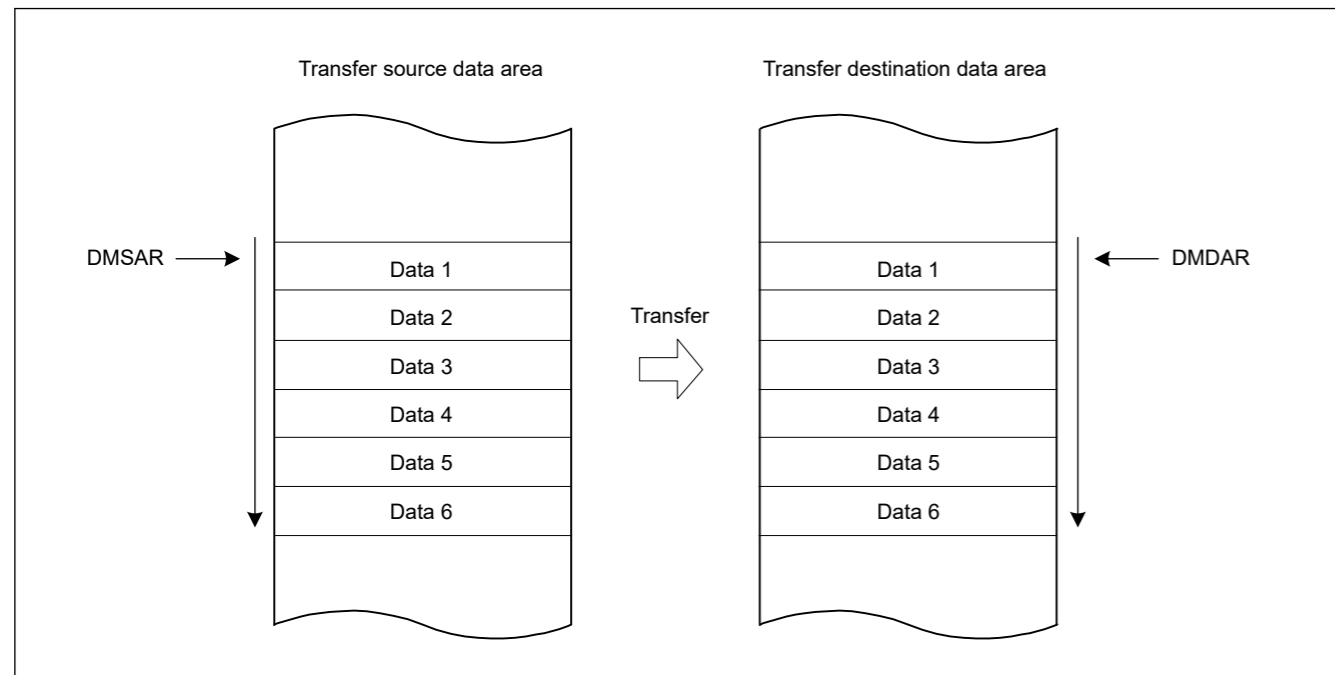


Figure 16.2 Operation in Normal Transfer Mode

##### 16.3.1.2 Repeat Transfer Mode

In repeat transfer mode, one data is transferred by one transfer request.

A maximum of 1K data can be set as a total repeat transfer size using DMCRA register.

A maximum of 64K can be set as the number of repeat transfer operations using DMCRB register; therefore, a maximum of 64M data (1K data × 64K counts of repeat transfer operations) can be set as a total data transfer size.

Note: 当DMECHSAM=1时，可以在安全状态和非安全状态下清零。DMECHSAM=0，在非安全状态下不能清零。

### 16.3 Operation

#### 16.3.1 传输模式

##### 16.3.1.1 正常传输模式

在正常传输模式下，一个数据由一个传输请求传输。使用DMCRAL寄存器最多可以设置65535个传输操作数。当这些位设置为0x0000时，没有设置具体的传输操作数；在传输计数器停止的情况下执行数据传输（自由运行功能）。在正常传输模式下设置DMCRB寄存器无效。除自由运行功能外，在完成指定次数的传输操作后可以产生传输结束中断请求。

表16.5总结了正常传输模式下的寄存器更新操作，图16.2显示了正常传输模式下的操作。

Table 16.5 正常传输模式下的寄存器更新操作

| Register | Function | 一次转账完成后更新操作 Request                      |
|----------|----------|--|
| DMSAR    | 传输源地址    | Increment/decrement/fixd/offset addition |
| DMDAR    | 转移目的地地址  | Increment/decrement/fixd/offset addition |
| DMCRAL   | 转移计数     | 减一未更新（在自由运行功能中）                          |
| DMCRAH   | —        | 未更新（未在正常传输模式下使用）                         |
| DMCRB    | —        | 未更新（未在正常传输模式下使用）                         |

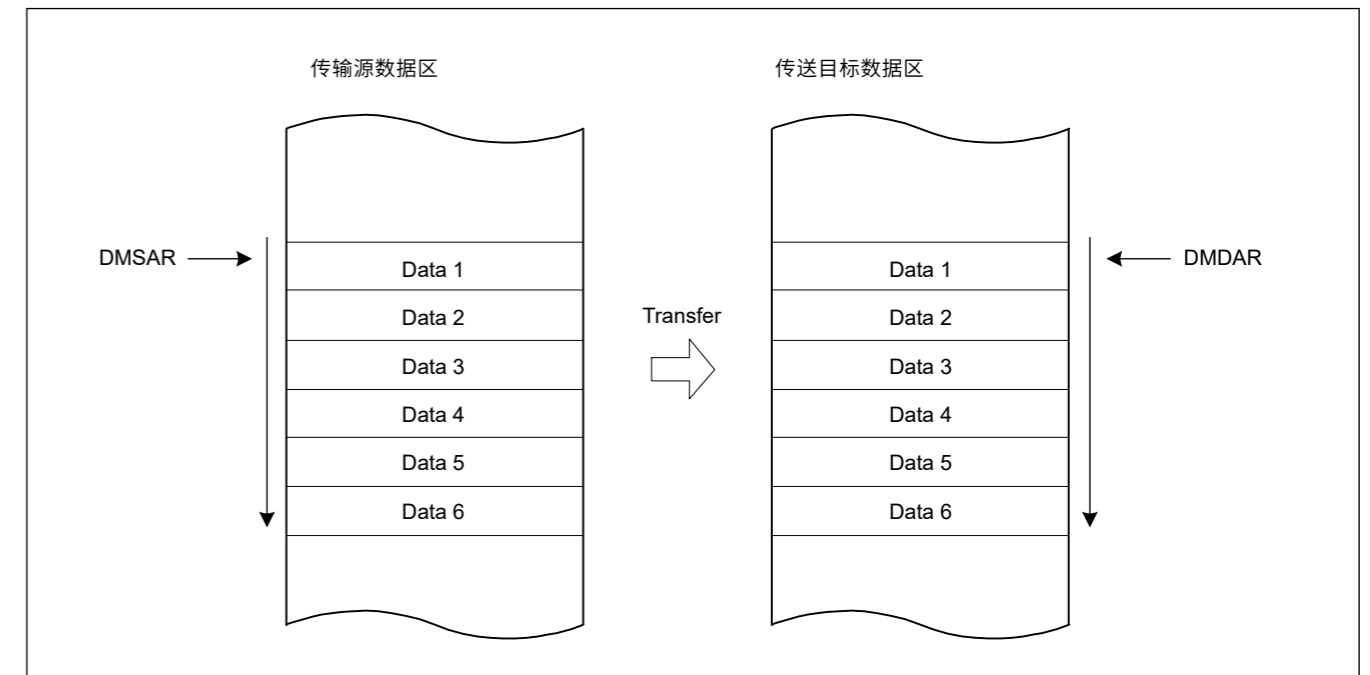


Figure 16.2 正常传输模式下的操作

##### 16.3.1.2 重复传输模式

在重复传输模式下，一个数据由一个传输请求传输。

使用DMCRA寄存器最多可以将1K数据设置为总重复传输大小。

使用DMCRB寄存器最多可以设置64K作为重复传输操作的次数；因此，最多可以将64M数据（1K数据×64K重复传输操作计数）设置为总数据传输大小。

Either the transfer source or transfer destination can be specified as a repeat area. When transfer of the repeat size data is completed, the address of the specified repeat area (DMSAR or DMDAR) returns to the transfer start address. When data of the specified repeat size has all been transferred in repeat transfer mode, DMA transfer can be stopped and the repeat size end interrupt can be requested. DMA transfer can be resumed by writing 1 to the DMCNT.DTE bit in the repeat size end interrupt handling.

A transfer end interrupt request can be generated after completion of the specified number of repeat transfer operations.

Table 16.6 summarizes the register update operation in repeat transfer mode, and Figure 16.3 shows the operation in repeat transfer mode.

Table 16.6 Register Update Operation in Repeat Transfer Mode

| Register | Function                             | Update Operation after Completion of a Transfer by One Transfer Request |   |
|----------|--------------------------------------|---|---|
|          |                                      | When DMCRAL register is not 1   | When DMCRAL register is 1 (Transfer of the Last Data in Repeat Size)  |
| DMSAR    | Transfer source address              | Increment/decrement/fixd/offset addition                                | <ul style="list-style-type: none"> <li>DMTMD.DTS[1:0] = 00b<br/>Increment/decrement/fixd/offset addition</li> <li>DMTMD.DTS[1:0] = 01b<br/>Initial value of DMSAR</li> <li>DMTMD.DTS[1:0] = 10b<br/>Increment/decrement/fixd/offset addition</li> </ul> |
| DMDAR    | Transfer destination address         | Increment/decrement/fixd/offset addition                                | <ul style="list-style-type: none"> <li>DMTMD.DTS[1:0] = 00b<br/>Initial value of DMDAR</li> <li>DMTMD.DTS[1:0] = 01b<br/>Increment/decrement/fixd/offset addition</li> <li>DMTMD.DTS[1:0] = 10b<br/>Increment/decrement/fixd/offset addition</li> </ul> |
| DMCRAH   | Repeat size                          | Not updated   | Not updated   |
| DMCRAL   | Transfer count                       | Decrementd by one   | DMCRAH  |
| DMCRBH   | Number of repeat transfer operations | Not updated   | Not updated   |
| DMCRBL   | Count of repeat transfer operations  | Not updated   | Decrementd by one   |

可以将传输源或传输目标指定为重复区域。当重复大小数据的传输完成时，指定的重复区域（DMSAR或DMDAR）的地址返回到传输起始地址。当指定重复大小的数据在重复传输模式下全部传输完毕后，可以停止DMA传输并请求重复大小结束中断。DMA传输可以通过在重复大小结束中断处理中向DMCNT.DTE位写入1来恢复。

完成指定次数的重复传输操作后，可以产生传输结束中断请求。

表16.6总结了重复传输模式下的寄存器更新操作，图16.3显示了重复传输模式下的操作。

Table 16.6 重复传输模式下的寄存器更新操作

| Register | Function  | 通过一个传输请求完成传输后更新操作                        |  |
|----------|-----------|--|--|
|          |           | 当DMCRAL寄存器不为1时                           | 当DMCRAL寄存器为1时（传输重复大小的最后一个数据）   |
| DMSAR    | 传输源地址     | Increment/decrement/fixd/offset addition | <ul style="list-style-type: none"> <li>DMTMD.DTS[1:0] = 00b<br/>Increment/decrement/fixd/offset addition</li> <li>DMTMD.DTS[1:0] = 01b<br/>DMSAR初始值</li> <li>DMTMD.DTS[1:0] = 10b<br/>Increment/decrement/fixd/offset addition</li> </ul>  |
| DMDAR    | 转移目的地地址   | Increment/decrement/fixd/offset addition | <ul style="list-style-type: none"> <li>DMTMD.DTS[1:0] = 00b<br/>DMDAR的初始值</li> <li>DMTMD.DTS[1:0] = 01b<br/>Increment/decrement/fixd/offset addition</li> <li>DMTMD.DTS[1:0] = 10b<br/>Increment/decrement/fixd/offset addition</li> </ul> |
| DMCRAH   | 重复大小      | 未更新                                      | 未更新  |
| DMCRAL   | 转移计数      | 减一                                       | DMCRAH   |
| DMCRBH   | 重复传输操作数   | 未更新                                      | 未更新  |
| DMCRBL   | 重复传输操作的计数 | 未更新                                      | 减一   |



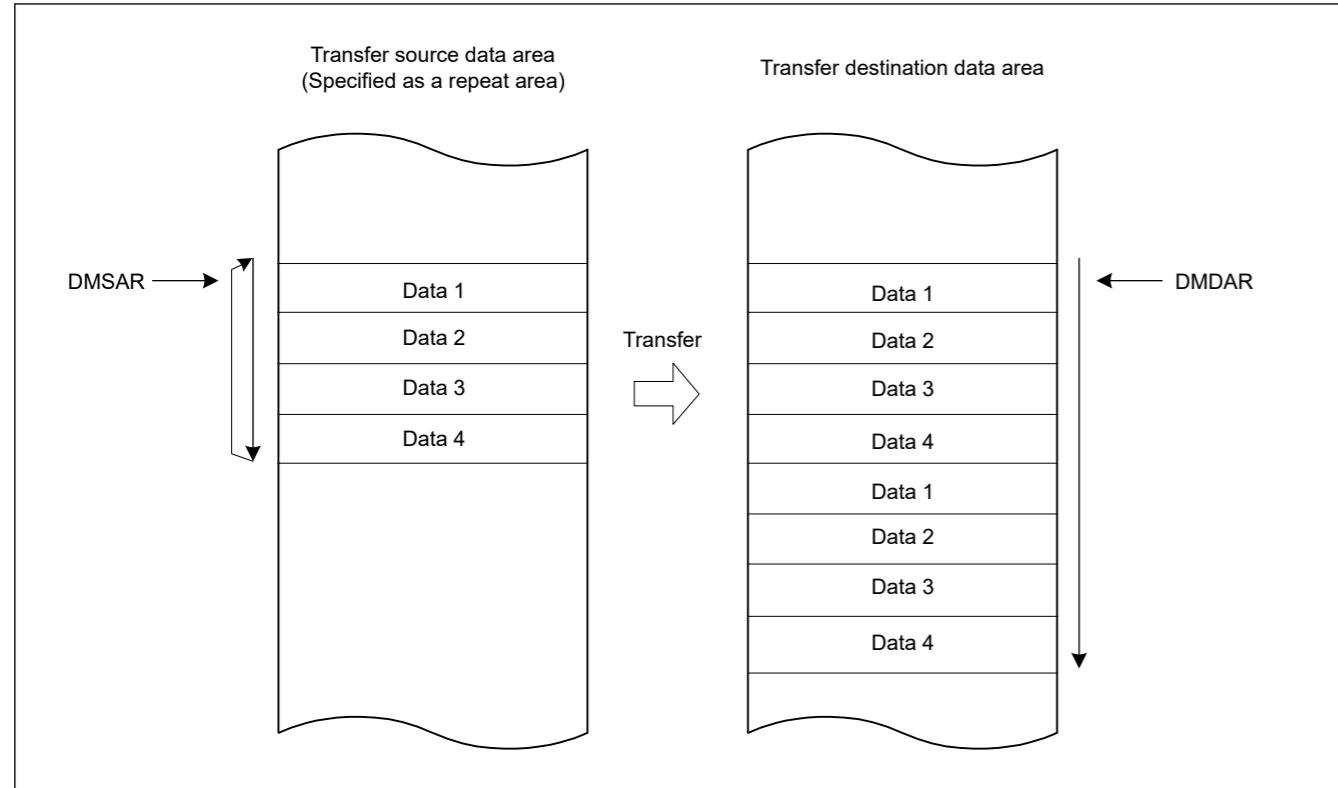


Figure 16.3 Operation in Repeat Transfer Mode

### 16.3.1.3 Block Transfer Mode

In block transfer mode, a single block data is transferred by one transfer request.

A maximum of 1K data can be set as a total block transfer size using DMCRA register.

A maximum of 64K can be set as the number of block transfer operations using DMCRB register; therefore, a maximum of 64M data (1K data × 64K counts of block transfer operations) can be set as a total data transfer size.

Either the transfer source or transfer destination can be specified as a block area. When transfer of a single block data is completed, the address of the specified block area (DMSAR or DMDAR) returns to the transfer start address. When a single block data has all been transferred in block transfer mode, DMA transfer can be stopped and the repeat size end interrupt can be requested. DMA transfer can be resumed by writing 1 to the DMCNT.DTE bit in the repeat size end interrupt handling.

Transfer end interrupt request can be generated after completion of the specified number of block transfer operations.

Table 16.7 summarizes the register update operation in block transfer mode, and Figure 16.4 shows the operation in block transfer mode.

Table 16.7 Register Update Operation in Block Transfer Mode (1 of 2)

| Register | Function                     | Update Operation after Completion of Single-Block Transfer by One Transfer Request  |
|----------|------------------------------|---|
| DMSAR    | Transfer source address      | <ul style="list-style-type: none"> <li>DMTMD.DTS[1:0] = 00b<br/>Increment/decrement/fixed/offset addition</li> <li>DMTMD.DTS[1:0] = 01b<br/>Initial value of DMSAR</li> <li>DMTMD.DTS[1:0] = 10b<br/>Increment/decrement/fixed/offset addition</li> </ul> |
| DMDAR    | Transfer destination address | <ul style="list-style-type: none"> <li>DMTMD.DTS[1:0] = 00b<br/>Initial value of DMDAR</li> <li>DMTMD.DTS[1:0] = 01b<br/>Increment/decrement/fixed/offset addition</li> <li>DMTMD.DTS[1:0] = 10b<br/>Increment/decrement/fixed/offset addition</li> </ul> |

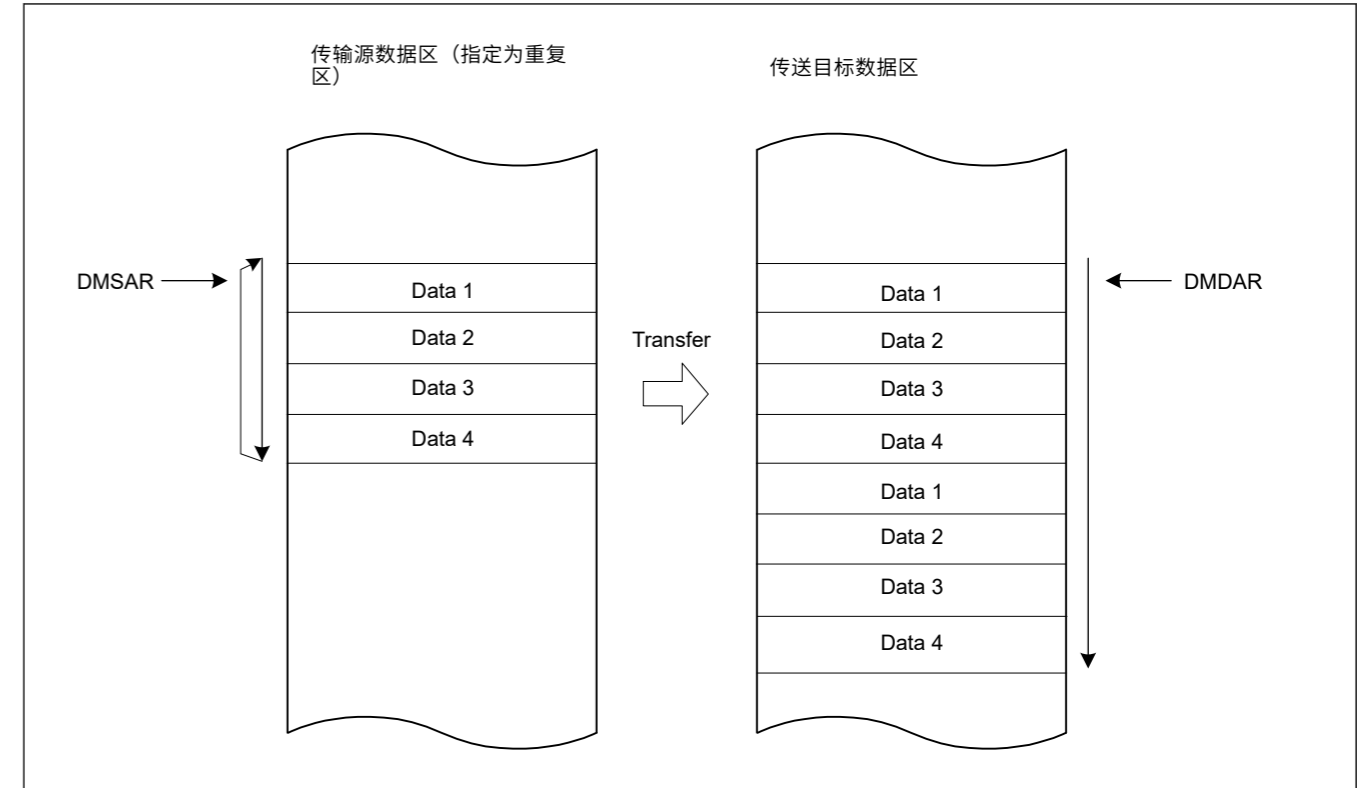


Figure 16.3 重复传输模式下的操作

### 16.3.1.3 块传输模式

在块传输模式下，单个块数据由一个传输请求传输。

使用DMCRA寄存器最多可以将1K数据设置为总块传输大小。

使用DMCRB寄存器最多可以设置64K作为块传输操作的数量；因此，最多可以将64M数据（1K数据×64K块传输操作计数）设置为总数据传输大小。

可以将传输源或传输目标指定为块区域。当单个块数据的传输完成时，指定块区域（DMSAR或DMDAR）的地址返回到传输起始地址。在块传输模式下，当单个块数据已全部传输完毕后，可以停止DMA传输并请求重复大小结束中断。DMA传输可以通过在重复大小结束中断处理中向DMCNT.DTE位写入1来恢复。

在完成指定数量的块传输操作后，可以产生传输结束中断请求。

表16.7总结了块传输模式下的寄存器更新操作，图16.4显示了块传输模式下的操作。

Table 16.7 块传输模式下的寄存器更新操作 (1 of 2)

| Register | Function | 一次传输完成单块传输后的更新操作 Request   |
|----------|----------|--|
| DMSAR    | 传输源地址    | <ul style="list-style-type: none"> <li>DMTMD.DTS[1:0] = 00b<br/>Increment/decrement/fixed/offset addition</li> <li>DMTMD.DTS[1:0] = 01b<br/>DMSAR初始值</li> <li>DMTMD.DTS[1:0] = 10b<br/>Increment/decrement/fixed/offset addition</li> </ul>  |
| DMDAR    | 转移目的地地址  | <ul style="list-style-type: none"> <li>DMTMD.DTS[1:0] = 00b<br/>DMDAR的初始值</li> <li>DMTMD.DTS[1:0] = 01b<br/>Increment/decrement/fixed/offset addition</li> <li>DMTMD.DTS[1:0] = 10b<br/>Increment/decrement/fixed/offset addition</li> </ul> |

Table 16.7 Register Update Operation in Block Transfer Mode (2 of 2)

| Register | Function                            | Update Operation after Completion of Single-Block Transfer by One Transfer Request |
|----------|-------------------------------------|--|
| DMCRAH   | Block size                          | Not updated  |
| DMCRAL   | Transfer count                      | DMCRAH   |
| DMCRBH   | Number of block transfer operations | Not updated  |
| DMCRBL   | Count of block transfer operations  | Decremented by one   |

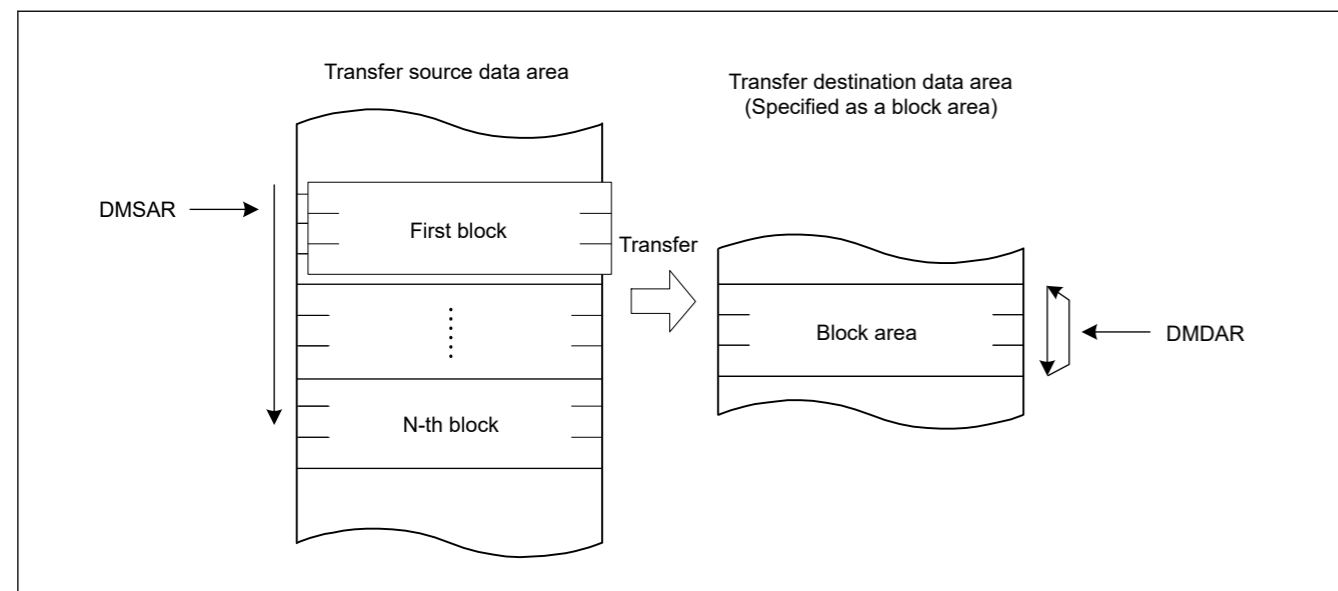


Figure 16.4 Operation in Block Transfer Mode

#### 16.3.1.4 Repeat-Block Transfer Mode

Repeat-block transfer is the operation mode with the following functions added to the block transfer function.

Repeat function: Added function (ring buffer) to repeat specified address area.

Offset function: Multiple areas with offset can be specified within one block transfer.

The repeat function and the offset function can be used for both the transfer source and the transfer destination of repeat-block transfer.

Figure 16.5 shows an example of adding a repeat function to the transfer destination.

Figure 16.6 shows repeat-block transfer with an offset to the transfer destination.

In repeat-block transfer mode, a single block data is transferred by one transfer request.

A maximum of 1K data can be set as a total block transfer size using DMCRA of the DMACn.

A maximum of 64K can be set as the number of block transfer operations using DMCRB of the DMACn; therefore, a maximum of 64M data (1K data × 64K counts of block transfer operations) can be set as a total data transfer size.

Table 16.7 块传输模式下的寄存器更新操作(2of2)

| Register | Function | 一次传输完成单块传输后的更新操作 Request |
|----------|----------|--------------------------|
| DMCRAH   | 块大小      | 未更新                      |
| DMCRAL   | 转移计数     | DMCRAH                   |
| DMCRBH   | 块传输操作数   | 未更新                      |
| DMCRBL   | 块传输操作的计数 | 减一                       |

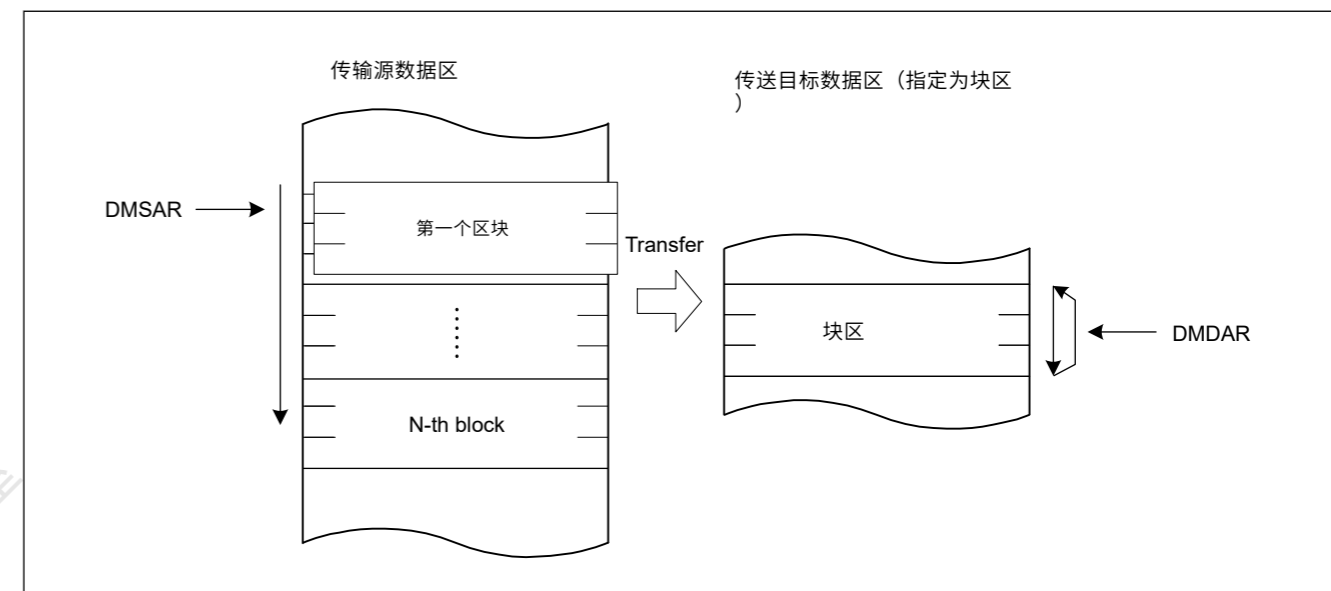


Figure 16.4 块传输模式下的操作

#### 16.3.1.4 重复块传输模式

重复块传输是在块传输功能中添加了以下功能的操作模式。

重复功能：增加了重复指定地址区域的功能（环形缓冲区）。

偏移功能：在一次块传输中可以指定多个带偏移的区域。

重复块传输的传输源和传输目标都可以使用重复函数和偏移函数。

图16.5显示了向传输目的地添加重复功能的示例。

图16.6显示了到传输目标的偏移量的重复块传输。

在重复块传输模式中，单个块数据由一个传输请求传输。

使用DMACn的DMCRA可以将最大1K数据设置为总块传输大小。

使用DMACn的DMCRB最多可以设置64K作为块传输操作的数量；因此，最多可以将64M数据（1K数据×64K块传输操作计数）设置为总数据传输大小。

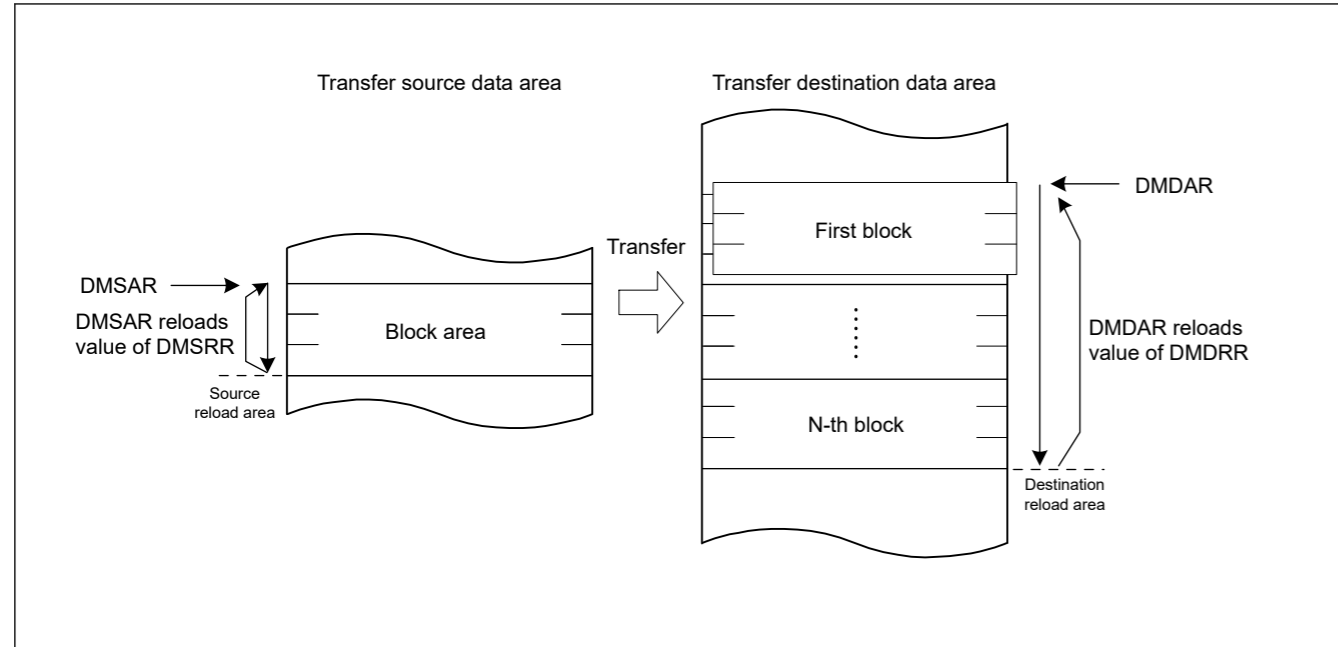


Figure 16.5 Operation in Repeat Block Transfer Mode

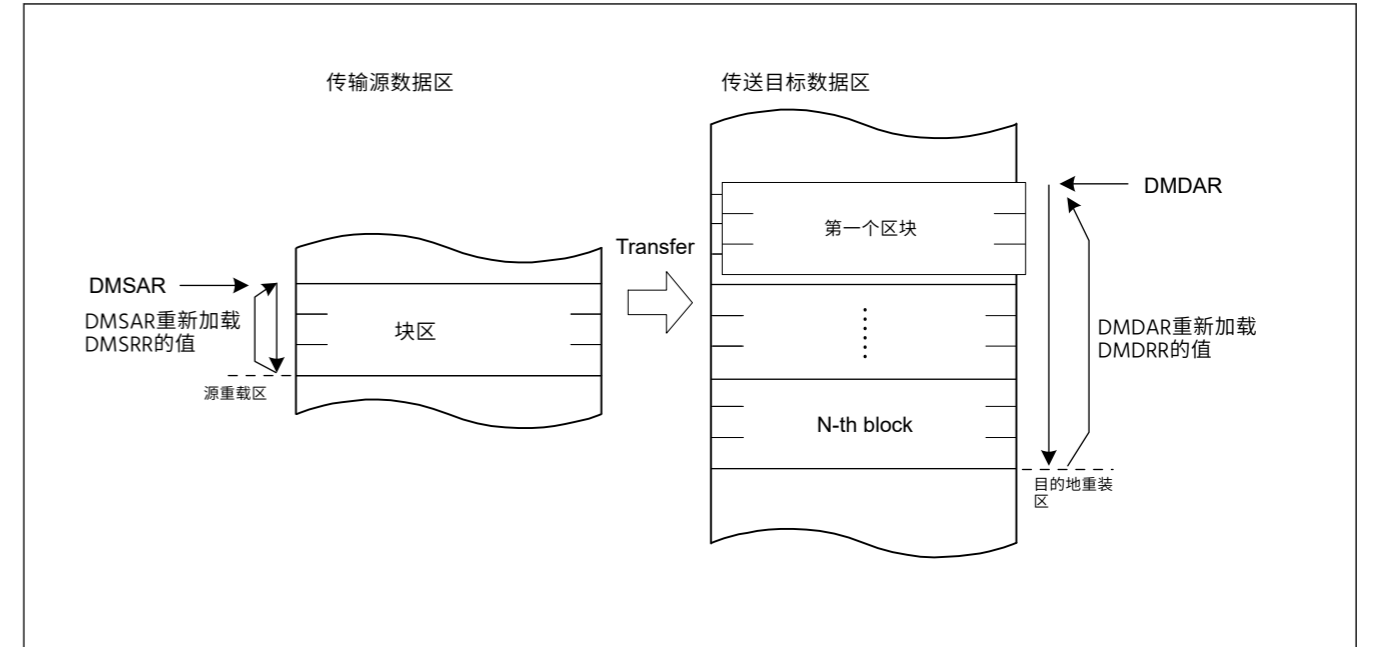


Figure 16.5 重复块传输模式下的操作

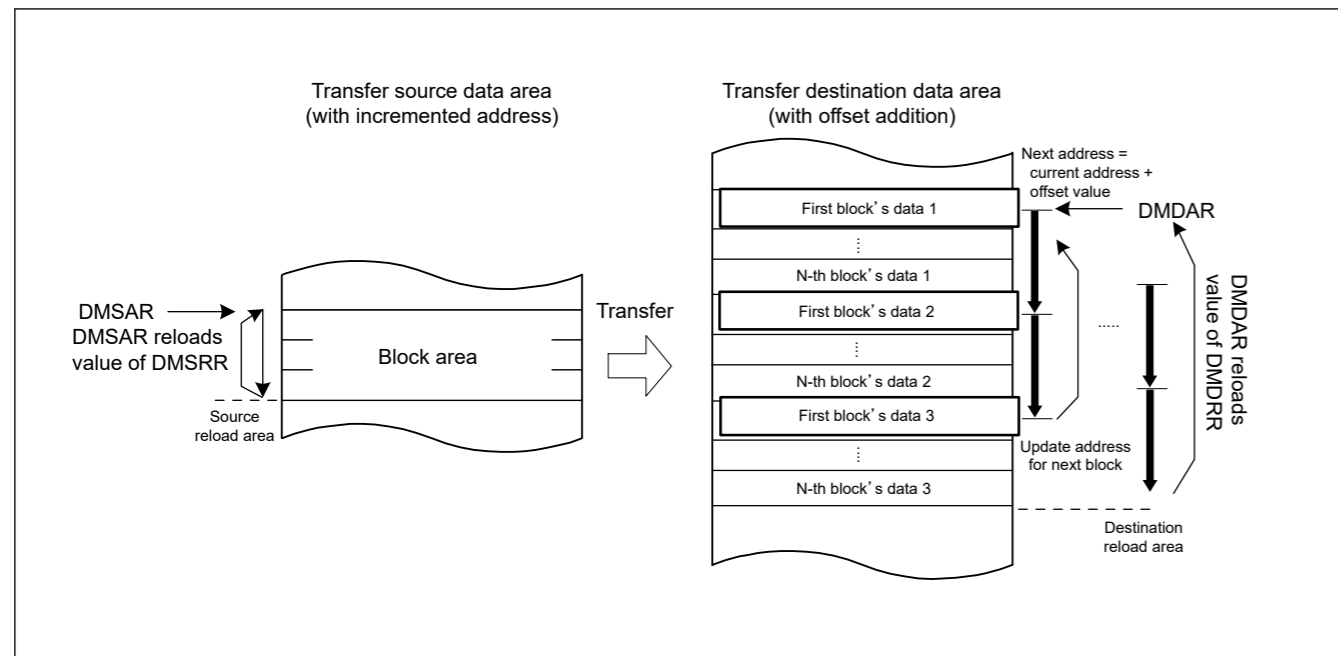


Figure 16.6 Operation in Repeat-Block Transfer Mode with offset addition

Table 16.8 to Table 16.13 summarize the register update operations in repeat-block transfer mode.

Table 16.8 Register Update Operation associated with source area in Repeat-Block Transfer Mode (Fixed address DMAMD.SM[1:0] = 00b) (1 of 2)

| Register    | Function                       | Update operation after single data is transferred |   |                   |
|-------------|--------------------------------|---|---|-------------------|
|             |                                | DMCRAL[15:0] is not 1                             | DMCRAL[15:0] is 1 (single block is transferred) |                   |
|             |                                |   | DMCRBL[15:0] is not 1                           | DMCRBL[15:0] is 1 |
| DMSRR       | Transfer source reload address | Not updated                                       | Not updated                                     | Not updated       |
| DMSAR       | Transfer source address        | Not updated                                       | Not updated                                     | Not updated       |
| DMCRAH[9:0] | Block size                     | Not updated                                       | Not updated                                     | Not updated       |

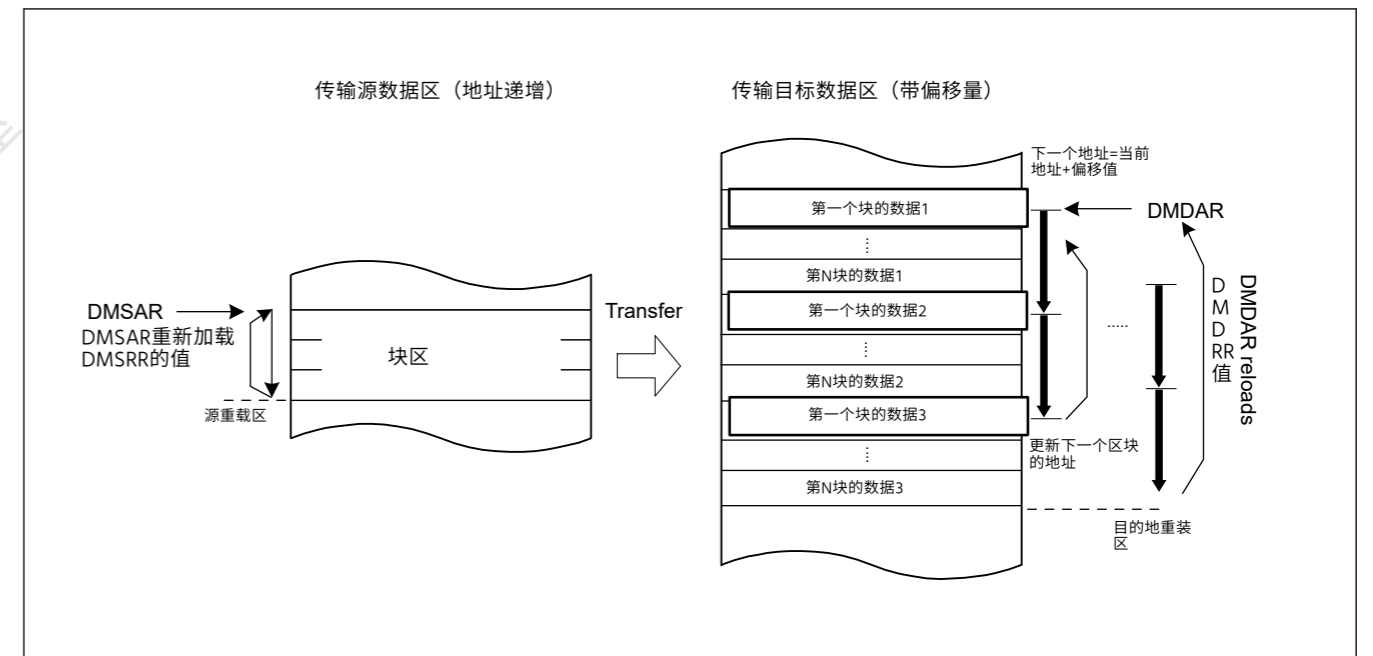


Figure 16.6 带偏移量的重复块传输模式下的操作

表16.8至表16.13总结了重复块传输模式下的寄存器更新操作。

Table 16.8 重复块传输模式下与源区域相关的寄存器更新操作 (固定地址 DMAMD.SM[1:0] = 00b) (1 of 2)

| Register    | Function | 单条数据传输后的更新操作    |                        |                |
|-------------|----------|-----------------|------------------------|----------------|
|             |          | DMCRAL[15:0]不是1 | DMCRAL[15:0]为1 (传输单个块) |                |
|             |          |                 | DMCRBL[15:0]不是1        | DMCRBL[15:0]是1 |
| DMSRR       | 传输源重载地址  | 未更新             | 未更新                    | 未更新            |
| DMSAR       | 传输源地址    | 未更新             | 未更新                    | 未更新            |
| DMCRAH[9:0] | 块大小      | 未更新             | 未更新                    | 未更新            |

**Table 16.8 Register Update Operation associated with source area in Repeat-Block Transfer Mode (Fixed address DMAMD.SM[1:0] = 00b) (2 of 2)**

| Register     | Function  | Update operation after single data is transferred |   |                   |
|--------------|---|---|---|-------------------|
|              |   | DMCRAL[15:0] is not 1                             | DMCRAL[15:0] is 1 (single block is transferred) |                   |
|              |   |   | DMCRBL[15:0] is not 1                           | DMCRBL[15:0] is 1 |
| DMCRAL[15:0] | Block size count                                      | Decrement by 1                                    | DMCRAH[9:0]                                     | DMCRAH[9:0]       |
| DMCRBH[15:0] | Number of block transfer operations                   | Not updated                                       | Not updated                                     | Not updated       |
| DMCRBL[15:0] | Count of block transfer operations when DMTMD.TKP = 0 | Not updated                                       | Decrement by 1                                  | 0                 |
|              | Count of block transfer operations when DMTMD.TKP = 1 |   |   | DMCRBH[15:0]      |

**Table 16.9 Register Update Operation associated with destination area in Repeat-Block Transfer Mode (Fixed address DMAMD.DM[1:0] = 00b)**

| Register     | Function  | Update operation after single data is transferred |   |                   |
|--------------|---|---|---|-------------------|
|              |   | DMCRAL[15:0] is not 1                             | DMCRAL[15:0] is 1 (single block is transferred) |                   |
|              |   |   | DMCRBL[15:0] is not 1                           | DMCRBL[15:0] is 1 |
| DMDRR        | Transfer destination reload address                   | Not updated                                       | Not updated                                     | Not updated       |
| DMDAR        | Transfer destination address                          | Not updated                                       | Not updated                                     | Not updated       |
| DMCRAH[9:0]  | Block size  | Not updated                                       | Not updated                                     | Not updated       |
| DMCRAL[15:0] | Block size count                                      | Decrement by 1                                    | DMCRAH[9:0]                                     | DMCRAH[9:0]       |
| DMCRBH[15:0] | Number of block transfer operations                   | Not updated                                       | Not updated                                     | Not updated       |
| DMCRBL[15:0] | Count of block transfer operations when DMTMD.TKP = 0 | Not updated                                       | Decrement by 1                                  | 0                 |
|              | Count of block transfer operations when DMTMD.TKP = 1 |   |   | DMCRBH[15:0]      |

**Table 16.10 Register Update Operation associated with source area in Repeat-Block Transfer Mode (Incremented or Decrement address DMAMD.SM[1:0] = 10b or 11b) (1 of 2)**

| Register | Function                       | Update operation after single data is transferred |   |                   |                       |   |                   |
|----------|--------------------------------|---|---|-------------------|-----------------------|---|-------------------|
|          |                                | DMSBSL[15:0] is not 1                             |   |                   | DMSBSL[15:0] is 1     |   |                   |
|          |                                | DMCRAL[15:0] is not 1                             | DMCRAL[15:0] is 1 (single block is transferred) |                   | DMCRAL[15:0] is not 1 | DMCRAL[15:0] is 1 (single block is transferred) |                   |
|          |                                |   | DMCRBL[15:0] is not 1                           | DMCRBL[15:0] is 1 |                       | DMCRBL[15:0] is not 1                           | DMCRBL[15:0] is 1 |
| DMSRR    | Transfer source reload address | Not updated                                       | Not updated                                     | Not updated       | Not updated           | Not updated                                     | Not updated       |

**Table 16.8 重复块传输模式下与源区域相关的寄存器更新操作 (固定地址 DMAMD.SM[1:0] = 00b) (2 of 2)**

| Register     | Function             | 单条数据传输后的更新操作    |                        |                   |
|--------------|----------------------|-----------------|------------------------|-------------------|
|              |                      | DMCRAL[15:0]不是1 | DMCRAL[15:0]为1 (传输单个块) |                   |
|              |                      |                 | DMCRBL[15:0]不是1        | DMCRBL[15:0] is 1 |
| DMCRAL[15:0] | 块大小计数                | Decrement by 1  | DMCRAH[9:0]            | DMCRAH[9:0]       |
| DMCRBH[15:0] | 块传输操作数               | 未更新             | 未更新                    | 未更新               |
| DMCRBL[15:0] | DMTMD.TKP=0时的块传输操作计数 | 未更新             | Decrement by 1         | 0                 |
|              | DMTMD.TKP=1时的块传输操作计数 |                 |                        | DMCRBH[15:0]      |

**Table 16.9 重复块传输模式下与目标区域相关的寄存器更新操作 (固定地址DMAMD.DM[1:0]=00b)**

| Register     | Function             | 单条数据传输后的更新操作    |                        |                   |
|--------------|----------------------|-----------------|------------------------|-------------------|
|              |                      | DMCRAL[15:0]不是1 | DMCRAL[15:0]为1 (传输单个块) |                   |
|              |                      |                 | DMCRBL[15:0]不是1        | DMCRBL[15:0] is 1 |
| DMDRR        | 传输目的地重载地址            | 未更新             | 未更新                    | 未更新               |
| DMDAR        | 转移目的地地址              | 未更新             | 未更新                    | 未更新               |
| DMCRAH[9:0]  | 块大小                  | 未更新             | 未更新                    | 未更新               |
| DMCRAL[15:0] | 块大小计数                | Decrement by 1  | DMCRAH[9:0]            | DMCRAH[9:0]       |
| DMCRBH[15:0] | 块传输操作数               | 未更新             | 未更新                    | 未更新               |
| DMCRBL[15:0] | DMTMD.TKP=0时的块传输操作计数 | 未更新             | Decrement by 1         | 0                 |
|              | DMTMD.TKP=1时的块传输操作计数 |                 |                        | DMCRBH[15:0]      |

**Table 16.10 与重复块传输模式中的源区域相关的寄存器更新操作 (递增或递减地址DMAMD.SM[1:0]=10b或11b) (1 of 2)**

| Register | Function | 单条数据传输后的更新操作    |                        |                   |                   |                        |                   |
|----------|----------|-----------------|------------------------|-------------------|-------------------|------------------------|-------------------|
|          |          | DMSBSL[15:0]不是1 |                        |                   | DMSBSL[15:0] is 1 |                        |                   |
|          |          | DMCRAL[15:0]不是1 | DMCRAL[15:0]为1 (传输单个块) |                   | DMCRAL[15:0]不是1   | DMCRAL[15:0]为1 (传输单个块) |                   |
|          |          |                 | DMCRBL[15:0]不是1        | DMCRBL[15:0] is 1 |                   | DMCRBL[15:0]不是1        | DMCRBL[15:0] is 1 |
| DMSRR    | 传输源重载地址  | 未更新             | 未更新                    | 未更新               | 未更新               | 未更新                    | 未更新               |

**Table 16.10 Register Update Operation associated with source area in Repeat-Block Transfer Mode (Incremented or Decremented address DMAMD.SM[1:0] = 10b or 11b) (2 of 2)**

| Register     | Function  | Update operation after single data is transferred |   |                |                       |   |              |
|--------------|---|---|---|----------------|-----------------------|---|--------------|
|              |   | DMSBSL[15:0] is not 1                             |   |                | DMSBSL[15:0] is 1     |   |              |
|              |   | DMCRAL[15:0] is not 1                             | DMCRAL[15:0] is 1 (single block is transferred) |                | DMCRAL[15:0] is not 1 | DMCRAL[15:0] is 1 (single block is transferred) |              |
|              |   | DMCRBL[15:0] is not 1                             | DMCRBL[15:0] is 1                               |                | DMCRBL[15:0] is not 1 | DMCRBL[15:0] is 1                               |              |
| DMSAR        | Transfer source address when DMTMD.SM[1:0] = 10b      | Incremented by Data Size                          |   |                | DMSRR                 |   |              |
|              | Transfer source address when DMTMD.SM[1:0] = 11b      | Decrement by Data Size                            |   |                | DMSRR                 |   |              |
| DMCRAH[9:0]  | Block size  | Not updated                                       | Not updated                                     | Not updated    | Not updated           | Not updated                                     | Not updated  |
| DMCRAL[15:0] | Block size count                                      | Decrement by 1                                    | DMCRAH[9:0]                                     | DMCRAH[9:0]    | Decrement by 1        | DMCRAH[9:0]                                     | DMCRAH[9:0]  |
| DMSBSH[15:0] | Source buffer size (Repeat-size)                      | Not updated                                       | Not updated                                     | Not updated    | Not updated           | Not updated                                     | Not updated  |
| DMSBSL[15:0] | Count of transfer data in source buffer               | Decrement by 1                                    | Decrement by 1                                  | Decrement by 1 | DMSBSH                | DMSBSH  | DMSBSH       |
| DMCRBH[15:0] | Number of block transfer operations                   | Not updated                                       | Not updated                                     | Not updated    | Not updated           | Not updated                                     | Not updated  |
| DMCRBL[15:0] | Count of block transfer operations when DMTMD.TKP = 0 | Not updated                                       | Decrement by 1                                  | 0              | Not updated           | Decrement by 1                                  | 0            |
|              | Count of block transfer operations when DMTMD.TKP = 1 |   |   | DMCRBH[15:0]   |                       |   | DMCRBH[15:0] |

**Table 16.11 Register Update Operation associated with destination area in Repeat-Block Transfer Mode (Incremented or Decremented address DMAMD.DM[1:0] = 10b or 11b) (1 of 2)**

| Register | Function                            | Update operation after single data is transferred |   |             |                       |   |             |
|----------|-------------------------------------|---|---|-------------|-----------------------|---|-------------|
|          |                                     | DMDBSL[15:0] is not 1                             |   |             | DMDBSL[15:0] is 1     |   |             |
|          |                                     | DMCRAL[15:0] is not 1                             | DMCRAL[15:0] is 1 (single block is transferred) |             | DMCRAL[15:0] is not 1 | DMCRAL[15:0] is 1 (single block is transferred) |             |
|          |                                     | DMCRBL[15:0] is not 1                             | DMCRBL[15:0] is 1                               |             | DMCRBL[15:0] is not 1 | DMCRBL[15:0] is 1                               |             |
| DMDRR    | Transfer destination reload address | Not updated                                       | Not updated                                     | Not updated | Not updated           | Not updated                                     | Not updated |

**Table 16.10 重复块传输模式中源区域相关的寄存器更新操作 (递增或递减地址DMAMD.SM[1:0]=10b或11b) (2of2)**

| Register     | Function                | 单条数据传输后的更新操作    |                        |                |                 |                        |              |
|--------------|-------------------------|-----------------|------------------------|----------------|-----------------|------------------------|--------------|
|              |                         | DMSBSL[15:0]不是1 |                        |                | DMSBSL[15:0]是1  |                        |              |
|              |                         | DMCRAL[15:0]不是1 | DMCRAL[15:0]为1 (传输单个块) |                | DMCRAL[15:0]不是1 | DMCRAL[15:0]为1 (传输单个块) |              |
|              |                         | DMCRBL[15:0]不是1 | DMCRBL[15:0]是1         |                | DMCRBL[15:0]不是1 | DMCRBL[15:0]是1         |              |
| DMSAR        | DMTMD.SM[1:0]=10b时传输源地址 | 按数据大小递增         |                        |                | DMSRR           |                        |              |
|              | DMTMD.SM[1:0]=11b时传输源地址 | 按数据大小递减         |                        |                | DMSRR           |                        |              |
| DMCRAH[9:0]  | 块大小                     | 未更新             | 未更新                    | 未更新            | 未更新             | 未更新                    | 未更新          |
| DMCRAL[15:0] | 块大小计数                   | Decrement by 1  | DMCRAH[9:0]            | DMCRAH[9:0]    | Decrement by 1  | DMCRAH[9:0]            | DMCRAH[9:0]  |
| DMSBSH[15:0] | 源缓冲区大小 (重复大小)           | 未更新             | 未更新                    | 未更新            | 未更新             | 未更新                    | 未更新          |
| DMSBSL[15:0] | 源缓冲区中的传输数据计数            | Decrement by 1  | Decrement by 1         | Decrement by 1 | DMSBSH          | DMSBSH                 | DMSBSH       |
| DMCRBH[15:0] | 块传输操作数                  | 未更新             | 未更新                    | 未更新            | 未更新             | 未更新                    | 未更新          |
| DMCRBL[15:0] | DMTMD.TKP=0时的块传输操作计数    | 未更新             | Decrement by 1         | 0              | 未更新             | Decrement by 1         | 0            |
|              | DMTMD.TKP=1时的块传输操作计数    |                 |                        | DMCRBH[15:0]   |                 |                        | DMCRBH[15:0] |

**Table 16.11 与重复块传输模式中的目标区域相关的寄存器更新操作 (递增或递减地址DMAMD.DM[1:0]=10b或11b) (1of2)**

| Register | Function  | 单条数据传输后的更新操作    |                        |     |                 |                        |     |
|----------|-----------|-----------------|------------------------|-----|-----------------|------------------------|-----|
|          |           | DMDBSL[15:0]不是1 |                        |     | DMDBSL[15:0]是1  |                        |     |
|          |           | DMCRAL[15:0]不是1 | DMCRAL[15:0]为1 (传输单个块) |     | DMCRAL[15:0]不是1 | DMCRAL[15:0]为1 (传输单个块) |     |
|          |           | DMCRBL[15:0]不是1 | DMCRBL[15:0]是1         |     | DMCRBL[15:0]不是1 | DMCRBL[15:0]是1         |     |
| DMDRR    | 传输目的地重载地址 | 未更新             | 未更新                    | 未更新 | 未更新             | 未更新                    | 未更新 |



**Table 16.11 Register Update Operation associated with destination area in Repeat-Block Transfer Mode (Incremented or Decrement address DMAMD.DM[1:0] = 10b or 11b) (2 of 2)**

| Register     | Function  | Update operation after single data is transferred |   |                |                       |   |              |
|--------------|---|---|---|----------------|-----------------------|---|--------------|
|              |   | DMDBSL[15:0] is not 1                             |   |                | DMDBSL[15:0] is 1     |   |              |
|              |   | DMCRAL[15:0] is not 1                             | DMCRAL[15:0] is 1 (single block is transferred) |                | DMCRAL[15:0] is not 1 | DMCRAL[15:0] is 1 (single block is transferred) |              |
|              |   | DMCRBL[15:0] is not 1                             | DMCRBL[15:0] is 1                               |                | DMCRBL[15:0] is not 1 | DMCRBL[15:0] is 1                               |              |
| DMDAR        | Transfer destination address when DMTMD.DM[1:0] = 10b | Incremented by Data Size                          |   |                | DMDRR                 |   |              |
|              | Transfer destination address when DMTMD.DM[1:0] = 11b | Decrement by Data Size                            |   |                | DMDRR                 |   |              |
| DMCRAH[9:0]  | Block size  | Not updated                                       | Not updated                                     | Not updated    | Not updated           | Not updated                                     | Not updated  |
| DMCRAL[15:0] | Block size count                                      | Decrement by 1                                    | DMCRAH[9:0]                                     | DMCRAH[9:0]    | Decrement by 1        | DMCRAH[9:0]                                     | DMCRAH[9:0]  |
| DMDBSH[15:0] | Destination buffer size (Repeat-size)                 | Not updated                                       | Not updated                                     | Not updated    | Not updated           | Not updated                                     | Not updated  |
| DMDBSL[15:0] | Count of transfer data in destination buffer          | Decrement by 1                                    | Decrement by 1                                  | Decrement by 1 | DMDBSH                | DMDBSH  | DMDBSH       |
| DMCRBH[15:0] | Number of block transfer operations                   | Not updated                                       | Not updated                                     | Not updated    | Not updated           | Not updated                                     | Not updated  |
| DMCRBL[15:0] | Count of block transfer operations when DMTMD.TKP = 0 | Not updated                                       | Decrement by 1                                  | 0              | Not updated           | Decrement by 1                                  | 0            |
|              | Count of block transfer operations when DMTMD.TKP = 1 |   |   | DMCRBH[15:0]   |                       |   | DMCRBH[15:0] |

**Table 16.12 Register Update Operation associated with source area in Repeat-Block Transfer Mode (Offset addition DMAMD.SM[1:0] = 01b) (1 of 2)**

| Register | Function                       | DMCRAL[15:0] is not 1 | DMCRAL[15:0] is 1 (single block is transferred) |                   |                       |                   |
|----------|--------------------------------|-----------------------|---|-------------------|-----------------------|-------------------|
|          |                                |                       | DMSBSL[15:0] is not 1                           |                   | DMSBSL[15:0] is 1     |                   |
|          |                                |                       | DMCRBL[15:0] is not 1                           | DMCRBL[15:0] is 1 | DMCRBL[15:0] is not 1 | DMCRBL[15:0] is 1 |
| DMSRR    | Transfer source reload address | Not updated           | Not updated                                     | Not updated       | Not updated           | Not updated       |

**Table 16.11 与重复块传输模式中的目标区域相关的寄存器更新操作 (递增或递减地址DMAMD.DM[1:0]=10b或11b) (2of2)**

| Register     | Function                 | 单条数据传输后的更新操作    |                        |                |                   |                        |              |
|--------------|--------------------------|-----------------|------------------------|----------------|-------------------|------------------------|--------------|
|              |                          | DMDBSL[15:0]不是1 |                        |                | DMDBSL[15:0] is 1 |                        |              |
|              |                          | DMCRAL[15:0]不是1 | DMCRAL[15:0]为1 (传输单个块) |                | DMCRAL[15:0]不是1   | DMCRAL[15:0]为1 (传输单个块) |              |
|              |                          | DMCRBL[15:0]不是1 | DMCRBL[15:0] is 1      |                | DMCRBL[15:0]不是1   | DMCRBL[15:0] is 1      |              |
| DMDAR        | DMTMD.DM[1:0]=10b时传输目标地址 | 按数据大小递增         |                        |                | DMDRR             |                        |              |
|              | DMTMD.DM[1:0]=11b时传输目标地址 | 按数据大小递减         |                        |                | DMDRR             |                        |              |
| DMCRAH[9:0]  | 块大小                      | 未更新             | 未更新                    | 未更新            | 未更新               | 未更新                    | 未更新          |
| DMCRAL[15:0] | 块大小计数                    | Decrement by 1  | DMCRAH[9:0]            | DMCRAH[9:0]    | Decrement by 1    | DMCRAH[9:0]            | DMCRAH[9:0]  |
| DMDBSH[15:0] | 目标缓冲区大小 (Repeat-size)    | 未更新             | 未更新                    | 未更新            | 未更新               | 未更新                    | 未更新          |
| DMDBSL[15:0] | 目标缓冲区中的传输数据计数            | Decrement by 1  | Decrement by 1         | Decrement by 1 | DMDBSH            | DMDBSH                 | DMDBSH       |
| DMCRBH[15:0] | 块传输操作数                   | 未更新             | 未更新                    | 未更新            | 未更新               | 未更新                    | 未更新          |
| DMCRBL[15:0] | DMTMD.TKP=0时的块传输操作计数     | 未更新             | Decrement by 1         | 0              | 未更新               | Decrement by 1         | 0            |
|              | DMTMD.TKP=1时的块传输操作计数     |                 |                        | DMCRBH[15:0]   |                   |                        | DMCRBH[15:0] |

**Table 16.12 与重复块传输模式中的源区域相关的寄存器更新操作 (偏移量加法DMAMD.SM[1:0]=01b) (1of2)**

| Register | Function | DMCRAL[15:0]不是1 | DMCRAL[15:0]为1 (传输单个块) |                   |                   |                   |
|----------|----------|-----------------|------------------------|-------------------|-------------------|-------------------|
|          |          |                 | DMSBSL[15:0]不是1        |                   | DMSBSL[15:0] is 1 |                   |
|          |          |                 | DMCRBL[15:0]不是1        | DMCRBL[15:0] is 1 | DMCRBL[15:0]不是1   | DMCRBL[15:0] is 1 |
| DMSRR    | 传输源重载地址  | 未更新             | 未更新                    | 未更新               | 未更新               | 未更新               |

**Table 16.12 Register Update Operation associated with source area in Repeat-Block Transfer Mode (Offset addition DMAMD.SM[1:0] = 01b) (2 of 2)**

| Register     | Function  | DMCRAL[15:0] is not 1     | DMCRAL[15:0] is 1 (single block is transferred) |                   |                                       |                   |
|--------------|---|---------------------------|---|-------------------|---------------------------------------|-------------------|
|              |   |                           | DMSBSL[15:0] is not 1                           |                   | DMSBSL[15:0] is 1                     |                   |
|              |   |                           | DMCRBL[15:0] is not 1                           | DMCRBL[15:0] is 1 | DMCRBL[15:0] is not 1                 | DMCRBL[15:0] is 1 |
| DMSAR        | Transfer source address when DMAMD.SADR = 0           | Offset addition by DMSBSH | DMSRR   |                   | DMSRR                                 |                   |
|              | Transfer source address when DMAMD.SADR = 1           |                           | DMSRR + (DMS-BSH - DMSBSL) × DataSize           |                   | DMSRR + (DMS-BSH - DMSBSL) × DataSize |                   |
| DMCRAH[9:0]  | Block size  | Not updated               | Not updated                                     | Not updated       | Not updated                           | Not updated       |
| DMCRAL[15:0] | Block size count                                      | Decrement by 1            | DMCRAH[9:0]                                     | DMCRAH[9:0]       | DMCRAH[9:0]                           | DMCRAH[9:0]       |
| DMSBSH[15:0] | Source buffer size (Repeat-size)                      | Not updated               | Not updated                                     | Not updated       | Not updated                           | Not updated       |
| DMSBSL[15:0] | Count of transfer data in source buffer               | Not updated               | Decrement by 1                                  | Decrement by 1    | DMSBSH                                | DMSBSH            |
| DMCRBH[15:0] | Number of block transfer operations                   | Not updated               | Not updated                                     | Not updated       | Not updated                           | Not updated       |
| DMCRBL[15:0] | Count of block transfer operations when DMTMD.TKP = 0 | Not updated               | Decrement by 1                                  | 0                 | Decrement by 1                        | 0                 |
|              | Count of block transfer operations when DMTMD.TKP = 1 |                           |   | DMCRBH[15:0]      |                                       | DMCRBH[15:0]      |

**Table 16.13 Register Update Operation associated with destination area in Repeat-Block Transfer Mode (Offset addition DMAMD.DM[1:0] = 01b) (1 of 2)**

| Register     | Function   | DMCRAL[15:0] is not 1     | DMCRAL[15:0] is 1 (single block is transferred) |                   |                                      |                   |
|--------------|--|---------------------------|---|-------------------|--------------------------------------|-------------------|
|              |  |                           | DMDBSL[15:0] is not 1                           |                   | DMDBSL[15:0] is 1                    |                   |
|              |  |                           | DMCRBL[15:0] is not 1                           | DMCRBL[15:0] is 1 | DMCRBL[15:0] is not 1                | DMCRBL[15:0] is 1 |
| DMDRR        | Transfer destination reload address              | Not updated               | Not updated                                     | Not updated       | Not updated                          | Not updated       |
| DMSAR        | Transfer destination address when DMAMD.DADR = 0 | Offset addition by DMDBSH | DMDRR   |                   | DMDRR                                |                   |
|              | Transfer destination address when DMAMD.DADR = 1 |                           | DMDRR + (DMDBSH - DMDBSL) × DataSize            |                   | DMDRR + (DMDBSH - DMDBSL) × DataSize |                   |
| DMCRAH[9:0]  | Block size                                       | Not updated               | Not updated                                     | Not updated       | Not updated                          | Not updated       |
| DMCRAL[15:0] | Block size count                                 | Decrement by 1            | DMCRAH[9:0]                                     | DMCRAH[9:0]       | DMCRAH[9:0]                          | DMCRAH[9:0]       |

**Table 16.12 重复块传输模式中与源区域相关的寄存器更新操作 (偏移量加法DMAMD.SM[1:0]=01b) (2of2)**

| Register     | Function               | DMCRAL[15:0]不是1 | DMCRAL[15:0]为1 (传输单个块)                |                   |                                       |                   |
|--------------|------------------------|-----------------|---------------------------------------|-------------------|---------------------------------------|-------------------|
|              |                        |                 | DMSBSL[15:0]不是1                       |                   | DMSBSL[15:0] is 1                     |                   |
|              |                        |                 | DMCRBL[15:0]不是1                       | DMCRBL[15:0] is 1 | DMCRBL[15:0]不是1                       | DMCRBL[15:0] is 1 |
| DMSAR        | DMAMD.SADR=时传输源地址<br>0 | 偏移量加法<br>DMSBSH | DMSRR                                 |                   | DMSRR                                 |                   |
|              | DMAMD.SADR=时传输源地址<br>1 |                 | DMSRR + (DMS-BSH - DMSBSL) × DataSize |                   | DMSRR + (DMS-BSH - DMSBSL) × DataSize |                   |
| DMCRAH[9:0]  | 块大小                    | 未更新             | 未更新                                   | 未更新               | 未更新                                   | 未更新               |
| DMCRAL[15:0] | 块大小计数                  | Decrement by 1  | DMCRAH[9:0]                           | DMCRAH[9:0]       | DMCRAH[9:0]                           | DMCRAH[9:0]       |
| DMSBSH[15:0] | 源缓冲区大小 (重复大小)          | 未更新             | 未更新                                   | 未更新               | 未更新                                   | 未更新               |
| DMSBSL[15:0] | 源缓冲区中的传输数据计数           | 未更新             | Decrement by 1                        | Decrement by 1    | DMSBSH                                | DMSBSH            |
| DMCRBH[15:0] | 块传输操作数                 | 未更新             | 未更新                                   | 未更新               | 未更新                                   | 未更新               |
| DMCRBL[15:0] | DMTMD.TKP=0时的块传输操作计数   | 未更新             | Decrement by 1                        | 0                 | Decrement by 1                        | 0                 |
|              | DMTMD.TKP=1时的块传输操作计数   |                 |                                       | DMCRBH[15:0]      |                                       | DMCRBH[15:0]      |

**Table 16.13 与重复块传输模式中的目标区域相关的寄存器更新操作 (偏移量加法DMAMD.DM[1:0]=01b) (1of2)**

| Register     | Function                 | DMCRAL[15:0]不是1 | DMCRAL[15:0]为1 (传输单个块)               |                   |                                      |                   |
|--------------|--------------------------|-----------------|--------------------------------------|-------------------|--------------------------------------|-------------------|
|              |                          |                 | DMDBSL[15:0]不是1                      |                   | DMDBSL[15:0] is 1                    |                   |
|              |                          |                 | DMCRBL[15:0]不是1                      | DMCRBL[15:0] is 1 | DMCRBL[15:0]不是1                      | DMCRBL[15:0] is 1 |
| DMDRR        | 传输目的地重载地址                | 未更新             | 未更新                                  | 未更新               | 未更新                                  | 未更新               |
| DMSAR        | 当DMAMD.DADR=时传输目标地址<br>0 | 偏移量加法<br>DMDBSH | DMDRR                                |                   | DMDRR                                |                   |
|              | 当DMAMD.DADR=时传输目标地址<br>1 |                 | DMDRR + (DMDBSH - DMDBSL) × DataSize |                   | DMDRR + (DMDBSH - DMDBSL) × DataSize |                   |
| DMCRAH[9:0]  | 块大小                      | 未更新             | 未更新                                  | 未更新               | 未更新                                  | 未更新               |
| DMCRAL[15:0] | 块大小计数                    | Decrement by 1  | DMCRAH[9:0]                          | DMCRAH[9:0]       | DMCRAH[9:0]                          | DMCRAH[9:0]       |

**Table 16.13 Register Update Operation associated with destination area in Repeat-Block Transfer Mode (Offset addition DMAMD.DM[1:0] = 01b) (2 of 2)**

| Register     | Function  | DMCRAL[15:0] is not 1 | DMCRAL[15:0] is 1 (single block is transferred) |                   |                       |                   |
|--------------|---|-----------------------|---|-------------------|-----------------------|-------------------|
|              |   |                       | DMDBSL[15:0] is not 1                           |                   | DMDBSL[15:0] is 1     |                   |
|              |   |                       | DMCRBL[15:0] is not 1                           | DMCRBL[15:0] is 1 | DMCRBL[15:0] is not 1 | DMCRBL[15:0] is 1 |
| DMDBSH[15:0] | Destination buffer size (Repeat-size)                 | Not updated           | Not updated                                     | Not updated       | Not updated           | Not updated       |
| DMDBSL[15:0] | Count of transfer data in destination buffer          | Not updated           | Decrement by 1                                  | Decrement by 1    | DMDBSH                | DMDBSH            |
| DMCRBH[15:0] | Number of block transfer operations                   | Not updated           | Not updated                                     | Not updated       | Not updated           | Not updated       |
| DMCRBL[15:0] | Count of block transfer operations when DMTMD.TKP = 0 | Not updated           | Decrement by 1                                  | 0                 | Decrement by 1        | 0                 |
|              | Count of block transfer operations when DMTMD.TKP = 1 |                       |   | DMCRBH[15:0]      |                       | DMCRBH[15:0]      |

### 16.3.2 Extended Repeat Area Function

The DMAC supports a function to specify the extended repeat areas on the transfer source and destination addresses. With the extended repeat areas set, the address registers repeatedly indicate the addresses of the specified extended repeat areas.

The extended repeat areas can be specified separately to the transfer source address register (DMSAR) and transfer destination address register (DMDAR).

The extended repeat area on the source address is specified by the DMAMD.SARA[4:0] bits. The extended repeat area on the destination address is specified by the DMAMD.DARA[4:0] bits. The size can be specified separately for the source and destination sides.

However, the area (of transfer source or transfer destination) which is specified as the repeat area or block area should not be specified as the extended repeat area.

When the address register value reaches the end address of the extended repeat area and the extended repeat area overflows, DMA transfer is stopped and an interrupt by an extended repeat area overflow can be requested. When an overflow occurs in the extended repeat area on the transfer source while the DMINT.SARIE bit is set to 1, the DMSTS.ESIF flag is set to 1 and the DMCNT.DTE bit is cleared to 0 to stop DMA transfer. At this time, if the DMINT.ESIE bit is set to 1, an interrupt by an extended repeat area overflow is requested. When the DMINT.DARIE bit is set to 1, the destination address register becomes a target to apply the function. DMA transfer can be resumed by writing 1 to the DMCNT.DTE bit in the interrupt handling.

Figure 16.7 shows an example of the extended repeat area operation.

**Table 16.13 与重复块传输模式中的目标区域相关的寄存器更新操作 (偏移量加法DMAMD.DM[1:0]=01b) (2之2)**

| Register     | Function              | DMCRAL[15:0]不是1 | DMCRAL[15:0]为1 (传输单个块) |                |                 |                |
|--------------|-----------------------|-----------------|------------------------|----------------|-----------------|----------------|
|              |                       |                 | DMDBSL[15:0]不是1        |                | DMDBSL[15:0]是1  |                |
|              |                       |                 | DMCRBL[15:0]不是1        | DMCRBL[15:0]是1 | DMCRBL[15:0]不是1 | DMCRBL[15:0]是1 |
| DMDBSH[15:0] | 目标缓冲区大小 (Repeat-size) | 未更新             | 未更新                    | 未更新            | 未更新             | 未更新            |
| DMDBSL[15:0] | 目标缓冲区中的传输数据计数         | 未更新             | Decrement by 1         | Decrement by 1 | DMDBSH          | DMDBSH         |
| DMCRBH[15:0] | 块传输操作数                | 未更新             | 未更新                    | 未更新            | 未更新             | 未更新            |
| DMCRBL[15:0] | DMTMD.TKP=0时的块传输操作计数  | 未更新             | Decrement by 1         | 0              | Decrement by 1  | 0              |
|              | DMTMD.TKP=1时的块传输操作计数  |                 |                        | DMCRBH[15:0]   |                 | DMCRBH[15:0]   |

### 16.3.2 扩展重复区域功能

DMAC支持在传输源地址和目标地址上指定扩展重复区域的功能。通过设置扩展重复区域，地址寄存器重复指示指定扩展重复区域的地址。

扩展重复区域可以分别指定到传输源地址寄存器(DMSAR)和传输目标地址寄存器(DMDAR)。

源地址上的扩展重复区域由DMAMD.SARA[4:0]位指定。目标地址上的扩展重复区域由DMAMD.DARA[4:0]位指定。可以为源端和目标端分别指定大小。

但是，指定为重复区域或块区域的区域（传输源或传输目的地）不应指定为扩展重复区域。

当地址寄存器值到达扩展重复区的结束地址且扩展重复区溢出时，DMA传输停止并且可以请求由扩展重复区域溢出引起的中断。当DMINT.SARIE位设置为1时传输源上的扩展重复区域发生溢出时，DMSTS.ESIF标志设置为1并且DMCNT.DTE位清零以停止DMA传输。此时，如果DMINT.ESIE位设置为1，则请求由扩展重复区域溢出引起的中断。当DMINT.DARIE位设置为1时，目标地址寄存器成为应用该功能的目标。可以通过在中断处理中向DMCNT.DTE位写入1来恢复DMA传输。

图16.7显示了扩展重复区域操作的示例。

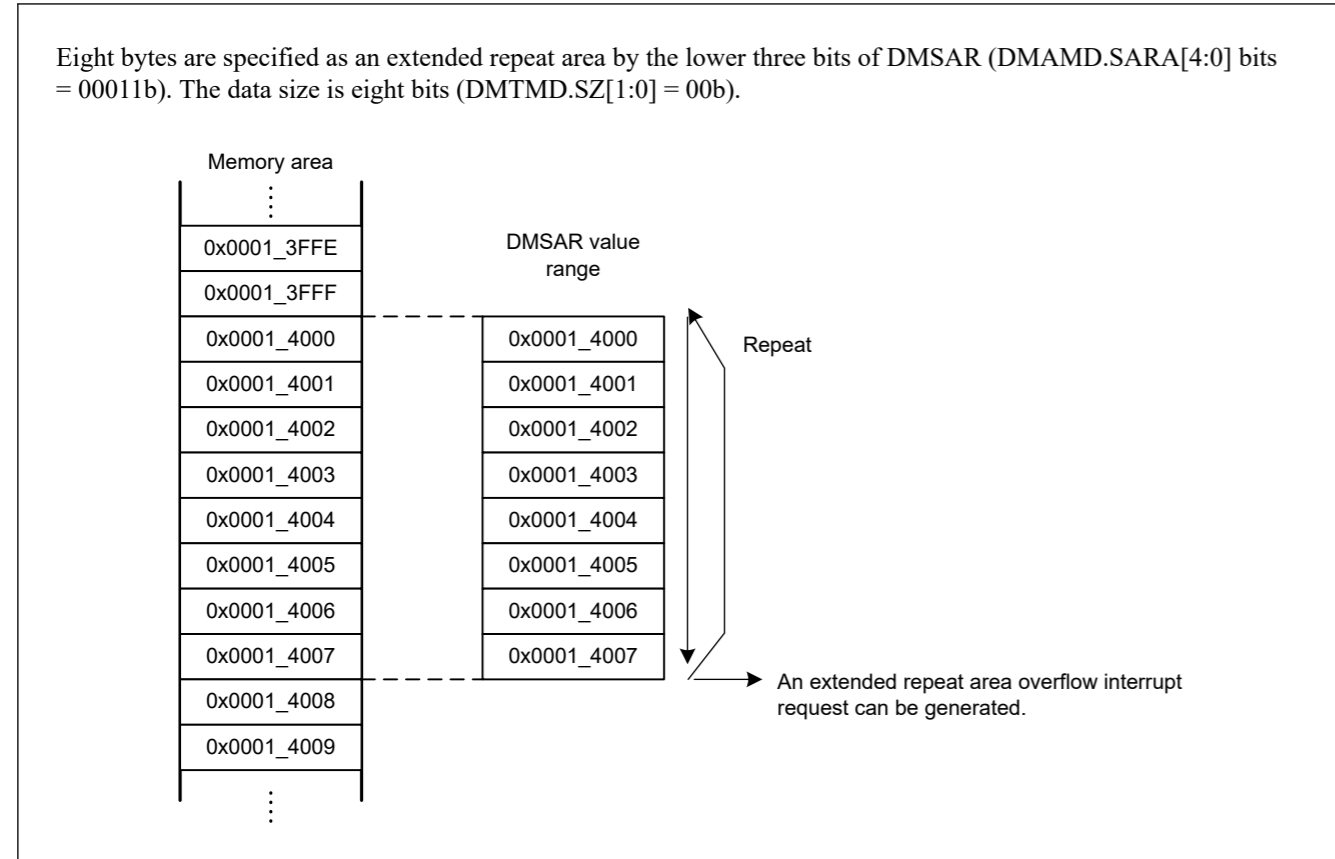


Figure 16.7 Example of Extended Repeat Area Operation

When an interrupt by an extended repeat area overflow is used in block transfer mode, the following should be taken into consideration.

When a transfer is stopped by an interrupt by an extended repeat area overflow, the address register must be set so that the block size is a power of 2 or the block size boundary is aligned with the extended repeat area boundary. When an overflow on the extended repeat area occurs during a transfer of one block, the interrupt by the overflow is suspended until transfer of the block is completed, and the transfer overruns.

Figure 16.8 shows an example when the extended repeat area function is used in block transfer mode.

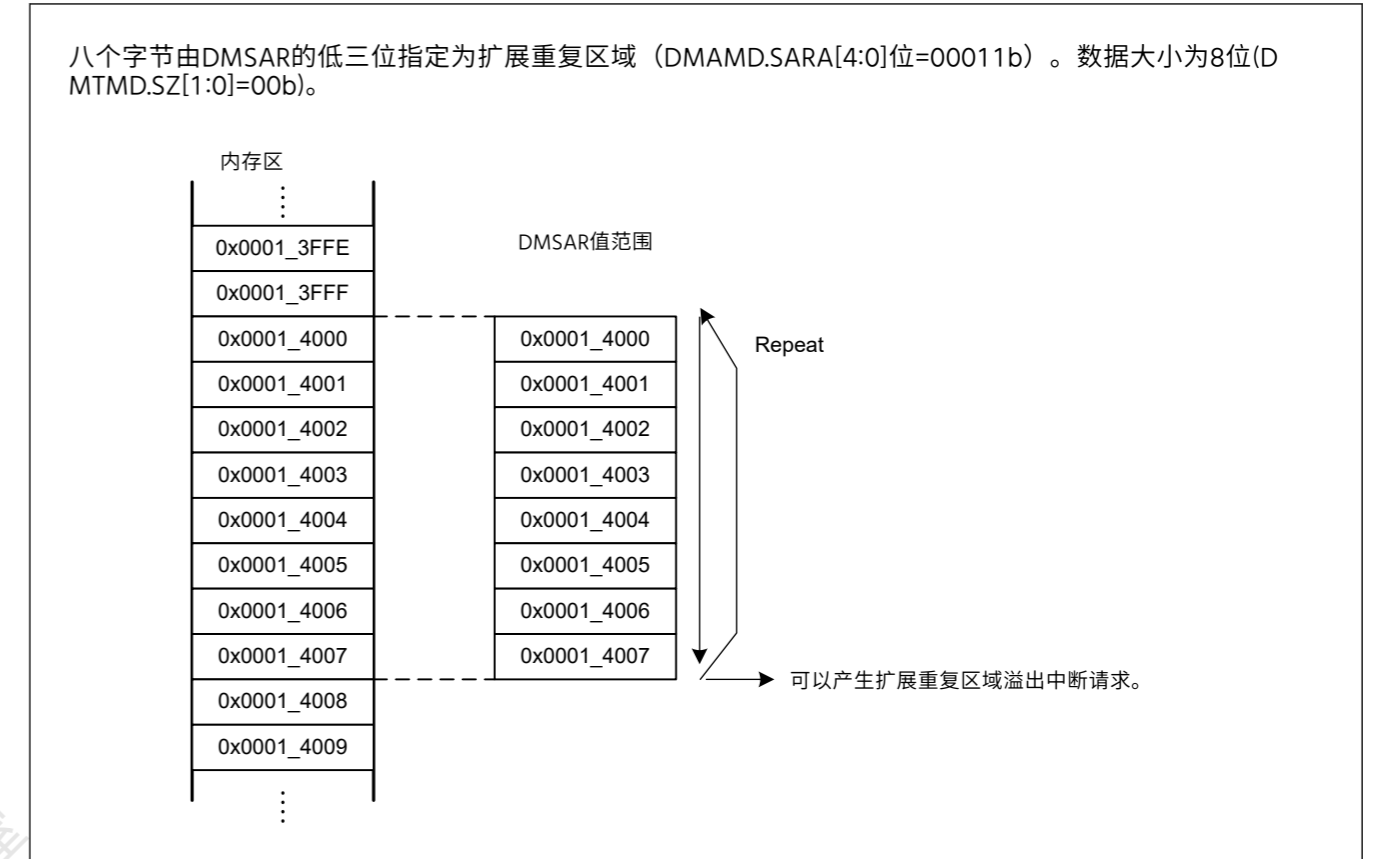


Figure 16.7 扩展重复区域操作示例

在块传输模式下使用扩展重复区域溢出中断时，应考虑以下事项。

当传输因扩展重复区域溢出中断而停止时，地址寄存器必须设置为块大小为2的幂或块大小边界与扩展重复区域边界对齐。当一个块的传输过程中扩展重复区域发生溢出时，溢出的中断被暂停，直到块的传输完成，传输溢出。

图16.8显示了在块传输模式下使用扩展重复区域功能的示例。

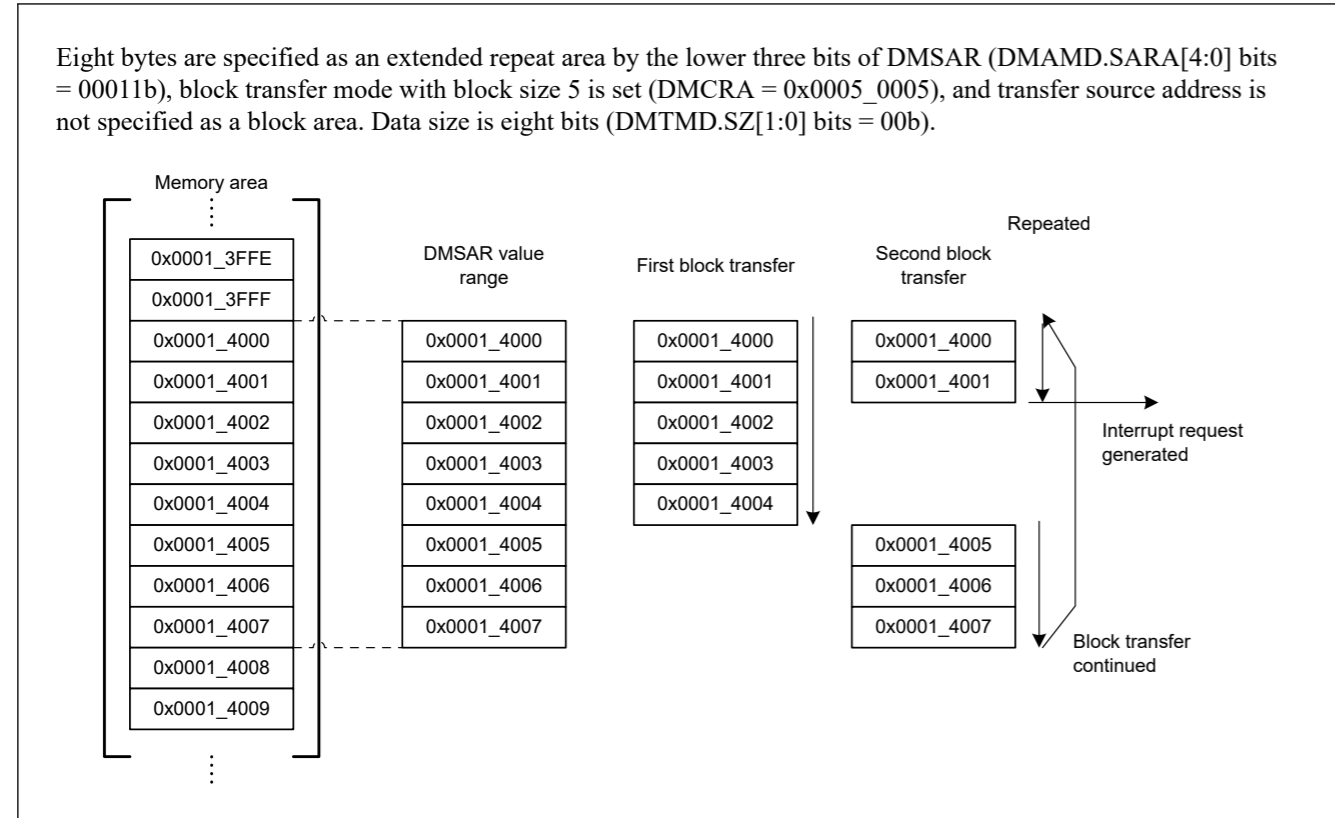


Figure 16.8 Example of Extended Repeat Area Function in Block Transfer Mode

### 16.3.3 Free-running Function

The DMAC supports free-running function. This function allows to transfer repeatedly without reconfiguring in interrupt handler.

#### 16.3.3.1 In Normal Transfer Mode

In normal transfer mode, when DMCRA.DMCRAL bits are set to 0000h, no specific number of transfer operations is set; data transfer is performed with the transfer counter stopped.

For more information, see [section 16.3.1.1. Normal Transfer Mode](#).

#### 16.3.3.2 In Other Transfer Mode

In repeat, block and repeat-block transfer mode, the DMAC supports free-running function using the DMTMD.TKP bit. If the DMTMD.TKP bit is to be set to 1, the transfer is not stopped by completion of specified total number of transfer operations and reloads DMCRBH repeatedly.

Figure 16.9 show an example of block transfer operation without free-running function.

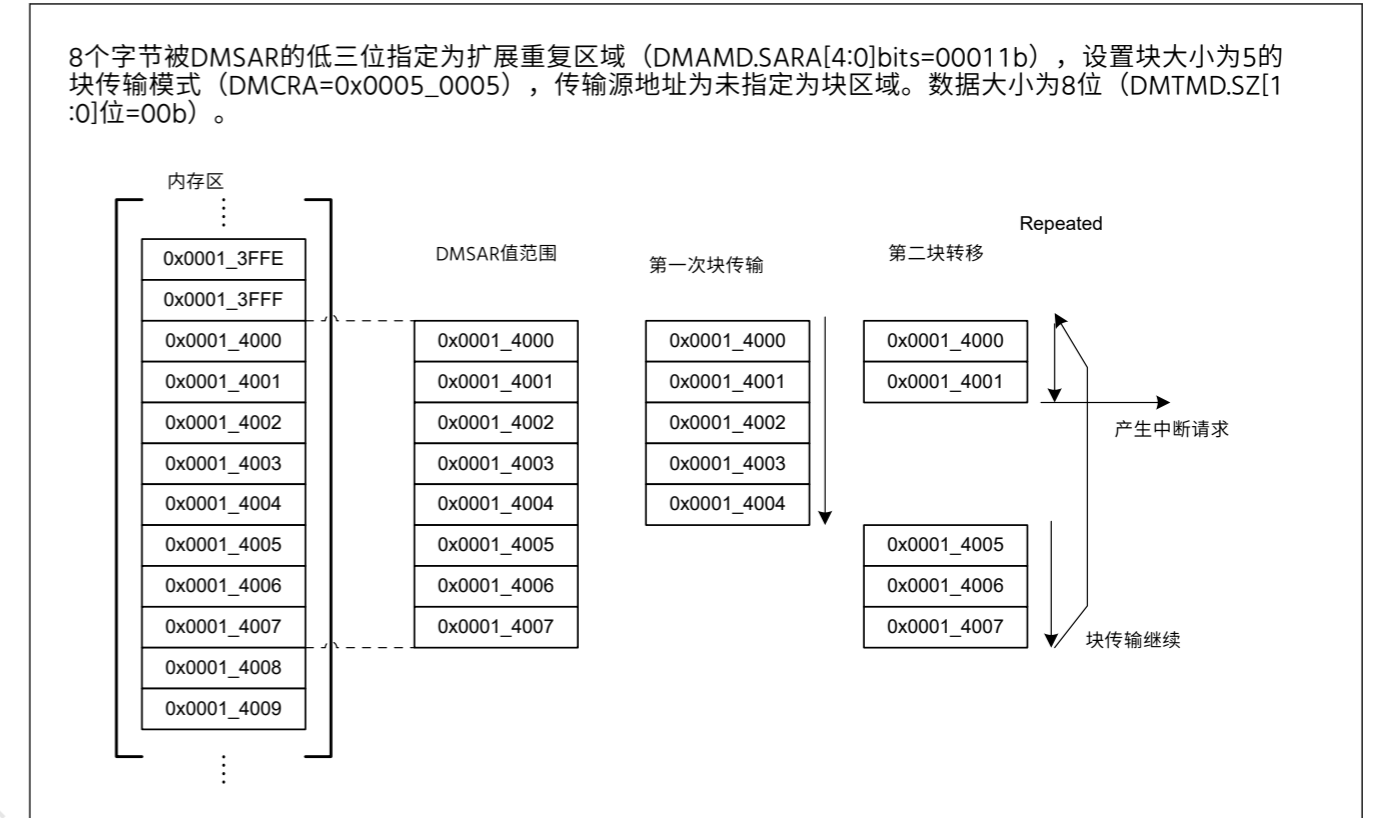


Figure 16.8 块传输模式下的扩展重复区域功能示例

### 16.3.3 Free-running Function

DMAC支持自由运行功能。此功能允许重复传输而无需在中断处理程序中重新配置。

#### 16.3.3.1 在正常传输模式下

在正常传输模式下, 当DMCRA.DMCRAL位设置为0000h时, 不设置具体的传输操作数; 在传输计数器停止的情况下执行数据传输。

有关详细信息, 请参阅第16.3.1.1节。正常传输模式。

#### 16.3.3.2 在其他传输模式下

在重复、块和重复块传输模式下, DMAC使用DMTMD.TKP位支持自由运行功能。如果要设置DMTMD.TKP位为1, 则在完成指定的传输操作总数时不会停止传输并重复重新加载DMCRBH。

图16.9显示了一个没有自由运行功能的块传输操作示例。



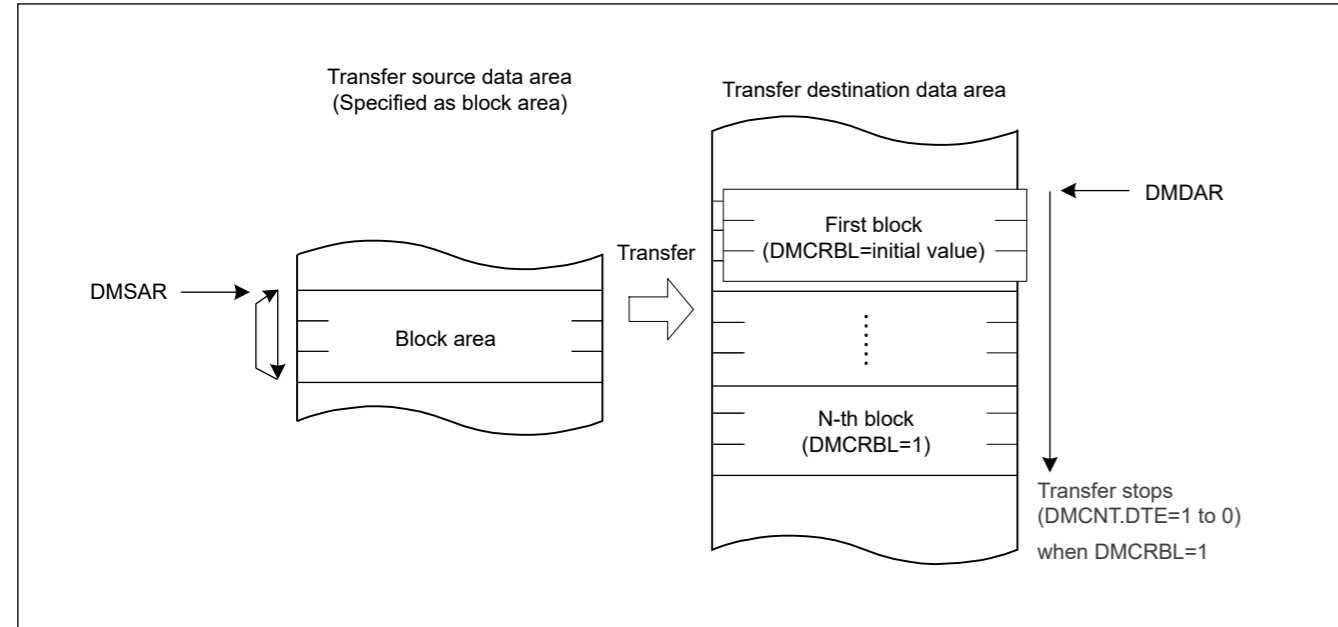


Figure 16.9 Operation in Block Transfer Mode when DMTMD.TKP bit is set to 0

Figure 16.10 show an example of block transfer operation with free-running function.

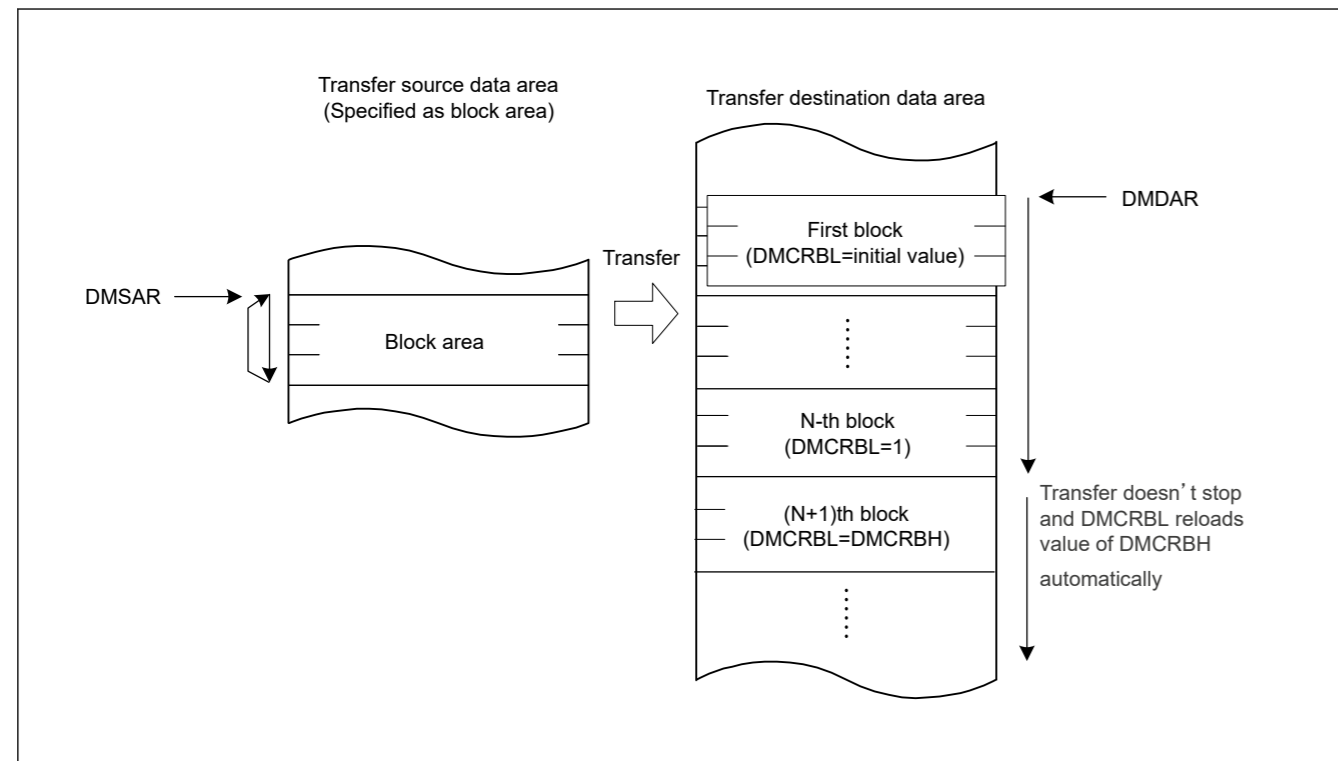


Figure 16.10 Operation in Block Transfer Mode when DMTMD.TKP bit is set to 1

### 16.3.4 Address Update Function using Offset

The source and destination addresses can be updated by fixing, increment, decrement, or offset addition. In normal, repeat and block transfer mode, when the offset addition is selected, the offset specified by the DMA offset register (DMOFR) is added to the address every time the DMAC performs one data transfer. This function realizes a data transfer where addresses are allocated to separated areas.

Offset subtraction can also be realized by setting a negative value in DMOFR. In this case, the negative value must be 2's complement.

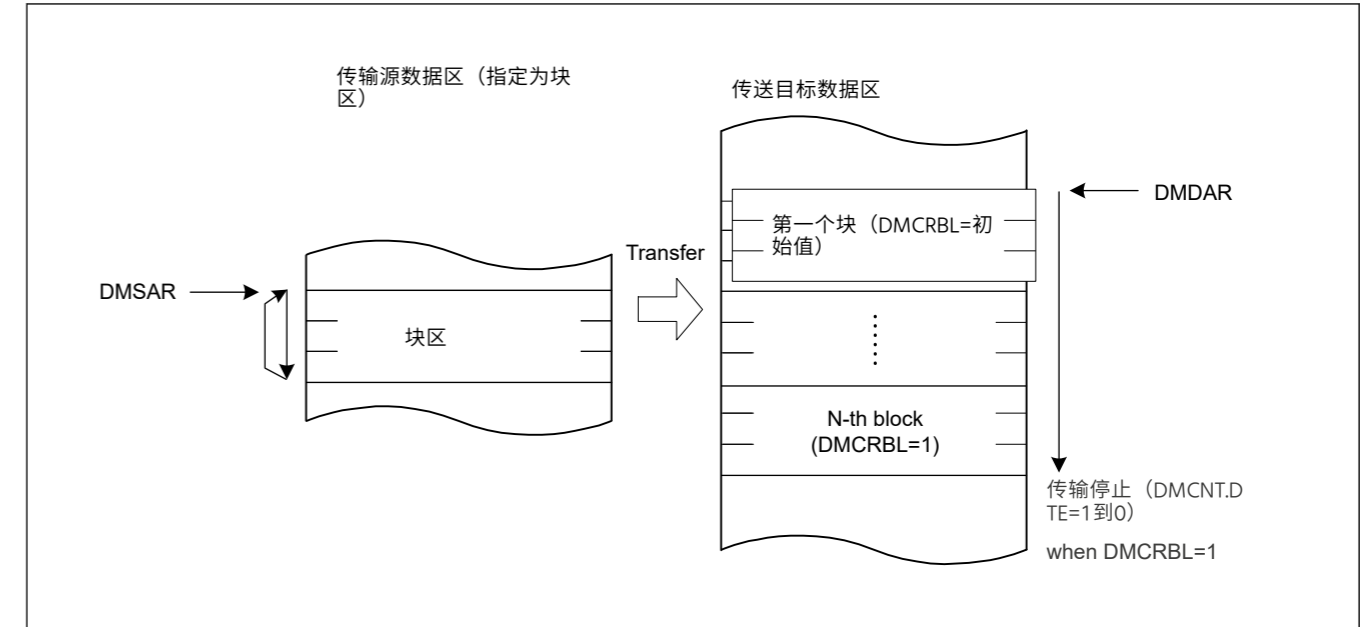


Figure 16.9 DMTMD.TKP位设置为0时块传输模式下的操作

图16.10显示了具有自由运行功能的块传输操作示例。

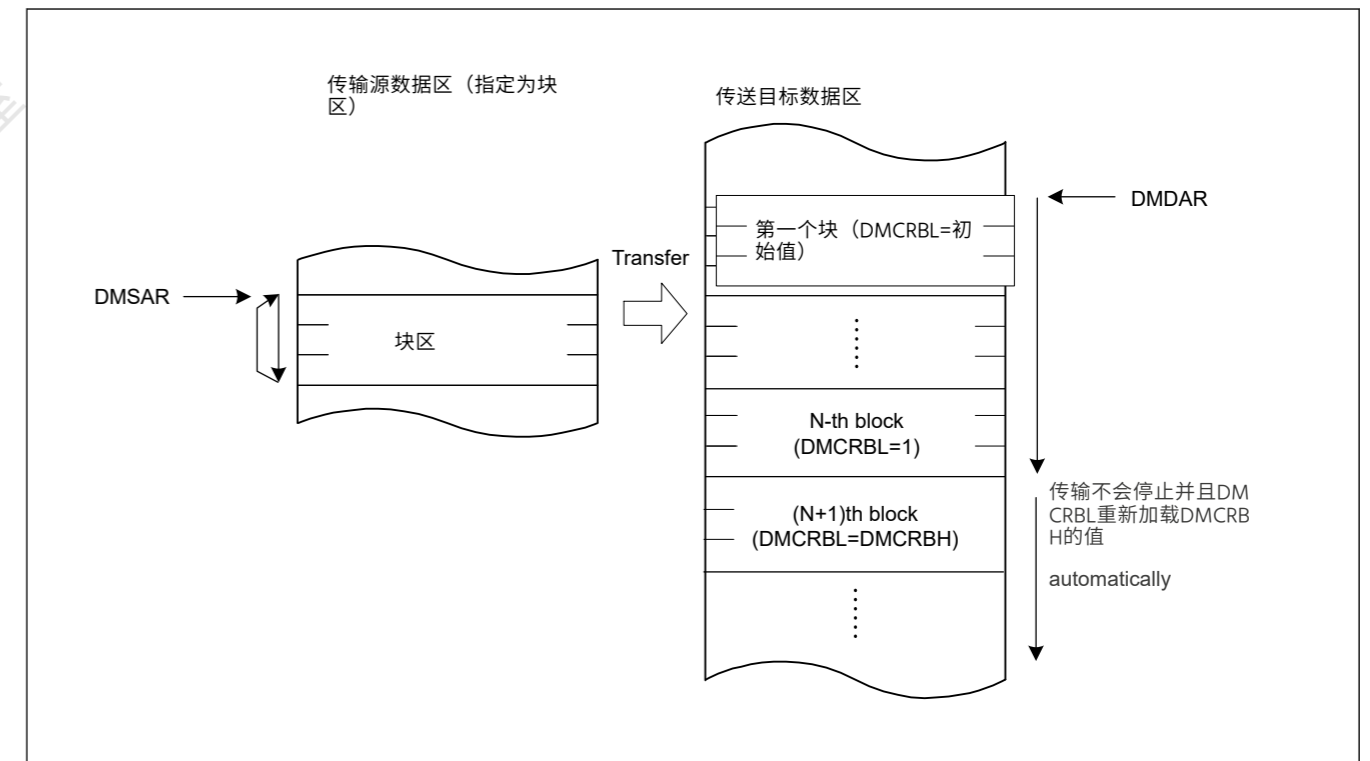


Figure 16.10 DMTMD.TKP位设置为1时块传输模式下的操作

### 16.3.4 使用偏移的地址更新功能

可以通过固定、递增、递减或偏移添加来更新源地址和目标地址。在正常的重复和块传输模式下，选择偏移添加时，每次DMAC执行一个数据传输时，DMA偏移寄存器（DMOFR）指定的偏移量都会添加到地址。该功能实现了将地址分配到不同区域的数据传输。

偏移量减法也可以通过在DMOFR中设置一个负值来实现。在这种情况下，负值必须是2的补码。

DMSBS or DMDBS are used instead of DMOFR in repeat-block transfer mode. For more information [section 16.3.1.4. Repeat-Block Transfer Mode](#)

Table 16.14 shows the address update method in each address update mode.

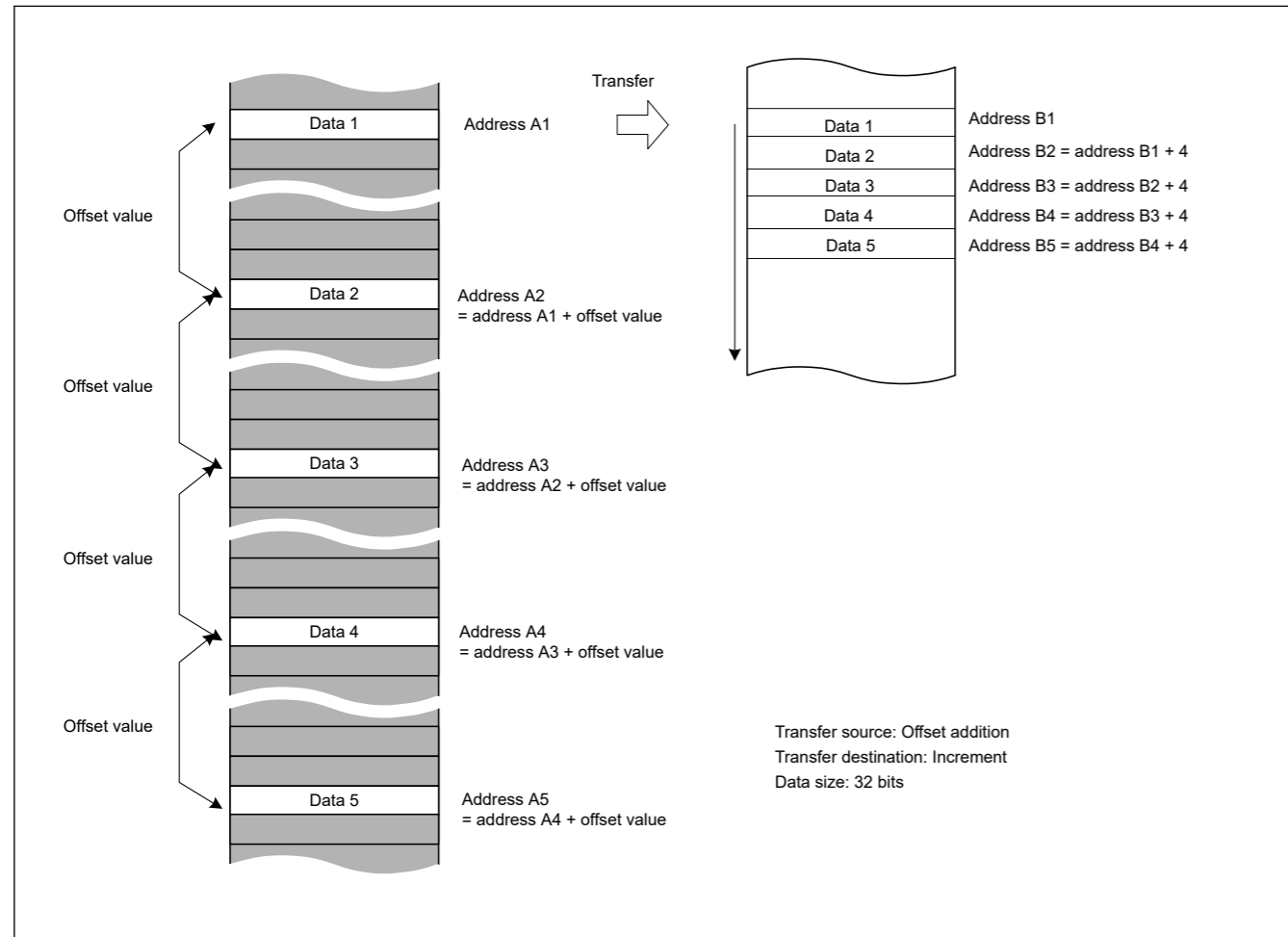
**Table 16.14 Address Update Method in Each Address Update Mode**

| Address Update Mode | Settings of DMAMD.SM[1:0] and DMAMD.DM[1:0] for Address Update Modes | Address Update Method (for Different SZ[1:0] Settings in DMTMD) |               |               |
|---------------------|--|---|---------------|---------------|
|                     |  | SZ[1:0] = 00b   | SZ[1:0] = 01b | SZ[1:0] = 10b |
| Address fixed       | 00b  | Fixed   |               |               |
| Offset addition     | 01b  | +DMOFR*1  |               |               |
| Increment           | 10b  | +1  | +2            | +4            |
| Decrement           | 11b  | -1  | -2            | -4            |

Note 1. When setting a negative value in the DMA Offset Register, the value must be in two's complement, obtained by the following formula:  
two's complement of a negative offset value =  $\sim(\text{offset}) + 1$  ( $\sim$  = bit inversion)

### 16.3.4.1 Basic Transfer Using Offset Addition

Figure 16.11 shows an example of address updating using offset addition.



**Figure 16.11 Example of Address Updating by Offset Addition**

Figure 16.11 shows the setting of the following.

- The transfer data is 32 bits long
- Offset addition is set as the transfer source address update

在重复块传输模式中使用DMSBS或DMDBS代替DMOFR。有关详细信息，请参阅第16.3.1.4节。  
[重复块传输模式](#)

表16.14显示了每种地址更新模式下的地址更新方法。

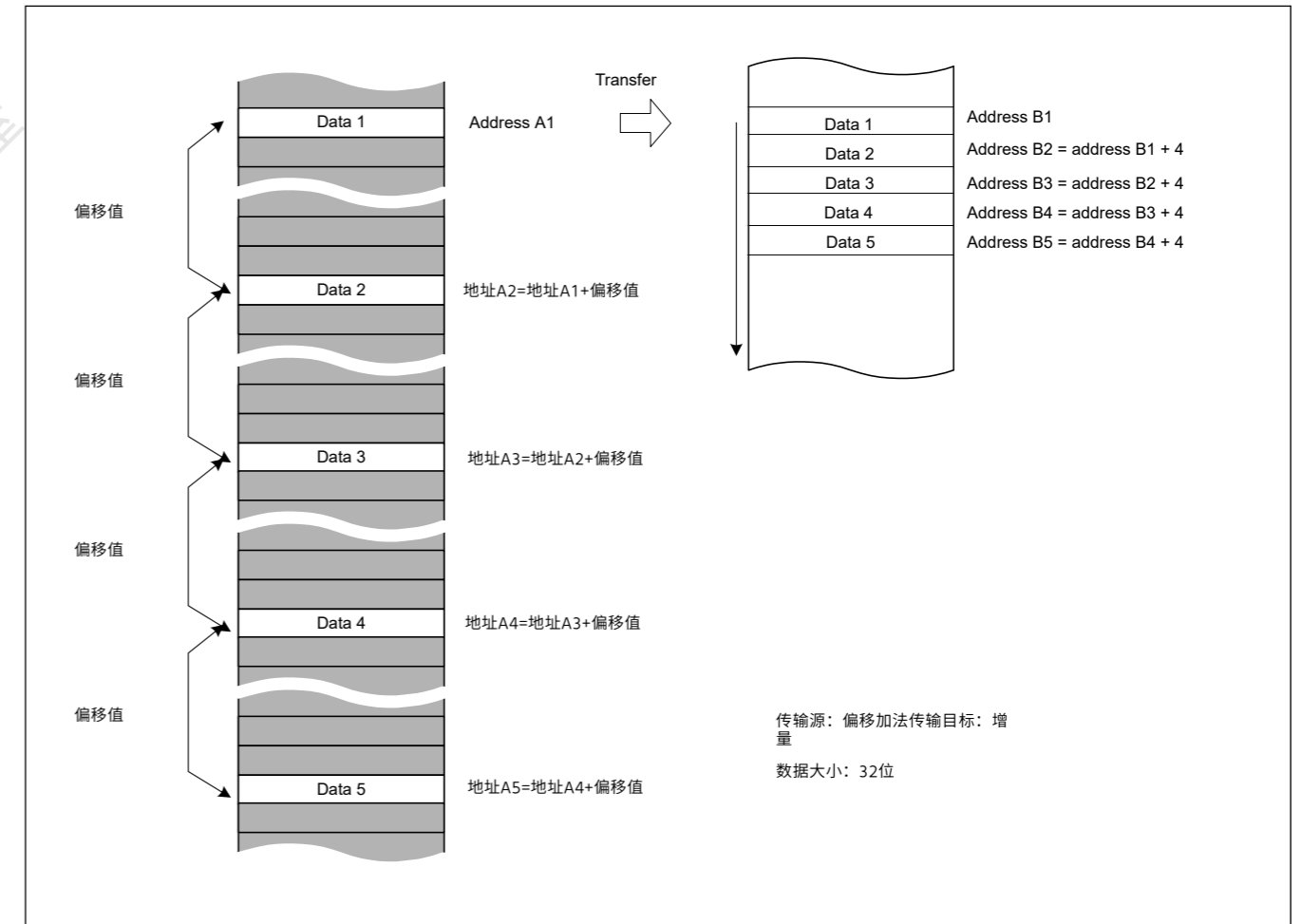
**Table 16.14 各地址更新模式下的地址更新方法**

| 地址更新模式    | DMAMD.SM[1:0]的设置和 DMAMD.DM[1:0]用于地址更新 Modes | 地址更新方法 (针对DMTMD中的不同SZ[1:0]设置) |               |               |
|-----------|---|-------------------------------|---------------|---------------|
|           |   | SZ[1:0] = 00b                 | SZ[1:0] = 01b | SZ[1:0] = 10b |
| 地址固定      | 00b   | Fixed                         |               |               |
| 偏移量加法     | 01b   | +DMOFR*1                      |               |               |
| Increment | 10b   | +1                            | +2            | +4            |
| Decrement | 11b   | -1                            | -2            | -4            |

注1.在DMA偏移寄存器中设置负值时，该值必须是二进制补码，由以下公式获得：负偏移值的二进制补码= $\sim(\text{offset})+1$ ( $\sim$ =bitinversion)

### 16.3.4.1 使用偏移加法的基本传输

图16.11显示了使用偏移量加法进行地址更新的示例。



**Figure 16.11 通过偏移加法更新地址的示例**

图16.11显示了以下设置。

- 传输数据为32位长
- 偏移量加法设置为传输源地址更新

- Increment is set as the transfer destination address update mode

The second and subsequent data is each read from the transfer source address obtained by adding the offset value to the previous address. The data read from the addresses at the specified intervals is written to the continuous locations on the destination.

### 16.3.4.2 Example of XY Conversion Using Offset Addition

Figure 16.12 shows the XY conversion using offset addition in repeat transfer mode.

Settings are as follows:

- DMAMD.SM — Transfer source address update mode: Offset addition
- DMAMD.DM — Transfer destination address update mode: Destination address is incremented.
- DMTMD.SZ — Transfer data size select: 32 bits
- DMTMD.MD — Transfer mode select: Repeat transfer
- DMTMD.DTS — Repeat area select: The source is specified as the repeat area.
- DMOFR — Offset address: 0x10
- DMCRA — Repeat size: 0x4
- DMINT.RPTIE — The repeat size end interrupt is enabled.

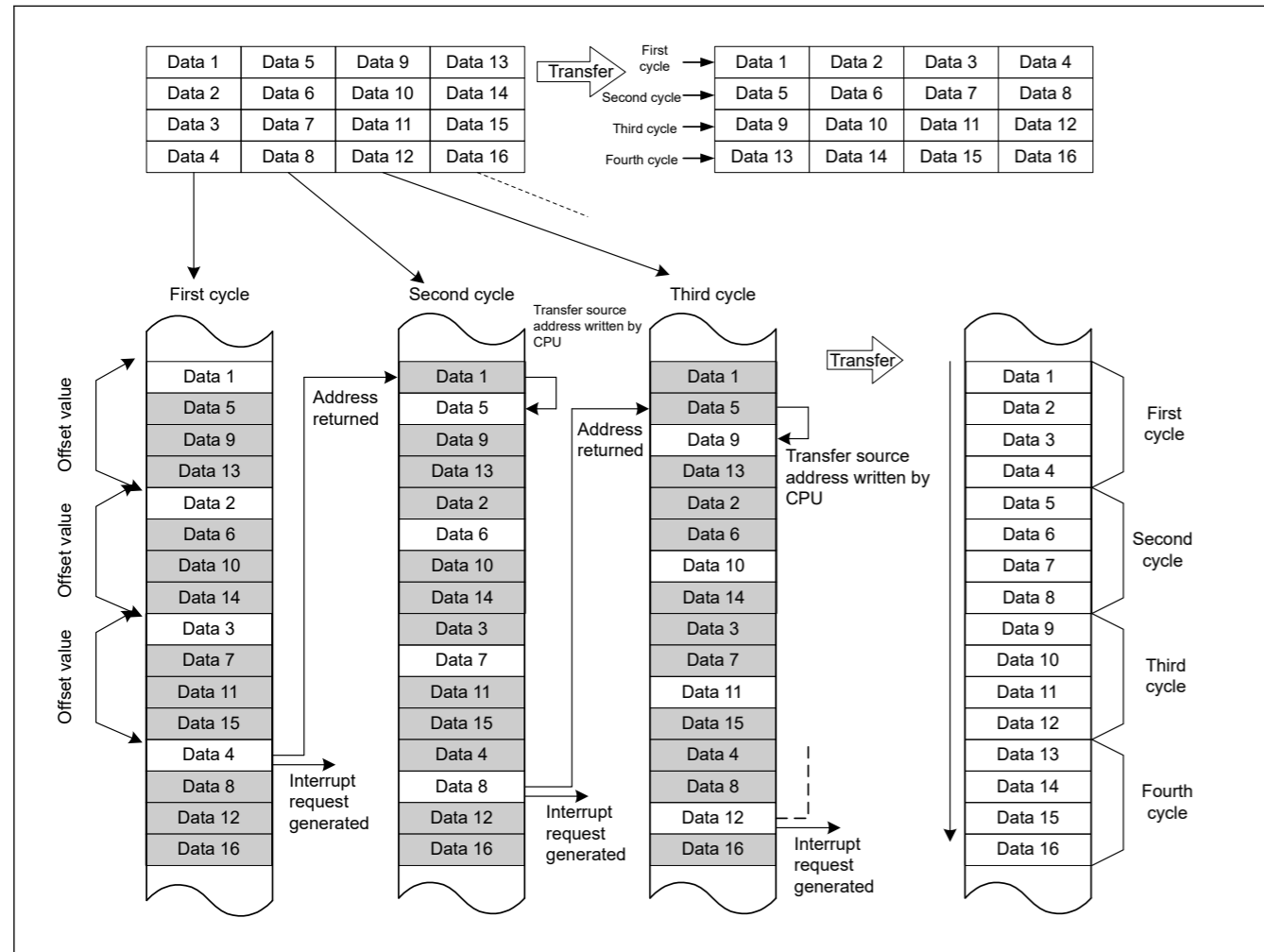


Figure 16.12 XY Conversion Operation Using Offset Addition in Repeat Transfer Mode

When a transfer starts, the offset value is added to the transfer source address every time data is transferred. The transfer data is written to continuous transfer destination addresses. When data 4 is transferred:

- The repeat size of data transfer is complete.

- 增量设置为传输目标地址更新模式

第二个和随后的数据分别从通过将偏移值与前一个地址相加而获得的传输源地址读取。以指定间隔从地址读取的数据被写入目标上的连续位置。

### 16.3.4.2 使用偏移加法的XY转换示例

图16.12显示了在重复传输模式下使用偏移添加的XY转换。

设置如下:

- DMAMD.SM—传输源地址更新模式: 偏移量加法
- DMAMD.DM—传输目标地址更新模式: 目标地址递增。
- DMTMD.SZ—传输数据大小选择: 32位
- DMTMD.MD—传输模式选择: 重复传输
- DMTMD.DTS—重复区域选择: 源被指定为重复区域。
- DMOFR — Offset address: 0x10
- DMCRA — Repeat size: 0x4
- DMINT.RPTIE—启用重复大小结束中断。

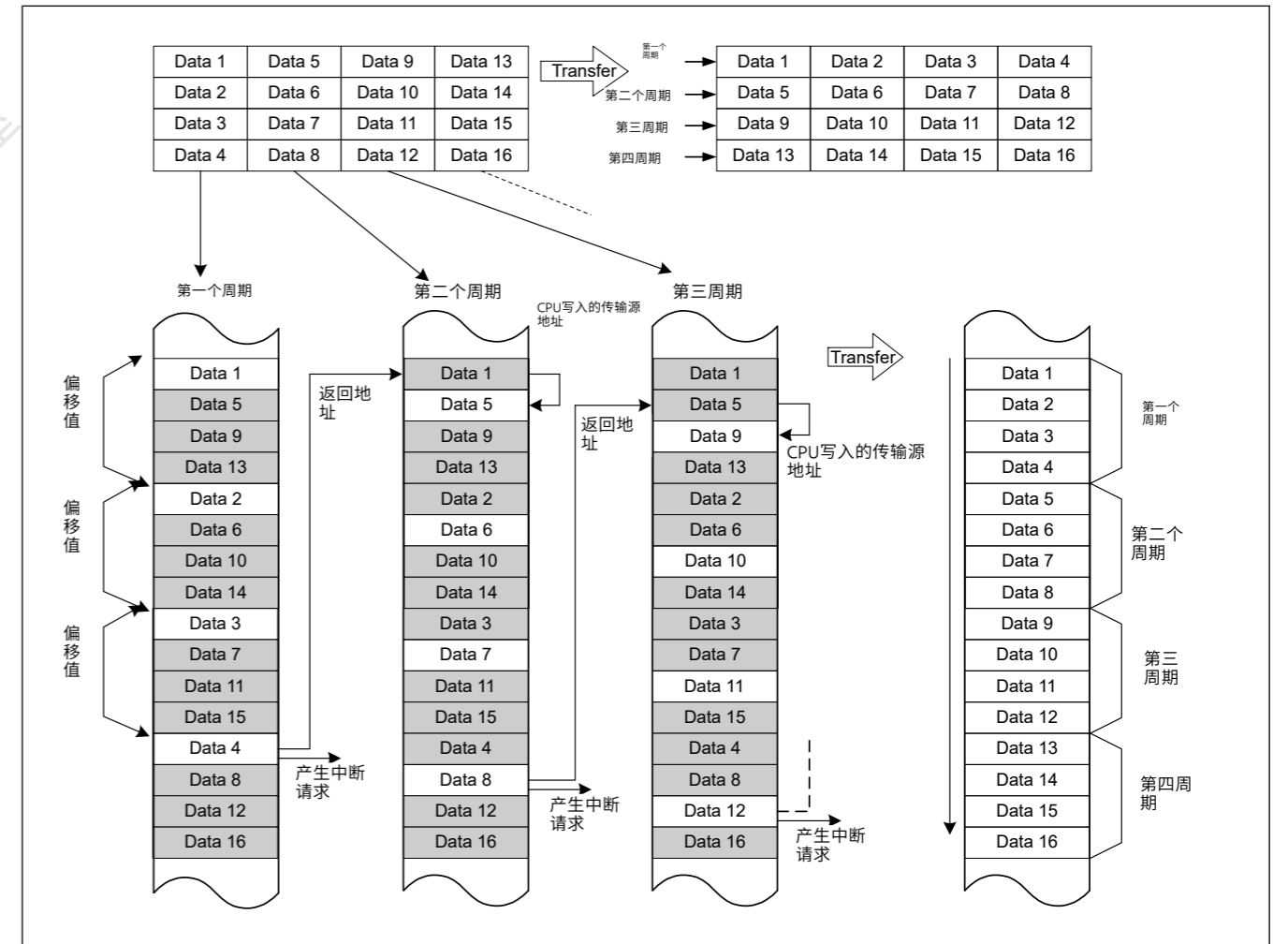


Figure 16.12 在重复传输模式下使用偏移加法的XY转换操作

传输开始时, 每次传输数据时, 都会将偏移值添加到传输源地址。传输数据被写入连续的传输目标地址。传输数据4时:

- 数据传输的重复大小已完成。

- The transfer source address returns to the transfer start address (the address of data 1 on the transfer source).
- A repeat size end interrupt is requested.

During the time this interrupt pauses the transfer, the following operations are performed.

- DMSAR — Rewrite the DMA transfer source address to the address of data 5 (with the above example, the data 1 address + 4).
- DMCNT — Set the DTE bit to 1.

The DMA transfer is resumed from the state when the DMA transfer is stopped. After that, the operations described above are repeated until the transfer source data is transposed to the destination area (XY conversion).

Figure 16.13 shows a flowchart of the XY conversion.

- 传输源地址返回传输起始地址（传输源上数据1的地址）。
- 请求重复大小结束中断。

在此中断暂停传输期间，将执行以下操作。

- DMSAR—将DMA传输源地址重写为数据5的地址（在上面的示例中，数据1地址+4）。
- DMCNT—将DTE位设置为1。

DMA传输从DMA传输停止时的状态恢复。之后，重复上述操作，直到将传送源数据转置到目的地区域（XY转换）。

图16.13显示了XY转换的流程图。

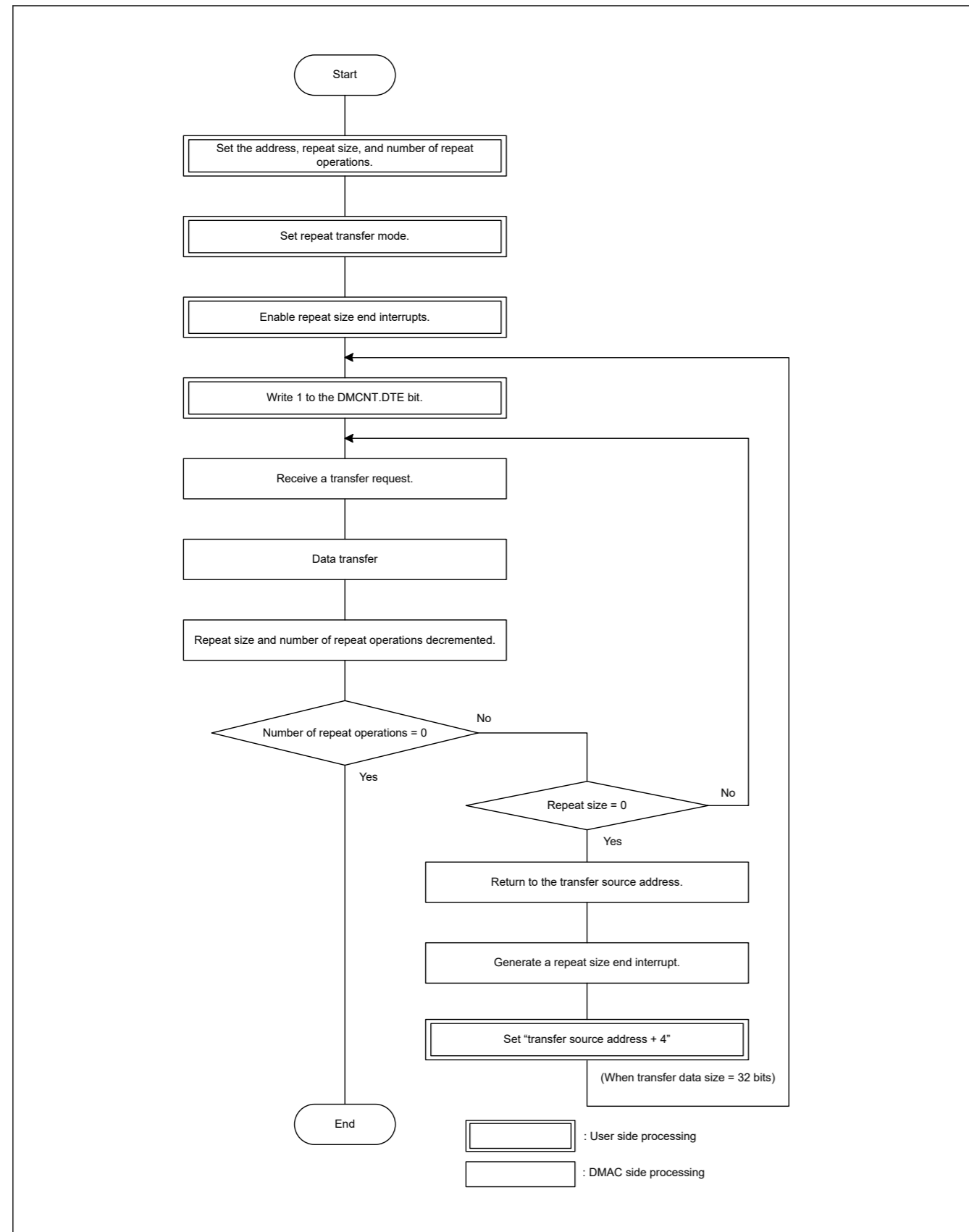


Figure 16.13 XY Conversion Flowchart Using Offset Addition in Repeat Transfer Mode

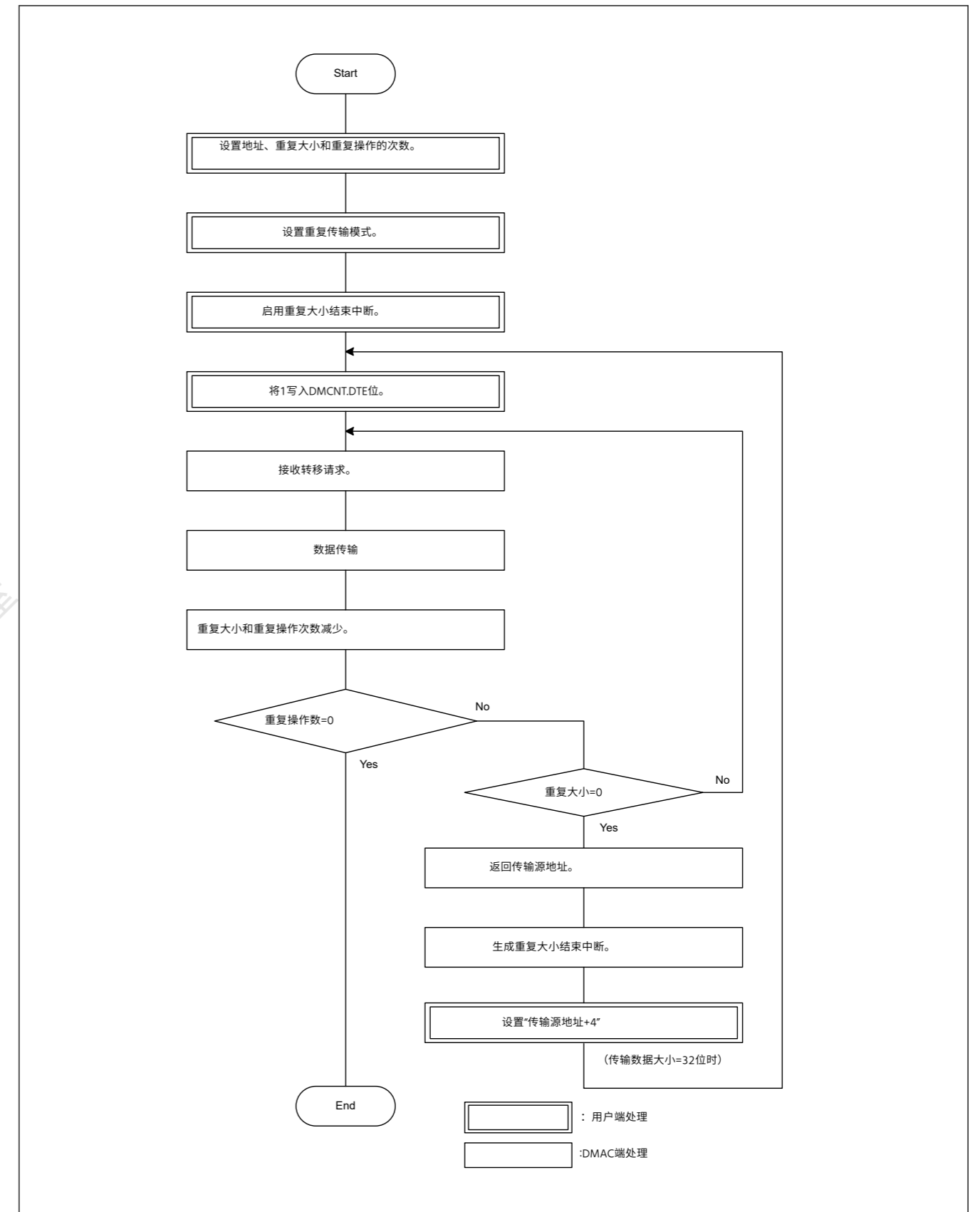


Figure 16.13 重复传输模式下使用偏移加法的XY转换流程图



### 16.3.5 Address Update Function in Repeat-Block Transfer Mode

Repeat-block transfer mode is an extension of repeat transfer mode and block transfer mode. However, the detailed behavior of the address update is different from these two modes. Here are the details of the address update function in repeat-block transfer mode.

#### 16.3.5.1 Fixed Address Mode

When DMAMD.SM[1:0] is set to 00b, the address update mode of the source is fixed address. And when DMAMD.DM[1:0] is set to 00b, the address update mode of the destination is fixed address.

In fixed address, the address is not updated from the initial value of DMSAR and DMDAR. If the block size (DMCRA) is larger than 1, the same data will be transferred multiple times for one request.

Figure 16.14 shows address update in fixed address.

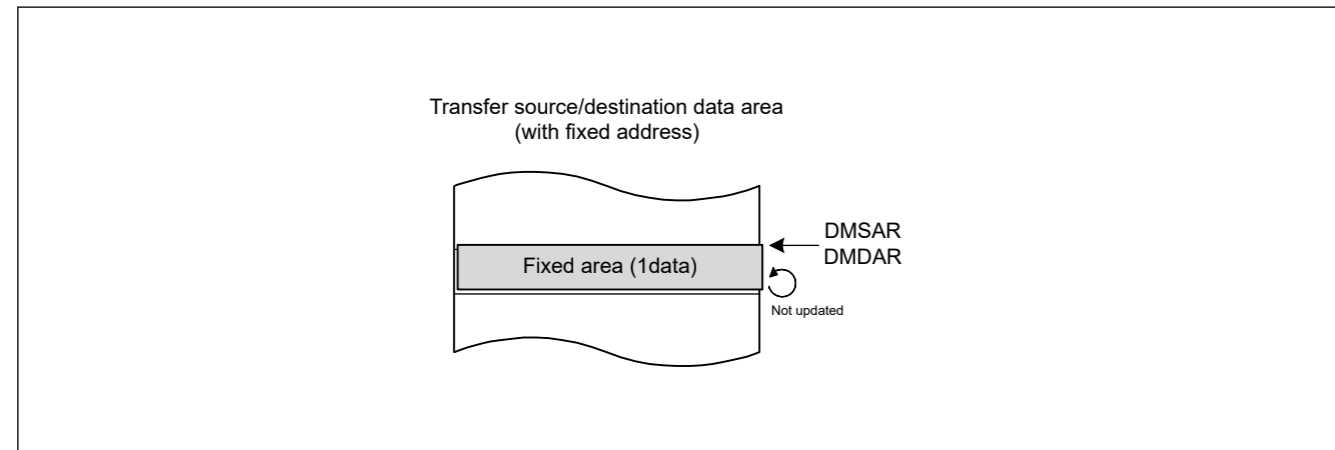


Figure 16.14 Address Update in Fixed Address

#### 16.3.5.2 Incremental and Decremental Address mode

When DMAMD.SM[1:0] is set to 10b, the address update mode of the source is incremental address. And when DMAMD.DM[1:0] is set to 10b, the address update mode of the destination is incremental address. When DMAMD.SM[1:0] is set to 11b, the address update mode of the source is decremental address. And when DMAMD.DM[1:0] is set to 11b, the address update mode of the destination is decremental address.

In these update modes, the address is incremented or decremented according to the setting of DMTMD.SZ[1:0].

In these update modes DMSBS and DMDBS indicates a reload area. The unit of DMSBS and DMDBS is "number of data". At the start of transfer, DMSBSL and DMDBSL, which is the lower 16 bits of DMSBS and DMDBS, operates as a down counter and decrements each time one data transfer is performed. When the value becomes 1, DMSAR and DMDAR reloads the value of DMSRR and DMDRR.

Figure 16.15 shows address update in incremental address.

### 16.3.5 重复块传输模式中的地址更新功能

重复块传输模式是重复传输模式和块传输模式的扩展。但是，地址更新的详细行为与这两种模式不同。以下是重复块传输模式下地址更新功能的详细信息。

#### 16.3.5.1 固定地址模式

当DMAMD.SM[1:0]设置为00b时，源的地址更新方式为固定地址。什么时候DMAMD.DM[1:0]设置为00b，目的地址更新方式为固定地址。

在固定地址中，地址不会从DMSAR和DMDAR的初始值更新。如果块大小（DMCRA）大于1，则一个请求将多次传输相同的数据。

图16.14显示了固定地址中的地址更新。

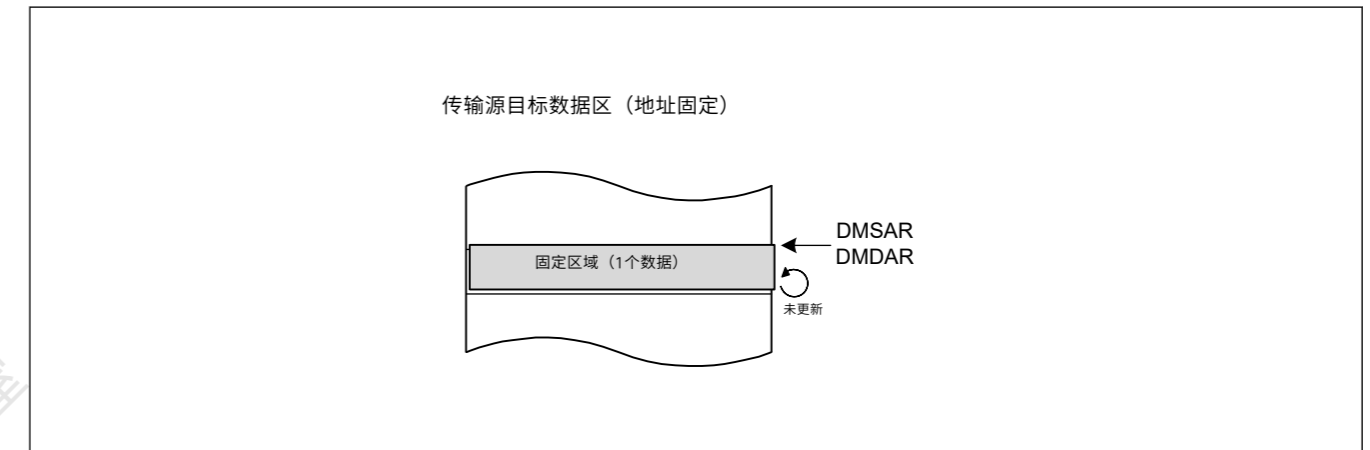


Figure 16.14 固定地址中的地址更新

#### 16.3.5.2 递增和递减地址模式

当DMAMD.SM[1:0]设置为10b时，源地址更新方式为增量地址。什么时候DMAMD.DM[1:0]设置为10b，目的地址更新方式为增量地址。当DMAMD.SM[1:0]设置为11b时，源地址更新方式为递减地址。什么时候

DMAMD.DM[1:0]设置为11b，目的地址更新方式为递减地址。

在这些更新模式中，地址根据DMTMD.SZ[1:0]的设置递增或递减。

在这些更新模式中，DMBS和DMDBS表示重新加载区域。DMSBS和DMDBS的单位是“数据数”。在传输开始时，作为DMSBS和DMDBS的低16位的DMSBSL和DMDBSL作为递减计数器运行，并在每次执行数据传输时递减。当值变为1时，DMSAR和DMDAR重新加载DMSRR和DMDRR的值。

图16.15显示了增量地址中的地址更新。

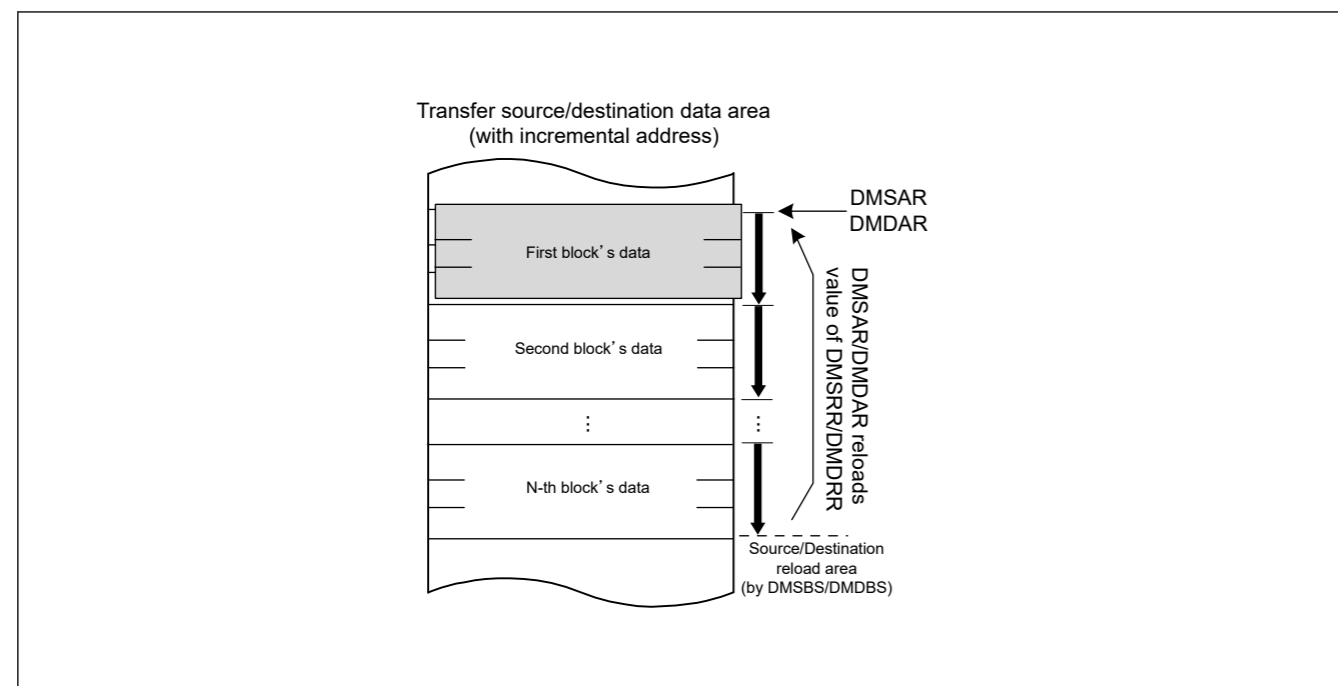


Figure 16.15 Address Update in Incremental Address

### 16.3.5.3 Offset Addition Mode

When DMAMD.SM[1:0] is set to 01b, the address update mode of the source is offset addition. And when DMAMD.DM[1:0] is set to 01b, the address update mode of the destination is offset addition.

In offset addition, DMSBS and DMDBS indicates reload area and also works as an access offset value. Unlike other transfer modes, DMOFR register is not used in repeat-block transfer mode. In offset addition, the unit of DMSBS and DMDBS is the number of blocks. When the transfer starts, DMCRAL operates as a down counter, DMSAR and DMDAR reloads the value of DMSRR and DMDRR every time one block is transferred. In addition, DMSBSL and DMDBSL, which is the lower 16 bits of DMSBS and DMDBS, also operates as a down counter and decrements every time one block is transferred. When the DMSBS and DMDBS value becomes 1, DMSAR and DMDAR reloads the value of DMSRR and DMDRR.

When DMAMD.SADR and DMAMD.DADR is set to 0, offset addition operation of the same area is repeated. DMDAR only reloads DMDRR. [section 16.3.5.3. Offset Addition Mode](#) shows address update in offset addition with DMAMD.SADR and DMAMD.DADR=0.

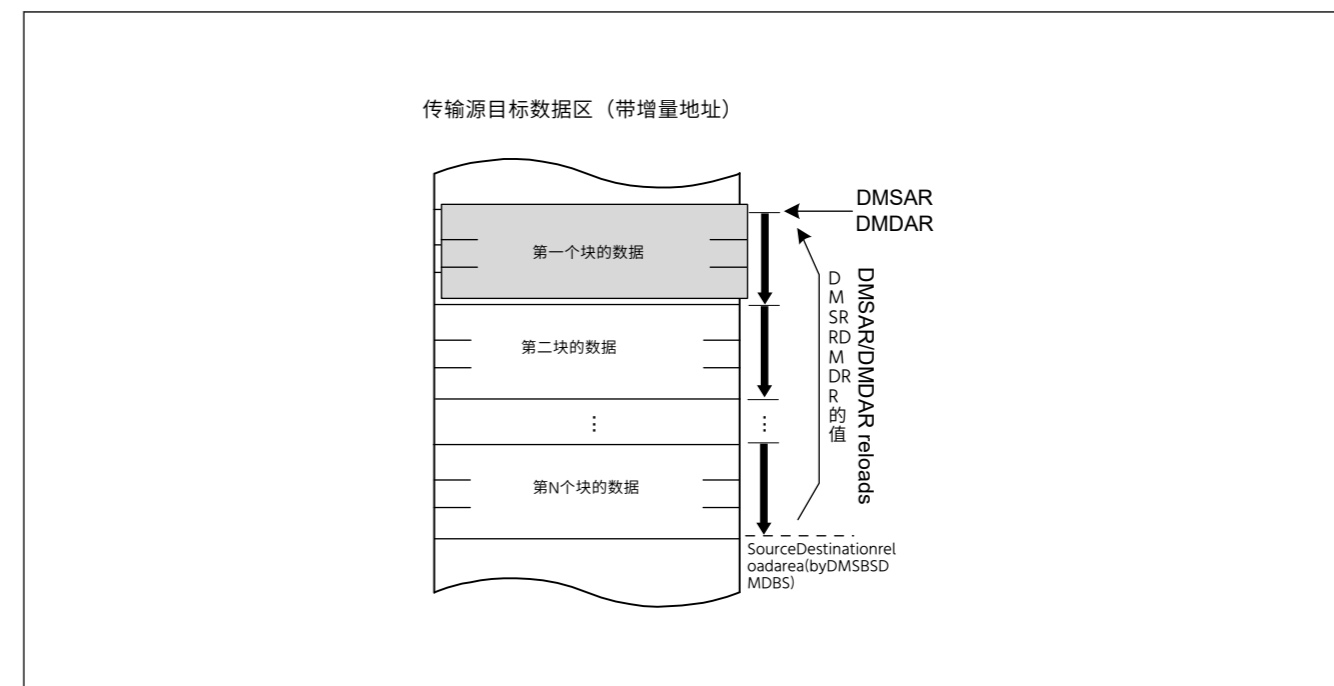


Figure 16.15 增量地址中的地址更新

### 16.3.5.3 偏移加法模式

当DMAMD.SM[1:0]设置为01b时，源地址更新方式为偏移加法。什么时候DMAMD.DM[1:0]设置为01b，目的地址更新方式为偏移加法。

除了偏移量之外，DMBS和DMDBS表示重载区域，也用作访问偏移量值。与其他传输模式不同，DMOFR寄存器不用于重复块传输模式。除了偏移量之外，DMSBS和DMDBS的单位是块数。当传输开始时，DMCRAL作为一个递减计数器运行，DMSAR和DMDAR在每次传输一个块时重新加载DMSRR和DMDRR的值。此外，作为DMSBS和DMDBS的低16位的DMSBSL和DMDBSL也用作递减计数器，并且每传输一个块就递减。当DMSBS和DMDBS的值变为1时，DMSAR和DMDAR重新加载DMSRR和DMDRR的值。

当DMAMD.SADR和DMAMD.DADR设置为0时，重复相同区域的偏移添加操作。DMDAR仅重新加载DMDRR。第16.3.5.3节。偏移加法模式显示偏移加法中的地址更新，其中DMAMD.SADR和DMAMD.DADR=0。

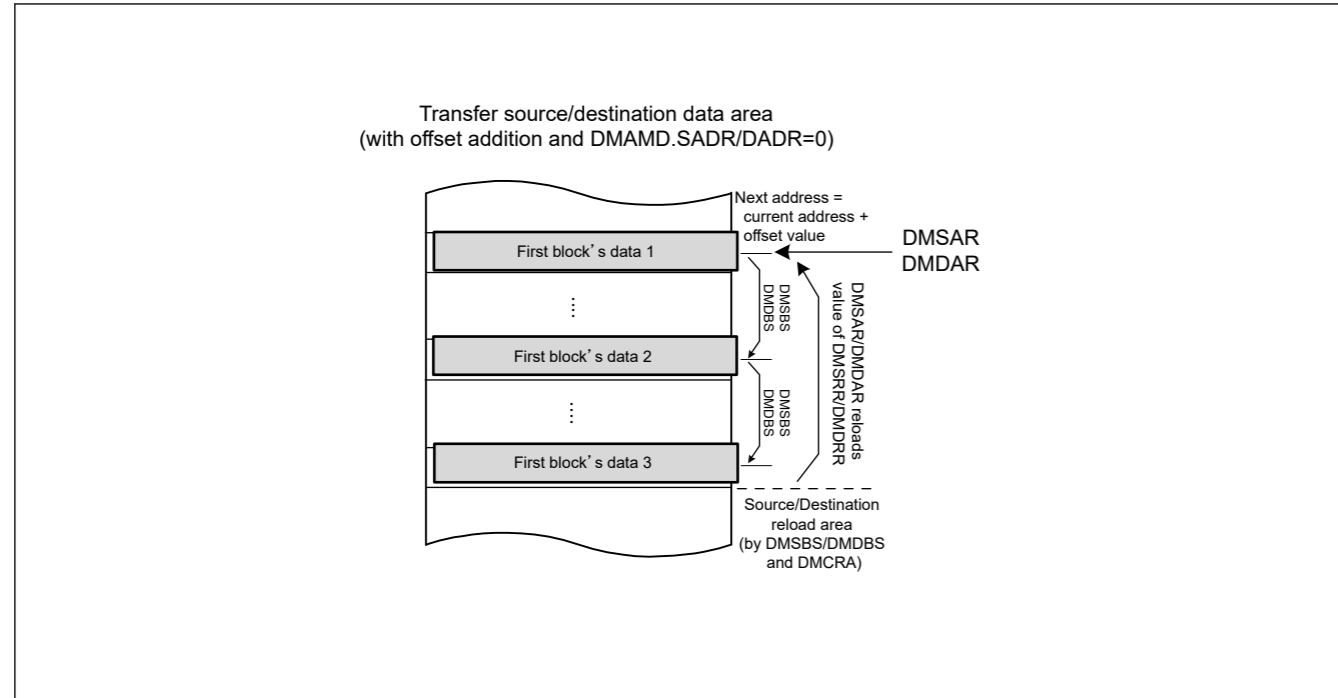


Figure 16.16 Address update in Offset Addition with DMAMD.SADR and DMAMD.DADR=0

When DMAMD.SADR and DMAMD.DADR is set to 1, the address is incremented by one data unit after DMSRR and DMDRR is reloaded by DMCRAL=1. In other words, an index value  $((DMDBSH-DMDBSL) \times DataSize)$  is added to DMDAR after DMDRR is reloaded. This behavior is used to implement multiple ring buffers. Figure 16.17 shows address update in offset addition with DMAMD.SADR and DMAMD.DADR=1.

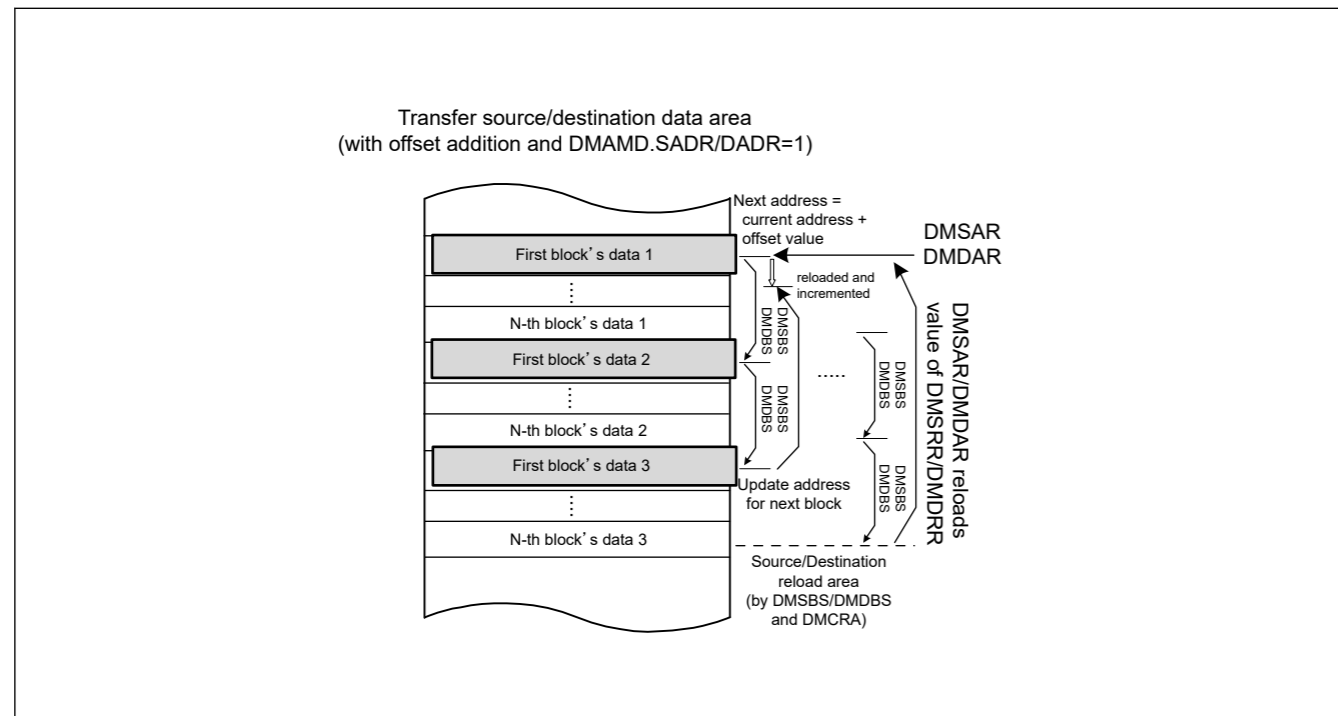


Figure 16.17 Address Update in Offset Addition with DMAMD.SADR and DMAMD.DADR=1

### 16.3.6 Example of Using Repeat-Block Transfer Mode

In repeat-block transfer mode, it is possible to realize repeated access to interval data and single or multiple ring buffers by combining the above address update modes. Following sections shows some usage examples.

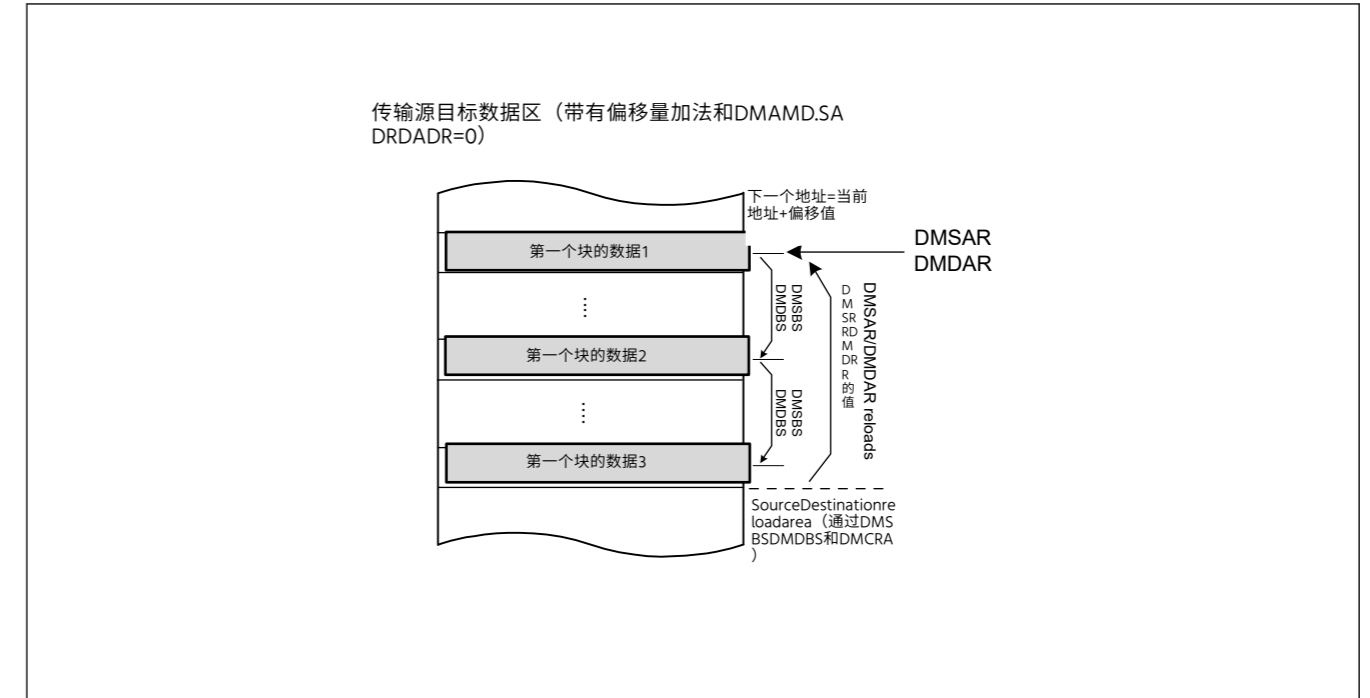


Figure 16.16 使用DMAMD.SADR和DMAMD.DADR=0进行偏移加法中的地址更新

当DMAMD.SADR和DMAMD.DADR设置为1时，在DMSRR和DMCRA=1重新加载DMDRR后，地址增加一个数据单元。换句话说，一个索引值  $((DMDBSH-DMDBSL) \times DataSize)$  被添加到重新加载DMDRR后的DMDAR。此行为用于实现多个环形缓冲区。图16.17显示了DMAMD.SADR和DMAMD.DADR=1的偏移加法中的地址更新。

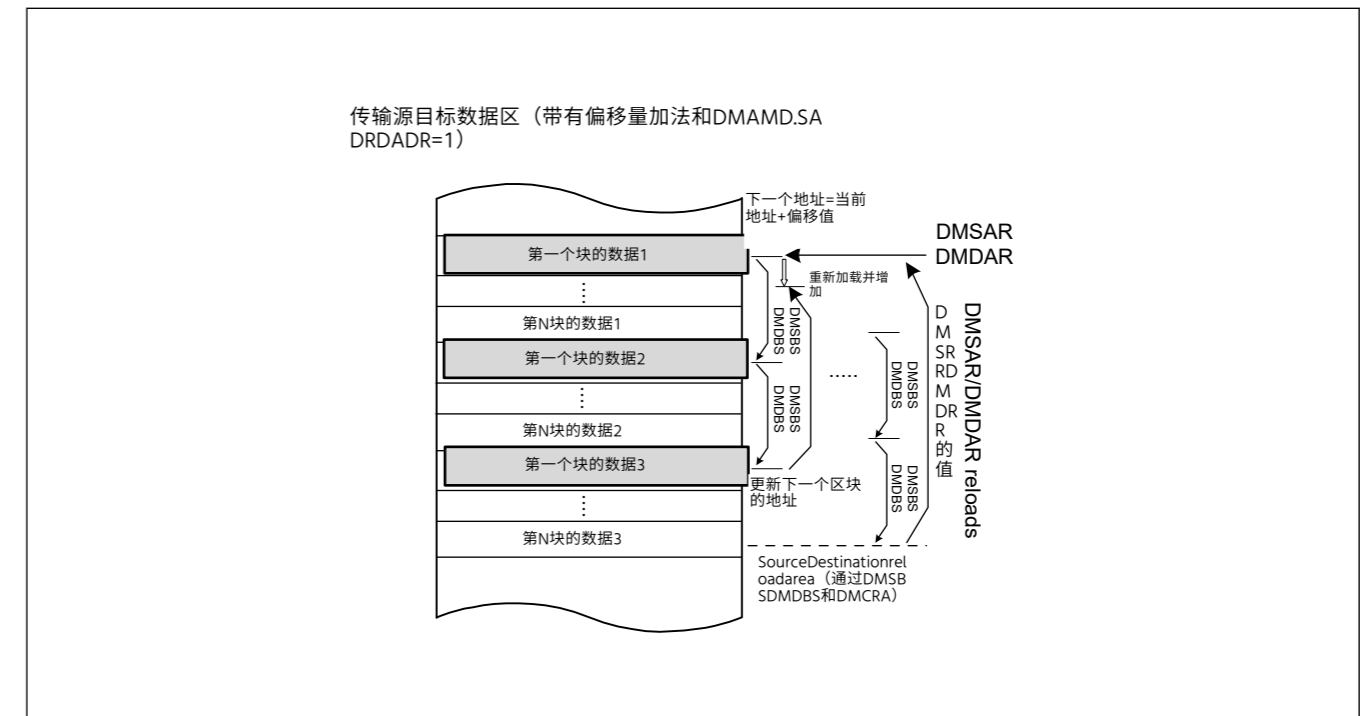


Figure 16.17 使用DMAMD.SADR和DMAMD.DADR=1进行偏移添加中的地址更新

### 16.3.6 使用重复块传输模式的示例

在重复块传输模式下，结合上述地址更新模式，可以实现对区间数据和单个或多个环形缓冲区的重复访问。以下部分显示了一些使用示例。

16.3.6.1 Interval Address to Single Ring Buffer

Figure 16.18 shows an example of reading interval ADDRn registers (data register) of ADC12 module and storing it in single ring buffer. It transfers 2 data every 4 halfwords per 1 request. DMSAR is incremented by one data every one request. This can be achieved by setting the transfer source to offset addition and DMAMD.SADR=1, the block size (DMCRA) to 2, and the transfer source offset (DMSBS) to 4. Table 16.15 shows setting of this example.

Table 16.15 Setting of use case: from interval address to single ring buffer

| Register       | Value        | Description   |
|----------------|--------------|---|
| DMSAR, DMSRR   | 0x4017_0020  | Initial source address  |
| DMDAR, DMDRR   | 0x2000_0000  | Initial destination address   |
| DMTMD.SZ[1:0]  | 10b          | Data size is halfword   |
| DMAMD.SADR     | 1            | Incremental source address after reloading  |
| DMAMD.SM[1:0]  | 01b          | Source update mode is offset addition   |
| DMAMD.DM[1:0]  | 10b          | Destination update mode is incremental address  |
| DMCRAH, DMCRAI | 2            | Transfer block size   |
| DMSBSH, DMSBSL | 4            | Source whole buffer size (unit is 'blocks') and Source access offset (unit is 'data') |
| DMDBSH, DMDBSL | N × 2(DMCRA) | Destination buffer size (unit is 'data')  |

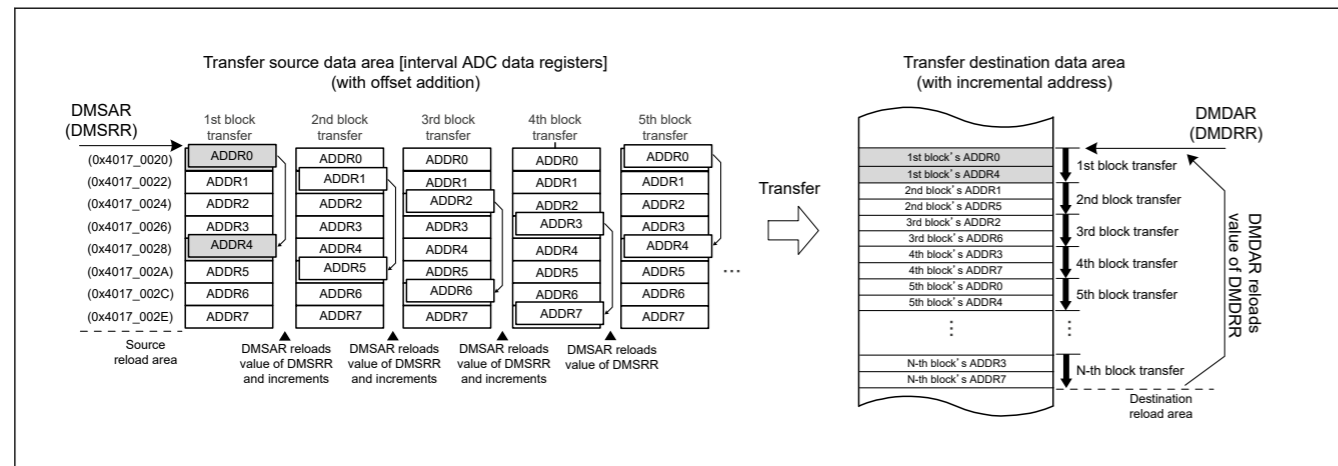


Figure 16.18 Example of Use Case: from Interval Address to Single Ring Buffer

16.3.6.2

16.3.6.2.1 Unaligned Ring Buffer to Single Ring Buffer

Figure 16.19 shows an example of reading ADBUFn registers of ADC12 module (conversion result storage ring buffer) incrementally and storing it in single ring buffer. In this example, wrapping occurs because ADBUFn overflows in the fourth scan, but transfer source address of DMAC is also updated accordingly. This can be realized by setting the transfer source to incremental address and setting the DMSBS register to 16 which is the length of ADBUFn. This makes it possible to continue transfer without performing CPU processing using interrupts. Table 16.16 shows setting of this example.

Table 16.16 Setting of use case: from unaligned ring buffer to single ring buffer (1 of 2)

| Register      | Value       | Description                               |
|---------------|-------------|---|
| DMSAR, DMSRR  | 0x4017_00B0 | Initial source address                    |
| DMDAR, DMDRR  | 0x2000_0000 | Initial destination address               |
| DMTMD.SZ[1:0] | 10b         | Data size is halfword                     |
| DMAMD.SM[1:0] | 10b         | Source update mode is incremental address |

16.3.6.1 单个环形缓冲区的间隔地址

图16.18显示了读取ADC12模块的间隔ADDRn寄存器（数据寄存器）并将其存储在单个环形缓冲区中的示例。它每1个请求每4个半字传输2个数据。DMSAR每请求一个数据就增加一个数据。这可以通过将传输源设置为偏移加法和DMAMD.SADR=1，将块大小(DMCRA)设置为2，将传输源偏移量(DMSBS)设置为4来实现。表16.15显示了此示例的设置。

Table 16.15 用例设置：从区间地址到单环缓冲区

| Register       | Value        | Description                      |
|----------------|--------------|----------------------------------|
| DMSAR, DMSRR   | 0x4017_0020  | 初始源地址                            |
| DMDAR, DMDRR   | 0x2000_0000  | 初始目标地址                           |
| DMTMD.SZ[1:0]  | 10b          | 数据大小为半字                          |
| DMAMD.SADR     | 1            | 重载后增量源地址                         |
| DMAMD.SM[1:0]  | 01b          | 源更新方式为偏移量加法                      |
| DMAMD.DM[1:0]  | 10b          | 目标更新方式为增量地址                      |
| DMCRAH, DMCRAI | 2            | 传输块大小                            |
| DMSBSH, DMSBSL | 4            | 源整个缓冲区大小（单位是“块”）和源访问偏移量（单位是“数据”） |
| DMDBSH, DMDBSL | N × 2(DMCRA) | 目标缓冲区大小（单位是“数据”）                 |

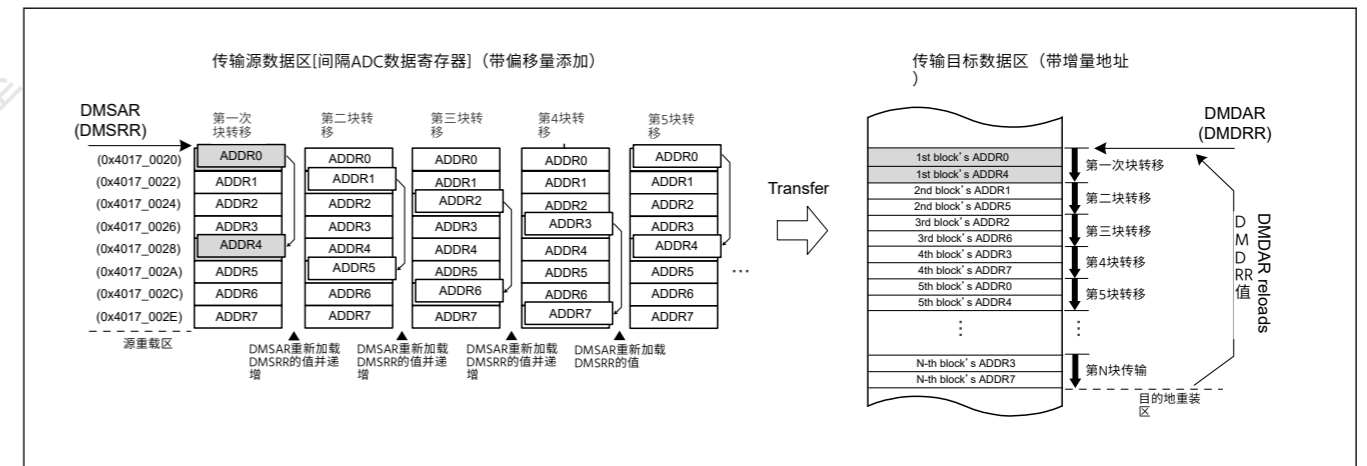


Figure 16.18 用例示例：从区间地址到单环缓冲区

16.3.6.2

16.3.6.2.1 未对齐的环形缓冲区到单个环形缓冲区

图16.19显示了增量读取ADC12模块（转换结果存储环形缓冲区）的ADBUFn寄存器并将其存储在单个环形缓冲区中的示例。在本例中，由于ADBUFn在第四次扫描中溢出，因此发生了回绕，但DMAC的传输源地址也相应更新。这可以通过将传输源设置为增量地址并将DMSBS寄存器设置为16来实现，即ADBUFn的长度。这使得可以在不使用中断执行CPU处理的情况下继续传输。表16.16显示了此示例的设置。

Table 16.16 用例设置：从未对齐的环形缓冲区到单个环形缓冲区（1of2）

| Register      | Value       | Description |
|---------------|-------------|-------------|
| DMSAR, DMSRR  | 0x4017_00B0 | 初始源地址       |
| DMDAR, DMDRR  | 0x2000_0000 | 初始目标地址      |
| DMTMD.SZ[1:0] | 10b         | 数据大小为半字     |
| DMAMD.SM[1:0] | 10b         | 源更新方式为增量地址  |



Table 16.16 Setting of use case: from unaligned ring buffer to single ring buffer (2 of 2)

| Register       | Value        | Description                                    |
|----------------|--------------|--|
| DMAMD.DM[1:0]  | 10b          | Destination update mode is incremental address |
| DMCRAH, DMCRA  | 5            | Transfer block size                            |
| DMSBSH, DMSBSL | 16           | Source buffer size (unit is 'data')            |
| DMDBSH, DMDBSL | N × 5(DMCRA) | Destination buffer size (unit is 'data')       |

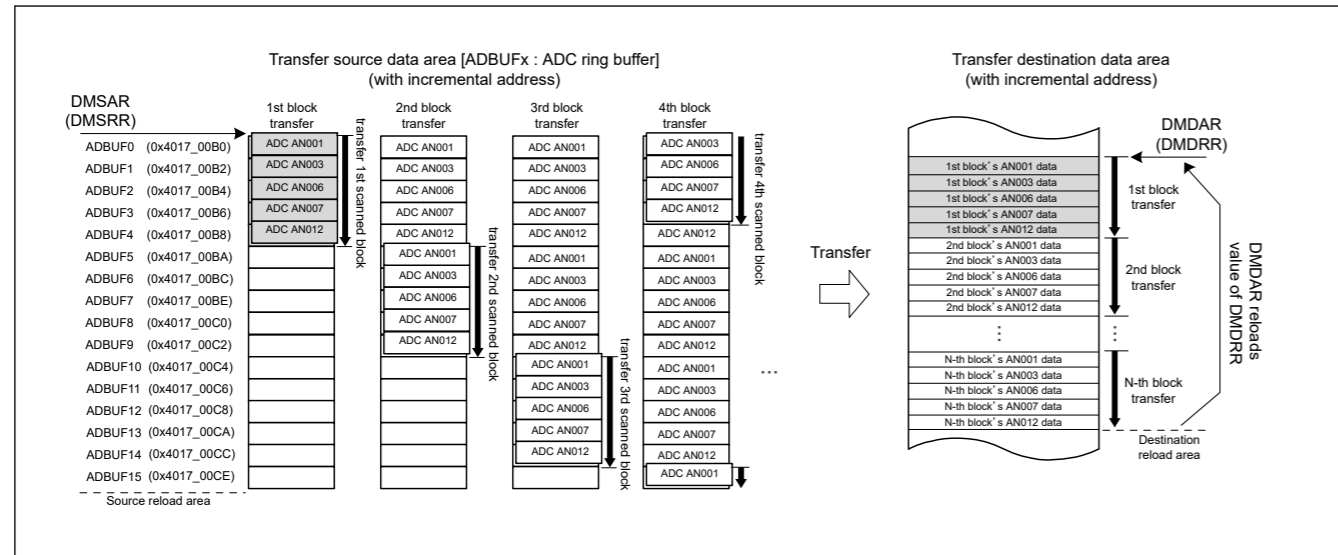


Figure 16.19 Example of Use Case: from Unaligned Ring Buffer to Single Ring Buffer

16.3.6.3 Single Block to Multi Ring Buffer

Figure 16.20 shows an example of storing the continuous ADDRn registers (data register) of ADC12 module individually in multiple ring buffers. In this example, a ring buffer in which only the first element (ADDR0) in a single block is arranged in transfer order is created at the destination. Also, in the next area, create a ring buffer in which only the second element (ADDR1) is arranged in transfer order. In the following case, create a ring buffer of length N, which is defined by DMDBS. And the number of data elements in the block is 3, which is defined by DMCRA. Table 16.17 shows setting of this example.

Table 16.17 Setting of use case: from single block to multi ring buffer

| Register       | Value       | Description   |
|----------------|-------------|---|
| DMSAR, DMSRR   | 0x4017_0020 | Initial source address  |
| DMDAR, DMDRR   | 0x2000_0000 | Initial destination address   |
| DMTMD.SZ[1:0]  | 10b         | Data size is halfword   |
| DMAMD.DADR     | 1           | Incremental destination address after reloading   |
| DMAMD.SM[1:0]  | 10b         | Source update mode is incremental address   |
| DMAMD.DM[1:0]  | 01b         | Destination update mode is offset addition  |
| DMCRAH, DMCRA  | 3           | Transfer block size   |
| DMSBSH, DMSBSL | 3           | Source buffer size (unit is 'data')   |
| DMDBSH, DMDBSL | N           | Destination whole buffer size (unit is 'blocks') and Destination access offset (unit is 'data') |

Table 16.16 用例设置：从未对齐的环形缓冲区到单个环形缓冲区 (2of2)

| Register       | Value        | Description       |
|----------------|--------------|-------------------|
| DMAMD.DM[1:0]  | 10b          | 目标更新方式为增量地址       |
| DMCRAH, DMCRA  | 5            | 传输块大小             |
| DMSBSH, DMSBSL | 16           | 源缓冲区大小 (单位是“数据”)  |
| DMDBSH, DMDBSL | N × 5(DMCRA) | 目标缓冲区大小 (单位是“数据”) |

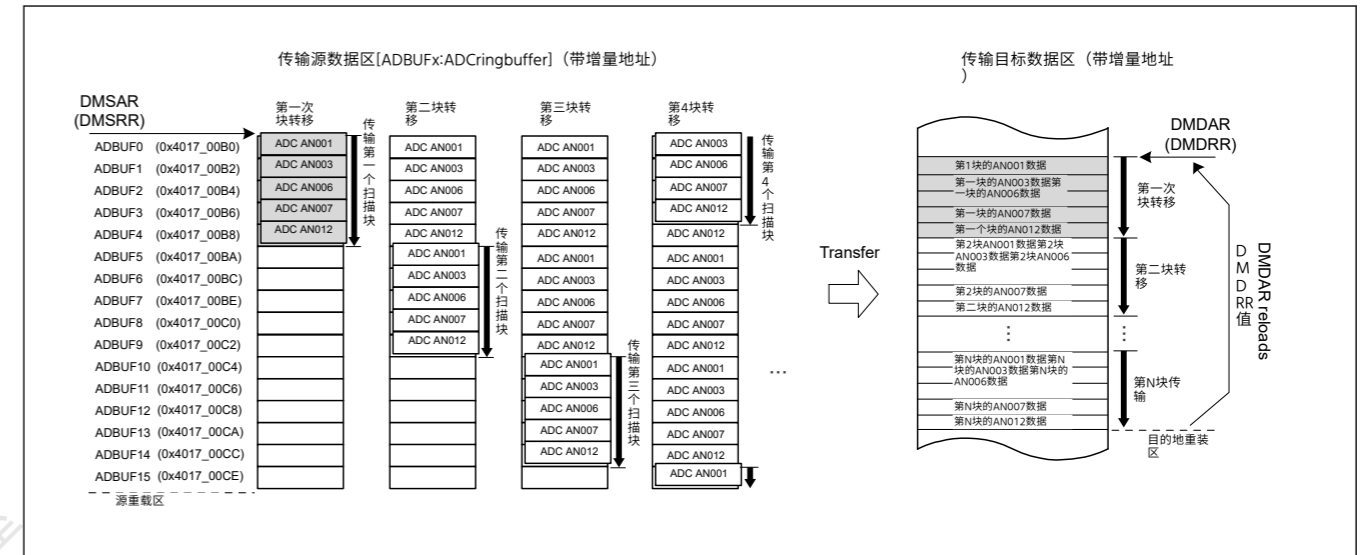


Figure 16.19 用例示例：从未对齐的环形缓冲区到单环形缓冲区

16.3.6.3 单块到多环缓冲区

图16.20显示了将ADC12模块的连续ADDRn寄存器（数据寄存器）单独存储在多个环形缓冲区中的示例。在此示例中，在目的地创建了一个环形缓冲区，其中仅单个块中的第一个元素（ADDR0）按传输顺序排列。此外，在下一个区域中，创建一个环形缓冲区，其中只有第二个元素(ADDR1)按传输顺序排列。在以下情况下，创建一个长度为N的环形缓冲区，由DMDBS定义。块中的数据元素个数为3，由DMCRA定义。表16.17显示了此示例的设置。

Table 16.17 用例设置：从单块到多环缓冲区

| Register       | Value       | Description                           |
|----------------|-------------|---------------------------------------|
| DMSAR, DMSRR   | 0x4017_0020 | 初始源地址                                 |
| DMDAR, DMDRR   | 0x2000_0000 | 初始目标地址                                |
| DMTMD.SZ[1:0]  | 10b         | 数据大小为半字                               |
| DMAMD.DADR     | 1           | 重新加载后的增量目标地址                          |
| DMAMD.SM[1:0]  | 10b         | 源更新方式为增量地址                            |
| DMAMD.DM[1:0]  | 01b         | 目的地更新方式为偏移量加法                         |
| DMCRAH, DMCRA  | 3           | 传输块大小                                 |
| DMSBSH, DMSBSL | 3           | 源缓冲区大小 (单位是“数据”)                      |
| DMDBSH, DMDBSL | N           | 目标整个缓冲区大小 (单位是“块”) 和目标访问偏移量 (单位是“数据”) |



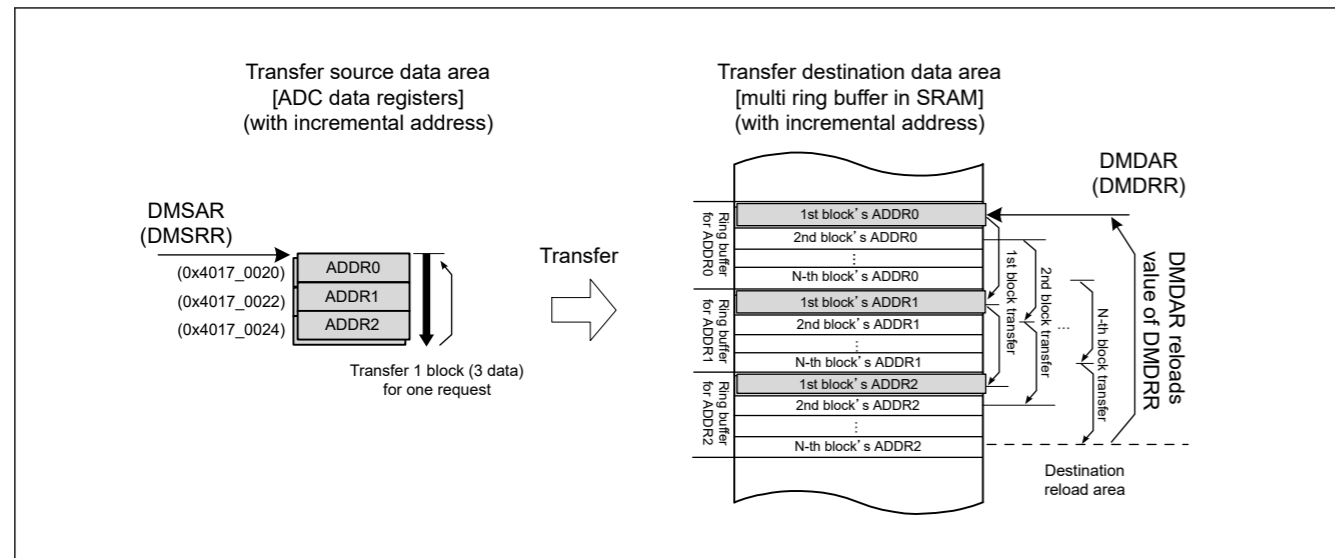


Figure 16.20 Example of Use Case: from Single Block to Multi Ring Buffer

### 16.3.7 Activation Sources

Software, interrupt requests from the peripheral modules, and external interrupt requests can all be specified as DMAC activation sources. Set the DMTMD.DCTG[1:0] bits to select the activation source.

#### 16.3.7.1 DMAC Activation by Software

When start DMA transfer by software, follow below procedure.

1. Set the DMTMD.DCTG[1:0] bits to 00b
2. Set the DMCNT.DTE bit to 1 (DMA transfer is enabled)
3. Set the DMAST.DMST bit set to 1 (DMAC activation enabled)
4. Set the DMREQ.SWREQ bit to 1 (DMA requested)

When the DMAC is activated by software while the DMREQ.CLRS bit is 0, the DMREQ.SWREQ bit is cleared to 0 after data transfer is started in response to a DMA transfer request.

When the DMAC is activated by software while the CLRS bit is 1, the SWREQ bit is not cleared to 0 after data transfer is started. In this case, a DMA transfer request is issued again after completion of a transfer.

#### 16.3.7.2 DMAC Activation through Interrupt Requests from On-Chip Peripheral Modules or External Interrupt Requests

You can specify interrupt requests from on-chip peripheral modules and external interrupt requests as DMAC activation sources. The activation sources can be selected individually for each channel in ICU.DELSRn.DELS[8:0] (n = 0 to 7).

To start DMA transfer through an interrupt request from an on-chip peripheral module or an external interrupt request, follow the procedures as indicated below.

1. Set ICU.DELSRn.DELS[8:0] (n = 0 to 7) to the event number (select the DMAC event link).
2. Set the DMTMD.DCTG[1:0] bits to 01b (interrupts from the peripheral modules and the external interrupt pins).
3. Set the DMCNT.DTE bit to 1 (enable DMA transfer).
4. Set the DMAST.DMST bit set to 1 (DMAC activation enabled)

For interrupt requests specified as DMAC activation sources, see Table 13.3, in section 13, Interrupt Controller Unit (ICU).

### 16.3.8 Operation Timing

The following timing charts have indicated the number of execution cycles of the minimum.

Figure 16.21 and Figure 16.22 show DMAC operation timing examples.

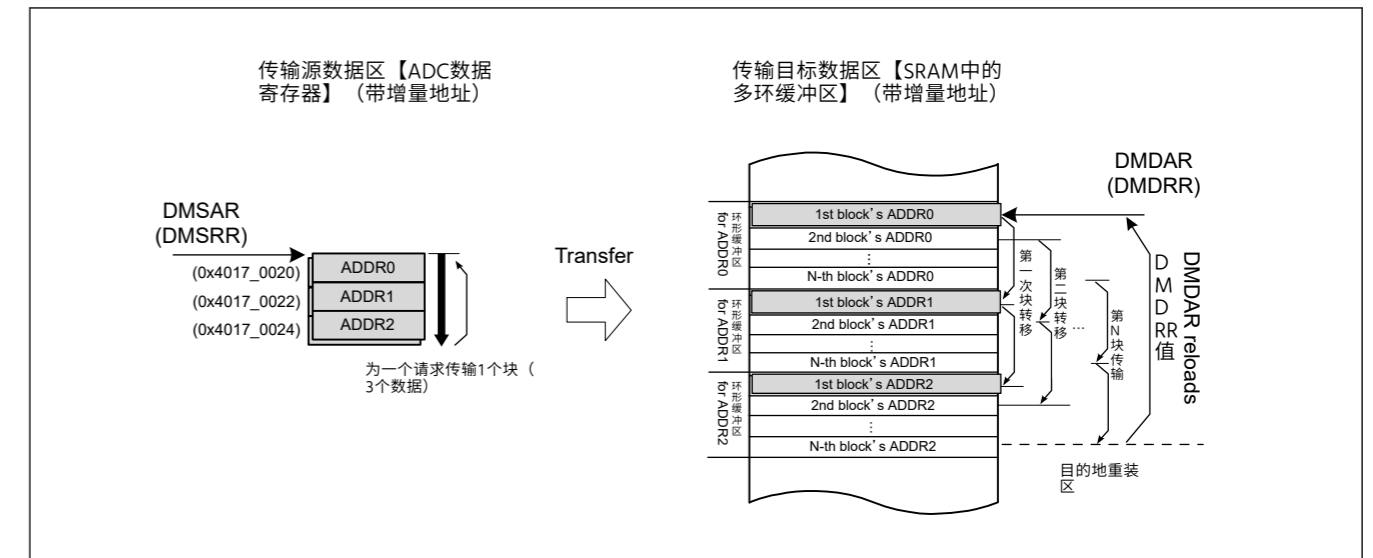


Figure 16.20 用例示例：从单块到多环缓冲区

### 16.3.7 激活源

软件、外设模块的 interrupt 请求和外部 interrupt 请求都可以指定为 DMAC 激活源。设置 DMTMD.DCTG[1:0] 位以选择激活源。

#### 16.3.7.1 软件激活 DMAC

当通过软件启动 DMA 传输时，请遵循以下步骤。

1. 将 DMTMD.DCTG[1:0] 位设置为 00b
2. 将 DMCNT.DTE 位设置为 1 (启用 DMA 传输)
3. 将 DMAST.DMST 位设置为 1 (启用 DMAC 激活)
4. 将 DMREQ.SWREQ 位设置为 1 (请求 DMA)

当 DMREQ.CLRS 位为 0 时由软件激活 DMAC 时，在响应 DMA 传输请求开始数据传输后，DMREQ.SWREQ 位清零。

当 CLRS 位为 1 时由软件激活 DMAC 时，数据传输开始后 SWREQ 位不会被清零。在这种情况下，在传输完成后再次发出 DMA 传输请求。

#### 16.3.7.2 通过来自片上外围模块或外部 interrupt 请求的 interrupt 请求激活 DMAC

您可以将来自片上外围模块的 interrupt 请求和外部 interrupt 请求指定为 DMAC 激活源。可以为 ICU.DELSRn.DELS[8:0] (n = 0 到 7) 中的每个通道单独选择激活源。

要通过来自片上外围模块的 interrupt 请求或外部 interrupt 请求启动 DMA 传输，请按照以下步骤操作。

1. 将 ICU.DELSRn.DELS[8:0] (n = 0 到 7) 设置为事件编号 (选择 DMAC 事件链接)。
2. 将 DMTMD.DCTG[1:0] 位设置为 01b (来自外围模块和外部 interrupt 引脚的 interrupt)。
3. 将 DMCNT.DTE 位设置为 1 (启用 DMA 传输)。
4. 将 DMAST.DMST 位设置为 1 (启用 DMAC 激活)

对于指定为 DMAC 激活源的 interrupt 请求，请参见第 13 节“中断控制器单元 (ICU)”中的表 13.3。

### 16.3.8 操作时间

下面的时序图已经表明了最小的执行周期数。

图 16.21 和图 16.22 显示了 DMAC 操作时序示例。

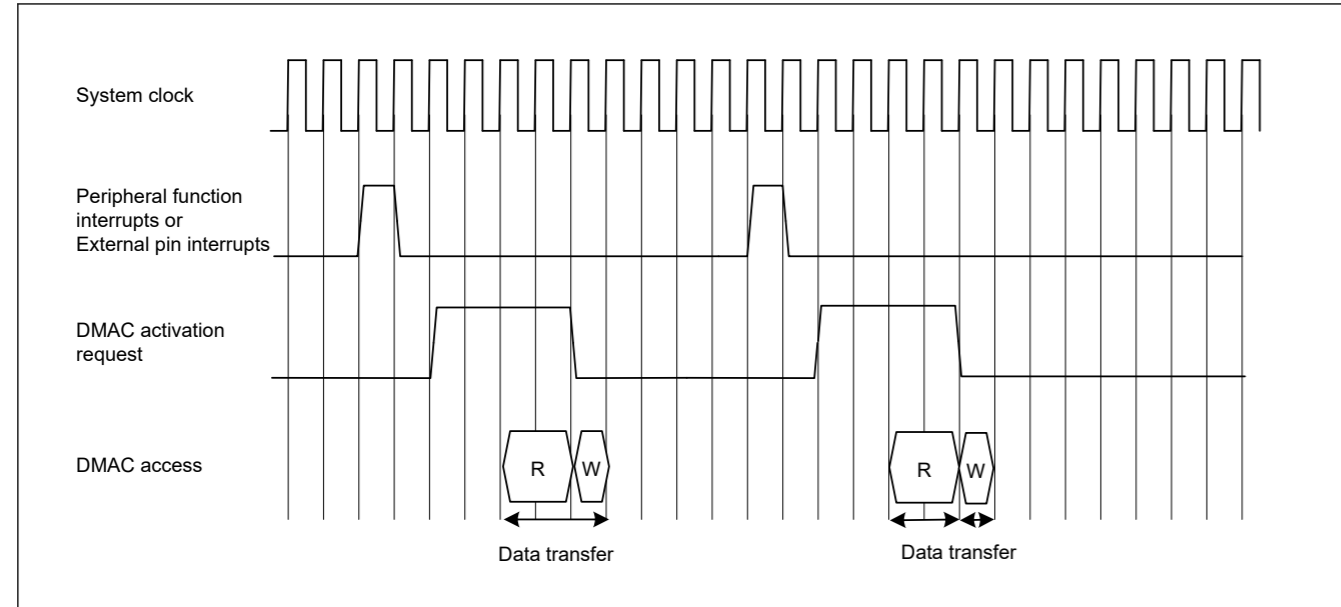


Figure 16.21 DMAC operation timing example 1 with DMAC activation by Interrupt from peripheral module or external interrupt input pin, in normal transfer mode or repeat transfer mode

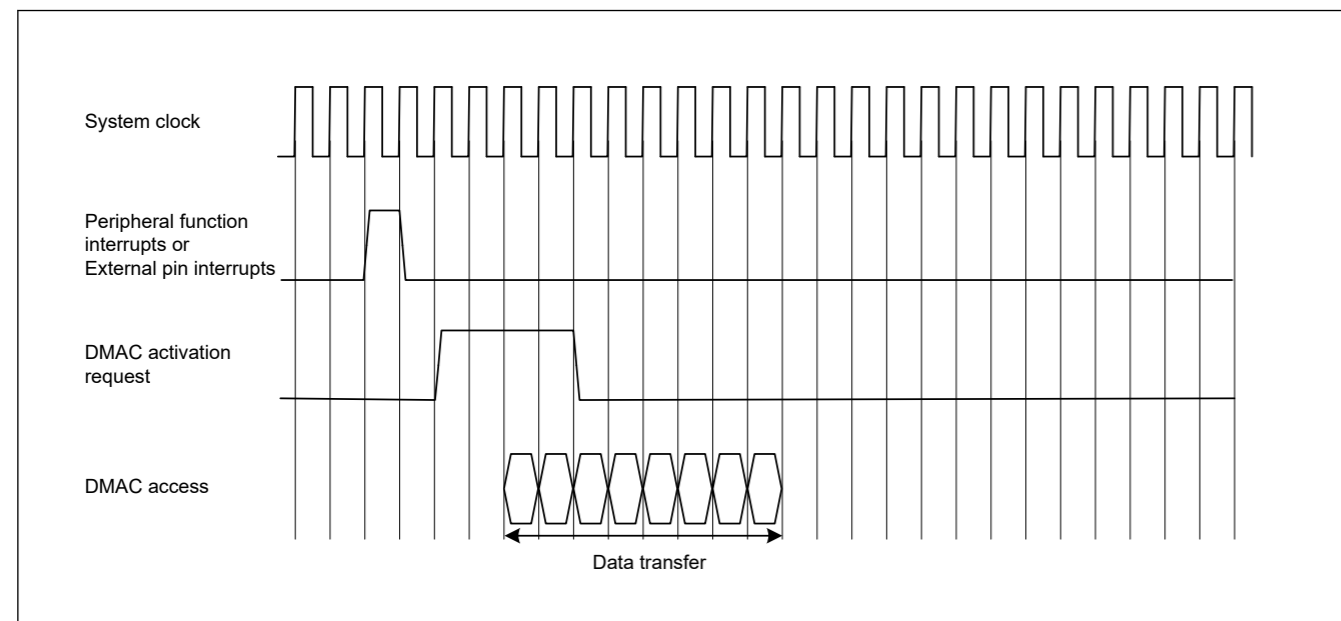


Figure 16.22 DMAC operation timing example 2 with DMAC activation by interrupt from peripheral module or external interrupt input pin, in block transfer mode with block size = 4

16.3.9 DMAC Execution Cycles

Table 16.18 lists execution cycles in one DMAC data transfer operation.

Table 16.18 DMAC Execution Cycles

| Transfer Mode | Data Transfer (Read) | Data Transfer (Write) |
|---------------|----------------------|-----------------------|
| Normal        | Cr+1                 | Cw                    |
| Repeat        | Cr+1                 | Cw                    |
| Block*1       | P × Cr               | P × Cw                |

Note: P: Block size (DMCRAH register setting)  
 Cr: Data read destination access cycle  
 Cw: Data write destination access cycle

Note 1. This is the case when the block size is 2 or more. When the block size is 1, normal transfer cycle is applied.

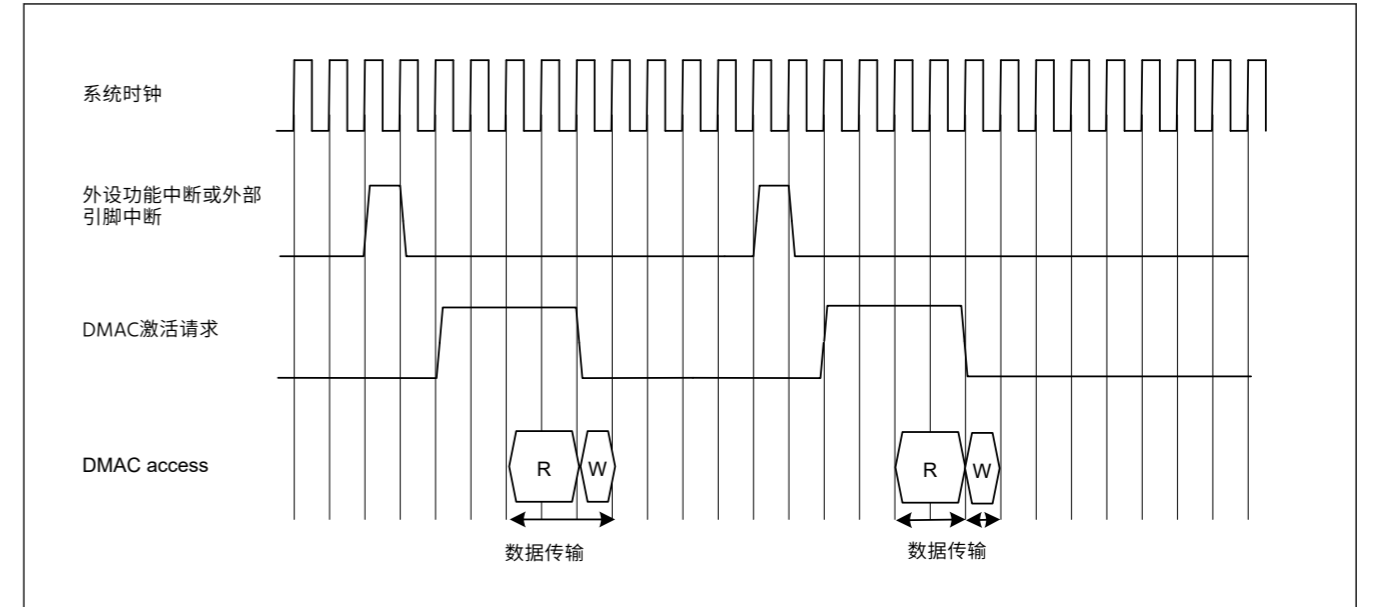


Figure 16.21 DMAC操作时序示例1通过来自外围模块的中断或外部中断输入引脚激活DMAC，处于正常传输模式或重复传输模式

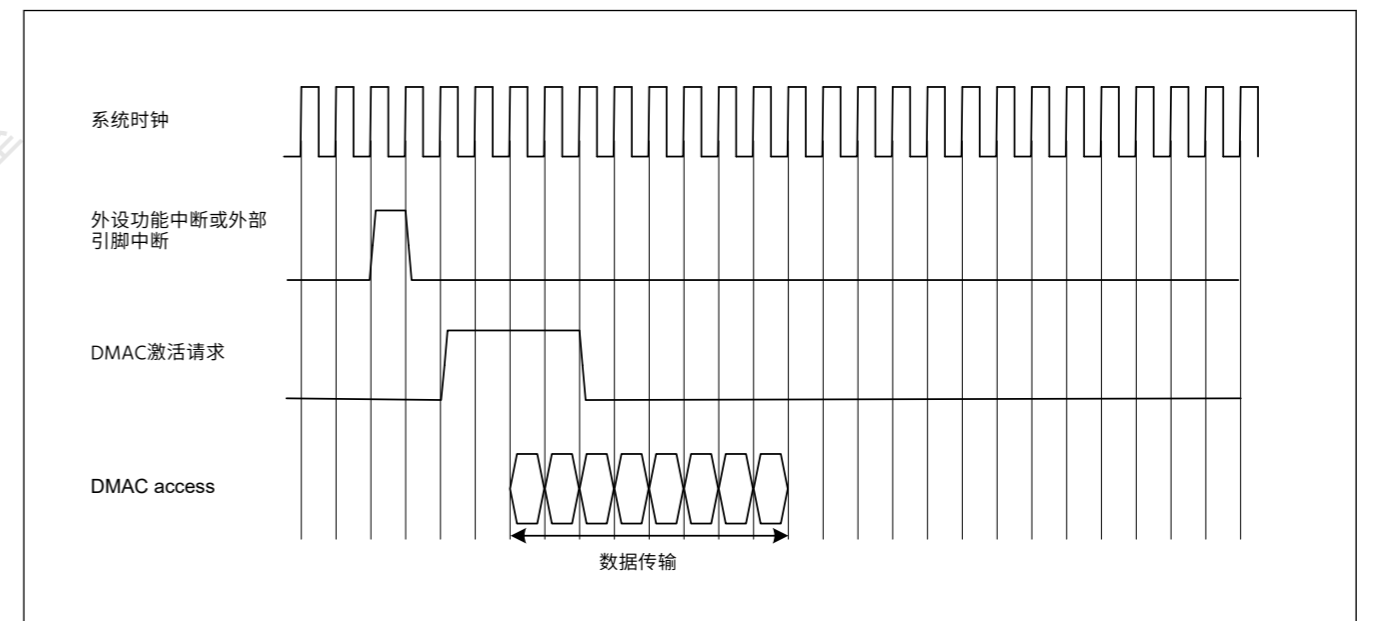


Figure 16.22 DMAC操作时序示例2，通过来自外围模块或外部中断输入引脚的中断激活DMAC，在块大小=4的块传输模式下

16.3.9 DMAC执行周期

表16.18列出了一个DMAC数据传输操作中的执行周期。

Table 16.18 DMAC执行周期

| 传输模式    | 数据传输 (读取) | 数据传输 (写入) |
|---------|-----------|-----------|
| Normal  | Cr+1      | Cw        |
| Repeat  | Cr+1      | Cw        |
| Block*1 | P × Cr    | P × Cw    |

Note: P: 块大小 (DMCRAH寄存器设置) Cr: 数据读取目标访问周期  
 Cw: 数据写入目标访问周期

注1.这是块大小为2或更大的情况。当块大小为1时，应用正常传输周期。

Cr and Cw depend on the access destination. For the number of cycles for each access destination, see [section 42, SRAM](#), [section 44, Flash Memory](#), [section 14, Buses](#). The frequency ratio of the system clock and the peripheral clock is also taken into consideration.

The unit for +1 in “Data Transfer (Read)” column is one system clock cycle (ICLK). For the operation example, see [section 16.3.8. Operation Timing](#).

### 16.3.10 Activating the DMAC

[Table 16.19](#) shows the register setting procedure of normal, repeat and block transfer mode and [Table 16.20](#) shows register setting procedure of repeat-block transfer mode.

**Table 16.19 Register Setting Procedure of Normal Transfer Mode, Repeat Transfer Mode and Block Transfer Mode (1 of 2)**

| No. | Step Name  | Description   |
|-----|--|---|
| 1   | Disable the peripheral function as the DMACn request source.   | To use peripheral function interrupts as DMAC activation sources.<br>Disable the control register for the peripheral function.  |
| 2   | Disable the IRQn pin as the DMACn request source.  | To use external pin interrupts as DMAC activation sources.  |
| 3   | Set the DMACn Event Link select (ICU.DELSRn.DELS[8:0]) to 0x00   | Disable the DMACn request.  |
| 4   | Clear the DMCNT.DTE bit to 0   | Disable DMA transfer.   |
| 5   | Set the interrupt request as a DMACn request source in the DMAC Event Link Setting Register (ICU.DELSRn) by using the ICU.                       | To use internal peripheral interrupts or external pin interrupts as DMAC activation sources.<br>Enable the interrupt bit for the activation source. Set the DMACn activation source.  |
| 6   | Set the peripheral module as a DMACn request source  | To use peripheral function interrupt as a DMAC activation source.<br>Set the control register for the peripheral function without starting it.  |
| 7   | Set the IRQn pin function by using the ICU.  | To use external pin interrupt as a DMAC activation source.<br>Set the IRQn pin function by using the Interrupt Controller Unit.   |
| 8   | Set the DMAMD.DM[1:0] bits<br>Set the DMAMD.SM[1:0] bits<br>Set the DMAMD.DARA[4:0] bits<br>Set the DMAMD.SARA[4:0] bits                         | Set the Transfer destination address update mode bits<br>Set the Transfer source address update mode bits<br>Set the Transfer destination address extended repeat area bits<br>Set the Transfer source address extended repeat area bits  |
| 9   | Set the DMTMD.DCTG[1:0] bits<br>Set the DMTMD.SZ[1:0] bits<br>Set the DMTMD.DTS[1:0] bits<br>Set the DMTMD.MD[1:0] bits<br>Set the DMTMD.TKB bit | Set the Transfer request select bits<br>Set the Data transfer size bits<br>Set the Repeat area select bits<br>Set the Transfer mode select bits<br>Set the transfer keeping select bit  |
| 10  | Set the DMSAR register<br>Set the DMDAR register<br>Set the DMCRA register   | Set the transfer source start address.<br>Set the transfer destination start address.<br>Set the number of transfer operations.   |
| 11  | Set the DMCRB register   | To use block transfer mode or repeat transfer mode.<br>Set the number of block transfer operations.   |
| 12  | Set the DMOFR register   | To use the address update function with offset.<br>Set the offset value.  |
| 13  | Set the DMINT.DTIE bit to 1  | To use the DMA transfer end interrupts.<br>Enable DMACn transfer end interrupts.  |
| 14  | Set the DMINT.RPTIE bit<br>Set the DMINT.SARIE bit<br>Set the DMINT.DARIE bit<br>Set the DMINT.ESIE bit to 1                                     | To use the DMA transfer escape end interrupts<br>Set the repeat size end interrupt.<br>Set the transfer source address extended repeat area overflow interrupt.<br>Set the transfer destination address extended repeat area overflow interrupt.<br>Enable the DMA transfer escape end interrupt. |
| 15  | Set the DMCNT.DTE bit to 1   | Enable DMA transfer.  |

Cr和Cw取决于访问目的地。对于每个访问目标的周期数，请参阅第42节，SRAM，第44节，闪存，第14节，总线。系统时钟和外设时钟的频率比也被考虑在内。

“数据传输（读取）”列中+1的单位是一个系统时钟周期（ICLK）。操作示例见16.3.8节。操作时间。

### 16.3.10 激活DMAC

表16.19显示了正常、重复和块传输模式的寄存器设置过程，表16.20显示了重复块传输模式的寄存器设置过程。

**Table 16.19 正常传输模式、重复传输模式和块传输的寄存器设置过程  
模式 (2个中的1个)**

| No. | 步骤名称  | Description  |
|-----|---|--|
| 1   | 禁用外设功能作为DMACn请求源。   | 使用外设功能中断作为DMAC激活源。禁用外围功能的控制寄存器。  |
| 2   | 禁用IRQn引脚作为DMACn请求源。   | 使用外部引脚中断作为DMAC激活源。   |
| 3   | 将DMACn事件链接选择(ICU.DELSRn.DELS[8:0])设置为0x00   | 禁用DMACn请求。   |
| 4   | 将DMCNT.DTE位清0   | 禁用DMA传输。   |
| 5   | 将中断请求设置为DMACn请求源<br>DMAC事件链接设置寄存器(ICU.DELSRn)通过使用ICU。   | 使用内部外设中断或外部引脚中断作为DMAC激活源。<br>启用激活源的中断位。设置DMACn激活源。                                 |
| 6   | 将外设模块设置为DMACn请求源  | 使用外设功能中断作为DMAC激活源。设置外围功能的控制寄存器而不启动它。   |
| 7   | 使用ICU设置IRQn引脚功能。  | 使用外部引脚中断作为DMAC激活源。<br>使用中断控制器单元设置IRQn引脚功能。   |
| 8   | 设置DMAMD.DM[1:0]位设置<br>DMAMD.SM[1:0]位<br>设置DMAMD.DARA[4:0]位设置<br>DMAMD.SARA[4:0]位                | 设置传输目标地址更新模式位<br>设置传输源地址更新模式位<br>设置传输目标地址扩展重复区域位<br>设置传输源地址扩展重复区域位                 |
| 9   | 设置DMTMD.DCTG[1:0]位<br>设置DMTMD.SZ[1:0]位<br>设置DMTMD.DTS[1:0]位<br>设置DMTMD.MD[1:0]位<br>设置DMTMD.TKB位 | 设置传输请求选择位<br>设置数据传输大小位<br>设置重复区域选择位<br>设置传输模式选择位<br>设置传输保持选择位                      |
| 10  | 设置DMSAR寄存器<br>设置DMDAR寄存器<br>设置DMCRA寄存器  | 设置传输源起始地址。设置传输目的地起始地址。<br>设置传输操作的次数。   |
| 11  | 设置DMCRB寄存器  | 使用块传输模式或重复传输模式。<br>设置块传输操作的数量。   |
| 12  | 设置DMOFR寄存器  | 使用带偏移量的地址更新功能。<br>设置偏移值。   |
| 13  | 将DMINT.DTIE位设置为1  | 使用DMA传输结束中断。启用DMACn传输结束中断。   |
| 14  | 设置DMINT.RPTIE位<br>设置DMINT.SARIE位<br>设置DMINT.DARIE位<br>将DMINT.ESIE位设置为1                          | 使用DMA传输转义结束中断<br>设置重复尺寸结束中断。<br>设置传输源地址扩展重复区溢出中断。设置传输目标地址扩展重复区域溢出中断。启用DMA传输转义结束中断。 |
| 15  | 将DMCNT.DTE位设置为1   | 启用DMA传输。   |



**Table 16.19 Register Setting Procedure of Normal Transfer Mode, Repeat Transfer Mode and Block Transfer Mode (2 of 2)**

| No. | Step Name   | Description   |
|-----|---|---|
| 16  | Set the DMAST.DMST bit to 1                             | Enable DMAC operation. *1<br>Common settings for DMAC   |
| 17  | Start the peripheral function as a DMACn request source | To use peripheral function interrupt as a DMAC activation source  |
| 18  | Enable the IRQn pin as a DMACn request source           | To use external pin interrupt as a DMAC activation source   |
| 19  | End of initial settings                                 | For activation by software<br>On completion of the initial settings, writing 1 to the DMA software start bit (DMREQ.SWREQ) starts DMA transfer. |

Note: n: DMAC channel (n = 0 to 7)

Note 1. The DMAST.DMST bit setting does not necessarily have to follow the settings for the individual activation sources.

**Table 16.20 Register Setting Procedure of Repeat-Block Transfer Mode (1 of 2)**

| No. | Step Name  | Description   |
|-----|--|---|
| 1   | Disable the peripheral function as the DMACn request source.   | To use peripheral function interrupts as DMA activation sources.<br>Disable the control register for the peripheral function.   |
| 2   | Disable the IRQ pin as the DMACn request source.   | To use external pin interrupts as DMA activation sources.   |
| 3   | Set the DMACn Event Link select (ICU.DELSRn.DELS[8:0]) to 00h  | Disable the DMACn request.  |
| 4   | Clear the DMCNT.DTE bit to 0   | Disable DMACn transfer.   |
| 5   | Set the interrupt request as a DMACn request source in the DMACn Event Link Setting Register (ICU.DELSRn) by using the ICU.  | To use internal peripheral interrupts or external pin interrupts as DMA activation sources.<br>Enable the interrupt bit for the activation source.<br>Set the DMACn activation source.  |
| 6   | Set the peripheral module as a DMACn request source  | To use peripheral function interrupt as a DMA activation source.<br>Set the control register for the peripheral function without starting it.   |
| 7   | Set the IRQ pin function by using the Interrupt Controller Unit.   | To use external pin interrupt as a DMA activation source.<br>Set the IRQ pin function by using the Interrupt Controller Unit.   |
| 8   | Set the DMAMD.DM[1:0] bits<br>Set the DMAMD.SM[1:0] bits<br>Set the DMAMD.DARA[4:0] bits<br>Set the DMAMD.SARA[4:0] bits<br>Set the DMAMD.DADR[4:0] bits<br>Set the DMAMD.SADR[4:0] bits | Set the Transfer destination address update mode bits<br>Set the Transfer source address update mode bits<br>Set the Transfer destination address extended repeat area bits<br>Set the Transfer source address extended repeat area bits<br>Set the Transfer destination address update select after reload<br>Set the Transfer source address update select after reload |
| 9   | Set the DMTMD.DCTG[1:0] bits<br>Set the DMTMD.SZ[1:0] bits<br>Set the DMTMD.MD[1:0] bits<br>Set the DMTMD.TKB bit  | Set the Transfer request select bits<br>Set the Data transfer size bits<br>Set the Transfer mode to repeat-block transfer mode<br>Set the transfer keeping select bit   |
| 10  | Set the DMSAR register<br>Set the DMDAR register<br>Set the DMSRR register<br>Set the DMDRR register<br>Set the DMCRA register<br>Set the DMCRB register                                 | Set the transfer source start address<br>Set the transfer destination start address<br>Set the initial value of source start address<br>Set the initial value of destination start address<br>Set the number of transfer operations<br>Set the number of block transfer operations  |
| 11  | Set the DMSBS register<br>Set the DMDBS register   | To use the address update function with incremental, decremental or offset<br>Set the source buffer size and access offset<br>Set the destination buffer size and access offset   |
| 12  | Set the DMINT.DTIE bit to 1  | To use DMA transfer end interrupts.<br>Enable DMACn transfer end interrupts.  |
| 13  | Set the DMCNT.DTE bit to 1   | Enable DMACn transfer   |
| 14  | Set the DMAST.DMST bit to 1  | Enable DMAC operation. *1*1   |
| 15  | Start the peripheral function as a DMACn request source  | To use peripheral function interrupt as a DMA activation source   |

**Table 16.19 正常传输模式、重复传输模式和块传输的寄存器设置过程模式 (2之2)**

| No. | 步骤名称               | Description   |
|-----|--------------------|---|
| 16  | 将DMAST.DMST位设置为1   | 启用DMAC操作。*1<br>DMAC的常用设置                            |
| 17  | 作为DMACn请求源启动外设功能   | 使用外设功能中断作为DMAC激活源                                   |
| 18  | 启用IRQn引脚作为DMACn请求源 | 使用外部引脚中断作为DMAC激活源                                   |
| 19  | 初始设置结束             | 通过软件激活<br>初始设置完成后，将1写入DMA软件启动位(DMREQ.SWREQ)开始DMA传输。 |

Note: n: DMAC通道 (n=0到7)

注1.DMAST.DMST位设置不一定要遵循各个激活源的设置。

**Table 16.20 重复块传输模式的寄存器设置过程 (1of2)**

| No. | 步骤名称   | Description   |
|-----|--|---|
| 1   | 禁用外设功能作为DMACn请求源。  | 使用外设功能中断作为DMA激活源。<br>禁用外围功能的控制寄存器。  |
| 2   | 禁用IRQ引脚作为DMACn请求源。   | 使用外部引脚中断作为DMA激活源。   |
| 3   | 将DMACn事件链接选择(ICU.DELSRn.DELS[8:0])设置为00h   | 禁用DMACn请求。  |
| 4   | 将DMCNT.DTE位清0  | 禁用DMACn传输。  |
| 5   | 将中断请求设置为DMACn请求源<br>DMACn事件链接设置寄存器(ICU.DELSRn)通过使用ICU。   | 使用内部外设中断或外部引脚中断作为DMA激活源。<br>启用激活源的中断位。<br>设置DMACn激活源。   |
| 6   | 将外设模块设置为DMACn请求源   | 使用外设功能中断作为DMA激活源。设置外围功能的控制寄存器而不启动它。   |
| 7   | 使用中断控制器单元设置IRQ引脚功能。  | 使用外部引脚中断作为DMA激活源。<br>使用中断控制器单元设置IRQ引脚功能。  |
| 8   | 设置DMAMD.DM[1:0]位<br>设置DMAMD.SM[1:0]位<br>设置DMAMD.DARA[4:0]位<br>设置DMAMD.SARA[4:0]位<br>设置DMAMD.DADR[4:0]位<br>设置DMAMD.SADR[4:0]位 | 设置传输目标地址更新模式位<br>设置传输源地址更新模式位<br>设置传输目标地址扩展重复区域位<br>设置传输源地址扩展重复区域位<br>设置重复后传输目标地址更新选择<br>重新加载后设置传输源地址更新选择 |
| 9   | 设置DMTMD.DCTG[1:0]位<br>设置DMTMD.SZ[1:0]位<br>设置DMTMD.MD[1:0]位<br>设置DMTMD.TKB位   | 设置传输请求选择位<br>设置数据传输大小位<br>将传输模式设置为重复块传输模式<br>设置传输保持选择位  |
| 10  | 设置DMSAR寄存器<br>设置DMDAR寄存器<br>设置DMSRR寄存器<br>设置DMDRR寄存器<br>设置DMCRA寄存器<br>设置DMCRB寄存器   | 设置传输源起始地址<br>设置传输目标起始地址<br>设置源起始地址的初始值<br>设置目的起始地址的初始值<br>设置传输操作的次数<br>设置块传输操作的数量                         |
| 11  | 设置DMSBS寄存器<br>设置DMDBS寄存器   | 使用增量、减量或偏移的地址更新功能设置源缓冲区大小和访问偏移量<br><br>设置目标缓冲区大小和访问偏移量  |
| 12  | 将DMINT.DTIE位设置为1   | 使用DMA传输结束中断。<br>启用DMACn传输结束中断。  |
| 13  | 将DMCNT.DTE位设置为1  | 启用DMACn传输   |
| 14  | 将DMAST.DMST位设置为1   | 启用DMAC操作。*1*1   |
| 15  | 作为DMACn请求源启动外设功能   | 使用外设功能中断作为DMA激活源  |

**Table 16.20 Register Setting Procedure of Repeat-Block Transfer Mode (2 of 2)**

| No. | Step Name                                    | Description   |
|-----|--|---|
| 16  | Enable the IRQ pin as a DMACn request source | To use external pin interrupt as a DMA activation source  |
| 17  | End of initial settings                      | For activation by software<br>On completion of the initial settings, writing 1 to the DMA software start bit (DMREQ.SWREQ) starts DMA transfer. |

Note: m: DELSRn.DELS bit number (m = 0 to 8)  
n: DMAC channel (n = 0 to 7)

Note 1. The DMAST.DMST bit setting does not necessarily have to follow the settings for the individual activation sources.

### 16.3.11 Starting DMA Transfer

To enable the DMA transfer, set the DMCNT.DTE bit to 1 (enable the DMA transfer), and then set the DMAST.DMST bit to 1 (enable the DMAC activation).

New activation requests are not accepted during the transfer of another DMAC channel or DTC. When the preceding transfer is complete, channel arbitration selects the DMA transfer request of the highest priority channel, and the DMA transfer of that channel starts. When the DMA transfer starts, the DMSTS.ACT flag is set to 1 (the DMAC is in the active state).

### 16.3.12 Registers during DMA Transfer

The DMAC registers are updated by a DMA transfer. The value to be updated differs according to the other settings and the transfer state. The registers to be updated are DMSAR, DMDAR, DMCRA, DMCRB, DMSBS, DMDBS, DMCNT, and DMSTS.

#### DMA Source Address Register (DMSAR)

When data has been transferred in response to one transfer request, the contents of DMSAR are updated to the address to be accessed by the next transfer request.

For details on register update operation in each transfer mode, see [Table 16.5](#) to [Table 16.13](#).

#### DMA Destination Address Register (DMDAR)

When data has been transferred in response to one transfer request, the contents of DMDAR are updated to the address to be accessed by the next transfer request.

For details on register update operation in each transfer mode, see [Table 16.5](#) to [Table 16.13](#).

#### DMA Transfer Count Register (DMCRA)

When data has been transferred in response to one transfer request, the count value is updated. The update operation depends on the transfer mode selected.

For details on register update operation in each transfer mode, see [Table 16.5](#) to [Table 16.13](#).

#### DMA Block Transfer Count Register (DMCRB)

When data has been transferred in response to one transfer request, the count value is updated. The update operation depends on the transfer mode selected.

For details on register update operation in each transfer mode, see [Table 16.5](#) to [Table 16.13](#).

#### DMA Source Buffer Size Register (DMSBS)

When data has been transferred in response to one transfer request, the count value is updated. The update operation depends on the transfer mode selected.

For details on register update operation in each transfer mode, refer to [Table 16.8](#) to [Table 16.13](#).

#### DMA Destination Buffer Size Register (DMDBS)

When data has been transferred in response to one transfer request, the count value is updated. The update operation depends on the transfer mode selected.

For details on register update operation in each transfer mode, refer to [Table 16.8](#) to [Table 16.13](#).

**Table 16.20 重复块传输模式的寄存器设置过程(2of2)**

| No. | 步骤名称              | Description   |
|-----|-------------------|---|
| 16  | 启用IRQ引脚作为DMACn请求源 | 使用外部引脚中断作为DMA激活源                                      |
| 17  | 初始设置结束            | 通过软件激活<br>初始设置完成后, 将1写入DMA软件启动位(DMREQ.SWR EQ)开始DMA传输。 |

Note: m: DELSRn.DELS位号 (m=0到8) n: DMAC通道 (n=0到7)

注1.DMAST.DMST位设置不一定要遵循各个激活源的设置。

### 16.3.11 启动DMA传输

要启用DMA传输, 请将DMCNT.DTE位设置为1 (启用DMA传输), 然后将DMAST.DMST位设置为1 (启用DMAC激活)。

在传输另一个DMAC通道或DTC期间不接受新的激活请求。当前面的传输完成后, 通道仲裁选择最高优先级通道的DMA传输请求, 并开始该通道的DMA传输。当DMA传输开始时, DMSTS.ACT标志设置为1 (DMAC处于活动状态)。

### 16.3.12 DMA传输期间的寄存器

DMAC寄存器由DMA传输更新。要更新的值根据其他设置和传输状态而有所不同。要更新的寄存器是DMSAR、DMDAR、DMCRA、DMCRB、DMSBS、DMDBS、DMCNT和DMSTS。

#### DMA源地址寄存器(DMSAR)

当响应一个传输请求而传输了数据时, DMSAR的内容将更新为下一个传输请求要访问的地址。

每种传输模式下寄存器更新操作的详细信息, 请参见表16.5至表16.13。

#### DMA目标地址寄存器(DMDAR)

当响应一个传输请求传输了数据时, DMDAR的内容被更新为下一个传输请求要访问的地址。

每种传输模式下寄存器更新操作的详细信息, 请参见表16.5至表16.13。

#### DMA传输计数寄存器(DMCRA)

当响应一个传输请求传输数据时, 更新计数值。更新操作取决于选择的传输模式。

每种传输模式下寄存器更新操作的详细信息, 请参见表16.5至表16.13。

#### DMA块传输计数寄存器(DMCRB)

当响应一个传输请求传输数据时, 更新计数值。更新操作取决于选择的传输模式。

每种传输模式下寄存器更新操作的详细信息, 请参见表16.5至表16.13。

#### DMA源缓冲区大小寄存器(DMSBS)

当响应一个传输请求传输数据时, 更新计数值。更新操作取决于选择的传输模式。

有关各传输模式下的寄存器更新操作的详细信息, 请参阅表16.8至表16.13。

#### DMA目标缓冲区大小寄存器(DMDBS)

当响应一个传输请求传输数据时, 更新计数值。更新操作取决于选择的传输模式。

有关各传输模式下的寄存器更新操作的详细信息, 请参阅表16.8至表16.13。



**DMA Transfer Enable Bit (DMCNT.DTE)**

Although the DMCNT.DTE bit enables or disables data transfer by the register write access, it is automatically cleared to 0 by the DMAC according to the DMA transfer state.

The conditions for clearing this bit by the DMAC are as follows:

- When the specified total volume of data transfer is completed
- When DMA transfer is stopped by the repeat size end interrupt
- When DMA transfer is stopped by the extended repeat area overflow interrupt
- When DMA transfer error occurs

Writing to the registers for the channels when the corresponding DMCNT.DTE bit is set to 1 is prohibited (except for DMCNT). In this case, writing must be performed after the bit is cleared to 0.

**DMAC Active Flag (DMSTS.ACT)**

The DMSTS.ACT flag indicates whether the DMACn is in the idle or active state.

This flag is set to 1 when the DMAC starts data transfer, and is cleared to 0 when data transfer in response to one transfer request is completed.

Even when DMA transfer is stopped by writing 0 to the DMCNT.DTE bit during DMA transfer, this flag remains 1 until DMA transfer is completed.

**Transfer End Interrupt Flag (DMSTS.DTIF)**

The DMSTS.DTIF flag is set to 1 after DMA transfer of the total transfer size of data is completed.

When both this flag and the DMINT.DTIE bit are set to 1, a transfer end interrupt is requested.

This flag is set to 1 when the DMA transfer bus cycle is completed and the DMSTS.ACT flag is cleared to 0 indicating the DMA transfer end.

This flag is automatically cleared to 0 when the DMCNT.DTE bit is set to 1 during the interrupt handling.

**Transfer Escape End Interrupt Flag (DMSTS.ESIF)**

The DMSTS.ESIF flag is set to 1 when a repeat size end interrupt or extended repeat area overflow interrupt is requested. When this bit and the DMINT.ESIE bit are set to 1, a transfer escape end interrupt is requested.

This flag is set to 1 when the bus cycle of the DMA transfer having caused the interrupt request is completed and the DMSTS.ACT flag is cleared to 0 indicating the DMA transfer end.

This flag is automatically cleared to 0 when the DMCNT.DTE bit is set to 1 during an interrupt handling.

Before sending an interrupt request from the DMAC to the CPU or the DTC, the interrupt control register must be set.

For details, see [section 13, Interrupt Controller Unit \(ICU\)](#).

**16.3.13 Channel Priority**

When multiple DMA transfer requests are present, the DMAC determines the priority of channels that have DMA transfer requests.

- The channel priority is fixed as follows: Channel 0 > Channel 1 > Channel 2 > Channel 3... > Channel 7 (Channel 0: Highest).

When a DMA transfer request is generated during data transfer, channel arbitration is started after the final data has been transferred, and DMA transfer of the higher-priority channel starts.

**16.3.14 Channel Security**

The security attribute of transfer access of DMACn, security attribute of access to register of DMACn, security attribute of access to the ICU.DELSRn register are controlled by ICUSARC.SADMACn bit. For details on the ICUSARC register, see [section 13, Interrupt Controller Unit \(ICU\)](#).

When the ICUSARC.SADMACn bit is 0, transfer of DMACn is secure access for both read and write. At the same time, the registers of channel n and the DELSRn register are protected from a non-secure access.

**DMA传输使能位(DMCNT.DTE)**

虽然DMCNT.DTE位通过寄存器写访问启用或禁用数据传输，但它会根据DMA传输状态由DMAC自动清零。

DMAC清除该位的条件如下：

- 当指定的总数据传输量完成时
- 当DMA传输因重复大小结束中断而停止时
- 当DMA传输因扩展重复区域溢出中断而停止时
- 发生DMA传输错误时

当相应的DMCNT.DTE位设置为1时，禁止写入通道的寄存器（除了DMCNT）。在这种情况下，必须在该位清0后进行写入。

**DMAC活动标志(DMSTS.ACT)**

DMSTS.ACT标志指示DMACn是处于空闲状态还是活动状态。

该标志在DMAC开始数据传输时设置为1，并在响应一个传输请求的数据传输完成时清除为0。

即使在DMA传输期间通过向DMCNT.DTE位写入0来停止DMA传输，该标志仍保持为1，直到DMA传输完成。

**传输结束中断标志(DMSTS.DTIF)**

在数据的总传输大小的DMA传输完成后，DMSTS.DTIF标志设置为1。

当该标志和DMINT.DTIE位都设置为1时，请求传输结束中断。

当DMA传输总线周期完成并且DMSTS.ACT标志被清除为0时，该标志设置为1，表示DMA传输结束。

在中断处理期间，当DMCNT.DTE位设置为1时，该标志自动清零。

**传输转义结束中断标志(DMSTS.ESIF)**

当请求重复大小结束中断或扩展重复区域溢出中断时，DMSTS.ESIF标志设置为1。当该位和DMINT.ESIE位设置为1时，请求传输转义结束中断。

当导致中断请求的DMA传输的总线周期完成并且DMSTS.ACT标志清零，表示DMA传输结束。

在中断处理期间，当DMCNT.DTE位设置为1时，该标志自动清零。

在从DMAC向CPU或DTC发送中断请求之前，必须设置中断控制寄存器。

[有关详细信息，请参阅第13节，中断控制器单元\(ICU\)。](#)

**16.3.13 频道优先级**

当存在多个DMA传输请求时，DMAC确定具有DMA传输请求的通道的优先级。

- 通道优先级固定如下：通道0>通道1>通道2>通道3...>通道7（通道0：最高）。

如果在数据传输过程中产生DMA传输请求，则在传输完最终数据后启动通道仲裁，并开始高优先级通道的DMA传输。

**16.3.14 渠道安全**

DMACn的传输访问的安全属性、DMACn的寄存器访问的安全属性、ICU.DELSRn寄存器的访问的安全属性由ICUSARC.SADMACn位控制。有关ICUSARC寄存器的详细信息，请参见第13节，中断控制器单元(ICU)。

当ICUSARC.SADMACn位为0时，DMACn的传输对于读和写都是安全访问。同时，通道n的寄存器和DELSRn寄存器受到保护，不会被非安全访问。

When the ICUSARC.SADMACn bit is 1, transfer of DMACn is non-secure access for both read and write. At the same time, the registers of channel n and the DELSRn register are non-secure attributes.

Do not write to the ICUSARC.SADMACn bit while DMA transfer of same channel is enabled or a bus master is writing to the DMA registers of same channel.

Figure 16.23 shows security attribute about each DMAC channels.

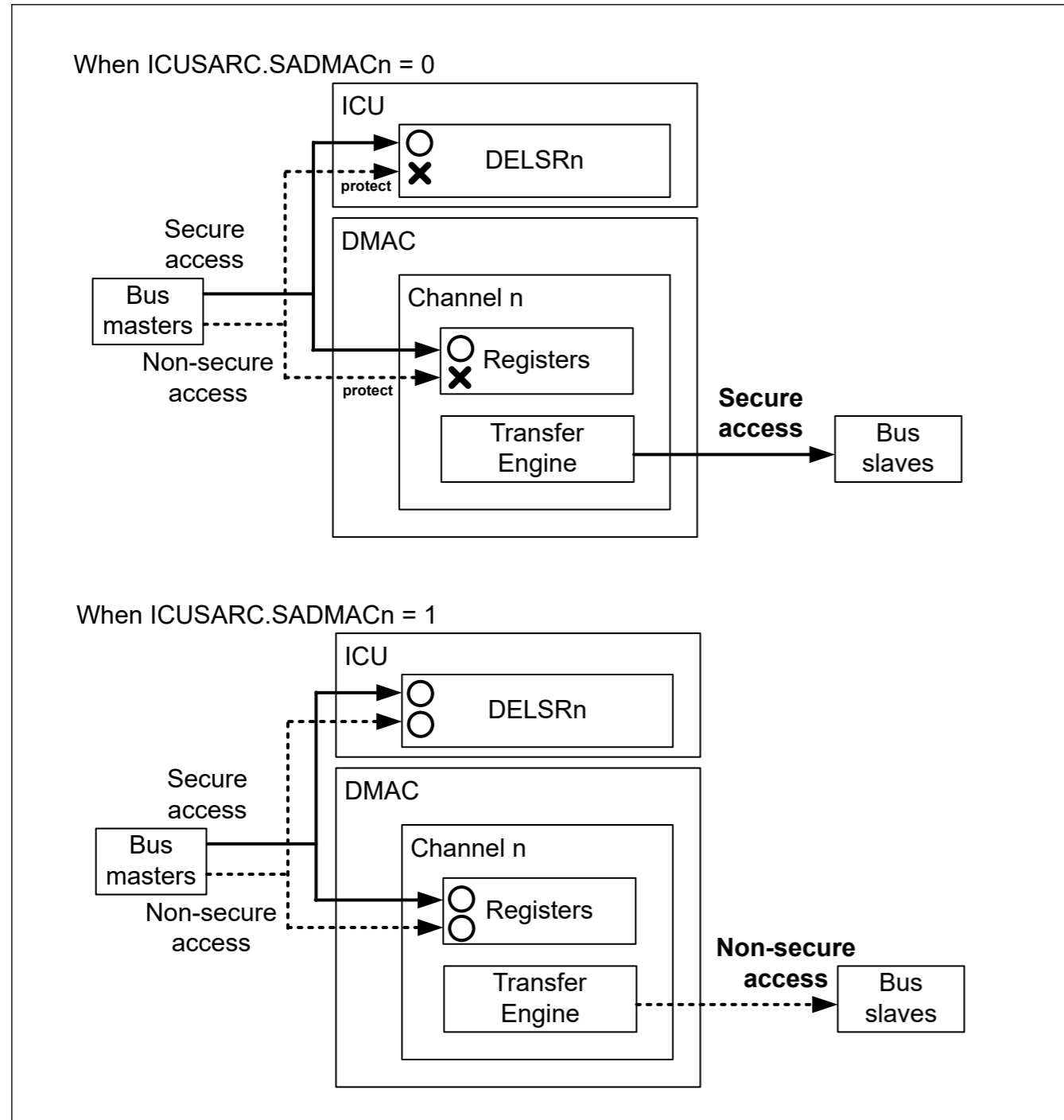


Figure 16.23 Security attribute about each DMAC channels

### 16.3.15 Master TrustZone Filter in DMAC

DMAC has the Master TrustZone Filter. The MasterTrustZone Filter in DMAC can detect the security areas of Flash area(code Flash and data Flash) and SRAM area(ECC / Parity RAM) defined by IDAU. When set No-secure channel

当ICUSARC.SADMACn位为1时，DMACn的传输对于读和写都是非安全访问。同时，通道n的寄存器和DELSRn寄存器是非安全属性。

当启用同一通道的DMA传输或总线主机正在写入同一通道的DMA寄存器时，请勿写入ICUSARC.SADMACn位。

图16.23显示了每个DMAC通道的安全属性。

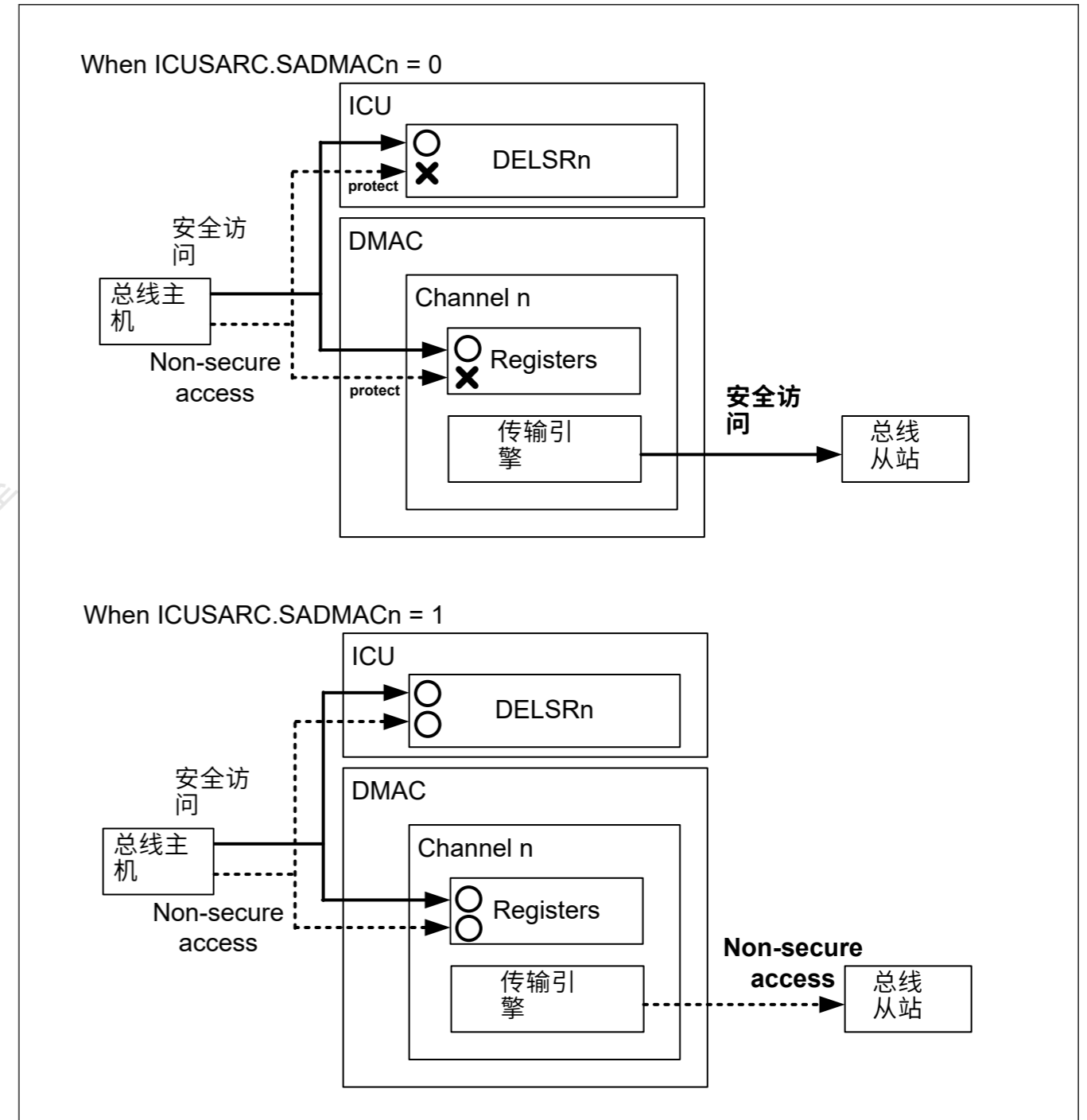


Figure 16.23 每个DMAC通道的安全属性

### 16.3.15 DMAC中的主TrustZone过滤器

DMAC具有MasterTrustZone过滤器。DMAC中的MasterTrustZoneFilter可以检测IDAU定义的Flash区域（代码Flash和数据Flash）和SRAM区域（ECCParityRAM）的安全区域。设置无安全通道时

accesses those addresses, it detects the security violation. Access of violation address is not performed. Detected the error is handled as the Master TrustZone Filter error.

## 16.4 Ending DMA Transfer

The operation for ending DMA transfer depends on the transfer end conditions. When DMA transfer ends, the DMCNT.DTE bit and the DMSTS.ACT flag are changed from 1 to 0, indicating that DMA transfer has ended.

### 16.4.1 Transfer End by Completion of Specified Total Number of Transfer Operations

#### (1) In Normal Transfer Mode (DMTMD.MD[1:0] = 00b)

When the value of DMCRAL changes from 1 to 0, DMA transfer ends on the corresponding channel, and the DMCNT.DTE bit is cleared to 0 and the DMSTS.DTIF flag is set to 1 at the same time. If the DMINT.DTIE bit is 1 at this time, a transfer end interrupt request is issued to the CPU or the DTC.

#### (2) In Repeat Transfer Mode (DMTMD.MD[1:0] = 01b)

When the value of DMCRL changes from 1 to 0, DMA transfer ends on the corresponding channel, and the DMCNT.DTE bit is cleared to 0 and the DMSTS.DTIF flag is set to 1 at the same time. If the DMINT.DTIE bit is 1 at this time, an interrupt request is issued to the CPU or the DTC.

If the DMTMD.TKP bit is 1 (in free-running function), the DMSTS.DTIF bit is set to 1, but the DMCNT.DTE bit is not cleared to 0.

#### (3) In Block Transfer Mode (DMTMD.MD[1:0] = 10b)

When the value of DMCRL changes from 1 to 0, DMA transfer ends on the corresponding channel, and the DMCNT.DTE bit is cleared to 0 and the DMSTS.DTIF flag is set to 1 at the same time. If the DMINT.DTIE bit is 1 at this time, an interrupt request is issued to the CPU or the DTC.

Before sending an interrupt request from the DMAC to the CPU or the DTC, the interrupt control register must be set.

For details, see [section 13, Interrupt Controller Unit \(ICU\)](#).

If the DMTMD.TKP bit is 1 (in free-running function), the DMSTS.DTIF bit is set to 1, but the DMCNT.DTE bit is not cleared to 0.

#### (4) In Repeat-Block Transfer Mode (DMTMD.MD[1:0] = 11b)

When the value of DMCRL changes from 1 to 0, DMA transfer ends on the corresponding channel, and the DMCNT.DTE bit is cleared to 0 and the DMSTS.DTIF flag is set to 1 at the same time. If the DMINT.DTIE bit is 1 at this time, an interrupt request is issued to the CPU or the DTC.

Before sending an interrupt request from the DMAC to the CPU or the DTC, the interrupt control register must be set. For details, see [section 13, Interrupt Controller Unit \(ICU\)](#).

If the DMTMD.TKP bit is 1 (in free-running function), the DMSTS.DTIF bit is set to 1, but the DMCNT.DTE bit is not cleared to 0.

### 16.4.2 Transfer End by Repeat Size End Interrupt

In repeat transfer mode, a repeat size end interrupt is requested when transfer of a 1-repeat size of data is completed while the DMINT.RPTIE bit is set to 1. When the interrupt is requested to complete DMA transfer, the DMCNT.DTE bit is cleared to 0 and the DMSTS.ESIF flag is set to 1 even if the DMTMD.TKP bit is 1 (in free-running function). If the DMINT.ESIE bit is 1 at this time, an interrupt request is issued to the CPU or the DTC. Here, the transfer can be resumed by writing 1 to the DMCNT.DTE bit.

A repeat size end interrupt can be requested also in block transfer mode. In block transfer mode, the interrupt is requested in the same way as in repeat transfer mode when transfer of a 1-block size data is completed.

Repeat size end interrupt cannot be requested in repeat-block transfer mode.

Before sending an interrupt request from the DMAC to the CPU or the DTC, the interrupt control register must be set. For details, see [section 13, Interrupt Controller Unit \(ICU\)](#).

访问这些地址时，它会检测到安全违规。不执行违规地址的访问。检测到的错误作为MasterTrustZoneFilter错误处理。

## 16.4 结束DMA传输

结束DMA传输的操作取决于传输结束条件。当DMA传输结束时，DMCNT.DTE位和DMSTS.ACT标志由1变为0，表示DMA传输已经结束。

### 16.4.1 完成指定的转移操作总数后转移结束

#### (1) 在正常传输模式下 (DMTMD.MD[1:0]=00b)

当DMCRAL的值由1变为0时，相应通道上的DMA传输结束，同时DMCNT.DTE位清0，同时DMSTS.DTIF标志置1。如果此时DMINT.DTIEbit为1，则向CPU或DTC发出传输结束中断请求。

#### (2) 在重复传输模式下(DMTMD.MD[1:0]=01b)

当DMCRBL的值从1变为0时，相应通道上的DMA传输结束，同时DMCNT.DTE位清0，同时DMSTS.DTIF标志置1。如果此时DMINT.DTIE位为1，则向CPU或DTC发出中断请求。

如果DMTMD.TKP位为1（在自由运行功能中），则DMSTS.DTIF位设置为1，但DMCNT.DTE位不清除为0。

#### (3) 在块传输模式下(DMTMD.MD[1:0]=10b)

当DMCRBL的值从1变为0时，相应通道上的DMA传输结束，同时DMCNT.DTE位清0，同时DMSTS.DTIF标志置1。如果此时DMINT.DTIE位为1，则向CPU或DTC发出中断请求。

在从DMAC向CPU或DTC发送中断请求之前，必须设置中断控制寄存器。

有关详细信息，请参阅第13节，中断控制器单元(ICU)。

如果DMTMD.TKP位为1（在自由运行功能中），则DMSTS.DTIF位设置为1，但DMCNT.DTE位不清除为0。

#### (4) 在重复块传输模式下(DMTMD.MD[1:0]=11b)

当DMCRBL的值从1变为0时，相应通道上的DMA传输结束，同时DMCNT.DTE位清0，同时DMSTS.DTIF标志置1。如果此时DMINT.DTIE位为1，则向CPU或DTC发出中断请求。

在从DMAC向CPU或DTC发送中断请求之前，必须设置中断控制寄存器。有关详细信息，请参阅第13节，中断控制器单元(ICU)。

如果DMTMD.TKP位为1（在自由运行功能中），则DMSTS.DTIF位设置为1，但DMCNT.DTE位不清除为0。

### 16.4.2 按重复大小结束传输结束中断

在重复传输模式下，当DMINT.RPTIE位设置为1时完成1次重复大小的数据传输时，请求重复大小结束中断。当请求中断以完成DMA传输时，DMCNT.DTE位即使DMTMD.TKP位为1（在自由运行功能中），清除为0并且DMSTS.ESIF标志设置为1。如果此时DMINT.ESIE位为1，则向CPU或DTC发出中断请求。在这里，可以通过将1写入DMCNT.DTE位来恢复传输。

在块传输模式下也可以请求重复大小结束中断。在块传输模式中，当1块大小的数据传输完成时，以与重复传输模式相同的方式请求中断。

在重复块传输模式下不能请求重复大小结束中断。

在从DMAC向CPU或DTC发送中断请求之前，必须设置中断控制寄存器。有关详细信息，请参阅第13节，中断控制器单元(ICU)。



### 16.4.3 Transfer End by Interrupt on Extended Repeat Area Overflow

When an overflow on the extended repeat area occurs while the extended repeat area is specified and the DMINT.SARIE or DMINT.DARIE bit is set to 1 even if the DMTMD.TKP bit is 1 (in free-running function), an interrupt by an extended repeat area overflow is requested. When the interrupt is requested, the DMA transfer is terminated, the DMCNT.DTE bit is cleared to 0, and the ESIF flag in DMSTS is set to 1. If the DMINT.ESIE bit is 1 at this time, an interrupt request is issued to the CPU or the DTC.

Even if an interrupt by an extended repeat area overflow is requested during a read cycle, the following write cycle is performed.

In block transfer mode, even if an interrupt by an extended repeat area overflow is requested during a 1-block transfer, the remaining data in the block is transferred; transfer is terminated after a block transfer.

An interrupt by an extended repeat area overflow cannot be requested in repeat-block transfer mode.

Before sending an interrupt request from the DMAC to the CPU or the DTC, the interrupt control register must be set. For details, see [section 13, Interrupt Controller Unit \(ICU\)](#).

## 16.5 Processing on DMA Transfer Error

DMA transfer error occurs with the Master TrustZone Filter error in DMAC, the Slave TrustZone Filter error, the Master MPU error, the Slave Bus Error or the Illegal Access Error. If the access error occurs during the DMA transfer, the DMAC immediately stops the transfer of error occurred channel. At this time, the ICU setting of the corresponding channel is also cleared. If there is a request other than the channel which caused the error, it will be re-arbitration as it is.

When the transfer error occurs, DMCNT.DTE of the error causing channel is set to 0. Also, the error response is informed to the ICU.DELSRn of the corresponding channel is cleared. Write back to each register is not performed. Furthermore, it generates the error response detection interrupt request (DMA\_TRANSERR) to notify that an error has occurred by DMAC/DTC transfer.

When the Master TrustZone Filter error occurs, the Slave TrustZone error occurs or the Master MPU error occurs, it is possible to confirm the error information of DMAC by selecting NMI. The DMAC error channel register is cleared by selecting reset. Under the conditions where NMI is generated due to transfer error in DMAC, two interrupts(NMI and DMA\_TRANSERR) are generated. In this case, NMI always responds first.

The error response detection interrupt request (DMA\_TRANSERR) occurs when the Slave Bus error or the Illegal Access error occurs. Furthermore, it occurs after NMI when the error response detection interrupt request (DMA\_TRANSERR) is not cleared in NMI handler.

[section 16.5.1. Processing on NMI handler](#) describes how to confirm the error information of the DMAC in the NMI handler.

[section 16.5.2. Processing on Error response detection interrupt request \(DMA\\_TRANSERR\) handler](#) describes how to confirm the error information of the DMAC in the DMA\_TRANSERR handler.

Interrupts and the error information generated due to transfer errors are shown in [section 16.6.2. Transfer Error Interrupt](#).

### 16.5.1 Processing on NMI handler

The cause of NMI due to the DMA transfer error is the Master TrustZone Filter error, the Slave TrustZone Filter error or the Master MPU error. When NMI occurs due to the DMAC transfer error, the error response detection interrupt request (DMA\_TRANSERR) will occur after the end of NMI handler. It is possible to confirm the cause of the error and the DMAC channel in which the error occurred. When NMI occurs, perform the necessary processing according to the flow described in the ICU chapter.

[Figure 16.24](#) shows the flow for confirm the channel that caused the Master TrustZone Filter Error in DMAC

[Figure 16.25](#) shows the flow for confirm the channel that caused the Slave TrustZone Filter Error in DMAC

[Figure 16.26](#) shows the flow for confirm the channel and Security Attribute that caused the Master MPU error in DMAC.

If completing all processing in NMI handler, it is possible to clear the error response detection interrupt request (DMA\_TRANSERR) that occurs subsequently.

### 16.4.3 扩展重复区溢出中断传输结束

如果在指定扩展重复区域时扩展重复区域发生溢出，并且即使DMTMD.TKP位为1，DMINT.SARIE或DMINT.DARIE位也设置为1（在自由运行功能中），中断由请求扩展重复区域溢出。请求中断时，终止DMA传输，DMCNT.DTE位清0，DMSTS中的ESIF标志置1。如果此时DMINT.ESIE位为1，则发出中断请求到CPU或DTC。

即使在读取周期期间请求由扩展重复区域溢出引起的中断，也会执行下一个写入周期。

在块传输模式下，即使在1块传输期间请求扩展重复区域溢出中断，也会传输块中剩余的数据；块传输后终止传输。

在重复块传输模式下不能请求由扩展重复区域溢出引起的中断。

在从DMAC向CPU或DTC发送中断请求之前，必须设置中断控制寄存器。有关详细信息，请参阅第13节，中断控制器单元(ICU)。

## 16.5 DMA传输错误处理

DMA传输错误发生在DMAC中的MasterTrustZoneFilter错误、SlaveTrustZoneFilter错误、Master MPU错误、从总线错误或非法访问错误。如果在DMA传输过程中发生访问错误，DMAC立即停止发生错误通道的传输。此时相应通道的ICU设置也被清除。如果存在引起错误的通道以外的请求，将按原样重新仲裁。

当发生传输错误时，错误引起通道的DMCNT.DTE设置为0。同时，错误响应被通知给ICU。相应通道的DELSRn被清除。不执行回写到每个寄存器。此外，它会生成错误响应检测中断请求(DMA\_TRANSERR)，以通知DMAC/DTC传输发生错误。

当MasterTrustZoneFilter发生错误、SlaveTrustZone错误或MasterMPU错误时，可以通过选择NMI来确认DMAC的错误信息。通过选择复位来清除DMAC错误通道寄存器。在由于DMAC中的传输错误而产生NMI的情况下，会产生两个中断（NMI和DMA\_TRANSERR）。在这种情况下，NMI总是首先响应。

当发生SlaveBus错误或IllegalAccess错误时，会发生错误响应检测中断请求(DMA\_TRANSERR)。此外，当NMI处理程序中未清除错误响应检测中断请求(DMA\_TRANSERR)时，它会在NMI之后发生。

第16.5.1节。NMIhandler上的处理描述了如何在NMIhandler中确认DMAC的错误信息。

第16.5.2节。错误响应检测中断请求（DMA\_TRANSERR）处理程序的处理描述了如何在DMA\_TRANSERR处理程序中确认DMAC的错误信息。

因传输错误而产生的中断和错误信息见16.6.2节。传输错误中断。

### 16.5.1 在NMI处理程序上处理

由于DMA传输错误导致NMI的原因是MasterTrustZoneFilter错误、SlaveTrustZoneFilter错误或MasterMPU错误。当由于DMAC传输错误而发生NMI时，错误响应检测中断请求(DMA\_TRANSERR)将在NMI处理程序结束后发生。可以确认错误的原因和发生错误的DMAC通道。当发生NMI时，按照ICU章节中描述的流程进行必要的处理。

图16.24显示了在DMAC中确认导致MasterTrustZoneFilterError的通道流程

图16.25显示了在DMAC中确认导致SlaveTrustZoneFilterError的通道流程

图16.26显示了在DMAC中确认导致MasterMPU错误的通道和安全属性的流程。

如果完成NMI处理程序中的所有处理，则可以清除随后发生的错误响应检测中断请求(DMA\_TRANSERR)。

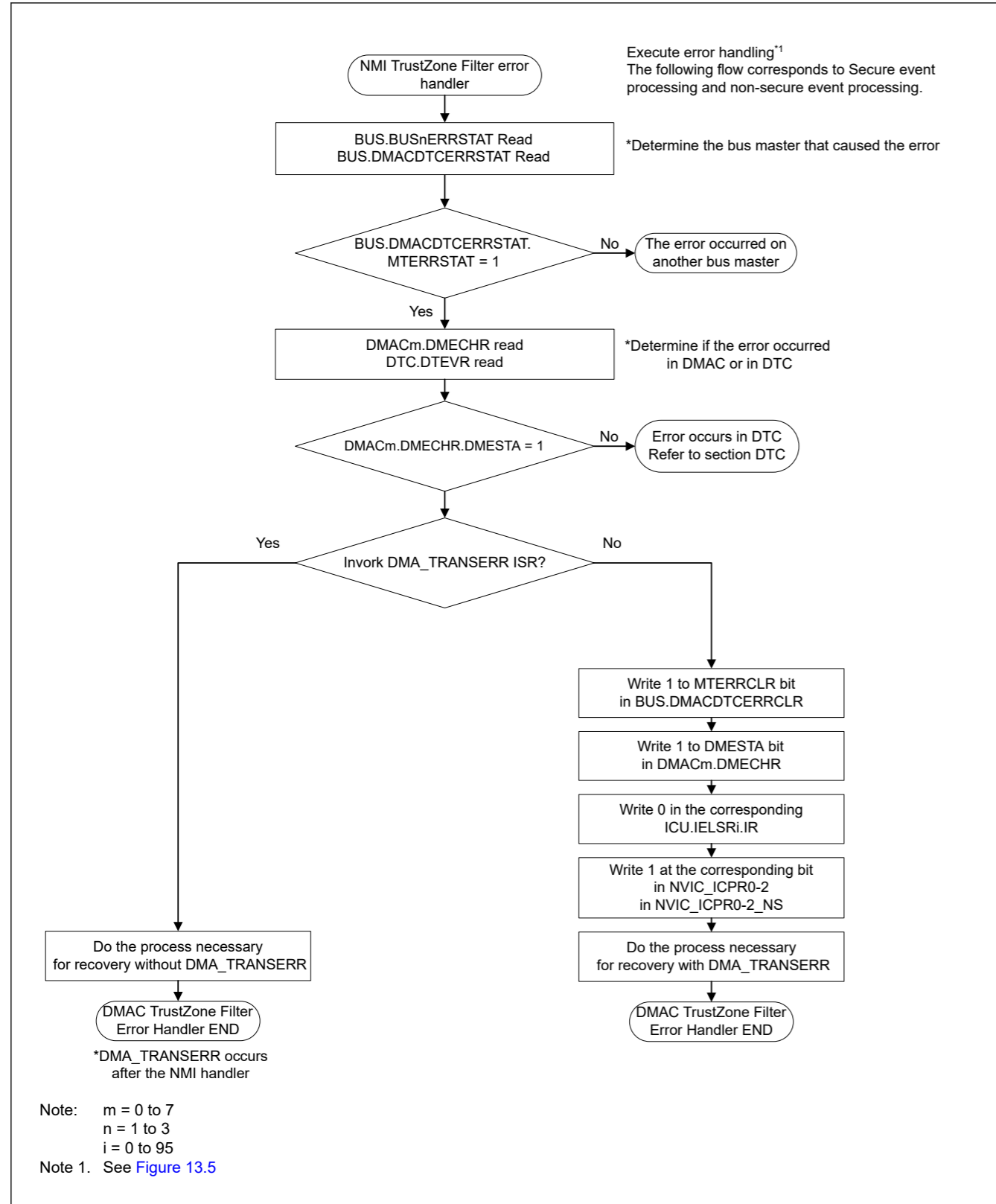


Figure 16.24 Processing in NMI handler by Master TrustZone Filter Error

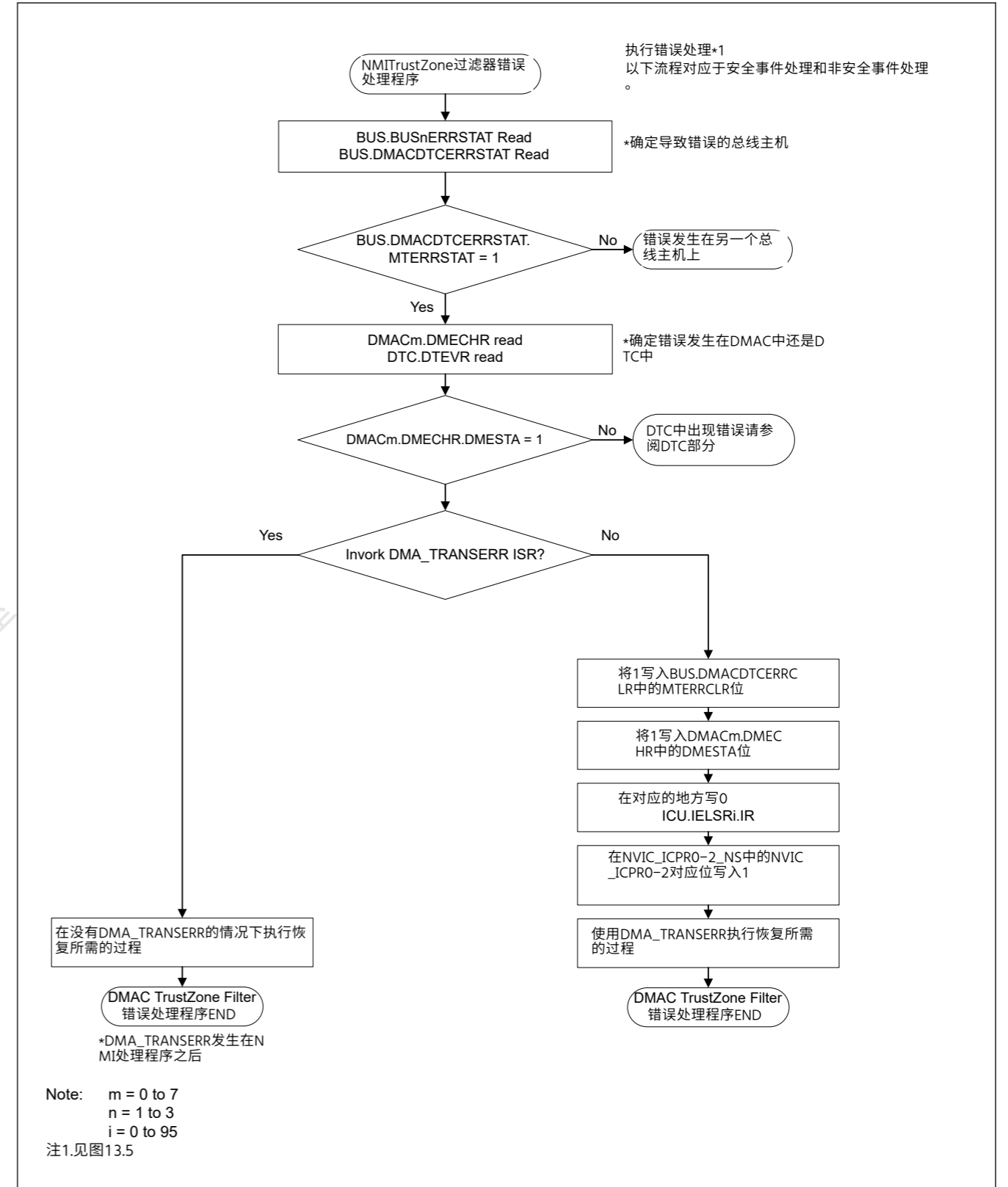


Figure 16.24 主TrustZone过滤器错误在NMI处理程序中的处理



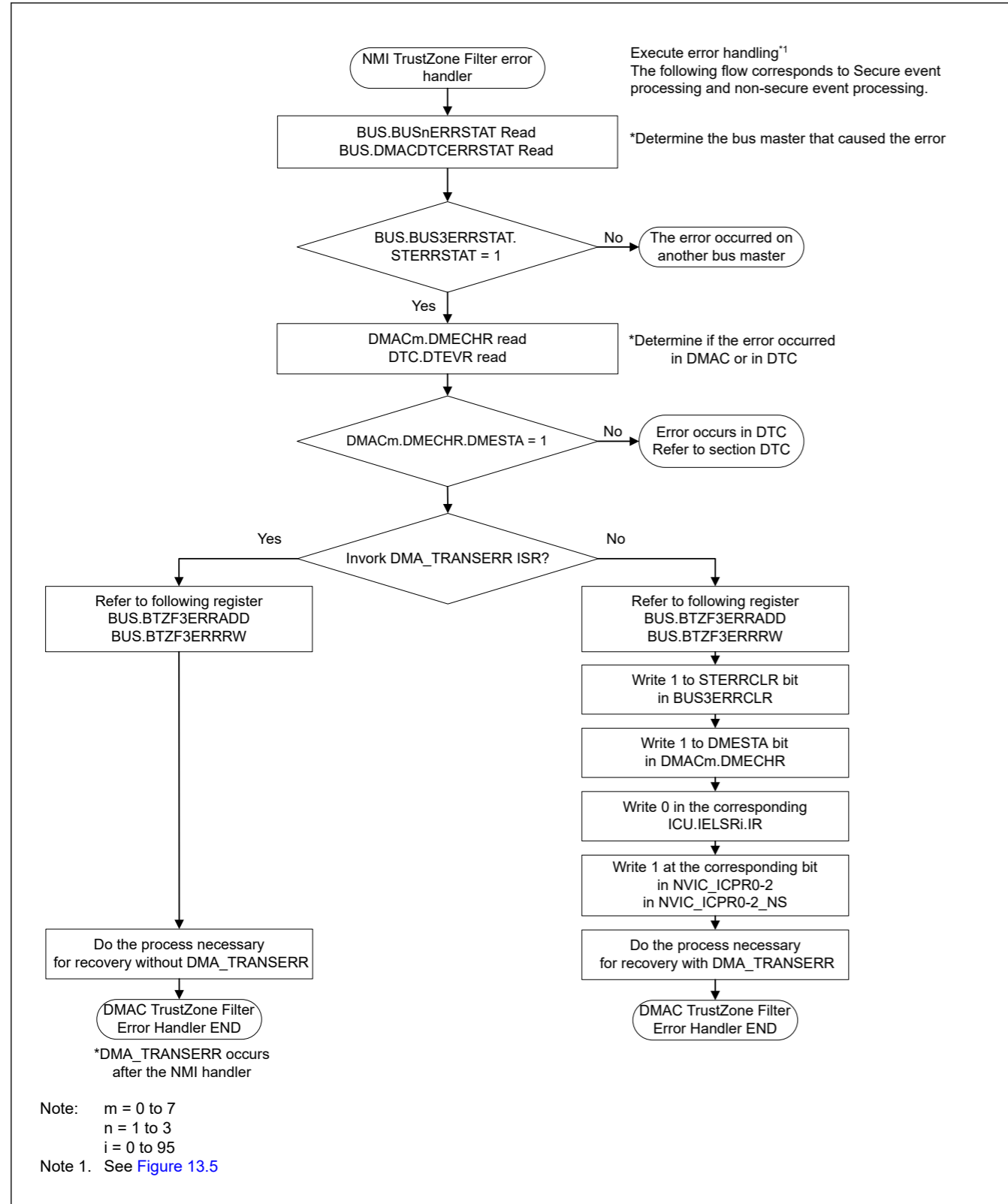


Figure 16.25 Processing in NMI handler by Slave TrustZone Filter Error

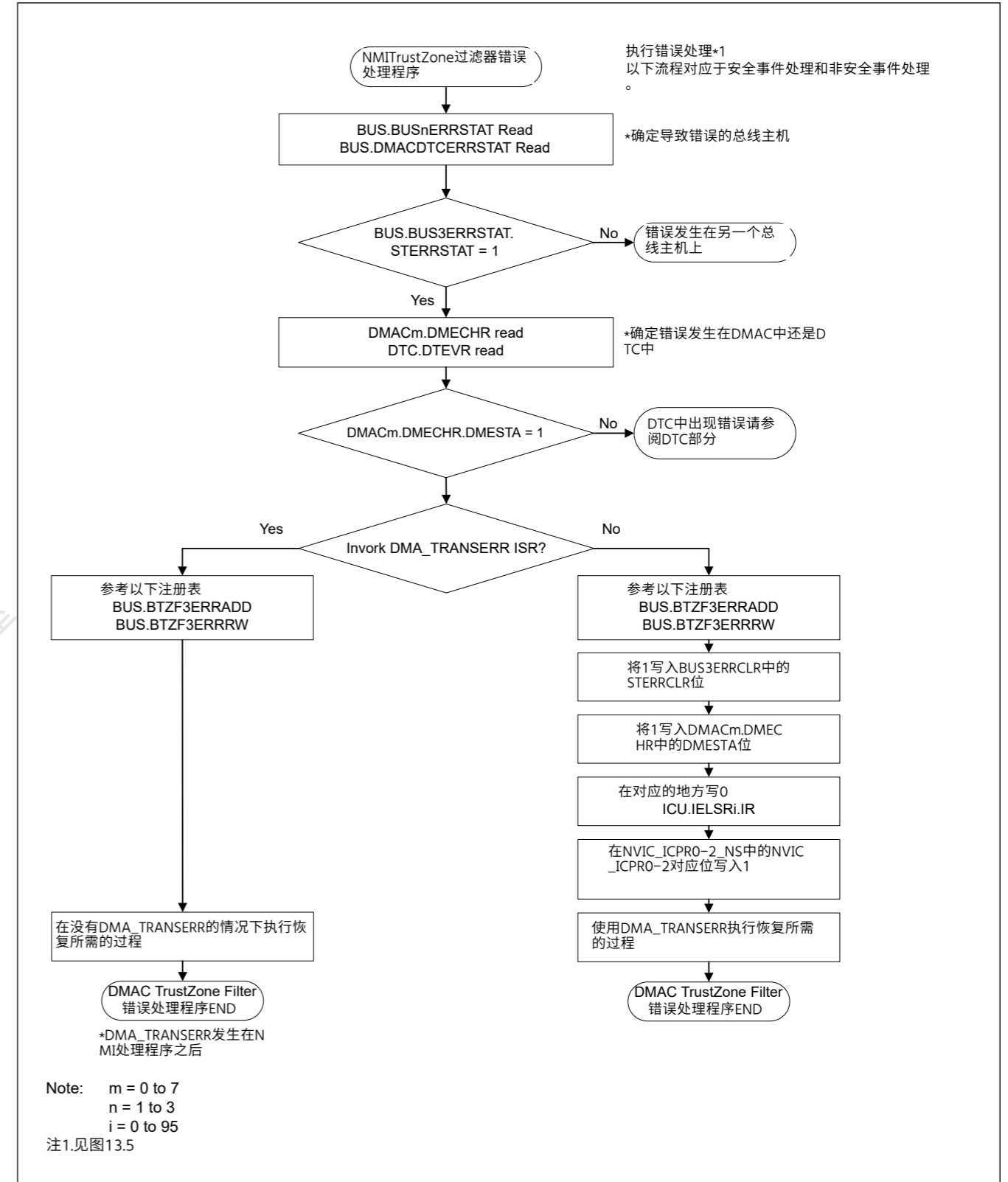


Figure 16.25 从属TrustZone过滤器错误在NMI处理程序中的处理

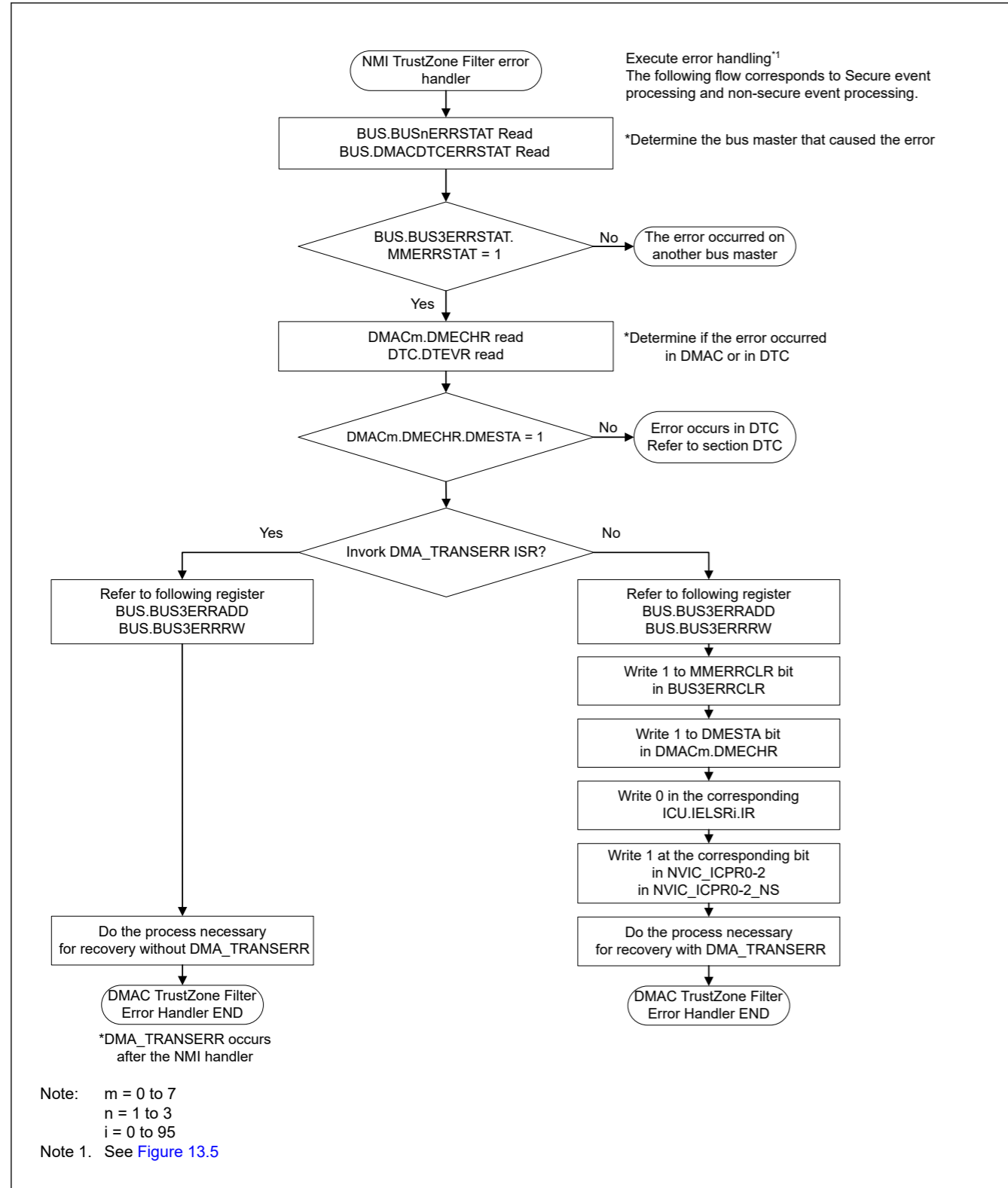


Figure 16.26 Processing in NMI handler by Master MPU Error

### 16.5.2 Processing on Error response detection interrupt request (DMA\_TRANSERR) handler

The cause of error response detection interrupt request (DMA\_TRANSERR) due to DMA transfer error is the Slave Bus Error or Illegal Access Error. Also, it occurs after the NMI handler error response detection interrupt request (DMA\_TRANSERR) is not cleared by the NMI handler.

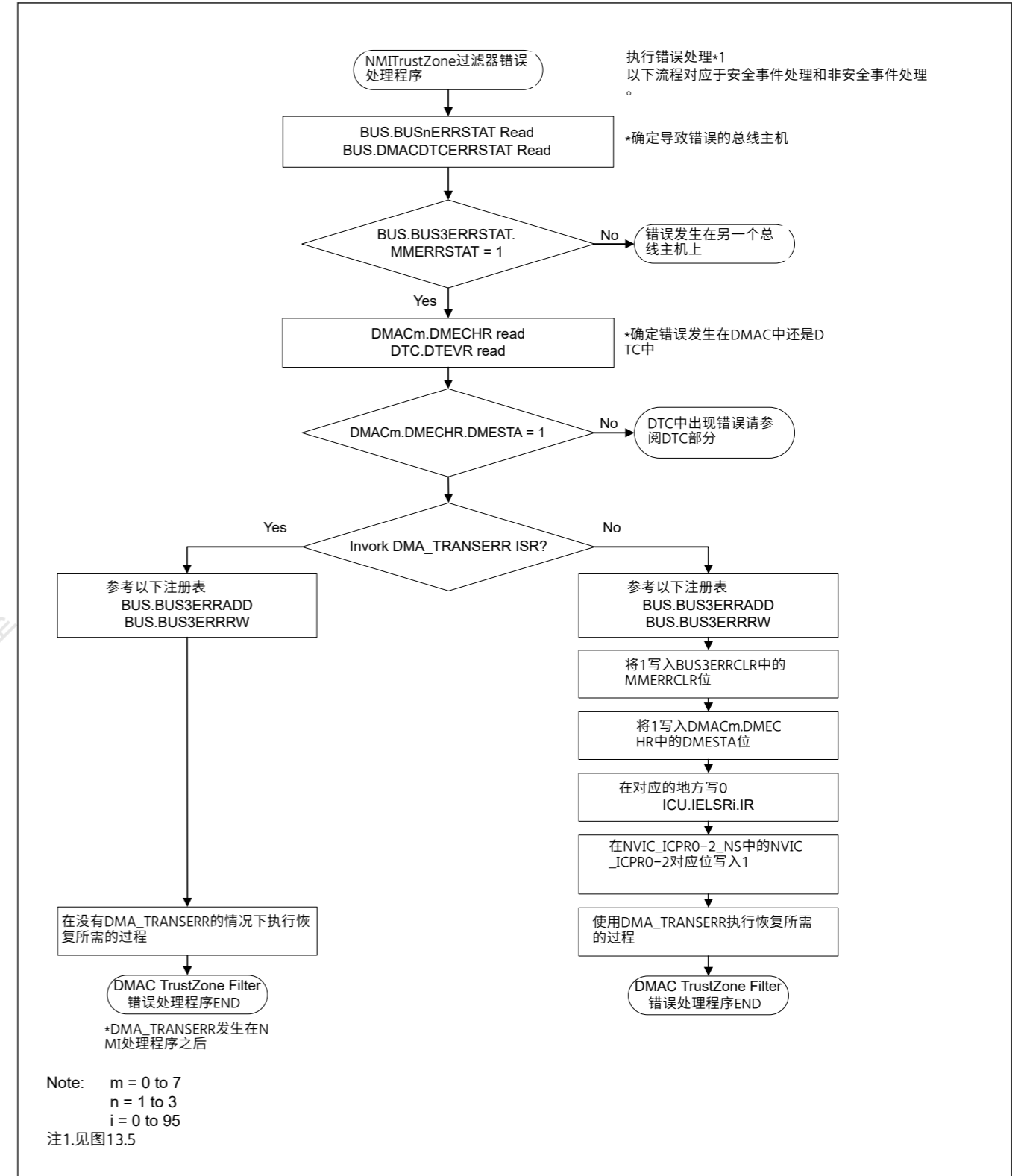


Figure 16.26 主MPU错误在NMI处理程序中的处理

### 16.5.2 错误响应检测中断请求(DMA\_TRANSERR)处理程序的处理

由于DMA传输错误导致错误响应检测中断请求(DMA\_TRANSERR)的原因是从总线错误或非法访问错误。此外，它发生在NMI处理程序错误响应检测中断请求(DMA\_TRANSERR)未被NMI处理程序清除之后。

It is possible to confirm the cause of the error and the DMAC channel in which the error occurred.

Error cause confirmation procedure is shown [Figure 16.27](#).

[Figure 16.28](#) shows the flow for confirm the channel that caused the Master TrustZone Filter Error in DMAC

[Figure 16.29](#) shows the flow for confirm the channel that caused the Slave TrustZone Filter Error in DMAC

[Figure 16.30](#) shows the flow for confirm the channel and Security Attribute that caused the Master MPU Error in DMAC

[Figure 16.31](#) shows the flow for confirm the channel and Security Attribute that caused the Slave Bus Error in DMAC

[Figure 16.32](#) shows the flow for confirm the channel and Security Attribute that caused the Illegal Access Error in DMAC

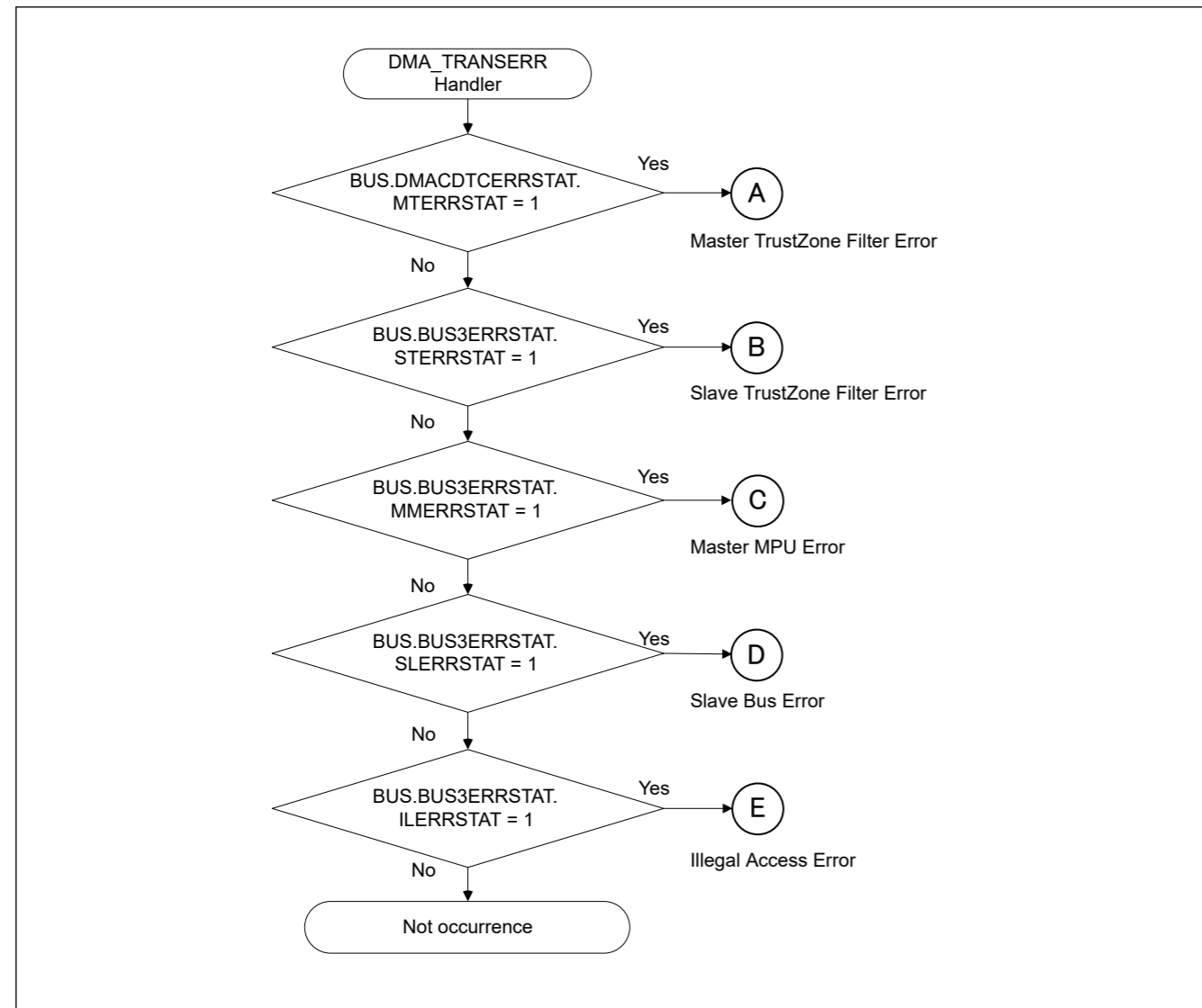


Figure 16.27 Transfer error factor judgment when the error response detection interrupt (DMA\_TRANSERR) occurs

可以确认错误的原因和发生错误的DMAC通道。

错误原因确认流程如图16.27所示。

图16.28显示了在DMAC中确认导致MasterTrustZoneFilterError的通道流程

图16.29显示了在DMAC中确认导致SlaveTrustZoneFilterError的通道流程

图16.30显示了在DMAC中确认导致MasterMPU错误的通道和安全属性的流程

图16.31显示了在DMAC中确认导致SlaveBusError的通道和安全属性的流程

图16.32显示了确认导致DMAC中非法访问错误的通道和安全属性的流程

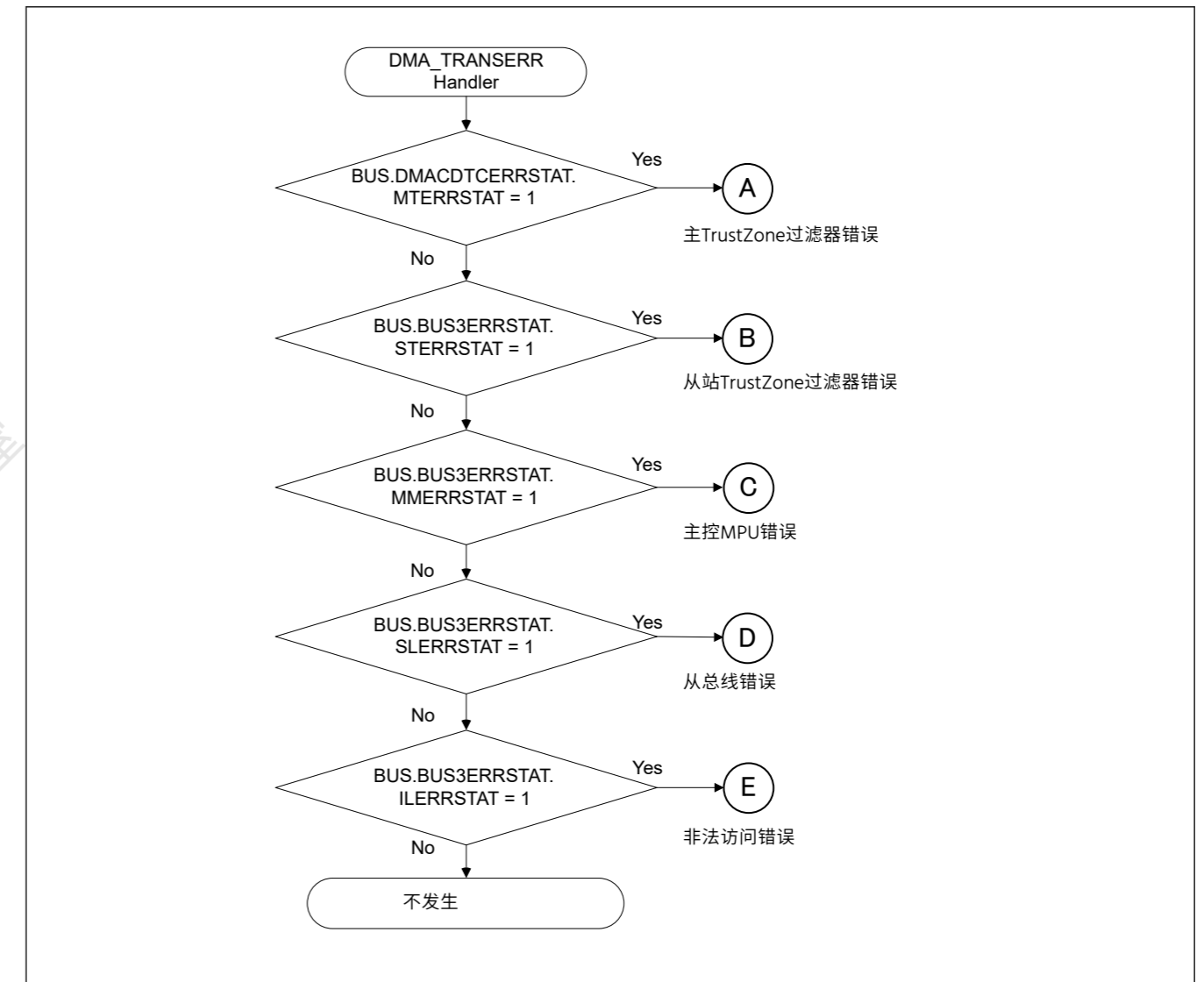


Figure 16.27 发生错误响应检测中断 (DMA\_TRANSERR) 时的传输错误因素判断

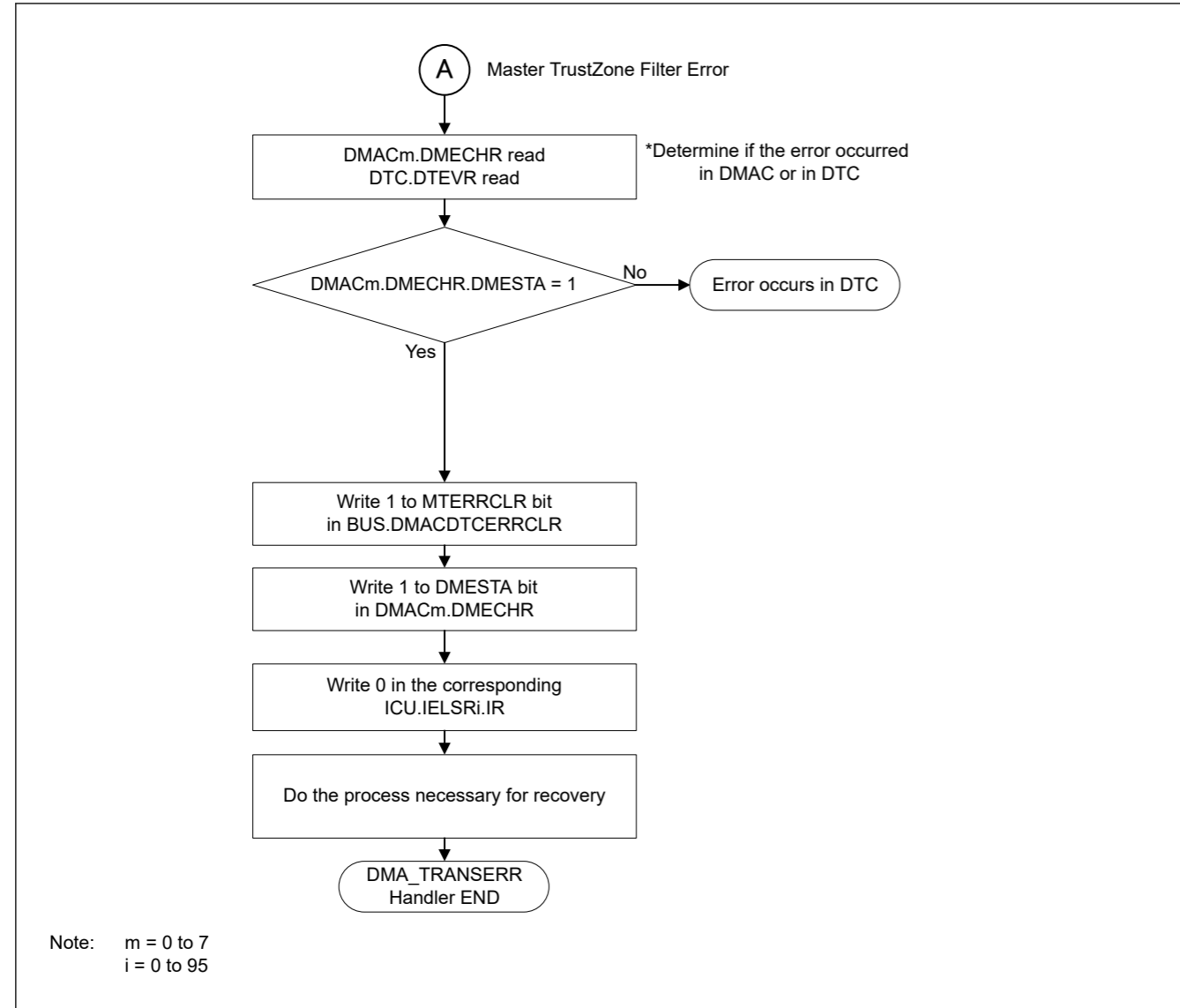


Figure 16.28 Processing in DMA\_TRANSERR handler by Master TrustZone Filter Error

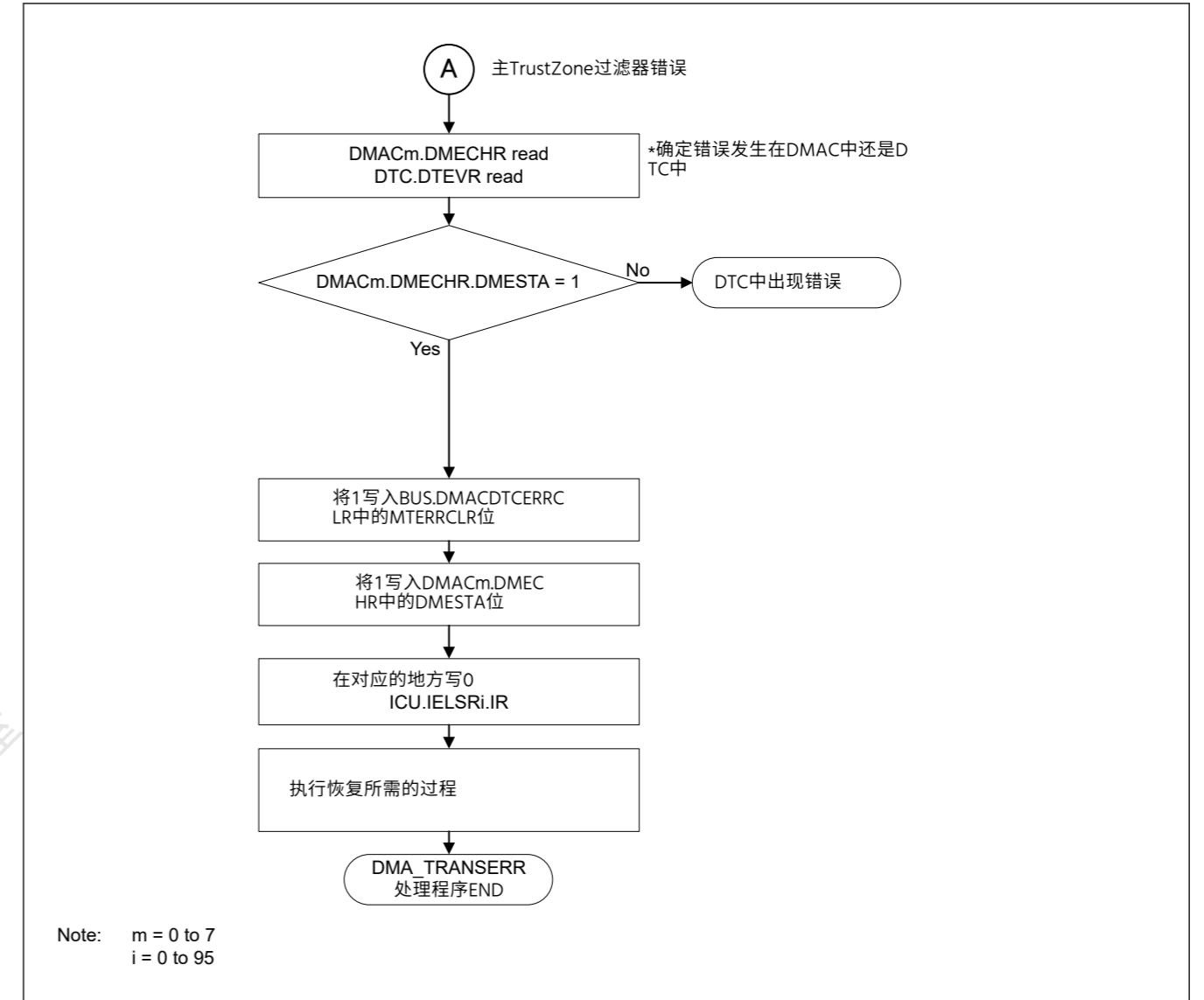


Figure 16.28 MasterTrustZone过滤器错误在DMA\_TRANSERR处理程序中的处理

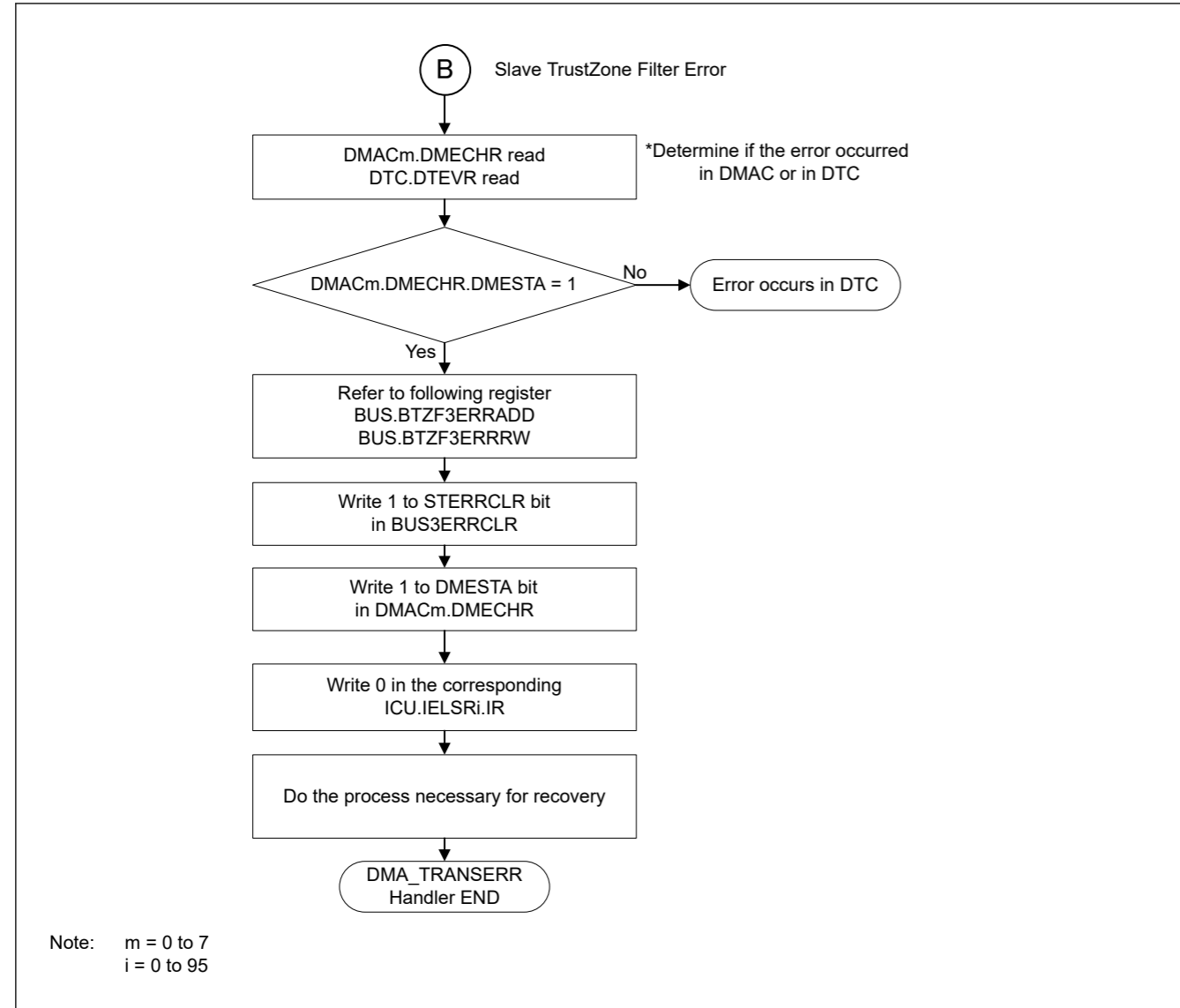


Figure 16.29 Processing in DMA\_TRANSERR handler by Slave TrustZone Filter Error

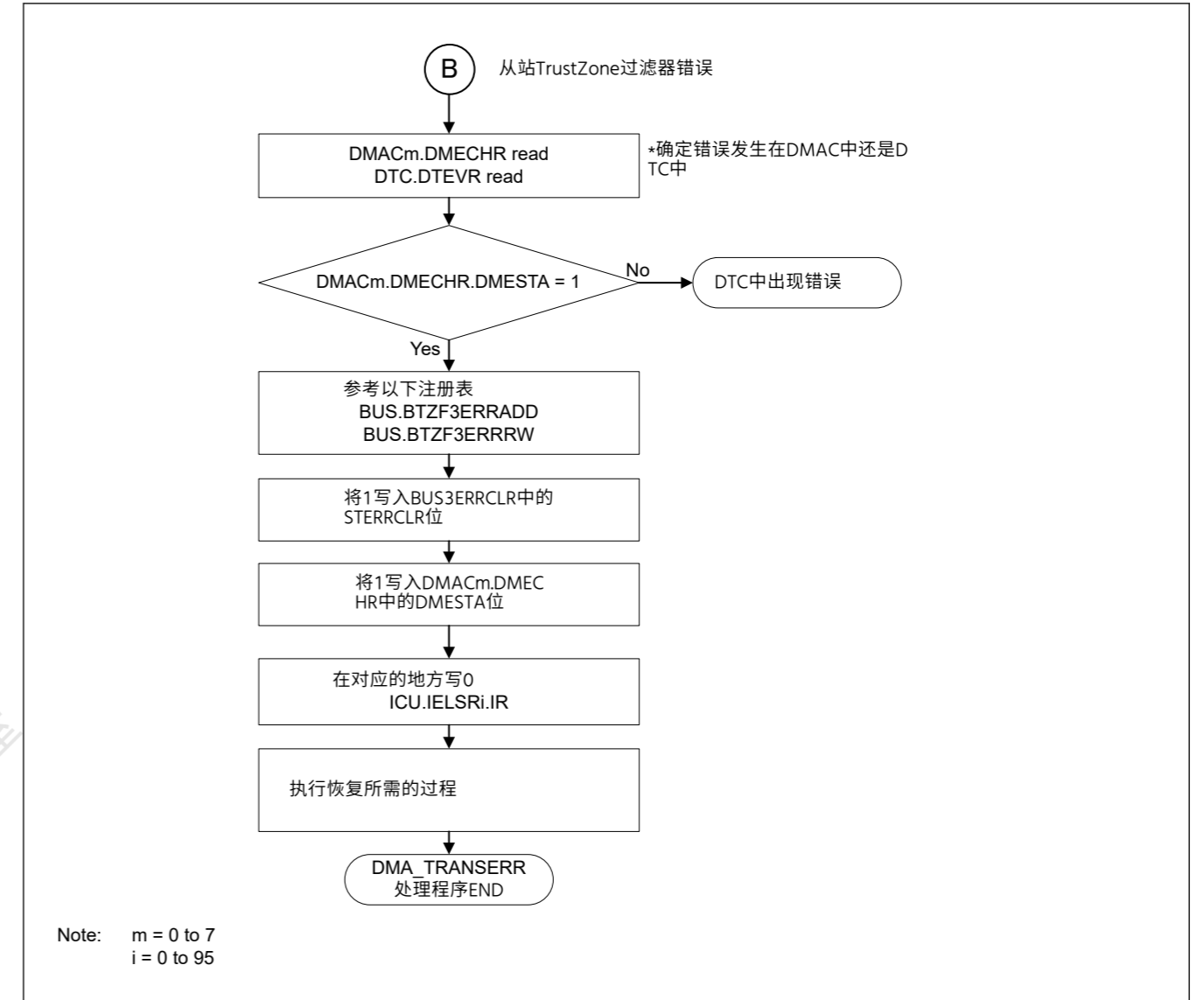


Figure 16.29 从站TrustZone过滤器错误在DMA\_TRANSERR处理程序中的处理



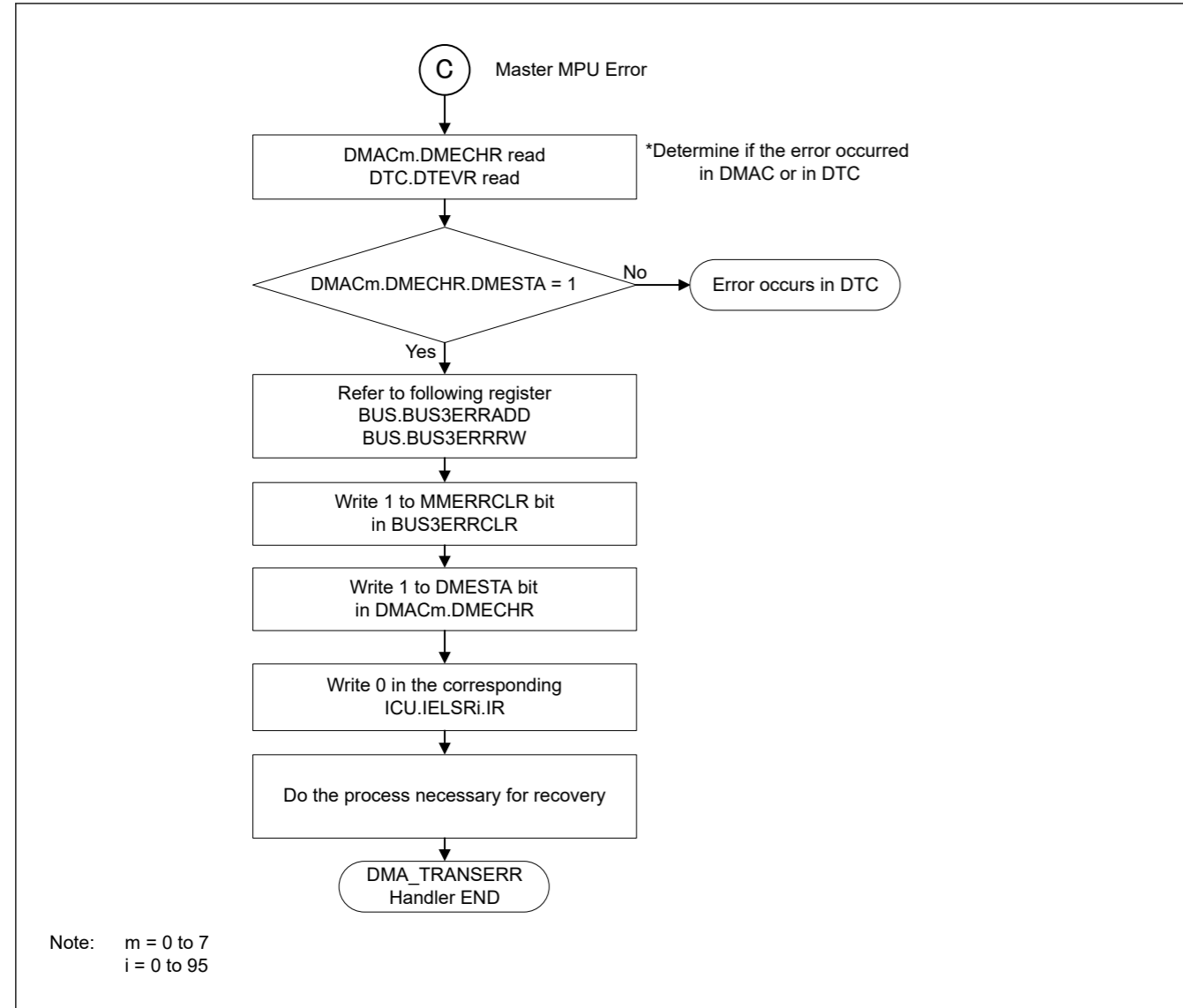


Figure 16.30 Processing in DMA\_TRANSERR handler by Master MPU Error

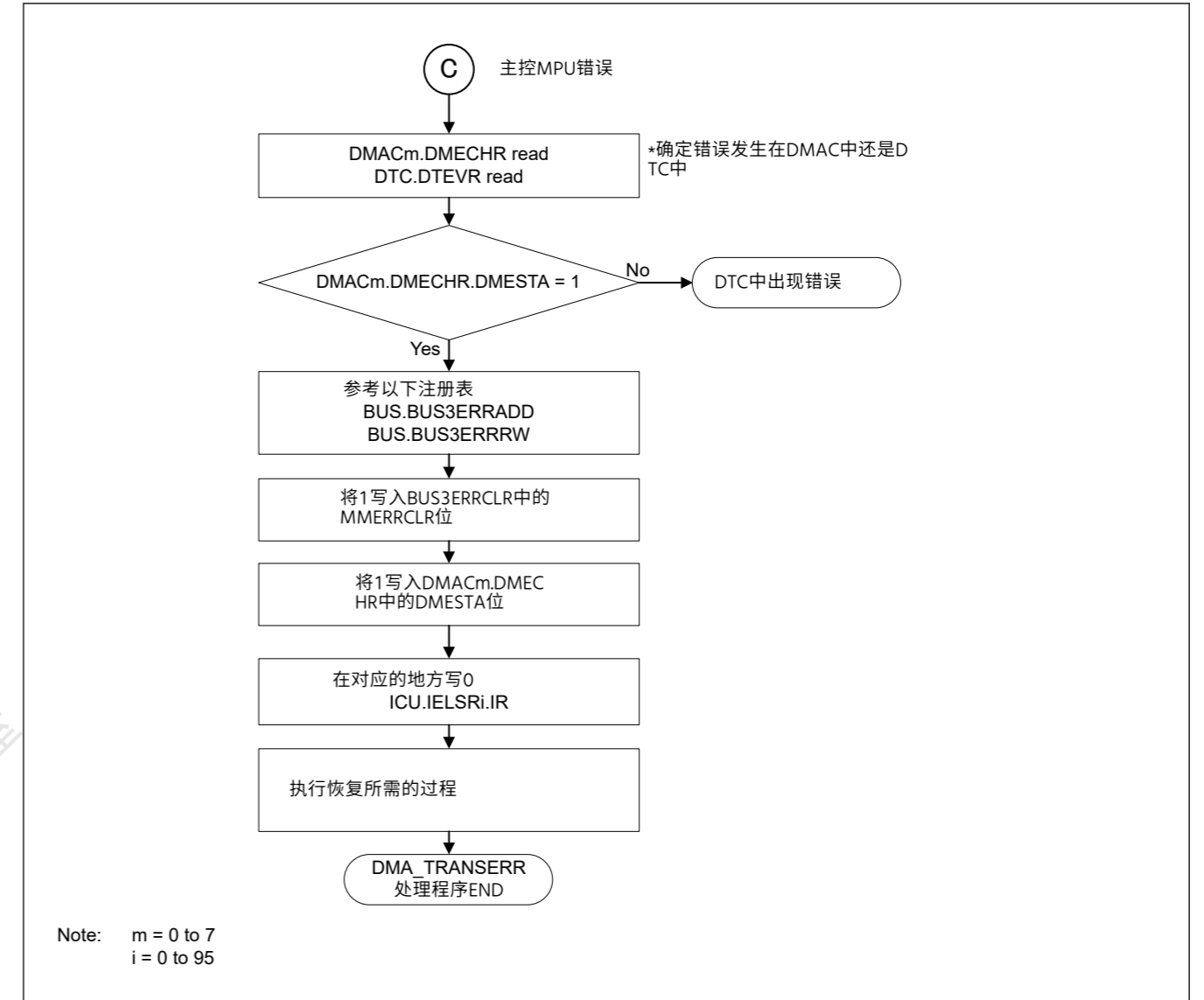


Figure 16.30 主MPU错误在DMA\_TRANSERR处理程序中的处理

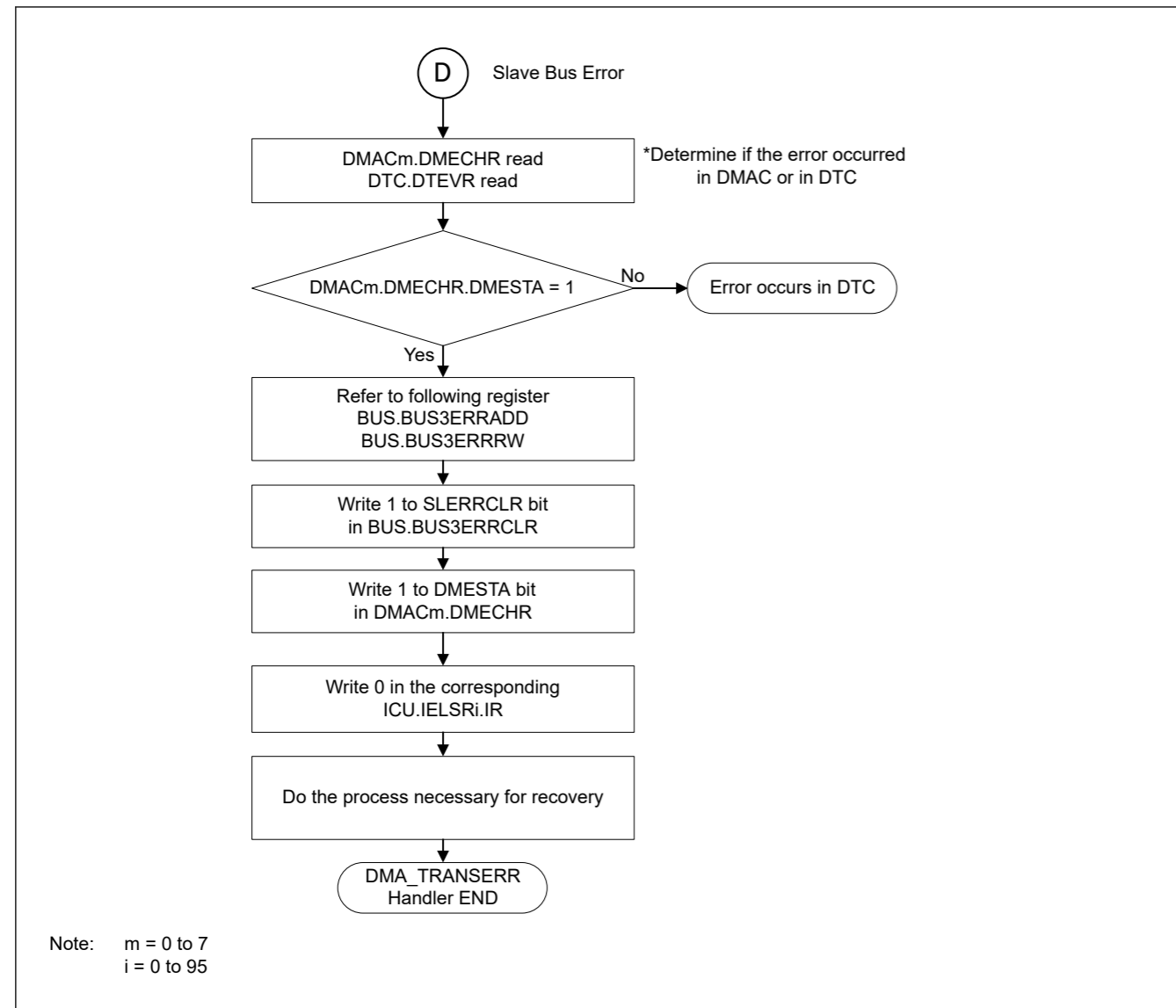


Figure 16.31 Processing in DMA\_TRANSERR handler by Slave Bus Error

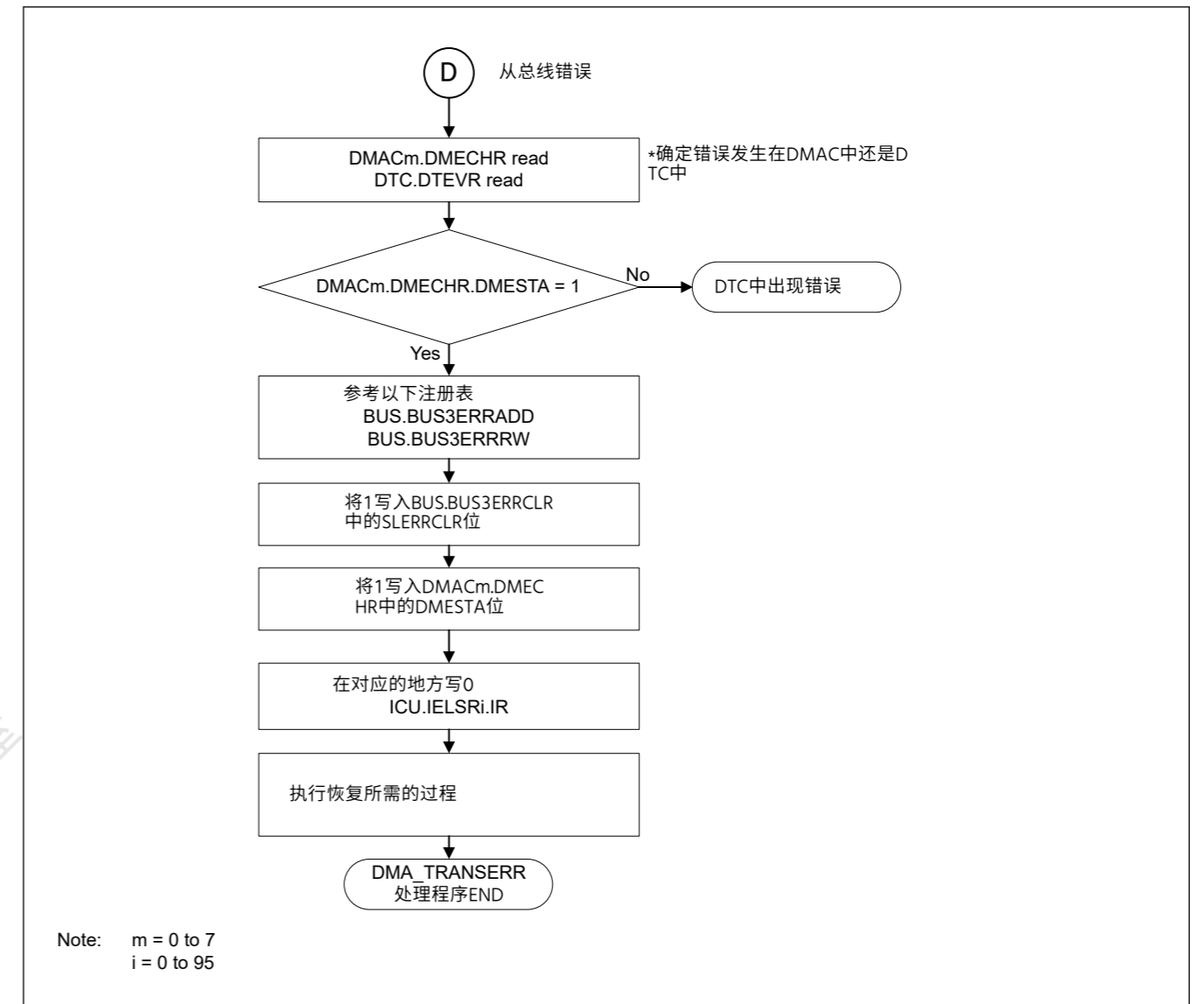


Figure 16.31 从总线错误在DMA\_TRANSERR处理程序中的处理

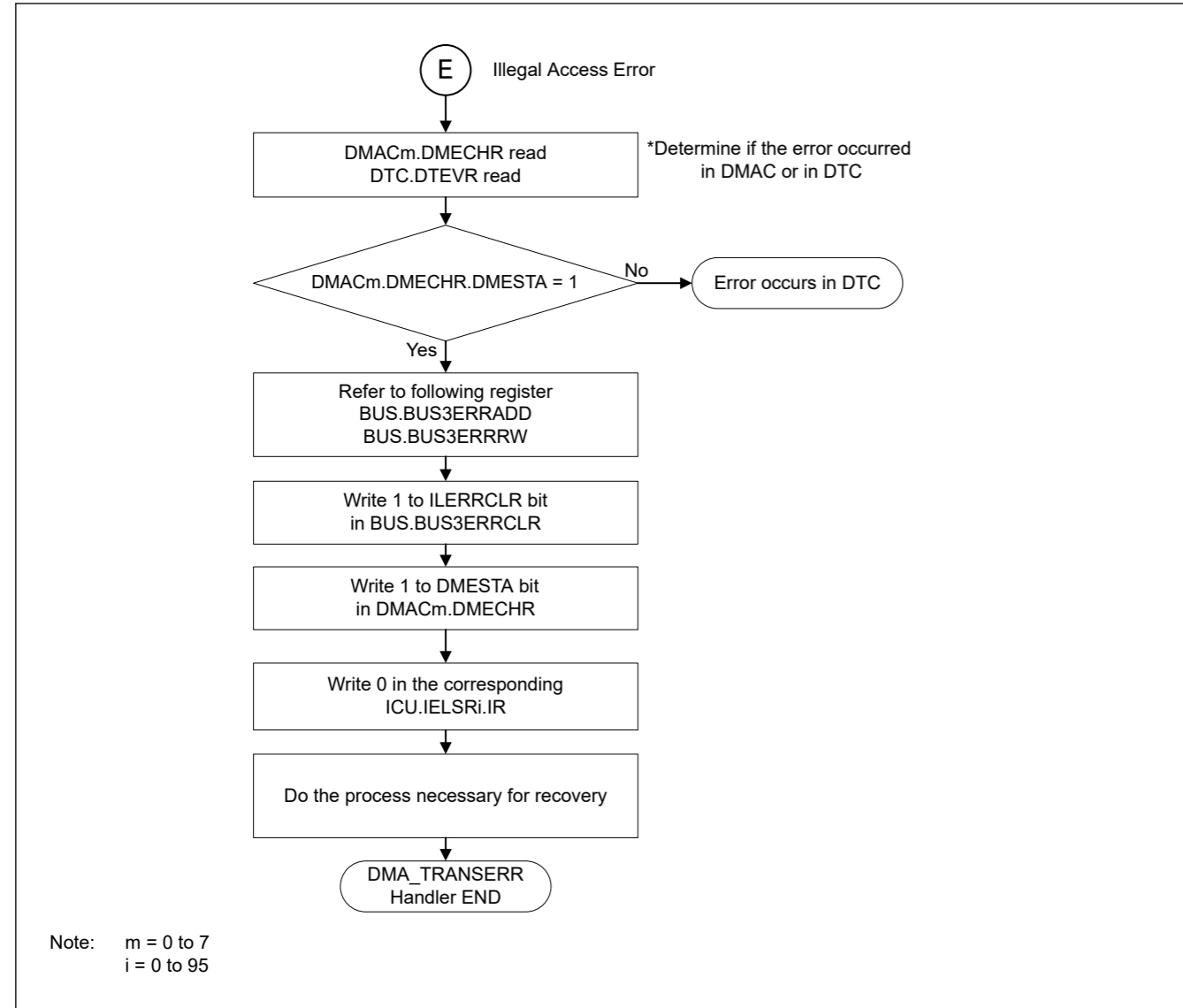


Figure 16.32 Processing in DMA\_TRANSERR handler by Illegal Access Error

## 16.6 Interrupts

### 16.6.1 Transfer End Interrupt

Each DMAC channel can output an interrupt request (DMACn\_INT) to the CPU or the DTC after transfer in response to one request is completed.

In repeat-block transfer mode, do not enable escape transfer end interrupt.

Table 16.21 lists the relation among the interrupt sources, the interrupt status flags, and the interrupt enable bits. Figure 16.33 shows the schematic logic diagram of interrupt outputs (DMACn (n = 0 to 7)). Figure 16.34 shows the DMAC interrupt handling routine to resume/terminate DMA transfer.

Table 16.21 Relation among Interrupt Sources, Interrupt Status Flags, and Interrupt Enable Bits (1 of 2)

| Interrupt Sources | Interrupt Enable Bits | Interrupt Status Flags | Request Output Enable Bits |
|-------------------|-----------------------|------------------------|----------------------------|
| Transfer end      | —                     | DMSTS.DTIF             | DMINT.DTIE                 |

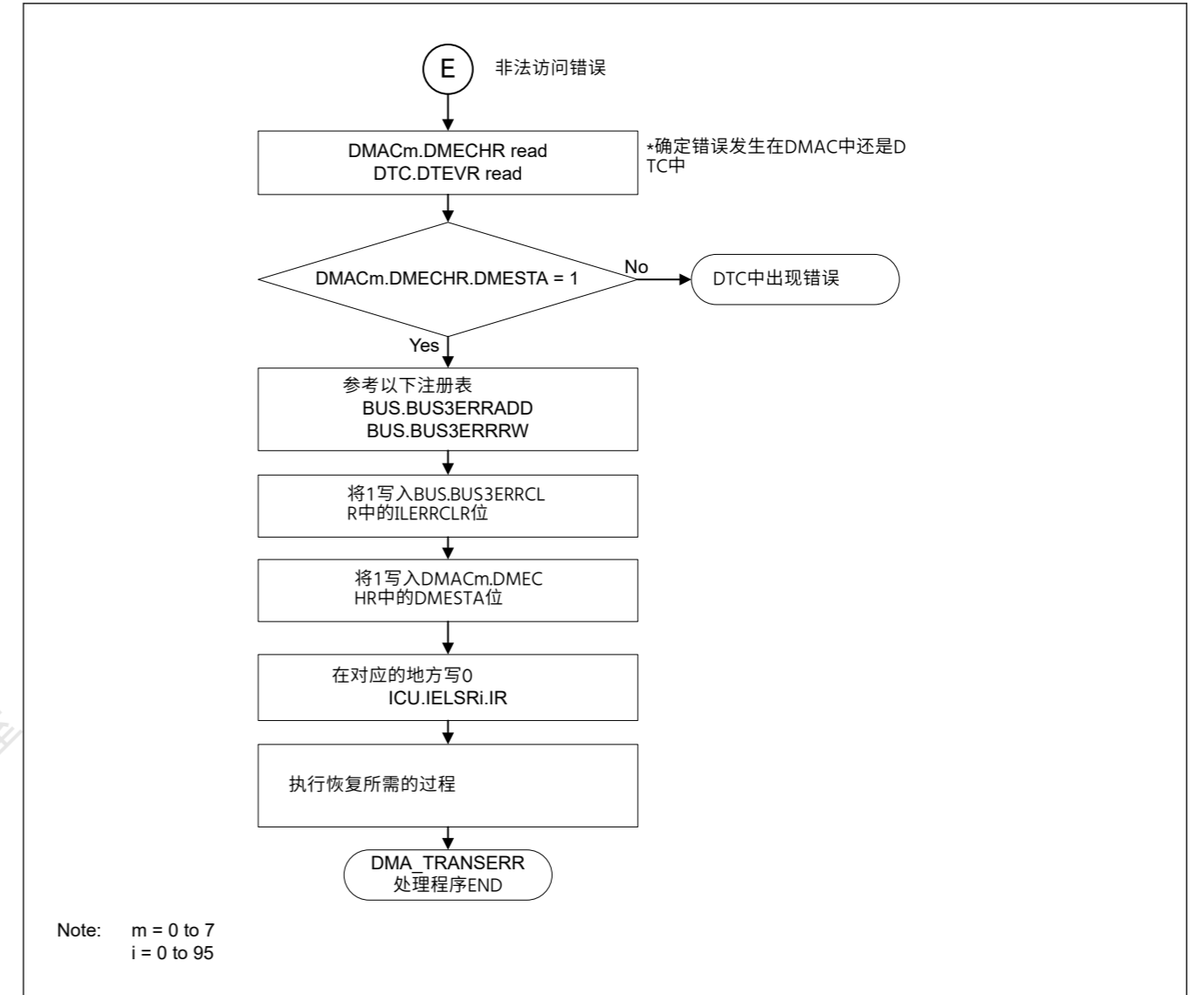


Figure 16.32 非法访问错误在DMA\_TRANSERR处理程序中的处理

## 16.6 Interrupts

### 16.6.1 传输结束中断

每个DMAC通道可以在响应一个请求的传输完成后向CPU或DTC输出一个中断请求 (DMACn\_INT)。

在重复块传输模式下，不要启用转义传输结束中断。

表16.21列出了中断源、中断状态标志和中断使能位之间的关系。图16.33显示了中断输出(DMACn(n=0to7))的逻辑示意图。图16.34显示了用于恢复终止DMA传输的DMAC中断处理程序。

Table 16.21 中断源、中断状态标志和中断允许位之间的关系 (1of2)

| 中断源  | 中断使能位 | 中断状态标志     | 请求输出使能 Bits |
|------|-------|------------|-------------|
| 转账结束 | —     | DMSTS.DTIF | DMINT.DTIE  |

Table 16.21 Relation among Interrupt Sources, Interrupt Status Flags, and Interrupt Enable Bits (2 of 2)

| Interrupt Sources   | Interrupt Enable Bits                             | Interrupt Status Flags | Request Output Enable Bits |
|---------------------|---|------------------------|----------------------------|
| Escape transfer end | Repeat size end                                   | DMINT.RPTIE            | DMINT.ESIE                 |
|                     | Source address extended repeat area overflow      | DMINT.SARIE            |                            |
|                     | Destination address extended repeat area overflow | DMINT.DARIE            |                            |

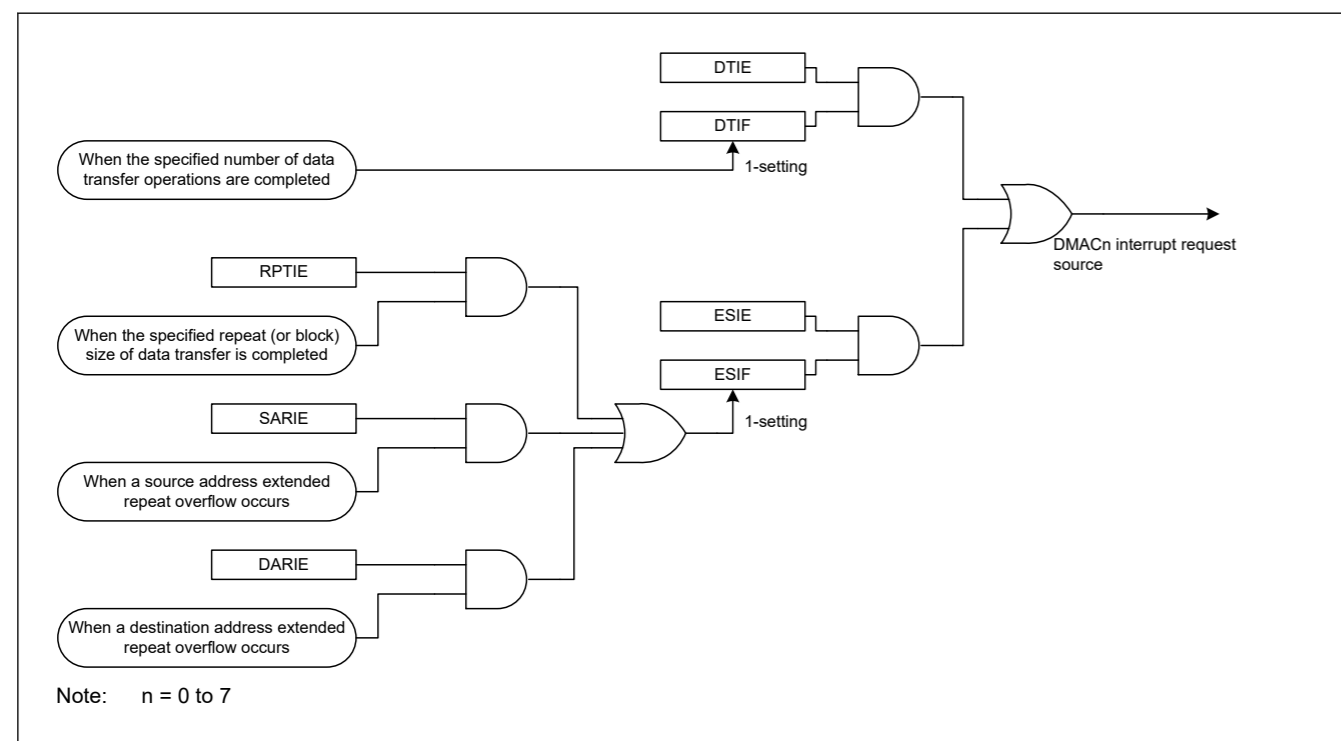


Figure 16.33 Schematic Logic Diagram of Interrupt Output Source (DMACn)

Specifically, the different procedures are used for canceling an interrupt to restart DMA transfer in the following two cases:

- When terminating a DMA transfer
- When continuing a DMA transfer

### 16.6.1.1 When Terminating a DMA Transfer

Write 0 to the DMSTS.DTIF flag to clear a transfer end interrupt, and to the DMSTS.ESIF flag to clear a repeat size interrupt and an extended repeat area overflow interrupt. The DMACn remains in the stop state. When starting another DMA transfer after that, set the appropriate registers, and set the DMCNT.DTE bit to 1 (DMA transfer enabled).

### 16.6.1.2 When Continuing a DMA Transfer

Write 1 to the DMCNT.DTE bit. The DMSTS.ESIF flag is automatically cleared to 0 (interrupt source cleared), and DMA transfer is resumed.

Table 16.21 中断源、中断状态标志和中断允许位之间的关系(2of2)

| 中断源    | 中断使能位       | 中断状态标志      | 请求输出使能 Bits |
|--------|-------------|-------------|-------------|
| 逃生转移结束 | 重复大小结束      | DMINT.RPTIE | DMINT.ESIE  |
|        | 源地址扩展重复区溢出  | DMINT.SARIE |             |
|        | 目的地址扩展重复区溢出 | DMINT.DARIE |             |

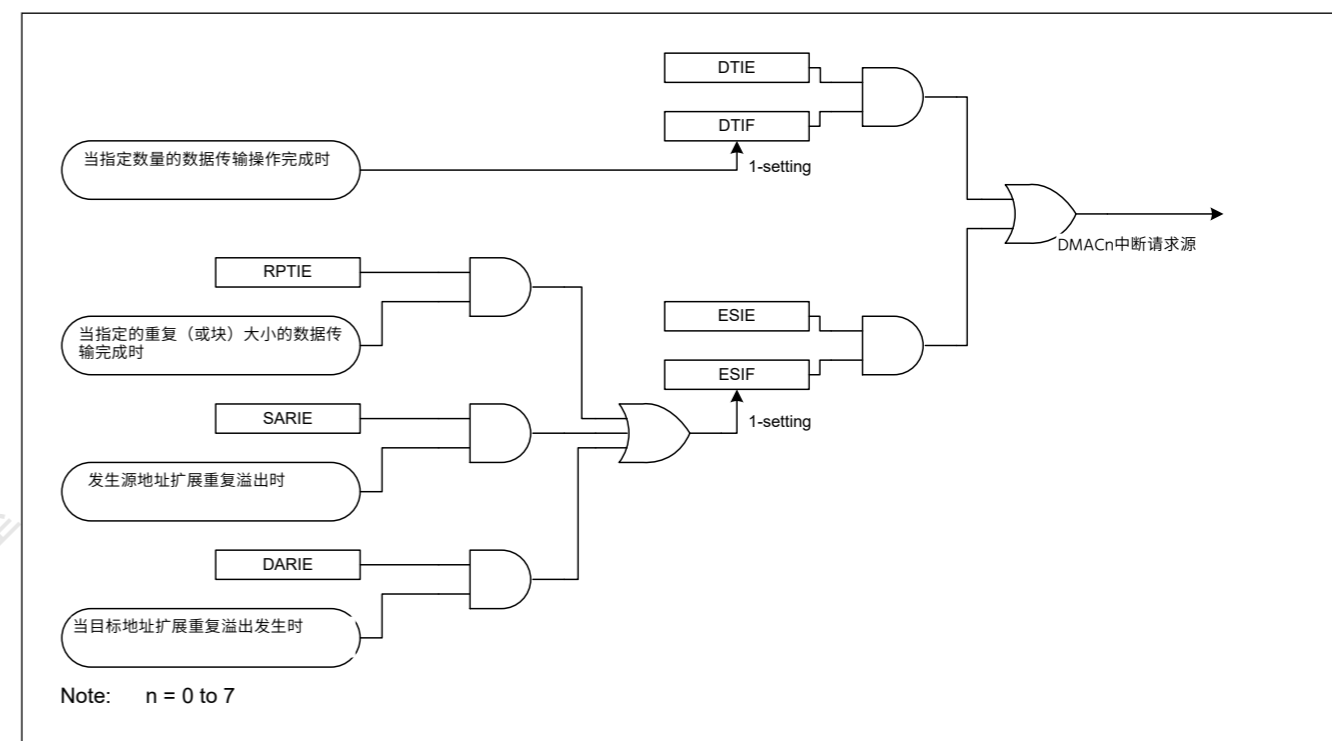


Figure 16.33 中断输出源 (DMACn) 逻辑示意图

具体来说，在以下两种情况下，不同的程序用于取消中断以重新启动DMA传输：

- 终止DMA传输时
- 继续DMA传输时

### 16.6.1.1 终止DMA传输时

将0写入DMSTS.DTIF标志以清除传输结束中断，写入DMSTS.ESIF标志以清除重复大小中断和扩展重复区域溢出中断。DMACn保持在停止状态。之后开始另一个DMA传输时，设置适当的寄存器，并将DMCNT.DTE位设置为1（启用DMA传输）。

### 16.6.1.2 继续DMA传输时

将1写入DMCNT.DTE位。DMSTS.ESIF标志自动清零（中断源清零），DMA传输恢复。

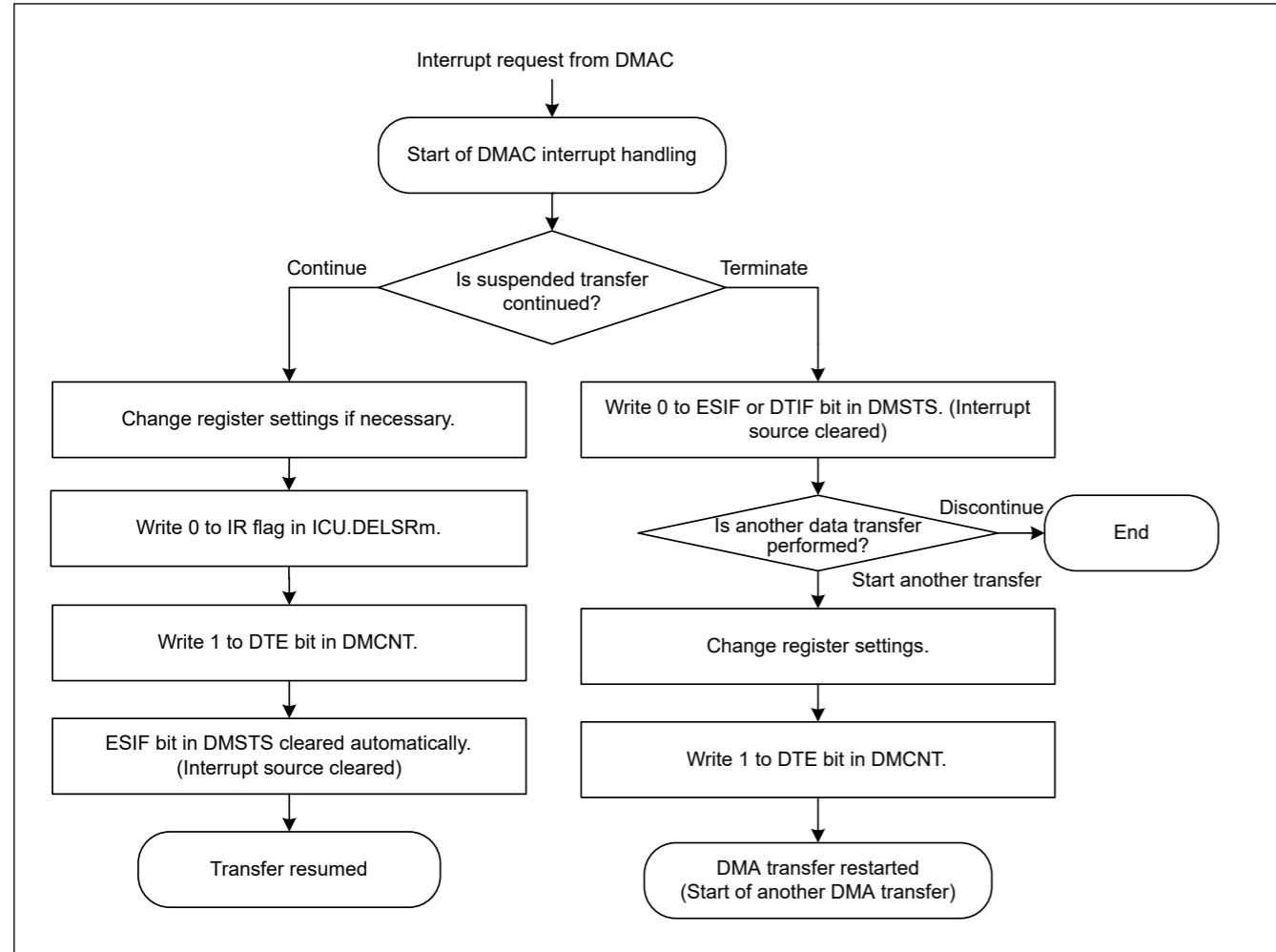


Figure 16.34 DMAC Interrupt Handling Routine to Resume/Terminate DMA Transfer

16.6.2 Transfer Error Interrupt

Error response detection interrupt request (DMA\_TRANSERR) is generated from the DMAC/DTC when the transfer error is detected during DMAC transfer. The types of interrupts that occur when a DMAC transfer error occurs are listed in the Table 16.22. The Table 16.22 also shows error information stored when a transfer error occurs.

Table 16.22 Interrupt and error information due to DMAC transfer error cause

| Transfer error factor                 | NMI/RESET <sup>*1</sup> Request | Interrupt Request | Bus Error Status                           | Error Address Error R/W           | Error Channel Information |
|---------------------------------------|---------------------------------|-------------------|--|-----------------------------------|---------------------------|
| Master TrustZone Filter (in DMAC/DTC) | ICU.NMISR.TZFST <sup>*1</sup>   | DMA_TRANSERR      | BUS.DMACDTCERRSTAT.MTERRSTAT <sup>*1</sup> | —                                 | DMACn.DMECHR              |
| Slave TrustZone Filter                | ICU.NMISR.TZFST <sup>*1</sup>   | DMA_TRANSERR      | BUS.BUS3ERRSTAT.STERRSTAT <sup>*1</sup>    | BUS.BTZF3ERRADD<br>BUS.BTZF3ERRRW | DMACn.DMECHR              |
| Master MPU                            | ICU.NMISR.BUSMST                | DMA_TRANSERR      | BUS.BUS3ERRSTAT.MMERRSTAT                  | BUS.BUS3ERRADD<br>BUS.BUS3ERRRW   | DMACn.DMECHR              |
| Slave Bus Error                       | — <sup>*2</sup>                 | DMA_TRANSERR      | BUS.BUS3ERRSTAT.SLERRSTAT <sup>*2</sup>    | BUS.BUS3ERRADD<br>BUS.BUS3ERRRW   | DMACn.DMECHR              |
| Illegal Access Error                  | — <sup>*2</sup>                 | DMA_TRANSERR      | BUS.BUS3ERRSTAT.ILERRSTAT <sup>*2</sup>    | BUS.BUS3ERRADD<br>BUS.BUS3ERRRW   | DMACn.DMECHR              |

Note 1. Interrupt generated, when NMI request selected as the operation after detection of the Master MPU error and the TrustZone Filter error. By confirming BUS.BUS3ERRSTAT and BUS.DMACDTCERRSTAT, judge whether it is the Master or the Slave.  
 Note 2. If the error response detection interrupt (DMA\_TRANSERR) occurs and NMI of the Master MPU or NMI of the TrustZone Filter has not occurred, treat it as the Illegal address access error or the Slave Bus Error. It can be judged also by BUS.BUS3ERRSTAT and BUS.DMACDTCERRSTAT.

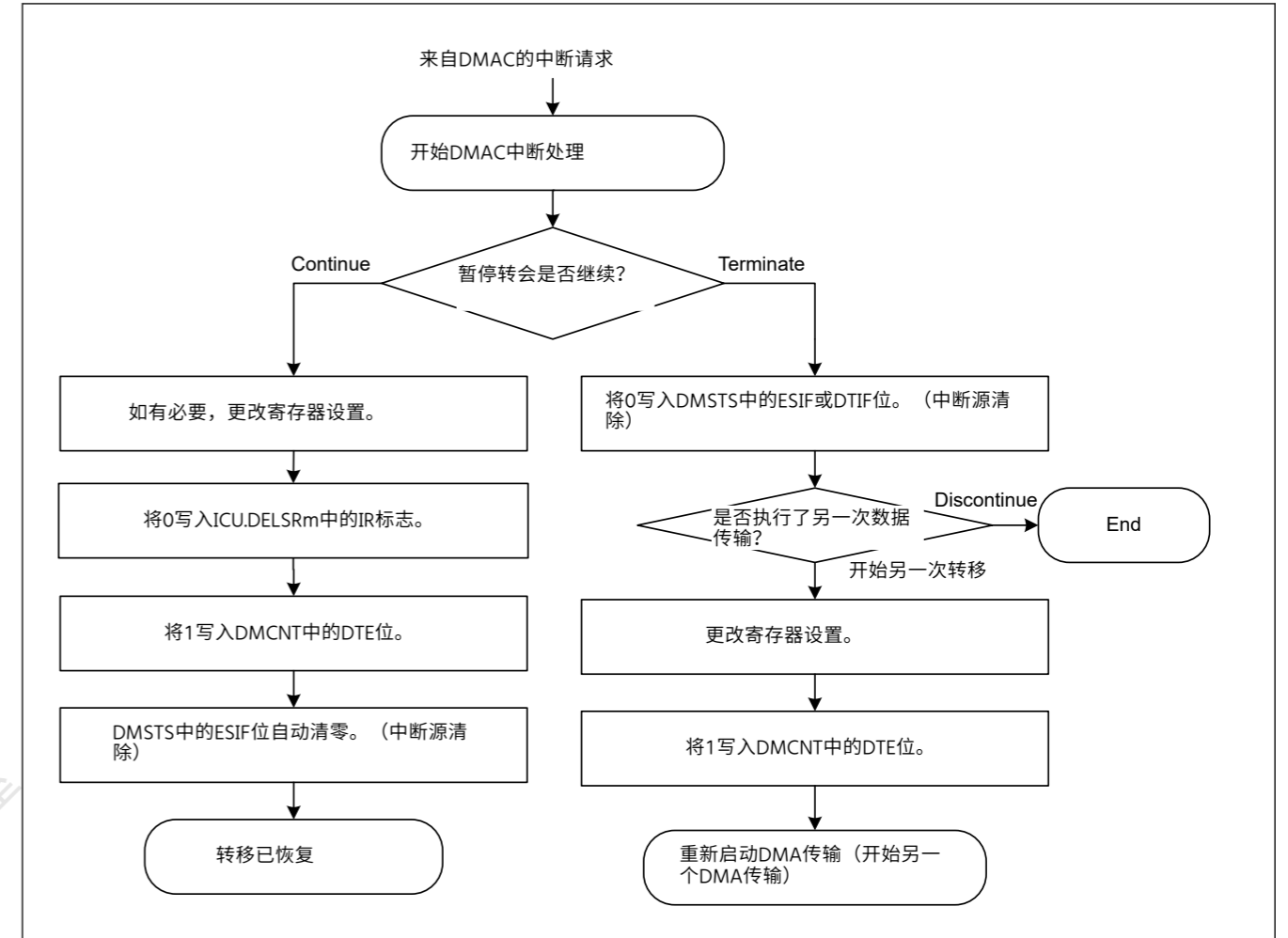


Figure 16.34 恢复终止DMA传输的DMAC中断处理例程

16.6.2 传输错误中断

在DMAC传输期间检测到传输错误时, 从DMACDTC生成错误响应检测中断请求(DMA\_TRANSERR)。发生DMAC传输错误时发生的中断类型在表16.22中列出。表16.22还显示了发生传输错误时存储的错误信息。

Table 16.22 由于DMAC传输错误原因导致的中断和错误信息

| 传递误差因子                                | NMI/RESET <sup>*1</sup> Request | 中断请求         | 总线错误状态                                     | 错误地址 Error R/W                    | 错误通道 Information |
|---------------------------------------|---------------------------------|--------------|--|-----------------------------------|------------------|
| Master TrustZone Filter (in DMAC/DTC) | ICU.NMISR.TZFST <sup>*1</sup>   | DMA_TRANSERR | BUS.DMACDTCERRSTAT.MTERRSTAT <sup>*1</sup> | —                                 | DMACn.DMECHR     |
| Slave TrustZone Filter                | ICU.NMISR.TZFST <sup>*1</sup>   | DMA_TRANSERR | BUS.BUS3ERRSTAT.STERRSTAT <sup>*1</sup>    | BUS.BTZF3ERRADD<br>BUS.BTZF3ERRRW | DMACn.DMECHR     |
| Master MPU                            | ICU.NMISR.BUSMST                | DMA_TRANSERR | BUS.BUS3ERRSTAT.MMERRSTAT                  | BUS.BUS3ERRADD<br>BUS.BUS3ERRRW   | DMACn.DMECHR     |
| 从总线错误                                 | — <sup>*2</sup>                 | DMA_TRANSERR | BUS.BUS3ERRSTAT.SLERRSTAT <sup>*2</sup>    | BUS.BUS3ERRADD<br>BUS.BUS3ERRRW   | DMACn.DMECHR     |
| 非法访问错误                                | — <sup>*2</sup>                 | DMA_TRANSERR | BUS.BUS3ERRSTAT.ILERRSTAT <sup>*2</sup>    | BUS.BUS3ERRADD<br>BUS.BUS3ERRRW   | DMACn.DMECHR     |

注意1.中断, 当NMI请求在检测主MPU错误和Trustzone滤波器错误后选择为操作时中断。通过确认BUS.BUS3ERRSTAT和BUS.DMACDTCERRSTAT, 判断是Master还是Slave。  
 注2.如果错误响应检测中断(DMA\_TRANSERR)发生且MasterMPU的NMI或TrustZoneFilter的NMI未发生, 则将其视为Illegaladdressaccesserror或SlaveBusError。也可以通过BUS.BUS3ERRSTAT和BUS来判断。DMACDTCERRSTAT。



Note that if the bus error occurs when writing the last data of transfer, the transfer end event and the error response detection interrupt (DMA\_TRANSERR) occurs.

## 16.7 Event Link

Each DMAC channel outputs an event link request signal (DMACn\_INT) every time it completes a data transfer, or a block transfer in block transfer mode.

For details, see [section 18, Event Link Controller \(ELC\)](#).

If a bus error occurs when writing the last data of transfer, a transfer end event and error response detection interrupt (DMA\_TRANSERR) occurs.

## 16.8 Low-Power Consumption Function

Before entering the module-stop state or Software Standby mode, or Deep Software Standby mode, you must first set the DMAST.DMST bit to 0 (the DMAC module suspended), and use the settings in the sections that follow.

### (1) Module-stop function

Writing 1 to the MSTPCRA.MSTPA22 bit enables the module-stop function of the DMAC. If a DMA transfer is in progress when 1 is written to the MSTPA22 bit, the transition to the module-stop state proceeds after the DMA transfer ends. Access to the DMAC registers is prohibited while the MSTPA22 bit is 1. Writing 0 to the MSTPA22 bit releases the DMAC from the module-stop state.

### (2) Software Standby mode and Deep Software Standby mode

Use the settings described in [section 10.7.1. Transitioning to Software Standby Mode](#), or in [section 10.9.1. Transitioning to Deep Software Standby Mode](#).

If DMA transfer operations are in progress when the WFI instruction is executed, the DMA transfer completes before the transition to Software Standby mode or Deep Software Standby mode.

### (3) Notes on low power consumption function

For information on the WFI instruction and register settings, see [section 10.10.7. Timing of WFI Instruction](#).

To perform a DMA transfer after returning from a low power consumption mode, set the DMAST.DMST bit to 1 again. To use a request that is generated in Software Standby mode as an interrupt request to the CPU but not as a DMAC startup request, specify the CPU as the interrupt request destination, as described in [section 13.4.1. Detecting Interrupts](#), and then execute the WFI instruction.

## 16.9 Usage Notes

### 16.9.1 Access to the Registers during DMA Transfer

Do not write to the following registers while the DMSTS.ACT flag of the same channel is set to 1 (DMAC active state) or the DMCNT.DTE bit of the same channel is set to 1 (DMA transfer enabled):

- DMSAR
- DMDAR
- DMCRA
- DMCRB
- DMTMD
- DMINT
- DMAMD
- DMOFR
- DMSBS
- DMDBS
- DMSRR

请注意，如果在写入传输的最后一个数据时发生总线错误，则会发生传输结束事件和错误响应检测中断 (DMA\_TRANSERR)。

## 16.7 活动链接

每个DMAC通道在每次完成数据传输或块传输模式下的块传输时都会输出一个事件链接请求信号(DMACn\_INT)。

有关详细信息，请参阅第18节，事件链接控制器(ELC)。

如果在写入传输的最后一个数据时发生总线错误，则会发生传输结束事件和错误响应检测中断(DMA\_TRANSERR)。

## 16.8 低功耗功能

在进入模块停止状态或软件待机模式或深度软件待机模式之前，您必须先设置DMAST.DMST位为0（DMAC模块挂起），并使用以下部分中的设置。

### (1) Module-stop function

向MSTPCRA.MSTPA22位写入1可启用DMAC的模块停止功能。如果在向MSTPA22位写入1时正在进行DMA传输，则在DMA传输结束后继续转换到模块停止状态。当MSTPA22位为1时，禁止访问DMAC寄存器。将0写入MSTPA22位可将DMAC从模块停止状态释放。

### (2) 软件待机模式和深度软件待机模式

使用第10.7.1节中描述的设置。转换到软件待机模式，或在第10.9.1节中。过渡到深度软件待机模式。

如果在执行WFI指令时DMA传输操作正在进行，则DMA传输在转换到软件待机模式或深度软件待机模式之前完成。

### (3) 低功耗功能注意事项

有关WFI指令和寄存器设置的信息，请参阅第10.10.7节。WFI指令的时间安排。

要在从低功耗模式返回后执行DMA传输，请将DMAST.DMST位再次设置为1。要将在软件待机模式下生成的请求用作对CPU的中断请求但不用作DMAC启动请求，请将CPU指定为中断请求目标，如第13.4.1节所述。检测中断，然后执行WFI指令。

## 16.9 使用说明

### 16.9.1 在DMA传输期间访问寄存器

当同一通道的DMSTS.ACT标志设置为1（DMAC活动状态）或同一通道的DMCNT.DTE位设置为1（启用DMA传输）时，请勿写入以下寄存器：

- DMSAR
- DMDAR
- DMCRA
- DMCRB
- DMTMD
- DMINT
- DMAMD
- DMOFR
- DMSBS
- DMDBS
- DMSRR

- DMDRR
- ICUSARC
- DMACSAR

### 16.9.2 DMA Transfer to Reserved Areas

DMA transfer to the reserved areas is prohibited. If such an access is made, transfer results are not guaranteed. For details on the reserved areas, see [section 4, Address Space](#).

### 16.9.3 Setting of DMAC Event Link Setting Register of the Interrupt Controller Unit (ICU.DELSRn n = 0 to 7)

The DMAC event link setting register (ICU.DELSRn) should be set while the DMA transfer enable bit (DMCNT.DTE) is cleared to 0 (DMA transfer is disabled). Moreover, the DTC activation enable register (ICU.IELSRn.DTCE (n = 0 to 95)) that corresponds to the same event number that has been set by the ICU.DELSRn register should not be set to 1. For details on the ICU.IELSRn.DTCE and ICU.DELSRn, see [section 13, Interrupt Controller Unit \(ICU\)](#).

### 16.9.4 Suspending or Restarting DMAC Activation

To suspend a DMAC activation request, write 0x00 to the DMAC Event Link select bits (ICU.DELSRn.DELS[8:0]). To restart the DMA transfer, write the event number to the ICU.DELSRn.DELS[8:0] bits following the settings shown in [section 16.3.10, Activating the DMAC](#).

### 16.9.5 Precautions for Resuming DMA Transfer

A DMAC activation request might occur in the next request after a DMA transfer completes. If this happens, the DMA transfer starts and the DMAC activation request is held in the DMAC. To prevent this, stop the DMAC activation requests by setting the DELSRn.DELS[8:0] bits in the ICU to 0.

When a DMAC activation request occurs after the last round of the DMA transfer is generated, clear the DMAC activation request with either of the following approaches.

- Clear the DMAC activation request with a DMA dummy transfer.
- Set the DMCNT.DTE bit to 0 and then set the ICU.DELSRn.IR flag to 0.

See [Figure 16.35](#).

- DMDRR
- ICUSARC
- DMACSAR

### 16.9.2 DMA传输到保留区域

禁止对保留区域进行DMA传输。如果进行此类访问，则无法保证传输结果。有关保留区域的详细信息，请参阅第4节，地址空间。

### 16.9.3 中断控制器单元的DMAC事件链接设置寄存器的设置(ICU.DELSRn=0到7)

DMAC事件链接设置寄存器(ICU.DELSRn)应在DMA传输启用位(DMCNT.DTE)清除为0(禁用DMA传输)时设置。此外，与已由ICU.DELSRn寄存器设置的相同事件编号对应的DTC激活使能寄存器(ICU.IELSRn.DTCE(n=0至95))不应设置为1。有关ICU的详细信息.IELSRn.DTCE和ICU.DELSRn，请参见第13节，中断控制器单元(ICU)。

### 16.9.4 暂停或重新启动DMAC激活

要暂停DMAC激活请求，请将0x00写入DMAC事件链接选择位(ICU.DELSRn.DELS[8:0])。要重新启动DMA传输，请按照第16.3.10节中所示的设置将事件编号写入ICU.DELSRn.DELS[8:0]位。激活DMAC。

### 16.9.5 恢复DMA传输的注意事项

DMA传输完成后的下一个请求中可能会出现DMAC激活请求。如果发生这种情况，DMA传输开始并且DMAC激活请求被保存在DMAC中。为防止这种情况，请通过将ICU中的DELSRn.DELS[8:0]位设置为0来停止DMAC激活请求。

当最后一轮DMA传输生成后出现DMAC激活请求时，可通过以下任一方法清除DMAC激活请求。

- 使用DMA虚拟传输清除DMAC激活请求。
- 将DMCNT.DTE位设置为0，然后将ICU.DELSRn.IR标志设置为0。

请参见图16.35。

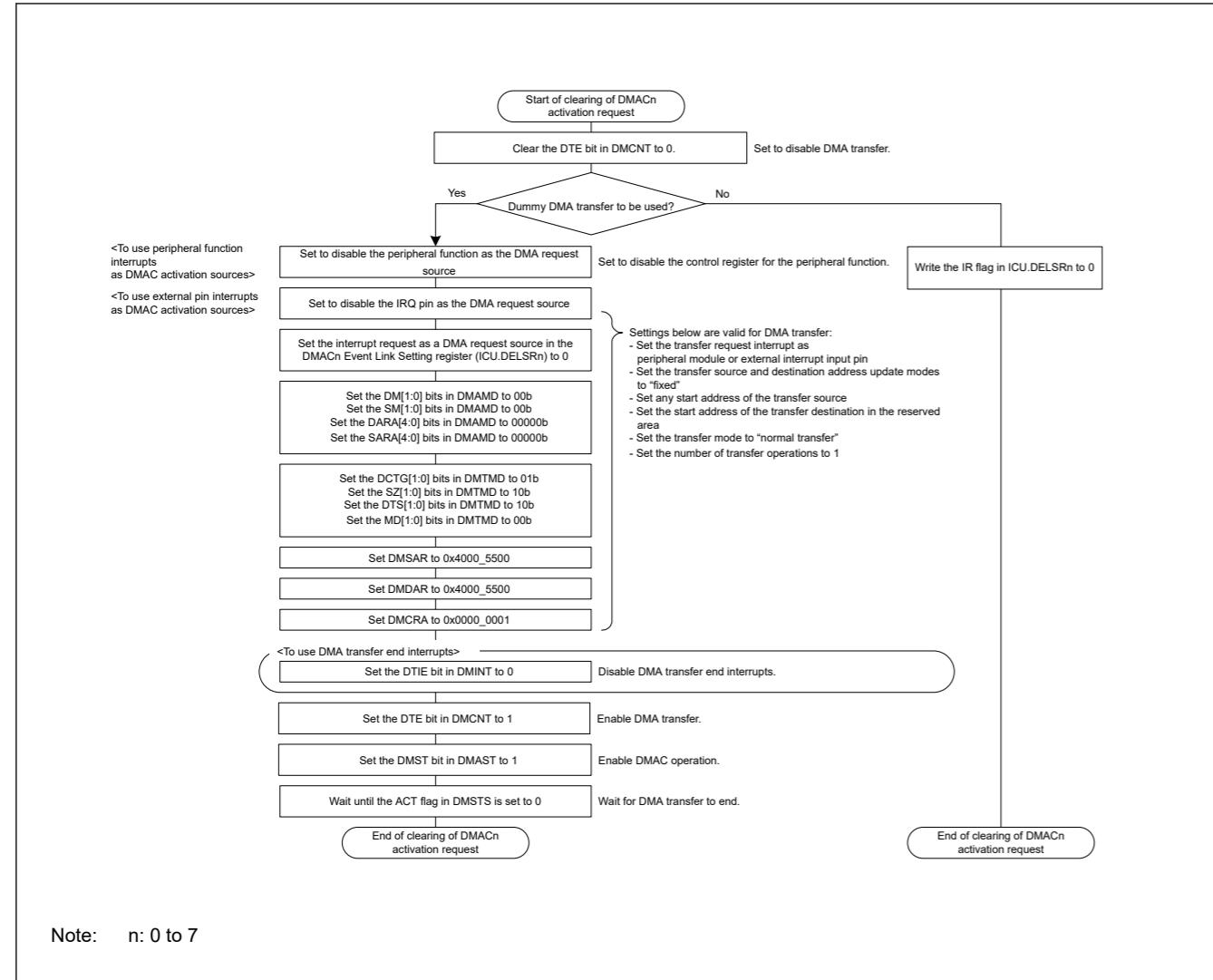


Figure 16.35 Example of register setting procedure to clear the DMAC activation interrupt

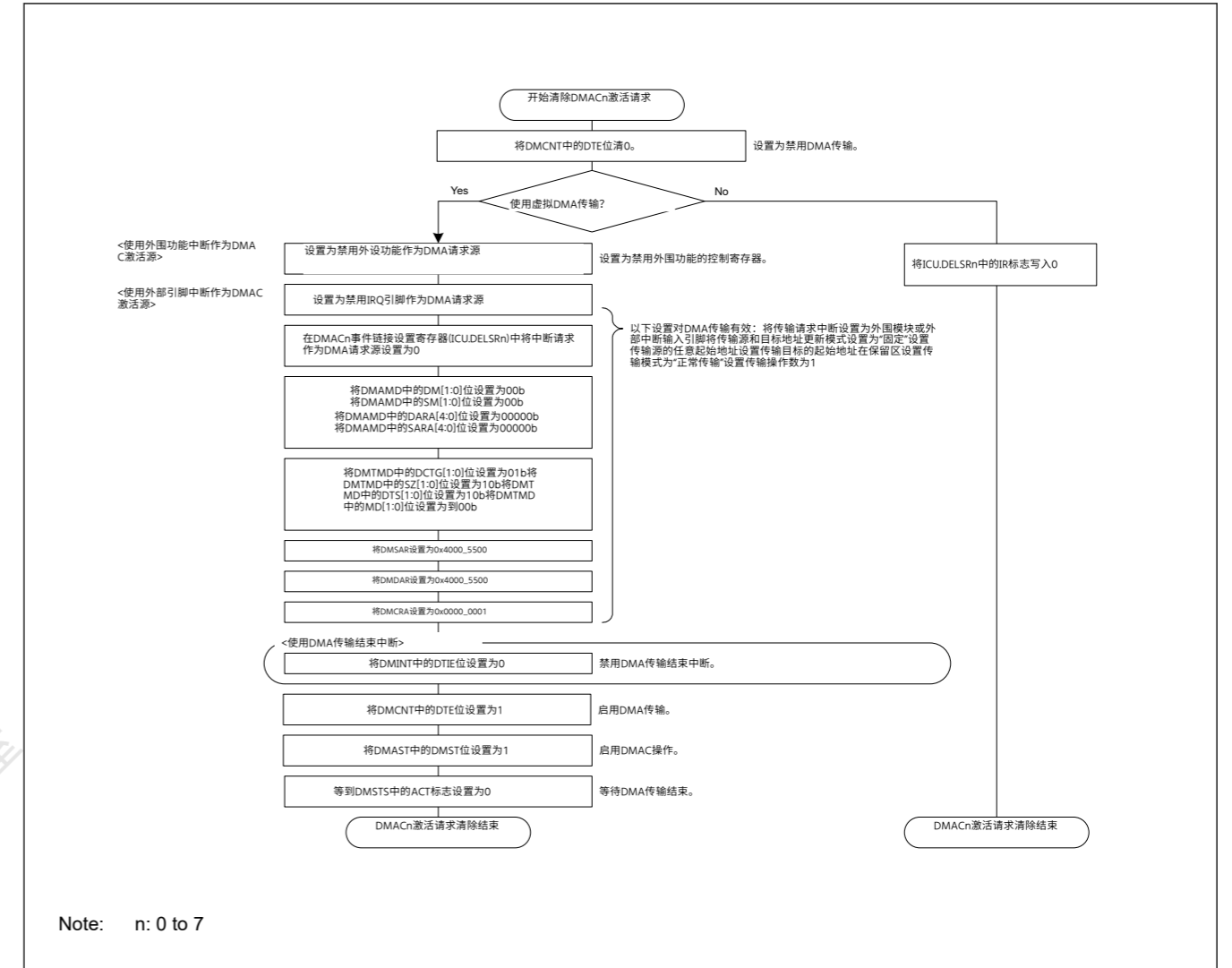


Figure 16.35 清除DMAC激活中断的寄存器设置过程示例

## 17. Data Transfer Controller (DTC)

### 17.1 Overview

A Data Transfer Controller (DTC) module is provided for transferring data when activated by an interrupt request.

Table 17.1 lists the DTC specifications and Figure 17.1 shows DTC block diagram.

**Table 17.1 DTC specifications**

| Parameter                          | Description   |
|------------------------------------|---|
| Transfer modes                     | <ul style="list-style-type: none"> <li>Normal transfer mode<br/>A single activation leads to a single data transfer.</li> <li>Repeat transfer mode<br/>A single activation leads to a single data transfer.<br/>The transfer address returns to the start address after the number of data transfers reaches the specified repeat size.<br/>The maximum number of repeat transfers is 256 and the maximum data transfer size is 256 × 32 bits (1024 bytes)</li> <li>Block transfer mode<br/>A single activation leads to a transfer of a single block.<br/>The maximum block size is 256 × 32 bits = 1024 bytes.</li> </ul> |
| Transfer channel                   | <ul style="list-style-type: none"> <li>Channel transfer can be associated with the interrupt source (transferred by a DTC activation request from the ICU)</li> <li>Multiple data units can be transferred on a single activation source (chain transfer)</li> <li>Chain transfers are selectable to either execute when the counter is 0, or always execute.</li> </ul>  |
| Transfer space                     | <ul style="list-style-type: none"> <li>4 GB area from 0x0000_0000 to 0xFFFF_FFFF, excluding reserved areas</li> </ul>   |
| Data transfer units                | <ul style="list-style-type: none"> <li>Single data unit: 1 byte (8 bits), 1 halfword (16 bits), 1 word (32 bits)</li> <li>Single block size: 1 to 256 data units.</li> </ul>  |
| CPU interrupt source               | <ul style="list-style-type: none"> <li>An interrupt request can be generated to the CPU on a DTC activation interrupt</li> <li>An interrupt request can be generated to the CPU after a single data transfer</li> <li>An interrupt request can be generated to the CPU after a data transfer of a specified volume.</li> </ul>  |
| Processing on DTC transfer error   | <ul style="list-style-type: none"> <li>When the DTC transfer error occurs, it stops the transfer that caused the error</li> <li>Request to clear the register for activation request of DTC error number to ICU</li> </ul>  |
| Error response detection interrupt | Generated when the DTC transfer error occurs  |
| Event link function                | An event link request is generated after one data transfer (for block, after one block transfer)  |
| Read skip                          | Read of transfer information can be skipped   |
| Write-back skip                    | When the transfer source or destination address is specified as fixed, a write-back of transfer information can be skipped  |
| TrustZone                          | TrustZone violation area of Flash and SRAM is detected in advance before access the bus.  |
| Module-stop function               | Module-stop state can be set to reduce power consumption  |
| TrustZone Filter                   | Security attribution can be set for each activation source  |

Note: Security attribution Register of DTC is described in ICU.ICUSRAG, ICU.ICUSRAH and ICU.ICUSRAI

## 17. 数据传输控制器(DTC)

### 17.1 Overview

数据传输控制器(DTC)模块用于在被中断请求激活时传输数据。

表17.1列出了DTC规范，图17.1显示了DTC框图。

**Table 17.1 DTC specifications**

| Parameter            | Description  |
|----------------------|--|
| 传输模式                 | <ul style="list-style-type: none"> <li>正常传输模式<br/>单次激活导致单次数据传输。</li> <li>重复传输模式<br/>单次激活导致单次数据传输。<br/>数据传输次数达到指定的重复大小后，传输地址返回起始地址。最大重复传输次数为256，最大数据传输大小为256×32位（1024字节）</li> <li>块传输模式<br/>单个激活导致单个块的传输。最大块大小为256×32位=1024字节。</li> </ul> |
| 传输通道                 | <ul style="list-style-type: none"> <li>通道传输可以与中断源相关联（由来自ICU的DTC激活请求传输）</li> <li>可以在单个激活源上传输多个数据单元（链式传输）</li> <li>链式传输可选择在计数器为0时执行或始终执行。</li> </ul>   |
| 转移空间                 | <ul style="list-style-type: none"> <li>4GB区域，从0x0000_0000到0xFFFF_FFFF，不包括保留区域</li> </ul>   |
| 数据传输单元               | <ul style="list-style-type: none"> <li>单个数据单元：1个字节（8位）、1个半字（16位）、1个字（32位）</li> <li>单块大小：1到256个数据单元。</li> </ul>   |
| CPU中断源               | <ul style="list-style-type: none"> <li>可以在DTC激活中断时向CPU生成中断请求</li> <li>单次数据传输后可向CPU产生中断请求</li> <li>在指定卷的数据传输后，可以向CPU产生中断请求。</li> </ul>  |
| DTC传输错误的处理           | <ul style="list-style-type: none"> <li>当发生DTC传输错误时，它会停止导致错误的传输</li> <li>向ICU请求清除DTC错误号激活请求的寄存器</li> </ul>  |
| 错误响应检测中断             | 发生DTC传输错误时生成   |
| 事件链接功能               | 一次数据传输后产生事件链接请求（对于块，在一次块传输后）   |
| 阅读跳过                 | 可以跳过读取传输信息   |
| Write-back skip      | 当传输源或目标地址指定为固定时，可以跳过传输信息的回写  |
| TrustZone            | 在访问总线之前，预先检测到Flash和SRAM的TrustZone违规区域。   |
| Module-stop function | 可设置模块停止状态以降低功耗   |
| TrustZone Filter     | 可以为每个激活源设置安全属性   |

Note: ICU.ICUSRAG、ICU.ICUSRAH和ICU.ICUSRAI中描述了DTC的安全属性寄存器

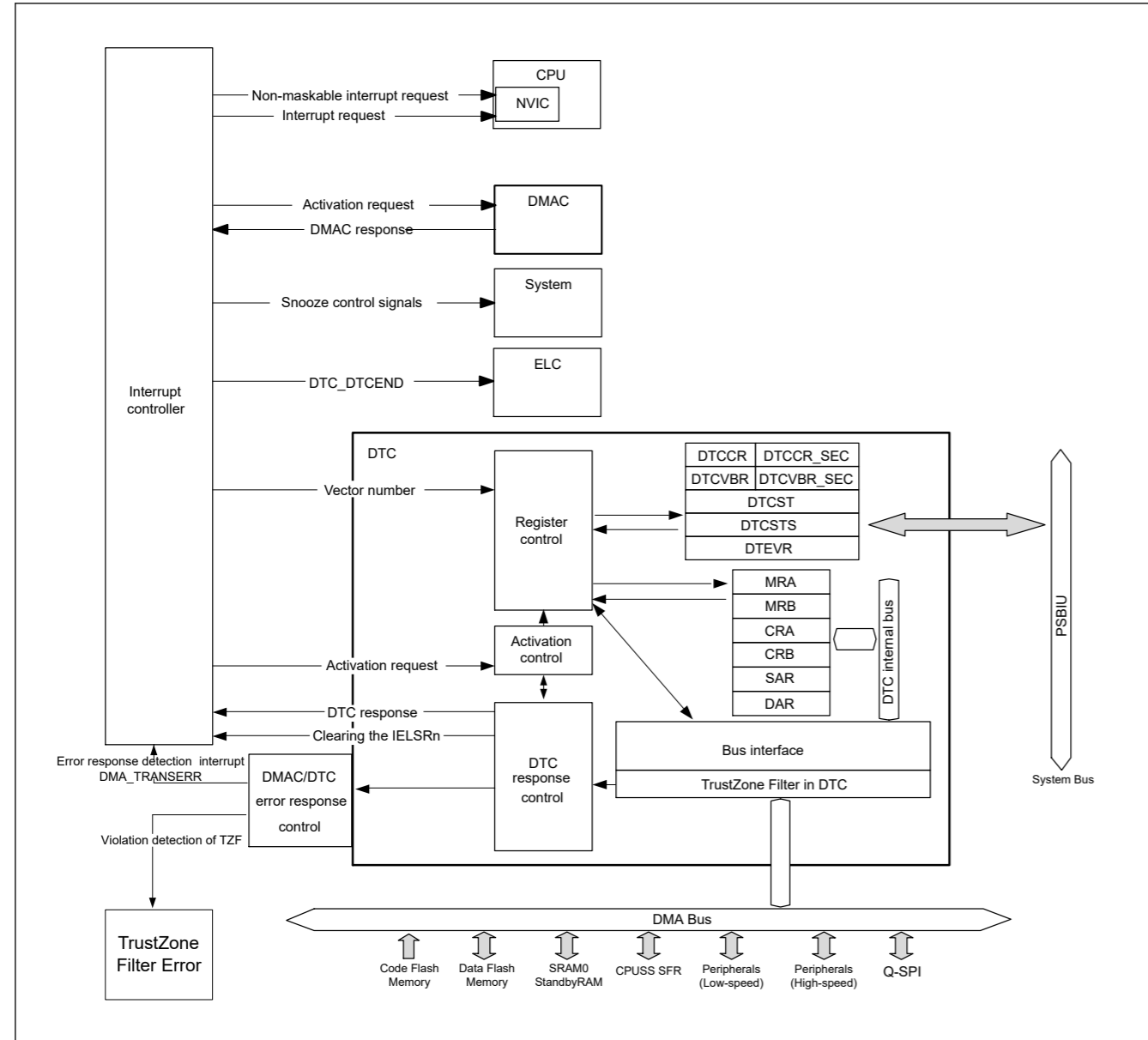


Figure 17.1 DTC block diagram

See section 13.1. Overview in section 13, Interrupt Controller Unit (ICU) for the connections between the DTC and NVIC in the CPU.

### 17.2 Register Descriptions

MRA, MRB, SAR, DAR, CRA, and CRB are all DTC internal registers that cannot be directly accessed from the CPU. Values to be set in these DTC internal registers are placed in the SRAM area as transfer information. When an activation request is generated, the DTC reads the transfer information from the SRAM area and sets it in its internal registers. After the data transfer ends, the internal register contents are written back to the SRAM area as transfer information.

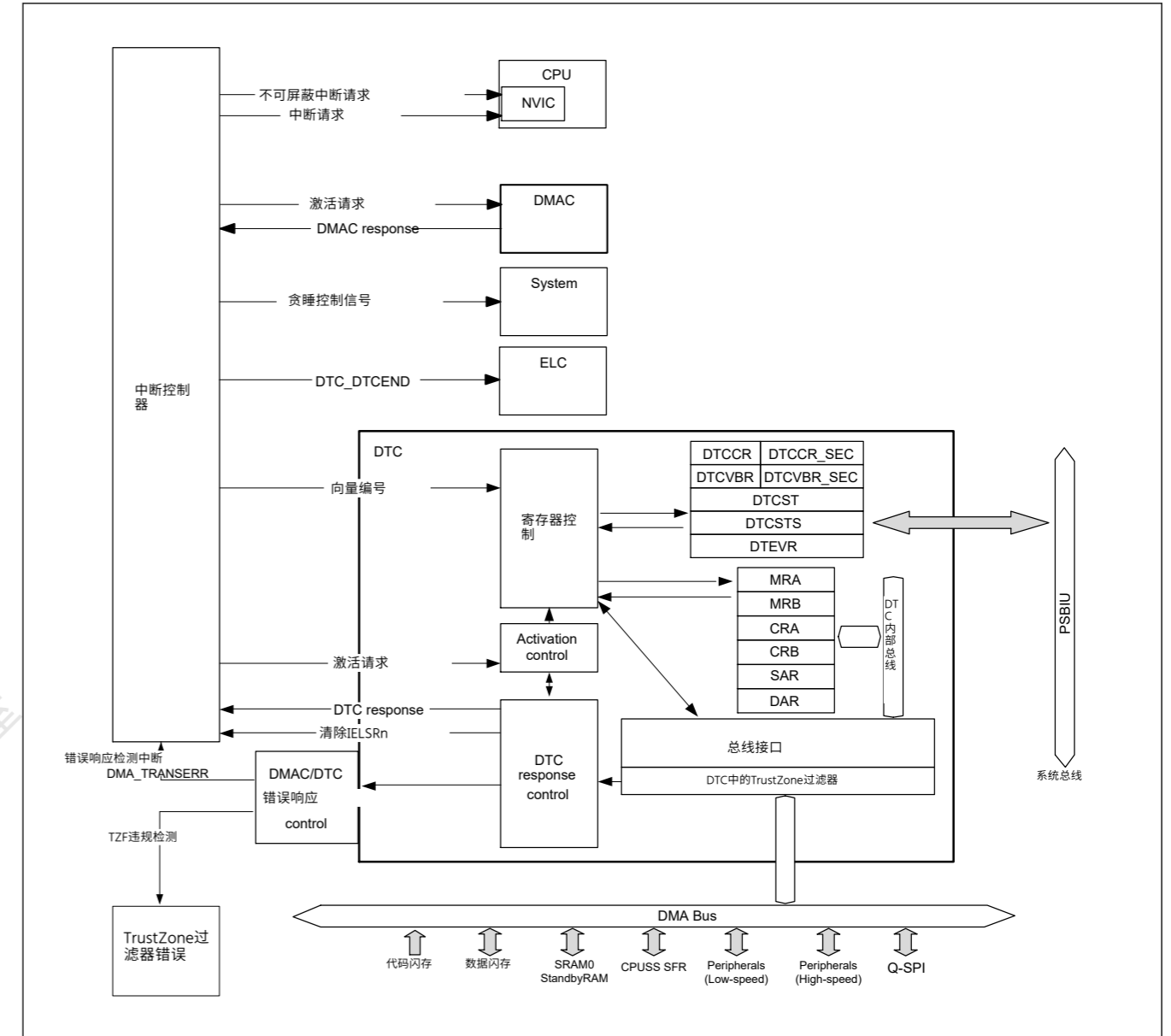


Figure 17.1 故障诊断代码框图

请参见第13.1节。第13节，中断控制器单元(ICU)中的概述，用于CPU中的DTC和NVIC之间的连接。

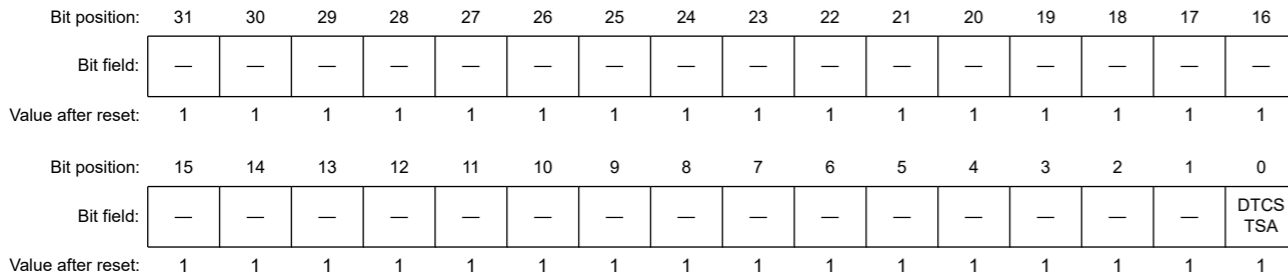
### 17.2 注册说明

MRA、MRB、SAR、DAR、CRA、CRB都是DTC内部寄存器，不能直接从CPU访问。在这些DTC内部寄存器中设置的值作为传输信息放置在SRAM区域中。当产生激活请求时，DTC从SRAM区域读取传输信息并将其设置在其内部寄存器中。数据传输结束后，内部寄存器内容作为传输信息回写到SRAM区域。



17.2.1 DTCSAR : DTC Controller Security Attribution Register

Base address: CPSCU = 0x4000\_8000  
Offset address: 0x30



| Bit  | Symbol  | Function   | R/W |
|------|---------|--|-----|
| 0    | DTCSTSA | DTC Security Attribution<br>0: Secure.<br>1: Non-Secure. | R/W |
| 31:1 | —       | This bit is read as 1.                                   | R/W |

Note: Only secure access can write to this register. Both secure access and Non-secure read access are allowed but Non-secure write access is not allowed and TrustZone access error is not generated.

Note: This register is write-protected by PRCR register.

This register only sets the DTCST security attribute.

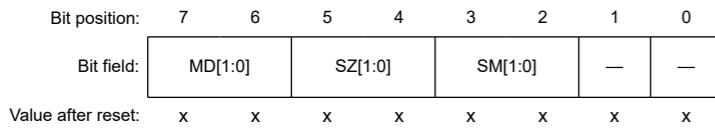
DTCSTSA bit (DTC Security Attribution)

Security attributes of registers for DTCST.

Do not write to the DTCSTSA bit while DTC transfer is enabled or a bus master is writing to the DTC registers.

17.2.2 MRA : DTC Mode Register A

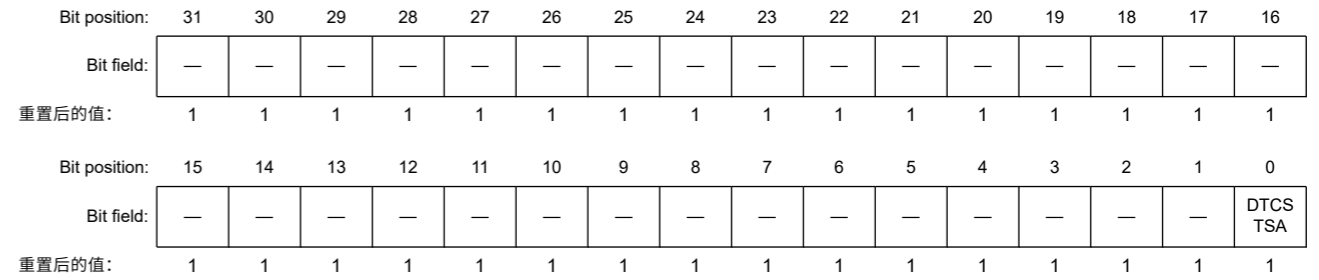
Base address: DTCVBR  
Offset address: 0x03 + 0x4 × Vector number  
(Inaccessible directly from the CPU. See section 17.3.1. Allocating Transfer Information and DTC Vector Table)



| Bit | Symbol  | Function  | R/W |
|-----|---------|---|-----|
| 1:0 | —       | The read values are undefined. The write value should be 0.   | —   |
| 3:2 | SM[1:0] | Transfer Source Address Addressing Mode<br>0 0: Address in the SAR register is fixed (write-back to SAR is skipped.)<br>0 1: Address in the SAR register is fixed (write-back to SAR is skipped.)<br>1 0: SAR value is incremented after data transfer:<br>+1 when SZ[1:0] = 00b<br>+2 when SZ[1:0] = 01b<br>+4 when SZ[1:0] = 10b<br>1 1: SAR value is decremented after data transfer:<br>-1 when SZ[1:0] = 00b<br>-2 when SZ[1:0] = 01b<br>-4 when SZ[1:0] = 10b | —   |

17.2.1 DTCSAR: DTC控制器安全属性寄存器

Base address: CPSCU = 0x4000\_8000  
Offset address: 0x30



| Bit  | Symbol  | Function                                | R/W |
|------|---------|---|-----|
| 0    | DTCSTSA | DTC安全归因<br>0: Secure.<br>1: Non-Secure. | R/W |
| 31:1 | —       | 该位读为1。                                  | R/W |

Note: 只有安全访问才能写入该寄存器。允许安全访问和非安全读取访问，但不允许非安全写入访问，并且不会生成TrustZone访问错误。

Note: 该寄存器由PRCR寄存器写保护。

该寄存器仅设置DTCST安全属性。

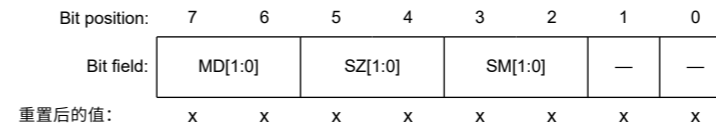
DTCSTSA位 (DTC安全属性)

DTCST寄存器的安全属性。

当DTC传输启用或总线主机正在写入DTC寄存器时，请勿写入DTCSTSA位。

17.2.2 MRA:DTC模式寄存器A

Base address: DTCVBR  
Offset address: 0x03+0x4×向量编号 (无法直接从CPU访问。请参阅第17.3.1节。分配传输信息和DTC向量表)



| Bit | Symbol  | Function  | R/W |
|-----|---------|---|-----|
| 1:0 | —       | 读取的值未定义。写入值应为0。   | —   |
| 3:2 | SM[1:0] | 传输源地址寻址方式<br>00: 固定SAR寄存器中的地址 (跳过对SAR的回写。) 01: 固定SAR寄存器中的地址 (跳过对SAR的回写。) 10: 数据传输后SAR值递增:+1当SZ[1:0]=00b时+2当SZ[1:0]=01b时+4当SZ[1:0]=10b时<br><br>11: 数据传输后SAR值递减: -1当SZ[1:0]=00b-2当SZ[1:0]=01b-4当SZ[1:0]=10b | —   |

| Bit | Symbol  | Function  | R/W |
|-----|---------|---|-----|
| 5:4 | SZ[1:0] | DTC Data Transfer Size<br>0 0: Byte (8-bit) transfer<br>0 1: Halfword (16-bit) transfer<br>1 0: Word (32-bit) transfer<br>1 1: Setting prohibited | —   |
| 7:6 | MD[1:0] | DTC Transfer Mode Select<br>0 0: Normal transfer mode<br>0 1: Repeat transfer mode<br>1 0: Block transfer mode<br>1 1: Setting prohibited         | —   |

The MRA register cannot be accessed directly from the CPU, however the CPU can access the SRAM area (transfer information (n) start address + 0x03) and DTC transfers it automatically to and from the MRA register. See [section 17.3.1. Allocating Transfer Information and DTC Vector Table](#).

### 17.2.3 MRB : DTC Mode Register B

Base address: DTCVBR

Offset address: 0x02 + 0x4 × Vector number  
(Inaccessible directly from the CPU. See [section 17.3.1. Allocating Transfer Information and DTC Vector Table](#))

Bit position: 7 6 5 4 3 2 1 0

|            |      |      |       |     |         |   |   |
|------------|------|------|-------|-----|---------|---|---|
| Bit field: | CHNE | CHNS | DISEL | DTS | DM[1:0] | — | — |
|------------|------|------|-------|-----|---------|---|---|

Value after reset: x x x x x x x x

| Bit | Symbol  | Function   | R/W |
|-----|---------|--|-----|
| 1:0 | —       | The read values are undefined. The write value should be 0.  | —   |
| 3:2 | DM[1:0] | Transfer Destination Address Addressing Mode<br>0 0: Address in the DAR register is fixed (write-back to DAR is skipped)<br>0 1: Address in the DAR register is fixed (write-back to DAR is skipped)<br>1 0: DAR value is incremented after data transfer:<br>+1 when MRA.SZ[1:0] = 00b<br>+2 when SZ[1:0] = 01b<br>+4 when SZ[1:0] = 10b<br>1 1: DAR value is decremented after data transfer:<br>-1 when MRA.SZ[1:0] = 00b<br>-2 when SZ[1:0] = 01b<br>-4 when SZ[1:0] = 10b | —   |
| 4   | DTS     | DTC Transfer Mode Select<br>0: Select transfer destination as repeat or block area<br>1: Select transfer source as repeat or block area  | —   |
| 5   | DISEL   | DTC Interrupt Select<br>0: Generate an interrupt request to the CPU when specified data transfer is complete<br>1: Generate an interrupt request to the CPU each time DTC data transfer is performed   | —   |
| 6   | CHNS    | DTC Chain Transfer Select<br>0: Chain transfer is continuous<br>1: Chain transfer occurs only when the transfer counter changes from 1 to 0 or 1 to CRAH   | —   |
| 7   | CHNE    | DTC Chain Transfer Enable<br>0: Chain transfer is disabled<br>1: Chain transfer is enabled   | —   |

The MRB register cannot be accessed directly from the CPU, however the CPU can access the SRAM area (transfer information (n) start address + 0x02) and DTC transfers it automatically to and from the MRB register. See [section 17.3.1. Allocating Transfer Information and DTC Vector Table](#).

| Bit | Symbol  | Function   | R/W |
|-----|---------|--|-----|
| 5:4 | SZ[1:0] | DTC数据传输大小<br>00: 字节 (8位) 传送01: 半字 (16位) 传送10: 字 (32位) 传送11: 禁止设置 | —   |
| 7:6 | MD[1:0] | DTC传输模式选择<br>00: 正常传输模式01: 重复传输模式10: 块传输模式11: 禁止设置               | —   |

MRA寄存器不能直接从CPU访问，但是CPU可以访问SRAM区域（传输信息(n)起始地址+0x03）并且DTC会自动将其传输到MRA寄存器或从MRA寄存器传输。请参阅第17.3.1节。分配传输信息和DTC向量表。

### 17.2.3 MRB:DTC模式寄存器B

Base address: DTCVBR

Offset address: 0x02+0x4×向量编号 (无法直接从CPU访问。请参阅第17.3.1节。分配传输信息和DTC向量表)

Bit position: 7 6 5 4 3 2 1 0

|            |      |      |       |     |         |   |   |
|------------|------|------|-------|-----|---------|---|---|
| Bit field: | CHNE | CHNS | DISEL | DTS | DM[1:0] | — | — |
|------------|------|------|-------|-----|---------|---|---|

重置后的值: x x x x x x x x

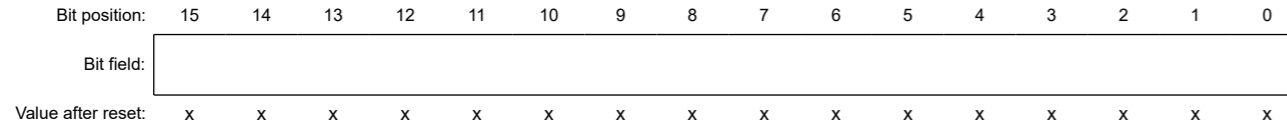
| Bit | Symbol  | Function   | R/W |
|-----|---------|--|-----|
| 1:0 | —       | 读取的值未定义。写入值应为0。  | —   |
| 3:2 | DM[1:0] | 传输目标地址寻址模式<br>00: DAR寄存器中的地址固定 (跳过DAR的回写) 01: DAR寄存器中的地址固定 (跳过DAR的回写) 10: 数据传输后DAR值递增: +1当MRA.SZ[1:0]=00b+2当SZ[1:0]=01b+4当SZ[1:0]=10b<br><br>11: 数据传输后DAR值递减: -1当MRA.SZ[1:0]=00b-2当SZ[1:0]=01b-4当SZ[1:0]=10b | —   |
| 4   | DTS     | DTC传输模式选择<br>0: 选择传输目标为重复区域或块区域1: 选择传输源为重复区域或块区域   | —   |
| 5   | DISEL   | DTC中断选择<br>0: 指定数据传输完成时向CPU产生中断请求1: 每次执行DTC数据传输时向CPU产生中断请求   | —   |
| 6   | CHNS    | DTC链转移选择<br>0: 链转移连续1: 链转移仅在转移计数器从1变为0或1变为CRAH时发生  | —   |
| 7   | CHNE    | DTC链转移启用<br>0: 禁止链式传输1: 启动链式传输   | —   |

MRB寄存器不能直接从CPU访问，但是CPU可以访问SRAM区域（传输信息(n)起始地址+0x02）并且DTC自动将其传输到MRB寄存器和从MRB寄存器传输。请参阅第17.3.1节。分配传输信息和DTC向量表。



## 17.2.6 CRA : DTC Transfer Count Register A

Base address: DTCVBR

Offset address: 0x0E + 0x4 × Vector number  
(Inaccessible directly from the CPU. See section 17.3.1. Allocating Transfer Information and DTC Vector Table)

| Bit  | Symbol | Function   | R/W |
|------|--------|--|-----|
| 7:0  | CRAL   | Transfer Counter A Lower Register<br>Specify the transfer count. | —   |
| 15:8 | CRAH   | Transfer Counter A Upper Register<br>Specify the transfer count. | —   |

Note: The function depends on the transfer mode.

Note: Set CRAH and CRAL to the same value in repeat transfer mode and block transfer mode.

The CRA register consists of 16 bits. CRAL is the lower 8 bits and CRAH is the upper 8 bits. CRA is used in normal mode. CRAL and CRAH are used in repeat transfer mode and block transfer mode.

The CRA register cannot be accessed directly from the CPU. However, the CPU can access the SRAM area (transfer information (n) start address + 0x0E) and DTC transfers it automatically to and from the CRA register. See section 17.3.1. Allocating Transfer Information and DTC Vector Table.

## (1) Normal transfer mode (MRA.MD[1:0] = 00b)

In normal transfer mode, CRA functions as a 16-bit transfer counter. The transfer count is 1, 65535, and 65536 when the set value is 0x0001, 0xFFFF, and 0x0000, respectively. The CRA value is decremented (-1) on each data transfer.

## (2) Repeat transfer mode (MRA.MD[1:0] = 01b)

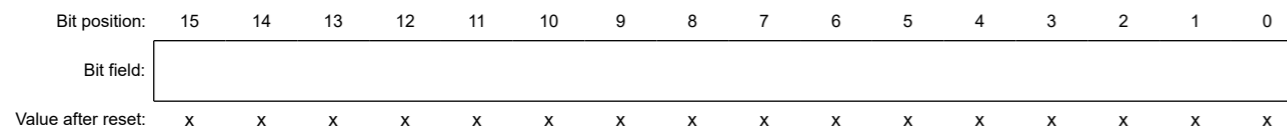
In repeat transfer mode, the CRAH register holds the transfer count and the CRAL register functions as an 8-bit transfer counter. The transfer count is 1, 255, and 256 when the set value is 0x01, 0xFF, and 0x00, respectively. The CRAL value is decremented (-1) on each data transfer. When it reaches 0x00, the CRAH value is transferred to CRAL.

## (3) Block transfer mode (MRA.MD[1:0] = 10b)

In block transfer mode, the CRAH register holds the block size and the CRAL register functions as an 8-bit block size counter. The transfer count is 1, 255, and 256 when the set value is 0x01, 0xFF, and 0x00, respectively. The CRAL value is decremented (-1) on each data transfer. When it reaches 0x00, the CRAH value is transferred to CRAL.

## 17.2.7 CRB : DTC Transfer Count Register B

Base address: DTCVBR

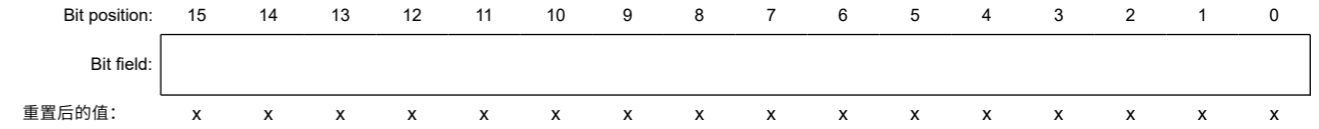
Offset address: 0x0C + 0x4 × Vector number  
(Inaccessible directly from the CPU. See section 17.3.1. Allocating Transfer Information and DTC Vector Table)

The CRB sets the block transfer count for block transfer mode. The transfer count is 1, 65535, and 65536 when the set value is 0x0001, 0xFFFF, and 0x0000, respectively. The CRB value is decremented (-1) when the final data of a single block size is transferred. When normal transfer mode or repeat transfer mode is selected, this register is not used and the set value is ignored.

## 17.2.6 CRA:DTC传输计数寄存器A

Base address: DTCVBR

Offset address: 0x0E+0x4×向量编号 (无法直接从CPU访问。请参阅第17.3.1节。分配传输信息和DTC向量表)



| Bit  | Symbol | Function               | R/W |
|------|--------|------------------------|-----|
| 7:0  | CRAL   | 传送计数器A低位寄存器<br>指定传输计数。 | —   |
| 15:8 | CRAH   | 传送计数器A高位寄存器<br>指定传输计数。 | —   |

Note: 该功能取决于传输模式。

Note: 在重复传输模式和块传输模式下, 将CRAH和CRAL设置为相同的值。

CRA寄存器由16位组成。CRAL是低8位, CRAH是高8位。CRA在正常模式下使用。

CRAL和CRAH用于重复传输模式和块传输模式。

CRA寄存器不能直接从CPU访问。但是, CPU可以访问SRAM区域(传输信息(n)起始地址+0x0E), DTC会自动将其传输到CRA寄存器或从CRA寄存器传输。请参阅第17.3.1节。分配传输信息和DTC向量表。

## (1) 正常传输模式 (MRA.MD[1:0]=00b)

在正常传输模式下, CRA用作16位传输计数器。当设置值为0x0001、0xFFFF和0x0000时, 传输计数分别为1、65535和65536。CRA值在每次数据传输时递减(-1)。

## (2) 重复传输模式(MRA.MD[1:0]=01b)

在重复传输模式下, CRAH寄存器保存传输计数, CRAL寄存器用作8位传输计数器。当设置值为0x01、0xFF和0x00时, 传输计数分别为1、255和256。CRAL值在每次数据传输时递减(-1)。当它达到0x00时, CRAH值被传送到CRAL。

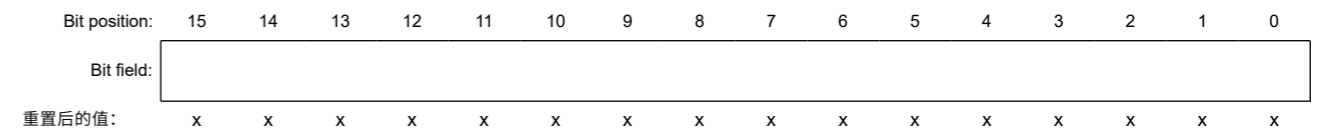
## (3) 块传输模式 (MRA.MD[1:0]=10b)

在块传输模式下, CRAH寄存器保存块大小, CRAL寄存器用作8位块大小计数器。当设置值为0x01、0xFF和0x00时, 传输计数分别为1、255和256。CRAL值在每次数据传输时递减(-1)。当它达到0x00时, CRAH值被传送到CRAL。

## 17.2.7 CRB:DTC传输计数寄存器B

Base address: DTCVBR

Offset address: 0x0C+0x4×向量编号 (无法直接从CPU访问。请参阅第17.3.1节。分配传输信息和DTC向量表)



CRB设置块传输模式的块传输计数。当设置值为0x0001、0xFFFF和0x0000时, 传输计数分别为1、65535和65536。当传输单个块大小的最终数据时, CRB值递减(-1)。When normal transfer mode or repeat transfer mode is selected, this register is not used and the set value is ignored.



The CRB cannot be accessed directly from the CPU. However, the CPU can access the SRAM area (transfer information (n) start address + 0x0C) and DTC transfers it automatically to and from the CRB register. See [section 17.3.1. Allocating Transfer Information and DTC Vector Table](#).

### 17.2.8 DTCCR : DTC Control Register

Base address: DTC = 0x4000\_5400

Offset address: 0x00

|                    |   |   |   |     |   |   |   |   |
|--------------------|---|---|---|-----|---|---|---|---|
| Bit position:      | 7 | 6 | 5 | 4   | 3 | 2 | 1 | 0 |
| Bit field:         | — | — | — | RRS | — | — | — | — |
| Value after reset: | 0 | 0 | 0 | 0   | 1 | 0 | 0 | 0 |

| Bit | Symbol | Function  | R/W |
|-----|--------|---|-----|
| 2:0 | —      | These bits are read as 0. The write value should be 0.  | R/W |
| 3   | —      | This bit is read as 1. The write value should be 1.   | R/W |
| 4   | RRS    | DTC Transfer Information Read Skip Enable<br>0: Transfer information read is not skipped<br>1: Transfer information read is skipped when vector numbers match | R/W |
| 7:5 | —      | These bits are read as 0. The write value should be 0.  | R/W |

#### RRS bit (DTC Transfer Information Read Skip Enable)

The RRS bit enables skipping of transfer information reads when vector numbers match. The DTC vector number is compared with the vector number in the previous activation process. When these vector numbers match and the RRS bit is set to 1, DTC data transfer is performed without reading the transfer information. However, when the previous transfer is a chain transfer, the transfer information is read regardless of the RRS bit.

When the transfer counter (CRA register) becomes 0 during the previous normal transfer and when the transfer counter (CRB register) becomes 0 during the previous block transfer, the transfer information is read regardless of the RRS bit value.

### 17.2.9 DTCCR\_SEC : DTC Control Register for secure Region

Base address: DTC = 0x4000\_5400

Offset address: 0x10

|                    |   |   |   |     |   |   |   |   |
|--------------------|---|---|---|-----|---|---|---|---|
| Bit position:      | 7 | 6 | 5 | 4   | 3 | 2 | 1 | 0 |
| Bit field:         | — | — | — | RRS | — | — | — | — |
| Value after reset: | 0 | 0 | 0 | 0   | 1 | 0 | 0 | 0 |

| Bit | Symbol | Function   | R/W |
|-----|--------|--|-----|
| 2:0 | —      | These bits are read as 0. The write value should be 0.   | R/W |
| 3   | —      | This bit is read as 1. The write value should be 1.  | R/W |
| 4   | RRS    | DTC Transfer Information Read Skip Enable for Secure<br>0: Transfer information read is not skipped.<br>1: Transfer information read is skipped when vector numbers match. | R/W |
| 7:5 | —      | These bits are read as 0. The write value should be 0.   | R/W |

Note: Secure access is allowed. Non-secure access is read-only.

#### RRS bit (DTC Transfer Information Read Skip Enable for Secure)

The RRS bit enables skipping of transfer information reads when vector numbers match. The DTC vector number is compared with the vector number in the previous activation process. When these vector numbers match and the RRS bit is

不能直接从CPU访问CRB。但是，CPU可以访问SRAM区域（传输信息(n)起始地址+0x0C），并且DTC会自动将其传输到CRB寄存器或从CRB寄存器传输。请参阅第17.3.1节。分配传输信息和DTC向量表。

### 17.2.8 DTCCR:DTC控制寄存器

Base address: DTC = 0x4000\_5400

Offset address: 0x00

|               |   |   |   |     |   |   |   |   |
|---------------|---|---|---|-----|---|---|---|---|
| Bit position: | 7 | 6 | 5 | 4   | 3 | 2 | 1 | 0 |
| Bit field:    | — | — | — | RRS | — | — | — | — |
| 重置后的值:        | 0 | 0 | 0 | 0   | 1 | 0 | 0 | 0 |

| Bit | Symbol | Function  | R/W |
|-----|--------|---|-----|
| 2:0 | —      | 这些位被读取为0。写入值应为0。                                  | R/W |
| 3   | —      | 该位读取为1。写入值应为1。                                    | R/W |
| 4   | RRS    | DTC传输信息读取跳过启用<br>0: 不跳过传输信息读取1: 当向量编号匹配时，跳过传输信息读取 | R/W |
| 7:5 | —      | 这些位被读取为0。写入值应为0。                                  | R/W |

#### RRS位 (DTC传输信息读取跳过使能)

当向量编号匹配时，RRS位允许跳过传输信息读取。将DTC向量编号与之前激活过程中的向量编号进行比较。当这些向量编号匹配并且RRS位设置为1时，执行DTC数据传输而不读取传输信息。但是，当前一次传输是链式传输时，无论RRS位如何，都会读取传输信息。

如果在前一次正常传输期间传输计数器（CRA寄存器）变为0，并且在前一次块传输期间传输计数器（CRB寄存器）变为0，则无论RRS位的值如何，都将读取传输信息。

### 17.2.9 DTCCR\_SEC: 安全区域的DTC控制寄存器

Base address: DTC = 0x4000\_5400

Offset address: 0x10

|               |   |   |   |     |   |   |   |   |
|---------------|---|---|---|-----|---|---|---|---|
| Bit position: | 7 | 6 | 5 | 4   | 3 | 2 | 1 | 0 |
| Bit field:    | — | — | — | RRS | — | — | — | — |
| 重置后的值:        | 0 | 0 | 0 | 0   | 1 | 0 | 0 | 0 |

| Bit | Symbol | Function   | R/W |
|-----|--------|--|-----|
| 2:0 | —      | 这些位被读取为0。写入值应为0。                                     | R/W |
| 3   | —      | 该位读取为1。写入值应为1。                                       | R/W |
| 4   | RRS    | DTC传输信息读取跳过启用安全<br>0: 不跳过读取的传输信息。1: 当向量号匹配时跳过传输信息读取。 | R/W |
| 7:5 | —      | 这些位被读取为0。写入值应为0。                                     | R/W |

Note: 允许安全访问。非安全访问是只读的。

#### RRS位 (用于安全的DTC传输信息读取跳过启用)

当向量编号匹配时，RRS位允许跳过传输信息读取。将DTC向量编号与之前激活过程中的向量编号进行比较。当这些向量编号匹配且RRS位为





| Bit | Symbol | Function   | R/W |
|-----|--------|--|-----|
| 7:1 | —      | These bits are read as 0. The write value should be 0. | R/W |

Note: If the security attribution is configured as secure:

- Secure access and Non-secure read access are allowed
- Non-secure write access is ignored, and TrustZone access error is not generated.

If the security attribution is configured as Non-secure:

- Secure and Non-secure access are allowed.

#### DTCST bit (DTC Module Start)

Set the DTCST bit to 1 to enable the DTC to accept transfer requests. When this bit is set to 0, transfer requests are no longer accepted. If this bit is set to 0 during a data transfer, the accepted transfer request is active until processing completes.

DTCST must be set to 0 before transitioning to one of the following state or mode:

- Module-stop state
- Software Standby mode without Snooze mode transition.
- Deep Software standby mode

For details on these transitions, see [section 17.10. Low Power Consumption Function](#) and [section 10, Low Power Modes](#).

#### 17.2.13 DTCSTS : DTC Status Register

Base address: DTC = 0x4000\_5400

Offset address: 0x0E

| Bit position:      | 15  | 14 | 13 | 12 | 11 | 10 | 9 | 8 | 7         | 6 | 5 | 4 | 3 | 2 | 1 | 0 |
|--------------------|-----|----|----|----|----|----|---|---|-----------|---|---|---|---|---|---|---|
| Bit field:         | ACT | —  | —  | —  | —  | —  | — | — | VECN[7:0] |   |   |   |   |   |   |   |
| Value after reset: | 0   | 0  | 0  | 0  | 0  | 0  | 0 | 0 | 0         | 0 | 0 | 0 | 0 | 0 | 0 | 0 |

| Bit  | Symbol    | Function  | R/W |
|------|-----------|---|-----|
| 7:0  | VECN[7:0] | DTC-Activating Vector Number Monitoring<br>These bits indicate the vector number for the activation source when a DTC transfer is in progress.<br>The value is only valid if a DTC transfer is in progress (ACT flag is 1). | R   |
| 14:8 | —         | These bits are read as 0.   | R   |
| 15   | ACT       | DTC Active Flag<br>0: DTC transfer operation is not in progress<br>1: DTC transfer operation is in progress   | R   |

#### VECN[7:0] bits (DTC-Activating Vector Number Monitoring)

While transfer by the DTC is in progress, the VECN[7:0] bits indicate the vector number associated with the activation source for the transfer. The value read from the VECN[7:0] bits is valid if the ACT flag is 1, indicating a DTC transfer in progress, and invalid if the ACT flag is 0, indicating no DTC transfer is in progress.

#### ACT flag (DTC Active Flag)

The ACT flag indicates the state of the DTC transfer operation.

[Setting condition]

- When the DTC is activated by a transfer request.

[Clearing condition]

- When transfer by the DTC, in response to a transfer request, is complete.

| Bit | Symbol | Function         | R/W |
|-----|--------|------------------|-----|
| 7:1 | —      | 这些位被读取为0。写入值应为0。 | R/W |

Note: 如果安全属性配置为安全: ●  
允许安全访问和非安全读取访问

- 忽略非安全写入访问, 不会生成TrustZone访问错误。

如果安全属性配置为非安全: ●  
允许安全和非安全访问。

#### DTCST位 (DTC模块启动)

将DTCST位设置为1以使DTC接受传输请求。当该位设置为0时, 不再接受传输请求。如果在数据传输期间该位设置为0, 则接受的传输请求将处于活动状态, 直到处理完成。

在转换到以下状态或模式之一之前, 必须将DTCST设置为0:

- Module-stop state
- 没有贪睡模式转换的软件待机模式。
- 深度软件待机模式

有关这些转换的详细信息, 请参阅第17.10节。低功耗功能和第10节, 低功耗模式。

#### 17.2.13 DTCSTS:DTC状态寄存器

Base address: DTC = 0x4000\_5400

Offset address: 0x0E

| Bit position: | 15  | 14 | 13 | 12 | 11 | 10 | 9 | 8 | 7         | 6 | 5 | 4 | 3 | 2 | 1 | 0 |
|---------------|-----|----|----|----|----|----|---|---|-----------|---|---|---|---|---|---|---|
| Bit field:    | ACT | —  | —  | —  | —  | —  | — | — | VECN[7:0] |   |   |   |   |   |   |   |
| 重置后的值:        | 0   | 0  | 0  | 0  | 0  | 0  | 0 | 0 | 0         | 0 | 0 | 0 | 0 | 0 | 0 | 0 |

| Bit  | Symbol    | Function  | R/W |
|------|-----------|---|-----|
| 7:0  | VECN[7:0] | DTC-激活向量数量监测<br>当DTC传输正在进行时, 这些位指示激活源的向量编号。该值仅在DTC传输正在进行 (ACT标志为1) 时有效。 | R   |
| 14:8 | —         | 这些位读为0。   | R   |
| 15   | ACT       | DTC活动标志<br>0: 未进行DTC传输操作1: 正在进行DTC传输操作                                  | R   |

#### VECN[7:0]位 (DTC-激活向量编号监控)

当DTC进行传输时, VECN[7:0]位指示与传输激活源相关的向量编号。如果ACT标志为1, 则从VECN[7:0]位读取的值有效, 表示正在进行DTC传输, 如果ACT标志为0, 则表示无效, 表示没有DTC传输正在进行。

#### ACT标志 (DTC活动标志)

ACT标志指示DTC传输操作的状态。

[Setting condition]

- 当DTC被传输请求激活时。

[Clearing condition]

- 当DTC传输完成时, 响应传输请求。

## 17.2.14 DTEVR : DTC Error Vector Register

Base address: DTC = 0x4000\_5400

Offset address: 0x20

|                    |    |    |    |    |    |    |    |         |           |    |    |    |    |    |    |        |
|--------------------|----|----|----|----|----|----|----|---------|-----------|----|----|----|----|----|----|--------|
| Bit position:      | 31 | 30 | 29 | 28 | 27 | 26 | 25 | 24      | 23        | 22 | 21 | 20 | 19 | 18 | 17 | 16     |
| Bit field:         | —  | —  | —  | —  | —  | —  | —  | —       | —         | —  | —  | —  | —  | —  | —  | DTESTA |
| Value after reset: | 0  | 0  | 0  | 0  | 0  | 0  | 0  | 0       | 0         | 0  | 0  | 0  | 0  | 0  | 0  | 0      |
| Bit position:      | 15 | 14 | 13 | 12 | 11 | 10 | 9  | 8       | 7         | 6  | 5  | 4  | 3  | 2  | 1  | 0      |
| Bit field:         | —  | —  | —  | —  | —  | —  | —  | DTEVSAM | DTEV[7:0] |    |    |    |    |    |    |        |
| Value after reset: | 0  | 0  | 0  | 0  | 0  | 0  | 0  | 0       | 0         | 0  | 0  | 0  | 0  | 0  | 0  | 0      |

| Bit   | Symbol    | Function   | R/W |
|-------|-----------|--|-----|
| 7:0   | DTEV[7:0] | DTC Error Vector Number<br>These bits represent error vector of the DTC.   | R   |
| 8     | DTEVSAM   | DTC Error Vector Number SA Monitor<br>Indicates the SA of vector number causing the error.<br>0: Secure vector number<br>1: Non-Secure vector number | R   |
| 15:9  | —         | These bits are read as 0. The write value should be 0.   | R   |
| 16    | DTESTA    | DTC Error Status Flag<br>0: No DTC transfer error occurred<br>1: DTC transfer error occurred   | R/W |
| 31:17 | —         | These bits are read as 0. The write value should be 0.   | R   |

Note: Writing to DTESTA depends on the value of DTEVSAM

**DTEV[7:0] bit (DTC Error Vector Number)**

When a transfer error due to DTC transfer occurs, it stores the channel of DTC that was violated.

When reset was selected in MPU.MMPUOAD.OAD and TZF.TZFOAD.OAD, Since this register is also reset. Please select NMI when you want to debug the program.

[Set condition]

- When the DTC transfer error occurs and DTESTA = 0.

[Clearing condition]

- When 1 is written to DTEVR.DTESTA.

**DTEVSAM bit (DTC Error Vector Number SA Monitor)**

When a transfer error due to DTC transfer occurs, it indicates the SA of the violating DTC vector number.

When reset was selected in MPU.MMPUOAD.OAD and TZF.TZFOAD.OAD, Since this register is also reset. Please select NMI when you want to debug the program.

[Set condition]

- When the DTC transfer error occurs and DTESTA = 0.

[Clearing condition].

- When 1 is written to DTEVR.DTESTA.

**DTESTA bit (DTC Error Status Flag)**

Indicates whether or not a DTC transfer error occurred.

DTEV, DTEVSAM, DTESTA are cleared by writing 1 to DTESTA.

## 17.2.14 DTEVR:DTC错误向量寄存器

Base address: DTC = 0x4000\_5400

Offset address: 0x20

|               |    |    |    |    |    |    |    |         |           |    |    |    |    |    |    |        |
|---------------|----|----|----|----|----|----|----|---------|-----------|----|----|----|----|----|----|--------|
| Bit position: | 31 | 30 | 29 | 28 | 27 | 26 | 25 | 24      | 23        | 22 | 21 | 20 | 19 | 18 | 17 | 16     |
| Bit field:    | —  | —  | —  | —  | —  | —  | —  | —       | —         | —  | —  | —  | —  | —  | —  | DTESTA |
| 重置后的值:        | 0  | 0  | 0  | 0  | 0  | 0  | 0  | 0       | 0         | 0  | 0  | 0  | 0  | 0  | 0  | 0      |
| Bit position: | 15 | 14 | 13 | 12 | 11 | 10 | 9  | 8       | 7         | 6  | 5  | 4  | 3  | 2  | 1  | 0      |
| Bit field:    | —  | —  | —  | —  | —  | —  | —  | DTEVSAM | DTEV[7:0] |    |    |    |    |    |    |        |
| 重置后的值:        | 0  | 0  | 0  | 0  | 0  | 0  | 0  | 0       | 0         | 0  | 0  | 0  | 0  | 0  | 0  | 0      |

| Bit   | Symbol    | Function   | R/W |
|-------|-----------|--|-----|
| 7:0   | DTEV[7:0] | DTC错误向量编号<br>这些位代表DTC的误差向量。                              | R   |
| 8     | DTEVSAM   | DTC错误向量编号SA监视器<br>指示导致错误的向量号的SA。<br>0: 安全向量编号 1: 非安全向量编号 | R   |
| 15:9  | —         | 这些位被读取为0。写入值应为0。   | R   |
| 16    | DTESTA    | DTC错误状态标志<br>0: 未发生DTC传输错误 1: 发生DTC传输错误                  | R/W |
| 31:17 | —         | 这些位被读取为0。写入值应为0。   | R   |

Note: 写入DTESTA取决于DTEVSAM的值

**DTEV[7:0]位 (DTC错误向量编号)**

当由于DTC传输而发生传输错误时, 它会存储违反的DTC通道。

当在MPU.MMPUOAD.OAD和TZF.TZFOAD.OAD中选择了复位时, 由于该寄存器也被复位。请选择NMI当你想调试程序时。

[Set condition]

- 发生DTC传输错误且DTESTA=0时。

[Clearing condition]

- 当1写入DTEVR.DTESTA时。

**DTEVSAM位 (DTC错误向量编号SA监视器)**

当由于DTC传输而发生传输错误时, 它指示违规DTC向量号的SA。

当在MPU.MMPUOAD.OAD和TZF.TZFOAD.OAD中选择了复位时, 由于该寄存器也被复位。请选择NMI当你想调试程序时。

[Set condition]

- 发生DTC传输错误且DTESTA=0时。

[Clearing condition].

- 当1写入DTEVR.DTESTA时。

**DTESTA位 (DTC错误状态标志)**

指示是否发生DTC传输错误。

DTEV、DTEVSAM、DTESTA通过向DTESTA写入1清零。

Writing 0 to DTESTA is ignored.

When reset was selected in MPU.MMPUOAD.OAD and TZF.TZFOAD.OAD, Since this register is also reset. Please select NMI when you want to debug the program.

[Set condition]

- When the DMAC transfer error occurs.

[Clearing condition]

- When 1 is written to DTEVR.DTESTA.

Note: When DTEVSAM = 1, it can be cleared in the secure state and non-secure state. DTEVSAM = 0, it cannot be cleared in the non-secure state.

### 17.3 Activation Sources

The DTC is activated by an interrupt request. Setting the ICU.IELSRn.DTCE bit to 1 enables activation of the DTC by the associated interrupt. The selector output  $n$  number set in ICU.IELSRn is defined as the interrupt vector number, where  $n = 0$  to 95. For an enabled interrupt, the specific DTC interrupt source associated with each interrupt vector number  $n$  is selected in ICU.IELSRn.IELS[8:0] where  $n = 0$  to 95, as listed in [section 13.3.2. Event Number](#) in [section 13, Interrupt Controller Unit \(ICU\)](#). For activation by software, see [section 18.2.2. ELSEGRn : Event Link Software Event Generation Register n \(n = 0, 1\)](#).

The interrupt vector number is equivalent to the DTC vector table number. After the DTC accepted an activation request, it does not accept another activation request until transfer for that single request is complete, regardless of the priority of the requests. When multiple activation requests are generated during a DTC transfer, a highest priority request is accepted on completion of the transfer. When multiple activation requests are generated while the DTC Module Start bit (DTCST.DTCST) is 0, the DTC accepts the highest priority request when DTCST.DTCST is subsequently set to 1. The smaller interrupt vector number has higher priority.

The DTC performs the following operations at the start of a single data transfer or for a chain transfer, after the last of the consecutive transfers:

- On completion of a specified round of data transfer, the ICU.IELSRn.DTCE bit is set to 0, and an interrupt request is sent to the CPU
- If the MRB.DISEL bit is 1, an interrupt request is sent to the CPU on completion of a data transfer
- For other transfers, the ICU.IELSRn.IR flag of the activation source is set to 0 at the start of the data transfer.

#### 17.3.1 Allocating Transfer Information and DTC Vector Table

The DTC reads the start address of the transfer information associated with each activation source from the vector table and reads the transfer information starting at that address.

DTC has two vector tables, non-secure side or secure side. Because the interrupt vector number that serves as a trigger for DTC is divided into non-secure or secure. Place the vector table of the interrupt vector number of SA = 1 in DTCVBR which is the non-secure side. Place the vector table of interrupt number SA = 0 in DTCVBR\_SEC which is the secure side.

The vector table must be located so that the lower 10 bits of the base address (start address) are 0. Use the DTC Vector Base Register (DTCVBR) to set the base address of the DTC vector table. Transfer information is allocated in the SRAM area. In the SRAM area, the start address of the transfer information  $n$  with vector number  $n$  must be  $4n$  added to the base address in the vector table.

[section 17.3.1. Allocating Transfer Information and DTC Vector Table](#) shows the relationship between the DTC vector table and transfer information. [Figure 17.3](#) shows the allocation of transfer information in the SRAM area.

将0写入DTESTA将被忽略。

当在MPU.MMPUOAD.OAD和TZF.TZFOAD.OAD中选择了复位时，由于该寄存器也被复位。请选择NMI当你想调试程序时。

[Set condition]

- 发生DMAC传输错误时。

[Clearing condition]

- 当1写入DTEVR.DTESTA时。

Note: 当DTEVSAM=1时，可以在安全状态和非安全状态下清零。DTEVSAM=0，在非安全状态下不能清零。

### 17.3 激活源

DTC由中断请求激活。将ICU.IELSRn.DTCE位设置为1可以通过相关中断激活DTC。ICU.IELSRn中设置的选择器输出 $n$ 个数被定义为中断向量号，其中 $n=0$ 到95。对于一个使能的中断，在ICU.IELSRn.IELS中选择与每个中断向量号 $n$ 相关的特定DTC中断源[8:0]其中 $n=0$ 到95，如第13.3.2节中所列。第13节，中断控制器单元(ICU)中的事件编号。关于通过软件激活，请参见第18.2.2节。ELSEGRn：事件链接软件事件生成寄存器 $n(n=0, 1)$ 。

中断向量编号相当于DTC向量表编号。在DTC接受激活请求后，它不会接受另一个激活请求，直到该单个请求的传输完成，无论请求的优先级如何。如果在DTC传输期间生成多个激活请求，则在传输完成时接受最高优先级的请求。当DTC模块起始位(DTCST.DTCST)为0时产生多个激活请求时，当DTCST.DTCST随后设置为1时，DTC接受最高优先级请求。较小的中断向量编号具有较高的优先级。

DTC在单次数据传输开始时执行以下操作，或者对于链式传输，在最后一次连续传输之后执行以下操作：

- 完成指定轮次的数据传输后，ICU.IELSRn.DTCE位设置为0，并向CPU发送中断请求
- 如果MRB.DISEL位为1，则在数据传输完成时向CPU发送中断请求
- 对于其他传输，激活源的ICU.IELSRn.IR标志在数据传输开始时设置为0。

#### 17.3.1 分配传输信息和DTC向量表

DTC从向量表中读取与每个激活源相关联的传输信息的起始地址，并读取从该地址开始的传输信息。

DTC有两个向量表，非安全端或安全端。因为作为DTC触发的中断向量号分为非安全和安全。将SA=1的中断向量号的向量表放在非安全端DTCVBR中。将中断号SA=0的向量表放在安全侧DTCVBR\_SEC中。

向量表的定位必须使基地址（起始地址）的低10位为0。使用DTC向量基址寄存器(DTCVBR)设置DTC向量表的基地址。传输信息分配在SRAM区域中。在SRAM区域中，向量编号为 $n$ 的传输信息 $n$ 的起始地址必须与向量表中的基地址相加 $4n$ 。

[第17.3.1节. 分配传输信息和DTC向量表](#)显示了DTC向量表和传输信息之间的关系。图17.3显示了SRAM区域中传输信息的分配。

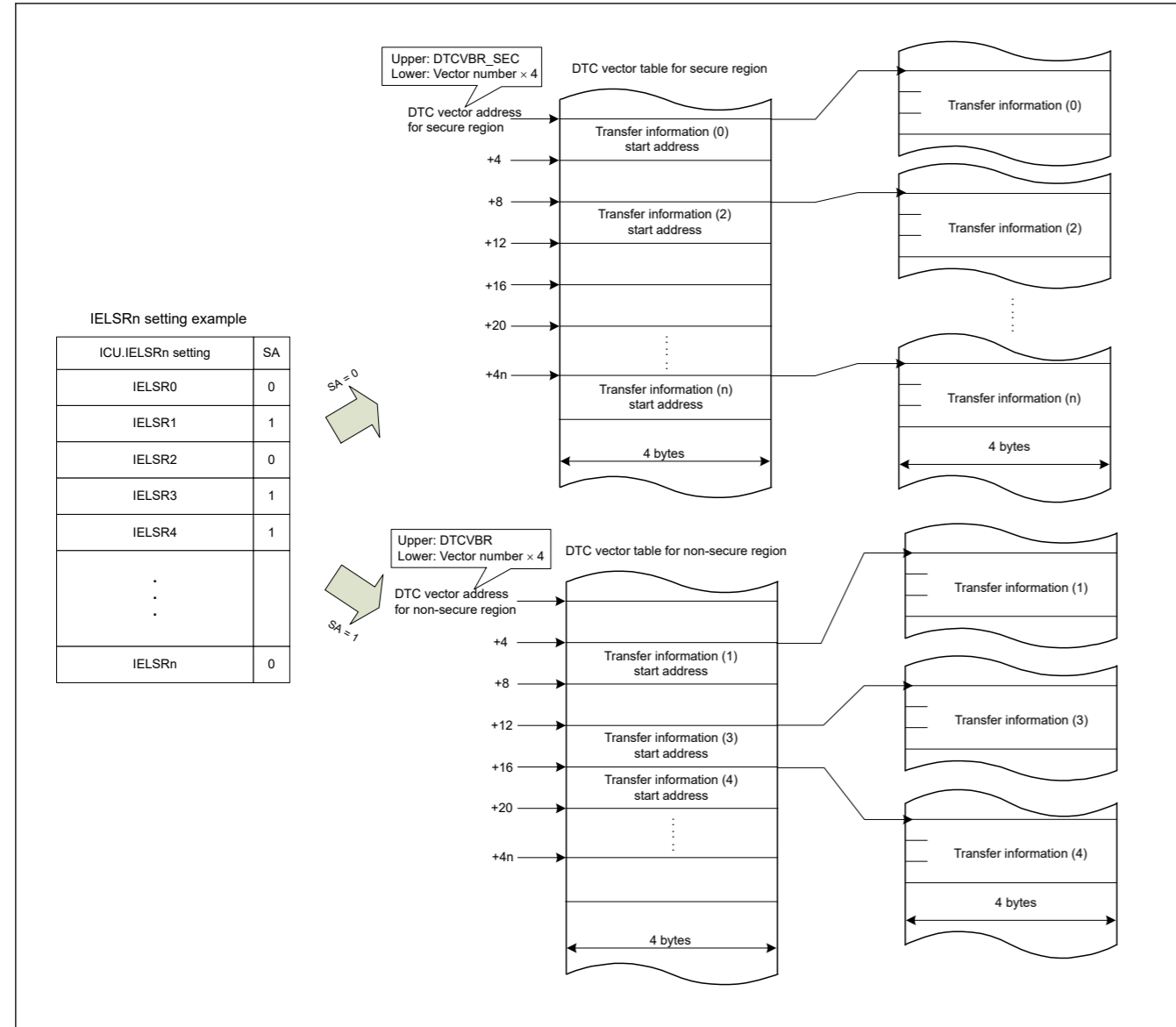


Figure 17.2 DTC vector table and transfer information

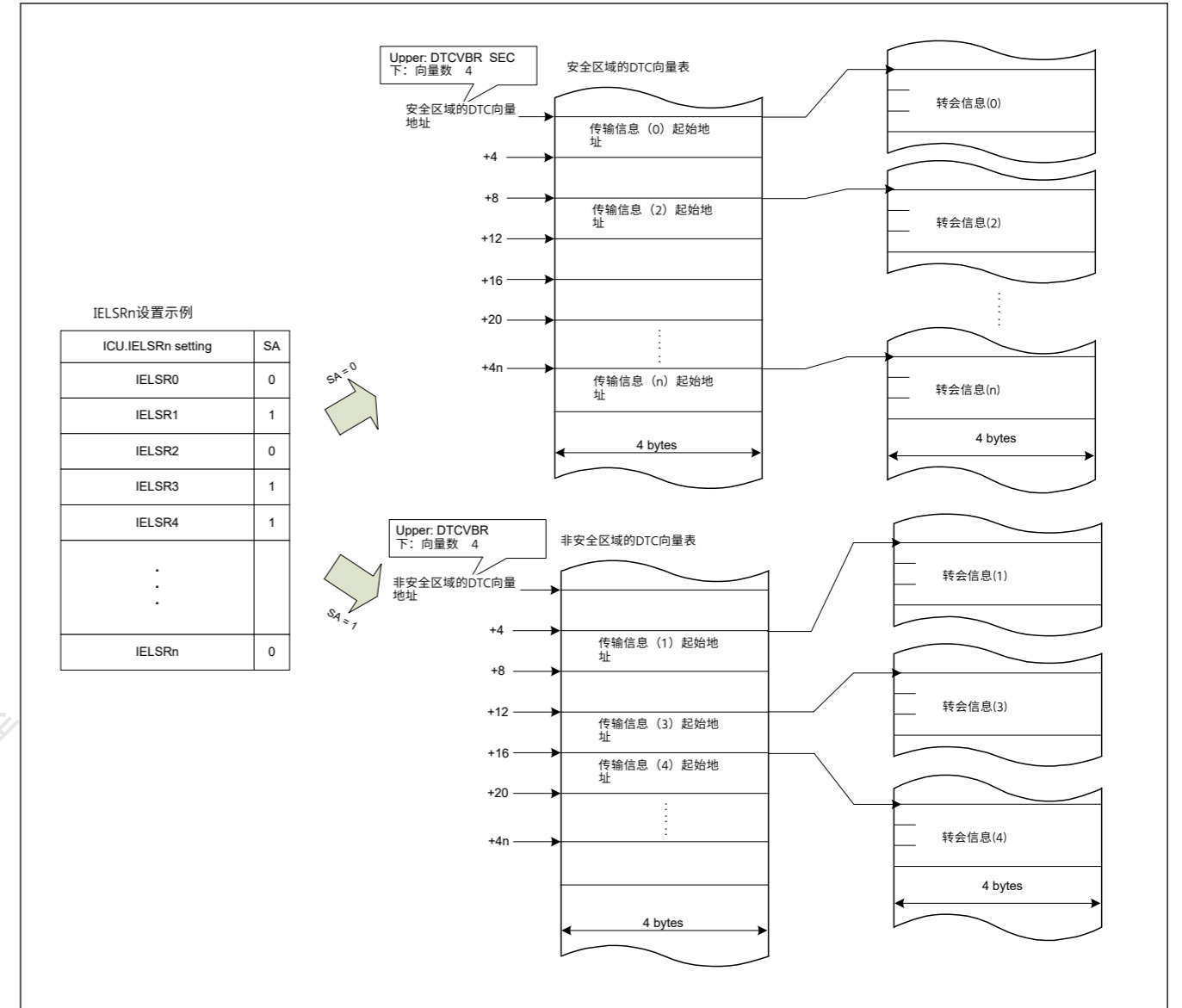


Figure 17.2 DTC向量表和传输信息



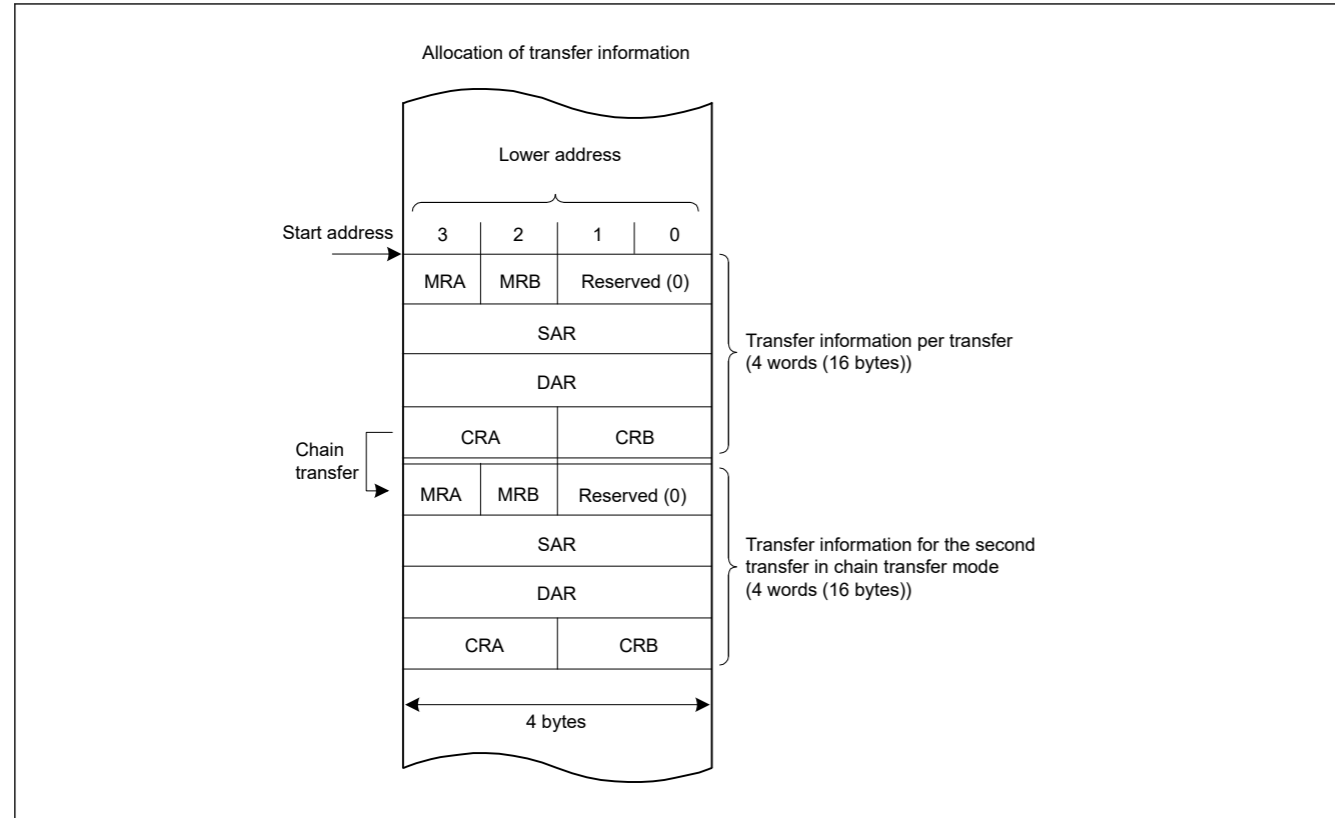


Figure 17.3 Allocation of transfer information in the SRAM area

### 17.4 Operation

The DTC transfers data according to the transfer information. Storage of the transfer information in the SRAM area is required before a DTC operation. When the DTC is activated, it reads the DTC vector associated with the vector number. The DTC reads the transfer information from the transfer information store address referenced by the DTC vector and transfers the data. After the data transfer, the DTC writes back the transfer information. Storing the transfer information in the SRAM area allows data transfer of any number of channels.

The transfer modes include:

- Normal transfer mode
- Repeat transfer mode
- Block transfer mode.

The DTC specifies a transfer source address in the SAR register and a transfer destination address in the DAR register. The values of these registers are incremented, decremented, or address-fixed independently after the data transfer.

Table 17.2 describes the DTC transfer modes.

Table 17.2 DTC transfer modes

| Transfer mode          | Data size transferred on single transfer request  | Increment or decrement of memory address                  | Settable transfer count |
|------------------------|---|---|-------------------------|
| Normal transfer mode   | 1 byte (8 bit), 1 halfword (16 bit), 1 word (32 bit)  | Incremented or decremented by 1, 2, or 4 or address fixed | 1 to 65536              |
| Repeat transfer mode*1 | 1 byte (8 bit), 1 halfword (16 bit), 1 word (32 bit)  | Incremented or decremented by 1, 2, or 4 or address fixed | 1 to 256 <sup>3</sup>   |
| Block transfer mode*2  | Block size specified in CRAH (1 to 256 bytes, 1 to 256 halfwords (2 to 512 bytes), or 1 to 256 words (4 to 1024 bytes)) | Incremented or decremented by 1, 2, or 4 or address fixed | 1 to 65536              |

Note 1. Set the transfer source or transfer destination as the repeat area.  
 Note 2. Set the transfer source or transfer destination as the block area.

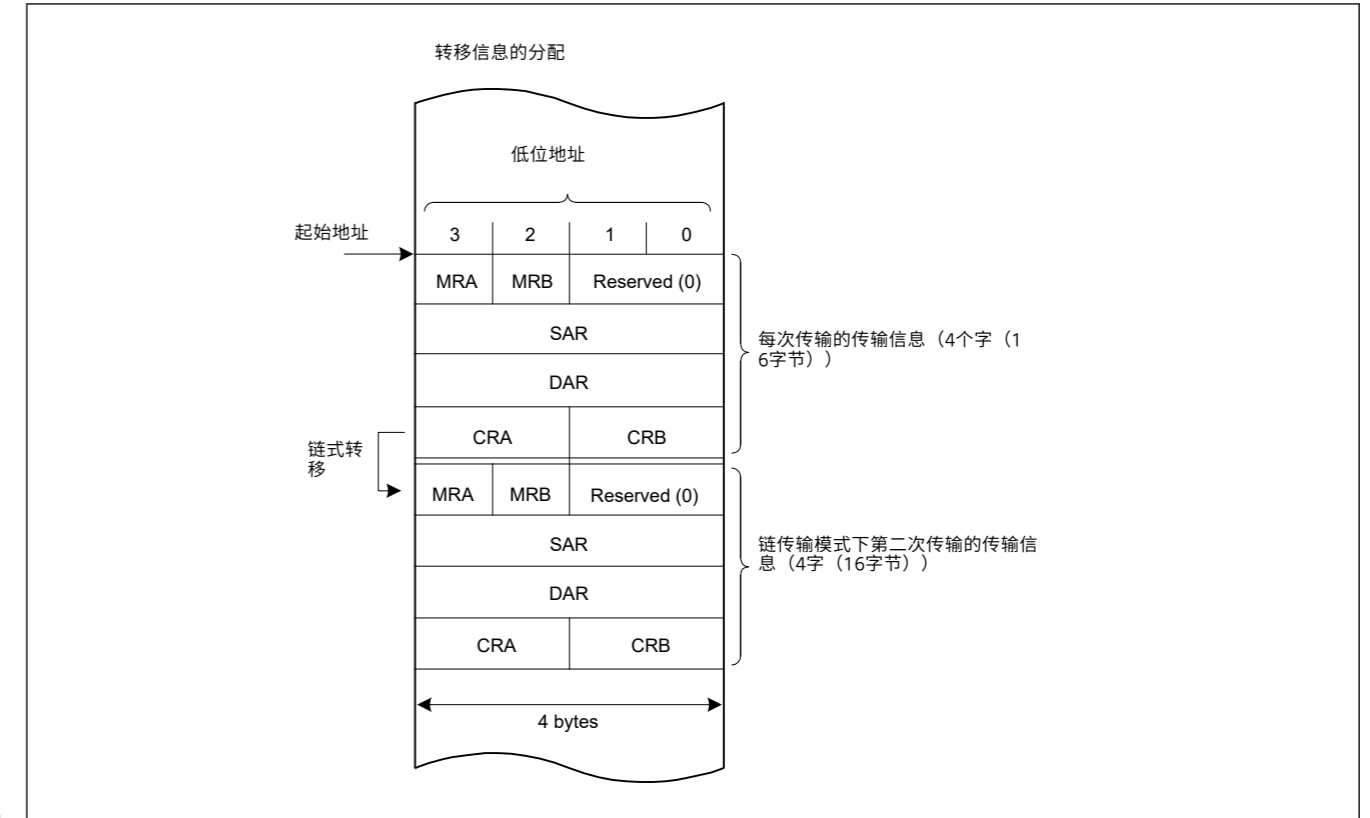


Figure 17.3 SRAM区域中传输信息的分配

### 17.4 Operation

DTC根据传输信息传输数据。在进行DTC操作之前，需要在SRAM区域中存储传输信息。当DTC被激活时，它会读取与向量编号相关联的DTC向量。DTC从DTC向量引用的传输信息存储地址中读取传输信息并传输数据。数据传输后，DTC写回传输信息。将传输信息存储在SRAM区域中可以实现任意数量的通道的数据传输。

传输模式包括：

- 普通传输模式
- 重复传输模式
- 块传输模式。

DTC指定SAR寄存器中的传输源地址和DAR寄存器中的传输目标地址。这些寄存器的值在数据传输后独立地递增、递减或固定地址。

表17.2描述了DTC传输模式。

Table 17.2 DTC传输模式

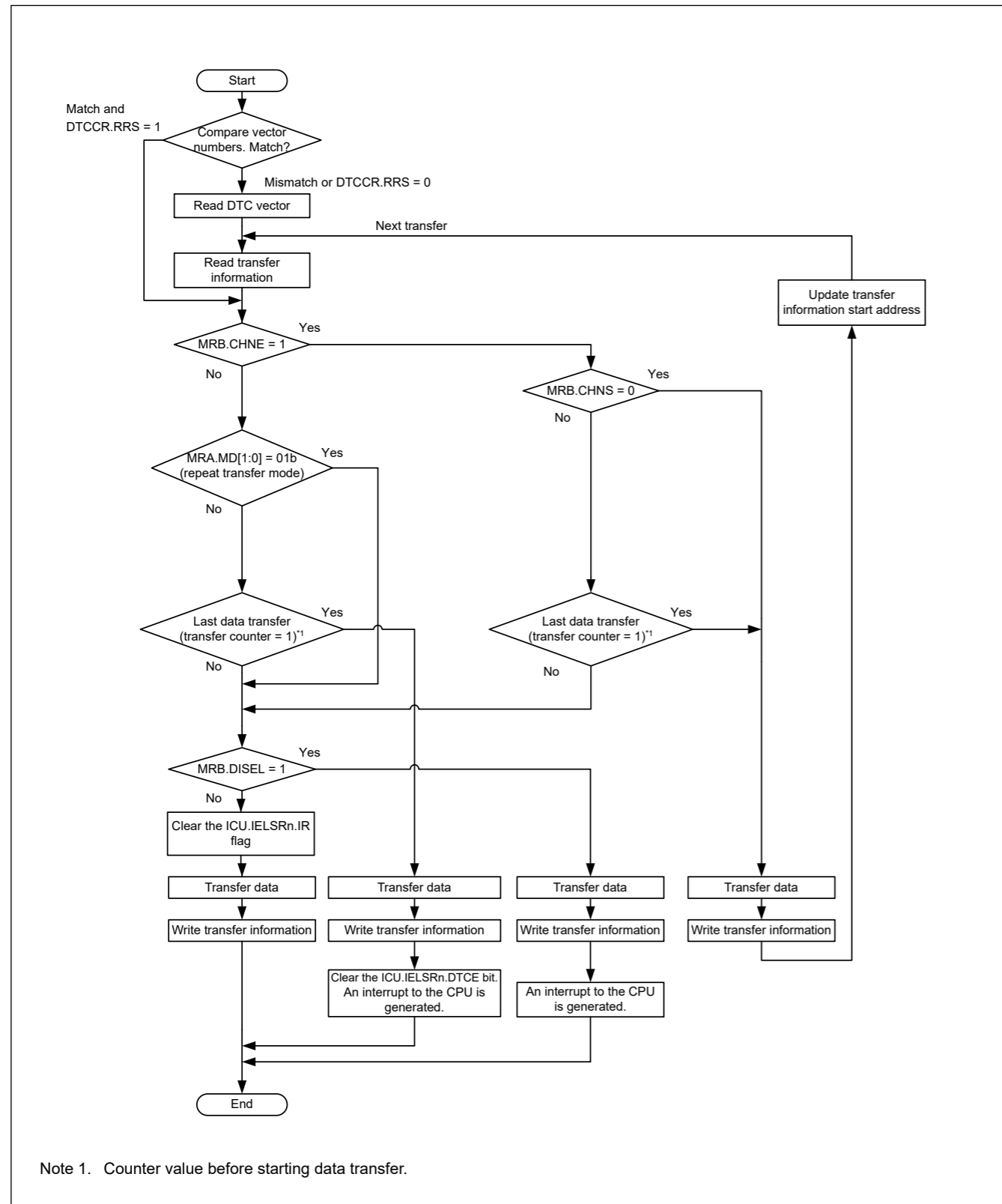
| 传输模式     | 在单个传输请求上传的数据大小  | 内存地址的递增或递减      | 可设置的传输次数              |
|----------|---|-----------------|-----------------------|
| 正常传输模式   | 1个字节 (8位)、1个半字 (16位)、1个字 (32位)                              | 递增或递减1、2或4或固定地址 | 1 to 65536            |
| 重复传输模式*1 | 1个字节 (8位)、1个半字 (16位)、1个字 (32位)                              | 递增或递减1、2或4或固定地址 | 1 to 256 <sup>3</sup> |
| 块传输模式*2  | CRAH中指定的块大小 (1到256字节、1到256个半字 (2到512字节) 或1到256字 (4到1024字节)) | 递增或递减1、2或4或固定地址 | 1 to 65536            |

注1.将传输源或传输目标设置为重复区域。注2.将传输源或传输目标设置为块区域。

Note 3. After a data transfer of the specified count, the initial state is restored and operation restarts.

Setting the MRB.CHNE bit to 1 allows multiple transfers or chain transfer on a single activation source. It also enables a chain transfer when the specified data transfer is complete.

Figure 17.4 shows the operation flow of the DTC. Table 17.3 lists the chain transfer conditions. The combination of control information for the second and subsequent transfers are omitted in this table.



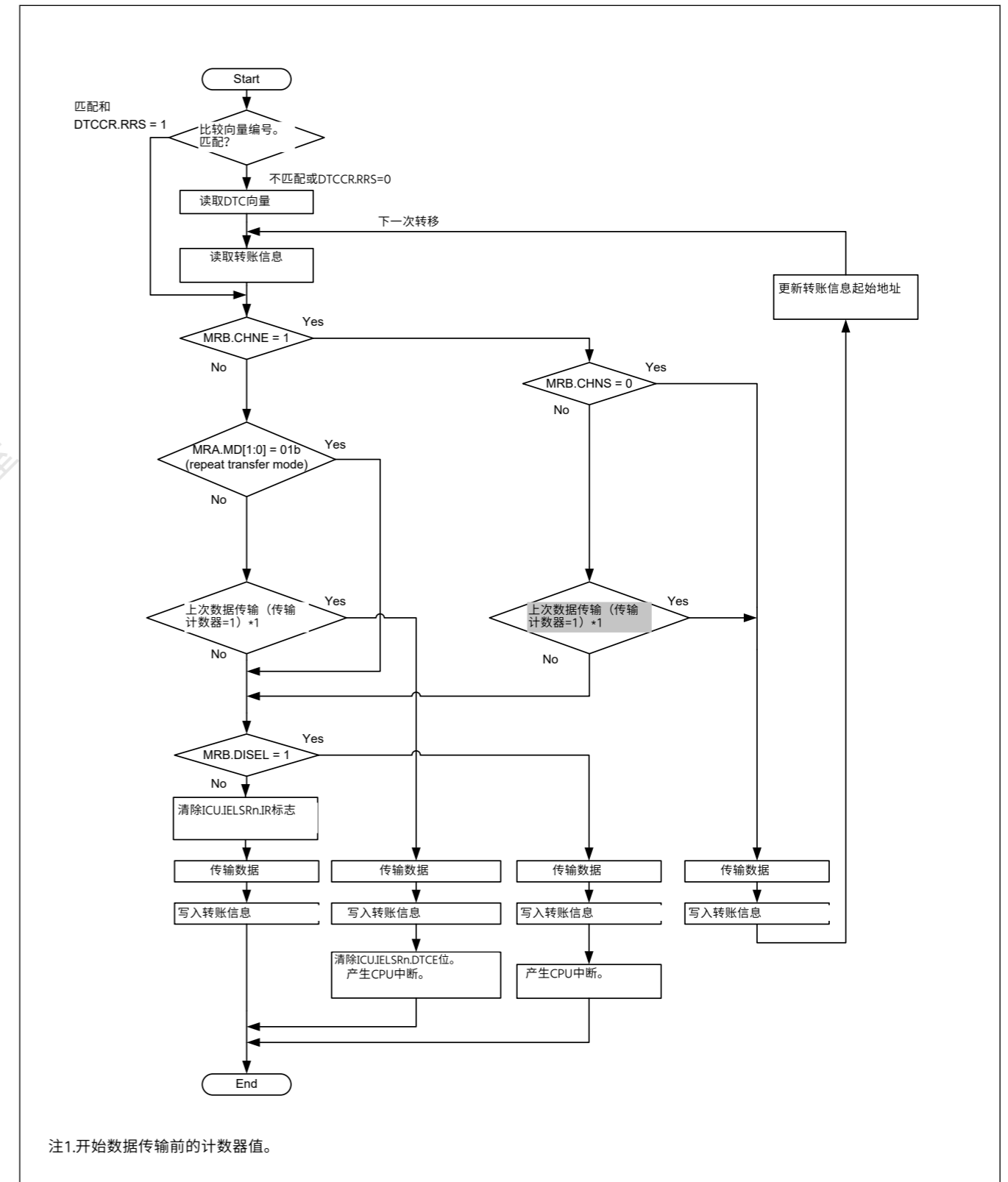
Note 1. Counter value before starting data transfer.

Figure 17.4 DTC operation flow

注3.指定计数的数据传输后，恢复初始状态并重新开始操作。

将MRB.CHNE位设置为1允许在单个激活源上进行多次传输或链式传输。当指定的数据传输完成时，它还启用链式传输。

图17.4显示了DTC的操作流程。表17.3列出了链转移条件。该表中省略了用于第二次和后续传输的控制信息的组合。



注1.开始数据传输前的计数器值。

Figure 17.4 DTC操作流程

Table 17.3 Chain transfer conditions

| First transfer |          |           |                                   | Second transfer <sup>*3</sup> |          |           |                                   | DTC transfer  |
|----------------|----------|-----------|-----------------------------------|-------------------------------|----------|-----------|-----------------------------------|---|
| CHNE bit       | CHNS bit | DISEL bit | Transfer counter <sup>*1 *2</sup> | CHNE bit                      | CHNS bit | DISEL bit | Transfer counter <sup>*1 *2</sup> |   |
| 0              | —        | 0         | Other than (1 → 0)                | —                             | —        | —         | —                                 | Ends after the first transfer                                       |
| 0              | —        | 0         | (1 → 0)                           | —                             | —        | —         | —                                 | Ends after the first transfer with an interrupt request to the CPU  |
| 0              | —        | 1         | —                                 | —                             | —        | —         | —                                 | Ends after the first transfer with an interrupt request to the CPU  |
| 1              | 0        | —         | —                                 | 0                             | —        | 0         | Other than (1 → 0)                | Ends after the second transfer                                      |
|                |          |           |                                   | 0                             | —        | 0         | (1 → 0)                           | Ends after the second transfer with an interrupt request to the CPU |
|                |          |           |                                   | 0                             | —        | 1         | —                                 | Ends after the second transfer with an interrupt request to the CPU |
| 1              | 1        | 0         | Other than (1 → *)                | —                             | —        | —         | —                                 | Ends after the first transfer                                       |
| 1              | 1        | —         | (1 → *)                           | 0                             | —        | 0         | Other than (1 → 0)                | Ends after the second transfer                                      |
|                |          |           |                                   | 0                             | —        | 0         | (1 → 0)                           | Ends after the second transfer with an interrupt request to the CPU |
|                |          |           |                                   | 0                             | —        | 1         | —                                 | Ends after the second transfer with an interrupt request to the CPU |
| 1              | 1        | 1         | Other than (1 → *)                | —                             | —        | —         | —                                 | Ends after the first transfer with an interrupt request to the CPU  |

Note 1. The transfer counter used depends on the transfer modes as follows:

- Normal transfer mode — CRA register
- Repeat transfer mode — CRAL register
- Block transfer mode — CRB register

Note 2. On completion of a data transfer, the counters operate as follows:

- 1 → 0 in normal and block transfer modes
- 1 → CRAH in repeat transfer mode
- (1 → \*) in the table indicates both of these two operations, depending on the mode.

Note 3. Chain transfer can be selected for the second or subsequent transfers. The conditions for the combination of the second transfer and CHNE = 1 is omitted.

### 17.4.1 Transfer Information Read Skip Function

Reading of vector addresses and transfer information can be skipped by setting the DTCCR.RRS bit. When a DTC activation request is generated, the current DTC vector number is compared with the DTC vector number in the previous activation process. When these vector numbers match and the RRS bit is set to 1, the DTC data transfer is performed without reading the vector address and transfer information. However, when the previous transfer is a chain transfer, the vector address and transfer information are read. Additionally, when the transfer counter (CRA register) becomes 0 during the previous normal transfer, and when the transfer counter (CRB register) becomes 0 during the previous block transfer, transfer information is read regardless of the RRS bit. Figure 17.12 shows an example of a transfer information read skip.

To update the vector table and transfer information, set the RRS bit to 0, update the vector table and transfer information, then set the RRS bit to 1. The stored vector number is discarded by setting the RRS bit to 0. The updated DTC vector table and transfer information are read in the next activation process.

### 17.4.2 Transfer Information Write-Back Skip Function

When the MRA.SM[1:0] bits or the MRB.DM[1:0] bits are set to address fixed, a part of the transfer information is not written back. Table 17.4 lists the transfer information write-back skip conditions and the associated registers. The CRA and CRB registers are written back, and the write-back of the MRA and MRB registers is skipped.

Table 17.3 链转移条件

| 首次转让     |          |           |           | 二次转让*3   |          |           |           | DTC transfer          |
|----------|----------|-----------|-----------|----------|----------|-----------|-----------|-----------------------|
| CHNE bit | CHNS bit | DISEL bit | 转帐计数器*1*2 | CHNE bit | CHNS bit | DISEL bit | 转帐计数器*1*2 |                       |
| 0        | —        | 0         | (1→0) 以外  | —        | —        | —         | —         | 在第一次传输后结束             |
| 0        | —        | 0         | (1 → 0)   | —        | —        | —         | —         | 在第一次传输后结束, 向CPU发出中断请求 |
| 0        | —        | 1         | —         | —        | —        | —         | —         | 在第一次传输后结束, 向CPU发出中断请求 |
| 1        | 0        | —         | —         | 0        | —        | 0         | (1→0) 以外  | 在第二次转移后结束             |
|          |          |           |           | 0        | —        | 0         | (1 → 0)   | 在第二次传输后结束, 向CPU发出中断请求 |
|          |          |           |           | 0        | —        | 1         | —         | 在第二次传输后结束, 向CPU发出中断请求 |
| 1        | 1        | 0         | (1→*)以外   | —        | —        | —         | —         | 在第一次传输后结束             |
| 1        | 1        | —         | (1 → *)   | 0        | —        | 0         | (1→0) 以外  | 在第二次转移后结束             |
|          |          |           |           | 0        | —        | 0         | (1 → 0)   | 在第二次传输后结束, 向CPU发出中断请求 |
|          |          |           |           | 0        | —        | 1         | —         | 在第二次传输后结束, 向CPU发出中断请求 |
| 1        | 1        | 1         | (1→*)以外   | —        | —        | —         | —         | 在第一次传输后结束, 向CPU发出中断请求 |

注1.使用的传输计数器取决于传输模式, 如下所示:

- 正常传输模式—CRA寄存器
- 重复传输模式—CRAL寄存器
- 块传输模式—CRB寄存器

注2.数据传输完成后, 计数器操作如下: 1→0在正常和块传输模式下1→CRAH在重复传输模式下(1→\*)表中表示这两种操作, 取决于模式。

注3.第二次及以后的转账可选择链式转账。省略了二次传输和CHNE=1的组合条件。

### 17.4.1 传输信息读取跳过功能

通过设置DTCCR.RRS位可以跳过向量地址和传输信息的读取。当产生DTC激活请求时, 将当前DTC向量编号与之前激活过程中的DTC向量编号进行比较。当这些向量编号匹配且RRS位设置为1时, 执行DTC数据传输而不读取向量地址和传输信息。但是, 当上一次传输是链式传输时, 会读取向量地址和传输信息。此外, 如果在上次正常传输期间传输计数器 (CRA寄存器) 变为0, 并且在前一次块传输期间传输计数器 (CRB寄存器) 变为0, 则无论RRS位如何, 都将读取传输信息。图17.12显示了传输信息读取跳过的示例。

要更新向量表和传输信息, 请将RRS位设置为0, 更新向量表和传输信息, 然后将RRS位设置为1。通过将RRS位设置为0, 丢弃存储的向量编号。更新的DTC向量在下一个激活过程中读取表和传输信息。

### 17.4.2 传输信息回写跳过功能

当MRA.SM[1:0]位或MRB.DM[1:0]位设置为地址固定时, 部分传输信息不会被写回。表17.4列出了传输信息回写跳过条件和相关寄存器。回写CRA和CRB寄存器, 跳过回写MRA和MRB寄存器。

Table 17.4 Transfer information write-back skip conditions and applicable registers

| MRA.SM[1:0] bits |    | MRB.DM[1:0] bits |    | SAR register | DAR register |
|------------------|----|------------------|----|--------------|--------------|
| b3               | b2 | b3               | b2 |              |              |
| 0                | 0  | 0                | 0  | Skip         | Skip         |
| 0                | 0  | 0                | 1  |              |              |
| 0                | 1  | 0                | 0  |              |              |
| 0                | 1  | 0                | 1  |              |              |
| 0                | 0  | 1                | 0  | Skip         | Write-back   |
| 0                | 0  | 1                | 1  |              |              |
| 0                | 1  | 1                | 0  |              |              |
| 0                | 1  | 1                | 1  |              |              |
| 1                | 0  | 0                | 0  | Write-back   | Skip         |
| 1                | 0  | 0                | 1  |              |              |
| 1                | 1  | 0                | 0  |              |              |
| 1                | 1  | 0                | 1  |              |              |
| 1                | 0  | 1                | 0  | Write-back   | Write-back   |
| 1                | 0  | 1                | 1  |              |              |
| 1                | 1  | 1                | 0  |              |              |
| 1                | 1  | 1                | 1  |              |              |

### 17.4.3 Normal Transfer Mode

The normal transfer mode allows a 1-byte (8 bit), 1-halfword (16 bit), 1-word (32 bit) data transfer on a single activation source. The transfer count can be set to 1 to 65536. Transfer source and destination addresses can be independently set to increment, decrement, or fixed. This mode enables an interrupt request to the CPU to be generated at the end of a specified-count transfer.

Table 17.5 lists register functions in normal transfer mode, and Figure 17.5 shows the memory map of normal transfer mode.

Table 17.5 Register functions in normal transfer mode

| Register | Description                  | Value written back by writing transfer information |
|----------|------------------------------|--|
| SAR      | Transfer source address      | Increment, decrement, or fixed <sup>*1</sup>       |
| DAR      | Transfer destination address | Increment, decrement, fixed <sup>*1</sup>          |
| CRA      | Transfer counter A           | CRA - 1  |
| CRB      | Transfer counter B           | Not updated  |

Note 1. Write-back operation is skipped in address-fixed mode.

Table 17.4 传输信息回写跳过条件和适用寄存器

| MRA.SM[1:0] bits |    | MRB.DM[1:0] bits |    | SAR寄存器     | DAR寄存器     |
|------------------|----|------------------|----|------------|------------|
| b3               | b2 | b3               | b2 |            |            |
| 0                | 0  | 0                | 0  | Skip       | Skip       |
| 0                | 0  | 0                | 1  |            |            |
| 0                | 1  | 0                | 0  |            |            |
| 0                | 1  | 0                | 1  |            |            |
| 0                | 0  | 1                | 0  | Skip       | Write-back |
| 0                | 0  | 1                | 1  |            |            |
| 0                | 1  | 1                | 0  |            |            |
| 0                | 1  | 1                | 1  |            |            |
| 1                | 0  | 0                | 0  | Write-back | Skip       |
| 1                | 0  | 0                | 1  |            |            |
| 1                | 1  | 0                | 0  |            |            |
| 1                | 1  | 0                | 1  |            |            |
| 1                | 0  | 1                | 0  | Write-back | Write-back |
| 1                | 0  | 1                | 1  |            |            |
| 1                | 1  | 1                | 0  |            |            |
| 1                | 1  | 1                | 1  |            |            |

### 17.4.3 正常传输模式

正常传输模式允许在单个激活源上传输1字节（8位）、1半字（16位）、1字（32位）数据。传输计数可以设置为1到65536。传输源地址和目标地址可以独立设置为递增、递减或固定。此模式允许在指定计数传输结束时向CPU生成中断请求。

表17.5列出了正常传输模式下的寄存器功能，图17.5显示了正常传输模式下的内存映射。

Table 17.5 正常传输模式下的寄存器功能

| Register | Description | 通过写入传输信息回写的值 |
|----------|-------------|--------------|
| SAR      | 传输源地址       | 递增、递减或固定*1   |
| DAR      | 转移目的地地址     | 递增、递减、固定*1   |
| CRA      | 转帐柜台A       | CRA - 1      |
| CRB      | 转帐柜台B       | 未更新          |

注1.在地址固定模式下会跳过回写操作。

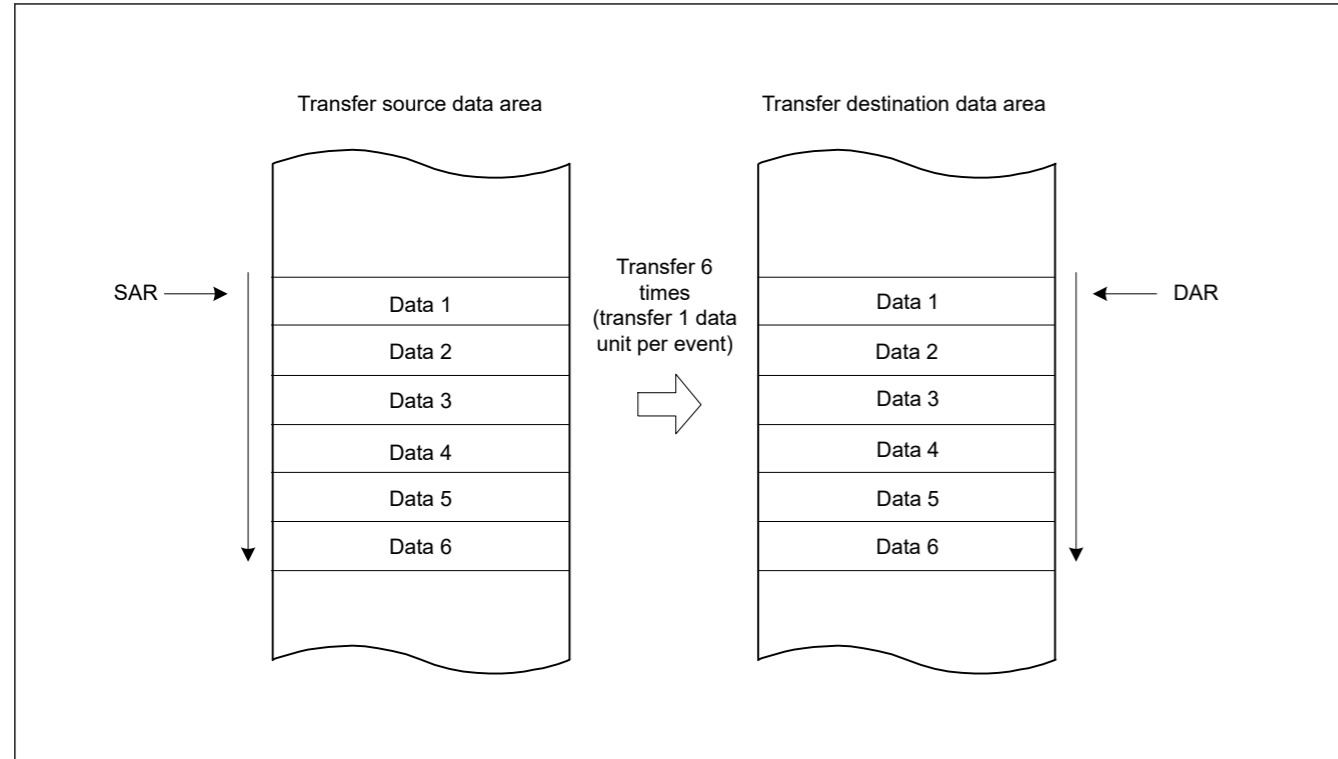


Figure 17.5 Memory map of normal transfer mode (MRA.SM[1:0] = 10b, MRB.DM[1:0] = 10b, CRA = 0x0006)

#### 17.4.4 Repeat Transfer Mode

The repeat transfer mode allows a 1-byte (8-bit), 1-halfword (16-bit), or 1-word (32-bit) data transfer on a single activation source. Transfer source or transfer destination for the repeat area must be specified in the MRB.DTS bit. The transfer count can be set from 1 to 256. When the specified transfer count is complete, the initial value of the address register specified in the repeat area is restored, the initial value of the transfer counter is restored, and transfer is repeated. The other address register is incremented or decremented continuously or remains unchanged.

When the transfer counter CRAL decrements to 0x00 in repeat transfer mode, the CRAL value is updated to the value set in the CRAH register. As a result, the transfer counter does not clear to 0x00, which disables interrupt requests to the CPU when the MRB.DISEL bit is set to 0. An interrupt request to the CPU is generated when the specified data transfer completes.

Table 17.6 lists the register functions in repeat transfer mode, and Figure 17.6 shows the memory map of repeat transfer mode.

Table 17.6 Register functions in repeat transfer mode

| Register | Description                  | Value written back by writing transfer information |  |
|----------|------------------------------|--|--|
|          |                              | When CRAL is not 1                                 | When CRAL is 1   |
| SAR      | Transfer source address      | Increment, decrement, fixed*1                      | <ul style="list-style-type: none"> <li>When the MRB.DTS bit is 0<br/>Increment, decrement, or fixed*1</li> <li>When the MRB.DTS bit is 1<br/>SAR register initial value</li> </ul> |
| DAR      | Transfer destination address | Increment, decrement, or fixed*1                   | <ul style="list-style-type: none"> <li>When the MRB.DTS bit is 0<br/>DAR register initial value</li> <li>When the MRB.DTS bit is 1<br/>Increment, decrement, or fixed*1</li> </ul> |
| CRAH     | Retains transfer counter     | CRAH   | CRAH   |
| CRAL     | Transfer counter A           | CRAL - 1   | CRAH   |
| CRB      | Transfer counter B           | Not updated  | Not updated  |

Note 1. Write-back is skipped in address-fixed mode.

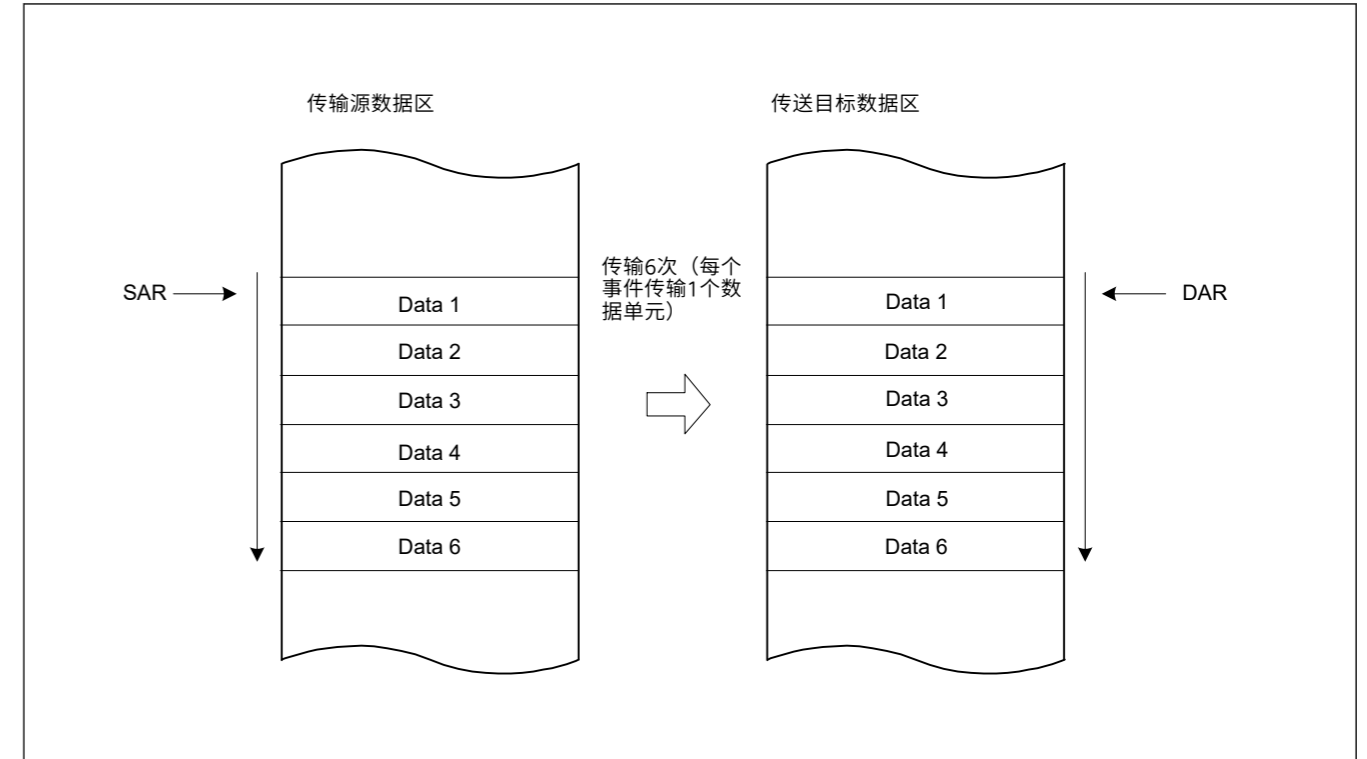


Figure 17.5 正常传输模式的内存映射(MRA.SM[1:0]=10b MRB.DM[1:0]=10b CRA=0x0006)

#### 17.4.4 重复传输模式

重复传输模式允许在单个激活源上传输1字节（8位）、1半字（16位）或1字（32位）数据。重复区域的传输源或传输目标必须在MRB.DTS位中指定。传输计数可设置为1到256。当指定的传输计数完成时，将恢复重复区域中指定的地址寄存器的初始值，恢复传输计数器的初始值，并重复传输。另一个地址寄存器连续递增或递减或保持不变。

当传输计数器CRAL在重复传输模式下递减到0x00时，CRAL值将更新为CRAH寄存器中设置的值。因此，传输计数器不会清为0x00，这会在MRB.DISEL位设置为0时禁用对CPU的中断请求。当指定的数据传输完成时，会向CPU发出中断请求。

表17.6列出了重复传输模式下的寄存器功能，图17.6显示了重复传输模式的内存映射。

Table 17.6 重复传输模式下的寄存器功能

| Register | Description | 通过写入传输信息回写的值 |  |
|----------|-------------|--------------|--|
|          |             | 当CRAL不为1时    | 当CRAL为1时   |
| SAR      | 传输源地址       | 递增、递减、固定*1   | <ul style="list-style-type: none"> <li>当MRB.DTS位为0时<br/>递增、递减或固定*1</li> <li>MRB.DTS位为1时<br/>SAR寄存器初始值</li> </ul> |
| DAR      | 转移目的地地址     | 递增、递减或固定*1   | <ul style="list-style-type: none"> <li>当MRB.DTS位为0时<br/>DAR寄存器初始值</li> <li>MRB.DTS位为1时<br/>递增、递减或固定*1</li> </ul> |
| CRAH     | 保留转帐计数器     | CRAH         | CRAH   |
| CRAL     | 转帐柜台A       | CRAL - 1     | CRAH   |
| CRB      | 转帐柜台B       | 未更新          | 未更新  |

注1.在地址固定模式下会跳过回写。



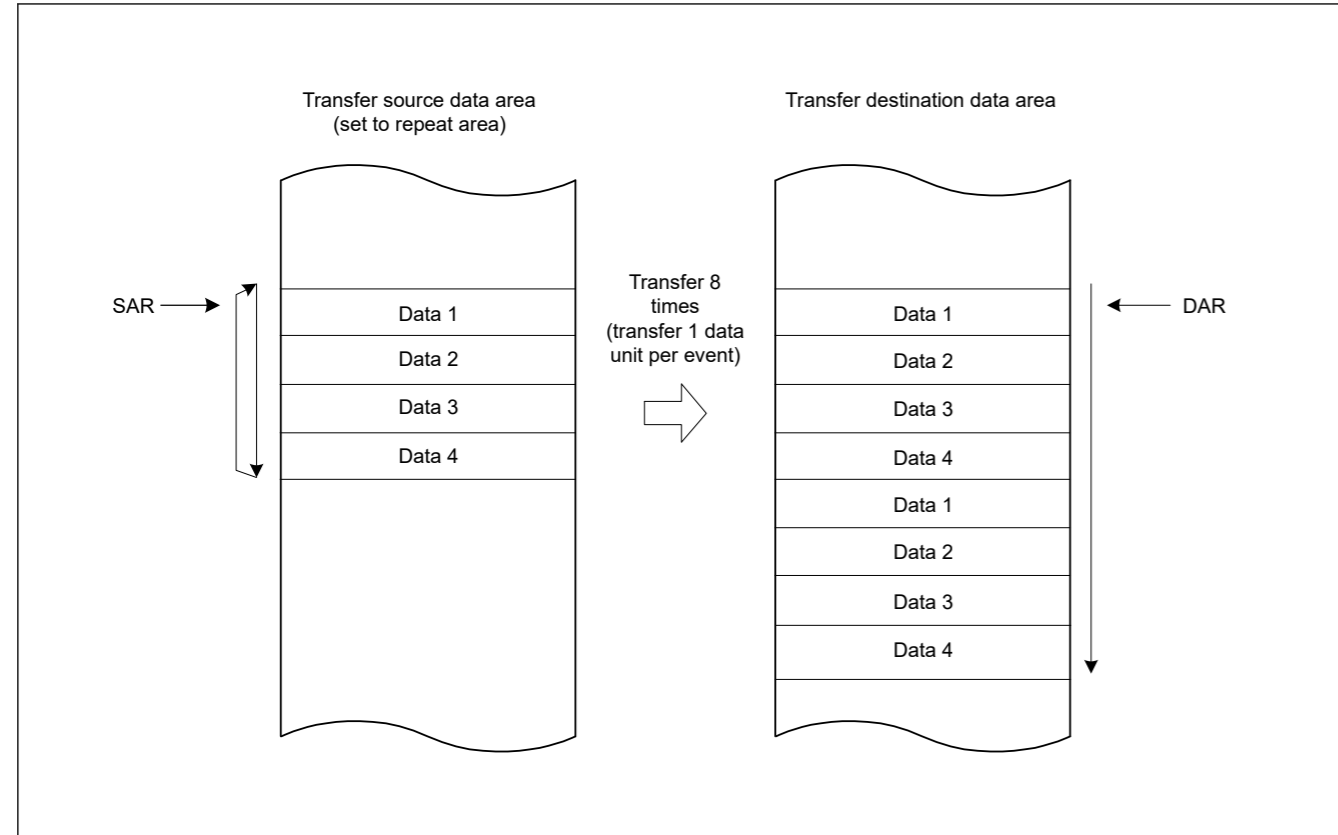


Figure 17.6 Memory map of repeat transfer mode when transfer source is a repeat area (MRA.SM[1:0] = 10b, MRB.DM[1:0] = 10b, CRAH = 0x04)

### 17.4.5 Block Transfer Mode

The block transfer mode allows single-block data transfer on a single activation source. Transfer source or transfer destination for the block area must be specified in the MRB.DTS bit. The block size can be set from 1 to 256 bytes, 1 to 256 halfwords (2 to 512 bytes), or 1 to 256 words (4 to 1024 bytes). When transfer of the specified block completes, the initial values of the block size counter CRAL and the address register (the SAR register when the MRB.DTS = 1 or the DAR register when the DTS = 0) specified in the block area are restored. The other address register is incremented or decremented continuously or remains unchanged.

The transfer count (block count) can be set from 1 to 65536. This mode enables an interrupt request to the CPU to be generated at the end of the specified-count block transfer.

Table 17.7 lists the register functions in block transfer mode, and Figure 17.7 shows the memory map for block transfer mode.

Table 17.7 Register functions in block transfer mode

| Register | Description                  | Value written back by writing transfer information  |
|----------|------------------------------|---|
| SAR      | Transfer source address      | <ul style="list-style-type: none"> <li>When MRB.DTS bit is 0<br/>Increment, decrement, or fixed*1</li> <li>When MRB.DTS bit is 1<br/>SAR register initial value.</li> </ul> |
| DAR      | Transfer destination address | <ul style="list-style-type: none"> <li>When MRB.DTS bit is 0<br/>DAR register initial value</li> <li>When MRB.DTS bit is 1<br/>Increment, decrement, or fixed*1.</li> </ul> |
| CRAH     | Holds block size             | CRAH  |
| CRAL     | Block size counter           | CRAH  |
| CRB      | Block transfer counter       | CRB - 1   |

Note 1. Write-back is skipped in address-fixed mode.

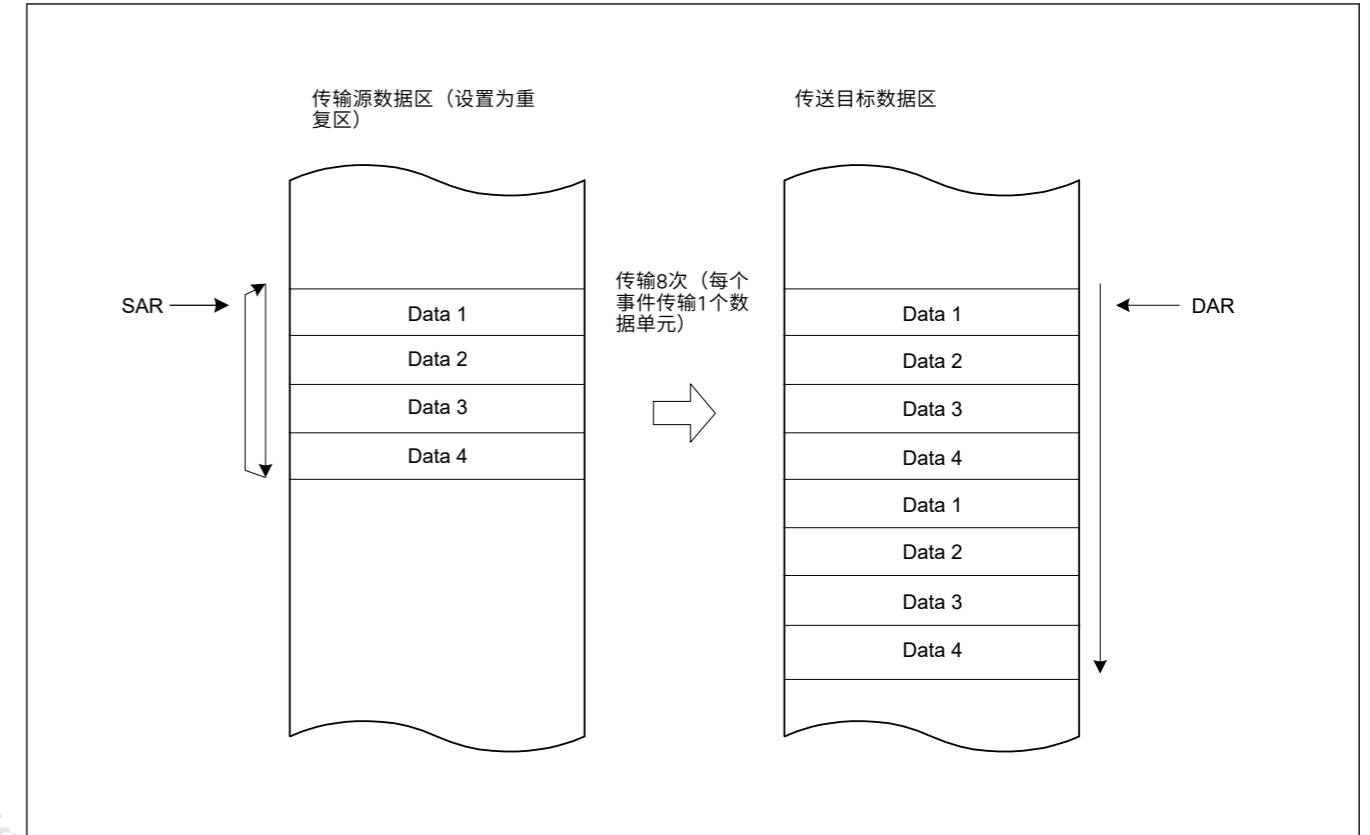


Figure 17.6 传输源为重复区域时重复传输模式的内存映射(MRA.SM[1:0]=10b MRB.DM[1:0]=10b CRAH=0x04)

### 17.4.5 块传输模式

块传输模式允许在单个激活源上进行单块数据传输。块区域的传输源或传输目标必须在MRB.DTS位中指定。块大小可以设置为1到256字节、1到256个半字（2到512字节）或1到256字（4到1024字节）。当指定块的传送完成时，块区域中指定的块大小计数器CRAL和地址寄存器（MRB.DTS=1时为SAR寄存器或DTS=0时为DAR寄存器）的初始值被恢复。另一个地址寄存器连续递增或递减或保持不变。

传输计数（块计数）可设置为1到65536。此模式允许在指定计数块传输结束时向CPU生成中断请求。

表17.7列出了块传输模式下的寄存器功能，图17.7显示了块传输模式下的存储器映射。

Table 17.7 块传输模式下的寄存器功能

| Register | Description | 通过写入传输信息回写的值   |
|----------|-------------|--|
| SAR      | 传输源地址       | <ul style="list-style-type: none"> <li>当MRB.DTS位为0时<br/>递增、递减或固定+1</li> <li>当MRB.DTS位为1时SAR<br/>寄存器初始值。</li> </ul> |
| DAR      | 转移目的地地址     | <ul style="list-style-type: none"> <li>当MRB.DTS位为0DAR寄<br/>存器初始值</li> <li>当MRB.DTS位为1时<br/>递增、递减或固定+1。</li> </ul>  |
| CRAH     | 保持块大小       | CRAH   |
| CRAL     | 块大小计数器      | CRAH   |
| CRB      | 块传输计数器      | CRB - 1  |

注1.在地址固定模式下会跳过回写。

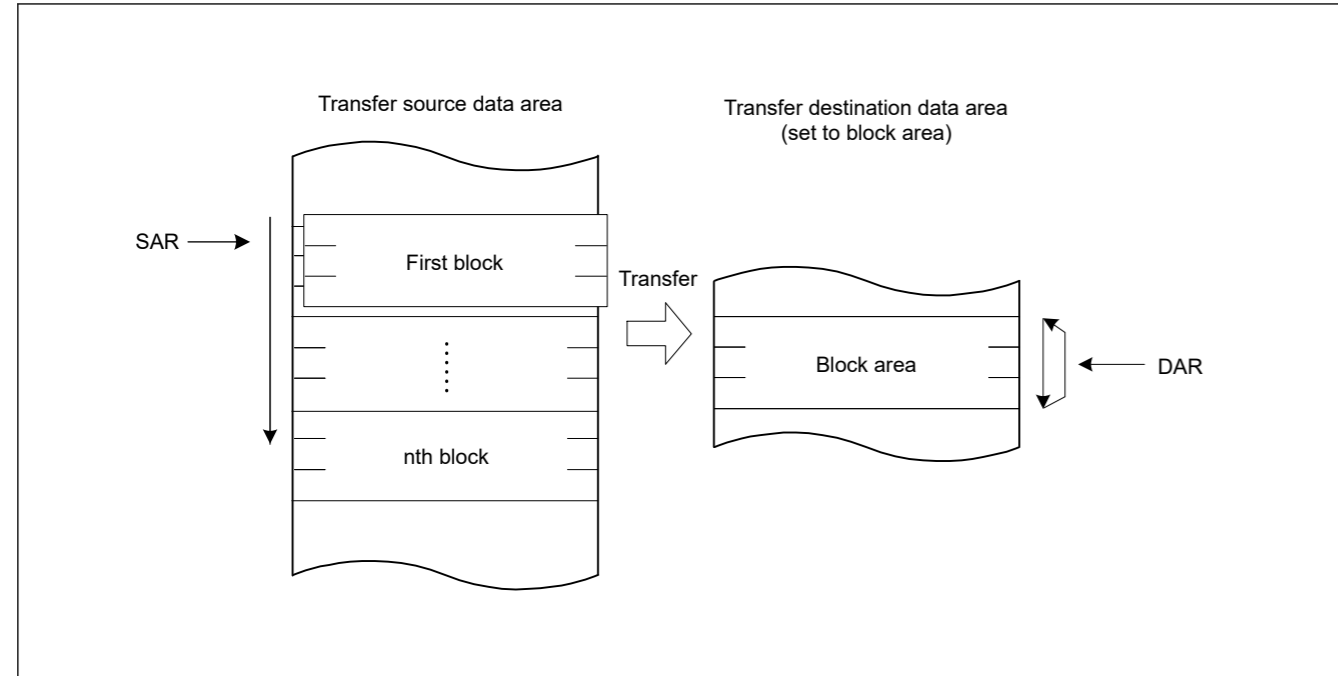


Figure 17.7 Memory map of block transfer mode

#### 17.4.6 Chain Transfer

Setting the MRB.CHNE bit to 1 allows chain transfer to be performed continuously on a single activation source. If the MRB.CHNE is set to 1 and CHNS to 0, an interrupt request to the CPU is not generated on completion of the specified number of rounds of transfer or by setting the MRB.DISEL bit to 1. An interrupt request is sent to the CPU each time DTC data transfer is performed. Data transfer has no effect on the ICU.IELSRn.IR flag of the activation source.

The SAR, DAR, CRA, CRB, MRA, and MRB registers can be set independently of each other to define the data transfer. Figure 17.8 shows a chain transfer operation.

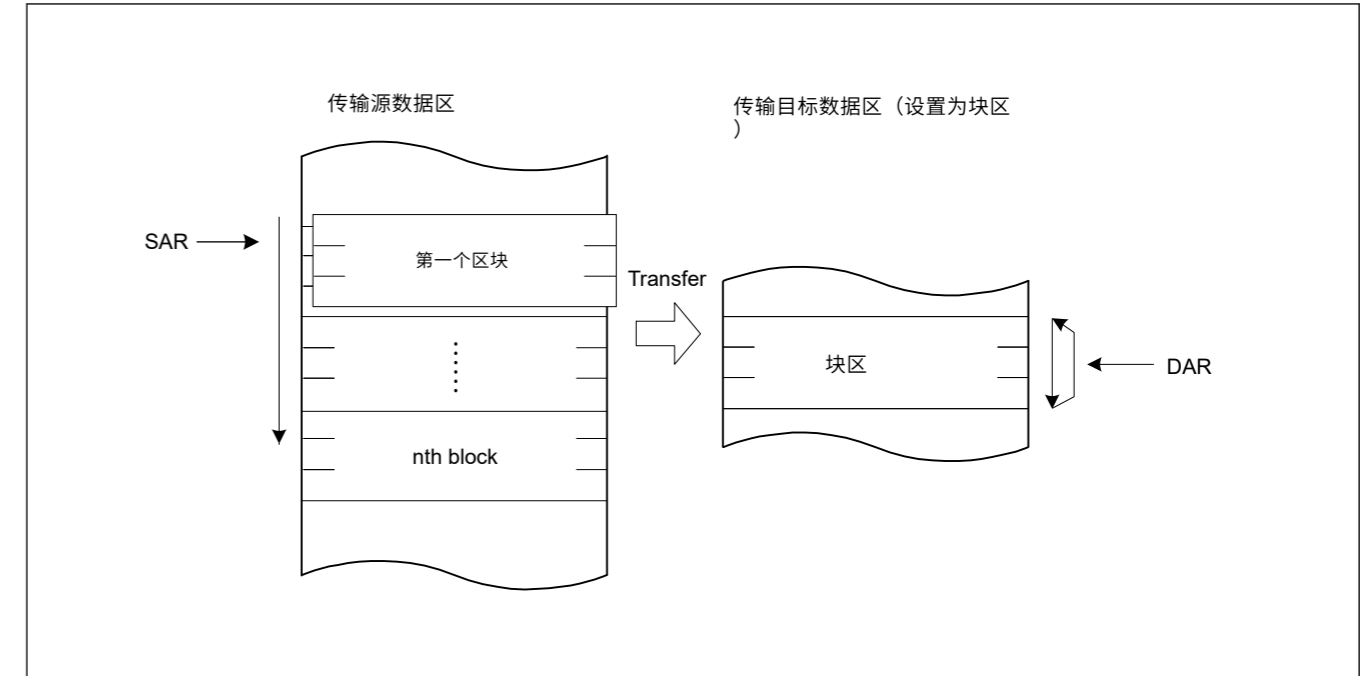


Figure 17.7 块传输模式的内存映射

#### 17.4.6 链转移

将MRB.CHNE位设置为1允许在单个激活源上连续执行链传输。如果MRB.CHNE设置为1，CHNS设置为0，则在完成指定的传输轮数或将MRB.DISEL位设置为1时不会向CPU产生中断请求。中断请求被发送到每次执行DTC数据传输时CPU。数据传输对激活源的ICU.IELSRn.IR标志没有影响。

SAR、DAR、CRA、CRB、MRA和MRB寄存器可以相互独立设置以定义数据传输。图17.8显示了链式转移操作。

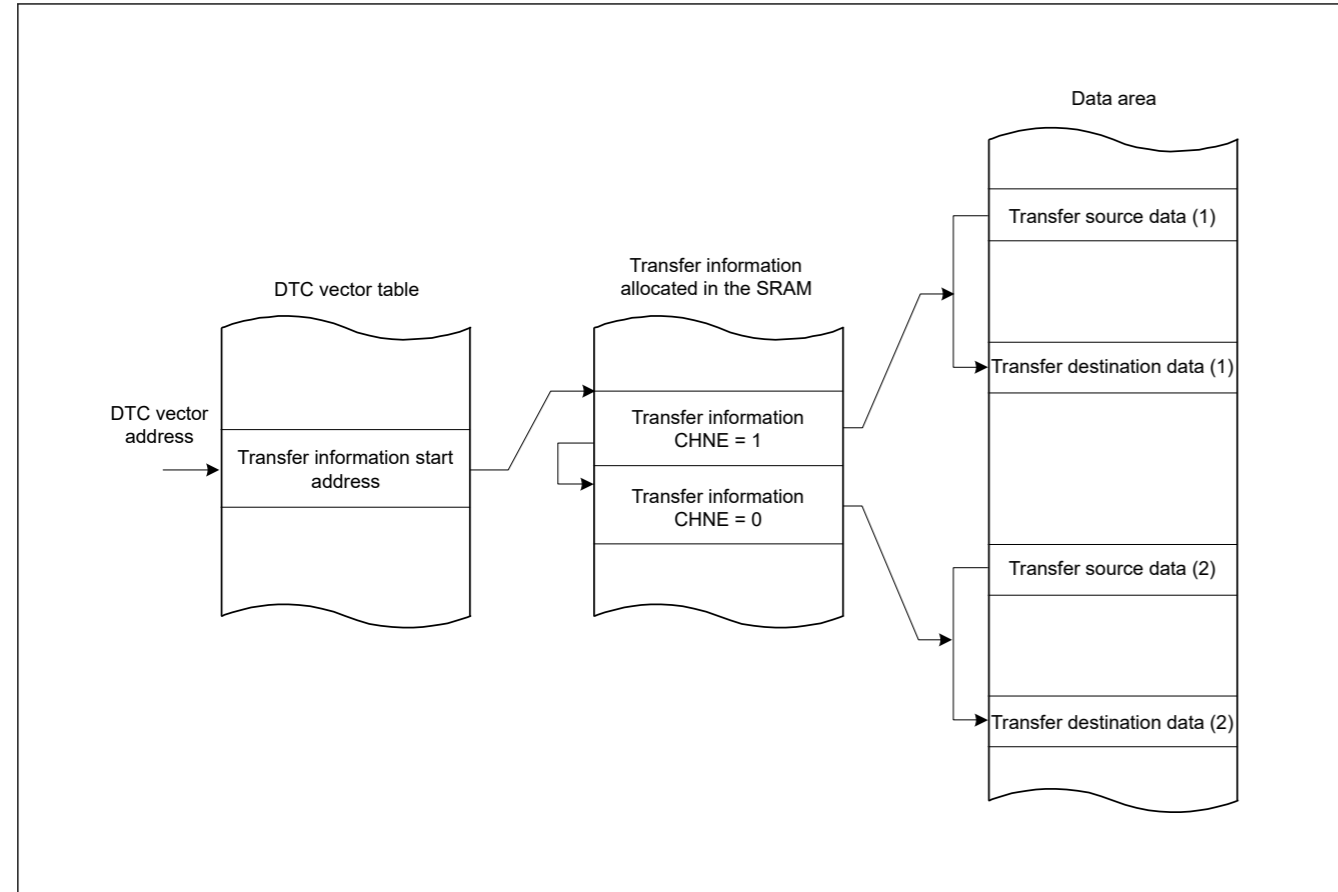


Figure 17.8 Chain transfer operation

Writing 1 to the MRB.CHNE and CHNS bits enables chain transfer to be performed only after completion of the specified data transfer. In repeat transfer mode, chain transfer is performed after completion of the specified data transfer. For details on chain transfer conditions, see Table 17.2.

17.4.7 Operation Timing

Figure 17.9 to Figure 17.12 are timing diagrams that show the minimum number of execution cycles.

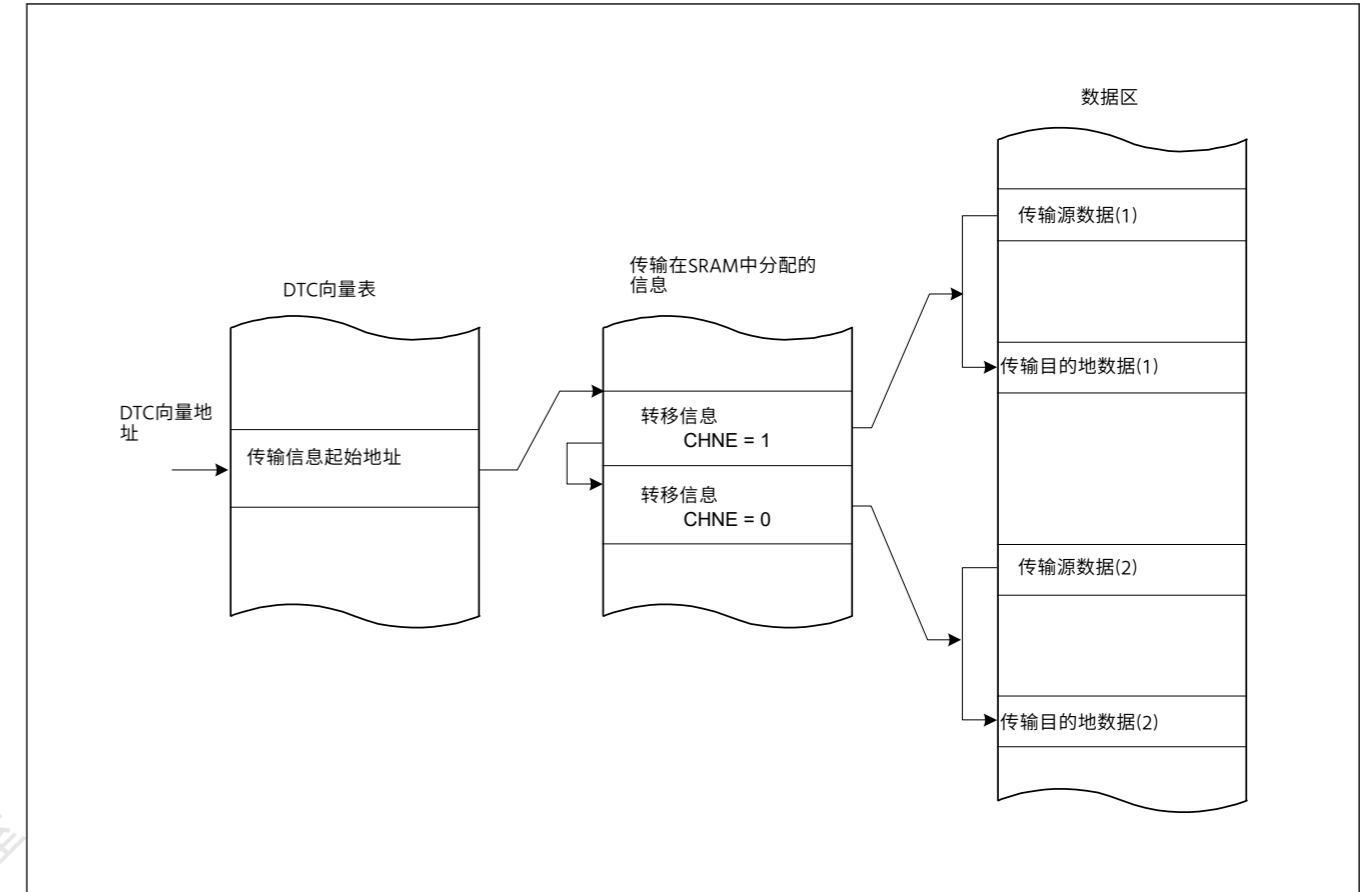


Figure 17.8 链转移操作

将1写入MRB.CHNE和CHNS位可以使链式传输仅在完成指定的数据传输后执行。在重复传输模式下，在完成指定的数据传输后执行链式传输。有关链转移条件的详细信息，请参见表17.2。

17.4.7 操作时间

图17.9至图17.12是显示最小执行周期数的时序图。

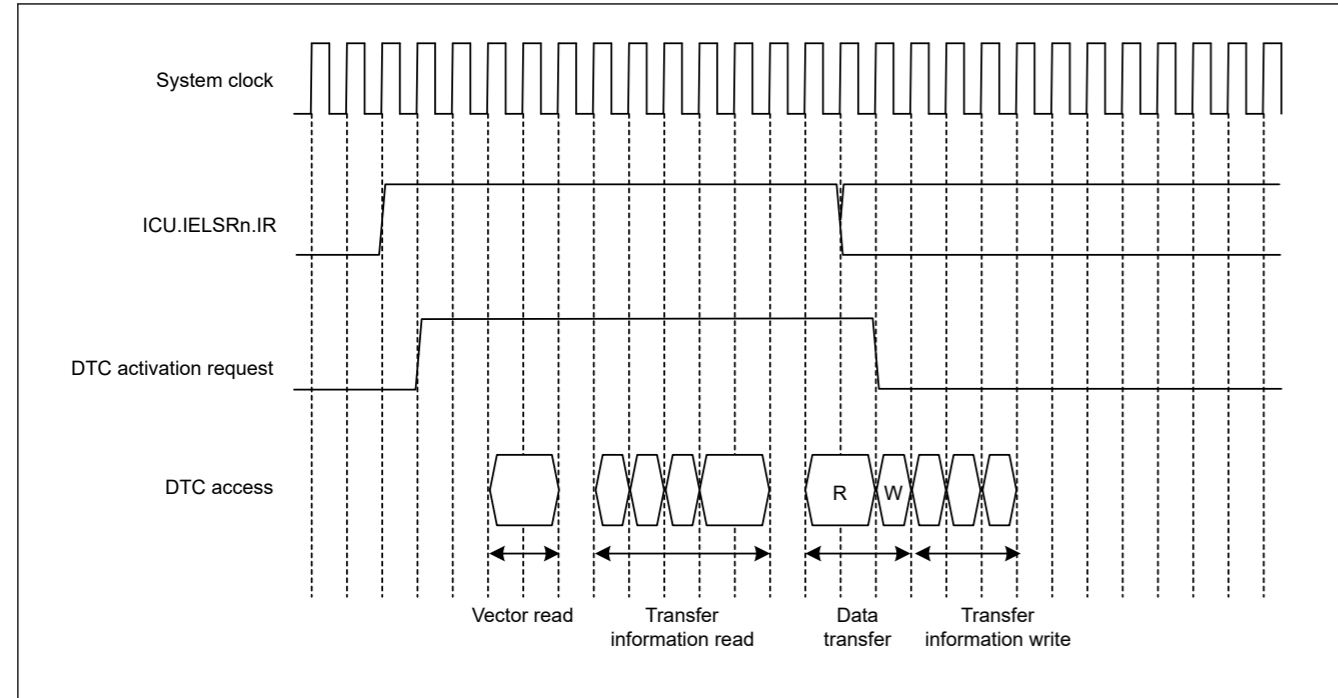


Figure 17.9 Example 1 of DTC operation timing in normal transfer and repeat transfer modes

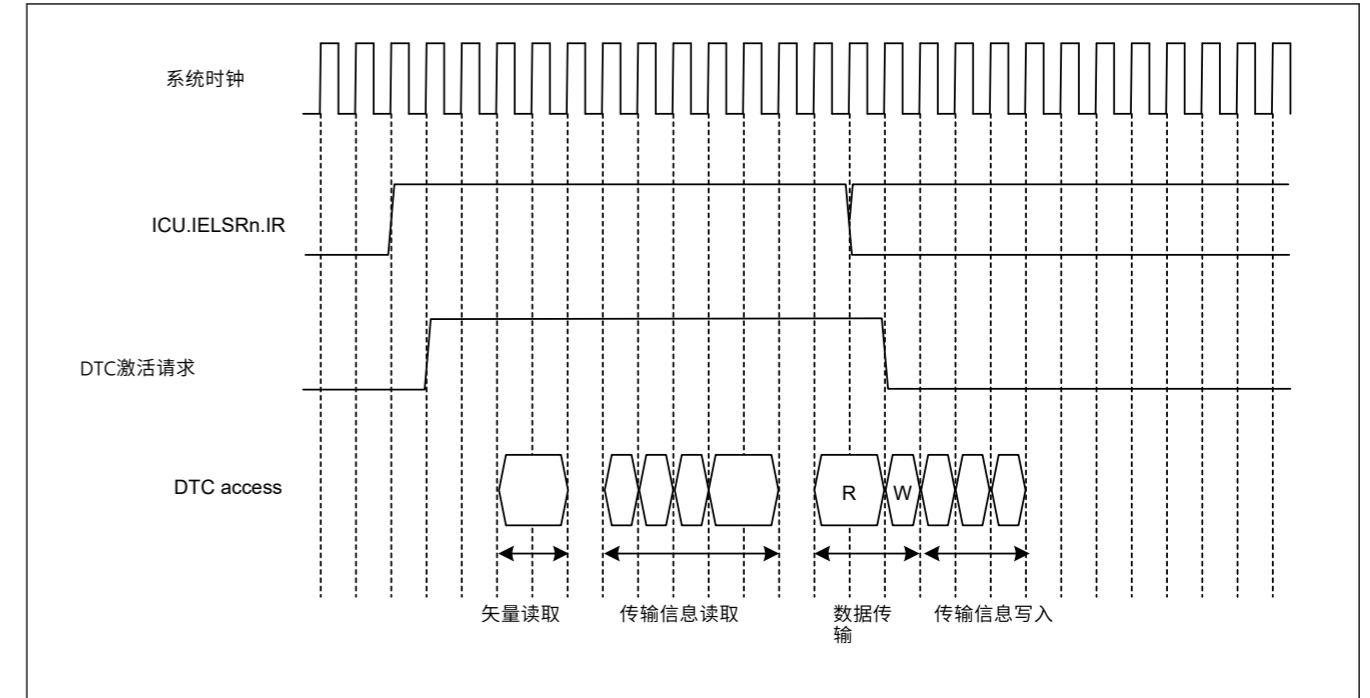


Figure 17.9 正常传输和重复传输模式下的DTC操作时序示例1

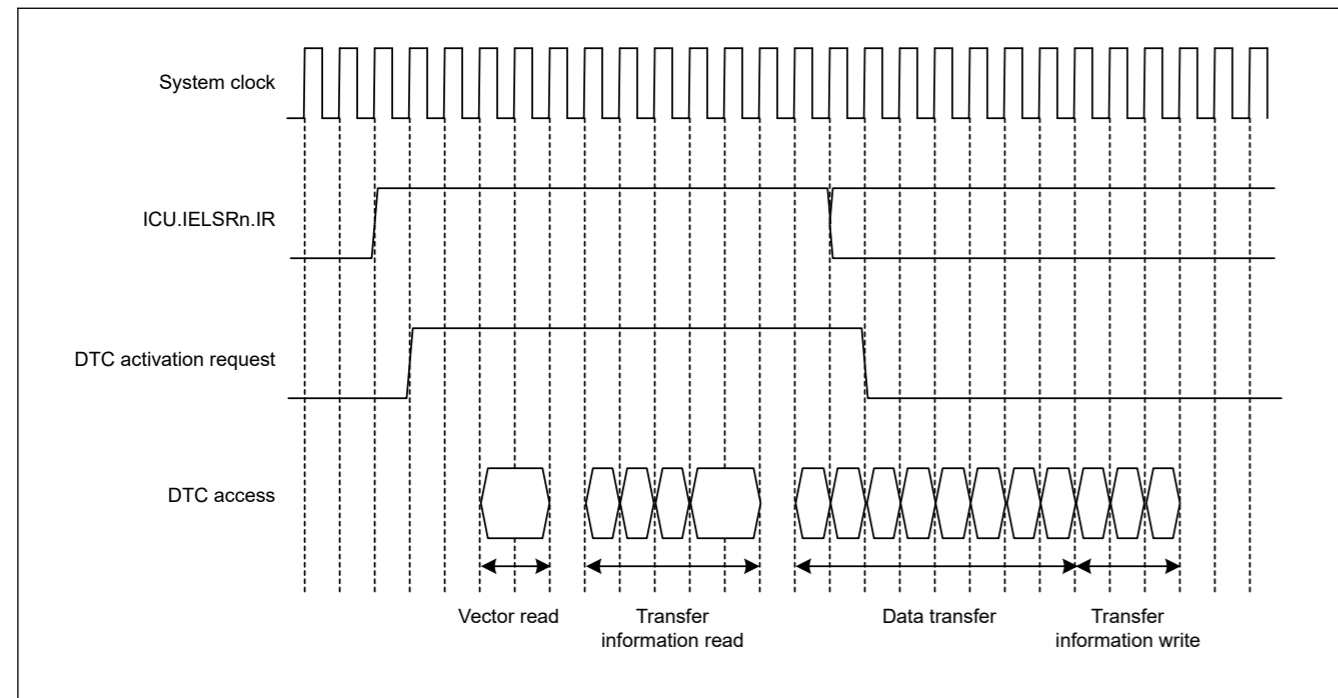


Figure 17.10 Example 2 of DTC operation timing in block transfer mode when the block size = 4

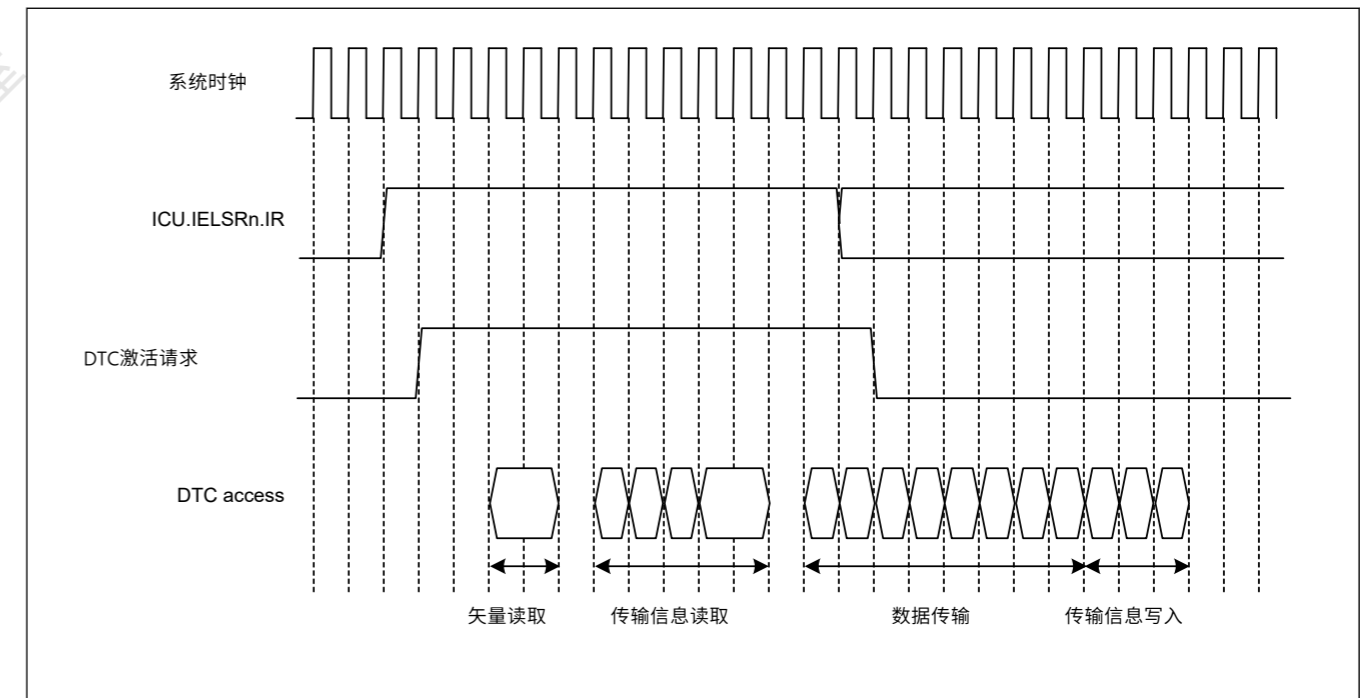


Figure 17.10 块大小=4时块传输模式下的DTC操作时序示例2

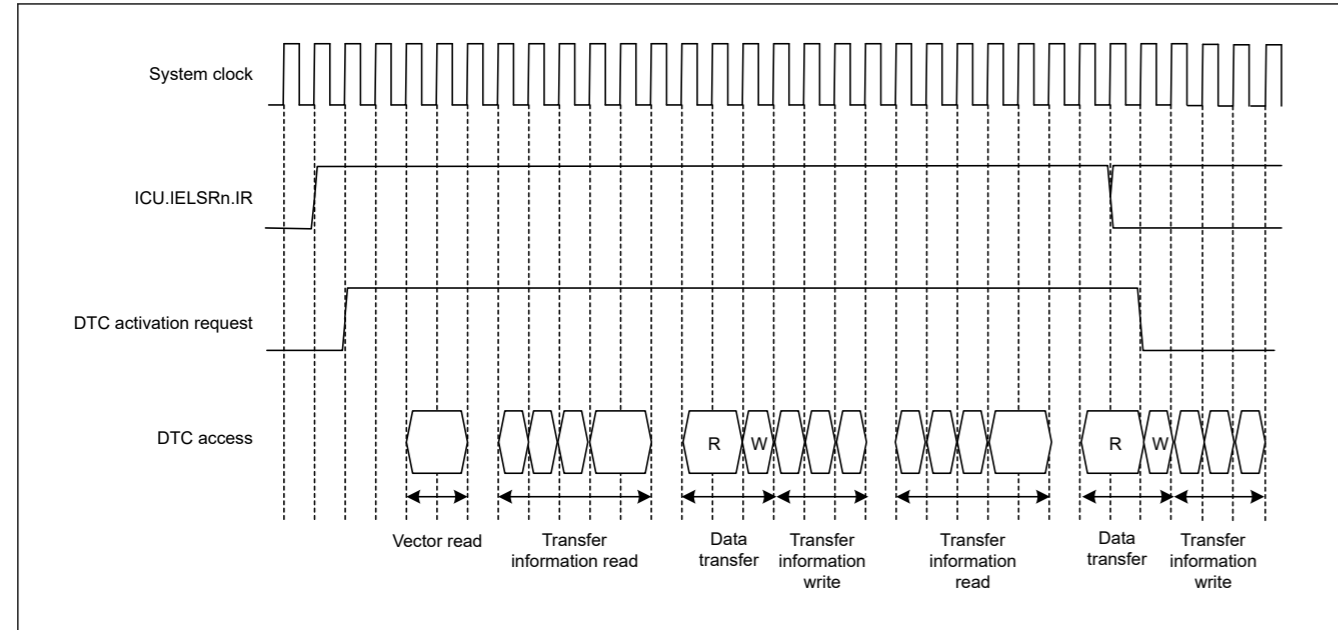


Figure 17.11 Example 3 of DTC operation timing for chain transfer

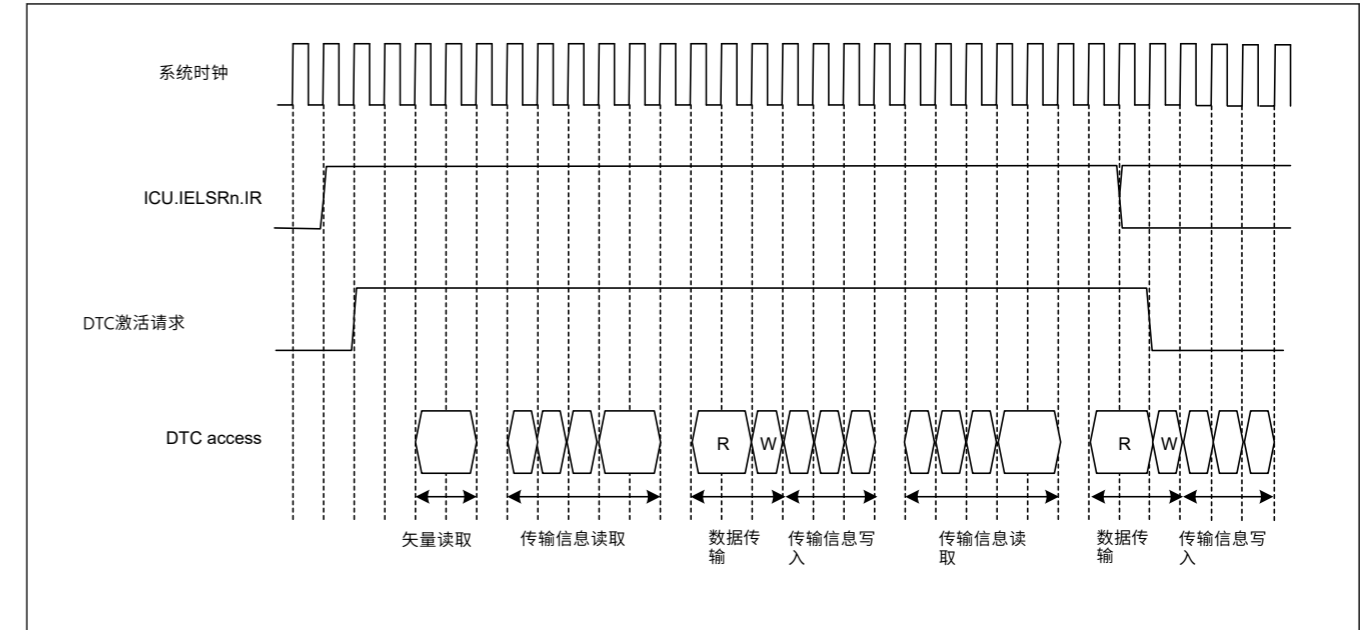


Figure 17.11 链转移的DTC操作时序示例3

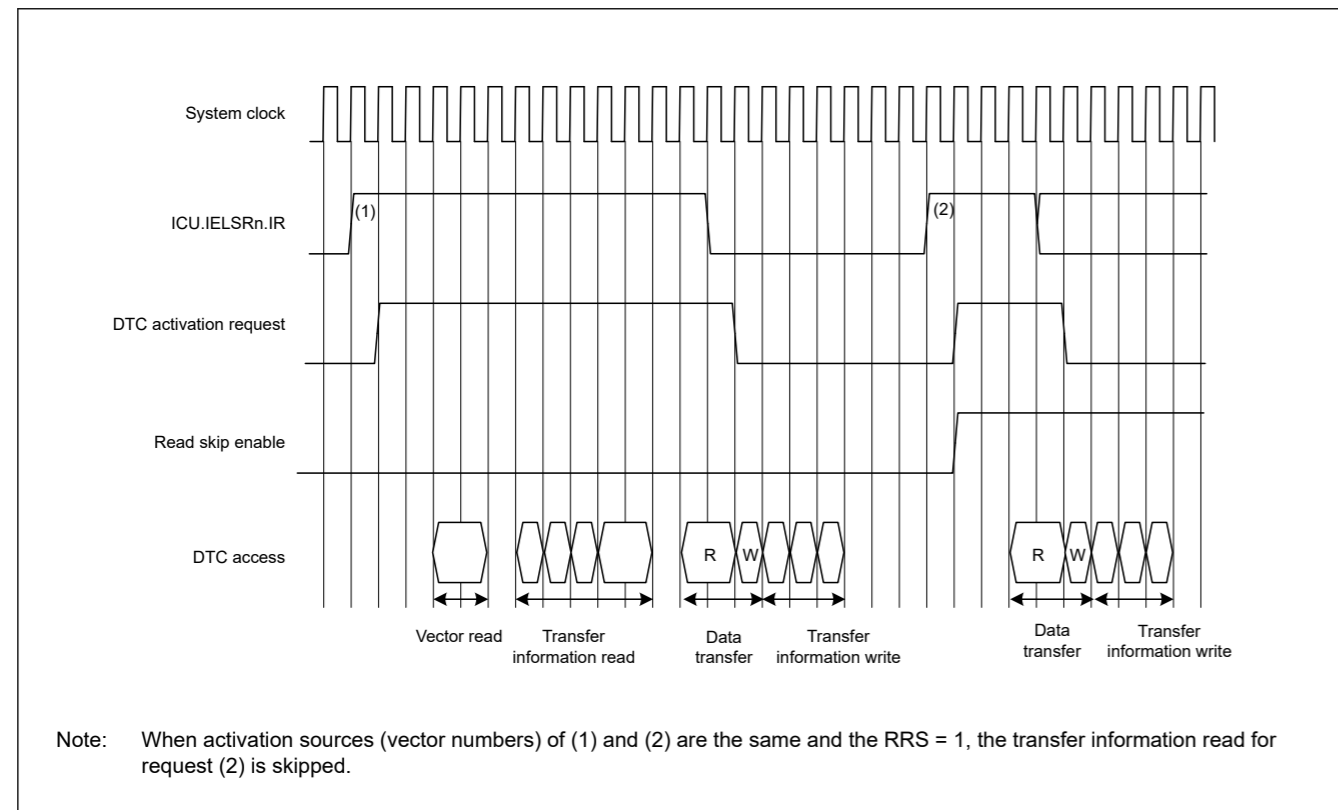


Figure 17.12 Example of operation when a transfer information read is skipped with the vector, transfer information, and transfer destination data on the SRAM, and the transfer source data on the peripheral module

17.4.8 Execution Cycles of DTC

Table 17.8 lists the execution cycles of single data transfer of the DTC. For the order of the execution states, see section 17.4.7. Operation Timing.

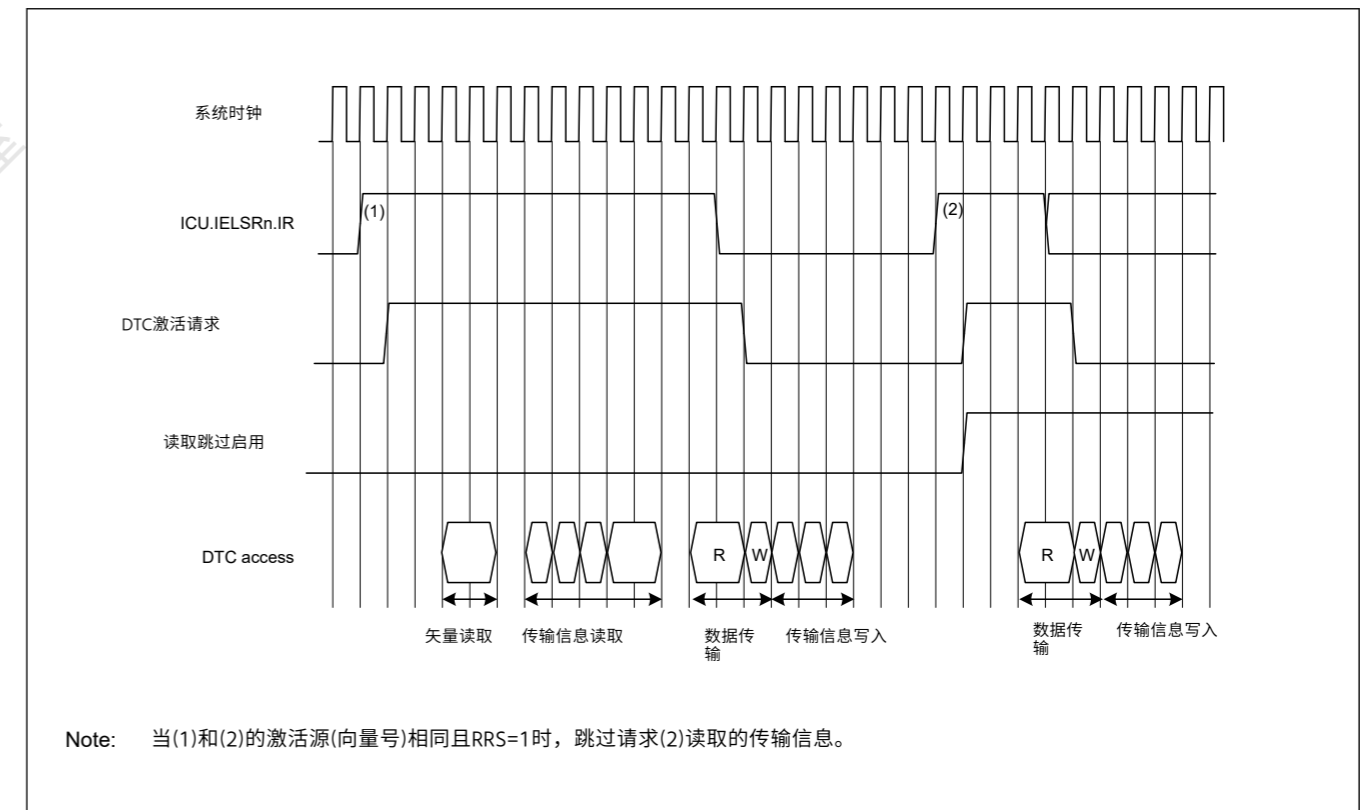


Figure 17.12 使用SRAM上的向量、传输信息和传输目标数据以及外围模块上的传输源数据跳过传输信息读取时的操作示例

17.4.8 DTC的执行周期

表17.8列出了DTC单次数据传输的执行周期。有关执行状态的顺序, 请参见第17.4.7节。操作时间。



**Table 17.8 Execution cycles of DTC**

P: Block size (initial settings of CRAH and CRAL)

Cv: Cycles for access to vector transfer information storage destination

Ci: Cycles for access to transfer information storage destination address

Cr: Cycles for access to data read destination

Cw: Cycles for access to data write destination

The unit is for system clocks (ICLK) + 1 in the Vector read, Transfer information read, and Data transfer read columns and 2 in the Internal operation column.

Cv, Ci, Cr, and Cw vary depending on the corresponding access destination. For the number of cycles for respective access destinations, see [section 42, SRAM](#), [section 44, Flash Memory](#), and [section 14, Buses](#).

The frequency ratio of the system clock and peripheral clock is also taken into consideration.

The DTC response time is the time from when the DTC activation source is detected until DTC transfer starts.

[Table 17.8](#) does not include the time until DTC data transfer starts after the DTC activation source becomes active.

| Transfer mode       | Vector read |                 | Transfer information read |                 | Transfer information write |                          |                  | Data transfer |        | Internal operation |                 |
|---------------------|-------------|-----------------|---------------------------|-----------------|----------------------------|--------------------------|------------------|---------------|--------|--------------------|-----------------|
|                     |             |                 |                           |                 |                            |                          |                  | Read          | Write  |                    |                 |
| Normal              | Cv + 1      | 0 <sup>*1</sup> | 4 × Ci + 1                | 0 <sup>*1</sup> | 3 × Ci + 1 <sup>*2</sup>   | 2 × Ci + 1 <sup>*3</sup> | Ci <sup>*4</sup> | Cr + 1        | Cw + 1 | 2                  | 0 <sup>*1</sup> |
| Repeat              |             |                 |                           |                 |                            |                          |                  | Cr + 1        | Cw + 1 |                    |                 |
| Block <sup>*5</sup> |             |                 |                           |                 |                            |                          |                  | P × Cr        | P × Cw |                    |                 |

Note 1. When transfer information read is skipped.

Note 2. When neither SAR nor DAR is set to address-fixed mode.

Note 3. When SAR or DAR is set to address-fixed mode.

Note 4. When SAR and DAR are set to address-fixed mode.

Note 5. When the block size is 2 or more. If the block size is 1, the cycle number for normal transfer applies.

#### 17.4.9 DTC Bus Mastership Release Timing

The DTC does not release the bus mastership during transfer information reads. Before the transfer information is read or written, the bus is arbitrated according to the priority determined by the bus master arbitrator. For bus arbitration, see [section 14, Buses](#).

#### 17.4.10 Vector Security

The security attribute of transfer access of DTC vector n and security attribute of access to the IELSRn(n = 0 to 95) register of ICU are controlled by SAIELSRn bit of ICUSARx(x = G, H or I) registers in CPSCU. For details on the CPSCU.ICUSARx registers, see [section 13, Interrupt Controller Unit \(ICU\)](#).

When the CPSCU.ICUSARx.SAIELSRn bit is 0, transfer of DTC vector n is secure access for both read and write. At the same time, the IELSRn register are protected from a non-secure access.

When the CPSCU.ICUSARx.SAIELSRn bit is 1, transfer of DTC vector n is non-secure access for both read and write. At the same time, the IELSRn register are non-secure attributes.

Do not write to the CPSCU.ICUSARx.SAIELSRn bit while DTC transfer is enabled or a bus master is writing to the DTC registers of same channel.

[section 17.3.1. Allocating Transfer Information and DTC Vector Table](#) shows security attribute about each DTC vectors.

#### 17.4.11 Master TrustZone Filter in DTC

DTC has the Master TrustZone Filter. The Master TrustZone Filter in DTC can detect the security areas of Flash area (code Flash and data Flash) and SRAM area (ECC / Parity RAM) defined by IDAU. When no-secure accesses those addresses, it detects the security violation. Access of violation address is not performed. Detected the error is handled as the Master TrustZone Filter error.

#### 17.5 DTC Setting Procedure

Before using the DTC, set the DTC Vector Base Register (DTCVBR). Set the ICU.IELSRn.IELS[8:0] bits to 0 to disable the interrupt in the NVIC and follow the procedure in [Table 17.9](#) to set the DTC.

**Table 17.8 DTC的执行周期**

P: 块大小 (CRAH和CRAL的初始设置)

Cv: 访问向量传输信息存储目标的周期 Ci: 访问传输信息存储目标地址的周期

Cr: 访问数据读取目标的周期 Cw: 访问数据写入目标的周期

单位为系统时钟(ICLK)+1在Vectorread、Transferinformationread和Datatransferread列中和2在内部操作列中。Cv、Ci、Cr和Cw根据相应的访问目的地而变化。有关各个访问目标的周期数,请参见第42节SRAM、第44节闪存和第14节总线。系统时钟和外设时钟的频率比也被考虑在内。

DTC响应时间是从检测到DTC激活源到DTC传输开始的时间。

表17.8不包括从DTC激活源激活到DTC数据传输开始的时间。

| 传输模式                | 矢量读取   |                 | 传输信息读取     |                 | 传输信息写入                   |                          |                  | 数据传输   |        | 内部运作 |                 |
|---------------------|--------|-----------------|------------|-----------------|--------------------------|--------------------------|------------------|--------|--------|------|-----------------|
|                     |        |                 |            |                 |                          |                          |                  | Read   | Write  |      |                 |
| Normal              | Cv + 1 | 0 <sup>*1</sup> | 4 × Ci + 1 | 0 <sup>*1</sup> | 3 × Ci + 1 <sup>*2</sup> | 2 × Ci + 1 <sup>*3</sup> | Ci <sup>*4</sup> | Cr + 1 | Cw + 1 | 2    | 0 <sup>*1</sup> |
| Repeat              |        |                 |            |                 |                          |                          |                  | Cr + 1 | Cw + 1 |      |                 |
| Block <sup>*5</sup> |        |                 |            |                 |                          |                          |                  | P × Cr | P × Cw |      |                 |

注1. 跳过传输信息读取时。

注2. 当SAR和DAR均未设置为地址固定模式时。

注3. 当SAR或DAR设置为地址固定模式时。

注4. 当SAR和DAR设置为地址固定模式时。

注5. 当块大小为2或更大时。如果块大小为1,则适用正常传输的周期数。

#### 17.4.9 DTC总线主控释放时序

在传输信息读取期间, DTC不会释放总线主控权。在读取或写入传输信息之前, 根据总线主仲裁器确定的优先级对总线进行仲裁。对于总线仲裁, 请参见第14节, 总线。

#### 17.4.10 矢量安全

DTC向量n的传输访问的安全属性和对ICU的IELSRn(n=0到95)寄存器的访问的安全属性由CPSCU中ICUSARx(x=G,H或I)寄存器的SAIELSRn位控制。有关CPSCU.ICUSARx寄存器的详细信息, 请参见第13节, 中断控制器单元(ICU)。

当CPSCU.ICUSARx.SAIELSRn位为0时, DTC向量n的传输对于读和写都是安全访问。同时, 保护IELSRn寄存器免受非安全访问。

当CPSCU.ICUSARx.SAIELSRn位为1时, DTC向量n的传输对于读取和写入都是非安全访问。同时, IELSRn寄存器是非安全属性。

当DTC传输使能或总线主机正在写入同一通道的DTC寄存器时, 请勿写入CPSCU.ICUSARx.SAIELSRn位。

[第17.3.1节. 分配传输信息和DTC向量表](#)显示每个DTC向量的安全属性。

#### 17.4.11 DTC中的主TrustZone过滤器

DTC具有MasterTrustZone过滤器。DTC中的MasterTrustZoneFilter可以检测IDAU定义的Flash区域(代码Flash和数据Flash)和SRAM区域(ECCParityRAM)的安全区域。当no-secure访问这些地址时, 它会检测到安全违规。不执行违规地址的访问。检测到的错误作为MasterTrustZoneFilter错误处理。

#### 17.5 DTC设置程序

在使用DTC之前, 请设置DTC向量基址寄存器(DTCVBR)。将ICU.IELSRn.IELS[8:0]位设置为0以禁用NVIC中的中断, 并按照表17.9中的程序设置DTC。

Table 17.9 DTC setting procedure

| No. | Step Name  | Description  |
|-----|--|--|
| 1   | Set the DTCCR <sup>*1</sup> .RRS bit to 0  | Set the DTCCR <sup>*1</sup> .RRS bit to 0 to reset the transfer information read skip flag. After that, the transfer information read is not skipped while the DTC is activated. Be sure to specify this setting when the transfer information is updated.   |
| 2   | Set transfer information (MRA, MRB, SAR, DAR, CRA, and CRB)  | Allocate transfer information (MRA, MRB, SAR, DAR, CRA, and CRB) in the data area. To set transfer information, see <a href="#">section 17.2. Register Descriptions</a> . To allocate transfer information, see <a href="#">section 17.3.1. Allocating Transfer Information and DTC Vector Table</a> . |
| 3   | Set transfer information start addresses in the DTC vector table   | Set the transfer information start addresses in the DTC vector table. To set the DTC vector table, see <a href="#">section 17.3.1. Allocating Transfer Information and DTC Vector Table</a> .  |
| 4   | Set the DTCCR <sup>*1</sup> .RRS bit to 1  | Set the DTCCR <sup>*1</sup> .RRS bit to 1 to enable skipping of the second and subsequent transfer information read cycles for continuous DTC activation from the same interrupt source. The RRS bit can be set to 1, but if this is set during DTC transfer, it becomes valid from the next transfer. |
| 5   | Set the ICU.IELSRn.DTCE bit to 1. Set the ICU.IELSRn.IELS[8:0] as interrupt source. The interrupt should be enabled in the NVIC. | Set the ICU.IELSRn.DTCE bit to 1. Set ICU.IELSRn.IELS[8:0] as interrupt sources that trigger DTC. The interrupt must be enabled in the NVIC. See <a href="#">section 13.3.2. Event Number</a> in <a href="#">section 13, Interrupt Controller Unit (ICU)</a> .   |
| 6   | Set the enable bit for an activation source interrupt  | Set the enable bit for the activation source interrupts to 1. When a source interrupt is generated, the DTC is activated. To set the interrupt source enable bit, see the settings for the modules that are to be the activation sources.  |
| 7   | Set the DTCST.DTCST bit to 1   | Set the DTC Module Start bit (DTCST.DTCST) to 1.   |

Note: The DTCST.DTCST bit can be set even if the setting for each activation source is not completed.

Note: When used in non-secure state, DTCSAR.DTCSTSA = 1 or DTCST.DTCST = 1 must be set.

Note 1. When used in secure state, access DTCCR\_SEC instead of DTCCR.

## 17.6 Examples of DTC Usage

### 17.6.1 Normal Transfer

This section provides an example of DTC usage and its application when receiving 128 bytes of data from an SCI.

#### (1) Transfer information settings

In the MRA register, select a fixed source address (MRA.SM[1:0] = 00b), normal transfer mode (MRA.MD[1:0] = 00b), and byte-sized transfer (MRA.SZ[1:0] = 00b). In the MRB register, specify incrementation of the destination address (MRB.DM[1:0] = 10b) and single data transfer by a single interrupt (MRB.CHNE = 0 and MRB.DISEL = 0). The MRB.DTS bit can be set to any value. Set the RDR register address of the SCI in the SAR register, the start address of the SRAM area for data storage in the DAR register, and 128 (0x0080) in the CRA register. The CRB register can be set to any value.

#### (2) DTC vector table settings

The start address of the transfer information for the RXI interrupt is set in the vector table for the DTC.

#### (3) ICU settings and DTC module activation

Set the ICU.IELSRn.DTCE bit to 1 and set ICU.IELSRn.IELS[8:0] as the SCI interrupt. The interrupt must be enabled in the NVIC. Set the DTCST.DTCST bit to 1.

#### (4) SCI settings

Enable the SCIn\_RXI interrupt by setting the SCR.RIE bit in the SCI to 1. If a reception error occurs during the SCI receive operation, reception stops. To manage this, use settings that allow the CPU to accept receive error interrupts.

Table 17.9 DTC设置程序

| No. | 步骤名称   | Description  |
|-----|--|--|
| 1   | 将DTCCR*1.RRS位设置为0  | 将DTCCR*1.RRS位设置为0以重置传输信息读取跳过标志。之后，在激活DTC时不会跳过读取的传输信息。请务必在传输信息更新时指定此设置。                                       |
| 2   | 设置传输信息 (MRA、MRB、SAR、DAR、CRA和CRB)                               | 在数据区分配传输信息 (MRA、MRB、SAR、DAR、CRA和CRB)。要设置传输信息，请参阅第17.2节。注册说明。要分配传输信息，请参阅第17.3.1节。分配传输信息和DTC向量表。               |
| 3   | 在DTC向量表中设置传输信息起始地址   | 在DTC向量表中设置传输信息起始地址。要设置DTC向量表，请参见第17.3.1节。分配传输信息和DTC向量表。  |
| 4   | 将DTCCR*1.RRS位设置为1  | 将DTCCR*1.RRS位设置为1，以允许跳过第二个和后续传输信息读取周期，以便从同一中断源连续激活DTC。RRS位可以设置为1，但如果在DTC传输期间设置，则从下一次传输开始生效。                  |
| 5   | 将ICU.IELSRn.DTCE位设置为1。将ICU.IELSRn.IELS[8:0]设置为中断源。应在NVIC中启用中断。 | 将ICU.IELSRn.DTCE位设置为1。将ICU.IELSRn.IELS[8:0]设置为触发的中断源故障诊断码。必须在NVIC中启用中断。请参阅第13.3.2节。第13节中的事件编号，中断控制器单元 (ICU)。 |
| 6   | 设置激活源中断的使能位  | 将激活源中断的使能位设置为1。当产生源中断时，将激活DTC。要设置中断源使能位，请参见要成为激活源的模块的设置。   |
| 7   | 将DTCST.DTCST位设置为1  | 将DTC模块起始位(DTCST.DTCST)设置为1。  |

Note: 即使每个激活源的设置未完成，也可以设置DTCST.DTCST位。

Note: 在非安全状态下使用时，必须设置DTCSAR.DTCSTSA=1或DTCST.DTCST=1。

注1.在安全状态下使用时，访问DTCCR\_SEC而不是DTCCR。

## 17.6 DTC使用示例

### 17.6.1 正常转移

本节提供从SCI接收128字节数据时的DTC用法及其应用示例。

#### (1) 传输信息设置

在MRA寄存器中，选择固定源地址 (MRA.SM[1:0]=00b)、正常传输模式 (MRA.MD[1:0]=00b) 和字节大小传输 (MRA.SZ[1:0]=00b)。在MRB寄存器中，指定目标地址的递增 (MRB.DM[1:0]=10b) 和单个中断的单个数据传输 (MRB.CHNE=0和MRB.DISEL=0)。MRB.DTS位可以设置为任何值。在SAR寄存器中设置SCI的RDR寄存器地址，

SRAM区域用于DAR寄存器中的数据存储，以及CRA寄存器中的128(0x0080)。CRB寄存器可以设置为任何值。

#### (2) DTC向量表设置

RXI中断的传输信息的起始地址在DTC的向量表中设置。

#### (3) ICU设置和DTC模块激活

将ICU.IELSRn.DTCE位设置为1，并将ICU.IELSRn.IELS[8:0]设置为SCI中断。必须在NVIC中启用中断。将DTCST.DTCST位设置为1。

#### (4) SCI设置

通过将SCI中的SCR.RIE位设置为1来使能SCIn\_RXI中断。如果在SCI接收操作期间发生接收错误，则接收停止。要管理此问题，请使用允许CPU接受接收错误中断的设置。

### (5) DTC transfer

Each time a reception of 1 byte by the SCI is complete, an SCIn\_RXI interrupt is generated to activate the DTC. The DTC transfers the received byte from the RDR of the SCI to the SRAM, after which the DAR register is incremented and the CRA register is decremented.

### (6) Interrupt handling

After 128 rounds of data transfer are complete and the value in the CRA register becomes 0, an SCIn\_RXI interrupt request is generated for the CPU. Complete the process in the handling routine for this interrupt.

## 17.6.2 Chain transfer

This section provides an example of chain transfer by the DTC and describes its use in the output of pulses by the General PWM Timer (GPT). You can use chain transfer to transfer PWM timer compare data and change the period of the PWM timer for the GPT.

For the first of the chain transfers, normal transfer mode is specified for transfer to the GPTm.GTCCRC register (m = 320 to 323, 164 to 167). For the second transfer, normal transfer mode is specified for transfer to the GPTm.GTCCRE register (m = 320 to 323, 164 to 167). For the third transfer of the chained transfer, normal transfer mode for transfer to the GPTm.GTPBR register (m = 320 to 323, 164 to 167) is specified. This is because clearing of the activation source and generation of an interrupt on completion of the specified number of transfers are restricted to the third of the chain transfers, that is, transfer while MRB.CHNE = 0.

The following example shows how to use the counter overflow interrupt with the GPT320.GTPR register as an activating source for the DTC.

#### (1) First transfer information setting

Set up transfer to the GPT320.GTCCRC register.

1. In the MRA register, select incrementation of the source address (MRA.SM[1:0] = 10b).
2. Set the transfer to normal transfer mode (MRA.MD[1:0] = 00b) and word-sized transfer (MRA.SZ[1:0] = 10b).
3. In the MRB register, select the destination address as fixed (MRB.DM[1:0] = 00b) and set up chain transfer (MRB.CHNE = 1 and MRB.CHNS = 0).
4. Set the SAR register to the first address of the data table.
5. Set the DAR register to the address of the GPT320.GTCCRC register.
6. Set the CRAH and CRAL registers to the size of the data table. The CRB register can be set to any value.

#### (2) Second transfer information setting

Set up for transfer to the GPT320.GTCCRE register.

1. In the MRA register, select incrementation of the source address (MRA.SM[1:0] = 10b).
2. Set the transfer to normal transfer mode (MRA.MD[1:0] = 00b) and word-sized transfer (MRA.SZ[1:0] = 10b).
3. In the MRB register, select the destination address as fixed (MRB.DM[1:0] = 00b) and set up chain transfer (MRB.CHNE = 1, MRB.CHNS = 0).
4. Set the SAR register to the first address of the data table.
5. Set the DAR register to the address of the GPT320.GTCCRE register.
6. Set the CRAH and CRAL registers to the size of the data table. The CRB register can be set to any value.

#### (3) Third transfer information set

Set up transfer to the GPT320.GTPBR register.

1. In the MRA register, select incrementation of the source address (MRA.SM[1:0] = 10b).
2. Set the transfer to normal transfer mode (MRA.MD[1:0] = 00b) and word-sized transfer (MRA.SZ[1:0] = 10b).
3. In the MRB register, select the destination address as fixed (MRB.DM[1:0] = 00b) and set up single data transfer per interrupt (MRB.CHNE = 0, MRB.DISEL = 0). The MRB.DTS bit can be set to any value.

### (5) DTC transfer

每次SCI完成1个字节的接收,就会产生一个SCIn\_RXI中断来激活DTC。DTC将接收到的字节从SCI的RDR传输到SRAM,之后DAR寄存器递增,CRA寄存器递减。

### (6) 中断处理

在128轮数据传输完成且CRA寄存器中的值变为0后,向CPU产生SCIn\_RXI中断请求。完成该中断处理程序中的处理。

## 17.6.2 链式转移

本节提供了一个DTC链式转移的示例,并描述了它在General输出脉冲中的使用。您可以使用链式转移来传输PWM定时器比较数据并更改GPT的PWM定时器的周期。

对于第一个链式转移,指定正常传输模式以传输到GPTm.GTCCRC寄存器(m=320到323、164到167)。对于第二次转移,指定正常传输模式以传输到GPTm.GTCCRE寄存器(m=320到323、164到167)。对于链式转移的第三次转移,指定用于传输到GPTm.GTPBR寄存器(m=320至323、164至167)的正常传输模式。这是因为在完成指定数量的传输时清除激活源和产生中断仅限于链式转移的第三个,即在MRB.CHNE=0时传输。

以下示例显示如何使用GPT320.GTPR寄存器的计数器溢出中断作为DTC的激活源。

#### (1) 首次转账信息设置

设置传输到GPT320.GTCCRC寄存器。

- 1.在MRA寄存器中,选择源地址的递增(MRA.SM[1:0]=10b)。
- 2.将传输设置为正常传输模式(MRA.MD[1:0]=00b)和字长传输(MRA.SZ[1:0]=10b)。
- 3.在MRB寄存器中,选择固定的目标地址(MRB.DM[1:0]=00b)并设置链式转移(MRB.CHNE=1和MRB.CHNS=0)。
- 4.将SAR寄存器设置为数据表的首地址。
- 5.将DAR寄存器设置为GPT320.GTCCRC寄存器的地址。
- 6.将CRAH和CRAL寄存器设置为数据表的大小。CRB寄存器可以设置为任何值。

#### (2) 二转信息设置

设置传输到GPT320.GTCCRE寄存器。

- 1.在MRA寄存器中,选择源地址的递增(MRA.SM[1:0]=10b)。
- 2.将传输设置为正常传输模式(MRA.MD[1:0]=00b)和字长传输(MRA.SZ[1:0]=10b)。
- 3.在MRB寄存器中,选择固定的目标地址(MRB.DM[1:0]=00b)并设置链式转移(MRB.CHNE=1,MRB.CHNS=0)。
- 4.将SAR寄存器设置为数据表的首地址。
- 5.将DAR寄存器设置为GPT320.GTCCRE寄存器的地址。
- 6.将CRAH和CRAL寄存器设置为数据表的大小。CRB寄存器可以设置为任何值。

#### (3) 三转信息集

设置传输到GPT320.GTPBR寄存器。

- 1.在MRA寄存器中,选择源地址的递增(MRA.SM[1:0]=10b)。
- 2.将传输设置为正常传输模式(MRA.MD[1:0]=00b)和字长传输(MRA.SZ[1:0]=10b)。
- 3.在MRB寄存器中,选择固定的目标地址(MRB.DM[1:0]=00b)并设置每次中断的单次数据传输(MRB.CHNE=0,MRB.DISEL=0)。MRB.DTS位可以设置为任何值。



4. Set the SAR register to the first address of the data table.
5. Set the DAR register to the address of the GPT320.GTPBR register.
6. Set the CRA register to the size of the data table. The CRB register can be set to any value.

#### (4) Transfer information assignment

Place the transfer information for use in the transfer to the GPT320.GTPBR immediately after the transfer control information for use in the GPT320.GTCCRC and GPT320.GTCCRE registers.

#### (5) DTC vector table

In the DTC vector table, set the address where the transfer control information for use in transfer to the GPT320.GTCCRC and GPT320.GTCCRE registers starts.

#### (6) ICU setting and DTC module activation

1. Set the ICU.IELSRn.DTCE bit associated with the GPT320 counter overflow interrupt.
2. Set the ICU.IELSRn.IELS[8:0] bits and specify the GPT320 counter overflow.
3. Set the DTCST.DTCST bit to 1.

#### (7) GPT settings

1. Set the GPT320.GTIOR register so that the GTCCRA and GTCCRB registers operate as output compare registers.
2. Set the default PWM timer compare values in the GPT320.GTCCRA and GPT320.GTCCRB registers and the next PWM timer compare values in the GPT320.GTCCRC and GPT320.GTCCRE registers.
3. Set the default PWM timer period values in the GPT320.GTPR register and the next PWM timer period values in the GPT320.GTPBR register.
4. Set 1 to the output bit in PmnPFS.PDR, and set 00011b to the Peripheral Select bits in PmnPFS.PSEL[4:0].

#### (8) GPT activation

Set the GPT320.GTSTR.CSTRT bits to 1 to start the GPT320.GTCNT counter.

#### (9) DTC transfer

Each time a GPT320 counter overflow is generated with the GPT320.GTPR register, the next PWM timer compare values are transferred to the GPT320.GTCCRC and GPT320.GTCCRE registers. The setting for the next PWM timer period is transferred to the GPT320.GTPBR register.

#### (10) Interrupt handling

After the specified rounds of data transfer are complete, for example when the value in the CRA register for GPT transfer becomes 0, a GPT320 counter overflow interrupt request is issued for the CPU. Complete the process for this interrupt in the handling routine.

### 17.6.3 Chain Transfer when Counter = 0

The second data transfer is performed only when the transfer counter is set to 0 in the first data transfer, and the first data transfer information is repeatedly changed in the second transfer. Chain transfer enables transfers to be repeated 256 times or more.

The following procedure shows an example of configuring a 1-KB input buffer, where the input buffer is set so that its lower address starts with 0x00. [Figure 17.13](#) shows a chain transfer when the counter = 0.

1. Set the normal transfer mode to input data for the first data transfer. Set the following:
  - (a) Transfer source address = fixed.
  - (b) CRA register = 0x0200 (512) times.
  - (c) MRB.CHNE bit = 1 (chain transfer is enabled).
  - (d) MRB.CHNS bit = 1 (chain transfer is performed only when the transfer counter is 0).

- 4.将SAR寄存器设置为数据表的首地址。
- 5.将DAR寄存器设置为GPT320.GTPBR寄存器的地址。
- 6.将CRA寄存器设置为数据表的大小。CRB寄存器可以设置为任何值。

#### (4) 转移信息分配

将用于传输到GPT320.GTPBR的传输信息放置在GPT320.GTCCRC和GPT320.GTCCRE寄存器中使用的传输控制信息之后。

#### (5) DTC向量表

在DTC向量表中，设置用于传输到GPT320.GTCCRC和GPT320.GTCCRE寄存器的传输控制信息的起始地址。

#### (6) ICU设置和DTC模块激活

- 1.设置与GPT320计数器溢出中断相关的ICU.IELSRn.DTCE位。
- 2.设置ICU.IELSRn.IELS[8:0]位并指定GPT320计数器溢出。
- 3.将DTCST.DTCST位设置为1。

#### (7) GPT settings

- 1.设置GPT320.GTIOR寄存器，使GTCCRA和GTCCRB寄存器作为输出比较寄存器运行。
- 2.在GPT320.GTCCRA和GPT320.GTCCRB寄存器中设置默认PWM定时器比较值，在GPT320.GTCCRC和GPT320.GTCCRE寄存器中设置下一个PWM定时器比较值。
- 3.在GPT320.GTPR寄存器中设置默认PWM定时器周期值，在GPT320.GTPBR寄存器中设置下一个PWM定时器周期值。
- 4.将PmnPFS.PDR中的输出位设置为1，并将PmnPFS.PSEL[4:0]中的外设选择位设置为00011b。

#### (8) GPT activation

将GPT320.GTSTR.CSTRT位设置为1以启动GPT320.GTCNT计数器。

#### (9) DTC transfer

每次使用GPT320.GTPR寄存器产生GPT320计数器溢出时，下一个PWM定时器比较值被传送到GPT320.GTCCRC和GPT320.GTCCRE寄存器。下一个PWM定时器周期的设置被传送到GPT320.GTPBR寄存器。

#### (10)中断处理

在指定轮次的数据传输完成后，例如当GPT传输的CRA寄存器中的值变为0时，会向CPU发出GPT320计数器溢出中断请求。在处理例程中完成该中断的处理。

### 17.6.3 Counter=0时的链式转移

仅当在第一次数据传输中将传输计数器设置为0时才执行第二次数据传输，并且在第二次传输中重复改变第一数据传输信息。链式转移使转移可以重复256次或更多。

以下过程显示了配置1KB输入缓冲区的示例，其中输入缓冲区设置为使其低地址从0x00开始。图17.13显示了当计数器=0时的链式传输。

- 1.将普通传输模式设置为第一次数据传输的输入数据。设置以下内容:
  - (a) 传输源地址=固定。
  - (b) CRA寄存器=0x0200(512)次。
  - (c) MRB.CHNE位=1 (启用链式传输)。
  - (d) MRB.CHNS位=1 (仅当传输计数器为0时才执行链式传输)。

- (e) MRB.DISEL bit = 0 (an interrupt request to the CPU is generated when the specified data transfer completes).
2. Prepare the upper 8-bit address of the start address at every 512 times of the transfer destination address for the first data transfer in different area such as the flash. For example, when setting the input buffer to 0x8000 to 0x83FF, prepare 0x82 and 0x80.
  3. For the second data transfer:
    - (a) Set the repeat transfer mode (with transfer source and destination address = fixed.) to reset the transfer counter of the first data transfer.
    - (b) Specify the CRA register in the first transfer information area for the transfer destination.
    - (c) Set the MRB.CHNE bit = 1 (chain transfer is enabled).
    - (d) Set the MRB.CHNS bit = 0 (select continuous chain transfer).
    - (e) Set the MRB.DISEL bit = 0 (an interrupt request to the CPU is generated when the specified data transfer completes).
    - (f) CRA register = 0x0101 (The transfer count is 1).
  4. For the third data transfer:
    - (a) Set the repeat transfer mode (with the source as the repeat area) to reset the transfer destination address of the first data transfer.
    - (b) Specify the upper 8 bits of the DAR register in the first transfer information area for the transfer destination.
    - (c) Set the MRB.CHNE bit = 0 (chain transfer is disabled).
    - (d) Set the MRB.DISEL bit = 0 (an interrupt request to the CPU is generated when the specified data transfer completes).
    - (e) When setting the input buffer to 0x8000 to 0x83FF, also set the transfer counter to 2.
  5. The first data transfer is performed by an interrupt 512 times. When the transfer counter of the first data transfer becomes 0, the second data transfer starts. Set the transfer counter of the first data transfer to 0x0200. The lower 8 bits of the transfer destination address and the transfer counter of the first data transfer becomes 0x0200.
  6. The second data transfer is performed by an interrupt 1 times. When the transfer counter of the first data transfer becomes 0, the third data transfer starts. Set the upper 8 bits of the transfer destination address of the first data transfer to 0x82. The lower 8 bits of the transfer destination address becomes 0x00 and the transfer counter of the first data transfer becomes 0x0200.
  7. In succession, the first data transfer is performed by an interrupt 512 times as specified for the first data transfer. When the transfer counter of the first data transfer becomes 0, the second data transfer starts. Set the transfer counter of the first data transfer to 0x0200. The lower 8 bits of the transfer destination address and the transfer counter of the first data transfer becomes 0x0200.
  8. The second data transfer is performed by an interrupt 1 times. When the transfer counter of the first data transfer becomes 0, the third data transfer starts. Set the upper 8 bits of the transfer destination address of the first data transfer to 0x80. The lower 8 bits of the transfer destination address becomes 0x00 and the transfer counter of the first data transfer becomes 0x0200.
  9. Steps 5 to 8 are repeated indefinitely. Because the second data transfer is in repeat transfer mode, no interrupt request to the CPU is generated.

- (e) MRB.DISEL位=0 (指定数据传输完成时向CPU产生中断请求)。
- 2.在flash等不同区域的第一次数据传输中, 每512次传输目标地址准备起始地址的高8位地址。比如设置输入缓冲区为0x8000到0x83FF时, 准备0x82和0x80。
  - 3.对于第二次数据传输:
    - (a) 设置重复传输模式 (传输源和目标地址=固定) 以重置第一次数据传输的传输计数器。
    - (b) 在传输目标的第一个传输信息区域中指定CRA寄存器。
    - (c) 设置MRB.CHNE位=1 (启用链式传输)。
    - (d) 设置MRB.CHNS位=0 (选择连续链传输)。
    - (e) 设置MRB.DISEL位=0 (当指定的数据传输完成时向CPU产生一个中断请求)。
    - (f) CRA寄存器=0x0101 (传输计数为1)。
  - 4.对于第三次数据传输:
    - (a) 设置重复传输模式 (以源为重复区域) 重置第一次数据传输的传输目标地址。
    - (b) 在传输目标的第一个传输信息区域中指定DAR寄存器的高8位。
    - (c) 设置MRB.CHNE位=0 (禁用链传输)。
    - (d) 设置MRB.DISEL位=0 (当指定的数据传输完成时向CPU产生一个中断请求)。
    - (e) 将输入缓冲区设置为0x8000到0x83FF时, 还要将传输计数器设置为2。
  - 5.第一次数据传输由中断执行512次。当第一次数据传输的传输计数器变为0, 第二次数据传输开始。将第一次数据传输的传输计数器设置为0x0200。第一次数据传输的传输目标地址和传输计数器的低8位变为0x0200。
  - 6.第二次数据传输由中断执行1次。当第一次数据传输的传输计数器变为0, 开始第三次数据传输。将第一次数据传输的传输目标地址的高8位设置为0x82。传送目标地址的低8位变为0x00, 第一次数据传送的传送计数器变为0x0200。
  - 7.接连地, 第一次数据传输由中断执行512次, 如为第一次数据传输指定的那样。当第一次数据传输的传输计数器变为0时, 第二次数据传输开始。将第一次数据传输的传输计数器设置为0x0200。第一次数据传输的传输目标地址和传输计数器的低8位变为0x0200。
  - 8.第二次数据传输由中断执行1次。当第一次数据传输的传输计数器变为0, 开始第三次数据传输。将第一次数据传输的传输目标地址的高8位设置为0x80。传送目标地址的低8位变为0x00, 第一次数据传送的传送计数器变为0x0200。
  - 9.步骤5到8无限重复。因为第二次数据传输是重复传输模式, 所以不会产生对CPU的中断请求。



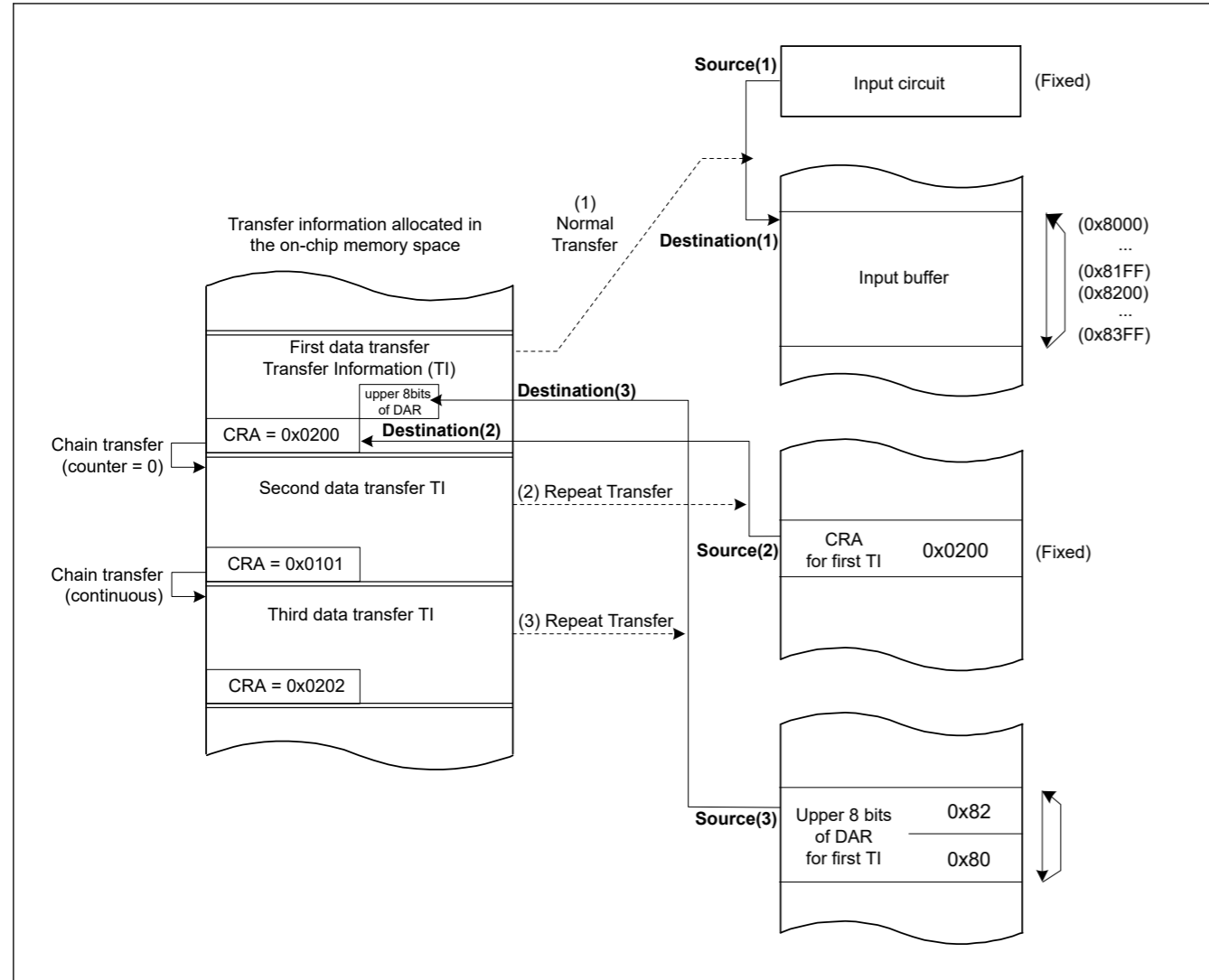


Figure 17.13 Chain transfer when counter = 0

### 17.7 Processing on DTC Transfer Error

If the access error occurs during DTC transfer, the DTC immediately stops access during transfer. To stop only the vector number that caused the error, inform the vector number that caused the error to the ICU and clear the corresponding ICU setting. After that, if there is a request other than the vector number which caused the error, it will be re-arbitration as it is. The condition under which the transfer error occurs is indicated when TrustZone Filter in DTC detects a violation.

The error response is informed to ICU when the transfer error occurs. ICU clears the ICU.IELSRn of the corresponding vector number which caused the transfer error. Furthermore, it generates an error response detection interrupt to notify that an error has occurred by DMAC/DTC transfer. (section 17.8.2. Interrupt Request of Transfer Error). Write back to SRAM is not performed.

When the Master TrustZone Filter error occurs, the Slave TrustZone error occurs or the Master MPU error occurs, it is possible to confirm the error information of DTC by selecting NMI. The DTC error vector register is cleared by selecting reset. Under the conditions where NMI is generated due to transfer error in DTC, two interrupts(NMI and DMAC\_TRANSERR) are generated. In this case, NMI always responds first.

The error response detection interrupt request (DMA\_TRANSERR) occurs when the Slave Bus error or the Illegal Access error occurs. Furthermore, it occurs after NMI when the error response detection interrupt request (DMA\_TRANSERR) is not cleared in NMI handler.

section 17.7.1. Processing on NMI handler describes how to confirm the error information of the DTC in the NMI handler. section 17.7.2. Processing on Error response detection interrupt request (DMA\_TRANSERR) handler describes how to confirm the error information of the DTC in the DMA\_TRANSERR handler.

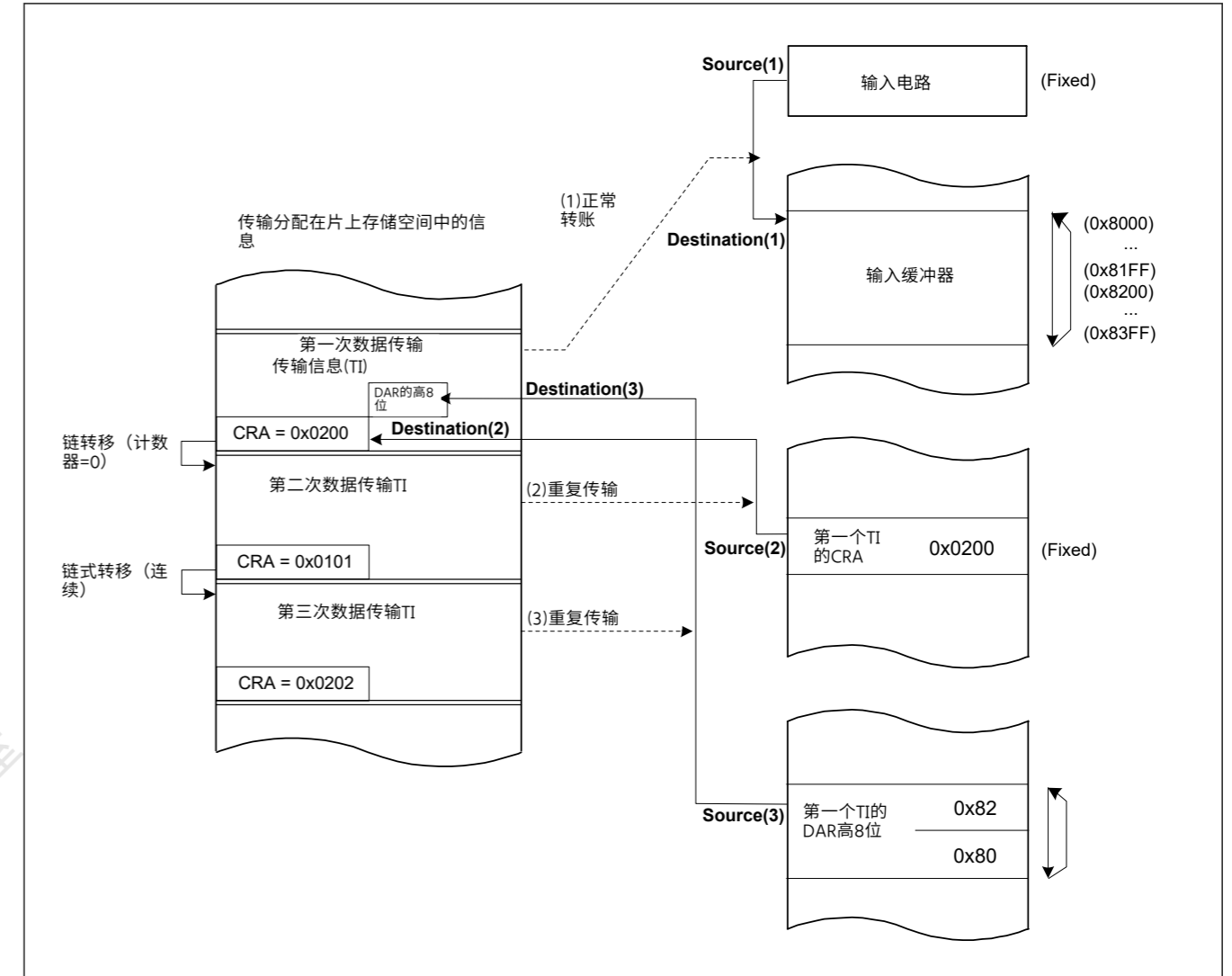


Figure 17.13 counter=0时的链转移

### 17.7 DTC传输错误的处理

如果在DTC传输过程中发生访问错误，则DTC会在传输过程中立即停止访问。要仅停止导致错误的向量编号，请将导致错误的向量编号通知ICU并清除相应的ICU设置。之后，如果有引起错误的向量号以外的请求，将按原样重新仲裁。当DTC中的TrustZone过滤器检测到违规时，会指示发生传输错误的条件。

当发生传输错误时，将错误响应通知给ICU。ICU清除导致传输错误的相应向量号的ICU.IELSRn。此外，它会生成错误响应检测中断，以通知DMACDTC传输发生错误。（第17.8.2节。传输错误的中断请求）。不执行回写到SRA M。

当出现MasterTrustZoneFilter错误、SlaveTrustZone错误或MasterMPU错误时，可以通过选择NMI来确认DTC的错误信息。通过选择复位清除DTC错误向量寄存器。在由于DTC中的传输错误而产生NMI的情况下，会产生两个中断（NMI和DMAC\_TRANSERR）。在这种情况下，NMI总是首先响应。

当发生SlaveBus错误或IllegalAccess错误时，会发生错误响应检测中断请求(DMA\_TRANSERR)。此外，当NMI处理程序中未清除错误响应检测中断请求(DMA\_TRANSERR)时，它会在NMI之后发生。

第17.7.1节。NMIhandler上的处理描述了如何在NMIhandler中确认DTC的错误信息。第17.7.2节。错误响应检测中断请求(DMA\_TRANSERR)处理程序的处理描述了如何在DMA\_TRANSERR处理程序中确认DTC的错误信息。

Interrupts and the error information generated due to transfer errors are shown in [section 17.8.2. Interrupt Request of Transfer Error](#).

### 17.7.1 Processing on NMI handler

The cause of NMI due to the DMA transfer error is the Master TrustZone Filter error, the Slave TrustZone Filter error or the Master MPU error. When NMI occurs due to the DTC transfer error, the error response detection interrupt request (DMA\_TRANSERR) will occur after the end of NMI handler. It is possible to confirm the cause of the error and the DTC vector number in which the error occurred. When NMI occurs, perform the necessary processing according to the flow described in the ICU chapter.

[Figure 17.14](#) shows the flow for confirm the vector number that caused the Master TrustZone Filter Error in DTC

[Figure 17.15](#) shows the flow for confirm the vector number that caused the Slave TrustZone Filter Error in DTC

[Figure 17.16](#) shows the flow for confirm the vector number and Security Attribute that caused the Master MPU error in DTC

If completing all processing in NMI handler, it is possible to clear the error response detection interrupt request (DMA\_TRANSERR) that occurs subsequently.

因传输错误而产生的中断和错误信息见17.8.2节。中断请求传输错误。

### 17.7.1 在NMI处理程序上处理

由于DMA传输错误导致NMI的原因是MasterTrustZoneFilter错误、SlaveTrustZoneFilter错误或主控MPU错误。当由于DTC传输错误而发生NMI时，错误响应检测中断请求(DMA\_TRANSERR)将在NMI处理程序结束后发生。可以确认错误的原因和发生错误的DTC向量编号。当发生NMI时，按照ICU章节中描述的流程进行必要的处理。

图17.14显示了在DTC中确认导致MasterTrustZoneFilterError的向量号的流程

图17.15显示了在DTC中确认导致SlaveTrustZoneFilterError的向量号的流程

图17.16显示了确认导致MasterMPU错误的向量号和安全属性的流程

如果完成NMI处理程序中的所有处理，则可以清除随后发生的错误响应检测中断请求(DMA\_TRANSERR)。

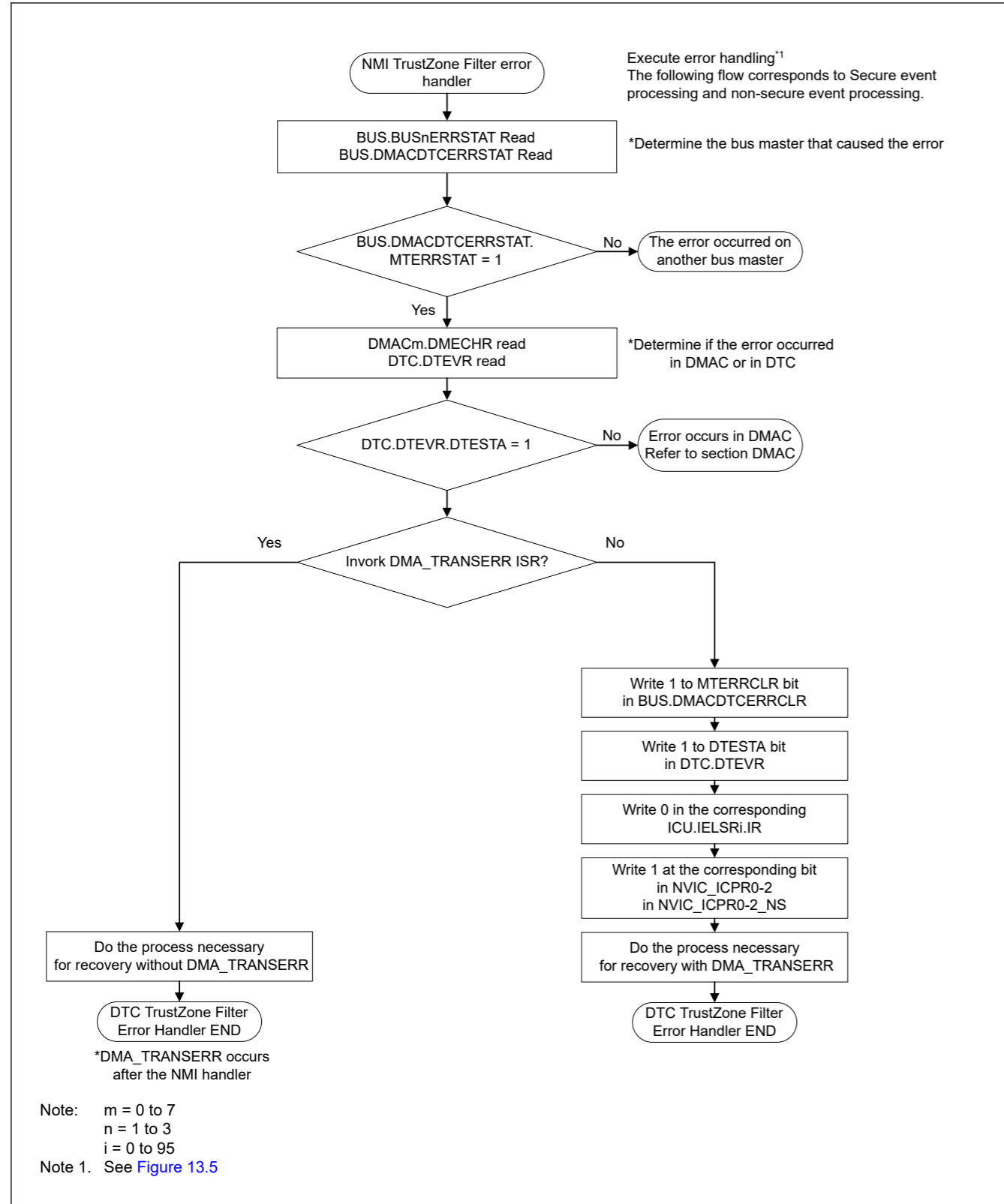


Figure 17.14 Processing in NMI handler by Master TrustZone Filter Error

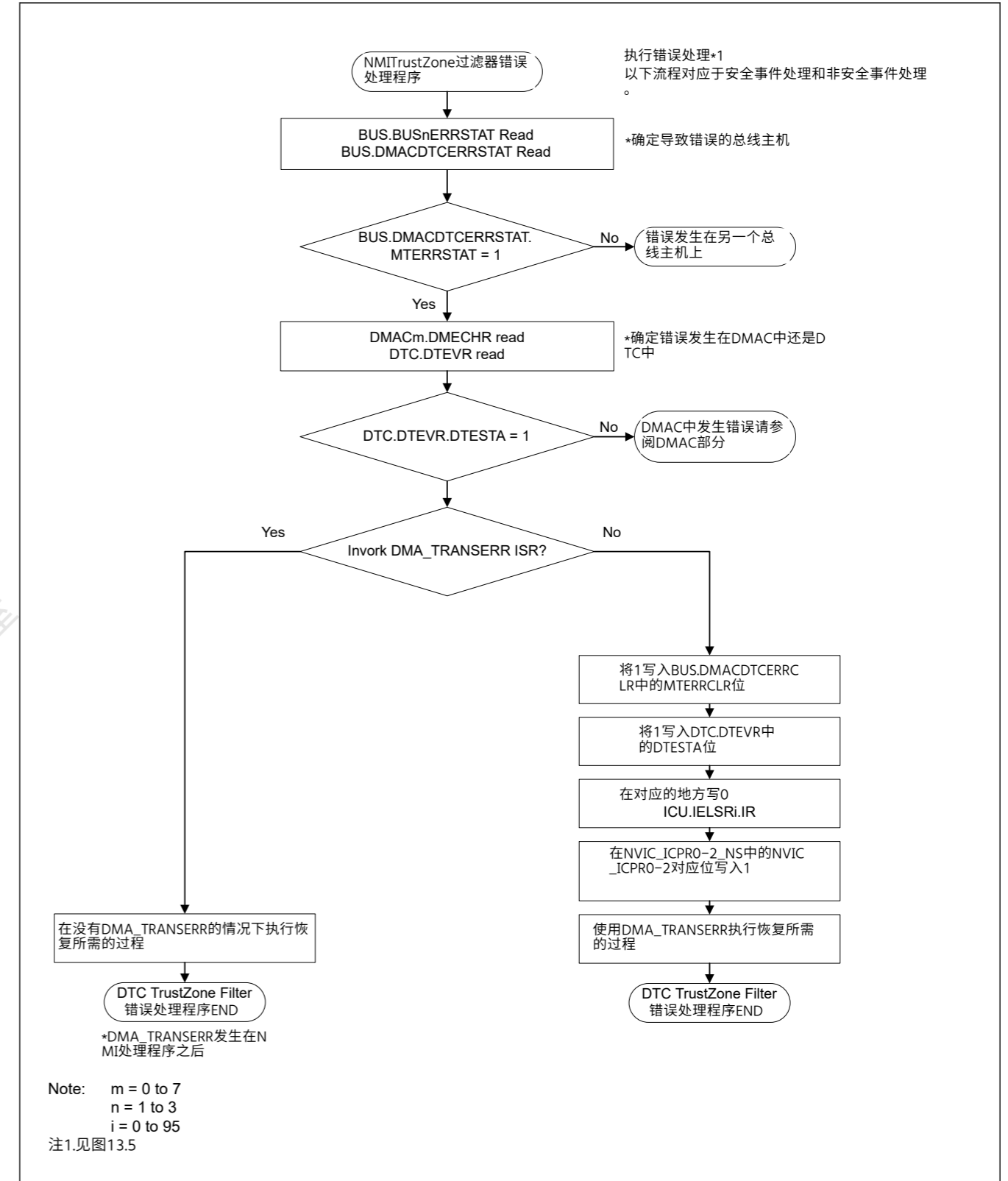


Figure 17.14 主TrustZone过滤器错误在NMI处理程序中的处理

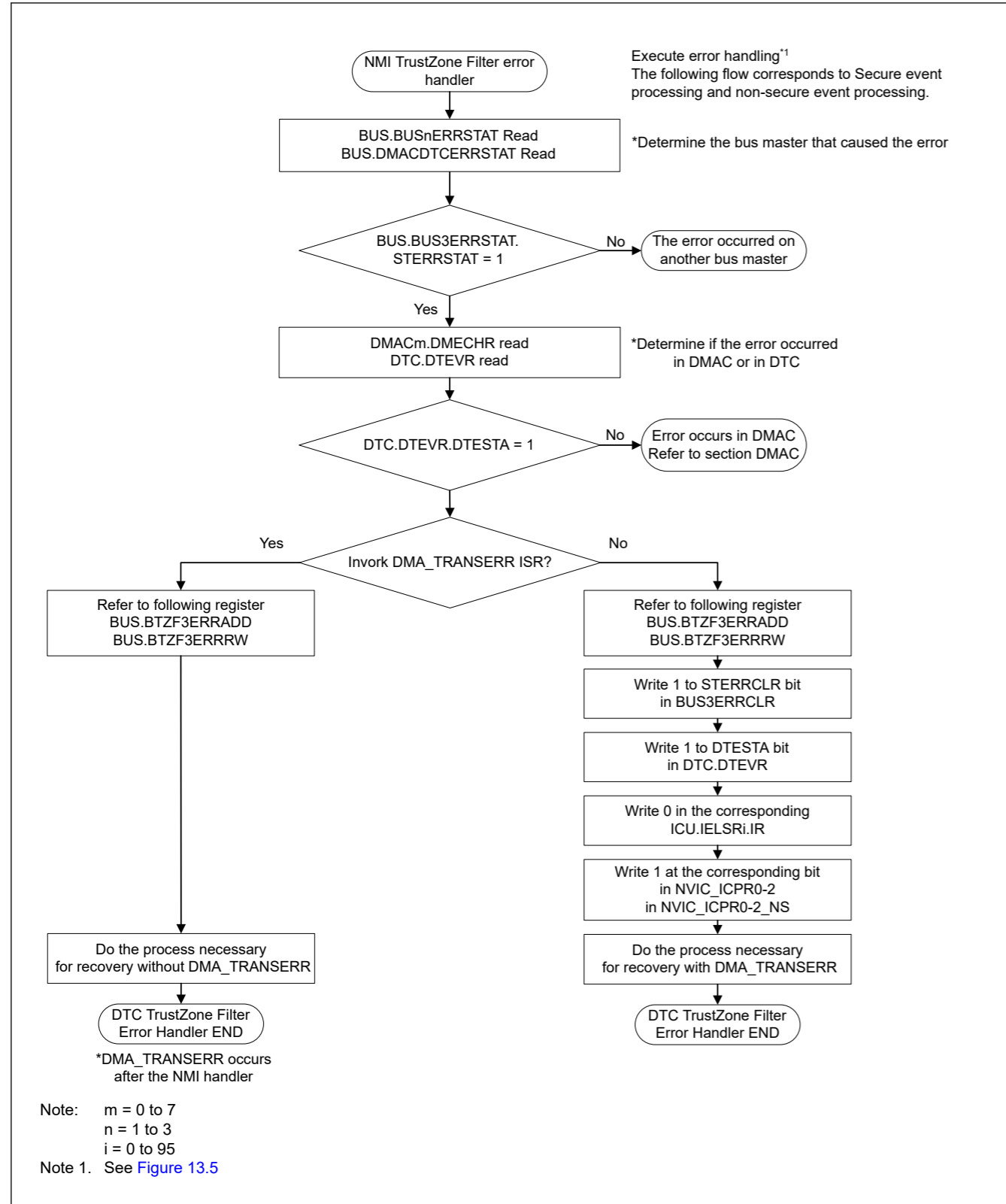


Figure 17.15 Processing in NMI handler by Slave TrustZone Filter Error

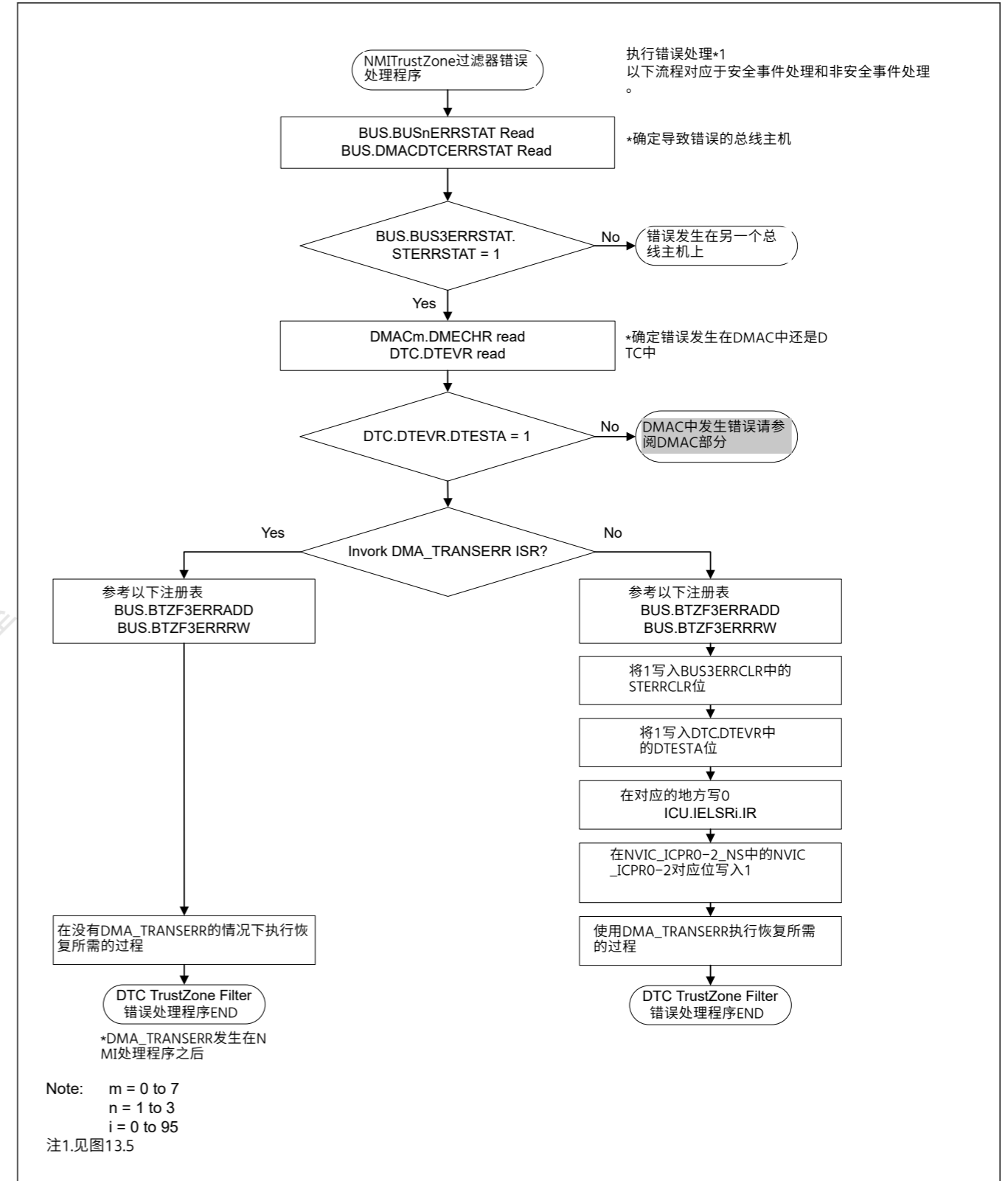


Figure 17.15 从属TrustZone过滤器错误在NMI处理程序中的处理

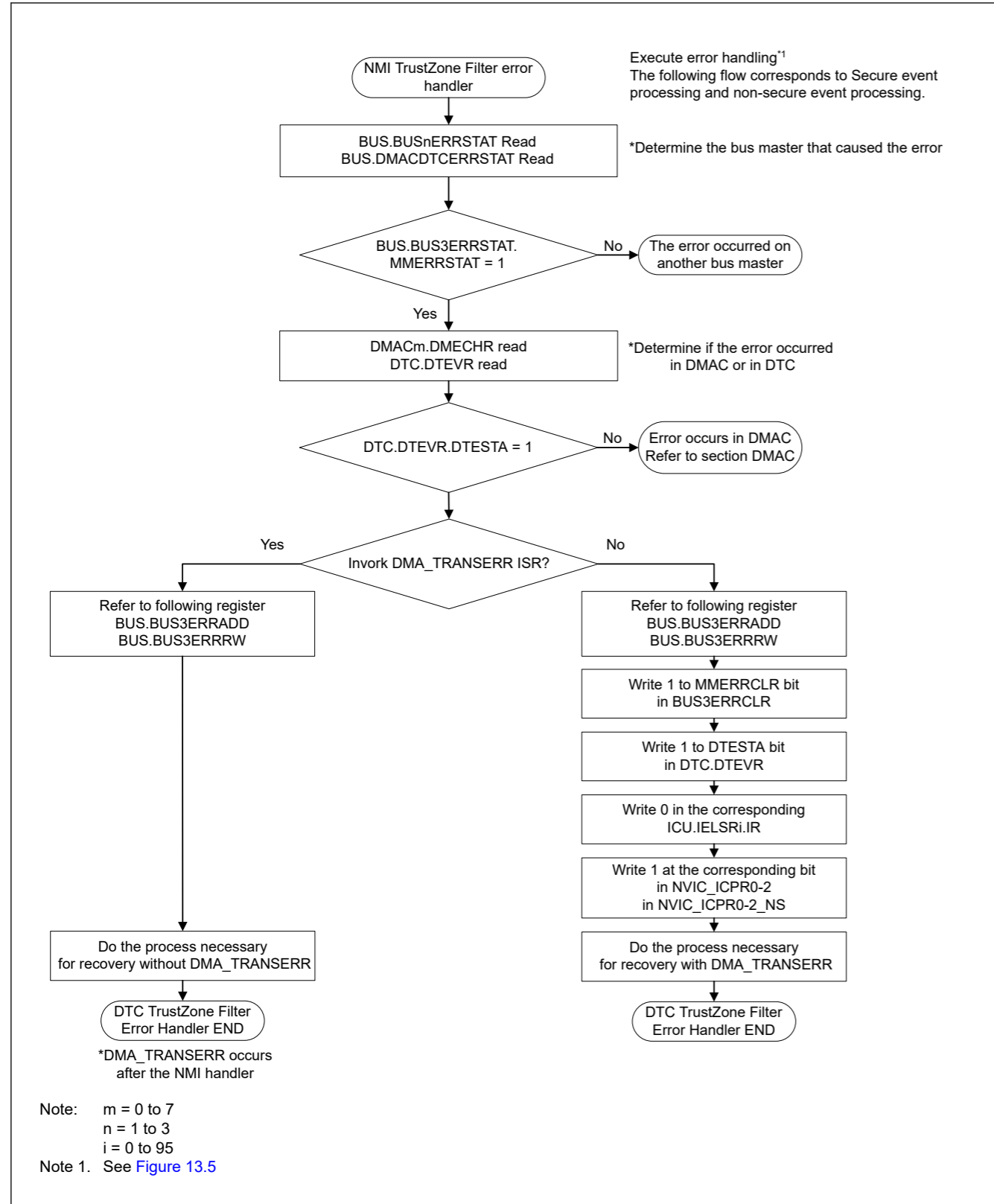


Figure 17.16 Processing in NMI handler by Master MPU Error

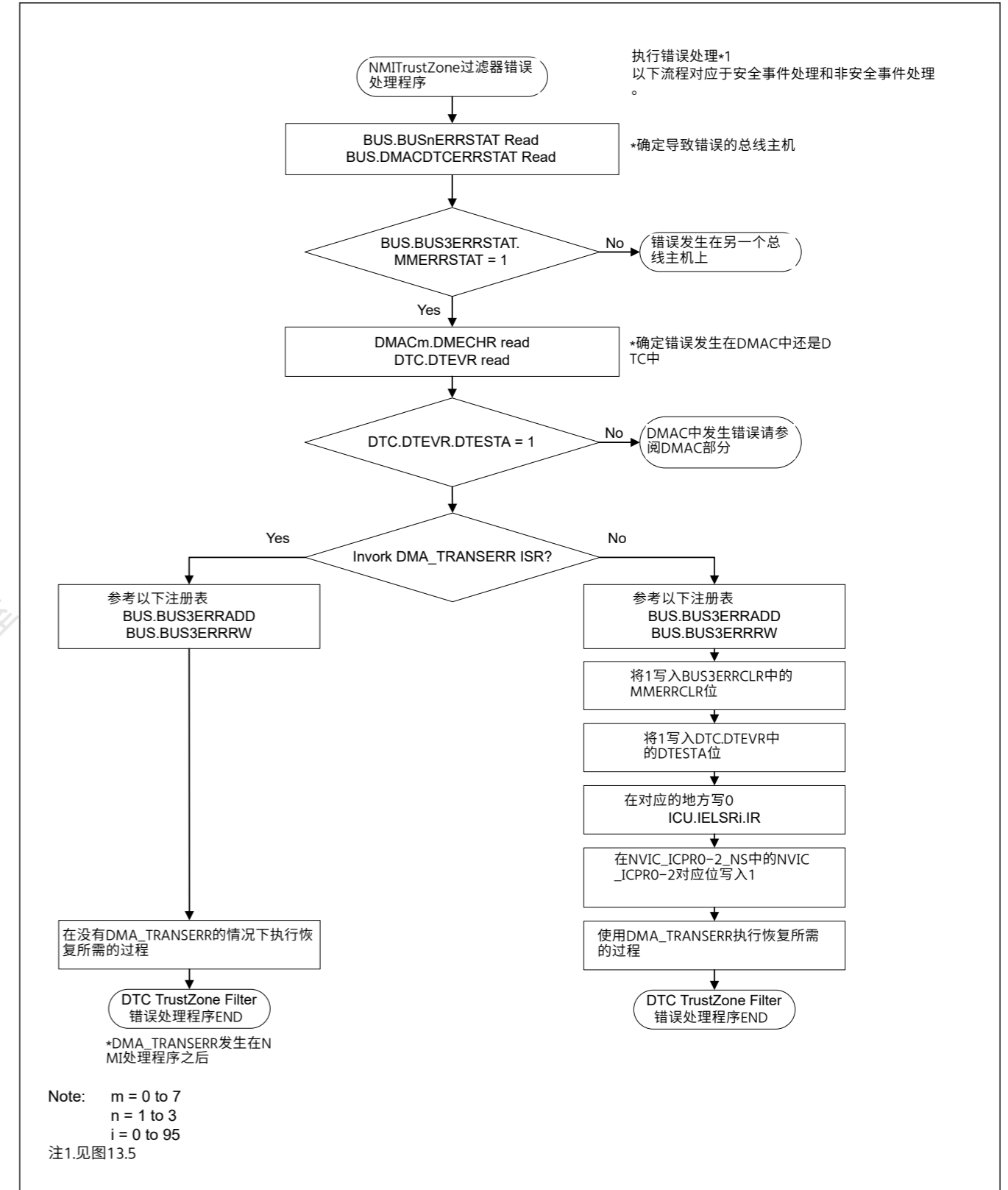


Figure 17.16 主MPU错误在NMI处理程序中的处理



17.7.2 Processing on Error response detection interrupt request (DMA\_TRANSERR) handler

The cause of error response detection interrupt request (DMA\_TRANSERR) due to DMA transfer error is the Slave Bus Error or Illegal Access Error. Also, it occurs after the NMI handler error response detection interrupt request (DMA\_TRANSERR) is not cleared by the NMI handler.

It is possible to confirm the cause of the error and the vector number of DTC in which the error occurred.

Error cause confirmation procedure is shown Figure 17.17.

Figure 17.18 shows the flow for confirm the vector number that caused the Master TrustZone Filter Error in DTC

Figure 17.19 shows the flow for confirm the vector number that caused the Slave TrustZone Filter Error in DTC

Figure 17.20 shows the flow for confirm the vector number and Security Attribute that caused the Master MPU Error in DTC

Figure 17.21 shows the flow for confirm the vector number and Security Attribute that caused the Slave Bus Error in DTC

Figure 17.22 shows the flow for confirm the vector number and Security Attribute that caused the Illegal Access Error in DTC

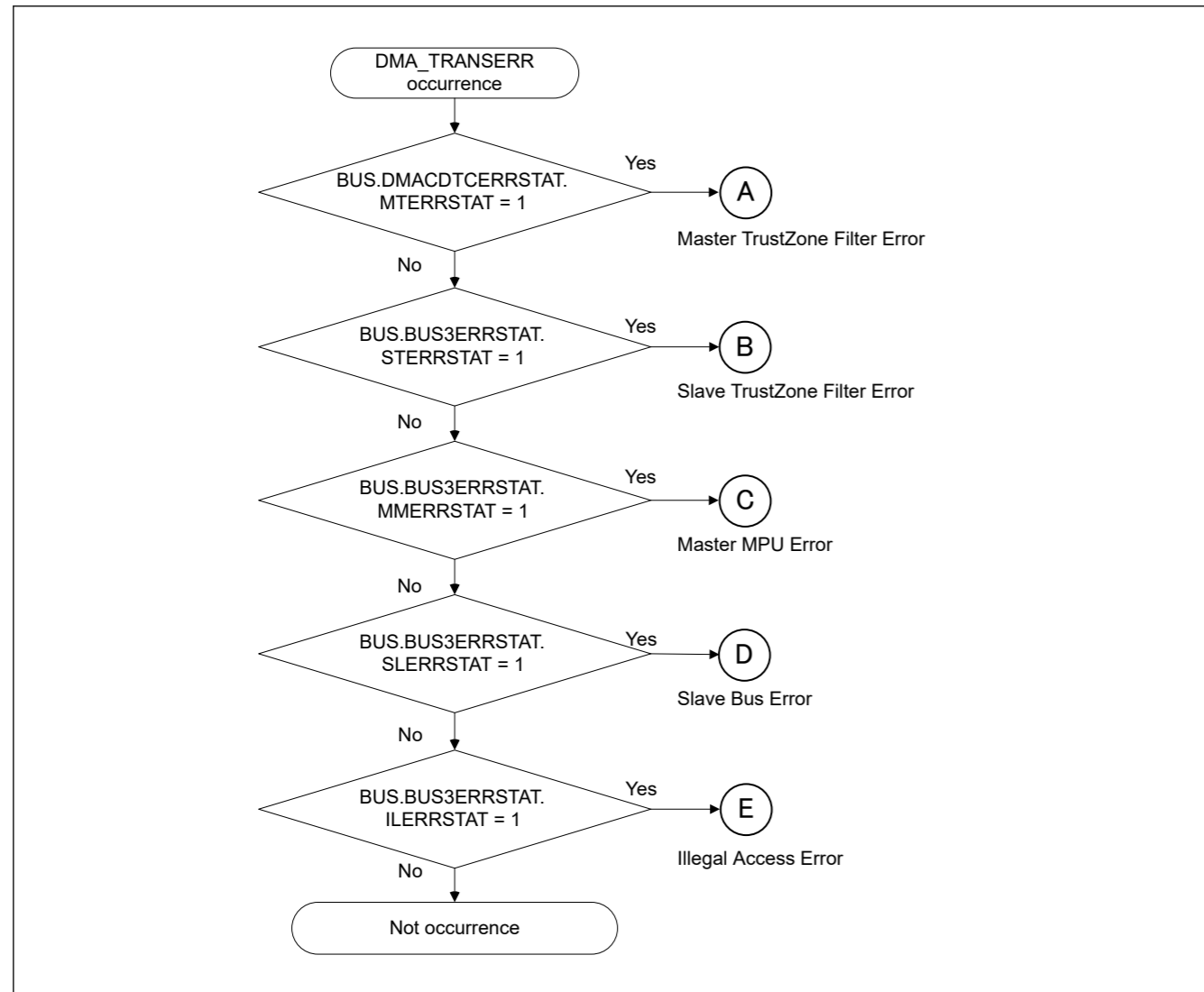


Figure 17.17 Transfer error factor judgment when the error response detection interrupt (DMA\_TRANSERR) occurs

17.7.2 错误响应检测中断请求(DMA\_TRANSERR)处理程序的处理

由于DMA传输错误导致错误响应检测中断请求(DMA\_TRANSERR)的原因是从总线错误或非法访问错误。此外，它发生在NMI处理程序错误响应检测中断请求(DMA\_TRANSERR)未被NMI处理程序清除之后。

可以确认错误的原因和发生错误的DTC的向量号。

错误原因确认流程如图17.17所示。

图17.18显示了在DTC中确认导致MasterTrustZoneFilterError的向量号的流程

图17.19显示了在DTC中确认导致SlaveTrustZoneFilterError的向量号的流程

图17.20显示了确认导致MasterMPU错误的向量号和安全属性的流程

图17.21显示了在DTC中确认导致从总线错误的向量号和安全属性的流程

图17.22显示了确认导致非法访问错误的向量号和安全属性的流程

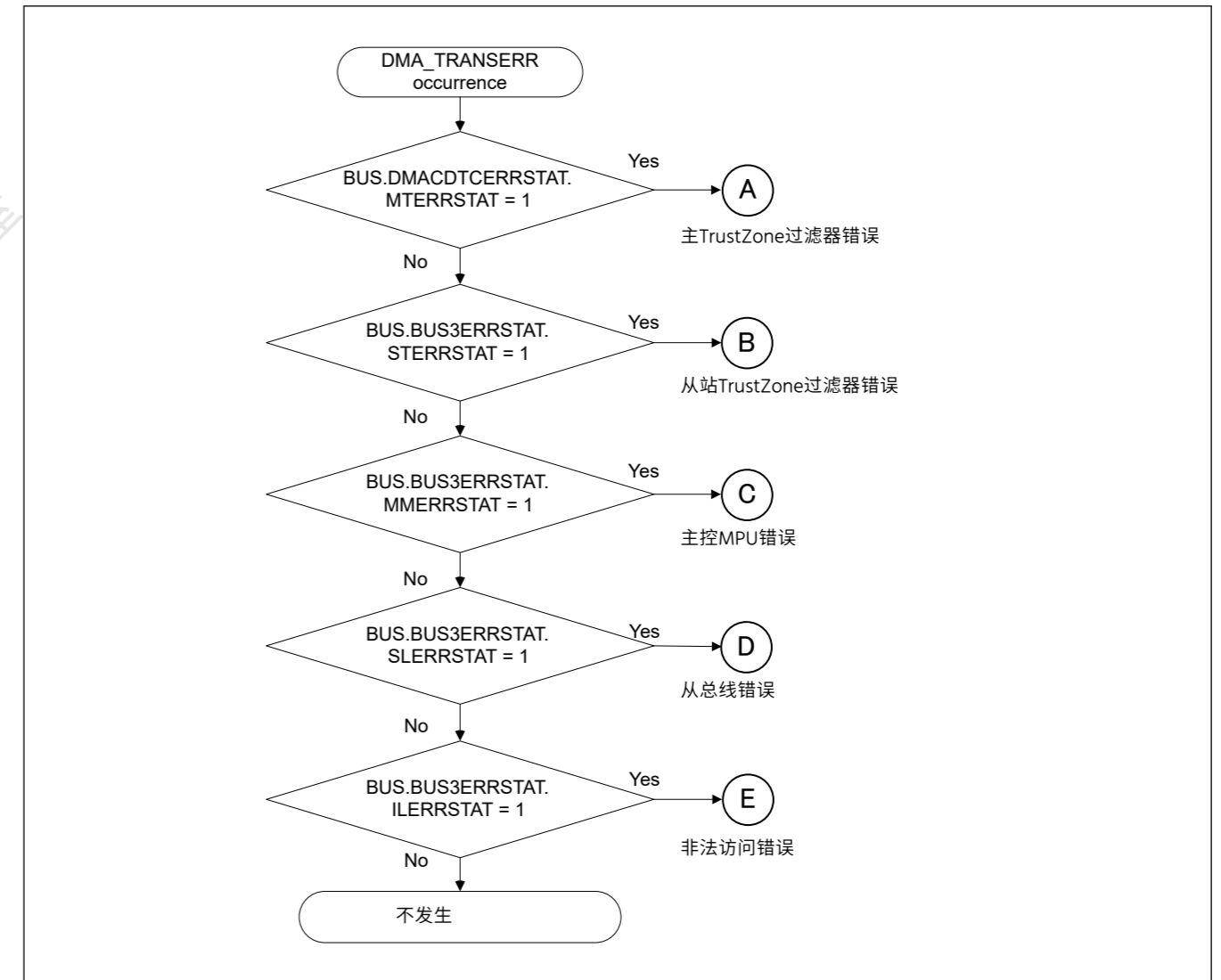


Figure 17.17 发生错误响应检测中断 (DMA\_TRANSERR) 时的传输错误因素判断

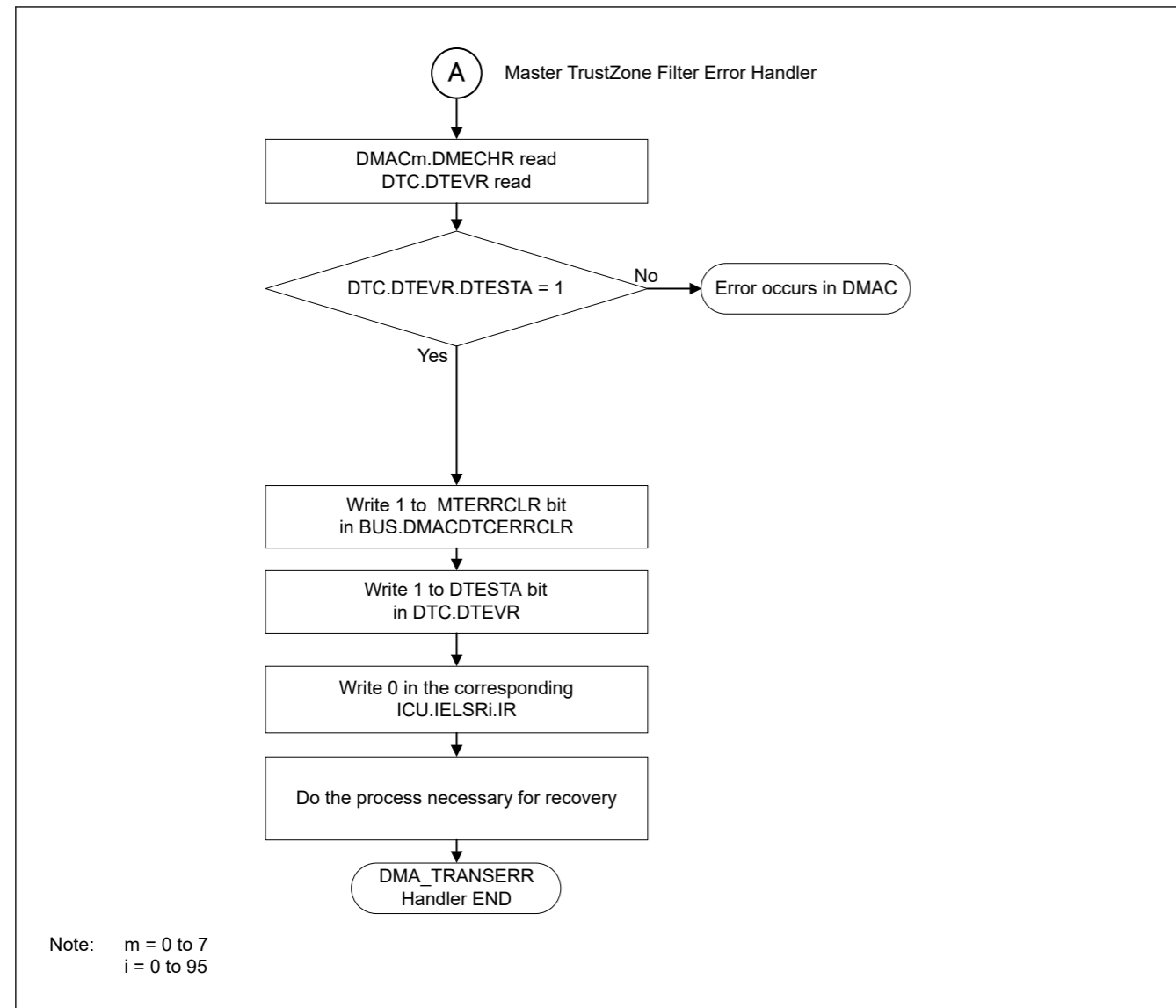


Figure 17.18 Processing in DMA\_TRANSERR handler by Master TrustZone Filter Error

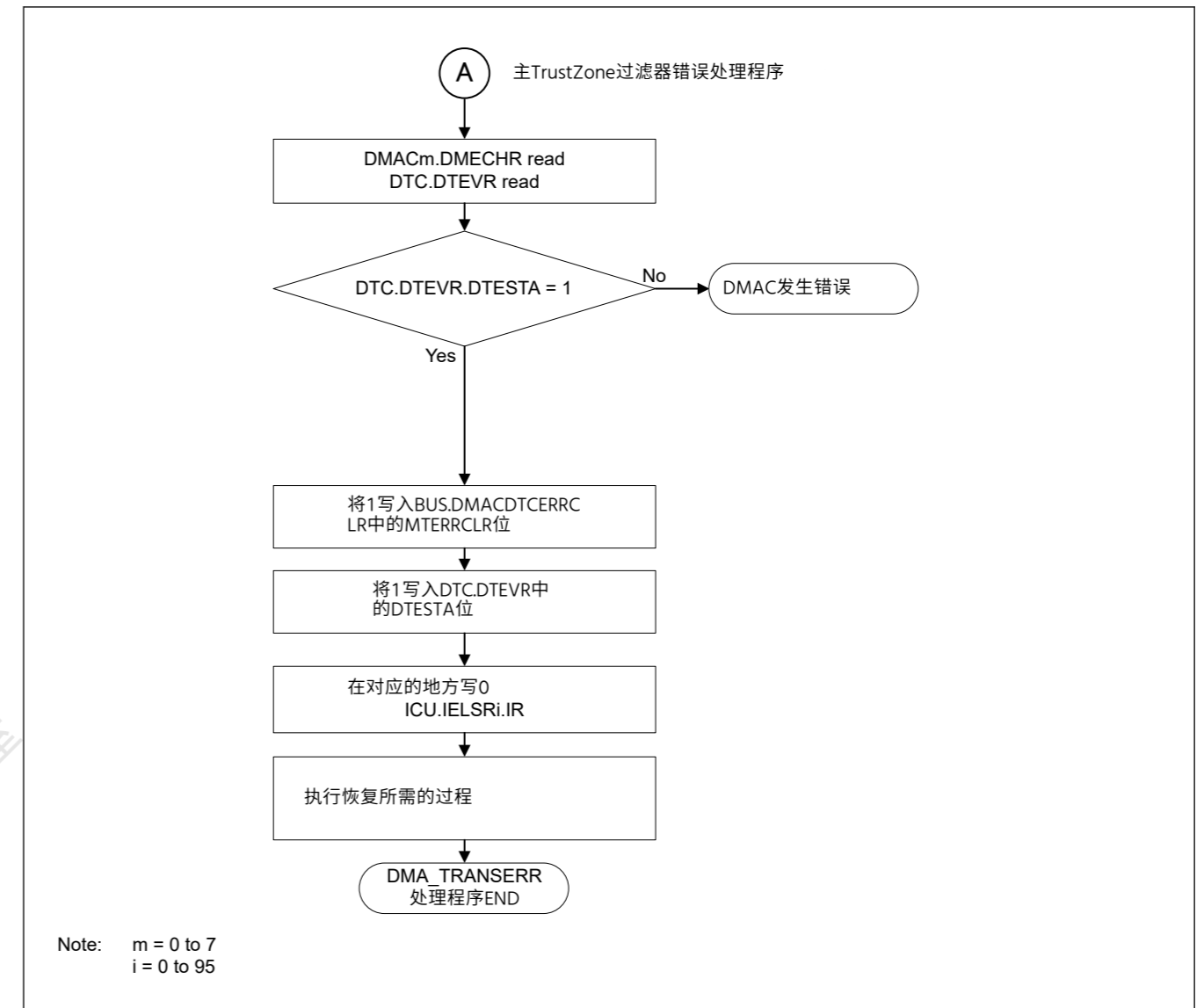


Figure 17.18 MasterTrustZone过滤器错误在DMA\_TRANSERR处理程序中的处理

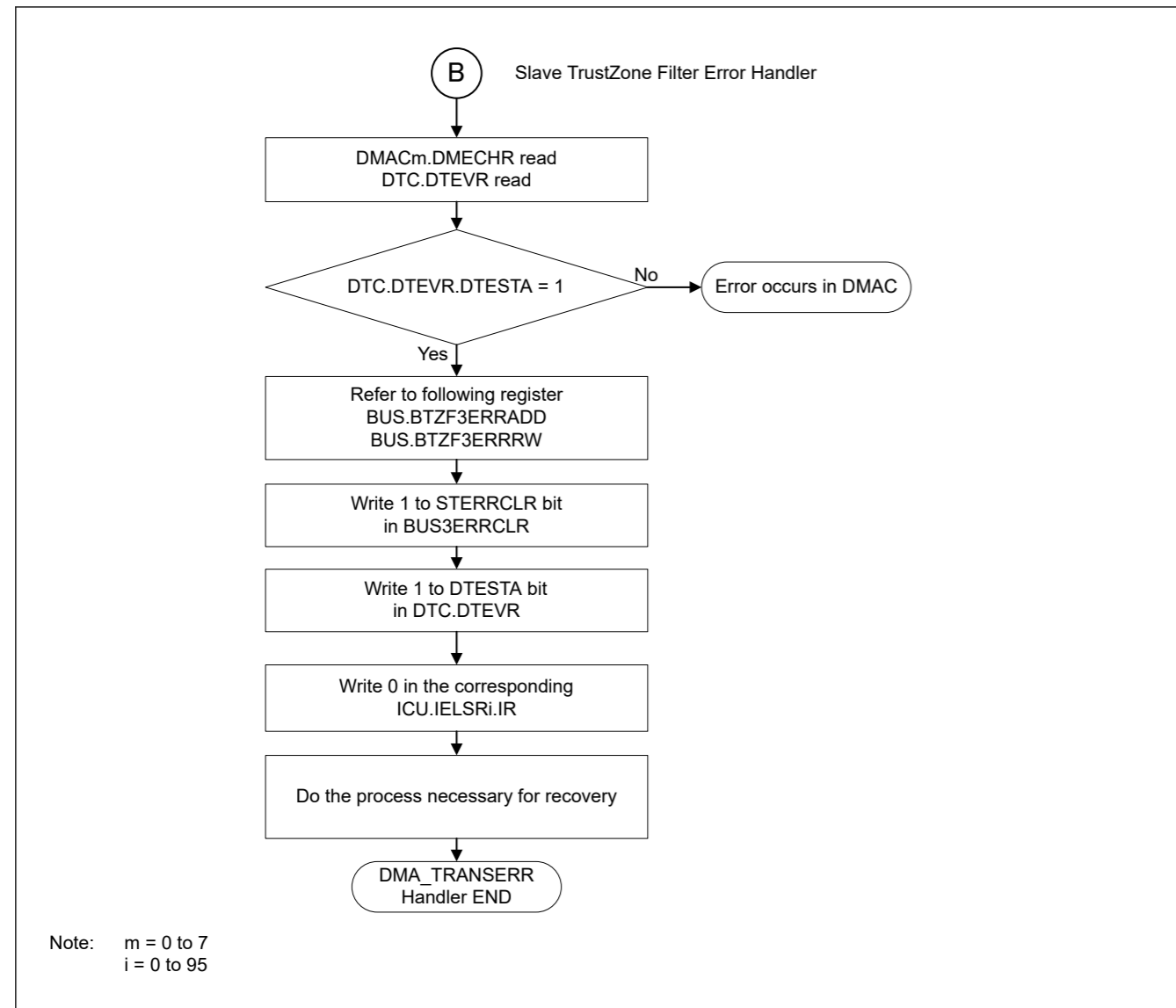


Figure 17.19 Processing in DMA\_TRANSERR handler by Slave TrustZone Filter Error

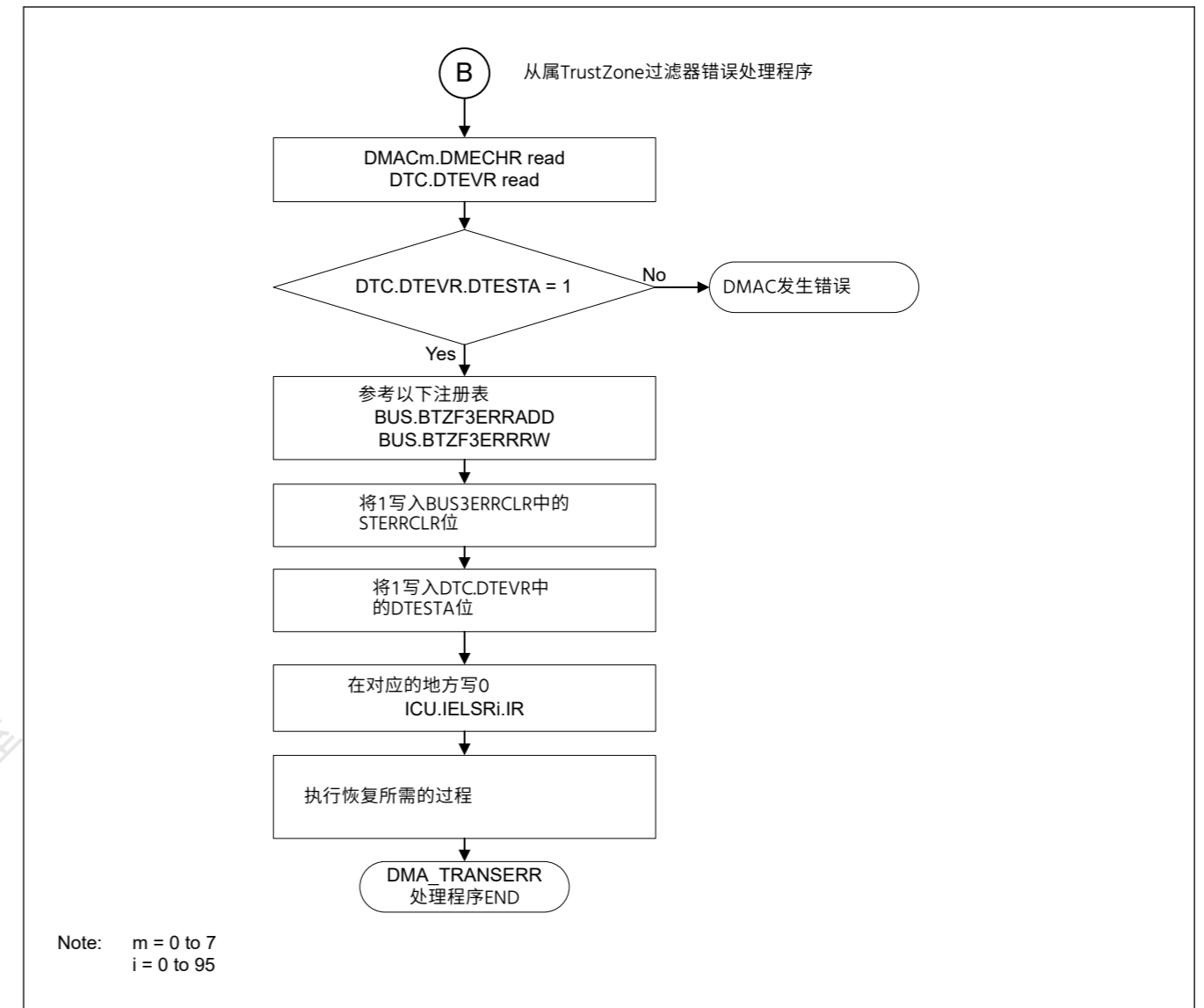


Figure 17.19 从站TrustZone过滤器错误在DMA\_TRANSERR处理程序中的处理

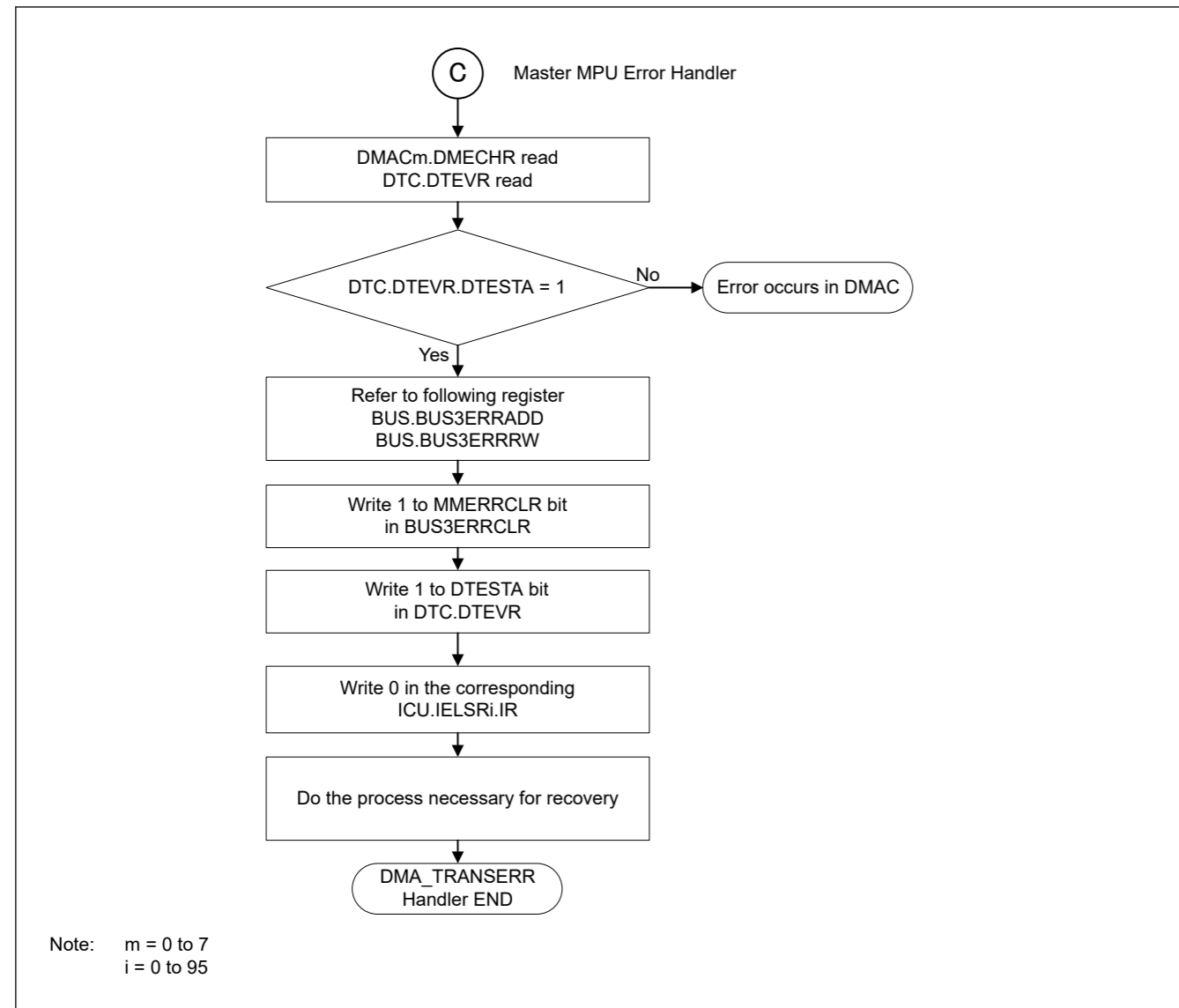


Figure 17.20 Processing in DMA\_TRANSERR handler by Master MPU Error

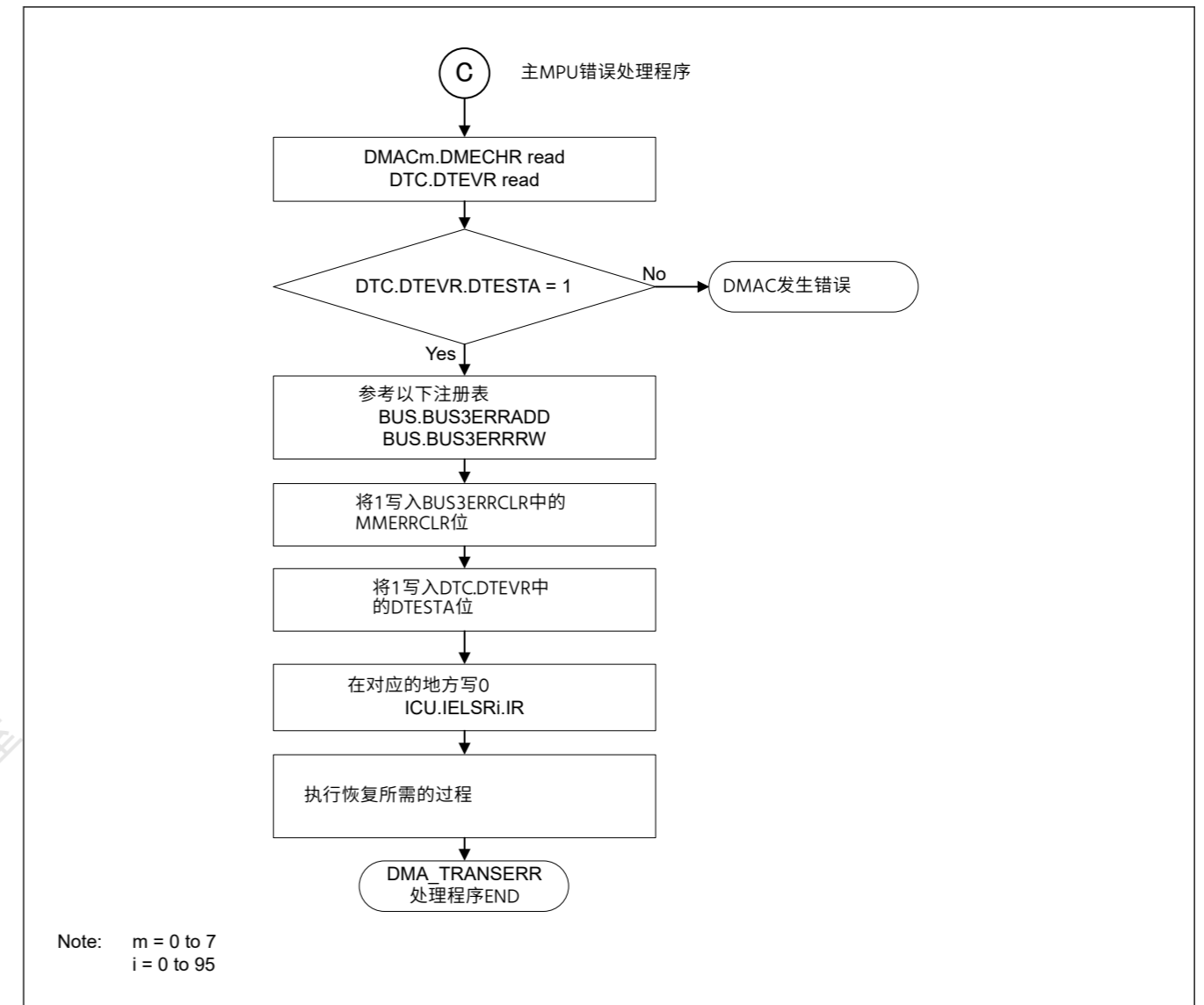


Figure 17.20 主MPU错误在DMA\_TRANSERR处理程序中的处理

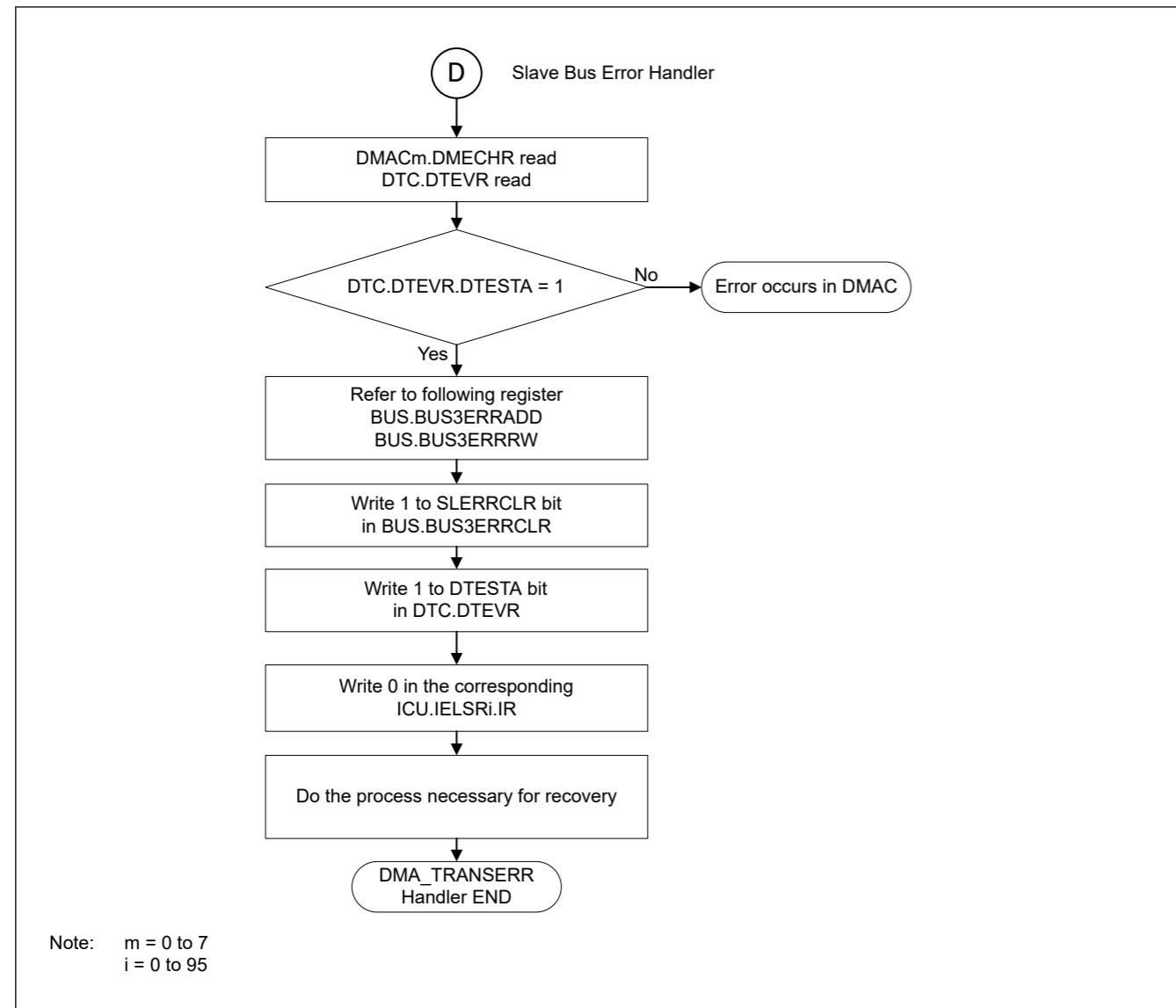


Figure 17.21 Processing in DMA\_TRANSERR handler by Slave Bus Error

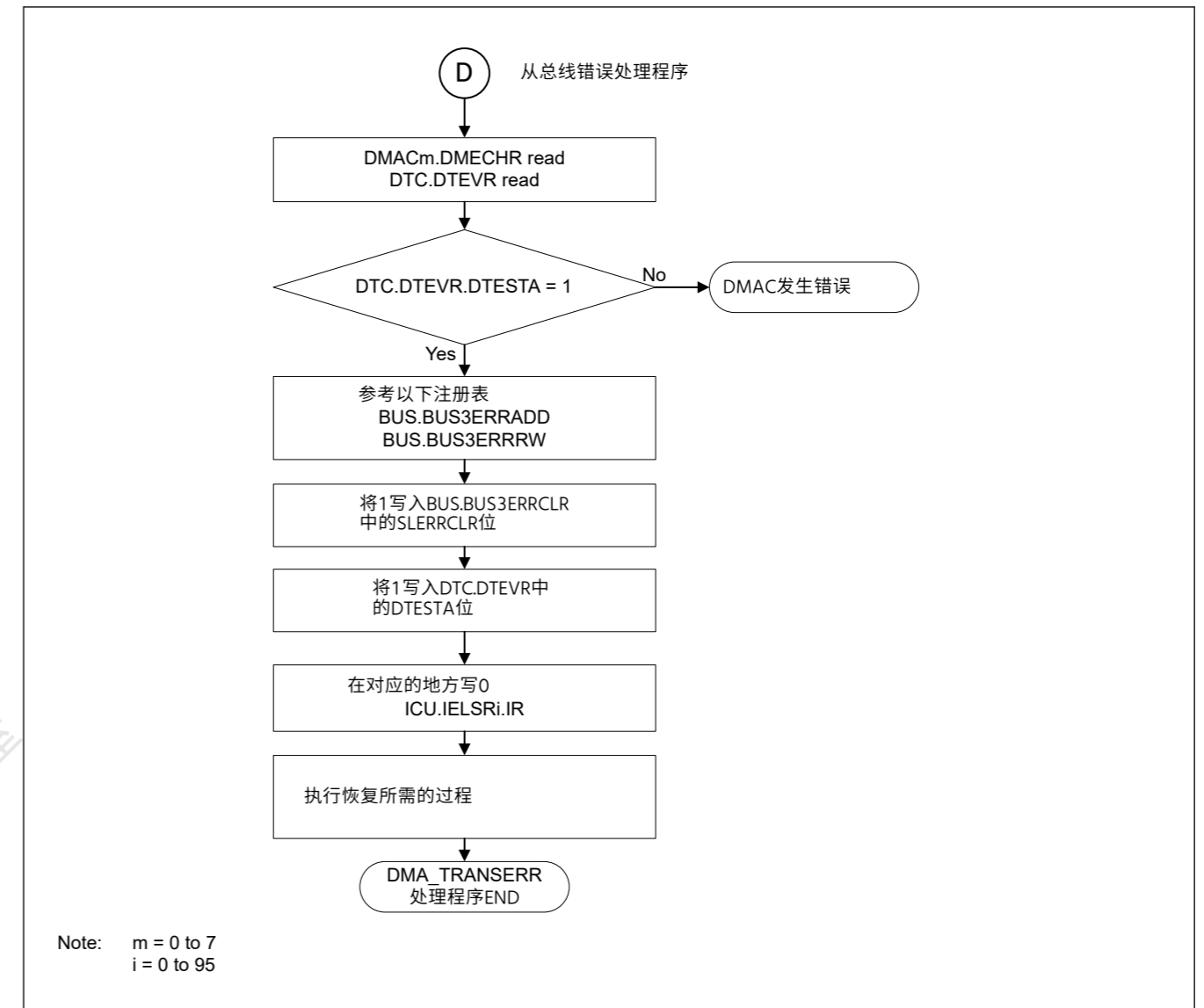


Figure 17.21 从总线错误在DMA\_TRANSERR处理程序中的处理



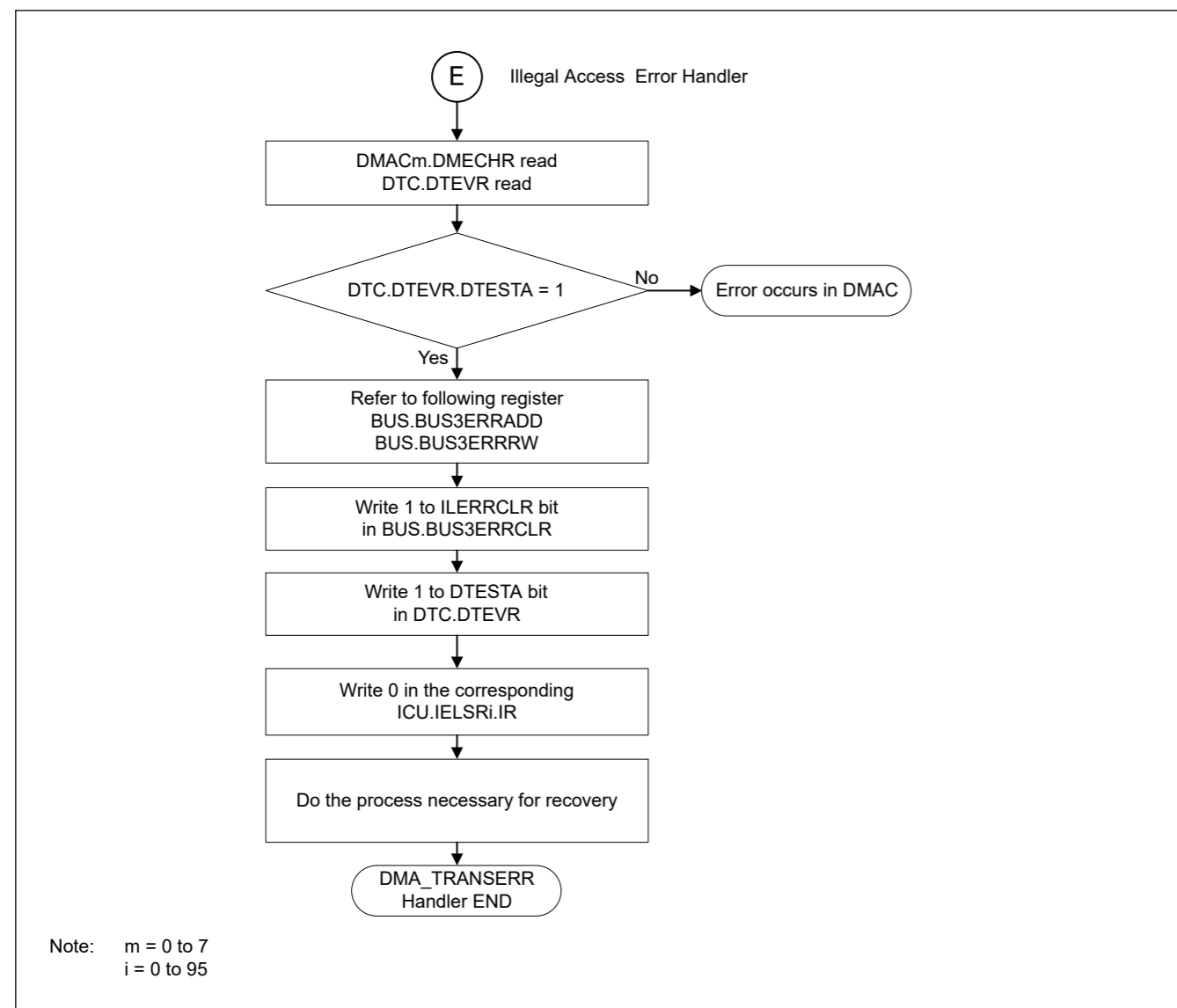


Figure 17.22 Processing in DMA\_TRANSERR handler by Illegal Access Error

## 17.8 Interrupt

### 17.8.1 Interrupt Request of Transfer End

When the DTC completes data transfer of the specified count or when data transfer with MRB.DISEL set to 1 is complete, a DTC activation source generates an interrupt to the CPU. Two types of interrupt are available: interrupts triggered by a DTC activation (per channel) and an interrupt triggered by the event signal DTC\_COMPLETE (common to all channels).

Interrupts to the CPU are controlled according to the settings in the NVIC and the ICU.IELSRn.IELS[8:0] bits. See [section 13, Interrupt Controller Unit \(ICU\)](#). The DTC prioritizes activation sources by granting the smaller interrupt vector numbers higher priority. The priority of interrupts to the CPU is determined by the NVIC priority.

### 17.8.2 Interrupt Request of Transfer Error

The error response detection interrupt request (DMA\_TRANSERR) is generated from the DMAC/DTC when the transfer error is detected during DTC transfer. The types of interrupts that occur when the DTC transfer error occurs are listed in [Table 17.10](#). The [Table 17.10](#) also shows error information stored when a transfer error occurs.

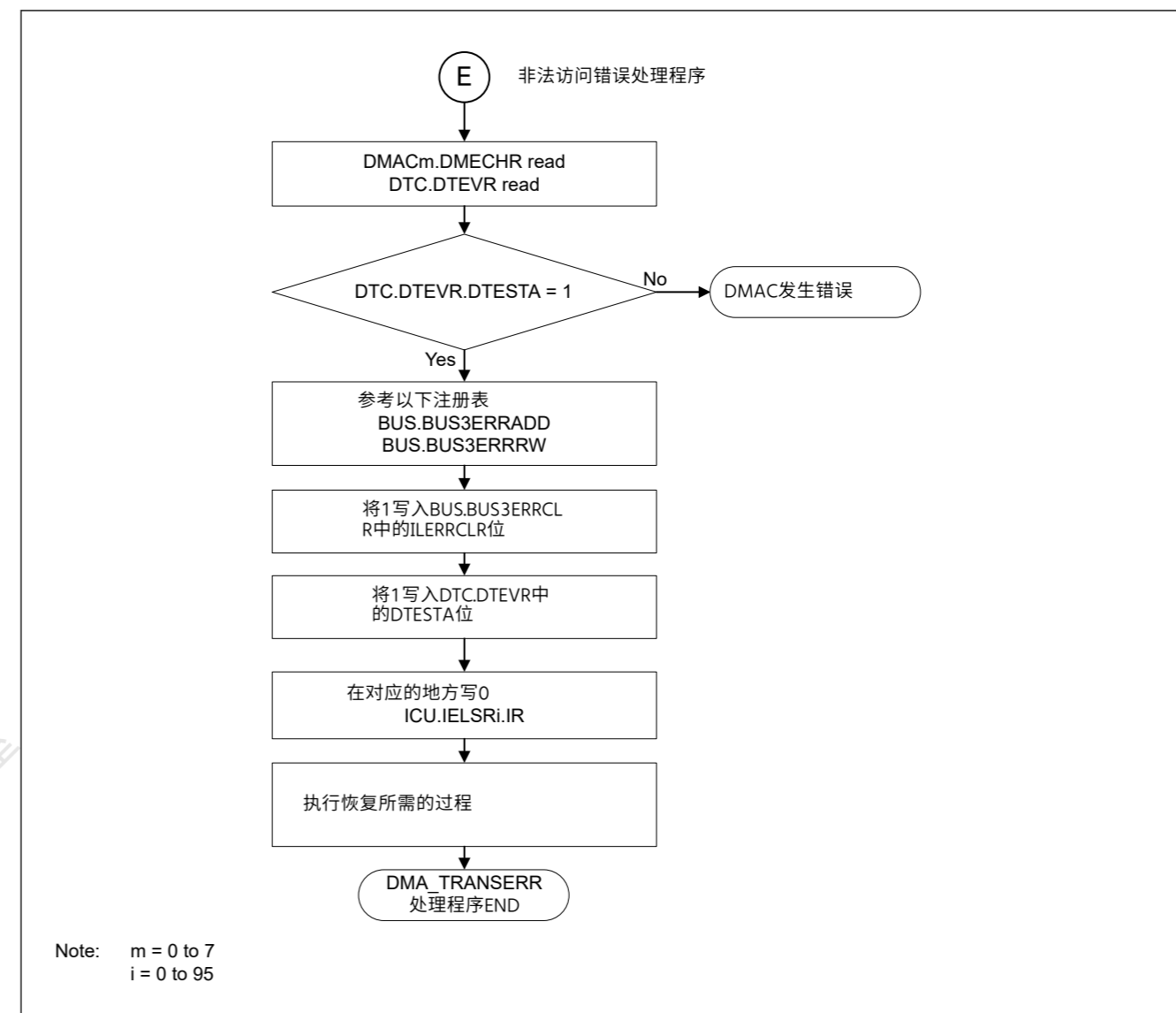


Figure 17.22 非法访问错误在DMA\_TRANSERR处理程序中的处理

## 17.8 Interrupt

### 17.8.1 传输结束中断请求

当DTC完成指定计数的数据传输或MRB.DISEL设置为1的数据传输完成时，DTC激活源向CPU生成中断。有两种类型的中断可用：由DTC激活触发的中断（每个通道）和由事件信号DTC\_COMPLETE触发的中断（所有通道通用）。CPU的中断根据NVIC和ICU.IELSRn.IELS[8:0]位中的设置进行控制。请参阅第13节，中断控制器单元(ICU)。DTC通过授予较小的中断向量编号较高的优先级来确定激活源的优先级。CPU中断的优先级由NVIC优先级决定。

### 17.8.2 传输错误中断请求

在DTC传输期间检测到传输错误时，从DMAC/DTC生成错误响应检测中断请求(DMA\_TRANSERR)。发生DTC传输错误时发生的中断类型在表17.10中列出。表17.10还显示了发生传输错误时存储的错误信息。

Table 17.10 Interrupt and error information due to DMAC transfer error cause

| Transfer error factor                 | NMI/RESET <sup>1</sup> Request | Interrupt Request | Bus Error Status                              | Error Address Error R/W           | Error Channel Information |
|---------------------------------------|--------------------------------|-------------------|---|-----------------------------------|---------------------------|
| Master TrustZone Filter (in DMAC/DTC) | ICU.NMISR.TZFST <sup>1</sup>   | DMA_TRANSERR      | BUS.DMACDTCERR<br>STAT.MTERRSTAT <sup>1</sup> | —                                 | DTC.DTEVR                 |
| Slave TrustZone Filter                | ICU.NMISR.TZFST <sup>1</sup>   | DMA_TRANSERR      | BUS.BUS3ERRSTAT<br>.STERRSTAT <sup>1</sup>    | BUS.BTZF3ERRADD<br>BUS.BTZF3ERRRW | DTC.DTEVR                 |
| Master MPU                            | ICU.NMISR.<br>BUSMST           | DMA_TRANSERR      | BUS.BUS3ERRSTAT<br>.MMERRSTAT                 | BUS.BUS3ERRADD<br>BUS.BUS3ERRRW   | DTC.DTEVR                 |
| Slave Bus Error                       | — <sup>2</sup>                 | DMA_TRANSERR      | BUS.BUS3ERRSTAT<br>.SLERRSTAT <sup>2</sup>    | BUS.BUS3ERRADD<br>BUS.BUS3ERRRW   | DTC.DTEVR                 |
| Illegal Access Error                  | — <sup>2</sup>                 | DMA_TRANSERR      | BUS.BUS3ERRSTAT<br>.ILERRSTAT <sup>2</sup>    | BUS.BUS3ERRADD<br>BUS.BUS3ERRRW   | DTC.DTEVR                 |

Note 1. Interrupt generated, when NMI request selected as the operation after detection of the Master MPU error and The TrustZone Filter error. By confirming BUS.BUS3ERRSTAT and BUS.DMACDTCERRSTAT, judge whether it is the Master or the Slave.

Note 2. If the error response detection interrupt (DMA\_TRANSERR) occurs and NMI of the Master MPU or NMI of the TrustZone Filter has not occurred, treat it as the Illegal address access error or the Slave Bus Error. It can be judged also by BUS.BUS3ERRSTAT and BUS.DMACDTCERRSTAT.

Note that if the bus error occurs when writing the last data of transfer, the transfer end event and the error response detection interrupt (DMA\_TRANSERR) occurs.

## 17.9 Event Link

The DTC can produce an event link request on completion of one transfer request.

## 17.10 Low Power Consumption Function

Before transitioning to the module-stop function, Software Standby mode without Snooze mode transition, deep software standby mode, set the DTCST.DTCST bit to 0, and then perform the operations described in the following sections. The DTC is available in Snooze mode by setting the SYSTEM.SNZCR.SNZDTCEN bit to 1. See [section 10, Low Power Modes](#).

### (1) Module-stop function

Writing 1 to the MSTPCRA.MSTPA22 bit enables the module-stop function of the DTC. If the DTC transfer is in progress at the time, 1 is written to the MSTPCRA.MSTPA22 bit. The transition to the module-stop state proceeds after DTC transfer ends. While the MSTPCRA.MSTPA22 bit is 1, accessing the DTC registers is prohibited. Writing 0 to the MSTPCRA.MSTPA22 bit releases the DTC from the module-stop state.

### (2) Software Standby mode, deep software standby mode

Use the settings described in [section 10.7.1. Transitioning to Software Standby Mode](#) or [section 10.9.1. Transitioning to Deep Software Standby Mode](#).

If DTC transfer operations are in progress when the WFI instruction is executed, the transition to Software Standby mode or deep software standby mode follows the completion of the DTC transfer.

### (3) Snooze Mode

When the snooze control circuit receives a snooze request in Software Standby mode, the MCU transfers to Snooze mode. See [section 10.8.1. Transition to Snooze Mode](#). DTC operation in Snooze mode can be selected in the SYSTEM.SNZCR.SNZDTCEN bit. If DTC operation is enabled in Snooze mode, before transitioning to Software Standby mode, set the DTCST.DTCST bit to 1. To return to Software Standby mode through DTC, set SYSTEM.SNZEDCR0.DTCZRED or SYSTEM.SNZEDCR0.DTCNZRED to 1. See [section 10.8.3. Returning from Snooze Mode to Software Standby Mode](#). SYSTEM.SNZEDCR0.DTCZRED enables or disables a snooze end request on completion of the last DTC transmission, detected on DTC transmission completion when CRA and CRB are 0. SYSTEM.SNZEDCR0.DTCNZRED enables or disables a snooze end request on a not last DTC transmission completion (CRA and CRB are not 0), detected on DTC transmission completion when CRA and CRB are not 0. The DTC activation request from the ICU is stopped during Software Standby mode but not stopped during Snooze mode.

Table 17.10 由于DMAC传输错误原因导致的中断和错误信息

| 传递误差因子                                | NMI/RESET <sup>1</sup> Request | 中断请求         | 总线错误状态  | 错误地址 Error R/W                    | 错误通道 Information |
|---------------------------------------|--------------------------------|--------------|---|-----------------------------------|------------------|
| Master TrustZone Filter (in DMAC/DTC) | ICU.NMISR.TZFST <sup>1</sup>   | DMA_TRANSERR | BUS.DMACDTCERR<br>STAT.MTERRSTAT <sup>1</sup> | —                                 | DTC.DTEVR        |
| Slave TrustZone Filter                | ICU.NMISR.TZFST <sup>1</sup>   | DMA_TRANSERR | BUS.BUS3ERRSTAT<br>.STERRSTAT <sup>1</sup>    | BUS.BTZF3ERRADD<br>BUS.BTZF3ERRRW | DTC.DTEVR        |
| Master MPU                            | ICU.NMISR.<br>BUSMST           | DMA_TRANSERR | BUS.BUS3ERRSTAT<br>.MMERRSTAT                 | BUS.BUS3ERRADD<br>BUS.BUS3ERRRW   | DTC.DTEVR        |
| 从总线错误                                 | — <sup>2</sup>                 | DMA_TRANSERR | BUS.BUS3ERRSTAT<br>.SLERRSTAT <sup>2</sup>    | BUS.BUS3ERRADD<br>BUS.BUS3ERRRW   | DTC.DTEVR        |
| 非法访问错误                                | — <sup>2</sup>                 | DMA_TRANSERR | BUS.BUS3ERRSTAT<br>.ILERRSTAT <sup>2</sup>    | BUS.BUS3ERRADD<br>BUS.BUS3ERRRW   | DTC.DTEVR        |

注意1.中断,当NMI请求在检测主MPU错误和Trustzone滤波器错误后选择为操作时中断。通过确认BUS.BUS3ERRSTAT和BUS.DMACDTCERRSTAT,判断是Master还是Slave。

注2.如果错误响应检测中断(DMA\_TRANSERR)发生且MasterMPU的NMI或TrustZoneFilter的NMI未发生,则将其视为Illegaladdressaccesserror或SlaveBusError。也可以通过BUS.BUS3ERRSTAT和BUS来判断。DMACDTCERRSTAT。

请注意,如果在写入传输的最后一个数据时发生总线错误,则会发生传输结束事件和错误响应检测中断(DMA\_TRANSERR)。

## 17.9 活动链接

DTC可以在一个传输请求完成时产生一个事件链接请求。

## 17.10 低功耗功能

在转换到模块停止功能、没有贪睡模式转换的软件待机模式、深度软件待机模式之前,将DTCST.DTCST位设置为0,然后执行以下部分中描述的操作。通过将SYSTEM.SNZCR.SNZDTCEN位设置为1,可以在贪睡模式下使用DTC。请参阅第10节,低功耗Modes。

### (1) Module-stop function

向MSTPCRA.MSTPA22位写入1可启用DTC的模块停止功能。如果此时DTC传输正在进行,则将1写入MSTPCRA.MSTPA22位。在DTC传输结束后继续向模块停止状态的转换。当MSTPCRA.MSTPA22位为1时,禁止访问DTC寄存器。将0写入MSTPCRA.MSTPA22位可将DTC从模块停止状态释放。

### (2) 软件待机模式,深度软件待机模式

使用第10.7.1节中描述的设置。转换到软件待机模式或第10.9.1节。过渡到深度软件待机模式。

如果在执行WFI指令时DTC传输操作正在进行,则在DTC传输完成后转换到软件待机模式或深度软件待机模式。

### (3) 贪睡模式

当贪睡控制电路在软件待机模式下接收到贪睡请求时,MCU转入贪睡模式。请参阅第10.8.1节。过渡到贪睡模式。贪睡模式下的DTC操作可以在

SYSTEM.SNZCR.SNZDTCEN位。如果在贪睡模式下启用DTC操作,则在转换到软件待机模式之前,将DTCST.DTCST位设置为1。要通过DTC返回到软件待机模式,请将SYSTEM.SNZEDCR0.DTCZRED或SYSTEM.SNZEDCR0.DTCNZRED设置为1。请参阅第10.8.3节。从贪睡回来

模式到软件待机模式。SYSTEM.SNZEDCR0.DTCZRED在最后一次DTC传输完成时启用或禁用贪睡结束请求,当CRA和CRB为0时在DTC传输完成时检测到。SYSTEM.SNZEDCR0.DTCNZRED在非最后一次DTC传输时启用或禁用贪睡结束请求完成(CRA和CRB不为0),当CRA和CRB不为0时,在DTC传输完成时检测到。来自ICU的DTC激活请求在软件待机模式期间停止,但在贪睡模式期间不停止。

#### (4) Notes on Low Power Consumption Function

For the WFI instruction and the register setting procedure, see [section 10, Low Power Modes](#).

To perform a DTC transfer after returning from a low power mode without a Snooze mode transition, set the DTCST.DTCST bit to 1 again.

To use a request that is generated in Software Standby mode as an interrupt request to the CPU but not as a DTC activation request, specify the CPU as the interrupt request destination as described in [section 13.4.1. Detecting Interrupts](#), then execute the WFI instruction. If DTC operation is enabled in Snooze mode, do not use the module-stop function of the DTC.

### 17.11 Usage Notes

#### 17.11.1 Transfer Information Start Address

You must set multiples of 4 for the transfer information start addresses in the vector table. Otherwise, such addresses are accessed with their lowest 2 bits regarded as 00b.

#### (4) 低功耗功能注意事项

关于WFI指令和寄存器设置过程，请参见第10节，低功耗模式。

要在从低功耗模式返回后执行DTC传输而不进行贪睡模式转换，请将DTCST.DTCST位再次为1。

要将在软件待机模式下生成的请求用作对CPU的中断请求，而不是用作DTC激活请求，请按照第13.4.1节中的说明将CPU指定为中断请求目标。检测中断，然后执行WFI指令。如果在贪睡模式下启用DTC操作，请勿使用DTC的模块停止功能。

### 17.11 使用说明

#### 17.11.1 传输信息起始地址

您必须为向量表中的传输信息起始地址设置4的倍数。否则，这些地址的最低2位被视为00b。

## 18. Event Link Controller (ELC)

### 18.1 Overview

The Event Link Controller (ELC) uses the event requests generated by various peripheral modules as source signals to connect them to different modules, allowing direct link between the modules without CPU intervention.

Table 18.1 lists the ELC specifications, and Figure 18.1 shows a block diagram.

**Table 18.1 ELC Specifications**

| Item                 | Description  |
|----------------------|--|
| Event link function  | 174 types of event signals can be directly connected to modules. The ELC generates the ELC event signal, and events that activate the DTC. |
| Module-stop function | Module-stop state can be set.  |
| TrustZone Filter     | Security attribution can be set for each registers   |

## 18. 事件链接控制器(ELC)

### 18.1 Overview

EventLinkController(ELC)使用各种外围模块产生的事件请求作为源信号，将它们连接到不同的模块，允许模块之间直接链接，无需CPU干预。

表18.1列出了ELC规范，图18.1显示了框图。

**Table 18.1 ELC Specifications**

| Item                 | Description                              |
|----------------------|--|
| 事件链接功能               | 174种事件信号可以直接连接到模块。ELC生成ELC事件信号和激活DTC的事件。 |
| Module-stop function | 可设置模块停止状态。                               |
| TrustZone Filter     | 可以为每个寄存器设置安全属性                           |

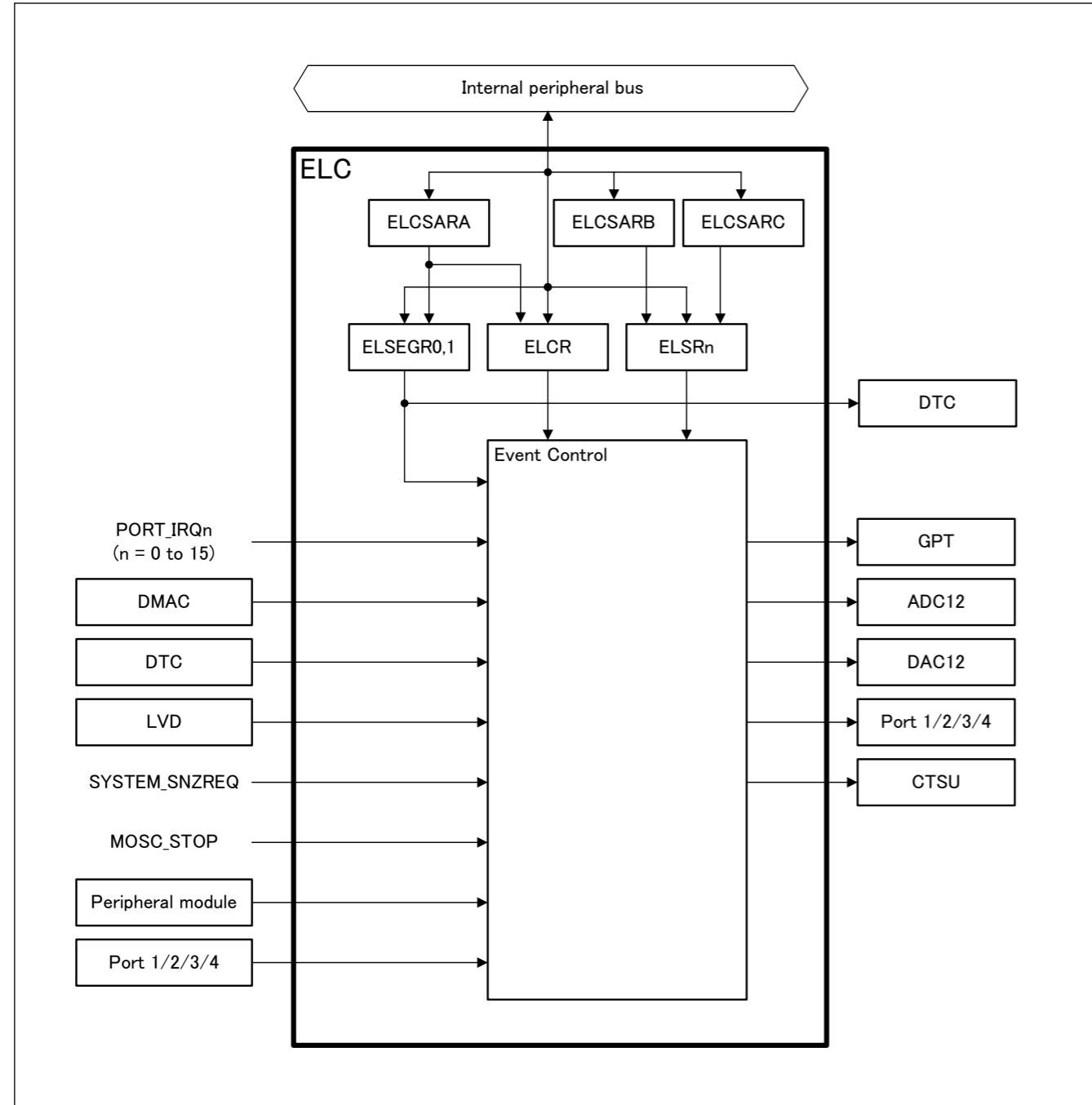


Figure 18.1 ELC block diagram

18.2 Register Descriptions

18.2.1 ELCR : Event Link Controller Register

Base address: ELC = 0x4008\_2000

Offset address: 0x00

|                    |           |   |   |   |   |   |   |   |
|--------------------|-----------|---|---|---|---|---|---|---|
| Bit position:      | 7         | 6 | 5 | 4 | 3 | 2 | 1 | 0 |
| Bit field:         | ELCO<br>N | — | — | — | — | — | — | — |
| Value after reset: | 0         | 0 | 0 | 0 | 0 | 0 | 0 | 0 |

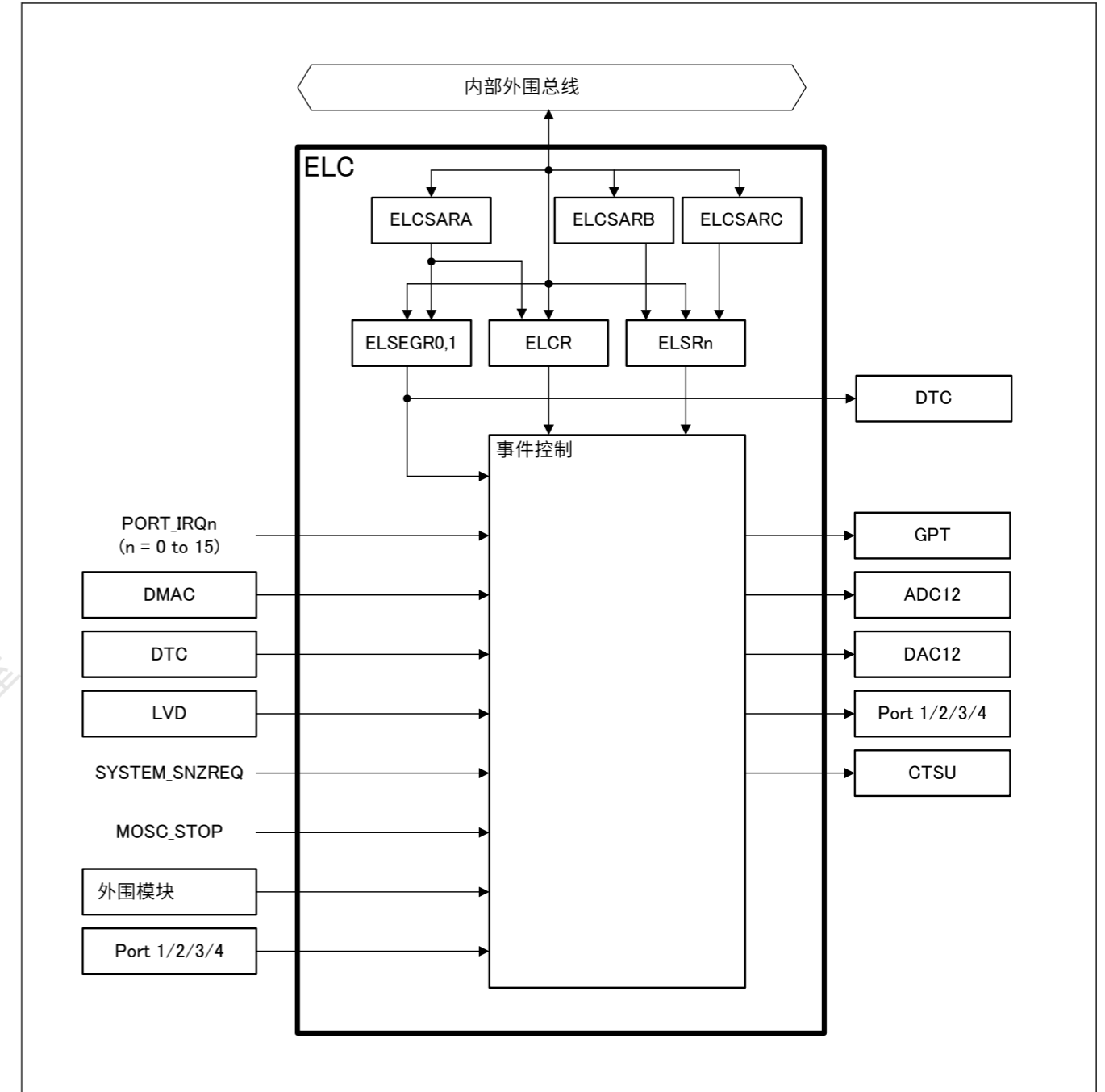


Figure 18.1 ELC框图

18.2 注册说明

18.2.1 ELCR:事件链接控制器寄存器

Base address: ELC = 0x4008\_2000

Offset address: 0x00

|               |           |   |   |   |   |   |   |   |
|---------------|-----------|---|---|---|---|---|---|---|
| Bit position: | 7         | 6 | 5 | 4 | 3 | 2 | 1 | 0 |
| Bit field:    | ELCO<br>N | — | — | — | — | — | — | — |
| 重置后的值:        | 0         | 0 | 0 | 0 | 0 | 0 | 0 | 0 |



| Bit | Symbol | Function   | R/W |
|-----|--------|--|-----|
| 6:0 | —      | These bits are read as 0. The write value should be 0.                               | R/W |
| 7   | ELCON  | All Event Link Enable<br>0: ELC function is disabled.<br>1: ELC function is enabled. | R/W |

Note: If the security attribution is configured as secure:

- Secure access and Non-secure read access are allowed
- Non-secure write access is ignored, and TrustZone access error is not generated.

If the security attribution is configured as Non-secure:

- Secure and Non-secure access are allowed.

The ELCR register controls the ELC operation.

### 18.2.2 ELSEGRn : Event Link Software Event Generation Register n (n = 0, 1)

Base address: ELC = 0x4008\_2000

Offset address: 0x02 + 0x02 × n

| Bit position:      | 7  | 6  | 5 | 4 | 3 | 2 | 1 | 0   |
|--------------------|----|----|---|---|---|---|---|-----|
| Bit field:         | WI | WE | — | — | — | — | — | SEG |
| Value after reset: | 1  | 0  | 0 | 0 | 0 | 0 | 0 | 0   |

| Bit | Symbol | Function   | R/W |
|-----|--------|--|-----|
| 0   | SEG    | Software Event Generation<br>0: Normal operation<br>1: Software event is generated.                            | W   |
| 5:1 | —      | These bits are read as 0. The write value should be 0.   | R/W |
| 6   | WE     | SEG Bit Write Enable<br>0: Write to SEG bit disabled.<br>1: Write to SEG bit enabled.                          | R/W |
| 7   | WI     | ELSEGR Register Write Disable<br>0: Write to ELSEGR register enabled.<br>1: Write to ELSEGR register disabled. | W   |

Note: If the security attribution is configured as secure:

- Secure access and Non-secure read access are allowed
- Non-secure write access is ignored, and TrustZone access error is not generated.

If the security attribution is configured as Non-secure:

- Secure and Non-secure access are allowed.

#### SEG bit (Software Event Generation)

When 1 is written to the SEG bit while the WE bit is 1, a software event is generated. This bit is read as 0. Even when 1 is written to this bit, data is not stored. The WE bit must be set to 1 before writing to this bit.

A software event can trigger a linked DTC event.

#### WE bit (SEG Bit Write Enable)

The SEG bit can only be written to when the WE bit is 1. Clear the WI bit to 0 before writing to this bit.

[Setting condition]

- If 1 is written to this bit while the WI bit is 0, this bit becomes 1.

[Clearing condition]

- If 0 is written to this bit while the WI bit is 0, this bit becomes 0.

#### WI bit (ELSEGR Register Write Disable)

The ELSEGR register can only be written to when the write value to the WI bit is 0. This bit is read as 1. Before setting the WE or SEG bit, the WI bit must be set to 0.

| Bit | Symbol | Function                           | R/W |
|-----|--------|------------------------------------|-----|
| 6:0 | —      | 这些位被读取为0。写入值应为0。                   | R/W |
| 7   | ELCON  | 所有事件链接启用<br>0: ELC功能关闭。1: ELC功能使能。 | R/W |

Note: 如果安全属性配置为安全: ●

- 允许安全访问和非安全读取访问
- 忽略非安全写入访问, 不会生成TrustZone访问错误。

如果安全属性配置为非安全: ●

- 允许安全和非安全访问。

ELCR寄存器控制ELC操作。

### 18.2.2 ELSEGRn:事件链接软件事件生成寄存器n(n=0 1)

Base address: ELC = 0x4008\_2000

Offset address: 0x02 + 0x02 × n

| Bit position: | 7  | 6  | 5 | 4 | 3 | 2 | 1 | 0   |
|---------------|----|----|---|---|---|---|---|-----|
| Bit field:    | WI | WE | — | — | — | — | — | SEG |
| 重置后的值:        | 1  | 0  | 0 | 0 | 0 | 0 | 0 | 0   |

| Bit | Symbol | Function  | R/W |
|-----|--------|---|-----|
| 0   | SEG    | 软件事件生成<br>0: 正常操作1: 产生软件事件。                         | W   |
| 5:1 | —      | 这些位被读取为0。写入值应为0。                                    | R/W |
| 6   | WE     | SEG位写使能<br>0: 禁止写入SEG位。1: 写入SEG位使能。                 | R/W |
| 7   | WI     | ELSEGR寄存器写入禁用<br>0: 允许写入ELSEGR寄存器。1: 禁止写入ELSEGR寄存器。 | W   |

Note: 如果安全属性配置为安全: ●

- 允许安全访问和非安全读取访问
- 忽略非安全写入访问, 不会生成TrustZone访问错误。

如果安全属性配置为非安全: ●

- 允许安全和非安全访问。

#### SEG位 (软件事件生成)

当WE位为1时向SEG位写入1时, 将产生软件事件。该位被读取为0。即使向该位写入1, 也不存储数据。在写入该位之前, WE位必须设置为1。

软件事件可以触发链接的DTC事件。

#### WE位 (SEG位写使能)

SEG位只能在WE位为1时写入。在写入该位之前将WI位清零。

[Setting condition]

- 如果在WI位为0时向该位写入1, 则该位变为1。

[Clearing condition]

- 如果在WI位为0时向该位写入0, 则该位变为0。

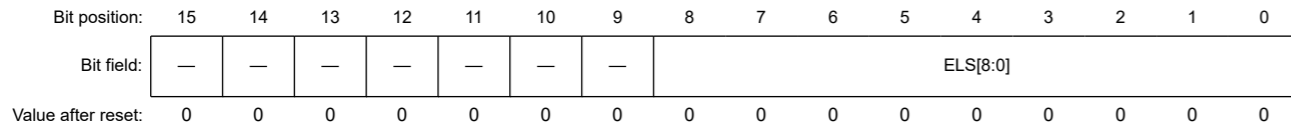
#### WI位 (ELSEGR寄存器写入禁止)

只有当WI位的写入值为0时, 才能写入ELSEGR寄存器。该位读为1。在设置之前WE或SEG位, WI位必须设置为0。

18.2.3 ELSRn : Event Link Setting Register n (n = 0 to 18)

Base address: ELC = 0x4008\_2000

Offset address: 0x10 + 0x04 × n



| Bit  | Symbol   | Function   | R/W |
|------|----------|--|-----|
| 8:0  | ELS[8:0] | Event Link Select<br>0x000: Event output disabled for the associated peripheral module<br>0x001: Number setting for the event signal to be linked<br>⋮<br>0x1DB: Number setting for the event signal to be linked<br>Others: Settings prohibited | R/W |
| 15:9 | —        | These bits are read as 0. The write value should be 0.   | R/W |

Note: If the security attribution is configured as secure:

- Secure access and Non-secure read access are allowed
- Non-secure write access is ignored, and TrustZone access error is not generated.

If the security attribution is configured as Non-secure:

- Secure and Non-secure access are allowed.

The ELSRn register specifies an event signal to be linked to each peripheral module. Table 18.2 shows the association between the ELSRn register and the peripheral modules. Table 18.3 shows the association between the event signal names set in the ELSRn register and the signal numbers.

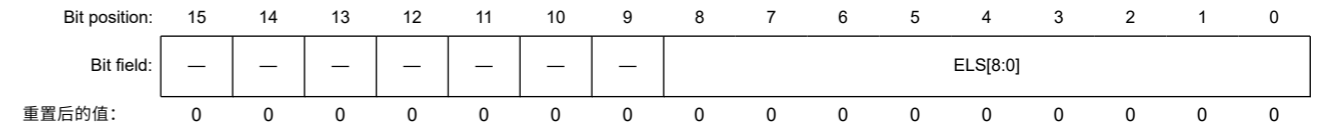
Table 18.2 Association between the ELSRn registers and peripheral functions

| Register name | Peripheral function (module) | Event name |
|---------------|------------------------------|------------|
| ELSR0         | GPT (A)                      | ELC_GPTA   |
| ELSR1         | GPT (B)                      | ELC_GPTB   |
| ELSR2         | GPT (C)                      | ELC_GPTC   |
| ELSR3         | GPT (D)                      | ELC_GPTD   |
| ELSR4         | GPT (E)                      | ELC_GPTE   |
| ELSR5         | GPT (F)                      | ELC_GPTF   |
| ELSR6         | GPT (G)                      | ELC_GPTG   |
| ELSR7         | GPT (H)                      | ELC_GPTH   |
| ELSR8         | ADC12A0                      | ELC_AD00   |
| ELSR9         | ADC12B0                      | ELC_AD01   |
| ELSR10        | ADC12A1                      | ELC_AD10   |
| ELSR11        | ADC12B1                      | ELC_AD11   |
| ELSR12        | DAC12 channel 0              | ELC_DA0    |
| ELSR13        | DAC12 channel 1              | ELC_DA1    |
| ELSR14        | PORT 1                       | ELC_PORT1  |
| ELSR15        | PORT 2                       | ELC_PORT2  |
| ELSR16        | PORT 3                       | ELC_PORT3  |
| ELSR17        | PORT 4                       | ELC_PORT4  |
| ELSR18        | CTSU                         | ELC_CTSU   |

18.2.3 ELSRn: 事件链接设置寄存器n (n=0到18)

Base address: ELC = 0x4008\_2000

Offset address: 0x10 + 0x04 × n



| Bit  | Symbol   | Function  | R/W |
|------|----------|---|-----|
| 8:0  | ELS[8:0] | 活动链接选择<br>0x000: 相关外围模块的事件输出禁用<br>0x001: 要链接的事件信号的编号设置<br>⋮<br>0x1DB: 要联动的事件信号的编号设置其他: 禁止设置 | R/W |
| 15:9 | —        | 这些位被读取为0。写入值应为0。  | R/W |

Note: 如果安全属性配置为安全: ●

- 允许安全访问和非安全读取访问
- 忽略非安全写入访问, 不会生成TrustZone访问错误。

如果安全属性配置为非安全: ●

- 允许安全和非安全访问。

ELSRn寄存器指定要链接到每个外围模块的事件信号。表18.2显示了ELSRn寄存器和外围模块之间的关联。表18.3显示了在ELSRn寄存器中设置的事件信号名称和信号编号之间的关联。

Table 18.2 ELSRn寄存器和外设功能之间的关联

| 注册名称   | 外设功能 (模块)       | 活动名称      |
|--------|-----------------|-----------|
| ELSR0  | GPT (A)         | ELC_GPTA  |
| ELSR1  | GPT (B)         | ELC_GPTB  |
| ELSR2  | GPT (C)         | ELC_GPTC  |
| ELSR3  | GPT (D)         | ELC_GPTD  |
| ELSR4  | GPT (E)         | ELC_GPTE  |
| ELSR5  | GPT (F)         | ELC_GPTF  |
| ELSR6  | GPT (G)         | ELC_GPTG  |
| ELSR7  | GPT (H)         | ELC_GPTH  |
| ELSR8  | ADC12A0         | ELC_AD00  |
| ELSR9  | ADC12B0         | ELC_AD01  |
| ELSR10 | ADC12A1         | ELC_AD10  |
| ELSR11 | ADC12B1         | ELC_AD11  |
| ELSR12 | DAC12 channel 0 | ELC_DA0   |
| ELSR13 | DAC12 channel 1 | ELC_DA1   |
| ELSR14 | PORT 1          | ELC_PORT1 |
| ELSR15 | PORT 2          | ELC_PORT2 |
| ELSR16 | PORT 3          | ELC_PORT3 |
| ELSR17 | PORT 4          | ELC_PORT4 |
| ELSR18 | CTSU            | ELC_CTSU  |

Table 18.3 Association between event signal names set in ELSRn.ELS[8:0] bits and signal numbers (1 of 5)

| Event number | Interrupt request source | Name                          | Description                 |
|--------------|--------------------------|-------------------------------|-----------------------------|
| 0x001        | Port                     | PORT_IRQ0 <sup>*1</sup>       | External pin interrupt 0    |
| 0x002        |                          | PORT_IRQ1 <sup>*1</sup>       | External pin interrupt 1    |
| 0x003        |                          | PORT_IRQ2 <sup>*1</sup>       | External pin interrupt 2    |
| 0x004        |                          | PORT_IRQ3 <sup>*1</sup>       | External pin interrupt 3    |
| 0x005        |                          | PORT_IRQ4 <sup>*1</sup>       | External pin interrupt 4    |
| 0x006        |                          | PORT_IRQ5 <sup>*1</sup>       | External pin interrupt 5    |
| 0x007        |                          | PORT_IRQ6 <sup>*1</sup>       | External pin interrupt 6    |
| 0x008        |                          | PORT_IRQ7 <sup>*1</sup>       | External pin interrupt 7    |
| 0x009        |                          | PORT_IRQ8 <sup>*1</sup>       | External pin interrupt 8    |
| 0x00A        |                          | PORT_IRQ9 <sup>*1</sup>       | External pin interrupt 9    |
| 0x00B        |                          | PORT_IRQ10 <sup>*1</sup>      | External pin interrupt 10   |
| 0x00C        |                          | PORT_IRQ11 <sup>*1</sup>      | External pin interrupt 11   |
| 0x00D        |                          | PORT_IRQ12 <sup>*1</sup>      | External pin interrupt 12   |
| 0x00E        |                          | PORT_IRQ13 <sup>*1</sup>      | External pin interrupt 13   |
| 0x00F        |                          | PORT_IRQ14 <sup>*1</sup>      | External pin interrupt 14   |
| 0x010        | PORT_IRQ15 <sup>*1</sup> | External pin interrupt 15     |                             |
| 0x020        | DMAC                     | DMAC0_INT                     | DMAC transfer end 0         |
| 0x021        |                          | DMAC1_INT                     | DMAC transfer end 1         |
| 0x022        |                          | DMAC2_INT                     | DMAC transfer end 2         |
| 0x023        |                          | DMAC3_INT                     | DMAC transfer end 3         |
| 0x024        |                          | DMAC4_INT                     | DMAC transfer end 4         |
| 0x025        |                          | DMAC5_INT                     | DMAC transfer end 5         |
| 0x026        |                          | DMAC6_INT                     | DMAC transfer end 6         |
| 0x027        |                          | DMAC7_INT                     | DMAC transfer end 7         |
| 0x02A        | DTC                      | DTC_DTCEND <sup>*4</sup>      | DTC transfer end            |
| 0x038        | LVD                      | LVD_LVD1                      | Voltage monitor 1 interrupt |
| 0x039        |                          | LVD_LVD2                      | Voltage monitor 2 interrupt |
| 0x03B        | MOSC                     | MOSC_STOP                     | Mail Clock oscillation stop |
| 0x03C        | LPW                      | SYSTEM_SNZREQ <sup>*3*4</sup> | Snooze entry                |
| 0x040        | AGT0                     | AGT0_AGTI                     | AGT interrupt               |
| 0x041        |                          | AGT0_AGTCMAI                  | Compare match A             |
| 0x042        |                          | AGT0_AGTCMBI                  | Compare match B             |
| 0x043        | AGT1                     | AGT1_AGTI                     | AGT interrupt               |
| 0x044        |                          | AGT1_AGTCMAI                  | Compare match A             |
| 0x045        |                          | AGT1_AGTCMBI                  | Compare match B             |
| 0x046        | AGT2                     | AGT2_AGTI                     | AGT interrupt               |
| 0x047        |                          | AGT2_AGTCMAI                  | Compare match A             |
| 0x048        |                          | AGT2_AGTCMBI                  | Compare match B             |

Table 18.3 在ELSRn.ELS[8:0]位中设置的事件信号名称与信号编号之间的关联 (1 of 5)

| 事件编号  | 中断请求源                    | Name                          | Description   |
|-------|--------------------------|-------------------------------|---------------|
| 0x001 | Port                     | PORT_IRQ0 <sup>*1</sup>       | 外部引脚中断0       |
| 0x002 |                          | PORT_IRQ1 <sup>*1</sup>       | 外部引脚中断1       |
| 0x003 |                          | PORT_IRQ2 <sup>*1</sup>       | 外部引脚中断2       |
| 0x004 |                          | PORT_IRQ3 <sup>*1</sup>       | 外部引脚中断3       |
| 0x005 |                          | PORT_IRQ4 <sup>*1</sup>       | 外部引脚中断4       |
| 0x006 |                          | PORT_IRQ5 <sup>*1</sup>       | 外部引脚中断5       |
| 0x007 |                          | PORT_IRQ6 <sup>*1</sup>       | 外部引脚中断6       |
| 0x008 |                          | PORT_IRQ7 <sup>*1</sup>       | 外部引脚中断7       |
| 0x009 |                          | PORT_IRQ8 <sup>*1</sup>       | 外部引脚中断8       |
| 0x00A |                          | PORT_IRQ9 <sup>*1</sup>       | 外部引脚中断9       |
| 0x00B |                          | PORT_IRQ10 <sup>*1</sup>      | 外部引脚中断10      |
| 0x00C |                          | PORT_IRQ11 <sup>*1</sup>      | 外部引脚中断11      |
| 0x00D |                          | PORT_IRQ12 <sup>*1</sup>      | 外部引脚中断12      |
| 0x00E |                          | PORT_IRQ13 <sup>*1</sup>      | 外部引脚中断13      |
| 0x00F |                          | PORT_IRQ14 <sup>*1</sup>      | 外部引脚中断14      |
| 0x010 | PORT_IRQ15 <sup>*1</sup> | 外部引脚中断15                      |               |
| 0x020 | DMAC                     | DMAC0_INT                     | DMAC传输结束0     |
| 0x021 |                          | DMAC1_INT                     | DMAC传输结束1     |
| 0x022 |                          | DMAC2_INT                     | DMAC传输结束2     |
| 0x023 |                          | DMAC3_INT                     | DMAC传输结束3     |
| 0x024 |                          | DMAC4_INT                     | DMAC传输结束4     |
| 0x025 |                          | DMAC5_INT                     | DMAC传输结束5     |
| 0x026 |                          | DMAC6_INT                     | DMAC传输结束6     |
| 0x027 |                          | DMAC7_INT                     | DMAC传输结束7     |
| 0x02A | DTC                      | DTC_DTCEND <sup>*4</sup>      | DTC传输结束       |
| 0x038 | LVD                      | LVD_LVD1                      | 电压监视器1中断      |
| 0x039 |                          | LVD_LVD2                      | 电压监视器2中断      |
| 0x03B | MOSC                     | MOSC_STOP                     | 邮件时钟振荡停止      |
| 0x03C | LPW                      | SYSTEM_SNZREQ <sup>*3*4</sup> | Snooze entry  |
| 0x040 | AGT0                     | AGT0_AGTI                     | AGT interrupt |
| 0x041 |                          | AGT0_AGTCMAI                  | 比较匹配A         |
| 0x042 |                          | AGT0_AGTCMBI                  | 比较匹配B         |
| 0x043 | AGT1                     | AGT1_AGTI                     | AGT interrupt |
| 0x044 |                          | AGT1_AGTCMAI                  | 比较匹配A         |
| 0x045 |                          | AGT1_AGTCMBI                  | 比较匹配B         |
| 0x046 | AGT2                     | AGT2_AGTI                     | AGT interrupt |
| 0x047 |                          | AGT2_AGTCMAI                  | 比较匹配A         |
| 0x048 |                          | AGT2_AGTCMBI                  | 比较匹配B         |

Table 18.3 Association between event signal names set in ELSRn.ELS[8:0] bits and signal numbers (2 of 5)

| Event number | Interrupt request source | Name          | Description              |
|--------------|--------------------------|---------------|--------------------------|
| 0x049        | AGT3                     | AGT3_AGTI     | AGT interrupt            |
| 0x04A        |                          | AGT3_AGTCMAI  | Compare match A          |
| 0x04B        |                          | AGT3_AGTCMBI  | Compare match B          |
| 0x04C        | AGT4                     | AGT4_AGTI     | AGT interrupt            |
| 0x04D        |                          | AGT4_AGTCMAI  | Compare match A          |
| 0x04E        |                          | AGT4_AGTCMBI  | Compare match B          |
| 0x04F        | AGT5                     | AGT5_AGTI     | AGT interrupt            |
| 0x050        |                          | AGT5_AGTCMAI  | Compare match A          |
| 0x051        |                          | AGT5_AGTCMBI  | Compare match B          |
| 0x052        | IWDT                     | IWDT_NMIUNDF  | IWDT underflow           |
| 0x053        | CWDT                     | WDT_NMIUNDF   | WDT underflow            |
| 0x055        | RTC                      | RTC_PRD       | Periodic interrupt       |
| 0x073        | IIC0                     | IIC0_RXI      | Receive data full        |
| 0x074        |                          | IIC0_TXI      | Transmit data empty      |
| 0x075        |                          | IIC0_TEI      | Transmit end             |
| 0x076        |                          | IIC0_EEI      | Transfer error           |
| 0x078        | IIC1                     | IIC1_RXI      | Receive data full        |
| 0x079        |                          | IIC1_TXI      | Transmit data empty      |
| 0x07A        |                          | IIC1_TEI      | Transmit end             |
| 0x07B        |                          | IIC1_EEI      | Transfer error           |
| 0x0B1        | I/O Port                 | IOPORT_GROUP1 | Port 1 event             |
| 0x0B2        |                          | IOPORT_GROUP2 | Port 2 event             |
| 0x0B3        |                          | IOPORT_GROUP3 | Port 3 event             |
| 0x0B4        |                          | IOPORT_GROUP4 | Port 4 event             |
| 0x0B5        | ELC                      | ELC_SWEVT0    | Software event 0         |
| 0x0B6        |                          | ELC_SWEVT1    | Software event 1         |
| 0x0C0        | GPT0                     | GPT0_CCMPA    | Compare match A          |
| 0x0C1        |                          | GPT0_CCMPB    | Compare match B          |
| 0x0C2        |                          | GPT0_CMPC     | Compare match C          |
| 0x0C3        |                          | GPT0_CMPD     | Compare match D          |
| 0x0C4        |                          | GPT0_CMPE     | Compare match E          |
| 0x0C5        |                          | GPT0_CMPF     | Compare match F          |
| 0x0C6        |                          | GPT0_OVF      | Overflow                 |
| 0x0C7        |                          | GPT0_UDF      | Underflow                |
| 0x0C8        |                          | GPT0_PC       | Cycle count function end |

Table 18.3 在ELSRn.ELS[8:0]位中设置的事件信号名称与信号编号之间的关联 (2of5)

| 事件编号  | 中断请求源    | Name          | Description    |
|-------|----------|---------------|----------------|
| 0x049 | AGT3     | AGT3_AGTI     | AGT interrupt  |
| 0x04A |          | AGT3_AGTCMAI  | 比较匹配A          |
| 0x04B |          | AGT3_AGTCMBI  | 比较匹配B          |
| 0x04C | AGT4     | AGT4_AGTI     | AGT interrupt  |
| 0x04D |          | AGT4_AGTCMAI  | 比较匹配A          |
| 0x04E |          | AGT4_AGTCMBI  | 比较匹配B          |
| 0x04F | AGT5     | AGT5_AGTI     | AGT interrupt  |
| 0x050 |          | AGT5_AGTCMAI  | 比较匹配A          |
| 0x051 |          | AGT5_AGTCMBI  | 比较匹配B          |
| 0x052 | IWDT     | IWDT_NMIUNDF  | IWDT underflow |
| 0x053 | CWDT     | WDT_NMIUNDF   | WDT underflow  |
| 0x055 | RTC      | RTC_PRD       | 周期性中断          |
| 0x073 | IIC0     | IIC0_RXI      | 接收数据已满         |
| 0x074 |          | IIC0_TXI      | 传输数据为空         |
| 0x075 |          | IIC0_TEI      | 发射端            |
| 0x076 |          | IIC0_EEI      | 传输错误           |
| 0x078 | IIC1     | IIC1_RXI      | 接收数据已满         |
| 0x079 |          | IIC1_TXI      | 传输数据为空         |
| 0x07A |          | IIC1_TEI      | 发射端            |
| 0x07B |          | IIC1_EEI      | 传输错误           |
| 0x0B1 | I/O Port | IOPORT_GROUP1 | 端口1事件          |
| 0x0B2 |          | IOPORT_GROUP2 | 端口2事件          |
| 0x0B3 |          | IOPORT_GROUP3 | 端口3事件          |
| 0x0B4 |          | IOPORT_GROUP4 | 端口4事件          |
| 0x0B5 | ELC      | ELC_SWEVT0    | 软件事件0          |
| 0x0B6 |          | ELC_SWEVT1    | 软件事件1          |
| 0x0C0 | GPT0     | GPT0_CCMPA    | 比较匹配A          |
| 0x0C1 |          | GPT0_CCMPB    | 比较匹配B          |
| 0x0C2 |          | GPT0_CMPC     | 比较匹配C          |
| 0x0C3 |          | GPT0_CMPD     | 比较匹配D          |
| 0x0C4 |          | GPT0_CMPE     | 比较匹配E          |
| 0x0C5 |          | GPT0_CMPF     | 比较匹配F          |
| 0x0C6 |          | GPT0_OVF      | Overflow       |
| 0x0C7 |          | GPT0_UDF      | Underflow      |
| 0x0C8 |          | GPT0_PC       | 循环计数功能结束       |

Table 18.3 Association between event signal names set in ELSRn.ELS[8:0] bits and signal numbers (3 of 5)

| Event number | Interrupt request source | Name       | Description              |                 |
|--------------|--------------------------|------------|--------------------------|-----------------|
| 0x0C9        | GPT1                     | GPT1_CCMPA | Compare match A          |                 |
| 0x0CA        |                          | GPT1_CCMPB | Compare match B          |                 |
| 0x0CB        |                          | GPT1_CMPC  | Compare match C          |                 |
| 0x0CC        |                          | GPT1_CMPD  | Compare match D          |                 |
| 0x0CD        |                          | GPT1_CMPE  | Compare match E          |                 |
| 0x0CE        |                          | GPT1_CMPF  | Compare match F          |                 |
| 0x0CF        |                          | GPT1_OVF   | Overflow                 |                 |
| 0x0D0        |                          | GPT1_UDF   | Underflow                |                 |
| 0x0D1        |                          | GPT1_PC    | Cycle count function end |                 |
| 0x0D2        |                          | GPT2       | GPT2_CCMPA               | Compare match A |
| 0x0D3        | GPT2_CCMPB               |            | Compare match B          |                 |
| 0x0D4        | GPT2_CMPC                |            | Compare match C          |                 |
| 0x0D5        | GPT2_CMPD                |            | Compare match D          |                 |
| 0x0D6        | GPT2_CMPE                |            | Compare match E          |                 |
| 0x0D7        | GPT2_CMPF                |            | Compare match F          |                 |
| 0x0D8        | GPT2_OVF                 |            | Overflow                 |                 |
| 0x0D9        | GPT2_UDF                 |            | Underflow                |                 |
| 0x0DB        | GPT3                     |            | GPT3_CCMPA               | Compare match A |
| 0x0DC        |                          |            | GPT3_CCMPB               | Compare match B |
| 0x0DD        |                          | GPT3_CMPC  | Compare match C          |                 |
| 0x0DE        |                          | GPT3_CMPD  | Compare match D          |                 |
| 0x0DF        |                          | GPT3_CMPE  | Compare match E          |                 |
| 0x0E0        |                          | GPT3_CMPF  | Compare match F          |                 |
| 0x0E1        |                          | GPT3_OVF   | Overflow                 |                 |
| 0x0E2        |                          | GPT3_UDF   | Underflow                |                 |
| 0x0E4        |                          | GPT4       | GPT4_CCMPA               | Compare match A |
| 0x0E5        |                          |            | GPT4_CCMPB               | Compare match B |
| 0x0E6        | GPT4_CMPC                |            | Compare match C          |                 |
| 0x0E7        | GPT4_CMPD                |            | Compare match D          |                 |
| 0x0E8        | GPT4_CMPE                |            | Compare match E          |                 |
| 0x0E9        | GPT4_CMPF                |            | Compare match F          |                 |
| 0x0EA        | GPT4_OVF                 |            | Overflow                 |                 |
| 0x0EB        | GPT4_UDF                 |            | Underflow                |                 |
| 0x0EC        | GPT4_PC                  |            | Cycle count function end |                 |

Table 18.3 在ELSRn.ELS[8:0]位中设置的事件信号名称与信号编号之间的关联 (3of5)

| 事件编号  | 中断请求源      | Name       | Description |       |
|-------|------------|------------|-------------|-------|
| 0x0C9 | GPT1       | GPT1_CCMPA | 比较匹配A       |       |
| 0x0CA |            | GPT1_CCMPB | 比较匹配B       |       |
| 0x0CB |            | GPT1_CMPC  | 比较匹配C       |       |
| 0x0CC |            | GPT1_CMPD  | 比较匹配D       |       |
| 0x0CD |            | GPT1_CMPE  | 比较匹配E       |       |
| 0x0CE |            | GPT1_CMPF  | 比较匹配F       |       |
| 0x0CF |            | GPT1_OVF   | Overflow    |       |
| 0x0D0 |            | GPT1_UDF   | Underflow   |       |
| 0x0D1 |            | GPT1_PC    | 循环计数功能结束    |       |
| 0x0D2 |            | GPT2       | GPT2_CCMPA  | 比较匹配A |
| 0x0D3 | GPT2_CCMPB |            | 比较匹配B       |       |
| 0x0D4 | GPT2_CMPC  |            | 比较匹配C       |       |
| 0x0D5 | GPT2_CMPD  |            | 比较匹配D       |       |
| 0x0D6 | GPT2_CMPE  |            | 比较匹配E       |       |
| 0x0D7 | GPT2_CMPF  |            | 比较匹配F       |       |
| 0x0D8 | GPT2_OVF   |            | Overflow    |       |
| 0x0D9 | GPT2_UDF   |            | Underflow   |       |
| 0x0DB | GPT3       |            | GPT3_CCMPA  | 比较匹配A |
| 0x0DC |            |            | GPT3_CCMPB  | 比较匹配B |
| 0x0DD |            | GPT3_CMPC  | 比较匹配C       |       |
| 0x0DE |            | GPT3_CMPD  | 比较匹配D       |       |
| 0x0DF |            | GPT3_CMPE  | 比较匹配E       |       |
| 0x0E0 |            | GPT3_CMPF  | 比较匹配F       |       |
| 0x0E1 |            | GPT3_OVF   | Overflow    |       |
| 0x0E2 |            | GPT3_UDF   | Underflow   |       |
| 0x0E4 |            | GPT4       | GPT4_CCMPA  | 比较匹配A |
| 0x0E5 |            |            | GPT4_CCMPB  | 比较匹配B |
| 0x0E6 | GPT4_CMPC  |            | 比较匹配C       |       |
| 0x0E7 | GPT4_CMPD  |            | 比较匹配D       |       |
| 0x0E8 | GPT4_CMPE  |            | 比较匹配E       |       |
| 0x0E9 | GPT4_CMPF  |            | 比较匹配F       |       |
| 0x0EA | GPT4_OVF   |            | Overflow    |       |
| 0x0EB | GPT4_UDF   |            | Underflow   |       |
| 0x0EC | GPT4_PC    |            | 循环计数功能结束    |       |



Table 18.3 Association between event signal names set in ELSRn.ELS[8:0] bits and signal numbers (4 of 5)

| Event number | Interrupt request source | Name                        | Description              |
|--------------|--------------------------|-----------------------------|--------------------------|
| 0x0ED        | GPT5                     | GPT5_CCMPA                  | Compare match A          |
| 0x0EE        |                          | GPT5_CCMPB                  | Compare match B          |
| 0x0EF        |                          | GPT5_CMPC                   | Compare match C          |
| 0x0F0        |                          | GPT5_CMPD                   | Compare match D          |
| 0x0F1        |                          | GPT5_CMPE                   | Compare match E          |
| 0x0F2        |                          | GPT5_CMPF                   | Compare match F          |
| 0x0F3        |                          | GPT5_OVF                    | Overflow                 |
| 0x0F4        |                          | GPT5_UDF                    | Underflow                |
| 0x0F5        |                          | GPT5_PC                     | Cycle count function end |
| 0x0F6        |                          | GPT6                        | GPT6_CCMPA               |
| 0x0F7        | GPT6_CCMPB               |                             | Compare match B          |
| 0x0F8        | GPT6_CMPC                |                             | Compare match C          |
| 0x0F9        | GPT6_CMPD                |                             | Compare match D          |
| 0x0FA        | GPT6_CMPE                |                             | Compare match E          |
| 0x0FB        | GPT6_CMPF                |                             | Compare match F          |
| 0x0FC        | GPT6_OVF                 |                             | Overflow                 |
| 0x0FD        | GPT6_UDF                 |                             | Underflow                |
| 0x0FE        | GPT6_PC                  |                             | Cycle count function end |
| 0x0FF        | GPT7                     |                             | GPT7_CCMPA               |
| 0x100        |                          | GPT7_CCMPB                  | Compare match B          |
| 0x101        |                          | GPT7_CMPC                   | Compare match C          |
| 0x102        |                          | GPT7_CMPD                   | Compare match D          |
| 0x103        |                          | GPT7_CMPE                   | Compare match E          |
| 0x104        |                          | GPT7_CMPF                   | Compare match F          |
| 0x105        |                          | GPT7_OVF                    | Overflow                 |
| 0x106        |                          | GPT7_UDF                    | Underflow                |
| 0x150        | GPT                      | GPT_UVWEDGE                 | UVW edge event           |
| 0x160        | ADC12                    | ADC120_ADI                  | A/D scan end interrupt   |
| 0x164        |                          | ADC120_WCMPM <sup>*4</sup>  | Compare match            |
| 0x165        |                          | ADC120_WCMPUM <sup>*4</sup> | Compare mismatch         |
| 0x166        |                          | ADC121_ADI                  | A/D scan end interrupt   |
| 0x16A        |                          | ADC121_WCMPM <sup>*4</sup>  | Compare match            |
| 0x16B        |                          | ADC121_WCMPUM <sup>*4</sup> | Compare mismatch         |
| 0x180        | SCI0                     | SCI0_RXI <sup>*2</sup>      | Receive data full        |
| 0x181        |                          | SCI0_TXI <sup>*2</sup>      | Transmit data empty      |
| 0x182        |                          | SCI0_TEI <sup>*2</sup>      | Transmit end             |
| 0x183        |                          | SCI0_ERI                    | Receive error            |
| 0x184        |                          | SCI0_AM                     | Address match event      |

Table 18.3 在ELSRn.ELS[8:0]位中设置的事件信号名称与信号编号之间的关联 (4of5)

| 事件编号  | 中断请求源      | Name                        | Description |
|-------|------------|-----------------------------|-------------|
| 0x0ED | GPT5       | GPT5_CCMPA                  | 比较匹配A       |
| 0x0EE |            | GPT5_CCMPB                  | 比较匹配B       |
| 0x0EF |            | GPT5_CMPC                   | 比较匹配C       |
| 0x0F0 |            | GPT5_CMPD                   | 比较匹配D       |
| 0x0F1 |            | GPT5_CMPE                   | 比较匹配E       |
| 0x0F2 |            | GPT5_CMPF                   | 比较匹配F       |
| 0x0F3 |            | GPT5_OVF                    | Overflow    |
| 0x0F4 |            | GPT5_UDF                    | Underflow   |
| 0x0F5 |            | GPT5_PC                     | 循环计数功能结束    |
| 0x0F6 |            | GPT6                        | GPT6_CCMPA  |
| 0x0F7 | GPT6_CCMPB |                             | 比较匹配B       |
| 0x0F8 | GPT6_CMPC  |                             | 比较匹配C       |
| 0x0F9 | GPT6_CMPD  |                             | 比较匹配D       |
| 0x0FA | GPT6_CMPE  |                             | 比较匹配E       |
| 0x0FB | GPT6_CMPF  |                             | 比较匹配F       |
| 0x0FC | GPT6_OVF   |                             | Overflow    |
| 0x0FD | GPT6_UDF   |                             | Underflow   |
| 0x0FE | GPT6_PC    |                             | 循环计数功能结束    |
| 0x0FF | GPT7       |                             | GPT7_CCMPA  |
| 0x100 |            | GPT7_CCMPB                  | 比较匹配B       |
| 0x101 |            | GPT7_CMPC                   | 比较匹配C       |
| 0x102 |            | GPT7_CMPD                   | 比较匹配D       |
| 0x103 |            | GPT7_CMPE                   | 比较匹配E       |
| 0x104 |            | GPT7_CMPF                   | 比较匹配F       |
| 0x105 |            | GPT7_OVF                    | Overflow    |
| 0x106 |            | GPT7_UDF                    | Underflow   |
| 0x150 | GPT        | GPT_UVWEDGE                 | UVW边缘事件     |
| 0x160 | ADC12      | ADC120_ADI                  | AD扫描结束中断    |
| 0x164 |            | ADC120_WCMPM <sup>*4</sup>  | 比较匹配        |
| 0x165 |            | ADC120_WCMPUM <sup>*4</sup> | 比较不匹配       |
| 0x166 |            | ADC121_ADI                  | AD扫描结束中断    |
| 0x16A |            | ADC121_WCMPM <sup>*4</sup>  | 比较匹配        |
| 0x16B |            | ADC121_WCMPUM <sup>*4</sup> | 比较不匹配       |
| 0x180 | SCI0       | SCI0_RXI <sup>*2</sup>      | 接收数据已满      |
| 0x181 |            | SCI0_TXI <sup>*2</sup>      | 传输数据为空      |
| 0x182 |            | SCI0_TEI <sup>*2</sup>      | 发射端         |
| 0x183 |            | SCI0_ERI                    | 接收错误        |
| 0x184 |            | SCI0_AM                     | 地址匹配事件      |

Table 18.3 Association between event signal names set in ELSRn.ELS[8:0] bits and signal numbers (5 of 5)

| Event number | Interrupt request source | Name                   | Description                      |
|--------------|--------------------------|------------------------|----------------------------------|
| 0x186        | SCI1                     | SCI1_RXI <sup>2</sup>  | Received data full               |
| 0x187        |                          | SCI1_TXI <sup>2</sup>  | Transmit data empty              |
| 0x188        |                          | SCI1_TEI <sup>2</sup>  | Transmit end                     |
| 0x189        |                          | SCI1_ERI               | Receive error                    |
| 0x18C        | SCI2                     | SCI2_RXI <sup>2</sup>  | Received data full               |
| 0x18D        |                          | SCI2_TXI <sup>2</sup>  | Transmit data empty              |
| 0x18E        |                          | SCI2_TEI <sup>2</sup>  | Transmit end                     |
| 0x18F        |                          | SCI2_ERI               | Receive error                    |
| 0x192        | SCI3                     | SCI3_RXI <sup>2</sup>  | Received data full               |
| 0x193        |                          | SCI3_TXI <sup>2</sup>  | Transmit data empty              |
| 0x194        |                          | SCI3_TEI <sup>2</sup>  | Transmit end                     |
| 0x195        |                          | SCI3_ERI               | Receive error                    |
| 0x196        |                          | SCI3_AM                | Address match event              |
| 0x198        | SCI4                     | SCI4_RXI <sup>2</sup>  | Received data full               |
| 0x199        |                          | SCI4_TXI <sup>2</sup>  | Transmit data empty              |
| 0x19A        |                          | SCI4_TEI <sup>2</sup>  | Transmit end                     |
| 0x19B        |                          | SCI4_ERI               | Receive error                    |
| 0x19C        |                          | SCI4_AM                | Address match event              |
| 0x1B6        | SCI9                     | SCI9_RXI <sup>2</sup>  | Received data full               |
| 0x1B7        |                          | SCI9_TXI <sup>2</sup>  | Transmit data empty              |
| 0x1B8        |                          | SCI9_TEI <sup>2</sup>  | Transmit end                     |
| 0x1B9        |                          | SCI9_ERI               | Receive error                    |
| 0x1BA        |                          | SCI9_AM                | Address match event              |
| 0x1C4        | SPI0                     | SPI0_SPRI              | Receive buffer full              |
| 0x1C5        |                          | SPI0_SPTI              | Transmit buffer empty            |
| 0x1C6        |                          | SPI0_SPII              | Idle                             |
| 0x1C7        |                          | SPI0_SPEI              | Error                            |
| 0x1C8        |                          | SPI0_SPCEND            | Communication complete event     |
| 0x1DB        | DOC                      | DOC_DOPCI <sup>4</sup> | Data operation circuit interrupt |

Note 1. Only pulse (edge detection) is supported.  
 Note 2. This event is not supported in FIFO mode.  
 Note 3. ELSR8 to ELSR11, ELSR14 to ELSR17, and ELSR18 can select this event.  
 Note 4. This event can occur in Snooze mode.

### 18.2.4 ELCSARA : Event Link Controller Security Attribution Register A

Base address: ELC = 0x4008\_2000

Offset address: 0x74

|                    |    |    |    |    |    |    |   |   |   |   |   |   |   |          |          |      |
|--------------------|----|----|----|----|----|----|---|---|---|---|---|---|---|----------|----------|------|
| Bit position:      | 15 | 14 | 13 | 12 | 11 | 10 | 9 | 8 | 7 | 6 | 5 | 4 | 3 | 2        | 1        | 0    |
| Bit field:         | —  | —  | —  | —  | —  | —  | — | — | — | — | — | — | — | ELSE GR1 | ELSE GR0 | ELCR |
| Value after reset: | 1  | 1  | 1  | 1  | 1  | 1  | 1 | 1 | 1 | 1 | 1 | 1 | 1 | 1        | 1        | 1    |

Table 18.3 在ELSRn.ELS[8:0]位中设置的事件信号名称与信号编号之间的关联 (5个, 共5个)

| 事件编号  | 中断请求源 | Name                   | Description |
|-------|-------|------------------------|-------------|
| 0x186 | SCI1  | SCI1_RXI <sup>2</sup>  | 接收数据已满      |
| 0x187 |       | SCI1_TXI <sup>2</sup>  | 传输数据为空      |
| 0x188 |       | SCI1_TEI <sup>2</sup>  | 发射端         |
| 0x189 |       | SCI1_ERI               | 接收错误        |
| 0x18C | SCI2  | SCI2_RXI <sup>2</sup>  | 接收数据已满      |
| 0x18D |       | SCI2_TXI <sup>2</sup>  | 传输数据为空      |
| 0x18E |       | SCI2_TEI <sup>2</sup>  | 发射端         |
| 0x18F |       | SCI2_ERI               | 接收错误        |
| 0x192 | SCI3  | SCI3_RXI <sup>2</sup>  | 接收数据已满      |
| 0x193 |       | SCI3_TXI <sup>2</sup>  | 传输数据为空      |
| 0x194 |       | SCI3_TEI <sup>2</sup>  | 发射端         |
| 0x195 |       | SCI3_ERI               | 接收错误        |
| 0x196 |       | SCI3_AM                | 地址匹配事件      |
| 0x198 | SCI4  | SCI4_RXI <sup>2</sup>  | 接收数据已满      |
| 0x199 |       | SCI4_TXI <sup>2</sup>  | 传输数据为空      |
| 0x19A |       | SCI4_TEI <sup>2</sup>  | 发射端         |
| 0x19B |       | SCI4_ERI               | 接收错误        |
| 0x19C |       | SCI4_AM                | 地址匹配事件      |
| 0x1B6 | SCI9  | SCI9_RXI <sup>2</sup>  | 接收数据已满      |
| 0x1B7 |       | SCI9_TXI <sup>2</sup>  | 传输数据为空      |
| 0x1B8 |       | SCI9_TEI <sup>2</sup>  | 发射端         |
| 0x1B9 |       | SCI9_ERI               | 接收错误        |
| 0x1BA |       | SCI9_AM                | 地址匹配事件      |
| 0x1C4 | SPI0  | SPI0_SPRI              | 接收缓冲区已满     |
| 0x1C5 |       | SPI0_SPTI              | 发送缓冲区为空     |
| 0x1C6 |       | SPI0_SPII              | Idle        |
| 0x1C7 |       | SPI0_SPEI              | Error       |
| 0x1C8 |       | SPI0_SPCEND            | 通讯完成事件      |
| 0x1DB | DOC   | DOC_DOPCI <sup>4</sup> | 数据运算电路中断    |

注1.仅支持脉冲 (边沿检测)。注2.FIFO模式不支持此事件。  
 注3.ELSR8到ELSR11、ELSR14到ELSR17和ELSR18可以选择此事件。  
 注4.此事件可能在贪睡模式下发生。

### 18.2.4 ELCSARA:事件链接控制器安全属性寄存器A

Base address: ELC = 0x4008\_2000

Offset address: 0x74

|               |    |    |    |    |    |    |   |   |   |   |   |   |   |          |          |      |
|---------------|----|----|----|----|----|----|---|---|---|---|---|---|---|----------|----------|------|
| Bit position: | 15 | 14 | 13 | 12 | 11 | 10 | 9 | 8 | 7 | 6 | 5 | 4 | 3 | 2        | 1        | 0    |
| Bit field:    | —  | —  | —  | —  | —  | —  | — | — | — | — | — | — | — | ELSE GR1 | ELSE GR0 | ELCR |
| 重置后的值:        | 1  | 1  | 1  | 1  | 1  | 1  | 1 | 1 | 1 | 1 | 1 | 1 | 1 | 1        | 1        | 1    |

| Bit  | Symbol  | Function   | R/W |
|------|---------|--|-----|
| 0    | ELCR    | Event Link Controller Register Security Attribution<br>Target register: ELCR<br>0: Secure<br>1: Non-secure | R/W |
| 1    | ELSEGR0 | Event Link Software Event Generation Register 0 Security Attribution<br>0: Secure<br>1: Non-secure         | R/W |
| 2    | ELSEGR1 | Event Link Software Event Generation Register 1 Security Attribution<br>0: Secure<br>1: Non-secure         | R/W |
| 15:3 | —       | These bits are read as 1. The write value should be 1.   | R/W |

Note: Only secure access can write to this register. Both secure access and Non-secure read access are allowed but Non-secure write access is not allowed and TrustZone access error is not generated.

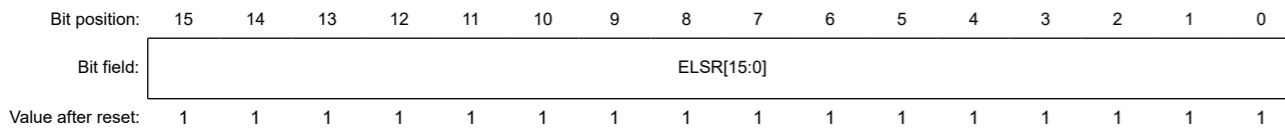
Note: This register is write-protected by PRCR register.

The ELCR register controls operation of the ELC.

### 18.2.5 ELCSARB : Event Link Controller Security Attribution Register B

Base address: ELC = 0x4008\_2000

Offset address: 0x78



| Bit  | Symbol     | Function   | R/W |
|------|------------|--|-----|
| 15:0 | ELSR[15:0] | Event Link Setting Register n Security Attribution<br>Target register: ELSRn (n = 0 to 15)<br>0: Secure<br>1: Non-secure | R/W |

Note: Only secure access can write to this register. Both secure access and Non-secure read access are allowed but Non-secure write access is not allowed and TrustZone access error is not generated.

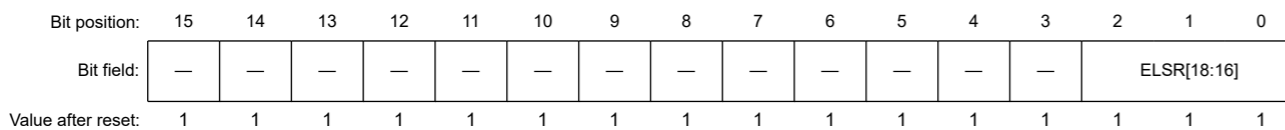
Note: This register is write-protected by PRCR register.

This register specifies the security attribution for the Register ELSRn (n = 0 to 15).

### 18.2.6 ELCSARC : Event Link Controller Security Attribution Register C

Base address: ELC = 0x4008\_2000

Offset address: 0x7C



| Bit  | Symbol      | Function   | R/W |
|------|-------------|--|-----|
| 2:0  | ELSR[18:16] | Event Link Setting Register n Security Attribution (n = 16 to 18)<br>Target register: ELSRn (n = 16 to 18)<br>0: Secure<br>1: Non-secure | R/W |
| 15:3 | —           | These bits are read as 1. The write value should be 1.   | R/W |

Note: Only secure access can write to this register. Both secure access and Non-secure read access are allowed but Non-secure write access is not allowed and TrustZone access error is not generated.

| Bit  | Symbol  | Function   | R/W |
|------|---------|--|-----|
| 0    | ELCR    | 事件链接控制器注册安全属性<br>Target register: ELCR<br>0: Secure<br>1: Non-secure | R/W |
| 1    | ELSEGR0 | 事件链接软件事件生成寄存器0安全属性<br>0: Secure<br>1: Non-secure                     | R/W |
| 2    | ELSEGR1 | 事件链接软件事件生成寄存器1安全属性<br>0: Secure<br>1: Non-secure                     | R/W |
| 15:3 | —       | 这些位被读取为1。写入值应为1。   | R/W |

Note: 只有安全访问才能写入该寄存器。允许安全访问和非安全读取访问，但不允许非安全写入访问，并且不会生成TrustZone访问错误。

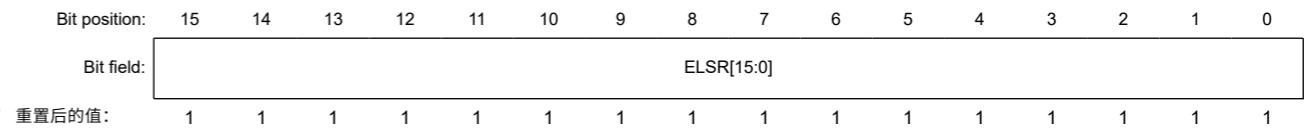
Note: 该寄存器由PRCR寄存器写保护。

ELCR寄存器控制ELC的操作。

### 18.2.5 ELCSARB:事件链接控制器安全属性寄存器B

Base address: ELC = 0x4008\_2000

Offset address: 0x78



| Bit  | Symbol     | Function  | R/W |
|------|------------|---|-----|
| 15:0 | ELSR[15:0] | 事件链接设置寄存器n安全属性<br>目标寄存器: ELSRn (n=0到15)<br>0: Secure<br>1: Non-secure | R/W |

Note: 只有安全访问才能写入该寄存器。允许安全访问和非安全读取访问，但不允许非安全写入访问，并且不会生成TrustZone访问错误。

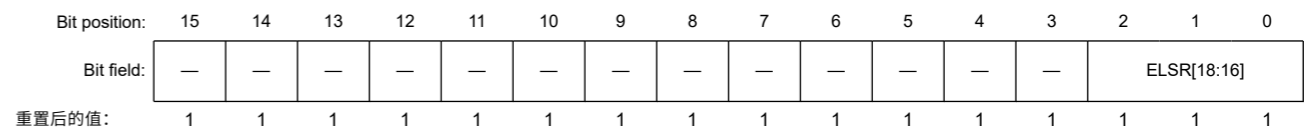
Note: 该寄存器由PRCR寄存器写保护。

该寄存器指定寄存器ELSRn (n=0到15) 的安全属性。

### 18.2.6 ELCSARC:事件链接控制器安全属性寄存器C

Base address: ELC = 0x4008\_2000

Offset address: 0x7C



| Bit  | Symbol      | Function   | R/W |
|------|-------------|--|-----|
| 2:0  | ELSR[18:16] | 事件链接设置寄存器n安全属性 (n=16到18)<br>目标寄存器: ELSRn (n=16到18)<br>0: Secure<br>1: Non-secure | R/W |
| 15:3 | —           | 这些位被读取为1。写入值应为1。   | R/W |

Note: 只有安全访问才能写入该寄存器。允许安全访问和非安全读取访问，但不允许非安全写入访问，并且不会生成TrustZone访问错误。

Note: This register is write-protected by PRCR register.

This register specifies the security attribution for the Register ELSRn (n = 16 to 18)

### 18.3 Operation

#### 18.3.1 Relation between Interrupt Handling and Event Linking

Event number for an event link is the same as that for the associated interrupt source. For information on generating event signals, see the explanation in the chapter for each event source module.

#### 18.3.2 Linking Events

When an event occurs and that event is already set as a trigger in the Event Link Setting Register (ELSRn), the associated module is activated. The operation of the module must be set up in advance. Table 18.4 lists the operations of modules when an event occurs.

Table 18.4 Module operations when event occurs

| Module    | Operations When Event is Input   |
|-----------|--|
| GPT       | <ul style="list-style-type: none"> <li>Start counting</li> <li>Stop counting</li> <li>Clear counting</li> <li>Up counting</li> <li>Down counting</li> <li>Input capture</li> </ul>   |
| DAC12     | Start D/A conversion   |
| I/O Ports | <ul style="list-style-type: none"> <li>Change pin output based on the EORR (reset) or EOSR (set)</li> <li>Latch pin state to EIDR</li> <li>The following ports can be used for the ELC:               <ul style="list-style-type: none"> <li>PORT 1</li> <li>PORT 2</li> <li>PORT 3</li> <li>PORT 4</li> </ul> </li> </ul> |
| CTSU      | Start measurement operation  |
| ADC12     | Start A/D conversion   |
| DTC       | Start DTC data transfer  |

#### 18.3.3 Example of Procedure for Linking Events

To link events:

1. Set the operation of the module for which an event is to be linked.
2. Set the appropriate ELSRn.ELS[8:0] bits for the module to be linked.
3. Set the ELCR.ELCON bit to 1 to enable linkage of all events.
4. Configure the module from which an event is output and activate the module. The link between the two modules is now active.
5. To stop event linkage of modules individually, set 0 to the ELSRn.ELS[8:0] bit associated with the modules. To stop linkage of all the events, set the ELCR.ELCON bit to 0.

If event link output from the RTC is to be used, set the ELC after the RTC settings, for example, for initialization and time setting. Unintended events may be generated if RTC settings are made after the ELC settings.

If event link output from the LVD is to be used, set the ELC after setting the LVD. To disable the LVD, do so after setting 0x00 to the associated ELSRn register.

Note: 该寄存器由PRCR寄存器写保护。

该寄存器指定寄存器ELSRn的安全属性 (n=16到18)

### 18.3 Operation

#### 18.3.1 中断处理和事件链接的关系

事件链接的事件编号与关联中断源的事件编号相同。有关生成事件信号的信息，请参阅每个事件源模块的章节中的说明。

#### 18.3.2 链接事件

当事件发生并且该事件已在事件链接设置寄存器(ELSRn)中设置为触发器时，将激活相关模块。模块的操作必须提前设置好。表18.4列出了事件发生时模块的操作。

Table 18.4 事件发生时的模块操作

| Module    | 输入事件时的操作   |
|-----------|--|
| GPT       | <ul style="list-style-type: none"> <li>开始计数</li> <li>停止计数</li> <li>清除计数</li> <li>向上计数</li> <li>向下计数</li> <li>输入捕捉</li> </ul>   |
| DAC12     | 开始DA转换   |
| I/O Ports | <ul style="list-style-type: none"> <li>根据EORR (复位) 或EOSR (设置) 更改引脚输出</li> <li>EIDR的锁存器引脚状态</li> <li>以下端口可用于ELC:               <ul style="list-style-type: none"> <li>PORT 1</li> <li>PORT 2</li> <li>PORT 3</li> <li>PORT 4</li> </ul> </li> </ul> |
| CTSU      | 开始测量操作   |
| ADC12     | 开始AD转换   |
| DTC       | 开始DTC数据传输  |

#### 18.3.3 链接事件的过程示例

链接事件:

- 1.设置要链接事件的模块的操作。
- 2.为要链接的模块设置适当的ELSRn.ELS[8:0]位。
- 3.将ELCR.ELCON位设置为1以启用所有事件的链接。
- 4.配置输出事件的模块并激活模块。两个模块之间的链接现在处于活动状态。
- 5.要单独停止模块的事件链接，请与模块关联的ELSRn.ELS[8:0]位设置为0。要停止所有事件的链接，请将ELCR.ELCON位设置为0。

如果要使用RTC的事件链接输出，请在RTC设置之后设置ELC，例如，用于初始化和时间设置。如果在ELC设置之后进行RTC设置，则可能会产生意外事件。

如果要使用来自LVD的事件链接输出，请在设置LVD后设置ELC。要禁用LVD，请在将0x00设置为相关的ELSRn寄存器后执行此操作。

18.4 Usage Notes

18.4.1 Linking DMAC/DTC Transfer End Signals as Events

When linking the DMAC/DTC transfer end signals as events, do not set the same peripheral module as the DMAC/DTC transfer destination and event link destination. If set, the peripheral module might be started before DMAC/DTC transfer to the peripheral module is complete.

18.4.2 Setting Clocks

To link events, you must enable the ELC and the related modules. The modules cannot operate if the related modules are in the module-stop state or in low power mode in which the module is stopped (Software Standby mode or Deep Software Standby mode).

Some modules can perform in Snooze mode. For more information, see Table 18.3 and section 10, Low Power Modes.

18.4.3 Module-Stop Function Setting

The Module Stop Control Register C (MSTPCRC) can enable or disable ELC operation. The ELC is initially stopped after reset. Releasing the module-stop state enables access to the registers. The ELCON bit must be set to 0 before disabling ELC operation using the Module Stop Control Register. For more information, see Table 18.3 and section 10, Low Power Modes.

18.4.4 ELC Delay Time

In Figure 18.2, module A accesses module B through the ELC. There is a delay time in the ELC between module A and module B. Table 18.5 shows the ELC delay time.

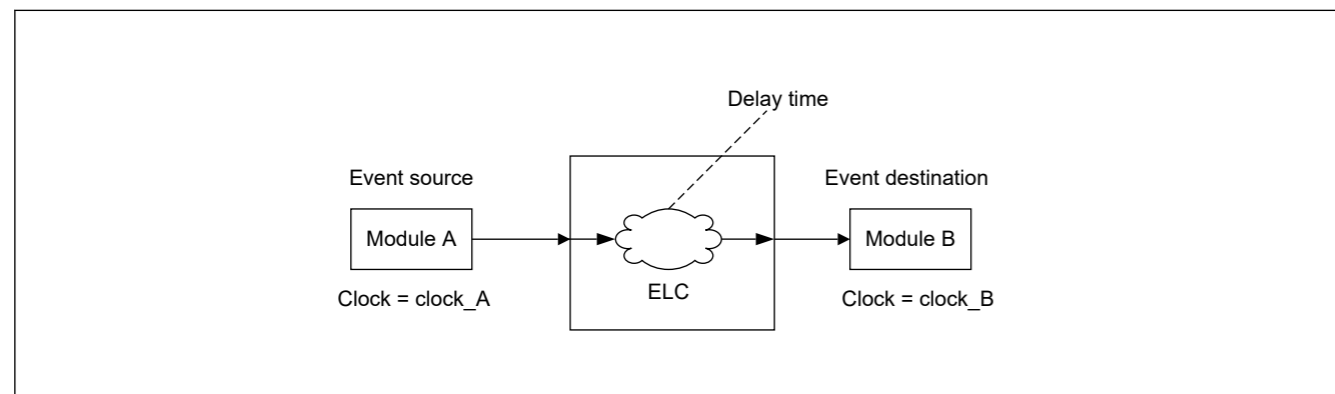


Figure 18.2 ELC delay time

Table 18.5 ELC delay time

| Clock domain      | Clock frequency   | ELC delay time                 |
|-------------------|-------------------|--------------------------------|
| clock_A = clock_B | clock_A = clock_B | 0 cycle                        |
| clock_A ≠ clock_B | clock_A = clock_B | 1 cycle to 2 cycles            |
|                   | clock_A > clock_B | 1 cycle to 2 cycles of clock_B |
|                   | clock_A < clock_B | 1 cycle to 2 cycles of clock_A |

18.4 使用说明

18.4.1 将DMACDTC传输结束信号作为事件链接

将DMACDTC传输结束信号作为事件链接时，请勿将外设模块设置为DMACDTC传输目标和事件链接目标。如果设置，则外围模块可能会在DMACDTC传输到外围模块完成之前启动。

18.4.2 设置时钟

要链接事件，您必须启用ELC和相关模块。如果相关模块处于模块停止状态或模块停止的低功耗模式（软件待机模式或深度软件待机模式），则模块无法运行。

某些模块可以在贪睡模式下执行。有关详细信息，请参阅表18.3和第10节，低功耗模式。

18.4.3 模块停止功能设置

模块停止控制寄存器C(MSTPCRC)可以启用或禁用ELC操作。ELC在复位后最初停止。释放模块停止状态可以访问寄存器。在使用模块停止控制寄存器禁用ELC操作之前，必须将ELCON位设置为0。有关详细信息，请参阅表18.3和第10节，低功耗模式。

18.4.4 ELC延迟时间

在图18.2中，模块A通过ELC访问模块B。模块A和模块B之间的ELC中有一个延迟时间。表18.5显示了ELC延迟时间。

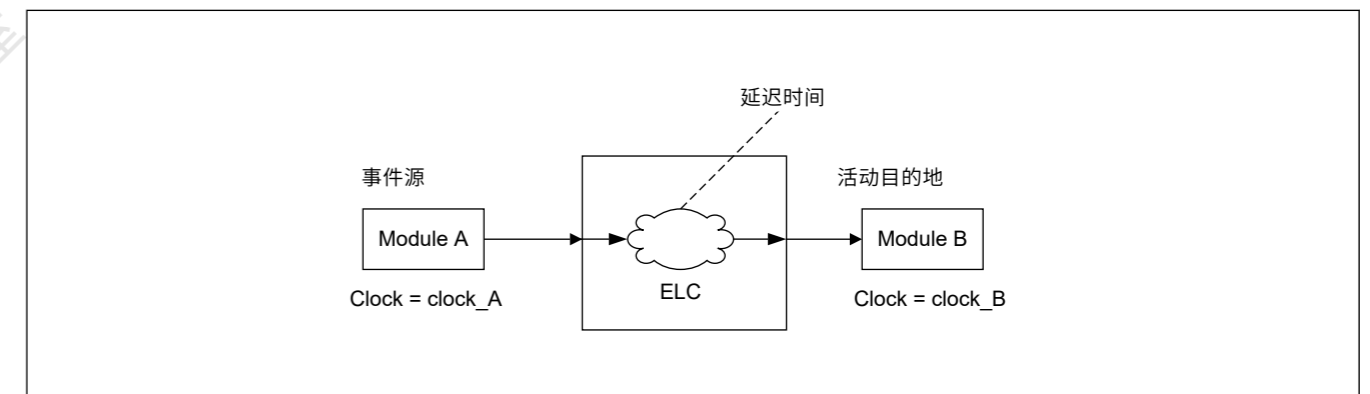


Figure 18.2 ELC延迟时间

Table 18.5 ELC延迟时间

| 时钟域               | 时钟频率              | ELC延迟时间          |
|-------------------|-------------------|------------------|
| clock_A = clock_B | clock_A = clock_B | 0 cycle          |
| clock_A ≠ clock_B | clock_A = clock_B | 1个周期到2个周期        |
|                   | clock_A > clock_B | 1个周期到2个clock_B周期 |
|                   | clock_A < clock_B | 1个周期到2个clock_A周期 |



## 19. I/O Ports

### 19.1 Overview

The I/O port pins operate as general I/O port pins, I/O pins for peripheral modules, interrupt input pins, analog I/O, port group function for the ELC.

All pins except P109 ( as TDO of JTAG ports ) operate as input pins immediately after a reset, and pin functions are switched by register settings. The I/O ports and peripheral modules for each pin are specified in the associated registers.

Figure 19.1 shows a connection diagram for the I/O port registers. The configuration of the I/O ports differs for different packages. Table 19.1 lists the I/O port specifications by package, and Table 19.2 lists the port functions.

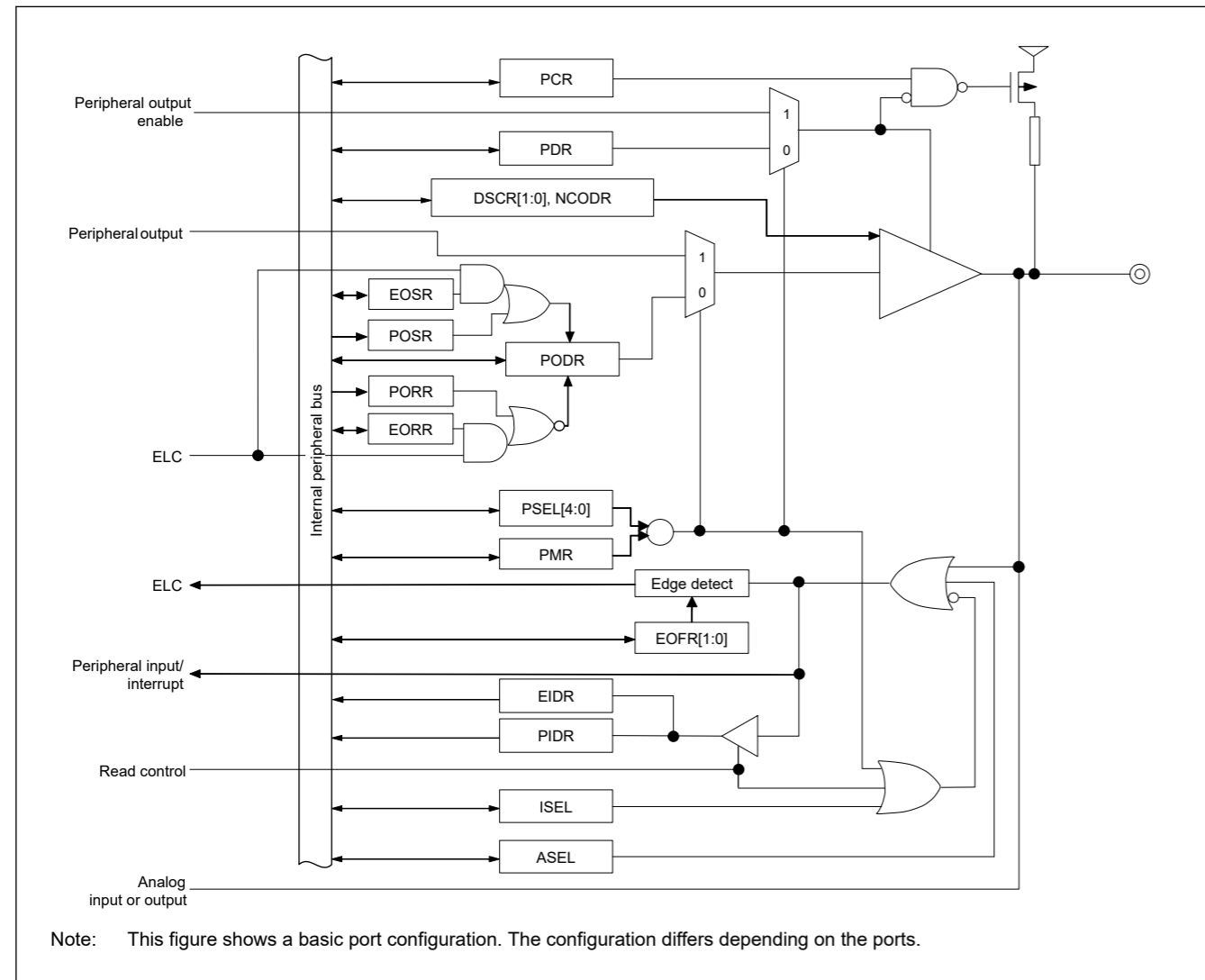


Figure 19.1 Connection diagram for I/O port registers

Table 19.1 I/O port specifications (1 of 2)

| Port  | Package                  |                | Package                  |                | Package                              |                |
|-------|--------------------------|----------------|--------------------------|----------------|--------------------------------------|----------------|
|       | 144 pins                 | Number of pins | 100 pins                 | Number of pins | 64 pins                              | Number of pins |
| PORT0 | P000 to P009, P014, P015 | 12             | P000 to P008, P014, P015 | 11             | P000 to P004, P014, P015             | 7              |
| PORT1 | P100 to P115             | 16             | P100 to P115             | 16             | P100 to P106, P108 to P113           | 13             |
| PORT2 | P200 to P214             | 15             | P200, P201, P205 to P214 | 12             | P200, P201, P205 to P208, P212, P213 | 8              |

## 19. I/O Ports

### 19.1 Overview

IO端口引脚用作通用IO端口引脚、外围模块的IO引脚、中断输入引脚、模拟IO、ELC的端口组功能。

除P109外的所有引脚（作为JTAG端口的TDO）在复位后立即作为输入引脚工作，引脚功能通过寄存器设置切换。每个引脚的IO端口和外围模块在相关寄存器中指定。

图19.1显示了IO端口寄存器的连接图。不同封装的IO端口配置不同。表19.1按封装列出了IO端口规格，表19.2列出了端口功能。

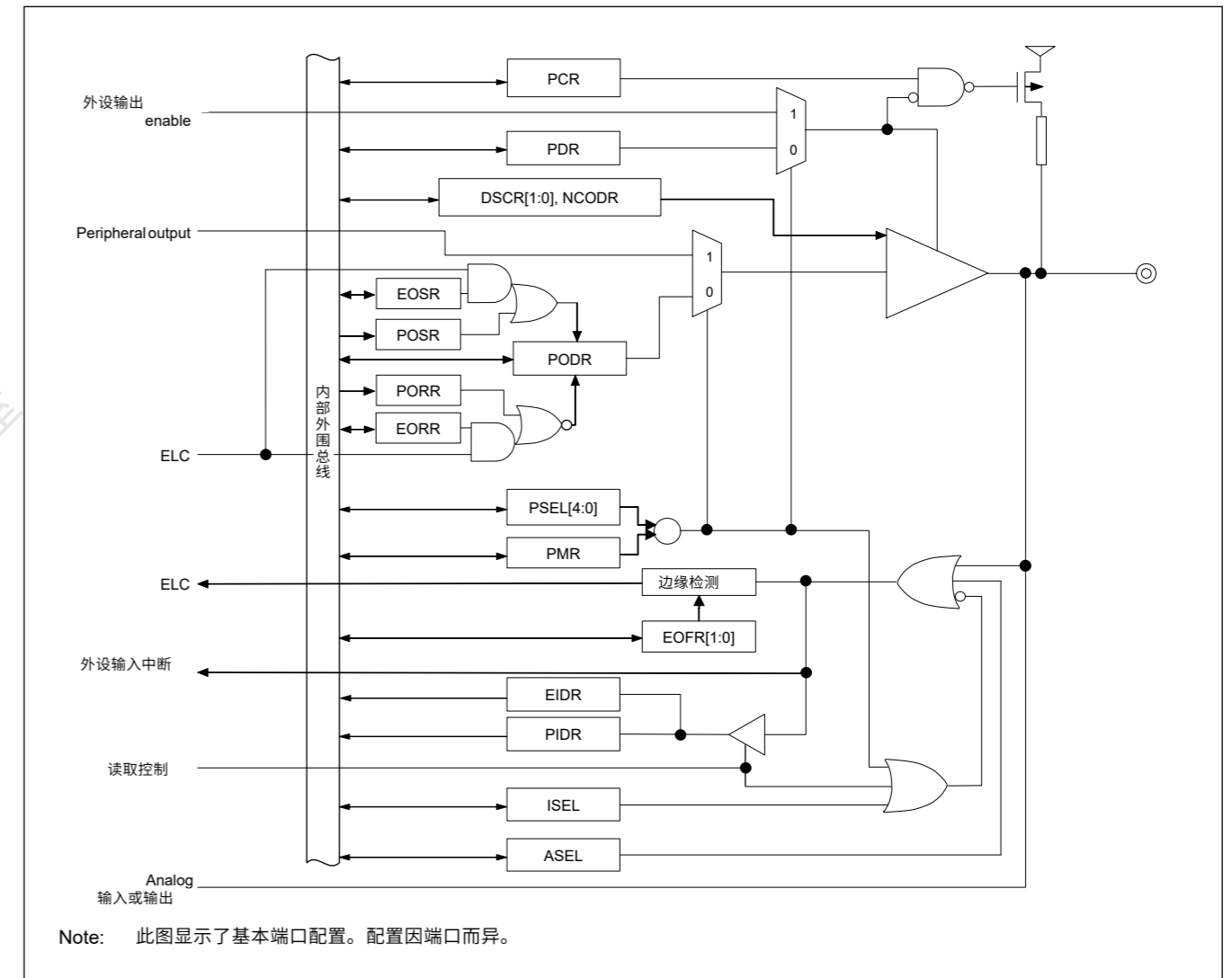


Figure 19.1 IO端口寄存器的连接图

Table 19.1 IO端口规格(1of2)

| Port  | Package                  |     | Package                  |     | Package                              |     |
|-------|--------------------------|-----|--------------------------|-----|--------------------------------------|-----|
|       | 144 pins                 | 引脚数 | 100 pins                 | 引脚数 | 64 pins                              | 引脚数 |
| PORT0 | P000 to P009, P014, P015 | 12  | P000 to P008, P014, P015 | 11  | P000 to P004, P014, P015             | 7   |
| PORT1 | P100 to P115             | 16  | P100 to P115             | 16  | P100 to P106, P108 to P113           | 13  |
| PORT2 | P200 to P214             | 15  | P200, P201, P205 to P214 | 12  | P200, P201, P205 to P208, P212, P213 | 8   |

Table 19.1 I/O port specifications (2 of 2)

| Port  | Package                    |                | Package                    |                | Package                    |                |
|-------|----------------------------|----------------|----------------------------|----------------|----------------------------|----------------|
|       | 144 pins                   | Number of pins | 100 pins                   | Number of pins | 64 pins                    | Number of pins |
| PORT3 | P300 to P313               | 14             | P300 to P307               | 8              | P300 to P304               | 5              |
| PORT4 | P400 to P415               | 16             | P400 to P415               | 16             | P400 to P402, P407 to P411 | 8              |
| PORT5 | P500 to P507,P511, P512    | 10             | P500 to P505               | 6              | P500                       | 1              |
| PORT6 | P600 to P605, P608 to P614 | 13             | P600 to P602, P608 to P610 | 6              | —                          | 0              |
| PORT7 | P700 to P705, P708 to P713 | 12             | P708                       | 1              | —                          | 0              |
| PORT8 | P800, P801                 | 2              | —                          | 0              | —                          | 0              |

Table 19.2 I/O port functions

| Port  | Port name                  | Input pull-up | Open-drain output | Drive capacity switching | 5V tolerant | I/O            |
|-------|----------------------------|---------------|-------------------|--------------------------|-------------|----------------|
| PORT0 | P000 to P009, P014, P015   | ✓             | ✓                 | Low                      | —           | Input / Output |
| PORT1 | P100 to P115               | ✓             | ✓                 | Low, middle, high        | —           | Input / Output |
| PORT2 | P200                       | ✓             | —                 | —                        | —           | Input          |
|       | P201                       | ✓             | ✓                 | Low                      | —           | Input / Output |
|       | P202 to P204, P207 to P214 | ✓             | ✓                 | Low, middle, high        | —           | Input / Output |
|       | P205, P206                 | ✓             | ✓                 | Low, middle, high        | ✓           | Input / Output |
| PORT3 | P300 to P313               | ✓             | ✓                 | Low, middle, high        | —           | Input / Output |
| PORT4 | P400, P401, P407 to P415   | ✓             | ✓                 | Low, middle, high        | ✓           | Input / Output |
|       | P402 to P406               | ✓             | ✓                 | Low, middle, high        | —           | Input / Output |
| PORT5 | P500 to P507               | ✓             | ✓                 | Low, middle, high        | —           | Input / Output |
|       | P511, P512                 | ✓             | ✓                 | Low, middle, high        | ✓           | Input / Output |
| PORT6 | P600 to P605, P608 to P614 | ✓             | ✓                 | Low, middle, high        | —           | Input / Output |
| PORT7 | P700 to P705               | ✓             | ✓                 | Low, middle, high        | —           | Input / Output |
|       | P708 to P713               | ✓             | ✓                 | Low, middle, high        | ✓           | Input / Output |
| PORT8 | P800, P801                 | ✓             | ✓                 | Low, middle, high        | —           | Input / Output |

Note: ✓ : Available  
 — : Setting prohibited

## 19.2 Register Descriptions

### 19.2.1 PCNTR1/PODR/PDR : Port Control Register 1

Base address: PORTm = 0x4008\_0000 + 0x0020 × m (m = 0 to 8)

Offset address: 0x000 (PCNTR1/PODR)  
 0x002 (PDR)

| Bit position:      | 31     | 30     | 29     | 28     | 27     | 26     | 25     | 24     | 23     | 22     | 21     | 20     | 19     | 18     | 17     | 16     |
|--------------------|--------|--------|--------|--------|--------|--------|--------|--------|--------|--------|--------|--------|--------|--------|--------|--------|
| Bit field:         | PODR15 | PODR14 | PODR13 | PODR12 | PODR11 | PODR10 | PODR09 | PODR08 | PODR07 | PODR06 | PODR05 | PODR04 | PODR03 | PODR02 | PODR01 | PODR00 |
| Value after reset: | 0      | 0      | 0      | 0      | 0      | 0      | 0      | 0      | 0      | 0      | 0      | 0      | 0      | 0      | 0      | 0      |
| Bit position:      | 15     | 14     | 13     | 12     | 11     | 10     | 9      | 8      | 7      | 6      | 5      | 4      | 3      | 2      | 1      | 0      |
| Bit field:         | PDR15  | PDR14  | PDR13  | PDR12  | PDR11  | PDR10  | PDR09  | PDR08  | PDR07  | PDR06  | PDR05  | PDR04  | PDR03  | PDR02  | PDR01  | PDR00  |
| Value after reset: | 0      | 0      | 0      | 0      | 0      | 0      | 0      | 0      | 0      | 0      | 0      | 0      | 0      | 0      | 0      | 0      |

Table 19.1 IO端口规格(2of2)

| Port  | Package                    |     | Package                    |     | Package                    |     |
|-------|----------------------------|-----|----------------------------|-----|----------------------------|-----|
|       | 144 pins                   | 引脚数 | 100 pins                   | 引脚数 | 64 pins                    | 引脚数 |
| PORT3 | P300 to P313               | 14  | P300 to P307               | 8   | P300 to P304               | 5   |
| PORT4 | P400 to P415               | 16  | P400 to P415               | 16  | P400 to P402, P407 to P411 | 8   |
| PORT5 | P500 to P507,P511, P512    | 10  | P500 to P505               | 6   | P500                       | 1   |
| PORT6 | P600 to P605, P608 to P614 | 13  | P600 to P602, P608 to P610 | 6   | —                          | 0   |
| PORT7 | P700 to P705, P708 to P713 | 12  | P708                       | 1   | —                          | 0   |
| PORT8 | P800, P801                 | 2   | —                          | 0   | —                          | 0   |

Table 19.2 IO口功能

| Port  | 端口名称                       | Input pull-up | Open-drain output | 驱动容量切换 | 5V tolerant | I/O   |
|-------|----------------------------|---------------|-------------------|--------|-------------|-------|
| PORT0 | P000 to P009, P014, P015   | ✓             | ✓                 | Low    | —           | 输入输出  |
| PORT1 | P100 to P115               | ✓             | ✓                 | 低、中、高  | —           | 输入输出  |
| PORT2 | P200                       | ✓             | —                 | —      | —           | Input |
|       | P201                       | ✓             | ✓                 | Low    | —           | 输入输出  |
|       | P202 to P204, P207 to P214 | ✓             | ✓                 | 低、中、高  | —           | 输入输出  |
|       | P205, P206                 | ✓             | ✓                 | 低、中、高  | ✓           | 输入输出  |
| PORT3 | P300 to P313               | ✓             | ✓                 | 低、中、高  | —           | 输入输出  |
| PORT4 | P400, P401, P407 to P415   | ✓             | ✓                 | 低、中、高  | ✓           | 输入输出  |
|       | P402 to P406               | ✓             | ✓                 | 低、中、高  | —           | 输入输出  |
| PORT5 | P500 to P507               | ✓             | ✓                 | 低、中、高  | —           | 输入输出  |
|       | P511, P512                 | ✓             | ✓                 | 低、中、高  | ✓           | 输入输出  |
| PORT6 | P600 to P605, P608 to P614 | ✓             | ✓                 | 低、中、高  | —           | 输入输出  |
| PORT7 | P700 to P705               | ✓             | ✓                 | 低、中、高  | —           | 输入输出  |
|       | P708 to P713               | ✓             | ✓                 | 低、中、高  | ✓           | 输入输出  |
| PORT8 | P800, P801                 | ✓             | ✓                 | 低、中、高  | —           | 输入输出  |

Note: :可用—:禁止设置

## 19.2 注册说明

### 19.2.1 PCNTR1PODRPDR:端口控制寄存器1

Base address: PORTm = 0x4008\_0000 + 0x0020 × m (m = 0 to 8)

Offset address: 0x000 (PCNTR1/PODR)  
 0x002 (PDR)

| Bit position: | 31     | 30     | 29     | 28     | 27     | 26     | 25     | 24     | 23     | 22     | 21     | 20     | 19     | 18     | 17     | 16     |
|---------------|--------|--------|--------|--------|--------|--------|--------|--------|--------|--------|--------|--------|--------|--------|--------|--------|
| Bit field:    | PODR15 | PODR14 | PODR13 | PODR12 | PODR11 | PODR10 | PODR09 | PODR08 | PODR07 | PODR06 | PODR05 | PODR04 | PODR03 | PODR02 | PODR01 | PODR00 |
| 重置后的值:        | 0      | 0      | 0      | 0      | 0      | 0      | 0      | 0      | 0      | 0      | 0      | 0      | 0      | 0      | 0      | 0      |
| Bit position: | 15     | 14     | 13     | 12     | 11     | 10     | 9      | 8      | 7      | 6      | 5      | 4      | 3      | 2      | 1      | 0      |
| Bit field:    | PDR15  | PDR14  | PDR13  | PDR12  | PDR11  | PDR10  | PDR09  | PDR08  | PDR07  | PDR06  | PDR05  | PDR04  | PDR03  | PDR02  | PDR01  | PDR00  |
| 重置后的值:        | 0      | 0      | 0      | 0      | 0      | 0      | 0      | 0      | 0      | 0      | 0      | 0      | 0      | 0      | 0      | 0      |

| Bit   | Symbol           | Function  | R/W              |
|-------|------------------|---|------------------|
| 15:0  | PDR15 to PDR00   | Pmn Direction<br>0: Input (functions as an input pin)<br>1: Output (functions as an output pin) | R/W <sup>1</sup> |
| 31:16 | PODR15 to PODR00 | Pmn Output Data<br>0: Low output<br>1: High output  | R/W <sup>2</sup> |

Note: m = 0 to 8, n = 00 to 15

Note 1. If the security attribution is configured as Secure,

- Secure access and Non-secure read access are allowed,
- Non-secure write access is ignored, but TrustZone access error is not generated.

If the security attribution is configured as Non-secure,

- Secure and Non-secure access are allowed.

Note 2. If the security attribution is configured as Secure,

- Secure access is allowed,
- Non-secure read value is 0, but TrustZone access error is not generated,
- Non-secure write access is ignored, but TrustZone access error is not generated.

If the security attribution is configured as Non-secure,

- Secure and Non-secure access are allowed.

The Port Control Register 1 (PCNTR1/PODR/PDR) is a 32-bit or 16-bit read/write register that controls port direction and port output data. The PCNTR1 specifies the port direction and output data, and is accessed in 32-bit units. The PDRn (bits [15:0] in PCNTR1) and PODRn (bits [31:16] in PCNTR1) respectively, are accessed in 16-bit units.

### PDRn bits (Pmn Direction)

The PDRn bits select the input or output direction for individual pins on the associated port when the pins are configured as general I/O pins. Each pin on port m is associated with a PORTm.PCNTR1.PDRn bit. The I/O direction can be specified in 1-bit unit. Bits associated with non-existent pins are reserved. Reserved bits are read as 0. The write value should be 0. In the case of input only ports, PDRn bits are reserved. See Table 19.2. The PDRn bit in the PORTm.PCNTR1 register serves the same function as the PDR bit in the PFS.PmnPFS register.

### PODRn bits (Pmn Output Data)

The PODRn bits hold data to be output from the general I/O pins. Bits of non-existent port m are reserved. Reserved bits are read as 0. The write value should be 0. In the case of input only ports, PODRn bits are reserved. See Table 19.2. The PODRn bit in the PORTm.PCNTR1 register serves the same function as the PODR bit in the PFS.PmnPFS register.

## 19.2.2 PCNTR2/EIDR/PIDR : Port Control Register 2

Base address: PORTm = 0x4008\_0000 + 0x0020 × m (m = 0 to 8)

Offset address: 0x004 (PCNTR2/EIDR)  
0x006 (PIDR)

|                    |            |            |            |            |            |            |            |            |            |            |            |            |            |            |            |            |
|--------------------|------------|------------|------------|------------|------------|------------|------------|------------|------------|------------|------------|------------|------------|------------|------------|------------|
| Bit position:      | 31         | 30         | 29         | 28         | 27         | 26         | 25         | 24         | 23         | 22         | 21         | 20         | 19         | 18         | 17         | 16         |
| Bit field:         | EIDR1<br>5 | EIDR1<br>4 | EIDR1<br>3 | EIDR1<br>2 | EIDR1<br>1 | EIDR1<br>0 | EIDR0<br>9 | EIDR0<br>8 | EIDR0<br>7 | EIDR0<br>6 | EIDR0<br>5 | EIDR0<br>4 | EIDR0<br>3 | EIDR0<br>2 | EIDR0<br>1 | EIDR0<br>0 |
| Value after reset: | 0          | 0          | 0          | 0          | 0          | 0          | 0          | 0          | 0          | 0          | 0          | 0          | 0          | 0          | 0          | 0          |
| Bit position:      | 15         | 14         | 13         | 12         | 11         | 10         | 9          | 8          | 7          | 6          | 5          | 4          | 3          | 2          | 1          | 0          |
| Bit field:         | PIDR1<br>5 | PIDR1<br>4 | PIDR1<br>3 | PIDR1<br>2 | PIDR1<br>1 | PIDR1<br>0 | PIDR0<br>9 | PIDR0<br>8 | PIDR0<br>7 | PIDR0<br>6 | PIDR0<br>5 | PIDR0<br>4 | PIDR0<br>3 | PIDR0<br>2 | PIDR0<br>1 | PIDR0<br>0 |
| Value after reset: | x          | x          | x          | x          | x          | x          | x          | x          | x          | x          | x          | x          | x          | x          | x          | x          |

| Bit  | Symbol           | Function                                   | R/W |
|------|------------------|--|-----|
| 15:0 | PIDR15 to PIDR00 | Pmn State<br>0: Low level<br>1: High level | R   |

| Bit   | Symbol           | Function                                       | R/W              |
|-------|------------------|--|------------------|
| 15:0  | PDR15 to PDR00   | Pmn Direction<br>0: 输入 (用作输入引脚) 1: 输出 (用作输出引脚) | R/W <sup>1</sup> |
| 31:16 | PODR15 to PODR00 | Pmn输出数据<br>0: 低输出1:<br>高输出                     | R/W <sup>2</sup> |

Note: m = 0 to 8, n = 00 to 15

注1.如果安全属性配置为Secure, ●

- 允许安全访问和非安全读取访问,
- 忽略非安全写入访问, 但不会生成TrustZone访问错误。

如果安全属性配置为非安全, ●

- 允许安全和非安全访问。

注2.如果安全属性配置为Secure, ●

- 允许安全访问,
- 非安全读取值为0, 但不会产生TrustZone访问错误,
- 忽略非安全写入访问, 但不会生成TrustZone访问错误。

如果安全属性配置为非安全, ●

- 允许安全和非安全访问。

端口控制寄存器1(PCNTR1PODRPDR)是一个32位或16位读写寄存器, 用于控制端口方向和端口输出数据。PCNTR1指定端口方向和输出数据, 并以32位为单位进行访问。PDRn (PCNTR1中的位[15:0])和PODRn (PCNTR1中的位[31:16]) 分别以16位为单位进行访问。

### PDRn bits (Pmn Direction)

当引脚配置为通用IO引脚时, PDRn位选择相关端口上各个引脚的输入或输出方向。端口m上的每个引脚都与一个PORTm.PCNTR1.PDRn位相关联。可以以1位为单位指定IO方向。与不存在的引脚相关的位被保留。保留位读取为0。写入值应为0。在仅输入端口的情况下, 保留PDRn位。见表19.2。PORTm.PCNTR1寄存器中的PDRn位与PFS.PmnPFS寄存器中的PDR位具有相同的功能。

### PODRn位 (Pmn输出数据)

PODRn位保存要从通用IO引脚输出的数据。不存在的端口m的位被保留。保留位读取为0。写入值应为0。在仅输入端口的情况下, 保留PODRn位。见表19.2。PORTm.PCNTR1寄存器中的PODRn位与PFS.PmnPFS寄存器中的PODR位具有相同的功能。

## 19.2.2 PCNTR2/EIDR/PIDR: 端口控制寄存器2

Base address: PORTm = 0x4008\_0000 + 0x0020 × m (m = 0 to 8)

Offset address: 0x004 (PCNTR2/EIDR)  
0x006 (PIDR)

|               |            |            |            |            |            |            |            |            |            |            |            |            |            |            |            |            |
|---------------|------------|------------|------------|------------|------------|------------|------------|------------|------------|------------|------------|------------|------------|------------|------------|------------|
| Bit position: | 31         | 30         | 29         | 28         | 27         | 26         | 25         | 24         | 23         | 22         | 21         | 20         | 19         | 18         | 17         | 16         |
| Bit field:    | EIDR1<br>5 | EIDR1<br>4 | EIDR1<br>3 | EIDR1<br>2 | EIDR1<br>1 | EIDR1<br>0 | EIDR0<br>9 | EIDR0<br>8 | EIDR0<br>7 | EIDR0<br>6 | EIDR0<br>5 | EIDR0<br>4 | EIDR0<br>3 | EIDR0<br>2 | EIDR0<br>1 | EIDR0<br>0 |
| 重置后的值:        | 0          | 0          | 0          | 0          | 0          | 0          | 0          | 0          | 0          | 0          | 0          | 0          | 0          | 0          | 0          | 0          |
| Bit position: | 15         | 14         | 13         | 12         | 11         | 10         | 9          | 8          | 7          | 6          | 5          | 4          | 3          | 2          | 1          | 0          |
| Bit field:    | PIDR1<br>5 | PIDR1<br>4 | PIDR1<br>3 | PIDR1<br>2 | PIDR1<br>1 | PIDR1<br>0 | PIDR0<br>9 | PIDR0<br>8 | PIDR0<br>7 | PIDR0<br>6 | PIDR0<br>5 | PIDR0<br>4 | PIDR0<br>3 | PIDR0<br>2 | PIDR0<br>1 | PIDR0<br>0 |
| 重置后的值:        | x          | x          | x          | x          | x          | x          | x          | x          | x          | x          | x          | x          | x          | x          | x          | x          |

| Bit  | Symbol           | Function                     | R/W |
|------|------------------|------------------------------|-----|
| 15:0 | PIDR15 to PIDR00 | Pmn State<br>0: 低电平1:<br>高电平 | R   |

| Bit   | Symbol              | Function  | R/W |
|-------|---------------------|---|-----|
| 31:16 | EIDR15 to EIDR00 *2 | Port Event Input Data*1<br>When an ELC_PORTx signal occurs<br>0: Low input<br>1: High input | R   |

Note: If the security attribution is configured as Secure,  
 • Secure read access is allowed,  
 • Non-secure read value is 0, but TrustZone access error is not generated.  
 If the security attribution is configured as Non-secure,  
 • Secure and Non-secure read access are allowed.

Note: m = 0 to 8, n = 00 to 15

Note 1. x = 1, 2, 3 or 4 for EIDR only

Note 2. Supported by ports 1, 2, 3 or 4.

The Port Control Register 2 (PCNTR2/EIDR/PIDR) allows read access to the Pmn state and the port event input data using 32-bit or 16-bit access.

The PCNTR2 specifies the Pmn state and the port event input data, and is accessed in 32-bit units.

The PIDRn (bits [15:0] in PCNTR2) and EIDRn (bits [31:16] in PCNTR2) respectively, are accessed in 16-bit units. Bits associated with non-existent pins are reserved. Reserved bits are read as undefined.

**PIDRn bits (Pmn State)**

The PIDRn bits reflect the individual pin states of the port, regardless of the values set in PmnPFS.PMR and PORTm.PCNTR1.PDRn. The PIDRn bit in the PORTm.PCNTR2 register serves the same function as the PIDR bit in the PFS.PmnPFS register.

A pin state cannot be reflected in PIDRn when one of the following functions is enabled:

- RTC Time Capture input (RTCIC)
- Analog function (ASEL = 1)
- Capacitive Touch Sensing Unit (CTSU)

**EIDRn bits (Port Event Input Data)**

The EIDRn bits latch a pin state when an ELC\_PORTx signal occurs. Pin states can only be input to EIDRn when PmnPFS.PMR and PORTm.PCNTR1.PDRn are 0. When the PmnPFS.ASEL bit is set to 1, the associated pin state is not reflected in EIDRn.

**19.2.3 PCNTR3/PORR/POSR : Port Control Register 3**

Base address: PORTm = 0x4008\_0000 + 0x0020 × m (m = 0 to 8)

Offset address: 0x008 (PCNTR3/PORR)  
0x00A (POSR)

|                    |            |            |            |            |            |            |            |            |            |            |            |            |            |            |            |            |
|--------------------|------------|------------|------------|------------|------------|------------|------------|------------|------------|------------|------------|------------|------------|------------|------------|------------|
| Bit position:      | 31         | 30         | 29         | 28         | 27         | 26         | 25         | 24         | 23         | 22         | 21         | 20         | 19         | 18         | 17         | 16         |
| Bit field:         | PORR<br>15 | PORR<br>14 | PORR<br>13 | PORR<br>12 | PORR<br>11 | PORR<br>10 | PORR<br>09 | PORR<br>08 | PORR<br>07 | PORR<br>06 | PORR<br>05 | PORR<br>04 | PORR<br>03 | PORR<br>02 | PORR<br>01 | PORR<br>00 |
| Value after reset: | 0          | 0          | 0          | 0          | 0          | 0          | 0          | 0          | 0          | 0          | 0          | 0          | 0          | 0          | 0          | 0          |
| Bit position:      | 15         | 14         | 13         | 12         | 11         | 10         | 9          | 8          | 7          | 6          | 5          | 4          | 3          | 2          | 1          | 0          |
| Bit field:         | POSR<br>15 | POSR<br>14 | POSR<br>13 | POSR<br>12 | POSR<br>11 | POSR<br>10 | POSR<br>09 | POSR<br>08 | POSR<br>07 | POSR<br>06 | POSR<br>05 | POSR<br>04 | POSR<br>03 | POSR<br>02 | POSR<br>01 | POSR<br>00 |
| Value after reset: | 0          | 0          | 0          | 0          | 0          | 0          | 0          | 0          | 0          | 0          | 0          | 0          | 0          | 0          | 0          | 0          |

| Bit  | Symbol           | Function   | R/W |
|------|------------------|--|-----|
| 15:0 | POSR15 to POSR00 | Pmn Output Set<br>0: No effect on output<br>1: High output | W   |

| Bit   | Symbol              | Function  | R/W |
|-------|---------------------|---|-----|
| 31:16 | EIDR15 to EIDR00 *2 | 端口事件输入数据*1<br>当发生ELC_PORTx信号时<br>0: 低输入<br>1: 高输入 | R   |

Note: 如果安全属性配置为安全, ●  
 允许安全读取访问,  
 • 非安全读取值为0, 但不会产生TrustZone访问错误。  
 如果安全属性配置为非安全, ●  
 允许安全和非安全读取访问。

Note: m = 0 to 8, n = 00 to 15

注1.x=1、2、3或4仅适用于EIDR

注2.端口1、2、3或4支持。

端口控制寄存器2(PCNTR2/EIDR/PIDR)允许使用32位或16位访问对Pmn状态和端口事件输入数据进行读取访问。

PCNTR2指定Pmn状态和端口事件输入数据, 并以32位为单位进行访问。

PIDRn (PCNTR2中的位[15:0]) 和EIDRn (PCNTR2中的位[31:16]) 分别以16位为单位进行访问。与不存在的引脚相关的位被保留。保留位被读取为未定义。

**PIDRn bits (Pmn State)**

PIDRn位反映端口的各个引脚状态, 与PmnPFS.PMR和PORTm.PCNTR1.PDRn。PORTm.PCNTR2寄存器中的PIDRn位与PFS.PmnPFS register。

当启用以下功能之一时, 引脚状态无法反映在PIDRn中:

- RTC时间捕捉输入(RTCIC)
- 模拟功能 (ASEL=1)
- 电容式触控感应单元(CTSU)

**EIDRn位 (端口事件输入数据)**

当ELC\_PORTx信号出现时, EIDRn位锁存引脚状态。引脚状态只能输入到EIDRn时PmnPFS.PMR和PORTm.PCNTR1.PDRn为0。当PmnPFS.ASEL位设置为1时, 相关引脚状态不会反映在EIDRn中。

**19.2.3 PCNTR3PORRPOSR: 端口控制寄存器3**

Base address: PORTm = 0x4008\_0000 + 0x0020 × m (m = 0 to 8)

Offset address: 0x008 (PCNTR3/PORR)  
0x00A (POSR)

|               |            |            |            |            |            |            |            |            |            |            |            |            |            |            |            |            |
|---------------|------------|------------|------------|------------|------------|------------|------------|------------|------------|------------|------------|------------|------------|------------|------------|------------|
| Bit position: | 31         | 30         | 29         | 28         | 27         | 26         | 25         | 24         | 23         | 22         | 21         | 20         | 19         | 18         | 17         | 16         |
| Bit field:    | PORR<br>15 | PORR<br>14 | PORR<br>13 | PORR<br>12 | PORR<br>11 | PORR<br>10 | PORR<br>09 | PORR<br>08 | PORR<br>07 | PORR<br>06 | PORR<br>05 | PORR<br>04 | PORR<br>03 | PORR<br>02 | PORR<br>01 | PORR<br>00 |
| 重置后的值:        | 0          | 0          | 0          | 0          | 0          | 0          | 0          | 0          | 0          | 0          | 0          | 0          | 0          | 0          | 0          | 0          |
| Bit position: | 15         | 14         | 13         | 12         | 11         | 10         | 9          | 8          | 7          | 6          | 5          | 4          | 3          | 2          | 1          | 0          |
| Bit field:    | POSR<br>15 | POSR<br>14 | POSR<br>13 | POSR<br>12 | POSR<br>11 | POSR<br>10 | POSR<br>09 | POSR<br>08 | POSR<br>07 | POSR<br>06 | POSR<br>05 | POSR<br>04 | POSR<br>03 | POSR<br>02 | POSR<br>01 | POSR<br>00 |
| 重置后的值:        | 0          | 0          | 0          | 0          | 0          | 0          | 0          | 0          | 0          | 0          | 0          | 0          | 0          | 0          | 0          | 0          |

| Bit  | Symbol           | Function                      | R/W |
|------|------------------|-------------------------------|-----|
| 15:0 | POSR15 to POSR00 | Pmn输出设置<br>0: 不影响输出<br>1: 高输出 | W   |



| Bit   | Symbol           | Function  | R/W |
|-------|------------------|---|-----|
| 31:16 | PORR15 to PORR00 | Pmn Output Reset<br>0: No effect on output<br>1: Low output | W   |

Note: If the security attribution is configured as Secure,  
 • Secure write access is allowed,  
 • Non-secure write access is ignored, but TrustZone access error is not generated.  
 If the security attribution is configured as Non-secure,  
 • Secure and Non-secure write access are allowed.

Note: m = 0 to 8, n = 00 to 15

The Port Control Register 3 (PCNTR3/PORR/POSR) is a 32-bit or 16-bit write register that controls the setting or resetting of the port output data.

The PCNTR3 controls the setting or resetting of the port output data, and is accessed in 32-bit units.

The POSRn (bits [15:0] in PCNTR3) and the PORRn (bits [31:16] in PCNTR3) respectively, are accessed in 16-bit units.

**POSRn bits (Pmn Output Set)**

POSR changes PODR when set by a software write. For example, for P100, when PORT1.PCNTR3.POSR00 = 1, PORT1.PCNTR1.PODR00 outputs 1. Bits associated with non-existent pins are reserved. The write value should always be 0. In the case of input only ports, POSRn bits are reserved. See Table 19.2.

**PORRn bits (Pmn Output Reset)**

PORR changes PODR when reset by a software write. For example, for P100, when PORT1.PCNTR3.PORR00 = 1, PORT1.PCNTR1.PODR00 outputs 0. Bits associated with non-existent pins are reserved. The write value should always be 0. In the case of input only ports, PORRn bits are reserved. See Table 19.2.

Note: When EORRn or EOSRn is set, writing is prohibited to PODRn, PORRn, and POSRn.  
 Note: PORRn and POSRn should not be set at the same time.

**19.2.4 PCNTR4/EORR/EOSR : Port Control Register 4**

Base address: PORTm = 0x4008\_0000 + 0x0020 × m (m = 1 to 4)

Offset address: 0x00C (PCNTR4/EORR)  
 0x00E (EOSR)

|                    |            |            |            |            |            |            |            |            |            |            |            |            |            |            |            |            |
|--------------------|------------|------------|------------|------------|------------|------------|------------|------------|------------|------------|------------|------------|------------|------------|------------|------------|
| Bit position:      | 31         | 30         | 29         | 28         | 27         | 26         | 25         | 24         | 23         | 22         | 21         | 20         | 19         | 18         | 17         | 16         |
| Bit field:         | EORR<br>15 | EORR<br>14 | EORR<br>13 | EORR<br>12 | EORR<br>11 | EORR<br>10 | EORR<br>09 | EORR<br>08 | EORR<br>07 | EORR<br>06 | EORR<br>05 | EORR<br>04 | EORR<br>03 | EORR<br>02 | EORR<br>01 | EORR<br>00 |
| Value after reset: | 0          | 0          | 0          | 0          | 0          | 0          | 0          | 0          | 0          | 0          | 0          | 0          | 0          | 0          | 0          | 0          |
| Bit position:      | 15         | 14         | 13         | 12         | 11         | 10         | 9          | 8          | 7          | 6          | 5          | 4          | 3          | 2          | 1          | 0          |
| Bit field:         | EOSR<br>15 | EOSR<br>14 | EOSR<br>13 | EOSR<br>12 | EOSR<br>11 | EOSR<br>10 | EOSR<br>09 | EOSR<br>08 | EOSR<br>07 | EOSR<br>06 | EOSR<br>05 | EOSR<br>04 | EOSR<br>03 | EOSR<br>02 | EOSR<br>01 | EOSR<br>00 |
| Value after reset: | 0          | 0          | 0          | 0          | 0          | 0          | 0          | 0          | 0          | 0          | 0          | 0          | 0          | 0          | 0          | 0          |

| Bit   | Symbol           | Function   | R/W |
|-------|------------------|--|-----|
| 15:0  | EOSR15 to EOSR00 | Pmn Event Output Set<br>When an ELC_PORTx signal occurs<br>0: No effect on output<br>1: High output  | R/W |
| 31:16 | EORR15 to EORR00 | Pmn Event Output Reset<br>When an ELC_PORTx signal occurs<br>0: No effect on output<br>1: Low output | R/W |

Note: If the security attribution is configured as Secure,  
 • Secure access is allowed,  
 • Non-secure read value is 0, but TrustZone access error is not generated,  
 • Non-secure write access is ignored, but TrustZone access error is not generated.  
 If the security attribution is configured as Non-secure,

| Bit   | Symbol           | Function                      | R/W |
|-------|------------------|-------------------------------|-----|
| 31:16 | PORR15 to PORR00 | Pmn输出复位<br>0: 对输出无影响1:<br>低输出 | W   |

Note: 如果安全属性配置为安全, ●  
 允许安全写访问,  
 • 忽略非安全写入访问, 但不会生成TrustZone访问错误。  
 如果安全属性配置为非安全, ●  
 允许安全和非安全写访问。

Note: m = 0 to 8, n = 00 to 15

端口控制寄存器3(PCNTR3PORRPOSR)是一个32位或16位写寄存器, 用于控制端口输出数据的设置或复位。

PCNTR3控制端口输出数据的设置或复位, 并以32位为单位进行访问。

POSRn (PCNTR3中的位[15:0]) 和PORRn (PCNTR3中的位[31:16]) 分别以16位为单位进行访问。

**POSRn位 (Pmn输出设置)**

POSR在通过软件写入设置时改变PODR。例如, 对于P100, 当PORT1.PCNTR3.POSR00=1时, PORT1.PCNTR1.PODR00输出1。与不存在的引脚相关的位被保留。写入值应始终为0。在仅输入端口的情况下, 保留POSRn位。见表19.2。

**PORRn位 (Pmn输出复位)**

PORR在通过软件写入复位时改变PODR。例如, 对于P100, 当PORT1.PCNTR3.PORR00=1时, PORT1.PCNTR1.PODR00输出0。与不存在的引脚相关的位被保留。写入值应始终为0。在仅输入端口的情况下, 保留PORRn位。见表19.2。

Note: 当设置EORRn或EOSRn时, 禁止写入PODRn、PORRn和POSRn。  
 Note: PORRn和POSRn不应同时设置。

**19.2.4 PCNTR4EORREOSR: 端口控制寄存器4**

Base address: PORTm = 0x4008\_0000 + 0x0020 × m (m = 1 to 4)

Offset address: 0x00C (PCNTR4/EORR)  
 0x00E (EOSR)

|               |            |            |            |            |            |            |            |            |            |            |            |            |            |            |            |            |
|---------------|------------|------------|------------|------------|------------|------------|------------|------------|------------|------------|------------|------------|------------|------------|------------|------------|
| Bit position: | 31         | 30         | 29         | 28         | 27         | 26         | 25         | 24         | 23         | 22         | 21         | 20         | 19         | 18         | 17         | 16         |
| Bit field:    | EORR<br>15 | EORR<br>14 | EORR<br>13 | EORR<br>12 | EORR<br>11 | EORR<br>10 | EORR<br>09 | EORR<br>08 | EORR<br>07 | EORR<br>06 | EORR<br>05 | EORR<br>04 | EORR<br>03 | EORR<br>02 | EORR<br>01 | EORR<br>00 |
| 重置后的值:        | 0          | 0          | 0          | 0          | 0          | 0          | 0          | 0          | 0          | 0          | 0          | 0          | 0          | 0          | 0          | 0          |
| Bit position: | 15         | 14         | 13         | 12         | 11         | 10         | 9          | 8          | 7          | 6          | 5          | 4          | 3          | 2          | 1          | 0          |
| Bit field:    | EOSR<br>15 | EOSR<br>14 | EOSR<br>13 | EOSR<br>12 | EOSR<br>11 | EOSR<br>10 | EOSR<br>09 | EOSR<br>08 | EOSR<br>07 | EOSR<br>06 | EOSR<br>05 | EOSR<br>04 | EOSR<br>03 | EOSR<br>02 | EOSR<br>01 | EOSR<br>00 |
| 重置后的值:        | 0          | 0          | 0          | 0          | 0          | 0          | 0          | 0          | 0          | 0          | 0          | 0          | 0          | 0          | 0          | 0          |

| Bit   | Symbol           | Function   | R/W |
|-------|------------------|--|-----|
| 15:0  | EOSR15 to EOSR00 | Pmn事件输出集<br>当发生ELC_PORTx信号时<br>0: 不影响输出1: 高<br>输出  | R/W |
| 31:16 | EORR15 to EORR00 | Pmn事件输出复位<br>当发生ELC_PORTx信号时<br>0: 对输出无影响1:<br>低输出 | R/W |

Note: 如果安全属性配置为安全, ●  
 允许安全访问,  
 • 非安全读取值为0, 但不会产生TrustZone访问错误,  
 • 忽略非安全写入访问, 但不会生成TrustZone访问错误。  
 如果安全属性配置为非安全,



- Secure and Non-secure access are allowed.

Note: m = 1 to 4, n = 00 to 15, x = 1 to 4

The Port Control Register 4 (PCNTR4/EORR/EOSR) is a 32-bit or 16-bit read/write register that controls the setting or resetting of the port output data by an event input from the ELC.

The PCNTR4 controls the setting or resetting of the port output data by an event input from the ELC, and is accessed in 32-bit units.

The EOSRn (bits [15:0] in PCNTR4) and EORRn (bits [31:16] in PCNTR4) respectively, are accessed in 16-bit units.

**EOSRn bits (Pmn Event Output Set)**

EOSR changes PODR when set because an ELC\_PORTx signal occurs. For example, for P100 if PORT1.PCNTR4.EOSR00 is set to 1 when the ELC\_PORTx occurs, PORT1.PCNTR1.PODR00 outputs 1. Bits associated with non-existent pins are reserved. The write value should always be 0. In the case of input only ports, EOSRn bits are reserved. See Table 19.2.

**EORRn bits (Pmn Event Output Reset)**

EORR changes PODR when reset because an ELC\_PORTx signal occurs. For example, for P100 if PORT1.PCNTR4.EORR00 = 1 when the ELC\_PORTx occurs, PORT1.PCNTR1.PODR00 outputs 0. Bits associated with non-existent pins are reserved. The write value should always be 0. In the case of input only ports, EORRn bits are reserved. See Table 19.2.

Note: When EORRn or EOSRn is set, writing is prohibited to PODRn, PORRn, and POSRn.

Note: EORRn and EOSRn should not be set at the same time.

**19.2.5 PmnPFS/PmnPFS\_HA/PmnPFS\_BY : Port mn Pin Function Select Register (m = 0 to 8, n = 00 to 15)**

Base address: PFS = 0x4008\_0800

Offset address: 0x000 + 0x040 × m + 0x004 × n (PmnPFS)  
 0x002 + 0x040 × m + 0x004 × n (PmnPFS\_HA)  
 0x003 + 0x040 × m + 0x004 × n (PmnPFS\_BY)

|                    |      |      |           |           |    |                 |    |        |    |     |    |                 |      |      |    |    |                 |
|--------------------|------|------|-----------|-----------|----|-----------------|----|--------|----|-----|----|-----------------|------|------|----|----|-----------------|
| Bit position:      | 31   | 30   | 29        | 28        | 27 | 26              | 25 | 24     | 23 | 22  | 21 | 20              | 19   | 18   | 17 | 16 |                 |
| Bit field:         | —    | —    | —         | PSEL[4:0] |    |                 |    | —      | —  | —   | —  | —               | —    | —    | —  | —  | PMR             |
| Value after reset: | 0    | 0    | 0         | 0         | 0  | 0               | 0  | 0      | 0  | 0   | 0  | 0               | 0    | 0    | 0  | 0  | 0 <sup>*1</sup> |
| Bit position:      | 15   | 14   | 13        | 12        | 11 | 10              | 9  | 8      | 7  | 6   | 5  | 4               | 3    | 2    | 1  | 0  |                 |
| Bit field:         | ASEL | ISEL | EOFR[1:0] | DSCR[1:0] | —  | —               | —  | NCOD R | —  | PCR | —  | PDR             | PIDR | PODR | —  | —  |                 |
| Value after reset: | 0    | 0    | 0         | 0         | 0  | 0 <sup>*1</sup> | 0  | 0      | 0  | 0   | 0  | 0 <sup>*1</sup> | 0    | 0    | x  | 0  |                 |

| Bit | Symbol | Function   | R/W              |
|-----|--------|--|------------------|
| 0   | PODR   | Port Output Data<br>0: Low output<br>1: High output  | R/W <sup>3</sup> |
| 1   | PIDR   | Pmn State<br>0: Low level<br>1: High level   | R <sup>4</sup>   |
| 2   | PDR    | Port Direction<br>0: Input (functions as an input pin)<br>1: Output (functions as an output pin) | R/W <sup>5</sup> |
| 3   | —      | This bit is read as 0. The write value should be 0.  | R/W              |
| 4   | PCR    | Pull-up Control<br>0: Disable input pull-up<br>1: Enable input pull-up                           | R/W <sup>5</sup> |
| 5   | —      | This bit is read as 0. The write value should be 0.  | R/W              |

- 允许安全和非安全访问。

Note: m = 1 to 4, n = 00 to 15, x = 1 to 4

端口控制寄存器4(PCNTR4/EORR/EOSR)是一个32位或16位读写寄存器，通过来自ELC的事件输入来控制端口输出数据的设置或复位。

PCNTR4通过来自ELC的事件输入来控制端口输出数据的设置或复位，并以32位为单位进行访问。

分别以16位为单位访问EOSRn (PCNTR4中的位[15:0])和EORRn (PCNTR4中的位[31:16])。

**EOSRn位 (Pmn事件输出设置)**

EOSR在设置时会更改PODR，因为发生ELC\_PORTx信号。例如，对于P100，如果在ELC\_PORTx发生时PORT1.PCNTR4.EOSR00设置为1，则PORT1.PCNTR1.PODR00输出1。与不存在的引脚相关的位被保留。写入值应始终为0。在仅输入端口的情况下，保留EOSRn位。见表19.2。

**EORRn位 (Pmn事件输出复位)**

EORR会在复位时更改PODR，因为发生ELC\_PORTx信号。例如，对于P100，如果PORT1.PCNTR4.EORR00=1当ELC\_PORTx发生时，PORT1.PCNTR1.PODR00输出0。与不存在的引脚相关的位被保留。写入值应始终为0。在仅输入端口的情况下，保留EORRn位。见表19.2。

Note: 当设置EORRn或EOSRn时，禁止写入PODRn、PORRn和POSRn。

Note: EORRn和EOSRn不应同时设置。

**19.2.5 PmnPFS/PmnPFS\_HA/PmnPFS\_BY:端口mn引脚功能选择寄存器 (m=0到8, n=00到15)**

Base address: PFS = 0x4008\_0800

Offset address: 0x000 + 0x040 × m + 0x004 × n (PmnPFS)  
 0x002 + 0x040 × m + 0x004 × n (PmnPFS\_HA)  
 0x003 + 0x040 × m + 0x004 × n (PmnPFS\_BY)

|               |      |      |           |           |    |                 |    |        |    |     |    |                 |      |      |    |    |                 |
|---------------|------|------|-----------|-----------|----|-----------------|----|--------|----|-----|----|-----------------|------|------|----|----|-----------------|
| Bit position: | 31   | 30   | 29        | 28        | 27 | 26              | 25 | 24     | 23 | 22  | 21 | 20              | 19   | 18   | 17 | 16 |                 |
| Bit field:    | —    | —    | —         | PSEL[4:0] |    |                 |    | —      | —  | —   | —  | —               | —    | —    | —  | —  | PMR             |
| 重置后的值:        | 0    | 0    | 0         | 0         | 0  | 0               | 0  | 0      | 0  | 0   | 0  | 0               | 0    | 0    | 0  | 0  | 0 <sup>*1</sup> |
| Bit position: | 15   | 14   | 13        | 12        | 11 | 10              | 9  | 8      | 7  | 6   | 5  | 4               | 3    | 2    | 1  | 0  |                 |
| Bit field:    | ASEL | ISEL | EOFR[1:0] | DSCR[1:0] | —  | —               | —  | NCOD R | —  | PCR | —  | PDR             | PIDR | PODR | —  | —  |                 |
| 重置后的值:        | 0    | 0    | 0         | 0         | 0  | 0 <sup>*1</sup> | 0  | 0      | 0  | 0   | 0  | 0 <sup>*1</sup> | 0    | 0    | x  | 0  |                 |

| Bit | Symbol | Function                                  | R/W              |
|-----|--------|---|------------------|
| 0   | PODR   | 端口输出数据<br>0: 低输出1:<br>高输出                 | R/W <sup>3</sup> |
| 1   | PIDR   | Pmn State<br>0: 低电平1:<br>: 高电平            | R <sup>4</sup>   |
| 2   | PDR    | 港口方向<br>0: 输入 (用作输入引脚) 1: 输出 (用作输出引脚)     | R/W <sup>5</sup> |
| 3   | —      | 该位读取为0。写入值应为0。                            | R/W              |
| 4   | PCR    | Pull-up Control<br>0: 禁止输入上拉1: 使<br>能输入上拉 | R/W <sup>5</sup> |
| 5   | —      | 该位读取为0。写入值应为0。                            | R/W              |

| Bit   | Symbol    | Function   | R/W              |
|-------|-----------|--|------------------|
| 6     | NCODR     | N-Channel Open-Drain Control<br>0: CMOS output<br>1: NMOS open-drain output  | R/W <sup>5</sup> |
| 9:7   | —         | These bits are read as 0. The write value should be 0.   | R/W              |
| 11:10 | DSCR[1:0] | Port Drive Capability<br>0 0: Low drive<br>0 1: Middle drive<br>1 0: Setting prohibited<br>1 1: High drive   | R/W <sup>5</sup> |
| 13:12 | EOFR[1:0] | Event on Falling/Event on Rising <sup>*2</sup><br>0 0: Don't care<br>0 1: Detect rising edge<br>1 0: Detect falling edge<br>1 1: Detect both edges | R/W <sup>5</sup> |
| 14    | ISEL      | IRQ Input Enable<br>0: Not used as an IRQn input pin<br>1: Used as an IRQn input pin   | R/W <sup>5</sup> |
| 15    | ASEL      | Analog Input Enable<br>0: Not used as an analog pin<br>1: Used as an analog pin  | R/W <sup>5</sup> |
| 16    | PMR       | Port Mode Control<br>0: Used as a general I/O pin<br>1: Used as an I/O port for peripheral functions   | R/W <sup>5</sup> |
| 23:17 | —         | These bits are read as 0. The write value should be 0.   | R/W              |
| 28:24 | PSEL[4:0] | Peripheral Select<br>These bits select the peripheral function. For individual pin functions, see the associated tables in this chapter.           | R/W <sup>5</sup> |
| 31:29 | —         | These bits are read as 0. The write value should be 0.   | R/W              |

Note 1. The initial value of P108, P109, P110, P201 and P300 is not 0x0000\_0000. P108 is 0x0001\_0410, P109 is 0x0001\_0400, P110 is 0x0001\_0010, P201 is 0x0000\_0010, and P300 is 0x0001\_0010.

Note 2. Supported by PORTn (n = 1 to 4).

Note 3. If the security attribution is configured as Secure,

- Secure access is allowed,
- Non-secure read value is 0, but TrustZone access error is not generated,
- Non-secure write access is ignored, but TrustZone access error is not generated.

If the security attribution is configured as Non-secure,

- Secure and Non-secure access are allowed.

Note 4. If the security attribution is configured as Secure,

- Secure read access is allowed,
- Non-secure read value is 0, but TrustZone access error is not generated.

If the security attribution is configured as Non-secure,

- Secure and Non-secure read access are allowed.

Note 5. If the security attribution is configured as Secure,

- Secure access and Non-secure read access are allowed,
- Non-secure write access is ignored, but TrustZone access error is not generated.

If the security attribution is configured as Non-secure,

- Secure and Non-secure access are allowed.

Port mn Pin Function Select Register (PmnPFS/PmnPFS\_HA/PmnPFS\_BY) is a 32-bit, 16-bit, or 8-bit read/write control register that selects the port mn pin function, and is accessed in 32-bit units. PmnPFS\_HA (PmnPFS [15:0] bits) is accessed in 16-bit units. PmnPFS\_BY (PmnPFS[7:0] bits) is accessed in 8-bit units.

The available Port mn pin depends on the product. For details, see [Table 19.1](#)

#### PODR bit (Port Output Data), PIDR bit (Port State), PDR bit (Port Direction)

The PDR, PIDR, and PODR bits serve the same function as the PCNTR. When these bits are read, the PCNTR value is read.

| Bit   | Symbol    | Function  | R/W              |
|-------|-----------|---|------------------|
| 6     | NCODR     | N-Channel Open-Drain Control<br>0: CMOS output<br>1: NMOS open-drain output | R/W <sup>5</sup> |
| 9:7   | —         | 这些位被读取为0。写入值应为0。  | R/W              |
| 11:10 | DSCR[1:0] | 端口驱动能力<br>00: 低驱动01: 中驱动10: 禁止设置11: 高驱动                                     | R/W <sup>5</sup> |
| 13:12 | EOFR[1:0] | 下降事件上升事件*2<br>00: 无关01: 检测上升沿10: 检测下降沿11: 检测两个沿                             | R/W <sup>5</sup> |
| 14    | ISEL      | IRQ输入使能<br>0: 不用作IRQn输入引脚1: 用作IRQn输入引脚                                      | R/W <sup>5</sup> |
| 15    | ASEL      | 模拟输入使能<br>0: 不用作模拟引脚1: 用作模拟引脚   | R/W <sup>5</sup> |
| 16    | PMR       | 端口模式控制<br>0: 用作通用IO引脚1: 用作外围功能的IO端口   | R/W <sup>5</sup> |
| 23:17 | —         | 这些位被读取为0。写入值应为0。  | R/W              |
| 28:24 | PSEL[4:0] | 外设选择<br>这些位选择外设功能。对于各个引脚功能，请参见本章中的相关表格。                                     | R/W <sup>5</sup> |
| 31:29 | —         | 这些位被读取为0。写入值应为0。  | R/W              |

注1.P108、P109、P110、P201、P300的初始值不是0x0000\_0000。P108为0x0001\_0410，P109为0x0001\_0400，P110为0x0001\_0010，P201为0x0000\_0010，P300为0x0001\_0010。

注2.受PORTn支持（n=1至4）。

注3.如果安全属性配置为Secure，●

- 允许安全访问，
- 非安全读取值为0，但不会产生TrustZone访问错误，
- 忽略非安全写入访问，但不会生成TrustZone访问错误。

如果安全属性配置为非安全，●

- 允许安全和非安全访问。

注4.如果安全属性配置为Secure，●

- 允许安全读取访问，
- 非安全读取值为0，但不会产生TrustZone访问错误。

如果安全属性配置为非安全，●

- 允许安全和非安全读取访问。

注5.如果安全属性配置为Secure，●

- 允许安全访问和非安全读取访问，
- 忽略非安全写入访问，但不会生成TrustZone访问错误。

如果安全属性配置为非安全，●

- 允许安全和非安全访问。

端口mn引脚功能选择寄存器（PmnPFS/PmnPFS\_HA/PmnPFS\_BY）是选择端口mn引脚功能的32位、16位或8位读写控制寄存器，以32位为单位进行访问。PmnPFS\_HA（PmnPFS[15:0]位）以16位为单位进行访问。PmnPFS\_BY（PmnPFS[7:0]位）以8位为单位进行访问。

可用的端口mn引脚取决于产品。详见表19.1

#### PODR位（端口输出数据）、PIDR位（端口状态）、PDR位（端口方向）

PDR、PIDR和PODR位的功能与PCNTR相同。读取这些位时，将读取PCNTR值。

**PCR bit (Pull-up Control)**

The PCR bit enables or disables an input pull-up resistor on the individual port pins. When a pin is in the input state with the associated bit in PmnPFS.PCR set to 1, the pull-up resistor connected to the pin is enabled. When a pin is set as a general port output pin, or a peripheral function output pin, the pull-up resistor for the pin is disabled regardless of the PCR setting. The pull-up resistor is also disabled in the reset state. Bits associated with non-existent pins are reserved. Reserved bits are read as 0. The write value should be 0.

**NCODR bit (N-Channel Open-Drain Control)**

The NCODR bit specifies the output type for the port pins. Bits associated with non-existent pins are reserved. Reserved bits are read as 0. The write value should be 0.

**DSCR[1:0] bits (Port Drive Capability)**

The DSCR[1:0] bits switches the drive capacity of the port. If the drive capacity of a pin is fixed, the associated bit is a read/write bit, but the drive capacity cannot be changed. Bits associated with non-existent pins are reserved. Reserved bits are read as 0. The write value should be 0.

**EOFR[1:0] bits (Event on Falling/Event on Rising)**

The EOFR[1:0] bits select the edge detection method for the port group input signal. These bits support rising, falling, or both edge detections. When the EOFR[1:0] bits are set to 01b, 10b, or 11b, the input enable of the I/O cell is asserted. Following that, the event pulse is input from the external pin, and the GPIO outputs the event pulse to the ELC. Bits associated with non-existent pins are reserved. Reserved bits are read as 0. The write value should be 0.

**ISEL bit (IRQ Input Enable)**

The ISEL bit specifies IRQ input pins. This setting can be used in combination with the peripheral functions, although an IRQn (external pin interrupt) of the same number must only be enabled for one pin. The ISEL bit for an unspecified IRQn is reserved.

**ASEL bit (Analog Input Enable)**

The ASEL bit specifies analog pins. When a pin is set as an analog pin by this bit:

1. Specify it as a general I/O port in the Port Mode Control bit (PmnPFS.PMR).
2. Disable the pull-up resistor in the Pull-up Control bit (PmnPFS.PCR).
3. Specify the input in the Port Direction bit (PmnPFS.PDR). The pin state cannot be read at this point. The PmnPFS register is protected by the Write-Protect Register (PWPR). Release write-protect before modifying the register.

The ASEL bit for an unspecified analog I/O pin is reserved.

**PMR bit (Port Mode Control)**

The PMR bit specifies the port pin function. Bits associated with non-existent pins are reserved. The write value should be 0.

**PSEL[4:0] bits (Peripheral Select)**

The PSEL[4:0] bits assign the peripheral function.

**19.2.6 PWPR : Write-Protect Register**

Base address: PFS = 0x4008\_0800

Offset address: 0x503

|                    |      |       |   |   |   |   |   |   |
|--------------------|------|-------|---|---|---|---|---|---|
| Bit position:      | 7    | 6     | 5 | 4 | 3 | 2 | 1 | 0 |
| Bit field:         | BOWI | PFSWE | — | — | — | — | — | — |
| Value after reset: | 1    | 0     | 0 | 0 | 0 | 0 | 0 | 0 |

**PCR bit (Pull-up Control)**

PCR位启用或禁用各个端口引脚上的输入上拉电阻。当引脚处于输入状态且PmnPFS.PCR中的相关位设置为1时，连接到该引脚的上拉电阻被启用。当引脚设置为通用端口输出引脚或外围功能输出引脚时，无论PCR设置如何，该引脚的上拉电阻都被禁用。上拉电阻在复位状态下也被禁用。与不存在的引脚相关的位被保留。保留位读取为0。写入值应为0。

**NCODR bit (N-Channel Open-Drain Control)**

NCODR位指定端口引脚的输出类型。与不存在的引脚相关的位被保留。保留位读取为0。写入值应为0。

**DSCR[1:0]位 (端口驱动能力)**

DSCR[1:0]位切换端口的驱动能力。如果某个管脚的驱动能力是固定的，那么相关的位就是一个读写位，但是驱动能力是不能改变的。与不存在的引脚相关的位被保留。保留位读取为0。写入值应为0。

**EOFR[1:0]位 (下降事件上升事件)**

EOFR[1:0]位选择端口组输入信号的边沿检测方法。这些位支持上升沿、下降沿或两个边沿检测。当EOFR[1:0]位设置为01b、10b或11b时，IO单元的输入使能有效。随后，事件脉冲从外部引脚输入，GPIO将事件脉冲输出到ELC。与不存在的引脚相关的位被保留。保留位读取为0。写入值应为0。

**ISEL位 (IRQ输入使能)**

ISEL位指定IRQ输入引脚。此设置可以与外围功能结合使用，尽管相同编号的IRQn (外部引脚中断) 只能为一个引脚启用。未指定的IRQn的ISEL位被保留。

**ASEL位 (模拟输入使能)**

ASEL位指定模拟引脚。当一个引脚被该位设置为模拟引脚时:

- 1.在端口模式控制位(PmnPFS.PMR)中将其指定为通用IO端口。
- 2.在上拉控制位(PmnPFS.PCR)中禁用上拉电阻。
- 3.在端口方向位(PmnPFS.PDR)中指定输入。此时无法读取引脚状态。PmnPFS寄存器受写保护寄存器(PWPR)保护。在修改寄存器之前释放写保护。

未指定的模拟IO引脚的ASEL位被保留。

**PMR位 (端口模式控制)**

PMR位指定端口引脚功能。与不存在的引脚相关的位被保留。写入值应为0。

**PSEL[4:0] bits (Peripheral Select)**

PSEL[4:0]位分配外设功能。

**19.2.6 PWPR : Write-Protect Register**

Base address: PFS = 0x4008\_0800

Offset address: 0x503

|               |      |       |   |   |   |   |   |   |
|---------------|------|-------|---|---|---|---|---|---|
| Bit position: | 7    | 6     | 5 | 4 | 3 | 2 | 1 | 0 |
| Bit field:    | BOWI | PFSWE | — | — | — | — | — | — |
| 重置后的值:        | 1    | 0     | 0 | 0 | 0 | 0 | 0 | 0 |

| Bit | Symbol | Function  | R/W |
|-----|--------|---|-----|
| 5:0 | —      | These bits are read as 0. The write value should be 0.  | R/W |
| 6   | PFSWE  | PmnPFS Register Write Enable<br>0: Writing to the PmnPFS register is disabled<br>1: Writing to the PmnPFS register is enabled | R/W |
| 7   | B0WI   | PFSWE Bit Write Disable<br>0: Writing to the PFSWE bit is enabled<br>1: Writing to the PFSWE bit is disabled                  | R/W |

**PFSWE bit (PmnPFS Register Write Enable)**

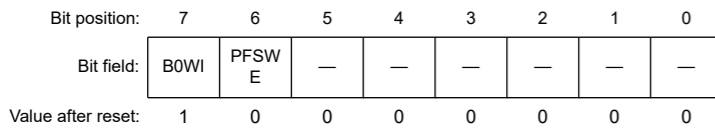
Writing to the PmnPFS register is enabled only when the PFSWE bit is set to 1. You must first write 0 to the B0WI bit before setting PFSWE to 1.

**B0WI bit (PFSWE Bit Write Disable)**

Writing to the PFSWE bit is enabled only when the B0WI bit is set to 0.

**19.2.7 PWPRS : Write-Protect Register for Secure**

Base address: PFS = 0x4008\_0800  
Offset address: 0x505



| Bit | Symbol | Function  | R/W |
|-----|--------|---|-----|
| 5:0 | —      | These bits are read as 0. The write value should be 0.  | R/W |
| 6   | PFSWE  | PmnPFS Register Write Enable<br>0: Disable writes to the PmnPFS register<br>1: Enable writes to the PmnPFS register | R/W |
| 7   | B0WI   | PFSWE Bit Write Disable<br>0: Enable writes the PFSWE bit<br>1: Disable writes to the PFSWE bit                     | R/W |

Note: Only secure access can write to this register. Both secure access and Non-secure read access are allowed but Non-secure write access is not allowed and TrustZone access error is not generated.  
Note: This register is write-protected by PRCR register.

**PFSWE bit (PmnPFS Register Write Enable)**

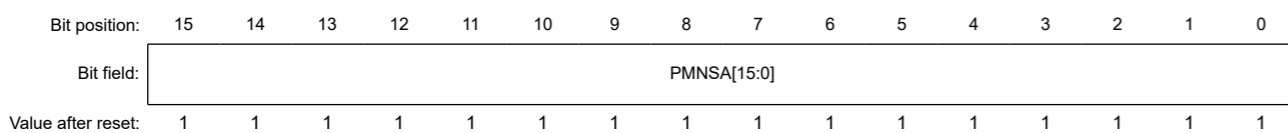
Writing to the PmnPFS register of the IO port pin set as secure by the PmSAR register is enabled only when the PFSWE bit is set to 1. You must first write 0 to the B0WI bit before setting PFSWE to 1.

**B0WI bit (PFSWE Bit Write Disable)**

Writing to the PFSWE bit is enabled only when the B0WI bit is set to 0.

**19.2.8 PmSAR : Port Security Attribution register (m = 0 to 8)**

Base address: PFS = 0x4008\_0800  
Offset address: 0x510 + 0x002 × m



| Bit | Symbol | Function   | R/W |
|-----|--------|--|-----|
| 5:0 | —      | 这些位被读取为0。写入值应为0。                                 | R/W |
| 6   | PFSWE  | PmnPFS寄存器写使能<br>0: 禁止写入PmnPFS寄存器1: 允许写入PmnPFS寄存器 | R/W |
| 7   | B0WI   | PFSWE位写入禁用<br>0: 允许写入PFSWE位1: 禁止写入PFSWE位         | R/W |

**PFSWE位 (PmnPFS寄存器写使能)**

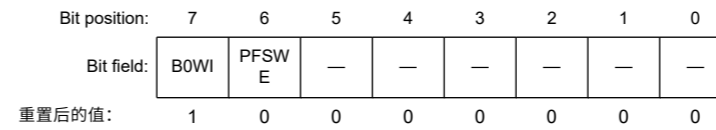
仅当PFSWE位设置为1时才允许写入PmnPFS寄存器。您必须先将0写入B0WI位，然后再将PFSWE设置为1。

**B0WI位 (PFSWE位写入禁用)**

仅当B0WI位设置为0时才允许写入PFSWE位。

**19.2.7 PWPRS:安全的写保护寄存器**

Base address: PFS = 0x4008\_0800  
Offset address: 0x505



| Bit | Symbol | Function   | R/W |
|-----|--------|--|-----|
| 5:0 | —      | 这些位被读取为0。写入值应为0。                                 | R/W |
| 6   | PFSWE  | PmnPFS寄存器写使能<br>0: 禁止写入PmnPFS寄存器1: 允许写入PmnPFS寄存器 | R/W |
| 7   | B0WI   | PFSWE位写入禁用<br>0: 允许写入PFSWE位1: 禁止写入PFSWE位         | R/W |

Note: 只有安全访问才能写入该寄存器。允许安全访问和非安全读取访问，但不允许非安全写入访问，并且不会生成TrustZone访问错误。  
Note: 该寄存器由PRCR寄存器写保护。

**PFSWE位 (PmnPFS寄存器写使能)**

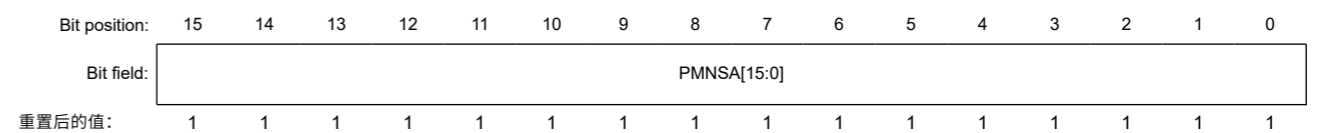
仅当PFSWE位设置为1时，才能写入由PmSAR寄存器设置为安全的IO端口引脚的PmnPFS寄存器。您必须先将0写入B0WI位，然后才能将PFSWE设置为1。

**B0WI位 (PFSWE位写入禁用)**

仅当B0WI位设置为0时才允许写入PFSWE位。

**19.2.8 PmSAR: 端口安全属性寄存器 (m=0到8)**

Base address: PFS = 0x4008\_0800  
Offset address: 0x510 + 0x002 × m





| Bit  | Symbol      | Function  | R/W |
|------|-------------|---|-----|
| 15:0 | PMNSA[15:0] | Pmn Security Attribution<br>Target I/O port pin : Pmn<br>0: Secure<br>1: Non Secure | R/W |

Note: Only secure access can write to this register. Both secure access and Non-secure read access are allowed but Non-secure write access is not allowed and TrustZone access error is not generated.

Note: This register is write-protected by PRCR register.

Note: m = 0 to 8, n = 00 to 15

Port Security Attribution Register is a 16-bit register that setting the Security Attribution of the each port, the registers are accessed only in 16-bit units.

### PMNSA[15:0] bits (Pmn Security Attribution)

The PmnSA bit specifies the Security Attribution of Pmn.

## 19.3 Operation

### 19.3.1 General I/O Ports

All pins except P108 to P110, and P300 operate as general I/O ports after reset. General I/O ports are organized as 16 bits per port and can be accessed by port with the Port Control Registers (PCNTRn, where n = 1 to 4), or by individual pins with the Port mn Pin Function Select register. For details on these registers, see [section 19.2. Register Descriptions](#).

Each port has the following bits:

- Port Security Attribution register (PmSAR)(m = 0 to 8), which indicates the security attribution.
- Port Direction bit (PDRn), which selects input or output direction
- Port Output Data bit (PODRn), which holds data for output
- Port Input Data bit (PIDRn), which indicates the pin states
- Event Input Data bit (EIDRn), which indicates the pin state when an ELC\_PORTn (n = 1, 2, 3 or 4) signal occurs
- Port Output Set bit (POSRn), which indicates the output value when a software write occurs
- Port Output Reset bit (PORRn), which indicates the output value when a software write occurs
- Event Output Set bit (EOSRn), which indicates the output value when an ELC\_PORTn (n = 1, 2, 3 or 4) signal occurs
- Event Output Reset bit (EORRn), which indicates the output value when an ELC\_PORTn (n = 1, 2, 3 or 4) signal occurs.

### 19.3.2 Port Function Select

The following port functions are available for configuring each pin:

- Security function: Security attribution for each pins.
- I/O configuration: Complementary or open-drain output, pull-up control, and drive strength
- General I/O port: Port direction, output data setting, and read input data
- Alternate function: Configured function mapping to the pin.

Each pin is associated with a Port mn Pin Function Select register (PmnPFS), which includes the associated PODR, PIDR, and PDR bits. In addition, the PmnPFS register includes the following:

- PCR: Pull-up resistor control bit that turns the input pull-up MOS on or off
- NCODR: N-channel open-drain control bit that selects the output type for each pin
- DSCR[1:0]: Drive capacity control bit that selects the drive capacity
- EOFR[1:0]: For selecting the edge of the event that input from the port group
- ISEL: IRQ input enable bit to specify an IRQ input pin
- ASEL: Analog input enable bit to specify an analog pin

| Bit  | Symbol      | Function                             | R/W |
|------|-------------|--------------------------------------|-----|
| 15:0 | PMNSA[15:0] | Pmn安全属性目标IO端口引脚: Pmn<br>0: 安全 1: 不安全 | R/W |

Note: 只有安全访问才能写入该寄存器。允许安全访问和非安全读取访问，但不允许非安全写入访问，并且不会生成TrustZone访问错误。

Note: 该寄存器由PRCR寄存器写保护。

Note: m = 0 to 8, n = 00 to 15

端口安全属性寄存器是一个16位的寄存器，用于设置每个端口的安全属性，寄存器只能以16位为单位访问。

### PMNSA[15:0]位 (Pmn安全属性)

PmnSA位指定Pmn的安全属性。

## 19.3 Operation

### 19.3.1 通用IO端口

除P108至P110和P300外的所有引脚在复位后都作为通用IO端口工作。通用IO端口组织为每个端口16位，可以通过端口控制寄存器 (PCNTRn, 其中n=1到4) 通过端口访问，或者通过端口mn引脚功能选择寄存器通过单个引脚访问。有关这些寄存器的详细信息，请参阅第19.2节。注册说明。

每个端口都有以下位:

- 端口安全属性寄存器 (PmSAR) (m=0~8)，表示安全属性。
- 端口方向位 (PDRn)，选择输入或输出方向
- 端口输出数据位 (PODRn)，用于保存输出数据
- 端口输入数据位 (PIDRn)，指示引脚状态
- 事件输入数据位 (EIDRn)，当ELC\_PORTn (n=1、2、3或4) 信号发生时指示引脚状态
- 端口输出设置位 (POSRn)，表示发生软件写时的输出值
- 端口输出复位位 (PORRn)，表示发生软件写入时的输出值
- 事件输出设置位 (EOSRn)，表示发生ELC\_PORTn (n=1、2、3或4) 信号时的输出值
- 事件输出复位位 (EORRn)，指示发生ELC\_PORTn (n=1、2、3或4) 信号时的输出值。

### 19.3.2 端口功能选择

以下端口功能可用于配置每个引脚:

- 安全功能: 每个引脚的安全属性。
- IO配置: 互补或开漏输出、上拉控制和驱动强度
- 通用IO口: 端口方向、输出数据设置、读取输入数据
- 备用功能: 配置的功能映射到引脚。

每个引脚都与一个端口mn引脚功能选择寄存器(PmnPFS)相关联，该寄存器包括相关的PODR、PIDR和PDR位。此外，PmnPFS寄存器包括以下内容:

- PCR: 上拉电阻控制位，打开或关闭输入上拉MOS
- NCODR: N沟道开漏控制位，用于选择每个引脚的输出类型
- DSCR[1:0]: 驱动容量控制位，选择驱动容量
- EOFR[1:0]: 用于选择从端口组输入的事件的边沿
- ISEL: IRQ输入使能位，用于指定IRQ输入引脚
- ASEL: 模拟输入使能位，用于指定模拟引脚



- PMR: Port mode bit to specify the pin function of each port
- PSEL[4:0]: Port function select bits to select the associated peripheral function.

These configurations can be made by a single-register access to the Port mn Pin Function Select register. For details, see [section 19.2.5. PmnPFS/PmnPFS\\_HA/PmnPFS\\_BY : Port mn Pin Function Select Register \(m = 0 to 8, n = 00 to 15\)](#).

### 19.3.3 Port Group Function for ELC

In the MCU, Port 1 to Port 4 are assigned for the ELC port group function.

#### 19.3.3.1 Behavior When ELC\_PORTn (n = 1, 2, 3 or 4) is Input from ELC

The MCU supports the two functions described in this section when an ELC\_PORTn (n = 1, 2, 3 or 4) signal comes from the ELC.

##### (1) Input to EIDR

For the GPI function (PDR = 0 and PMR = 0 in the PmnPFS register), when an ELC\_PORTn (n = 1, 2, 3 or 4) signal comes from the ELC, the input enable of the I/O cell is asserted, and data from the external pins are read into the EIDR bit. See [Figure 19.2](#)

For the GPO function (PDR = 1) or the peripheral mode (PMR = 1), 0 is input into the EIDR bit from the external pins.

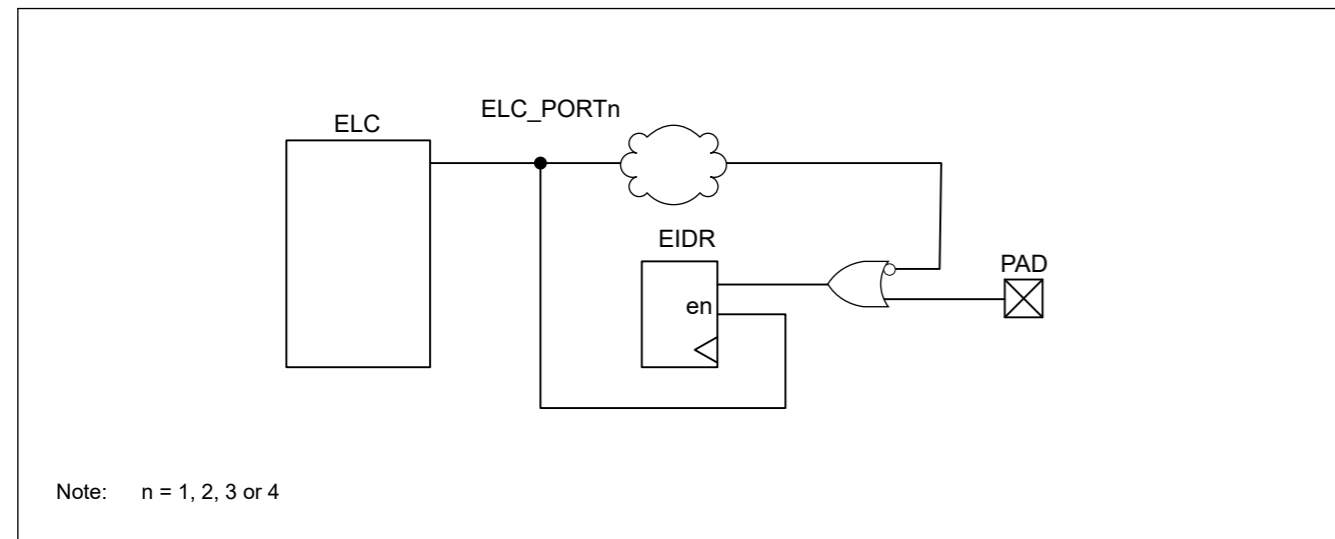


Figure 19.2 Event ports input data

##### (2) Output from PODR by EOSR and EORR

When an ELC\_PORTn (n = 1, 2, 3 or 4) signal occurs, the data is output from the PODR to the external pin based on the settings in the EOSR and EORR registers.

- If EOSR is set to 1, when an ELC\_PORTn (n = 1, 2, 3 or 4) signal occurs, the PODR register outputs 1 to the external pin. Otherwise, when EOSR = 0, the PODR value is retained.
- If EORR is set to 1, when ELC\_PORTn (n = 1, 2, 3 or 4) signal occurs, the PODR register outputs 0 to the external pin. Otherwise, when EORR = 0, the PODR value is retained.

- PMR: 端口模式位, 指定每个端口的引脚功能
- PSEL[4:0]: 端口功能选择位, 用于选择相关的外设功能。

这些配置可以通过单个寄存器访问端口mn引脚功能选择寄存器来进行。详见19.2.5节。PmnPFS/PmnPFS\_HA/PmnPFS\_BY: 端口mn引脚功能选择寄存器 (m=0到8, n=00到15)。

### 19.3.3 ELC的端口组功能

在MCU中, 端口1到端口4被分配用于ELC端口组功能。

#### 19.3.3.1 当ELC\_PORTn (n=1、2、3或4) 从ELC输入时的行为

当ELC\_PORTn (n=1、2、3或4) 信号来自ELC时, MCU支持本节中描述的两种功能。

##### (1) 输入到EIDR

对于GPI功能 (PmnPFS寄存器中的PDR=0和PMR=0), 当ELC\_PORTn (n=1、2、3或4) 信号来自ELC时, IO单元的输入使能有效, 并且数据从外部引脚读入EIDR位。见图19.2

对于GPO功能(PDR=1)或外设模式(PMR=1), 0从外部引脚输入到EIDR位。

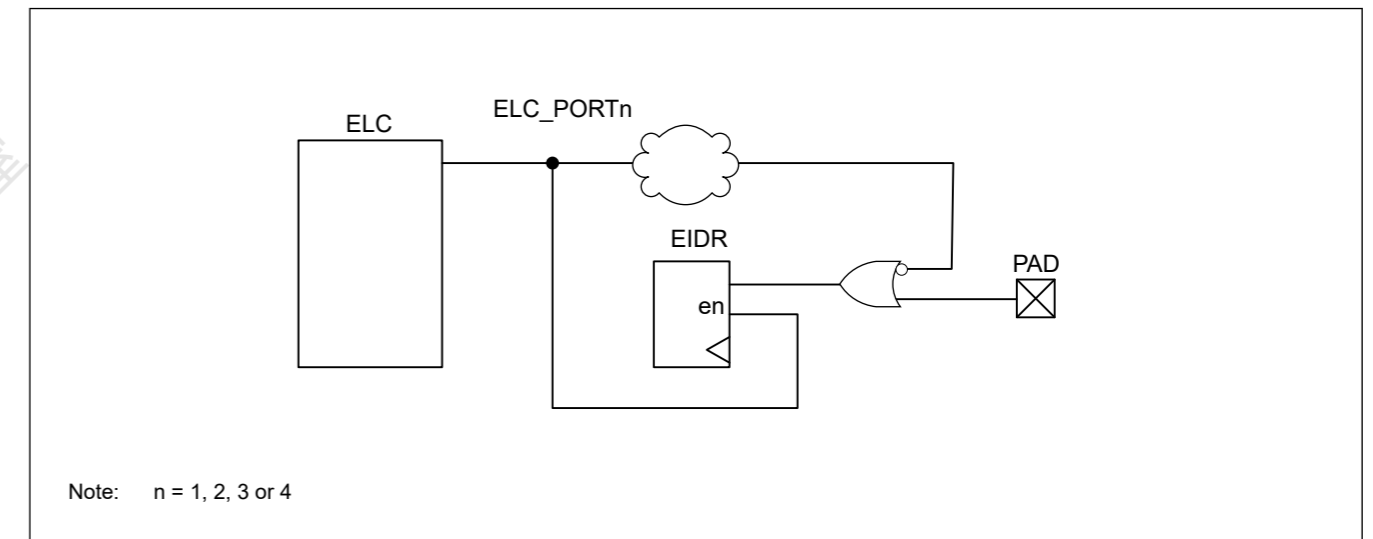


Figure 19.2 事件端口输入数据

##### (2) EOSR和EORR从PODR输出

当ELC\_PORTn (n=1、2、3或4) 信号发生时, 数据会根据EOSR和EORR寄存器中的设置从PODR输出到外部引脚。

- 如果EOSR设置为1, 当ELC\_PORTn(n=1 2 3or4)信号出现时, PODR寄存器输出1到外部引脚。否则, 当EOSR=0时, 保留PODR值。
- 如果EORR设置为1, 当ELC\_PORTn(n=1 2 3or4)信号出现时, PODR寄存器输出0到外部引脚。否则, 当EORR=0时, 保留PODR值。

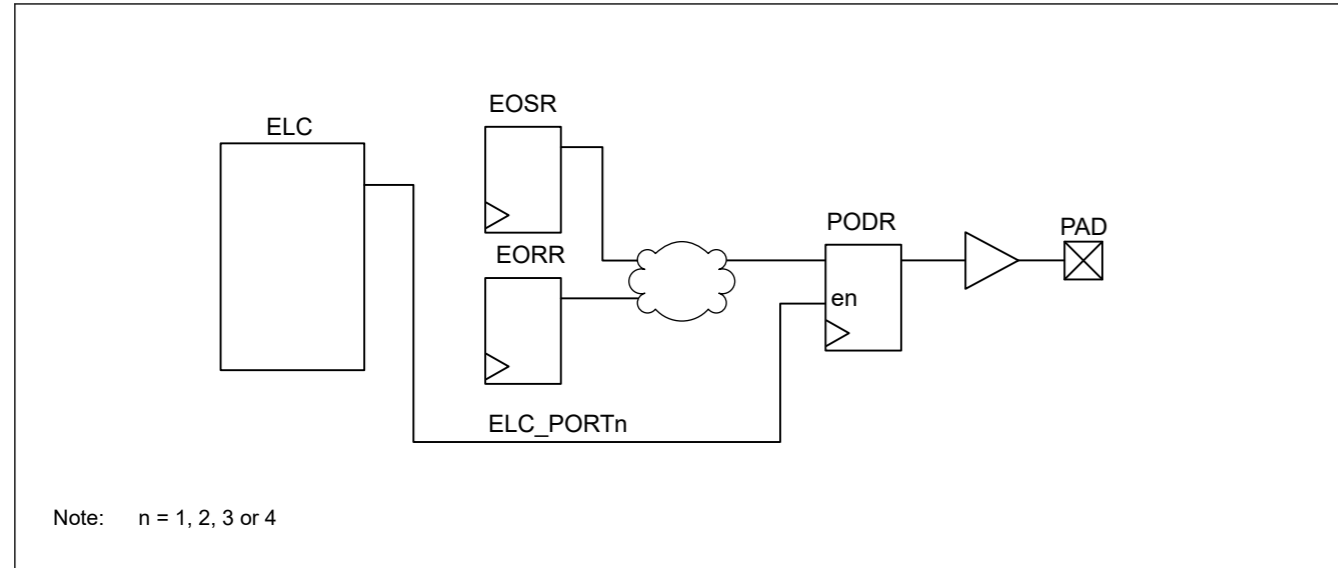


Figure 19.3 Event ports output data

### 19.3.3.2 Behavior When an Event Pulse is Output to ELC

To output the event pulse from the external pins to the ELC, set the EOFR[1:0] bits in the PmnPFS register. For details, see section 19.2.5. PmnPFS/PmnPFS\_HA/PmnPFS\_BY : Port mn Pin Function Select Register (m = 0 to 8, n = 00 to 15). When the EOFR[1:0] bits are set, the input enable of the I/O cell is asserted.

Data from the external pin is the input. For example, for PORT1, when the data is input from P100 to P115, the data of those 16 pins is organized by OR logic. This data is formed into a one-shot pulse that goes to the ELC. The operation of PORTn (n = 2 to 4) is also the same as PORT1. See Figure 19.4.

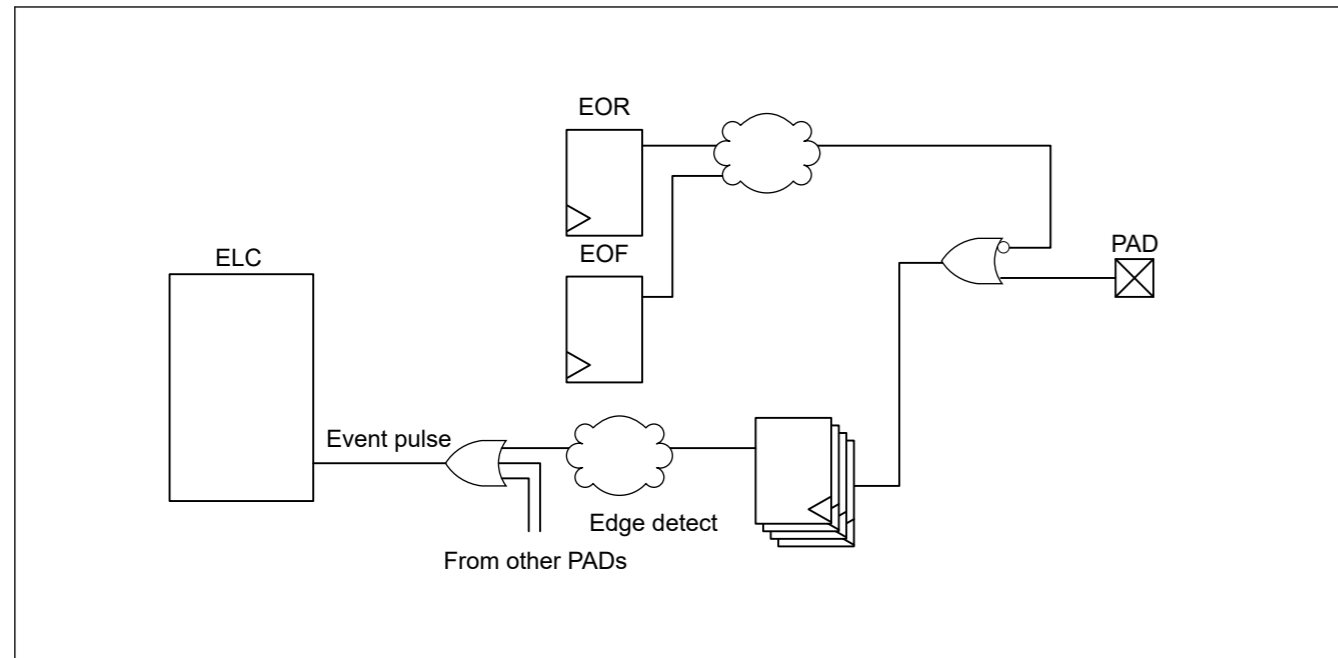


Figure 19.4 Generation of event pulse

## 19.4 Handling of Unused Pins

Table 19.3 shows how to handle unused pins.

Table 19.3 Handling of unused pins (1 of 2)

| Pin name | Description |
|----------|-------------|
|----------|-------------|

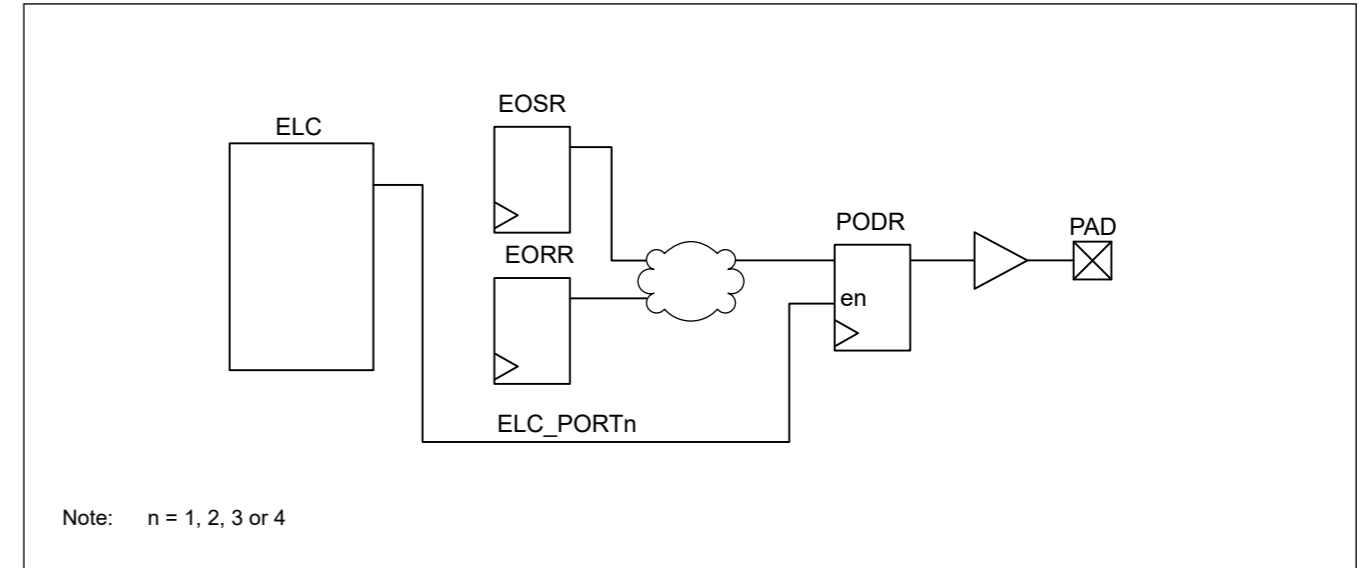


Figure 19.3 事件端口输出数据

### 19.3.3.2 事件脉冲输出到ELC时的行为

要将事件脉冲从外部引脚输出到ELC，请设置PmnPFS寄存器中的EOF[1:0]位。详见19.2.5节。PmnPFS/PmnPFS\_HA/PmnPFS\_BY：端口mn引脚功能选择寄存器（m=0到8，n=00到15）。当EOF[1:0]位被置位时，IO单元的输入使能被置位。

来自外部引脚的数据是输入。例如，对于PORT1，当数据从P100输入到P115时，这16个引脚的数据由OR逻辑组织。该数据形成一个单次脉冲，该脉冲进入ELC。PORTn（n=2至4）的操作也与PORT1相同。请参见图19.4。

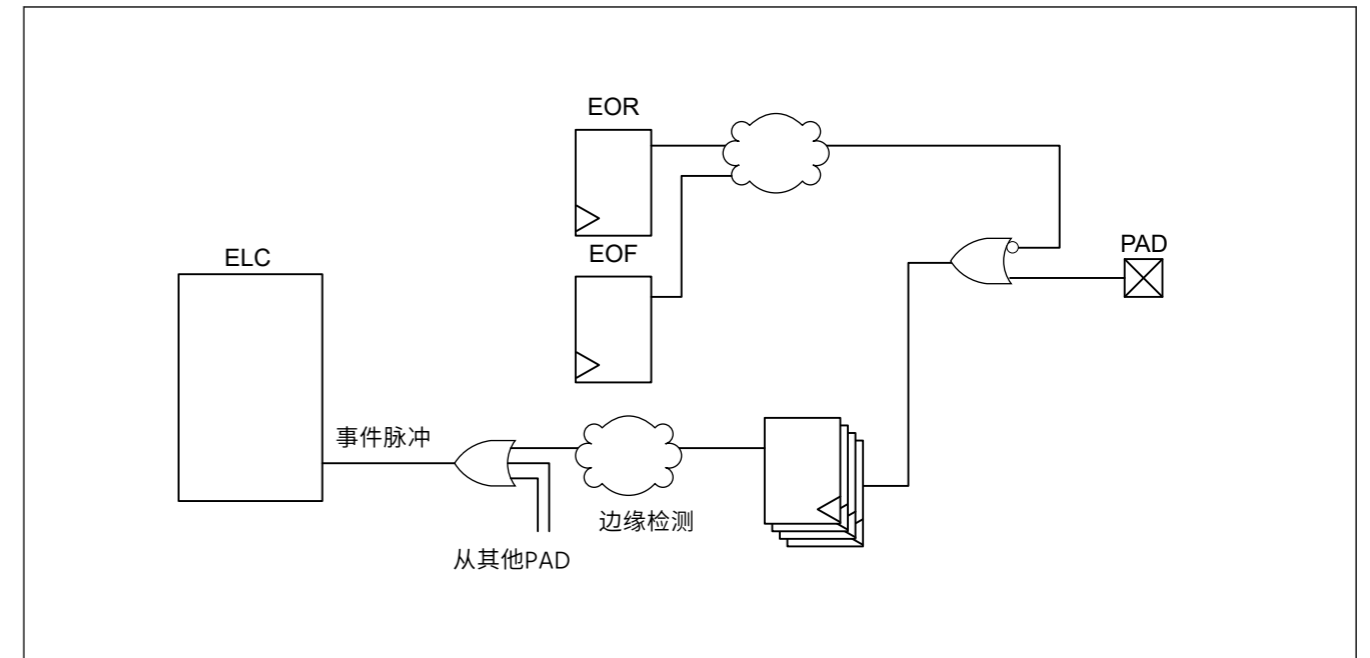


Figure 19.4 事件脉冲的产生

## 19.4 未使用引脚的处理

表19.3显示了如何处理未使用的引脚。

Table 19.3 处理未使用的引脚(1of2)

| 引脚名称 | Description |
|------|-------------|
|------|-------------|

Table 19.3 Handling of unused pins (2 of 2)

|               |   |
|---------------|---|
| MD            | Use as a mode selection pin   |
| RES           | Connect to VCC through a resistor (pulling up)  |
| USB_DP        | Keep pin open   |
| USB_DM        | Keep pin open   |
| P200/NMI      | Connect to VCC through a resistor (pulling up)  |
| EXTAL         | When the main clock oscillator is not used, set the MOSCCR.MOSTP bit to 1 (general port P212). When this pin is not used as port P212, configure it in the same way as ports 1 to 8.  |
| XTAL          | When the main clock oscillator is not used, set the MOSCCR.MOSTP bit to 1 (general port P213). When the external clock is input to the EXTAL pin, the XTAL pin functions as P213. When this pin is not used as port P213, configure it in the same way as ports 1 to 8.                                 |
| XCIN          | Connect to VSS through a resistor (pulling down)  |
| XCOU          | Keep pin open   |
| P000 to P015  | <ul style="list-style-type: none"> <li>If the direction is set to input (PCNTR1.PDRn = 0), connect the associated pin to AVCC0 (pulled up) through a resistor or to AVSS0 (pulled down) through a resistor.*1</li> <li>If the direction is set to output (PCNTR1.PDRn = 1), keep pin open.*1</li> </ul> |
| P1x to P8x    | <ul style="list-style-type: none"> <li>If the direction is set to input (PCNTR1.PDRn = 0), connect the associated pin to VCC (pulled up) through a resistor or to VSS (pulled down) through a resistor.*1*2</li> <li>If the direction is set to output (PCNTR1.PDRn = 1), keep pin open.*1*3</li> </ul> |
| VREFH0, VREFH | Connect to AVCC0  |
| VREFL0, VREFL | Connect to AVSS0  |
| VBATT         | Connect to VCC or VSS.  |

Note 1. Clear the PmnPFS.PMR, PmnPFS.ISEL, PmnPFS.PCR, and PmnPFS.ASEL bits to 0.

Note 2. P108, P110, and P300 are recommended for pull up VCC (pulled up) through a resistor, because these pins are input pull-up enabled from the initial value (PmnPFS.PCR = 1).

Note 3. P109 is recommended for setting the direction to output (PCNTR1.PDRn = 1), because this pin is output from the initial value.

## 19.5 Usage Notes

### 19.5.1 Procedure for Specifying the Pin Functions

To specify the I/O pin functions:

1. Clear the B0WI bit in the PWPR register. This enables writing to the PFSWE bit in the PWPR register.\*1
2. Set 1 to the PFSWE bit in the PWPR register. This enables writing to the PmnPFS register.\*1
3. Clear the Port Mode Control bit in the PMR to 0 for the target pin to select the general I/O port.
4. Specify the I/O function for the pin through the PSEL[4:0] bits settings in the PmnPFS register.
5. Set the PMR bit to 1 as required to switch to the selected I/O function for the pin.
6. Clear the PFSWE bit in the PWPR register. This disables writing to the PmnPFS register.\*1
7. Set 1 to the B0WI bit in the PWPR register. This disables writing to the PFSWE bit in the PWPR register.\*1

Note 1. When the security attribution of Pmn is set to 0, should to set the PWPRS register to enable writing the PmnPFS register.

### 19.5.2 Procedure for Using Port Group Input

To use the port group input (port n (n = 1 to 4)):

1. Set the ELSRx.ELS[8:0] bits to all 0 to ignore unexpected pulses. For more information, see [section 18, Event Link Controller \(ELC\)](#).
2. Set the EOFR[1:0] bits of the PmnPFS register to specify the rising, falling, or both edge detections.
3. Execute a dummy read or wait for a short time, for example 100 ns. Ignoring of unexpected pulses depends on the initial value of the external pin.

Table 19.3 处理未使用的引脚 (2个中的2个)

|               |  |
|---------------|--|
| MD            | 用作模式选择引脚   |
| RES           | 通过一个电阻连接到VCC (上拉)  |
| USB_DP        | 保持引脚打开   |
| USB_DM        | 保持引脚打开   |
| P200/NMI      | 通过一个电阻连接到VCC (上拉)  |
| EXTAL         | 不使用主时钟振荡器时, 将MOSCCR.MOSTP位设置为1 (通用端口P212)。当该管脚不作为端口P212使用时, 配置方式与端口1到8相同。  |
| XTAL          | 不使用主时钟振荡器时, 将MOSCCR.MOSTP位设置为1 (通用端口P213)。当外部时钟输入到EXTAL引脚时, XTAL引脚起到P213的作用。当该管脚不作为端口P213使用时, 配置方式与端口1到8相同。  |
| XCIN          | 通过一个电阻连接到VSS (下拉)  |
| XCOU          | 保持引脚打开   |
| P000 to P015  | <ul style="list-style-type: none"> <li>如果方向设置为输入(PCNTR1.PDRn=0), 则通过电阻器将相关引脚连接到AVCC0 (上拉) 或通过电阻器连接到AVSS0 (下拉)*1</li> <li>如果方向设置为输出(PCNTR1.PDRn=1), 则保持引脚开路。*1</li> </ul> |
| P1x to P8x    | <ul style="list-style-type: none"> <li>如果方向设置为输入(PCNTR1.PDRn=0), 则通过电阻将相关引脚连接到VCC (上拉) 或通过电阻连接到VSS (下拉)。*1*2</li> <li>如果方向设置为输出(PCNTR1.PDRn=1), 则保持引脚开路。*1*3</li> </ul>  |
| VREFH0, VREFH | 连接到AVCC0   |
| VREFL0, VREFL | 连接到AVSS0   |
| VBATT         | 连接到VCC或VSS。  |

注1.将PmnPFS.PMR、PmnPFS.ISEL、PmnPFS.PCR和PmnPFS.ASEL位清零。

注2.推荐使用P108、P110和P300通过电阻上拉VCC (上拉), 因为这些引脚从初始值 (PmnPFS.PCR=1) 开始输入上拉使能。

注3.推荐使用P109设置输出方向 (PCNTR1.PDRn=1), 因为该引脚是从初始值输出的。

## 19.5 使用说明

### 19.5.1 指定引脚功能的步骤

要指定IO引脚功能:

- 1.将PWPR寄存器中的B0WI位清零。这允许写入PWPR寄存器中的PFSWE位。\*1
- 2.将PWPR寄存器中的PFSWE位设置为1。这允许写入PmnPFS寄存器。\*1
- 3.将PMR中的PortModeControl位清为0, 以便目标引脚选择通用IO端口。
- 4.通过PmnPFS寄存器中的PSEL[4:0]位设置指定引脚的IO功能。
- 5.根据需要PMR位设置为1, 以切换到为引脚选择的IO功能。
- 6.将PWPR寄存器中的PFSWE位清零。这将禁止写入PmnPFS寄存器。\*1
- 7.将PWPR寄存器中的B0WI位设置为1。这将禁止写入PWPR寄存器中的PFSWE位。\*1

注1.当Pmn的安全属性设置为0时, 应设置PWPRS寄存器以允许写入PmnPFS寄存器。

### 19.5.2 使用端口组输入的过程

要使用端口组输入 (端口n (n=1到4)):

- 1.将ELSRx.ELS[8:0]位设置为全0以忽略意外脉冲。有关详细信息, 请参阅第18节, 事件链接控制器(ELC)。
- 2.设置PmnPFS寄存器的EOFR[1:0]位以指定上升沿、下降沿或两个边沿检测。
- 3.执行虚拟读取或等待一小段时间, 例如100ns。忽略意外脉冲取决于外部引脚的初始值。

- Set the ELSRx.ELS[8:0] bits to enable the event signals.

### 19.5.3 Port Output Data Register (PODR) Summary

This register outputs data as follows:

- Outputs 0 if PCNTR4.EORR is set to 1 when ELC\_PORTn (n = 1, 2, 3 or 4) signal occurs.
- Outputs 1 if PCNTR4.EOSR is set to 1 when ELC\_PORTn (n = 1, 2, 3 or 4) signal occurs.
- Outputs 0 if PCNTR3.PORR is set to 1.
- Outputs 1 if PCNTR3.POSR is set to 1.
- Outputs 0 or 1 because PCNTR1.PODRn is set.
- Outputs 0 or 1 because PmnPFS.PODRn is set.

Numbers in this list correspond to the priority for writing to the PODRn. For example, if 1. and 3. from the list occur at the same time, the higher priority event 1. is executed.

### 19.5.4 Notes on Using Analog Functions

To use an analog function, set the Port Mode Control bit (PMR) and the Port Direction bit (PDRn) to 0 so that the pin acts as a general input port. Next, set the Analog Input Enable bit (ASEL) in the Port mn Pin Function Select Register (PmnPFS.ASEL) to 1.

### 19.5.5 I/O Buffer Specification

The P402, P403, and P404 can be used as the RTC input, AGT input and other peripheral functions. Table 19.4 lists the P402, P403, P404 specifications.

Table 19.4 P402, P403, P404 specifications

| I/O port | RTC and AGT                       |        |                                      | Other peripheral                 |   |
|----------|-----------------------------------|--------|--------------------------------------|----------------------------------|---|
|          | RTC and AGT input enable register | RTC    | AGT                                  | other peripheral enable register | CAC, GPT, CAN, SCI, SSIE, and interrupt   |
| P402     | VBCTICLR.VCH0INEN                 | RTCIC0 | AGTIO0<br>AGTIO1<br>AGTIO2<br>AGTIO3 | P402PFS.PSEL and PMR             | For details, see <a href="#">section 19.6. Peripheral Select Settings for Each Product.</a> |
| P403     | VBCTICLR.VCH1INEN                 | RTCIC1 | AGTIO0<br>AGTIO1<br>AGTIO2<br>AGTIO3 | P403PFS.PSEL and PMR             |   |
| P404     | VBCTICLR.VCH2INEN                 | RTCIC2 | AGTIO0<br>AGTIO1<br>AGTIO2<br>AGTIO3 | P404PFS.PSEL and PMR             |   |

These RTC and AGT inputs are controlled by the VBCTICLR register. And this register is the highest priority which selecting the functions.

P402, P403, and P404 can be used as IRQn-DS(n = 4, 14, 15) whether RTC and AGT inputs are selected or not. When using these interrupts, set the interrupt procedure after setting the VBCTICLR register. (see [section 11.2.6. VBCTICLR : VBATT Input Control Register.](#))

See [Figure 19.5.](#)

The VBCTICLR register is not initialized on reset. Therefore, when not using the RTC or AGT inputs, the associated bit of VBCTICLR register must be set to 0 after reset.

- 设置ELSRx.ELS[8:0]位以启用事件信号。

### 19.5.3 端口输出数据寄存器(PODR)摘要

该寄存器输出数据如下:

- 如果PCNTR4.EORR在ELC\_PORTn (n=1、2、3或4) 信号发生时设置为1, 则输出0。
- 如果PCNTR4.EOSR在ELC\_PORTn (n=1、2、3或4) 信号发生时设置为1, 则输出1。
- 如果PCNTR3.PORR设置为1, 则输出0。
- 如果PCNTR3.POSR设置为1, 则输出1。
- 输出0或1, 因为PCNTR1.PODRn已设置。
- 输出0或1, 因为PmnPFS.PODRn已设置。

此列表中的数字对应于写入PODRn的优先级。例如, 如果列表中的1和3同时发生, 则执行优先级较高的事件1。

### 19.5.4 使用模拟功能的注意事项

要使用模拟功能, 请将端口模式控制位(PMR)和端口方向位(PDRn)设置为0, 以便引脚用作通用输入端口。接下来, 将端口mn引脚功能选择寄存器(PmnPFS.ASEL)中的模拟输入启用位(ASEL)设置为1。

### 19.5.5 IO缓冲器规格

P402、P403和P404可用作RTC输入、AGT输入和其他外围功能。表19.4列出了P402、P403、P404 specifications.

Table 19.4 P402, P403, P404 specifications

| IO端口 | RTC和AGT           |        |                                      | 其他周边                 |                                |
|------|-------------------|--------|--------------------------------------|----------------------|--------------------------------|
|      | RTC和AGT输入使能寄存器    | RTC    | AGT                                  | 其他外设使能寄存器            | CAC、GPT、CAN、SCI、SSIE和中断        |
| P402 | VBCTICLR.VCH0INEN | RTCIC0 | AGTIO0<br>AGTIO1<br>AGTIO2<br>AGTIO3 | P402PFS.PSEL and PMR | 有关详细信息, 请参阅第19.6节。外设选择每个产品的设置。 |
| P403 | VBCTICLR.VCH1INEN | RTCIC1 | AGTIO0<br>AGTIO1<br>AGTIO2<br>AGTIO3 | P403PFS.PSEL and PMR |                                |
| P404 | VBCTICLR.VCH2INEN | RTCIC2 | AGTIO0<br>AGTIO1<br>AGTIO2<br>AGTIO3 | P404PFS.PSEL and PMR |                                |

这些RTC和AGT输入由VBCTICLR寄存器控制。而这个寄存器是选择功能的最高优先级。

无论是否选择RTC和AGT输入, P402、P403和P404都可以用作IRQn-DS(n=4 14 15)。使用这些中断时, 请在设置VBCTICLR寄存器后设置中断程序。(参见第11.2.6节。VBCTICLR: VBATT输入控制寄存器。)

请参见图19.5。

VBCTICLR寄存器在复位时未初始化。因此, 当不使用RTC或AGT输入时, 相关的位复位后VBCTICLR寄存器必须设置为0。



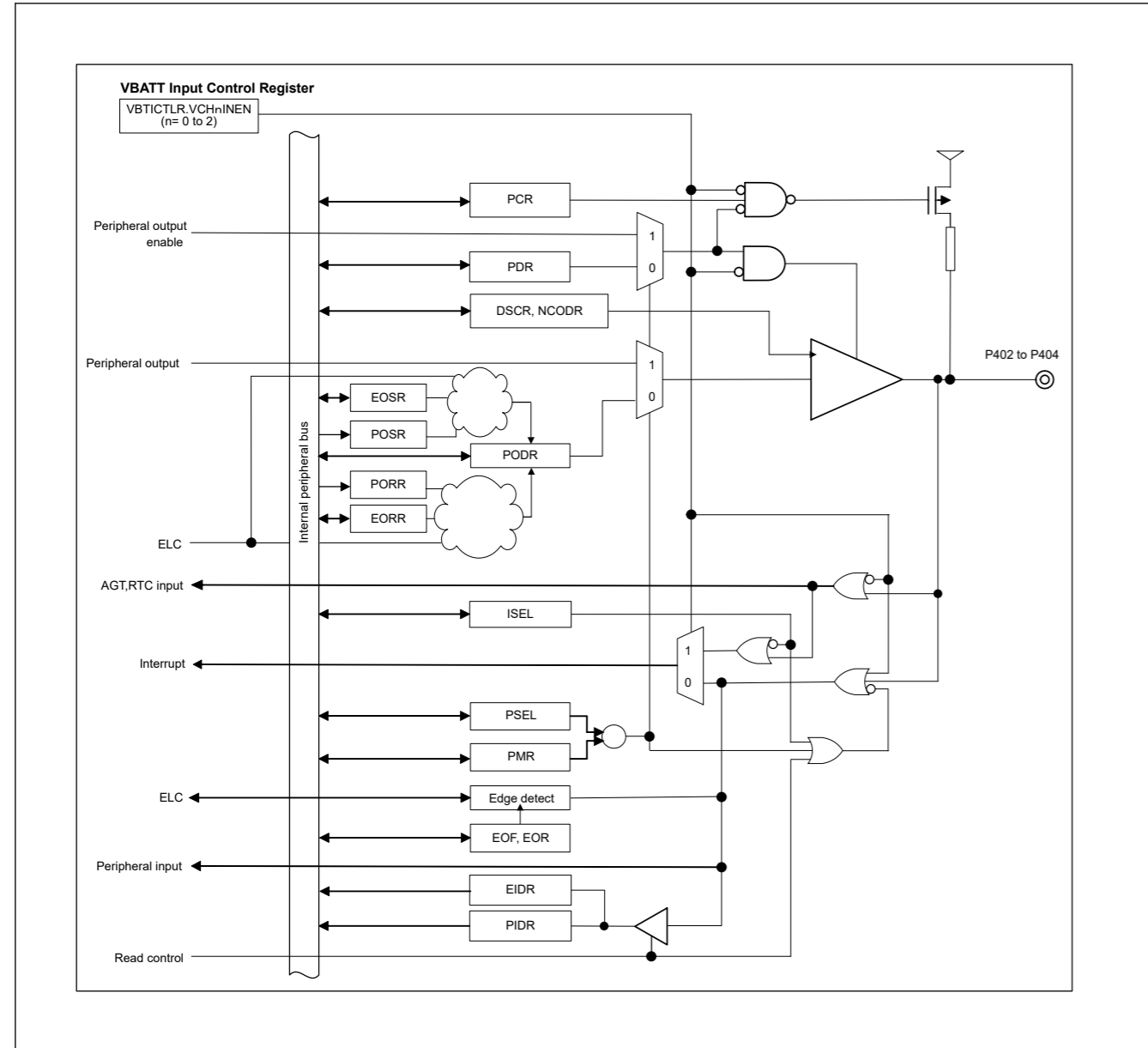


Figure 19.5 P402, P403, P404 diagram

### 19.6 Peripheral Select Settings for Each Product

This section describes the pin function select configuration using the PmnPFS register. Some pin names have added \_A, \_B, or \_C suffixes. When assigning IIC, SPI, SSIE, and SDHI functionality, select the functional pins having the same suffix. The other pins can be selected regardless of the suffix. Assigning the same function to two or more pins simultaneously is prohibited.

1. In Pmn pin function select register (PmnPFS), the PSEL bits have to be set when the PMR bit of the target pin is 0. If the PSEL bits are set when the PMR bit is 1, the unexpected edges may be input at the input function or the unexpected pulses may be output to the external pin at the output function.
2. Only the allowed values (functions) should be specified in the PSEL bits of PmnPFS register. If a value which is not allowed for the register is specified, the correct operation is not guaranteed.
3. The single function should not be assigned to the multiple pins by PmnPFS register. When the GPT1, GPT5, SCI3, IIC0 or SPI0 are configured as secure and these pin function is being assigned to the pin which security attribution is set as secure by the PmSAR register, the write access to the PSEL bits for setting same function as secure pin in other pins is ignored when the security attribution of that pin is non-secure. For example, if the PSARE.PSARE30 bit is 0 (GPT1 is secure) and the P109PFS.PSEL bits is 00011b (pin function is GTIOC1A) and the P1SAR.109SA bit is 0 (P109 is secure), the write 00011b to the P405PFS.PSEL bits is ignored when the P4SAR.405SA bit is 1 (P405 is non-secure).

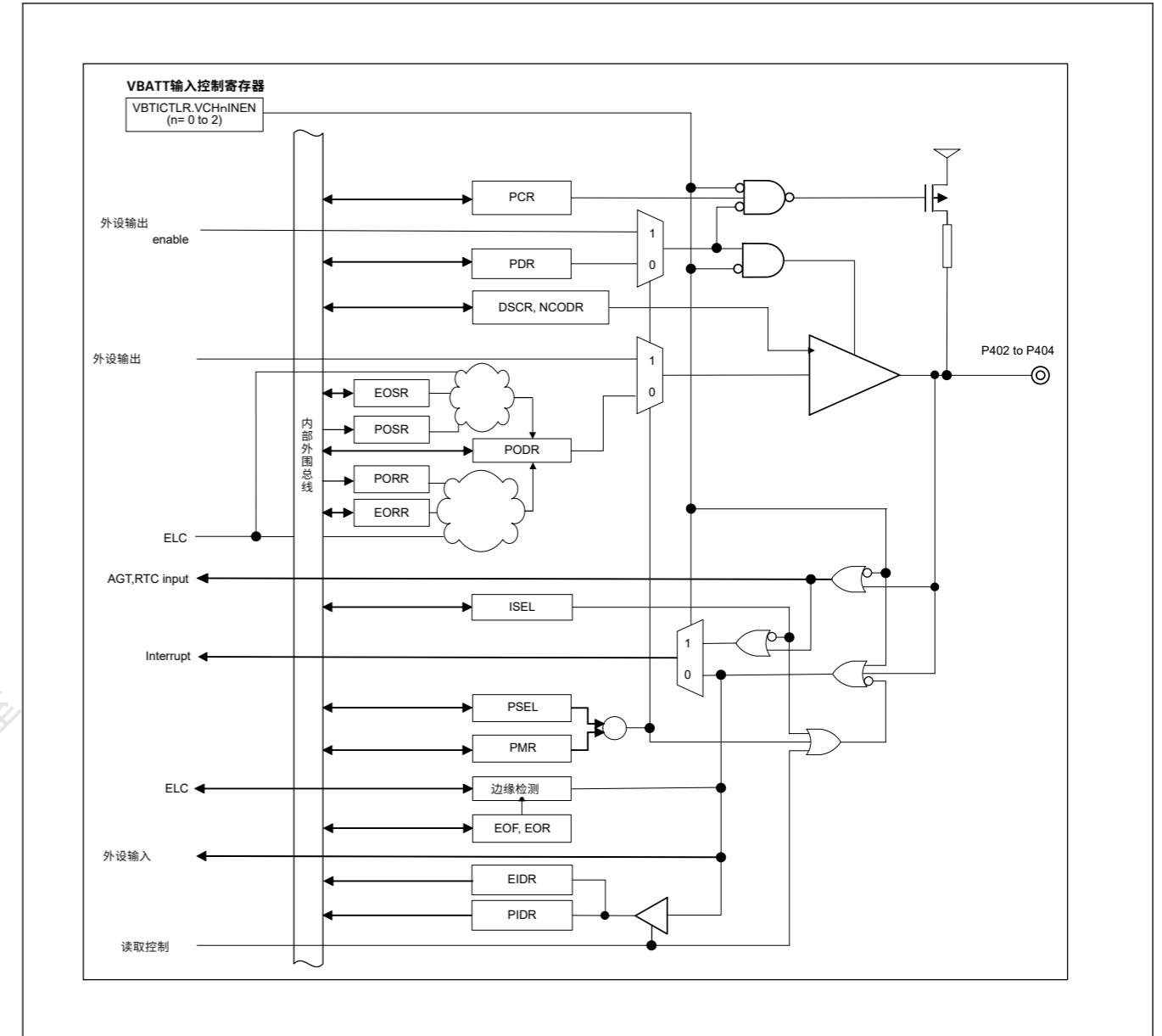


Figure 19.5 P402, P403, P404 diagram

### 19.6 每个产品的外设选择设置

本节介绍使用PmnPFS寄存器的引脚功能选择配置。一些引脚名称添加了\_A、\_B或\_C后缀。分配IIC、SPI、SSIE和SDHI功能时，选择具有相同后缀的功能引脚。无论后缀如何，都可以选择其他引脚。禁止将相同的功能同时分配给两个或多个引脚。

- 1.在Pmn引脚功能选择寄存器（PmnPFS）中，当目标引脚的PMR位为0时，必须设置PSEL位。如果在PMR位为1时设置PSEL位，可能会在输入功能或意外脉冲可能会在输出功能处输出到外部引脚。
- 2.PmnPFS寄存器的PSEL位只能指定允许的值（功能）。如果指定了寄存器不允许的值，则不能保证正确操作。
- 3.PmnPFS寄存器不应将单一功能分配给多个引脚。当GPT1、GPT5、SCI3、IIC0或SPI0配置为安全且这些引脚功能被分配给由PmSAR寄存器设置安全属性为安全的引脚时，对PSEL位的写访问以将相同功能设置为安全当该pin的安全属性为非安全时，其他pin中的pin将被忽略。例如，如果PSARE.PSARE30位为0（GPT1是安全的）并且P109PFS.PSEL位是00011b（引脚功能是GTIOC1A）并且P1SAR.109SA位是0（P109是安全的），则将00011b写入P405PFS当P4SAR.405SA位为1（P405不安全）时，.PSEL位被忽略。



4. The PORT0 and 5 have the analog functions such as A/D converter. When these pins are used as an analog function, for avoiding the loss of resolution, the PMR bit should be set to 0 and PDR bit should be set to 0. After that, ASEL bit should be set to 1

Table 19.5 Register settings for input/output pin function (PORT0)

| PSEL[4:0] settings         | Function                            | pin         |             |             |       |         |          |          |       |          |          |           |           |  |
|----------------------------|-------------------------------------|-------------|-------------|-------------|-------|---------|----------|----------|-------|----------|----------|-----------|-----------|--|
|                            |                                     | P000        | P001        | P002        | P003  | P004    | P005     | P006     | P007  | P008     | P009     | P014      | P015      |  |
| 00000b (value after reset) | Hi-Z/JTAG/SWD                       | Hi-Z        |             |             |       |         |          |          |       |          |          |           |           |  |
| ASEL bit                   |                                     | AN000/AN100 | AN001/AN101 | AN002/AN102 | AN003 | AN004   | AN005    | AN006    | AN007 | AN008    | AN009    | AN012/DA0 | AN013/DA1 |  |
| ISEL bit                   |                                     | IRQ6-DS     | IRQ7-DS     | IRQ8-DS     | —     | IRQ9-DS | IRQ10-DS | IRQ11-DS | —     | IRQ12-DS | IRQ13-DS | —         | IRQ13     |  |
| DSCR[1:0] bits             | Drive capacity control <sup>1</sup> | L           | L           | L           | L     | L       | L        | L        | L     | L        | L        | L         | L         |  |
| NCODR bit                  | N-ch open-drain                     | ✓           | ✓           | ✓           | ✓     | ✓       | ✓        | ✓        | ✓     | ✓        | ✓        | ✓         | ✓         |  |
| PCR bit                    | Pull-up                             | ✓           | ✓           | ✓           | ✓     | ✓       | ✓        | ✓        | ✓     | ✓        | ✓        | ✓         | ✓         |  |
| 144 pins product           |                                     | ✓           | ✓           | ✓           | ✓     | ✓       | ✓        | ✓        | ✓     | ✓        | ✓        | ✓         | ✓         |  |
| 100 pins product           |                                     | ✓           | ✓           | ✓           | ✓     | ✓       | ✓        | ✓        | ✓     | —        | ✓        | ✓         | ✓         |  |
| 64 pins product            |                                     | ✓           | ✓           | ✓           | ✓     | ✓       | —        | —        | —     | —        | —        | ✓         | ✓         |  |

✓: Available  
—: Setting prohibited

Note 1. The drive strength of this port cannot be controlled by PmnPFS.DSCR[1:0] bits.

Table 19.6 Register settings for input/output pin function (PORT1) (1 of 2)

| PSEL[4:0] settings         | Function               | pin             |                 |         |               |         |         |        |        |               |                 |                 |           |                            |                      |           |       |  |
|----------------------------|------------------------|-----------------|-----------------|---------|---------------|---------|---------|--------|--------|---------------|-----------------|-----------------|-----------|----------------------------|----------------------|-----------|-------|--|
|                            |                        | P100            | P101            | P102    | P103          | P104    | P105    | P106   | P107   | P108          | P109            | P110            | P111      | P112                       | P113                 | P114      | P115  |  |
| 00000b (value after reset) | Hi-Z/JTAG/SWD          | Hi-Z            |                 |         |               |         |         |        |        |               |                 | TMS/SWDIO       | TDO/SWO   | TDI                        | Hi-Z                 |           |       |  |
| 00001b                     | AGT                    | AGTIO0          | AGTEE0          | AGTO0   | AGTIO2        | AGTEE2  | AGTO2   | AGTOB0 | AGTOA0 | AGTOA3        | AGTOB3          | AGTEE5          | AGTIO5    | —                          | —                    | —         | —     |  |
| 00010b                     | GPT <sup>2</sup>       | GTETRGA         | GTETRGB         | GTOWLO  | GTOWUP        | GTETRGA | GTETRGA | —      | —      | GTOULO        | GTOVUP          | GTOVLO          | —         | —                          | —                    | —         | —     |  |
| 00011b                     | GPT <sup>2</sup>       | GTIOC5B         | GTIOC5A         | GTIOC2B | GTIOC2A       | GTIOC1B | GTIOC1A | —      | —      | GTIOC0B       | GTIOC1A         | GTIOC1B         | GTIOC3A   | GTIOC2A                    | GTIOC2B              | GTIOC4A   | —     |  |
| 00100b                     | SCI                    | RXD0/MISO0/SCL0 | TXD0/MOSI0/SDA0 | SCK0    | CTS0/RTS0/SS0 | —       | —       | —      | —      | —             | —               | CTS2/RTS2/SS2   | SCK2      | TXD2/MOSI2/SDA2/TXD2/SIOX2 | RXD2/MISO2/SCL2/RXD2 | —         | —     |  |
| 00101b                     | SCI                    | SCK1            | CTS1/RTS1/SS1   | —       | —             | —       | —       | —      | —      | CTS9/RTS9/SS9 | TXD9/MOSI9/SDA9 | RXD9/MISO9/SCL9 | SCK9      | SCK1                       | —                    | CTS9      | —     |  |
| 00110b                     | SPi <sup>1</sup>       | —               | —               | —       | —             | —       | —       | —      | —      | SSLA0_B       | MOSIA_B         | MISOA_B         | RSPCKA_B  | SSLA0_B                    | —                    | —         | —     |  |
| 01001b                     | CLKOUT/RTC             | —               | —               | —       | —             | —       | —       | —      | —      | —             | CLKOUT          | —               | —         | —                          | —                    | —         | —     |  |
| 01010b                     | CAC/ADC12              | —               | —               | ADTRG0  | —             | —       | —       | —      | —      | —             | —               | —               | —         | —                          | —                    | —         | —     |  |
| 10000b                     | CAN                    | —               | —               | CRX0    | CTX0          | —       | —       | —      | —      | —             | CTX1            | CRX1            | —         | —                          | —                    | —         | —     |  |
| 10001b                     | QSPI                   | QSPCLK          | QIO1            | QIO0    | QIO3          | QIO2    | —       | —      | —      | —             | —               | —               | QSSL      | —                          | —                    | —         | —     |  |
| 10010b                     | SSIE <sup>1</sup>      | —               | —               | —       | —             | —       | —       | —      | —      | —             | —               | —               | SSIBCK0_B | SSILRC0/SSIFS0_B           | SSIRXD0_B            | SSITXD0_B | —     |  |
| ASEL bit                   |                        | —               | —               | —       | —             | —       | —       | —      | —      | —             | —               | —               | —         | —                          | —                    | —         | —     |  |
| ISEL bit                   |                        | IRQ2            | IRQ1            | —       | —             | IRQ1    | IRQ0    | —      | —      | —             | —               | IRQ3            | IRQ4      | —                          | —                    | —         | —     |  |
| DSCR[1:0] bits             | Drive capacity control | L/M/H           | L/M/H           | L/M/H   | L/M/H         | L/M/H   | L/M/H   | L/M/H  | L/M/H  | L/M/H         | L/M/H           | L/M/H           | L/M/H     | L/M/H                      | L/M/H                | L/M/H     | L/M/H |  |
| NCODR bit                  | N-ch open-drain        | ✓               | ✓               | ✓       | ✓             | ✓       | ✓       | ✓      | ✓      | ✓             | ✓               | ✓               | ✓         | ✓                          | ✓                    | ✓         | ✓     |  |
| PCR bit                    | Pull-up                | ✓               | ✓               | ✓       | ✓             | ✓       | ✓       | ✓      | ✓      | ✓             | ✓               | ✓               | ✓         | ✓                          | ✓                    | ✓         | ✓     |  |
| 144 pins product           |                        | ✓               | ✓               | ✓       | ✓             | ✓       | ✓       | ✓      | ✓      | ✓             | ✓               | ✓               | ✓         | ✓                          | ✓                    | ✓         | ✓     |  |

4.PORT0和5具有AD转换器等模拟功能。当这些引脚用作模拟功能时，为避免分辨率损失，PMR位应设置为0，PDR位应设置为0。之后，ASEL位应设置为1

Table 19.5 输入输出引脚功能 (PORT0) 的寄存器设置

| PSEL[4:0] settings         | Function            | pin         |             |             |       |         |          |          |       |          |          |           |           |  |
|----------------------------|---------------------|-------------|-------------|-------------|-------|---------|----------|----------|-------|----------|----------|-----------|-----------|--|
|                            |                     | P000        | P001        | P002        | P003  | P004    | P005     | P006     | P007  | P008     | P009     | P014      | P015      |  |
| 00000b (value after reset) | Hi-Z/JTAG/SWD       | Hi-Z        |             |             |       |         |          |          |       |          |          |           |           |  |
| ASEL bit                   |                     | AN000/AN100 | AN001/AN101 | AN002/AN102 | AN003 | AN004   | AN005    | AN006    | AN007 | AN008    | AN009    | AN012/DA0 | AN013/DA1 |  |
| ISEL bit                   |                     | IRQ6-DS     | IRQ7-DS     | IRQ8-DS     | —     | IRQ9-DS | IRQ10-DS | IRQ11-DS | —     | IRQ12-DS | IRQ13-DS | —         | IRQ13     |  |
| DSCR[1:0] bits             | 驱动容量控制 <sup>1</sup> | L           | L           | L           | L     | L       | L        | L        | L     | L        | L        | L         | L         |  |
| NCODR bit                  | N-ch open-drain     | ✓           | ✓           | ✓           | ✓     | ✓       | ✓        | ✓        | ✓     | ✓        | ✓        | ✓         | ✓         |  |
| PCR bit                    | Pull-up             | ✓           | ✓           | ✓           | ✓     | ✓       | ✓        | ✓        | ✓     | ✓        | ✓        | ✓         | ✓         |  |
| 144针产品                     |                     | ✓           | ✓           | ✓           | ✓     | ✓       | ✓        | ✓        | ✓     | ✓        | ✓        | ✓         | ✓         |  |
| 100针产品                     |                     | ✓           | ✓           | ✓           | ✓     | ✓       | ✓        | ✓        | ✓     | —        | ✓        | ✓         | ✓         |  |
| 64针产品                      |                     | ✓           | ✓           | ✓           | ✓     | ✓       | —        | —        | —     | —        | —        | ✓         | ✓         |  |

:可用—:禁止设置

注1.此端口的驱动强度不能由PmnPFS.DSCR[1:0]位控制。

Table 19.6 输入输出引脚功能的寄存器设置(PORT1)(1of2)

| PSEL[4:0] settings         | Function          | pin             |                 |         |               |         |         |        |        |               |                 |                 |           |                            |                      |           |       |  |
|----------------------------|-------------------|-----------------|-----------------|---------|---------------|---------|---------|--------|--------|---------------|-----------------|-----------------|-----------|----------------------------|----------------------|-----------|-------|--|
|                            |                   | P100            | P101            | P102    | P103          | P104    | P105    | P106   | P107   | P108          | P109            | P110            | P111      | P112                       | P113                 | P114      | P115  |  |
| 00000b (value after reset) | Hi-Z/JTAG/SWD     | Hi-Z            |                 |         |               |         |         |        |        |               |                 | TMS/SWDIO       | TDO/SWO   | TDI                        | Hi-Z                 |           |       |  |
| 00001b                     | AGT               | AGTIO0          | AGTEE0          | AGTO0   | AGTIO2        | AGTEE2  | AGTO2   | AGTOB0 | AGTOA0 | AGTOA3        | AGTOB3          | AGTEE5          | AGTIO5    | —                          | —                    | —         | —     |  |
| 00010b                     | GPT <sup>2</sup>  | GTETRGA         | GTETRGB         | GTOWLO  | GTOWUP        | GTETRGA | GTETRGA | —      | —      | GTOULO        | GTOVUP          | GTOVLO          | —         | —                          | —                    | —         | —     |  |
| 00011b                     | GPT <sup>2</sup>  | GTIOC5B         | GTIOC5A         | GTIOC2B | GTIOC2A       | GTIOC1B | GTIOC1A | —      | —      | GTIOC0B       | GTIOC1A         | GTIOC1B         | GTIOC3A   | GTIOC2A                    | GTIOC2B              | GTIOC4A   | —     |  |
| 00100b                     | SCI               | RXD0/MISO0/SCL0 | TXD0/MOSI0/SDA0 | SCK0    | CTS0/RTS0/SS0 | —       | —       | —      | —      | —             | —               | CTS2/RTS2/SS2   | SCK2      | TXD2/MOSI2/SDA2/TXD2/SIOX2 | RXD2/MISO2/SCL2/RXD2 | —         | —     |  |
| 00101b                     | SCI               | SCK1            | CTS1/RTS1/SS1   | —       | —             | —       | —       | —      | —      | CTS9/RTS9/SS9 | TXD9/MOSI9/SDA9 | RXD9/MISO9/SCL9 | SCK9      | SCK1                       | —                    | CTS9      | —     |  |
| 00110b                     | SPi <sup>1</sup>  | —               | —               | —       | —             | —       | —       | —      | —      | SSLA0_B       | MOSIA_B         | MISOA_B         | RSPCKA_B  | SSLA0_B                    | —                    | —         | —     |  |
| 01001b                     | CLKOUT/RTC        | —               | —               | —       | —             | —       | —       | —      | —      | —             | CLKOUT          | —               | —         | —                          | —                    | —         | —     |  |
| 01010b                     | CAC/ADC12         | —               | —               | ADTRG0  | —             | —       | —       | —      | —      | —             | —               | —               | —         | —                          | —                    | —         | —     |  |
| 10000b                     | CAN               | —               | —               | CRX0    | CTX0          | —       | —       | —      | —      | —             | CTX1            | CRX1            | —         | —                          | —                    | —         | —     |  |
| 10001b                     | QSPI              | QSPCLK          | QIO1            | QIO0    | QIO3          | QIO2    | —       | —      | —      | —             | —               | —               | QSSL      | —                          | —                    | —         | —     |  |
| 10010b                     | SSIE <sup>1</sup> | —               | —               | —       | —             | —       | —       | —      | —      | —             | —               | —               | SSIBCK0_B | SSILRC0/SSIFS0_B           | SSIRXD0_B            | SSITXD0_B | —     |  |
| ASEL bit                   |                   | —               | —               | —       | —             | —       | —       | —      | —      | —             | —               | —               | —         | —                          | —                    | —         | —     |  |
| ISEL bit                   |                   | IRQ2            | IRQ1            | —       | —             | IRQ1    | IRQ0    | —      | —      | —             | —               | IRQ3            | IRQ4      | —                          | —                    | —         | —     |  |
| DSCR[1:0] bits             | 驱动容量控制            | L/M/H           | L/M/H           | L/M/H   | L/M/H         | L/M/H   | L/M/H   | L/M/H  | L/M/H  | L/M/H         | L/M/H           | L/M/H           | L/M/H     | L/M/H                      | L/M/H                | L/M/H     | L/M/H |  |
| NCODR bit                  | N-ch open-drain   | ✓               | ✓               | ✓       | ✓             | ✓       | ✓       | ✓      | ✓      | ✓             | ✓               | ✓               | ✓         | ✓                          | ✓                    | ✓         | ✓     |  |
| PCR bit                    | Pull-up           | ✓               | ✓               | ✓       | ✓             | ✓       | ✓       | ✓      | ✓      | ✓             | ✓               | ✓               | ✓         | ✓                          | ✓                    | ✓         | ✓     |  |
| 144针产品                     |                   | ✓               | ✓               | ✓       | ✓             | ✓       | ✓       | ✓      | ✓      | ✓             | ✓               | ✓               | ✓         | ✓                          | ✓                    | ✓         | ✓     |  |

Table 19.6 Register settings for input/output pin function (PORT1) (2 of 2)

| PSEL[4:0] settings | Function | pin  |      |      |      |      |      |      |      |      |      |      |      |      |      |      |      |
|--------------------|----------|------|------|------|------|------|------|------|------|------|------|------|------|------|------|------|------|
|                    |          | P100 | P101 | P102 | P103 | P104 | P105 | P106 | P107 | P108 | P109 | P110 | P111 | P112 | P113 | P114 | P115 |
| 100 pins product   |          | ✓    | ✓    | ✓    | ✓    | ✓    | ✓    | ✓    | ✓    | ✓    | ✓    | ✓    | ✓    | ✓    | ✓    | ✓    | ✓    |
| 64 pins product    |          | ✓    | ✓    | ✓    | ✓    | ✓    | ✓    | —    | ✓    | ✓    | ✓    | ✓    | ✓    | ✓    | —    | —    |      |

✓: Available  
—: Setting prohibited

Note 1. Recommend using pins that have a letter appended to their names, for instance “\_A” or “\_B”, to indicate group membership. For the interface, the AC portion of the electrical characteristics is measured for each group.

Note 2. There are 2 types output buffer which are middle drive and high drive. Recommend using same drive buffer for output skew spec (tGTISK)

Table 19.7 Register settings for input/output pin function (PORT2)

| PSEL[4:0] settings         | Function               | Pin               |                |                 |                 |                |                  |                 |                 |           |        |        |            |                            |                            |          |  |
|----------------------------|------------------------|-------------------|----------------|-----------------|-----------------|----------------|------------------|-----------------|-----------------|-----------|--------|--------|------------|----------------------------|----------------------------|----------|--|
|                            |                        | P200 <sup>4</sup> | P201           | P202            | P203            | P204           | P205             | P206            | P207            | P208      | P209   | P210   | P211       | P212                       | P213                       | P214     |  |
| 00000b (value after reset) | Hi-Z/JTAG/SWD          | Hi-Z              |                |                 |                 |                |                  |                 |                 |           |        |        |            |                            |                            |          |  |
| 00001b                     | AGT                    | —                 | —              | AGTOB3          | AGTOA3          | AGTIO1         | AGTO1            | —               | —               | —         | AGTEE5 | AGTOB5 | AGTOA5     | AGTEE1                     | AGTEE2                     | AGTO5    |  |
| 00010b                     | GPT <sup>2</sup>       | —                 | —              | —               | —               | GTIW           | GTIV             | GTIU            | —               | GTOVLO    | GTOVUP | GTIW   | GTIV       | GTETRGD                    | GTETRG                     | GTIU     |  |
| 00011b                     | GPT <sup>2</sup>       | —                 | —              | GTIOC5B         | GTIOC5A         | GTIOC4B        | GTIOC4A          | —               | —               | —         | —      | —      | —          | GTIOC0B                    | GTIOC0A                    | —        |  |
| 00100b                     | SCI                    | —                 | —              | SCK2            | CTS2_RTS2/SS2   | SCK4           | TXD4/MOSI4/SDA4  | RXD4/MOSI4/SCL4 | TXD4/MOSI4/SDA4 | —         | —      | —      | —          | —                          | —                          | —        |  |
| 00101b                     | SCI                    | —                 | —              | RXD9/MISO9/SCL9 | TXD9/MOSI9/SDA9 | SCK9           | CTS9_RTS9/SS9    | CTS9            | —               | —         | —      | —      | —          | RXD1/MISO1/SCL1/RXD1/SIOX1 | TXD1/MOSI1/SDA1/TXD1/SIOX1 | —        |  |
| 00110b                     | SPI <sup>1</sup>       | —                 | —              | MISOA_A         | MOSIA_A         | RSPCKA_A       | SSLA0_A          | SSLA1_A         | SSLA2_A         | —         | —      | —      | —          | —                          | —                          | —        |  |
| 00111b                     | IIC <sup>1</sup>       | —                 | —              | —               | —               | —              | SCL1_B           | SDA1_B          | —               | —         | —      | —      | —          | —                          | —                          | —        |  |
| 01001b                     | CLKOUT/RTC             | —                 | —              | —               | —               | —              | CLKOUT           | —               | —               | —         | —      | —      | —          | —                          | —                          | —        |  |
| 01010b                     | CAC/ADC12              | —                 | —              | —               | —               | CACRE          | F                | —               | —               | —         | —      | —      | —          | ADTRG1                     | —                          | —        |  |
| 01100b                     | CTSU                   | —                 | —              | TS19            | TS18            | TS00           | TS01             | TS02            | TSCAP           | —         | —      | —      | —          | —                          | —                          | —        |  |
| 10000b                     | CAN                    | —                 | —              | CRX0            | CTX0            | —              | —                | —               | —               | —         | —      | —      | —          | —                          | —                          | —        |  |
| 10001b                     | QSPI                   | —                 | —              | —               | —               | —              | —                | —               | QSSL            | QIO3      | QIO2   | QIO1   | QIO0       | —                          | —                          | QSPCLK   |  |
| 10010b                     | SSIE <sup>1</sup>      | —                 | —              | —               | —               | SSIBCK0_C      | SSILRC0/SSIFS0_C | SSIDAT0_C       | —               | —         | —      | —      | —          | —                          | —                          | —        |  |
| 10011b                     | USBFS                  | —                 | —              | —               | —               | USB_OVRCURB-DS | USB_OVRCURB-DS   | USB_VBUSEN      | —               | —         | —      | —      | —          | —                          | —                          | —        |  |
| 10101b                     | SDHI <sup>1</sup>      | —                 | —              | SD0DAT6_A       | SD0DAT5_A       | SD0DAT4_A      | SD0DAT3_A        | SD0DAT2_A       | —               | SD0DAT0_B | SD0WP  | SD0CD  | SD0CDM_D_B | —                          | —                          | SD0CLK_B |  |
| 11010b                     | Trace (Debug)          | —                 | —              | —               | —               | —              | —                | —               | —               | TDATA3    | TDATA2 | TDATA1 | TDATA0     | —                          | —                          | TCLK     |  |
| ASEL bit                   |                        | —                 | —              | —               | —               | —              | —                | —               | —               | —         | —      | —      | —          | —                          | —                          | —        |  |
| ISEL bit                   |                        | —                 | —              | IRQ3-DS         | IRQ2-DS         | —              | IRQ1-DS          | IRQ0-DS         | —               | —         | —      | —      | —          | IRQ3                       | IRQ2                       | —        |  |
| DSCR[1:0] bits             | Drive capacity control | —                 | L <sup>3</sup> | L/M/H           | L/M/H           | L/M/H          | L/M/H            | L/M/H           | L/M/H           | L/M/H     | L/M/H  | L/M/H  | L/M/H      | L/M/H                      | L/M/H                      | L/M/H    |  |
| NCODR bit                  | N-ch open-drain        | —                 | ✓              | ✓               | ✓               | ✓              | ✓                | ✓               | ✓               | ✓         | ✓      | ✓      | ✓          | ✓                          | ✓                          | ✓        |  |
| PCR bit                    | Pull-up                | ✓                 | ✓              | ✓               | ✓               | ✓              | ✓                | ✓               | ✓               | ✓         | ✓      | ✓      | ✓          | ✓                          | ✓                          | ✓        |  |
| 144 pins product           |                        | ✓                 | ✓              | ✓               | ✓               | ✓              | ✓                | ✓               | ✓               | ✓         | ✓      | ✓      | ✓          | ✓                          | ✓                          | ✓        |  |
| 100 pins product           |                        | ✓                 | ✓              | —               | —               | —              | ✓                | ✓               | ✓               | ✓         | ✓      | ✓      | ✓          | ✓                          | ✓                          | ✓        |  |
| 64 pins product            |                        | ✓                 | ✓              | —               | —               | —              | ✓                | ✓               | ✓               | ✓         | —      | —      | —          | ✓                          | ✓                          | —        |  |

Table 19.6 输入输出引脚功能的寄存器设置(PORT1)(2of2)

| PSEL[4:0] settings | Function | pin  |      |      |      |      |      |      |      |      |      |      |      |      |      |      |      |
|--------------------|----------|------|------|------|------|------|------|------|------|------|------|------|------|------|------|------|------|
|                    |          | P100 | P101 | P102 | P103 | P104 | P105 | P106 | P107 | P108 | P109 | P110 | P111 | P112 | P113 | P114 | P115 |
| 100针产品             |          | ✓    | ✓    | ✓    | ✓    | ✓    | ✓    | ✓    | ✓    | ✓    | ✓    | ✓    | ✓    | ✓    | ✓    | ✓    | ✓    |
| 64针产品              |          | ✓    | ✓    | ✓    | ✓    | ✓    | ✓    | —    | ✓    | ✓    | ✓    | ✓    | ✓    | ✓    | —    | —    |      |

:可用—禁止设置

注1.建议使用名称后附有字母的引脚，例如“\_A”或“\_B”，以表示组成员身份。对于接口，测量每组电气特性的交流部分。

注2.输出缓冲器中有中驱动和高驱动两种。推荐使用相同的驱动缓冲器输出歪斜规格(tGTISK)

Table 19.7 输入输出引脚功能 (PORT2) 的寄存器设置

| PSEL[4:0] settings         | Function          | Pin               |                |                 |                 |                |                  |                 |                 |           |        |        |            |                            |                            |          |  |
|----------------------------|-------------------|-------------------|----------------|-----------------|-----------------|----------------|------------------|-----------------|-----------------|-----------|--------|--------|------------|----------------------------|----------------------------|----------|--|
|                            |                   | P200 <sup>4</sup> | P201           | P202            | P203            | P204           | P205             | P206            | P207            | P208      | P209   | P210   | P211       | P212                       | P213                       | P214     |  |
| 00000b (value after reset) | Hi-Z/JTAG/SWD     | Hi-Z              |                |                 |                 |                |                  |                 |                 |           |        |        |            |                            |                            |          |  |
| 00001b                     | AGT               | —                 | —              | AGTOB3          | AGTOA3          | AGTIO1         | AGTO1            | —               | —               | —         | AGTEE5 | AGTOB5 | AGTOA5     | AGTEE1                     | AGTEE2                     | AGTO5    |  |
| 00010b                     | GPT <sup>2</sup>  | —                 | —              | —               | —               | GTIW           | GTIV             | GTIU            | —               | GTOVLO    | GTOVUP | GTIW   | GTIV       | GTETRGD                    | GTETRG                     | GTIU     |  |
| 00011b                     | GPT <sup>2</sup>  | —                 | —              | GTIOC5B         | GTIOC5A         | GTIOC4B        | GTIOC4A          | —               | —               | —         | —      | —      | —          | GTIOC0B                    | GTIOC0A                    | —        |  |
| 00100b                     | SCI               | —                 | —              | SCK2            | CTS2_RTS2/SS2   | SCK4           | TXD4/MOSI4/SDA4  | RXD4/MOSI4/SCL4 | TXD4/MOSI4/SDA4 | —         | —      | —      | —          | —                          | —                          | —        |  |
| 00101b                     | SCI               | —                 | —              | RXD9/MISO9/SCL9 | TXD9/MOSI9/SDA9 | SCK9           | CTS9_RTS9/SS9    | CTS9            | —               | —         | —      | —      | —          | RXD1/MISO1/SCL1/RXD1/SIOX1 | TXD1/MOSI1/SDA1/TXD1/SIOX1 | —        |  |
| 00110b                     | SPI <sup>1</sup>  | —                 | —              | MISOA_A         | MOSIA_A         | RSPCKA_A       | SSLA0_A          | SSLA1_A         | SSLA2_A         | —         | —      | —      | —          | —                          | —                          | —        |  |
| 00111b                     | IIC <sup>1</sup>  | —                 | —              | —               | —               | —              | SCL1_B           | SDA1_B          | —               | —         | —      | —      | —          | —                          | —                          | —        |  |
| 01001b                     | CLKOUT/RTC        | —                 | —              | —               | —               | —              | CLKOUT           | —               | —               | —         | —      | —      | —          | —                          | —                          | —        |  |
| 01010b                     | CAC/ADC12         | —                 | —              | —               | —               | CACRE          | F                | —               | —               | —         | —      | —      | —          | ADTRG1                     | —                          | —        |  |
| 01100b                     | CTSU              | —                 | —              | TS19            | TS18            | TS00           | TS01             | TS02            | TSCAP           | —         | —      | —      | —          | —                          | —                          | —        |  |
| 10000b                     | CAN               | —                 | —              | CRX0            | CTX0            | —              | —                | —               | —               | —         | —      | —      | —          | —                          | —                          | —        |  |
| 10001b                     | QSPI              | —                 | —              | —               | —               | —              | —                | —               | QSSL            | QIO3      | QIO2   | QIO1   | QIO0       | —                          | —                          | QSPCLK   |  |
| 10010b                     | SSIE <sup>1</sup> | —                 | —              | —               | —               | SSIBCK0_C      | SSILRC0/SSIFS0_C | SSIDAT0_C       | —               | —         | —      | —      | —          | —                          | —                          | —        |  |
| 10011b                     | USBFS             | —                 | —              | —               | —               | USB_OVRCURB-DS | USB_OVRCURB-DS   | USB_VBUSEN      | —               | —         | —      | —      | —          | —                          | —                          | —        |  |
| 10101b                     | SDHI <sup>1</sup> | —                 | —              | SD0DAT6_A       | SD0DAT5_A       | SD0DAT4_A      | SD0DAT3_A        | SD0DAT2_A       | —               | SD0DAT0_B | SD0WP  | SD0CD  | SD0CDM_D_B | —                          | —                          | SD0CLK_B |  |
| 11010b                     | Trace (Debug)     | —                 | —              | —               | —               | —              | —                | —               | —               | TDATA3    | TDATA2 | TDATA1 | TDATA0     | —                          | —                          | TCLK     |  |
| ASEL bit                   |                   | —                 | —              | —               | —               | —              | —                | —               | —               | —         | —      | —      | —          | —                          | —                          | —        |  |
| ISEL bit                   |                   | —                 | —              | IRQ3-DS         | IRQ2-DS         | —              | IRQ1-DS          | IRQ0-DS         | —               | —         | —      | —      | —          | IRQ3                       | IRQ2                       | —        |  |
| DSCR[1:0] bits             | 驱动容量控制            | —                 | L <sup>3</sup> | L/M/H           | L/M/H           | L/M/H          | L/M/H            | L/M/H           | L/M/H           | L/M/H     | L/M/H  | L/M/H  | L/M/H      | L/M/H                      | L/M/H                      | L/M/H    |  |
| NCODR bit                  | N沟道开漏             | —                 | ✓              | ✓               | ✓               | ✓              | ✓                | ✓               | ✓               | ✓         | ✓      | ✓      | ✓          | ✓                          | ✓                          | ✓        |  |
| PCR bit                    | Pull-up           | ✓                 | ✓              | ✓               | ✓               | ✓              | ✓                | ✓               | ✓               | ✓         | ✓      | ✓      | ✓          | ✓                          | ✓                          | ✓        |  |
| 144针产品                     |                   | ✓                 | ✓              | ✓               | ✓               | ✓              | ✓                | ✓               | ✓               | ✓         | ✓      | ✓      | ✓          | ✓                          | ✓                          | ✓        |  |
| 100针产品                     |                   | ✓                 | ✓              | —               | —               | —              | ✓                | ✓               | ✓               | ✓         | ✓      | ✓      | ✓          | ✓                          | ✓                          | ✓        |  |
| 64针产品                      |                   | ✓                 | ✓              | —               | —               | —              | ✓                | ✓               | ✓               | ✓         | —      | —      | —          | ✓                          | ✓                          | —        |  |

✓: Available  
 —: Setting prohibited

- Note 1. Recommend using pins that have a letter appended to their names, for instance “\_A” or “\_B”, to indicate group membership. For the interface, the AC portion of the electrical characteristics is measured for each group.
- Note 2. There are 2 types output buffer which are middle drive and high drive. Recommend using same drive buffer for output skew spec (t<sub>GTISK</sub>)
- Note 3. The driver strength of this port can not be controlled by PmnPFS.DSCR[1:0] bits.
- Note 4. When using NMI pin interrupt, Port related registers setting are not required.

Table 19.8 Register settings for input/output pin function (PORT3)

| PSEL[4:0] settings        | Function               | Pin       |                      |                            |         |         |        |        |        |        |                 |                 |        |               |           |
|---------------------------|------------------------|-----------|----------------------|----------------------------|---------|---------|--------|--------|--------|--------|-----------------|-----------------|--------|---------------|-----------|
|                           |                        | P300      | P301                 | P302                       | P303    | P304    | P305   | P306   | P307   | P308   | P309            | P310            | P311   | P312          | P313      |
| 0000b (value after reset) | Hi-Z/JTAG/SWD          | TCK/SWCLK | Hi-Z                 |                            |         |         |        |        |        |        |                 |                 |        |               |           |
| 0001b                     | AGT                    | —         | AGTIO0               | —                          | —       | AGTEE2  | AGTOB2 | AGTOA2 | AGTEE4 | AGTOB4 | AGTOA4          | AGTEE1          | AGTOB1 | AGTOA1        | —         |
| 0010b                     | GPT <sup>2</sup>       | GTOUUP    | GTOULO               | GTOUUP                     | —       | GTOWLO  | GTOWUP | GTOULO | GTOUUP | —      | —               | —               | —      | —             | —         |
| 0011b                     | GPT <sup>2</sup>       | GTIOC0A   | GTIOC4B              | GTIOC4A                    | GTIOC7B | GTIOC7A | —      | —      | —      | —      | —               | —               | —      | —             | —         |
| 00100b                    | SCI                    | —         | RXD2/MISO2/SCL2/RXD2 | TXD2/MOSI2/SDA2/TXD2/SIOX2 | —       | —       | —      | —      | —      | —      | —               | —               | —      | —             | —         |
| 00101b                    | SCI                    | —         | CTS9_RTS9/SS9        | —                          | CTS9    | —       | —      | —      | —      | CTS3   | RXD3/MISO3/SCL3 | TXD3/MOSI3/SDA3 | SCK3   | CTS3_RTS3/SS3 | —         |
| 00110b                    | SPI <sup>1</sup>       | SSLA1_B   | SSLA2_B              | SSLA3_B                    | —       | —       | —      | —      | —      | —      | —               | —               | —      | —             | —         |
| 10001b                    | QSPI                   | —         | —                    | —                          | —       | —       | QSPCLK | QSSL   | QIO0   | QIO1   | QIO2            | QIO3            | —      | —             | —         |
| 10101b                    | SDHI                   | —         | —                    | —                          | —       | —       | —      | —      | —      | —      | —               | —               | —      | —             | SD0DAT7_A |
| ASEL bit                  |                        | —         | —                    | —                          | —       | —       | —      | —      | —      | —      | —               | —               | —      | —             | —         |
| ISEL bit                  |                        | —         | IRQ6                 | IRQ5                       | —       | IRQ9    | IRQ8   | —      | —      | —      | —               | —               | —      | —             | —         |
| DSCR[1:0] bits            | Drive capacity control | L/M/H     | L/M/H                | L/M/H                      | L/M/H   | L/M/H   | L/M/H  | L/M/H  | L/M/H  | L/M/H  | L/M/H           | L/M/H           | L/M/H  | L/M/H         | L/M/H     |
| NCODR bit                 | N-ch open-drain        | ✓         | ✓                    | ✓                          | ✓       | ✓       | ✓      | ✓      | ✓      | ✓      | ✓               | ✓               | ✓      | ✓             | ✓         |
| PCR bit                   | Pull-up                | ✓         | ✓                    | ✓                          | ✓       | ✓       | ✓      | ✓      | ✓      | ✓      | ✓               | ✓               | ✓      | ✓             | ✓         |
| 144 pins product          |                        | ✓         | ✓                    | ✓                          | ✓       | ✓       | ✓      | ✓      | ✓      | ✓      | ✓               | ✓               | ✓      | ✓             | ✓         |
| 100 pins product          |                        | ✓         | ✓                    | ✓                          | ✓       | ✓       | ✓      | ✓      | ✓      | —      | —               | —               | —      | —             | —         |
| 64 pins product           |                        | ✓         | ✓                    | ✓                          | ✓       | ✓       | —      | —      | —      | —      | —               | —               | —      | —             | —         |

✓: Available  
 —: Setting prohibited

- Note 1. Recommend using pins that have a letter appended to their names, for instance “\_A” or “\_B”, to indicate group membership. For the interface, the AC portion of the electrical characteristics is measured for each group.
- Note 2. There are 2 types output buffer which are middle drive and high drive. Recommend using same drive buffer for output skew spec (t<sub>GTISK</sub>)

Table 19.9 Register settings for input/output pin function (PORT4) (1 of 2)

| PSEL[4:0] settings        | Function         | pin     |               |      |         |         |         |         |               |                 |                 |                 |                 |        |               |         |      |
|---------------------------|------------------|---------|---------------|------|---------|---------|---------|---------|---------------|-----------------|-----------------|-----------------|-----------------|--------|---------------|---------|------|
|                           |                  | P400    | P401          | P402 | P403    | P404    | P405    | P406    | P407          | P408            | P409            | P410            | P411            | P412   | P413          | P414    | P415 |
| 0000b (value after reset) | Hi-Z/JTAG/SWD    | Hi-Z    |               |      |         |         |         |         |               |                 |                 |                 |                 |        |               |         |      |
| 0001b                     | AGT              | AGTIO1  | —             | —    | —       | —       | —       | AGTO5   | AGTIO0        | AGTOB2          | AGTOA2          | AGTOB1          | AGTOA1          | AGTEE3 | AGTEE5        | AGTIO4  |      |
| 0010b                     | GPT <sup>3</sup> | —       | GTETRGA       | —    | —       | —       | —       | —       | —             | GTOWLO          | GTOWUP          | GTOVLO          | GTOVUP          | GTOULO | GTOUUP        | —       |      |
| 0011b                     | GPT <sup>3</sup> | GTIOC6A | GTIOC6B       | —    | GTIOC3A | GTIOC3B | GTIOC1A | GTIOC1B | GTIOC6A       | GTIOC6B         | —               | —               | —               | —      | GTIOC0B       | GTIOC0A |      |
| 00100b                    | SCI              | SCK4    | CTS4_RTS4/SS4 | CTS4 | —       | —       | —       | —       | CTS4_RTS4/SS4 | CTS4            | —               | RXD0/MISO0/SCL0 | TXD0/MOSI0/SDA0 | SCK0   | CTS0_RTS0/SS0 | CTS0    |      |
| 00101b                    | SCI              | —       | —             | —    | —       | —       | —       | —       | —             | RXD3/MISO3/SCL3 | TXD3/MOSI3/SDA3 | SCK3            | CTS3_RTS3/SS3   | CTS3   | —             | —       |      |

:可用—:禁止设置

- 注1.建议使用名称后附有字母的引脚，例如“\_A”或“\_B”，以表示组成员身份。对于接口，测量每组电气特性的交流部分。
- 注2.输出缓冲器中有中驱动和高驱动两种。推荐使用相同的驱动缓冲器输出歪斜规格(t<sub>GTISK</sub>)
- 注3.此端口的驱动强度不能由PmnPFS.DSCR[1:0]位控制。
- 注4.当使用NMI引脚中断时，不需要设置端口相关的寄存器。

Table 19.8 输入输出引脚功能 (PORT3) 的寄存器设置

| PSEL[4:0] settings        | Function         | Pin       |                      |                            |         |         |        |        |        |        |                 |                 |        |               |           |
|---------------------------|------------------|-----------|----------------------|----------------------------|---------|---------|--------|--------|--------|--------|-----------------|-----------------|--------|---------------|-----------|
|                           |                  | P300      | P301                 | P302                       | P303    | P304    | P305   | P306   | P307   | P308   | P309            | P310            | P311   | P312          | P313      |
| 0000b (value after reset) | Hi-Z/JTAG/SWD    | TCK/SWCLK | Hi-Z                 |                            |         |         |        |        |        |        |                 |                 |        |               |           |
| 0001b                     | AGT              | —         | AGTIO0               | —                          | —       | AGTEE2  | AGTOB2 | AGTOA2 | AGTEE4 | AGTOB4 | AGTOA4          | AGTEE1          | AGTOB1 | AGTOA1        | —         |
| 0010b                     | GPT <sup>2</sup> | GTOUUP    | GTOULO               | GTOUUP                     | —       | GTOWLO  | GTOWUP | GTOULO | GTOUUP | —      | —               | —               | —      | —             | —         |
| 0011b                     | GPT <sup>2</sup> | GTIOC0A   | GTIOC4B              | GTIOC4A                    | GTIOC7B | GTIOC7A | —      | —      | —      | —      | —               | —               | —      | —             | —         |
| 00100b                    | SCI              | —         | RXD2/MISO2/SCL2/RXD2 | TXD2/MOSI2/SDA2/TXD2/SIOX2 | —       | —       | —      | —      | —      | —      | —               | —               | —      | —             | —         |
| 00101b                    | SCI              | —         | CTS9_RTS9/SS9        | —                          | CTS9    | —       | —      | —      | —      | CTS3   | RXD3/MISO3/SCL3 | TXD3/MOSI3/SDA3 | SCK3   | CTS3_RTS3/SS3 | —         |
| 00110b                    | SPI <sup>1</sup> | SSLA1_B   | SSLA2_B              | SSLA3_B                    | —       | —       | —      | —      | —      | —      | —               | —               | —      | —             | —         |
| 10001b                    | QSPI             | —         | —                    | —                          | —       | —       | QSPCLK | QSSL   | QIO0   | QIO1   | QIO2            | QIO3            | —      | —             | —         |
| 10101b                    | SDHI             | —         | —                    | —                          | —       | —       | —      | —      | —      | —      | —               | —               | —      | —             | SD0DAT7_A |
| ASEL bit                  |                  | —         | —                    | —                          | —       | —       | —      | —      | —      | —      | —               | —               | —      | —             | —         |
| ISEL bit                  |                  | —         | IRQ6                 | IRQ5                       | —       | IRQ9    | IRQ8   | —      | —      | —      | —               | —               | —      | —             | —         |
| DSCR[1:0] bits            | 驱动容量控制           | L/M/H     | L/M/H                | L/M/H                      | L/M/H   | L/M/H   | L/M/H  | L/M/H  | L/M/H  | L/M/H  | L/M/H           | L/M/H           | L/M/H  | L/M/H         | L/M/H     |
| NCODR bit                 | N-ch open-drain  | ✓         | ✓                    | ✓                          | ✓       | ✓       | ✓      | ✓      | ✓      | ✓      | ✓               | ✓               | ✓      | ✓             | ✓         |
| PCR bit                   | Pull-up          | ✓         | ✓                    | ✓                          | ✓       | ✓       | ✓      | ✓      | ✓      | ✓      | ✓               | ✓               | ✓      | ✓             | ✓         |
| 144针产品                    |                  | ✓         | ✓                    | ✓                          | ✓       | ✓       | ✓      | ✓      | ✓      | ✓      | ✓               | ✓               | ✓      | ✓             | ✓         |
| 100针产品                    |                  | ✓         | ✓                    | ✓                          | ✓       | ✓       | ✓      | ✓      | ✓      | —      | —               | —               | —      | —             | —         |
| 64针产品                     |                  | ✓         | ✓                    | ✓                          | ✓       | ✓       | —      | —      | —      | —      | —               | —               | —      | —             | —         |

:可用—:禁止设置

- 注1.建议使用名称后附有字母的引脚，例如“\_A”或“\_B”，以表示组成员身份。对于接口，测量每组电气特性的交流部分。
- 注2.输出缓冲器中有中驱动和高驱动两种。推荐使用相同的驱动缓冲器输出歪斜规格(t<sub>GTISK</sub>)

Table 19.9 输入输出引脚功能的寄存器设置(PORT4)(1of2)

| PSEL[4:0] settings        | Function         | pin     |               |      |         |         |         |         |               |                 |                 |                 |                 |        |               |         |      |
|---------------------------|------------------|---------|---------------|------|---------|---------|---------|---------|---------------|-----------------|-----------------|-----------------|-----------------|--------|---------------|---------|------|
|                           |                  | P400    | P401          | P402 | P403    | P404    | P405    | P406    | P407          | P408            | P409            | P410            | P411            | P412   | P413          | P414    | P415 |
| 0000b (value after reset) | Hi-Z/JTAG/SWD    | Hi-Z    |               |      |         |         |         |         |               |                 |                 |                 |                 |        |               |         |      |
| 0001b                     | AGT              | AGTIO1  | —             | —    | —       | —       | —       | AGTO5   | AGTIO0        | AGTOB2          | AGTOA2          | AGTOB1          | AGTOA1          | AGTEE3 | AGTEE5        | AGTIO4  |      |
| 0010b                     | GPT <sup>3</sup> | —       | GTETRGA       | —    | —       | —       | —       | —       | —             | GTOWLO          | GTOWUP          | GTOVLO          | GTOVUP          | GTOULO | GTOUUP        | —       |      |
| 0011b                     | GPT <sup>3</sup> | GTIOC6A | GTIOC6B       | —    | GTIOC3A | GTIOC3B | GTIOC1A | GTIOC1B | GTIOC6A       | GTIOC6B         | —               | —               | —               | —      | GTIOC0B       | GTIOC0A |      |
| 00100b                    | SCI              | SCK4    | CTS4_RTS4/SS4 | CTS4 | —       | —       | —       | —       | CTS4_RTS4/SS4 | CTS4            | —               | RXD0/MISO0/SCL0 | TXD0/MOSI0/SDA0 | SCK0   | CTS0_RTS0/SS0 | CTS0    |      |
| 00101b                    | SCI              | —       | —             | —    | —       | —       | —       | —       | —             | RXD3/MISO3/SCL3 | TXD3/MOSI3/SDA3 | SCK3            | CTS3_RTS3/SS3   | CTS3   | —             | —       |      |

Table 19.9 Register settings for input/output pin function (PORT4) (2 of 2)

| PSEL[4:0] settings | Function               | pin       |         |   |   |   |           |           |          |        |            |            |           |           |       |       |            |
|--------------------|------------------------|-----------|---------|---|---|---|-----------|-----------|----------|--------|------------|------------|-----------|-----------|-------|-------|------------|
|                    |                        | P400      | P401    | P402  | P403  | P404  | P405      | P406      | P407     | P408   | P409       | P410       | P411      | P412      | P413  | P414  | P415       |
| 00110b             | SPI <sup>2</sup>       | —         | —       | —   | —   | —   | —         | SSLA3_C   | SSLA3_A  | —      | —          | —          | —         | —         | —     | —     | —          |
| 00111b             | IIC <sup>2</sup>       | SCL0_A    | SDA0_A  | —   | —   | —   | —         | —         | SDA0_B   | SCL0_B | —          | —          | —         | —         | —     | —     | —          |
| 01001b             | CLKOUT/RTC             | —         | —       | —   | —   | —   | —         | —         | RTCOU_T  | —      | —          | —          | —         | —         | —     | —     | —          |
| 01010b             | CAC/ADC12              | ADTRG1    | —       | CACRE_F   | —   | —   | —         | —         | ADTRG0   | —      | —          | —          | —         | —         | —     | —     | —          |
| 01100b             | CTSUS                  | —         | —       | —   | —   | —   | —         | —         | TS03     | TS04   | TS05       | TS06       | TS07      | TS08      | TS09  | TS10  | TS11       |
| 10000b             | CAN                    | —         | CTX0    | CRX0  | —   | —   | —         | —         | —        | —      | —          | —          | —         | —         | —     | —     | —          |
| 10010b             | SSIE <sup>2</sup>      | AUDIO_CLK | —       | AUDIO_CLK   | SSIBCK0_A   | SSILRC0/SSI FS0_A   | SSITXD0_A | SSIRXD0_A | —        | —      | —          | —          | —         | —         | —     | —     | —          |
| 10011b             | USBFS                  | —         | —       | —   | —   | —   | —         | —         | USB_VBUS | USB_ID | USB_XICEN  | —          | —         | —         | —     | —     | USB_VBUSEN |
| 10101b             | SDHI <sup>2</sup>      | —         | —       | —   | —   | —   | —         | —         | —        | —      | SD0DA T1_A | SD0DA T0_A | SD0CM D_A | SD0CL K_A | SD0WP | SD0CD | —          |
| Don't-care         | AGT, RTC               | —         | —       | AGTIO 0 <sup>1</sup> / <sub>1</sub><br>AGTIO 1 <sup>1</sup> / <sub>1</sub><br>AGTIO 2 <sup>1</sup> / <sub>1</sub><br>AGTIO 3 <sup>1</sup> / <sub>1</sub><br>RTICIC0 <sup>1</sup> / <sub>1</sub> | AGTIO 0 <sup>1</sup> / <sub>1</sub><br>AGTIO 1 <sup>1</sup> / <sub>1</sub><br>AGTIO 2 <sup>1</sup> / <sub>1</sub><br>AGTIO 3 <sup>1</sup> / <sub>1</sub><br>RTICIC1 <sup>1</sup> / <sub>1</sub> | AGTIO 0 <sup>1</sup> / <sub>1</sub><br>AGTIO 1 <sup>1</sup> / <sub>1</sub><br>AGTIO 2 <sup>1</sup> / <sub>1</sub><br>AGTIO 3 <sup>1</sup> / <sub>1</sub><br>RTICIC2 <sup>1</sup> / <sub>1</sub> | —         | —         | —        | —      | —          | —          | —         | —         | —     | —     | —          |
| ASEL bit           | —                      | —         | —       | —   | —   | —   | —         | —         | —        | —      | —          | —          | —         | —         | —     | —     | —          |
| ISEL bit           | —                      | IRQ0      | IRQ5-DS | IRQ4-DS   | IRQ14-DS  | IRQ15-DS  | —         | —         | —        | IRQ7   | IRQ6       | IRQ5       | IRQ4      | —         | —     | IRQ9  | IRQ8       |
| DSCR[1:0] bits     | Drive capacity control | L/M/H     | L/M/H   | L/M/H   | L/M/H   | L/M/H   | L/M/H     | L/M/H     | L/M/H    | L/M/H  | L/M/H      | L/M/H      | L/M/H     | L/M/H     | L/M/H | L/M/H | L/M/H      |
| NCODR bit          | N-ch open-drain        | ✓         | ✓       | ✓   | ✓   | ✓   | ✓         | ✓         | ✓        | ✓      | ✓          | ✓          | ✓         | ✓         | ✓     | ✓     | ✓          |
| PCR bit            | Pull-up                | ✓         | ✓       | ✓   | ✓   | ✓   | ✓         | ✓         | ✓        | ✓      | ✓          | ✓          | ✓         | ✓         | ✓     | ✓     | ✓          |
| 144 pins product   | —                      | ✓         | ✓       | ✓   | ✓   | ✓   | ✓         | ✓         | ✓        | ✓      | ✓          | ✓          | ✓         | ✓         | ✓     | ✓     | ✓          |
| 100 pins product   | —                      | ✓         | ✓       | ✓   | ✓   | ✓   | ✓         | ✓         | ✓        | ✓      | ✓          | ✓          | ✓         | ✓         | ✓     | ✓     | ✓          |
| 64 pins product    | —                      | ✓         | ✓       | ✓   | —   | —   | —         | —         | ✓        | ✓      | ✓          | ✓          | —         | —         | —     | —     | —          |

✓: Available  
—: Setting prohibited

- Note 1. To use this pin function, set the associated pin as a general input (set the PmnPFS.PDR and PmnPFS.PMR bits to 0).
- Note 2. Recommend using pins that have a letter appended to their names, for instance “\_A” or “\_B”, to indicate group membership. For the interface, the AC portion of the electrical characteristics is measured for each group.
- Note 3. There are 2 types output buffer which are middle drive and high drive. Recommend using same drive buffer for output skew spec (tGTISK)

Table 19.10 Register settings for input/output pin function (PORT5) (1 of 2)

| PSEL[4:0] settings         | Function         | pin    |        |        |         |         |        |      |                 |                 |      |
|----------------------------|------------------|--------|--------|--------|---------|---------|--------|------|-----------------|-----------------|------|
|                            |                  | P500   | P501   | P502   | P503    | P504    | P505   | P506 | P507            | P511            | P512 |
| 00000b (value after reset) | Hi-Z/JTAG/SWD    | Hi-Z   |        |        |         |         |        |      |                 |                 |      |
| 00001b                     | AGT              | AGTOA0 | AGTOB0 | AGTOA2 | AGTOB2  | AGTOA3  | AGTOB3 | —    | —               | —               | —    |
| 00010b                     | GPT <sup>1</sup> | GTIU   | GTIV   | GTIW   | GTETRGC | GTETRGD | —      | —    | —               | —               | —    |
| 00011b                     | GPT <sup>1</sup> | —      | —      | —      | —       | —       | —      | —    | GTIOC0B         | GTIOC0A         | —    |
| 00100b                     | SCI              | —      | —      | —      | —       | —       | —      | —    | RXD4/MISO4/SCL4 | TXD4/MOSI4/SDA4 | —    |
| 00111b                     | IIC              | —      | —      | —      | —       | —       | —      | —    | —               | —               | —    |
| 01010b                     | CAC/ADC12        | CACREF | —      | —      | —       | —       | —      | —    | —               | —               | —    |
| 10000b                     | CAN              | —      | —      | —      | —       | —       | —      | —    | —               | —               | —    |
| 10001b                     | QSPI             | QSPCLK | QSSL   | QIO0   | QIO1    | QIO2    | QIO3   | —    | —               | —               | —    |

Table 19.9 输入输出引脚功能的寄存器设置(PORT4)(2of2)

| PSEL[4:0] settings | Function          | pin       |         |   |   |   |           |           |          |        |            |            |           |           |       |       |            |
|--------------------|-------------------|-----------|---------|---|---|---|-----------|-----------|----------|--------|------------|------------|-----------|-----------|-------|-------|------------|
|                    |                   | P400      | P401    | P402  | P403  | P404  | P405      | P406      | P407     | P408   | P409       | P410       | P411      | P412      | P413  | P414  | P415       |
| 00110b             | SPI <sup>2</sup>  | —         | —       | —   | —   | —   | —         | SSLA3_C   | SSLA3_A  | —      | —          | —          | —         | —         | —     | —     | —          |
| 00111b             | IIC <sup>2</sup>  | SCL0_A    | SDA0_A  | —   | —   | —   | —         | —         | SDA0_B   | SCL0_B | —          | —          | —         | —         | —     | —     | —          |
| 01001b             | CLKOUT/RTC        | —         | —       | —   | —   | —   | —         | —         | RTCOU_T  | —      | —          | —          | —         | —         | —     | —     | —          |
| 01010b             | CAC/ADC12         | ADTRG1    | —       | CACRE_F   | —   | —   | —         | —         | ADTRG0   | —      | —          | —          | —         | —         | —     | —     | —          |
| 01100b             | CTSUS             | —         | —       | —   | —   | —   | —         | —         | TS03     | TS04   | TS05       | TS06       | TS07      | TS08      | TS09  | TS10  | TS11       |
| 10000b             | CAN               | —         | CTX0    | CRX0  | —   | —   | —         | —         | —        | —      | —          | —          | —         | —         | —     | —     | —          |
| 10010b             | SSIE <sup>2</sup> | AUDIO_CLK | —       | AUDIO_CLK   | SSIBCK0_A   | SSILRC0/SSI FS0_A   | SSITXD0_A | SSIRXD0_A | —        | —      | —          | —          | —         | —         | —     | —     | —          |
| 10011b             | USBFS             | —         | —       | —   | —   | —   | —         | —         | USB_VBUS | USB_ID | USB_XICEN  | —          | —         | —         | —     | —     | USB_VBUSEN |
| 10101b             | SDHI <sup>2</sup> | —         | —       | —   | —   | —   | —         | —         | —        | —      | SD0DA T1_A | SD0DA T0_A | SD0CM D_A | SD0CL K_A | SD0WP | SD0CD | —          |
| Don't-care         | AGT, RTC          | —         | —       | AGTIO 0 <sup>1</sup> / <sub>1</sub><br>AGTIO 1 <sup>1</sup> / <sub>1</sub><br>AGTIO 2 <sup>1</sup> / <sub>1</sub><br>AGTIO 3 <sup>1</sup> / <sub>1</sub><br>RTICIC0 <sup>1</sup> / <sub>1</sub> | AGTIO 0 <sup>1</sup> / <sub>1</sub><br>AGTIO 1 <sup>1</sup> / <sub>1</sub><br>AGTIO 2 <sup>1</sup> / <sub>1</sub><br>AGTIO 3 <sup>1</sup> / <sub>1</sub><br>RTICIC1 <sup>1</sup> / <sub>1</sub> | AGTIO 0 <sup>1</sup> / <sub>1</sub><br>AGTIO 1 <sup>1</sup> / <sub>1</sub><br>AGTIO 2 <sup>1</sup> / <sub>1</sub><br>AGTIO 3 <sup>1</sup> / <sub>1</sub><br>RTICIC2 <sup>1</sup> / <sub>1</sub> | —         | —         | —        | —      | —          | —          | —         | —         | —     | —     | —          |
| ASEL bit           | —                 | —         | —       | —   | —   | —   | —         | —         | —        | —      | —          | —          | —         | —         | —     | —     | —          |
| ISEL bit           | —                 | IRQ0      | IRQ5-DS | IRQ4-DS   | IRQ14-DS  | IRQ15-DS  | —         | —         | —        | IRQ7   | IRQ6       | IRQ5       | IRQ4      | —         | —     | IRQ9  | IRQ8       |
| DSCR[1:0] bits     | 驱动容量控制            | L/M/H     | L/M/H   | L/M/H   | L/M/H   | L/M/H   | L/M/H     | L/M/H     | L/M/H    | L/M/H  | L/M/H      | L/M/H      | L/M/H     | L/M/H     | L/M/H | L/M/H | L/M/H      |
| NCODR bit          | N-ch open-drain   | ✓         | ✓       | ✓   | ✓   | ✓   | ✓         | ✓         | ✓        | ✓      | ✓          | ✓          | ✓         | ✓         | ✓     | ✓     | ✓          |
| PCR bit            | Pull-up           | ✓         | ✓       | ✓   | ✓   | ✓   | ✓         | ✓         | ✓        | ✓      | ✓          | ✓          | ✓         | ✓         | ✓     | ✓     | ✓          |
| 144针产品             | —                 | ✓         | ✓       | ✓   | ✓   | ✓   | ✓         | ✓         | ✓        | ✓      | ✓          | ✓          | ✓         | ✓         | ✓     | ✓     | ✓          |
| 100针产品             | —                 | ✓         | ✓       | ✓   | ✓   | ✓   | ✓         | ✓         | ✓        | ✓      | ✓          | ✓          | ✓         | ✓         | ✓     | ✓     | ✓          |
| 64针产品              | —                 | ✓         | ✓       | ✓   | —   | —   | —         | —         | ✓        | ✓      | ✓          | ✓          | —         | —         | —     | —     | —          |

:可用-禁止设置

- 注1.要使用此引脚功能，请将相关引脚设置为通用输入（将PmnPFS.PDR和PmnPFS.PMR位设置为0）。
- 注2.建议使用名称后附有字母的引脚，例如“\_A”或“\_B”，以表示组成员身份。对于接口，测量每组电气特性的交流部分。
- 注3.输出缓冲器中有中驱动和高驱动两种。推荐使用相同的驱动缓冲器输出歪斜规格(tGTISK)

Table 19.10 输入输出引脚功能的寄存器设置(PORT5)(1of2)

| PSEL[4:0] settings         | Function         | pin    |        |        |         |         |        |      |                 |                 |      |
|----------------------------|------------------|--------|--------|--------|---------|---------|--------|------|-----------------|-----------------|------|
|                            |                  | P500   | P501   | P502   | P503    | P504    | P505   | P506 | P507            | P511            | P512 |
| 00000b (value after reset) | Hi-Z/JTAG/SWD    | Hi-Z   |        |        |         |         |        |      |                 |                 |      |
| 00001b                     | AGT              | AGTOA0 | AGTOB0 | AGTOA2 | AGTOB2  | AGTOA3  | AGTOB3 | —    | —               | —               | —    |
| 00010b                     | GPT <sup>1</sup> | GTIU   | GTIV   | GTIW   | GTETRGC | GTETRGD | —      | —    | —               | —               | —    |
| 00011b                     | GPT <sup>1</sup> | —      | —      | —      | —       | —       | —      | —    | GTIOC0B         | GTIOC0A         | —    |
| 00100b                     | SCI              | —      | —      | —      | —       | —       | —      | —    | RXD4/MISO4/SCL4 | TXD4/MOSI4/SDA4 | —    |
| 00111b                     | IIC              | —      | —      | —      | —       | —       | —      | —    | —               | —               | —    |
| 01010b                     | CAC/ADC12        | CACREF | —      | —      | —       | —       | —      | —    | —               | —               | —    |
| 10000b                     | CAN              | —      | —      | —      | —       | —       | —      | —    | —               | —               | —    |
| 10001b                     | QSPI             | QSPCLK | QSSL   | QIO0   | QIO1    | QIO2    | QIO3   | —    | —               | —               | —    |

Table 19.10 Register settings for input/output pin function (PORT5) (2 of 2)

| PSEL[4:0] settings | Function | pin                    |              |              |             |        |       |       |       |       |       |       |       |
|--------------------|----------|------------------------|--------------|--------------|-------------|--------|-------|-------|-------|-------|-------|-------|-------|
|                    |          | P500                   | P501         | P502         | P503        | P504   | P505  | P506  | P507  | P511  | P512  |       |       |
| 10011b             | USBFS    | USB_VBUS EN            | USB_OVRC URA | USB_OVRC URB | USB_EXICE N | USB_ID | —     | —     | —     | —     | —     | —     | —     |
| ASEL bit           |          | AN116                  | AN117        | AN118        | AN119       | AN120  | AN121 | AN122 | —     | —     | —     | —     | —     |
| ISEL bit           |          | —                      | IRQ11        | IRQ12        | —           | —      | IRQ14 | IRQ15 | —     | IRQ15 | IRQ14 | —     | —     |
| DSCR[1:0] bits     |          | Drive capacity control | L/M/H        | L/M/H        | L/M/H       | L/M/H  | L/M/H | L/M/H | L/M/H | L/M/H | L/M/H | L/M/H | L/M/H |
| NCODR bit          |          | N-ch open-drain        | ✓            | ✓            | ✓           | ✓      | ✓     | ✓     | ✓     | ✓     | ✓     | ✓     | ✓     |
| PCR bit            |          | Pull-up                | ✓            | ✓            | ✓           | ✓      | ✓     | ✓     | ✓     | ✓     | ✓     | ✓     | ✓     |
| 144 pins product   |          | ✓                      | ✓            | ✓            | ✓           | ✓      | ✓     | ✓     | ✓     | ✓     | ✓     | ✓     | ✓     |
| 100 pins product   |          | ✓                      | ✓            | ✓            | ✓           | ✓      | —     | —     | —     | —     | —     | —     | —     |
| 64 pins product    |          | ✓                      | —            | —            | —           | —      | —     | —     | —     | —     | —     | —     | —     |

✓: Available  
—: Setting prohibited

Note 1. There are 2 types output buffer which are middle drive and high drive. Recommend using same drive buffer for output skew spec (tGTISK)

Table 19.11 Register settings for input/output pin function (PORT6)

| PSEL[4:0] settings         | Function      | Pin                    |                   |                   |                 |        |       |         |         |         |        |       |       |       |  |
|----------------------------|---------------|------------------------|-------------------|-------------------|-----------------|--------|-------|---------|---------|---------|--------|-------|-------|-------|--|
|                            |               | P600                   | P601              | P602              | P603            | P604   | P605  | P608    | P609    | P610    | P611   | P612  | P613  | P614  |  |
| 00000b (value after reset) | Hi-Z/JTAG/SWD | Hi-Z                   |                   |                   |                 |        |       |         |         |         |        |       |       |       |  |
| 00001b                     | AGT           | AGTIO3                 | AGTEE3            | AGTO3             | AGTIO4          | AGTEE4 | AGTO4 | —       | AGTO5   | AGTO4   | AGTO3  | AGTO2 | AGTO1 | AGTO0 |  |
| 00011b                     | GPT           | GTIOC6B                | GTIOC6A           | GTIOC7B           | GTIOC7A         | —      | —     | GTIOC4B | GTIOC5A | GTIOC5B | —      | —     | —     | —     |  |
| 00101b                     | SCI           | SCK9                   | RXD9/ MISO9/ SCL9 | TXD9/ MOSI9/ SDA9 | CTS9_RT S9/ SS9 | CTS9   | —     | —       | —       | —       | —      | —     | —     | —     |  |
| 01001b                     | CLKOUT/RTC    | CLKOUT                 | —                 | —                 | —               | —      | —     | —       | —       | —       | CLKOUT | —     | —     | —     |  |
| 01010b                     | CAC/ADC12     | CACREF                 | —                 | —                 | —               | —      | —     | —       | —       | —       | CACREF | —     | —     | —     |  |
| 10000b                     | CAN           | —                      | —                 | —                 | —               | —      | —     | CTX1    | CRX1    | —       | —      | —     | —     | —     |  |
| ASEL bit                   |               | —                      | —                 | —                 | —               | —      | —     | —       | —       | —       | —      | —     | —     | —     |  |
| ISEL bit                   |               | —                      | —                 | —                 | —               | —      | —     | —       | —       | —       | —      | —     | —     | —     |  |
| DSCR[1:0] bits             |               | Drive capacity control | L/M/H             | L/M/H             | L/M/H           | L/M/H  | L/M/H | L/M/H   | L/M/H   | L/M/H   | L/M/H  | L/M/H | L/M/H | L/M/H |  |
| NCODR bit                  |               | N-ch open-drain        | ✓                 | ✓                 | ✓               | ✓      | ✓     | ✓       | ✓       | ✓       | ✓      | ✓     | ✓     | ✓     |  |
| PCR bit                    |               | Pull-up                | ✓                 | ✓                 | ✓               | ✓      | ✓     | ✓       | ✓       | ✓       | ✓      | ✓     | ✓     | ✓     |  |
| 144 pins product           |               | ✓                      | ✓                 | ✓                 | ✓               | ✓      | ✓     | ✓       | ✓       | ✓       | ✓      | ✓     | ✓     | ✓     |  |
| 100 pins product           |               | ✓                      | ✓                 | ✓                 | —               | —      | —     | ✓       | ✓       | —       | —      | —     | —     | —     |  |
| 64 pins product            |               | —                      | —                 | —                 | —               | —      | —     | —       | —       | —       | —      | —     | —     | —     |  |

✓: Available  
—: Setting prohibited

Table 19.12 Register settings for input/output pin function (PORT7) (1 of 2)

| PSEL[4:0] settings         | Function         | Pin     |         |         |         |       |        |                          |                                 |      |                 |         |        |  |
|----------------------------|------------------|---------|---------|---------|---------|-------|--------|--------------------------|---------------------------------|------|-----------------|---------|--------|--|
|                            |                  | P700    | P701    | P702    | P703    | P704  | P705   | P708                     | P709                            | P710 | P711            | P712    | P713   |  |
| 00000b (value after reset) | Hi-Z/JTAG/SWD    | Hi-Z    |         |         |         |       |        |                          |                                 |      |                 |         |        |  |
| 00001b                     | AGT              | AGTO4   | AGTO3   | AGTO2   | AGTO1   | AGTO0 | AGTIO0 | —                        | —                               | —    | AGTEE0          | AGTOB0  | AGTOA0 |  |
| 00011b                     | GPT <sup>1</sup> | GTIOC5A | GTIOC5B | GTIOC6A | GTIOC6B | —     | —      | —                        | —                               | —    | GTIOC2B         | GTIOC2A | —      |  |
| 00101b                     | SCI              | —       | —       | —       | —       | —     | CTS3   | RXD1/ MISO1/ SCL1/ RXDX1 | TXD1/ MOSI1/ SDA1/ TXDX1/ SIOX1 | SCK1 | CTS1_RT S1/ SS1 | —       | —      |  |

Table 19.10 输入输出引脚功能的寄存器设置(PORT5)(2of2)

| PSEL[4:0] settings | Function | pin             |              |              |             |        |       |       |       |       |       |       |       |
|--------------------|----------|-----------------|--------------|--------------|-------------|--------|-------|-------|-------|-------|-------|-------|-------|
|                    |          | P500            | P501         | P502         | P503        | P504   | P505  | P506  | P507  | P511  | P512  |       |       |
| 10011b             | USBFS    | USB_VBUS EN     | USB_OVRC URA | USB_OVRC URB | USB_EXICE N | USB_ID | —     | —     | —     | —     | —     | —     | —     |
| ASEL bit           |          | AN116           | AN117        | AN118        | AN119       | AN120  | AN121 | AN122 | —     | —     | —     | —     | —     |
| ISEL bit           |          | —               | IRQ11        | IRQ12        | —           | —      | IRQ14 | IRQ15 | —     | IRQ15 | IRQ14 | —     | —     |
| DSCR[1:0] bits     |          | 驱动容量控制          | L/M/H        | L/M/H        | L/M/H       | L/M/H  | L/M/H | L/M/H | L/M/H | L/M/H | L/M/H | L/M/H | L/M/H |
| NCODR bit          |          | N-ch open-drain | ✓            | ✓            | ✓           | ✓      | ✓     | ✓     | ✓     | ✓     | ✓     | ✓     | ✓     |
| PCR bit            |          | Pull-up         | ✓            | ✓            | ✓           | ✓      | ✓     | ✓     | ✓     | ✓     | ✓     | ✓     | ✓     |
| 144针产品             |          | ✓               | ✓            | ✓            | ✓           | ✓      | ✓     | ✓     | ✓     | ✓     | ✓     | ✓     | ✓     |
| 100针产品             |          | ✓               | ✓            | ✓            | ✓           | ✓      | —     | —     | —     | —     | —     | —     | —     |
| 64针产品              |          | ✓               | —            | —            | —           | —      | —     | —     | —     | —     | —     | —     | —     |

:可用—:禁止设置

注1.输出缓冲器有中驱动和高驱动两种。推荐使用相同的驱动缓冲器输出歪斜规格(tGTISK)

Table 19.11 输入输出引脚功能 (PORT6) 的寄存器设置

| PSEL[4:0] settings         | Function      | Pin     |                   |                   |                 |        |       |         |         |         |        |       |       |       |  |
|----------------------------|---------------|---------|-------------------|-------------------|-----------------|--------|-------|---------|---------|---------|--------|-------|-------|-------|--|
|                            |               | P600    | P601              | P602              | P603            | P604   | P605  | P608    | P609    | P610    | P611   | P612  | P613  | P614  |  |
| 00000b (value after reset) | Hi-Z/JTAG/SWD | Hi-Z    |                   |                   |                 |        |       |         |         |         |        |       |       |       |  |
| 00001b                     | AGT           | AGTIO3  | AGTEE3            | AGTO3             | AGTIO4          | AGTEE4 | AGTO4 | —       | AGTO5   | AGTO4   | AGTO3  | AGTO2 | AGTO1 | AGTO0 |  |
| 00011b                     | GPT           | GTIOC6B | GTIOC6A           | GTIOC7B           | GTIOC7A         | —      | —     | GTIOC4B | GTIOC5A | GTIOC5B | —      | —     | —     | —     |  |
| 00101b                     | SCI           | SCK9    | RXD9/ MISO9/ SCL9 | TXD9/ MOSI9/ SDA9 | CTS9_RT S9/ SS9 | CTS9   | —     | —       | —       | —       | —      | —     | —     | —     |  |
| 01001b                     | CLKOUT/RTC    | CLKOUT  | —                 | —                 | —               | —      | —     | —       | —       | —       | CLKOUT | —     | —     | —     |  |
| 01010b                     | CAC/ADC12     | CACREF  | —                 | —                 | —               | —      | —     | —       | —       | —       | CACREF | —     | —     | —     |  |
| 10000b                     | CAN           | —       | —                 | —                 | —               | —      | —     | CTX1    | CRX1    | —       | —      | —     | —     | —     |  |
| ASEL bit                   |               | —       | —                 | —                 | —               | —      | —     | —       | —       | —       | —      | —     | —     | —     |  |
| ISEL bit                   |               | —       | —                 | —                 | —               | —      | —     | —       | —       | —       | —      | —     | —     | —     |  |
| DSCR[1:0] bits             |               | 驱动容量控制  | L/M/H             | L/M/H             | L/M/H           | L/M/H  | L/M/H | L/M/H   | L/M/H   | L/M/H   | L/M/H  | L/M/H | L/M/H | L/M/H |  |
| NCODR bit                  |               | N沟道开漏   | ✓                 | ✓                 | ✓               | ✓      | ✓     | ✓       | ✓       | ✓       | ✓      | ✓     | ✓     | ✓     |  |
| PCR bit                    |               | Pull-up | ✓                 | ✓                 | ✓               | ✓      | ✓     | ✓       | ✓       | ✓       | ✓      | ✓     | ✓     | ✓     |  |
| 144针产品                     |               | ✓       | ✓                 | ✓                 | ✓               | ✓      | ✓     | ✓       | ✓       | ✓       | ✓      | ✓     | ✓     | ✓     |  |
| 100针产品                     |               | ✓       | ✓                 | ✓                 | —               | —      | —     | ✓       | ✓       | —       | —      | —     | —     | —     |  |
| 64针产品                      |               | —       | —                 | —                 | —               | —      | —     | —       | —       | —       | —      | —     | —     | —     |  |

:可用—:禁止设置

Table 19.12 输入输出引脚功能的寄存器设置(PORT7)(1of2)

| PSEL[4:0] settings         | Function         | Pin     |         |         |         |       |        |                          |                                 |      |                 |         |        |  |
|----------------------------|------------------|---------|---------|---------|---------|-------|--------|--------------------------|---------------------------------|------|-----------------|---------|--------|--|
|                            |                  | P700    | P701    | P702    | P703    | P704  | P705   | P708                     | P709                            | P710 | P711            | P712    | P713   |  |
| 00000b (value after reset) | Hi-Z/JTAG/SWD    | Hi-Z    |         |         |         |       |        |                          |                                 |      |                 |         |        |  |
| 00001b                     | AGT              | AGTO4   | AGTO3   | AGTO2   | AGTO1   | AGTO0 | AGTIO0 | —                        | —                               | —    | AGTEE0          | AGTOB0  | AGTOA0 |  |
| 00011b                     | GPT <sup>1</sup> | GTIOC5A | GTIOC5B | GTIOC6A | GTIOC6B | —     | —      | —                        | —                               | —    | GTIOC2B         | GTIOC2A | —      |  |
| 00101b                     | SCI              | —       | —       | —       | —       | —     | CTS3   | RXD1/ MISO1/ SCL1/ RXDX1 | TXD1/ MOSI1/ SDA1/ TXDX1/ SIOX1 | SCK1 | CTS1_RT S1/ SS1 | —       | —      |  |



Table 19.12 Register settings for input/output pin function (PORT7) (2 of 2)

| PSEL[4:0] settings | Function               | Pin     |         |          |         |         |         |            |       |       |       |       |       |
|--------------------|------------------------|---------|---------|----------|---------|---------|---------|------------|-------|-------|-------|-------|-------|
|                    |                        | P700    | P701    | P702     | P703    | P704    | P705    | P708       | P709  | P710  | P711  | P712  | P713  |
| 00110b             | SPI                    | MISOA_C | MOSIA_C | RSPCKA_C | SSLA0_C | SSLA1_C | SSLA2_C | —          | —     | —     | —     | —     | —     |
| 01010b             | CAC/ADC12              | —       | —       | —        | —       | —       | —       | CACREF     | —     | —     | —     | —     | —     |
| 01100b             | CTSUS                  | —       | —       | —        | —       | —       | —       | TS12       | TS13  | TS14  | TS15  | TS16  | TS17  |
| 10000b             | CAN                    | —       | —       | —        | —       | —       | CTX0    | CRX0       | —     | —     | —     | —     | —     |
| 10010b             | SSIE                   | —       | —       | —        | —       | —       | —       | AUDIO_C LK | —     | —     | —     | —     | —     |
| ASEL bit           |                        | —       | —       | —        | —       | —       | —       | —          | —     | —     | —     | —     | —     |
| ISEL bit           |                        | —       | —       | —        | —       | —       | —       | IRQ11      | IRQ10 | —     | —     | —     | —     |
| DSCR[1:0] bits     | Drive capacity control | L/M/H   | L/M/H   | L/M/H    | L/M/H   | L/M/H   | L/M/H   | L/M/H      | L/M/H | L/M/H | L/M/H | L/M/H | L/M/H |
| NCODR bit          | N-ch open-drain        | ✓       | ✓       | ✓        | ✓       | ✓       | ✓       | ✓          | ✓     | ✓     | ✓     | ✓     | ✓     |
| PCR bit            | Pull-up                | ✓       | ✓       | ✓        | ✓       | ✓       | ✓       | ✓          | ✓     | ✓     | ✓     | ✓     | ✓     |
| 144 pins product   |                        | ✓       | ✓       | ✓        | ✓       | ✓       | ✓       | ✓          | ✓     | ✓     | ✓     | ✓     | ✓     |
| 100 pins product   |                        | —       | —       | —        | —       | —       | —       | ✓          | —     | —     | —     | —     | —     |
| 64 pins product    |                        | —       | —       | —        | —       | —       | —       | —          | —     | —     | —     | —     | —     |

✓: Available  
—: Setting prohibited

Note 1. There are 2 types output buffer which are middle drive and high drive. Recommend using same drive buffer for output skew spec (tGTISK)

Table 19.13 Register settings for input/output pin function (PORT8)

| PSEL[4:0] settings         | Function               | Pin    |        |
|----------------------------|------------------------|--------|--------|
|                            |                        | P800   | P801   |
| 00000b (value after reset) | Hi-Z/JTAG/SWD          | Hi-Z   |        |
| 00001b                     | AGT                    | AGTOA4 | AGTOB4 |
| 00101b                     | SCI,SCI-E              | CTS0   | —      |
| ASEL bit                   |                        | —      | —      |
| ISEL bit                   |                        | —      | —      |
| DSCR[1:0] bits             | Drive capacity control | L/M/H  | L/M/H  |
| NCODR bit                  | N-ch open-drain        | ✓      | ✓      |
| PCR bit                    | Pull-up                | ✓      | ✓      |
| 144 pins product           |                        | ✓      | ✓      |
| 100 pins product           |                        | —      | —      |
| 64 pins product            |                        | —      | —      |

✓: Available  
—: Setting prohibited

Table 19.12 输入输出引脚功能的寄存器设置(PORT7)(2of2)

| PSEL[4:0] settings | Function  | Pin     |         |          |         |         |         |            |       |       |       |       |       |
|--------------------|-----------|---------|---------|----------|---------|---------|---------|------------|-------|-------|-------|-------|-------|
|                    |           | P700    | P701    | P702     | P703    | P704    | P705    | P708       | P709  | P710  | P711  | P712  | P713  |
| 00110b             | SPI       | MISOA_C | MOSIA_C | RSPCKA_C | SSLA0_C | SSLA1_C | SSLA2_C | —          | —     | —     | —     | —     | —     |
| 01010b             | CAC/ADC12 | —       | —       | —        | —       | —       | —       | CACREF     | —     | —     | —     | —     | —     |
| 01100b             | CTSUS     | —       | —       | —        | —       | —       | —       | TS12       | TS13  | TS14  | TS15  | TS16  | TS17  |
| 10000b             | CAN       | —       | —       | —        | —       | —       | CTX0    | CRX0       | —     | —     | —     | —     | —     |
| 10010b             | SSIE      | —       | —       | —        | —       | —       | —       | AUDIO_C LK | —     | —     | —     | —     | —     |
| ASEL bit           |           | —       | —       | —        | —       | —       | —       | —          | —     | —     | —     | —     | —     |
| ISEL bit           |           | —       | —       | —        | —       | —       | —       | IRQ11      | IRQ10 | —     | —     | —     | —     |
| DSCR[1:0] bits     | 驱动容量控制    | L/M/H   | L/M/H   | L/M/H    | L/M/H   | L/M/H   | L/M/H   | L/M/H      | L/M/H | L/M/H | L/M/H | L/M/H | L/M/H |
| NCODR bit          | N通道开漏     | ✓       | ✓       | ✓        | ✓       | ✓       | ✓       | ✓          | ✓     | ✓     | ✓     | ✓     | ✓     |
| PCR bit            | Pull-up   | ✓       | ✓       | ✓        | ✓       | ✓       | ✓       | ✓          | ✓     | ✓     | ✓     | ✓     | ✓     |
| 144针产品             |           | ✓       | ✓       | ✓        | ✓       | ✓       | ✓       | ✓          | ✓     | ✓     | ✓     | ✓     | ✓     |
| 100针产品             |           | —       | —       | —        | —       | —       | —       | ✓          | —     | —     | —     | —     | —     |
| 64针产品              |           | —       | —       | —        | —       | —       | —       | —          | —     | —     | —     | —     | —     |

:可用—:禁止设置

注1.输出缓冲器有中驱动和高驱动两种。推荐使用相同的驱动缓冲器输出歪斜规格(tGTISK)

Table 19.13 输入输出引脚功能 (PORT8) 的寄存器设置

| PSEL[4:0] settings         | Function        | Pin    |        |
|----------------------------|-----------------|--------|--------|
|                            |                 | P800   | P801   |
| 00000b (value after reset) | Hi-Z/JTAG/SWD   | Hi-Z   |        |
| 00001b                     | AGT             | AGTOA4 | AGTOB4 |
| 00101b                     | SCI,SCI-E       | CTS0   | —      |
| ASEL bit                   |                 | —      | —      |
| ISEL bit                   |                 | —      | —      |
| DSCR[1:0] bits             | 驱动容量控制          | L/M/H  | L/M/H  |
| NCODR bit                  | N-ch open-drain | ✓      | ✓      |
| PCR bit                    | Pull-up         | ✓      | ✓      |
| 144针产品                     |                 | ✓      | ✓      |
| 100针产品                     |                 | —      | —      |
| 64针产品                      |                 | —      | —      |

:可用—:禁止设置

## 20. Port Output Enable for GPT (POEG)

### 20.1 Overview

The Port Output Enable (POEG) function can place the General PWM Timer (GPT) output pins in the output disable state in one of the following ways:

- Input level detection of the GTETRn (n = A to D) pins
- Output-disable request from the GPT
- Oscillation stop detection of the clock generation circuit
- Register settings

The GTETRn (n = A to D) pins can be used as GPT external trigger input pins.

Table 20.1 lists the POEG specifications, Figure 20.1 shows a block diagram, and Table 20.2 lists the input pins.

**Table 20.1 POEG specifications**

| Parameter   | Specifications   |
|---|--|
| Output-disable control through input level detection      | <ul style="list-style-type: none"> <li>● The GPT output pins can be disabled when a GTETRn rising edge or high level is sampled after polarity and filter selection.</li> </ul>  |
| Output-disable request from the GPT                       | <ul style="list-style-type: none"> <li>● When the GTIOCxA pin and the GTIOCxB pin are driven to an active level simultaneously, the GPT generates an output-disable request to the POEG. Through reception of these requests, the POEG can control whether the GTIOCxA and GTIOCxB pins are output-disabled.</li> </ul>  |
| Output-disable control through oscillation stop detection | <ul style="list-style-type: none"> <li>● The GPT output pins can be disabled when oscillation of the clock generation circuit stops.</li> </ul>  |
| Output-disable control by software (registers)            | <ul style="list-style-type: none"> <li>● The GPT output pins can be disabled by modifying the register settings.</li> </ul>  |
| Interrupt   | <ul style="list-style-type: none"> <li>● Interrupts can be generated by detecting the input level of external trigger input pins (GTETRn pins).</li> <li>● Interrupts can be generated when all GPT output pins are driven to an active level simultaneously.</li> </ul>   |
| External trigger output to the GPT                        | <ul style="list-style-type: none"> <li>● The GTETRn signals can be output to the GPT after polarity and filter selection. (count start, count stop, count clear, up-count, down-count, or input capture function)</li> </ul>   |
| Noise filtering   | <ul style="list-style-type: none"> <li>● For input from the GTETRn pins, PCLKB/1, PCLKB/8, PCLKB/32, or PCLKB/128 can be selected as the noise filtering clock. (Filtering is performed by sampling the input signals three times using the selected clock.)</li> <li>● Positive or negative polarity can be selected for any of the GTETRn input pins.</li> <li>● Signal state after polarity and filter selection can be monitored.</li> </ul> |
| TrustZone Filter  | <ul style="list-style-type: none"> <li>● Security attribution can be set for each groups.</li> </ul>   |

Note: n = A to D, x = 0 to 7

## 20. GPT(POEG)的端口输出使能

### 20.1 Overview

端口输出使能(POEG)功能可以通过以下方式之一将通用PWM定时器(GPT)输出引脚置于输出禁用状态:

- GTETRn(n=AtoD)引脚的输入电平检测
- 来自GPT的输出禁用请求
- 时钟发生电路的振荡停止检测
- 注册设置

GTETRn(n=AtoD)引脚可用作GPT外部触发输入引脚。

表20.1列出了POEG规范, 图20.1显示了框图, 表20.2列出了输入引脚。

**Table 20.1 POEG specifications**

| Parameter         | Specifications  |
|-------------------|---|
| 通过输入电平检测进行输出禁用控制  | <ul style="list-style-type: none"> <li>● 在极性和滤波器选择后采样GTETRn上升沿或高电平时, 可以禁用GPT输出引脚。</li> </ul>  |
| 来自GPT的输出禁用请求      | <ul style="list-style-type: none"> <li>● 当GTIOCxA引脚和GTIOCxB引脚同时被驱动为有效电平时, GPT向POEG生成一个输出禁用请求。通过接收这些请求, POEG可以控制GTIOCxA和GTIOCxB引脚是否输出禁用。</li> </ul>  |
| 通过振荡停止检测进行输出禁用控制  | <ul style="list-style-type: none"> <li>● 当时钟生成电路的振荡停止时, 可以禁用GPT输出引脚。</li> </ul>   |
| 通过软件(寄存器)进行输出禁用控制 | <ul style="list-style-type: none"> <li>● 通过修改寄存器设置可以禁用GPT输出引脚。</li> </ul>   |
| Interrupt         | <ul style="list-style-type: none"> <li>● 可以通过检测外部触发输入引脚(GTETRn引脚)的输入电平来产生中断。</li> <li>● 当所有GPT输出引脚同时驱动到有效电平时, 可能会产生中断。</li> </ul>   |
| 到GPT的外部触发输出       | <ul style="list-style-type: none"> <li>● GTETRn信号可以在极性和滤波器选择后输出到GPT。(计数开始、计数停止、计数清除、递增计数、递减计数或输入捕捉功能)</li> </ul>  |
| 噪声过滤              | <ul style="list-style-type: none"> <li>● 对于来自GTETRn引脚的输入, 可以选择PCLKB1、PCLKB8、PCLKB32或PCLKB128作为噪声过滤时钟。(通过使用所选时钟对输入信号进行3次采样来执行滤波。)</li> <li>● 可以为任何GTETRn输入引脚选择正极性或负极性。</li> <li>● 可以监控极性和滤波器选择后的信号状态。</li> </ul> |
| TrustZone Filter  | <ul style="list-style-type: none"> <li>● 可以为每个组设置安全属性。</li> </ul>   |

Note: n = A to D, x = 0 to 7

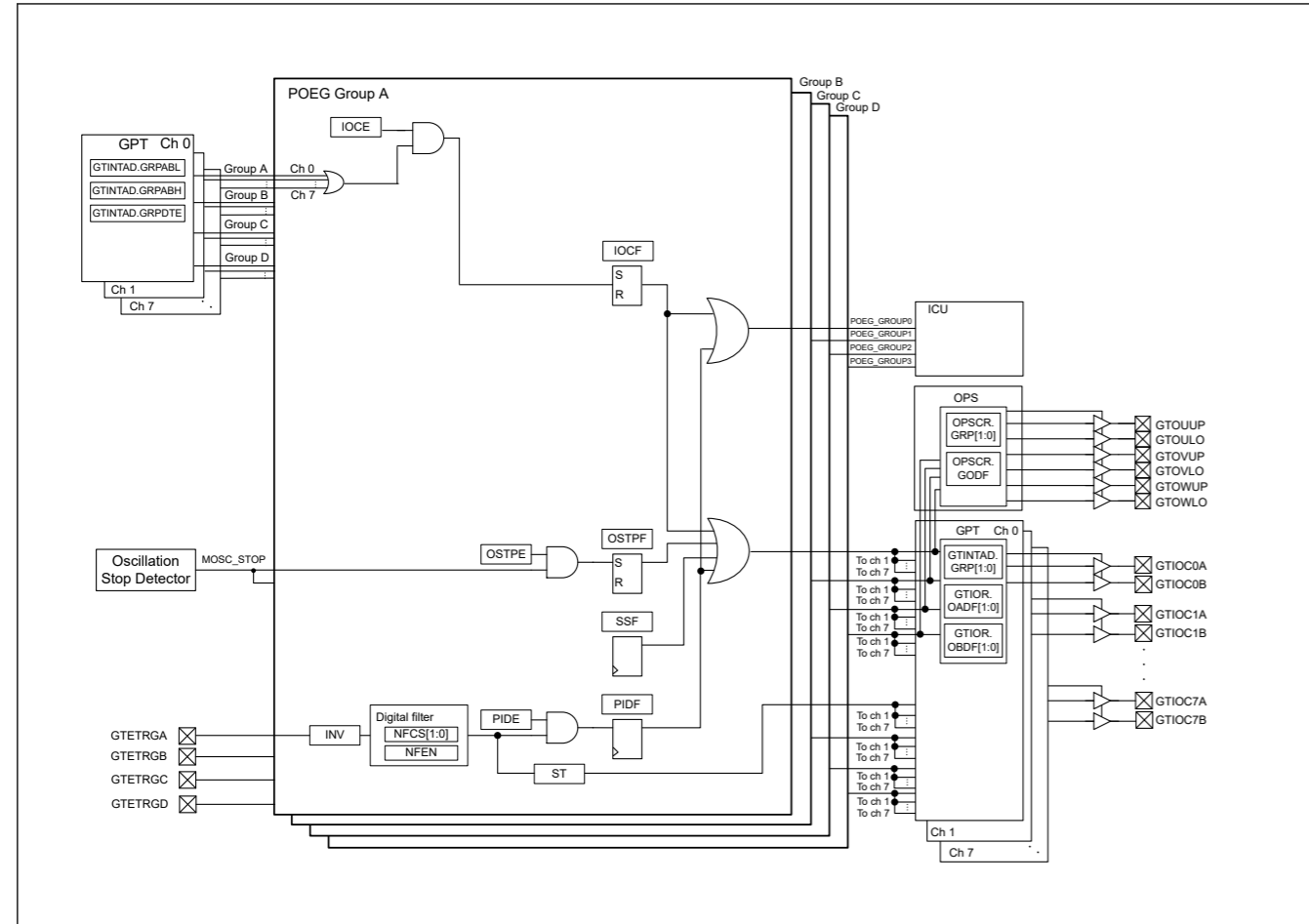


Figure 20.1 POEG block diagram

Table 20.2 POEG input pins

| Pin name | I/O   | Description  |
|----------|-------|--|
| GTETRGA  | Input | GPT output pin output-disable request signal or GPT external trigger input pin A |
| GTETRGB  | Input | GPT output pin output-disable request signal or GPT external trigger input pin B |
| GTETRGC  | Input | GPT output pin output-disable request signal or GPT external trigger input pin C |
| GTETRGD  | Input | GPT output pin output-disable request signal or GPT external trigger input pin D |

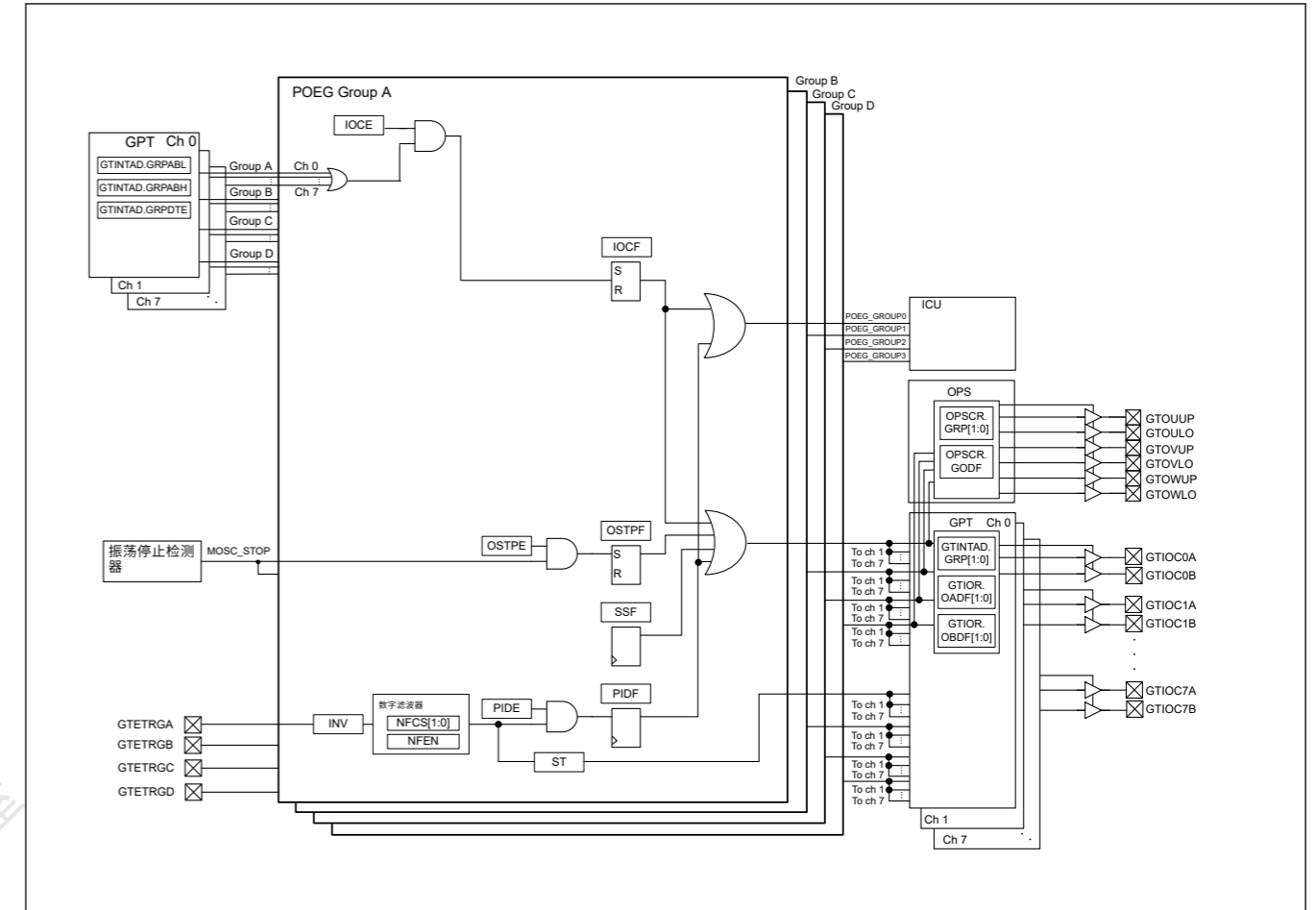


Figure 20.1 POEG框图

Table 20.2 POEG输入引脚

| 引脚名称    | I/O   | Description                  |
|---------|-------|------------------------------|
| GTETRGA | Input | GPT输出引脚输出禁止请求信号或GPT外部触发输入引脚A |
| GTETRGB | Input | GPT输出引脚输出禁止请求信号或GPT外部触发输入引脚B |
| GTETRGC | Input | GPT输出引脚输出禁止请求信号或GPT外部触发输入引脚C |
| GTETRGD | Input | GPT输出引脚输出禁止请求信号或GPT外部触发输入引脚D |

## 20.2 Register Descriptions

## 20.2.1 POEGGn : POEG Group n Setting Register (n = A to D)

Base address: POEG = 0x4008\_A000

Offset address: 0x000 (POEGGA)  
0x100 (POEGGB)  
0x200 (POEGGC)  
0x300 (POEGGD)

|                    |           |    |      |     |    |    |    |    |    |           |      |      |     |           |      |      |
|--------------------|-----------|----|------|-----|----|----|----|----|----|-----------|------|------|-----|-----------|------|------|
| Bit position:      | 31        | 30 | 29   | 28  | 27 | 26 | 25 | 24 | 23 | 22        | 21   | 20   | 19  | 18        | 17   | 16   |
| Bit field:         | NFCS[1:0] |    | NFEN | INV | —  | —  | —  | —  | —  | —         | —    | —    | —   | —         | —    | ST   |
| Value after reset: | 0         | 0  | 0    | 0   | 0  | 0  | 0  | 0  | 0  | 0         | 0    | 0    | 0   | 0         | 0    | 0    |
| Bit position:      | 15        | 14 | 13   | 12  | 11 | 10 | 9  | 8  | 7  | 6         | 5    | 4    | 3   | 2         | 1    | 0    |
| Bit field:         | —         | —  | —    | —   | —  | —  | —  | —  | —  | OSTP<br>E | IOCE | PIDE | SSF | OSTP<br>F | IOCF | PIDF |
| Value after reset: | 0         | 0  | 0    | 0   | 0  | 0  | 0  | 0  | 0  | 0         | 0    | 0    | 0   | 0         | 0    | 0    |

| Bit   | Symbol | Function   | R/W              |
|-------|--------|--|------------------|
| 0     | PIDF   | Port Input Detection Flag<br>0: No output-disable request from the GTETRn pin occurred<br>1: Output-disable request from the GTETRn pin occurred.                              | R/W <sup>1</sup> |
| 1     | IOCF   | Detection Flag for GPT Output-Disable Request<br>0: No output-disable request from GPT occurred.<br>1: Output-disable request from GPT occurred.                               | R/W <sup>1</sup> |
| 2     | OSTPF  | Oscillation Stop Detection Flag<br>0: No output-disable request from oscillation stop detection occurred<br>1: Output-disable request from oscillation stop detection occurred | R/W <sup>1</sup> |
| 3     | SSF    | Software Stop Flag<br>0: No output-disable request from software occurred<br>1: Output-disable request from software occurred  | R/W              |
| 4     | PIDE   | Port Input Detection Enable<br>0: Disable output-disable requests from the GTETRn pins<br>1: Enable output-disable requests from the GTETRn pins                               | R/W <sup>2</sup> |
| 5     | IOCE   | Enable for GPT Output-Disable Request<br>0: Disable output-disable requests from GPT<br>1: Enable output-disable requests from GPT   | R/W <sup>2</sup> |
| 6     | OSTPE  | Oscillation Stop Detection Enable<br>0: Disable output-disable requests from oscillation stop detection<br>1: Enable output-disable requests from oscillation stop detection   | R/W <sup>2</sup> |
| 15:7  | —      | These bits are read as 0. The write value should be 0.   | R/W              |
| 16    | ST     | GTETRn Input Status Flag<br>0: GTETRn input after filtering was 0<br>1: GTETRn input after filtering was 1   | R                |
| 27:17 | —      | These bits are read as 0. The write value should be 0.   | R/W              |
| 28    | INV    | GTETRn Input Reverse<br>0: Input GTETRn as-is<br>1: Input GTETRn in reverse  | R/W              |
| 29    | NFEN   | Noise Filter Enable<br>0: Disable noise filtering<br>1: Enable noise filtering   | R/W              |

## 20.2 注册说明

## 20.2.1 POEGGn:POEG组n设置寄存器(n=A到D)

Base address: POEG = 0x4008\_A000

Offset address: 0x000 (POEGGA)  
0x100 (POEGGB)  
0x200 (POEGGC)  
0x300 (POEGGD)

|               |           |    |      |     |    |    |    |    |    |    |    |    |    |    |    |    |
|---------------|-----------|----|------|-----|----|----|----|----|----|----|----|----|----|----|----|----|
| Bit position: | 31        | 30 | 29   | 28  | 27 | 26 | 25 | 24 | 23 | 22 | 21 | 20 | 19 | 18 | 17 | 16 |
| Bit field:    | NFCS[1:0] |    | NFEN | INV | —  | —  | —  | —  | —  | —  | —  | —  | —  | —  | —  | ST |
| 重置后的值:        | 0         | 0  | 0    | 0   | 0  | 0  | 0  | 0  | 0  | 0  | 0  | 0  | 0  | 0  | 0  | 0  |
| Bit position: | 15        | 14 | 13   | 12  | 11 | 10 | 9  | 8  | 7  | 6  | 5  | 4  | 3  | 2  | 1  | 0  |
| Bit field:    | —         | —  | —    | —   | —  | —  | —  | —  | —  | —  | —  | —  | —  | —  | —  | —  |
| 重置后的值:        | 0         | 0  | 0    | 0   | 0  | 0  | 0  | 0  | 0  | 0  | 0  | 0  | 0  | 0  | 0  | 0  |

| Bit   | Symbol | Function  | R/W              |
|-------|--------|---|------------------|
| 0     | PIDF   | 端口输入检测标志<br>0: 未发生来自GTETRn引脚的输出禁止请求1: 发生了来自GTETRn引脚的输出禁止请求。 | R/W <sup>1</sup> |
| 1     | IOCF   | GPT输出禁用请求的检测标志<br>0: 未发生来自GPT的输出禁用请求。1: 发生了来自GPT的输出禁用请求。    | R/W <sup>1</sup> |
| 2     | OSTPF  | 振荡停止检测标志<br>0: 未发生振荡停止检测的输出禁止请求1: 发生了振荡停止检测的输出禁止请求          | R/W <sup>1</sup> |
| 3     | SSF    | 软件停止标志<br>0: 没有来自软件输出禁止请求1: 有来自软件输出禁止请求                     | R/W              |
| 4     | PIDE   | 端口输入检测启用<br>0: 禁止来自GTETRn引脚的输出禁止请求1: 使能来自GTETRn引脚的输出禁止请求    | R/W <sup>2</sup> |
| 5     | IOCE   | 启用GPT输出禁用请求<br>0: 禁用来自GPT的输出禁用请求1: 启用来自GPT的输出禁用请求           | R/W <sup>2</sup> |
| 6     | OSTPE  | 振荡停止检测使能<br>0: 禁止来自振荡停止检测的输出禁止请求1: 允许来自振荡停止检测的输出禁止请求        | R/W <sup>2</sup> |
| 15:7  | —      | 这些位被读取为0。写入值应为0。  | R/W              |
| 16    | ST     | GTETRn输入状态标志<br>0: 滤波后的GTETRn输入为01: 滤波后的GTETRn输入为1          | R                |
| 27:17 | —      | 这些位被读取为0。写入值应为0。  | R/W              |
| 28    | INV    | GTETRn输入反向<br>0: 按原样输入GTETRn1: 反向输入GTETRn                   | R/W              |
| 29    | NFEN   | 噪声过滤器启用<br>0: 禁用噪声过滤1: 启用噪声过滤                               | R/W              |

| Bit   | Symbol    | Function   | R/W |
|-------|-----------|--|-----|
| 31:30 | NFCS[1:0] | Noise Filter Clock Select<br>0 0: Sample GTETRn pin input level three times every PCLKB<br>0 1: Sample GTETRn pin input level three times every PCLKB/8<br>1 0: Sample GTETRn pin input level three times every PCLKB/32<br>1 1: Sample GTETRn pin input level three times every PCLKB/128 | R/W |

Note 1. Only 0 can be written to clear the flag.

Note 2. Can be modified only once after a reset.

The POEGn (n = A to D) registers control the output-disable state of the GPT pins, interrupts, and the external trigger input to the GPT.

In the descriptions, POEGn represents the POEGn (n = A to D) registers.

### 20.3 Output-Disable Control Operation

If any of the following conditions is satisfied, the GTIOCxA, GTIOCxB, and the 3-phase PWM output for BLDC motor control pins can be set to output-disable:

- Input level or edge detection of the GTETRn pins  
When POEGn.PIDE is 1, the POEGn.PIDF flag is set to 1.
- Output-disable request from the GPT  
When POEGn.IOCE is 1, the POEGn.IOCF flag is set to 1 if the disable request is enabled by GTINTAD. The GTINTAD.GRPABH and GTINTAD.GRPABL settings apply to the group selected by the GPT register GTINTAD.GRP[1:0] or OPSCR.GRP[1:0].
- Oscillation stop detection for the clock generation circuit  
While POEGn.OSTPE is 1, the halt status of the main clock oscillator is detected and the POEGn.OSTPF flag is set to 1.
- SSF bit setting  
When POEGn.SSF is set to 1, the PWM output is disabled.

The output-disable state is controlled in the GPT module. The output-disable of the GTIOCxA and GTIOCxB pins is set in the GTINTAD.GRP[1:0], GTIOR.OADF[1:0], and GTIOR.OBDF[1:0] bits in GPTx. The output-disable of the 3-phase PWM output for BLDC motor control pins is set in the OPSCR.GRP[1:0] bits and OPSCR.GODF bit in GPT OPS.

#### 20.3.1 Pin Input Level Detection Operation

If the input conditions set in POEGn.PIDE, POEGn.NFCS[1:0], POEGn.NFEN, and POEGn.INV occur on the GTETRn pins, the GPT output pins are output-disabled.

##### 20.3.1.1 Digital Filter

Figure 20.2 shows high-level detection by the digital filter. When a high level associated with the POEGn.INV polarity setting is detected three times consecutively with the sampling clock selected in POEGn.NFCS[1:0] and POEGn.NFEN, the detected level is recognized as high, and the GPT output pins are output-disabled. If even one low level is detected during this interval, the detected level is not recognized as high. In addition, in an interval where the sampling clock is not output, changes of the levels on the GTETRn pins are ignored.

| Bit   | Symbol    | Function   | R/W |
|-------|-----------|--|-----|
| 31:30 | NFCS[1:0] | 噪声滤波器时钟选择<br>00: 每PCLKB采样GTETRn引脚输入电平3次<br>01: 每PCLKB采样GTETRn引脚输入电平3次/8<br>10: 每PCLKB采样GTETRn引脚输入电平3次/32<br>11: 每PCLKB采样GTETRn引脚输入电平3次/128 | R/W |

注1.只能写入0来清除标志。

注2.复位后只能修改一次。

POEGn(n=AtoD)寄存器控制GPT引脚的输出禁用状态、中断和GPT的外部触发输入。

在描述中, POEGn代表POEGn (n=A到D) 寄存器。

### 20.3 输出禁用控制操作

如果满足以下任一条件, 则GTIOCxA、GTIOCxB和BLDC电机控制引脚的3相PWM输出可设置为输出禁用:

- GTETRn引脚的输入电平或边沿检测  
当POEGn.PIDE为1时, POEGn.PIDF标志设置为1。
- 来自GPT的输出禁用请求  
当POEGn.IOCE为1时, 如果禁用请求由GTINTAD启用, 则POEGn.IOCF标志设置为1。这GTINTAD.GRPABH和GTINTAD.GRPABL设置适用于GPT寄存器选择的组GTINTAD.GRP[1:0] or OPSCR.GRP[1:0].
- 时钟产生电路的振荡停止检测  
当POEGn.OSTPE为1时, 检测到主时钟振荡器的停止状态和POEGn.OSTPF标志设置为1。
- SSF位设置  
当POEGn.SSF设置为1时, PWM输出被禁用。

输出禁用状态由GPT模块控制。GTIOCxA和GTIOCxB引脚的输出禁用在GPTx中的GTINTAD.GRP[1:0]、GTIOR.OADF[1:0]和GTIOR.OBDF[1:0]位中设置。BLDC电机控制引脚的3相PWM输出的输出禁用在GPT OPS中的OPSCR.GRP[1:0]位和OPSCR.GODF位中设置。

#### 20.3.1 引脚输入电平检测操作

如果在POEGn.PIDE、POEGn.NFCS[1:0]、POEGn.NFEN和POEGn.INV中设置的输入条件发生在GTETRn引脚, GPT输出引脚输出禁用。

##### 20.3.1.1 数字滤波器

图20.2显示了数字滤波器的高电平检测。当在POEGn.NFCS[1:0]和POEGn.NFEN中选择的采样时钟连续3次检测到与POEGn.INV极性设置相关的高电平时, 检测到的电平被识别为高电平, 并且GPT输出引脚为输出禁用。如果在此间隔期间甚至检测到一个低电平, 则检测到的电平不会被识别为高电平。此外, 在不输出采样时钟的时间间隔内, GTETRn引脚的电平变化被忽略。



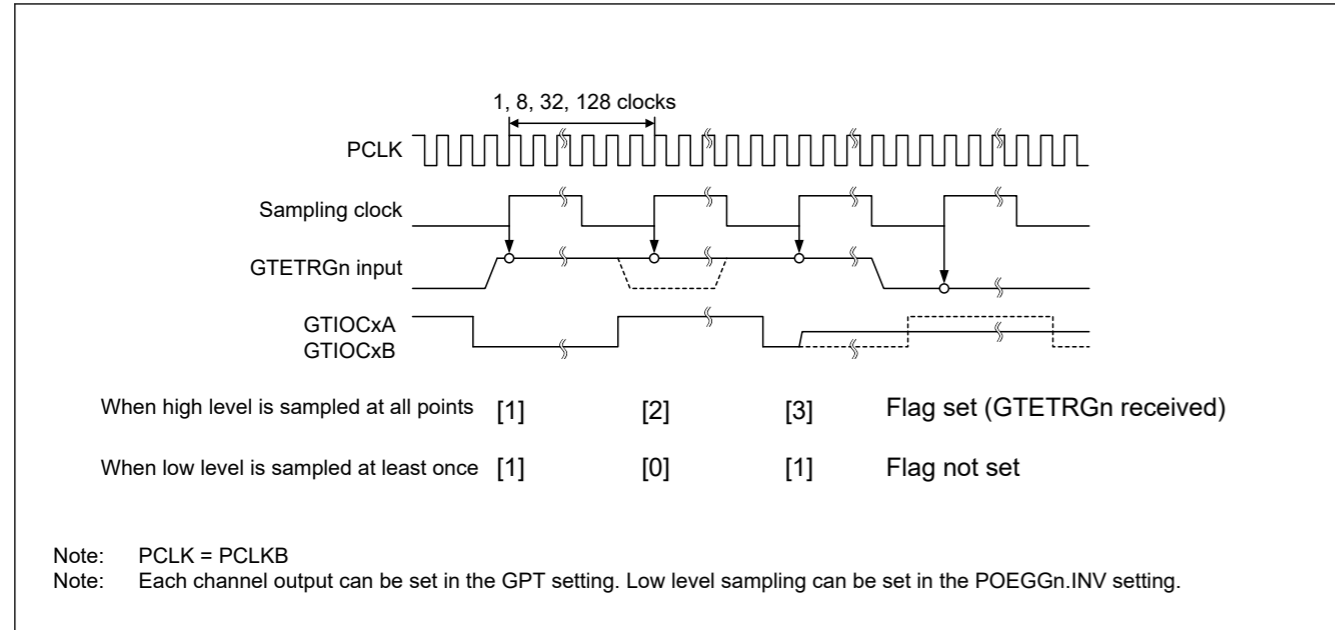


Figure 20.2 Example of digital filter operation

### 20.3.2 Output-Disable Requests from the GPT

For details on the operation, see the description for GTIOC Pin Output Negate Control in [section 21, General PWM Timer \(GPT\)](#).

### 20.3.3 Output-Disable Control Using Detection of Stopped Oscillation

When the oscillation stop detection function in the clock generation circuit detects stopped oscillation while POEGn.OSTPE is 1, the GPT output pins are output-disabled for each group.

### 20.3.4 Output-Disable Control Using Registers

The GPT output pins can be directly controlled by writing 1 to the Software Stop flag, POEGn.SSF.

### 20.3.5 Release from Output-Disable

To release the GPT output pins placed in the output-disable state, either return them to their initial state with a reset or clear all of the following flags:

- POEGn.PIDF
- POEGn.IOCF
- POEGn.OSTPF
- POEGn.SSF

Writing 0 to the POEGn.PIDF flag is ignored (the flag is not cleared) if the external input pins, GTETRn are not disabled and the POEGn.ST bit is not set to 0.

Writing 0 to the POEGn.IOCF flag is valid (the flag is cleared) only if all of the GTST.OABHF and GTST.OABLF flags in the GPT are set to 0.

Writing 0 to the POEGn.OSTPF flag is ignored (the flag is not cleared) if the OSTDSR.OSTDF flag in the clock generation circuit is not set to 0. In addition, when the flag set and release occur at the same time, the flag set takes precedence.

Figure 20.3 shows the release timing for output-disable. The output-disable is released at the beginning of the next count cycle of the GPT after the flag is cleared.

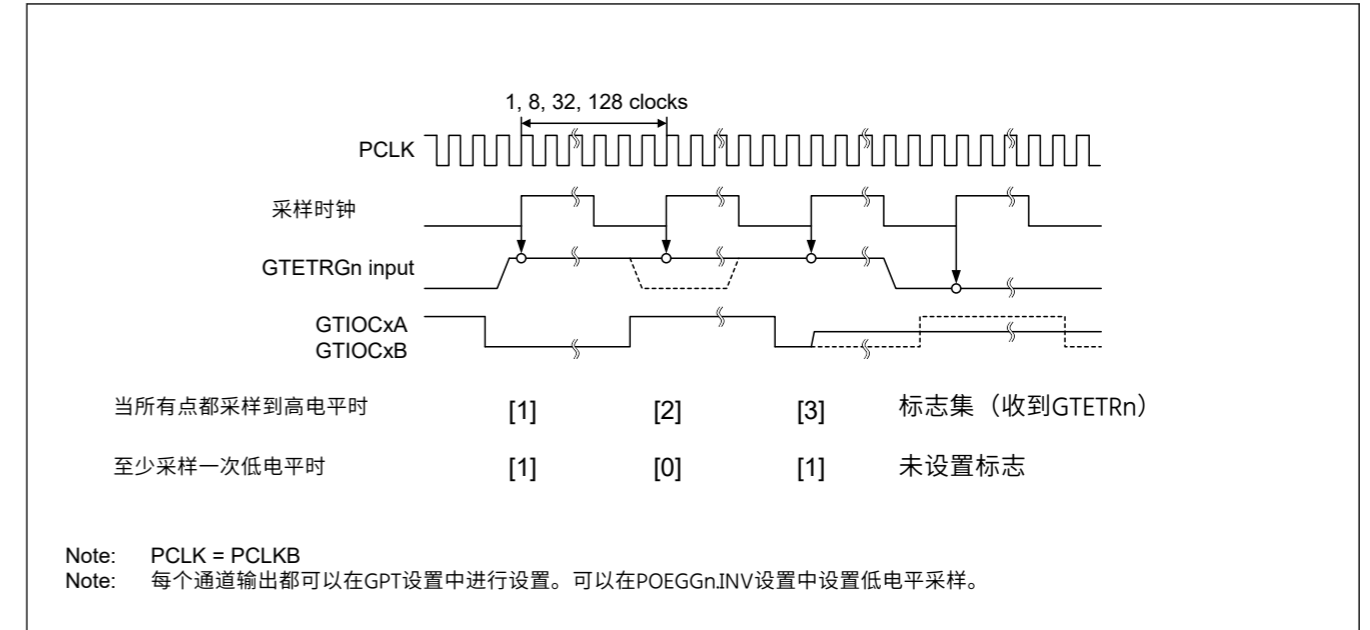


Figure 20.2 数字滤波器操作示例

### 20.3.2 来自GPT的输出禁用请求

有关操作的详细信息，请参见第21节通用PWM定时器(GPT)中对GTIOC引脚输出取反控制的描述。

### 20.3.3 使用停止振荡检测的输出禁用控制

当时钟发生电路中的振荡停止检测功能检测到停止振荡时 POEGn.OSTPE为1，每组的GPT输出引脚输出禁用。

### 20.3.4 使用寄存器的输出禁用控制

GPT输出引脚可以通过将1写入软件停止标志POEGn.SSF来直接控制。

### 20.3.5 从输出禁用释放

要释放处于输出禁用状态的GPT输出引脚，可以通过复位将它们返回到初始状态，或者清除以下所有标志：

- POEGn.PIDF
- POEGn.IOCF
- POEGn.OSTPF
- POEGn.SSF

如果外部输入引脚GTETRn未被禁用且POEGn.ST位未设置为0，则忽略向POEGn.PIDF标志写入0（该标志不被清除）。

仅当GPT中的所有GTST.OABHF和GTST.OABLF标志都设置为0时，向POEGn.IOCF标志写入0才有效（该标志被清除）。

如果时钟生成电路中的OSTDSR.OSTDF标志未设置为0，则忽略向POEGn.OSTPF标志写入0（该标志不被清除）。此外，当标志设置和释放同时发生时，标志集优先。

图20.3显示了输出禁用的释放时序。标志清零后，在GPT的下一个计数周期开始时，输出禁用被释放。

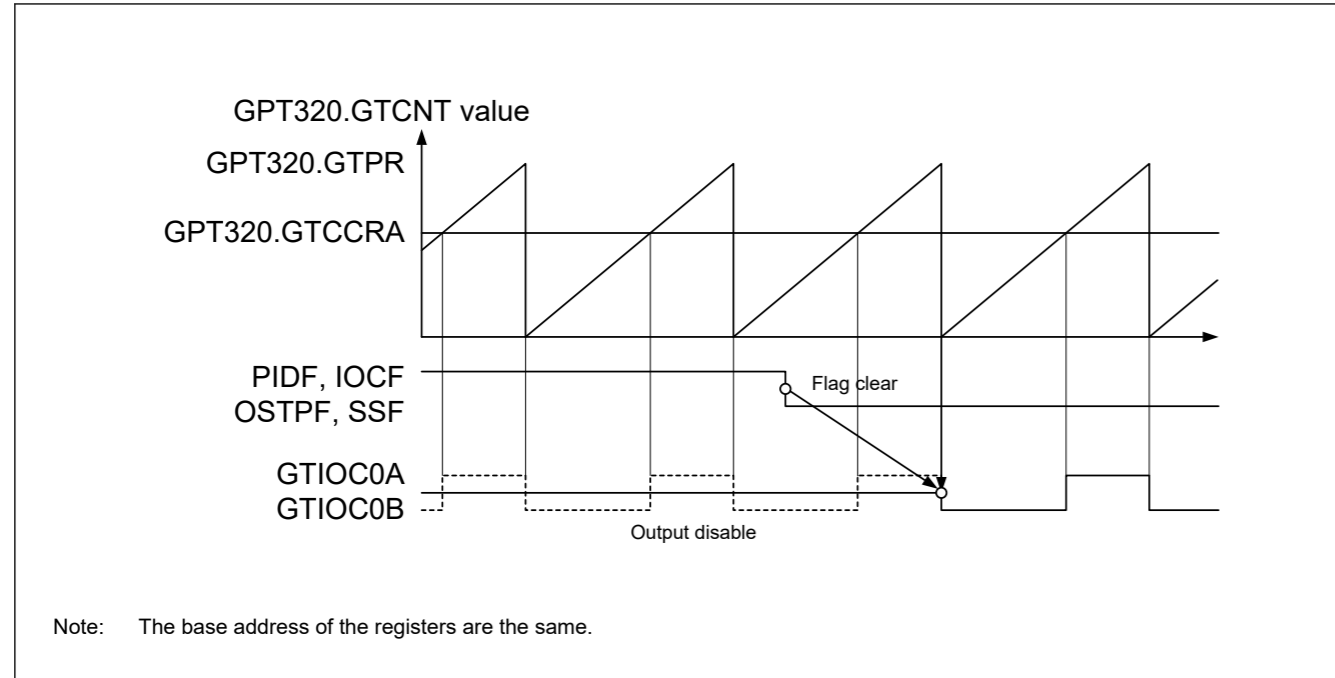


Figure 20.3 Output-disable release timing for GPT pin outputs

### 20.4 Interrupt Sources

The POEG generates an interrupt request when triggered by these sources:

- Output-disable control by the input level detection
- Output-disable request from the GPT

Table 20.3 lists the conditions for interrupt requests.

Table 20.3 Interrupt sources and conditions

| Interrupt source       | Symbol      | Associated flag | Trigger conditions  |
|------------------------|-------------|-----------------|---|
| POEG group A interrupt | POEG_GROUPA | POEGGA.IOCF     | An output-disable request from a GPT disable request occurred |
|                        |             | POEGGA.PIDF     | An output-disable request from the GTETRGA pin occurred       |
| POEG group B interrupt | POEG_GROUPB | POEGGB.IOCF     | An output-disable request from a GPT disable request occurred |
|                        |             | POEGGB.PIDF     | An output-disable request from the GTETRGB pin occurred       |
| POEG group C interrupt | POEG_GROUPC | POEGGC.IOCF     | An output-disable request from a GPT disable request occurred |
|                        |             | POEGGC.PIDF     | An output-disable request from the GTETRGC pin occurred       |
| POEG group D interrupt | POEG_GROUPD | POEGGD.IOCF     | An output-disable request from a GPT disable request occurred |
|                        |             | POEGGD.PIDF     | An output-disable request from the GTETRGD pin occurred       |

### 20.5 External Trigger Output to the GPT

The POEG outputs signals generated by filtering and level detection of GTETRn pins input signals as the GPT operation trigger signal for the following:

- Count start
- Count stop
- Count clear
- Up-count
- Down-count
- Input capture

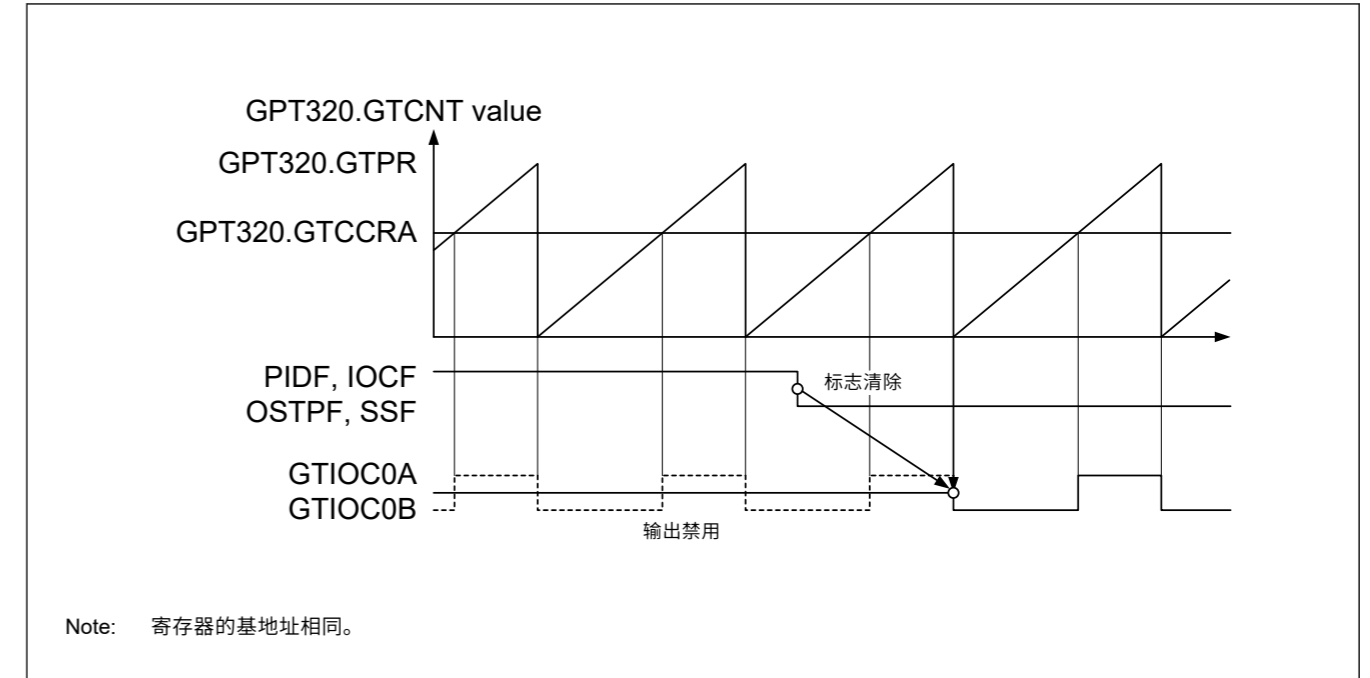


Figure 20.3 GPT引脚输出的输出禁用释放时序

### 20.4 中断源

当这些源触发时，POEG会产生一个中断请求：

- 通过输入电平检测进行输出禁止控制
- 来自GPT的输出禁用请求

表20.3列出了中断请求的条件。

Table 20.3 中断源和条件

| 中断源      | Symbol      | 相关标志        | 触发条件                  |
|----------|-------------|-------------|-----------------------|
| POEGA组中断 | POEG_GROUPA | POEGGA.IOCF | 发生了来自GPT禁用请求的输出禁用请求   |
|          |             | POEGGA.PIDF | 发生了来自GTETRGA引脚的输出禁用请求 |
| POEGB组中断 | POEG_GROUPB | POEGGB.IOCF | 发生了来自GPT禁用请求的输出禁用请求   |
|          |             | POEGGB.PIDF | 发生来自GTETRGB引脚的输出禁用请求  |
| POEGC组中断 | POEG_GROUPC | POEGGC.IOCF | 发生了来自GPT禁用请求的输出禁用请求   |
|          |             | POEGGC.PIDF | 发生了来自GTETRGC引脚的输出禁用请求 |
| POEGD组中断 | POEG_GROUPD | POEGGD.IOCF | 发生了来自GPT禁用请求的输出禁用请求   |
|          |             | POEGGD.PIDF | 发生来自GTETRGD引脚的输出禁用请求  |

### 20.5 到GPT的外部触发输出

POEG输出GTETRn管脚输入信号滤波和电平检测产生的信号作为GPT操作触发信号，用于以下用途：

- 计数开始
- 计数停止
- 清点
- Up-count
- Down-count
- 输入捕捉

For the POEGn.INV polarity setting signal, when the same level is input three times continuously with the sampling clock selected in POEGn.NFCS[1:0] and POEGn.NFEN, that value is output. Set the control registers the same as for the input level detection operation described in section 20.3.1. Pin Input Level Detection Operation. The state after filtering can be monitored in POEGn.ST.

Figure 20.4 shows the output timing of an external trigger to the GPT.

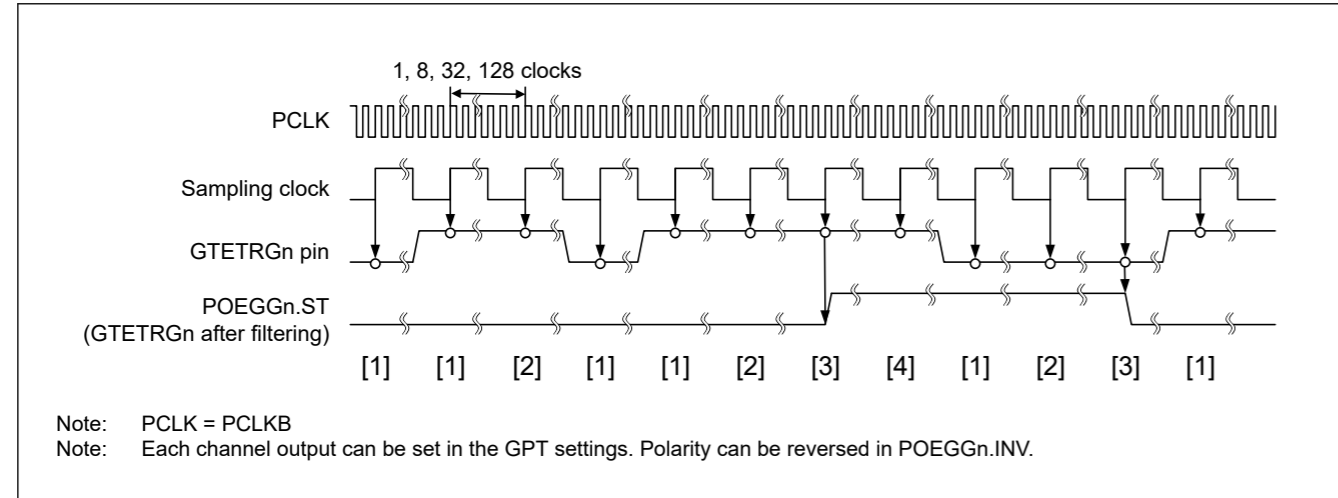


Figure 20.4 Output timing of external trigger to the GPT

## 20.6 Usage Notes

### 20.6.1 Transition to Software Standby Mode

When using the POEG, do not invoke Software Standby mode. In this mode, the POEG stops and therefore output disable of the pins cannot be controlled.

### 20.6.2 Specifying Pins Associated with the GPT

The POEG controls output-disable only when a pin is associated with the GPT in the PmnPFS.PMR and PmnPFS.PSEL settings. When the pin is specified as a general I/O pin, the POEG does not perform output-disable control.

对于POEGn.INV极性设置信号，当在POEGn.NFCS[1:0]和POEGn.NFEN中选择的采样时钟连续输入相同电平3次时，输出该值。控制寄存器的设置与20.3.1节中描述的输入电平检测操作相同。引脚输入电平检测操作滤波后的状态可以在POEGn.ST中监控。

图20.4显示了外部触发到GPT的输出时序。

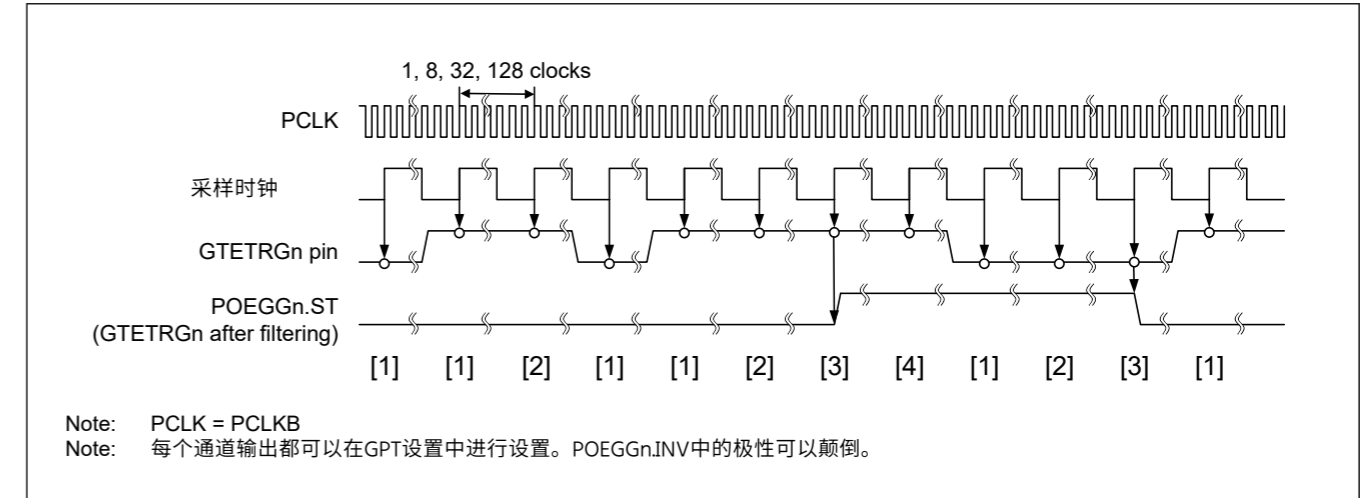


Figure 20.4 外部触发到GPT的输出时序

## 20.6 使用说明

### 20.6.1 过渡到软件待机模式

使用POEG时，请勿调用软件待机模式。在此模式下，POEG停止，因此无法控制引脚的输出禁用。

### 20.6.2 指定与GPT关联的引脚

仅当引脚与PmnPFS.PMR和PmnPFS.PSEL设置中的GPT关联时，POEG才控制输出禁用。当引脚指定为通用IO引脚时，POEG不执行输出禁用控制。

## 21. General PWM Timer (GPT)

### 21.1 Overview

The General PWM Timer (GPT) is a 32-bit timer with GPT32 × 4 channels and a 16-bit timer with GPT16 × 4 channels. PWM waveforms can be generated by controlling the up-counter, down-counter, or the up- and down-counter. In addition, PWM waveforms can be generated for controlling brushless DC motors. The GPT can also be used as a general-purpose timer.

Table 21.1 lists the GPT specifications, Table 21.2 shows the GPT functions, and Figure 21.1 shows a block diagram.

Table 21.1 GPT specifications

| Parameter | Description  |
|-----------|--|
| Functions | <ul style="list-style-type: none"> <li>32 bits × 4 channels (GPT32n (n = 0 to 3))</li> <li>16 bits × 4 channels (GPT16m (m = 4 to 7))</li> <li>Up-counting or down-counting (saw waves) or up/down-counting (triangle waves) for each counter</li> <li>Clock sources independently selectable for each channel</li> <li>Two input/output pins per channel</li> <li>Two output compare/input capture registers per channel</li> <li>For the two output compare/input capture registers of each channel, four registers are provided as buffer registers and are capable of operating as comparison registers when buffering is not in use</li> <li>In output compare operation, buffer switching can be at crests or troughs, enabling the generation of laterally asymmetric PWM waveforms</li> <li>Registers for setting up frame cycles in each channel with capability for generating interrupts at overflow or underflow</li> <li>Generation of dead times in PWM operation</li> <li>Synchronous starting, stopping and clearing counters for arbitrary channels</li> <li>Count start, count stop, count clear, up-count, down-count, or input capture operation in response to a maximum of 8 ELC events</li> <li>Count start, count stop, count clear, up-count, down-count, or input capture operation in response to the status of two input pins</li> <li>Count start, count stop, count clear, up-count, down-count, or input capture operation in response to a maximum of 4 external triggers</li> <li>Period count function</li> <li>Output pin disable function by detected short-circuits between output pins</li> <li>PWM waveform for controlling brushless DC motors can be generated</li> <li>Compare match A to F event, overflow/underflow event, and input UVW edge event can be output to the ELC</li> <li>Enables the noise filter for input capture and input UVW.</li> <li>Logical operation between the channel output</li> <li>Bus clock: PCLKA, Core clock: PCLKD</li> <li>Frequency ratio: PCLKA:PCLKD = 1:N (N = 1/2/4/8/16/32/64)</li> </ul> |

Table 21.2 GPT functions (1 of 2)

| Parameter                                      | Description  |
|--|--|
| Count clock                                    | PCLKD<br>PCLKD/2<br>PCLKD/4<br>PCLKD/8<br>PCLKD/16<br>PCLKD/32<br>PCLKD/64<br>PCLKD/256<br>PCLKD/1024<br>GTETRG, GTETRGA, GTETRGC, GTETRGD |
| Output compare/input capture registers (GTCCR) | GTCCRA<br>GTCCRB   |
| Compare/buffer registers                       | GTCCRC<br>GTCCRD<br>GTCCRE<br>GTCCRF   |
| Cycle setting register                         | GTPR   |
| Cycle setting buffer register                  | GTPBR  |

## 21. 通用PWM定时器(GPT)

### 21.1 Overview

通用PWM定时器(GPT)是一个具有GPT32×4通道的32位定时器和一个具有GPT16×4通道的16位定时器。PWM波形可以通过控制加计数器、减计数器或加减计数器来产生。此外，可以生成PWM波形来控制无刷直流电机。GPT也可以用作通用定时器。

表21.1列出了GPT规范，表21.2显示了GPT功能，图21.1显示了框图。

Table 21.1 GPT specifications

| Parameter | Description   |
|-----------|---|
| Functions | <ul style="list-style-type: none"> <li>32位×4通道(GPT32n(n=0到3))</li> <li>16位×4通道(GPT16m(m=4到7))</li> <li>每个计数器的递增计数或递减计数(锯齿波)或递增递减计数(三角波)</li> <li>每个通道可独立选择时钟源</li> <li>每个通道两个输入输出引脚</li> <li>每个通道两个输出比较输入捕捉寄存器</li> <li>每个通道的两个输出比较输入捕捉寄存器，提供四个寄存器作为缓冲寄存器，在不使用缓冲时可以作为比较寄存器工作</li> <li>在输出比较操作中，缓冲器切换可以处于波峰或波谷，从而能够生成横向不对称的PWM波形</li> <li>用于在每个通道中设置帧周期的寄存器，能够在上溢或下溢时产生中断</li> <li>在PWM操作中产生死区</li> <li>任意通道的同步启动、停止和清除计数器</li> <li>响应最多8个ELC事件的计数开始、计数停止、计数清除、递增计数、递减计数或输入捕获操作</li> <li>计数开始、计数停止、计数清除、递增计数、递减计数或输入捕获操作以响应两个输入引脚的状态</li> <li>计数开始、计数停止、计数清除、递增计数、递减计数或输入捕获操作，以响应最多4个外部触发</li> <li>周期计数功能</li> <li>通过检测到输出引脚之间的短路禁用输出引脚功能</li> <li>可生成控制无刷直流电机的PWM波形</li> <li>比较匹配A到F事件、上溢下溢事件和输入UVW边缘事件可以输出到ELC</li> <li>为输入捕获和输入UVW启用噪声滤波器。</li> <li>通道输出之间的逻辑运算</li> <li>总线时钟: PCLKA, 核心时钟: PCLKD</li> <li>Frequency ratio: PCLKA:PCLKD = 1:N (N = 1/2/4/8/16/32/64)</li> </ul> |

Table 21.2 GPT函数(1of2)

| Parameter                | Description  |
|--------------------------|--|
| 计数时钟                     | PCLKD<br>PCLKD/2<br>PCLKD/4<br>PCLKD/8<br>PCLKD/16<br>PCLKD/32<br>PCLKD/64<br>PCLKD/256<br>PCLKD/1024<br>GTETRG, GTETRGA, GTETRGC, GTETRGD |
| 输出比较输入捕捉寄存器(GTCCR)       | GTCCRA<br>GTCCRB   |
| Compare/buffer registers | GTCCRC<br>GTCCRD<br>GTCCRE<br>GTCCRF   |
| 周期设定寄存器                  | GTPR   |
| 周期设置缓冲寄存器                | GTPBR  |

Table 21.2 GPT functions (2 of 2)

| Parameter                                    | Description  |           |
|--|--|-----------|
| I/O pins                                     | GTIOCnA<br>GTIOCnB<br>(n = 0 to 7)   |           |
| External trigger input pin*1                 | GTETRGA<br>GTETRGB<br>GTETRGC<br>GTETRGD   |           |
| Counter clear sources                        | GTPR register compare match, input capture, input pin status, ELC event input, and GTETRn (n = A to D) pin input   |           |
| Period count function                        | Available (GPT32n (n = 0, 1), GPT16m (m = 4 to 6))   |           |
| Compare match output                         | Low output   | Available |
|  | High output  | Available |
|  | Toggle output  | Available |
| Input capture function                       | Available  |           |
| Automatic addition of dead time              | Available<br>(no dead time buffer)   |           |
| PWM mode                                     | Available  |           |
| Phase count function                         | Available  |           |
| Buffer operation                             | Double buffer<br>Simultaneous operation disable control for multiple channels  |           |
| One-shot operation                           | Available  |           |
| DTC activation                               | All the interrupt sources  |           |
| Brushless DC motor control function          | Available  |           |
| Interrupt sources                            | 9 sources <ul style="list-style-type: none"> <li>• GTCCRA comare match/input capture(GPTn_CCMPA)</li> <li>• GTCCRB comare match/input capture(GPTn_CCMPB)</li> <li>• GTCCRC comare match(GPTn_CMPC)</li> <li>• GTCCRD comare match(GPTn_CMPD)</li> <li>• GTCCRE comare match(GPTn_CMPE)</li> <li>• GTCCRF comare match(GPTn_CMPF)</li> <li>• GTCNT overflow (GTPR compare match) (GPTn_OVF)</li> <li>• GTCNT underflow (GPTn_UDF)</li> <li>• GTPC count stop(GPTx_PC) (x = 0,1,4-6)</li> </ul> |           |
| Event linking (ELC) function                 | Available*2  |           |
| Noise filtering function                     | Available  |           |
| Logical operation between the channel output | Available  |           |
| TrustZone Filter                             | Available  |           |

Note 1. GTETRn connects to GPT through the POEG module. Therefore, to use the GPT function, supply the POEG clock by clearing the MSTPCRD.MSTPDn (n = 11 to 14) bit.

Note 2. see [section 21.5. Operations Linked by ELC](#)

Table 21.2 GPT功能 (2个中的2个)

| Parameter          | Description   |           |
|--------------------|---|-----------|
| I/O pins           | GTIOCnA<br>GTIOCnB<br>(n = 0 to 7)  |           |
| 外部触发输入引脚*1         | GTETRGA<br>GTETRGB<br>GTETRGC<br>GTETRGD  |           |
| 反清源                | GTPR寄存器比较匹配、输入捕捉、输入引脚状态、ELC事件输入和GTETRn (n=A到D) 引脚输入   |           |
| 周期计数功能             | 可用 (GPT32n (n=0、1)、GPT16m (m=4到6))  |           |
| 比较匹配输出             | 低输出   | Available |
|                    | 高输出   | Available |
|                    | 切换输出  | Available |
| 输入捕捉功能             | Available   |           |
| 自动添加死区时间           | 可用 (无死区时间缓冲区)   |           |
| PWM mode           | Available   |           |
| 相位计数功能             | Available   |           |
| 缓冲操作               | 双缓冲<br>多通道同时操作禁用控制  |           |
| One-shot operation | Available   |           |
| DTC activation     | 所有中断源   |           |
| 直流无刷电机控制功能         | Available   |           |
| 中断源                | 9 sources <ul style="list-style-type: none"> <li>• GTCCRA comare match/input capture(GPTn_CCMPA)</li> <li>• GTCCRB comare match/input capture(GPTn_CCMPB)</li> <li>• GTCCRC comare match(GPTn_CMPC)</li> <li>• GTCCRD comare match(GPTn_CMPD)</li> <li>• GTCCRE comare match(GPTn_CMPE)</li> <li>• GTCCRF comare match(GPTn_CMPF)</li> <li>• GTCNT溢出 (GTPR比较匹配) (GPTn_OVF)</li> <li>• GTCNT underflow (GPTn_UDF)</li> <li>• GTPC count stop(GPTx_PC) (x = 0,1,4-6)</li> </ul> |           |
| 事件链接(ELC)功能        | Available*2   |           |
| 噪音过滤功能             | Available   |           |
| 通道输出之间的逻辑运算        | Available   |           |
| TrustZone Filter   | Available   |           |

注1.GTETRn通过POEG模块连接到GPT。因此，要使用GPT功能，通过清除MSTPCRD.MSTPDn (n=11到14) 位。

注2: 见第21.5节。由ELC链接的操作



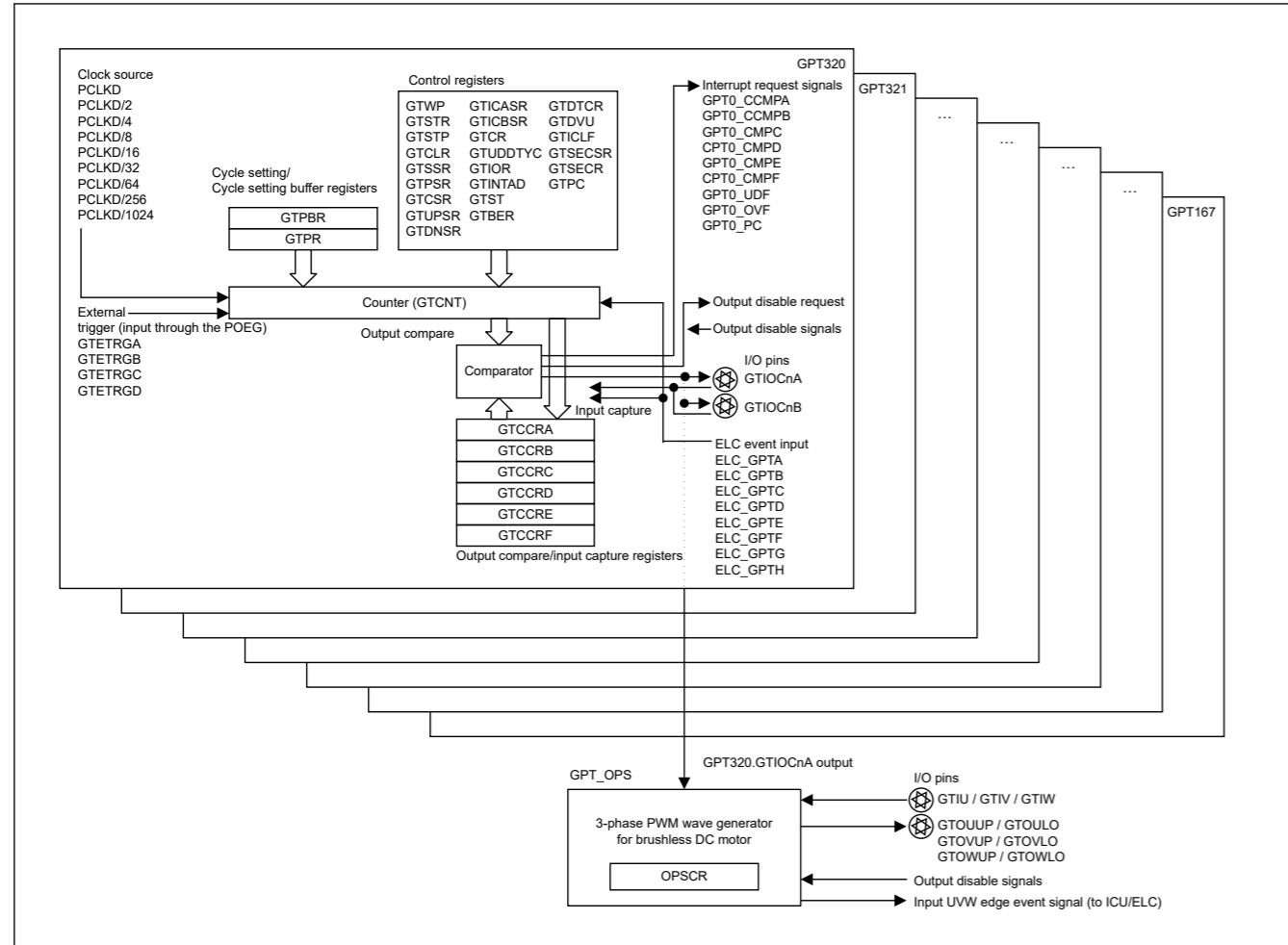


Figure 21.1 GPT block diagram

Figure 21.2 shows an example using multiple GPTs.

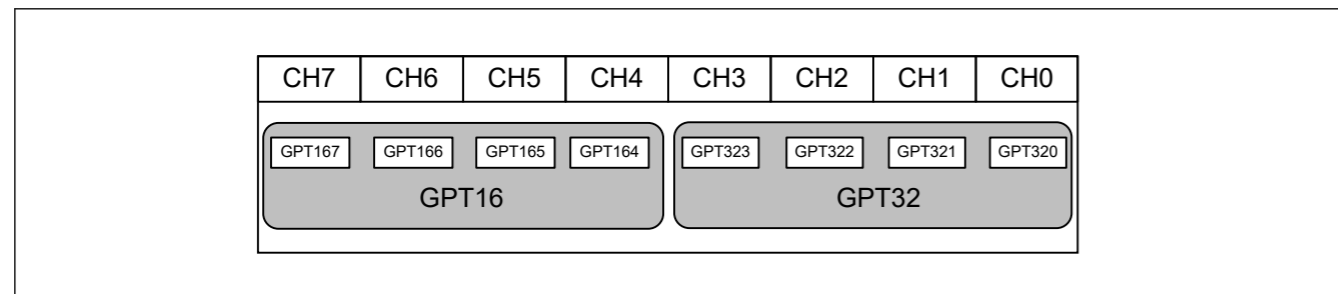


Figure 21.2 Association between GPT channels and module names

Table 21.3 lists the I/O pins.

Table 21.3 GPT I/O pins (1 of 2)

| Channel | Pin name | I/O   | Function   |
|---------|----------|-------|--|
| Common  | GTETRGx  | Input | External trigger input pin x (input through the POEG)                    |
| GPT32n  | GTIOCnA  | I/O   | GTCCRA register input capture input/output compare output/PWM output pin |
|         | GTIOCnB  | I/O   | GTCCRB register input capture input/output compare output/PWM output pin |
| GPT16m  | GTIOCnA  | I/O   | GTCCRA register input capture input/output compare output/PWM output pin |
|         | GTIOCnB  | I/O   | GTCCRB register input capture input/output compare output/PWM output pin |
| GPT OPS | GTIU     | Input | Hall sensor input pin U  |

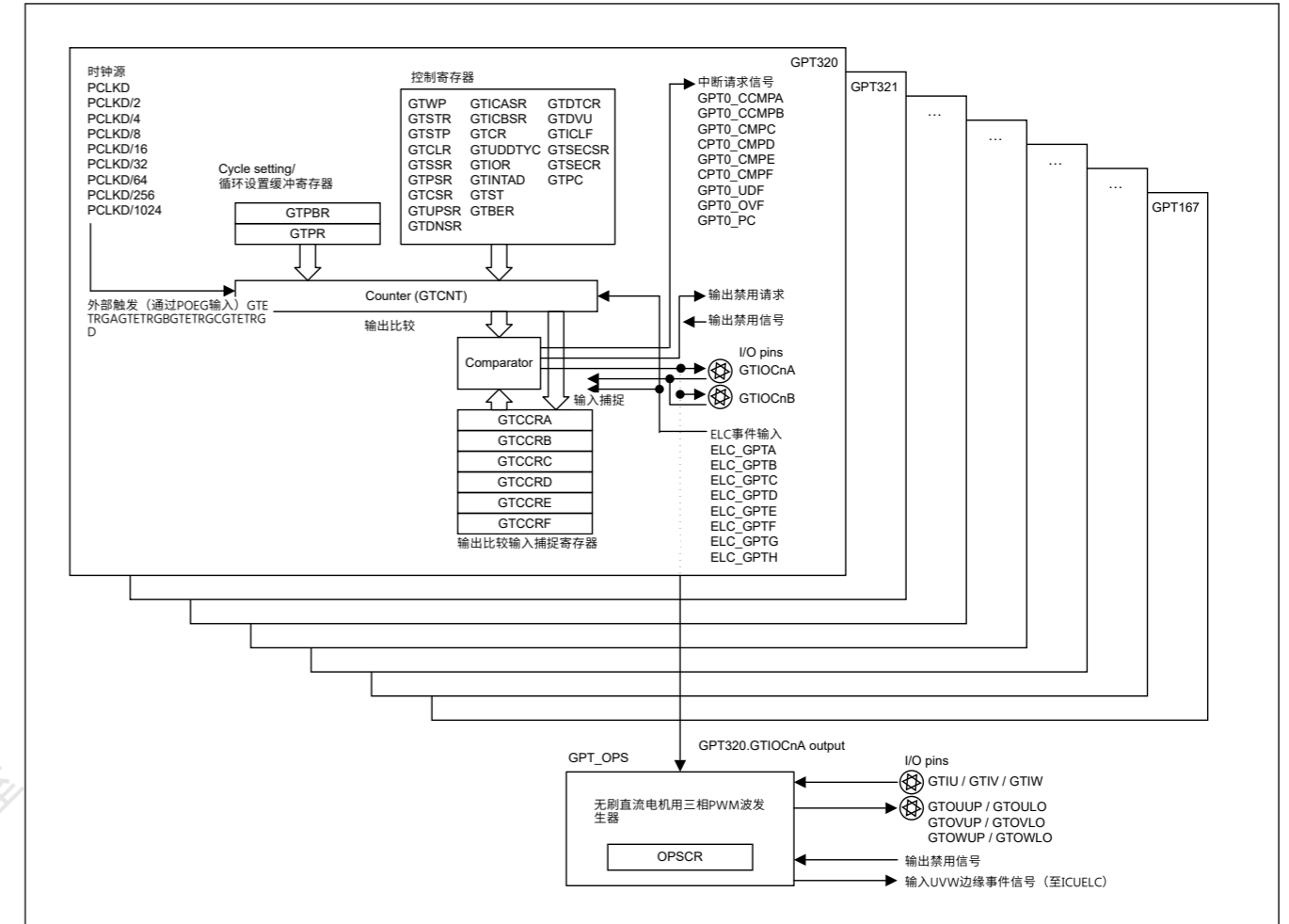


Figure 21.1 GPT框图

图21.2显示了一个使用多个GPT的示例。

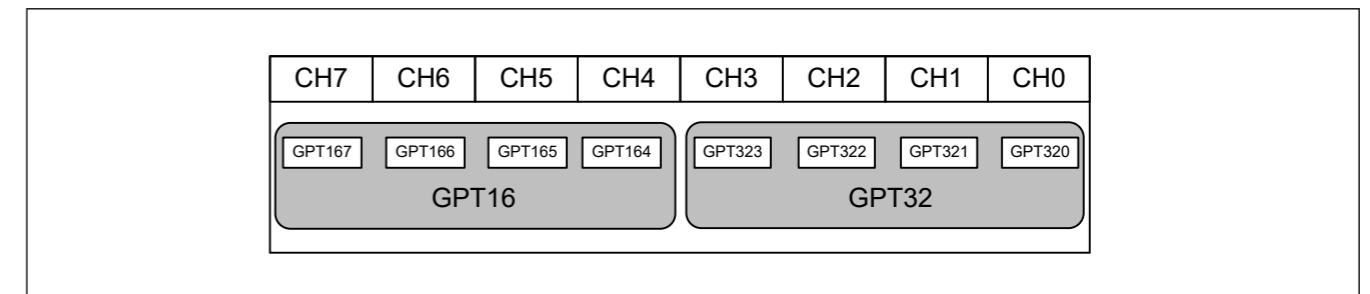


Figure 21.2 GPT通道和模块名称之间的关联

表21.3列出了IO引脚。

Table 21.3 GPTIO引脚 (2个中的1个)

| Channel | 引脚名称    | I/O   | Function                     |
|---------|---------|-------|------------------------------|
| Common  | GTETRGx | Input | 外部触发输入引脚x (通过POEG输入)         |
| GPT32n  | GTIOCnA | I/O   | GTCCRA寄存器输入捕捉输入输出比较输出PWM输出引脚 |
|         | GTIOCnB | I/O   | GTCCRB寄存器输入捕捉输入输出比较输出PWM输出引脚 |
| GPT16m  | GTIOCnA | I/O   | GTCCRA寄存器输入捕捉输入输出比较输出PWM输出引脚 |
|         | GTIOCnB | I/O   | GTCCRB寄存器输入捕捉输入输出比较输出PWM输出引脚 |
| GPT OPS | GTIU    | Input | 霍尔传感器输入引脚U                   |

Table 21.3 GPT I/O pins (2 of 2)

| Channel | Pin name | I/O    | Function   |
|---------|----------|--------|--|
|         | GTIV     | Input  | Hall sensor input pin V                                      |
|         | GTIW     | Input  | Hall sensor input pin W                                      |
|         | GTOUUP   | Output | 3-phase PWM output for BLDC motor control (positive U-phase) |
|         | GTOULO   | Output | 3-phase PWM output for BLDC motor control (negative U-phase) |
|         | GTOVUP   | Output | 3-phase PWM output for BLDC motor control (positive V-phase) |
|         | GTOVLO   | Output | 3-phase PWM output for BLDC motor control (negative V-phase) |
|         | GTOWUP   | Output | 3-phase PWM output for BLDC motor control (positive W-phase) |
|         | GTOWLO   | Output | 3-phase PWM output for BLDC motor control (negative W-phase) |

Note: x: A to D  
n: 0 to 3  
m: 4 to 7

## 21.2 Register Descriptions

### 21.2.1 GTWP : General PWM Timer Write-Protection Register

Base address: GPT32n = 0x4016\_9000 + 0x0100 × n (n = 0 to 3)  
GPT16m = 0x4016\_9000 + 0x0100 × m (m = 4 to 7)

Offset address: 0x00

|                    |            |    |    |    |    |    |    |    |    |    |        |       |       |       |    |    |
|--------------------|------------|----|----|----|----|----|----|----|----|----|--------|-------|-------|-------|----|----|
| Bit position:      | 31         | 30 | 29 | 28 | 27 | 26 | 25 | 24 | 23 | 22 | 21     | 20    | 19    | 18    | 17 | 16 |
| Bit field:         | —          | —  | —  | —  | —  | —  | —  | —  | —  | —  | —      | —     | —     | —     | —  | —  |
| Value after reset: | 0          | 0  | 0  | 0  | 0  | 0  | 0  | 0  | 0  | 0  | 0      | 0     | 0     | 0     | 0  | 0  |
| Bit position:      | 15         | 14 | 13 | 12 | 11 | 10 | 9  | 8  | 7  | 6  | 5      | 4     | 3     | 2     | 1  | 0  |
| Bit field:         | PRKEY[7:0] |    |    |    |    |    |    | —  | —  | —  | CMN WP | CLRWP | STPWP | STRWP | WP |    |
| Value after reset: | 0          | 0  | 0  | 0  | 0  | 0  | 0  | 0  | 0  | 0  | 0      | 0     | 0     | 0     | 0  | 0  |

| Bit   | Symbol     | Function   | R/W |
|-------|------------|--|-----|
| 0     | WP         | Register Write Disable<br>0: Write to the register enabled<br>1: Write to the register disabled  | R/W |
| 1     | STRWP      | GTSTR.CSTRT Bit Write Disable<br>0: Write to the bit is enabled<br>1: Write to the bit is disabled   | R/W |
| 2     | STPWP      | GTSTP.CSTOP Bit Write Disable<br>0: Write to the bit is enabled<br>1: Write to the bit is disabled   | R/W |
| 3     | CLRWP      | GTCLR.CCLR Bit Write Disable<br>0: Write to the bit is enabled<br>1: Write to the bit is disabled  | R/W |
| 4     | CMNWP      | Common Register Write Disabled<br>0: Write to the register is enabled<br>1: Write to the register is disabled  | R/W |
| 7:5   | —          | These bits are read as 0. The write value should be 0.   | R/W |
| 15:8  | PRKEY[7:0] | GTWP Key Code<br>When 0xA5 is written to these bits, writing to the WP, STRWP, STPWP, CLRWP, and CMNWP bits are permitted. These bits are read as 0. | W   |
| 31:16 | —          | These bits are read as 0. The write value should be 0.   | R/W |

Table 21.3 GPTIO引脚 (2个中的2个)

| Channel | 引脚名称   | I/O    | Function                 |
|---------|--------|--------|--------------------------|
|         | GTIV   | Input  | 霍尔传感器输入引脚V               |
|         | GTIW   | Input  | 霍尔传感器输入引脚W               |
|         | GTOUUP | Output | 用于BLDC电机控制的3相PWM输出 (正U相) |
|         | GTOULO | Output | 用于BLDC电机控制的3相PWM输出 (负U相) |
|         | GTOVUP | Output | 用于BLDC电机控制的3相PWM输出 (正V相) |
|         | GTOVLO | Output | 用于BLDC电机控制的3相PWM输出 (负V相) |
|         | GTOWUP | Output | 用于BLDC电机控制的3相PWM输出 (正W相) |
|         | GTOWLO | Output | 用于BLDC电机控制的3相PWM输出 (负W相) |

Note: x: A to D  
n: 0 to 3  
m: 4 to 7

## 21.2 注册说明

### 21.2.1 GTWP:通用PWM定时器写保护寄存器

Base address: GPT32n = 0x4016\_9000 + 0x0100 × n (n = 0 to 3)  
GPT16m = 0x4016\_9000 + 0x0100 × m (m = 4 to 7)

Offset address: 0x00

|               |            |    |    |    |    |    |    |    |    |    |        |       |       |       |    |    |
|---------------|------------|----|----|----|----|----|----|----|----|----|--------|-------|-------|-------|----|----|
| Bit position: | 31         | 30 | 29 | 28 | 27 | 26 | 25 | 24 | 23 | 22 | 21     | 20    | 19    | 18    | 17 | 16 |
| Bit field:    | —          | —  | —  | —  | —  | —  | —  | —  | —  | —  | —      | —     | —     | —     | —  | —  |
| 重置后的值:        | 0          | 0  | 0  | 0  | 0  | 0  | 0  | 0  | 0  | 0  | 0      | 0     | 0     | 0     | 0  | 0  |
| Bit position: | 15         | 14 | 13 | 12 | 11 | 10 | 9  | 8  | 7  | 6  | 5      | 4     | 3     | 2     | 1  | 0  |
| Bit field:    | PRKEY[7:0] |    |    |    |    |    |    | —  | —  | —  | CMN WP | CLRWP | STPWP | STRWP | WP |    |
| 重置后的值:        | 0          | 0  | 0  | 0  | 0  | 0  | 0  | 0  | 0  | 0  | 0      | 0     | 0     | 0     | 0  | 0  |

| Bit   | Symbol     | Function   | R/W |
|-------|------------|--|-----|
| 0     | WP         | 寄存器写禁用<br>0: 允许写入寄存器1: 禁止写入寄存器                                   | R/W |
| 1     | STRWP      | GTSTR.CSTRT位写入禁止<br>0: 允许写入位1: 禁止写入位                             | R/W |
| 2     | STPWP      | GTSTP.CSTOP位写入禁止<br>0: 允许写入位1: 禁止写入位                             | R/W |
| 3     | CLRWP      | GTCLR.CCLR位写入禁止<br>0: 允许写入位1: 禁止写入位                              | R/W |
| 4     | CMNWP      | 公共寄存器写入禁用<br>0: 允许写入寄存器1: 禁止写入寄存器                                | R/W |
| 7:5   | —          | 这些位被读取为0。写入值应为0。   | R/W |
| 15:8  | PRKEY[7:0] | GTWP密钥代码<br>当0xA5写入这些位时, 写入WP、STRWP、STPWP、CLRWP和允许CMNWP位。这些位读为0。 | W   |
| 31:16 | —          | 这些位被读取为0。写入值应为0。   | R/W |

GTWP enables or disables writing to registers to prevent accidental modification. Protection by the GTWP register is only for the writes by the CPU. GTWP does not protect registers from updates that occur in association with CPU writes.

#### WP bit (Register Write Disable)

The following is a list of write enabled or disabled registers:

GTSSR, GTPSR, GTCSR, GTUPSR, GTDNSR, GTICASR, GTICBSR, GTCR, GTUDDTYC, GTIOR, GTINTAD, GTST, GTBER, GTCNT, GTCCRA, GTCCRB, GTCCRC, GTCCRD, GTCCRE, GTCCRF, GTPR, GTPBR, GTDTCR, GTDVU, GTICLF, GTPC.

#### STRWP bit (GTSTR.CSTRT Bit Write Disable)

The STRWP bit enables or disables starting the updating of counter values by writing to the CSTRTn bit (n = 0 to 7) corresponding to a channel number in the GTSTR register.

The bit position of each CSTRTn bit in the GTSTR register is allocated to the channel with the corresponding number, and writing to the GTSTR register for any channel results in writing to the registers of all channels. The STRWP bit for each channel does not control writing but only controls updating of the CSTRT bit for the corresponding channel in the case of simultaneous writing to all channels.

Thus, in the case of writing to the CSTRT bits of a channel for which the setting of the STRWP bit is 1 (disabling writing), the CSTRT bit for the given channel will not be updated, but the CSTRT bits corresponding to channel for which the setting of the STRWP bit is 0 (enabling writing) will be updated. For example, when the setting of the GTWP.STRWP bit of GPT channel 0 is 0 (enabling writing), writing 1 to the GTSTR.CSTRT0 bit of GPT channel 1 when its current setting is 0 will lead to updating of the value, and the GPT320.GTCNT counter starts running. When the setting of the GTWP.STRWP bit of GPT channel 0 is 1 (disabling writing), writing 1 to the GTSTR.CSTRT0 bit of GPT channel 1 when its current setting is 0 will leave the bit with the value 0, and the GPT320.GTCNT counter will not start running.

If you want to protect all bits in the GTSTR register from being updated, set the STRWP bits of all channels to 1.

#### STPWP bit (GTSTP.CSTOP Bit Write Disable)

The STPWP bit enables or disables starting the updating of counter values by writing to the CSTOPn bit (n = 0 to 7) corresponding to a channel number in the GTSTP register.

The bit position of each CSTOPn bit in the GTSTP registers is allocated to the channel with the corresponding number, and the writing to the GTSTP register for any channel results in writing to the registers of all channels. The STPWP bit for each channel does not control writing but only controls updating of the CSTOP bit for the corresponding channel in the case of simultaneous writing to all channels.

Thus, in the case of writing to the CSTOP bits of a channel for which the setting of the STPWP bit is 1 (disabling writing), the CSTOP bit for the given channel will not be updated, but the CSTOP bits corresponding to channel for which the setting of the STPWP bit is 0 (enabling writing) will be updated. For example, when the setting of the GTWP.STPWP bit of GPT channel 0 is 0 (enabling writing), writing 1 to the GTSTP.CSTOP0 bit of GPT channel 1 when its current setting is 0 will lead to updating of the value, and the GPT320.GTCNT counter is stopped. When the setting of the GTWP.STPWP bit of GPT channel 0 is 1 (disabling writing), writing 1 to the GTSTP.CSTOP0 bit of GPT channel 1 when its current setting is 0 will leave the bit with the value 0, and the GPT320.GTCNT counter will not be stopped.

If you want to protect all bits in the GTSTP register from being updated, set the STPWP bits of all channels to 1.

#### CLRWP bit (GTCLR.CCLR Bit Write Disable)

CLRWP bit enables or disables starting the updating of counter values by writing to the CCLRn bit (n = 0 to 7) corresponding to a channel number in the GTCLR register.

The bit position of each CCLRn bit in the GTCLR registers is allocated to the channel with the corresponding number, and the writing to the GTCLR register for any channel results in writing to the registers of all channels. The CLRWP bit for each channel does not control writing but only controls updating of the CCLR bit for the corresponding channel in the case of simultaneous writing to all channels.

Thus, in the case of writing to the CCLR bits of a channel for which the setting of the CLRWP bit is 1 (disabling writing), the CCLR bit for the given channel will not be updated, but the CCLR bits corresponding to channel for which the setting of the CLRWP bit is 0 (enabling writing) will be updated. For example, when the setting of the GTWP.CLRWP bit of GPT channel 0 is 0 (enabling writing), writing 1 to the GTCLR.CCLR0 bit of GPT channel 1 when its current setting is 0 will lead to updating of the value, and the GPT320.GTCNT counter is cleared. When the setting of the GTWP.CLRWP bit of

GTWP启用或禁用写入寄存器以防止意外修改。GTWP寄存器的保护只针对CPU的写操作。GTWP不保护寄存器免受与CPU写入相关的更新。

#### WP位 (寄存器写禁止)

以下是写启用或禁用寄存器的列表：

GTSSR, GTPSR, GTCSR, GTUPSR, GTDNSR, GTICASR, GTICBSR, GTCR, GTUDDTYC, GTIOR, GTINTAD, GTST, GTBER, GTCNT, GTCCRA, GTCCRB, GTCCRC, GTCCRD, GTCCRE, GTCCRF, GTPR, GTPBR, GTDTCR, GTDVU, GTICLF, GTPC.

#### STRWP位 (GTSTR.CSTRT位写入禁止)

STRWP位通过写入与GTSTR寄存器中的通道号对应的CSTRTn位 (n=0至7) 来启用或禁用开始更新计数器值。

GTSTR寄存器中每个CSTRTn位的位位置分配给对应编号的通道，对任何通道写入GTSTR寄存器都会导致写入所有通道的寄存器。每个通道的STRWP位不控制写入，而仅控制在同时写入所有通道的情况下相应通道的CSTRT位的更新。

因此，在写入STRWP位设置为1的通道的CSTRT位（禁止写入）的情况下，给定通道的CSTRT位将不会被更新，但对应于通道的CSTRT位将被更新。STRWP位的设置为0（允许写入）将被更新。例如，当GPT通道0的GTWP.STRWP位设置为0（允许写入）时，当前设置为0时向GPT通道1的GTSTR.CSTRT0位写入1将导致值更新，并且GPT320.GTCNT计数器开始运行。当GPT通道0的GTWP.STRWP位设置为1时（禁止写入），当前设置为0时，向GPT通道1的GTSTR.CSTRT0位写入1将保留该位的值0，而GPT320.GTCNT计数器不会开始运行。

如果要保护GTSTR寄存器中的所有位不被更新，请将所有通道的STRWP位设置为1。

#### STPWP位 (GTSTP.CSTOP位写入禁用)

STPWP位通过写入与GTSTP寄存器中的通道号对应的CSTOPn位 (n=0到7) 来启用或禁用开始更新计数器值。

GTSTP寄存器中每个CSTOPn位的位位置分配给对应编号的通道，对任何通道写入GTSTP寄存器都会导致写入所有通道的寄存器。每个通道的STPWP位不控制写入，而仅控制在同时写入所有通道的情况下相应通道的CSTOP位的更新。

因此，在写入STPWP位设置为1的通道的CSTOP位（禁止写入）的情况下，给定通道的CSTOP位将不会被更新，但对应于其通道的CSTOP位STPWP位的设置为0（允许写入）将被更新。例如，当GPT通道0的GTWP.STPWP位设置为0（允许写入）时，当前设置为0时向GPT通道1的GTSTP.CSTOP0位写入1将导致值更新，并且GPT320.GTCNT计数器停止。当GPT通道0的GTWP.STPWP位设置为1时（禁止写入），当前设置为0时向GPT通道1的GTSTP.CSTOP0位写入1将保留该位的值0，而GPT320.GTCNT计数器不会停止。

如果要保护GTSTP寄存器中的所有位不被更新，请将所有通道的STPWP位设置为1。

#### CLRWP位 (GTCLR.CCLR位写入禁止)

CLRWP位通过写入与GTCLR寄存器中的通道号对应的CCLRn位 (n=0至7) 来启用或禁用开始更新计数器值。

GTCLR寄存器中每个CCLRn位的位位置分配给对应编号的通道，对任何通道写入GTCLR寄存器都会导致写入所有通道的寄存器。每个通道的CLRWP位不控制写入，而仅控制在同时写入所有通道的情况下相应通道的CCLR位的更新。

因此，在写入CLRWP位设置为1（禁止写入）的通道CCLR位的情况下，给定通道的CCLR位将不会被更新，但对应于通道的CCLR位将被更新。CLRWP位的设置为0（允许写入）将被更新。例如，当GPT通道0的GTWP.CLRWP位设置为0（允许写入）时，当前设置为0时向GPT通道1的GTCLR.CCLR0位写入1将导致值更新，并且GPT320.GTCNT计数器清零。当设置GTWP.CLRWP位





non-secure access in the same security configuratin as the previous example, the GTCNT counter operation status of GPT channel 0 (CSTRT0 bit) can be read.

For the association between GTSTR bit number and a channel number, see [Figure 21.2](#).

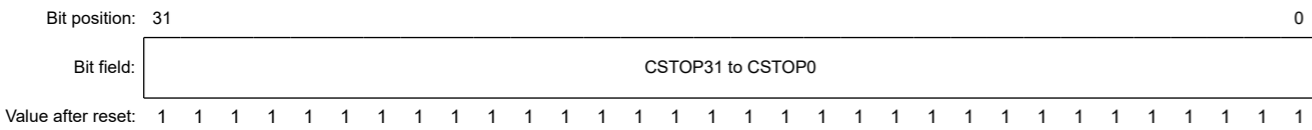
**CSTRTn bits (Channel n GTCNT Count Start (n = 0 to 7))**

The CSTRTn bits start channel n of the GTCNT counter operation. Writing to the GTSTR.CSTRTn bit (n = 0 to 7) has no effect unless the GTSSR.CSTRT bit is set to 1.

The read data shows the counter status of each channel (GTCR.CST bit). Zero means the counter is stopped and 1 means the counter is running.

**21.2.3 GTSTP : General PWM Timer Software Stop Register**

Base address: GPT32n = 0x4016\_9000 + 0x0100 × n (n = 0 to 3)  
GPT16m = 0x4016\_9000 + 0x0100 × m (m = 4 to 7)  
Offset address: 0x08



| Bit  | Symbol              | Function  | R/W |
|------|---------------------|---|-----|
| 31:0 | CSTOP0 to CSTOP31*1 | Channel n GTCNT Count Stop (n : the same as bit position value)<br>0: GTCNT counter not stop<br>1: GTCNT counter stop | R/W |

Note 1. The bits that can be used vary depending on the product. The n of CSTOPn is the same as the GPT channel number. For this product, n is 0 to 7.

The GTSTP stops the GTCNT counter operation for each channel n, where n = 0 to 7.

The GTSTP bit number represents the channel number. The GTSTP register of each channel is shared by all the channels. The GTCNT counter stops for the channel associated with the GTSTP bit number where 1 is written. Writing 0 has no effect on the status of the GTCNT counter and the value of GTSTP register.

The bit corresponding to channel which security attribution is configured as secure can be read by non-secure access but can not be written by non-secure access. For example, if GPT channel 0 is configured as secure and other GPTs are configured as non-secure, the CSTOP0 bit can not be written by non-secure access to GTSTP register in GPT channel 1, and the GTCNT counter operation status of GPT channel 0 is not changed. When the GTSTP register in GPT 1 is read by non-secure access in the same security configuratin as the previous example, the GTCNT counter operation status of GPT channel 0 (CSTOP0 bit) can be read.

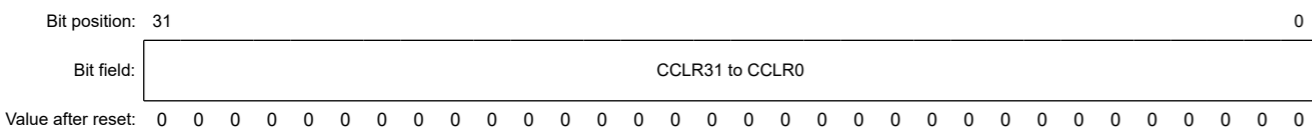
For the association between GTSTP bit number and a channel number, see [Figure 21.2](#).

**CSTOPn bits (Channel n GTCNT Count Stop (n = 0 to 7))**

The CSTOPn bits stop channel n of the GTCNT counter operation. Writing to the GTSTP.CSTOPn bit (n = 0 to 7) has no effect unless the GTPSR.CSTOPn bit is set to 1. The read data shows the counter status of each channel (invert of GTCR.CST bit). Zero means the counter is running and 1 means the counter is stopped.

**21.2.4 GTCLR : General PWM Timer Software Clear Register**

Base address: GPT32n = 0x4016\_9000 + 0x0100 × n (n = 0 to 3)  
GPT16m = 0x4016\_9000 + 0x0100 × m (m = 4 to 7)  
Offset address: 0x0C



non-secureaccess在与上一个示例相同的安全配置中，可以读取GPT通道0 (CSTRT0位) 的GTCNT计数器操作状态。

GTSTR位号与通道号的关系见图21.2。

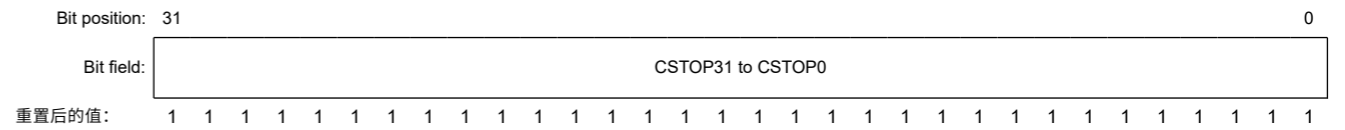
**CSTRTn位 (通道nGTCNT计数开始 (n=0到7) )**

CSTRTn位启动GTCNT计数器操作的通道n。除非GTSSR.CSTRT位设置为1，否则写入GTSTR.CSTRTn位 (n=0到7) 无效。

读取的数据显示每个通道的计数器状态 (GTCR.CST位)。零表示计数器停止，1表示计数器正在运行。

**21.2.3 GTSTP:通用PWM定时器软件停止寄存器**

Base address: GPT32n = 0x4016\_9000 + 0x0100 × n (n = 0 to 3)  
GPT16m = 0x4016\_9000 + 0x0100 × m (m = 4 to 7)  
Offset address: 0x08



| Bit  | Symbol              | Function  | R/W |
|------|---------------------|---|-----|
| 31:0 | CSTOP0 to CSTOP31*1 | 通道nGTCNT计数停止 (n: 与位位置值相同)<br>0: GTCNT计数器不停止1:<br>GTCNT计数器停止 | R/W |

注1.可使用的钻头因产品而异。CSTOPn的n与GPT通道号相同。对于本产品，n为0到7。

GTSTP停止每个通道n的GTCNT计数器操作，其中n=0到7。

GTSTP位号代表通道号。每个通道的GTSTP寄存器由所有通道共享。对于与写入1的GTSTP位号相关的通道，GTCNT计数器停止。写0对GTCNT计数器的状态和GTSTP寄存器的值没有影响。

安全属性配置为安全的通道对应的位可以被非安全访问读取，但不能被非安全访问写入。例如，如果GPT通道0配置为安全，其他GPT配置为非安全，则不能通过非安全访问GPT通道1中的GTSTP寄存器来写入CSTOP0位，以及GPT通道的GTCNT计数器操作状态0不变。当GPT1中的GTSTP寄存器通过与上例相同的安全配置中的非安全访问读取时，可以读取GPT通道0 (CSTOP0位) 的GTCNT计数器操作状态。

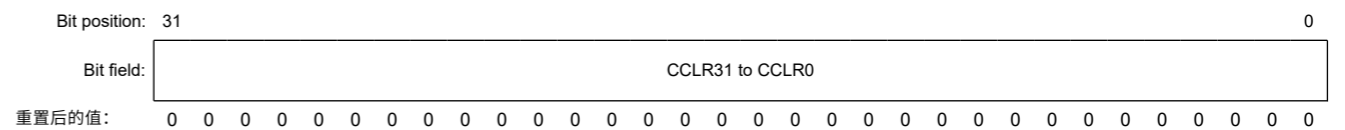
GTSTP位号与通道号的关系见图21.2。

**CSTOPn位 (通道nGTCNT计数停止 (n=0到7) )**

CSTOPn位停止GTCNT计数器操作的通道n。除非GTPSR.CSTOPn位设置为1，否则写入GTSTP.CSTOPn位 (n=0至7) 无效。读取的数据显示每个通道的计数器状态 (反转GTCR.CST位)。零表示计数器正在运行，1表示计数器停止。

**21.2.4 GTCLR:通用PWM定时器软件清零寄存器**

Base address: GPT32n = 0x4016\_9000 + 0x0100 × n (n = 0 to 3)  
GPT16m = 0x4016\_9000 + 0x0100 × m (m = 4 to 7)  
Offset address: 0x0C





| Bit  | Symbol            | Function   | R/W |
|------|-------------------|--|-----|
| 31:0 | CCLR0 to CCLR31*1 | Channel n GTCNT Count Clear (n : the same as bit position value)<br>0: GTCNT counter is not cleared<br>1: GTCNT counter is cleared | W   |

Note 1. The bits that can be used vary depending on the product. The n of CCLRn is the same as the GPT channel number. For this product, n is 0 to 7.

The GTCLR is a write-only register that clears the GTCNT counter operation for each channel n, where n = 0 to 7.

The GTCLR bit number represents the channel number. The GTCLR register of each channel is shared by all the channels. The GTCNT counter is cleared for the channel associated with the GTCLR bit number where 1 is written. Writing 0 has no effect on the status of GTCNT counter.

The bit corresponding to channel which security attribution is configured as secure can not be written by non-secure access. For example, if GPT channel 0 is configured as secure and other GPTs are configured as non-secure, the CCLR0 bit can not be written by non-secure access to GTCLR register in GPT channel 1, and the GTCNT counter of GPT channel 0 is not cleared.

For the association between GTCLR bit number and a channel number, see Figure 21.2.

### CCLRn bits (Channel n GTCNT Count Clear (n = 0 to 7))

Channel n of the GTCNT counter value is cleared on writing 1 to this bit. This bit is read as 0.

### 21.2.5 GTSSR : General PWM Timer Start Source Select Register

Base address: GPT32n = 0x4016\_9000 + 0x0100 × n (n = 0 to 3)  
GPT16m = 0x4016\_9000 + 0x0100 × m (m = 4 to 7)

Offset address: 0x10

|                    |             |             |             |             |             |             |             |             |              |              |              |              |              |              |              |              |
|--------------------|-------------|-------------|-------------|-------------|-------------|-------------|-------------|-------------|--------------|--------------|--------------|--------------|--------------|--------------|--------------|--------------|
| Bit position:      | 31          | 30          | 29          | 28          | 27          | 26          | 25          | 24          | 23           | 22           | 21           | 20           | 19           | 18           | 17           | 16           |
| Bit field:         | CSTR<br>T   | —           | —           | —           | —           | —           | —           | —           | SSEL<br>CH   | SSEL<br>CG   | SSEL<br>CF   | SSEL<br>CE   | SSEL<br>CD   | SSEL<br>CC   | SSEL<br>CB   | SSEL<br>CA   |
| Value after reset: | 0           | 0           | 0           | 0           | 0           | 0           | 0           | 0           | 0            | 0            | 0            | 0            | 0            | 0            | 0            | 0            |
| Bit position:      | 15          | 14          | 13          | 12          | 11          | 10          | 9           | 8           | 7            | 6            | 5            | 4            | 3            | 2            | 1            | 0            |
| Bit field:         | SSCB<br>FAH | SSCB<br>FAL | SSCB<br>RAH | SSCB<br>RAL | SSCA<br>FBH | SSCA<br>FBL | SSCA<br>RBH | SSCA<br>RBL | SSGT<br>RGDF | SSGT<br>RGDR | SSGT<br>RGCF | SSGT<br>RGCR | SSGT<br>RGBF | SSGT<br>RGBR | SSGT<br>RGAF | SSGT<br>RGAR |
| Value after reset: | 0           | 0           | 0           | 0           | 0           | 0           | 0           | 0           | 0            | 0            | 0            | 0            | 0            | 0            | 0            | 0            |

| Bit | Symbol   | Function   | R/W |
|-----|----------|--|-----|
| 0   | SSGTRGAR | GTETRGA Pin Rising Input Source Counter Start Enable<br>0: Counter start disabled on the rising edge of GTETRGA input<br>1: Counter start enabled on the rising edge of GTETRGA input    | R/W |
| 1   | SSGTRGAF | GTETRGA Pin Falling Input Source Counter Start Enable<br>0: Counter start disabled on the falling edge of GTETRGA input<br>1: Counter start enabled on the falling edge of GTETRGA input | R/W |
| 2   | SSGTRGBR | GTETRGB Pin Rising Input Source Counter Start Enable<br>0: Counter start disabled on the rising edge of GTETRGB input<br>1: Counter start enabled on the rising edge of GTETRGB input    | R/W |
| 3   | SSGTRGBF | GTETRGB Pin Falling Input Source Counter Start Enable<br>0: Counter start disabled on the falling edge of GTETRGB input<br>1: Counter start enabled on the falling edge of GTETRGB input | R/W |
| 4   | SSGTRGCR | GTETRGC Pin Rising Input Source Counter Start Enable<br>0: Counter start disabled on the rising edge of GTETRGC input<br>1: Counter start enabled on the rising edge of GTETRGC input    | R/W |
| 5   | SSGTRGCF | GTETRGC Pin Falling Input Source Counter Start Enable<br>0: Counter start disabled on the falling edge of GTETRGC input<br>1: Counter start enabled on the falling edge of GTETRGC input | R/W |

| Bit  | Symbol            | Function   | R/W |
|------|-------------------|--|-----|
| 31:0 | CCLR0 to CCLR31*1 | ChannelnGTCNTCountClear (n : 与位位置值相同)<br>0: GTCNT计数器不清零1: GTCNT计数器清零 | W   |

注1.可使用的钻头因产品而异。CCLRn的n与GPT通道号相同。对于本产品，n为0到7。

GTCLR是一个只写寄存器，用于清除每个通道n的GTCNT计数器操作，其中n=0到7。

GTCLR位号代表通道号。每个通道的GTCLR寄存器由所有通道共享。与写入1的GTCLR位号关联的通道的GTCNT计数器清零。写0对GTCNT计数器的状态没有影响。

安全属性配置为安全的通道对应的位不能被非安全访问写入。例如，如果GPT通道0配置为安全，而其他GPT配置为非安全，则CCLR0位不能通过对GPT通道1中的GTCLR寄存器的非安全访问来写入，并且GPT通道0的GTCNT计数器为未清除。

GTCLR位号与通道号的关系见图21.2。

### CCLRn位 (通道nGTCNT计数清除 (n=0至7))

GTCNT计数器值的通道n在向该位写入1时被清除。该位读为0。

### 21.2.5 GTSSR: 通用PWM定时器启动源选择寄存器

Base address: GPT32n = 0x4016\_9000 + 0x0100 × n (n = 0 to 3)  
GPT16m = 0x4016\_9000 + 0x0100 × m (m = 4 to 7)

Offset address: 0x10

|               |             |             |             |             |             |             |             |             |              |              |              |              |              |              |              |              |
|---------------|-------------|-------------|-------------|-------------|-------------|-------------|-------------|-------------|--------------|--------------|--------------|--------------|--------------|--------------|--------------|--------------|
| Bit position: | 31          | 30          | 29          | 28          | 27          | 26          | 25          | 24          | 23           | 22           | 21           | 20           | 19           | 18           | 17           | 16           |
| Bit field:    | CSTR<br>T   | —           | —           | —           | —           | —           | —           | —           | SSEL<br>CH   | SSEL<br>CG   | SSEL<br>CF   | SSEL<br>CE   | SSEL<br>CD   | SSEL<br>CC   | SSEL<br>CB   | SSEL<br>CA   |
| 重置后的值:        | 0           | 0           | 0           | 0           | 0           | 0           | 0           | 0           | 0            | 0            | 0            | 0            | 0            | 0            | 0            | 0            |
| Bit position: | 15          | 14          | 13          | 12          | 11          | 10          | 9           | 8           | 7            | 6            | 5            | 4            | 3            | 2            | 1            | 0            |
| Bit field:    | SSCB<br>FAH | SSCB<br>FAL | SSCB<br>RAH | SSCB<br>RAL | SSCA<br>FBH | SSCA<br>FBL | SSCA<br>RBH | SSCA<br>RBL | SSGT<br>RGDF | SSGT<br>RGDR | SSGT<br>RGCF | SSGT<br>RGCR | SSGT<br>RGBF | SSGT<br>RGBR | SSGT<br>RGAF | SSGT<br>RGAR |
| 重置后的值:        | 0           | 0           | 0           | 0           | 0           | 0           | 0           | 0           | 0            | 0            | 0            | 0            | 0            | 0            | 0            | 0            |

| Bit | Symbol   | Function  | R/W |
|-----|----------|---|-----|
| 0   | SSGTRGAR | GTETRGA引脚上升输入源计数器启动使能<br>0: 在GTETRGA输入的上升沿禁止计数器启动1: 在GTETRGA输入的上升沿使能计数器启动 | R/W |
| 1   | SSGTRGAF | GTETRGA引脚下降输入源计数器启动使能<br>0: 在GTETRGA输入的下降沿禁用计数器启动1: 在GTETRGA输入的下降沿启用计数器启动 | R/W |
| 2   | SSGTRGBR | GTETRGB引脚上升输入源计数器启动使能<br>0: 在GTETRGB输入的上升沿禁止计数器启动1: 在GTETRGB输入的上升沿使能计数器启动 | R/W |
| 3   | SSGTRGBF | GTETRGB引脚下降输入源计数器启动使能<br>0: 在GTETRGB输入的下降沿禁用计数器启动1: 在GTETRGB输入的下降沿启用计数器启动 | R/W |
| 4   | SSGTRGCR | GTETRGC引脚上升输入源计数器启动使能<br>0: 在GTETRGC输入的上升沿禁止计数器启动1: 在GTETRGC输入的上升沿使能计数器启动 | R/W |
| 5   | SSGTRGCF | GTETRGC引脚下降输入源计数器启动使能<br>0: 在GTETRGC输入的下降沿禁止计数器启动1: 在GTETRGC输入的下降沿使能计数器启动 | R/W |

| Bit | Symbol   | Function   | R/W |
|-----|----------|--|-----|
| 6   | SSGTRGDR | GTETRGD Pin Rising Input Source Counter Start Enable<br>0: Counter start disabled on the rising edge of GTETRGD input<br>1: Counter start enabled on the rising edge of GTETRGD input  | R/W |
| 7   | SSGTRGDF | GTETRGD Pin Falling Input Source Counter Start Enable<br>0: Counter start disabled on the falling edge of GTETRGD input<br>1: Counter start enabled on the falling edge of GTETRGD input   | R/W |
| 8   | SSCARBL  | GTIOCnA Pin Rising Input during GTIOCnB Value Low Source Counter Start Enable<br>0: Counter start disabled on the rising edge of GTIOCnA input when GTIOCnB input is 0<br>1: Counter start enabled on the rising edge of GTIOCnA input when GTIOCnB input is 0     | R/W |
| 9   | SSCARBH  | GTIOCnA Pin Rising Input during GTIOCnB Value High Source Counter Start Enable<br>0: Counter start disabled on the rising edge of GTIOCnA input when GTIOCnB input is 1<br>1: Counter start enabled on the rising edge of GTIOCnA input when GTIOCnB input is 1    | R/W |
| 10  | SSCAFBL  | GTIOCnA Pin Falling Input during GTIOCnB Value Low Source Counter Start Enable<br>0: Counter start disabled on the falling edge of GTIOCnA input when GTIOCnB input is 0<br>1: Counter start enabled on the falling edge of GTIOCnA input when GTIOCnB input is 0  | R/W |
| 11  | SSCAFBH  | GTIOCnA Pin Falling Input during GTIOCnB Value High Source Counter Start Enable<br>0: Counter start disabled on the falling edge of GTIOCnA input when GTIOCnB input is 1<br>1: Counter start enabled on the falling edge of GTIOCnA input when GTIOCnB input is 1 | R/W |
| 12  | SSCBRAL  | GTIOCnB Pin Rising Input during GTIOCnA Value Low Source Counter Start Enable<br>0: Counter start disabled on the rising edge of GTIOCnB input when GTIOCnA input is 0<br>1: Counter start enabled on the rising edge of GTIOCnB input when GTIOCnA input is 0     | R/W |
| 13  | SSCBRAH  | GTIOCnB Pin Rising Input during GTIOCnA Value High Source Counter Start Enable<br>0: Counter start disabled on the rising edge of GTIOCnB input when GTIOCnA input is 1<br>1: Counter start enabled on the rising edge of GTIOCnB input when GTIOCnA input is 1    | R/W |
| 14  | SSCBFAL  | GTIOCnB Pin Falling Input during GTIOCnA Value Low Source Counter Start Enable<br>0: Counter start disabled on the falling edge of GTIOCnB input when GTIOCnA input is 0<br>1: Counter start enabled on the falling edge of GTIOCnB input when GTIOCnA input is 0  | R/W |
| 15  | SSCBFAH  | GTIOCnB Pin Falling Input during GTIOCnA Value High Source Counter Start Enable<br>0: Counter start disabled on the falling edge of GTIOCnB input when GTIOCnA input is 1<br>1: Counter start enabled on the falling edge of GTIOCnB input when GTIOCnA input is 1 | R/W |
| 16  | SSELCA   | ELC_GPTA Event Source Counter Start Enable<br>0: Counter start disabled at the ELC_GPTA input<br>1: Counter start enabled at the ELC_GPTA input  | R/W |
| 17  | SSELCB   | ELC_GPTB Event Source Counter Start Enable<br>0: Counter start disabled at the ELC_GPTB input<br>1: Counter start enabled at the ELC_GPTB input  | R/W |
| 18  | SSELCC   | ELC_GPTC Event Source Counter Start Enable<br>0: Counter start disabled at the ELC_GPTC input<br>1: Counter start enabled at the ELC_GPTC input  | R/W |
| 19  | SSELCD   | ELC_GPTD Event Source Counter Start Enable<br>0: Counter start disabled at the ELC_GPTD input<br>1: Counter start enabled at the ELC_GPTD input  | R/W |

| Bit | Symbol   | Function   | R/W |
|-----|----------|--|-----|
| 6   | SSGTRGDR | GTETRGD引脚上升沿输入源计数器启动使能<br>0: 在GTETRGD输入的上升沿禁止计数器启动1: 在GTETRGD输入的上升沿使能计数器启动   | R/W |
| 7   | SSGTRGDF | GTETRGD引脚下降沿输入源计数器启动使能<br>0: 在GTETRGD输入的下降沿禁止计数器启动1: 在GTETRGD输入的下降沿使能计数器启动   | R/W |
| 8   | SSCARBL  | GTIOCnB值低电平期间的GTIOCnA引脚上升沿输入源计数器启动使能<br>0: 当GTIOCnB输入为0时, 在GTIOCnA输入的上升沿禁止计数器启动<br>1: 当GTIOCnB输入为0时, 在GTIOCnA输入的上升沿启用计数器启动 | R/W |
| 9   | SSCARBH  | GTIOCnB值高电平期间的GTIOCnA引脚上升沿输入源计数器启动使能<br>0: 当GTIOCnB输入为1时, 在GTIOCnA输入的上升沿禁止计数器启动<br>1: 当GTIOCnB输入为1时, 在GTIOCnA输入的上升沿启用计数器启动 | R/W |
| 10  | SSCAFBL  | GTIOCnB值低电平期间的GTIOCnA引脚下降沿输入源计数器启动使能<br>0: 当GTIOCnB输入为0时, 在GTIOCnA输入的下降沿禁止计数器启动<br>1: 当GTIOCnB输入为0时, 在GTIOCnA输入的下降沿启用计数器启动 | R/W |
| 11  | SSCAFBH  | GTIOCnB值高电平期间的GTIOCnA引脚下降沿输入源计数器启动使能<br>0: 当GTIOCnB输入为1时, 在GTIOCnA输入的下降沿禁止计数器启动<br>1: 当GTIOCnB输入为1时, 在GTIOCnA输入的下降沿启用计数器启动 | R/W |
| 12  | SSCBRAL  | GTIOCnA值低电平期间的GTIOCnB引脚上升沿输入源计数器启动使能<br>0: 当GTIOCnA输入为0时, 在GTIOCnB输入的上升沿禁止计数器启动<br>1: 当GTIOCnA输入为0时, 在GTIOCnB输入的上升沿启用计数器启动 | R/W |
| 13  | SSCBRAH  | GTIOCnA值高电平期间的GTIOCnB引脚上升沿输入源计数器启动使能<br>0: 当GTIOCnA输入为1时, 在GTIOCnB输入的上升沿禁止计数器启动<br>1: 当GTIOCnA输入为1时, 在GTIOCnB输入的上升沿启用计数器启动 | R/W |
| 14  | SSCBFAL  | GTIOCnA值低电平期间的GTIOCnB引脚下降沿输入源计数器启动使能<br>0: 当GTIOCnA输入为0时, 在GTIOCnB输入的下降沿禁止计数器启动<br>1: 当GTIOCnA输入为0时, 在GTIOCnB输入的下降沿启用计数器启动 | R/W |
| 15  | SSCBFAH  | GTIOCnA值高电平期间的GTIOCnB引脚下降沿输入源计数器启动使能<br>0: 当GTIOCnA输入为1时, 在GTIOCnB输入的下降沿禁止计数器启动<br>1: 当GTIOCnA输入为1时, 在GTIOCnB输入的下降沿启用计数器启动 | R/W |
| 16  | SSELCA   | ELC_GPTA事件源计数器启动启用<br>0: 在ELC_GPTA输入处禁用计数器启动1: 在ELC_GPTA输入处启用计数器启动   | R/W |
| 17  | SSELCB   | ELC_GPTB事件源计数器启动启用<br>0: 在ELC_GPTB输入处禁用计数器启动1: 在ELC_GPTB输入处启用计数器启动   | R/W |
| 18  | SSELCC   | ELC_GPTC事件源计数器启动启用<br>0: 在ELC_GPTC输入处禁用计数器启动1: 在ELC_GPTC输入处启用计数器启动   | R/W |
| 19  | SSELCD   | ELC_GPTD事件源计数器启动启用<br>0: 在ELC_GPTD输入处禁用计数器启动1: 在ELC_GPTD输入处启用计数器启动   | R/W |

| Bit   | Symbol | Function  | R/W |
|-------|--------|---|-----|
| 20    | SSELCE | ELC_GPTE Event Source Counter Start Enable<br>0: Counter start disabled at the ELC_GPTE input<br>1: Counter start enabled at the ELC_GPTE input | R/W |
| 21    | SSELCF | ELC_GPTF Event Source Counter Start Enable<br>0: Counter start disabled at the ELC_GPTF input<br>1: Counter start enabled at the ELC_GPTF input | R/W |
| 22    | SSELCG | ELC_GPTG Event Source Counter Start Enable<br>0: Counter start disabled at the ELC_GPTG input<br>1: Counter start enabled at the ELC_GPTG input | R/W |
| 23    | SSELCH | ELC_GPTH Event Source Counter Start Enable<br>0: Counter start disabled at the ELC_GPTH input<br>1: Counter start enabled at the ELC_GPTH input | R/W |
| 30:24 | —      | These bits are read as 0. The write value should be 0.  | R/W |
| 31    | CSTRT  | Software Source Counter Start Enable<br>0: Counter start disabled by the GTSTR register<br>1: Counter start enabled by the GTSTR register       | R/W |

The GTSSR sets the source to start the GTCNT counter.

#### SSGTRGAR bit (GTETRGA Pin Rising Input Source Counter Start Enable)

The SSGTRGAR bit enables or disables the GTCNT counter start on the rising edge of the GTETRGA pin input.

#### SSGTRGAF bit (GTETRGA Pin Falling Input Source Counter Start Enable)

The SSGTRGAF bit enables or disables the GTCNT counter start on the falling edge of the GTETRGA pin input.

#### SSGTRGBR bit (GTETRGB Pin Rising Input Source Counter Start Enable)

The SSGTRGBR bit enables or disables the GTCNT counter start on the rising edge of the GTETRGB pin input.

#### SSGTRGBF bit (GTETRGB Pin Falling Input Source Counter Start Enable)

The SSGTRGBF bit enables or disables the GTCNT counter start on the falling edge of the GTETRGB pin input.

#### SSGTRGCR bit (GTETRGC Pin Rising Input Source Counter Start Enable)

The SSGTRGCR bit enables or disables the GTCNT counter start on the rising edge of the GTETRGC pin input.

#### SSGTRGCF bit (GTETRGC Pin Falling Input Source Counter Start Enable)

The SSGTRGCF bit enables or disables the GTCNT counter start on the falling edge of the GTETRGC pin input.

#### SSGTRGDR bit (GTETRGD Pin Rising Input Source Counter Start Enable)

The SSGTRGDR bit enables or disables the GTCNT counter start on the rising edge of the GTETRGD pin input.

#### SSGTRGDF bit (GTETRGD Pin Falling Input Source Counter Start Enable)

The SSGTRGDF bit enables or disables the GTCNT counter start on the falling edge of the GTETRGD pin input.

#### SSCARBL bit (GTIOCnA Pin Rising Input during GTIOCnB Value Low Source Counter Start Enable)

The SSCARBL bit enables or disables the GTCNT counter start on the rising edge of the GTIOCnA pin input, when GTIOCnB input is 0.

#### SSCARBH bit (GTIOCnA Pin Rising Input during GTIOCnB Value High Source Counter Start Enable)

The SSCARBH bit enables or disables the GTCNT counter start on the rising edge of the GTIOCnA pin input, when GTIOCnB input is 1.

#### SSCAFBL bit (GTIOCnA Pin Falling Input during GTIOCnB Value Low Source Counter Start Enable)

The SSCAFBL bit enables or disables the GTCNT counter start on the falling edge of the GTIOCnA pin input, when GTIOCnB input is 0.

| Bit   | Symbol | Function   | R/W |
|-------|--------|--|-----|
| 20    | SSELCE | ELC_GPTE事件源计数器启动启用<br>0: 在ELC_GPTE输入处禁用计数器启动1: 在ELC_GPTE输入处启用计数器启动 | R/W |
| 21    | SSELCF | ELC_GPTF事件源计数器启动启用<br>0: 在ELC_GPTF输入处禁用计数器启动1: 在ELC_GPTF输入处启用计数器启动 | R/W |
| 22    | SSELCG | ELC_GPTG事件源计数器启动启用<br>0: 在ELC_GPTG输入处禁用计数器启动1: 在ELC_GPTG输入处启用计数器启动 | R/W |
| 23    | SSELCH | ELC_GPTH事件源计数器启动启用<br>0: 在ELC_GPTH输入处禁用计数器启动1: 在ELC_GPTH输入处启用计数器启动 | R/W |
| 30:24 | —      | 这些位被读取为0。写入值应为0。   | R/W |
| 31    | CSTRT  | 软件源计数器启动使能<br>0: 由GTSTR寄存器禁止计数器启动1: 由GTSTR寄存器使能计数器启动               | R/W |

GTSSR设置启动GTCNT计数器的源。

#### SSGTRGAR位 (GTETRGA引脚上升沿输入源计数器启动使能)

SSGTRGAR位启用或禁用GTCNT计数器在GTETRGA引脚输入的上升沿启动。

#### SSGTRGAF位 (GTETRGA引脚下降沿输入源计数器启动使能)

SSGTRGAF位启用或禁用GTCNT计数器在GTETRGA引脚输入的下降沿启动。

#### SSGTRGBR位 (GTETRGB引脚上升沿输入源计数器启动使能)

SSGTRGBR位在GTETRGB引脚输入的上升沿启用或禁用GTCNT计数器启动。

#### SSGTRGBF位 (GTETRGB引脚下降沿输入源计数器启动使能)

SSGTRGBF位在GTETRGB引脚输入的下降沿启用或禁用GTCNT计数器启动。

#### SSGTRGCR位 (GTETRGC引脚上升沿输入源计数器启动使能)

SSGTRGCR位启用或禁用GTCNT计数器在GTETRGC引脚输入的上升沿启动。

#### SSGTRGCF位 (GTETRGC引脚下降沿输入源计数器启动使能)

SSGTRGCF位启用或禁用GTCNT计数器在GTETRGC引脚输入的下降沿启动。

#### SSGTRGDR位 (GTETRGD引脚上升沿输入源计数器启动使能)

SSGTRGDR位启用或禁用GTCNT计数器在GTETRGD引脚输入的上升沿启动。

#### SSGTRGDF位 (GTETRGD引脚下降沿输入源计数器启动使能)

SSGTRGDF位启用或禁用GTCNT计数器在GTETRGD引脚输入的下降沿启动。

#### SSCARBL位 (GTIOCnB值低电平期间的GTIOCnA引脚上升沿输入源计数器启动使能)

SSCARBL位启用或禁用GTCNT计数器在GTIOCnA引脚输入的上升沿启动，当GTIOCnB输入为0。

#### SSCARBH位 (GTIOCnB值高电平期间的GTIOCnA引脚上升沿输入源计数器启动使能)

SSCARBH位启用或禁用GTCNT计数器在GTIOCnA引脚输入的上升沿启动，当GTIOCnB输入为1。

#### SSCAFBL位 (在GTIOCnB值低电平源计数器启动使能期间GTIOCnA引脚下降输入)

SSCAFBL位启用或禁用GTCNT计数器在GTIOCnA引脚输入的下降沿启动，当GTIOCnB输入为0。



**SSCAFBH bit (GTIOCnA Pin Falling Input during GTIOCnB Value High Source Counter Start Enable)**

The SSCAFBH bit enables or disables the GTCNT counter start on the falling edge of the GTIOCnA pin input, when GTIOCnB input is 1.

**SSCBRAL bit (GTIOCnB Pin Rising Input during GTIOCnA Value Low Source Counter Start Enable)**

The SSCBRAL bit enables or disables the GTCNT counter start on the rising edge of the GTIOCnB pin input, when GTIOCnA input is 0.

**SSCBRAH bit (GTIOCnB Pin Rising Input during GTIOCnA Value High Source Counter Start Enable)**

The SSCBRAH bit enables or disables the GTCNT counter start on the rising edge of the GTIOCnB pin input, when GTIOCnA input is 1.

**SSCBFAL bit (GTIOCnB Pin Falling Input during GTIOCnA Value Low Source Counter Start Enable)**

The SSCBFAL bit enables or disables the GTCNT counter start on the falling edge of the GTIOCnB pin input, when GTIOCnA input is 0.

**SSCBFAH bit (GTIOCnB Pin Falling Input during GTIOCnA Value High Source Counter Start Enable)**

The SSCBFAH bit enables or disables the GTCNT counter start on the falling edge of the GTIOCnB pin input, when GTIOCnA input is 1.

**SSELCm bit (ELC\_GPTm Event Source Counter Start Enable) (m = A to H)**

The SSELCm bit enables or disables the GTCNT counter start at the ELC\_GPTm event input.

**CSTRT bit (Software Source Counter Start Enable)**

The CSTRT bit enables or disables the GTCNT counter start by GTSTR register.

**21.2.6 GTPSR : General PWM Timer Stop Source Select Register**

Base address: GPT32n = 0x4016\_9000 + 0x0100 × n (n = 0 to 3)  
GPT16m = 0x4016\_9000 + 0x0100 × m (m = 4 to 7)

Offset address: 0x14

|                    |             |             |             |             |             |             |             |             |              |              |              |              |              |              |              |              |
|--------------------|-------------|-------------|-------------|-------------|-------------|-------------|-------------|-------------|--------------|--------------|--------------|--------------|--------------|--------------|--------------|--------------|
| Bit position:      | 31          | 30          | 29          | 28          | 27          | 26          | 25          | 24          | 23           | 22           | 21           | 20           | 19           | 18           | 17           | 16           |
| Bit field:         | CSTO<br>P   | —           | —           | —           | —           | —           | —           | —           | PSEL<br>CH   | PSEL<br>CG   | PSEL<br>CF   | PSEL<br>CE   | PSEL<br>CD   | PSEL<br>CC   | PSEL<br>CB   | PSEL<br>CA   |
| Value after reset: | 0           | 0           | 0           | 0           | 0           | 0           | 0           | 0           | 0            | 0            | 0            | 0            | 0            | 0            | 0            | 0            |
| Bit position:      | 15          | 14          | 13          | 12          | 11          | 10          | 9           | 8           | 7            | 6            | 5            | 4            | 3            | 2            | 1            | 0            |
| Bit field:         | PSCB<br>FAH | PSCB<br>FAL | PSCB<br>RAH | PSCB<br>RAL | PSCA<br>FBH | PSCA<br>FBL | PSCA<br>RBH | PSCA<br>RBL | PSGT<br>RGDF | PSGT<br>RGDR | PSGT<br>RGCF | PSGT<br>RGCR | PSGT<br>RGBF | PSGT<br>RGBR | PSGT<br>RGAF | PSGT<br>RGAR |
| Value after reset: | 0           | 0           | 0           | 0           | 0           | 0           | 0           | 0           | 0            | 0            | 0            | 0            | 0            | 0            | 0            | 0            |

| Bit | Symbol   | Function  | R/W |
|-----|----------|---|-----|
| 0   | PSGTRGAR | GTETRGA Pin Rising Input Source Counter Stop Enable<br>0: Counter stop disabled on the rising edge of GTETRGA input<br>1: Counter stop enabled on the rising edge of GTETRGA input    | R/W |
| 1   | PSGTRGAF | GTETRGA Pin Falling Input Source Counter Stop Enable<br>0: Counter stop disabled on the falling edge of GTETRGA input<br>1: Counter stop enabled on the falling edge of GTETRGA input | R/W |
| 2   | PSGTRGBR | GTETRGA Pin Rising Input Source Counter Stop Enable<br>0: Counter stop disabled on the rising edge of GTETRGA input<br>1: Counter stop enabled on the rising edge of GTETRGA input    | R/W |
| 3   | PSGTRGBF | GTETRGA Pin Falling Input Source Counter Stop Enable<br>0: Counter stop disabled on the falling edge of GTETRGA input<br>1: Counter stop enabled on the falling edge of GTETRGA input | R/W |

**SSCAFBH位 (GTIOCnB值高电平期间GTIOCnA引脚下降输入源计数器启动使能)**

SSCAFBH位启用或禁用GTCNT计数器在GTIOCnA引脚输入的下降沿启动，当GTIOCnB输入为1。

**SSCBRAL位 (GTIOCnA值低电平期间的GTIOCnB引脚上升沿输入源计数器启动使能)**

SSCBRAL位启用或禁用GTCNT计数器在GTIOCnB引脚输入的上升沿启动，当GTIOCnA输入为0。

**SSCBRAH位 (GTIOCnA值高电平期间的GTIOCnB引脚上升沿输入源计数器启动使能)**

SSCBRAH位使能或禁止GTCNT计数器在GTIOCnB引脚输入的上升沿启动，当GTIOCnA输入为1。

**SSCBFAL位 (GTIOCnA值低电平源计数器启动使能期间GTIOCnB引脚下降输入)**

SSCBFAL位使能或禁止GTCNT计数器在GTIOCnB引脚输入的下降沿启动，当GTIOCnA输入为0。

**SSCBFAH位 (GTIOCnA值高电平源计数器启动使能期间的GTIOCnB引脚下降输入)**

SSCBFAH位启用或禁用GTCNT计数器在GTIOCnB引脚输入的下降沿启动，当GTIOCnA输入为1。

**SSELCm位 (ELC\_GPTm事件源计数器启动启用) (m=A到H)**

SSELCm位启用或禁用在ELC\_GPTm事件输入时启动的GTCNT计数器。

**CSTRT位 (软件源计数器启动使能)**

CSTRT位启用或禁用由GTSTR寄存器启动的GTCNT计数器。

**21.2.6 GTPSR: 通用PWM定时器停止源选择寄存器**

Base address: GPT32n = 0x4016\_9000 + 0x0100 × n (n = 0 to 3)  
GPT16m = 0x4016\_9000 + 0x0100 × m (m = 4 to 7)

Offset address: 0x14

|               |             |             |             |             |             |             |             |             |              |              |              |              |              |              |              |              |
|---------------|-------------|-------------|-------------|-------------|-------------|-------------|-------------|-------------|--------------|--------------|--------------|--------------|--------------|--------------|--------------|--------------|
| Bit position: | 31          | 30          | 29          | 28          | 27          | 26          | 25          | 24          | 23           | 22           | 21           | 20           | 19           | 18           | 17           | 16           |
| Bit field:    | CSTO<br>P   | —           | —           | —           | —           | —           | —           | —           | PSEL<br>CH   | PSEL<br>CG   | PSEL<br>CF   | PSEL<br>CE   | PSEL<br>CD   | PSEL<br>CC   | PSEL<br>CB   | PSEL<br>CA   |
| 重置后的值:        | 0           | 0           | 0           | 0           | 0           | 0           | 0           | 0           | 0            | 0            | 0            | 0            | 0            | 0            | 0            | 0            |
| Bit position: | 15          | 14          | 13          | 12          | 11          | 10          | 9           | 8           | 7            | 6            | 5            | 4            | 3            | 2            | 1            | 0            |
| Bit field:    | PSCB<br>FAH | PSCB<br>FAL | PSCB<br>RAH | PSCB<br>RAL | PSCA<br>FBH | PSCA<br>FBL | PSCA<br>RBH | PSCA<br>RBL | PSGT<br>RGDF | PSGT<br>RGDR | PSGT<br>RGCF | PSGT<br>RGCR | PSGT<br>RGBF | PSGT<br>RGBR | PSGT<br>RGAF | PSGT<br>RGAR |
| 重置后的值:        | 0           | 0           | 0           | 0           | 0           | 0           | 0           | 0           | 0            | 0            | 0            | 0            | 0            | 0            | 0            | 0            |

| Bit | Symbol   | Function  | R/W |
|-----|----------|---|-----|
| 0   | PSGTRGAR | GTETRGA引脚上升输入源计数器停止使能<br>0: 在GTETRGA输入的上升沿禁止计数器停止1: 在GTETRGA输入的上升沿使能计数器停止 | R/W |
| 1   | PSGTRGAF | GTETRGA引脚下降输入源计数器停止使能<br>0: 在GTETRGA输入的下降沿禁止计数器停止1: 在GTETRGA输入的下降沿使能计数器停止 | R/W |
| 2   | PSGTRGBR | GTETRGA引脚上升输入源计数器停止使能<br>0: 在GTETRGA输入的上升沿禁止计数器停止1: 在GTETRGA输入的上升沿使能计数器停止 | R/W |
| 3   | PSGTRGBF | GTETRGA引脚下降输入源计数器停止使能<br>0: 在GTETRGA输入的下降沿禁用计数器停止1: 在GTETRGA输入的下降沿启用计数器停止 | R/W |

| Bit | Symbol   | Function  | R/W |
|-----|----------|---|-----|
| 4   | PSGTRGCR | GTETRGC Pin Rising Input Source Counter Stop Enable<br>0: Counter stop disabled on the rising edge of GTETRGC input<br>1: Counter stop enabled on the rising edge of GTETRGC input  | R/W |
| 5   | PSGTRGCF | GTETRGC Pin Falling Input Source Counter Stop Enable<br>0: Counter stop disabled on the falling edge of GTETRGC input<br>1: Counter stop enabled on the falling edge of GTETRGC input   | R/W |
| 6   | PSGTRGDR | GTETRGD Pin Rising Input Source Counter Stop Enable<br>0: Counter stop disabled on the rising edge of GTETRGD input<br>1: Counter stop enabled on the rising edge of GTETRGD input  | R/W |
| 7   | PSGTRGDF | GTETRGD Pin Falling Input Source Counter Stop Enable<br>0: Counter stop disabled on the falling edge of GTETRGD input<br>1: Counter stop enabled on the falling edge of GTETRGD input   | R/W |
| 8   | PSCARBL  | GTIOCnA Pin Rising Input during GTIOCnB Value Low Source Counter Stop Enable<br>0: Counter stop disabled on the rising edge of GTIOCnA input when GTIOCnB input is 0<br>1: Counter stop enabled on the rising edge of GTIOCnA input when GTIOCnB input is 0     | R/W |
| 9   | PSCARBH  | GTIOCnA Pin Rising Input during GTIOCnB Value High Source Counter Stop Enable<br>0: Counter stop disabled on the rising edge of GTIOCnA input when GTIOCnB input is 1<br>1: Counter stop enabled on the rising edge of GTIOCnA input when GTIOCnB input is 1    | R/W |
| 10  | PSCAFBL  | GTIOCnA Pin Falling Input during GTIOCnB Value Low Source Counter Stop Enable<br>0: Counter stop disabled on the falling edge of GTIOCnA input when GTIOCnB input is 0<br>1: Counter stop enabled on the falling edge of GTIOCnA input when GTIOCnB input is 0  | R/W |
| 11  | PSCAFBH  | GTIOCnA Pin Falling Input during GTIOCnB Value High Source Counter Stop Enable<br>0: Counter stop disabled on the falling edge of GTIOCnA input when GTIOCnB input is 1<br>1: Counter stop enabled on the falling edge of GTIOCnA input when GTIOCnB input is 1 | R/W |
| 12  | PSCBRAL  | GTIOCnB Pin Rising Input during GTIOCnA Value Low Source Counter Stop Enable<br>0: Counter stop disabled on the rising edge of GTIOCnB input when GTIOCnA input is 0<br>1: Counter stop enabled on the rising edge of GTIOCnB input when GTIOCnA input is 0     | R/W |
| 13  | PSCBRAH  | GTIOCnB Pin Rising Input during GTIOCnA Value High Source Counter Stop Enable<br>0: Counter stop disabled on the rising edge of GTIOCnB input when GTIOCnA input is 1<br>1: Counter stop enabled on the rising edge of GTIOCnB input when GTIOCnA input is 1    | R/W |
| 14  | PSCBFAL  | GTIOCnB Pin Falling Input during GTIOCnA Value Low Source Counter Stop Enable<br>0: Counter stop disabled on the falling edge of GTIOCnB input when GTIOCnA input is 0<br>1: Counter stop enabled on the falling edge of GTIOCnB input when GTIOCnA input is 0  | R/W |
| 15  | PSCBFAH  | GTIOCnB Pin Falling Input during GTIOCnA Value High Source Counter Stop Enable<br>0: Counter stop disabled on the falling edge of GTIOCnB input when GTIOCnA input is 1<br>1: Counter stop enabled on the falling edge of GTIOCnB input when GTIOCnA input is 1 | R/W |
| 16  | PSELCA   | ELC_GPTA Event Source Counter Stop Enable<br>0: Counter stop disabled at the ELC_GPTA input<br>1: Counter stop enabled at the ELC_GPTA input  | R/W |
| 17  | PSELCB   | ELC_GPTB Event Source Counter Stop Enable<br>0: Counter stop disabled at the ELC_GPTB input<br>1: Counter stop enabled at the ELC_GPTB input  | R/W |

| Bit | Symbol   | Function   | R/W |
|-----|----------|--|-----|
| 4   | PSGTRGCR | GTETRGC引脚上升输入源计数器停止使能<br>0: 在GTETRGC输入的上升沿禁止计数器停止1: 在GTETRGC输入的上升沿使能计数器停止  | R/W |
| 5   | PSGTRGCF | GTETRGC引脚下降输入源计数器停止使能<br>0: 在GTETRGC输入的下降沿禁止计数器停止1: 在GTETRGC输入的下降沿使能计数器停止  | R/W |
| 6   | PSGTRGDR | GTETRGD引脚上升输入源计数器停止使能<br>0: 在GTETRGD输入的上升沿禁止计数器停止1: 在GTETRGD输入的上升沿使能计数器停止  | R/W |
| 7   | PSGTRGDF | GTETRGD引脚下降输入源计数器停止使能<br>0: 在GTETRGD输入的下降沿禁止计数器停止1: 在GTETRGD输入的下降沿使能计数器停止  | R/W |
| 8   | PSCARBL  | GTIOCnB值低电平期间的GTIOCnA引脚上升沿输入源计数器停止使能<br>0: 当GTIOCnB输入为0时, 在GTIOCnA输入的上升沿禁止计数器停止<br>1: 当GTIOCnB输入为0时, 在GTIOCnA输入上升沿使能计数器停止  | R/W |
| 9   | PSCARBH  | GTIOCnB值高电平期间的GTIOCnA引脚上升沿输入源计数器停止使能<br>0: 当GTIOCnB输入为1时, 在GTIOCnA输入的上升沿禁止计数器停止<br>1: 当GTIOCnB输入为1时, 在GTIOCnA输入上升沿使能计数器停止  | R/W |
| 10  | PSCAFBL  | GTIOCnB值低电平期间的GTIOCnA引脚下降沿输入源计数器停止使能<br>0: 当GTIOCnB输入为0时, 在GTIOCnA输入的下降沿禁止计数器停止<br>1: 当GTIOCnB输入为0时, 在GTIOCnA输入下降沿使能计数器停止  | R/W |
| 11  | PSCAFBH  | GTIOCnB值高电平期间的GTIOCnA引脚下降沿输入源计数器停止使能<br>0: 当GTIOCnB输入为1时, 在GTIOCnA输入的下降沿禁止计数器停止<br>1: 当GTIOCnB输入为1时, 在GTIOCnA输入的下降沿使能计数器停止 | R/W |
| 12  | PSCBRAL  | GTIOCnA值低电平期间的GTIOCnB引脚上升沿输入源计数器停止使能<br>0: 当GTIOCnA输入为0时, 在GTIOCnB输入上升沿禁止计数器停止<br>1: 当GTIOCnA输入为0时, 在GTIOCnB输入上升沿使能计数器停止   | R/W |
| 13  | PSCBRAH  | GTIOCnA值高电平期间的GTIOCnB引脚上升沿输入源计数器停止使能<br>0: 当GTIOCnA输入为1时, 在GTIOCnB输入的上升沿禁止计数器停止<br>1: 当GTIOCnA输入为1时, 在GTIOCnB输入上升沿使能计数器停止  | R/W |
| 14  | PSCBFAL  | GTIOCnA值低电平期间的GTIOCnB引脚下降沿输入源计数器停止使能<br>0: 当GTIOCnA输入为0时, 在GTIOCnB输入的下降沿禁止计数器停止<br>1: 当GTIOCnA输入为0时, 在GTIOCnB输入下降沿使能计数器停止  | R/W |
| 15  | PSCBFAH  | GTIOCnA值高电平期间的GTIOCnB引脚下降沿输入源计数器停止使能<br>0: 当GTIOCnA输入为1时, 在GTIOCnB输入的下降沿禁止计数器停止<br>1: 当GTIOCnA输入为1时, 在GTIOCnB输入下降沿使能计数器停止  | R/W |
| 16  | PSELCA   | ELC_GPTA事件源计数器停止启用<br>0: 在ELC_GPTA输入处禁用计数器停止1: 在ELC_GPTA输入处启用计数器停止   | R/W |
| 17  | PSELCB   | ELC_GPTB事件源计数器停止启用<br>0: 在ELC_GPTB输入处禁用计数器停止1: 在ELC_GPTB输入处启用计数器停止   | R/W |



| Bit   | Symbol | Function   | R/W |
|-------|--------|--|-----|
| 18    | PSELCC | ELC_GPTC Event Source Counter Stop Enable<br>0: Counter stop disabled at the ELC_GPTC input<br>1: Counter stop enabled at the ELC_GPTC input | R/W |
| 19    | PSELCD | ELC_GPTD Event Source Counter Stop Enable<br>0: Counter stop disabled at the ELC_GPTD input<br>1: Counter stop enabled at the ELC_GPTD input | R/W |
| 20    | PSELCE | ELC_GPTE Event Source Counter Stop Enable<br>0: Counter stop disabled at the ELC_GPTE input<br>1: Counter stop enabled at the ELC_GPTE input | R/W |
| 21    | PSELCF | ELC_GPTF Event Source Counter Stop Enable<br>0: Counter stop disabled at the ELC_GPTF input<br>1: Counter stop enabled at the ELC_GPTF input | R/W |
| 22    | PSELCG | ELC_GPTG Event Source Counter Stop Enable<br>0: Counter stop disabled at the ELC_GPTG input<br>1: Counter stop enabled at the ELC_GPTG input | R/W |
| 23    | PSELCH | ELC_GPTH Event Source Counter Stop Enable<br>0: Counter stop disabled at the ELC_GPTH input<br>1: Counter stop enabled at the ELC_GPTH input | R/W |
| 30:24 | —      | These bits are read as 0. The write value should be 0.   | R/W |
| 31    | CSTOP  | Software Source Counter Stop Enable<br>0: Counter stop disabled by the GTSTP register<br>1: Counter stop enabled by the GTSTP register       | R/W |

The GTPSR sets the source to stop the GTCNT counter.

#### PSGTRGAR bit (GTETRGA Pin Rising Input Source Counter Stop Enable)

The PSGTRGAR bit enables or disables the GTCNT counter stop on the rising edge of the GTETRGA pin input.

#### PSGTRGAF bit (GTETRGA Pin Falling Input Source Counter Stop Enable)

The PSGTRGAF bit enables or disables the GTCNT counter stop on the falling edge of the GTETRGA pin input.

#### PSGTRGBR bit (GTETRGB Pin Rising Input Source Counter Stop Enable)

PSGTRGBR bit enables or disables the GTCNT counter stop on the rising edge of the GTETRGB pin input.

#### PSGTRGBF bit (GTETRGB Pin Falling Input Source Counter Stop Enable)

The PSGTRGBF bit enables or disables the GTCNT counter stop on the falling edge of the GTETRGB pin input.

#### PSGTRGCR bit (GTETRGC Pin Rising Input Source Counter Stop Enable)

PSGTRGCR bit enables or disables the GTCNT counter stop on the rising edge of the GTETRGC pin input.

#### PSGTRGCF bit (GTETRGC Pin Falling Input Source Counter Stop Enable)

The PSGTRGCF bit enables or disables the GTCNT counter stop on the falling edge of the GTETRGC pin input.

#### PSGTRGDR bit (GTETRGD Pin Rising Input Source Counter Stop Enable)

PSGTRGDR bit enables or disables the GTCNT counter stop on the rising edge of the GTETRGD pin input.

#### PSGTRGDF bit (GTETRGD Pin Falling Input Source Counter Stop Enable)

The PSGTRGDF bit enables or disables the GTCNT counter stop on the falling edge of the GTETRGD pin input.

#### PSCARBL bit (GTIOCnA Pin Rising Input during GTIOCnB Value Low Source Counter Stop Enable)

The PSCARBL bit enables or disables the GTCNT counter stop on the rising edge of the GTIOCnA pin input, when GTIOCnB input is 0.

| Bit   | Symbol | Function   | R/W |
|-------|--------|--|-----|
| 18    | PSELCC | ELC_GPTC事件源计数器停止使能<br>0: 在ELC_GPTC输入处禁用计数器停止1: 在ELC_GPTC输入处启用计数器停止 | R/W |
| 19    | PSELCD | ELC_GPTD事件源计数器停止启用<br>0: 在ELC_GPTD输入处禁用计数器停止1: 在ELC_GPTD输入处启用计数器停止 | R/W |
| 20    | PSELCE | ELC_GPTE事件源计数器停止启用<br>0: 在ELC_GPTE输入处禁用计数器停止1: 在ELC_GPTE输入处启用计数器停止 | R/W |
| 21    | PSELCF | ELC_GPTF事件源计数器停止启用<br>0: 在ELC_GPTF输入处禁用计数器停止1: 在ELC_GPTF输入处启用计数器停止 | R/W |
| 22    | PSELCG | ELC_GPTG事件源计数器停止使能<br>0: 在ELC_GPTG输入处禁用计数器停止1: 在ELC_GPTG输入处启用计数器停止 | R/W |
| 23    | PSELCH | ELC_GPTH事件源计数器停止启用<br>0: 在ELC_GPTH输入处禁用计数器停止1: 在ELC_GPTH输入处启用计数器停止 | R/W |
| 30:24 | —      | 这些位被读取为0。写入值应为0。   | R/W |
| 31    | CSTOP  | 软件源计数器停止使能<br>0: GTSTP寄存器禁止计数器停止1: GTSTP寄存器使能计数器停止                 | R/W |

GTPSR设置源以停止GTCNT计数器。

#### PSGTRGAR位 (GTETRGA引脚上升沿输入源计数器停止使能)

PSGTRGAR位在GTETRGA引脚输入的上升沿启用或禁用GTCNT计数器停止。

#### PSGTRGAF位 (GTETRGA引脚下降沿输入源计数器停止使能)

PSGTRGAF位在GTETRGA引脚输入的下降沿启用或禁用GTCNT计数器停止。

#### PSGTRGBR位 (GTETRGB引脚上升沿输入源计数器停止使能)

PSGTRGBR位在GTETRGB引脚输入的上升沿启用或禁用GTCNT计数器停止。

#### PSGTRGBF位 (GTETRGB引脚下降沿输入源计数器停止使能)

PSGTRGBF位在GTETRGB引脚输入的下降沿启用或禁用GTCNT计数器停止。

#### PSGTRGCR位 (GTETRGC引脚上升沿输入源计数器停止使能)

PSGTRGCR位使能或禁止GTCNT计数器在GTETRGC引脚输入的上升沿停止。

#### PSGTRGCF位 (GTETRGC引脚下降沿输入源计数器停止使能)

PSGTRGCF位在GTETRGC引脚输入的下降沿启用或禁用GTCNT计数器停止。

#### PSGTRGDR位 (GTETRGD引脚上升沿输入源计数器停止使能)

PSGTRGDR位启用或禁用GTCNT计数器在GTETRGD引脚输入的上升沿停止。

#### PSGTRGDF位 (GTETRGD引脚下降沿输入源计数器停止使能)

PSGTRGDF位在GTETRGD引脚输入的下降沿启用或禁用GTCNT计数器停止。

#### PSCARBL位 (GTIOCnB值低电平期间的GTIOCnA引脚上升沿输入源计数器停止使能)

PSCARBL位在GTIOCnA引脚输入的上升沿启用或禁用GTCNT计数器停止，当GTIOCnB输入为0。

**PSCARBH bit (GTIOCnA Pin Rising Input during GTIOCnB Value High Source Counter Stop Enable)**

This bit enables or disables the GTCNT counter stop on the rising edge of the GTIOCnA pin input, when GTIOCnB input is 1.

**PSCAFBL bit (GTIOCnA Pin Falling Input during GTIOCnB Value Low Source Counter Stop Enable)**

The PSCAFBL bit enables or disables the GTCNT counter stop on the falling edge of the GTIOCnA pin input, when GTIOCnB input is 0.

**PSCAFBH bit (GTIOCnA Pin Falling Input during GTIOCnB Value High Source Counter Stop Enable)**

The PSCAFBH bit enables or disables the GTCNT counter stop on the falling edge of the GTIOCnA pin input, when GTIOCnB input is 1.

**PSCBRAL bit (GTIOCnB Pin Rising Input during GTIOCnA Value Low Source Counter Stop Enable)**

The PSCBRAL bit enables or disables the GTCNT counter stop on the rising edge of the GTIOCnB pin input, when GTIOCnA input is 0.

**PSCBRAH bit (GTIOCnB Pin Rising Input during GTIOCnA Value High Source Counter Stop Enable)**

The PSCBRAH bit enables or disables the GTCNT counter stop on the rising edge of the GTIOCnB pin input, when GTIOCnA input is 1.

**PSCBFAL bit (GTIOCnB Pin Falling Input during GTIOCnA Value Low Source Counter Stop Enable)**

The PSCBFAL bit enables or disables the GTCNT counter stop on the falling edge of the GTIOCnB pin input, when GTIOCnA input is 0.

**PSCBFAH bit (GTIOCnB Pin Falling Input during GTIOCnA Value High Source Counter Stop Enable)**

The PSCBFAH bit enables or disables the GTCNT counter stop on the falling edge of the GTIOCnB pin input, when GTIOCnA input is 1.

**PSELCm bit (ELCm Event Source Counter Stop Enable) (m = A to H)**

The PSELCm bit enables or disables the GTCNT counter stop at the ELC\_GPTm event input.

**CSTOP bit (Software Source Counter Stop Enable)**

The CSTOP bit enables or disables the GTCNT counter stop by the GTSTP register.

**21.2.7 GTCSR : General PWM Timer Clear Source Select Register**

Base address: GPT32n = 0x4016\_9000 + 0x0100 × n (n = 0 to 3)  
GPT16m = 0x4016\_9000 + 0x0100 × m (m = 4 to 7)

Offset address: 0x18

|                    |          |          |          |          |          |          |          |          |           |           |           |           |           |           |           |           |
|--------------------|----------|----------|----------|----------|----------|----------|----------|----------|-----------|-----------|-----------|-----------|-----------|-----------|-----------|-----------|
| Bit position:      | 31       | 30       | 29       | 28       | 27       | 26       | 25       | 24       | 23        | 22        | 21        | 20        | 19        | 18        | 17        | 16        |
| Bit field:         | CCLR     | —        | —        | —        | —        | —        | —        | —        | CSEL CH   | CSEL CG   | CSEL CF   | CSEL CE   | CSEL CD   | CSEL CC   | CSEL CB   | CSEL CA   |
| Value after reset: | 0        | 0        | 0        | 0        | 0        | 0        | 0        | 0        | 0         | 0         | 0         | 0         | 0         | 0         | 0         | 0         |
| Bit position:      | 15       | 14       | 13       | 12       | 11       | 10       | 9        | 8        | 7         | 6         | 5         | 4         | 3         | 2         | 1         | 0         |
| Bit field:         | CSCB FAH | CSCB FAL | CSCB RAH | CSCB RAL | CSCA FBH | CSCA FBL | CSCA RBH | CSCA RBL | CSGT RGDF | CSGT RGDR | CSGT RGCF | CSGT RGCR | CSGT RGBF | CSGT RGBR | CSGT RGAF | CSGT RGAR |
| Value after reset: | 0        | 0        | 0        | 0        | 0        | 0        | 0        | 0        | 0         | 0         | 0         | 0         | 0         | 0         | 0         | 0         |

| Bit | Symbol   | Function  | R/W |
|-----|----------|---|-----|
| 0   | CSGTRGAR | GTETRGA Pin Rising Input Source Counter Clear Enable<br>0: Counter clear disabled on the rising edge of GTETRGA input<br>1: Counter clear enabled on the rising edge of GTETRGA input | R/W |

**PSCARBH位 (GTIOCnB值高电平期间的GTIOCnA引脚上升沿输入源计数器停止使能)**

当GTIOCnB输入为1时, 该位在GTIOCnA引脚输入的上升沿启用或禁用GTCNT计数器停止。

**PSCAFBL位 (GTIOCnB值低电平源计数器停止使能期间GTIOCnA引脚下降输入)**

PSCAFBL位在GTIOCnA引脚输入的下降沿启用或禁用GTCNT计数器停止, 当GTIOCnB输入为0。

**PSCAFBH位 (GTIOCnB值高电平期间的GTIOCnA引脚下降输入源计数器停止使能)**

PSCAFBH位在GTIOCnA引脚输入的下降沿启用或禁用GTCNT计数器停止, 当GTIOCnB输入为1。

**PSCBRAL位 (GTIOCnA值低电平期间的GTIOCnB引脚上升沿输入源计数器停止使能)**

PSCBRAL位在GTIOCnB引脚输入的上升沿启用或禁用GTCNT计数器停止, 当GTIOCnA输入为0。

**PSCBRAH位 (GTIOCnA值高电平期间的GTIOCnB引脚上升沿输入源计数器停止使能)**

PSCBRAH位使能或禁止GTCNT计数器在GTIOCnB引脚输入的上升沿停止, 当GTIOCnA输入为1。

**PSCBFAL位 (GTIOCnA值低源计数器停止使能期间GTIOCnB引脚下降输入)**

PSCBFAL位在GTIOCnB引脚输入的下降沿启用或禁用GTCNT计数器停止, 当GTIOCnA输入为0。

**PSCBFAH位 (GTIOCnA值高电平源计数器停止使能期间的GTIOCnB引脚下降输入)**

PSCBFAH位使能或禁止GTCNT计数器在GTIOCnB引脚输入的下降沿停止, 当GTIOCnA输入为1。

**PSELCm位 (ELCm事件源计数器停止使能) (m=A到H)**

PSELCm位启用或禁用GTCNT计数器在ELC\_GPTm事件输入处停止。

**CSTOP位 (软件源计数器停止使能)**

CSTOP位通过GTSTP寄存器启用或禁用GTCNT计数器停止。

**21.2.7 GTCSR: 通用PWM定时器清零源选择寄存器**

Base address: GPT32n = 0x4016\_9000 + 0x0100 × n (n = 0 to 3)  
GPT16m = 0x4016\_9000 + 0x0100 × m (m = 4 to 7)

Offset address: 0x18

|               |          |          |          |          |          |          |          |          |           |           |           |           |           |           |           |           |
|---------------|----------|----------|----------|----------|----------|----------|----------|----------|-----------|-----------|-----------|-----------|-----------|-----------|-----------|-----------|
| Bit position: | 31       | 30       | 29       | 28       | 27       | 26       | 25       | 24       | 23        | 22        | 21        | 20        | 19        | 18        | 17        | 16        |
| Bit field:    | CCLR     | —        | —        | —        | —        | —        | —        | —        | CSEL CH   | CSEL CG   | CSEL CF   | CSEL CE   | CSEL CD   | CSEL CC   | CSEL CB   | CSEL CA   |
| 重置后的值:        | 0        | 0        | 0        | 0        | 0        | 0        | 0        | 0        | 0         | 0         | 0         | 0         | 0         | 0         | 0         | 0         |
| Bit position: | 15       | 14       | 13       | 12       | 11       | 10       | 9        | 8        | 7         | 6         | 5         | 4         | 3         | 2         | 1         | 0         |
| Bit field:    | CSCB FAH | CSCB FAL | CSCB RAH | CSCB RAL | CSCA FBH | CSCA FBL | CSCA RBH | CSCA RBL | CSGT RGDF | CSGT RGDR | CSGT RGCF | CSGT RGCR | CSGT RGBF | CSGT RGBR | CSGT RGAF | CSGT RGAR |
| 重置后的值:        | 0        | 0        | 0        | 0        | 0        | 0        | 0        | 0        | 0         | 0         | 0         | 0         | 0         | 0         | 0         | 0         |

| Bit | Symbol   | Function  | R/W |
|-----|----------|---|-----|
| 0   | CSGTRGAR | GTETRGA引脚上升输入源计数器清零使能<br>0: 在GTETRGA输入的上升沿禁止计数器清除<br>1: 在GTETRGA输入的上升沿使能计数器清除 | R/W |

| Bit | Symbol   | Function   | R/W |
|-----|----------|--|-----|
| 1   | CSGTRGAF | GTETRGA Pin Falling Input Source Counter Clear Enable<br>0: Counter clear disabled on the falling edge of GTETRGA input<br>1: Counter clear enabled on the falling edge of GTETRGA input   | R/W |
| 2   | CSGTRGBR | GTETRGB Pin Rising Input Source Counter Clear Enable<br>0: Disable counter clear on the rising edge of GTETRGB input<br>1: Enable counter clear on the rising edge of GTETRGB input  | R/W |
| 3   | CSGTRGBF | GTETRGB Pin Falling Input Source Counter Clear Enable<br>0: Counter clear disabled on the falling edge of GTETRGB input<br>1: Counter clear enabled on the falling edge of GTETRGB input   | R/W |
| 4   | CSGTRGCR | GTETRGC Pin Rising Input Source Counter Clear Enable<br>0: Disable counter clear on the rising edge of GTETRGC input<br>1: Enable counter clear on the rising edge of GTETRGC input  | R/W |
| 5   | CSGTRGCF | GTETRGC Pin Falling Input Source Counter Clear Enable<br>0: Counter clear disabled on the falling edge of GTETRGC input<br>1: Counter clear enabled on the falling edge of GTETRGC input   | R/W |
| 6   | CSGTRGDR | GTETRGD Pin Rising Input Source Counter Clear Enable<br>0: Disable counter clear on the rising edge of GTETRGD input<br>1: Enable counter clear on the rising edge of GTETRGD input  | R/W |
| 7   | CSGTRGDF | GTETRGD Pin Falling Input Source Counter Clear Enable<br>0: Counter clear disabled on the falling edge of GTETRGD input<br>1: Counter clear enabled on the falling edge of GTETRGD input   | R/W |
| 8   | CSCARBL  | GTIOCnA Pin Rising Input during GTIOCnB Value Low Source Counter Clear Enable<br>0: Counter clear disabled on the rising edge of GTIOCnA input when GTIOCnB input is 0<br>1: Counter clear enabled on the rising edge of GTIOCnA input when GTIOCnB input is 0     | R/W |
| 9   | CSCARBH  | GTIOCnA Pin Rising Input during GTIOCnB Value High Source Counter Clear Enable<br>0: Counter clear disabled on the rising edge of GTIOCnA input when GTIOCnB input is 1<br>1: Counter clear enabled on the rising edge of GTIOCnA input when GTIOCnB input is 1    | R/W |
| 10  | CSCAFBL  | GTIOCnA Pin Falling Input during GTIOCnB Value Low Source Counter Clear Enable<br>0: Counter clear disabled on the falling edge of GTIOCnA input when GTIOCnB input is 0<br>1: Counter clear enabled on the falling edge of GTIOCnA input when GTIOCnB input is 0  | R/W |
| 11  | CSCAFBH  | GTIOCnA Pin Falling Input during GTIOCnB Value High Source Counter Clear Enable<br>0: Counter clear disabled on the falling edge of GTIOCnA input when GTIOCnB input is 1<br>1: Counter clear enabled on the falling edge of GTIOCnA input when GTIOCnB input is 1 | R/W |
| 12  | CSCBRAL  | GTIOCnB Pin Rising Input during GTIOCnA Value Low Source Counter Clear Enable<br>0: Counter clear disabled on the rising edge of GTIOCnB input when GTIOCnA input is 0<br>1: Counter clear enabled on the rising edge of GTIOCnB input when GTIOCnA input is 0     | R/W |
| 13  | CSCBRAH  | GTIOCnB Pin Rising Input during GTIOCnA Value High Source Counter Clear Enable<br>0: Counter clear disabled on the rising edge of GTIOCnB input when GTIOCnA input is 1<br>1: Counter clear enabled on the rising edge of GTIOCnB input when GTIOCnA input is 1    | R/W |
| 14  | CSCBFAL  | GTIOCnB Pin Falling Input during GTIOCnA Value Low Source Counter Clear Enable<br>0: Counter clear disabled on the falling edge of GTIOCnB input when GTIOCnA input is 0<br>1: Counter clear enabled on the falling edge of GTIOCnB input when GTIOCnA input is 0  | R/W |

| Bit | Symbol   | Function  | R/W |
|-----|----------|---|-----|
| 1   | CSGTRGAF | GTETRGA引脚下降输入源计数器清零使能<br>0: 在GTETRGA输入的下降沿禁止计数器清除1: 在GTETRGA输入的下降沿使能计数器清除   | R/W |
| 2   | CSGTRGBR | GTETRGB引脚上升输入源计数器清零使能<br>0: 在GTETRGB输入的上升沿禁止计数器清零1: 在GTETRGB输入的上升沿使能计数器清零   | R/W |
| 3   | CSGTRGBF | GTETRGB引脚下降输入源计数器清除启用<br>0: 在GTETRGB输入的下降沿禁用计数器清除1: 在GTETRGB输入的下降沿启用计数器清除   | R/W |
| 4   | CSGTRGCR | GTETRGC引脚上升沿输入源计数器清零使能<br>0: 在GTETRGC输入的上升沿禁止计数器清零1: 在GTETRGC输入的上升沿使能计数器清零  | R/W |
| 5   | CSGTRGCF | GTETRGC引脚下降输入源计数器清零使能<br>0: 在GTETRGC输入的下降沿禁止计数器清除1: 在GTETRGC输入的下降沿使能计数器清除   | R/W |
| 6   | CSGTRGDR | GTETRGD引脚上升沿输入源计数器清零使能<br>0: 在GTETRGD输入的上升沿禁止计数器清零1: 在GTETRGD输入的上升沿使能计数器清零  | R/W |
| 7   | CSGTRGDF | GTETRGD引脚下降输入源计数器清零使能<br>0: 在GTETRGD输入的下降沿禁止计数器清除1: 在GTETRGD输入的下降沿使能计数器清除   | R/W |
| 8   | CSCARBL  | GTIOCnB值低电平期间的GTIOCnA引脚上升沿输入源计数器清零使能<br>0: 当GTIOCnB输入为0时, 在GTIOCnA输入的上升沿禁止计数器清零<br>1: 当GTIOCnB输入为0时, 在GTIOCnA输入的上升沿使能计数器清零  | R/W |
| 9   | CSCARBH  | GTIOCnB值高电平期间的GTIOCnA引脚上升沿输入源计数器清零使能<br>0: 当GTIOCnB输入为1时, 在GTIOCnA输入的上升沿禁止计数器清零<br>1: 当GTIOCnB输入为1时, 在GTIOCnA输入的上升沿使能计数器清零  | R/W |
| 10  | CSCAFBL  | GTIOCnB值低电平源计数器清除启用期间的GTIOCnA引脚下降输入<br>0: 当GTIOCnB输入为0时, 在GTIOCnA输入的下降沿禁止计数器清零<br>1: 当GTIOCnB输入为0时, 在GTIOCnA输入的下降沿使能计数器清零   | R/W |
| 11  | CSCAFBH  | GTIOCnB值高电平期间的GTIOCnA引脚下降输入源计数器清零使能<br>0: 当GTIOCnB输入为1时, 在GTIOCnA输入的下降沿禁止计数器清零<br>1: 当GTIOCnB输入为1时, 在GTIOCnA输入的下降沿使能计数器清零   | R/W |
| 12  | CSCBRAL  | GTIOCnB引脚在GTIOCnA值低电平期间的上升沿输入源计数器清零使能<br>0: 当GTIOCnA输入为0时, 在GTIOCnB输入的上升沿禁止计数器清零<br>1: 当GTIOCnA输入为0时, 在GTIOCnB输入的上升沿使能计数器清零 | R/W |
| 13  | CSCBRAH  | GTIOCnA值高电平期间的GTIOCnB引脚上升沿输入源计数器清零使能<br>0: 当GTIOCnA输入为1时, 在GTIOCnB输入的上升沿禁止计数器清零<br>1: 当GTIOCnA输入为1时, 在GTIOCnB输入的上升沿使能计数器清零  | R/W |
| 14  | CSCBFAL  | GTIOCnA值低电平期间的GTIOCnB引脚下降输入源计数器清零使能<br>0: 当GTIOCnA输入为0时, 在GTIOCnB输入的下降沿禁止计数器清零<br>1: 当GTIOCnA输入为0时, 在GTIOCnB输入下降沿使能计数器清零    | R/W |



| Bit   | Symbol  | Function   | R/W |
|-------|---------|--|-----|
| 15    | CSCBFAH | GTIOcNB Pin Falling Input during GTIOcNA Value High Source Counter Clear Enable<br>0: Counter clear disabled on the falling edge of GTIOcNB input when GTIOcNA input is 1<br>1: Counter clear enabled on the falling edge of GTIOcNB input when GTIOcNA input is 1 | R/W |
| 16    | CSELCA  | ELC_GPTA Event Source Counter Clear Enable<br>0: Counter clear disabled at the ELC_GPTA input<br>1: Counter clear enabled at the ELC_GPTA input  | R/W |
| 17    | CSELCB  | ELC_GPTB Event Source Counter Clear Enable<br>0: Counter clear disabled at the ELC_GPTB input<br>1: Counter clear enabled at the ELC_GPTB input  | R/W |
| 18    | CSELCC  | ELC_GPTC Event Source Counter Clear Enable<br>0: Counter clear disabled at the ELC_GPTC input<br>1: Counter clear enabled at the ELC_GPTC input  | R/W |
| 19    | CSELCD  | ELC_GPTD Event Source Counter Clear Enable<br>0: Counter clear disabled at the ELC_GPTD input<br>1: Counter clear enabled at the ELC_GPTD input  | R/W |
| 20    | CSELCE  | ELC_GPTE Event Source Counter Clear Enable<br>0: Counter clear disabled at the ELC_GPTE input<br>1: Counter clear enabled at the ELC_GPTE input  | R/W |
| 21    | CSELCF  | ELC_GPTF Event Source Counter Clear Enable<br>0: Counter clear disabled at the ELC_GPTF input<br>1: Counter clear enabled at the ELC_GPTF input  | R/W |
| 22    | CSELCG  | ELC_GPTG Event Source Counter Clear Enable<br>0: Counter clear disabled at the ELC_GPTG input<br>1: Counter clear enabled at the ELC_GPTG input  | R/W |
| 23    | CSELCH  | ELC_GPTH Event Source Counter Clear Enable<br>0: Counter clear disabled at the ELC_GPTH input<br>1: Counter clear enabled at the ELC_GPTH input  | R/W |
| 30:24 | —       | These bits are read as 0. The write value should be 0.   | R/W |
| 31    | CCLR    | Software Source Counter Clear Enable<br>0: Counter clear disabled by the GTCLR register<br>1: Counter clear enabled by the GTCLR register  | R/W |

The GTCSR sets the source to clear the GTCNT counter.

#### CSGTRGAR bit (GTETRGA Pin Rising Input Source Counter Clear Enable)

The CSGTRGAR bit enables or disables the GTCNT counter clear on the rising edge of the GTETRGA pin input.

#### CSGTRGAF bit (GTETRGA Pin Falling Input Source Counter Clear Enable)

The CSGTRGAF bit enables or disables the GTCNT counter clear on the falling edge of the GTETRGA pin input.

#### CSGTRGBR bit (GTETRGB Pin Rising Input Source Counter Clear Enable)

The CSGTRGBR bit enables or disables the GTCNT counter clear on the rising edge of the GTETRGB pin input.

#### CSGTRGBF bit (GTETRGB Pin Falling Input Source Counter Clear Enable)

The CSGTRGBF bit enables or disables the GTCNT counter clear on the falling edge of the GTETRGB pin input.

#### CSGTRGCR bit (GTETRGC Pin Rising Input Source Counter Clear Enable)

The CSGTRGCR bit enables or disables the GTCNT counter clear on the rising edge of the GTETRGC pin input.

#### CSGTRGCF bit (GTETRGC Pin Falling Input Source Counter Clear Enable)

The CSGTRGCF bit enables or disables the GTCNT counter clear on the falling edge of the GTETRGC pin input.

#### CSGTRGDR bit (GTETRGD Pin Rising Input Source Counter Clear Enable)

The CSGTRGDR bit enables or disables the GTCNT counter clear on the rising edge of the GTETRGD pin input.

| Bit   | Symbol  | Function   | R/W |
|-------|---------|--|-----|
| 15    | CSCBFAH | GTIOcNA值高电平期间GTIOcNB引脚下降输入源计数器清零使能<br>0: 当GTIOcNA输入为1时, 在GTIOcNB输入的下沿禁止计数器清零<br>1: 当GTIOcNA输入为1时, 在GTIOcNB输入下降沿启用计数器清零 | R/W |
| 16    | CSELCA  | ELC_GPTA事件源计数器清除启用<br>0: 在ELC_GPTA输入处禁用计数器清除1: 在ELC_GPTA输入处启用计数器清除   | R/W |
| 17    | CSELCB  | ELC_GPTB事件源计数器清除启用<br>0: 在ELC_GPTB输入处禁用计数器清除1: 在ELC_GPTB输入处启用计数器清除   | R/W |
| 18    | CSELCC  | ELC_GPTC事件源计数器清除启用<br>0: 在ELC_GPTC输入处禁用计数器清除1: 在ELC_GPTC输入处启用计数器清除   | R/W |
| 19    | CSELCD  | ELC_GPTD事件源计数器清除启用<br>0: 在ELC_GPTD输入处禁用计数器清除1: 在ELC_GPTD输入处启用计数器清除   | R/W |
| 20    | CSELCE  | ELC_GPTE事件源计数器清除启用<br>0: 在ELC_GPTE输入处禁用计数器清除1: 在ELC_GPTE输入处启用计数器清除   | R/W |
| 21    | CSELCF  | ELC_GPTF事件源计数器清除启用<br>0: 在ELC_GPTF输入处禁用计数器清除1: 在ELC_GPTF输入处启用计数器清除   | R/W |
| 22    | CSELCG  | ELC_GPTG事件源计数器清除启用<br>0: 在ELC_GPTG输入处禁用计数器清除1: 在ELC_GPTG输入处启用计数器清除   | R/W |
| 23    | CSELCH  | ELC_GPTH事件源计数器清除启用<br>0: 在ELC_GPTH输入处禁用计数器清除1: 在ELC_GPTH输入处启用计数器清除   | R/W |
| 30:24 | —       | 这些位被读取为0。写入值应为0。   | R/W |
| 31    | CCLR    | 软件源计数器清除启用<br>0: GTCLR寄存器禁止计数器清零1: GTCLR寄存器使能计数器清零   | R/W |

GTCSR设置源以清除GTCNT计数器。

#### CSGTRGAR位 (GTETRGA引脚上升沿输入源计数器清零使能)

CSGTRGAR位在GTETRGA引脚输入的上升沿启用或禁用GTCNT计数器清零。

#### CSGTRGAF位 (GTETRGA引脚下降输入源计数器清零使能)

CSGTRGAF位在GTETRGA引脚输入的下沿启用或禁用GTCNT计数器清零。

#### CSGTRGBR位 (GTETRGB引脚上升沿输入源计数器清零使能)

CSGTRGBR位在GTETRGB引脚输入的上升沿启用或禁用GTCNT计数器清零。

#### CSGTRGBF位 (GTETRGB引脚下降输入源计数器清零使能)

CSGTRGBF位在GTETRGB引脚输入的下沿启用或禁用GTCNT计数器清零。

#### CSGTRGCR位 (GTETRGC引脚上升沿输入源计数器清零使能)

CSGTRGCR位在GTETRGC引脚输入的上升沿启用或禁用GTCNT计数器清零。

#### CSGTRGCF位 (GTETRGC引脚下降输入源计数器清零使能)

CSGTRGCF位在GTETRGC引脚输入的下沿启用或禁用GTCNT计数器清零。

#### CSGTRGDR位 (GTETRGD引脚上升沿输入源计数器清零使能)

CSGTRGDR位在GTETRGD引脚输入的上升沿启用或禁用GTCNT计数器清零。

**CSGTRGDF bit (GTETRGD Pin Falling Input Source Counter Clear Enable)**

The CSGTRGDF bit enables or disables the GTCNT counter clear on the falling edge of the GTETRGD pin input.

**CSCARBL bit (GTIOCnA Pin Rising Input during GTIOCnB Value Low Source Counter Clear Enable)**

The CSCARBL bit enables or disables the GTCNT counter clear on the rising edge of the GTIOCnA pin input, when GTIOCnB input is 0.

**CSCARBH bit (GTIOCnA Pin Rising Input during GTIOCnB Value High Source Counter Clear Enable)**

The CSCARBH bit enables or disables the GTCNT counter clear on the rising edge of the GTIOCnA pin input, when GTIOCnB input is 1.

**CSCAFBL bit (GTIOCnA Pin Falling Input during GTIOCnB Value Low Source Counter Clear Enable)**

The CSCAFBL bit enables or disables the GTCNT counter clear on the falling edge of the GTIOCnA pin input, when GTIOCnB input is 0.

**CSCAFBH bit (GTIOCnA Pin Falling Input during GTIOCnB Value High Source Counter Clear Enable)**

The CSCAFBH bit enables or disables the GTCNT counter clear on the falling edge of the GTIOCnA pin input, when GTIOCnB input is 1.

**CSCBRAL bit (GTIOCnB Pin Rising Input during GTIOCnA Value Low Source Counter Clear Enable)**

The CSCBRAL bit enables or disables the GTCNT counter clear on the rising edge of the GTIOCnB pin input, when GTIOCnA input is 0.

**CSCBRAH bit (GTIOCnB Pin Rising Input during GTIOCnA Value High Source Counter Clear Enable)**

The CSCBRAH bit enables or disables the GTCNT counter clear on the rising edge of the GTIOCnB pin input, when GTIOCnA input is 1.

**CSCBFAL bit (GTIOCnB Pin Falling Input during GTIOCnA Value Low Source Counter Clear Enable)**

The CSCBFAL bit enables or disables the GTCNT counter clear on the falling edge of the GTIOCnB pin input, when GTIOCnA input is 0.

**CSCBFAH bit (GTIOCnB Pin Falling Input during GTIOCnA Value High Source Counter Clear Enable)**

The CSCBFAH bit enables or disables the GTCNT counter clear on the falling edge of the GTIOCnB pin input, when GTIOCnA input is 1.

**CSELCm bit (ELCm Event Source Counter Clear Enable) (m = A to H)**

The CSELCm bit enables or disables the GTCNT counter clear at the ELC\_GPTm event input.

**CCLR bit (Software Source Counter Clear Enable)**

The CCLR bit enables or disables the GTCNT counter clear by the GTCLR register.

**21.2.8 GTUPSR : General PWM Timer Up Count Source Select Register**

Base address: GPT32n = 0x4016\_9000 + 0x0100 × n (n = 0 to 3)  
GPT16m = 0x4016\_9000 + 0x0100 × m (m = 4 to 7)

Offset address: 0x1C

|                    |          |          |          |          |          |          |          |          |           |           |           |           |           |           |           |           |
|--------------------|----------|----------|----------|----------|----------|----------|----------|----------|-----------|-----------|-----------|-----------|-----------|-----------|-----------|-----------|
| Bit position:      | 31       | 30       | 29       | 28       | 27       | 26       | 25       | 24       | 23        | 22        | 21        | 20        | 19        | 18        | 17        | 16        |
| Bit field:         | —        | —        | —        | —        | —        | —        | —        | —        | USEL CH   | USEL CG   | USEL CF   | USEL CE   | USEL CD   | USEL CC   | USEL CB   | USEL CA   |
| Value after reset: | 0        | 0        | 0        | 0        | 0        | 0        | 0        | 0        | 0         | 0         | 0         | 0         | 0         | 0         | 0         | 0         |
| Bit position:      | 15       | 14       | 13       | 12       | 11       | 10       | 9        | 8        | 7         | 6         | 5         | 4         | 3         | 2         | 1         | 0         |
| Bit field:         | USCB FAH | USCB FAL | USCB RAH | USCB RAL | USCA FBH | USCA FBL | USCA RBH | USCA RBL | USGT RGDF | USGT RGDR | USGT RGCF | USGT RGCR | USGT RGBF | USGT RGBR | USGT RGAF | USGT RGAR |
| Value after reset: | 0        | 0        | 0        | 0        | 0        | 0        | 0        | 0        | 0         | 0         | 0         | 0         | 0         | 0         | 0         | 0         |

**CSGTRGDF位 (GTETRGD引脚下降输入源计数器清零使能)**

CSGTRGDF位在GTETRGD引脚输入的下降沿启用或禁用GTCNT计数器清零。

**CSCARBL位 (GTIOCnB值低电平期间的GTIOCnA引脚上升沿输入源计数器清零使能)**

CSCARBL位在GTIOCnA引脚输入的上升沿启用或禁用GTCNT计数器清零，当GTIOCnB输入为0。

**CSCARBH位 (GTIOCnB值高电平期间GTIOCnA引脚上升沿输入源计数器清零使能)**

CSCARBH位在GTIOCnA引脚输入的上升沿启用或禁用GTCNT计数器清零，当GTIOCnB输入为1。

**CSCAFBL位 (GTIOCnB值低电平源计数器清除使能期间GTIOCnA引脚下降输入)**

CSCAFBL位在GTIOCnA引脚输入的下降沿启用或禁用GTCNT计数器清零，当GTIOCnB输入为0。

**CSCAFBH位 (GTIOCnB值高电平源计数器清零使能期间GTIOCnA引脚下降输入)**

CSCAFBH位在GTIOCnA引脚输入的下降沿启用或禁用GTCNT计数器清零，当GTIOCnB输入为1。

**CSCBRAL位 (GTIOCnA值低电平期间的GTIOCnB引脚上升沿输入源计数器清零使能)**

CSCBRAL位在GTIOCnB引脚输入的上升沿启用或禁用GTCNT计数器清零，当GTIOCnA输入为0。

**CSCBRAH位 (GTIOCnA值高电平期间GTIOCnB引脚上升沿输入源计数器清零使能)**

CSCBRAH位在GTIOCnB引脚输入的上升沿启用或禁用GTCNT计数器清零，当GTIOCnA输入为1。

**CSCBFAL位 (GTIOCnA值低电平源计数器清零使能期间GTIOCnB引脚下降输入)**

CSCBFAL位在GTIOCnB引脚输入的下降沿启用或禁用GTCNT计数器清零，当GTIOCnA输入为0。

**CSCBFAH位 (GTIOCnA值高电平期间GTIOCnB引脚下降输入源计数器清零使能)**

CSCBFAH位在GTIOCnB引脚输入的下降沿启用或禁用GTCNT计数器清零，当GTIOCnA输入为1。

**CSELCm位 (ELCm事件源计数器清除启用) (m=A到H)**

CSELCm位在ELC\_GPTm事件输入处启用或禁用GTCNT计数器清零。

**CCLR位 (软件源计数器清除启用)**

CCLR位启用或禁用由GTCLR寄存器清除的GTCNT计数器。

**21.2.8 GTUPSR: 通用PWM定时器向上计数源选择寄存器**

Base address: GPT32n = 0x4016\_9000 + 0x0100 × n (n = 0 to 3)  
GPT16m = 0x4016\_9000 + 0x0100 × m (m = 4 to 7)

Offset address: 0x1C

|               |          |          |          |          |          |          |          |          |           |           |           |           |           |           |           |           |
|---------------|----------|----------|----------|----------|----------|----------|----------|----------|-----------|-----------|-----------|-----------|-----------|-----------|-----------|-----------|
| Bit position: | 31       | 30       | 29       | 28       | 27       | 26       | 25       | 24       | 23        | 22        | 21        | 20        | 19        | 18        | 17        | 16        |
| Bit field:    | —        | —        | —        | —        | —        | —        | —        | —        | USEL CH   | USEL CG   | USEL CF   | USEL CE   | USEL CD   | USEL CC   | USEL CB   | USEL CA   |
| 重置后的值:        | 0        | 0        | 0        | 0        | 0        | 0        | 0        | 0        | 0         | 0         | 0         | 0         | 0         | 0         | 0         | 0         |
| Bit position: | 15       | 14       | 13       | 12       | 11       | 10       | 9        | 8        | 7         | 6         | 5         | 4         | 3         | 2         | 1         | 0         |
| Bit field:    | USCB FAH | USCB FAL | USCB RAH | USCB RAL | USCA FBH | USCA FBL | USCA RBH | USCA RBL | USGT RGDF | USGT RGDR | USGT RGCF | USGT RGCR | USGT RGBF | USGT RGBR | USGT RGAF | USGT RGAR |
| 重置后的值:        | 0        | 0        | 0        | 0        | 0        | 0        | 0        | 0        | 0         | 0         | 0         | 0         | 0         | 0         | 0         | 0         |



| Bit | Symbol   | Function  | R/W |
|-----|----------|---|-----|
| 0   | USGTRGAR | GTETRGA Pin Rising Input Source Counter Count Up Enable<br>0: Counter count up disabled on the rising edge of GTETRGA input<br>1: Counter count up enabled on the rising edge of GTETRGA input  | R/W |
| 1   | USGTRGAF | GTETRGA Pin Falling Input Source Counter Count Up Enable<br>0: Counter count up disabled on the falling edge of GTETRGA input<br>1: Counter count up enabled on the falling edge of GTETRGA input   | R/W |
| 2   | USGTRGBR | GTETRGB Pin Rising Input Source Counter Count Up Enable<br>0: Counter count up disabled on the rising edge of GTETRGB input<br>1: Counter count up enabled on the rising edge of GTETRGB input  | R/W |
| 3   | USGTRGBF | GTETRGB Pin Falling Input Source Counter Count Up Enable<br>0: Counter count up disabled on the falling edge of GTETRGB input<br>1: Counter count up enabled on the falling edge of GTETRGB input   | R/W |
| 4   | USGTRGCR | GTETRC Pin Rising Input Source Counter Count Up Enable<br>0: Counter count up disabled on the rising edge of GTETRC input<br>1: Counter count up enabled on the rising edge of GTETRC input   | R/W |
| 5   | USGTRGCF | GTETRC Pin Falling Input Source Counter Count Up Enable<br>0: Counter count up disabled on the falling edge of GTETRC input<br>1: Counter count up enabled on the falling edge of GTETRC input  | R/W |
| 6   | USGTRGDR | GTETRGD Pin Rising Input Source Counter Count Up Enable<br>0: Counter count up disabled on the rising edge of GTETRGD input<br>1: Counter count up enabled on the rising edge of GTETRGD input  | R/W |
| 7   | USGTRGDF | GTETRGD Pin Falling Input Source Counter Count Up Enable<br>0: Counter count up disabled on the falling edge of GTETRGD input<br>1: Counter count up enabled on the falling edge of GTETRGD input   | R/W |
| 8   | USCARBL  | GTIOCnA Pin Rising Input during GTIOCnB Value Low Source Counter Count Up Enable<br>0: Counter count up disabled on the rising edge of GTIOCnA input when GTIOCnB input is 0<br>1: Counter count up enabled on the rising edge of GTIOCnA input when GTIOCnB input is 0     | R/W |
| 9   | USCARBH  | GTIOCnA Pin Rising Input during GTIOCnB Value High Source Counter Count Up Enable<br>0: Counter count up disabled on the rising edge of GTIOCnA input when GTIOCnB input is 1<br>1: Counter count up enabled on the rising edge of GTIOCnA input when GTIOCnB input is 1    | R/W |
| 10  | USCAFBL  | GTIOCnA Pin Falling Input during GTIOCnB Value Low Source Counter Count Up Enable<br>0: Counter count up disabled on the falling edge of GTIOCnA input when GTIOCnB input is 0<br>1: Counter count up enabled on the falling edge of GTIOCnA input when GTIOCnB input is 0  | R/W |
| 11  | USCAFBH  | GTIOCnA Pin Falling Input during GTIOCnB Value High Source Counter Count Up Enable<br>0: Counter count up disabled on the falling edge of GTIOCnA input when GTIOCnB input is 1<br>1: Counter count up enabled on the falling edge of GTIOCnA input when GTIOCnB input is 1 | R/W |
| 12  | USCBRAL  | GTIOCnB Pin Rising Input during GTIOCnA Value Low Source Counter Count Up Enable<br>0: Counter count up disabled on the rising edge of GTIOCnB input when GTIOCnA input is 0<br>1: Counter count up enabled on the rising edge of GTIOCnB input when GTIOCnA input is 0     | R/W |
| 13  | USCBRAH  | GTIOCnB Pin Rising Input during GTIOCnA Value High Source Counter Count Up Enable<br>0: Counter count up disabled on the rising edge of GTIOCnB input when GTIOCnA input is 1<br>1: Counter count up enabled on the rising edge of GTIOCnB input when GTIOCnA input is 1    | R/W |

| Bit | Symbol   | Function  | R/W |
|-----|----------|---|-----|
| 0   | USGTRGAR | GTETRGA引脚上升输入源计数器向上计数使能<br>0: 在GTETRGA输入的上升沿禁止向上计数1: 在GTETRGA输入的上升沿使能向上计数   | R/W |
| 1   | USGTRGAF | GTETRGA引脚下降输入源计数器向上计数使能<br>0: 在GTETRGA输入的下降沿禁止向上计数1: 在GTETRGA输入的下降沿使能向上计数   | R/W |
| 2   | USGTRGBR | GTETRGB引脚上升输入源计数器向上计数使能<br>0: 在GTETRGB输入的上升沿禁止向上计数1: 在GTETRGB输入的上升沿使能向上计数   | R/W |
| 3   | USGTRGBF | GTETRGB引脚下降输入源计数器向上计数使能<br>0: 在GTETRGB输入的下降沿禁止向上计数1: 在GTETRGB输入的下降沿使能向上计数   | R/W |
| 4   | USGTRGCR | GTETRC引脚上升沿输入源计数器向上计数使能<br>0: 在GTETRC输入的上升沿禁止向上计数1: 在GTETRC输入的上升沿使能向上计数   | R/W |
| 5   | USGTRGCF | GTETRC引脚下降输入源计数器向上计数使能<br>0: 在GTETRC输入的下降沿禁止向上计数1: 在GTETRC输入的下降沿使能向上计数  | R/W |
| 6   | USGTRGDR | GTETRGD引脚上升输入源计数器向上计数使能<br>0: 在GTETRGD输入的上升沿禁止计数器向上计数1: 在GTETRGD输入的上升沿使能计数器向上计数   | R/W |
| 7   | USGTRGDF | GTETRGD引脚下降输入源计数器向上计数使能<br>0: 在GTETRGD输入的下降沿禁止向上计数1: 在GTETRGD输入的下降沿使能向上计数   | R/W |
| 8   | USCARBL  | GTIOCnB值低电平期间的GTIOCnA引脚上升输入源计数器向上计数使能<br>0: 当GTIOCnB输入为0时, 在GTIOCnA输入的上升沿禁止计数器向上计数<br>1: 当GTIOCnB输入为0时, 在GTIOCnA输入的上升沿使能计数器向上计数 | R/W |
| 9   | USCARBH  | GTIOCnB值高电平期间的GTIOCnA引脚上升输入源计数器向上计数使能<br>0: 当GTIOCnB输入为1时, 在GTIOCnA输入的上升沿禁止计数器向上计数<br>1: 当GTIOCnB输入为1时, 在GTIOCnA输入的上升沿使能计数器向上计数 | R/W |
| 10  | USCAFBL  | GTIOCnB值低电平期间的GTIOCnA引脚下降输入源计数器向上计数使能<br>0: 当GTIOCnB输入为0时, 在GTIOCnA输入的下降沿禁止计数器向上计数<br>1: 当GTIOCnB输入为0时, 在GTIOCnA输入的下降沿使能计数器向上计数 | R/W |
| 11  | USCAFBH  | GTIOCnB值高电平期间的GTIOCnA引脚下降输入源计数器向上计数使能<br>0: 当GTIOCnB输入为1时, 在GTIOCnA输入的下降沿禁止计数器向上计数<br>1: 当GTIOCnB输入为1时, 在GTIOCnA输入的下降沿使能计数器向上计数 | R/W |
| 12  | USCBRAL  | GTIOCnA值低电平期间的GTIOCnB引脚上升输入源计数器向上计数使能<br>0: 当GTIOCnA输入为0时, 在GTIOCnB输入的上升沿禁止计数器向上计数<br>1: 当GTIOCnA输入为0时, 在GTIOCnB输入的上升沿使能计数器向上计数 | R/W |
| 13  | USCBRAH  | GTIOCnA值高电平期间的GTIOCnB引脚上升输入源计数器向上计数使能<br>0: 当GTIOCnA输入为1时, 在GTIOCnB输入的上升沿禁止计数器向上计数<br>1: 当GTIOCnA输入为1时, 在GTIOCnB输入的上升沿使能计数器向上计数 | R/W |

| Bit   | Symbol  | Function  | R/W |
|-------|---------|---|-----|
| 14    | USCBFAL | GTIOCnB Pin Falling Input during GTIOCnA Value Low Source Counter Count Up Enable<br>0: Counter count up disabled on the falling edge of GTIOCnB input when GTIOCnA input is 0<br>1: Counter count up enabled on the falling edge of GTIOCnB input when GTIOCnA input is 0  | R/W |
| 15    | USCBFAH | GTIOCnB Pin Falling Input during GTIOCnA Value High Source Counter Count Up Enable<br>0: Counter count up disabled on the falling edge of GTIOCnB input when GTIOCnA input is 1<br>1: Counter count up enabled on the falling edge of GTIOCnB input when GTIOCnA input is 1 | R/W |
| 16    | USELCA  | ELC_GPTA Event Source Counter Count Up Enable<br>0: Counter count up disabled at the ELC_GPTA input<br>1: Counter count up enabled at the ELC_GPTA input  | R/W |
| 17    | USELCB  | ELC_GPTB Event Source Counter Count Up Enable<br>0: Counter count up disabled at the ELC_GPTB input<br>1: Counter count up enabled at the ELC_GPTB input  | R/W |
| 18    | USELCC  | ELC_GPTC Event Source Counter Count Up Enable<br>0: Counter count up disabled at the ELC_GPTC input<br>1: Counter count up enabled at the ELC_GPTC input  | R/W |
| 19    | USELCD  | ELC_GPTD Event Source Counter Count Up Enable<br>0: Counter count up disabled at the ELC_GPTD input<br>1: Counter count up enabled at the ELC_GPTD input  | R/W |
| 20    | USELCE  | ELC_GPTE Event Source Counter Count Up Enable<br>0: Counter count up disabled at the ELC_GPTE input<br>1: Counter count up enabled at the ELC_GPTE input  | R/W |
| 21    | USELCF  | ELC_GPTF Event Source Counter Count Up Enable<br>0: Counter count up disabled at the ELC_GPTF input<br>1: Counter count up enabled at the ELC_GPTF input  | R/W |
| 22    | USELCG  | ELC_GPTG Event Source Counter Count Up Enable<br>0: Counter count up disabled at the ELC_GPTG input<br>1: Counter count up enabled at the ELC_GPTG input  | R/W |
| 23    | USELCH  | ELC_GPTH Event Source Counter Count Up Enable<br>0: Counter count up disabled at the ELC_GPTH input<br>1: Counter count up enabled at the ELC_GPTH input  | R/W |
| 31:24 | —       | These bits are read as 0. The write value should be 0.  | R/W |

The GTUPSR sets the source to count up the GTCNT counter.

When at least one bit in the GTUPSR register is set to 1, the GTCNT counter is counted up by the source that is set to 1 in this register. In this case, GTCR.TPCS has no effect.

#### USGTRGAR bit (GTETRGA Pin Rising Input Source Counter Count Up Enable)

The USGTRGAR bit enables or disables the GTCNT counter count up on the rising edge of the GTETRGA pin input.

#### USGTRGAF bit (GTETRGA Pin Falling Input Source Counter Count Up Enable)

The USGTRGAF bit enables or disables the GTCNT counter count up on the falling edge of the GTETRGA pin input.

#### USGTRGBR bit (GTETRGB Pin Rising Input Source Counter Count Up Enable)

The USGTRGBR bit enables or disables the GTCNT counter count up on the rising edge of the GTETRGB pin input.

#### USGTRGBF bit (GTETRGB Pin Falling Input Source Counter Count Up Enable)

The USGTRGBF bit enables or disables the GTCNT counter count up on the falling edge of the GTETRGB pin input.

#### USGTRGCR bit (GTETRGC Pin Rising Input Source Counter Count Up Enable)

The USGTRGCR bit enables or disables the GTCNT counter count up on the rising edge of the GTETRGC pin input.

| Bit   | Symbol  | Function  | R/W |
|-------|---------|---|-----|
| 14    | USCBFAL | GTIOCnA值低电平期间的GTIOCnB引脚下降输入源计数器向上计数使能<br>0: 当GTIOCnA输入为0时, 在GTIOCnB输入的下沿禁止计数器向上计数<br>1: 当GTIOCnA输入为0时, 在GTIOCnB输入下降沿使能计数器向上计数 | R/W |
| 15    | USCBFAH | GTIOCnA值高电平期间GTIOCnB引脚下降输入源计数器向上计数使能<br>0: 当GTIOCnA输入为1时, 在GTIOCnB输入的下沿禁止计数器向上计数<br>1: 当GTIOCnA输入为1时, 在GTIOCnB输入的下沿使能计数器向上计数  | R/W |
| 16    | USELCA  | ELC_GPTA事件源计数器向上计数启用<br>0: 在ELC_GPTA输入处禁用计数器向上计数1: 在ELC_GPTA输入处启用计数器向上计数  | R/W |
| 17    | USELCB  | ELC_GPTB事件源计数器向上计数使能<br>0: 在ELC_GPTB输入处禁用计数器向上计数1: 在ELC_GPTB输入处启用计数器向上计数  | R/W |
| 18    | USELCC  | ELC_GPTC事件源计数器向上计数使能<br>0: 在ELC_GPTC输入处禁用计数器向上计数1: 在ELC_GPTC输入处启用计数器向上计数  | R/W |
| 19    | USELCD  | ELC_GPTD事件源计数器向上计数启用<br>0: 在ELC_GPTD输入处禁用计数器向上计数1: 在ELC_GPTD输入处启用计数器向上计数  | R/W |
| 20    | USELCE  | ELC_GPTE事件源计数器向上计数启用<br>0: 在ELC_GPTE输入处禁用计数器向上计数1: 在ELC_GPTE输入处启用计数器向上计数  | R/W |
| 21    | USELCF  | ELC_GPTF事件源计数器向上计数启用<br>0: 在ELC_GPTF输入处禁用计数器向上计数1: 在ELC_GPTF输入处启用计数器向上计数  | R/W |
| 22    | USELCG  | ELC_GPTG事件源计数器向上计数使能<br>0: 在ELC_GPTG输入处禁用计数器向上计数1: 在ELC_GPTG输入处启用计数器向上计数  | R/W |
| 23    | USELCH  | ELC_GPTH事件源计数器向上计数启用<br>0: 在ELC_GPTH输入处禁用计数器向上计数1: 在ELC_GPTH输入处启用计数器向上计数  | R/W |
| 31:24 | —       | 这些位被读取为0。写入值应为0。  | R/W |

GTUPSR将源设置为对GTCNT计数器进行计数。

当GTUPSR寄存器中的至少一位设置为1时, GTCNT计数器由该寄存器中设置为1的源进行计数。在这种情况下, GTCR.TPCS无效。

#### USGTRGAR位 (GTETRGA引脚上升沿输入源计数器向上计数使能)

USGTRGAR位在GTETRGA引脚输入的上升沿启用或禁用GTCNT计数器向上计数。

#### USGTRGAF位 (GTETRGA引脚下降沿输入源计数器向上计数使能)

USGTRGAF位在GTETRGA引脚输入的下沿启用或禁用GTCNT计数器向上计数。

#### USGTRGBR位 (GTETRGB引脚上升沿输入源计数器向上计数使能)

USGTRGBR位在GTETRGB引脚输入的上升沿启用或禁用GTCNT计数器向上计数。

#### USGTRGBF位 (GTETRGB引脚下降沿输入源计数器向上计数使能)

USGTRGBF位在GTETRGB引脚输入的下沿启用或禁用GTCNT计数器向上计数。

#### USGTRGCR位 (GTETRGC引脚上升沿输入源计数器向上计数使能)

USGTRGCR位在GTETRGC引脚输入的上升沿启用或禁用GTCNT计数器向上计数。

**USGTRGCF bit (GTETRG C Pin Falling Input Source Counter Count Up Enable)**

The USGTRGCF bit enables or disables the GTCNT counter count up on the falling edge of the GTETRG C pin input.

**USGTRGDR bit (GTETRG D Pin Rising Input Source Counter Count Up Enable)**

The USGTRGDR bit enables or disables the GTCNT counter count up on the rising edge of the GTETRG D pin input.

**USGTRGDF bit (GTETRG D Pin Falling Input Source Counter Count Up Enable)**

The USGTRGDF bit enables or disables the GTCNT counter count up on the falling edge of the GTETRG D pin input.

**USCARBL bit (GTIOCnA Pin Rising Input during GTIOCnB Value Low Source Counter Count Up Enable)**

The USCARBL bit enables or disables GTCNT counter count up on the rising edge of GTIOCnA pin input, when GTIOCnB input is 0.

**USCARBH bit (GTIOCnA Pin Rising Input during GTIOCnB Value High Source Counter Count Up Enable)**

The USCARBH bit enables or disables the GTCNT counter count up on the rising edge of the GTIOCnA pin input, when GTIOCnB input is 1.

**USCAFBL bit (GTIOCnA Pin Falling Input during GTIOCnB Value Low Source Counter Count Up Enable)**

The USCAFBL bit enables or disables the GTCNT counter count up on the falling edge of the GTIOCnA pin input, when GTIOCnB input is 0.

**USCAFBL bit (GTIOCnA Pin Falling Input during GTIOCnB Value High Source Counter Count Up Enable)**

The USCAFBL bit enables or disables the GTCNT counter count up on the falling edge of the GTIOCnA pin input, when GTIOCnB input is 1.

**USCBRAL bit (GTIOCnB Pin Rising Input during GTIOCnA Value Low Source Counter Count Up Enable)**

The USCBRAL bit enables or disables the GTCNT counter count up on the rising edge of the GTIOCnB pin input, when GTIOCnA input is 0.

**USCBRAH bit (GTIOCnB Pin Rising Input during GTIOCnA Value High Source Counter Count Up Enable)**

The USCBRAH bit enables or disables the GTCNT counter count up on the rising edge of the GTIOCnB pin input, when the GTIOCnA input is 1.

**USCBFAL bit (GTIOCnB Pin Falling Input during GTIOCnA Value Low Source Counter Count Up Enable)**

The USCBFAL bit enables or disables the GTCNT counter count up on the falling edge of the GTIOCnB pin input, when the GTIOCnA input is 0.

**USCBFAH bit (GTIOCnB Pin Falling Input during GTIOCnA Value High Source Counter Count Up Enable)**

The USCBFAH bit enables or disables the GTCNT counter count up on the falling edge of the GTIOCnB pin input, when the GTIOCnA input is 1.

**USELCm bit (ELC\_GPTm Event Source Counter Count Up Enable) (m = A to H)**

The USELCm bit enables or disables the GTCNT counter count up at the ELC\_GPTm event input.

**21.2.9 GTDNSR : General PWM Timer Down Count Source Select Register**

Base address: GPT32n = 0x4016\_9000 + 0x0100 × n (n = 0 to 3)  
GPT16m = 0x4016\_9000 + 0x0100 × m (m = 4 to 7)

Offset address: 0x20

| Bit position:      | 31 | 30 | 29 | 28 | 27 | 26 | 25 | 24 | 23      | 22      | 21      | 20      | 19      | 18      | 17      | 16      |
|--------------------|----|----|----|----|----|----|----|----|---------|---------|---------|---------|---------|---------|---------|---------|
| Bit field:         | —  | —  | —  | —  | —  | —  | —  | —  | DSEL CH | DSEL CG | DSEL CF | DSEL CE | DSEL CD | DSEL CC | DSEL CB | DSEL CA |
| Value after reset: | 0  | 0  | 0  | 0  | 0  | 0  | 0  | 0  | 0       | 0       | 0       | 0       | 0       | 0       | 0       | 0       |
| Bit position:      | 15 | 14 | 13 | 12 | 11 | 10 | 9  | 8  | 7       | 6       | 5       | 4       | 3       | 2       | 1       | 0       |

**USGTRGCF位 (GTETRG C引脚下降输入源计数器向上计数使能)**

USGTRGCF位在GTETRG C引脚输入的下降沿启用或禁用GTCNT计数器向上计数。

**USGTRGDR位 (GTETRG D引脚上升沿输入源计数器向上计数使能)**

USGTRGDR位在GTETRG D引脚输入的上升沿启用或禁用GTCNT计数器向上计数。

**USGTRGDF位 (GTETRG D引脚下降输入源计数器向上计数使能)**

USGTRGDF位在GTETRG D引脚输入的下降沿启用或禁用GTCNT计数器向上计数。

**USCARBL位 (GTIOCnB值低电平期间的GTIOCnA引脚上升沿输入源计数器向上计数使能)**

USCARBL位在GTIOCnA引脚输入的上升沿启用或禁用GTCNT计数器向上计数，当GTIOCnB输入为0。

**USCARBH位 (GTIOCnB值高电平期间的GTIOCnA引脚上升沿输入源计数器向上计数使能)**

USCARBH位在GTIOCnA引脚输入的上升沿启用或禁用GTCNT计数器向上计数，当GTIOCnB输入为1。

**USCAFBL位 (GTIOCnB值低电平源计数器向上计数启用期间的GTIOCnA引脚下降输入)**

USCAFBL位在GTIOCnA引脚输入的下降沿启用或禁用GTCNT计数器向上计数，当GTIOCnB输入为0。

**USCAFBL位 (GTIOCnB值高电平期间GTIOCnA引脚下降输入源计数器向上计数使能)**

USCAFBL位在GTIOCnA引脚输入的下降沿启用或禁用GTCNT计数器向上计数，当GTIOCnB输入为1。

**USCBRAL位 (GTIOCnA值低电平源计数器向上计数启用期间的GTIOCnB引脚上升沿输入)**

USCBRAL位在GTIOCnB引脚输入的上升沿启用或禁用GTCNT计数器向上计数，当GTIOCnA输入为0。

**USCBRAH位 (GTIOCnA值高电平期间GTIOCnB引脚上升沿输入源计数器向上计数使能)**

当GTIOCnA输入为1时，USCBRAH位在GTIOCnB引脚输入的上升沿启用或禁用GTCNT计数器向上计数。

**USCBFAL位 (GTIOCnA值低电平源计数器向上计数启用期间的GTIOCnB引脚下降输入)**

当GTIOCnA输入为0时，USCBFAL位在GTIOCnB引脚输入的下降沿启用或禁用GTCNT计数器向上计数。

**USCBFAH位 (GTIOCnA值高电平期间的GTIOCnB引脚下降输入源计数器向上计数使能)**

当GTIOCnA输入为1时，USCBFAH位在GTIOCnB引脚输入的下降沿启用或禁用GTCNT计数器向上计数。

**USELCm位 (ELC\_GPTm事件源计数器向上计数启用) (m=A到H)**

USELCm位在ELC\_GPTm事件输入处启用或禁用GTCNT计数器向上计数。

**21.2.9 GTDNSR: 通用PWM定时器递减计数源选择寄存器**

Base address: GPT32n = 0x4016\_9000 + 0x0100 × n (n = 0 to 3)  
GPT16m = 0x4016\_9000 + 0x0100 × m (m = 4 to 7)

Offset address: 0x20

| Bit position: | 31 | 30 | 29 | 28 | 27 | 26 | 25 | 24 | 23      | 22      | 21      | 20      | 19      | 18      | 17      | 16      |
|---------------|----|----|----|----|----|----|----|----|---------|---------|---------|---------|---------|---------|---------|---------|
| Bit field:    | —  | —  | —  | —  | —  | —  | —  | —  | DSEL CH | DSEL CG | DSEL CF | DSEL CE | DSEL CD | DSEL CC | DSEL CB | DSEL CA |
| 重置后的值:        | 0  | 0  | 0  | 0  | 0  | 0  | 0  | 0  | 0       | 0       | 0       | 0       | 0       | 0       | 0       | 0       |
| Bit position: | 15 | 14 | 13 | 12 | 11 | 10 | 9  | 8  | 7       | 6       | 5       | 4       | 3       | 2       | 1       | 0       |



|                    |             |             |             |             |             |             |             |             |              |              |              |              |              |              |              |              |
|--------------------|-------------|-------------|-------------|-------------|-------------|-------------|-------------|-------------|--------------|--------------|--------------|--------------|--------------|--------------|--------------|--------------|
| Bit field:         | DSCB<br>FAH | DSCB<br>FAL | DSCB<br>RAH | DSCB<br>RAL | DSCA<br>FBH | DSCA<br>FBL | DSCA<br>RBH | DSCA<br>RBL | DSGT<br>RGDF | DSGT<br>RGDR | DSGT<br>RGCF | DSGT<br>RGCR | DSGT<br>RGBF | DSGT<br>RGBR | DSGT<br>RGAF | DSGT<br>RGAR |
| Value after reset: | 0           | 0           | 0           | 0           | 0           | 0           | 0           | 0           | 0            | 0            | 0            | 0            | 0            | 0            | 0            | 0            |

| Bit | Symbol   | Function  | R/W |
|-----|----------|---|-----|
| 0   | DSGTRGAR | GTETRG A Pin Rising Input Source Counter Count Down Enable<br>0: Counter count down disabled on the rising edge of GTETRG A input<br>1: Counter count down enabled on the rising edge of GTETRG A input   | R/W |
| 1   | DSGTRGAF | GTETRG A Pin Falling Input Source Counter Count Down Enable<br>0: Counter count down disabled on the falling edge of GTETRG A input<br>1: Counter count down enabled on the falling edge of GTETRG A input  | R/W |
| 2   | DSGTRGBR | GTETRG B Pin Rising Input Source Counter Count Down Enable<br>0: Counter count down disabled on the rising edge of GTETRG B input<br>1: Counter count down enabled on the rising edge of GTETRG B input   | R/W |
| 3   | DSGTRGBF | GTETRG B Pin Falling Input Source Counter Count Down Enable<br>0: Counter count down disabled on the falling edge of GTETRG B input<br>1: Counter count down enabled on the falling edge of GTETRG B input  | R/W |
| 4   | DSGTRGCR | GTETRG C Pin Rising Input Source Counter Count Down Enable<br>0: Counter count down disabled on the rising edge of GTETRG C input<br>1: Counter count down enabled on the rising edge of GTETRG C input   | R/W |
| 5   | DSGTRGCF | GTETRG C Pin Falling Input Source Counter Count Down Enable<br>0: Counter count down disabled on the falling edge of GTETRG C input<br>1: Counter count down enabled on the falling edge of GTETRG C input  | R/W |
| 6   | DSGTRGDR | GTETRG D Pin Rising Input Source Counter Count Down Enable<br>0: Counter count down disabled on the rising edge of GTETRG D input<br>1: Counter count down enabled on the rising edge of GTETRG D input   | R/W |
| 7   | DSGTRGDF | GTETRG D Pin Falling Input Source Counter Count Down Enable<br>0: Counter count down disabled on the falling edge of GTETRG D input<br>1: Counter count down enabled on the falling edge of GTETRG D input  | R/W |
| 8   | DSCARBL  | GTIOCn A Pin Rising Input during GTIOCn B Value Low Source Counter Count Down Enable<br>0: Counter count down disabled on the rising edge of GTIOCn A input when GTIOCn B input is 0<br>1: Counter count down enabled on the rising edge of GTIOCn A input when GTIOCn B input is 0     | R/W |
| 9   | DSCARBH  | GTIOCn A Pin Rising Input during GTIOCn B Value High Source Counter Count Down Enable<br>0: Counter count down disabled on the rising edge of GTIOCn A input when GTIOCn B input is 1<br>1: Counter count down enabled on the rising edge of GTIOCn A input when GTIOCn B input is 1    | R/W |
| 10  | DSCAFBL  | GTIOCn A Pin Falling Input during GTIOCn B Value Low Source Counter Count Down Enable<br>0: Counter count down disabled on the falling edge of GTIOCn A input when GTIOCn B input is 0<br>1: Counter count down enabled on the falling edge of GTIOCn A input when GTIOCn B input is 0  | R/W |
| 11  | DSCAFBH  | GTIOCn A Pin Falling Input during GTIOCn B Value High Source Counter Count Down Enable<br>0: Counter count down disabled on the falling edge of GTIOCn A input when GTIOCn B input is 1<br>1: Counter count down enabled on the falling edge of GTIOCn A input when GTIOCn B input is 1 | R/W |
| 12  | DSCBRAL  | GTIOCn B Pin Rising Input during GTIOCn A Value Low Source Counter Count Down Enable<br>0: Counter count down disabled on the rising edge of GTIOCn B input when GTIOCn A input is 0<br>1: Counter count down enabled on the rising edge of GTIOCn B input when GTIOCn A input is 0     | R/W |

|            |             |             |             |             |             |             |             |             |              |              |              |              |              |              |              |              |
|------------|-------------|-------------|-------------|-------------|-------------|-------------|-------------|-------------|--------------|--------------|--------------|--------------|--------------|--------------|--------------|--------------|
| Bit field: | DSCB<br>FAH | DSCB<br>FAL | DSCB<br>RAH | DSCB<br>RAL | DSCA<br>FBH | DSCA<br>FBL | DSCA<br>RBH | DSCA<br>RBL | DSGT<br>RGDF | DSGT<br>RGDR | DSGT<br>RGCF | DSGT<br>RGCR | DSGT<br>RGBF | DSGT<br>RGBR | DSGT<br>RGAF | DSGT<br>RGAR |
| 重置后的值:     | 0           | 0           | 0           | 0           | 0           | 0           | 0           | 0           | 0            | 0            | 0            | 0            | 0            | 0            | 0            | 0            |

| Bit | Symbol   | Function  | R/W |
|-----|----------|---|-----|
| 0   | DSGTRGAR | GTETRG A引脚上升输入源计数器倒计时使能<br>0: 在GTETRG A输入的上升沿禁用计数器递减计数1: 在GTETRG A输入的上升沿启用计数器递减计数   | R/W |
| 1   | DSGTRGAF | GTETRG A引脚下降输入源计数器倒计时使能<br>0: 在GTETRG A输入的下降沿禁用计数器递减计数1: 在GTETRG A输入的下降沿启用计数器递减计数   | R/W |
| 2   | DSGTRGBR | GTETRG B引脚上升输入源计数器倒计时使能<br>0: 在GTETRG B输入的上升沿禁用计数器递减计数1: 在GTETRG B输入的上升沿启用计数器递减计数   | R/W |
| 3   | DSGTRGBF | GTETRG B引脚下降输入源计数器倒计时使能<br>0: 在GTETRG B输入的下降沿禁用计数器递减计数1: 在GTETRG B输入的下降沿启用计数器递减计数   | R/W |
| 4   | DSGTRGCR | GTETRG C引脚上升输入源计数器倒计时使能<br>0: 在GTETRG C输入的上升沿禁用计数器递减计数1: 在GTETRG C输入的上升沿启用计数器递减计数   | R/W |
| 5   | DSGTRGCF | GTETRG C引脚下降输入源计数器倒计时使能<br>0: 在GTETRG C输入的下降沿禁用计数器递减计数1: 在GTETRG C输入的下降沿启用计数器递减计数   | R/W |
| 6   | DSGTRGDR | GTETRG D引脚上升输入源计数器倒计时使能<br>0: 在GTETRG D输入的上升沿禁用计数器递减计数1: 在GTETRG D输入的上升沿启用计数器递减计数   | R/W |
| 7   | DSGTRGDF | GTETRG D引脚下降输入源计数器倒计时使能<br>0: 在GTETRG D输入的下降沿禁用计数器递减计数1: 在GTETRG D输入的下降沿启用计数器递减计数   | R/W |
| 8   | DSCARBL  | GTIOCn B值低电平期间的GTIOCn A引脚上升输入源计数器向下计数 Enable<br>0: 当GTIOCn B输入为0时, 在GTIOCn A输入的上升沿禁止计数器递减计数<br>1: 当GTIOCn B输入为0时, 在GTIOCn A输入上升沿使能计数器递减计数 | R/W |
| 9   | DSCARBH  | GTIOCn B值高电平期间的GTIOCn A引脚上升输入源计数器向下计数 Enable<br>0: 当GTIOCn B输入为1时, 在GTIOCn A输入的上升沿禁止计数器递减计数<br>1: 当GTIOCn B输入为1时, 在GTIOCn A输入上升沿使能计数器递减计数 | R/W |
| 10  | DSCAFBL  | GTIOCn B值低源计数器倒计时期间的GTIOCn A引脚下降输入 Enable<br>0: 当GTIOCn B输入为0时, 在GTIOCn A输入的下降沿禁止计数器递减计数<br>1: 当GTIOCn B输入为0时, 在GTIOCn A输入下降沿使能计数器递减计数    | R/W |
| 11  | DSCAFBH  | GTIOCn B值高电平期间的GTIOCn A引脚下降输入源计数器倒计时 Enable<br>0: 当GTIOCn B输入为1时, 在GTIOCn A输入的下降沿禁止计数器递减计数<br>1: 当GTIOCn B输入为1时, 在GTIOCn A输入下降沿使能计数器递减计数  | R/W |
| 12  | DSCBRAL  | GTIOCn A值低电平期间的GTIOCn B引脚上升输入源计数器向下计数 Enable<br>0: 当GTIOCn A输入为0时, 在GTIOCn B输入的上升沿禁止计数器递减计数<br>1: 当GTIOCn A输入为0时, 在GTIOCn B输入上升沿使能计数器递减计数 | R/W |

| Bit   | Symbol  | Function  | R/W |
|-------|---------|---|-----|
| 13    | DSCBRAH | GTIOCnB Pin Rising Input during GTIOCnA Value High Source Counter Count Down Enable<br>0: Counter count down disabled on the rising edge of GTIOCnB input when GTIOCnA input is 1<br>1: Counter count down enabled on the rising edge of GTIOCnB input when GTIOCnA input is 1    | R/W |
| 14    | DSCBFAL | GTIOCnB Pin Falling Input during GTIOCnA Value Low Source Counter Count Down Enable<br>0: Counter count down disabled on the falling edge of GTIOCnB input when GTIOCnA input is 0<br>1: Counter count down enabled on the falling edge of GTIOCnB input when GTIOCnA input is 0  | R/W |
| 15    | DSCBFAH | GTIOCnB Pin Falling Input during GTIOCnA Value High Source Counter Count Down Enable<br>0: Counter count down disabled on the falling edge of GTIOCnB input when GTIOCnA input is 1<br>1: Counter count down enabled on the falling edge of GTIOCnB input when GTIOCnA input is 1 | R/W |
| 16    | DSELCA  | ELC_GPTA Event Source Counter Count Down Enable<br>0: Counter count down disabled at the ELC_GPTA input<br>1: Counter count down enabled at the ELC_GPTA input  | R/W |
| 17    | DSELCB  | ELC_GPTB Event Source Counter Count Down Enable<br>0: Counter count down disabled at the ELC_GPTB input<br>1: Counter count down enabled at the ELC_GPTB input  | R/W |
| 18    | DSELCC  | ELC_GPTC Event Source Counter Count Down Enable<br>0: Counter count down disabled at the ELC_GPTC input<br>1: Counter count down enabled at the ELC_GPTC input  | R/W |
| 19    | DSELCD  | ELC_GPTD Event Source Counter Count Down Enable<br>0: Counter count down disabled at the ELC_GPTD input<br>1: Counter count down enabled at the ELC_GPTD input  | R/W |
| 20    | DSELCE  | ELC_GPTE Event Source Counter Count Down Enable<br>0: Counter count down disabled at the ELC_GPTE input<br>1: Counter count down enabled at the ELC_GPTE input  | R/W |
| 21    | DSELCF  | ELC_GPTF Event Source Counter Count Down Enable<br>0: Counter count down disabled at the ELC_GPTF input<br>1: Counter count down enabled at the ELC_GPTF input  | R/W |
| 22    | DSELCG  | ELC_GPTG Event Source Counter Count Down Enable<br>0: Counter count down disabled at the ELC_GPTG input<br>1: Counter count down enabled at the ELC_GPTG input  | R/W |
| 23    | DSELCH  | ELC_GPTF Event Source Counter Count Down Enable<br>0: Counter count down disabled at the ELC_GPTF input<br>1: Counter count down enabled at the ELC_GPTF input  | R/W |
| 31:24 | —       | These bits are read as 0. The write value should be 0.  | R/W |

The GTDNSR sets the source to count down the GTCNT counter.

When at least one bit in the GTDNSR register is set to 1, the GTCNT counter is counted down by the source that is set to 1 in this register. In this case, GTCR.TPCS has no effect.

#### DSGTRGAR bit (GTETRGA Pin Rising Input Source Counter Count Down Enable)

The DSGTRGAR bit enables or disables the GTCNT counter count down on the rising edge of the GTETRGA pin input.

#### DSGTRGAF bit (GTETRGA Pin Falling Input Source Counter Count Down Enable)

The DSGTRGAF bit enables or disables the GTCNT counter count down on the falling edge of the GTETRGA pin input.

#### DSGTRGBR bit (GTETRGB Pin Rising Input Source Counter Count Down Enable)

The DSGTRGBR bit enables or disables the GTCNT counter count down on the rising edge of the GTETRGB pin input.

| Bit   | Symbol  | Function   | R/W |
|-------|---------|--|-----|
| 13    | DSCBRAH | GTIOCnA值高电平期间的GTIOCnB引脚上升沿输入源计数器向下计数 Enable<br>0: 当GTIOCnA输入为1时, 在GTIOCnB输入的上升沿禁止计数器递减计数<br>1: 当GTIOCnA输入为1时, 在GTIOCnB输入上升沿使能计数器递减计数 | R/W |
| 14    | DSCBFAL | GTIOCnA值低源计数器倒计时的GTIOCnB引脚下降输入 Enable<br>0: 当GTIOCnA输入为0时, 在GTIOCnB输入的下沿禁止计数器递减计数<br>1: 当GTIOCnA输入为0时, 在GTIOCnB输入下降沿使能计数器递减计数        | R/W |
| 15    | DSCBFAH | GTIOCnA值高电平期间的GTIOCnB引脚下降输入源计数器倒计 Enable<br>0: 当GTIOCnA输入为1时, 在GTIOCnB输入的下沿禁止计数器递减计数<br>1: 当GTIOCnA输入为1时, 在GTIOCnB输入下降沿使能计数器递减计数     | R/W |
| 16    | DSELCA  | ELC_GPTA事件源计数器倒计启用<br>0: 在ELC_GPTA输入处禁用计数器递减计数1: 在ELC_GPTA输入处启用计数器递减计数   | R/W |
| 17    | DSELCB  | ELC_GPTB事件源计数器倒计启用<br>0: 在ELC_GPTB输入处禁用计数器递减计数1: 在ELC_GPTB输入处启用计数器递减计数   | R/W |
| 18    | DSELCC  | ELC_GPTC事件源计数器倒计使能<br>0: 在ELC_GPTC输入处禁用计数器递减计数1: 在ELC_GPTC输入处启用计数器递减计数   | R/W |
| 19    | DSELCD  | ELC_GPTD事件源计数器倒计启用<br>0: 在ELC_GPTD输入处禁用计数器递减计数1: 在ELC_GPTD输入处启用计数器递减计数   | R/W |
| 20    | DSELCE  | ELC_GPTE事件源计数器倒计启用<br>0: 在ELC_GPTE输入处禁用计数器递减计数1: 在ELC_GPTE输入处启用计数器递减计数   | R/W |
| 21    | DSELCF  | ELC_GPTF事件源计数器倒计启用<br>0: 在ELC_GPTF输入处禁用计数器递减计数1: 在ELC_GPTF输入处启用计数器递减计数   | R/W |
| 22    | DSELCG  | ELC_GPTG事件源计数器倒计使能<br>0: 在ELC_GPTG输入处禁用计数器递减计数1: 在ELC_GPTG输入处启用计数器递减计数   | R/W |
| 23    | DSELCH  | ELC_GPTF事件源计数器倒计启用<br>0: 在ELC_GPTF输入处禁用计数器递减计数1: 在ELC_GPTF输入处启用计数器递减计数   | R/W |
| 31:24 | —       | 这些位被读取为0。写入值应为0。   | R/W |

GTDNSR将源设置为对GTCNT计数器进行倒计时。

当GTDNSR寄存器中的至少一位设置为1时, GTCNT计数器由该寄存器中设置为1的源进行倒数计数。在这种情况下, GTCR.TPCS无效。

#### DSGTRGAR位 (GTETRGA引脚上升沿输入源计数器倒计使能)

DSGTRGAR位在GTETRGA引脚输入的上升沿启用或禁用GTCNT计数器倒计。

#### DSGTRGAF位 (GTETRGA引脚下降输入源计数器倒计使能)

DSGTRGAF位在GTETRGA引脚输入的下沿启用或禁用GTCNT计数器倒计。

#### DSGTRGBR位 (GTETRGB引脚上升输入源计数器倒计使能)

DSGTRGBR位在GTETRGB引脚输入的上升沿启用或禁用GTCNT计数器倒计。



**DSGTRGBF bit (GTETRGB Pin Falling Input Source Counter Count Down Enable)**

The DSGTRGBF bit enables or disables the GTCNT counter count down on the falling edge of the GTETRGB pin input.

**DSGTRGCR bit (GTETRGC Pin Rising Input Source Counter Count Down Enable)**

The DSGTRGCR bit enables or disables the GTCNT counter count down on the rising edge of the GTETRGC pin input.

**DSGTRGCF bit (GTETRGC Pin Falling Input Source Counter Count Down Enable)**

The DSGTRGCF bit enables or disables the GTCNT counter count down on the falling edge of the GTETRGC pin input.

**DSGTRGDR bit (GTETRGD Pin Rising Input Source Counter Count Down Enable)**

The DSGTRGDR bit enables or disables the GTCNT counter count down on the rising edge of the GTETRGD pin input.

**DSGTRGDF bit (GTETRGD Pin Falling Input Source Counter Count Down Enable)**

The DSGTRGDF bit enables or disables the GTCNT counter count down on the falling edge of the GTETRGD pin input.

**DSCARBL bit (GTIOCnA Pin Rising Input during GTIOCnB Value Low Source Counter Count Down Enable)**

The DSCARBL bit enables or disables the GTCNT counter count down on the rising edge of the GTIOCnA pin input, when the GTIOCnB input is 0.

**DSCARBH bit (GTIOCnA Pin Rising Input during GTIOCnB Value High Source Counter Count Down Enable)**

The DSCARBH bit enables or disables the GTCNT counter count down on the rising edge of the GTIOCnA pin input, when GTIOCnB input is 1.

**DSCAFBL bit (GTIOCnA Pin Falling Input during GTIOCnB Value Low Source Counter Count Down Enable)**

The DSCAFBL bit enables or disables the GTCNT counter count down on the falling edge of the GTIOCnA pin input, when GTIOCnB input is 0.

**DSCAFBH bit (GTIOCnA Pin Falling Input during GTIOCnB Value High Source Counter Count Down Enable)**

The DSCAFBH bit enables or disables the GTCNT counter count down on the falling edge of the GTIOCnA pin input, when GTIOCnB input is 1.

**DSCBRAL bit (GTIOCnB Pin Rising Input during GTIOCnA Value Low Source Counter Count Down Enable)**

The DSCBRAL bit enables or disables the GTCNT counter count down on the rising edge of the GTIOCnB pin input, when GTIOCnA input is 0.

**DSCBRAH bit (GTIOCnB Pin Rising Input during GTIOCnA Value High Source Counter Count Down Enable)**

The DSCBRAH bit enables or disables the GTCNT counter count down on the rising edge of GTIOCnB pin input, when GTIOCnA input is 1.

**DSCBFAL bit (GTIOCnB Pin Falling Input during GTIOCnA Value Low Source Counter Count Down Enable)**

The DSCBFAL bit enables or disables the GTCNT counter count down on the falling edge of the GTIOCnB pin input, when GTIOCnA input is 0.

**DSCBFAH bit (GTIOCnB Pin Falling Input during GTIOCnA Value High Source Counter Count Down Enable)**

The DSCBFAH bit enables or disables the GTCNT counter count down on the falling edge of the GTIOCnB pin input, when GTIOCnA input is 1.

**DSGTRGBF位 (GTETRGB引脚下降输入源计数器倒计时使能)**

DSGTRGBF位在GTETRGB引脚输入的下降沿启用或禁用GTCNT计数器倒计时。

**DSGTRGCR位 (GTETRGC引脚上升沿输入源计数器向下计数使能)**

DSGTRGCR位在GTETRGC引脚输入的上升沿启用或禁用GTCNT计数器倒计时。

**DSGTRGCF位 (GTETRGC引脚下降输入源计数器倒计时使能)**

DSGTRGCF位在GTETRGC引脚输入的下降沿启用或禁用GTCNT计数器倒计时。

**DSGTRGDR位 (GTETRGD引脚上升沿输入源计数器倒计时使能)**

DSGTRGDR位在GTETRGD引脚输入的上升沿启用或禁用GTCNT计数器倒计时。

**DSGTRGDF位 (GTETRGD引脚下降输入源计数器倒计时使能)**

DSGTRGDF位在GTETRGD引脚输入的下降沿启用或禁用GTCNT计数器倒计时。

**DSCARBL位 (GTIOCnB值低电平期间GTIOCnA引脚上升沿输入源计数器向下计数使能)**

当GTIOCnB输入为0时，DSCARBL位在GTIOCnA引脚输入的上升沿启用或禁用GTCNT计数器倒计时。

**DSCARBH位 (GTIOCnB值高电平期间GTIOCnA引脚上升沿输入源计数器向下计数使能)**

DSCARBH位在GTIOCnA引脚输入的上升沿启用或禁用GTCNT计数器倒计时，当GTIOCnB输入为1。

**DSCAFBL位 (GTIOCnB值低电平期间GTIOCnA引脚下降输入源计数器倒计时使能)**

当GTIOCnB输入为0时，DSCAFBL位在GTIOCnA引脚输入的下降沿启用或禁用GTCNT计数器倒计时。

**DSCAFBH位 (GTIOCnB值高电平期间GTIOCnA引脚下降输入源计数器向下计数使能)**

当GTIOCnB输入为1时，DSCAFBH位在GTIOCnA引脚输入的下降沿启用或禁用GTCNT计数器倒计时。

**DSCBRAL位 (GTIOCnA值低电平期间的GTIOCnB引脚上升沿输入源计数器向下计数使能)**

DSCBRAL位在GTIOCnB引脚输入的上升沿启用或禁用GTCNT计数器倒计时，当GTIOCnA输入为0。

**DSCBRAH位 (GTIOCnA值高电平期间GTIOCnB引脚上升沿输入源计数器向下计数使能)**

DSCBRAH位在GTIOCnB引脚输入的上升沿启用或禁用GTCNT计数器倒计时，当GTIOCnA输入为1。

**DSCBFAL位 (GTIOCnA值低电平期间GTIOCnB引脚下降输入源计数器向下计数使能)**

DSCBFAL位在GTIOCnB引脚输入的下降沿启用或禁用GTCNT计数器倒计时，当GTIOCnA输入为0。

**DSCBFAH位 (GTIOCnA值高电平期间GTIOCnB引脚下降输入源计数器倒计时使能)**

当GTIOCnA输入为1时，DSCBFAH位在GTIOCnB引脚输入的下降沿启用或禁用GTCNT计数器倒计时。

**DSELCm bit (ELC\_GPTm Event Source Counter Count Down Enable) (m = A to H)**

The DSELCm bit enables or disables the GTCNT counter count down at the ELC\_GPTm event input.

**21.2.10 GTICASR : General PWM Timer Input Capture Source Select Register A**

Base address: GPT32n = 0x4016\_9000 + 0x0100 × n (n = 0 to 3)  
GPT16m = 0x4016\_9000 + 0x0100 × m (m = 4 to 7)

Offset address: 0x24

|                    |          |          |          |          |          |          |          |          |           |           |           |           |           |           |           |           |
|--------------------|----------|----------|----------|----------|----------|----------|----------|----------|-----------|-----------|-----------|-----------|-----------|-----------|-----------|-----------|
| Bit position:      | 31       | 30       | 29       | 28       | 27       | 26       | 25       | 24       | 23        | 22        | 21        | 20        | 19        | 18        | 17        | 16        |
| Bit field:         | —        | —        | —        | —        | —        | —        | —        | —        | ASEL CH   | ASEL CG   | ASEL CF   | ASEL CE   | ASEL CD   | ASEL CC   | ASEL CB   | ASEL CA   |
| Value after reset: | 0        | 0        | 0        | 0        | 0        | 0        | 0        | 0        | 0         | 0         | 0         | 0         | 0         | 0         | 0         | 0         |
| Bit position:      | 15       | 14       | 13       | 12       | 11       | 10       | 9        | 8        | 7         | 6         | 5         | 4         | 3         | 2         | 1         | 0         |
| Bit field:         | ASCB FAH | ASCB FAL | ASCB RAH | ASCB RAL | ASCA FBH | ASCA FBL | ASCA RBH | ASCA RBL | ASGT RGDF | ASGT RGDR | ASGT RGCF | ASGT RGCR | ASGT RGBF | ASGT RGBR | ASGT RGAF | ASGT RGAR |
| Value after reset: | 0        | 0        | 0        | 0        | 0        | 0        | 0        | 0        | 0         | 0         | 0         | 0         | 0         | 0         | 0         | 0         |

| Bit | Symbol   | Function  | R/W |
|-----|----------|---|-----|
| 0   | ASGTRGAR | GTETRG A Pin Rising Input Source GTCRA Input Capture Enable<br>0: GTCRA input capture disabled on the rising edge of GTETRG A input<br>1: GTCRA input capture enabled on the rising edge of GTETRG A input  | R/W |
| 1   | ASGTRGAF | GTETRG A Pin Falling Input Source GTCRA Input Capture Enable<br>0: GTCRA input capture disabled on the falling edge of GTETRG A input<br>1: GTCRA input capture enabled on the falling edge of GTETRG A input   | R/W |
| 2   | ASGTRGBR | GTETRG B Pin Rising Input Source GTCRA Input Capture Enable<br>0: GTCRA input capture disabled on the rising edge of GTETRG B input<br>1: GTCRA input capture enabled on the rising edge of GTETRG B input  | R/W |
| 3   | ASGTRGBF | GTETRG B Pin Falling Input Source GTCRA Input Capture Enable<br>0: GTCRA input capture disabled on the falling edge of GTETRG B input<br>1: GTCRA input capture enabled on the falling edge of GTETRG B input   | R/W |
| 4   | ASGTRGCR | GTETRG C Pin Rising Input Source GTCRA Input Capture Enable<br>0: GTCRA input capture disabled on the rising edge of GTETRG C input<br>1: GTCRA input capture enabled on the rising edge of GTETRG C input  | R/W |
| 5   | ASGTRGCF | GTETRG C Pin Falling Input Source GTCRA Input Capture Enable<br>0: GTCRA input capture disabled on the falling edge of GTETRG C input<br>1: GTCRA input capture enabled on the falling edge of GTETRG C input   | R/W |
| 6   | ASGTRGDR | GTETRG D Pin Rising Input Source GTCRA Input Capture Enable<br>0: GTCRA input capture disabled on the rising edge of GTETRG D input<br>1: GTCRA input capture enabled on the rising edge of GTETRG D input  | R/W |
| 7   | ASGTRGDF | GTETRG D Pin Falling Input Source GTCRA Input Capture Enable<br>0: GTCRA input capture disabled on the falling edge of GTETRG D input<br>1: GTCRA input capture enabled on the falling edge of GTETRG D input   | R/W |
| 8   | ASCARBL  | GTIOCn A Pin Rising Input during GTIOCn B Value Low Source GTCRA Input Capture Enable<br>0: GTCRA input capture disabled on the rising edge of GTIOCn A input when GTIOCn B input is 0<br>1: GTCRA input capture enabled on the rising edge of GTIOCn A input when GTIOCn B input is 0  | R/W |
| 9   | ASCARBH  | GTIOCn A Pin Rising Input during GTIOCn B Value High Source GTCRA Input Capture Enable<br>0: GTCRA input capture disabled on the rising edge of GTIOCn A input when GTIOCn B input is 1<br>1: GTCRA input capture enabled on the rising edge of GTIOCn A input when GTIOCn B input is 1 | R/W |

**DSELCm位 (ELC\_GPTm事件源计数器倒计时启用) (m=A到H)**

DSELCm位在ELC\_GPTm事件输入处启用或禁用GTCNT计数器倒计时。

**21.2.10 GTICASR: 通用PWM定时器输入捕捉源选择寄存器A**

Base address: GPT32n = 0x4016\_9000 + 0x0100 × n (n = 0 to 3)  
GPT16m = 0x4016\_9000 + 0x0100 × m (m = 4 to 7)

Offset address: 0x24

|               |          |          |          |          |          |          |          |          |           |           |           |           |           |           |           |           |
|---------------|----------|----------|----------|----------|----------|----------|----------|----------|-----------|-----------|-----------|-----------|-----------|-----------|-----------|-----------|
| Bit position: | 31       | 30       | 29       | 28       | 27       | 26       | 25       | 24       | 23        | 22        | 21        | 20        | 19        | 18        | 17        | 16        |
| Bit field:    | —        | —        | —        | —        | —        | —        | —        | —        | ASEL CH   | ASEL CG   | ASEL CF   | ASEL CE   | ASEL CD   | ASEL CC   | ASEL CB   | ASEL CA   |
| 重置后的值:        | 0        | 0        | 0        | 0        | 0        | 0        | 0        | 0        | 0         | 0         | 0         | 0         | 0         | 0         | 0         | 0         |
| Bit position: | 15       | 14       | 13       | 12       | 11       | 10       | 9        | 8        | 7         | 6         | 5         | 4         | 3         | 2         | 1         | 0         |
| Bit field:    | ASCB FAH | ASCB FAL | ASCB RAH | ASCB RAL | ASCA FBH | ASCA FBL | ASCA RBH | ASCA RBL | ASGT RGDF | ASGT RGDR | ASGT RGCF | ASGT RGCR | ASGT RGBF | ASGT RGBR | ASGT RGAF | ASGT RGAR |
| 重置后的值:        | 0        | 0        | 0        | 0        | 0        | 0        | 0        | 0        | 0         | 0         | 0         | 0         | 0         | 0         | 0         | 0         |

| Bit | Symbol   | Function   | R/W |
|-----|----------|--|-----|
| 0   | ASGTRGAR | GTETRG A引脚上升输入源GTCRA输入捕捉使能<br>0: 在GTETRG A输入的上升沿禁用GTCRA输入捕捉1: 在GTETRG A输入的上升沿启用GTCRA输入捕捉   | R/W |
| 1   | ASGTRGAF | GTETRG A引脚下降输入源GTCRA输入捕捉使能<br>0: 在GTETRG A输入的下降沿禁用GTCRA输入捕捉1: 在GTETRG A输入的下降沿启用GTCRA输入捕捉   | R/W |
| 2   | ASGTRGBR | GTETRG B引脚上升输入源GTCRA输入捕捉使能<br>0: 在GTETRG B输入的上升沿禁用GTCRA输入捕捉1: 在GTETRG B输入的上升沿启用GTCRA输入捕捉   | R/W |
| 3   | ASGTRGBF | GTETRG B引脚下降输入源GTCRA输入捕捉使能<br>0: 在GTETRG B输入的下降沿禁用GTCRA输入捕捉1: 在GTETRG B输入的下下降沿启用GTCRA输入捕捉  | R/W |
| 4   | ASGTRGCR | GTETRG C引脚上升沿输入源GTCRA输入捕捉使能<br>0: 在GTETRG C输入的上升沿禁用GTCRA输入捕捉1: 在GTETRG C输入的上升沿启用GTCRA输入捕捉  | R/W |
| 5   | ASGTRGCF | GTETRG C引脚下降输入源GTCRA输入捕捉使能<br>0: 在GTETRG C输入的下降沿禁用GTCRA输入捕捉1: 在GTETRG C输入的下下降沿启用GTCRA输入捕捉  | R/W |
| 6   | ASGTRGDR | GTETRG D引脚上升沿输入源GTCRA输入捕捉使能<br>0: 在GTETRG D输入的上升沿禁用GTCRA输入捕捉1: 在GTETRG D输入的上升沿启用GTCRA输入捕捉  | R/W |
| 7   | ASGTRGDF | GTETRG D引脚下降输入源GTCRA输入捕捉使能<br>0: 在GTETRG D输入的下降沿禁用GTCRA输入捕捉1: 在GTETRG D输入的下下降沿启用GTCRA输入捕捉  | R/W |
| 8   | ASCARBL  | GTIOCn B值低电平期间的GTIOCn A引脚上升沿输入源GTCRA输入捕捉使能<br>0: 当GTIOCn B输入为0时, 在GTIOCn A输入的上升沿禁止GTCRA输入捕捉<br>1: 当GTIOCn B输入为0时, 在GTIOCn A输入的上升沿使能GTCRA输入捕捉 | R/W |
| 9   | ASCARBH  | GTIOCn B值高电平期间的GTIOCn A引脚上升沿输入源GTCRA输入捕捉使能<br>0: 当GTIOCn B输入为1时, 在GTIOCn A输入的上升沿禁止GTCRA输入捕捉<br>1: 当GTIOCn B输入为1时, 在GTIOCn A输入的上升沿使能GTCRA输入捕捉 | R/W |

| Bit | Symbol  | Function  | R/W |
|-----|---------|---|-----|
| 10  | ASCAFBL | GTIOcNA Pin Falling Input during GTIOcNB Value Low Source GTCCRA Input Capture Enable<br>0: GTCCRA input capture disabled on the falling edge of GTIOcNA input when GTIOcNB input is 0<br>1: GTCCRA input capture enabled on the falling edge of GTIOcNA input when GTIOcNB input is 0  | R/W |
| 11  | ASCFBH  | GTIOcNA Pin Falling Input during GTIOcNB Value High Source GTCCRA Input Capture Enable<br>0: GTCCRA input capture disabled on the falling edge of GTIOcNA input when GTIOcNB input is 1<br>1: GTCCRA input capture enabled on the falling edge of GTIOcNA input when GTIOcNB input is 1 | R/W |
| 12  | ASCBRAL | GTIOcNB Pin Rising Input during GTIOcNA Value Low Source GTCCRA Input Capture Enable<br>0: GTCCRA input capture disabled on the rising edge of GTIOcNB input when GTIOcNA input is 0<br>1: GTCCRA input capture enabled on the rising edge of GTIOcNB input when GTIOcNA input is 0     | R/W |
| 13  | ASCBRAH | GTIOcNB Pin Rising Input during GTIOcNA Value High Source GTCCRA Input Capture Enable<br>0: GTCCRA input capture disabled on the rising edge of GTIOcNB input when GTIOcNA input is 1<br>1: GTCCRA input capture enabled on the rising edge of GTIOcNB input when GTIOcNA input is 1    | R/W |
| 14  | ASCBFAL | GTIOcNB Pin Falling Input during GTIOcNA Value Low Source GTCCRA Input Capture Enable<br>0: GTCCRA input capture disabled on the falling edge of GTIOcNB input when GTIOcNA input is 0<br>1: GTCCRA input capture enabled on the falling edge of GTIOcNB input when GTIOcNA input is 0  | R/W |
| 15  | ASCBFAH | GTIOcNB Pin Falling Input during GTIOcNA Value High Source GTCCRA Input Capture Enable<br>0: GTCCRA input capture disabled on the falling edge of GTIOcNB input when GTIOcNA input is 1<br>1: GTCCRA input capture enabled on the falling edge of GTIOcNB input when GTIOcNA input is 1 | R/W |
| 16  | ASELCA  | ELC_GPTA Event Source GTCCRA Input Capture Enable<br>0: GTCCRA input capture disabled at the ELC_GPTA input<br>1: GTCCRA input capture enabled at the ELC_GPTA input  | R/W |
| 17  | ASELCB  | ELC_GPTB Event Source GTCCRA Input Capture Enable<br>0: GTCCRA input capture disabled at the ELC_GPTB input<br>1: GTCCRA input capture enabled at the ELC_GPTB input  | R/W |
| 18  | ASELCC  | ELC_GPTC Event Source GTCCRA Input Capture Enable<br>0: GTCCRA input capture disabled at the ELC_GPTC input<br>1: GTCCRA input capture enabled at the ELC_GPTC input  | R/W |
| 19  | ASELCD  | ELC_GPTD Event Source GTCCRA Input Capture Enable<br>0: GTCCRA input capture disabled at the ELC_GPTD input<br>1: GTCCRA input capture enabled at the ELC_GPTD input  | R/W |
| 20  | ASELCE  | ELC_GPTE Event Source GTCCRA Input Capture Enable<br>0: GTCCRA input capture disabled at the ELC_GPTE input<br>1: GTCCRA input capture enabled at the ELC_GPTE input  | R/W |
| 21  | ASELCF  | ELC_GPTF Event Source GTCCRA Input Capture Enable<br>0: GTCCRA input capture disabled at the ELC_GPTF input<br>1: GTCCRA input capture enabled at the ELC_GPTF input  | R/W |
| 22  | ASELCG  | ELC_GPTG Event Source GTCCRA Input Capture Enable<br>0: GTCCRA input capture disabled at the ELC_GPTG input<br>1: GTCCRA input capture enabled at the ELC_GPTG input  | R/W |

| Bit | Symbol  | Function  | R/W |
|-----|---------|---|-----|
| 10  | ASCAFBL | GTIOcNB值低电平期间的GTIOcNA引脚下降输入源GTCCRA输入捕捉 Enable<br>0: 当GTIOcNB输入为0时, 在GTIOcNA输入的下降沿禁止GTCCRA输入捕捉<br>1: 当GTIOcNB输入为0时, 在GTIOcNA输入的下降沿使能GTCCRA输入捕捉   | R/W |
| 11  | ASCFBH  | GTIOcNB值高电平期间的GTIOcNA引脚下降输入源GTCCRA输入捕捉 Enable<br>0: 当GTIOcNB输入为1时, 在GTIOcNA输入的下降沿禁用GTCCRA输入捕捉<br>1: 当GTIOcNB输入为1时, 在GTIOcNA输入的下降沿启用GTCCRA输入捕捉   | R/W |
| 12  | ASCBRAL | GTIOcNB引脚在GTIOcNA值低电平期间的上升沿输入源GTCCRA输入捕捉 Enable<br>0: 当GTIOcNA输入为0时, 在GTIOcNB输入的上升沿禁止GTCCRA输入捕捉<br>1: 当GTIOcNA输入为0时, 在GTIOcNB输入的上升沿使能GTCCRA输入捕捉 | R/W |
| 13  | ASCBRAH | GTIOcNB值高电平期间的GTIOcNB引脚上升沿输入源GTCCRA输入捕捉 Enable<br>0: 当GTIOcNA输入为1时, 在GTIOcNB输入的上升沿禁止GTCCRA输入捕捉<br>1: 当GTIOcNA输入为1时, 在GTIOcNB输入的上升沿使能GTCCRA输入捕捉  | R/W |
| 14  | ASCBFAL | GTIOcNA值低电平期间的GTIOcNB引脚下降输入源GTCCRA输入捕捉 Enable<br>0: 当GTIOcNA输入为0时, 在GTIOcNB输入的下降沿禁用GTCCRA输入捕捉<br>1: 当GTIOcNA输入为0时, 在GTIOcNB输入的下降沿启用GTCCRA输入捕捉   | R/W |
| 15  | ASCBFAH | GTIOcNA值高电平期间GTIOcNB引脚下降输入源GTCCRA输入捕捉 Enable<br>0: 当GTIOcNA输入为1时, 在GTIOcNB输入的下降沿禁用GTCCRA输入捕捉<br>1: 当GTIOcNA输入为1时, 在GTIOcNB输入的下降沿启用GTCCRA输入捕捉    | R/W |
| 16  | ASELCA  | ELC_GPTA事件源GTCCRA输入捕获启用<br>0: 在ELC_GPTA输入处禁用GTCCRA输入捕捉<br>1: 在ELC_GPTA输入处启用GTCCRA输入捕捉   | R/W |
| 17  | ASELCB  | ELC_GPTB事件源GTCCRA输入捕获启用<br>0: 在ELC_GPTB输入处禁用GTCCRA输入捕捉<br>1: 在ELC_GPTB输入处启用GTCCRA输入捕捉   | R/W |
| 18  | ASELCC  | ELC_GPTC事件源GTCCRA输入捕捉使能<br>0: 在ELC_GPTC输入处禁用GTCCRA输入捕捉<br>1: 在ELC_GPTC输入处启用GTCCRA输入捕捉   | R/W |
| 19  | ASELCD  | ELC_GPTD事件源GTCCRA输入捕获启用<br>0: 在ELC_GPTD输入处禁用GTCCRA输入捕捉<br>1: 在ELC_GPTD输入处启用GTCCRA输入捕捉   | R/W |
| 20  | ASELCE  | ELC_GPTE事件源GTCCRA输入捕获启用<br>0: 在ELC_GPTE输入处禁用GTCCRA输入捕捉<br>1: 在ELC_GPTE输入处启用GTCCRA输入捕捉   | R/W |
| 21  | ASELCF  | ELC_GPTF事件源GTCCRA输入捕获启用<br>0: 在ELC_GPTF输入处禁用GTCCRA输入捕捉<br>1: 在ELC_GPTF输入处启用GTCCRA输入捕捉   | R/W |
| 22  | ASELCG  | ELC_GPTG事件源GTCCRA输入捕捉使能<br>0: 在ELC_GPTG输入处禁用GTCCRA输入捕捉<br>1: 在ELC_GPTG输入处启用GTCCRA输入捕捉   | R/W |



| Bit   | Symbol | Function   | R/W |
|-------|--------|--|-----|
| 23    | ASELCH | ELC_GPTH Event Source GTCCRA Input Capture Enable<br>0: GTCCRA input capture disabled at the ELC_GPTH input<br>1: GTCCRA input capture enabled at the ELC_GPTH input | R/W |
| 31:24 | —      | These bits are read as 0. The write value should be 0.   | R/W |

The GTICASR sets the source of input capture for GTCCRA.

#### ASGTRGAR bit (GTETRGA Pin Rising Input Source GTCCRA Input Capture Enable)

The ASGTRGAR bit enables or disables the input capture for GTCCRA on the rising edge of the GTETRGA pin input.

#### ASGTRGAF bit (GTETRGA Pin Falling Input Source GTCCRA Input Capture Enable)

The ASGTRGAF bit enables or disables the input capture for GTCCRA on the falling edge of the GTETRGA pin input.

#### ASGTRGBR bit (GTETRGB Pin Rising Input Source GTCCRA Input Capture Enable)

The ASGTRGBR bit enables or disables the input capture for GTCCRA on the rising edge of the GTETRGB pin input.

#### ASGTRGBF bit (GTETRGB Pin Falling Input Source GTCCRA Input Capture Enable)

The ASGTRGBF bit enables or disables the input capture for GTCCRA on the falling edge of the GTETRGB pin input.

#### ASGTRGCR bit (GTETRGC Pin Rising Input Source GTCCRA Input Capture Enable)

The ASGTRGCR bit enables or disables the input capture for GTCCRA on the rising edge of the GTETRGC pin input.

#### ASGTRGCF bit (GTETRGC Pin Falling Input Source GTCCRA Input Capture Enable)

The ASGTRGCF bit enables or disables the input capture for GTCCRA on the falling edge of the GTETRGC pin input.

#### ASGTRGDR bit (GTETRGD Pin Rising Input Source GTCCRA Input Capture Enable)

The ASGTRGDR bit enables or disables the input capture for GTCCRA on the rising edge of the GTETRGD pin input.

#### ASGTRGDF bit (GTETRGD Pin Falling Input Source GTCCRA Input Capture Enable)

The ASGTRGDF bit enables or disables the input capture for GTCCRA on the falling edge of the GTETRGD pin input.

#### ASCARBL bit (GTIOCnA Pin Rising Input during GTIOCnB Value Low Source GTCCRA Input Capture Enable)

The ASCARBL bit enables or disables the input capture for GTCCRA on the rising edge of the GTIOCnA pin input, when GTIOCnB input is 0.

#### ASCARBH bit (GTIOCnA Pin Rising Input during GTIOCnB Value High Source GTCCRA Input Capture Enable)

The ASCARBH bit enables or disables the input capture for GTCCRA on the rising edge of the GTIOCnA pin input, when GTIOCnB input is 1.

#### ASCAFBL bit (GTIOCnA Pin Falling Input during GTIOCnB Value Low Source GTCCRA Input Capture Enable)

The ASCAFBL bit enables or disables the input capture for GTCCRA on the falling edge of the GTIOCnA pin input, when GTIOCnB input is 0.

#### ASCAFBH bit (GTIOCnA Pin Falling Input during GTIOCnB Value High Source GTCCRA Input Capture Enable)

The ASCAFBH bit enables or disables the input capture for GTCCRA on the falling edge of the GTIOCnA pin input, when the GTIOCnB input is 1.

#### ASCBRAL bit (GTIOCnB Pin Rising Input during GTIOCnA Value Low Source GTCCRA Input Capture Enable)

The ASCBRAL bit enables or disables the input capture for GTCCRA on the rising edge of the GTIOCnB pin input, when the GTIOCnA input is 0.

| Bit   | Symbol | Function  | R/W |
|-------|--------|---|-----|
| 23    | ASELCH | ELC_GPTH事件源GTCCRA输入捕获启用<br>0: 在ELC_GPTH输入处禁用GTCCRA输入捕捉1: 在ELC_GPTH输入处启用GTCCRA输入捕捉 | R/W |
| 31:24 | —      | 这些位被读取为0。写入值应为0。  | R/W |

GTICASR设置GTCCRA的输入捕获源。

#### ASGTRGAR位 (GTETRGA引脚上升沿输入源GTCCRA输入捕捉使能)

ASGTRGAR位在GTETRGA引脚输入的上升沿启用或禁用GTCCRA的输入捕捉。

#### ASGTRGAF位 (GTETRGA引脚下降输入源GTCCRA输入捕捉使能)

ASGTRGAF位在GTETRGA引脚输入的下降沿启用或禁用GTCCRA的输入捕捉。

#### ASGTRGBR位 (GTETRGB引脚上升沿输入源GTCCRA输入捕捉使能)

ASGTRGBR位在GTETRGB引脚输入的上升沿启用或禁用GTCCRA的输入捕捉。

#### ASGTRGBF位 (GTETRGB引脚下降输入源GTCCRA输入捕捉使能)

ASGTRGBF位在GTETRGB引脚输入的下降沿启用或禁用GTCCRA的输入捕捉。

#### ASGTRGCR位 (GTETRGC引脚上升沿输入源GTCCRA输入捕捉使能)

ASGTRGCR位在GTETRGC引脚输入的上升沿启用或禁用GTCCRA的输入捕捉。

#### ASGTRGCF位 (GTETRGC引脚下降输入源GTCCRA输入捕捉使能)

ASGTRGCF位在GTETRGC引脚输入的下降沿启用或禁用GTCCRA的输入捕捉。

#### ASGTRGDR位 (GTETRGD引脚上升沿输入源GTCCRA输入捕捉使能)

ASGTRGDR位在GTETRGD引脚输入的上升沿启用或禁用GTCCRA的输入捕捉。

#### ASGTRGDF位 (GTETRGD引脚下降输入源GTCCRA输入捕捉使能)

ASGTRGDF位在GTETRGD引脚输入的下降沿启用或禁用GTCCRA的输入捕捉。

#### ASCARBL位 (GTIOCnB值低电平期间的GTIOCnA引脚上升沿输入源GTCCRA输入捕捉使能)

当GTIOCnB输入为0时，ASCARBL位在GTIOCnA引脚输入的上升沿启用或禁用GTCCRA的输入捕捉。

#### ASCARBH位 (GTIOCnB值高电平期间的GTIOCnA引脚上升沿输入源GTCCRA输入捕捉使能)

ASCARBH位在GTIOCnA引脚输入的上升沿启用或禁用GTCCRA的输入捕捉，当GTIOCnB输入为1。

#### ASCAFBL位 (GTIOCnB值低电平期间GTIOCnA引脚下降输入源GTCCRA输入捕捉使能)

ASCAFBL位在GTIOCnA引脚输入的下降沿启用或禁用GTCCRA的输入捕捉，当GTIOCnB输入为0。

#### ASCAFBH位 (GTIOCnB值高电平期间GTIOCnA引脚下降输入源GTCCRA输入捕捉使能)

当GTIOCnB输入为1时，ASCAFBH位在GTIOCnA引脚输入的下降沿启用或禁用GTCCRA的输入捕捉。

#### ASCBRAL位 (GTIOCnA值低电平期间的GTIOCnB引脚上升沿输入源GTCCRA输入捕捉使能)

当GTIOCnA输入为0时，ASCBRAL位在GTIOCnB引脚输入的上升沿启用或禁用GTCCRA的输入捕捉。

**ASCBRAH bit (GTIOCnB Pin Rising Input during GTIOCnA Value High Source GTCCRA Input Capture Enable)**

The ASCBRAH bit enables or disables the input capture for GTCCRA on the rising edge of the GTIOCnB pin input, when GTIOCnA input is 1.

**ASCBFAL bit (GTIOCnB Pin Falling Input during GTIOCnA Value Low Source GTCCRA Input Capture Enable)**

The ASCBFAL bit enables or disables the input capture for GTCCRA on the falling edge of the GTIOCnB pin input, when GTIOCnA input is 0.

**ASCBFAH bit (GTIOCnB Pin Falling Input during GTIOCnA Value High Source GTCCRA Input Capture Enable)**

The ASCBFAH bit enables or disables the input capture for GTCCRA on the falling edge of the GTIOCnB pin input, when GTIOCnA input is 1.

**ASELCm bit (ELC\_GPTm Event Source Counter GTCCRA Input Capture Enable) (m = A to H)**

The ASELCm bit enables or disables the input capture for GTCCRA at the ELC\_GPTm event input.

**21.2.11 GTICBSR : General PWM Timer Input Capture Source Select Register B**

Base address: GPT32n = 0x4016\_9000 + 0x0100 × n (n = 0 to 3)  
GPT16m = 0x4016\_9000 + 0x0100 × m (m = 4 to 7)

Offset address: 0x28

|                    |          |          |          |          |          |          |          |          |           |           |           |           |           |           |           |           |
|--------------------|----------|----------|----------|----------|----------|----------|----------|----------|-----------|-----------|-----------|-----------|-----------|-----------|-----------|-----------|
| Bit position:      | 31       | 30       | 29       | 28       | 27       | 26       | 25       | 24       | 23        | 22        | 21        | 20        | 19        | 18        | 17        | 16        |
| Bit field:         | —        | —        | —        | —        | —        | —        | —        | —        | BSEL CH   | BSEL CG   | BSEL CF   | BSEL CE   | BSEL CD   | BSEL CC   | BSEL CB   | BSEL CA   |
| Value after reset: | 0        | 0        | 0        | 0        | 0        | 0        | 0        | 0        | 0         | 0         | 0         | 0         | 0         | 0         | 0         | 0         |
| Bit position:      | 15       | 14       | 13       | 12       | 11       | 10       | 9        | 8        | 7         | 6         | 5         | 4         | 3         | 2         | 1         | 0         |
| Bit field:         | BSCB FAH | BSCB FAL | BSCB RAH | BSCB RAL | BSCA FBH | BSCA FBL | BSCA RBH | BSCA RBL | BSGT RGDF | BSGT RGDR | BSGT RGCF | BSGT RGCR | BSGT RGBF | BSGT RGBR | BSGT RGAF | BSGT RGAR |
| Value after reset: | 0        | 0        | 0        | 0        | 0        | 0        | 0        | 0        | 0         | 0         | 0         | 0         | 0         | 0         | 0         | 0         |

| Bit | Symbol   | Function   | R/W |
|-----|----------|--|-----|
| 0   | BSGTRGAR | GTETRG A Pin Rising Input Source GTCCRB Input Capture Enable<br>0: GTCCRB input capture disabled on the rising edge of GTETRG A input<br>1: GTCCRB input capture enabled on the rising edge of GTETRG A input    | R/W |
| 1   | BSGTRGAF | GTETRG A Pin Falling Input Source GTCCRB Input Capture Enable<br>0: GTCCRB input capture disabled on the falling edge of GTETRG A input<br>1: GTCCRB input capture enabled on the falling edge of GTETRG A input | R/W |
| 2   | BSGTRGBR | GTETRG B Pin Rising Input Source GTCCRB Input Capture Enable<br>0: GTCCRB input capture disabled on the rising edge of GTETRG B input<br>1: GTCCRB input capture enabled on the rising edge of GTETRG B input    | R/W |
| 3   | BSGTRGBF | GTETRG B Pin Falling Input Source GTCCRB Input Capture Enable<br>0: GTCCRB input capture disabled on the falling edge of GTETRG B input<br>1: GTCCRB input capture enabled on the falling edge of GTETRG B input | R/W |
| 4   | BSGTRGCR | GTETRG C Pin Rising Input Source GTCCRB Input Capture Enable<br>0: GTCCRB input capture disabled on the rising edge of GTETRG C input<br>1: GTCCRB input capture enabled on the rising edge of GTETRG C input    | R/W |
| 5   | BSGTRGCF | GTETRG C Pin Falling Input Source GTCCRB Input Capture Enable<br>0: GTCCRB input capture disabled on the falling edge of GTETRG C input<br>1: GTCCRB input capture enabled on the falling edge of GTETRG C input | R/W |
| 6   | BSGTRGDR | GTETRG D Pin Rising Input Source GTCCRB Input Capture Enable<br>0: GTCCRB input capture disabled on the rising edge of GTETRG D input<br>1: GTCCRB input capture enabled on the rising edge of GTETRG D input    | R/W |

**ASCBRAH位 (GTIOCnA值高电平期间GTIOCnB引脚上升沿输入源GTCCRA输入捕捉 Enable)**

ASCBRAH位在GTIOCnB引脚输入的上升沿启用或禁用GTCCRA的输入捕捉，当GTIOCnA输入为1。

**ASCBFAL位 (GTIOCnA值低电平期间GTIOCnB引脚下降输入源GTCCRA输入捕捉 Enable)**

ASCBFAL位在GTIOCnB引脚输入的下降沿启用或禁用GTCCRA的输入捕捉，当GTIOCnA输入为0。

**ASCBFAH位 (GTIOCnA值高电平期间GTIOCnB引脚下降输入源GTCCRA输入捕捉 Enable)**

ASCBFAH位在GTIOCnB引脚输入的下降沿启用或禁用GTCCRA的输入捕捉，当GTIOCnA输入为1。

**ASELCm位 (ELC\_GPTm事件源计数器GTCCRA输入捕捉使能) (m=A到H)**

ASELCm位在ELC\_GPTm事件输入处启用或禁用GTCCRA的输入捕捉。

**21.2.11 GTICBSR: 通用PWM定时器输入捕捉源选择寄存器B**

Base address: GPT32n = 0x4016\_9000 + 0x0100 × n (n = 0 to 3)  
GPT16m = 0x4016\_9000 + 0x0100 × m (m = 4 to 7)

Offset address: 0x28

|               |          |          |          |          |          |          |          |          |           |           |           |           |           |           |           |           |
|---------------|----------|----------|----------|----------|----------|----------|----------|----------|-----------|-----------|-----------|-----------|-----------|-----------|-----------|-----------|
| Bit position: | 31       | 30       | 29       | 28       | 27       | 26       | 25       | 24       | 23        | 22        | 21        | 20        | 19        | 18        | 17        | 16        |
| Bit field:    | —        | —        | —        | —        | —        | —        | —        | —        | BSEL CH   | BSEL CG   | BSEL CF   | BSEL CE   | BSEL CD   | BSEL CC   | BSEL CB   | BSEL CA   |
| 重置后的值:        | 0        | 0        | 0        | 0        | 0        | 0        | 0        | 0        | 0         | 0         | 0         | 0         | 0         | 0         | 0         | 0         |
| Bit position: | 15       | 14       | 13       | 12       | 11       | 10       | 9        | 8        | 7         | 6         | 5         | 4         | 3         | 2         | 1         | 0         |
| Bit field:    | BSCB FAH | BSCB FAL | BSCB RAH | BSCB RAL | BSCA FBH | BSCA FBL | BSCA RBH | BSCA RBL | BSGT RGDF | BSGT RGDR | BSGT RGCF | BSGT RGCR | BSGT RGBF | BSGT RGBR | BSGT RGAF | BSGT RGAR |
| 重置后的值:        | 0        | 0        | 0        | 0        | 0        | 0        | 0        | 0        | 0         | 0         | 0         | 0         | 0         | 0         | 0         | 0         |

| Bit | Symbol   | Function   | R/W |
|-----|----------|--|-----|
| 0   | BSGTRGAR | GTETRG A引脚上升沿输入源GTCCRB输入捕捉使能<br>0: 在GTETRG A输入的上升沿禁用GTCCRB输入捕捉1: 在GTETRG A输入的上升沿启用GTCCRB输入捕捉     | R/W |
| 1   | BSGTRGAF | GTETRG A引脚下降输入源GTCCRB输入捕捉使能<br>0: 在GTETRG A输入的下降沿禁用GTCCRB输入捕捉1: 在GTETRG A输入的下降沿启用GTCCRB输入捕捉      | R/W |
| 2   | BSGTRGBR | GTETRG B引脚上升输入源GTCCRB输入捕捉使能<br>0: 在GTETRG B输入的上升沿禁用GTCCRB输入捕捉1: 在GTETRG B输入的上升沿启用GTCCRB输入捕捉      | R/W |
| 3   | BSGTRGBF | GTETRG B引脚下降输入源GTCCRB输入捕捉使能<br>0: 在GTETRG B输入的下降沿禁用GTCCRB输入捕捉1: 在GTETRG B输入的下<br>降沿启用GTCCRB输入捕捉  | R/W |
| 4   | BSGTRGCR | GTETRG C引脚上升沿输入源GTCCRB输入捕捉使能<br>0: 在GTETRG C输入的上升沿禁用GTCCRB输入捕捉1: 在GTETRG C输入的<br>上升沿启用GTCCRB输入捕捉 | R/W |
| 5   | BSGTRGCF | GTETRG C引脚下降输入源GTCCRB输入捕捉使能<br>0: 在GTETRG C输入的下降沿禁用GTCCRB输入捕捉1: 在GTETRG C输入的下<br>降沿启用GTCCRB输入捕捉  | R/W |
| 6   | BSGTRGDR | GTETRG D引脚上升沿输入源GTCCRB输入捕捉使能<br>0: 在GTETRG D输入的上升沿禁用GTCCRB输入捕捉1: 在GTETRG D输入的<br>上升沿启用GTCCRB输入捕捉 | R/W |



| Bit | Symbol   | Function  | R/W |
|-----|----------|---|-----|
| 7   | BSGTRGDF | GTETRGD Pin Falling Input Source GTCCRB Input Capture Enable<br>0: GTCCRB input capture disabled on the falling edge of GTETRGD input<br>1: GTCCRB input capture enabled on the falling edge of GTETRGD input   | R/W |
| 8   | BSCARBL  | GTIOCnA Pin Rising Input during GTIOCnB Value Low Source GTCCRB Input Capture Enable<br>0: GTCCRB input capture disabled on the rising edge of GTIOCnA input when GTIOCnB input is 0<br>1: GTCCRB input capture enabled on the rising edge of GTIOCnA input when GTIOCnB input is 0     | R/W |
| 9   | BSCARBH  | GTIOCnA Pin Rising Input during GTIOCnB Value High Source GTCCRB Input Capture Enable<br>0: GTCCRB input capture disabled on the rising edge of GTIOCnA input when GTIOCnB input is 1<br>1: GTCCRB input capture enabled on the rising edge of GTIOCnA input when GTIOCnB input is 1    | R/W |
| 10  | BSCAFBL  | GTIOCnA Pin Falling Input during GTIOCnB Value Low Source GTCCRB Input Capture Enable<br>0: GTCCRB input capture disabled on the falling edge of GTIOCnA input when GTIOCnB input is 0<br>1: GTCCRB input capture enabled on the falling edge of GTIOCnA input when GTIOCnB input is 0  | R/W |
| 11  | BSCAFBH  | GTIOCnA Pin Falling Input during GTIOCnB Value High Source GTCCRB Input Capture Enable<br>0: GTCCRB input capture disabled on the falling edge of GTIOCnA input when GTIOCnB input is 1<br>1: GTCCRB input capture enabled on the falling edge of GTIOCnA input when GTIOCnB input is 1 | R/W |
| 12  | BSCBRAL  | GTIOCnB Pin Rising Input during GTIOCnA Value Low Source GTCCRB Input Capture Enable<br>0: GTCCRB input capture disabled on the rising edge of GTIOCnB input when GTIOCnA input is 0<br>1: GTCCRB input capture enabled on the rising edge of GTIOCnB input when GTIOCnA input is 0     | R/W |
| 13  | BSCBRAH  | GTIOCnB Pin Rising Input during GTIOCnA Value High Source GTCCRB Input Capture Enable<br>0: GTCCRB input capture disabled on the rising edge of GTIOCnB input when GTIOCnA input is 1<br>1: GTCCRB input capture enabled on the rising edge of GTIOCnB input when GTIOCnA input is 1    | R/W |
| 14  | BSCBFAL  | GTIOCnB Pin Falling Input during GTIOCnA Value Low Source GTCCRB Input Capture Enable<br>0: GTCCRB input capture disabled on the falling edge of GTIOCnB input when GTIOCnA input is 0<br>1: GTCCRB input capture enabled on the falling edge of GTIOCnB input when GTIOCnA input is 0  | R/W |
| 15  | BSCBFAH  | GTIOCnB Pin Falling Input during GTIOCnA Value High Source GTCCRB Input Capture Enable<br>0: GTCCRB input capture disabled on the falling edge of GTIOCnB input when GTIOCnA input is 1<br>1: GTCCRB input capture enabled on the falling edge of GTIOCnB input when GTIOCnA input is 1 | R/W |
| 16  | BSELCA   | ELC_GPTA Event Source GTCCRB Input Capture Enable<br>0: GTCCRB input capture disabled at the ELC_GPTA input<br>1: GTCCRB input capture enabled at the ELC_GPTA input  | R/W |
| 17  | BSELCB   | ELC_GPTB Event Source GTCCRB Input Capture Enable<br>0: GTCCRB input capture disabled at the ELC_GPTB input<br>1: GTCCRB input capture enabled at the ELC_GPTB input  | R/W |
| 18  | BSELCC   | ELC_GPTC Event Source GTCCRB Input Capture Enable<br>0: GTCCRB input capture disabled at the ELC_GPTC input<br>1: GTCCRB input capture enabled at the ELC_GPTC input  | R/W |

| Bit | Symbol   | Function  | R/W |
|-----|----------|---|-----|
| 7   | BSGTRGDF | GTETRGD引脚下降输入源GTCCRB输入捕捉使能<br>0: 在GTETRGD输入的下降沿禁用GTCCRB输入捕捉1: 在GTETRGD输入的下沿沿启用GTCCRB输入捕捉  | R/W |
| 8   | BSCARBL  | GTIOCnB值低电平期间的GTIOCnA引脚上升沿输入源GTCCRB输入捕捉使能<br>0: 当GTIOCnB输入为0时, 在GTIOCnA输入的上升沿禁止GTCCRB输入捕捉<br>1: 当GTIOCnB输入为0时, 在GTIOCnA输入的上升沿使能GTCCRB输入捕捉 | R/W |
| 9   | BSCARBH  | GTIOCnB值高电平期间的GTIOCnA引脚上升沿输入源GTCCRB输入捕捉使能<br>0: 当GTIOCnB输入为1时, 在GTIOCnA输入的上升沿禁止GTCCRB输入捕捉<br>1: 当GTIOCnB输入为1时, 在GTIOCnA输入的上升沿使能GTCCRB输入捕捉 | R/W |
| 10  | BSCAFBL  | GTIOCnB值低电平期间的GTIOCnA引脚下降输入源GTCCRB输入捕捉使能<br>0: 当GTIOCnB输入为0时, 在GTIOCnA输入的下沿沿禁止GTCCRB输入捕捉<br>1: 当GTIOCnB输入为0时, 在GTIOCnA输入的下沿沿使能GTCCRB输入捕捉  | R/W |
| 11  | BSCAFBH  | GTIOCnB值高电平期间的GTIOCnA引脚下降输入源GTCCRB输入捕捉使能<br>0: 当GTIOCnB输入为1时, 在GTIOCnA输入的下沿沿禁止GTCCRB输入捕捉<br>1: 当GTIOCnB输入为1时, 在GTIOCnA输入的下沿沿使能GTCCRB输入捕捉  | R/W |
| 12  | BSCBRAL  | GTIOCnA值低电平期间的GTIOCnB引脚上升沿输入源GTCCRB输入捕捉使能<br>0: 当GTIOCnA输入为0时, 在GTIOCnB输入的上升沿禁止GTCCRB输入捕捉<br>1: 当GTIOCnA输入为0时, 在GTIOCnB输入的上升沿使能GTCCRB输入捕捉 | R/W |
| 13  | BSCBRAH  | GTIOCnA值高电平期间的GTIOCnB引脚上升沿输入源GTCCRB输入捕捉使能<br>0: 当GTIOCnA输入为1时, 在GTIOCnB输入的上升沿禁止GTCCRB输入捕捉<br>1: 当GTIOCnA输入为1时, 在GTIOCnB输入的上升沿使能GTCCRB输入捕捉 | R/W |
| 14  | BSCBFAL  | GTIOCnA值低电平期间的GTIOCnB引脚下降输入源GTCCRB输入捕捉使能<br>0: 当GTIOCnA输入为0时, 在GTIOCnB输入的下沿沿禁止GTCCRB输入捕捉<br>1: 当GTIOCnA输入为0时, 在GTIOCnB输入的下沿沿使能GTCCRB输入捕捉  | R/W |
| 15  | BSCBFAH  | GTIOCnA值高电平期间的GTIOCnB引脚下降输入源GTCCRB输入捕捉使能<br>0: 当GTIOCnA输入为1时, 在GTIOCnB输入的下沿沿禁止GTCCRB输入捕捉<br>1: 当GTIOCnA输入为1时, 在GTIOCnB输入的下沿沿启用GTCCRB输入捕捉  | R/W |
| 16  | BSELCA   | ELC_GPTA事件源GTCCRB输入捕捉启用<br>0: 在ELC_GPTA输入处禁用GTCCRB输入捕捉1: 在ELC_GPTA输入处启用GTCCRB输入捕捉   | R/W |
| 17  | BSELCB   | ELC_GPTB事件源GTCCRB输入捕捉使能<br>0: 在ELC_GPTB输入处禁用GTCCRB输入捕捉1: 在ELC_GPTB输入处启用GTCCRB输入捕捉   | R/W |
| 18  | BSELCC   | ELC_GPTC事件源GTCCRB输入捕捉使能<br>0: 在ELC_GPTC输入处禁用GTCCRB输入捕捉1: 在ELC_GPTC输入处启用GTCCRB输入捕捉   | R/W |

| Bit   | Symbol | Function   | R/W |
|-------|--------|--|-----|
| 19    | BSELCD | ELC_GPTD Event Source GTCCRB Input Capture Enable<br>0: GTCCRB input capture disabled at the ELC_GPTD input<br>1: GTCCRB input capture enabled at the ELC_GPTD input | R/W |
| 20    | BSELCE | ELC_GPTE Event Source GTCCRB Input Capture Enable<br>0: GTCCRB input capture disabled at the ELC_GPTE input<br>1: GTCCRB input capture enabled at the ELC_GPTE input | R/W |
| 21    | BSELCF | ELC_GPTF Event Source GTCCRB Input Capture Enable<br>0: GTCCRB input capture disabled at the ELC_GPTF input<br>1: GTCCRB input capture enabled at the ELC_GPTF input | R/W |
| 22    | BSELCG | ELC_GPTG Event Source GTCCRB Input Capture Enable<br>0: GTCCRB input capture disabled at the ELC_GPTG input<br>1: GTCCRB input capture enabled at the ELC_GPTG input | R/W |
| 23    | BSELCH | ELC_GPTH Event Source GTCCRB Input Capture Enable<br>0: GTCCRB input capture disabled at the ELC_GPTH input<br>1: GTCCRB input capture enabled at the ELC_GPTH input | R/W |
| 31:24 | —      | These bits are read as 0. The write value should be 0.   | R/W |

The GTICBSR sets the source of input capture for GTCCRB.

#### **BSGTRGAR bit (GTETRGA Pin Rising Input Source GTCCRB Input Capture Enable)**

The BSGTRGAR bit enables or disables the input capture for GTCCRB on the rising edge of the GTETRGA pin input.

#### **BSGTRGAF bit (GTETRGA Pin Falling Input Source GTCCRB Input Capture Enable)**

The BSGTRGAF bit enables or disables the input capture for GTCCRB on the falling edge of the GTETRGA pin input.

#### **BSGTRGBR bit (GTETRGB Pin Rising Input Source GTCCRB Input Capture Enable)**

The BSGTRGBR bit enables or disables the input capture for GTCCRB on the rising edge of GTETRGB pin input.

#### **BSGTRGBF bit (GTETRGB Pin Falling Input Source GTCCRB Input Capture Enable)**

The BSGTRGBF bit enables or disables the input capture for GTCCRB on the falling edge of the GTETRGB pin input.

#### **BSGTRGCR bit (GTETRGC Pin Rising Input Source GTCCRB Input Capture Enable)**

The BSGTRGCR bit enables or disables the input capture for GTCCRB on the rising edge of GTETRGC pin input.

#### **BSGTRGCF bit (GTETRGC Pin Falling Input Source GTCCRB Input Capture Enable)**

The BSGTRGCF bit enables or disables the input capture for GTCCRB on the falling edge of the GTETRGC pin input.

#### **BSGTRGDR bit (GTETRGD Pin Rising Input Source GTCCRB Input Capture Enable)**

The BSGTRGDR bit enables or disables the input capture for GTCCRB on the rising edge of GTETRGD pin input.

#### **BSGTRGDF bit (GTETRGD Pin Falling Input Source GTCCRB Input Capture Enable)**

The BSGTRGDF bit enables or disables the input capture for GTCCRB on the falling edge of the GTETRGD pin input.

#### **BSCARBL bit (GTIOCnA Pin Rising Input during GTIOCnB Value Low Source GTCCRB Input Capture Enable)**

The BSCARBL bit enables or disables the input capture for GTCCRB on the rising edge of the GTIOCnA pin input, when the GTIOCnB input is 0.

#### **BSCARBH bit (GTIOCnA Pin Rising Input during GTIOCnB Value High Source GTCCRB Input Capture Enable)**

The BSCARBH bit enables or disables the input capture for GTCCRB on the rising edge of the GTIOCnA pin input, when GTIOCnB input is 1.

| Bit   | Symbol | Function  | R/W |
|-------|--------|---|-----|
| 19    | BSELCD | ELC_GPTD事件源GTCCRB输入捕获启用<br>0: 在ELC_GPTD输入处禁用GTCCRB输入捕捉<br>1: 在ELC_GPTD输入处启用GTCCRB输入捕捉 | R/W |
| 20    | BSELCE | ELC_GPTE事件源GTCCRB输入捕获启用<br>0: 在ELC_GPTE输入处禁用GTCCRB输入捕捉<br>1: 在ELC_GPTE输入处启用GTCCRB输入捕捉 | R/W |
| 21    | BSELCF | ELC_GPTF事件源GTCCRB输入捕获启用<br>0: 在ELC_GPTF输入处禁用GTCCRB输入捕捉<br>1: 在ELC_GPTF输入处启用GTCCRB输入捕捉 | R/W |
| 22    | BSELCG | ELC_GPTG事件源GTCCRB输入捕捉使能<br>0: 在ELC_GPTG输入处禁用GTCCRB输入捕捉<br>1: 在ELC_GPTG输入处启用GTCCRB输入捕捉 | R/W |
| 23    | BSELCH | ELC_GPTH事件源GTCCRB输入捕捉使能<br>0: 在ELC_GPTH输入处禁用GTCCRB输入捕捉<br>1: 在ELC_GPTH输入处启用GTCCRB输入捕捉 | R/W |
| 31:24 | —      | 这些位被读取为0。写入值应为0。  | R/W |

GTICBSR设置GTCCRB的输入捕获源。

#### **BSGTRGAR位 (GTETRGA引脚上升沿输入源GTCCRB输入捕捉使能)**

BSGTRGAR位在GTETRGA引脚输入的上升沿启用或禁用GTCCRB的输入捕捉。

#### **BSGTRGAF位 (GTETRGA引脚下降输入源GTCCRB输入捕捉使能)**

BSGTRGAF位在GTETRGA引脚输入的下降沿启用或禁用GTCCRB的输入捕捉。

#### **BSGTRGBR位 (GTETRGB引脚上升沿输入源GTCCRB输入捕捉使能)**

BSGTRGBR位在GTETRGB引脚输入的上升沿启用或禁用GTCCRB的输入捕捉。

#### **BSGTRGBF位 (GTETRGB引脚下降输入源GTCCRB输入捕捉使能)**

BSGTRGBF位在GTETRGB引脚输入的下降沿启用或禁用GTCCRB的输入捕捉。

#### **BSGTRGCR位 (GTETRGC引脚上升沿输入源GTCCRB输入捕捉使能)**

BSGTRGCR位在GTETRGC引脚输入的上升沿启用或禁用GTCCRB的输入捕捉。

#### **BSGTRGCF位 (GTETRGC引脚下降输入源GTCCRB输入捕捉使能)**

BSGTRGCF位在GTETRGC引脚输入的下降沿启用或禁用GTCCRB的输入捕捉。

#### **BSGTRGDR位 (GTETRGD引脚上升沿输入源GTCCRB输入捕捉使能)**

BSGTRGDR位在GTETRGD引脚输入的上升沿启用或禁用GTCCRB的输入捕捉。

#### **BSGTRGDF位 (GTETRGD引脚下降输入源GTCCRB输入捕捉使能)**

BSGTRGDF位在GTETRGD引脚输入的下降沿启用或禁用GTCCRB的输入捕捉。

#### **BSCARBL位 (GTIOCnB值低电平期间GTIOCnA引脚上升沿输入源GTCCRB输入捕捉使能)**

当GTIOCnB输入为0时，BSCARBL位在GTIOCnA引脚输入的上升沿启用或禁用GTCCRB的输入捕捉。

#### **BSCARBH位 (GTIOCnB值高电平期间GTIOCnA引脚的上升沿输入源GTCCRB输入捕捉使能)**

BSCARBH位在GTIOCnA引脚输入的上升沿启用或禁用GTCCRB的输入捕捉，当GTIOCnB输入为1。

**BSCAFBL bit (GTIOCnA Pin Falling Input during GTIOCnB Value Low Source GTCCRB Input Capture Enable)**

The BSCAFBL bit enables or disables the input capture for GTCCRB on the falling edge of the GTIOCnA pin input, when GTIOCnB input is 0.

**BSCAFBH bit (GTIOCnA Pin Falling Input during GTIOCnB Value High Source GTCCRB Input Capture Enable)**

The BSCAFBH bit enables or disables the input capture for GTCCRB on the falling edge of the GTIOCnA pin input, when GTIOCnB input is 1.

**BSCBRAL bit (GTIOCnB Pin Rising Input during GTIOCnA Value Low Source GTCCRB Input Capture Enable)**

The BSCBRAL bit enables or disables the input capture for GTCCRB on the rising edge of the GTIOCnB pin input, when GTIOCnA input is 0.

**BSCBRAH bit (GTIOCnB Pin Rising Input during GTIOCnA Value High Source GTCCRB Input Capture Enable)**

The BSCBRAH bit enables or disables the input capture for GTCCRB on the rising edge of the GTIOCnB pin input, when GTIOCnA input is 1.

**BSCBFAL bit (GTIOCnB Pin Falling Input during GTIOCnA Value Low Source GTCCRB Input Capture Enable)**

The BSCBFAL bit enables or disables the input capture for GTCCRB on the falling edge of the GTIOCnB pin input, when GTIOCnA input is 0.

**BSCBFAH bit (GTIOCnB Pin Falling Input during GTIOCnA Value High Source GTCCRB Input Capture Enable)**

The BSCBFAH bit enables or disables the input capture for GTCCRB on the falling edge of the GTIOCnB pin input, when GTIOCnA input is 1.

**BSELCm bit (ELC\_GPTm Event Source Counter GTCCRB Input Capture Enable) (m = A to H)**

The BSELCm bit enables or disables the input capture for GTCCRB at the ELC\_GPTm event input.

21.2.12 GTCR : General PWM Timer Control Register

Base address: GPT32n = 0x4016\_9000 + 0x0100 × n (n = 0 to 3)  
GPT16m = 0x4016\_9000 + 0x0100 × m (m = 4 to 7)

Offset address: 0x2C

|                    |    |    |    |    |    |           |    |    |    |    |    |    |    |    |    |         |  |
|--------------------|----|----|----|----|----|-----------|----|----|----|----|----|----|----|----|----|---------|--|
| Bit position:      | 31 | 30 | 29 | 28 | 27 | 26        | 25 | 24 | 23 | 22 | 21 | 20 | 19 | 18 | 17 | 16      |  |
| Bit field:         | —  | —  | —  | —  | —  | TPCS[3:0] |    |    |    |    |    | —  | —  | —  | —  | MD[2:0] |  |
| Value after reset: | 0  | 0  | 0  | 0  | 0  | 0         | 0  | 0  | 0  | 0  | 0  | 0  | 0  | 0  | 0  | 0       |  |
| Bit position:      | 15 | 14 | 13 | 12 | 11 | 10        | 9  | 8  | 7  | 6  | 5  | 4  | 3  | 2  | 1  | 0       |  |
| Bit field:         | —  | —  | —  | —  | —  | —         | —  | —  | —  | —  | —  | —  | —  | —  | —  | CST     |  |
| Value after reset: | 0  | 0  | 0  | 0  | 0  | 0         | 0  | 0  | 0  | 0  | 0  | 0  | 0  | 0  | 0  | 0       |  |

| Bit  | Symbol | Function  | R/W |
|------|--------|---|-----|
| 0    | CST    | Count Start<br>0: Count operation is stopped<br>1: Count operation is performed | R/W |
| 15:1 | —      | These bits are read as 0. The write value should be 0.                          | R/W |

**BSCAFBL位 (GTIOCnB值低电平期间GTIOCnA引脚下降输入源GTCCRB输入捕捉 Enable)**

当GTIOCnB输入为0时, BSCAFBL位在GTIOCnA引脚输入的下降沿启用或禁用GTCCRB的输入捕捉。

**BSCAFBH位 (GTIOCnB值高电平期间GTIOCnA引脚下降输入源GTCCRB输入捕捉 Enable)**

BSCAFBH位在GTIOCnA引脚输入的下降沿启用或禁用GTCCRB的输入捕捉, 当GTIOCnB输入为1。

**BSCBRAL位 (GTIOCnA值低电平期间GTIOCnB引脚上升沿输入源GTCCRB输入捕捉 Enable)**

BSCBRAL位在GTIOCnB引脚输入的上升沿启用或禁用GTCCRB的输入捕捉, 当GTIOCnA输入为0。

**BSCBRAH位 (GTIOCnA值高电平期间的GTIOCnB引脚上升沿输入源GTCCRB输入捕捉 Enable)**

BSCBRAH位在GTIOCnB引脚输入的上升沿启用或禁用GTCCRB的输入捕捉, 当GTIOCnA输入为1。

**BSCBFAL位 (GTIOCnA值低电平期间GTIOCnB引脚下降输入源GTCCRB输入捕捉 Enable)**

BSCBFAL位在GTIOCnB引脚输入的下降沿启用或禁用GTCCRB的输入捕捉, 当GTIOCnA输入为0。

**BSCBFAH位 (GTIOCnA值高电平期间GTIOCnB引脚下降输入源GTCCRB输入捕捉 Enable)**

BSCBFAH位在GTIOCnB引脚输入的下降沿启用或禁用GTCCRB的输入捕捉, 当GTIOCnA输入为1。

**BSELCm位 (ELC\_GPTm事件源计数器GTCCRB输入捕捉使能) (m=A到H)**

BSELCm位在ELC\_GPTm事件输入处启用或禁用GTCCRB的输入捕捉。

21.2.12 GTCR:通用PWM定时器控制寄存器

Base address: GPT32n = 0x4016\_9000 + 0x0100 × n (n = 0 to 3)  
GPT16m = 0x4016\_9000 + 0x0100 × m (m = 4 to 7)

Offset address: 0x2C

|               |    |    |    |    |    |           |    |    |    |    |    |    |    |    |    |         |  |
|---------------|----|----|----|----|----|-----------|----|----|----|----|----|----|----|----|----|---------|--|
| Bit position: | 31 | 30 | 29 | 28 | 27 | 26        | 25 | 24 | 23 | 22 | 21 | 20 | 19 | 18 | 17 | 16      |  |
| Bit field:    | —  | —  | —  | —  | —  | TPCS[3:0] |    |    |    |    |    | —  | —  | —  | —  | MD[2:0] |  |
| 重置后的值:        | 0  | 0  | 0  | 0  | 0  | 0         | 0  | 0  | 0  | 0  | 0  | 0  | 0  | 0  | 0  | 0       |  |
| Bit position: | 15 | 14 | 13 | 12 | 11 | 10        | 9  | 8  | 7  | 6  | 5  | 4  | 3  | 2  | 1  | 0       |  |
| Bit field:    | —  | —  | —  | —  | —  | —         | —  | —  | —  | —  | —  | —  | —  | —  | —  | CST     |  |
| 重置后的值:        | 0  | 0  | 0  | 0  | 0  | 0         | 0  | 0  | 0  | 0  | 0  | 0  | 0  | 0  | 0  | 0       |  |

| Bit  | Symbol | Function               | R/W |
|------|--------|------------------------|-----|
| 0    | CST    | 计数开始<br>0: 停止计数1: 进行计数 | R/W |
| 15:1 | —      | 这些位被读取为0。写入值应为0。       | R/W |



| Bit   | Symbol    | Function   | R/W |
|-------|-----------|--|-----|
| 18:16 | MD[2:0]   | Mode Select<br>0 0 0: Saw-wave PWM mode (single buffer or double buffer possible)<br>0 0 1: Saw-wave one-shot pulse mode (fixed buffer operation)<br>0 1 0: Setting prohibited<br>0 1 1: Setting prohibited<br>1 0 0: Triangle-wave PWM mode 1 (32-bit transfer at trough) (single buffer or double buffer is possible)<br>1 0 1: Triangle-wave PWM mode 2 (32-bit transfer at crest and trough) (single buffer or double buffer is possible)<br>1 1 0: Triangle-wave PWM mode 3 (64-bit transfer at trough) (fixed buffer operation)<br>1 1 1: Setting prohibited | R/W |
| 22:19 | —         | These bits are read as 0. The write value should be 0.   | R/W |
| 26:23 | TPCS[3:0] | Timer Prescaler Select<br>0 0 0 0: PCLKD/1<br>0 0 0 1: PCLKD/2<br>0 0 1 0: PCLKD/4<br>0 0 1 1: PCLKD/8<br>0 1 0 0: PCLKD/16<br>0 1 0 1: PCLKD/32<br>0 1 1 0: PCLKD/64<br>0 1 1 1: Setting prohibited<br>1 0 0 0: PCLKD/256<br>1 0 0 1: Setting prohibited<br>1 0 1 0: PCLKD/1024<br>1 0 1 1: Setting prohibited<br>1 1 0 0: GTETRGA (Via the POEG)<br>1 1 0 1: GTETRGB (Via the POEG)<br>1 1 1 0: GTETRGC (Via the POEG)<br>1 1 1 1: GTETRGD (Via the POEG)  | R/W |
| 31:27 | —         | These bits are read as 0. The write value should be 0.   | R/W |

The GTCR controls GTCNT.

#### CST bit (Count Start)

The CST bit controls the GTCNT counter start and stop.

[Setting conditions]

- The GTSTR value where the channel number associated with the bit number is set to 1 with the GTSSR.CSTRT bit at 1
- The ELC event input, the external trigger, or the GTIOCnA/GTIOCnB input that are enabled by GTSSR for the starting counter source, occurs (n = 0 to 7)
- 1 is written by software directly.

[Clearing conditions]

- The GTSTP value where the channel number associated with the bit number is set to 1 with the GTPSR.CSTOP bit at 1
- The ELC event input, the external trigger, or the GTIOCnA/GTIOCnB input enabled by GTSSR as the counter stop source, occurs (n = 0 to 7)
- 0 is written by software directly.

When the period count function is finished while the GTPC.ASTP bit is 1.

#### MD[2:0] bits (Mode Select)

The MD[2:0] bits select the GPT operating mode. The MD[2:0] bits must be set while the GTCNT operation is stopped.

#### TPCS[3:0] bits (Timer Prescaler Select)

The TPCS[3:0] bits select the clock for GTCNT. A clock prescaler can be selected independently for each channel. The TPCS[3:0] bits must be set while the GTCNT operation is stopped.

| Bit   | Symbol    | Function  | R/W |
|-------|-----------|---|-----|
| 18:16 | MD[2:0]   | 模式选择<br>000: Saw-wave PWM模式 (单缓存或双缓存均可) 001: Saw-wave One-shot脉冲模式 (固定缓存操作) 010: 禁止设置 011: 禁止设置 100: 三角波 PWM 模式1 (波谷32位传输) (单缓冲器或双缓冲器均可)<br><br>101: 三角波 PWM 模式2 (波峰和波谷32位传输) (单缓冲器或双缓冲器均可)<br><br>110: 三角波 PWM 模式3 (谷底64位传输) (固定缓冲操作) 111: 禁止设置                  | R/W |
| 22:19 | —         | 这些位被读取为0。写入值应为0。  | R/W |
| 26:23 | TPCS[3:0] | 定时器预分频器选择<br>0000: PCLKD10001: PCLKD20010<br>: PCLKD40011: PCLKD80100: PCLKD160101: PCLKD320110: PCLKD640111: 禁止设置 1000: PCLKD2561001: 禁止设置 1010: PCLKD10241011: 禁止设置 1100: GTETRGA (通过POEG) 1101: GTETRGB (通过POEG) 1110: GTETRGC (通过POEG) 1111: GTETRGD (通过POEG) | R/W |
| 31:27 | —         | 这些位被读取为0。写入值应为0。  | R/W |

GTCR控制GTCNT。

#### CST bit (Count Start)

CST位控制GTCNT计数器的启动和停止。

[Setting conditions]

- GTSTR值，其中与位号关联的通道号设置为1，GTSSR.CSTRT位为1
- 发生由GTSSR为启动计数器源启用的ELC事件输入、外部触发或GTIOCnAGTIOCnB输入 (n=0到7)
- 1由软件直接写入。

[Clearing conditions]

- GTSTP值，其中与位号关联的通道号设置为1，且GTPSR.CSTOP位为1
- 发生ELC事件输入、外部触发或GTSSR作为计数器停止源启用的GTIOCnAGTIOCnB输入 (n=0至7)
- 0由软件直接写入。

当GTPC.ASTP位为1时完成周期计数功能。

#### MD[2:0] bits (Mode Select)

MD[2:0]位选择GPT操作模式。当GTCNT操作停止时，必须设置MD[2:0]位。

#### TPCS[3:0] bits (Timer Prescaler Select)

TPCS[3:0]位选择GTCNT的时钟。可为每个通道独立选择时钟预分频器。这当GTCNT操作停止时，必须设置TPCS[3:0]位。

21.2.13 GTUDDTYC : General PWM Timer Count Direction and Duty Setting Register

Base address: GPT32n = 0x4016\_9000 + 0x0100 × n (n = 0 to 3)  
GPT16m = 0x4016\_9000 + 0x0100 × m (m = 4 to 7)

Offset address: 0x30

|                    |    |    |    |    |            |            |            |    |    |    |    |            |            |            |     |    |
|--------------------|----|----|----|----|------------|------------|------------|----|----|----|----|------------|------------|------------|-----|----|
| Bit position:      | 31 | 30 | 29 | 28 | 27         | 26         | 25         | 24 | 23 | 22 | 21 | 20         | 19         | 18         | 17  | 16 |
| Bit field:         | —  | —  | —  | —  | OBDT<br>YR | OBDT<br>YF | OBDTY[1:0] | —  | —  | —  | —  | OADT<br>YR | OADT<br>YF | OADTY[1:0] | —   | —  |
| Value after reset: | 0  | 0  | 0  | 0  | 0          | 0          | 0          | 0  | 0  | 0  | 0  | 0          | 0          | 0          | 0   | 0  |
| Bit position:      | 15 | 14 | 13 | 12 | 11         | 10         | 9          | 8  | 7  | 6  | 5  | 4          | 3          | 2          | 1   | 0  |
| Bit field:         | —  | —  | —  | —  | —          | —          | —          | —  | —  | —  | —  | —          | —          | —          | UDF | UD |
| Value after reset: | 0  | 0  | 0  | 0  | 0          | 0          | 0          | 0  | 0  | 0  | 0  | 0          | 0          | 0          | 0   | 1  |

| Bit   | Symbol     | Function   | R/W |
|-------|------------|--|-----|
| 0     | UD         | Count Direction Setting<br>0: GTCNT counts down<br>1: GTCNT counts up  | R/W |
| 1     | UDF        | Forcible Count Direction Setting<br>0: Not forcibly set<br>1: Forcibly set   | R/W |
| 15:2  | —          | These bits are read as 0. The write value should be 0.   | R/W |
| 17:16 | OADTY[1:0] | GTIOCnA Output Duty Setting<br>00: GTIOCnA pin duty depends on the compare match<br>01: GTIOCnA pin duty depends on the compare match<br>10: GTIOCnA pin duty 0%<br>11: GTIOCnA pin duty 100%  | R/W |
| 18    | OADTYF     | Forcible GTIOCnA Output Duty Setting<br>0: Not forcibly set<br>1: Forcibly set   | R/W |
| 19    | OADTYR     | GTIOCnA Output Value Selecting after Releasing 0%/100% Duty Setting<br>0: Apply output value set in 0%/100% duty to GTIOA[3:2] function after releasing 0%/100% duty setting<br>1: Apply masked compare match output value to GTIOA[3:2] function after releasing 0%/100% duty setting | R/W |
| 23:20 | —          | These bits are read as 0. The write value should be 0.   | R/W |
| 25:24 | OBDTY[1:0] | GTIOCnB Output Duty Setting<br>00: GTIOCnB pin duty depends on the compare match<br>01: GTIOCnB pin duty depends on the compare match<br>10: GTIOCnB pin duty 0%<br>11: GTIOCnB pin duty 100%  | R/W |
| 26    | OBDTYF     | Forcible GTIOCnB Output Duty Setting<br>0: Not forcibly set<br>1: Forcibly set   | R/W |
| 27    | OBDTYR     | GTIOCnB Output Value Selecting after Releasing 0%/100% Duty Setting<br>0: Apply output value set in 0%/100% duty to GTIOB[3:2] function after releasing 0%/100% duty setting<br>1: Apply masked compare match output value to GTIOB[3:2] function after releasing 0%/100% duty setting | R/W |
| 31:28 | —          | These bits are read as 0. The write value should be 0.   | R/W |

The GTUDDTYC sets the direction in which the GTCNT counts (up-counting or down-counting), and sets the duty of the GTIOCnA/GTIOCnB pin output.

Count Direction:

- In saw-wave mode.

21.2.13 GTUDDTYC:通用PWM定时器计数方向和占空比设置寄存器

Base address: GPT32n = 0x4016\_9000 + 0x0100 × n (n = 0 to 3)  
GPT16m = 0x4016\_9000 + 0x0100 × m (m = 4 to 7)

Offset address: 0x30

|               |    |    |    |    |            |            |            |    |    |    |    |            |            |            |     |    |
|---------------|----|----|----|----|------------|------------|------------|----|----|----|----|------------|------------|------------|-----|----|
| Bit position: | 31 | 30 | 29 | 28 | 27         | 26         | 25         | 24 | 23 | 22 | 21 | 20         | 19         | 18         | 17  | 16 |
| Bit field:    | —  | —  | —  | —  | OBDT<br>YR | OBDT<br>YF | OBDTY[1:0] | —  | —  | —  | —  | OADT<br>YR | OADT<br>YF | OADTY[1:0] | —   | —  |
| 重置后的值:        | 0  | 0  | 0  | 0  | 0          | 0          | 0          | 0  | 0  | 0  | 0  | 0          | 0          | 0          | 0   | 0  |
| Bit position: | 15 | 14 | 13 | 12 | 11         | 10         | 9          | 8  | 7  | 6  | 5  | 4          | 3          | 2          | 1   | 0  |
| Bit field:    | —  | —  | —  | —  | —          | —          | —          | —  | —  | —  | —  | —          | —          | —          | UDF | UD |
| 重置后的值:        | 0  | 0  | 0  | 0  | 0          | 0          | 0          | 0  | 0  | 0  | 0  | 0          | 0          | 0          | 0   | 1  |

| Bit   | Symbol     | Function   | R/W |
|-------|------------|--|-----|
| 0     | UD         | 计数方向设置<br>0: GTCNT向下计数1: GTCNT向上计数   | R/W |
| 1     | UDF        | 强制计数方向设置<br>0: 不强制设置1: 强制设置  | R/W |
| 15:2  | —          | 这些位被读取为0。写入值应为0。   | R/W |
| 17:16 | OADTY[1:0] | GTIOCnA输出占空比设置<br>00: GTIOCnA引脚占空比取决于比较匹配01: GTIOCnA引脚占空比取决于比较匹配10: GTIOCnA引脚占空比0%<br>11: GTIOCnA引脚占空比100%                         | R/W |
| 18    | OADTYF     | 强制GTIOCnA输出占空比设置<br>0: 不强制设置1: 强制设置  | R/W |
| 19    | OADTYR     | 解除0%100%占空比设置后GTIOCnA输出值选择<br>0: 释放0%100%占空比设置后, 将0%100%占空比中设置的输出值应用于GTIOA[3:2]功能<br>1: 释放0%100%占空比设置后, 将屏蔽比较匹配输出值应用于GTIOA[3:2]函数  | R/W |
| 23:20 | —          | 这些位被读取为0。写入值应为0。   | R/W |
| 25:24 | OBDTY[1:0] | GTIOCnB输出占空比设置<br>00: GTIOCnB引脚占空比取决于比较匹配01: GTIOCnB引脚占空比取决于比较匹配10: GTIOCnB引脚占空比0%<br>11: GTIOCnB引脚占空比100%                         | R/W |
| 26    | OBDTYF     | 强制GTIOCnB输出占空比设置<br>0: 不强制设置1: 强制设置  | R/W |
| 27    | OBDTYR     | GTIOCnB释放后输出值选择0%100%占空比设置<br>0: 解除0%100%占空比设置后, 将0%100%占空比中设置的输出值应用于GTIOB[3:2]功能<br>1: 在释放0%100%占空比设置后, 将屏蔽比较匹配输出值应用到GTIOB[3:2]函数 | R/W |
| 31:28 | —          | 这些位被读取为0。写入值应为0。   | R/W |

GTUDDTYC设置GTCNT计数的方向（向上计数或向下计数），并设置GTIOCnAGTIOCnB引脚输出。

Count Direction:

- 在锯齿波模式下。



When the UD value is set to 0 during up-counting, the count direction changes at an overflow (the timing synchronous with count clock after the GTCNT value becomes the GTPR value). When the UD value is set to 1 during down-counting, the count direction changes at an underflow (the timing synchronous with count clock after the GTCNT value becomes 0).

When the UD value changes from 1 to 0 with the UDF bit being 0 and while counting stops, the counter starts up-counting and the count direction changes at an overflow (the timing synchronous with count clock after the GTCNT value becomes the GTPR value). When the UD value changes from 0 to 1 with the UDF bit being 0 and while counting stops, the counter starts down-counting and the count direction changes at an underflow (the timing synchronous with count clock after the GTCNT value becomes 0).

When the UDF bit is set to 1 while counting stops, the UD bit value is reflected in the count direction when counting starts.

- In triangle-wave mode.

When the UD value changes during counting, the count direction does not change. When the UD value changes while the UDF bit is 0 and counting stops, the change is not reflected in the count direction when counting starts.

When the UDF bit is set to 1 while counting is stopped, the UD value is reflected in the count direction when counting starts.

### UD bit (Count Direction Setting)

The UD bit sets the count direction (up-counting or down-counting) for GTCNT.

### UDF bit (Forcible Count Direction Setting)

The UDF bit forcibly sets the count direction when GTCNT starts operation as the UD value. Only 0 should be written to this bit during counter operation. When 1 is written to this bit while counting stops, return this bit to 0 before counting starts.

### Output duty

- In saw-wave mode.

When the OADTY/OBDTY value changes during up-counting, the duty is reflected at an overflow (GTCNT = GTPR). When the OADTY/OBDTY value is changed during down-counting, the duty is reflected at an underflow (GTCNT = 0).

When the OADTY/OBDTY value changes to 1 with the OADTYF/OBDTYF bit being 0 and while counting stops the output duty is not reflected at the starting counter operation. When the count direction is up, the output duty is reflected at an overflow (GTCNT = GTPR). When the count direction is down, the output duty is reflected at an underflow (GTCNT = 0).

When the OADTY/OBDTY value changes to 0 with the OADTYF/OBDTYF bit being 1 and while counting stops, the output duty is reflected at starting counter operation.

- In triangle-wave mode.

When the OADTY/OBDTY value changes during counting, the duty is reflected at an underflow.

When the OADTY/OBDTY value changes to 1 with the OADTYF/OBDTYF bit being 0 and while counting stops, the output duty is not reflected at the starting counter operation. The output duty is reflected at an underflow.

When the OADTY/OBDTY value changes to 0 with the OADTYF/OBDTYF bit being 1 and while counting stops, the output duty is reflected at starting counter operation.

### OmDTY[1:0] bits (GTIOCm Output Duty Setting) (m = A, B)

The OmDTY[1:0] bits set the output duty (0%, 100% or compare match control) of the GTIOCm pin.

### OmDTYF bit (Forcible GTIOCm Output Duty Setting) (m = A, B)

The OmDTYF bit forcibly sets the output duty cycle to the OmDTY setting. Set this bit to 0 during counter operation. When OmDTYF bit is set to 1 while counting stops, return this bit to 0 until the first period ends after the counter starts.

### OmDTYR bit (GTIOCm Output Value Selecting after Releasing 0%/100% Duty Setting) (m = A, B)

The OmDTYR bit selects the value that is the object of output retained or toggled at cycle end, when the control changes from 0% or 100% duty setting to compare match for the GTIOCm pin and GTIOR. The GTIOM[3:2] bits are set to 00b (output retained at cycle end) or the GTIOR.GTIOM[3:2] bits are set to 11b (output toggled at cycle end).

The GPT internally continues to perform compare match operation while 0% or 100% duty operation is running. When the OmDTYR bit is set to 1, the value of the compare match at cycle end is applied to the GTIOR.GTIOM [3:2] bits.

如果在向上计数期间将UD值设置为0, 则计数方向会在溢出时发生变化 (GTCNT值变为GTPR值后与计数时钟同步的时序)。在递减计数期间将UD值设置为1时, 计数方向会在下溢 (GTCNT值变为0后与计数时钟同步的时序) 下发生变化。当UDF位为0时UD值从1变为0并且在计数停止时, 计数器开始向上计数并且计数方向在溢出时改变 (在GTCNT值变为GTPR值之后与计数时钟同步的时序)。当UDF位为0且UD值从0变为1且计数停止时, 计数器开始递减计数并且计数方向在下溢时改变 (GTCNT值变为0后与计数时钟同步的时序)。当计数停止时UDF位设置为1时, UD位值在计数开始时反映在计数方向上。

- 三角波模式。

计数过程中UD值变化时, 计数方向不变。当UDF位为0时UD值发生变化并且计数停止时, 该变化不会反映在计数开始时的计数方向上。当计数停止时UDF位设置为1时, UD值在计数开始时反映在计数方向上。

### UD位 (计数方向设置)

UD位设置GTCNT的计数方向 (向上计数或向下计数)。

### UDF位 (强制计数方向设置)

当GTCNT开始操作时, UDF位将计数方向强制设置为UD值。在计数器操作期间, 只能将0写入该位。当计数停止时向该位写入1时, 在计数开始前将该位返回0。

### 输出占空比

- 在锯齿波模式下。

当OADTYOBDTY值在递增计数期间发生变化时, 占空比反映在溢出处(GTCNT=GTPR)。

在递减计数期间更改OADTYOBDTY值时, 占空比反映为下溢(GTCNT=0)。当OADTYOBDTY值变为1且OADTYF/OBDTYF位为0并且在计数停止时, 输出占空比不会反映在开始计数器操作中。当计数方向向上时, 输出占空比反映在溢出处(GTCNT=GTPR)。当计数方向向下时, 输出占空比反映为下溢(GTCNT=0)。当OADTYOBDTY值变为0且OADTYFOBDTYF位为1且计数停止时, 输出占空比反映在开始计数器操作时。

- 三角波模式。

当计数期间OADTYOBDTY值发生变化时, 占空比反映为下溢。

当OADTYFOBDTYF位为0且OADTYOBDTY值变为1且计数停止时, 输出占空比不会反映在开始计数器操作中。输出占空比反映在下溢处。当OADTYOBDTY值变为0且OADTYFOBDTYF位为1且计数停止时, 输出占空比反映在开始计数器操作时。

### OmDTY[1:0]位 (GTIOCm输出占空比设置) (m=A, B)

OmDTY[1:0]位设置GTIOCm引脚的输出占空比 (0%、100%或比较匹配控制)。

### OmDTYF位 (强制GTIOCm输出占空比设置) (m=A, B)

OmDTYF位强制将输出占空比设置为OmDTY设置。在计数器操作期间将此位设置为0。什么时候OmDTYF位在计数停止时设置为1, 在计数器开始后第一个周期结束之前将该位返回0。

### OmDTYR位 (释放0%100%占空比设置后选择GTIOCm输出值) (m=A, B)

当控制从0%或100%占空比设置更改为GTIOCm引脚和GTIOR比较匹配时, OmDTYR位选择作为输出对象在周期结束时保留或切换的值。GTIOM[3:2]位设置为00b (输出在循环结束时保留) 或GTIOR.GTIOM[3:2]位设置为11b (输出在循环结束时切换)。

GPT在内部继续执行比较匹配操作, 而0%或100%占空比操作正在运行。当。。。的时候OmDTYR位设置为1, 循环结束时比较匹配的值应用于GTIOR.GTIOM[3:2]位。

21.2.14 GTIOR : General PWM Timer I/O Control Register

Base address: GPT32n = 0x4016\_9000 + 0x0100 × n (n = 0 to 3)  
GPT16m = 0x4016\_9000 + 0x0100 × m (m = 4 to 7)

Offset address: 0x34

|                    |            |    |       |    |    |           |    |     |        |         |    |            |    |    |    |    |
|--------------------|------------|----|-------|----|----|-----------|----|-----|--------|---------|----|------------|----|----|----|----|
| Bit position:      | 31         | 30 | 29    | 28 | 27 | 26        | 25 | 24  | 23     | 22      | 21 | 20         | 19 | 18 | 17 | 16 |
| Bit field:         | NFCSB[1:0] |    | NFBEN | —  | —  | OBDF[1:0] |    | OBE | OBHLD  | OBDFLT  | —  | GTIOB[4:0] |    |    |    |    |
| Value after reset: | 0          |    | 0     | 0  | 0  | 0         | 0  | 0   | 0      | 0       | 0  | 0          | 0  | 0  | 0  | 0  |
| Bit position:      | 15         | 14 | 13    | 12 | 11 | 10        | 9  | 8   | 7      | 6       | 5  | 4          | 3  | 2  | 1  | 0  |
| Bit field:         | NFCSA[1:0] |    | NFAEN | —  | —  | OADF[1:0] |    | OAE | OAHL D | OADFL T | —  | GTIOA[4:0] |    |    |    |    |
| Value after reset: | 0          |    | 0     | 0  | 0  | 0         | 0  | 0   | 0      | 0       | 0  | 0          | 0  | 0  | 0  | 0  |

| Bit   | Symbol     | Function   | R/W |
|-------|------------|--|-----|
| 4:0   | GTIOA[4:0] | GTIOCnA Pin Function Select<br>See Table 21.4.   | R/W |
| 5     | —          | This bit is read as 0. The write value should be 0.  | R/W |
| 6     | OADFLT     | GTIOCnA Pin Output Value Setting at the Count Stop<br>0: The GTIOCnA pin outputs low when counting stops<br>1: The GTIOCnA pin outputs high when counting stops  | R/W |
| 7     | OAHL D     | GTIOCnA Pin Output Setting at the Start/Stop Count<br>0: The GTIOCnA pin output level at the start or stop of counting depends on the register setting<br>1: The GTIOCnA pin output level is retained at the start or stop of counting | R/W |
| 8     | OAE        | GTIOCnA Pin Output Enable<br>0: Output is disabled<br>1: Output is enabled   | R/W |
| 10:9  | OADF[1:0]  | GTIOCnA Pin Disable Value Setting<br>00: Output disable is prohibited<br>01: GTIOCnA pin is set to Hi-Z on output disable<br>10: GTIOCnA pin is set to 0 on output disable<br>11: GTIOCnA pin is set to 1 on output disable            | R/W |
| 12:11 | —          | These bits are read as 0. The write value should be 0.   | R/W |
| 13    | NFAEN      | Noise Filter A Enable<br>0: The noise filter for the GTIOCnA pin is disabled<br>1: The noise filter for the GTIOCnA pin is enabled   | R/W |
| 15:14 | NFCSA[1:0] | Noise Filter A Sampling Clock Select<br>00: PCLKD/1<br>01: PCLKD/4<br>10: PCLKD/16<br>11: PCLKD/64   | R/W |
| 20:16 | GTIOB[4:0] | GTIOCnB Pin Function Select<br>See Table 21.4.   | R/W |
| 21    | —          | This bit is read as 0. The write value should be 0.  | R/W |
| 22    | OBDFLT     | GTIOCnB Pin Output Value Setting at the Count Stop<br>0: The GTIOCnB pin outputs low when counting stops<br>1: The GTIOCnB pin outputs high when counting stops  | R/W |
| 23    | OBHLD      | GTIOCnB Pin Output Setting at the Start/Stop Count<br>0: The GTIOCnB pin output level at the start/stop of counting depends on the register setting<br>1: The GTIOCnB pin output level is retained at the start/stop of counting       | R/W |
| 24    | OBE        | GTIOCnB Pin Output Enable<br>0: Output is disabled<br>1: Output is enabled   | R/W |

21.2.14 GTIOR: 通用PWM定时器IO控制寄存器

Base address: GPT32n = 0x4016\_9000 + 0x0100 × n (n = 0 to 3)  
GPT16m = 0x4016\_9000 + 0x0100 × m (m = 4 to 7)

Offset address: 0x34

|               |            |    |       |    |    |           |    |     |        |         |    |            |    |    |    |    |
|---------------|------------|----|-------|----|----|-----------|----|-----|--------|---------|----|------------|----|----|----|----|
| Bit position: | 31         | 30 | 29    | 28 | 27 | 26        | 25 | 24  | 23     | 22      | 21 | 20         | 19 | 18 | 17 | 16 |
| Bit field:    | NFCSB[1:0] |    | NFBEN | —  | —  | OBDF[1:0] |    | OBE | OBHLD  | OBDFLT  | —  | GTIOB[4:0] |    |    |    |    |
| 重置后的值:        | 0          |    | 0     | 0  | 0  | 0         | 0  | 0   | 0      | 0       | 0  | 0          | 0  | 0  | 0  | 0  |
| Bit position: | 15         | 14 | 13    | 12 | 11 | 10        | 9  | 8   | 7      | 6       | 5  | 4          | 3  | 2  | 1  | 0  |
| Bit field:    | NFCSA[1:0] |    | NFAEN | —  | —  | OADF[1:0] |    | OAE | OAHL D | OADFL T | —  | GTIOA[4:0] |    |    |    |    |
| 重置后的值:        | 0          |    | 0     | 0  | 0  | 0         | 0  | 0   | 0      | 0       | 0  | 0          | 0  | 0  | 0  | 0  |

| Bit   | Symbol     | Function   | R/W |
|-------|------------|--|-----|
| 4:0   | GTIOA[4:0] | GTIOCnA引脚功能选择<br>见表21.4。   | R/W |
| 5     | —          | 该位读取为0。写入值应为0。   | R/W |
| 6     | OADFLT     | 计数停止时的GTIOCnA引脚输出值设置<br>0: 计数停止时GTIOCnA引脚输出低电平<br>1: 计数停止时GTIOCnA引脚输出高电平                                       | R/W |
| 7     | OAHL D     | 开始停止计数时的GTIOCnA引脚输出设置<br>0: GTIOCnA引脚在计数开始或停止时的输出电平取决于寄存器设置<br>1: GTIOCnA引脚输出电平在计数开始或停止时保持不变                   | R/W |
| 8     | OAE        | GTIOCnA引脚输出使能<br>0: 禁用输出<br>1: 启用输出  | R/W |
| 10:9  | OADF[1:0]  | GTIOCnA引脚禁用值设置<br>00: 禁止输出<br>01: GTIOCnA引脚设置为Hi-Z, 输出禁止<br>10: GTIOCnA引脚设置为0, 输出禁止<br>11: GTIOCnA引脚设置为1, 输出禁止 | R/W |
| 12:11 | —          | 这些位被读取为0。写入值应为0。   | R/W |
| 13    | NFAEN      | 噪声滤波器A启用<br>0: GTIOCnA引脚的噪声滤波器禁用<br>1: GTIOCnA引脚的噪声滤波器启用   | R/W |
| 15:14 | NFCSA[1:0] | 噪声滤波器A采样时钟选择<br>00: PCLKD/1<br>01: PCLKD/4<br>10: PCLKD/16<br>11: PCLKD/64                                     | R/W |
| 20:16 | GTIOB[4:0] | GTIOCnB引脚功能选择<br>见表21.4。   | R/W |
| 21    | —          | 该位读取为0。写入值应为0。   | R/W |
| 22    | OBDFLT     | 计数停止时GTIOCnB引脚输出值设置<br>0: 计数停止时GTIOCnB引脚输出低电平<br>1: 计数停止时GTIOCnB引脚输出高电平  | R/W |
| 23    | OBHLD      | 开始停止计数时的GTIOCnB引脚输出设置<br>0: GTIOCnB引脚在计数开始停止时的输出电平取决于寄存器设置<br>1: GTIOCnB引脚输出电平在计数开始停止时保持                       | R/W |
| 24    | OBE        | GTIOCnB引脚输出使能<br>0: 禁用输出<br>1: 启用输出  | R/W |

| Bit   | Symbol     | Function  | R/W |
|-------|------------|---|-----|
| 26:25 | OBDF[1:0]  | GTIOCnB Pin Disable Value Setting<br>0 0: Output disable is prohibited<br>0 1: GTIOCnB pin is set to Hi-Z on output disable<br>1 0: GTIOCnB pin is set to 0 on output disable<br>1 1: GTIOCnB pin is set to 1 on output disable | R/W |
| 28:27 | —          | These bits are read as 0. The write value should be 0.  | R/W |
| 29    | NFBEN      | Noise Filter B Enable<br>0: The noise filter for the GTIOCnB pin is disabled<br>1: The noise filter for the GTIOCnB pin is enabled  | R/W |
| 31:30 | NFCSB[1:0] | Noise Filter B Sampling Clock Select<br>0 0: PCLKD/1<br>0 1: PCLKD/4<br>1 0: PCLKD/16<br>1 1: PCLKD/64  | R/W |

The GTIOR sets the functions of the GTIOCnA and GTIOCnB pins.

#### GTIOA[4:0] bits (GTIOCnA Pin Function Select)

The GTIOA[4:0] bits select the GTIOCnA pin function. For details, see [Table 21.4](#).

#### OADFLT bit (GTIOCnA Pin Output Value Setting at the Count Stop)

The OADFLT bit sets whether the GTIOCnA pin outputs high or low when counting stops.

#### OAHLDBit (GTIOCnA Pin Output Setting at the Start/Stop Count)

The OAHLDBit specifies whether the GTIOCnA pin output level is retained or the level at the start or stop of counting depends on the register setting.

When the OAHLDBit is set to 0:

- The value specified in bit [4] of the GTIOA[4:0] bits is output when counting starts
- The value specified in the OADFLT bit is output when counting stops
- If the OADFLT bit is modified while counting stops, the new value is immediately reflected in the output.

When the OAHLDBit is set to 1:

- The output is retained when counting starts or stops.

#### OAE bit (GTIOCnA Pin Output Enable)

The OAE bit disables or enables the GTIOCnA pin output.

When GTCCRA register is used as the input capture register (at least one bit in the GTICASR register is set to 1), the GTIOCnA pin does not output regardless of the OAE bit value.

#### OADF[1:0] bits (GTIOCnA Pin Disable Value Setting)

The OADF[1:0] bits select the output value of the GTIOCnA pin when an output disable request occurs.

#### NFAEN bit (Noise Filter A Enable)

The NFAEN bit disables or enables the noise filter for input from the GTIOCnA pin. Because changing the value of the bit might lead to the internal generation of an unexpected edge, select the output compare function for the relevant pin in the GTIOR register before doing so.

#### NFCSA[1:0] bits (Noise Filter A Sampling Clock Select)

The NFCSA[1:0] bits set the sampling interval for the noise filter of the GTIOCnA pin. When setting these bits, wait for 2 cycles of the selected sampling interval before setting the input capture function.

#### GTIOB[4:0] bits (GTIOCnB Pin Function Select)

The GTIOB[4:0] bits select the GTIOCnB pin function. For details, see [Table 21.4](#).

| Bit   | Symbol     | Function   | R/W |
|-------|------------|--|-----|
| 26:25 | OBDF[1:0]  | GTIOCnB引脚禁用值设置<br>00: 禁止输出01: GTIOCnB引脚在输出禁止时设置为Hi-Z10: GTIOCnB引脚在输出禁止时设置为0<br>11: GTIOCnB引脚在输出禁止时设置为1 | R/W |
| 28:27 | —          | 这些位被读取为0。写入值应为0。   | R/W |
| 29    | NFBEN      | 噪声滤波器B启用<br>0: GTIOCnB引脚的噪声滤波器禁用1: GTIOCnB引脚的噪声滤波器启用   | R/W |
| 31:30 | NFCSB[1:0] | 噪声滤波器B采样时钟选择<br>0 0: PCLKD/1<br>0 1: PCLKD/4<br>1 0: PCLKD/16<br>1 1: PCLKD/64                         | R/W |

GTIOR设置GTIOCnA和GTIOCnB引脚的功能。

#### GTIOA[4:0]位 (GTIOCnA引脚功能选择)

GTIOA[4:0]位选择GTIOCnA引脚功能。详见表21.4。

#### OADFLT位 (计数停止时的GTIOCnA引脚输出值设置)

OADFLT位设置当计数停止时GTIOCnA引脚输出高电平还是低电平。

#### OAHLDB位 (开始停止计数时的GTIOCnA引脚输出设置)

OAHLDB位指定是保留GTIOCnA引脚输出电平还是计数开始或停止时的电平取决于寄存器设置。

当OAHLDB位设置为0时:

- GTIOA[4:0]位的位[4]中指定的值在计数开始时输出
- 计数停止时输出OADFLT位中指定的值
- 如果在计数停止时修改OADFLT位，则新值会立即反映在输出中。

当OAHLDB位设置为1时:

- 计数开始或停止时保持输出。

#### OAE位 (GTIOCnA引脚输出使能)

OAE位禁用或启用GTIOCnA引脚输出。

当GTCCRA寄存器用作输入捕捉寄存器时 (GTICASR寄存器中至少有一位设置为1)，无论OAE位值如何，GTIOCnA引脚都不输出。

#### OADF[1:0]位 (GTIOCnA引脚禁用值设置)

当出现输出禁用请求时，OADF[1:0]位选择GTIOCnA引脚的输出值。

#### NFAEN位 (噪声滤波器A使能)

NFAEN位禁用或启用来自GTIOCnA引脚的输入的噪声滤波器。因为更改位的值可能会导致内部产生意外边沿，所以在此之前选择GTIOR寄存器中相关引脚的输出比较功能。

#### NFCSA[1:0]位 (噪声滤波器A采样时钟选择)

NFCSA[1:0]位设置GTIOCnA引脚噪声滤波器的采样间隔。设置这些位时，请等待所选采样间隔的2个周期，然后再设置输入捕捉功能。

#### GTIOB[4:0]位 (GTIOCnB引脚功能选择)

GTIOB[4:0]位选择GTIOCnB引脚功能。详见表21.4。



**OBDFLT bit (GTIOCnB Pin Output Value Setting at the Count Stop)**

The OBDFLT bit sets whether the GTIOCnB pin outputs high or low when counting stops.

**OBHLD bit (GTIOCnB Pin Output Setting at the Start/Stop Count)**

The OBHLD bit specifies whether the GTIOCnB pin output level is retained or the level at the start or stop of counting depends on the register setting.

When the OBHLD bit is set to 0:

- The value specified in bit [4] of the GTIOB[4:0] bits is output when counting starts
- The value specified in the OBDFLT bit is output when counting stops
- If the OBDFLT bit is modified while counting stops, the new value is immediately reflected in the output.

When the OBHLD bit is set to 1:

- The output is retained when counting starts or stops.

**OBE bit (GTIOCnB Pin Output Enable)**

The OBE bit disables or enables the GTIOCnB pin output.

When GTCCRB register is used as the input capture register (at least one bit in the GTICBSR register is set to 1), the GTIOCnB pin does not output regardless of the OBE bit value.

**OBDF[1:0] bits (GTIOCnB Pin Disable Value Setting)**

The OBDF[1:0] bits select the output value of the GTIOCnB pin, when an output disable request occurs.

**NFBEN bit (Noise Filter B Enable)**

The NFBEN bit disables or enables the noise filter for input from the GTIOCnB pin. Because changing the value of the bit might lead to the internal generation of an unexpected edge, select the output compare function for the relevant pin in the GTIOR register before doing so.

**NFCSB[1:0] bits (Noise Filter B Sampling Clock Select)**

The NFCSB[1:0] bits set the sampling interval for the noise filter of the GTIOCnB pin. When setting these bits, wait for 2 cycles of the selected sampling interval before setting the input capture function.

**OBDFLT位 (计数停止时GTIOCnB引脚输出值设置)**

OBDFLT位设置当计数停止时GTIOCnB引脚输出高电平还是低电平。

**OBHLD位 (GTIOCnB引脚输出设置在开始停止计数)**

OBHLD位指定是保留GTIOCnB引脚输出电平还是计数开始或停止时的电平取决于寄存器设置。

当OBHLD位设置为0时:

- GTIOB[4:0]位的位[4]中指定的值在计数开始时输出
- 计数停止时输出OBDFLT位中指定的值
- 如果在计数停止时修改了OBDFLT位, 则新值会立即反映在输出中。

当OBHLD位设置为1时:

- 计数开始或停止时保持输出。

**OBE位 (GTIOCnB引脚输出使能)**

OBE位禁用或启用GTIOCnB引脚输出。

当GTCCRB寄存器用作输入捕捉寄存器时 (GTICBSR寄存器中至少有一位设置为1), 无论OBE位值如何, GTIOCnB引脚都不输出。

**OBDF[1:0]位 (GTIOCnB引脚禁用值设置)**

当输出禁用请求发生时, OBDF[1:0]位选择GTIOCnB引脚的输出值。

**NFBEN位 (噪声滤波器B启用)**

NFBEN位禁用或启用来自GTIOCnB引脚的输入的噪声滤波器。因为更改位的值可能会导致内部产生意外边沿, 所以在此之前选择GTIOR寄存器中相关引脚的输出比较功能。

**NFCSB[1:0]位 (噪声滤波器B采样时钟选择)**

NFCSB[1:0]位设置GTIOCnB引脚噪声滤波器的采样间隔。设置这些位时, 请等待所选采样间隔的2个周期, 然后再设置输入捕捉功能。

Table 21.4 Settings of GTIOA[4:0] and GTIOB[4:0] bits

| GTIOA/GTIOB[4:0] bits |    |    |    |    | Function               |                              |  |
|-----------------------|----|----|----|----|------------------------|------------------------------|--|
| b4                    | b3 | b2 | b1 | b0 | b4                     | b3, b2 <sup>*1</sup> *2 *3   | b1, b0 <sup>*2</sup>                           |
| 0                     | 0  | 0  | 0  | 0  | Initial output is low  | Output retained at cycle end | Output retained at GTCCRA/GTCCRB compare match |
| 0                     | 0  | 0  | 0  | 1  |                        |                              | Low output at GTCCRA/GTCCRB compare match      |
| 0                     | 0  | 0  | 1  | 0  |                        |                              | High output at GTCCRA/GTCCRB compare match     |
| 0                     | 0  | 0  | 1  | 1  |                        |                              | Output toggled at GTCCRA/GTCCRB compare match  |
| 0                     | 0  | 1  | 0  | 0  |                        | Low output at cycle end      | Output retained at GTCCRA/GTCCRB compare match |
| 0                     | 0  | 1  | 0  | 1  |                        |                              | Low output at GTCCRA/GTCCRB compare match      |
| 0                     | 0  | 1  | 1  | 0  |                        |                              | High output at GTCCRA/GTCCRB compare match     |
| 0                     | 0  | 1  | 1  | 1  |                        |                              | Output toggled at GTCCRA/GTCCRB compare match  |
| 0                     | 1  | 0  | 0  | 0  |                        | High output at cycle end     | Output retained at GTCCRA/GTCCRB compare match |
| 0                     | 1  | 0  | 0  | 1  |                        |                              | Low output at GTCCRA/GTCCRB compare match      |
| 0                     | 1  | 0  | 1  | 0  |                        |                              | High output at GTCCRA/GTCCRB compare match     |
| 0                     | 1  | 0  | 1  | 1  |                        |                              | Output toggled at GTCCRA/GTCCRB compare match  |
| 0                     | 1  | 1  | 0  | 0  |                        | Output toggled at cycle end  | Output retained at GTCCRA/GTCCRB compare match |
| 0                     | 1  | 1  | 0  | 1  |                        |                              | Low output at GTCCRA/GTCCRB compare match      |
| 0                     | 1  | 1  | 1  | 0  |                        |                              | High output at GTCCRA/GTCCRB compare match     |
| 0                     | 1  | 1  | 1  | 1  |                        |                              | Output toggled at GTCCRA/GTCCRB compare match  |
| 1                     | 0  | 0  | 0  | 0  | Initial output is high | Output retained at cycle end | Output retained at GTCCRA/GTCCRB compare match |
| 1                     | 0  | 0  | 0  | 1  |                        |                              | Low output at GTCCRA/GTCCRB compare match      |
| 1                     | 0  | 0  | 1  | 0  |                        |                              | High output at GTCCRA/GTCCRB compare match     |
| 1                     | 0  | 0  | 1  | 1  |                        |                              | Output toggled at GTCCRA/GTCCRB compare match  |
| 1                     | 0  | 1  | 0  | 0  |                        | Low output at cycle end      | Output retained at GTCCRA/GTCCRB compare match |
| 1                     | 0  | 1  | 0  | 1  |                        |                              | Low output at GTCCRA/GTCCRB compare match      |
| 1                     | 0  | 1  | 1  | 0  |                        |                              | High output at GTCCRA/GTCCRB compare match     |
| 1                     | 0  | 1  | 1  | 1  |                        |                              | Output toggled at GTCCRA/GTCCRB compare match  |
| 1                     | 1  | 0  | 0  | 0  |                        | High output at cycle end     | Output retained at GTCCRA/GTCCRB compare match |
| 1                     | 1  | 0  | 0  | 1  |                        |                              | Low output at GTCCRA/GTCCRB compare match      |
| 1                     | 1  | 0  | 1  | 0  |                        |                              | High output at GTCCRA/GTCCRB compare match     |
| 1                     | 1  | 0  | 1  | 1  |                        |                              | Output toggled at GTCCRA/GTCCRB compare match  |
| 1                     | 1  | 1  | 0  | 0  |                        | Output toggled at cycle end  | Output retained at GTCCRA/GTCCRB compare match |
| 1                     | 1  | 1  | 0  | 1  |                        |                              | Low output at GTCCRA/GTCCRB compare match      |
| 1                     | 1  | 1  | 1  | 0  |                        |                              | High output at GTCCRA/GTCCRB compare match     |
| 1                     | 1  | 1  | 1  | 1  |                        |                              | Output toggled at GTCCRA/GTCCRB compare match  |

Note 1. The cycle end means an overflow (GTCNT changes from GTPR to 0 in up-counting) or underflow (GTCNT changes from 0 to GTPR in down-counting). The GTCNT counter is cleared for saw waves and for the trough (GTCNT changes from 0 to 1) for triangle waves.

Note 2. When the timing of a cycle end and the timing of a GTCCRA/GTCCRB compare match are the same in a compare-match operation, the b3 and b2 settings are given priority in saw-wave PWM mode, and the b1 and b0 settings are given priority in any other mode.

Note 3. In event count operation where at least one bit in GTUPSR or GTDNSR is set to 1, the setting of b3 and b2 is ignored.

Table 21.4 GTIOA[4:0]和GTIOB[4:0]位的设置

| GTIOA/GTIOB[4:0] bits |    |    |    |    | Function |                            |                        |
|-----------------------|----|----|----|----|----------|----------------------------|------------------------|
| b4                    | b3 | b2 | b1 | b0 | b4       | b3, b2 <sup>*1</sup> *2 *3 | b1, b0 <sup>*2</sup>   |
| 0                     | 0  | 0  | 0  | 0  | 初始输出低    | 输出在循环结束时保留                 | GTCCRAGTCCRB比较匹配时保留的输出 |
| 0                     | 0  | 0  | 0  | 1  |          |                            | GTCCRAGTCCRB比较匹配时的低输出  |
| 0                     | 0  | 0  | 1  | 0  |          |                            | GTCCRAGTCCRB比较匹配时的高输出  |
| 0                     | 0  | 0  | 1  | 1  |          |                            | 在GTCCRAGTCCRB比较匹配时切换输出 |
| 0                     | 0  | 1  | 0  | 0  |          | 循环结束时输出低                   | GTCCRAGTCCRB比较匹配时保留的输出 |
| 0                     | 0  | 1  | 0  | 1  |          |                            | GTCCRAGTCCRB比较匹配时的低输出  |
| 0                     | 0  | 1  | 1  | 0  |          |                            | GTCCRAGTCCRB比较匹配时的高输出  |
| 0                     | 0  | 1  | 1  | 1  |          |                            | 在GTCCRAGTCCRB比较匹配时切换输出 |
| 0                     | 1  | 0  | 0  | 0  |          | 循环结束时的高输出                  | GTCCRAGTCCRB比较匹配时保留的输出 |
| 0                     | 1  | 0  | 0  | 1  |          |                            | GTCCRAGTCCRB比较匹配时的低输出  |
| 0                     | 1  | 0  | 1  | 0  |          |                            | GTCCRAGTCCRB比较匹配时的高输出  |
| 0                     | 1  | 0  | 1  | 1  |          |                            | 在GTCCRAGTCCRB比较匹配时切换输出 |
| 0                     | 1  | 1  | 0  | 0  |          | 输出在循环结束时切换                 | GTCCRAGTCCRB比较匹配时保留的输出 |
| 0                     | 1  | 1  | 0  | 1  |          |                            | GTCCRAGTCCRB比较匹配时的低输出  |
| 0                     | 1  | 1  | 1  | 0  |          |                            | GTCCRAGTCCRB比较匹配时的高输出  |
| 0                     | 1  | 1  | 1  | 1  |          |                            | 在GTCCRAGTCCRB比较匹配时切换输出 |
| 1                     | 0  | 0  | 0  | 0  | 初始输出高    | 输出在循环结束时保留                 | GTCCRAGTCCRB比较匹配时保留的输出 |
| 1                     | 0  | 0  | 0  | 1  |          |                            | GTCCRAGTCCRB比较匹配时的低输出  |
| 1                     | 0  | 0  | 1  | 0  |          |                            | GTCCRAGTCCRB比较匹配时的高输出  |
| 1                     | 0  | 0  | 1  | 1  |          |                            | 在GTCCRAGTCCRB比较匹配时切换输出 |
| 1                     | 0  | 1  | 0  | 0  |          | 循环结束时输出低                   | GTCCRAGTCCRB比较匹配时保留的输出 |
| 1                     | 0  | 1  | 0  | 1  |          |                            | GTCCRAGTCCRB比较匹配时的低输出  |
| 1                     | 0  | 1  | 1  | 0  |          |                            | GTCCRAGTCCRB比较匹配时的高输出  |
| 1                     | 0  | 1  | 1  | 1  |          |                            | 在GTCCRAGTCCRB比较匹配时切换输出 |
| 1                     | 1  | 0  | 0  | 0  |          | 循环结束时的高输出                  | GTCCRAGTCCRB比较匹配时保留的输出 |
| 1                     | 1  | 0  | 0  | 1  |          |                            | GTCCRAGTCCRB比较匹配时的低输出  |
| 1                     | 1  | 0  | 1  | 0  |          |                            | GTCCRAGTCCRB比较匹配时的高输出  |
| 1                     | 1  | 0  | 1  | 1  |          |                            | 在GTCCRAGTCCRB比较匹配时切换输出 |
| 1                     | 1  | 1  | 0  | 0  |          | 输出在循环结束时切换                 | GTCCRAGTCCRB比较匹配时保留的输出 |
| 1                     | 1  | 1  | 0  | 1  |          |                            | GTCCRAGTCCRB比较匹配时的低输出  |
| 1                     | 1  | 1  | 1  | 0  |          |                            | GTCCRAGTCCRB比较匹配时的高输出  |
| 1                     | 1  | 1  | 1  | 1  |          |                            | 在GTCCRAGTCCRB比较匹配时切换输出 |

注1.循环结束是指上溢（递增计数时GTCNT从GTPR变为0）或下溢（递减计数时GTCNT从0变为GTPR）。锯齿波和波谷（GTCNT从0变为1）的三角波清除GTCNT计数器。

注2.在比较匹配操作中，当一个周期结束的时序和GTCCRAGTCCRB比较匹配的时序相同时，在锯齿波PWM模式下，b3和b2设置优先，b1和b0设置优先在任何其他模式下都具有优先权。

注3.在GTUPSR或GTDNSR中至少一位设置为1的事件计数操作中，忽略b3和b2的设置。



## 21.2.15 GTINTAD : General PWM Timer Interrupt Output Setting Register

Base address: GPT32n = 0x4016\_9000 + 0x0100 × n (n = 0 to 3)  
GPT16m = 0x4016\_9000 + 0x0100 × m (m = 4 to 7)

Offset address: 0x38

|                    |    |            |            |    |    |    |          |    |    |    |    |    |    |    |    |    |
|--------------------|----|------------|------------|----|----|----|----------|----|----|----|----|----|----|----|----|----|
| Bit position:      | 31 | 30         | 29         | 28 | 27 | 26 | 25       | 24 | 23 | 22 | 21 | 20 | 19 | 18 | 17 | 16 |
| Bit field:         | —  | GRPA<br>BL | GRPA<br>BH | —  | —  | —  | GRP[1:0] | —  | —  | —  | —  | —  | —  | —  | —  | —  |
| Value after reset: | 0  | 0          | 0          | 0  | 0  | 0  | 0        | 0  | 0  | 0  | 0  | 0  | 0  | 0  | 0  | 0  |
| Bit position:      | 15 | 14         | 13         | 12 | 11 | 10 | 9        | 8  | 7  | 6  | 5  | 4  | 3  | 2  | 1  | 0  |
| Bit field:         | —  | —          | —          | —  | —  | —  | —        | —  | —  | —  | —  | —  | —  | —  | —  | —  |
| Value after reset: | 0  | 0          | 0          | 0  | 0  | 0  | 0        | 0  | 0  | 0  | 0  | 0  | 0  | 0  | 0  | 0  |

| Bit   | Symbol   | Function   | R/W |
|-------|----------|--|-----|
| 23:0  | —        | These bits are read as 0. The write value should be 0.   | R/W |
| 25:24 | GRP[1:0] | Output Disable Source Select<br>0 0: Group A output disable request is selected<br>0 1: Group B output disable request is selected<br>1 0: Group C output disable request is selected<br>1 1: Group D output disable request is selected | R/W |
| 28:26 | —        | These bits are read as 0. The write value should be 0.   | R/W |
| 29    | GRPABH   | Same Time Output Level High Disable Request Enable<br>0: Same time output level high disable request disabled<br>1: Same time output level high disable request enabled  | R/W |
| 30    | GRPABL   | Same Time Output Level Low Disable Request Enable<br>0: Same time output level low disable request disabled<br>1: Same time output level low disable request enabled   | R/W |
| 31    | —        | This bit is read as 0. The write value should be 0.  | R/W |

The GTINTAD enables or disables interrupt requests and output disable requests.

**GRP[1:0] bits (Output Disable Source Select)**

The GRP[1:0] bits select the GTIOCnA pin and GTIOCnB pin output disable sources.

GTST.ODF shows the request of the output disable source group that is selected with the GRP[1:0] bits. Set the GRP[1:0] bits when both GTIOR.OAE and GTIOR.OBE bits are 0.

**GRPABH bit (Same Time Output Level High Disable Request Enable)**

The GRPABH bit enables or disables the output disable request when the GTIOCnA pin and GTIOCnB pin output 1 at the same time.

**GRPABL bit (Same Time Output Level Low Disable Request Enable)**

The GRPABL bit enables or disables the output disable request when the GTIOCnA pin and GTIOCnB pin output 0 at the same time.

## 21.2.15 GTINTAD:通用PWM定时器中断输出设置寄存器

Base address: GPT32n = 0x4016\_9000 + 0x0100 × n (n = 0 to 3)  
GPT16m = 0x4016\_9000 + 0x0100 × m (m = 4 to 7)

Offset address: 0x38

|               |    |            |            |    |    |    |          |    |    |    |    |    |    |    |    |    |
|---------------|----|------------|------------|----|----|----|----------|----|----|----|----|----|----|----|----|----|
| Bit position: | 31 | 30         | 29         | 28 | 27 | 26 | 25       | 24 | 23 | 22 | 21 | 20 | 19 | 18 | 17 | 16 |
| Bit field:    | —  | GRPA<br>BL | GRPA<br>BH | —  | —  | —  | GRP[1:0] | —  | —  | —  | —  | —  | —  | —  | —  | —  |
| 重置后的值:        | 0  | 0          | 0          | 0  | 0  | 0  | 0        | 0  | 0  | 0  | 0  | 0  | 0  | 0  | 0  | 0  |
| Bit position: | 15 | 14         | 13         | 12 | 11 | 10 | 9        | 8  | 7  | 6  | 5  | 4  | 3  | 2  | 1  | 0  |
| Bit field:    | —  | —          | —          | —  | —  | —  | —        | —  | —  | —  | —  | —  | —  | —  | —  | —  |
| 重置后的值:        | 0  | 0          | 0          | 0  | 0  | 0  | 0        | 0  | 0  | 0  | 0  | 0  | 0  | 0  | 0  | 0  |

| Bit   | Symbol   | Function  | R/W |
|-------|----------|---|-----|
| 23:0  | —        | 这些位被读取为0。写入值应为0。  | R/W |
| 25:24 | GRP[1:0] | 输出禁用源选择<br>0 0: 选择A组输出禁用请求选择B组输出禁用请<br>0 1: 求选择C 组输出禁用请求选择D组输出禁用<br>1 0: 请求<br>1 1: | R/W |
| 28:26 | —        | 这些位被读取为0。写入值应为0。  | R/W |
| 29    | GRPABH   | 同时输出电平高禁用请求启用<br>0: 禁止同时输出电平高禁止请求1: 允许同时输出电<br>高禁止请求                                | R/W |
| 30    | GRPABL   | 同时输出电平低禁用请求启用<br>0: 禁止同时输出电平低禁止请求1: 允许同时输出电<br>低禁止请求                                | R/W |
| 31    | —        | 该位读取为0。写入值应为0。  | R/W |

GTINTAD启用或禁用中断请求和输出禁用请求。

**GRP[1:0]位 (输出禁用源选择)**

GRP[1:0]位选择GTIOCnA引脚和GTIOCnB引脚输出禁用源。

GTST.ODF显示了使用GRP[1:0]位选择的输出禁用源组的请求。当GTIOR.OAE和GTIOR.OBE位均为0时，设置GRP[1:0]位。

**GRPABH位 (同时输出电平高禁用请求启用)**

GRPABH位允许或禁止GTIOCnA引脚和GTIOCnB引脚同时输出1时的输出禁止请求。

**GRPABL位 (同时输出电平低禁用请求启用)**

当GTIOCnA引脚和GTIOCnB引脚同时输出0时，GRPABL位允许或禁止输出禁止请求。

21.2.16 GTST : General PWM Timer Status Register

Base address: GPT32n = 0x4016\_9000 + 0x0100 × n (n = 0 to 3)  
GPT16m = 0x4016\_9000 + 0x0100 × m (m = 4 to 7)

Offset address: 0x3C

|                    |      |           |           |    |    |    |    |     |           |           |      |      |      |      |      |      |
|--------------------|------|-----------|-----------|----|----|----|----|-----|-----------|-----------|------|------|------|------|------|------|
| Bit position:      | 31   | 30        | 29        | 28 | 27 | 26 | 25 | 24  | 23        | 22        | 21   | 20   | 19   | 18   | 17   | 16   |
| Bit field:         | PCF  | OABL<br>F | OABH<br>F | —  | —  | —  | —  | ODF | —         | —         | —    | —    | —    | —    | —    | —    |
| Value after reset: | 0    | 0         | 0         | 0  | 0  | 0  | 0  | 0   | 0         | 0         | 0    | 0    | 0    | 0    | 0    | 0    |
| Bit position:      | 15   | 14        | 13        | 12 | 11 | 10 | 9  | 8   | 7         | 6         | 5    | 4    | 3    | 2    | 1    | 0    |
| Bit field:         | TUCF | —         | —         | —  | —  | —  | —  | —   | TCFP<br>U | TCFP<br>O | TCFF | TCFE | TCFD | TCFC | TCFB | TCFA |
| Value after reset: | 1    | 0         | 0         | 0  | 0  | 0  | 0  | 0   | 0         | 0         | 0    | 0    | 0    | 0    | 0    | 0    |

| Bit   | Symbol | Function  | R/W     |
|-------|--------|---|---------|
| 0     | TCFA   | Input Capture/Compare Match Flag A<br>0: No input capture/compare match of GTCCRA is generated<br>1: An input capture/compare match of GTCCRA is generated      | R/(W)*1 |
| 1     | TCFB   | Input Capture/Compare Match Flag B<br>0: No input capture/compare match of GTCCRB is generated<br>1: An input capture/compare match of GTCCRB is generated      | R/(W)*1 |
| 2     | TCFC   | Input Compare Match Flag C<br>0: No compare match of GTCCRC is generated<br>1: A compare match of GTCCRC is generated   | R/(W)*1 |
| 3     | TCFD   | Input Compare Match Flag D<br>0: No compare match of GTCCRD is generated<br>1: A compare match of GTCCRD is generated   | R/(W)*1 |
| 4     | TCFE   | Input Compare Match Flag E<br>0: No compare match of GTCCRE is generated<br>1: A compare match of GTCCRE is generated   | R/(W)*1 |
| 5     | TCFF   | Input Compare Match Flag F<br>0: No compare match of GTCCRF is generated<br>1: A compare match of GTCCRF is generated   | R/(W)*1 |
| 6     | TCFPO  | Overflow Flag<br>0: No overflow (crest) occurred<br>1: An overflow (crest) occurred   | R/(W)*1 |
| 7     | TCFPU  | Underflow Flag<br>0: No underflow (trough) occurred<br>1: An underflow (trough) occurred  | R/(W)*1 |
| 14:8  | —      | These bits are read as 0. The write value should be 0.  | R/W     |
| 15    | TUCF   | Count Direction Flag<br>0: GTCNT counter counts downward<br>1: GTCNT counter counts upward  | R       |
| 23:16 | —      | These bits are read as 0. The write value should be 0.  | R/W     |
| 24    | ODF    | Output Disable Flag<br>0: No output disable request is generated<br>1: An output disable request is generated   | R       |
| 28:25 | —      | These bits are read as 0. The write value should be 0.  | R/W     |
| 29    | OABHF  | Same Time Output Level High Flag<br>0: GTIOCnA pin and GTIOCnB pin do not output 1 at the same time<br>1: GTIOCnA pin and GTIOCnB pin output 1 at the same time | R       |
| 30    | OABLF  | Same Time Output Level Low Flag<br>0: GTIOCnA pin and GTIOCnB pin do not output 0 at the same time<br>1: GTIOCnA pin and GTIOCnB pin output 0 at the same time  | R       |

21.2.16 GTST: 通用PWM定时器状态寄存器

Base address: GPT32n = 0x4016\_9000 + 0x0100 × n (n = 0 to 3)  
GPT16m = 0x4016\_9000 + 0x0100 × m (m = 4 to 7)

Offset address: 0x3C

|               |      |           |           |    |    |    |    |     |           |           |      |      |      |      |      |      |
|---------------|------|-----------|-----------|----|----|----|----|-----|-----------|-----------|------|------|------|------|------|------|
| Bit position: | 31   | 30        | 29        | 28 | 27 | 26 | 25 | 24  | 23        | 22        | 21   | 20   | 19   | 18   | 17   | 16   |
| Bit field:    | PCF  | OABL<br>F | OABH<br>F | —  | —  | —  | —  | ODF | —         | —         | —    | —    | —    | —    | —    | —    |
| 重置后的值:        | 0    | 0         | 0         | 0  | 0  | 0  | 0  | 0   | 0         | 0         | 0    | 0    | 0    | 0    | 0    | 0    |
| Bit position: | 15   | 14        | 13        | 12 | 11 | 10 | 9  | 8   | 7         | 6         | 5    | 4    | 3    | 2    | 1    | 0    |
| Bit field:    | TUCF | —         | —         | —  | —  | —  | —  | —   | TCFP<br>U | TCFP<br>O | TCFF | TCFE | TCFD | TCFC | TCFB | TCFA |
| 重置后的值:        | 1    | 0         | 0         | 0  | 0  | 0  | 0  | 0   | 0         | 0         | 0    | 0    | 0    | 0    | 0    | 0    |

| Bit   | Symbol | Function   | R/W     |
|-------|--------|--|---------|
| 0     | TCFA   | 输入捕捉比较匹配标志A<br>0: 不产生GTCCRA的输入捕捉比较匹配1: 产生GTCCRA的输入捕捉比较匹配             | R/(W)*1 |
| 1     | TCFB   | 输入捕捉比较匹配标志B<br>0: 不生成GTCCRB的输入捕捉比较匹配1: 生成GTCCRB的输入捕捉比较匹配             | R/(W)*1 |
| 2     | TCFC   | 输入比较匹配标志C<br>0: 没有生成GTCCRC的比较匹配1: 生成了GTCCRC的比较匹配                     | R/(W)*1 |
| 3     | TCFD   | 输入比较匹配标志D<br>0: 不产生GTCCRD的比较匹配1: 产生GTCCRD的比较匹配                       | R/(W)*1 |
| 4     | TCFE   | 输入比较匹配标志E<br>0: 不生成GTCCRE的比较匹配1: 生成GTCCRE的比较匹配                       | R/(W)*1 |
| 5     | TCFF   | 输入比较匹配标志F<br>0: 不产生GTCCRF的比较匹配1: 产生GTCCRF的比较匹配                       | R/(W)*1 |
| 6     | TCFPO  | 溢出标志<br>0: 未发生溢出 (波峰) 1: 发生溢出 (波峰)                                   | R/(W)*1 |
| 7     | TCFPU  | Underflow Flag<br>0: 未发生下溢 (波谷) 1: 发生下溢 (波谷)                         | R/(W)*1 |
| 14:8  | —      | 这些位被读取为0。写入值应为0。   | R/W     |
| 15    | TUCF   | 计数方向标志<br>0: GTCNT计数器向下计数1: GTCNT计数器向上计数                             | R       |
| 23:16 | —      | 这些位被读取为0。写入值应为0。   | R/W     |
| 24    | ODF    | 输出禁用标志<br>0: 不产生输出禁止请求1: 产生输出禁止请求                                    | R       |
| 28:25 | —      | 这些位被读取为0。写入值应为0。   | R/W     |
| 29    | OABHF  | 同时输出电平高标志<br>0: GTIOCnA管脚和GTIOCnB管脚不同时输出11: GTIOCnA管脚和GTIOCnB管脚同时输出1 | R       |
| 30    | OABLF  | 同时输出电平低标志<br>0: GTIOCnA管脚和GTIOCnB管脚不同时输出01: GTIOCnA管脚和GTIOCnB管脚同时输出0 | R       |

| Bit | Symbol | Function   | R/W     |
|-----|--------|--|---------|
| 31  | PCF    | Period Count Function Finish Flag<br>0: No period count function finish has occurred<br>1: A period count function finish has occurred | R/(W)*1 |

Note 1. Only 0 can be written to this bit. Do not write 1.

The GTST indicates the status of the GPT.

#### TCFA flag (Input Capture/Compare Match Flag A)

The TCFA flag indicates the status for the input capture or compare match of GTCCRA.

[Setting conditions]

- GTCNT = GTCCRA, when the GTCCRA register functions as a compare match register
- GTCNT counter value is transferred to GTCCRA by the input capture signal when the GTCCRA register functions as an input capture register.

[Clearing condition]

- 0 is written to this flag.

#### TCFB flag (Input Capture/Compare Match Flag B)

The TCFB flag indicates the status for the input capture or compare match of GTCCRB.

[Setting conditions]

- GTCNT = GTCCRB, when the GTCCRB register functions as a compare match register
- GTCNT counter value is transferred to GTCCRB by the input capture signal when the GTCCRB register functions as an input capture register.

[Clearing condition]

- 0 is written to this flag.

#### TCFC flag (Input Compare Match Flag C)

The TCFC flag indicates the status for the compare match of GTCCRC.

[Setting condition]

- GTCNT = GTCCRC.

[Clearing condition]

- 0 is written to this flag.

[Not comparing condition]

- GTCR.MD[2:0] = 001b (saw-wave one-shot pulse mode)
- GTCR.MD[2:0] = 110b (triangle-wave PWM mode 3)
- GTBER.CCRA[1:0] = 01b, 10b, 11b (GTCCRC performs buffer operation).

#### TCFD flag (Input Compare Match Flag D)

The TCFD flag indicates the status for the compare match of GTCCRD.

[Setting condition]

- GTCNT = GTCCRD.

[Clearing condition]

- 0 is written to this flag.

[Not comparing condition]

- GTCR.MD[2:0] = 001b (saw-wave one-shot pulse mode)

| Bit | Symbol | Function                                       | R/W     |
|-----|--------|--|---------|
| 31  | PCF    | 周期计数功能完成标志<br>0: 未发生周期计数功能完成<br>1: 已发生周期计数功能完成 | R/(W)*1 |

注1.该位只能写入0。不要写1。

GTST指示GPT的状态。

#### TCFA标志 (输入捕捉比较匹配标志A)

TCFA标志指示GTCCRA的输入捕获或比较匹配的状态。

[Setting conditions]

- GTCNT=GTCCRA，当GTCCRA寄存器用作比较匹配寄存器时
- 当GTCCRA寄存器用作输入捕捉寄存器时，GTCNT计数器值通过输入捕捉信号传送到GTCCRA。

[Clearing condition]

- 0写入此标志。

#### TCFB标志 (输入捕捉比较匹配标志B)

TCFB标志指示GTCCRB的输入捕获或比较匹配的状态。

[Setting conditions]

- GTCNT=GTCCRB，当GTCCRB寄存器用作比较匹配寄存器时
- 当GTCCRB寄存器用作输入捕捉寄存器时，GTCNT计数器值通过输入捕捉信号传送到GTCCRB。

[Clearing condition]

- 0写入此标志。

#### TCFC标志 (输入比较匹配标志C)

TCFC标志指示GTCCRC比较匹配的状态。

[Setting condition]

- GTCNT = GTCCRC.

[Clearing condition]

- 0写入此标志。

[Not comparing condition]

- GTCR.MD[2:0] = 001b (saw-wave one-shot pulse mode)
- GTCR.MD[2:0] = 110b (triangle-wave PWM mode 3)
- GTBER.CCRA[1:0]=01b 10b 11b (GTCCRC执行缓冲操作)。

#### TCFD标志 (输入比较匹配标志D)

TCFD标志指示GTCCRD比较匹配的状态。

[Setting condition]

- GTCNT = GTCCRD.

[Clearing condition]

- 0写入此标志。

[Not comparing condition]

- GTCR.MD[2:0] = 001b (saw-wave one-shot pulse mode)

- GTCR.MD[2:0] = 110b (Triangle-wave PWM mode 3)
- GTBER.CCRA[1:0] = 10b, 11b (GTCCRD performs buffer operation).

**TCFE flag (Input Compare Match Flag E)**

The TCFE flag indicates the status for the compare match of GTCCRE.

[Setting condition]

- GTCNT = GTCCRE.

[Clearing condition]

- 0 is written to this flag.

[Not comparing condition]

- GTCR.MD[2:0] = 001b (saw-wave one-shot pulse mode)
- GTCR.MD[2:0] = 110b (Triangle-wave PWM mode 3)
- GTBER.CCRB[1:0] = 01b, 10b, 11b (GTCCRE performs buffer operation).

**TCFF flag (Input Compare Match Flag F)**

The TCFF flag indicates the status for the compare match of GTCCRF.

[Setting condition]

- GTCNT = GTCCRF.

[Clearing condition]

- 0 is written to this flag.

[Not comparing condition]

- GTCR.MD[2:0] = 001b (saw-wave one-shot pulse mode)
- GTCR.MD[2:0] = 110b (Triangle-wave PWM mode 3)
- GTBER.CCRB[1:0] = 10b, 11b (GTCCRF performs buffer operation).

**TCFPO flag (Overflow Flag)**

The TCFPO flag indicates when an overflow or crest has occurred.

[Setting conditions]

- In saw-wave mode, an overflow (GTCNT changes from GTPR to 0 in up-counting) has occurred
- In triangle-wave mode, a crest (GTCNT changes from GTPR to GTPR - 1) has occurred
- In counting by hardware sources, an overflow (GTCNT changes from GTPR to 0 in up-counting) has occurred.

[Clearing condition]

- 0 is written to this flag.

**TCFPU flag (Underflow Flag)**

The TCFPU flag indicates when an underflow or trough has occurred.

[Setting conditions]

- In saw-wave mode, an underflow (GTCNT changes from 0 to GTPR in down-counting) has occurred
- In triangle-wave mode, a crest (GTCNT changes from 0 to 1) has occurred
- In counting by hardware sources, an underflow (GTCNT changes from 0 to GTPR in down-counting) has occurred.

[Clearing condition]

- 0 is written to this bit.

- GTCR.MD[2:0] = 110b (Triangle-wave PWM mode 3)
- GTBER.CCRA[1:0]=10b 11b (GTCCRD执行缓冲操作)。

**TCFE标志 (输入比较匹配标志E)**

TCFE标志指示GTCCRE比较匹配的状态。

[Setting condition]

- GTCNT = GTCCRE.

[Clearing condition]

- 0写入此标志。

[Not comparing condition]

- GTCR.MD[2:0] = 001b (saw-wave one-shot pulse mode)
- GTCR.MD[2:0] = 110b (Triangle-wave PWM mode 3)
- GTBER.CCRB[1:0]=01b 10b 11b (GTCCRE执行缓冲操作)。

**TCFF标志 (输入比较匹配标志F)**

TCFF标志表示GTCCRF比较匹配的状态。

[Setting condition]

- GTCNT = GTCCRF.

[Clearing condition]

- 0写入此标志。

[Not comparing condition]

- GTCR.MD[2:0] = 001b (saw-wave one-shot pulse mode)
- GTCR.MD[2:0] = 110b (Triangle-wave PWM mode 3)
- GTBER.CCRB[1:0]=10b 11b (GTCCRF执行缓冲操作)。

**TCFPO flag (Overflow Flag)**

TCFPO标志指示何时发生溢出或波峰。

[Setting conditions]

- 在锯齿波模式下，发生溢出 (GTCNT在递增计数中从GTPR变为0)
- 在三角波模式中，出现波峰 (GTCNT从GTPR变为GTPR1)
- 在硬件源的计数中，发生了溢出 (GTCNT在递增计数中从GTPR变为0)。

[Clearing condition]

- 0写入此标志。

**TCFPU flag (Underflow Flag)**

TCFPU标志指示何时发生下溢或波谷。

[Setting conditions]

- 在锯齿波模式下，发生下溢 (GTCNT在向下计数中从0变为GTPR)
- 在三角波模式下，出现波峰 (GTCNT从0变为1)
- 在硬件源计数中，发生了下溢 (向下计数时GTCNT从0变为GTPR)。

[Clearing condition]

- 0写入该位。



**TUCF flag (Count Direction Flag)**

The TUCF flag indicates the count direction of GTCNT. In event count operation, this flag is set to 1 in up-counting and to 0 in down-counting.

**ODF flag (Output Disable Flag)**

The ODF flag shows the request of the output disable source group that is selected in the GRP[1:0] bits.

When output is disabled, an output disable control is not released within the same cycle in which an output disable request is negated. It is released in the next cycle.

**OABHF flag (Same Time Output Level High Flag)**

The OABHF flag indicates that the GTIOCnA pin and GTIOCnB pin output 1 at the same time.

When the GTIOCnA or GTIOCnB pin outputs 0, this flag returns to 0. This flag is read only. Writing 0 to clear the flag is prohibited.

When an interrupt by the OABHF flag is enabled (GTINTAD.GRPABH = 1), the OABHF flag is output to POEG as an output disable request.

[Setting condition]

- The GTIOCnA and GTIOCnB pins output 1 at the same time when both OAE and OBE bits are set to 1.

[Clearing conditions]

- The GTIOCnA pin output value is different from the GTIOCnB pin output value when both OAE and OBE bits are set to 1
- The GTIOCnA and GTIOCnB pins output 0 at the same time when both OAE and OBE bits are set to 1
- Either the OAE bit or OBE bit is set to 0.

**OABLF flag (Same Time Output Level Low Flag)**

The OABLF flag indicates that the GTIOCnA and GTIOCnB pins output 0 at the same time.

When the GTIOCnA pin or GTIOCnB pin outputs 1, this flag returns to 0. This flag is read only. Writing 0 to clear the flag is prohibited.

When an interrupt by the OABLF flag is enabled (GTINTAD.GRPABL = 1), the OABLF flag is output to POEG as an output disable request.

[Setting condition]

- The GTIOCnA and GTIOCnB pins output 0 at the same time when both OAE and OBE bits are set to 1.

[Clearing conditions]

- The GTIOCnA pin output value is different from the GTIOCnB pin output value when both OAE and OBE bits are set to 1
- The GTIOCnA and GTIOCnB pins output 1 at the same time when both OAE and OBE bits are set to 1
- Either the OAE bit or the OBE bit is set to 0.

The compare-target signals to generate the OABHF/OABLF flag are the compare match outputs (PWM outputs) signals before they are masked by the output disable function. When the output disable state is active, a compare match is performed continuously in the GPT and the OABHF/OABLF flag is updated in association with the result of the compared value.

**PCF flag (Period Count Function Finish Flag)**

This bit is status flag of period count function finish.

[Setting condition]

- The GTPC.PCEN bit is 1 and the GTPC.PCNT counter is 1 at the end of cycle.
- The GTPC.PCEN bit is 1 and the GTPC.PCNT counter is 0 at the count clock.

[Clearing condition]

**TUCF标志 (计数方向标志)**

TUCF标志表示GTCNT的计数方向。在事件计数操作中, 该标志在递增计数时设置为1, 在递减计数时设置为0。

**ODF标志 (输出禁用标志)**

ODF标志显示在GRP[1:0]位中选择的输出禁用源组的请求。

当输出禁用时, 输出禁用控制不会在输出禁用请求被否定的同一周期内释放。它在下一个周期中发布。

**OABHF标志 (同时输出电平高标志)**

OABHF标志表示GTIOCnA引脚和GTIOCnB引脚同时输出1。

当GTIOCnA或GTIOCnB引脚输出0时, 该标志返回0。该标志为只读。禁止写入0清除标志。

当通过OABHF标志启用中断时(GTINTAD.GRPABH=1), OABHF标志作为输出禁用请求输出到POEG。

[Setting condition]

- 当OAE和OBE位都设置为1时, GTIOCnA和GTIOCnB引脚同时输出1。

[Clearing conditions]

- 当OAE和OBE位都设置为1时, GTIOCnA引脚输出值与GTIOCnB引脚输出值不同
- 当OAE和OBE位都设置为1时, GTIOCnA和GTIOCnB引脚同时输出0
- OAE位或OBE位设置为0。

**OABLF标志 (同时输出电平低标志)**

OABLF标志表示GTIOCnA和GTIOCnB管脚同时输出0。

当GTIOCnA引脚或GTIOCnB引脚输出1时, 该标志返回0。该标志为只读。禁止写入0清除标志。

当启用OABLF标志的中断时(GTINTAD.GRPABL=1), OABLF标志作为输出禁用请求输出到POEG。

[Setting condition]

- 当OAE和OBE位都设置为1时, GTIOCnA和GTIOCnB引脚同时输出0。

[Clearing conditions]

- 当OAE和OBE位都设置为1时, GTIOCnA引脚输出值与GTIOCnB引脚输出值不同
- 当OAE和OBE位都设置为1时, GTIOCnA和GTIOCnB管脚同时输出1
- OAE位或OBE位都设置为0。

生成OABHF/OABLF标志的比较目标信号是比较匹配输出 (PWM输出) 信号, 在它们被输出禁用功能屏蔽之前。当输出禁用状态激活时, 在GPT中连续执行比较匹配, 并根据比较值的结果更新OABHF/OABLF标志。

**PCF标志 (周期计数功能完成标志)**

该位是周期计数功能完成的状态标志。

[Setting condition]

- GTPC.PCEN位为1, GTPC.PCNT计数器在周期结束时为1。
- GTPC.PCEN位为1, GTPC.PCNT计数器在计数时钟为0。

[Clearing condition]



- 0 is written to this bit.

### 21.2.17 GTBER : General PWM Timer Buffer Enable Register

Base address: GPT32n = 0x4016\_9000 + 0x0100 × n (n = 0 to 3)  
GPT16m = 0x4016\_9000 + 0x0100 × m (m = 4 to 7)

Offset address: 0x40

|                    |    |    |    |    |    |    |    |    |    |            |         |           |           |    |     |     |
|--------------------|----|----|----|----|----|----|----|----|----|------------|---------|-----------|-----------|----|-----|-----|
| Bit position:      | 31 | 30 | 29 | 28 | 27 | 26 | 25 | 24 | 23 | 22         | 21      | 20        | 19        | 18 | 17  | 16  |
| Bit field:         | —  | —  | —  | —  | —  | —  | —  | —  | —  | CCRS<br>WT | PR[1:0] | CCRB[1:0] | CCRA[1:0] |    |     |     |
| Value after reset: | 0  | 0  | 0  | 0  | 0  | 0  | 0  | 0  | 0  | 0          | 0       | 0         | 0         | 0  | 0   | 0   |
| Bit position:      | 15 | 14 | 13 | 12 | 11 | 10 | 9  | 8  | 7  | 6          | 5       | 4         | 3         | 2  | 1   | 0   |
| Bit field:         | —  | —  | —  | —  | —  | —  | —  | —  | —  | —          | —       | —         | —         | —  | BD1 | BD0 |
| Value after reset: | 0  | 0  | 0  | 0  | 0  | 0  | 0  | 0  | 0  | 0          | 0       | 0         | 0         | 0  | 0   | 0   |

| Bit   | Symbol    | Function   | R/W |
|-------|-----------|--|-----|
| 0     | BD0       | GTCCR Buffer Operation Disable<br>0: Buffer operation is enabled<br>1: Buffer operation is disabled  | R/W |
| 1     | BD1       | GTPR Buffer Operation Disable<br>0: Buffer operation is enabled<br>1: Buffer operation is disabled   | R/W |
| 15:2  | —         | These bits are read as 0. The write value should be 0.   | R/W |
| 17:16 | CCRA[1:0] | GTCCRA Buffer Operation<br>00: No buffer operation<br>01: Single buffer operation (GTCCRA ↔ GTCCRC)<br>Others: Double buffer operation (GTCCRA ↔ GTCCRC ↔ GTCCRD)                                  | R/W |
| 19:18 | CCRB[1:0] | GTCCRB Buffer Operation<br>00: No buffer operation<br>01: Single buffer operation (GTCCRB ↔ GTCCRE)<br>Others: Double buffer operation (GTCCRB ↔ GTCCRE ↔ GTCCRF)                                  | R/W |
| 21:20 | PR[1:0]   | GTPR Buffer Operation<br>00: No buffer operation<br>01: Single buffer operation (GTPBR → GTPR)<br>Others: Setting prohibited   | R/W |
| 22    | CCRSWT    | GTCCRA and GTCCRB Forcible Buffer Operation<br>Writing 1 to this bit forces a buffer transfer of GTCCRA and GTCCRB. This bit automatically returns to 0 after 1 is written. This bit is read as 0. | W   |
| 31:23 | —         | These bits are read as 0. The write value should be 0.   | R/W |

The GTBER register provides settings for the buffer operation and must be set while the GTCNT operation stops.

#### BD0 bit (GTCCR Buffer Operation Disable)

The BD0 bit disables the buffer operation using GTCCRA, GTCCRB, GTCCRC, GTCCRD, GTCCRE, and GTCCRF combined.

When GTDTCR.TDE is 1 and when BD0 is set to 0, GTCCRB does not perform buffer operation. The GTCCRB register is automatically set to a compare match value for negative-phase waveform with dead time.

A value for the BD0 bit in the channel related to the position of the bit written with 1 by the GTSECSR register can be set when 1 is written to the GTSECR.SBDCE or GTSECR.SBDCE.

#### BD1 bit (GTPR Buffer Operation Disable)

The BD1 bit disables the buffer operation using GTPR and GTPBR combined.

A value for the BD1 bit in the channel related to the position of the bit written with 1 by the GTSECSR register can be set when 1 is written to the GTSECR.SBDPE or GTSECR.SBDPE.

- 0写入该位。

### 21.2.17 GTBER:通用PWM定时器缓冲器使能寄存器

Base address: GPT32n = 0x4016\_9000 + 0x0100 × n (n = 0 to 3)  
GPT16m = 0x4016\_9000 + 0x0100 × m (m = 4 to 7)

Offset address: 0x40

|               |    |    |    |    |    |    |    |    |    |            |         |           |           |    |     |     |
|---------------|----|----|----|----|----|----|----|----|----|------------|---------|-----------|-----------|----|-----|-----|
| Bit position: | 31 | 30 | 29 | 28 | 27 | 26 | 25 | 24 | 23 | 22         | 21      | 20        | 19        | 18 | 17  | 16  |
| Bit field:    | —  | —  | —  | —  | —  | —  | —  | —  | —  | CCRS<br>WT | PR[1:0] | CCRB[1:0] | CCRA[1:0] |    |     |     |
| 重置后的值:        | 0  | 0  | 0  | 0  | 0  | 0  | 0  | 0  | 0  | 0          | 0       | 0         | 0         | 0  | 0   | 0   |
| Bit position: | 15 | 14 | 13 | 12 | 11 | 10 | 9  | 8  | 7  | 6          | 5       | 4         | 3         | 2  | 1   | 0   |
| Bit field:    | —  | —  | —  | —  | —  | —  | —  | —  | —  | —          | —       | —         | —         | —  | BD1 | BD0 |
| 重置后的值:        | 0  | 0  | 0  | 0  | 0  | 0  | 0  | 0  | 0  | 0          | 0       | 0         | 0         | 0  | 0   | 0   |

| Bit   | Symbol    | Function  | R/W |
|-------|-----------|---|-----|
| 0     | BD0       | GTCCR缓冲区操作禁用<br>0: 启用缓冲操作1: 禁用缓冲操作  | R/W |
| 1     | BD1       | GTPR缓冲区操作禁用<br>0: 启用缓冲操作1: 禁用缓冲操作   | R/W |
| 15:2  | —         | 这些位被读取为0。写入值应为0。  | R/W |
| 17:16 | CCRA[1:0] | GTCCRA缓冲区操作<br>00: 无缓冲操作01: 单缓冲操作 (GTCCRA ↔ GTCCRC)<br>其他: 双缓冲操作 (GTCCRA ↔ GTCCRC ↔ GTCCRD) | R/W |
| 19:18 | CCRB[1:0] | GTCCRB缓冲区操作<br>00: 无缓冲操作01: 单缓冲操作 (GTCCRB ↔ GTCCRE)<br>其他: 双缓冲操作 (GTCCRB ↔ GTCCRE ↔ GTCCRF) | R/W |
| 21:20 | PR[1:0]   | GTPR缓冲区操作<br>00: 无缓冲操作01: 单缓冲操作 (GTPBR → GTPR)<br>其他: 禁止设置                                  | R/W |
| 22    | CCRSWT    | GTCCRA和GTCCRB强制缓冲区操作向该位写入1会强制GTCCRA和GTCCRB进行缓冲区传输。该位在写入1后自动返回0。该位读为0。                       | W   |
| 31:23 | —         | 这些位被读取为0。写入值应为0。  | R/W |

GTBER寄存器为缓冲区操作提供设置，并且必须在GTCNT操作停止时设置。

#### BD0位 (GTCCR缓冲区操作禁用)

BD0位使用GTCCRA、GTCCRB、GTCCRC、GTCCRD、GTCCRE和GTCCRF组合禁用缓冲区操作。

当GTDTCR.TDE为1且BD0设置为0时，GTCCRB不执行缓冲操作。GTCCRB寄存器自动设置为带有死区时间的负相位波形的比较匹配值。

当向GTSECR.SBDCE或GTSECR.SBDCE写入1时，可以设置与由GTSECSR寄存器写入1的位的位置相关的通道中的BD0位的值。

#### BD1位 (GTPR缓冲区操作禁用)

BD1位禁用使用GTPR和GTPBR组合的缓冲区操作。

当向GTSECR.SBDPE或GTSECR.SBDPE写入1时，可以设置与由GTSECSR寄存器写入1的位的位置相关的通道中的BD1位的值。

**CCRA[1:0] bits (GTCCRA Buffer Operation)**

The CCRA[1:0] bits set the buffer operation with GTCCRA, GTCCRC, and GTCCRD combined. When the buffer operation is restricted by the operating mode set in GTCR, the GTCR setting is given priority.

The buffer operation mode is fixed in saw-wave one-shot pulse mode or triangle-wave PWM mode 3 (64-bit transfer at trough).

**CCRB[1:0] bits (GTCCRB Buffer Operation)**

The CCRB[1:0] bits set the buffer operation using GTCCRB, GTCCRE, and GTCCRF combined. When the buffer operation is restricted by the operating mode set in GTCR, the GTCR setting is given priority.

The buffer operation mode is fixed in saw-wave one-shot pulse mode or triangle-wave PWM mode 3 (64-bit transfer at trough).

**PR[1:0] bits (GTPR Buffer Operation)**

The PR[1:0] bits set the buffer operation with GTPR and GTPBR combined.

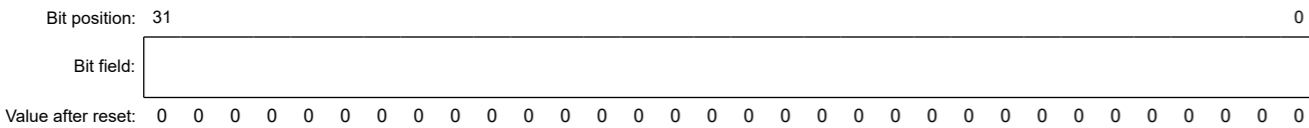
**CCRSWT bit (GTCCRA and GTCCRB Forcible Buffer Operation)**

Writing 1 to the CCRSWT bit forces a buffer transfer of GTCCRA and GTCCRB. This bit automatically returns to 0 after the 1 is written. This bit is read as 0, and is valid only when counting is stopped with a compare match operation specified.

**21.2.18 GTCNT : General PWM Timer Counter**

Base address: GPT32n = 0x4016\_9000 + 0x0100 × n (n = 0 to 3)  
GPT16m = 0x4016\_9000 + 0x0100 × m (m = 4 to 7)

Offset address: 0x48

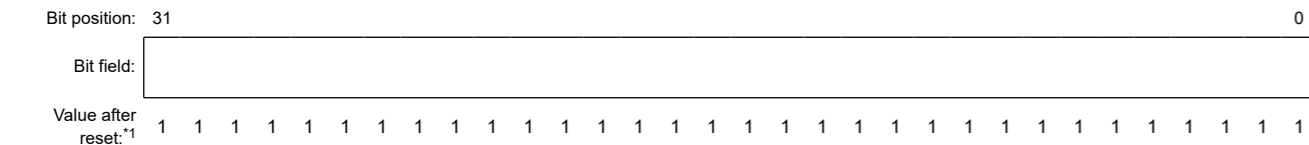


| Bit  | Symbol | Function  | R/W |
|------|--------|---|-----|
| 31:0 | n/a    | GTCNT is a 32-bit read/write counter for GPT32n (n = 0 to 3). For GPT16m (m = 4 to 7), GTCNT is a 16-bit register. GTCNT can only be written to after counting stops. For GPT16m (m = 4 to 7), the upper 16 bits for access in a 32-bit unit are always read as 0x0000, and writing to these bits is ignored. GTCNT must be set within the range of 0 ≤ GTCNT ≤ GTPR. | R/W |

**21.2.19 GTCCRn : General PWM Timer Compare Capture Register n (n = A to F)**

Base address: GPT32n = 0x4016\_9000 + 0x0100 × n (n = 0 to 3)  
GPT16m = 0x4016\_9000 + 0x0100 × m (m = 4 to 7)

Offset address: 0x4C (GTCCRA)  
0x50 (GTCCRB)  
0x54 (GTCCRC)  
0x58 (GTCCRE)  
0x5C (GTCCRD)  
0x60 (GTCCRF)



**CCRA[1:0]位 (GTCCRA缓冲区操作)**

CCRA[1:0]位设置与GTCCRA、GTCCRC和GTCCRD组合的缓冲区操作。当缓冲操作受到GTCR中设置的操作模式限制时，GTCR设置优先。

缓冲器操作模式固定为锯齿波单次脉冲模式或三角波PWM模式3（波谷64位传输）。

**CCRB[1:0]位 (GTCCRB缓冲区操作)**

CCRB[1:0]位使用GTCCRB、GTCCRE和GTCCRF组合设置缓冲区操作。当缓冲操作受到GTCR中设置的操作模式限制时，GTCR设置优先。

缓冲器操作模式固定为锯齿波单次脉冲模式或三角波PWM模式3（波谷64位传输）。

**PR[1:0]位 (GTPR缓冲区操作)**

PR[1:0]位设置结合GTPR和GTPBR的缓冲区操作。

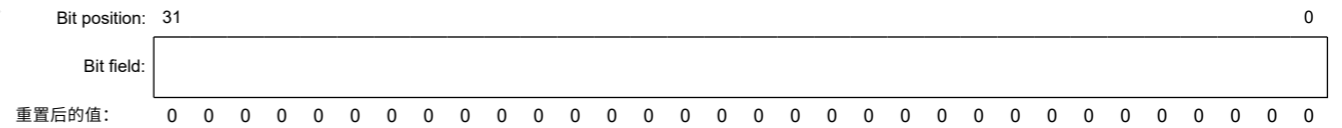
**CCRSWT位 (GTCCRA和GTCCRB强制缓冲操作)**

向CCRSWT位写入1会强制GTCCRA和GTCCRB进行缓冲区传输。该位在写入1后自动返回0。该位读为0，仅当计数停止并指定比较匹配操作时才有效。

**21.2.18 GTCNT:通用PWM定时器计数器**

Base address: GPT32n = 0x4016\_9000 + 0x0100 × n (n = 0 to 3)  
GPT16m = 0x4016\_9000 + 0x0100 × m (m = 4 to 7)

Offset address: 0x48

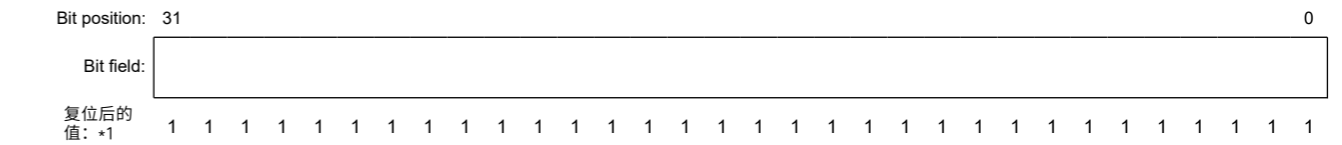


| Bit  | Symbol | Function  | R/W |
|------|--------|---|-----|
| 31:0 | n/a    | GTCNT是GPT32n (n=0到3)的32位读写计数器。对于GPT16m (m=4到7)，GTCNT是一个16位寄存器。GTCNT只能在计数停止后写入。对于GPT16m (m=4到7)，用于访问32位单元的高16位始终读为0x0000，并且忽略写入这些位。GTCNT必须设置在0≤GTCNT≤GTPR的范围内。 | R/W |

**21.2.19 GTCCRn:通用PWM定时器比较捕捉寄存器n(n=AtoF)**

Base address: GPT32n = 0x4016\_9000 + 0x0100 × n (n = 0 to 3)  
GPT16m = 0x4016\_9000 + 0x0100 × m (m = 4 to 7)

Offset address: 0x4C (GTCCRA)  
0x50 (GTCCRB)  
0x54 (GTCCRC)  
0x58 (GTCCRE)  
0x5C (GTCCRD)  
0x60 (GTCCRF)



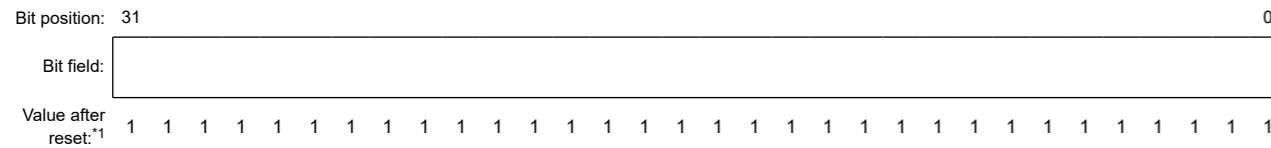
| Bit  | Symbol | Function   | R/W |
|------|--------|--|-----|
| 31:0 | n/a    | GTCCRn registers are read/write registers. The effective size of GTCCRn is the same as GTCNT (16- or 32-bit). If the effective size of GTCCRn is 16 bits, the upper 16 bits for access in a 32-bit unit are always read as 0x0000, and writing to these bits is ignored. GTCCRA and GTCCRB are registers used for both output compare and input capture. GTCCRC and GTCCRE are compare match registers that can also function as buffer registers for GTCCRA and GTCCRB. GTCCRD and GTCCRF are compare match registers that can also function as buffer registers for GTCCRC and GTCCRE (double-buffer registers for GTCCRA and GTCCRB). | R/W |

Note 1. For GPT16m (m = 4 to 7), the value of the upper 16 bits after reset is 0x0000.

### 21.2.20 GTPR : General PWM Timer Cycle Setting Register

Base address: GPT32n = 0x4016\_9000 + 0x0100 × n (n = 0 to 3)  
 GPT16m = 0x4016\_9000 + 0x0100 × m (m = 4 to 7)

Offset address: 0x64



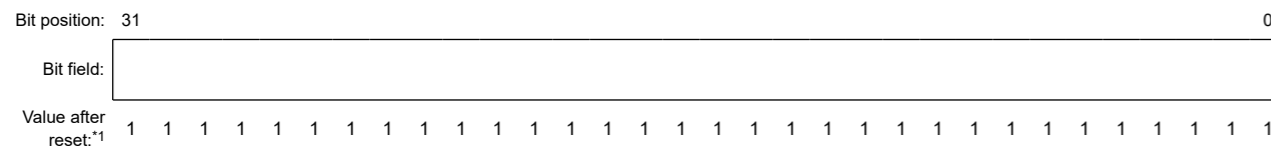
| Bit  | Symbol | Function   | R/W |
|------|--------|--|-----|
| 31:0 | n/a    | GTPR is a read/write register that sets the maximum count value of GTCNT. The effective size of GTPR is the same as GTCNT (16- or 32-bit). If the effective size of GTPR is 16 bits, the upper 16 bits for access in a 32-bit unit are always read as 0x0000, and writing to these bits is ignored. For saw waves, the value of (GTPR + 1) is the cycle. For triangle waves, the value of (GTPR value × 2) is the cycle. | R/W |

Note 1. For GPT16m (m = 4 to 7), the value of the upper 16 bits after reset is 0x0000.

### 21.2.21 GTPBR : General PWM Timer Cycle Setting Buffer Register

Base address: GPT32n = 0x4016\_9000 + 0x0100 × n (n = 0 to 3)  
 GPT16m = 0x4016\_9000 + 0x0100 × m (m = 4 to 7)

Offset address: 0x68



| Bit  | Symbol | Function   | R/W |
|------|--------|--|-----|
| 31:0 | n/a    | GTPBR is a read/write register that functions as a buffer register for GTPR. The effective size of GTPBR is the same as GTCNT (16- or 32-bit). If the effective size of GTPBR is 16 bits, the upper 16 bits for access in a 32-bit unit are always read as 0x0000, and writing to these bits is ignored. | R/W |

Note 1. For GPT16m (m = 4 to 7), the value of the upper 16 bits after reset is 0x0000.

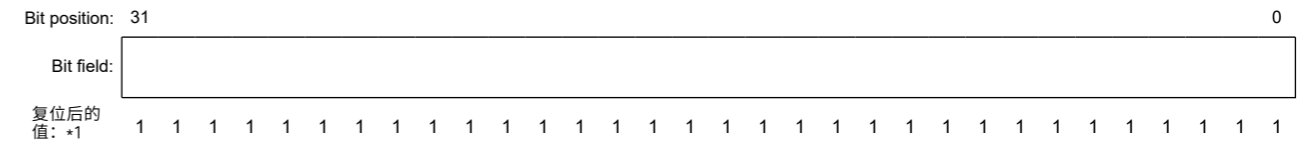
| Bit  | Symbol | Function  | R/W |
|------|--------|---|-----|
| 31:0 | n/a    | GTCCRn寄存器是读写寄存器。GTCCRn的有效大小与GTCNT（16位或32位）。如果GTCCRn的有效大小为16位，则在32位单元中访问的高16位始终被读取为0x0000，并且忽略写入这些位。GTCCRA和GTCCRB是用于输出比较和输入捕捉的寄存器。GTCCRC和GTCCRE是比较匹配寄存器，也可以用作GTCCRA和GTCCRB的缓冲寄存器。GTCCRD和GTCCRF是比较匹配寄存器，也可以用作GTCCRC和GTCCRE的缓冲寄存器（GTCCRA和GTCCRB的双缓冲寄存器）。 | R/W |

注1.对于GPT16m (m=4到7)，复位后高16位的值为0x0000。

### 21.2.20 GTPR：通用PWM定时器周期设置寄存器

Base address: GPT32n = 0x4016\_9000 + 0x0100 × n (n = 0 to 3)  
 GPT16m = 0x4016\_9000 + 0x0100 × m (m = 4 to 7)

Offset address: 0x64



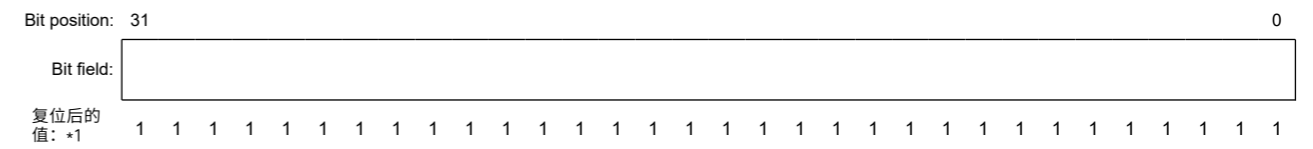
| Bit  | Symbol | Function  | R/W |
|------|--------|---|-----|
| 31:0 | n/a    | GTPR是一个读写寄存器，设置GTCNT的最大计数值。GTPR的有效大小与GTCNT（16位或32位）相同。如果GTPR的有效大小为16位，则在32位单元中访问的高16位始终被读取为0x0000，并且忽略写入这些位。对于锯齿波，(GTPR+1)的值就是周期。对于三角波，(GTPR值×2)的值就是周期。 | R/W |

注1.对于GPT16m (m=4到7)，复位后高16位的值为0x0000。

### 21.2.21 GTPBR:通用PWM定时器周期设置缓冲寄存器

Base address: GPT32n = 0x4016\_9000 + 0x0100 × n (n = 0 to 3)  
 GPT16m = 0x4016\_9000 + 0x0100 × m (m = 4 to 7)

Offset address: 0x68



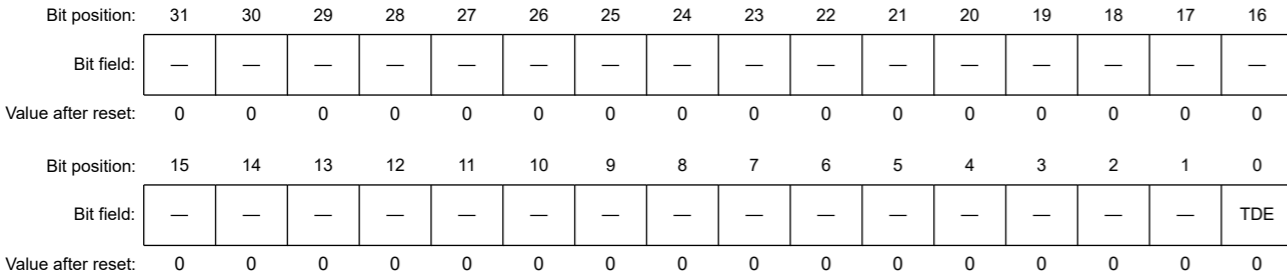
| Bit  | Symbol | Function   | R/W |
|------|--------|--|-----|
| 31:0 | n/a    | GTPBR是一个读写寄存器，用作GTPR的缓冲寄存器。GTPBR的有效大小与GTCNT（16位或32位）相同。如果GTPBR的有效大小为16位，则在32位单元中访问的高16位始终被读取为0x0000，并且忽略写入这些位。 | R/W |

注1.对于GPT16m (m=4到7)，复位后高16位的值为0x0000。

21.2.22 GTDTCR : General PWM Timer Dead Time Control Register

Base address: GPT32n = 0x4016\_9000 + 0x0100 × n (n = 0 to 3)  
GPT16m = 0x4016\_9000 + 0x0100 × m (m = 4 to 7)

Offset address: 0x88



| Bit  | Symbol | Function  | R/W |
|------|--------|---|-----|
| 0    | TDE    | Negative-Phase Waveform Setting<br>0: GTCCRB is set without using GTDVU<br>1: GTDVU sets the compare match value for negative-phase waveform with automatic dead time in GTCCRB | R/W |
| 31:1 | —      | These bits are read as 0. The write value should be 0.  | R/W |

GTDTCR enables automatic setting of a compare match value for negative-phase waveform with dead time. GPT has a dead time control function and the GTDVU register is used for setting dead time value.

TDE bit (Negative-Phase Waveform Setting)

The TDE bit specifies whether to use GTDVU. When GTDVU is used, the compare match value for a negative-phase waveform with dead time obtained by the compare match value of a positive-phase waveform (GTCCRA) and the dead time value (GTDVU) is automatically set in GTCCRB.

The TDE bit setting is ignored in saw-wave PWM mode, and automatic setting does not take place.

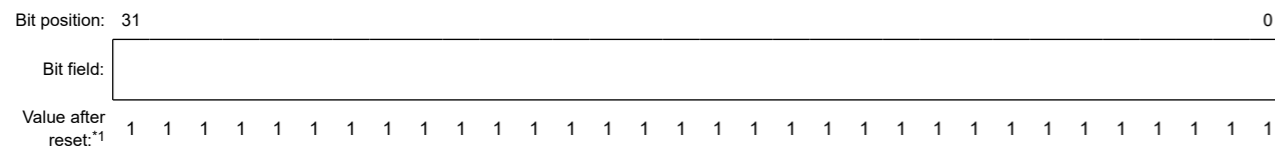
The GTCCRB value is automatically set and has the following upper and lower limit values. If the obtained GTCCRB value is not within the upper or lower limit, the following limit value is set in GTCCRB:

- Triangle waves:  
Upper limit value: GTPR - 1  
Lower limit value: 1 in up-counting, 0 in down-counting
- Saw-wave one-shot pulse mode:  
Upper limit value: GTPR  
Lower limit value: 0.

21.2.23 GTDVU : General PWM Timer Dead Time Value Register U

Base address: GPT32n = 0x4016\_9000 + 0x0100 × n (n = 0 to 3)  
GPT16m = 0x4016\_9000 + 0x0100 × m (m = 4 to 7)

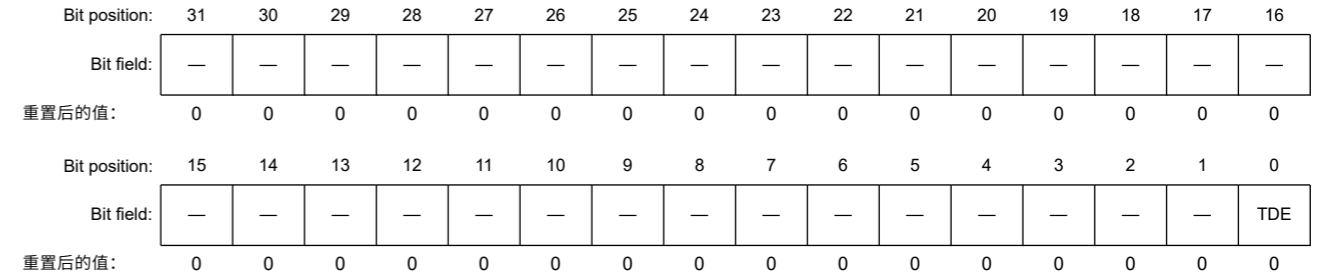
Offset address: 0x8C



21.2.22 GTDTCR:通用PWM定时器死区时间控制寄存器

Base address: GPT32n = 0x4016\_9000 + 0x0100 × n (n = 0 to 3)  
GPT16m = 0x4016\_9000 + 0x0100 × m (m = 4 to 7)

Offset address: 0x88



| Bit  | Symbol | Function  | R/W |
|------|--------|---|-----|
| 0    | TDE    | 负相位波形设置<br>0: 不使用GTDVU设置GTCCRB1: GTDVU在GTCCRB中设置带自动死区时间的反相波形比较匹配值 | R/W |
| 31:1 | —      | 这些位被读取为0。写入值应为0。  | R/W |

GTDTCR可以自动设置带死区时间的负相位波形的比较匹配值。GPT具有死区时间控制功能，GTDVU寄存器用于设置死区时间值。

TDE位 (负相位波形设置)

TDE位指定是否使用GTDVU。使用GTDVU时，通过正相波形的比较匹配值(GTCCRA)和死区时间值(GTDVU)获得的带死区时间的负相波形的比较匹配值自动设置在GTCCRB中。

TDE位设置在锯齿波PWM模式下被忽略，并且不会进行自动设置。

GTCCRB值是自动设置的，具有以下上下限值。如果得到的GTCCRB值不在上限或下限范围内，则在GTCCRB中设置以下限制值：

- Triangle waves:  
上限值: GTPR-1  
下限值: 加1, 减0
- 锯齿波单发脉冲模式: 上限值: GTPR  
下限值: 0。

21.2.23 GTDVU:通用PWM定时器死区值寄存器U

Base address: GPT32n = 0x4016\_9000 + 0x0100 × n (n = 0 to 3)  
GPT16m = 0x4016\_9000 + 0x0100 × m (m = 4 to 7)

Offset address: 0x8C





| Bit  | Symbol | Function  | R/W |
|------|--------|---|-----|
| 31:0 | n/a    | GTDVU is a read/write register that sets the dead time for generating PWM waveforms with dead time. The effective size of GTDVU is the same as GTCNT (16 or 32 bits). If the effective size of GTDVU is 16 bits, the upper 16 bits for access in a 32-bit unit are always read as 0x0000, and writing to these bits is ignored.<br>Setting a GTDVU value greater than or equal to GTPR is prohibited. When using the automatic dead time setting function, do not set a value that makes a change point of the waveform exceeding the count period. The set value can be confirmed by reading from GTCCRB. When GTDVU is used, writing to GTCCRB is prohibited. When this register is set to 0, waveforms without dead time are output.<br>While GPT is running, changing the GTDVU values is prohibited. To change GTDVU to a new value, stop the GPT with the CST bit in the GTCR register. | R/W |

Note 1. For GPT16m (m = 4 to 7), the value of the upper 16 bits after reset is 0x0000.

### 21.2.24 GTICLF : General PWM Timer Inter Channel Logical Operation Function Setting Register

Base address: GPT32n = 0x4016\_9000 + 0x0100 × n (n = 0 to 3)  
GPT16m = 0x4016\_9000 + 0x0100 × m (m = 4 to 7)

Offset address: 0xB8

|                    |    |    |    |    |    |    |              |    |    |    |    |    |            |    |    |    |
|--------------------|----|----|----|----|----|----|--------------|----|----|----|----|----|------------|----|----|----|
| Bit position:      | 31 | 30 | 29 | 28 | 27 | 26 | 25           | 24 | 23 | 22 | 21 | 20 | 19         | 18 | 17 | 16 |
| Bit field:         | —  | —  | —  | —  | —  | —  | ICLSELD[5:0] |    |    |    |    | —  | ICLFB[2:0] |    |    |    |
| Value after reset: | 0  | 0  | 0  | 0  | 0  | 0  | 0            | 0  | 0  | 0  | 0  | 0  | 0          | 0  | 0  | 0  |
| Bit position:      | 15 | 14 | 13 | 12 | 11 | 10 | 9            | 8  | 7  | 6  | 5  | 4  | 3          | 2  | 1  | 0  |
| Bit field:         | —  | —  | —  | —  | —  | —  | ICLSELC[5:0] |    |    |    |    | —  | ICLFA[2:0] |    |    |    |
| Value after reset: | 0  | 0  | 0  | 0  | 0  | 0  | 0            | 0  | 0  | 0  | 0  | 0  | 0          | 0  | 0  | 0  |

| Bit   | Symbol       | Function   | R/W |
|-------|--------------|--|-----|
| 2:0   | ICLFA[2:0]   | GTIOCnA Output Logical Operation Function Select<br>0 0 0: A (no delay)<br>0 0 1: NOT A (no delay)<br>0 1 0: C (1PCLKD delay)<br>0 1 1: NOT C (1PCLKD delay)<br>1 0 0: A AND C (1PCLKD delay) <sup>*2</sup><br>1 0 1: A OR C (1PCLKD delay) <sup>*2</sup><br>1 1 0: A EXOR C (1PCLKD delay) <sup>*2</sup><br>1 1 1: A NOR C (1PCLKD delay) <sup>*2</sup> | R/W |
| 3     | —            | This bit is read as 0. The write value should be 0.  | R/W |
| 9:4   | ICLSELC[5:0] | Inter Channel Signal C Select <sup>*1*2</sup><br>0x00: GTIOC0A<br>0x01: GTIOC0B<br>0x02: GTIOC1A<br>0x03: GTIOC1B<br>0x04: GTIOC2A<br>0x05: GTIOC2B<br>0x06: GTIOC3A<br>0x07: GTIOC3B<br>0x3E: GTIOC31A<br>0x3F: GTIOC31B  | R/W |
| 15:10 | —            | These bits are read as 0. The write value should be 0.   | R/W |

| Bit  | Symbol | Function   | R/W |
|------|--------|--|-----|
| 31:0 | n/a    | GTDVU是一个读写寄存器，用于设置死区时间，以生成带死区时间的PWM波形。GTDVU的有效大小与GTCNT相同（16或32位）。如果GTDVU的有效大小为16位，则在32位单元中访问的高16位始终被读取为0x0000，并且忽略写入这些位。禁止将GTDVU值设置为大于或等于GTPR。使用自动死区时间设置功能时，请勿设置使波形变化点超过计数周期的值。设定值可以通过读取GTCCRB来确认。使用GTDVU时，禁止写入GTCCRB。当该寄存器设置为0时，输出无死区时间的波形。在GPT运行时，禁止更改GTDVU值。要将GTDVU更改为新值，请使用GTCR寄存器中的CST位停止GPT。 | R/W |

注1.对于GPT16m (m=4到7)，复位后高16位的值为0x0000。

### 21.2.24 GTICLF:通用PWM定时器通道间逻辑运算功能设置 Register

Base address: GPT32n = 0x4016\_9000 + 0x0100 × n (n = 0 to 3)  
GPT16m = 0x4016\_9000 + 0x0100 × m (m = 4 to 7)

Offset address: 0xB8

|               |    |    |    |    |    |    |              |    |    |    |    |    |            |    |    |    |
|---------------|----|----|----|----|----|----|--------------|----|----|----|----|----|------------|----|----|----|
| Bit position: | 31 | 30 | 29 | 28 | 27 | 26 | 25           | 24 | 23 | 22 | 21 | 20 | 19         | 18 | 17 | 16 |
| Bit field:    | —  | —  | —  | —  | —  | —  | ICLSELD[5:0] |    |    |    |    | —  | ICLFB[2:0] |    |    |    |
| 重置后的值:        | 0  | 0  | 0  | 0  | 0  | 0  | 0            | 0  | 0  | 0  | 0  | 0  | 0          | 0  | 0  | 0  |
| Bit position: | 15 | 14 | 13 | 12 | 11 | 10 | 9            | 8  | 7  | 6  | 5  | 4  | 3          | 2  | 1  | 0  |
| Bit field:    | —  | —  | —  | —  | —  | —  | ICLSELC[5:0] |    |    |    |    | —  | ICLFA[2:0] |    |    |    |
| 重置后的值:        | 0  | 0  | 0  | 0  | 0  | 0  | 0            | 0  | 0  | 0  | 0  | 0  | 0          | 0  | 0  | 0  |

| Bit   | Symbol       | Function   | R/W |
|-------|--------------|--|-----|
| 2:0   | ICLFA[2:0]   | GTIOCnA输出逻辑运算功能选择<br>000: A (无延迟) 001: NOT A (无延迟) 010: C (1PCLKD延迟) 011: NOT C (1PCLKD延迟) 100: A AND C (1PCLKD延迟) <sup>*2</sup> 101: A OR C (1PCLKD延迟) <sup>*2</sup> 110: A EXOR C (1PCLKD延迟) <sup>*2</sup> 111: A NOR C (1PCLKD延迟) <sup>*2</sup> | R/W |
| 3     | —            | 该位读取为0。写入值应为0。   | R/W |
| 9:4   | ICLSELC[5:0] | 通道间信号C选择 <sup>*1*2</sup><br>0x00: GTIOC0A<br>0x01: GTIOC0B<br>0x02: GTIOC1A<br>0x03: GTIOC1B<br>0x04: GTIOC2A<br>0x05: GTIOC2B<br>0x06: GTIOC3A<br>0x07: GTIOC3B<br>0x3E: GTIOC31A<br>0x3F: GTIOC31B   | R/W |
| 15:10 | —            | 这些位被读取为0。写入值应为0。   | R/W |



| Bit   | Symbol       | Function   | R/W |
|-------|--------------|--|-----|
| 18:16 | ICLFB[2:0]   | GTIOCnB Output Logical Operation Function Select<br>0 0 0: B (no delay)<br>0 0 1: NOT B (no delay)<br>0 1 0: D (1PCLKD delay)<br>0 1 1: NOT D (1PCLKD delay)<br>1 0 0: B AND D (1PCLKD delay)*3<br>1 0 1: B OR D (1PCLKD delay)*3<br>1 1 0: B EXOR D (1PCLKD delay)*3<br>1 1 1: B NOR D (1PCLKD delay)*3 | R/W |
| 19    | —            | This bit is read as 0. The write value should be 0.  | R/W |
| 25:20 | ICLFSEL[5:0] | Inter Channel Signal D Select*1*3<br>0x00: GTIOC0A<br>0x01: GTIOC0B<br>0x02: GTIOC1A<br>0x03: GTIOC1B<br>0x04: GTIOC2A<br>0x05: GTIOC2B<br>0x06: GTIOC3A<br>0x07: GTIOC3B<br>0x3E: GTIOC31A<br>0x3F: GTIOC31B  | R/W |
| 31:26 | —            | These bits are read as 0. The write value should be 0.   | R/W |

Note 1. The signal before performing output disable control is selected.  
 Note 2. When channel's own GTIOCnA is selected, C is treated as "1".  
 Note 3. When channel's own GTIOCnB is selected, D is treated as "1".

The GTICLF register sets the logical operation function between compare match outputs. The logical operation is performed with the signals that the duty 0%/100% control is performed after compare match control. (The output disable control is performed with the signal after logical operation.)

Access in 8-bit units to GTICLF is prohibited.

**ICLFm[2:0] bit (GTIOCm Output Logical Operation Function Select) (m = A, B)**

These bits select the logical operation function between signals before performing output disable control for GTIOCm. To prevent hazard to the GPT output, the signal after logical operation is latched with PCLKD. After latching, the output disable control is performed. When the logical operation function which causes the delay of 1 PCLKD is selected, the output enable signal is also delayed with 1 PCLKD and input to the output disable control.

When the same signal to operate logical function AND, OR, EXOR and NOR is selected, one signal is treated as "1".

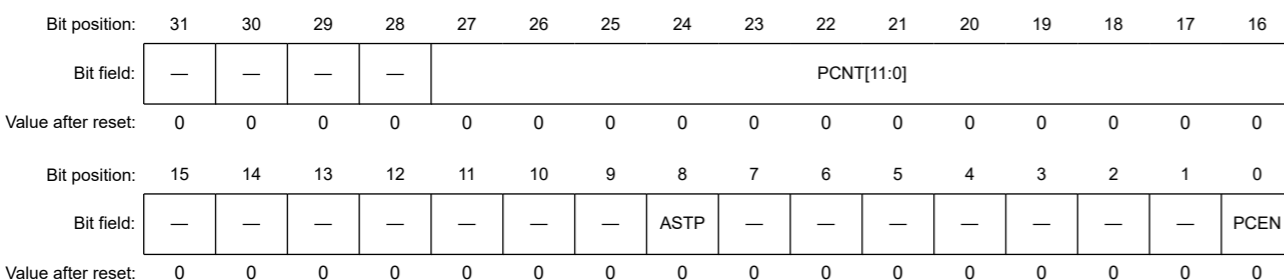
**ICLFSELk[5:0] bit (Inter Channel Signal k Select) (k = C, D)**

These bits select the signal k that the logical operation is performed with the signal before performing output disable control for GTIOCnm.

**21.2.25 GTPC : General PWM Timer Period Count Register**

Base address: GPT32n = 0x4016\_9000 + 0x0100 × n (n = 0, 1)  
 GPT16m = 0x4016\_9000 + 0x0100 × m (m = 4 to 6)

Offset address: 0xBC



| Bit   | Symbol       | Function   | R/W |
|-------|--------------|--|-----|
| 18:16 | ICLFB[2:0]   | GTIOCnB输出逻辑运算功能选择<br>000: B (无延迟) 001: NOTB (无延迟) 010: D (1PCLKD延迟) 0<br>11: NOTD (1PCLKD延迟) 100: BANDD (1PCLKD延迟) *3<br><br>1 0 1: B OR D (1PCLKD delay)*3<br>1 1 0: B EXOR D (1PCLKD delay)*3<br>1 1 1: B NOR D (1PCLKD delay)*3 | R/W |
| 19    | —            | 该位读取为0。写入值应为0。   | R/W |
| 25:20 | ICLFSEL[5:0] | 通道间信号D选择*1*3<br>0x00: GTIOC0A<br>0x01: GTIOC0B<br>0x02: GTIOC1A<br>0x03: GTIOC1B<br>0x04: GTIOC2A<br>0x05: GTIOC2B<br>0x06: GTIOC3A<br>0x07: GTIOC3B<br>0x3E: GTIOC31A<br>0x3F: GTIOC31B   | R/W |
| 31:26 | —            | 这些位被读取为0。写入值应为0。   | R/W |

注1.选择执行输出禁用控制之前的信号。注意2.选择频道自己的GTIOCNA时，C将其视为“1”。注意3.选择频道自己的GTIOCnB时，D将视为“1”。

GTICLF寄存器设置比较匹配输出之间的逻辑运算功能。通过比较匹配控制后执行占空比0%100%控制的信号执行逻辑运算。（输出禁止控制是通过逻辑运算后的信号进行的。）

禁止以8位为单位访问GTICLF。

**ICLFm[2:0]位 (GTIOCm输出逻辑运算功能选择) (m=A B)**

这些位在执行GTIOCm的输出禁用控制之前选择信号之间的逻辑运算功能。为防止对GPT输出造成危害，逻辑运算后的信号由PCLKD锁存。锁存后，执行输出禁用控制。When the logical operation function which causes the delay of 1 PCLKD is selected, the output enable signal is also delayed with 1 PCLKD and input to the output disable control.

当相同的信号运行逻辑函数，或者选择exorand也没有选择时，一个信号被视为“1”。

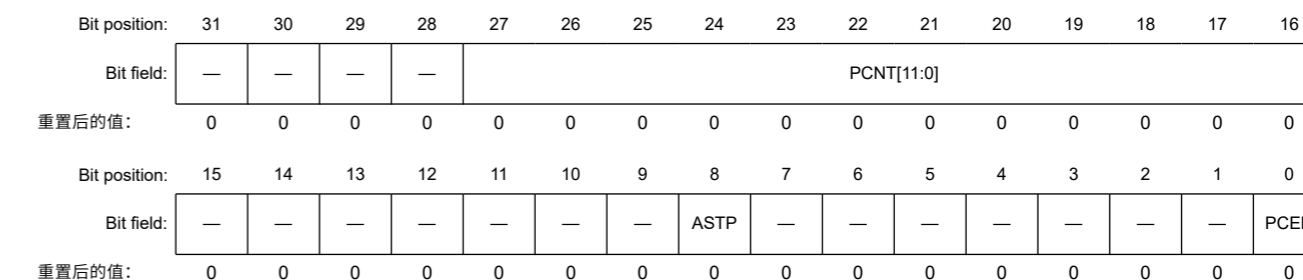
**ICLFSELk[5:0]位 (通道间信号k选择) (k=C D)**

这些位选择在执行GTIOCnm的输出禁用控制之前的信号执行逻辑运算的信号k。

**21.2.25 GTPC: 通用PWM定时器周期计数寄存器**

Base address: GPT32n = 0x4016\_9000 + 0x0100 × n (n = 0, 1)  
 GPT16m = 0x4016\_9000 + 0x0100 × m (m = 4 to 6)

Offset address: 0xBC



| Bit   | Symbol     | Function  | R/W |
|-------|------------|---|-----|
| 0     | PCEN       | Period Count Function Enable<br>0: Period count function is disabled<br>1: Period count function is enabled       | R/W |
| 7:1   | —          | These bits are read as 0. The write value should be 0.  | R/W |
| 8     | ASTP       | Automatic Stop Function Enable<br>0: Automatic stop function is disabled<br>1: Automatic stop function is enabled | R/W |
| 15:9  | —          | These bits are read as 0. The write value should be 0.  | R/W |
| 27:16 | PCNT[11:0] | Period Counter<br>Counter for the number of period  | R/W |
| 31:28 | —          | These bits are read as 0. The write value should be 0.  | R/W |

The GTPC register counts the number of period.

#### PCEN bit (Period Count Function Enable)

This bit enables or disables period count function.

Writing is available when counting is both in progress and stopped.

When 1 is written to either the GTSECR.SPCE bit or the GTSECR.SPCD bit, the value is simultaneously set to the PCEN bit in the channels set to 1 by the GTSECSR register.

#### ASTP bit (Automatic Stop Function Enable)

This bit enables or disables the GTCNT counter automatic stopping after finishing counting the number of period.

When the PCEN bit is 0, writing is available.

When the PCEN bit is 1, writing is disabled.

When the PCEN bit is 1, the ASTP bit is 1, and the PCNT counter is stopped at PCNT = 0, the GTCNT counter is also stopped. When the ASTP bit is 0, the GTCNT counter continues to count.

#### PCNT[11:0] bit (Period Counter)

This counter counts the number of period.

When the PCEN bit is 0, writing the number of period is available.

When the PCEN bit is 1, writing is disabled, and down-counting is performed at the end of period. In sawtooth-wave mode, the end of period refers to overflow, underflow, or counter clearing. In triangle-wave mode, it refers to trough.

When the PCNT counter is 1 at the end of period, it becomes 0 and counting is stopped.

When the GTCNT counter is stopped while period count function is enabled, the PCNT counter keeps its value. When the GTCNT counter restarts counting and the PCEN bit is 1, the PCNT counter restarts down-counting from the hold value.

When the PCEN bit is changed from 0 to 1 while the PCNT counter is 0 and the ASTP bit is 1, the GTCNT counter is stopped at the count clock immediately after that.

| Bit   | Symbol     | Function                               | R/W |
|-------|------------|--|-----|
| 0     | PCEN       | 周期计数功能启用<br>0: 周期计数功能无效<br>1: 周期计数功能有效 | R/W |
| 7:1   | —          | 这些位被读取为0。写入值应为0。                       | R/W |
| 8     | ASTP       | 自动停止功能启用<br>0: 自动停机功能无效<br>1: 自动停机功能有效 | R/W |
| 15:9  | —          | 这些位被读取为0。写入值应为0。                       | R/W |
| 27:16 | PCNT[11:0] | 周期计数器<br>周期数计数器                        | R/W |
| 31:28 | —          | 这些位被读取为0。写入值应为0。                       | R/W |

GTPC寄存器计算周期数。

#### PCEN位 (周期计数功能使能)

该位启用或禁用周期计数功能。

当计数正在进行和停止时，可以写入。

当向GTSECR.SPCE位或GTSECR.SPCD位写入1时，该值同时设置到由GTSECSR寄存器设置为1的通道中的PCEN位。

#### ASTP位 (自动停止功能使能)

该位使能或禁止GTCNT计数器在完成周期数计数后自动停止。

当PCENbit为0时，可以写入。

当PCEN位为1时，禁止写入。

当PCEN位为1，ASTP位为1，PCNT计数器在PCNT=0时停止，GTCNT计数器也停止。当ASTP位为0时，GTCNT计数器继续计数。

#### PCNT[11:0] bit (Period Counter)

该计数器计算周期数。

当PCENbit为0时，可写入周期数。

当PCEN位为1时，写入被禁止，并且在周期结束时执行递减计数。在锯齿波模式中，周期结束是指上溢、下溢或计数器清零。在三角波模式中，它指的是波谷。

当PCNT计数器在周期结束时为1时，它变为0并停止计数。

当GTCNT计数器停止而周期计数功能使能时，PCNT计数器保持其值。当。。。的时候GTCNT计数器重新开始计数且PCEN位为1，PCNT计数器重新从保持值开始向下计数。

当PCNT计数器为0且ASTP位为1时PCEN位从0变为1时，GTCNT计数器立即停止在计数时钟处。

21.2.26 GTSECSR : General PWM Timer Operation Enable Bit Simultaneous Control Channel Select Register

Base address: GPT32n = 0x4016\_9000 + 0x0100 × n (n = 0 to 3)  
GPT16m = 0x4016\_9000 + 0x0100 × m (m = 4 to 7)

Offset address: 0xD0

|                    |    |    |    |    |    |    |    |    |          |          |          |          |          |          |          |          |
|--------------------|----|----|----|----|----|----|----|----|----------|----------|----------|----------|----------|----------|----------|----------|
| Bit position:      | 31 | 30 | 29 | 28 | 27 | 26 | 25 | 24 | 23       | 22       | 21       | 20       | 19       | 18       | 17       | 16       |
| Bit field:         | —  | —  | —  | —  | —  | —  | —  | —  | —        | —        | —        | —        | —        | —        | —        | —        |
| Value after reset: | 0  | 0  | 0  | 0  | 0  | 0  | 0  | 0  | 0        | 0        | 0        | 0        | 0        | 0        | 0        | 0        |
| Bit position:      | 15 | 14 | 13 | 12 | 11 | 10 | 9  | 8  | 7        | 6        | 5        | 4        | 3        | 2        | 1        | 0        |
| Bit field:         | —  | —  | —  | —  | —  | —  | —  | —  | SECS EL7 | SECS EL6 | SECS EL5 | SECS EL4 | SECS EL3 | SECS EL2 | SECS EL1 | SECS EL0 |
| Value after reset: | 0  | 0  | 0  | 0  | 0  | 0  | 0  | 0  | 0        | 0        | 0        | 0        | 0        | 0        | 0        | 0        |

| Bit   | Symbol  | Function  | R/W |
|-------|---------|---|-----|
| 0     | SECSEL0 | Channel 0 Operation Enable Bit Simultaneous Control Channel Select<br>0: Disable simultaneous control<br>1: Enable simultaneous control | R/W |
| 1     | SECSEL1 | Channel 1 Operation Enable Bit Simultaneous Control Channel Select<br>0: Disable simultaneous control<br>1: Enable simultaneous control | R/W |
| 2     | SECSEL2 | Channel 2 Operation Enable Bit Simultaneous Control Channel Select<br>0: Disable simultaneous control<br>1: Enable simultaneous control | R/W |
| 3     | SECSEL3 | Channel 3 Operation Enable Bit Simultaneous Control Channel Select<br>0: Disable simultaneous control<br>1: Enable simultaneous control | R/W |
| 4     | SECSEL4 | Channel 4 Operation Enable Bit Simultaneous Control Channel Select<br>0: Disable simultaneous control<br>1: Enable simultaneous control | R/W |
| 5     | SECSEL5 | Channel 5 Operation Enable Bit Simultaneous Control Channel Select<br>0: Disable simultaneous control<br>1: Enable simultaneous control | R/W |
| 6     | SECSEL6 | Channel 6 Operation Enable Bit Simultaneous Control Channel Select<br>0: Disable simultaneous control<br>1: Enable simultaneous control | R/W |
| 7     | SECSEL7 | Channel 7 Operation Enable Bit Simultaneous Control Channel Select<br>0: Disable simultaneous control<br>1: Enable simultaneous control | R/W |
| 9:8   | —       | These bits are read as 0. The write value should be 0.  | R/W |
| 31:10 | —       | These bits are read as 0. The write value should be 0.  | R/W |

The GTSECSR register selects an intended channel for updating an operation enable bit by the GTSECR register. A bit position for the GTSECSR register indicates a channel number. The GTSECSR register of each channel is a common register, and writing 1 to a bit in the GTSECSR register in any channel and updating it changes a channel, related to the position of the bit written with 1 by the GTSECSR register, to be simultaneously controlled of the operation enable bit by the GTSECR register.

The bit corresponding to channel which security attribution is configured as secure can be read by non-secure access but can not be written by non-secure access. For example, if GPT0 is configured as secure and other GPTs are configured as non-secure, the SECSEL0 bit can not be written by non-secure access to GPT1.GTSECSR register, and the simultaneous control status of GPT0 is not changed. When the GPT1.GTSECSR register is read by non-secure access in the same security configuratin as the previous example, the simultaneous control status of GPT0 (SECSEL0 bit) can be read.

Access in 8-bit or 16-bit units to GTSECSR is prohibited, and it should be accessed in 32-bit units.

21.2.26 GTSECSR: 通用PWM定时器操作使能位同时控制通道选择寄存器

Base address: GPT32n = 0x4016\_9000 + 0x0100 × n (n = 0 to 3)  
GPT16m = 0x4016\_9000 + 0x0100 × m (m = 4 to 7)

Offset address: 0xD0

|               |    |    |    |    |    |    |    |    |          |          |          |          |          |          |          |          |
|---------------|----|----|----|----|----|----|----|----|----------|----------|----------|----------|----------|----------|----------|----------|
| Bit position: | 31 | 30 | 29 | 28 | 27 | 26 | 25 | 24 | 23       | 22       | 21       | 20       | 19       | 18       | 17       | 16       |
| Bit field:    | —  | —  | —  | —  | —  | —  | —  | —  | —        | —        | —        | —        | —        | —        | —        | —        |
| 重置后的值:        | 0  | 0  | 0  | 0  | 0  | 0  | 0  | 0  | 0        | 0        | 0        | 0        | 0        | 0        | 0        | 0        |
| Bit position: | 15 | 14 | 13 | 12 | 11 | 10 | 9  | 8  | 7        | 6        | 5        | 4        | 3        | 2        | 1        | 0        |
| Bit field:    | —  | —  | —  | —  | —  | —  | —  | —  | SECS EL7 | SECS EL6 | SECS EL5 | SECS EL4 | SECS EL3 | SECS EL2 | SECS EL1 | SECS EL0 |
| 重置后的值:        | 0  | 0  | 0  | 0  | 0  | 0  | 0  | 0  | 0        | 0        | 0        | 0        | 0        | 0        | 0        | 0        |

| Bit   | Symbol  | Function                               | R/W |
|-------|---------|--|-----|
| 0     | SECSEL0 | 通道0操作使能位同时控制通道选择<br>0: 同时控制无效1: 同时控制有效 | R/W |
| 1     | SECSEL1 | 通道1操作使能位同时控制通道选择<br>0: 同时控制无效1: 同时控制有效 | R/W |
| 2     | SECSEL2 | 通道2操作使能位同时控制通道选择<br>0: 同时控制无效1: 同时控制有效 | R/W |
| 3     | SECSEL3 | 通道3操作使能位同时控制通道选择<br>0: 同时控制无效1: 同时控制有效 | R/W |
| 4     | SECSEL4 | 通道4操作使能位同时控制通道选择<br>0: 同时控制无效1: 同时控制有效 | R/W |
| 5     | SECSEL5 | 通道5操作使能位同时控制通道选择<br>0: 同时控制无效1: 同时控制有效 | R/W |
| 6     | SECSEL6 | 通道6操作使能位同时控制通道选择<br>0: 同时控制无效1: 同时控制有效 | R/W |
| 7     | SECSEL7 | 通道7操作使能位同时控制通道选择<br>0: 同时控制无效1: 同时控制有效 | R/W |
| 9:8   | —       | 这些位被读取为0。写入值应为0。                       | R/W |
| 31:10 | —       | 这些位被读取为0。写入值应为0。                       | R/W |

GTSECSR寄存器通过GTSECR寄存器选择用于更新操作使能位的预期通道。GTSECSR寄存器的位位置表示通道号。每个通道的GTSECSR寄存器是一个公共寄存器，在任何通道的GTSECSR寄存器中写入1并更新它会改变一个通道，与GTSECSR寄存器写入1的位的位置有关，同时被控制GTSECR寄存器的操作使能位。

安全属性配置为安全的通道对应的位可以被非安全访问读取，但不能被非安全访问写入。例如，如果GPT0配置为安全，而其他GPT配置为非安全，则SECSEL0位不能通过对GPT1.GTSECSR寄存器的非安全访问来写入，并且GPT0的同时控制状态不会改变。当GPT1.GTSECSR寄存器通过与上例相同的安全配置中的非安全访问读取时，可以读取GPT0 (SECSEL0位) 的同时控制状态。

禁止以8位或16位为单位访问GTSECSR，应以32位为单位进行访问。

**SECSELn bit (Operation Enable Bit Simultaneous Control Channel Select) (n = 0 to 7)**

This bit enables or disables the simultaneous control of operation enable in channel n.

When the bit is set to 1, the simultaneous control is enabled, and disabled when the bit is 0.

**21.2.27 GTSECR : General PWM Timer Operation Enable Bit Simultaneous Control Register**

Base address: GPT32n = 0x4016\_9000 + 0x0100 × n (n = 0 to 3)  
GPT16m = 0x4016\_9000 + 0x0100 × m (m = 4 to 7)

Offset address: 0xD4

|                    |    |    |    |    |    |    |      |      |    |    |    |    |    |    |      |      |
|--------------------|----|----|----|----|----|----|------|------|----|----|----|----|----|----|------|------|
| Bit position:      | 31 | 30 | 29 | 28 | 27 | 26 | 25   | 24   | 23 | 22 | 21 | 20 | 19 | 18 | 17   | 16   |
| Bit field:         | —  | —  | —  | —  | —  | —  | —    | SPCD | —  | —  | —  | —  | —  | —  | —    | SPCE |
| Value after reset: | 0  | 0  | 0  | 0  | 0  | 0  | 0    | 0    | 0  | 0  | 0  | 0  | 0  | 0  | 0    | 0    |
| Bit position:      | 15 | 14 | 13 | 12 | 11 | 10 | 9    | 8    | 7  | 6  | 5  | 4  | 3  | 2  | 1    | 0    |
| Bit field:         | —  | —  | —  | —  | —  | —  | SBDC | SBDC | —  | —  | —  | —  | —  | —  | SBDC | SBDC |
| Value after reset: | 0  | 0  | 0  | 0  | 0  | 0  | 0    | 0    | 0  | 0  | 0  | 0  | 0  | 0  | 0    | 0    |

| Bit   | Symbol | Function  | R/W |
|-------|--------|---|-----|
| 0     | SBDCE  | GTCCR Register Buffer Operation Simultaneous Enable<br>0: Disable simultaneous enabling GTCCR buffer operations<br>1: Enable GTCCR register buffer operations simultaneously    | R/W |
| 1     | SBDPE  | GTPR Register Buffer Operation Simultaneous Enable<br>0: Disable simultaneous enabling GTPR buffer operations<br>1: Enable GTPR register buffer operations simultaneously       | R/W |
| 7:2   | —      | These bits are read as 0. The write value should be 0.  | R/W |
| 8     | SBDCD  | GTCCR Register Buffer Operation Simultaneous Disable<br>0: Disable simultaneous disabling GTCCR buffer operations<br>1: Disable GTCCR register buffer operations simultaneously | R/W |
| 9     | SBDPD  | GTPR Register Buffer Operation Simultaneous Disable<br>0: Disable simultaneous disabling GTPR buffer operations<br>1: Disable GTPR register buffer operations simultaneously    | R/W |
| 11:10 | —      | These bits are read as 0. The write value should be 0.  | R/W |
| 15:12 | —      | These bits are read as 0. The write value should be 0.  | R/W |
| 16    | SPCE   | Period Count Function Simultaneous Enable<br>0: Disable simultaneous enabling period count function<br>1: Enable period count function simultaneously                           | R/W |
| 23:17 | —      | These bits are read as 0. The write value should be 0.  | R/W |
| 24    | SPCD   | Period Count Function Simultaneous Disable<br>0: Disable simultaneous disabling period count function<br>1: Disable period count function simultaneously                        | R/W |
| 31:25 | —      | These bits are read as 0. The write value should be 0.  | R/W |

The GTSECR register simultaneously updates the value for operation enable bits of a channel set by the GTSECSR register.

Writing 1 to a bit in the GTSECR register in any channel and updating it updates an operation enable bit for all channels, related to the position of the bit written with 1 by the all GTSECSR registers.

The GTSECR register of channel which security attribution is configured as secure can not be written by non-secure access. For example, if GPT0 is configured as secure and other GPTs are configured as non-secure, the GPT0.GTSECR register can not be written by non-secure access to GPT1.GTSECR register even if the simultaneous control of GPT0 is enabled, and the simultaneous control status of GPT0 is not changed.

Setting enable and disable bits for the same operation enable bit to 1 in the GTSECR is prohibited.

**SECSELn位 (操作使能位同时控制通道选择) (n=0至7)**

该位启用或禁用通道n中操作启用的同时控制。

该位设置为1时启用同步控制，该位设置为0时禁用同步控制。

**21.2.27 GTSECR: 通用PWM定时器操作使能位同时控制 Register**

Base address: GPT32n = 0x4016\_9000 + 0x0100 × n (n = 0 to 3)  
GPT16m = 0x4016\_9000 + 0x0100 × m (m = 4 to 7)

Offset address: 0xD4

|               |    |    |    |    |    |    |      |      |    |    |    |    |    |    |      |      |
|---------------|----|----|----|----|----|----|------|------|----|----|----|----|----|----|------|------|
| Bit position: | 31 | 30 | 29 | 28 | 27 | 26 | 25   | 24   | 23 | 22 | 21 | 20 | 19 | 18 | 17   | 16   |
| Bit field:    | —  | —  | —  | —  | —  | —  | —    | SPCD | —  | —  | —  | —  | —  | —  | —    | SPCE |
| 重置后的值:        | 0  | 0  | 0  | 0  | 0  | 0  | 0    | 0    | 0  | 0  | 0  | 0  | 0  | 0  | 0    | 0    |
| Bit position: | 15 | 14 | 13 | 12 | 11 | 10 | 9    | 8    | 7  | 6  | 5  | 4  | 3  | 2  | 1    | 0    |
| Bit field:    | —  | —  | —  | —  | —  | —  | SBDC | SBDC | —  | —  | —  | —  | —  | —  | SBDC | SBDC |
| 重置后的值:        | 0  | 0  | 0  | 0  | 0  | 0  | 0    | 0    | 0  | 0  | 0  | 0  | 0  | 0  | 0    | 0    |

| Bit   | Symbol | Function   | R/W |
|-------|--------|--|-----|
| 0     | SBDCE  | GTCCR寄存器缓冲器操作同时使能<br>0: 禁止同时使能GTCCR缓冲操作1: 同时使能GTCCR寄存器缓冲操作   | R/W |
| 1     | SBDPE  | GTPR寄存器缓冲器操作同时使能<br>0: 禁止同时使能GTPR缓冲器操作1: 同时使能GTPR寄存器缓冲器操作    | R/W |
| 7:2   | —      | 这些位被读取为0。写入值应为0。   | R/W |
| 8     | SBDCD  | GTCCR寄存器缓冲器操作同时禁用<br>0: 禁用同时禁用GTCCR缓冲器操作1: 同时禁用GTCCR寄存器缓冲器操作 | R/W |
| 9     | SBDPD  | GTPR寄存器缓冲器操作同时禁用<br>0: 禁用同时禁用GTPR缓冲器操作1: 同时禁用GTPR寄存器缓冲器操作    | R/W |
| 11:10 | —      | 这些位被读取为0。写入值应为0。   | R/W |
| 15:12 | —      | 这些位被读取为0。写入值应为0。   | R/W |
| 16    | SPCE   | 周期计数功能同时启用<br>0: 禁用同时启用周期计数功能1: 同时启用周期计数功能                   | R/W |
| 23:17 | —      | 这些位被读取为0。写入值应为0。   | R/W |
| 24    | SPCD   | 期间计数功能同时禁用<br>0: 禁用同时禁用周期计数功能1: 同时禁用周期计数功能                   | R/W |
| 31:25 | —      | 这些位被读取为0。写入值应为0。   | R/W |

GTSECR寄存器同时更新由GTSECSR寄存器设置的通道的操作使能位的值。

将1写入任何通道的GTSECR寄存器中的位并更新它会更新所有通道的操作使能位，这与所有GTSECSR寄存器写入1的位的位置有关。

安全属性配置为安全的通道的GTSECR寄存器不能被非安全访问写入。例如，如果GPT0配置为安全，而其他GPT配置为非安全，则即使GPT0的同时控制使能，也不能通过非安全访问GPT1.GTSECR寄存器来写入GPT0.GTSECR寄存器，并且GPT0的同时控制状态不变。

禁止在GTSECR中将同一操作使能位的使能位和禁用位设置为1。



A bit written to 1 is automatically cleared. When the GTSECR is read, 0 is read.

Access in 8-bit or 16-bit units to the GTSECR register is prohibited, and it should be accessed in 32-bit units.

**SBDCE bit (GTCCR Register Buffer Operation Simultaneous Enable)**

When 1 is written to this bit, 0 is simultaneously set to a GTBER.BD[0] bit in the channels set to 1 by the GTSECSR register, and buffer operations using the GTCCRA, GTCCRC, and GTCCRD registers and using the GTCCRB, GTCCRE, and GTCCRF registers are enabled.

Simultaneous setting of SBDCE and SBDCD bits to 1 is prohibited.

**SBDPE bit (GTPR Register Buffer Operation Simultaneous Enable)**

When 1 is written to this bit, 0 is simultaneously set to a GTBER.BD[1] bit in the channels set to 1 by the GTSECSR register, and buffer operations using the GTPR, GTPBR, registers are enabled.

Simultaneous setting of SBDPE and SBDCD bits to 1 is prohibited.

**SBDCD bit (GTCCR Register Buffer Operation Simultaneous Disable)**

When 1 is written to this bit, 1 is simultaneously set to a GTBER.BD[0] bit in the channels set to 1 by the GTSECSR register, and buffer operations using the GTCCRA, GTCCRC, and GTCCRD registers and using the GTCCRB, GTCCRE, and GTCCRF registers are disabled.

Simultaneous setting of SBDCE and SBDCD bits to 1 is prohibited.

**SBDPD bit (GTPR Register Buffer Operation Simultaneous Disable)**

When 1 is written to this bit, 1 is simultaneously set to a GTBER.BD[1] bit in the channels set to 1 by the GTSECSR register, and buffer operations using the GTPR, GTPBR, registers are disabled.

Simultaneous setting of SBDPE and SBDPD bits to 1 is prohibited.

**SPCE bit (Period Count Function Simultaneous Enable)**

When 1 is written to this bit, 1 is simultaneously set to GTPC.PCEN bit in the channels set to 1 by the GTSECSR register, and period count function is enabled.

Simultaneous setting of SPCE and SPCD bits to 1 is prohibited.

**SPCD bit (Period Count Function Simultaneous Disable)**

When 1 is written to this bit, 0 is simultaneously set to GTPC.PCEN bit in the channels set to 1 by the GTSECSR register, and period count function is disabled.

Simultaneous setting of SPCE and SPCD bits to 1 is prohibited.

**21.2.28 OPSCR : Output Phase Switching Control Register**

Base address: GPT\_OPS = 0x4016\_9A00

Offset address: 0x00

|                    |           |      |    |    |      |          |    |    |       |    |     |    |    |    |    |    |
|--------------------|-----------|------|----|----|------|----------|----|----|-------|----|-----|----|----|----|----|----|
| Bit position:      | 31        | 30   | 29 | 28 | 27   | 26       | 25 | 24 | 23    | 22 | 21  | 20 | 19 | 18 | 17 | 16 |
| Bit field:         | NFCS[1:0] | NFEN | —  | —  | GODF | GRP[1:0] | —  | —  | ALIGN | RV | INV | N  | P  | FB |    |    |
| Value after reset: | 0         | 0    | 0  | 0  | 0    | 0        | 0  | 0  | 0     | 0  | 0   | 0  | 0  | 0  | 0  | 0  |
| Bit position:      | 15        | 14   | 13 | 12 | 11   | 10       | 9  | 8  | 7     | 6  | 5   | 4  | 3  | 2  | 1  | 0  |
| Bit field:         | —         | —    | —  | —  | —    | —        | EN | —  | W     | V  | U   | —  | WF | VF | UF |    |
| Value after reset: | 0         | 0    | 0  | 0  | 0    | 0        | 0  | 0  | 0     | 0  | 0   | 0  | 0  | 0  | 0  | 0  |

| Bit | Symbol | Function  | R/W |
|-----|--------|---|-----|
| 0   | UF     | Input Phase Soft Setting  | R/W |
| 1   | VF     | These bits set the input phase from software settings. Setting these bits is valid when OPSCR.FB = 1. | R/W |
| 2   | WF     |   | R/W |

写入1的位会自动清除。读取GTSECR时，读取0。

禁止以8位或16位为单位访问GTSECR寄存器，应以32位为单位进行访问。

**SBDCE位 (GTCCR寄存器缓冲区操作同时使能)**

向该位写入1时，通过GTSECSR寄存器设置为1的通道中的GTBER.BD[0]位同时设置为0，并且使用GTCCRA、GTCRC和GTCCRD寄存器以及使用GTCCRB、GTCCRE进行缓冲操作和GTCCRF寄存器被启用。

禁止将SBDCE和SBDCD位同时设置为1。

**SBDPE位 (GTPR寄存器缓冲区操作同时使能)**

向该位写入1时，同时将GTSECSR寄存器设置为1的通道中的GTBER.BD[1]位设置为0，并启用使用GTPR、GTPBR寄存器的缓冲操作。

禁止将SBDPE和SBDCD位同时设置为1。

**SBDCD位 (GTCCR寄存器缓冲区操作同时禁用)**

当向该位写入1时，同时将1设置为由GTSECSR寄存器设置为1的通道中的GTBER.BD[0]位，并使用GTCCRA、GTCRC和GTCCRD寄存器以及使用GTCCRB、GTCCRE进行缓冲操作和GTCCRF寄存器被禁用。

禁止将SBDCE和SBDCD位同时设置为1。

**SBDPD位 (GTPR寄存器缓冲区操作同时禁用)**

当向该位写入1时，同时将1设置到由GTSECSR寄存器设置为1的通道中的GTBER.BD[1]位，并且使用GTPR、GTPBR寄存器的缓冲操作被禁用。

禁止将SBDPE和SBDCD位同时设置为1。

**SPCE位 (周期计数功能同时使能)**

向该位写入1时，通过GTSECSR寄存器设置为1的通道中的GTPC.PCEN位同时设置为1，并启用周期计数功能。

禁止将SPCE和SPCD位同时设置为1。

**SPCD位 (周期计数功能同时禁用)**

向该位写入1时，通过GTSECSR寄存器设置为1的通道中的GTPC.PCEN位同时设置为0，并且禁用周期计数功能。

禁止将SPCE和SPCD位同时设置为1。

**21.2.28 OPSCR: 输出相位切换控制寄存器**

Base address: GPT\_OPS = 0x4016\_9A00

Offset address: 0x00

|               |           |      |    |    |      |          |    |    |       |    |     |    |    |    |    |    |
|---------------|-----------|------|----|----|------|----------|----|----|-------|----|-----|----|----|----|----|----|
| Bit position: | 31        | 30   | 29 | 28 | 27   | 26       | 25 | 24 | 23    | 22 | 21  | 20 | 19 | 18 | 17 | 16 |
| Bit field:    | NFCS[1:0] | NFEN | —  | —  | GODF | GRP[1:0] | —  | —  | ALIGN | RV | INV | N  | P  | FB |    |    |
| 重置后的值:        | 0         | 0    | 0  | 0  | 0    | 0        | 0  | 0  | 0     | 0  | 0   | 0  | 0  | 0  | 0  | 0  |
| Bit position: | 15        | 14   | 13 | 12 | 11   | 10       | 9  | 8  | 7     | 6  | 5   | 4  | 3  | 2  | 1  | 0  |
| Bit field:    | —         | —    | —  | —  | —    | —        | EN | —  | W     | V  | U   | —  | WF | VF | UF |    |
| 重置后的值:        | 0         | 0    | 0  | 0  | 0    | 0        | 0  | 0  | 0     | 0  | 0   | 0  | 0  | 0  | 0  | 0  |

| Bit | Symbol | Function                              | R/W |
|-----|--------|---------------------------------------|-----|
| 0   | UF     | 输入相位软设置                               | R/W |
| 1   | VF     | 这些位通过软件设置设置输入相位。当OPSCR.FB=1时，设置这些位有效。 | R/W |
| 2   | WF     |                                       | R/W |



| Bit   | Symbol   | Function   | R/W |
|-------|----------|--|-----|
| 3     | —        | This bit is read as 0. The write value should be 0.  | R/W |
| 4     | U        | Input U-Phase Monitor<br>This bit monitors the state of the input phase.<br>OPSCR.FB = 0 : External input that are synchronized by PCLKD<br>OPSCR.FB = 1 : Software settings (UF)                                | R   |
| 5     | V        | Input V-Phase Monitor<br>This bit monitors the state of the input phase.<br>OPSCR.FB = 0 : External input that are synchronized by PCLKD<br>OPSCR.FB = 1 : Software settings (VF)                                | R   |
| 6     | W        | Input W-Phase Monitor<br>This bit monitors the state of the input phase.<br>OPSCR.FB = 0 : External input that are synchronized by PCLKD<br>OPSCR.FB = 1 : Software settings (WF)                                | R   |
| 7     | —        | This bit is read as 0. The write value should be 0.  | R/W |
| 8     | EN       | Enable-Phase Output Control<br>0: Do not output (Hi-Z external pin)<br>1: Output*1   | R/W |
| 15:9  | —        | These bits are read as 0. The write value should be 0.   | R/W |
| 16    | FB       | External Feedback Signal Enable<br>This bit selects the input phase from software settings and external input.<br>0: Select the external input<br>1: Select the soft setting (OPSCR.UF, VF, WF)                  | R/W |
| 17    | P        | Positive-Phase Output (P) Control<br>0: Level signal output<br>1: PWM signal output (PWM of GPT320)  | R/W |
| 18    | N        | Negative-Phase Output (N) Control<br>0: Level signal output<br>1: PWM signal output (PWM of GPT320)  | R/W |
| 19    | INV      | Invert-Phase Output Control<br>0: Positive logic (active-high) output<br>1: Negative logic (active-low) output   | R/W |
| 20    | RV       | Output Phase Rotation Direction Reversal Control<br>0: Positive rotation<br>1: Reverse rotation  | R/W |
| 21    | ALIGN    | Input Phase Alignment<br>0: Input phase aligned to PCLKD<br>1: Input phase aligned to PWM  | R/W |
| 23:22 | —        | These bits are read as 0. The write value should be 0.   | R/W |
| 25:24 | GRP[1:0] | Output Disabled Source Selection<br>00: Select group A output disable source<br>01: Select group B output disable source<br>10: Select group C output disable source<br>11: Select group D output disable source | R/W |
| 26    | GODF     | Group Output Disable Function<br>0: This bit function is ignored<br>1: Group disable clears the OPSCR.EN bit*1   | R/W |
| 28:27 | —        | These bits are read as 0. The write value should be 0.   | R/W |
| 29    | NFEN     | External Input Noise Filter Enable<br>0: Do not use a noise filter on the external input<br>1: Use a noise filter on the external input  | R/W |

| Bit   | Symbol   | Function  | R/W |
|-------|----------|---|-----|
| 3     | —        | 该位读取为0。写入值应为0。  | R/W |
| 4     | U        | 输入U相监视器<br>该位监控输入相位的状态。<br>OPSCR.FB=0: 由PCLKD同步的外部输入<br>OPSCR.FB=1: 软件设置 (UF) | R   |
| 5     | V        | 输入V相监视器<br>该位监控输入相位的状态。<br>OPSCR.FB=0: 由PCLKD同步的外部输入<br>OPSCR.FB=1: 软件设置 (VF) | R   |
| 6     | W        | 输入W相监视器<br>该位监控输入相位的状态。<br>OPSCR.FB=0: 由PCLKD同步的外部输入<br>OPSCR.FB=1: 软件设置 (WF) | R   |
| 7     | —        | 该位读取为0。写入值应为0。  | R/W |
| 8     | EN       | 使能相输出控制<br>0: 不输出 (Hi-Z外部引脚) 1: 输出*1  | R/W |
| 15:9  | —        | 这些位被读取为0。写入值应为0。  | R/W |
| 16    | FB       | 外部反馈信号使能<br>该位从软件设置和外部输入中选择输入相位。<br>0: 选择外部输入 1: 选择软设置 (OPSCR.UF、VF、WF)       | R/W |
| 17    | P        | 正相输出(P)控制<br>0: 电平信号输出 1: PWM信号输出 (GPT 320的PWM)                               | R/W |
| 18    | N        | 负相输出(N)控制<br>0: 电平信号输出 1: PWM信号输出 (GPT 320的PWM)                               | R/W |
| 19    | INV      | 反相输出控制<br>0: 正逻辑 (高电平有效) 输出 1: 负逻辑 (低电平有效) 输出                                 | R/W |
| 20    | RV       | 输出相位旋转方向反转控制<br>0: 正转 1: 反转   | R/W |
| 21    | ALIGN    | 输入相位对齐<br>0: 输入相位与PCLKD对齐 1: 输入相位与PWM对齐                                       | R/W |
| 23:22 | —        | 这些位被读取为0。写入值应为0。  | R/W |
| 25:24 | GRP[1:0] | 输出禁用源选择<br>00: 选择A组输出禁用源选择B组输出禁用<br>01: 源选择C 组输出禁用源选择D组输出禁用<br>10: 用源<br>11:  | R/W |
| 26    | GODF     | 组输出禁用功能<br>0: 忽略该位功能 1: 组禁止清除OPSCR.EN位*1                                      | R/W |
| 28:27 | —        | 这些位被读取为0。写入值应为0。  | R/W |
| 29    | NFEN     | 外部输入噪声滤波器启用<br>0: 外部输入不使用噪声滤波器 1: 外部输入使用噪声滤波器                                 | R/W |

| Bit   | Symbol    | Function  | R/W |
|-------|-----------|---|-----|
| 31:30 | NFCS[1:0] | External Input Noise Filter Clock Selection<br>Noise filter sampling clock setting of the external input.<br>0 0: PCLKD/1<br>0 1: PCLKD/4<br>1 0: PCLKD/16<br>1 1: PCLKD/64 | R/W |

Note 1. When OPSCR.GODF = 1 and the signal value selected by the OPSCR.GRP[1:0] bit is high, the OPSCR.EN bit is set to 0.

The OPSCR register sets the output of the signal waveform required for brushless DC motor control.

#### UF , VF , WF bits (Input Phase Soft Setting)

The UF , VF , WF bits set the input phase from the software settings. When OPSCR.FB bit is 1, these bits are valid. The set value of the UF /VF /WF takes the place of the U/V/W external input.

#### U, V, W bits (Input Phase Monitor)

When the OPSCR.FB bit is 0, external inputs that are synchronized by PCLKD are monitored by these bits. When the OPSCR.FB bit is 1, the OPSCR.U, OPSCR.V, and OPSCR.W bits can read the OPSCR.UF , OPSCR.VF , and OPSCR.WF bits.

#### EN bit (Enable-Phase Output Control)

The EN bit controls the output enable signal output phase (positive phase/reverse phase).

When the OPSCR.EN bit is 1, the signal waveform is output.

When the OPSCR.EN bit is 0, first set OPSCR.FB, OPSCR.UF /VF /WF (software setting is selected), OPSCR.P/N, OPSCR.INV, OPSCR.RV, OPSCR.ALIGN, OPSCR.GRP[1:0], OPSCR.GODF, OPSCR.NFEN, OPSCR.NFCS. Then, set the bit to 1. Also when OPSCR.GODF is 1 and the signal value selected in the OPSCR.GRP[1:0] bit is high, the OPSCR.EN bit is set to 0.

#### FB bit (External Feedback Signal Enable)

The FB bit selects the input phase from the software settings (OPSCR.UF, VF, WF) and external input such as a Hall element.

#### P bit (Positive-Phase Output (P) Control)

The P bit selects one of the level signal output (PWM of GPT320) or PWM signal output for the positive-phase output (GTOUUP pin, GTOVUP pin, GTOWUP pin).

#### N bit (Negative-Phase Output (N) Control)

The N bit selects one of the level signal output (PWM of GPT320) or PWM signal output for the negative-phase output (GTOULO pin, GTOVLO pin, GTOWLO pin).

#### INV bit (Invert-Phase Output Control)

The INV bit selects one of the positive logic (active-high) output or negative logic (active-low) output for the output phase.

#### RV bit (Output Phase Rotation Direction Reversal Control)

The RV bit reverses the direction of rotation of the motor by inverting the input phase.

#### ALIGN bit (Input Phase Alignment)

The ALIGN bit selects the PCLKD or PWM for the sampling of the input phase (input phase is specified in the OPSCR.FB bit). When OPSCR.ALIGN bit is 0, input phase is aligned to PCLKD.

Note: When PWM output is selected (OPSCR.P/N is 1) and the PCLKD input phase is aligned, the PWM pulse can be short-pulsed.

Note: When OPSCR.ALIGN bit is 1, input phase is aligned with PWM output.

#### GRP[1:0] bit (Output Disabled Source Selection)

The GRP[1:0] bit selects the output disable source.

| Bit   | Symbol    | Function   | R/W |
|-------|-----------|--|-----|
| 31:30 | NFCS[1:0] | 外部输入噪声滤波器时钟选择<br>外部输入的噪声滤波器采样时钟设置。<br>0 0: PCLKD/1<br>0 1: PCLKD/4<br>1 0: PCLKD/16<br>1 1: PCLKD/64 | R/W |

注1.当OPSCR.GODF=1且OPSCR.GRP[1:0]位选择的信号值为高时，OPSCR.EN位设置为0。

OPSCR寄存器设置无刷直流电机控制所需的信号波形输出。

#### UF VF WF位 (输入相位软设置)

UF、VF、WF位从软件设置中设置输入相位。当OPSCR.FB位为1时，这些位有效。UFVFWF的设定值代替了UVW外部输入。

#### U、V、W位 (输入相位监视器)

当OPSCR.FB位为0时，由PCLKD同步的外部输入由这些位监控。当。。。的时候OPSCR.FB位为1，OPSCR.U、OPSCR.V和OPSCR.W位可以读取OPSCR.UF、OPSCR.VF和OPSCR.WF位。

#### EN位 (使能阶段输出控制)

EN位控制输出使能信号的输出相位 (正相反相)。

当OPSCR.EN位为1时，输出信号波形。

当OPSCR.EN位为0时，先设置OPSCR.FB、OPSCR.UFVFWF (选择软件设置)、OPSCR.PN、OPSCR.INV、OPSCR.RV、OPSCR.ALIGN、OPSCR.GRP[1:0]、OPSCR.GODF、OPSCR.NFEN、OPSCR.NFCS。然后，将该位设置为1。同样，当OPSCR.GODF为1且在OPSCR.GRP[1:0]位中选择的信号值为高时，OPSCR.EN位设置为0。

#### FB位 (外部反馈信号使能)

FB位从软件设置 (OPSCR.UF、VF、WF) 和霍尔元件等外部输入中选择输入相位。

#### P位 (正相输出(P)控制)

P位选择电平信号输出 (GPT320的PWM) 或正相输出 (GTOUUP引脚、GTOVUP引脚、GTOWUP引脚) 的PWM信号输出之一。

#### N位 (负相输出(N)控制)

N位选择电平信号输出 (GPT320的PWM) 或负相输出 (GTOULO引脚、GTOVLO引脚、GTOWLO引脚) 的PWM信号输出之一。

#### INV位 (反相输出控制)

INV位选择输出相位的正逻辑 (高电平有效) 输出或负逻辑 (低电平有效) 输出之一。

#### RV位 (输出相位旋转方向反转控制)

RV位通过反转输入相位来反转电机的旋转方向。

#### ALIGN位 (输入相位对齐)

ALIGN位选择PCLKD或PWM对输入相位进行采样 (输入相位在OPSCR.FB位中指定)。当OPSCR.ALIGN位为0时，输入相位与PCLKD对齐。

Note: When PWM output is selected (OPSCR.P/N is 1) and the PCLKD input phase is aligned, the PWM pulse can be short-pulsed.

Note: 当OPSCR.ALIGN位为1时，输入相位与PWM输出对齐。

#### GRP[1:0]位 (输出禁用源选择)

GRP[1:0]位选择输出禁用源。

**GODF bit (Group Output Disable Function)**

When OPSCR.GODF is 1 and the signal value selected by the OPSCR.GRP[1:0] bit is high, the OPSCR.EN bit is set to 0.

When OPSCR.GODF bit is 0, this bit is ignored.

**NFEN bit (External Input Noise Filter Enable)**

The NFEN bit selects the noise filter for external input. When OPSCR.NFEN bit is 0, a noise filter for the external input is not used.

Note: When this bit is switched because of an unintentional internal edge, set the OPSCR.EN bit to 0.

**NFCS[1:0] bits (External Input Noise Filter Clock Selection)**

The NFCS[1:0] bits select the clock for the external input noise filter. When the OPSCR.NFEN bit is 1, noise filter sampling clock setting of the external input is enabled.

1. Set the NFCS[1:0].
2. Wait for 2 cycles.
3. Set the OPSCR.EN bit to 1.

**21.3 Operation****21.3.1 Basic Operation**

Each channel has a 32-bit and 16-bit timer that performs a periodic count operation using the count clock and hardware sources. The count function provides both up-counting and down-counting. The GTPR controls the count cycle.

When the GTCNT counter value matches the value in GTCCRA or GTCCRB, the output from the associated GTIOCnA or GTIOCnB can be changed (n = 0 to 7). GTCCRA or GTCCRB can be used as an input capture register with hardware resources.

GTCCRC and GTCCRD can function as buffer registers for GTCCRA. GTCCRE and GTCCRF can function as buffer registers for GTCCRB.

**21.3.1.1 Counter operation****(1) Counter start and stop**

The counter of each channel starts the count operation when GTCR.CST is set to 1. The GTCR.CST bit value is changed by the following sources:

- Writing to GTCR register
- Writing 1 to the bit in GTSTR associated with the GPT channel number when the GTSSR.CSTRT bit set to 1
- Writing 1 to the bit in GTSTP associated with the GPT channel number when the GTPSR.CSTOP bit set to 1
- The hardware source selected in the GTSSR register
- The hardware source selected in the GTPSR register.
- Completion of the period count function while the GTPC.ASTP bit is 1.

**(2) Periodic count operation in up-counting by count clock**

The GTCNT counter in each channel starts up-counting when the associated GTCR.CST bit is set to 1 with GTUPSR and GTDNSR registers set to 0x00000000. When the GTCNT value changes from the GTPR value to 0 (overflow), the GTST.TCFPO flag is set to 1. After GTCNT overflows, up-counting resumes from 0x00000000.

Figure 21.3 shows an example of a periodic count operation in up-counting by the count clock.

**GODF位 (组输出禁用功能)**

当OPSCR.GODF为1且OPSCR.GRP[1:0]位选择的信号值为高时，OPSCR.EN位设置为0。

当OPSCR.GODF位为0时，该位被忽略。

**NFEN位 (外部输入噪声滤波器使能)**

NFEN位选择外部输入的噪声滤波器。当OPSCR.NFEN位为0时，不使用外部输入的噪声滤波器。

Note: 由于无意的内部边沿而切换该位时，将OPSCR.EN位设置为0。

**NFCS[1:0]位 (外部输入噪声滤波器时钟选择)**

NFCS[1:0]位选择外部输入噪声滤波器的时钟。当OPSCR.NFEN位为1时，使能外部输入的噪声滤波器采样时钟设置。

- 1.设置NFCS[1:0]。
- 2.等待2个周期。
- 3.将OPSCR.EN位设置为1。

**21.3 Operation****21.3.1 基本操作**

每个通道都有一个32位和16位定时器，它们使用计数时钟和硬件源执行周期性计数操作。计数功能提供向上计数和向下计数。GTPR控制计数周期。

当GTCNT计数器值与GTCCRA或GTCCRB中的值匹配时，相关GTIOCnA或GTIOCnB可以更改（n=0到7）。GTCCRA或GTCCRB可用作具有硬件资源的输入捕捉寄存器。

GTCCRC和GTCCRD可以作为GTCCRA的缓冲寄存器。GTCCRE和GTCCRF可以作为GTCCRB的缓冲寄存器。

**21.3.1.1 计数器操作****(1) 计数器启动和停止**

当GTCR.CST设置为1时，每个通道的计数器开始计数操作。GTCR.CST位值由以下来源更改：

- 写入GTCR寄存器
- 当GTSSR.CSTRT位设置为1时，将1写入GTSTR中与GPT通道号相关的位
- 当GTPSR.CSTOP位设置为1时，将1写入GTSTP中与GPT通道号相关的位
- GTSSR寄存器中选择的硬件源
- GTPSR寄存器中选择的硬件源。
- GTPC.ASTP位为1时完成周期计数功能。

**(2) 计数时钟递增计数中的周期计数操作**

当相关的GTCR.CST位通过GTUPSR和GTDNSR寄存器设置为0x00000000。当GTCNT值从GTPR值变为0（溢出）时，GTST.TCFPO标志设置为1。GTCNT溢出后，向上计数从0x00000000恢复。

图21.3显示了计数时钟递增计数中的周期性计数操作的示例。

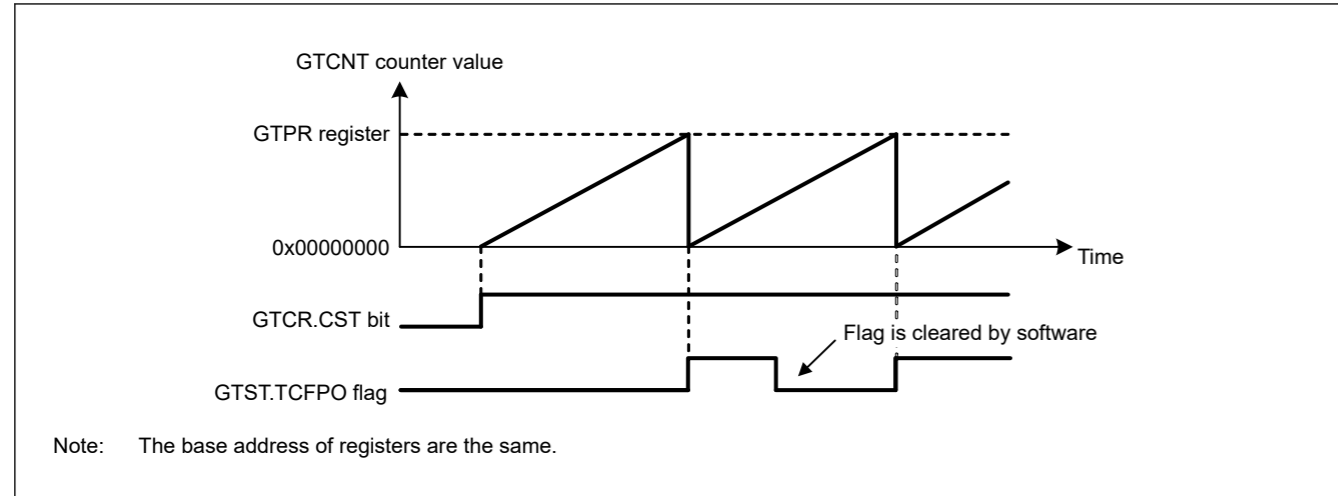


Figure 21.3 Example of periodic count operation in up-counting by the count clock

Table 21.5 shows an example for setting periodic count operation in up-counting.

Table 21.5 Example for setting a periodic count operation in up-counting by the count clock

| No. | Step Name                     | Description  |
|-----|-------------------------------|--|
| 1   | Set operating mode            | Set the operating mode with GTCR.MD[2:0]. In Figure 21.3, 000b (saw-wave PWM mode) is set.   |
| 2   | Set count direction           | Select the count direction with the GTUDDTYC register. In Figure 21.3, after 11b is set in GTUDDTYC[1:0], 01b is set in GTUDDTYC[1:0] (up-counting). |
| 3   | Select count clock            | Select the count clock with GTCR.TPCS[3:0].  |
| 4   | Set cycle                     | Set the cycle in GTPR.   |
| 5   | Set initial value for counter | Set the initial value in the GTCNT counter. In Figure 21.3, 0x00000000 is set.   |
| 6   | Start count operation         | Set GTCR.CST to 1 to start count operation.  |

(3) Periodic count operation in down-counting by count clock

The GTCNT counter in each channel can perform down-counting by setting GTUDDTYC.UD with GTUPSR and GTDNSR registers set to 0x00000000. When GTCNT changes from 0 to the GTPR value (underflow), GTST.TCFPU is set to 1. After the GTCNT counter underflows, down-counting resumes from the GTPR value.

Figure 21.4 shows an example of periodic count operation in down-counting by the count clock.

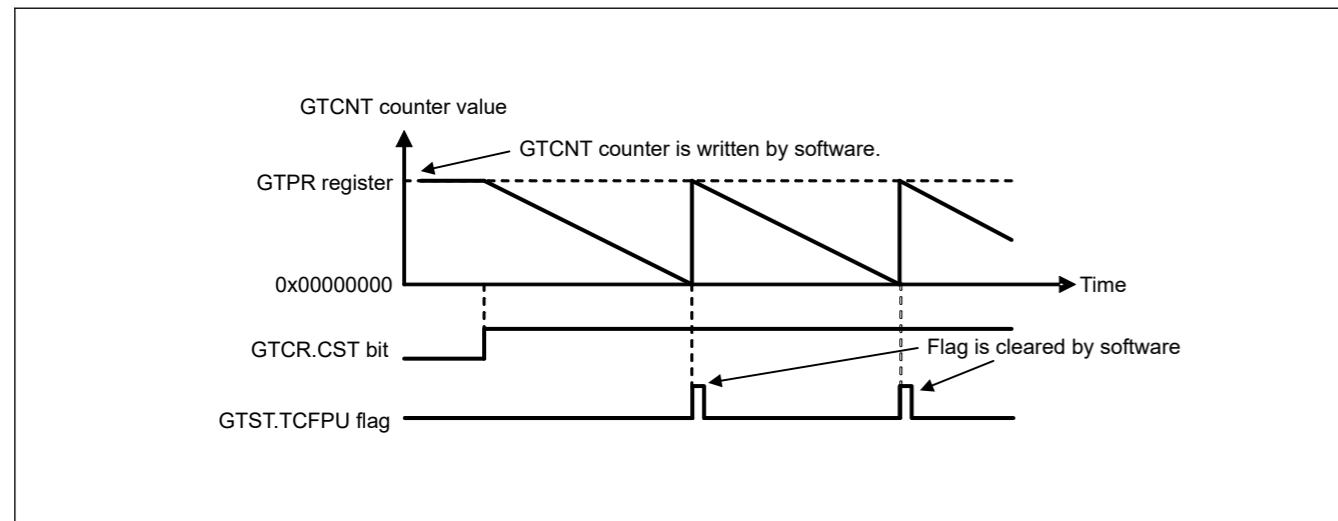


Figure 21.4 Example of periodic count operation in down-counting by the count clock

Table 21.6 shows an example for setting periodic count operation in down-counting by the count clock.

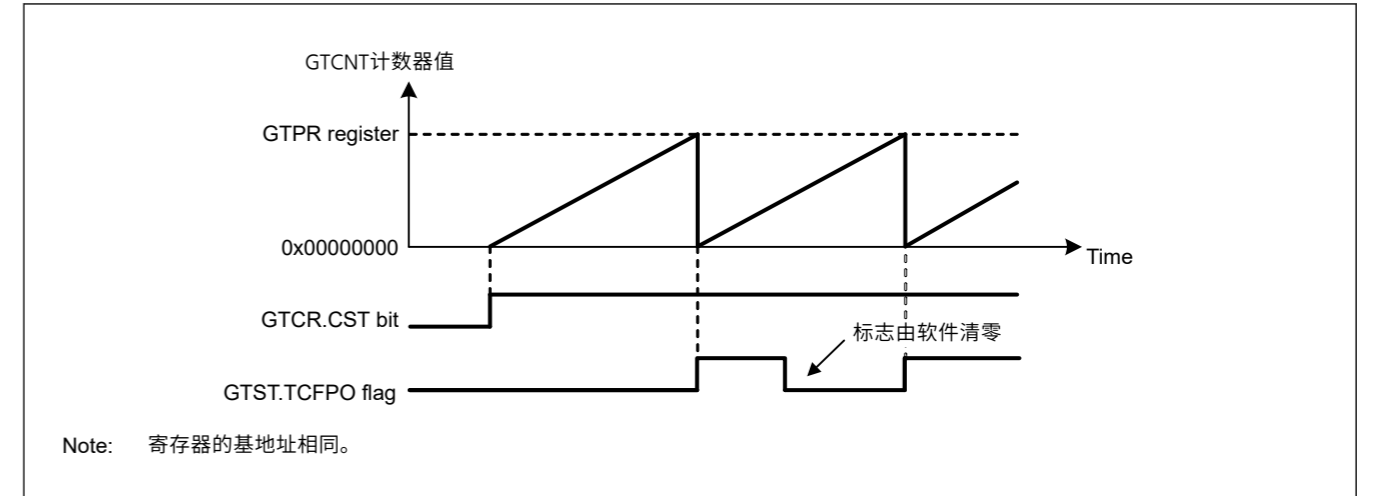


Figure 21.3 计数时钟递增计数中的周期计数操作示例

表21.5显示了在递增计数中设置周期性计数操作的示例。

Table 21.5 使用计数时钟在递增计数中设置周期性计数操作的示例

| No. | 步骤名称      | Description  |
|-----|-----------|--|
| 1   | 设置操作模式    | 使用GTCR.MD[2:0]设置操作模式。在图21.3中，设置了000b（锯齿波PWM模式）。                                  |
| 2   | 设置计数方向    | 使用GTUDDTYC寄存器选择计数方向。在图21.3中，在GTUDDTYC[1:0]中设置了11b之后，在GTUDDTYC[1:0]中设置了01b（向上计数）。 |
| 3   | 选择计数时钟    | 使用GTCR.TPCS[3:0]选择计数时钟。  |
| 4   | 设置周期      | 在GTPR中设置循环。  |
| 5   | 设置计数器的初始值 | 在GTCNT计数器中设置初始值。在图21.3中，设置了0x00000000。   |
| 6   | 开始计数操作    | 将GTCR.CST设置为1以启动计数操作。  |

(3) 计数时钟递减计数中的周期计数操作

每个通道中的GTCNT计数器可以通过使用GTUPSR设置GTUDDTYC.UD和GTDNSR寄存器设置为0x00000000。当GTCNT从0变为GTPR值（下溢）时，GTST.TCFPU设置为1。在GTCNT计数器下溢后，从GTPR值开始向下计数。

图21.4显示了计数时钟递减计数中周期性计数操作的示例。

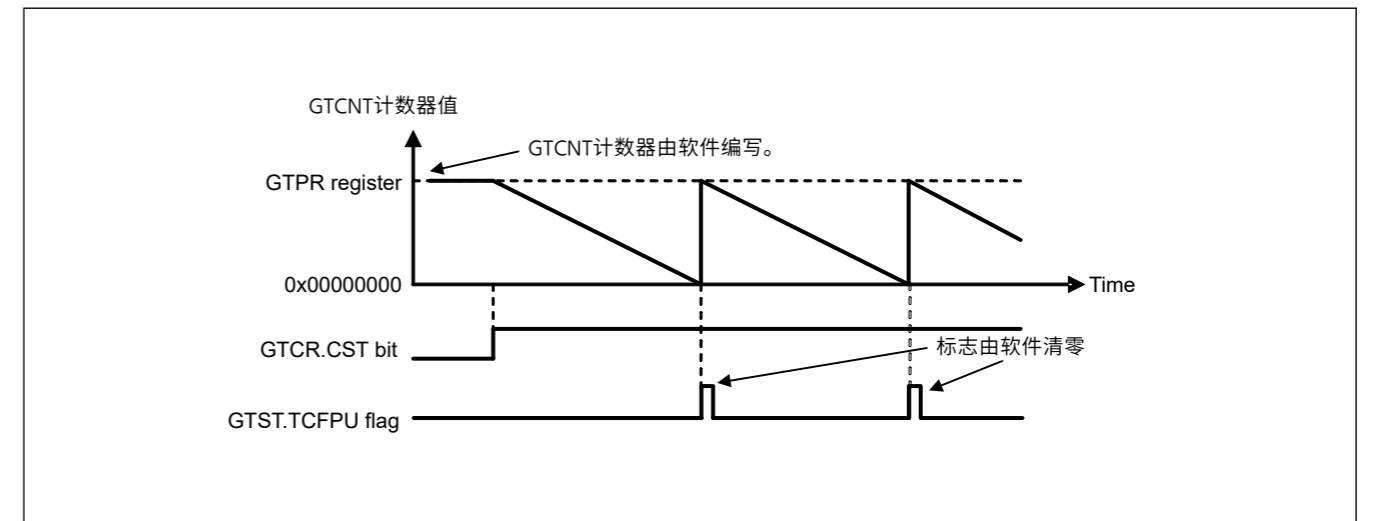


Figure 21.4 计数时钟递减计数中的周期计数操作示例

表21.6显示了在计数时钟的递减计数中设置周期性计数操作的示例。



Table 21.6 Example for setting periodic count operation in down-counting by count clock

| No. | Step Name                     | Description   |
|-----|-------------------------------|---|
| 1   | Set operating mode            | Set the operating mode with GTCR.MD[2:0].<br>In Figure 21.4, 000b (saw-wave PWM mode) is set.   |
| 2   | Set count direction           | Select the count direction with the GTUDDTYC register.<br>In Figure 21.4, after 10b is set in GTUDDTYC[1:0], 00b is set in GTUDDTYC[1:0] (down-counting). |
| 3   | Select count clock            | Select the count clock with GTCR.TPCS[3:0].   |
| 4   | Set cycle                     | Set the cycle in GTPR.  |
| 5   | Set initial value for counter | Set the initial value in the GTCNT counter.<br>In Figure 21.4, the GTPR value is set.   |
| 6   | Start count operation         | Set GTCR.CST to 1 to start count operation.   |

#### (4) Event count operation in up-counting using hardware sources

The GTCNT counter in each channel can perform up-counting using hardware sources as set in GTUPSR.

When GTUPSR is set to enable, the count clock selected in GTCR.TPCS[3:0] and the count direction selected in GTUDDTYC.UD are ignored. If up-counting and down-counting using hardware sources occur at the same time, the GTCNT counter value does not change. The overflow behavior when up-counting using hardware sources is the same as when up-counting by the count clock.

When GTCR.CST bit is set to 1 to count up using hardware sources, the count operation is enabled. After GTCR.CST is set to 1, the counter cannot count up for 1 clock cycle as specified in GTCR.TPCS[3:0] because the count operation is synchronized by the count clock selected in GTCR.TPCS[3:0]. Set GTCR.TPCS[3:0] to 000b to count up with a 1 PCLKD delay after GTCR.CST is set to 1.

Figure 21.5 shows an example of an event count operation in up-counting by a hardware resource (rising edge of GTETRGA pin).

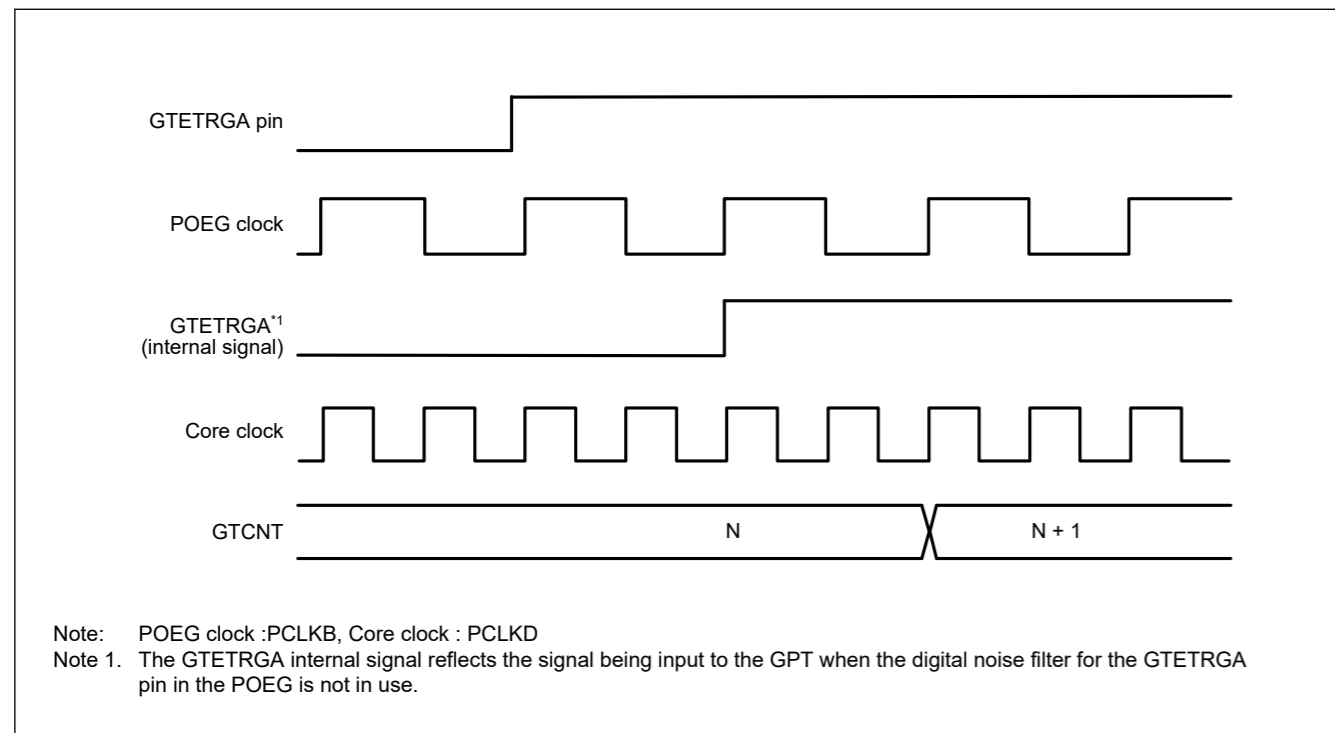


Figure 21.5 Example of event count operation in up-counting using hardware sources

Table 21.7 shows an example for setting event count operation in up-counting by the count clock.

Table 21.6 计数时钟递减计数中设置周期计数操作的示例

| No. | 步骤名称      | Description  |
|-----|-----------|--|
| 1   | 设置操作模式    | 使用GTCR.MD[2:0]设置操作模式。<br>在图21.4中, 设置了000b (锯齿波PWM模式)。                                |
| 2   | 设置计数方向    | 使用GTUDDTYC寄存器选择计数方向。<br>在图21.4中, 在GTUDDTYC[1:0]中设置10b后, 在GTUDDTYC[1:0]中设置00b (向下计数)。 |
| 3   | 选择计数时钟    | 使用GTCR.TPCS[3:0]选择计数时钟。  |
| 4   | 设置周期      | 在GTPR中设置循环。  |
| 5   | 设置计数器的初始值 | 在GTCNT计数器中设置初始值。<br>在图21.4中, 设置了GTPR值。   |
| 6   | 开始计数操作    | 将GTCR.CST设置为1以启动计数操作。  |

#### (4) 使用硬件源的递增计数中的事件计数操作

每个通道中的GTCNT计数器可以使用GTUPSR中设置的硬件源执行递增计数。

当GTUPSR设置为使能时, 在GTCR.TPCS[3:0]中选择的计数时钟和在GTUDDTYC.UD被忽略。如果同时使用硬件源进行向上计数和向下计数, 则GTCNT计数器值不会改变。使用硬件源递增计数时的溢出行为与使用计数时钟递增计数时的溢出行为相同。

当GTCR.CST位设置为1以使用硬件源进行计数时, 计数操作被启用。GTCR.CST设置为1后, 计数器无法按GTCR.TPCS[3:0]中指定的1个时钟周期向上计数, 因为计数操作与GTCR.TPCS[3:0]中选择的计数时钟同步。将GTCR.TPCS[3:0]设置为000b以在GTCR.CST设置为1后以1个PCLKD延迟向上计数。

图21.5显示了一个硬件资源递增计数中的事件计数操作示例 (上升沿GTETRGA pin)。

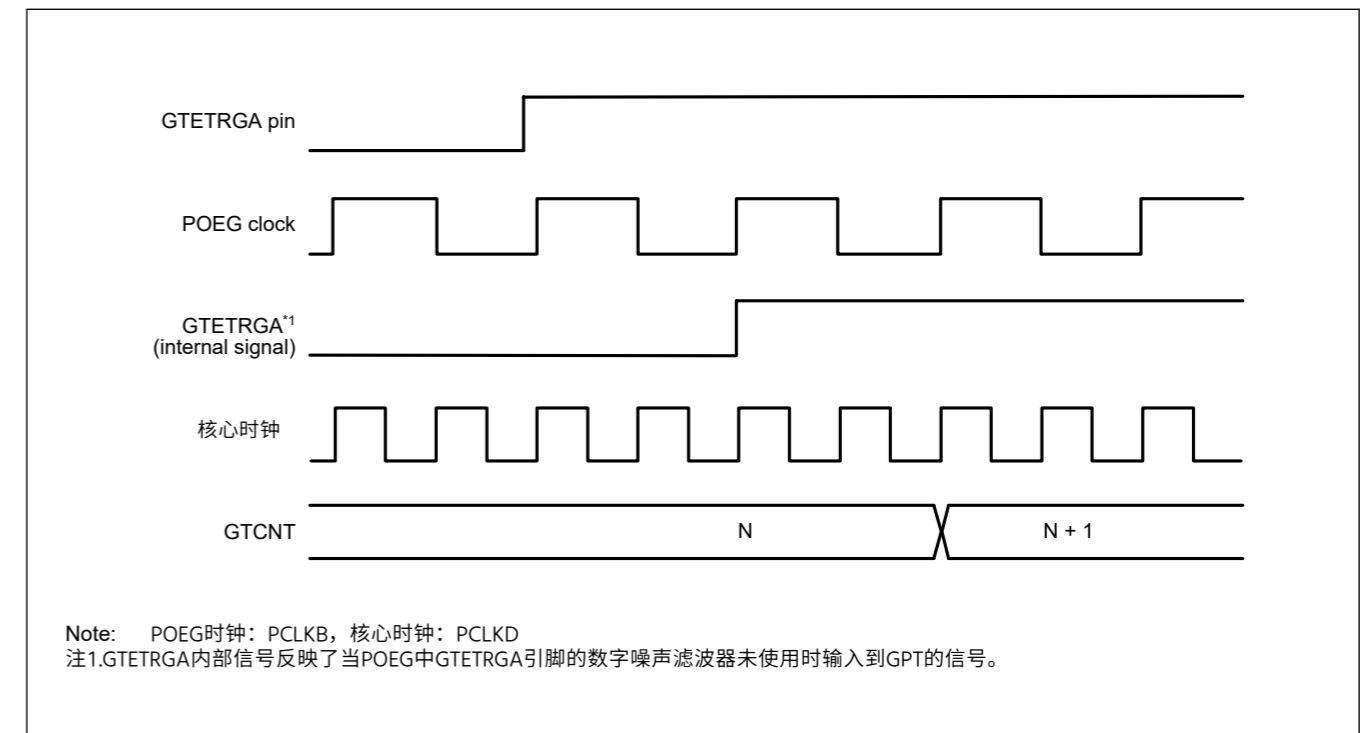


Figure 21.5 使用硬件源进行递增计数的事件计数操作示例

表21.7显示了在计数时钟递增计数中设置事件计数操作的示例。



Table 21.7 Example for setting an event count operation in up-counting using hardware sources

| No. | Step Name                     | Description   |
|-----|-------------------------------|---|
| 1   | Set count source              | Select the counting-up source with the GTUPSR register. |
| 2   | Set cycle                     | Set the cycle in GTPR.                                  |
| 3   | Set initial value for counter | Set the initial value in the GTCNT counter.             |
| 4   | Start count operation         | Set GTCR.CST to 1 to start count operation.             |

(5) Event count operation in down-counting using hardware sources

The GTCNT counter in each channel can perform down-counting using hardware sources set in the GTDNSR.

When GTDNSR is set to enable, the count clock selected in GTCR.TPCS[3:0] and the count direction selected in GTUDDTYC.UD are ignored. If up-counting and down-counting using hardware sources occur at the same time, the GTCNT counter value does not change. The underflow behavior when down-counting using hardware sources is the same as when down-counting by the count clock.

When GTCR.CST bit is set to 1 to count down using hardware sources, the count operation is enabled. After GTCR.CST is set to 1, the counter cannot count down for 1 clock cycle as specified in GTCR.TPCS[3:0] because the count operation is synchronized with the count clock selected in GTCR.TPCS[3:0]. Set GTCR.TPCS[3:0] to 000b to count down with a 1 PCLKD delay after GTCR.CST is set to 1.

Figure 21.6 shows an example of a event count operation in down-counting by a hardware resource (rising edge of GTETRGA pin).

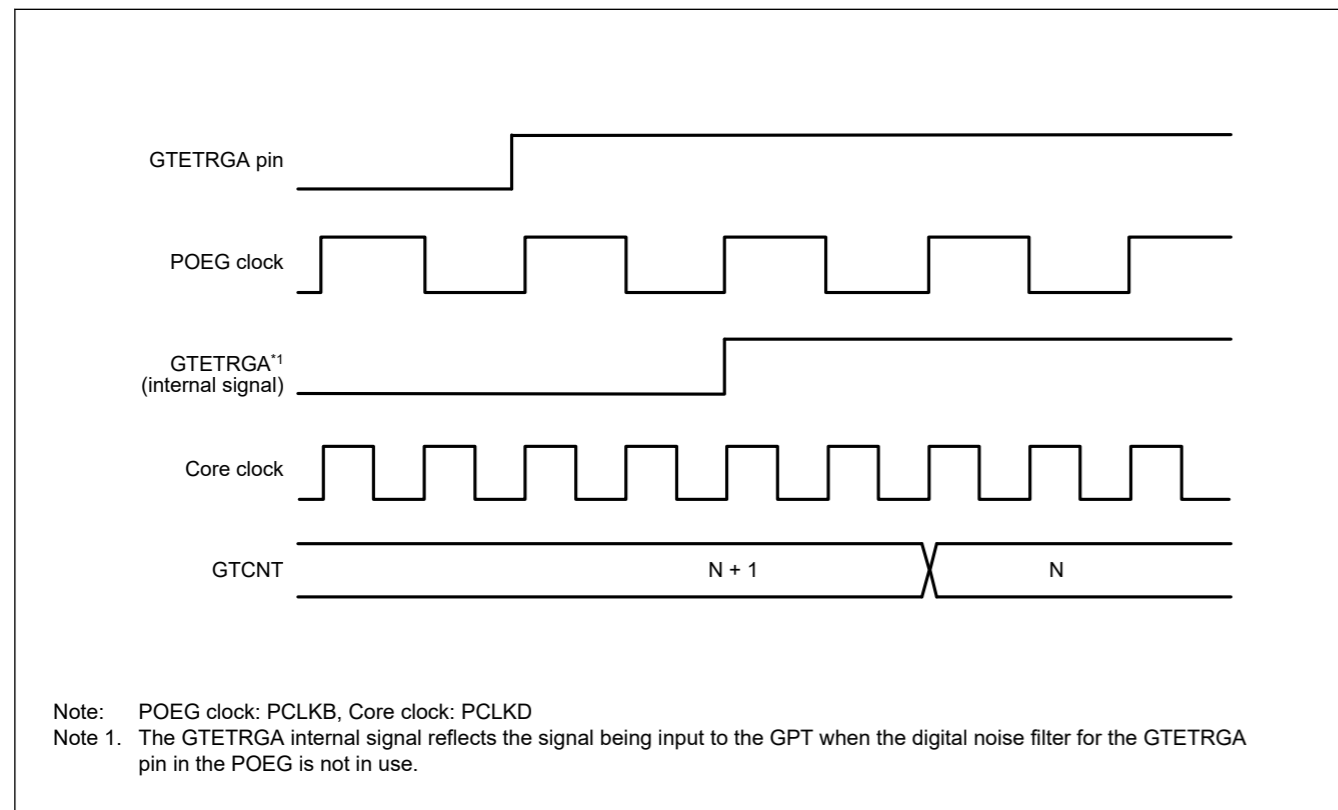


Figure 21.6 Example of event count operation in down-counting using hardware sources

Table 21.8 shows an example for setting a periodic count operation in down-counting using a hardware resource.

Table 21.8 Example for setting an event count operation in down-counting using hardware sources (1 of 2)

| No. | Step Name        | Description   |
|-----|------------------|---|
| 1   | Set count source | Select the counting-down source with the GTDNSR register. |
| 2   | Set cycle        | Set the cycle in GTPR.                                    |

Table 21.7 使用硬件源在递增计数中设置事件计数操作的示例

| No. | 步骤名称      | Description           |
|-----|-----------|-----------------------|
| 1   | 设置计数源     | 使用GTUPSR寄存器选择递增计数源。   |
| 2   | 设置周期      | 在GTPR中设置循环。           |
| 3   | 设置计数器的初始值 | 在GTCNT计数器中设置初始值。      |
| 4   | 开始计数操作    | 将GTCR.CST设置为1以启动计数操作。 |

(5) 使用硬件源的递减计数中的事件计数操作

每个通道中的GTCNT计数器可以使用GTDNSR中设置的硬件源进行递减计数。

当GTDNSR设置为使能时，在GTCR.TPCS[3:0]中选择的计数时钟和在GTUDDTYC.UD被忽略。如果同时使用硬件源进行向上计数和向下计数，则GTCNT计数器值不会改变。使用硬件源向下计数时的下溢行为与使用计数时钟向下计数时相同。

当GTCR.CST位设置为1以使用硬件源进行递减计数时，启用计数操作。在GTCR.CST设置为1后，计数器无法按照GTCR.TPCS[3:0]中的规定向下计数1个时钟周期，因为计数操作与GTCR.TPCS[3:0]中选择的计数时钟同步。将GTCR.TPCS[3:0]设置为000b以在GTCR.CST设置为1后以1个PCLKD延迟递减计数。

图21.6显示了一个事件计数操作的例子，通过硬件资源进行递减计数（上升沿GTETRGA pin）。

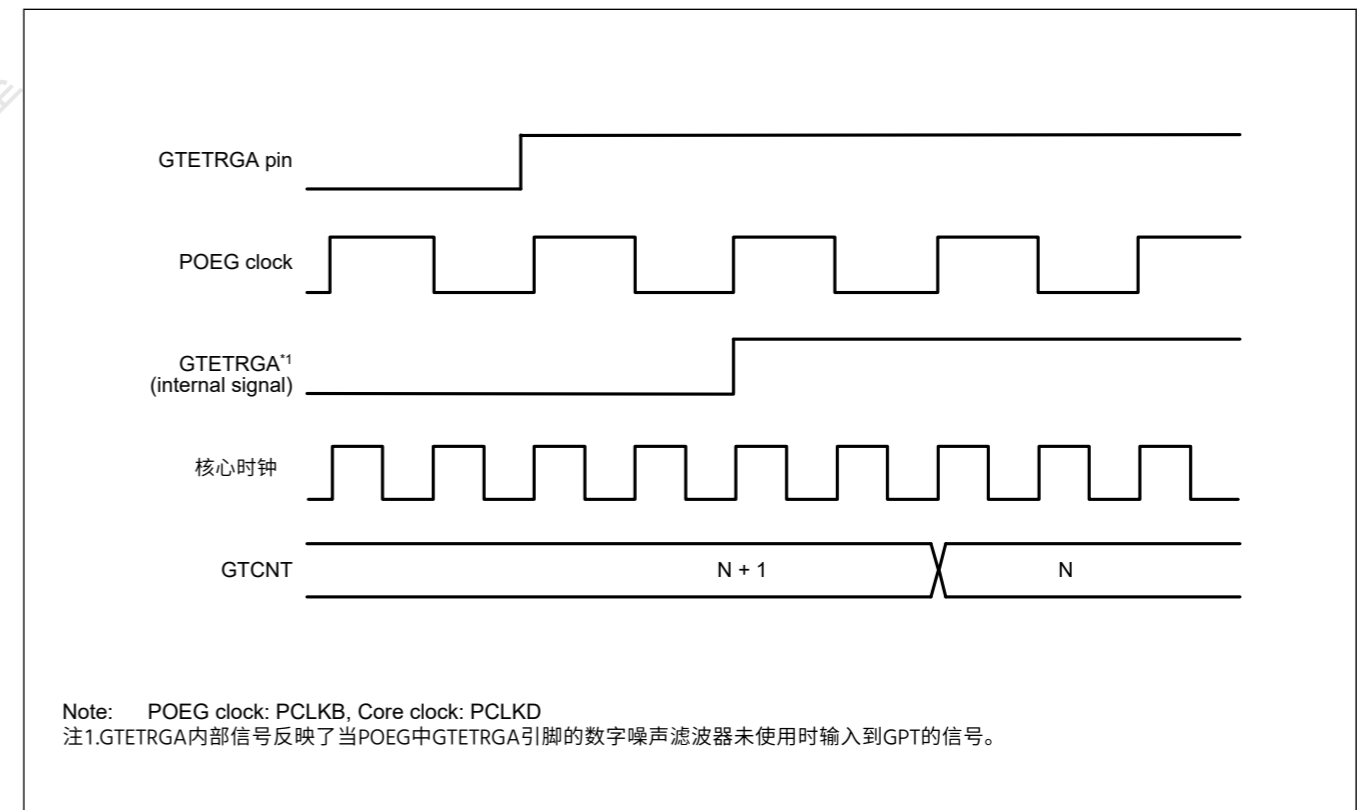


Figure 21.6 使用硬件源递减计数中的事件计数操作示例

表21.8显示了使用硬件资源在递减计数中设置周期性计数操作的示例。

Table 21.8 使用硬件源在递减计数中设置事件计数操作的示例 (1 of 2)

| No. | 步骤名称  | Description        |
|-----|-------|--------------------|
| 1   | 设置计数源 | 使用GTDNSR寄存器选择倒计时源。 |
| 2   | 设置周期  | 在GTPR中设置循环。        |

Table 21.8 Example for setting an event count operation in down-counting using hardware sources (2 of 2)

| No. | Step Name                     | Description                                 |
|-----|-------------------------------|---|
| 3   | Set initial value for counter | Set the initial value in the GTCNT counter. |
| 4   | Start count operation         | Set GTCR.CST to 1 to start count operation. |

### (6) Counter clear operation

The counter of each channel is cleared by following sources:

- Writing 0 to GTCNT register
- Writing 1 to the bit in GTCLR associated with the GPT channel number when the GTCSR.CCLR bit set to 1
- The hardware source selected in GTCSR register.

Writing to the GTCNT register is prohibited during count operation. The GTCNT counter can be cleared both by writing 1 to the GTCLR and by the clear request of hardware sources, whether GTCNT is counting (GTCR.CST is 1) or not (GTCR.CST is 0).

For saw waves selected by setting GTCR.MD[2:0] and the count direction flag showing down-counting (GTST.TUCF is 0), the GTCNT register is set to the value of the GTPR register when writing 1 to the GTCLR register and when clearing by hardware sources are performed.

When not in saw waves mode and down-counting, the GTCNT register is set to 0 when writing 1 to the GTCLR register and when clearing by hardware sources are performed.

In event count operation when at least 1 bit in the GTUPSR or GTDNSR is set to 1, after clear sources occur, both writing to GTCLR register and clearing by hardware sources are performed immediately to synchronize with PCLKD. If other settings are used, clear is synchronized with the counter clock selected in GTCR.TPCS[3:0].

### 21.3.1.2 Waveform output by compare match

Compare match means that the GTCNT counter value matches the value of GTCCRA or GTCCRB. When a compare match occurs, the compare match flag is generated synchronously with the count clock, including the event count. At the same time, the GPT can output low, high, or toggled output from the associated GTIOCnA or GTIOCnB output pin (n = 0 to 7). In addition, the GTIOCnA or GTIOCnB pin output can be low, high, or toggled at the cycle end which is determined by GTPR (n = 0 to 7).

The cycle end is:

- For saw waves in up-counting – when GTCNT changes from the GTPR value to 0 (overflow)
- For saw waves in down-counting – when GTCNT changes from 0 to GTPR value (underflow)
- For saw waves – when the GTCNT counter is cleared
- For triangle waves – when the GTCNT changes from 0 to 1 (trough).

#### (1) Low output and high output

Figure 21.7 shows an example of low output and high output operation by a compare match of GTCCRA and GTCCRB.

In this example, the GTCNT counter performs up-counting, and settings are made so that high is output from the GTIOCnA pin by a GTCCRA compare match, and low is output from the GTIOCnB pin by a GTCCRB compare match. The pin level does not change when the specified level and pin level match.

Table 21.8 使用硬件源在递减计数中设置事件计数操作的示例(2of2)

| No. | 步骤名称      | Description           |
|-----|-----------|-----------------------|
| 3   | 设置计数器的初始值 | 在GTCNT计数器中设置初始值。      |
| 4   | 开始计数操作    | 将GTCR.CST设置为1以启动计数操作。 |

### (6) 计数器清零操作

每个通道的计数器由以下来源清零:

- 将0写入GTCNT寄存器
- 当GTCSR.CCLR位设置为1时, 将1写入GTCLR中与GPT通道号相关的位
- GTCSR寄存器中选择的硬件源。

计数操作期间禁止写入GTCNT寄存器。GTCNT计数器可以通过向GTCLR写入1和硬件源的清除请求来清除, 无论GTCNT正在计数 (GTCR.CST为1) 还是不计数 (GTCR.CST为0)。

对于通过设置GTCR.MD[2:0]和显示递减计数的计数方向标志 (GTST.TUCF为0) 选择的锯齿波, 当向GTCLR寄存器写入1时, GTCNT寄存器设置为GTPR寄存器的值并在执行硬件源清除时。

当不处于锯齿波模式和递减计数时, 当向GTCLR寄存器写入1和执行硬件源清零时, GTCNT寄存器设置为0。

在GTUPSR或GTDNSR中至少有1位设置为1的事件计数操作中, 清除源发生后, 立即执行写入GTCLR寄存器和通过硬件源清除以与PCLKD同步。如果使用其他设置, 则清除与GTCR.TPCS[3:0]中选择的计数器时钟同步。

### 21.3.1.2 比较匹配的波形输出

比较匹配意味着GTCNT计数器值与GTCCRA或GTCCRB的值匹配。当比较匹配发生时, 比较匹配标志与计数时钟同步生成, 包括事件计数。同时, GPT可以从相关的GTIOCnA或GTIOCnB输出引脚 (n=0到7) 输出低电平、高电平或翻转输出。此外, GTIOCnA或GTIOCnB引脚输出可以是低电平、高电平或在周期结束时切换, 由下式确定

GTPR (n = 0 to 7).

循环结束为:

- 对于递增计数中的锯齿波 当GTCNT从GTPR值变为0时 (溢出)
- 对于向下计数中的锯齿波 当GTCNT从0变为GTPR值时 (下溢)
- 对于锯齿波 当GTCNT计数器清零时
- 对于三角波——当GTCNT从0变为1 (波谷) 时。

#### (1) 低输出和高输出

图21.7显示了通过GTCCRA和GTCCRB比较匹配的低输出和高输出操作示例。

在本例中, GTCNT计数器进行递增计数, 设定为通过GTCCRA比较匹配从GTIOCnA引脚输出高电平, 通过GTCCRB比较匹配从GTIOCnB引脚输出低电平。当指定电平和引脚电平匹配时, 引脚电平不会改变。

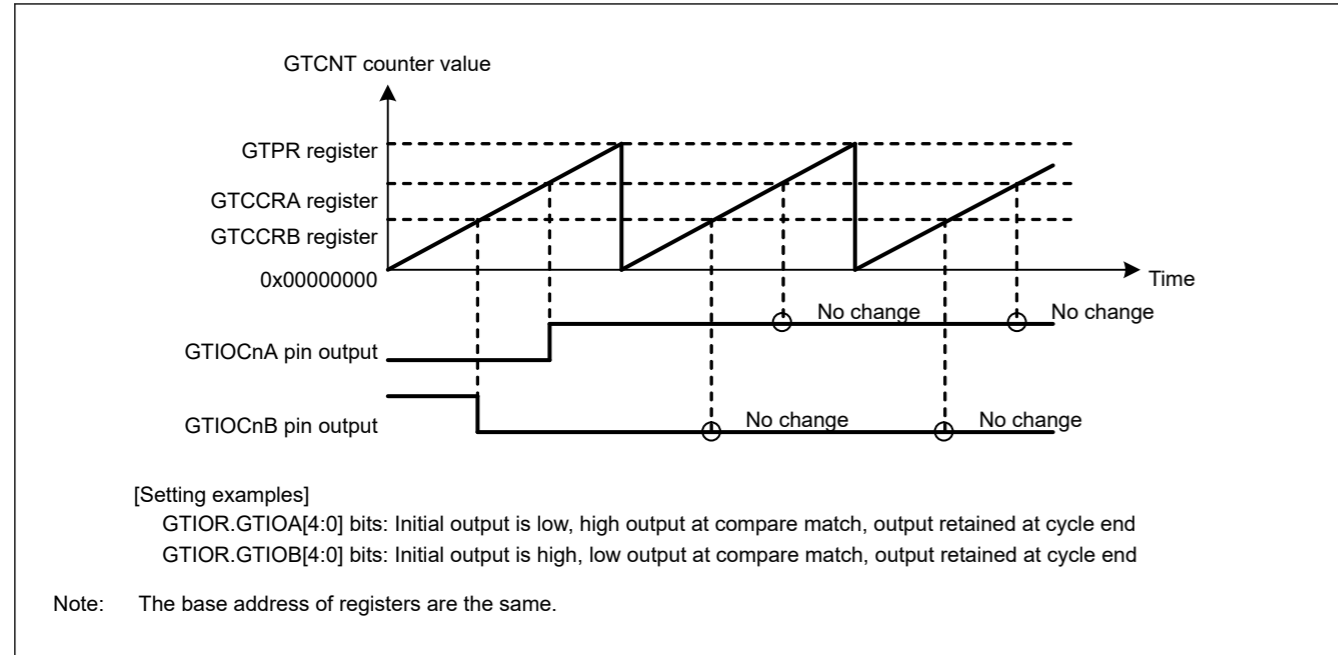


Figure 21.7 Example of low output and high output operation

Table 21.9 shows an example for setting low output and high output operation.

Table 21.9 Example for setting low output and high output operation

| No. | Step Name                     | Description   |
|-----|-------------------------------|---|
| 1   | Set operating mode            | Set the operating mode with GTCR.MD[2:0]. In Figure 21.7, 000b (saw-wave PWM mode) is set.  |
| 2   | Set count direction           | Select the count direction (up or down) with the GTUDDTYC register. In Figure 21.7, after 11b is set in GTUDDTYC[1:0], 01b is set in GTUDDTYC[1:0] (up-counting). |
| 3   | Select count clock            | Select the count clock with GTCR.TPCS[3:0].   |
| 4   | Set cycle                     | Set the cycle in GTPR.  |
| 5   | Set initial value for counter | Set the initial value in the GTCNT counter.   |
| 6   | Set GTIOCnm pin function      | Set the GTIOCnm pin function with GTIOA[4:0] and GTIOB[4:0] in GTIOR. In Figure 21.7, GTIOA[4:0] = 00010b, GTIOB[4:0] = 10001b.                                   |
| 7   | Enable GTIOCnm pin output     | Set to enable the GTIOCnm pin output with OAE and OBE in GTIOR.   |
| 8   | Set compare match value       | Set compare match values in the GTCCRA and GTCCRB registers.  |
| 9   | Start count operation         | Set GTCR.CST to 1 to start count operation.   |

Note: n: 0 to 7  
m: A, B

(2) Toggled output

Figure 21.8 and Figure 21.9 show examples of toggled output operation by compare matches of GTCCRA and GTCCRB.

In Figure 21.8, the GTCNT counter performs up-counting, and settings are made so that the GTIOCnA pin output by a GTCCRA compare match and GTIOCnB pin output by a GTCCRB compare match are toggled.

In Figure 21.9, the GTCNT counter performs up-counting, and settings are made so that a GTCCRA compare match toggles the GTIOCnA pin output level and a cycle end toggles the GTIOCnB pin output level.

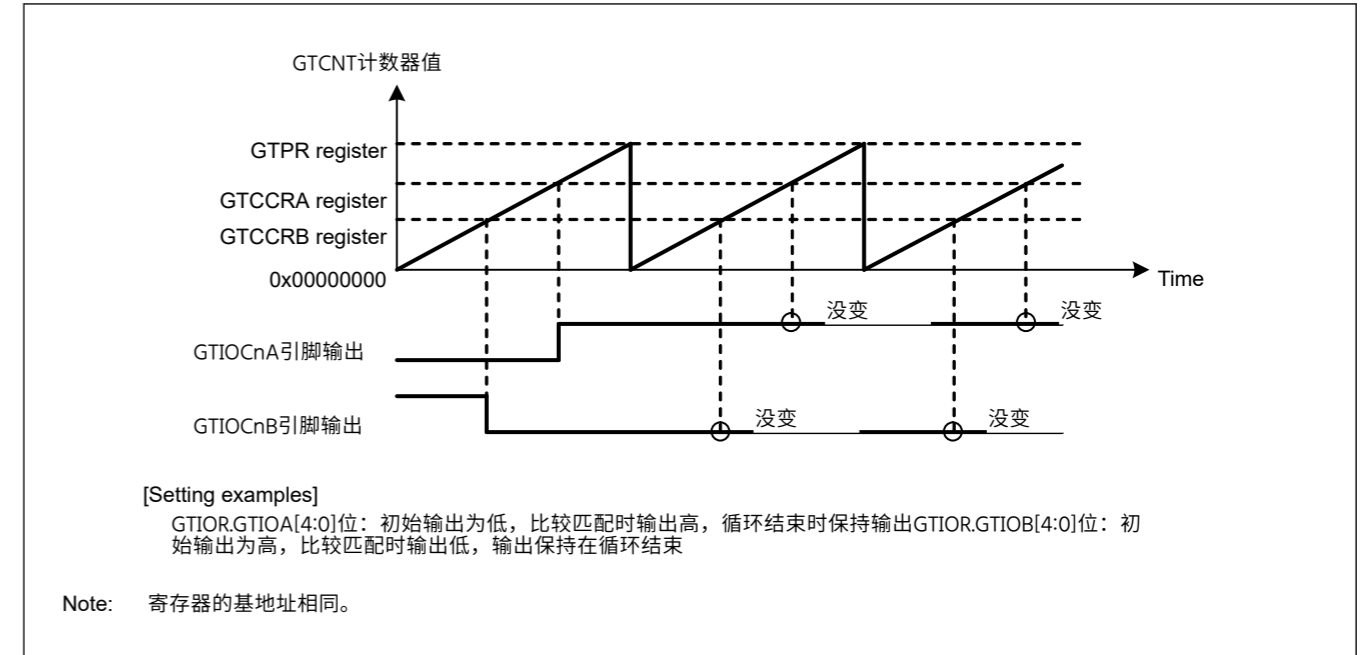


Figure 21.7 低输出和高输出操作示例

表21.9显示了设置低输出和高输出操作的示例。

Table 21.9 设置低输出和高输出操作的示例

| No. | 步骤名称          | Description  |
|-----|---------------|--|
| 1   | 设置操作模式        | 使用GTCR.MD[2:0]设置操作模式。在图21.7中, 设置了000b (锯齿波PWM模式)。  |
| 2   | 设置计数方向        | 使用GTUDDTYC寄存器选择计数方向 (向上或向下)。在图21.7中, 在GTUDDTYC[1:0]中设置了11b后, 在GTUDDTYC[1:0]中设置了01b (向上计数)。 |
| 3   | 选择计数时钟        | 使用GTCR.TPCS[3:0]选择计数时钟。  |
| 4   | 设置周期          | 在GTPR中设置循环。  |
| 5   | 设置计数器的初始值     | 在GTCNT计数器中设置初始值。   |
| 6   | 设置GTIOCnm引脚功能 | 使用GTIOR中的GTIOA[4:0]和GTIOB[4:0]设置GTIOCnm引脚功能。在图21.7中, GTIOA[4:0]=00010b, GTIOB[4:0]=10001b。 |
| 7   | 启用GTIOCnm引脚输出 | 设置为在GTIOR中使用OAE和OBE启用GTIOCnm引脚输出。  |
| 8   | 设置比较匹配值       | 在GTCCRA和GTCCRB寄存器中设置比较匹配值。   |
| 9   | 开始计数操作        | 将GTCR.CST设置为1以启动计数操作。  |

Note: n: 0 to 7  
m: A, B

(2) Toggled output

图21.8和图21.9通过GTCCRA和GTCCRB的比较匹配显示了切换输出操作的示例。

在图21.8中, GTCNT计数器进行递增计数, 并进行设置以使GTIOCnA引脚输出GTCCRA比较匹配和GTCCRB比较匹配的GTIOCnB引脚输出被切换。

在图21.9中, GTCNT计数器执行递增计数, 并进行设置, 以便GTCCRA比较匹配切换GTIOCnA引脚输出电平, 循环结束切换GTIOCnB引脚输出电平。

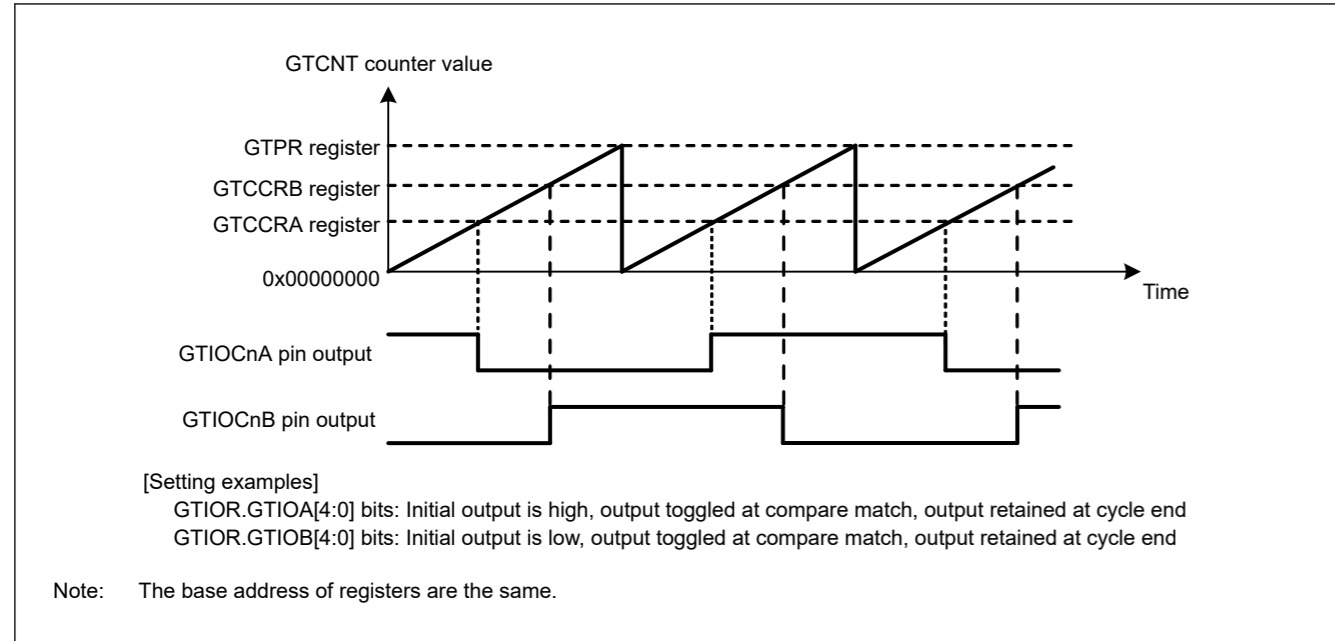


Figure 21.8 Example of toggled output operation (1)

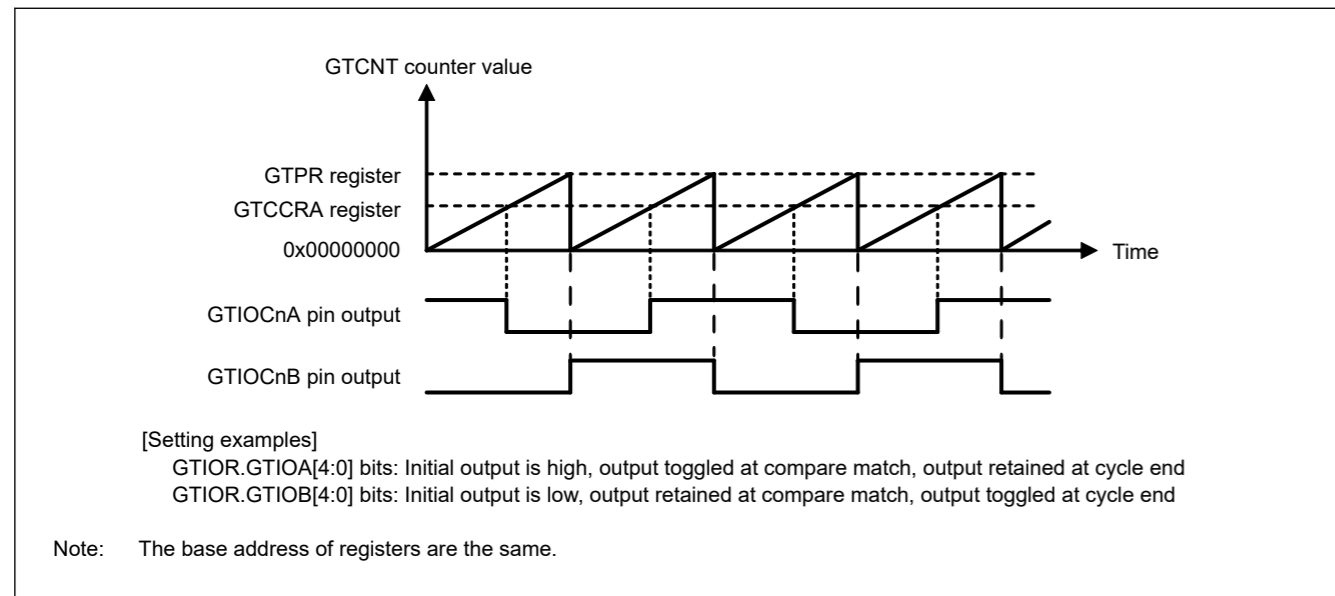


Figure 21.9 Example of toggled output operation (2)

Figure 21.15 shows an example for setting toggled output operation.

Table 21.10 Example for setting toggled output operation (1 of 2)

| No. | Step Name                     | Description   |
|-----|-------------------------------|---|
| 1   | Set operating mode            | Set the operating mode with GTCR.MD[2:0].<br>In Figure 21.8 and Figure 21.9, 000b (saw-wave PWM mode) is set.   |
| 2   | Set count direction           | Select the count direction (up or down) with the GTUDDTYC register. In Figure 21.8 and Figure 21.9, after 11b is set in GTUDDTYC[1:0], 01b is set in GTUDDTYC[1:0] (up-counting).           |
| 3   | Select count clock            | Select the count clock with GTCR.TPCS[3:0].   |
| 4   | Set cycle                     | Set the cycle in GTPR.  |
| 5   | Set initial value for counter | Set the initial value in the GTCNT counter.   |
| 6   | Set GTIOcNm pin function      | Set the GTIOcNm pin function with GTIOA[4:0] and GTIOB[4:0] in GTIOR.<br>In Figure 21.8, GTIOA[4:0] = 10011b, GTIOB[4:0] = 00011b in Figure 21.9, GTIOA[4:0] = 10011b, GTIOB[4:0] = 01100b. |

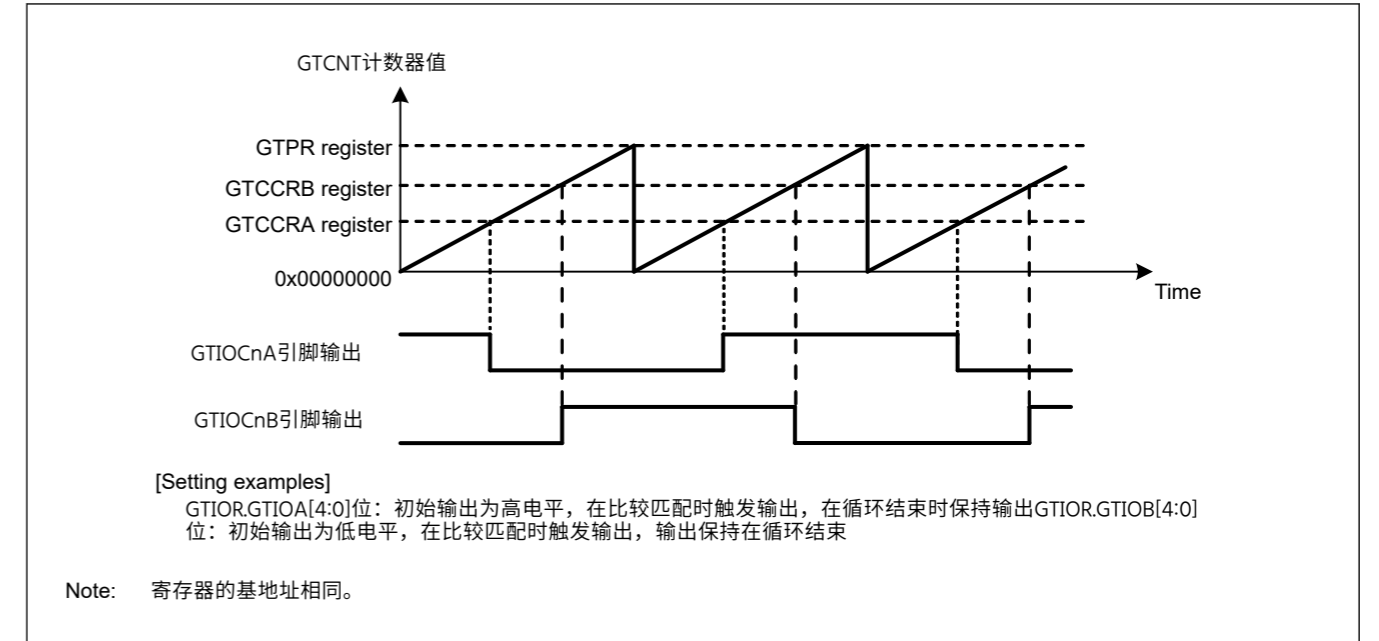


Figure 21.8 切换输出操作示例(1)

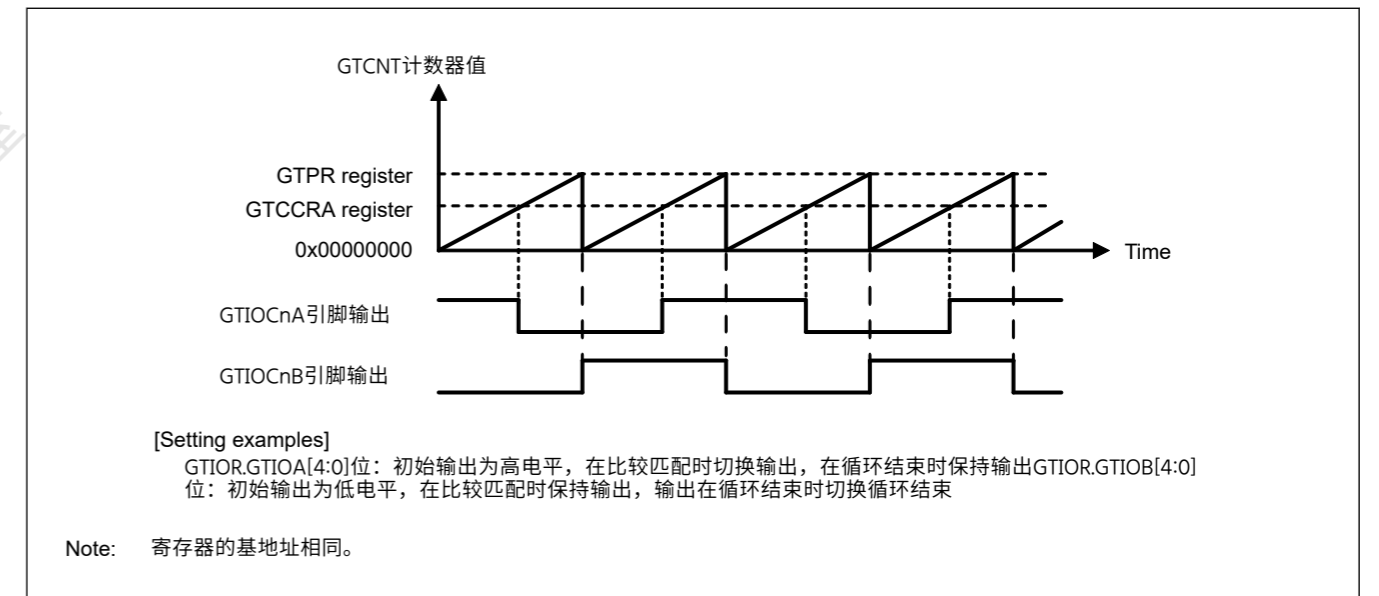


Figure 21.9 切换输出操作示例(2)

图21.15显示了设置切换输出操作的示例。

Table 21.10 设置切换输出操作的示例(1of2)

| No. | 步骤名称          | Description   |
|-----|---------------|---|
| 1   | 设置操作模式        | 使用GTCR.MD[2:0]设置操作模式。<br>在图21.8和图21.9中, 设置了000b (锯齿波PWM模式)。   |
| 2   | 设置计数方向        | 使用GTUDDTYC寄存器选择计数方向 (向上或向下)。在图21.8和图21.9中, 在GTUDDTYC[1:0]中设置了11b之后, 在GTUDDTYC[1:0]中设置了01b (向上计数)。   |
| 3   | 选择计数时钟        | 使用GTCR.TPCS[3:0]选择计数时钟。   |
| 4   | 设置周期          | 在GTPR中设置循环。   |
| 5   | 设置计数器的初始值     | 在GTCNT计数器中设置初始值。  |
| 6   | 设置GTIOcNm引脚功能 | 使用GTIOR中的GTIOA[4:0]和GTIOB[4:0]设置GTIOcNm引脚功能。<br>在图21.8中, GTIOA[4:0]=10011b, GTIOB[4:0]=00011b在图21.9中, GTIOA[4:0]=10011b, GTIOB[4:0] = 01100b。 |



Table 21.10 Example for setting toggled output operation (2 of 2)

| No. | Step Name                 | Description   |
|-----|---------------------------|---|
| 7   | Enable GTIOCnm pin output | Set to enable the GTIOCnm pin output with OAE and OBE in GTIOR. |
| 8   | Set compare match value   | Set compare match values in the GTCCRA and GTCCRB registers.    |
| 9   | Start count operation     | Set GTCR.CST to 1 to start count operation.                     |

Note: n: 0 to 7  
m: A, B

### 21.3.1.3 Input capture function

The GTCNT counter value can be transferred to either GTCCRA or GTCCRB on detection of the hardware source that is set in GTICASR and GTICBSR.

Figure 21.10 shows an example of the input capture function.

In this example, the GTCNT counter performs up-counting by the count clock, and settings are made so that an input capture is performed to GTCCRA at both edges of the GTIOCnA input pin and to GTCCRB on the rising edge of the GTIOCnB input pin.

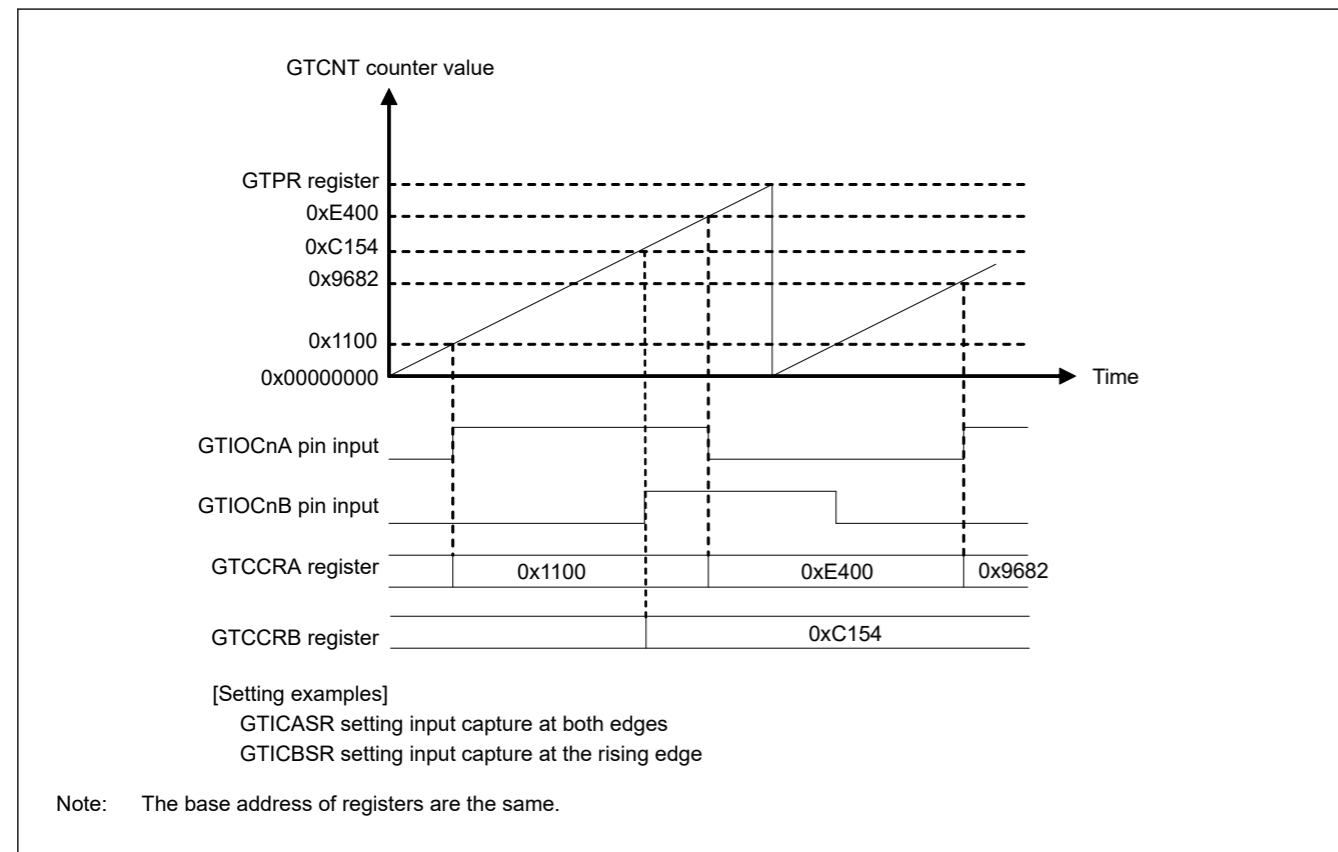


Figure 21.10 Example of input capture operation

Table 21.11 shows an example for setting an input capture operation with count operation by the count clock.

Table 21.11 Example for setting input capture operation (1 of 2)

| No. | Step Name           | Description  |
|-----|---------------------|--|
| 1   | Set operating mode  | Set the operating mode with GTCR.MD[2:0]. In Figure 21.10, 000b (saw-wave PWM mode) is set.  |
| 2   | Set count direction | Select the count direction (up or down) with the GTUDDTYC register. In Figure 21.10, after 11b is set in GTUDDTYC[1:0], 01b is set in GTUDDTYC[1:0] (up-counting). |
| 3   | Select count clock  | Select the count clock with GTCR.TPCS[3:0].  |

Table 21.10 设置切换输出操作的示例(2of2)

| No. | 步骤名称          | Description                       |
|-----|---------------|-----------------------------------|
| 7   | 启用GTIOCnm引脚输出 | 设置为在GTIOR中使用OAE和OBE启用GTIOCnm引脚输出。 |
| 8   | 设置比较匹配值       | 在GTCCRA和GTCCRB寄存器中设置比较匹配值。        |
| 9   | 开始计数操作        | 将GTCR.CST设置为1以启动计数操作。             |

Note: n: 0 to 7  
m: A, B

### 21.3.1.3 输入捕捉功能

在检测到在GTICASR和GTICBSR中设置的硬件源时，可以将GTCNT计数器值传输到GTCCRA或GTCCRB。

图21.10显示了输入捕捉函数的示例。

在本例中，GTCNT计数器通过计数时钟进行递增计数，并设置为在GTIOCnA输入引脚的两个边沿对GTCCRA执行输入捕捉，在GTIOCnB输入引脚的上升沿对GTCCRB执行输入捕捉。

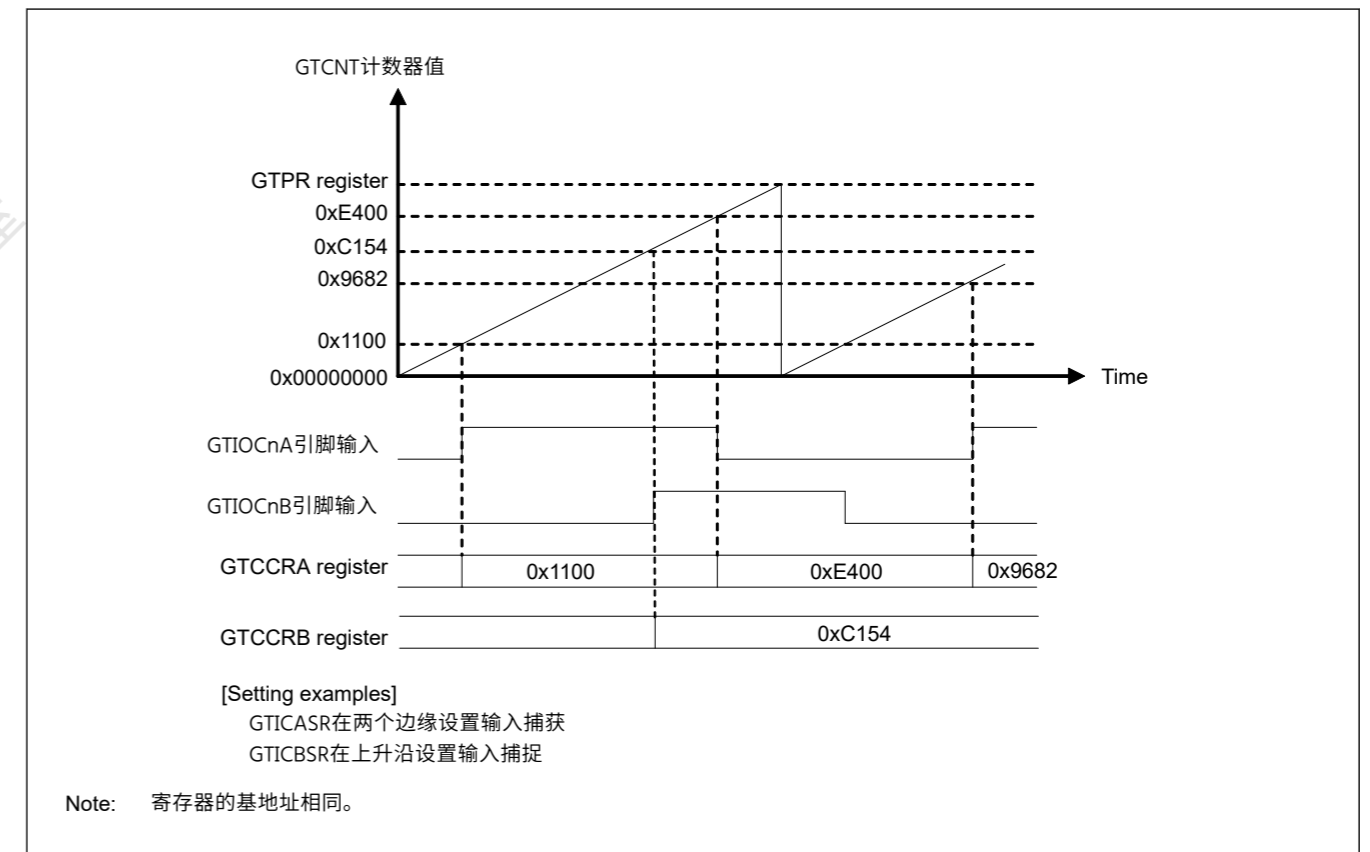


Figure 21.10 输入捕捉操作示例

表21.11显示了通过计数时钟设置计数操作的输入捕捉操作的示例。

Table 21.11 设置输入捕捉操作的示例(1of2)

| No. | 步骤名称   | Description  |
|-----|--------|--|
| 1   | 设置操作模式 | 使用GTCR.MD[2:0]设置操作模式。在图21.10中，设置了000b（锯齿波PWM模式）。   |
| 2   | 设置计数方向 | 使用GTUDDTYC寄存器选择计数方向（向上或向下）。在图21.10中，在GTUDDTYC[1:0]中设置了11b之后，在GTUDDTYC[1:0]中设置了01b（向上计数）。 |
| 3   | 选择计数时钟 | 使用GTCR.TPCS[3:0]选择计数时钟。  |



Table 21.11 Example for setting input capture operation (2 of 2)

| No. | Step Name                     | Description   |
|-----|-------------------------------|---|
| 4   | Set cycle                     | Set the cycle in GTPR.  |
| 5   | Set initial value for counter | Set the initial value in the GTCNT counter.   |
| 6   | Select input capture source   | Select the input capture source in GTICASR and GTICBSR.<br>In Figure 21.10, GTICASR = 0x00000F00, GTICBSR = 0x00003000. |
| 7   | Start count operation         | Set GTCR.CST to 1 to start count operation.   |

### 21.3.2 Buffer Operation

The following buffer operations can be set with GTBER:

- GTPR and GTPBR
- GTCCRA, GTCCRC, and GTCCRD
- GTCCRB, GTCCRE, and GTCCRF.

#### 21.3.2.1 GTPR register buffer operation

GTPBR can function as a buffer register for GTPR. The buffer transfer is performed at an overflow (during up-counting) or an underflow (during down-counting) in saw-wave mode or in event count, and at a trough in triangle-wave mode.

In saw-wave mode or in event count, the buffer transfer is performed when the following counter clear operations occur during counting:

- Clear by hardware sources (the clear source is selected in CTCSR register)
- Clear by software (when GTCSR.CCLR bit is 1 and GTCLR.CCLRn bit is set to 1, n = 0 to 7).

To set GTPR to function as a buffer, set the GTBER.PR bit to 1. To set GTPR not to function as a buffer, set the GTBER.PR bit to 0.

Figure 21.11 to Figure 21.13 show examples of GTPR buffer operation and Table 21.12 shows an example for setting GTPR buffer operation.

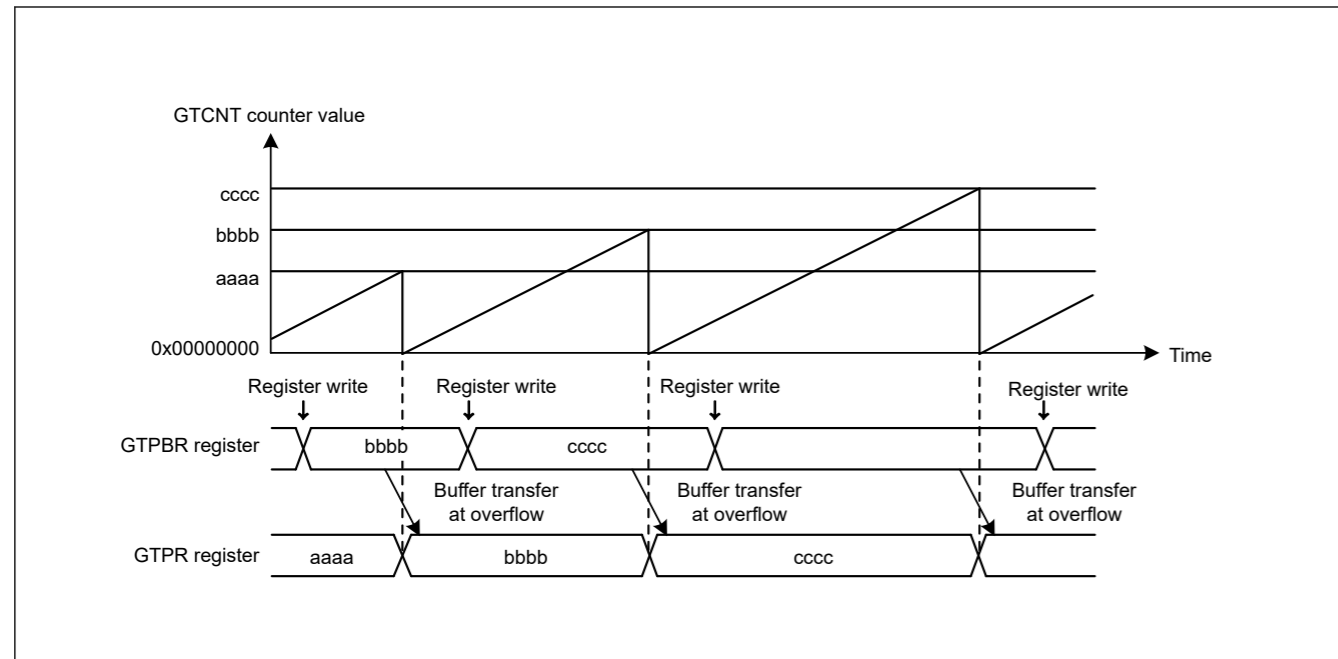


Figure 21.11 Example of GTPR buffer operation with saw waves in up-counting

Table 21.11 设置输入捕捉操作的示例(2of2)

| No. | 步骤名称      | Description  |
|-----|-----------|--|
| 4   | 设置周期      | 在GTPR中设置循环。  |
| 5   | 设置计数器的初始值 | 在GTCNT计数器中设置初始值。   |
| 6   | 选择输入捕捉源   | 在GTICASR和GTICBSR中选择输入捕获源。<br>在图21.10中, GTICASR=0x00000F00, GTICBSR=0x00003000。 |
| 7   | 开始计数操作    | 将GTCR.CST设置为1以启动计数操作。  |

### 21.3.2 缓冲操作

可以使用GTBER设置以下缓冲区操作:

- GTPR and GTPBR
- GTCCRA, GTCCRC, and GTCCRD
- GTCCRB, GTCCRE, and GTCCRF.

#### 21.3.2.1 GTPR寄存器缓冲操作

GTPBR可以作为GTPR的缓冲寄存器。缓冲区传输在锯齿波模式或事件计数中的上溢(向上计数期间)或下溢(向下计数期间)以及三角波模式的波谷处执行。

在锯齿波模式或事件计数中,当计数期间发生以下计数器清零操作时,将执行缓冲区传输:

- 通过硬件源清除(清除源在CTCSR寄存器中选择)
- 软件清零(当GTCSR.CCLR位为1且GTCLR.CCLRn位设置为1时,n=0至7)。

要将GTPR设置为缓冲区,请将GTBER.PR位设置为1。要将GTPR设置为不作为缓冲区,请将GTBER.PR位设置为0。

图21.11至图21.13显示了GTPR缓冲区操作的示例,表21.12显示了设置GTPR缓冲区操作的示例。

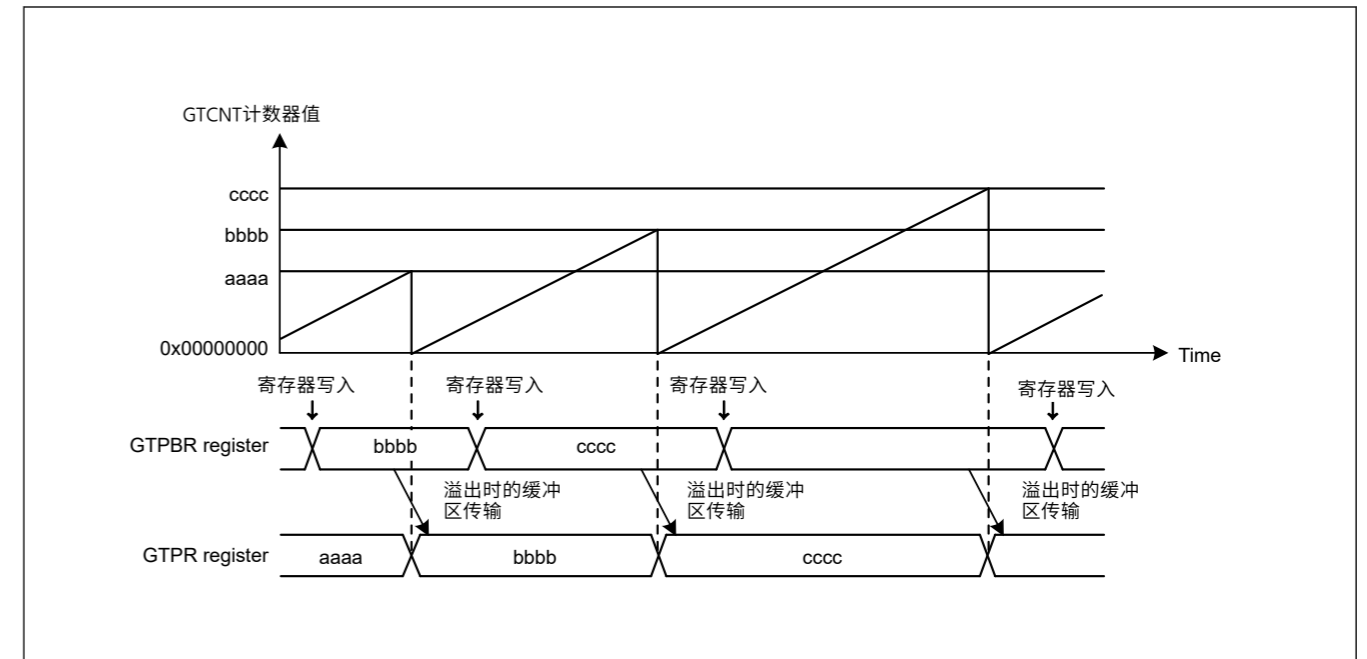


Figure 21.11 GTPR缓冲区操作示例,在向上计数中使用锯齿波

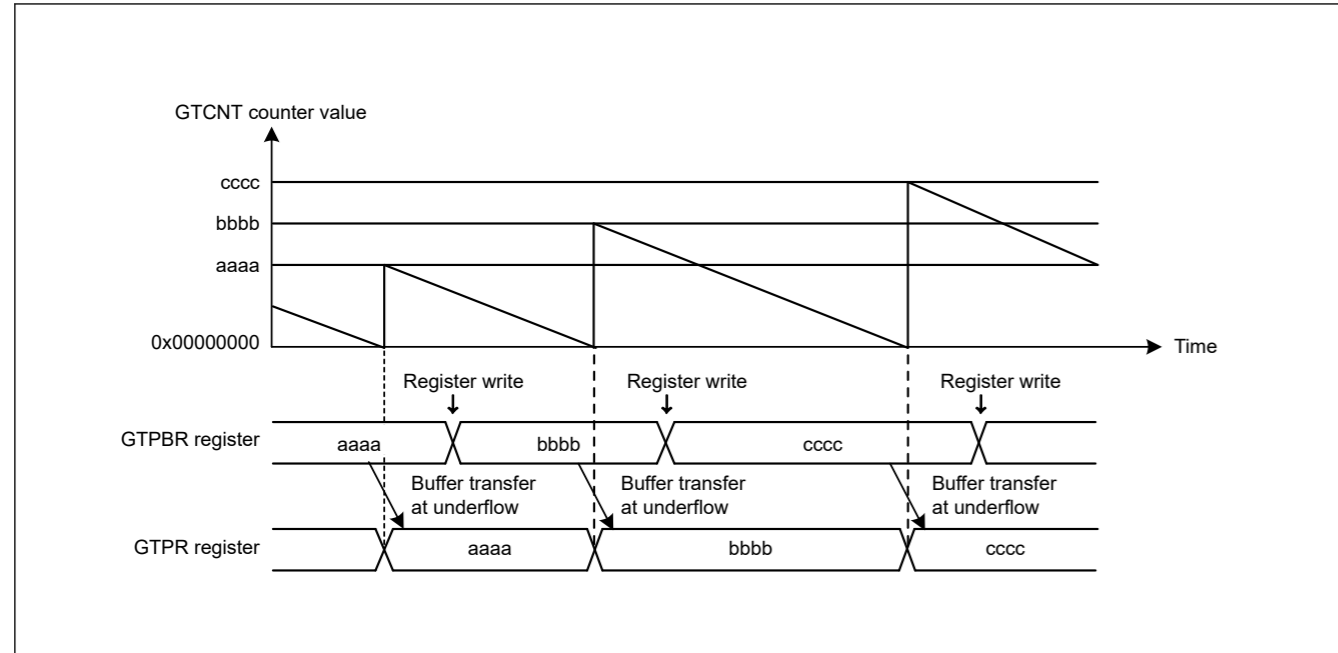


Figure 21.12 Example of GTPR buffer operation with saw waves in down-counting

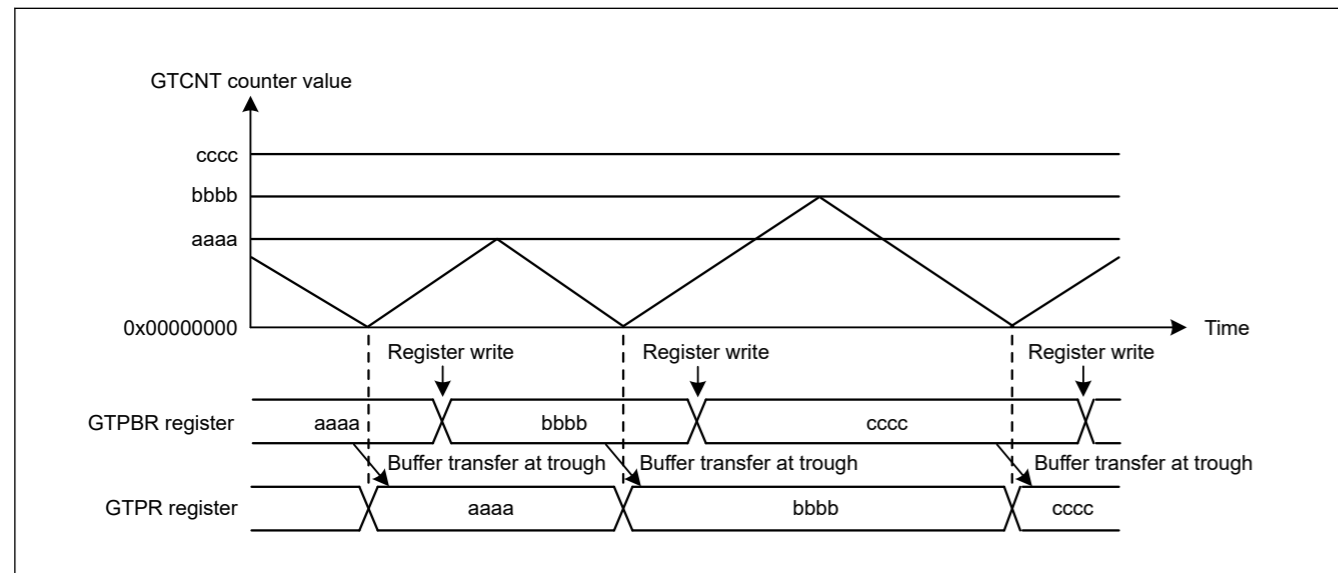


Figure 21.13 Example of GTPR buffer operation with triangle waves

Table 21.12 Example for setting GTPR buffer operation (1 of 2)

| No. | Step Name                     | Description   |
|-----|-------------------------------|---|
| 1   | Set operating mode            | Set the operating mode with GTCR.MD[2:0]. In Figure 21.11 and Figure 21.12, 000b (saw-wave PWM mode) is set, and in Figure 21.13, 100b (triangle-wave PWM mode 1) is set.   |
| 2   | Set count direction           | Select the count direction (up or down) with the GTUDDTYC register. In Figure 21.11, after 11b is set in GTUDDTYC[1:0], 01b is set in GTUDDTYC[1:0] (up-counting). In Figure 21.12, after 10b is set in GTUDDTYC[1:0], 00b is set in GTUDDTYC[1:0] (down-counting). |
| 3   | Select count clock            | Select the count clock with GTCR.TPCS[3:0].   |
| 4   | Set cycle                     | Set the cycle in GTPR.  |
| 5   | Set initial value for counter | Set the initial value in the GTCNT counter.   |
| 6   | Set buffer operation          | Set buffer operation with GTBER.PR[1:0]. In Figure 21.11, Figure 21.12, and Figure 21.13, PR[1:0] = 01b.  |

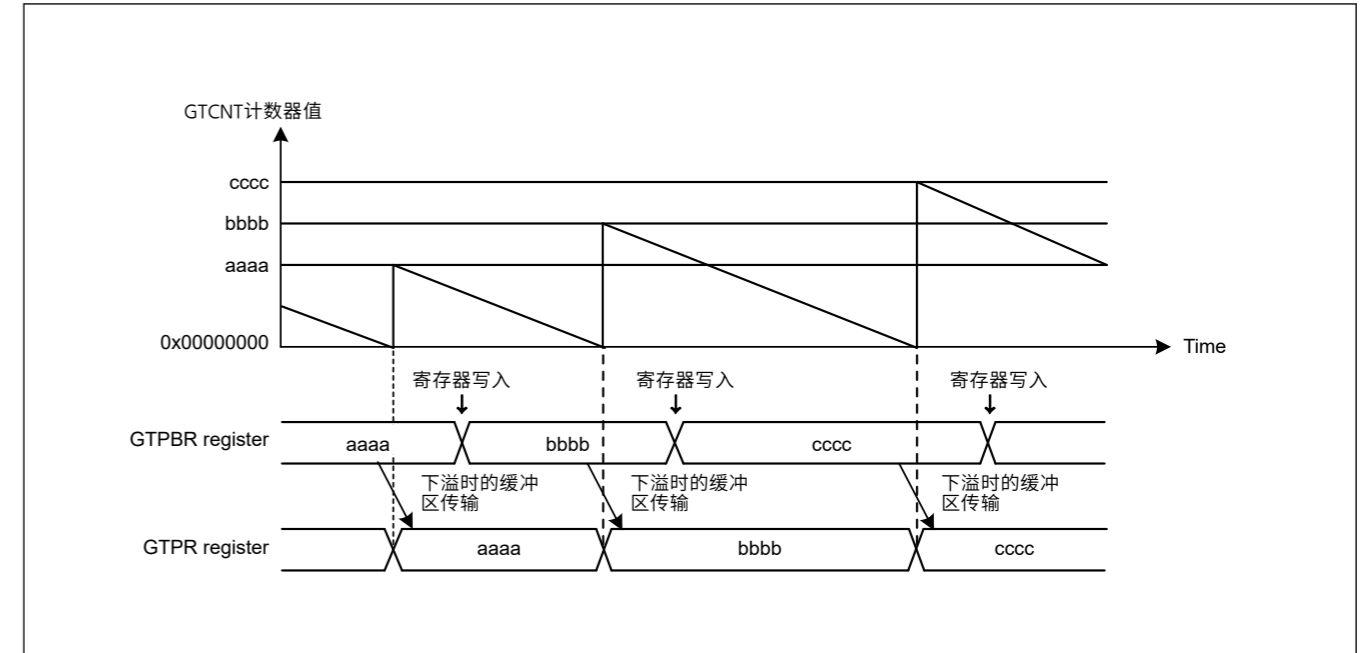


Figure 21.12 向下计数中锯齿波的GTPR缓冲区操作示例

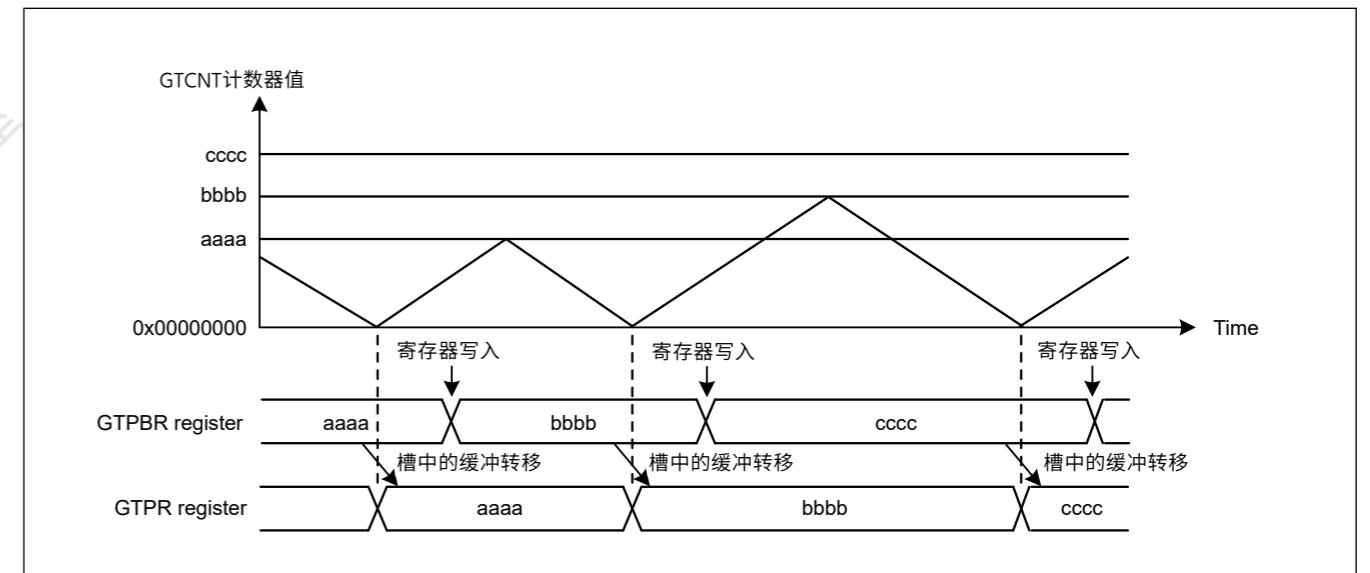


Figure 21.13 使用三角波的GTPR缓冲操作示例

Table 21.12 设置GTPR缓冲区操作的示例(1of2)

| No. | 步骤名称      | Description   |
|-----|-----------|---|
| 1   | 设置操作模式    | 使用GTCR.MD[2:0]设置操作模式。在图21.11和图21.12中，设置了000b（锯齿波PWM模式），在图21.13中，设置了100b（三角波PWM模式1）。   |
| 2   | 设置计数方向    | 使用GTUDDTYC寄存器选择计数方向（向上或向下）。在图21.11中，在GTUDDTYC[1:0]中设置了11b之后，在GTUDDTYC[1:0]中设置了01b（向上计数）。在图21.12中，在GTUDDTYC[1:0]中设置了10b后，在GTUDDTYC[1:0]中设置00b（向下计数）。 |
| 3   | 选择计数时钟    | 使用GTCR.TPCS[3:0]选择计数时钟。   |
| 4   | 设置周期      | 在GTPR中设置循环。   |
| 5   | 设置计数器的初始值 | 在GTCNT计数器中设置初始值。  |
| 6   | 设置缓冲操作    | 使用GTBER.PR[1:0]设置缓冲区操作。在图21.11、图21.12和图21.13中，PR[1:0]=01b。  |

Table 21.12 Example for setting GTPR buffer operation (2 of 2)

| No. | Step Name                       | Description  |
|-----|---------------------------------|--|
| 7   | Set buffer value                | For buffer operation, set a value in one cycle after the current cycle in GTPBR. |
| 8   | Start count operation           | Set GTCR.CST to 1 to start count operation.                                      |
| 9   | Set buffer value for each cycle | For buffer operation, set a value in one cycle after the current cycle in GTPBR. |

### 21.3.2.2 Buffer operation for GTCCRA and GTCCRB

GTCCRC can function as the GTCCRA buffer register and GTCCRD can function as the GTCCRC buffer register (double-buffer register for GTCCRA). Similarly, GTCCRE can function as the GTCCRB buffer register and GTCCRF can function as the GTCCRE buffer register (double-buffer register for GTCCRB).

To set GTCCRA or GTCCRB to function as a double buffer, set GTBER.CCRA[1:0] or GTBER.CCRB[1:0] to 10b or 11b. For single buffer operation, set 01b. To set GTCCRA or GTCCRB to not function as a buffer, set 00b.

#### (1) When GTCCRA or GTCCRB functions as an output compare register

Buffer transfer occurs in the following situations:

- Buffer transfer by overflow or underflow  
Buffer transfer is performed at an overflow (during up-counting) or an underflow (during down-counting) in saw-wave mode or in event count operation. In triangle-wave mode, buffer transfer is performed at a trough (triangle-wave PWM mode 1) or a crest and trough (triangle-wave PWM mode 2).
- Buffer transfer by counter clear  
In saw-wave mode or in event count operation, during counting, buffer transfer (which is the same as an overflow during up-counting or an underflow during down-counting) is performed by the counter clear sources similar to the case shown in [section 21.3.2.1. GTPR register buffer operation](#).  
In triangle-wave mode, buffer transfer is not performed by the counter clear.
- Forcible buffer transfer  
When GTBER.CCRSWT bit is set to 1 while the count operation is stopped, the GTCCRA and the GTCCRB register buffer transfer are performed forcibly in saw-wave mode, in event count operation and in triangle-wave mode. Additionally buffer transfer from the GTCCRD register to temporary register A and from the GTCCRF register to temporary register B are performed in saw-wave 1 shot pulse mode or triangle-wave PWM mode 3.

[Figure 21.14](#) to [Figure 21.16](#) show examples of GTCCRA and GTCCRB buffer operation and [Table 21.13](#) shows an example for setting GTCCRA and GTCCRB buffer operation.

Table 21.12 设置GTPR缓冲区操作的示例(2of2)

| No. | 步骤名称        | Description                        |
|-----|-------------|------------------------------------|
| 7   | 设置缓冲区值      | 对于缓冲操作, 在GTPBR中的当前周期之后的一个周期内设置一个值。 |
| 8   | 开始计数操作      | 将GTCR.CST设置为1以启动计数操作。              |
| 9   | 为每个周期设置缓冲区值 | 对于缓冲操作, 在GTPBR中的当前周期之后的一个周期内设置一个值。 |

### 21.3.2.2 GTCCRA和GTCCRB的缓冲操作

GTCCRC可以作为GTCCRA缓冲寄存器, GTCCRD可以作为GTCCRC缓冲寄存器 (GTCCRA的双缓冲寄存器)。同样, GTCCRE可以作为GTCCRB缓冲寄存器, GTCCRF可以作为GTCCRE缓冲寄存器 (GTCCRB的双缓冲寄存器)。

要将GTCCRA或GTCCRB设置为双缓冲区, 请将GTBER.CCRA[1:0]或GTBER.CCRB[1:0]设置为10b或11b。对于单缓冲操作, 设置01b。要将GTCCRA或GTCCRB设置为不用作缓冲区, 请设置00b。

#### (1) 当GTCCRA或GTCCRB用作输出比较寄存器时

缓冲区传输发生在以下情况:

- 上溢或下溢的缓冲区传输  
在锯齿波模式或事件计数操作中, 在溢出 (向上计数期间) 或下溢 (向下计数期间) 时执行缓冲区传输。在三角波模式中, 缓冲区传输在波谷 (三角波PWM模式1) 或波峰和波谷 (三角波PWM模式2) 处执行。
- 通过计数器清除缓冲区传输  
在锯齿波模式或事件计数操作中, 在计数期间, 缓冲区传输 (与向上计数期间的溢出或向下计数期间的下溢相同) 由计数器清零源执行, 类似于章节中所示的情况21.3.2.1。GTPR寄存器缓冲操作。在三角波模式下, 计数器清零不执行缓冲区传输。
- 强制缓冲转移  
当GTBER.CCRSWT位在计数操作停止时设置为1时, 在锯齿波模式、事件计数操作和三角波模式下强制执行GTCCRA和GTCCRB寄存器缓冲传输。此外, 从GTCCRD寄存器到临时寄存器A以及从GTCCRF寄存器到临时寄存器B的缓冲区传输在锯齿波1发射脉冲模式或三角波PWM模式3中执行。

图21.14至图21.16显示了GTCCRA和GTCCRB缓冲操作的示例, 表21.13显示了设置GTCCRA和GTCCRB缓冲操作的示例。

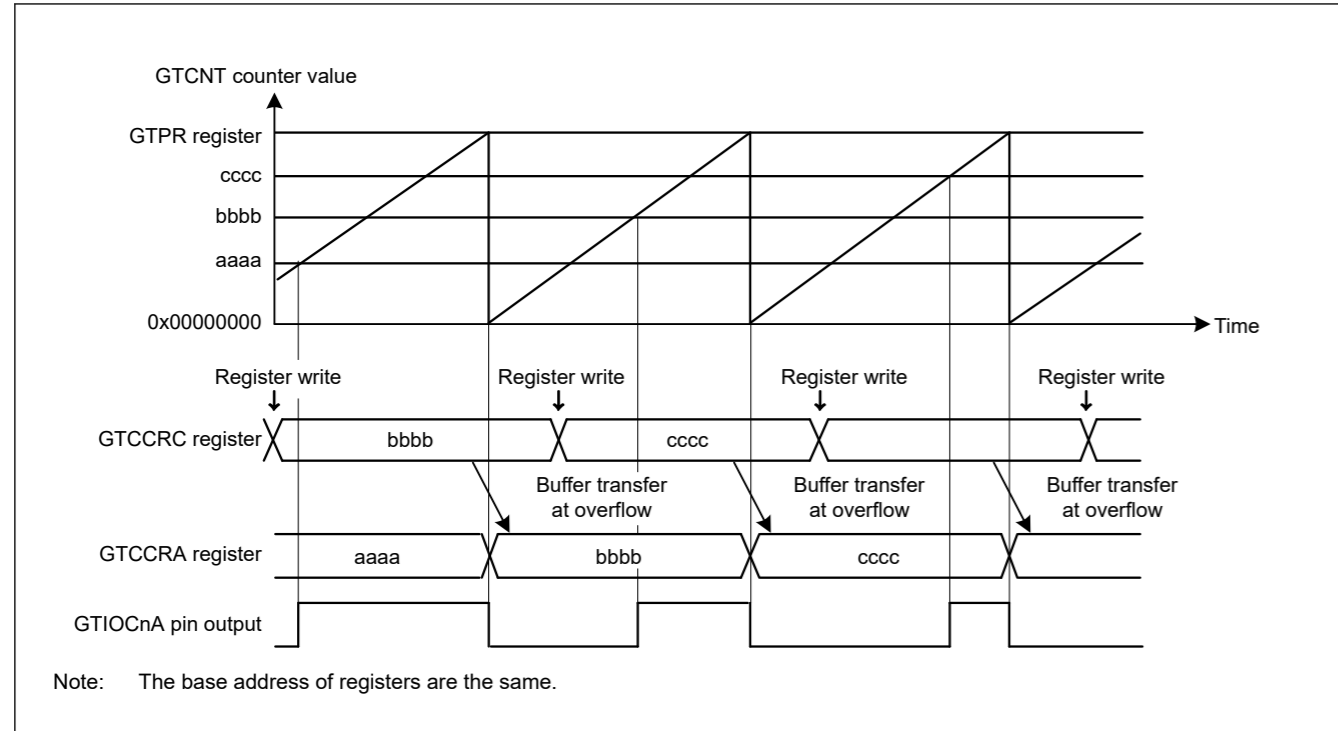


Figure 21.14 Example of GTCCRA and GTCCRB buffer operation with output compare, saw waves in up-counting, high output at GTCCRA compare match, and low output at cycle end

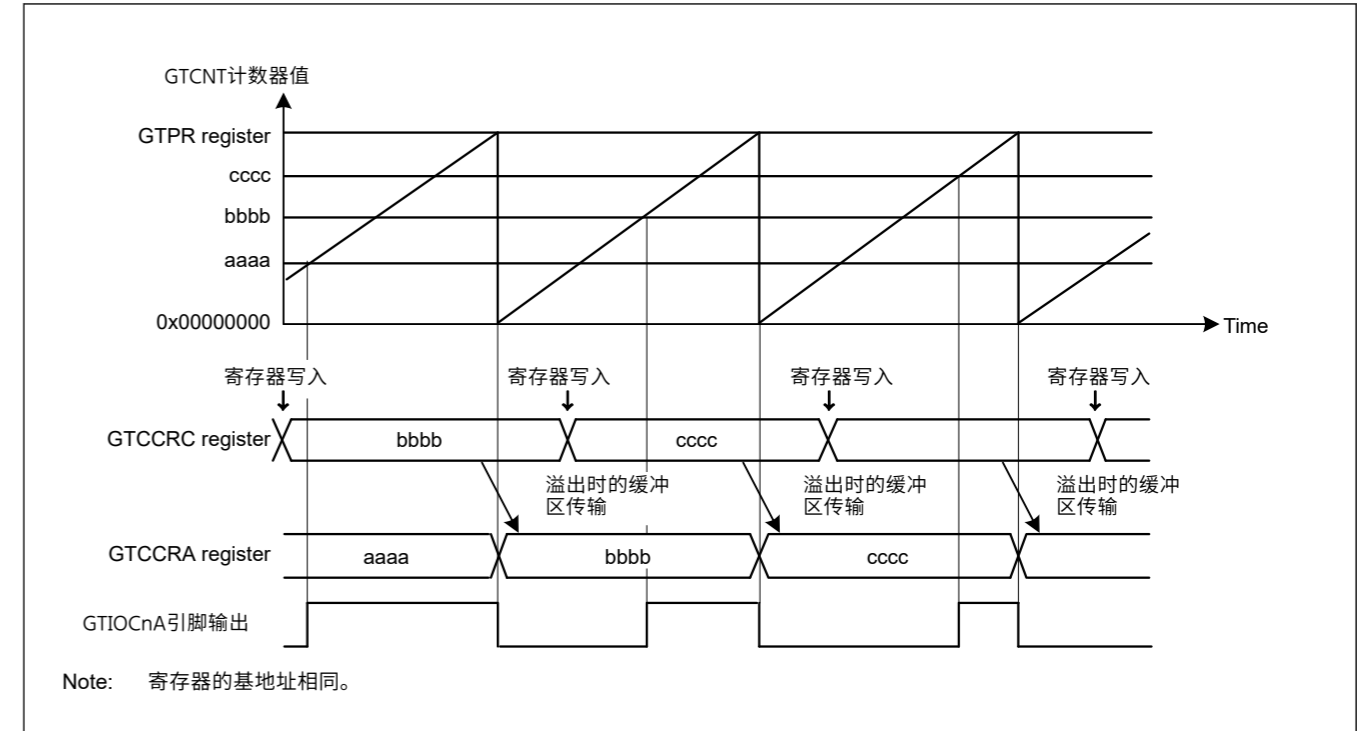


Figure 21.14 GTCCRA和GTCCRB缓冲器操作示例，输出比较、递增计数中的锯齿波、GTCCRA比较匹配时的高输出和周期结束时的低输出

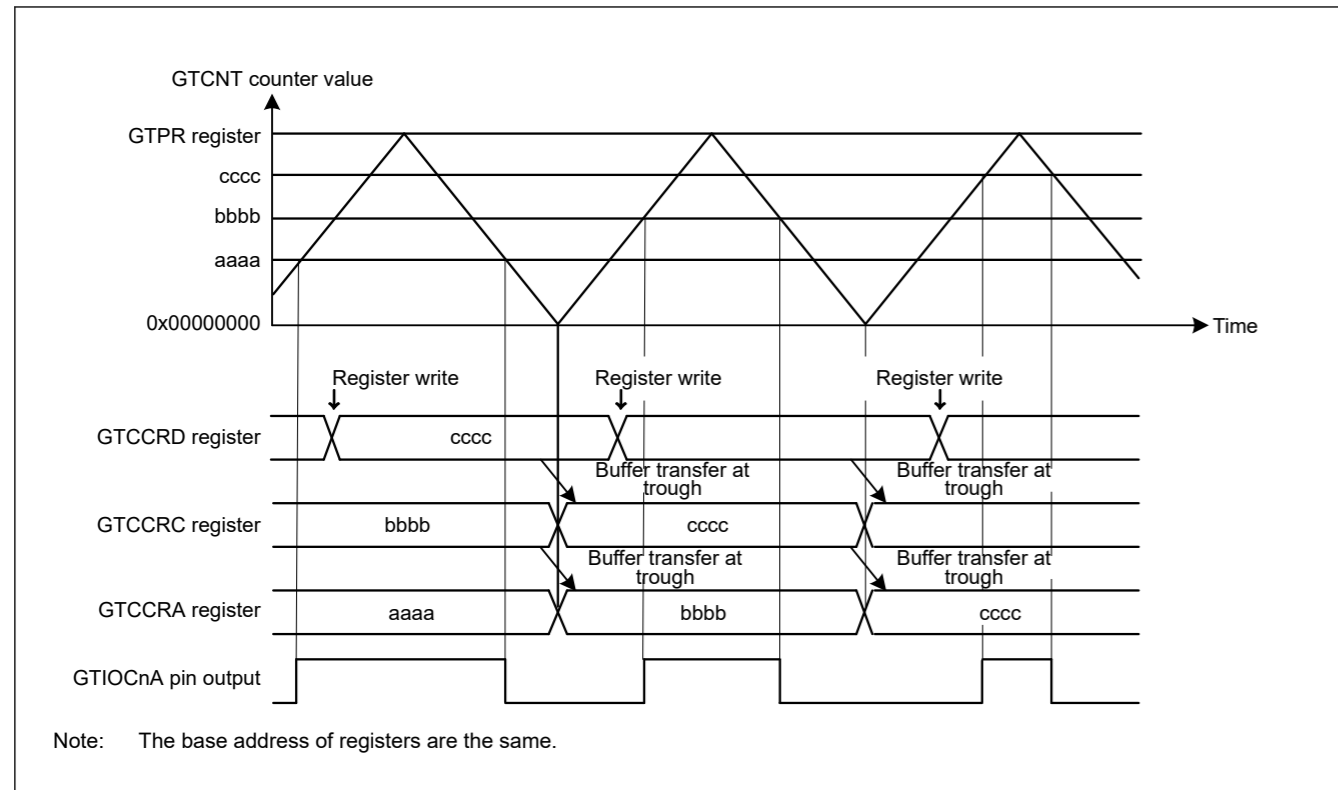


Figure 21.15 Example of GTCCRA and GTCCRB double buffer operation with output compare, triangle waves, buffer operation at trough, output toggled at GTCCRA compare match, and output retained at cycle end

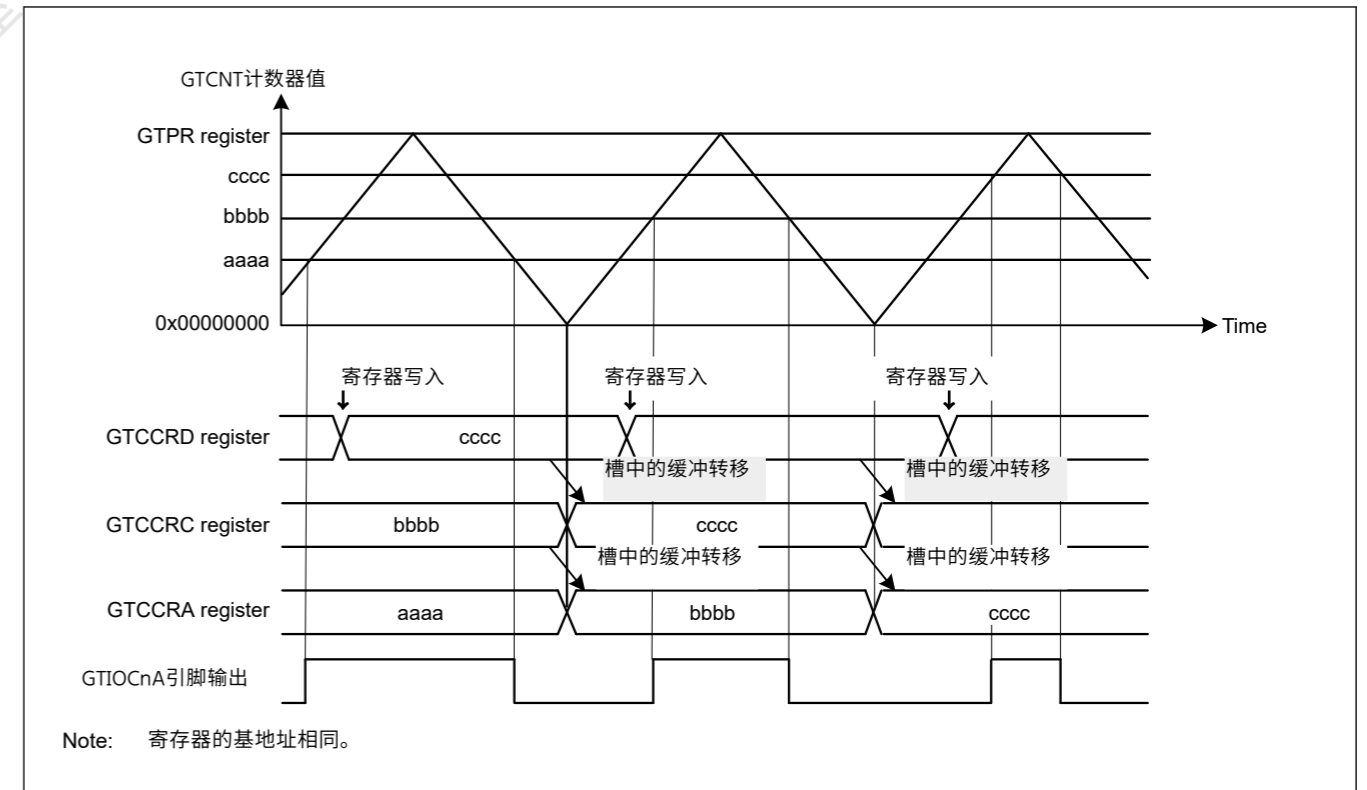


Figure 21.15 GTCCRA和GTCCRB双缓冲操作示例，输出比较、三角波、波谷缓冲操作、GTCCRA比较匹配时切换输出、循环结束时保留输出

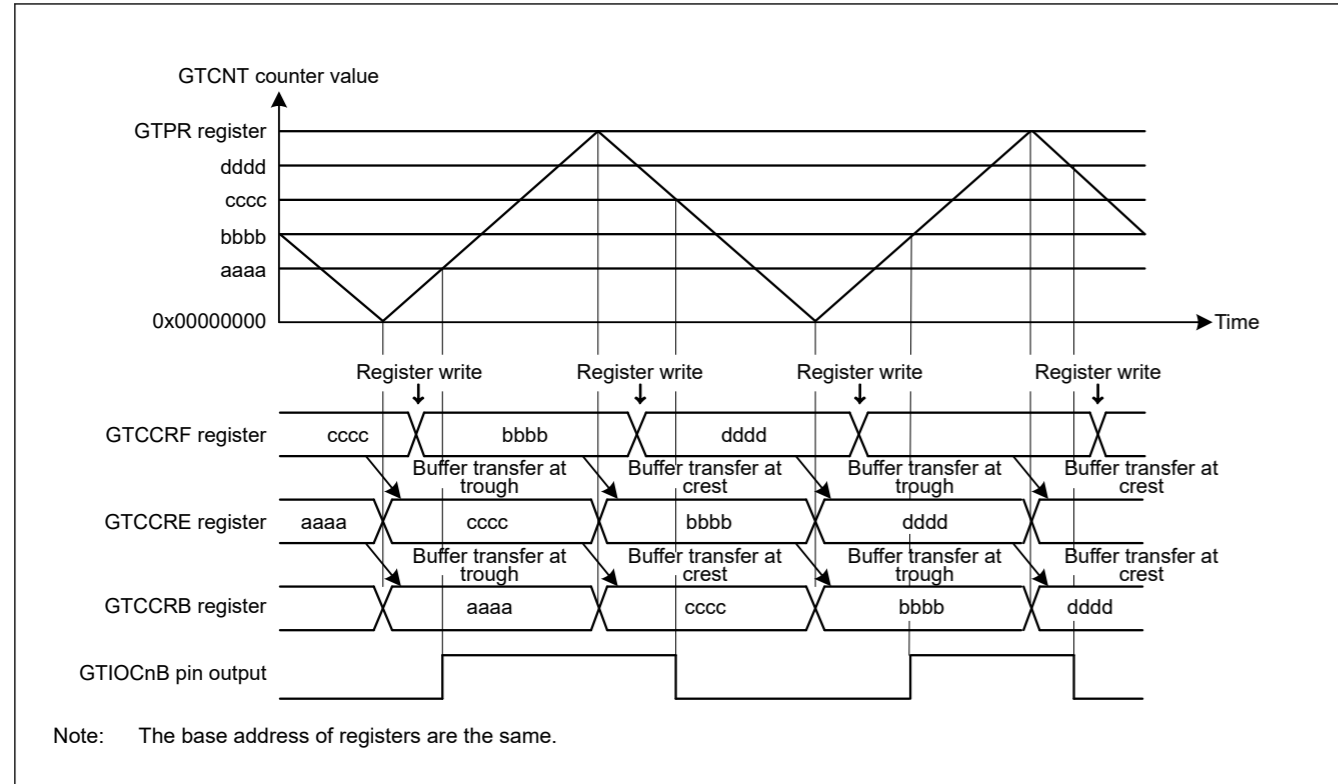


Figure 21.16 Example of GTCCRA and GTCCRB double buffer operation with output compare, triangle waves, buffer operation at both troughs and crests, output toggled at GTCCRB compare match, and output retained at cycle end

Table 21.13 Example for setting GTCCRA and GTCCRB buffer operation for output compare (1 of 2)

| No. | Step Name                     | Description  |
|-----|-------------------------------|--|
| 1   | Set operating mode            | Set the operating mode with GTCR.MD[2:0].<br>In Figure 21.14, 000b (saw-wave PWM mode) is set, in Figure 21.15, 100b (triangle-wave PWM mode 1) is set, and in Figure 21.16, 101b (triangle-wave PWM mode 2) is set.   |
| 2   | Set count direction           | Select the count direction (up or down) with the GTUDDTYC register.<br>In Figure 21.14, after 11b is set in GTUDDTYC[1:0], 01b is set in GTUDDTYC[1:0] (up-counting).  |
| 3   | Select count clock            | Select the count clock with GTCR.TPCS[3:0].  |
| 4   | Set cycle                     | Set the cycle in GTPR.   |
| 5   | Set initial value for counter | Set the initial value in the GTCNT counter.  |
| 6   | Set GTIOcNm pin function      | Set the GTIOcNm pin function with GTIOA[4:0] and GTIOB[4:0] in GTIOR.<br>In Figure 21.14, GTIOA[4:0] = 00110b, in Figure 21.15, GTIOA[4:0] = 00011b, and in Figure 21.16, GTIOB[4:0] = 00011b.   |
| 7   | Enable GTIOcNm pin output     | Set to enable the GTIOcNm pin output with OAE and OBE in GTIOR.  |
| 8   | Set buffer operation          | Set buffer operation with CCRA and CCRB in GTBER.<br>In Figure 21.14, CCRA[1:0] = 01b, in Figure 21.15, CCRA[1:0] = 1xb, and in Figure 21.16, CCRB[1:0] = 1xb.   |
| 9   | Set compare match value       | Set the GTIOcNA pin transition in GTCCRA and GTIOcNB pin transition in the GTCCRB.   |
| 10  | Set buffer value              | For buffer operation, set the GTIOcNA pin and GTIOcNB pin transitions in 1 cycle after the current cycle (in saw-wave mode or triangle-wave mode with buffer transfer at trough or crest) or half cycle after the current cycle (in triangle-wave mode with buffer transfer at both trough and crest) in GTCCRC and GTCCRE, respectively.<br>For double buffer operation, also set the GTIOcNA pin and GTIOcNB pin transitions in 2 cycles after the current cycle (in saw-wave mode or triangle-wave mode with buffer transfer at trough or crest) or 1 cycle after the current cycle (in triangle-wave mode with buffer transfer at both trough and crest) in GTCCRD and GTCCRF, respectively. |
| 11  | Start count operation         | Set GTCR.CST to 1 to start count operation.  |

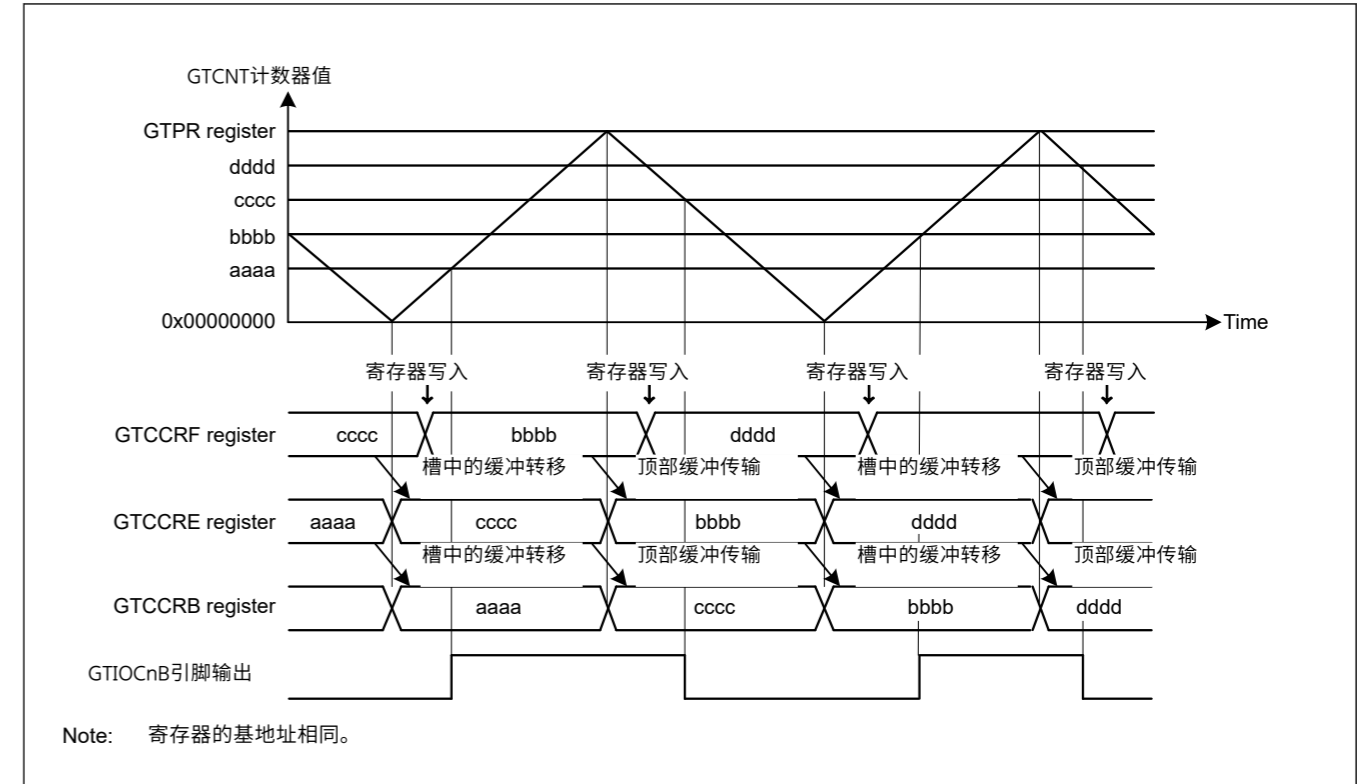


Figure 21.16 GTCCRA和GTCCRB双缓冲操作示例，输出比较、三角波、波谷和波峰缓冲操作、在GTCCRB比较匹配时切换输出以及在周期结束时保留输出

Table 21.13 为输出比较设置GTCCRA和GTCCRB缓冲操作的示例 (1of2)

| No. | 步骤名称          | Description   |
|-----|---------------|---|
| 1   | 设置操作模式        | 使用GTCR.MD[2:0]设置操作模式。<br>在图21.14中，设置了000b（锯齿波PWM模式），在图21.15中，设置了100b（三角波PWM模式1），在图21.16中，设置了101b（三角波PWM模式2）。  |
| 2   | 设置计数方向        | 使用GTUDDTYC寄存器选择计数方向（向上或向下）。<br>在图21.14中，在GTUDDTYC[1:0]中设置了11b之后，在GTUDDTYC[1:0]中设置了01b（向上计数）。  |
| 3   | 选择计数时钟        | 使用GTCR.TPCS[3:0]选择计数时钟。   |
| 4   | 设置周期          | 在GTPR中设置循环。   |
| 5   | 设置计数器的初始值     | 在GTCNT计数器中设置初始值。  |
| 6   | 设置GTIOcNm引脚功能 | 使用GTIOR中的GTIOA[4:0]和GTIOB[4:0]设置GTIOcNm引脚功能。<br>在图21.14中，GTIOA[4:0]=00110b，在图21.15中，GTIOA[4:0]=00011b，在图21.16中，GTIOB[4:0] = 00011b。   |
| 7   | 启用GTIOcNm引脚输出 | 设置为在GTIOR中使用OAE和OBE启用GTIOcNm引脚输出。   |
| 8   | 设置缓冲操作        | 在GTBER中使用CCRA和CCRB设置缓冲区操作。<br>在图21.14中，CCRA[1:0]=01b，在图21.15中，CCRA[1:0]=1xb，在图21.16中，CCRB[1:0] = 1xb。   |
| 9   | 设置比较匹配值       | 在GTCCRA中设置GTIOcNA引脚转换，在GTCCRB中设置GTIOcNB引脚转换。  |
| 10  | 设置缓冲区值        | 对于缓冲操作，设置GTIOcNA引脚和GTIOcNB引脚在当前周期后的1个周期（在锯齿波模式或在波谷或波峰处缓冲传输的三角波模式）或当前周期后的半个周期（在三角波在GTCCRC和GTCCRE中分别在波谷和波峰进行缓冲传输的模式）。<br>对于双缓冲器操作，也将GTIOcNA引脚和GTIOcNB引脚转换设置在当前周期之后的2个周期（在锯齿波模式或在波谷或波峰处缓冲传输的三角波模式）或当前周期之后的1个周期（在三角形波模式，在波谷和波峰都有缓冲转移）分别在GTCCRD和GTCCRF中。 |
| 11  | 开始计数操作        | 将GTCR.CST设置为1以启动计数操作。   |



Table 21.13 Example for setting GTCCRA and GTCCRB buffer operation for output compare (2 of 2)

| No. | Step Name                       | Description  |
|-----|---------------------------------|--|
| 12  | Set buffer value for each cycle | For buffer operation, set the GTIOCnA pin and GTIOCnB pin transitions in 1 cycle after the current cycle (in saw-wave mode or triangle-wave mode with buffer transfer at trough or crest) or half cycle after the current cycle (in triangle-wave mode with buffer transfer at both trough and crest) in GTCCRC and GTCCRE, respectively.<br>For double buffer operation, also set the GTIOCnA pin and GTIOCnB pin transitions in 2 cycles after the current cycle (in saw-wave mode or triangle-wave mode with buffer transfer at trough or crest) or 1 cycle after the current cycle (in triangle-wave mode with buffer transfer at both trough and crest) in GTCCRD and GTCCRF, respectively. |

Note: n: 0 to 7  
m: A, B

(2) When GTCCRA or GTCCRB functions as an input capture register

When an input capture is generated, the GTCNT counter value is transferred to GTCCRA and GTCCRB and the stored GTCCRA and GTCCRB register values are transferred to the buffer registers. In input capture operation, the buffer transfer is not performed by the counter clear.

Figure 21.17 and Figure 21.18 show examples of GTCCRA and GTCCRB buffer operation and Table 21.14 shows an example for setting GTCCRA and GTCCRB buffer operation.

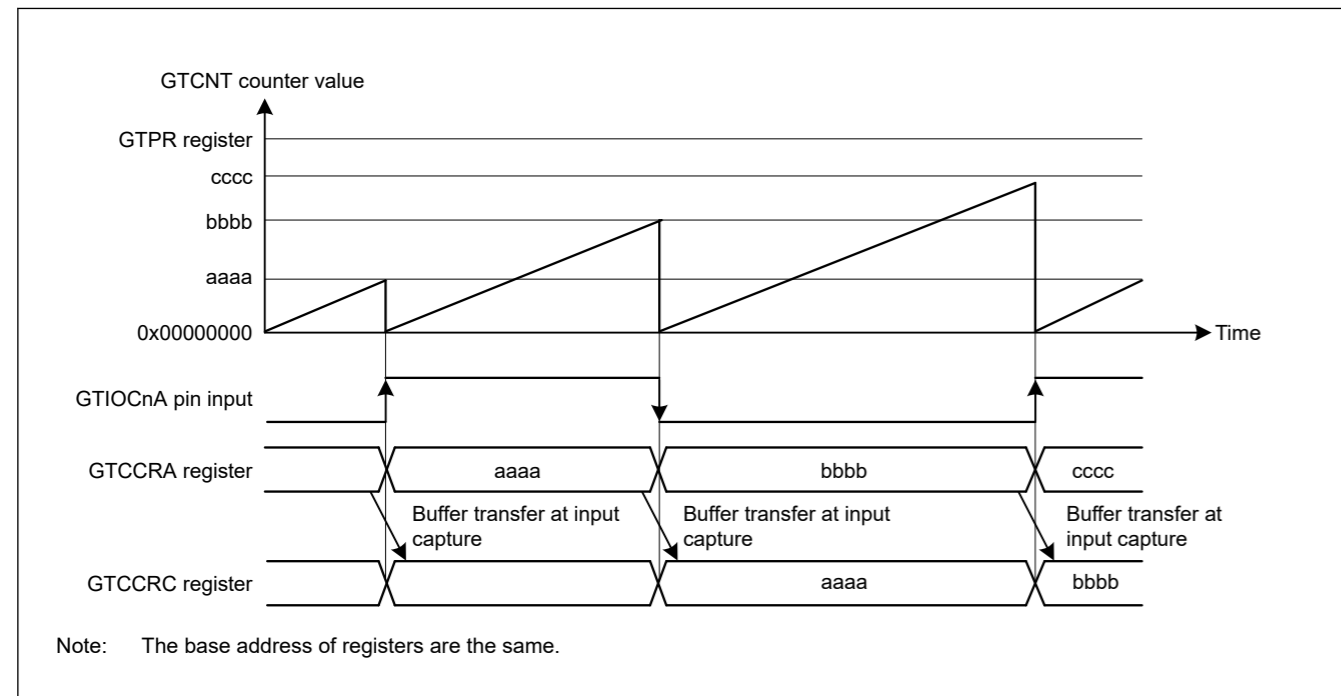


Figure 21.17 Example of GTCCRA and GTCCRB buffer operation with input capture at both edges of GTIOCnA input, saw waves in up-counting, and GTCNT counter cleared at both edges of GTIOCnA input

Table 21.13 为输出比较设置GTCCRA和GTCCRB缓冲操作的示例(2of2)

| No. | 步骤名称        | Description   |
|-----|-------------|---|
| 12  | 为每个周期设置缓冲区值 | 对于缓冲操作，设置GTIOCnA引脚和GTIOCnB引脚在当前周期后的1个周期（在锯齿波模式或在波谷或波峰处缓冲传输的三角波模式）或当前周期后的半个周期（在三角波在GTCCRC和GTCCRE中分别在波谷和波峰进行缓冲传输的模式）。<br>对于双缓冲器操作，也将GTIOCnA引脚和GTIOCnB引脚转换设置在当前周期之后的2个周期（在锯齿波模式或在波谷或波峰处缓冲传输的三角波模式）或当前周期之后的1个周期（在三角形波模式，在波谷和波峰都有缓冲转移）分别在GTCCRD和GTCCRF中。 |

Note: n: 0 to 7  
m: A, B

(2) 当GTCCRA或GTCCRB用作输入捕捉寄存器时

当产生输入捕捉时，GTCNT计数器值被传送到GTCCRA和GTCCRB并存储。GTCCRA和GTCCRB寄存器值被传送到缓冲寄存器。在输入捕捉操作中，缓冲区传输不是由计数器清零来执行的。

图21.17和图21.18显示了GTCCRA和GTCCRB缓冲操作的示例，表21.14显示了设置GTCCRA和GTCCRB缓冲操作的示例。

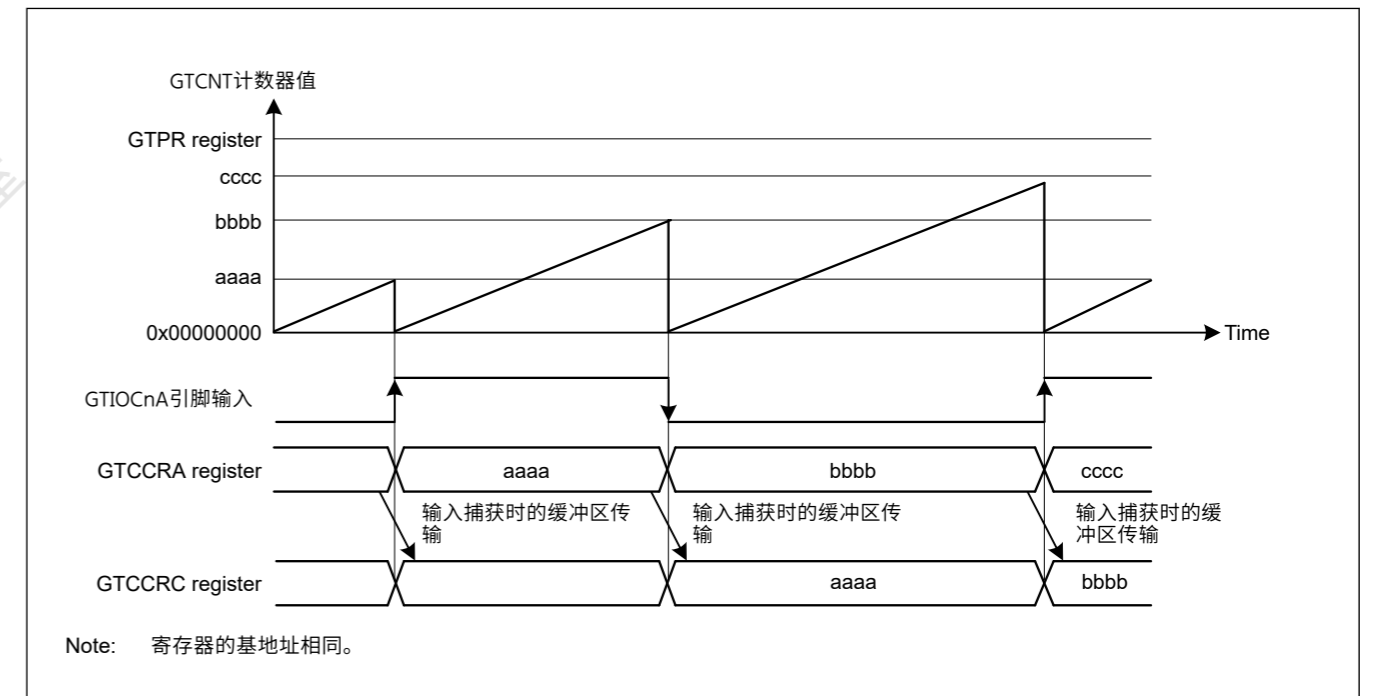


Figure 21.17 GTCCRA和GTCCRB缓冲区操作的示例，在两个边沿都有输入捕捉GTIOCnA输入，递增计数中的锯齿波，并且GTCNT计数器在GTIOCnA输入

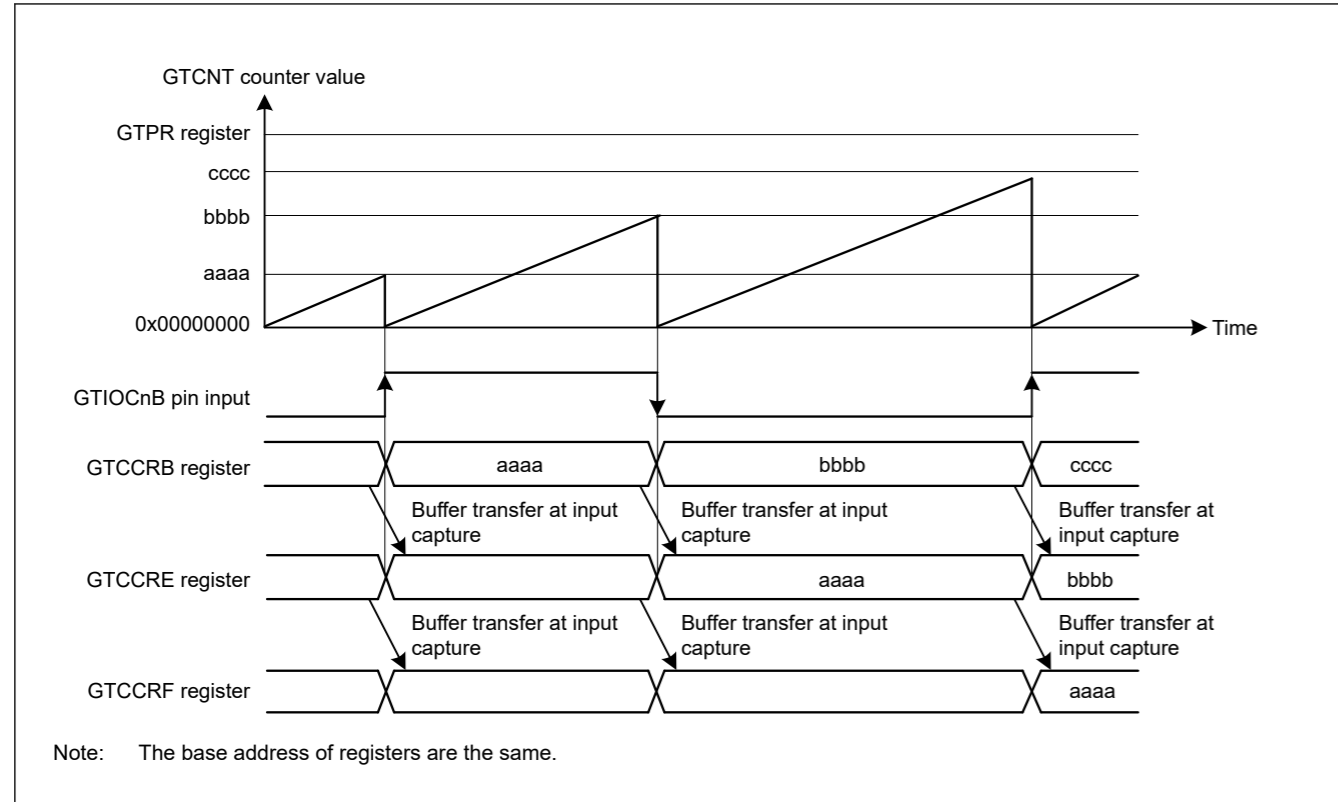


Figure 21.18 Example of GTCCRA and GTCCRB double buffer operation with input capture at both edges of GTIOcNB input, saw waves in up-counting, and GTCNT counter cleared at both edges of GTIOcNB input

Table 21.14 Example for setting GTCCRA and GTCCRB buffer operation for input capture

| No. | Step Name                     | Description  |
|-----|-------------------------------|--|
| 1   | Set operating mode            | Set the operating mode with GTCR.MD[2:0] and count clear source with GTCSCR. In Figure 21.17, MD[2:0] = 000b (saw-wave PWM mode) and GTCSCR = 0x00000F00, and in Figure 21.18, MD[2:0] = 000b (saw-wave PWM mode) and GTCSCR = 0x0000F000. |
| 2   | Set count direction           | Select the count direction (up or down) with the GTUDDTYC register. In Figure 21.17, after 11b is set in GTUDDTYC[1:0], 01b is set in GTUDDTYC[1:0] (up-counting).   |
| 3   | Select count clock            | Select the count clock with GTCR.TPCS[3:0].  |
| 4   | Set cycle                     | Set the cycle in GTPR.   |
| 5   | Set initial value for counter | Set the initial value in the GTCNT counter.  |
| 6   | Select input capture source   | Select input capture source in the GTICASR register and GTICBSR register. In Figure 21.17, GTICASR = 0x00000F00, and in Figure 21.18, GTICBSR = 0x0000F000.  |
| 7   | Set buffer operation          | Set buffer operation with CCRA and CCRB in GTBER. In Figure 21.17, CCRA[1:0] = 01b, and in Figure 21.18, CCRB = 1xb.   |
| 8   | Start count operation         | Set GTCR.CST to 1 to start count operation.  |

### 21.3.3 PWM Output Operating Mode

The GPT can output PWM waveforms to the GTIOcNA pin or GTIOcNB pin (n = 0 to 7) by a compare match between the GTCNT counter and GTCCRA or GTCCRB.

By setting GTDTCR and GTDVU, the compare match value for a negative-phase waveform with dead time can automatically be set to GTCCRB.

#### 21.3.3.1 Saw-Wave PWM Mode

In saw-wave PWM mode, GTCNT performs saw-wave (half-wave) operation by setting the cycle in GTPR and a PWM waveform is output to the GTIOcNA pin or GTIOcNB pin (n = 0 to 7) when a GTCCRA or GTCCRB compare match

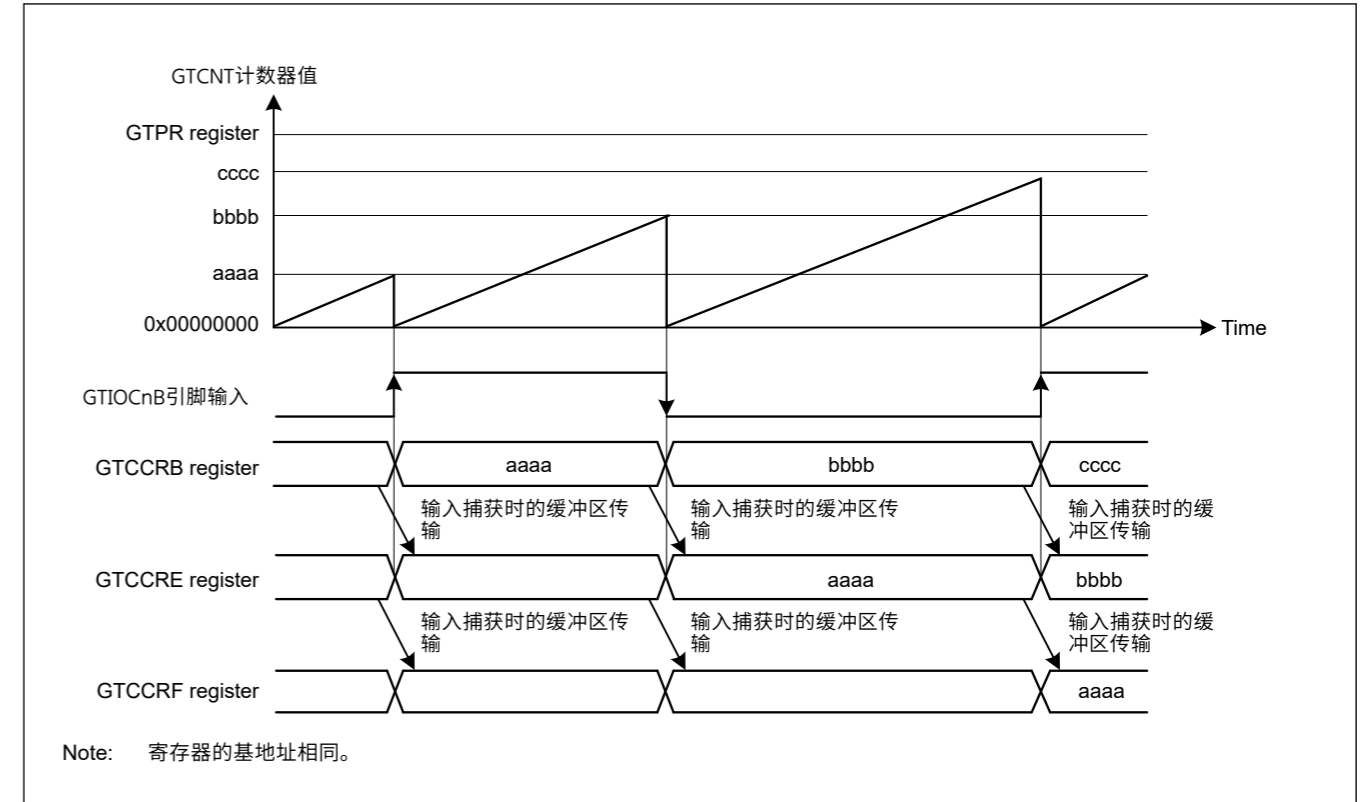


Figure 21.18 GTCCRA和GTCCRB双缓冲操作示例，在两个边沿进行输入捕获 GTIOcNB输入，递增计数中的锯齿波，GTCNT计数器在两个边缘清零 GTIOcNB input

Table 21.14 为输入捕捉设置GTCCRA和GTCCRB缓冲操作的示例

| No. | 步骤名称      | Description  |
|-----|-----------|--|
| 1   | 设置操作模式    | 用GTCR.MD[2:0]设置工作模式，用GTCSCR计数清零。在图21.17中，MD[2:0]=000b（锯齿波PWM模式）和GTCSCR=0x00000F00，并且在图21.18中，MD[2:0]=000b（锯齿波PWM模式）和GTCSCR=0x0000F000。 |
| 2   | 设置计数方向    | 使用GTUDDTYC寄存器选择计数方向（向上或向下）。在图21.17中，在GTUDDTYC[1:0]中设置了11b后，在GTUDDTYC[1:0]中设置了01b（向上计数）。  |
| 3   | 选择计数时钟    | 使用GTCR.TPCS[3:0]选择计数时钟。  |
| 4   | 设置周期      | 在GTPR中设置循环。  |
| 5   | 设置计数器的初始值 | 在GTCNT计数器中设置初始值。   |
| 6   | 选择输入捕捉源   | 在GTICASR寄存器和GTICBSR寄存器中选择输入捕捉源。在图21.17中，GTICASR=0x00000F00，在图21.18中，GTICBSR=0x0000F000。  |
| 7   | 设置缓冲操作    | 在GTBER中使用CCRA和CCRB设置缓冲区操作。在图21.17中，CCRA[1:0]=01b，在图21.18中，CCRB=1xb。  |
| 8   | 开始计数操作    | 将GTCR.CST设置为1以启动计数操作。  |

### 21.3.3 PWM输出工作模式

GPT可以通过两者之间的比较匹配将PWM波形输出到GTIOcNA引脚或GTIOcNB引脚（n=0到7）。GTCNT计数器和GTCCRA或GTCCRB。

通过设置GTDTCR和GTDVU，可以自动将带死区时间的反相波形的比较匹配值设置为GTCCRB。

#### 21.3.3.1 Saw-Wave PWM Mode

在锯齿波PWM模式下，GTCNT通过设置GTPR的周期执行锯齿波（半波）操作，当GTCCRA或GTCCRB比较时，PWM波形输出到GTIOcNA引脚或GTIOcNB引脚（n=0至7）匹配

occurs. The pin output value can be selected from low output, high output, or toggle output separately for a compare match and for the cycle end according to the GTIOR setting.

Figure 21.19 shows an example of saw-wave PWM mode operation, and Table 21.15 shows an example for setting saw-wave PWM mode.

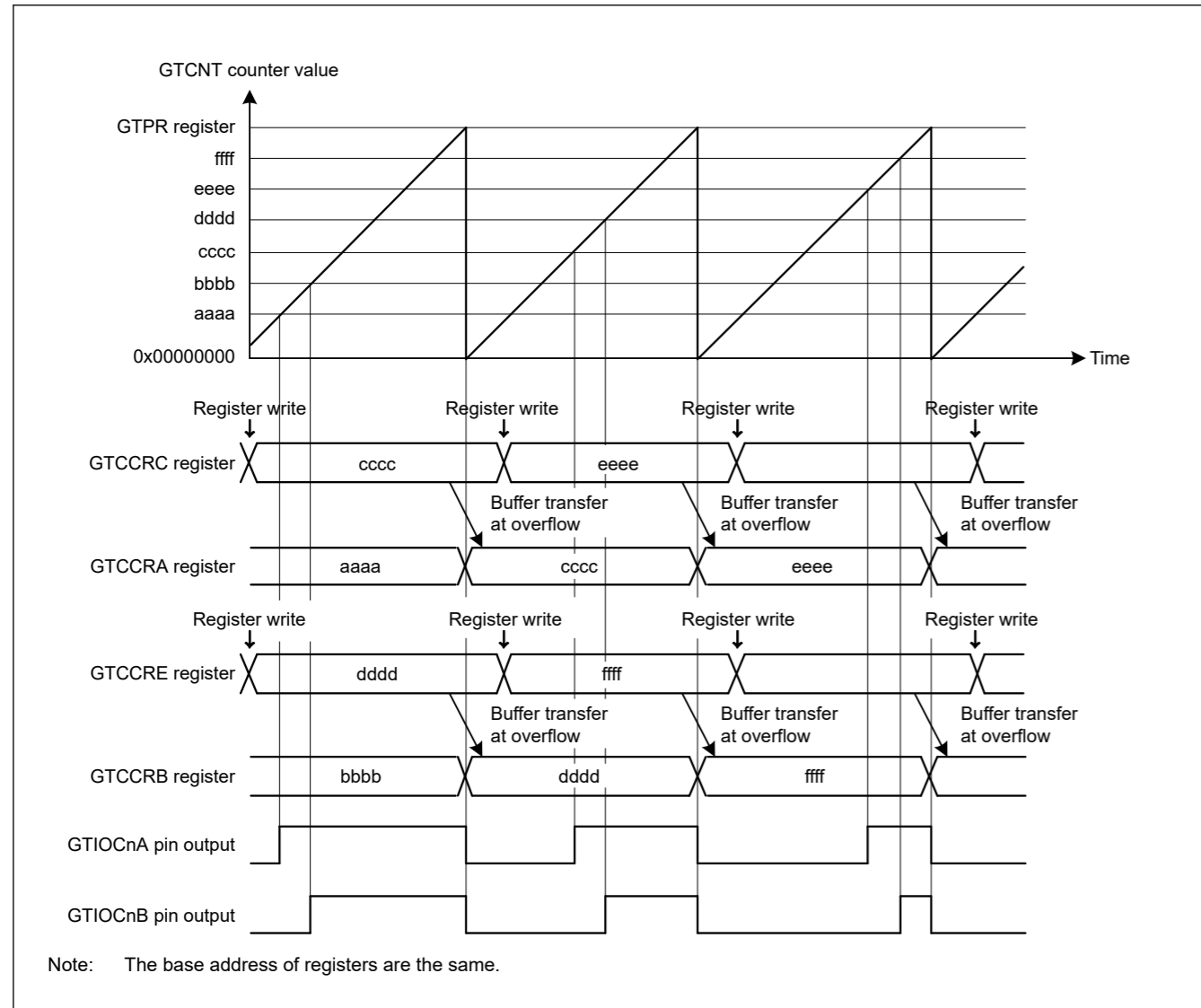


Figure 21.19 Example of saw-wave PWM mode operation with up-counting, buffer operation, high output at GTCCRA/GTCCRB compare match, and low output at cycle end

Table 21.15 Example for setting saw-wave PWM mode (1 of 2)

| No. | Step Name                     | Description  |
|-----|-------------------------------|--|
| 1   | Set operating mode            | Set the operating mode with GTCR.MD[2:0]. In Figure 21.19, 000b (saw-wave PWM mode) is set.  |
| 2   | Set count direction           | Select the count direction (up or down) with the GTUDDTYC register. In Figure 21.19, after 11b is set in GTUDDTYC[1:0], 01b is set in GTUDDTYC[1:0] (up-counting). |
| 3   | Select count clock            | Select the count clock with GTCR.TPCS[3:0].  |
| 4   | Set cycle                     | Set the cycle in GTPR.   |
| 5   | Set initial value for counter | Set the initial value in the GTCNT counter.  |
| 6   | Set GTIOCnm pin function      | Set the GTIOCnm pin function with GTIOA[4:0] and GTIOB[4:0] in GTIOR. In Figure 21.19, GTIOA[4:0] = 00110b and GTIOB[4:0] = 00110b.                                |
| 7   | Enable GTIOCnm pin output     | Set to enable the GTIOCnm pin output with OAE and OBE in GTIOR.  |

发生。引脚输出值可以根据GTIOR设置分别从低输出、高输出或切换输出中选择，用于比较匹配和循环结束。

图21.19显示了锯齿PWM模式操作的示例，表21.15显示了设置锯齿PWM模式的示例。

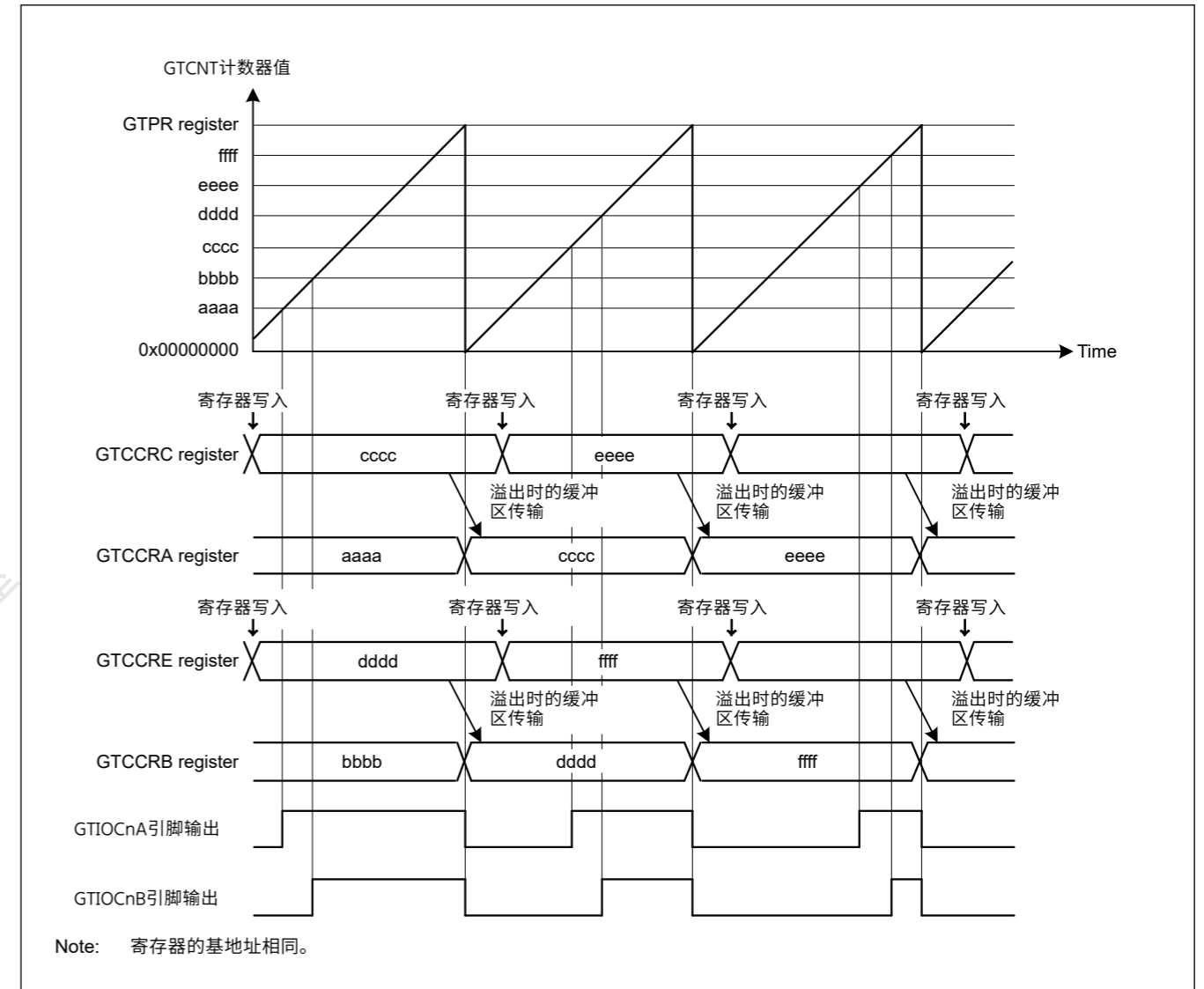


Figure 21.19 具有递增计数、缓冲操作、高输出的锯齿波PWM模式操作示例  
GTCCRAGTCCRB比较匹配，循环结束时输出低

Table 21.15 设置锯齿波PWM模式的示例 (1of2)

| No. | 步骤名称          | Description   |
|-----|---------------|---|
| 1   | 设置操作模式        | 使用GTCR.MD[2:0]设置操作模式。在图21.19中，设置了000b（锯齿波PWM模式）。  |
| 2   | 设置计数方向        | 使用GTUDDTYC寄存器选择计数方向（向上或向下）。在图21.19中，在GTUDDTYC[1:0]中设置了11b之后，在GTUDDTYC[1:0]中设置了01b（向上计数）。  |
| 3   | 选择计数时钟        | 使用GTCR.TPCS[3:0]选择计数时钟。   |
| 4   | 设置周期          | 在GTPR中设置循环。   |
| 5   | 设置计数器的初始值     | 在GTCNT计数器中设置初始值。  |
| 6   | 设置GTIOCnm引脚功能 | 使用GTIOR中的GTIOA[4:0]和GTIOB[4:0]设置GTIOCnm引脚功能。在图21.19中，GTIOA[4:0]=00110b和GTIOB[4:0]=00110b。 |
| 7   | 启用GTIOCnm引脚输出 | 设置为在GTIOR中使用OAE和OBE启用GTIOCnm引脚输出。   |

Table 21.15 Example for setting saw-wave PWM mode (2 of 2)

| No. | Step Name                       | Description   |
|-----|---------------------------------|---|
| 8   | Set buffer operation            | Set buffer operation with CCRA and CCRB in GTBER. In Figure 21.19, CCRA[1:0] = 01b and CCRB[1:0] = 01b.   |
| 9   | Set compare match value         | Set the GTIOCnA pin transition in GTCCRA and GTIOCnB pin transition in GTCCRB.  |
| 10  | Set buffer value                | For buffer operation, set the GTIOCnA pin and GTIOCnB pin transitions in 1 cycle after the current cycle in GTCCRC and GTCCRE, respectively.<br>For double buffer operation, also set the GTIOCnA pin and GTIOCnB pin transitions in 2 cycles after the current cycle in GTCCRD and GTCCRF, respectively. |
| 11  | Start count operation           | Set GTCR.CST to 1 to start count operation.   |
| 12  | Set buffer value for each cycle | For buffer operation, set the GTIOCnA pin and GTIOCnB pin transitions in 1 cycle after the current cycle in GTCCRC and GTCCRE, respectively.<br>For double buffer operation, also set the GTIOCnA pin and GTIOCnB pin transitions in 2 cycles after the current cycle in GTCCRD and GTCCRF, respectively. |

Note: n: 0 to 7  
m: A, B

### 21.3.3.2 Saw-Wave One-Shot Pulse Mode

The saw-wave one-shot pulse mode is a mode in which the cycle is set in GTPR, the GTCNT counter performs saw-wave (half-wave) operation and a PWM waveform is output to the GTIOCnA pin or GTIOCnB pin (n = 0 to 7) at a compare match of GTCCRA or GTCCRB with buffer operation fixed.

Buffer operation in saw-wave one-shot pulse mode is different from the usual buffer operation. Buffer transfer is performed from:

- GTCCRC to GTCCRA at the cycle end
- GTCCRE to GTCCRB at the cycle end
- GTCCRD to temporary register A at the cycle end
- GTCCRF to temporary register B at the cycle end
- Temporary register A to GTCCRA at a GTCCRA compare match
- Temporary register B to GTCCRB at a GTCCRB compare match.

The pin output value can be selected from low output, high output, or toggled output separately for a compare match and the cycle end according to the GTIOR setting. When the GTBER.CCRSWT bit is set to 1 while count operation is stopped, the buffer is transferred forcibly from the GTCCRD register to temporary register A and from the GTCCRF register to temporary register B. By setting GTDTCR and GTDVU, a compare match value for a negative-phase waveform with dead time can automatically be set to GTCCRB.

Figure 21.20 shows an example of saw-wave one-shot pulse mode operation, and Table 21.16 shows an example for setting saw-wave one-shot pulse mode.

Table 21.15 设置锯齿波PWM模式的示例(2of2)

| No. | 步骤名称        | Description   |
|-----|-------------|---|
| 8   | 设置缓冲操作      | 在GTBER中使用CCRA和CCRB设置缓冲区操作。在图21.19中，CCRA[1:0]=01b和CCRB[1:0]=01b。   |
| 9   | 设置比较匹配值     | 在GTCCRA中设置GTIOCnA引脚转换，在GTCCRB中设置GTIOCnB引脚转换。  |
| 10  | 设置缓冲区值      | 对于缓冲操作，分别在GTCCRC和GTCCRE中的当前周期之后的1个周期内设置GTIOCnA引脚和GTIOCnB引脚转换。对于双缓冲器操作，还分别在GTCCRD和GTCCRF中的当前周期之后的2个周期内设置GTIOCnA引脚和GTIOCnB引脚转换。 |
| 11  | 开始计数操作      | 将GTCR.CST设置为1以启动计数操作。   |
| 12  | 为每个周期设置缓冲区值 | 对于缓冲操作，分别在GTCCRC和GTCCRE中的当前周期之后的1个周期内设置GTIOCnA引脚和GTIOCnB引脚转换。对于双缓冲器操作，还分别在GTCCRD和GTCCRF中的当前周期之后的2个周期内设置GTIOCnA引脚和GTIOCnB引脚转换。 |

Note: n: 0 to 7  
m: A, B

### 21.3.3.2 锯齿波单发脉冲模式

锯齿波单次脉冲模式是在GTPR中设置周期，GTCNT计数器执行锯齿波（半波）操作并将PWM波形输出到GTIOCnA引脚或GTIOCnB引脚（n=0到7）在GTCCRA或GTCCRB的比较匹配中，缓冲区操作固定。

锯齿波单次脉冲模式中的缓冲操作不同于通常的缓冲操作。缓冲区传输从以下位置执行：

- GTCCRC到GTCCRA在循环结束
- 循环结束时GTCCRE到GTCCRB
- GTCCRD在循环结束时到临时寄存器A
- GTCCRF在循环结束时到临时寄存器B
- GTCCRA比较匹配时到GTCCRA的临时寄存器A
- GTCCRB比较匹配时的临时寄存器B到GTCCRB。

引脚输出值可以根据GTIOR设置分别从低输出、高输出或切换输出中选择，以进行比较匹配和循环结束。当GTBER.CCRSWT位在计数操作停止时设置为1时，缓冲区被强制从GTCCRD寄存器传送到临时寄存器A，并从GTCCRF寄存器传送到临时寄存器B。通过设置GTDTCR和GTDVU，比较匹配值带有死区时间的负相位波形可以自动设置为GTCCRB。

图21.20显示了锯齿波单次脉冲模式操作的示例，表21.16显示了设置锯齿波单次脉冲模式的示例。



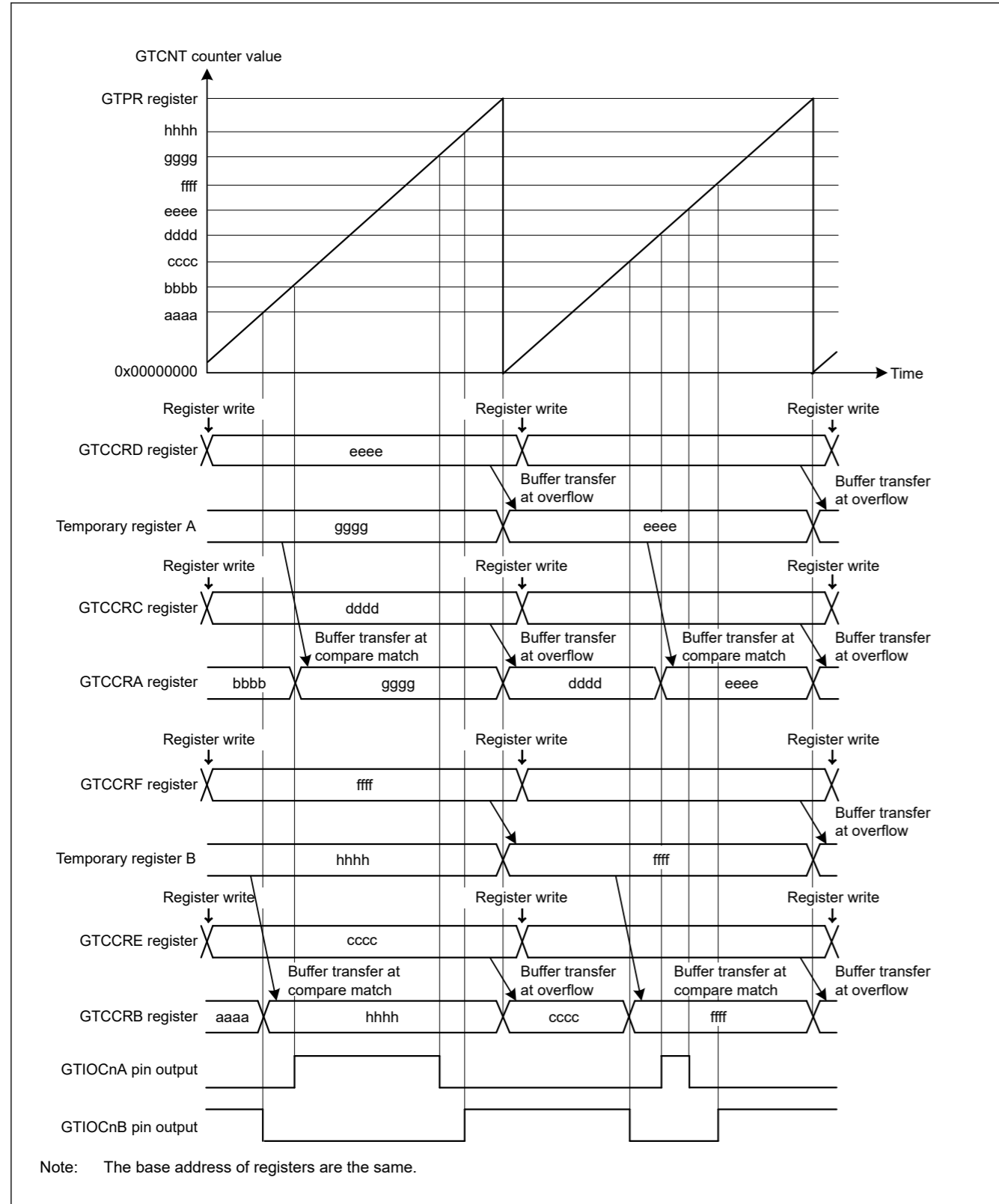


Figure 21.20 Example of saw-wave one-shot pulse mode operation with up-counting, low output from the GTIOCnA pin and high output from the GTIOCnB pin at count start, output toggled at GTCCRA/GTCCRB compare match, and output retained at cycle end

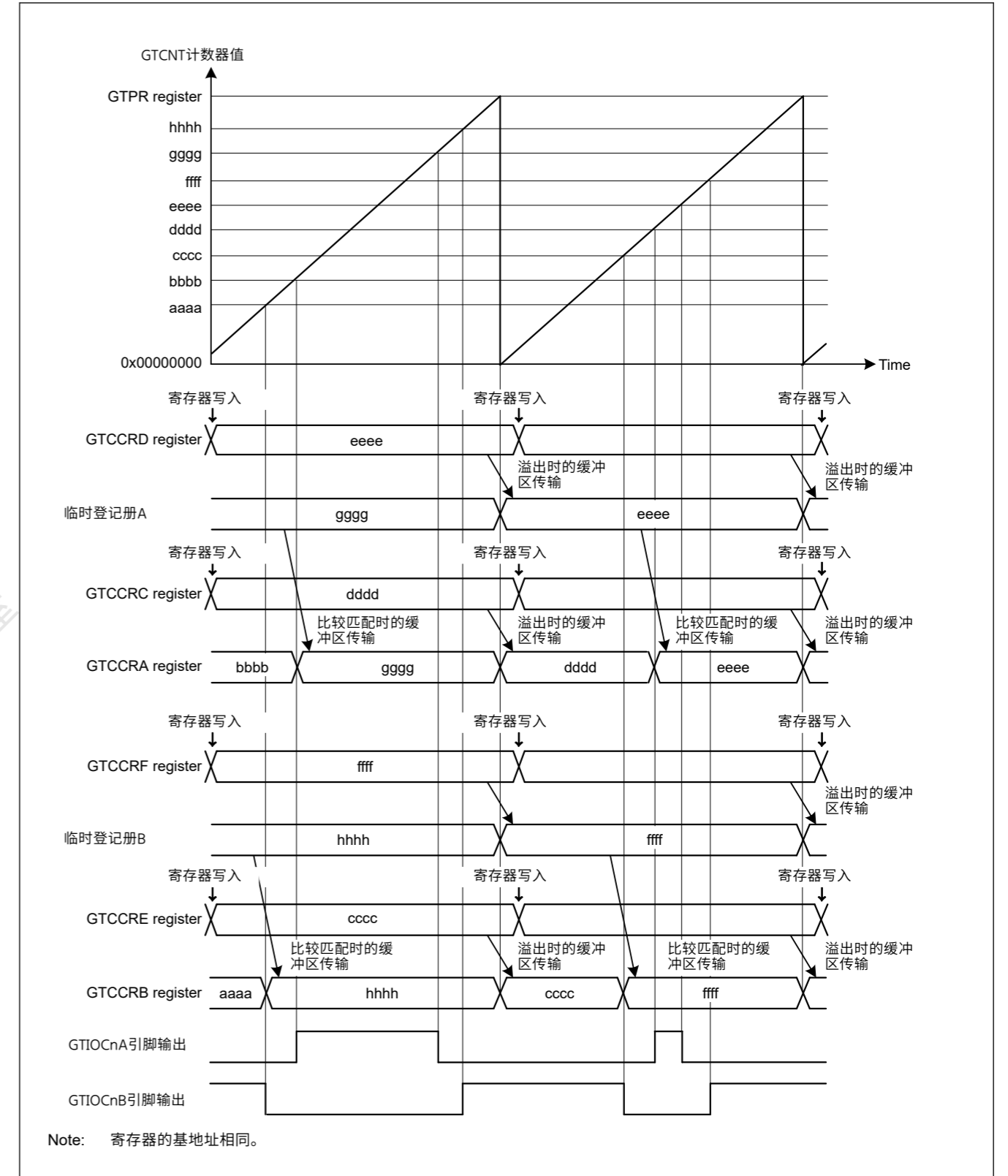


Figure 21.20 具有递增计数、低输出的锯齿波单次脉冲模式操作示例  
GTIOCnA引脚和GTIOCnB引脚在计数开始时的高电平输出，输出在GTCCRA切换GTCCRB比较匹配，并在循环结束时保留输出



Table 21.16 Example setting for saw-wave one-shot pulse mode

| No. | Step Name                       | Description   |
|-----|---------------------------------|---|
| 1   | Set operating mode              | Set the operating mode with GTCR.MD[2:0].<br>In Figure 21.20, 001b (saw-wave one-shot pulse mode) is set.   |
| 2   | Set count direction             | Select the count direction (up or down) with the GTUDDTYC register.<br>In Figure 21.20, after 11b is set in GTUDDTYC[1:0], 01b is set in GTUDDTYC[1:0] (up-counting). |
| 3   | Select count clock              | Select the count clock with GTCR.TPCS[3:0].   |
| 4   | Set cycle                       | Set the cycle in GTPR.  |
| 5   | Set initial value for counter   | Set the initial value in the GTCNT counter.   |
| 6   | Set GTIOcnm pin function        | Set the GTIOcnm pin function with GTIOA[4:0] and GTIOB[4:0] in GTIOR.<br>In Figure 21.20, GTIOA[4:0] = 00011b and GTIOB[4:0] = 10011b.                                |
| 7   | Enable GTIOcnm pin output       | Set to enable the GTIOcnm pin output with OAE and OBE in GTIOR.   |
| 8   | Set buffer value                | Set the GTIOcnA pin transition immediately after the count start in GTCCRC and GTCCRD and the GTIOcnB pin transition in GTCCRE and GTCCRF.                            |
| 9   | Set forcible buffer transfer    | Set GTBER.CCRSWT to 1 to transfer buffer register data forcibly.  |
| 10  | Set buffer value                | Set the GTIOcnA pin transition in one cycle after the current cycle in GTCCRC and GTCCRD and the GTIOcnB pin transition in GTCCRE and GTCCRF.                         |
| 11  | Start count operation           | Set GTCR.CST to 1 to start count operation.   |
| 12  | Set buffer value for each cycle | Set the GTIOcnA pin transition in one cycle after the current cycle in GTCCRC and GTCCRD and the GTIOcnB pin transition in GTCCRE and GTCCRF.                         |

Note: n: 0 to 7  
m: A, B

### 21.3.3.3 Triangle-wave PWM mode 1 (32-bit transfer at trough)

The triangle-wave PWM mode 1 is a mode in which the cycle is set in GTPR. The GTCNT counter performs triangle-wave (full-wave) operation, and a PWM waveform is output to the GTIOcnA pin or GTIOcnB pin (n = 0 to 7) when a GTCCRA or GTCCRB compare match occurs. Buffer transfer is performed at the trough. The pin output value can be selected from low output, high output, or toggled output separately for a compare match and for the cycle end according to the GTIOR setting.

By setting GTDTCR and GTDVU, a compare match value for a negative-phase waveform with dead time can automatically be set to GTCCRB.

Figure 21.21 shows an example of a triangle-wave PWM mode 1 operation, and Table 21.17 shows an example for setting a triangle-wave PWM mode 1.

Table 21.16 锯齿单发脉冲模式设置示例

| No. | 步骤名称          | Description   |
|-----|---------------|---|
| 1   | 设置操作模式        | 使用GTCR.MD[2:0]设置操作模式。<br>在图21.20中，设置了001b（锯齿单次脉冲模式）。  |
| 2   | 设置计数方向        | 使用GTUDDTYC寄存器选择计数方向（向上或向下）。<br>在图21.20中，在GTUDDTYC[1:0]中设置了11b之后，在GTUDDTYC[1:0]中设置了01b（向上计数）。  |
| 3   | 选择计数时钟        | 使用GTCR.TPCS[3:0]选择计数时钟。   |
| 4   | 设置周期          | 在GTPR中设置循环。   |
| 5   | 设置计数器的初始值     | 在GTCNT计数器中设置初始值。  |
| 6   | 设置GTIOcnm引脚功能 | 使用GTIOR中的GTIOA[4:0]和GTIOB[4:0]设置GTIOcnm引脚功能。<br>在图21.20中，GTIOA[4:0]=00011b和GTIOB[4:0]=10011b。 |
| 7   | 启用GTIOcnm引脚输出 | 设置为在GTIOR中使用OAE和OBE启用GTIOcnm引脚输出。   |
| 8   | 设置缓冲区值        | 在GTCCRC和GTCCRD中计数开始后立即设置GTIOcnA引脚转换，在GTCCRE和GTCCRF中设置GTIOcnB引脚转换。                             |
| 9   | 设置强制缓冲区传输     | 将GTBER.CCRSWT设置为1以强制传输缓冲寄存器数据。  |
| 10  | 设置缓冲区值        | 在GTCCRC和GTCCRD中的当前周期以及GTCCRE和GTCCRF中的GTIOcnB引脚转换之后的一个周期内设置GTIOcnA引脚转换。                        |
| 11  | 开始计数操作        | 将GTCR.CST设置为1以启动计数操作。   |
| 12  | 为每个周期设置缓冲区值   | 在GTCCRC和GTCCRD中的当前周期以及GTCCRE和GTCCRF中的GTIOcnB引脚转换之后的一个周期内设置GTIOcnA引脚转换。                        |

Note: n: 0 to 7  
m: A, B

### 21.3.3.3 三角波PWM模式1（波谷32位传输）

三角波PWM模式1是在GTPR中设定周期的模式。GTCNT计数器执行三角波（全波）操作，当发生GTCCRA或GTCCRB比较匹配时，PWM波形输出到GTIOcnA引脚或GTIOcnB引脚（n=0至7）。在槽中进行缓冲转移。引脚输出值可以根据GTIOR设置分别从低输出、高输出或切换输出中选择，用于比较匹配和循环结束。

通过设置GTDTCR和GTDVU，可以自动将带死区时间的反相波形的比较匹配值设置为GTCCRB。

图21.21显示了三角波PWM模式1操作的示例，表21.17显示了设置三角波PWM模式1的示例。

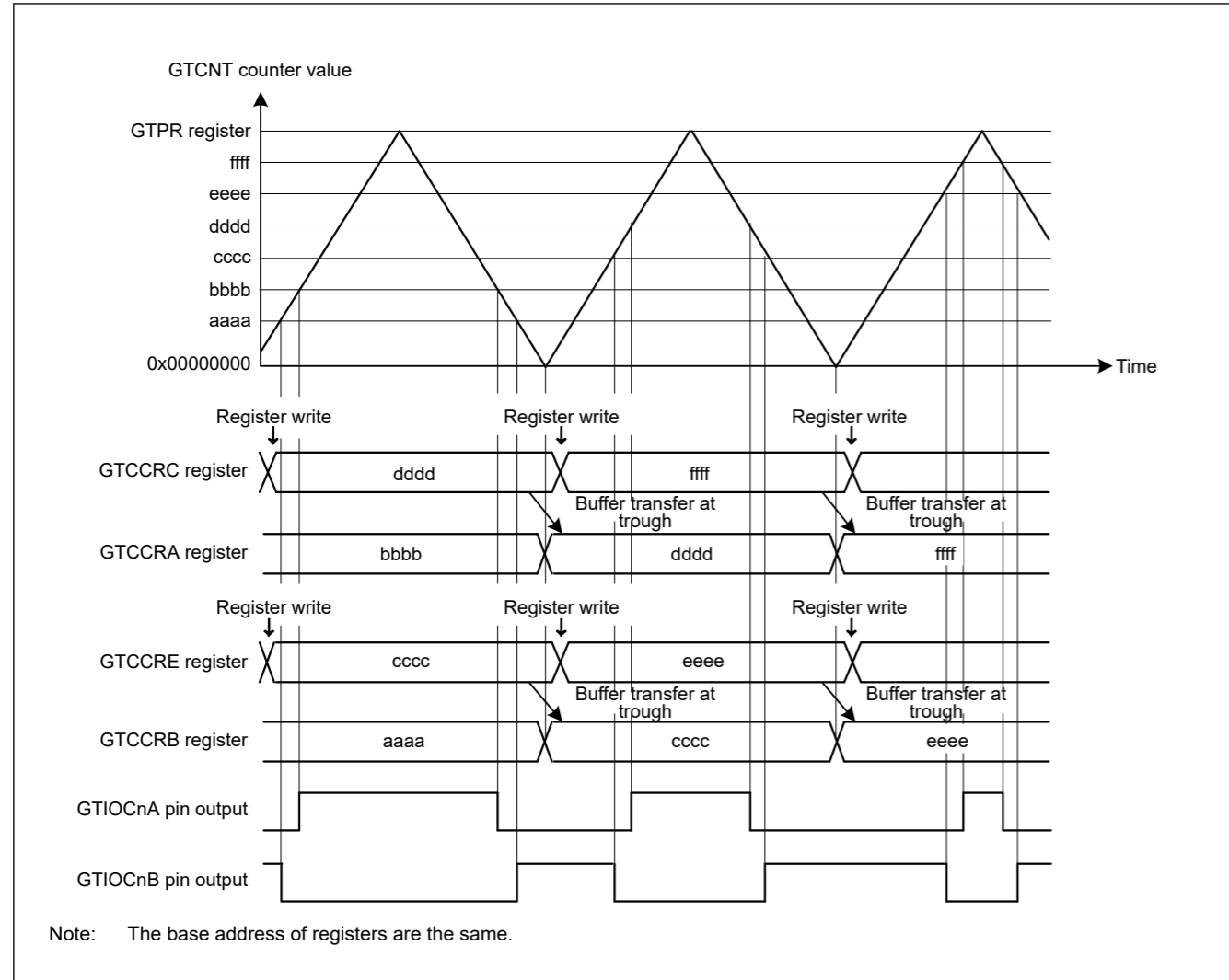


Figure 21.21 Example of triangle-wave PWM mode 1 operation with buffer operation, low output from the GTIOCnA pin and high output from the GTIOCnB pin at count start, output toggled at GTCCRA/GTCCRB register compare match, and output retained at cycle end

Table 21.17 Example setting for triangle-wave PWM mode 1 (1 of 2)

| No. | Step Name                     | Description  |
|-----|-------------------------------|--|
| 1   | Set operating mode            | Set the operating mode with GTCR.MD[2:0]. In Figure 21.21, 100b (triangle-wave PWM mode 1) is set.   |
| 2   | Select count clock            | Select the count clock with GTCR.TPCS[3:0].  |
| 3   | Set cycle                     | Set the cycle in GTPR.   |
| 4   | Set initial value for counter | Set the initial value in the GTCNT counter.  |
| 5   | Set GTIOCnm pin function      | Set the GTIOCnm pin function with GTIOA[4:0] and GTIOB[4:0] in GTIOR. In Figure 21.21, GTIOA[4:0] = 00011b and GTIOB[4:0] = 10011b.  |
| 6   | Enable GTIOCnm pin output     | Set to enable the GTIOCnm pin output with OAE and OBE in GTIOR.  |
| 7   | Set buffer operation          | Set buffer operation with CCRA and CCRB in GTBER. In Figure 21.21, CCRA[1:0] = 01b and CCRB[1:0] = 01b.  |
| 8   | Set compare match value       | Set the GTIOCnA pin and GTIOCnB pin transitions in GTCCRA and GTCCRB, respectively.  |
| 9   | Set buffer value              | For buffer operation, set the GTIOCnA pin and GTIOCnB pin transitions in 1 cycle after the current cycle in GTCCRC and GTCCRE, respectively. For double buffer operation, also set the GTIOCnA pin and GTIOCnB pin transitions in 2 cycles after the current cycle in GTCCRD and GTCCRF, respectively. |
| 10  | Start count operation         | Set GTCR.CST to 1 to start count operation.  |

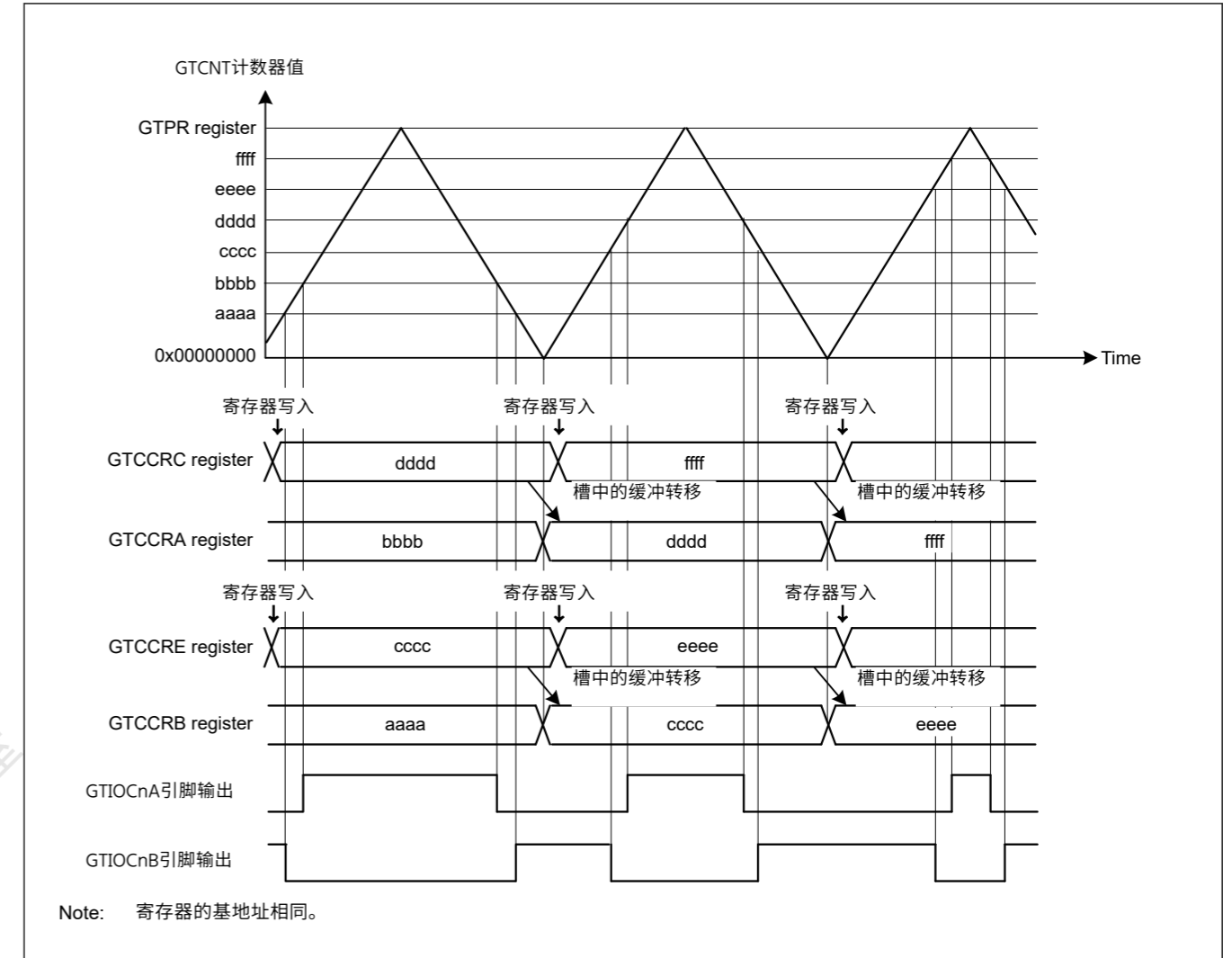


Figure 21.21 带缓冲操作的三角波PWM模式1操作示例，从GTIOCnA引脚和GTIOCnB引脚在计数开始时的高电平输出，输出在GTCCRA/GTCCRB寄存器比较匹配，并在循环结束时保留输出

Table 21.17 三角波PWM模式1的设置示例 (1of2)

| No. | 步骤名称          | Description   |
|-----|---------------|---|
| 1   | 设置操作模式        | 使用GTCR.MD[2:0]设置操作模式。在图21.21中，设置了100b（三角波PWM模式1）。   |
| 2   | 选择计数时钟        | 使用GTCR.TPCS[3:0]选择计数时钟。   |
| 3   | 设置周期          | 在GTPR中设置循环。   |
| 4   | 设置计数器的初始值     | 在GTCNT计数器中设置初始值。  |
| 5   | 设置GTIOCnm引脚功能 | 使用GTIOR中的GTIOA[4:0]和GTIOB[4:0]设置GTIOCnm引脚功能。在图21.21中，GTIOA[4:0]=00011b和GTIOB[4:0]=10011b。                                     |
| 6   | 启用GTIOCnm引脚输出 | 设置为在GTIOR中使用OAE和OBE启用GTIOCnm引脚输出。   |
| 7   | 设置缓冲操作        | 在GTBER中使用CCRA和CCRB设置缓冲区操作。在图21.21中，CCRA[1:0]=01b和CCRB[1:0]=01b。   |
| 8   | 设置比较匹配值       | 分别在GTCCRA和GTCCRB中设置GTIOCnA引脚和GTIOCnB引脚转换。   |
| 9   | 设置缓冲区值        | 对于缓冲操作，分别在GTCCRC和GTCCRE中的当前周期之后的1个周期内设置GTIOCnA引脚和GTIOCnB引脚转换。对于双缓冲器操作，还分别在GTCCRD和GTCCRF中的当前周期之后的2个周期内设置GTIOCnA引脚和GTIOCnB引脚转换。 |
| 10  | 开始计数操作        | 将GTCR.CST设置为1以启动计数操作。   |

Table 21.17 Example setting for triangle-wave PWM mode 1 (2 of 2)

| No. | Step Name                       | Description   |
|-----|---------------------------------|---|
| 11  | Set buffer value for each cycle | For buffer operation, set the GTIOCnA pin and GTIOCnB pin transitions in 1 cycle after the current cycle in GTCCRC and GTCCRE, respectively.<br>For double buffer operation, also set the GTIOCnA pin and GTIOCnB pin transitions in 2 cycles after the current cycle in GTCCRD and GTCCRF, respectively. |

Note: n: 0 to 7  
m: A, B

#### 21.3.3.4 Triangle-wave PWM mode 2 (32-bit transfer at crest and trough)

Similarly to triangle-wave PWM mode 1, in triangle-wave PWM mode 2 the cycle is set in GTPR. The GTCNT counter performs triangle-wave (full-wave) operation, and a PWM waveform is output to the GTIOCnA pin or GTIOCnB pin (n = 0 to 7) when a GTCCRA or GTCCRB compare match occurs. The buffer transfer is performed at both crests and troughs. The pin output value can be selected from low output, high output, or toggle output separately for a compare match and for the cycle end according to the GTIOR setting.

By setting GTDTCR and GTDVU, a compare match value for a negative-phase waveform with dead time can automatically be set to GTCCRB.

Figure 21.22 shows an example of triangle-wave PWM mode 2 operation, and Table 21.18 shows an example for setting triangle-wave PWM mode 2.

Table 21.17 三角波PWM模式1(2of2)的示例设置

| No. | 步骤名称         | Description   |
|-----|--------------|---|
| 11  | 为每个周期设置缓冲区间值 | 对于缓冲操作，分别在GTCCRC和GTCCRE中的当前周期之后的1个周期内设置GTIOCnA引脚和GTIOCnB引脚转换。对于双缓冲器操作，还分别在GTCCRD和GTCCRF中的当前周期之后的2个周期内设置GTIOCnA引脚和GTIOCnB引脚转换。 |

Note: n: 0 to 7  
m: A, B

#### 21.3.3.4 三角波PWM模式2 (波峰和波谷32位传输)

与三角波PWM模式1类似，在三角波PWM模式2中，周期在GTPR中设置。GTCNT计数器执行三角波（全波）操作，当发生GTCCRA或GTCCRB比较匹配时，PWM波形输出到GTIOCnA引脚或GTIOCnB引脚（n=0至7）。缓冲转移在波峰和波谷进行。引脚输出值可以根据GTIOR设置分别从低输出、高输出或切换输出中选择，用于比较匹配和循环结束。

通过设置GTDTCR和GTDVU，可以自动将带死区时间的反相波形的比较匹配值设置为GTCCRB。

图21.22显示了三角波PWM模式2操作的示例，表21.18显示了设置三角波PWM模式2的示例。

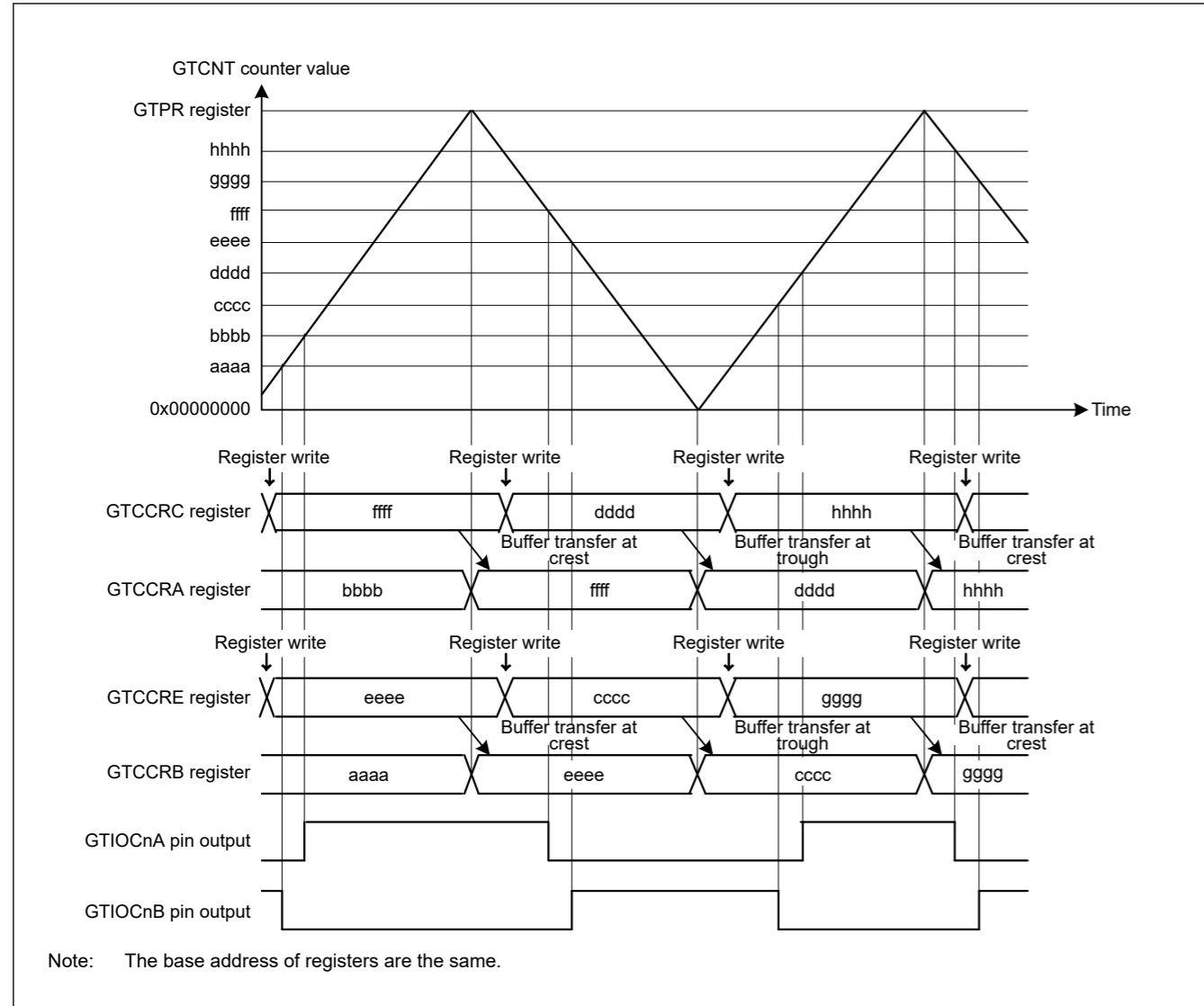


Figure 21.22 Example of triangle-wave PWM mode 2 operation with buffer operation, low output from the GTIOCnA pin and high output from the GTIOCnB pin at count start, output toggled at GTCCRA/GTCCRB compare match, and output retained at cycle end

Table 21.18 Example for setting triangle-wave PWM mode 2 (1 of 2)

| No. | Step Name                     | Description  |
|-----|-------------------------------|--|
| 1   | Set operating mode            | Set the operating mode with GTCR.MD[2:0].<br>In Figure 21.22, 101b (triangle-wave PWM mode 2) is set.                                  |
| 2   | Select count clock            | Select the count clock with GTCR.TPCS[3:0].  |
| 3   | Set cycle                     | Set the cycle in GTPR.   |
| 4   | Set initial value for counter | Set the initial value in the GTCNT counter.  |
| 5   | Set GTIOCnm pin function      | Set the GTIOCnm pin function with GTIOA[4:0] and GTIOB[4:0] in GTIOR.<br>In Figure 21.22, GTIOA[4:0] = 00011b and GTIOB[4:0] = 10011b. |
| 6   | Enable GTIOCnm pin output     | Set to enable the GTIOCnm pin output with OAE and OBE in GTIOR.  |
| 7   | Set buffer operation          | Set buffer operation with CCRA and CCRB in GTBER.<br>In Figure 21.22, CCRA[1:0] = 01b and CCRB[1:0] = 01b.                             |
| 8   | Set compare match value       | Set the GTIOCnA pin and GTIOCnB pin transitions in GTCCRA and GTCCRB, respectively.  |

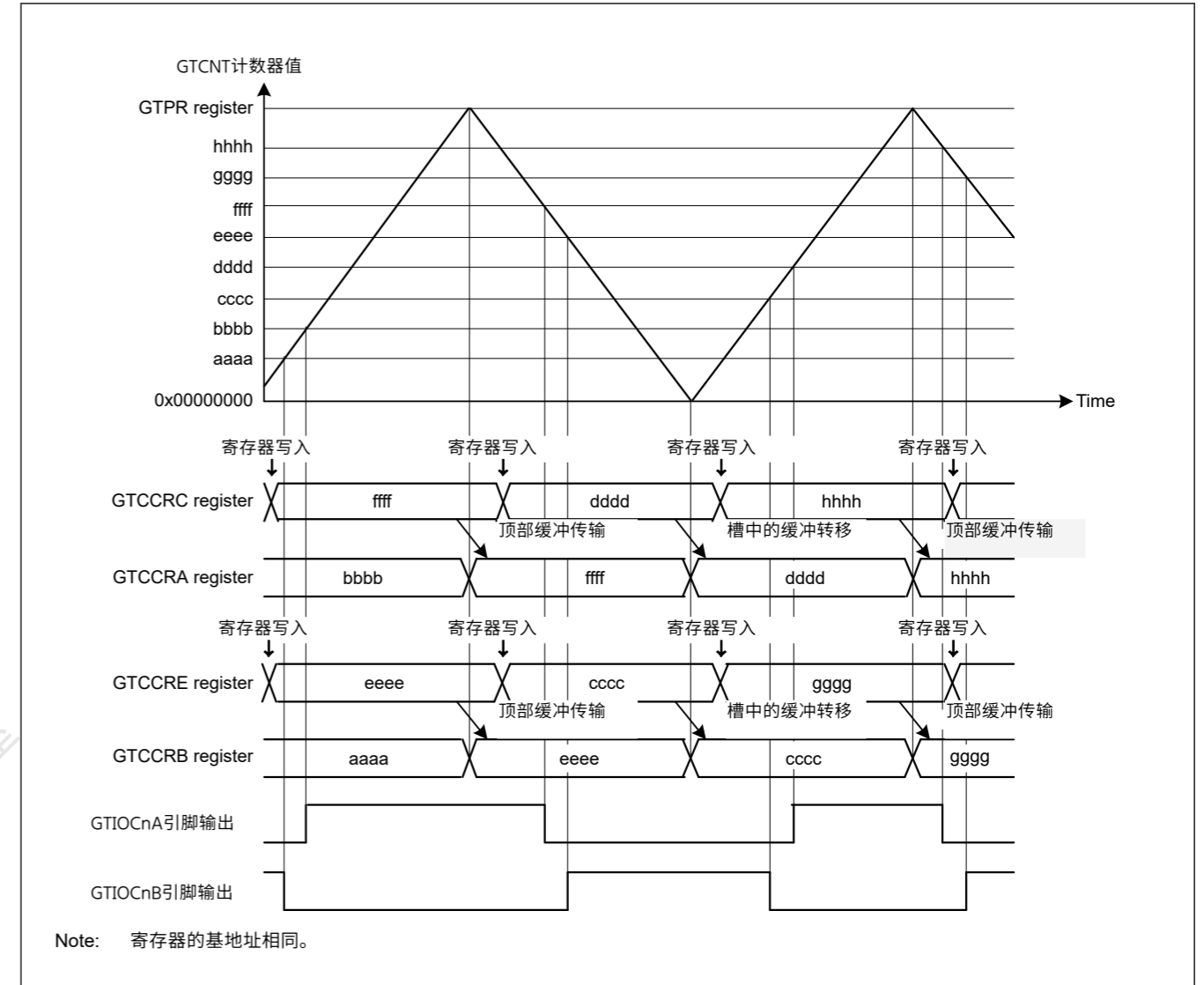


Figure 21.22 带缓冲操作的三角波PWM模式2操作示例，从GTIOCnA引脚和GTIOCnB引脚在计数开始时的高电平输出，输出在GTCCRA/GTCCRB比较匹配，并在循环结束时保留输出

Table 21.18 设置三角波PWM模式2的示例 (1 of 2)

| No. | 步骤名称          | Description   |
|-----|---------------|---|
| 1   | 设置操作模式        | 使用GTCR.MD[2:0]设置操作模式。<br>在图21.22中，设置了101b（三角波PWM模式2）。   |
| 2   | 选择计数时钟        | 使用GTCR.TPCS[3:0]选择计数时钟。   |
| 3   | 设置周期          | 在GTPR中设置循环。   |
| 4   | 设置计数器的初始值     | 在GTCNT计数器中设置初始值。  |
| 5   | 设置GTIOCnm引脚功能 | 使用GTIOR中的GTIOA[4:0]和GTIOB[4:0]设置GTIOCnm引脚功能。<br>在图21.22中，GTIOA[4:0]=00011b和GTIOB[4:0]=10011b。 |
| 6   | 启用GTIOCnm引脚输出 | 设置为在GTIOR中使用OAE和OBE启用GTIOCnm引脚输出。   |
| 7   | 设置缓冲操作        | 在GTBER中使用CCRA和CCRB设置缓冲区操作。<br>在图21.22中，CCRA[1:0]=01b和CCRB[1:0]=01b。                           |
| 8   | 设置比较匹配值       | 分别在GTCCRA和GTCCRB中设置GTIOCnA引脚和GTIOCnB引脚转换。   |

Table 21.18 Example for setting triangle-wave PWM mode 2 (2 of 2)

| No. | Step Name                       | Description   |
|-----|---------------------------------|---|
| 9   | Set buffer value                | For buffer operation, set the GTIOcNA pin and GTIOcNB pin transitions in 1 cycle after the current cycle in GTCCRC and GTCCRE, respectively.<br>For double buffer operation, also set the GTIOcNA pin and GTIOcNB pin transitions in 1 cycle after the current cycle in GTCCRD and GTCCRF, respectively.    |
| 10  | Start count operation           | Set GTCR.CST to 1 to start count operation.   |
| 11  | Set buffer value for each cycle | For buffer operation, set the GTIOcNA pin and GTIOcNB pin transitions in half cycle after the current cycle in GTCCRC and GTCCRE, respectively.<br>For double buffer operation, also set the GTIOcNA pin and GTIOcNB pin transitions in 1 cycle after the current cycle in GTCCRD and GTCCRF, respectively. |

Note: n: 0 to 7  
m: A, B

### 21.3.3.5 Triangle-wave PWM mode 3 (64-bit transfer at trough)

The triangle-wave PWM mode 3 is a mode in which the cycle is set in GTPR. The GTCNT counter performs triangle-wave (full-wave) operation and a PWM waveform is output to the GTIOcNA pin or GTIOcNB pin ( $n = 0$  to 7) at a compare match of GTCCRA or GTCCRB with buffer operation fixed. Buffer operation in triangle-wave PWM mode 3 is different from the usual buffer operation. Buffer transfer is performed from the following:

- GTCCRC to GTCCRA at the trough
- GTCCRE to GTCCRB at the trough
- GTCCRD to temporary register A at the trough
- GTCCRF to temporary register B at the trough
- Temporary register A to GTCCRA at the crest
- Temporary register B to GTCCRB at the crest.

The pin output value can be selected from low output, high output, or toggled output separately for a compare match and for the cycle end according to the GTIOR setting.

By setting GTDTCR and GTDVU, a compare match value for a negative-phase waveform with dead time can automatically be set to GTCCRB.

Figure 21.23 shows an example of triangle-wave PWM mode 3 operation, and Table 21.19 shows an example for setting triangle-wave PWM mode 3.

Table 21.18 设置三角波PWM模式2的示例(2of2)

| No. | 步骤名称         | Description   |
|-----|--------------|---|
| 9   | 设置缓冲区间值      | 对于缓冲操作，分别在GTCCRC和GTCCRE中的当前周期之后的1个周期内设置GTIOcNA引脚和GTIOcNB引脚转换。对于双缓冲器操作，还分别在GTCCRD和GTCCRF中的当前周期之后的1个周期内设置GTIOcNA引脚和GTIOcNB引脚转换。 |
| 10  | 开始计数操作       | 将GTCR.CST设置为1以启动计数操作。   |
| 11  | 为每个周期设置缓冲区间值 | 对于缓冲操作，分别在GTCCRC和GTCCRE中的当前周期之后的半个周期中设置GTIOcNA引脚和GTIOcNB引脚转换。对于双缓冲器操作，还分别在GTCCRD和GTCCRF中的当前周期之后的1个周期内设置GTIOcNA引脚和GTIOcNB引脚转换。 |

Note: n: 0 to 7  
m: A, B

### 21.3.3.5 三角波PWM模式3 (波谷64位传输)

三角波PWM模式3是在GTPR中设定周期的模式。GTCNT计数器执行三角波（全波）操作，并且在GTCCRA或GTCCRB的比较匹配（缓冲器操作固定）时，PWM波形输出到GTIOcNA引脚或GTIOcNB引脚（ $n=0$ 至7）。三角波PWM模式3中的缓冲操作与通常的缓冲操作不同。缓冲区传输从以下位置执行：

- GTCCRC到GTCCRA处于低谷
- GTCCRE至GTCCRB处于低谷
- GTCCRD到谷底临时寄存器A
- GTCCRF到波谷的临时寄存器B
- 顶部为GTCCRA的临时寄存器A
- 在顶部的GTCCRB临时寄存器B。

引脚输出值可以根据GTIOR设置分别从低输出、高输出或切换输出中选择，用于比较匹配和循环结束。

通过设置GTDTCR和GTDVU，可以自动将带死区时间的反相波形的比较匹配值设置为GTCCRB。

图21.23显示了三角波PWM模式3操作的示例，表21.19显示了设置三角波PWM模式3的示例。



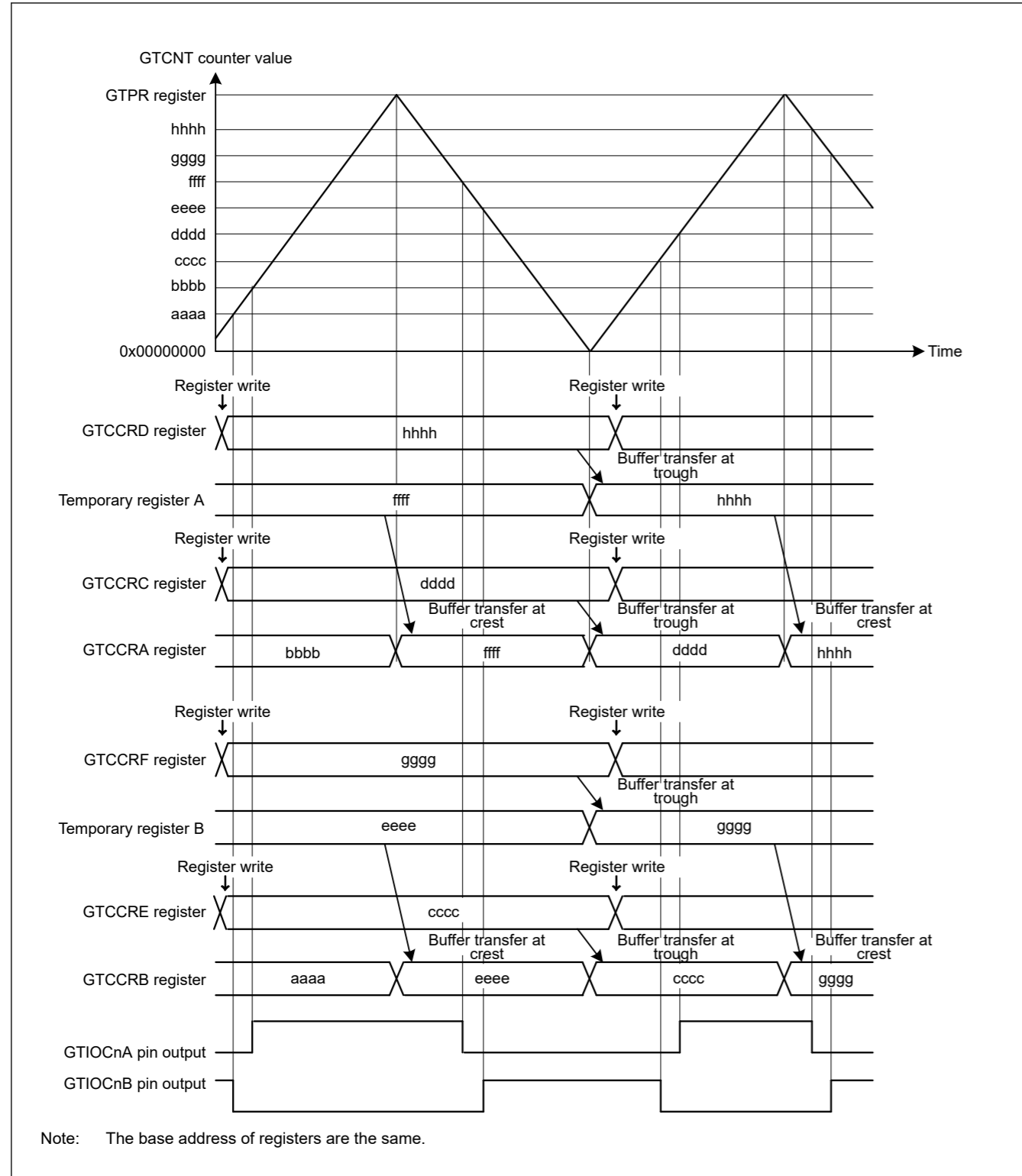


Figure 21.23 Example of triangle-wave PWM mode 3 operation with low output from the GTIOCnA pin and high output from the GTIOCnB pin at count start, output toggled at GTCRA/GTCRBB compare match, and output retained at cycle end

Table 21.19 Example setting for triangle-wave PWM mode 3 (1 of 2)

| No. | Step Name          | Description   |
|-----|--------------------|---|
| 1   | Set operating mode | Set the operating mode with GTCR.MD[2:0].<br>In Figure 21.23, 110b (triangle-wave PWM mode 3) is set. |

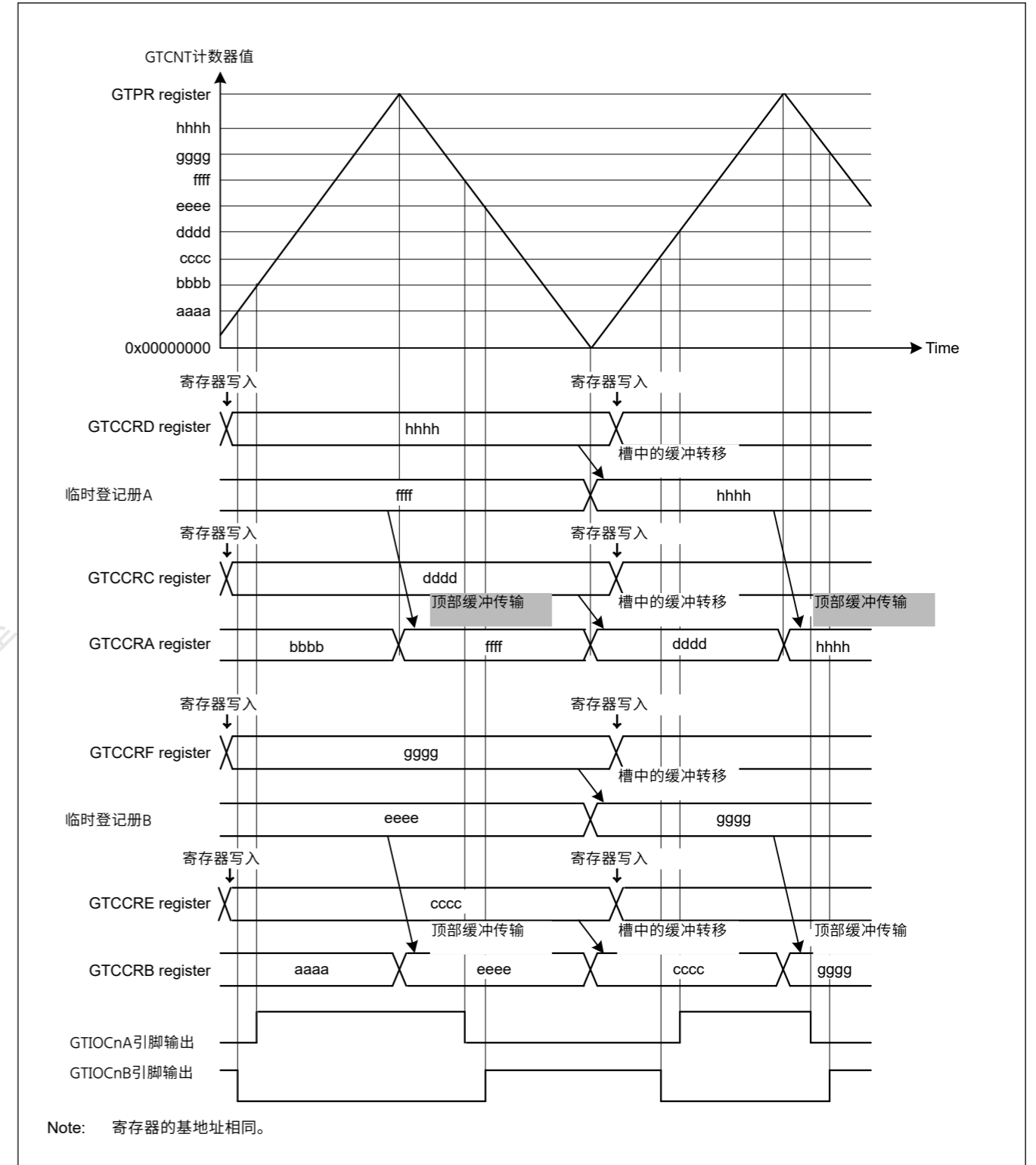


Figure 21.23 三角波PWM模式3操作示例，计数开始时GTIOCnA引脚输出低电平，GTIOCnB引脚输出高电平，在GTCCRAGTCRBB比较匹配时切换输出，并在周期结束时保持输出

Table 21.19 三角波PWM模式3的设置示例 (1of2)

| No. | 步骤名称   | Description   |
|-----|--------|---|
| 1   | 设置操作模式 | 使用GTCR.MD[2:0]设置操作模式。<br>在图21.23中，设置了110b（三角波PWM模式3）。 |

Table 21.19 Example setting for triangle-wave PWM mode 3 (2 of 2)

| No. | Step Name                       | Description   |
|-----|---------------------------------|---|
| 2   | Select count clock              | Select the count clock with GTCR.TPCS[3:0].   |
| 3   | Set cycle                       | Set the cycle in GTPR.  |
| 4   | Set initial value for counter   | Set the initial value in the GTCNT counter.   |
| 5   | Set GTIOCnm pin function        | Set the GTIOCnm pin function with GTIOA[4:0] and GTIOB[4:0] in GTIOR.<br>In Figure 21.23, GTIOA[4:0] = 00011b and GTIOB[4:0] = 10011b.      |
| 6   | Enable GTIOCnm pin output       | Set to enable the GTIOCnm pin output with OAE and OBE in GTIOR.   |
| 7   | Set buffer value                | Set the GTIOCnA pin transition immediately after the count start in GTCCRC and GTCCRD and the GTIOCnB pin transition in GTCCRE and GTCCRF.  |
| 8   | Set forcible buffer transfer    | Set GTCR.CCRSWT to 1 to transfer buffer register data forcibly.   |
| 9   | Set buffer value                | Set the GTIOCnA pin transition in 1 cycle after the current cycle in GTCCRC and GTCCRD and the GTIOCnB pin transition in GTCCRE and GTCCRF. |
| 10  | Start count operation           | Set GTCR.CST to 1 to start count operation.   |
| 11  | Set buffer value for each cycle | Set the GTIOCnA pin transition in 1 cycle after the current cycle in GTCCRC and GTCCRD and the GTIOCnB pin transition in GTCCRE and GTCCRF. |

Note: n: 0 to 7  
m: A, B

### 21.3.4 Automatic Dead Time Setting Function

By setting GTDTCR, a compare match value for a negative waveform with dead time obtained by a compare match value for a positive waveform (GTCCRA value) and specified dead time value (GTDVU value) can automatically be set to GTCCRB. The automatic dead time setting function can be used in saw-wave one-shot pulse mode and all the triangle PWM modes.

Writing to GTCCRB is prohibited when the automatic dead time setting function is used. Dead time setting beyond the cycle is also prohibited. Values for automatic dead time setting can be read from GTCCRB. In triangle-wave mode, when the dead time is beyond the cycle by setting the value  $GTCCRA = 0$  or  $GTCCRA \geq GTPR$  for GTCCRA, the output protection function keeps the level of output. For details, see section 21.7.3. **GTIOCnm Pin Output Negate Control (n = 0 to 7, m = A, B)**. The automatic dead time value setting to GTCCRB is performed at the next clock cycle count when registers that are used for calculating the automatic dead time value are updated.

When a dead time error occurs, the compare match values for positive and negative waveforms are adjusted to generate the waveforms with the dead time as shown in Table 21.20.

The adjusted value for the negative waveform is set for GTCCRB automatically.

The adjusted value for the positive waveform is used as internal signal and not set for GTCCRA.

Table 21.20 Adjustment of the Waveform Change Point When a Dead-Time Error Occurs

| Mode                              | Count Direction | Period        | Condition for Dead Time Error | Change Point of the Positive-Phase Waveform after Adjustment | Change Point of the Negative-Phase Waveform after Adjustment |
|-----------------------------------|-----------------|---------------|-------------------------------|--|--|
| Sawtooth-wave one-shot pulse mode | Up-counting     | First half    | $GTCCRA - GTDVU < 0$          | GTDVU  | 0  |
|                                   |                 | Second half   | $GTCCRA + GTDVU > GTPR$       | $GTPR - GTDVU$   | GTPR   |
|                                   | Down-counting   | First half    | $GTCCRA + GTDVU > GTPR$       | $GTPR - GTDVU$   | GTPR   |
|                                   |                 | Second half   | $GTCCRA - GTDVU < 0$          | GTDVU  | 0  |
| Triangle-wave PWM mode 1/2/3      | Up-counting     | (First half)  | $GTCCRA - GTDVU \leq 0$       | $GTDVU + 1$  | 1  |
|                                   | Down-counting   | (Second half) | $GTCCRA - GTDVU < 0$          | GTDVU  | 0  |

Figure 21.24 to Figure 21.27 show examples of automatic dead time setting function operation. Table 21.21 and Table 21.22 show the setting examples.

Table 21.19 三角波PWM模式3(2of2)的示例设置

| No. | 步骤名称          | Description  |
|-----|---------------|--|
| 2   | 选择计数时钟        | 使用GTCR.TPCS[3:0]选择计数时钟。  |
| 3   | 设置周期          | 在GTPR中设置循环。  |
| 4   | 设置计数器的初始值     | 在GTCNT计数器中设置初始值。   |
| 5   | 设置GTIOCnm引脚功能 | 使用GTIOR中的GTIOA[4:0]和GTIOB[4:0]设置GTIOCnm引脚功能。<br>在图21.23中, GTIOA[4:0]=00011b和GTIOB[4:0]=10011b。 |
| 6   | 启用GTIOCnm引脚输出 | 设置为在GTIOR中使用OAE和OBE启用GTIOCnm引脚输出。  |
| 7   | 设置缓冲区值        | 在GTCCRC和GTCCRD中计数开始后立即设置GTIOCnA引脚转换, 在GTCCRE和GTCCRF中设置GTIOCnB引脚转换。                             |
| 8   | 设置强制缓冲区传输     | 将GTCR.CCRSWT设置为1以强制传输缓冲寄存器数据。  |
| 9   | 设置缓冲区值        | 在GTCCRC和GTCCRD中的当前周期和GTCCRE和GTCCRF中的GTIOCnB引脚转换之后的1个周期内设置GTIOCnA引脚转换。                          |
| 10  | 开始计数操作        | 将GTCR.CST设置为1以启动计数操作。  |
| 11  | 为每个周期设置缓冲区值   | 在GTCCRC和GTCCRD中的当前周期和GTCCRE和GTCCRF中的GTIOCnB引脚转换之后的1个周期内设置GTIOCnA引脚转换。                          |

Note: n: 0 to 7  
m: A, B

### 21.3.4 自动死区时间设置功能

通过设置GTDTCR, 可以自动将正波形的比较匹配值 (GTCCRA值) 和指定死区时间值 (GTDVU值) 得到的负波形与死区时间的比较匹配值设置为GTCCRB。自动死区时间设置功能可用于锯齿单次脉冲模式和所有三角形

PWM modes.

使用自动死区时间设置功能时, 禁止写入GTCCRB。超出周期的死区时间设置也被禁止。自动死区时间设置的值可以从GTCCRB中读取。在三角波模式下, 当设置 $GTCCRA=0$ 或 $GTCCRA \geq GTPR$ 时, 死区时间超出周期时, 输出保护功能保持输出电平。详见21.7.3节。GTIOCnm引脚输出否定控制 (n=0到7, m=A, B)。当用于计算自动死区时间值的寄存器被更新时, 在下一个时钟周期计数时执行GTCCRB的自动死区时间值设置。

当出现死区时间错误时, 调整正负波形的比较匹配值以生成具有死区时间的波形, 如表21.20所示。

负波形的调整值自动为GTCCRB设置。

正波形的调整值用作内部信号, 而不是为GTCCRA设置的。

Table 21.20 发生死区错误时波形变化点的调整

| Mode                         | Count Direction | Period        | 死区时间错误的条件               | 变化点正相波形后 Adjustment | 变化点后的负相位波形 Adjustment |
|------------------------------|-----------------|---------------|-------------------------|---------------------|-----------------------|
| 锯齿波单次脉冲模式                    | Up-counting     | 上半场           | $GTCCRA - GTDVU < 0$    | GTDVU               | 0                     |
|                              |                 | 下半场           | $GTCCRA + GTDVU > GTPR$ | $GTPR - GTDVU$      | GTPR                  |
|                              | Down-counting   | 上半场           | $GTCCRA + GTDVU > GTPR$ | $GTPR - GTDVU$      | GTPR                  |
|                              |                 | 下半场           | $GTCCRA - GTDVU < 0$    | GTDVU               | 0                     |
| Triangle-wave PWM mode 1/2/3 | Up-counting     | (First half)  | $GTCCRA - GTDVU \leq 0$ | $GTDVU + 1$         | 1                     |
|                              | Down-counting   | (Second half) | $GTCCRA - GTDVU < 0$    | GTDVU               | 0                     |

图21.24至图21.27显示了自动死区时间设置功能操作的示例。表21.21和表21.22显示了设置示例。

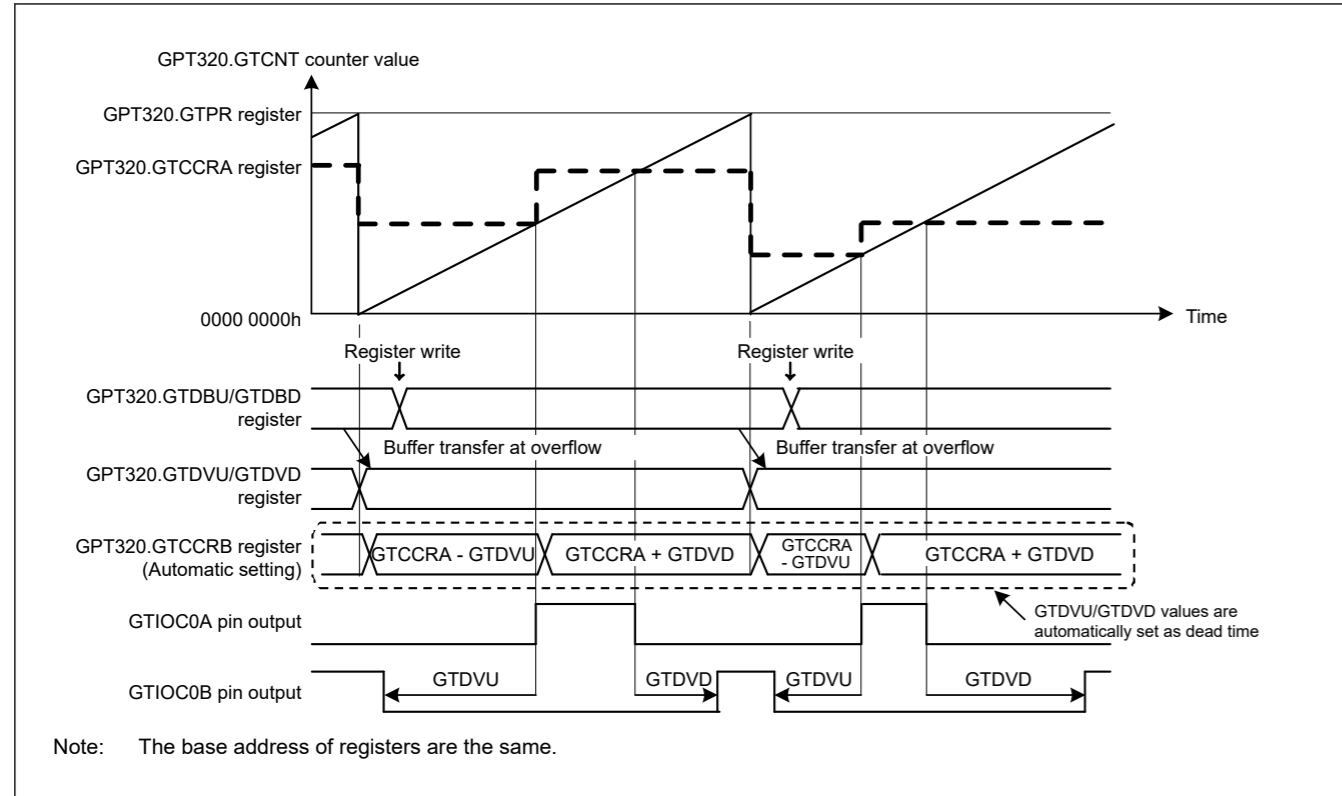


Figure 21.24 Example of automatic dead time setting function operation in saw-wave one-shot pulse mode, up-counting, and active-high

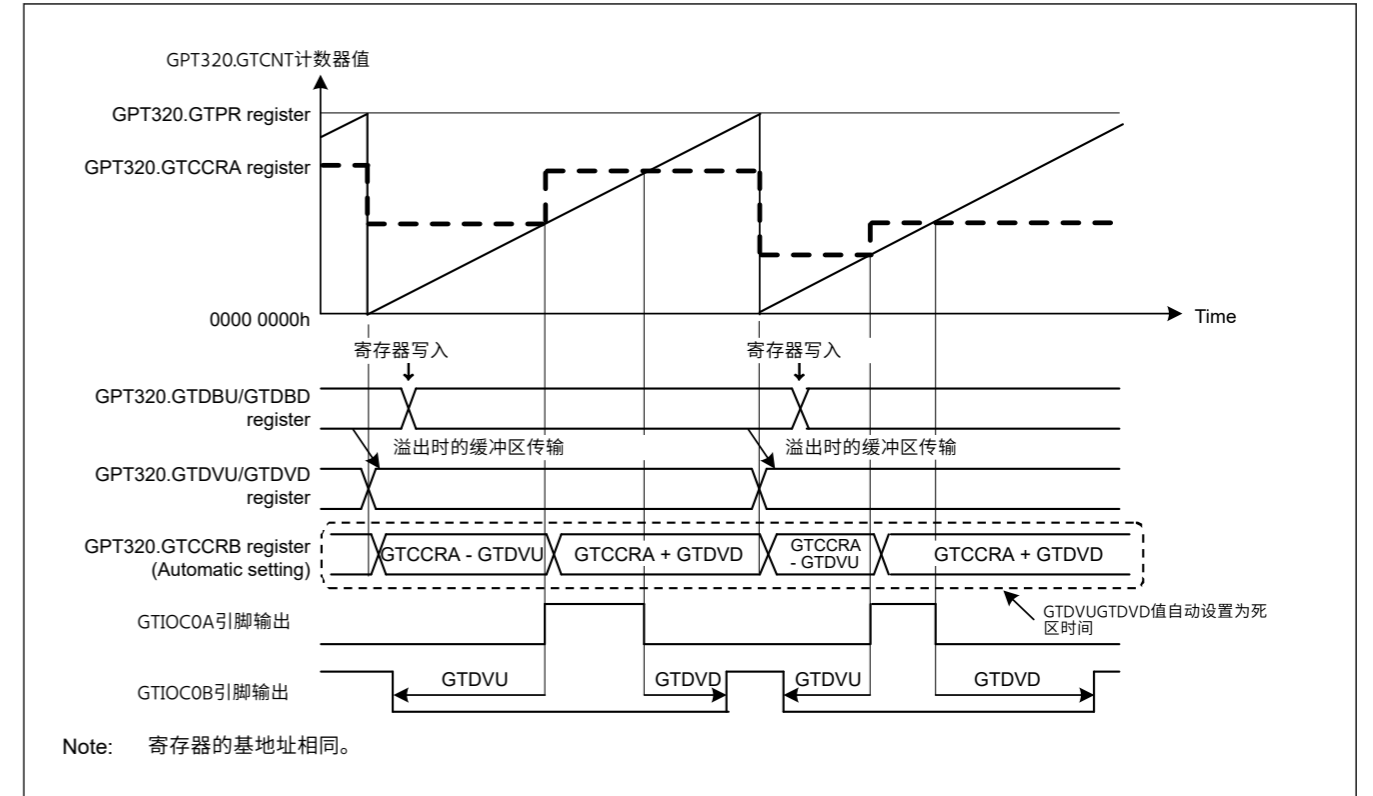


Figure 21.24 锯齿波单发脉冲模式、递增计数和高电平有效的自动死区时间设置功能操作示例

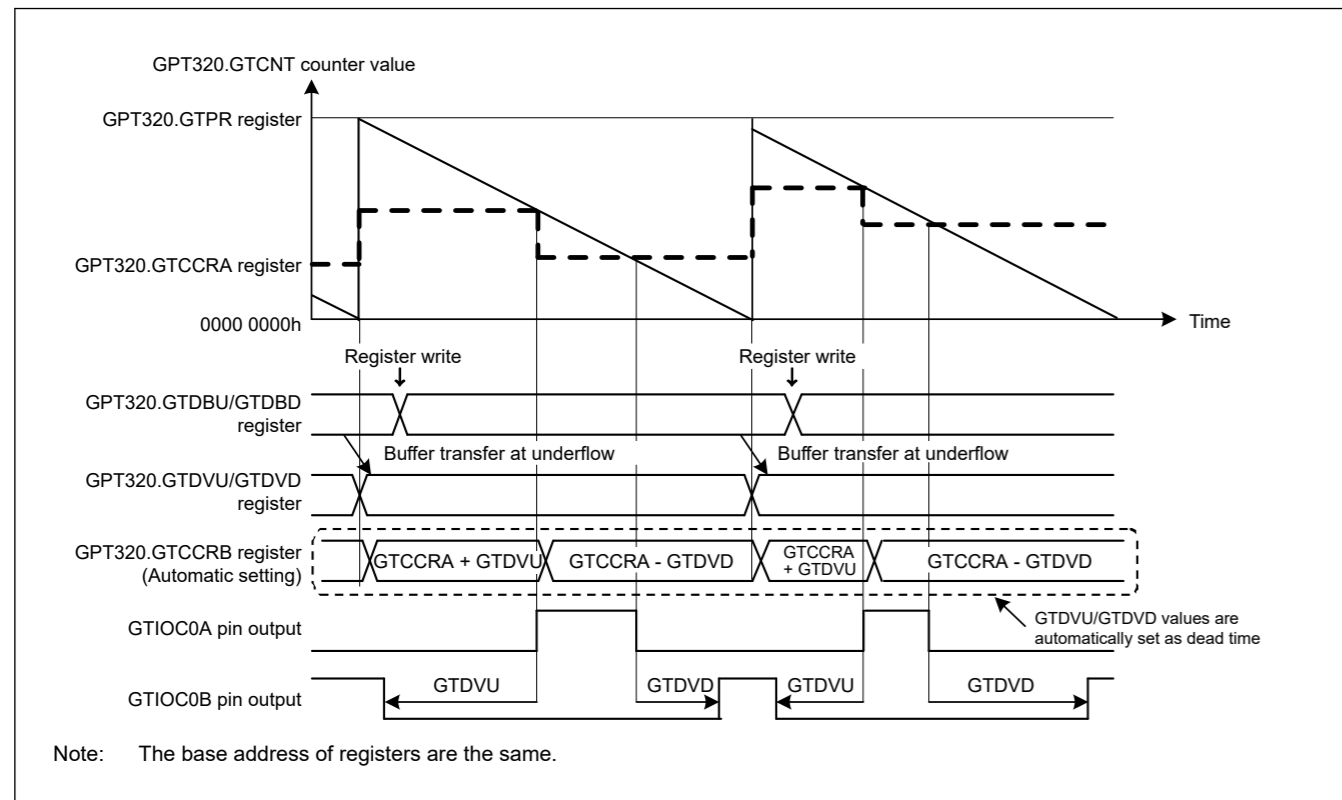


Figure 21.25 Example of automatic dead time setting function operation in saw-wave one-shot pulse mode, down-counting, and active-high

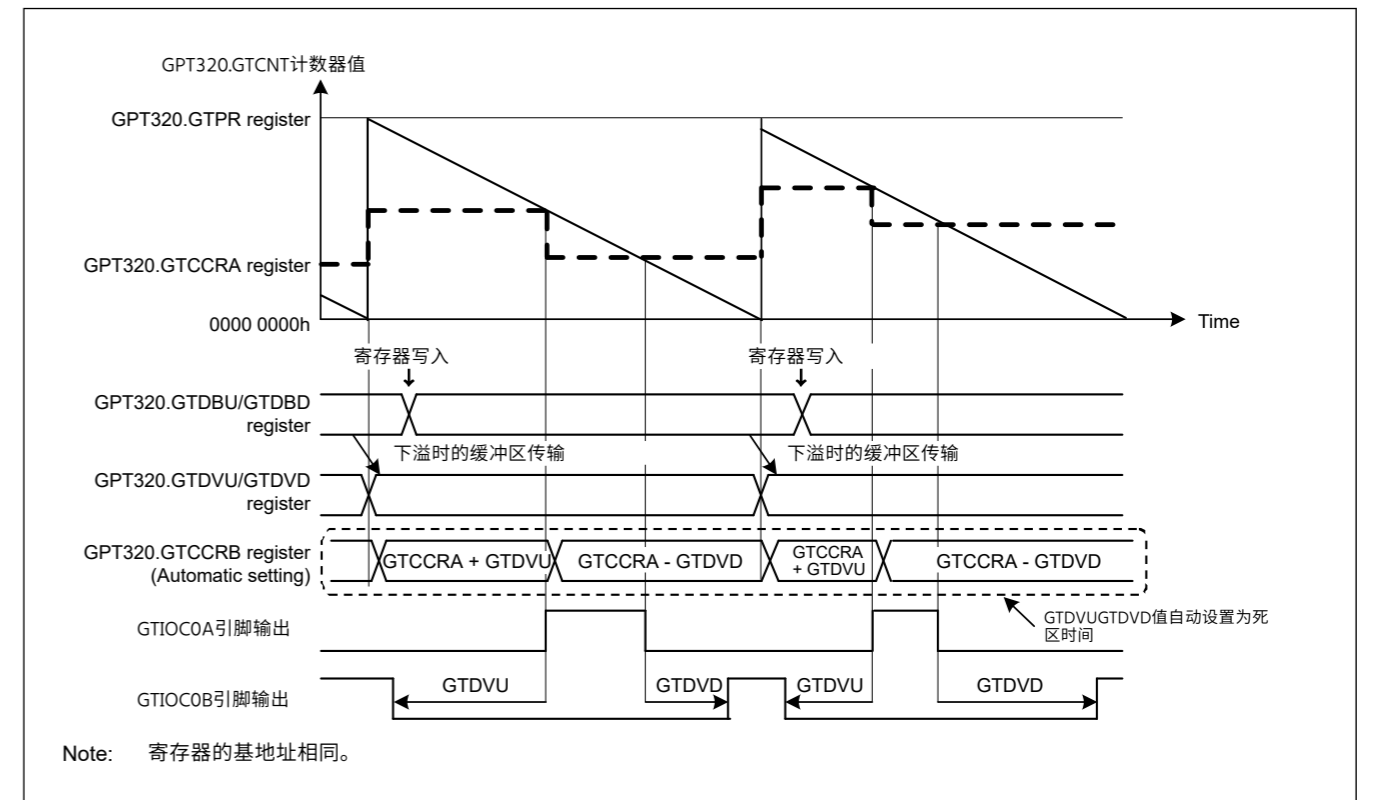


Figure 21.25 锯齿波单发脉冲模式、递减计数和高电平有效的自动死区时间设置功能操作示例

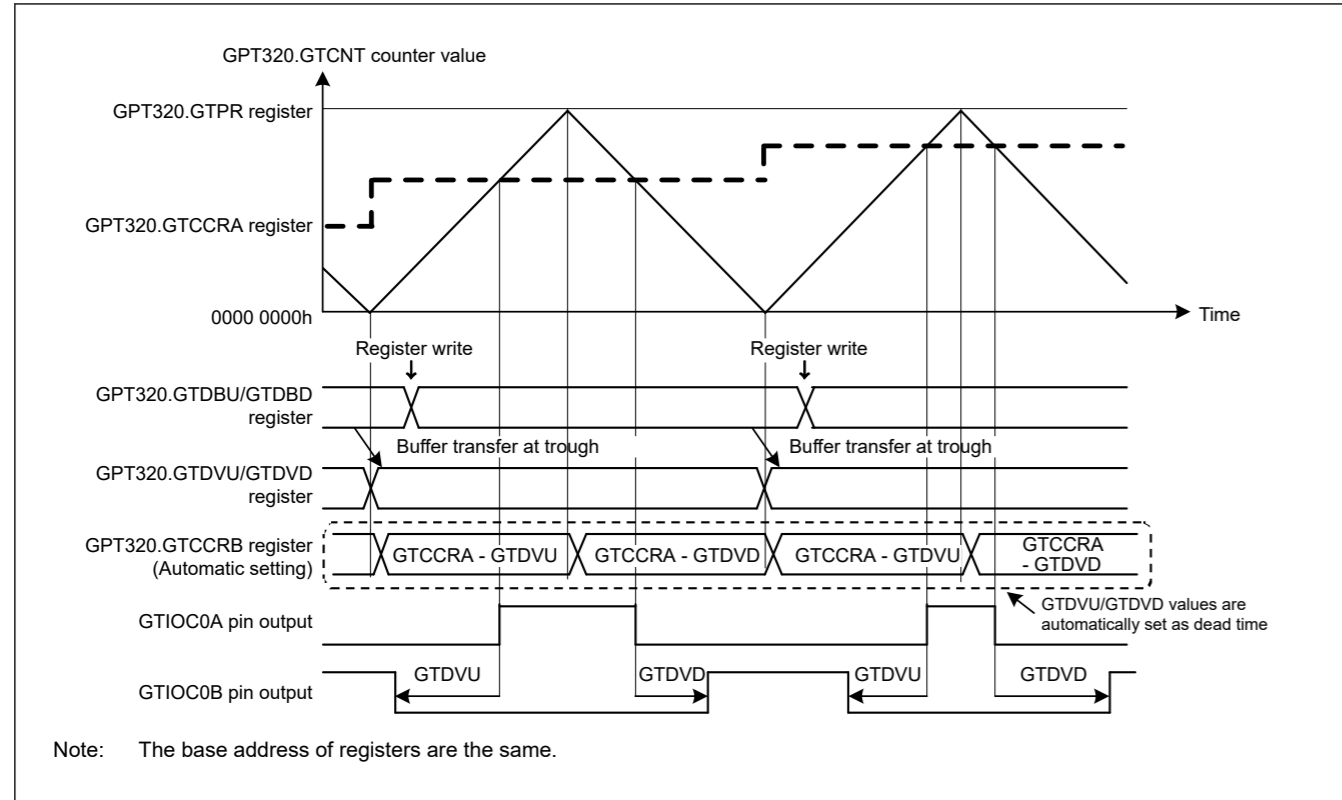


Figure 21.26 Example of automatic compare-match value setting function with dead time in triangle-wave PWM mode 1, and active-high

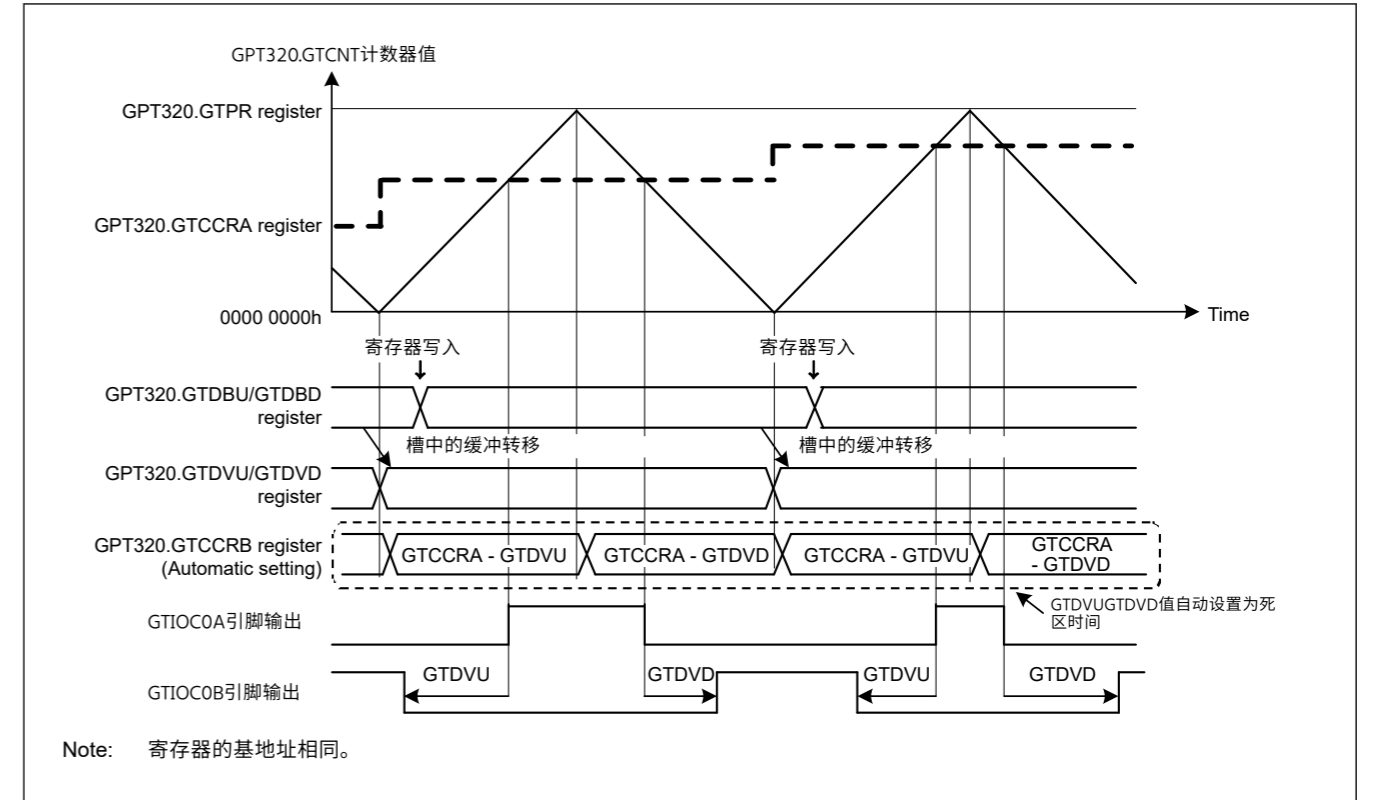


Figure 21.26 三角波中带死区时间的自动比较匹配值设置功能示例 PWM模式1, 高电平有效

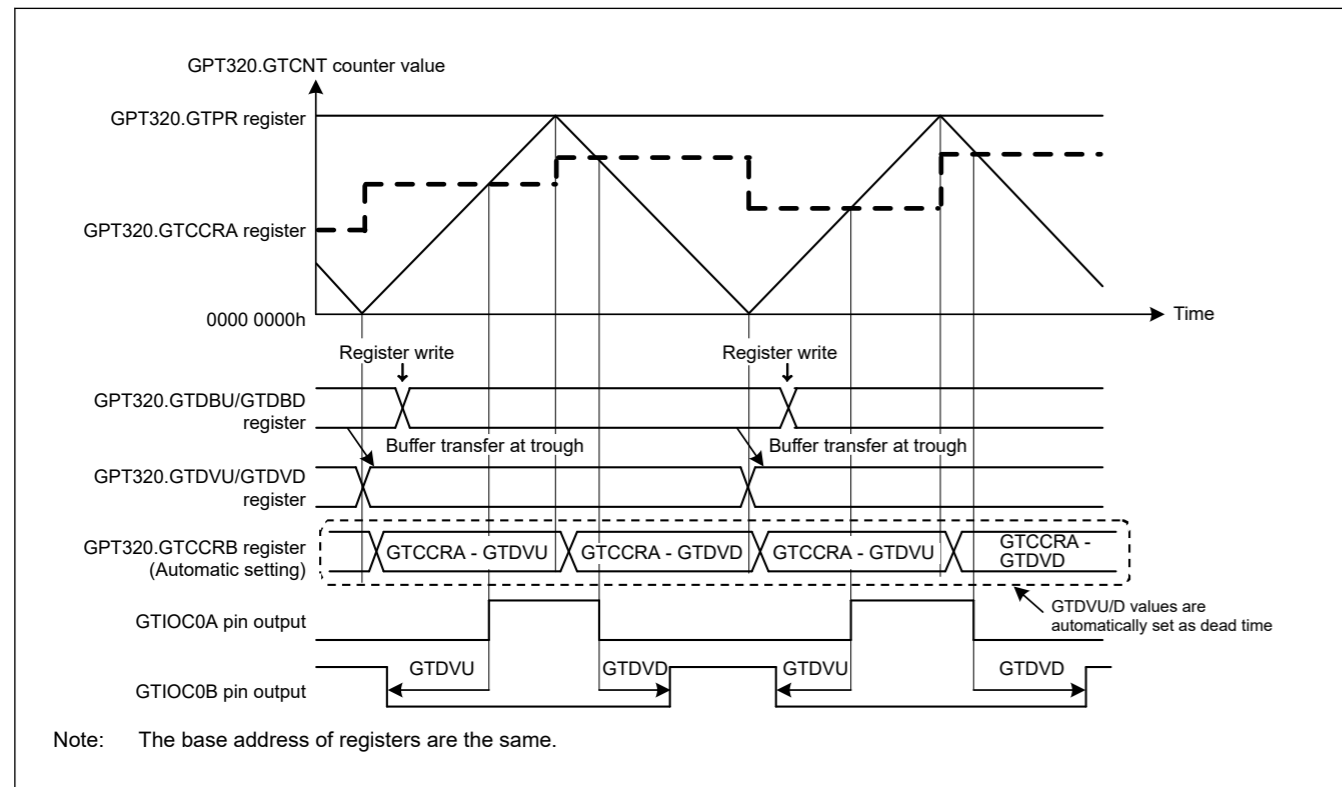


Figure 21.27 Example of automatic compare-match value setting function with dead time in triangle-wave PWM mode 2 or 3, and active-high

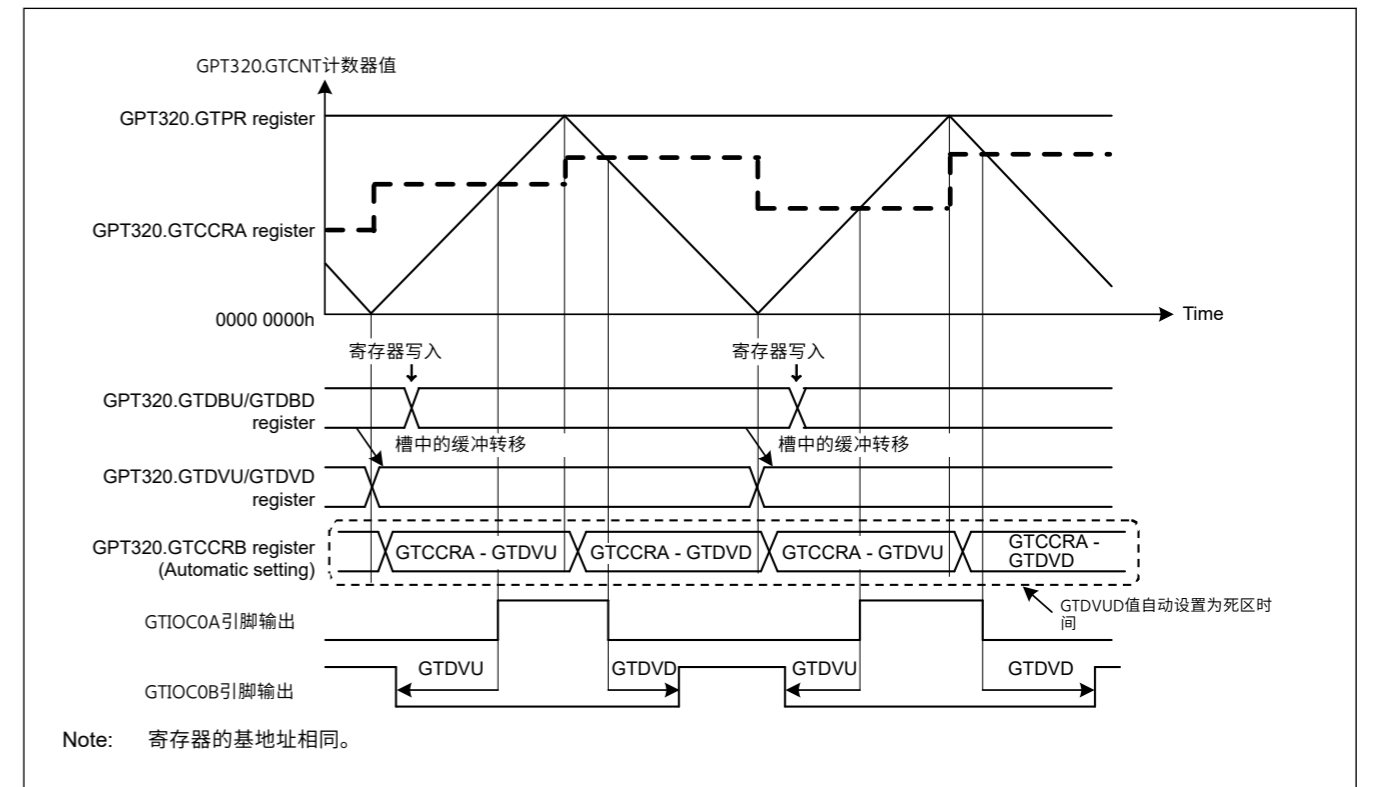


Figure 21.27 三角波中带死区时间的自动比较匹配值设置功能示例 PWM模式2或3, 高电平有效



**Table 21.21 Example setting for automatic dead time setting function in saw-wave one-shot pulse mode, and triangle-wave PWM mode 3**

| No. | Step Name                                      | Description   |
|-----|--|---|
| 1   | Set operating mode                             | Set the operating mode with GTCR.MD[2:0]. In Figure 21.24 and Figure 21.25, 001b (saw-wave one-shot pulse mode) is set. In Figure 21.27, 110b (triangle-wave PWM mode 3) is set.  |
| 2   | Set count direction                            | Select the count direction (up or down) with the GTUDDTYC register. In Figure 21.24, 01b is set after 11b is set in GTUDDTYC[1:0] (up count). In Figure 21.25, 00b is set after 10b is set in GTUDDTYC[1:0] (down count). |
| 3   | Select count clock                             | Select the count clock with GTCR.TPCS[3:0].   |
| 4   | Set cycle                                      | Set the cycle in GTPR.  |
| 5   | Set initial value for counter                  | Set the initial value in the GTCNT counter.   |
| 6   | Set GTIOCnm pin function                       | Set the GTIOCnm pin function with GTIOA[4:0] and GTIOB[4:0] in GTIOR. In Figure 21.24, Figure 21.26, and Figure 21.27, GTIOA[4:0] = 00011b and GTIOB[4:0] = 10011b.   |
| 7   | Enable GTIOCnm pin output                      | Set to enable the GTIOCnm pin output with OAE and OBE in GTIOR.   |
| 8   | Set buffer value for compare match             | Set the GTIOCnA pin transition immediately after the count start in GTCCRC and GTCCRD.  |
| 9   | Set forcible buffer transfer for compare match | Set GTBER.CCRSWT to 1 to transfer buffer register data forcibly to GTCRA.   |
| 10  | Set buffer value for compare match             | Set the GTIOCnA pin transition in 1 cycle after the current cycle in GTCCRC and GTCCRD.   |
| 11  | Set automatic dead time setting function       | Set GTDTCR.TDE to 1 to enable the automatic dead time setting function.   |
| 12  | Set dead time value                            | Set the dead time value in GTDVU.   |
| 13  | Start count operation                          | Set GTCR.CST to 1 to start count operation.   |
| 14  | Set buffer value for each cycle                | Set the GTIOCnA pin transition in 1 cycle after the current cycle in GTCCRC and GTCCRD.   |

Note: n: 0 to 7  
m: A, B

**Table 21.22 Example setting for automatic dead time setting function in triangle-wave PWM mode 1 or 2 (1 of 2)**

| No. | Step Name                                | Description   |
|-----|--|---|
| 1   | Set operating mode                       | Set the operating mode with GTCR.MD[2:0]. In Figure 21.26, 100b (triangle-wave PWM mode 1) is set. In Figure 21.27, 101b (triangle-wave PWM mode 2) is set.   |
| 2   | Select count clock                       | Select the count clock with GTCR.TPCS[3:0].   |
| 3   | Set cycle                                | Set the cycle in GTPR.  |
| 4   | Set initial value for counter            | Set the initial value in the GTCNT counter.   |
| 5   | Set GTIOCnm pin function                 | Set the GTIOCnm pin function with GTIOA[4:0] and GTIOB[4:0] in GTIOR. In Figure 21.26 and Figure 21.27, GTIOA[4:0] = 00011b and GTIOB[4:0] = 10011b.  |
| 6   | Enable GTIOCnm pin output                | Set to enable the GTIOCnm pin output with OAE and OBE in GTIOR.   |
| 7   | Set buffer operation for compare match   | Set buffer operation with CCRA in GTBER.  |
| 8   | Set compare match value                  | Set the GTIOCnA pin transition in GTCRA.  |
| 9   | Set buffer value for compare match       | For buffer operation, set the GTIOCnA pin transition in 1 cycle after the current cycle (in triangle-wave PWM mode 1) or half cycle after the current cycle (in triangle-wave PWM mode 2) in GTCCRC. For double buffer operation, also set the GTIOCnA pin transition in 2 cycles after the current cycle (in triangle-wave PWM mode 1) or 1 cycle after the current cycle (in triangle-wave PWM mode 2) in GTCCRD. |
| 10  | Set automatic dead time setting function | Set GTDTCR.TDE to 1 to enable the automatic dead time setting function.   |
| 11  | Set dead time value                      | Set the dead time value in GTDVU.   |
| 12  | Start count operation                    | Set GTCR.CST to 1 to start count operation.   |

**Table 21.21 锯齿波一次性脉冲模式和三角波PWM模式3中自动死区时间设置功能的设置示例**

| No. | 步骤名称            | Description   |
|-----|-----------------|---|
| 1   | 设置操作模式          | 使用GTCR.MD[2:0]设置操作模式。在图21.24和图21.25中，设置了001b（锯齿波单发脉冲模式）。在图21.27中，设置了110b（三角波PWM模式3）。                                  |
| 2   | 设置计数方向          | 使用GTUDDTYC寄存器选择计数方向（向上或向下）。在图21.24中，在GTUDDTYC[1:0]中设置了11b之后设置了01b（向上计数）。在图21.25中，在GTUDDTYC[1:0]中设置了10b之后设置了00b（向下计数）。 |
| 3   | 选择计数时钟          | 使用GTCR.TPCS[3:0]选择计数时钟。   |
| 4   | 设置周期            | 在GTPR中设置循环。   |
| 5   | 设置计数器的初始值       | 在GTCNT计数器中设置初始值。  |
| 6   | 设置GTIOCnm引脚功能   | 使用GTIOR中的GTIOA[4:0]和GTIOB[4:0]设置GTIOCnm引脚功能。在图21.24、图21.26和图21.27中，GTIOA[4:0]=00011b和GTIOB[4:0]=10011b。               |
| 7   | 启用GTIOCnm引脚输出   | 设置为在GTIOR中使用OAE和OBE启用GTIOCnm引脚输出。   |
| 8   | 设置比较匹配的缓冲区间值    | 在GTCCRC和GTCCRD中计数开始后立即设置GTIOCnA引脚转换。  |
| 9   | 为比较匹配设置强制缓冲区间传输 | 将GTBER.CCRSWT设置为1以强制将缓冲寄存器数据传输到GTCRA。   |
| 10  | 设置比较匹配的缓冲区间值    | 在GTCCRC和GTCCRD中的当前周期之后的1个周期内设置GTIOCnA引脚转换。  |
| 11  | 设置自动死区时间设置功能    | 将GTDTCR.TDE设置为1以启用自动死区时间设置功能。   |
| 12  | 设置死区时间值         | 在GTDVU中设置死区时间值。   |
| 13  | 开始计数操作          | 将GTCR.CST设置为1以启动计数操作。   |
| 14  | 为每个周期设置缓冲区间值    | 在GTCCRC和GTCCRD中的当前周期之后的1个周期内设置GTIOCnA引脚转换。  |

Note: n: 0 to 7  
m: A, B

**Table 21.22 三角波PWM模式1或2(1of2)中自动死区时间设置功能的设置示例**

| No. | 步骤名称          | Description  |
|-----|---------------|--|
| 1   | 设置操作模式        | 使用GTCR.MD[2:0]设置操作模式。在图21.26中，设置了100b（三角波PWM模式1）。在图21.27中，设置了101b（三角波PWM模式2）。  |
| 2   | 选择计数时钟        | 使用GTCR.TPCS[3:0]选择计数时钟。  |
| 3   | 设置周期          | 在GTPR中设置循环。  |
| 4   | 设置计数器的初始值     | 在GTCNT计数器中设置初始值。   |
| 5   | 设置GTIOCnm引脚功能 | 使用GTIOR中的GTIOA[4:0]和GTIOB[4:0]设置GTIOCnm引脚功能。在图21.26和图21.27中，GTIOA[4:0]=00011b和GTIOB[4:0]=10011b。   |
| 6   | 启用GTIOCnm引脚输出 | 设置为在GTIOR中使用OAE和OBE启用GTIOCnm引脚输出。  |
| 7   | 为比较匹配设置缓冲区间操作 | 在GTBER中使用CCRA设置缓冲区间操作。   |
| 8   | 设置比较匹配值       | 在GTCRA中设置GTIOCnA引脚转换。  |
| 9   | 设置比较匹配的缓冲区间值  | 对于缓冲操作，在GTCCRC中将GTIOCnA引脚转换设置为当前周期后的1个周期（三角波PWM模式1）或当前周期后的半个周期（三角波PWM模式2）。对于双缓冲器操作，在GTCCRD中还设置GTIOCnA引脚在当前周期后2个周期（三角波PWM模式1）或当前周期后1个周期（三角波PWM模式2）。 |
| 10  | 设置自动死区时间设置功能  | 将GTDTCR.TDE设置为1以启用自动死区时间设置功能。  |
| 11  | 设置死区时间值       | 在GTDVU中设置死区时间值。  |
| 12  | 开始计数操作        | 将GTCR.CST设置为1以启动计数操作。  |



Table 21.22 Example setting for automatic dead time setting function in triangle-wave PWM mode 1 or 2 (2 of 2)

| No. | Step Name                       | Description  |
|-----|---------------------------------|--|
| 13  | Set buffer value for each cycle | When the compare match register is used for buffer operation, set the GTIOCnA pin transition in 1 cycle after the current cycle (in triangle-wave PWM mode 1) or half cycle after the current cycle (in triangle-wave PWM mode 2) in GTCCRC. |

Note: n: 0 to 7  
m: A, B

### 21.3.5 Count Direction Changing Function

The count direction of the GTCNT counter can be changed by modifying the UD bit in GTUDDTYC.

In saw-wave mode, if the UD bit in GTUDDTYC is modified during count operation, the count direction is changed at an overflow (when modified during up-counting) or an underflow (when modified during down-counting). If the GTUDDTYC.UD bit is modified while the count operation stops and the GTUDDTYC.UDF bit is 0, the GTUDDTYC.UD bit modification is not reflected at the start of counting and the count direction is changed at an overflow or an underflow. If the UDF bit is set to 1 while the count operation stops, the GTUDDTYC.UD bit value at that time is reflected at the start of counting.

In triangle-wave mode, the count direction does not change even though the UD bit in GTUDDTYC is modified during the count operation. Similarly, even though the GTUDDTYC.UD bit is modified while the count operation stops and GTUDDTYC.UDF bit is 0, the GTUDDTYC.UD bit value is not reflected to the count operation. If the GTUDDTYC.UDF bit is set to 1 while the count operation is stopped, the GTUDDTYC.UD bit value at that time is reflected at the start of counting.

If the count direction changes during a saw-wave count operation, the GTPR value after the start of up-counting is reflected in the count cycle during up-counting and the GTPR value before the start of down-counting is reflected during down-counting.

Figure 21.28 shows an example of count direction changing function operation.

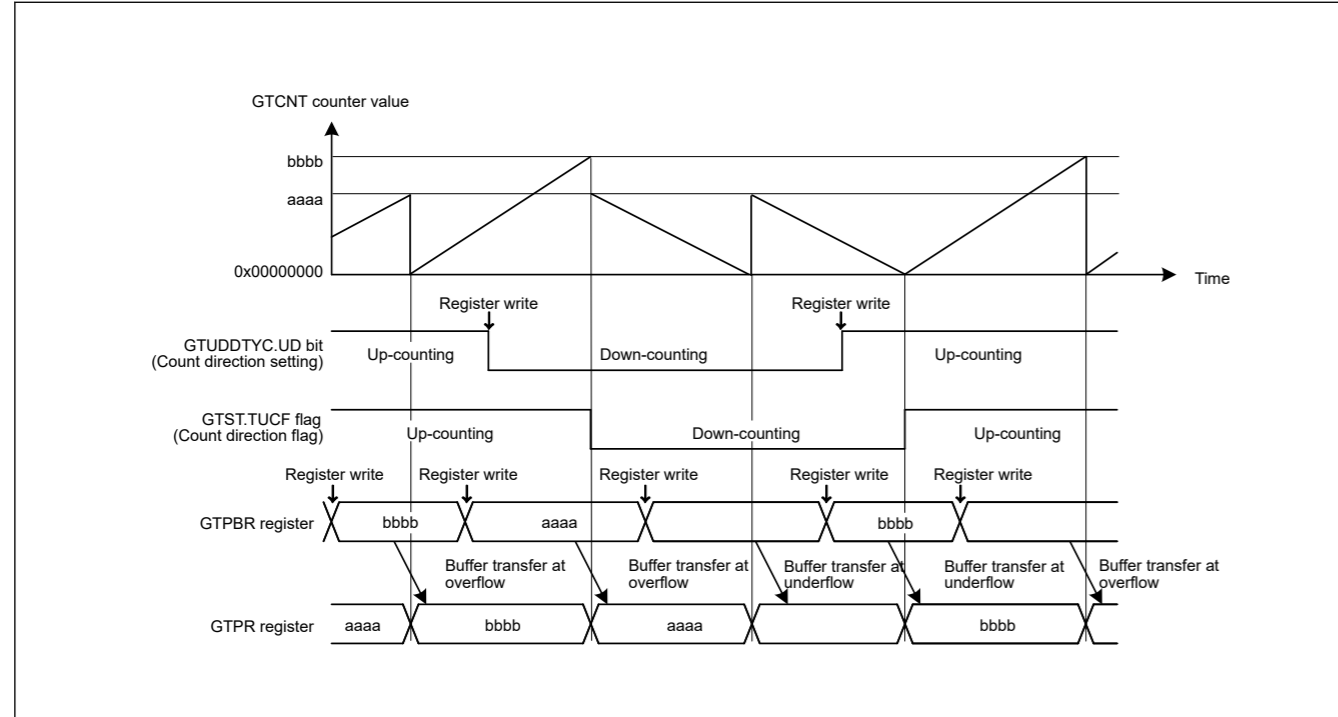


Figure 21.28 Example of a count direction changing function operation during buffer operation

### 21.3.6 Function of Output Duty 0% and 100%

The output duty of the GTIOCnA pin and the GTIOCnB pin (n = 0 to 7) are set to 0% or 100% by changing the GTUDDTYC.OADTY bit or GTUDDTYC.OBDTY bit.

Table 21.22 三角波PWM模式1或2(2of2)中自动死区时间设置功能的设置示例

| No. | 步骤名称        | Description   |
|-----|-------------|---|
| 13  | 为每个周期设置缓冲区值 | 当比较匹配寄存器用于缓冲操作时，在GTCCRC中设置GTIOCnA引脚在当前周期后1个周期（三角波PWM模式1）或当前周期后半周期（三角波PWM模式2）。 |

Note: n: 0 to 7  
m: A, B

### 21.3.5 计数方向改变功能

GTCNT计数器的计数方向可以通过修改GTUDDTYC中的UD位来改变。

在锯齿波模式下，如果在计数操作期间修改GTUDDTYC中的UD位，则计数方向会在溢出（在向上计数期间修改时）或下溢（在向下计数期间修改时）改变。如果在计数操作停止时修改GTUDDTYC.UD位且GTUDDTYC.UDF位为0，则GTUDDTYC.UD位的修改不会反映在计数开始时，并且计数方向会在上溢或下溢时改变。如果在计数操作停止时UDF位设置为1，则此时的GTUDDTYC.UD位值将反映在计数开始时。

在三角波模式下，即使在计数操作期间修改GTUDDTYC中的UD位，计数方向也不会改变。同样，即使在计数操作停止且GTUDDTYC.UDF位为0时修改GTUDDTYC.UD位，GTUDDTYC.UD位的值也不会反映到计数操作中。如果在计数操作停止时将GTUDDTYC.UDF位设置为1，则此时的GTUDDTYC.UD位值将反映在计数开始时。

如果在锯齿波计数操作期间计数方向发生变化，则加计数开始后的GTPR值反映在加计数期间的计数周期中，而减计数开始之前的GTPR值反映在减计数期间。

图21.28显示了计数方向改变功能操作的示例。

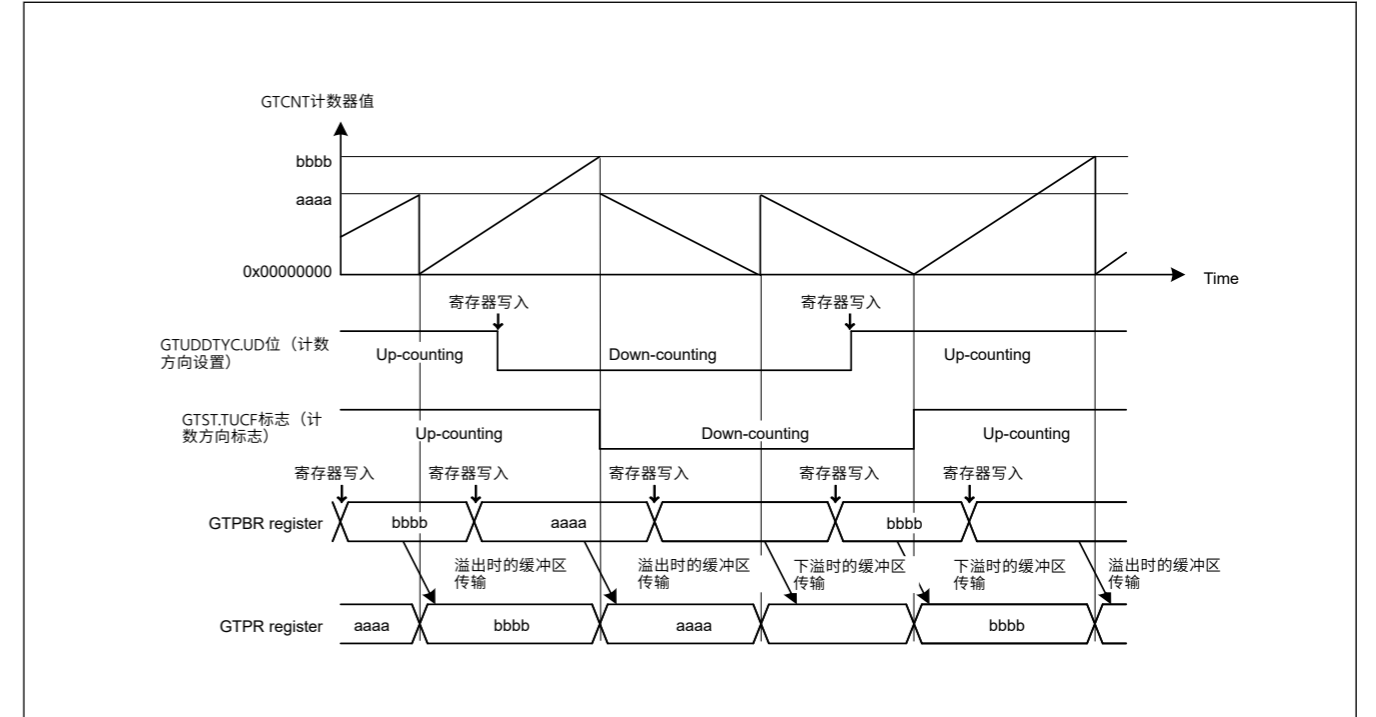


Figure 21.28 缓冲操作期间的计数方向改变功能操作示例

### 21.3.6 输出占空比0%和100%的功能

GTIOCnA引脚和GTIOCnB引脚（n=0至7）的输出占空比通过更改GTUDDTYC.OADTY位或GTUDDTYC.OBDTY位。

In saw-wave mode, if the GTUDDTYC.OADTY bit or the GTUDDTYC.OBDTY bit is modified during the count operation, the output duty setting is reflected at an overflow (when modified during up-counting) or an underflow (when modified during down-counting). If the GTUDDTYC.OADTY bit or the GTUDDTYC.OBDTY bit is modified while the count operation is stopped and the GTUDDTYC.OADTYF or the GTUDDTYC.OBDTYF bit is 0, the output duty modification is not reflected at the start of counting. The output duty changes at an overflow or an underflow. If the GTUDDTYC.OADTYF or the GTUDDTYC.OBDTYF bit is set to 1 while the count operation is stopped, the GTUDDTYC.OADTY bit or the GTUDDTYC.OBDTY bit value at that time is reflected at the start of counting.

In triangle-wave mode, if the GTUDDTYC.OADTY bit or the GTUDDTYC.OBDTY bit is modified during the count operation, the output duty setting is reflected an underflow.

If the GTUDDTYC.OADTY bit or the GTUDDTYC.OBDTY bit is modified while the count operation is stopped and the GTUDDTYC.OADTYF or the GTUDDTYC.OBDTYF bit is 0, the output duty modification is not reflected at the start of counting. The output duty changes at an underflow. If the GTUDDTYC.OADTY bit or the GTUDDTYC.OBDTY bit is modified while the count operation stops and the GTUDDTYC.OADTYF or the GTUDDTYC.OBDTYF bit is 1, the output duty modification is reflected at the start of counting.

In performing 0% or 100% duty operation, GPT internally continues to:

- Perform compare match operation
- Set compare match flag
- Output interrupt
- Perform buffer operation.

When the control is changed from 0% or 100% duty setting to compare match, the output value of GTIOCnA pin at cycle end is decided by GTIOR.GTIOA[3:2] and GTUDDTYC.OADTYR. The output value of GTIOCnB pin at cycle end is decided by GTIOR.GTIOB[3:2] and GTUDDTYC.OBDTYR.

When GTIOR.GTIOA[3:2] and GTIOR.GTIOB[3:2] are set to 01b, the output pins output low at cycle end. When GTIOR.GTIOA[3:2] and GTIOR.GTIOB[3:2] are set to 10b, the output pins output high at cycle end.

GTUDDTYC.OADTYR selects the value that is the object of output retained/toggled at cycle end, when GTIOR.GTIOm[3:2] are set to 00b (output retained at cycle end) or when GTIOR.GTIOm[3:2] are set to 11b (output toggled at cycle end). Table 21.23 shows the values of GTIOCnA and GTIOCnB pin output at cycle end.

Table 21.23 Output values after releasing 0% or 100% duty setting (m = A, B)

| GTIOR.GTIOm[3:2]                     | Compare match value at cycle end masked by 0% or 100% duty setting | GTUDDTYC.OmDTYR in duty 0% setting |   | GTUDDTYC.OmDTYR in duty 100% setting |   |
|--------------------------------------|--|------------------------------------|---|--------------------------------------|---|
|                                      |  | 0                                  | 1 | 0                                    | 1 |
| 00<br>(output retained at cycle end) | 0  | 0                                  | 0 | 1                                    | 0 |
|                                      | 1  | 0                                  | 1 | 1                                    | 1 |
| 01<br>(low output at cycle end)      | —  | 0                                  | 0 | 0                                    | 0 |
| 10<br>(high output at cycle end)     | —  | 1                                  | 1 | 1                                    | 1 |
| 11<br>(output toggled at cycle end)  | 0  | 1                                  | 1 | 0                                    | 1 |
|                                      | 1  | 1                                  | 0 | 0                                    | 0 |

Figure 21.29 shows an example of output duty 0% and 100% function.

在锯齿波模式下，如果在计数操作期间修改GTUDDTYC.OADTY位或GTUDDTYC.OBDTY位，则输出占空比设置反映在溢出（在向上计数期间修改时）或下溢（在向下期间修改时-数数）。如果在计数操作停止且GTUDDTYC.OADTYF或GTUDDTYC.OBDTYF位为0时修改GTUDDTYC.OADTY位或GTUDDTYC.OBDTY位，则在计数开始时不反映输出占空比修改。输出占空比在上溢或下溢时发生变化。如果在计数操作停止时GTUDDTYC.OADTYF或GTUDDTYC.OBDTYF位设置为1，则

GTUDDTYC.OADTY位或当时的GTUDDTYC.OBDTY位值反映在计数开始时。

在三角波模式下，如果在计数操作期间修改GTUDDTYC.OADTY位或GTUDDTYC.OBDTY位，则输出占空比设置反映为下溢。

如果在计数操作停止且GTUDDTYC.OADTYF或GTUDDTYC.OBDTYF位为0时修改GTUDDTYC.OADTY位或GTUDDTYC.OBDTY位，则在计数开始时不反映输出占空比修改。输出占空比在下溢时发生变化。如果在计数操作停止且GTUDDTYC.OADTYF或GTUDDTYC.OBDTYF位为1时修改了GTUDDTYC.OADTY位或GTUDDTYC.OBDTY位，则输出占空比修改将反映在计数开始时。

在执行0%或100%占空比操作时，GPT在内部继续：

- 执行比较匹配操作
- 设置比较匹配标志
- 输出中断
- 执行缓冲操作。

当控制从0%或100%占空比设置更改为比较匹配时，周期结束时GTIOCnA引脚的输出值由GTIOR.GTIOA[3:2]和GTUDDTYC.OADTYR决定。周期结束时GTIOCnB引脚的输出值由GTIOR.GTIOB[3:2]和GTUDDTYC.OBDTYR决定。

当GTIOR.GTIOA[3:2]和GTIOR.GTIOB[3:2]设置为01b时，输出引脚在周期结束时输出低电平。什么时候GTIOR.GTIOA[3:2]和GTIOR.GTIOB[3:2]设置为10b，输出引脚在周期结束时输出高电平。

GTUDDTYC.OADTYR当GTIOR.GTIOm[3:2]设置为00b（在循环结束时保持输出）或GTIOR.GTIOm[3:2]设置为11b（选择作为在循环结束时切换的输出保留对象的值到11b（输出在循环结束时切换））。表21.23显示了循环结束时GTIOCnA和GTIOCnB引脚输出的值。

Table 21.23 释放0%或100%占空比设置后的输出值(m=A B)

| GTIOR.GTIOm[3:2] | 比较被0%或100%占空比设置屏蔽的循环结束时的匹配值 | GTUDDTYC.OmDTYR在占空比0%设置 |   | GTUDDTYC.OmDTYR占空比100%设置 |   |
|------------------|-----------------------------|-------------------------|---|--------------------------|---|
|                  |                             | 0                       | 1 | 0                        | 1 |
| 00（循环结束时保留输出）    | 0                           | 0                       | 0 | 1                        | 0 |
|                  | 1                           | 0                       | 1 | 1                        | 1 |
| 01（循环结束时输出低）     | —                           | 0                       | 0 | 0                        | 0 |
| 10（循环结束时的高输出）    | —                           | 1                       | 1 | 1                        | 1 |
| 11（循环结束时切换输出）    | 0                           | 1                       | 1 | 0                        | 1 |
|                  | 1                           | 1                       | 0 | 0                        | 0 |

图21.29显示了输出占空比0%和100%功能的示例。

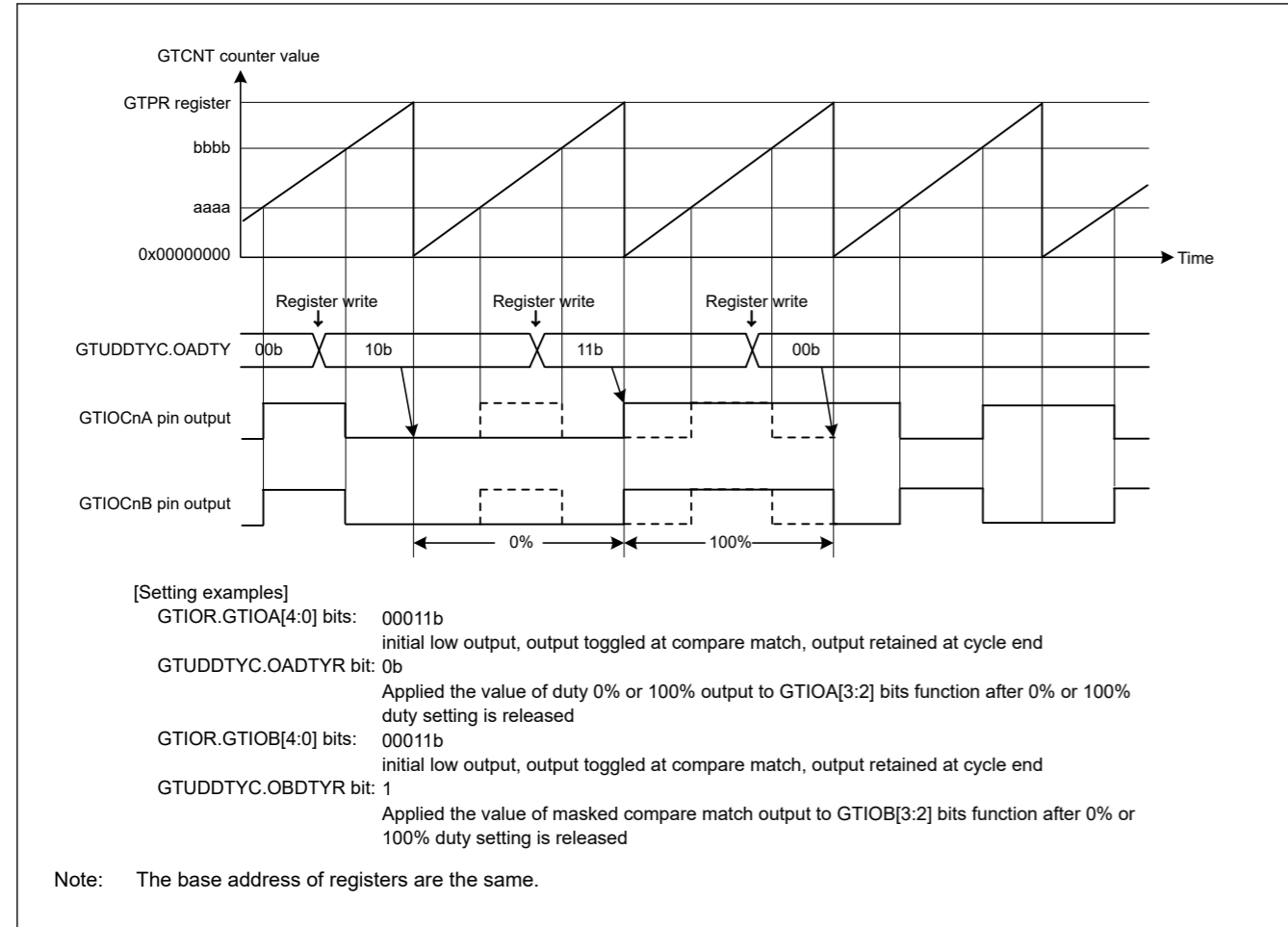


Figure 21.29 Example of output duty 0% and 100% function

### 21.3.7 Hardware Count Start/Count Stop and Clear Operation

The GTCNT counter can be started, stopped, or cleared by the following hardware sources:

- External trigger input
- ELC event input
- GTIOCnA and GTIOCnB pin input (n = 0 to 7).

#### 21.3.7.1 Hardware Start Operation

The GTCNT counter can be started by selecting a hardware source using GTSSR.

Figure 21.30 shows an example of a count start operation by a hardware source. Table 21.24 shows the setting example.

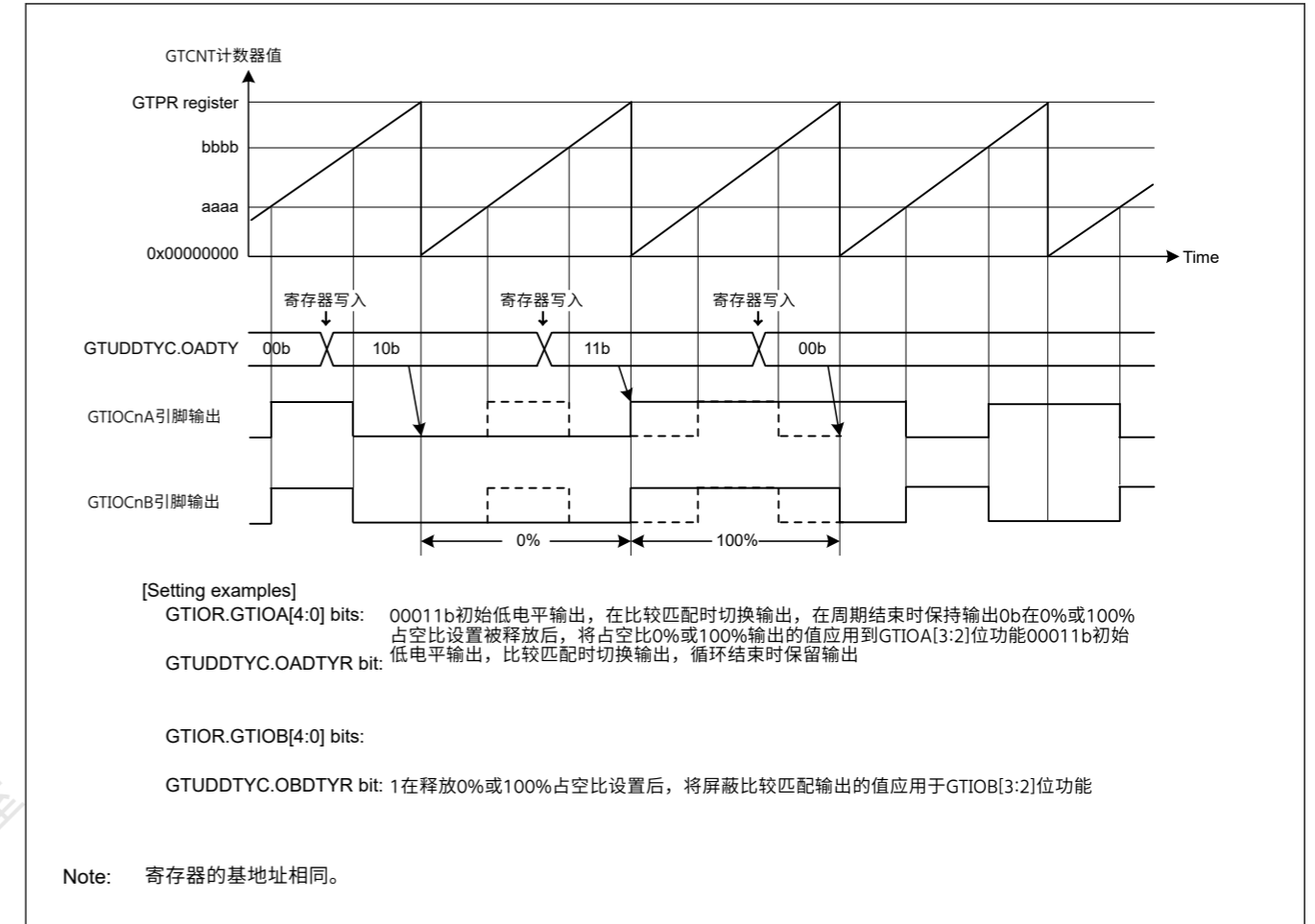


Figure 21.29 输出占空比0%和100%功能示例

### 21.3.7 硬件计数开始计数停止和清除操作

GTCNT计数器可以由以下硬件源启动、停止或清除：

- 外部触发输入
- ELC事件输入
- GTIOCnA和GTIOCnB引脚输入 (n=0至7)。

#### 21.3.7.1 硬件启动操作

GTCNT计数器可以通过使用GTSSR选择硬件源来启动。

图21.30显示了一个硬件源的计数开始操作示例。表21.24显示了设置示例。

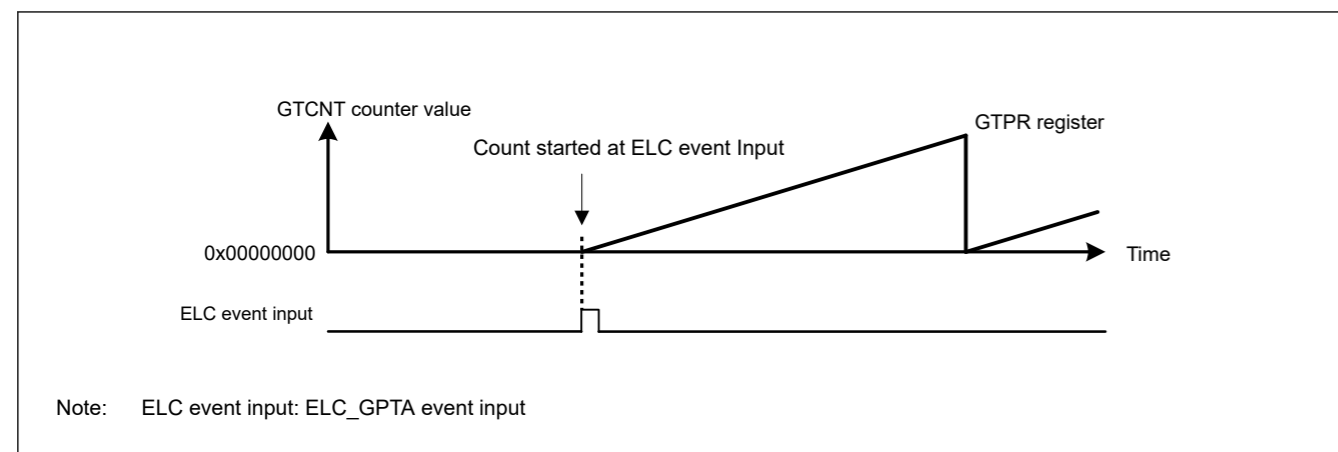


Figure 21.30 Example of count start operation by a hardware source started at the input of the signal from the ELC\_GPTA event

Table 21.24 Example setting for count start operation by a hardware source

| No. | Step Name                     | Description   |
|-----|-------------------------------|---|
| 1   | Set operating mode            | Set the operating mode with GTCR.MD[2:0].<br>In Figure 21.30, 000b (saw-wave PWM mode) is set.  |
| 2   | Set count direction           | Select the count direction (up or down) with the GTUDDTYC register.<br>In Figure 21.30, after 11b is set in GTUDDTYC[1:0], 01b is set in GTUDDTYC[1:0] (up-counting). |
| 3   | Select count clock            | Select the count clock with GTCR.TPCS[3:0].   |
| 4   | Set cycle                     | Set the cycle in GTPR.  |
| 5   | Set initial value for counter | Set the initial value in the GTCNT counter.<br>In Figure 21.30, 0x00000000 is set.  |
| 6   | Set hardware count start      | Select a hardware source for starting count operation in GTSSR register.<br>In Figure 21.30, GTSSR.SSELCA = 1   |
| 7   | Set hardware source operation | Set operation of the hardware source selected by GTSSR register and start counting.<br>In Figure 21.30, the ELC_GPTA event input operation is set.                    |

### 21.3.7.2 Hardware stop operation

The GTCNT counter can be stopped by selecting a hardware source using GTPSR.

Figure 21.31 shows an example of a count stop operation by a hardware source. Table 21.25 shows the setting example. In this example, the count operation stops at the edge of the ELC\_GPTA event input and restarts at the edges of the ELC\_GPTB event input.

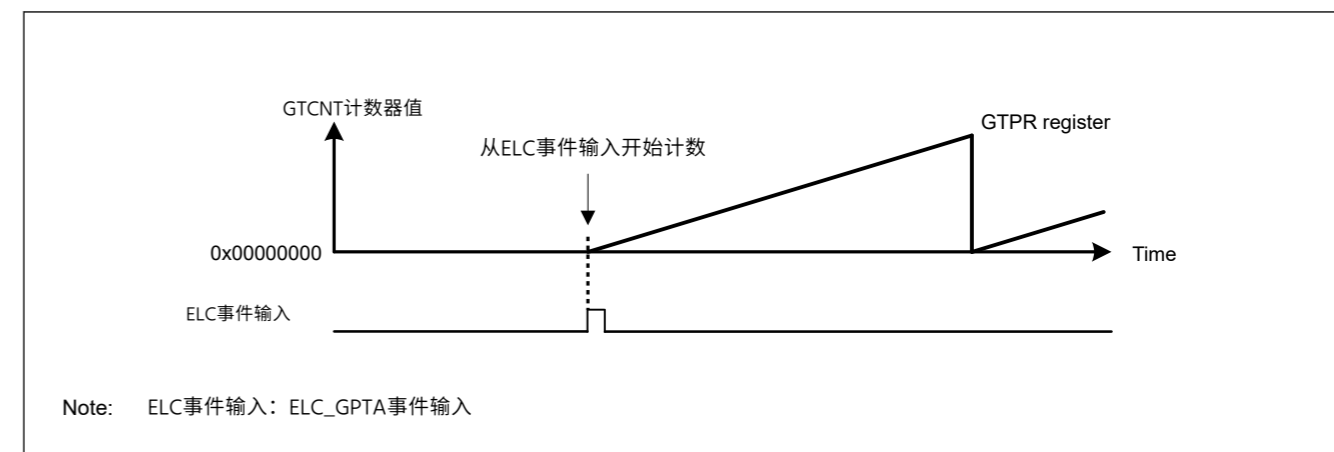


Figure 21.30 从ELC\_GPTA事件的信号输入开始的硬件源的计数开始操作示例

Table 21.24 硬件源的计数开始操作设置示例

| No. | 步骤名称      | Description  |
|-----|-----------|--|
| 1   | 设置操作模式    | 使用GTCR.MD[2:0]设置操作模式。<br>在图21.30中, 设置了000b (锯齿波PWM模式)。   |
| 2   | 设置计数方向    | 使用GTUDDTYC寄存器选择计数方向 (向上或向下)。<br>在图21.30中, 在GTUDDTYC[1:0]中设置了11b之后, 在GTUDDTYC[1:0]中设置了01b (向上计数)。 |
| 3   | 选择计数时钟    | 使用GTCR.TPCS[3:0]选择计数时钟。  |
| 4   | 设置周期      | 在GTPR中设置循环。  |
| 5   | 设置计数器的初始值 | 在GTCNT计数器中设置初始值。<br>在图21.30中, 设置了0x00000000。   |
| 6   | 设置硬件计数开始  | 在GTSSR寄存器中选择启动计数操作的硬件源。<br>在图21.30中, GTSSR.SSELCA=1  |
| 7   | 设置硬件源操作   | 设置GTSSR寄存器选择的硬件源的操作并开始计数。<br>在图21.30中, 设置了ELC_GPTA事件输入操作。  |

### 21.3.7.2 硬件停止操作

GTCNT计数器可以通过使用GTPSR选择硬件源来停止。

图21.31显示了一个硬件源的计数停止操作示例。表21.25显示了设置示例。在此示例中, 计数操作在ELC\_GPTA事件输入的边沿停止, 并在ELC\_GPTB事件输入的边沿重新开始。



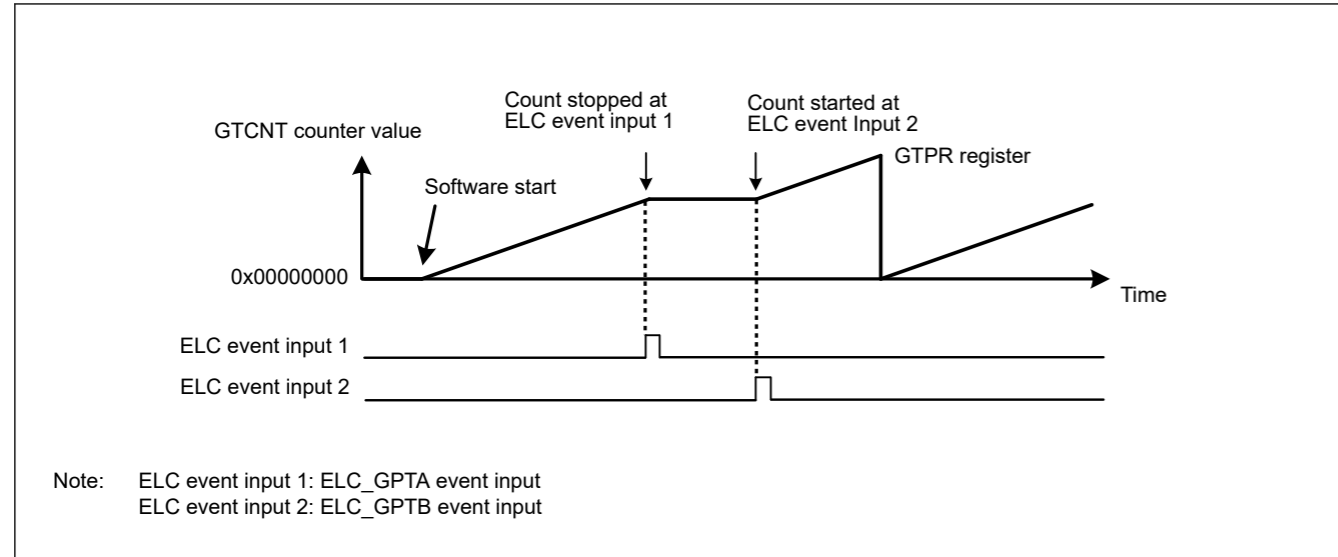


Figure 21.31 Example of count stop operation by hardware source started by software, stopped at ELC\_GPTA input, and restarted at ELC\_GPTB input

Table 21.25 Example setting for count stop operation by a hardware source

| No. | Step Name                     | Description  |
|-----|-------------------------------|--|
| 1   | Set operating mode            | Set the operating mode with GTCR.MD[2:0]. In Figure 21.31, 000b (saw-wave PWM mode) is set.  |
| 2   | Set count direction           | Select the count direction (up or down) with the GTUDDTYC register. In Figure 21.31, after 11b is set in GTUDDTYC[1:0], 01b is set in GTUDDTYC[1:0] (up-counting).                             |
| 3   | Select count clock            | Select the count clock with GTCR.TPCS[3:0].  |
| 4   | Set cycle                     | Set the cycle in GTPR.   |
| 5   | Set initial value for counter | Set the initial value in the GTCNT counter. In Figure 21.31, 0x00000000 is set.  |
| 6   | Set hardware count start      | Select a hardware source for starting count operation in GTSSR register, and wait for count start by the hardware source. In Figure 21.31, GTSSR.SSELCB = 1.                                   |
| 7   | Set hardware count stop       | Select a hardware source for stopping count operation in GTPSR register and wait for count stop by the hardware source. In Figure 21.31, GTPSR.PSELCA = 1.                                     |
| 8   | Set hardware source operation | Set operation of the hardware source selected in GTSSR register or GTPSR register, and start or stop counting. In Figure 21.31, ELC_GPTA input operation and ELC_GPTB input operation are set. |

Figure 21.32 shows an example of a count start/stop operation by a hardware source. Table 21.26 shows the setting example. In this example, the counter operates during the high-level periods of the external trigger input GTETRGA.

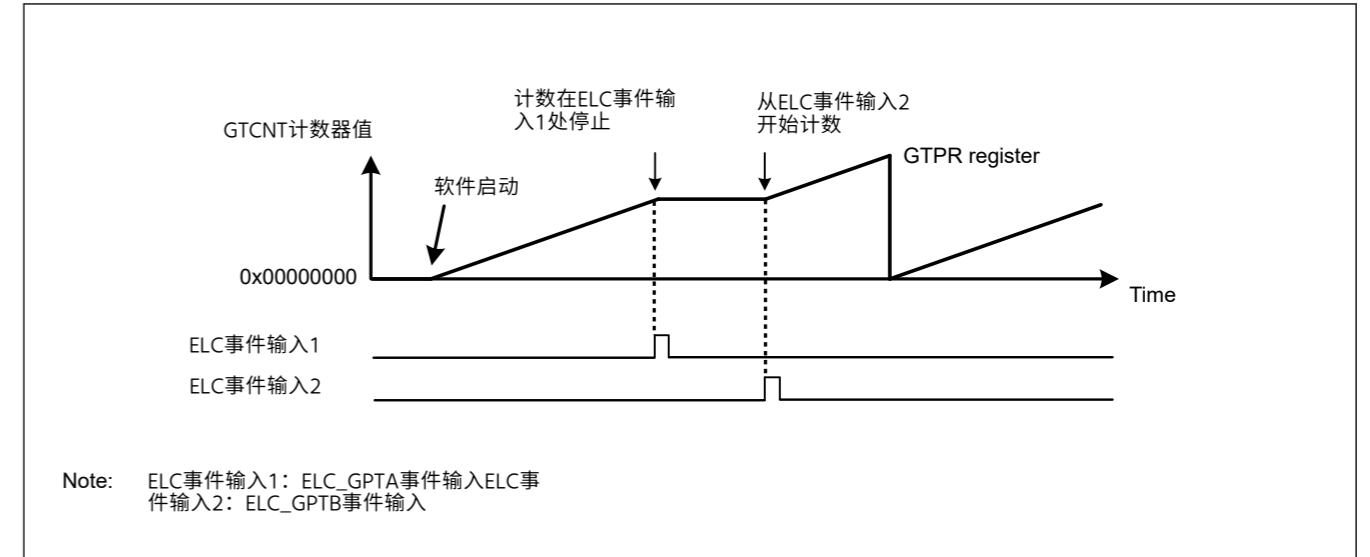


Figure 21.31 由软件启动的硬件源的计数停止操作示例，停止于 ELC\_GPTA 输入，并在 ELC\_GPTB 输入处重新启动

Table 21.25 硬件源的计数停止操作设置示例

| No. | 步骤名称      | Description  |
|-----|-----------|--|
| 1   | 设置操作模式    | 使用GTCR.MD[2:0]设置操作模式。在图21.31中，设置了000b（锯齿波PWM模式）。   |
| 2   | 设置计数方向    | 使用GTUDDTYC寄存器选择计数方向（向上或向下）。在图21.31中，在GTUDDTYC[1:0]中设置了11b之后，在GTUDDTYC[1:0]中设置了01b（向上计数）。 |
| 3   | 选择计数时钟    | 使用GTCR.TPCS[3:0]选择计数时钟。  |
| 4   | 设置周期      | 在GTPR中设置循环。  |
| 5   | 设置计数器的初始值 | 在GTCNT计数器中设置初始值。在图21.31中，设置了0x00000000。  |
| 6   | 设置硬件计数开始  | 在GTSSR寄存器中选择一个开始计数操作的硬件源，等待硬件源开始计数。在图21.31中，GTSSR.SSELCB=1。                              |
| 7   | 设置硬件计数停止  | 在GTPSR寄存器中选择一个停止计数操作的硬件源，等待硬件源停止计数。在图21.31中，GTPSR.PSELCA=1。                              |
| 8   | 设置硬件源操作   | 设置在GTSSR寄存器或GTPSR寄存器中选择的硬件源的操作，并开始或停止计数。在图21.31中，设置了ELC_GPTA输入操作和ELC_GPTB输入操作。           |

图21.32显示了一个硬件源的计数开始停止操作示例。表21.26显示了设置示例。在本例中，计数器在外部触发输入GTETRGA的高电平期间运行。



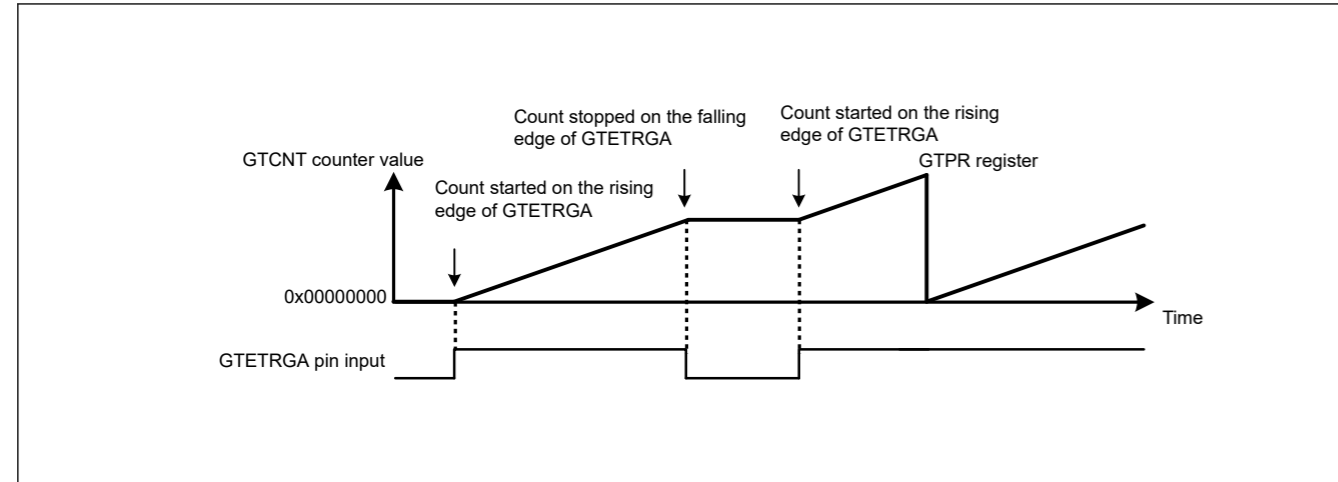


Figure 21.32 Example of count start/stop operation by a hardware source started on the rising edge of GTETRGA pin input, and stopped on the falling edge of GTETRGA pin input

Table 21.26 Example setting for count start/stop operation by a hardware source

| No. | Step Name                     | Description  |
|-----|-------------------------------|--|
| 1   | Set operating mode            | Set the operating mode with GTCR.MD[2:0]. In Figure 21.32, 000b (saw-wave PWM mode) is set.  |
| 2   | Set count direction           | Select the count direction (up or down) with the GTUDDTYC register. In Figure 21.32, after 11b is set in GTUDDTYC[1:0], 01b is set in GTUDDTYC[1:0] (up-counting). |
| 3   | Select count clock            | Select the count clock with GTCR.TPCS[3:0].  |
| 4   | Set cycle                     | Set the cycle in GTPR.   |
| 5   | Set initial value for counter | Set the initial value in the GTCNT counter. In Figure 21.32, 0x00000000 is set.  |
| 6   | Set hardware count start      | Select a hardware source for starting count operation with GTSSR register and wait for count start by the hardware source. In Figure 21.32, GTSSR.SSGTRGAR = 1.    |
| 7   | Set hardware count stop       | Select a hardware source for stopping count operation with GTPSR register and wait for count stop by the hardware source. In Figure 21.32, GTPSR.PSGTRGAF = 1.     |
| 8   | Set hardware source operation | Set operation of the hardware source selected in GTSSR or GTPSR and start or stop counting. In Figure 21.32, the GTETRGA pin operation is set.                     |

### 21.3.7.3 Hardware clear operation

The GTCNT counter can be cleared by selecting a hardware source using GTCR. The GPTn\_OVF/GPTn\_UDF (n = 0 to 7) interrupt (overflow/underflow interrupt) is not generated when the GTCNT counter is cleared by a hardware source or by software.

Figure 21.33 and Figure 21.34 show examples of the GTCNT counter clearing operation by a hardware source. Table 21.27 shows the setting example. In this example, the GTCNT counter starts at the edge of the ELC\_GPTA input, and the counter stops and clears at the edge of the ELC\_GPTB input.

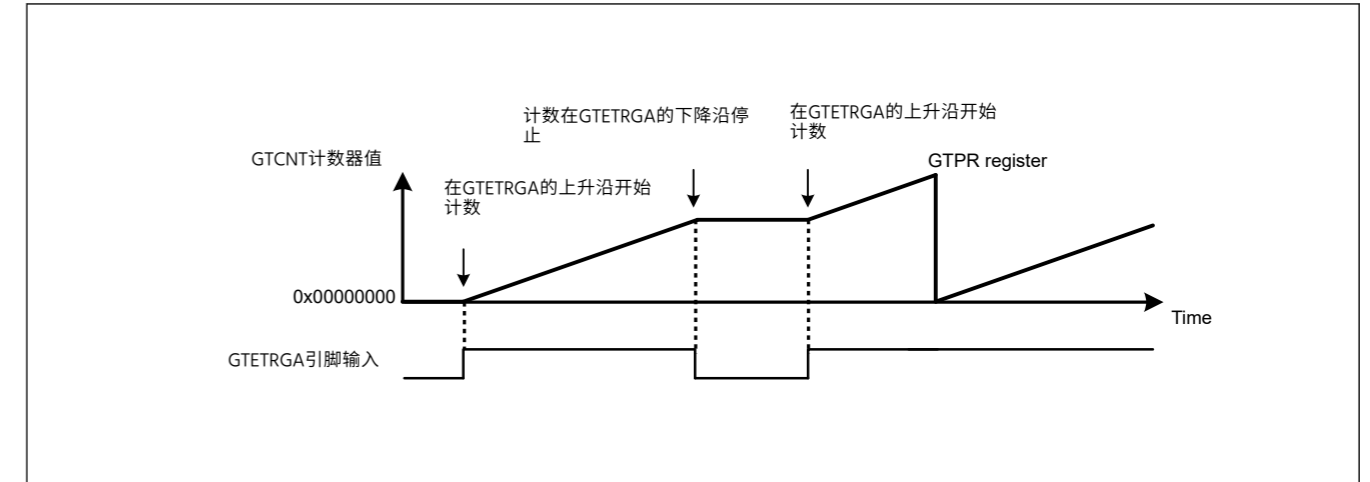


Figure 21.32 由硬件源在上升沿开始的计数开始停止操作示例  
GTETRGA引脚输入，并在GTETRGA引脚输入的下降沿停止

Table 21.26 硬件源的计数开始停止操作设置示例

| No. | 步骤名称      | Description  |
|-----|-----------|--|
| 1   | 设置操作模式    | 使用GTCR.MD[2:0]设置操作模式。在图21.32中，设置了000b（锯齿波PWM模式）。   |
| 2   | 设置计数方向    | 使用GTUDDTYC寄存器选择计数方向（向上或向下）。在图21.32中，在GTUDDTYC[1:0]中设置了11b之后，在GTUDDTYC[1:0]中设置了01b（向上计数）。 |
| 3   | 选择计数时钟    | 使用GTCR.TPCS[3:0]选择计数时钟。  |
| 4   | 设置周期      | 在GTPR中设置循环。  |
| 5   | 设置计数器的初始值 | 在GTCNT计数器中设置初始值。在图21.32中，设置了0x00000000。  |
| 6   | 设置硬件计数开始  | 使用GTSSR寄存器选择开始计数操作的硬件源，并等待硬件源开始计数。在图21.32中，GTSSR.SSGTRGAR=1。                             |
| 7   | 设置硬件计数停止  | 使用GTPSR寄存器选择停止计数操作的硬件源，并等待硬件源停止计数。在图21.32中，GTPSR.PSGTRGAF=1。                             |
| 8   | 设置硬件源操作   | 设置在GTSSR或GTPSR中选择的硬件源的操作并开始或停止计数。在图21.32中，设置了GTETRGA引脚操作。                                |

### 21.3.7.3 硬件清除操作

GTCNT计数器可以通过使用GTCR选择硬件源来清除。当GTCNT计数器被硬件或软件清零时，不会产生GPTn\_OVF/GPTn\_UDF (n=0到7) 中断（上溢下溢中断）。

图21.33和图21.34显示了通过硬件源清除GTCNT计数器操作的示例。表21.27显示了设置示例。在本例中，GTCNT计数器在ELC\_GPTA输入的边沿开始，计数器在ELC\_GPTB输入的边沿停止并清零。

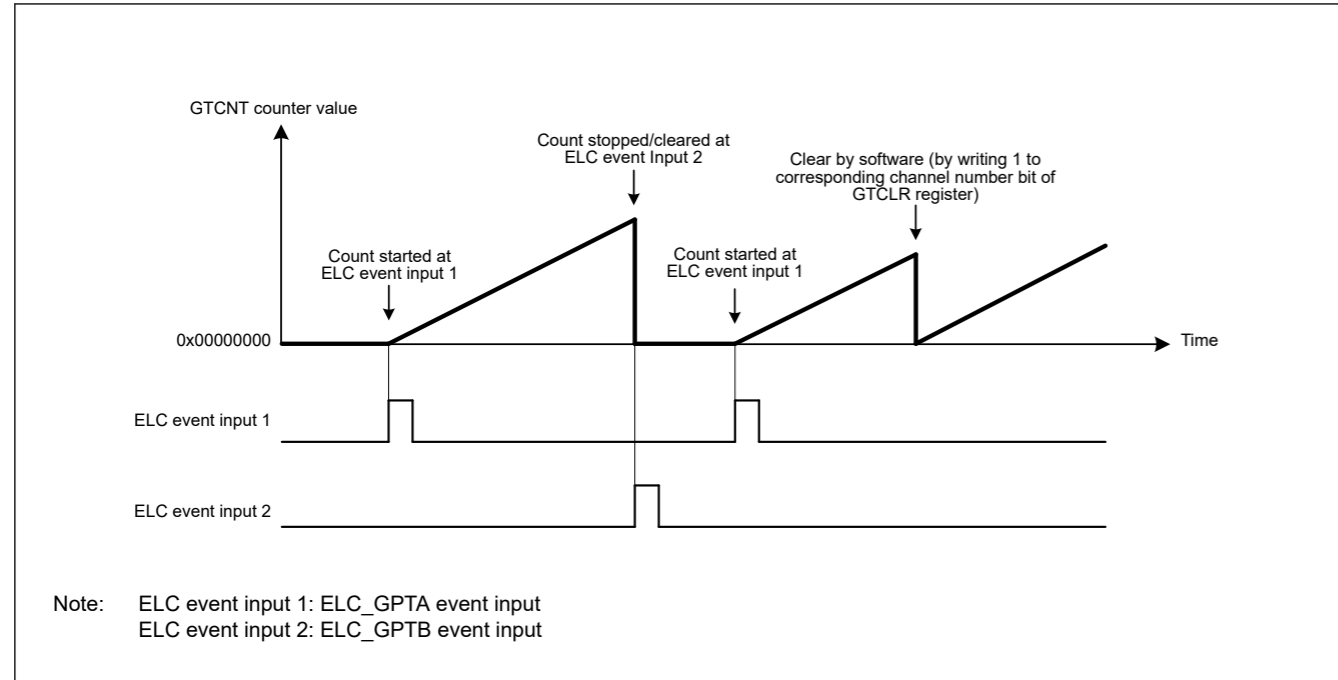


Figure 21.33 Examples of count clearing operation by hardware source in saw wave up-counting, started at ELC\_GPTA input, and stopped/cleared at ELC\_GPTB input

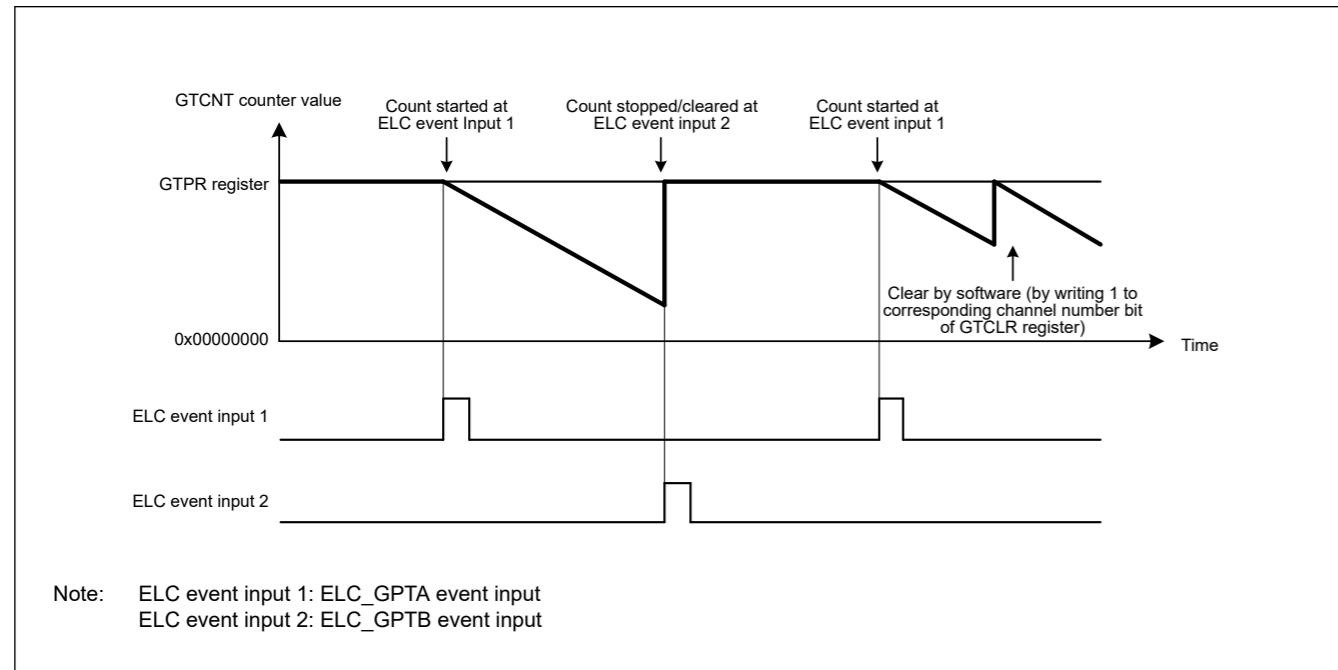


Figure 21.34 Examples of count clearing operation by hardware source in saw wave down-counting, started at ELC\_GPTA input, and stopped/cleared at ELC\_GPTB input

Table 21.27 Example setting for count clearing operation by a hardware source (1 of 2)

| No. | Step Name           | Description   |
|-----|---------------------|---|
| 1   | Set operating mode  | Set the operating mode with GTCR.MD[2:0].<br>In Figure 21.33 and Figure 21.34, 000b (saw-wave PWM mode) is set.   |
| 2   | Set count direction | Select the count direction (up or down) with the GTUDDTYC register.<br>In Figure 21.33, after 11b is set in GTUDDTYC[1:0], 01b is set in GTUDDTYC[1:0] (up-counting).<br>In Figure 21.34, after 10b is set in GTUDDTYC[1:0], 00b is set in GTUDDTYC[1:0] (down-counting). |
| 3   | Select count clock  | Select the count clock with GTCR.TPCS[3:0].   |

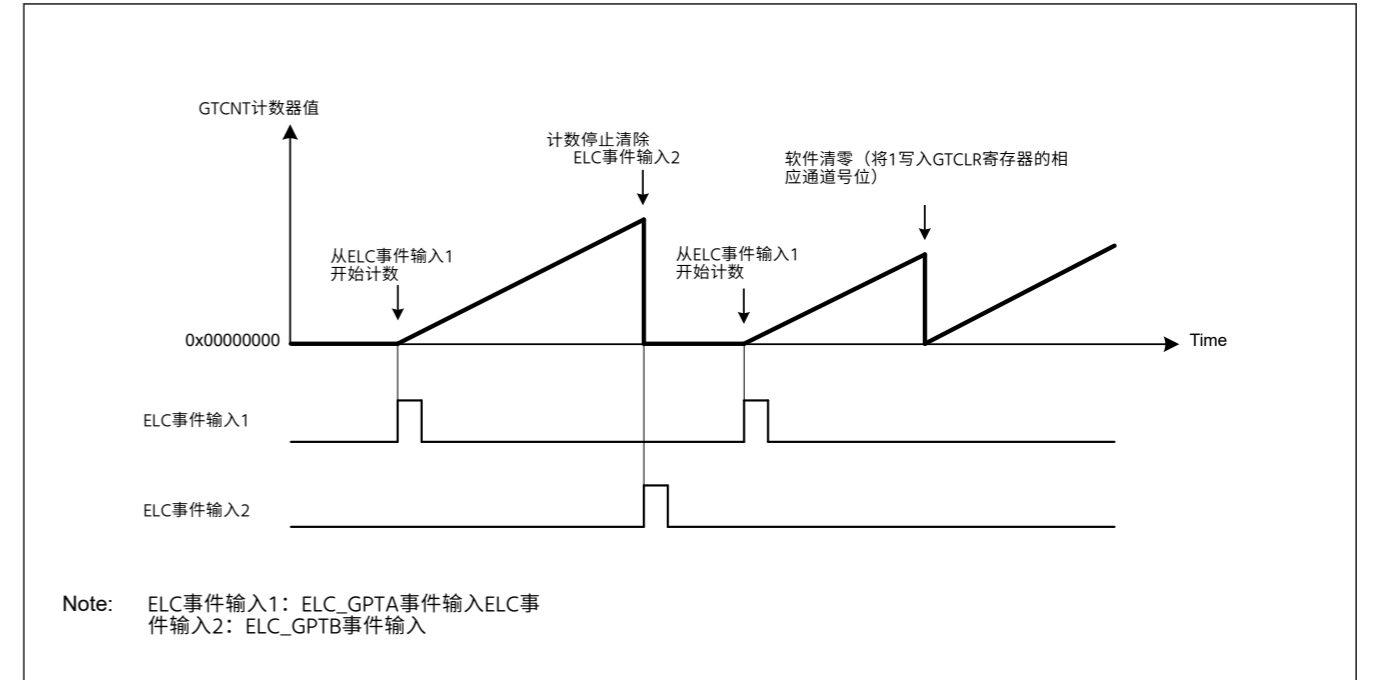


Figure 21.33 锯齿递增计数中硬件源的计数清除操作示例，开始于 ELC\_GPTA输入，并在ELC\_GPTB输入处停止清除

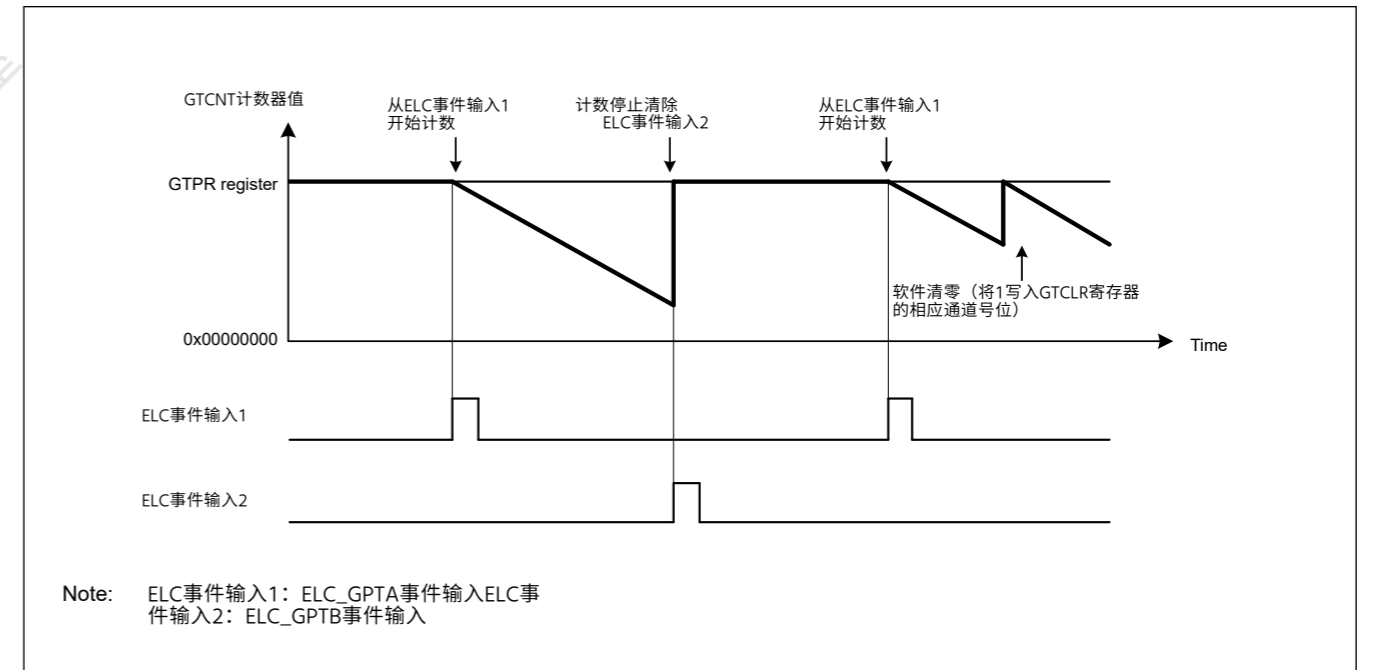


Figure 21.34 锯齿递减计数中硬件源的计数清除操作示例，从ELC\_GPTA输入开始，在ELC\_GPTB输入处停止清除

Table 21.27 通过硬件源进行计数清除操作的示例设置 (2个中的1个)

| No. | 步骤名称   | Description  |
|-----|--------|--|
| 1   | 设置操作模式 | 使用GTCR.MD[2:0]设置操作模式。<br>在图21.33和图21.34中，设置了000b (锯齿波PWM模式)。   |
| 2   | 设置计数方向 | 使用GTUDDTYC寄存器选择计数方向 (向上或向下)。<br>在图21.33中，在GTUDDTYC[1:0]中设置了11b之后，在GTUDDTYC[1:0]中设置了01b (向上计数)。<br>在图21.34中，在GTUDDTYC[1:0]中设置了10b之后，在GTUDDTYC[1:0]中设置了00b (向下计数)。 |
| 3   | 选择计数时钟 | 使用GTCR.TPCS[3:0]选择计数时钟。  |

Table 21.27 Example setting for count clearing operation by a hardware source (2 of 2)

| No. | Step Name                     | Description  |
|-----|-------------------------------|--|
| 4   | Set cycle                     | Set the cycle in the GTPR register.  |
| 5   | Set initial value for counter | Set the initial value in the GTCNT counter.<br>In Figure 21.33, 0x00000000 is set. In Figure 21.34, the GTPR value is set.   |
| 6   | Set hardware count start      | Select a hardware source for starting count operation in GTSSR register and wait for count start by the hardware source. In Figure 21.33 and Figure 21.34, GTSSR.SSELCA = 1.   |
| 7   | Set hardware count stop       | Select a hardware source for stopping count operation in GTPSR register and wait for count stop by the hardware source. In Figure 21.33 and Figure 21.34, GTPSR.PSELCA = 1.  |
| 8   | Set hardware count clear      | Select a hardware source for clearing count operation in GTCSR register and wait for count clear by the hardware source. In Figure 21.33 and Figure 21.34, GTCSR.CSELCA = 1.   |
| 9   | Set hardware source operation | Set operation of the hardware source selected in GTSSR register, GTPSR Register or GTCSR register and start, stop or clear counting.<br>In Figure 21.33 and Figure 21.34, the ELC_GPTA input and ELC_GPTB input are set. |

The GPTn\_OVF/GPTn\_UDF (n = 0 to 7) interrupt (overflow/underflow interrupt) is not generated when the counter is cleared by a hardware source or by software.

Figure 21.35 shows the relationship between the counter clearing by a hardware source and the GPTn\_OVF (n = 0 to 7) interrupt.

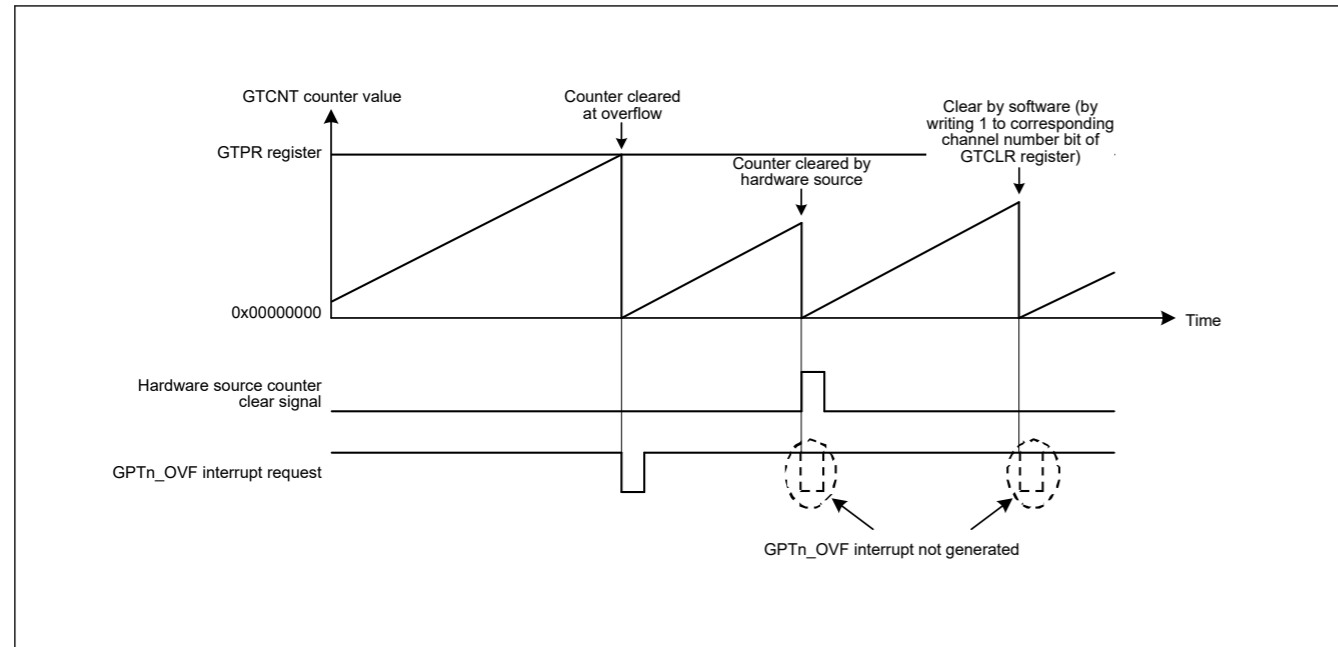


Figure 21.35 Relationship between counter clearing by hardware source and GPTn\_OVF (n = 0 to 7) interrupt

### 21.3.8 Synchronized Operation

Synchronized operation on channels such as a synchronized start, stop, and clear operation can be performed.

#### 21.3.8.1 Synchronized operation by software

The GTCNT counters can be started, stopped, and cleared on multiple channels by setting the associated GTSTR, GTSTP, or GTCLR bits simultaneously to 1.

Count start with a phase difference is possible by setting the initial value in the GTCNT counter and setting the associated GTSTR bits simultaneously to 1.

Figure 21.36 shows an example of a simultaneous start, stop, and clear by software. Figure 21.37 shows an example of phase start operation by software.

Table 21.27 通过硬件源进行计数清除操作的示例设置(2of2)

| No. | 步骤名称      | Description  |
|-----|-----------|--|
| 4   | 设置周期      | 在GTPR寄存器中设置周期。   |
| 5   | 设置计数器的初始值 | 在GTCNT计数器中设置初始值。<br>在图21.33中, 设置了0x00000000。在图21.34中, 设置了GTPR值。                                |
| 6   | 设置硬件计数开始  | 在GTSSR寄存器中选择一个开始计数操作的硬件源, 等待硬件源开始计数。在图21.33和图21.34中, GTSSR.SSELCA=1。                           |
| 7   | 设置硬件计数停止  | 在GTPSR寄存器中选择一个停止计数操作的硬件源, 等待硬件源停止计数。在图21.33和图21.34中, GTPSR.PSELCA=1。                           |
| 8   | 设置硬件计数清除  | 在GTCSR寄存器中选择一个清除计数操作的硬件源, 等待硬件源清除计数。在图21.33和图21.34中, GTCSR.CSELCA=1。                           |
| 9   | 设置硬件源操作   | 设置在GTSSR寄存器、GTPSR寄存器或GTCSR寄存器中选择的硬件源的操作以及开始、停止或清除计数。在图21.33和图21.34中, 设置了ELC_GPTA输入和ELC_GPTB输入。 |

GPTn\_OVFGPTn\_UDF (n=0到7) 中断 (溢出下溢中断) 不会在计数器被硬件源或软件清零时产生。

图21.35显示了通过硬件源清除计数器和GPTn\_OVF (n=0到7) 中断之间的关系。

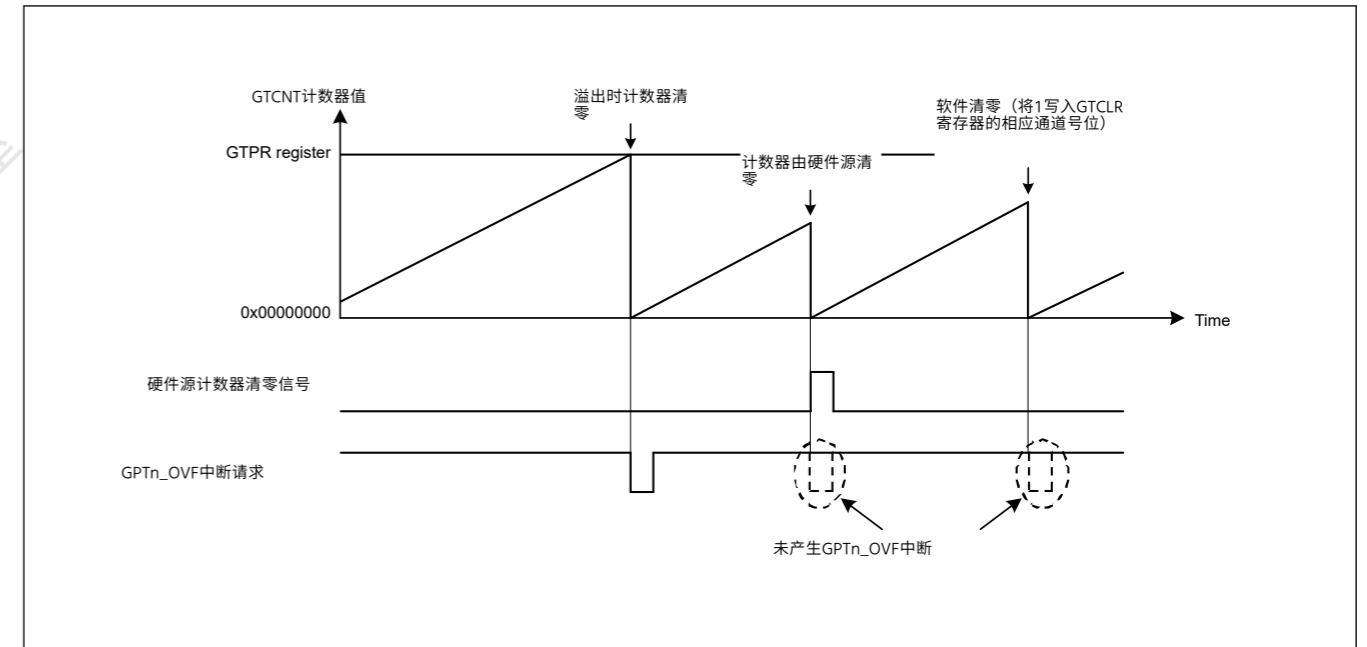


Figure 21.35 硬件源计数器清零与GPTn\_OVF(n=0to7)中断的关系

### 21.3.8 同步操作

可以对通道进行同步操作, 例如同步启动、停止和清除操作。

#### 21.3.8.1 软件同步操作

通过将相关的GTSTR、GTSTP或GTCLR位同时设置为1, 可以在多个通道上启动、停止和清除GTCNT计数器。

通过在GTCNT计数器中设置初始值并设置相关的GTSTR位同时为1。

图21.36显示了通过软件同时启动、停止和清除的示例。图21.37显示了通过软件进行相位启动操作的示例。

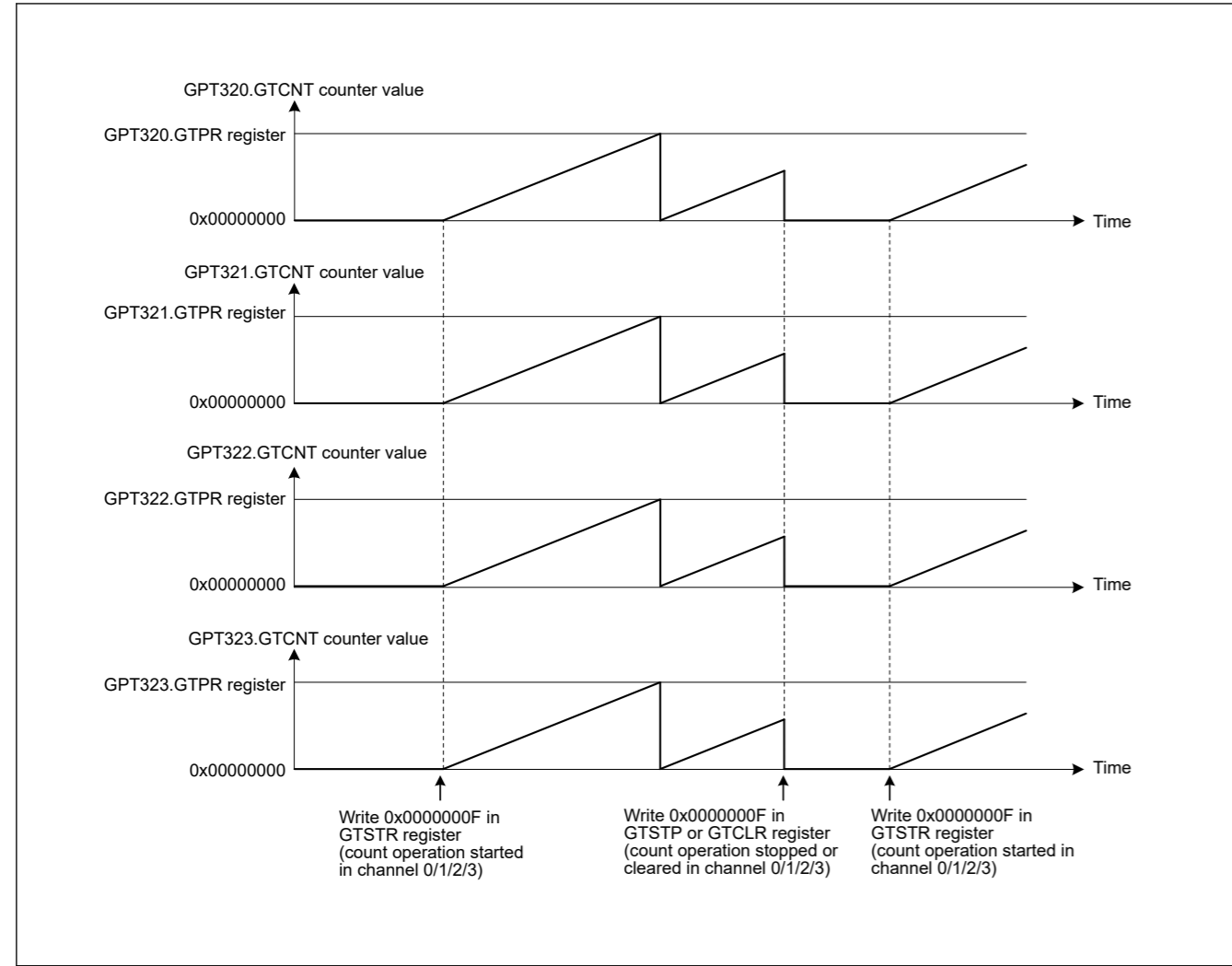


Figure 21.36 Example of a simultaneous start, stop, and clear by software with the same count cycle (GTPR register value)

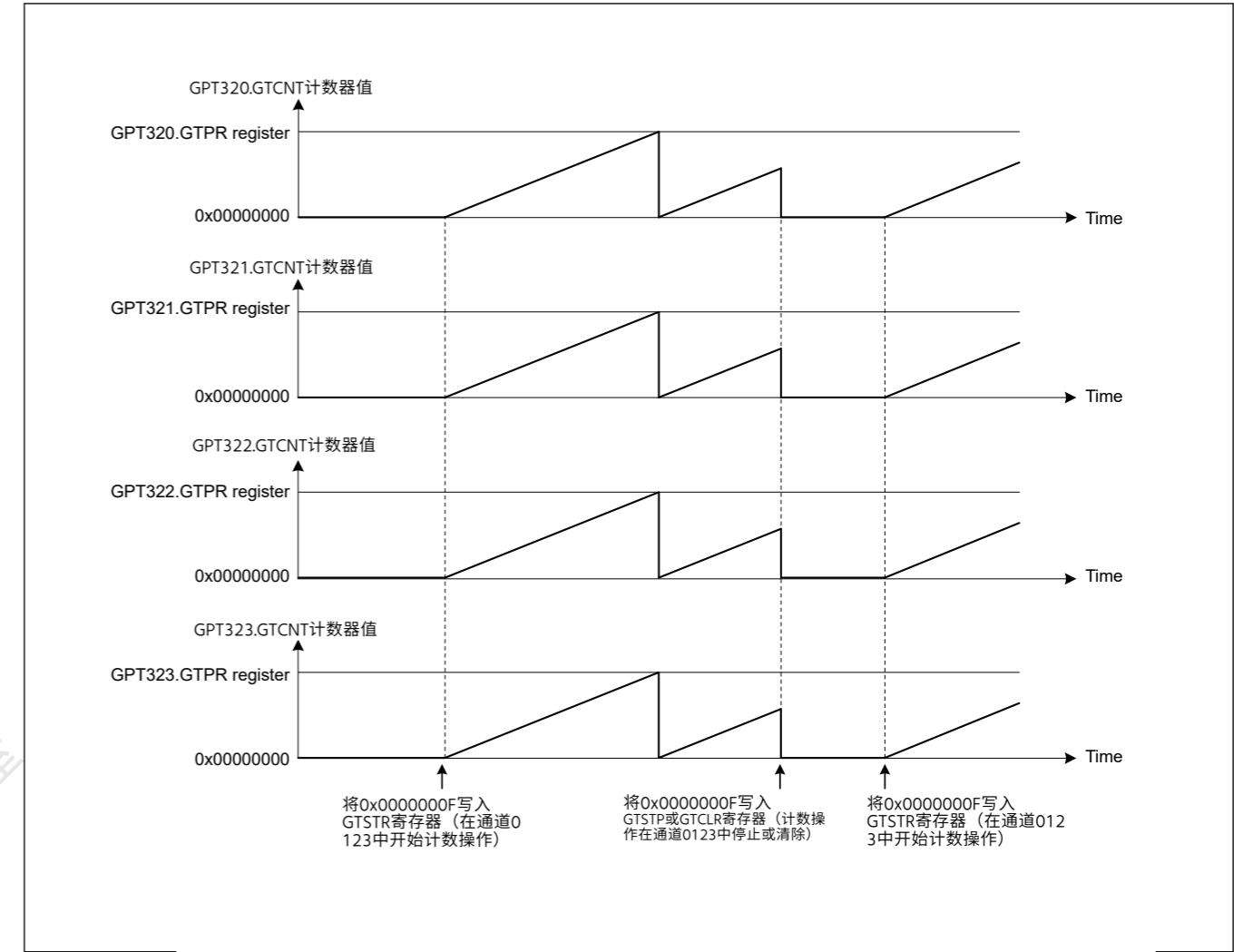


Figure 21.36 使用相同计数周期 (GTPR寄存器值) 的软件同时启动、停止和清除的示例

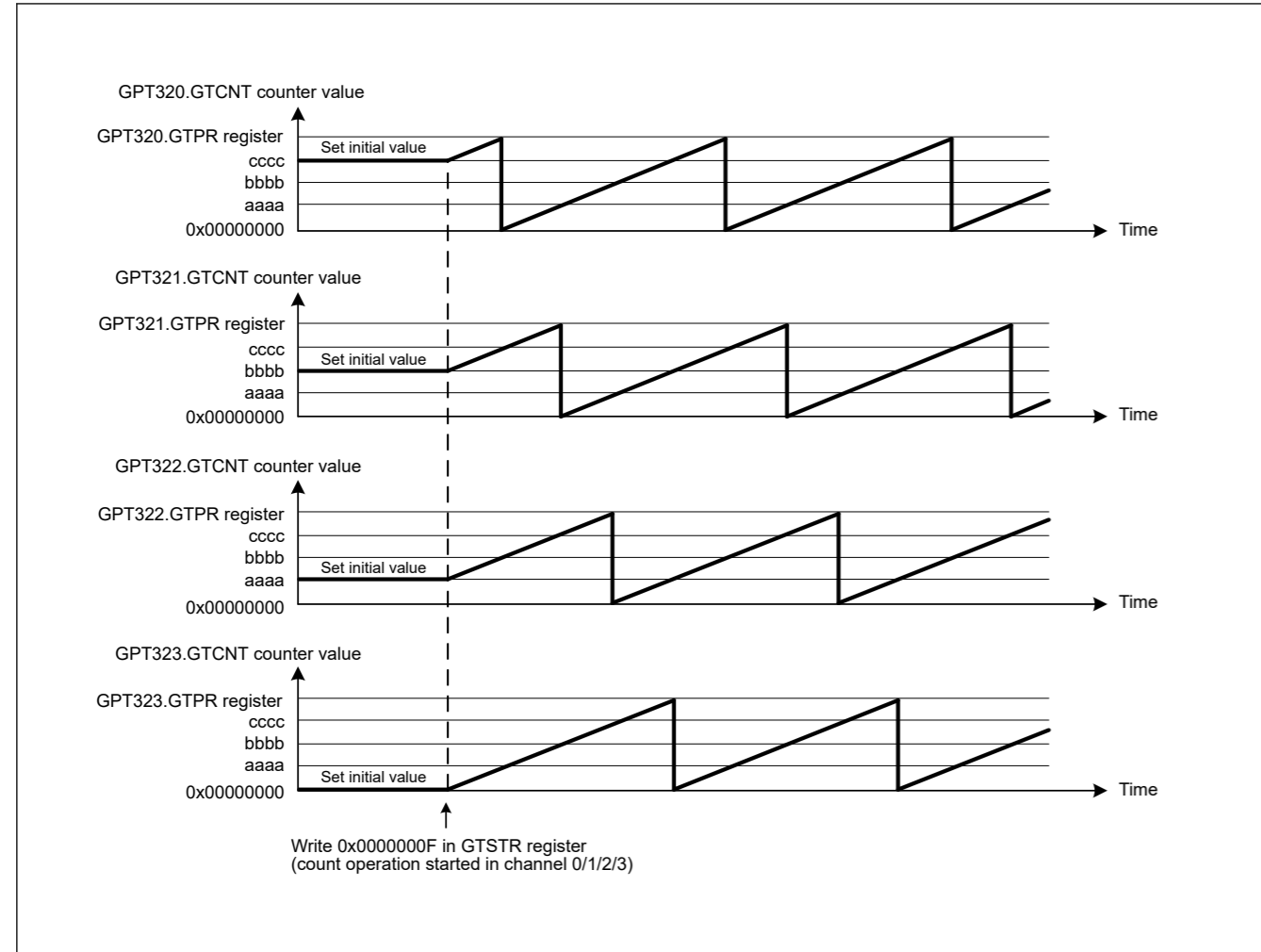


Figure 21.37 Example of software phase start with the same count cycle (GTPR register value)

### 21.3.8.2 Synchronized operation by hardware

The counters for multiple channels can be started, stopped, and cleared simultaneously by the following hardware sources. Hardware sources that can cause a synchronized operation are external trigger input and ELC event input. Synchronized operations through GTIOCnA and GTIOCnB pin input are possible by setting an ELC event due to input capture as a hardware source (n = 0 to 7).

Figure 21.38 shows an example of a simultaneous start, stop, and clear operation by a hardware source. Table 21.28 shows the setting example.

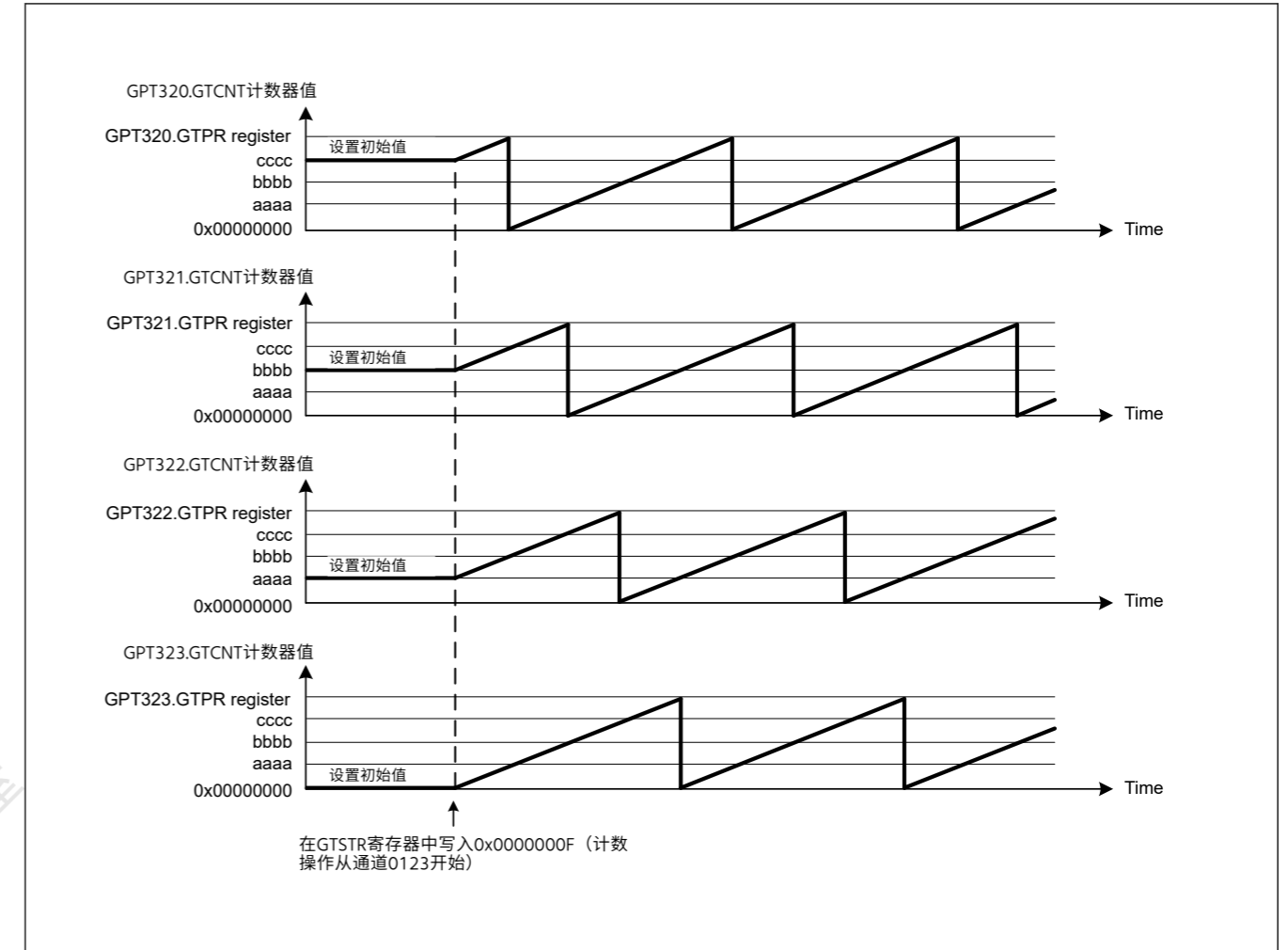


Figure 21.37 以相同计数周期开始的软件阶段示例 (GTPR寄存器值)

### 21.3.8.2 硬件同步操作

多个通道的计数器可以通过以下硬件源同时启动、停止和清除。可以导致同步操作的硬件源是外部触发输入和ELC事件输入。通过将输入捕获导致的ELC事件设置为硬件源 (n = 0到7)，可以通过GTIOCnA和GTIOCnB引脚输入进行同步操作。

图21.38显示了一个硬件源同时启动、停止和清除操作的示例。表21.28显示了设置示例。



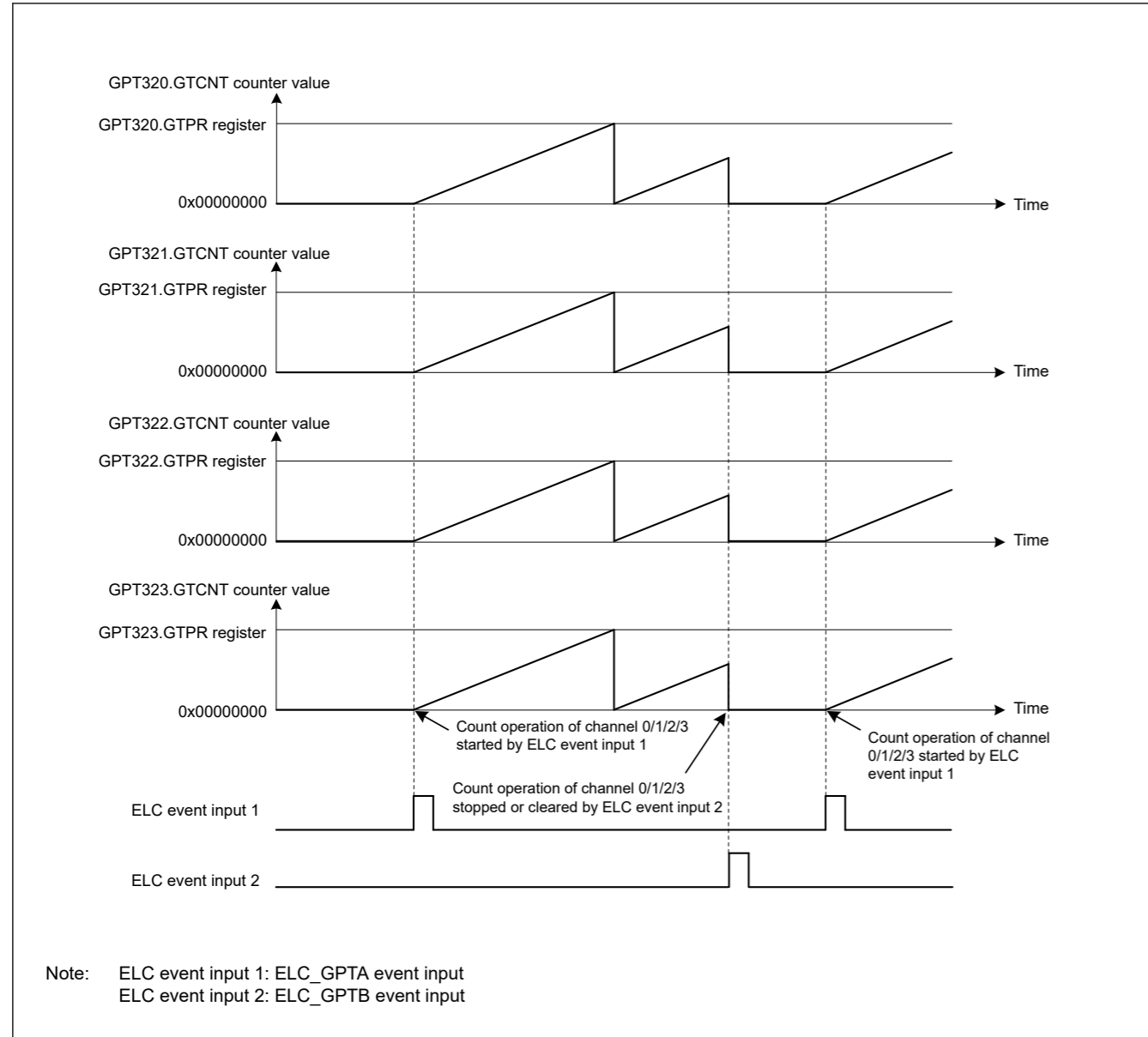


Figure 21.38 Example of a simultaneous start, stop, and clear by a hardware source with the same count cycle (GTPR register value)

Table 21.28 Example setting for simultaneous start by a hardware source (1 of 2)

| No. | Step Name                     | Description  |
|-----|-------------------------------|--|
| 1   | Set operating mode            | Set the operating mode with GTCR.MD[2:0]. In Figure 21.38, 000b (saw-wave PWM mode) is set.  |
| 2   | Set count direction           | Select the count direction (up or down) with the GTUDDTYC register. In Figure 21.38, after 11b is set in GTUDDTYC[1:0], 01b is set in GTUDDTYC[1:0] (up-counting). |
| 3   | Select count clock            | Select the count clock with GTCR.TPCS[3:0].  |
| 4   | Set cycle                     | Set the cycle in the GTPR register.  |
| 5   | Set initial value for counter | Set the initial value in the GTCNT counter. In Figure 21.38, 0x00000000 is set.  |
| 6   | Set hardware count start      | Select a hardware source for starting count operation with GTSSR register and wait for count start by the hardware source. In Figure 21.38, GTSSR.SSELCA = 1.      |

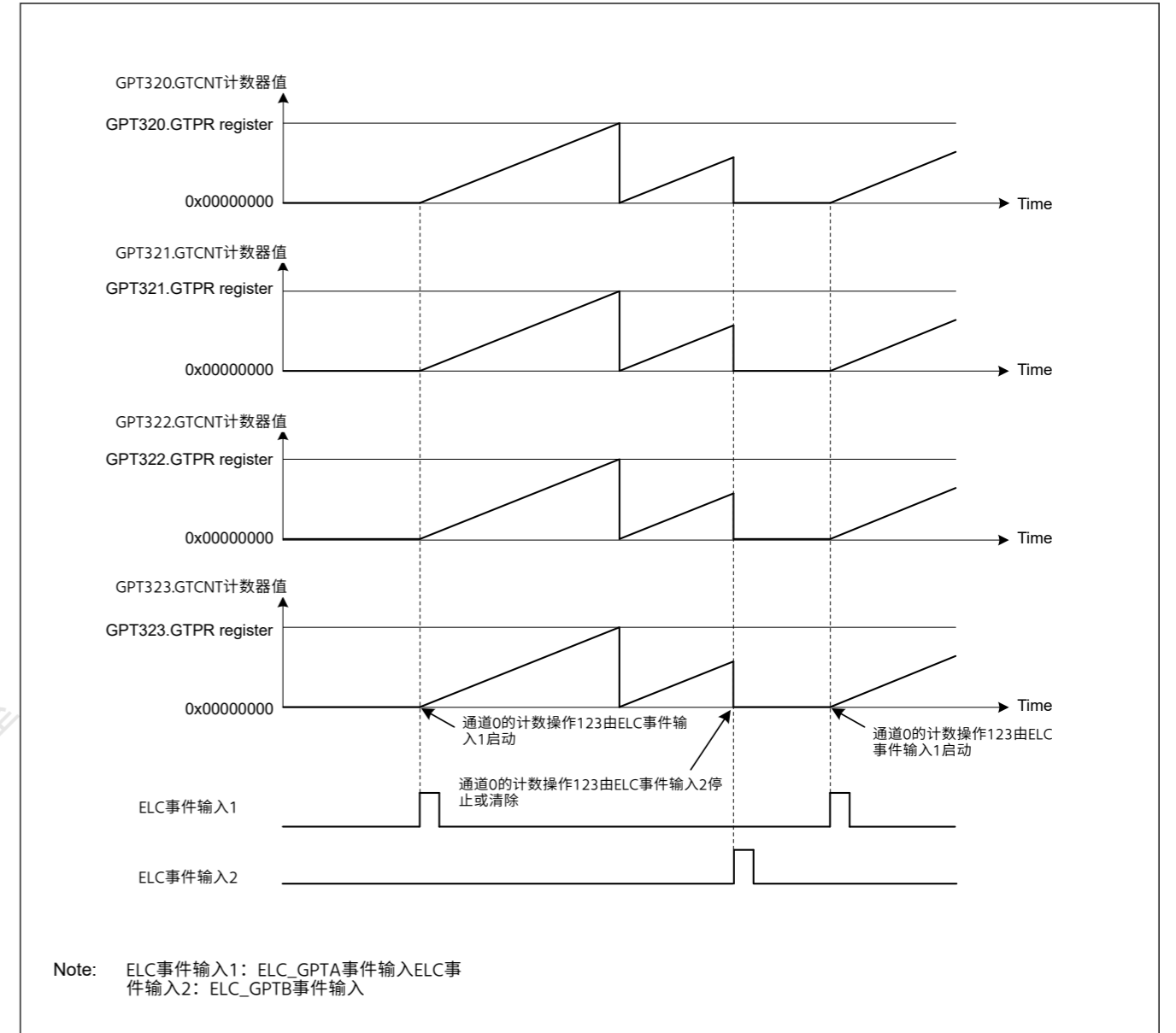


Figure 21.38 具有相同计数周期 (GTPR寄存器值) 的硬件源同时启动、停止和清除的示例

Table 21.28 通过硬件源同时启动的示例设置 (2个中的1个)

| No. | 步骤名称      | Description  |
|-----|-----------|--|
| 1   | 设置操作模式    | 使用GTCR.MD[2:0]设置操作模式。在图21.38中，设置了000b (锯齿波PWM模式)。  |
| 2   | 设置计数方向    | 使用GTUDDTYC寄存器选择计数方向 (向上或向下)。在图21.38中，在GTUDDTYC[1:0]中设置了11b之后，在GTUDDTYC[1:0]中设置了01b (向上计数)。 |
| 3   | 选择计数时钟    | 使用GTCR.TPCS[3:0]选择计数时钟。  |
| 4   | 设置周期      | 在GTPR寄存器中设置周期。   |
| 5   | 设置计数器的初始值 | 在GTCNT计数器中设置初始值。在图21.38中，设置了0x00000000。  |
| 6   | 设置硬件计数开始  | 使用GTSSR寄存器选择开始计数操作的硬件源，并等待硬件源开始计数。在图21.38中，GTSSR.SSELCA=1。                                 |

Table 21.28 Example setting for simultaneous start by a hardware source (2 of 2)

| No. | Step Name                     | Description   |
|-----|-------------------------------|---|
| 7   | Set hardware count stop       | Select a hardware source for stopping count operation with GTPSR register and wait for count stop by the hardware source<br>In Figure 21.38, GTPSR.PSEL CB = 1.             |
| 8   | Set hardware count clear      | Select a hardware source for clearing count operation with GTCSR register and wait for count clear by the hardware source<br>In Figure 21.38, GTCSR.CSEL CB = 1.            |
| 9   | Set hardware source operation | Set operation of the hardware source selected in GTSSR or GTPSR or GTCSR and start or stop or clear counting<br>In Figure 21.38, ELC_GPTA input and ELC_GPTB input are set. |

### 21.3.9 PWM Output Operation Examples

#### (1) Synchronized PWM output

The GPT outputs  $8 \times 2$  phases of linked PWM waveforms for a maximum of  $GPT \times 8$  channels.

Figure 21.39 shows an example in which four channels perform synchronized operation in saw-wave PWM mode and eight phases of PWM waveforms are output. The GTIOcNA is set so that it outputs low as the initial value, high at a GTCCRA compare match, and low at the cycle end. The GTIOcNB is set so that it outputs low as the initial value, high at a GTCCRB compare match, and low at the cycle end.

Table 21.28 通过硬件源同时启动的示例设置(2of2)

| No. | 步骤名称     | Description   |
|-----|----------|---|
| 7   | 设置硬件计数停止 | 使用GTPSR寄存器选择停止计数操作的硬件源并等待硬件源停止计数在图21.38中, GTPSR.PSEL CB=1。                    |
| 8   | 设置硬件计数清除 | 使用GTCSR寄存器选择清除计数操作的硬件源, 等待硬件源清除计数在图21.38中, GTCSR.CSEL LCB=1。                  |
| 9   | 设置硬件源操作  | 设置在GTSSR或GTPSR或GTCSR中选择的硬件源的操作以及开始或停止或清除计数在图21.38中, 设置了ELC_GPTA输入和ELC_GPTB输入。 |

### 21.3.9 PWM输出操作示例

#### (1) 同步PWM输出

GPT为最多 $GPT \times 8$ 通道输出 $8 \times 2$ 相链接的PWM波形。

图21.39显示了一个示例, 其中4个通道在锯齿波PWM模式下执行同步操作并输出8相PWM波形。GTIOcNA设置为输出低作为初始值, 在GTCCRA比较匹配时输出高, 在循环结束时输出低。GTIOcNB设置为输出低作为初始值, 在GTCCRB比较匹配时输出高, 在循环结束时输出低。

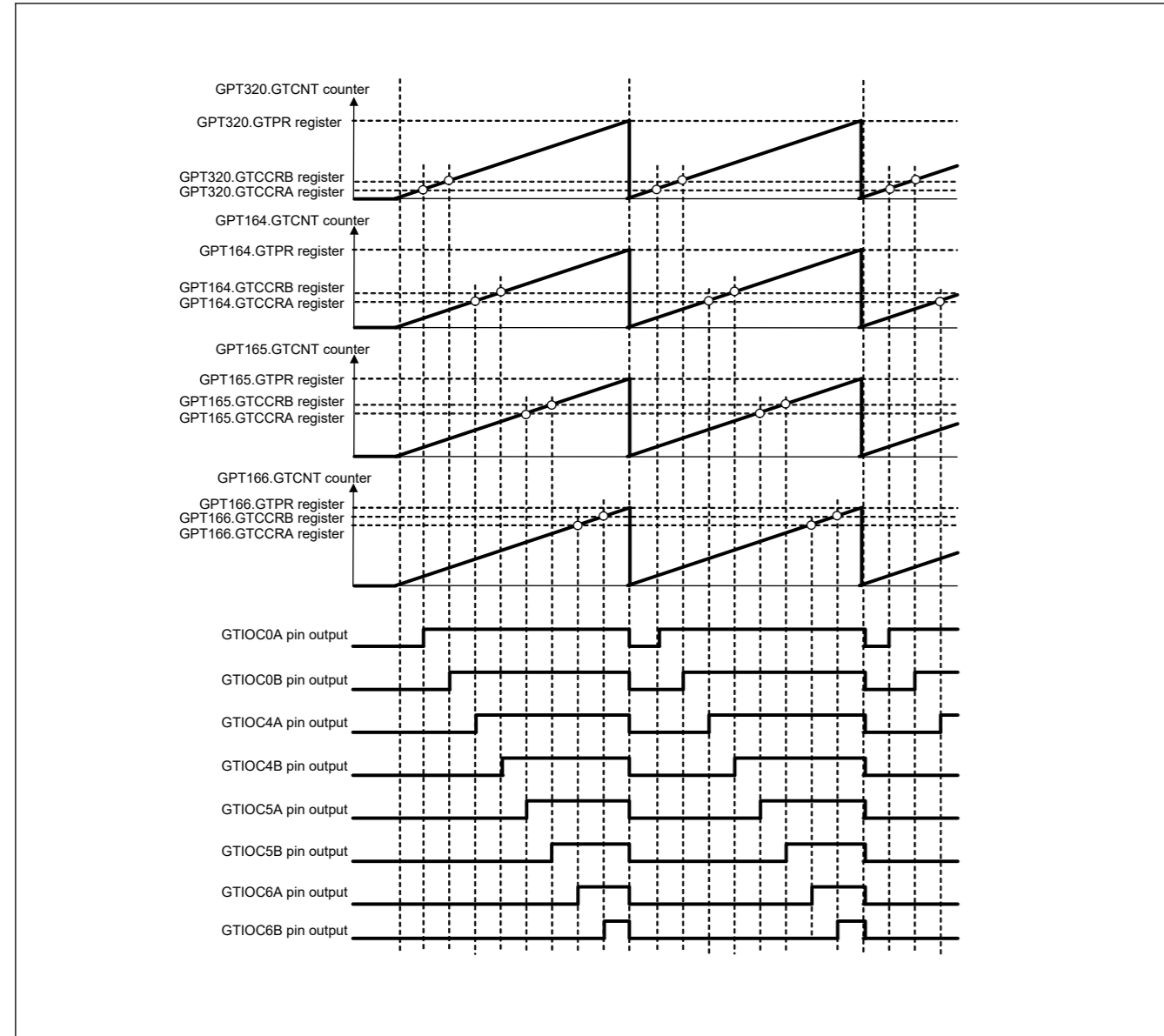


Figure 21.39 Example of synchronized PWM output

(2) 3-phase saw-wave complementary PWM output

Figure 21.40 shows an example in which three channels perform synchronized operation in saw-wave PWM mode and 3-phase complementary PWM waveforms are output. The GTIOCnA pin is set so that it outputs low as the initial value, high at a GTCCRA compare match, and low at the cycle end. The GTIOCnB pin is set so that it outputs high as the initial value, low at a GTCCRB compare match, and high at the cycle end.

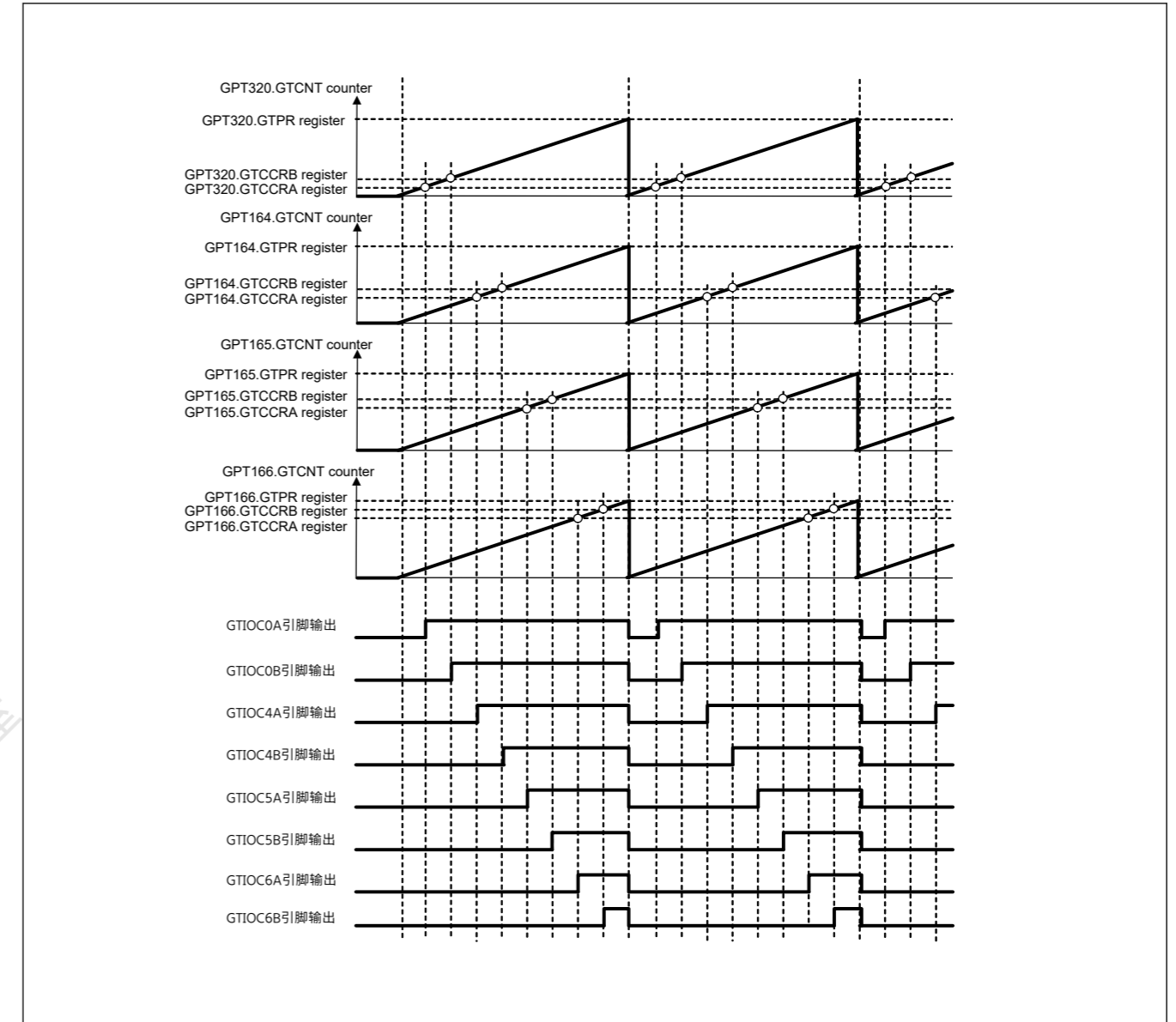


Figure 21.39 同步PWM输出示例

(2) 三相锯齿波互补PWM输出

图21.40显示了一个示例，其中三个通道在锯齿波PWM模式下执行同步操作并输出三相互补PWM波形。GTIOCnA引脚设置为输出低作为初始值，在GTCCRA比较匹配时输出高，在周期结束时输出低。GTIOCnB引脚设置为输出高作为初始值，在GTCCRB比较匹配时输出低，在周期结束时输出高。

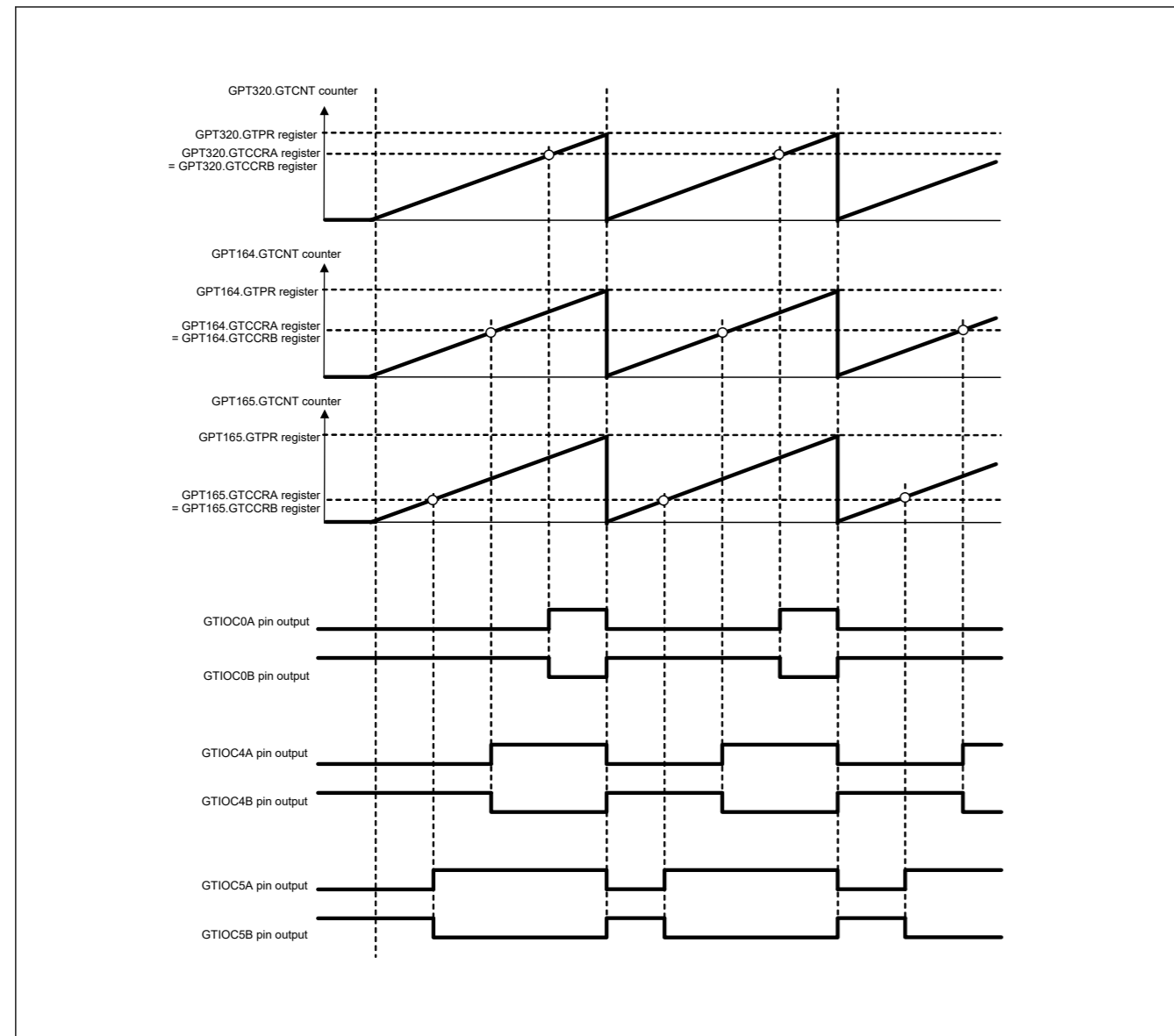


Figure 21.40 Example of 3-phase saw-wave complementary PWM output

(3) 3-phase saw-wave complementary PWM output with automatic dead time setting

Figure 21.41 shows an example in which three channels perform synchronized operation in saw-wave one-shot pulse mode with automatic dead time setting and 3-phase complementary PWM waveforms are output. The GTIOCnA pin is set so that it outputs low as the initial value, toggles the output at a GTCCRA compare match, and retains the output at the cycle end. The GTIOCnB pin is set so that it outputs high as the initial value, toggles the output at a GTIOCnB compare match, and retains the output at the cycle end.

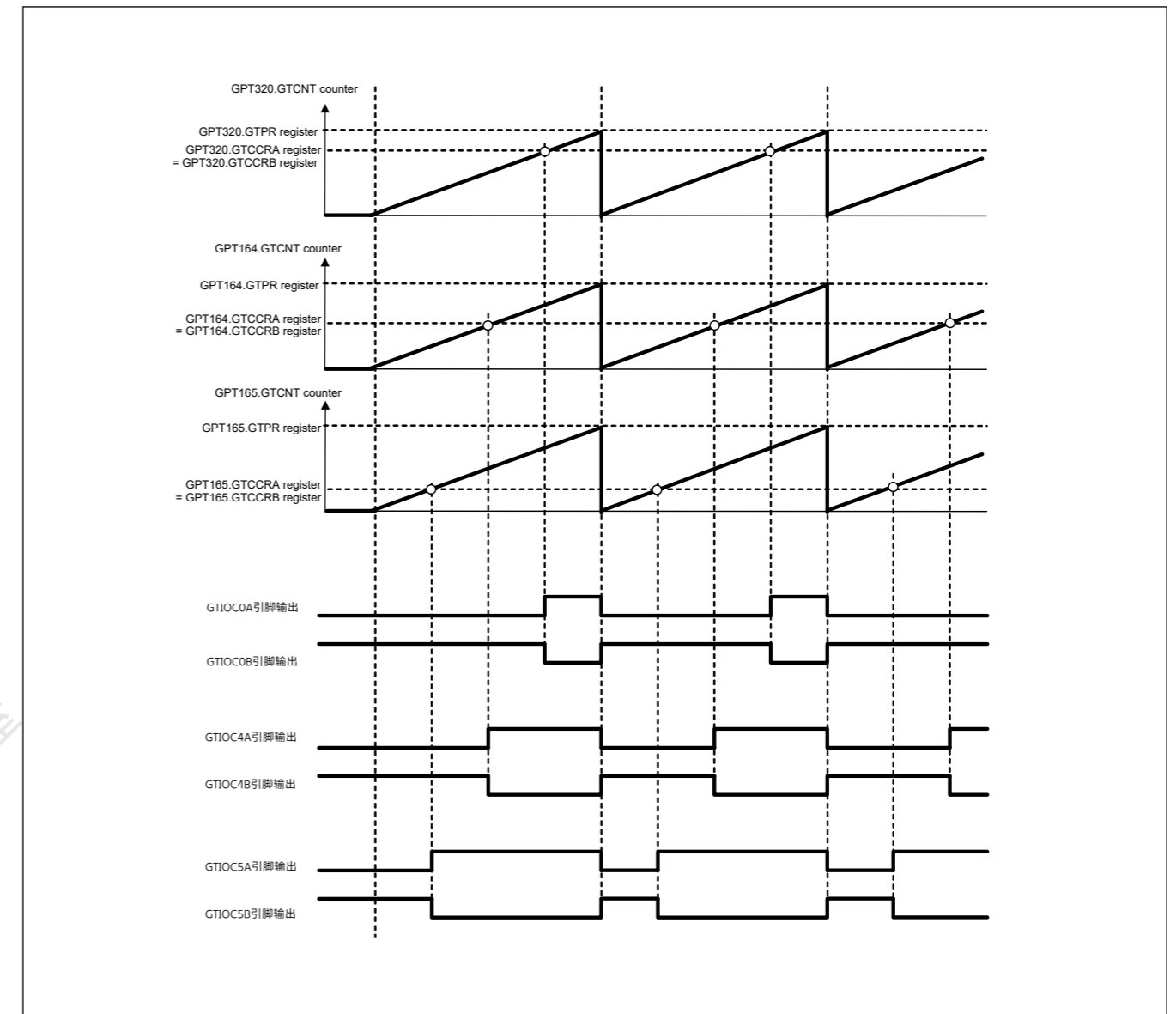


Figure 21.40 三相锯齿波互补PWM输出示例

(3) 具有自动死区时间设置的三相锯齿波互补PWM输出

图21.41显示了一个示例，其中三个通道在具有自动死区时间设置的锯齿波一次性脉冲模式下执行同步操作并输出三相互补PWM波形。GTIOCnA引脚设置为输出低电平作为初始值，在GTCCRA比较匹配时切换输出，并在周期结束时保持输出。GTIOCnB引脚设置为输出高电平作为初始值，在GTIOCnB比较匹配时切换输出，并在周期结束时保持输出。

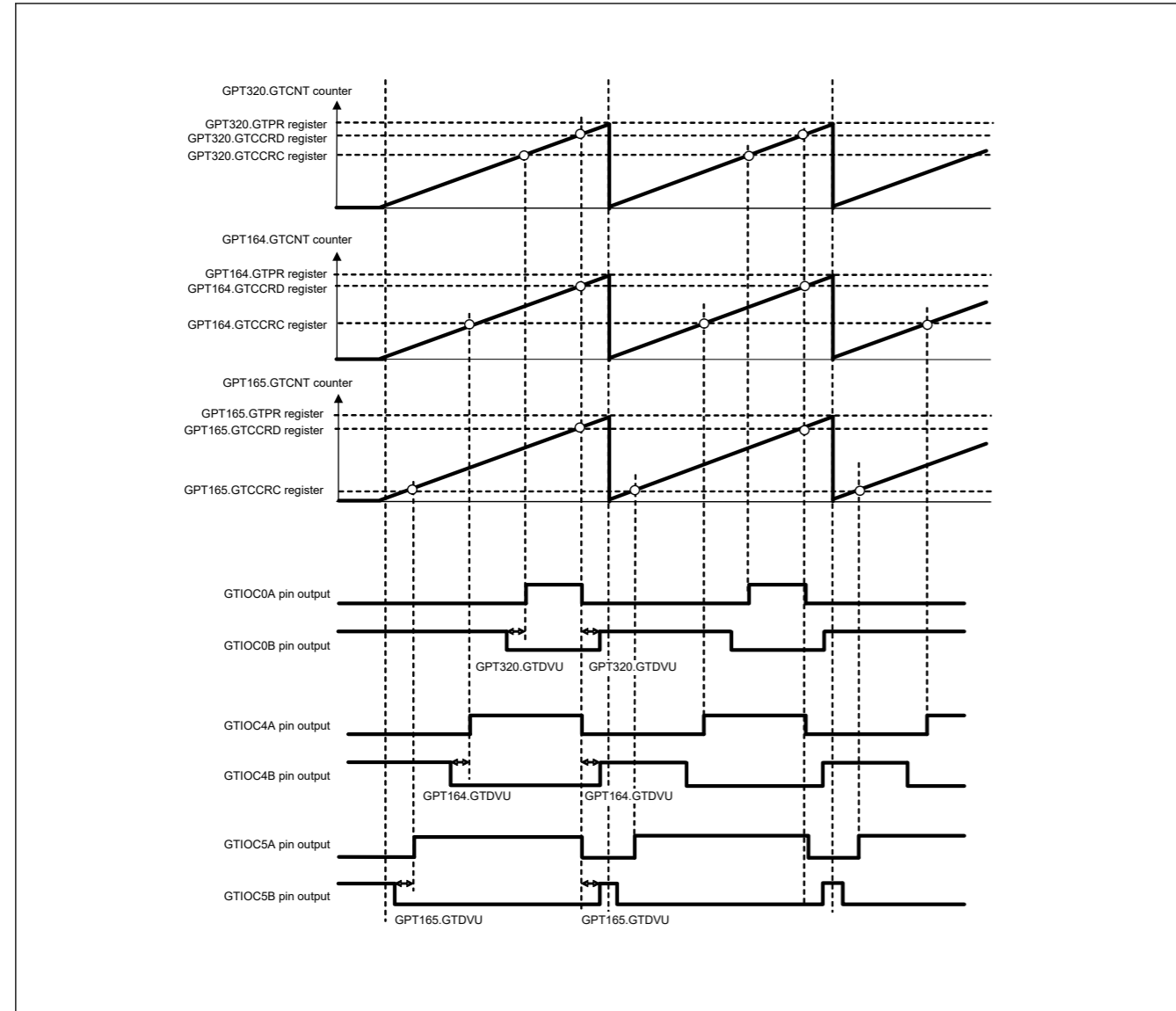


Figure 21.41 Example of 3-phase saw-wave complementary PWM output with automatic dead time setting

(4) 3-phase triangle-wave complementary PWM output

Figure 21.42 shows an example in which three channels perform synchronized operation in triangle-wave PWM mode 1 and 3-phase complementary PWM waveforms are output. The GTIOCnA pin is set so that it outputs low as the initial value, toggles the output at a GTCCRA compare match, and retains the output at the cycle end. The GTIOCnB pin is set so that it outputs high as the initial value, toggles the output at a GTCCRB compare match, and retains the output at the cycle end.

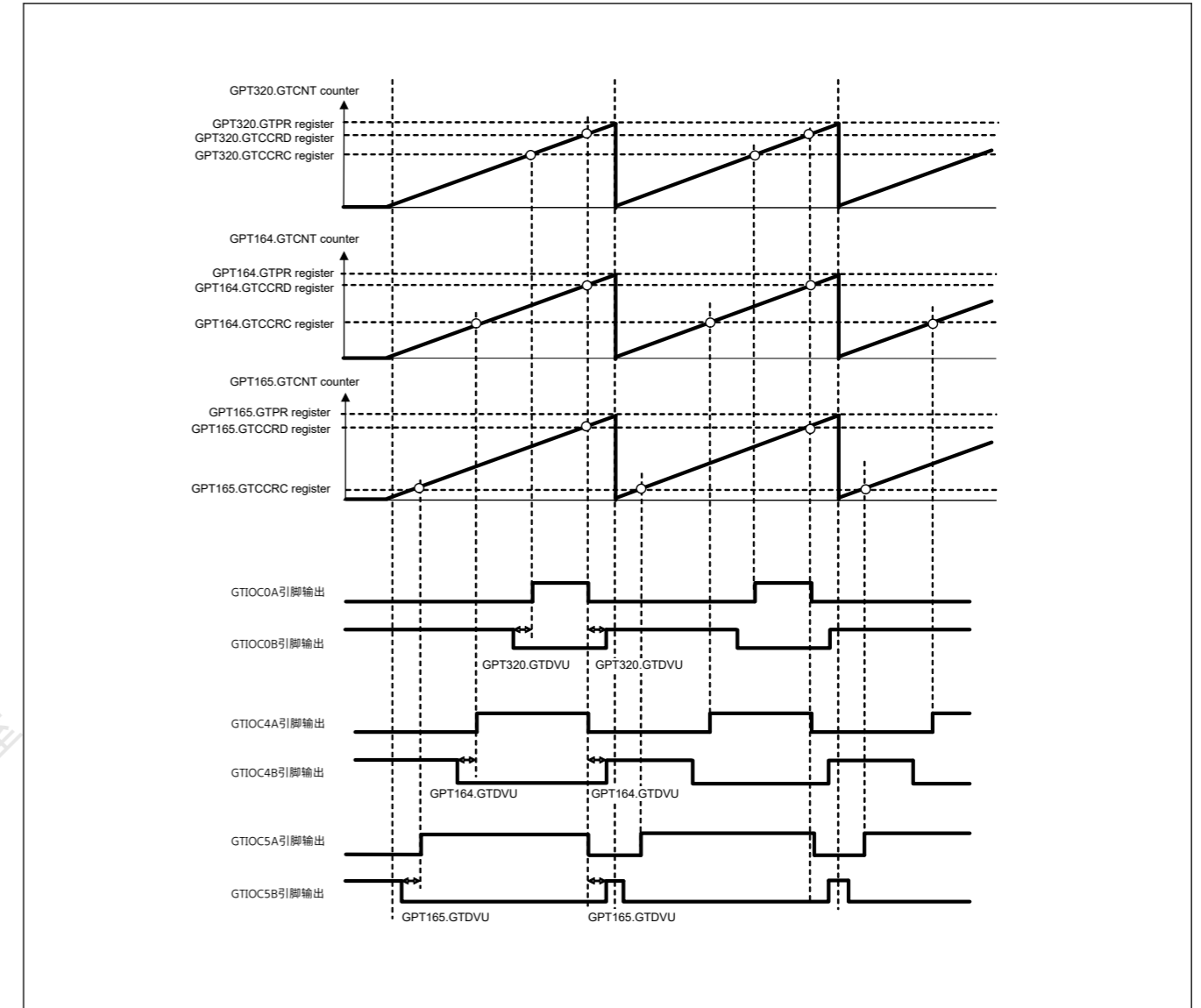


Figure 21.41 具有自动死区时间设置的三相锯齿波互补PWM输出示例

(4) 三相三角波互补PWM输出

图21.42显示了一个示例，其中三个通道在三角波PWM模式1中执行同步操作并输出三相互补PWM波形。GTIOCnA引脚设置为输出低电平作为初始值，在GTCCRA比较匹配时切换输出，并在周期结束时保持输出。GTIOCnB引脚设置为输出高电平作为初始值，在GTCCRB比较匹配时切换输出，并在周期结束时保持输出。



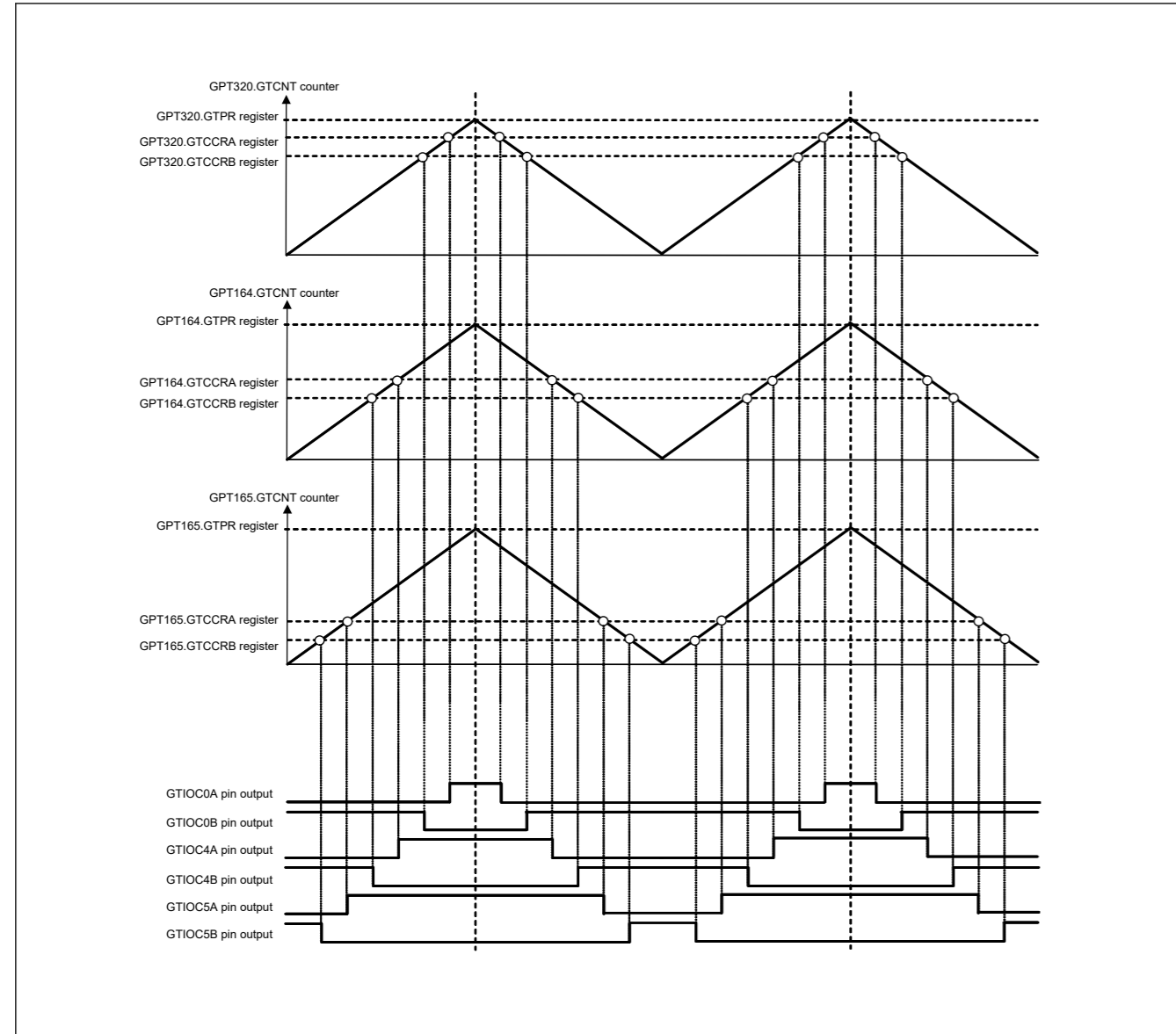


Figure 21.42 Example of 3-phase triangle-wave complementary PWM output

(5) 3-phase triangle-wave complementary PWM output with automatic dead time setting

Figure 21.43 shows an example in which three channels perform synchronized operation in triangle-wave PWM mode 1 with automatic dead time setting and 3-phase complementary PWM waveforms are output. The GTIOCnA pin is set so that it outputs low as the initial value, toggles the output at a GTCCRA compare match, and retains the output at the cycle end. The GTIOCnB pin is set so that it outputs high as the initial value, toggles the output at a GTCCRB compare match, and retains the output at the cycle end.

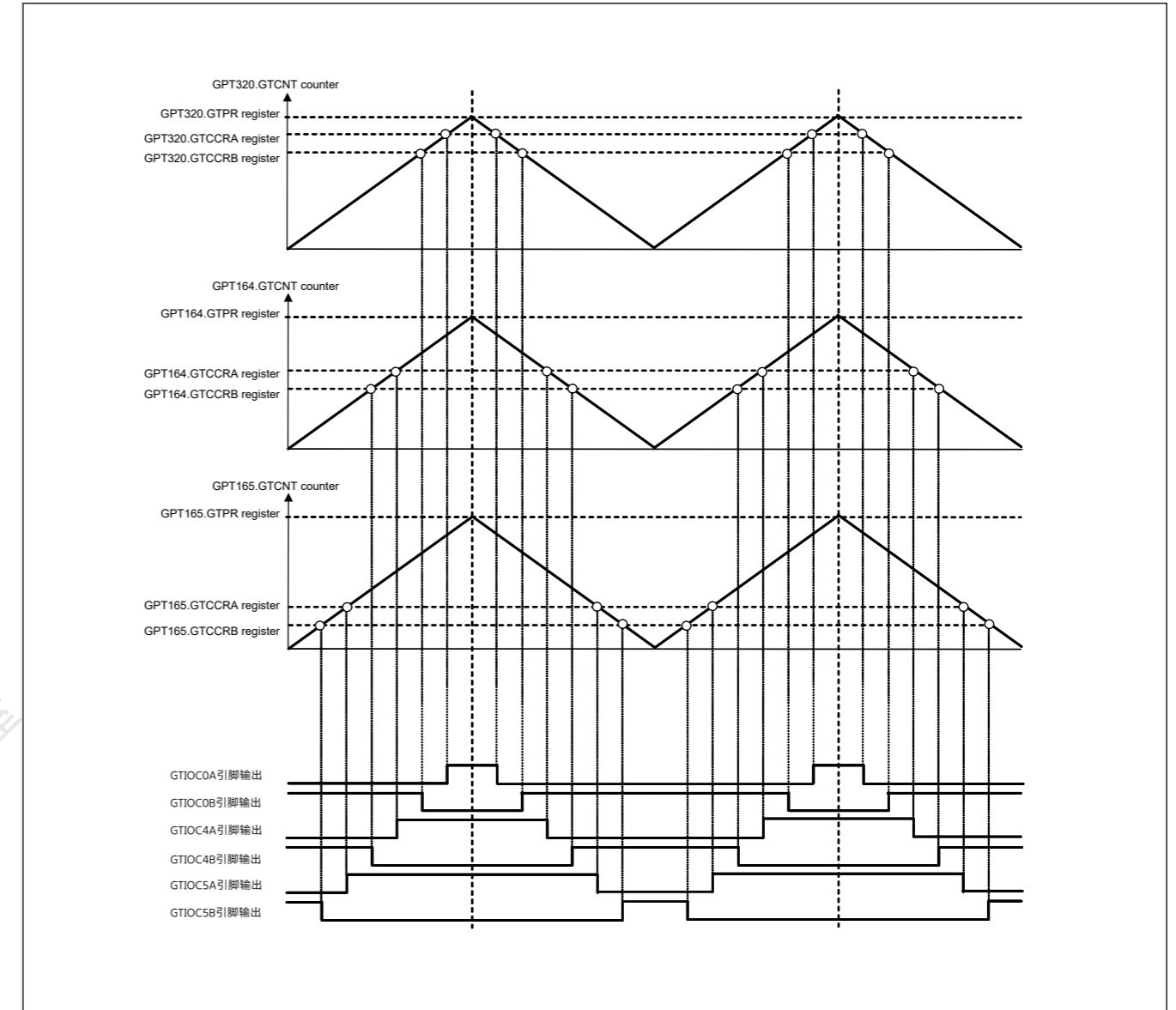


Figure 21.42 三相三角波互补PWM输出示例

(5) 具有自动死区时间设置的三相三角波互补PWM输出

图21.43显示了一个示例，其中三个通道在三角波PWM模式1下执行同步操作，自动设置死区时间并输出三相互补PWM波形。GTIOCnA引脚设置为输出低电平作为初始值，在GTCCRA比较匹配时切换输出，并在周期结束时保持输出。GTIOCnB引脚设置为输出高电平作为初始值，在GTCCRB比较匹配时切换输出，并在周期结束时保持输出。

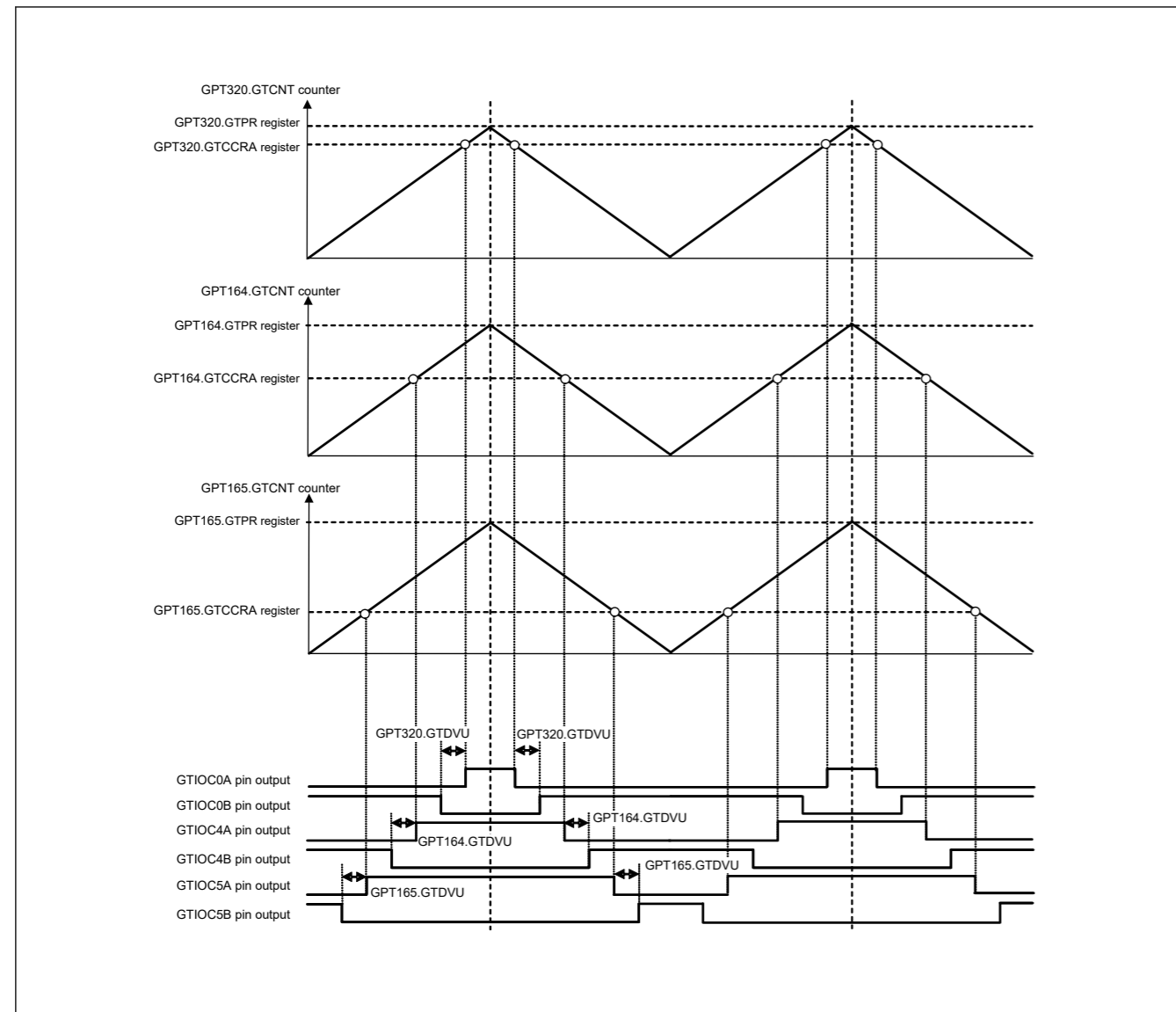


Figure 21.43 Example of 3-phase triangle-wave complementary PWM output with automatic dead time setting

(6) 3-phase asymmetric triangle-wave complementary PWM output with automatic dead time setting

Figure 21.44 shows an example in which three channels perform synchronized operation in triangle-wave PWM mode 3 with automatic dead time setting and 3-phase complementary PWM waveforms are output. The GTIOCnA is set so that it outputs low as the initial value, toggles the output at a GTCCRA compare match, and retains the output at the cycle end. The GTIOCnB is set so that it outputs high as the initial value, toggles the output at a GTCCRB compare match, and retains the output at the cycle end.

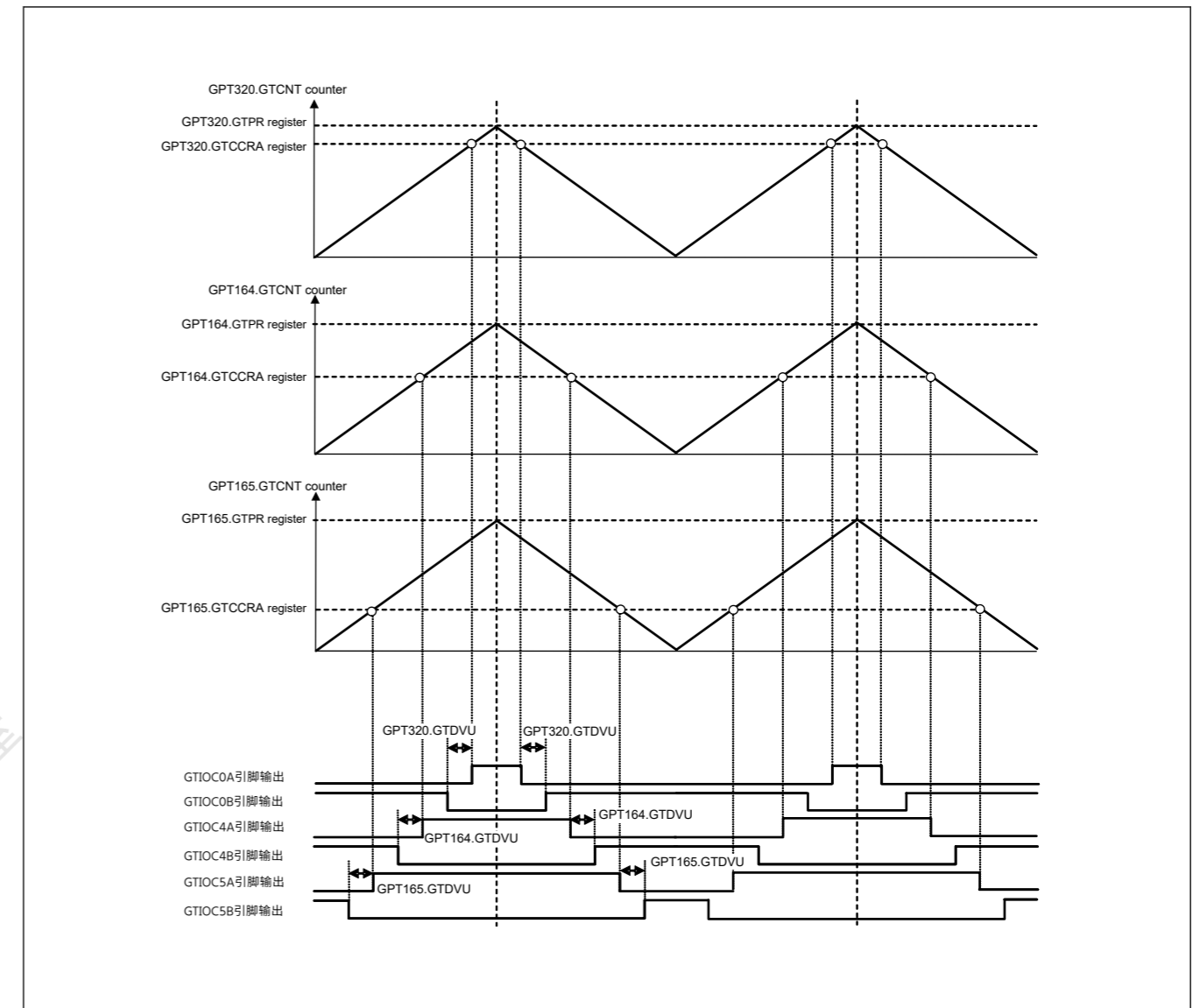


Figure 21.43 具有自动死区时间设置的三相三角波互补PWM输出示例

(6) 具有自动死区时间设置的三相不对称三角波互补PWM输出

图21.44显示了一个示例，其中三个通道在三角波PWM模式3下执行同步操作，自动设置死区时间并输出三相互补PWM波形。GTIOCnA设置为输出低电平作为初始值，在GTCCRA比较匹配时切换输出，并在循环结束时保留输出。GTIOCnB设置为输出高电平作为初始值，在GTCCRB比较匹配时切换输出，并在循环结束时保留输出。

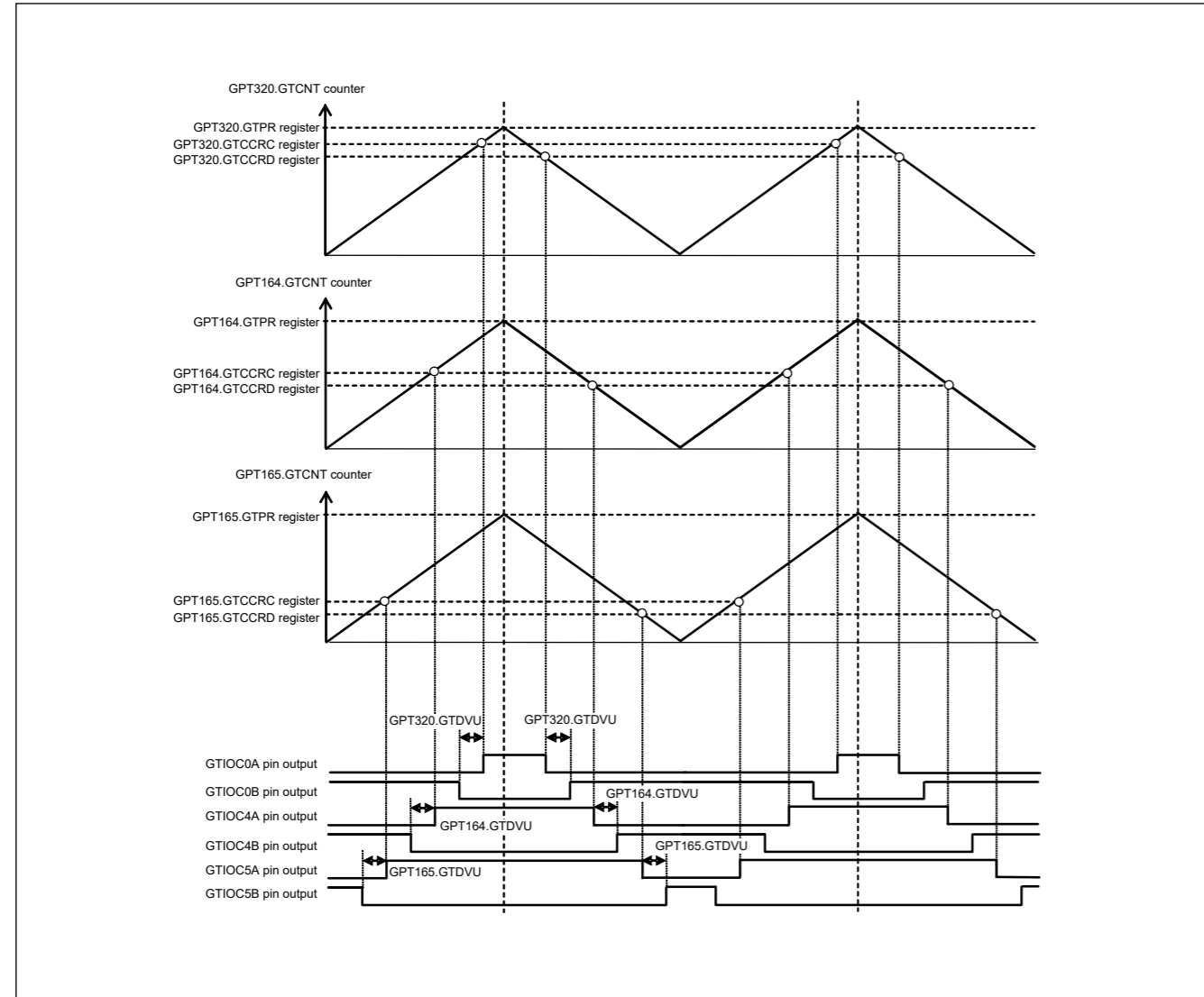


Figure 21.44 Example of 3-phase asymmetric triangle-wave complementary PWM output with automatic dead time setting

### 21.3.10 Period Count Function

By setting the GTPC register, the end of period can be counted.

The number of period to be counted should be set into the GTPC.PCNT counter when the GTPC.PCEN bit is 0. When the PCEN bit is 1, the PCNT counter can be read, but writing is disabled. When the PCEN bit is 1, down-counting is performed at the end of period. When the PCNT counter is 1 at the end of period, it becomes 0 and counting is stopped to finish the period count function. At that time, the GTST.PCF flag is set. When the GTPC.ASTP bit is 1, the GTCNT counter is also stopped at the same time that the period count function is finished.

When the GTCNT counter is stopped while period count function is enabled, the PCNT counter keeps its value. When the GTCNT counter restarts counting and the PCEN bit is 1, the PCNT counter restarts down-counting from the hold value.

When the PCEN bit is changed from 0 to 1 while the PCNT counter is 0 and the ASTP bit is 1, the GTCNT counter is stopped at the count clock immediately after that.

When either GTSECR.SPCE bit or GTSECR.SPCD bit is set to 1, the PCEN bit in the channels set to 1 by the GTSECSR register is simultaneously set the value to enable or disable the period count function for multiple channels.

Figure 21.45 and Figure 21.46 show examples of PWM cycle count function.

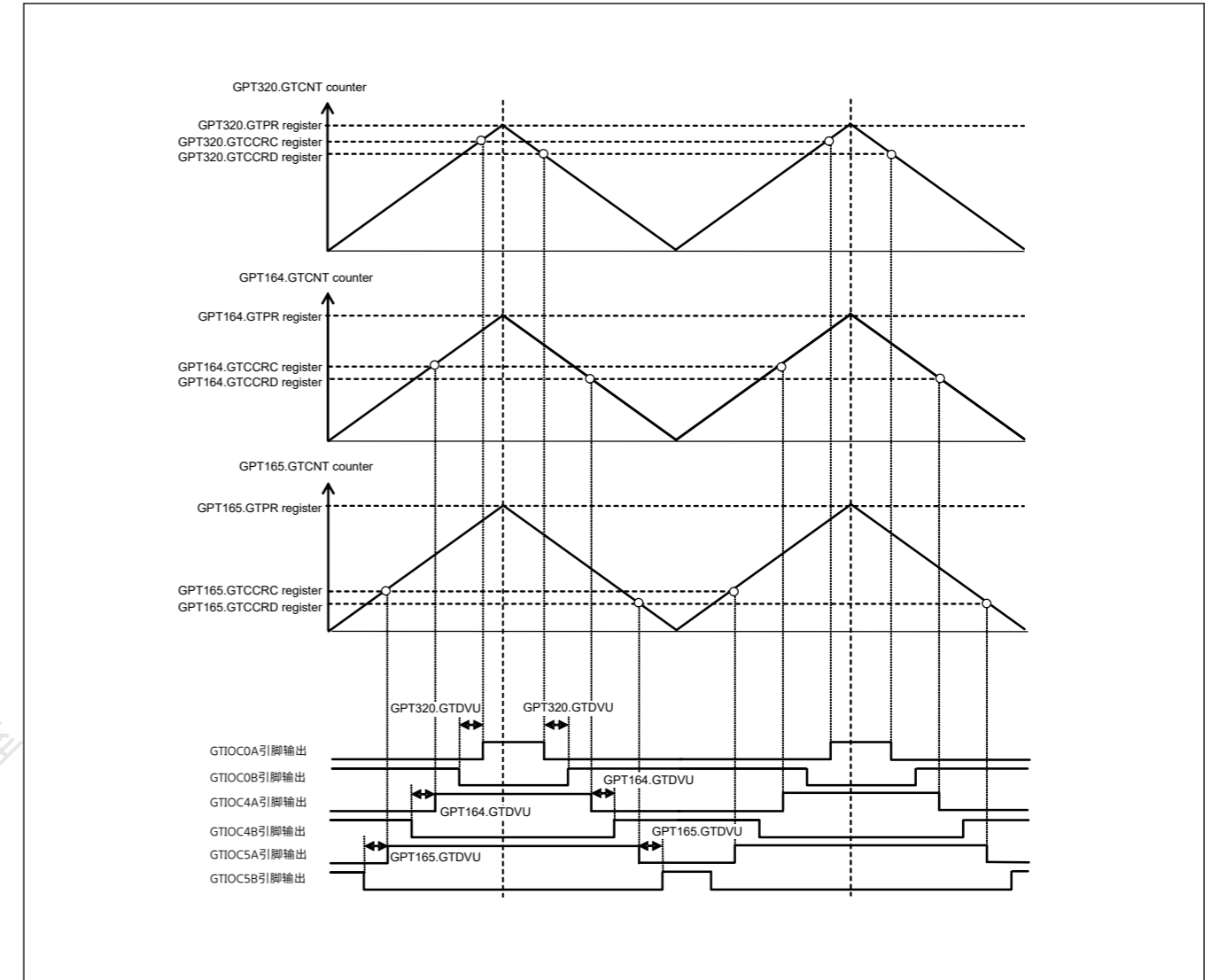


Figure 21.44 具有自动死区时间设置的三相不对称三角波互补PWM输出示例

### 21.3.10 周期计数功能

通过设置GTPC寄存器，可以计算周期结束。

当GTPC.PCEN位为0时，要计数的周期数应设置到GTPC.PCNT计数器中。当PCEN位为1，可以读取PCNT计数器，但禁止写入。当PCEN位为1时，在周期结束时进行递减计数。当PCNT计数器在周期结束时为1时，它变为0并停止计数以完成周期计数功能。此时，设置了GTST.PCF标志。当GTPC.ASTP位为1时，GTCNT计数器也在周期计数功能完成的同时停止。

当GTCNT计数器停止而周期计数功能使能时，PCNT计数器保持其值。当。。。的时候GTCNT计数器重新开始计数且PCEN位为1，PCNT计数器重新从保持值开始向下计数。

当PCNT计数器为0且ASTP位为1时PCEN位从0变为1时，GTCNT计数器立即停止在计数时钟处。

当GTSECR.SPCE位或GTSECR.SPCD位设置为1时，通过GTSECSR寄存器设置为1的通道中的PCEN位同时设置该值以启用或禁用多个通道的周期计数功能。

图21.45和图21.46显示了PWM周期计数功能的示例。

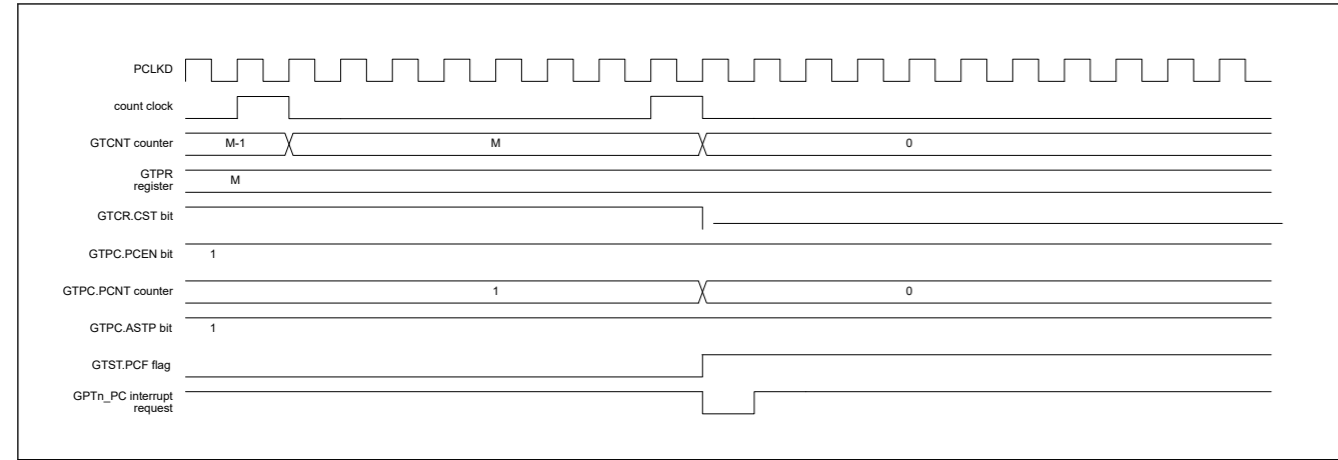


Figure 21.45 Example of PWM Cycle Count Function (Saw-Wave One-Shot Pulse Mode)

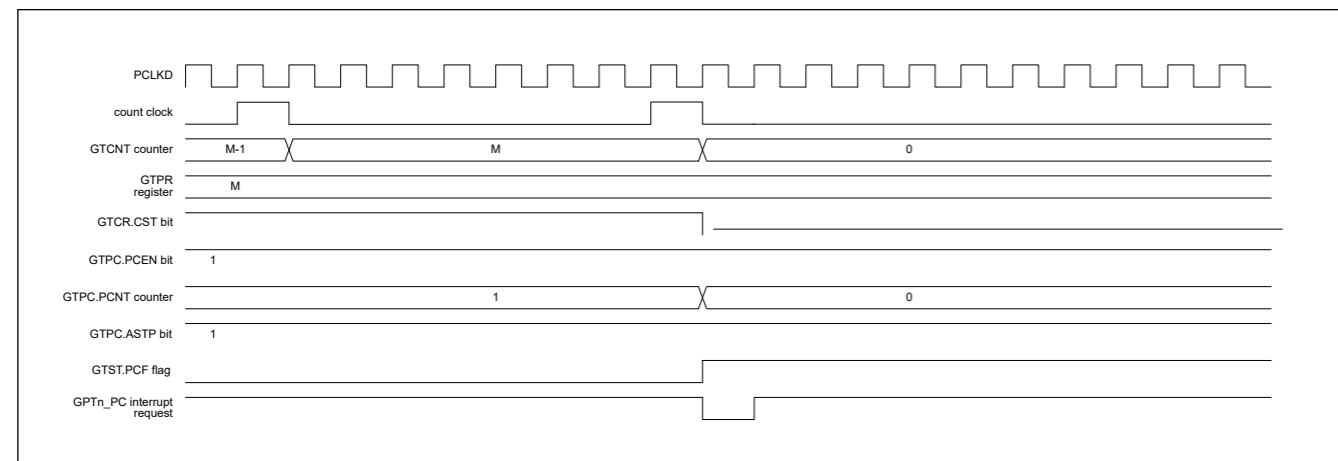


Figure 21.46 Example of the Timig of Operations for PWM Cycle Count Function (Saw-Wave One-Shot Pulse mode, Up-Counting)

### 21.3.11 Phase Counting Function

The phase difference between the GTIOCnA and GTIOCnB pin (n = 0 to 7) inputs is detected and the associated GTCNT counts up or counts down. The detectable phase difference is available in any combination with the relationship between the edge and the level of GTIOCnA and GTIOCnB pin inputs being set in the GTUPSR and GTDNSR registers. For details on count operation, see [section 21.3.1.1. Counter operation](#).

Figure 21.47 to Figure 21.56 show an example of phase counting modes 1 to 5 operation when the GTIOCnA, GTIOCnB pins are used. Table 21.29 to Table 21.38 show conditions of up-counting or down-counting and list settings for the GTUPSR and GTDNSR registers which is corresponding to Figure 21.47 to Figure 21.56.

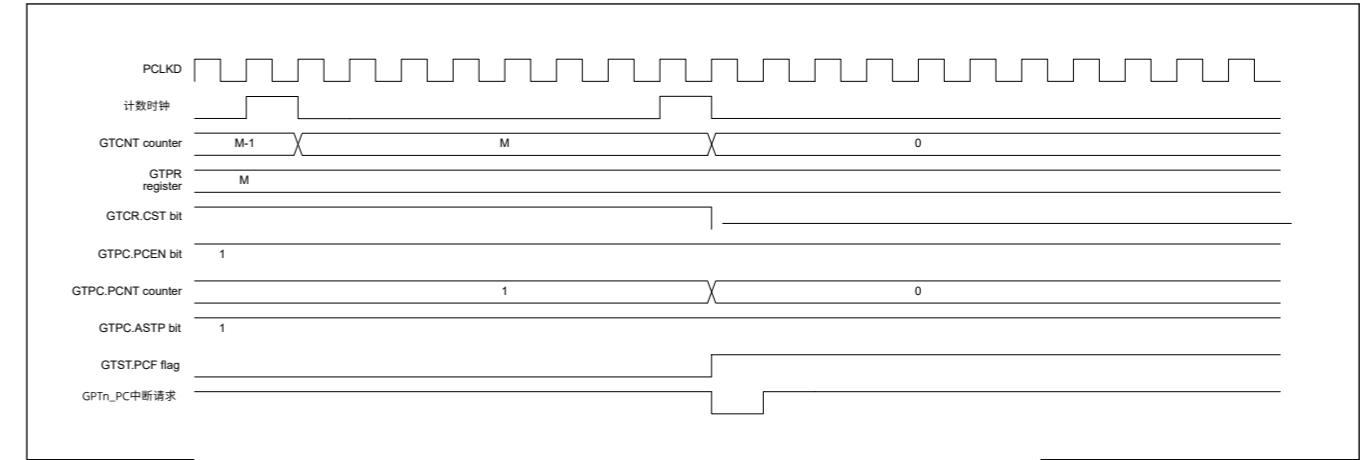


Figure 21.45 PWM周期计数功能示例 (Saw-WaveOne-Shot脉冲模式)

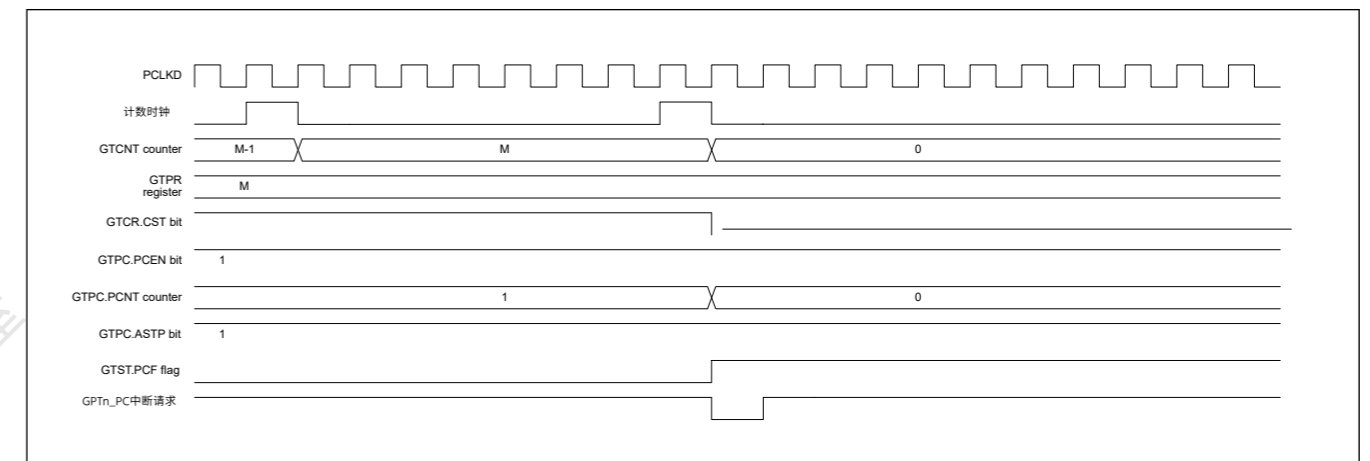


Figure 21.46 PWM周期计数功能的操作时序示例 (Saw-WaveOne-Shot脉冲模式, 递增计数)

### 21.3.11 相位计数功能

检测到GTIOCnA和GTIOCnB引脚 (n=0到7) 输入之间的相位差, 并且相关的GTCNT向上计数或向下计数。可检测的相位差可与在GTUPSR和GTDNSR寄存器中设置的GTIOCnA和GTIOCnB引脚输入的边沿和电平之间的关系进行任何组合。有关计数操作的详细信息, 请参阅第21.3.1.1节。柜台操作。

图21.47至图21.56显示了使用GTIOCnA、GTIOCnB引脚时相位计数模式1至5操作的示例。表21.29至表21.38显示了向上计数或向下计数的条件, 并列出了GTUPSR和GTDNSR寄存器的设置, 对应于图21.47至图21.56。

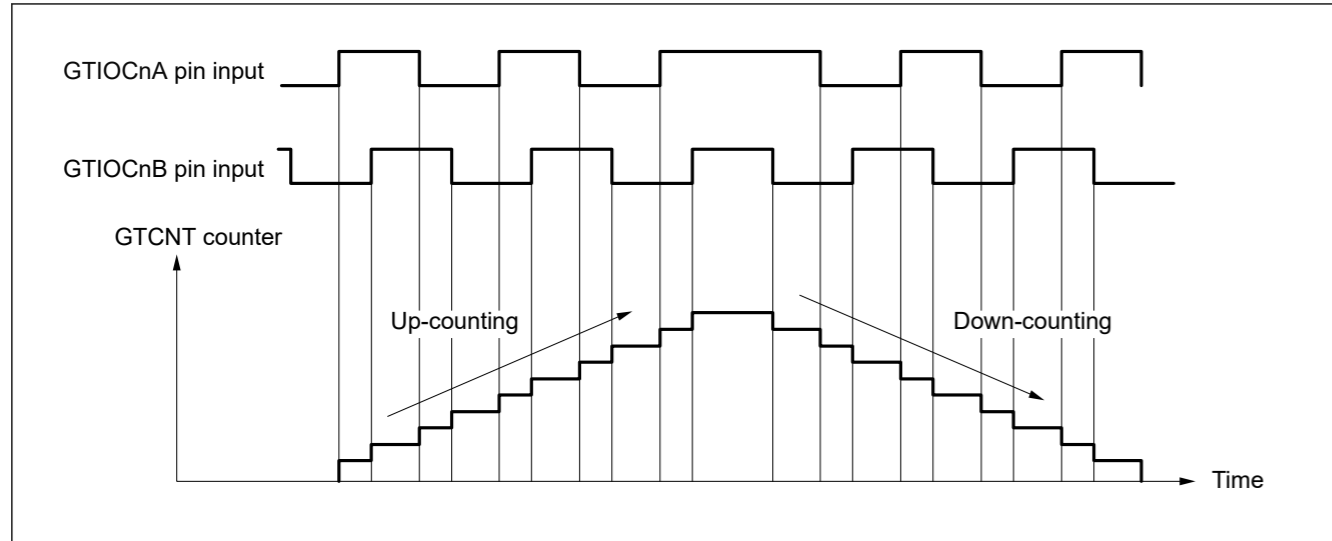


Figure 21.47 Example of phase counting mode 1

Table 21.29 Conditions of up-counting/down-counting in phase counting mode 1

⤴ : Rising edge  
 ⤵ : Falling edge

| GTIOcNA pin input | GTIOcNB pin input | Operation     | Register setting                           |
|-------------------|-------------------|---------------|--|
| High              | ⤴                 | Up-counting   | GTUPSR = 0x00006900<br>GTDNSR = 0x00009600 |
| Low               | ⤵                 |               |  |
| ⤴                 | Low               |               |  |
| ⤵                 | High              |               |  |
| High              | ⤵                 | Down-counting |  |
| Low               | ⤴                 |               |  |
| ⤴                 | High              |               |  |
| ⤵                 | Low               |               |  |

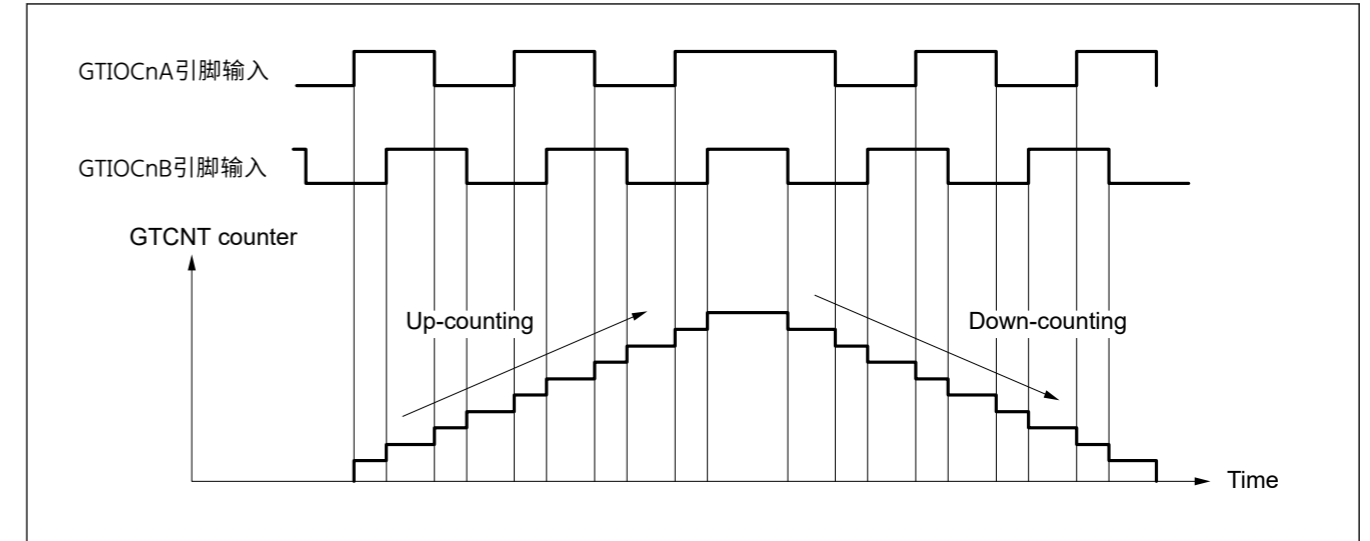


Figure 21.47 相位计数模式示例1

Table 21.29 相位计数模式加减计数条件1

⤴ : 上升沿  
 ⤵ : 下降沿

| GTIOcNA引脚输入 | GTIOcNB引脚输入 | Operation     | 注册设置                                       |
|-------------|-------------|---------------|--|
| High        | ⤴           | Up-counting   | GTUPSR = 0x00006900<br>GTDNSR = 0x00009600 |
| Low         | ⤵           |               |  |
| ⤴           | Low         |               |  |
| ⤵           | High        |               |  |
| High        | ⤵           | Down-counting |  |
| Low         | ⤴           |               |  |
| ⤴           | High        |               |  |
| ⤵           | Low         |               |  |



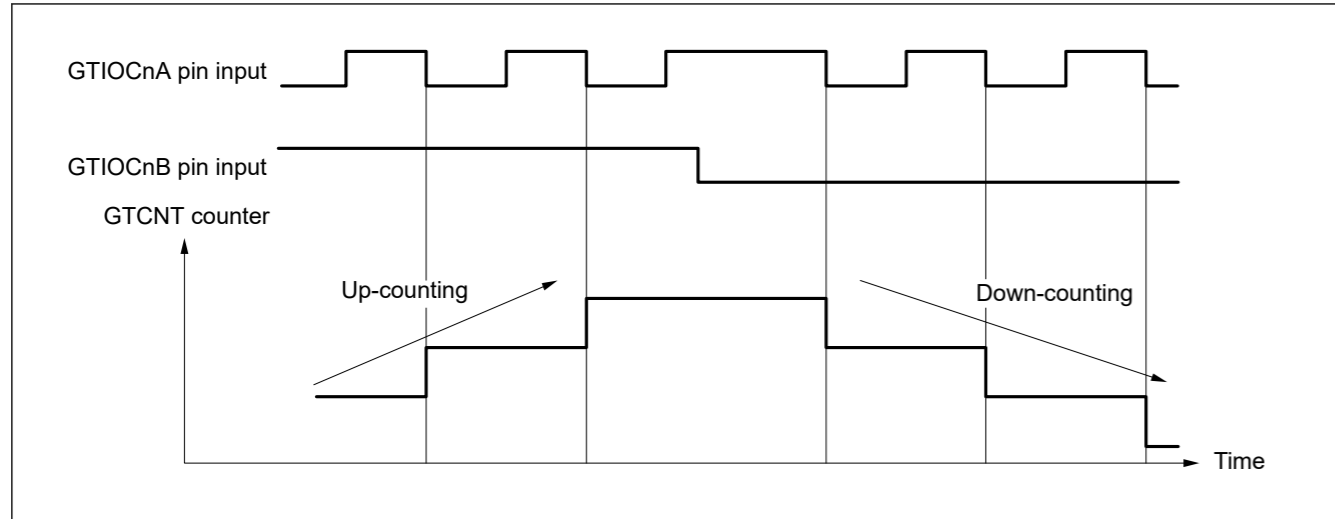


Figure 21.48 Example of phase counting mode 2 (A)

Table 21.30 Conditions of up-counting/down-counting in phase counting mode 2 (A)

↑ : Rising edge  
↓ : Falling edge

| GTIOCnA pin input | GTIOCnB pin input | Operation     | Register setting                           |
|-------------------|-------------------|---------------|--|
| High              | ↑                 | Not counting  | GTUPSR = 0x00000800<br>GTDNSR = 0x00000400 |
| Low               | ↓                 |               |  |
| ↑                 | Low               |               |  |
| ↓                 | High              | Up-counting   |  |
| High              | ↓                 | Not counting  |  |
| Low               | ↑                 |               |  |
| ↑                 | High              |               |  |
| ↓                 | Low               | Down-counting |  |

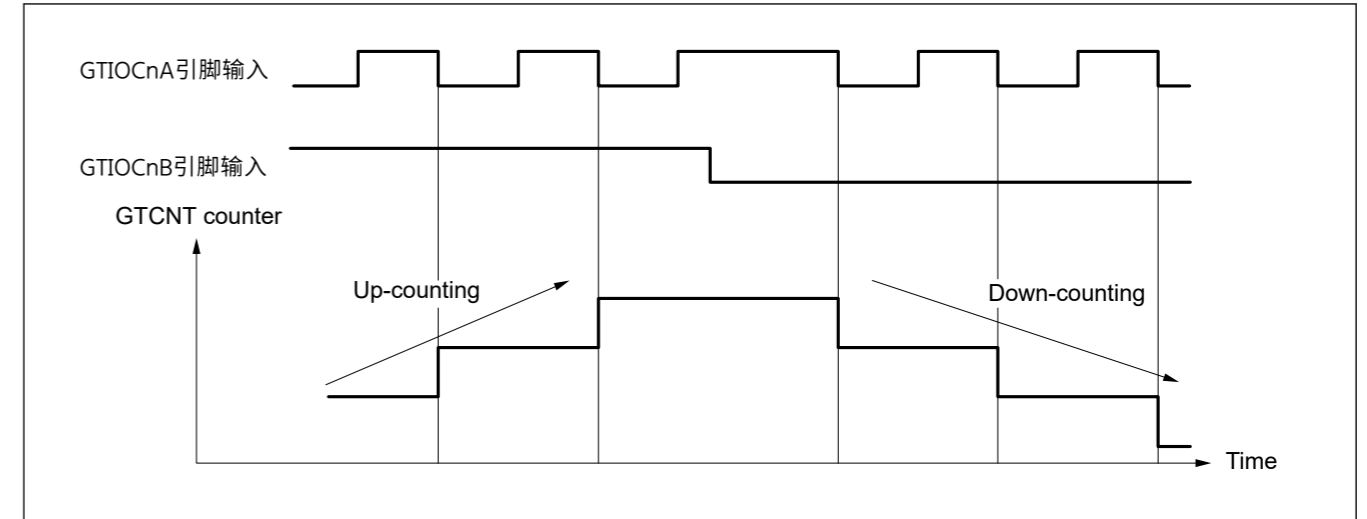


Figure 21.48 相位计数模式示例2(A)

Table 21.30 相位计数模式2(A)加减计数条件

↑ : 上升沿  
↓ : 下降沿

| GTIOCnA引脚输入 | GTIOCnB引脚输入 | Operation     | 注册设置                                       |
|-------------|-------------|---------------|--|
| High        | ↑           | 不算数           | GTUPSR = 0x00000800<br>GTDNSR = 0x00000400 |
| Low         | ↓           |               |  |
| ↑           | Low         |               |  |
| ↓           | High        | Up-counting   |  |
| High        | ↓           | 不算数           |  |
| Low         | ↑           |               |  |
| ↑           | High        |               |  |
| ↓           | Low         | Down-counting |  |

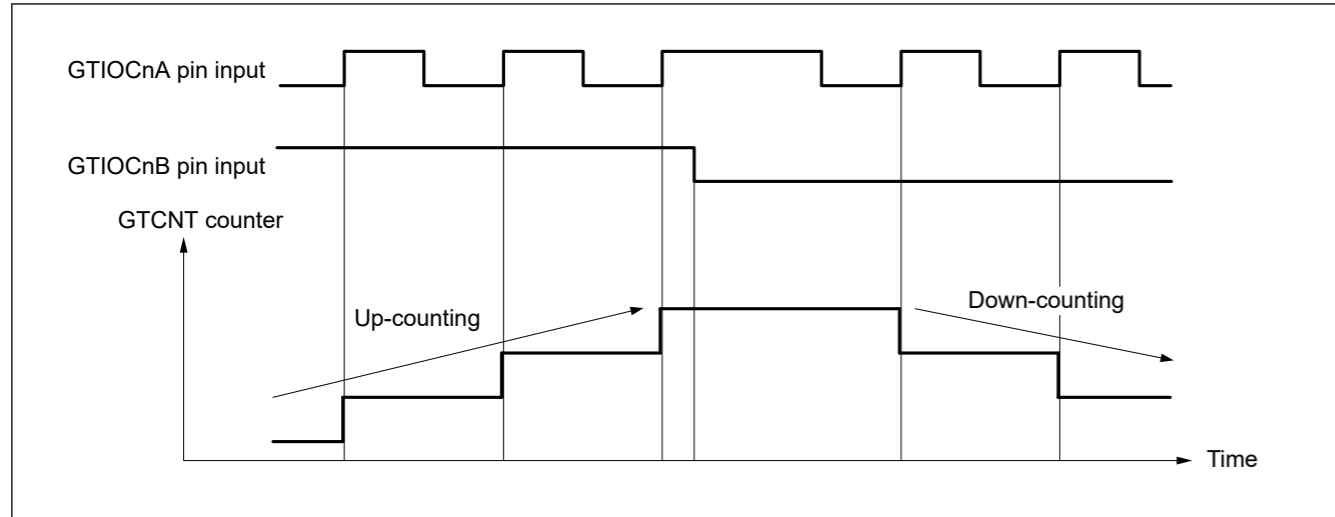


Figure 21.49 Example of phase counting mode 2 (B)

Table 21.31 Conditions of up-counting/down-counting in phase counting mode 2 (B)

↑ : Rising edge

↓ : Falling edge

| GTIOcNA pin input | GTIOcNB pin input | Operation     | Register setting                           |
|-------------------|-------------------|---------------|--|
| High              | ↑                 | Not counting  | GTUPSR = 0x00000200<br>GTDNSR = 0x00000100 |
| Low               | ↓                 |               |  |
| ↑                 | Low               | Down-counting |  |
| ↓                 | High              | Not counting  |  |
| High              | ↓                 |               |  |
| Low               | ↑                 | Up-counting   |  |
| ↑                 | High              |               |  |
| ↓                 | Low               | Not counting  |  |

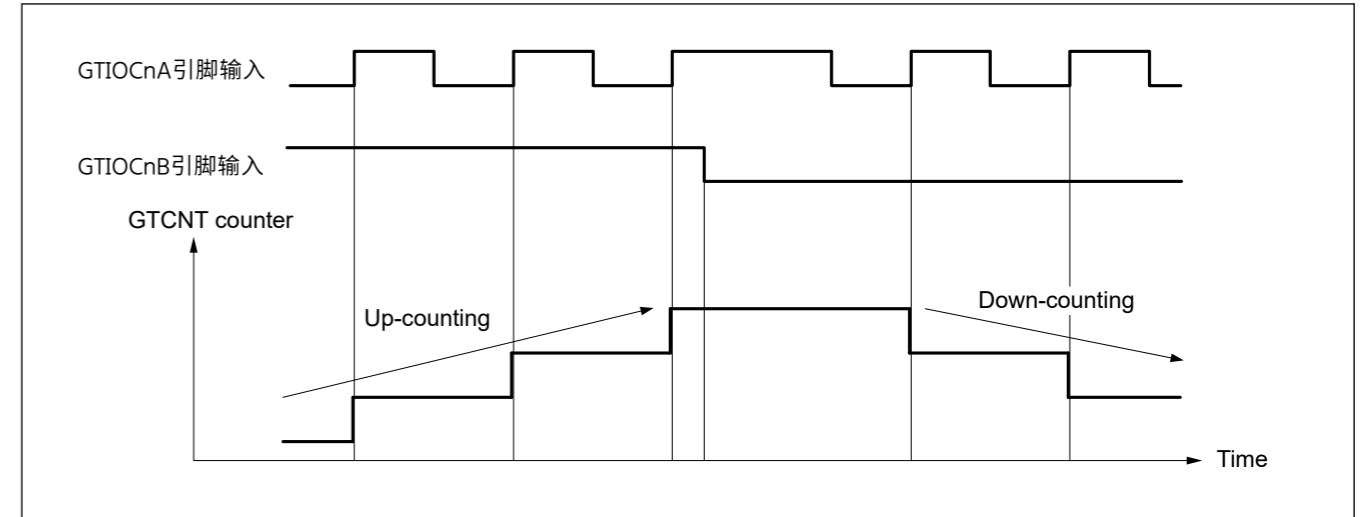


Figure 21.49 相位计数模式示例2(B)

Table 21.31 相位计数模式2(B)加减计数条件

↑ : 上升沿

↓ : 下降沿

| GTIOcNA引脚输入 | GTIOcNB引脚输入 | Operation     | 注册设置                                       |
|-------------|-------------|---------------|--|
| High        | ↑           | 不算数           | GTUPSR = 0x00000200<br>GTDNSR = 0x00000100 |
| Low         | ↓           |               |  |
| ↑           | Low         | Down-counting |  |
| ↓           | High        | 不算数           |  |
| High        | ↓           |               |  |
| Low         | ↑           | Up-counting   |  |
| ↑           | High        |               |  |
| ↓           | Low         | 不算数           |  |

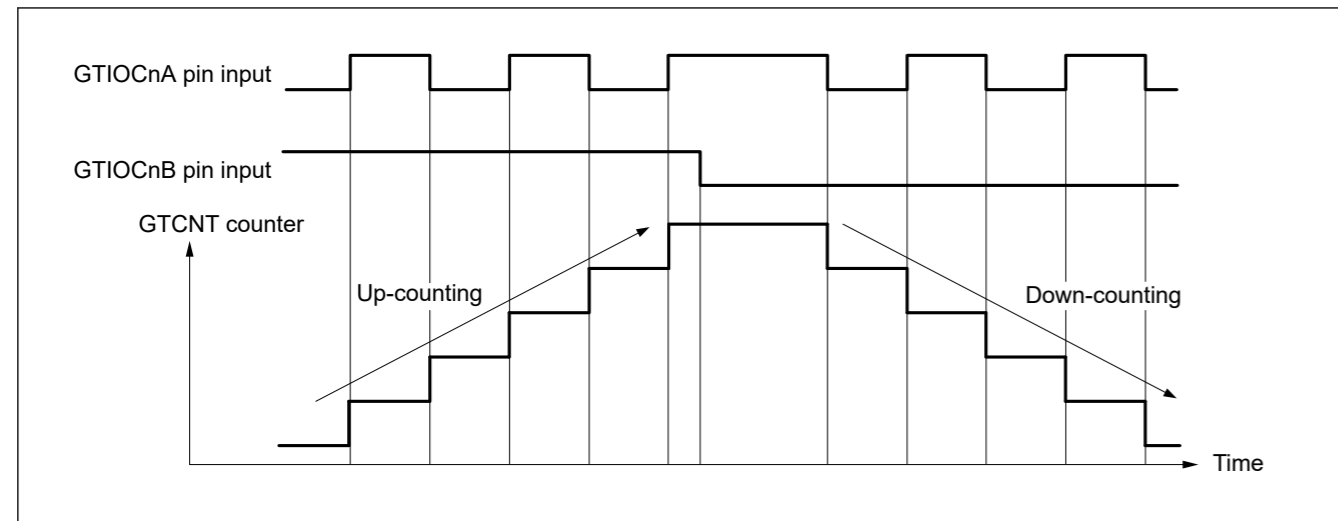


Figure 21.50 Example of phase counting mode 2 (C)

Table 21.32 Conditions of up-counting/down-counting in phase counting mode 2 (C)

↑ : Rising edge  
↓ : Falling edge

| GTIOcNA pin input | GTIOcNB pin input | Operation     | Register setting                           |
|-------------------|-------------------|---------------|--|
| High              | ↑                 | Not counting  | GTUPSR = 0x00000A00<br>GTDNSR = 0x00000500 |
| Low               | ↓                 |               |  |
| ↑                 | Low               | Down-counting |  |
| ↓                 | High              | Up-counting   |  |
| High              | ↓                 | Not counting  |  |
| Low               | ↑                 |               |  |
| ↑                 | High              | Up-counting   |  |
| ↓                 | Low               | Down-counting |  |

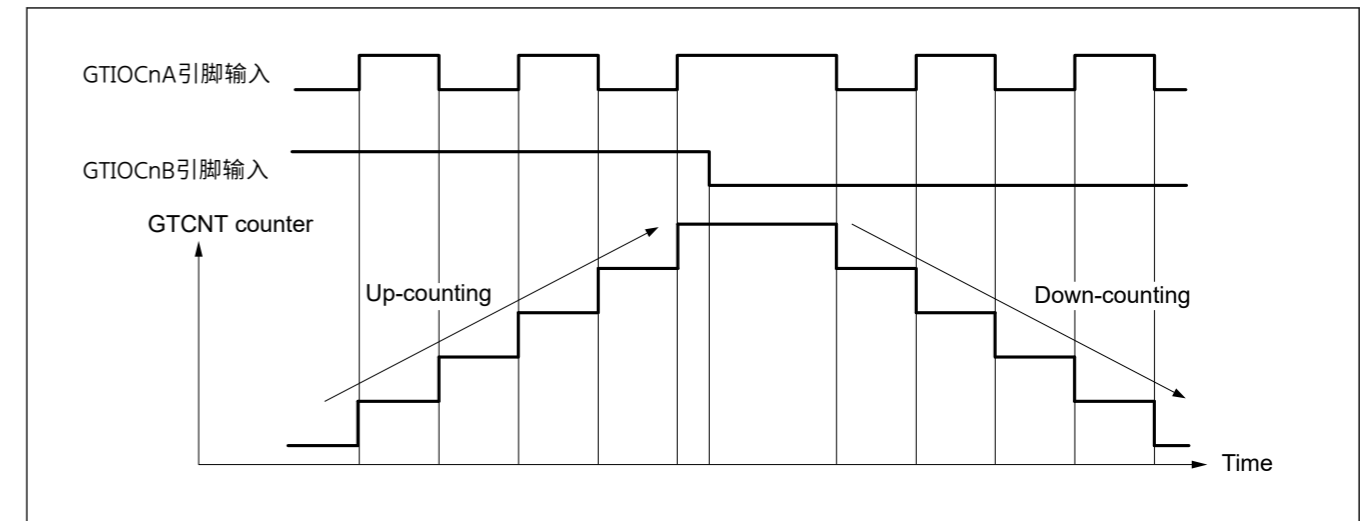


Figure 21.50 相位计数模式示例2(C)

Table 21.32 相位计数模式2(C)加减计数条件

↑ : 上升沿  
↓ : 下降沿

| GTIOcNA引脚输入 | GTIOcNB引脚输入 | Operation     | 注册设置                                       |
|-------------|-------------|---------------|--|
| High        | ↑           | 不算数           | GTUPSR = 0x00000A00<br>GTDNSR = 0x00000500 |
| Low         | ↓           |               |  |
| ↑           | Low         | Down-counting |  |
| ↓           | High        | Up-counting   |  |
| High        | ↓           | 不算数           |  |
| Low         | ↑           |               |  |
| ↑           | High        | Up-counting   |  |
| ↓           | Low         | Down-counting |  |

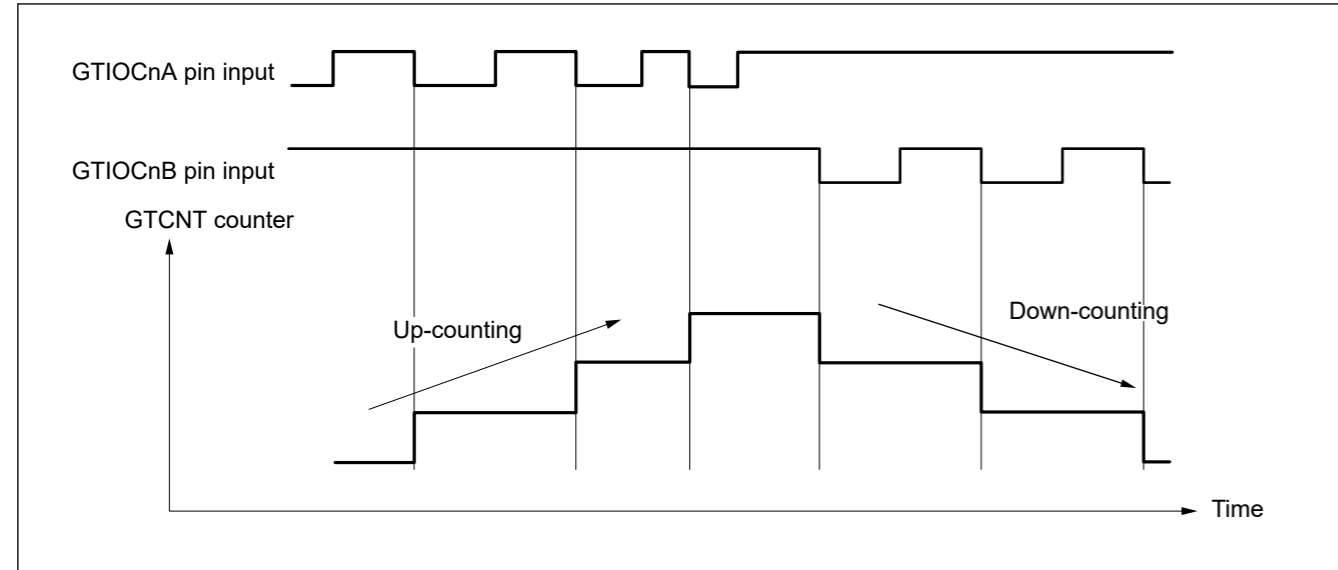


Figure 21.51 Example of phase counting mode 3 (A)

Table 21.33 Conditions of up-counting/down-counting in phase counting mode 3 (A)

: Rising edge  
 : Falling edge

| GTIOcNA pin input | GTIOcNB pin input | Operation     | Register setting                           |
|-------------------|-------------------|---------------|--|
| High              |                   | Not counting  | GTUPSR = 0x00000800<br>GTDNSR = 0x00008000 |
| Low               |                   |               |  |
|                   | Low               | Up-counting   |  |
|                   | High              |               |  |
| High              |                   | Down-counting |  |
| Low               |                   | Not counting  |  |
|                   | High              |               |  |
|                   | Low               |               |  |

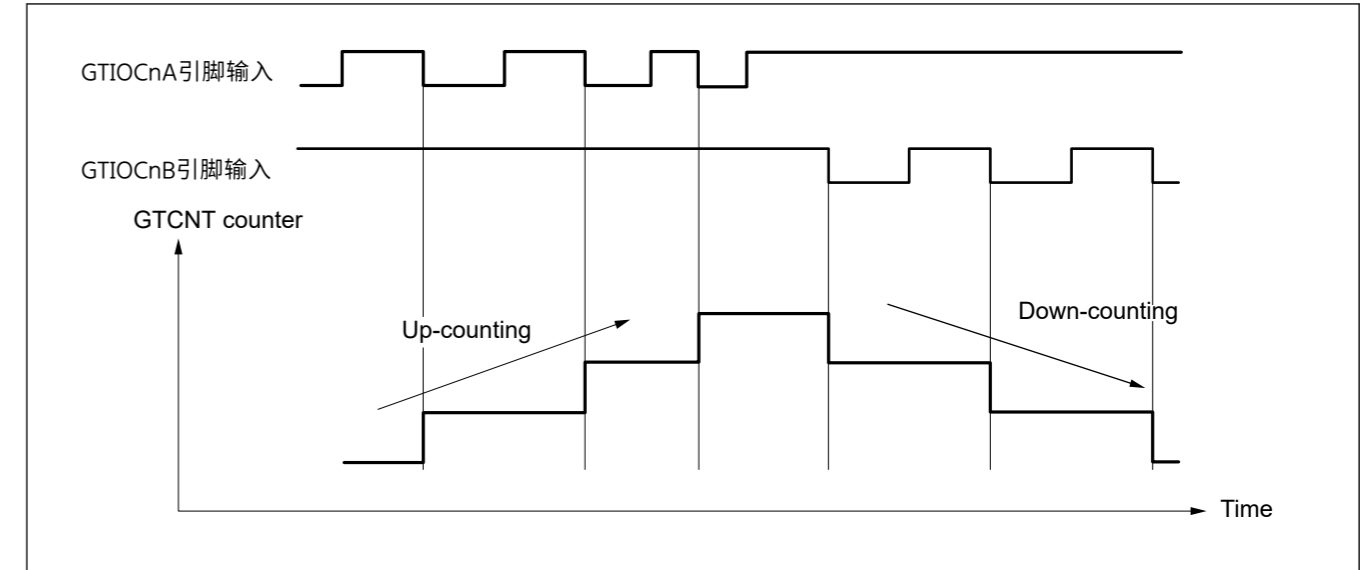


Figure 21.51 相位计数模式示例3(A)

Table 21.33 相位计数模式3(A)加减计数条件

: 上升沿  
 : 下降沿

| GTIOcNA引脚输入 | GTIOcNB引脚输入 | Operation     | 注册设置                                       |
|-------------|-------------|---------------|--|
| High        |             | 不算数           | GTUPSR = 0x00000800<br>GTDNSR = 0x00008000 |
| Low         |             |               |  |
|             | Low         | Up-counting   |  |
|             | High        |               |  |
| High        |             | Down-counting |  |
| Low         |             | 不算数           |  |
|             | High        |               |  |
|             | Low         |               |  |

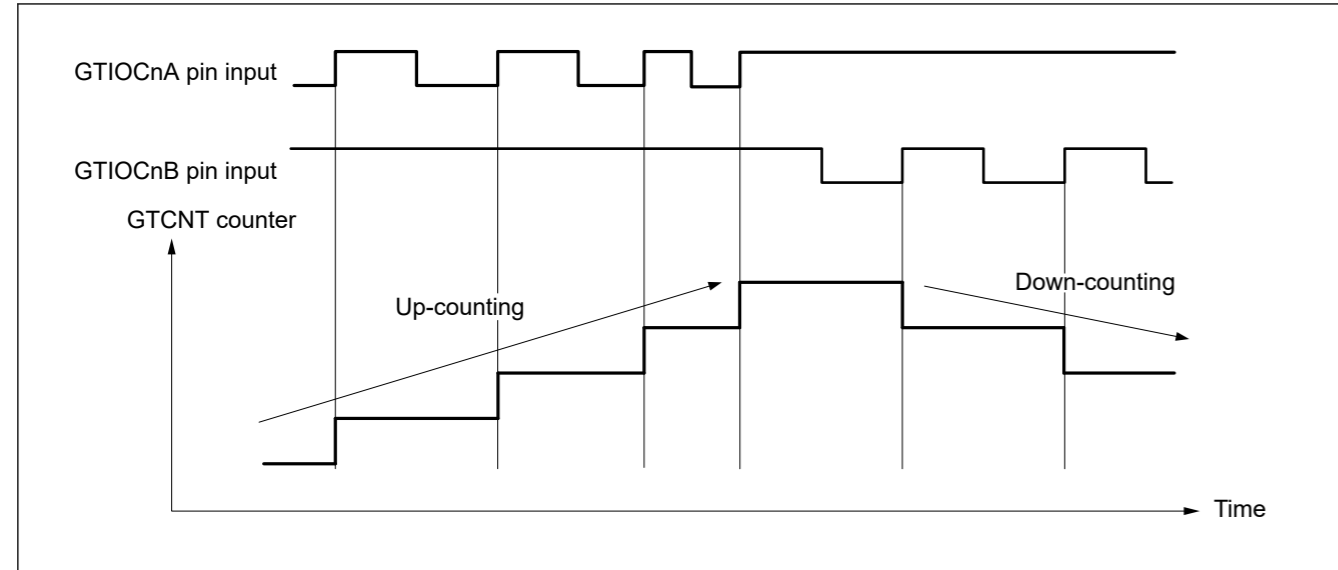


Figure 21.52 Example of phase counting mode 3 (B)

Table 21.34 Conditions of up-counting/down-counting in phase counting mode 3 (B)

: Rising edge  
 : Falling edge

| GTIOcNA pin input | GTIOcNB pin input | Operation     | Register setting                           |
|-------------------|-------------------|---------------|--|
| High              |                   | Down-counting | GTUPSR = 0x00000200<br>GTDNSR = 0x00002000 |
| Low               |                   | Not counting  |  |
|                   | Low               |               |  |
|                   | High              |               |  |
| High              |                   |               |  |
| Low               |                   |               |  |
|                   | High              | Not counting  |  |
|                   | Low               |               |  |

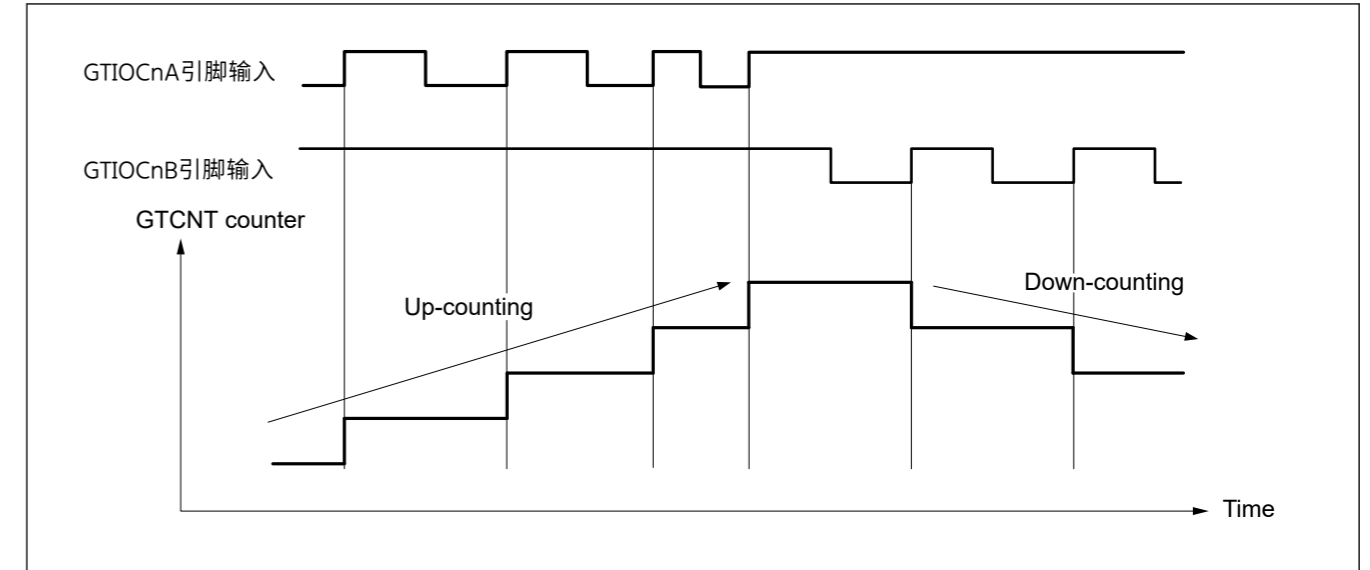


Figure 21.52 相位计数模式示例3(B)

Table 21.34 相位计数模式3(B)加减计数条件

: 上升沿  
 : 下降沿

| GTIOcNA引脚输入 | GTIOcNB引脚输入 | Operation     | 注册设置                                       |
|-------------|-------------|---------------|--|
| High        |             | Down-counting | GTUPSR = 0x00000200<br>GTDNSR = 0x00002000 |
| Low         |             | 不算数           |  |
|             | Low         |               |  |
|             | High        |               |  |
| High        |             |               |  |
| Low         |             |               |  |
|             | High        | 不算数           |  |
|             | Low         |               |  |



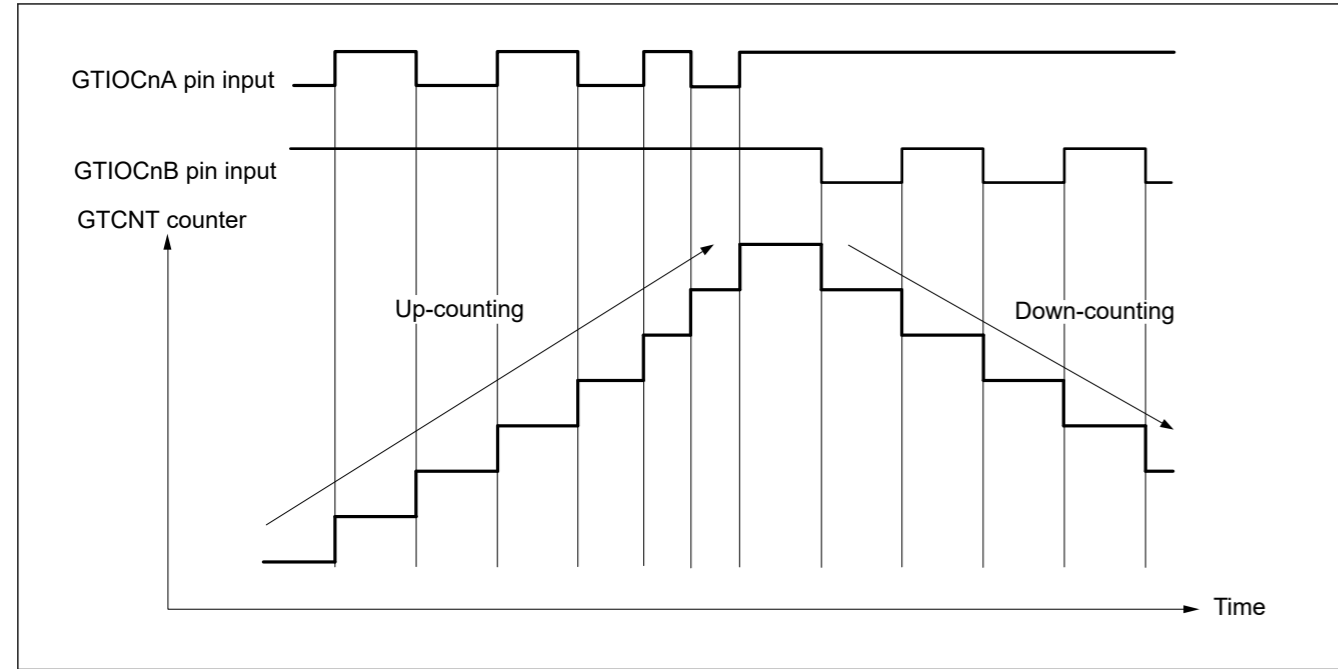


Figure 21.53 Example of phase counting mode 3 (C)

Table 21.35 Conditions of up-counting/down-counting in phase counting mode 3 (C)

↑ : Rising edge  
 ↓ : Falling edge

| GTIOcNA pin input | GTIOcNB pin input | Operation     | Register setting                           |
|-------------------|-------------------|---------------|--|
| High              | ↑                 | Down-counting | GTUPSR = 0x00000A00<br>GTDNSR = 0x0000A000 |
| Low               | ↓                 | Not counting  |  |
| ↑                 | Low               |               |  |
| ↓                 | High              | Up-counting   |  |
| High              | ↓                 | Down-counting |  |
| Low               | ↑                 | Not counting  |  |
| ↑                 | High              | Up-counting   |  |
| ↓                 | Low               | Not counting  |  |

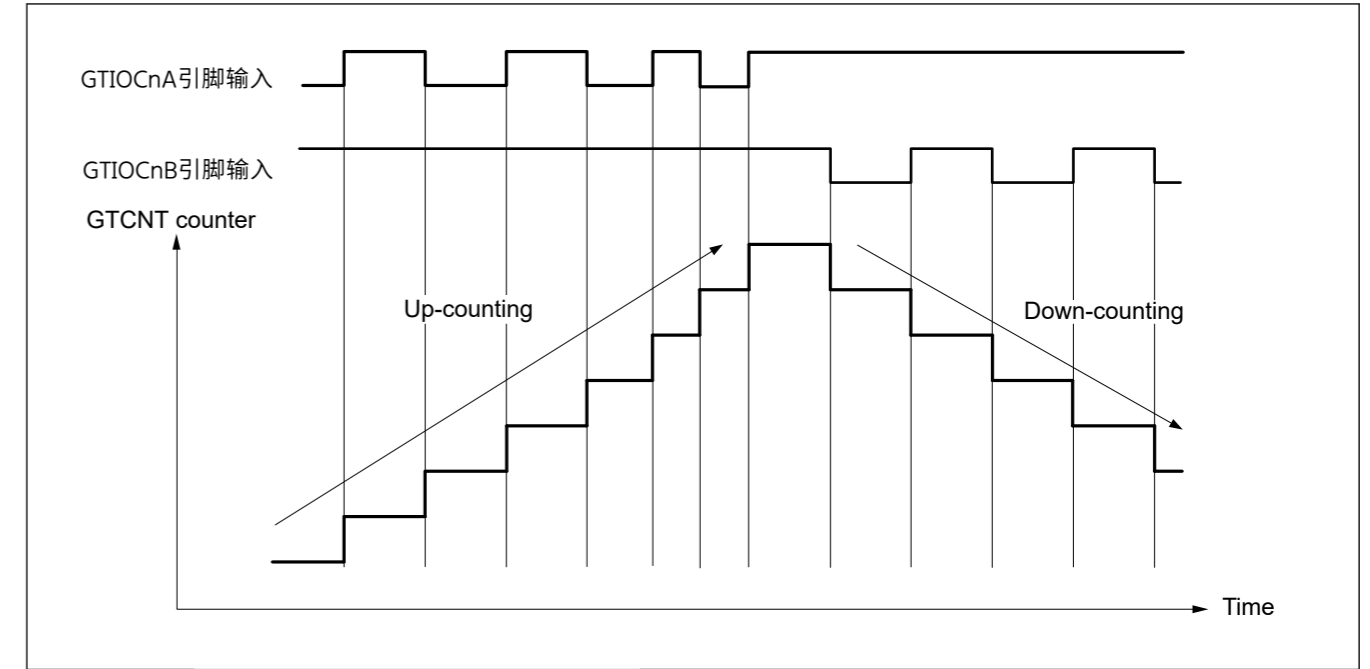


Figure 21.53 相位计数模式示例3(C)

Table 21.35 相位计数模式3(C)加减计数条件

↑ : 上升沿  
 ↓ : 下降沿

| GTIOcNA引脚输入 | GTIOcNB引脚输入 | Operation     | 注册设置                                       |
|-------------|-------------|---------------|--|
| High        | ↑           | Down-counting | GTUPSR = 0x00000A00<br>GTDNSR = 0x0000A000 |
| Low         | ↓           | 不算数           |  |
| ↑           | Low         |               |  |
| ↓           | High        | Up-counting   |  |
| High        | ↓           | Down-counting |  |
| Low         | ↑           | 不算数           |  |
| ↑           | High        | Up-counting   |  |
| ↓           | Low         | 不算数           |  |

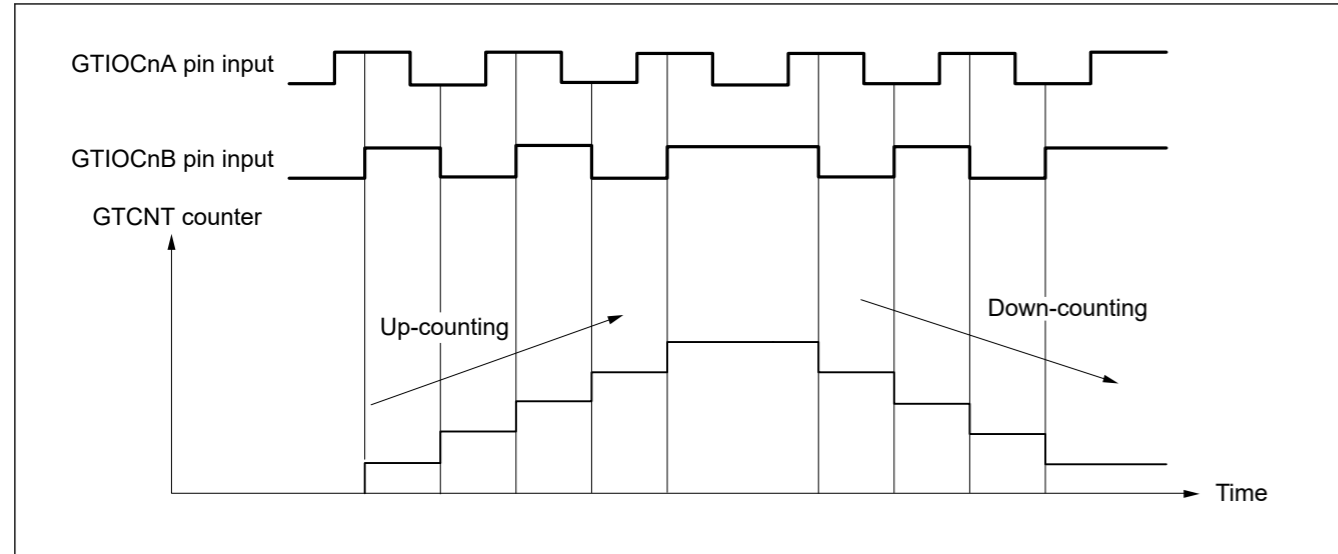


Figure 21.54 Example of phase counting mode 4

Table 21.36 Conditions of up-counting/down-counting in phase counting mode 4

: Rising edge  
 : Falling edge

| GTIOCnA pin input | GTIOCnB pin input | Operation     | Register setting                           |
|-------------------|-------------------|---------------|--|
| High              |                   | Up-counting   | GTUPSR = 0x00006000<br>GTDNSR = 0x00009000 |
| Low               |                   |               |  |
|                   | Low               | Not counting  |  |
|                   | High              |               |  |
| High              |                   | Down-counting |  |
| Low               |                   |               |  |
|                   | High              | Not counting  |  |
|                   | Low               |               |  |

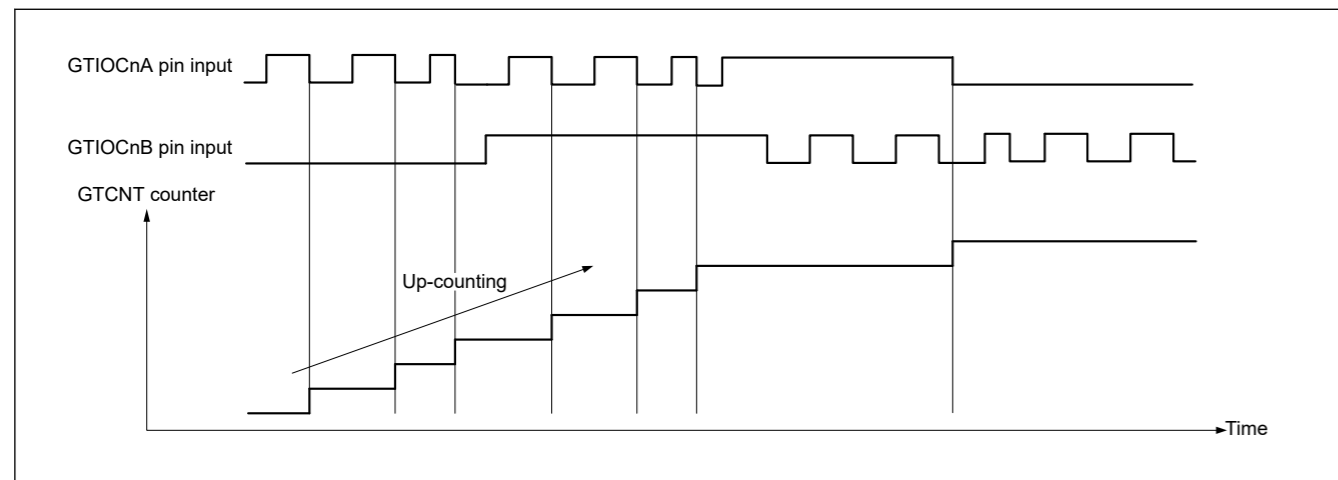


Figure 21.55 Example of phase counting mode 5 (A)

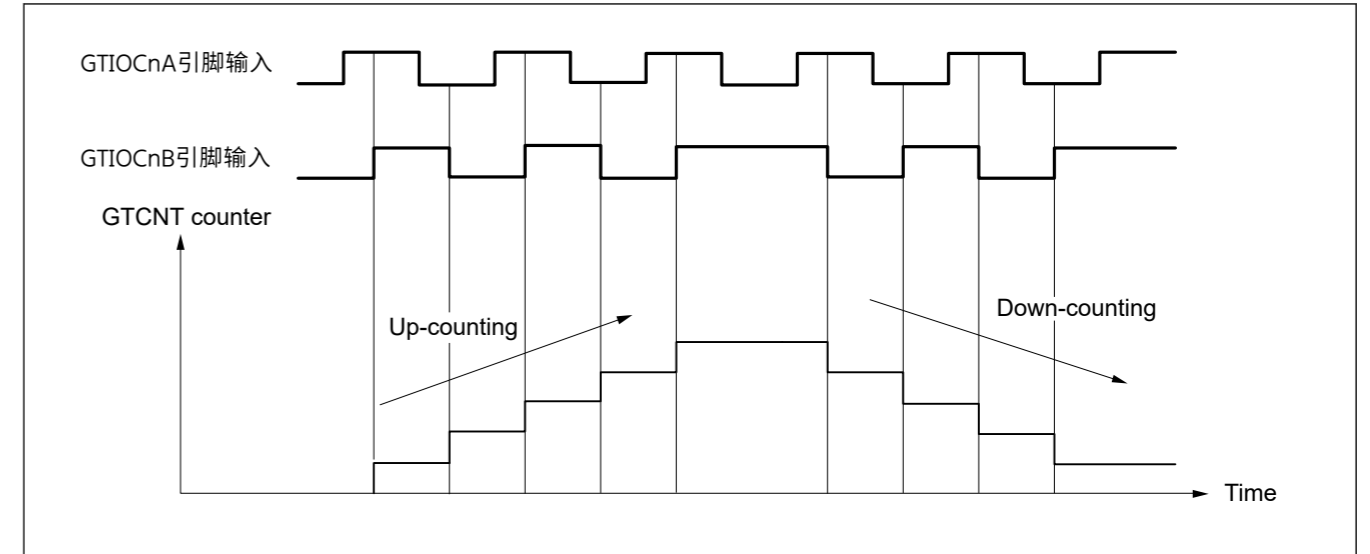


Figure 21.54 相位计数模式示例4

Table 21.36 相位计数方式4加减计数条件

: 上升沿  
 : 下降沿

| GTIOCnA引脚输入 | GTIOCnB引脚输入 | Operation     | 注册设置                                       |
|-------------|-------------|---------------|--|
| High        |             | Up-counting   | GTUPSR = 0x00006000<br>GTDNSR = 0x00009000 |
| Low         |             |               |  |
|             | Low         | 不算数           |  |
|             | High        |               |  |
| High        |             | Down-counting |  |
| Low         |             |               |  |
|             | High        | 不算数           |  |
|             | Low         |               |  |

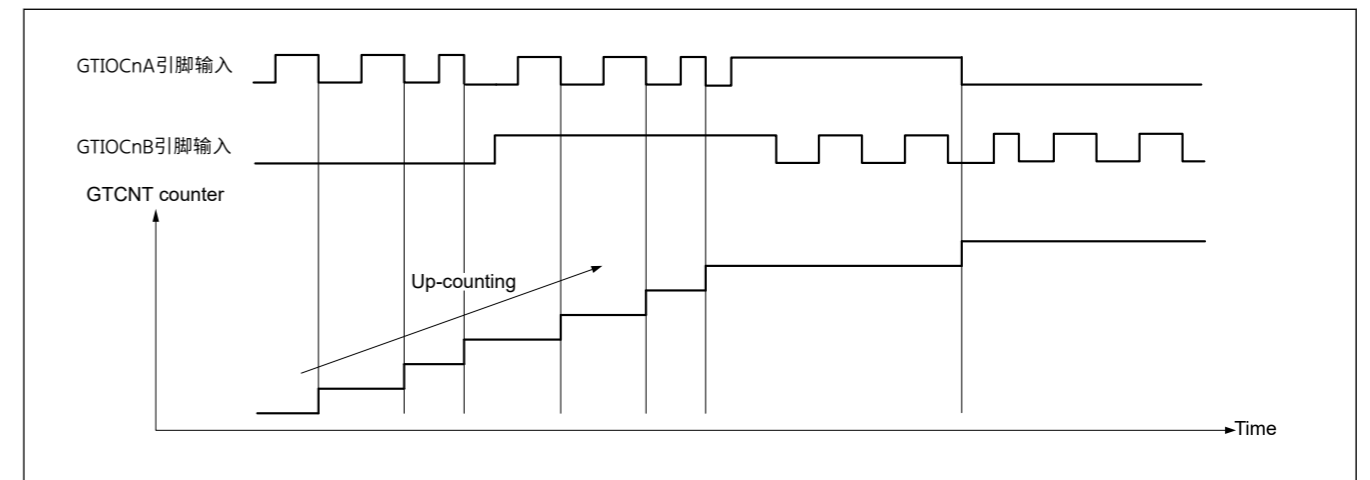


Figure 21.55 相位计数模式示例5(A)

Table 21.37 Conditions of up-counting/down-counting in phase counting mode 5 (A)

↑ : Rising edge  
↓ : Falling edge

| GTIOCnA pin input | GTIOCnB pin input | Operation    | Register setting                           |
|-------------------|-------------------|--------------|--|
| High              | ↑                 | Not counting | GTUPSR = 0x00000C00<br>GTDNSR = 0x00000000 |
| Low               | ↓                 |              |  |
| ↑                 | Low               | Up-counting  |  |
| ↓                 | High              |              |  |
| High              | ↓                 | Not counting |  |
| Low               | ↑                 |              |  |
| ↑                 | High              | Up-counting  |  |
| ↓                 | Low               |              |  |

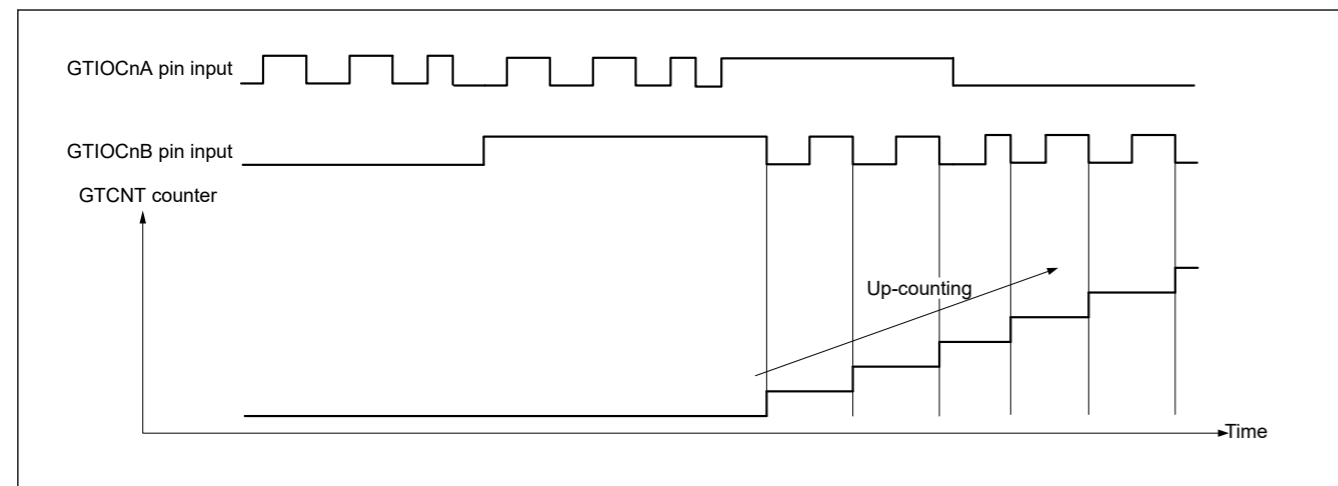


Figure 21.56 Example of phase counting mode 5 (B)

Table 21.37 相位计数模式下加减计数条件5 (A)

↑ : 上升沿  
↓ : 下降沿

| GTIOCnA引脚输入 | GTIOCnB引脚输入 | Operation   | 注册设置                                       |
|-------------|-------------|-------------|--|
| High        | ↑           | 不算数         | GTUPSR = 0x00000C00<br>GTDNSR = 0x00000000 |
| Low         | ↓           |             |  |
| ↑           | Low         | Up-counting |  |
| ↓           | High        |             |  |
| High        | ↓           | 不算数         |  |
| Low         | ↑           |             |  |
| ↑           | High        | Up-counting |  |
| ↓           | Low         |             |  |

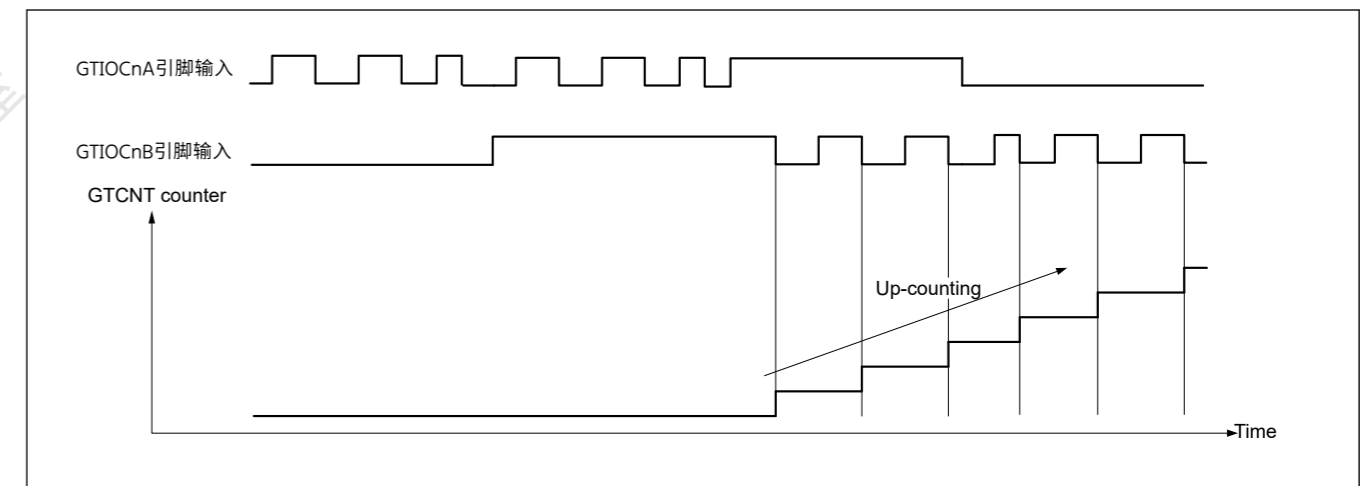












Figure 21.56 相位计数模式示例5(B)

Table 21.38 Conditions of up-counting/down-counting in phase counting mode 5 (B)

 : Rising edge  
 : Falling edge

| GTIOCnA pin input   | GTIOCnB pin input   | Operation    | Register setting                           |
|---|---|--------------|--|
| High  |  | Not counting | GTUPSR = 0x0000C000<br>GTDNSR = 0x00000000 |
| Low   |  | Up-counting  |  |
|  | Low   | Not counting |  |
|  | High  |              |  |
| High  |  | Up-counting  |  |
| Low   |  | Not counting |  |
|  | High  |              |  |
|  | Low   |              |  |



### 21.3.12 Output Phase Switching (GPT\_OPS)









GPT\_OPS provides a function for easy control of brushless DC motor operation using the Output Phase Switching Control Register (OPSCR).

GPT\_OPS outputs a PWM signal to be used for chopper control or level signal for each phase (U-positive phase/negative phase, V-positive phase/negative phase, W-positive phase/negative phase) of the 6-phase motor control. This function uses a soft setting value (OPSCR.UF, VF, WF) set by software or external signals detected by the Hall element, a PWM waveform of GPT320.GTIOC0A.

Figure 21.57 shows the conceptual diagram of GPT\_OPS control flow.

Table 21.38 相位计数模式下加减计数条件5(B)

 : 上升沿  
 : 下降沿

| GTIOCnA引脚输入   | GTIOCnB引脚输入   | Operation   | 注册设置                                       |
|---|---|-------------|--|
| High  |  | 不算数         | GTUPSR = 0x0000C000<br>GTDNSR = 0x00000000 |
| Low   |  | Up-counting |  |
|  | Low   | 不算数         |  |
|  | High  |             |  |
| High  |  | Up-counting |  |
| Low   |  | 不算数         |  |
|  | High  |             |  |
|  | Low   |             |  |

### 21.3.12 输出相位切换(GPT\_OPS)

GPT\_OPS提供使用输出相位切换控制轻松控制无刷直流电机运行的功能 Register (OPSCR).

GPT\_OPS输出用于斩波控制的PWM信号或6相电机控制的每一相 (U正相负相、V正相负相、W正相负相) 的电平信号。该功能使用软件设置的软设置值 (OPSCR.UF、VF、WF) 或霍尔元件检测到的外部信号, GPT320.GTIOC0A的PWM波形。

图21.57显示了GPT\_OPS控制流程的概念图。

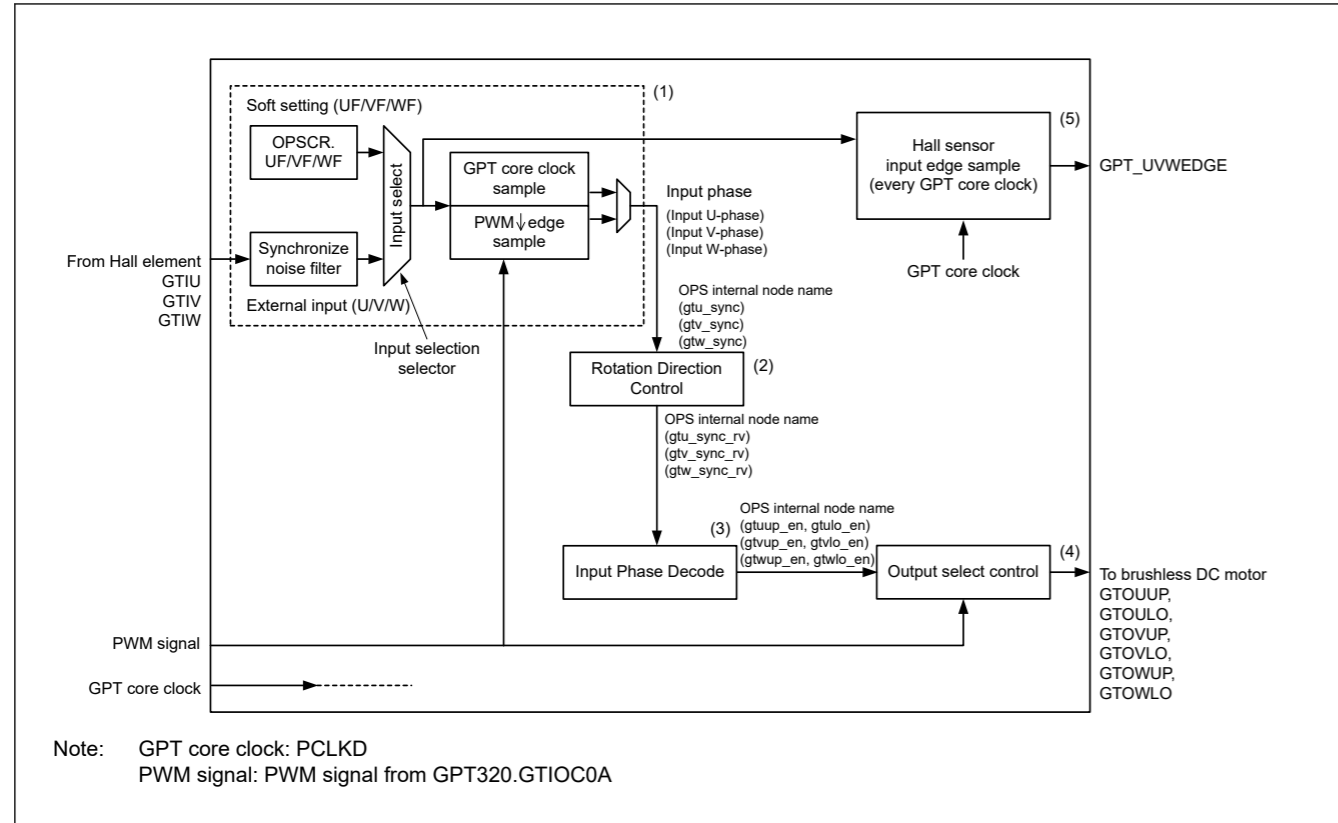


Figure 21.57 Conceptual diagram of GPT\_OPS control flow

Figure 21.58 shows a 6-phase level signals output example of a GPT\_OPS operation.

The GPT\_UVWEDGE signal in Figure 21.58 is the Hall sensor input edge to ELC output.

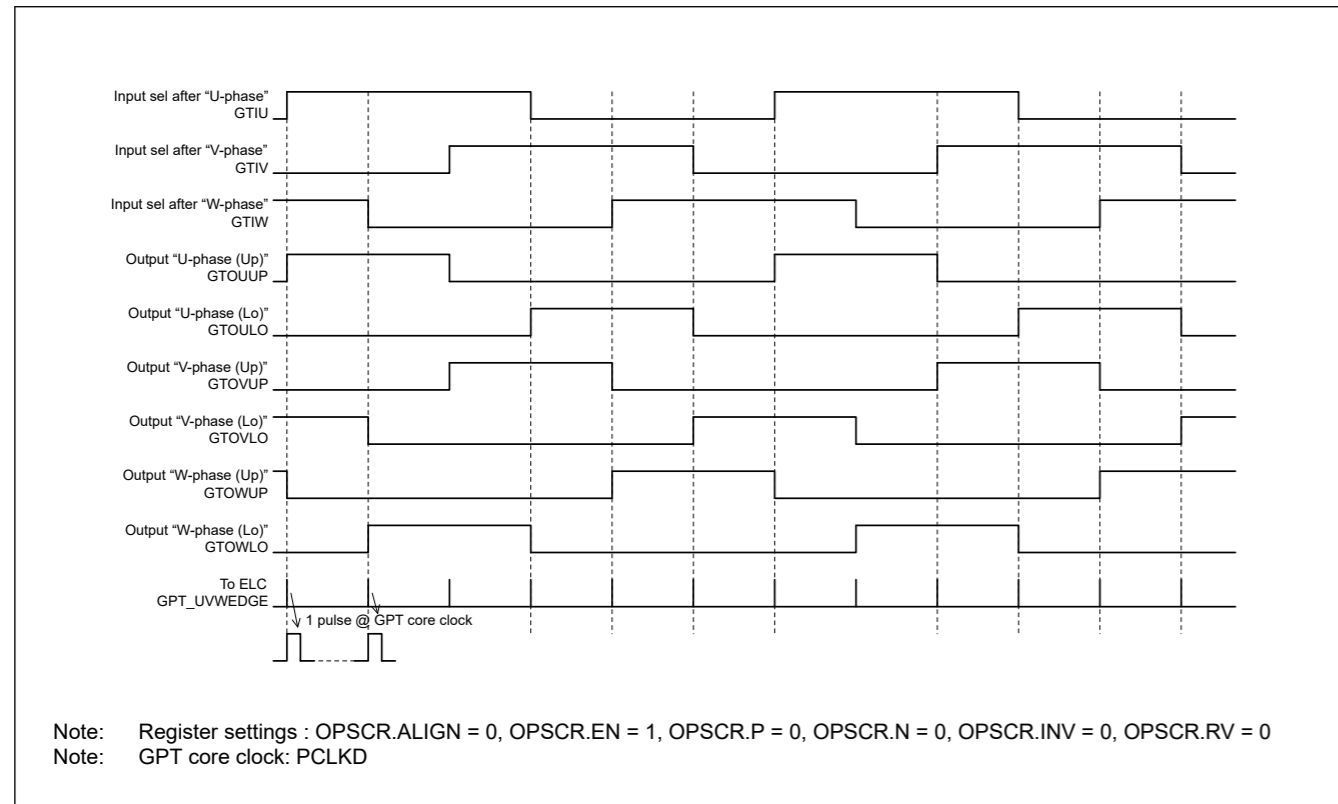


Figure 21.58 Example of 6-phase level output operation

Figure 21.59 shows a 6-phase PWM output example of a GPT\_OPS operation with chopper control.

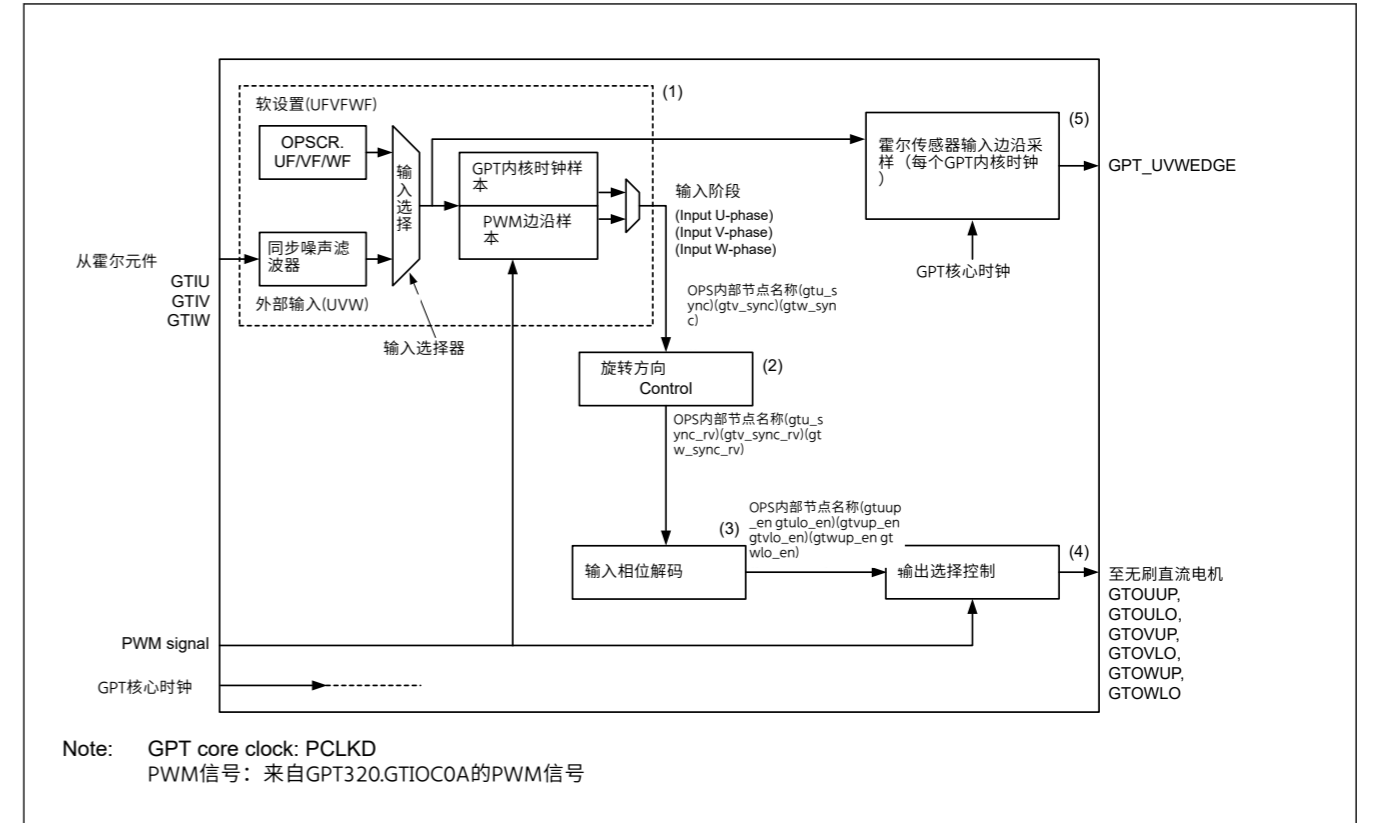


Figure 21.57 GPT\_OPS控制流程概念图

图21.58显示了GPT\_OPS操作的6相电平信号输出示例。

图21.58中的GPT\_UVWEDGE信号是霍尔传感器输入边沿到ELC输出。

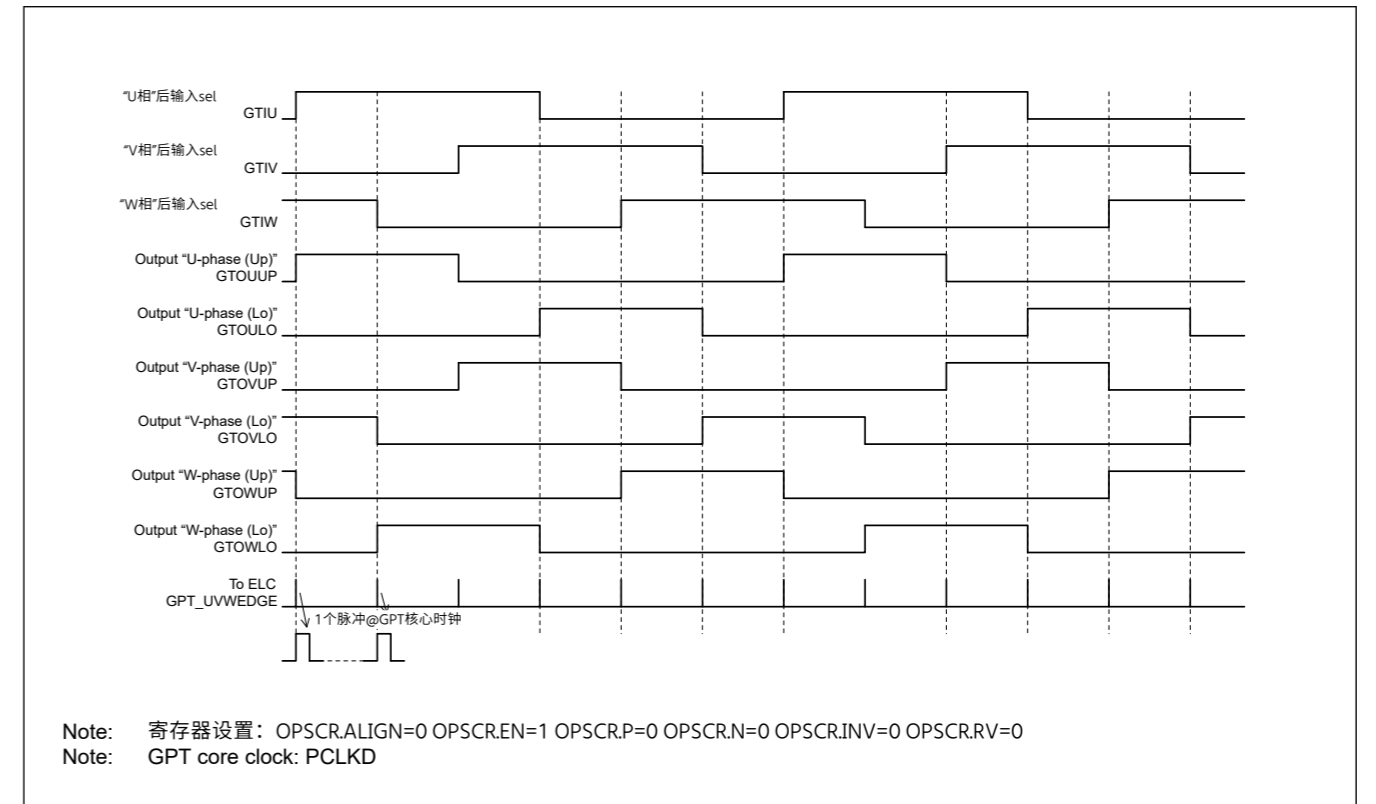


Figure 21.58 6相电平输出动作示例

图21.59显示了带斩波器控制的GPT\_OPS操作的6相PWM输出示例。



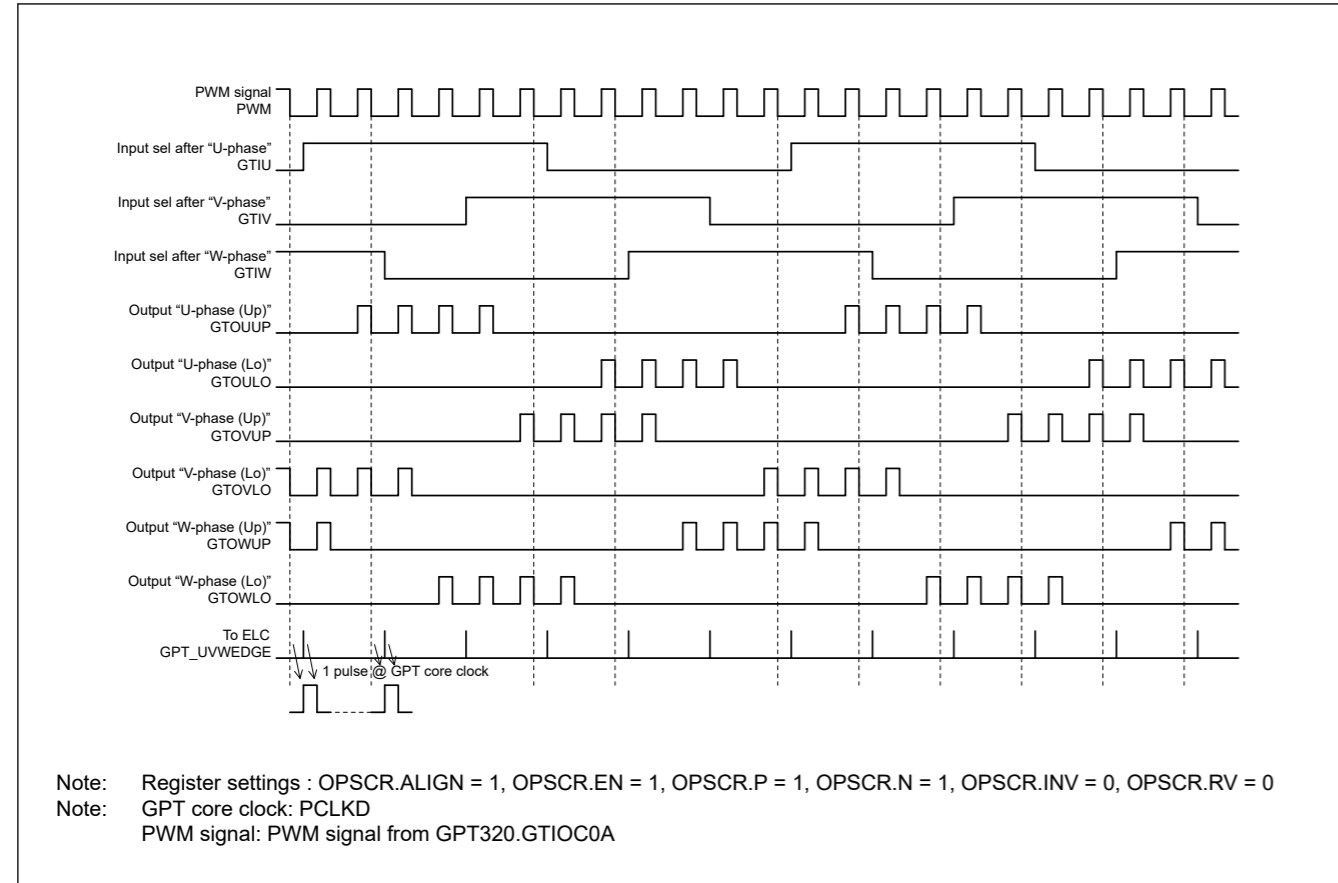


Figure 21.59 Example of 6-phase PWM output operation with chopper control

Figure 21.60 shows a 6-phase PWM output example of an output disable control operation.

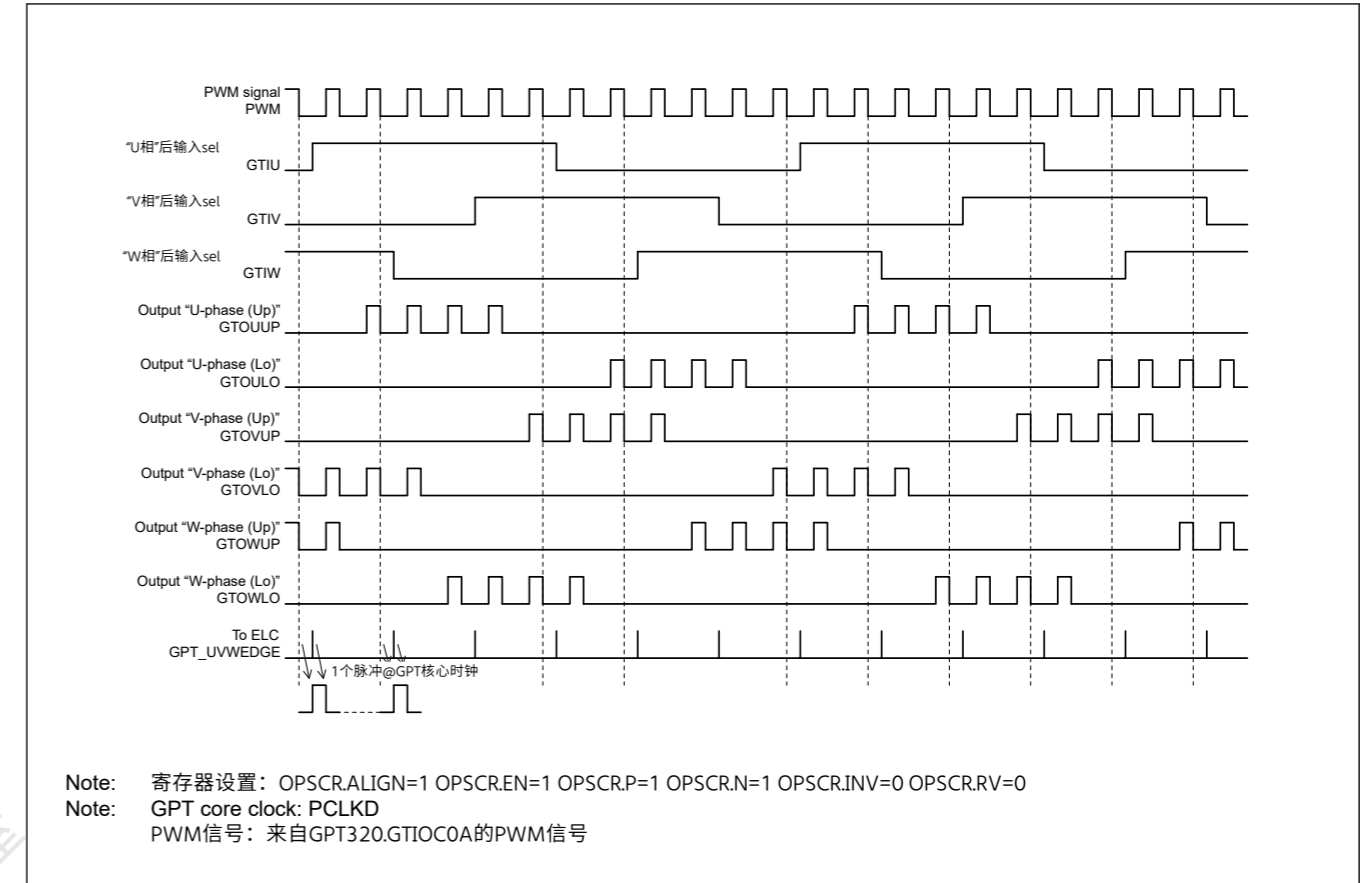


Figure 21.59 带斩波器控制的6相PWM输出操作示例

图21.60显示了输出禁用控制操作的6相PWM输出示例。

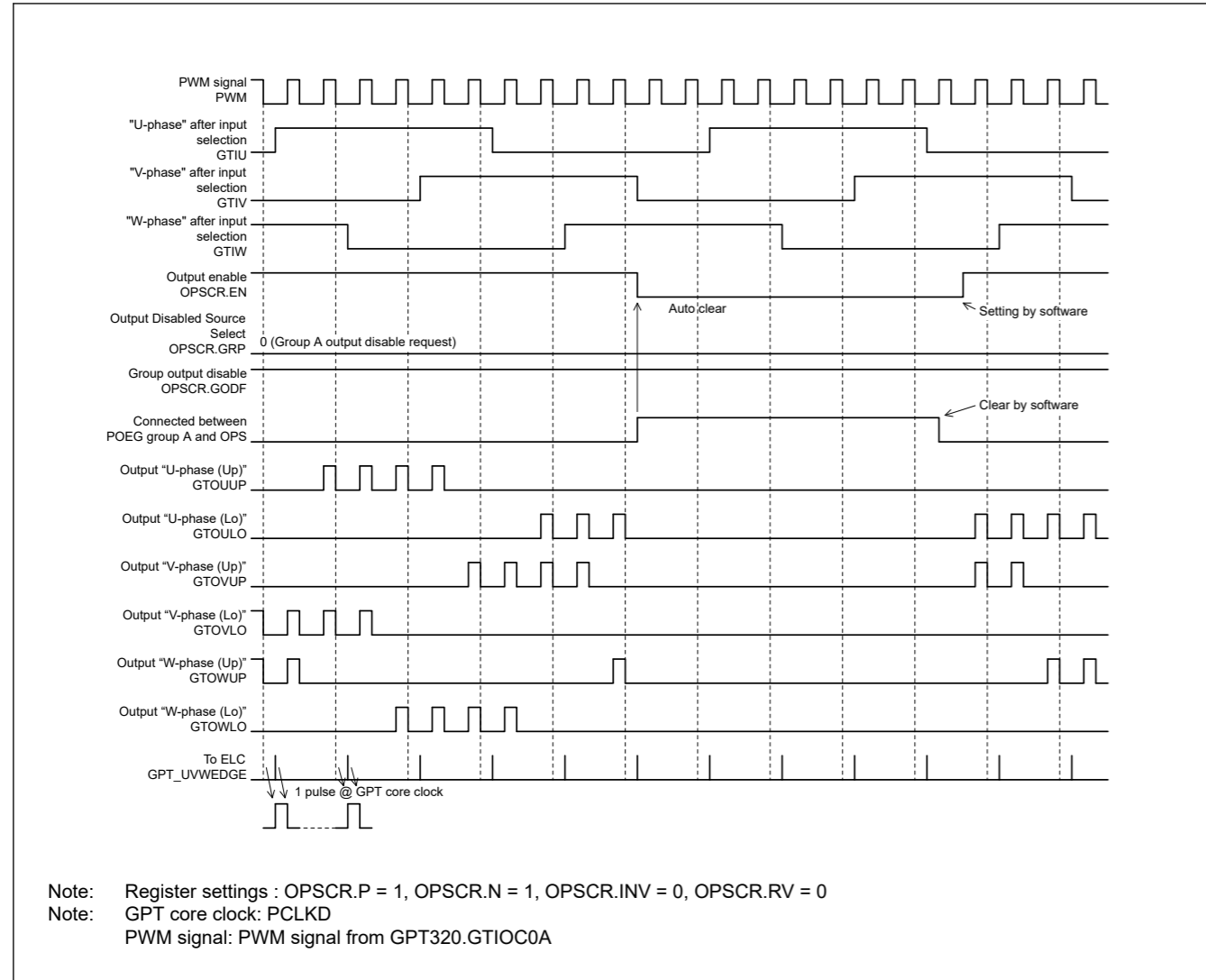


Figure 21.60 Example of group output disable control operation

21.3.12.1 Input selection and synchronization of external input signal

In the GPT\_ OPS control flow conceptual diagram shown in Figure 21.57, (1) is a selection of input phase from the software settings and external input by the OPSCR.FB bit.

When OPSCR.FB bit is 0, select the external input. Enable the input signal after synchronization with the GPT core clock (PCLKD). After carrying out noise filtering (optional), set the external input to the input phase of PWM (PWM of GPT320.GTIOC0A) using falling edge sampling with OPSCR.ALIGN bit set to 1.

When OPSCR.FB bit is 1, select the soft setting (OPSCR.UF, VF, WF) with the value of the input phase of PWM (PWM of GPT320.GTIOC0A) using falling edge sampling with OPSCR.ALIGN bit set to 1.

When OPSCR.ALIGN bit is 0, GPT\_ OPS operates with the input phase of PCLKD synchronization with either OPSCR.FB bit set to 0 or OPSCR.FB bit set to 1. However, there are cases where the PWM pulse width of the output U/V/W phases (PWM output mode) of switch timing (just before/just after) is shortened.

Table 21.39 shows the input selection process and setting of associated OPSCR bits.

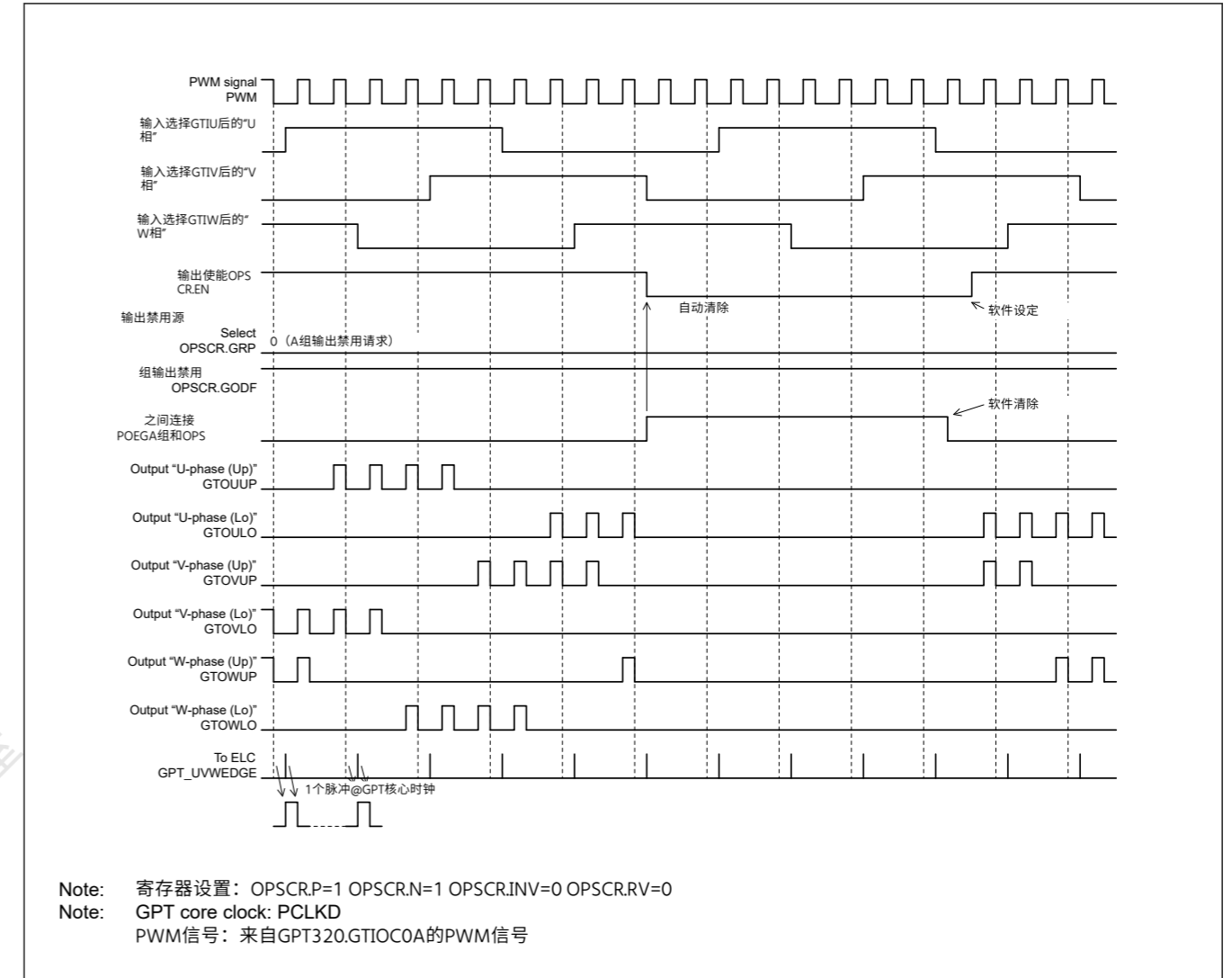


Figure 21.60 组输出禁用控制操作示例

21.3.12.1 外部输入信号的输入选择和同步

在图21.57所示的GPT\_ OPS控制流程概念图中, (1)是通过OPSCR.FB位从软件设置和外部输入中选择输入相位。

当OPSCR.FB位为0时, 选择外部输入。与GPT内核时钟(PCLKD)同步后启用输入信号。执行噪声过滤(可选)后, 使用下降沿采样将外部输入设置为PWM的输入相位 (GPT320.GTIOC0A的PWM), 并将OPSCR.ALIGN位设置为1。

当OPSCR.FB位为1时, 选择软设置 (OPSCR.UF、VF、WF) 与PWM的输入相位值 (PWM的GPT320.GTIOC0A)使用下降沿采样, 并将OPSCR.ALIGN位设置为1。

当OPSCR.ALIGN位为0时, GPT\_ OPS以PCLKD同步的输入相位运行, 其中OPSCR.FB位设置为0或OPSCR.FB位设置为1。但是, 输出UVW相位的PWM脉冲宽度存在某些情况 (PWM输出模式) 的开关时间 (就在之前) 被缩短了。

表21.39显示了输入选择过程和相关OPSCR位的设置。

Table 21.39 Input selection processing method

| Register OPSCR |           | Selection of input phase sampling method (U/V/W-phase)                                    | Synchronization input/output selection process (GPT_OPS internal node name)                     |
|----------------|-----------|---|---|
| FB bit         | ALIGN bit |   |   |
| 0              | 1         | External Input at PWM Falling Edge Sampling (PCLKD synchronization + falling edge sample) | Input Phase<br>Input U-Phase (gtu_sync)<br>Input V-Phase (gtv_sync)<br>Input W-Phase (gtw_sync) |
|                | 0         | External Input at PCLKD Synchronization Output (PCLKD synchronization + through mode)     |   |
| 1              | 1         | Software Settings at PWM Falling Edge Sampling (OPSCR.UF, VF, WF of falling edge sample)  |   |
|                | 0         | Software Setting Value Selection (= OPSCR.UF/VF/WF value) (= PCLKD synchronization)       |   |

21.3.12.2 Input sampling

The OPSCR.U, V, W bits indicate the PCLKD sampling results of the input selected in the OPSCR.FB bit. When OPSCR.FB bit is 0 and after synchronization with the GPT core clock (PCLKD) and noise filtering (optional), OPSCR.U, V, W bits indicate the sampling results of the external input. When OPSCR.FB bit is 1, OPSCR.U, V, W bits are the value (OPSCR.UF, VF, WF) of the soft setting.

21.3.12.3 Input phase decode

In the GPT\_OPS control flow conceptual diagram shown in Figure 21.57, (3) enables the 6-phase signals by decoding the input phase selected in the OPSCR.FB bit.

Table 21.40 shows the decode table of input phase when OPSCR.RV bit is 0.

Table 21.40 Decode table of input phase (OPSCR.RV = 0)

| Input phase (U/V/W) (GPT_OPS internal node name) |               |               | 6-phase enable {U/V/W (Up/Lo)} by decoding input phase (GPT_OPS internal node name) |              |              |              |              |              |
|--|---------------|---------------|---|--------------|--------------|--------------|--------------|--------------|
| Input U-Phase                                    | Input V-Phase | Input W-Phase | U-phase (Up)  | U-phase (Lo) | V-phase (Up) | V-phase (Lo) | W-phase (Up) | W-phase (Lo) |
| (gtu_sync)                                       | (gtv_sync)    | (gtw_sync)    | (gtuup_en)  | (gtulo_en)   | (gtvup_en)   | (gtvlo_en)   | (gtwup_en)   | (gtwlo_en)   |
| 1  | 0             | 1             | 1   | 0            | 0            | 1            | 0            | 0            |
| 1  | 0             | 0             | 1   | 0            | 0            | 0            | 0            | 1            |
| 1  | 1             | 0             | 0   | 0            | 1            | 0            | 0            | 1            |
| 0  | 1             | 0             | 0   | 1            | 1            | 0            | 0            | 0            |
| 0  | 1             | 1             | 0   | 1            | 0            | 0            | 1            | 0            |
| 0  | 0             | 1             | 0   | 0            | 0            | 1            | 1            | 0            |
| 0  | 0             | 0             | 0   | 0            | 0            | 0            | 0            | 0            |
| 1  | 1             | 1             | 0   | 0            | 0            | 0            | 0            | 0            |

Table 21.41 Decode table of input phase (OPSCR.RV = 1) (1 of 2)

| Input phase (U/V/W) (GPT_OPS internal node name) |               |               | 6-phase enable {U/V/W (Up/Lo)} by decoding input phase (GPT_OPS internal node name) |              |              |              |              |              |
|--|---------------|---------------|---|--------------|--------------|--------------|--------------|--------------|
| Input U-Phase                                    | Input V-Phase | Input W-Phase | U-phase (Up)  | U-phase (Lo) | V-phase (Up) | V-phase (Lo) | W-phase (Up) | W-phase (Lo) |
| (gtu_sync)                                       | (gtv_sync)    | (gtw_sync)    | (gtuup_en)  | (gtulo_en)   | (gtvup_en)   | (gtvlo_en)   | (gtwup_en)   | (gtwlo_en)   |
| 1  | 0             | 1             | 0   | 1            | 1            | 0            | 0            | 0            |
| 1  | 0             | 0             | 0   | 1            | 0            | 0            | 1            | 0            |
| 1  | 1             | 0             | 0   | 0            | 0            | 1            | 1            | 0            |

Table 21.39 输入选择处理方法

| Register OPSCR |     | 输入相位采样方式的选择 (UVW-phase)               | 同步输入输出选择过程 (GPT_OPS内部节点名)  |
|----------------|-----|---------------------------------------|--|
| FB bit         | 对齐位 |                                       |  |
| 0              | 1   | PWM下降沿采样的外部输入 (PCLKD同步+下降沿采样)         | 输入相位<br>Input U-Phase (gtu_sync)<br>Input V-Phase (gtv_sync)<br>Input W-Phase (gtw_sync) |
|                | 0   | PCLKD同步输出端的外部输入 (PCLKD同步+直通模式)        |  |
| 1              | 1   | PWM下降沿采样的软件设置 (下降沿采样的OPSCR.UF、VF、WF)  |  |
|                | 0   | 软件设置值选择 (=OPSCR.UF/VF/WF值) (=PCLKD同步) |  |

21.3.12.2 输入采样

OPSCR.U、V、W位指示在OPSCR.FB位中选择的输入的PCLKD采样结果。当OPSCR.FB位为0并与GPT内核时钟(PCLKD)和噪声过滤(可选)同步后, OPSCR.U、V、W位表示外部输入的采样结果。当OPSCR.FB位为1时, OPSCR.U、V、W位为软设置的值 (OPSCR.UF、VF、WF)。

21.3.12.3 输入相位解码

在图21.57所示的GPT\_OPS控制流程概念图中, (3)通过解码在OPSCR.FB位中选择的输入相位来启用6相位信号。

表21.40为OPSCR.RV位为0时的输入相位解码表。

Table 21.40 输入相位解码表(OPSCR.RV=0)

| 输入相位(UVW) (GPT_OPS内部节点名称) |               |               | 6-phase enable {UVW(UpLo)} 通过解码输入相位 (GPT_OPS内部节点名称) |              |              |              |              |              |
|---------------------------|---------------|---------------|---|--------------|--------------|--------------|--------------|--------------|
| Input U-Phase             | Input V-Phase | Input W-Phase | U-phase (Up)  | U-phase (Lo) | V-phase (Up) | V-phase (Lo) | W-phase (Up) | W-phase (Lo) |
| (gtu_sync)                | (gtv_sync)    | (gtw_sync)    | (gtuup_en)  | (gtulo_en)   | (gtvup_en)   | (gtvlo_en)   | (gtwup_en)   | (gtwlo_en)   |
| 1                         | 0             | 1             | 1   | 0            | 0            | 1            | 0            | 0            |
| 1                         | 0             | 0             | 1   | 0            | 0            | 0            | 0            | 1            |
| 1                         | 1             | 0             | 0   | 0            | 1            | 0            | 0            | 1            |
| 0                         | 1             | 0             | 0   | 1            | 1            | 0            | 0            | 0            |
| 0                         | 1             | 1             | 0   | 1            | 0            | 0            | 1            | 0            |
| 0                         | 0             | 1             | 0   | 0            | 0            | 1            | 1            | 0            |
| 0                         | 0             | 0             | 0   | 0            | 0            | 0            | 0            | 0            |
| 1                         | 1             | 1             | 0   | 0            | 0            | 0            | 0            | 0            |

Table 21.41 输入相位解码表(OPSCR.RV=1)(1of2)

| 输入相位(UVW) (GPT_OPS内部节点名称) |               |               | 6-phase enable {UVW(UpLo)} 通过解码输入相位 (GPT_OPS内部节点名称) |              |              |              |              |              |
|---------------------------|---------------|---------------|---|--------------|--------------|--------------|--------------|--------------|
| Input U-Phase             | Input V-Phase | Input W-Phase | U-phase (Up)  | U-phase (Lo) | V-phase (Up) | V-phase (Lo) | W-phase (Up) | W-phase (Lo) |
| (gtu_sync)                | (gtv_sync)    | (gtw_sync)    | (gtuup_en)  | (gtulo_en)   | (gtvup_en)   | (gtvlo_en)   | (gtwup_en)   | (gtwlo_en)   |
| 1                         | 0             | 1             | 0   | 1            | 1            | 0            | 0            | 0            |
| 1                         | 0             | 0             | 0   | 1            | 0            | 0            | 1            | 0            |
| 1                         | 1             | 0             | 0   | 0            | 0            | 1            | 1            | 0            |

Table 21.41 Decode table of input phase (OPSCR.RV = 1) (2 of 2)

| Input phase (U/V/W)<br>(GPT_OPS internal node name) |               |               | 6-phase enable {U/V/W (Up/Lo)} by decoding input phase<br>(GPT_OPS internal node name) |              |              |              |              |              |
|---|---------------|---------------|--|--------------|--------------|--------------|--------------|--------------|
| Input U-Phase                                       | Input V-Phase | Input W-Phase | U-phase (Up)   | U-phase (Lo) | V-phase (Up) | V-phase (Lo) | W-phase (Up) | W-phase (Lo) |
| (gtu_sync)  | (gtv_sync)    | (gtw_sync)    | (gtuup_en)   | (gtulo_en)   | (gtvup_en)   | (gtvlo_en)   | (gtwup_en)   | (gtwlo_en)   |
| 0   | 1             | 0             | 1  | 0            | 0            | 1            | 0            | 0            |
| 0   | 1             | 1             | 1  | 0            | 0            | 0            | 0            | 1            |
| 0   | 0             | 1             | 0  | 0            | 1            | 0            | 0            | 1            |
| 0   | 0             | 0             | 0  | 0            | 0            | 0            | 0            | 0            |
| 1   | 1             | 1             | 0  | 0            | 0            | 0            | 0            | 0            |

21.3.12.4 Rotation Direction Control

In the GPT\_OPS control flow conceptual diagram shown in Figure 21.57, (2) controls the direction of rotation of a 3-phase motor using the OPSCR.RV bit.

When the rotation direction is reverse (RV bit = 1), the input phase is inverted.

Table 21.42 shows the assigned output phases based on the OPSCR.RV bit setting (before and after rotation direction control).

Table 21.42 Rotation Direction Control Method

| Reversal of Direction of Rotation Using Output Phases as Specified in OPSCR Register | Output of Rotation Direction Control [U/V/W (Positive/Negative)]<br>(GPT_OPS Internal Node Name after Control) |                            |                            |                            |                            |                            |
|--|--|----------------------------|----------------------------|----------------------------|----------------------------|----------------------------|
|  | OPSCR.RV bit   | (gtuup_ren)                | (gtulo_ren)                | (gtvup_ren)                | (gtvlo_ren)                | (gtwup_ren)                |
| 0  | U-phase (Up)<br>(gtuup_en)   | U-phase (Lo)<br>(gtulo_en) | V-phase (Up)<br>(gtvup_en) | V-phase (Lo)<br>(gtvlo_en) | W-phase (Up)<br>(gtwup_en) | W-phase (Lo)<br>(gtwlo_en) |
| 1  | U-phase (Up)<br>(gtuup_en)   | U-phase (Lo)<br>(gtulo_en) | W-phase (Up)<br>(gtwup_en) | W-phase (Lo)<br>(gtwlo_en) | V-phase (Up)<br>(gtvup_en) | V-phase (Lo)<br>(gtvlo_en) |

21.3.12.5 Output selection control

In the GPT\_OPS control flow conceptual diagram in Figure 21.57, (4) represents the selection of the output waveform by setting the OPSCR register bit.

For output selection, the following bits are relevant:

- The OPSCR.EN bit controls whether to output the 6-phase output, or to stop
- The OPSCR.P and OPSCR.N bits can select from the level signal or PWM signal (chopper output) for the output phase
- The polarity of the output phase can be set to a positive logic or negative logic by the OPSCR.INV bit.

Table 21.43 and Table 21.44 show the output selection control method using the OPSCR register bit.

Table 21.43 Output selection control method (positive phase) (1 of 2)

| Enable-phase output control | Positive-phase output (P) control | Invert-phase output control | Output port name (positive phase = up)<br>(output selection internal node allocation) |   |
|-----------------------------|-----------------------------------|-----------------------------|---|---|
| OPSCR.EN                    | OPSCR.P                           | OPSCR.INV                   | GTOUUP<br>GTOVUP<br>GTOWUP  | Mode  |
| 0                           | x                                 | x                           | 0   | Output Stop<br>(External pin: Hi-Z)<br>GPT_OPS → 0 output |

Table 21.41 输入相位解码表(OPSCR.RV=1)(2of2)

| 输入相位(U/V/W) (GPT_OPS内部节点名称) |               |               | 6-phaseenable{UVW(UpLo) 通过解码输入相位 (GPT_OPS内部节点名称) |              |              |              |              |              |
|-----------------------------|---------------|---------------|--|--------------|--------------|--------------|--------------|--------------|
| Input U-Phase               | Input V-Phase | Input W-Phase | U-phase (Up)                                     | U-phase (Lo) | V-phase (Up) | V-phase (Lo) | W-phase (Up) | W-phase (Lo) |
| (gtu_sync)                  | (gtv_sync)    | (gtw_sync)    | (gtuup_en)                                       | (gtulo_en)   | (gtvup_en)   | (gtvlo_en)   | (gtwup_en)   | (gtwlo_en)   |
| 0                           | 1             | 0             | 1  | 0            | 0            | 1            | 0            | 0            |
| 0                           | 1             | 1             | 1  | 0            | 0            | 0            | 0            | 1            |
| 0                           | 0             | 1             | 0  | 0            | 1            | 0            | 0            | 1            |
| 0                           | 0             | 0             | 0  | 0            | 0            | 0            | 0            | 0            |
| 1                           | 1             | 1             | 0  | 0            | 0            | 0            | 0            | 0            |

21.3.12.4 旋转方向控制

在图21.57所示的GPT\_OPS控制流程概念图中，(2)使用OPSCR.RV位控制三相电机的旋转方向。

当旋转方向为反向时 (RV位=1)，输入相位反转。

表21.42显示了基于OPSCR.RV位设置 (旋转方向控制之前和之后) 分配的输出相位。

Table 21.42 旋转方向控制方式

| 使用输出相位反转旋转方向<br>在OPSCR中指定Register | 旋转方向控制输出[UVW (正负)]<br>(GPT_OPS控制后的内部节点名称) |                            |                            |                            |                            |                            |
|-----------------------------------|---|----------------------------|----------------------------|----------------------------|----------------------------|----------------------------|
|                                   | OPSCR.RV bit                              | (gtuup_ren)                | (gtulo_ren)                | (gtvup_ren)                | (gtvlo_ren)                | (gtwup_ren)                |
| 0                                 | U-phase (Up)<br>(gtuup_en)                | U-phase (Lo)<br>(gtulo_en) | V-phase (Up)<br>(gtvup_en) | V-phase (Lo)<br>(gtvlo_en) | W-phase (Up)<br>(gtwup_en) | W-phase (Lo)<br>(gtwlo_en) |
| 1                                 | U-phase (Up)<br>(gtuup_en)                | U-phase (Lo)<br>(gtulo_en) | W-phase (Up)<br>(gtwup_en) | W-phase (Lo)<br>(gtwlo_en) | V-phase (Up)<br>(gtvup_en) | V-phase (Lo)<br>(gtvlo_en) |

21.3.12.5 输出选择控制

在图21.57的GPT\_OPS控制流程概念图中，(4)表示通过设置OPSCR寄存器位来选择输出波形。

对于输出选择，以下是相关的：

- OPSCR.EN位控制是输出6相输出，还是停止
- OPSCR.P和OPSCR.N位可以选择输出相位的电平信号或PWM信号 (斩波器输出)
- 输出相的极性可以通过OPSCR设置为正逻辑或负逻辑。INV位。

表21.43和表21.44显示了使用OPSCR寄存器位的输出选择控制方法。

Table 21.43 输出选择控制方式 (正相) (1of2)

| 使能相位输出控制 | 正相输出(P)控制 | 反相输出控制    | 输出端口名称 (正相=向上) (输出选择内部节点分配) |                                |
|----------|-----------|-----------|-----------------------------|--------------------------------|
| OPSCR.EN | OPSCR.P   | OPSCR.INV | GTOUUP<br>GTOVUP<br>GTOWUP  | Mode                           |
| 0        | x         | x         | 0                           | 输出停止 (外部引脚: Hi-Z) GPT_OPS→0 输出 |

Table 21.43 Output selection control method (positive phase) (2 of 2)

| Enable-phase output control | Positive-phase output (P) control | Invert-phase output control | Output port name (positive phase = up) (output selection internal node allocation) |   |
|-----------------------------|-----------------------------------|-----------------------------|--|---|
| OPSCR.EN                    | OPSCR.P                           | OPSCR.INV                   | GTOUUP<br>GTOVUP<br>GTOWUP   | Mode  |
| 1                           | 0                                 | 0                           | Level signal (gtuup_ren)<br>(gtvup_ren)<br>(gtwup_ren)                             | Level Output Mode (Positive phase) (Positive logic) |
| 1                           | 0                                 | 1                           | Level signal (~gtuup_ren)<br>(~gtvup_ren)<br>(~gtwup_ren)                          | Level Output Mode (Positive phase) (Negative logic) |
| 1                           | 1                                 | 0                           | PWM signal (PWM & gtuup_ren)<br>(PWM & gtvup_ren)<br>(PWM & gtwup_ren)             | PWM Output Mode (Positive phase) (Positive logic)   |
| 1                           | 1                                 | 1                           | PWM signal ~(PWM & gtuup_ren)<br>(~(PWM & gtvup_ren))<br>(~(PWM & gtwup_ren))      | PWM Output Mode (Positive phase) (Negative logic)   |

Table 21.44 Output selection control method (negative phase)

| Enable-phase output control | Positive-phase output (N) control | Invert-phase output control | Output port name (negative phase = Lo) (output selection internal node allocation) |   |
|-----------------------------|-----------------------------------|-----------------------------|--|---|
| OPSCR.EN                    | OPSCR.N                           | OPSCR.INV                   | GTOULO<br>GTOVLO<br>GTOWLO   | Mode  |
| 0                           | x                                 | x                           | 0  | Output Stop (External pin: Hi-Z) GPT_OPS → 0 output |
| 1                           | 0                                 | 0                           | Level signal (gtulo_ren)<br>(gtvlo_ren)<br>(gtwlo_ren)                             | Level Output Mode (Negative phase) (Positive logic) |
| 1                           | 0                                 | 1                           | Level signal (~gtulo_ren)<br>(~gtvlo_ren)<br>(~gtwlo_ren)                          | Level Output Mode (Negative phase) (Negative logic) |
| 1                           | 1                                 | 0                           | PWM signal (PWM & gtulo_ren)<br>(PWM & gtvlo_ren)<br>(PWM & gtwlo_ren)             | PWM Output Mode (Negative phase) (Positive logic)   |
| 1                           | 1                                 | 1                           | PWM signal ~(PWM & gtulo_ren)<br>(~(PWM & gtvlo_ren))<br>(~(PWM & gtwlo_ren))      | PWM Output Mode (Negative phase) (Negative logic)   |

21.3.12.6 Output selection control (group output disable function)

When OPSCR.GODF is 1 and the signal value selected by the OPSCR.GRP bit is high (output disable request), the group output-disable function asynchronously sets the output to Hi-Z. When an output-disable request is generated, the OPSCR.EN bit is cleared to 0. For the return, set the OPSCR.EN bit to 1 after clearing the output disable request by software.

To ensure output-disable control, use the POEG\_GROUPn (n = A to D) interrupt to clear the flag in the POE or check that the OPSCR.EN bit is 0 and then clear the flag. For an example of the operation of group output disable control, see Figure 21.60.

Table 21.43 输出选择控制方式 (正相) (2of2)

| 使能相位输出控制 | 正相输出(P)控制 | 反相输出控制    | 输出端口名称 (正相=向上) (输出选择内部节点分配)   |                    |
|----------|-----------|-----------|---|--------------------|
| OPSCR.EN | OPSCR.P   | OPSCR.INV | GTOUUP<br>GTOVUP<br>GTOWUP  | Mode               |
| 1        | 0         | 0         | 电平信号(gt uup_ren)(gt vup_ren)(gt wup_ren)                                      | 电平输出模式 (正相) (正逻辑)  |
| 1        | 0         | 1         | 电平信号(~gt uup_ren)(~gt vup_ren)(~gt wup_ren)                                   | 电平输出模式 (正相) (负逻辑)  |
| 1        | 1         | 0         | PWM signal (PWM & gtuup_ren)<br>(PWM & gtvup_ren)<br>(PWM & gtwup_ren)        | PWM输出模式 (正相) (正逻辑) |
| 1        | 1         | 1         | PWM signal ~(PWM & gtuup_ren)<br>(~(PWM & gtvup_ren))<br>(~(PWM & gtwup_ren)) | PWM输出模式 (正相) (负逻辑) |

Table 21.44 输出选择控制方式 (负相)

| 使能相位输出控制 | 正相输出(N)控制 | 反相输出控制    | 输出端口名称 (负相=Lo) (输出选择内部节点分配)   |                                  |
|----------|-----------|-----------|---|----------------------------------|
| OPSCR.EN | OPSCR.N   | OPSCR.INV | GTOULO<br>GTOVLO<br>GTOWLO  | Mode                             |
| 0        | x         | x         | 0   | 输出停止 (外部引脚: Hi-Z) GPT_OPS → 0 输出 |
| 1        | 0         | 0         | 电平信号(gt ulo_ren)(gt vlo_ren)(gt wlo_ren)                                      | 电平输出模式 (负相) (正逻辑)                |
| 1        | 0         | 1         | 电平信号(~g tulo_ren)(~g tvlo_ren)(~g twlo_ren)                                   | 电平输出模式 (负相) (负逻辑)                |
| 1        | 1         | 0         | PWM signal (PWM & gtulo_ren)<br>(PWM & gtvlo_ren)<br>(PWM & gtwlo_ren)        | PWM输出模式 (负相) (正逻辑)               |
| 1        | 1         | 1         | PWM signal ~(PWM & gtulo_ren)<br>(~(PWM & gtvlo_ren))<br>(~(PWM & gtwlo_ren)) | PWM输出模式 (负相) (负逻辑)               |

21.3.12.6 输出选择控制 (组输出禁用功能)

当OPSCR.GODF为1且OPSCR.GRP位选择的信号值为高电平 (输出禁用请求) 时, 组输出禁用功能异步将输出设置为Hi-Z。产生输出禁止请求时, OPSCR.EN位清零。返回时, 请在软件清除输出禁止请求后将OPSCR.EN位设置为1。

为确保输出禁用控制, 请使用POEG\_GROUPn (n=A到D) 中断清除POE中的标志或检查OPSCR.EN位是否为0, 然后清除标志。组输出禁用控制的操作示例见图21.60。



### 21.3.12.7 Event Link Controller (ELC) output

In the GPT\_OPS control flow conceptual diagram shown in [Figure 21.57](#), (5) outputs the Hall sensor input signal edge to the ELC.

The Hall sensor input edge signal is the logical OR of the rising and falling edge signals of each U-phase/V-phase/W-phase input sampled at PCLKD. That is, if the high period of each of the U-phase/V-phase/W-phase of the input phase is short in duration, the Hall sensor edge input signal is not output at that time.

When the OPSCR.FB bit is 0, the Hall sensor input edge signal is the logical OR of the edge signals of the external input phase sampled at PCLKD.

When OPSCR.FB bit is 1, the Hall sensor input edge signal is the logical OR of the edge of the soft setting (OPSCR.UF, VF, WF) sampled at PCLKD.

See [Figure 21.58](#) to [Figure 21.60](#) for examples of the output signal to the ELC.

### 21.3.12.8 GPT\_OPS start operation setting flow

**Table 21.45 Example setting of GPT\_OPS start operation**

| No. | Step Name   | Description   |
|-----|---|---|
| 1   | GPT320 operation mode setting   | GPT320.GTIOC0A set the PWM output operation mode of the saw-wave or triangle-wave. For details, see <a href="#">section 21.3.3. PWM Output Operating Mode</a> .   |
| 2   | Counting of GPT320  | Start the count operation of GPT320, and outputs a PWM waveform.  |
| 3   | GPT_OPS input data set (only software setting is selected)                        | Set software setting to OPSCR.UF, VF, and WF bits.  |
| 4   | Noise filter settings of GPT_OPS external input (only external input is selected) | When using a noise filter, set the sampling clock of the noise filter by OPSCR.NFCS[1:0] bits. Then the noise filter is enabled if OPSCR.NFEN = 1.  |
| 5   | GPT_OPS input phase selection setting/input phase alignment setting               | Select the input phase from the external input or software setting by OPSCR.FB bit. Select the alignment of the input phase by OPSCR.ALIGN bit.   |
| 6   | Setting the GPT_OPS output phase  | Set the level output/PWM output of the positive/negative phase output by OPSCR.P/OPSCR.N bit. Set the positive logic/negative logic of the output phase by OPSCR.INV bit. Set the rotation direction by OPSCR.RV bit. |
| 7   | GPT_OPS setting the group output disable function                                 | Set the selection of output disable source by OPSCR.GRP bit. Perform the setting of on/off of the group output disable function by OPSCR.GODF bit.  |
| 8   | GPT_OPS Working   | Setting the OPSCR.EN = 1 outputs the 6-phase output to drive the brushless DC motor from the GPT_OPS.   |

### 21.3.13 Inter Channel Logical Operation Function

The logical operation function between compare match outputs can be performed.

[Figure 21.61](#) shows the block diagram of inter channel logical operation.

To prevent hazard to the GPT output, the signal after logical operation is latched with PCLKD. After latching, the output disable control is performed.

When the logical operation function which causes the delay of 1 PCLKD is selected, the output enable signal is also delayed with 1 PCLKD and input to the output disable control.

When the same signal (C = A or D = B) to operate logical function AND, OR, EXOR and NOR is selected, C or D is treated as "1". In the case of GTIOCnA pin output, when A of same channel is selected for C, the result of AND is "A", the result of OR is "1", the result of EXOR is "NOT A", and the result of NOR is "0".

### 21.3.12.7 事件链接控制器(ELC)输出

在图21.57所示的GPT\_OPS控制流程概念图中，(5)将霍尔传感器输入信号沿输出到ELC。

霍尔传感器输入边沿信号是在PCLKD采样的每个U相V相W相输入的上升沿和下降沿信号的逻辑或。也就是说，如果输入相的U相V相W相中的每一个的高电平时段持续时间短，则此时不输出霍尔传感器边沿输入信号。

当OPSCR.FB位为0时，霍尔传感器输入边沿信号为在PCLKD采样的外部输入相位边沿信号的逻辑或。

当OPSCR.FB位为1时，霍尔传感器输入边沿信号为软设置边沿的逻辑或（OPSCR.UF, VF, WF）在PCLKD采样。

有关ELC的输出信号示例，请参见图21.58至图21.60。

### 21.3.12.8 GPT\_OPS启动操作设置流程

**Table 21.45 GPT\_OPS启动操作的示例设置**

| No. | 步骤名称                            | Description  |
|-----|---------------------------------|--|
| 1   | GPT320操作模式设置                    | GPT320.GTIOC0A设置PWM输出工作模式为锯齿波或三角波。详见21.3.3节。PWM输出工作模式。                         |
| 2   | GPT320的计数                       | 启动GPT320的计数操作，并输出一个PWM波形。  |
| 3   | GPT_OPS输入数据集（仅选择软件设置）           | 将软件设置设置为OPSCR.UF、VF和WF位。   |
| 4   | 噪声滤波器设置<br>GPT_OPS外部输入（仅选择外部输入） | 使用噪声滤波器时，通过OPSCR.NFCS[1:0]位设置噪声滤波器的采样时钟。如果OPSCR.NFEN=1，则启用噪声滤波器。               |
| 5   | GPT_OPS输入相位选择设置<br>输入相位对齐设置     | 通过OPSCR.FB位从外部输入或软件设置中选择输入相位。通过OPSCR.ALIGN位选择输入相位的对齐方式。                        |
| 6   | 设置GPT_OPS输出阶段                   | 通过OPSCR.POPSCR.N位设置正负相输出的电平输出PWM输出。通过OPSCR.INV位设置输出相位的正逻辑负逻辑。通过OPSCR.RV位设置旋转方向 |
| 7   | GPT_OPS设置组输出禁用功能                | 通过OPSCR.GRP位设置输出禁用源的选择。通过OPSCR.GODF位执行组输出禁用功能的开关设置。                            |
| 8   | GPT_OPS Working                 | 设置OPSCR.EN=1输出6相输出驱动直流无刷电机GPT_OPS。   |

### 21.3.13 通道间逻辑运算功能

可以执行比较匹配输出之间的逻辑运算功能。

图21.61显示了通道间逻辑操作的框图。

为防止对GPT输出造成危害，逻辑运算后的信号由PCLKD锁存。锁存后，执行输出禁用控制。

When the logical operation function which causes the delay of 1 PCLKD is selected, the output enable signal is also delayed with 1 PCLKD and input to the output disable control.

当相同的信号 (c=a或d=b) 操作逻辑函数，或者，或者选择也没有选择，C或D也被视为“1”。在GTIOCnA引脚输出的情况下，当C选择相同通道的A时，AND的结果为“A”，OR的结果为“1”，EXOR的结果为“NOT A”，NOR为“0”。

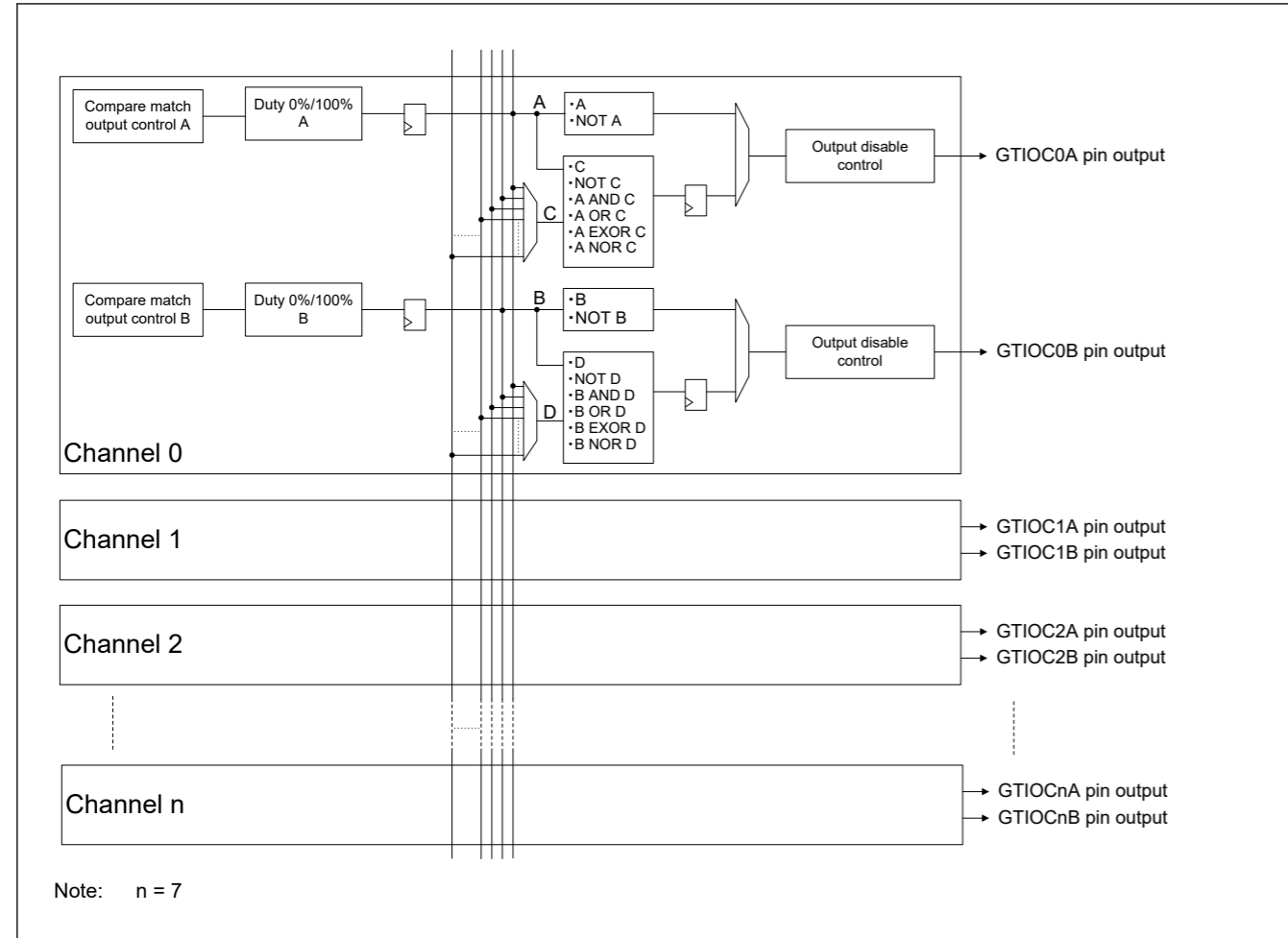


Figure 21.61 Block Diagram of Inter Channel Logical Operation

Figure 21.62 shows an example of inter channel logical operation.

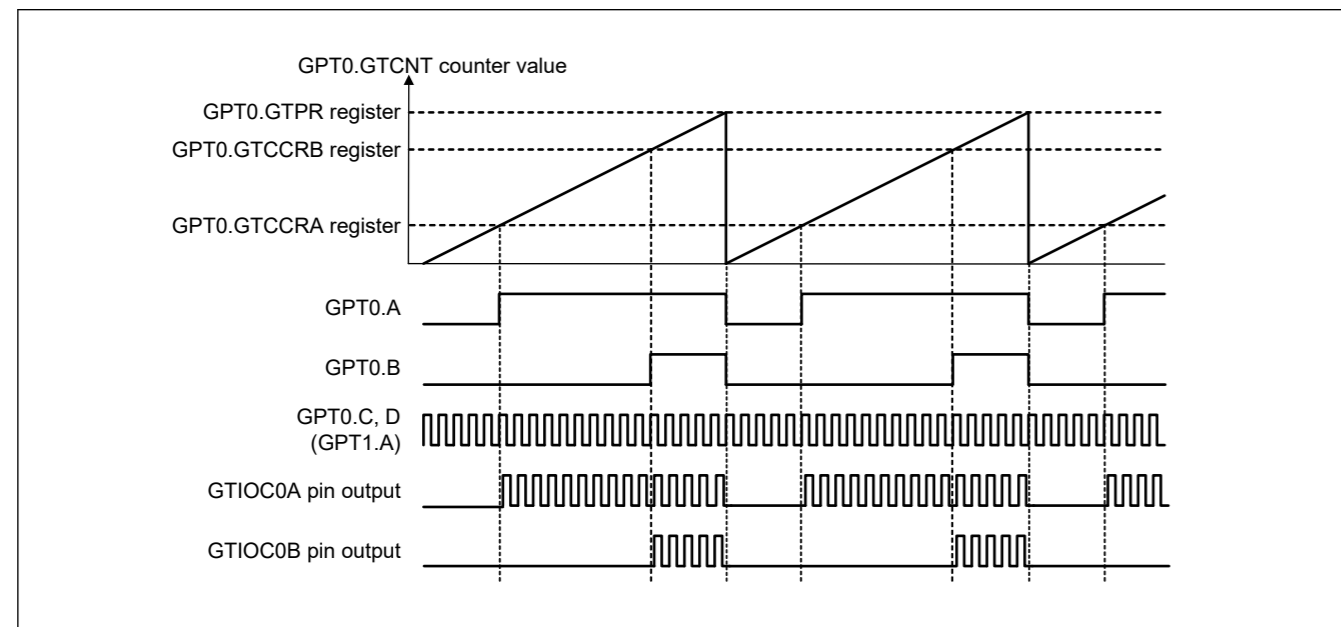


Figure 21.62 Example of Inter Channel Logical Operation

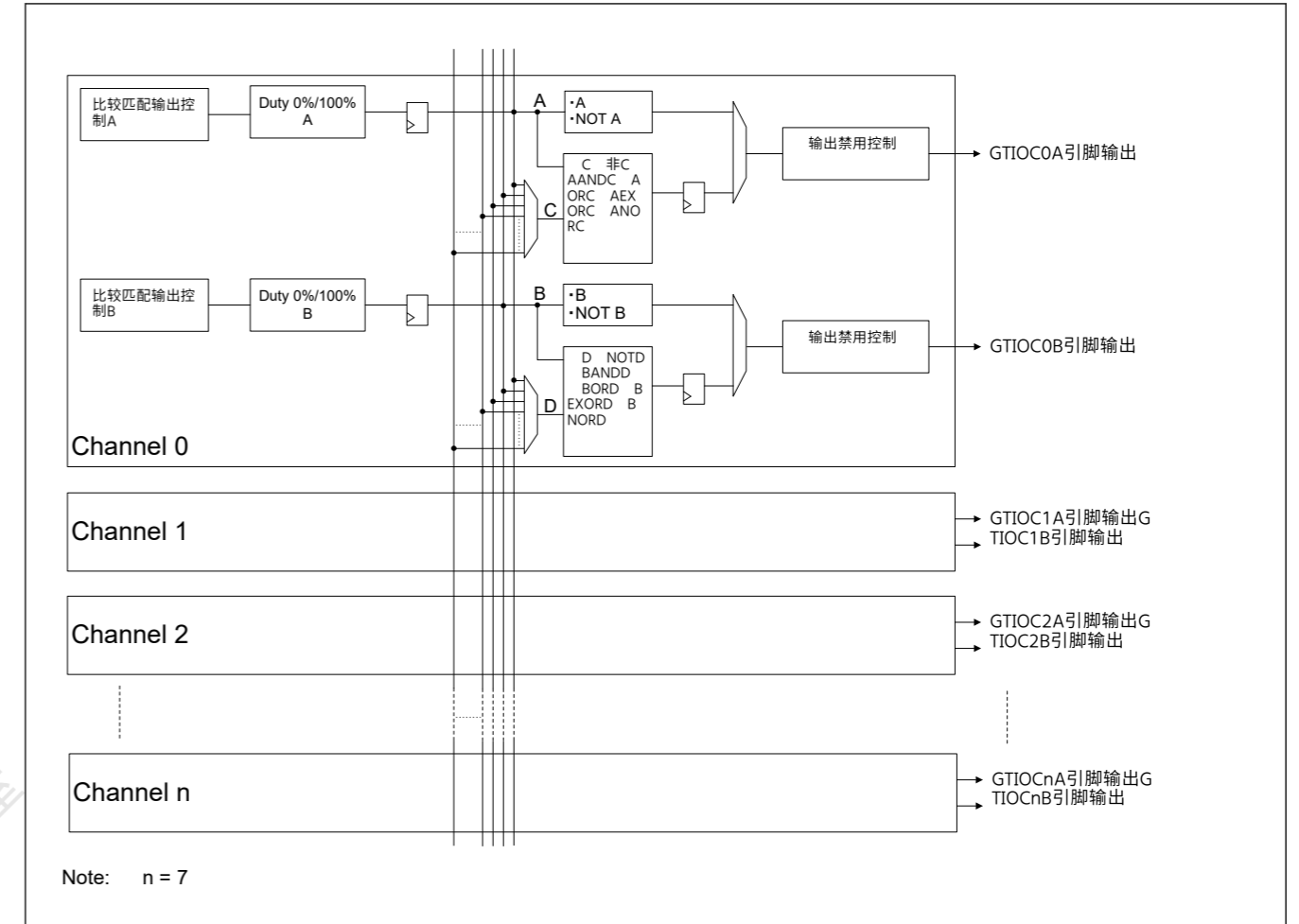


Figure 21.61 通道间逻辑操作框图

图21.62显示了通道间逻辑操作的示例。

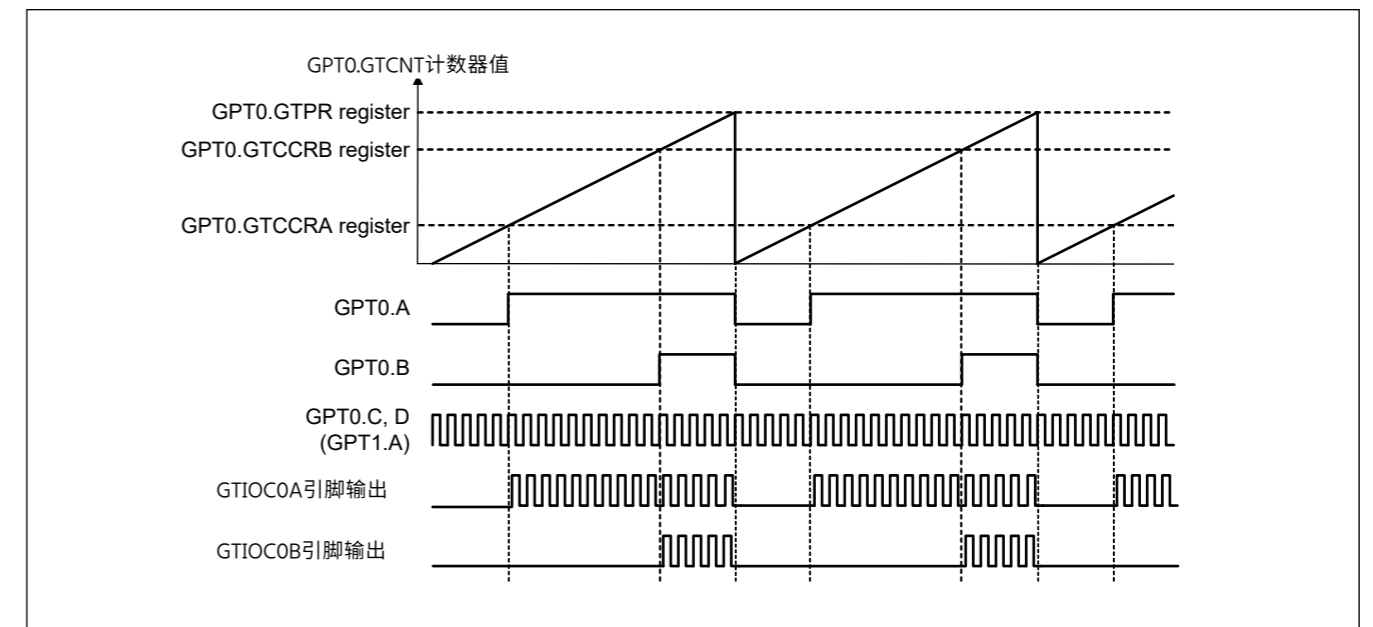


Figure 21.62 通道间逻辑运算示例

## 21.4 Interrupt Sources

### 21.4.1 Interrupt Sources

The GPT provides the following interrupt sources:

- GTCCR input capture/compare match
- GTCNT counter overflow (GTPR compare match)/underflow.
- period count function finish

Each interrupt source has its own status flag. When an interrupt source signal is generated, the associated status flag in GTST is set to 1. The associated status flag in GTST can be cleared by writing 0. If flag set and flag clear occur at the same time, flag clear takes priority over flag set. These flags are automatically updated by the internal state. The Interrupt Controller Unit can change the relative channel priorities. However, the priority within a channel is fixed. For details, see [section 13, Interrupt Controller Unit \(ICU\)](#).

Table 21.46 lists the GPT interrupt sources.

**Table 21.46 Interrupt sources**

| Channel    | Name       | Interrupt source                                  | Interrupt flag  | DTC activation |
|------------|------------|---|-----------------|----------------|
| n = 0 to 3 | GPTn_CCMPA | GPT32n.GTCCRA input capture/compare match         | GTST[0] (TCFA)  | Possible       |
|            | GPTn_CCMPB | GPT32n.GTCCRB input capture/compare match         | GTST[1] (TCFB)  | Possible       |
|            | GPTn_CMPC  | GPT32n.GTCCRC compare match                       | GTST[2] (TCFC)  | Possible       |
|            | GPTn_CMPD  | GPT32n.GTCCRD compare match                       | GTST[3] (TCFD)  | Possible       |
|            | GPTn_CMPE  | GPT32n.GTCCRE compare match                       | GTST[4] (TCFE)  | Possible       |
|            | GPTn_CMPF  | GPT32n.GTCCRF compare match                       | GTST[5] (TCFF)  | Possible       |
|            | GPTn_OVF   | GPT32n.GTCNT overflow (GPT32m.GTPR compare match) | GTST[6] (TCFPO) | Possible       |
|            | GPTn_UDF   | GPT32n.GTCNT underflow                            | GTST[7] (TCFPU) | Possible       |
|            | GPTn_PC    | Period count function finish (n = 0, 1)           | GTST[31] (PCF)  | Possible       |
| n = 4 to 7 | GPTn_CCMPA | GPT16n.GTCCRA input capture/compare match         | GTST[0] (TCFA)  | Possible       |
|            | GPTn_CCMPB | GPT16n.GTCCRB input capture/compare match         | GTST[1] (TCFB)  | Possible       |
|            | GPTn_CMPC  | GPT16n.GTCCRC compare match                       | GTST[2] (TCFC)  | Possible       |
|            | GPTn_CMPD  | GPT16n.GTCCRD compare match                       | GTST[3] (TCFD)  | Possible       |
|            | GPTn_CMPE  | GPT16n.GTCCRE compare match                       | GTST[4] (TCFE)  | Possible       |
|            | GPTn_CMPF  | GPT16n.GTCCRF compare match                       | GTST[5] (TCFF)  | Possible       |
|            | GPTn_OVF   | GPT16n.GTCNT overflow (GPT320.GTPR compare match) | GTST[6] (TCFPO) | Possible       |
|            | GPTn_UDF   | GPT16n.GTCNT underflow                            | GTST[7] (TCFPU) | Possible       |
|            | GPTn_PC    | Period count function finish (n = 4 to 6)         | GTST[31] (PCF)  | Possible       |

#### (1) GPTn\_CCMPA interrupt (n = 0 to 7)

An interrupt request is generated under the following conditions:

- When the GTCCRA register functions as a compare match register, the GTCNT counter value matches with the GTCCRA register
- When the GTCCRA register functions as an input capture register, the input-capture signal causes transfer of the GTCNT counter value to the GTCCRA register.

#### (2) GPTn\_CCMPB interrupt (n = 0 to 7)

An interrupt request is generated under the following conditions:

- When the GTCCRB register functions as a compare match register, the GTCNT counter value matches with the GTCCRB register

## 21.4 中断源

### 21.4.1 中断源

GPT提供以下中断源:

- GTCCR输入捕捉比较匹配
- GTCNT计数器上溢 (GTPR比较匹配) 下溢。
- 周期计数功能完成

每个中断源都有自己的状态标志。当一个中断源信号产生时, 相关的状态标志在GTST设置为1。GTST中相关的状态标志可以通过写入0来清除。如果标志设置和标志清除同时发生, 标志清除优先于标志设置。这些标志由内部状态自动更新。中断控制器单元可以改变相关的通道优先级。但是, 通道内的优先级是固定的。有关详细信息, 请参阅第13节, 中断控制器单元(ICU)。

表21.46列出了GPT中断源。

**Table 21.46 中断源**

| Channel    | Name       | 中断源                              | 中断标志            | DTC activation |
|------------|------------|----------------------------------|-----------------|----------------|
| n = 0 to 3 | GPTn_CCMPA | GPT32n.GTCCRA输入捕捉比较匹配            | GTST[0] (TCFA)  | Possible       |
|            | GPTn_CCMPB | GPT32n.GTCCRB输入捕捉比较匹配            | GTST[1] (TCFB)  | Possible       |
|            | GPTn_CMPC  | GPT32n.GTCCRC比较匹配                | GTST[2] (TCFC)  | Possible       |
|            | GPTn_CMPD  | GPT32n.GTCCRD比较匹配                | GTST[3] (TCFD)  | Possible       |
|            | GPTn_CMPE  | GPT32n.GTCCRE比较匹配                | GTST[4] (TCFE)  | Possible       |
|            | GPTn_CMPF  | GPT32n.GTCCRF比较匹配                | GTST[5] (TCFF)  | Possible       |
|            | GPTn_OVF   | GPT32n.GTCNT溢出 (GPT32m.GTPR比较匹配) | GTST[6] (TCFPO) | Possible       |
|            | GPTn_UDF   | GPT32n.GTCNT underflow           | GTST[7] (TCFPU) | Possible       |
|            | GPTn_PC    | 周期计数功能完成(n=0 1)                  | GTST[31] (PCF)  | Possible       |
| n = 4 to 7 | GPTn_CCMPA | GPT16n.GTCCRA输入捕捉比较匹配            | GTST[0] (TCFA)  | Possible       |
|            | GPTn_CCMPB | GPT16n.GTCCRB输入捕捉比较匹配            | GTST[1] (TCFB)  | Possible       |
|            | GPTn_CMPC  | GPT16n.GTCCRC比较匹配                | GTST[2] (TCFC)  | Possible       |
|            | GPTn_CMPD  | GPT16n.GTCCRD比较匹配                | GTST[3] (TCFD)  | Possible       |
|            | GPTn_CMPE  | GPT16n.GTCCRE比较匹配                | GTST[4] (TCFE)  | Possible       |
|            | GPTn_CMPF  | GPT16n.GTCCRF比较匹配                | GTST[5] (TCFF)  | Possible       |
|            | GPTn_OVF   | GPT16n.GTCNT溢出 (GPT320.GTPR比较匹配) | GTST[6] (TCFPO) | Possible       |
|            | GPTn_UDF   | GPT16n.GTCNT underflow           | GTST[7] (TCFPU) | Possible       |
|            | GPTn_PC    | 周期计数功能完成 (n=4到6)                 | GTST[31] (PCF)  | Possible       |

#### (1) GPTn\_CCMPA中断 (n=0到7)

在以下情况下会产生中断请求:

- 当GTCCRA寄存器用作比较匹配寄存器时, GTCNT计数器值与GTCCRA寄存器匹配
- 当GTCCRA寄存器用作输入捕捉寄存器时, 输入捕捉信号导致GTCNT计数器值传送到GTCCRA寄存器。

#### (2) GPTn\_CCMPB中断 (n=0到7)

在以下情况下会产生中断请求:

- 当GTCCRB寄存器用作比较匹配寄存器时, GTCNT计数器值与GTCCRB寄存器匹配

- When the GTCCRB register functions as an input capture register, the input-capture signal causes transfer of the GTCNT counter value to the GTCCRB register.

### (3) GPTn\_CMPC interrupt (n = 0 to 7)

An interrupt request is generated under the following condition:

- When the GTCCRC register functions as a compare match register, the GTCNT counter value matches with the GTCCRC register.

A compare match is not performed and therefore, an interrupt is not requested in the following conditions:

- GTCR.MD[2:0] = 001b (saw-wave one-shot pulse mode)
- GTCR.MD[2:0] = 110b (triangle-wave PWM mode 3)
- GTBER.CCRA[1:0] = 01b, 10b, 11b (buffer operation with the GTCCRC register).

### (4) GPTn\_CMPD interrupt (n = 0 to 7)

An interrupt request is generated under the following condition:

- When the GTCCRD register functions as a compare match register, the GTCNT counter value matches with the GTCCRD register.

A compare match is not performed and therefore, an interrupt is not requested in the following conditions:

- GTCR.MD[2:0] = 001b (saw-wave one-shot pulse mode)
- GTCR.MD[2:0] = 110b (triangle-wave PWM mode 3)
- GTBER.CCRA[1:0] = 10b, 11b (buffer operation with the GTCCRD register).

### (5) GPTn\_CMPE interrupt (n = 0 to 7)

An interrupt request is generated under the following condition:

- When the GTCCRE register functions as a compare match register, the GTCNT counter value matches with the GTCCRE register.

A compare match is not performed and therefore, an interrupt is not requested in the following conditions:

- GTCR.MD[2:0] = 001b (saw-wave one-shot pulse mode)
- GTCR.MD[2:0] = 110b (triangle-wave PWM mode 3)
- GTBER.CCRB[1:0] = 01b, 10b, 11b (buffer operation with the GTCCRE register).

### (6) GPTn\_CMPF interrupt (n = 0 to 7)

An interrupt request is generated under the following condition:

- When the GTCCRF register functions as a compare match register, the GTCNT counter value matches with the GTCCRF register.

A compare match is not performed and therefore, an interrupt is not requested in the following conditions:

- GTCR.MD[2:0] = 001b (saw-wave one-shot pulse mode)
- GTCR.MD[2:0] = 110b (triangle-wave PWM mode 3)
- GTBER.CCRB[1:0] = 10b, 11b (buffer operation with the GTCCRF register).

### (7) GPTn\_OVF interrupt (n = 0 to 7)

An interrupt request is generated in the following conditions:

- In saw-wave mode, interrupt requests are enabled at overflows (when the GTCNT counter value changes from GTPR to 0 during up-counting)
- In triangle-wave mode, interrupt requests are enabled at crests (the GTCNT changes from GTPR to GTPR-1)

- 当GTCCRB寄存器用作输入捕捉寄存器时，输入捕捉信号导致GTCNT计数器值传送到GTCCRB寄存器。

### (3) GPTn\_CMPC中断 (n=0到7)

在以下情况下会产生中断请求：

- GTCCRC寄存器用作比较匹配寄存器时，GTCNT计数器值与GTCCRC寄存器匹配。

不执行比较匹配，因此在以下情况下不请求中断：

- GTCR.MD[2:0] = 001b (saw-wave one-shot pulse mode)
- GTCR.MD[2:0] = 110b (triangle-wave PWM mode 3)
- GTBER.CCRA[1:0]=01b 10b 11b（使用GTCCRC寄存器进行缓冲操作）。

### (4) GPTn\_CMPD中断 (n=0到7)

在以下情况下会产生中断请求：

- 当GTCCRD寄存器用作比较匹配寄存器时，GTCNT计数器值与GTCCRD寄存器匹配。

不执行比较匹配，因此在以下情况下不请求中断：

- GTCR.MD[2:0] = 001b (saw-wave one-shot pulse mode)
- GTCR.MD[2:0] = 110b (triangle-wave PWM mode 3)
- GTBER.CCRA[1:0]=10b 11b（使用GTCCRD寄存器进行缓冲操作）。

### (5) GPTn\_CMPE中断 (n=0到7)

在以下情况下会产生中断请求：

- 当GTCCRE寄存器用作比较匹配寄存器时，GTCNT计数器值与GTCCRE寄存器匹配。

不执行比较匹配，因此在以下情况下不请求中断：

- GTCR.MD[2:0] = 001b (saw-wave one-shot pulse mode)
- GTCR.MD[2:0] = 110b (triangle-wave PWM mode 3)
- GTBER.CCRB[1:0]=01b 10b 11b（使用GTCCRE寄存器进行缓冲操作）。

### (6) GPTn\_CMPF中断 (n=0到7)

在以下情况下会产生中断请求：

- 当GTCCRF寄存器用作比较匹配寄存器时，GTCNT计数器值与GTCCRF寄存器匹配。

不执行比较匹配，因此在以下情况下不请求中断：

- GTCR.MD[2:0] = 001b (saw-wave one-shot pulse mode)
- GTCR.MD[2:0] = 110b (triangle-wave PWM mode 3)
- GTBER.CCRB[1:0]=10b 11b（使用GTCCRF寄存器进行缓冲操作）。

### (7) GPTn\_OVF中断 (n=0到7)

在以下情况下会产生中断请求：

- 在锯齿波模式下，溢出时允许中断请求（在向上计数期间，当GTCNT计数器值从GTPR变为0时）
- 在三角波模式下，在波峰处启用中断请求（GTCNT从GTPR变为GTPR-1）



- In counting by hardware sources, an overflow (GTCNT changes from GTPR to 0 in up count) has occurred.

#### (8) GPTn\_UDF interrupt (n = 0 to 7)

An interrupt request is generated in the following conditions.

- In saw-wave mode, interrupt requests are enabled at underflows (when the GTCNT counter value changes from 0 to GTPR during down-counting)
- In triangle-wave mode, interrupt requests are enabled at troughs (the GTCNT changes from 0 to 1)
- In counting by hardware sources, underflow (GTCNT changes from 0 to GTPR in down count) has occurred.

About Interrupt signals and interrupt status flags, see [section 21.2.16. GTST : General PWM Timer Status Register](#).

#### (9) GPTn\_PC Interrupt (n = 0, 1, 4 to 6)

When the GTPC.PCEN bit is 1 and the GTPC.PCNT counter is 1, an interrupt request is generated at the end of cycle.

### 21.4.2 DMAC and DTC Activation

The DMAC and DTC can be activated by the interrupt in each channel. For details, see [section 13, Interrupt Controller Unit \(ICU\)](#), [section 16, DMA Controller \(DMAC\)](#), and [section 17, Data Transfer Controller \(DTC\)](#).

## 21.5 Operations Linked by ELC

### 21.5.1 Event Signal Output to ELC

The GPT can perform operation linked with another module set in advance when its interrupt request signal is used as an event signal by the Event Link Controller (ELC).

The GPT has the following ELC event signals:

- Generation of compare match and input capture A interrupt (GPTn\_CCMPA)
- Generation of compare match and input capture B interrupt (GPTn\_CCMPB)
- Generation of compare match C interrupt (GPTn\_CMPC)
- Generation of compare match D interrupt (GPTn\_CMPD)
- Generation of compare match E interrupt (GPTn\_CMPE)
- Generation of compare match F interrupt (GPTn\_CMPF)
- Generation of overflow interrupt (GPTn\_OVF)
- Generation of underflow interrupt (GPTn\_UDF)
- Finish of period count function (GPTm\_PC)

Note: n = 0 to 7  
m = 0, 1, 4 to 6

### 21.5.2 Event Signal Inputs from ELC

The GPT can perform the following operations in response to a maximum of 8 events from the ELC:

- Start counting, stop counting, clear counting
- Up-counting, down-counting
- Input capture.

See [section 18, Event Link Controller \(ELC\)](#) for the connection between the ELC and the event signal input.

## 21.6 Noise Filter Function

Each pin for use in input capture and Hall sensor input to the GPT is equipped with a noise filter. The noise filter samples input signals at the sampling clock and removes the pulses whose length is less than 3 sampling cycles.

- 在硬件源的计数中, 发生了溢出 (GTCNT在向上计数中从GTPR变为0)。

#### (8) GPTn\_UDF中断 (n=0到7)

在以下情况下会产生中断请求。

- 在锯齿波模式下, 下溢时允许中断请求 (在向下计数期间, 当GTCNT计数器值从0变为GTPR时)
- 在三角波模式下, 在波谷处启用中断请求 (GTCNT由0变为1)
- 在硬件源的计数中, 发生了下溢 (向下计数时GTCNT从0变为GTPR)。

关于中断信号和中断状态标志, 请参见第21.2.16节。GTST: 通用PWM定时器状态寄存器。

#### (9) GPTn\_PC中断 (n=0、1、4到6)

当GTPC.PCEN位为1且GTPC.PCNT计数器为1时, 在周期结束时产生中断请求。

### 21.4.2 DMAC和DTC激活

DMAC和DTC可以通过每个通道中的中断来激活。有关详细信息, 请参见第13节, 中断控制器单元(ICU), 第16节, DMA控制器(DMAC), 和第17节, 数据传输控制器(DTC)。

## 21.5 由ELC链接的操作

### 21.5.1 事件信号输出到ELC

当GPT的中断请求信号被事件链接控制器(ELC)用作事件信号时, GPT可以执行与预先设置的另一个模块链接的操作。

GPT具有以下ELC事件信号:

- 产生比较匹配和输入捕捉A中断(GPTn\_CCMPA)
- 产生比较匹配和输入捕捉B中断(GPTn\_CCMPB)
- 产生比较匹配C中断(GPTn\_CMPC)
- 产生比较匹配D中断(GPTn\_CMPD)
- 产生比较匹配E中断(GPTn\_CMPE)
- 产生比较匹配F中断(GPTn\_CMPF)
- 产生溢出中断 (GPTn\_OVF)
- 产生下溢中断 (GPTn\_UDF)
- 周期计数功能完成 (GPTm\_PC)

Note: n = 0 to 7  
m = 0, 1, 4 to 6

### 21.5.2 来自ELC的事件信号输入

GPT可以执行以下操作以响应来自ELC的最多8个事件:

- 开始计数、停止计数、清计数
  - Up-counting, down-counting
- 输入捕捉。

有关ELC和事件信号输入之间的连接, 请参见第18节, 事件链接控制器(ELC)。

## 21.6 噪音过滤功能

用于GPT的输入捕捉和霍尔传感器输入的每个引脚都配备了噪声滤波器。噪声滤波器以采样时钟对输入信号进行采样, 并去除长度小于3个采样周期的脉冲。



The noise filter functionality includes enabling and disabling the noise filter for each pin and setting of the sampling clock for each channel.

Figure 21.63 shows the timing of noise filtering.

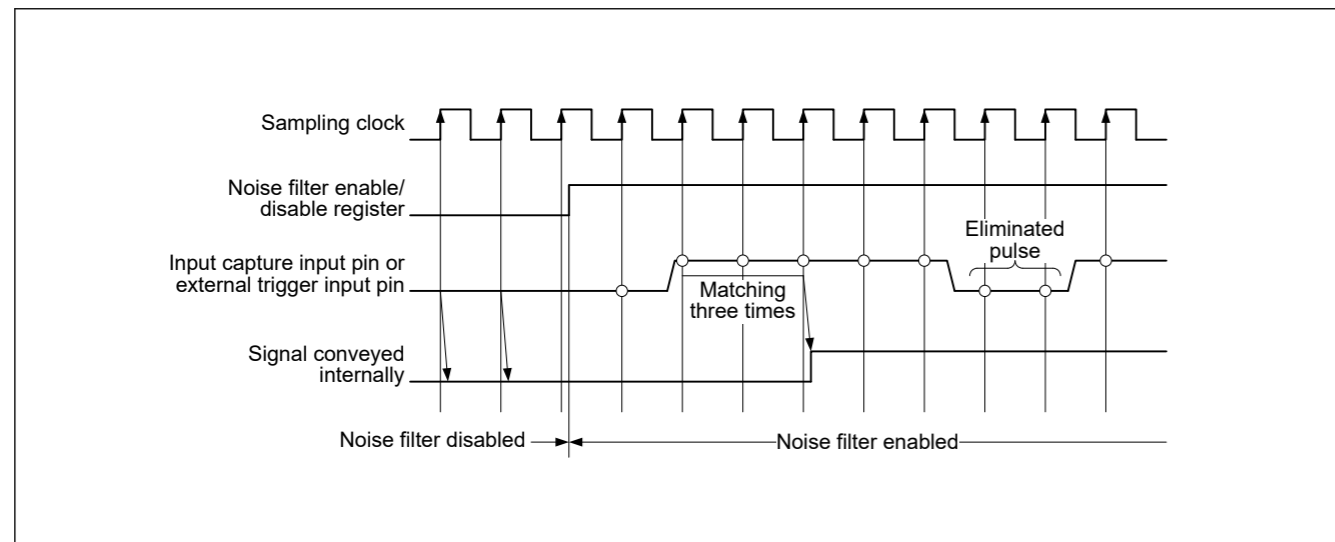


Figure 21.63 Timing of noise filtering

If noise filtering is enabled, the input capture operation or external trigger operation is performed on the edges of the noise filtered signal after a delay of a sampling interval  $\times 2 + \text{PCLKD}$ . This is due to the noise filtering for the input capture input or external trigger operation.

## 21.7 Protection Function

### 21.7.1 Write-Protection for Registers

To prevent registers from being accidentally modified, registers can be write-protected in channel units by setting GTWP.WP. Write-protection can be set for the following registers:

GTSSR, GTPSR, GTCSR, GTUPSR, GTDNSR, GTICASR, GTICBSR, GTCR, GTUDDTYC, GTIOR, GTINTAD, GTST, GTBER, GTCNT, GTCCRA, GTCCRB, GTCCRC, GTCCRD, GTCCRE, GTCCRF, GTPR, GTPBR, GTDTCR, GTDVU, GTICLF, GTPC.

Every bit in registers GTSTR, GTSTP and GTCLR which can update the corresponding registers in other channels and can be updated by any of the corresponding registers in other channels conversely, can be protected by setting the GTWP.STRWP, STPWP, and CLRWP bits, respectively, per channel.

Likewise, writing to the GTSECSR and GTSECR registers, which can control all channels by writing to the GTSECSR and GTSECR registers of a given channel, can be enabled or disabled by the setting of the GTWP.CMNWP bit.

Protection using the GTWP register is only for write operations by the CPU. This protection does not cover updates to registers that occur in association with CPU writes.

### 21.7.2 Disabling of Buffer Operation

If the timing of the buffer register write is delayed relative to the timing for the buffer transfer, buffer operation can be suspended with the GTBER.BD[1] and BD[0] bit settings. Specifically, buffer transfer can be temporarily disabled even though a buffer transfer condition is generated during buffer register write.

0 can be set simultaneously by setting the GTSECR register for multiple channels which were set by the GTSECSR register.

Figure 21.64 shows an example of operation for disabling buffer operation.

噪声过滤器功能包括为每个引脚启用和禁用噪声过滤器以及为每个通道设置采样时钟。

图21.63显示了噪声过滤的时序。

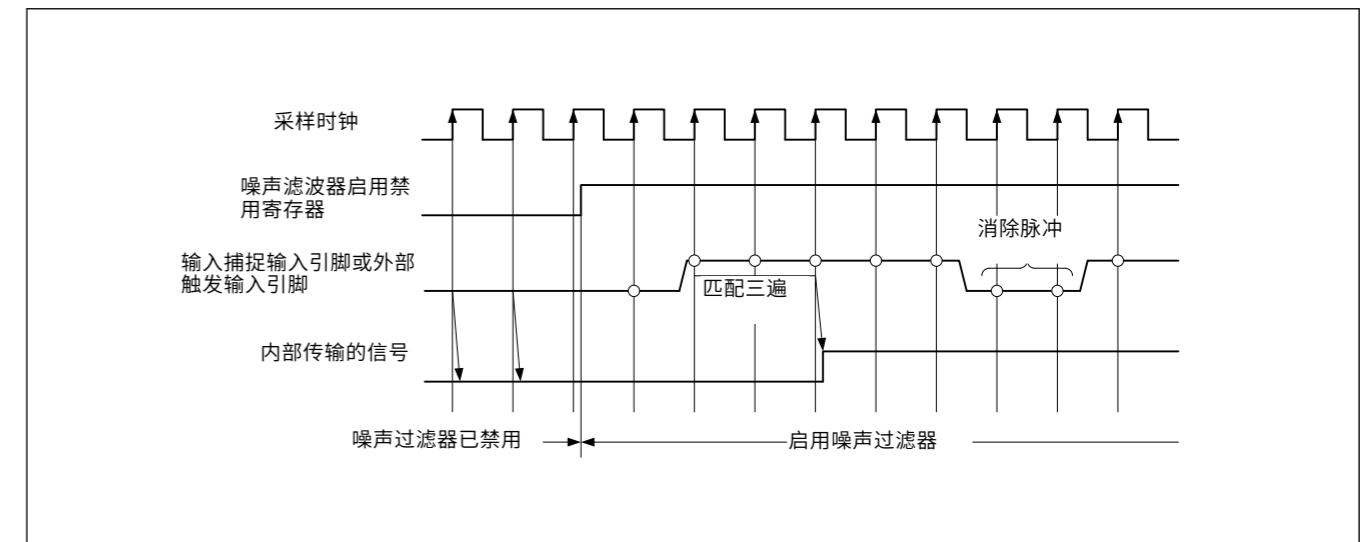


Figure 21.63 噪声过滤的时序

如果噪声过滤使能，输入捕捉操作或外部触发操作在经过一个采样间隔 $\times 2 + \text{PCLKD}$ 的延迟后在噪声过滤信号的边沿上执行。这是由于输入捕捉输入或外部触发操作的噪声过滤。

## 21.7 保护功能

### 21.7.1 寄存器的写保护

为了防止寄存器被意外修改，可以通过设置以通道为单位对寄存器进行写保护 GTWP.WP。可以为以下寄存器设置写保护：

GTSSR, GTPSR, GTCSR, GTUPSR, GTDNSR, GTICASR, GTICBSR, GTCR, GTUDDTYC, GTIOR, GTINTAD, GTST, GTBER, GTCNT, GTCCRA, GTCCRB, GTCCRC, GTCCRD, GTCCRE, GTCCRF, GTPR, GTPBR, GTDTCR, GTDVU, GTICLF, GTPC.

寄存器GTSTR、GTSTP和GTCLR中的每个位可以更新其他通道中的相应寄存器，反之也可以由其他通道中的任何相应寄存器更新，可以分别通过设置GTWP.STRWP、STPWP和CLRWP位来保护每个频道。

同样，写入GTSECSR和GTSECR寄存器，它们可以通过写入GTSECSR和给定通道的GTSECR寄存器可以通过设置GTWP.CMNWP位来启用或禁用。

使用GTWP寄存器的保护仅适用于CPU的写操作。此保护不涵盖与CPU写入相关的寄存器更新。

### 21.7.2 禁用缓冲区操作

如果缓冲寄存器写入的时序相对于缓冲传输的时序延迟，则可以通过GTBER.BD[1]和BD[0]位设置暂停缓冲操作。具体来说，即使在缓冲寄存器写入期间产生了缓冲传送条件，也可以暂时禁用缓冲传送。

0可以通过设置GTSECSR寄存器为由GTSECSR寄存器设置的多个通道同时设置。

图21.64显示了禁用缓冲区操作的操作示例。

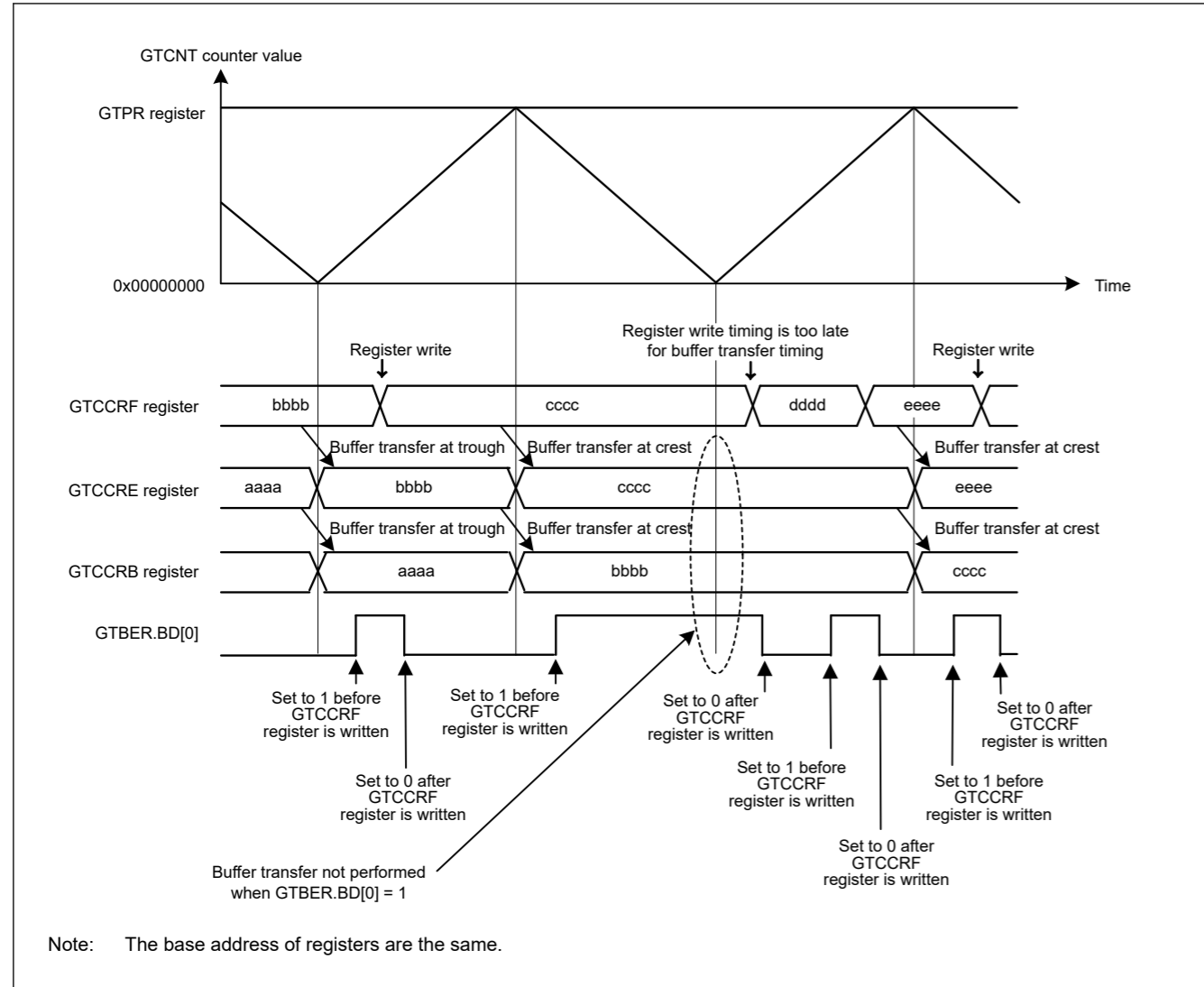


Figure 21.64 Example of operation for disabling buffer operation with triangle waves, double buffer operation, and buffer transfer at both troughs and crests

### 21.7.2.1 Simultaneous Control of Buffer Operations of Multiple Channels

The GTBER.BD bit can be set by writing directly to the GTBER register per channel or by making settings in the GTSECR register for multiple channels that have already set in the GTSECSR register.

Follow the procedure below to simultaneously set the GTBER.BD bits of multiple channels.

1. Select the channels for simultaneously setting of the GTSECSR register  
Set the GTSECSR register so that the values at the bit positions for the corresponding channels for simultaneously setting of the GTBER.BD bits become 1. All GTSECSR registers can be updated by writing to the GTSECSR register of any channel.
2. Simultaneously set the GTBER.BD bits by updating the GTSECR register  
In the GTSECR register, set the operation of the GTBER.BD bits (enabling or disabling of buffer operation) which are to be simultaneously set. Writing to a GTSECR register from any channel updates the GTBER.BD bits in all channels corresponding to the bits set as 1 in the GTSECSR register, in accordance with the value of the GTSECR register.

Figure 21.65 show examples of simultaneously controlling the enabling or disabling of buffer operation for multiple channels.

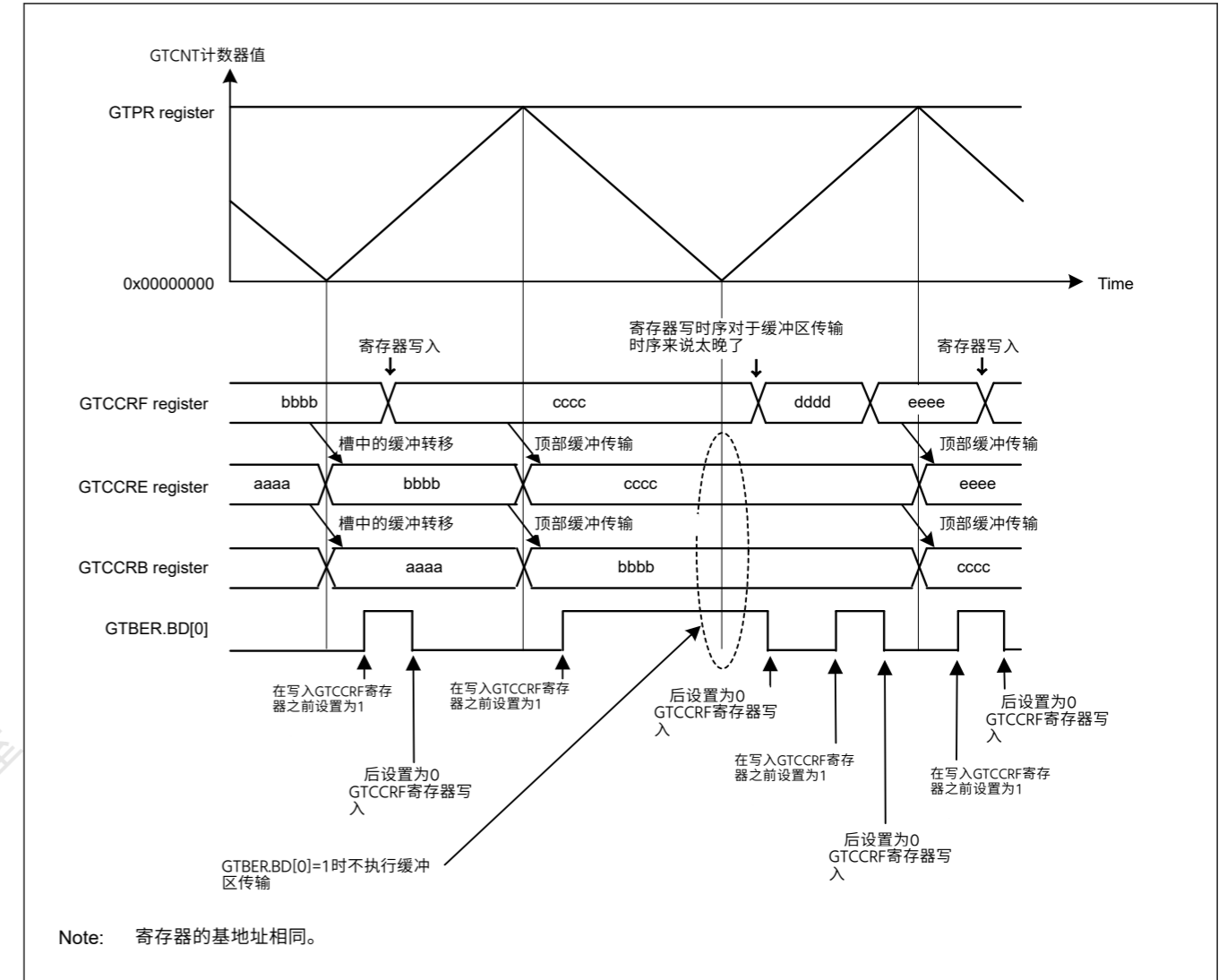


Figure 21.64 三角波缓冲操作、双缓冲操作、波谷和波峰缓冲转移的禁用操作示例

### 21.7.2.1 多通道缓冲操作的同时控制

GTBER.BD位可以通过直接写入每个通道的GTBER寄存器或通过已在GTSECSR寄存器中设置的多个通道进行设置来设置。

按照以下步骤同时设置多个通道的GTBER.BD位。

- 1.选择同时设置GTSECSR寄存器的通道  
设置GTSECSR寄存器，使用于同时设置GTBER.BD位的相应通道的位位置的值变为1。通过写入任何通道的GTSECSR寄存器，可以更新所有GTSECSR寄存器。
- 2.通过更新GTSECR寄存器同时设置GTBER.BD位  
在GTSECR寄存器中，设置要同时设置的GTBER.BD位的操作（启用或禁用缓冲区操作）。根据GTSECR寄存器的值，从任何通道写入GTSECR寄存器会更新与GTSECSR寄存器中设置为1的位相对应的所有通道中的GTBER.BD位。

图21.65显示了同时控制多个通道的缓冲区操作的启用或禁用的示例。

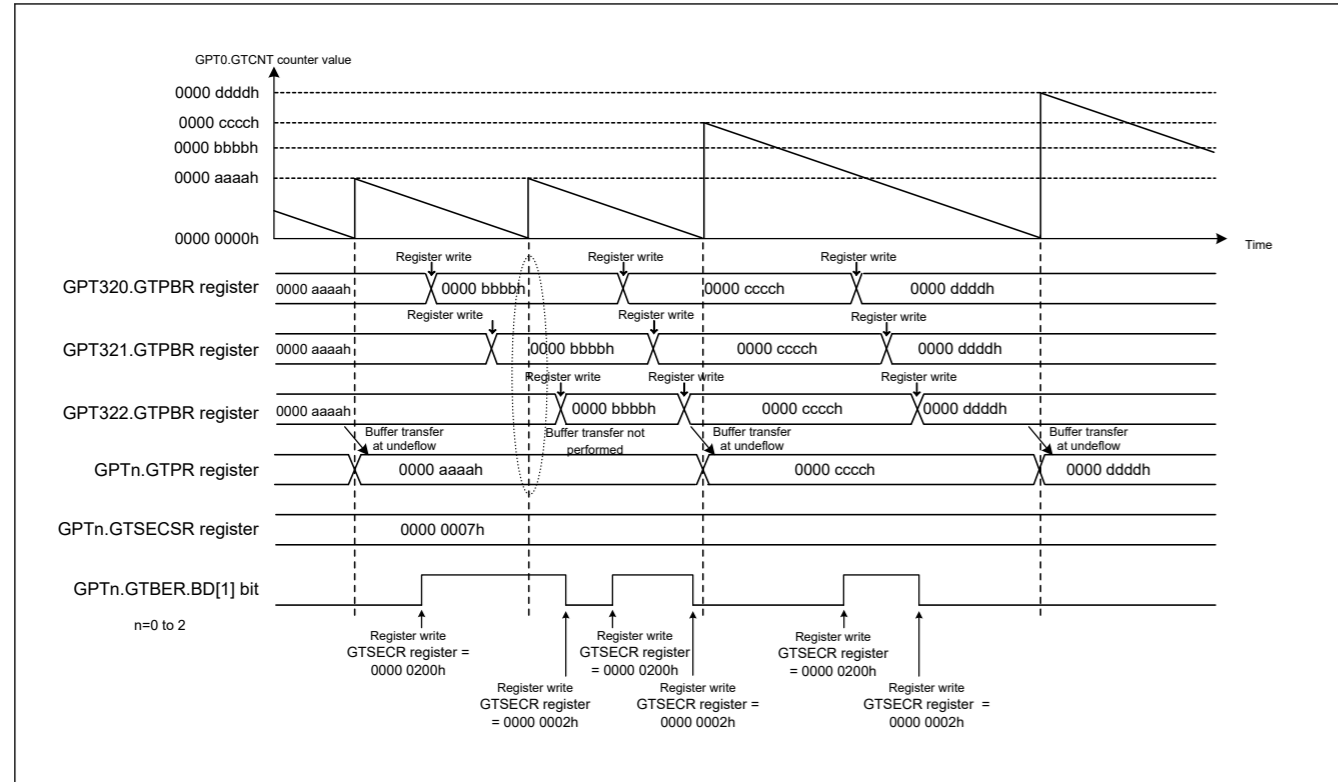


Figure 21.65 Example of Multiple Channel Operation for Disabling Buffer Operation (Sawtooth Waves, Single Buffer Operation)

21.7.3 GTIOCnm Pin Output Negate Control (n = 0 to 7, m = A, B)

For protection from system failure, the output disable control that changes the GTIOCnm pin output value forcibly is provided for GTIOCnm pin output by the request of output disable from POEG. When the GTIOCnA pin output value is the same as the GTIOCnB pin output value, output protection is required. GPT detects this condition and generates output disable requests to POEG according to the setting of the output disable request permission bits, such as GTINTAD.GRPABH, GTINTAD.GRPABL. After the POEG receives output disable requests from each channel and calculates external input using an OR operation, the POEG generates output disable requests to GPT.

One output disable signal (representing the shared output disable request signal of the GTIOCnA pin and the GTIOCnB pin) out of 4 output disable requests generated by the POEG is selected by setting GTINTAD.GRP[1:0]. The status of the selected disable output request is monitored by reading the GTST.ODF bit. The output level during output disable is set based on the GTIOR.OADF[1:0] bits for the GTIOCnA pin and the GTIOR.OBDF[1:0] setting for the GTIOCnB pin.

The change to the output disable state is performed asynchronously by generating the output disable request from the POEG. The release of the output disable state is performed at end of cycle by terminating the output disable request.

When event count is performed or when the output disable state should be released immediately without waiting for end of cycle, GTIOR.OADF[1:0] should be set to 00b (for GTIOCnA pin) or GTIOR.OBDF[1:0] should be set to 00b (for the GTIOCnB pin).

Figure 21.66 shows an example of the GTIOCnm pin output disable control operation. (n = 0 to 7, m = A, B)

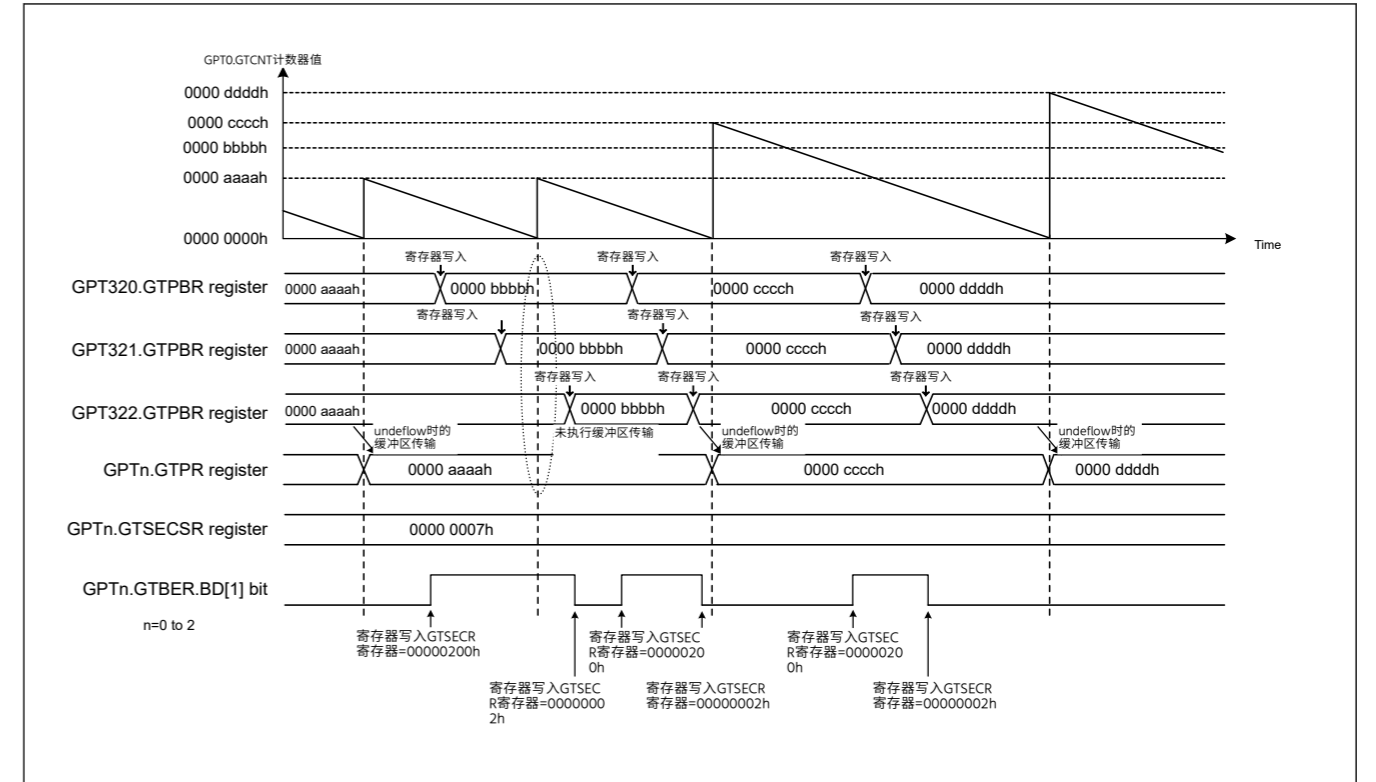


Figure 21.65 禁用缓冲区操作的多通道操作示例 (锯齿波, 单缓冲操作)

21.7.3 GTIOCnm引脚输出负控制 (n=0至7, m=A, B)

为防止系统故障, 根据POEG的输出禁用请求, 为GTIOCnm引脚输出提供强制改变GTIOCnm引脚输出值的输出禁用控制。当GTIOCnA引脚输出值与GTIOCnB引脚输出值相同时, 需要输出保护。GPT检测到这种情况并根据输出禁用请求许可位的设置, 如GTINTAD.GRPABH、GTINTAD.GRPABL向POEG生成输出禁用请求。在POEG接收到来自每个通道的输出禁用请求并使用OR运算计算外部输入后, POEG向GPT生成输出禁用请求。

通过设置GTINTAD.GRP[1:0], 在POEG产生的4个输出禁止请求中选择一个输出禁止信号 (代表GTIOCnA引脚和GTIOCnB引脚的共享输出禁止请求信号)。通过读取GTST.ODF位来监控所选禁用输出请求的状态。输出禁用期间的输出电平根据GTIOCnA引脚的GTIOR.OADF[1:0]位和GTIOCnB引脚的GTIOR.OBDF[1:0]设置来设置。

通过从POEG生成输出禁用请求异步执行对输出禁用状态的更改。通过终止输出禁用请求, 在循环结束时执行输出禁用状态的释放。

当执行事件计数或应立即释放输出禁用状态而不等待周期结束时, 应将GTIOR.OADF[1:0]设置为00b (对于GTIOCnA引脚) 或GTIOR.OBDF[1:0]应设置为设置为00b (对于GTIOCnB引脚)。

图21.66显示了GTIOCnm引脚输出禁用控制操作的示例。 (n=0到7, m=A, B)

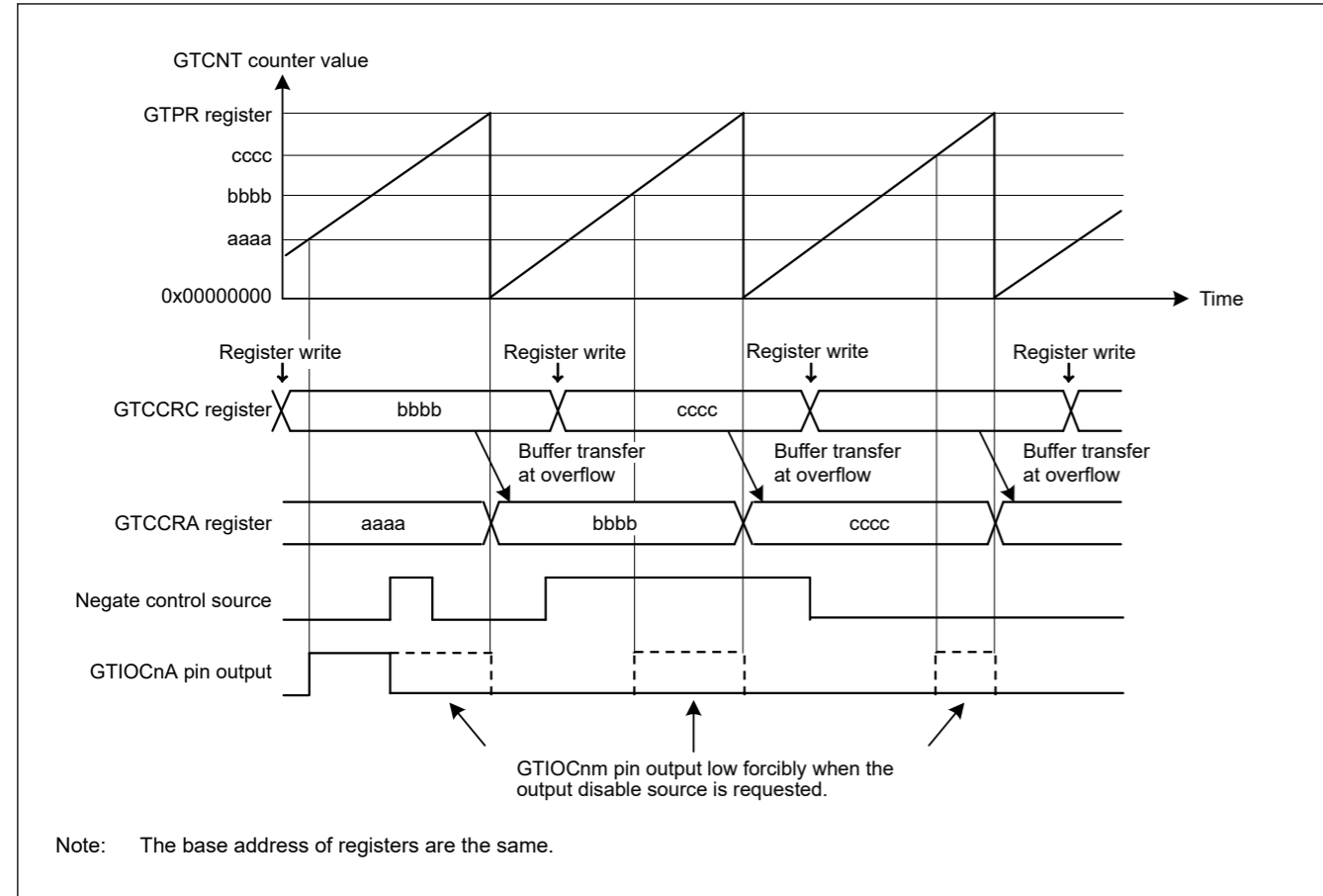


Figure 21.66 Example of GTIOcNm pin output disable control operation in saw-wave up-counting, buffer operation, active level 1, high output at GTCCRA compare match, low output at cycle end, and low output at output disable (n = 0 to 7, m = A, B)

## 21.8 Initialization Method of Output Pins

### 21.8.1 Pin Settings after Reset

The GPT registers are initialized at a reset. Start counting after selecting the port pin function with the PmnPFS register, setting GTIOR.OAE and GTIOR.OBE bits, and outputting the GPT function to external pins.

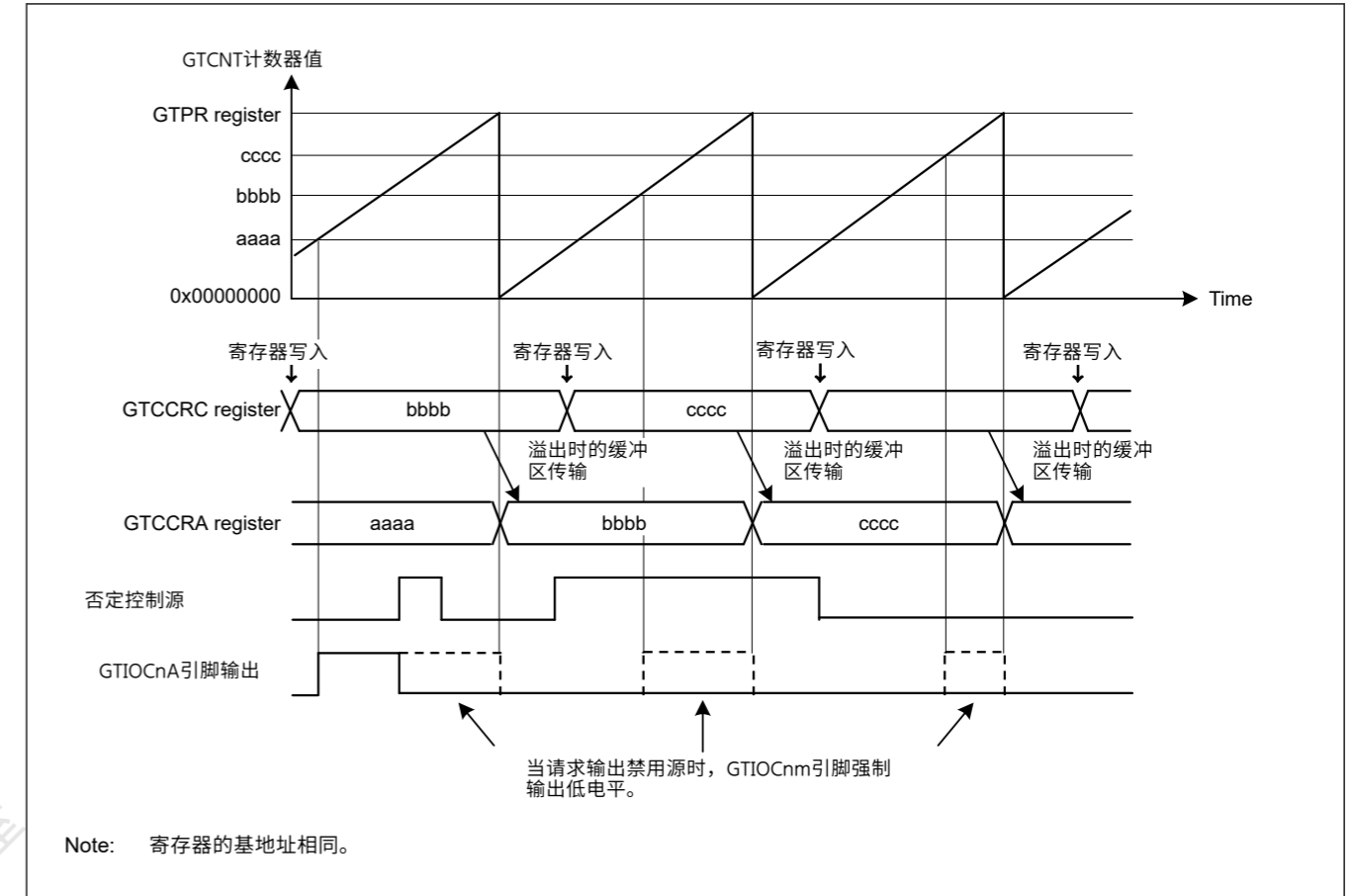


Figure 21.66 GTIOcNm引脚输出禁用控制操作示例在锯齿波递增计数、缓冲器操作、有效电平1、GTCCRA比较匹配时的高输出、周期结束时的低输出和输出禁用时的低输出 (n=0到7, m=A, B)

## 21.8 输出管脚的初始化方法

### 21.8.1 复位后的引脚设置

GPT寄存器在复位时被初始化。通过PmnPFS寄存器选择端口引脚功能，设置GTIOR.OAE和GTIOR.OBE位，并将GPT功能输出到外部引脚后开始计数。



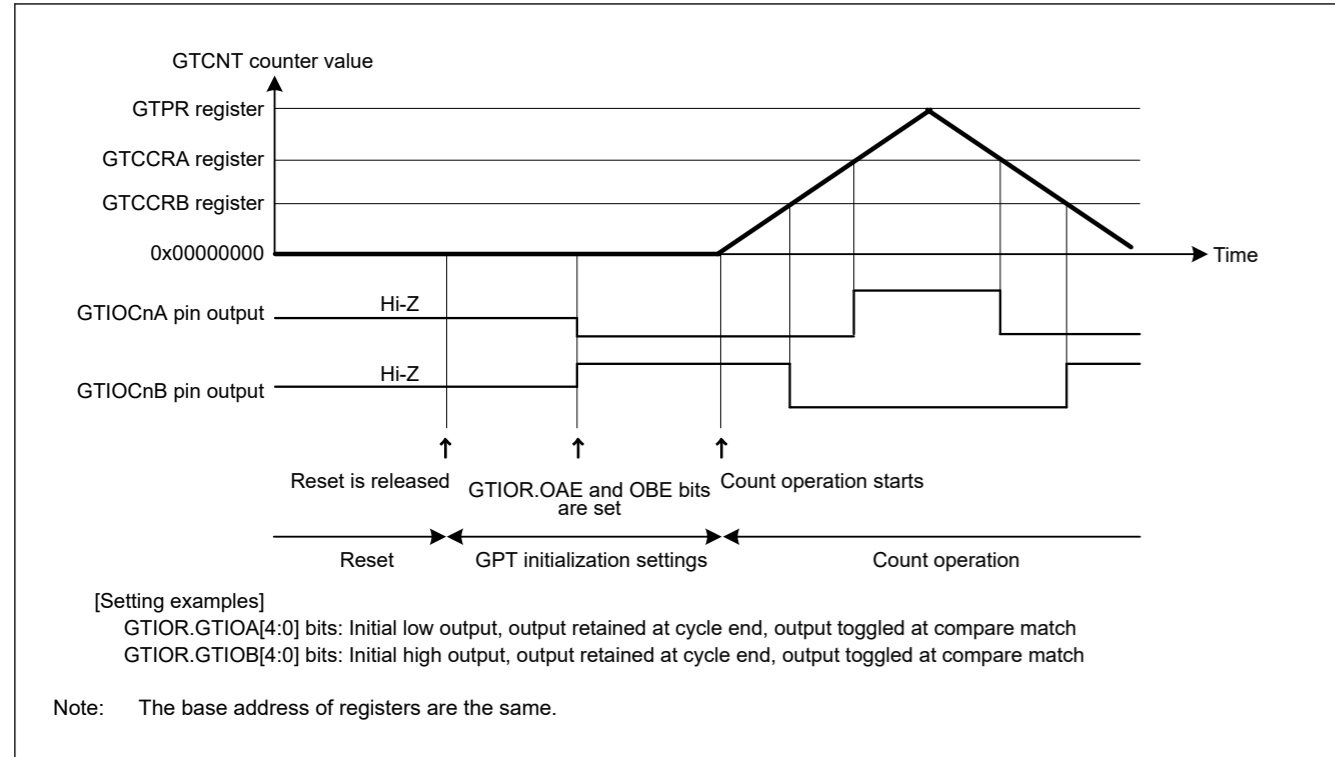


Figure 21.67 Example of pin settings after reset

### 21.8.2 Pin Initialization Due to Error during Operation

If an error occurs during GPT operation, the following four types of pin processing can be performed before pin initialization:

- Set the OAHL and OBHL bits in GTIOR to 1 and retain the outputs at count stop
- Set the OAHL and OBHL bits in GTIOR to 0, specify arbitrary output values at OADFLT and OBDFLT in GTIOR, and output the arbitrary values at count stop
- Set the pin to output an arbitrary value as a general output port by setting the PDR, PODR registers and PmnPFS.PMR bit of the I/O port in advance. Set the OAE and OBE bits in GTIOR to 0, and the control bit associated with the pin in the PMR to 0 to allow arbitrary values to be output from the pin set as a general output port when an error occurs.
- Drive the output to a high impedance state using the POEG function.

After the automatic dead time setting is made, clear the GTDTCR.TDE bit to 0 after counting stops. When counting stops, only the values of registers that are changed by a GPT external source change. If counting is resumed, operation continues from where it stopped. If counting is stopped, the registers must be initialized before counting starts.

## 21.9 Usage Notes

### 21.9.1 Module-Stop Function Setting

The Module Stop Control Register can enable or disable GPT operation. The GPT is initially stopped after a reset. Releasing the module-stop state enables access to the registers. For details, see [section 10, Low Power Modes](#).

### 21.9.2 GTCCRn Settings during Compare Match Operation (n = A to F)

#### (1) When automatic dead time setting is made in triangle-wave PWM mode

The GTCCRA register must satisfy both of the following conditions:

- $GTDVU < GTCCRA$
- $0 < GTCCRA < GTPR$

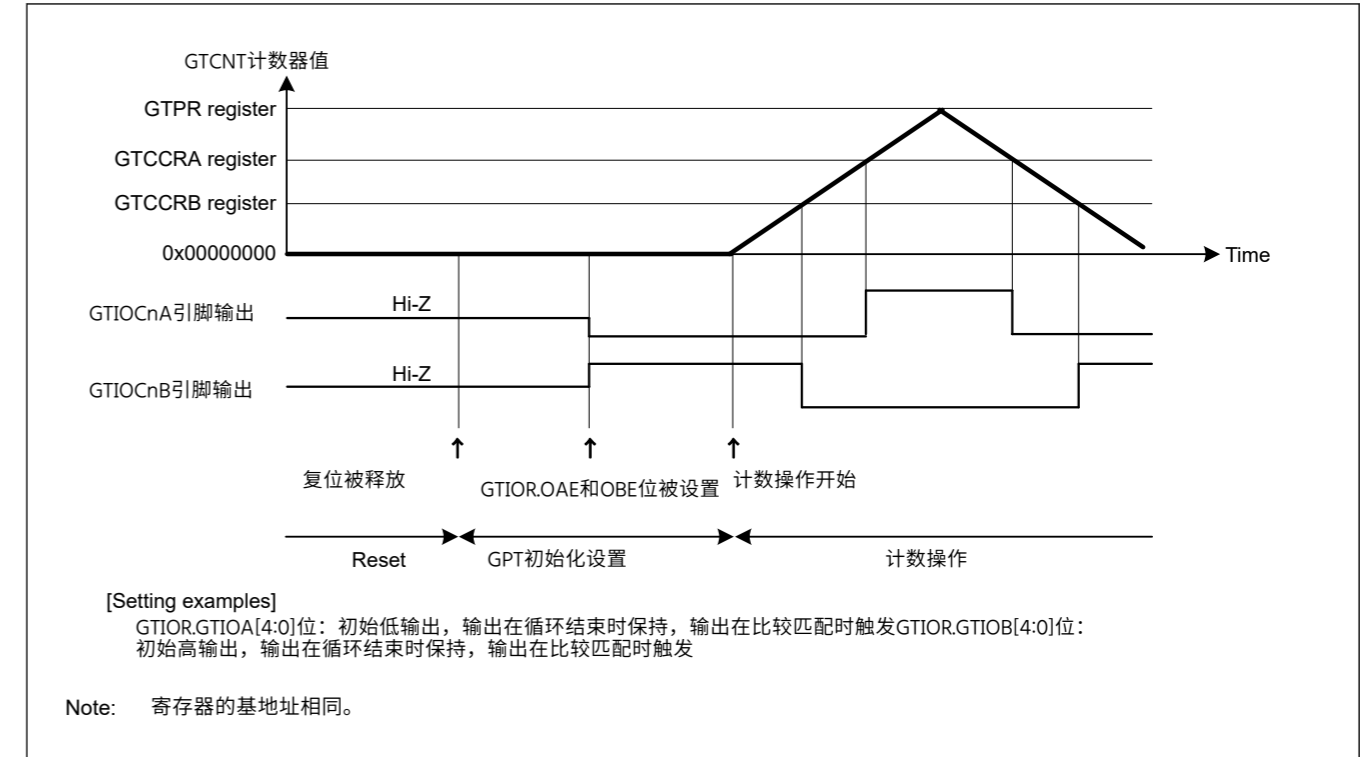


Figure 21.67 复位后的引脚设置示例

### 21.8.2 由于操作过程中的错误而导致的引脚初始化

如果在GPT操作过程中发生错误，可以在引脚初始化之前进行以下四种引脚处理：

- 将GTIOR中的OAHL和OBHL位设置为1，并在计数停止时保留输出
- 将GTIOR中的OAHL和OBHL位设置为0，在GTIOR中的OADFLT和OBDFLT指定任意输出值，并在计数停止时输出任意值
- 通过预先设置IO端口的PDR、PODR寄存器和PmnPFS.PMR位，将引脚设置为输出任意值作为通用输出端口。将GTIOR中的OAE和OBE位设置为0，并将与PMR中的引脚相关的控制位设置为0，以允许在发生错误时从设置为通用输出端口的引脚输出任意值。
- 使用POEG功能将输出驱动为高阻抗状态。

进行自动死区时间设置后，计数停止后将GTDTCR.TDE位清零。当计数停止时，只有被GPT外部源改变的寄存器的值会改变。如果重新开始计数，则从停止处继续操作。如果停止计数，则必须在计数开始前初始化寄存器。

## 21.9 使用说明

### 21.9.1 模块停止功能设置

模块停止控制寄存器可以启用或禁用GPT操作。GPT在重置后最初停止。释放模块停止状态可以访问寄存器。有关详细信息，请参阅第10节，低功耗模式。

### 21.9.2 比较匹配操作期间的GTCCRn设置 (n=A到F)

#### (1) 在三角波PWM模式下进行自动死区时间设置时

GTCCRA寄存器必须满足以下两个条件：

- $GTDVU < GTCCRA$
- $0 < GTCCRA < GTPR$



When the setting of  $GTCCRA = 0$  or  $GTCCRA \geq GTPR$  is made for the  $GTCCRA$  register during count operation, the output protection function is activated. However, if the following condition is not satisfied, the output protection function does not work normally:

- The value of the  $GTCCRA$  register at the start of counting is larger than 0 and less than  $GTPR$ .

For details, see [section 21.7.3. GTIOCNm Pin Output Negate Control \(n = 0 to 7, m = A, B\)](#)

### (2) When automatic dead time setting is not made in triangle-wave PWM mode

The  $GTCCRA$  register must be set within the range of  $0 < GTCCRA < GTPR$ . If  $GTCCRA = 0$  or  $GTCCRA = GTPR$  is set, a compare match occurs within the cycle only when  $GTCCRA = 0$  or  $GTCCRA = GTPR$  is satisfied. When  $GTCCRA > GTPR$ , no compare match occurs.

Similarly,  $GTCCRB$  must be set within the range of  $0 < GTCCRB < GTPR$ . If  $GTCCRB = 0$  or  $GTCCRB = GTPR$  is set, a compare match occurs within the cycle only when  $GTCCRB = 0$  or  $GTCCRB = GTPR$  is satisfied. When  $GTCCRB > GTPR$ , no compare match occurs.

### (3) When automatic dead time setting is made in saw-wave one-shot pulse mode

The  $GTCCRC$  and  $GTCCRD$  registers must be set to satisfy the following restrictions. If the restrictions are not satisfied, the correct output waveforms with secured dead time may not be obtained.

- In up-counting:  $GTCCRC < GTCCRD$ ,  $GTCCRC > GTDVU$ ,  $GTCCRD < GTPR - GTDVU$
- In down-counting:  $GTCCRC > GTCCRD$ ,  $GTCCRC < GTPR - GTDVU$ ,  $GTCCRD > GTDVU$

Similarly, the  $GTCCRE$  and  $GTCCRF$  registers must be set to satisfy the following restrictions. If the restrictions are not satisfied, correct output waveforms with secured dead time might not be obtained:

- In up-counting:  $GTCCRE < GTCCRF$ ,  $GTCCRE > GTDVU$ ,  $GTCCRF < GTPR - GTDVU$
- In down-counting:  $GTCCRE > GTCCRF$ ,  $GTCCRE < GTPR - GTDVU$ ,  $GTCCRF > GTDVU$

### (4) When automatic dead time setting is not made in saw-wave one-shot pulse mode

The  $GTCCRC$  and  $GTCCRD$  registers must be set to satisfy the following restrictions. If the restrictions are not satisfied, two compare matches do not occur and pulse output cannot be performed.

- In up-counting:  $0 < GTCCRC < GTCCRD < GTPR$
- In down-counting:  $GTPR > GTCCRC > GTCCRD > 0$

Similarly,  $GTCCRE$  and  $GTCCRF$  must be set to satisfy the following restrictions. If the restrictions are not satisfied, two compare matches do not occur and pulse output cannot be performed.

- In up-counting:  $0 < GTCCRE < GTCCRF < GTPR$
- In down-counting:  $GTPR > GTCCRE > GTCCRF > 0$ .

### (5) In saw-wave PWM mode

The  $GTCCRA$  register must be set with the range of  $0 < GTCCRA < GTPR$ . If  $GTCCRA = 0$  or  $GTCCRA = GTPR$  is set, a compare match occurs within the cycle only when  $GTCCRA = 0$  or  $GTCCRA = GTPR$  is satisfied. If  $GTCCRA > GTPR$  is set, no compare match occurs.

Similarly,  $GTCCRB$  must be set with the range of  $0 < GTCCRB < GTPR$ . If  $GTCCRB = 0$  or  $GTCCRB = GTPR$  is set, a compare match occurs within the cycle only when  $GTCCRB = 0$  or  $GTCCRB = GTPR$  is satisfied. If  $GTCCRB > GTPR$  is set, no compare match occurs.

## 21.9.3 Setting Range for GTCNT Counter

The  $GTCNT$  counter register must be set with the range of  $0 \leq GTCNT \leq GTPR$ .

## 21.9.4 Starting and Stopping the GTCNT Counter

The control timing of starting and stopping the  $GTCNT$  counter by the  $GTCR.CST$  bit synchronizes the count clock that is selected in  $GTCR.TPCS[3:0]$ . When  $GTCR.CST$  is updated, the  $GTCNT$  counter starts/stops after a count clock that is

当在计数操作期间对 $GTCCRA$ 寄存器设置 $GTCCRA=0$ 或 $GTCCRA \geq GTPR$ 时, 输出保护功能被激活。但是, 如果不满足以下条件, 则输出保护功能不能正常工作:

- 计数开始时 $GTCCRA$ 寄存器的值大于0小于 $GTPR$ 。

详见21.7.3节。GTIOCNm引脚输出负控制 (n=0至7, m=A, B)

### (2) 在三角波PWM模式下未进行自动死区时间设置时

$GTCCRA$ 寄存器必须设置在 $0 < GTCCRA < GTPR$ 的范围内。如果设置了 $GTCCRA=0$ 或 $GTCCRA=GTPR$ , 则仅当满足 $GTCCRA=0$ 或 $GTCCRA=GTPR$ 时, 才会在周期内发生比较匹配。当 $GTCCRA > GTPR$ 时, 不发生比较匹配。

同样,  $GTCCRB$ 必须设置在 $0 < GTCCRB < GTPR$ 的范围内。如果设置了 $GTCCRB=0$ 或 $GTCCRB=GTPR$ , 则仅当 $GTCCRB=0$ 或 $GTCCRB=GTPR$ 满足时, 才会在周期内发生比较匹配。当 $GTCCRB > GTPR$ 时, 不发生比较匹配。

### (3) 在锯齿单发脉冲模式下进行自动死区时间设置时

$GTCCRC$ 和 $GTCCRD$ 寄存器必须设置为满足以下限制。如果不满足这些限制, 则可能无法获得具有安全死区时间的正确输出波形。

- In up-counting:  $GTCCRC < GTCCRD$ ,  $GTCCRC > GTDVU$ ,  $GTCCRD < GTPR - GTDVU$
- In down-counting:  $GTCCRC > GTCCRD$ ,  $GTCCRC < GTPR - GTDVU$ ,  $GTCCRD > GTDVU$

同样, 必须设置 $GTCCRE$ 和 $GTCCRF$ 寄存器以满足以下限制。如果不满足限制条件, 则可能无法获得具有安全死区时间的正确输出波形:

- In up-counting:  $GTCCRE < GTCCRF$ ,  $GTCCRE > GTDVU$ ,  $GTCCRF < GTPR - GTDVU$
- In down-counting:  $GTCCRE > GTCCRF$ ,  $GTCCRE < GTPR - GTDVU$ ,  $GTCCRF > GTDVU$

### (4) 在锯齿单发脉冲模式下未进行自动死区时间设置时

$GTCCRC$ 和 $GTCCRD$ 寄存器必须设置为满足以下限制。如果不满足限制, 则不会发生两个比较匹配, 并且无法执行脉冲输出。

- In up-counting:  $0 < GTCCRC < GTCCRD < GTPR$
- In down-counting:  $GTPR > GTCCRC > GTCCRD > 0$

同样, 必须设置 $GTCCRE$ 和 $GTCCRF$ 以满足以下限制。如果不满足限制, 则不会发生两个比较匹配, 并且无法执行脉冲输出。

- In up-counting:  $0 < GTCCRE < GTCCRF < GTPR$
- In down-counting:  $GTPR > GTCCRE > GTCCRF > 0$ .

### (5) 在锯齿波PWM模式下

$GTCCRA$ 寄存器必须设置为 $0 < GTCCRA < GTPR$ 。如果设置了 $GTCCRA=0$ 或 $GTCCRA=GTPR$ , 则仅当满足 $GTCCRA=0$ 或 $GTCCRA=GTPR$ 时, 才会在周期内发生比较匹配。如果设置了 $GTCCRA > GTPR$ , 则不会发生比较匹配。

类似地,  $GTCCRB$ 必须设置在 $0 < GTCCRB < GTPR$ 的范围内。如果设置了 $GTCCRB=0$ 或 $GTCCRB=GTPR$ , 则仅当满足 $GTCCRB=0$ 或 $GTCCRB=GTPR$ 时, 才会在周期内发生比较匹配。如果设置了 $GTCCRB > GTPR$ , 则不会发生比较匹配。

## 21.9.3 GTCNT计数器的设置范围

$GTCNT$ 计数器寄存器的设置范围必须为 $0 \leq GTCNT \leq GTPR$ 。

## 21.9.4 启动和停止GTCNT计数器

通过 $GTCR.CST$ 位启动和停止 $GTCNT$ 计数器的控制时序与在 $GTCR.TPCS[3:0]$ 中选择的计数时钟同步。当 $GTCR.CST$ 被更新时,  $GTCNT$ 计数器开始在一个计数时钟后停止

selected in GTCR.TPCS[3:0]. Therefore, an event generated before the GTCNT counter actually starts is ignored, resulting in situations in which an event is accepted or an interrupt occurs after GTCR.CST is set to 0.

### 21.9.5 Priority Order of Each Event

#### (1) GTCNT register

Table 21.47 shows a priority order of events updating the GTCNT register.

**Table 21.47 Priority order of sources updating GTCNT**

| Source updating GTCNT                                     | Priority order |
|---|----------------|
| Writing by CPU (writing to GTCNT/GTCLR)                   | High           |
| Clear by hardware sources set in GTCR                     | ↑              |
| Count up or down by hardware sources set in GTUPSR/GTDNSR | ↑              |
| Count operation   | Low            |

If up-counting and down-counting by hardware sources occur at the same time, the GTCNT counter value does not change. When there is a conflict between updating the GTCNT register and reading by the CPU, pre-update data is read.

#### (2) GTCR.CST bit

When there is a conflict between starting/stopping by hardware sources set in the GTSSR/GTPSR registers and writing by the CPU (writing to GTCR/GTSTR/GTSTP registers), the writing by CPU has priority over the starting/stopping by hardware sources.

In case that stop by the period count function conflicts with start by the CPU writing (GTCR register writing/GTSTR register writing), the period count function is finished with setting the GTST.PCF flag. The CST bit is not changed and the GTCNT continues to count.

When there is a conflict between starting by hardware sources set in the GTSSR register and stopping by hardware sources set in GTPSR register, the GTCR.CST bit value does not change. When there is a conflict between updating the GTCR.CST bit and reading by the CPU, pre-update data is read.

#### (3) GTCCRm registers (m = A to F)

When there is a conflict between input capture/buffer transfer operation and writing to the GTCCRm registers, the writing to GTCCRm registers has priority over input capture/buffer transfer operation. When there is a conflict between input capture and writing to the counter register by the CPU or updating the counter register by hardware sources, the pre-update counter value is captured. When there is a conflict between updating the GTCCRm registers and reading by the CPU, pre-update data is read.

#### (4) GTPR registers

When there is a conflict between buffer transfer operation and writing to the GTPR register, writing to GTPR register has priority over buffer transfer operation. When there is a conflict between updating GTPR register and reading by the CPU, pre-update data is read.

在GTCR.TPCS[3:0]中选择。因此，在GTCNT计数器实际启动之前产生的事件将被忽略，从而导致在GTCR.CST设置为0之后接受事件或发生中断的情况。

### 21.9.5 每个事件的优先顺序

#### (1) GTCNT register

表21.47显示了更新GTCNT寄存器的事件的优先顺序。

**Table 21.47 更新GTCNT的源的优先顺序**

| 源更新GTCNT                        | 优先顺序 |
|---------------------------------|------|
| CPU写入 (写入GTCNT/GTCLR)           | High |
| 由GTCR中设置的硬件源清除                  | ↑    |
| 通过GTUPSR/GTDNSR中设置的硬件源进行向上或向下计数 | ↑    |
| 计数操作                            | Low  |

如果硬件源的递增计数和递减计数同时发生，GTCNT计数器值不会改变。当更新GTCNT寄存器和CPU读取之间存在冲突时，会读取更新前的数据。

#### (2) GTCR.CST bit

当GTSSR/GTPSR寄存器中设置的硬件源启动停止与CPU写入 (写入GTCR/GTSTR/GTSTP寄存器) 发生冲突时，CPU写入优先于硬件源启动停止。

如果周期计数功能停止与CPU写入启动 (GTCR寄存器写入/GTSTR寄存器写入) 发生冲突，则周期计数功能通过设置GTST.PCF标志结束。CST位不变，GTCNT继续计数。

当GTSSR寄存器中设置的硬件源启动和GTPSR寄存器中设置的硬件源停止之间存在冲突时，GTCR.CST位的值不会改变。当更新GTCR.CST位与CPU读取之间存在冲突时，会读取更新前的数据。

#### (3) GTCCRm寄存器 (m=A到F)

当输入捕捉缓冲区传输操作与写入GTCCRm寄存器之间存在冲突时，写入GTCCRm寄存器优先于输入捕捉缓冲区传输操作。当输入捕捉与CPU写入计数器寄存器或硬件源更新计数器寄存器之间存在冲突时，将捕获更新前的计数器值。当更新GTCCRm寄存器和CPU读取之间存在冲突时，会读取更新前的数据。

#### (4) GTPR registers

当缓冲区传输操作与写入GTPR寄存器之间存在冲突时，写入GTPR寄存器优先于缓冲区传输操作。当更新GTPR寄存器与CPU读取发生冲突时，读取更新前的数据。

## 22. Low Power Asynchronous General Purpose Timer (AGT)

### 22.1 Overview

The low power Asynchronous General Purpose Timer (AGT) is a 16-bit timer that can be used for pulse output, external pulse width or period measurement, and counting external events. This timer consists of a reload register and a down counter. The reload register and the down counter are allocated to the same address, and can be accessed with the AGT register.

Table 22.1 lists the AGT specifications, Figure 22.1 shows a block diagram, and Table 22.2 lists the I/O pins.

**Table 22.1 AGT specifications**

| Parameter                                       | Description   |   |
|---|---|---|
| Operating modes                                 | Timer mode  | The count source is counted   |
|   | Pulse output mode   | The count source is counted and the output is inverted at each timer underflow  |
|   | Event counter mode  | An external event is counted  |
|   | Pulse width measurement mode  | An external pulse width is measured   |
|   | Pulse period measurement mode   | An external pulse period is measured  |
| Number of Channels                              | 16 bits × 6 channels (AGTn (n = 0 to 5))  |   |
| Count source (operating clock) <sup>*2</sup>    | Timer mode  | PCLKB, PCLKB/2, PCLKB/8, AGTLCLK/d, AGTSCLK/d (d = 1, 2, 4, 8, 16, 32, 64, or 128), or underflow signal of AGTn (n = 0, 2, 4) selectable. <sup>*1</sup> |
|   | Pulse output mode   |   |
|   | Pulse width measurement mode  |   |
|   | Pulse period measurement mode   |   |
|   | Event counting mode   | External event input  |
| Interrupt and Event Link function <sup>*3</sup> | <ul style="list-style-type: none"> <li>Underflow event signal or measurement complete event signal           <ul style="list-style-type: none"> <li>When the counter underflows</li> <li>When the measurement of the active width of the external input pin (AGTIOn) completes in pulse width measurement mode</li> <li>When the set edge of the external input pin (AGTIOn) is input in pulse period measurement mode.</li> </ul> </li> <li>Compare match A event signal           <ul style="list-style-type: none"> <li>When the values of AGT register and AGTCMA register matched (compare match A function enabled).</li> </ul> </li> <li>Compare match B event signal           <ul style="list-style-type: none"> <li>When the values of AGT register and AGTCMB register matched (compare match B function enabled).</li> </ul> </li> <li>Return from Snooze mode or Software Standby mode can be performed with AGTn_AGTI, AGTn_AGTCMAI, or AGTn_AGTCMBI (n = 1, 3)<sup>*4</sup></li> </ul> |   |
| Selectable functions                            | <ul style="list-style-type: none"> <li>Compare match function</li> </ul> One or two of the AGT Compare Match A register and AGT Compare Match B register is selectable.   |   |
| TrustZone Filter                                | Security attribution can be set for each channels   |   |

Note 1. AGTn (n = 0, 2, 4) cannot use underflow signal. AGTn (n = 1, 3, 5) connects directly with the underflow event signal from the AGTn (n = 0, 2, 4) timer.

Note 2. Satisfy the frequency of the peripheral module clock (PCLKB) ≥ the frequency of the count source clock.

Note 3. The AGT1 cannot use the Event Link function. AGT0 event signals can be used.

Note 4. In details, see section 10, Low Power Modes.

## 22. 低功耗异步通用定时器(AGT)

### 22.1 Overview

低功耗异步通用定时器(AGT)是一个16位定时器，可用于脉冲输出、外部脉冲宽度或周期测量以及外部事件计数。该定时器由一个重载寄存器和一个递减计数器组成。重载寄存器和递减计数器分配到同一个地址，可以通过AGT寄存器访问。

表22.1列出了AGT规格，图22.1显示了框图，表22.2列出了IO引脚。

**Table 22.1 AGT specifications**

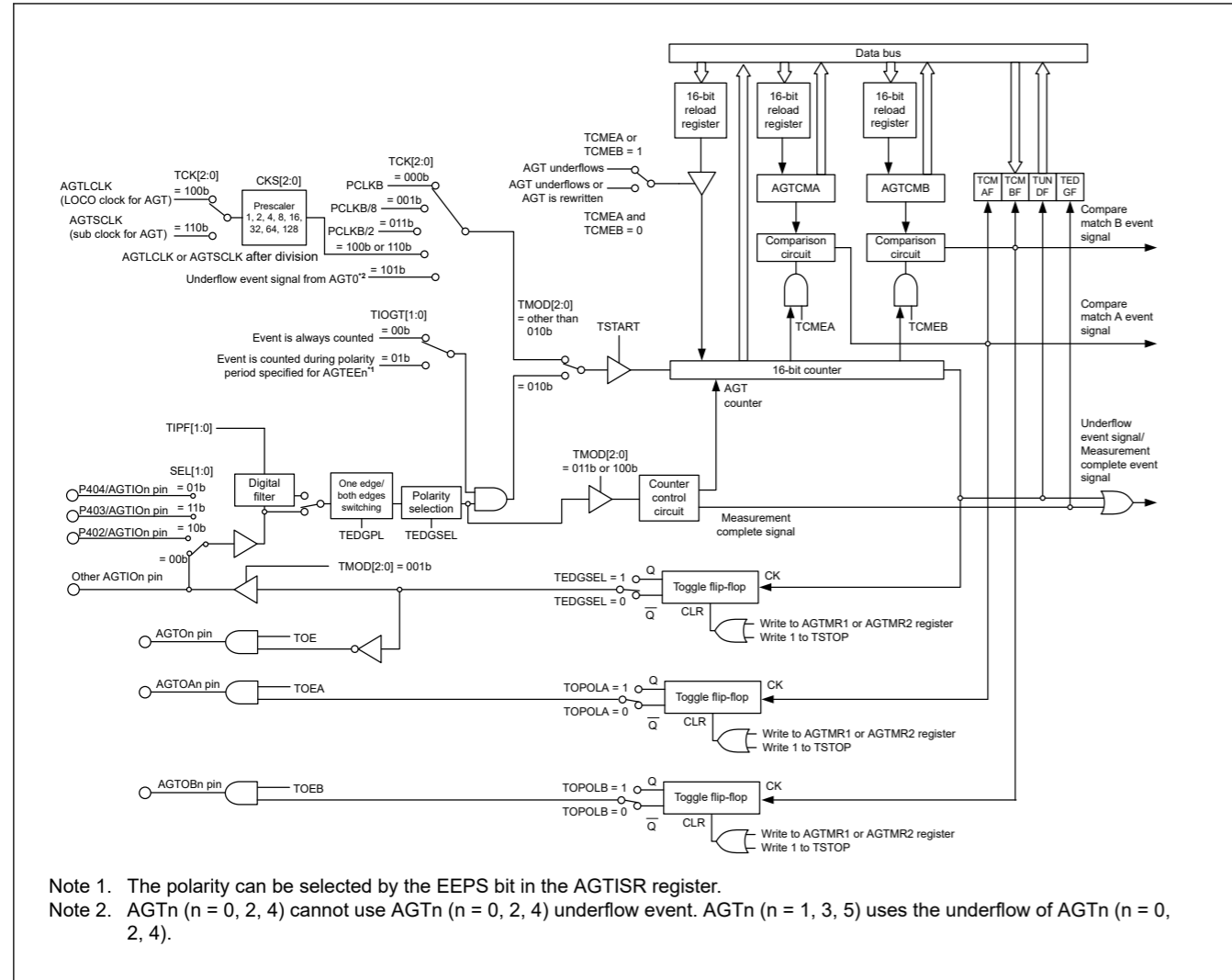
| Parameter        | Description   |   |
|------------------|---|---|
| 操作模式             | 定时器模式   | 计数源被计数  |
|                  | 脉冲输出方式  | 计数源被计数并在每次定时器下溢时反转输出  |
|                  | 事件计数器模式   | 计算外部事件  |
|                  | 脉宽测量模式  | 测量外部脉冲宽度  |
|                  | 脉冲周期测量模式  | 测量外部脉冲周期  |
| 通道数              | 16位×6通道(AGTn(n=0到5))  |   |
| 计数源 (工作时钟) *2    | 定时器模式   | PCLKB、PCLKB2、PCLKB8、AGTLCLKd、AGTSCLKd (d=1、2、4、8、16、32、64或128) 或AGTn的下溢信号 (n=0、2、4) 可选。*1 |
|                  | 脉冲输出方式  |   |
|                  | 脉宽测量模式  |   |
|                  | 脉冲周期测量模式  |   |
|                  | 事件计数模式  | 外部事件输入  |
| 中断和事件链接功能*3      | <ul style="list-style-type: none"> <li>下溢事件信号或测量完成事件信号           <ul style="list-style-type: none"> <li>当计数器下溢时</li> <li>在脉冲宽度测量模式下，外部输入引脚(AGTIOn)的有效宽度测量完成时</li> <li>在脉冲周期测量模式下输入外部输入引脚(AGTIOn)的设置边沿时。</li> </ul> </li> <li>比较匹配A事件信号           <ul style="list-style-type: none"> <li>当AGT寄存器和AGTCMA寄存器的值匹配时 (比较匹配A功能启用)。</li> </ul> </li> <li>比较匹配B事件信号           <ul style="list-style-type: none"> <li>当AGT寄存器和AGTCMB寄存器的值匹配时 (比较匹配B功能启用)。</li> </ul> </li> <li>从贪睡模式或软件待机模式返回可以通过 AGTn_AGTI, AGTn_AGTCMAI, or AGTn_AGTCMBI (n = 1, 3)<sup>*4</sup></li> </ul> |   |
| 可选择的功能           | <ul style="list-style-type: none"> <li>比较匹配功能AGT比较匹配A寄存器和AGT比较匹配中的一个或两个B寄存器是可选的。</li> </ul>   |   |
| TrustZone Filter | 可以为每个通道设置安全属性   |   |

注1.AGTn(n=0 2 4)不能使用下溢信号。AGTn(n=1 3 5)直接连接来自AGTn(n=0 2 4)定时器的下溢事件信号。

注2.满足外设模块时钟 (PCLKB) 的频率≥计数源时钟的频率。

注3.AGT1 不能使用EventLink功能。可以使用AGT0事件信号。

注4.详细信息请参见第10节，低功耗模式。



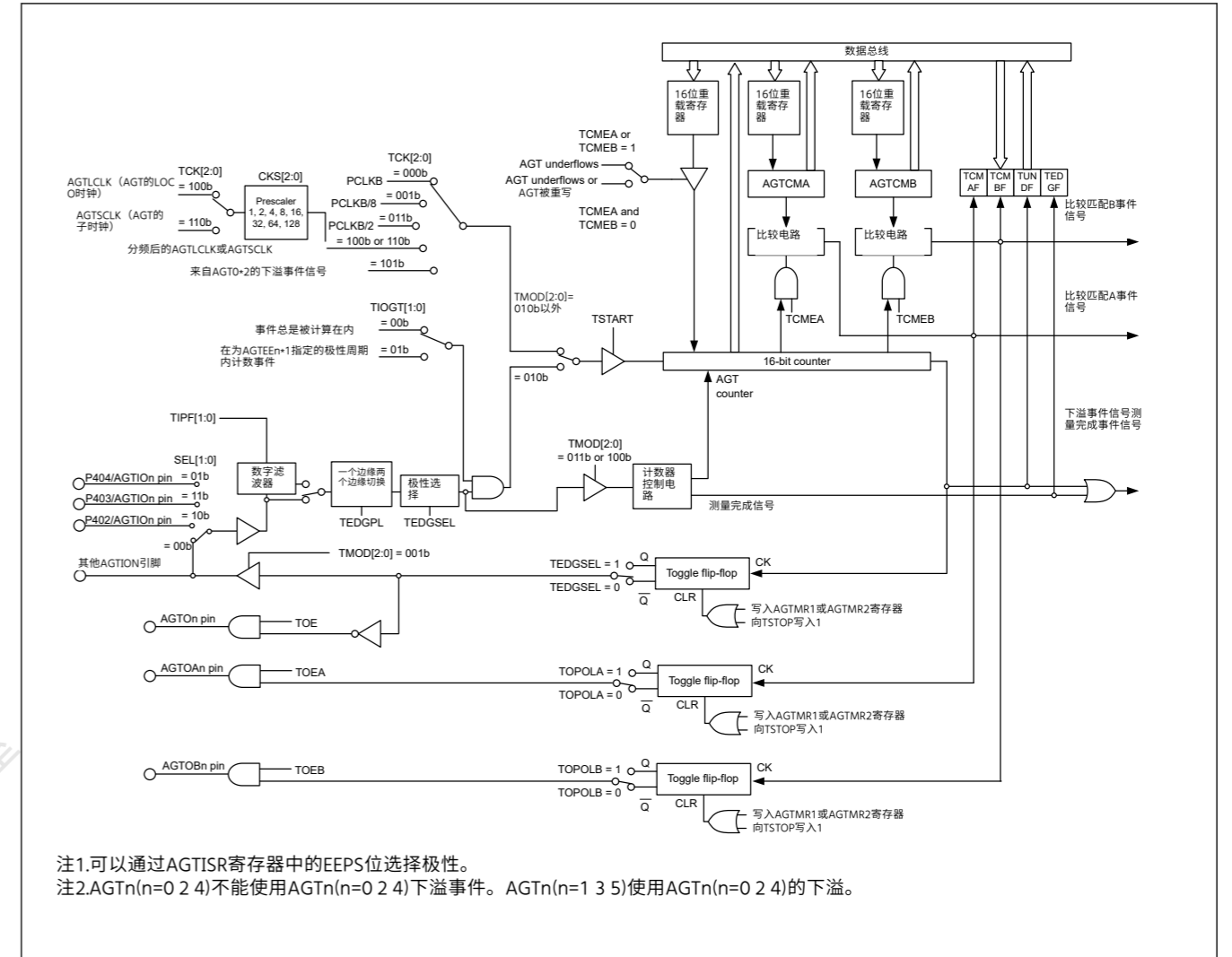
Note 1. The polarity can be selected by the EEPS bit in the AGTISR register.  
 Note 2. AGTn (n = 0, 2, 4) cannot use AGTn (n = 0, 2, 4) underflow event. AGTn (n = 1, 3, 5) uses the underflow of AGTn (n = 0, 2, 4).

Figure 22.1 AGT block diagram

Table 22.2 AGT I/O pins

| Pin name | I/O          | Function                                      |
|----------|--------------|---|
| AGTEEn   | Input        | External event input enable for AGT           |
| AGTIOn   | Input/output | External event input and pulse output for AGT |
| AGTOn    | Output       | Pulse output for AGT                          |
| AGTOAn   | Output       | Compare match A output for AGT                |
| AGTOBn   | Output       | Compare match B output for AGT                |

Note: Channel number: n = 0 to 5  
 Note: P402, P403, P404 can only be used as input.



注1.可以通过AGTISR寄存器中的EEPS位选择极性。  
 注2.AGTn(n=0 2 4)不能使用AGTn(n=0 2 4)下溢事件。AGTn(n=1 3 5)使用AGTn(n=0 2 4)的下溢。

Figure 22.1 AGT框图

Table 22.2 AGT I/O pins

| 引脚名称   | I/O          | Function        |
|--------|--------------|-----------------|
| AGTEEn | Input        | AGT的外部事件输入使能    |
| AGTIOn | Input/output | AGT的外部事件输入和脉冲输出 |
| AGTOn  | Output       | AGT的脉冲输出        |
| AGTOAn | Output       | 比较AGT的匹配A输出     |
| AGTOBn | Output       | 比较AGT的匹配B输出     |

Note: 通道号: n=0到5  
 Note: P402、P403、P404只能用作输入。

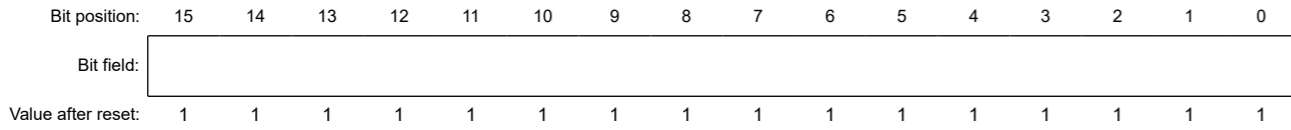


## 22.2 Register Descriptions

## 22.2.1 AGT : AGT Counter Register

Base address:  $AGTn = 0x400E\_8000 + 0x0100 \times n$  (n = 0 to 5)

Offset address: 0x00



| Bit  | Symbol | Function   | R/W |
|------|--------|--|-----|
| 15:0 | n/a    | 16-bit counter and reload register<br>Setting range : 0x0000 to 0xFFFF | R/W |

AGTn.AGT is a 16-bit register. The write value is written to the reload register and the read value is read from the counter.

The states of the reload register and the counter change according to the TSTART bit in the AGTCR register and TCMEA/TCMEB bit in the AGTCMSR register. For details, see [section 22.3.1. Reload Register and Counter Rewrite Operation](#).

When 1 is written to the TSTOP bit in the AGTCR register, AGT counter is forcibly stopped and set to 0xFFFF.

When the TCK[2:0] bits setting in the AGTMR1 register are a value other than 001b (PCLKB/8) or 011b (PCLKB/2), if the AGT register is set to 0x0000, a request signal to the ICU, the DTC, the DMAC, and the ELC is generated once immediately after the count starts. The AGTOn, AGTIO pin output are toggled.

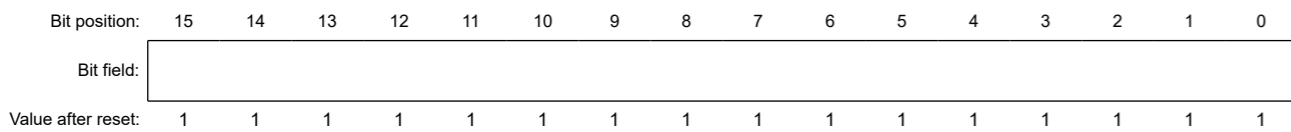
When the AGT register is set to 0x0000 in event counter mode, regardless of the value of TCK[2:0] bits, a request signal to the ICU, the DTC, the DMAC, and the ELC is generated once immediately after the count starts.

In addition, the AGTOn pin output is toggled even during a period other than the specified count period. When the AGT register is set to 0x0001 or more, a request signal is generated each time AGT underflows.

## 22.2.2 AGTCMA : AGT Compare Match A Register

Base address:  $AGTn = 0x400E\_8000 + 0x0100 \times n$  (n = 0 to 5)

Offset address: 0x02



| Bit  | Symbol | Function   | R/W |
|------|--------|--|-----|
| 15:0 | n/a    | 16-bit compare match A data is stored.*1<br>Setting range : 0x0000 to 0xFFFF | R/W |

Note 1. Set the AGTCMA register to 0xFFFF when compare match A is not used.

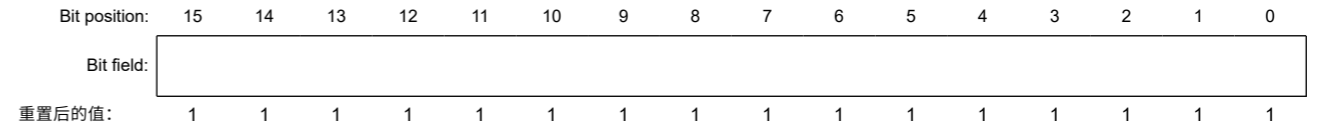
The AGTCMA register is a read/write register to set a value for compare match with the AGT counter. The states of the reload register and compare register A change according to the TSTART bit in the AGTCR register. For details, see [section 22.3.2. Reload Register and AGT Compare Match A/B Register Rewrite Operation](#).

## 22.2 注册说明

## 22.2.1 AGT:AGT计数器寄存器

Base address:  $AGTn = 0x400E\_8000 + 0x0100 \times n$  (n = 0 to 5)

Offset address: 0x00



| Bit  | Symbol | Function                        | R/W |
|------|--------|---------------------------------|-----|
| 15:0 | n/a    | 16位计数器和重载寄存器设置范围: 0x0000到0xFFFF | R/W |

AGTn.AGT是一个16位寄存器。写入值写入重载寄存器，读取值从计数器中读取。

重载寄存器和计数器的状态根据AGTCR寄存器和TCMEA中的TSTART位改变AGTCMSR寄存器中的TCMEB位。详见22.3.1节。重载寄存器和计数器重写操作。

当AGTCR寄存器的TSTOP位写入1时，AGT计数器被强制停止并设置为0xFFFF。

当AGTMR1寄存器中的TCK[2:0]位设置为001b(PCLKB8)或011b(PCLKB2)以外的值时，如果AGT寄存器设置为0x0000，在计数开始后立即生成一次对ICU、DTC、DMAC和ELC的请求信号。AGTOn、AGTIO引脚输出被切换。

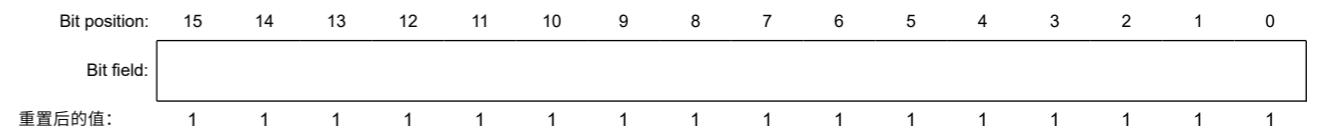
当AGT寄存器在事件计数器模式下设置为0x0000时，无论TCK[2:0]位的值如何，都会在计数开始后立即生成一次对ICU、DTC、DMAC和ELC的请求信号。

此外，即使在指定计数周期以外的周期内，AGTOn引脚输出也会切换。当AGT寄存器设置为0x0001或更大时，每次AGT下溢时都会产生一个请求信号。

## 22.2.2 AGTCMA:AGT比较匹配A寄存器

Base address:  $AGTn = 0x400E\_8000 + 0x0100 \times n$  (n = 0 to 5)

Offset address: 0x02



| Bit  | Symbol | Function                                | R/W |
|------|--------|---|-----|
| 15:0 | n/a    | 16位比较匹配A数据被存储。*1<br>设置范围: 0x0000到0xFFFF | R/W |

注1.不使用比较匹配A时，将AGTCMA寄存器设置为0xFFFF。

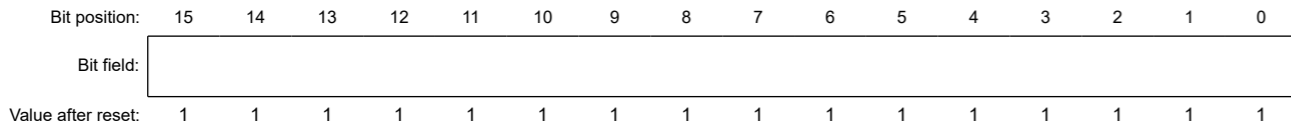
AGTCMA寄存器是一个读写寄存器，用于设置与AGT计数器比较匹配的值。重载寄存器和比较寄存器A的状态根据AGTCR寄存器中的TSTART位而改变。详见22.3.2节。重载寄存器和AGT比较匹配AB寄存器重写操作。



## 22.2.3 AGTCMB : AGT Compare Match B Register

Base address:  $AGTn = 0x400E\_8000 + 0x0100 \times n$  ( $n = 0$  to 5)

Offset address: 0x04



| Bit  | Symbol | Function   | R/W |
|------|--------|--|-----|
| 15:0 | n/a    | 16-bit compare match B data is stored.*1<br>Setting range : 0x0000 to 0xFFFF | R/W |

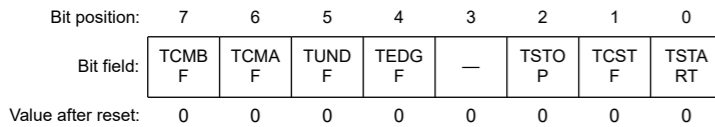
Note 1. Set the AGTCMB register to 0xFFFF when compare match B is not used.

The AGTCMB register is a read/write register to set a value for compare match with the AGT counter. The states of the reload register and compare register B change according to the TSTART bit in the AGTCR register. For details, see [section 22.3.2. Reload Register and AGT Compare Match A/B Register Rewrite Operation](#).

## 22.2.4 AGTCR : AGT Control Register

Base address:  $AGTn = 0x400E\_8000 + 0x0100 \times n$  ( $n = 0$  to 5)

Offset address: 0x08



| Bit | Symbol | Function   | R/W     |
|-----|--------|--|---------|
| 0   | TSTART | AGT Count Start*2<br>0: Count stops<br>1: Count starts                               | R/W     |
| 1   | TCSTF  | AGT Count Status Flag*2<br>0: Count stopped<br>1: Count in progress                  | R       |
| 2   | TSTOP  | AGT Count Forced Stop*1<br>0: Writing is invalid<br>1: The count is forcibly stopped | W       |
| 3   | —      | This bit is read as 0. The write value should be 0.                                  | R/W     |
| 4   | TEDGF  | Active Edge Judgment Flag<br>0: No active edge received<br>1: Active edge received   | R/(W)*3 |
| 5   | TUNDF  | Underflow Flag<br>0: No underflow<br>1: Underflow                                    | R/(W)*3 |
| 6   | TCMAF  | Compare Match A Flag<br>0: No match<br>1: Match                                      | R/(W)*3 |
| 7   | TCMBF  | Compare Match B Flag<br>0: No match<br>1: Match                                      | R/(W)*3 |

Note 1. When 1 (count is forcibly stopped) is written to the TSTOP bit, the TSTART bit and TCSTF flag are initialized at the same time. The pulse output level is also initialized. The read value is 0.

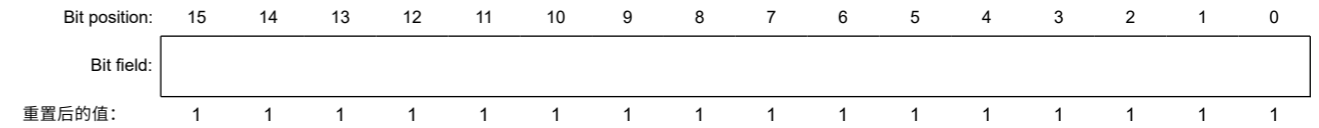
Note 2. For information on using the TSTART bit and TCSTF flag, see [section 22.4.1. Count Operation Start and Stop Control](#).

Note 3. Only 0 can be written to clear the flag.

## 22.2.3 AGTCMB:AGT比较匹配B寄存器

Base address:  $AGTn = 0x400E\_8000 + 0x0100 \times n$  ( $n = 0$  to 5)

Offset address: 0x04



| Bit  | Symbol | Function                               | R/W |
|------|--------|--|-----|
| 15:0 | n/a    | 存储16位比较匹配B数据。*1<br>设置范围: 0x0000到0xFFFF | R/W |

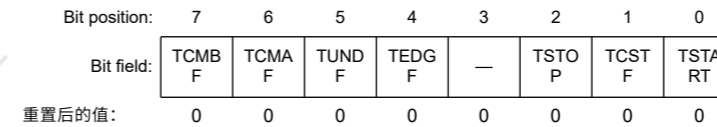
注1.不使用比较匹配B时, 将AGTCMB寄存器设置为0xFFFF。

AGTCMB寄存器是一个读写寄存器, 用于设置与AGT计数器比较匹配的值。重载寄存器和比较寄存器B的状态根据AGTCR寄存器中的TSTART位而改变。详见22.3.2节。重载寄存器和AGT比较匹配AB寄存器重写操作。

## 22.2.4 AGTCR:AGT控制寄存器

Base address:  $AGTn = 0x400E\_8000 + 0x0100 \times n$  ( $n = 0$  to 5)

Offset address: 0x08



| Bit | Symbol | Function  | R/W     |
|-----|--------|---|---------|
| 0   | TSTART | AGT计数开始*2<br>0: 计数停止1<br>: 计数开始                   | R/W     |
| 1   | TCSTF  | AGT计数状态标志*2<br>0: 计数停止1: 计数中                      | R       |
| 2   | TSTOP  | AGTCount强制停止*1<br>0: 写入无效1: 强制停止计数                | W       |
| 3   | —      | 该位读取为0。写入值应为0。                                    | R/W     |
| 4   | TEDGF  | 主动边缘判断标志<br>0: 未收到有效边沿1: 收到有效边沿                   | R/(W)*3 |
| 5   | TUNDF  | Underflow Flag<br>0: No underflow<br>1: Underflow | R/(W)*3 |
| 6   | TCMAF  | 比较匹配标志<br>0: 不匹配1<br>: 匹配                         | R/(W)*3 |
| 7   | TCMBF  | 比较匹配B标志<br>0: 不匹配1<br>: 匹配                        | R/(W)*3 |

注1.当1 (强制停止计数) 写入TSTOP位时, TSTART位和TCSTF标志同时初始化。脉冲输出电平也被初始化。读取值为0。

注2.有关使用TSTART位和TCSTF标志的信息, 请参阅第22.4.1节。计数操作启动和停止控制。

注3.只能写入0来清除标志。

**TSTART bit (AGT Count Start)**

The count operation is started by writing 1 to the TSTART bit and stopped by writing 0. When the TSTART bit is set to 1 (count starts), the TCSTF flag is set to 1 (count in progress) in synchronization with the count source. Also, after 0 is written to the TSTART bit, the TCSTF flag is set to 0 (count stops) in synchronization with the count source. For details, see [section 22.4.1. Count Operation Start and Stop Control](#).

**TCSTF flag (AGT Count Status Flag)**

The TCSTF flag indicates the AGT count status.

[Setting condition]

- When 1 is written to the TSTART bit (the TCSTF flag is set to 1 in synchronization with the count source).

[Clearing conditions]

- When 0 is written to the TSTART bit (the TCSTF flag is set to 0 in synchronization with the count source)
- When 1 is written to the TSTOP bit.

**TSTOP bit (AGT Count Forced Stop)**

When 1 is written to the TSTOP bit, the count is forcibly stopped. The read value is 0.

**TEDGF flag (Active Edge Judgment Flag)**

The TEDGF flag indicates that an active edge was detected.

[Setting condition]

- When the measurement of the active width of the external input pin (AGTIO<sub>n</sub>) is complete in pulse width measurement mode
- When the set edge of the external input pin (AGTIO<sub>n</sub>) is input in pulse period measurement mode.

[Clearing condition]

- When 0 is written to this flag by software.

**TUNDF flag (Underflow Flag)**

The TUNDF flag indicates that the counter underflowed.

[Setting condition]

- When the counter underflows.

[Clearing condition]

- When 0 is written to this flag by software.

**TCMAF flag (Compare Match A Flag)**

The TCMAF flag indicates that compare match A was detected.

[Setting condition]

- When the value in the AGT register matches the value in the AGTCMA register.

[Clearing condition]

- When 0 is written to this flag by software.

**TCMBF flag (Compare Match B Flag)**

The TCMBF flag indicates that compare match B was detected.

[Setting condition]

- When the value in the AGT register matches the value in the AGTCMB register.

[Clearing condition]

- When 0 is written to this flag by software.

**TSTART位 (AGT计数开始)**

通过向TSTART位写入1开始计数操作，通过写入0停止计数操作。当TSTART位设置为1（计数开始）时，TCSTF标志设置为1（计数进行中）与计数源同步。此外，在TSTART位写入0后，TCSTF标志与计数源同步设置为0（计数停止）。详见22.4.1节。计数操作启动和停止控制。

**TCSTF标志 (AGT计数状态标志)**

TCSTF标志指示AGT计数状态。

[Setting condition]

- 当TSTART位写入1时（TCSTF标志设置为1，与计数源同步）。

[Clearing conditions]

- TSTART位写入0时（TCSTF标志设置为0与计数源同步）
- TSTOP位写入1时。

**TSTOP位 (AGT计数强制停止)**

向TSTOP位写入1时，强制停止计数。读取值为0。

**TEDGF标志 (活动边缘判断标志)**

TEDGF标志表示检测到有效边沿。

[Setting condition]

- 在脉冲宽度测量模式下，外部输入引脚(AGTIO<sub>n</sub>)的有效宽度测量完成时
- 在脉冲周期测量模式下输入外部输入引脚(AGTIO<sub>n</sub>)的设置边沿时。

[Clearing condition]

- 当软件向该标志写入0时。

**TUNDF flag (Underflow Flag)**

TUNDF标志指示计数器下溢。

[Setting condition]

- 当计数器下溢时。

[Clearing condition]

- 当软件向该标志写入0时。

**TCMAF标志 (比较匹配A标志)**

TCMAF标志表示检测到比较匹配A。

[Setting condition]

- 当AGT寄存器中的值与AGTCMA寄存器中的值匹配时。

[Clearing condition]

- 当软件向该标志写入0时。

**TCMBF标志 (比较匹配B标志)**

TCMBF标志表示检测到比较匹配B。

[Setting condition]

- 当AGT寄存器中的值与AGTCMB寄存器中的值匹配时。

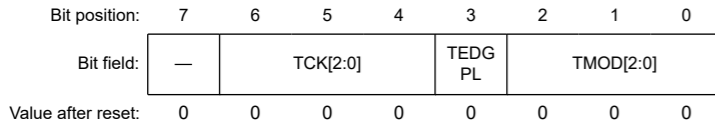
[Clearing condition]

- 当软件向该标志写入0时。

22.2.5 AGTMR1 : AGT Mode Register 1

Base address: AGTn = 0x400E\_8000 + 0x0100 × n (n = 0 to 5)

Offset address: 0x09



| Bit | Symbol    | Function   | R/W |
|-----|-----------|--|-----|
| 2:0 | TMOD[2:0] | Operating Mode*3<br>0 0 0: Timer mode<br>0 0 1: Pulse output mode<br>0 1 0: Event counter mode<br>0 1 1: Pulse width measurement mode<br>1 0 0: Pulse period measurement mode<br>Others: Setting prohibited  | R/W |
| 3   | TEDGPL    | Edge Polarity*4<br>0: Single-edge<br>1: Both-edge  | R/W |
| 6:4 | TCK[2:0]  | Count Source*1 *2 *5 *7<br>0 0 0: PCLKB<br>0 0 1: PCLKB/8<br>0 1 1: PCLKB/2<br>1 0 0: Divided clock AGTLCLK specified by CKS[2:0] bits in the AGTMR2 register<br>1 0 1: Underflow event signal from AGTn (n = 0, 2, 4)*6<br>1 1 0: Divided clock AGTSCLK specified by CKS[2:0] bits in the AGTMR2 register<br>Others: Setting prohibited | R/W |
| 7   | —         | This bit is read as 0. The write value should be 0.  | R/W |

Note: Write access to the AGTMR1 register initializes the output from the AGTOn, AGTIO n, AGTOAn, AGTOBn pins of the AGT (n = 0 to 5). For details on the output level at initialization, see section 22.2.7. AGTIOC : AGT I/O Control Register.

Note 1. When event counter mode is selected, the external input pin (AGTIO n) is selected as the count source regardless of the setting of TCK[2:0] bits.

Note 2. Do not switch count sources during count operation. Only switch count sources when both the TSTART bit and TCSTF flag in the AGTCR register are set to 0 (count stops).

Note 3. The operating mode can only be changed when the count is stopped while both the TSTART bit and TCSTF flag in the AGTCR register are set to 0 (count is stopped). Do not change the operating mode during count operation.

Note 4. The TEDGPL bit is enabled only in event counter mode.

Note 5. To run AGT in Software Standby and Deep Software Standby mode, select AGTLCLK or AGTSCLK (TCK[2:0] = 100b, 110b).

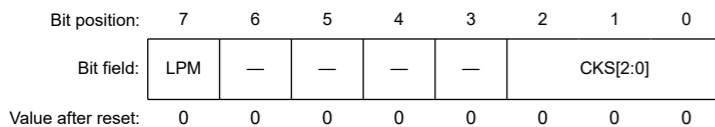
Note 6. AGTn (n = 0, 2, 4) cannot use AGTn (n = 0, 2, 4) underflow (setting prohibited). AGTn (n = 1, 3, 5) uses the AGTn (n = 0, 2, 4) underflow.

Note 7. Do not change the TCK[2:0] bits when the CKS[2:0] bits in the AGTMR2 register is not 000b. First, change the CKS[2:0] bits in the AGTMR2 register to 000b. Then change the TCK[2:0] bits and wait for one cycle of the count source.

22.2.6 AGTMR2 : AGT Mode Register 2

Base address: AGTn = 0x400E\_8000 + 0x0100 × n (n = 0 to 5)

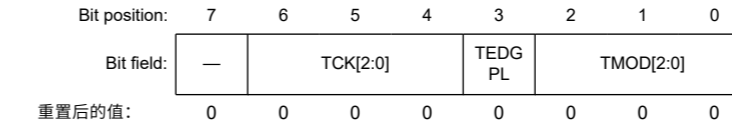
Offset address: 0x0A



22.2.5 AGTMR1 : AGT模式寄存器1

Base address: AGTn = 0x400E\_8000 + 0x0100 × n (n = 0 to 5)

Offset address: 0x09



| Bit | Symbol    | Function   | R/W |
|-----|-----------|--|-----|
| 2:0 | TMOD[2:0] | 操作模式*3<br>000: 定时器模式001: 脉冲输出模式010: 事件计数器模式011: 脉冲宽度测量模式100: 脉冲周期测量模式<br>其他: 禁止设置  | R/W |
| 3   | TEDGPL    | 边缘极性*4<br>0: Single-edge<br>1: Both-edge   | R/W |
| 6:4 | TCK[2:0]  | 计数源*1*2*5*7<br>000:PCLKB001:PCLKB8011:PCLKB2100:分频时钟AGTLCLK由AGTMR2寄存器中的CKS[2:0]位指定101:来自AGTn(n=0)的下溢事件信号2 4)*6<br>110: 由AGTMR2寄存器中的CKS[2:0]位指定的分频时钟AGTSCLK<br>其他: 禁止设置 | R/W |
| 7   | —         | 该位读取为0。写入值应为0。   | R/W |

Note: 对AGTMR1寄存器的写访问会初始化AGT (n=0到5) 的AGTOn、AGTIO n、AGTOAn、AGTOBn引脚的输出。有关初始化时的输出电平的信息，请参阅第22.2.7节。AGTIOC: AGTIO控制寄存器。

注意1.选择事件计数器模式时，无论设置如何

TCK[2:0] bits.

注2.在计数操作期间不要切换计数源。只有当TSTART位和TCSTF标志都在AGTCR寄存器设置为0 (计数停止)。

注3.只有在AGTCR寄存器中的TSTART位和TCSTF标志都设置为0 (计数停止) 时停止计数才能更改操作模式。请勿在计数操作期间更改操作模式。

注4.TEDGPL位仅在事件计数器模式下启用。

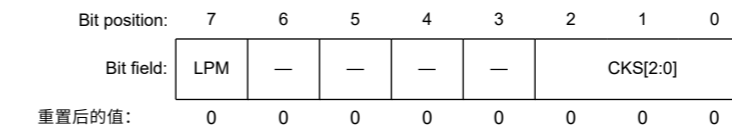
注5.要在软件待机和深度软件待机模式下运行AGT，请选择AGTLCLK或AGTSCLK(TCK[2:0]=100b 110b)。注6.AGTn(n=0 2 4)不能使用AGTn(n=0 2 4)下溢 (禁止设置)。AGTn(n=1 3 5)使用AGTn(n=0 2 4)下溢。

注7.当AGTMR2寄存器中的CKS[2:0]位不是000b时，不要更改TCK[2:0]位。首先，更改CKS[2:0]位AGTMR2寄存器到000b。然后改变TCK[2:0]位并等待计数源的一个周期。

22.2.6 AGTMR2:AGT模式寄存器2

Base address: AGTn = 0x400E\_8000 + 0x0100 × n (n = 0 to 5)

Offset address: 0x0A



| Bit | Symbol   | Function  | R/W |
|-----|----------|---|-----|
| 2:0 | CKS[2:0] | AGTLCLK or AGTSCLK Count Source Clock Frequency Division Ratio*1*2*3<br>0 0 0: 1/1<br>0 0 1: 1/2<br>0 1 0: 1/4<br>0 1 1: 1/8<br>1 0 0: 1/16<br>1 0 1: 1/32<br>1 1 0: 1/64<br>1 1 1: 1/128 | R/W |
| 6:3 | —        | These bits are read as 0. The write value should be 0.  | R/W |
| 7   | LPM      | Low Power Mode<br>0: Normal mode<br>1: Low power mode   | R/W |

Note 1. Do not rewrite the CKS[2:0] bits during count operation. Only rewrite the CKS[2:0] bits when both the TSTART bit and TCSTF flag in the AGTCR register are set to 0 (count stops).

Note 2. When count source is AGTLCLK or AGTSCLK, the switch of CKS[2:0] bits is valid.

Note 3. Do not switch the TCK[2:0] bits in the AGTMR1 register when CKS[2:0] bits are not 000b. Switch the TCK[2:0] bits in the AGTMR1 register after CKS[2:0] bits are set to 000b, and wait for 1 cycle of the count source.

#### CKS[2:0] bit (AGTLCLK or AGTSCLK Count Source Clock Frequency Division Ratio)

CKS[2:0] bits select the Count Source Clock Frequency Division Ratio for AGTLCLK or AGTSCLK.

#### LPM bit (Low Power Mode)

The LPM bit sets the low power operation, which impacts access to certain AGT registers. Set this bit to 1 to operate in low power.

When this bit is 1, access to the following registers is prohibited:

- AGT/AGTCMA/AGTCMB/AGTCR.

After this bit is switched from 1 to 0, the first access to the register is constrained as follows:

- When reading from the AGT register, read AGT register twice. Only the second reading of data is valid.
- When writing to the AGT, AGTCMA, AGTCMB, and AGTCR register, allow at least 2 cycles of the count source clock when writing to the register.
- When confirm the value written to the AGT, AGTCMA, AGTCMB, and AGTCR registers.
  - When the count operation is stopped; after writing data, it can be read in the next cycle.
  - When the count operation is operating; after writing data, it can be written 4 cycles after the count source clock.

Figure 22.2 shows the flow of how to write LPM bit

| Bit | Symbol   | Function   | R/W |
|-----|----------|--|-----|
| 2:0 | CKS[2:0] | AGTLCLK或AGTSCLK计数源时钟分频比*1*2*3<br>0 0 0: 1/1<br>0 0 1: 1/2<br>0 1 0: 1/4<br>0 1 1: 1/8<br>1 0 0: 1/16<br>1 0 1: 1/32<br>1 1 0: 1/64<br>1 1 1: 1/128 | R/W |
| 6:3 | —        | 这些位被读取为0。写入值应为0。   | R/W |
| 7   | LPM      | 低功耗模式<br>0: 正常模式1: 低功耗模式   | R/W |

注1.在计数操作期间不要重写CKS[2:0]位。仅当AGTCR寄存器中的TSTART位和TCSTF标志都设置为0（计数停止）时才重写CKS[2:0]位。

注2.当计数源为AGTLCLK或AGTSCLK时，CKS[2:0]位的切换有效。

注3.当CKS[2:0]位不是000b时，不要切换AGTMR1寄存器中的TCK[2:0]位。在CKS[2:0]位设置为000b后，切换AGTMR1寄存器中的TCK[2:0]位，并等待计数源的1个周期。

#### CKS[2:0]位 (AGTLCLK或AGTSCLK计数源时钟分频比)

CKS[2:0]位选择AGTLCLK或AGTSCLK的计数源时钟分频比。

#### LPM位 (低功耗模式)

LPM位设置低功耗操作，这会影响对某些AGT寄存器的访问。将此位设置为1以在低功耗下工作。

该位为1时，禁止访问以下寄存器：

- AGT/AGTCMA/AGTCMB/AGTCR.

该位由1变为0后，对寄存器的第一次访问受到如下约束：

- 读取AGT寄存器时，读取AGT寄存器两次。只有第二次读取数据是有效的。
- 写入AGT、AGTCMA、AGTCMB和AGTCR寄存器时，写入寄存器时至少允许计数源时钟的2个周期。
- 确认写入AGT、AGTCMA、AGTCMB、AGTCR寄存器的值时。
  - 当计数操作停止时；写入数据后，可以在下一个周期读取。
  - 当计数操作正在运行时；写入数据后，可在计数源时钟后4个周期写入。

图22.2显示如何写入LPM位的流程

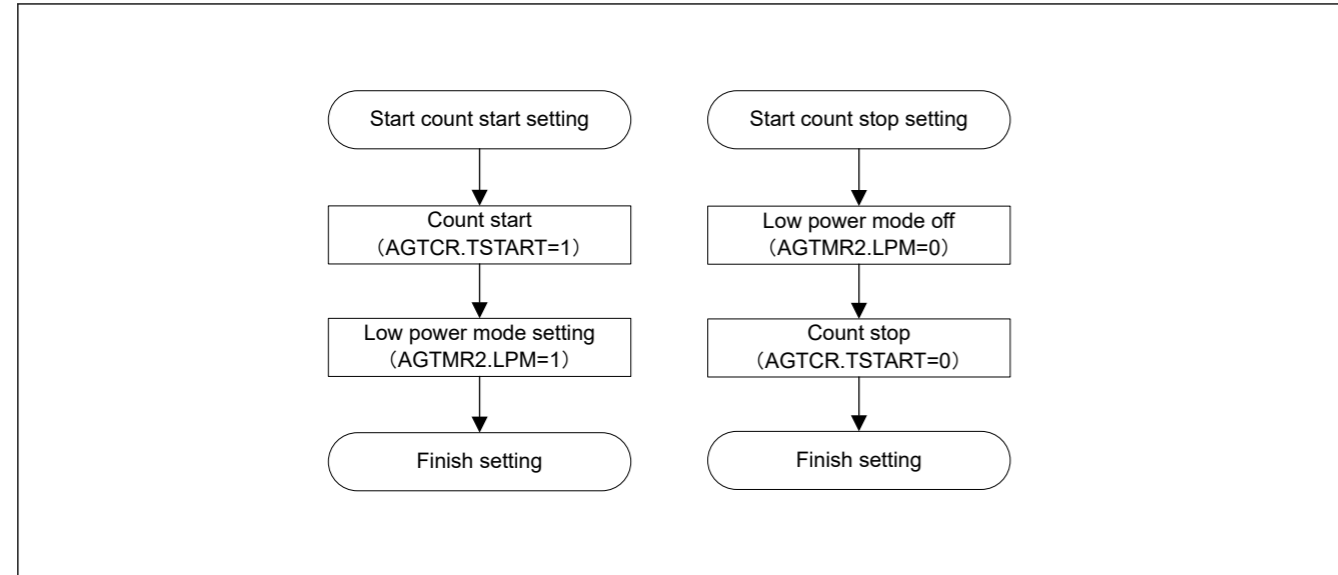


Figure 22.2 LPM how to write flow chart

### 22.2.7 AGTIOC : AGT I/O Control Register

Base address: AGTn = 0x400E\_8000 + 0x0100 × n (n = 0 to 5)

Offset address: 0x0C

|                    |            |           |   |     |   |         |   |   |
|--------------------|------------|-----------|---|-----|---|---------|---|---|
| Bit position:      | 7          | 6         | 5 | 4   | 3 | 2       | 1 | 0 |
| Bit field:         | TIOGT[1:0] | TIPF[1:0] | — | TOE | — | TEDGSEL |   |   |
| Value after reset: | 0          | 0         | 0 | 0   | 0 | 0       | 0 | 0 |

| Bit | Symbol     | Function   | R/W |
|-----|------------|--|-----|
| 0   | TEDGSEL    | I/O Polarity Switch<br>Function varies depending on the operating mode (see Table 22.3 and Table 22.4).  | R/W |
| 1   | —          | This bit is read as 0. The write value should be 0.  | R/W |
| 2   | TOE        | AGTOn pin Output Enable<br>0: AGTOn pin output disabled<br>1: AGTOn pin output enabled   | R/W |
| 3   | —          | This bit is read as 0. The write value should be 0.  | R/W |
| 5:4 | TIPF[1:0]  | Input Filter*3<br>These bits specifies the sampling frequency of the filter for the AGTIO pin. If the input to the AGTIO pin is sampled and the value matches three successive times, that value is taken as the input value.<br>0 0: No filter<br>0 1: Filter sampled at PCLKB<br>1 0: Filter sampled at PCLKB/8<br>1 1: Filter sampled at PCLKB/32 | R/W |
| 7:6 | TIOGT[1:0] | Count Control*1 *2<br>0 0: Event is always counted<br>0 1: Event is counted during polarity period specified for AGTEEn pin<br>Others: Setting prohibited  | R/W |

Note 1. When AGTEEn pin is used, the polarity to count an event can be selected with the EEPS bit in the AGTISR register.

Note 2. TIOGT[1:0] bits are enabled only in event counter mode.

Note 3. When event counter mode operation is performed during Software Standby and Deep Software Standby mode, the digital filter function cannot be used.

#### TEDGSEL bit (I/O Polarity Switch)

The TEDGSEL bit switches the AGTOn pin output polarity and the AGTIO pin input/output edge and polarity.

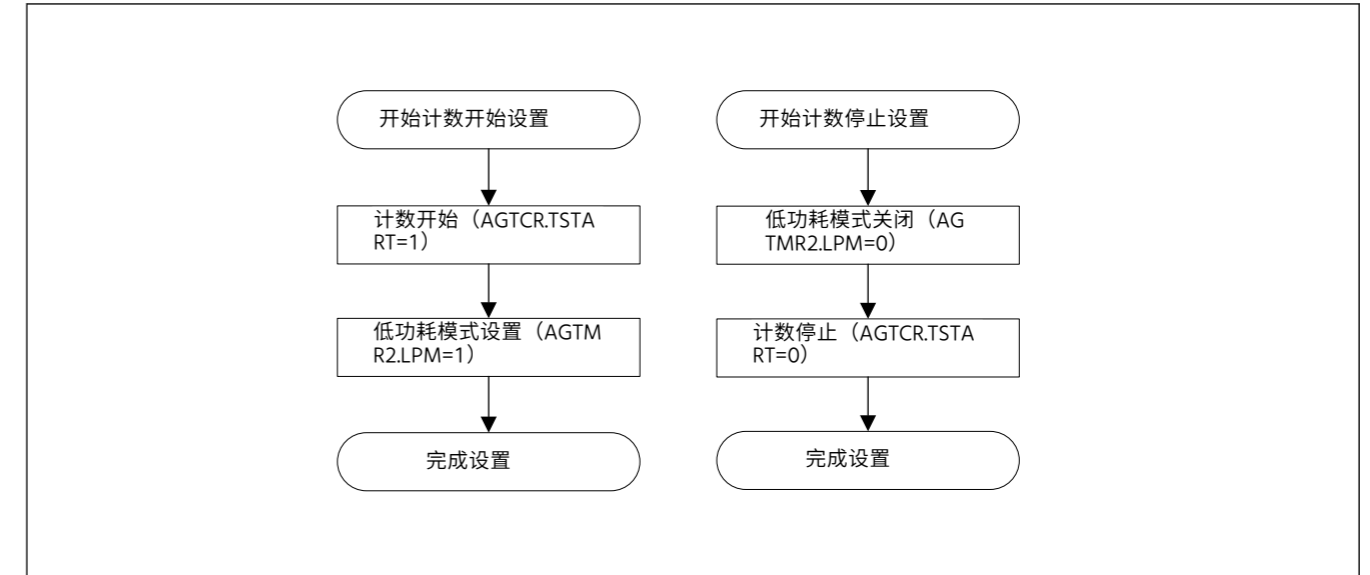


Figure 22.2 LPM如何写流程图

### 22.2.7 AGTIOC:AGTIO控制寄存器

Base address: AGTn = 0x400E\_8000 + 0x0100 × n (n = 0 to 5)

Offset address: 0x0C

|               |            |           |   |     |   |         |   |   |
|---------------|------------|-----------|---|-----|---|---------|---|---|
| Bit position: | 7          | 6         | 5 | 4   | 3 | 2       | 1 | 0 |
| Bit field:    | TIOGT[1:0] | TIPF[1:0] | — | TOE | — | TEDGSEL |   |   |
| 重置后的值:        | 0          | 0         | 0 | 0   | 0 | 0       | 0 | 0 |

| Bit | Symbol     | Function   | R/W |
|-----|------------|--|-----|
| 0   | TEDGSEL    | IO极性开关<br>功能因操作模式而异 (参见表22.3和表22.4)。   | R/W |
| 1   | —          | 该位读取为0。写入值应为0。   | R/W |
| 2   | TOE        | AGTOn引脚输出使能<br>0: 禁止AGTOn引脚输出1: 使能AGTOn引脚输出  | R/W |
| 3   | —          | 该位读取为0。写入值应为0。   | R/W |
| 5:4 | TIPF[1:0]  | 输入滤波器*3<br>这些位指定AGTIO pin输入的滤波器采样频率。如果对AGTIO pin的输入进行采样并且值连续匹配3次, 则将该值作为输入值。<br>00: 无滤波器01: 滤波器在PCLKB1采样0: 滤波器在PCLKB8采样<br>11: 滤波器在PCLKB32采样 | R/W |
| 7:6 | TIOGT[1:0] | 计数控制*1*2<br>00: 始终计数事件01: 在为AGTEEn引脚指定的极性周期内计数事件<br>其他: 禁止设置   | R/W |

注1.使用AGTEEn引脚时, 可以通过AGTISR寄存器中的EEPS位选择计数事件的极性。

注2.TIOGT[1:0]位仅在事件计数器模式下启用。

注3.在软件待机和深度软件待机模式期间执行事件计数器模式操作时, 不能使用数字滤波器功能。

#### TEDGSEL位 (IO极性开关)

TEDGSEL位切换AGTOn引脚输出极性和AGTIO pin输入输出边沿和极性。



In pulse output mode, it only controls polarity of the AGTOn pin output and AGTIO pin output. AGTOn pin output and AGTIO pin output are initialized when the AGTMR1 register is written or the TSTOP bit in the AGTCR register is written with 1.

#### TOE bit (AGTOn pin Output Enable)

The TOE bit selects whether the AGTOn pin output is disabled or enabled.

#### TIPF[1:0] bits (Input Filter)

The TIPF[1:0] bits specify the sampling frequency of the AGTIO pin input filter. When the input to the AGTIO pin is sampled and the values match three times in succession, the value is regarded as the input value.

#### TIOGT[1:0] bits (Count Control)

The TIOGT[1:0] bits control the event count.

Table 22.3 AGTIO pin I/O edge and polarity switching

| Operating mode                | Function  |
|-------------------------------|---|
| Timer mode                    | Not used  |
| Pulse output mode             | 0: Output is started at high (initialization level: high) i.e. inverted output<br>1: Output is started at low (initialization level: low). i.e. normal output |
| Event counter mode            | 0: Count on rising edge<br>1: Count on falling edge.  |
| Pulse width measurement mode  | 0: Low-level width is measured<br>1: High-level width is measured.  |
| Pulse period measurement mode | 0: Measure from one rising edge to the next rising edge<br>1: Measure from one falling edge to the next falling edge.   |

Note: When the TOE bit is 0, the pin state is Hi-Z.

Table 22.4 AGTOn pin output polarity switching

| Operating mode | Function   |
|----------------|--|
| All modes      | 0: Output is started at low (initial level: low): Normal output<br>1: Output is started at high (initial level: high): Inverted output |

Note: When the TOE bit is 0, a value according to the set value of the TEDGSEL bit in the pulse output mode is output.

### 22.2.8 AGTISR : AGT Event Pin Select Register

Base address:  $AGTn = 0x400E\_8000 + 0x0100 \times n$  (n = 0 to 5)

Offset address: 0x0D

| Bit position:      | 7 | 6 | 5 | 4 | 3 | 2    | 1 | 0 |
|--------------------|---|---|---|---|---|------|---|---|
| Bit field:         | — | — | — | — | — | EEPS | — | — |
| Value after reset: | 0 | 0 | 0 | 0 | 0 | 0    | 0 | 0 |

| Bit | Symbol | Function   | R/W |
|-----|--------|--|-----|
| 1:0 | —      | These bits are read as 0. The write value should be 0.   | R/W |
| 2   | EEPS   | AGTEEn Polarity Selection<br>0: An event is counted during the low-level period<br>1: An event is counted during the high-level period | R/W |
| 7:3 | —      | These bits are read as 0. The write value should be 0.   | R/W |

#### EEPS bit (AGTEEn Polarity Selection)

The EEPS bit selects the polarity of events to be counted.

在脉冲输出模式下，它只控制AGTOn引脚输出和AGTIO引脚输出的极性。AGTOn引脚输出和AGTIO引脚输出被初始化。当AGTMR1寄存器被写入或AGTCR寄存器中的TSTOP位被写入1时，AGTIO引脚输出被初始化。

#### TOE位 (AGTOn引脚输出使能)

TOE位选择是禁用还是启用AGTOn引脚输出。

#### TIPF[1:0] bits (Input Filter)

TIPF[1:0]位指定AGTIO引脚输入滤波器的采样频率。当AGTIO引脚的输入被采样并且值连续匹配3次时，该值被认为是输入值。

#### TIOGT[1:0] bits (Count Control)

TIOGT[1:0]位控制事件计数。

Table 22.3 AGTIO引脚IO边沿和极性切换

| 操作模式     | Function  |
|----------|---|
| 定时器模式    | 不曾用过  |
| 脉冲输出方式   | 0: 输出从高开始 (初始化电平: 高), 即反相输出<br>1: 输出从低开始 (初始化电平: 低)。即正常输出 |
| 事件计数器模式  | 0: 上升沿计数<br>1: 下降沿计数。                                     |
| 脉宽测量模式   | 0: 测量低电平宽度<br>1: 测量高电平宽度。                                 |
| 脉冲周期测量模式 | 0: 从一个上升沿测量到下一个上升沿<br>1: 从一个下降沿测量到下一个下降沿。                 |

Note: 当TOE位为0时，引脚状态为Hi-Z。

Table 22.4 AGTOn引脚输出极性切换

| 操作模式 | Function   |
|------|--|
| 所有模式 | 0: 低电平开始输出 (初始电平: 低电平): 正常输出<br>1: 高电平开始输出 (初始电平: 高电平): 反相输出 |

Note: TOE位为0时，输出与脉冲输出模式下的TEDGSEL位的设定值对应的值。

### 22.2.8 AGTISR:AGT事件引脚选择寄存器

Base address:  $AGTn = 0x400E\_8000 + 0x0100 \times n$  (n = 0 to 5)

Offset address: 0x0D

| Bit position: | 7 | 6 | 5 | 4 | 3 | 2    | 1 | 0 |
|---------------|---|---|---|---|---|------|---|---|
| Bit field:    | — | — | — | — | — | EEPS | — | — |
| 重置后的值:        | 0 | 0 | 0 | 0 | 0 | 0    | 0 | 0 |

| Bit | Symbol | Function   | R/W |
|-----|--------|--|-----|
| 1:0 | —      | 这些位被读取为0。写入值应为0。                                 | R/W |
| 2   | EEPS   | AGTEEn极性选择<br>0: 在低电平期间计数一个事件<br>1: 在高电平期间计数一个事件 | R/W |
| 7:3 | —      | 这些位被读取为0。写入值应为0。                                 | R/W |

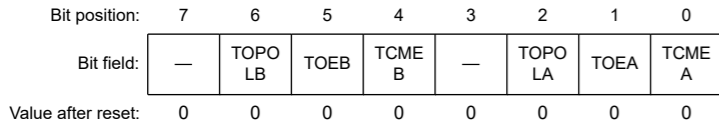
#### EEPS位 (AGTEEn极性选择)

EEPS位选择要计数的事件的极性。

22.2.9 AGTCMSR : AGT Compare Match Function Select Register

Base address:  $AGTn = 0x400E\_8000 + 0x0100 \times n$  (n = 0 to 5)

Offset address: 0x0E



| Bit | Symbol | Function   | R/W |
|-----|--------|--|-----|
| 0   | TCMEA  | AGT Compare Match A Register Enable*1 *2<br>0: AGT Compare match A register disabled<br>1: AGT Compare match A register enabled                                | R/W |
| 1   | TOEA   | AGTOAn Pin Output Enable*1 *2<br>0: AGTOAn pin output disabled<br>1: AGTOAn pin output enabled   | R/W |
| 2   | TOPOLA | AGTOAn Pin Polarity Select*1 *2<br>0: AGTOAn pin output is started on low. i.e. normal output<br>1: AGTOAn pin output is started on high. i.e. inverted output | R/W |
| 3   | —      | This bit is read as 0. The write value should be 0.  | R/W |
| 4   | TCMEB  | AGT Compare Match B Register Enable*1 *2<br>0: Compare match B register disabled<br>1: Compare match B register enabled  | R/W |
| 5   | TOEB   | AGTOBn Pin Output Enable*1 *2<br>0: AGTOBn pin output disabled<br>1: AGTOBn pin output enabled   | R/W |
| 6   | TOPOLB | AGTOBn Pin Polarity Select*1 *2<br>0: AGTOBn pin output is started on low. i.e. normal output<br>1: AGTOBn pin output is started on high. i.e. inverted output | R/W |
| 7   | —      | This bit is read as 0. The write value should be 0.  | R/W |

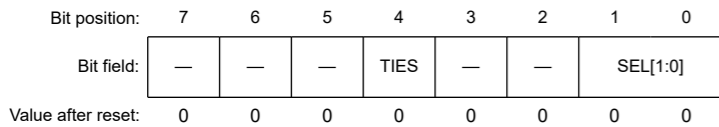
Note 1. Do not rewrite the AGTCMSR register during a count operation. Only rewrite the AGTCMSR register when both the TSTART bit and TCSTF flag in the AGTCR register are set to 0 (count stops).

Note 2. Do not set 1 when in pulse width measurement mode or pulse period measurement mode.

22.2.10 AGTIOSEL : AGT Pin Select Register

Base address:  $AGTn = 0x400E\_8000 + 0x0100 \times n$  (n = 0 to 5)

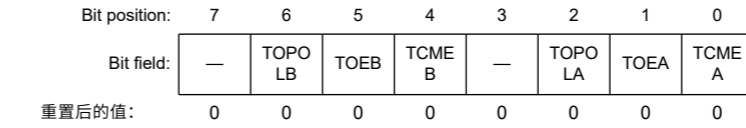
Offset address: 0x0F



22.2.9 AGTCMSR:AGT比较匹配功能选择寄存器

Base address:  $AGTn = 0x400E\_8000 + 0x0100 \times n$  (n = 0 to 5)

Offset address: 0x0E



| Bit | Symbol | Function  | R/W |
|-----|--------|---|-----|
| 0   | TCMEA  | AGT比较匹配A寄存器使能*1*2<br>0: 禁用AGT比较匹配A寄存器1: 启用AGT比较匹配A寄存器                 | R/W |
| 1   | TOEA   | AGTOAn引脚输出使能*1*2<br>0: 禁止AGTOAn引脚输出1: 使能AGTOAn引脚输出                    | R/W |
| 2   | TOPOLA | AGTOAn引脚极性选择*1*2<br>0: AGTOAn引脚输出低电平启动。即正常输出1: AGTOAn引脚输出以高电平启动。即反相输出 | R/W |
| 3   | —      | 该位读取为0。写入值应为0。  | R/W |
| 4   | TCMEB  | AGT比较匹配B寄存器使能*1*2<br>0: 比较匹配B寄存器禁用1: 比较匹配B寄存器启用                       | R/W |
| 5   | TOEB   | AGTOBn引脚输出使能*1*2<br>0: AGTOBn引脚输出禁止1: AGTOBn引脚输出使能                    | R/W |
| 6   | TOPOLB | AGTOBn引脚极性选择*1*2<br>0: AGTOBn引脚输出低电平启动。即正常输出1: AGTOBn引脚输出以高电平启动。即反相输出 | R/W |
| 7   | —      | 该位读取为0。写入值应为0。  | R/W |

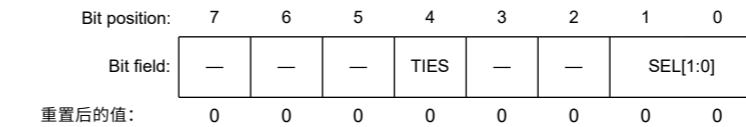
注1.在计数操作期间不要重写AGTCMSR寄存器。只有在TSTART位和AGTCR寄存器中的TCSTF标志设置为0 (计数停止)。

注2.在脉冲宽度测量模式或脉冲周期测量模式下不要设置为1。

22.2.10 AGTIOSEL:AGT引脚选择寄存器

Base address:  $AGTn = 0x400E\_8000 + 0x0100 \times n$  (n = 0 to 5)

Offset address: 0x0F



| Bit | Symbol   | Function  | R/W |
|-----|----------|---|-----|
| 1:0 | SEL[1:0] | AGTIO pin Select*1<br>0 0: Select Pm/AGTIO as AGTIO. Pm/AGTIO can not be used as AGTIO input pin in Deep Software Standby mode. (m = 100, 301, 407, and 705 (AGT0), m = 204 and 400 (AGT1), m = 103 (AGT2), m = 600 (AGT3).)<br>0 1: Select P404/AGTIO as AGTIO. P404/AGTIO can be used as AGTIO input pin in Deep Software Standby mode. P404/AGTIO is input only. It cannot be used for output.<br>1 0: Select P402/AGTIO as AGTIO. P402/AGTIO can be used as AGTIO input pin in Deep Software Standby mode. P402/AGTIO is input only. It cannot be used for output.<br>1 1: Select P403/AGTIO as AGTIO. P403/AGTIO can be used as AGTIO input pin in Deep Software Standby mode. P403/AGTIO is input only. It cannot be used for output. | R/W |
| 3:2 | —        | These bits are read as 0. The write value should be 0.  | R/W |
| 4   | TIES     | AGTIO pin Input Enable<br>0: External event input is disabled during Software Standby mode<br>1: External event input is enabled during Software Standby mode   | R/W |
| 7:5 | —        | These bits are read as 0. The write value should be 0.  | R/W |

Note 1. You must set the Pin Function Select Register. See [section 19, I/O Ports](#).

The AGTIOSEL register sets the AGTIO pin when using the AGTIO pin in Deep Software Standby mode and Software Standby mode.

#### SEL[1:0] bits (AGTIO pin Select)

The SEL[1:0] bits select the AGTIO pin function.

#### TIES bit (AGTIO pin Input Enable)

The TIES bit enables or disables an external event input.

## 22.3 Operation

### 22.3.1 Reload Register and Counter Rewrite Operation

Regardless of the operating mode, the timing of the rewrite operation to the reload register and the counter differs depending on the value of the TSTART bit in the AGTCR register and of the TCMEA or TCMEB bit in the AGTCMSR register. When the TSTART bit is 0 (count stops), the count value is directly written to the reload register and the counter. When the TSTART bit is 1 (count starts) and the TCMEA bit and TCMEB bit are 0 (AGT compare match A/B register are invalid), the value is written to the reload register in synchronization with the count source, and then to the counter in synchronization with the next count source. When the TSTART bit is 1 (count starts) and the TCMEA bit or the TCMEB bit is 1 (AGT compare match A register or compare match B register is valid), the value is written to the reload register in synchronization with the count source, and then to the counter in synchronization with the underflow of the counter.

[Figure 22.3](#) and [Figure 22.4](#) show the timing of rewrite operation with TSTART bit value and TCMEA/TCMEB bit value.

| Bit | Symbol   | Function  | R/W |
|-----|----------|---|-----|
| 1:0 | SEL[1:0] | AGTIO引脚选择*1<br>00: 选择PmAGTIO作为AGTIO。PmAGTIO在深度软件待机模式下不能用作AGTIO输入引脚。(m=100、301、407和705(AGT0), m=204和400(AGT1), m=103(AGT2), m=600(AGT3).)<br>01: 选择P404AGTIO作为AGTIO。P404AGTIO可在深度软件待机模式下用作AGTIO输入引脚。P404AGTIO仅为输入。它不能用于输出。<br>10: 选择P402AGTIO作为AGTIO。P402AGTIO可在深度软件待机模式下用作AGTIO输入引脚。P402AGTIO仅为输入。它不能用于输出。<br>11: 选择P403AGTIO作为AGTIO。P403AGTIO可用作深度软件待机模式下的AGTIO输入引脚。P403AGTIO仅为输入。它不能用于输出。 | R/W |
| 3:2 | —        | 这些位被读取为0。写入值应为0。  | R/W |
| 4   | TIES     | AGTIO引脚输入使能<br>0: 在软件待机模式下禁用外部事件输入<br>1: 在软件待机模式下启用外部事件输入   | R/W |
| 7:5 | —        | 这些位被读取为0。写入值应为0。  | R/W |

注1.您必须设置引脚功能选择寄存器。请参阅第19节，IO端口。

当在深度软件待机模式和软件中使用AGTIO引脚时，AGTIOSEL寄存器设置AGTIO引脚待机模式。

#### SEL[1:0]位 (AGTIO引脚选择)

SEL[1:0]位选择AGTIO引脚功能。

#### TIES位 (AGTIO引脚输入使能)

TIES位启用或禁用外部事件输入。

## 22.3 Operation

### 22.3.1 重载寄存器和计数器重写操作

无论操作模式如何，对重载寄存器和计数器的重写操作的时序根据AGTCR寄存器中的TSTART位和AGTCMSR寄存器中的TCMEA或TCMEB位的值而有所不同。当TSTART位为0（计数停止）时，计数值直接写入重载寄存器和计数器。当TSTART位为1（计数开始）且TCMEA位和TCMEB位为0（AGT比较匹配A/B寄存器无效）时，将值与计数源同步写入重载寄存器，然后写入计数器与下一个计数源同步。当TSTART位为1（计数开始）且TCMEA位或TCMEB位为1（AGT比较匹配A寄存器或比较匹配B寄存器有效）时，值与计数源同步写入重载寄存器，然后与计数器的下溢同步到计数器。

图22.3和图22.4显示了使用TSTART位值和TCMEA/TCMEB位值进行重写操作的时序。

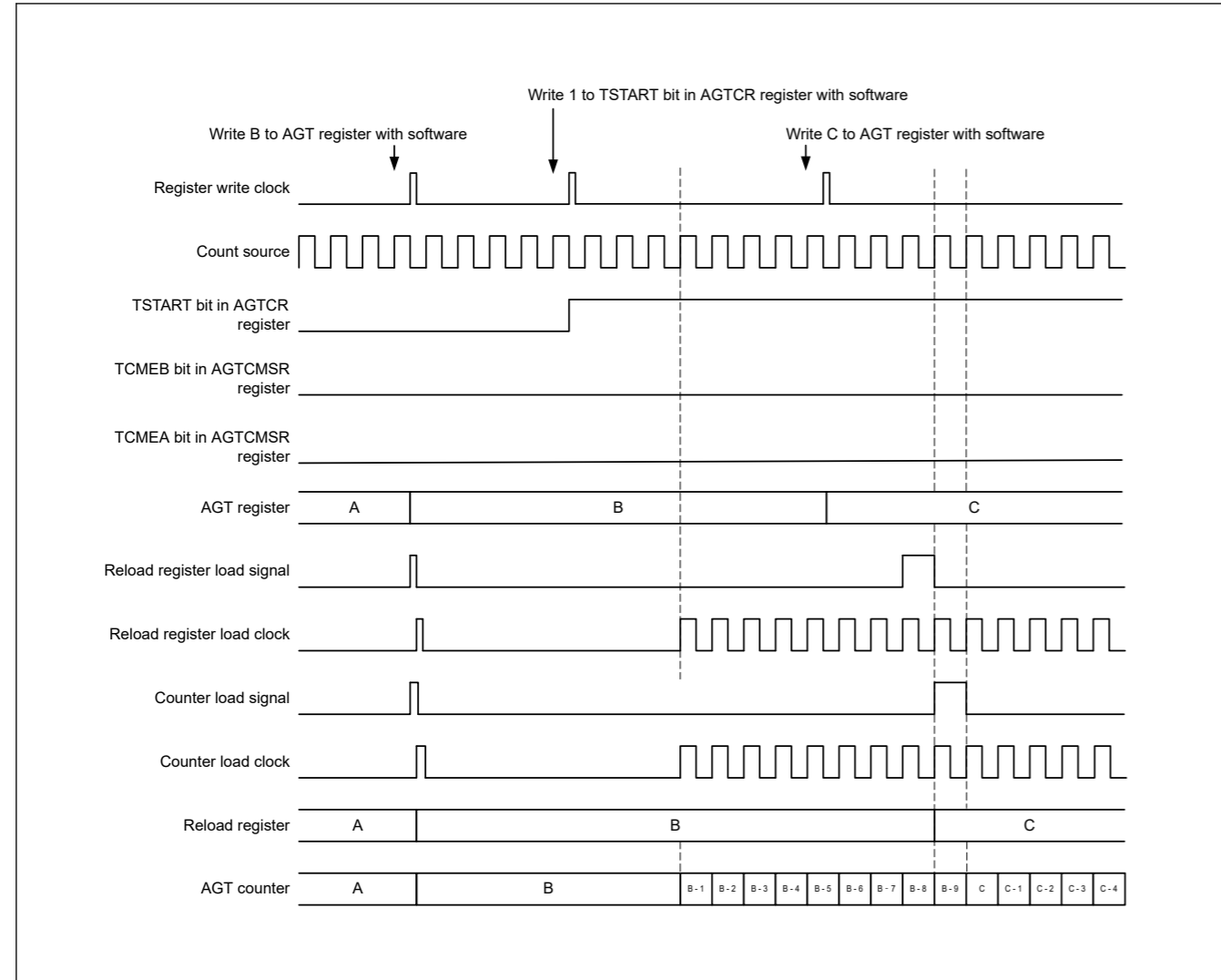


Figure 22.3 Timing of rewrite operation with TSTART bit value and TCMEA or TCMEB bit value when AGT compare match A register or AGT compare match B register is invalid

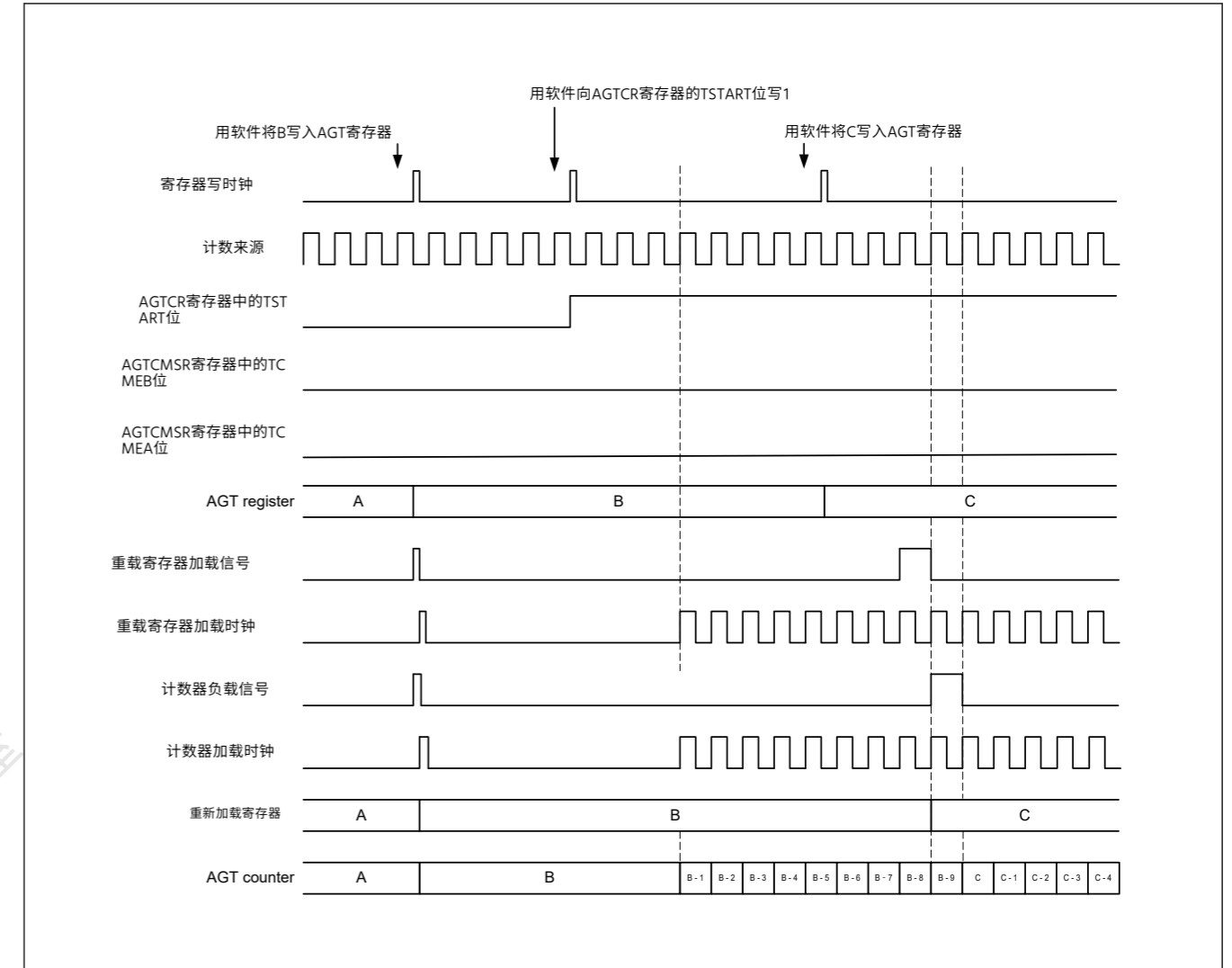


Figure 22.3 当AGT比较匹配A寄存器或AGT比较匹配B寄存器无效时，使用TSTART位值和TCMEA或TCMEB位值进行重写操作的时序

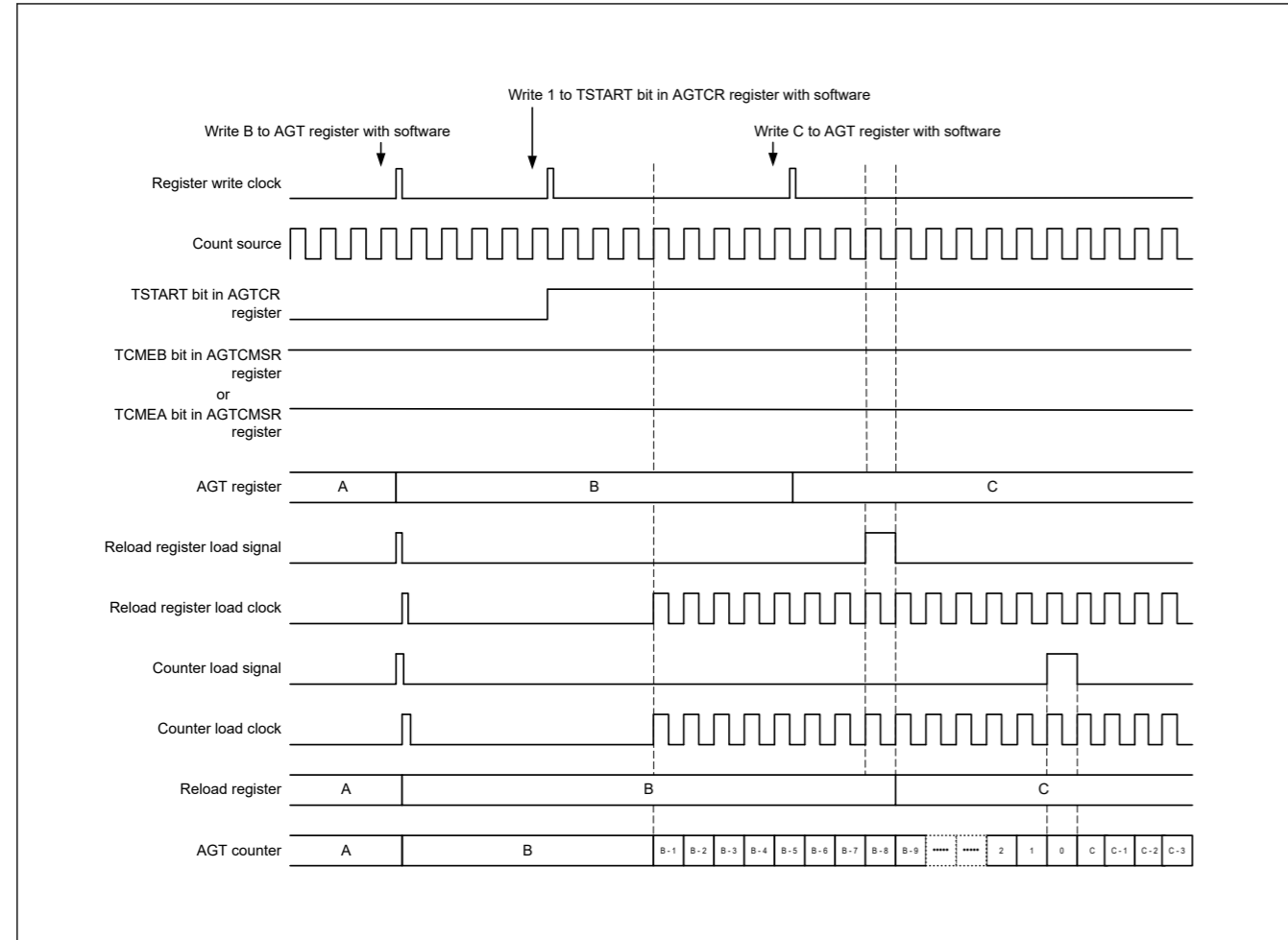


Figure 22.4 Timing of rewrite operation with TSTART bit value and TCMEA or TCMEB bit value when AGT compare match A register or AGT compare match B register is valid

### 22.3.2 Reload Register and AGT Compare Match A/B Register Rewrite Operation

Regardless of the operating mode, the timing of the rewrite operation to the reload register and AGT compare register A/B depends on the value of the TSTART bit in the AGTCR register. When the TSTART bit is 0 (count stops), the count value is directly written to the reload register and AGT compare register A/B. When the TSTART bit is 1 (count starts), the value is written to the reload register in synchronization with the count source, and then to the compare register in synchronization with the underflow of the counter.

Figure 22.5 shows the timing of rewrite operation with TSTART bit value for compare register A. AGT Compare register B is of the same timing as AGT compare register A.

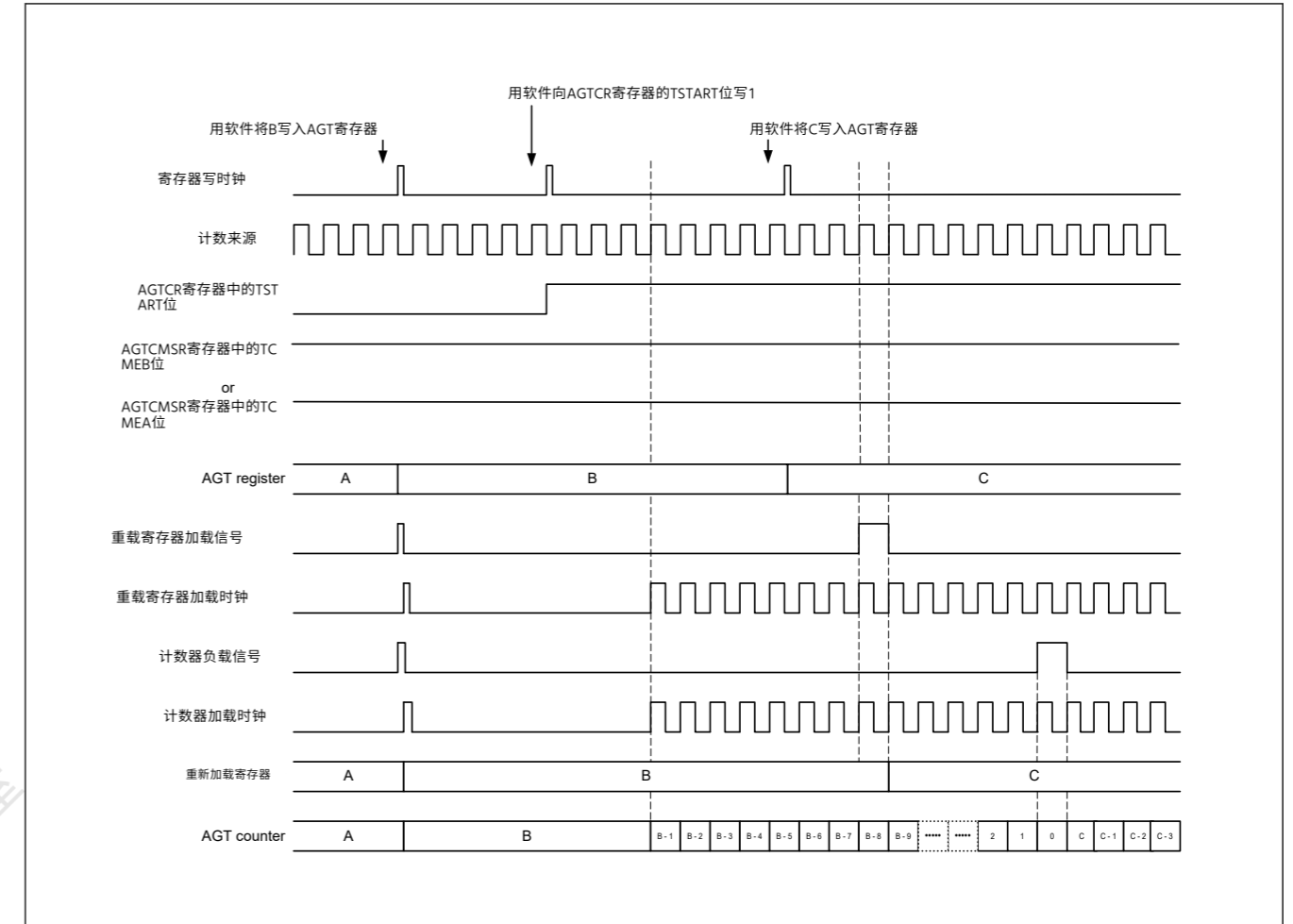


Figure 22.4 当AGT比较匹配A寄存器或AGT比较匹配B寄存器有效时，使用TSTART位值和TCMEA或TCMEB位值进行重写操作的时序

### 22.3.2 重载寄存器和AGT比较匹配AB寄存器重写操作

不管操作模式如何，对重载寄存器和AGT比较寄存器AB的重写操作的时序取决于AGTCR寄存器中TSTART位的值。当TSTART位为0（计数停止）时，计数值直接写入重载寄存器和AGT比较寄存器AB。当TSTART位为1（计数开始）时，该值同步写入重载寄存器计数源，然后与计数器的下溢同步到比较寄存器。

图22.5显示了比较寄存器A的TSTART位值的重写操作时序。AGT比较寄存器B与AGT比较寄存器A的时序相同。



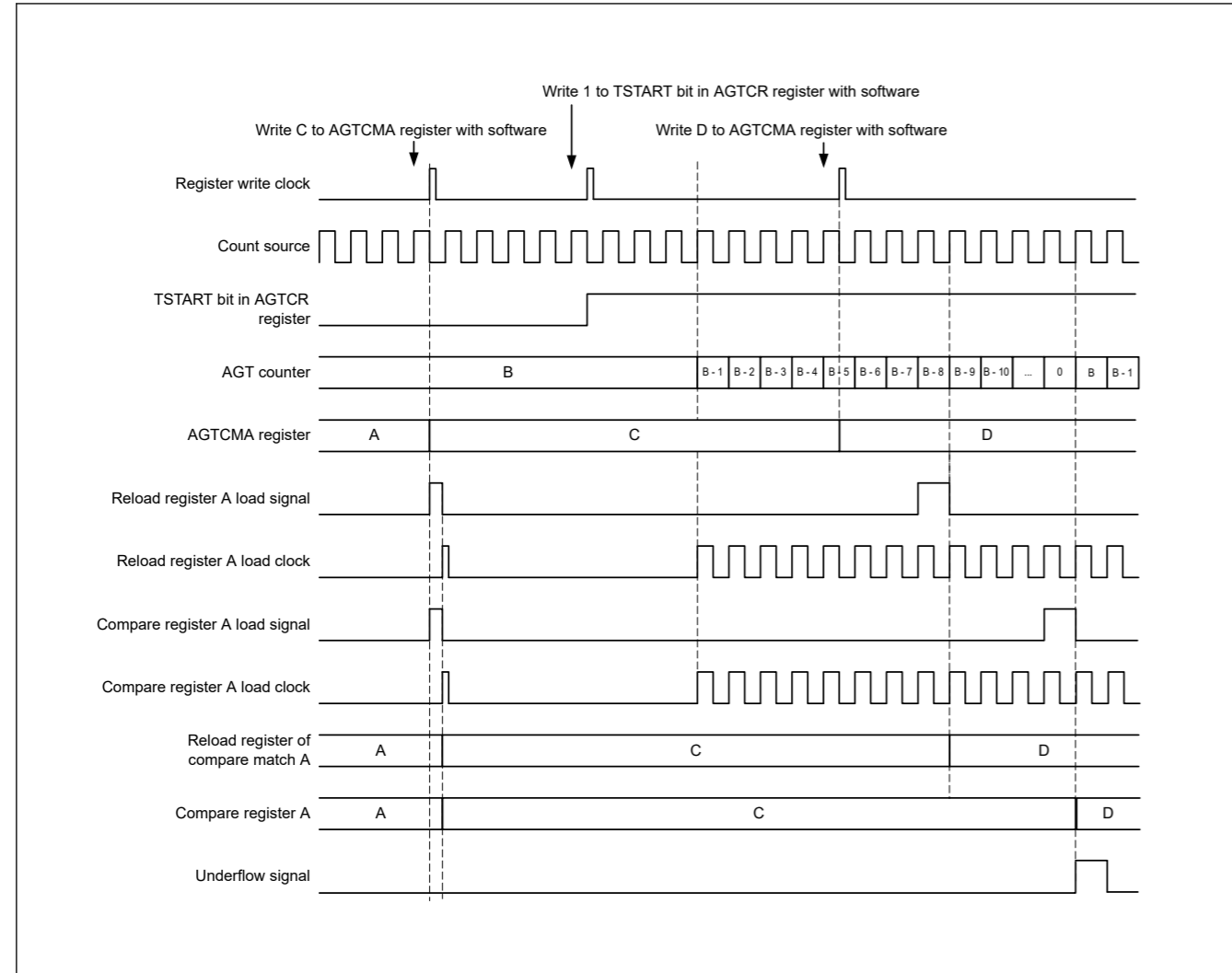


Figure 22.5 Timing of rewrite operation with the TSTART bit value for AGT compare register A

### 22.3.3 Timer Mode

In this mode, the AGT counter is decremented by the count source selected with the TCK[2:0] bits in the AGTMR1 register. In timer mode, the count value is decremented by 1 on each rising edge of the count source. When the count value reaches 0x0000 and the next count source is input, an underflow occurs and an interrupt request is generated.

Figure 22.6 shows the operation example in timer mode.

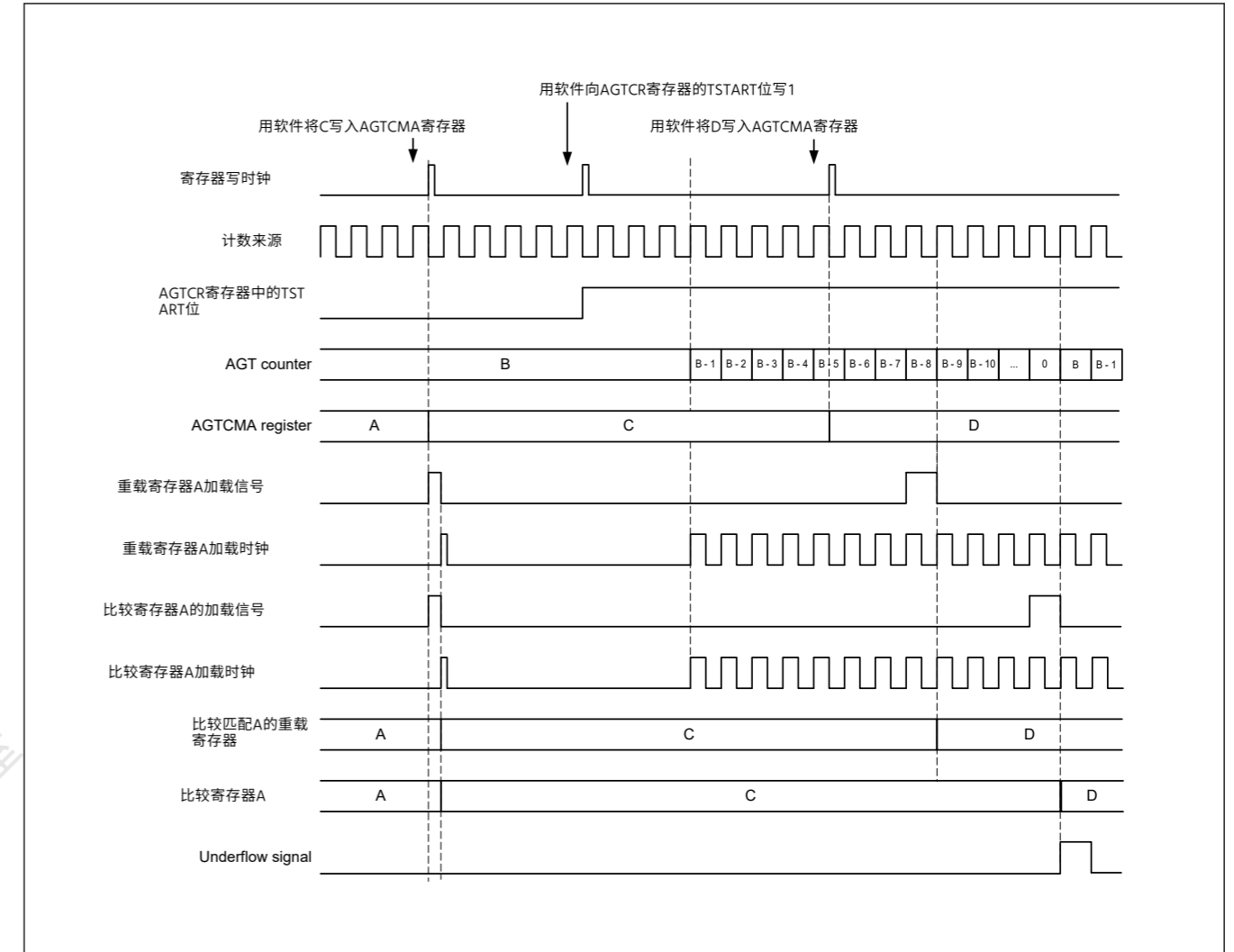


Figure 22.5 AGT比较寄存器A的TSTART位值的重写操作时序

### 22.3.3 定时器模式

在此模式下，AGT计数器按AGTMR1寄存器中的TCK[2:0]位选择的计数源递减。在定时器模式下，计数值在计数源的每个上升沿减1。当计数值达到0x0000并输入下一个计数源时，发生下溢并产生中断请求。

图22.6显示了定时器模式下的操作示例。

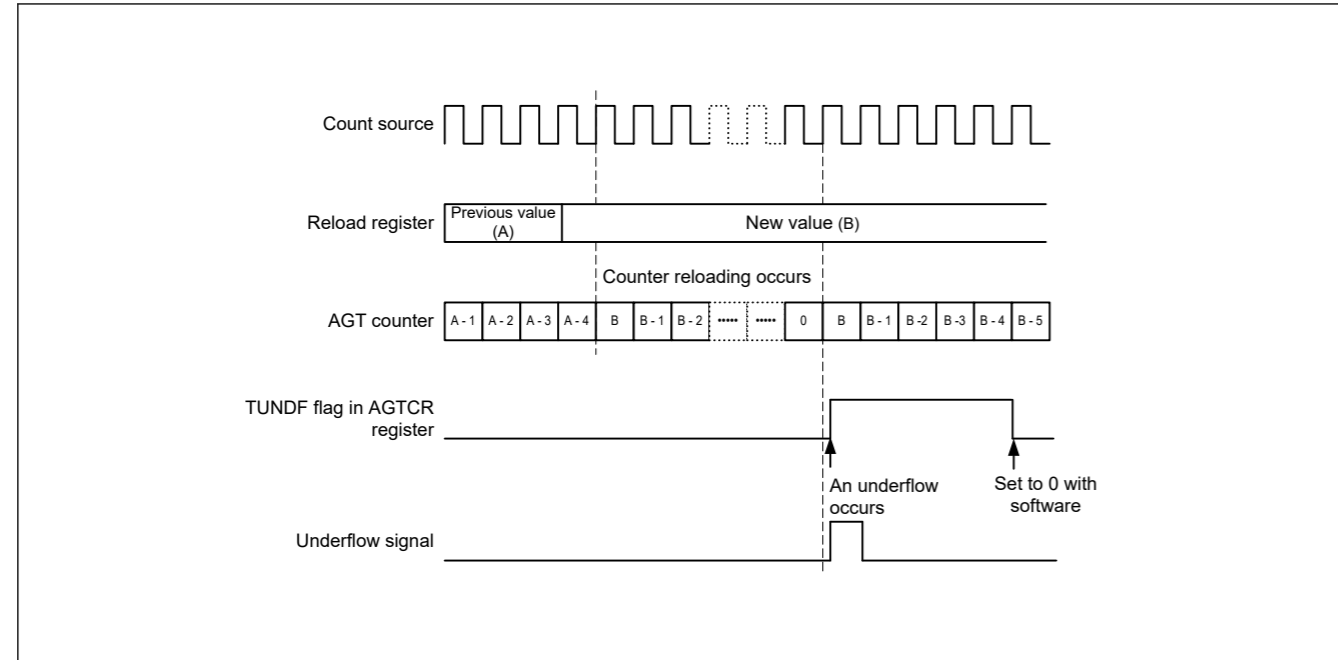


Figure 22.6 Operation example in timer mode

### 22.3.4 Pulse Output Mode

In pulse output mode, the counter is decremented by the count source selected with the TCK[2:0] bits in the AGTMR1 register, and the output level of the AGTIO<sub>n</sub> and AGTOn pins inverted each time an underflow occurs.

In pulse output mode, the count value is decremented by 1 on each rising edge of the count source. When the count value reaches 0x0000 and the next count source is input, an underflow occurs and an interrupt request is generated. In addition, a pulse can be output from the AGTIO<sub>n</sub> and AGTOn pins. The output level is inverted each time an underflow occurs. The pulse output from the AGTOn pin can be stopped with the TOE bit in the AGTIOC register. The output level can be selected with the TEDGSEL bit in the AGTIOC register.

Figure 22.7 shows the operation example in pulse output mode.

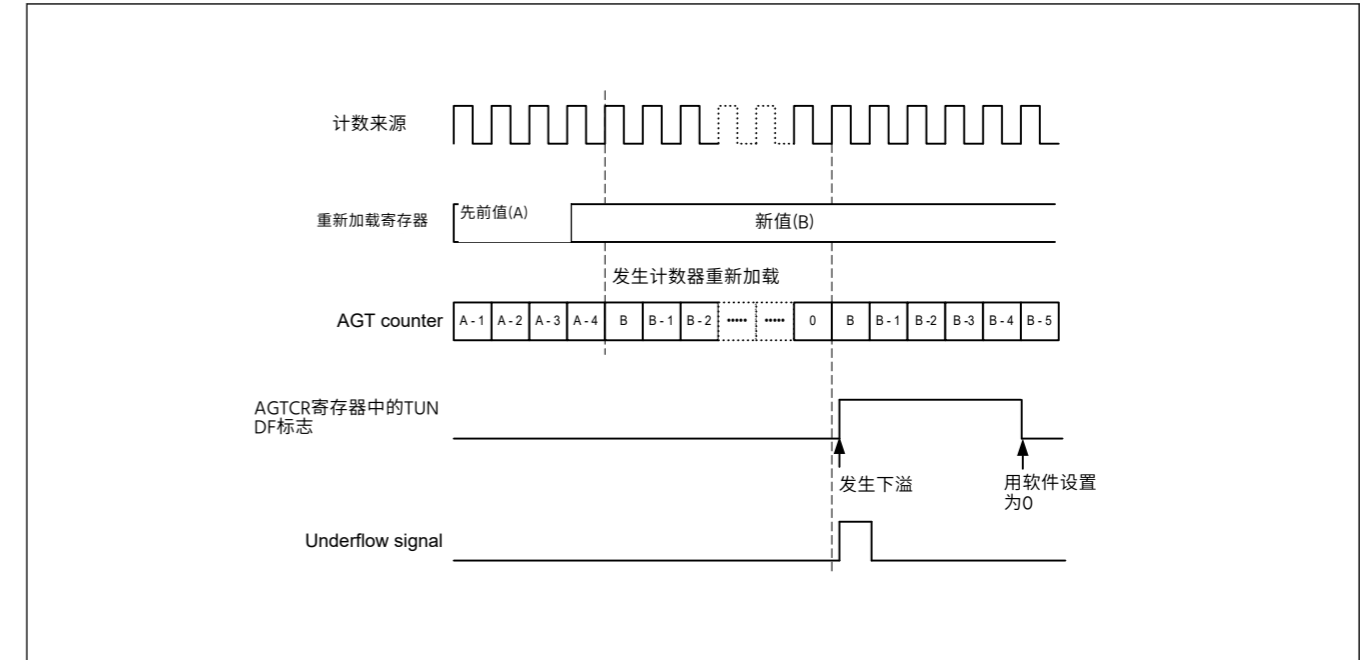


Figure 22.6 定时器模式下的操作示例

### 22.3.4 脉冲输出方式

在脉冲输出模式下，计数器由AGTMR1寄存器中的TCK[2:0]位选择的计数源递减，并且每次发生下溢时反转AGTIO<sub>n</sub>和AGTOn引脚的输出电平。

在脉冲输出模式下，计数值在计数源的每个上升沿减1。当计数值达到0x0000并输入下一个计数源时，发生下溢并产生中断请求。此外，可以从AGTIO<sub>n</sub>和AGTOn引脚输出脉冲。每次发生下溢时，输出电平都会反转。AGTOn引脚的脉冲输出可通过AGTIOC寄存器中的TOE位停止。可以通过AGTIOC寄存器中的TEDGSEL位选择输出电平。

图22.7显示了脉冲输出模式下的操作示例。

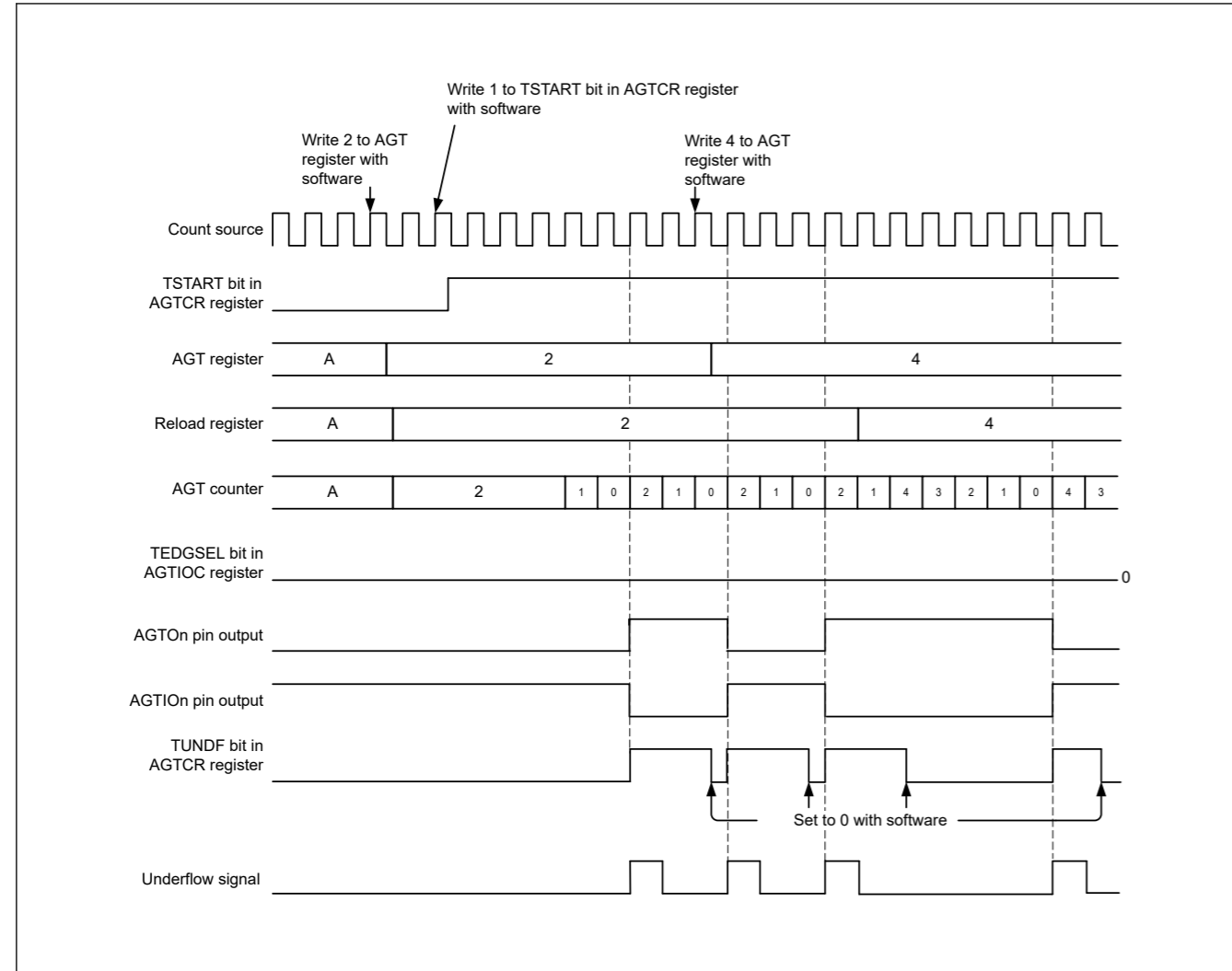


Figure 22.7 Operation example in pulse output mode

### 22.3.5 Event Counter Mode

In event counter mode, the counter is decremented by an external event signal (count source) input to the AGTIO pin. Various periods for counting events can be set with the TIOGT[1:0] bits in the AGTIOC register and AGTISR registers. In addition, the filter function for the AGTIO pin input can be specified with bits TIPF[1:0] in the AGTIOC register. The output from the AGTOn pin can be toggled even in event counter mode.

Figure 22.8 shows the operation example in event counter mode.

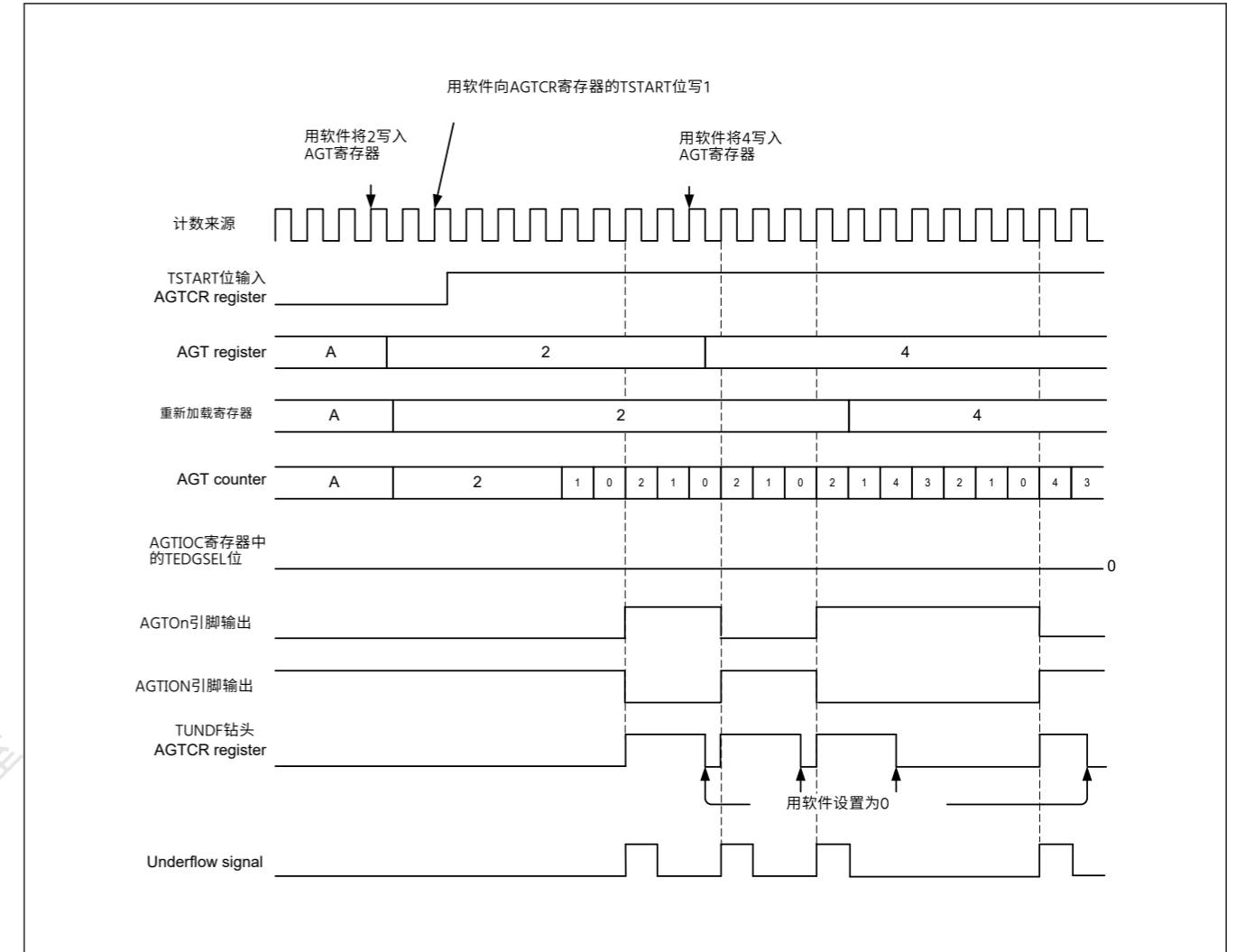


Figure 22.7 脉冲输出模式的动作示例

### 22.3.5 事件计数器模式

在事件计数器模式下，计数器由输入到AGTIO pin的外部事件信号（计数源）递减。可以使用AGTIOC寄存器和AGTISR寄存器中的TIOGT[1:0]位设置计数事件的各种周期。此外，AGTIO pin输入的过滤功能可通过AGTIOC寄存器中的位TIPF[1:0]指定。即使在事件计数器模式下，也可以切换AGTOn pin的输出。

图22.8显示了事件计数器模式下的操作示例。

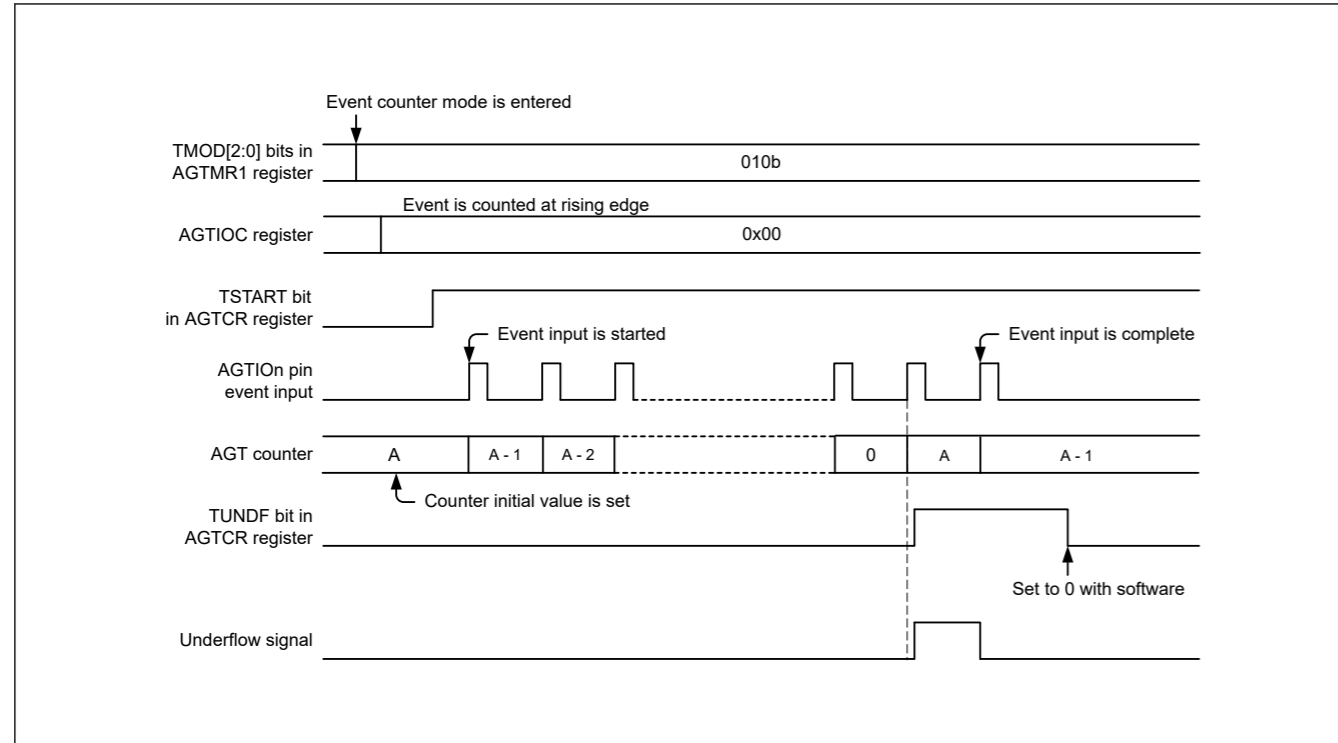


Figure 22.8 Operation example 1 in event counter mode

Figure 22.9 shows an operation example for counting during the specified period in event counter mode (TIOGT[1:0] bits in the AGTIOC register are set to 01b).

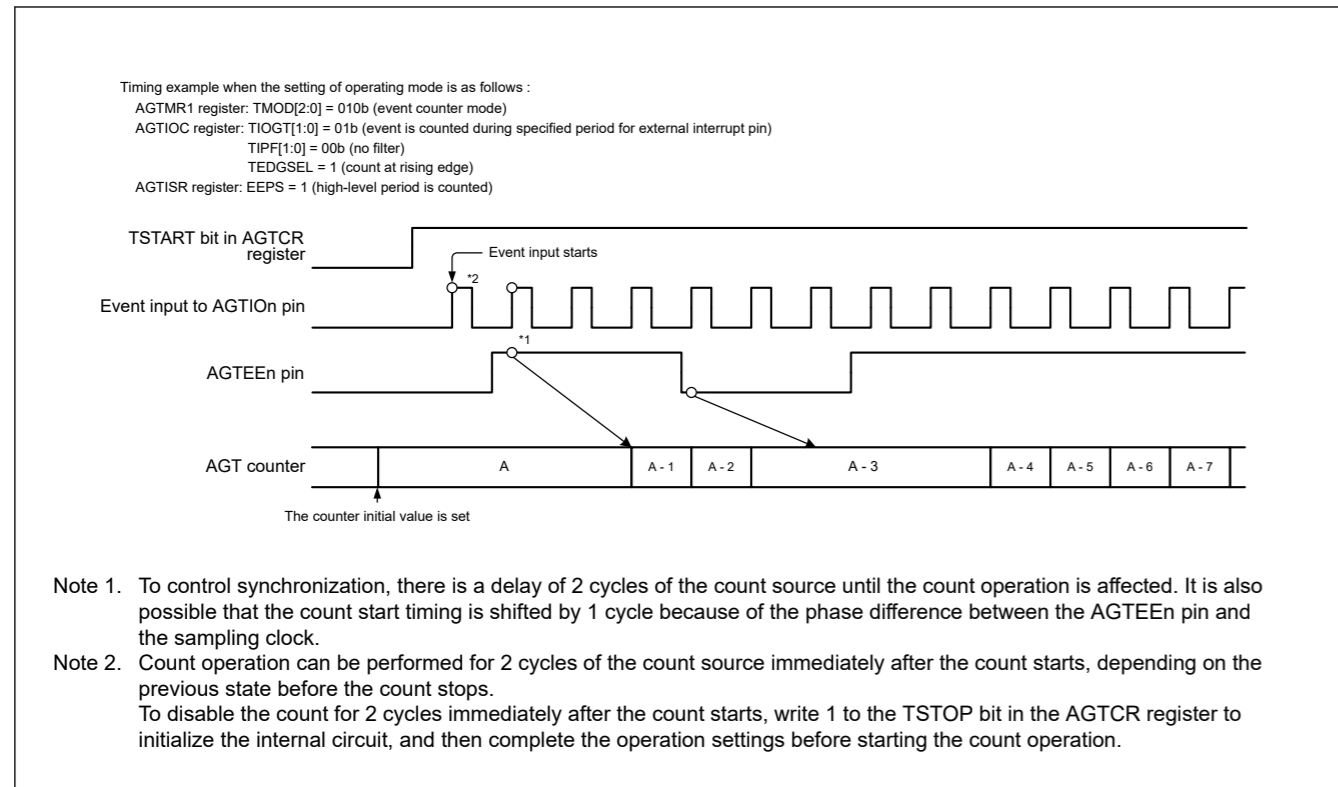


Figure 22.9 Operation example 2 in event counter mode

### 22.3.6 Pulse Width Measurement Mode

In pulse width measurement mode, the pulse width of an external signal input to the AGTIO pin is measured. When the level specified by the TEDGSEL bit in the AGTIOC register is input to the AGTIO pin, the counter is decremented by the

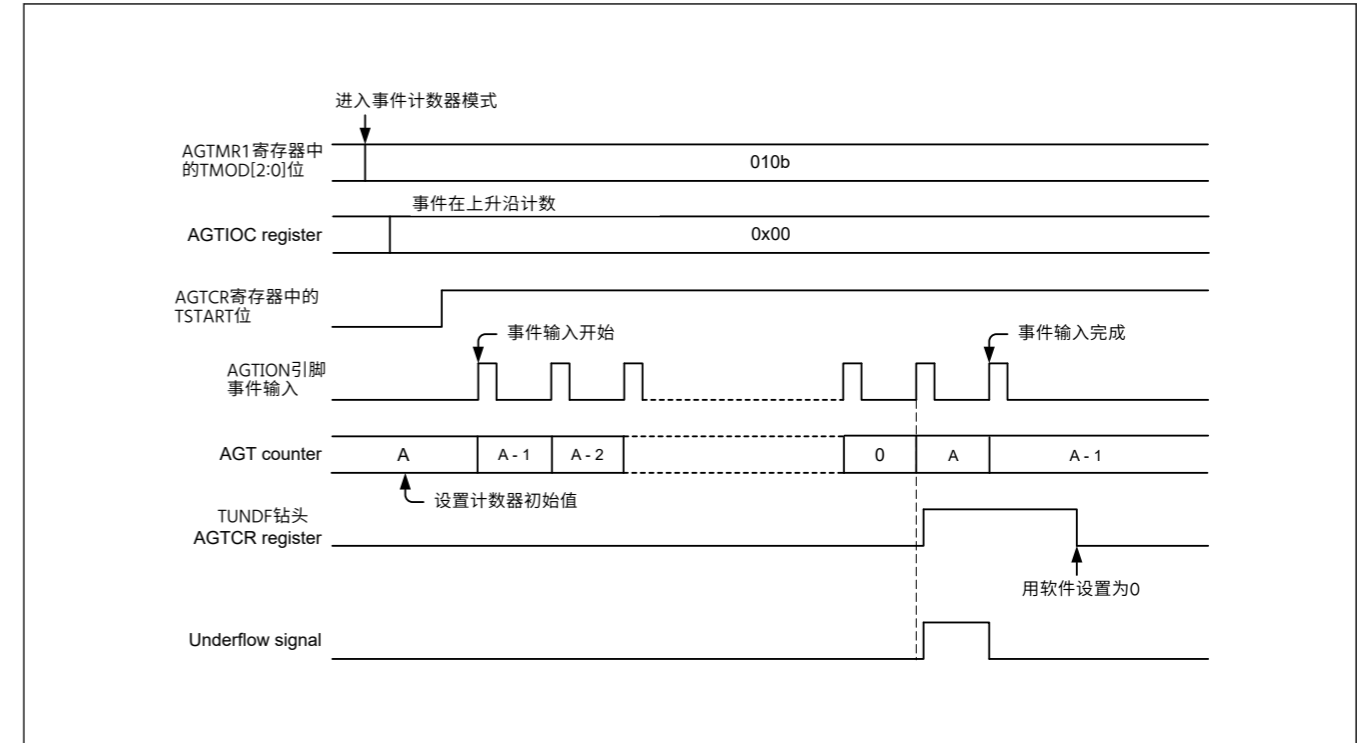


Figure 22.8 事件计数器模式下的操作示例1

图22.9显示了在事件计数器模式下在指定周期内进行计数的操作示例 (AGTIOC寄存器中的TIOGT[1:0]位设置为01b)。

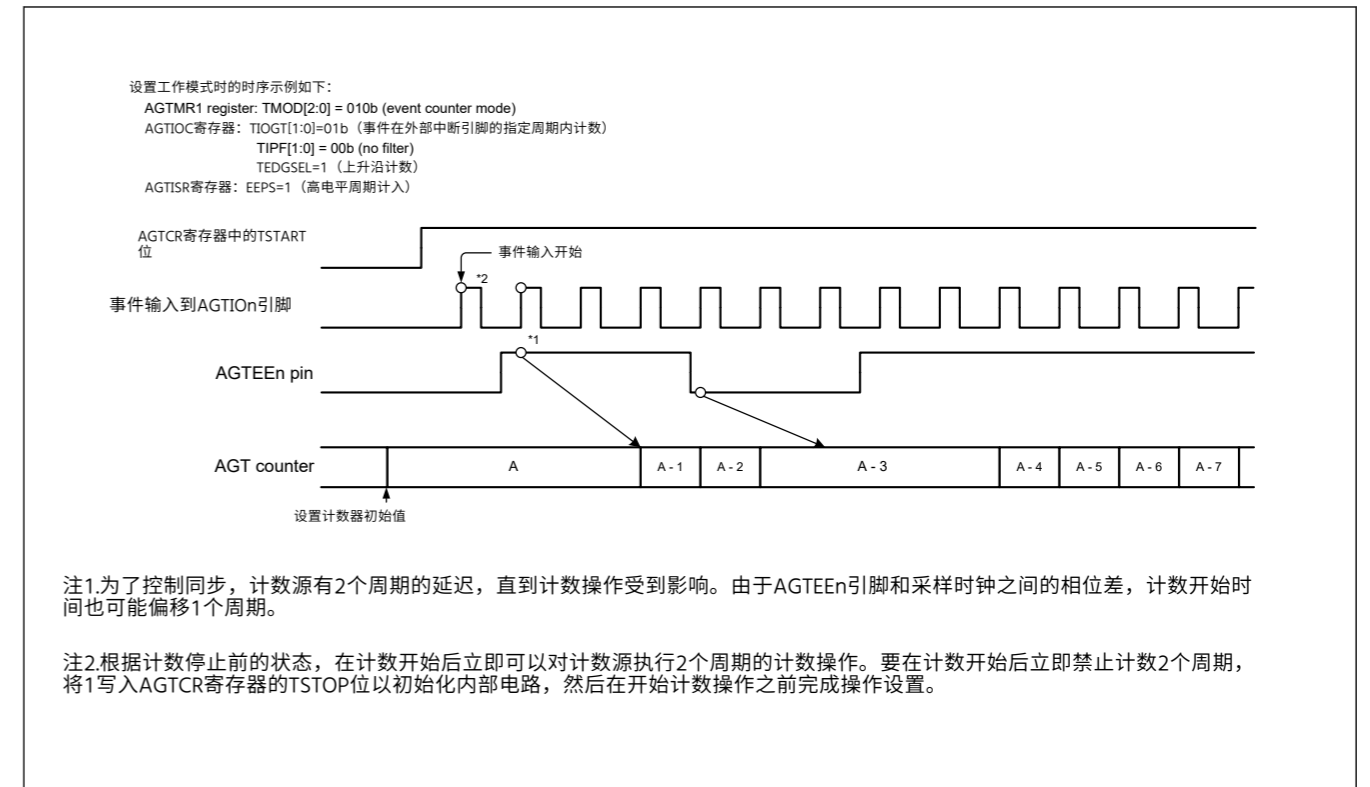


Figure 22.9 事件计数器模式下的操作示例2

### 22.3.6 脉冲宽度测量模式

在脉冲宽度测量模式下，测量输入到AGTIO引脚的外部信号的脉冲宽度。当AGTIOC寄存器中的TEDGSEL位指定的电平输入到AGTIO引脚时，计数器递减

count source selected with the TCK[2:0] bits in the AGTMR1 register. When the specified level on the AGTIO pin ends, the counter is stopped, the TEDGF bit in the AGTCR register is set to 1 (active edge received), and an interrupt request is generated. The measurement of pulse width data is performed by reading the count value while the counter is stopped. Also, when the counter underflows during measurement, the TUNDF bit in the AGTCR register is set to 1 and an interrupt request is generated.

Figure 22.10 shows the operation example in pulse width measurement mode.

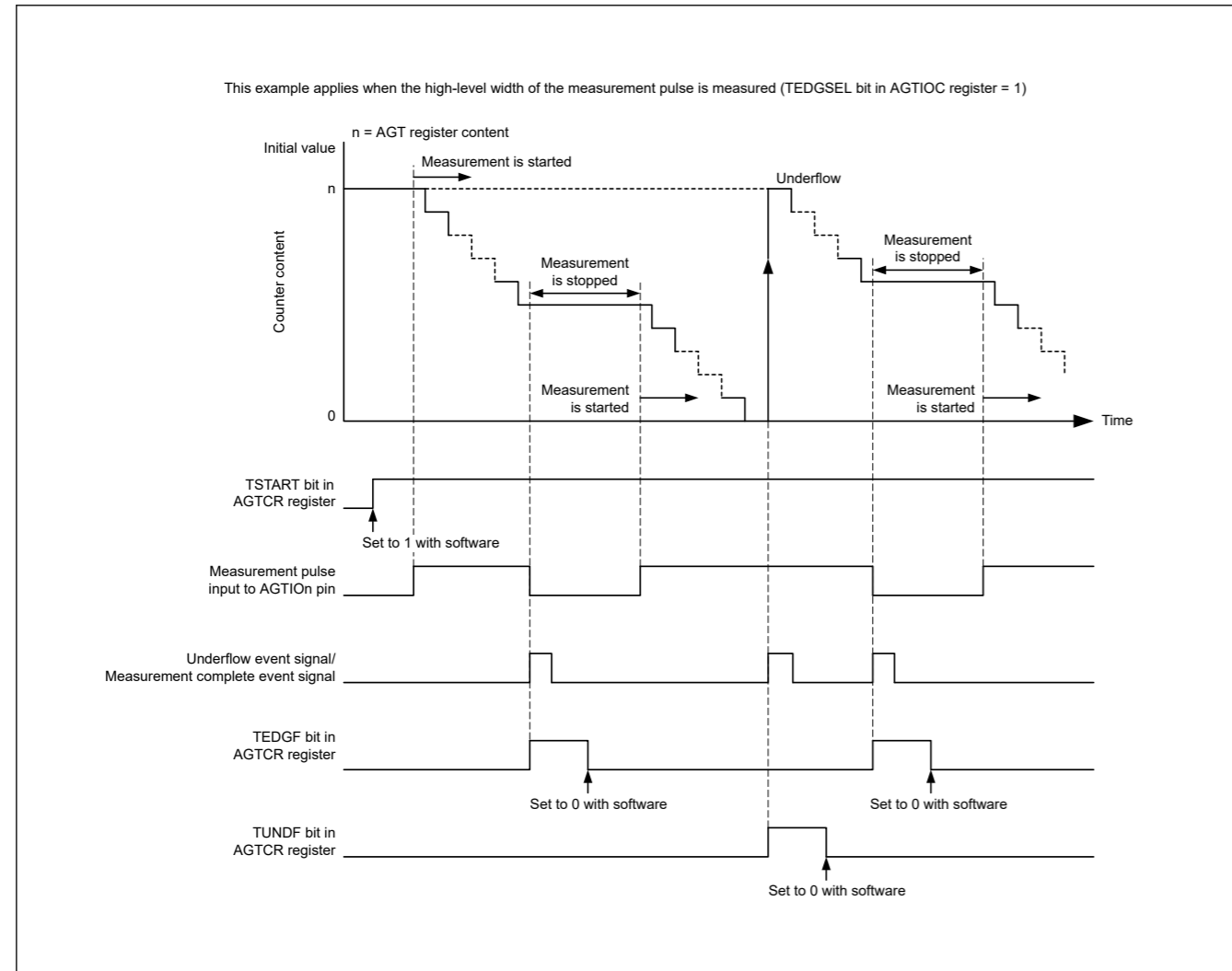


Figure 22.10 Operation example in pulse width measurement mode

### 22.3.7 Pulse Period Measurement Mode

In pulse period measurement mode, the pulse period of an external signal input to the AGTIO pin is measured. The counter is decremented by the count source selected with TCK[2:0] bits in the AGTMR1 register. When a pulse with the period specified by the TEDGSEL bit in the AGTIOC register is input to the AGTIO pin, the count value is transferred to the read-out buffer on the rising edge of the count source. The value in the reload register is loaded to the counter at the next rising edge. Simultaneously, the TEDGF flag in the AGTCR register is set to 1 (active edge received) and an interrupt request is generated. The read-out buffer (AGT register) is read at this time and the difference from the reload value (see section 22.4.6. How to Calculate Event Number, Pulse Width, and Pulse Period) is the period data of the input pulse. The period data is retained until the read-out buffer is read. When the counter underflows, the TUNDF flag in the AGTCR register is set to 1 (underflow) and an interrupt request is generated.

Figure 22.11 shows the operation example in pulse period measurement mode.

Only input pulses with a period longer than twice the period of the count source are measured. Also, the low-level and high-level widths must both be longer than the period of the count source. If a pulse period shorter than these conditions is input, the input might be ignored.

通过AGTMR1寄存器中的TCK[2:0]位选择计数源。当AGTIO引脚上的指定电平结束时，计数器停止，AGTCR寄存器中的TEDGF位设置为1（接收到有效沿），并产生中断请求。通过在计数器停止时读取计数值来执行脉冲宽度数据的测量。此外，当测量期间计数器下溢时，AGTCR寄存器中的TUNDF位设置为1，并产生中断请求。

图22.10显示了脉宽测量模式下的操作示例。

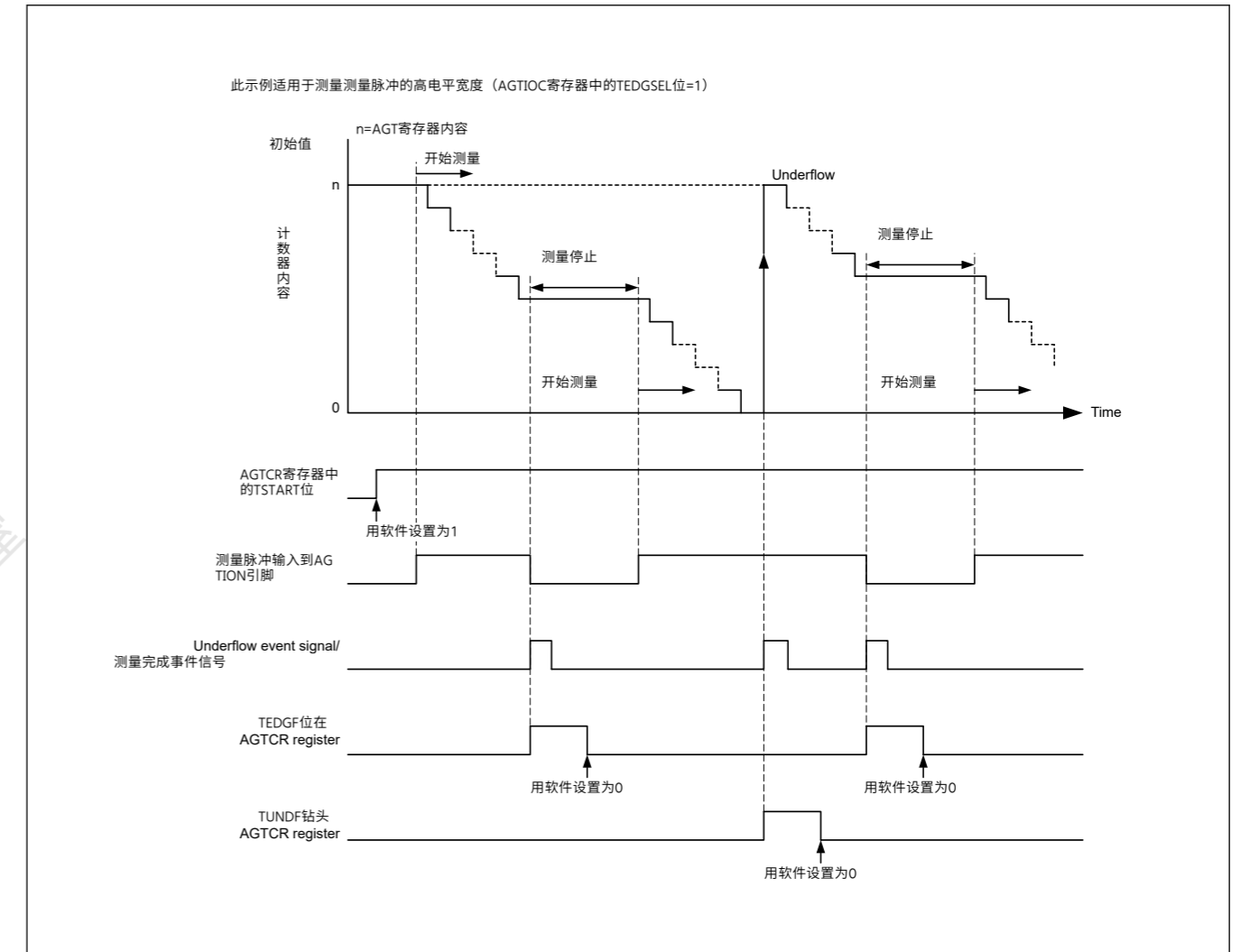


Figure 22.10 脉宽测量模式下的操作示例

### 22.3.7 脉冲周期测量模式

在脉冲周期测量模式下，测量输入到AGTIO引脚的外部信号的脉冲周期。计数器由AGTMR1寄存器中的TCK[2:0]位选择的计数源递减。当AGTIOC寄存器中TEDGSEL位指定周期的脉冲输入到AGTIO引脚时，计数值在计数源的上升沿传送到读出缓冲器。重载寄存器中的值在下一个上升沿加载到计数器。同时，AGTCR寄存器中的TEDGF标志设置为1（接收到有效沿）并产生中断请求。此时读取读出缓冲器（AGT寄存器），与重载值的差值（见22.4.6.如何计算事件数、脉冲宽度和脉冲周期）是输入脉冲的周期数据。周期数据被保留，直到读出缓冲器被读取。当计数器下溢时，AGTCR寄存器中的TUNDF标志设置为1（下溢）并产生中断请求。

图22.11显示了脉冲周期测量模式下的操作示例。

仅测量周期长于计数源周期两倍的输入脉冲。此外，低电平和高电平宽度都必须长于计数源的周期。如果输入比这些条件短的脉冲周期，输入可能会被忽略。



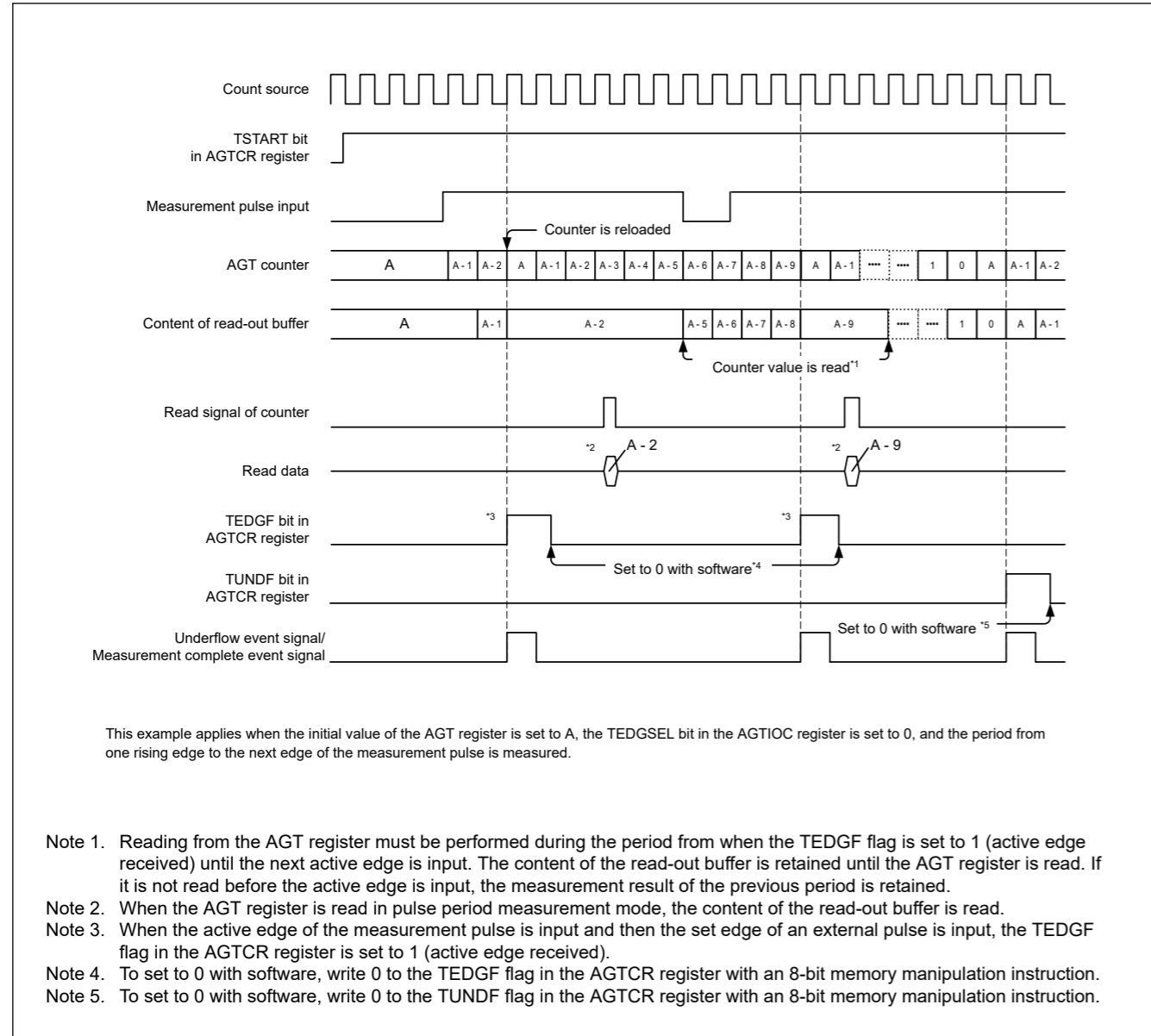


Figure 22.11 Operation example in pulse period measurement mode

### 22.3.8 Compare Match function

The compare match function detects matches (compare match) between the content of the AGTCMA or AGTCMB register and the content of the AGT register. This function is enabled when the TCMEA or TCMEB bit in the AGTCMSR register is 1 (compare match A register or compare match B register is valid). The counter is decremented by the count source selected with the TCK[2:0] bits in the AGTMR1 register, and when the values of AGT and AGTCMA or AGTCMB match, the TCMAF/TCMBF flag in the AGTCR register is set to 1 (match), and an interrupt request is generated.

When the compare match function is enabled, the timing of the rewrite operation to the reload register and the counter differs. See section 22.3.1. [Reload Register and Counter Rewrite Operation](#) for details. In addition, the output level of the AGTOAn, AGTOBn pins is inverted by the match and by the underflow. The output level can be selected with the TOPOLA or TOPOLB bit in the AGTCMSR register.

Figure 22.12 shows the operation example in compare match mode.

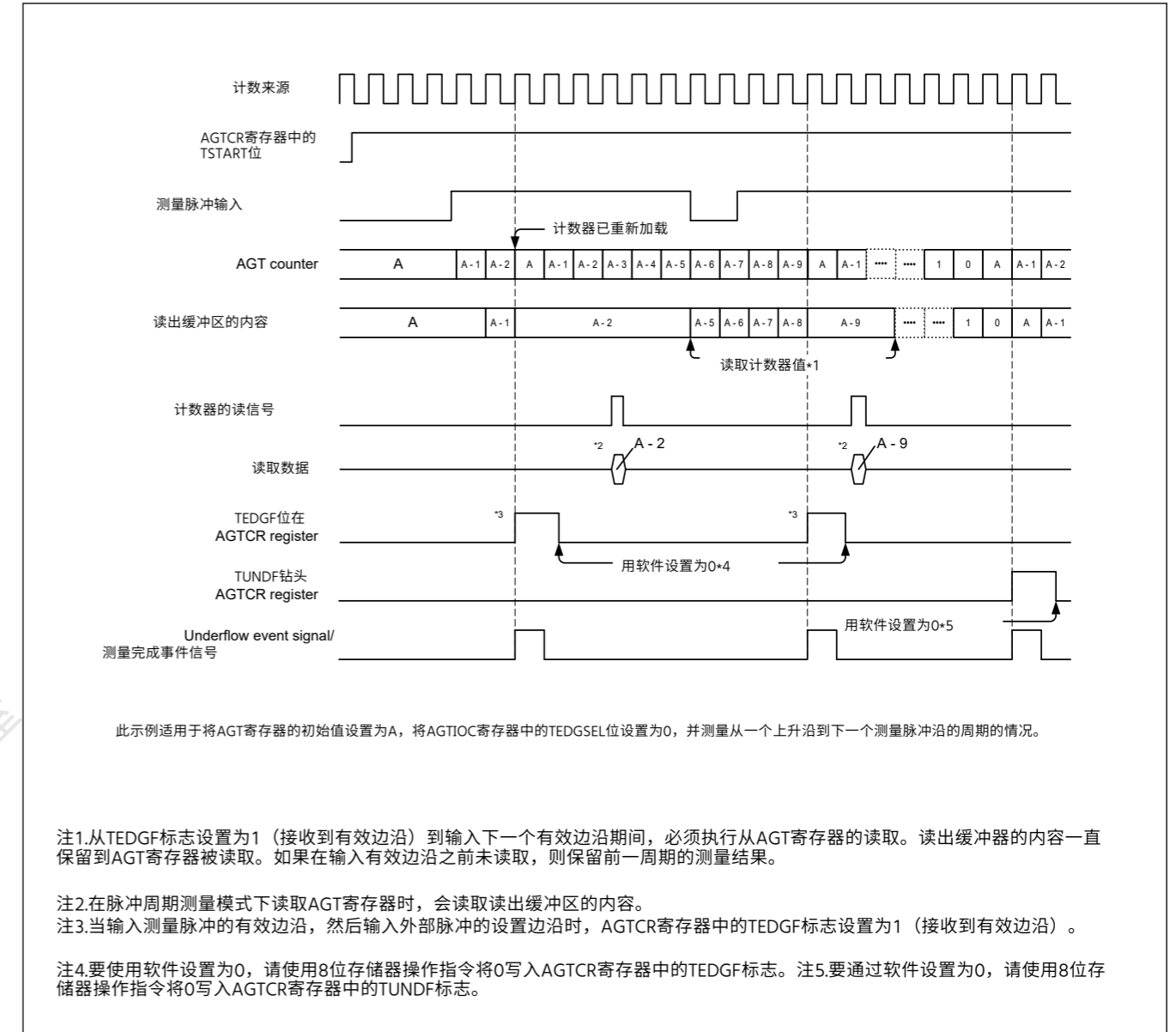


Figure 22.11 脉冲周期测量模式下的操作示例

### 22.3.8 比较匹配功能

比较匹配功能检测AGTCMA或AGTCMB寄存器的内容与AGT寄存器的内容之间的匹配（比较匹配）。该功能在AGTCMSR寄存器中的TCMEA或TCMEB位为1时使能（比较匹配A寄存器或比较匹配B寄存器有效）。计数器按AGTMR1寄存器中TCK[2:0]位选择的计数源递减，当AGT和AGTCMA或AGTCMB的值匹配时，AGTCR寄存器中的TCMAFTCMBF标志设置为1（匹配），并产生中断请求。

当比较匹配功能启用时，对重载寄存器和计数器的重写操作的时序不同。请参阅第22.3.1节。重载寄存器和计数器重写操作了解详情。此外，AGTOAn、AGTOBn引脚的输出电平通过匹配和下溢反转。输出电平可以选择与

AGTCMSR寄存器中的TOPOLA或TOPOLB位。

图22.12显示了比较匹配模式下的操作示例。

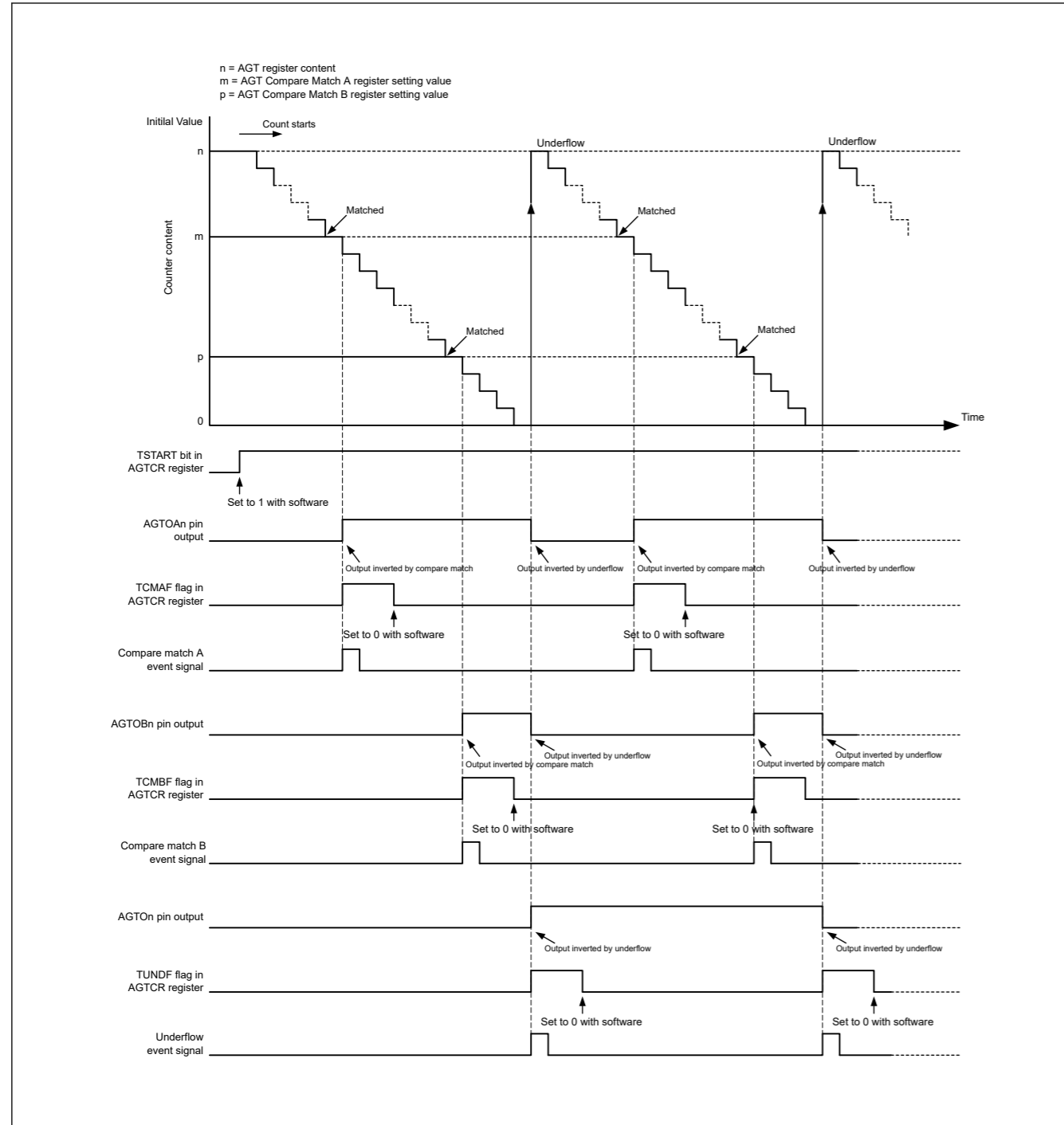


Figure 22.12 Operation example in compare match mode (TOPOLA = 0, TOPOLB = 0)

22.3.9 Output Settings for Each Mode

Table 22.5 to Table 22.8 list the states of pins AGTON, AGTIO, AGTOAn, and AGTOBn pins in each mode.

Table 22.5 AGTON pin setting

| Operating mode | AGTIOC register |             | AGTON pin output |
|----------------|-----------------|-------------|------------------|
|                | TOE bit         | TEDGSEL bit |                  |
| All modes      | 1               | 1           | Inverted output  |
|                |                 | 0           | Normal output    |
|                | 0               | 0 or 1      | Output disabled  |

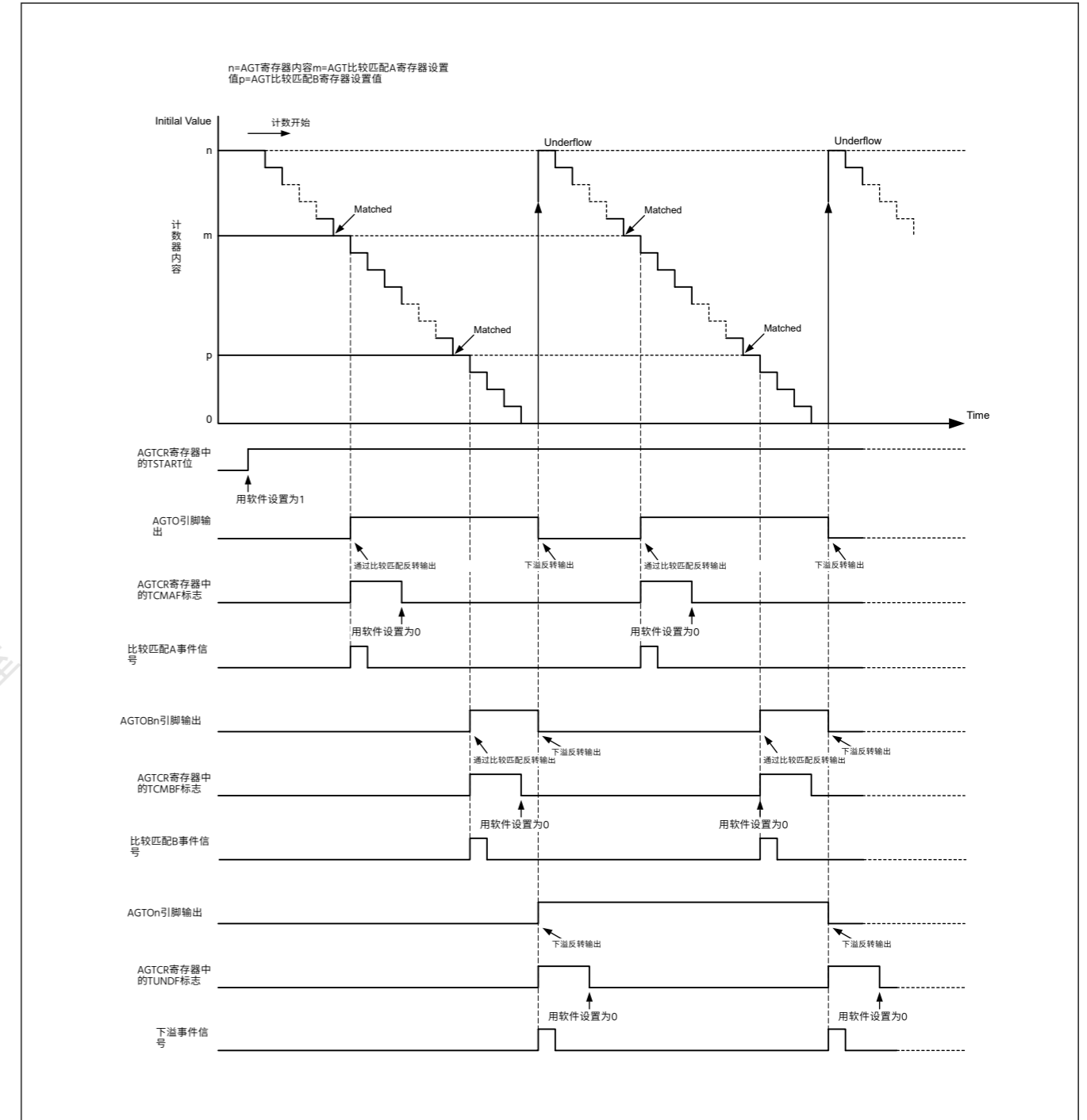


Figure 22.12 比较匹配模式下的操作示例(TOPOLA=0 TOPOLB=0)

22.3.9 每种模式的输出设置

表22.5至表22.8列出了每种模式下引脚AGTON、AGTIO、AGTOAn和AGTOBn引脚的状态。

Table 22.5 AGTON引脚设置

| 操作模式 | AGTIOC register |             | AGTON引脚输出 |
|------|-----------------|-------------|-----------|
|      | 脚趾位             | TEDGSEL bit |           |
| 所有模式 | 1               | 1           | 反相输出      |
|      |                 | 0           | 正常输出      |
|      | 0               | 0 or 1      | 输出禁用      |

Table 22.6 AGTIO pin setting

| Operating mode                | AGTIOC register |                  |
|-------------------------------|-----------------|------------------|
|                               | TEDGSEL bit     | AGTIO pin I/O    |
| Timer mode                    | 0 or 1          | Input (not used) |
| Pulse output mode             | 1               | Normal output    |
|                               | 0               | Inverted output  |
| Event counter mode            | 0 or 1          | Input            |
| Pulse width measurement mode  |                 |                  |
| Pulse period measurement mode |                 |                  |

Table 22.7 AGTO pin setting

| Operating mode                | AGTCMSR register |            | AGTO pin output            |
|-------------------------------|------------------|------------|----------------------------|
|                               | TOEA bit         | TOPOLA bit |                            |
| Timer mode                    | 1                | 1          | Inverted output            |
|                               |                  | 0          | Normal output              |
|                               | 0                | 0 or 1     | Output disabled (not used) |
| Pulse output mode             | 1                | 1          | Inverted output            |
|                               |                  | 0          | Normal output              |
|                               | 0                | 0 or 1     | Output disabled (not used) |
| Event counter mode            | 1                | 1          | Inverted output            |
|                               |                  | 0          | Normal output              |
|                               | 0                | 0 or 1     | Output disabled (not used) |
| Pulse width measurement mode  | 0                | 0          | Prohibited                 |
| Pulse period measurement mode |                  |            |                            |

Table 22.8 AGTOB pin setting

| Operating mode                | AGTCMSR register |            | AGTOB pin output           |
|-------------------------------|------------------|------------|----------------------------|
|                               | TOEB bit         | TOPOLB bit |                            |
| Timer mode                    | 1                | 1          | Inverted output            |
|                               |                  | 0          | Normal output              |
|                               | 0                | 0 or 1     | Output disabled (not used) |
| Pulse output mode             | 1                | 1          | Inverted output            |
|                               |                  | 0          | Normal output              |
|                               | 0                | 0 or 1     | Output disabled (not used) |
| Event counter mode            | 1                | 1          | Inverted output            |
|                               |                  | 0          | Normal output              |
|                               | 0                | 0 or 1     | Output disabled (not used) |
| Pulse width measurement mode  | 0                | 0          | Prohibited                 |
| Pulse period measurement mode |                  |            |                            |

### 22.3.10 Standby Mode

The AGT can operate in Software Standby and Deep Software Standby mode. Set it to Software Standby or Deep Software Standby mode with count operation start (TSTART = 1, TCSTF = 1).

Table 22.9 and Table 22.10 show the setting that can be used in Software Standby and Deep Software Standby mode.

Table 22.6 AGTIO引脚设置

| 操作模式     | AGTIOC register |                  |
|----------|-----------------|------------------|
|          | TEDGSEL bit     | AGTIO pin I/O    |
| 定时器模式    | 0 or 1          | Input (not used) |
| 脉冲输出方式   | 1               | 正常输出             |
|          | 0               | 反相输出             |
| 事件计数器模式  | 0 or 1          | Input            |
| 脉宽测量模式   |                 |                  |
| 脉冲周期测量模式 |                 |                  |

Table 22.7 AGTO引脚设置

| 操作模式     | AGTCMSR register |            | AGTO引脚输出   |
|----------|------------------|------------|------------|
|          | TOEA bit         | TOPOLA bit |            |
| 定时器模式    | 1                | 1          | 反相输出       |
|          |                  | 0          | 正常输出       |
|          | 0                | 0 or 1     | 输出禁用 (未使用) |
| 脉冲输出方式   | 1                | 1          | 反相输出       |
|          |                  | 0          | 正常输出       |
|          | 0                | 0 or 1     | 输出禁用 (未使用) |
| 事件计数器模式  | 1                | 1          | 反相输出       |
|          |                  | 0          | 正常输出       |
|          | 0                | 0 or 1     | 输出禁用 (未使用) |
| 脉宽测量模式   | 0                | 0          | Prohibited |
| 脉冲周期测量模式 |                  |            |            |

Table 22.8 AGTOB引脚设置

| 操作模式     | AGTCMSR register |            | AGTOB引脚输出  |
|----------|------------------|------------|------------|
|          | TOEB bit         | TOPOLB bit |            |
| 定时器模式    | 1                | 1          | 反相输出       |
|          |                  | 0          | 正常输出       |
|          | 0                | 0 or 1     | 输出禁用 (未使用) |
| 脉冲输出方式   | 1                | 1          | 反相输出       |
|          |                  | 0          | 正常输出       |
|          | 0                | 0 or 1     | 输出禁用 (未使用) |
| 事件计数器模式  | 1                | 1          | 反相输出       |
|          |                  | 0          | 正常输出       |
|          | 0                | 0 or 1     | 输出禁用 (未使用) |
| 脉宽测量模式   | 0                | 0          | Prohibited |
| 脉冲周期测量模式 |                  |            |            |

### 22.3.10 待机模式

AGT可以在软件待机和深度软件待机模式下运行。将其设置为软件待机或深度软件计数操作开始的待机模式 (TSTART=1, TCSTF=1)。

表22.9和表22.10显示了可在软件待机和深度软件待机模式下使用的设置。

**Table 22.9 Usable settings in Software Standby and Deep Software Standby mode (AGTn (n = 0, 2, 4)<sup>\*2</sup>)**

| Operating mode                | AGTMR1.TCK[2:0] | Operating clock      | Resurgence factor of CPU |
|-------------------------------|-----------------|----------------------|--------------------------|
| Timer mode                    | 100b or 110b    | AGTLCLK or AGTSCLK   | —                        |
| Pulse output mode             | 100b or 110b    | AGTLCLK or AGTSCLK   | —                        |
| Event counter mode            | —               | AGTIO <sup>n</sup> 1 | —                        |
| Pulse width measurement mode  | 100b or 110b    | AGTLCLK or AGTSCLK   | —                        |
| Pulse period measurement mode | 100b or 110b    | AGTLCLK or AGTSCLK   | —                        |

Note: —: invalid

Note 1. When using the AGTIO<sup>n</sup> pin for external event input in Software Standby mode, set AGTIOSEL.TIES = 1.

Note 2. AGT4 cannot operate in Deep Software Standby mode.

**Table 22.10 Usable settings in Software Standby and Deep Software Standby mode (AGTn (n = 1, 3, 5)<sup>\*3</sup>)**

| Operating mode                | AGTMR1.TCK[2:0]                    | Operating clock                                    | Resurgence factor of CPU   |
|-------------------------------|------------------------------------|--|--|
| Timer mode                    | 100b or 110b or 101b <sup>*1</sup> | AGTLCLK or AGTSCLK or AGTn (n = 0, 2, 4) underflow | <ul style="list-style-type: none"> <li>Underflow</li> <li>Compare match A/B</li> </ul> |
| Pulse output mode             | 100b or 110b or 101b <sup>*1</sup> | AGTLCLK or AGTSCLK or AGTn (n = 0, 2, 4) underflow | <ul style="list-style-type: none"> <li>Underflow</li> <li>Compare match A/B</li> </ul> |
| Event counter mode            | —                                  | AGTIO <sup>n</sup> 2                               | <ul style="list-style-type: none"> <li>Underflow</li> <li>Compare match A/B</li> </ul> |
| Pulse width measurement mode  | 100b or 110b or 101b <sup>*1</sup> | AGTLCLK or AGTSCLK or AGTn (n = 0, 2, 4) underflow | <ul style="list-style-type: none"> <li>Underflow</li> <li>Active edge</li> </ul>       |
| Pulse period measurement mode | 100b or 110b or 101b <sup>*1</sup> | AGTLCLK or AGTSCLK or AGTn (n = 0, 2, 4) underflow | <ul style="list-style-type: none"> <li>Underflow</li> <li>Active edge</li> </ul>       |

Note: —: invalid

Note: Release of Software Standby or Deep Software Standby mode is only AGT1.

Note: Compare match A/B is resurgence factor of CPU from Software Standby mode.

Note 1. Only when AGTn (n = 0, 2, 4) operates in Table 22.9

Note 2. When using the AGTIO<sup>n</sup> pin for external event input in Software Standby mode, set AGTIOSEL.TIES = 1.

Note 3. AGT5 cannot operate in Deep Software Standby mode.

### 22.3.11 Interrupt Sources

The AGTn has three interrupt sources for channels n (n = 0 to 5) as listed in Table 22.11.

**Table 22.11 AGT interrupt sources**

| Name         | Interrupt source  | DMAC/DTC activation |
|--------------|---|---------------------|
| AGTn_AGTI    | <ul style="list-style-type: none"> <li>When the counter underflows</li> <li>When measurement of the active width of the external input pin (AGTIO<sup>n</sup>) is complete in pulse width measurement mode</li> <li>When the set edge of the external input pin (AGTIO<sup>n</sup>) is input in pulse period measurement mode.</li> </ul> | Possible            |
| AGTn_AGTCMAI | <ul style="list-style-type: none"> <li>When the values of AGT register and AGTCMA register match</li> </ul>   | Possible            |
| AGTn_AGTCMBI | <ul style="list-style-type: none"> <li>When the values of AGT register and AGTCMB register match</li> </ul>   | Possible            |

Note: Channel number (n = 0 to 5)

### 22.3.12 Event Signal Output to ELC

The AGT0 uses the Event Link Controller (ELC) to perform a link operation to a specified module using the interrupt request signal as the event signal. The AGT0 outputs compare match A, compare match B, and underflow/measurement complete signals as event signals. For details, see section 18, Event Link Controller (ELC).

**Table 22.9 软件待机和深度软件待机模式下的可用设置(AGTn(n=0 2 4)\*2)**

| 操作模式     | AGTMR1.TCK[2:0] | 工作时钟                 | CPU的中兴系数 |
|----------|-----------------|----------------------|----------|
| 定时器模式    | 100b or 110b    | AGTLCLK or AGTSCLK   | —        |
| 脉冲输出方式   | 100b or 110b    | AGTLCLK or AGTSCLK   | —        |
| 事件计数器模式  | —               | AGTIO <sup>n</sup> 1 | —        |
| 脉宽测量模式   | 100b or 110b    | AGTLCLK or AGTSCLK   | —        |
| 脉冲周期测量模式 | 100b or 110b    | AGTLCLK or AGTSCLK   | —        |

Note: —: invalid

注1.在软件待机模式下将AGTIO<sup>n</sup>引脚用于外部事件输入时, 设置AGTIOSEL.TIES=1。

注2.AGT4不能在深度软件待机模式下运行。

**Table 22.10 软件待机和深度软件待机模式下的可用设置(AGTn(n=1 3 5)\*3)**

| 操作模式     | AGTMR1.TCK[2:0]                    | 工作时钟   | CPU的中兴系数  |
|----------|------------------------------------|--|---|
| 定时器模式    | 100b or 110b or 101b <sup>*1</sup> | AGTLCLK or AGTSCLK or AGTn (n = 0, 2, 4) underflow | <ul style="list-style-type: none"> <li>Underflow</li> <li>比较匹配AB</li> </ul> |
| 脉冲输出方式   | 100b or 110b or 101b <sup>*1</sup> | AGTLCLK or AGTSCLK or AGTn (n = 0, 2, 4) underflow | <ul style="list-style-type: none"> <li>Underflow</li> <li>比较匹配AB</li> </ul> |
| 事件计数器模式  | —                                  | AGTIO <sup>n</sup> 2                               | <ul style="list-style-type: none"> <li>Underflow</li> <li>比较匹配AB</li> </ul> |
| 脉宽测量模式   | 100b or 110b or 101b <sup>*1</sup> | AGTLCLK or AGTSCLK or AGTn (n = 0, 2, 4) underflow | <ul style="list-style-type: none"> <li>Underflow</li> <li>主动边缘</li> </ul>   |
| 脉冲周期测量模式 | 100b or 110b or 101b <sup>*1</sup> | AGTLCLK or AGTSCLK or AGTn (n = 0, 2, 4) underflow | <ul style="list-style-type: none"> <li>Underflow</li> <li>主动边缘</li> </ul>   |

Note: —: invalid

Note: 软件待机或深度软件待机模式的释放只有AGT1。

Note: 比较匹配AB是CPU从软件待机模式中恢复的因素。

注1.仅当AGTn(n=0 2 4)在表22.9中运行时

注2.在软件待机模式下将AGTIO<sup>n</sup>引脚用于外部事件输入时, 设置AGTIOSEL.TIES=1。

注3.AGT5不能在深度软件待机模式下运行。

### 22.3.11 中断源

AGTn具有三个用于通道n (n=0到5) 的中断源, 如表22.11中所列。

**Table 22.11 AGT中断源**

| Name         | 中断源  | DMAC/DTC activation |
|--------------|--|---------------------|
| AGTn_AGTI    | <ul style="list-style-type: none"> <li>当计数器下溢时</li> <li>在脉冲宽度测量模式下完成外部输入引脚(AGTIO<sup>n</sup>)的有效宽度测量时</li> <li>在脉冲周期测量模式下输入外部输入引脚(AGTIO<sup>n</sup>)的设置边沿时。</li> </ul> | Possible            |
| AGTn_AGTCMAI | <ul style="list-style-type: none"> <li>当AGT寄存器和AGTCMA寄存器的值匹配时</li> </ul>   | Possible            |
| AGTn_AGTCMBI | <ul style="list-style-type: none"> <li>当AGT寄存器和AGTCMB寄存器的值匹配时</li> </ul>   | Possible            |

Note: 通道号 (n=0到5)

### 22.3.12 事件信号输出到ELC

AGT0使用事件链接控制器(ELC)使用中断请求信号作为事件信号对指定模块执行链接操作。AGT0输出比较匹配A、比较匹配B和下溢测量完成信号作为事件信号。有关详细信息, 请参阅第18节, 事件链接控制器(ELC)。



## 22.4 Usage Notes

### 22.4.1 Count Operation Start and Stop Control

- When the operating mode (see Table 22.1) is set to other than the event counter mode, or the count source is set to other than AGTn underflow event signal (TCK[2:0] = 101b):
  - After 1 (count starts) is written to the TSTART bit in the AGTCR register while the count is stopped, the TCSTF flag in the AGTCR register remains 0 (count stops) for 3 cycles of the count source. Do not access the registers associated with AGT other than the TCSTF flag until this bit is set to 1 (count in progress).
  - After 0 (count stops) is written to the TSTART bit during a count operation, the TCSTF flag remains 1 for 3 cycles of the count source. When the TCSTF flag is set to 0, the count is stopped. Do not access the registers associated with AGT. Other than the TCSTF flag until this bit is set to 0.
- When the operating mode (see Table 22.1) is set to event counter mode, or the count source is set to AGT1 underflow event signal (TCK[2:0] = 101b):
  - After 1 (count starts) is written to the TSTART bit in the AGTCR register while the count is stopped, the TCSTF flag in the AGTCR register remains 0 (count stops) for 2 PCLKB cycles. Do not access the registers associated with AGT other than the TCSTF flag until this bit is set to 1 (count in progress).
  - After 0 (count stops) is written to the TSTART bit during a count operation, the TCSTF flag remains 1 for 2 PCLKB cycles. When the TCSTF flag is set to 0, the count is stopped. Do not access the registers associated with AGT other than the TCSTF flag until this bit is set to 0.

### 22.4.2 Access to Counter Register

When the TSTART bit and TCSTF flag in the AGTCR register are both 1 (count starts), allow at least 3 cycles of the count source clock between writes when writing to the AGT register successively.

### 22.4.3 When Changing Mode

The registers associated with AGT operating mode (AGTMR1, AGTMR2, AGTIOC, AGTISR, AGTCMSR and AGTIOCR) can be changed only when the count is stopped with both the TSTART bit and TCSTF flag set to 0 (count stops). Do not change these registers during count operation.

When the registers associated with AGT operating mode are changed, the values of TEDGF, TUNDF, TCMAF, and TCMBF flags are undefined. Before starting the count, write 0 to the following flags:

- TEDGF (no active edge received)
- TUNDF (no underflow)
- TCMAF (no match)
- TCMBF (no match).

### 22.4.4 Output pin setting

When using the AGTOn, AGTIOOn, AGTOAn, or AGTOBn as an output pin, set up the Operation and determine the initial output values. Then set an output mode in the port register.

When using the AGTIOOn as an input pin in pulse width measurement mode or pulse period measurement mode, set up the Operation and start count operation. Then start to enter external events from the AGTIOOn pin. Invalidate the first measurement and validate the second and later completed measurements.

### 22.4.5 Digital Filter

When using the digital filter, do not start the timer operation for 5 cycles of the digital filter clock after setting TIPF[1:0] bits and when the TEDGSEL bit in the AGTIOC register changes.

### 22.4.6 How to Calculate Event Number, Pulse Width, and Pulse Period

- In event counter mode, event number is expressed mathematically as follows:  
Event number = initial value of counter [AGT register] - counter value of active event end

## 22.4 使用说明

### 22.4.1 计数操作启动和停止控制

- 当操作模式 (见表22.1) 设置为非事件计数器模式, 或计数源设置为非AGTn下溢事件信号 (TCK[2:0]=101b) 时:

在计数停止期间将1 (计数开始) 写入AGTCR寄存器中的TSTART位后, AGTCR寄存器中的TCSTF标志在计数源的3个周期内保持为0 (计数停止)。在此位设置为1 (正在进行计数) 之前, 不要访问与AGT相关的寄存器, 而不是TCSTF标志。

在计数操作期间将0 (计数停止) 写入TSTART位后, TCSTF标志在计数源的3个周期内保持为1。当TCSTF标志设置为0时, 停止计数。不要访问与AGT关联的寄存器。除TCSTF标志外, 直到该位设置为0。

- 当工作模式 (见表22.1) 设置为事件计数器模式, 或计数源设置为AGT1下溢事件信号 (TCK[2:0]=101b) 时:

在停止计数时将1 (计数开始) 写入AGTCR寄存器中的TSTART位后, AGTCR寄存器中的TCSTF标志在2个PCLKB周期内保持为0 (计数停止)。在此位设置为1 (正在进行计数) 之前, 不要访问与AGT相关的寄存器, 而不是TCSTF标志。

在计数操作期间将0 (计数停止) 写入TSTART位后, TCSTF标志保持1持续2 PCLKB周期。当TCSTF标志设置为0时, 停止计数。不要访问与相关的寄存器 AGT不是TCSTF标志, 直到该位设置为0。

### 22.4.2 访问计数器寄存器

当AGTCR寄存器中的TSTART位和TCSTF标志都为1 (计数开始) 时, 连续写入AGT寄存器时, 在两次写入之间至少允许计数源时钟的3个周期。

### 22.4.3 更改模式时

与AGT操作模式相关的寄存器 (AGTMR1、AGTMR2、AGTIOC、AGTISR、AGTCMSR和AGTIOCR) 只有在TSTART位和TCSTF标志都设置为0 (计数停止) 时停止计数时才能更改。在计数操作期间不要更改这些寄存器。

当与AGT工作模式相关的寄存器发生变化时, TEDGF、TUNDF、TCMAF和TCMBF标志未定义。在开始计数之前, 将0写入以下标志:

- TEDGF (未收到有效边沿)
- TUNDF (no underflow)
- TCMAF (no match)
- TCMBF (no match).

### 22.4.4 输出引脚设置

当使用AGTOn、AGTIOOn、AGTOAn或AGTOBn作为输出引脚时, 设置操作并确定初始输出值。然后在端口寄存器中设置一个输出模式。

在脉冲宽度测量模式或脉冲周期测量模式下使用AGTIOOn作为输入引脚时, 设置操作并开始计数操作。然后开始从AGTIOOn引脚输入外部事件。使第一次测量无效并验证第二次和以后完成的测量。

### 22.4.5 数字滤波器

使用数字滤波器时, 在设置TIPF[1:0]位后以及AGTIOC寄存器中的TEDGSEL位发生变化时, 在数字滤波器时钟的5个周期内不要启动定时器操作。

### 22.4.6 如何计算事件编号、脉冲宽度和脉冲周期

- 在事件计数器模式下, 事件编号以数学方式表示如下:  
事件编号=计数器的初始值[AGT寄存器]活动事件结束的计数器值



- In pulse width measurement mode, pulse width is expressed mathematically as follows:  
Pulse width = counter value of stopping measurement - counter value of next stopping measurement
- In pulse period measurement mode, input pulse period is expressed mathematically as follows:  
Period of input pulse = (initial value of counter [AGT register] - reading value of the read-out buffer) + 1.

#### 22.4.7 When Count is Forcibly Stopped by TSTOP Bit

After the counter is forcibly stopped by the TSTOP bit in the AGTCR register, do not access the following I/O registers for 1 cycle of the count source:

- AGT
- AGTCMA
- AGTCMB
- AGTCR
- AGTMR1
- AGTMR2.

#### 22.4.8 When Selecting AGTn (n = 0, 2, 4) Underflow as the Count Source

Operate according to the following procedures described in this section when selecting the underflow event signal as the count source.

##### (1) Procedure for starting operation

1. Set AGT.
2. Start the count operation of AGTn (n = 1, 3, 5).
3. Start the count operation of AGTn (n = 0, 2, 4).

##### (2) Procedure for stopping operation

1. Stop the count operation of AGTn (n = 0, 2, 4).
2. Stop the count operation of AGTn (n = 1, 3, 5).
3. Stop the count source clock of AGTn (n = 1, 3, 5) (write 000b in the AGTMR1.TCK[2:0] bits).

#### 22.4.9 Module-stop function

AGT operation can be disabled or enabled using Module Stop Control Register D (MSTPCRD) and Module Stop Control Register E (MSTPCRE). The AGT module is initially stopped after reset. Releasing the module-stop state enables access to the registers. For details, see [section 10, Low Power Modes](#)

#### 22.4.10 When Switching Source Clock

When switching a clock source by changing SCKSCR.CKSEL[2:0], the clock output from the selector stops for 4 cycles of the switched clock. Therefore, when using the AGTIO, AGTEE, or both input as external event input, the clock source should not be switched. If switching the clock source while using the external event input, extend the input pulse width by 4 clock cycles of the switched source clock cycles.

- 在脉冲宽度测量模式下，脉冲宽度以数学方式表示如下：  
脉冲宽度=停止测量的计数器值下一个停止测量的计数器值
- 在脉冲周期测量模式下，输入脉冲周期的数学表达式如下：  
输入脉冲周期=（计数器初始值[AGT寄存器]读出缓冲器的读取值）+1。

#### 22.4.7 当计数被TSTOP位强制停止时

计数器被AGTCR寄存器中的TSTOP位强制停止后，在计数源的1个周期内不要访问以下IO寄存器：

- AGT
- AGTCMA
- AGTCMB
- AGTCR
- AGTMR1
- AGTMR2.

#### 22.4.8 选择AGTn(n=0 2 4)下溢作为计数源时

选择下溢事件信号作为计数源时，请按照本节所述的以下步骤进行操作。

##### (1) 开始运行的步骤

1. Set AGT.
- 2.启动AGTn(n=1 3 5)的计数操作。
- 3.启动AGTn(n=0 2 4)的计数操作。

##### (2) 停止运行的步骤

- 1.停止AGTn(n=0 2 4)的计数操作。
- 2.停止AGTn(n=1 3 5)的计数操作。
- 3.停止AGTn(n=1 3 5)的计数源时钟（将000b写入AGTMR1.TCK[2:0]位）。

#### 22.4.9 Module-stop function

可以使用模块停止控制寄存器D(MSTPCRD)和模块停止控制来禁用或启用AGT操作寄存器E(MSTPCRE)。AGT模块在复位后最初停止。释放模块停止状态可以访问寄存器。有关详细信息，请参阅第10节，低功耗模式

#### 22.4.10 切换源时钟时

当通过改变SCKSCR.CKSEL[2:0]来切换时钟源时，选择器的时钟输出在切换时钟的4个周期内停止。因此，当使用AGTIO、AGTEE或两者输入作为外部事件输入时，不应切换时钟源。如果在使用外部事件输入时切换时钟源，请将输入脉冲宽度延长4个切换源时钟周期的时钟周期。

## 23. Realtime Clock (RTC)

### 23.1 Overview

The realtime clock (RTC) has two counting modes, calendar count mode and binary count mode, that are used by switching register settings. For calendar count mode, the RTC has a 100-year calendar from 2000 to 2099 and automatically adjusts dates for leap years. For binary count mode, the RTC counts seconds and retains the information as a serial value. Binary count mode can be used for calendars other than the Gregorian (Western) calendar.

The sub-clock oscillator or LOCO can be selected as the count source of the time counters. The RTC uses a 128-Hz clock acquired by dividing the count source by a prescaler. Year, month, date, day-of-week, a.m. /p.m. (in 12-hour mode), hour, minute, second, or 32-bit binary is counted by 1/128 second.

Table 23.1 lists the RTC specifications, Figure 23.1 shows a block diagram, and Table 23.2 lists the I/O pins.

**Table 23.1 RTC specifications**

| Parameter                    | Specifications   |
|------------------------------|--|
| Count mode                   | Calendar count mode/binary count mode  |
| Count source*1               | Sub-clock (XCIN) or LOCO   |
| Clock and calendar functions | <ul style="list-style-type: none"> <li>Calendar count mode               <ul style="list-style-type: none"> <li>Year, month, date, day of week, hour, minute, second are counted, BCD display</li> <li>12 hours/24 hours mode switching function</li> <li>30 seconds adjustment function (a number less than 30 is rounded down to 00 seconds, and 30 seconds or more are rounded up to 1 minute)</li> <li>Automatic adjustment function for leap years</li> </ul> </li> <li>Binary count mode               <ul style="list-style-type: none"> <li>Count seconds in 32 bits, binary display</li> </ul> </li> <li>Shared by both modes               <ul style="list-style-type: none"> <li>Start/stop function</li> <li>The sub-second digit is displayed in binary units (1 Hz, 2 Hz, 4 Hz, 8 Hz, 16 Hz, 32 Hz, or 64 Hz)</li> <li>Clock error correction function</li> <li>Clock (1-Hz/64-Hz) output</li> </ul> </li> </ul>   |
| Interrupts                   | <ul style="list-style-type: none"> <li>Alarm interrupt (RTC_ALM)               <ul style="list-style-type: none"> <li>As an alarm interrupt condition, selectable for comparison with the following:                   <ul style="list-style-type: none"> <li>Calendar count mode: Year, month, date, day-of-week, hour, minute, or second can be selected</li> <li>Binary count mode: Each bit of the 32-bit binary counter</li> </ul> </li> </ul> </li> <li>Periodic interrupt (RTC_PRD)               <ul style="list-style-type: none"> <li>2 seconds, 1 second, 1/2 second, 1/4 second, 1/8 second, 1/16 second, 1/32 second, 1/64 second, 1/128 second, or 1/256 second can be selected as an interrupt period.</li> </ul> </li> <li>Carry interrupt (RTC_CUP)               <ul style="list-style-type: none"> <li>An interrupt is generated at either of the following conditions:                   <ul style="list-style-type: none"> <li>When a carry from the 64-Hz counter to the second counter is generated.</li> <li>When the 64-Hz counter is changed and the R64CNT register is read at the same time. (32-KHz count mode is only for 64-Hz counter reading) <a href="#">section 23.1. Overview</a></li> </ul> </li> </ul> </li> <li>Return from Software Standby or Deep Software Standby mode mode can be performed by an alarm interrupt or periodic interrupt</li> </ul> |
| Time capture function        | <ul style="list-style-type: none"> <li>Times can be captured when the edge of the time capture event input pin is detected. For every event input, month, date, hour, minute, and second are captured or the 32-bit binary counter value is captured. <a href="#">section 23.1. Overview</a></li> <li>Interrupt can be generated when the edge of the time capture event input is detected. The time capture event input pin and IRQ are shared.</li> </ul>  |
| Event link function          | Periodic event output (RTC_PRD)  |
| TrustZone filter             | Security attribution can be set  |

Note 1. The frequency of the peripheral module clock (PCLKB)  $\geq$  the frequency of the count source should be satisfied.

## 23. 实时时钟(RTC)

### 23.1 Overview

实时时钟(RTC)有两种计数模式，日历计数模式和二进制计数模式，通过切换寄存器设置使用。对于日历计数模式，RTC有一个从2000年到2099年的100年日历，并自动调整闰年的日期。对于二进制计数模式，RTC会计算秒数并将信息保留为序列值。二进制计数模式可用于公历（西方）以外的日历。

可以选择子时钟振荡器或LOCO作为时间计数器的计数源。RTC使用一个128-Hz时钟，通过预分频器将计数源分频获得。年、月、日、星期、上午、下午（在12小时模式下）时、分、秒或32位二进制按1/128秒计数。

表23.1列出了RTC规格，图23.1显示了框图，表23.2列出了IO引脚。

**Table 23.1 RTC specifications**

| Parameter        | Specifications  |
|------------------|---|
| 计数模式             | 日历计数模式二进制计数模式   |
| 计数来源*1           | 副时钟(XCIN)或LOCO  |
| 时钟和日历功能          | <ul style="list-style-type: none"> <li>日历计数模式               <ul style="list-style-type: none"> <li>年、月、日、星期、时、分、秒计数，BCD显示</li> <li>12小时24小时模式切换功能</li> <li>30秒调整功能（小于30的数字向下取整为00秒，大于等于30秒向上取整为1分钟）</li> <li>闰年自动调整功能</li> </ul> </li> <li>二进制计数模式               <ul style="list-style-type: none"> <li>以32位计算秒数，二进制显示</li> </ul> </li> <li>两种模式共享               <ul style="list-style-type: none"> <li>Start/stop function</li> <li>亚秒数字以二进制单位显示（1Hz、2Hz、4Hz、8Hz、16Hz、32Hz或64Hz）</li> <li>时钟纠错功能</li> <li>时钟(1-Hz/64-Hz)输出</li> </ul> </li> </ul>  |
| Interrupts       | <ul style="list-style-type: none"> <li>闹钟中断(RTC_ALM)               <ul style="list-style-type: none"> <li>作为报警中断条件，可选择用于与以下比较:                   <ul style="list-style-type: none"> <li>日历计数模式: 可选择年、月、日、星期、小时、分钟或秒</li> <li>二进制计数方式: 32位二进制计数器的每一位</li> </ul> </li> </ul> </li> <li>周期性中断(RTC_PRD)               <ul style="list-style-type: none"> <li>可以选择2秒、1秒、12秒、14秒、18秒、116秒、132秒、164秒、1128秒或1256秒作为中断周期。</li> </ul> </li> <li>进位中断(RTC_CUP)               <ul style="list-style-type: none"> <li>在以下任一情况下都会产生中断:                   <ul style="list-style-type: none"> <li>当产生从64-Hz计数器到第二个计数器的进位时。</li> <li>当64-Hz计数器改变并同时读取R64CNT寄存器时。（32-KHz计数模式仅适用于64-Hz计数器读数）第23.1节。概述</li> </ul> </li> </ul> </li> <li>从软件待机或深度软件待机模式模式中返回可以通过警报中断或周期性中断来执行</li> </ul> |
| 时间捕捉功能           | <ul style="list-style-type: none"> <li>当检测到时间捕捉事件输入引脚的边沿时，可以捕捉时间。对于每个事件输入，都会捕获月、日、小时、分钟和秒，或者捕获32位二进制计数器值。第23.1节。概述</li> <li>当检测到时间捕捉事件输入的边沿时可以产生中断。时间捕捉事件输入引脚和IRQ是共享的。</li> </ul>   |
| 事件链接功能           | 周期性事件输出(RTC_PRD)  |
| TrustZone filter | 可设置安全属性   |

注1.外围模块时钟（PCLKB）的频率 $\geq$ 计数源的频率应满足。

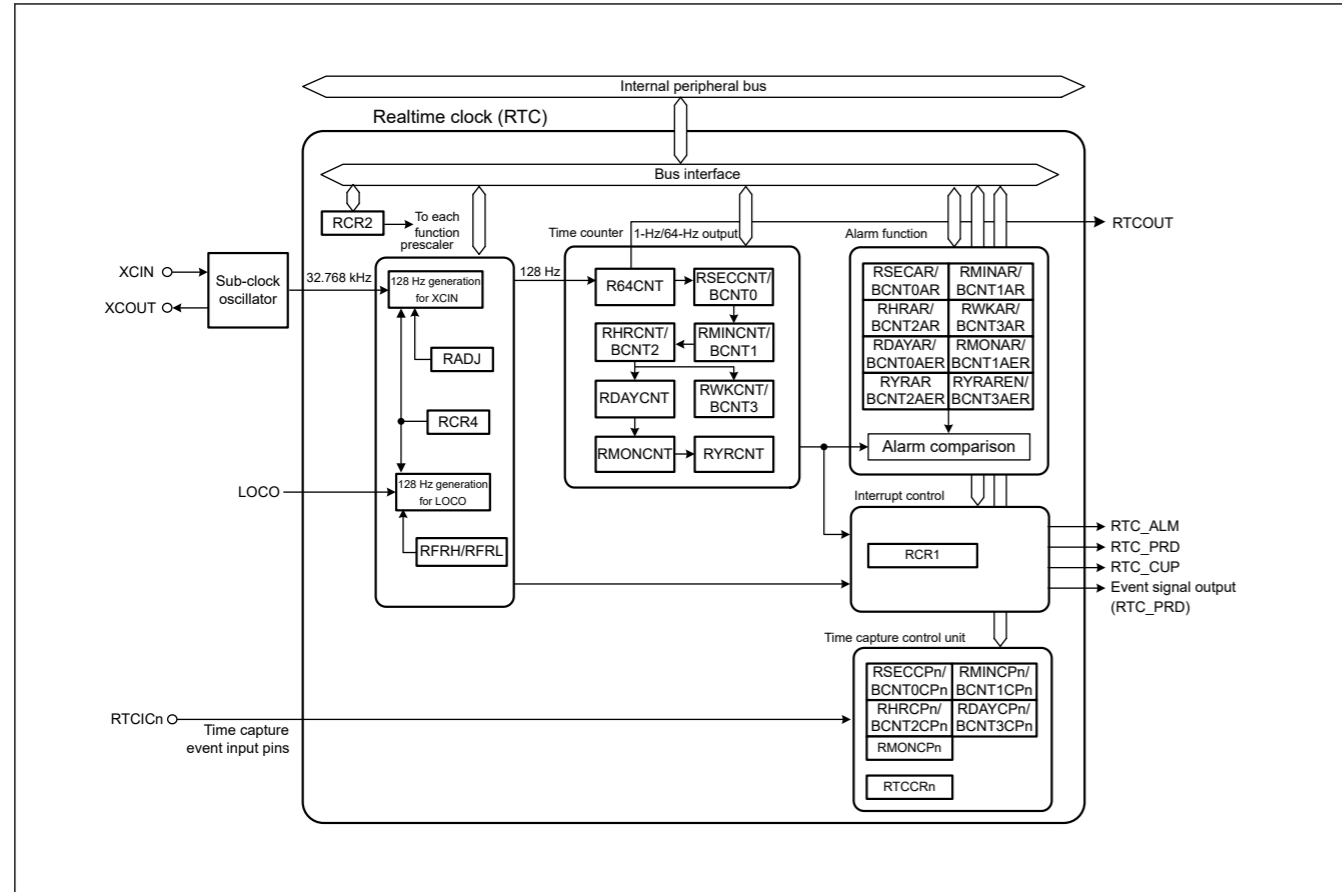


Figure 23.1 RTC block diagram

Table 23.2 RTC I/O pins

| Pin name            | I/O    | Description   |
|---------------------|--------|---|
| XCIN                | Input  | Connect a 32.768-kHz crystal to these pins  |
| XCOU                | Output |   |
| RTCOUT              | Output | This pin is used to output a 1-Hz/64-Hz waveform, but not in Deep Software Standby mode   |
| RTCICn (n = 0 to 2) | Input  | Time capture event input pins<br>RTCICn can be controlled by the VBTICTLR register. For more information, see <a href="#">section 11, Battery Backup Function</a> and <a href="#">section 19, I/O Ports</a> . |

### 23.2 Register Descriptions

Write or read from the RTC registers as described in [section 23.6.5. Notes on Writing to and Reading from Registers](#).

If the value in an RTC register after a reset is given as x (undefined bits) in the list, it is not initialized by a reset. When RTC enters the reset state or a low power state during counting operations, for example, while the RCR2.START bit is 1, the year, month, day of the week, date, hours, minutes, seconds, and 64-Hz counters continue to operate.

Note: A reset generated while writing to a register might destroy the register value. In addition, do not allow the MCU to enter Software Standby or Deep Software Standby mode immediately after setting any of these registers. For details, see [section 23.6.4. Transitions to Low Power Modes after Setting Registers](#).

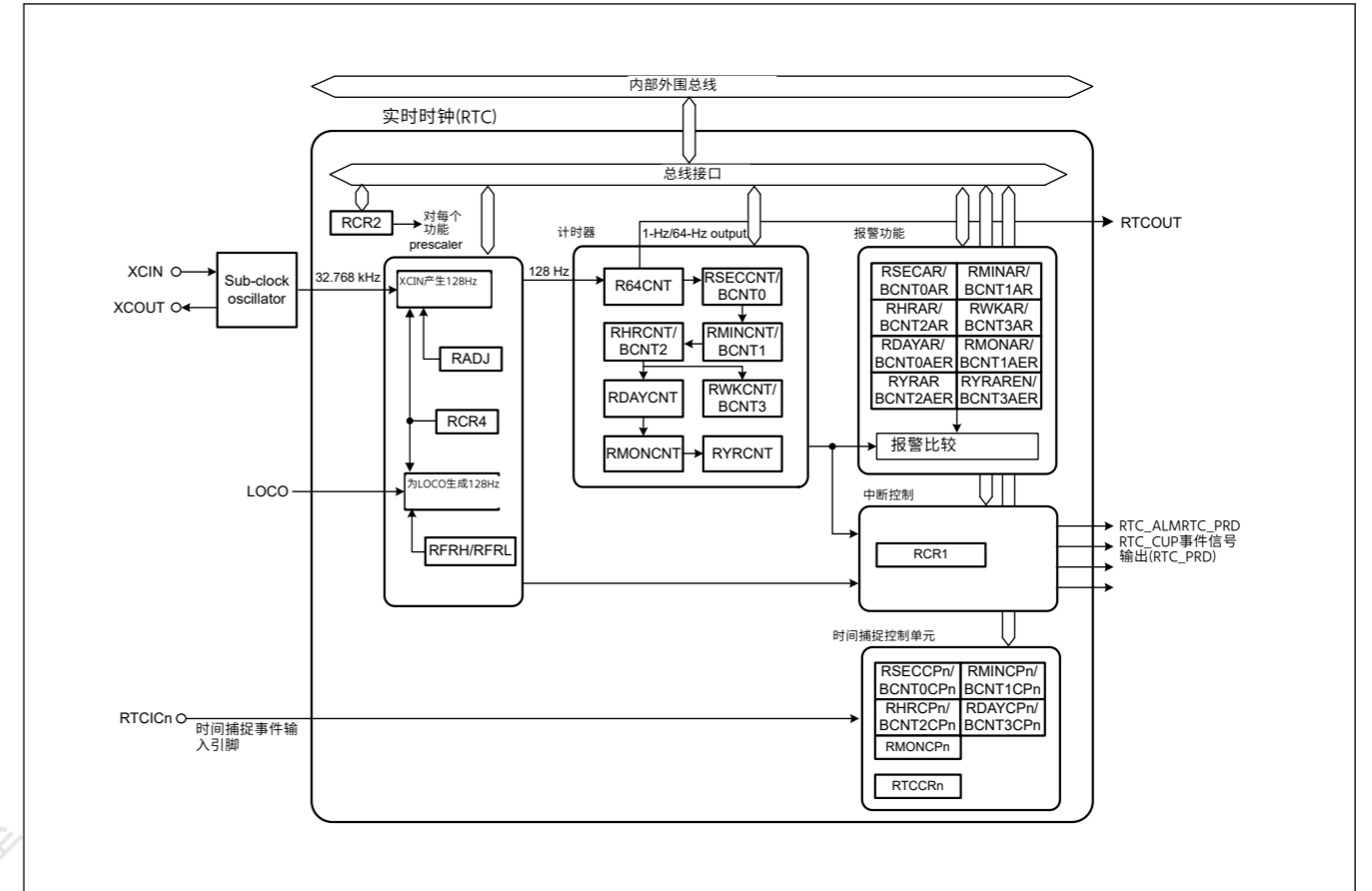


Figure 23.1 实时时钟框图

Table 23.2 RTC I/O pins

| 引脚名称                | I/O    | Description  |
|---------------------|--------|--|
| XCIN                | Input  | 将32.768kHz晶振连接到这些引脚  |
| XCOU                | Output |  |
| RTCOUT              | Output | 此引脚用于输出1-Hz/64-Hz波形，但在DeepSoftware中不使用待机模式                           |
| RTCICn (n = 0 to 2) | Input  | 时间捕捉事件输入引脚<br>RTCICn可由VBTICTLR寄存器控制。有关详细信息，请参阅第11节，电池备份功能和第19节，IO端口。 |

### 23.2 注册说明

如第23.6.5节所述，从RTC寄存器写入或读取。关于写入和读取寄存器的注意事项。

如果复位后RTC寄存器中的值在列表中以x（未定义位）的形式给出，则它不会被复位初始化。当RTC在计数操作期间进入复位状态或低功耗状态时，例如，当RCR2.START位为1时，年、月、星期、日期、小时、分钟、秒和64-Hz计数器继续经营。

Note: 写入寄存器时产生的复位可能会破坏寄存器值。此外，不要让MCU在设置任何这些寄存器后立即进入软件待机或深度软件待机模式。详见23.6.4节。设置寄存器后转换到低功耗模式。

## 23.2.1 R64CNT : 64-Hz Counter

Base address: RTC = 0x4008\_3000

Offset address: 0x00

|                    |   |      |      |      |      |       |       |       |
|--------------------|---|------|------|------|------|-------|-------|-------|
| Bit position:      | 7 | 6    | 5    | 4    | 3    | 2     | 1     | 0     |
| Bit field:         | — | F1HZ | F2HZ | F4HZ | F8HZ | F16HZ | F32HZ | F64HZ |
| Value after reset: | 0 | x    | x    | x    | x    | x     | x     | x     |

| Bit | Symbol | Function  | R/W |
|-----|--------|---|-----|
| 0   | F64HZ  | 64-Hz Flag<br>This bit indicates the 64-Hz state of the sub-second digit. | R   |
| 1   | F32HZ  | 32-Hz Flag<br>This bit indicates the 32-Hz state of the sub-second digit. | R   |
| 2   | F16HZ  | 16-Hz Flag<br>This bit indicates the 16-Hz state of the sub-second digit. | R   |
| 3   | F8HZ   | 8-Hz Flag<br>This bit indicates the 8-Hz state of the sub-second digit.   | R   |
| 4   | F4HZ   | 4-Hz Flag<br>This bit indicates the 4-Hz state of the sub-second digit.   | R   |
| 5   | F2HZ   | 2-Hz Flag<br>This bit indicates the 2-Hz state of the sub-second digit.   | R   |
| 6   | F1HZ   | 1-Hz Flag<br>This bit indicates the 1-Hz state of the sub-second digit.   | R   |
| 7   | —      | This bit is read as 0.  | R   |

The R64CNT counter is used in both calendar count mode and binary count mode. The 64-Hz counter (R64CNT) generates the period for a second by counting up periods of the 128-Hz clock. The state in the sub-second range can be confirmed by reading this counter.

This counter is set to 0x00 by an RTC software reset or an execution of a 30-second adjustment. To read this counter, follow the procedure in [section 23.3.5. Reading 64-Hz Counter and Time](#).

## 23.2.2 RSECCNT : Second Counter (in Calendar Count Mode)

Base address: RTC = 0x4008\_3000

Offset address: 0x02

|                    |   |            |   |   |           |   |   |   |
|--------------------|---|------------|---|---|-----------|---|---|---|
| Bit position:      | 7 | 6          | 5 | 4 | 3         | 2 | 1 | 0 |
| Bit field:         | — | SEC10[2:0] |   |   | SEC1[3:0] |   |   |   |
| Value after reset: | x | x          | x | x | x         | x | x | x |

| Bit | Symbol     | Function  | R/W |
|-----|------------|---|-----|
| 3:0 | SEC1[3:0]  | 1-Second Count<br>Counts from 0 to 9 every second. When a carry is generated, 1 is added to the tens place. | R/W |
| 6:4 | SEC10[2:0] | 10-Second Count<br>Counts from 0 to 5 for 60-second counting.   | R/W |
| 7   | —          | The read value is undefined. The write value should be 0.   | R/W |

The RSECCNT counter sets and counts the BCD-coded second value. It counts the carries generated once per second in the 64-Hz counter.

The setting range is decimal 00 to 59. The RTC does not operate normally if any other value is set. Before writing to this register, you must stop the count operation using the START bit in RCR2.

## 23.2.1 R64CNT : 64-Hz Counter

Base address: RTC = 0x4008\_3000

Offset address: 0x00

|               |   |      |      |      |      |       |       |       |
|---------------|---|------|------|------|------|-------|-------|-------|
| Bit position: | 7 | 6    | 5    | 4    | 3    | 2     | 1     | 0     |
| Bit field:    | — | F1HZ | F2HZ | F4HZ | F8HZ | F16HZ | F32HZ | F64HZ |
| 重置后的值:        | 0 | x    | x    | x    | x    | x     | x     | x     |

| Bit | Symbol | Function                 | R/W |
|-----|--------|--------------------------|-----|
| 0   | F64HZ  | 64-Hz标志该位指示亚秒数字的64-Hz状态。 | R   |
| 1   | F32HZ  | 32-Hz标志该位指示亚秒数字的32-Hz状态。 | R   |
| 2   | F16HZ  | 16-Hz标志该位指示亚秒数字的16-Hz状态。 | R   |
| 3   | F8HZ   | 8-Hz标志该位指示亚秒数字的8-Hz状态。   | R   |
| 4   | F4HZ   | 4-Hz标志该位指示亚秒数字的4-Hz状态。   | R   |
| 5   | F2HZ   | 2-Hz标志该位指示亚秒数字的2-Hz状态。   | R   |
| 6   | F1HZ   | 1-Hz标志该位指示亚秒数字的1-Hz状态。   | R   |
| 7   | —      | 该位读为0。                   | R   |

R64CNT计数器用于日历计数模式和二进制计数模式。64-Hz计数器(R64CNT)通过向上计数128-Hz时钟的周期来产生一秒的周期。亚秒范围内的状态可以通过读取该计数器来确认。

该计数器通过RTC软件复位或执行30秒调整设置为0x00。要读取此计数器，请按照第23.3.5节中的程序进行。读取64-Hz计数器和时间。

## 23.2.2 RSECCNT:第二个计数器 (在日历计数模式下)

Base address: RTC = 0x4008\_3000

Offset address: 0x02

|               |   |            |   |   |           |   |   |   |
|---------------|---|------------|---|---|-----------|---|---|---|
| Bit position: | 7 | 6          | 5 | 4 | 3         | 2 | 1 | 0 |
| Bit field:    | — | SEC10[2:0] |   |   | SEC1[3:0] |   |   |   |
| 重置后的值:        | x | x          | x | x | x         | x | x | x |

| Bit | Symbol     | Function                          | R/W |
|-----|------------|-----------------------------------|-----|
| 3:0 | SEC1[3:0]  | 1-SecondCount每秒从0计数到9。产生进位时，十位加1。 | R/W |
| 6:4 | SEC10[2:0] | 10秒计数从0计数到5以进行60秒计数。              | R/W |
| 7   | —          | 读取值未定义。写入值应为0。                    | R/W |

RSECCNT计数器设置并计算BCD编码的第二个值。它对64-Hz计数器中每秒生成一次的进位进行计数。

设置范围为十进制00到59。如果设置任何其他值，RTC将无法正常工作。在写入该寄存器之前，您必须使用RCR2中的START位停止计数操作。

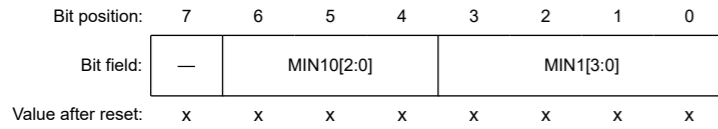


To read this counter, follow the procedure in [section 23.3.5. Reading 64-Hz Counter and Time](#).

### 23.2.3 RMINCNT : Minute Counter (in Calendar Count Mode)

Base address: RTC = 0x4008\_3000

Offset address: 0x04



| Bit | Symbol     | Function  | R/W |
|-----|------------|---|-----|
| 3:0 | MIN1[3:0]  | 1-Minute Count<br>Counts from 0 to 9 every minute. When a carry is generated, 1 is added to the tens place. | R/W |
| 6:4 | MIN10[2:0] | 10-Minute Count<br>Counts from 0 to 5 for 60-minute counting.   | R/W |
| 7   | —          | The read value is undefined. The write value should be 0.   | R/W |

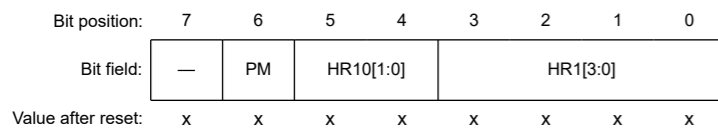
The RMINCNT counter sets and counts the BCD-coded minute value. It counts the carries generated once every minute in the second counter.

A value from 00 through 59 (in BCD) can be specified. If a value outside of this range is specified, the RTC does not operate correctly. Before writing to this register, you must stop the count operation using the START bit in RCR2. To read this counter, follow the procedure in [section 23.3.5. Reading 64-Hz Counter and Time](#).

### 23.2.4 RHRCNT : Hour Counter (in Calendar Count Mode)

Base address: RTC = 0x4008\_3000

Offset address: 0x06



| Bit | Symbol    | Function   | R/W |
|-----|-----------|--|-----|
| 3:0 | HR1[3:0]  | 1-Hour Count<br>Counts from 0 to 9 once per hour. When a carry is generated, 1 is added to the tens place. | R/W |
| 5:4 | HR10[1:0] | 10-Hour Count<br>Counts from 0 to 2 once per carry from the ones place.                                    | R/W |
| 6   | PM        | AM/PM select for time counter setting.<br>0: AM<br>1: PM   | R/W |
| 7   | —         | The read value is undefined. The write value should be 0.  | R/W |

The RHRCNT counter sets and counts the BCD-coded hour value. It counts the carries generated once per hour in the minute counter. The specifiable time differs based on the setting in the hours mode bit (RCR2.HR24):

- When the RCR2.HR24 bit is 0 – from 00 to 11 (in BCD).
- When the RCR2.HR24 bit is 1 – from 00 to 23 (in BCD).

If a value outside of this range is specified, the RTC does not operate correctly. Before writing to this register, you must stop the count operation using the START bit in RCR2. The PM bit is only enabled when the RCR2.HR24 bit is 0.

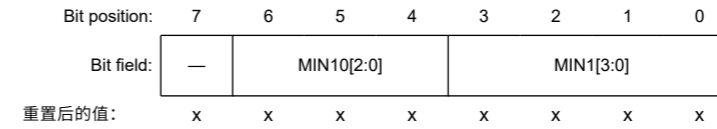
Otherwise, the setting in the PM bit has no effect. To read this counter, follow the procedure in [section 23.3.5. Reading 64-Hz Counter and Time](#).

要读取此计数器，请按照第23.3.5节中的程序进行。读取64-Hz计数器和时间。

### 23.2.3 RMINCNT：分钟计数器（在日历计数模式下）

Base address: RTC = 0x4008\_3000

Offset address: 0x04



| Bit | Symbol     | Function                   | R/W |
|-----|------------|----------------------------|-----|
| 3:0 | MIN1[3:0]  | 1分钟计数每分钟从0计数到9。产生进位时，十位加1。 | R/W |
| 6:4 | MIN10[2:0] | 10分钟计数从0到5计数60分钟。          | R/W |
| 7   | —          | 读取值未定义。写入值应为0。             | R/W |

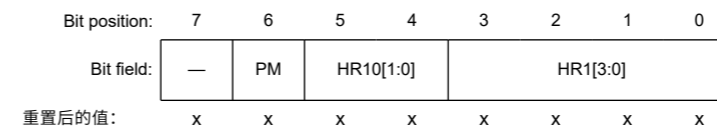
RMINCNT计数器设置并计算BCD编码的分钟值。它对第二个计数器中每分钟产生一次的进位进行计数。

可以指定从00到59的值（以BCD表示）。如果指定的值超出此范围，则RTC将无法正确运行。在写入该寄存器之前，您必须使用RCR2中的START位停止计数操作。要读取此计数器，请按照第23.3.5节中的程序进行。读取64-Hz计数器和时间。

### 23.2.4 RHRCNT：小时计数器（在日历计数模式下）

Base address: RTC = 0x4008\_3000

Offset address: 0x06



| Bit | Symbol    | Function                          | R/W |
|-----|-----------|-----------------------------------|-----|
| 3:0 | HR1[3:0]  | 1小时计数每小时从0计数到9次。产生进位时，十位加1。       | R/W |
| 5:4 | HR10[1:0] | 10小时计数从0到2计数一次，每次从一个位置进行。         | R/W |
| 6   | PM        | AM/PM选择时间计数器设置。<br>0: AM<br>1: PM | R/W |
| 7   | —         | 读取值未定义。写入值应为0。                    | R/W |

RHRCNT计数器设置并计算BCD编码的小时值。它在分钟计数器中计算每小时生成一次的进位。可指定的时间因小时模式位(RCR2.HR24)中的设置而异：

- 当RCR2.HR24位为0时——从00到11（以BCD表示）。
- 当RCR2.HR24位为1时 从00到23（以BCD表示）。

如果指定的值超出此范围，则RTC将无法正确运行。在写入该寄存器之前，您必须使用RCR2中的START位停止计数操作。PM位仅在RCR2.HR24位为0时启用。

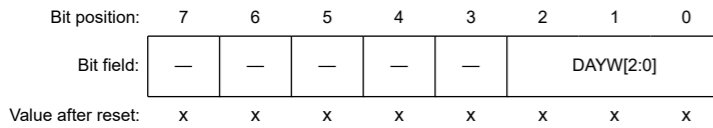
否则，PM位中的设置无效。要读取此计数器，请按照第23.3.5节中的程序进行。阅读64-Hz计数器和时间。



## 23.2.5 RWKCNT : Day-of-Week Counter (in Calendar Count Mode)

Base address: RTC = 0x4008\_3000

Offset address: 0x08



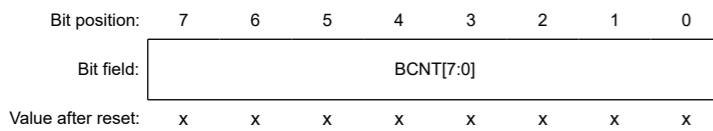
| Bit | Symbol    | Function   | R/W |
|-----|-----------|--|-----|
| 2:0 | DAYW[2:0] | Day-of-Week Counting<br>0 0 0: Sunday<br>0 0 1: Monday<br>0 1 0: Tuesday<br>0 1 1: Wednesday<br>1 0 0: Thursday<br>1 0 1: Friday<br>1 1 0: Saturday<br>1 1 1: Setting prohibited | R/W |
| 7:3 | —         | The read values are undefined. The write value should be 0.  | R/W |

The RWKCNT counter sets and counts in the coded day-of-week value. It counts the carries generated once per day in the hour counter. A value from 0 through 6 can be specified. If a value outside of this range is specified, the RTC does not operate correctly. Before writing to this register, you must stop the count operation using the START bit in RCR2. To read this counter, follow the procedure in [section 23.3.5. Reading 64-Hz Counter and Time](#).

## 23.2.6 BCNTn : Binary Counter n (n = 0 to 3) (in Binary Count Mode)

Base address: RTC = 0x4008\_3000

Offset address: 0x02 + 0x02 × n



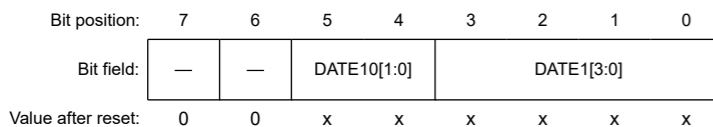
| Bit | Symbol    | Function       | R/W |
|-----|-----------|----------------|-----|
| 7:0 | BCNT[7:0] | Binary Counter | R/W |

BCNTn is a read/write 8-bit register to access BCNT[31:0] that is a 32-bit binary counter. BCNT3 is assigned to the BCNT[31:24] bits, BCNT2 is assigned to the BCNT[23:16] bits, BCNT1 is assigned to the BCNT[15:8] bits, and BCNT0 is assigned to the BCNT[7:0] bits. BCNTn performs count operation by a carry generated for each second of the 64-Hz counter. Before writing to this register, you must stop the count operation using the START bit in RCR2. To read this counter, follow the procedure in [section 23.3.5. Reading 64-Hz Counter and Time](#).

## 23.2.7 RDAYCNT : Day Counter

Base address: RTC = 0x4008\_3000

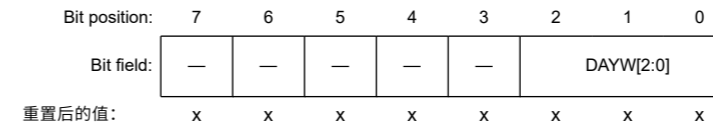
Offset address: 0x0A



## 23.2.5 RWKCNT: 星期计数器 (在日历计数模式下)

Base address: RTC = 0x4008\_3000

Offset address: 0x08



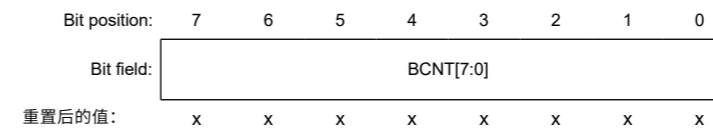
| Bit | Symbol    | Function  | R/W |
|-----|-----------|---|-----|
| 2:0 | DAYW[2:0] | Day-of-Week Counting<br>000: 星期日001: 星期一<br>010: 星期二011: 星期三<br>100: 星期四101: 星期五<br>110: 星期六111: 禁止设置 | R/W |
| 7:3 | —         | 读取的值未定义。写入值应为0。   | R/W |

RWKCNT计数器在编码的星期值中设置和计数。它计算小时计数器中每天生成一次的进位。可以指定从0到6的值。如果指定的值超出此范围，则RTC将无法正确运行。在写入该寄存器之前，您必须使用RCR2中的START位停止计数操作。要读取此计数器，请按照第23.3.5节中的程序进行。读取64-Hz计数器和时间。

## 23.2.6 BCNTn: 二进制计数器n (n=0到3) (在二进制计数模式下)

Base address: RTC = 0x4008\_3000

Offset address: 0x02 + 0x02 × n



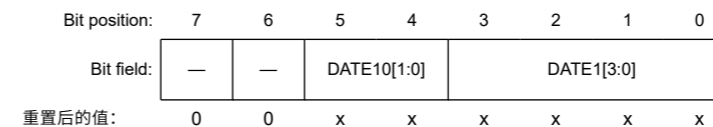
| Bit | Symbol    | Function | R/W |
|-----|-----------|----------|-----|
| 7:0 | BCNT[7:0] | 二进制计数器   | R/W |

BCNTn是一个读写8位寄存器，用于访问BCNT[31:0]，它是一个32位二进制计数器。BCNT3分配给BCNT[31:24]位，BCNT2分配给BCNT[23:16]位，BCNT1分配给BCNT[15:8]位，BCNT0分配给BCNT[7:0]位。BCNTn通过64-Hz计数器每秒生成的进位执行计数操作。在写入该寄存器之前，您必须使用RCR2中的START位停止计数操作。要读取此计数器，请按照第23.3.5节中的程序进行。读取64-Hz计数器和时间。

## 23.2.7 RDAYCNT: 日计数器

Base address: RTC = 0x4008\_3000

Offset address: 0x0A



| Bit | Symbol      | Function   | R/W |
|-----|-------------|--|-----|
| 3:0 | DATE1[3:0]  | 1-Day Count<br>Counts from 0 to 9 once per day. When a carry is generated, 1 is added to the tens place. | R/W |
| 5:4 | DATE10[1:0] | 10-Day Count<br>Counts from 0 to 3 once per carry from the ones place.                                   | R/W |
| 7:6 | —           | These bits are read as 0. The write value should be 0.   | R/W |

The RDAYCNT counter is used in calendar count mode to set and count the BCD-coded date value. It counts the carries generated once per day in the hour counter. The count operation depends on the month and whether the year is a leap year. Leap years are determined according to whether the year counter (RYRCNT) value is divisible by 400, 100, and 4.

A value from 01 through 31 (in BCD) can be specified. If a value outside of this range is specified, the RTC does not operate correctly. When specifying a value, the range of specifiable days depends on the month and whether the year is a leap year. Before writing to this register, you must stop the count operation using the START bit in RCR2. To read this counter, follow the procedure in [section 23.3.5. Reading 64-Hz Counter and Time](#).

### 23.2.8 RMONCNT : Month Counter

Base address: RTC = 0x4008\_3000

Offset address: 0x0C

|                    |   |   |   |           |           |   |   |   |
|--------------------|---|---|---|-----------|-----------|---|---|---|
| Bit position:      | 7 | 6 | 5 | 4         | 3         | 2 | 1 | 0 |
| Bit field:         | — | — | — | MON1<br>0 | MON1[3:0] |   |   |   |
| Value after reset: | 0 | 0 | 0 | x         | x         | x | x | x |

| Bit | Symbol    | Function   | R/W |
|-----|-----------|--|-----|
| 3:0 | MON1[3:0] | 1-Month Count<br>Counts from 0 to 9 once per month. When a carry is generated, 1 is added to the tens place. | R/W |
| 4   | MON10     | 10-Month Count<br>Counts from 0 to 1 once per carry from the ones place.                                     | R/W |
| 7:5 | —         | These bits are read as 0. The write value should be 0.   | R/W |

The RMONCNT counter is used in calendar count mode to set and count the BCD-coded month value. It counts the carries generated once per month in the date counter.

A value from 01 through 12 (in BCD) can be specified. If a value outside of this range is specified, the RTC does not operate correctly. Before writing to this register, you must stop the count operation using the START bit in RCR2. To read this counter, follow the procedure in [section 23.3.5. Reading 64-Hz Counter and Time](#).

### 23.2.9 RYRCNT : Year Counter

Base address: RTC = 0x4008\_3000

Offset address: 0x0E

|                    |    |    |    |    |    |    |   |   |           |   |   |   |          |   |   |   |
|--------------------|----|----|----|----|----|----|---|---|-----------|---|---|---|----------|---|---|---|
| Bit position:      | 15 | 14 | 13 | 12 | 11 | 10 | 9 | 8 | 7         | 6 | 5 | 4 | 3        | 2 | 1 | 0 |
| Bit field:         | —  | —  | —  | —  | —  | —  | — | — | YR10[3:0] |   |   |   | YR1[3:0] |   |   |   |
| Value after reset: | 0  | 0  | 0  | 0  | 0  | 0  | 0 | 0 | x         | x | x | x | x        | x | x | x |

| Bit | Symbol   | Function   | R/W |
|-----|----------|--|-----|
| 3:0 | YR1[3:0] | 1-Year Count<br>Counts from 0 to 9 once per year. When a carry is generated, 1 is added to the tens place. | R/W |

| Bit | Symbol      | Function                  | R/W |
|-----|-------------|---------------------------|-----|
| 3:0 | DATE1[3:0]  | 1天计数每天从0计数到9次。产生进位时，十位加1。 | R/W |
| 5:4 | DATE10[1:0] | 10天计数从0到3计数一次，每次从一个位置进行。  | R/W |
| 7:6 | —           | 这些位被读取为0。写入值应为0。          | R/W |

RDAYCNT计数器用于日历计数模式以设置和计数BCD编码的日期值。它计算小时计数器中每天生成一次的进位。计数操作取决于月份以及年份是否为闰年。闰年根据年份计数器(RYRCNT)值是否可被400、100和4整除来确定。

可以指定从01到31的值（以BCD表示）。如果指定的值超出此范围，则RTC将无法正确运行。指定值时，可指定天数的范围取决于月份以及年份是否为闰年。在写入该寄存器之前，您必须使用RCR2中的START位停止计数操作。要读取此计数器，请按照第23.3.5节中的程序进行。读取64-Hz计数器和时间。

### 23.2.8 RMONCNT:月计数器

Base address: RTC = 0x4008\_3000

Offset address: 0x0C

|               |   |   |   |           |           |   |   |   |
|---------------|---|---|---|-----------|-----------|---|---|---|
| Bit position: | 7 | 6 | 5 | 4         | 3         | 2 | 1 | 0 |
| Bit field:    | — | — | — | MON1<br>0 | MON1[3:0] |   |   |   |
| 重置后的值:        | 0 | 0 | 0 | x         | x         | x | x | x |

| Bit | Symbol    | Function                    | R/W |
|-----|-----------|-----------------------------|-----|
| 3:0 | MON1[3:0] | 1个月计数每月一次从0计数到9。产生进位时，十位加1。 | R/W |
| 4   | MON10     | 10-MonthCount从0到1计数一次，每次进位。 | R/W |
| 7:5 | —         | 这些位被读取为0。写入值应为0。            | R/W |

RMONCNT计数器用于日历计数模式以设置和计数BCD编码的月份值。它在日期计数器中计算每月生成一次的进位。

可以指定从01到12的值（以BCD表示）。如果指定的值超出此范围，则RTC将无法正确运行。在写入该寄存器之前，您必须使用RCR2中的START位停止计数操作。要读取此计数器，请按照第23.3.5节中的程序进行。读取64-Hz计数器和时间。

### 23.2.9 RYRCNT:年计数器

Base address: RTC = 0x4008\_3000

Offset address: 0x0E

|               |    |    |    |    |    |    |   |   |           |   |   |   |          |   |   |   |
|---------------|----|----|----|----|----|----|---|---|-----------|---|---|---|----------|---|---|---|
| Bit position: | 15 | 14 | 13 | 12 | 11 | 10 | 9 | 8 | 7         | 6 | 5 | 4 | 3        | 2 | 1 | 0 |
| Bit field:    | —  | —  | —  | —  | —  | —  | — | — | YR10[3:0] |   |   |   | YR1[3:0] |   |   |   |
| 重置后的值:        | 0  | 0  | 0  | 0  | 0  | 0  | 0 | 0 | x         | x | x | x | x        | x | x | x |

| Bit | Symbol   | Function                  | R/W |
|-----|----------|---------------------------|-----|
| 3:0 | YR1[3:0] | 1年计数每年从0计数到9次。产生进位时，十位加1。 | R/W |

| Bit  | Symbol    | Function   | R/W |
|------|-----------|--|-----|
| 7:4  | YR10[3:0] | 10-Year Count<br>Counts from 0 to 9 once per carry from ones place. When a carry is generated in the tens place, 1 is added to the hundreds place. | R/W |
| 15:8 | —         | These bits are read as 0. The write value should be 0.   | R/W |

The RYRCNT counter is used in calendar count mode to set and count the BCD-coded year value. It counts the carries generated once per year in the month counter.

A value from 00 through 99 (in BCD) can be specified. If a value outside of this range is specified, the RTC does not operate correctly. Before writing to this register, you must stop the count operation using the START bit in RCR2. To read this counter, follow the procedure in [section 23.3.5. Reading 64-Hz Counter and Time](#).

### 23.2.10 RSECAR : Second Alarm Register (in Calendar Count Mode)

Base address: RTC = 0x4008\_3000

Offset address: 0x10

|                    |     |            |   |           |   |   |   |   |
|--------------------|-----|------------|---|-----------|---|---|---|---|
| Bit position:      | 7   | 6          | 5 | 4         | 3 | 2 | 1 | 0 |
| Bit field:         | ENB | SEC10[2:0] |   | SEC1[3:0] |   |   |   |   |
| Value after reset: | x   | x          | x | x         | x | x | x | x |

| Bit | Symbol     | Function   | R/W |
|-----|------------|--|-----|
| 3:0 | SEC1[3:0]  | 1 Second<br>Value for the ones place of seconds.   | R/W |
| 6:4 | SEC10[2:0] | 10 Seconds<br>Value for the tens place of seconds.   | R/W |
| 7   | ENB        | ENB<br>0: Do not compare register value with RSECCNT counter value<br>1: Compare register value with RSECCNT counter value | R/W |

RSECAR is an alarm register associated with the BCD-coded second counter RSECCNT. When the ENB bit is set to 1, the RSECAR value is compared with the RSECCNT value. From the following alarm registers, only those selected with the ENB bits set to 1 are compared with the associated counters:

- RSECAR
- RMINAR
- RHRAR
- RWKAR
- RDAYAR
- RMONAR
- RYRAREN

When all the respective values match, the IR flag associated with the RTC\_ALM interrupt is set to 1. RSECAR values from 00 through 59 (in BCD) can be specified. If a value outside of this range is specified, the RTC does not operate correctly. This register is set to 0x00 by an RTC software reset.

| Bit  | Symbol    | Function                                      | R/W |
|------|-----------|---|-----|
| 7:4  | YR10[3:0] | 10-YearCount从0到9计数一次，每次从一个位置进位。当十位产生进位时，百位加1。 | R/W |
| 15:8 | —         | 这些位被读取为0。写入值应为0。                              | R/W |

RYRCNT计数器在日历计数模式下用于设置和计数BCD编码的年份值。它计算月份计数器中每年生成一次的进位。

可以指定从00到99（BCD格式）的值。如果指定的值超出此范围，则RTC将无法正确运行。在写入该寄存器之前，您必须使用RCR2中的START位停止计数操作。要读取此计数器，请按照第23.3.5节中的程序进行。读取64-Hz计数器和时间。

### 23.2.10 RSCAR: 第二个警报寄存器（在日历计数模式下）

Base address: RTC = 0x4008\_3000

Offset address: 0x10

|               |     |            |   |           |   |   |   |   |
|---------------|-----|------------|---|-----------|---|---|---|---|
| Bit position: | 7   | 6          | 5 | 4         | 3 | 2 | 1 | 0 |
| Bit field:    | ENB | SEC10[2:0] |   | SEC1[3:0] |   |   |   |   |
| 重置后的值:        | x   | x          | x | x         | x | x | x | x |

| Bit | Symbol     | Function   | R/W |
|-----|------------|--|-----|
| 3:0 | SEC1[3:0]  | 1秒个位的秒值。   | R/W |
| 6:4 | SEC10[2:0] | 10秒十位秒的值。  | R/W |
| 7   | ENB        | ENB<br>0: 不将寄存器值与RSECCNT计数器值进行比较<br>1: 将寄存器值与RSECCNT计数器值进行比较 | R/W |

RSCAR是与BCD编码的第二个计数器RSECCNT相关的警报寄存器。当ENB位设置为1时，RSCAR值与RSECCNT值进行比较。从下面的报警寄存器中，只有那些选择与设置为1的ENB位与相关计数器进行比较：

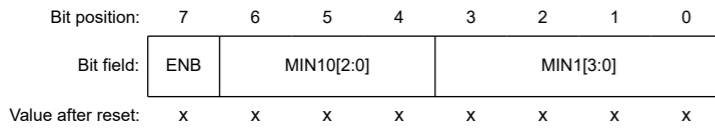
- RSECAR
- RMINAR
- RHRAR
- RWKAR
- RDAYAR
- RMONAR
- RYRAREN

当所有各自的值都匹配时，与RTC\_ALM中断相关的IR标志设置为1。可以指定从00到59（以BCD表示）的RSCAR值。如果指定的值超出此范围，则RTC将无法正确运行。该寄存器通过RTC软件复位设置为0x00。

## 23.2.11 RMINAR : Minute Alarm Register (in Calendar Count Mode)

Base address: RTC = 0x4008\_3000

Offset address: 0x12



| Bit | Symbol     | Function   | R/W |
|-----|------------|--|-----|
| 3:0 | MIN1[3:0]  | 1 Minute<br>Value for the ones place of minutes.   | R/W |
| 6:4 | MIN10[2:0] | 10 Minutes<br>Value for the tens place of minutes.   | R/W |
| 7   | ENB        | ENB<br>0: Do not compare register value with RMINCNT counter value<br>1: Compare register value with RMINCNT counter value | R/W |

RMINAR is an alarm register associated with the BCD-coded minute counter RMINCNT. When the ENB bit is set to 1, the RMINAR value is compared with the RMINCNT value. From the following alarm registers, only those selected with the ENB bits set to 1 are compared with the associated counters:

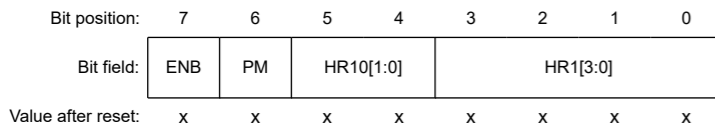
- RSECAR
- RMINAR
- RHRAR
- RWKAR
- RDAYAR
- RMONAR
- RYRAREN

When all the respective values match, the IR flag associated with the RTC\_ALM interrupt is set to 1. RMINAR values from 00 through 59 (in BCD) can be specified. If a value outside of this range is specified, the RTC does not operate correctly. This register is set to 0x00 by an RTC software reset.

## 23.2.12 RHRAR : Hour Alarm Register (in Calendar Count Mode)

Base address: RTC = 0x4008\_3000

Offset address: 0x14

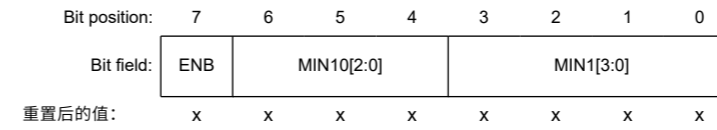


| Bit | Symbol    | Function  | R/W |
|-----|-----------|---|-----|
| 3:0 | HR1[3:0]  | 1 Hour<br>Value for the ones place of hours.      | R/W |
| 5:4 | HR10[1:0] | 10 Hours<br>Value for the tens place of hours.    | R/W |
| 6   | PM        | AM/PM select for alarm setting.<br>0: AM<br>1: PM | R/W |

## 23.2.11 RMINAR: 分钟报警寄存器 (日历计数模式)

Base address: RTC = 0x4008\_3000

Offset address: 0x12



| Bit | Symbol     | Function   | R/W |
|-----|------------|--|-----|
| 3:0 | MIN1[3:0]  | 分钟的个位的1分钟值。  | R/W |
| 6:4 | MIN10[2:0] | 十位分钟的10分钟值。  | R/W |
| 7   | ENB        | ENB<br>0: 不将寄存器值与RMINCNT计数器值进行比较<br>1: 将寄存器值与RMINCNT计数器值进行比较 | R/W |

RMINAR是一个与BCD编码的分钟计数器RMINCNT相关的报警寄存器。当ENB位设置为1时，RMINAR值与RMINCNT值进行比较。从下面的报警寄存器中，只有那些选择与设置为1的ENB位与相关计数器进行比较：

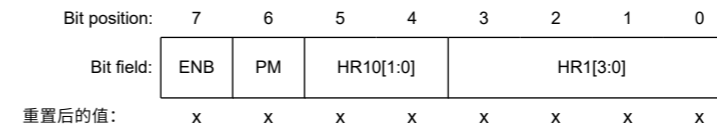
- RSECAR
- RMINAR
- RHRAR
- RWKAR
- RDAYAR
- RMONAR
- RYRAREN

当所有各自的值都匹配时，与RTC\_ALM中断相关的IR标志设置为1。可以指定从00到59（以BCD表示）的RMINAR值。如果指定的值超出此范围，则RTC将无法正常运行。该寄存器通过RTC软件复位设置为0x00。

## 23.2.12 RHRAR: 小时报警寄存器 (日历计数模式)

Base address: RTC = 0x4008\_3000

Offset address: 0x14



| Bit | Symbol    | Function                      | R/W |
|-----|-----------|-------------------------------|-----|
| 3:0 | HR1[3:0]  | 1小时值的个数。                      | R/W |
| 5:4 | HR10[1:0] | 十位小时的10小时值。                   | R/W |
| 6   | PM        | AMPM选择闹钟设置。<br>0: AM<br>1: PM | R/W |

| Bit | Symbol | Function   | R/W |
|-----|--------|--|-----|
| 7   | ENB    | ENB<br>0: Do not compare register value with RHCNT counter value<br>1: Compare register value with RHCNT counter value | R/W |

RHRAR is an alarm register associated with the BCD-coded hour counter RHCNT. When the ENB bit is set to 1, the RHRAR value is compared with the RHCNT value. From the following alarm registers, only those selected with the ENB bits set to 1 are compared with the associated counters:

- RSECAR
- RMINAR
- RHRAR
- RWKAR
- RDAYAR
- RMONAR
- RYRAREN

When all the respective values match, the IR flag associated with the RTC\_ALM interrupt is set to 1. The specifiable time differs according to the setting in the hours mode bit (RCR2.HR24):

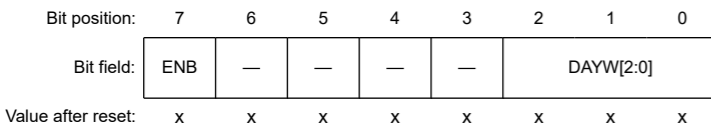
- When the RCR2.HR24 bit is 0 – From 00 to 11 (in BCD).
- When the RCR2.HR24 bit is 1 – From 00 to 23 (in BCD).

If a value outside of this range is specified, the RTC does not operate correctly. When the RCR2.HR24 bit is 0, you must set the PM bit. When the RCR2.HR24 bit is 1, the setting in the PM bit has no effect. This register is set to 0x00 by an RTC software reset.

### 23.2.13 RWKAR : Day-of-Week Alarm Register (in Calendar Count Mode)

Base address: RTC = 0x4008\_3000

Offset address: 0x16



| Bit | Symbol    | Function  | R/W |
|-----|-----------|---|-----|
| 2:0 | DAYW[2:0] | Day-of-Week Setting<br>0 0 0: Sunday<br>0 0 1: Monday<br>0 1 0: Tuesday<br>0 1 1: Wednesday<br>1 0 0: Thursday<br>1 0 1: Friday<br>1 1 0: Saturday<br>1 1 1: Setting prohibited | R/W |
| 6:3 | —         | The read values are undefined. The write value should be 0.   | R/W |
| 7   | ENB       | ENB<br>0: Do not compare register value with RWKCNT counter value<br>1: Compare register value with RWKCNT counter value  | R/W |

RWKAR is an alarm register associated with the coded day-of-week counter RWKCNT. When the ENB bit is set to 1, the RWKAR value is compared with the RWKCNT value. From the following alarm registers, only those selected with the ENB bits set to 1 are compared with the associated counters:

- RSECAR

| Bit | Symbol | Function   | R/W |
|-----|--------|--|-----|
| 7   | ENB    | ENB<br>0: 不将寄存器值与RHCNT计数器值进行比较<br>1: 将寄存器值与RHCNT计数器值进行比较 | R/W |

RHRAR是一个与BCD编码的小时计数器RHCNT相关的报警寄存器。当ENB位设置为1时，RHRAR值与RHCNT值进行比较。从以下报警寄存器中，只有选择ENB位设置为1的报警寄存器与相关计数器进行比较：

- RSECAR
- RMINAR
- RHRAR
- RWKAR
- RDAYAR
- RMONAR
- RYRAREN

当所有各自的值都匹配时，与RTC\_ALM中断相关的IR标志设置为1。可指定的时间根据小时模式位(RCR2.HR24)中的设置而有所不同：

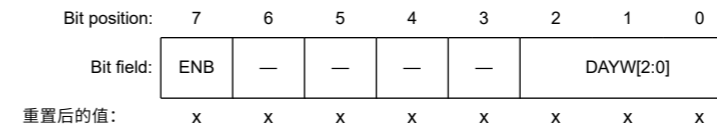
- 当RCR2.HR24位为0时 从00到11（以BCD表示）。
- 当RCR2.HR24位为1时 从00到23（BCD格式）。

如果指定的值超出此范围，则RTC将无法正确运行。当RCR2.HR24位为0时，必须设置PM位。当RCR2.HR24位为1时，PM位中的设置无效。该寄存器通过RTC软件复位设置为0x00。

### 23.2.13 RWKAR：星期报警寄存器（日历计数模式）

Base address: RTC = 0x4008\_3000

Offset address: 0x16



| Bit | Symbol    | Function   | R/W |
|-----|-----------|--|-----|
| 2:0 | DAYW[2:0] | Day-of-Week Setting<br>000: 星期日001: 星期一<br>010: 星期二011: 星期三<br>100: 星期四101: 星期五<br>110: 星期六111: 禁止设置 | R/W |
| 6:3 | —         | 读取的值未定义。写入值应为0。  | R/W |
| 7   | ENB       | ENB<br>0: 不将寄存器值与RWKCNT计数器值进行比较<br>1: 将寄存器值与RWKCNT计数器值进行比较   | R/W |

RWKAR是与编码的星期计数器RWKCNT相关的报警寄存器。当ENB位设置为1时，RWKAR值与RWKCNT值进行比较。从下面的报警寄存器中，只有那些选择与设置为1的ENB位与相关计数器进行比较：

- RSECAR



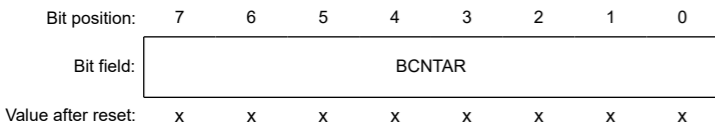
- RMINAR
- RHRAR
- RWKAR
- RDAYAR
- RMONAR
- RYRAREN

When all the respective values match, the IR flag associated with the RTC\_ALM interrupt is set to 1. RWKAR values from 0 through 6 (in BCD) can be specified. If a value outside of this range is specified, the RTC does not operate correctly. This register is set to 0x00 by an RTC software reset.

23.2.14 BCNTnAR : Binary Counter n Alarm Register (n = 0 to 3) (in Binary Count Mode)

Base address: RTC = 0x4008\_3000

Offset address: 0x10 + 0x02 × n



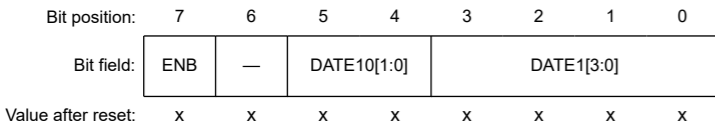
| Bit | Symbol | Function   | R/W |
|-----|--------|--|-----|
| 7:0 | BCNTAR | Alarm register associated with the 32-bit binary counter | R/W |

BCNTnAR is a read/write alarm register associated with the 32-bit binary counter. BCNT3AR is assigned to the BCNTAR[31:24] bits, BCNT2AR is assigned to the BCNTAR[23:16] bits, BCNT1AR is assigned to the BCNTAR[15:8] bits, and BCNT0AR is assigned to the BCNTAR[7:0]. This register is set to 0x00 by an RTC software reset.

23.2.15 RDAYAR : Date Alarm Register (in Calendar Count Mode)

Base address: RTC = 0x4008\_3000

Offset address: 0x18



| Bit | Symbol      | Function   | R/W |
|-----|-------------|--|-----|
| 3:0 | DATE1[3:0]  | 1 Day<br>Value for the ones place of days.   | R/W |
| 5:4 | DATE10[1:0] | 10 Days<br>Value for the tens place of days.   | R/W |
| 6   | —           | The read value is undefined. The write value should be 0.  | R/W |
| 7   | ENB         | ENB<br>0: Do not compare register value with RDAYCNT counter value<br>1: Compare register value with RDAYCNT counter value | R/W |

RDAYAR is an alarm register associated with the BCD-coded date counter RDAYCNT. When the ENB bit is set to 1, the RDAYAR value is compared with the RDAYCNT value. From the following alarm registers, only those selected with the ENB bits set to 1 are compared with the associated counters:

- RSECAR
- RMINAR
- RHRAR

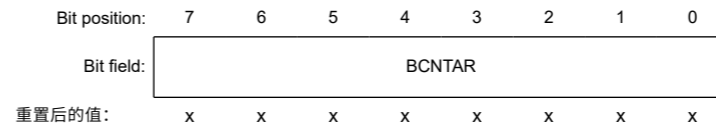
- RMINAR
- RHRAR
- RWKAR
- RDAYAR
- RMONAR
- RYRAREN

当所有各自的值都匹配时，与RTC\_ALM中断相关的IR标志设置为1。可以指定从0到6（以BCD表示）的RWKAR值。如果指定的值超出此范围，则RTC将无法正确运行。该寄存器通过RTC软件复位设置为0x00。

23.2.14 BCNTnAR: 二进制计数器n报警寄存器 (n=0到3) (在二进制计数模式下)

Base address: RTC = 0x4008\_3000

Offset address: 0x10 + 0x02 × n



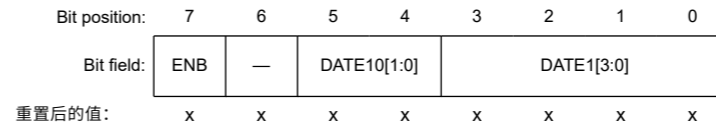
| Bit | Symbol | Function           | R/W |
|-----|--------|--------------------|-----|
| 7:0 | BCNTAR | 与32位二进制计数器关联的报警寄存器 | R/W |

BCNTnAR是一个与32位二进制计数器相关的读写报警寄存器。BCNT3AR分配给BCNTAR[31:24]位，BCNT2AR分配给BCNTAR[23:16]位，BCNT1AR分配给BCNTAR[15:8]位，BCNT0AR分配给BCNTAR[7:0]。该寄存器通过RTC软件复位设置为0x00。

23.2.15 RDAYAR:日期报警寄存器 (日历计数模式)

Base address: RTC = 0x4008\_3000

Offset address: 0x18



| Bit | Symbol      | Function   | R/W |
|-----|-------------|--|-----|
| 3:0 | DATE1[3:0]  | 1天的个位数的值。  | R/W |
| 5:4 | DATE10[1:0] | 10天十位天的价值。   | R/W |
| 6   | —           | 读取值未定义。写入值应为0。   | R/W |
| 7   | ENB         | ENB<br>0: 不将寄存器值与RDAYCNT计数器值进行比较1: 将寄存器值与RDAYCNT计数器值进行比较 | R/W |

RDAYAR是一个与BCD编码日期计数器RDAYCNT相关的报警寄存器。当ENB位设置为1时，将RDAYAR值与RDAYCNT值进行比较。从下面的报警寄存器中，只有那些选择与设置为1的ENB位与相关计数器进行比较：

- RSECAR
- RMINAR
- RHRAR

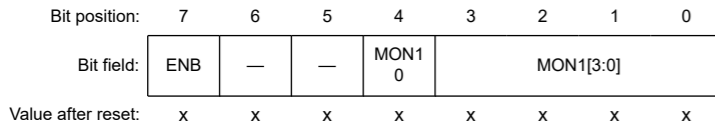
- RWKAR
- RDAYAR
- RMONAR
- RYRAREN

When all the respective values match, the IR flag associated with the RTC\_ALM interrupt is set to 1. The RDAYAR values from 01 through 31 (in BCD) can be specified. If a value outside of this range is specified, the RTC does not operate correctly. This register is set to 0x00 by an RTC software reset.

### 23.2.16 RMONAR : Month Alarm Register (in Calendar Count Mode)

Base address: RTC = 0x4008\_3000

Offset address: 0x1A



| Bit | Symbol    | Function   | R/W |
|-----|-----------|--|-----|
| 3:0 | MON1[3:0] | 1 Month<br>Value for the ones place of months.   | R/W |
| 4   | MON10     | 10 Months<br>Value for the tens place of months.   | R/W |
| 6:5 | —         | The read values are undefined. The write value should be 0.  | R/W |
| 7   | ENB       | ENB<br>0: Do not compare register value with RMONCNT counter value<br>1: Compare register value with RMONCNT counter value | R/W |

RMONAR is an alarm register associated with the BCD-coded month counter RMONCNT. When the ENB bit is set to 1, the RMONAR value is compared with the RMONCNT value. From the following alarm registers, only those selected with the ENB bits set to 1 are compared with the associated counters:

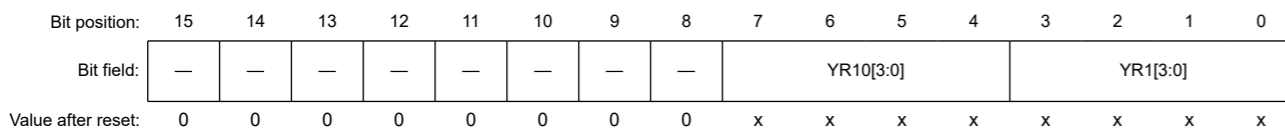
- RSECAR
- RMINAR
- RHRAR
- RWKAR
- RDAYAR
- RMONAR
- RYRAREN

When all the respective values match, the IR flag associated with the RTC\_ALM interrupt is set to 1. The RMONAR values from 01 through 12 (in BCD) can be specified. If a value outside of this range is specified, the RTC does not operate correctly. This register is set to 0x00 by an RTC software reset.

### 23.2.17 RYRAR : Year Alarm Register (in Calendar Count Mode)

Base address: RTC = 0x4008\_3000

Offset address: 0x1C



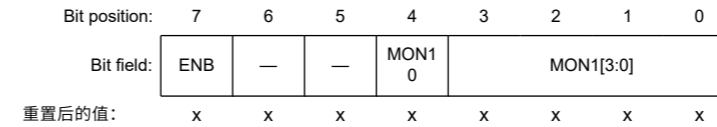
- RWKAR
- RDAYAR
- RMONAR
- RYRAREN

当所有各自的值都匹配时，与RTC\_ALM中断相关的IR标志设置为1。可以指定从01到31（以BCD表示）的RDAYA R值。如果指定的值超出此范围，则RTC将无法正确运行。该寄存器通过RTC软件复位设置为0x00。

### 23.2.16 RMONAR: 月报警寄存器（日历计数模式）

Base address: RTC = 0x4008\_3000

Offset address: 0x1A



| Bit | Symbol    | Function   | R/W |
|-----|-----------|--|-----|
| 3:0 | MON1[3:0] | 1月份的个位数的月份值。   | R/W |
| 4   | MON10     | 10个月十位月份的值。  | R/W |
| 6:5 | —         | 读取的值未定义。写入值应为0。  | R/W |
| 7   | ENB       | ENB<br>0: 不将寄存器值与RMONCNT计数器值进行比较1: 将寄存器值与RMONCNT计数器值进行比较 | R/W |

RMONAR是一个与BCD编码月份计数器RMONCNT相关的报警寄存器。当ENB位设置为1时，RMONAR值与RMONCNT值进行比较。从以下报警寄存器中，只有选择ENB位设置为1的报警寄存器与相关计数器进行比较：

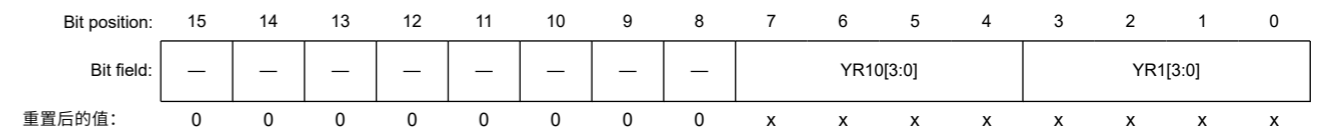
- RSECAR
- RMINAR
- RHRAR
- RWKAR
- RDAYAR
- RMONAR
- RYRAREN

当所有各自的值都匹配时，与RTC\_ALM中断相关的IR标志设置为1。可以指定从01到12（以BCD表示）的RMONAR值。如果指定的值超出此范围，则RTC将无法正确运行。该寄存器通过RTC软件复位设置为0x00。

### 23.2.17 RYRAR: 年报警寄存器（在日历计数模式下）

Base address: RTC = 0x4008\_3000

Offset address: 0x1C



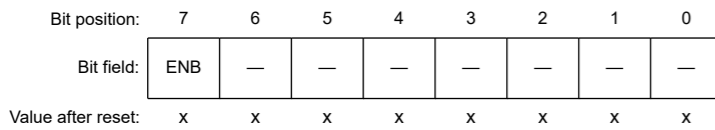
| Bit  | Symbol    | Function   | R/W |
|------|-----------|--|-----|
| 3:0  | YR1[3:0]  | 1 Year<br>Value for the ones place of years.           | R/W |
| 7:4  | YR10[3:0] | 10 Years<br>Value for the tens place of years.         | R/W |
| 15:8 | —         | These bits are read as 0. The write value should be 0. | R/W |

RYRAR is an alarm register associated with the BCD-coded year counter RYRCNT. The RYRAR values from 00 through 99 (in BCD) can be specified. If a value outside of this range is specified, the RTC does not operate correctly. This register is set to 0x0000 by an RTC software reset.

### 23.2.18 RYRAREN : Year Alarm Enable Register (in Calendar Count Mode)

Base address: RTC = 0x4008\_3000

Offset address: 0x1E



| Bit | Symbol | Function   | R/W |
|-----|--------|--|-----|
| 6:0 | —      | The read values are undefined. The write value should be 0.  | R/W |
| 7   | ENB    | ENB<br>0: Do not compare register value with the RYRCNT counter value<br>1: Compare register value with the RYRCNT counter value | R/W |

When the ENB bit in the RYRAREN register is set to 1, the RYRAR value is compared with the RYRCNT value. From the following alarm registers, only those selected with the ENB bits set to 1 are compared with the associated counters:

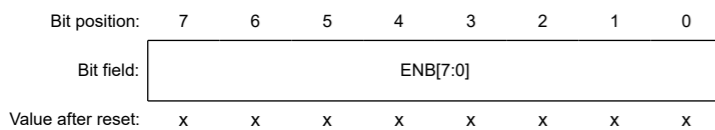
- RSECAR
- RMINAR
- RHRAR
- RWKAR
- RDAYAR
- RMONAR
- RYRAREN

When all the respective values match, the IR flag associated with the RTC\_ALM interrupt is set to 1. This register is set to 0x00 by an RTC software reset.

### 23.2.19 BCNTnAER : Binary Counter n Alarm Enable Register (n = 0, 1) (in Binary Count Mode)

Base address: RTC = 0x4008\_3000

Offset address: 0x18 + 0x02 × n



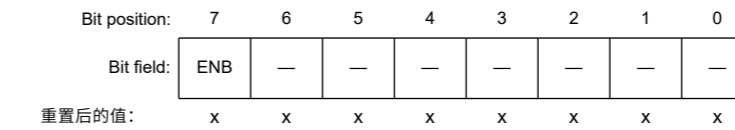
| Bit  | Symbol    | Function         | R/W |
|------|-----------|------------------|-----|
| 3:0  | YR1[3:0]  | 年的个位的1年值。        | R/W |
| 7:4  | YR10[3:0] | 10年十位年份的值。       | R/W |
| 15:8 | —         | 这些位被读取为0。写入值应为0。 | R/W |

RYRAR是一个与BCD编码年份计数器RYRCNT相关联的警报寄存器。可以指定从00到99（BCD格式）的RYRAR值。如果指定的值超出此范围，则RTC将无法正确运行。该寄存器通过RTC软件复位设置为0x0000。

### 23.2.18 RYRAREN:年警报启用寄存器（在日历计数模式下）

Base address: RTC = 0x4008\_3000

Offset address: 0x1E



| Bit | Symbol | Function   | R/W |
|-----|--------|--|-----|
| 6:0 | —      | 读取的值未定义。写入值应为0。  | R/W |
| 7   | ENB    | ENB<br>0: 不将寄存器值与RYRCNT计数器值进行比较<br>1: 将寄存器值与RYRCNT计数器值进行比较 | R/W |

当RYRAREN寄存器中的ENB位设置为1时，RYRAR值与RYRCNT值进行比较。从以下报警寄存器中，只有选择ENB位设置为1的报警寄存器与相关计数器进行比较：

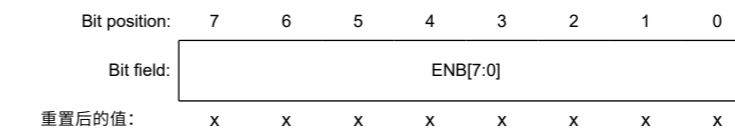
- RSECAR
- RMINAR
- RHRAR
- RWKAR
- RDAYAR
- RMONAR
- RYRAREN

当所有各自的值都匹配时，与RTC\_ALM中断相关的IR标志设置为1。该寄存器通过RTC软件复位设置为0x00。

### 23.2.19 BCNTnAER:二进制计数器n报警使能寄存器(n=0 1)(以二进制计数 Mode)

Base address: RTC = 0x4008\_3000

Offset address: 0x18 + 0x02 × n



| Bit | Symbol   | Function   | R/W |
|-----|----------|--|-----|
| 7:0 | ENB[7:0] | Setting the alarm enable associated with the 32-bit binary counter | R/W |

BCNTnAER is a read/write register for setting the alarm enable (BCNTAER) associated with the 32-bit binary counter. BCNT3AER is assigned to the BCNTAER.ENB[31:24] bits, BCNT2AER register is assigned to the BCNTAER.ENB[23:16] bits, BCNT1AER is assigned to the BCNTAER.ENB[15:8] bits, and BCNT0AER is assigned to the BCNTAER.ENB[7:0] bits. The binary counter (BCNT[31:0]) associated with the BCNTAER.ENB[31:0] bits that are set to 1 is compared with the binary alarm register (BCNTAR) and, when all match, the IR flag associated with the RTC\_ALM interrupt is set to 1. This register is set to 0x00 by an RTC software reset.

### 23.2.20 BCNT2AER : Binary Counter 2 Alarm Enable Register (in Binary Count Mode)

Base address: RTC = 0x4008\_3000

Offset address: 0x1C

| Bit position:      | 15 | 14 | 13 | 12 | 11 | 10 | 9 | 8 | 7        | 6 | 5 | 4 | 3 | 2 | 1 | 0 |
|--------------------|----|----|----|----|----|----|---|---|----------|---|---|---|---|---|---|---|
| Bit field:         | —  |    |    |    |    |    |   |   | ENB[7:0] |   |   |   |   |   |   |   |
| Value after reset: | 0  | 0  | 0  | 0  | 0  | 0  | 0 | 0 | x        | x | x | x | x | x | x | x |

| Bit  | Symbol   | Function   | R/W |
|------|----------|--|-----|
| 7:0  | ENB[7:0] | Setting the alarm enable associated with the 32-bit binary counter | R/W |
| 15:8 | —        | These bits are read as 0. The write value should be 0.             | R/W |

BCNT2AER is a read/write register for setting the alarm enable (BCNTAER) associated with the 32-bit binary counter. BCNT3AER is assigned to the BCNTAER.ENB[31:24] bits, BCNT2AER register is assigned to the BCNTAER.ENB[23:16] bits, BCNT1AER is assigned to the BCNTAER.ENB[15:8] bits, and BCNT0AER is assigned to the BCNTAER.ENB[7:0] bits. The binary counter (BCNT[31:0]) associated with the BCNTAER.ENB[31:0] bits that are set to 1 is compared with the binary alarm register (BCNTAR) and, when all match, the IR flag associated with the RTC\_ALM interrupt is set to 1. This register is set to 0x00 by an RTC software reset.

### 23.2.21 BCNT3AER : Binary Counter 3 Alarm Enable Register (in Binary Count Mode)

Base address: RTC = 0x4008\_3000

Offset address: 0x1E

| Bit position:      | 7        | 6 | 5 | 4 | 3 | 2 | 1 | 0 |
|--------------------|----------|---|---|---|---|---|---|---|
| Bit field:         | ENB[7:0] |   |   |   |   |   |   |   |
| Value after reset: | x        | x | x | x | x | x | x | x |

| Bit | Symbol   | Function   | R/W |
|-----|----------|--|-----|
| 7:0 | ENB[7:0] | Setting the alarm enable associated with the 32-bit binary counter | R/W |

BCNT3AER is a read/write register for setting the alarm enable (BCNTAER) associated with the 32-bit binary counter. BCNT3AER is assigned to the BCNTAER.ENB[31:24] bits, BCNT2AER register is assigned to the BCNTAER.ENB[23:16] bits, BCNT1AER is assigned to the BCNTAER.ENB[15:8] bits, and BCNT0AER is assigned to the BCNTAER.ENB[7:0] bits. The binary counter (BCNT[31:0]) associated with the BCNTAER.ENB[31:0] bits that are set to 1 is compared with the binary alarm register (BCNTAR) and, when all match, the IR flag associated with the RTC\_ALM interrupt is set to 1. This register is set to 0x00 by an RTC software reset.

| Bit | Symbol   | Function            | R/W |
|-----|----------|---------------------|-----|
| 7:0 | ENB[7:0] | 设置与32位二进制计数器关联的报警启用 | R/W |

BCNTnAER是一个读写寄存器，用于设置与32位二进制计数器相关的报警使能(BCNTAER)。BCNT3AER分配给BCNTAER.ENB[31:24]位，BCNT2AER寄存器分配给BCNTAER.ENB[23:16]位，BCNT1AER分配给BCNTAER.ENB[15:8]位，BCNT0AER分配给BCNTAER.ENB[7:0]位。与设置为1的BCNTAER.ENB[31:0]位相关的二进制计数器(BCNT[31:0])与二进制报警寄存器(BCNTAR)进行比较，当全部匹配时，与RTC\_ALM中断设置为1。该寄存器通过RTC软件复位设置为0x00。

### 23.2.20 BCNT2AER：二进制计数器2报警使能寄存器（在二进制计数模式下）

Base address: RTC = 0x4008\_3000

Offset address: 0x1C

| Bit position: | 15 | 14 | 13 | 12 | 11 | 10 | 9 | 8 | 7        | 6 | 5 | 4 | 3 | 2 | 1 | 0 |
|---------------|----|----|----|----|----|----|---|---|----------|---|---|---|---|---|---|---|
| Bit field:    | —  |    |    |    |    |    |   |   | ENB[7:0] |   |   |   |   |   |   |   |
| 重置后的值:        | 0  | 0  | 0  | 0  | 0  | 0  | 0 | 0 | x        | x | x | x | x | x | x | x |

| Bit  | Symbol   | Function            | R/W |
|------|----------|---------------------|-----|
| 7:0  | ENB[7:0] | 设置与32位二进制计数器关联的报警启用 | R/W |
| 15:8 | —        | 这些位被读取为0。写入值应为0。    | R/W |

BCNT2AER是一个读写寄存器，用于设置与32位二进制计数器相关的报警使能(BCNTAER)。BCNT3AER分配给BCNTAER.ENB[31:24]位，BCNT2AER寄存器分配给BCNTAER.ENB[23:16]位，BCNT1AER分配给BCNTAER.ENB[15:8]位，BCNT0AER分配给BCNTAER.ENB[7:0]位。与设置为1的BCNTAER.ENB[31:0]位相关的二进制计数器(BCNT[31:0])与二进制报警寄存器(BCNTAR)进行比较，当全部匹配时，与RTC\_ALM中断设置为1。该寄存器通过RTC软件复位设置为0x00。

### 23.2.21 BCNT3AER：二进制计数器3报警使能寄存器（在二进制计数模式下）

Base address: RTC = 0x4008\_3000

Offset address: 0x1E

| Bit position: | 7        | 6 | 5 | 4 | 3 | 2 | 1 | 0 |
|---------------|----------|---|---|---|---|---|---|---|
| Bit field:    | ENB[7:0] |   |   |   |   |   |   |   |
| 重置后的值:        | x        | x | x | x | x | x | x | x |

| Bit | Symbol   | Function            | R/W |
|-----|----------|---------------------|-----|
| 7:0 | ENB[7:0] | 设置与32位二进制计数器关联的报警启用 | R/W |

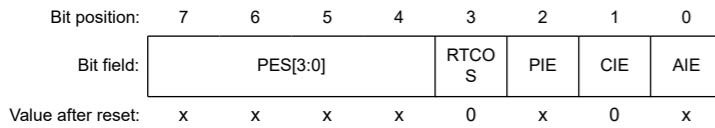
BCNT3AER是一个读写寄存器，用于设置与32位二进制计数器相关的报警使能(BCNTAER)。BCNT3AER分配给BCNTAER.ENB[31:24]位，BCNT2AER寄存器分配给BCNTAER.ENB[23:16]位，BCNT1AER分配给BCNTAER.ENB[15:8]位，BCNT0AER分配给BCNTAER.ENB[7:0]位。与设置为1的BCNTAER.ENB[31:0]位相关的二进制计数器(BCNT[31:0])与二进制报警寄存器(BCNTAR)进行比较，当全部匹配时，与RTC\_ALM中断设置为1。该寄存器通过RTC软件复位设置为0x00。



## 23.2.22 RCR1 : RTC Control Register 1

Base address: RTC = 0x4008\_3000

Offset address: 0x22



| Bit | Symbol   | Function   | R/W |
|-----|----------|--|-----|
| 0   | AIE      | Alarm Interrupt Enable<br>0: Disable alarm interrupt requests<br>1: Enable alarm interrupt requests  | R/W |
| 1   | CIE      | Carry Interrupt Enable<br>0: Disable carry interrupt requests<br>1: Enable carry interrupt requests  | R/W |
| 2   | PIE      | Periodic Interrupt Enable<br>0: Disable periodic interrupt requests<br>1: Enable periodic interrupt requests   | R/W |
| 3   | RTCOS    | RTCOUT Output Select<br>0: Outputs 1 Hz on RTCOUT<br>1: Outputs 64 Hz RTCOUT   | R/W |
| 7:4 | PES[3:0] | Periodic Interrupt Select<br>0x6: Generate periodic interrupt every 1/256 second*1<br>0x7: Generate periodic interrupt every 1/128 second<br>0x8: Generate periodic interrupt every 1/64 second<br>0x9: Generate periodic interrupt every 1/32 second<br>0xA: Generate periodic interrupt every 1/16 second<br>0xB: Generate periodic interrupt every 1/8 second<br>0xC: Generate periodic interrupt every 1/4 second<br>0xD: Generate periodic interrupt every 1/2 second<br>0xE: Generate periodic interrupt every 1 second<br>0xF: Generate periodic interrupt every 2 seconds<br>Others: Do not generate periodic interrupts | R/W |

Note 1. When LOCO is selected (RCR4.RCKSEL = 1) while PES[3:0] = 0x6, a periodic interrupt is generated every 1/128 second.

The RCR1 register is used in both calendar count mode and binary count mode. Bits AIE, PIE, and PES[3:0] are updated synchronously with the count source. When the RCR1 register is modified, check that all the bits are updated before proceeding.

**AIE bit (Alarm Interrupt Enable)**

The AIE bit enables or disables alarm interrupt requests.

If the times indicated in the counters and alarm settings match in Deep Software Standby mode, the MCU returns from the regardless of the AIE bit value.

**CIE bit (Carry Interrupt Enable)**

The CIE bit enables or disables interrupt requests when a carry to the RSECCNT/BCNT0 register occurs, or when a carry to the 64-Hz counter (R64CNT) occurs while reading the 64-Hz counter.

**PIE bit (Periodic Interrupt Enable)**

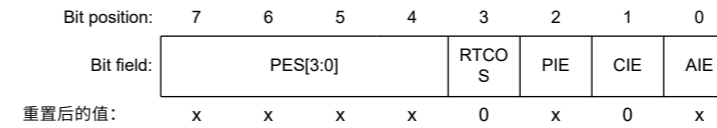
The PIE bit enables or disabled a periodic interrupt.

If the periods indicated in the counters and PES[3:0] settings match in Deep Software Standby mode, the MCU returns from the regardless of the PIE bit value.

## 23.2.22 RCR1:RTC控制寄存器1

Base address: RTC = 0x4008\_3000

Offset address: 0x22



| Bit | Symbol   | Function   | R/W |
|-----|----------|--|-----|
| 0   | AIE      | 报警中断使能<br>0: 禁用报警中断请求<br>1: 启用报警中断请求   | R/W |
| 1   | CIE      | 进位中断使能<br>0: 禁止进位中断请求<br>1: 使能进位中断请求   | R/W |
| 2   | PIE      | 周期性中断使能<br>0: 禁用周期性中断请求<br>1: 启用周期性中断请求  | R/W |
| 3   | RTCOS    | RTCOUT输出选择<br>0: 在RTCOUT上输出1Hz<br>1: 输出64HzRTCOUT  | R/W |
| 7:4 | PES[3:0] | 周期性中断选择<br>0x6: 每1256秒产生周期性中断*1<br>0x7: 每1128秒产生周期中断<br>0x8: 每164秒产生周期中断<br>0x9: 每132秒产生周期中断<br>0xA: 每116秒产生周期中断<br>0xB: 每18秒产生周期中断<br>0xC: 产生周期中断每14秒<br>0xD: 每12秒产生周期性中断<br>0xE: 每1秒产生周期性中断<br>0xF: 每2秒产生周期性中断<br>其他: 不产生周期性中断 | R/W |

注意1.选择LOCO (RCR4.RCKSEL=1) 时, PES[3:0]=0x6时, 每1128秒都会生成周期性中断。

RCR1寄存器用于日历计数模式和二进制计数模式。AIE、PIE和PES[3:0]位与计数源同步更新。修改RCR1寄存器时, 在继续之前检查所有位是否都已更新。

**AIE位 (报警中断允许)**

AIE位启用或禁用报警中断请求。

如果计数器和警报设置中指示的时间在深度软件待机模式下匹配, 则MCU从不考虑AIE位值返回。

**CIE位 (进位中断使能)**

当发生对RSECCNT/BCNT0寄存器的进位, 或在读取64-Hz计数器时发生对64-Hz计数器(R64CNT)的进位时, CIE位启用或禁用中断请求。

**PIE位 (周期性中断使能)**

PIE位启用或禁用周期性中断。

如果计数器中指示的周期和PES[3:0]设置在深度软件待机模式下匹配, 则MCU将从无论PIE位值如何返回。



**RTCOS bit (RTCOUT Output Select)**

The RTCOS bit selects the RTCOUT output period. The RTCOS bit must be rewritten while the count operation is stopped (RCR2.START = 0) and the RTCOUT output is disabled (RCR2.RTCOE = 0). When RTCOUT is output to an external pin, the RCR2.RTCOE bit must be enabled.

**PES[3:0] bits (Periodic Interrupt Select)**

The PES[3:0] bits specify the period for the periodic interrupt. A periodic interrupt is generated with the period specified in these bits.

**23.2.23 RCR2 : RTC Control Register 2 (in Calendar Count Mode)**

Base address: RTC = 0x4008\_3000

Offset address: 0x24

|                    |           |      |           |           |           |       |           |       |
|--------------------|-----------|------|-----------|-----------|-----------|-------|-----------|-------|
| Bit position:      | 7         | 6    | 5         | 4         | 3         | 2     | 1         | 0     |
| Bit field:         | CNTM<br>D | HR24 | AADJ<br>P | AADJ<br>E | RTCO<br>E | ADJ30 | RESE<br>T | START |
| Value after reset: | x         | x    | x         | x         | 0         | 0     | 0         | x     |

| Bit | Symbol | Function   | R/W |
|-----|--------|--|-----|
| 0   | START  | Start<br>0: Stop prescaler and time counter<br>1: Operate prescaler and time counter normally  | R/W |
| 1   | RESET  | RTC Software Reset<br>0: In writing: Invalid (writing 0 has no effect).<br>In reading: Normal time operation in progress, or an RTC software reset has completed.<br>1: In writing: Initialize the prescaler and target registers for RTC software reset*1.<br>In reading: RTC software reset in progress. | R/W |
| 2   | ADJ30  | 30-Second Adjustment<br>0: In writing: Invalid (writing 0 has no effect).<br>In reading: Normal time operation in progress, or 30-second adjustment has completed.<br>1: In writing: Execute 30-second adjustment.<br>In reading: 30-second adjustment in progress.  | R/W |
| 3   | RTCOE  | RTCOUT Output Enable<br>0: Disable RTCOUT output<br>1: Enable RTCOUT output  | R/W |
| 4   | AADJE  | Automatic Adjustment Enable*2*3<br>0: Disable automatic adjustment<br>1: Enable automatic adjustment   | R/W |
| 5   | AADJP  | Automatic Adjustment Period Select*2*3<br>0: The RADJ.ADJ[5:0] setting from the count value of the prescaler every minute.<br>1: The RADJ.ADJ[5:0] setting value is adjusted from the count value of the prescaler every 10 seconds.   | R/W |
| 6   | HR24   | Hours Mode*3<br>0: Operate RTC in 12-hour mode<br>1: Operate RTC in 24-hour mode   | R/W |
| 7   | CNTMD  | Count Mode Select*4<br>0: Calendar count mode<br>1: Binary count mode  | R/W |

Note 1. R64CNT, RSECAR, RMINAR, RHRAR, RWKAR, RDAYAR, RMONAR, RYRAR, RYRAREN, RADJ, RTCCRn, RSECCPn, RMINCPn, RHRCPn, RDAYCPn, RMONCPn, RCR2.ADJ30, RCR2.AADJE, RCR2.AADJP.

Note 2. When LOCO is selected, the setting of this bit is disabled.

Note 3. When rewriting this bit, confirm that the value has been rewritten before performing the following processing. See [section 23.6.5. Notes on Writing to and Reading from Registers](#) for notes on register writing/reading.

Note 4. When rewriting this bit, confirm that the value has been rewritten before performing the following processing.

**RTCOS位 (RTCOUT输出选择)**

RTCOS位选择RTCOUT输出周期。当计数操作停止(RCR2.START=0)并且RTCOUT输出被禁用(RCR2.RTCOE=0)时，必须重写RTCOS位。当RTCOUT输出到外部引脚时，必须使能RCR2.RTCOE位。

**PES[3:0]位 (周期性中断选择)**

PES[3:0]位指定周期性中断的周期。以这些位中指定的周期生成周期性中断。

**23.2.23 RCR2: RTC控制寄存器2 (日历计数模式)**

Base address: RTC = 0x4008\_3000

Offset address: 0x24

|               |           |      |           |           |           |       |           |       |
|---------------|-----------|------|-----------|-----------|-----------|-------|-----------|-------|
| Bit position: | 7         | 6    | 5         | 4         | 3         | 2     | 1         | 0     |
| Bit field:    | CNTM<br>D | HR24 | AADJ<br>P | AADJ<br>E | RTCO<br>E | ADJ30 | RESE<br>T | START |
| 重置后的值:        | x         | x    | x         | x         | 0         | 0     | 0         | x     |

| Bit | Symbol | Function  | R/W |
|-----|--------|---|-----|
| 0   | START  | Start<br>0: 停止预分频器和时间计数器<br>1: 正常运行预分频器和时间计数器   | R/W |
| 1   | RESET  | RTC软件复位<br>0: 写入中: 无效 (写入0无效)。<br>读取中: 正常时间操作正在进行, 或RTC软件复位已完成。<br>1: 书面: 初始化RTC软件复位的预分频器和目标寄存器*1。读取中: RTC软件正在复位。 | R/W |
| 2   | ADJ30  | 30-Second Adjustment<br>0: 写入中: 无效 (写入0无效)。<br>读数中: 正常时间操作正在进行, 或30秒调整已完成。<br>1: 书面: 执行30秒调整。<br>阅读中: 正在进行30秒调整。  | R/W |
| 3   | RTCOE  | RTCOUT输出使能<br>0: 禁用RTCOUT输出<br>1: 启用RTCOUT输出  | R/W |
| 4   | AADJE  | 自动调整启用*2*3<br>0: 禁用自动调整<br>1: 启用自动调整  | R/W |
| 5   | AADJP  | 自动调整周期选择*2*3<br>0: RADJ.ADJ[5:0]设置来自每分钟预分频器的计数值。1: RADJ.ADJ[5:0]设置值每10秒从预分频器的计数值调整一次。                             | R/W |
| 6   | HR24   | 小时模式*3<br>0: 以12小时模式运行RTC<br>1: 以24小时模式运行RTC  | R/W |
| 7   | CNTMD  | 计数模式选择*4<br>0: 日历计数模式<br>1: 二进制计数模式   | R/W |

Note 1. R64CNT, RSECAR, RMINAR, RHRAR, RWKAR, RDAYAR, RMONAR, RYRAR, RYRAREN, RADJ, RTCCRn, RSECCPn, RMINCPn, RHRCPn, RDAYCPn, RMONCPn, RCR2.ADJ30, RCR2.AADJE, RCR2.AADJP.

注意2.选择机车时, 该位的设置被禁用。

注3.改写该位时, 请确认该值已被改写, 然后再进行以下处理。请参阅第23.6.5节。  
[Notes on Writing to and Reading from Registers](#)有关寄存器写入读取的说明。

注4.改写该位时, 请确认该值已被改写, 然后再进行以下处理。

The RCR2 register is related to hours mode, automatic adjustment function, enabling RTCOUT output, 30-second adjustment, RTC software reset, and controlling count operation.

#### START bit (Start)

The START bit stops or restarts the prescaler or time counter operation. This bit is updated in synchronization with the next cycle of the count source. When the START bit is modified, check that the bit is updated before proceeding.

#### RESET bit (RTC Software Reset)

The RESET bit initializes the prescaler and registers to be reset by RTC software. When 1 is written to this bit, initialization starts in synchronization with the count source. When the initialization is complete, the RESET bit is automatically set to 0. Check that this bit is 0 before proceeding.

#### ADJ30 bit (30-Second Adjustment)

The ADJ30 bit is for 30-second adjustment.

When 1 is written to the ADJ30 bit, the RSECCNT value of 30 seconds or less is rounded down to 00 second and the value of 30 seconds or more is rounded up to 1 minute.

The 30-second adjustment is performed in synchronization with the count source. When 1 is written to this bit, the ADJ30 bit is automatically set to 0 after the 30-second adjustment completes. If 1 is written to the ADJ30 bit, check that the bit is 0 before proceeding. When the 30-second adjustment is performed, the prescaler and R64CNT are also reset. The ADJ30 bit is set to 0 by an RTC software reset.

#### RTCOE bit (RTCOUT Output Enable)

The RTCOE bit enables output of a 1-Hz/64-Hz clock signal from the RTCOUT pin.

Use the START bit to stop counting before changing the value of the RTCOE bit. Do not stop counting (write 0 to the START bit) and change the value of the RTCOE bit at the same time.

When RTCOUT is to be output from an external pin, enable the RTCOE bit and set up the port control for the pin.

#### AADJE bit (Automatic Adjustment Enable)

The AADJE bit controls (enables or disables) automatic adjustment.

Set the plus-minus bits (RADJ.PMADJ[1:0]) to 00b (adjustment is not performed) before changing the value of the AADJE bit.

The AADJE bit is set to 0 by an RTC software reset.

#### AADJP bit (Automatic Adjustment Period Select)

The AADJP bit selects the automatic-adjustment period.

Set the plus-minus bits (RADJ.PMADJ[1:0]) to 00b (adjustment is not performed) before changing the value of the AADJP bit.

The AADJP bit is set to 0 by an RTC software reset.

#### HR24 bit (Hours Mode)

The HR24 bit specifies whether the RTC operates in 12- or 24-hour mode.

Use the START bit to stop counting before changing the value of the HR24 bit. Do not stop counting (write 0 to the START bit) and change the value of the HR24 bit at the same time.

#### CNTMD bit (Count Mode Select)

The CNTMD bit specifies whether the RTC count mode operates in calendar count mode or in binary count mode.

When setting the count mode, execute an RTC software reset and start again from the initial settings. This bit is updated in synchronization with the count source. However, the count mode switches only after the RTC software reset. (Bit switches before RTC reset, mode switches after RTC reset.)

For details on initial settings, see [section 23.3.1. Outline of Initial Settings of Registers after Power On.](#)

RCR2寄存器与小时模式、自动调整功能、启用RTCOUT输出、30秒调整、RTC软件复位和控制计数操作有关。

#### 开始位 (开始)

START位停止或重新启动预分频器或时间计数器操作。该位与计数源的下一个周期同步更新。修改START位后，请在继续之前检查该位是否已更新。

#### RESET位 (RTC软件复位)

RESET位初始化预分频器和寄存器以由RTC软件复位。当向该位写入1时，初始化与计数源同步开始。初始化完成后，RESET位自动设置为0。在继续之前检查该位是否为0。

#### ADJ30位 (30-Second Adjustment)

ADJ30位用于30秒调整。

向ADJ30位写入1时，30秒以下的RSECCNT值向下舍入为00秒，30秒以上的值向上舍入为1分钟。

30秒调整与计数源同步进行。向该位写入1时，30秒调整完成后ADJ30位自动设置为0。如果将1写入ADJ30位，请在继续之前检查该位是否为0。当执行30秒调整时，预分频器和R64CNT也被复位。RTC软件复位将ADJ30位设置为0。

#### RTCOE位 (RTCOUT输出使能)

RTCOE位使能从RTCOUT引脚输出1-Hz/64-Hz时钟信号。

在更改RTCOE位的值之前，使用START位停止计数。不要停止计数（将0写入START位）并同时更改RTCOE位的值。

当RTCOUT要从外部引脚输出时，使能RTCOE位并设置引脚的端口控制。

#### ADJE位 (自动调整使能)

AADJE位控制（启用或禁用）自动调整。

在更改ADJE位的值之前，将正负位(RADJ.PMADJ[1:0])设置为00b（不执行调整）。

RTC软件复位将ADJE位设置为0。

#### AADJP位 (自动调整周期选择)

AADJP位选择自动调整周期。

在更改AADJP位的值之前，将正负位(RADJ.PMADJ[1:0])设置为00b（不执行调整）。

AADJP位通过RTC软件复位设置为0。

#### HR24位 (Hours Mode)

HR24位指定RTC是在12小时还是24小时模式下运行。

在更改HR24位的值之前，使用START位停止计数。不要停止计数（将0写入START位）并同时更改HR24位的值。

#### CNTMD位 (计数模式选择)

CNTMD位指定RTC计数模式是在日历计数模式还是二进制计数模式下运行。

设置计数模式时，执行RTC软件复位并从初始设置重新开始。该位与计数源同步更新。但是，计数模式仅在RTC软件复位后切换。（RTC复位前位切换，RTC复位后模式切换。）

有关初始设置的详细信息，请参阅第23.3.1节。上电后寄存器的初始设置概要。

## 23.2.24 RCR2 : RTC Control Register 2 (in Binary Count Mode)

Base address: RTC = 0x4008\_3000

Offset address: 0x24

|                    |           |   |           |           |           |   |           |       |
|--------------------|-----------|---|-----------|-----------|-----------|---|-----------|-------|
| Bit position:      | 7         | 6 | 5         | 4         | 3         | 2 | 1         | 0     |
| Bit field:         | CNTM<br>D | — | AADJ<br>P | AADJ<br>E | RTCO<br>E | — | RESE<br>T | START |
| Value after reset: | x         | x | x         | x         | 0         | 0 | 0         | x     |

| Bit | Symbol | Function   | R/W |
|-----|--------|--|-----|
| 0   | START  | Start<br>0: Stop the 32-bit binary counter, 64-Hz counter, and prescaler<br>1: Operate the 32-bit binary counter, 64-Hz counter, and prescaler normally  | R/W |
| 1   | RESET  | RTC Software Reset<br>0: In writing: Invalid (writing 0 has no effect).<br>In reading: Normal time operation in progress, or an RTC software reset has completed.<br>1: In writing: Initialize the prescaler and target registers for RTC software reset*1.<br>In reading: RTC software reset in progress. | R/W |
| 2   | —      | This bit is read as 0. The write value should be 0.  | R/W |
| 3   | RTCOE  | RTCOOUT Output Enable<br>0: Disable RTCOUT output<br>1: Enable RTCOUT output   | R/W |
| 4   | AADJE  | Automatic Adjustment Enable*2*3<br>0: Disable automatic adjustment<br>1: Enable automatic adjustment   | R/W |
| 5   | AADJP  | Automatic Adjustment Period Select*2*3<br>0: Add or subtract RADJ.ADJ [5:0] bits from prescaler count value every 32 seconds<br>1: Add or subtract RADJ.ADJ [5:0] bits from prescaler countvalue every 8 seconds.  | R/W |
| 6   | —      | The read value is undefined. The write value should be 0.  | R/W |
| 7   | CNTMD  | Count Mode Select*4<br>0: Calendar count mode<br>1: Binary count mode  | R/W |

Note 1. R64CNT, BCNTnAR, BCNTnAER, RADJ, RTCCRn, BCNTnCPm, RCR2.ADJ30, RCR2.AADJE, RCR2.AADJP.

Note 2. When LOCO is selected, the setting of this bit is disabled.

Note 3. When rewriting this bit, confirm that the value has been rewritten before performing the following processing. See [section 23.6.5. Notes on Writing to and Reading from Registers](#) for notes on register writing/reading.

Note 4. When rewriting this bit, confirm that the value has been rewritten before performing the following processing.

RCR2 in the binary count mode is a register related to the automatic correction function, RTCOUT output enable, RTC software reset, and count mode control.

**START bit (Start)**

The START bit stops or restarts the prescaler or counter (clock) operation. This bit is updated in synchronization with the count source. When the START bit is modified, check that the bit is updated before proceeding.

**RESET bit (RTC Software Reset)**

The RESET bit initializes the prescaler and registers to be reset by RTC software. When 1 is written to this bit, initialization starts in synchronization with the count source. When the initialization is complete, the RESET bit is automatically set to 0. When 1 is written to the RESET bit, check that the bit is 0 before proceeding.

**RTCOE bit (RTCOUT Output Enable)**

The RTCOE bit enables output of a 1-Hz/64-Hz clock signal from the RTCOUT pin.

Use the START bit to stop counting before changing the value of the RTCOE bit. Do not stop counting (write 0 to the START bit) and change the value of the RTCOE bit at the same time. When an RTCOUT signal is to be output from an external pin, enable the port control in addition to setting this bit.

## 23.2.24 RCR2: RTC控制寄存器2 (二进制计数模式)

Base address: RTC = 0x4008\_3000

Offset address: 0x24

|               |           |   |           |           |           |   |           |       |
|---------------|-----------|---|-----------|-----------|-----------|---|-----------|-------|
| Bit position: | 7         | 6 | 5         | 4         | 3         | 2 | 1         | 0     |
| Bit field:    | CNTM<br>D | — | AADJ<br>P | AADJ<br>E | RTCO<br>E | — | RESE<br>T | START |
| 重置后的值:        | x         | x | x         | x         | 0         | 0 | 0         | x     |

| Bit | Symbol | Function   | R/W |
|-----|--------|--|-----|
| 0   | START  | Start<br>0: 停止32位二进制计数器、64-Hz计数器和预分频器1: 正常操作32位二进制计数器、64-Hz计数器和预分频器  | R/W |
| 1   | RESET  | RTC软件复位<br>0: 写入中: 无效(写入0无效)。<br>读取中: 正常时间操作正在进行, 或RTC软件复位已完成。<br>1: 书面: 初始化RTC软件复位的预分频器和目标寄存器*1。读取中: RTC软件正在复位。 | R/W |
| 2   | —      | 该位读取为0。写入值应为0。   | R/W |
| 3   | RTCOE  | RTCOUT输出使能<br>0: 禁用RTCOUT输出1: 启用RTCOUT输出   | R/W |
| 4   | AADJE  | 自动调整启用*2*3<br>0: 禁用自动调整1: 启用自动调整   | R/W |
| 5   | AADJP  | 自动调整周期选择*2*3<br>0: 每32秒从预分频器计数值加或减RADJ.ADJ[5:0]位1: 每8秒从预分频器计数值加或减RADJ.ADJ[5:0]位。                                 | R/W |
| 6   | —      | 读取值未定义。写入值应为0。   | R/W |
| 7   | CNTMD  | 计数模式选择*4<br>0: 日历计数模式1: 二进制计数模式  | R/W |

Note 1. R64CNT, BCNTnAR, BCNTnAER, RADJ, RTCCRn, BCNTnCPm, RCR2.ADJ30, RCR2.AADJE, RCR2.AADJP.

注意2.选择机车时, 该位的设置被禁用。

注3.改写该位时, 请确认该值已被改写, 然后再进行以下处理。请参阅第23.6.5节。

[NotesonWritetoandReadingfromRegisters](#)有关寄存器写入读取的说明。

注4.改写该位时, 请确认该值已被改写, 然后再进行以下处理。

二进制计数模式下的RCR2是与自动校正功能、RTCOUT输出使能、RTC软件复位和计数模式控制相关的寄存器。

**开始位 (开始)**

START位停止或重新启动预分频器或计数器(时钟)操作。该位与计数源同步更新。修改START位后, 请在继续之前检查该位是否已更新。

**RESET位 (RTC软件复位)**

RESET位初始化预分频器和寄存器以由RTC软件复位。当向该位写入1时, 初始化与计数源同步开始。初始化完成后, RESET位自动设置为0。当向RESET位写入1时, 在继续之前检查该位是否为0。

**RTCOE位 (RTCOUT输出使能)**

RTCOE位使能从RTCOUT引脚输出1-Hz/64-Hz时钟信号。

在更改RTCOE位的值之前, 使用START位停止计数。不要停止计数(将0写入START位)并同时更改RTCOE位的值。当要从外部引脚输出RTCOUT信号时, 除了设置该位外, 还启用端口控制。



**AADJE bit (Automatic Adjustment Enable)**

The AADJE bit controls (enables or disables) automatic adjustment.

Set the plus-minus bits (RADJ.PMADJ[1:0]) to 00b (adjustment is not performed) before changing the value of the AADJE bit. The AADJE bit is set to 0 by an RTC software reset.

**AADJP bit (Automatic Adjustment Period Select)**

The AADJP bit selects the automatic-adjustment period.

Correction period can be selected from 32 second units or 8 second units in binary count mode.

Set the plus-minus bits (RADJ.PMADJ[1:0]) to 00b (adjustment is not performed) before changing the value of the AADJP bit. The AADJP bit is set to 0 by an RTC software reset.

**CNTMD bit (Count Mode Select)**

The CNTMD bit specifies whether the RTC count mode operates in calendar count mode or in binary count mode.

When setting the count mode, execute an RTC software reset and start again from the initial settings. This bit is updated in synchronization with the count source. However, the count mode switches only after the RTC software reset. (Bit switches before RTC reset, mode switches after RTC reset.)

For details on initial settings, see [section 23.3.1. Outline of Initial Settings of Registers after Power On](#).

**23.2.25 RCR4 : RTC Control Register 4**

Base address: RTC = 0x4008\_3000

Offset address: 0x28

|                    |   |   |   |   |   |   |   |        |
|--------------------|---|---|---|---|---|---|---|--------|
| Bit position:      | 7 | 6 | 5 | 4 | 3 | 2 | 1 | 0      |
| Bit field:         | — | — | — | — | — | — | — | RCKSEL |
| Value after reset: | 0 | 0 | 0 | 0 | 0 | 0 | 0 | x      |

| Bit | Symbol | Function  | R/W |
|-----|--------|---|-----|
| 0   | RCKSEL | Count Source Select<br>0: Sub-clock oscillator is selected<br>1: LOCO is selected | R/W |
| 7:1 | —      | These bits are read as 0. The write value should be 0.                            | R/W |

The RCR4 register is used in both calendar count mode and binary count mode.

**RCKSEL bit (Count Source Select)**

The RCKSEL bit selects the count source from the sub-clock oscillator and LOCO.

The RCKSEL bit is only used in normal operation mode. When the RCKSEL bit is set to 0, the time is counted with the sub-clock oscillator. When the bit is set to 1, the time is counted with LOCO.

For details on count source setting, see [section 23.3.1. Outline of Initial Settings of Registers after Power On](#) and [section 23.3.2. Clock and Count Mode Setting Procedure](#). The count source must be selected only once before specifying the initial settings of the RTC registers at power on.

**23.2.26 RFRL : Frequency Register L**

Base address: RTC = 0x4008\_3000

Offset address: 0x2C

|                    |           |    |    |    |    |    |   |   |   |   |   |   |   |   |   |   |
|--------------------|-----------|----|----|----|----|----|---|---|---|---|---|---|---|---|---|---|
| Bit position:      | 15        | 14 | 13 | 12 | 11 | 10 | 9 | 8 | 7 | 6 | 5 | 4 | 3 | 2 | 1 | 0 |
| Bit field:         | RFC[15:0] |    |    |    |    |    |   |   |   |   |   |   |   |   |   |   |
| Value after reset: | x         | x  | x  | x  | x  | x  | x | x | x | x | x | x | x | x | x | x |

**ADJE位 (自动调整使能)**

AADJE位控制 (启用或禁用) 自动调整。

在更改ADJE位的值之前, 将正负位(RADJ.PMADJ[1:0])设置为00b (不执行调整)。RTC软件复位将ADJE位设置为0。

**AADJP位 (自动调整周期选择)**

AADJP位选择自动调整周期。

在二进制计数模式下, 校正周期可以从32秒单位或8秒单位中选择。

在更改AADJP位的值之前, 将正负位(RADJ.PMADJ[1:0])设置为00b (不执行调整)。AADJP位通过RTC软件复位设置为0。

**CNTMD位 (计数模式选择)**

CNTMD位指定RTC计数模式是在日历计数模式还是二进制计数模式下运行。

设置计数模式时, 执行RTC软件复位并从初始设置重新开始。该位与计数源同步更新。但是, 计数模式仅在RTC软件复位后切换。(RTC复位前位切换, RTC复位后模式切换。)

有关初始设置的详细信息, 请参阅第23.3.1节。上电后寄存器的初始设置概要。

**23.2.25 RCR4:RTC控制寄存器4**

Base address: RTC = 0x4008\_3000

Offset address: 0x28

|               |   |   |   |   |   |   |   |        |
|---------------|---|---|---|---|---|---|---|--------|
| Bit position: | 7 | 6 | 5 | 4 | 3 | 2 | 1 | 0      |
| Bit field:    | — | — | — | — | — | — | — | RCKSEL |
| 重置后的值:        | 0 | 0 | 0 | 0 | 0 | 0 | 0 | x      |

| Bit | Symbol | Function                          | R/W |
|-----|--------|-----------------------------------|-----|
| 0   | RCKSEL | 计数源选择<br>0: 选择副时钟振荡器1: 选择LOC<br>0 | R/W |
| 7:1 | —      | 这些位被读取为0。写入值应为0。                  | R/W |

RCR4寄存器用于日历计数模式和二进制计数模式。

**RCKSEL位 (计数源选择)**

RCKSEL位从副时钟振荡器和LOCO中选择计数源。

RCKSEL位仅用于正常操作模式。当RCKSEL位设置为0时, 时间由副时钟振荡器计数。当该位设置为1时, 时间以LOCO计数。

有关计数源设置的详细信息, 请参阅第23.3.1节。上电后寄存器的初始设置概要和第23.3.2节。时钟和计数模式设置程序。在上电时指定RTC寄存器的初始设置之前, 必须只选择一次计数源。

**23.2.26 RFRL:频率寄存器L**

Base address: RTC = 0x4008\_3000

Offset address: 0x2C

|               |           |    |    |    |    |    |   |   |   |   |   |   |   |   |   |   |
|---------------|-----------|----|----|----|----|----|---|---|---|---|---|---|---|---|---|---|
| Bit position: | 15        | 14 | 13 | 12 | 11 | 10 | 9 | 8 | 7 | 6 | 5 | 4 | 3 | 2 | 1 | 0 |
| Bit field:    | RFC[15:0] |    |    |    |    |    |   |   |   |   |   |   |   |   |   |   |
| 重置后的值:        | x         | x  | x  | x  | x  | x  | x | x | x | x | x | x | x | x | x | x |

| Bit  | Symbol    | Function   | R/W |
|------|-----------|--|-----|
| 15:0 | RFC[15:0] | Frequency Comparison Value<br>Write 0x00FF to this register when using the LOCO. | R/W |

RFRL is a register for controlling the prescaler when LOCO is selected.

The RTC time counter operates on a 128-Hz clock signal as the base clock. Therefore, when LOCO is selected, LOCO is divided by the prescaler to generate a 128-Hz clock signal. Set the frequency comparison value in the RFC[15:0] bits to generate a 128-Hz clock from the LOCO frequency. Before writing to RFC[15:0] after a cold start, write 0x0000 to the RFRH register.

A value from 0x0007 through 0x01FF can be specified as the frequency comparison value. If a value outside of this range is specified, the RTC does not operate correctly. Before writing to this register, be sure to stop the count operation through the setting of the START bit in RCR2. The operating frequency of the peripheral module clock and the LOCO should be such that the peripheral module clock is ≥ LOCO.

Calculation method of frequency comparison value:

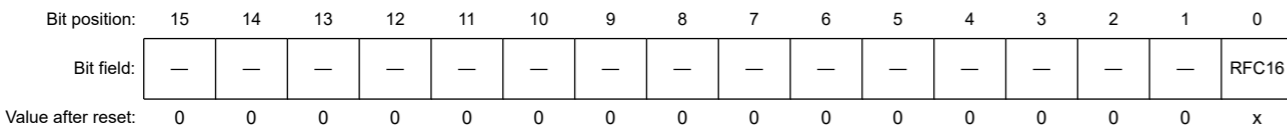
$$RFC[15:0] = (\text{LOCO clock frequency}) / 128 - 1$$

When the LOCO frequency is 32.768 kHz, the RFRL register should be set to 0x00FF.

### 23.2.27 RFRH : Frequency Register H

Base address: RTC = 0x4008\_3000

Offset address: 0x2A



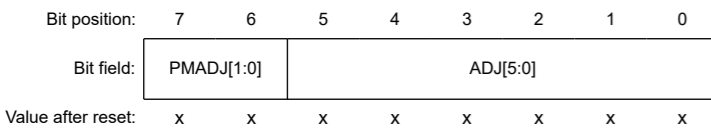
| Bit  | Symbol | Function  | R/W |
|------|--------|---|-----|
| 0    | RFC16  | Write 0 before writing to the RFRL register after a cold start. | R/W |
| 15:1 | —      | These bits are read as 0. The write value should be 0.          | R/W |

Before writing to RFRHL.RFC[15:0] after a cold start, write 0x0000 to the RFRH register.

### 23.2.28 RADJ : Time Error Adjustment Register

Base address: RTC = 0x4008\_3000

Offset address: 0x2E



| Bit | Symbol     | Function   | R/W |
|-----|------------|--|-----|
| 5:0 | ADJ[5:0]   | Adjustment Value<br>These bits specify the adjustment value from the prescaler.  | R/W |
| 7:6 | PMADJ[1:0] | Plus-Minus<br>0 0: Do not perform adjustment.<br>0 1: Adjustment is performed by the addition to the prescaler<br>1 0: Adjustment is performed by the subtraction from the prescaler<br>1 1: Setting prohibited. | R/W |

The RADJ register is used in both calendar count mode and binary count mode. Adjustment is performed by the addition to or subtraction from the prescaler or 64-Hz counter. If the Automatic Adjustment Enable (RCR2.AADJE) bit is 0, adjustment

| Bit  | Symbol    | Function                       | R/W |
|------|-----------|--------------------------------|-----|
| 15:0 | RFC[15:0] | 频率比较值<br>使用LOCO时将0x00FF写入该寄存器。 | R/W |

RFRL是一个寄存器，用于在选择LOCO时控制预分频器。

RTC时间计数器以128-Hz时钟信号作为基本时钟运行。Therefore when LOCO is selected LOCO is divided by the prescaler to generate a 128-Hz clock signal. 设置RFC[15:0]位中的频率比较值以从LOCO频率生成128-Hz时钟。在冷启动后写入RFC[15:0]之前，将0x0000写入RFRH寄存器。

从0x0007到0x01FF的值可以指定为频率比较值。如果指定的值超出此范围，则RTC将无法正确运行。在写入该寄存器之前，请务必通过设置RCR2中的START位来停止计数操作。外围模块时钟和LOCO的工作频率应使外围模块时钟 ≥ LOCO。

频率比较值的计算方法：

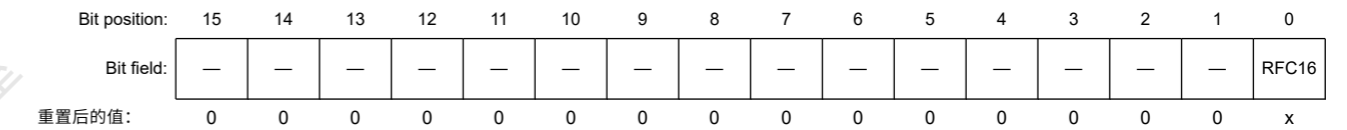
$$RFC[15:0] = (\text{LOCO clock frequency}) / 128 - 1$$

当LOCO频率为32.768kHz时，RFRL寄存器应设置为0x00FF。

### 23.2.27 RFRH:频率寄存器H

Base address: RTC = 0x4008\_3000

Offset address: 0x2A



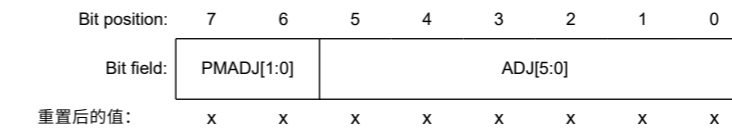
| Bit  | Symbol | Function             | R/W |
|------|--------|----------------------|-----|
| 0    | RFC16  | 在冷启动后写入RFRL寄存器之前写入0。 | R/W |
| 15:1 | —      | 这些位被读取为0。写入值应为0。     | R/W |

在冷启动后写入RFRHL.RFC[15:0]之前，将0x0000写入RFRH寄存器。

### 23.2.28 RADJ:时间误差调整寄存器

Base address: RTC = 0x4008\_3000

Offset address: 0x2E



| Bit | Symbol     | Function  | R/W |
|-----|------------|---|-----|
| 5:0 | ADJ[5:0]   | 调整值<br>这些位指定来自预分频器的调整值。   | R/W |
| 7:6 | PMADJ[1:0] | Plus-Minus<br>00: 不进行调整。01: 通过预分频器1的加法进行调整<br>0: 通过预分频器1的减法进行调整<br>1: 禁止设置。 | R/W |

RADJ寄存器用于日历计数模式和二进制计数模式。通过对预分频器或64-Hz计数器进行加法或减法来执行调整。如果自动调整启用(RCR2.AADJE)位为0，则调整



is performed when writing to the RADJ. If the RCR2.AADJE bit is 1, adjustment is performed in the interval specified in the Automatic Adjustment Period Select (RCR2.AADJP) bit.

The current adjustment by software (disabling automatic adjustment) may be invalid if the following adjustment value is specified within 320 cycles of the count source after the register setting. To perform adjustment consecutively, wait for 320 cycles or more of the count source after the register setting, then specify the next adjustment value.

RADJ is updated in synchronization with the count source. When RADJ is modified, check that all the bits are updated before continuing with more processing. This register is set to 0x00 by an RTC software reset. The setting of this register is enabled only when the sub-clock oscillator is selected. When LOCO is selected, adjustment is not performed.

#### ADJ[5:0] bits (Adjustment Value)

The ADJ[5:0] bits specify the adjustment value (number of sub-clock cycles) from the prescaler.

#### PMADJ[1:0] bits (Plus-Minus)

The PMADJ[1:0] bits select whether the clock is set ahead or back depending on the error-adjustment value set in the ADJ[5:0] bits.

### 23.2.29 RTCCRn : Time Capture Control Register n (n = 0 to 2)

Base address: RTC = 0x4008\_3000

Offset address: 0x40 + 0x02 × n

|                    |      |   |           |   |      |           |   |   |
|--------------------|------|---|-----------|---|------|-----------|---|---|
| Bit position:      | 7    | 6 | 5         | 4 | 3    | 2         | 1 | 0 |
| Bit field:         | TCEN | — | TCNF[1:0] | — | TCST | TCCT[1:0] |   |   |
| Value after reset: | x    | 0 | x         | x | 0    | x         | x | x |

| Bit | Symbol    | Function  | R/W |
|-----|-----------|---|-----|
| 1:0 | TCCT[1:0] | Time Capture Control<br>0 0: Do not detect events<br>0 1: Detect rising edge<br>1 0: Detect falling edge<br>1 1: Detect both edges  | R/W |
| 2   | TCST      | Time Capture Status<br>0: No event detected<br>1: Event detected*1  | R/W |
| 3   | —         | This bit is read as 0. The write value should be 0.   | R/W |
| 5:4 | TCNF[1:0] | Time Capture Noise Filter Control<br>0 0: Turn noise filter off<br>0 1: Setting prohibited<br>1 0: Turn noise filter on (count source)<br>1 1: Turn noise filter on (count source by divided by 32) | R/W |
| 6   | —         | These bits are read as 0. The write value should be 0.  | R/W |
| 7   | TCEN      | Time Capture Event Input Pin Enable<br>0: Disable the RTCICn pin as the time capture event input pin<br>1: Enable the RTCICn pin as the time capture event input pin                                | R/W |

Note 1. Indicates that an event is detected. Writing 1 to this bit has no effect. Writing 0 sets this bit to 0.

The RTCCRn register is used both in calendar count mode and in binary count mode. RTCCR0, RTCCR1, and RTCCR2 control the RTCIC0, RTCIC1, and RTCIC2 pins, respectively.

RTCCRn is updated in synchronization with the count source. When RTCCRn is modified, check that all the bits except the TCST bit are updated before continuing with additional processing. This register is cleared to 0x00 by an RTC software reset. When RTCICm is used as the time capture pin, VBTICTLR.VCHnIEN (n = 0 to 2) must be set to 1.

#### TCCT[1:0] bits (Time Capture Control)

The TCCT[1:0] bits control the edge detection of the time capture event input pins, RTCIC0, RTCIC1, and RTCIC2. The detection edge is selectable. The TCCT[1:0] bits must be set while the VBTICTLR.VCHnIEN bit is 1.

在写入RADJ时执行。如果RCR2.AADJE位为1，则在自动调整周期选择(RCR2.AADJP)位指定的间隔内执行调整。

如果在寄存器设置后的计数源的320个周期内指定了以下调整值，则通过软件进行的当前调整（禁用自动调整）可能无效。要连续执行调整，请在寄存器设置后等待计数源的320个或更多周期，然后指定下一个调整值。

RADJ与计数源同步更新。修改RADJ后，在继续进行更多处理之前检查所有位是否已更新。该寄存器通过RTC软件复位设置为0x00。该寄存器的设置仅在选择了副时钟振荡器时启用。选择LOCO时，不进行调整。

#### ADJ[5:0] bits (Adjustment Value)

ADJ[5:0]位指定来自预分频器的调整值（子时钟周期数）。

#### PMADJ[1:0] bits (Plus-Minus)

PMADJ[1:0]位根据在ADJ[5:0] bits。

### 23.2.29 RTCCRn:时间捕捉控制寄存器n(n=0to2)

Base address: RTC = 0x4008\_3000

Offset address: 0x40 + 0x02 × n

|               |      |   |           |   |      |           |   |   |
|---------------|------|---|-----------|---|------|-----------|---|---|
| Bit position: | 7    | 6 | 5         | 4 | 3    | 2         | 1 | 0 |
| Bit field:    | TCEN | — | TCNF[1:0] | — | TCST | TCCT[1:0] |   |   |
| 重置后的值:        | x    | 0 | x         | x | 0    | x         | x | x |

| Bit | Symbol    | Function  | R/W |
|-----|-----------|---|-----|
| 1:0 | TCCT[1:0] | 时间捕捉控制<br>00: 不检测事件01: 检测上升沿10: 检测下降沿11: 检测两个沿                          | R/W |
| 2   | TCST      | 时间捕捉状态<br>0: 未检测到事件1: 检测到事件*1   | R/W |
| 3   | —         | 该位读取为0。写入值应为0。  | R/W |
| 5:4 | TCNF[1:0] | 时间捕捉噪声滤波器控制<br>00: 关闭噪声过滤器01: 设置禁止10: 打开噪声过滤器(计数源) 11: 打开噪声过滤器(计数源除以32) | R/W |
| 6   | —         | 这些位被读取为0。写入值应为0。  | R/W |
| 7   | TCEN      | 时间捕捉事件输入引脚使能<br>0: 禁止RTCICn引脚作为时间捕捉事件输入引脚1: 使能RTCICn引脚作为时间捕捉事件输入引脚      | R/W |

注1.表示检测到事件。向该位写入1无效。写入0将该位设置为0。

RTCCRn寄存器用于日历计数模式和二进制计数模式。RTCCR0、RTCCR1和RTCCR2分别控制RTCIC0、RTCIC1和RTCIC2引脚。

RTCCRn与计数源同步更新。当RTCCRn被修改时，检查除TCST位在继续进行附加处理之前被更新。RTC软件复位将该寄存器清零为0x00。当RTCICm用作时间捕捉引脚时，VBTICTLR.VCHnIEN(n=0to2)必须设置为1。

#### TCCT[1:0]位(时间捕捉控制)

TCCT[1:0]位控制时间捕捉事件输入引脚RTCIC0、RTCIC1和RTCIC2的边沿检测。检测边缘是可选的。当VBTICTLR.VCHnIEN位为1时，必须设置TCCT[1:0]位。

**TCST bit (Time Capture Status)**

The TCST bit indicates that an event on the time capture event input pins, RTCIC0, RTCIC1, and RTCIC2, was detected. When the TCST bit is 0, no event is detected. When the TCST bit is 1, this bit indicates that an event was detected on the associated pin and the capture register is valid. When multiple events are detected, the capture time for the first event is retained.

The event is detected only during count operation (RCR2.START bit = 1). Before reading the capture register, make sure that this bit is set to 1.

Set the TCST bit while the TCCT[1:0] bits are 00b (no event is detected). The TCST bit is set to 0 in synchronization with the count source. When the TCST bit is set to 0, check that the bit is updated before continuing with additional processing.

**TCNF[1:0] bits (Time Capture Noise Filter Control)**

The TCNF[1:0] bits control the noise filter of the time capture event input pins (RTCIC0, RTCIC1, and RTCIC2).

When the noise filter is on, the count source divided by 1 or divided by 32 is selectable. In this case, when the input level on the time capture event input pin matches three consecutive times at the set sampling period, the input level is determined.

Set the TCNF[1:0] bits while the TCCT[1:0] bits are 00b (no event is detected). When the noise filter is used, set the TCNF[1:0] bits, wait for 3 cycles of the specified sampling period, then set the TCCT[1:0] bits. Set the TCNF[1:0] bits when the VBTICTLR.VCHnIEN bit is 1.

**TCEN bit (Time Capture Event Input Pin Enable)**

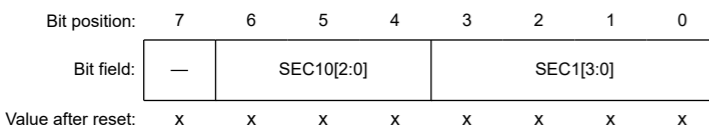
The TCEN bit enables or disables the time capture event input pins RTCIC0, RTCIC1, and RTCIC2. When the functions of the time capture event input pins are multiplexed, set VBTICTLR first. If the TCEN bit is set to 0, also set the TCCT[1:0] bits to 00b.

section 23.2.29. RTCCRN: Time Capture Control Register n (n = 0 to 2) lists the conditions for enabling the RTCICn pin. Before setting this bit to 1, be sure to set the count source setting bit (RCR4.RCKSEL), RTC time capture event enable bit (RCPE.RTCEN), port control setting bits (PmnPFS.PDR, and PmnPFS.PMR). For details on the port control setting bits (PmnPFS.PDR and PmnPFS.PMR), see section 19, I/O Ports.

**23.2.30 RSECCPn : Second Capture Register n (n = 0 to 2) (in Calendar Count Mode)**

Base address: RTC = 0x4008\_3000

Offset address: 0x52 + 0x10 × n



| Bit | Symbol     | Function  | R/W |
|-----|------------|---|-----|
| 3:0 | SEC1[3:0]  | 1-Second Capture<br>Capture value for the ones place of seconds.  | R   |
| 6:4 | SEC10[2:0] | 10-Second Capture<br>Capture value for the tens place of seconds. | R   |
| 7   | —          | The read value is undefined.                                      | R   |

RSECCPn is a read-only register that captures the RSECCNT value when a time capture event is detected.

The event detection times detected by the RTCIC0, RTCIC1, and RTCIC2 pins are stored in the RSECCP0, RSECCP1, and RSECCP2 registers, respectively. This register is cleared to 0x00 by an RTC software reset. Before reading from this register, the time capture event detection should be stopped using the RTCCRN.TCCT[1:0] bits.

**TCST位 (时间捕捉状态)**

TCST位指示检测到时间捕捉事件输入引脚RTCIC0、RTCIC1和RTCIC2上的事件。当TCST位为0时，未检测到任何事件。当TCST位为1时，该位表示在相关引脚上检测到事件并且捕捉寄存器有效。当检测到多个事件时，将保留第一个事件的捕获时间。

仅在计数操作期间检测到事件 (RCR2.START位=1)。在读取捕获寄存器之前，请确保该位设置为1。

当TCCT[1:0]位为00b (未检测到事件) 时，设置TCST位。TCST位与计数源同步设置为0。当TCST位设置为0时，在继续进行其他处理之前检查该位是否已更新。

**TCNF[1:0]位 (时间捕捉噪声滤波器控制)**

TCNF[1:0]位控制时间捕捉事件输入引脚 (RTCIC0、RTCIC1和RTCIC2) 的噪声滤波器。

当噪声滤波器打开时，计数源除以1或除以32是可选的。在这种情况下，当时间捕捉事件输入引脚上的输入电平在设置的采样周期内连续匹配3次时，确定输入电平。

当TCCT[1:0]位为00b (未检测到事件) 时，设置TCNF[1:0]位。使用噪声滤波器时，设置TCNF[1:0]位，等待指定采样周期的3个周期，然后设置TCCT[1:0]位。当VBTICTLR.VCHnIEN位为1时，设置TCNF[1:0]位。

**TCEN位 (时间捕捉事件输入引脚使能)**

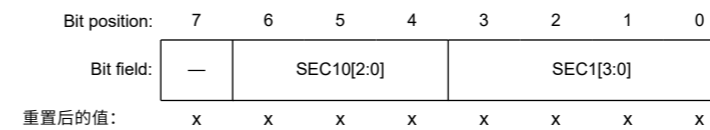
TCEN位启用或禁用时间捕捉事件输入引脚RTCIC0、RTCIC1和RTCIC2。当时间捕捉事件输入引脚的功能复用时，首先设置VBTICTLR。如果TCEN位设置为0，也将TCCT[1:0]位设置为00b。

第23.2.29节。RTCCRN: 时间捕捉控制寄存器n (n=0到2) 列出了启用RTCICn引脚的条件。在将此位设置为1之前，请务必设置计数源设置位(RCR4.RCKSEL)、RTC时间捕捉事件使能位(RCPE.RTCEN)、端口控制设置位(PmnPFS.PDR和PmnPFS.PMR)。有关端口控制设置位 (PmnPFS.PDR和PmnPFS.PMR) 的详细信息，请参阅第19节，IO端口。

**23.2.30 RSCCPn: 第二个捕捉寄存器n (n=0到2) (在日历计数模式下)**

Base address: RTC = 0x4008\_3000

Offset address: 0x52 + 0x10 × n



| Bit | Symbol     | Function      | R/W |
|-----|------------|---------------|-----|
| 3:0 | SEC1[3:0]  | 1秒捕获捕获秒的个位的值。 | R   |
| 6:4 | SEC10[2:0] | 10秒捕获十位秒的捕获值。 | R   |
| 7   | —          | 读取值未定义。       | R   |

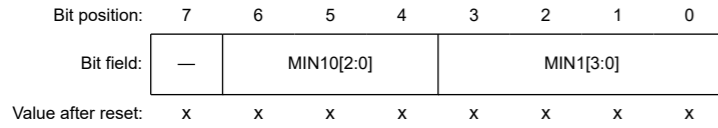
RSCCPn是一个只读寄存器，当检测到时间捕捉事件时，它会捕捉RSECCNT值。

RTCIC0、RTCIC1和RTCIC2引脚检测到的事件检测时间存储在RSCCP0、RSCCP1和RSCCP2寄存器，分别。RTC软件复位将该寄存器清零为0x00。在读取该寄存器之前，应使用RTCCRN.TCCT[1:0]位停止时间捕捉事件检测。

## 23.2.31 RMINCPn : Minute Capture Register n (n = 0 to 2) (in Calendar Count Mode)

Base address: RTC = 0x4008\_3000

Offset address: 0x54 + 0x10 × n



| Bit | Symbol     | Function  | R/W |
|-----|------------|---|-----|
| 3:0 | MIN1[3:0]  | 1-Minute Capture<br>Capture value for the ones place of minutes.  | R   |
| 6:4 | MIN10[2:0] | 10-Minute Capture<br>Capture value for the tens place of minutes. | R   |
| 7   | —          | The read value is undefined.                                      | R   |

RMINCPn is a read-only register that captures the RMINCNT value when a time capture event is detected.

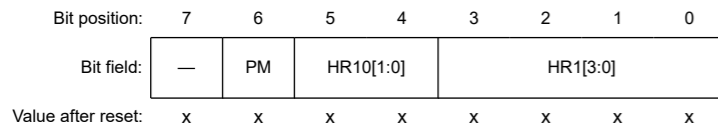
The event detection times detected by the RTCIC0, RTCIC1, and RTCIC2 pins are stored in the RMINCP0, RMINCP1, and RMINCP2 registers, respectively.

This register is cleared to 0x00 by an RTC software reset. Before reading from this register, the time capture event detection should be stopped using the RTCCRn.TCCT[1:0] bits.

## 23.2.32 RHRCpN : Hour Capture Register n (n = 0 to 2) (in Calendar Count Mode)

Base address: RTC = 0x4008\_3000

Offset address: 0x56 + 0x10 × n



| Bit | Symbol    | Function   | R/W |
|-----|-----------|--|-----|
| 3:0 | HR1[3:0]  | 1-Hour Capture<br>Capture value for the ones place of hours  | R   |
| 5:4 | HR10[1:0] | 10-Hour Capture<br>Capture value for the tens place of hours | R   |
| 6   | PM        | PM<br>0: AM<br>1: PM   | R   |
| 7   | —         | The read value is undefined.                                 | R   |

RHRCpN is a read-only register that captures the RHRCNT value when a time capture event is detected.

The event detection times detected by the RTCIC0, RTCIC1, and RTCIC2 pins are stored in the RHRCp0, RHRCp1, and RHRCp2 registers, respectively.

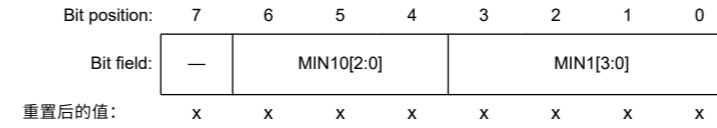
The PM bit is only enabled when the RCR2.HR24 bit is 0 (in 12-hour mode).

This register is cleared to 0x00 by an RTC software reset. Before reading from this register, you must stop the time capture event detection using the RTCCRn.TCCT[1:0] bits.

## 23.2.31 RMINCPn: 分钟捕捉寄存器n (n=0到2) (在日历计数模式下)

Base address: RTC = 0x4008\_3000

Offset address: 0x54 + 0x10 × n



| Bit | Symbol     | Function                   | R/W |
|-----|------------|----------------------------|-----|
| 3:0 | MIN1[3:0]  | 1-MinuteCapture以分钟为单位的捕获值。 | R   |
| 6:4 | MIN10[2:0] | 10分钟捕获十位分钟的捕获值。            | R   |
| 7   | —          | 读取值未定义。                    | R   |

RMINCPn是一个只读寄存器，它在检测到时间捕捉事件时捕捉RMINCNT值。

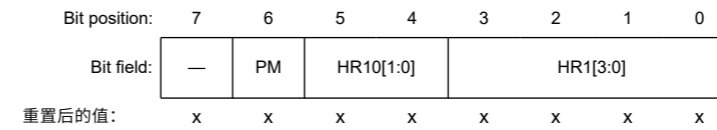
RTCIC0、RTCIC1和RTCIC2引脚检测到的事件检测时间存储在RMINCP0、RMINCP1和RMINCP2寄存器，分别。

RTC软件复位将该寄存器清零为0x00。在读取该寄存器之前，应使用RTCCRn.TCCT[1:0]位停止时间捕捉事件检测。

## 23.2.32 RHRCpN: 小时捕捉寄存器n (n=0到2) (在日历计数模式下)

Base address: RTC = 0x4008\_3000

Offset address: 0x56 + 0x10 × n



| Bit | Symbol    | Function                | R/W |
|-----|-----------|-------------------------|-----|
| 3:0 | HR1[3:0]  | 1-HourCapture以小时为单位的捕获值 | R   |
| 5:4 | HR10[1:0] | 10-HourCapture十位小时的捕获值  | R   |
| 6   | PM        | PM<br>0: AM<br>1: PM    | R   |
| 7   | —         | 读取值未定义。                 | R   |

RHRCpN是一个只读寄存器，它在检测到时间捕捉事件时捕捉RHRCNT值。

RTCIC0、RTCIC1和RTCIC2引脚检测到的事件检测时间存储在RHRCp0、RHRCp1和RHRCp2寄存器，分别。

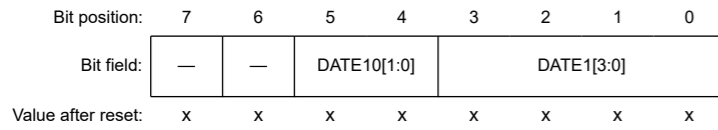
PM位仅在RCR2.HR24位为0时启用（在12小时模式下）。

RTC软件复位将该寄存器清零为0x00。在读取该寄存器之前，您必须使用RTCCRn.TCCT[1:0]位停止时间捕捉事件检测。

## 23.2.33 RDAYCPn : Date Capture Register n (n = 0 to 2) (in Calendar Count Mode)

Base address: RTC = 0x4008\_3000

Offset address: 0x5A + 0x10 × n



| Bit | Symbol      | Function  | R/W |
|-----|-------------|---|-----|
| 3:0 | DATE1[3:0]  | 1-Day Capture<br>Capture value for the ones place of days.  | R   |
| 5:4 | DATE10[1:0] | 10-Day Capture<br>Capture value for the tens place of days. | R   |
| 7:6 | —           | The read value is undefined.                                | R   |

RDAYCPn is a read-only register that captures the RDAYCNT value when a time capture event is detected.

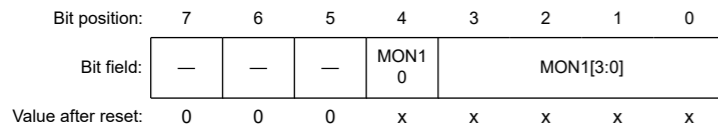
The event detection times detected by the RTCIC0, RTCIC1, and RTCIC2 pins are stored in the RDAYCP0, RDAYCP1, and RDAYCP2 registers, respectively.

This register is cleared to 0x00 by an RTC software reset. Before reading from this register, the time capture event detection should be stopped using the RTCCRn.TCCT[1:0] bits.

## 23.2.34 RMONCPn : Month Capture Register n (n = 0 to 2) (in Calendar Count Mode)

Base address: RTC = 0x4008\_3000

Offset address: 0x5C + 0x10 × n



| Bit | Symbol    | Function  | R/W |
|-----|-----------|---|-----|
| 3:0 | MON1[3:0] | 1-Month Capture<br>Capture value for the ones place of months.  | R   |
| 4   | MON10     | 10-Month Capture<br>Capture value for the tens place of months. | R   |
| 7:5 | —         | These bits are read as 0.                                       | R   |

RMONCPn is a read-only register that captures the RMONCNT value when a time capture event is detected.

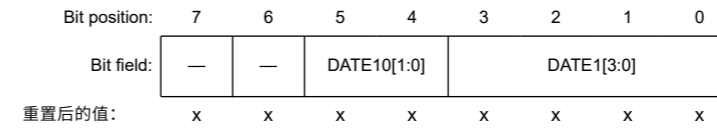
The event detection times detected by the RTCIC0, RTCIC1, and RTCIC2 pins are stored in the RMONCP0, RMONCP1, and RMONCP2 registers, respectively.

This register is cleared to 0x00 by an RTC software reset. Before reading from this register, the time capture event detection should be stopped using the RTCCRn.TCCT[1:0] bits.

## 23.2.33 RDAYCPn: 日期捕捉寄存器n (n=0到2) (在日历计数模式下)

Base address: RTC = 0x4008\_3000

Offset address: 0x5A + 0x10 × n



| Bit | Symbol      | Function      | R/W |
|-----|-------------|---------------|-----|
| 3:0 | DATE1[3:0]  | 1天捕获捕获天数的值。   | R   |
| 5:4 | DATE10[1:0] | 10天捕获十位天的捕获值。 | R   |
| 7:6 | —           | 读取值未定义。       | R   |

RDAYCPn是一个只读寄存器，它在检测到时间捕捉事件时捕捉RDAYCNT值。

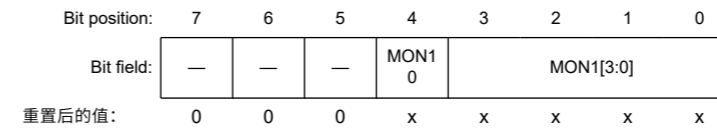
RTCIC0、RTCIC1和RTCIC2引脚检测到的事件检测时间分别存储在RDAYCP0、RDAYCP1和RDAYCP2寄存器中。

RTC软件复位将该寄存器清零为0x00。在读取该寄存器之前，应使用RTCCRn.TCCT[1:0]位停止时间捕捉事件检测。

## 23.2.34 RMONCPn: 月份捕捉寄存器n (n=0到2) (在日历计数模式下)

Base address: RTC = 0x4008\_3000

Offset address: 0x5C + 0x10 × n



| Bit | Symbol    | Function                 | R/W |
|-----|-----------|--------------------------|-----|
| 3:0 | MON1[3:0] | 1-MonthCapture捕获月份个位数的值。 | R   |
| 4   | MON10     | 10个月捕获捕获十个月份的值。          | R   |
| 7:5 | —         | 这些位读为0。                  | R   |

RMONCPn是一个只读寄存器，它在检测到时间捕捉事件时捕捉RMONCNT值。

RTCIC0、RTCIC1和RTCIC2引脚检测到的事件检测时间分别存储在RMONCP0、RMONCP1和RMONCP2寄存器中。

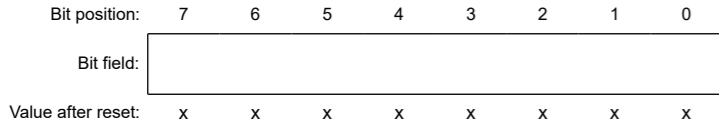
RTC软件复位将该寄存器清零为0x00。在读取该寄存器之前，应使用RTCCRn.TCCT[1:0]位停止时间捕捉事件检测。



### 23.2.35 BCNTnCPm : BCNTn Capture Register m (n= 0 to 3, m = 0 to 2) (in Binary Count Mode)

Base address: RTC = 0x4008\_3000

Offset address: 0x52 + 0x10 × m (BCNT0CPm)  
 0x54 + 0x10 × m (BCNT1CPm)  
 0x56 + 0x10 × m (BCNT2CPm)  
 0x5A + 0x10 × m (BCNT3CPm)



BCNTnCPm is a read-only register that captures the BCNTn value when a time capture event is detected. BCNT3CPm is assigned to the BCNTCPm[31:24] bits, BCNT2CPm is assigned to the BCNTCPm[23:16] bits, BCNT1CPm is assigned to the BCNTCPm[15:8] bits and BCNT0CPm is assigned to the BCNTCPm[7:0] bits. The event detection times detected by the RTCIC0, RTCIC1, and RTCIC2 pins are stored in the BCNTnCP0, BCNTnCP1, and BCNTnCP2 registers, respectively.

This register is cleared to 0x00 by an RTC software reset. Before reading from this register, you must stop the time capture event detection using the RTCCRn.TCCT[1:0] bits.

### 23.3 Operation

#### 23.3.1 Outline of Initial Settings of Registers after Power On

After the power is turned on, perform the initial settings for the clock, count mode, time error adjustment, time, alarm, interrupts, and time capture.

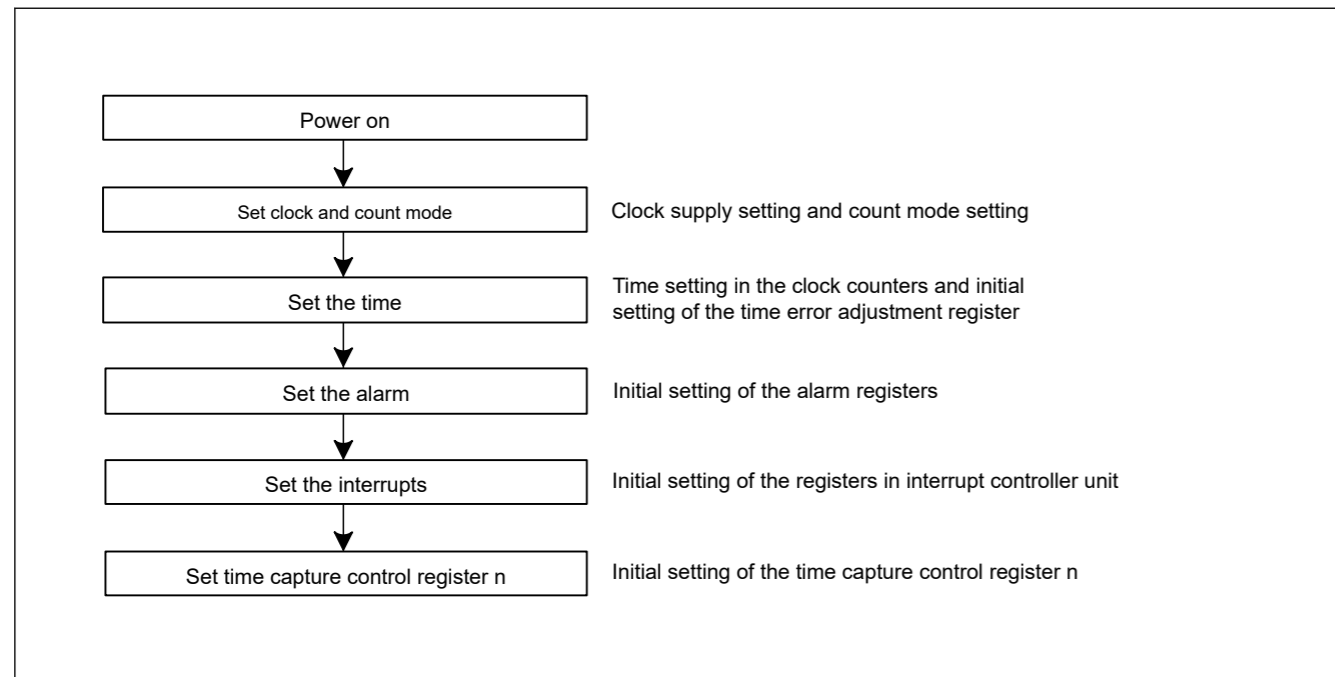


Figure 23.2 Outline of initial settings after a power on

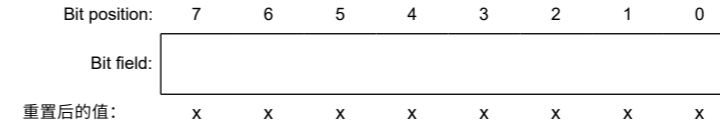
#### 23.3.2 Clock and Count Mode Setting Procedure

Figure 23.3 shows how to set the clock and the count mode.

### 23.2.35 BCNTnCPm:BCNTn捕捉寄存器m(n=0to3 m=0to2)(以二进制计数 Mode)

Base address: RTC = 0x4008\_3000

Offset address: 0x52 + 0x10 × m (BCNT0CPm)  
 0x54 + 0x10 × m (BCNT1CPm)  
 0x56 + 0x10 × m (BCNT2CPm)  
 0x5A + 0x10 × m (BCNT3CPm)



BCNTnCPm是一个只读寄存器，它在检测到时间捕捉事件时捕捉BCNTn值。BCNT3CPm分配给BCNTCPm[31:24]位，BCNT2CPm分配给BCNTCPm[23:16]位，BCNT1CPm分配给BCNTCPm[15:8]位，BCNT0CPm分配给BCNTCPm[7:0]位。RTCIC0、RTCIC1和RTCIC2引脚检测到的事件检测时间分别存储在BCNTnCP0、BCNTnCP1和BCNTnCP2寄存器中。

RTC软件复位将该寄存器清零为0x00。在读取该寄存器之前，您必须使用RTCCRn.TCCT[1:0]位停止时间捕捉事件检测。

### 23.3 Operation

#### 23.3.1 上电后寄存器的初始设置概要

上电后，对时钟、计数方式、时间误差调整、时间、闹钟、中断、时间捕捉进行初始设置。

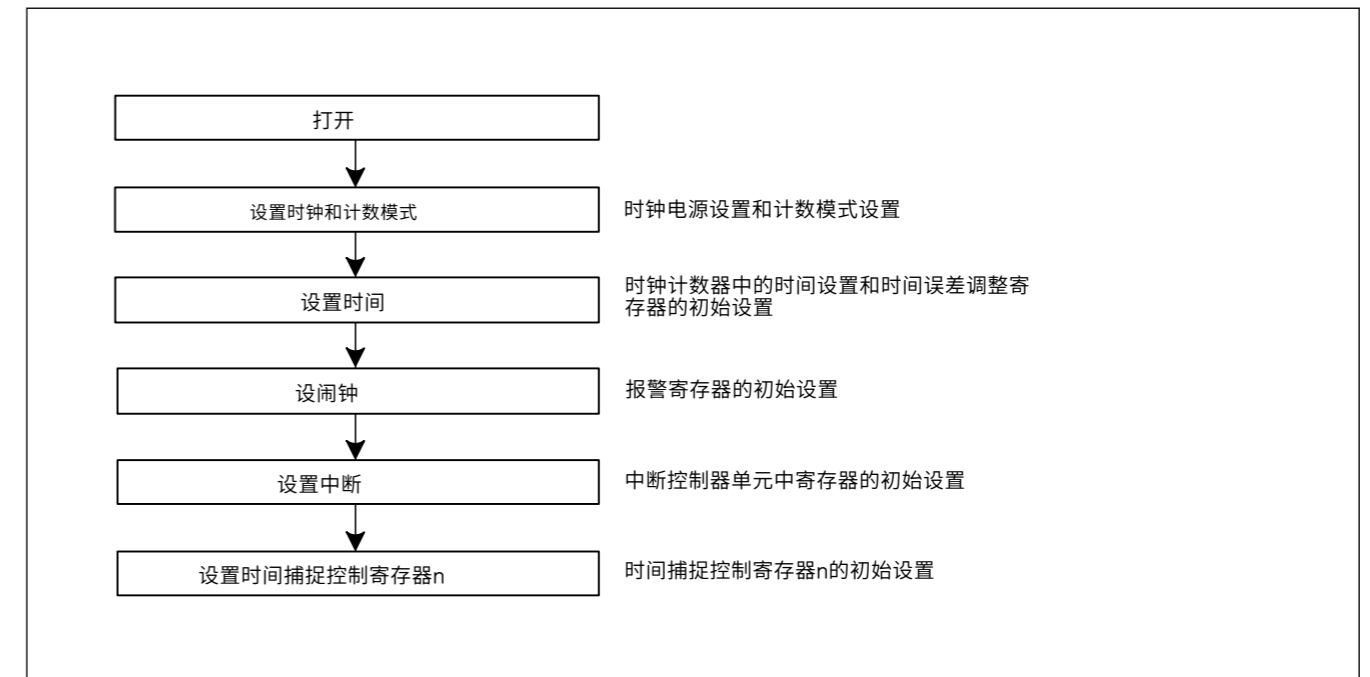


Figure 23.2 通电后的初始设定概要

#### 23.3.2 时钟和计数模式设置程序

图23.3显示了如何设置时钟和计数模式。



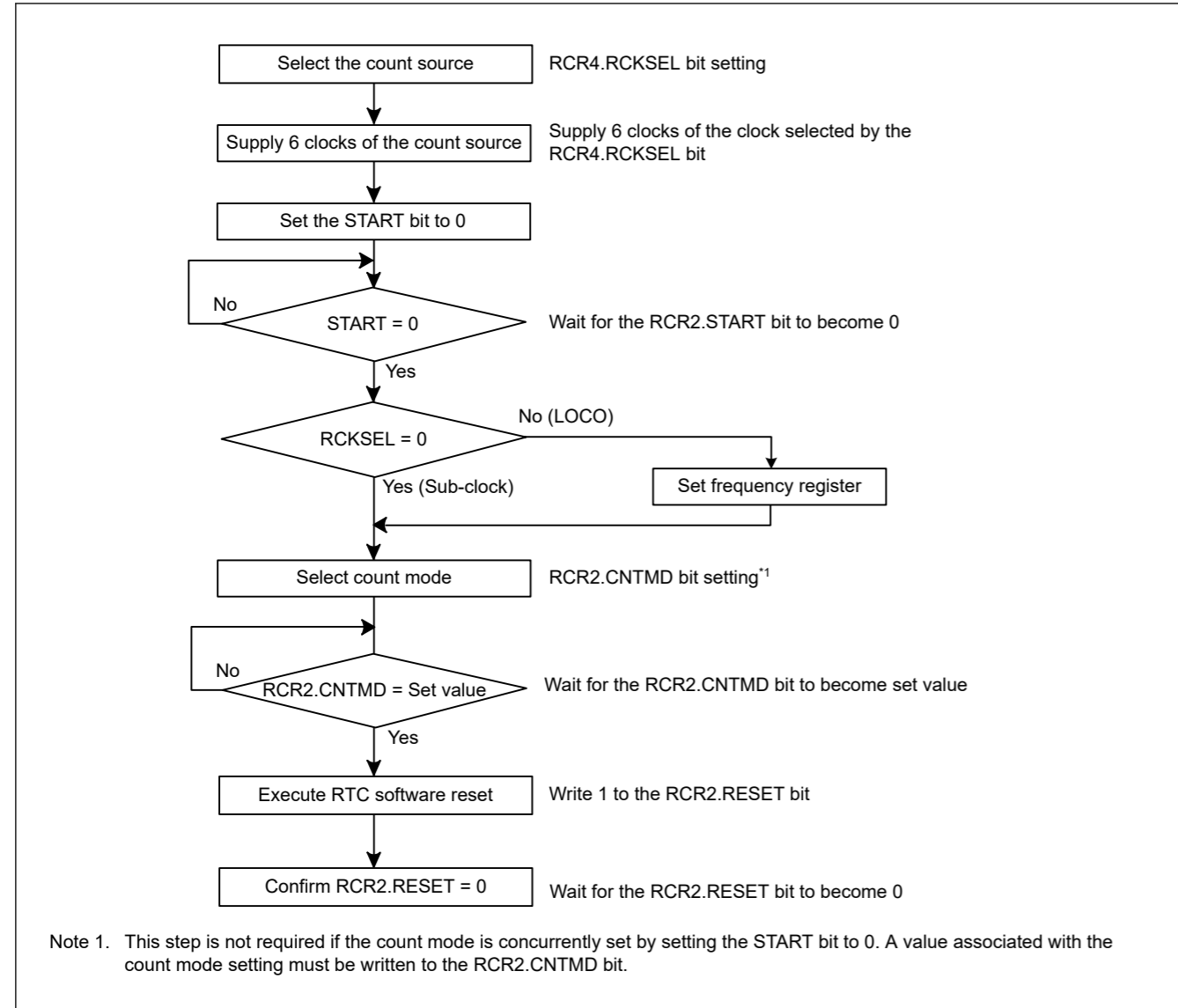


Figure 23.3 Clock and count mode setting procedure

### 23.3.3 Setting the Time

Figure 23.4 shows how to set the time.

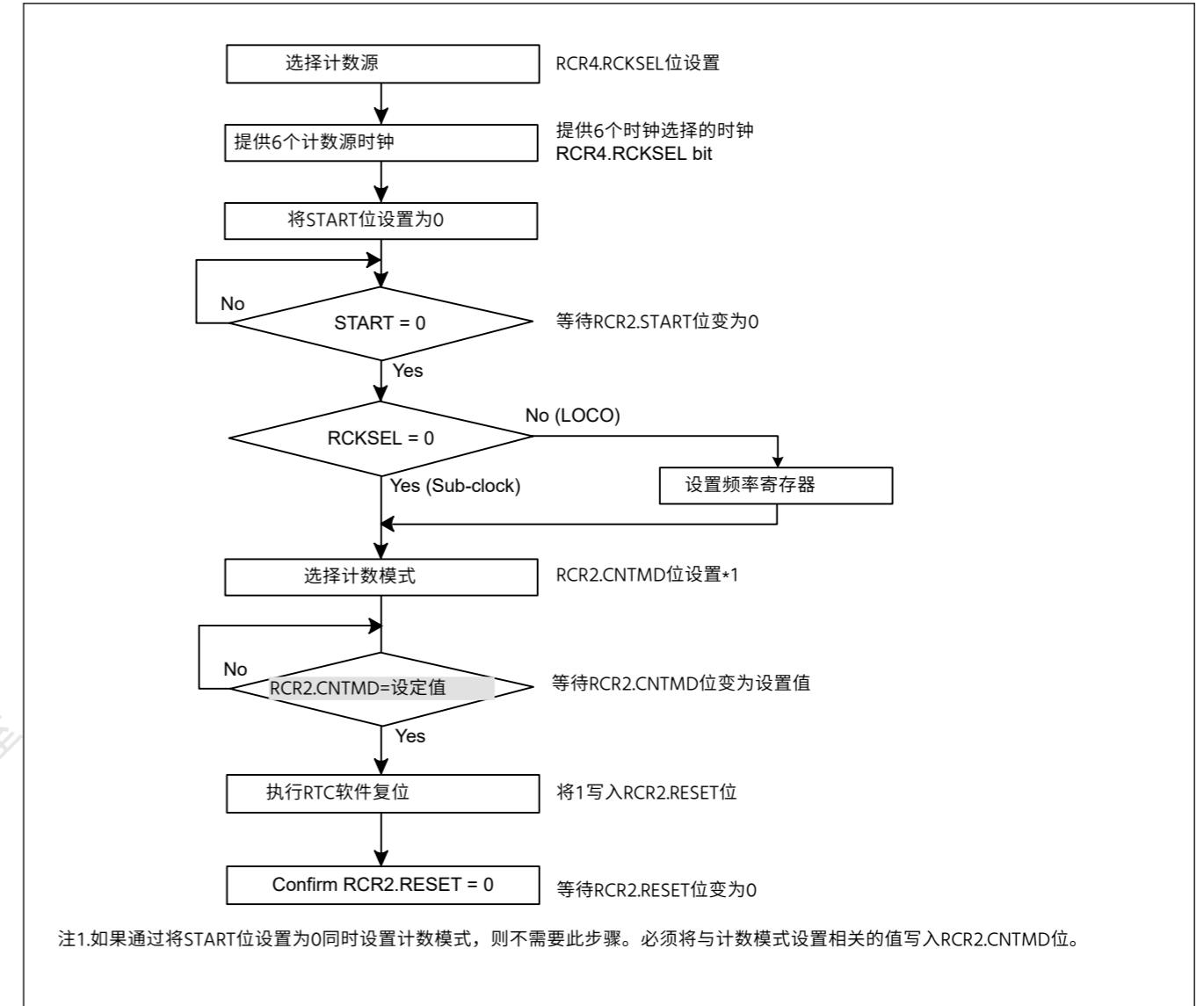


Figure 23.3 时钟和计数模式设置程序

### 23.3.3 设置时间

图23.4显示了如何设置时间。

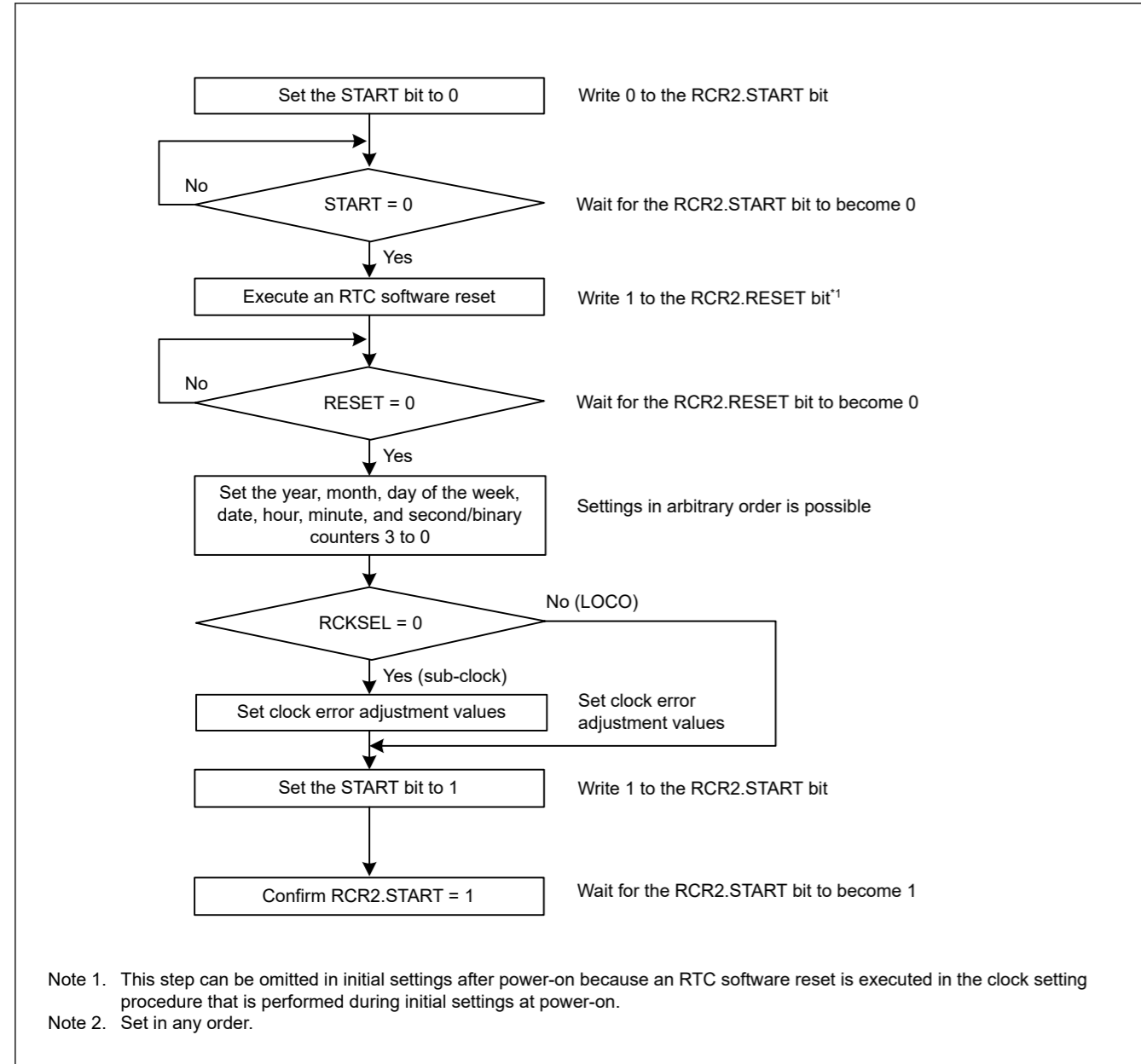


Figure 23.4 Setting the time

23.3.4 30-Second Adjustment

Figure 23.5 shows how to execute a 30-second adjustment.

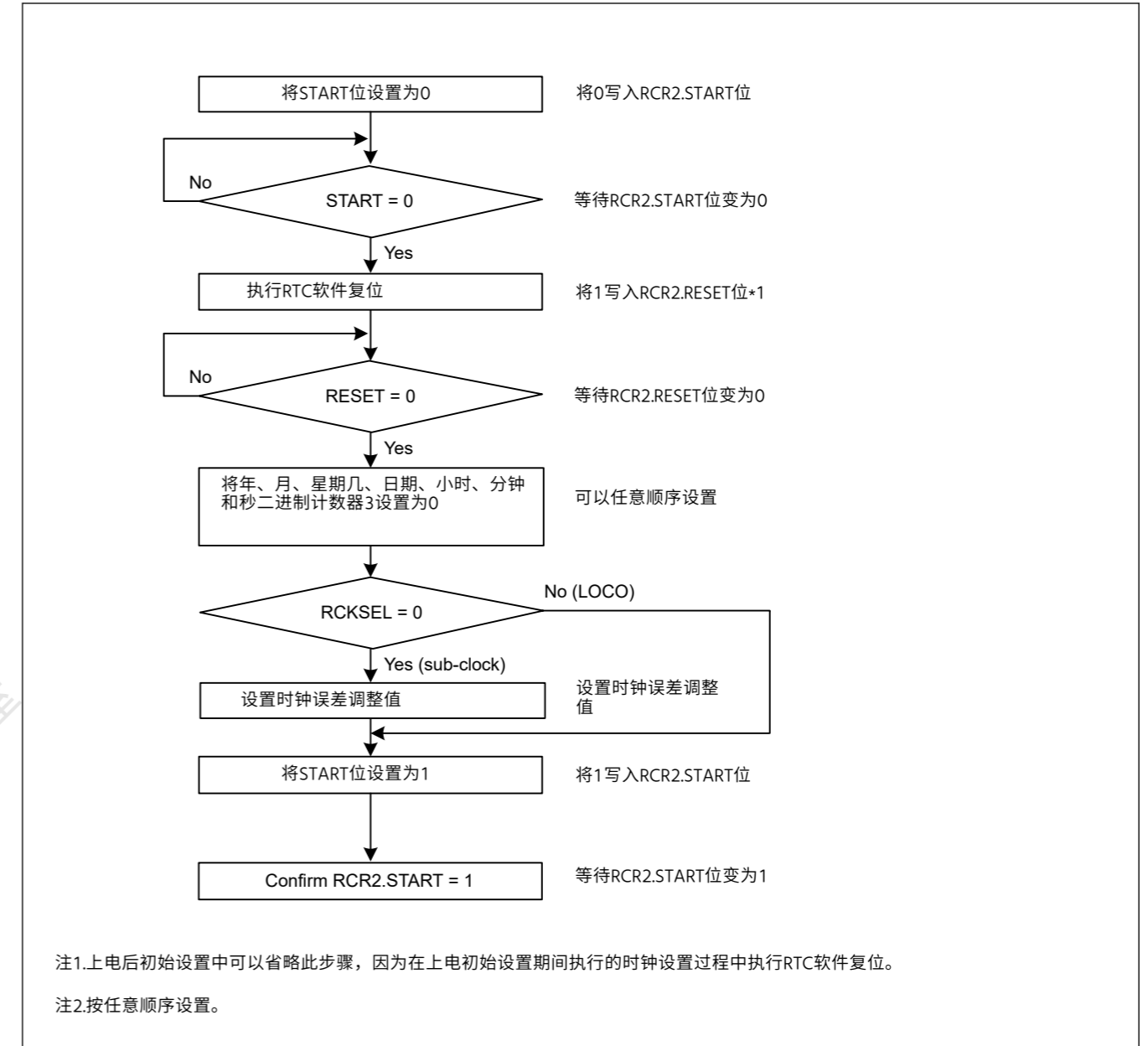


Figure 23.4 设定时间

23.3.4 30-Second Adjustment

图23.5显示了如何执行30秒的调整。

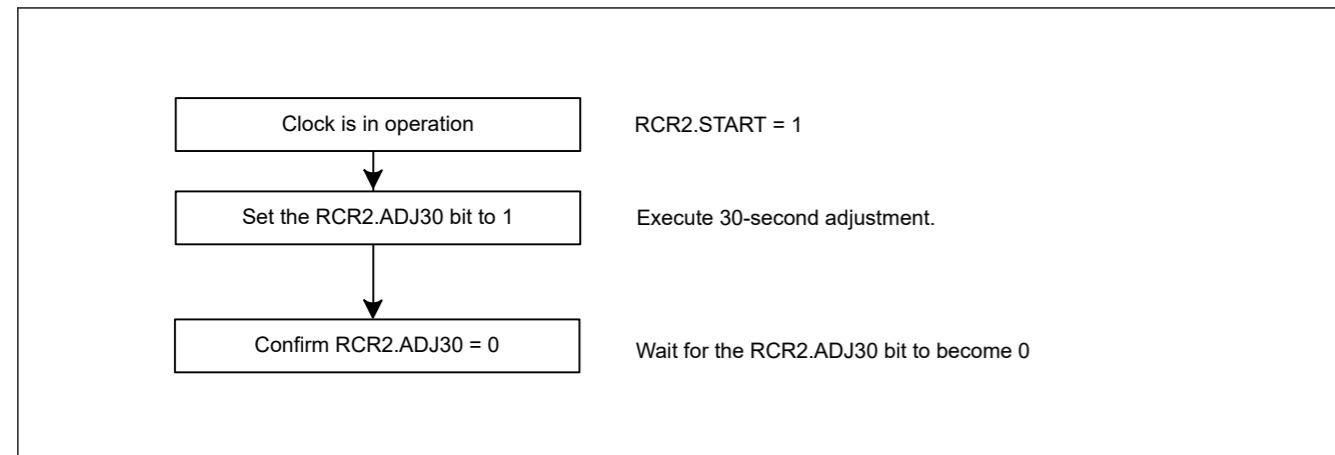


Figure 23.5 30-second adjustment

### 23.3.5 Reading 64-Hz Counter and Time

Figure 23.6 shows how to read a 64-Hz counter and time.



Figure 23.5 30-second adjustment

### 23.3.5 读取64-Hz计数器和时间

图23.6显示了如何读取64-Hz计数器和时间。

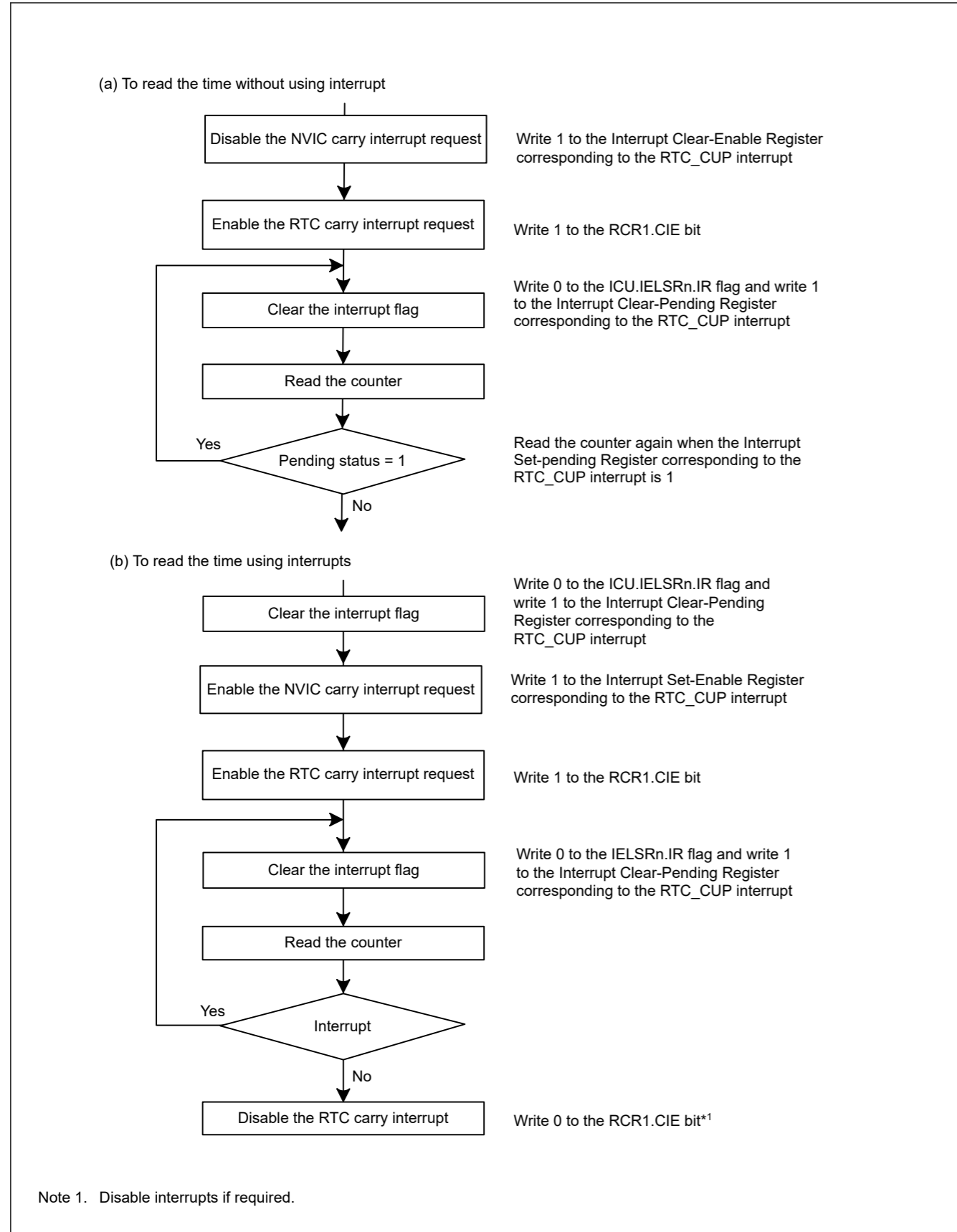


Figure 23.6 Reading time

If a carry occurs while the 64-Hz counter and time are read, the correct time is not obtained, therefore they must be read again. The procedure for reading the time without using interrupts is shown in (a) in Figure 23.6, and the procedure using carry interrupts is shown in (b). To keep the program simple, method (a) should be used in most cases.

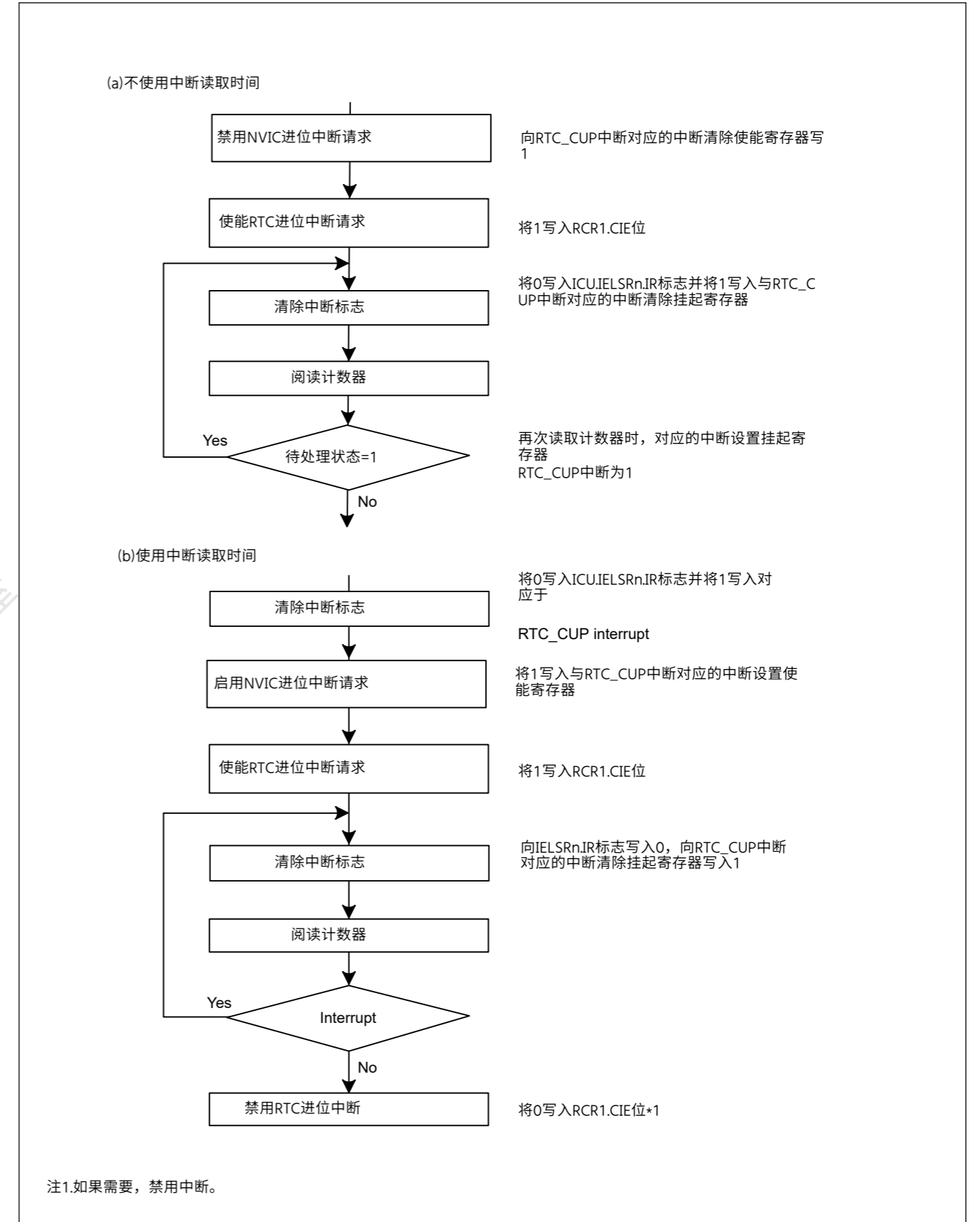


Figure 23.6 阅读时间

如果在读取64-Hz计数器和时间时发生进位, 则无法获得正确的时间, 因此必须再次读取它们。不使用中断读取时间的过程如图23.6(a)所示, 使用进位中断的过程如图23.6(b)所示。为保持程序简单, 在大多数情况下应使用方法(a)。

## 23.3.6 Alarm Function

Figure 23.7 shows how to use the alarm function.

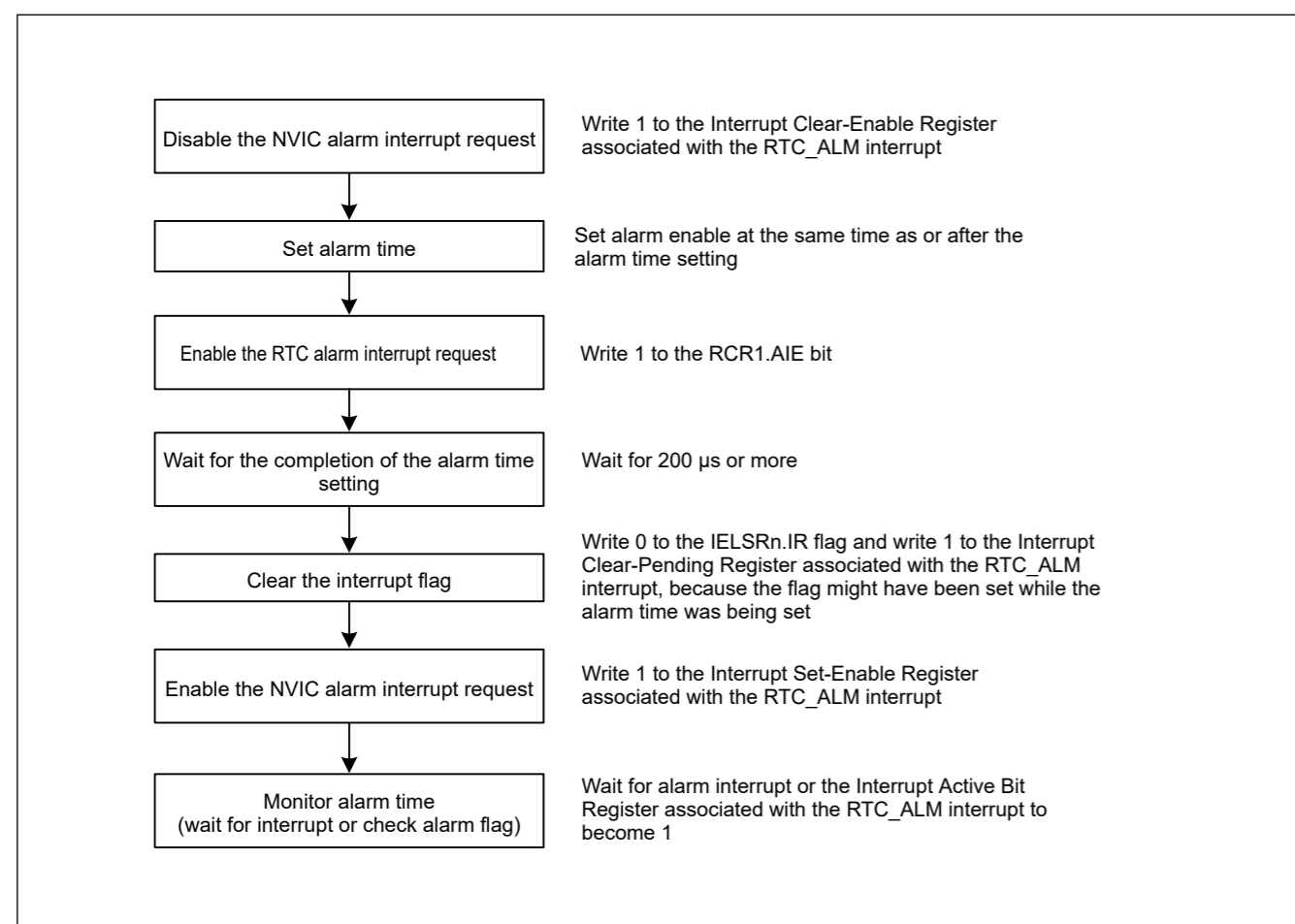


Figure 23.7 Using the alarm function

In calendar count mode, an alarm can be generated by any one of year, month, date, day-of-week, hour, minute or second, or any combination of those. Write 1 to the ENB bit in the alarm registers involved in the alarm setting, and set the alarm time in the lower bits. Write 0 to the ENB bit in registers not involved in the alarm setting.

In binary count mode, an alarm can be generated in any bit combination of 32 bits. Write 1 to the ENB bit of the Alarm Enable register associated with the target bit of the alarm, and set the alarm time in the alarm register. For bits that are not the target of the alarm, write 0 to the ENB bit of the Alarm Enable register.\*1

For any of the ENB[31:0] bits that are set to 1, the bits in the corresponding positions in the binary counter (BCNT[31:0]) are compared with the values of the corresponding bits in the binary alarm registers\*1. When all such bits match, the IR flag associated with the RTC\_ALM interrupt is set to 1 and the corresponding bits in the Interrupt Set-Pending/Clear-Pending Registers are set to 1. Alarm detection can be confirmed by reading the Interrupt Set-Pending Register associated with the RTC\_ALM interrupt, but an interrupt should be used in most cases. If 1 is set in the Interrupt Set-Enable Register associated with the RTC\_ALM interrupt, an alarm interrupt is generated in the event of the alarm, enabling the alarm to be detected.

Writing 0 sets the IELSRn.IR flag associated with the RTC\_ALM interrupt to 0. If interrupt is enabled, the Interrupt Set-Pending/Clear-Pending Register associated with the RTC\_ALM interrupt is cleared automatically after exiting the interrupt handler. Otherwise, write 1 to the Interrupt Clear-Pending Register associated with the RTC\_ALM interrupt to clear it.

When the counter and the alarm time match in a low power state, the MCU returns from the low power state.

Note 1. For any bits in the ENB bits that are set to 1, the values in the corresponding positions in the alarm registers from the following registers are compared with the corresponding bits of the counted values.

Counter registers: RSECCNT, RMINCNT, RHRCNT, RWKCNT, RDAYCNT, RMONCNT, RYRCNT

Alarm registers: RSECAR, RMINAR, RHRAR, RWKAR, RDAYAR, RMONAR, RYRAREN

## 23.3.6 报警功能

图23.7显示了如何使用报警功能。

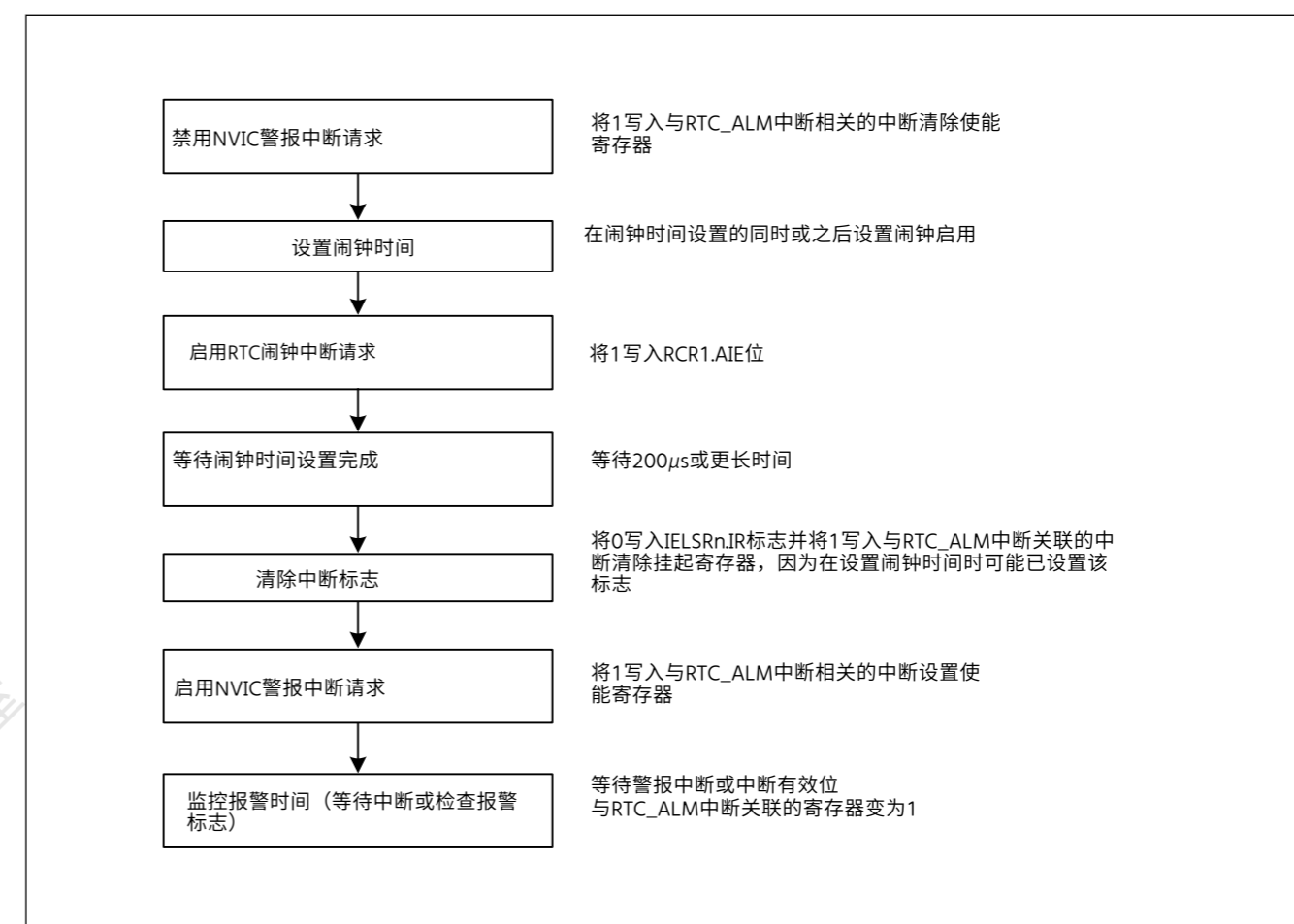


Figure 23.7 使用报警功能

在日历计数模式下，可以通过年、月、日、星期、小时、分钟或秒中的任何一个或它们的任意组合来生成警报。将1写入涉及闹钟设置的闹钟寄存器的ENB位，并在低位设置闹钟时间。将0写入与报警设置无关的寄存器中的ENB位。

在二进制计数模式下，可以以32位的任意位组合产生报警。将1写入闹钟的ENB位与报警的目标位相关联的使能寄存器，并在报警寄存器中设置报警时间。对于不是报警目标的位，将0写入报警启用寄存器的ENB位。\*1

对于任何设置为1的ENB[31:0]位，二进制计数器(BCNT[31:0])中相应位置的位与二进制报警寄存器中相应位的值进行比较\*1。当所有这些位匹配时，与RTC\_ALM中断相关的IR标志设置为1，并且中断设置挂起清除挂起寄存器中的相应位设置为1。可以通过读取中断设置挂起寄存器来确认警报检测与RTC\_ALM中断相关联，但在大多数情况下应使用中断。如果在与RTC\_ALM中断相关的中断设置使能寄存器中设置为1，则在发生警报时会产生警报中断，从而能够检测到警报。

写入0将与RTC\_ALM中断关联的IELSRn.IR标志设置为0。如果启用中断，则中断设置与RTC\_ALM中断关联的PendingClear-Pending寄存器在退出中断处理程序后自动清除。否则，将1写入与RTC\_ALM中断相关的中断清除挂起寄存器以将其清除。

当计数器和闹钟时间在低功耗状态下匹配时，MCU从低功耗状态返回。

注1.对于设置为1的ENB位中的任何位，将以下寄存器中报警寄存器中相应位置的位与计数值的相应位进行比较。

Counter registers: RSECCNT, RMINCNT, RHRCNT, RWKCNT, RDAYCNT, RMONCNT, RYRCNT

Alarm registers: RSECAR, RMINAR, RHRAR, RWKAR, RDAYAR, RMONAR, RYRAREN



### 23.3.7 Procedure for Disabling Alarm Interrupt

Figure 23.8 shows the procedure for disabling the enabled alarm interrupt request.

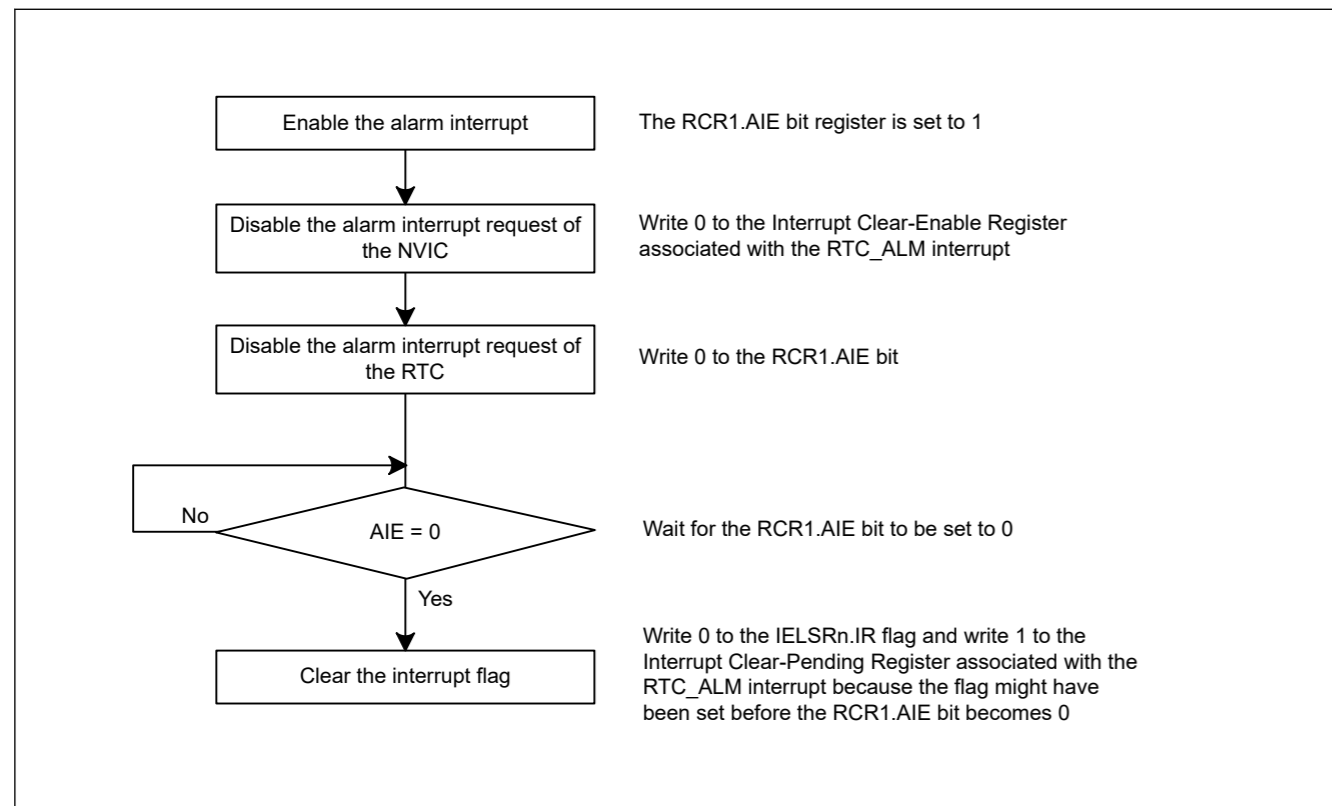


Figure 23.8 Procedure for disabling alarm interrupt request

### 23.3.8 Time Error Adjustment Function

The time error adjustment function is used to correct errors, running fast or slow, in the time caused by variation in the precision of oscillation by the sub-clock oscillator. Because 32768 cycles of the sub-clock oscillator constitute 1 second of operation when the sub-clock oscillator is selected, the clock runs fast if the sub-clock frequency is high and slow if the sub-clock frequency is low.

The time error adjustment functions include:

- Automatic adjustment
- Adjustment by software

Use the RCR2.AADJE bit to select automatic adjustment or adjustment by software.

#### 23.3.8.1 Automatic adjustment

Enable automatic adjustment by setting the RCR2.AADJE bit to 1.

Automatic adjustment is the addition or subtraction of the value counted by the prescaler to or from the value in the RADJ register every time the adjustment period selected by the RCR2.AADJP bit elapses.

##### (1) Example 1: Sub-clock oscillator running at 32.769 kHz

#### Adjustment procedure

When the sub-clock oscillator is running at 32.769 kHz, 1 second elapses every 32769 clock cycles. The RTC is meant to run at 32768 clock cycles, so the clock runs fast by 1 clock cycle every second. The time on the clock is fast by 60 clock cycles per minute, so adjustment can take the form of setting the clock back by 60 cycles every minute.

### 23.3.7 禁用警报中断的步骤

图23.8显示了禁用启用的警报中断请求的过程。

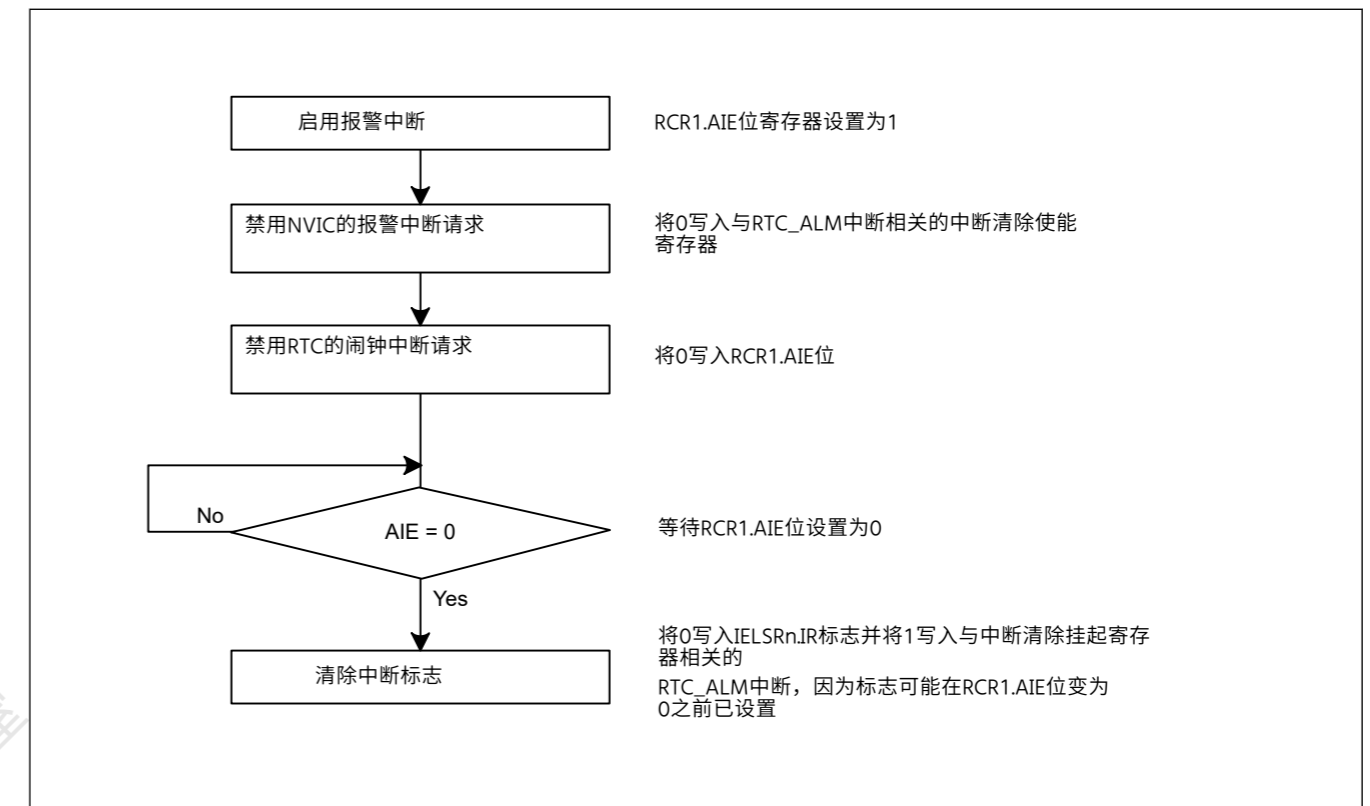


Figure 23.8 禁用报警中断请求的步骤

### 23.3.8 时间误差调整功能

时间误差调整功能用于校正子时钟振荡器振荡精度变化引起的时间误差, 运行速度快或慢。由于在选择子时钟振荡器时, 子时钟振荡器的32768个周期构成1秒的操作, 因此如果子时钟频率高, 则时钟运行快, 如果子时钟频率低, 则时钟运行慢。

时间误差调整功能包括:

- 自动调整
- 软件调整

使用RCR2.AADJE位选择自动调整或软件调整。

#### 23.3.8.1 自动调整

通过将RCR2.AADJE位设置为1来启用自动调整。

自动调整是每次经过RCR2.AADJP位选择的调整周期后, 将预分频器计数的值与RADJ寄存器中的值相加或相减。

##### (1) 示例1: 运行在32.769kHz的子时钟振荡器

#### 调整程序

当副时钟振荡器以32.769kHz运行时, 每32769个时钟周期经过1秒。RTC旨在以32768个时钟周期运行, 因此时钟以每秒1个时钟周期的速度运行。时钟上的时间每分钟快60个时钟周期, 因此调整可以采取将时钟每分钟调回60个周期的形式。

**Register settings when RCR2.CNTMD = 0:**

- RCR2.AADJP = 0 (adjustment every minute)
- RADJ.PMADJ[1:0] = 10b (adjustment is performed by the subtraction from the prescaler)
- RADJ.ADJ[5:0] = 60 (0x3C)

(2) Example 2: Sub-clock oscillator running at 32.766 kHz

**Adjustment procedure**

When the sub-clock oscillator is running at 32.766 kHz, 1 second elapses every 32766 clock cycles. The RTC is meant to run at 32768 clock cycles, so the clock runs slow by 2 clock cycles every second. The time on the clock is slow by 20 clock cycles every 10 seconds, so adjustment can take the form of setting the clock forward by 20 cycles every 10 seconds.

**Register settings when RCR2.CNTMD = 0:**

- RCR2.AADJP = 1 (adjustment every 10 seconds)
- RADJ.PMADJ[1:0] = 01b (adjustment is performed by the addition to the prescaler)
- RADJ.ADJ[5:0] = 20 (0x14)

(3) Example 3: Sub-clock oscillator running at 32.764 kHz

**Adjustment procedure**

When the sub-clock oscillator is running at 32.764 kHz, 1 second elapses on 32764 clock cycles. Because the RTC operates for 32768 clock cycles as 1 second, the clock is delayed for 4 clock cycles per second. In 8 seconds, the delay is 32 clock cycles, therefore correction can be made by advancing the clock 32 clock cycles every 8 seconds.

**Register settings when RCR2.CNTMD = 1:**

- RCR2.AADJP = 1 (adjustment every 8 seconds)
- RADJ.PMADJ[1:0] = 01b (adjustment is performed by the addition to the prescaler)
- RADJ.ADJ[5:0] = 32 (0x20)

**23.3.8.2 Adjustment by software**

Enable adjustment by software by setting the RCR2.AADJE bit to 0. Adjustment by software is the addition or subtraction of the value counted by the prescaler to or from the value in the RADJ register on execution of a write instruction to the RADJ register.

(1) Example 1: Sub-clock oscillator running at 32.769 kHz

**Adjustment procedure**

When the sub-clock oscillator is running at 32.769 kHz, 1 second elapses every 32769 clock cycles. The RTC is meant to run at 32768 clock cycles, so the clock runs fast by 1 clock cycle every second. The time on the clock is fast by 1 clock cycle per second, so adjustment can take the form of setting the clock back by 1 cycle every second.

**Register settings**

- RADJ.PMADJ[1:0] = 10b (adjustment is performed by the subtraction from the prescaler)
- RADJ.ADJ[5:0] = 1 (0x10)  
This is written to the RADJ register once per 1-second interrupt.

**23.3.8.3 Procedure to change the mode of adjustment**

When changing the mode of adjustment, change the value of the AADJE bit in RCR2 after setting the RADJ.PMADJ[1:0] bits to 00b (adjustment is not performed).

To change adjustment by software to automatic adjustment:

1. Set the RADJ.PMADJ[1:0] bits to 00b (adjustment is not performed).
2. Set the RCR2.AADJE bit to 1 (automatic adjustment is enabled).

**RCR2.CNTMD=0时的寄存器设置:**

- RCR2.AADJP = 0 (adjustment every minute)
- RADJ.PMADJ[1:0]=10b (通过预分频器的减法进行调整)
- RADJ.ADJ[5:0] = 60 (0x3C)

(2) 示例2: 以32.766kHz运行的子时钟振荡器

**调整程序**

当子时钟振荡器以32.766kHz运行时, 每32766个时钟周期经过1秒。RTC旨在以32768个时钟周期运行, 因此时钟每秒运行2个时钟周期。时钟上的时间每10秒慢20个时钟周期, 因此调整可以采取将时钟每10秒向前设置20个周期的形式。

**RCR2.CNTMD=0时的寄存器设置:**

- RCR2.AADJP = 1 (adjustment every 10 seconds)
- RADJ.PMADJ[1:0]=01b (通过加到预分频器进行调整)
- RADJ.ADJ[5:0] = 20 (0x14)

(3) 示例3: 以32.764kHz运行的子时钟振荡器

**调整程序**

当副时钟振荡器以32.764kHz运行时, 32764个时钟周期经过1秒。由于RTC以1秒为单位运行32768个时钟周期, 因此时钟每秒延迟4个时钟周期。在8秒内, 延迟为32个时钟周期, 因此可以通过每8秒将时钟提前32个时钟周期来进行校正。

**RCR2.CNTMD=1时的寄存器设置:**

- RCR2.AADJP = 1 (adjustment every 8 seconds)
- RADJ.PMADJ[1:0]=01b (通过加到预分频器进行调整)
- RADJ.ADJ[5:0] = 32 (0x20)

**23.3.8.2 软件调整**

通过将RCR2.AADJE位设置为0来启用软件调整。软件调整是在对RADJ寄存器执行写指令时, 将预分频器计数的值与RADJ寄存器中的值相加或相减。

(1) 示例1: 运行在32.769kHz的子时钟振荡器

**调整程序**

当副时钟振荡器以32.769kHz运行时, 每32769个时钟周期经过1秒。RTC旨在以32768个时钟周期运行, 因此时钟以每秒1个时钟周期的速度运行。时钟上的时间每秒快1个时钟周期, 因此调整可以采取将时钟每秒调回1个周期的形式。

**注册设置**

- RADJ.PMADJ[1:0]=10b (通过预分频器的减法进行调整)
- RADJ.ADJ[5:0] = 1 (0x10)  
每1秒中断一次将其写入RADJ寄存器。

**23.3.8.3 更改调整模式的程序**

改变调整模式时, 将RADJ.PMADJ[1:0]位设置为00b后改变RCR2中的AADJE位的值 (不进行调整)。

将软件调整改为自动调整:

- 1.将RADJ.PMADJ[1:0]位设置为00b (不进行调整)。
- 2.将RCR2.AADJE位设置为1 (启用自动调整)。

- Use the RCR2.AADJP bit to select the period of adjustment.
- In RADJ, set the PMADJ[1:0] bits for addition or subtraction and the ADJ[5:0] bits to the value for use in time error adjustment.

To change automatic adjustment to adjustment by software:

- Set the RADJ.PMADJ[1:0] bits to 00b (adjustment is not performed).
- Set the RCR2.AADJE bit to 0 (adjustment by software is enabled).
- Proceed with the adjustment by setting the RADJ.PMADJ[1:0] bits for addition or subtraction and the RADJ.ADJ[5:0] bits to the value for use in time error adjustment at the wanted time. After that, the time is adjusted every time a value is written to the RADJ register.

#### 23.3.8.4 Procedure to stop adjustment

Stop the adjustment by setting the RADJ.PMADJ[1:0] bits to 00b (adjustment is not performed).

#### 23.3.9 Capturing the time

The RTC is capable of storing the month, date, hour, minute and second/binary counters 3 to 0 by detecting an edge of a signal on a time capture event input pin in calendar count mode or binary count mode.

A noise filter can also be used on a time capture event input pin. If the noise filter is enabled, the RTCCRn.TCST bit is set to 1 when the input level on the pin matches three times.

The noise filter can be switched on or off for each of the time capture event input pins. Set VBTICTLR.VCHnIEN (n = 0 to 2) to 1 to enable the RTCICn input. Operation when the noise filter is off is shown in Figure 23.9 and operation when the noise filter is on is shown in Figure 23.10.

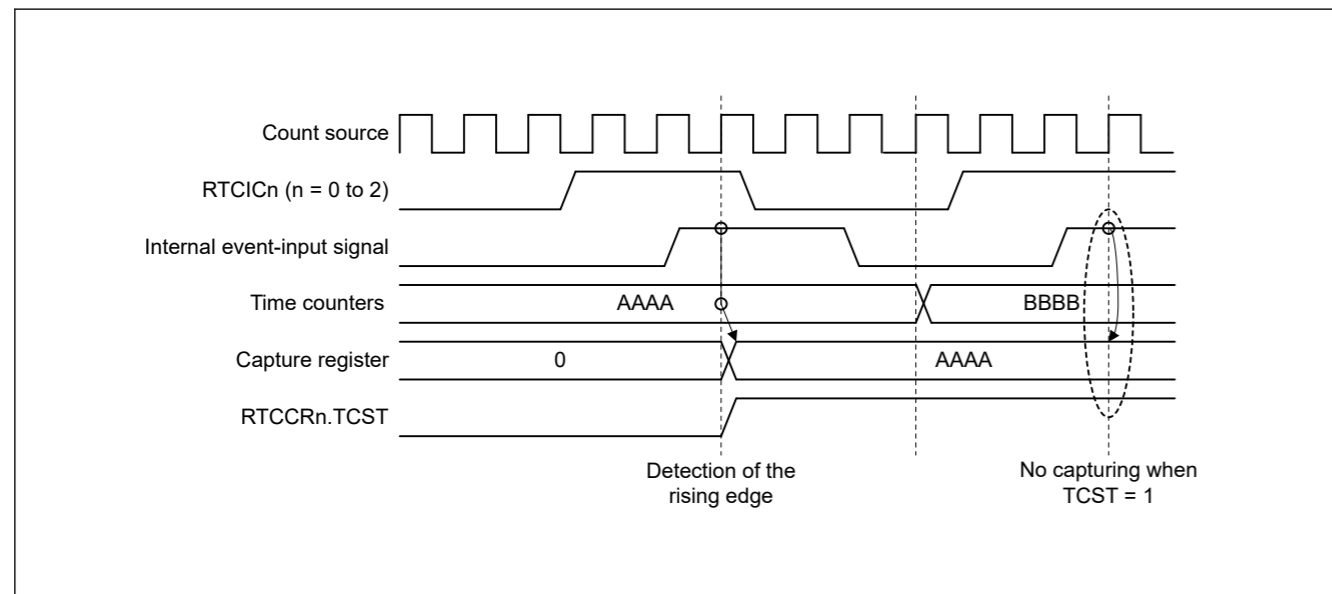


Figure 23.9 Timing of a time capture operation with the noise filter off

- 使用RCR2.AADJP位选择调整周期。
- 在RADJ中，将PMADJ[1:0]位设置为加法或减法，并将ADJ[5:0]位设置为用于时间误差调整的值。

将自动调整更改为软件调整：

- 将RADJ.PMADJ[1:0]位设置为00b（不进行调整）。
- 将RCR2.AADJE位设置为0（启用软件调整）。
- 通过将RADJ.PMADJ[1:0]位设置为加法或减法并将RADJ.ADJ[5:0]位设置为在所需时间用于时间误差调整的值，继续进行调整。之后，每次将值写入RADJ寄存器时都会调整时间。

#### 23.3.8.4 停止调整的程序

通过将RADJ.PMADJ[1:0]位设置为00b来停止调整（不执行调整）。

#### 23.3.9 捕捉时间

通过在日历计数模式或二进制计数模式下检测时间捕捉事件输入引脚上的信号沿，RTC能够存储月、日、小时、分钟和秒二进制计数器3到0。

噪声滤波器也可用于时间捕捉事件输入引脚。如果启用噪声滤波器，则当引脚上的输入电平匹配3次时，RTCCRn.TCST位设置为1。

可以为每个时间捕捉事件输入引脚打开或关闭噪声滤波器。将VBTICTLR.VCHnIEN（n=0到2）设置为1以启用RTCICn输入。噪声滤波器关闭时的操作如图23.9所示，噪声滤波器打开时的操作如图23.10所示。

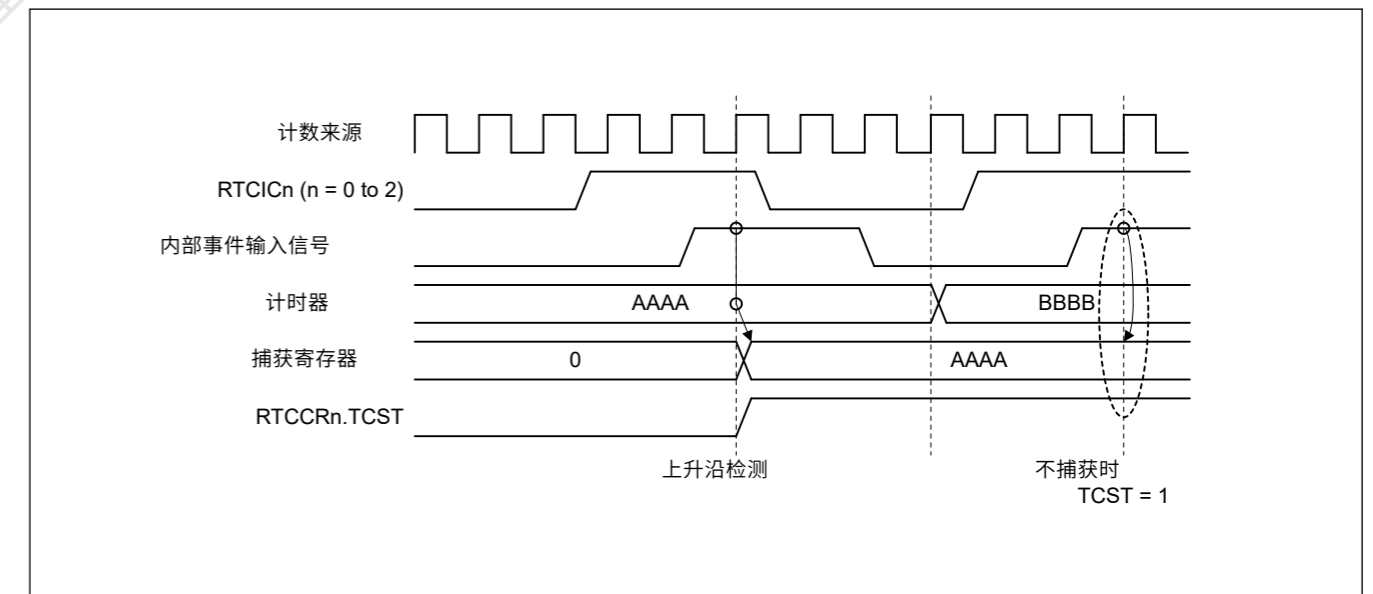


Figure 23.9 关闭噪声过滤器的时间捕捉操作的时序

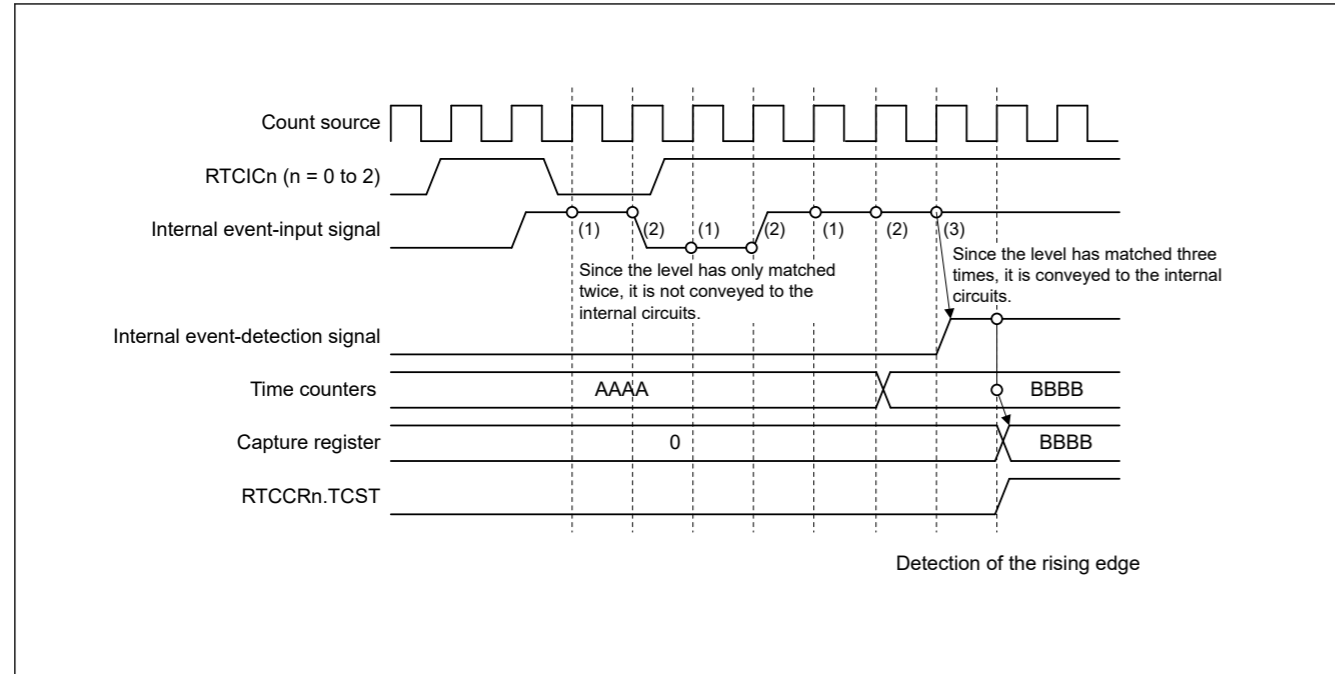


Figure 23.10 Timing of a time capture operation with the noise filter on

### 23.4 Interrupt Sources

The RTC has three interrupt sources, as listed in Table 23.3.

Table 23.3 RTC interrupt sources

| Name    | Interrupt source   |
|---------|--------------------|
| RTC_ALM | Alarm interrupt    |
| RTC_PRD | Periodic interrupt |
| RTC_CUP | Carry interrupt    |

#### (1) Alarm interrupt (RTC\_ALM)

This interrupt is generated based on the comparison result between the alarm registers and RTC counters. For details, see section 23.3.6. Alarm Function.

Because there is a possibility that the interrupt flag might be set to 1 when the settings of the alarm registers match the clock counters, wait for the alarm time settings to be confirmed and clear the IELSRn.IR flag and the interrupt Set-Pending Register associated with the RTC\_ALM interrupt to 0 again after modifying values of the alarm registers. After the interrupt flag for the alarm interrupt is set to 1 and the state is returned to mismatching of the alarm registers and clock counters, the flag is not 1 again until there is another match or the values of the alarm registers are modified again.

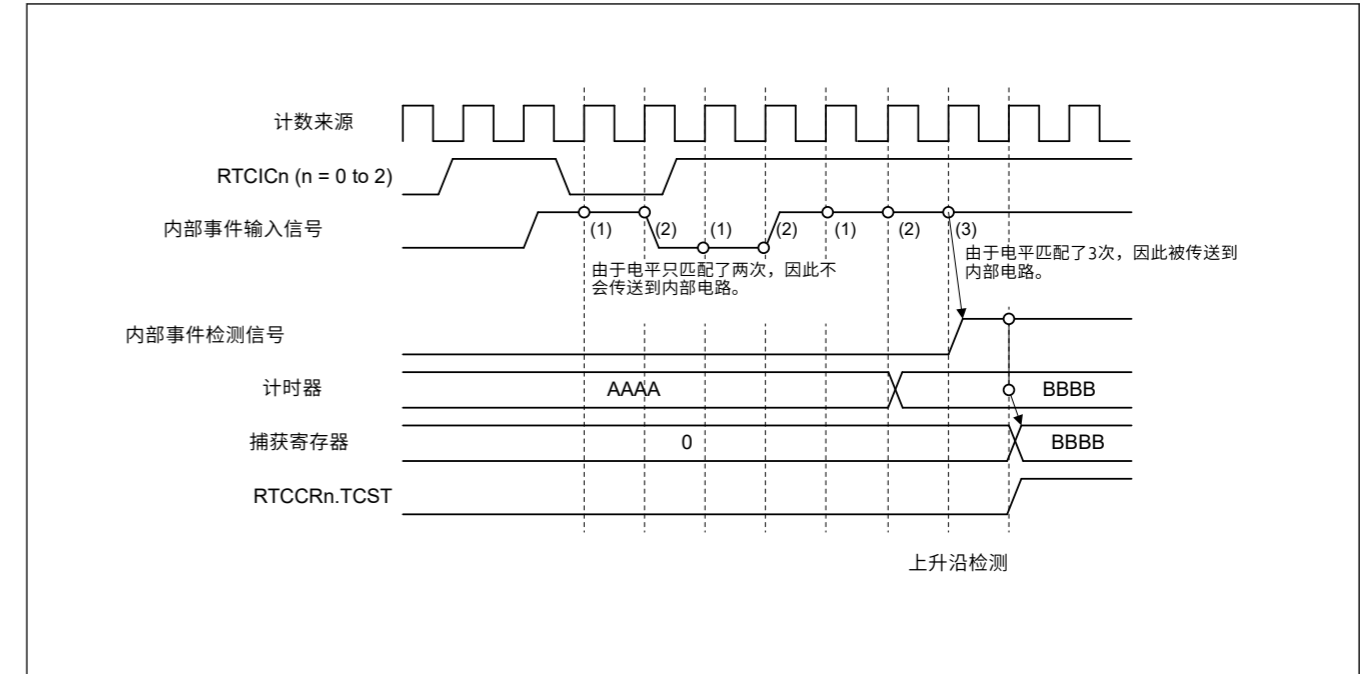


Figure 23.10 开启噪声滤波器的时间捕获操作的时序

### 23.4 中断源

RTC具有三个中断源，如表23.3中所列。

Table 23.3 RTC中断源

| Name    | 中断源   |
|---------|-------|
| RTC_ALM | 报警中断  |
| RTC_PRD | 周期性中断 |
| RTC_CUP | 进位中断  |

#### (1) 闹钟中断(RTC\_ALM)

该中断是根据闹钟寄存器和RTC计数器之间的比较结果产生的。详见23.3.6节。报警功能。

因为当闹钟寄存器的设置与时钟计数器匹配时中断标志可能被设置为1，请等待闹钟时间设置被确认并清除IELSRn.IR标志和相关的中断设置挂起寄存器修改闹钟寄存器的值后，RTC\_ALM中断再次为0。报警中断的中断标志置1并返回报警寄存器和时钟计数器不匹配状态后，该标志不再为1，直到再次匹配或再次修改报警寄存器的值。



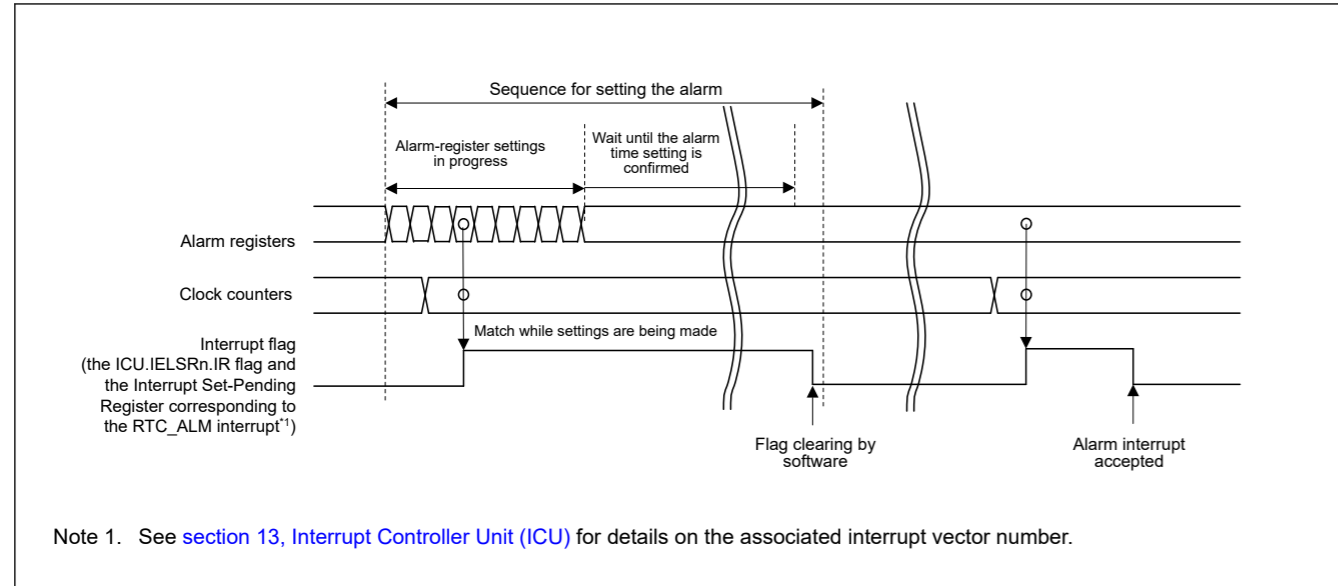


Figure 23.11 Timing for the alarm interrupt (RTC\_ALM)

(2) Periodic interrupt (RTC\_PRD)

This interrupt is generated at intervals of 2 seconds, 1 second, 1/2 second, 1/4 second, 1/8 second, 1/16 second, 1/32 second, 1/64 second, 1/128 second, or 1/256 second. The interrupt interval can be selected in the RCR1.PES[3:0] bits.

(3) Carry interrupt (RTC\_CUP)

This interrupt is generated when a carry to the second counter/binary counter 0 occurred or a carry to the R64CNT counter occurred during read access to the 64-Hz counter.

Figure 23.12 shows the timing of the carry interrupt (RTC\_CPU).

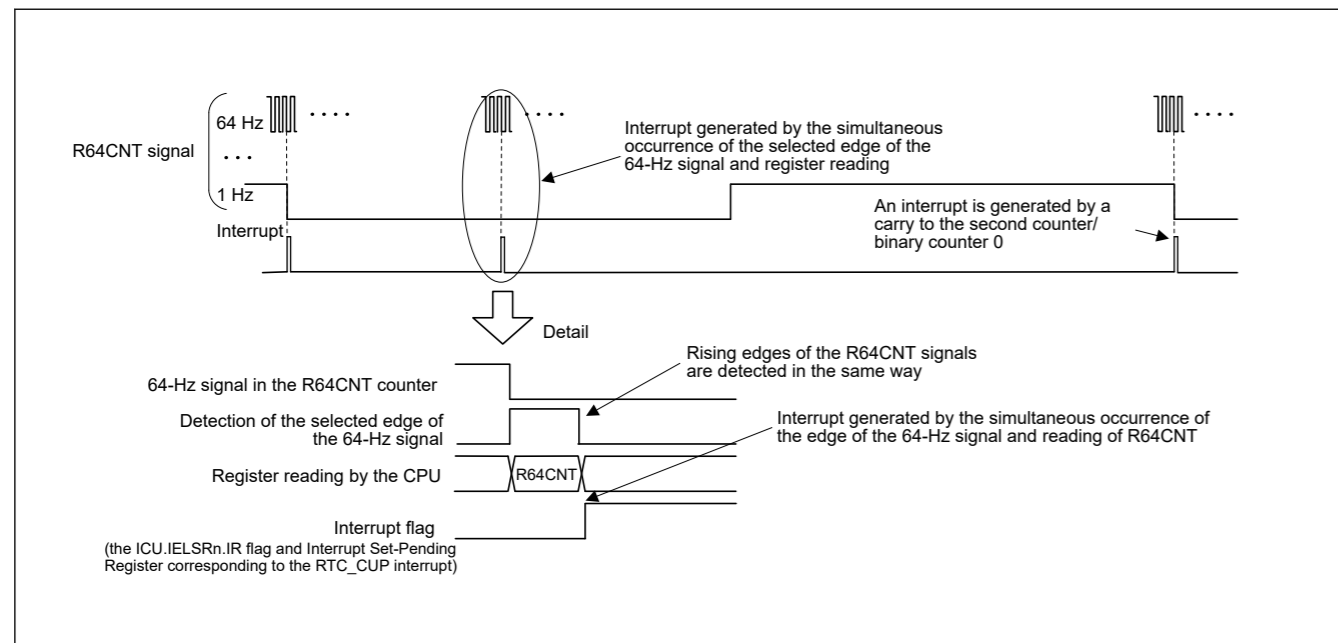


Figure 23.12 Timing for the carry interrupt (RTC\_CUP)

23.5 Event Link Output

The RTC generates periodic event output (RTC\_PRD) event signal for the ELC that can be used to initiate operations by other modules selected in advance.

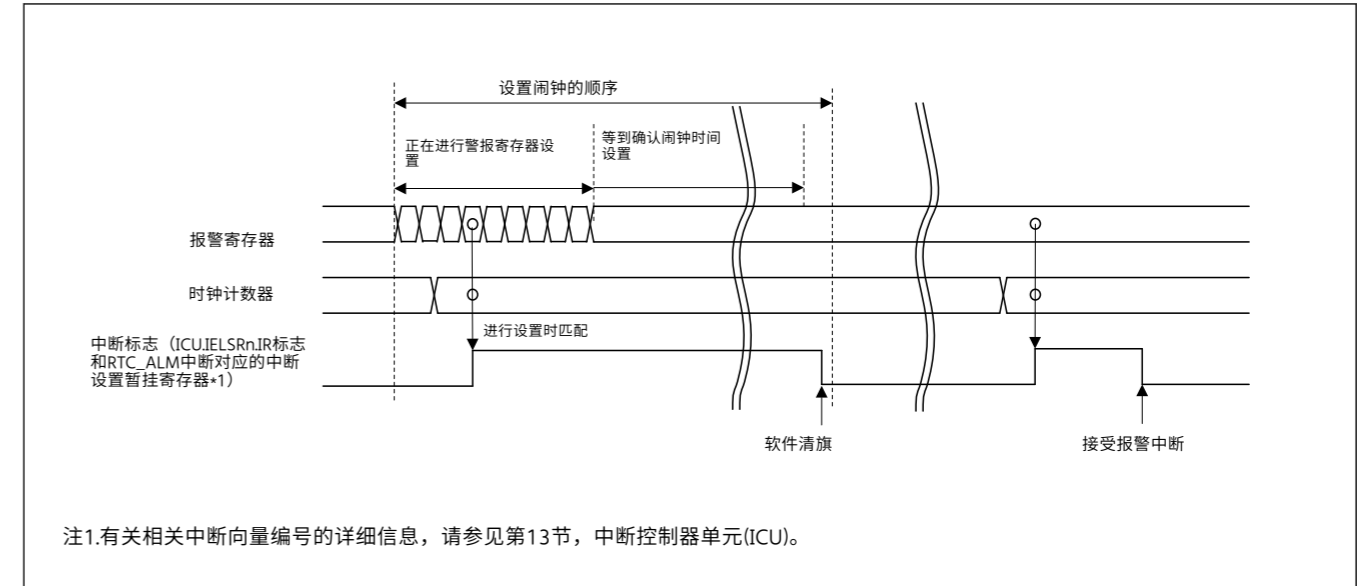


Figure 23.11 闹钟中断的时序(RTC\_ALM)

(2) 周期性中断(RTC\_PRD)

此中断以2秒、1秒、1/2秒、1/4秒、1/8秒、1/16秒、1/32秒、1/64秒、1/128秒或1/256秒的间隔生成。可以在RCR1.PES[3:0]位中选择中断间隔。

(3) 进位中断(RTC\_CUP)

当第二个计数器二进制计数器0的进位发生或在对64-Hz计数器的读访问期间发生对R64CNT计数器的进位时, 将产生此中断。

图23.12显示了进位中断(RTC\_CPU)的时序。

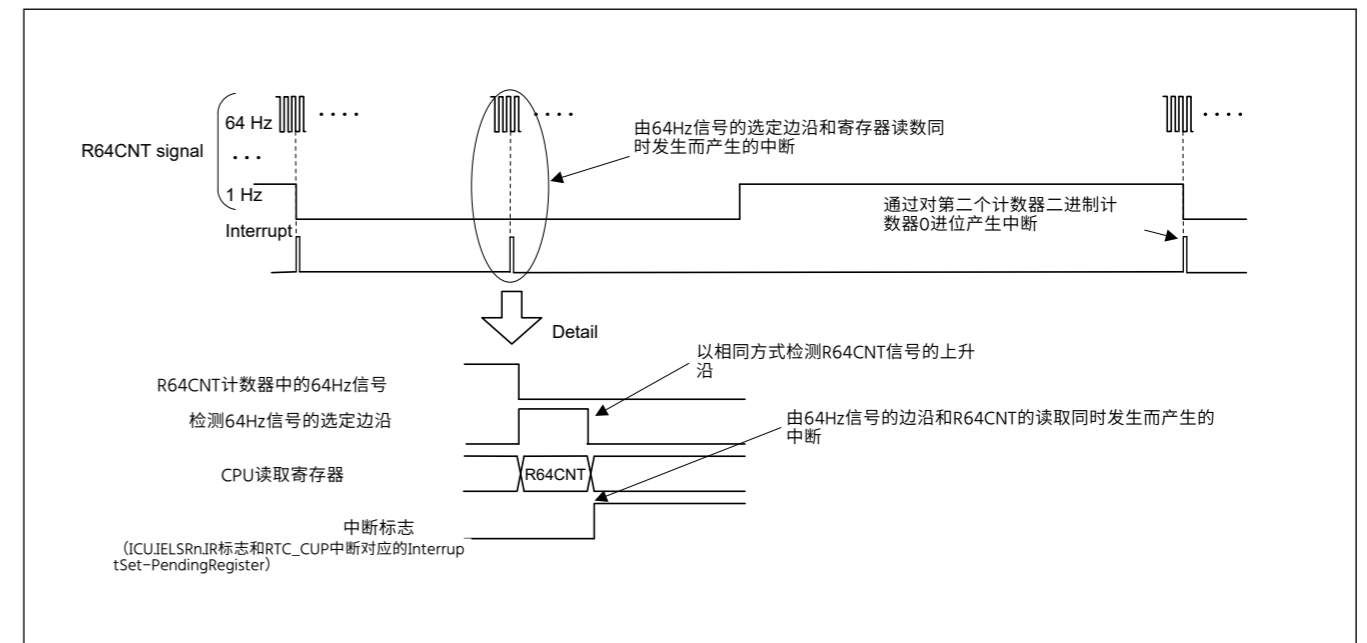


Figure 23.12 进位中断(RTC\_CUP)的时序

23.5 事件链接输出

RTC为ELC生成周期性事件输出(RTC\_PRD)事件信号, 该信号可用于启动预先选择的其他模块的操作。



The periodic event signal is output at the interval selected from 1/256, 1/128, 1/64, 1/32, 1/16, 1/8, 1/4, 1/2, 1, and 2 seconds by setting the RCR1.PES[3:0] bits.

The event generation period immediately after the event generation is selected is not guaranteed.

**Note:** If event linking from the RTC is used, only set the ELC after setting the RTC, for example initialization and time settings. Setting the RTC after the ELC can lead to output of unexpected event signals.

### 23.5.1 Interrupt Handling and Event Linking

The RTC has a bit to enable or disable periodic interrupts. An interrupt request signal is output to the CPU when an interrupt source is generated while the associated enable bit is enabled.

In contrast, an event link output signal is sent to other modules as an event signal through the ELC when an interrupt source is generated, regardless of the setting of the associated interrupt enable bit.

**Note:** Although alarm and periodic interrupts can still be output during Software Standby or Deep Software Standby mode, the periodic event signals for the ELC are not output.

## 23.6 Usage Notes

### 23.6.1 Register Writing during Counting

The following registers should not be written to during counting, that is, while the RCR2.START bit is 1:

- RSECCNT/BCNT0
- RMINCNT/BCNT1
- RHRCNT/BCNT2
- RDAYCNT
- RWKCNT/BCNT3
- RMONCNT
- RYRCNT
- RCR1.RTCOS
- RCR2.RTCOE
- RCR2.HR24
- RFRL

The counter should be stopped before writing to any of these registers.

### 23.6.2 Use of Periodic Interrupts

**Figure 23.13** shows the procedure for using periodic interrupts.

The generation and period of the periodic interrupt can be changed by setting the RCR1.PES[3:0] bits. However, because the prescaler R64CNT and RSECCNT/BCNT0 are used to generate interrupts, the interrupt period is not guaranteed immediately after setting the RCR1.PES[3:0] bits.

In addition, any of the following operation can affect the interrupt period:

- Stopping/restarting or resetting counter operation
- Reset by RTC software
- 30-second adjustment by changing the RCR2 value

When the time error adjustment function is used, the interrupt generation period after adjustment is added or subtracted based on the adjustment value.

通过设置RCR1.PES[3:0]，以从1256、1128、164、132、116、18、14、12、1和2秒中选择的间隔输出周期性事件信号)位。

不保证选择事件生成后的事件生成周期。

**Note:** 如果使用来自RTC的事件链接，请仅在设置RTC后设置ELC，例如初始化和时间设置。在ELC之后设置RTC会导致意外事件信号的输出。

### 23.5.1 中断处理和事件链接

RTC有一个位来启用或禁用周期性中断。当相关使能位使能时产生中断源时，将向CPU输出中断请求信号。

相反，当产生中断源时，事件链接输出信号作为事件信号通过ELC发送到其他模块，而不管相关中断使能位的设置如何。

**Note:** 尽管在软件待机或深度软件待机模式下仍可输出警报和周期性中断，但不会输出ELC的周期性事件信号。

## 23.6 使用说明

### 23.6.1 计数期间的寄存器写入

计数期间不应写入以下寄存器，即RCR2.START位为1时：

- RSECCNT/BCNT0
- RMINCNT/BCNT1
- RHRCNT/BCNT2
- RDAYCNT
- RWKCNT/BCNT3
- RMONCNT
- RYRCNT
- RCR1.RTCOS
- RCR2.RTCOE
- RCR2.HR24
- RFRL

在写入任何这些寄存器之前，应停止计数器。

### 23.6.2 使用周期性中断

图23.13显示了使用周期性中断的过程。

可以通过设置RCR1.PES[3:0]位来更改周期性中断的产生和周期。但是，因为预分频器R64CNT和RSECCNT/BCNT0用于产生中断，所以在设置RCR1.PES[3:0]位后不能立即保证中断周期。

此外，以下任何操作都会影响中断周期：

- 停止重新启动或重置计数器操作
- RTC软件复位
- 通过改变RCR2值进行30秒调整

使用时间误差调整功能时，根据调整值加减调整后的中断产生周期。

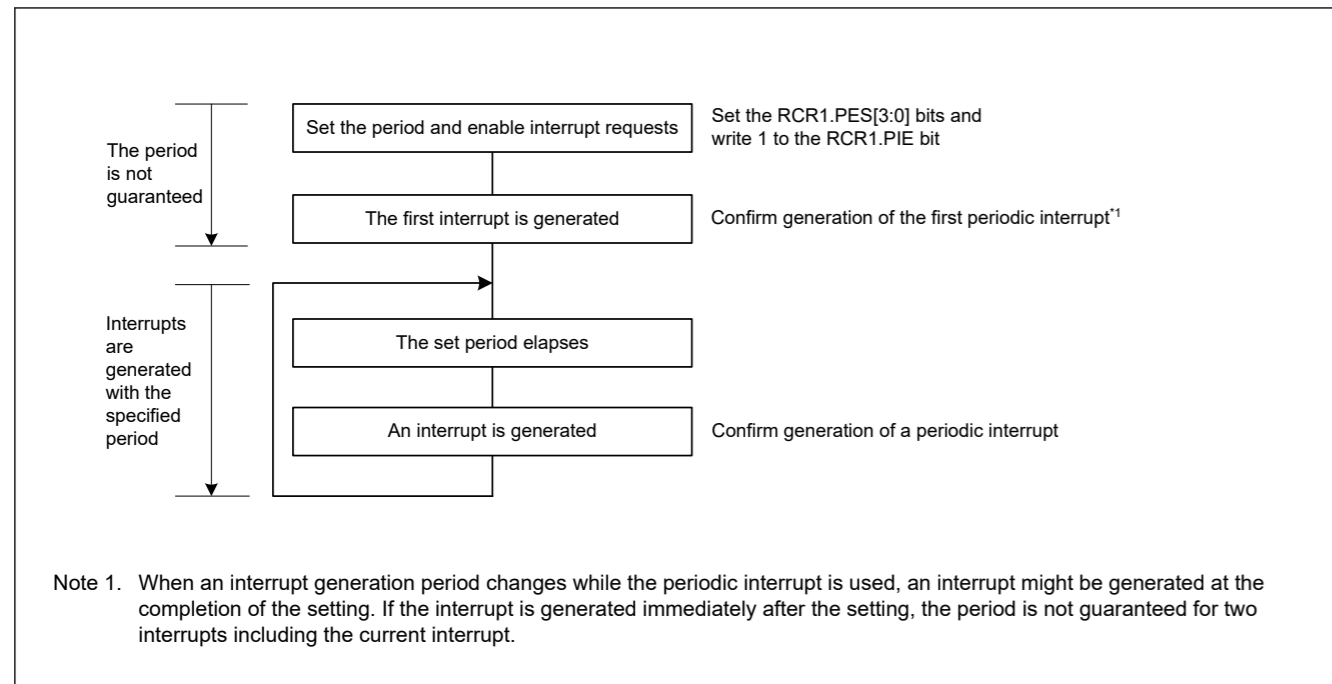


Figure 23.13 Using the periodic interrupt function

### 23.6.3 RTCOUT (1-Hz/64-Hz) Clock Output

Stopping/restarting or resetting counter operation, reset by RTC software, and the 30-second adjustment by changing the RCR2 value affects the period of RTCOUT (1-Hz/64-Hz) output. When the time error adjustment function is used, the period of RTCOUT (1-Hz/64-Hz) output after adjustment is added or subtracted based on the adjustment value.

### 23.6.4 Transitions to Low Power Modes after Setting Registers

A transition to a low power state (Software Standby mode, Deep Software Standby mode, or battery backup state) during a write to an RTC register might corrupt the value of the register. After setting the register, confirm that the setting is in place before initiating a transition to a low power state.

### 23.6.5 Notes on Writing to and Reading from Registers

- When reading a counter register such as the second counter after writing to the counter register, follow the procedure in [section 23.3.5. Reading 64-Hz Counter and Time](#).
- The value written to the count registers, alarm registers, year alarm enable register, bits RCR2.AADJE, AADJP, and HR24, RCR4 register, or frequency register is reflected when fourth read operations are performed after writing.
- The values written to the RCR1.CIE, RCR1.RTCOS, and RCR2.RTCOE bits can be read immediately after writing.
- To read the value from the timer counter after returning from a reset or a period in Software Standby mode, Deep Software Standby mode, or battery backup state, wait for 1/128 second while the clock is operating (RCR2.START bit = 1).
- After a reset is generated, write to the RTC register after 6 cycles of the count source clock have elapsed.

### 23.6.6 Changing the Count Mode

When changing the count mode (calendar count mode/binary count mode), set the RCR2.START bit to 0, stop the counting operation, then start it again from the initial setting. For details on the initial setting, see [section 23.3.1. Outline of Initial Settings of Registers after Power On](#).

### 23.6.7 Initialization Procedure When the RTC Is Not to Be Used

Registers in the RTC are not initialized by a reset. Depending on the initial state, the generation of an unintentional interrupt request or operation of the counter might lead to increased power consumption.

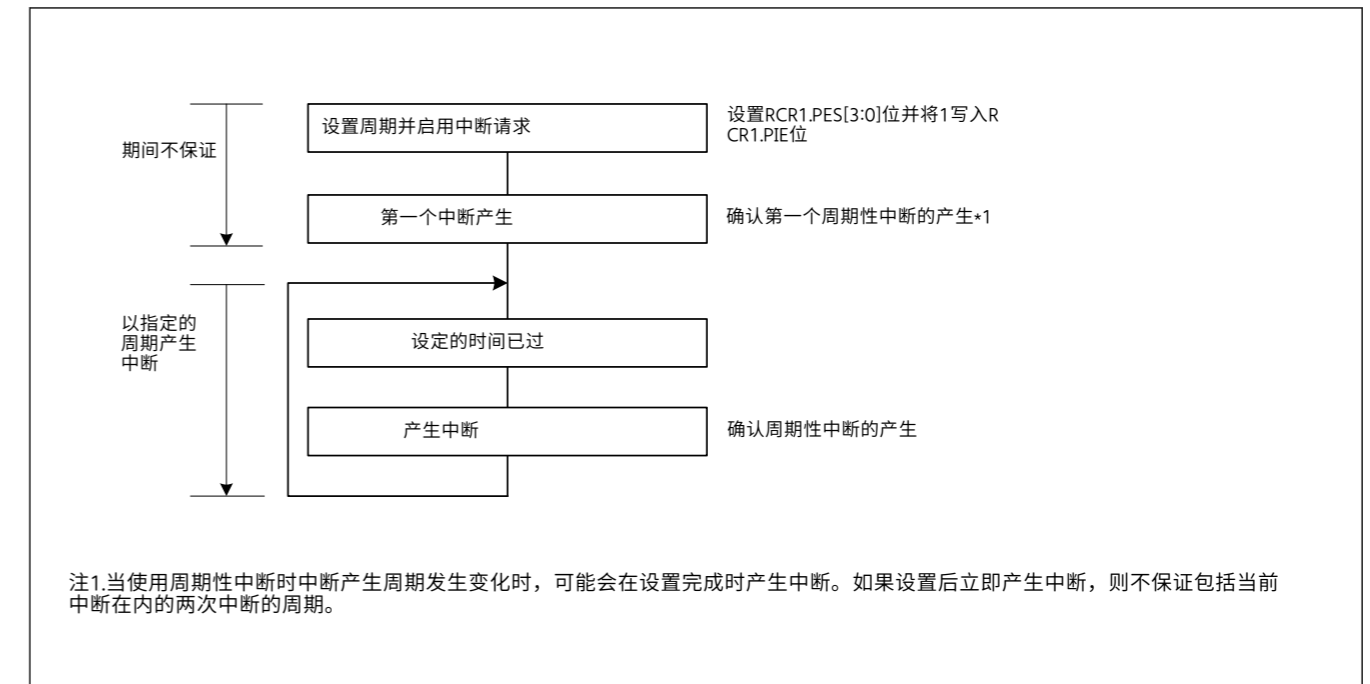


Figure 23.13 使用周期性中断功能

### 23.6.3 RTCOUT(1-Hz/64-Hz)时钟输出

停止重新启动或重置计数器操作,通过RTC软件重置,并通过更改30秒调整RCR2值影响RTCOUT(1-Hz/64-Hz)输出的周期。使用时间误差调整功能时,调整后的RTCOUT(1-Hz/64-Hz)输出的周期根据调整值加减。

### 23.6.4 设置寄存器后转换到低功耗模式

在写入RTC寄存器期间转换到低功耗状态(软件待机模式、深度软件待机模式或电池备份状态)可能会损坏寄存器的值。设置寄存器后,在开始转换到低功耗状态之前确认设置到位。

### 23.6.5 关于写入和读取寄存器的注意事项

- 在写入计数器寄存器后读取第二个计数器寄存器时,请按照[第23.3.5节.读取64-Hz计数器和时间](#)。
- 写入计数寄存器、报警寄存器、年报警使能寄存器、RCR2.AADJE、AADJP位和HR24、RCR4寄存器或频率寄存器的值在写入后执行第四次读操作时反映。
- 写入RCR1.CIE、RCR1.RTCOS和RCR2.RTCOE位的值可在写入后立即读取。
- 要在软件待机模式下从复位或一段时间返回后从定时器计数器读取值,Deep软件待机模式或电池备份状态在时钟运行时等待1/128秒(RCR2.START位=1)。
- 产生复位后,经过6个计数源时钟周期后写入RTC寄存器。

### 23.6.6 更改计数模式

当改变计数模式(日历计数模式/二进制计数模式)时,将RCR2.START位设置为0,停止计数操作,然后从初始设置重新开始。有关初始设置的详细信息,请参阅[第23.3.1节.上电后寄存器的初始设置概要](#)。

### 23.6.7 不使用RTC时的初始化程序

RTC中的寄存器不会因复位而初始化。根据初始状态,意外中断请求的生成或计数器的操作可能会导致功耗增加。

For applications that do not require a realtime clock, initialize the registers by following the initialization procedure shown in Figure 23.14.

Alternatively, when the sub-clock oscillator is not used as the system clock or realtime clock, the counter can be stopped by writing 0 (sub-clock oscillator is selected) to the RCR4.RCKSEL bit and stopping the sub-clock oscillator. To stop the sub-clock oscillator, write 1 to the SOSCCR.SOSTP bit.

For details on the setting of the SOSCCR.SOSTP bit, see section 8, Clock Generation Circuit.

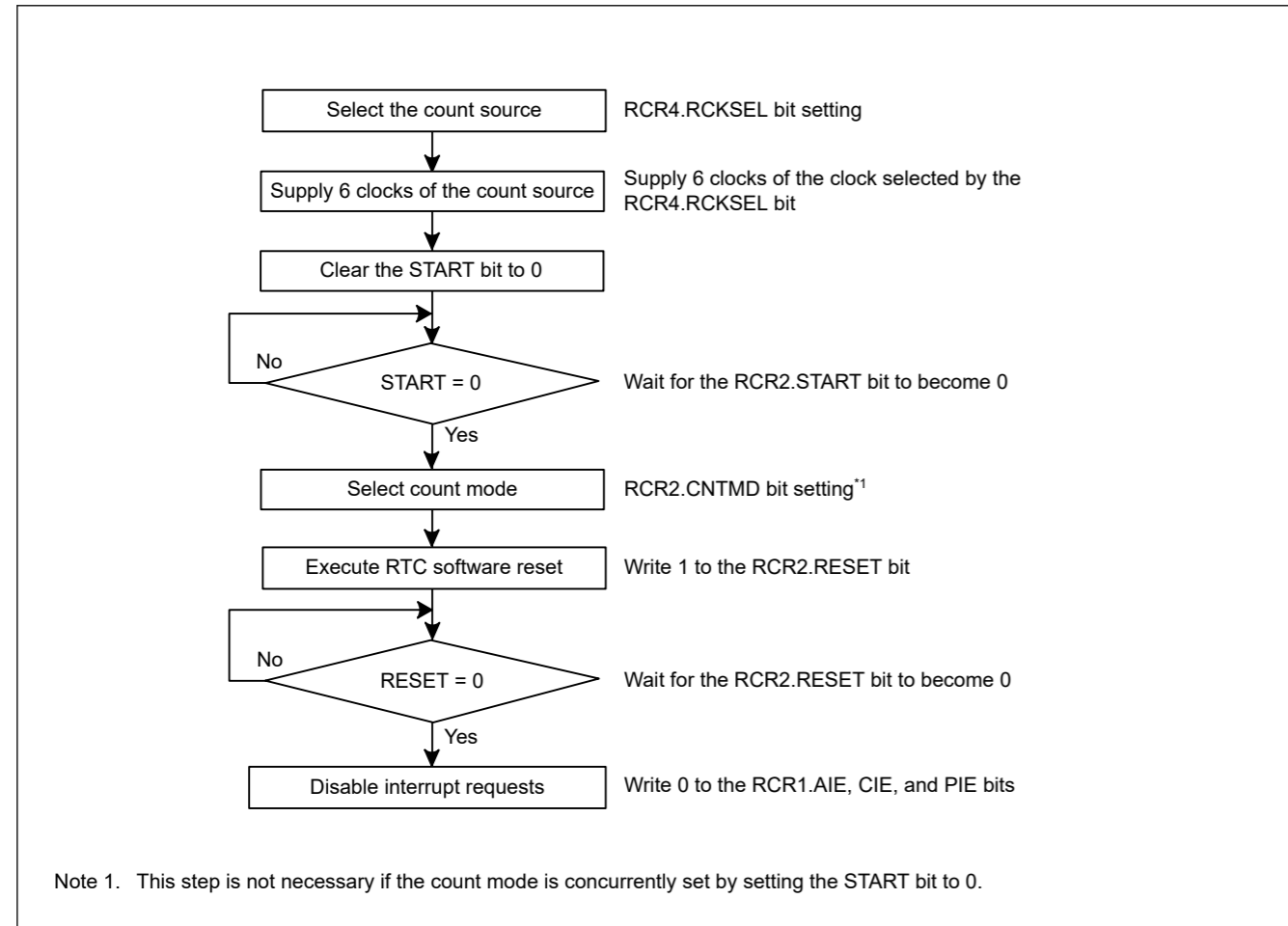


Figure 23.14 Initialization procedure

### 23.6.8 When Switching Source Clock

When switching a clock source by changing SCKSCR.CKSEL[2:0], the clock output from the selector stops for 4 cycles of the switched clock. If the RTC periodical interrupt or RTC periodical event output was generated at this time, the interrupt or event is invalid.

对于不需要实时时钟的应用程序，按照图23.14所示的初始化过程初始化寄存器。

或者，当副时钟振荡器不用作系统时钟或实时时钟时，可以通过向RCR4.RCKSEL位写入0（选择副时钟振荡器）并停止副时钟振荡器来停止计数器。要停止副时钟振荡器，向SOSCCR.SOSTP位写入1。

有关SOSCCR.SOSTP位设置的详细信息，请参见第8节，时钟生成电路。

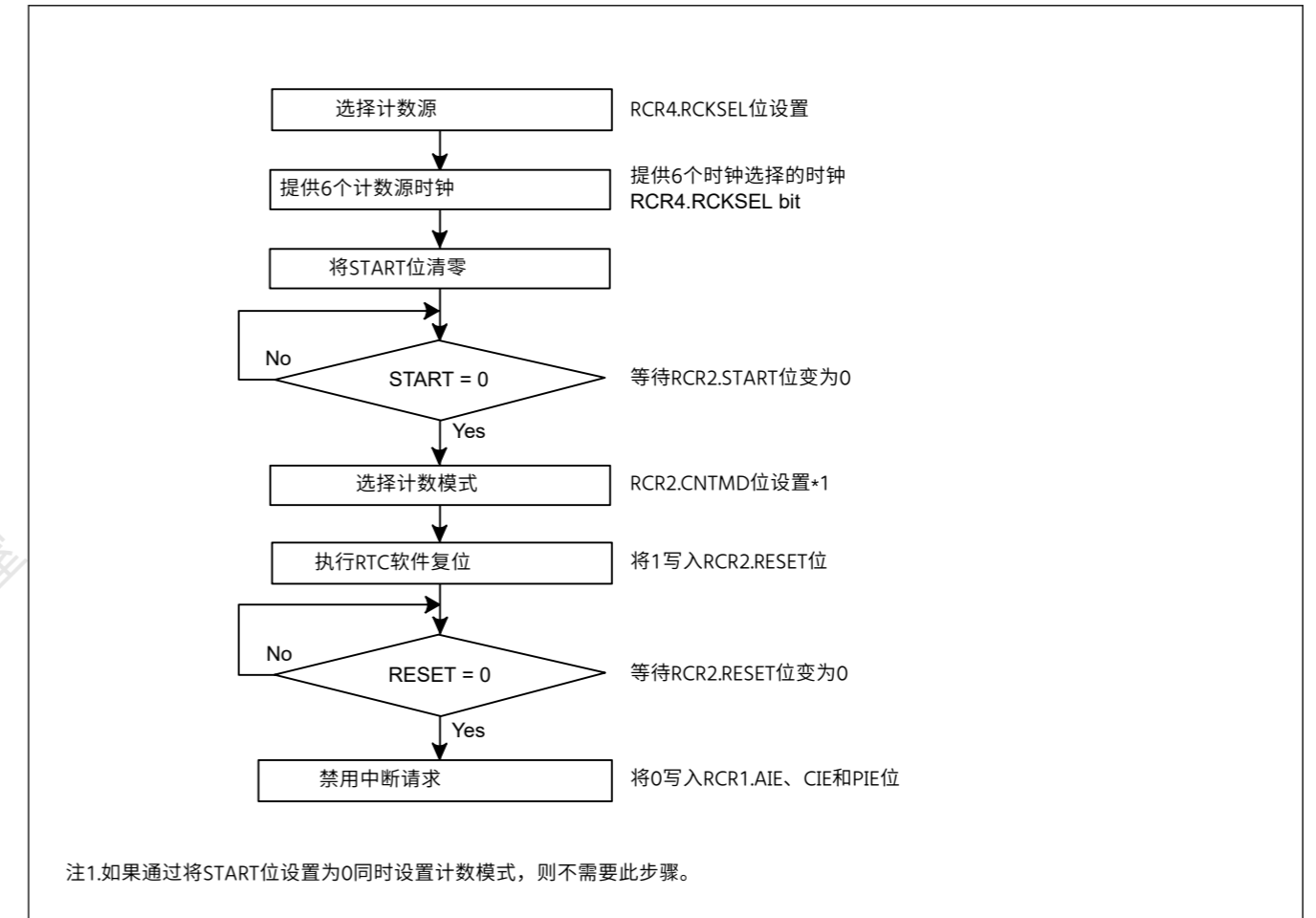


Figure 23.14 初始化程序

### 23.6.8 切换源时钟时

当通过改变SCKSCR.CKSEL[2:0]来切换时钟源时，选择器的时钟输出在切换时钟的4个周期内停止。如果此时产生了RTC周期性中断或RTC周期性事件输出，则该中断或事件无效。

## 24. Watchdog Timer (WDT)

### 24.1 Overview

The Watchdog Timer (WDT) is a 14-bit down counter that can be used to reset the MCU when the counter underflows because the system has run out of control and is unable to refresh the WDT. In addition, the WDT can be used to generate a non-maskable interrupt or an underflow interrupt.

Table 24.1 lists the WDT specifications and Figure 24.1 shows a block diagram.

**Table 24.1 WDT specifications**

| Parameter                                | Specifications  |
|--|---|
| Count source*1                           | Peripheral clock (PCLKB)  |
| Clock division ratio                     | Division by 4, 64, 128, 512, 2048, or 8192  |
| Counter operation                        | Counting down using a 14-bit down-counter   |
| Condition for starting the counter       | <ul style="list-style-type: none"> <li>Auto start mode: Counting automatically starts after a reset or after an underflow or refresh error occurs</li> <li>Register start mode: Counting is started with a refresh by writing to the WDTRR register</li> <li>Only secure developer can select Auto-start mode or Register-start mode</li> </ul> |
| Conditions for stopping the counter      | <ul style="list-style-type: none"> <li>Reset (the down-counter and other registers return to their initial values)</li> <li>A counter underflows or a refresh error is generated</li> </ul>   |
| Window function                          | Window start and end positions can be specified (refresh-permitted and refresh-prohibited periods)  |
| Watchdog timer reset sources             | <ul style="list-style-type: none"> <li>Down-counter underflows</li> <li>Refreshing outside the refresh-permitted period (refresh error)</li> </ul>  |
| Non-maskable interrupt/interrupt sources | <ul style="list-style-type: none"> <li>Down-counter underflows</li> <li>Refreshing outside the refresh-permitted period (refresh error)</li> </ul>  |
| Reading of the counter value             | The down-counter value can be read by the WDTSR register  |
| Event link function (output)             | <ul style="list-style-type: none"> <li>Down-counter underflow event output</li> <li>Refresh error event output</li> </ul>   |
| Output signal (internal signal)          | <ul style="list-style-type: none"> <li>Reset output</li> <li>Interrupt request output</li> <li>Sleep-mode count stop control output</li> </ul>  |
| TrustZone Filter                         | Security attribution can be set   |

Note 1. Satisfy the frequency of the peripheral module clock (PCLKB)  $\geq 4 \times$  (the frequency of the count clock source after division).

## 24. 看门狗定时器(WDT)

### 24.1 Overview

看门狗定时器(WDT)是一个14位递减计数器，可用于在计数器下溢时复位MCU，因为系统已失控且无法刷新WDT。此外，WDT可用于产生不可屏蔽中断或下溢中断。

表24.1列出了WDT规范，图24.1显示了框图。

**Table 24.1 WDT specifications**

| Parameter                                | Specifications   |
|--|--|
| 计数来源*1                                   | 外设时钟(PCLKB)  |
| 时钟分频比                                    | 除以4、64、128、512、2048或8192   |
| 计数器操作                                    | 使用14位递减计数器进行递减计数   |
| 启动计数器的条件                                 | <ul style="list-style-type: none"> <li>自动启动模式：复位后或发生下溢或刷新错误后自动开始计数</li> <li>寄存器启动模式：通过写入WDTRR寄存器以刷新开始计数</li> <li>只有安全的开发人员可以选择自动启动模式或注册启动模式</li> </ul> |
| 停止计数器的条件                                 | <ul style="list-style-type: none"> <li>复位（递减计数器和其他寄存器恢复初始值）</li> <li>计数器下溢或产生刷新错误</li> </ul>   |
| 窗口功能                                     | 可以指定窗口开始和结束位置（允许刷新和禁止刷新期间）   |
| 看门狗定时器复位源                                | <ul style="list-style-type: none"> <li>Down-counter underflows</li> <li>刷新允许时间之外的刷新（刷新错误）</li> </ul>   |
| Non-maskable interrupt/interrupt sources | <ul style="list-style-type: none"> <li>Down-counter underflows</li> <li>刷新允许时间之外的刷新（刷新错误）</li> </ul>   |
| 读取计数器值                                   | 递减计数器的值可以通过WDTSR寄存器读取  |
| 事件链接功能（输出）                               | <ul style="list-style-type: none"> <li>递减计数器下溢事件输出</li> <li>刷新错误事件输出</li> </ul>  |
| 输出信号（内部信号）                               | <ul style="list-style-type: none"> <li>复位输出</li> <li>中断请求输出</li> <li>休眠模式计数停止控制输出</li> </ul>   |
| TrustZone Filter                         | 可设置安全属性  |

注1.满足外设模块时钟（PCLKB）的频率 $\geq 4 \times$ （分频后的计数时钟源的频率）。

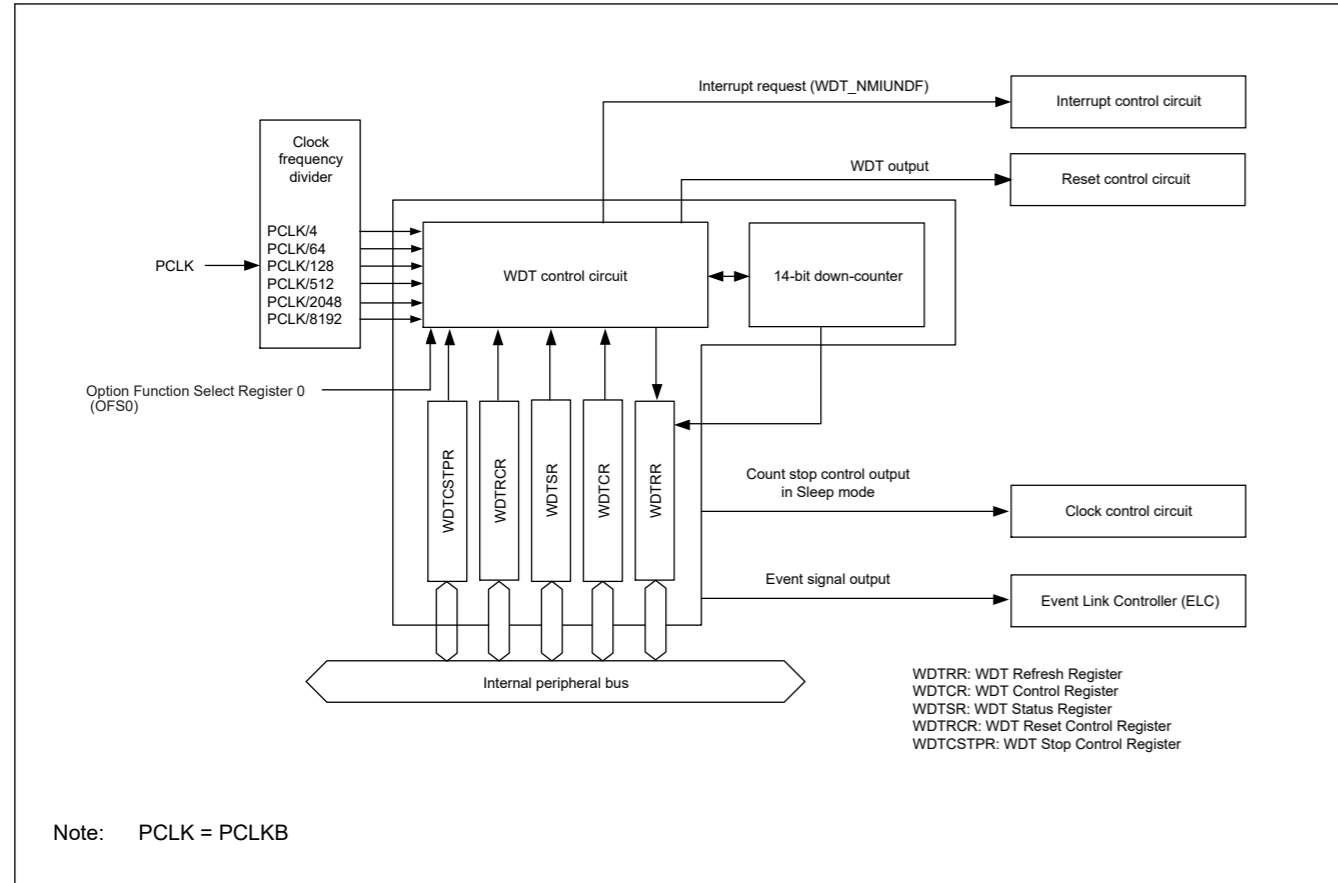


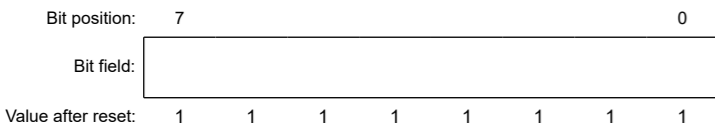
Figure 24.1 WDT block diagram

24.2 Register Descriptions

24.2.1 WDTRR : WDT Refresh Register

Base address: WDT = 0x4008\_3400

Offset address: 0x00



| Bit | Symbol | Function  | R/W |
|-----|--------|---|-----|
| 7:0 | n/a    | The down-counter is refreshed by writing 0x00 and then writing 0xFF to this register. | R/W |

The WDTRR register refreshes the down-counter of the WDT.

The down-counter of the WDT is refreshed by writing 0x00 and then writing 0xFF to WDTRR register (refresh operation) within the refresh-permitted period.

After the down-counter is refreshed, it starts counting down from the value selected by setting the WDT Timeout Period Select bits (OFS0.WDTTOPS[1:0]) in the Option Function Select Register 0 in auto start mode. In register start mode, counting down starts from the value selected by setting the Timeout Period Select bits (WDTTCR.TOPS[1:0]) in the WDT Control Register.

When 0x00 is written, the read value is 0x00. When a value other than 0x00 is written, the read value is 0xFF. For details of the refresh operation, see section 24.3.3. Refresh Operation.

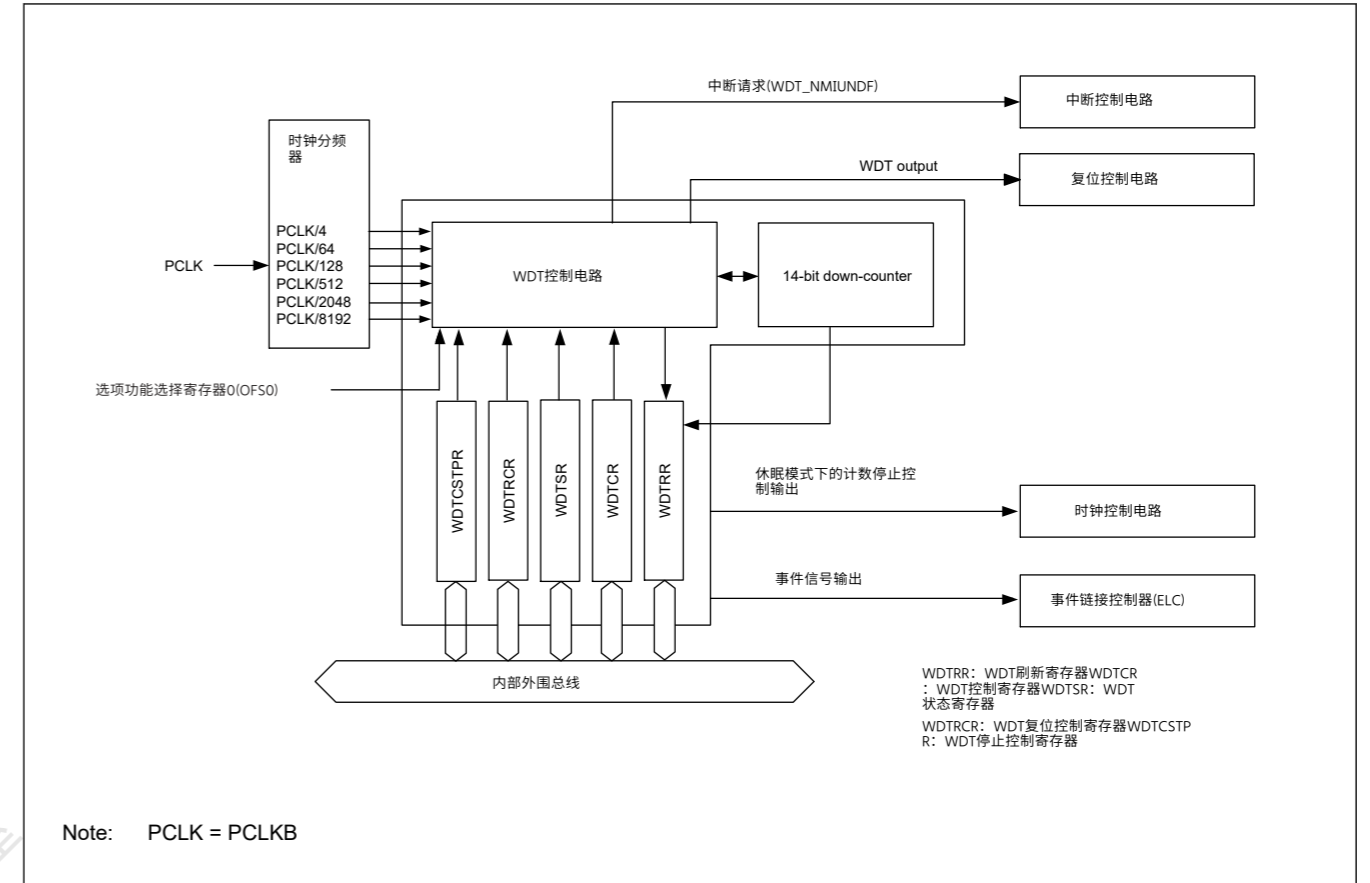


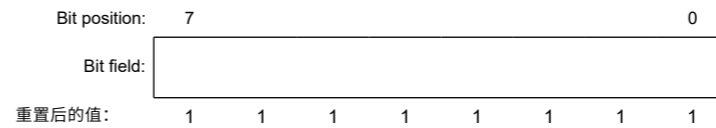
Figure 24.1 看门狗框图

24.2 注册说明

24.2.1 WDTRR:WDT刷新寄存器

Base address: WDT = 0x4008\_3400

Offset address: 0x00



| Bit | Symbol | Function                       | R/W |
|-----|--------|--------------------------------|-----|
| 7:0 | n/a    | 通过写入0x00然后将0xFF写入该寄存器来刷新递减计数器。 | R/W |

WDTRR寄存器刷新WDT的递减计数器。

WDT的递减计数器通过在允许刷新期间内写入0x00然后将0xFF写入WDTRR寄存器（刷新操作）来刷新。

递减计数器刷新后，在自动启动模式下，它从通过设置选项功能选择寄存器0中的WDT超时周期选择位(OFS0.WDTTOPS[1:0])选择的值开始递减计数。在寄存器启动模式下，倒计时从通过设置WDT控制寄存器中的超时周期选择位(WDTTCR.TOPS[1:0])选择的值开始。

写入0x00时，读取值为0x00。写入0x00以外的值时，读取的值为0xFF。有关刷新操作的详细信息，请参阅第24.3.3节。刷新操作。



## 24.2.2 WDTCR : WDT Control Register

Base address: WDT = 0x4008\_3400

Offset address: 0x02

|                    |    |    |           |    |    |           |          |   |   |   |   |           |   |   |   |   |
|--------------------|----|----|-----------|----|----|-----------|----------|---|---|---|---|-----------|---|---|---|---|
| Bit position:      | 15 | 14 | 13        | 12 | 11 | 10        | 9        | 8 | 7 | 6 | 5 | 4         | 3 | 2 | 1 | 0 |
| Bit field:         | —  | —  | RPSS[1:0] | —  | —  | RPES[1:0] | CKS[3:0] |   |   | — | — | TOPS[1:0] |   |   |   |   |
| Value after reset: | 0  | 0  | 1         | 1  | 0  | 0         | 1        | 1 | 1 | 1 | 1 | 1         | 0 | 0 | 1 | 1 |

| Bit   | Symbol    | Function   | R/W |
|-------|-----------|--|-----|
| 1:0   | TOPS[1:0] | Timeout Period Select<br>0 0: 1024 cycles (0x03FF)<br>0 1: 4096 cycles (0x0FFF)<br>1 0: 8192 cycles (0x1FFF)<br>1 1: 16384 cycles (0x3FFF)                           | R/W |
| 3:2   | —         | These bits are read as 0. The write value should be 0.   | R/W |
| 7:4   | CKS[3:0]  | Clock Division Ratio Select<br>0x1: PCLKB/4<br>0x4: PCLKB/64<br>0xF: PCLKB/128<br>0x6: PCLKB/512<br>0x7: PCLKB/2048<br>0x8: PCLKB/8192<br>Others: Setting prohibited | R/W |
| 9:8   | RPES[1:0] | Window End Position Select<br>0 0: 75%<br>0 1: 50%<br>1 0: 25%<br>1 1: 0% (do not specify window end position).  | R/W |
| 11:10 | —         | These bits are read as 0. The write value should be 0.   | R/W |
| 13:12 | RPSS[1:0] | Window Start Position Select<br>0 0: 25%<br>0 1: 50%<br>1 0: 75%<br>1 1: 100% (do not specify window start position).  | R/W |
| 15:14 | —         | These bits are read as 0. The write value should be 0.   | R/W |

The WDTCR register is used to set the clock division ratio, and window start and end positions for refresh, and the timeout period until the down-counter underflows in register start mode.

Some constraints apply to writes to the WDTCR register. For details, see [section 24.3.2. Controlling Writes to the WDTCR, WDTCR, and WDTCSR Registers](#).

In auto start mode, the settings in the WDTCR register are disabled, and the settings in the Option Function Select Register 0 (OFS0) are enabled. The settings for the WDTCR register can also be made in the OFS0 register. For details, see [section 24.3.8. Association between Option Function Select Register 0 \(OFS0\) and WDT Registers](#).

**TOPS[1:0] bits (Timeout Period Select)**

The TOPS[1:0] bits select the timeout period, the period until the down-counter underflows, from 1024, 4096, 8192, and 16384 cycles, taking the divided clock specified in the CKS[3:0] bits as 1 cycle. After the down-counter is refreshed, the combination of the CKS[3:0] and TOPS[1:0] bits determines the number of PCLKB cycles until the counter underflows.

[Table 24.2](#) lists the relationship between the CKS[3:0] and TOPS[1:0] bit settings, the timeout period, and the number of PCLKB cycles.

## 24.2.2 WDTCR:WDT控制寄存器

Base address: WDT = 0x4008\_3400

Offset address: 0x02

|               |    |    |           |    |    |           |          |   |   |   |   |           |   |   |   |   |
|---------------|----|----|-----------|----|----|-----------|----------|---|---|---|---|-----------|---|---|---|---|
| Bit position: | 15 | 14 | 13        | 12 | 11 | 10        | 9        | 8 | 7 | 6 | 5 | 4         | 3 | 2 | 1 | 0 |
| Bit field:    | —  | —  | RPSS[1:0] | —  | —  | RPES[1:0] | CKS[3:0] |   |   | — | — | TOPS[1:0] |   |   |   |   |
| 重置后的值:        | 0  | 0  | 1         | 1  | 0  | 0         | 1        | 1 | 1 | 1 | 1 | 1         | 0 | 0 | 1 | 1 |

| Bit   | Symbol    | Function   | R/W |
|-------|-----------|--|-----|
| 1:0   | TOPS[1:0] | 超时时间选择<br>0 0: 1024 cycles (0x03FF)<br>0 1: 4096 cycles (0x0FFF)<br>1 0: 8192 cycles (0x1FFF)<br>1 1: 16384 cycles (0x3FFF)    | R/W |
| 3:2   | —         | 这些位被读取为0。写入值应为0。   | R/W |
| 7:4   | CKS[3:0]  | 时钟分频比选择<br>0x1: PCLKB/4<br>0x4: PCLKB/64<br>0xF: PCLKB/128<br>0x6: PCLKB/512<br>0x7: PCLKB/2048<br>0x8: PCLKB/8192<br>其他: 禁止设置 | R/W |
| 9:8   | RPES[1:0] | 窗口结束位置选择<br>00: 75%01: 50%10: 25%11: 0% (不指定窗口结束位置)。   | R/W |
| 11:10 | —         | 这些位被读取为0。写入值应为0。   | R/W |
| 13:12 | RPSS[1:0] | 窗口起始位置选择<br>00: 25%01: 50%10: 75%11: 100% (不指定窗口起始位置)。   | R/W |
| 15:14 | —         | 这些位被读取为0。写入值应为0。   | R/W |

WDTCR寄存器用于设置时钟分频比、刷新的窗口开始和结束位置，以及在寄存器开始模式下直到递减计数器下溢的超时时间。

一些限制适用于写入WDTCR寄存器。详见24.3.2节。控制对WDTCR的写入，[WDTCSR和WDTCSR寄存器](#)。

在自动启动模式下，禁用WDTCR寄存器中的设置，启用选项功能选择寄存器0(OFS0)中的设置。WDTCR寄存器的设置也可以在OFS0寄存器中进行。详见24.3.8节。选项功能选择寄存器0(OFS0)和WDT寄存器之间的关联。

**TOPS[1:0]位 (超时周期选择)**

TOPS[1:0]位从1024、4096、8192和16384个周期中选择超时周期，直到递减计数器下溢的周期，以CKS[3:0]位中指定的分频时钟为1个周期。向下计数器刷新后，CKS[3:0]和TOPS[1:0]位的组合决定了PCLKB周期数，直到计数器下溢。

表24.2列出了CKS[3:0]和TOPS[1:0]位设置、超时时间和PCLKB cycles。

Table 24.2 Timeout period settings

| CKS[3:0] bits | TOPS[1:0] bits | Clock division ratio | Timeout period (number of cycles) | PCLKB clock cycles |
|---------------|----------------|----------------------|-----------------------------------|--------------------|
| 0x1           | 00b            | PCLKB/4              | 1024                              | 4096               |
|               | 01b            |                      | 4096                              | 16384              |
|               | 10b            |                      | 8192                              | 32768              |
|               | 11b            |                      | 16384                             | 65536              |
| 0x4           | 00b            | PCLKB/64             | 1024                              | 65536              |
|               | 01b            |                      | 4096                              | 262144             |
|               | 10b            |                      | 8192                              | 524288             |
|               | 11b            |                      | 16384                             | 1048576            |
| 0xF           | 00b            | PCLKB/128            | 1024                              | 131072             |
|               | 01b            |                      | 4096                              | 524288             |
|               | 10b            |                      | 8192                              | 1048576            |
|               | 11b            |                      | 16384                             | 2097152            |
| 0x6           | 00b            | PCLKB/512            | 1024                              | 524288             |
|               | 01b            |                      | 4096                              | 2097152            |
|               | 10b            |                      | 8192                              | 4194304            |
|               | 11b            |                      | 16384                             | 8388608            |
| 0x7           | 00b            | PCLKB/2048           | 1024                              | 2097152            |
|               | 01b            |                      | 4096                              | 8388608            |
|               | 10b            |                      | 8192                              | 16777216           |
|               | 11b            |                      | 16384                             | 33554432           |
| 0x8           | 00b            | PCLKB/8192           | 1024                              | 8388608            |
|               | 01b            |                      | 4096                              | 33554432           |
|               | 10b            |                      | 8192                              | 67108864           |
|               | 11b            |                      | 16384                             | 134217728          |

**CKS[3:0] bits (Clock Division Ratio Select)**

The CKS[3:0] bits specify the division ratio of the clock used for the down-counter. The division ratio can be selected from the PCLKB divided by 4, 64, 128, 512, 2048, and 8192. Combined with the TOPS[1:0] bit setting, this allows the WDT to be configured to a count period between 4096 and 134217728 PCLKB clock cycles.

**RPES[1:0] bits (Window End Position Select)**

The RPES[1:0] bits specify the window end position that indicates the refresh-permitted period. 75%, 50%, 25%, or 0% of the timeout period can be selected for the window end position. Set the window end position to a value less than the value for the window start position (window start position > window end position). If the window end position is greater than the window start position, only the window start position setting is enabled.

**RPSS[1:0] bits (Window Start Position Select)**

The RPSS[1:0] bits specify the window start position that indicates the refresh-permitted period. 100%, 75%, 50%, or 25% of the timeout period can be selected for the window start position. Set the window start position to a value greater than the value for the window end position. If the window start position is set to a value less than or equal to the window end position, the window end position is set to 0%.

Table 24.3 lists the counter values for the window start and end positions, and Figure 24.2 shows the refresh-permitted period set in the RPSS[1:0], RPES[1:0], and TOPS[1:0] bits.

Table 24.2 超时时间设置

| CKS[3:0] bits | TOPS[1:0] bits | 时钟分频比      | 超时时间 (周期数) | PCLKB时钟周期 |
|---------------|----------------|------------|------------|-----------|
| 0x1           | 00b            | PCLKB/4    | 1024       | 4096      |
|               | 01b            |            | 4096       | 16384     |
|               | 10b            |            | 8192       | 32768     |
|               | 11b            |            | 16384      | 65536     |
| 0x4           | 00b            | PCLKB/64   | 1024       | 65536     |
|               | 01b            |            | 4096       | 262144    |
|               | 10b            |            | 8192       | 524288    |
|               | 11b            |            | 16384      | 1048576   |
| 0xF           | 00b            | PCLKB/128  | 1024       | 131072    |
|               | 01b            |            | 4096       | 524288    |
|               | 10b            |            | 8192       | 1048576   |
|               | 11b            |            | 16384      | 2097152   |
| 0x6           | 00b            | PCLKB/512  | 1024       | 524288    |
|               | 01b            |            | 4096       | 2097152   |
|               | 10b            |            | 8192       | 4194304   |
|               | 11b            |            | 16384      | 8388608   |
| 0x7           | 00b            | PCLKB/2048 | 1024       | 2097152   |
|               | 01b            |            | 4096       | 8388608   |
|               | 10b            |            | 8192       | 16777216  |
|               | 11b            |            | 16384      | 33554432  |
| 0x8           | 00b            | PCLKB/8192 | 1024       | 8388608   |
|               | 01b            |            | 4096       | 33554432  |
|               | 10b            |            | 8192       | 67108864  |
|               | 11b            |            | 16384      | 134217728 |

**CKS[3:0]位 (时钟分频比选择)**

CKS[3:0]位指定用于递减计数器的时钟的分频比。分频比可以从PCLKB除以4、64、128、512、2048和8192中选择。结合TOPS[1:0]位设置，这允许将WDT配置为4096和134217728个PCLKB时钟周期。

**RPES[1:0]位 (窗口结束位置选择)**

RPES[1:0]位指定指示刷新允许周期的窗口结束位置。可以为窗口结束位置选择75%、50%、25%或0%的超时时间。将窗口结束位置设置为小于窗口起始位置的值 (窗口起始位置 > 窗口结束位置)。如果窗口结束位置大于窗口起始位置，则仅启用窗口起始位置设置。

**RPSS[1:0]位 (窗口起始位置选择)**

RPSS[1:0]位指定指示允许刷新周期的窗口起始位置。可以为窗口起始位置选择100%、75%、50%或25%的超时时间。将窗口起始位置设置为大于窗口结束位置的值。如果窗口起始位置设置为小于或等于窗口结束位置的值，则窗口结束位置设置为0%。

表24.3列出了窗口开始和结束位置的计数器值，图24.2显示了在RPSS[1:0]、RPES[1:0]和TOPS[1:0]位中设置的允许刷新周期。

Table 24.3 Relationship between the timeout period and window start and end counter values

| TOPS[1:0] | Timeout period |               | Window start and end counter value |        |        |        |
|-----------|----------------|---------------|------------------------------------|--------|--------|--------|
|           | Cycles         | Counter value | 100%                               | 75%    | 50%    | 25%    |
| 00b       | 1024           | 0x03FF        | 0x03FF                             | 0x02FF | 0x01FF | 0x00FF |
| 01b       | 4096           | 0x0FFF        | 0x0FFF                             | 0x0BFF | 0x07FF | 0x03FF |
| 10b       | 8192           | 0x1FFF        | 0x1FFF                             | 0x17FF | 0x0FFF | 0x07FF |
| 11b       | 16384          | 0x3FFF        | 0x3FFF                             | 0x2FFF | 0x1FFF | 0x0FFF |

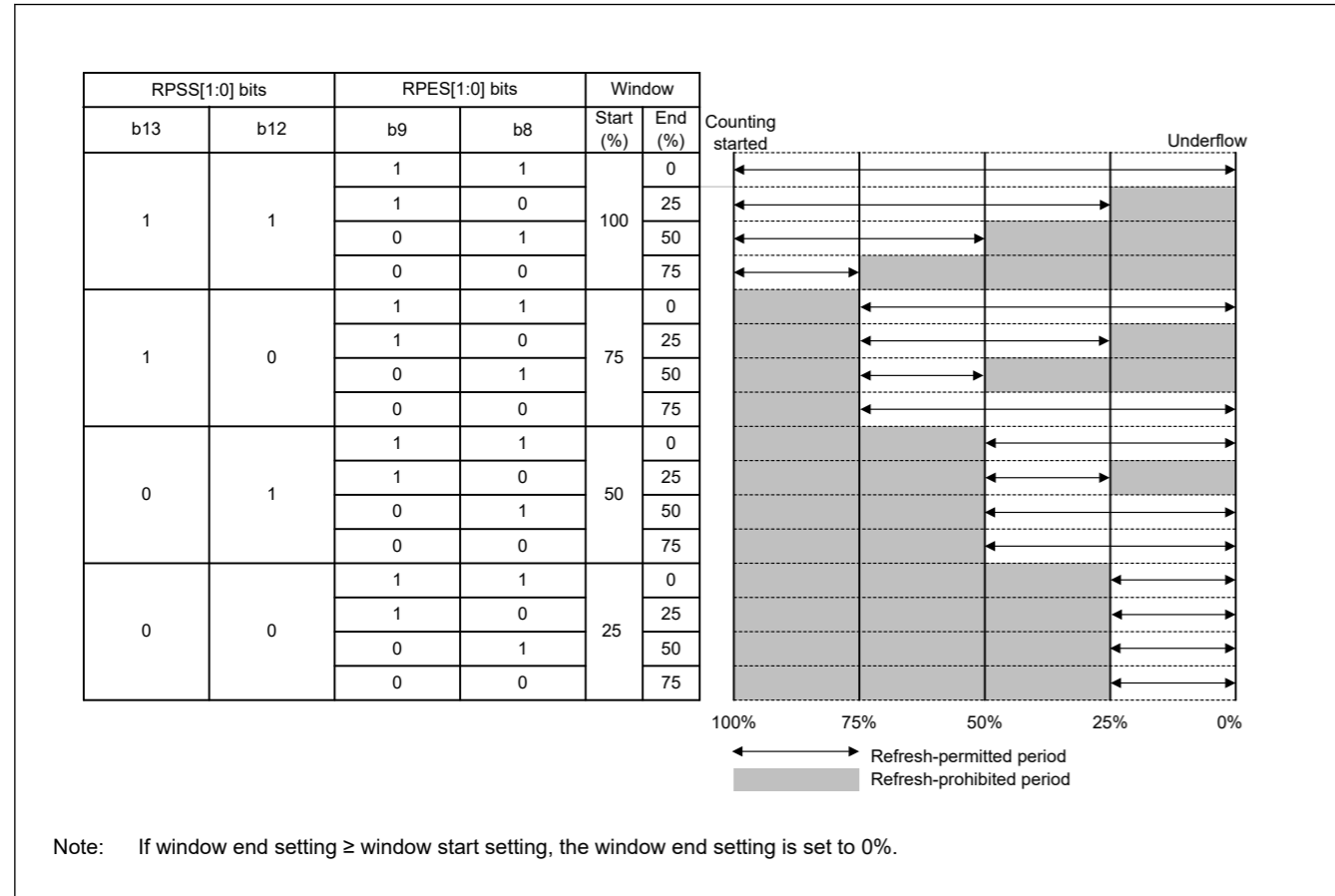


Figure 24.2 RPSS[1:0] and RPES[1:0] bits setting and refresh-permitted period

### 24.2.3 WDTSR : WDT Status Register

Base address: WDT = 0x4008\_3400

Offset address: 0x04

Bit position: 15 14 13 12 11 10 9 8 7 6 5 4 3 2 1 0

Bit field: REFE F UNDF F CNTVAL[13:0]

Value after reset: 0 0 0 0 0 0 0 0 0 0 0 0 0 0 0 0

| Bit  | Symbol       | Function  | R/W              |
|------|--------------|---|------------------|
| 13:0 | CNTVAL[13:0] | Down-Counter Value<br>Value counted by the down-counter             | R                |
| 14   | UNDF         | Underflow Flag<br>0: No underflow occurred<br>1: Underflow occurred | R/W <sup>1</sup> |

Table 24.3 超时时间与窗口开始和结束计数器值之间的关系

| TOPS[1:0] | 超时时间   |        | 窗口开始和结束计数器值 |        |        |        |
|-----------|--------|--------|-------------|--------|--------|--------|
|           | Cycles | 计数器值   | 100%        | 75%    | 50%    | 25%    |
| 00b       | 1024   | 0x03FF | 0x03FF      | 0x02FF | 0x01FF | 0x00FF |
| 01b       | 4096   | 0x0FFF | 0x0FFF      | 0x0BFF | 0x07FF | 0x03FF |
| 10b       | 8192   | 0x1FFF | 0x1FFF      | 0x17FF | 0x0FFF | 0x07FF |
| 11b       | 16384  | 0x3FFF | 0x3FFF      | 0x2FFF | 0x1FFF | 0x0FFF |

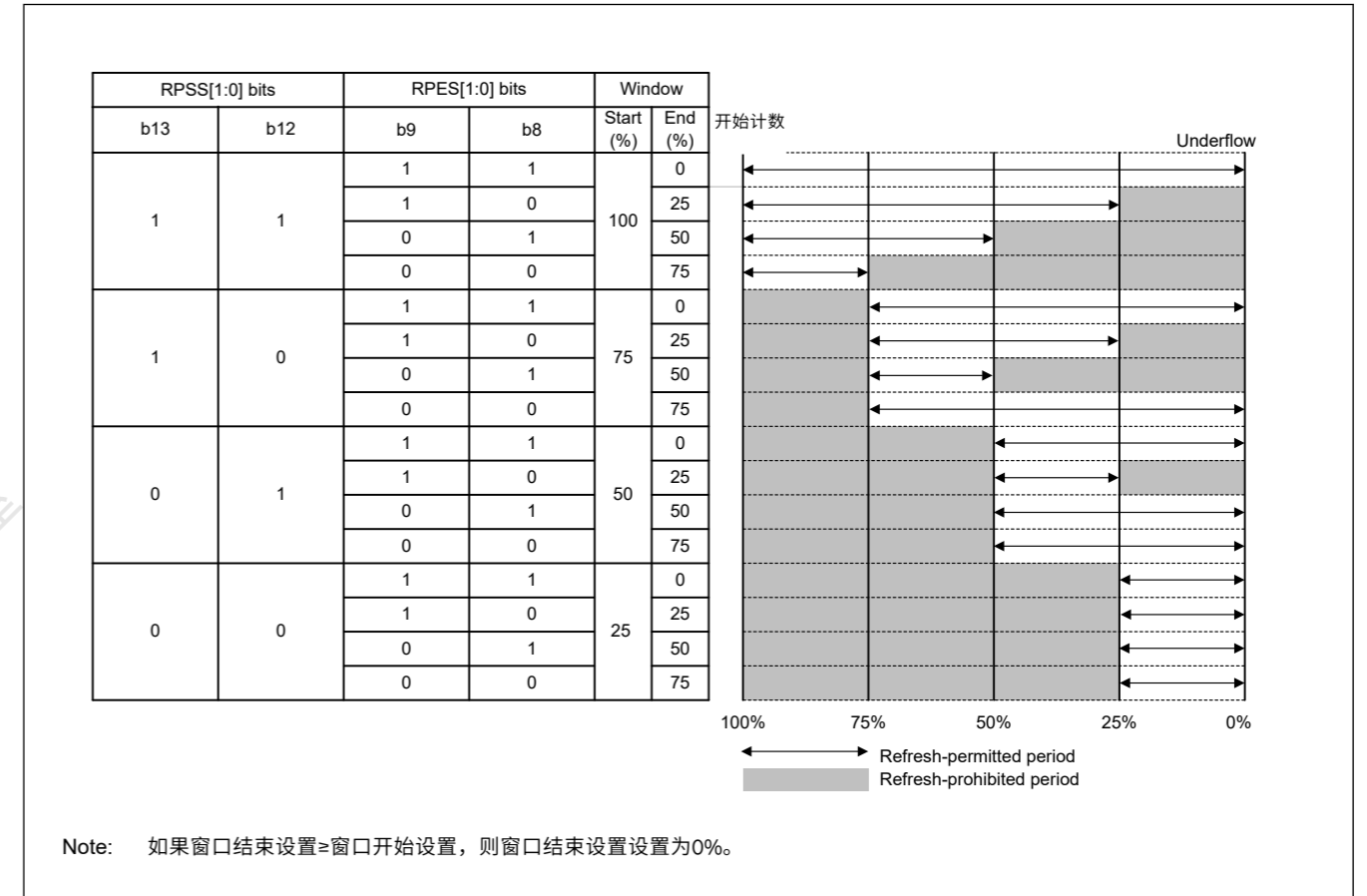


Figure 24.2 RPSS[1:0]和RPES[1:0]位设置和允许刷新周期

### 24.2.3 WDTSR:WDT状态寄存器

Base address: WDT = 0x4008\_3400

Offset address: 0x04

Bit position: 15 14 13 12 11 10 9 8 7 6 5 4 3 2 1 0

Bit field: REFE F UNDF F CNTVAL[13:0]

重置后的值: 0 0 0 0 0 0 0 0 0 0 0 0 0 0 0 0

| Bit  | Symbol       | Function                              | R/W              |
|------|--------------|---------------------------------------|------------------|
| 13:0 | CNTVAL[13:0] | Down-Counter Value<br>递减计数器计数的值       | R                |
| 14   | UNDF         | Underflow Flag<br>0: 未发生下溢<br>1: 发生下溢 | R/W <sup>1</sup> |

| Bit | Symbol | Function  | R/W              |
|-----|--------|---|------------------|
| 15  | REFEF  | Refresh Error Flag<br>0: No refresh error occurred<br>1: Refresh error occurred | R/W <sup>1</sup> |

Note 1. Only 0 can be written to clear the flag.

The WDTSR register indicates the counter value of the down-counter and the status of whether an underflow or refresh error occurred in the down-counter.

#### CNTVAL[13:0] bits (Down-Counter Value)

Read the CNTVAL[13:0] bits to confirm the value of the down-counter. The read value might differ from the actual count by 1.

#### UNDF flag (Underflow Flag)

Read the UNDF flag to confirm whether an underflow occurred in the counter. A value of 1 indicates that the down counter underflowed. Write 0 to the flag to set the value to 0. Writing 1 has no effect.

Clearing of the UNDF flag takes (N+1) PCLKB cycles. In addition, clearing of the flag is ignored for (N+1) PCLKB cycles after an underflow. N is specified in the WDTCR.CKS[3:0] bits as follows:

- When WDTCR.CKS[3:0] = 0x1, N = 4
- When WDTCR.CKS[3:0] = 0x4, N = 64
- When WDTCR.CKS[3:0] = 0xF, N = 128
- When WDTCR.CKS[3:0] = 0x6, N = 512
- When WDTCR.CKS[3:0] = 0x7, N = 2048
- When WDTCR.CKS[3:0] = 0x8, N = 8192

#### REFEF flag (Refresh Error Flag)

Read the REFEF flag to confirm whether a refresh error occurred, indicating that a refresh operation was performed during a prohibited period. A value of 1 indicates that a refresh error occurred. Write 0 to the flag to set the value to 0. Writing 1 has no effect.

Clearing of the REFEF flag takes (N+1) PCLKB cycles. In addition, clearing of the flag is ignored for (N+1) PCLKB cycles after a refresh error. N is specified in the WDTCR.CKS[3:0] bits as follows:

- When WDTCR.CKS[3:0] = 0x1, N = 4
- When WDTCR.CKS[3:0] = 0x4, N = 64
- When WDTCR.CKS[3:0] = 0xF, N = 128
- When WDTCR.CKS[3:0] = 0x6, N = 512
- When WDTCR.CKS[3:0] = 0x7, N = 2048
- When WDTCR.CKS[3:0] = 0x8, N = 8192

#### 24.2.4 WDTRCR : WDT Reset Control Register

Base address: WDT = 0x4008\_3400

Offset address: 0x06

| Bit position:      | 7           | 6 | 5 | 4 | 3 | 2 | 1 | 0 |
|--------------------|-------------|---|---|---|---|---|---|---|
| Bit field:         | RSTIR<br>QS | — | — | — | — | — | — | — |
| Value after reset: | 1           | 0 | 0 | 0 | 0 | 0 | 0 | 0 |

| Bit | Symbol | Function   | R/W |
|-----|--------|--|-----|
| 6:0 | —      | These bits are read as 0. The write value should be 0. | R/W |

| Bit | Symbol | Function                          | R/W              |
|-----|--------|-----------------------------------|------------------|
| 15  | REFEF  | 刷新错误标志<br>0: 未发生刷新错误<br>1: 发生刷新错误 | R/W <sup>1</sup> |

注1.只能写入0来清除标志。

WDTSR寄存器指示递减计数器的计数值以及递减计数器是否发生下溢或刷新错误的状态。

#### CNTVAL[13:0] bits (Down-Counter Value)

读取CNTVAL[13:0]位以确认递减计数器的值。读取的值可能与实际计数相差1。

#### UNDF flag (Underflow Flag)

读取UNDF标志以确认计数器是否发生下溢。值1表示递减计数器下溢。将0写入标志以将值设置为0。写入1无效。

清除UNDF标志需要(N+1)个PCLKB周期。此外，在下溢后的(N+1)个PCLKB周期内忽略标志的清除。N在WDTCR.CKS[3:0]位中指定如下：

- When WDTCR.CKS[3:0] = 0x1, N = 4
- When WDTCR.CKS[3:0] = 0x4, N = 64
- When WDTCR.CKS[3:0] = 0xF, N = 128
- When WDTCR.CKS[3:0] = 0x6, N = 512
- When WDTCR.CKS[3:0] = 0x7, N = 2048
- When WDTCR.CKS[3:0] = 0x8, N = 8192

#### REFEF标志 (刷新错误标志)

读取REFEF标志，确认是否发生刷新错误，表示在禁止期间进行了刷新操作。值1表示发生了刷新错误。将0写入标志以将值设置为0。写入1无效。

清除REFEF标志需要(N+1)个PCLKB周期。此外，在刷新错误后的(N+1)个PCLKB周期内，标志的清除将被忽略。N在WDTCR.CKS[3:0]位中指定如下：

- When WDTCR.CKS[3:0] = 0x1, N = 4
- When WDTCR.CKS[3:0] = 0x4, N = 64
- When WDTCR.CKS[3:0] = 0xF, N = 128
- When WDTCR.CKS[3:0] = 0x6, N = 512
- When WDTCR.CKS[3:0] = 0x7, N = 2048
- When WDTCR.CKS[3:0] = 0x8, N = 8192

#### 24.2.4 WDTRCR:WDT复位控制寄存器

Base address: WDT = 0x4008\_3400

Offset address: 0x06

| Bit position: | 7           | 6 | 5 | 4 | 3 | 2 | 1 | 0 |
|---------------|-------------|---|---|---|---|---|---|---|
| Bit field:    | RSTIR<br>QS | — | — | — | — | — | — | — |
| 重置后的值:        | 1           | 0 | 0 | 0 | 0 | 0 | 0 | 0 |

| Bit | Symbol | Function         | R/W |
|-----|--------|------------------|-----|
| 6:0 | —      | 这些位被读取为0。写入值应为0。 | R/W |



| Bit | Symbol  | Function   | R/W |
|-----|---------|--|-----|
| 7   | RSTIRQS | Reset Interrupt Request Select<br>0: Enable non-maskable interrupt request or interrupt request output<br>1: Enable reset output | R/W |

The WDTRCR register controls reset output by a WDT down-counter underflow or interrupt request output.

Some constraints apply to writes to the WDTRCR register. For details, see [section 24.3.2. Controlling Writes to the WDTCSR, WDTRCR, and WDTCSNPR Registers](#).

In auto start mode, the WDTRCR register settings are disabled, and the settings in the Option Function Select register 0 (OFS0) are enabled. The settings for the WDTRCR register can also be made for the OFS0 register. For details, see [section 24.3.8. Association between Option Function Select Register 0 \(OFS0\) and WDT Registers](#).

### 24.2.5 WDTCSNPR : WDT Count Stop Control Register

Base address: WDT = 0x4008\_3400

Offset address: 0x08

| Bit position:      | 7          | 6 | 5 | 4 | 3 | 2 | 1 | 0 |
|--------------------|------------|---|---|---|---|---|---|---|
| Bit field:         | SLCS<br>TP | — | — | — | — | — | — | — |
| Value after reset: | 1          | 0 | 0 | 0 | 0 | 0 | 0 | 0 |

| Bit | Symbol | Function  | R/W |
|-----|--------|---|-----|
| 6:0 | —      | These bits are read as 0. The write value should be 0.  | R/W |
| 7   | SLCSTP | WDT Count Stop Control Register<br>0: Disable count stop<br>1: Stop count on transition to Sleep mode | R/W |

The WDTCSNPR register controls whether to stop the WDT counter in a low power mode. Some constraints apply to writes to the WDTCSNPR register. For details, see [section 24.3.2. Controlling Writes to the WDTCSR, WDTRCR, and WDTCSNPR Registers](#).

In auto start mode, the WDTCSNPR register settings are disabled, and the settings in the Option Function Select register 0 (OFS0) are enabled. The settings for the WDTCSNPR register can also be made for the OFS0 register. For details, see [section 24.3.8. Association between Option Function Select Register 0 \(OFS0\) and WDT Registers](#).

#### SLCSTP bit (WDT Count Stop Control Register)

The SLCSTP bit selects whether to stop counting on transition to Sleep mode, Snooze, or Software Standby mode.

### 24.2.6 Option Function Select Register 0 (OFS0)

For information on the OFS0 register, see [section 24.3.8. Association between Option Function Select Register 0 \(OFS0\) and WDT Registers](#).

## 24.3 Operation

### 24.3.1 Count Operation in each Start Mode

The WDT has two start modes:

- Auto start mode, in which counting automatically starts after a release from the reset state
- Register start mode, in which counting starts with a refresh by writing to the register.

In auto start mode, counting automatically starts after a release from the reset state according to the settings in the Option Function Select register 0 (OFS0) in the flash.

In register start mode, counting starts with a refresh by writing to the WDTRR register after the respective registers are set after a release from the reset state.

| Bit | Symbol  | Function                                  | R/W |
|-----|---------|---|-----|
| 7   | RSTIRQS | 复位中断请求选择<br>0: 使能不可屏蔽中断请求或中断请求输出1: 使能复位输出 | R/W |

WDTRCR寄存器通过WDT递减计数器下溢或中断请求输出控制复位输出。

一些限制适用于写入WDTRCR寄存器。详见24.3.2节。控制写入WDTCSR、WDTRCR和WDTCSNPR寄存器。

在自动启动模式下，WDTRCR寄存器设置被禁用，而选项功能选择寄存器0(OFS0)中的设置被启用。WDTRCR寄存器的设置也可以对OFS0寄存器进行。详见24.3.8节。选项功能选择寄存器0(OFS0)和WDT寄存器之间的关联。

### 24.2.5 WDTCSNPR:WDT计数停止控制寄存器

Base address: WDT = 0x4008\_3400

Offset address: 0x08

| Bit position: | 7          | 6 | 5 | 4 | 3 | 2 | 1 | 0 |
|---------------|------------|---|---|---|---|---|---|---|
| Bit field:    | SLCS<br>TP | — | — | — | — | — | — | — |
| 重置后的值:        | 1          | 0 | 0 | 0 | 0 | 0 | 0 | 0 |

| Bit | Symbol | Function                                 | R/W |
|-----|--------|--|-----|
| 6:0 | —      | 这些位被读取为0。写入值应为0。                         | R/W |
| 7   | SLCSTP | WDT计数停止控制寄存器<br>0: 禁用计数停止1: 转换到睡眠模式时停止计数 | R/W |

WDTCSNPR寄存器控制是否在低功耗模式下停止WDT计数器。一些限制适用于写入WDTCSNPR寄存器。详见24.3.2节。控制对WDTCSR、WDTRCR和WDTCSNPR寄存器的写入。

在自动启动模式下，WDTCSNPR寄存器设置被禁用，而选项功能选择寄存器0(OFS0)中的设置被启用。也可以对OFS0寄存器进行WDTCSNPR寄存器的设置。详见24.3.8节。选项功能选择寄存器0(OFS0)和WDT寄存器之间的关联。

#### SLCSTP位 (WDT计数停止控制寄存器)

SLCSTP位选择在转换到休眠模式、贪睡或软件待机模式时是否停止计数。

### 24.2.6 选项功能选择寄存器0(OFS0)

有关OFS0寄存器的信息，请参见第24.3.8节。选项功能选择寄存器0(OFS0)和WDT寄存器之间的关联。

## 24.3 Operation

### 24.3.1 每种启动模式下的计数操作

WDT有两种启动模式:

- 自动启动模式，从复位状态释放后自动开始计数
- 寄存器启动模式，通过写入寄存器，从刷新开始计数。

在自动启动模式下，根据选项中的设置从复位状态释放后自动开始计数功能选择闪存中的寄存器0(OFS0)。

在寄存器启动模式下，在从复位状态释放后，在设置各个寄存器后，通过写入WDTRR寄存器，从刷新开始计数。



Select auto start mode or register start mode by setting the WDT Start Mode Select bit (OFS0.WDTSTRT) in the OFS0 register.

When the auto start mode is selected, the settings in the WDT Control Register (WDTCR), WDT Reset Control Register (WDTRCR), and WDT Count Stop Control Register (WDTCSSTPR) are disabled while the settings in the OFS0 register are enabled.

When the register start mode is selected, the setting for the OFS0 register is disabled while the settings for the WDT Control Register (WDTCR), WDT Reset Control Register (WDTRCR), and WDT Count Stop Control Register (WDTCSSTPR) are enabled.

### 24.3.1.1 Register start mode

When the WDT Start Mode Select bit (OFS0.WDTSTRT) is 1, register start mode is selected and the WDT Control Register (WDTCR), WDT Reset Control Register (WDTRCR), and WDT Count Stop Control Register (WDTCSSTPR) are enabled.

After the reset state is released, set the following to Sleep mode in the WDTCSSTPR register:

- Clock division ratio
- Window start and end positions
- Timeout period in the WDTCR register
- Reset output or interrupt request output in the WDTRCR register
- Counter stop control during transitions to Sleep mode in the WDTCSSTPR register

Refresh the down-counter to start counting down from the value set in the Timeout Period Selection bits (WDTCR.TOPS[1:0]).

Thereafter, as long as the counter is refreshed in the refresh-permitted period, the value in the counter is reset each time the counter is refreshed and counting down continues. The WDT does not output the reset signal as long as counting continues. However, if the down-counter underflows because the down-counter cannot be refreshed due to a program runaway, or if a refresh error occurs because the counter was refreshed outside the refresh-permitted period, the WDT outputs the reset signal or a non-maskable interrupt request/interrupt request (WDT\_NMIUNDF). Reset output or interrupt request output can be selected in the WDT Reset Interrupt Request Select bit (WDTRCR.RSTIRQS). Non-maskable interrupt requests or interrupt requests can be selected in the WDT Underflow/Refresh Error Interrupt Enable bit (NMIER.WDTEN).

Figure 24.3 shows an example of operation under the following conditions:

- Register start mode (OFS0.WDTSTRT = 1)
- Reset output is enabled (WDTRCR.RSTIRQS = 1)
- The window start position is 75% (WDTCR.RPSS[1:0] = 10b)
- The window end position is 25% (WDTCR.RPES[1:0] = 10b)

通过设置OFS0寄存器中的WDT启动模式选择位(OFS0.WDTSTRT)来选择自动启动模式或寄存器启动模式。

选择自动启动模式后，WDT控制寄存器 (WDTCR) 中的设置，WDTRESET控制寄存器 (WDTRCR) 和WDT计数停止控制寄存器 (WDTCSSTPR) 在启用OFS0寄存器中的设置时被禁用。

选择寄存器启动模式时，在WDT控件的设置时禁用OFS0寄存器的设置使能寄存器(WDTCR)、WDT复位控制寄存器(WDTRCR)和WDT计数停止控制寄存器(WDTCSSTPR)。

### 24.3.1.1 注册启动模式

当WDT启动模式选择位(OFS0.WDTSTRT)为1时，选择寄存器启动模式并启用WDT控制寄存器(WDTCR)、WDT复位控制寄存器(WDTRCR)和WDT计数停止控制寄存器(WDTCSSTPR)。

释放复位状态后，在WDTCSSTPR寄存器中将以下内容设置为休眠模式：

- 时钟分频比
- 窗口开始和结束位置
- WDTCR寄存器中的超时时间
- WDTRCR寄存器中的复位输出或中断请求输出
- WDTCSSTPR寄存器中转换到休眠模式期间的计数器停止控制

刷新递减计数器以从超时周期选择位(WDTCR.TOPS[1:0])中设置的值开始递减计数。

此后，只要在可刷新期间刷新了计数器，则每次刷新计数器时都会重置计数器中的值，并继续递减计数。只要继续计数，WDT就不会输出复位信号。但是，如果由于程序失控导致递减计数器无法刷新而导致递减计数器下溢，或者由于计数器在刷新允许时间之外刷新而发生刷新错误，则WDT输出复位信号或非可屏蔽中断请求中断请求(WDT\_NMIUNDF)。可以在WDT复位中断请求选择位(WDTRCR.RSTIRQS)中选择复位输出或中断请求输出。可以在WDT下溢刷新错误中断允许位(NMIER.WDTEN)中选择不可屏蔽的中断请求或中断请求。

图24.3显示了以下条件下的操作示例：

- 寄存器启动模式 (OFS0.WDTSTRT=1)
- 启用复位输出(WDTRCR.RSTIRQS=1)
- 窗口起始位置为75%(WDTCR.RPSS[1:0]=10b)
- 窗口结束位置为25%(WDTCR.RPES[1:0]=10b)

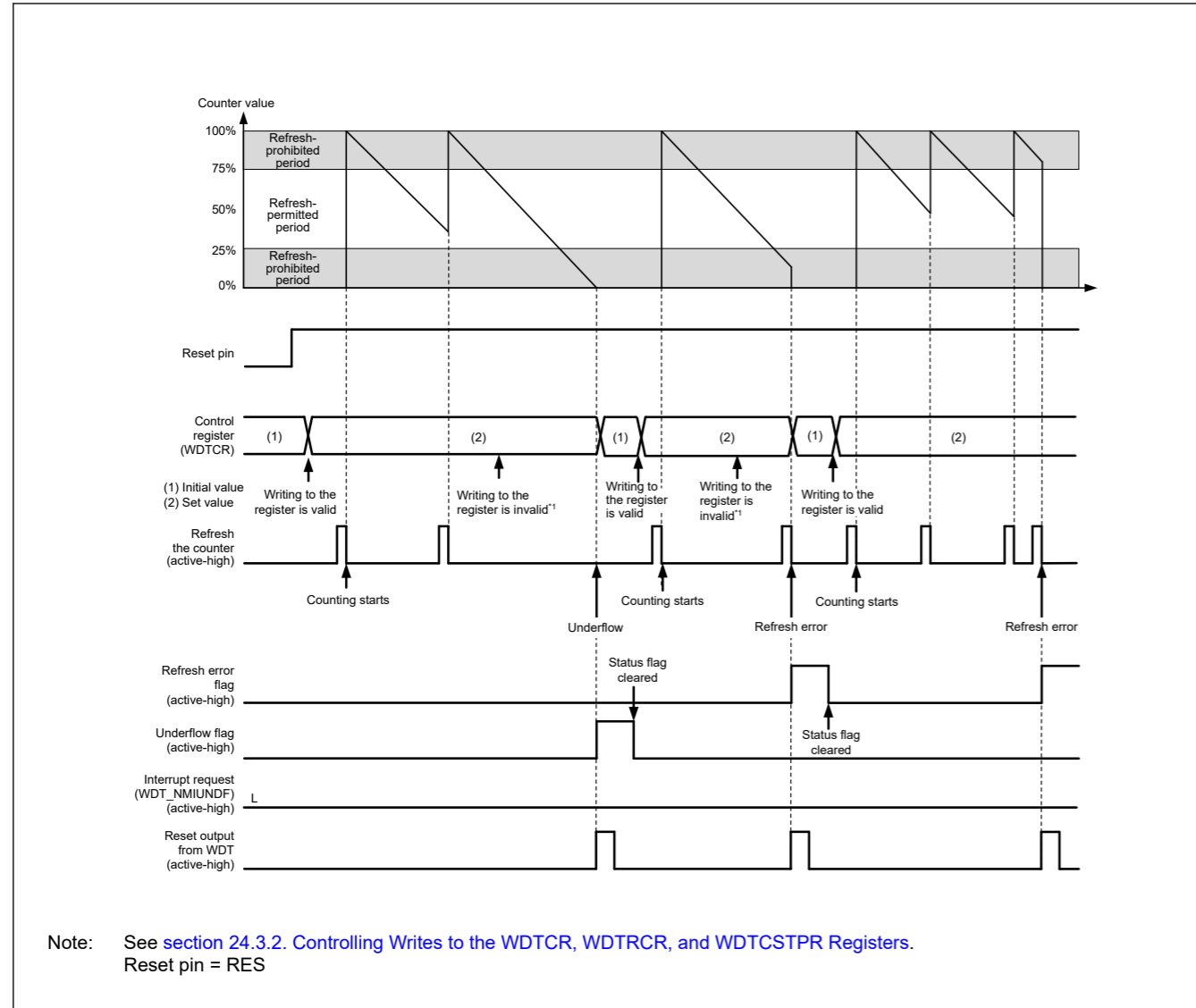


Figure 24.3 Operation example in register start mode

### 24.3.1.2 Auto start mode

When the WDT Start Mode Select bit (OFS0.WDTSTRT) in the Option Function Select Register 0 (OFS0) is 0, auto start mode is selected, the WDT Control Register (WDTCR), WDT Reset Control Register (WDTRCR), and WDT Count Stop Control Register (WDTCSPTPR) are disabled, and the settings in the OFS0 register are enabled.

Within the reset state, the setting values for the following in the Option Function Select Register 0 (OFS0) are set in the WDT registers:

- Clock division ratio
- Window start and end positions
- Timeout period
- Reset output or interrupt request
- Counter stop control during transition to Sleep mode

When the reset state is released, the down-counter automatically starts counting down from the value set in the WDT Timeout Period Select bits (OFS0.WDTPOPS[1:0]).

Thereafter, as long as the counter is refreshed in the refresh-permitted period, the value in the counter is reset each time the counter is refreshed and counting down continues. The WDT does not output the reset signal as long as the counting continues. However, if the down-counter underflows because refreshing of the down-counter is not possible due to a

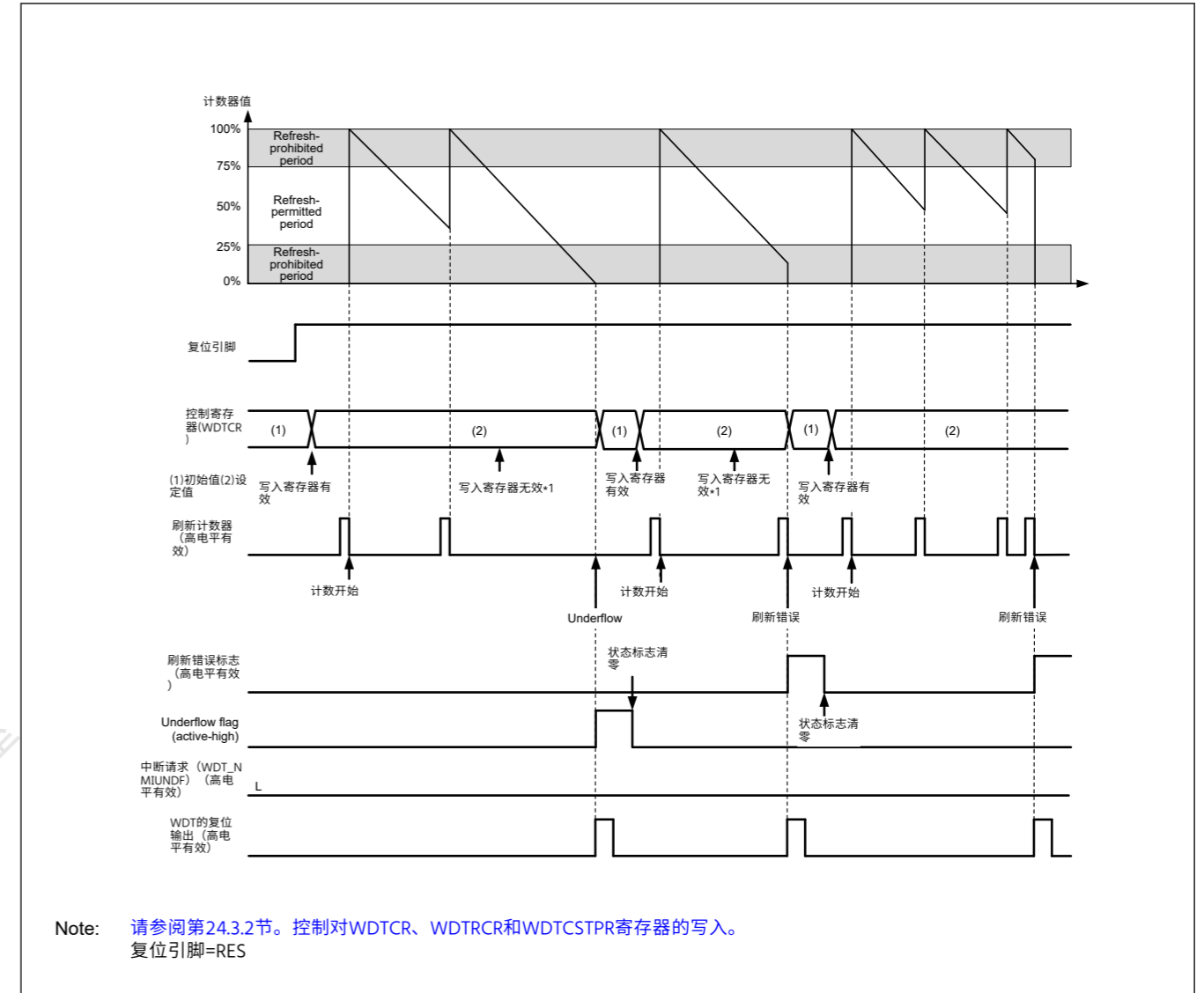


Figure 24.3 寄存器启动模式下的操作示例

### 24.3.1.2 自动启动模式

当WDT启动模式选择位置 (OFS0.WDTSTRT) 中的选项功能选择寄存器0 (OFS0) 为0时, 选择了自动启动模式, WDT控制寄存器 (WDTCR) (WDTCR), WDTRESETRESETCONTROMCONTROL寄存器 (WDTRCR) 和WDTCountCountCountCountCount停止控制寄存器(WDTCSPTPR)被禁用, 而OFS0寄存器中的设置被启用。

在复位状态下, 选项功能选择寄存器0(OFS0)中的以下设置值在WDT registers:

- 时钟分频比
- 窗口开始和结束位置
- 超时时间
- 复位输出或中断请求
- 转换到睡眠模式期间的计数器停止控制

当复位状态解除时, 递减计数器自动从WDT中设置的值开始递减计数超时周期选择位(OFS0.WDTPOPS[1:0])。

此后, 只要在可刷新期间刷新了计数器, 则每次刷新计数器时都会重置计数器中的值, 并继续递减计数。只要继续计数, WDT就不会输出复位信号。但是, 如果递减计数器下溢, 因为递减计数器的刷新是不可能的, 因为

runaway program or if a refresh error occurs due to refreshing outside the refresh-permitted period, the WDT outputs the reset signal or non-maskable interrupt request/interrupt request (WDT\_NMIUNDF).

After the reset signal or non-maskable interrupt request/interrupt request is generated, the counter reloads the timeout period after counting for 1 cycle. The value of the timeout period is set in the down-counter and counting restarts.

Reset output or interrupt request output can be selected by setting the WDT Reset Interrupt Request Select bit (OFS0.WDTRSTIRQS). Non-maskable interrupt request or interrupt request can be selected in the WDT Underflow/Refresh Error Interrupt Enable bit (NMIER.WDTEN).

Figure 24.4 shows an example of operation (non-maskable interrupt) under the following conditions:

- Auto start mode (OFS0.WDTSTRT = 0)
- Non-maskable interrupt request output is enabled (OFS0.WDTRSTIRQS = 0)
- The window start position is 75% (OFS0.WDTRPSS[1:0] = 10b)
- The window end position is 25% (OFS0.WDTRPES[1:0] = 10b)

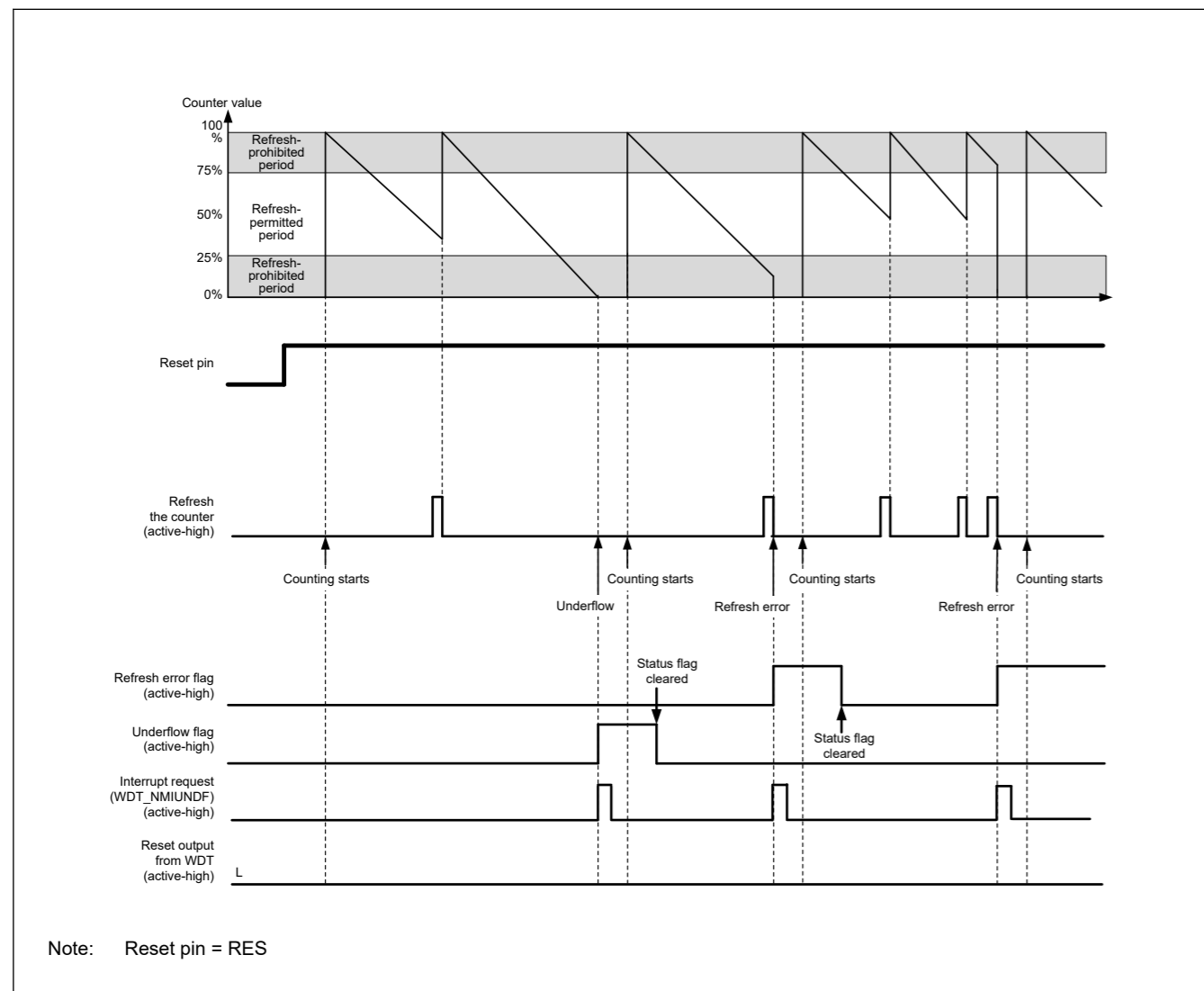


Figure 24.4 Operation example in auto start mode

### 24.3.2 Controlling Writes to the WDTCR, WDTRCR, and WDTCSSTPR Registers

Writing to the WDT Control Register (WDTCR), WDT Reset Control Register (WDTRCR), or WDT Count Stop Control Register (WDTCSSTPR) is possible once between the release from the reset state and the first refresh operation.

如果程序失控或由于刷新允许刷新周期之外的刷新而发生刷新错误，则WDT输出复位信号或不可屏蔽中断请求中断请求(WDT\_NMIUNDF)。

复位信号或不可屏蔽中断请求中断请求产生后，计数器在计数1个周期后重新加载超时周期。超时时间的值在递减计数器中设置并重新开始计数。

通过设置WDT复位中断请求选择位(OFS0.WDTRSTIRQS)可以选择复位输出或中断请求输出。可以在WDT下溢刷新错误中断允许位(NMIER.WDTEN)中选择不可屏蔽的中断请求或中断请求。

图24.4显示了以下条件下的操作示例（不可屏蔽中断）：

- 自动启动模式 (OFS0.WDTSTRT=0)
- 使能不可屏蔽中断请求输出 (OFS0.WDTRSTIRQS=0)
- 窗口起始位置为75%(OFS0.WDTRPSS[1:0]=10b)
- 窗口结束位置为25%(OFS0.WDTRPES[1:0]=10b)

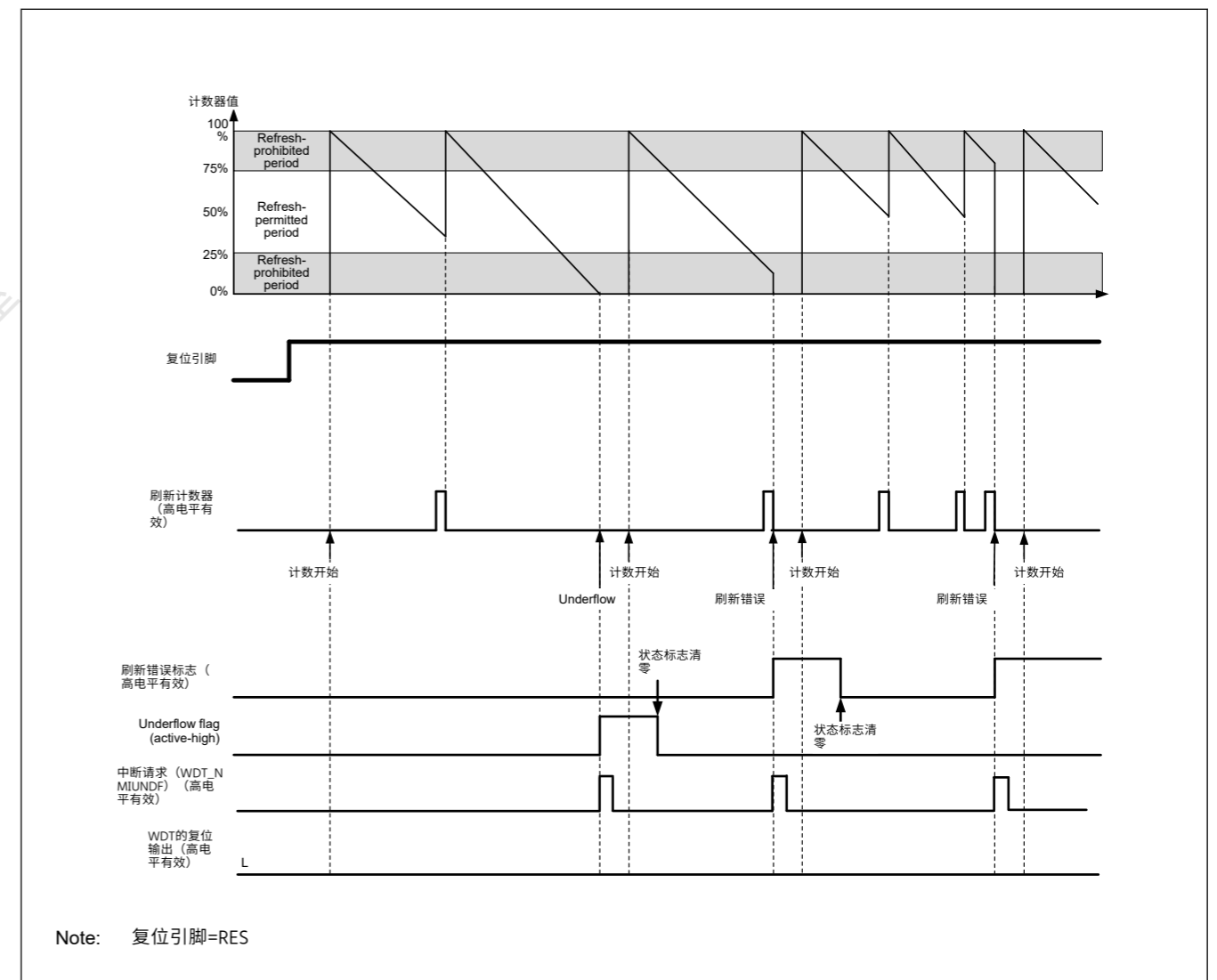


Figure 24.4 自动启动模式下的操作示例

### 24.3.2 控制对WDTCR、WDTRCR和WDTCSSTPR寄存器的写入

写入WDT控制寄存器(WDTCR)、WDT复位控制寄存器(WDTRCR)或WDT计数停止控制在从复位状态释放到第一次刷新操作之间，寄存器(WDTCSSTPR)是可能的。

After a refresh (counting starts) or a write to WDTCR, WDTRCR or WDTCSSTPR register, the protection signal in the WDT becomes 1 to protect WDTCR, WDTRCR and WDTCSSTPR register against subsequent write attempts. This protection is released by the reset source of the WDT. With other reset sources, the protection is not released.

Figure 24.5 shows control waveforms produced in response to writing to the WDTCR.

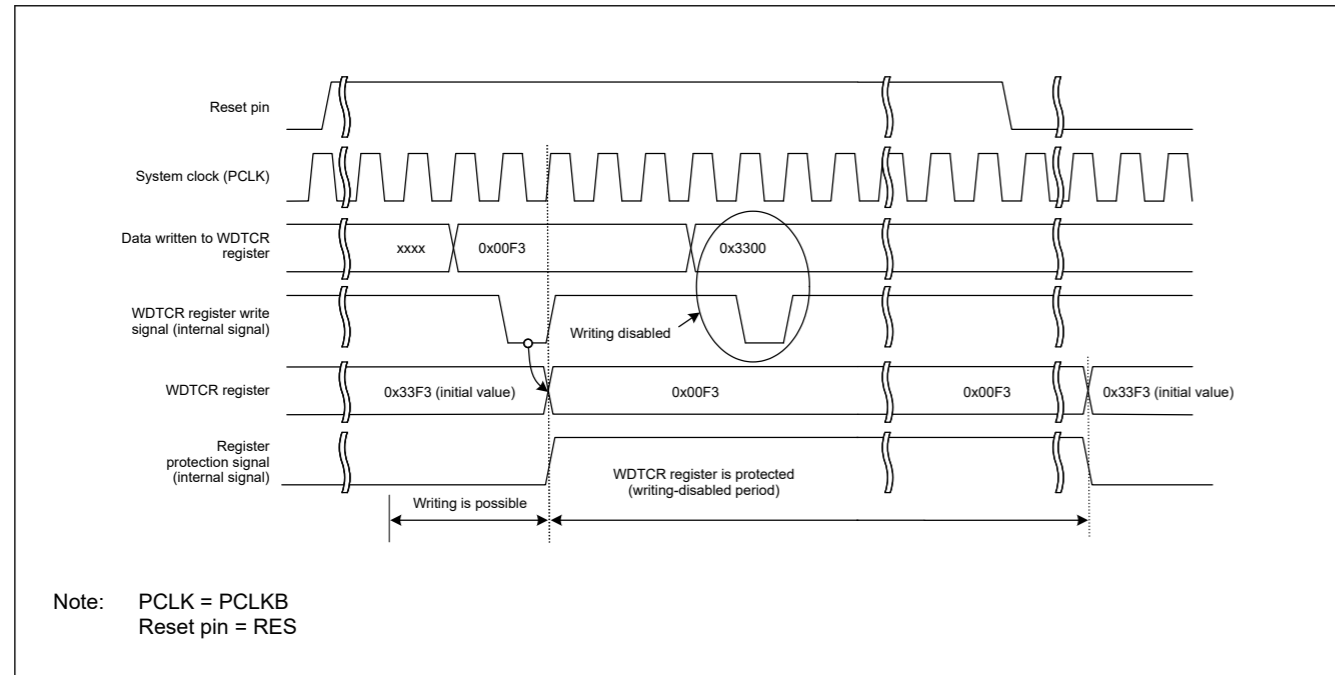


Figure 24.5 Control waveforms produced in response to writes to the WDTCR register

### 24.3.3 Refresh Operation

The down-counter is refreshed and starts counting operation on a write of the values 0x00 and 0xFF to the WDT Refresh Register (WDTRR). If a value other than 0xFF is written after 0x00, the down-counter is not refreshed. If an invalid value is written, correct refreshing resumes on a write of 0x00 and 0xFF to the WDTRR register.

Correct refreshing is also performed when a register other than WDTRR is accessed or WDTRR is read between writing 0x00 and writing 0xFF to WDTRR. Writes to refresh the counter must be made within the refresh-permitted period, and this is determined by the 0xFF write. For this reason, correct refreshing is performed even when 0x00 is written outside the refresh-permitted period.

[Example write sequences that are valid for refreshing the counter]

- 0x00 → 0xFF
- 0x00 ((n-1)th time) → 0x00 (nth time) → 0xFF
- 0x00 → access to another register or read from WDTRR → 0xFF

[Example write sequences that are invalid for refreshing the counter]

- 0x23 (a value other than 0x00) → 0xFF
- 0x00 → 0x54 (a value other than 0xFF)
- 0x00 → 0xAA (0x00 and a value other than 0xFF) → 0xFF

After 0xFF is written to the WDT Refresh Register (WDTRR), refreshing the down-counter requires up to 4 cycles of the signal for counting. To meet this requirement, complete writing 0xFF to WDTRR 4 count cycles before the down-counter underflows.

Figure 24.6 shows the WDT refresh-operation waveforms when the clock division ratio is PCLKB/64.

在刷新（计数开始）或写入WDTCR、WDTRCR或WDTCSSTPR寄存器后，WDT变为1以保护WDTCR、WDTRCR和WDTCSSTPR寄存器免受后续写入尝试。该保护由WDT的复位源解除。使用其他复位源时，不会解除保护。

图24.5显示了响应写入WDTCR产生的控制波形。

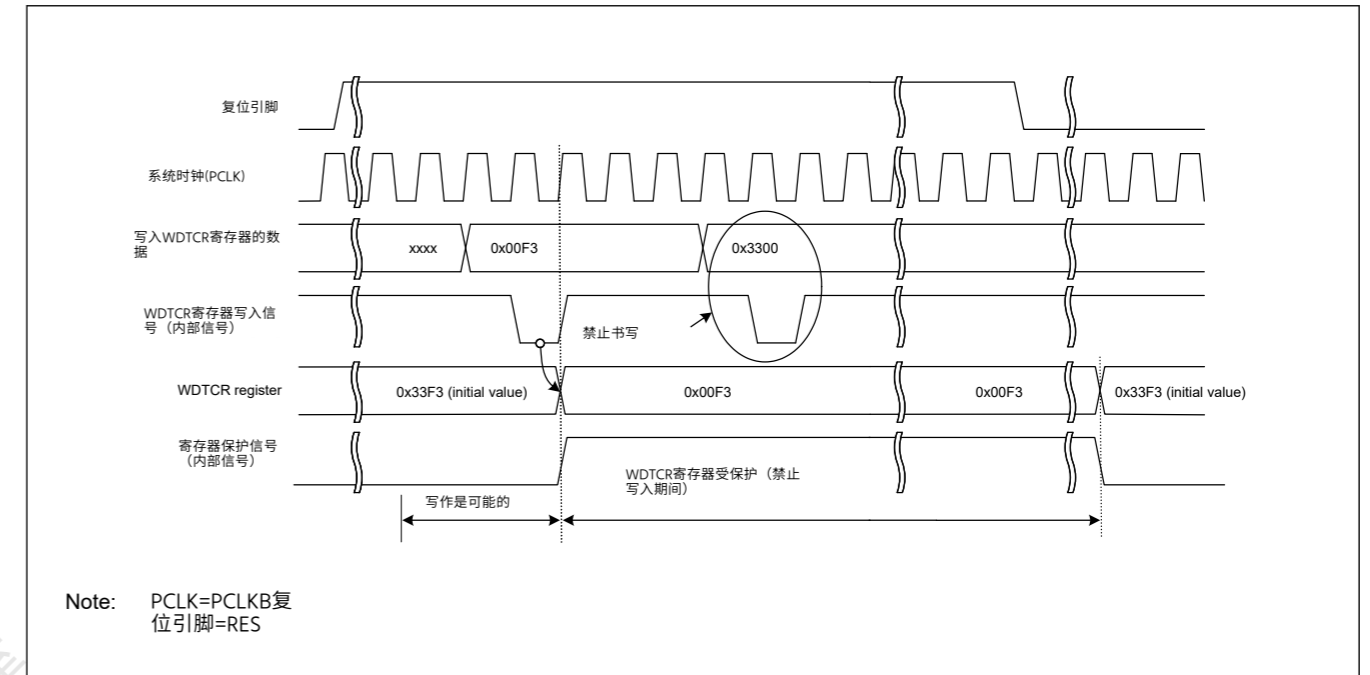


Figure 24.5 响应写入WDTCR寄存器而产生的控制波形

### 24.3.3 刷新操作

向下计数器刷新并在将值0x00和0xFF写入WDT刷新寄存器(WDTRR)时开始计数操作。如果在0x00之后写入0xFF以外的值，则不刷新递减计数器。如果写入无效值，则在向WDTRR寄存器写入0x00和0xFF时会恢复正确刷新。

在写入0x00和写入0xFF到WDTRR之间访问WDTRR以外的寄存器或读取WDTRR时，也会执行正确刷新。刷新计数器的写入必须在允许刷新的周期内进行，这由0xFF写入决定。因此，即使在可刷新期间外写入0x00，也会执行正确的刷新。

[对刷新计数器有效的示例写入序列]

- 0x00 → 0xFF
- 0x00 ((n-1)th time) → 0x00 (nth time) → 0xFF
- 0x00 → 访问另一个寄存器或从WDTRR读取 → 0xFF

[对刷新计数器无效的示例写入序列]

- 0x23 (0x00以外的值) → 0xFF
- 0x00 → 0x54 (0xFF以外的值)
- 0x00 → 0xAA (0x00和0xFF以外的值) → 0xFF

将0xFF写入WDT刷新寄存器(WDTRR)后，刷新递减计数器最多需要4个信号周期进行计数。为满足此要求，请在递减计数器下溢之前的4个计数周期内将0xFF写入WDTRR。

图24.6显示了时钟分频比为PCLKB/64时的WDT刷新操作波形。



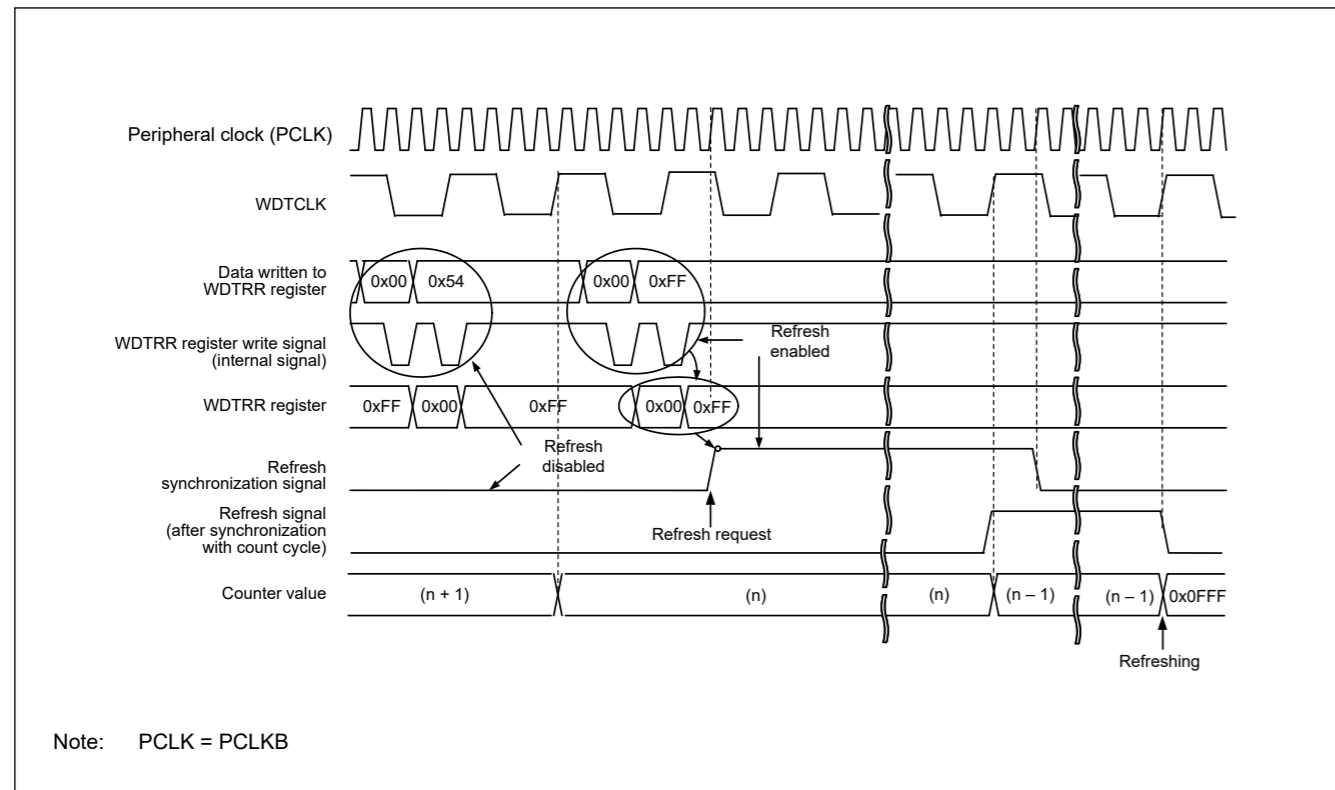


Figure 24.6 WDT refresh operation waveforms when WDTCSR.CKS[3:0] = 0x4 and WDTCSR.TOPS[1:0] = 01b

Note: When setting the refresh time, consider the oscillation accuracy of the clock sources of the PCLKB and WDTCLK. Set values which ensure that refreshing is possible even when the frequency varies in the range of error of the oscillation accuracy.

#### 24.3.4 Status Flags

The refresh error (WDTSR.REFEF) and underflow (WDTSR.UNDF) flags retain the source of the interrupt request from the WDT. After a release from the interrupt request generation, read the WDTSR.REFEF and WDTSR.UNDF flags to check for the interrupt source. For each flag, writing 0 clears the bit. Writing 1 has no effect. Leaving the status flags unchanged does not affect operation. If the flags are not cleared at the next interrupt request from the WDT, the earlier interrupt source is cleared and the new interrupt source is written. For the time period between when 0 is written in each flag and when its value is reflected, see [section 24.2.3. WDTSR : WDT Status Register](#).

#### 24.3.5 Reset Output

When the Reset Interrupt Select bit (WDTRCR.RSTIRQS) is set to 1 in register start mode, or when the WDT Reset Interrupt Request Select bit (OFS0.WDTRSTIRQS) in the Option Function Select Register 0 (OFS0) is set to 1 in auto start mode, a reset signal is output for 1 cycle count when an underflow in the down-counter or a refresh error occurs.

In register start mode, the down-counter is initialized (all bits set to 0) and stopped in that state after output of a reset signal. After the reset state is released and the program is restarted, the counter is set up again and counting down starts again with a refresh. In auto start mode, counting down starts automatically after the reset state is released.

#### 24.3.6 Interrupt Sources

When the Reset Interrupt Select bit (WDTRCR.RSTIRQS) is set to 0 in register start mode or when the WDT Reset Interrupt Request Select bit (OFS0.WDTRSTIRQS) in the Option Function Select Register 0 (OFS0) is set to 0 in auto start mode, an interrupt (WDT\_NMIUNDF) signal is generated when an underflow in the counter or a refresh error occurs. This interrupt can be used as a non-maskable interrupt or an interrupt. For details, see [section 13, Interrupt Controller Unit \(ICU\)](#).

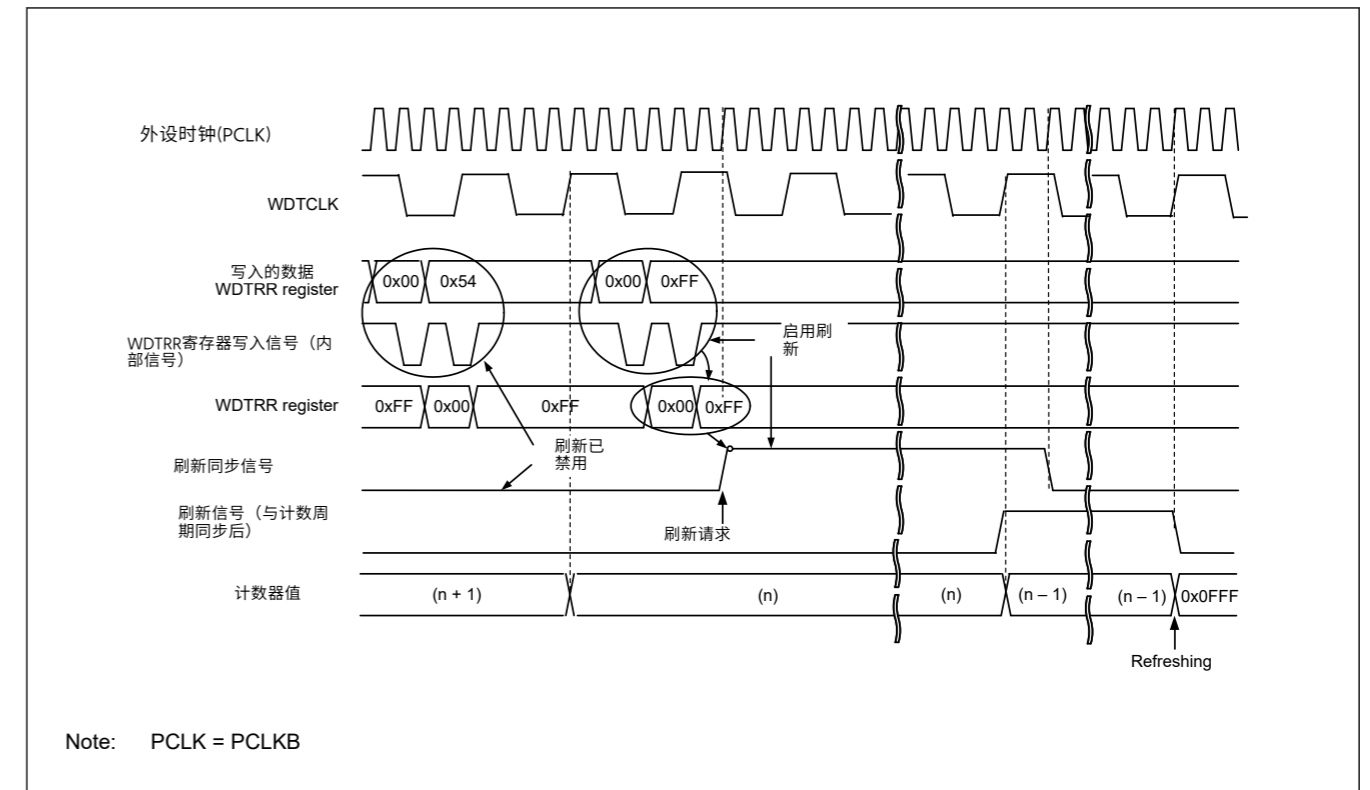


Figure 24.6 WDTCSR.CKS[3:0]=0x4和WDTCSR.TOPS[1:0]=01b时的WDT刷新操作波形

Note: 设置刷新时间时, 要考虑PCLKB和WDTCLK时钟源的振荡精度。设定即使频率在振荡精度的误差范围内变化也能进行刷新的值。

#### 24.3.4 状态标志

刷新错误(WDTSR.REFEF)和下溢(WDTSR.UNDF)标志保留来自WDT的 interrupt 请求源。释放 interrupt 请求生成后, 读取 WDTSR.REFEF和WDTSR.UNDF标志以检查中断源。对于每个标志, 写入0会清除该位。写1无效。保持状态标志不变不会影响操作。如果在WDT发出下一个中断请求时未清除标志, 则清除较早的中断源并写入新的中断源。关于从各标志写入0到反映其值的时间段, 请参阅第24.2.3节。WDTSR: WDT状态寄存器。

#### 24.3.5 复位输出

当复位中断选择位(WDTRCR.RSTIRQS)在寄存器启动模式下设置为1时, 或当WDT复位时在自动启动模式下, 选项功能选择寄存器0(OFS0)中的中断请求选择位(OFS0.WDTRSTIRQS)设置为1, 当递减计数器中的下溢或刷新错误发生时, 在1个周期计数内输出复位信号。

在寄存器启动模式下, 递减计数器被初始化(所有位设置为0)并在输出复位信号后停止在该状态。复位状态解除并重新启动程序后, 再次设置计数器, 并通过刷新再次开始倒计时。在自动启动模式下, 复位状态解除后自动开始倒计时。

#### 24.3.6 中断源

当在寄存器启动模式下复位中断选择位(WDTRCR.RSTIRQS)设置为0或WDT复位时在自动启动模式下, 选项功能选择寄存器0(OFS0)中的中断请求选择位(OFS0.WDTRSTIRQS)设置为0, 当计数器下溢或发生刷新错误时, 将产生中断(WDT\_NMIUNDF)信号。此中断可用作不可屏蔽中断或中断。有关详细信息, 请参阅第13节, 中断控制器单元(ICU)。



Table 24.4 WDT interrupt source

| Name        | Interrupt source  | Interrupt to CPU | Start DMAC or DTC |
|-------------|---|------------------|-------------------|
| WDT_NMIUNDF | <ul style="list-style-type: none"> <li>Down-counter underflow</li> <li>Refresh error</li> </ul> | Possible         | Not possible      |

### 24.3.7 Reading the Down-Counter Value

The WDT stores the counter value in the down-counter value bits (WDTSR.CNTVAL[13:0]) of the WDT Status Register. Check these bits to obtain the counter value. The read value of the down-counter might differ from the actual count by one.

Figure 24.7 shows the processing for reading the WDT down-counter value when the clock division ratio is PCLKB/64.

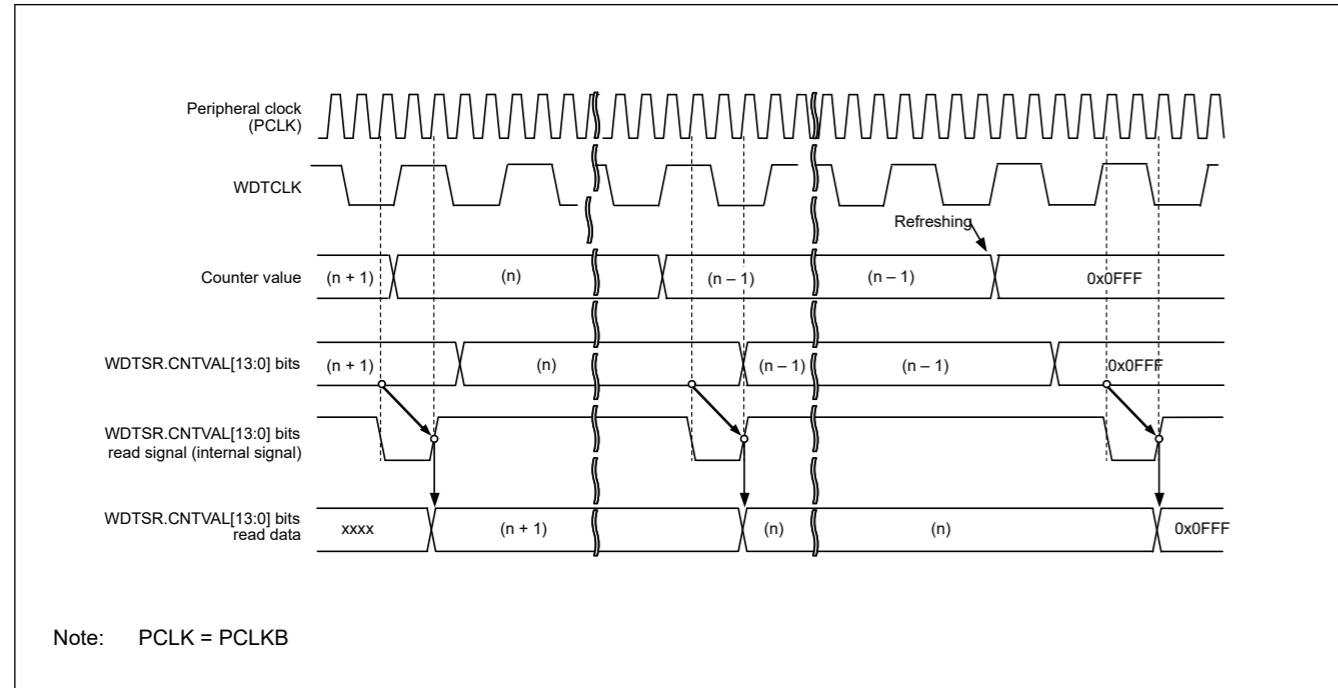


Figure 24.7 Processing for reading WDT down-counter value when WDTCR.CKS[3:0] = 0x4 and WDTCR.TOPS[1:0] = 01b

### 24.3.8 Association between Option Function Select Register 0 (OFS0) and WDT Registers

Table 24.5 lists the association between the Option Function Select Register 0 (OFS0) used in auto start mode, and the registers used in register start mode. For details on the Option Function Select Register 0 (OFS0), see section 6.2.1. [OFS0: Option Function Select Register 0](#).

Table 24.5 Association between Option Function Select Register 0 (OFS0) and the WDT registers

| Control target                           | Function   | OFS0 register (enabled in auto start mode) OFS0.WDTSTRT = 0 | WDT registers (enabled in register start mode) OFS0.WDTSTRT = 1 |
|--|--|---|---|
| Down-counter                             | Timeout period selection                           | OFS0.WDTTOPS[1:0]   | WDTCR.TOPS[1:0]   |
|  | Clock division ratio selection                     | OFS0.WDTCKS[3:0]  | WDTCR.CKS[3:0]  |
|  | Window start position selection                    | OFS0.WDTRPSS[1:0]   | WDTCR.RPSS[1:0]   |
|  | Window end position selection                      | OFS0.WDTRPES[1:0]   | WDTCR.RPES[1:0]   |
| Reset output or interrupt request output | Reset output or interrupt request output selection | OFS0.WDTRSTIRQS   | WDTCCR.RSTIRQS  |
| Count stop                               | Sleep or Snooze mode count stop control            | OFS0.WDTSTPCTL  | WDTGSTPR.SLCSTP   |

Table 24.4 WDT中断源

| Name        | 中断源  | 对CPU的中断  | 启动DMAC或DTC |
|-------------|--|----------|------------|
| WDT_NMIUNDF | <ul style="list-style-type: none"> <li>Down-counter underflow</li> <li>刷新错误</li> </ul> | Possible | 不可能        |

### 24.3.7 读取递减计数器值

WDT将计数器值存储在WDT状态寄存器的递减计数器值位(WDTSR.CNTVAL[13:0])中。检查这些位以获得计数器值。递减计数器的读取值可能与实际计数相差1。

图24.7显示了在时钟分频比为PCLKB/64时读取WDT递减计数器值的处理。

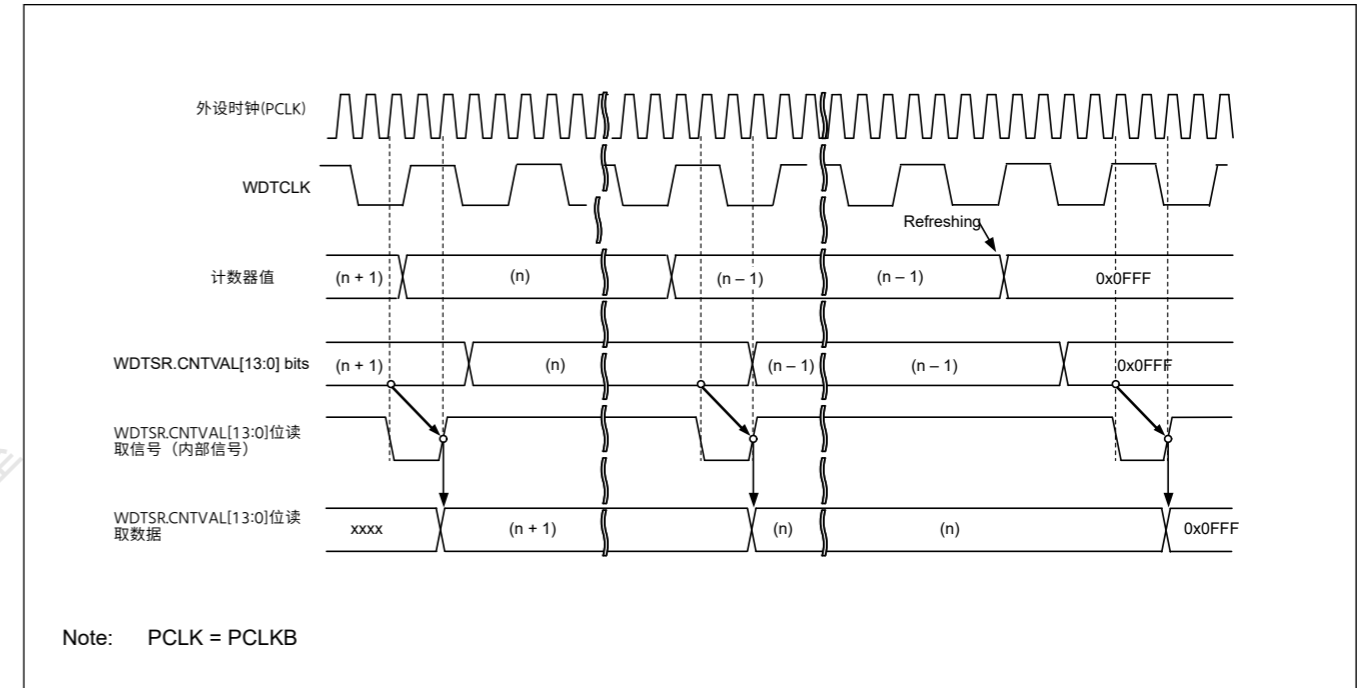


Figure 24.7 当WDTCR.CKS[3:0]=0x4和WDTCR.TOPS[1:0] = 01b

### 24.3.8 选项功能选择寄存器0(OFS0)和WDT之间的关联 Registers

表24.5列出了用于自动启动模式的选项功能选择寄存器0(OFS0)和用于寄存器启动模式的寄存器之间的关联。有关选项功能选择寄存器0(OFS0)的详细信息，请参见第6.2.1节。OFS0: 选项功能选择寄存器0。

Table 24.5 选项功能选择寄存器0(OFS0)和WDT寄存器之间的关联

| 控制目标         | Function      | OFS0寄存器 (在自动启动模式下启用) OFS0.WDTSTRT=0 | WDT寄存器 (在寄存器启动模式下启用) OFS0.WDTSTRT=1 |
|--------------|---------------|-------------------------------------|-------------------------------------|
| Down-counter | 超时时间选择        | OFS0.WDTTOPS[1:0]                   | WDTCR.TOPS[1:0]                     |
|              | 时钟分频比选择       | OFS0.WDTCKS[3:0]                    | WDTCR.CKS[3:0]                      |
|              | 窗口起始位置选择      | OFS0.WDTRPSS[1:0]                   | WDTCR.RPSS[1:0]                     |
|              | 窗口结束位置选择      | OFS0.WDTRPES[1:0]                   | WDTCR.RPES[1:0]                     |
| 复位输出或中断请求输出  | 复位输出或中断请求输出选择 | OFS0.WDTRSTIRQS                     | WDTCCR.RSTIRQS                      |
| 计数停止         | 睡眠或贪睡模式计数停止控制 | OFS0.WDTSTPCTL                      | WDTGSTPR.SLCSTP                     |

## 24.4 Output to the Event Link Controller (ELC)

The WDT is capable of a link operation for the previously specified module when interrupt request signal is used as an event signal by the ELC. The event signal is output by the counter underflow and refresh error. An event signal is output regardless of the setting of the Reset Interrupt Request Select bit (WDTRCR.RSTIRQS) in register start mode or auto start mode. An event signal can also be output when the next interrupt source is generated while the Refresh Error flag (WDTSR.REFEF) or Underflow flag (WDTSR.UNDF) is 1. For details, see [section 18, Event Link Controller \(ELC\)](#).

## 24.5 Usage Notes

### 24.5.1 ICU Event Link Setting Register n (IELSRn) Setting

Setting 0x53 to ICU Event Link Setting Register n (ICU.IELSRn) is prohibited when enabling the WDT reset assertion (OFS0.WDTRSTIRQS = 0 or WDTRCR.RSTIRQS = 0) or when enabling event link operation (ELSRn.ELS[8:0] = 0x53).

## 24.4 输出到事件链接控制器(ELC)

当ELC将中断请求信号用作事件信号时，WDT能够对先前指定的模块进行链接操作。事件信号由计数器下溢和刷新错误输出。在寄存器启动模式或自动启动模式下，无论复位中断请求选择位(WDTRCR.RSTIRQS)的设置如何，都会输出事件信号。当刷新错误标志(WDTSR.REFEF)或下溢标志(WDTSR.UNDF)为1时，也可以在产生下一个中断源时输出事件信号。有关详细信息，请参阅第18节，事件链接控制器(ELC)。

## 24.5 使用说明

### 24.5.1 ICU事件链接设置寄存器n(IELSRn)设置

当启用WDT复位断言(OFS0.WDTRSTIRQS=0或WDTRCR.RSTIRQS=0)或启用事件链接操作(ELSRn.ELS[8:0])时，禁止将0x53设置为ICU事件链接设置寄存器n(ICU.IELSRn)=0x53)。

## 25. Independent Watchdog Timer (IWDT)

### 25.1 Overview

The Independent Watchdog Timer (IWDT) consists of a 14-bit down counter that must be serviced periodically to prevent counter underflow. The IWDT provides functionality to reset the MCU or to generate a non-maskable interrupt or an underflow interrupt. Because the timer operates with an independent, dedicated clock source, it is particularly useful in returning the MCU to a known state as a fail-safe mechanism when the system runs out of control. The IWDT can be triggered automatically by a reset, underflow, refresh error, or a refresh of the count value in the registers.

The IWDT functions differ from those of the WDT in the following respects:

- The divided IWDT-dedicated clock (IWDTCLK) is used as the count source (not affected by PCLKB)
- IWDT does not support register start mode

Table 25.1 lists the IWDT specifications and Figure 25.1 shows a block diagram.

**Table 25.1 IWDT specifications**

| Parameter                                | Description   |
|--|---|
| Count source*1                           | IWDT-dedicated clock (IWDTCLK)  |
| Clock division ratio                     | Division by 1, 16, 32, 64, 128, or 256  |
| Counter operation                        | Counting down using a 14-bit down-counter   |
| Condition for starting the counter       | <ul style="list-style-type: none"> <li>● Counting automatically starts after a reset</li> <li>● Only secure developer can start the IWDT</li> </ul>   |
| Conditions for stopping the counter      | <ul style="list-style-type: none"> <li>● Reset (the down-counter and other registers return to their initial values)</li> <li>● A counter underflows or a refresh error is generated (counting restarts automatically).</li> </ul>  |
| Window function                          | Window start and end positions can be specified (refresh-permitted and refresh-prohibited periods)  |
| Reset output sources                     | <ul style="list-style-type: none"> <li>● Down-counter underflows</li> <li>● Refreshing outside the refresh-permitted period (refresh error).</li> </ul>   |
| Non-maskable interrupt/interrupt sources | <ul style="list-style-type: none"> <li>● Down-counter underflows</li> <li>● Refreshing outside the refresh-permitted period (refresh error).</li> </ul>   |
| Reading the counter value                | The down-counter value can be read by the IWDTSR register   |
| Event link function                      | <ul style="list-style-type: none"> <li>● Down-counter underflow event output</li> <li>● Refresh error event output.</li> </ul>  |
| Output signal (internal signal)          | <ul style="list-style-type: none"> <li>● Reset output</li> <li>● Interrupt request output</li> <li>● Sleep-mode count stop control output.</li> </ul>   |
| Auto start mode                          | Configurable to the following triggers: <ul style="list-style-type: none"> <li>● Clock frequency division ratio after a reset (OFS0.IWDTCKS[3:0] bits)</li> <li>● Timeout period of the Independent Watchdog Timer (OFS0.IWDTTOPS[1:0] bits)</li> <li>● Window start position in the Independent Watchdog Timer (OFS0.IWDRPSS[1:0] bits)</li> <li>● Window end position in the Independent Watchdog Timer (OFS0.IWDRPES[1:0] bits)</li> <li>● Reset output or interrupt request output (OFS0.IWDRSTIRQS bit)</li> <li>● Down-count stop function at transition to Sleep mode, Software Standby mode, or Snooze mode (OFS0.IWDTSTPCTL bit).</li> </ul> |
| TrustZone Filter                         | Security attribution can be set   |

Note 1. Satisfy the frequency of the peripheral module clock (PCLKB)  $\geq 4 \times$  (the frequency of the count clock source after division).

The bus interface and registers operate with PCLKB, and the 14-bit counter and control circuits operate with IWDTCLK.

## 25. 独立看门狗定时器(IWDT)

### 25.1 Overview

独立看门狗定时器(IWDT)包含一个14位递减计数器, 必须定期对其进行服务以防止计数器下溢。IWDT提供复位MCU或生成不可屏蔽中断或下溢中断的功能。由于定时器使用独立的专用时钟源运行, 因此当系统失控时, 它在将MCU作为故障安全机制返回到已知状态时特别有用。IWDT可以通过复位、下溢、刷新错误或寄存器中的计数值的刷新来自动触发。

IWDT的功能与WDT的功能有以下不同:

- 分频IWDT专用时钟 (IWDTCLK) 用作计数源 (不受PCLKB影响)
- IWDT不支持寄存器启动方式

表25.1列出了IWDT规范, 图25.1显示了框图。

**Table 25.1 IWDT specifications**

| Parameter                                | Description  |
|--|--|
| 计数来源*1                                   | IWDT-dedicated clock (IWDTCLK)   |
| 时钟分频比                                    | 除以1、16、32、64、128或256   |
| 计数器操作                                    | 使用14位递减计数器进行递减计数   |
| 启动计数器的条件                                 | <ul style="list-style-type: none"> <li>● 复位后自动开始计数</li> <li>● 只有安全的开发人员才能启动IWDT</li> </ul>   |
| 停止计数器的条件                                 | <ul style="list-style-type: none"> <li>● 复位 (递减计数器和其他寄存器恢复初始值)</li> <li>● 计数器下溢或产生刷新错误 (计数自动重新开始)。</li> </ul>  |
| 窗口功能                                     | 可以指定窗口开始和结束位置 (允许刷新和禁止刷新期间)  |
| 重置输出源                                    | <ul style="list-style-type: none"> <li>● Down-counter underflows</li> <li>● 在允许刷新的期限之外刷新 (刷新错误)。</li> </ul>  |
| Non-maskable interrupt/interrupt sources | <ul style="list-style-type: none"> <li>● Down-counter underflows</li> <li>● 在允许刷新的期限之外刷新 (刷新错误)。</li> </ul>  |
| 读取计数器值                                   | 递减计数器的值可以通过IWDTSR寄存器读取   |
| 事件链接功能                                   | <ul style="list-style-type: none"> <li>● 递减计数器下溢事件输出</li> <li>● 刷新错误事件输出。</li> </ul>   |
| 输出信号 (内部信号)                              | <ul style="list-style-type: none"> <li>● 复位输出</li> <li>● 中断请求输出</li> <li>● 休眠模式计数停止控制输出。</li> </ul>  |
| 自动启动模式                                   | 可配置为以下触发器: ● <ul style="list-style-type: none"> <li>● 复位后的时钟分频比 (OFS0.IWDTCKS[3:0]位)</li> <li>● 独立看门狗定时器的超时周期 (OFS0.IWDTTOPS[1:0]位)</li> <li>● 独立看门狗定时器中的窗口起始位置 (OFS0.IWDRPSS[1:0]位)</li> <li>● 独立看门狗定时器中的窗口结束位置 (OFS0.IWDRPES[1:0]位)</li> <li>● 复位输出或中断请求输出 (OFS0.IWDRSTIRQS位)</li> <li>● 转换到休眠模式、软件待机模式或贪睡模式时的减计数停止功能 (OFS0.IWDTSTPCTL位)。</li> </ul> |
| TrustZone Filter                         | 可设置安全属性  |

注1.满足外设模块时钟 (PCLKB) 的频率 $\geq 4 \times$  (分频后的计数时钟源的频率)。

总线接口和寄存器使用PCLKB运行, 14位计数器和控制电路使用IWDTCLK运行。

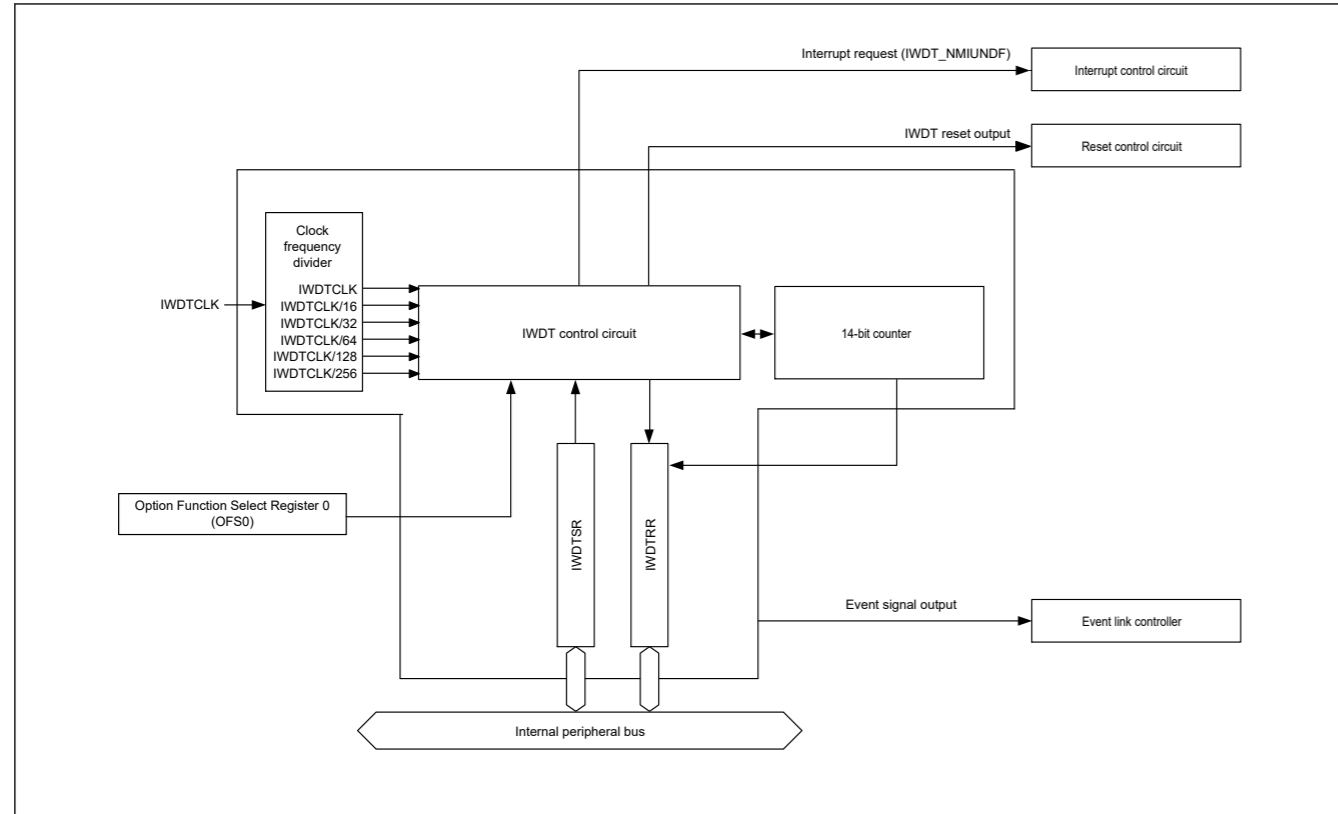


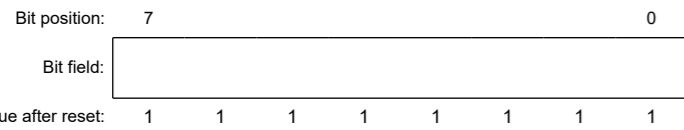
Figure 25.1 IWDT block diagram

## 25.2 Register Descriptions

### 25.2.1 IWDTRR : IWDT Refresh Register

Base address: IWDT = 0x4008\_3200

Offset address: 0x00



| Bit | Symbol | Function   | R/W |
|-----|--------|--|-----|
| 7:0 | n/a    | The down-counter is refreshed by writing 0x00 and then writing 0xFF to this register | R/W |

The IWDTRR register refreshes the down-counter of the IWDT. The down-counter of the IWDT is refreshed by writing 0x00 and then writing 0xFF to IWDTRR (refresh operation) within the refresh-permitted period. After the down-counter is refreshed, it starts counting down from the value selected in the IWDT Timeout Period Select bits (OFS0.IWDTTOPS[1:0]) in the Option Function Select Register 0 (OFS0).

When 0x00 is written, the read value is 0x00. When a value other than 0x00 is written, the read value is 0xFF. For details of the refresh operation, see [section 25.3.2. Refresh Operation](#).

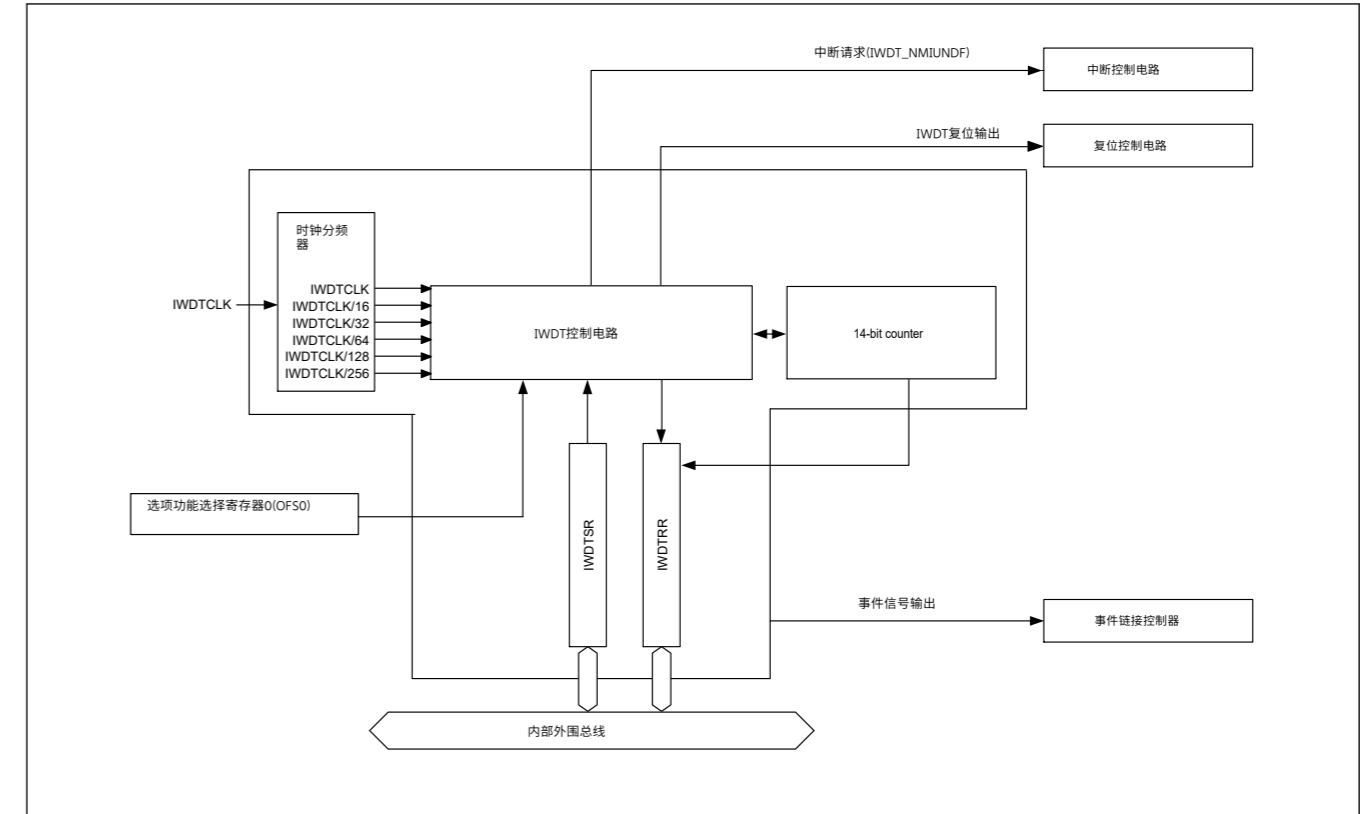


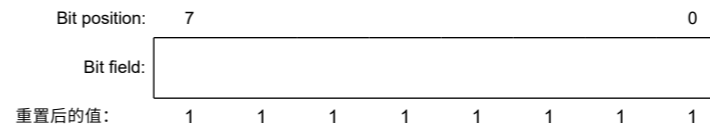
Figure 25.1 IWDT框图

## 25.2 注册说明

### 25.2.1 IWDTRR: IWDT刷新寄存器

Base address: IWDT = 0x4008\_3200

Offset address: 0x00



| Bit | Symbol | Function                      | R/W |
|-----|--------|-------------------------------|-----|
| 7:0 | n/a    | 通过写入0x00然后将0xFF写入该寄存器来刷新递减计数器 | R/W |

IWDTRR寄存器刷新IWDT的递减计数器。IWDT的递减计数器通过在允许刷新的周期内写入0x00然后将0xFF写入IWDTRR (刷新操作) 来刷新。递减计数器刷新后, 它从选项功能选择寄存器0(OFS0)的IWDT超时周期选择位(OFS0.IWDTTOPS[1:0])中选择的值开始递减计数。

写入0x00时, 读取值为0x00。写入0x00以外的值时, 读取的值为0xFF。有关刷新操作的详细信息, 请参阅第25.3.2节。刷新操作。

## 25.2.2 IWDTSR : IWDT Status Register

Base address: IWDT = 0x4008\_3200

Offset address: 0x04



| Bit  | Symbol       | Function  | R/W              |
|------|--------------|---|------------------|
| 13:0 | CNTVAL[13:0] | Down-counter Value<br>Value counted by the down-counter                         | R                |
| 14   | UNDF         | Underflow Flag<br>0: No underflow occurred<br>1: Underflow occurred             | R/W <sup>1</sup> |
| 15   | REFEF        | Refresh Error Flag<br>0: No refresh error occurred<br>1: Refresh error occurred | R/W <sup>1</sup> |

Note 1. Only 0 can be written to clear the flag.

The IWDTSR register indicates the counter value of the down-counter and whether an underflow or refresh error occurred in the down-counter.

**CNTVAL[13:0] bits (Down-counter Value)**

Read the CNTVAL[13:0] bits to confirm the value of the down-counter. The read value might differ from the actual count by 1.

**UNDF flag (Underflow Flag)**

Read the UNDF flag to confirm whether an underflow occurred in the down-counter. The value 1 indicates that the down-counter underflowed. Write 0 to the UNDF flag to set the value to 0. Writing 1 has no effect.

Clearing of the UNDF flag takes (N + 2) IWDTCLK cycles and 2 PCLKB cycles. In addition, clearing of this flag is ignored for (N + 2) IWDTCLK cycles after an underflow. N is specified in the IWDTCKS[3:0] bits as follows:

- When OFS0.IWDTCKS[3:0] = 0x0, N = 1
- When OFS0.IWDTCKS[3:0] = 0x2, N = 16
- When OFS0.IWDTCKS[3:0] = 0x3, N = 32
- When OFS0.IWDTCKS[3:0] = 0x4, N = 64
- When OFS0.IWDTCKS[3:0] = 0xF, N = 128
- When OFS0.IWDTCKS[3:0] = 0x5, N = 256.

**REFEF flag (Refresh Error Flag)**

Read the REFEF flag to confirm whether a refresh error occurred. This indicates that a refresh operation was performed during a prohibited period. The value 1 indicates that a refresh error occurred. Write 0 to the REFEF flag to set the value to 0. Writing 1 has no effect.

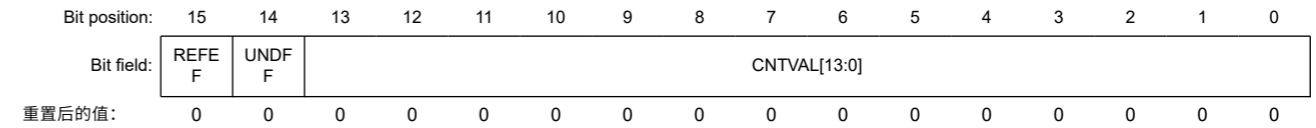
Clearing of the REFEF flag takes (N + 2) IWDTCLK cycles and 2 PCLKB cycles. In addition, clearing of this flag is ignored for (N + 2) IWDTCLK cycles following a refresh error. N is specified in the IWDTCKS[3:0] bits as follows:

- When OFS0.IWDTCKS[3:0] = 0x0, N = 1
- When OFS0.IWDTCKS[3:0] = 0x2, N = 16
- When OFS0.IWDTCKS[3:0] = 0x3, N = 32
- When OFS0.IWDTCKS[3:0] = 0x4, N = 64
- When OFS0.IWDTCKS[3:0] = 0xF, N = 128

## 25.2.2 IWDTSR:IWDT状态寄存器

Base address: IWDT = 0x4008\_3200

Offset address: 0x04



| Bit  | Symbol       | Function                              | R/W              |
|------|--------------|---------------------------------------|------------------|
| 13:0 | CNTVAL[13:0] | Down-counter Value<br>递减计数器计数的值       | R                |
| 14   | UNDF         | Underflow Flag<br>0: 未发生下溢<br>1: 发生下溢 | R/W <sup>1</sup> |
| 15   | REFEF        | 刷新错误标志<br>0: 未发生刷新错误<br>1: 发生刷新错误     | R/W <sup>1</sup> |

注1.只能写入0来清除标志。

IWDTSR寄存器指示递减计数器的计数值以及递减计数器是否发生下溢或刷新错误。

**CNTVAL[13:0] bits (Down-counter Value)**

读取CNTVAL[13:0]位以确认递减计数器的值。读取的值可能与实际计数相差1。

**UNDF flag (Underflow Flag)**

读取UNDF标志以确认递减计数器中是否发生下溢。值1表示递减计数器下溢。将0写入UNDF标志以将值设置为0。写入1无效。

清除UNDF标志需要(N+2)个IWDTCLK周期和2个PCLKB周期。此外，在下溢后的(N+2)个IWDTCLK周期内，该标志的清除将被忽略。N在IWDTCKS[3:0]位中指定如下：

- When OFS0.IWDTCKS[3:0] = 0x0, N = 1
- When OFS0.IWDTCKS[3:0] = 0x2, N = 16
- When OFS0.IWDTCKS[3:0] = 0x3, N = 32
- When OFS0.IWDTCKS[3:0] = 0x4, N = 64
- When OFS0.IWDTCKS[3:0] = 0xF, N = 128
- When OFS0.IWDTCKS[3:0] = 0x5, N = 256.

**REFEF标志 (刷新错误标志)**

读取REFEF标志以确认是否发生刷新错误。这表示在禁止期间执行了刷新操作。值1表示发生了刷新错误。将0写入REFEF标志以将值设置为0。写入1无效。

清除REFEF标志需要(N+2)个IWDTCLK周期和2个PCLKB周期。此外，在刷新错误后的(N+2)个IWDTCLK周期内，该标志的清除将被忽略。N在IWDTCKS[3:0]位中指定如下：

- When OFS0.IWDTCKS[3:0] = 0x0, N = 1
- When OFS0.IWDTCKS[3:0] = 0x2, N = 16
- When OFS0.IWDTCKS[3:0] = 0x3, N = 32
- When OFS0.IWDTCKS[3:0] = 0x4, N = 64
- When OFS0.IWDTCKS[3:0] = 0xF, N = 128



- When  $OFS0.IWDTCKS[3:0] = 0x5$ ,  $N = 256$ .

### 25.2.3 OFS0 : Option Function Select Register 0

For information on the Option Function Select Register 0 (OFS0), see [section 6.2.1. OFS0 : Option Function Select Register 0](#).

#### IWDTTOPS[1:0] bits (IWDT Timeout Period Select)

The IWDTTOPS[1:0] bits select the timeout period, that is, the period until the down-counter underflows, from 128, 512, 1024, or 2048 cycles, taking the divided clock specified in the IWDTCKS[3:0] bits as 1 cycle.

After the down-counter is refreshed, the combination of the IWDTCKS[3:0] and IWDTTOPS[1:0] bits determines the number of IWDTCLK cycles until the counter underflows.

[Table 25.2](#) lists the relationship between the IWDTCKS[3:0] and IWDTTOPS[1:0] bit settings, the timeout period, and the number of IWDTCLK cycles.

**Table 25.2 Timeout period settings**

| IWDTCKS[3:0] bits |    |    |    | IWDTTOPS[1:0] bits |    | Clock division ratio | Timeout period (number of cycles) | IWDTCLK cycles |
|-------------------|----|----|----|--------------------|----|----------------------|-----------------------------------|----------------|
| b7                | b6 | b5 | b4 | b1                 | b0 |                      |                                   |                |
| 0                 | 0  | 0  | 0  | 0                  | 0  | IWDTCLK              | 128                               | 128            |
|                   |    |    |    | 0                  | 1  |                      | 512                               | 512            |
|                   |    |    |    | 1                  | 0  |                      | 1024                              | 1024           |
|                   |    |    |    | 1                  | 1  |                      | 2048                              | 2048           |
| 0                 | 0  | 1  | 0  | 0                  | 0  | IWDTCLK/16           | 128                               | 2048           |
|                   |    |    |    | 0                  | 1  |                      | 512                               | 8192           |
|                   |    |    |    | 1                  | 0  |                      | 1024                              | 16384          |
|                   |    |    |    | 1                  | 1  |                      | 2048                              | 32768          |
| 0                 | 0  | 1  | 1  | 0                  | 0  | IWDTCLK/32           | 128                               | 4096           |
|                   |    |    |    | 0                  | 1  |                      | 512                               | 16384          |
|                   |    |    |    | 1                  | 0  |                      | 1024                              | 32768          |
|                   |    |    |    | 1                  | 1  |                      | 2048                              | 65536          |
| 0                 | 1  | 0  | 0  | 0                  | 0  | IWDTCLK/64           | 128                               | 8192           |
|                   |    |    |    | 0                  | 1  |                      | 512                               | 32768          |
|                   |    |    |    | 1                  | 0  |                      | 1024                              | 65536          |
|                   |    |    |    | 1                  | 1  |                      | 2048                              | 131072         |
| 1                 | 1  | 1  | 1  | 0                  | 0  | IWDTCLK/128          | 128                               | 16384          |
|                   |    |    |    | 0                  | 1  |                      | 512                               | 65536          |
|                   |    |    |    | 1                  | 0  |                      | 1024                              | 131072         |
|                   |    |    |    | 1                  | 1  |                      | 2048                              | 262144         |
| 0                 | 1  | 0  | 1  | 0                  | 0  | IWDTCLK/256          | 128                               | 32768          |
|                   |    |    |    | 0                  | 1  |                      | 512                               | 131072         |
|                   |    |    |    | 1                  | 0  |                      | 1024                              | 262144         |
|                   |    |    |    | 1                  | 1  |                      | 2048                              | 524288         |

#### IWDTCKS[3:0] bits (IWDT-Dedicated Clock Frequency Division Ratio Select)

The IWDTCKS[3:0] bits specify the division ratio of the clock used for the down-counter. The division ratio can be selected from the IWDT-dedicated clock (IWDTCLK) divided by 1, 16, 32, 64, 128, and 256. Combined with the IWDTTOPS[1:0] bit setting, the IWDT can be configured to a count period between 128 and 524,288 IWDTCLK cycles.

- When  $OFS0.IWDTCKS[3:0] = 0x5$ ,  $N = 256$ .

### 25.2.3 OFS0: 选项功能选择寄存器0

有关选项功能选择寄存器0(OFS0)的信息, 请参见第6.2.1节。OFS0: 选项功能选择寄存器0。

#### IWDTTOPS[1:0]位 (IWDT超时周期选择)

IWDTTOPS[1:0]位选择超时周期, 即从128、512、1024或2048个周期到递减计数器下溢的周期, 采用IWDTCKS[3:0]位中指定的分频时钟作为1个周期。

向下计数器刷新后, IWDTCKS[3:0]和IWDTTOPS[1:0]位的组合决定了在计数器下溢之前的IWDTCLK周期数。

表25.2列出了IWDTCKS[3:0]和IWDTTOPS[1:0]位设置、超时周期和IWDTCLK周期数之间的关系。

**Table 25.2 超时时间设置**

| IWDTCKS[3:0] bits |    |    |    | IWDTTOPS[1:0] bits |    | 时钟分频比       | 超时时间 (周期数) | IWDTCLK cycles |
|-------------------|----|----|----|--------------------|----|-------------|------------|----------------|
| b7                | b6 | b5 | b4 | b1                 | b0 |             |            |                |
| 0                 | 0  | 0  | 0  | 0                  | 0  | IWDTCLK     | 128        | 128            |
|                   |    |    |    | 0                  | 1  |             | 512        | 512            |
|                   |    |    |    | 1                  | 0  |             | 1024       | 1024           |
|                   |    |    |    | 1                  | 1  |             | 2048       | 2048           |
| 0                 | 0  | 1  | 0  | 0                  | 0  | IWDTCLK/16  | 128        | 2048           |
|                   |    |    |    | 0                  | 1  |             | 512        | 8192           |
|                   |    |    |    | 1                  | 0  |             | 1024       | 16384          |
|                   |    |    |    | 1                  | 1  |             | 2048       | 32768          |
| 0                 | 0  | 1  | 1  | 0                  | 0  | IWDTCLK/32  | 128        | 4096           |
|                   |    |    |    | 0                  | 1  |             | 512        | 16384          |
|                   |    |    |    | 1                  | 0  |             | 1024       | 32768          |
|                   |    |    |    | 1                  | 1  |             | 2048       | 65536          |
| 0                 | 1  | 0  | 0  | 0                  | 0  | IWDTCLK/64  | 128        | 8192           |
|                   |    |    |    | 0                  | 1  |             | 512        | 32768          |
|                   |    |    |    | 1                  | 0  |             | 1024       | 65536          |
|                   |    |    |    | 1                  | 1  |             | 2048       | 131072         |
| 1                 | 1  | 1  | 1  | 0                  | 0  | IWDTCLK/128 | 128        | 16384          |
|                   |    |    |    | 0                  | 1  |             | 512        | 65536          |
|                   |    |    |    | 1                  | 0  |             | 1024       | 131072         |
|                   |    |    |    | 1                  | 1  |             | 2048       | 262144         |
| 0                 | 1  | 0  | 1  | 0                  | 0  | IWDTCLK/256 | 128        | 32768          |
|                   |    |    |    | 0                  | 1  |             | 512        | 131072         |
|                   |    |    |    | 1                  | 0  |             | 1024       | 262144         |
|                   |    |    |    | 1                  | 1  |             | 2048       | 524288         |

#### IWDTCKS[3:0]位 (IWDT专用时钟分频比选择)

IWDTCKS[3:0]位指定用于递减计数器的时钟分频比。分频比可以从IWDT专用时钟(IWDTCLK)除以1、16、32、64、128和256中选择。结合IWDTTOPS[1:0]位设置, 可以将IWDT配置为计数128到524 288个IWDTCLK周期之间的周期。

**IWDTRPES[1:0] bits (IWDT Window End Position Select)**

The IWDTRPES[1:0] bits specify the window end position that indicates the refresh-permitted period. 75%, 50%, 25%, or 0% of the timeout period can be selected for the window end position. Set the window end position to a value less than the window start position (window start position > window end position). If the window end position is greater than the window start position, only the window start position setting is enabled.

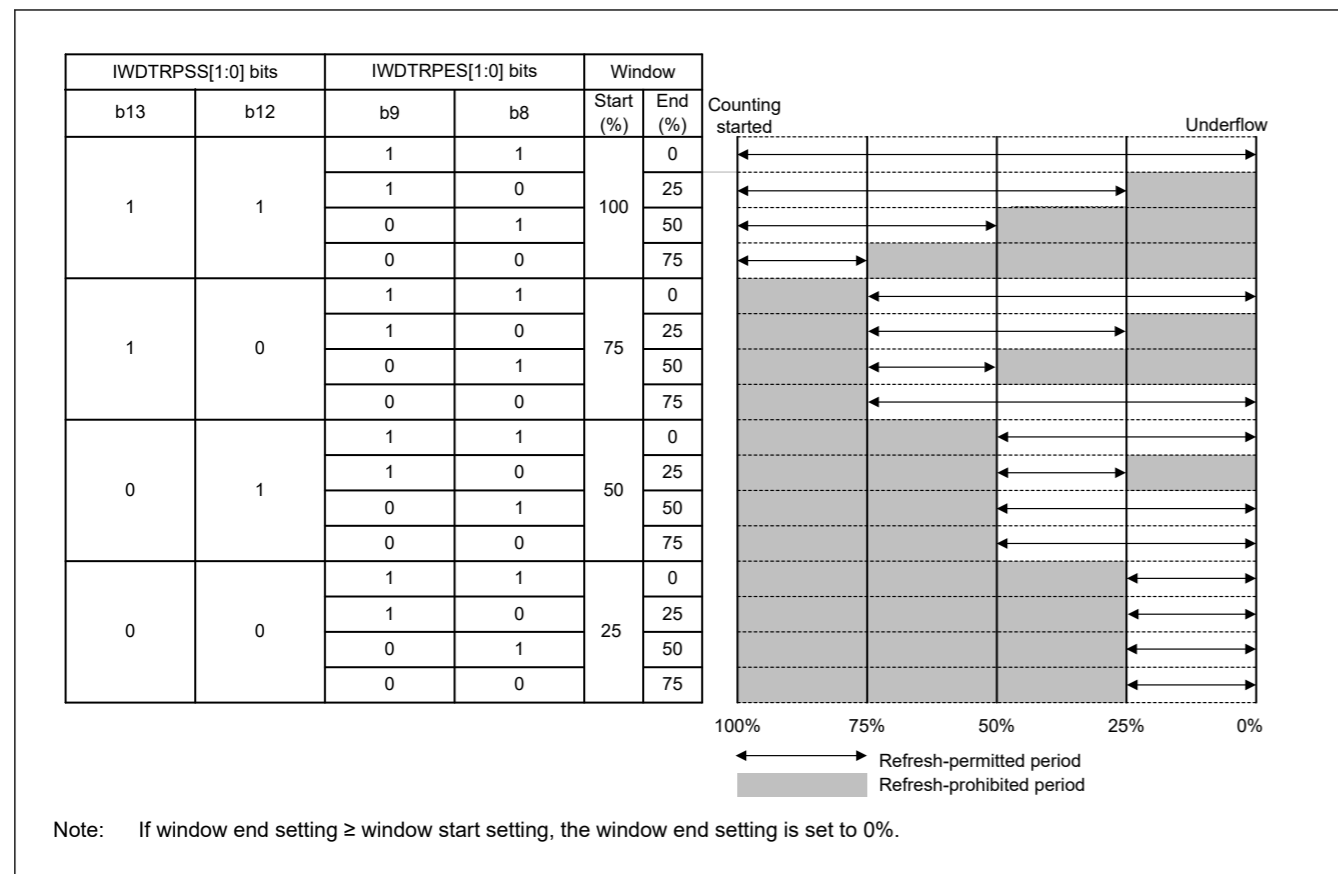
**IWDTRPSS[1:0] bits (IWDT Window Start Position Select)**

The IWDTRPSS[1:0] bits specify the window start position that indicates the refresh-permitted period. 100%, 75%, 50%, or 25% of the timeout period can be selected for the window start position. Set the window start position to a value greater than the window end position. If the window start position is less than or equal to the window end position, the window end position is set to 0%.

Table 25.3 lists the counter values for the window start and end positions, and Figure 25.2 shows the refresh-permitted period set in the IWDTRPSS[1:0], IWDTRPES[1:0], and IWDTTOPS[1:0] bits.

**Table 25.3 Relationship between the timeout period and window start and end counter values**

| IWDTTOPS[1:0] bits |    | Timeout period |               | Window start and end counter value |        |        |        |
|--------------------|----|----------------|---------------|------------------------------------|--------|--------|--------|
| b1                 | b0 | Cycles         | Counter value | 100%                               | 75%    | 50%    | 25%    |
| 0                  | 0  | 128            | 0x007F        | 0x007F                             | 0x005F | 0x003F | 0x001F |
| 0                  | 1  | 512            | 0x01FF        | 0x01FF                             | 0x017F | 0x00FF | 0x007F |
| 1                  | 0  | 1024           | 0x03FF        | 0x03FF                             | 0x02FF | 0x01FF | 0x00FF |
| 1                  | 1  | 2048           | 0x07FF        | 0x07FF                             | 0x05FF | 0x03FF | 0x01FF |



**Figure 25.2 IWDTRPSS[1:0] and IWDTRPES[1:0] bit settings and refresh-permitted period**

**IWDTRSTIRQS bit (IWDT Reset Interrupt Request Select)**

The IWDTRSTIRQS bit specifies the behavior when an underflow or a refresh error occurs. Setting 1 selects reset output. Setting 0 selects non-maskable interrupt or interrupt.

**IWDTRPES[1:0]位 (IWDT窗口结束位置选择)**

IWDTRPES[1:0]位指定指示刷新允许周期的窗口结束位置。可以为窗口结束位置选择75%、50%、25%或0%的超时时间。将窗口结束位置设置为小于窗口开始位置的值（窗口开始位置>窗口结束位置）。如果窗口结束位置大于窗口起始位置，则仅启用窗口起始位置设置。

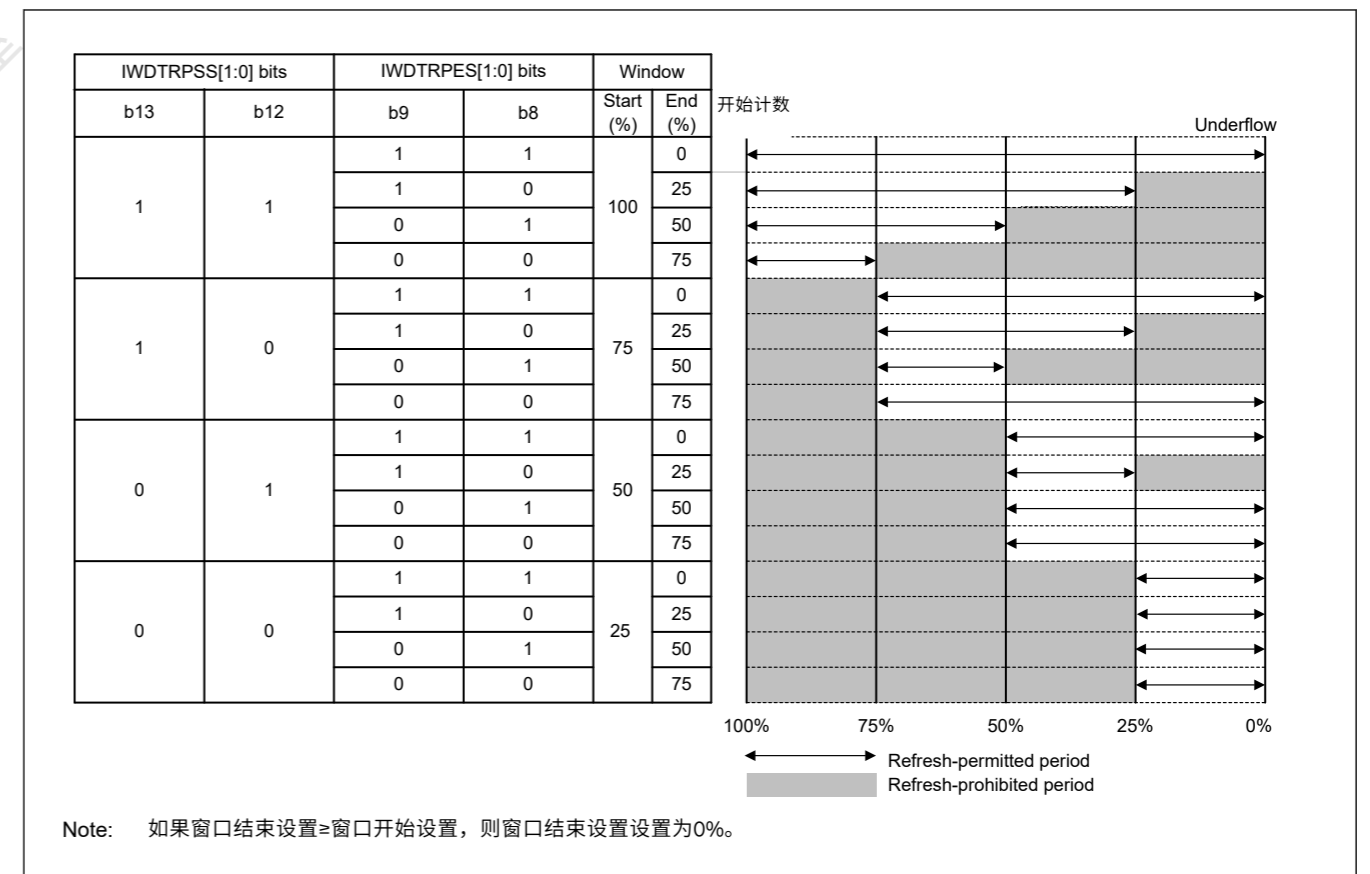
**IWDTRPSS[1:0]位 (IWDT窗口起始位置选择)**

IWDTRPSS[1:0]位指定指示刷新允许周期的窗口起始位置。可以为窗口起始位置选择100%、75%、50%或25%的超时时间。将窗口起始位置设置为大于窗口结束位置的值。如果窗口起始位置小于或等于窗口结束位置，则窗口结束位置设置为0%。

表25.3列出了窗口开始和结束位置的计数器值，图25.2显示了在IWDTRPSS[1:0]、IWDTRPES[1:0]和IWDTTOPS[1:0]位中设置的允许刷新周期。

**Table 25.3 超时时间与窗口开始和结束计数器值之间的关系**

| IWDTTOPS[1:0] bits |    | 超时时间   |        | 窗口开始和结束计数器值 |        |        |        |
|--------------------|----|--------|--------|-------------|--------|--------|--------|
| b1                 | b0 | Cycles | 计数器值   | 100%        | 75%    | 50%    | 25%    |
| 0                  | 0  | 128    | 0x007F | 0x007F      | 0x005F | 0x003F | 0x001F |
| 0                  | 1  | 512    | 0x01FF | 0x01FF      | 0x017F | 0x00FF | 0x007F |
| 1                  | 0  | 1024   | 0x03FF | 0x03FF      | 0x02FF | 0x01FF | 0x00FF |
| 1                  | 1  | 2048   | 0x07FF | 0x07FF      | 0x05FF | 0x03FF | 0x01FF |



**Figure 25.2 IWDTRPSS[1:0]和IWDTRPES[1:0]位设置和允许刷新周期**

**IWDTRSTIRQS位 (IWDT复位中断请求选择)**

IWDTRSTIRQS位指定发生下溢或刷新错误时的行为。设置1选择复位输出。设置0选择不可屏蔽中断或中断。

**IWDTSTPCTL bit (IWDT Stop Control)**

The IWDTSTPCTL bit selects whether to stop counting on transition to Sleep, Snooze, or Software Standby mode.

**25.3 Operation****25.3.1 Auto Start Mode**

When the IWDT Start Mode Select bit (OFS0.IWDTSTRT) in the Option Function Select Register 0 is 0, auto start mode is selected, otherwise the IWDT is disabled.

Within the reset state, the setting values for the following in the Option Function Select Register 0 (OFS0) are set in the IWDT registers:

- Clock division ratio (OFS0.IWDTCKS[3:0])
- Window start and end positions (OFS0.IWDRPSS[1:0], OFS0.IWDRPES[1:0])
- Timeout period (OFS0.IWDTTOPS[1:0])
- Reset output or interrupt request (OFS0.IWDRSTIRQS)

When the reset state is released, the counter automatically starts counting down from the value selected in the IWDT Timeout Period Select bits (OFS0.IWDTTOPS[1:0]).

After that, as long as the program continues normal operation and the counter is refreshed within the refresh-permitted period, the value in the counter is reset each time the counter is refreshed and down-counting continues. The IWDT does not output the reset signal as long as this procedure continues. However, if the counter underflows because the program crashed or because a refresh error occurred when an attempt is made to refresh outside the refresh-permitted period, the IWDT asserts the reset signal or non-maskable interrupt request/interrupt request (IWDT\_NMIUNDF).

After the reset signal or non-maskable interrupt request/interrupt request is generated, the counter reloads the timeout period after counting for 1 cycle, the value of the timeout period is set in the down-counter and counting starts. The reset output or interrupt request output can be selected with the IWDT Reset Interrupt Request Select bit (OFS0.IWDRSTIRQS). Non-maskable interrupt request or interrupt request can be selected with the IWDT Underflow/Refresh Error Interrupt Enable bit (NMIER.IWDTEN).

Figure 25.3 shows an example of operation under the following conditions:

- Auto start mode (OFS0.IWDTSTRT = 0)
- Non-maskable interrupt request output is enabled (OFS0.IWDRSTIRQS = 0)
- The window start position is 75% (OFS0.IWDRPSS[1:0] = 10b)
- The window end position is 25% (OFS0.IWDRPES[1:0] = 10b).

**IWDTSTPCTL位 (IWDT停止控制)**

IWDTSTPCTL位选择在转换到休眠、贪睡或软件待机模式时是否停止计数。

**25.3 Operation****25.3.1 自动启动模式**

当IWDT启动模式选择位置 (OFS0.IWDTSTRT) 中的选项函数选择寄存器0为0时, 选择了自动启动模式, 否则IWDT将被禁用。

在复位状态下, 选项功能选择寄存器0(OFS0)中的以下设置值在IWDT registers:

- 时钟分频比 (OFS0.IWDTCKS[3:0])
- 窗口开始和结束位置 (OFS0.IWDRPSS[1:0]、OFS0.IWDRPES[1:0])
- 超时周期 (OFS0.IWDTTOPS[1:0])
- 复位输出或中断请求 (OFS0.IWDRSTIRQS)

解除复位状态后, 计数器自动从IWDT中选择的值开始倒计时  
超时周期选择位(OFS0.IWDTTOPS[1:0])。

之后, 只要程序继续正常运行, 并且在允许刷新的时间内刷新计数器, 每次刷新计数器并继续递减计数时, 计数器中的值都会被复位。只要此过程继续, IWDT就不会输出复位信号。但是, 如果由于程序崩溃或在刷新允许周期之外尝试刷新时发生刷新错误而导致计数器下溢, 则IWDT将置位复位信号或不可屏蔽中断请求中断请求(IWDT\_NMIUNDF)。

在产生复位信号或不可屏蔽中断请求中断请求后, 计数器在计数1个周期后重新加载超时周期, 超时周期的值设置在递减计数器中并开始计数。可以通过IWDT复位中断请求选择位(OFS0.IWDRSTIRQS)选择复位输出或中断请求输出。可以使用IWDT下溢刷新错误中断 允许位(NMIER.IWDTEN)选择不可屏蔽的中断请求或中断请求。

图25.3显示了以下条件下的操作示例:

- 自动启动模式 (OFS0.IWDTSTRT=0)
- 使能不可屏蔽中断请求输出 (OFS0.IWDRSTIRQS=0)
- 窗口起始位置为75%(OFS0.IWDRPSS[1:0]=10b)
- 窗口结束位置为25%(OFS0.IWDRPES[1:0]=10b)。

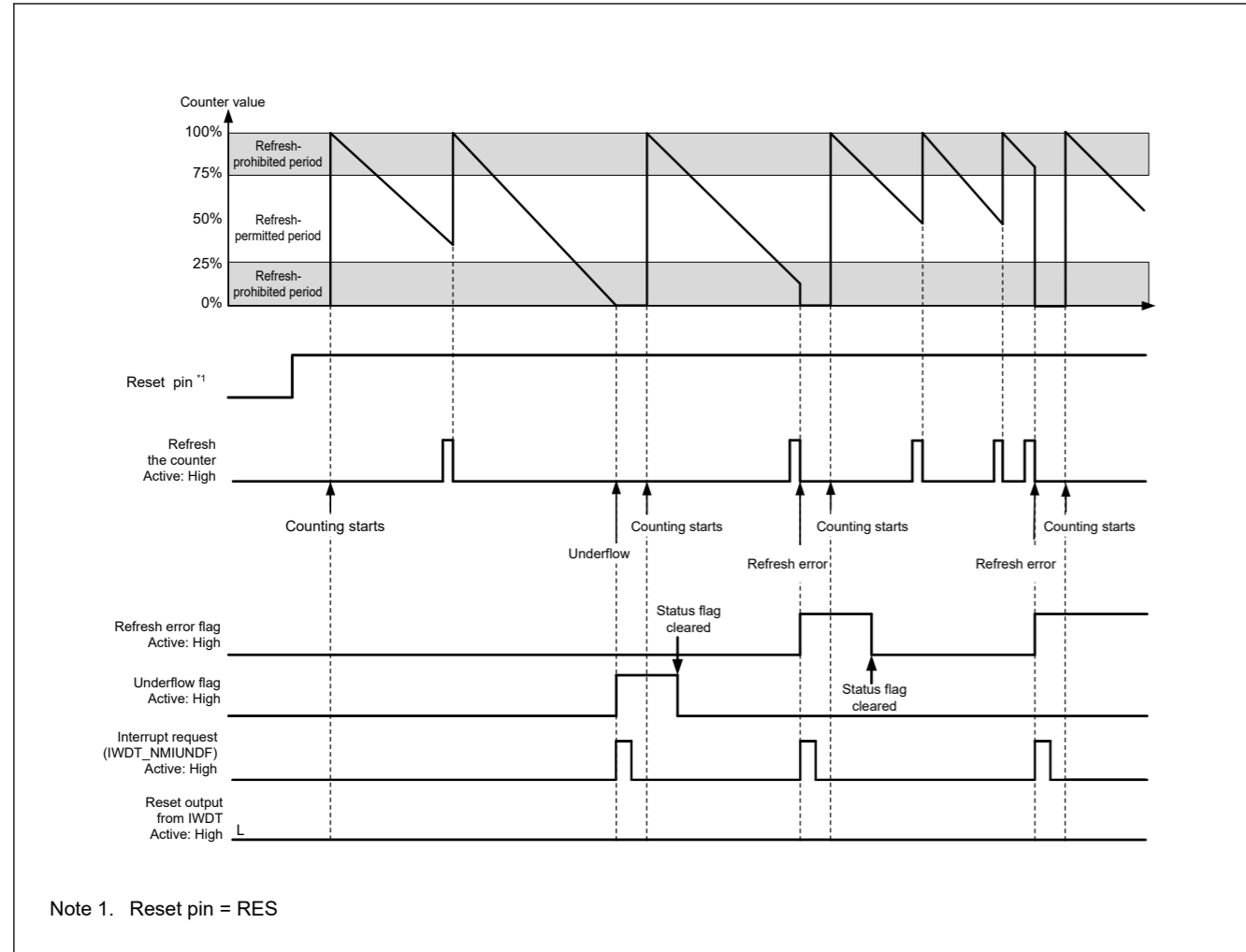


Figure 25.3 Operation example in auto start mode

### 25.3.2 Refresh Operation

The down-counter is refreshed and operation starts (counting is started by refreshing) by writing the values 0x00 and 0xFF to the IWDT Refresh Register (IWDTRR). If a value other than 0xFF is written after 0x00, the down-counter is not refreshed. If an invalid value is written, correct refreshing resumes on a write of 0x00 and 0xFF to the IWDTRR.

When writes are made in the order of 0x00 (first time) → 0x00 (second time), and if 0xFF is written after that, the writing order 0x00 → 0xFF is satisfied. Writing 0x00 ((n - 1)th time) → 0x00 (nth time) → 0xFF is valid, and the refresh is performed correctly. Even when the first value written before 0x00 is not 0x00, correct refreshing is performed as long as the operation contains the write sequence of 0x00 → 0xFF.

Correct refreshing is also performed regardless of whether a register other than IWDTRR is accessed or IWDTRR is read between writing 0x00 and writing 0xFF to IWDTRR. Writes to refresh the counter must be made within the refresh-permitted period. Whether writing is done within the refresh-permitted period is determined when 0xFF is written. For this reason, correct refreshing is performed even when 0x00 is written outside the refresh-permitted period.

[Example write sequences that are valid to refresh the counter]

- 0x00 → 0xFF
- 0x00 ((n - 1)th time) → 0x00 (nth time) → 0xFF
- 0x00 → access to another register or read from IWDTRR → 0xFF.

[Example write sequences that are not valid to refresh the counter]

- 0x23 (a value other than 0x00) → 0xFF
- 0x00 → 0x54 (a value other than 0xFF)

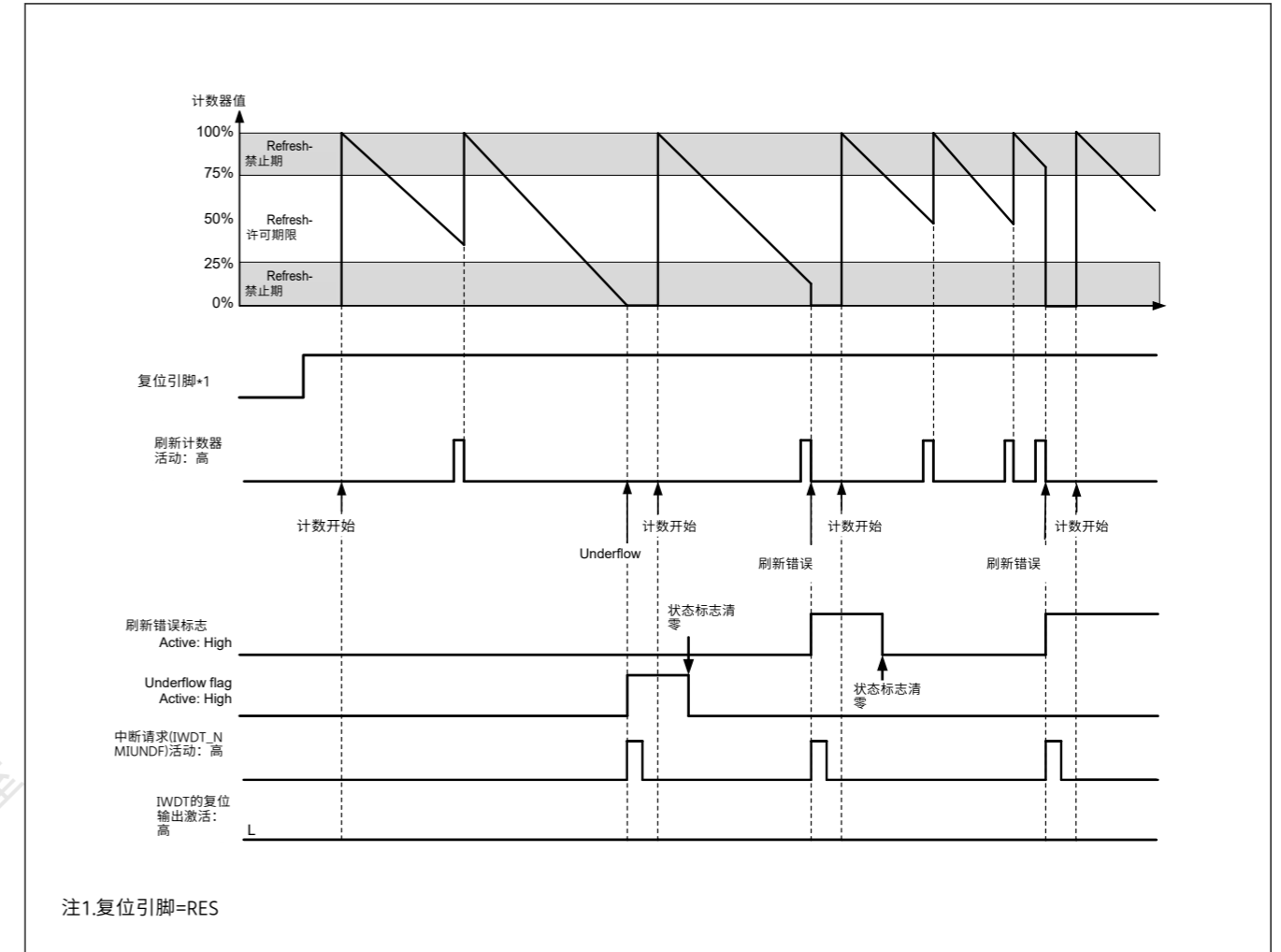


Figure 25.3 自动启动模式下的操作示例

### 25.3.2 刷新操作

通过将值0x00和0xFF写入IWDT刷新寄存器(IWDTRR)来刷新递减计数器并开始操作(通过刷新开始计数)。如果在0x00之后写入0xFF以外的值,则不刷新递减计数器。如果写入无效值,则在向IWDTRR写入0x00和0xFF时会恢复正确刷新。

当以0x00(第一次)→0x00(第二次)的顺序进行写入时,如果在此之后写入0xFF,则满足写入顺序0x00→0xFF。写入0x00((n-1)次)→0x00(n次)→0xFF有效,刷新正确。即使在0x00之前写入的第一个值不是0x00时,只要操作包含0x00→0xFF的写入序列,就会执行正确的刷新。

无论在写入0x00和写入0xFF到IWDTRR之间是否访问IWDTRR以外的寄存器或读取IWDTRR,也会执行正确刷新。刷新计数器的写入必须在允许刷新的期限内进行。在写入0xFF时确定是否在可刷新周期内完成写入。因此,即使在可刷新期间外写入0x00,也会执行正确的刷新。

[对刷新计数器有效的示例写入序列]

- 0x00 → 0xFF
- 0x00 ((n - 1)th time) → 0x00 (nth time) → 0xFF
- 0x00 → 访问另一个寄存器或从IWDTRR读取 → 0xFF。

[对刷新计数器无效的示例写入序列]

- 0x23 (0x00以外的值) → 0xFF
- 0x00 → 0x54 (0xFF以外的值)







### 25.3.4 Reset Output

When the IWDT Reset Interrupt Request Select bit (OFS0.IWDTRSTIRQS) in the Option Function Select Register 0 (OFS0) is set to 1, a reset signal is output when an underflow in the counter or a refresh error occurs. Counting down automatically starts after the reset output.

### 25.3.5 Interrupt Sources

When the IWDT Reset Interrupt Request Select bit (OFS0.IWDTRSTIRQS) in the Option Function Select Register 0 (OFS0) is set to 0, an interrupt (IWDT\_NMIUNDF) signal occurs when an underflow in the counter or a refresh error occurs. This interrupt can be used as a non-maskable interrupt or an interrupt. For details, see [section 13, Interrupt Controller Unit \(ICU\)](#).

Table 25.4 IWDT interrupt source

| Name         | Interrupt source  | Interrupt to CPU | Start DMAC or DTC |
|--------------|---|------------------|-------------------|
| IWDT_NMIUNDF | <ul style="list-style-type: none"> <li>Down-counter underflow</li> <li>Refresh error</li> </ul> | Possible         | Not possible      |

### 25.3.6 Reading the Down-Counter Value

As the counter is a IWDT-dedicated clock (IWDTCLK), the counter value cannot be read directly. The IWDT synchronizes the counter value with the peripheral clock (PCLKB) and stores it in the down-counter value bits (IWDTSR.CNTVAL[13:0]) of the IWDT Status Register. Check these bits to obtain the counter value indirectly.

Reading the counter value requires multiple PCLKB clock cycles (up to 4 clock cycles), and the read counter value might differ from the actual counter value by a value of one count.

Figure 25.5 shows the processing for reading the IWDT counter value when PCLKB > IWDTCLK and the clock division ratio is IWDTCLK.

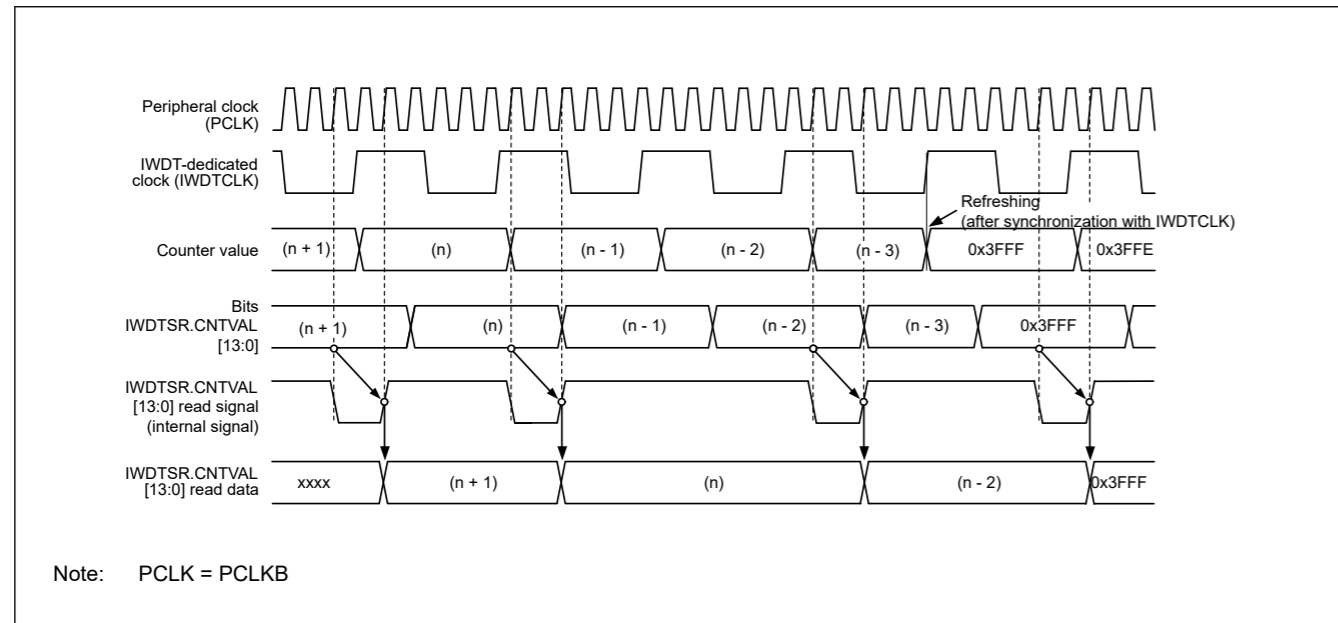


Figure 25.5 Processing for reading IWDT counter value when OFS0.IWDTCCKS[3:0] = 0000b, OFS0.IWDTTOPS[1:0] = 11b

## 25.4 Output to the Event Link Controller (ELC)

The IWDT is capable of link operation for a specified module when the interrupt request signal is used as an event signal by the event link controller (ELC). The event signal is output by the counter underflow or refresh error.

An event signal is output regardless of the setting of the OFS0.IWDTRSTIRQS bit. An event signal can also be output at generation of the next interrupt source while the Refresh Error flag (IWDTSR.REFEF) or Underflow flag (IWDTSR.UNDF) is 1. For details, see [section 18, Event Link Controller \(ELC\)](#).

### 25.3.4 复位输出

当IWDT重置中断请求选择位置 (OFS0.IWDTRSTIRQS) 中的选项函数选择寄存器0 (OFS0) 的位置为1时, 当计数器中的下流或刷新错误发生时, 将输出重置信号。复位输出后自动开始倒计时。

### 25.3.5 中断源

当IWDT重置中断请求选择位置 (OFS0.IWDTRSTIRQS) 中的选项函数选择寄存器0 (OFS0) 设置为0时, 当计数器中的下流或刷新错误发生时, 会发生中断 (IWDT\_NMIUNDF) 信号。此中断可用作不可屏蔽中断或中断。有关详细信息, 请参阅第13节, 中断控制器单元(ICU)。

Table 25.4 IWDT中断源

| Name         | 中断源  | 对CPU的中断  | 启动DMAC或DTC |
|--------------|--|----------|------------|
| IWDT_NMIUNDF | <ul style="list-style-type: none"> <li>Down-counter underflow</li> <li>刷新错误</li> </ul> | Possible | 不可能        |

### 25.3.6 读取递减计数器值

由于计数器是IWDT专用时钟(IWDTCLK), 因此无法直接读取计数器值。IWDT将计数器值与外设时钟(PCLKB)同步, 并将其存储在IWDT状态寄存器的递减计数器值位(IWDTSR.CNTVAL[13:0])中。检查这些位以间接获得计数器值。

读取计数器值需要多个PCLKB时钟周期 (最多4个时钟周期), 读取的计数器值可能与实际计数器值相差一个计数值。

图25.5显示了当PCLKB>IWDTCLK且时钟分频比为IWDTCLK时读取IWDT计数器值的处理。

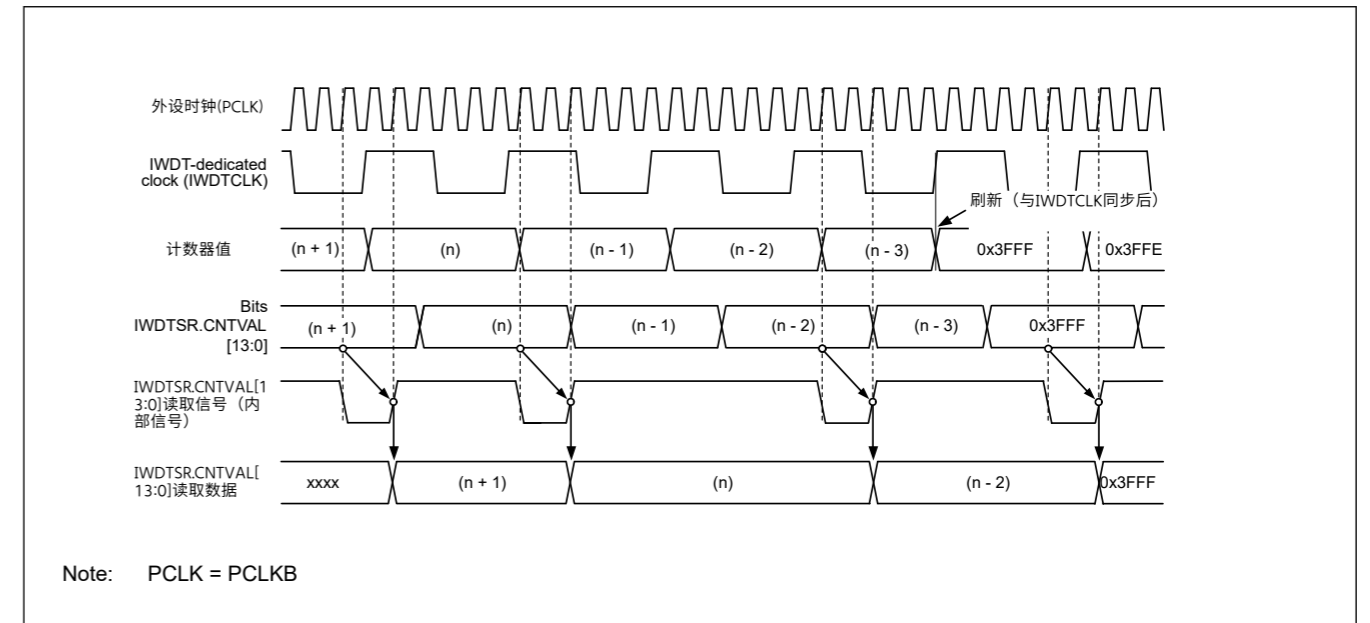


Figure 25.5 OFS0.IWDTCCKS[3:0]=0000b时读取IWDT计数器值的处理, OFS0.IWDTTOPS[1:0] = 11b

## 25.4 输出到事件链接控制器(ELC)

当中断请求信号被事件链接控制器(ELC)用作事件信号时, IWDT能够对指定模块进行链接操作。事件信号由计数器下溢或刷新错误输出。

无论OFS0.IWDTRSTIRQS位的设置如何, 都会输出事件信号。当刷新错误标志(IWDTSR.REFEF)或下溢标志(IWDTSR.UNDF)为1时, 也可以在生成下一个中断源时输出事件信号。有关详细信息, 请参阅第18节, 事件链接控制器(ELC)。

## 25.5 Usage Notes

### 25.5.1 Refresh Operations

While configuring the refresh time, consider variations in the range of errors given the accuracy of PCLKB and IWDTCLK. Set values that ensure refreshing is possible.

### 25.5.2 Clock Division Ratio Setting

Satisfy the frequency of the peripheral module clock (PCLKB)  $\geq 4 \times$  (the frequency of the count clock source after division).

### 25.5.3 Constraints on the ICU Event Link Setting Register n (IELSRn) Setting

Setting 0x52 to ICU Event Link Setting Register n (IELSRn.IELS[8:0]) is prohibited when enabling the IWDT reset assertion (OFS0.IWDRSTIRQS = 0) or when enabling event link operation (ELSRn.ELS[8:0] = 0x52).

## 25.5 使用说明

### 25.5.1 刷新操作

在配置刷新时间时，请考虑给定PCLKB和IWDTCLK精度的误差范围的变化。设置确保可以刷新的值。

### 25.5.2 时钟分频比设置

满足外设模块时钟 (PCLKB) 的频率 $\geq 4 \times$  (分频后的计数时钟源的频率)。

### 25.5.3 ICU事件链接设置寄存器n(IELSRn)设置的约束

当启用IWDT复位断言(OFS0.IWDRSTIRQS=0)或启用事件链接操作(ELSRn.ELS[8:0]=0x52)。

## 26. USB 2.0 Full-Speed Module (USBFS)

### 26.1 Overview

The USB 2.0 Full-Speed module (USBFS) operates as a host or device controller compliant with the Universal Serial Bus (USB) specification revision 2.0. The host controller supports USB 2.0 full-speed and low-speed transfers, and the device controller supports USB 2.0 full-speed transfers. The USBFS has an internal USB transceiver and supports all of the transfer types defined in the USB 2.0 specification

The USBFS has FIFO buffer for data transfers, providing a maximum of 10 pipes. Any endpoint number can be assigned to pipes 1 to 9, based on the peripheral devices or the communication requirements for your system.

Table 26.1 lists the USBFS specifications, Figure 26.1 shows a block diagram, and Table 26.2 lists the I/O pins.

**Table 26.1 USBFS specifications**

| Parameter                | Specifications  |
|--------------------------|---|
| Features                 | <ul style="list-style-type: none"> <li>USB Device Controller (UDC) and USB 2.0 transceiver supporting host controller, device controller, and On-The-Go (OTG) functions (one channel)</li> <li>Host and device controller can be switched by software</li> <li>Self-power or bus power mode selectable</li> <li>Revision 1.2 of battery charging specification is supported</li> </ul> <p>Host controller features:</p> <ul style="list-style-type: none"> <li>Full-speed transfer (12 Mbps) and low-speed transfer (1.5 Mbps)</li> <li>Automatic scheduling for SOF and packet transmissions</li> <li>Programmable intervals for isochronous and interrupt transfers</li> <li>Communications with multiple peripheral devices connected through a single hub</li> </ul> <p>Device controller features:</p> <ul style="list-style-type: none"> <li>Full-speed transfer (12 Mbps)<sup>*1</sup></li> <li>Control transfer stage control function</li> <li>Device state control function</li> <li>Auto response function for SET_ADDRESS request</li> <li>SOF interpolation</li> </ul> |
| Supported transfer types | <ul style="list-style-type: none"> <li>Control transfer</li> <li>Bulk transfer</li> <li>Interrupt transfer</li> <li>Isochronous transfer</li> </ul>   |
| Pipe configuration       | <ul style="list-style-type: none"> <li>FIFO buffer for USB communication</li> <li>Up to 10 pipes selectable, including the Default Control Pipe (DCP)</li> <li>Pipes 1 to 9 assignable to any endpoint number</li> </ul> <p>Transfer conditions specifiable for each pipe:</p> <ul style="list-style-type: none"> <li>Pipe 0: Control transfer with 64-byte single buffer</li> <li>Pipes 1 and 2: Selectable to bulk transfer with 64-byte double buffer or isochronous transfer with 256-byte double buffer</li> <li>Pipes 3 to 5: Bulk transfer with 64-byte double buffer</li> <li>Pipes 6 to 9: Interrupt transfer with 64-byte single buffer</li> </ul>  |
| Other features           | <ul style="list-style-type: none"> <li>Reception end function using transaction count</li> <li>Function that changes the BRDY interrupt event notification timing (BFRE)</li> <li>Automatic clearing of the FIFO buffer after the data for the pipe specified in the DnFIFO port (n = 0, 1) is read (DCLRM)</li> <li>NAK setting function for response PID generated on transfer end (SHTNAK)</li> <li>On-chip pull-up and pull-down resistors for D+ and D-</li> <li>Compliance with Battery Charging Class Specification Revision 1.2</li> </ul>  |
| Module-stop function     | Module-stop state can be set  |
| TrustZone Filter         | Security attribution can be set   |

Note 1. Low-speed transfer (1.5 Mbps) is not supported.

## 26. USB2.0全速模块(USBFS)

### 26.1 Overview

USB2.0全速模块(USBFS)作为主机或设备控制器运行，符合通用串行总线(USB)规范修订版2.0。主机控制器支持USB 2.0全速和低速传输，设备控制器支持USB2.0全速传输。USBFS具有内部USB收发器并支持USB2.0规范中定义的所有传输类型

USBFS具有用于数据传输的FIFO缓冲区，最多提供10个管道。根据外围设备或系统的通信要求，可以将任何端点编号分配给管道1到9。

表26.1列出了USBFS规范，图26.1显示了框图，表26.2列出了IO引脚。

**Table 26.1 USBFS specifications**

| Parameter            | Specifications  |
|----------------------|---|
| Features             | <ul style="list-style-type: none"> <li>USB设备控制器(UDC)和USB2.0收发器，支持主机控制器、设备控制器和On-The-Go(OTG)功能（一个通道）</li> <li>主机和设备控制器可通过软件切换</li> <li>自供电或总线供电模式可选</li> <li>支持电池充电规范1.2版</li> </ul> <p>主机控制器特点：●</p> <ul style="list-style-type: none"> <li>全速传输(12Mbps)和低速传输(1.5Mbps)</li> <li>SOF和数据包传输的自动调度</li> <li>同步和中断传输的可编程间隔</li> <li>与通过单个集线器连接的多个外围设备进行通信</li> </ul> <p>设备控制器特点：●</p> <ul style="list-style-type: none"> <li>控制转移级控制功能</li> <li>设备状态控制功能</li> <li>SET_ADDRESS请求的自动响应功能</li> <li>SOF插值</li> </ul> |
| 支持的传输类型              | <ul style="list-style-type: none"> <li>控制转移</li> <li>批量传输</li> <li>中断传输</li> <li>Isochronous transfer</li> </ul>  |
| 管道配置                 | <ul style="list-style-type: none"> <li>用于USB通信的FIFO缓冲区</li> <li>最多可选择10个管道，包括默认控制管道(DCP)</li> <li>管道1到9可分配给任何端点编号</li> </ul> <p>可为每根管道指定传输条件：●</p> <ul style="list-style-type: none"> <li>管道0：使用64字节单缓冲区进行控制传输</li> <li>管道1和2：可选择使用64字节双缓冲区进行批量传输或使用256字节双缓冲区进行同步传输</li> <li>管道3到5：使用64字节双缓冲区进行批量传输</li> <li>管道6到9：使用64字节单缓冲区的中断传输</li> </ul>   |
| 其它功能                 | <ul style="list-style-type: none"> <li>使用事务计数的接收端函数</li> <li>更改BRDY中断事件通知时间(BFRE)的函数</li> <li>读取DnFIFO端口(n=0-1)中指定管道的数据后自动清除FIFO缓冲区(DCLRM)</li> <li>传输结束时产生的响应PID的NAK设置功能 (SHTNAK)</li> <li>用于D+和D-的片上上拉和下拉电阻</li> <li>符合电池充电类规范修订版1.2</li> </ul>   |
| Module-stop function | 模块停止状态可设置   |
| TrustZone Filter     | 可设置安全属性   |

注1.不支持低速传输(1.5Mbps)。

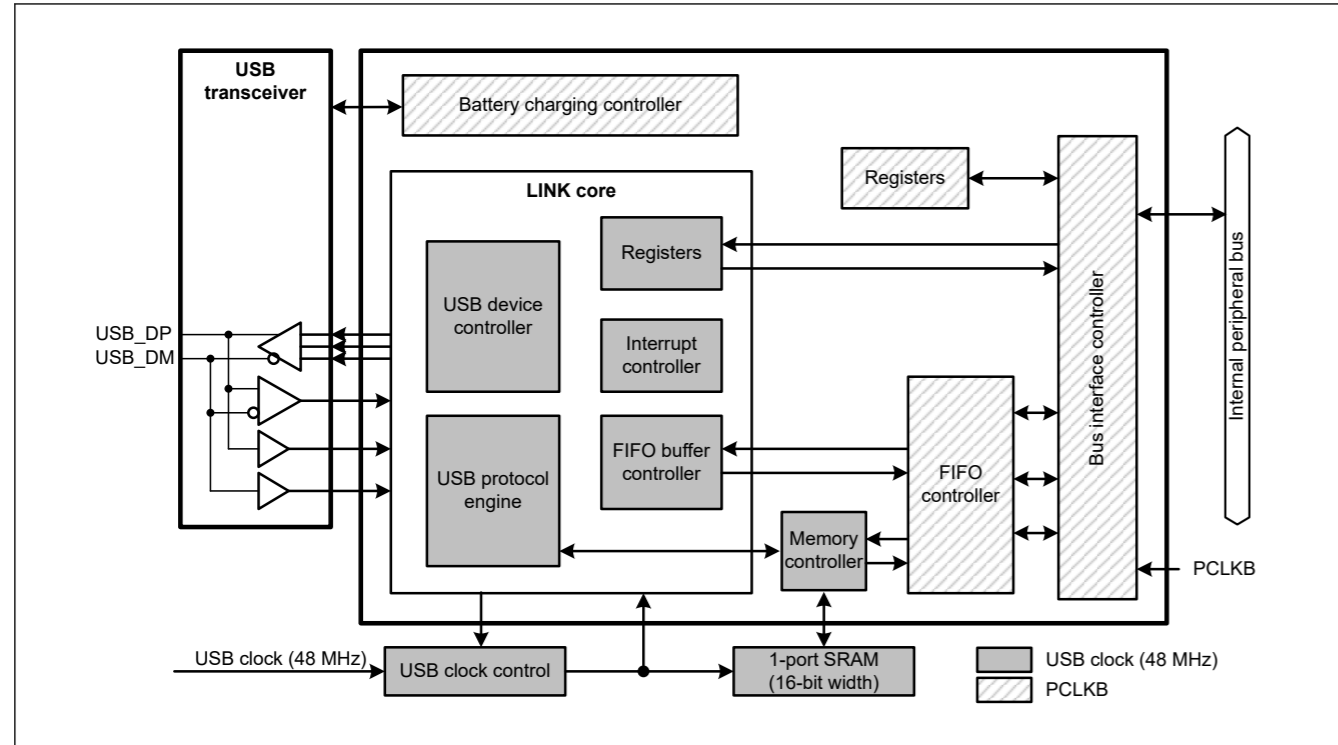


Figure 26.1 USBFS block diagram

Table 26.2 USBFS pin configuration

| Function | Pin name                 | I/O    | Description   |
|----------|--------------------------|--------|---|
| USBFS    | USB_DP                   | I/O    | D+ I/O pin of the USB on-chip transceiver. This pin should be connected to the D+ pin of the USB bus.   |
|          | USB_DM                   | I/O    | D- I/O pin of the USB on-chip transceiver. This pin should be connected to the D- pin of the USB bus.   |
|          | USB_VBUS                 | Input  | USB cable connection monitor pin. This pin should be connected to VBUS of the USB bus. The VBUS pin status (connected or disconnected) can be detected when the USB module is operating as a function controller. |
|          | USB_EXICEN               | Output | Low-power control signal for external power supply (OTG) chip.  |
|          | USB_VBUSEN               | Output | VBUS (5 V) supply enable signal for external power supply chip.   |
|          | USB_OVRCURA, USB_OVRCURB | Input  | External overcurrent detection signals should be connected to these pins. VBUS comparator signals should be connected to these pins when the OTG power supply chip is connected.                                  |
|          | USB_ID                   | Input  | MicroAB connector ID input signal should be connected to this pin during operation in OTG mode.   |
|          | VCC_USB                  | Input  | Power supply pins.  |
|          | VSS_USB                  | Input  | Ground pins.  |

26.2 Register Descriptions

26.2.1 SYSCFG : System Configuration Control Register

Base address: USBFS = 0x4009\_0000

Offset address: 0x000

|                    |    |    |    |    |      |    |   |   |      |      |        |   |   |   |   |      |
|--------------------|----|----|----|----|------|----|---|---|------|------|--------|---|---|---|---|------|
| Bit position:      | 15 | 14 | 13 | 12 | 11   | 10 | 9 | 8 | 7    | 6    | 5      | 4 | 3 | 2 | 1 | 0    |
| Bit field:         | —  | —  | —  | —  | SCKE | —  | — | — | DCFM | DRPD | DPRP U | — | — | — | — | USBE |
| Value after reset: | 0  | 0  | 0  | 0  | 0    | 0  | 0 | 0 | 0    | 0    | 0      | 0 | 0 | 0 | 0 | 0    |

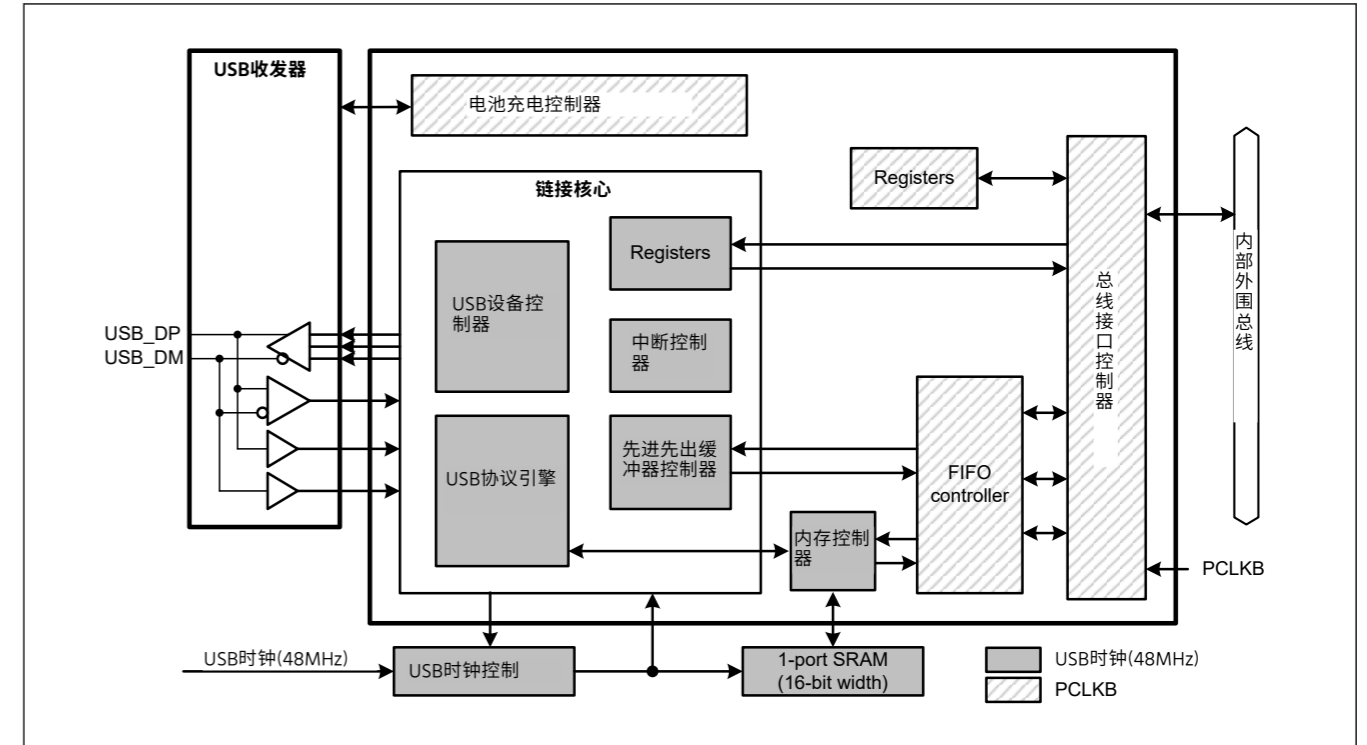


Figure 26.1 USBFS框图

Table 26.2 USBFS引脚配置

| Function | 引脚名称                     | I/O    | Description  |
|----------|--------------------------|--------|--|
| USBFS    | USB_DP                   | I/O    | USB片上收发器的D+IO引脚。该引脚应连接到USB总线的D+引脚。                                   |
|          | USB_DM                   | I/O    | D USB片上收发器的IO引脚。该引脚应连接到USB总线的D 引脚。                                   |
|          | USB_VBUS                 | Input  | USB电缆连接监视器引脚。该引脚应连接到USB总线的VBUS。当USB模块作为功能控制器运行时，可以检测VBUS引脚状态（连接或断开）。 |
|          | USB_EXICEN               | Output | 用于外部电源(OTG)芯片的低功耗控制信号。   |
|          | USB_VBUSEN               | Output | VBUS(5V)为外部供电芯片供电使能信号。   |
|          | USB_OVRCURA, USB_OVRCURB | Input  | 外部过流检测信号应连接到这些引脚。连接OTG电源芯片时，应将VBUS比较器信号连接到这些引脚。                      |
|          | USB_ID                   | Input  | MicroAB连接器ID输入信号应在操作期间连接到此引脚 OTG mode.                               |
|          | VCC_USB                  | Input  | 电源引脚。  |
|          | VSS_USB                  | Input  | 接地引脚。  |

26.2 注册说明

26.2.1 SYSCFG: 系统配置控制寄存器

Base address: USBFS = 0x4009\_0000

Offset address: 0x000

|               |    |    |    |    |      |    |   |   |      |      |        |   |   |   |   |      |
|---------------|----|----|----|----|------|----|---|---|------|------|--------|---|---|---|---|------|
| Bit position: | 15 | 14 | 13 | 12 | 11   | 10 | 9 | 8 | 7    | 6    | 5      | 4 | 3 | 2 | 1 | 0    |
| Bit field:    | —  | —  | —  | —  | SCKE | —  | — | — | DCFM | DRPD | DPRP U | — | — | — | — | USBE |
| 重置后的值:        | 0  | 0  | 0  | 0  | 0    | 0  | 0 | 0 | 0    | 0    | 0      | 0 | 0 | 0 | 0 | 0    |



| Bit   | Symbol | Function   | R/W |
|-------|--------|--|-----|
| 0     | USBE   | USBFS Operation Enable<br>0: Disable<br>1: Enable  | R/W |
| 2:1   | —      | These bits are read as 0. The write value should be 0.                                       | R/W |
| 3     | —      | This bit is read as 0. The write value should be 0.  | R/W |
| 4     | DPRPU  | D+ Line Resistor Control<br>0: Disable line pull-up<br>1: Enable line pull-up                | R/W |
| 5     | DRPD   | D+/D- Line Resistor Control<br>0: Disable line pull-down<br>1: Enable line pull-down         | R/W |
| 6     | DCFM   | Controller Function Select<br>0: Select device controller<br>1: Select host controller       | R/W |
| 7     | —      | This bit is read as 0. The write value should be 0.  | R/W |
| 9:8   | —      | These bits are read as 0. The write value should be 0.                                       | R/W |
| 10    | SCKE   | USB Clock Enable<br>0: Stop clock supply to the USBFS<br>1: Enable clock supply to the USBFS | R/W |
| 15:11 | —      | These bits are read as 0. The write value should be 0.                                       | R/W |

Note: After writing 1 to the SCKE bit, read it to confirm that it is set to 1.

#### USBE bit (USBFS Operation Enable)

The USBE bit enables or disables operation of the USBFS.

Changing the USBE bit from 1 to 0 initializes the bits listed in Table 26.3. Only change this bit while the SCKE bit is 1. In host controller mode, this bit must be set to 1 after setting the DRPD bit to 1, eliminating SYSSTS0.LNST[1:0] flags chattering, and confirming that the USB bus state is stable.

Table 26.3 Registers initialized by writing 0 to the SYSCFG.USBE bit

| Selected function | Register | Bit                                  | Remarks                                  |
|-------------------|----------|--------------------------------------|--|
| Device controller | SYSSTS0  | LNST[1:0]                            | Value is saved in host controller mode   |
|                   | DVSTCTR0 | RHST[2:0]                            | —  |
|                   | INTSTS0  | DVSQ[2:0]                            | Value is saved in host controller mode   |
|                   | USBADDR  | USBADDR[6:0]                         | Value is saved in host controller mode   |
|                   | USBREQ   | BREQUEST[7:0],<br>BMREQUESTTYPE[7:0] | Value is saved in host controller mode   |
|                   | USBVAL   | WVALUE[15:0]                         | Value is saved in host controller mode   |
|                   | USBINDX  | WINDEX[15:0]                         | Value is saved in host controller mode   |
|                   | USBLENG  | WLENTUH[15:0]                        | Value is saved in host controller mode   |
| Host controller   | DVSTCTR0 | RHST[2:0]                            | —  |
|                   | FRMNUM   | FRNM[10:0]                           | Value is saved in device controller mode |

#### DPRPU bit (D+ Line Resistor Control)

The DPRPU bit enables or disables pulling up the D+ line in device controller mode.

When the DPRPU bit is set to 1 in device controller mode, the USBFS pulls up the D+ line to notify the USB host that it attached. Changing the DPRPU bit from 1 to 0 releases the pull-up, thereby notifying the USB host that it detached.

Set this bit to 1 in device controller mode and to 0 in host controller mode.

| Bit   | Symbol | Function                                      | R/W |
|-------|--------|---|-----|
| 0     | USBE   | USBFS操作启用<br>0: 禁用<br>1: 启用                   | R/W |
| 2:1   | —      | 这些位被读取为0。写入值应为0。                              | R/W |
| 3     | —      | 该位读取为0。写入值应为0。                                | R/W |
| 4     | DPRPU  | D+线路电阻控制<br>0: 禁用线路上拉<br>1: 启用线路上拉            | R/W |
| 5     | DRPD   | D+D- 线路电阻控制<br>0: 禁用线下拉<br>1: 启用线下拉           | R/W |
| 6     | DCFM   | 控制器功能选择<br>0: 选择设备控制器<br>1: 选择主机控制器           | R/W |
| 7     | —      | 该位读取为0。写入值应为0。                                | R/W |
| 9:8   | —      | 这些位被读取为0。写入值应为0。                              | R/W |
| 10    | SCKE   | USB时钟使能<br>0: 停止向USBFS提供时钟<br>1: 使能向USBFS提供时钟 | R/W |
| 15:11 | —      | 这些位被读取为0。写入值应为0。                              | R/W |

Note: 将1写入SCKE位后，读取它以确认其设置为1。

#### USBE位 (USBFS操作使能)

USBE位启用或禁用USBFS的操作。

将USBE位从1更改为0会初始化表26.3中列出的位。仅在SCKE位为1时更改该位。在主机控制器模式下，必须在将DRPD位设置为1后将该位设置为1，消除SYSSTS0.LNST[1:0]标志抖动，并确认USB总线状态是稳定的。

Table 26.3 通过向SYSCFG.USBE位写入0来初始化寄存器

| 所选功能  | Register | Bit                                  | Remarks      |
|-------|----------|--------------------------------------|--------------|
| 设备控制器 | SYSSTS0  | LNST[1:0]                            | 值以主机控制器模式保存  |
|       | DVSTCTR0 | RHST[2:0]                            | —            |
|       | INTSTS0  | DVSQ[2:0]                            | 值以主机控制器模式保存  |
|       | USBADDR  | USBADDR[6:0]                         | 值以主机控制器模式保存  |
|       | USBREQ   | BREQUEST[7:0],<br>BMREQUESTTYPE[7:0] | 值以主机控制器模式保存  |
|       | USBVAL   | WVALUE[15:0]                         | 值以主机控制器模式保存  |
|       | USBINDX  | WINDEX[15:0]                         | 值以主机控制器模式保存  |
|       | USBLENG  | WLENTUH[15:0]                        | 值以主机控制器模式保存  |
| 主机控制器 | DVSTCTR0 | RHST[2:0]                            | —            |
|       | FRMNUM   | FRNM[10:0]                           | 值保存在设备控制器模式中 |

#### DPRPU位 (D+线路电阻控制)

DPRPU位启用或禁用设备控制器模式下上拉D+线。

当DPRPU位在设备控制器模式下设置为1时，USBFS拉高D+线以通知USB主机它已连接。将DPRPU位从1更改为0会释放上拉电阻，从而通知USB主机它已分离。

在设备控制器模式下将此位设置为1，在主机控制器模式下设置为0。



**DRPD bit (D+/D- Line Resistor Control)**

TheDRPD bit enables or disables pulling down D+ and D- lines in host controller mode. Set this bit to 1 in host controller mode and to 0 in device controller mode.

**DCFM bit (Controller Function Select)**

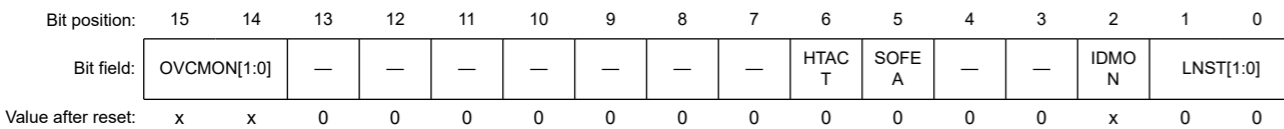
The DCFM bit selects the host or device function of the USBFS. Only change this bit when the DPRPU and DRPD bits are both 0.

**SCKE bit (USB Clock Enable)**

The SCKE bit stops or enables the 48-MHz clock supply to the USBFS. When this bit is 0, only SYSCFG is permitted to be read from and written to; the other registers related to the USB should not be read from or written to.

**26.2.2 SYSSTS0 : System Configuration Status Register 0**

Base address: USBFS = 0x4009\_0000  
Offset address: 0x004



| Bit   | Symbol      | Function   | R/W |
|-------|-------------|--|-----|
| 1:0   | LNST[1:0]   | USB Data Line Status Monitor<br>Indicates the status of the USB data lines, see Table 26.4   | R   |
| 2     | IDMON       | External ID0 Input Pin Monitor<br>0: USB_ID pin is low<br>1: USB_ID pin is high  | R   |
| 4:3   | —           | These bits are read as 0.  | R   |
| 5     | SOFEA       | Active Monitor When the Host Controller Is Selected<br>0: SOF output stopped<br>1: SOF output operating  | R   |
| 6     | HTACT       | USB Host Sequencer Status Monitor<br>0: Host sequencer completely stopped<br>1: Host sequencer not completely stopped                                  | R   |
| 13:7  | —           | These bits are read as 0.  | R   |
| 15:14 | OVCMON[1:0] | External USB_OVRCURA/ USB_OVRCURB Input Pin Monitor<br>OVCMON[1] indicates the USB_OVRCURA pin status. OVCMON[0] indicates the USB_OVRCURB pin status. | R   |

Note: The values of the OVCMON[1:0] and IDMON bits depend on the status of the USB\_OVRCURA, USB\_OVRCURB, and USB\_ID pins.

**LNST[1:0] bits (USB Data Line Status Monitor)**

The LNST[1:0] bits indicate the state of the USB data lines, D+ and D-. For details, see Table 26.4. In device controller mode, read the LNST[1:0] bits after connection processing (SYSCFG.DPRPU bit = 1). In host controller mode, read them after enabling pull-down of the lines (SYSCFG.DRPD bit = 1).

**Table 26.4 Status of the USB data bus lines (D+ and D-) (1 of 2)**

| LNST[1:0] bits | During full-speed operation | During low-speed operation |
|----------------|-----------------------------|----------------------------|
| 00b            | SE0                         | SE0                        |
| 01b            | J-State                     | K-State                    |

**DRPD位 (D+D- 线路电阻控制)**

DRPD位启用或禁用在主机控制器模式下下拉D+和D- 线。在主机控制器模式下将此位设置为1，在设备控制器模式下设置为0。

**DCFM位 (控制器功能选择)**

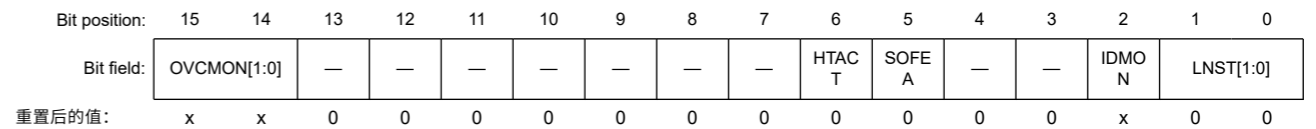
DCFM位选择USBFS的主机或设备功能。仅当DPRPU和DRPD位都为0时更改该位。

**SCKE位 (USB时钟使能)**

SCKE位停止或启用向USBFS提供48MHz时钟。该位为0时，只允许读写SYSCFG；不应读取或写入与USB相关的其他寄存器。

**26.2.2 SYSSTS0: 系统配置状态寄存器0**

Base address: USBFS = 0x4009\_0000  
Offset address: 0x004



| Bit   | Symbol      | Function   | R/W |
|-------|-------------|--|-----|
| 1:0   | LNST[1:0]   | USB数据线状态监视器<br>指示USB数据线的状态，见表26.4  | R   |
| 2     | IDMON       | 外部ID0输入引脚监视器<br>0: USB_ID引脚为低电平<br>1: USB_ID引脚为高电平   | R   |
| 4:3   | —           | 这些位读为0。  | R   |
| 5     | SOFEA       | 选择主机控制器时的活动监视器<br>0: SOF输出停止1: SOF输出工作   | R   |
| 6     | HTACT       | USB主机定序器状态监视器<br>0: 主机定序器完全停止1: 主机定序器未完全停止   | R   |
| 13:7  | —           | 这些位读为0。  | R   |
| 15:14 | OVCMON[1:0] | 外部USB_OVRCURA/USB_OVRCURB输入引脚监视器<br>OVCMON[1]指示USB_OVRCURA引脚状态。OVCMON[0]表示USB_OVRCURB引脚状态。 | R   |

Note: OVCMON[1:0]和IDMON位的值取决于USB\_OVRCURA、USB\_OVRCURB和USB\_ID引脚的状态。

**LNST[1:0]位 (USB数据线状态监视器)**

LNST[1:0]位指示USB数据线D+和D-的状态。详见表26.4。在设备控制器模式下，在连接处理后读取LNST[1:0]位 (SYSCFG.DPRPU=1)。在主机控制器模式下，在启用线路下拉后读取它们 (SYSCFG.DRPD=1)。

**Table 26.4 USB数据总线的状态 (D+和D-) (1of2)**

| LNST[1:0] bits | 全速运行期间  | 低速运转时   |
|----------------|---------|---------|
| 00b            | SE0     | SE0     |
| 01b            | J-State | K-State |

Table 26.4 Status of the USB data bus lines (D+ and D-) (2 of 2)

| LNST[1:0] bits | During full-speed operation | During low-speed operation |
|----------------|-----------------------------|----------------------------|
| 10b            | K-State                     | J-State                    |
| 11b            | SE1                         | SE1                        |

**SOFEA bit (Active Monitor When the Host Controller Is Selected)**

The SOFEA bit is used in host controller mode to check whether the output of the last SOF is complete when the USBFS is suspended because of a 0 setting to the DVSTCTR0.UACT bit.

In host controller mode, check that both the HTACT and SOFEA bits are 0 before setting the SYSCFG.USBE bit to 0 to stop the USBFS or setting the SYSCFG.SCKE bit to 0 to stop the clock signal supply during communication.

**HTACT bit (USB Host Sequencer Status Monitor)**

The HTACT bit is set to 0 when the host sequencer of the USBFS is completely stopped.

In host controller mode, check that the HTACT bit is 0 before setting the DVSTCTR0.UACT bit to 0 to place the USBFS in the suspended state or setting the SCKE bit to 0 to stop the clock signal supply during communication.

**OVCMON[1:0] bits (External USB\_OVRCURA/ USB\_OVRCURB Input Pin Monitor)**

The OVCMON[1:0] bits indicate the status of the overcurrent signals from an external power supply IC.

26.2.3 DVSTCTR0 : Device State Control Register 0

Base address: USBFS = 0x4009\_0000

Offset address: 0x008

|                    |    |    |    |    |          |         |         |      |        |         |         |      |   |   |           |   |
|--------------------|----|----|----|----|----------|---------|---------|------|--------|---------|---------|------|---|---|-----------|---|
| Bit position:      | 15 | 14 | 13 | 12 | 11       | 10      | 9       | 8    | 7      | 6       | 5       | 4    | 3 | 2 | 1         | 0 |
| Bit field:         | —  | —  | —  | —  | HNPB TOA | EXICE N | VBUS EN | WKUP | RWUP E | USBR ST | RESU ME | UACT | — | — | RHST[2:0] | — |
| Value after reset: | 0  | 0  | 0  | 0  | 0        | 0       | 0       | 0    | 0      | 0       | 0       | 0    | 0 | 0 | 0         | 0 |

| Bit | Symbol    | Function   | R/W |
|-----|-----------|--|-----|
| 2:0 | RHST[2:0] | USB Bus Reset Status<br>0 0 0: In host controller mode: Communication speed indeterminate (powered state or no connection)<br>In device controller mode: Communication speed indeterminate<br>0 0 1: In host controller mode: Low-speed connection<br>In device controller mode: USB bus reset in progress<br>0 1 0: In host controller mode: Full-speed connection<br>In device controller mode: USB bus reset in progress or full-speed connection<br>0 1 1: Setting prohibited<br>Others: In host controller mode: USB bus reset in progress<br>In device controller mode: Setting prohibited | R   |
| 3   | —         | These bits are read as 0. The write value should be 0.   | R/W |
| 4   | UACT      | USB Bus Enable<br>0: Disable downstream port (disable SOF transmission)<br>1: Enable downstream port (enable SOF transmission)   | R/W |
| 5   | RESUME    | Resume Output<br>0: Do not output resume signal<br>1: Output resume signal   | R/W |
| 6   | USBRST    | USB Bus Reset Output<br>0: Do not output USB bus reset signal<br>1: Output USB bus reset signal  | R/W |
| 7   | RWUPE     | Wakeup Detection Enable<br>0: Disable downstream port remote wakeup<br>1: Enable downstream port remote wakeup   | R/W |

Table 26.4 USB数据总线的状态 (D+和D-) (2之2)

| LNST[1:0] bits | 全速运行期间  | 低速运转时   |
|----------------|---------|---------|
| 10b            | K-State | J-State |
| 11b            | SE1     | SE1     |

**SOFEA位 (选择主机控制器时的主动监视器)**

SOFEA位在主机控制器模式下用于检查当USBFS由于DVSTCTR0.UACT位设置为0而暂停时最后一个SOF的输出是否完成。

在主机控制器模式下，在将SYSCFG.USBE位设置为0以停止USBFS或将SYSCFG.SCKE位设置为0以在通信期间停止时钟信号供应之前，请检查HTACT和SOFEA位是否都为0。

**HTACT位 (USB主机定序器状态监视器)**

当USBFS的主机定序器完全停止时，HTACT位设置为0。

在主机控制器模式下，在将DVSTCTR0.UACT位设置为0以将USBFS置于挂起状态或将SCKE位设置为0以在通信期间停止时钟信号供应之前，请检查HTACT位是否为0。

**OVCMON[1:0]位 (外部USB\_OVRCURA/USB\_OVRCURB输入引脚监视器)**

OVCMON[1:0]位指示来自外部电源IC的过流信号的状态。

26.2.3 DVSTCTR0: 设备状态控制寄存器0

Base address: USBFS = 0x4009\_0000

Offset address: 0x008

|               |    |    |    |    |          |         |         |      |        |         |         |      |   |   |           |   |
|---------------|----|----|----|----|----------|---------|---------|------|--------|---------|---------|------|---|---|-----------|---|
| Bit position: | 15 | 14 | 13 | 12 | 11       | 10      | 9       | 8    | 7      | 6       | 5       | 4    | 3 | 2 | 1         | 0 |
| Bit field:    | —  | —  | —  | —  | HNPB TOA | EXICE N | VBUS EN | WKUP | RWUP E | USBR ST | RESU ME | UACT | — | — | RHST[2:0] | — |
| 重置后的值:        | 0  | 0  | 0  | 0  | 0        | 0       | 0       | 0    | 0      | 0       | 0       | 0    | 0 | 0 | 0         | 0 |

| Bit | Symbol    | Function   | R/W |
|-----|-----------|--|-----|
| 2:0 | RHST[2:0] | USB总线复位状态<br>000: 在主机控制器模式下: 通信速度不确定 (通电状态或无连接) 在设备控制器模式下: 通信速度不确定<br>001: 在主控制器模式下: 低速连接<br>在设备控制器模式下: 正在进行USB总线复位<br>010: 在主控制器模式下: 全速连接<br>在设备控制器模式下: USB总线正在复位或全速连接<br>011: 禁止设定<br>其他: 在主机控制器模式下: USB总线复位正在进行中<br>在设备控制器模式下: 禁止设置 | R   |
| 3   | —         | 这些位被读取为0。写入值应为0。   | R/W |
| 4   | UACT      | USB总线启用<br>0: 禁用下行端口 (禁用SOF传输) 1: 启用下行端口 (启用SOF传输)   | R/W |
| 5   | RESUME    | 恢复输出<br>0: 不输出恢复信号 1: 输出恢复信号   | R/W |
| 6   | USBRST    | USB总线复位输出<br>0: 不输出USB总线复位信号 1: 输出USB总线复位信号  | R/W |
| 7   | RWUPE     | 唤醒检测启用<br>0: 禁用下游端口远程唤醒 1: 启用下游端口远程唤醒  | R/W |

| Bit   | Symbol  | Function   | R/W |
|-------|---------|--|-----|
| 8     | WKUP    | Wakeup Output<br>0: Do not output remote wakeup signal<br>1: Output remote wakeup signal   | R/W |
| 9     | VBUSEN  | USB_VBUSEN Output Pin Control<br>0: Output low on external USB_VBUSEN pin<br>1: Output high on external USB_VBUSEN pin   | R/W |
| 10    | EXICEN  | USB_EXICEN Output Pin Control<br>0: Output low on external USB_EXICEN pin<br>1: Output high on external USB_EXICEN pin   | R/W |
| 11    | HNPBTOA | Host Negotiation Protocol (HNP) Control<br>Use this bit when switching from device B to device A in OTG mode. If the HNPBTOA bit is 1, the internal function control remains in the Suspend state until the HNP processing ends even if SYSCFG.DPRPU = 0 or SYSCFG.DCFM = 1. | R/W |
| 15:12 | —       | These bits are read as 0. The write value should be 0.   | R/W |

The USBFS controller does not support low-speed connections in device controller mode. When this value is read, abnormal connection processing must be executed in higher level application software.

#### RHST[2:0] bits (USB Bus Reset Status)

RHST[2:0] bits indicate the status of the USB bus reset.

In host controller mode, writing 1 to the USBRST bit causes the RHST[2:0] bits to set to 100b. When 0 is written to the USBRST bit and the USBFS ends the SE0 state, the RHST[2:0] bits update to a new value.

In device controller mode, if the USBFS detects a USB bus reset, the RHST[2:0] bits indicate 010b if the DPRPU bit is 1, and a DVST interrupt is generated.

#### UACT bit (USB Bus Enable)

When set to 1 in host controller mode, the UACT bit enables USB bus operation by controlling SOF packet transmission to the USB bus in addition to data and reception. The USBFS starts SOF packet output within one frame period after the UACT bit is set to 1. When UACT is set to 0, the USBFS enters the idle state after the SOF packet output.

The USBFS sets the UACT bit to 0 on any of the following conditions:

- A DTCH interrupt is detected during communication (when UACT = 1)
- An EOFERR interrupt is detected during communication (when UACT = 1)

Always write 1 to the UACT bit at the end of the USB bus reset processing (writing 0 to the USBRST bit) or at the end of resume processing from the suspended state (writing 0 to the RESUME bit).

In device controller mode, always set this bit to 0.

#### RESUME bit (Resume Output)

The RESUME bit controls the resume signal output in host controller mode.

When this bit is set to 1, the USBFS drives the USB port to the K-state and outputs the resume signal. The USBFS sets the bit to 1 on detection of a remote wakeup signal while the RWUPE bit is 1 and in the USB Suspend state.

The USBFS continues outputting the K-state while the RESUME bit is 1, until the bit is cleared to 0 by software. The RESUME bit must be 1 (resume period) for the time defined in the USB 2.0 specification. Only set this bit to 1 while the interface is in the Suspend state. Write 1 to the UACT bit simultaneously with the end of the resume processing (writing 0 to the RESUME bit).

Always set this bit to 0 in device controller mode.

#### USBRST bit (USB Bus Reset Output)

The USBRST bit controls the output of the USB bus signal in host controller mode. When this bit set to 1, the USBFS drives the USB port to the SE0 state to reset the USB bus. The USBFS continues outputting SE0 while the USBRST bit is 1, until the bit is cleared to 0 by software. The USBRST bit must be 1 (USB bus reset period) for the time defined in the USB 2.0 specification. Writing 1 to the USBRST bit during communication (UACT = 1) or during resume processing (RESUME

| Bit   | Symbol  | Function  | R/W |
|-------|---------|---|-----|
| 8     | WKUP    | 唤醒输出<br>0: 不输出远程唤醒信号1: 输出远程唤醒信号   | R/W |
| 9     | VBUSEN  | USB_VBUSEN输出引脚控制<br>0: 外部USB_VBUSEN引脚输出低电平1: 外部USB_VBUSEN引脚输出高电平  | R/W |
| 10    | EXICEN  | USB_EXICEN输出引脚控制<br>0: 外部USB_EXICEN引脚输出低电平1: 外部USB_EXICEN引脚输出高电平  | R/W |
| 11    | HNPBTOA | 主机协商协议(HNP)控制<br>在OTG模式下从设备B切换到设备A时使用该位。如果HNPBTOA位为1, 即使SYSCFG.DPRPU=0或SYSCFG.DCFM=1, 内部功能控制仍保持暂停状态直到HNP处理结束。 | R/W |
| 15:12 | —       | 这些位被读取为0。写入值应为0。  | R/W |

USBFS控制器不支持设备控制器模式下的低速连接。当读取此值时, 必须在更高级别的应用软件中执行异常连接处理。

#### RHST[2:0]位 (USB总线复位状态)

RHST[2:0]位指示USB总线复位的状态。

在主机控制器模式下, 将1写入USBRST位会导致RHST[2:0]位设置为100b。当0被写入USBRST位和USBFS结束SE0状态, RHST[2:0]位更新为新值。

在设备控制器模式下, 如果USBFS检测到USB总线复位, 如果DPRPU位为1, 则RHST[2:0]位指示010b, 并产生DVST中断。

#### UACT位 (USB总线使能)

在主机控制器模式下设置为1时, UACT位通过控制向USB总线发送SOF数据包以及数据和接收来启用USB总线操作。USBFS在UACT位设置为1后的一帧周期内开始SOF数据包输出。当UACT设置为0时, USBFS在SOF数据包输出后进入空闲状态。

USBFS在以下任何条件下将UACT位设置为0:

- 通信期间检测到DTCH中断 (当UACT=1时)
- 通信期间检测到EOFERR中断 (当UACT=1时)

在USB总线复位处理结束 (将0写入USBRST位) 或从挂起状态恢复处理结束 (将0写入RESUME位) 时, 始终向UACT位写入1。

在设备控制器模式下, 始终将此位设置为0。

#### RESUME位 (恢复输出)

RESUME位控制主机控制器模式下的恢复信号输出。

当该位设置为1时, USBFS将USB端口驱动到K状态并输出恢复信号。当RWUPE位为1且处于USB挂起状态时, USBFS在检测到远程唤醒信号时将该位设置为1。

当RESUME位为1时, USBFS继续输出K状态, 直到该位被软件清除为0。这在USB2.0规范中定义的时间内, RESUME位必须为1 (恢复周期)。仅当接口处于挂起状态时将此位设置为1。在恢复处理结束的同时向UACT位写入1 (向RESUME位写入0)。

在设备控制器模式下始终将此位设置为0。

#### USBRST位 (USB总线复位输出)

USBRST位控制主机控制器模式下USB总线信号的输出。当该位设置为1时, USBFS将USB端口驱动到SE0状态以复位USB总线。当USBRST位为1时, USBFS继续输出SE0, 直到该位被软件清零。在USB2.0规范中定义的时间内, USBRST位必须为1 (USB总线复位周期)。通信期间(UACT=1)或恢复处理期间(RESUME)向USBRST位写入1



= 1) prevents the USBFS from starting USB bus reset processing until both the UACT and RESUME bits become 0. Write 1 to the UACT bit simultaneously with the end of the USB bus reset processing (writing 0 to the USBRST bit).

Always set this bit to 0 in device controller mode.

#### RWUPE bit (Wakeup Detection Enable)

The RWUPE bit enables or disables remote wakeup signals (resume signals) from downstream peripheral devices in host controller mode. When this bit is set to 1, the USBFS detects a remote wakeup signal (K-state for 2.5 μs) from a downstream peripheral device, and performs resume processing, driving the K-state. When the RWUPE bit is set to 0, the USBFS ignores remote wakeup signals (K-states) from peripheral devices connected to the USB port.

Do not stop the internal clock when the RWUPE bit is 1, even in the Suspend state (SYSCFG.SCKE bit must be set to 1).

Always set this bit to 0 in device controller mode.

#### WKUP bit (Wakeup Output)

The WKUP bit enables or disables remote wakeup signals (resume signals) to the USB bus in device controller mode.

The USBFS controls the output timing of the remote wakeup signals. When this bit is set to 1, the USBFS clears it to 0 after outputting the K-state for 10 ms. The USB 2.0 specification specifies that the USB bus idle state must be kept for 5 ms or longer before a remote wakeup signal is sent. If the USBFS writes 1 to the WKUP bit immediately after detecting the Suspend state, the K-state is output after 2 ms.

Only write 1 to the WKUP bit when the device is in the Suspend state (INTSTS0.DVSSQ[2:0] = 1xxb) and the USB host enables the remote wakeup signal (RWUPE = 1). Do not stop the internal clock while this bit is 1, even in the Suspend state (SYSCFG.SCKE bit must be set to 1).

Always set this bit to 0 in host controller mode.

#### HNPBTOA bit (Host Negotiation Protocol (HNP) Control)

The HNPBTOA bit is used when switching from device B to device A while in OTG mode.

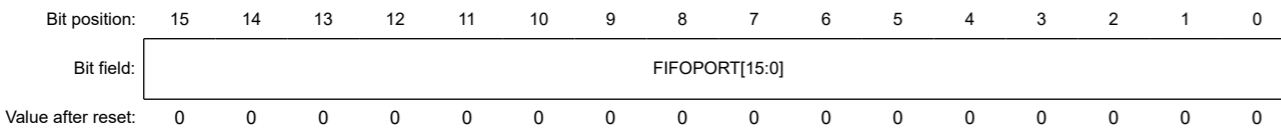
If the HNPBTOA bit is 1, the internal function control maintains the Suspend state until HNP processing ends, even if the SYSCFG.DPRPU bit is set to 0 or the SYSCFG.DCFM bit is set to 1. Resume interrupts (RESM) are not generated even if a falling edge of D+ is detected.

The HNP processing ends when a host attach event is detected, because of a pull-up by the initiating party, or the HNPBTOA bit is cleared to 0 by software because the HNP processing times out.

### 26.2.4 CFIFO/CFIFOL : CFIFO Port Register

Base address: USBFS = 0x4009\_0000

Offset address: 0x014



| Bit  | Symbol                      | Function  | R/W |
|------|-----------------------------|---|-----|
| 15:0 | FIFOPORT[15:0] <sup>1</sup> | FIFO Port<br>Read receive data from the FIFO buffer or write transmit data to the FIFO buffer by accessing these bits | R/W |

Note 1. The valid bits depend on the MBW settings (CFIFOSEL.MBW) and BIGEND settings (CFIFOSEL.BIGEND) in the associated port selection register. See Table 26.5 and Table 26.6.

Three FIFO ports are available:

- CFIFO
- D0FIFO
- D1FIFO

=1)防止USBFS开始USB总线复位处理，直到UACT和RESUME位都变为0。在USB总线复位处理结束的同时向UACT位写入1（向USBRST位写入0）。

在设备控制器模式下始终将此位设置为0。

#### RHUPE位（唤醒检测使能）

在主机控制器模式下，RWUPE位启用或禁用来自下游外围设备的远程唤醒信号（恢复信号）。当该位设置为1时，USBFS检测到来自下游外围设备的远程唤醒信号（K状态持续2.5μs），并执行恢复处理，驱动K状态。当RHUPE位设置为0时，USBFS忽略来自连接到USB端口的的外围设备的远程唤醒信号（K状态）。

当RHUPE位为1时不要停止内部时钟，即使处于挂起状态（SYSCFG.SCKE位必须设置为1）。

在设备控制器模式下始终将此位设置为0。

#### WKUP bit (Wakeup Output)

WKUP位在设备控制器模式下启用或禁用到USB总线的远程唤醒信号（恢复信号）。

USBFS控制远程唤醒信号的输出时序。当该位设置为1时，USBFS在输出K状态10ms后将其清除为0。USB2.0规范规定，在发送远程唤醒信号之前，USB总线空闲状态必须保持5ms或更长时间。如果USBFS在检测到Suspend状态后立即向WKUP位写入1，则在2ms后输出K-state。

仅当设备处于挂起状态（INTSTS0.DVSSQ[2:0]=1xxb）且USB主机使能远程唤醒信号（RWUPE=1）时向WKUP位写入1。当该位为1时不要停止内部时钟，即使处于挂起状态（SYSCFG.SCKE位必须设置为1）。

在主机控制器模式下始终将此位设置为0。

#### HNPBTOA位（主机协商协议(HNP)控制)

在OTG模式下从设备B切换到设备A时使用HNPBTOA位。

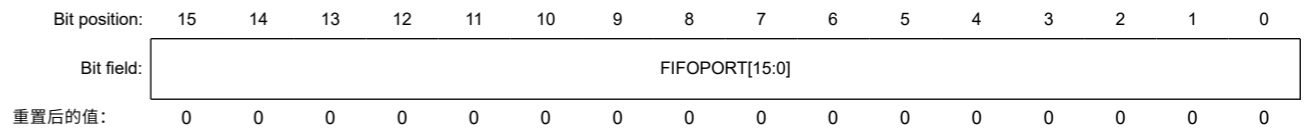
如果HNPBTOA位为1，内部功能控制保持暂停状态直到HNP处理结束，即使SYSCFG.DPRPU位设置为0或SYSCFG.DCFM位设置为1。不产生恢复中断(RESM)即使检测到D+的下降沿。

当检测到主机连接事件时，HNP处理结束，因为发起方的上拉，或者由于HNP处理超时，HNPBTOA位由软件清零。

### 26.2.4 CFIFOCFIFOL:CFIFO端口寄存器

Base address: USBFS = 0x4009\_0000

Offset address: 0x014



| Bit  | Symbol                      | Function  | R/W |
|------|-----------------------------|---|-----|
| 15:0 | FIFOPORT[15:0] <sup>1</sup> | FIFO Port<br>通过访问这些位从FIFO缓冲区读取接收数据或将发送数据写入FIFO缓冲区 | R/W |

注1.有效位取决于相关端口选择寄存器中的MBW设置(CFIFOSEL.MBW)和BIGEND设置(CFIFOSEL.BIGEND)。请参见表26.5和表26.6。

三个FIFO端口可用：

- CFIFO
- D0FIFO
- D1FIFO

Each FIFO port is configured with:

- A port register (CFIFO, D0FIFO, or D1FIFO) that handles reading of data from the FIFO buffer and writing of data to the FIFO buffer
- A port selection register (CFIFOSEL, D0FIFOSEL, or D1FIFOSEL) that selects the pipe assigned to the FIFO port
- A port control register (CFIFOCTR, D0FIFOCTR, or D1FIFOCTR)

Each FIFO port has the following constraints:

- Access to the FIFO buffer for DCP control transfers is through the CFIFO port
- Access to the FIFO buffer for DMA or DTC transfers is through the D0FIFO or D1FIFO port
- The D0FIFO and D1FIFO ports can also be accessed by the CPU
- When using functions specific to the FIFO port, such as the DMA or DTC transfer function, you cannot change the pipe number selected in the CURPIPE[3:0] bits of the port selection register
- Registers configuring a FIFO port do not affect other FIFO ports
- The same pipe must not be assigned to two or more FIFO ports
- There are two FIFO buffer states, one giving access rights to the CPU and the other to the serial interface engine (SIE). When the SIE has access rights, the FIFO buffer cannot be accessed by the CPU

**FIFOPORT[15:0] bits (FIFO Port)**

When the FIFOPORT[15:0] bit is accessed, the USBFS reads the received data from the FIFO buffer or writes the transmit data to the FIFO buffer. The FIFO port register can be accessed only when the FRDY bit in the associated port control register (CFIFOCTR, D0FIFOCTR, or D1FIFOCTR) is 1.

The valid bits in the FIFO port register depend on the MBW and BIGEND settings in the port selection register (CFIFOSEL, D0FIFOSEL, or D1FIFOSEL). See Table 26.5 and Table 26.6.

**Table 26.5 Endian operation in 16-bit access**

| CFIFOSEL.BIGEND bit | Bits [15:8] | Bits [7:0] |
|---------------------|-------------|------------|
| 0                   | N + 1 data  | N + 0 data |
| 1                   | N + 0 data  | N + 1 data |

**Table 26.6 Endian operation in 8-bit access**

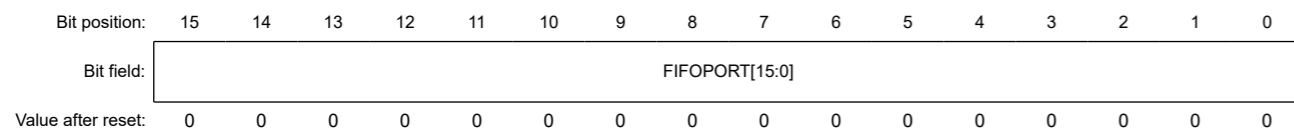
| CFIFOSEL.BIGEND bit | Bits [15:8]         | Bits [7:0] |
|---------------------|---------------------|------------|
| 0                   | Access prohibited*1 | N + 0 data |
| 1                   | Access prohibited*1 | N + 0 data |

Note 1. Writing to or reading from these areas is not allowed.

**26.2.5 DnFIFO/DnFIFOL : DnFIFO Port Register (n = 0, 1)**

Base address: USBFS = 0x4009\_0000

Offset address: 0x018 + 0x4 × n



| Bit  | Symbol                       | Function  | R/W |
|------|------------------------------|---|-----|
| 15:0 | FIFOPORT[15:0] <sup>*1</sup> | FIFO Port<br>Read receive data from the FIFO buffer or write transmit data to the FIFO buffer by accessing these bits | R/W |

每个FIFO端口配置有:

- 一个端口寄存器 (CFIFO、D0FIFO或D1FIFO)，用于处理从FIFO缓冲区读取数据并将数据写入FIFO缓冲区
- 端口选择寄存器 (CFIFOSEL、D0FIFOSEL或D1FIFOSEL)，用于选择分配给FIFO端口的管道
- 一个端口控制寄存器 (CFIFOCTR、D0FIFOCTR或D1FIFOCTR)

每个FIFO端口具有以下约束:

- 通过CFIFO端口访问DCP控制传输的FIFO缓冲区
- 通过D0FIFO或D1FIFO端口访问DMA或DTC传输的FIFO缓冲区
- D0FIFO和D1FIFO端口也可以被CPU访问
- 当使用特定于FIFO端口的功能时，例如DMA或DTC传输功能，您不能更改在端口选择寄存器的CURPIPE[3:0]位中选择的管道号
- 配置FIFO端口的寄存器不会影响其他FIFO端口
- 不能将同一管道分配给两个或多个FIFO端口
- 有两种FIFO缓冲区状态，一种授予CPU访问权限，另一种授予串行接口引擎(SIE)。当SIE有访问权限时，CPU不能访问FIFO缓冲区

**FIFOPORT[15:0] bits (FIFO Port)**

当访问FIFOPORT[15:0]位时，USBFS从FIFO缓冲区读取接收数据或将发送数据写入FIFO缓冲区。只有当相关端口控制寄存器 (CFIFOCTR、D0FIFOCTR或D1FIFOCTR) 中的FRDY位为1时，才能访问FIFO端口寄存器。

FIFO端口寄存器中的有效位取决于端口选择寄存器 (CFIFOSEL、D0FIFOSEL或D1FIFOSEL) 中的MBW和BIGEND设置。请参见表26.5和表26.6。

**Table 26.5 16位访问中的字节序操作**

| CFIFOSEL.BIGEND bit | Bits [15:8] | Bits [7:0] |
|---------------------|-------------|------------|
| 0                   | N + 1 data  | N + 0 data |
| 1                   | N + 0 data  | N + 1 data |

**Table 26.6 8位访问中的字节序操作**

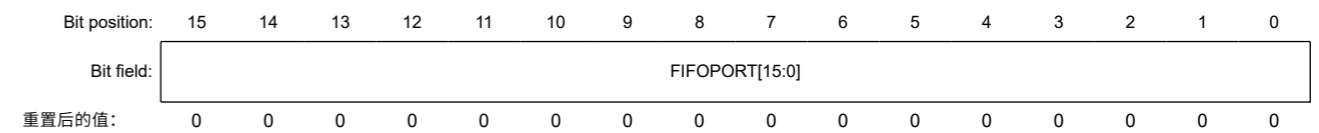
| CFIFOSEL.BIGEND bit | Bits [15:8] | Bits [7:0] |
|---------------------|-------------|------------|
| 0                   | 禁止访问*1      | N + 0 data |
| 1                   | 禁止访问*1      | N + 0 data |

注1.不允许对这些区域进行写入或读取。

**26.2.5 DnFIFODnFIFOL:DnFIFO端口寄存器(n=0 1)**

Base address: USBFS = 0x4009\_0000

Offset address: 0x018 + 0x4 × n



| Bit  | Symbol                       | Function  | R/W |
|------|------------------------------|---|-----|
| 15:0 | FIFOPORT[15:0] <sup>*1</sup> | FIFO Port<br>通过访问这些位从FIFO缓冲区读取接收数据或将发送数据写入FIFO缓冲区 | R/W |



Note 1. The valid bits depend on the MBW settings (CFIFOSEL.MBW, D0FIFOSEL.MBW, and D1FIFOSEL.MBW) and BIGEND settings (CFIFOSEL.BIGEND, D0FIFOSEL.BIGEND, and D1FIFOSEL.BIGEND) in the associated port selection register. See Table 26.7 and Table 26.8.

Three FIFO ports are available:

- CFIFO
- D0FIFO
- D1FIFO

Each FIFO port is configured with:

- A port register (CFIFO, D0FIFO, or D1FIFO) that handles reading of data from the FIFO buffer and writing of data to the FIFO buffer
- A port selection register (CFIFOSEL, D0FIFOSEL, or D1FIFOSEL) that selects the pipe assigned to the FIFO port
- A port control register (CFIFOCTR, D0FIFOCTR, or D1FIFOCTR)

Each FIFO port has the following constraints:

- Access to the FIFO buffer for DCP control transfers is through the CFIFO port
- Access to the FIFO buffer for DMA or DTC transfers is through the D0FIFO or D1FIFO port
- The D0FIFO and D1FIFO ports can also be accessed by the CPU
- When using functions specific to the FIFO port, such as the DMA or DTC transfer function, you cannot change the pipe number selected in the CURPIPE[3:0] bits of the port selection register
- Registers configuring a FIFO port do not affect other FIFO ports
- The same pipe must not be assigned to two or more FIFO ports
- There are two FIFO buffer states, one giving access rights to the CPU and the other to the serial interface engine (SIE). When the SIE has access rights, the FIFO buffer cannot be accessed by the CPU

#### FIFOPORT[15:0] bits (FIFO Port)

When the FIFOPORT bit is accessed, the USBFS reads the received data from the FIFO buffer or writes the transmit data to the FIFO buffer. The FIFO port register can be accessed only when the FRDY bit in the associated port control register (CFIFOCTR, D0FIFOCTR, or D1FIFOCTR) is 1.

The valid bits in the FIFO port register depend on the MBW and BIGEND settings in the port selection register (CFIFOSEL, D0FIFOSEL, or D1FIFOSEL). See Table 26.7 and Table 26.8.

Table 26.7 Endian operation in 16-bit access

| CFIFOSEL.BIGEND bit<br>D0FIFOSEL.BIGEND bit<br>D1FIFOSEL.BIGEND bit | Bits [15:8] | Bits [7:0] |
|---|-------------|------------|
| 0   | N + 1 data  | N + 0 data |
| 1   | N + 0 data  | N + 1 data |

Table 26.8 Endian operation in 8-bit access

| CFIFOSEL.BIGEND bit<br>D0FIFOSEL.BIGEND bit<br>D1FIFOSEL.BIGEND bit | Bits [15:8]         | Bits [7:0] |
|---|---------------------|------------|
| 0   | Access prohibited*1 | N + 0 data |
| 1   | Access prohibited*1 | N + 0 data |

Note 1. Writing to or reading from these areas is not allowed.

注1.有效位取决于相关端口选择寄存器中的MBW设置 (CFIFOSEL.MBW、D0FIFOSEL.MBW和D1FIFOSEL.MBW) 和BIGEND设置 (CFIFOSEL.BIGEND、D0FIFOSEL.BIGEND和D1FIFOSEL.BIGEND)。请参见表26.7和表26.8。

三个FIFO端口可用:

- CFIFO
- D0FIFO
- D1FIFO

每个FIFO端口配置有:

- 一个端口寄存器 (CFIFO、D0FIFO或D1FIFO)，用于处理从FIFO缓冲区读取数据并将数据写入FIFO缓冲区
- 端口选择寄存器 (CFIFOSEL、D0FIFOSEL或D1FIFOSEL)，用于选择分配给FIFO端口的管道
- 一个端口控制寄存器 (CFIFOCTR、D0FIFOCTR或D1FIFOCTR)

每个FIFO端口具有以下约束:

- 通过CFIFO端口访问DCP控制传输的FIFO缓冲区
- 通过D0FIFO或D1FIFO端口访问DMA或DTC传输的FIFO缓冲区
- D0FIFO和D1FIFO端口也可以被CPU访问
- 当使用特定于FIFO端口的功能时，例如DMA或DTC传输功能，您不能更改在端口选择寄存器的CURPIPE[3:0]位中选择的管道号
- 配置FIFO端口的寄存器不会影响其他FIFO端口
- 不能将同一管道分配给两个或多个FIFO端口
- 有两种FIFO缓冲区状态，一种授予CPU访问权限，另一种授予串行接口引擎(SIE)。当SIE有访问权限时，CPU不能访问FIFO缓冲区

#### FIFOPORT[15:0] bits (FIFO Port)

当访问FIFOPORT位时，USBFS从FIFO缓冲区读取接收数据或将发送数据写入FIFO缓冲区。只有当相关端口控制寄存器 (CFIFOCTR、D0FIFOCTR或D1FIFOCTR) 中的FRDY位为1时，才能访问FIFO端口寄存器。

FIFO端口寄存器中的有效位取决于端口选择寄存器 (CFIFOSEL、D0FIFOSEL或D1FIFOSEL) 中的MBW和BIGEND设置。请参见表26.7和表26.8。

Table 26.7 16位访问中的字节序操作

| CFIFOSEL.BIGEND bit<br>D0FIFOSEL.BIGEND bit<br>D1FIFOSEL.BIGEND bit | Bits [15:8] | Bits [7:0] |
|---|-------------|------------|
| 0   | N + 1 data  | N + 0 data |
| 1   | N + 0 data  | N + 1 data |

Table 26.8 8位访问中的字节序操作

| CFIFOSEL.BIGEND bit<br>D0FIFOSEL.BIGEND bit<br>D1FIFOSEL.BIGEND bit | Bits [15:8] | Bits [7:0] |
|---|-------------|------------|
| 0   | 禁止访问*1      | N + 0 data |
| 1   | 禁止访问*1      | N + 0 data |

注1.不允许对这些区域进行写入或读取。

## 26.2.6 CFIFOSEL : CFIFO Port Select Register

Base address: USBFS = 0x4009\_0000

Offset address: 0x020

|                    |      |     |    |    |    |     |   |        |   |   |      |   |              |   |   |   |
|--------------------|------|-----|----|----|----|-----|---|--------|---|---|------|---|--------------|---|---|---|
| Bit position:      | 15   | 14  | 13 | 12 | 11 | 10  | 9 | 8      | 7 | 6 | 5    | 4 | 3            | 2 | 1 | 0 |
| Bit field:         | RCNT | REW | —  | —  | —  | MBW | — | BIGEND | — | — | ISEL | — | CURPIPE[3:0] |   |   |   |
| Value after reset: | 0    | 0   | 0  | 0  | 0  | 0   | 0 | 0      | 0 | 0 | 0    | 0 | 0            | 0 | 0 | 0 |

| Bit   | Symbol       | Function  | R/W            |
|-------|--------------|---|----------------|
| 3:0   | CURPIPE[3:0] | CFIFO Port Access Pipe Specification<br>0x0: Default Control Pipe<br>0x1: Pipe 1<br>0x2: Pipe 2<br>0x3: Pipe 3<br>0x4: Pipe 4<br>0x5: Pipe 5<br>0x6: Pipe 6<br>0x7: Pipe 7<br>0x8: Pipe 8<br>0x9: Pipe 9<br>Others: Setting prohibited  | R/W            |
| 4     | —            | This bit is read as 0. The write value should be 0. This bit is read as 0. The write value should be 0.   | R/W            |
| 5     | ISEL         | CFIFO Port Access Direction When DCP Is Selected<br>0: Select reading from the FIFO buffer<br>1: Select writing to the FIFO buffer  | R/W            |
| 7:6   | —            | These bits are read as 0. The write value should be 0. These bits are read as 0. The write value should be 0.   | R/W            |
| 8     | BIGEND       | CFIFO Port Endian Control<br>0: Little endian<br>1: Big endian  | R/W            |
| 9     | —            | This bit is read as 0. The write value should be 0.   | R/W            |
| 10    | MBW          | CFIFO Port Access Bit Width<br>0: 8-bit width<br>1: 16-bit width  | R/W            |
| 13:11 | —            | These bits are read as 0. The write value should be 0.  | R/W            |
| 14    | REW          | Buffer Pointer Rewind<br>0: Do not rewind buffer pointer<br>1: Rewind buffer pointer  | W <sup>1</sup> |
| 15    | RCNT         | Read Count Mode<br>0: The DTLN[8:0] bits (CFIFOCTR.DTLN[8:0], D0FIFOCTR.DTLN[8:0], D1FIFOCTR.DTLN[8:0]) are cleared when all receive data is read from the CFIFO. In double buffer mode, the DTLN[8:0] value is cleared when all data is read from only a single plane.<br>1: The DTLN[8:0] bits are decremented each time the receive data is read from the CFIFO. | R/W            |

Note 1. Only 0 can be read.

Do not specify the same pipe number in the CURPIPE[3:0] bits in the CFIFOSEL, D0FIFOSEL, and D1FIFOSEL registers. When the CURPIPE[3:0] bits in the D0FIFOSEL and D1FIFOSEL registers are set to 0000b, no pipe is selected.

Do not change the pipe number while DMA or DTC transfer is enabled.

**CURPIPE[3:0] bits (CFIFO Port Access Pipe Specification)**

The CURPIPE[3:0] bits specify the pipe number to use for reading or writing data through the CFIFO port. After writing to these bits, read them to check that the written value agrees with the read value before proceeding to the next process. Do not set the same pipe number to the CURPIPE[3:0] bits in CFIFOSEL, D0FIFOSEL, and D1FIFOSEL.

## 26.2.6 CFIFOSEL:CFIFO端口选择寄存器

Base address: USBFS = 0x4009\_0000

Offset address: 0x020

|               |      |     |    |    |    |     |   |        |   |   |      |   |              |   |   |   |
|---------------|------|-----|----|----|----|-----|---|--------|---|---|------|---|--------------|---|---|---|
| Bit position: | 15   | 14  | 13 | 12 | 11 | 10  | 9 | 8      | 7 | 6 | 5    | 4 | 3            | 2 | 1 | 0 |
| Bit field:    | RCNT | REW | —  | —  | —  | MBW | — | BIGEND | — | — | ISEL | — | CURPIPE[3:0] |   |   |   |
| 重置后的值:        | 0    | 0   | 0  | 0  | 0  | 0   | 0 | 0      | 0 | 0 | 0    | 0 | 0            | 0 | 0 | 0 |

| Bit   | Symbol       | Function  | R/W            |
|-------|--------------|---|----------------|
| 3:0   | CURPIPE[3:0] | CFIFO端口访问管道规范<br>0x0: 默认控制管道0x1: 管道10x2: 管道20x3: 管道30x4: 管道40x5: 管道50x6: 管道60x7: 管道70x8: 管道80x9: 管道9<br>其他: 禁止设置  | R/W            |
| 4     | —            | 该位读取为0。写入值应为0。该位读取为0。写入值应为0。  | R/W            |
| 5     | ISEL         | 选择DCP时的CFIFO端口访问方向<br>0: 选择从FIFO缓冲区读取1: 选择写入FIFO缓冲区   | R/W            |
| 7:6   | —            | 这些位读取为0。写入值应为0。这些位读取为0。写入值应为0。  | R/W            |
| 8     | BIGEND       | CFIFO端口字节序控制<br>0: 小端1: 大端  | R/W            |
| 9     | —            | 该位读取为0。写入值应为0。  | R/W            |
| 10    | MBW          | CFIFO端口访问位宽<br>0: 8-bit width<br>1: 16-bit width  | R/W            |
| 13:11 | —            | 这些位被读取为0。写入值应为0。  | R/W            |
| 14    | REW          | 缓冲区指针倒带<br>0: 不倒回缓冲区指针1: 倒回缓冲区指针  | W <sup>1</sup> |
| 15    | RCNT         | 读取计数模式<br>0: DTLN[8:0]位 (CFIFOCTR.DTLN[8:0]、D0FIFOCTR.DTLN[8:0]、D1FIFOCTR.DTLN[8:0]) 在所有接收数据从先进先出。在双缓冲模式下, 当仅从单个平面读取所有数据时, 清除DTLN[8:0]值。<br>1: 每次从CFIFO读取接收数据时, DTLN[8:0]位递减。 | R/W            |

注1.只能读取0。

不要在CFIFOSEL、D0FIFOSEL和D1FIFOSEL寄存器的CURPIPE[3:0]位中指定相同的管道编号。当D0FIFOSEL和D1FIFOSEL寄存器中的CURPIPE[3:0]位设置为0000b时, 不选择管道。

启用DMA或DTC传输时不要更改管道编号。

**CURPIPE[3:0]位 (CFIFO端口访问管道规范)**

CURPIPE[3:0]位指定用于通过CFIFO端口读取或写入数据的管道编号。写入这些位后, 读取它们以检查写入的值是否与读取的值一致, 然后再进行下一个过程。不要为CFIFOSEL、D0FIFOSEL和D1FIFOSEL中的CURPIPE[3:0]位设置相同的管道编号。

During FIFO buffer access, even when an attempt is made to change the CURPIPE[3:0] setting, the current access setting is retained until access is complete.

**ISEL bit (CFIFO Port Access Direction When DCP Is Selected)**

After writing a new value to the ISEL bit with the DCP as the selected pipe, read the ISEL bit to check that the written value agrees with the read value before proceeding to the next process. Set the ISEL and CURPIPE[3:0] bits simultaneously.

**MBW bit (CFIFO Port Access Bit Width)**

The MBW bit specifies the bit width for accessing the CFIFO port.

When the selected pipe is receiving, set the CURPIPE[3:0] and MBW bits simultaneously. After a write to these bits starts a data read from the FIFO buffer, do not change the bits until all of the data is read.

When the selected pipe is transmitting, the bit width cannot be changed from 8-bit to 16-bit while data is being written to the FIFO buffer.

An odd number of bytes can also be written through byte-access control even when 16-bit width is selected.

**REW bit (Buffer Pointer Rewind)**

The REW bit specifies whether to rewind the buffer pointer.

When the selected pipe is receiving, setting this bit to 1 while the FIFO buffer is being read allows re-reading of the FIFO buffer from the first data. In double buffering, this setting enables re-reading of the currently-read FIFO buffer plane from the first entry.

Do not set this bit to 1 while simultaneously changing the CURPIPE[3:0] bits. Before setting the REW bit to 1, be sure to check that the FRDY bit is 1.

To rewrite to the FIFO buffer from the first data for the transmitting pipe, use the BCLR bit.

**26.2.7 DnFIFOSEL : DnFIFO Port Select Register (n = 0, 1)**

Base address: USBFS = 0x4009\_0000

Offset address: 0x028 + 0x4 × n



| Bit | Symbol       | Function  | R/W |
|-----|--------------|---|-----|
| 3:0 | CURPIPE[3:0] | FIFO Port Access Pipe Specification<br>0x0: Default Control Pipe<br>0x1: Pipe 1<br>0x2: Pipe 2<br>0x3: Pipe 3<br>0x4: Pipe 4<br>0x5: Pipe 5<br>0x6: Pipe 6<br>0x7: Pipe 7<br>0x8: Pipe 8<br>0x9: Pipe 9<br>Others: Setting prohibited | R/W |
| 7:4 | —            | These bits are read as 0. The write value should be 0.  | R/W |
| 8   | BIGEND       | FIFO Port Endian Control<br>0: Little endian<br>1: Big endian   | R/W |
| 9   | —            | This bit is read as 0. The write value should be 0.   | R/W |
| 10  | MBW          | FIFO Port Access Bit Width<br>0: 8-bit width<br>1: 16-bit width   | R/W |

在FIFO缓冲区访问期间，即使尝试更改CURPIPE[3:0]设置，当前访问设置也会保留，直到访问完成。

**ISEL位 (选择DCP时的CFIFO端口访问方向)**

在以DCP作为选定管道的情况下将新值写入ISEL位后，读取ISEL位以检查写入的值是否与读取的值一致，然后再进行下一个过程。同时设置ISEL和CURPIPE[3:0]位。

**MBW位 (CFIFO端口访问位宽度)**

MBW位指定访问CFIFO端口的位宽。

当所选管道正在接收时，同时设置CURPIPE[3:0]和MBW位。在写入这些位开始从FIFO缓冲区读取数据后，在读取所有数据之前不要更改这些位。

当所选管道正在传输时，位宽不能从8位更改为16位，同时数据正在写入FIFO缓冲区。

即使选择了16位宽度，也可以通过字节访问控制写入奇数个字节。

**REW位 (缓冲区指针倒带)**

REW位指定是否倒回缓冲区指针。

当所选管道正在接收时，在读取FIFO缓冲区时将此位设置为1允许从第一个数据重新读取FIFO缓冲区。在双缓冲中，此设置允许从第一个条目重新读取当前读取的FIFO缓冲区平面。

请勿在同时更改CURPIPE[3:0]位时将此位设置为1。在将REW位设置为1之前，请务必检查FRDY位是否为1。

要从传输管道的第一个数据重写FIFO缓冲区，请使用BCLR位。

**26.2.7 DnFIFOSEL:DnFIFO端口选择寄存器(n=0 1)**

Base address: USBFS = 0x4009\_0000

Offset address: 0x028 + 0x4 × n



| Bit | Symbol       | Function   | R/W |
|-----|--------------|--|-----|
| 3:0 | CURPIPE[3:0] | FIFO端口访问管道规范<br>0x0: 默认控制管道0x1:<br>管道10x2: 管道20x3: 管<br>道30x4: 管道40x5: 管道<br>50x6: 管道60x7: 管道7<br>0x8: 管道80x9: 管道9<br><br>其他: 禁止设置 | R/W |
| 7:4 | —            | 这些位被读取为0。写入值应为0。   | R/W |
| 8   | BIGEND       | FIFO端口字节序控制<br>0: 小端1: 大<br>端  | R/W |
| 9   | —            | 该位读取为0。写入值应为0。   | R/W |
| 10  | MBW          | FIFO端口访问位宽<br>0: 8-bit width<br>1: 16-bit width  | R/W |



| Bit | Symbol | Function  | R/W |
|-----|--------|---|-----|
| 11  | —      | This bit is read as 0. The write value should be 0.   | R/W |
| 12  | DREQE  | DMA/DTC Transfer Request Enable<br>0: Disable DMA/DTC transfer request<br>1: Enable DMA/DTC transfer request  | R/W |
| 13  | DCLRM  | Auto Buffer Memory Clear Mode Accessed after Specified Pipe Data is Read<br>0: Disable auto buffer clear mode<br>1: Enable auto buffer clear mode   | R/W |
| 14  | REW    | Buffer Pointer Rewind<br>0: Do not rewind buffer pointer<br>1: Rewind buffer pointer  | W   |
| 15  | RCNT   | Read Count Mode<br>0: Clear DTLN[8:0] bits in (CFIFOCTR.DTLN[8:0], D0FIFOCTR.DTLN[8:0], D1FIFOCTR.DTLN[8:0]) when all receive data is read from DnFIFO (after read of a single plane in double buffer mode)<br>1: Decrement DTLN[8:0] bits each time receive data is read from DnFIFO | R/W |

The same pipe must not be specified in the CURPIPE[3:0] bits in the CFIFOSEL, D0FIFOSEL, and D1FIFOSEL registers. When the CURPIPE[3:0] bits in the D0FIFOSEL and D1FIFOSEL registers are set to 0000b, no pipe is selected. The pipe number must not be changed while DMA or DTC transfer is enabled.

#### CURPIPE[3:0] bits (FIFO Port Access Pipe Specification)

The CURPIPE[3:0] bits specify the pipe number to use for reading or writing data through the DnFIFO port. After writing to these bits, read them to check that the written value agrees with the read value before proceeding to the next process. Do not set the same pipe number to the CURPIPE[3:0] bits in CFIFOSEL, D0FIFOSEL, and D1FIFOSEL.

During FIFO buffer access, even when an attempt is made to change the CURPIPE[3:0] setting, the current access setting is retained until access is complete.

#### MBW bit (FIFO Port Access Bit Width)

The MBW bit specifies the bit width for accessing the DnFIFO port.

When the selected pipe is receiving, after a write to these bits starts a data read from the FIFO buffer, do not change the bits until all of the data is read. Set the CURPIPE[3:0] and MBW bits simultaneously.

When the selected pipe is transmitting, the bit width cannot be changed from 8-bit to 16-bit while data is being written to the FIFO buffer.

An odd number of bytes can also be written through byte-access control even when 16-bit width is selected.

#### DREQE bit (DMA/DTC Transfer Request Enable)

The DREQE bit enables or disables issuing of DMA or DTC transfer requests. To enable DMA or DTC transfer requests, set this bit to 1 after setting the CURPIPE[3:0] bits. To change the CURPIPE[3:0] setting, first set this bit to 0.

#### DCLRM bit (Auto Buffer Memory Clear Mode Accessed after Specified Pipe Data is Read)

The DCLRM bit enables or disables automatic FIFO buffer clearing after data in the selected pipe is read.

When this bit is set to 1, on receiving a zero-length packet while the FIFO buffer assigned to the selected pipe is empty, or when reading of a received short packet is complete while the PIPECFG.BFRE bit is 1, the USBFS sets the BCLR bit in the FIFO port control register to 1.

When using the USBFS with the SOFCFG.BRDYM bit set to 1, set this bit to 0.

#### REW bit (Buffer Pointer Rewind)

The REW bit specifies whether to rewind the buffer pointer.

When the selected pipe is receiving, setting this bit to 1 while the FIFO buffer is being read allows re-reading of the FIFO buffer from the first data. In double buffering, this setting enables re-reading of the currently-read FIFO buffer plane from the first entry.

Do not set this bit to 1 while simultaneously changing the CURPIPE[3:0] bits. Before setting the bit to 1, be sure to check that the FRDY bit is 1.

| Bit | Symbol | Function   | R/W |
|-----|--------|--|-----|
| 11  | —      | 该位读取为0。写入值应为0。   | R/W |
| 12  | DREQE  | DMADTC传输请求启用<br>0: 禁用DMADTC传输请求1: 启用DMADTC传输请求   | R/W |
| 13  | DCLRM  | 读取指定管道数据后访问的自动缓冲存储器清除模式<br>0: 禁用自动缓冲区清除模式1: 启用自动缓冲区清除模式  | R/W |
| 14  | REW    | 缓冲区指针倒带<br>0: 不倒回缓冲区指针1: 倒回缓冲区指针   | W   |
| 15  | RCNT   | 读取计数模式<br>0: 清除 (CFIFOCTR.DTLN[8:0]、D0FIFOCTR.DTLN[8:0]、D1FIFOCTR.DTLN[8:0])当从DnFIFO中读取所有接收数据时 (在双缓冲模式下读取单个平面后)<br>1: 每次从DnFIFO读取接收数据时, 递减DTLN[8:0]位 | R/W |

不能在CFIFOSEL、D0FIFOSEL和D1FIFOSEL寄存器的CURPIPE[3:0]位中指定相同的管道。当D0FIFOSEL和D1FIFOSEL寄存器中的CURPIPE[3:0]位设置为0000b时, 不选择管道。启用DMA或DTC传输时, 不得更改管道编号。

#### CURPIPE[3:0]位 (FIFO端口访问管道规范)

CURPIPE[3:0]位指定用于通过DnFIFO端口读取或写入数据的管道编号。写入这些位后, 读取它们以检查写入的值是否与读取的值一致, 然后再进行下一个过程。不要为CFIFOSEL、D0FIFOSEL和D1FIFOSEL中的CURPIPE[3:0]位设置相同的管道编号。

在FIFO缓冲区访问期间, 即使尝试更改CURPIPE[3:0]设置, 当前访问设置也会保留, 直到访问完成。

#### MBW位 (FIFO端口访问位宽度)

MBW位指定访问DnFIFO端口的位宽。

当所选管道正在接收时, 在写入这些位后开始从FIFO缓冲区读取数据, 在读取所有数据之前不要更改这些位。同时设置CURPIPE[3:0]和MBW位。

当所选管道正在传输时, 位宽不能从8位更改为16位, 同时数据正在写入FIFO缓冲区。

即使选择了16位宽度, 也可以通过字节访问控制写入奇数个字节。

#### DREQE位 (DMADTC传输请求使能)

DREQE位启用或禁用DMA或DTC传输请求的发出。要启用DMA或DTC传输请求, 请在设置CURPIPE[3:0]位后将此位设置为1。要更改CURPIPE[3:0]设置, 首先将该位设置为0。

#### DCLRM位 (读取指定管道数据后访问的自动缓冲存储器清除模式)

在读取所选管道中的数据后, DCLRM位启用或禁用自动FIFO缓冲区清除。

当该位设置为1时, 在分配给所选管道的FIFO缓冲区为空时接收到零长度数据包, 或在PIPECFG.BFRE位为1时完成读取接收到的短数据包时, USBFS设置FIFO端口控制寄存器中的BCLR位为1。

当使用SOFCFG.BRDYM位设置为1的USBFS时, 将此位设置为0。

#### REW位 (缓冲区指针倒带)

REW位指定是否倒回缓冲区指针。

当所选管道正在接收时, 在读取FIFO缓冲区时将此位设置为1允许从第一个数据重新读取FIFO缓冲区。在双缓冲中, 此设置允许从第一个条目重新读取当前读取的FIFO缓冲区平面。

请勿在同时更改CURPIPE[3:0]位时将此位设置为1。在将该位设置为1之前, 请务必检查FRDY位是否为1。

To rewrite to the FIFO buffer from the first data for the transmitting pipe, use the BCLR bit.

### RCNT bit (Read Count Mode)

The RCNT bit specifies the read mode for the value in the CFIFOCTR.DTLN bit. When accessing DnFIFO with the PIPECFG.BFRE bit set to 1, set the RCNT bit to 0.

## 26.2.8 CFIFOCTR : CFIFO Port Control Register

Base address: USBFS = 0x4009\_0000

Offset address: 0x022

|                    |      |      |      |    |    |    |   |           |   |   |   |   |   |   |   |   |
|--------------------|------|------|------|----|----|----|---|-----------|---|---|---|---|---|---|---|---|
| Bit position:      | 15   | 14   | 13   | 12 | 11 | 10 | 9 | 8         | 7 | 6 | 5 | 4 | 3 | 2 | 1 | 0 |
| Bit field:         | BVAL | BCLR | FRDY | —  | —  | —  | — | DTLN[8:0] |   |   |   |   |   |   |   |   |
| Value after reset: | 0    | 0    | 0    | 0  | 0  | 0  | 0 | 0         | 0 | 0 | 0 | 0 | 0 | 0 | 0 | 0 |

| Bit  | Symbol    | Function  | R/W |
|------|-----------|---|-----|
| 8:0  | DTLN[8:0] | Receive Data Length<br>Indicates the receive data length.<br>The meaning of the values differs depending on the RCNT bit setting in the port select register. For details, see the description of the DTLN[8:0] bits. | R   |
| 12:9 | —         | These bits are read as 0. The write value should be 0.  | R/W |
| 13   | FRDY      | FIFO Port Ready<br>0: FIFO port access disabled<br>1: FIFO port access enabled  | R   |
| 14   | BCLR      | CPU Buffer Clear<br>0: No operation<br>1: Clear FIFO buffer on the CPU side   | W   |
| 15   | BVAL      | Buffer Memory Valid Flag<br>0: Invalid (writing 0 has no effect)<br>1: Writing ended  | R/W |

The CFIFOCTR, D0FIFOCTR, and D1FIFOCTR registers correspond to the CFIFO, D0FIFO, and D1FIFO buffers.

### DTLN[8:0] bits (Receive Data Length)

The DTLN[8:0] bits indicate the length of the receive data.

While the FIFO buffer is being read, the DTLN[8:0] bits indicate different values depending on the DnFIFOSEL.RCNT bit (n = 0, 1), as follows:

- RCNT = 0

The USBFS sets the DTLN[8:0] bits to indicate the length of the receive data until the CPU or DMA/DTC has read all of the received data from a single FIFO buffer plane.

While the PIPECFG.BFRE bit = 1, the USBFS retains the length of the receive data until the BCLR bit is set to 1, even after all the data is read.

- RCNT = 1

The USBFS decrements the value indicated in the DTLN[8:0] bits each time data is read from the FIFO buffer. The value is decremented by 1 when MBW = 0, and by 2 when MBW = 1.

The USBFS sets these bits to 0 when all the data is read from one FIFO buffer plane. In double buffer mode, if data is received in one FIFO buffer plane before all of the data is read from the other plane, the USBFS sets these bits to indicate the length of the receive data in the former plane when all of the data is read from the latter plane.

### FRDY bit (FIFO Port Ready)

The FRDY bit indicates whether the FIFO port can be accessed by the CPU or DMA/DTC.

In the following cases, the USBFS sets the FRDY bit to 1 but data cannot be read through the FIFO port because there is no data to be read:

要从传输管道的第一个数据重写FIFO缓冲区, 请使用BCLR位。

### RCNT位 (读取计数模式)

RCNT位指定CFIFOCTR.DTLN位中值的读取模式。当使用DnFIFO访问PIPECFG.BFRE位设置为1, 将RCNT位设置为0。

## 26.2.8 CFIFOCTR:CFIFO端口控制寄存器

Base address: USBFS = 0x4009\_0000

Offset address: 0x022

|               |      |      |      |    |    |    |   |           |   |   |   |   |   |   |   |   |
|---------------|------|------|------|----|----|----|---|-----------|---|---|---|---|---|---|---|---|
| Bit position: | 15   | 14   | 13   | 12 | 11 | 10 | 9 | 8         | 7 | 6 | 5 | 4 | 3 | 2 | 1 | 0 |
| Bit field:    | BVAL | BCLR | FRDY | —  | —  | —  | — | DTLN[8:0] |   |   |   |   |   |   |   |   |
| 重置后的值:        | 0    | 0    | 0    | 0  | 0  | 0  | 0 | 0         | 0 | 0 | 0 | 0 | 0 | 0 | 0 | 0 |

| Bit  | Symbol    | Function   | R/W |
|------|-----------|--|-----|
| 8:0  | DTLN[8:0] | 接收数据长度<br>表示接收数据长度。<br>这些值的含义因端口选择寄存器中的RCNT位设置而异。有关详细信息, 请参见DTLN[8:0]位的说明。 | R   |
| 12:9 | —         | 这些位被读取为0。写入值应为0。   | R/W |
| 13   | FRDY      | FIFO端口就绪<br>0: 禁止FIFO端口访问1: 使能FIFO端口访问                                     | R   |
| 14   | BCLR      | CPU缓冲区清除<br>0: 无操作1: 清除CPU端的FIFO缓冲区  | W   |
| 15   | BVAL      | 缓冲存储器有效标志<br>0: 无效 (写入0无效) 1: 写入结束   | R/W |

CFIFOCTR、D0FIFOCTR和D1FIFOCTR寄存器对应于CFIFO、D0FIFO和D1FIFO缓冲区。

### DTLN[8:0]位 (接收数据长度)

DTLN[8:0]位指示接收数据的长度。

在读取FIFO缓冲区时, DTLN[8:0]位指示不同的值, 具体取决于DnFIFOSEL.RCNT位(n=0 1), 如下所示:

- RCNT = 0

USBFS设置DTLN[8:0]位以指示接收数据的长度, 直到CPU或DMADTC从单个FIFO缓冲区平面读取所有接收数据。

当PIPECFG.BFRE位=1时, USBFS将保留接收数据的长度, 直到BCLR位设置为1, 即使在读取所有数据之后也是如此。

- RCNT = 1

每次从FIFO缓冲区读取数据时, USBFS都会递减DTLN[8:0]位中指示的值。当MBW=0时该值减1, 当MBW=1时该值减2。

当从一个FIFO缓冲平面读取所有数据时, USBFS将这些位设置为0。在双缓冲模式下, 如果在一个FIFO缓冲平面中的数据在从另一个平面读取所有数据之前接收到数据, 则USBFS设置这些位以指示在读取所有数据时在前一个平面中接收数据的长度从后一个平面。

### FRDY位 (FIFO端口就绪)

FRDY位指示FIFO端口是否可以被CPU或DMADTC访问。

在以下情况下, USBFS将FRDY位设置为1, 但由于没有数据可读取, 因此无法通过FIFO端口读取数据:



- A zero-length packet is received when the FIFO buffer assigned to the selected pipe is empty
- A short packet is received and the data is completely read while the PIPECFG.BFRE bit = 1

In these cases, set the BCLR bit to 1 to clear the FIFO buffer, and enable transmission and reception of the next data.

**BCLR bit (CPU Buffer Clear)**

Set the BCLR bit to 1 to clear the FIFO buffer on the CPU side for the selected pipe.

When double buffer mode is set for the FIFO buffer assigned to the selected pipe, the USBFS clears only one plane of the FIFO buffer even when both planes are read-enabled.

When the DCP is the selected pipe, setting the BCLR bit to 1 allows the USBFS to clear the FIFO buffer regardless of whether the CPU or SIE has access rights. To clear the buffer when the SIE has access rights, set the DCPCTR.PID[1:0] bits to 00b (NAK response) before setting the BCLR bit to 1.

When the selected pipe is transmitting, if 1 is written to the BVAL flag and the BCLR bit simultaneously, the USBFS clears the data that is already written, enabling transmission of a zero-length packet.

When the selected pipe is not the DCP, only write 1 to the BCLR bit while the FRDY bit in the FIFO port control register is 1 (set by the USBFS).

**BVAL flag (Buffer Memory Valid Flag)**

Set the BVAL flag to 1 when data is completely written to the FIFO buffer on the CPU side for the pipe selected in CURPIPE[3:0].

When the selected pipe is transmitting, set this flag to 1 in the following cases:

- To transmit a short packet, set this flag to 1 after data is written
- To transmit a zero-length packet, set this flag to 1 before data is written to the FIFO buffer

The USBFS then switches the FIFO buffer from the CPU side to the SIE side, enabling transmission.

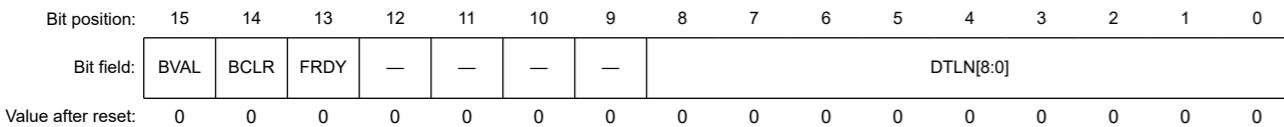
When data of the maximum packet size is written for the pipe in continuous transfer mode, the USBFS sets the BVAL flag to 1 and switches the FIFO buffer from the CPU side to the SIE side, enabling transmission.

Only write 1 to the BVAL flag while the FRDY bit is 1 (set by the USBFS). When the selected pipe is receiving, do not set the BVAL flag to 1.

**26.2.9 DnFIFOCTR : DnFIFO Port Control Register (n = 0, 1)**

Base address: USBFS = 0x4009\_0000

Offset address: 0x02A + 0x4 × n



| Bit  | Symbol    | Function  | R/W              |
|------|-----------|---|------------------|
| 8:0  | DTLN[8:0] | Receive Data Length<br>Indicates the receive data length.<br>The meaning of the values differs depending on the RCNT bit setting in the port select register. For details, see the description of the DTLN[8:0] bits. | R                |
| 12:9 | —         | These bits are read as 0. The write value should be 0.  | R/W              |
| 13   | FRDY      | FIFO Port Ready<br>0: FIFO port access disabled<br>1: FIFO port access enabled  | R                |
| 14   | BCLR      | CPU Buffer Clear<br>0: No operation<br>1: Clear FIFO buffer on the CPU side   | R/W <sup>1</sup> |

- 当分配给所选管道的FIFO缓冲区为空时，接收到一个长度为零的数据包
- PIPECFG.BFRE位=1时接收到一个短数据包并完全读取数据

在这些情况下，将BCLR位设置为1以清除FIFO缓冲区，并启用下一个数据的发送和接收。

**BCLR位 (CPU缓冲区清除)**

将BCLR位设置为1以清除所选管道的CPU端的FIFO缓冲区。

当分配给所选管道的FIFO缓冲区设置为双缓冲区模式时，USBFS仅清除即使两个平面都已启用读取，也有FIFO缓冲区。

当DCP为选定管道时，将BCLR位设置为1允许USBFS清除FIFO缓冲区，而不管CPU或SIE是否具有访问权限。要在SIE具有访问权限时清除缓冲区，请将DCPCTR.PID[1:0]位设置为00b (NAK响应)，然后再将BCLR位设置为1。

当所选管道正在传输时，如果同时向BVAL标志和BCLR位写入1，则USBFS会清除已写入的数据，从而可以传输零长度数据包。

当所选管道不是DCP时，仅在FIFO端口控制寄存器中的frdy位为1 (由USBFS设置) 时，仅将1个写入BCLR位。

**BVAL标志 (缓冲存储器有效标志)**

当数据完全写入CPU端的FIFO缓冲区时，将BVAL标志设置为1，用于在CURPIPE[3:0].

当所选管道正在传输时，在以下情况下将此标志设置为1:

- 要发送一个短包，在数据写入后将此标志设置为1
- 要发送零长度数据包，请在数据写入FIFO缓冲区之前将此标志设置为1

然后USBFS将FIFO缓冲区从CPU端切换到SIE端，从而启用传输。

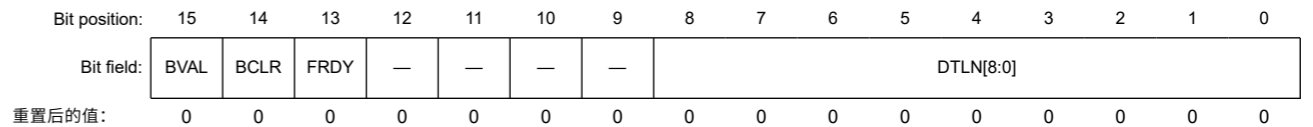
当在连续传输模式下为管道写入最大数据包大小的数据时，USBFS将BVAL标志设置为1，并将FIFO缓冲区从CPU侧切换到SIE侧，从而启用传输。

仅在FRDY位为1 (由USBFS设置) 时将1写入BVAL标志。当所选管道正在接收时，不要将BVAL标志设置为1。

**26.2.9 DnFIFOCTR:DnFIFO端口控制寄存器(n=0 1)**

Base address: USBFS = 0x4009\_0000

Offset address: 0x02A + 0x4 × n



| Bit  | Symbol    | Function  | R/W              |
|------|-----------|---|------------------|
| 8:0  | DTLN[8:0] | 接收数据长度<br>表示接收数据长度。<br>这些值的含义因端口选择寄存器中的RCNT位设置而异。有关详细信息，请参见DTLN[8:0]位的说明。 | R                |
| 12:9 | —         | 这些位被读取为0。写入值应为0。  | R/W              |
| 13   | FRDY      | FIFO端口就绪<br>0: 禁止FIFO端口访问<br>1: 使能FIFO端口访问                                | R                |
| 14   | BCLR      | CPU缓冲区清除<br>0: 无操作<br>1: 清除CPU端的FIFO缓冲区                                   | R/W <sup>1</sup> |

| Bit | Symbol | Function   | R/W |
|-----|--------|--|-----|
| 15  | BVAL   | Buffer Memory Valid Flag<br>0: Invalid (writing 0 has no effect)<br>1: Writing ended | R/W |

Note 1. Only 0 can be read.

The CFIFOCTR, D0FIFOCTR, and D1FIFOCTR registers correspond to the CFIFO, D0FIFO, and D1FIFO buffers.

#### DTLN[8:0] bits (Receive Data Length)

The DTLN[8:0] bits indicate the length of the receive data.

While the FIFO buffer is being read, the DTLN[8:0] bits indicate different values depending on the DnFIFOSEL.RCNT bit (n = 0, 1), as follows:

- RCNT = 0

The USBFS sets the DTLN[8:0] bits to indicate the length of the receive data until the CPU or DMA/DTC has read all of the received data from a single FIFO buffer plane.

While the PIPECFG.BFRE bit = 1, the USBFS retains the length of the receive data until the BCLR bit is set to 1, even after all the data is read.

- RCNT = 1

The USBFS decrements the value indicated in the DTLN[8:0] bits each time data is read from the FIFO buffer. The value is decremented by 1 when MBW = 0, and by 2 when MBW = 1.

The USBFS sets these bits to 0 when all the data is read from one FIFO buffer plane. In double buffer mode, if data is received in one FIFO buffer plane before all of the data is read from the other plane, the USBFS sets these bits to indicate the length of the receive data in the former plane when all of the data is read from the latter plane.

#### FRDY bit (FIFO Port Ready)

The FRDY bit indicates whether the FIFO port can be accessed by the CPU or DMA/DTC.

In the following cases, the USBFS sets the FRDY bit to 1 but data cannot be read through the FIFO port because there is no data to be read:

- A zero-length packet is received when the FIFO buffer assigned to the selected pipe is empty
- A short packet is received and the data is completely read while the PIPECFG.BFRE bit = 1

In these cases, set the BCLR bit to 1 to clear the FIFO buffer, and enable transmission and reception of the next data.

#### BCLR bit (CPU Buffer Clear)

Set the BCLR bit to 1 to clear the FIFO buffer on the CPU side for the selected pipe.

When double buffer mode is set for the FIFO buffer assigned to the selected pipe, the USBFS clears only one plane of the FIFO buffer even when both planes are read-enabled.

When the DCP is the selected pipe, setting the BCLR bit to 1 allows the USBFS to clear the FIFO buffer regardless of whether the CPU or SIE has access rights. To clear the buffer when the SIE has access rights, set the DCPCTR.PID[1:0] bits to 00b (NAK response) before setting the BCLR bit to 1.

When the selected pipe is transmitting, if 1 is written to the BVAL flag and the BCLR bit simultaneously, the USBFS clears the data that is already written, enabling transmission of a zero-length packet.

When the selected pipe is not the DCP, only write 1 to the BCLR bit while the FRDY bit in the FIFO port control register is 1 (set by the USBFS).

#### BVAL flag (Buffer Memory Valid Flag)

Set the BVAL flag to 1 when data is completely written to the FIFO buffer on the CPU side for the pipe selected in CURPIPE[3:0].

When the selected pipe is transmitting, set this flag to 1 in the following cases:

- To transmit a short packet, set this flag to 1 after data is written

| Bit | Symbol | Function                           | R/W |
|-----|--------|------------------------------------|-----|
| 15  | BVAL   | 缓冲存储器有效标志<br>0: 无效 (写入0无效) 1: 写入结束 | R/W |

注1.只能读取0。

CFIFOCTR、D0FIFOCTR和D1FIFOCTR寄存器对应于CFIFO、D0FIFO和D1FIFO缓冲区。

#### DTLN[8:0]位 (接收数据长度)

DTLN[8:0]位指示接收数据的长度。

在读取FIFO缓冲区时, DTLN[8:0]位指示不同的值, 具体取决于DnFIFOSEL.RCNT位(n=0 1), 如下所示:

- RCNT = 0

USBFS设置DTLN[8:0]位以指示接收数据的长度, 直到CPU或DMADTC从单个FIFO缓冲区平面读取所有接收数据。

当PIPECFG.BFRE位=1时, USBFS将保留接收数据的长度, 直到BCLR位设置为1, 即使在读取所有数据之后也是如此。

- RCNT = 1

每次从FIFO缓冲区读取数据时, USBFS都会递减DTLN[8:0]位中指示的值。当MBW=0时该值减1, 当MBW=1时该值减2。

当从一个FIFO缓冲平面读取所有数据时, USBFS将这些位设置为0。在双缓冲模式下, 如果在一个FIFO缓冲平面中的数据在从另一个平面读取所有数据之前接收到数据, 则USBFS设置这些位以指示在读取所有数据时在前一个平面中接收数据的长度从后一个平面。

#### FRDY位 (FIFO端口就绪)

FRDY位指示FIFO端口是否可以被CPU或DMADTC访问。

在以下情况下, USBFS将FRDY位设置为1, 但由于没有数据可读取, 因此无法通过FIFO端口读取数据:

- 当分配给所选管道的FIFO缓冲区为空时, 接收到一个长度为零的数据包
- PIPECFG.BFRE位=1时接收到一个短数据包并完全读取数据

在这些情况下, 将BCLR位设置为1以清除FIFO缓冲区, 并启用下一个数据的发送和接收。

#### BCLR位 (CPU缓冲区清除)

将BCLR位设置为1以清除所选管道的CPU端的FIFO缓冲区。

当分配给所选管道的FIFO缓冲区设置为双缓冲区模式时, USBFS仅清除即使两个平面都已启用读取, 也有FIFO缓冲区。

当DCP为选定管道时, 将BCLR位设置为1允许USBFS清除FIFO缓冲区, 而不管CPU或SIE是否具有访问权限。要在SIE具有访问权限时清除缓冲区, 请将DCPCTR.PID[1:0]位设置为00b (NAK响应), 然后再将BCLR位设置为1。

当所选管道正在传输时, 如果同时向BVAL标志和BCLR位写入1, 则USBFS会清除已写入的数据, 从而可以传输零长度数据包。

当所选管道不是DCP时, 仅在FIFO端口控制寄存器中的frdy位为1 (由USBFS设置) 时, 仅将1写入BCLR位。

#### BVAL标志 (缓冲存储器有效标志)

当数据完全写入CPU端的FIFO缓冲区时, 将BVAL标志设置为1, 用于在CURPIPE[3:0].

当所选管道正在传输时, 在以下情况下将此标志设置为1:

- 要发送一个短包, 在数据写入后将此标志设置为1

- To transmit a zero-length packet, set this flag to 1 before data is written to the FIFO buffer

The USBFS then switches the FIFO buffer from the CPU side to the SIE side, enabling transmission.

When data of the maximum packet size is written for the pipe in continuous transfer mode, the USBFS sets the BVAL flag to 1 and switches the FIFO buffer from the CPU side to the SIE side, enabling transmission.

Only write 1 to the BVAL flag while the FRDY bit is 1 (set by the USBFS). When the selected pipe is receiving, do not set the BVAL flag to 1.

### 26.2.10 INTENB0 : Interrupt Enable Register 0

Base address: USBFS = 0x4009\_0000

Offset address: 0x030

|                    |      |      |      |      |      |       |       |       |   |   |   |   |   |   |   |   |
|--------------------|------|------|------|------|------|-------|-------|-------|---|---|---|---|---|---|---|---|
| Bit position:      | 15   | 14   | 13   | 12   | 11   | 10    | 9     | 8     | 7 | 6 | 5 | 4 | 3 | 2 | 1 | 0 |
| Bit field:         | VBSE | RSME | SOFE | DVSE | CTRE | BEMPE | NRDYE | BRDYE | — | — | — | — | — | — | — | — |
| Value after reset: | 0    | 0    | 0    | 0    | 0    | 0     | 0     | 0     | 0 | 0 | 0 | 0 | 0 | 0 | 0 | 0 |

| Bit | Symbol | Function   | R/W |
|-----|--------|--|-----|
| 7:0 | —      | These bits are read as 0. The write value should be 0.   | R/W |
| 8   | BRDYE  | Buffer Ready Interrupt Enable<br>0: Disable interrupt request<br>1: Enable interrupt request                         | R/W |
| 9   | NRDYE  | Buffer Not Ready Response Interrupt Enable<br>0: Disable interrupt request<br>1: Enable interrupt request            | R/W |
| 10  | BEMPE  | Buffer Empty Interrupt Enable<br>0: Disable interrupt request<br>1: Enable interrupt request                         | R/W |
| 11  | CTRE   | Control Transfer Stage Transition Interrupt Enable *1<br>0: Disable interrupt request<br>1: Enable interrupt request | R/W |
| 12  | DVSE   | Device State Transition Interrupt Enable *1<br>0: Disable interrupt request<br>1: Enable interrupt request           | R/W |
| 13  | SOFE   | Frame Number Update Interrupt Enable<br>0: Disable interrupt request<br>1: Enable interrupt request                  | R/W |
| 14  | RSME   | Resume Interrupt Enable*1<br>0: Disable interrupt request<br>1: Enable interrupt request                             | R/W |
| 15  | VBSE   | VBUS Interrupt Enable<br>0: Disable interrupt request<br>1: Enable interrupt request                                 | R/W |

Note 1. The RSME, DVSE, and CTRE bits can only be set to 1 in device controller mode. Do not set these bits to 1 in host controller mode.

When a status flag in the INTSTS0 register sets to 1 and the associated interrupt request enable bit setting in theINTENB0 register is 1, the USBFS issues a USBFS interrupt request.

Regardless of the INTENB0 register setting, the status flag in the INTSTS0 register sets to 1 in response to a state change that satisfies the associated condition.

When an interrupt request enable bit in the INTENB0 register is switched from 0 to 1 while the associated status flag in the INTSTS0 register is set to 1, a USBFS interrupt is requested.

- 要发送零长度数据包，请在数据写入FIFO缓冲区之前将此标志设置为1

然后USBFS将FIFO缓冲区从CPU端切换到SIE端，从而启用传输。

当在连续传输模式下为管道写入最大数据包大小的数据时，USBFS将BVAL标志设置为1，并将FIFO缓冲区从CPU侧切换到SIE侧，从而启用传输。

仅在FRDY位为1（由USBFS设置）时将1写入BVAL标志。当所选管道正在接收时，不要将BVAL标志设置为1。

### 26.2.10 INTENB0:中断使能寄存器0

Base address: USBFS = 0x4009\_0000

Offset address: 0x030

|               |      |      |      |      |      |       |       |       |   |   |   |   |   |   |   |   |
|---------------|------|------|------|------|------|-------|-------|-------|---|---|---|---|---|---|---|---|
| Bit position: | 15   | 14   | 13   | 12   | 11   | 10    | 9     | 8     | 7 | 6 | 5 | 4 | 3 | 2 | 1 | 0 |
| Bit field:    | VBSE | RSME | SOFE | DVSE | CTRE | BEMPE | NRDYE | BRDYE | — | — | — | — | — | — | — | — |
| 重置后的值:        | 0    | 0    | 0    | 0    | 0    | 0     | 0     | 0     | 0 | 0 | 0 | 0 | 0 | 0 | 0 | 0 |

| Bit | Symbol | Function                            | R/W |
|-----|--------|-------------------------------------|-----|
| 7:0 | —      | 这些位被读取为0。写入值应为0。                    | R/W |
| 8   | BRDYE  | 缓冲区就绪中断使能<br>0: 禁止中断请求1: 允许中断请求     | R/W |
| 9   | NRDYE  | 缓冲区未就绪响应中断使能<br>0: 禁止中断请求1: 允许中断请求  | R/W |
| 10  | BEMPE  | 缓冲区空中断使能<br>0: 禁止中断请求1: 允许中断请求      | R/W |
| 11  | CTRE   | 控制传输级转换中断使能*1<br>0: 禁止中断请求1: 允许中断请求 | R/W |
| 12  | DVSE   | 设备状态转换中断使能*1<br>0: 禁止中断请求1: 允许中断请求  | R/W |
| 13  | SOFE   | 帧号更新中断使能<br>0: 禁止中断请求1: 允许中断请求      | R/W |
| 14  | RSME   | 恢复中断使能*1<br>0: 禁止中断请求1: 允许中断请求      | R/W |
| 15  | VBSE   | VBUS中断使能<br>0: 禁止中断请求1: 允许中断请求      | R/W |

注1.RSME、DVSE和CTRE位只能在设备控制器模式下设置为1。不要在主机控制器模式下将这些位设置为1。

当INTSTS0寄存器中的状态标志设置为1并且INTENB0寄存器中相关的中断请求使能位设置为1时，USBFS发出USBFS中断请求。

无论INTENB0寄存器设置如何，INTSTS0寄存器中的状态标志都会设置为1，以响应满足相关条件的状态变化。

当INTENB0寄存器中的中断请求使能位从0切换到1时，而相关的状态标志在INTSTS0寄存器设置为1，请求USBFS中断。



## 26.2.11 INTENB1 : Interrupt Enable Register 1

Base address: USBFS = 0x4009\_0000

Offset address: 0x032

|                    |        |       |    |       |        |    |   |   |   |         |       |        |   |   |   |           |
|--------------------|--------|-------|----|-------|--------|----|---|---|---|---------|-------|--------|---|---|---|-----------|
| Bit position:      | 15     | 14    | 13 | 12    | 11     | 10 | 9 | 8 | 7 | 6       | 5     | 4      | 3 | 2 | 1 | 0         |
| Bit field:         | OVRCRE | BCHGE | —  | DTCHE | ATTCHE | —  | — | — | — | EOFERRE | SIGNE | SACK E | — | — | — | PDDETINTE |
| Value after reset: | 0      | 0     | 0  | 0     | 0      | 0  | 0 | 0 | 0 | 0       | 0     | 0      | 0 | 0 | 0 | 0         |

| Bit  | Symbol    | Function  | R/W |
|------|-----------|---|-----|
| 0    | PDDETINTE | PDDETINT Detection Interrupt Request Enable<br>0: Disable interrupt request<br>1: Enable interrupt request        | R/W |
| 3:1  | —         | These bits are read as 0. The write value should be 0.  | R/W |
| 4    | SACK E    | Setup Transaction Normal Response Interrupt Enable<br>0: Disable interrupt request<br>1: Enable interrupt request | R/W |
| 5    | SIGNE     | Setup Transaction Error Interrupt Enable<br>0: Disable interrupt request<br>1: Enable interrupt request           | R/W |
| 6    | EOFERRE   | EOF Error Detection Interrupt Enable<br>0: Disable interrupt request<br>1: Enable interrupt request               | R/W |
| 10:7 | —         | These bits are read as 0. The write value should be 0.  | R/W |
| 11   | ATTCHE    | Connection Detection Interrupt Enable<br>0: Disable interrupt request<br>1: Enable interrupt request              | R/W |
| 12   | DTCHE     | Disconnection Detection Interrupt Enable<br>0: Disable interrupt request<br>1: Enable interrupt request           | R/W |
| 13   | —         | This bit is read as 0. The write value should be 0.   | R/W |
| 14   | BCHGE     | USB Bus Change Interrupt Enable<br>0: Disable interrupt request<br>1: Enable interrupt request                    | R/W |
| 15   | OVRCRE    | Overcurrent Input Change Interrupt Enable<br>0: Disable interrupt request<br>1: Enable interrupt request          | R/W |

Note: The bits in INTENB1 can only be set to 1 in host controller mode. Do not set these bits to 1 in device controller mode.

INTENB1 specifies the interrupt masks in host controller mode and for the setup transaction.

When a status flag in the INTSTS1 register sets to 1 and the associated interrupt request enable bit setting in the INTENB1 register is 1, the USBFS issues a USBFS interrupt request.

Regardless of the INTENB1 register setting, the status flag in the INTSTS1 register sets to 1 in response to a state change that satisfies the associated condition.

When an interrupt request enable bit in the INTENB1 register is switched from 0 to 1 while the associated status flag in the INTSTS1 register is set to 1, a USBFS interrupt is requested.

Do not enable interrupts in device controller mode.

## 26.2.11 INTENB1：中断使能寄存器1

Base address: USBFS = 0x4009\_0000

Offset address: 0x032

|               |        |       |    |       |        |    |   |   |   |         |       |        |   |   |   |           |
|---------------|--------|-------|----|-------|--------|----|---|---|---|---------|-------|--------|---|---|---|-----------|
| Bit position: | 15     | 14    | 13 | 12    | 11     | 10 | 9 | 8 | 7 | 6       | 5     | 4      | 3 | 2 | 1 | 0         |
| Bit field:    | OVRCRE | BCHGE | —  | DTCHE | ATTCHE | —  | — | — | — | EOFERRE | SIGNE | SACK E | — | — | — | PDDETINTE |
| 重置后的值:        | 0      | 0     | 0  | 0     | 0      | 0  | 0 | 0 | 0 | 0       | 0     | 0      | 0 | 0 | 0 | 0         |

| Bit  | Symbol    | Function                               | R/W |
|------|-----------|--|-----|
| 0    | PDDETINTE | PDDETINT检测中断请求使能<br>0: 禁止中断请求1: 允许中断请求 | R/W |
| 3:1  | —         | 这些位被读取为0。写入值应为0。                       | R/W |
| 4    | SACK E    | 设置事务正常响应中断使能<br>0: 禁止中断请求1: 允许中断请求     | R/W |
| 5    | SIGNE     | 设置事务错误中断使能<br>0: 禁止中断请求1: 允许中断请求       | R/W |
| 6    | EOFERRE   | EOF错误检测中断使能<br>0: 禁止中断请求1: 允许中断请求      | R/W |
| 10:7 | —         | 这些位被读取为0。写入值应为0。                       | R/W |
| 11   | ATTCHE    | 连接检测中断使能<br>0: 禁止中断请求1: 允许中断请求         | R/W |
| 12   | DTCHE     | 断线检测中断使能<br>0: 禁止中断请求1: 允许中断请求         | R/W |
| 13   | —         | 该位读取为0。写入值应为0。                         | R/W |
| 14   | BCHGE     | USB总线变化中断使能<br>0: 禁止中断请求1: 允许中断请求      | R/W |
| 15   | OVRCRE    | 过流输入变化中断使能<br>0: 禁止中断请求1: 允许中断请求       | R/W |

Note: INTENB1中的位只能在主机控制器模式下设置为1。不要在设备控制器模式下将这些位设置为1。

INTENB1指定主机控制器模式和设置事务的中断掩码。

当INTSTS1寄存器中的状态标志设置为1并且INTENB1寄存器中相关的中断请求使能位设置为1时，USBFS发出USBFS中断请求。

无论INTENB1寄存器设置如何，INTSTS1寄存器中的状态标志都会设置为1，以响应满足相关条件的状态更改。

当INTENB1寄存器中的中断请求使能位从0切换到1时，而相关的状态标志在INTSTS1寄存器设置为1，请求USBFS中断。

不要在设备控制器模式下启用中断。

## 26.2.12 BRDYENB : BRDY Interrupt Enable Register

Base address: USBFS = 0x4009\_0000

Offset address: 0x036

|                    |    |    |    |    |    |    |                    |                    |                    |                    |                    |                    |                    |                    |                    |                    |
|--------------------|----|----|----|----|----|----|--------------------|--------------------|--------------------|--------------------|--------------------|--------------------|--------------------|--------------------|--------------------|--------------------|
| Bit position:      | 15 | 14 | 13 | 12 | 11 | 10 | 9                  | 8                  | 7                  | 6                  | 5                  | 4                  | 3                  | 2                  | 1                  | 0                  |
| Bit field:         | —  | —  | —  | —  | —  | —  | PIPE9<br>BRDY<br>E | PIPE8<br>BRDY<br>E | PIPE7<br>BRDY<br>E | PIPE6<br>BRDY<br>E | PIPE5<br>BRDY<br>E | PIPE4<br>BRDY<br>E | PIPE3<br>BRDY<br>E | PIPE2<br>BRDY<br>E | PIPE1<br>BRDY<br>E | PIPE0<br>BRDY<br>E |
| Value after reset: | 0  | 0  | 0  | 0  | 0  | 0  | 0                  | 0                  | 0                  | 0                  | 0                  | 0                  | 0                  | 0                  | 0                  | 0                  |

| Bit   | Symbol     | Function  | R/W |
|-------|------------|---|-----|
| 0     | PIPE0BRDYE | BRDY Interrupt Enable for Pipe 0<br>0: Disable interrupt request<br>1: Enable interrupt request | R/W |
| 1     | PIPE1BRDYE | BRDY Interrupt Enable for Pipe 1<br>0: Disable interrupt request<br>1: Enable interrupt request | R/W |
| 2     | PIPE2BRDYE | BRDY Interrupt Enable for Pipe 2<br>0: Disable interrupt request<br>1: Enable interrupt request | R/W |
| 3     | PIPE3BRDYE | BRDY Interrupt Enable for Pipe 3<br>0: Disable interrupt request<br>1: Enable interrupt request | R/W |
| 4     | PIPE4BRDYE | BRDY Interrupt Enable for Pipe 4<br>0: Disable interrupt request<br>1: Enable interrupt request | R/W |
| 5     | PIPE5BRDYE | BRDY Interrupt Enable for Pipe 5<br>0: Disable interrupt request<br>1: Enable interrupt request | R/W |
| 6     | PIPE6BRDYE | BRDY Interrupt Enable for Pipe 6<br>0: Disable interrupt request<br>1: Enable interrupt request | R/W |
| 7     | PIPE7BRDYE | BRDY Interrupt Enable for Pipe 7<br>0: Disable interrupt request<br>1: Enable interrupt request | R/W |
| 8     | PIPE8BRDYE | BRDY Interrupt Enable for Pipe 8<br>0: Disable interrupt request<br>1: Enable interrupt request | R/W |
| 9     | PIPE9BRDYE | BRDY Interrupt Enable for Pipe 9<br>0: Disable interrupt request<br>1: Enable interrupt request | R/W |
| 15:10 | —          | This bit is read as 0. The write value should be 0.   | R/W |

The BRDYENB register enables or disables the INTSTS0.BRDY bit to be set to 1 when a BRDY interrupt is detected for each pipe.

When a status flag in the BRDYSTS register sets to 1 and the associated PIPE<sub>n</sub>BRDYE bit (n = 0 to 9) setting in the BRDYENB register is 1, the INTSTS0.BRDY flag sets to 1. In this case, if the BRDYE bit in INTENB0 is 1, the USBFS generates a BRDY interrupt request. While at least one PIPE<sub>n</sub>BRDYE bit indicates 1, the USB generates the BRDY interrupt request when the associated interrupt request enable bit in the BRDYENB register is changed from 0 to 1 by software.

## 26.2.12 BRDYENB:BRDY中断使能寄存器

Base address: USBFS = 0x4009\_0000

Offset address: 0x036

|               |    |    |    |    |    |    |                    |                    |                    |                    |                    |                    |                    |                    |                    |                    |
|---------------|----|----|----|----|----|----|--------------------|--------------------|--------------------|--------------------|--------------------|--------------------|--------------------|--------------------|--------------------|--------------------|
| Bit position: | 15 | 14 | 13 | 12 | 11 | 10 | 9                  | 8                  | 7                  | 6                  | 5                  | 4                  | 3                  | 2                  | 1                  | 0                  |
| Bit field:    | —  | —  | —  | —  | —  | —  | PIPE9<br>BRDY<br>E | PIPE8<br>BRDY<br>E | PIPE7<br>BRDY<br>E | PIPE6<br>BRDY<br>E | PIPE5<br>BRDY<br>E | PIPE4<br>BRDY<br>E | PIPE3<br>BRDY<br>E | PIPE2<br>BRDY<br>E | PIPE1<br>BRDY<br>E | PIPE0<br>BRDY<br>E |
| 重置后的值:        | 0  | 0  | 0  | 0  | 0  | 0  | 0                  | 0                  | 0                  | 0                  | 0                  | 0                  | 0                  | 0                  | 0                  | 0                  |

| Bit   | Symbol     | Function                               | R/W |
|-------|------------|--|-----|
| 0     | PIPE0BRDYE | 管道0的BRDY中断使能<br>0: 禁止中断请求<br>1: 允许中断请求 | R/W |
| 1     | PIPE1BRDYE | 管道1的BRDY中断使能<br>0: 禁止中断请求<br>1: 允许中断请求 | R/W |
| 2     | PIPE2BRDYE | 管道2的BRDY中断启用<br>0: 禁止中断请求<br>1: 允许中断请求 | R/W |
| 3     | PIPE3BRDYE | 管道3的BRDY中断启用<br>0: 禁止中断请求<br>1: 允许中断请求 | R/W |
| 4     | PIPE4BRDYE | 管道4的BRDY中断启用<br>0: 禁止中断请求<br>1: 允许中断请求 | R/W |
| 5     | PIPE5BRDYE | 管道5的BRDY中断启用<br>0: 禁止中断请求<br>1: 允许中断请求 | R/W |
| 6     | PIPE6BRDYE | 管道6的BRDY中断启用<br>0: 禁止中断请求<br>1: 允许中断请求 | R/W |
| 7     | PIPE7BRDYE | 管道7的BRDY中断启用<br>0: 禁止中断请求<br>1: 允许中断请求 | R/W |
| 8     | PIPE8BRDYE | 管道8的BRDY中断启用<br>0: 禁止中断请求<br>1: 允许中断请求 | R/W |
| 9     | PIPE9BRDYE | 管道9的BRDY中断启用<br>0: 禁止中断请求<br>1: 允许中断请求 | R/W |
| 15:10 | —          | 该位读取为0。写入值应为0。                         | R/W |

当检测到每个管道的BRDY中断时，BRDYENB寄存器启用或禁用INTSTS0.BRDY位以设置为1。

当BRDYSTS寄存器中的状态标志设置为1并且BRDYENB寄存器中相关的PIPE<sub>n</sub>BRDYE位 (n=0到9) 设置为1时，INTSTS0.BRDY标志设置为1。在这种情况下，如果INTENB0中的BRDYE位为1，USBFS产生一个BRDY中断请求。当至少一个PIPE<sub>n</sub>BRDYE位指示1时，当BRDYENB寄存器中相关的中断请求使能位由软件从0变为1时，USB产生BRDY中断请求。



## 26.2.13 NRDYENB : NRDY Interrupt Enable Register

Base address: USBFS = 0x4009\_0000

Offset address: 0x038

|                    |    |    |    |    |    |    |                    |                    |                    |                    |                    |                    |                    |                    |                    |                    |
|--------------------|----|----|----|----|----|----|--------------------|--------------------|--------------------|--------------------|--------------------|--------------------|--------------------|--------------------|--------------------|--------------------|
| Bit position:      | 15 | 14 | 13 | 12 | 11 | 10 | 9                  | 8                  | 7                  | 6                  | 5                  | 4                  | 3                  | 2                  | 1                  | 0                  |
| Bit field:         | —  | —  | —  | —  | —  | —  | PIPE9<br>NRDY<br>E | PIPE8<br>NRDY<br>E | PIPE7<br>NRDY<br>E | PIPE6<br>NRDY<br>E | PIPE5<br>NRDY<br>E | PIPE4<br>NRDY<br>E | PIPE3<br>NRDY<br>E | PIPE2<br>NRDY<br>E | PIPE1<br>NRDY<br>E | PIPE0<br>NRDY<br>E |
| Value after reset: | 0  | 0  | 0  | 0  | 0  | 0  | 0                  | 0                  | 0                  | 0                  | 0                  | 0                  | 0                  | 0                  | 0                  | 0                  |

| Bit   | Symbol     | Function  | R/W |
|-------|------------|---|-----|
| 0     | PIPE0NRDYE | NRDY Interrupt Enable for Pipe 0<br>0: Disable interrupt request<br>1: Enable interrupt request | R/W |
| 1     | PIPE1NRDYE | NRDY Interrupt Enable for Pipe 1<br>0: Disable interrupt request<br>1: Enable interrupt request | R/W |
| 2     | PIPE2NRDYE | NRDY Interrupt Enable for Pipe 2<br>0: Disable interrupt request<br>1: Enable interrupt request | R/W |
| 3     | PIPE3NRDYE | NRDY Interrupt Enable for Pipe 3<br>0: Disable interrupt request<br>1: Enable interrupt request | R/W |
| 4     | PIPE4NRDYE | NRDY Interrupt Enable for Pipe 4<br>0: Disable interrupt request<br>1: Enable interrupt request | R/W |
| 5     | PIPE5NRDYE | NRDY Interrupt Enable for Pipe 5<br>0: Disable interrupt request<br>1: Enable interrupt request | R/W |
| 6     | PIPE6NRDYE | NRDY Interrupt Enable for Pipe 6<br>0: Disable interrupt request<br>1: Enable interrupt request | R/W |
| 7     | PIPE7NRDYE | NRDY Interrupt Enable for Pipe 7<br>0: Disable interrupt request<br>1: Enable interrupt request | R/W |
| 8     | PIPE8NRDYE | NRDY Interrupt Enable for Pipe 8<br>0: Disable interrupt request<br>1: Enable interrupt request | R/W |
| 9     | PIPE9NRDYE | NRDY Interrupt Enable for Pipe 9<br>0: Disable interrupt request<br>1: Enable interrupt request | R/W |
| 15:10 | —          | This bit is read as 0. The write value should be 0.   | R/W |

The NRDYENB register enables or disables the INTSTS0.NRDY bit to be set to 1 when a NRDY interrupt is detected for each pipe.

When a status flag in the NRDYSTS register sets to 1 and the associated PIPE<sub>n</sub>NRDYE (n = 0 to 9) bit setting in the NRDYENB register is 1, the INTSTS0.NRDY flag sets to 1. In this case, if the NRDYE bit in INTENB0 is 1, the USBFS generates a NRDY interrupt request. While at least one PIPE<sub>n</sub>NRDYE bit indicates 1, the USBFS generates the NRDY interrupt request when the associated interrupt request enable bit in the NRDYENB register is changed from 0 to 1 by software.

## 26.2.13 NRDYENB:NRDY中断使能寄存器

Base address: USBFS = 0x4009\_0000

Offset address: 0x038

|               |    |    |    |    |    |    |                    |                    |                    |                    |                    |                    |                    |                    |                    |                    |
|---------------|----|----|----|----|----|----|--------------------|--------------------|--------------------|--------------------|--------------------|--------------------|--------------------|--------------------|--------------------|--------------------|
| Bit position: | 15 | 14 | 13 | 12 | 11 | 10 | 9                  | 8                  | 7                  | 6                  | 5                  | 4                  | 3                  | 2                  | 1                  | 0                  |
| Bit field:    | —  | —  | —  | —  | —  | —  | PIPE9<br>NRDY<br>E | PIPE8<br>NRDY<br>E | PIPE7<br>NRDY<br>E | PIPE6<br>NRDY<br>E | PIPE5<br>NRDY<br>E | PIPE4<br>NRDY<br>E | PIPE3<br>NRDY<br>E | PIPE2<br>NRDY<br>E | PIPE1<br>NRDY<br>E | PIPE0<br>NRDY<br>E |
| 重置后的值:        | 0  | 0  | 0  | 0  | 0  | 0  | 0                  | 0                  | 0                  | 0                  | 0                  | 0                  | 0                  | 0                  | 0                  | 0                  |

| Bit   | Symbol     | Function                               | R/W |
|-------|------------|--|-----|
| 0     | PIPE0NRDYE | 管道0的NRDY中断使能<br>0: 禁止中断请求<br>1: 允许中断请求 | R/W |
| 1     | PIPE1NRDYE | 管道1的NRDY中断使能<br>0: 禁止中断请求<br>1: 允许中断请求 | R/W |
| 2     | PIPE2NRDYE | 管道2的NRDY中断使能<br>0: 禁止中断请求<br>1: 允许中断请求 | R/W |
| 3     | PIPE3NRDYE | 管道3的NRDY中断使能<br>0: 禁止中断请求<br>1: 允许中断请求 | R/W |
| 4     | PIPE4NRDYE | 管道4的NRDY中断使能<br>0: 禁止中断请求<br>1: 允许中断请求 | R/W |
| 5     | PIPE5NRDYE | 管道5的NRDY中断使能<br>0: 禁止中断请求<br>1: 允许中断请求 | R/W |
| 6     | PIPE6NRDYE | 管道6的NRDY中断使能<br>0: 禁止中断请求<br>1: 允许中断请求 | R/W |
| 7     | PIPE7NRDYE | 管道7的NRDY中断使能<br>0: 禁止中断请求<br>1: 允许中断请求 | R/W |
| 8     | PIPE8NRDYE | 管道8的NRDY中断使能<br>0: 禁止中断请求<br>1: 允许中断请求 | R/W |
| 9     | PIPE9NRDYE | 管道9的NRDY中断使能<br>0: 禁止中断请求<br>1: 允许中断请求 | R/W |
| 15:10 | —          | 该位读取为0。写入值应为0。                         | R/W |

当检测到每个管道的NRDY中断时，NRDYENB寄存器启用或禁用INTSTS0.NRDY位设置为1。

当NRDYSTS寄存器中的状态标志设置为1并且NRDYENB寄存器中相关的PIPE<sub>n</sub>NRDYE (n=0到9) 位设置为1时，INTSTS0.NRDY标志设置为1。在这种情况下，如果INTENB0中的NRDYE位为1、USBFS产生一个NRDY中断请求。当至少一个PIPE<sub>n</sub>NRDYE位指示1时，USBFS生成

当NRDYENB寄存器中的相关中断请求使能位由软件从0变为1时，发出NRDY中断请求。

## 26.2.14 BEMPENB : BEMP Interrupt Enable Register

Base address: USBFS = 0x4009\_0000

Offset address: 0x03A

|                    |    |    |    |    |    |    |                |                |                |                |                |                |                |                |                |                |
|--------------------|----|----|----|----|----|----|----------------|----------------|----------------|----------------|----------------|----------------|----------------|----------------|----------------|----------------|
| Bit position:      | 15 | 14 | 13 | 12 | 11 | 10 | 9              | 8              | 7              | 6              | 5              | 4              | 3              | 2              | 1              | 0              |
| Bit field:         | —  | —  | —  | —  | —  | —  | PIPE9<br>BEMPE | PIPE8<br>BEMPE | PIPE7<br>BEMPE | PIPE6<br>BEMPE | PIPE5<br>BEMPE | PIPE4<br>BEMPE | PIPE3<br>BEMPE | PIPE2<br>BEMPE | PIPE1<br>BEMPE | PIPE0<br>BEMPE |
| Value after reset: | 0  | 0  | 0  | 0  | 0  | 0  | 0              | 0              | 0              | 0              | 0              | 0              | 0              | 0              | 0              | 0              |

| Bit   | Symbol     | Function  | R/W |
|-------|------------|---|-----|
| 0     | PIPE0BEMPE | BEMP Interrupt Enable for Pipe 0<br>0: Disable interrupt request<br>1: Enable interrupt request | R/W |
| 1     | PIPE1BEMPE | BEMP Interrupt Enable for Pipe 1<br>0: Disable interrupt request<br>1: Enable interrupt request | R/W |
| 2     | PIPE2BEMPE | BEMP Interrupt Enable for Pipe 2<br>0: Disable interrupt request<br>1: Enable interrupt request | R/W |
| 3     | PIPE3BEMPE | BEMP Interrupt Enable for Pipe 3<br>0: Disable interrupt request<br>1: Enable interrupt request | R/W |
| 4     | PIPE4BEMPE | BEMP Interrupt Enable for Pipe 4<br>0: Disable interrupt request<br>1: Enable interrupt request | R/W |
| 5     | PIPE5BEMPE | BEMP Interrupt Enable for Pipe 5<br>0: Disable interrupt request<br>1: Enable interrupt request | R/W |
| 6     | PIPE6BEMPE | BEMP Interrupt Enable for Pipe 6<br>0: Disable interrupt request<br>1: Enable interrupt request | R/W |
| 7     | PIPE7BEMPE | BEMP Interrupt Enable for Pipe 7<br>0: Disable interrupt request<br>1: Enable interrupt request | R/W |
| 8     | PIPE8BEMPE | BEMP Interrupt Enable for Pipe 8<br>0: Disable interrupt request<br>1: Enable interrupt request | R/W |
| 9     | PIPE9BEMPE | BEMP Interrupt Enable for Pipe 9<br>0: Disable interrupt request<br>1: Enable interrupt request | R/W |
| 15:10 | —          | This bit is read as 0. The write value should be 0.   | R/W |

The BEMPENB register enables or disables the INTSTS0.BEMP bit to be set to 1 when a BEMP interrupt is detected for each pipe.

When a status flag in the BEMPSTS register sets to 1 and the associated PIPE<sub>n</sub>BEMPE (n = 0 to 9) bit setting in the BEMPENB register is 1, the INTSTS0.BEMP flag sets to 1. In this case, if the BEMPE bit in INTENB0 is 1, the USBFS generates a BEMP interrupt request. While at least one PIPE<sub>n</sub>BEMPE bit indicates 1, the USBFS generates the BEMP interrupt request when the associated interrupt request enable bit in the BEMPENB register is changed from 0 to 1 by software.

## 26.2.14 BEMPENB:BEMP中断使能寄存器

Base address: USBFS = 0x4009\_0000

Offset address: 0x03A

|               |    |    |    |    |    |    |                |                |                |                |                |                |                |                |                |                |
|---------------|----|----|----|----|----|----|----------------|----------------|----------------|----------------|----------------|----------------|----------------|----------------|----------------|----------------|
| Bit position: | 15 | 14 | 13 | 12 | 11 | 10 | 9              | 8              | 7              | 6              | 5              | 4              | 3              | 2              | 1              | 0              |
| Bit field:    | —  | —  | —  | —  | —  | —  | PIPE9<br>BEMPE | PIPE8<br>BEMPE | PIPE7<br>BEMPE | PIPE6<br>BEMPE | PIPE5<br>BEMPE | PIPE4<br>BEMPE | PIPE3<br>BEMPE | PIPE2<br>BEMPE | PIPE1<br>BEMPE | PIPE0<br>BEMPE |
| 重置后的值:        | 0  | 0  | 0  | 0  | 0  | 0  | 0              | 0              | 0              | 0              | 0              | 0              | 0              | 0              | 0              | 0              |

| Bit   | Symbol     | Function                               | R/W |
|-------|------------|--|-----|
| 0     | PIPE0BEMPE | 管道0的BEMP中断启用<br>0: 禁止中断请求<br>1: 允许中断请求 | R/W |
| 1     | PIPE1BEMPE | 管道1的BEMP中断启用<br>0: 禁止中断请求<br>1: 允许中断请求 | R/W |
| 2     | PIPE2BEMPE | 管道2的BEMP中断启用<br>0: 禁止中断请求<br>1: 允许中断请求 | R/W |
| 3     | PIPE3BEMPE | 管道3的BEMP中断启用<br>0: 禁止中断请求<br>1: 允许中断请求 | R/W |
| 4     | PIPE4BEMPE | 管道4的BEMP中断启用<br>0: 禁止中断请求<br>1: 允许中断请求 | R/W |
| 5     | PIPE5BEMPE | 管道5的BEMP中断启用<br>0: 禁止中断请求<br>1: 允许中断请求 | R/W |
| 6     | PIPE6BEMPE | 管道6的BEMP中断启用<br>0: 禁止中断请求<br>1: 允许中断请求 | R/W |
| 7     | PIPE7BEMPE | 管道7的BEMP中断启用<br>0: 禁止中断请求<br>1: 允许中断请求 | R/W |
| 8     | PIPE8BEMPE | 管道8的BEMP中断启用<br>0: 禁止中断请求<br>1: 允许中断请求 | R/W |
| 9     | PIPE9BEMPE | 管道9的BEMP中断启用<br>0: 禁止中断请求<br>1: 允许中断请求 | R/W |
| 15:10 | —          | 该位读取为0。写入值应为0。                         | R/W |

当检测到每个管道的BEMP中断时，BEMPENB寄存器启用或禁用INTSTS0.BEMP位设置为1。

当BEMPSTS寄存器中的状态标志设置为1并且BEMPENB寄存器中相关的PIPE<sub>n</sub>BEMPE (n=0到9) 位设置为1时，INTSTS0.BEMP标志设置为1。在这种情况下，如果INTENB0中的BEMPE位为1，USBFS产生一个BEMP中断请求。当至少一个PIPE<sub>n</sub>BEMPE位指示1时，当BEMPENB寄存器中相关的中断请求使能位由软件从0变为1时，USBFS产生BEMP中断请求。

## 26.2.15 SOFCFG : SOF Output Configuration Register

Base address: USBFS = 0x4009\_0000

Offset address: 0x03C

|                    |    |    |    |    |    |    |   |              |   |           |   |             |   |   |   |   |
|--------------------|----|----|----|----|----|----|---|--------------|---|-----------|---|-------------|---|---|---|---|
| Bit position:      | 15 | 14 | 13 | 12 | 11 | 10 | 9 | 8            | 7 | 6         | 5 | 4           | 3 | 2 | 1 | 0 |
| Bit field:         | —  | —  | —  | —  | —  | —  | — | TRNE<br>NSEL | — | BRDY<br>M | — | EDGE<br>STS | — | — | — | — |
| Value after reset: | 0  | 0  | 0  | 0  | 0  | 0  | 0 | 0            | 0 | 0         | 0 | 0           | 0 | 0 | 0 | 0 |

| Bit  | Symbol   | Function  | R/W |
|------|----------|---|-----|
| 3:0  | —        | These bits are read as 0. The write value should be 0.  | R/W |
| 4    | EDGESTS  | Edge Interrupt Output Status Monitor*1<br>Indicates 1 during the edge processing of an edge interrupt output signal.  | R   |
| 5    | —        | This bit is read as 0. The write value should be 0.   | R/W |
| 6    | BRDYM    | BRDY Interrupt Status Clear Timing<br>0: Clear BRDY flag by software<br>1: Clear BRDY flag by the USBFS through a data read from the FIFO buffer or data write to the FIFO buffer | R/W |
| 7    | —        | This bit is read as 0. The write value should be 0.   | R/W |
| 8    | TRNENSEL | Transaction-Enabled Time Select*1<br>0: Not low-speed communication<br>1: Low-speed communication   | R/W |
| 15:9 | —        | These bits are read as 0. The write value should be 0.  | R/W |

Note 1. Confirm that the EDGESTS flag is 0 before stopping the clock supply to the USBFS.

**EDGESTS bit (Edge Interrupt Output Status Monitor)**

The EDGESTS bit indicates 1 during the edge processing of an edge interrupt output signal. Confirm that this bit is 0 before stopping the clock supply to the USBFS.

**BRDYM bit (BRDY Interrupt Status Clear Timing)**

The BRDYM bit specifies how the BRDY interrupt status flags for the pipes are cleared.

**TRNENSEL bit (Transaction-Enabled Time Select)**

When the USB port is in use for full- or low-speed communications, the TRNENSEL bit specifies the timing with which the USBFS issues tokens in a frame (transaction-enabled time).

Set this bit to 1 when a low-speed device is connected. The bit is only valid in host controller mode. Set this bit to 0 in device controller mode.

## 26.2.16 INTSTS0 : Interrupt Status Register 0

Base address: USBFS = 0x4009\_0000

Offset address: 0x040

|                    |       |      |      |      |      |      |      |      |           |           |       |           |   |   |   |   |
|--------------------|-------|------|------|------|------|------|------|------|-----------|-----------|-------|-----------|---|---|---|---|
| Bit position:      | 15    | 14   | 13   | 12   | 11   | 10   | 9    | 8    | 7         | 6         | 5     | 4         | 3 | 2 | 1 | 0 |
| Bit field:         | VBINT | RESM | SOFR | DVST | CTRT | BEMP | NRDY | BRDY | VBST<br>S | DVSQ[2:0] | VALID | CTSQ[2:0] | — | — | — | — |
| Value after reset: | 0     | 0    | 0    | x    | 0    | 0    | 0    | 0    | x         | 0         | 0     | x         | 0 | 0 | 0 | 0 |

## 26.2.15 SOFCFG:SOE输出配置寄存器

Base address: USBFS = 0x4009\_0000

Offset address: 0x03C

|               |    |    |    |    |    |    |   |              |   |           |   |             |   |   |   |   |
|---------------|----|----|----|----|----|----|---|--------------|---|-----------|---|-------------|---|---|---|---|
| Bit position: | 15 | 14 | 13 | 12 | 11 | 10 | 9 | 8            | 7 | 6         | 5 | 4           | 3 | 2 | 1 | 0 |
| Bit field:    | —  | —  | —  | —  | —  | —  | — | TRNE<br>NSEL | — | BRDY<br>M | — | EDGE<br>STS | — | — | — | — |
| 重置后的值:        | 0  | 0  | 0  | 0  | 0  | 0  | 0 | 0            | 0 | 0         | 0 | 0           | 0 | 0 | 0 | 0 |

| Bit  | Symbol   | Function   | R/W |
|------|----------|--|-----|
| 3:0  | —        | 这些位被读取为0。写入值应为0。   | R/W |
| 4    | EDGESTS  | 边沿中断输出状态监视器*1<br>在边沿中断输出信号的边沿处理期间表示1。                                    | R   |
| 5    | —        | 该位读取为0。写入值应为0。   | R/W |
| 6    | BRDYM    | BRDY中断状态清除时序<br>0: 软件清除BRDY标志1: USBFS通过从FIFO缓冲区读取数据或向FIFO缓冲区写入数据清除BRDY标志 | R/W |
| 7    | —        | 该位读取为0。写入值应为0。   | R/W |
| 8    | TRNENSEL | 事务启用时间选择*1<br>0: 非低速通讯1: 低速通讯  | R/W |
| 15:9 | —        | 这些位被读取为0。写入值应为0。   | R/W |

注1.在停止向USBFS提供时钟之前，请确认EDGESTS标志为0。

**EDGESTS位 (边缘中断输出状态监视器)**

在边沿中断输出信号的边沿处理期间，EDGESTS位指示1。在停止向USBFS提供时钟之前，请确认该位为0。

**BRDYM位 (BRDY中断状态清除时序)**

BRDYM位指定如何清除管道的BRDY中断状态标志。

**TRNENSEL位 (事务使能时间选择)**

当USB端口用于全速或低速通信时，TRNENSEL位指定USBFS在一个帧中发布令牌 (事务启用时间)。

当连接了低速设备时，将此位设置为1。该位仅在主机控制器模式下有效。在设备控制器模式下将此位设置为0。

## 26.2.16 INTSTS0: 中断状态寄存器0

Base address: USBFS = 0x4009\_0000

Offset address: 0x040

|               |       |      |      |      |      |      |      |      |           |           |       |           |   |   |   |   |
|---------------|-------|------|------|------|------|------|------|------|-----------|-----------|-------|-----------|---|---|---|---|
| Bit position: | 15    | 14   | 13   | 12   | 11   | 10   | 9    | 8    | 7         | 6         | 5     | 4         | 3 | 2 | 1 | 0 |
| Bit field:    | VBINT | RESM | SOFR | DVST | CTRT | BEMP | NRDY | BRDY | VBST<br>S | DVSQ[2:0] | VALID | CTSQ[2:0] | — | — | — | — |
| 重置后的值:        | 0     | 0    | 0    | x    | 0    | 0    | 0    | 0    | x         | 0         | 0     | x         | 0 | 0 | 0 | 0 |

| Bit | Symbol    | Function  | R/W   |
|-----|-----------|---|-------|
| 2:0 | CTSQ[2:0] | Control Transfer Stage<br>0 0 0: Idle or setup stage<br>0 0 1: Control read data stage<br>0 1 0: Control read status stage<br>0 1 1: Control write data stage<br>1 0 0: Control write status stage<br>1 0 1: Control write (no data) status stage<br>1 1 0: Control transfer sequence error | R     |
| 3   | VALID     | USB Request Reception<br>0: Setup packet not received<br>1: Setup packet received   | R/W   |
| 6:4 | DVSQ[2:0] | Device State<br>Indicates the device state.<br>0 0 0: Powered state<br>0 0 1: Default state<br>0 1 0: Address state<br>0 1 1: Configured state<br>Others: Suspend state   | R     |
| 7   | VBSTS     | VBUS Input Status<br>0: USB_VBUS pin is low<br>1: USB_VBUS pin is high  | R     |
| 8   | BRDY      | Buffer Ready Interrupt Status<br>0: No BRDY interrupt occurred<br>1: BRDY interrupt occurred  | R     |
| 9   | NRDY      | Buffer Not Ready Interrupt Status<br>0: No NRDY interrupt occurred<br>1: NRDY interrupt occurred  | R     |
| 10  | BEMP      | Buffer Empty Interrupt Status<br>0: No BEMP interrupt occurred<br>1: BEMP interrupt occurred  | R     |
| 11  | CTRT      | Control Transfer Stage Transition Interrupt Status*2<br>0: No control transfer stage transition interrupt occurred<br>1: Control transfer stage transition interrupt occurred   | R/W*1 |
| 12  | DVST      | Device State Transition Interrupt Status*2<br>0: No device state transition interrupt occurred<br>1: Device state transition interrupt occurred   | R/W*1 |
| 13  | SOFR      | Frame Number Refresh Interrupt Status<br>0: No SOF interrupt occurred<br>1: SOF interrupt occurred  | R/W*1 |
| 14  | RESM      | Resume Interrupt Status*2 *3<br>0: No resume interrupt occurred<br>1: Resume interrupt occurred   | R/W*1 |
| 15  | VBINT     | VBUS Interrupt Status*3<br>0: No VBUS interrupt occurred<br>1: VBUS interrupt occurred  | R/W*1 |

Note: The value of the DVST bit is 0 when the MCU is reset and 1 after a USB bus reset.

Note: The value of the VBSTS bit is 1 when the USB\_VBUS pin is high and 0 when the USB\_VBUS pin is low.

Note: The value of the DVSQ[2:0] bits is 000b when the MCU is reset and 001b after a USB bus reset.

Note 1. To clear the VBINT, RESM, SOFR, DVST, CTRT, or VALID bits, write 0 only to the bits to be cleared. Write 1 to the other bits. Do not write 0 to the status bits indicating 0.

Note 2. The status of the RESM, DVST, and CTRT bits are changed only in device controller mode. Set the associated interrupt enable bits to 0 (disabled) in host controller mode.

Note 3. The USBFS detects a change in the status indicated in the VBINT and RESM bits even while the clock supply is stopped (SCKE bit = 0), and it requests the interrupt when the associated interrupt request bit is 1. Enable the clock supply before clearing the status by software.

### CTSQ[2:0] bits (Control Transfer Stage)

In host controller mode, the read value of the CTSQ[2:0] bits is invalid.

| Bit | Symbol    | Function  | R/W   |
|-----|-----------|---|-------|
| 2:0 | CTSQ[2:0] | 控制转移阶段<br>000: 空闲或设置阶段001: 控制读取数据阶段010: 控制读取状态阶段011: 控制写入数据阶段100: 控制写入状态阶段101: 控制写入(无数据)状态阶段110: 控制传输顺序错误 | R     |
| 3   | VALID     | USB请求接收<br>0: 未收到设置包1: 收到设置包  | R/W   |
| 6:4 | DVSQ[2:0] | 设备状态<br>指示设备状态。<br>000: 通电状态001: 默认状态010: 地址状态011: 配置状态<br>其他: 暂停状态                                       | R     |
| 7   | VBSTS     | VBUS输入状态<br>0: USB_VBUS引脚为低电平<br>1: USB_VBUS引脚为高电平  | R     |
| 8   | BRDY      | 缓冲区就绪中断状态<br>0: 未发生BRDY中断1: 发生BRDY中断  | R     |
| 9   | NRDY      | 缓冲区未就绪中断状态<br>0: 未发生NRDY中断1: 发生NRDY中断   | R     |
| 10  | BEMP      | 缓冲区空中断状态<br>0: 未发生BEMP中断1: 发生BEMP中断   | R     |
| 11  | CTRT      | 控制传输阶段转换中断状态*2<br>0: 未发生控制转移阶段转换中断1: 发生控制转移阶段转换中断   | R/W*1 |
| 12  | DVST      | 设备状态转换中断状态*2<br>0: 未发生设备状态转换中断1: 发生设备状态转换中断   | R/W*1 |
| 13  | SOFR      | 帧号刷新中断状态<br>0: 未发生SOF中断1: 发生SOF中断   | R/W*1 |
| 14  | RESM      | 恢复中断状态*2*3<br>0: 未发生恢复中断1: 发生恢复中断   | R/W*1 |
| 15  | VBINT     | VBUS中断状态*3<br>0: 未发生VBUS中断1: 发生VBUS中断   | R/W*1 |

Note: DVST位的值在MCU复位时为0, 在USB总线复位后为1。

Note: 当USB\_VBUS引脚为高电平时VBSTS位的值为1, 当USB\_VBUS引脚为低电平时为0。

Note: DVSQ[2:0]位的值在MCU复位时为000b, 在USB总线复位后为001b。

注1.要清除VBINT、RESM、SOFR、DVST、CTRT或VALID位, 只需将0写入要清除的位。将1写入其他位。不要将0写入指示0的状态位。

注2.RESM、DVST和CTRT位的状态仅在设备控制器模式下更改。在主机控制器模式下, 将相关的中断使能位设置为0(禁用)。

注3.即使在时钟供应停止(SCKE位=0)时, USBFS也会检测到VBINT和RESM位指示的状态变化, 并在相关中断请求位为1时请求中断。在之前启用时钟供应通过软件清除状态。

### CTSQ[2:0]位 (控制传输级)

在主机控制器模式下, CTSQ[2:0]位的读取值无效。



**VALID bit (USB Request Reception)**

In host controller mode, the read value of the VALID bit is invalid.

**DVSQ[2:0] bits (Device State)**

The DVSQ[2:0] bits are initialized by a USB bus reset. In host controller mode, the read value is invalid.

**BRDY flag (Buffer Ready Interrupt Status)**

The BRDY flag indicates the BRDY interrupt status.

The USBFS sets the BRDY bit to 1 when it detects a BRDY interrupt status (PIPE<sub>n</sub>BRDY = 1, n = 0 to 9) on at least one pipe for which BRDY interrupts are enabled (BRDYENB.PIPE<sub>n</sub>BRDYE = 1).

For the conditions that cause the PIPE<sub>n</sub>BRDY status to be asserted, see [section 26.3.3.1. BRDY interrupt](#).

The USBFS sets the BRDY bit to 0 when the software writes 0 to all of the PIPE<sub>n</sub>BRDY bits associated with the PIPE<sub>n</sub>BRDYE bits that are set to 1. Writing 0 to the BRDY flag in the software does not clear the flag.

**NRDY flag (Buffer Not Ready Interrupt Status)**

The NRDY flag indicates the NRDY interrupt status.

The USBFS sets the NRDY bit to 1 when it detects a NRDY interrupt status (PIPE<sub>n</sub>NRDY = 1, n = 0 to 9) on at least one pipe for which NRDY interrupts are enabled (NRDYENB.PIPE<sub>n</sub>NRDYE = 1).

For the conditions that cause the PIPE<sub>n</sub>NRDY status to be asserted, see [section 26.3.3.2. NRDY interrupt](#).

The USBFS sets the NRDY bit to 0 when the software writes 0 to all of the PIPE<sub>n</sub>NRDY bits associated with the PIPE<sub>n</sub>NRDYE bits that are set to 1. Writing 0 to the NRDY flag in the software does not clear the flag.

**NRDY flag (Buffer Empty Interrupt Status)**

The NRDY flag indicates the NRDY interrupt status.

The USBFS sets the NRDY bit to 1 when it detects a NRDY interrupt status (PIPE<sub>n</sub>BEMP = 1, n = 0 to 9) on at least one pipe for which NRDY interrupts are enabled (BEMPENB.PIPE<sub>n</sub>BEMPE = 1).

For the conditions that cause the PIPE<sub>n</sub>BEMP status to be asserted, see [section 26.3.3.3. BEMP interrupt](#).

The USBFS sets the NRDY bit to 0 when the software writes 0 to all of the PIPE<sub>n</sub>BEMP bits associated with the PIPE<sub>n</sub>BEMPE bits that are set to 1. Writing 0 to the NRDY flag in the software does not clear the flag.

**CTRT flag (Control Transfer Stage Transition Interrupt Status)**

In device controller mode, the USBFS updates the value of the CTSQ[2:0] bits and sets the CTRT flag to 1 on detecting a transition in the control transfer stage. When a control transfer stage transition interrupt occurs, clear the CTRT flag before the USBFS detects the next control transfer stage transition.

Values read from the CTRT flag in host controller mode are invalid.

**DVST flag (Device State Transition Interrupt Status)**

In device controller mode, the USBFS updates the value of the DVSQ[2:0] bits and sets the DVST flag to 1 on detecting a change in the device state. When a device state transition interrupt occurs, clear the DVST flag before the USBFS detects the next device state transition.

Values read from the DVST flag in host controller mode are invalid.

**SOFR flag (Frame Number Refresh Interrupt Status)**

In host controller mode, the USBFS sets the SOFR flag to 1 on updating the frame number when the DVSTCTR0.UACT bit is set to 1 by software. A SOFR interrupt is detected every 1 ms.

In device controller mode, the USBFS sets the SOFR flag to 1 on updating the frame number. A frame number refresh interrupt is detected every 1 ms.

The USBFS can detect an SOFR interrupt through the internal interpolation function even when a corrupted SOF packet is received from the USB host.

**有效位 (USB请求接收)**

在主机控制器模式下，VALID位的读取值无效。

**DVSQ[2:0] bits (Device State)**

DVSQ[2:0]位由USB总线复位初始化。在主机控制器模式下，读取的值无效。

**BRDY标志 (缓冲区就绪中断状态)**

BRDY标志指示BRDY中断状态。

当USBFS在至少一个启用了BRDY中断(BRDYENB.PIPE<sub>n</sub>BRDYE=1)的管道上检测到BRDY中断状态(PIPE<sub>n</sub>BRDY=1 n=0到9)时，将BRDY位设置为1。

有关导致PIPE<sub>n</sub>BRDY状态被断言的条件，请参见第26.3.3.1节。BRDY中断。

当软件将0写入与设置为1的PIPE<sub>n</sub>BRDYE位。在软件中将0写入BRDY标志不会清除该标志。

**NRDY标志 (缓冲区未就绪中断状态)**

NRDY标志指示NRDY中断状态。

当USBFS在至少一个启用了NRDY中断(NRDYENB.PIPE<sub>n</sub>NRDYE=1)的管道上检测到NRDY中断状态(PIPE<sub>n</sub>NRDY=1 n=0到9)时，将NRDY位设置为1。

有关导致PIPE<sub>n</sub>NRDY状态被断言的条件，请参见第26.3.3.2节。NRDY中断。

USBFS将NRDY位设置为0，当软件将0写入与设置为1的PIPE<sub>n</sub>NRDYE位。在软件中将0写入NRDY标志不会清除该标志。

**NRDY标志 (缓冲区空中断状态)**

NRDY标志指示NRDY中断状态。

当USBFS在至少一个启用了NRDY中断(BEMPENB.PIPE<sub>n</sub>BEMPE=1)的管道上检测到NRDY中断状态(PIPE<sub>n</sub>BEMP=1 n=0到9)时，将NRDY位设置为1。

有关导致PIPE<sub>n</sub>BEMP状态被断言的条件，请参见第26.3.3.3节。BEMP中断。

当软件将0写入与设置为1的PIPE<sub>n</sub>BEMPE位。在软件中将0写入NRDY标志不会清除该标志。

**CTRT标志 (控制传输阶段转换中断状态)**

在设备控制器模式下，USBFS更新CTSQ[2:0]位的值，并在检测到控制传输阶段的转换时将CTRT标志设置为1。当控制传输阶段转换中断发生时，在USBFS检测到下一个控制传输阶段转换之前清除CTRT标志。

在主机控制器模式下从CTRT标志读取的值无效。

**DVST标志 (设备状态转换中断状态)**

在设备控制器模式下，USBFS更新DVSQ[2:0]位的值，并在检测到设备状态发生变化时将DVST标志设置为1。当设备状态转换中断发生时，在USBFS检测到下一个设备状态转换之前清除DVST标志。

在主机控制器模式下从DVST标志读取的值无效。

**SOFR标志 (帧号刷新中断状态)**

在主机控制器模式下，当软件将DVSTCTR0.UACT位设置为1时，USBFS在更新帧号时将SOFR标志设置为1。每1ms检测一次SOFR中断。

在设备控制器模式下，USBFS在更新帧号时将SOFR标志设置为1。每1ms检测一次帧号刷新中断。

即使从USB主机接收到损坏的SOF数据包，USBFS也可以通过内部插值功能检测SOFR中断。



**RESM flag (Resume Interrupt Status)**

In device controller mode, the USBFS sets the RESM flag to 1 on detecting the falling edge of the signal on the USB\_DP pin in the Suspend state (DVSQ[2:0] = 1xxb). Values read from the RESM flag in host controller mode are invalid.

**VBINT flag (VBUS Interrupt Status)**

The USBFS sets the VBINT flag to 1 on detecting a level change (high to low or low to high) in the USB\_VBUS pin input value. The USBFS sets the VBSTS flag to indicate the USB\_VBUS pin input value. When a VBUS interrupt occurs, eliminate transient elements by reading the VBSTS flag at least three times through software processing and check that the values read are the same.

**26.2.17 INTSTS1 : Interrupt Status Register 1**

Base address: USBFS = 0x4009\_0000

Offset address: 0x042

|                    |           |      |    |      |           |    |   |   |   |            |      |      |   |   |   |              |
|--------------------|-----------|------|----|------|-----------|----|---|---|---|------------|------|------|---|---|---|--------------|
| Bit position:      | 15        | 14   | 13 | 12   | 11        | 10 | 9 | 8 | 7 | 6          | 5    | 4    | 3 | 2 | 1 | 0            |
| Bit field:         | OVR<br>CR | BCHG | —  | DTCH | ATT<br>CH | —  | — | — | — | EOFE<br>RR | SIGN | SACK | — | — | — | PDDE<br>TINT |
| Value after reset: | 0         | 0    | 0  | 0    | 0         | 0  | 0 | 0 | 0 | 0          | 0    | 0    | 0 | 0 | 0 | 0            |

| Bit  | Symbol                | Function  | R/W              |
|------|-----------------------|---|------------------|
| 0    | PDDETINT <sup>1</sup> | PDDET Detection Interrupt Status Flag<br>0: No PDDET interrupt occurred<br>1: PDDET interrupt occurred                    | R/W <sup>2</sup> |
| 3:1  | —                     | These bits are read as 0. The write value should be 0.  | R/W              |
| 4    | SACK                  | Setup Transaction Normal Response Interrupt Status<br>0: No SACK interrupt occurred<br>1: SACK interrupt occurred         | R/W <sup>3</sup> |
| 5    | SIGN                  | Setup Transaction Error Interrupt Status<br>0: No SIGN interrupt occurred<br>1: SIGN interrupt occurred                   | R/W <sup>3</sup> |
| 6    | EOFERR                | EOF Error Detection Interrupt Status<br>0: No EOFERR interrupt occurred<br>1: EOFERR interrupt occurred                   | R/W <sup>3</sup> |
| 10:7 | —                     | These bits are read as 0. The write value should be 0.  | R/W              |
| 11   | ATTCH                 | ATTCH Interrupt Status<br>0: No ATTCH interrupt occurred<br>1: ATTCH interrupt occurred                                   | R/W <sup>3</sup> |
| 12   | DTCH                  | USB Disconnection Detection Interrupt Status<br>0: No DTCH interrupt occurred<br>1: DTCH interrupt occurred               | R/W <sup>3</sup> |
| 13   | —                     | This bit is read as 0. The write value should be 0.   | R/W              |
| 14   | BCHG                  | USB Bus Change Interrupt Status <sup>4</sup><br>0: No BCHG interrupt occurred<br>1: BCHG interrupt occurred               | R/W <sup>3</sup> |
| 15   | OVRRCR                | Overcurrent Input Change Interrupt Status <sup>4</sup><br>0: No OVRRCR interrupt occurred<br>1: OVRRCR interrupt occurred | R/W <sup>3</sup> |

Note 1. The USBFS detects a change in the status in the PDDETINT, OVRRCR or BCHG bit even when the clock supply is stopped (SYSCFG.SCKE = 0), and it requests the interrupt when the associated interrupt request bit is 1. Enable the clock supply (SYSCFG.SCKE = 1) before clearing the status through software. No other interrupts can be detected while the clock supply is stopped (SYSCFG.SCKE bit = 0).

Note 2. To clear the bits in the INTSTS1 register, write 0 only to the bits to be cleared. Write 1 to the other bits.

Note 3. To clear the bits in INTSTS1, write 0 only to the bits to be cleared. Write 1 to the other bits.

Note 4. The USBFS detects a change in the status in the OVRRCR or BCHG bit even when the clock supply is stopped (SYSCFG.SCKE = 0), and it requests the interrupt when the associated interrupt request bit is 1. Enable the clock supply (SYSCFG.SCKE = 1) before

**RESM标志 (恢复中断状态)**

在设备控制器模式下，USBFS在检测到处于挂起状态(DVSQ[2:0]=1xxb)的USB\_DP引脚上的信号下降沿时将RESM标志设置为1。在主机控制器模式下从RESM标志读取的值无效。

**VBINT标志 (VBUS中断状态)**

USBFS在检测到USB\_VBUS引脚输入值的电平变化 (从高到低或从低到高) 时将VBINT标志设置为1。USBFS设置VBSTS标志以指示USB\_VBUS引脚输入值。当发生VBUS中断时，通过软件处理至少3次读取VBSTS标志来消除瞬态元素，并检查读取的值是否相同。

**26.2.17 INTSTS1: 中断状态寄存器1**

Base address: USBFS = 0x4009\_0000

Offset address: 0x042

|               |           |      |    |      |           |    |   |   |   |            |      |      |   |   |   |              |
|---------------|-----------|------|----|------|-----------|----|---|---|---|------------|------|------|---|---|---|--------------|
| Bit position: | 15        | 14   | 13 | 12   | 11        | 10 | 9 | 8 | 7 | 6          | 5    | 4    | 3 | 2 | 1 | 0            |
| Bit field:    | OVR<br>CR | BCHG | —  | DTCH | ATT<br>CH | —  | — | — | — | EOFE<br>RR | SIGN | SACK | — | — | — | PDDE<br>TINT |
| 重置后的值:        | 0         | 0    | 0  | 0    | 0         | 0  | 0 | 0 | 0 | 0          | 0    | 0    | 0 | 0 | 0 | 0            |

| Bit  | Symbol                | Function   | R/W              |
|------|-----------------------|--|------------------|
| 0    | PDDETINT <sup>1</sup> | PDDET检测中断状态标志<br>0: 未发生PDDET中断1: 发生PD<br>DET中断             | R/W <sup>2</sup> |
| 3:1  | —                     | 这些位被读取为0。写入值应为0。   | R/W              |
| 4    | SACK                  | 设置事务正常响应中断状态<br>0: 未发生SACK中断1: 发生SA<br>CK中断                | R/W <sup>3</sup> |
| 5    | SIGN                  | 设置事务错误中断状态<br>0: 未发生SIGN中断1: 发生SI<br>GN中断                  | R/W <sup>3</sup> |
| 6    | EOFERR                | EOF错误检测中断状态<br>0: 未发生EOFERR中断1: 发生EOF<br>ERR中断             | R/W <sup>3</sup> |
| 10:7 | —                     | 这些位被读取为0。写入值应为0。   | R/W              |
| 11   | ATTCH                 | ATTCH中断状态<br>0: 未发生ATTCH中断1: 发生AT<br>TCH中断                 | R/W <sup>3</sup> |
| 12   | DTCH                  | USB断线检测中断状态<br>0: 未发生DTCH中断1: 发生DT<br>CH中断                 | R/W <sup>3</sup> |
| 13   | —                     | 该位读取为0。写入值应为0。   | R/W              |
| 14   | BCHG                  | USB总线更改中断状态 <sup>4</sup><br>0: 未发生BCHG中断1: 发生BC<br>HG中断    | R/W <sup>3</sup> |
| 15   | OVRRCR                | 过电流输入变化中断状态 <sup>4</sup><br>0: 未发生OVRRCR中断1: 发生OV<br>RCR中断 | R/W <sup>3</sup> |

注1.即使停止时钟供应(SYSCFG.SCKE=0)，USBFS也会检测到PDDETINT、OVRRCR或BCHG位的状态变化，并在相关中断请求位为1时请求中断。使能在通过软件清除状态之前提供时钟 (SYSCFG.SCKE=1)。停止提供时钟 (SYSCFG.SCKE位=0) 时，不会检测到其他中断。

注2.要清除INTSTS1寄存器中的位，只需将0写入要清除的位。将1写入其他位。

注3.要清除INTSTS1中的位，只需将0写入要清除的位。将1写入其他位。

注4.即使停止时钟供应(SYSCFG.SCKE=0)，USBFS也会检测到OVRRCR或BCHG位的状态变化，并在相关中断请求位为1时请求中断。使能时钟供应(SYSCFG.SCKE=1)之前

clearing the status through the software. No other interrupts can be detected while the clock supply is stopped (SYSCFG.SCKE bit = 0).

INTSTS1 is used to confirm the status of each interrupt in host controller mode. Only enable the status change interrupts indicated in the bits in INTSTS1 in host controller mode.

#### PDETECTINT flag (PDETECTINT Detection Interrupt Status Flag)

The USBFS sets the PDETECTINT flag to 1 on detecting a level change (high to low or low to high) in the PDETECT pin input value. When the PDETECTINT interrupt is generated, perform debouncing by reading the BCCTRL1.PDETECTSTS flag at least three times through software processing and checking that the values read are the same.

#### SACK flag (Setup Transaction Normal Response Interrupt Status)

The SACK flag indicates the status of the setup transaction normal response interrupt in host controller mode.

The USBFS detects the SACK interrupt and sets this flag to 1 when an ACK response is returned from a peripheral device during the setup transactions issued by the USBFS. If the associated interrupt enable bit is set to 1 by software, the USBFS generates the interrupt.

Values read from the SACK flag in device controller mode are invalid.

#### SIGN flag (Setup Transaction Error Interrupt Status)

The SIGN flag indicates the status of setup transaction error interrupts in host controller mode.

The USBFS detects the SIGN interrupt and sets this flag to 1 when an ACK response is not returned from a peripheral device three consecutive times during the setup transactions issued by the USBFS. If the associated interrupt enable bit is set to 1 by software, the USBFS generates the interrupt.

The USBFS detects the SIGN interrupt when any of the following response conditions occur for three consecutive setup transactions:

- Timeout is detected by the USBFS when the peripheral device has returned no response
- A corrupted ACK packet is received
- A handshake other than ACK (NAK, NYET, or STALL) is received

Values read from the SIGN flag in device controller mode are invalid.

#### EOFERR flag (EOF Error Detection Interrupt Status)

The EOFERR flag indicates the status of EOF error detection interrupts in host controller mode.

The USBFS detects the EOFERR interrupt and sets this flag to 1 on detecting that communication did not complete at the EOF2 timing defined in the USB 2.0 specification. If the associated interrupt enable bit is set to 1 by software, the USBFS generates the interrupt.

After detecting the EOFERR interrupt, the USBFS controls the hardware as follows, regardless of the associated interrupt enable bit setting:

- Sets the DVSTCTR0.UACT bit for the port in which the EOFERR interrupt was detected to 0
- Puts the port in which the EOFERR interrupt occurred into the idle state

The software must terminate all pipes in which communications are being carried out and re-enumerate the USB port.

Values read from the EOFERR flag in device controller mode are invalid.

#### ATTCH flag (ATTCH Interrupt Status)

The ATTCH flag indicates the status of USB attach detection interrupts in host controller mode.

The USBFS detects the ATTCH interrupt and sets this flag to 1 on detecting a J- or K-state on the full- or low-speed signal level for 2.5  $\mu$ s. If the associated interrupt enable bit is set to 1 by software, the USBFS generates the interrupt.

The USBFS detects the ATTCH interrupt on any of the following conditions.

- K-state, SE0, or SE1 changes to J-state, and J-state continues for 2.5  $\mu$ s
- J-state, SE0, or SE1 changes to K-state, and K-state continues for 2.5  $\mu$ s

Values read from the ATTCH flag in device controller mode are invalid.

通过软件清除状态。停止提供时钟 (SYSCFG.SCKE位=0) 时, 不会检测到其他中断。

INTSTS1用于确认主机控制器模式下每个中断的状态。仅在主机控制器模式下启用INTSTS1位中指示的状态更改中断。

#### PDETECTINT标志 (PDETECTINT检测中断状态标志)

USBFS在检测到PDETECT引脚输入值的电平变化 (从高到低或从低到高) 时将PDETECTINT标志设置为1。当产生PDETECTINT中断时, 通过软件处理至少3次读取BCCTRL1.PDETECTSTS标志并检查读取的值是否相同来执行去抖动。

#### SACK标志 (设置事务正常响应中断状态)

SACK标志指示主机控制器模式下设置事务正常响应中断的状态。

在USBFS发出的设置事务期间, 当外围设备返回ACK响应时, USBFS检测到SACK中断并将该标志设置为1。如果相关的中断使能位由软件设置为1, 则USBFS产生中断。

在设备控制器模式下从SACK标志读取的值无效。

#### SIGN标志 (设置事务错误中断状态)

SIGN标志指示主机控制器模式下设置事务错误中断的状态。

在USBFS发出的设置事务期间, 如果外围设备连续3次没有返回ACK响应, 则USBFS检测到SIGN中断并将该标志设置为1。如果相关的中断使能位由软件设置为1, 则USBFS产生中断。

当三个连续的设置事务发生以下任何响应条件时, USBFS检测到SIGN中断:

- 当外围设备没有返回响应时, USBFS检测到超时
- 收到损坏的ACK数据包
- 收到ACK (NAK、NYET或STALL) 以外的握手

在设备控制器模式下从SIGN标志读取的值无效。

#### EOFERR标志 (EOF错误检测中断状态)

EOFERR标志指示主机控制器模式下EOF错误检测中断的状态。

USBFS检测到EOFERR中断, 并在检测到通信未在USB2.0规范中定义的EOF2时序完成时将该标志设置为1。如果相关的中断使能位由软件设置为1, 则USBFS产生中断。

检测到EOFERR中断后, USBFS对硬件进行如下控制, 而不考虑相关的中断使能位设置:

- 将检测到EOFERR中断的端口的DVSTCTR0.UACT位设置为0
- 将发生EOFERR中断的端口置于空闲状态

软件必须终止正在执行通信的所有管道并重新枚举USB端口。

在设备控制器模式下从EOFERR标志读取的值无效。

#### ATTCH标志 (ATTCH中断状态)

ATTCH标志指示主机控制器模式下USB连接检测中断的状态。

USBFS检测到ATTCH中断, 并在检测到全速或低速信号电平上的JorK状态持续2.5 $\mu$ s时将此标志设置为1。如果相关的中断使能位由软件设置为1, 则USBFS产生中断。

USBFS在以下任何条件下检测ATTCH中断。

- K-state、SE0或SE1变为J-state, J-state持续2.5 $\mu$ s
- J-state、SE0或SE1变为K-state, K-state持续2.5 $\mu$ s

在设备控制器模式下从ATTCH标志读取的值无效。

**DTCH flag (USB Disconnection Detection Interrupt Status)**

The DTCH flag indicates the status of USB disconnection detection interrupts in host controller mode.

The USBFS detects the DTCH interrupt and sets this flag to 1 on detecting a USB bus detach event. If the associated interrupt enable bit is set to 1 by software, the USBFS generates the interrupt.

The USBFS detects bus detach events based on the USB 2.0 specification.

After detecting the DTCH interrupt, the USBFS controls hardware as follows, regardless of the associated interrupt enable bit setting:

- Sets the DVSTCTR0.UACT bit for the port in which the DTCH interrupt was detected to 0
- Puts the port in which the DTCH interrupt occurred into the idle state

The software must terminate all pipes in which communications are being carried out and invoke the wait state for attaching to the USB port (waiting for ATTCH interrupt generation).

Values read from the DTCH flag in device controller mode are invalid.

**BCHG flag (USB Bus Change Interrupt Status)**

The BCHG flag indicates the status of USB bus change interrupts in host controller mode.

The USBFS detects the BCHG interrupt and sets this flag to 1 when a change in the full- or low-speed signal level occurs on the USB port. This includes any change from J-state, K-state, or SE0 to J-state, K-state, or SE0. If the associated interrupt enable bit is set to 1 by software, the USBFS generates the interrupt.

The USBFS sets the LNST[1:0] flags to indicate the input state of the USB port. When a BCHG interrupt occurs, eliminate transient elements by repeat reading the LNST[1:0] flags by software until the same value is read at least three times.

Change in the USB bus state can be detected while the internal clock is stopped.

Values read from the BCHG flag in device controller mode are invalid.

**OVRCCR flag (Overcurrent Input Change Interrupt Status)**

The OVRCCR flag indicates the status of USB\_OVRCURA and USB\_OVRCURB input pin change interrupts.

The USBFS detects the OVRCCR interrupt and sets this flag to 1 when a change (high to low or low to high) occurs in at least one of the input values to the USB\_OVRCURA and USB\_OVRCURB pins. If the associated interrupt enable bit is set to 1 by software, the USBFS generates the interrupt.

**26.2.18 BRDYSTS : BRDY Interrupt Status Register**

Base address: USBFS = 0x4009\_0000

Offset address: 0x046

|                    |    |    |    |    |    |    |            |            |            |            |            |            |            |            |            |            |
|--------------------|----|----|----|----|----|----|------------|------------|------------|------------|------------|------------|------------|------------|------------|------------|
| Bit position:      | 15 | 14 | 13 | 12 | 11 | 10 | 9          | 8          | 7          | 6          | 5          | 4          | 3          | 2          | 1          | 0          |
| Bit field:         | —  | —  | —  | —  | —  | —  | PIPE9 BRDY | PIPE8 BRDY | PIPE7 BRDY | PIPE6 BRDY | PIPE5 BRDY | PIPE4 BRDY | PIPE3 BRDY | PIPE2 BRDY | PIPE1 BRDY | PIPE0 BRDY |
| Value after reset: | 0  | 0  | 0  | 0  | 0  | 0  | 0          | 0          | 0          | 0          | 0          | 0          | 0          | 0          | 0          | 0          |

| Bit | Symbol    | Function   | R/W              |
|-----|-----------|--|------------------|
| 0   | PIPE0BRDY | BRDY Interrupt Status for Pipe 0 *2<br>0: No BRDY interrupt occurred<br>1: BRDY interrupt occurred | R/W <sup>1</sup> |
| 1   | PIPE1BRDY | BRDY Interrupt Status for Pipe 1 *2<br>0: No BRDY interrupt occurred<br>1: BRDY interrupt occurred | R/W <sup>1</sup> |
| 2   | PIPE2BRDY | BRDY Interrupt Status for Pipe 2 *2<br>0: No BRDY interrupt occurred<br>1: BRDY interrupt occurred | R/W <sup>1</sup> |

**DTCH标志 (USB断线检测中断状态)**

DTCH标志指示主机控制器模式下USB断开检测中断的状态。

USBFS检测到DTCH中断并在检测到USB总线分离事件时将此标志设置为1。如果相关的中断使能位由软件设置为1，则USBFS产生中断。

USBFS根据USB2.0规范检测总线分离事件。

检测到DTCH中断后，USBFS对硬件进行如下控制，而不管相关的中断使能位设置如何：

- 将检测到DTCH中断的端口的DVSTCTR0.UACT位设置为0
- 将发生DTCH中断的端口置于空闲状态

软件必须终止正在执行通信的所有管道并调用等待状态以连接到USB端口（等待ATTCH中断生成）。

在设备控制器模式下从DTCH标志读取的值无效。

**BCHG标志 (USB总线更改中断状态)**

BCHG标志指示主机控制器模式下USB总线更改中断的状态。

当USB端口上发生全速或低速信号电平变化时，USBFS检测到BCHG中断并将该标志设置为1。这包括从J-state、K-state或SE0到J-state、K-state或SE0的任何更改。如果相关的中断使能位由软件设置为1，则USBFS产生中断。

USBFS设置LNST[1:0]标志以指示USB端口的输入状态。当发生BCHG中断时，通过软件重复读取LNST[1:0]标志来消除瞬态元素，直到至少读取相同的值3次。

当内部时钟停止时，可以检测到USB总线状态的变化。

在设备控制器模式下从BCHG标志读取的值无效。

**OVRCCR标志 (过流输入变化中断状态)**

OVRCCR标志指示USB\_OVRCURA和USB\_OVRCURB输入引脚变化中断的状态。

当USB\_OVRCURA和USB\_OVRCURB引脚的至少一个输入值发生变化（从高到低或从低到高）时，USBFS检测到OVRCCR中断并将该标志设置为1。如果相关的中断使能位由软件设置为1，则USBFS产生中断。

**26.2.18 BRDYSTS:BRDY中断状态寄存器**

Base address: USBFS = 0x4009\_0000

Offset address: 0x046

|               |    |    |    |    |    |    |            |            |            |            |            |            |            |            |            |            |
|---------------|----|----|----|----|----|----|------------|------------|------------|------------|------------|------------|------------|------------|------------|------------|
| Bit position: | 15 | 14 | 13 | 12 | 11 | 10 | 9          | 8          | 7          | 6          | 5          | 4          | 3          | 2          | 1          | 0          |
| Bit field:    | —  | —  | —  | —  | —  | —  | PIPE9 BRDY | PIPE8 BRDY | PIPE7 BRDY | PIPE6 BRDY | PIPE5 BRDY | PIPE4 BRDY | PIPE3 BRDY | PIPE2 BRDY | PIPE1 BRDY | PIPE0 BRDY |
| 重置后的值:        | 0  | 0  | 0  | 0  | 0  | 0  | 0          | 0          | 0          | 0          | 0          | 0          | 0          | 0          | 0          | 0          |

| Bit | Symbol    | Function                                  | R/W              |
|-----|-----------|---|------------------|
| 0   | PIPE0BRDY | 管道0*2的BRDY中断状态<br>0: 未发生BRDY中断1: 发生BRDY中断 | R/W <sup>1</sup> |
| 1   | PIPE1BRDY | 管道1*2的BRDY中断状态<br>0: 未发生BRDY中断1: 发生BRDY中断 | R/W <sup>1</sup> |
| 2   | PIPE2BRDY | 管道2*2的BRDY中断状态<br>0: 未发生BRDY中断1: 发生BRDY中断 | R/W <sup>1</sup> |



| Bit   | Symbol    | Function  | R/W               |
|-------|-----------|---|-------------------|
| 3     | PIPE3BRDY | BRDY Interrupt Status for Pipe 3 <sup>*2</sup><br>0: No BRDY interrupt occurred<br>1: BRDY interrupt occurred | R/W <sup>*1</sup> |
| 4     | PIPE4BRDY | BRDY Interrupt Status for Pipe 4 <sup>*2</sup><br>0: No BRDY interrupt occurred<br>1: BRDY interrupt occurred | R/W <sup>*1</sup> |
| 5     | PIPE5BRDY | BRDY Interrupt Status for Pipe 5 <sup>*2</sup><br>0: No BRDY interrupt occurred<br>1: BRDY interrupt occurred | R/W <sup>*1</sup> |
| 6     | PIPE6BRDY | BRDY Interrupt Status for Pipe 6 <sup>*2</sup><br>0: No BRDY interrupt occurred<br>1: BRDY interrupt occurred | R/W <sup>*1</sup> |
| 7     | PIPE7BRDY | BRDY Interrupt Status for Pipe 7 <sup>*2</sup><br>0: No BRDY interrupt occurred<br>1: BRDY interrupt occurred | R/W <sup>*1</sup> |
| 8     | PIPE8BRDY | BRDY Interrupt Status for Pipe 8 <sup>*2</sup><br>0: No BRDY interrupt occurred<br>1: BRDY interrupt occurred | R/W <sup>*1</sup> |
| 9     | PIPE9BRDY | BRDY Interrupt Status for Pipe 9 <sup>*2</sup><br>0: No BRDY interrupt occurred<br>1: BRDY interrupt occurred | R/W <sup>*1</sup> |
| 15:10 | —         | These bits are read as 0. The write value should be 0.  | R/W               |

Note 1. When the SOFCFG.BRDYM bit is set to 0, to clear the status indicated in the bits in BRDYSTS, write 0 only to the bits to be cleared. Write 1 to the other bits.

Note 2. When the SOFCFG.BRDYM bit is set to 0, clear BRDY interrupts before accessing the FIFO.

### 26.2.19 NRDYSTS : NRDY Interrupt Status Register

Base address: USBFS = 0x4009\_0000

Offset address: 0x048

|                    |    |    |    |    |    |    |               |               |               |               |               |               |               |               |               |               |
|--------------------|----|----|----|----|----|----|---------------|---------------|---------------|---------------|---------------|---------------|---------------|---------------|---------------|---------------|
| Bit position:      | 15 | 14 | 13 | 12 | 11 | 10 | 9             | 8             | 7             | 6             | 5             | 4             | 3             | 2             | 1             | 0             |
| Bit field:         | —  | —  | —  | —  | —  | —  | PIPE9<br>NRDY | PIPE8<br>NRDY | PIPE7<br>NRDY | PIPE6<br>NRDY | PIPE5<br>NRDY | PIPE4<br>NRDY | PIPE3<br>NRDY | PIPE2<br>NRDY | PIPE1<br>NRDY | PIPE0<br>NRDY |
| Value after reset: | 0  | 0  | 0  | 0  | 0  | 0  | 0             | 0             | 0             | 0             | 0             | 0             | 0             | 0             | 0             | 0             |

| Bit | Symbol    | Function  | R/W               |
|-----|-----------|---|-------------------|
| 0   | PIPE0NRDY | NRDY Interrupt Status for Pipe 0<br>0: No NRDY interrupt occurred<br>1: NRDY interrupt occurred | R/W <sup>*1</sup> |
| 1   | PIPE1NRDY | NRDY Interrupt Status for Pipe 1<br>0: No NRDY interrupt occurred<br>1: NRDY interrupt occurred | R/W <sup>*1</sup> |
| 2   | PIPE2NRDY | NRDY Interrupt Status for Pipe 2<br>0: No NRDY interrupt occurred<br>1: NRDY interrupt occurred | R/W <sup>*1</sup> |
| 3   | PIPE3NRDY | NRDY Interrupt Status for Pipe 3<br>0: No NRDY interrupt occurred<br>1: NRDY interrupt occurred | R/W <sup>*1</sup> |
| 4   | PIPE4NRDY | NRDY Interrupt Status for Pipe 4<br>0: No NRDY interrupt occurred<br>1: NRDY interrupt occurred | R/W <sup>*1</sup> |

| Bit   | Symbol    | Function                                  | R/W               |
|-------|-----------|---|-------------------|
| 3     | PIPE3BRDY | 管道3*2的BRDY中断状态<br>0: 未发生BRDY中断1: 发生BRDY中断 | R/W <sup>*1</sup> |
| 4     | PIPE4BRDY | 管道4*2的BRDY中断状态<br>0: 未发生BRDY中断1: 发生BRDY中断 | R/W <sup>*1</sup> |
| 5     | PIPE5BRDY | 管道5*2的BRDY中断状态<br>0: 未发生BRDY中断1: 发生BRDY中断 | R/W <sup>*1</sup> |
| 6     | PIPE6BRDY | 管道6*2的BRDY中断状态<br>0: 未发生BRDY中断1: 发生BRDY中断 | R/W <sup>*1</sup> |
| 7     | PIPE7BRDY | 管道7*2的BRDY中断状态<br>0: 未发生BRDY中断1: 发生BRDY中断 | R/W <sup>*1</sup> |
| 8     | PIPE8BRDY | 管道8*2的BRDY中断状态<br>0: 未发生BRDY中断1: 发生BRDY中断 | R/W <sup>*1</sup> |
| 9     | PIPE9BRDY | 管道9*2的BRDY中断状态<br>0: 未发生BRDY中断1: 发生BRDY中断 | R/W <sup>*1</sup> |
| 15:10 | —         | 这些位被读取为0。写入值应为0。                          | R/W               |

注1.当SOFCFG.BRDYM位设置为0时，要清除BRDYSTS中位指示的状态，只需将0写入要清除的位。将1写入其他位。

注2.当SOFCFG.BRDYM位设置为0时，在访问FIFO之前清除BRDY中断。

### 26.2.19 NRDYSTS:NRDY中断状态寄存器

Base address: USBFS = 0x4009\_0000

Offset address: 0x048

|               |    |    |    |    |    |    |               |               |               |               |               |               |               |               |               |               |
|---------------|----|----|----|----|----|----|---------------|---------------|---------------|---------------|---------------|---------------|---------------|---------------|---------------|---------------|
| Bit position: | 15 | 14 | 13 | 12 | 11 | 10 | 9             | 8             | 7             | 6             | 5             | 4             | 3             | 2             | 1             | 0             |
| Bit field:    | —  | —  | —  | —  | —  | —  | PIPE9<br>NRDY | PIPE8<br>NRDY | PIPE7<br>NRDY | PIPE6<br>NRDY | PIPE5<br>NRDY | PIPE4<br>NRDY | PIPE3<br>NRDY | PIPE2<br>NRDY | PIPE1<br>NRDY | PIPE0<br>NRDY |
| 重置后的值:        | 0  | 0  | 0  | 0  | 0  | 0  | 0             | 0             | 0             | 0             | 0             | 0             | 0             | 0             | 0             | 0             |

| Bit | Symbol    | Function                                | R/W               |
|-----|-----------|---|-------------------|
| 0   | PIPE0NRDY | 管道0的NRDY中断状态<br>0: 未发生NRDY中断1: 发生NRDY中断 | R/W <sup>*1</sup> |
| 1   | PIPE1NRDY | 管道1的NRDY中断状态<br>0: 未发生NRDY中断1: 发生NRDY中断 | R/W <sup>*1</sup> |
| 2   | PIPE2NRDY | 管道2的NRDY中断状态<br>0: 未发生NRDY中断1: 发生NRDY中断 | R/W <sup>*1</sup> |
| 3   | PIPE3NRDY | 管道3的NRDY中断状态<br>0: 未发生NRDY中断1: 发生NRDY中断 | R/W <sup>*1</sup> |
| 4   | PIPE4NRDY | 管道4的NRDY中断状态<br>0: 未发生NRDY中断1: 发生NRDY中断 | R/W <sup>*1</sup> |

| Bit   | Symbol    | Function  | R/W              |
|-------|-----------|---|------------------|
| 5     | PIPE5NRDY | NRDY Interrupt Status for Pipe 5<br>0: No NRDY interrupt occurred<br>1: NRDY interrupt occurred | R/W <sup>1</sup> |
| 6     | PIPE6NRDY | NRDY Interrupt Status for Pipe 6<br>0: No NRDY interrupt occurred<br>1: NRDY interrupt occurred | R/W <sup>1</sup> |
| 7     | PIPE7NRDY | NRDY Interrupt Status for Pipe 7<br>0: No NRDY interrupt occurred<br>1: NRDY interrupt occurred | R/W <sup>1</sup> |
| 8     | PIPE8NRDY | NRDY Interrupt Status for Pipe 8<br>0: No NRDY interrupt occurred<br>1: NRDY interrupt occurred | R/W <sup>1</sup> |
| 9     | PIPE9NRDY | NRDY Interrupt Status for Pipe 9<br>0: No NRDY interrupt occurred<br>1: NRDY interrupt occurred | R/W <sup>1</sup> |
| 15:10 | —         | These bits are read as 0. The write value should be 0.  | R/W              |

Note 1. To clear the status indicated in the bits in NRDYSTS, write 0 only to the bits to be cleared. Write 1 to the other bits.

### 26.2.20 BEMPSTS : BEMP Interrupt Status Register

Base address: USBFS = 0x4009\_0000

Offset address: 0x04A

| Bit position:      | 15 | 14 | 13 | 12 | 11 | 10 | 9          | 8          | 7          | 6          | 5          | 4          | 3          | 2          | 1          | 0          |
|--------------------|----|----|----|----|----|----|------------|------------|------------|------------|------------|------------|------------|------------|------------|------------|
| Bit field:         | —  | —  | —  | —  | —  | —  | PIPE9 BEMP | PIPE8 BEMP | PIPE7 BEMP | PIPE6 BEMP | PIPE5 BEMP | PIPE4 BEMP | PIPE3 BEMP | PIPE2 BEMP | PIPE1 BEMP | PIPE0 BEMP |
| Value after reset: | 0  | 0  | 0  | 0  | 0  | 0  | 0          | 0          | 0          | 0          | 0          | 0          | 0          | 0          | 0          | 0          |

| Bit | Symbol    | Function  | R/W              |
|-----|-----------|---|------------------|
| 0   | PIPE0BEMP | BEMP Interrupt Status for Pipe 0<br>0: No BEMP interrupt occurred<br>1: BEMP interrupt occurred | R/W <sup>1</sup> |
| 1   | PIPE1BEMP | BEMP Interrupt Status for Pipe 1<br>0: No BEMP interrupt occurred<br>1: BEMP interrupt occurred | R/W <sup>1</sup> |
| 2   | PIPE2BEMP | BEMP Interrupt Status for Pipe 2<br>0: No BEMP interrupt occurred<br>1: BEMP interrupt occurred | R/W <sup>1</sup> |
| 3   | PIPE3BEMP | BEMP Interrupt Status for Pipe 3<br>0: No BEMP interrupt occurred<br>1: BEMP interrupt occurred | R/W <sup>1</sup> |
| 4   | PIPE4BEMP | BEMP Interrupt Status for Pipe 4<br>0: No BEMP interrupt occurred<br>1: BEMP interrupt occurred | R/W <sup>1</sup> |
| 5   | PIPE5BEMP | BEMP Interrupt Status for Pipe 5<br>0: No BEMP interrupt occurred<br>1: BEMP interrupt occurred | R/W <sup>1</sup> |
| 6   | PIPE6BEMP | BEMP Interrupt Status for Pipe 6<br>0: No BEMP interrupt occurred<br>1: BEMP interrupt occurred | R/W <sup>1</sup> |
| 7   | PIPE7BEMP | BEMP Interrupt Status for Pipe 7<br>0: No BEMP interrupt occurred<br>1: BEMP interrupt occurred | R/W <sup>1</sup> |

| Bit   | Symbol    | Function                                | R/W              |
|-------|-----------|---|------------------|
| 5     | PIPE5NRDY | 管道5的NRDY中断状态<br>0: 未发生NRDY中断1: 发生NRDY中断 | R/W <sup>1</sup> |
| 6     | PIPE6NRDY | 管道6的NRDY中断状态<br>0: 未发生NRDY中断1: 发生NRDY中断 | R/W <sup>1</sup> |
| 7     | PIPE7NRDY | 管道7的NRDY中断状态<br>0: 未发生NRDY中断1: 发生NRDY中断 | R/W <sup>1</sup> |
| 8     | PIPE8NRDY | 管道8的NRDY中断状态<br>0: 未发生NRDY中断1: 发生NRDY中断 | R/W <sup>1</sup> |
| 9     | PIPE9NRDY | 管道9的NRDY中断状态<br>0: 未发生NRDY中断1: 发生NRDY中断 | R/W <sup>1</sup> |
| 15:10 | —         | 这些位被读取为0。写入值应为0。                        | R/W              |

注1.要清除NRDYSTS中位中指示的状态，请仅将0写入要清除的位。将1写入其他位。

### 26.2.20 BEMPSTS:BEMP中断状态寄存器

Base address: USBFS = 0x4009\_0000

Offset address: 0x04A

| Bit position: | 15 | 14 | 13 | 12 | 11 | 10 | 9          | 8          | 7          | 6          | 5          | 4          | 3          | 2          | 1          | 0          |
|---------------|----|----|----|----|----|----|------------|------------|------------|------------|------------|------------|------------|------------|------------|------------|
| Bit field:    | —  | —  | —  | —  | —  | —  | PIPE9 BEMP | PIPE8 BEMP | PIPE7 BEMP | PIPE6 BEMP | PIPE5 BEMP | PIPE4 BEMP | PIPE3 BEMP | PIPE2 BEMP | PIPE1 BEMP | PIPE0 BEMP |
| 重置后的值:        | 0  | 0  | 0  | 0  | 0  | 0  | 0          | 0          | 0          | 0          | 0          | 0          | 0          | 0          | 0          | 0          |

| Bit | Symbol    | Function                                | R/W              |
|-----|-----------|---|------------------|
| 0   | PIPE0BEMP | 管道0的BEMP中断状态<br>0: 未发生BEMP中断1: 发生BEMP中断 | R/W <sup>1</sup> |
| 1   | PIPE1BEMP | 管道1的BEMP中断状态<br>0: 未发生BEMP中断1: 发生BEMP中断 | R/W <sup>1</sup> |
| 2   | PIPE2BEMP | 管道2的BEMP中断状态<br>0: 未发生BEMP中断1: 发生BEMP中断 | R/W <sup>1</sup> |
| 3   | PIPE3BEMP | 管道3的BEMP中断状态<br>0: 未发生BEMP中断1: 发生BEMP中断 | R/W <sup>1</sup> |
| 4   | PIPE4BEMP | 管道4的BEMP中断状态<br>0: 未发生BEMP中断1: 发生BEMP中断 | R/W <sup>1</sup> |
| 5   | PIPE5BEMP | 管道5的BEMP中断状态<br>0: 未发生BEMP中断1: 发生BEMP中断 | R/W <sup>1</sup> |
| 6   | PIPE6BEMP | 管道6的BEMP中断状态<br>0: 未发生BEMP中断1: 发生BEMP中断 | R/W <sup>1</sup> |
| 7   | PIPE7BEMP | 管道7的BEMP中断状态<br>0: 未发生BEMP中断1: 发生BEMP中断 | R/W <sup>1</sup> |



| Bit   | Symbol    | Function  | R/W              |
|-------|-----------|---|------------------|
| 8     | PIPE8BEMP | BEMP Interrupt Status for Pipe 8<br>0: No BEMP interrupt occurred<br>1: BEMP interrupt occurred | R/W <sup>1</sup> |
| 9     | PIPE9BEMP | BEMP Interrupt Status for Pipe 9<br>0: No BEMP interrupt occurred<br>1: BEMP interrupt occurred | R/W <sup>1</sup> |
| 15:10 | —         | These bits are read as 0. The write value should be 0.  | R/W              |

Note 1. To clear the status indicated in the bits in BEMPSTS, write 0 only to the bits to be cleared. Write 1 to the other bits.

### 26.2.21 FRMNUM : Frame Number Register

Base address: USBFS = 0x4009\_0000

Offset address: 0x04C

| Bit position:      | 15   | 14   | 13 | 12 | 11 | 10         | 9 | 8 | 7 | 6 | 5 | 4 | 3 | 2 | 1 | 0 |
|--------------------|------|------|----|----|----|------------|---|---|---|---|---|---|---|---|---|---|
| Bit field:         | OVRN | CRCE | —  | —  | —  | FRNM[10:0] |   |   |   |   |   |   |   |   |   |   |
| Value after reset: | 0    | 0    | 0  | 0  | 0  | 0          | 0 | 0 | 0 | 0 | 0 | 0 | 0 | 0 | 0 | 0 |

| Bit   | Symbol     | Function   | R/W              |
|-------|------------|--|------------------|
| 10:0  | FRNM[10:0] | Frame Number<br>Latest frame number.   | R                |
| 13:11 | —          | These bits are read as 0. The write value should be 0.                         | R/W              |
| 14    | CRCE       | Receive Data Error<br>0: No error occurred<br>1: Error occurred                | R/W <sup>1</sup> |
| 15    | OVRN       | Overrun/Underrun Detection Status<br>0: No error occurred<br>1: Error occurred | R/W <sup>1</sup> |

Note 1. To clear the status, write 0 only to the bits to be cleared. Write 1 to the other bits.

#### FRNM[10:0] flags (Frame Number)

The USBFS sets the FRNM[10:0] flags to indicate the latest frame number, which is updated every 1 ms, when an SOF packet is issued or received.

#### CRCE flag (Receive Data Error)

The CRCE flag sets to 1 when a CRC error or bit stuffing error occurs during isochronous transfer. On detecting a CRC error in host controller mode, the USBFS generates an internal NRDY interrupt.

To clear the CRCE flag, write 0 to it while writing 1 to the other bits in the FRMNUM register.

#### OVRN flag (Overrun/Underrun Detection Status)

The OVRN flag sets to 1 when an overrun or underrun error occurs during isochronous transfer. To clear the flag, write 0 to it while writing 1 to the other bits in the FRMNUM register.

In host controller mode, the OVRN flag sets to 1 on any of the following conditions:

- For a transmitting isochronous pipe, the time to issue an OUT token comes before all of the transmit data is written to the FIFO buffer
- For a receiving isochronous pipe, the time to issue an IN token comes when no FIFO buffer planes are empty

In device controller mode, the OVRN flag sets to 1 on any of the following conditions:

- For a transmitting isochronous pipe, the IN token is received before all of the transmit data is written to the FIFO buffer
- For a receiving isochronous pipe, the OUT token is received when no FIFO buffer planes are empty

| Bit   | Symbol    | Function                                | R/W              |
|-------|-----------|---|------------------|
| 8     | PIPE8BEMP | 管道8的BEMP中断状态<br>0: 未发生BEMP中断1: 发生BEMP中断 | R/W <sup>1</sup> |
| 9     | PIPE9BEMP | 管道9的BEMP中断状态<br>0: 未发生BEMP中断1: 发生BEMP中断 | R/W <sup>1</sup> |
| 15:10 | —         | 这些位被读取为0。写入值应为0。                        | R/W              |

注1.要清除BEMPSTS中位指示的状态, 请仅将0写入要清除的位。将1写入其他位。

### 26.2.21 FRMNUM:帧号寄存器

Base address: USBFS = 0x4009\_0000

Offset address: 0x04C

| Bit position: | 15   | 14   | 13 | 12 | 11 | 10         | 9 | 8 | 7 | 6 | 5 | 4 | 3 | 2 | 1 | 0 |
|---------------|------|------|----|----|----|------------|---|---|---|---|---|---|---|---|---|---|
| Bit field:    | OVRN | CRCE | —  | —  | —  | FRNM[10:0] |   |   |   |   |   |   |   |   |   |   |
| 重置后的值:        | 0    | 0    | 0  | 0  | 0  | 0          | 0 | 0 | 0 | 0 | 0 | 0 | 0 | 0 | 0 | 0 |

| Bit   | Symbol     | Function                               | R/W              |
|-------|------------|--|------------------|
| 10:0  | FRNM[10:0] | 帧号<br>最新帧号。                            | R                |
| 13:11 | —          | 这些位被读取为0。写入值应为0。                       | R/W              |
| 14    | CRCE       | 接收数据错误<br>0: 未发生错误1: 发生错误              | R/W <sup>1</sup> |
| 15    | OVRN       | OverrunUnderrun检测状态<br>0: 未发生错误1: 发生错误 | R/W <sup>1</sup> |

注1.要清除状态, 只需将0写入要清除的位。将1写入其他位。

#### FRNM[10:0] flags (Frame Number)

USBFS设置FRNM[10:0]标志以指示最新的帧号, 该帧号每1ms更新一次, 当发出或接收SOF数据包时。

#### CRCE标志 (接收数据错误)

当同步传输期间发生CRC错误或位填充错误时, CRCE标志设置为1。在主机控制器模式下检测到CRC错误时, USBFS会生成内部NRDY中断。

要清除CRCE标志, 向其写入0, 同时向FRMNUM寄存器中的其他位写入1。

#### OVRN标志 (溢出/欠载检测状态)

当同步传输期间发生溢出或欠载错误时, OVRN标志设置为1。要清除该标志, 请向其写入0, 同时向FRMNUM寄存器中的其他位写入1。

在主机控制器模式下, OVRN标志在以下任何条件下设置为1:

- 对于传输同步管道, 发出OUT令牌的时间是在所有传输数据写入FIFO缓冲区之前
- 对于接收同步管道, 在没有FIFO缓冲平面为空时发出IN令牌

在设备控制器模式下, OVRN标志在以下任何条件下设置为1:

- 对于传输同步管道, 在所有传输数据写入FIFO缓冲区之前接收到IN令牌
- 对于接收同步管道, 当没有FIFO缓冲平面为空时接收OUT令牌

## 26.2.22 DVCHGR : Device State Change Register

Base address: USBFS = 0x4009\_0000

Offset address: 0x04E

|                    |       |    |    |    |    |    |   |   |   |   |   |   |   |   |   |   |
|--------------------|-------|----|----|----|----|----|---|---|---|---|---|---|---|---|---|---|
| Bit position:      | 15    | 14 | 13 | 12 | 11 | 10 | 9 | 8 | 7 | 6 | 5 | 4 | 3 | 2 | 1 | 0 |
| Bit field:         | DVCHG | —  | —  | —  | —  | —  | — | — | — | — | — | — | — | — | — | — |
| Value after reset: | 0     | 0  | 0  | 0  | 0  | 0  | 0 | 0 | 0 | 0 | 0 | 0 | 0 | 0 | 0 | 0 |

| Bit  | Symbol | Function   | R/W |
|------|--------|--|-----|
| 14:0 | —      | These bits are read as 0. The write value should be 0.   | R/W |
| 15   | DVCHG  | Device State Change<br>0: Disable writes to the USBADDR.STSRECOV[3:0] and USBADDR.USBADDR[6:0] bits<br>1: Enable writes to the USBADDR.STSRECOV[3:0] and USBADDR.USBADDR[6:0] bits | R/W |

For details, see [section 26.3.1.5. Release from deep software standby mode because of USB suspend/resume interrupts.](#)

## 26.2.23 USBADDR : USB Address Register

Base address: USBFS = 0x4009\_0000

Offset address: 0x050

|                    |    |    |    |    |               |    |   |   |              |   |   |   |   |   |   |   |
|--------------------|----|----|----|----|---------------|----|---|---|--------------|---|---|---|---|---|---|---|
| Bit position:      | 15 | 14 | 13 | 12 | 11            | 10 | 9 | 8 | 7            | 6 | 5 | 4 | 3 | 2 | 1 | 0 |
| Bit field:         | —  | —  | —  | —  | STSRECOV[3:0] |    |   | — | USBADDR[6:0] |   |   |   |   |   |   |   |
| Value after reset: | 0  | 0  | 0  | 0  | 0             | 0  | 0 | 0 | 0            | 0 | 0 | 0 | 0 | 0 | 0 | 0 |

| Bit   | Symbol        | Function  | R/W |
|-------|---------------|---|-----|
| 6:0   | USBADDR[6:0]  | USB Address<br>In device controller mode, these bits indicate the USB address assigned by the host when the USBFS processed the SET_ADDRESS request successfully.   | R/W |
| 7     | —             | This bit is read as 0. The write value should be 0.   | R/W |
| 11:8  | STSRECOV[3:0] | Status Recovery<br>0x4: Recovery in device controller mode: Setting prohibited<br>Recovery in host controller mode:<br>Return to the low-speed state (bits DVSTCTR0.RHST[2:0] = 001b)<br>0x8: Recovery in device controller mode: Setting prohibited<br>Recovery in host controller mode:<br>Return to the full-speed state (bits DVSTCTR0.RHST[2:0] = 010b)<br>0x9: Recovery in device controller mode:<br>Return to the full-speed state (bits DVSTCTR0.RHST[2:0] = 010b), bits INTSTS0.DVSQ[2:0] = 001b (default state)<br>Recovery in host controller mode: Setting prohibited<br>0xA: Recovery in device controller mode:<br>Return to the full-speed state (bits DVSTCTR0.RHST[2:0] = 010b), bits INTSTS0.DVSQ[2:0] = 010b (address state)<br>Recovery in host controller mode: Setting prohibited<br>0xB: Recovery in device controller mode:<br>Return to the full-speed state (bits DVSTCTR0.RHST[2:0] = 010b), bits INTSTS0.DVSQ[2:0] = 011b (configured state)<br>Recovery in host controller mode: Setting prohibited<br>Others: Setting prohibited | R/W |
| 15:12 | —             | These bits are read as 0. The write value should be 0.  | R/W |

**USBADDR[6:0] bits (USB Address)**

In device controller mode, the USBADDR[6:0] flags indicate the USB address received when the USBFS processed a SetAddress request successfully. The USBFS sets the USBADDR[6:0] bits to 0x00 on detecting a USB bus reset.

## 26.2.22 DVCHGR:设备状态改变寄存器

Base address: USBFS = 0x4009\_0000

Offset address: 0x04E

|               |       |    |    |    |    |    |   |   |   |   |   |   |   |   |   |   |
|---------------|-------|----|----|----|----|----|---|---|---|---|---|---|---|---|---|---|
| Bit position: | 15    | 14 | 13 | 12 | 11 | 10 | 9 | 8 | 7 | 6 | 5 | 4 | 3 | 2 | 1 | 0 |
| Bit field:    | DVCHG | —  | —  | —  | —  | —  | — | — | — | — | — | — | — | — | — | — |
| 重置后的值:        | 0     | 0  | 0  | 0  | 0  | 0  | 0 | 0 | 0 | 0 | 0 | 0 | 0 | 0 | 0 | 0 |

| Bit  | Symbol | Function   | R/W |
|------|--------|--|-----|
| 14:0 | —      | 这些位被读取为0。写入值应为0。   | R/W |
| 15   | DVCHG  | 设备状态更改<br>0: 禁止写入USBADDR.STSRECOV[3:0]和USBADDR.USBADDR[6:0]位<br>1: 允许写入USBADDR.STSRECOV[3:0]和USBADDR.USBADDR[6:0]位 | R/W |

有关详细信息，请参阅第26.3.1.5节。由于USB挂起恢复中断而从深度软件待机模式中释放。

## 26.2.23 USBADDR:USB地址寄存器

Base address: USBFS = 0x4009\_0000

Offset address: 0x050

|               |    |    |    |    |               |    |   |   |              |   |   |   |   |   |   |   |
|---------------|----|----|----|----|---------------|----|---|---|--------------|---|---|---|---|---|---|---|
| Bit position: | 15 | 14 | 13 | 12 | 11            | 10 | 9 | 8 | 7            | 6 | 5 | 4 | 3 | 2 | 1 | 0 |
| Bit field:    | —  | —  | —  | —  | STSRECOV[3:0] |    |   | — | USBADDR[6:0] |   |   |   |   |   |   |   |
| 重置后的值:        | 0  | 0  | 0  | 0  | 0             | 0  | 0 | 0 | 0            | 0 | 0 | 0 | 0 | 0 | 0 | 0 |

| Bit   | Symbol        | Function  | R/W |
|-------|---------------|---|-----|
| 6:0   | USBADDR[6:0]  | USB地址<br>在设备控制器模式下，这些位指示USBFS成功处理SET_ADDRESS请求时主机分配的USB地址。  | R/W |
| 7     | —             | 该位读取为0。写入值应为0。  | R/W |
| 11:8  | STSRECOV[3:0] | 状态恢复<br>0x4: 设备控制器模式下的恢复：在主机控制器模式下设置禁止恢复：<br>返回低速状态（位DVSTCTR0.RHST[2:0]=001b）<br>0x8: 设备控制器模式下的恢复：在主机控制器模式下设置禁止恢复：<br>返回全速状态（位DVSTCTR0.RHST[2:0]=010b）<br>0x9: 设备控制器模式下的恢复：<br>返回全速状态（位DVSTCTR0.RHST[2:0]=010b），位INTSTS0.DVSQ[2:0] = 001b (default state)<br>主机控制器模式下的恢复：禁止设置<br>0xA: 设备控制器模式下的恢复：<br>返回全速状态（位DVSTCTR0.RHST[2:0]=010b），位INTSTS0.DVSQ[2:0] = 010b (address state)<br>主机控制器模式下的恢复：禁止设置<br>0xB: 设备控制器模式下的恢复：<br>返回全速状态（位DVSTCTR0.RHST[2:0]=010b），位INTSTS0.DVSQ[2:0] = 011b (configured state)<br>主机控制器模式下的恢复：禁止设置<br>其他：禁止设置 | R/W |
| 15:12 | —             | 这些位被读取为0。写入值应为0。  | R/W |

**USBADDR[6:0] bits (USB Address)**

在设备控制器模式下，USBADDR[6:0]标志指示当USBFS处理一个SetAddress请求成功。USBFS在检测到USB总线复位时将USBADDR[6:0]位设置为0x00。

Writing to these bits is enabled while the DVCHGR.DVCHG bit is set to 1. On recovering from a USB power shut-off, the operation can resume from the USB address set before the software shut-off.

In host controller mode, the USBADDR[6:0] bits are invalid.

### STSRECOV[3:0] bits (Status Recovery)

Use the STSRECOV[3:0] bits to resume the state of the internal sequencer on recovering from USB power shut-off. For details, see [section 26.3.1.5. Release from deep software standby mode because of USB suspend/resume interrupts.](#)

Writing to these bits is enabled while the DVCHGR.DVCHG bit is set to 1.

## 26.2.24 USBREQ : USB Request Type Register

Base address: USBFS = 0x4009\_0000

Offset address: 0x054



| Bit  | Symbol             | Function  | R/W              |
|------|--------------------|---|------------------|
| 7:0  | BMREQUESTTYPE[7:0] | Request Type<br>USB request bmRequestType value | R/W <sup>1</sup> |
| 15:8 | BREQUEST[7:0]      | Request<br>USB request bRequest value           | R/W <sup>1</sup> |

Note 1. In device controller mode, these bits can be read, but writing to them has no effect. In host controller mode, these bits are both read/write bits.

USBREQ stores setup requests for control transfers.

In device controller mode, the USBREQ stores the received bRequest and bmRequestType values. In host controller mode, it sets to the bRequest and bmRequestType values to be transmitted.

USBREQ is initialized by a USB bus reset.

### BMREQUESTTYPE[7:0] bits (Request Type)

The BMREQUESTTYPE[7:0] bits hold the bmRequestType value of USB requests.

- In host controller mode:  
Set these bits to the value of the USB request data in transmission setup transactions. Do not change the value of the bits while the DCPCTR.SUREQ bit is 1.
- In device controller mode:  
These bits indicate the value of the USB request data in reception setup transactions. Writing to the bits has no effect.

### BREQUEST[7:0] bits (Request)

The BREQUEST[7:0] bits store bRequest value of the USB request.

- In host controller mode:  
Set these bits to the value of the USB request data in setup transmission transactions. Do not change the value of the bits while the DCPCTR.SUREQ bit is 1.
- In device controller mode:  
These bits indicate the value of the USB request data in reception setup transactions. Writing to the bits has no effect.

当DVCHGR.DVCHG位设置为1时，允许写入这些位。从USB电源关闭恢复后，操作可以从软件关闭前设置的USB地址恢复。

在主机控制器模式下，USBADDR[6:0]位无效。

### STSRECOV[3:0] bits (Status Recovery)

使用STSRECOV[3:0]位在从USB电源关闭恢复时恢复内部定序器的状态。有关详细信息，请参阅第26.3.1.5节。由于USB挂起恢复中断而从深度软件待机模式中释放。

当DVCHGR.DVCHG位设置为1时，可以写入这些位。

## 26.2.24 USBREQ:USB请求类型寄存器

Base address: USBFS = 0x4009\_0000

Offset address: 0x054



| Bit  | Symbol             | Function                    | R/W              |
|------|--------------------|-----------------------------|------------------|
| 7:0  | BMREQUESTTYPE[7:0] | 请求类型<br>USB请求bmRequestType值 | R/W <sup>1</sup> |
| 15:8 | BREQUEST[7:0]      | Request<br>USB请求bRequest值   | R/W <sup>1</sup> |

注1.在设备控制器模式下，可以读取这些位，但写入它们无效。在主机控制器模式下，这些位都是读写位。

USBREQ存储控制传输的设置请求。

在设备控制器模式下，USBREQ存储接收到的bRequest和bmRequestType值。在主机控制器模式下，它设置为要传输的bRequest和bmRequestType值。

USBREQ由USB总线复位初始化。

### BMREQUESTTYPE[7:0] bits (Request Type)

BMREQUESTTYPE[7:0]位保存USB请求的bmRequestType值。

- 在主机控制器模式下:  
在传输设置事务中将这些位设置为USB请求数据的值。当DCPCTR.SUREQ位为1时，不要更改位的值。
- 在设备控制器模式下:  
这些位指示接收设置事务中USB请求数据的值。写入位无效。

### BREQUEST[7:0] bits (Request)

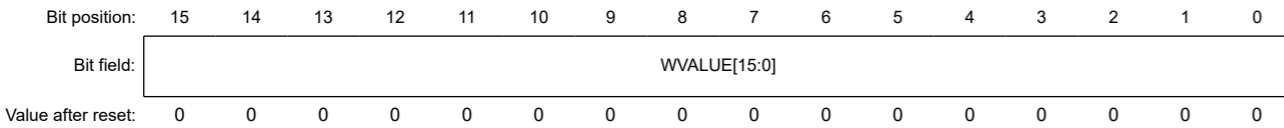
BREQUEST[7:0]位存储USB请求的bRequest值。

- 在主机控制器模式下:  
在设置传输事务中将这些位设置为USB请求数据的值。当DCPCTR.SUREQ位为1时，不要更改位的值。
- 在设备控制器模式下:  
这些位指示接收设置事务中USB请求数据的值。写入位无效。

## 26.2.25 USBVAL : USB Request Value Register

Base address: USBFS = 0x4009\_0000

Offset address: 0x056



| Bit  | Symbol       | Function                          | R/W              |
|------|--------------|-----------------------------------|------------------|
| 15:0 | WVALUE[15:0] | Value<br>USB request wValue value | R/W <sup>1</sup> |

Note 1. In device controller mode, these bits can be read, but writing to them has no effect. In host controller mode, these bits are both read/write bits.

In device controller mode, USBVAL stores the received wValue value. In host controller mode, it sets to the wValue value to be transmitted is set.

USBVAL is initialized by a USB bus reset.

**WVALUE[15:0] bits (Value)**

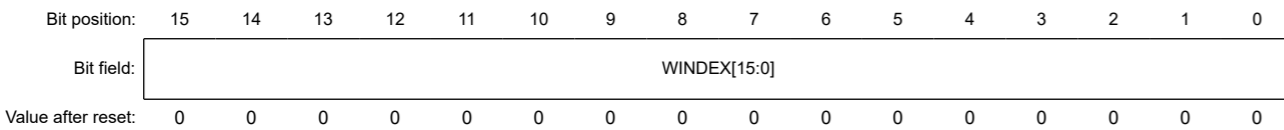
The WVALUE[15:0] bits store wValue value of the USB request.

- In host controller mode:  
Set these bits to the value of the wValue field in USB requests of transmission setup transactions. Do not change the value of the bits while the DCPCTR.SUREQ bit is 1.
- In device controller mode:  
These bits indicate the wValue value of USB requests in reception setup transactions. Writing to the bits has no effect.

## 26.2.26 USBINDX : USB Request Index Register

Base address: USBFS = 0x4009\_0000

Offset address: 0x058



| Bit  | Symbol       | Function                          | R/W              |
|------|--------------|-----------------------------------|------------------|
| 15:0 | WINDEX[15:0] | Index<br>USB request wIndex value | R/W <sup>1</sup> |

Note 1. In device controller mode, these bits can be read, but writing to them has no effect. In host controller mode, these bits are both read/write bits.

USBINDX stores setup requests for control transfers.

In device controller mode, it stores the received wIndex value. In host controller mode, it sets to the wIndex value to be transmitted.

USBINDX is initialized by a USB bus reset.

**WINDEX[15:0] bits (Index)**

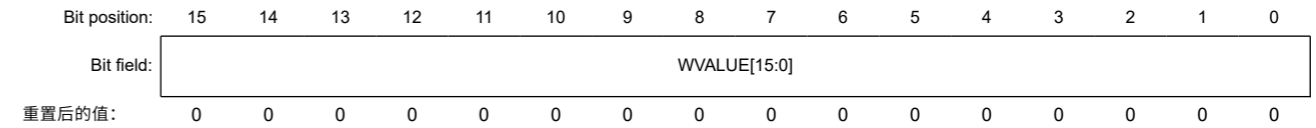
The WINDEX[15:0] bits hold the wIndex value of a USB request.

- In host controller mode:

## 26.2.25 USBVAL:USB请求值寄存器

Base address: USBFS = 0x4009\_0000

Offset address: 0x056



| Bit  | Symbol       | Function              | R/W              |
|------|--------------|-----------------------|------------------|
| 15:0 | WVALUE[15:0] | Value<br>USB请求wValue值 | R/W <sup>1</sup> |

注1.在设备控制器模式下，可以读取这些位，但写入它们无效。在主机控制器模式下，这些位都是读写位。

在设备控制器模式下，USBVAL存储接收到的wValue值。在主机控制器模式下，它设置为要传输的wValue值。

USBVAL由USB总线复位初始化。

**WVALUE[15:0] bits (Value)**

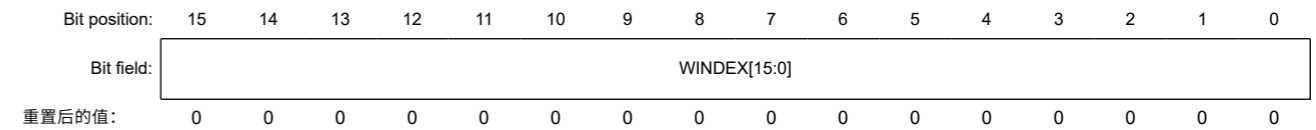
WVALUE[15:0]位存储USB请求的wValue值。

- 在主机控制器模式下:  
将这些位设置为USB传输设置事务请求中wValue字段的值。当DCPCTR.SUREQ位为1时，不要更改位的值。
- 在设备控制器模式下:  
这些位指示接收设置事务中USB请求的wValue值。写入位无效。

## 26.2.26 USBINDX:USB请求索引寄存器

Base address: USBFS = 0x4009\_0000

Offset address: 0x058



| Bit  | Symbol       | Function              | R/W              |
|------|--------------|-----------------------|------------------|
| 15:0 | WINDEX[15:0] | Index<br>USB请求wIndex值 | R/W <sup>1</sup> |

注1.在设备控制器模式下，可以读取这些位，但写入它们无效。在主机控制器模式下，这些位都是读写位。

USBINDX存储控制传输的设置请求。

在设备控制器模式下，它存储接收到的wIndex值。在主机控制器模式下，它设置为要传输的wIndex值。

USBINDX由USB总线复位初始化。

**WINDEX[15:0] bits (Index)**

WINDEX[15:0]位保存USB请求的wIndex值。

- 在主机控制器模式下:



Set these bits to the wIndex value in USB requests in transmission setup transactions. Do not change the value of the bits while the DCPCTR.SUREQ bit is 1.

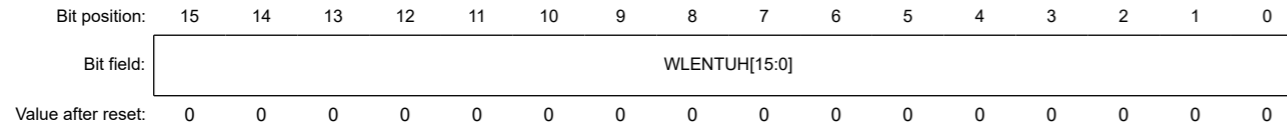
- In device controller mode:

These bits indicate the wIndex value in USB requests received in reception setup transactions. Writing to the bits has no effect.

### 26.2.27 USBLENG : USB Request Length Register

Base address: USBFS = 0x4009\_0000

Offset address: 0x05A



| Bit  | Symbol        | Function                            | R/W              |
|------|---------------|-------------------------------------|------------------|
| 15:0 | WLENTUH[15:0] | Length<br>USB request wLength value | R/W <sup>1</sup> |

Note 1. In device controller mode, these bits can be read, but writing to them has no effect. In host controller mode, these bits are both read/write bits.

USBLENG stores setup requests for control transfers.

In device controller mode, the value of wLength that is received is stored. In host controller mode, the value of wLength to be transmitted is set.

USBLENG is initialized by a USB bus reset.

#### WLENTUH[15:0] bits (Length)

The WLENTUH[15:0]bits hold the wLength value of a USB request.

- In host controller mode:

Set these bits to the wLength value in USB requests in transmission setup transactions. Do not change the value of the bits while the DCPCTR.SUREQ bit is 1.

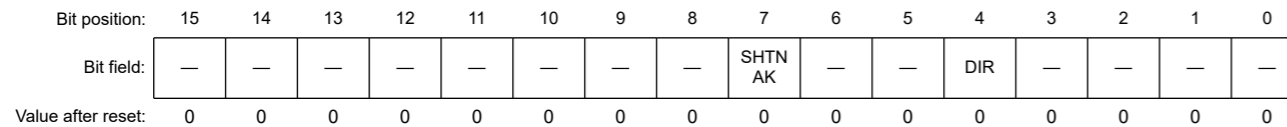
- In device controller mode:

These bits indicate the wLength value in USB requests received in reception setup transactions. Writing to the bits has no effect.

### 26.2.28 DCPCFG : DCP Configuration Register

Base address: USBFS = 0x4009\_0000

Offset address: 0x05C



| Bit | Symbol | Function  | R/W |
|-----|--------|---|-----|
| 3:0 | —      | These bits are read as 0. The write value should be 0.                                | R/W |
| 4   | DIR    | Transfer Direction*1<br>0: Data receiving direction<br>1: Data transmitting direction | R/W |

在传输设置事务中将这些位设置为USB请求中的wIndex值。当DCPCTR.SUREQ位为1时，不要更改位的值。

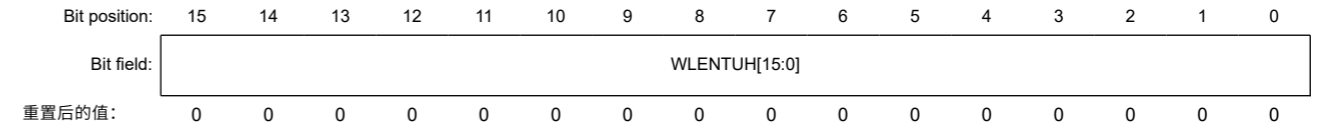
- 在设备控制器模式下:

这些位指示在接收设置事务中收到的USB请求中的wIndex值。写入位无效。

### 26.2.27 USBLENG:USB请求长度寄存器

Base address: USBFS = 0x4009\_0000

Offset address: 0x05A



| Bit  | Symbol        | Function                | R/W              |
|------|---------------|-------------------------|------------------|
| 15:0 | WLENTUH[15:0] | Length<br>USB请求wLength值 | R/W <sup>1</sup> |

注1.在设备控制器模式下，可以读取这些位，但写入它们无效。在主机控制器模式下，这些位都是读写位。

USBLENG存储控制传输的设置请求。

在设备控制器模式下，存储接收到的wLength的值。在主机控制器模式下，设置要传输的wLength的值。

USBLENG由USB总线复位初始化。

#### WLENTUH[15:0] bits (Length)

WLENTUH[15:0]位保存USB请求的wLength值。

- 在主机控制器模式下:

在传输设置事务中将这些位设置为USB请求中的wLength值。当DCPCTR.SUREQ位为1时，不要更改位的值。

- 在设备控制器模式下:

这些位指示在接收设置事务中收到的USB请求中的wLength值。写入位无效。

### 26.2.28 DCPCFG:DCP配置寄存器

Base address: USBFS = 0x4009\_0000

Offset address: 0x05C



| Bit | Symbol | Function                         | R/W |
|-----|--------|----------------------------------|-----|
| 3:0 | —      | 这些位被读取为0。写入值应为0。                 | R/W |
| 4   | DIR    | 传输方向*1<br>0: 数据接收方向<br>1: 数据发送方向 | R/W |



| Bit  | Symbol | Function   | R/W |
|------|--------|--|-----|
| 6:5  | —      | These bits are read as 0. The write value should be 0.   | R/W |
| 7    | SHTNAK | Pipe Disabled at End of Transfer*1<br>0: Keep pipe open after transfer ends<br>1: Disable pipe after transfer ends | R/W |
| 15:8 | —      | These bits are read as 0. The write value should be 0.   | R/W |

Note 1. Only set this bit while the PID is NAK. Before setting this bit, check that the DCPCTR.PBUSY bit is 0, and then change the DCPCTR.PID[1:0] bits for the DCP from BUF to NAK. If the PID[1:0] bits are changed to NAK by the USBFS, checking the PBUSY bit through the software is not necessary.

#### DIR bit (Transfer Direction)

In host controller mode, the DIR bit sets the transfer direction of the data stage and status stage for control transfers. In device controller mode, set the DIR bit to 0.

#### SHTNAK bit (Pipe Disabled at End of Transfer)

The SHTNAK bit specifies whether to change PID to NAK on transfer end when the selected pipe is receiving. It is only valid when the selected pipe is receiving.

When the SHTNAK bit is 1, the USBFS changes the DCPCTR.PID[1:0] bits for the DCP to NAK on determining that a transfer has ended. The USBFS determines transfer end on the following condition:

- A short packet, including a zero-length packet, is successfully received.

### 26.2.29 DCPMAXP : DCP Maximum Packet Size Register

Base address: USBFS = 0x4009\_0000

Offset address: 0x05E

| Bit position:      | 15          | 14 | 13 | 12 | 11 | 10 | 9 | 8 | 7 | 6         | 5 | 4 | 3 | 2 | 1 | 0 |
|--------------------|-------------|----|----|----|----|----|---|---|---|-----------|---|---|---|---|---|---|
| Bit field:         | DEVSEL[3:0] |    |    | —  | —  | —  | — | — | — | MXPS[6:0] |   |   |   |   |   |   |
| Value after reset: | 0           | 0  | 0  | 0  | 0  | 0  | 0 | 0 | 0 | 1         | 0 | 0 | 0 | 0 | 0 | 0 |

| Bit   | Symbol      | Function  | R/W |
|-------|-------------|---|-----|
| 6:0   | MXPS[6:0]   | Maximum Packet Size*1<br>Maximum data payload specification (maximum packet size) for the DCP   | R/W |
| 11:7  | —           | These bits are read as 0. The write value should be 0.  | R/W |
| 15:12 | DEVSEL[3:0] | Device Select*2<br>0x0: Address 0000b<br>0x1: Address 0001b<br>0x2: Address 0010b<br>0x3: Address 0011b<br>0x4: Address 0100b<br>0x5: Address 0101b<br>Others: Setting prohibited | R/W |

Note 1. Only set the MXPS[6:0] bits while PID is NAK. Before setting these bits, check that the DCPCTR.PBUSY bit is 0, and then change the DCPCTR.PID[1:0] bits for the DCP from BUF to NAK. If the PID[1:0] bits are changed to NAK by the USBFS, checking the PBUSY bit through the software is not necessary. After the MXPS[6:0] bits are set and the DCP is set to the CURPIPE[3:0] bits in a port select register, clear the buffer by setting the BCLR bit in the port control register to 1.

Note 2. Only set the DEVSEL[3:0] bits while PID is NAK and the DCPCTR.SUREQ bit is 0. Before setting these bits, check that the DCPCTR.PBUSY bit is 0, and then change the DCPCTR.PID[1:0] bits for the DCP from BUF to NAK. If the PID[1:0] bits are changed to NAK by the USBFS, checking the PBUSY bit through the software is not necessary.

#### MXPS[6:0] bits (Maximum Packet Size)

The MXPS[6:0] bits specify the maximum data payload (maximum packet size) for the DCP. The initial value is 0x40 (64 bytes). Set the bits to a USB 2.0-compliant value. Do not write to the FIFO buffer or set PID = BUF while MXPS[6:0] is set to 0.

| Bit  | Symbol | Function                                  | R/W |
|------|--------|---|-----|
| 6:5  | —      | 这些位被读取为0。写入值应为0。                          | R/W |
| 7    | SHTNAK | 传输结束时管道禁用*1<br>0: 传输结束后保持管道打开1: 传输结束后禁用管道 | R/W |
| 15:8 | —      | 这些位被读取为0。写入值应为0。                          | R/W |

注1.仅当PID为NAK时设置该位。在设置该位之前,请检查DCPCTR.PBUSY位是否为0,然后更改DCPCTR.PID[1:0]位用于DCP从BUF到NAK。如果PID[1:0]位被USBFS更改为NAK,则无需通过软件检查PBUSY位。

#### DIR位 (传输方向)

在主机控制器模式下, DIR位设置控制传输的数据阶段和状态阶段的传输方向。在设备控制器模式下, 将DIR位设置为0。

#### SHTNAK位 (传输结束时禁用管道)

SHTNAK位指定当所选管道正在接收时, 是否在传输结束时将PID更改为NAK。仅在所选管道正在接收时有效。

当SHTNAK位为1时, USBFS在确定传输已结束时将DCPCR.PID[1:0]位更改为DCP为NAK。USBFS在以下条件下确定传输结束:

- 成功接收到短报文, 包括零长度报文。

### 26.2.29 DCPMAXP:DCP最大数据包大小寄存器

Base address: USBFS = 0x4009\_0000

Offset address: 0x05E

| Bit position: | 15          | 14 | 13 | 12 | 11 | 10 | 9 | 8 | 7 | 6         | 5 | 4 | 3 | 2 | 1 | 0 |
|---------------|-------------|----|----|----|----|----|---|---|---|-----------|---|---|---|---|---|---|
| Bit field:    | DEVSEL[3:0] |    |    | —  | —  | —  | — | — | — | MXPS[6:0] |   |   |   |   |   |   |
| 重置后的值:        | 0           | 0  | 0  | 0  | 0  | 0  | 0 | 0 | 0 | 1         | 0 | 0 | 0 | 0 | 0 | 0 |

| Bit   | Symbol      | Function   | R/W |
|-------|-------------|--|-----|
| 6:0   | MXPS[6:0]   | 最大数据包大小*1<br>DCP的最大数据有效负载规范 (最大数据包大小)  | R/W |
| 11:7  | —           | 这些位被读取为0。写入值应为0。   | R/W |
| 15:12 | DEVSEL[3:0] | 设备选择*2<br>0x0: Address 0000b<br>0x1: Address 0001b<br>0x2: Address 0010b<br>0x3: Address 0011b<br>0x4: Address 0100b<br>0x5: Address 0101b<br>其他: 禁止设置 | R/W |

注1.仅在PID为NAK时设置MXPS[6:0]位。在设置这些位之前,请检查DCPCTR.PBUSY位是否为0,然后将DCP的DCPCTR.PID[1:0]位从BUF更改为NAK。如果PID[1:0]位被USBFS更改为NAK,则无需通过软件检查PBUSY位。在设置MXPS[6:0]位并将DCP设置为端口选择寄存器中的CURPIPE[3:0]位后,通过将端口控制寄存器中的BCLR位设置为1来清除缓冲区。

注2.仅在PID为NAK且DCPCTR.SUREQ位为0时设置DEVSEL[3:0]位。在设置这些位之前,请检查DCPCTR.PBUSY位为0,然后将DCPCR.PID[1:0]位从BUF更改为NAK。如果PID[1:0]位被USBFS更改为NAK,则无需通过软件检查PBUSY位。

#### MXPS[6:0]位 (最大数据包大小)

MXPS[6:0]位指定DCP的最大数据有效载荷 (最大数据包大小)。初始值为0x40 (64字节)。将这些位设置为符合USB2.0的值。当MXPS[6:0]设置为0时,不要写入FIFO缓冲区或设置PID=BUF。

**DEVSEL[3:0] bits (Device Select)**

In host controller mode, the DEVSEL[3:0] bits specify the address of the target peripheral device for a control transfer. Set up the device address in the associated DEVADDn (n = 0 to 5) register first, and then set these bits to the corresponding value. To set the DEVSEL[3:0] bits to 0010b, for example, first set the address in the DEVADD2 register.

In device controller mode, set these bits to 0000b.

**26.2.30 DCPCTR : DCP Control Register**

Base address: USBFS = 0x4009\_0000

Offset address: 0x060

|                    |      |       |    |    |          |    |   |       |       |       |       |   |   |      |          |   |
|--------------------|------|-------|----|----|----------|----|---|-------|-------|-------|-------|---|---|------|----------|---|
| Bit position:      | 15   | 14    | 13 | 12 | 11       | 10 | 9 | 8     | 7     | 6     | 5     | 4 | 3 | 2    | 1        | 0 |
| Bit field:         | BSTS | SUREQ | —  | —  | SUREQCLR | —  | — | SQCLR | SQSET | SQMON | PBUSY | — | — | CCPL | PID[1:0] |   |
| Value after reset: | 0    | 0     | 0  | 0  | 0        | 0  | 0 | 0     | 0     | 1     | 0     | 0 | 0 | 0    | 0        | 0 |

| Bit   | Symbol   | Function   | R/W   |
|-------|----------|--|-------|
| 1:0   | PID[1:0] | Response PID<br>0 0: NAK response<br>0 1: BUF response (depends on the buffer state)<br>1 0: STALL response<br>1 1: STALL response   | R/W   |
| 2     | CCPL     | Control Transfer End Enable<br>0: Disable control transfer completion<br>1: Enable control transfer completion   | R/W   |
| 4:3   | —        | These bits are read as 0. The write value should be 0.   | R/W   |
| 5     | PBUSY    | Pipe Busy<br>0: DCP not used for the USB bus<br>1: DCP in use for the USB bus  | R     |
| 6     | SQMON    | Sequence Toggle Bit Monitor<br>0: DATA0<br>1: ATA1   | R     |
| 7     | SQSET    | Sequence Toggle Bit Set*2<br>Sets the sequence toggle bit in DCP transfers.<br>This bit is read as 0.<br>0: Invalid (writing 0 has no effect)<br>1: Set the expected value for the next transaction to DATA1       | R/W*1 |
| 8     | SQCLR    | Sequence Toggle Bit Clear*2<br>Clears the sequence toggle bit in DCP transfers.<br>This bit is read as 0.<br>0: Invalid (writing 0 has no effect)<br>1: Clear the expected value for the next transaction to DATA0 | R/W*1 |
| 10:9  | —        | These bits are read as 0. The write value should be 0.   | R/W   |
| 11    | SUREQCLR | SUREQ Bit Clear<br>Clears the SUREQ bit in host controller mode.<br>This bit is read as 0.<br>0: Invalid (writing 0 has no effect)<br>1: Clear SUREQ to 0  | R/W   |
| 13:12 | —        | These bits are read as 0. The write value should be 0.   | R/W   |
| 14    | SUREQ    | Setup Token Transmission<br>Sets up token transmission in host controller mode.<br>0: Invalid (writing 0 has no effect)<br>1: Transmit setup packet  | R/W   |
| 15    | BSTS     | Buffer Status<br>0: Buffer access disabled<br>1: Buffer access enabled   | R     |

**DEVSEL[3:0] bits (Device Select)**

在主机控制器模式下，DEVSEL[3:0]位指定目标外围设备的地址以进行控制传输。首先在相关的DEVADDn (n=0到5)寄存器中设置设备地址，然后将这些位设置为相应的值。例如，要将DEVSEL[3:0]位设置为0010b，首先要设置DEVADD2寄存器中的地址。

在设备控制器模式下，将这些位设置为0000b。

**26.2.30 DCPCTR:DCP控制寄存器**

Base address: USBFS = 0x4009\_0000

Offset address: 0x060

|               |      |       |    |    |          |    |   |       |       |       |       |   |   |      |          |   |
|---------------|------|-------|----|----|----------|----|---|-------|-------|-------|-------|---|---|------|----------|---|
| Bit position: | 15   | 14    | 13 | 12 | 11       | 10 | 9 | 8     | 7     | 6     | 5     | 4 | 3 | 2    | 1        | 0 |
| Bit field:    | BSTS | SUREQ | —  | —  | SUREQCLR | —  | — | SQCLR | SQSET | SQMON | PBUSY | — | — | CCPL | PID[1:0] |   |
| 重置后的值:        | 0    | 0     | 0  | 0  | 0        | 0  | 0 | 0     | 0     | 1     | 0     | 0 | 0 | 0    | 0        | 0 |

| Bit   | Symbol   | Function   | R/W   |
|-------|----------|--|-------|
| 1:0   | PID[1:0] | 响应PID<br>00: NAK响应01: BUF响应 (取决于缓冲区状态)<br>10: STALL响应11: STALL响应             | R/W   |
| 2     | CCPL     | 控制传输结束使能<br>0: 禁止控制传输完成<br>1: 使能控制传输完成                                       | R/W   |
| 4:3   | —        | 这些位被读取为0。写入值应为0。   | R/W   |
| 5     | PBUSY    | 管道忙<br>0: USB总线不使用DCP1: USB总线使用DCP   | R     |
| 6     | SQMON    | 序列切换位监视器<br>0: DATA0<br>1: ATA1  | R     |
| 7     | SQSET    | 序列切换位设置*2<br>设置DCP传输中的序列切换位。<br>该位读为0。<br>0: 无效 (写0无效) 1: 将下一笔交易的期望值设置为DATA1 | R/W*1 |
| 8     | SQCLR    | 序列切换位清除*2<br>清除DCP传输中的序列切换位。<br>该位读为0。<br>0: 无效 (写0无效) 1: 清除下一笔交易的期望值到DATA0  | R/W*1 |
| 10:9  | —        | 这些位被读取为0。写入值应为0。   | R/W   |
| 11    | SUREQCLR | SUREQ位清零<br>在主机控制器模式下清除SUREQ位。<br>该位读为0。<br>0: 无效 (写0无效) 1: 清除SUREQ为0        | R/W   |
| 13:12 | —        | 这些位被读取为0。写入值应为0。   | R/W   |
| 14    | SUREQ    | 设置令牌传输<br>在主机控制器模式下设置令牌传输。<br>0: 无效 (写0无效) 1: 发送设置包                          | R/W   |
| 15    | BSTS     | 缓冲区状态<br>0: 禁止缓冲区访问<br>1: 允许缓冲区访问  | R     |

Note 1. This bit is read as 0.

Note 2. Only set the SQSET and SQCLR bits while PID is NAK. Before setting these bits, check that the PBUSY bit is 0, and then change the PID[1:0] bits for the DCP from BUF to NAK. If the PID[1:0] bits are changed to NAK by the USBFS, checking the PBUSY bit through the software is not necessary.

### PID[1:0] bits (Response PID)

The PID[1:0] bits control the USB response type during control transfers.

In host controller mode, to change the PID[1:0] setting from NAK to BUF:

- When the transmitting direction is set:
  - a. Write all of the transmit data to the FIFO buffer while the DVSTCTR0.UACT bit is 1 and PID is NAK.
  - b. Set PID[1:0] bits to 01b (BUF).  
The USBFS then executes the OUT transaction.
- When the receiving direction is set:
  - a. Check that the FIFO buffer is empty (or empty the buffer) while the DVSTCTR0.UACT bit is 1 and PID is NAK.
  - b. Set PID[1:0] bits to 01b (BUF).  
The USBFS then executes the IN transaction.

The USBFS changes the PID[1:0] setting as follows:

- When the PID[1:0] bits are set to BUF (01b) by software and the USBFS has received data exceeding MaxPacketSize, the USBFS sets the PID[1:0] to STALL (11b)
- When a reception error, such as a CRC error, is detected three times consecutively, the USBFS sets the PID[1:0] bits to NAK (00b)
- On receiving the STALL handshake, the USBFS sets PID[1:0] to STALL (11b)

In device controller mode, the USBFS changes the PID[1:0] setting as follows:

- On receiving a setup packet, the USBFS sets PID[1:0] to NAK (00b). The USBFS then sets the INTSTS0.VALID flag to 1, and the PID[1:0] setting cannot be changed until the software clears the VALID flag to 0.
- When the PID[1:0] bits are set to BUF (01b) by software and the USBFS has received data exceeding MaxPacketSize, the USBFS sets PID[1:0] to STALL (11b)
- On detecting a control transfer sequence error, the USBFS sets PID[1:0] to STALL (1xb)
- On detecting a USB bus reset, the USBFS sets PID[1:0] to NAK

The USBFS does not check the PID[1:0] setting while processing a SET\_ADDRESS request.

The PID[1:0] bits are initialized by a USB bus reset.

### CCPL bit (Control Transfer End Enable)

In device controller mode, setting the CCPL bit to 1 enables the status stage of the control transfer to be completed. When the bit is set to 1 by software while the associated PID[1:0] bits are set to BUF, the USBFS completes the control transfer status stage.

During control read transfers, the USBFS transmits the ACK handshake in response to the OUT transaction from the USB host. During control write or no-data control transfers, it transmits the zero-length packet in response to the IN transaction from the USB host. On detecting a SET\_ADDRESS request, the USBFS operates in auto response mode from the setup stage up to status stage completion regardless of the CCPL bit setting.

The USBFS changes the CCPL bit from 1 to 0 on receiving a new setup packet. The software cannot write 1 to the bit while the INTSTS0.VALID bit is 1. The bit is initialized by a USB bus reset.

In host controller mode, always write 0 to the CCPL bit.

### PBUSY bit (Pipe Busy)

The PBUSY bit indicates whether DCP is used for the transaction when USBFS changes the PID[1:0] bits from BUF to NAK. The USBFS changes the PBUSY bit from 0 to 1 on start of a USB transaction for the selected pipe. It changes the PBUSY bit from 1 to 0 on completion of one transaction.

注1.该位读为0。

注2.仅在PID为NAK时设置SQSET和SQCLR位。在设置这些位之前，请检查PBUSY位是否为0，然后将DCP的PID[1:0]位从BUF更改为NAK。如果PID[1:0]位被USBFS更改为NAK，则无需通过软件检查PBUSY位。

### PID[1:0] bits (Response PID)

PID[1:0]位在控制传输期间控制USB响应类型。

在主机控制器模式下，要将PID[1:0]设置从NAK更改为BUF：

- 设置传输方向时：
  - a. 当DVSTCTR0.UACT位为1且PID为NAK时，将所有发送数据写入FIFO缓冲区。  
将PID[1:0]位设置为01b(BUF)。  
然后USBFS执行OUT事务。
- 设置接收方向时：
  - a. 在DVSTCTR0.UACT位为1且PID为NAK时检查FIFO缓冲区是否为空（或清空缓冲区）。  
将PID[1:0]位设置为01b(BUF)。  
然后USBFS执行IN事务。

USBFS更改PID[1:0]设置如下：

- 当PID[1:0]位被软件设置为BUF(01b)并且USBFS接收到超过MaxPacketSize的数据时，USBFS将PID[1:0]设置为STALL(11b)
- 当连续3次检测到接收错误（例如CRC错误）时，USBFS将PID[1:0]位设置为NAK(00b)
- 在接收到STALL握手时，USBFS将PID[1:0]设置为STALL(11b)

在设备控制器模式下，USBFS将PID[1:0]设置更改如下：

- 在接收到设置数据包时，USBFS将PID[1:0]设置为NAK(00b)。然后USBFS将INTSTS0.VALID标志设置为1，并且在软件将VALID标志清除为0之前无法更改PID[1:0]设置。
- 当PID[1:0]位被软件设置为BUF(01b)并且USBFS接收到超过MaxPacketSize的数据时，USBFS将PID[1:0]设置为STALL(11b)
- 在检测到控制传输序列错误时，USBFS将PID[1:0]设置为STALL(1xb)
- 在检测到USB总线复位时，USBFS将PID[1:0]设置为NAK

USBFS在处理SET\_ADDRESS请求时不检查PID[1:0]设置。

PID[1:0]位由USB总线复位初始化。

### CCPL位 (控制传输结束使能)

在设备控制器模式下，将CCPL位设置为1可以完成控制传输的状态阶段。当该位由软件设置为1且相关的PID[1:0]位设置为BUF时，USBFS完成控制传输状态阶段。

在控制读取传输期间，USBFS发送ACK握手以响应来自USB主机的OUT事务。在控制写入或无数据控制传输期间，它传输零长度数据包以响应来自USB主机的IN事务。在检测到SET\_ADDRESS请求时，USBFS从设置阶段到状态阶段完成以自动响应模式运行，无论CCPL位设置如何。

USBFS在接收到新的设置数据包时将CCPL位从1更改为0。当INTSTS0.VALID位为1时，软件无法向该位写入1。该位由USB总线复位初始化。

在主机控制器模式下，始终将0写入CCPL位。

### PBUSY bit (Pipe Busy)

PBUSY位指示当USBFS将PID[1:0]位从BUF更改为NAK时是否使用DCP进行事务处理。USBFS在所选管道的USB事务开始时将PBUSY位从0更改为1。它改变了

PBUSY位在一个事务完成时从1变为0。



After PID is set to NAK by software, the value in the PBUSY bit indicates whether changes to pipe settings can proceed.

For details, see [section 26.3.4.1. Pipe control register switching procedures](#).

#### SQMON bit (Sequence Toggle Bit Monitor)

The SQMON bit indicates the expected value of the sequence toggle bit for the next transaction during a DCP transfer.

The USBFS toggles the bit on normal completion of the transaction. It does not toggle the bit, however, when a DATAPID mismatch occurs during a transfer in the receiving direction.

In device controller mode, the USBFS sets the SQMON bit to 1 (specifies DATA1 as the expected value) on successful reception of the setup packet.

In device controller mode, the USBFS does not reference this bit during IN or OUT transactions at the status stage, and it does not toggle the bit on normal completion.

#### SQSET bit (Sequence Toggle Bit Set)

The SQSET bit specifies DATA1 as the expected value of the sequence toggle bit for the next transaction during a DCP transfer.

Do not set the SQCLR and SQSET bits to 1 simultaneously.

#### SQCLR bit (Sequence Toggle Bit Clear)

The SQCLR bit specifies DATA0 as the expected value of the sequence toggle bit for the next transaction during a DCP transfer. It is read as 0.

Do not set the SQCLR and SQSET bits to 1 simultaneously.

#### SUREQCLR bit (SUREQ Bit Clear)

In host controller mode, setting the SUREQCLR bit to 1 clears the SUREQ bit to 0. The bit is read as 0.

If transfer stops while the SUREQ bit is set to 1 in a setup transaction, set the SUREQCLR bit to 1 by software. This is not necessary at the end of a normal setup transaction, because the USBFS automatically clears the SUREQ bit to 0.

Only control the SUREQ bit through the SUREQCLR bit while the DVSTCTR0.UACT bit is 0. When UACT is 0, communication is halted or no transfer is occurring because a bus disconnection was detected.

In device controller mode, always write 0 to this bit.

#### SUREQ bit (Setup Token Transmission)

In host controller mode, setting the SUREQ bit to 1 triggers the USBFS to transmit the setup packet. After completing the setup transaction process, the USBFS generates either the SACK or SIGN interrupt and clears the SUREQ bit to 0. The USBFS also clears the SUREQ bit to 0 when the software sets the SUREQCLR bit to 1.

Before setting the SUREQ bit to 1, set the DCPMAXP.DEVSEL[3:0] bits, USBREQ, USBVAL, USBINDX, and USBLENG appropriately to transmit the target USB request in the setup transaction. Also check that the PID[1:0] bits for the DCP are set to NAK. After setting the SUREQ bit to 1, do not change the DCPMAXP.DEVSEL[3:0] bits, USBREQ, USBVAL, USBINDX, or USBLENG until the setup transaction is complete (SUREQ bit = 1). Write 1 to the SUREQ bit only when transmitting the setup token. Otherwise, write 0.

In device controller mode, always write 0 to this bit.

#### BSTS flag (Buffer Status)

The BSTS flag indicates the status of access to the DCP FIFO buffer. The meaning of this flag varies as follows depending on the CFIFOSEL.ISEL setting:

- When ISEL = 0, the bit indicates whether receive data can be read from the buffer
- When ISEL = 1, the bit indicates whether transmit data can be written to the buffer

在软件将PID设置为NAK后，PBUSY位中的值指示是否可以继续对管道设置进行更改。

详见26.3.4.1节。管道控制寄存器切换程序。

#### SQMON位 (序列切换位监视器)

SQMON位指示DCP传输期间下一个事务的序列切换位的预期值。

USBFS在事务正常完成时切换该位。但是，当在接收方向的传输过程中发生DATAPID不匹配时，它不会切换该位。

在设备控制器模式下，USBFS在成功接收到设置数据包时将SQMON位设置为1（指定DATA1作为预期值）。

在设备控制器模式下，USBFS在状态阶段的IN或OUT事务期间不引用该位，并且它不会在正常完成时切换该位。

#### SQSET位 (序列切换位设置)

SQSET位将DATA1指定为DCP传输期间下一个事务的序列切换位的预期值。

不要同时将SQCLR和SQSET位设置为1。

#### SQCLR位 (序列翻转位清除)

SQCLR位将DATA0指定为DCP传输期间下一个事务的序列切换位的预期值。读为0。

不要同时将SQCLR和SQSET位设置为1。

#### SUREQCLR bit (SUREQ Bit Clear)

在主机控制器模式下，将SUREQCLR位设置为1会将SUREQ位清除为0。该位被读取为0。

如果在设置事务中将SUREQ位设置为1时传输停止，则通过软件将SUREQCLR位设置为1。这在正常设置事务结束时不是必需的，因为USBFS会自动将SUREQ位清除为0。

当DVSTCTR0.UACT位为0时，仅通过SUREQCLR位控制SUREQ位。当UACT为0时，由于检测到总线断开，通信停止或没有传输发生。

在设备控制器模式下，始终向该位写入0。

#### SUREQ位 (设置令牌传输)

在主机控制器模式下，将SUREQ位设置为1会触发USBFS发送设置数据包。完成设置事务处理后，USBFS产生SACK或SIGN中断并将SUREQ位清零。当软件将SUREQCLR位设置为1时，USBFS也将SUREQ位清零。

在将SUREQ位设置为1之前，将DCPMAXP.DEVSEL[3:0]位、USBREQ、USBVAL、USBINDX和USBLENG适当地在设置事务中传输目标USB请求。还要检查DCP的PID[1:0]位是否设置为NAK。将SUREQ位设置为1后，在设置事务完成（SUREQ位=1）之前，不要更改DCPMAXP.DEVSEL[3:0]位、USBREQ、USBVAL、USBINDX或USBLENG。仅在发送设置令牌时向SUREQ位写入1。否则，写0。

在设备控制器模式下，始终向该位写入0。

#### BSTS flag (Buffer Status)

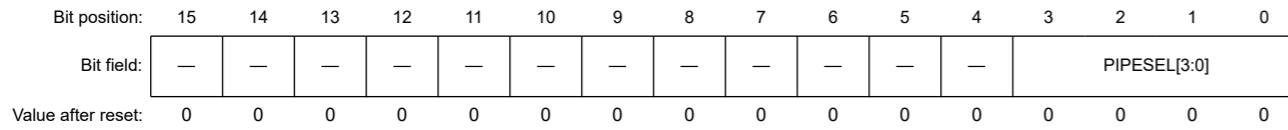
BSTS标志指示访问DCPFIFO缓冲区的状态。根据CFIFOSEL.ISEL设置，该标志的含义如下：

- ISEL=0时，该位指示是否可以从缓冲区读取接收数据
- ISEL=1时，该位指示发送数据是否可以写入缓冲区

## 26.2.31 PIPESEL : Pipe Window Select Register

Base address: USBFS = 0x4009\_0000

Offset address: 0x064



| Bit  | Symbol       | Function   | R/W |
|------|--------------|--|-----|
| 3:0  | PIPESEL[3:0] | Pipe Window Select<br>0x0: No pipe selected<br>0x1: Pipe 1<br>0x2: Pipe 2<br>0x3: Pipe 3<br>0x4: Pipe 4<br>0x5: Pipe 5<br>0x6: Pipe 6<br>0x7: Pipe 7<br>0x8: Pipe 8<br>0x9: Pipe 9<br>Others: Setting prohibited | R/W |
| 15:4 | —            | These bits are read as 0. The write value should be 0.   | R/W |

Set pipes 1 to 9 using the PIPESEL, PIPECFG, PIPEMAXP, PIPEPERI, PIPEnCTR, PIPEnTRE, and PIPEnTRN registers (n = 0 to 9).

After selecting the pipe in the PIPESEL register, pipe functions must be set in the associated PIPECFG, PIPEMAXP, and PIPEPERI registers. PIPEnCTR, PIPEnTRE, and PIPEnTRN can be set independently of the pipe selection in this register.

**PIPESEL[3:0] bits (Pipe Window Select)**

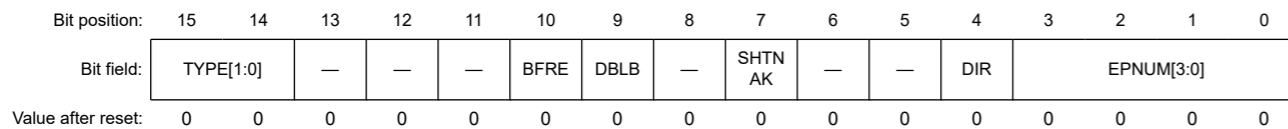
The PIPESEL[3:0] bits select the pipe number associated with the PIPECFG, PIPEMAXP, and PIPEPERI registers used for data writing and reading. Selecting a pipe number in the PIPESEL[3:0] bits allows writing to and reading from PIPECFG, PIPEMAXP, and PIPEPERI associated with the selected pipe number.

When PIPESEL[3:0] = 0000b, 0 is read from all of the bits in PIPECFG, PIPEMAXP, and PIPEPERI. Writing to these bits has no effect.

## 26.2.32 PIPECFG : Pipe Configuration Register

Base address: USBFS = 0x4009\_0000

Offset address: 0x068

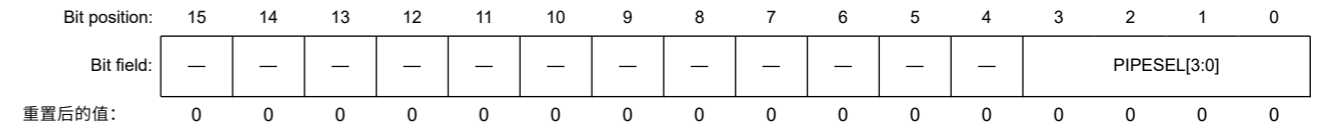


| Bit | Symbol     | Function   | R/W |
|-----|------------|--|-----|
| 3:0 | EPNUM[3:0] | Endpoint Number*1<br>Specifies the endpoint number for the selected pipe. Setting 0000b indicates that the pipe is not used. | R/W |
| 4   | DIR        | Transfer Direction*2 *3<br>0: Receiving direction<br>1: Transmitting direction   | R/W |
| 6:5 | —          | These bits are read as 0. The write value should be 0.   | R/W |

## 26.2.31 PIPESEL:管道窗口选择寄存器

Base address: USBFS = 0x4009\_0000

Offset address: 0x064



| Bit  | Symbol       | Function   | R/W |
|------|--------------|--|-----|
| 3:0  | PIPESEL[3:0] | 管道窗口选择<br>0x0: 未选择管道0x1<br>: 管道10x2: 管道20x<br>3: 管道30x4: 管道40<br>x5: 管道50x6: 管道6<br>0x7: 管道70x8: 管道<br>80x9: 管道9<br><br>其他: 禁止设置 | R/W |
| 15:4 | —            | 这些位被读取为0。写入值应为0。   | R/W |

使用PIPESEL、PIPECFG、PIPEMAXP、PIPEPERI、PIPEnCTR、PIPEnTRE和PIPEnTRN寄存器 (n=0到9) 设置管道1到9。

在PIPESEL寄存器中选择管道后, 必须在相关的PIPECFG、PIPEMAXP和PIPEPERI寄存器。PIPEnCTR、PIPEnTRE和PIPEnTRN可以独立于该寄存器中的管道选择进行设置。

**PIPESEL[3:0]位 (管道窗口选择)**

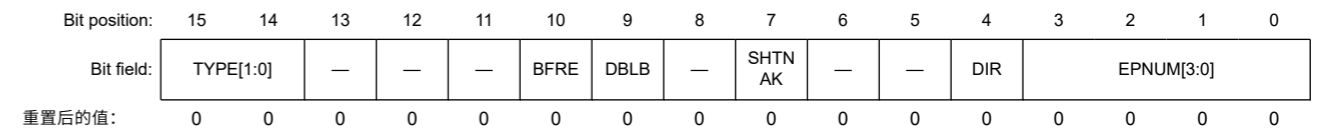
PIPESEL[3:0]位选择与用于数据写入和读取的PIPECFG、PIPEMAXP和PIPEPERI寄存器相关的管道编号。在PIPESEL[3:0]位中选择一个管道编号允许写入和读取与所选管道编号相关的PIPECFG、PIPEMAXP和PIPEPERI。

当PIPESEL[3:0]=0000b时, 从PIPECFG、PIPEMAXP和PIPEPERI中的所有位读取0。写入这些位无效。

## 26.2.32 PIPECFG:管道配置寄存器

Base address: USBFS = 0x4009\_0000

Offset address: 0x068



| Bit | Symbol     | Function                              | R/W |
|-----|------------|---------------------------------------|-----|
| 3:0 | EPNUM[3:0] | 端点编号*1<br>指定选定管道的端点编号。设置0000b表示不使用管道。 | R/W |
| 4   | DIR        | 传输方向*2*3<br>0: 接收方向1: 发送方向            | R/W |
| 6:5 | —          | 这些位被读取为0。写入值应为0。                      | R/W |



| Bit   | Symbol    | Function  | R/W |
|-------|-----------|---|-----|
| 7     | SHTNAK    | Pipe Disabled at End of Transfer*1<br>0: Continue pipe operation after transfer ends<br>1: Disable pipe after transfer ends   | R/W |
| 8     | —         | This bit is read as 0. The write value should be 0.   | R/W |
| 9     | DBLB      | Double Buffer Mode*2 *3<br>0: Single buffer<br>1: Double buffer   | R/W |
| 10    | BFRE      | BRDY Interrupt Operation Specification*2 *3<br>0: Generate BRDY interrupt on transmitting or receiving data<br>1: Generate BRDY interrupt on completion of reading data   | R/W |
| 13:11 | —         | These bits are read as 0. The write value should be 0.  | R/W |
| 15:14 | TYPE[1:0] | Transfer Type*1<br>0 0: Pipe not used<br>0 1: Pipes 1 and 2: Bulk transfer<br>Pipes 3 to 5: Bulk transfer<br>Pipes 6 to 9: Setting prohibited<br>1 0: Pipes 1 and 2: Setting prohibited<br>Pipes 3 to 5: Setting prohibited<br>Pipes 6 to 9: Interrupt transfer<br>1 1: Pipes 1 and 2: Isochronous transfer<br>Pipes 3 to 5: Setting prohibited<br>Pipes 6 to 9: Setting prohibited | R/W |

Note 1. Only set the TYPE[1:0], SHTNAK, and EPNUM[3:0] bits while PID is NAK. Before setting these bits, check that the PIPEnCTR.PBUSY bit is 0, and then change the PIPEnCTR.PID[1:0] bits from 01b (BUF) to 00b (NAK). If the PID[1:0] bits are changed to 00 (NAK) by the USBFS, checking the PBUSY bit through the software is not necessary.

Note 2. Only set the BFRE, DBLB, and DIR bits while PID is NAK and before the pipe is selected in the CURPIPE[3:0] bits in the port select register. Before setting these bits, check that the PIPEnCTR.PBUSY bit is 0, and then change the PIPEnCTR.PID[1:0] bits from 01b (BUF) to 00b (NAK). If the PID[1:0] bits are changed to 00 (NAK) by the USBFS, checking the PBUSY bit through the software is not necessary.

Note 3. To change the BFRE, DBLB, or DIR bits after completing USB communication on the selected pipe, in addition to the constraints described in Note 2, write 1 and 0 to the PIPEnCTR.ACLRM bit continuously through the software and clear the FIFO buffer assigned to the pipe.

PIPECFG specifies the transfer type, FIFO buffer access direction, and endpoint numbers for pipes 1 to 9. It also selects single or double buffer mode, and whether to continue or disable pipe operation at the end of transfer.

#### EPNUM[3:0] bits (Endpoint Number)

The EPNUM[3:0] bits specify the endpoint number for the selected pipe. Setting 0000b indicates the pipe not used.

Set these bits so that the combination of the DIR and EPNUM[3:0] settings is different from those for other pipes. The EPNUM[3:0] bits can be set to 0000b for all pipes.

#### DIR bit (Transfer Direction)

The DIR bit specifies the transfer direction for the selected pipe.

When the software sets this bit to 0, the USBFS uses the selected pipe for receiving. When the software sets this bit to 1, the USBFS uses the selected pipe for transmitting.

#### SHTNAK bit (Pipe Disabled at End of Transfer)

The SHTNAK bit specifies whether to change the PIPEnCTR.PID[1:0] bits to 00b (NAK) at the end of transfer when the selected pipe is set in the receiving direction. The bit is valid for pipes 1 to 5 in the receiving direction.

When the software sets this bit to 1 for a receiving pipe, the USBFS changes the associated PIPEnCTR.PID[1:0] bits to 00b (NAK) on determining the transfer end. The USBFS determines that the transfer has ended on the following conditions:

- A short packet data (including a zero-length packet) was successfully received
- The transaction counter is used and the number of packets specified for the transaction counter are successfully received

| Bit   | Symbol    | Function   | R/W |
|-------|-----------|--|-----|
| 7     | SHTNAK    | 传输结束时管道禁用*1<br>0: 传输结束后继续管道操作1: 传输结束后禁用管道  | R/W |
| 8     | —         | 该位读取为0。写入值应为0。   | R/W |
| 9     | DBLB      | 双缓冲模式*2*3<br>0: 单缓冲区1:<br>双缓冲区   | R/W |
| 10    | BFRE      | BRDY中断操作规范*2*3<br>0: 发送或接收数据时产生BRDY中断1: 读取数据完成时产生BRDY中断  | R/W |
| 13:11 | —         | 这些位被读取为0。写入值应为0。   | R/W |
| 15:14 | TYPE[1:0] | 传输类型*1<br>00: 未使用管道01: 管道1和2:<br>批量传输管道3到5: 批量传输<br><br>管道6至9: 禁止设置<br>10: 管道1和2: 设置禁止管道3至5:<br>设置禁止管道6至9: 中断传输<br><br>11: 管道1和2: 同步传输管道3至5: 禁止设置管道6至9: 禁止设置 | R/W |

注1.PID为NAK时，仅设置TYPE[1:0]、SHTNAK和EPNUM[3:0]位。在设置这些位之前，请检查PIPEnCTR.PBUSY位为0，然后将PIPEnCTR.PID[1:0]位从01b(BUF)更改为00b(NAK)。如果PID[1:0]位被USBFS更改为00(NAK)，则无需通过软件检查PBUSY位。

注2.仅在PID为NAK且在端口选择寄存器的CURPIPE[3:0]位中选择管道之前设置BFRE、DBLB和DIR位。在设置这些位之前，请检查PIPEnCTR.PBUSY位是否为0，然后将PIPEnCTR.PID[1:0]位从01b(BUF)更改为00b(NAK)。如果PID[1:0]位被USBFS更改为00(NAK)，则无需通过软件检查PBUSY位。

注3.要在选定管道上完成USB通信后更改BFRE、DBLB或DIR位，除了注2中描述的约束外，通过软件连续向PIPEnCTR.ACLRM位写入1和0并清除FIFO分配给管道的缓冲区。

PIPECFG指定管道1到9的传输类型、FIFO缓冲区访问方向和端点编号。它还选择单缓冲区或双缓冲区模式，以及在传输结束时是继续还是禁用管道操作。

#### EPNUM[3:0] bits (Endpoint Number)

EPNUM[3:0]位指定所选管道的端点号。设置0000b表示管道未使用。

设置这些位，以便DIR和EPNUM[3:0]设置的组合不同于其他管道的设置。这对于所有管道，EPNUM[3:0]位可以设置为0000b。

#### DIR位 (传输方向)

DIR位指定所选管道的传输方向。

当软件将此位设置为0时，USBFS使用所选管道进行接收。当软件将该位设置为1时，USBFS使用选定的管道进行传输。

#### SHTNAK位 (传输结束时禁用管道)

SHTNAK位指定当所选管道设置为接收方向时，是否在传输结束时将PIPEnCTR.PID[1:0]位更改为00b(NAK)。该位对接收方向的管道1到5有效。

当软件将该位设置为1用于接收管道时，USBFS在确定传输结束时将相关的PIPEnCTR.PID[1:0]位更改为00b(NAK)。USBFS在以下条件下确定传输已结束:

- 成功接收短包数据 (包括零长度包)
- 使用事务计数器，成功接收事务计数器指定的包数

**DBLB bit (Double Buffer Mode)**

The DBLB bit selects either single or double buffer mode for the FIFO buffer used by the selected pipe. The bit is valid for pipes 1 to 5.

**BFRE bit (BRDY Interrupt Operation Specification)**

The BFRE bit specifies the BRDY interrupt generation timing from the USBFS to the CPU for the selected pipe.

When the software sets the BFRE bit to 1 and the selected pipe is in the receiving direction, the USBFS detects the transfer completion and generates the BRDY interrupt on reading the packet.

When a BRDY interrupt is generated with this setting, the software must write 1 to the BCLR bit in the port control register. The FIFO buffer assigned to the selected pipe is not enabled for reception until 1 is written to the BCLR bit.

When the BFRE bit is set to 1 by software and the selected pipe is in the transmitting direction, the USBFS does not generate the BRDY interrupt. For details, see [section 26.3.3.1. BRDY interrupt](#).

**TYPE[1:0] bits (Transfer Type)**

The TYPE[1:0] bits specify the transfer type for the pipe selected in the PIPESEL.PIPESEL[3:0] bits. Before setting PID to BUF and starting USB communication on the selected pipe, set the TYPE[1:0] bits to a value other than 00b.

**26.2.33 PIPEMAXP : Pipe Maximum Packet Size Register**

Base address: USBFS = 0x4009\_0000

Offset address: 0x06C

|                    |             |    |    |    |    |    |           |   |   |   |   |   |   |   |   |   |
|--------------------|-------------|----|----|----|----|----|-----------|---|---|---|---|---|---|---|---|---|
| Bit position:      | 15          | 14 | 13 | 12 | 11 | 10 | 9         | 8 | 7 | 6 | 5 | 4 | 3 | 2 | 1 | 0 |
| Bit field:         | DEVSEL[3:0] |    |    | —  | —  | —  | MXPS[8:0] |   |   |   |   |   |   |   |   |   |
| Value after reset: | 0           | 0  | 0  | 0  | 0  | 0  | 0         | 0 | 0 | x | 0 | 0 | 0 | 0 | 0 | 0 |

| Bit   | Symbol      | Function   | R/W |
|-------|-------------|--|-----|
| 8:0   | MXPS[8:0]   | Maximum Packet Size*1<br><ul style="list-style-type: none"> <li>Pipes 1 and 2<br/>1 byte (0x001) to 256 bytes (0x100) (Bit [9] not supported.)</li> <li>Pipes 3 to 5<br/>8 bytes (0x008), 16 bytes (0x010), 32 bytes (0x020), 64 bytes (0x040) (Bits [9:7] and [2:0] not supported.)</li> <li>Pipes 6 to 9<br/>1 byte (0x001) to 64 bytes (0x040) (Bits [9:7] not supported.)</li> </ul> | R/W |
| 11:9  | —           | These bits are read as 0. The write value should be 0.   | R/W |
| 15:12 | DEVSEL[3:0] | Device Select*2<br>0x0: Address 0000b<br>0x1: Address 0001b<br>0x2: Address 0010b<br>0x3: Address 0011b<br>0x4: Address 0100b<br>0x5: Address 0101b<br>Others: Setting prohibited  | R/W |

Note: The value of the MXPS[8:0] bits is 0x000 when no pipe is selected in the PIPESEL.PIPESEL[3:0] bits and 0x040 when a pipe is selected.

Note 1. Only set the MXPS[8:0] bits while PID is NAK and before the pipe is selected in the CURPIPE[3:0] bits in the port select register. Before setting these bits, check that the PIPEnCTR.PBUSY bit is 0, and then change the PIPEnCTR.PID[1:0] bits from 01b (BUF) to 00b (NAK). If the PID[1:0] bits are changed to 00 (NAK) by the USBFS, checking the PBUSY bit through the software is not necessary.

Note 2. Only set the DEVSEL[3:0] bits while PID is NAK. Before setting these bits, check that the PIPEnCTR.PBUSY bit is 0, and then change the PIPEnCTR.PID[1:0] bits from 01b (BUF) to 00b (NAK). If the PID[1:0] bits are changed to 00b (NAK) by the USBFS, checking the PBUSY bit through the software is not necessary.

PIPEMAXP specifies the maximum packet size for pipes 1 to 9.

**DBLB位 (双缓冲模式)**

DBLB位为所选管道使用的FIFO缓冲区选择单缓冲区模式或双缓冲区模式。该位对管道1到5有效。

**BFRE位 (BRDY中断操作规范)**

BFRE位为所选管道指定从USBFS到CPU的BRDY中断生成时序。

当软件将BFRE位设置为1且所选管道处于接收方向时，USBFS检测到传输完成并在读取数据包时产生BRDY中断。

当使用该设置产生BRDY中断时，软件必须将1写入端口控制寄存器中的BCLR位。在将1写入BCLR位之前，分配给所选管道的FIFO缓冲区不会用于接收。

当BFRE位由软件设置为1且所选管道处于发送方向时，USBFS不会产生BRDY中断。详见26.3.3.1节。BRDY中断。

**TYPE[1:0] bits (Transfer Type)**

TYPE[1:0]位指定在PIPESEL.PIPESEL[3:0]位中选择的管道的传输类型。设置PID之前BUF并在所选管道上启动USB通信，将TYPE[1:0]位设置为00b以外的值。

**26.2.33 PIPEMAXP:管道最大数据包大小寄存器**

Base address: USBFS = 0x4009\_0000

Offset address: 0x06C

|               |             |    |    |    |    |    |           |   |   |   |   |   |   |   |   |   |
|---------------|-------------|----|----|----|----|----|-----------|---|---|---|---|---|---|---|---|---|
| Bit position: | 15          | 14 | 13 | 12 | 11 | 10 | 9         | 8 | 7 | 6 | 5 | 4 | 3 | 2 | 1 | 0 |
| Bit field:    | DEVSEL[3:0] |    |    | —  | —  | —  | MXPS[8:0] |   |   |   |   |   |   |   |   |   |
| 重置后的值:        | 0           | 0  | 0  | 0  | 0  | 0  | 0         | 0 | 0 | x | 0 | 0 | 0 | 0 | 0 | 0 |

| Bit   | Symbol      | Function  | R/W |
|-------|-------------|---|-----|
| 8:0   | MXPS[8:0]   | 最大数据包大小*1<br><ul style="list-style-type: none"> <li>管道1和2<br/>1字节(0x001)到256字节(0x100) (不支持位[9]。)</li> <li>管道3至5<br/>8字节(0x008)、16字节(0x010)、32字节(0x020)、64字节(0x040) (不支持位[9:7]和[2:0]。)</li> <li>管道6至9<br/>1字节(0x001)到64字节(0x040) (不支持位[9:7]。)</li> </ul> | R/W |
| 11:9  | —           | 这些位被读取为0。写入值应为0。  | R/W |
| 15:12 | DEVSEL[3:0] | 设备选择*2<br>0x0: Address 0000b<br>0x1: Address 0001b<br>0x2: Address 0010b<br>0x3: Address 0011b<br>0x4: Address 0100b<br>0x5: Address 0101b<br>其他: 禁止设置  | R/W |

Note: The value of the MXPS[8:0] bits is 0x000 when no pipe is selected in the PIPESEL.PIPESEL[3:0] bits and 0x040 when a pipe is selected.

注1.仅在PID为NAK且在端口选择寄存器的CURPIPE[3:0]位中选择管道之前设置MXPS[8:0]位。在设置这些位之前，请检查PIPEnCTR.PBUSY位是否为0，然后将PIPEnCTR.PID[1:0]位从01b(BUF)更改为00b(NAK)。如果PID[1:0]位被USBFS更改为00(NAK)，则无需通过软件检查PBUSY位。

注2.仅在PID为NAK时设置DEVSEL[3:0]位。在设置这些位之前，请检查PIPEnCTR.PBUSY位是否为0，然后将PIPEnCTR.PID[1:0]位从01b(BUF)更改为00b(NAK)。如果PID[1:0]位被USBFS更改为00b(NAK)，则无需通过软件检查PBUSY位。

PIPEMAXP指定管道1到9的最大数据包大小。

**MXPS[8:0] bits (Maximum Packet Size)**

The MXPS[8:0] bits specify the maximum data payload (maximum packet size) for the selected pipe.

Set these bits to the appropriate value for each transfer type based on the USB 2.0 specification. When MXPS[8:0] = 0, do not write to the FIFO buffer or set PID to BUF. These writes have no effect.

**DEVSEL[3:0] bits (Device Select)**

In host controller mode, the DEVSEL[3:0] bits specify the address of the target device for USB communication. Set up the device address in the associated DEVADDn (n = 0 to 5) register first, and then set these bits to the corresponding value. To set the DEVSEL[3:0] bits to 0x2, for example, first set the address in the DEVADD2 register.

In device controller mode, set these bits to 0x0.

**26.2.34 PIPEPERI : Pipe Cycle Control Register**

Base address: USBFS = 0x4009\_0000

Offset address: 0x06E

|                    |    |    |    |      |    |    |   |   |   |   |   |   |   |           |   |   |
|--------------------|----|----|----|------|----|----|---|---|---|---|---|---|---|-----------|---|---|
| Bit position:      | 15 | 14 | 13 | 12   | 11 | 10 | 9 | 8 | 7 | 6 | 5 | 4 | 3 | 2         | 1 | 0 |
| Bit field:         | —  | —  | —  | IFIS | —  | —  | — | — | — | — | — | — | — | IITV[2:0] |   |   |
| Value after reset: | 0  | 0  | 0  | 0    | 0  | 0  | 0 | 0 | 0 | 0 | 0 | 0 | 0 | 0         | 0 | 0 |

| Bit   | Symbol                 | Function  | R/W |
|-------|------------------------|---|-----|
| 2:0   | IITV[2:0] <sup>1</sup> | Interval Error Detection Interval<br>Specifies the interval error detection timing for the selected pipe as the n-th power of 2 of the frame timing | R/W |
| 11:3  | —                      | These bits are read as 0. The write value should be 0.  | R/W |
| 12    | IFIS                   | Isochronous IN Buffer Flush<br>0: Do not flush buffer<br>1: Flush buffer  | R/W |
| 15:13 | —                      | These bits are read as 0. The write value should be 0.  | R/W |

Note 1. Only set the IITV[2:0] bits while PID is NAK. Before setting these bits, check that the PBUSY bit is 0, and then change the PID[1:0] bits from 01b (BUF) to 00b (NAK). If the PID[1:0] bits are changed to 00 (NAK) by the USBFS, checking the PBUSY bit through the software is not necessary.

PIPEPERI selects whether the buffer is flushed or not when an interval error occurred during isochronous IN transfers, and sets the interval error detection interval for pipes 1 to 9.

**IITV[2:0] bits (Interval Error Detection Interval)**

To change the IITV[2:0] bits to another value after they are set and USB communication is performed, set the PIPEnCTR.PID[1:0] bits to 00b (NAK) and then set the PIPEnCTR.ACLRM bit to 1 to initialize the interval timer.

The IITV[2:0] bits are not provided for pipes 3 to 5. Write 000b to bit positions of the IITV[2:0] bits associated with pipes 3 to 5.

**IFIS bit (Isochronous IN Buffer Flush)**

The IFIS bit specifies whether to flush the buffer when the pipe selected in the PIPESEL.PIPESEL[3:0] bits is used for isochronous IN transfers.

In device controller mode when the selected pipe is for isochronous IN transfers, the USBFS automatically clears the FIFO buffer if the USBFS fails to receive the IN token from the USB host within the interval set in the IITV[2:0] bits in terms of frames.

When double buffering is specified (PIPECFG.DBLEB = 1), the USBFS only clears the data in the previously used plane.

The USBFS clears the FIFO buffer on receiving the SOF packet immediately after the frame in which the USBFS expected to receive the IN token. Even if the SOF packet is corrupted, the FIFO buffer is cleared at the time the SOF packet is expected to be received by using the internal interpolation function.

In host controller mode, set the IITV[2:0] bits to 000b.

**MXPS[8:0]位 (最大数据包大小)**

MXPS[8:0]位指定所选管道的最大数据有效负载 (最大数据包大小)。

根据USB2.0规范将这些位设置为每种传输类型的适当值。当MXPS[8:0]=0时, 不要写入FIFO缓冲区或将PID设置为BUF。这些写入没有效果。

**DEVSEL[3:0] bits (Device Select)**

在主机控制器模式下, DEVSEL[3:0]位指定USB通信的目标设备的地址。首先在相关的DEVADDn (n=0到5) 寄存器中设置设备地址, 然后将这些位设置为相应的值。例如, 要将DEVSEL[3:0]位设置为0x2, 首先设置DEVADD2寄存器中的地址。

在设备控制器模式下, 将这些位设置为0x0。

**26.2.34 PIPEPERI:管道循环控制寄存器**

Base address: USBFS = 0x4009\_0000

Offset address: 0x06E

|               |    |    |    |      |    |    |   |   |   |   |   |   |   |           |   |   |
|---------------|----|----|----|------|----|----|---|---|---|---|---|---|---|-----------|---|---|
| Bit position: | 15 | 14 | 13 | 12   | 11 | 10 | 9 | 8 | 7 | 6 | 5 | 4 | 3 | 2         | 1 | 0 |
| Bit field:    | —  | —  | —  | IFIS | —  | —  | — | — | — | — | — | — | — | IITV[2:0] |   |   |
| 重置后的值:        | 0  | 0  | 0  | 0    | 0  | 0  | 0 | 0 | 0 | 0 | 0 | 0 | 0 | 0         | 0 | 0 |

| Bit   | Symbol                 | Function                               | R/W |
|-------|------------------------|--|-----|
| 2:0   | IITV[2:0] <sup>1</sup> | 间隔错误检测间隔<br>将所选管道的间隔错误检测时间指定为帧时间的2的n次方 | R/W |
| 11:3  | —                      | 这些位被读取为0。写入值应为0。                       | R/W |
| 12    | IFIS                   | 同步IN缓冲区刷新<br>0: 不刷新缓冲区1:<br>刷新缓冲区      | R/W |
| 15:13 | —                      | 这些位被读取为0。写入值应为0。                       | R/W |

注1.仅在PID为NAK时设置IITV[2:0]位。在设置这些位之前, 请检查PBUSY位是否为0, 然后将PID[1:0]位从01b(BUF)更改为00b(NAK)。如果PID[1:0]位被USBFS更改为00(NAK), 则无需通过软件检查PBUSY位。

PIPEPERI选择在同步IN传输期间发生间隔错误时是否刷新缓冲区, 并设置管道1到9的间隔错误检测间隔。

**IITV[2:0]位 (间隔错误检测间隔)**

要在设置IITV[2:0]位并在执行USB通信后将其更改为另一个值, 请设置PIPEnCTR.PID[1:0]位为00b(NAK), 然后将PIPEnCTR.ACLRM位设置为1以初始化间隔定时器。

不为管道3到5提供IITV[2:0]位。将000b写入与管道3到5相关联的IITV[2:0]位的位位置。

**IFIS位 (同步IN缓冲区刷新)**

IFIS位指定当在PIPESEL.PIPESEL[3:0]位中选择的管道用于同步IN传输时是否刷新缓冲区。

在设备控制器模式下, 当所选管道用于同步IN传输时, 如果USBFS未能在IITV[2:0]位 (以帧为单位) 设置的间隔内从USB主机接收IN令牌, 则USBFS自动清除FIFO缓冲区。

当指定双缓冲时 (PIPECFG.DBLEB=1), USBFS只清除先前使用的平面中的数据。

在USBFS预期接收IN令牌的帧之后, USBFS在接收到SOF数据包后立即清除FIFO缓冲区。即使SOF数据包损坏, FIFO缓冲区也会在预期接收SOF数据包时使用内部插值功能清除。

在主机控制器模式下, 将IITV[2:0]位设置为000b。



Set the IITV[2:0] bits to 000b when the selected pipe is not used for isochronous transfers.

### 26.2.35 PIPEnCTR : PIPEn Control Registers (n = 1 to 5)

Base address: USBFS = 0x4009\_0000

Offset address: 0x070 + 0x2 × (n - 1)

|                    |      |        |    |    |    |        |       |       |       |       |       |   |   |   |          |   |
|--------------------|------|--------|----|----|----|--------|-------|-------|-------|-------|-------|---|---|---|----------|---|
| Bit position:      | 15   | 14     | 13 | 12 | 11 | 10     | 9     | 8     | 7     | 6     | 5     | 4 | 3 | 2 | 1        | 0 |
| Bit field:         | BSTS | INBUFM | —  | —  | —  | ATREPM | ACLRM | SQCLR | SQSET | SQMON | PBUSY | — | — | — | PID[1:0] |   |
| Value after reset: | 0    | 0      | 0  | 0  | 0  | 0      | 0     | 0     | 0     | 0     | 0     | 0 | 0 | 0 | 0        | 0 |

| Bit   | Symbol   | Function   | R/W   |
|-------|----------|--|-------|
| 1:0   | PID[1:0] | Response PID<br>0 0: NAK response<br>0 1: BUF response (depends buffer state)<br>1 0: STALL response<br>1 1: STALL response  | R/W   |
| 4:2   | —        | These bits are read as 0. The write value should be 0.   | R/W   |
| 5     | PBUSY    | Pipe Busy<br>0: Pipe n not in use for the transaction<br>1: Pipe n in use for the transaction  | R     |
| 6     | SQMON    | Sequence Toggle Bit Confirmation<br>0: DATA0<br>1: DATA1   | R     |
| 7     | SQSET    | Sequence Toggle Bit Set*2<br>Sets the sequence toggle bit for pipe n.<br>This bit is read as 0.<br>0: Invalid (writing 0 has no effect)<br>1: Set the expected value for the next transaction to DATA1       | R/W*1 |
| 8     | SQCLR    | Sequence Toggle Bit Clear*2<br>Clears the sequence toggle bit for pipe n.<br>This bit is read as 0.<br>0: Invalid (writing 0 has no effect)<br>1: Clear the expected value for the next transaction to DATA0 | R/W*1 |
| 9     | ACLRM    | Auto Buffer Clear Mode*3<br>0: Disable<br>1: Enable (initialize all buffers)   | R/W   |
| 10    | ATREPM   | Auto Response Mode*2<br>0: Disable auto response mode<br>1: Enable auto response mode  | R/W   |
| 13:11 | —        | These bits are read as 0. The write value should be 0.   | R/W   |
| 14    | INBUFM   | Transmit Buffer Monitor<br>0: No data to be transmitted is in the FIFO buffer<br>1: Data to be transmitted is in the FIFO buffer   | R     |
| 15    | BSTS     | Buffer Status<br>0: Buffer access by the CPU disabled<br>1: Buffer access by the CPU enabled   | R     |

Note 1. Only 0 can be read.

Note 2. Only set the ATREPM bit or write 1 to the SQCLR or SQSET bit while PID is NAK. Before setting these bits, check that the PBUSY bit is 0, and then change the PID[1:0] bits from 01b (BUF) to 00b (NAK). If the PID[1:0] bits are changed to 00 (NAK) by the USBFS, checking the PBUSY bit through the software is not necessary.

Note 3. Only set the ACLRM bit while PID is NAK and before the pipe is selected in the CURPIPE[3:0] bits in the port select register. Before setting this bit, check that the PBUSY bit is 0, and then change the PID[1:0] bits from 01b (BUF) to 00b (NAK). If the PID[1:0] bits are changed to 00 (NAK) by the USBFS, checking the PBUSY bit through the software is not necessary.

PIPEnCTR can be set for any pipe selection in the PIPESEL register.

当所选管道不用于同步传输时，将IITV[2:0]位设置为000b。

### 26.2.35 PIPEnCTR:PIPEn控制寄存器(n=1到5)

Base address: USBFS = 0x4009\_0000

Offset address: 0x070 + 0x2 × (n - 1)

|               |      |        |    |    |    |        |       |       |       |       |       |   |   |   |          |   |
|---------------|------|--------|----|----|----|--------|-------|-------|-------|-------|-------|---|---|---|----------|---|
| Bit position: | 15   | 14     | 13 | 12 | 11 | 10     | 9     | 8     | 7     | 6     | 5     | 4 | 3 | 2 | 1        | 0 |
| Bit field:    | BSTS | INBUFM | —  | —  | —  | ATREPM | ACLRM | SQCLR | SQSET | SQMON | PBUSY | — | — | — | PID[1:0] |   |
| 重置后的值:        | 0    | 0      | 0  | 0  | 0  | 0      | 0     | 0     | 0     | 0     | 0     | 0 | 0 | 0 | 0        | 0 |

| Bit   | Symbol   | Function  | R/W   |
|-------|----------|---|-------|
| 1:0   | PID[1:0] | 响应PID<br>00: NAK响应01: BUF响应 (取决于缓冲区状态) 10: STALL响应11: STALL响应             | R/W   |
| 4:2   | —        | 这些位被读取为0。写入值应为0。  | R/W   |
| 5     | PBUSY    | 管道忙<br>0: 管道n未用于事务1: 管道n正在用于事务  | R     |
| 6     | SQMON    | 序列切换位确认<br>0: DATA0<br>1: DATA1   | R     |
| 7     | SQSET    | 序列切换位设置*2<br>设置管道n的序列切换位。<br>该位读为0。<br>0: 无效 (写0无效) 1: 将下一笔交易的期望值设置为DATA1 | R/W*1 |
| 8     | SQCLR    | 序列切换位清除*2<br>清除管道n的序列切换位。<br>该位读为0。<br>0: 无效 (写0无效) 1: 清除下一笔交易的期望值到DATA0  | R/W*1 |
| 9     | ACLRM    | 自动缓冲区清除模式*3<br>0: 禁用1: 启用 (初始化所有缓冲区)                                      | R/W   |
| 10    | ATREPM   | 自动响应模式*2<br>0: 禁用自动响应模式1: 启用自动响应模式  | R/W   |
| 13:11 | —        | 这些位被读取为0。写入值应为0。  | R/W   |
| 14    | INBUFM   | 发送缓冲区监视器<br>0: FIFO缓冲区中没有要发送的数据1: FIFO缓冲区中没有要发送的数据                        | R     |
| 15    | BSTS     | 缓冲区状态<br>0: 禁止CPU访问缓冲区1: 允许CPU访问缓冲区                                       | R     |

注1.只能读取0。

注2.PID为NAK时，仅设置ATREPM位或向SQCLR或SQSET位写入1。在设置这些位之前，请检查PBUSY位是否为0，然后将PID[1:0]位从01b(BUF)更改为00b(NAK)。如果PID[1:0]位被USBFS更改为00(NAK)，则无需通过软件检查PBUSY位。

注3.仅在PID为NAK且在端口选择寄存器的CURPIPE[3:0]位中选择管道之前设置ACLRM位。在设置该位之前，请检查PBUSY位是否为0，然后将PID[1:0]位从01b(BUF)更改为00b(NAK)。如果PID[1:0]位被USBFS更改为00(NAK)，则无需通过软件检查PBUSY位。

PIPEnCTR可以为PIPESEL寄存器中的任何管道选择设置。



**PID[1:0] bits (Response PID)**

The PID[1:0]bits specify the response type for the next transaction on the selected pipe.

The default PID[1:0] setting is NAK. Change the PID[1:0] setting to BUF to use the associated pipe for USB transfer. Table 26.9 and Table 26.10 show the basic operations of the USBFS (when there are no errors in the communication packets) based on the PID[1:0] bit setting.

After changing the PID[1:0] setting from BUF to NAK through the software during USB communication on the selected pipe, check that the PBUSY bit is 1 to see if USB transfer on the pipe has actually entered the NAK state. If the USBFS changes the PID[1:0] bits to NAK, checking the PBUSY bit through the software is not necessary.

The USBFS changes the PIPEnCTR.PID[1:0] setting in the following cases:

- The USBFS sets PID to NAK on recognizing completion of the transfer when the selected pipe is in the receiving direction and the PIPECFG.SHTNAK bit for the selected pipe is set to 1 by software
- The USBFS sets PID to STALL (11b) on receiving a data packet with a payload exceeding the maximum packet size of the selected pipe
- The USBFS sets PID to NAK on detecting a USB bus reset in device controller mode
- The USBFS sets PID to NAK on detecting a reception error, such as a CRC error, three consecutive times in host controller mode
- The USBFS sets PID to STALL (11b) on receiving the STALL handshake in host controller mode

To specify the response type, set the PID[1:0] bits as follows:

- To transition from NAK (00b) to STALL, set 10b
- To transition from BUF (01b) to STALL, set 11b
- To transition from STALL (11b) to NAK, set 10b and then 00b
- To transition from STALL to BUF, set 00b (NAK) and then 01b (BUF)

**Table 26.9 Operation of the USBFS based on the PID[1:0] setting in host controller mode**

| PID[1:0] value             | Transfer type                  | Transfer direction (DIR bit)   | USBFS operation  |
|----------------------------|--------------------------------|--------------------------------|--|
| 00b (NAK)                  | Does not depend on the setting | Does not depend on the setting | Does not issue tokens  |
| 01b (BUF)                  | Bulk or interrupt              | Does not depend on the setting | Issues tokens when the DVSTCTR0.UACT bit is 1 and the FIFO buffer associated with the selected pipe is ready for transmission and reception.<br>Does not issue tokens when the DVSTCTR0.UACT bit is 0 or the FIFO buffer associated with the selected pipe is not ready for transmission or reception. |
|                            | Isochronous                    | Does not depend on the setting | Issues tokens regardless of the status of the FIFO buffer associated with the selected pipe.   |
| 10b (STALL) or 11b (STALL) | Does not depend on the setting | Does not depend on the setting | Does not issue tokens.   |

**Table 26.10 Operation of the USBFS based on the PID[1:0] setting in device controller mode (1 of 2)**

| PID[1:0] value | Transfer type     | Transfer direction (DIR bit)   | USBFS operation  |
|----------------|-------------------|--------------------------------|--|
| 00b (NAK)      | Bulk or interrupt | Does not depend on the setting | Returns NAK in response to the token from the USB host     |
|                | Isochronous       | Does not depend on the setting | Returns nothing in response to the token from the USB host |

**PID[1:0] bits (Response PID)**

PID[1:0]位指定所选管道上下一个事务的响应类型。

默认PID[1:0]设置为NAK。将PID[1:0]设置更改为BUF以使用关联的管道进行USB传输。表26.9和表26.10显示了基于PID[1:0]位设置的USBFS的基本操作（当通信数据包中没有错误时）。

在选定管道上进行USB通信期间，通过软件将PID[1:0]设置从BUF更改为NAK后，检查PBUSY位是否为1，以查看管道上的USB传输是否真正进入了NAK状态。如果USBFS将PID[1:0]位更改为NAK，则无需通过软件检查PBUSY位。

USBFS在以下情况下更改PIPEnCTR.PID[1:0]设置：

- 当所选管道处于接收方向并且所选管道的PIPECFG.SHTNAK位由软件设置为1时，USBFS在识别到传输完成时将PID设置为NAK
- USBFS在接收到负载超过所选管道的最大数据包大小的数据包时将PID设置为STALL(11b)
- USBFS在设备控制器模式下检测到USB总线复位时将PID设置为NAK
- USBFS在主机控制器模式下连续3次检测到接收错误（例如CRC错误）时将PID设置为NAK
- USBFS在主机控制器模式下接收到STALL握手时将PID设置为STALL(11b)

要指定响应类型，请按如下方式设置PID[1:0]位：

- 要从NAK(00b)转换到STALL，设置10b
- 要从BUF(01b)转换到STALL，设置11b
- 要从STALL(11b)转换为NAK，请设置10b，然后设置00b
- 要从STALL转换到BUF，请设置00b(NAK)，然后设置01b(BUF)

**Table 26.9 USBFS在主机控制器模式下基于PID[1:0]设置的操作**

| PID[1:0] value             | 传输类型        | 传输方向 (DIR位) | USBFS operation  |
|----------------------------|-------------|-------------|--|
| 00b (NAK)                  | 不依赖于设置      | 不依赖于设置      | 不发行代币  |
| 01b (BUF)                  | 批量或中断       | 不依赖于设置      | 当DVSTCTR0.UACT位为1并且与所选管道关联的FIFO缓冲区已准备好进行发送和接收时，发出令牌。当DVSTCTR0.UACT位为0或与所选管道关联的FIFO缓冲区尚未准备好进行发送或接收。 |
|                            | Isochronous | 不依赖于设置      | 无论与所选管道关联的FIFO缓冲区的状态如何，都会发出令牌。   |
| 10b (STALL) or 11b (STALL) | 不依赖于设置      | 不依赖于设置      | 不发行代币。   |

**Table 26.10 基于设备控制器模式下的PID[1:0]设置的USBFS操作 (1of2)**

| PID[1:0] value | 传输类型        | 传输方向 (DIR位) | USBFS operation      |
|----------------|-------------|-------------|----------------------|
| 00b (NAK)      | 批量或中断       | 不依赖于设置      | 返回NAK以响应来自USB主机的令牌   |
|                | Isochronous | 不依赖于设置      | 响应来自USB主机的令牌，不返回任何内容 |

Table 26.10 Operation of the USBFS based on the PID[1:0] setting in device controller mode (2 of 2)

| PID[1:0] value             | Transfer type     | Transfer direction (DIR bit)     | USBFS operation   |
|----------------------------|-------------------|----------------------------------|---|
| 01b (BUF)                  | Bulk              | Receiving direction (DIR = 0)    | Receives data and returns ACK in response to the OUT token from the USB host if the FIFO buffer associated with the selected pipe is ready for reception                |
|                            | Interrupt         | Receiving direction (DIR = 0)    | Receives data and returns ACK in response to the OUT token from the USB host if the FIFO buffer associated with the selected pipe is ready for reception                |
|                            | Bulk or interrupt | Transmitting direction (DIR = 1) | Transmits data in response to the token from the USB host if the FIFO buffer associated with the selected pipe is ready for transmission. Otherwise, returns NAK.       |
|                            | Isochronous       | Receiving direction (DIR = 0)    | Receives data in response to the OUT token from the USB host if the FIFO buffer associated with the selected pipe is ready for reception. Otherwise, discards the data. |
|                            | Isochronous       | Transmitting direction (DIR = 1) | Transmits data in response to the token from the USB host if the associated FIFO buffer is ready for transmission. Otherwise, transmits a zero-length packet.           |
| 10b (STALL) or 11b (STALL) | Bulk or interrupt | Does not depend on the setting   | Returns STALL in response to the token from the USB host  |
|                            | Isochronous       | Does not depend on the setting   | Returns nothing in response to the token from the USB host  |

**PBUSY bit (Pipe Busy)**

The PBUSY bit indicates whether the selected pipe is being used for the current transaction.

The USBFS changes the PBUSY bit from 0 to 1 on start of the USB transaction for the selected pipe, and changes the PBUSY bit from 1 to 0 on completion of one transaction.

Reading the PBUSY bit by software after PID is set to NAK allows you to check whether changing the pipe setting is possible. For details, see [section 26.3.4.1. Pipe control register switching procedures](#).

**SQMON bit (Sequence Toggle Bit Confirmation)**

The SQMON bit indicates the expected value of the sequence toggle bit for the next transaction of the selected pipe.

When the selected pipe is not the isochronous transfer type, the USBFS toggles the SQMON flag on successful completion of the transaction. However, the USBFS does not toggle the SQMON flag when a DATA-PID mismatch occurs during transfer in the receiving direction.

**SQSET bit (Sequence Toggle Bit Set)**

Setting the SQSET bit to 1 through the software causes the USBFS to set DATA1 as the expected value of the sequence toggle bit for the next transaction on the selected pipe. The USBFS clears the SQSET bit to 0.

**SQCLR bit (Sequence Toggle Bit Clear)**

Setting the SQCLR bit to 1 through the software causes the USBFS to clear the expected value of the sequence toggle bit for the next transaction on the selected pipe to DATA0. The USBFS clears the SQCLR bit to 0.

**ACLRM bit (Auto Buffer Clear Mode)**

The ACLRM bit enables or disables auto buffer clear mode for the selected pipe. To completely clear the data in the FIFO buffer allocated to the selected pipe, write 1 and then 0 to the ACLRM bit continuously.

Table 26.11 shows the data cleared by writing 1 and 0 to the ACLRM bit continuously and the cases in which this processing is required.

Table 26.11 Data cleared by the USBFS when ACLRM = 1 (1 of 2)

| Number | Data cleared by setting the ACLRM bit   | Situations requiring data clear     |
|--------|---|-------------------------------------|
| 1      | All data in the FIFO buffer allocated to the selected pipe (two FIFO buffers in double buffer mode) | When initializing the selected pipe |

Table 26.10 基于设备控制器模式下的PID[1:0]设置的USBFS操作 (2之2)

| PID[1:0] value             | 传输类型        | 传输方向 (DIR位) | USBFS operation  |
|----------------------------|-------------|-------------|--|
| 01b (BUF)                  | Bulk        | 接收方向(DIR=0) | 如果与所选管道关联的FIFO缓冲区已准备好接收, 则接收数据并返回ACK以响应来自USB主机的OUT令牌     |
|                            | Interrupt   | 接收方向(DIR=0) | 如果与所选管道关联的FIFO缓冲区已准备好接收, 则接收数据并返回ACK以响应来自USB主机的OUT令牌     |
|                            | 批量或中断       | 发射方向(DIR=1) | 传输数据以响应来自USB主机的令牌, 如果与所选管道关联的FIFO缓冲区已准备好进行传输。否则, 返回NAK。  |
|                            | Isochronous | 接收方向(DIR=0) | 如果与所选管道关联的FIFO缓冲区已准备好接收, 则接收数据以响应来自USB主机的OUT令牌。否则, 丢弃数据。 |
|                            | Isochronous | 发射方向(DIR=1) | 如果关联的FIFO缓冲区已准备好传输, 则传输数据以响应来自USB主机的令牌。否则, 发送零长度数据包。     |
| 10b (STALL) or 11b (STALL) | 批量或中断       | 不依赖于设置      | 返回STALL以响应来自USB主机的令牌                                     |
|                            | Isochronous | 不依赖于设置      | 响应来自USB主机的令牌, 不返回任何内容                                    |

**PBUSY bit (Pipe Busy)**

PBUSY位指示所选管道是否正在用于当前事务。

USBFS在所选管道的USB事务开始时将PBUSY位从0更改为1, 并更改PBUSY位在一个事务完成时从1变为0。

在PID设置为NAK后, 通过软件读取PBUSY位可以检查是否可以更改管道设置。详见26.3.4.1节。管道控制寄存器切换程序。

**SQMON位 (序列切换位确认)**

SQMON位指示所选管道的下一个事务的序列切换位的预期值。

当所选管道不是同步传输类型时, USBFS在事务成功完成时切换SQMON标志。但是, 当在接收方向的传输过程中发生DATA-PID不匹配时, USBFS不会切换SQMON标志。

**SQSET位 (序列切换位设置)**

通过软件将SQSET位设置为1会导致USBFS将DATA1设置为所选管道上下一个事务的序列切换位的预期值。USBFS将SQSET位清0。

**SQCLR位 (序列翻转位清除)**

通过软件将SQCLR位设置为1会导致USBFS将所选管道上下一个事务的序列切换位的预期值清除为DATA0。USBFS将SQCLR位清0。

**ACLRM位 (自动缓冲区清除模式)**

ACLRM位启用或禁用所选管道的自动缓冲区清除模式。要完全清除分配给所选管道的FIFO缓冲区中的数据, 请向ACLRM位连续写入1和0。

表26.11显示了通过向ACLRM位连续写入1和0来清除的数据以及需要进行此处理的情况。

Table 26.11 当ACLRM=1(1of2)时USBFS清除的数据

| Number | 通过设置ACLRM位清除数据                          | 需要数据清楚的情况 |
|--------|---|-----------|
| 1      | FIFO缓冲区中的所有数据分配给选定的管道 (两个双缓冲模式下的FIFO缓冲) | 初始化选定管道时  |

Table 26.11 Data cleared by the USBFS when ACLRM = 1 (2 of 2)

| Number | Data cleared by setting the ACLRM bit  | Situations requiring data clear                          |
|--------|--|--|
| 2      | Interval count value when the selected pipe is the isochronous transfer type | When resetting the interval count value                  |
| 3      | Internal flags related to the PIPECFG.BFRE bit                               | When changing the PIPECFG.BFRE setting                   |
| 4      | FIFO buffer toggle control   | When changing the PIPECFG.DBLB setting                   |
| 5      | Internal flags related to the transaction count                              | When forcing the transaction count function to terminate |

**ATREPM bit (Auto Response Mode)**

The ATREPM bit enables or disables auto response mode for the selected pipe.

This bit can be set to 1 in device controller mode when the selected pipe is the bulk transfer type. When the bit is set to 1, the USBFS responds to the token from the USB host as follows:

- When the selected pipe is set for bulk IN transfers (PIPECFG.TYPE[1:0] = 01b and PIPECFG.DIR = 1):
  - When the ATREPM bit = 1 and PID = BUF, the USBFS transmits a zero-length packet in response to the IN token.
  - The USBFS updates (allows toggling of) the sequence toggle bit (DATA-PID) each time the USBFS receives ACK from the USB host. In a single transaction, the IN token is received, a zero-length packet is transmitted, and then ACK is received. The USBFS does not generate the BRDY or BEMP interrupt.
- When the selected pipe is set for bulk OUT transfers (PIPECFG.TYPE[1:0] = 01b and PIPECFG.DIR = 0):
 

When the ATREPM bit = 1 and PID = BUF, the USBFS returns NAK in response to the OUT token and generates an NRDY interrupt.

For USB communication in auto response mode, set the ATREPM bit to 1 while the FIFO buffer is empty. Do not write to the FIFO buffer during USB communication in auto response mode. When the selected pipe uses isochronous transfer, always set this bit to 0.

In host controller mode, always set the ATREPM bit to 0.

**INBUFM bit (Transmit Buffer Monitor)**

The INBUFM bit indicates the FIFO buffer status for the selected pipe in the transmitting direction.

When the selected pipe is set in the transmitting direction (PIPECFG.DIR = 1), the USBFS sets this bit to 1 when the CPU or DMA/DTC completes writing data to at least one FIFO buffer plane.

The USBFS sets this bit to 0 when the USBFS completes transmission of the data from the FIFO buffer plane to which all the data is written. In double buffer mode (PIPECFG.DBLB = 1), the USBFS sets the INBUFM bit to 0 when the USBFS completes transmission of the data from the two FIFO buffer planes before the CPU or DMA/DTC completes writing data to one FIFO buffer plane.

The INBUFM bit indicates the same value as the BSTS bit when the selected pipe is in the receiving direction (PIPECFG.DIR = 0).

**BSTS bit (Buffer Status)**

The BSTS bit indicates the FIFO buffer status for the selected pipe.

The meaning of the BSTS bit depends on the PIPECFG.DIR, PIPECFG.BFRE, and DnFIFOSEL.DCLRM settings, as shown in Table 26.12.

Table 26.11 当ACLRM=1(2of2)时USBFS清除的数据

| Number | 通过设置ACLRM位清除数据        | 需要数据清楚的情况         |
|--------|-----------------------|-------------------|
| 2      | 选择管道为等时传输类型时的间隔计数值    | 重置间隔计数值时          |
| 3      | 与PIPECFG.BFRE位相关的内部标志 | 更改PIPECFG.BFRE设置时 |
| 4      | FIFO缓冲区切换控制           | 更改PIPECFG.DBLB设置时 |
| 5      | 与事务计数相关的内部标志          | 强制事务计数函数终止时       |

**ATREPM位 (自动响应模式)**

ATREPM位启用或禁用所选管道的自动响应模式。

当所选管道为批量传输类型时，该位可以在设备控制器模式下设置为1。当该位设置为1时，USBFS响应来自USB主机的令牌，如下所示：

- 当所选管道设置为批量IN传输时 (PIPECFG.TYPE[1:0]=01b和PIPECFG.DIR=1):
  - 当ATREPM位=1且PID=BUF时，USBFS发送一个长度为零的数据包以响应IN令牌。  
湾。每次USBFS从USB主机接收到ACK时，USBFS都会更新（允许切换）序列切换位(DATA-PID)。在单个事务中，收到IN令牌，发送零长度数据包，然后收到ACK。USBFS不会产生BRDY或BEMP中断。
- 当所选管道设置为批量OUT传输时 (PIPECFG.TYPE[1:0]=01b和PIPECFG.DIR=0) :
 

当ATREPM位=1且PID=BUF时，USBFS返回NAK以响应OUT令牌并生成一个NRDY interrupt。

对于自动响应模式下的USB通信，当FIFO缓冲区为空时，将ATREPM位设置为1。在自动响应模式下的USB通信期间不要写入FIFO缓冲区。当所选管道使用同步传输时，始终将此位设置为0。

在主机控制器模式下，始终将ATREPM位设置为0。

**INBUFM位 (发送缓冲区监视器)**

INBUFM位指示发送方向上所选管道的FIFO缓冲区状态。

当所选管道设置为发送方向(PIPECFG.DIR=1)时，当CPU或DMADTC完成将数据写入至少一个FIFO缓冲区平面时，USBFS将该位设置为1。

当USBFS完成从写入所有数据的FIFO缓冲区平面传输数据时，USBFS将该位设置为0。在双缓冲模式(PIPECFG.DBLB=1)下，当USBFS在CPU或DMADTC完成将数据写入一个FIFO缓冲层之前完成从两个FIFO缓冲层的数据传输时，USBFS将INBUFM位设置为0。

当所选管道处于接收方向时 (PIPECFG.DIR=0)，INBUFM位指示与BSTS位相同的值。

**BSTS bit (Buffer Status)**

BSTS位指示所选管道的FIFO缓冲区状态。

BSTS位的含义取决于PIPECFG.DIR、PIPECFG.BFRE和DnFIFOSEL.DCLRM设置，如表26.12所示。



Table 26.12 BSTS bit operation

| DIR value | BFRE value | DCLRM value | BSTS bit function   |
|-----------|------------|-------------|---|
| 0         | 0          | 0           | Sets to 1 when receive data can be read from the FIFO buffer, and clears to 0 on completion of data read  |
|           |            | 1           | Setting prohibited  |
|           | 1          | 0           | Sets to 1 when receive data can be read from the FIFO buffer, and clears to 0 when the software sets the BCLR bit in the port control register to 1 after the data read is complete |
|           |            | 1           | Sets to 1 when receive data can be read from the FIFO buffer, and clears to 0 on completion of data read  |
| 1         | 0          | 0           | Sets to 1 when transmit data can be written to the FIFO buffer, and clears to 0 on completion of data write   |
|           |            | 1           | Setting prohibited  |
|           | 1          | 0           | Setting prohibited  |
|           |            | 1           | Setting prohibited  |

26.2.36 PIPEnCTR : PIPEn Control Registers (n = 6 to 9)

Base address: USBFS = 0x4009\_0000

Offset address: 0x07A + 0x2 × (n - 6)

|                    |      |    |    |    |    |    |          |           |           |           |           |   |   |   |          |   |
|--------------------|------|----|----|----|----|----|----------|-----------|-----------|-----------|-----------|---|---|---|----------|---|
| Bit position:      | 15   | 14 | 13 | 12 | 11 | 10 | 9        | 8         | 7         | 6         | 5         | 4 | 3 | 2 | 1        | 0 |
| Bit field:         | BSTS | —  | —  | —  | —  | —  | ACL<br>M | SQCL<br>R | SQSE<br>T | SQM<br>ON | PBUS<br>Y | — | — | — | PID[1:0] |   |
| Value after reset: | 0    | 0  | 0  | 0  | 0  | 0  | 0        | 0         | 0         | 0         | 0         | 0 | 0 | 0 | 0        | 0 |

| Bit   | Symbol   | Function   | R/W |
|-------|----------|--|-----|
| 1:0   | PID[1:0] | Response PID<br>0 0: NAK response<br>0 1: BUF response (depends buffer state)<br>1 0: STALL response<br>1 1: STALL response  | R/W |
| 4:2   | —        | These bits are read as 0. The write value should be 0.   | R/W |
| 5     | PBUSY    | Pipe Busy<br>0: Pipe n not in use for the transaction<br>1: Pipe n in use for the transaction  | R   |
| 6     | SQMON    | Sequence Toggle Bit Confirmation<br>0: DATA0<br>1: DATA1   | R   |
| 7     | SQSET    | Sequence Toggle Bit Set*1<br>Sets the sequence toggle bit for pipe n.<br>0: Invalid (writing 0 has no effect)<br>1: Set the expected value for the next transaction to DATA0       | W   |
| 8     | SQCLR    | Sequence Toggle Bit Clear*1<br>Clears the sequence toggle bit for pipe n.<br>0: Invalid (writing 0 has no effect)<br>1: Clear the expected value for the next transaction to DATA0 | W   |
| 9     | ACLRM    | Auto Buffer Clear Mode*2<br>0: Disable<br>1: Enable (all buffers initialized)  | R/W |
| 14:10 | —        | These bits are read as 0. The write value should be 0.   | R/W |
| 15    | BSTS     | Buffer Status<br>0: Buffer access disabled<br>1: Buffer access enabled   | R   |

Table 26.12 BSTS位操作

| 方向值 | BFRE value | DCLRM value | BSTS位功能  |
|-----|------------|-------------|--|
| 0   | 0          | 0           | 当接收数据可以从FIFO缓冲区读取时设置为1，并在数据读取完成时清除为0                     |
|     |            | 1           | 禁止设定   |
|     | 1          | 0           | 接收数据可以从FIFO缓冲区读取时设置为1，当数据读取完成后软件将端口控制寄存器中的BCLR位设置为1时清除为0 |
|     |            | 1           | 当接收数据可以从FIFO缓冲区读取时设置为1，并在数据读取完成时清除为0                     |
| 1   | 0          | 0           | 当发送数据可以写入FIFO缓冲区时设置为1，并在数据写入完成时清除为0                      |
|     |            | 1           | 禁止设定   |
|     | 1          | 0           | 禁止设定   |
|     |            | 1           | 禁止设定   |

26.2.36 PIPEnCTR:PIPEn控制寄存器(n=6到9)

Base address: USBFS = 0x4009\_0000

Offset address: 0x07A + 0x2 × (n - 6)

|               |      |    |    |    |    |    |          |           |           |           |           |   |   |   |          |   |
|---------------|------|----|----|----|----|----|----------|-----------|-----------|-----------|-----------|---|---|---|----------|---|
| Bit position: | 15   | 14 | 13 | 12 | 11 | 10 | 9        | 8         | 7         | 6         | 5         | 4 | 3 | 2 | 1        | 0 |
| Bit field:    | BSTS | —  | —  | —  | —  | —  | ACL<br>M | SQCL<br>R | SQSE<br>T | SQM<br>ON | PBUS<br>Y | — | — | — | PID[1:0] |   |
| 重置后的值:        | 0    | 0  | 0  | 0  | 0  | 0  | 0        | 0         | 0         | 0         | 0         | 0 | 0 | 0 | 0        | 0 |

| Bit   | Symbol   | Function  | R/W |
|-------|----------|---|-----|
| 1:0   | PID[1:0] | 响应PID<br>00: NAK响应01: BUF响应 (取决于缓冲区状态) 10: STALL响应11: STALL响应   | R/W |
| 4:2   | —        | 这些位被读取为0。写入值应为0。  | R/W |
| 5     | PBUSY    | 管道忙<br>0: 管道n未用于事务1: 管道n正在用于事务                                  | R   |
| 6     | SQMON    | 序列切换位确认<br>0: DATA0<br>1: DATA1                                 | R   |
| 7     | SQSET    | 序列切换位设置*1<br>设置管道n的序列切换位。<br>0: 无效 (写0无效) 1: 将下一笔交易的期望值设置为DATA0 | W   |
| 8     | SQCLR    | 序列切换位清除*1<br>清除管道n的序列切换位。<br>0: 无效 (写0无效) 1: 清除下一笔交易的期望值到DATA0  | W   |
| 9     | ACLRM    | 自动缓冲区清除模式*2<br>0: 禁用1: 启用 (所有缓冲区已初始化)                           | R/W |
| 14:10 | —        | 这些位被读取为0。写入值应为0。  | R/W |
| 15    | BSTS     | 缓冲区状态<br>0: 禁止缓冲区访问1: 允许缓冲区访问                                   | R   |



- Note 1. Only write 1 to the SQCLR or SQSET bit while PID is NAK. Before setting these bits, check that the PBUSY bit is 0, and then change the PID[1:0] bits from 01b (BUF) to 00b (NAK). If the PID[1:0] bits are changed to 00b (NAK) by the USBFS, checking the PBUSY bit through the software is not necessary.
- Note 2. Only set the ACLRM bit while PID is NAK and before the pipe is selected in the CURPIPE[3:0] bits in the port select register. Before setting this bits, check that the PIPEnCTR.PBUSY bit is 0, and then change the PIPEnCTR.PID[1:0] bits from 01b (BUF) to 00b (NAK). If the PID[1:0] bits are changed to 00b (NAK) by the USBFS, checking the PBUSY bit through the software is not necessary.

### PID[1:0] bits (Response PID)

The PID[1:0]bits specify the response type for the next transaction of the selected pipe.

The default PID[1:0] setting is NAK. Change the PID[1:0] setting to BUF to use the associated pipe for USB transfer. Table 26.9 and Table 26.10 show the basic operation (when there are no errors in the transmitted and received packets) of the USBFS depending on the PID[1:0] setting.

After changing the PID[1:0] setting from BUF to NAK through the software during USB communication on the selected pipe, check that the PBUSY bit is 1 to see if USB transfer on the selected pipe has actually entered the NAK state. If the USBFS changes the PID[1:0] bits to NAK, checking the PBUSY bit through the software is not necessary.

The USBFS changes the PIPEnCTR.PID[1:0] setting in the following cases:

- The USBFS sets PID to STALL (11b) on receiving a data packet with a payload exceeding the maximum packet size of the selected pipe
- The USBFS sets PID to NAK on detecting a USB bus reset in device controller mode
- The USBFS sets PID to NAK on detecting a reception error, such as a CRC error, three consecutive times in host controller mode
- The USBFS sets PID to STALL (11b) on receiving the STALL handshake in host controller mode

To specify each response type, set the PID[1:0] bits as follows:

- To transition from NAK (00b) to STALL, set 10b
- To transition from BUF (01b) to STALL, set 11b
- To transition from STALL (11b) to NAK, set 10b and then 00b
- To transition from STALL to BUF, set 00b (NAK) and then 01b (BUF)

### PBUSY bit (Pipe Busy)

The PBUSY bit indicates whether the selected pipe is being used for the current transaction.

The USBFS changes the PBUSY bit from 0 to 1 on start of the USB transaction for the selected pipe, and changes the PBUSY bit from 1 to 0 on completion of one transaction.

Reading the PBUSY bit by software after PID is set to NAK allows you to check whether changing the pipe setting is possible.

### SQMON bit (Sequence Toggle Bit Confirmation)

The SQMON bit indicates the expected value of the sequence toggle bit for the next transaction of the selected pipe.

The USBFS toggles the SQMON bit on successful completion of the transaction. However, the USBFS does not toggle the SQMON bit when a DATA-PID mismatch occurs during transfer in the receiving direction.

### SQSET bit (Sequence Toggle Bit Set)

Setting the SQSET bit to 1 through the software causes the USBFS to set DATA1 as the expected value of the sequence toggle bit for the next transaction on the selected pipe. The USBFS sets the SQSET bit to 0.

### SQCLR bit (Sequence Toggle Bit Clear)

Setting the SQCLR bit to 1 through the software causes the USBFS to clear the expected value of the sequence toggle bit for the next transaction on the selected pipe to DATA0. The USBFS sets the SQCLR bit to 0.

### ACLRM bit (Auto Buffer Clear Mode)

The ACLRM bit enables or disables auto buffer clear mode for the selected pipe. To completely clear the data in the FIFO buffer allocated to the selected pipe, write 1 and then 0 to the ACLRM bit continuously.

注1.PID为NAK时, 仅向SQCLR或SQSET位写入1。在设置这些位之前, 请检查PBUSY位是否为0, 然后将PID[1:0]位从01b(BUF)更改为00b(NAK)。如果PID[1:0]位被USBFS更改为00b(NAK), 则无需通过软件检查PBUSY位。

注2.仅在PID为NAK时和在端口选择寄存器的CURPIPE[3:0]位中选择管道之前设置ACLRM位。在设置该位之前, 请检查PIPEnCTR.PBUSY位是否为0, 然后将PIPEnCTR.PID[1:0]位从01b(BUF)更改为00b(NAK)。如果PID[1:0]位被USBFS更改为00b(NAK), 则无需通过软件检查PBUSY位。

### PID[1:0] bits (Response PID)

PID[1:0]位指定所选管道的下一个事务的响应类型。

默认PID[1:0]设置为NAK。将PID[1:0]设置更改为BUF以使用关联的管道进行USB传输。表26.9和表26.10显示了取决于PID[1:0]设置的USBFS的基本操作 (在发送和接收的数据包中没有错误时)。

在选定管道上进行USB通信期间, 通过软件将PID[1:0]设置从BUF更改为NAK后, 检查PBUSY位是否为1, 以查看选定管道上的USB传输是否真正进入了NAK状态。如果USBFS将PID[1:0]位更改为NAK, 则无需通过软件检查PBUSY位。

USBFS在以下情况下更改PIPEnCTR.PID[1:0]设置:

- USBFS在接收到负载超过所选管道的最大数据包大小的数据包时将PID设置为STALL(11b)
- USBFS在设备控制器模式下检测到USB总线复位时将PID设置为NAK
- USBFS在主机控制器模式下连续3次检测到接收错误 (例如CRC错误) 时将PID设置为NAK
- USBFS在主机控制器模式下接收到STALL握手时将PID设置为STALL(11b)

要指定每种响应类型, 请按如下方式设置PID[1:0]位:

- 要从NAK(00b)转换到STALL, 设置10b
- 要从BUF(01b)转换到STALL, 设置11b
- 要从STALL(11b)转换为NAK, 请设置10b, 然后设置00b
- 要从STALL转换到BUF, 请设置00b(NAK), 然后设置01b(BUF)

### PBUSY bit (Pipe Busy)

PBUSY位指示所选管道是否正在用于当前事务。

USBFS在所选管道的USB事务开始时将PBUSY位从0更改为1, 并更改PBUSY位在一个事务完成时从1变为0。

在PID设置为NAK后, 通过软件读取PBUSY位可以检查是否可以更改管道设置。

### SQMON位 (序列切换位确认)

SQMON位指示所选管道的下一个事务的序列切换位的预期值。

USBFS在事务成功完成时切换SQMON位。但是, USBFS不会切换SQMON位, 当在接收方向的传输过程中发生DATA-PID不匹配时。

### SQSET位 (序列切换位设置)

通过软件将SQSET位设置为1会导致USBFS将DATA1设置为所选管道上下一个事务的序列切换位的预期值。USBFS将SQSET位设置为0。

### SQCLR位 (序列翻转位清除)

通过软件将SQCLR位设置为1会导致USBFS将所选管道上下一个事务的序列切换位的预期值清除为DATA0。USBFS将SQCLR位设置为0。

### ACLRM位 (自动缓冲区清除模式)

ACLRM位启用或禁用所选管道的自动缓冲区清除模式。要完全清除分配给所选管道的FIFO缓冲区中的数据, 请向ACLRM位连续写入1和0。

Table 26.13 shows the data cleared by writing 1 and 0 continuously to the ACLRM bit and the cases in which this processing is required.

Table 26.13 Data cleared by the USBFS when ACLRM = 1

| Number | Data cleared by setting the ACLRM bit  | Situations requiring data clear                          |
|--------|--|--|
| 1      | All data in the FIFO buffer allocated to the selected pipe                   | When initializing the selected pipe                      |
| 2      | Interval count value when the selected pipe is the isochronous transfer type | When resetting the interval count value                  |
| 3      | Internal flags related to the PIPECFG.BFRE bit                               | When changing the PIPECFG.BFRE setting                   |
| 4      | Internal flags related to the transaction count                              | When forcing the transaction count function to terminate |

**BSTS bit (Buffer Status)**

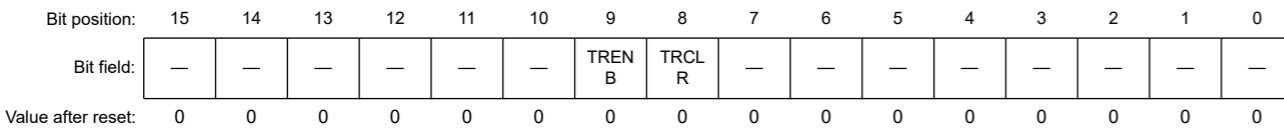
The BSTS bit indicates the FIFO buffer status for the selected pipe.

The meaning of the BSTS bit depends on the PIPECFG.DIR, PIPECFG.BFRE, and DnFIFOSEL.DCLRM settings, as shown in Table 26.12.

26.2.37 PIPEnTRE : PIPEn Transaction Counter Enable Register (n = 1 to 5)

Base address: USBFS = 0x4009\_0000

Offset address: 0x090 + 0x4 × (n - 1)



| Bit   | Symbol | Function  | R/W |
|-------|--------|---|-----|
| 7:0   | —      | These bits are read as 0. The write value should be 0.  | R/W |
| 8     | TRCLR  | Transaction Counter Clear<br>0: Invalid (writing 0 has no effect)<br>1: Clear counter value   | R/W |
| 9     | TRENB  | Transaction Counter Enable<br>0: Disable transaction counter<br>1: Enable transaction counter | R/W |
| 15:10 | —      | These bits are read as 0. The write value should be 0.  | R/W |

Note: Set each bit in PIPEnTRE while PID is NAK. Before setting these bits after changing the PIPEnCTR.PID[1:0] bits for the selected pipe from BUF to NAK, check that the PIPEnCTR.PBUSY bit is 0. However, if the PID[1:0] bits are changed to NAK by the USBFS, checking the PBUSY bit through the software is not necessary.

**TRCLR bit (Transaction Counter Clear)**

When the TRCLR bit sets to 1, the USBFS clears the value of the transaction counter associated with the selected pipe and then sets the TRCLR bit to 0.

**TRENB bit (Transaction Counter Enable)**

The TRENB bit enables or disables the transaction counter.

For receiving pipes, setting the TRENB bit to 1 after setting the total number of the packets to be received in the PIPEnTRN.TRNCNT[15:0] bits through the software allows the USBFS to control hardware on having received the number of packets equal to the TRNCNT[15:0] setting, as follows:

- When the PIPECFG.SHTNAK bit is 1, the USBFS changes the PID bits to NAK for the associated pipe on having received the number of packets equal to the TRNCNT[15:0] setting
- When the PIPECFG.BFRE bit is 1, the USBFS asserts the BRDY interrupt on having received the number of packets equal to the TRNCNT[15:0] setting and then reading the last received data

表26.13显示了通过向ACLRM位连续写入1和0来清除的数据以及需要进行此处理的情况。

Table 26.13 ACLRM=1时USBFS清除的数据

| Number | 通过设置ACLRM位清除数据        | 需要数据清楚的情况         |
|--------|-----------------------|-------------------|
| 1      | 分配给所选管道的FIFO缓冲区中的所有数据 | 初始化选定管道时          |
| 2      | 选择管道为等时传输类型时的间隔计数值    | 重置间隔计数值时          |
| 3      | 与PIPECFG.BFRE位相关的内部标志 | 更改PIPECFG.BFRE设置时 |
| 4      | 与事务计数相关的内部标志          | 强制事务计数函数终止时       |

**BSTS bit (Buffer Status)**

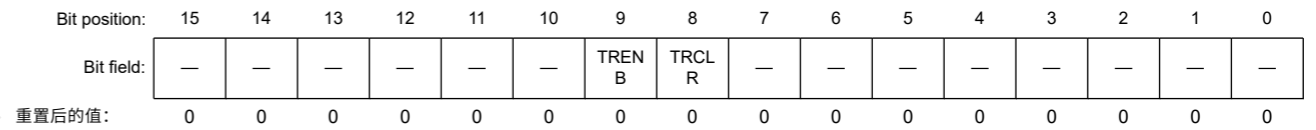
BSTS位指示所选管道的FIFO缓冲区状态。

BSTS位的含义取决于PIPECFG.DIR、PIPECFG.BFRE和DnFIFOSEL.DCLRM设置，如表26.12所示。

26.2.37 PIPEnTRE:PIPEn事务计数器使能寄存器(n=1到5)

Base address: USBFS = 0x4009\_0000

Offset address: 0x090 + 0x4 × (n - 1)



| Bit   | Symbol | Function                          | R/W |
|-------|--------|-----------------------------------|-----|
| 7:0   | —      | 这些位被读取为0。写入值应为0。                  | R/W |
| 8     | TRCLR  | 交易计数器清除<br>0: 无效 (写0无效) 1: 清除计数器值 | R/W |
| 9     | TRENB  | 事务计数器启用<br>0: 禁用事务计数器1: 启用事务计数器   | R/W |
| 15:10 | —      | 这些位被读取为0。写入值应为0。                  | R/W |

Note: 当PID为NAK时，设置PIPEnTRE中的每个位。在将所选管道的PIPEnCTR.PID[1:0]位从BUF更改为NAK之后设置这些位之前，请检查PIPEnCTR.PBUSY位是否为0。但是，如果PID[1:0]位更改为NAK通过USBFS，无需通过软件检查PBUSY位。

**TRCLR位 (事务计数器清零)**

当TRCLR位设置为1时，USBFS清除与所选管道关联的事务计数器的值，然后将TRCLR位设置为0。

**TRENB位 (事务计数器使能)**

TRENB位启用或禁用事务计数器。

对于接收管道，在设置接收管道的总包数后，将TRENB位设置为1 PIPEnTRN.TRNCNT[15:0]位通过软件允许USBFS在接收到等于TRNCNT[15:0]设置的数据包数量时控制硬件，如下所示：

- 当PIPECFG.SHTNAK位为1时，USBFS在接收到等于TRNCNT[15:0]设置的数据包数时将关联管道的PID位更改为NAK
- 当PIPECFG.BFRE位为1时，USBFS在接收到等于TRNCNT[15:0]设置的数据包数量并读取最后接收到的数据时断言BRDY中断

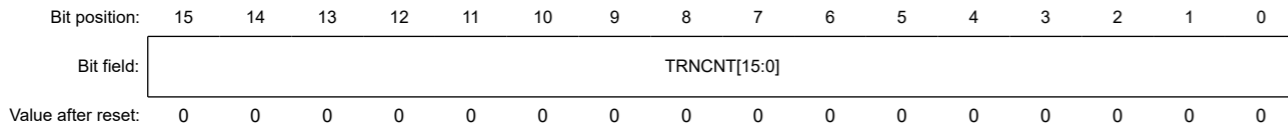
For transmitting pipes, set the TRENB bit to 0.

When the transaction counter is not used, set this bit to 0. When the transaction counter is used, set the TRNCNT[15:0] bits before setting this bit to 1. Set this bit to 1 before receiving the first packet to be counted by the transaction counter.

### 26.2.38 PIPEnTRN : PIPEn Transaction Counter Register (n = 1 to 5)

Base address: USBFS = 0x4009\_0000

Offset address: 0x092 + 0x4 × (n - 1)



| Bit  | Symbol       | Function  | R/W |
|------|--------------|---|-----|
| 15:0 | TRNCNT[15:0] | Transaction Counter<br>When written to, this bit specifies the total packets (number of transactions) to be received by the selected pipe.<br>When read from, when PIPEnTRE.TRENB is 0, this bit indicates the specified number of transactions.<br>When PIPEnTRE.TRENB is 1, this bit indicates the current transaction count. | R/W |

The PIPEnTRN registers retain their settings during a USB bus reset.

#### TRNCNT[15:0] bits (Transaction Counter)

The USBFS increments the value of the TRNCNT[15:0] bits by 1 when all of the following conditions are satisfied on receiving the packet:

- The PIPEnTRE.TRENB bit = 1
- (TRNCNT[15:0] set value ≠ current counter value + 1) on receiving the packet
- The payload of the received packet agrees with the PIPEMAXP.MXPS[9:0] setting

The USBFS clears the value of the TRNCNT[15:0] bits to 0 when any of the following conditions are satisfied:

All of the following conditions are satisfied:

- The PIPEnTRE.TRENB bit = 1
- (TRNCNT[15:0] set value = current counter value + 1) on receiving the packet
- The payload of the received packet agrees with the PIPEMAXP.MXPS[9:0] setting

Both of the following conditions are satisfied:

- The PIPEnTRE.TRENB bit = 1
- The USBFS received a short packet

Both of the following conditions are satisfied:

- The PIPEnTRE.TRENB bit = 1
- The PIPEnTRE.TRCLR bit was set to 1 by software

For transmitting pipes, set the TRNCNT[15:0] bits to 0. When the transaction counter is not used, set the TRNCNT[15:0] bits to 0.

Setting the number of transactions to be transferred to the TRNCNT[15:0] bits is only enabled when the PIPEnTRE.TRENB bit is 0. To set the number of transactions to be transferred, set the TRCLR bit to 1 to clear the current counter value before setting the PIPEnTRE.TRENB bit to 1.

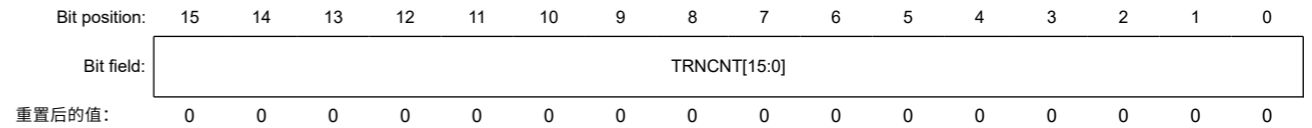
对于传输管道，将TRENB位设置为0。

当不使用事务计数器时，将该位设置为0。当使用事务计数器时，将该位设置为1之前设置TRNCNT[15:0]位。在接收第一个要计数的数据包之前将该位设置为1由交易柜台。

### 26.2.38 PIPEnTRN:PIPEn事务计数器寄存器(n=1到5)

Base address: USBFS = 0x4009\_0000

Offset address: 0x092 + 0x4 × (n - 1)



| Bit  | Symbol       | Function  | R/W |
|------|--------------|---|-----|
| 15:0 | TRNCNT[15:0] | 事务计数器写入时，该位指定所选管道要接收的总数据包（事务数）。读取时，当PIPEnTRE.TRENB为0时，该位指示指定的事务数。当PIPEnTRE.TRENB为1时，该位指示当前事务计数。 | R/W |

PIPEnTRN寄存器在USB总线复位期间保留其设置。

#### TRNCNT[15:0] bits (Transaction Counter)

当接收到数据包时满足以下所有条件时，USBFS将TRNCNT[15:0]位的值加1：

- PIPEnTRE.TRENB位=1
- (TRNCNT[15:0]设定值≠当前计数器值+1)收到数据包
- 接收数据包的有效载荷与PIPEMAXP.MXPS[9:0]设置一致

当满足以下任一条件时，USBFS将TRNCNT[15:0]位的值清零：

满足以下所有条件：

- PIPEnTRE.TRENB位=1
- (TRNCNT[15:0]setvalue=currentcountervalue+1)收到数据包
- 接收数据包的有效载荷与PIPEMAXP.MXPS[9:0]设置一致

满足以下两个条件：

- PIPEnTRE.TRENB位=1
- USBFS收到一个短数据包

满足以下两个条件：

- PIPEnTRE.TRENB位=1
- PIPEnTRE.TRCLR位由软件设置为1

对于传输管道，将TRNCNT[15:0]位设置为0。当不使用事务计数器时，将TRNCNT[15:0]位设置为0。

仅当PIPEnTRE.TRENB位为0时才使能将要传输的事务数设置到TRNCNT[15:0]位。要设置要传输的事务数，请将TRCLR位设置为1以清除当前计数器将PIPEnTRE.TRENB位设置为1之前的值。



## 26.2.39 BCCTRL1 : Battery Charging Control Register 1

Base address: USBFS = 0x4009\_0000

Offset address: 0x0B0

|                    |    |    |    |    |    |    |               |              |    |    |             |            |             |             |             |           |
|--------------------|----|----|----|----|----|----|---------------|--------------|----|----|-------------|------------|-------------|-------------|-------------|-----------|
| Bit position:      | 31 | 30 | 29 | 28 | 27 | 26 | 25            | 24           | 23 | 22 | 21          | 20         | 19          | 18          | 17          | 16        |
| Bit field:         | —  | —  | —  | —  | —  | —  | —             | —            | —  | —  | —           | —          | —           | —           | —           | —         |
| Value after reset: | 0  | 0  | 0  | 0  | 0  | 0  | 0             | 0            | 0  | 0  | 0           | 0          | 0           | 0           | 0           | 0         |
| Bit position:      | 15 | 14 | 13 | 12 | 11 | 10 | 9             | 8            | 7  | 6  | 5           | 4          | 3           | 2           | 1           | 0         |
| Bit field:         | —  | —  | —  | —  | —  | —  | CHGD<br>ETSTS | PDDE<br>TSTS | —  | —  | CHGD<br>ETE | PDDE<br>TE | VDPS<br>RCE | VDMS<br>RCE | IDPSR<br>CE | RPDM<br>E |
| Value after reset: | 0  | 0  | 0  | 0  | 0  | 0  | 0             | 0            | 0  | 0  | 0           | 0          | 0           | 0           | 0           | 0         |

| Bit   | Symbol    | Function  | R/W |
|-------|-----------|---|-----|
| 0     | RPDME     | D- Line Pull-down Control<br>0: Disable D- Line Pull-down<br>1: Enable D- Line Pull-down                            | R/W |
| 1     | IDPSRCE   | D+ Line IDPSRC Output Control<br>0: Stopped<br>1: 10 μA output  | R/W |
| 2     | VDMSRCE   | D- Line VDMSRC (0.6 V) Output Control<br>0: Stopped<br>1: 0.6 V output  | R/W |
| 3     | VDPSRCE   | D+ Line VDPSRC (0.6 V) Output Control<br>0: Stopped<br>1: 0.6 V output  | R/W |
| 4     | PDDETE    | D+ Line 0.6 V Input Detection Control<br>0: Disable detection<br>1: Enable detection                                | R/W |
| 5     | CHGDETE   | D- Line 0.6 V Input Detection Control<br>0: Disable detection<br>1: Enable detection                                | R/W |
| 7:6   | —         | These bits are read as 0. The write value should be 0.  | R/W |
| 8     | PDDETSTS  | D+ Line 0.6 V Input Detection Status Flag<br>This flag is valid when PDDETE = 1.<br>0: Not detected<br>1: Detected  | R   |
| 9     | CHGDETSTS | D- Line 0.6 V Input Detection Status Flag<br>This flag is valid when CHGDETE = 1.<br>0: Not detected<br>1: Detected | R   |
| 31:10 | —         | These bits are read as 0. The write value should be 0.  | R/W |

**RPDME bit (D- Line Pull-down Control)**

In device controller operation, set this bit to 1 to perform Data Contact Detect. In the Battery Charging Specification Revision 1.2, there are two methods to handle Data Contact Detect; the method realized by software wait and the method to contact the data line by hardware. The RPDME bit adopts the latter method. When RPDME = 1, the USBFS controls D- line pull-down.

**IDPSRCE bit (D+ Line IDPSRC Output Control)**

In device controller operation, set this bit to 1 to perform Data Contact Detect. In the Battery Charging Specification Revision 1.2, there are two methods to handle Data Contact Detect; the method realized by software wait and the method to contact the data line by hardware. The IDPSRCE bit adopts the latter method. When IDPSRCE = 1, the USBFS enables the IDP\_SRC circuit

## 26.2.39 BCCTRL1: 电池充电控制寄存器1

Base address: USBFS = 0x4009\_0000

Offset address: 0x0B0

|               |    |    |    |    |    |    |               |              |    |    |             |            |             |             |             |           |
|---------------|----|----|----|----|----|----|---------------|--------------|----|----|-------------|------------|-------------|-------------|-------------|-----------|
| Bit position: | 31 | 30 | 29 | 28 | 27 | 26 | 25            | 24           | 23 | 22 | 21          | 20         | 19          | 18          | 17          | 16        |
| Bit field:    | —  | —  | —  | —  | —  | —  | —             | —            | —  | —  | —           | —          | —           | —           | —           | —         |
| 重置后的值:        | 0  | 0  | 0  | 0  | 0  | 0  | 0             | 0            | 0  | 0  | 0           | 0          | 0           | 0           | 0           | 0         |
| Bit position: | 15 | 14 | 13 | 12 | 11 | 10 | 9             | 8            | 7  | 6  | 5           | 4          | 3           | 2           | 1           | 0         |
| Bit field:    | —  | —  | —  | —  | —  | —  | CHGD<br>ETSTS | PDDE<br>TSTS | —  | —  | CHGD<br>ETE | PDDE<br>TE | VDPS<br>RCE | VDMS<br>RCE | IDPSR<br>CE | RPDM<br>E |
| 重置后的值:        | 0  | 0  | 0  | 0  | 0  | 0  | 0             | 0            | 0  | 0  | 0           | 0          | 0           | 0           | 0           | 0         |

| Bit   | Symbol    | Function  | R/W |
|-------|-----------|---|-----|
| 0     | RPDME     | D- Line Pull-down Control<br>0: 禁用DLine下拉1: 启用DLine下拉   | R/W |
| 1     | IDPSRCE   | D+线IDPSRC输出控制<br>0: 停止1: 10μA输出                         | R/W |
| 2     | VDMSRCE   | DLineVDMSRC(0.6V)输出控制<br>0: 停止1: 0.6V输出                 | R/W |
| 3     | VDPSRCE   | D+线VDPSRC(0.6V)输出控制<br>0: 停止1: 0.6V输出                   | R/W |
| 4     | PDDETE    | D+线0.6V输入检测控制<br>0: 禁用检测1: 启用检测                         | R/W |
| 5     | CHGDETE   | DLine0.6V输入检测控制<br>0: 禁用检测1: 启用检测                       | R/W |
| 7:6   | —         | 这些位被读取为0。写入值应为0。  | R/W |
| 8     | PDDETSTS  | D+线0.6V输入检测状态标志<br>该标志在PDDETE=1时有效。<br>0: 未检测到1: 检测到    | R   |
| 9     | CHGDETSTS | DLine0.6V输入检测状态标志<br>该标志在CHGDETE=1时有效。<br>0: 未检测到1: 检测到 | R   |
| 31:10 | —         | 这些位被读取为0。写入值应为0。  | R/W |

**RPDME bit (D- Line Pull-down Control)**

在设备控制器操作中，将此位设置为1以执行数据接触检测。在电池充电规范中修订版1.2，有两种方法来处理DataContactDetect；软件等待实现的方法和硬件连接数据线的方法。RPDME比特采用后一种方法。当RPDME=1时，USBFS控制Dline下拉。

**IDPSRCE位 (D+线IDPSRC输出控制)**

在设备控制器操作中，将此位设置为1以执行数据接触检测。在电池充电规范中修订版1.2，有两种方法来处理DataContactDetect；软件等待实现的方法和硬件连接数据线的方法。IDPSRCE位采用后一种方法。当IDPSRCE=1时，USBFS使能IDP\_SRC电路



**VDMSRCE bit (D- Line VDMSRC (0.6 V) Output Control)**

In host controller operation, during Primary Detection, this bit controls VDMSRC (0.6 V) output from the USB\_DM pin.

In device controller operation, during Secondary Detection, this bit controls VDMSRC (0.6 V) output from the USB\_DM pin.

**VDPSRCE bit (D+ Line VDPSRC (0.6 V) Output Control)**

In device controller operation, if Primary Detection is executed, this bit controls VDPSRC (0.6 V) output from the USB\_DP pin.

**PDDETE bit (D+ Line 0.6 V Input Detection Control)**

When the PDDETE bit is set to 1, the following states can be detected.

In host controller operation, during Primary Detection, VDPSRC (0.6 V) is input to the USB\_DP pin from a peripheral device.

In device controller operation, during Secondary Detection, VDPSRC (0.6 V) output from the USBFS to the USB\_DM pin is input to the USB\_DP pin via the host.

**CHGDETE bit (D- Line 0.6 V Input Detection Control)**

In device controller operation, the following can be detected when the CHGDETE bit is set to 1.

During Primary Detection, VDMSRC (0.6 V) is input to the USB\_DM pin from the host.

During Primary Detection, VDPSRC (0.6 V) output from the USBFS to the USB\_DP pin is input to the USB\_DM pin via the USB host.

**PDDETSTS flag (D+ Line 0.6 V Input Detection Status Flag)**

The PDDETSTS flag is enabled when the PDDETE bit is 1. The PDDETSTS flag becomes 1 under the following conditions.

In host controller operation, during Primary Detection, VDPSRC (0.6V) is input to the USB\_DP pin from a peripheral device.

In device controller operation, during Secondary Detection, the VDMSRC (0.6V) output from the USBFS to the USB\_DM pin is input to the USB\_DP pin via the host.

**CHGDETSTS flag (D- Line 0.6 V Input Detection Status Flag)**

In device controller operation, this flag is enabled when the CHGDETE bit is 1. The CHGDETSTS flag becomes 1 under the following conditions.

During Primary Detection, VDMSRC (0.6V) is input to the USB\_DM pin from the USB host.

During Primary Detection, the VDPSRC (0.6V) output from the USBFS to the USB\_DP pin is input to the USB\_DM pin via the USB host.

**26.2.40 BCCTRL2 : Battery Charging Control Register 2**

Base address: USBFS = 0x4009\_0000

Offset address: 0x0B4

|                    |    |    |             |    |    |    |    |          |          |    |    |    |    |    |    |    |
|--------------------|----|----|-------------|----|----|----|----|----------|----------|----|----|----|----|----|----|----|
| Bit position:      | 31 | 30 | 29          | 28 | 27 | 26 | 25 | 24       | 23       | 22 | 21 | 20 | 19 | 18 | 17 | 16 |
| Bit field:         | —  | —  | —           | —  | —  | —  | —  | —        | —        | —  | —  | —  | —  | —  | —  | —  |
| Value after reset: | 0  | 0  | 0           | 0  | 0  | 0  | 0  | 0        | 0        | 0  | 0  | 0  | 0  | 0  | 0  | 0  |
| Bit position:      | 15 | 14 | 13          | 12 | 11 | 10 | 9  | 8        | 7        | 6  | 5  | 4  | 3  | 2  | 1  | 0  |
| Bit field:         | —  | —  | PHYDET[1:0] | —  | —  | —  | —  | BATC HGE | DCPM ODE | —  | —  | —  | —  | —  | —  | —  |
| Value after reset: | 0  | 0  | 1           | 0  | 0  | 0  | 0  | 0        | 0        | 0  | 0  | 0  | 0  | 0  | 0  | 0  |

**VDMSRCE位 (DLineVDMSRC(0.6V)输出控制)**

在主机控制器操作中, 在主检测期间, 该位控制USB\_DM引脚的VDMSRC(0.6V)输出。

在设备控制器操作中, 在辅助检测期间, 该位控制USB\_DM引脚的VDMSRC(0.6V)输出。

**VDPSRCE位 (D+线VDPSRC(0.6V)输出控制)**

在设备控制器操作中, 如果执行PrimaryDetection, 该位控制USB\_DP引脚的VDPSRC(0.6V)输出。

**PDDETE位 (D+线0.6V输入检测控制)**

当PDDETE位设置为1时, 可以检测到以下状态。

在主机控制器操作中, 在初级检测期间, VDPSRC(0.6V)从外围设备输入到USB\_DP引脚。

在设备控制器操作中, 在二次检测期间, 从USBFS到USB\_DM引脚的VDPSRC(0.6V)输出通过主机输入到USB\_DP引脚。

**CHGDETE位 (DLine0.6V输入检测控制)**

在设备控制器操作中, 当CHGDETE位设置为1时, 可以检测到以下情况。

在主要检测期间, VDMSRC(0.6V)从主机输入到USB\_DM引脚。

在初级检测期间, 从USBFS到USB\_DP引脚的VDPSRC(0.6V)输出通过USB主机输入到USB\_DM引脚。

**PDDETSTS标志 (D+线0.6V输入检测状态标志)**

当PDDETE位为1时, 使能PDDETSTS标志。在以下条件下, PDDETSTS标志变为1。

在主机控制器操作中, 在初级检测期间, VDPSRC(0.6V)从外围设备输入到USB\_DP引脚。

在设备控制器操作中, 在二次检测期间, 从USBFS到USB\_DM引脚的VDMSRC(0.6V)输出通过主机输入到USB\_DP引脚。

**CHGDETSTS标志 (DLine0.6V输入检测状态标志)**

在设备控制器操作中, 当CHGDETE位为1时启用该标志。在以下条件下, CHGDETSTS标志变为1。

在初级检测期间, VDMSRC(0.6V)从USB主机输入到USB\_DM引脚。

在初级检测期间, 从USBFS到USB\_DP引脚的VDPSRC(0.6V)输出通过USB主机输入到USB\_DM引脚。

**26.2.40 BCCTRL2: 电池充电控制寄存器2**

Base address: USBFS = 0x4009\_0000

Offset address: 0x0B4

|               |    |    |             |    |    |    |    |          |          |    |    |    |    |    |    |    |
|---------------|----|----|-------------|----|----|----|----|----------|----------|----|----|----|----|----|----|----|
| Bit position: | 31 | 30 | 29          | 28 | 27 | 26 | 25 | 24       | 23       | 22 | 21 | 20 | 19 | 18 | 17 | 16 |
| Bit field:    | —  | —  | —           | —  | —  | —  | —  | —        | —        | —  | —  | —  | —  | —  | —  | —  |
| 重置后的值:        | 0  | 0  | 0           | 0  | 0  | 0  | 0  | 0        | 0        | 0  | 0  | 0  | 0  | 0  | 0  | 0  |
| Bit position: | 15 | 14 | 13          | 12 | 11 | 10 | 9  | 8        | 7        | 6  | 5  | 4  | 3  | 2  | 1  | 0  |
| Bit field:    | —  | —  | PHYDET[1:0] | —  | —  | —  | —  | BATC HGE | DCPM ODE | —  | —  | —  | —  | —  | —  | —  |
| 重置后的值:        | 0  | 0  | 1           | 0  | 0  | 0  | 0  | 0        | 0        | 0  | 0  | 0  | 0  | 0  | 0  | 0  |

| Bit   | Symbol      | Function   | R/W |
|-------|-------------|--|-----|
| 5:0   | —           | These bits are read as 0. The write value should be 0.   | R/W |
| 6     | DCPMODE     | Dedicated Charging Port (DCP) Mode Control<br>In host controller mode, setting this bit to 1 connects the D+ line and D- line. If USBFS is configured as DCP, this bit should be set to 1 before driving VBUS.<br>In device controller mode, this bit should be set to 0.<br>0: Disable DCP<br>1: Enable DCP | R/W |
| 7     | BATCHGE     | Battery Charging Enable<br>0: Disable Battery Charging<br>1: Enable Battery Charging   | R/W |
| 11:8  | —           | These bits are read as 0. The write value should be 0.   | R/W |
| 13:12 | PHYDET[1:0] | Detect Sensitivity Adjustment<br>Adjusts the detect sensitivity of Portable Device and Charging D- Port<br>Initial value is 10b, but need to be set 01b.   | R/W |
| 31:14 | —           | These bits are read as 0. The write value should be 0.   | R/W |

### 26.2.41 DEVADDn : Device Address n Configuration Register (n = 0 to 5)

Base address: USBFS = 0x4009\_0000

Offset address: 0x0D0 + 0x2 × n

| Bit position:      | 15 | 14 | 13 | 12 | 11 | 10 | 9 | 8 | 7           | 6 | 5 | 4 | 3 | 2 | 1 | 0 |
|--------------------|----|----|----|----|----|----|---|---|-------------|---|---|---|---|---|---|---|
| Bit field:         | —  | —  | —  | —  | —  | —  | — | — | USBSPD[1:0] | — | — | — | — | — | — | — |
| Value after reset: | 0  | 0  | 0  | 0  | 0  | 0  | 0 | 0 | 0           | 0 | 0 | 0 | 0 | 0 | 0 | 0 |

| Bit  | Symbol      | Function   | R/W |
|------|-------------|--|-----|
| 5:0  | —           | These bits are read as 0. The write value should be 0.   | R/W |
| 7:6  | USBSPD[1:0] | Transfer Speed of Communication Target Device<br>0 0: Do not use DEVADDn<br>0 1: Low-speed<br>1 0: Full-speed<br>1 1: Setting prohibited | R/W |
| 15:8 | —           | These bits are read as 0. The write value should be 0.   | R/W |

The DEVADDn register specifies the transfer speed of the peripheral device that is the communication target for pipes 0 to 9.

In host controller mode, set all DEVADDn bits before starting communication to any pipes. Only change the bits in DEVADDn when no valid pipes are using the bit settings. A valid pipe is defined as one that satisfies both of the following conditions:

- DEVADDn is selected in the DEVSEL[3:0] bits
- The PID[1:0] bits are set to BUF for the selected pipe, or the selected pipe is the DCP with the DCPCTR.SUREQ bit set to 1

In device controller mode, set all bits in this register to 0.

#### USBSPD[1:0] bits (Transfer Speed of Communication Target Device)

The USBSPD[1:0] bits specify the USB transfer speed of the target peripheral device. Set these bits to 10b when a full-speed device is connected through the hub. In host controller mode, the USBFS generates packets based on the USBSPD[1:0] setting. In device controller mode, set these bits to 00b.

| Bit   | Symbol      | Function   | R/W |
|-------|-------------|--|-----|
| 5:0   | —           | 这些位被读取为0。写入值应为0。   | R/W |
| 6     | DCPMODE     | 专用充电端口(DCP)模式控制<br>在主机控制器模式下, 将此位设置为1连接D+线和Dline。如果USBFS配置为DCP, 则该位应在驱动VBUS之前设置为1。在设备控制器模式下, 该位应设置为0。<br>0: 禁用DCP1:<br>启用DCP | R/W |
| 7     | BATCHGE     | 电池充电启用<br>0: 禁用电池充电1: 启用电<br>池充电   | R/W |
| 11:8  | —           | 这些位被读取为0。写入值应为0。   | R/W |
| 13:12 | PHYDET[1:0] | 检测灵敏度调整<br>调整便携式设备和充电DPort的检测灵敏度<br>初始值为10b, 但需要设置为01b。  | R/W |
| 31:14 | —           | 这些位被读取为0。写入值应为0。   | R/W |

### 26.2.41 DEVADDn: 器件地址n配置寄存器 (n=0到5)

Base address: USBFS = 0x4009\_0000

Offset address: 0x0D0 + 0x2 × n

| Bit position: | 15 | 14 | 13 | 12 | 11 | 10 | 9 | 8 | 7           | 6 | 5 | 4 | 3 | 2 | 1 | 0 |
|---------------|----|----|----|----|----|----|---|---|-------------|---|---|---|---|---|---|---|
| Bit field:    | —  | —  | —  | —  | —  | —  | — | — | USBSPD[1:0] | — | — | — | — | — | — | — |
| 重置后的值:        | 0  | 0  | 0  | 0  | 0  | 0  | 0 | 0 | 0           | 0 | 0 | 0 | 0 | 0 | 0 | 0 |

| Bit  | Symbol      | Function   | R/W |
|------|-------------|--|-----|
| 5:0  | —           | 这些位被读取为0。写入值应为0。   | R/W |
| 7:6  | USBSPD[1:0] | 通信目标设备的传输速度<br>00: 不使用DEVADDn01:<br>低速10: 全速11: 禁止设<br>置 | R/W |
| 15:8 | —           | 这些位被读取为0。写入值应为0。   | R/W |

DEVADDn寄存器指定作为管道0到9的通信目标的外围设备的传输速度。

在主机控制器模式下, 在开始与任何管道通信之前设置所有DEVADDn位。仅更改中的位DEVADDn当没有有效管道使用位设置时。有效管道被定义为同时满足以下两个条件的管道:

- DEVADDn在DEVSEL[3:0]位中选择
- 所选管道的PID[1:0]位设置为BUF, 或者所选管道是DCPCTR.SUREQ位设置为1的DCP

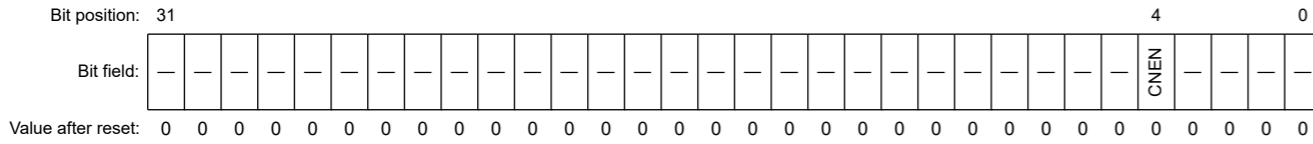
在设备控制器模式下, 将此寄存器中的所有位设置为0。

#### USBSPD[1:0]位 (通信目标设备的传输速度)

USBSPD[1:0]位指定目标外围设备的USB传输速度。当通过集线器连接全速设备时, 将这些位设置为10b。在主机控制器模式下, USBFS根据USBSPD[1:0]设置生成数据包。在设备控制器模式下, 将这些位设置为00b。

26.2.42 PHYSECTRL : PHY Single-ended Receiver Control Register

Base address: USBFS = 0x4009\_0000  
Offset address: 0x0F4



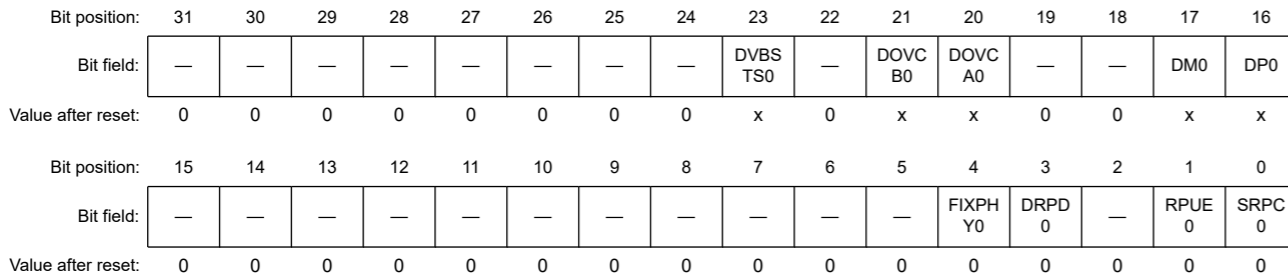
| Bit  | Symbol | Function  | R/W |
|------|--------|---|-----|
| 3:0  | —      | These bits are read as 0. The write value should be 0.  | R/W |
| 4    | CNEN   | Single-ended Receiver Enable<br>0: Single-ended receiver operation is disabled<br>1: Single-ended receiver operation is enabled | R/W |
| 31:5 | —      | These bits are read as 0. The write value should be 0.  | R/W |

**CNEN bit (Single-ended Receiver Enable)**

Setting the CNEN bit to 1 enables single-ended receiver operation. Set this bit to 1 when perform the hardware-based Data Contact Detection using the battery charging function in device controller mode.

26.2.43 DPUSR0R : Deep Software Standby USB Transceiver Control/Pin Monitor Register

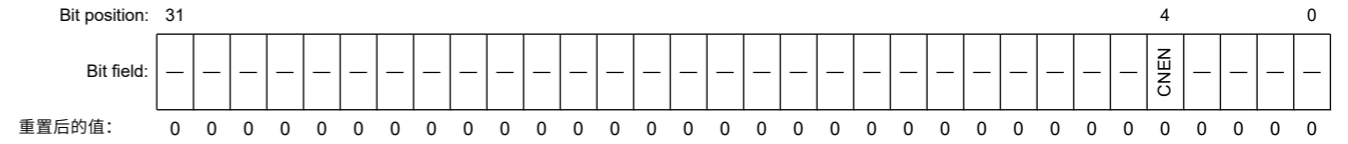
Base address: USBFS = 0x4009\_0000  
Offset address: 0x400



| Bit  | Symbol  | Function  | R/W |
|------|---------|---|-----|
| 0    | SRPC0*1 | USB Single-ended Receiver Control<br>0: Disable input through DP and DM inputs<br>1: Enable input through DP and DM inputs  | R/W |
| 1    | RPUE0*1 | DP Pull-Up Resistor Control<br>0: Disable DP pull-up resistor<br>1: Enable DP pull-up resistor  | R/W |
| 2    | —       | These bits are read as 0. The write value should be 0.  | R/W |
| 3    | DRPD0*1 | D+/D- Pull-Down Resistor Control<br>0: Disable DP/DM pull-down resistor<br>1: Enable DP/DM pull-down resistor   | R/W |
| 4    | FIXPHY0 | USB Transceiver Output Fix<br>0: Fix outputs in Normal mode and on return from Deep Software Standby mode<br>1: Fix outputs on transition to Deep Software Standby mode | R/W |
| 15:5 | —       | These bits are read as 0. The write value should be 0.  | R/W |
| 16   | DP0     | USB D+ Input<br>Indicates D+ input signal on the USBFS side   | R   |

26.2.42 PHYSECTRL:PHY单端接收器控制寄存器

Base address: USBFS = 0x4009\_0000  
Offset address: 0x0F4



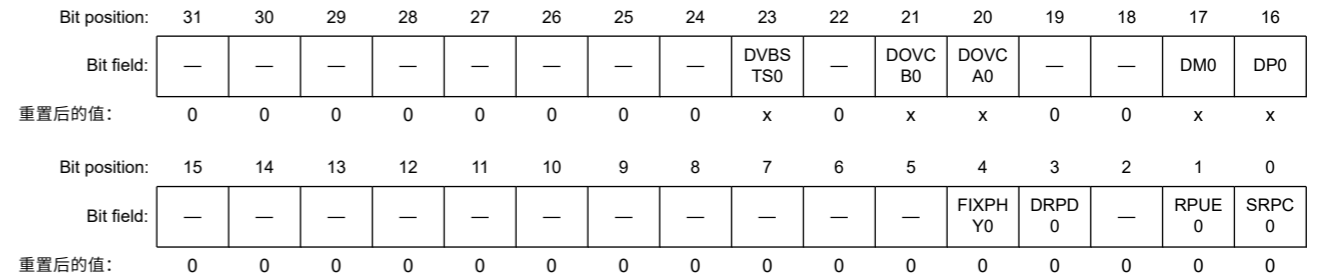
| Bit  | Symbol | Function                            | R/W |
|------|--------|-------------------------------------|-----|
| 3:0  | —      | 这些位被读取为0。写入值应为0。                    | R/W |
| 4    | CNEN   | 单端接收器使能<br>0: 禁止单端接收器操作1: 使能单端接收器操作 | R/W |
| 31:5 | —      | 这些位被读取为0。写入值应为0。                    | R/W |

**CNEN位 (单端接收器使能)**

将CNEN位设置为1可启用单端接收器操作。执行基于硬件的数据时将此位设置为1在设备控制器模式下使用电池充电功能进行接触检测。

26.2.43 DPUSR0R:DeepSoftwareStandbyUSBTransceiverControlPinMonitor Register

Base address: USBFS = 0x4009\_0000  
Offset address: 0x400



| Bit  | Symbol  | Function  | R/W |
|------|---------|---|-----|
| 0    | SRPC0*1 | USB单端接收器控制<br>0: 通过DP和DM输入禁用输入1: 通过DP和DM输入启用输入              | R/W |
| 1    | RPUE0*1 | DP上拉电阻控制<br>0: 禁用DP上拉电阻1: 启用DP上拉电阻                          | R/W |
| 2    | —       | 这些位被读取为0。写入值应为0。  | R/W |
| 3    | DRPD0*1 | D+D-下拉电阻控制<br>0: 禁用DPDM下拉电阻1: 启用DPDM下拉电阻                    | R/W |
| 4    | FIXPHY0 | USB收发器输出修复<br>0: 在正常模式和从深度软件待机模式返回时修复输出1: 在转换到深度软件待机模式时修复输出 | R/W |
| 15:5 | —       | 这些位被读取为0。写入值应为0。  | R/W |
| 16   | DP0     | USB D+输入<br>指示USBFS侧的D+输入 信号                                | R   |

| Bit   | Symbol | Function  | R/W |
|-------|--------|---|-----|
| 17    | DM0    | USB D- Input<br>Indicates D- input signal on the USBFS side           | R   |
| 19:18 | —      | These bits are read as 0. The write value should be 0.                | R/W |
| 20    | DOVCA0 | USB OVRCURA Input<br>Indicates OVRCURA input signal on the USBFS side | R   |
| 21    | DOVCB0 | USB OVRCURB Input<br>Indicates OVRCURB input signal on the USBFS side | R   |
| 22    | —      | The read value is undefined. The write value should be 0.             | R/W |
| 23    | DVBST0 | USB VBUS Input<br>Indicates VBUS input signal on the USBFS side       | R   |
| 31:24 | —      | These bits are read as 0. The write value should be 0.                | R/W |

Note 1. Use this bit during operation in Deep Software Standby mode. For details, see [section 26.3.1.5. Release from deep software standby mode because of USB suspend/resume interrupts.](#)

### SRPC0 bit (USB Single-ended Receiver Control)

The SRPC0 bit controls the D+ and D- inputs of the USB transceiver. In host controller mode, set this bit to 1. In device controller mode, set this bit to 0 when disconnected, set to 1 when suspended. This bit is only valid when the FIXPHY0 bit is 1.

### FIXPHY0 bit (USB Transceiver Output Fix)

The FIXPHY0 bit keeps the outputs of the USB transceiver disabled.

## 26.2.44 DPUSR1R : Deep Software Standby USB Suspend/Resume Interrupt Register

Base address: USBFS = 0x4009\_0000

Offset address: 0x404

| Bit position:      | 31 | 30 | 29 | 28 | 27 | 26 | 25 | 24 | 23          | 22 | 21                | 20                | 19 | 18 | 17          | 16          |
|--------------------|----|----|----|----|----|----|----|----|-------------|----|-------------------|-------------------|----|----|-------------|-------------|
| Bit field:         | —  | —  | —  | —  | —  | —  | —  | —  | DVBIN<br>T0 | —  | DOVR<br>CRB0      | DOVR<br>CRA0      | —  | —  | DMINT<br>0  | DPINT<br>0  |
| Value after reset: | 0  | 0  | 0  | 0  | 0  | 0  | 0  | 0  | 0           | 0  | 0                 | 0                 | 0  | 0  | 0           | 0           |
| Bit position:      | 15 | 14 | 13 | 12 | 11 | 10 | 9  | 8  | 7           | 6  | 5                 | 4                 | 3  | 2  | 1           | 0           |
| Bit field:         | —  | —  | —  | —  | —  | —  | —  | —  | DVBS<br>E0  | —  | DOVR<br>CRBE<br>0 | DOVR<br>CRAE<br>0 | —  | —  | DMINT<br>E0 | DPINT<br>E0 |
| Value after reset: | 0  | 0  | 0  | 0  | 0  | 0  | 0  | 0  | 0           | 0  | 0                 | 0                 | 0  | 0  | 0           | 0           |

| Bit | Symbol    | Function  | R/W |
|-----|-----------|---|-----|
| 0   | DPINTE0   | USB DP Interrupt Enable/Clear<br>0: Disable recovery from Deep Software Standby mode by DP input<br>1: Enable recovery from Deep Software Standby mode by DP input                | R/W |
| 1   | DMINTE0   | USB DM Interrupt Enable/Clear<br>0: Disable recovery from Deep Software Standby mode by DM input<br>1: Enable recovery from Deep Software Standby mode by DM input                | R/W |
| 3:2 | —         | These bits are read as 0. The write value should be 0.  | R/W |
| 4   | DOVRCRAE0 | USB OVRCURA Interrupt Enable/Clear<br>0: Disable recovery from Deep Software Standby mode by OVRCURA input<br>1: Enable recovery from Deep Software Standby mode by OVRCURA input | R/W |
| 5   | DOVRCRBE0 | USB OVRCURB Interrupt Enable/Clear<br>0: Disable recovery from Deep Software Standby mode by OVRCURB input<br>1: Enable recovery from Deep Software Standby mode by OVRCURB input | R/W |
| 6   | —         | This bit is read as 0. The write value should be 0.   | R/W |

| Bit   | Symbol | Function                             | R/W |
|-------|--------|--------------------------------------|-----|
| 17    | DM0    | USB D- Input<br>指示USBFS侧的D 输入信号      | R   |
| 19:18 | —      | 这些位被读取为0。写入值应为0。                     | R/W |
| 20    | DOVCA0 | USBOVRCURA输入<br>指示USBFS侧的OVRCURA输入信号 | R   |
| 21    | DOVCB0 | USBOVRCURB输入<br>指示USBFS侧的OVRCURB输入信号 | R   |
| 22    | —      | 读取值未定义。写入值应为0。                       | R/W |
| 23    | DVBST0 | USBVBUS输入<br>指示USBFS侧的VBUS输入信号       | R   |
| 31:24 | —      | 这些位被读取为0。写入值应为0。                     | R/W |

注1.在深度软件待机模式下操作期间使用该位。有关详细信息，请参阅第26.3.1.5节。由于USB挂起恢复中断而从深度软件待机模式中释放。

### SRPC0位 (USB单端接收器控制)

SRPC0位控制USB收发器的D+和D输入。在主机控制器模式下，将此位设置为1。在设备控制器模式下，断开连接时将此位设置为0，暂停时设置为1。该位仅在FIXPHY0位为1时有效。

### FIXPHY0位 (USB收发器输出修复)

FIXPHY0位保持禁用USB收发器的输出。

## 26.2.44 DPUSR1R:深度软件待机USB暂停恢复中断寄存器

Base address: USBFS = 0x4009\_0000

Offset address: 0x404

| Bit position: | 31 | 30 | 29 | 28 | 27 | 26 | 25 | 24 | 23          | 22 | 21                | 20                | 19 | 18 | 17          | 16          |
|---------------|----|----|----|----|----|----|----|----|-------------|----|-------------------|-------------------|----|----|-------------|-------------|
| Bit field:    | —  | —  | —  | —  | —  | —  | —  | —  | DVBIN<br>T0 | —  | DOVR<br>CRB0      | DOVR<br>CRA0      | —  | —  | DMINT<br>0  | DPINT<br>0  |
| 重置后的值:        | 0  | 0  | 0  | 0  | 0  | 0  | 0  | 0  | 0           | 0  | 0                 | 0                 | 0  | 0  | 0           | 0           |
| Bit position: | 15 | 14 | 13 | 12 | 11 | 10 | 9  | 8  | 7           | 6  | 5                 | 4                 | 3  | 2  | 1           | 0           |
| Bit field:    | —  | —  | —  | —  | —  | —  | —  | —  | DVBS<br>E0  | —  | DOVR<br>CRBE<br>0 | DOVR<br>CRAE<br>0 | —  | —  | DMINT<br>E0 | DPINT<br>E0 |
| 重置后的值:        | 0  | 0  | 0  | 0  | 0  | 0  | 0  | 0  | 0           | 0  | 0                 | 0                 | 0  | 0  | 0           | 0           |

| Bit | Symbol    | Function   | R/W |
|-----|-----------|--|-----|
| 0   | DPINTE0   | USBDP中断使能清除<br>0: 禁止通过DP输入从深度软件待机模式恢复1: 允许通过DP输入从深度软件待机模式恢复                | R/W |
| 1   | DMINTE0   | USBDM中断使能清除<br>0: 禁止通过DM输入从深度软件待机模式恢复1: 允许通过DM输入从深度软件待机模式恢复                | R/W |
| 3:2 | —         | 这些位被读取为0。写入值应为0。   | R/W |
| 4   | DOVRCRAE0 | USBOVRCURA中断使能清除<br>0: 通过OVRCURA输入禁止从深度软件待机模式恢复1: 通过OVRCURA输入允许从深度软件待机模式恢复 | R/W |
| 5   | DOVRCRBE0 | USBOVRCURB中断使能清除<br>0: 通过OVRCURB输入禁用从深度软件待机模式恢复1: 通过OVRCURB输入从深度软件待机模式启用恢复 | R/W |
| 6   | —         | 该位读取为0。写入值应为0。   | R/W |



| Bit   | Symbol   | Function   | R/W |
|-------|----------|--|-----|
| 7     | DVBSE0   | USB VBUS Interrupt Enable/Clear<br>0: Disable recovery from Deep Software Standby mode by VBUS input<br>1: Enable recovery from Deep Software Standby mode by VBUS input             | R/W |
| 15:8  | —        | T These bits are read as 0. The write value should be 0. .   | R/W |
| 16    | DPINT0   | USB DP Interrupt Source Recovery<br>0: System has not recovered from Deep Software Standby mode<br>1: System recovered from Deep Software Standby mode because of DP                 | R   |
| 17    | DMINT0   | USB DM Interrupt Source Recovery<br>0: System has not recovered from Deep Software Standby mode<br>1: System recovered from Deep Software Standby mode because of DM input           | R   |
| 19:18 | —        | This bit is read as 0. The write value should be 0.  | R/W |
| 20    | DOVRCRA0 | USB OVRCURA Interrupt Source Recovery<br>0: System has not recovered from Deep Software Standby mode<br>1: System recovered from Deep Software Standby mode because of OVRCURA input | R   |
| 21    | DOVRCRB0 | USB OVRCURB Interrupt Source Recovery<br>0: System has not recovered from Deep Software Standby mode<br>1: System recovered from Deep Software Standby mode because of OVRCURB input | R   |
| 22    | —        | This bit is read as 0. The write value should be 0.  | R/W |
| 23    | DVBINT0  | USB VBUS Interrupt Source Recovery<br>0: System has not recovered from Deep Software Standby mode<br>1: System recovered from Deep Software Standby mode because of VBUS input       | R   |
| 31:24 | —        | These bits are read as 0. The write value should be 0.   | R/W |

**DPINTE0 bit (USB DP Interrupt Enable/Clear)**

The DPINTE0 bit enables or disables triggering of recovery from Deep Software Standby mode by the DP input of the USBFS. Writing 0 to this bit while the DPINT0 bit is 1 sets the DPINT0 bit to 0.

**DMINTE0 bit (USB DM Interrupt Enable/Clear)**

The DMINTE0 bit enables or disables triggering of recovery from Deep Software Standby mode by the DM input of the USBFS. Writing 0 to this bit while the DMINT0 bit is 1 clears the DMINT0 bit to 0.

**DOVRCRAE0 bit (USB OVRCURA Interrupt Enable/Clear)**

The DOVRCRAE0 bit enables or disables triggering of recovery from Deep Software Standby mode by the OVRCURA input of the USBFS. Writing 0 to this bit while the DOVRCRA0 bit is 1 clears the DOVRCRA0 bit to 0.

**DOVRCRBE0 bit (USB OVRCURB Interrupt Enable/Clear)**

The DOVRCRBE0 bit enables or disables triggering of recovery from Deep Software Standby mode by the OVRCURB input of the USBFS. Writing 0 to this bit while the DOVRCRB0 bit is 1 clears the DOVRCRB0 bit to 0.

**DVBSE0 bit (USB VBUS Interrupt Enable/Clear)**

The DVBSE0 bit enables or disables triggering of recovery from Deep Software Standby mode by the VBUS input of the USBFS. Writing 0 to this bit while the DVBINT0 bit is 1 clears the DVBINT0 bit to 0.

**DPINT0 bit (USB DP Interrupt Source Recovery)**

The DPINT0 bit indicates that the system has returned from Deep Software Standby mode because of the DP input of the USBFS. This recovery is only enabled when the DPINTE0 bit is 1. Writing 0 to the DPINTE0 bit while this bit is 1 clears this bit to 0.

**DMINT0 bit (USB DM Interrupt Source Recovery)**

The DMINT0 bit indicates that the system has returned from Deep Software Standby mode because of the DM input of the USBFS. This recovery is only enabled when the DMINTE0 bit is 1. Writing 0 to the DMINTE0 bit while this bit is 1 clears this bit to 0.

| Bit   | Symbol   | Function  | R/W |
|-------|----------|---|-----|
| 7     | DVBSE0   | USBVBUS中断使能清除<br>0: 禁止通过VBUS输入从深度软件待机模式恢复1: 使能通过VBUS输入从深度软件待机模式恢复   | R/W |
| 15:8  | —        | T这些位被读取为0。写入值应为0。   | R/W |
| 16    | DPINT0   | USBDP中断源恢复<br>0: 系统尚未从深度软件待机模式中恢复1: 系统由于DP从深度软件待机模式中恢复              | R   |
| 17    | DMINT0   | USBDM中断源恢复<br>0: 系统尚未从深度软件待机模式中恢复1: 系统由于DM输入而从深度软件待机模式中恢复           | R   |
| 19:18 | —        | 该位读取为0。写入值应为0。  | R/W |
| 20    | DOVRCRA0 | USBOVRCURA中断源恢复<br>0: 系统尚未从深度软件待机模式中恢复1: 系统由于OVRCURA输入而从深度软件待机模式中恢复 | R   |
| 21    | DOVRCRB0 | USBOVRCURB中断源恢复<br>0: 系统尚未从深度软件待机模式中恢复1: 系统由于OVRCURB输入而从深度软件待机模式中恢复 | R   |
| 22    | —        | 该位读取为0。写入值应为0。  | R/W |
| 23    | DVBINT0  | USBVBUS中断源恢复<br>0: 系统尚未从深度软件待机模式中恢复1: 系统由于VBUS输入而从深度软件待机模式中恢复       | R   |
| 31:24 | —        | 这些位被读取为0。写入值应为0。  | R/W |

**DPINTE0位 (USBDP中断使能清除)**

DPINTE0位启用或禁用触发从深度软件待机模式恢复由DP输入USBFS。当DPINT0位为1时向该位写入0会将DPINT0位设置为0。

**DMINTE0位 (USBDM中断使能清除)**

DMINTE0位启用或禁用触发从深度软件待机模式恢复由DM输入USBFS。当DMINT0位为1时向该位写入0会将DMINT0位清除为0。

**DOVRCRAE0位 (USBOVRCURA中断使能清除)**

DOVRCRAE0位通过USBFS的OVRCURA输入启用或禁用从深度软件待机模式恢复的触发。当DOVRCRA0位为1时向该位写入0会将DOVRCRA0位清除为0。

**DOVRCRBE0位 (USBOVRCURB中断使能清除)**

DOVRCRBE0位通过USBFS的OVRCURB输入启用或禁用从深度软件待机模式恢复的触发。当DOVRCRB0位为1时向该位写入0会将DOVRCRB0位清除为0。

**DVBSE0位 (USBVBUS中断使能清除)**

DVBSE0位通过VBUS输入启用或禁用从深度软件待机模式恢复的触发USBFS。当DVBINT0位为1时向该位写入0会将DVBINT0位清除为0。

**DPINT0位 (USBDP中断源恢复)**

由于USBFS的DP输入，DPINT0位指示系统已从深度软件待机模式返回。此恢复仅在DPINTE0位为1时启用。当该位为1时向DPINTE0位写入0将该位清除为0。

**DMINT0位 (USBDM中断源恢复)**

由于USBFS的DM输入，DMINT0位指示系统已从深度软件待机模式返回。此恢复仅在DMINTE0位为1时启用。当该位为1时向DMINTE0位写入0会将该位清除为0。

**DOVRCRA0 bit (USB OVRCURA Interrupt Source Recovery)**

The DOVRCRA0 bit indicates that the system has returned from Deep Software Standby mode because of the OVRCURA input of the USBFS. This recovery is only enabled when the DOVRCRAE0 bit is 1. Writing 0 to the DOVRCRAE0 bit while this bit is 1 clears this bit to 0.

**DOVRCRB0 bit (USB OVRCURB Interrupt Source Recovery)**

The DOVRCRB0 bit indicates that the system has returned from Deep Software Standby mode because of the OVRCURB input of the USBFS. This recovery is only enabled when the DOVRCRBE0 bit is 1. Writing 0 to the DOVRCRBE0 bit while this bit is 1 clears this bit to 0.

**DVBINT0 bit (USB VBUS Interrupt Source Recovery)**

The DVBINT0 bit indicates that the system has returned from Deep Software Standby mode because of the VBUS input of the USBFS. This recovery is only enabled when the DVBSE0 bit is 1. Writing 0 to the DVBSE0 bit while this bit is 1 clears this bit to 0.

**26.3 Operation****26.3.1 System Control**

This section describes register settings required for initializing the USBFS and controlling power consumption.

**26.3.1.1 Setting data to the USBFS registers**

Setting the SYSCFG.USBE bit to 1 after starting the clock supply (SYSCFG.SCKE bit = 1) enables and starts USBFS operation.

**26.3.1.2 Selecting the controller function**

The USBFS can operate as either a host or device controller.

Use the SYSCFG.DCFM bit to select one of these USBFS functions. The DCFM bit must be changed in the initial settings immediately after a reset or in the D+ pull-up-disabled state (SYSCFG.DPRPU bit = 0) and D+ and D- pull-down-disabled state (SYSCFG.DRPD bit = 0).

**26.3.1.3 Controlling the USB data bus using resistors**

The USBFS provides pull-up and pull-down resistors for the D+ and D- lines. Pull these lines up or down by setting the SYSCFG.DPRPU and DRPD bits.

In device controller mode, confirm that connection to the USB host is made, and then set the SYSCFG.DPRPU bit to 1 and pull up the D+ line (in full-speed communication).

When the SYSCFG.DPRPU bit is set to 0 during communication with a PC, the USBFS disables the pull-up resistor of the USB data line, thereby notifying the USB host of disconnection.

In host controller mode, set the SYSCFG.DRPD bit to 1 to pull down the D+ and D- lines.

**Table 26.14 USB data bus resistor control**

| SYSCFG register settings |           | USB data bus control |           | Function  |
|--------------------------|-----------|----------------------|-----------|---|
| DRPD bit                 | DPRPU bit | D-                   | D+        |   |
| 0                        | 0         | Open                 | Open      | When resistors not used                             |
| 0                        | 1         | Open                 | Pull-up   | When operating as a device controller at full-speed |
| 1                        | 0         | Pull-down            | Pull-down | When operating as a host controller                 |
| 1                        | 1         | —                    | —         | Setting prohibited                                  |

**26.3.1.4 Example external connection circuits**

Figure 26.2 shows an example OTG connection in the self-powered system. The USBFS controls the pull-up resistor of the D+ line and the pull-down resistor of D+ and D- lines. Select pull-up and pull-down for the lines in the SYSCFG.DPRPU

**DOVRCRA0位 (USBOVRCURA中断源恢复)**

由于USBFS的OVRCURA输入，DOVRCRA0位指示系统已从深度软件待机模式返回。此恢复仅在DOVRCRAE0位为1时启用。当此位为1时向DOVRCRAE0位写入0会将该位清除为0。

**DOVRCRB0位 (USBOVRCURB中断源恢复)**

DOVRCRB0位指示由于USBFS的OVRCURB输入，系统已从深度软件待机模式返回。此恢复仅在DOVRCRBE0位为1时启用。当此位为1时向DOVRCRBE0位写入0会将该位清除为0。

**DVBINT0位 (USBVBUS中断源恢复)**

由于USBFS的VBUS输入，DVBINT0位指示系统已从深度软件待机模式返回。此恢复仅在DVBSE0位为1时启用。当该位为1时将0写入DVBSE0位可将该位清除为0。

**26.3 Operation****26.3.1 系统控制**

本节介绍初始化USBFS和控制功耗所需的寄存器设置。

**26.3.1.1 将数据设置到USBFS寄存器**

启动时钟供应 (SYSCFG.SCKE位=1) 后将SYSCFG.USBE位设置为1启用并启动USBFS操作。

**26.3.1.2 选择控制器功能**

USBFS可以作为主机或设备控制器运行。

使用SYSCFG.DCFM位选择这些USBFS功能之一。DCFm位必须在复位后立即更改为初始设置或在D+上拉禁用状态 (SYSCFG.DPRPU位=0) 和D+和D- 下拉禁用状态 (SYSCFG.DRPD位=0) 。

**26.3.1.3 使用电阻控制USB数据总线**

USBFS为D+和D-线提供上拉和下拉电阻。通过设置SYSCFG.DPRPU和DRPD位。

在设备控制器模式下，确认与USB主机的连接已建立，然后将SYSCFG.DPRPU位设置为1并拉高D+线 (全速通信)。

当SYSCFG.DPRPU位在与PC通信期间设置为0时，USBFS禁用上拉电阻USB数据线，从而通知USB主机断开。

在主机控制器模式下，将SYSCFG.DRPD位设置为1以拉低D+和D-线。

**Table 26.14 USB数据总线电阻控制**

| SYSCFG寄存器设置 |           | USB数据总线控制 |           | Function     |
|-------------|-----------|-----------|-----------|--------------|
| DRPD bit    | DPRPU bit | D-        | D+        |              |
| 0           | 0         | Open      | Open      | 不使用电阻时       |
| 0           | 1         | Open      | Pull-up   | 作为设备控制器全速运行时 |
| 1           | 0         | Pull-down | Pull-down | 作为主机控制器运行时   |
| 1           | 1         | —         | —         | 禁止设定         |

**26.3.1.4 外部连接电路示例**

图26.2显示了自供电系统中的示例OTG连接。USBFS控制的上拉电阻D+线和D+和D-线的下拉电阻。为SYSCFG.DPRPU中的行选择上拉和下拉

and SYSCFG.DRPD bits. In device controller mode, the pull-up resistor of USB data line is disabled if SYSCFG.DPRPU bit is set to 0 while communicating with the USB host. The USBFS can use this to notify the USB host of a device disconnect.

和SYSCFG.DRPD位。在设备控制器模式下，如果在与USB主机通信时将SYSCFG.DPRPU位设置为0，则禁用USB数据线的上拉电阻。USBFS可以使用它来通知USB主机设备断开连接。

RA生态工作室

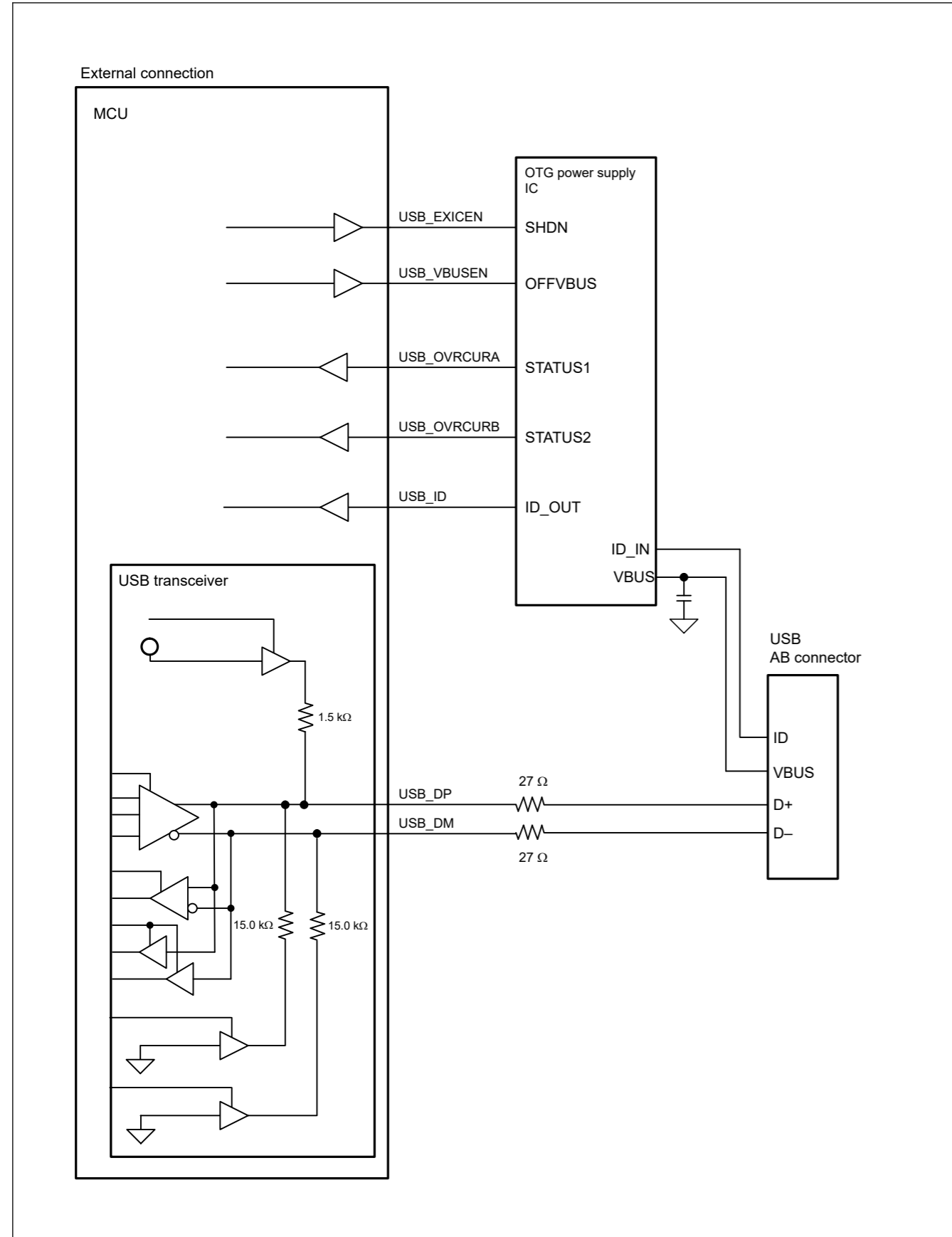


Figure 26.2 Example OTG connection in a self-powered system

Figure 26.3 shows an example device connection in a self-powered system.

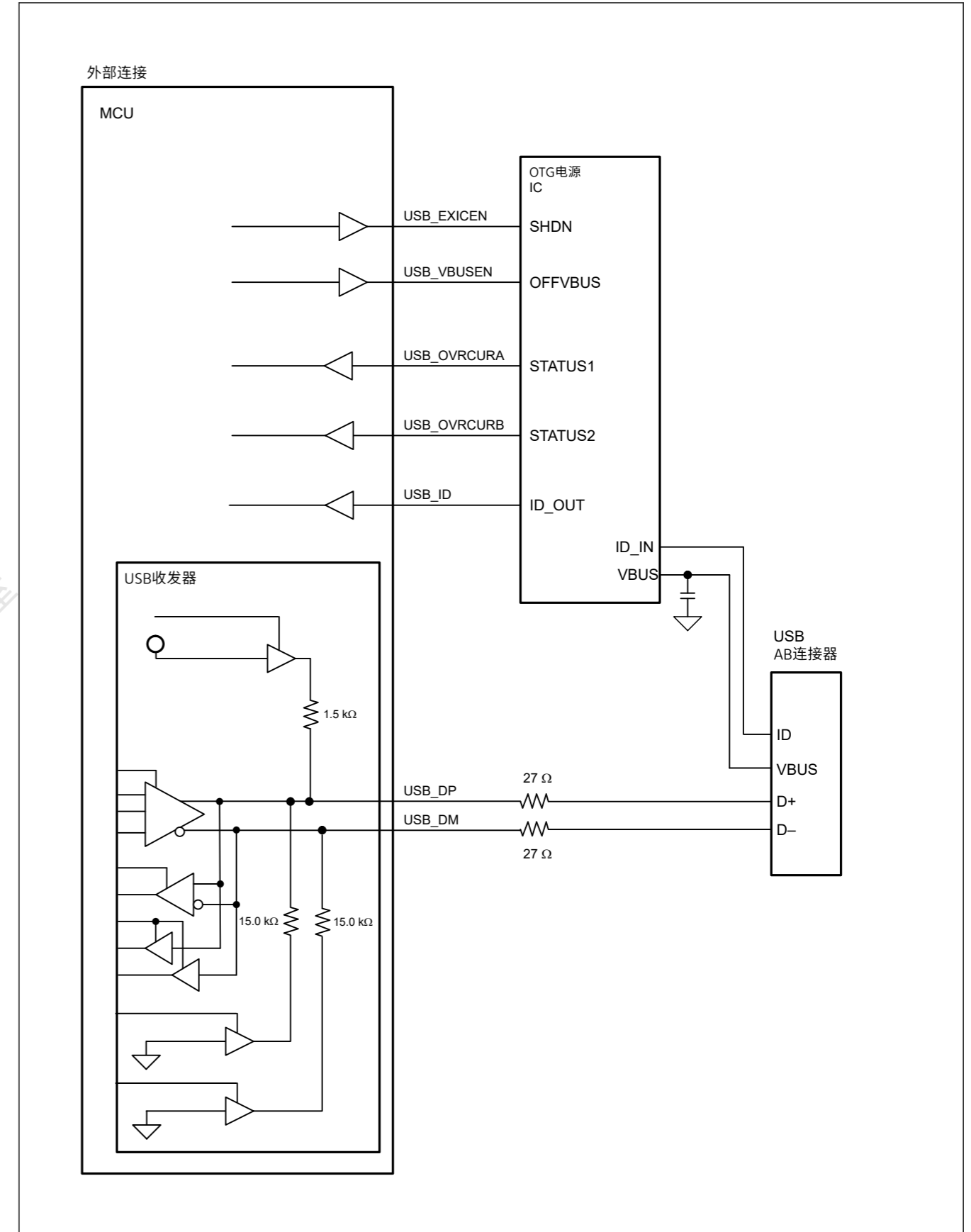


Figure 26.2 自供电系统中的示例OTG连接

图26.3显示了自供电系统中的示例设备连接。



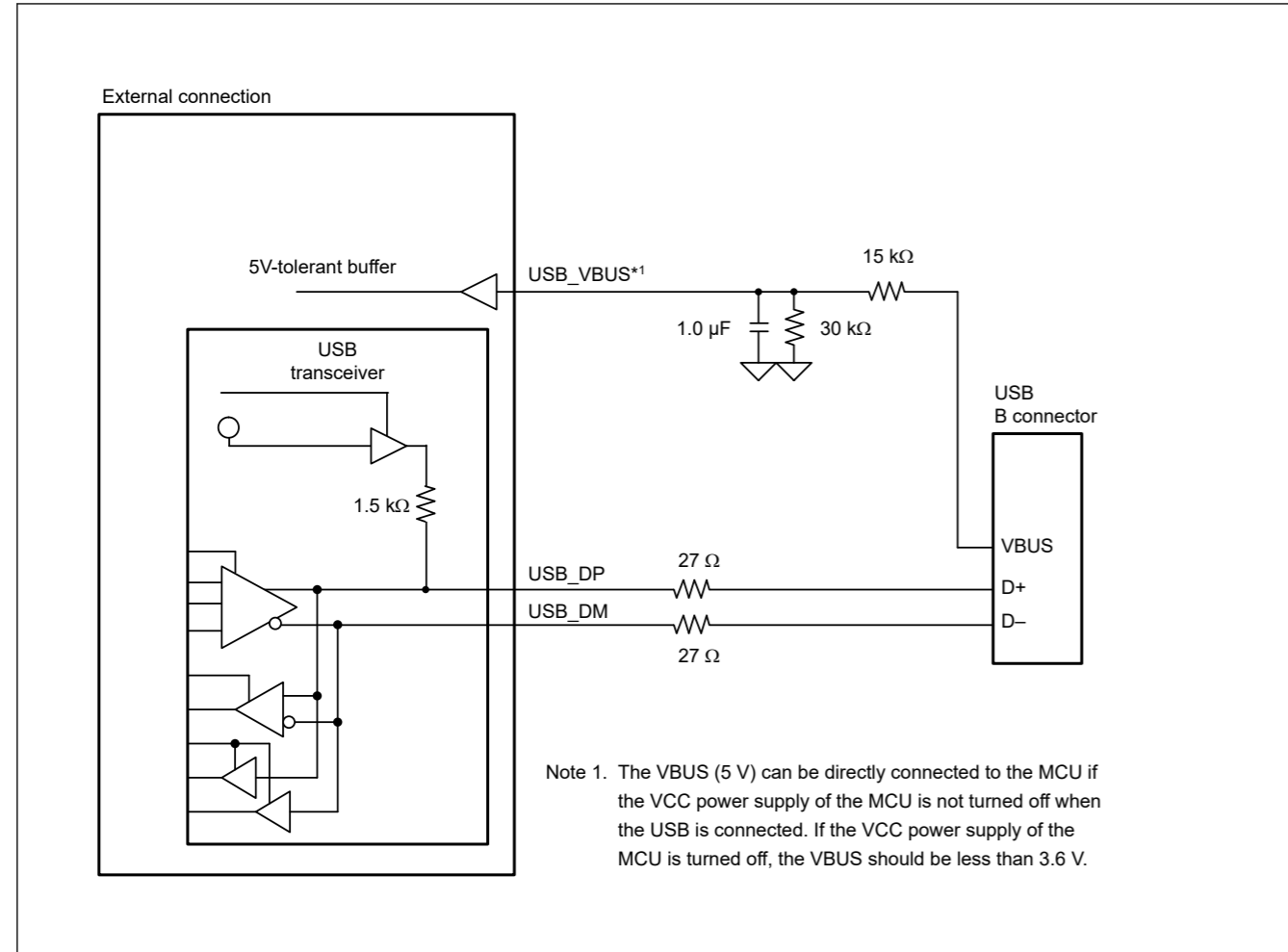


Figure 26.3 Example device connection in a self-powered system

Figure 26.4 shows an example host connection.

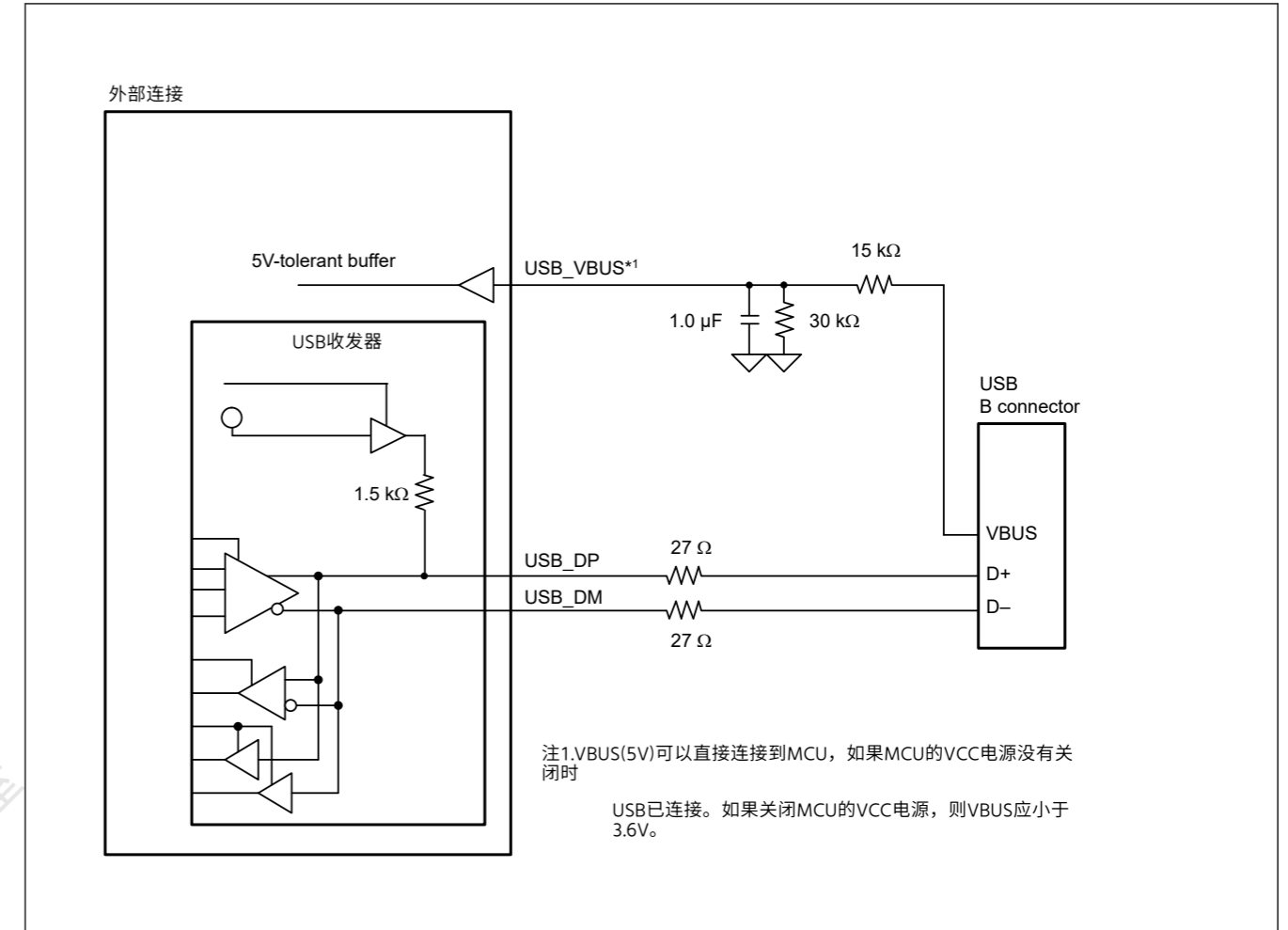


Figure 26.3 自供电系统中的示例设备连接

图26.4显示了一个示例主机连接。

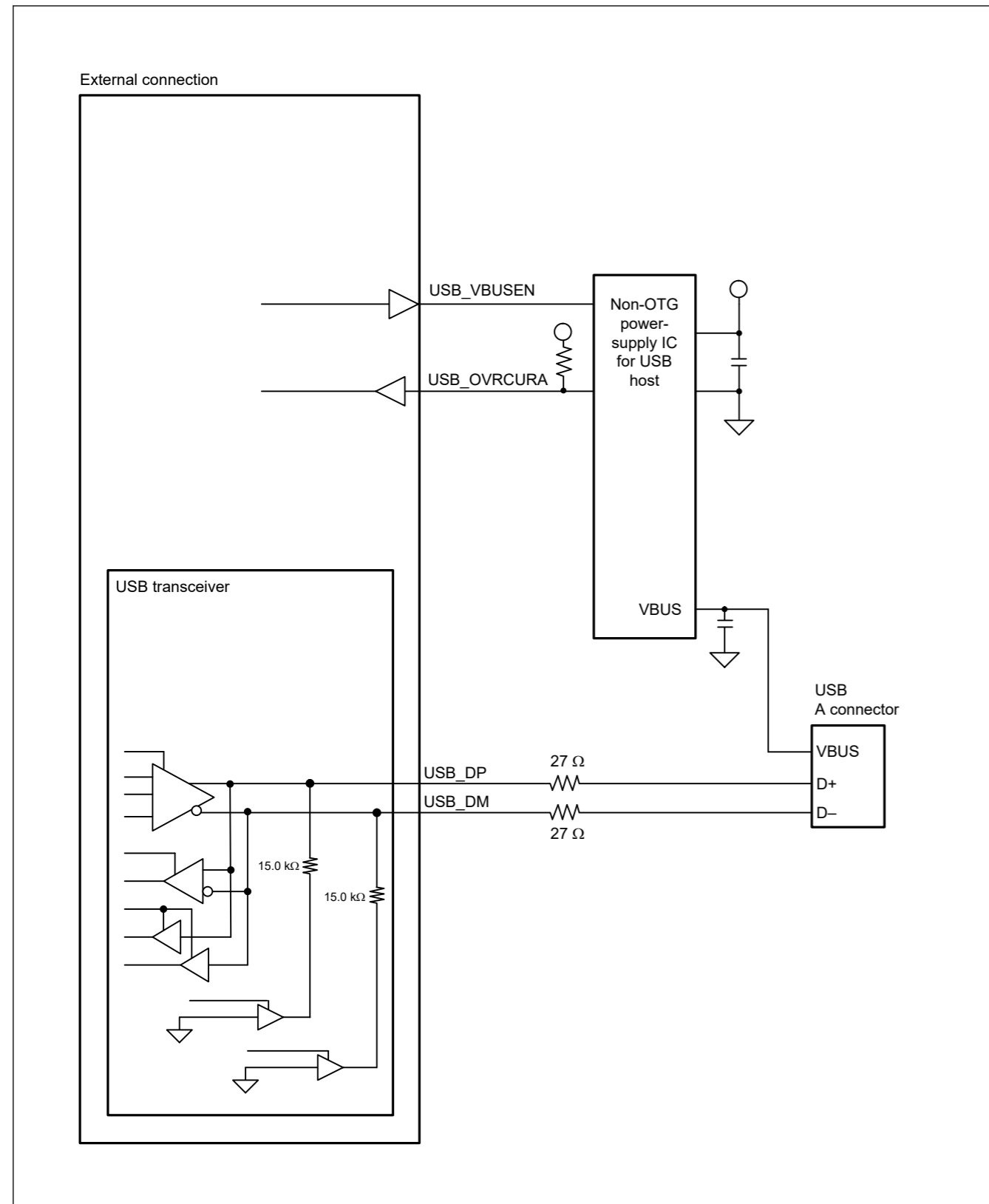


Figure 26.4 Example host connection

Figure 26.5 shows an example device connection in a bus-powered system.

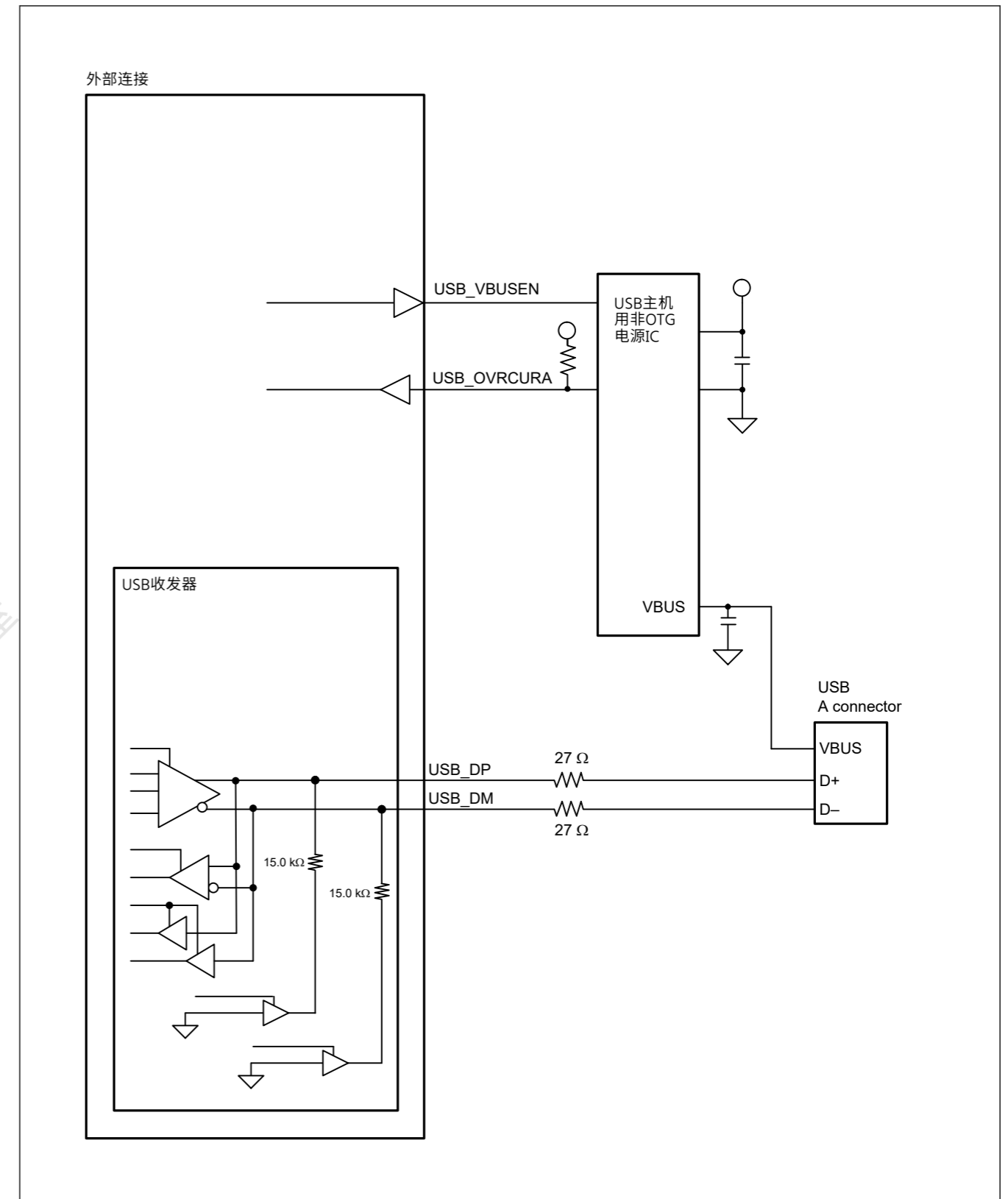


Figure 26.4 主机连接示例

图26.5显示了总线供电系统中的示例设备连接。

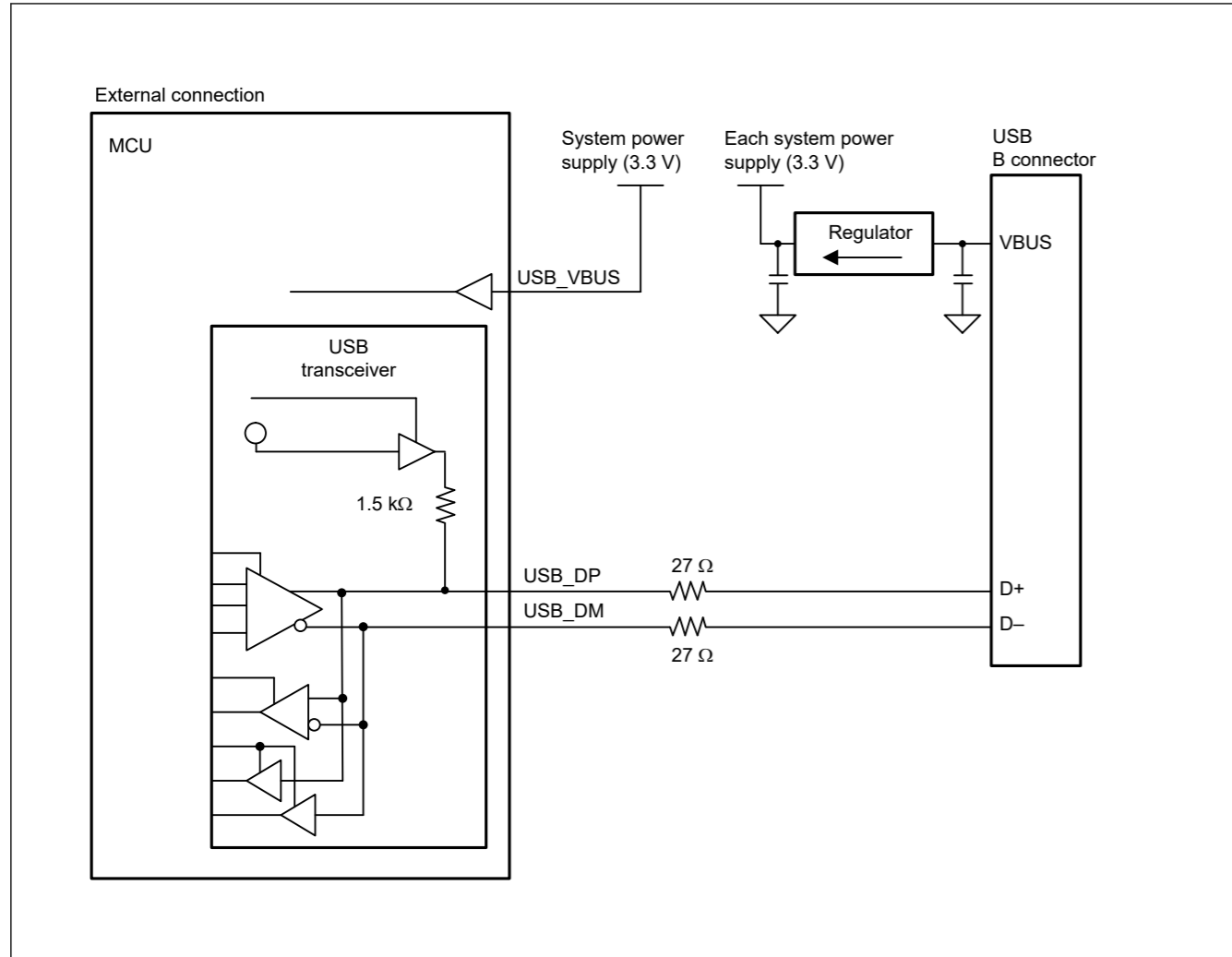


Figure 26.5 Example device connection in a bus-powered state

Figure 26.6 shows an example of functional connection of the USB connector with Battery Charging Rev 1.2 supported.

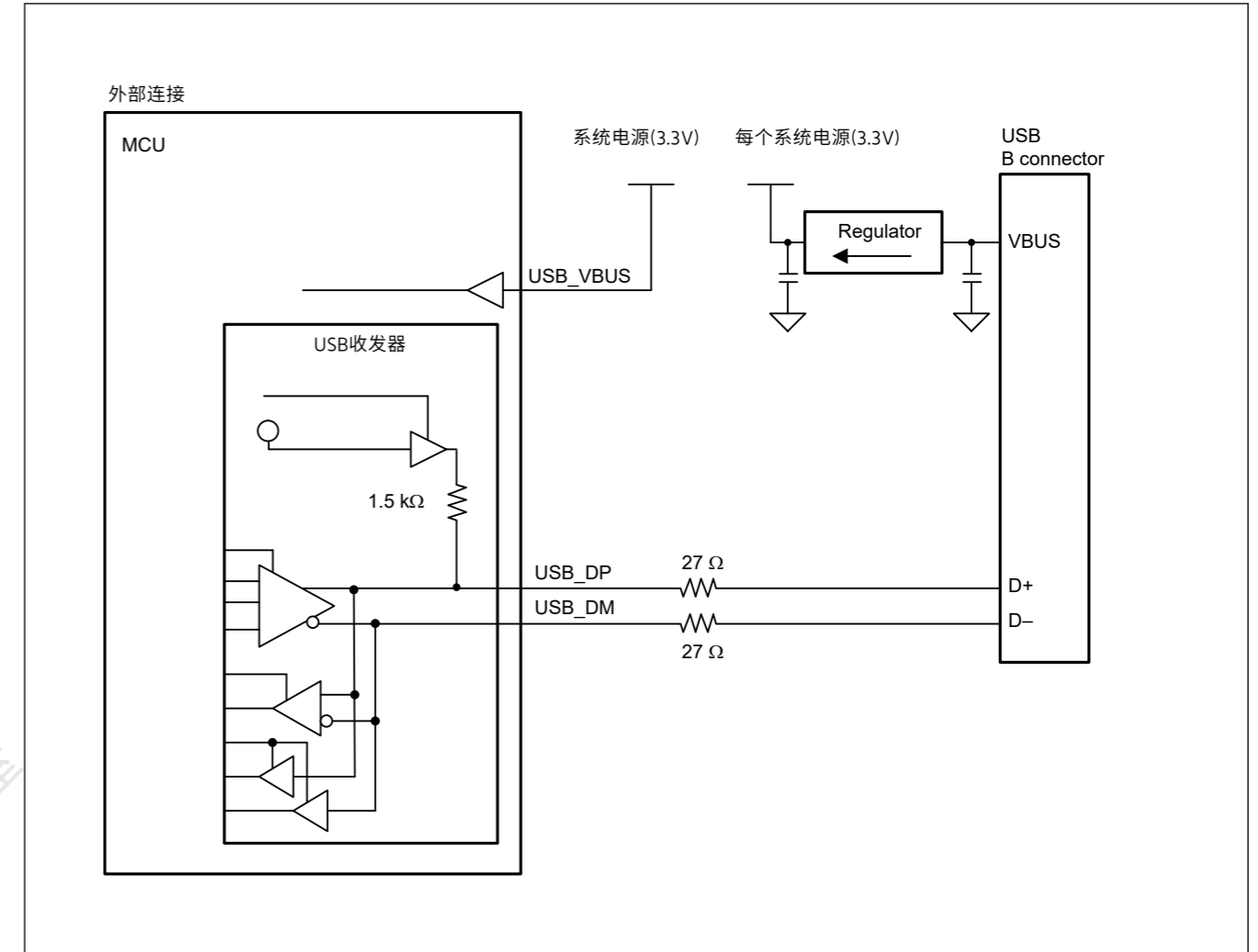


Figure 26.5 总线供电状态下的示例设备连接

图26.6显示了支持电池充电Rev1.2的USB连接器的功能连接示例。

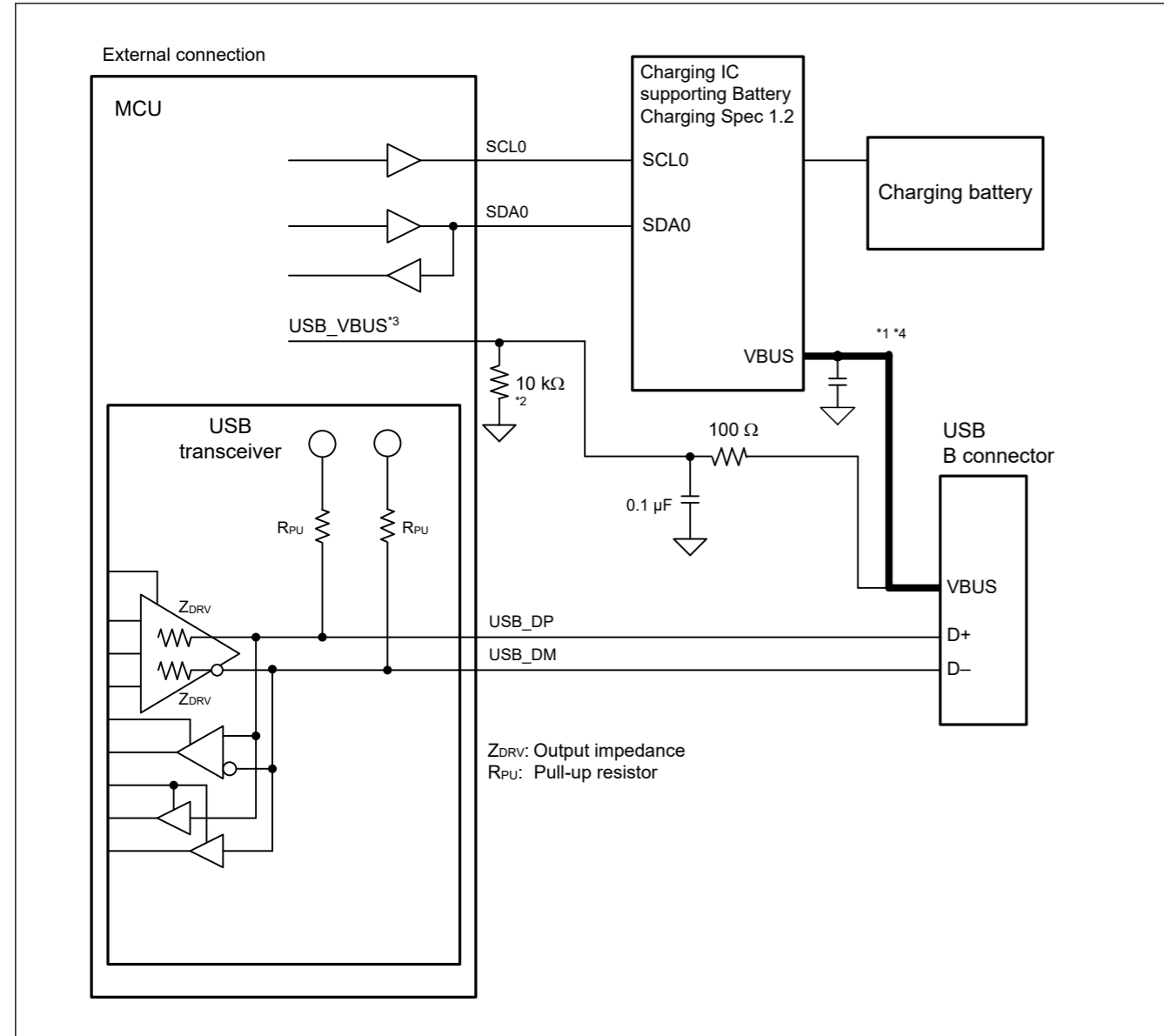


Figure 26.6 Example of functional connection with Battery Charging Rev 1.2 supported

The examples of external circuits given in this section are simplified circuits, and their operation in every system is not guaranteed.

### 26.3.1.5 Release from deep software standby mode because of USB suspend/resume interrupts

Deep Software Standby mode can be canceled by a USB suspend/resume interrupt. USB suspend/resume interrupts are detected by the USB resume detecting unit, which controls and monitors the USB I/O pins to detect the interrupts.

Figure 26.7 shows a schematic diagram of the connection between the USB resume detecting unit and the USB I/O pins.

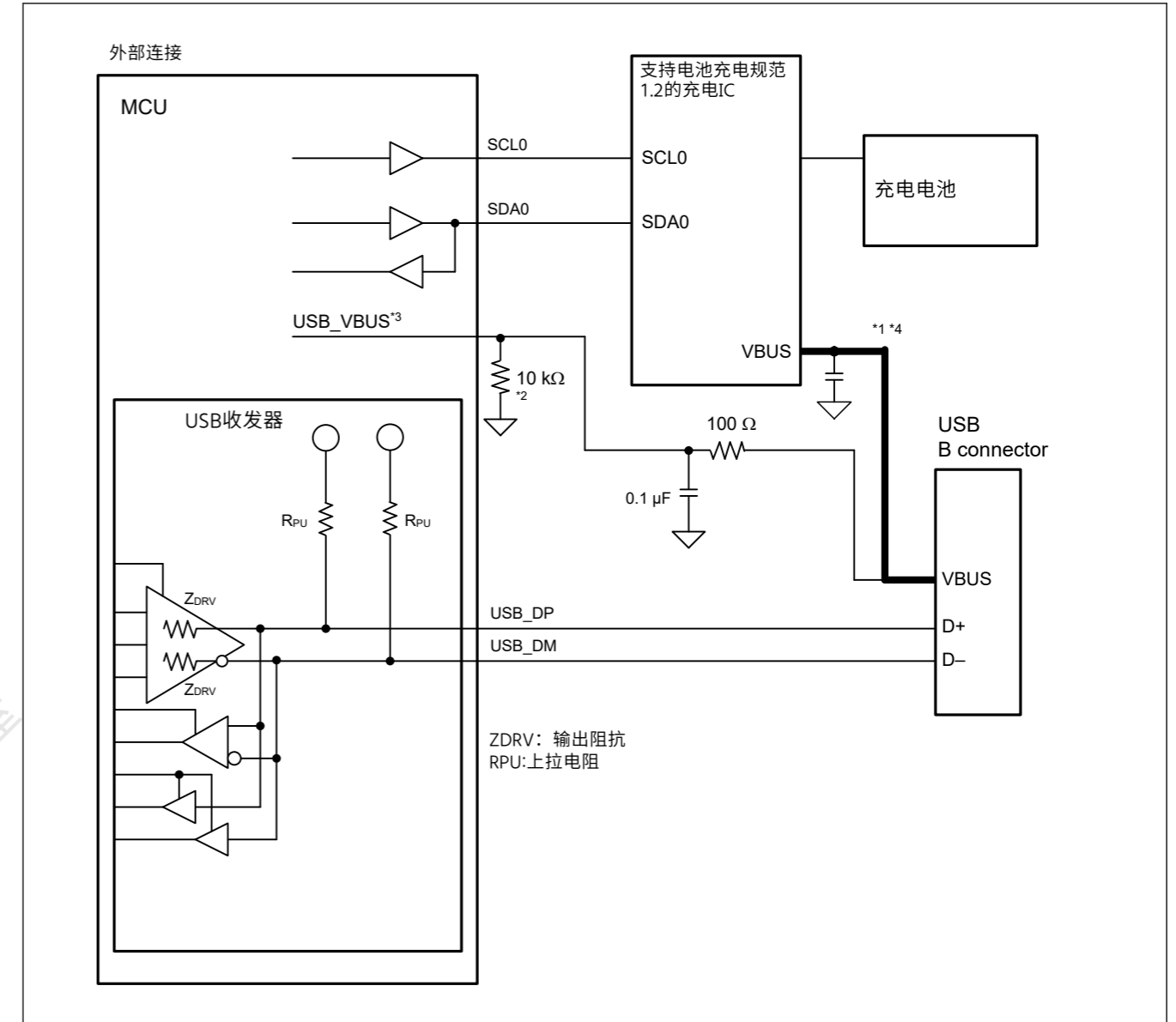


Figure 26.6 支持电池充电版本1.2的功能连接示例

本节中给出的外部电路示例是简化电路，不保证它们在每个系统中的操作。

### 26.3.1.5 由于USB挂起恢复中断而从深度软件待机模式中释放

深度软件待机模式可以通过USB挂起恢复中断来取消。USB暂停恢复中断由USB恢复检测单元检测，该单元控制和监视USBIO引脚以检测中断。

图26.7显示了USB恢复检测单元与USBIO引脚之间的连接示意图。



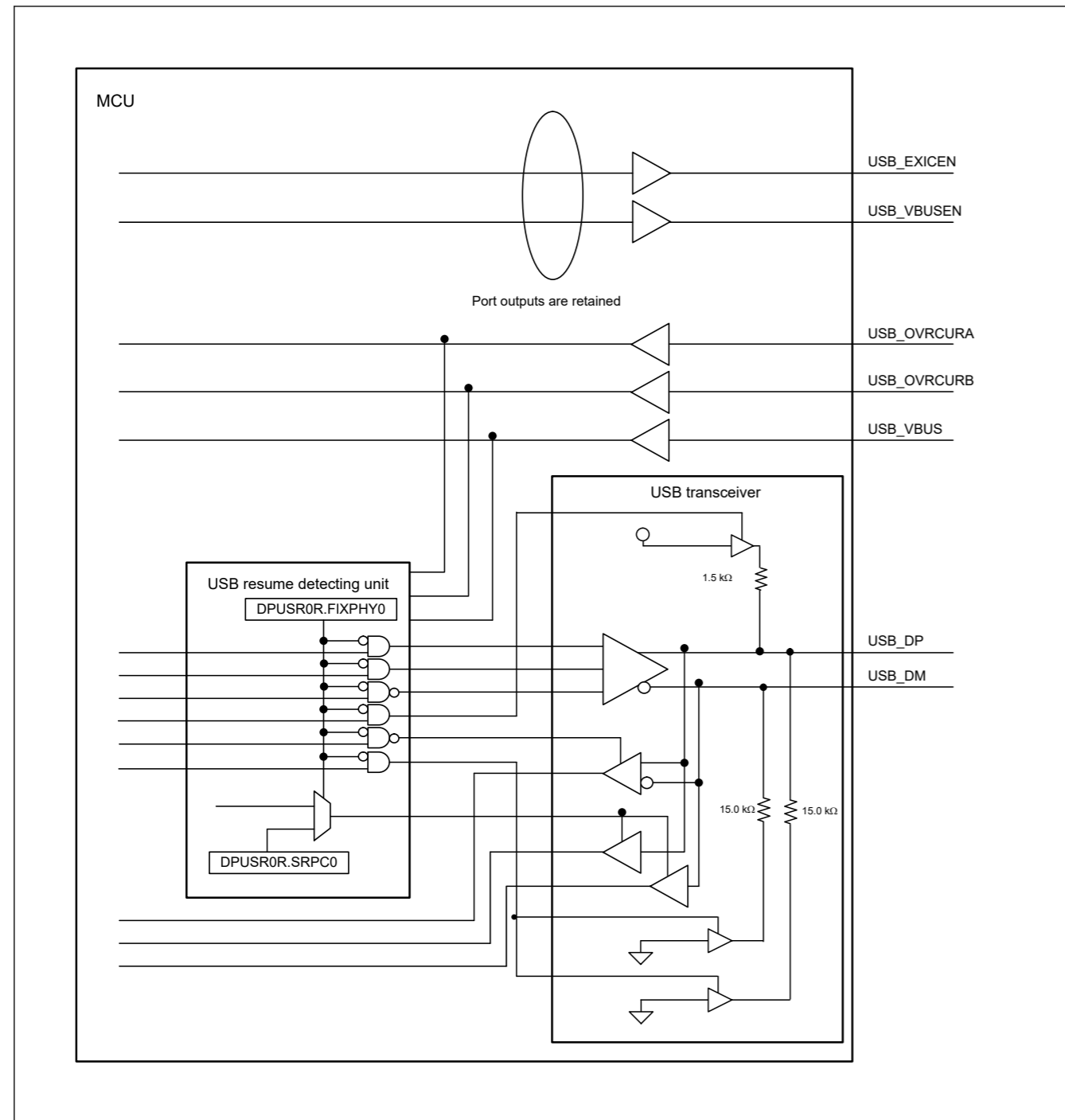


Figure 26.7 Connection between the USB resume detecting unit and the USB I/O pins

Table 26.15 shows the USB suspend and resume interrupt sources and their associated I/O pins.

Table 26.15 USB suspend and resume interrupt sources and their associated I/O pins

| USB operating mode | Source                | Pin name                 |
|--------------------|-----------------------|--------------------------|
| Device, OTG        | Resume                | USB_DP                   |
| Host, OTG          | Attach or detach      | USB_DP, USB_DM           |
| Device             | Attach or detach      | USB_VBUS                 |
| Host               | Overcurrent detection | USB_OVRCURA              |
| OTG                | Overcurrent detection | USB_OVRCURA, USB_OVRCURB |

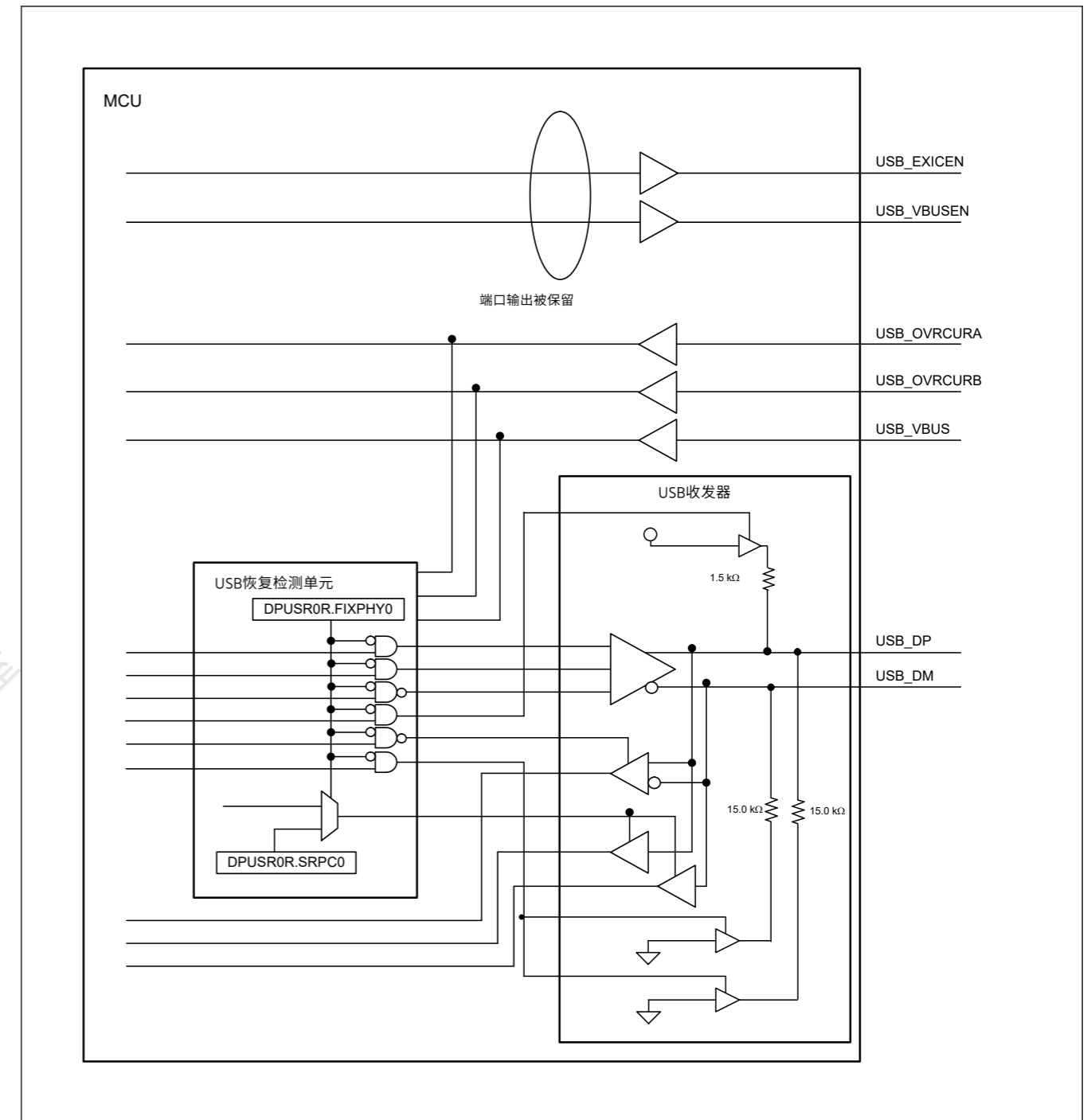


Figure 26.7 USB恢复检测单元与USBIO管脚的连接

表26.15显示了USB挂起和恢复中断源及其相关的IO引脚。

Table 26.15 USB挂起和恢复中断源及其相关的IO引脚

| USB操作模式     | Source                | 引脚名称                     |
|-------------|-----------------------|--------------------------|
| Device, OTG | Resume                | USB_DP                   |
| Host, OTG   | 连接或分离                 | USB_DP, USB_DM           |
| Device      | 连接或分离                 | USB_VBUS                 |
| Host        | Overcurrent detection | USB_OVRCURA              |
| OTG         | Overcurrent detection | USB_OVRCURA, USB_OVRCURB |

Figure 26.8 shows the flow for setting the USBFS when entering Deep Software Standby mode from either host or device controller mode. Figure 26.9 shows the flow for setting the USBFS when canceling Deep Software Standby mode from host controller mode. Figure 26.10 shows the flow for setting the USBFS when canceling Deep Software Standby mode from device controller mode.

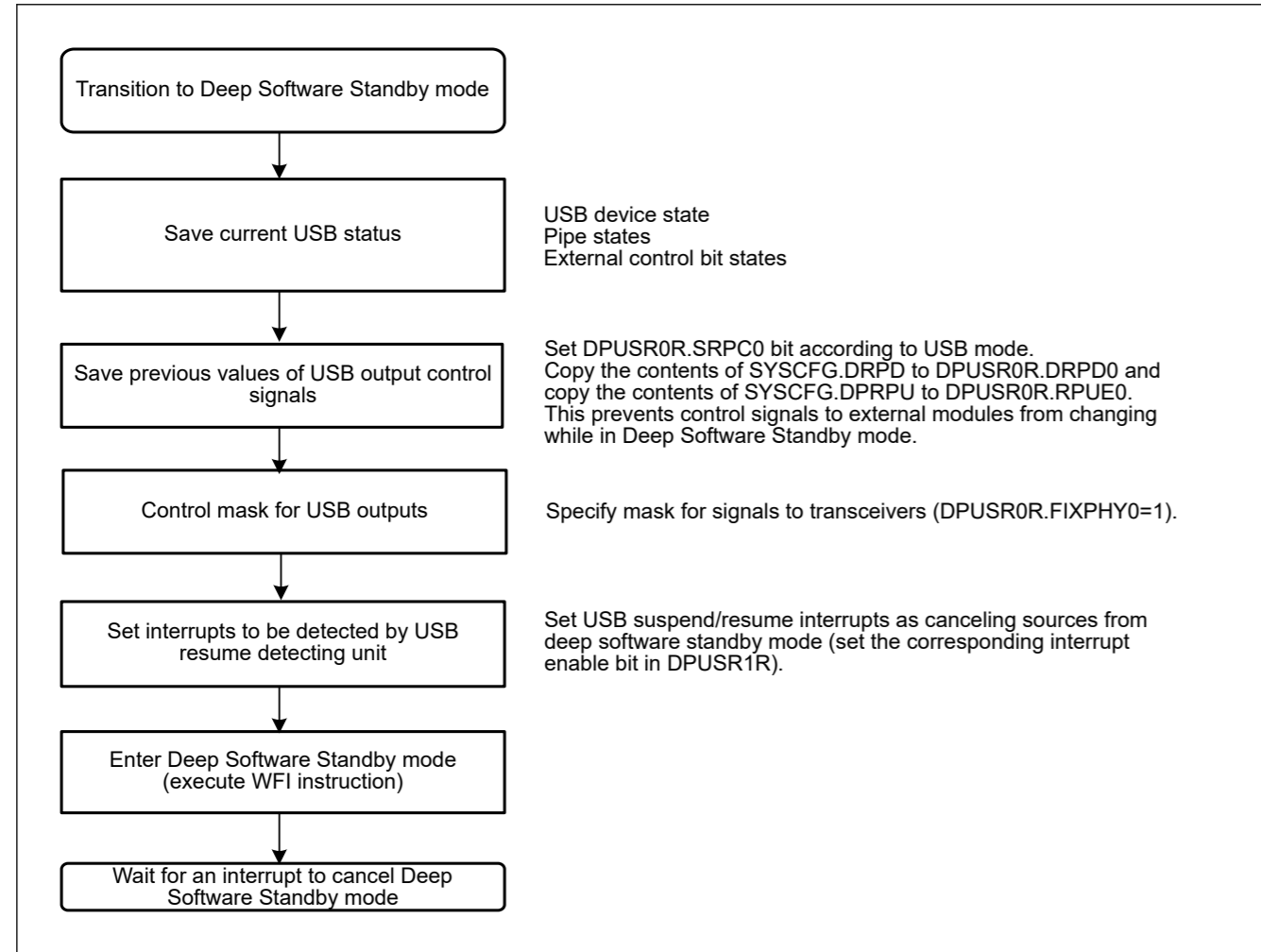


Figure 26.8 USBFS setup flow for transition to Deep Software Standby mode as host or device controller

图26.8显示了从主机或设备控制器模式进入深度软件待机模式时设置USBFS的流程。图26.9显示了从主机控制器模式取消深度软件待机模式时设置USBFS的流程。图26.10显示了从设备控制器模式取消深度软件待机模式时设置USBFS的流程。

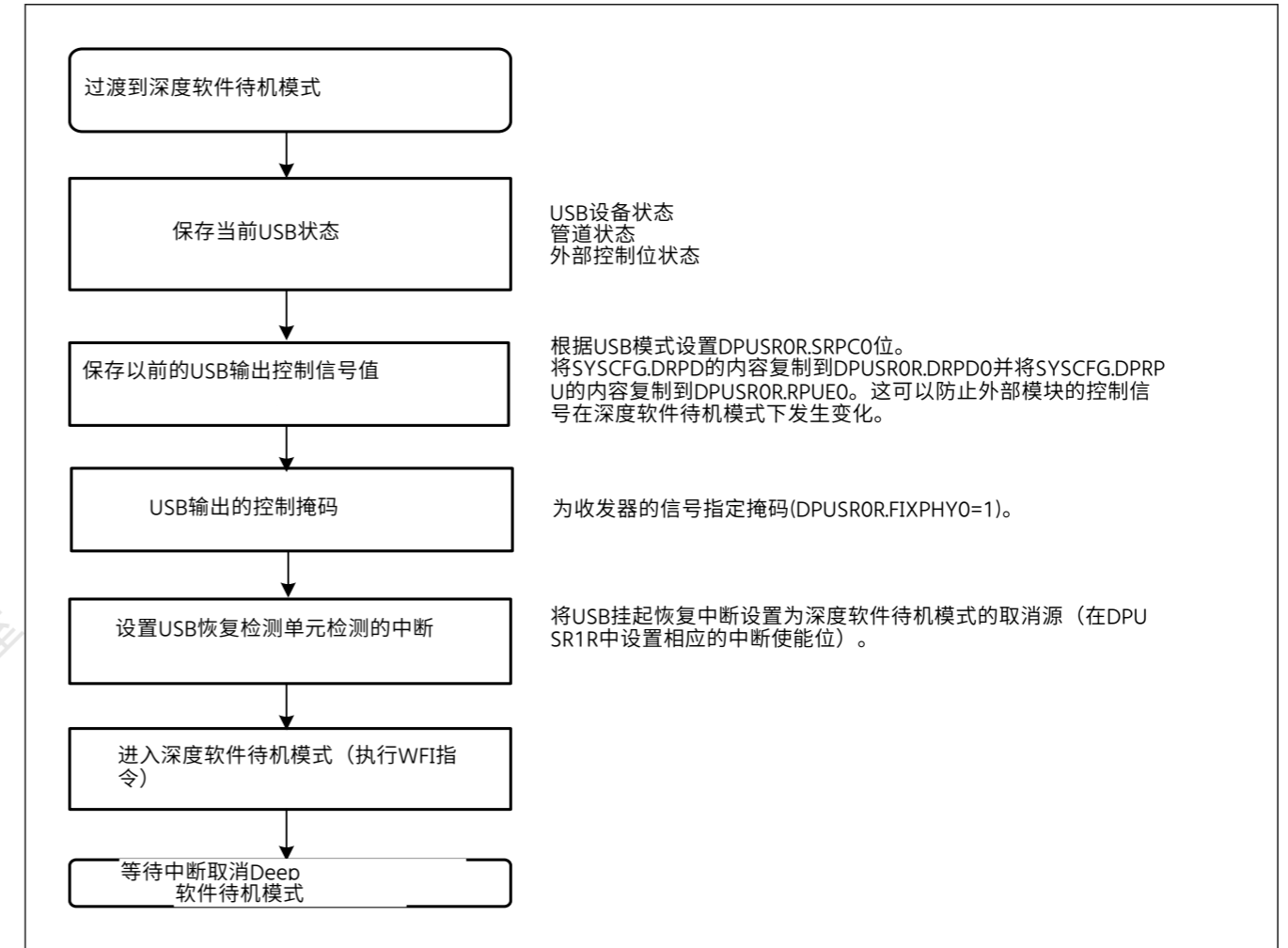


Figure 26.8 作为主机或设备控制器转换到深度软件待机模式的USBFS设置流程

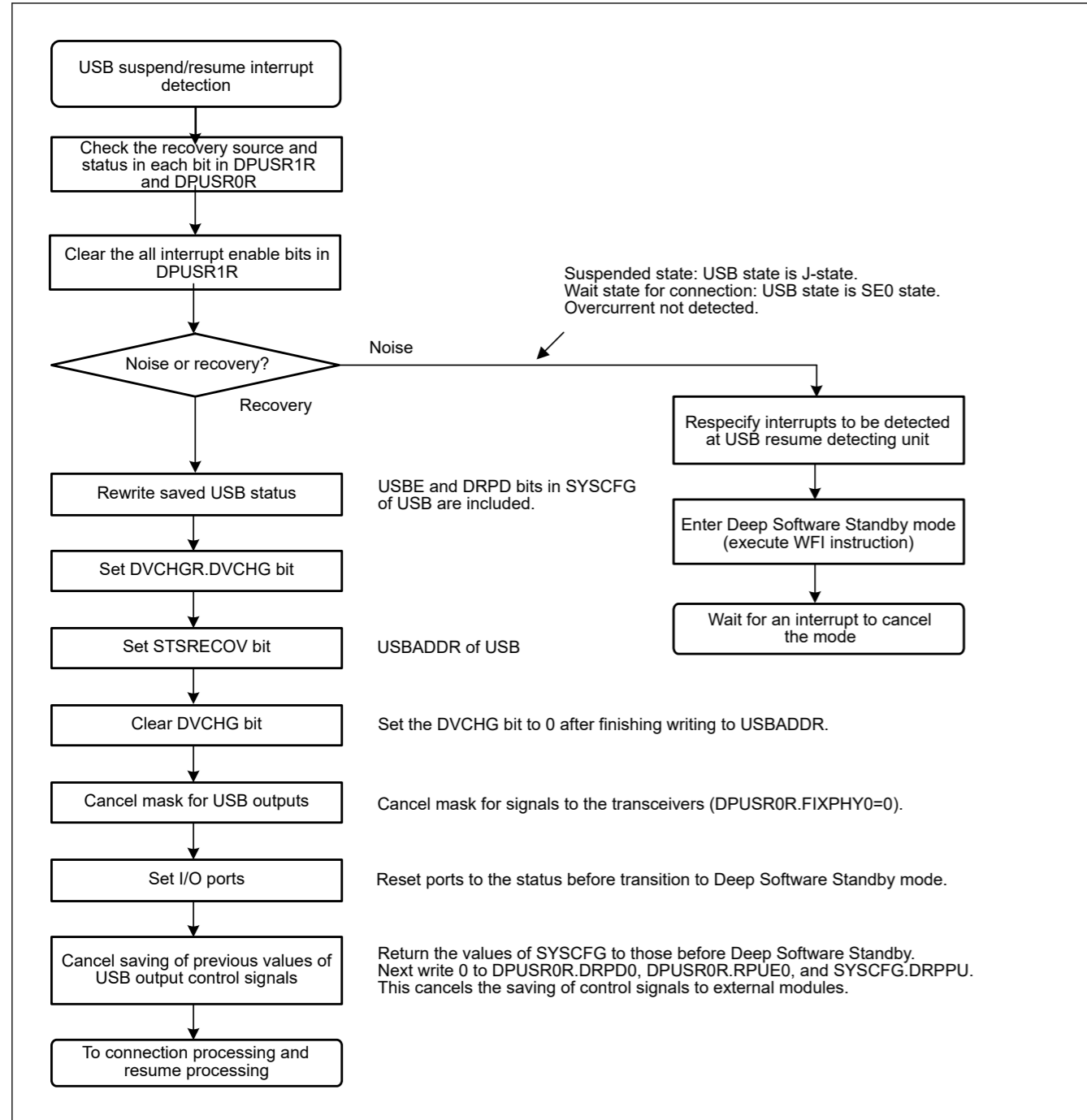


Figure 26.9 USBFS setup flow for canceling Deep Software Standby mode as host controller

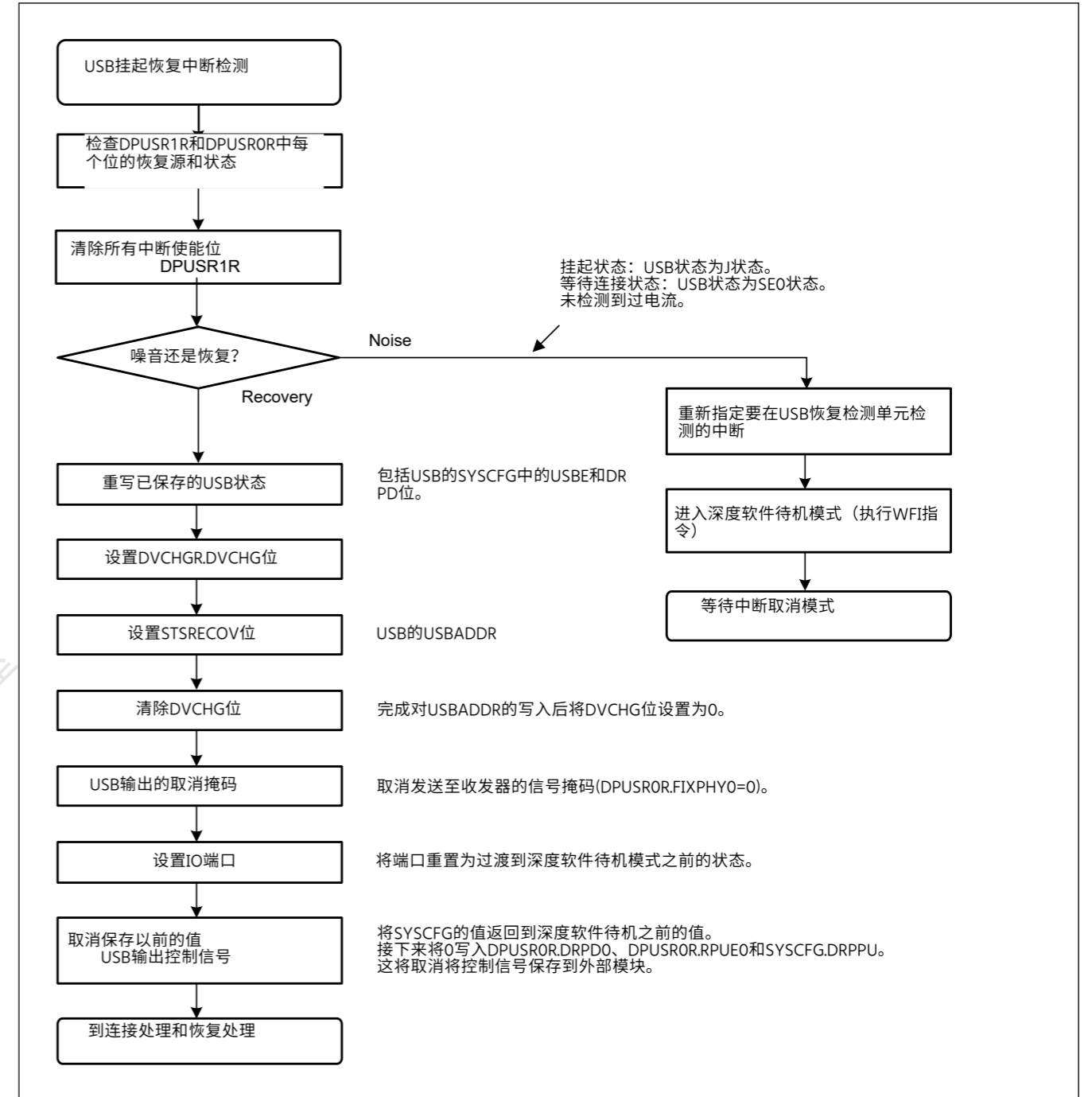


Figure 26.9 用于取消作为主机控制器的深度软件待机模式的USBFS设置流程

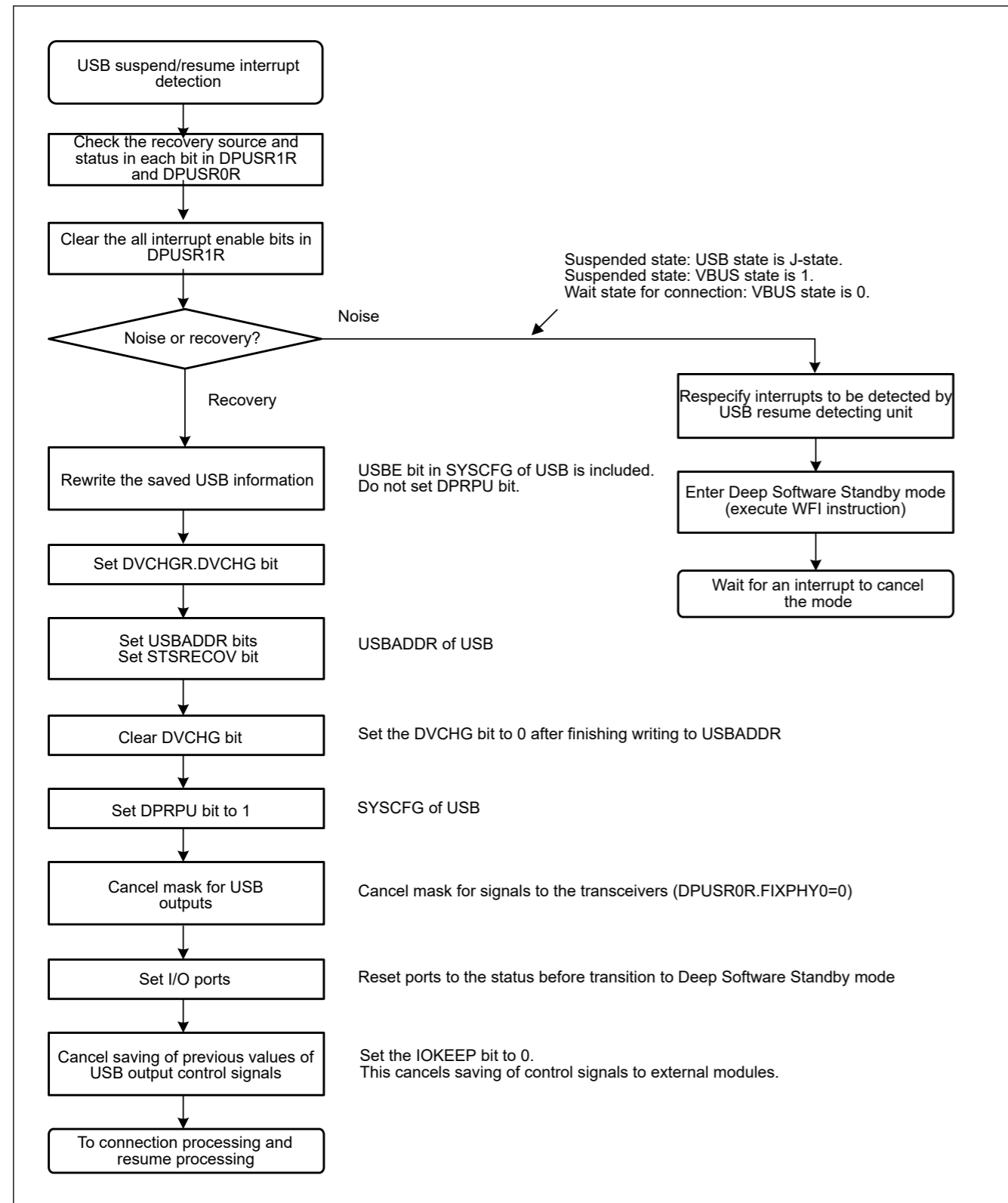


Figure 26.10 USBFS setup flow for canceling Deep Software Standby mode as device controller

26.3.2 Interrupts

Table 26.16 lists the interrupt sources in the USBFS. When an interrupt generation condition is satisfied and the interrupt output is enabled using the associated interrupt enable register, a USBFS interrupt request is issued to the Interrupt Controller Unit (ICU) and an USBFS interrupt is generated.

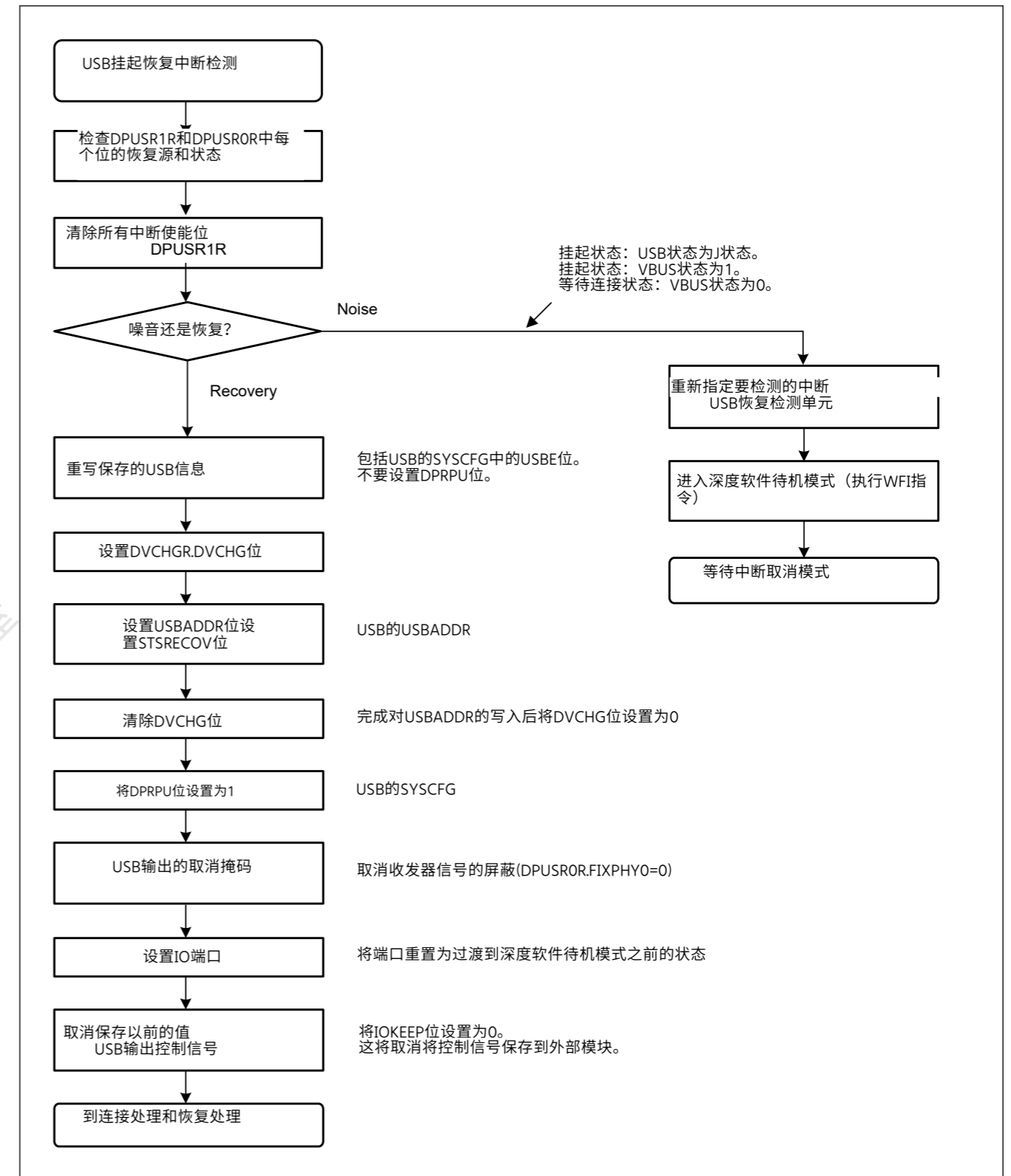


Figure 26.10 用于取消作为设备控制器的深度软件待机模式的USBFS设置流程

26.3.2 Interrupts

表26.16列出了USBFS中的中断源。当满足中断生成条件并使用相关的中断使能寄存器启用中断输出时，将向中断控制器单元(ICU)发出USBFS中断请求并生成USBFS中断。



Table 26.16 Interrupt sources (1 of 2)

| Bit to be set to 1 | Name   | Interrupt source  | Applicable controller function | Status flag        |
|--------------------|--|---|--------------------------------|--------------------|
| VBINT              | VBUS interrupt                                   | <ul style="list-style-type: none"> <li>A change in the state of the USB_VBUS input pin was detected (low to high or high to low)</li> </ul>   | Host or device*1               | INTSTS0.VBSTS      |
| RESM               | Resume interrupt                                 | <ul style="list-style-type: none"> <li>A change in the state of the USB bus was detected in the Suspend state (J-state to K-state or J-state to SE0)</li> </ul>   | Device                         | —                  |
| SOFR               | Frame number update interrupt                    | <p>In host controller mode:</p> <ul style="list-style-type: none"> <li>An SOF packet with a different frame number was transmitted</li> </ul> <p>In device controller mode:</p> <ul style="list-style-type: none"> <li>An SOF packet with a different frame number was received</li> </ul>  | Host or device                 | —                  |
| DVST               | Device state transition interrupt                | <ul style="list-style-type: none"> <li>One of the following device state transitions was detected: <ul style="list-style-type: none"> <li>USB bus reset was detected</li> <li>Suspend state was detected</li> <li>SET_ADDRESS request was received</li> <li>SET_CONFIGURATION request was received</li> </ul> </li> </ul>   | Device                         | INTSTS0.DVSQ[2:0]  |
| CTRT               | Control transfer stage transition interrupt      | <ul style="list-style-type: none"> <li>A control transfer stage transition was detected because of one of the following: <ul style="list-style-type: none"> <li>Setup stage completed</li> <li>Control write transfer status stage transition occurred</li> <li>Control read transfer status stage transition occurred</li> <li>Control transfer completed</li> <li>Control transfer sequence error occurred</li> </ul> </li> </ul>   | Device                         | INTSTS0.CTSQ[2:0]  |
| BEMP               | Buffer empty interrupt                           | <ul style="list-style-type: none"> <li>The buffer is empty after all FIFO buffer data was transmitted</li> <li>A packet larger than the maximum packet size was received</li> </ul>   | Host or device                 | BEMPSTS.PIPEnBEMP  |
| NRDY               | Buffer not ready interrupt                       | <p>In host controller mode</p> <ul style="list-style-type: none"> <li>A STALL response was received from the peripheral device in response to the issued token</li> <li>The response from the peripheral device in response to the issued token was not received successfully (no response three times consecutively or packet reception error three times consecutively)</li> <li>An overrun or underrun error occurred during isochronous transfer</li> </ul> <p>In device controller mode</p> <ul style="list-style-type: none"> <li>NAK was returned for an IN or OUT token while the PID[1:0] bits were set to 01b (BUF)</li> <li>A CRC error or bit stuffing error occurred during data reception in isochronous transfer</li> <li>An overrun or underrun occurred during data reception in isochronous transfer</li> </ul> | Host or device                 | NRDYSTS.PIPEnNRDY  |
| BRDY               | Buffer ready interrupt                           | <ul style="list-style-type: none"> <li>The buffer is ready (readable or writable state)</li> </ul>  | Host or device                 | BRDYSTS.PIPEnBRDY  |
| OVRRCR             | Overcurrent input change interrupt               | <ul style="list-style-type: none"> <li>USB_OVRCURA or USB_OVRCURB input pin state change was detected (low to high or high to low)</li> </ul>   | Host                           | INTSTS1.OVRRCR     |
| BCHG               | Bus change interrupt                             | <ul style="list-style-type: none"> <li>USB bus state change was detected</li> </ul>   | Host or device                 | SYSSTS0.LNST[1:0]  |
| DTCH               | Disconnect detection during full-speed operation | Peripheral device disconnect was detected in full-speed operation   | Host                           | DVSTCTR0.RHST[2:0] |
| ATTCH              | Device connect detection interrupt               | <ul style="list-style-type: none"> <li>J-state or K-state was detected on the USB bus for 2.5 μs continuously</li> </ul> <p>This interrupt can be used to check whether peripheral devices are connected</p>  | Host                           | —                  |

Table 26.16 中断源(1of2)

| 要设置为1的位 | Name           | 中断源   | 通用控制器功能 | 状态标志               |
|---------|----------------|---|---------|--------------------|
| VBINT   | VBUS interrupt | <ul style="list-style-type: none"> <li>检测到USB_VBUS输入引脚的状态发生变化 (从低到高或从高到低)</li> </ul>  | 主机或设备*1 | INTSTS0.VBSTS      |
| RESM    | 恢复中断           | <ul style="list-style-type: none"> <li>检测到USB总线的状态发生变化挂起状态 (J状态到K状态或J状态到SE0)</li> </ul>   | Device  | —                  |
| SOFR    | 帧号更新中断         | <p>在主机控制器模式下:<br/>在设备控制器模式下传输了具有不同帧号SOF数据包:</p> <ul style="list-style-type: none"> <li>接收到具有不同帧号SOF数据包</li> </ul>   | 主机或设备   | —                  |
| DVST    | 设备状态转换中断       | <ul style="list-style-type: none"> <li>检测到以下设备状态转换之一: <ul style="list-style-type: none"> <li>检测到USB总线复位</li> <li>检测到挂起状态</li> <li>收到SET_ADDRESS请求</li> <li>已收到SET_CONFIGURATION请求</li> </ul> </li> </ul>  | Device  | INTSTS0.DVSQ[2:0]  |
| CTRT    | 控制转移阶段转换中断     | <ul style="list-style-type: none"> <li>由于以下原因之一, 检测到控制转移阶段转换: <ul style="list-style-type: none"> <li>设置阶段完成</li> <li>发生控制写传输状态阶段转换</li> <li>发生控制读取传输状态阶段转换</li> <li>控制转移完成</li> <li>发生控制传输序列错误</li> </ul> </li> </ul>   | Device  | INTSTS0.CTSQ[2:0]  |
| BEMP    | 缓冲区空中断         | <ul style="list-style-type: none"> <li>传输完所有FIFO缓冲区数据后缓冲区为空</li> <li>接收到大于最大数据包大小的数据包</li> </ul>  | 主机或设备   | BEMPSTS.PIPEnBEMP  |
| NRDY    | 缓冲区未就绪中断       | <p>在主机控制器模式下</p> <ul style="list-style-type: none"> <li>从外围设备接收到一个STALL响应以响应颁发的令牌</li> <li>外围设备对下发令牌的响应未成功接收 (连续3次无响应或连续3次报文接收错误)</li> </ul> <p>同步传输期间发生溢出或欠载错误在设备控制器模式下</p> <ul style="list-style-type: none"> <li>为IN或OUT令牌返回NAK, 而PID[1:0]位设置为01b(BUF)</li> <li>同步传输中的数据接收过程中发生CRC错误或位填充错误</li> <li>同步传输的数据接收过程中发生溢出或欠载</li> </ul> | 主机或设备   | NRDYSTS.PIPEnNRDY  |
| BRDY    | 缓冲区就绪中断        | <ul style="list-style-type: none"> <li>缓冲区就绪 (可读或可写状态)</li> </ul>   | 主机或设备   | BRDYSTS.PIPEnBRDY  |
| OVRRCR  | 过流输入变化中断       | <ul style="list-style-type: none"> <li>检测到USB_OVRCURA或USB_OVRCURB输入引脚状态变化 (从低到高或从高到低)</li> </ul>  | Host    | INTSTS1.OVRRCR     |
| BCHG    | 总线变化中断         | <ul style="list-style-type: none"> <li>检测到USB总线状态更改</li> </ul>  | 主机或设备   | SYSSTS0.LNST[1:0]  |
| DTCH    | 全速运行时断线检测      | 全速运行时检测到外围设备断开  | Host    | DVSTCTR0.RHST[2:0] |
| ATTCH   | 设备连接检测中断       | <ul style="list-style-type: none"> <li>在USB总线上连续检测到J状态或K状态2.5μs</li> </ul> <p>这个中断可以用来检查外围设备是否连接</p>  | Host    | —                  |

Table 26.16 Interrupt sources (2 of 2)

| Bit to be set to 1 | Name                                | Interrupt source  | Applicable controller function | Status flag       |
|--------------------|-------------------------------------|---|--------------------------------|-------------------|
| EOFERR             | EOF error detection interrupt       | <ul style="list-style-type: none"> <li>An EOF error was detected for a peripheral device</li> </ul>   | Host                           | —                 |
| SACK               | Setup normal interrupt              | <ul style="list-style-type: none"> <li>A setup transaction normal response (ACK) was received</li> </ul>  | Host                           | —                 |
| SIGN               | Setup error interrupt               | <ul style="list-style-type: none"> <li>A setup transaction error (no response or ACK packet corruption) was detected three consecutive times</li> </ul> | Host                           | —                 |
| PDDDETINT          | Portable Device detection interrupt | <ul style="list-style-type: none"> <li>Portable Device connection was detected</li> </ul>   | Host                           | BCCTRL1.PDDDETSTS |

Note 1. Although this interrupt can be generated in host controller mode, it is not usually used in this mode.

Figure 26.11 shows the circuits related to the USBFS interrupts.

Table 26.16 中断源 (2个中的2个)

| 要设置为1的位   | Name      | 中断源  | 通用控制器功能 | 状态标志              |
|-----------|-----------|--|---------|-------------------|
| EOFERR    | EOF错误检测中断 | <ul style="list-style-type: none"> <li>检测到外围设备的EOF错误</li> </ul>                | Host    | —                 |
| SACK      | 设置正常中断    | <ul style="list-style-type: none"> <li>收到设置事务正常响应(ACK)</li> </ul>              | Host    | —                 |
| SIGN      | 设置错误中断    | <ul style="list-style-type: none"> <li>连续3次检测到设置事务错误 (无响应或ACK数据包损坏)</li> </ul> | Host    | —                 |
| PDDDETINT | 便携式设备检测中断 | <ul style="list-style-type: none"> <li>检测到便携式设备连接</li> </ul>                   | Host    | BCCTRL1.PDDDETSTS |

注1.虽然该中断可以在主机控制器模式下产生，但通常不用于该模式。

图26.11显示了与USBFS中断相关的电路。

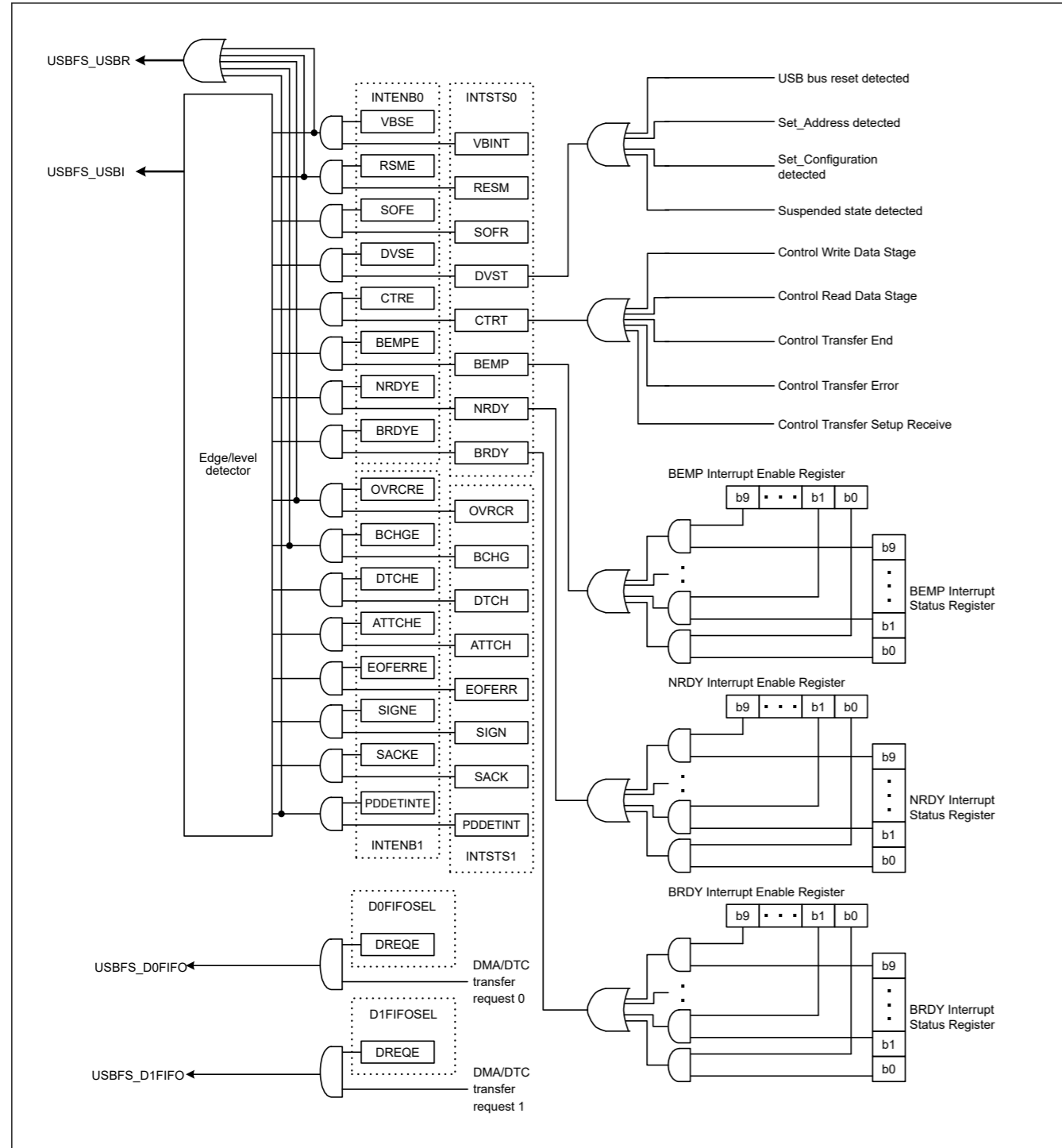


Figure 26.11 USBFS interrupt-related circuits

Table 26.17 shows the interrupts generated by the USBFS.

Table 26.17 USBFS interrupts (1 of 2)

| Interrupt name | Interrupt status flag  | DTC activation | DMAC activation | Priority |
|----------------|------------------------|----------------|-----------------|----------|
| USBFS_D0FIFO   | DMA transfer request 0 | Possible       | Possible        | High     |
| USBFS_D1FIFO   | DMA transfer request 1 | Possible       | Possible        |          |

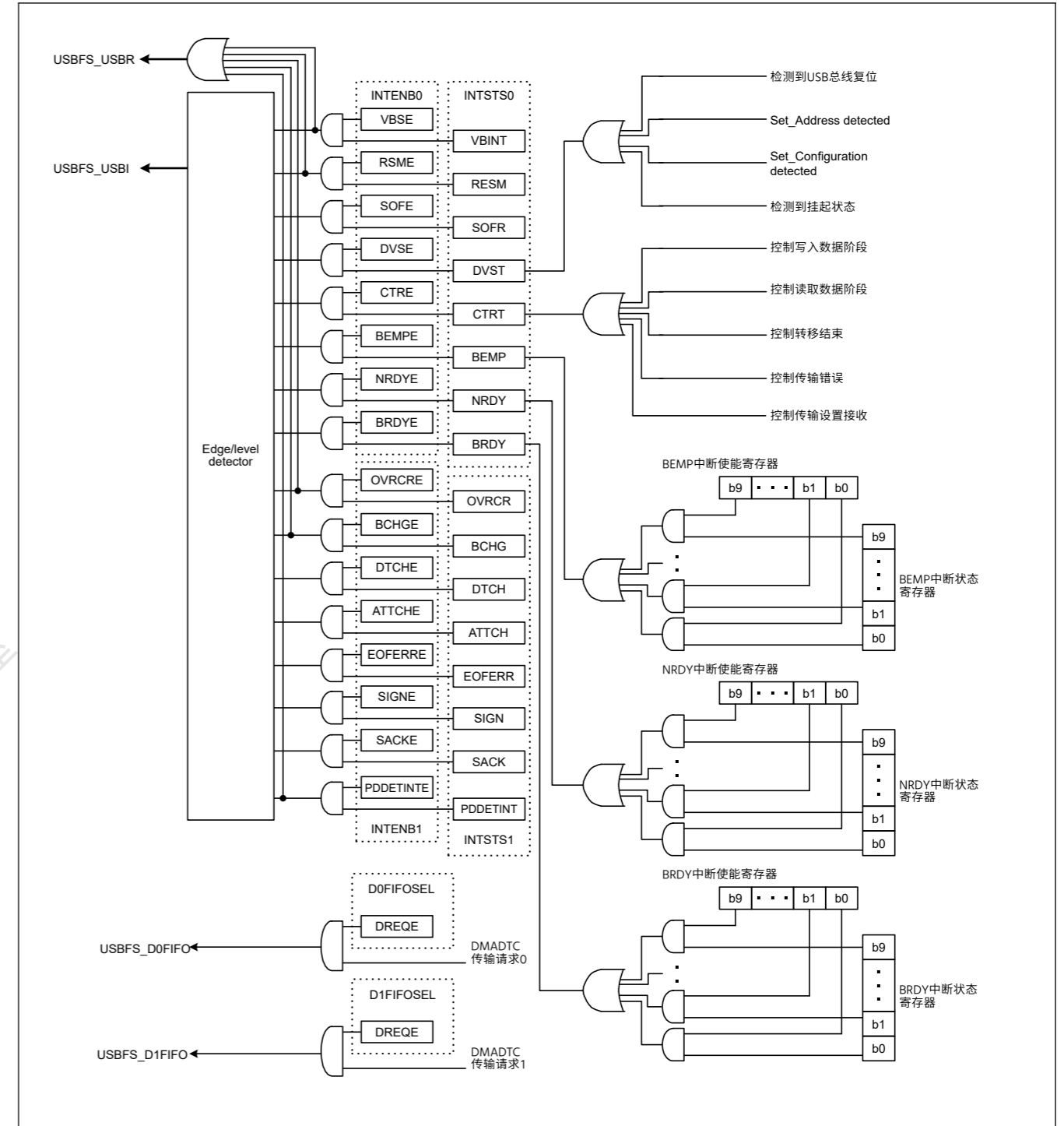


Figure 26.11 USBFS interrupt-related circuits

表26.17显示了USBFS产生的中断。

Table 26.17 USBFS中断(1of2)

| 中断名称         | 中断状态标志   | DTC activation | DMAC activation | Priority |
|--------------|----------|----------------|-----------------|----------|
| USBFS_D0FIFO | DMA传输请求0 | Possible       | Possible        | High     |
| USBFS_D1FIFO | DMA传输请求1 | Possible       | Possible        |          |

Table 26.17 USBFS interrupts (2 of 2)

| Interrupt name | Interrupt status flag  | DTC activation | DMAC activation | Priority |
|----------------|--|----------------|-----------------|----------|
| USBFS_USBI     | VBUS interrupt, resume interrupt, frame number update interrupt, device state transition interrupt, control transfer stage transition interrupt, buffer empty interrupt, buffer not ready interrupt, buffer ready interrupt, overcurrent input change interrupt, bus change interrupt, disconnect detection interrupt during full-speed operation, device connect detection interrupt, EOF error detection interrupt, normal setup operation interrupt, setup error interrupt, and Portable Device detection interrupt | Not possible   | Not possible    | Low      |
| USBFS_USBR     | VBUS interrupt, resume interrupt, overcurrent input change interrupt, bus change interrupt, and Portable Device detection interrupt  | Not possible   | Not possible    | —        |

### 26.3.3 Interrupt Descriptions

#### 26.3.3.1 BRDY interrupt

The BRDY interrupt is generated in both host and device controller modes. This section describes the conditions in which the USBFS sets the associated bit in BRDYSTS to 1. Under these conditions, the USBFS generates a BRDY interrupt if the software has set the bit in BRDYENB associated with the given pipe to 1 and the INTENB0.BRDYE bit to 1.

The conditions for generating and clearing the BRDY interrupt depend on the SOFCFG.BRDYM and PIPECFG.BFRE settings for each pipe as follows:

##### (1) When SOFCFG.BRDYM = 0 and PIPECFG.BFRE = 0

With these settings, the BRDY interrupt indicates that the FIFO port is accessible.

On any of the following conditions, the USBFS generates an internal BRDY interrupt request trigger and sets the BRDYSTS.PIPEnBRDY bit associated with the selected pipe to 1.

##### For transmitting pipes

- When the DIR bit is changed from 0 to 1 by software
- When packet transmission is complete for a pipe while write-access from the CPU to the FIFO buffer for the pipe is disabled (when the BSTS bit is read as 0)
- When one FIFO buffer is empty on completion of writing data to the other FIFO buffer in double buffer mode
- No request trigger is generated until completion of writing data to the currently-written FIFO buffer even if transmission to the other FIFO buffer is complete
- When the hardware flushes the buffer of the pipe for isochronous transfers
- When 1 is written to the PIPECTR.ACLRM bit, which causes the FIFO buffer to transition from the write-disabled to write-enabled state

No request trigger is generated for the DCP, that is, during data transmission for control transfers.

##### For receiving pipes

- When packet reception is successfully complete, enabling the FIFO buffer to be read while read-access from the CPU to the FIFO buffer for the given pipe is disabled (when the BSTS bit is read as 0). No request trigger is generated for transactions in which a DATA-PID mismatch has occurred.
- When one FIFO buffer is read-enabled on completion of reading data from the other FIFO buffer in double buffer mode. No request trigger is generated until completion of reading data from the currently-read FIFO buffer, even if reception by the other FIFO buffer is complete.

In device controller mode, the BRDY interrupt is not generated in the status stage of control transfers. The PIPEBRDY interrupt status of the selected pipe can be set to 0 by writing 0 to the associated PIPEnBRDY bit through software. In this case, the other PIPEBRDY bit should be set to 1.

Clear the BRDY status before accessing the FIFO buffer.

Table 26.17 USBFS中断 (2个中的2个)

| 中断名称       | 中断状态标志   | DTC activation | DMAC activation | Priority |
|------------|--|----------------|-----------------|----------|
| USBFS_USBI | VBUS中断、恢复中断、帧号更新中断、设备状态转换中断、控制传输阶段转换中断、缓冲区空中断、缓冲区未就绪中断、缓冲区就绪中断、过流输入改变中断、总线改变中断、满时断开检测中断速度操作、设备连接检测中断、EOF错误检测中断、正常设置操作中断、设置错误中断和便携式设备检测中断 | 不可能            | 不可能             | Low      |
| USBFS_USBR | VBUS中断、恢复中断、过流输入变化中断、总线变化中断和便携式设备检测中断  | 不可能            | 不可能             | —        |

### 26.3.3 中断说明

#### 26.3.3.1 BRDY interrupt

在主机和设备控制器模式下都会产生BRDY中断。本节描述USBFS将BRDYSTS中的相关位设置为1的条件。在这些条件下，如果软件将BRDYENB中与给定管道相关的位设置为1并且INTENB0.BRDYE位，USBFS将生成BRDY中断为1。

产生和清除BRDY中断的条件取决于每个管道的SOFCFG.BRDYM和PIPECFG.BFRE设置，如下所示：

##### (1) 当SOFCFG.BRDYM=0且PIPECFG.BFRE=0时

通过这些设置，BRDY中断指示FIFO端口可访问。

在以下任何一种情况下，USBFS都会产生一个内部BRDY中断请求触发器并设置BRDYSTS.PIPEnBRDY位与所选管道相关联为1。

##### 用于传输管道

- DIR位由软件从0变为1时
- 当一个管道的数据包传输完成而从CPU到该管道的FIFO缓冲区的写访问被禁用时（当BSTS位被读取为0时）
- 双缓冲模式下，当一个FIFO缓冲区完成向另一个FIFO缓冲区写入数据时为空闲
- 直到向当前写入的FIFO缓冲区写入数据完成，才会产生请求触发，即使传输到另一个FIFO缓冲区已完成
- 当硬件刷新管道缓冲区以进行同步传输时
- 当PIPECTR.ACLRM位写入1时，导致FIFO缓冲区从写禁止状态转变为写使能状态

没有为DCP生成请求触发，即在控制传输的数据传输期间。

##### 用于接收管道

- 当数据包接收成功完成时，允许读取FIFO缓冲区，同时禁止CPU对给定管道的FIFO缓冲区的读取访问（当BSTS位被读取为0时）。对于发生DATA-PID不匹配的事务，不会生成请求触发器。
- 当一个FIFO缓冲区在双缓冲模式下从另一个FIFO缓冲区读取数据完成后使能读取。在从当前读取的FIFO缓冲区读取数据完成之前，不会生成请求触发，即使其他FIFO缓冲区的接收已完成。

在设备控制器模式下，在控制传输的状态阶段不会产生BRDY中断。通过软件将0写入相关的PIPEnBRDY位，可以将所选管道的PIPEBRDY中断状态设置为0。在这种情况下，另一个PIPEBRDY位应设置为1。

在访问FIFO缓冲区之前清除BRDY状态。



**(2) When SOFCFG.BRDYM = 0 and PIPECFG.BFRE = 1**

With these settings, the USBFS generates a BRDY interrupt on completion of reading all data for a single transfer using the receiving pipe, and sets the bit in BRDYSTS associated with the pipe to 1.

On any of the following conditions, the USBFS determines that the last data for a single transfer was received.

- When a short packet including a zero-length packet is received
- When the PIPEn transaction counter register (PIPEnTRN) is used and the number of packets specified in the PIPEnTRN.TRCNT[15:0] bits are completely received

When the data is completely read after any of these conditions is satisfied, the USBFS determines that all data for a single transfer is completely read.

When a zero-length packet is received while the FIFO buffer is empty, the USBFS determines that all data for a single transfer is completely read when the FRDY bit in the FIFO port control register is 1 and the DTLN[8:0] bits are 0. In this case, to start the next transfer, write 1 to the BCLR bit in the associated port control register through the software. With these settings, the USBFS does not detect a BRDY interrupt for the transmitting pipe.

The PIPEBRDY interrupt status of a pipe can be set to 0 by writing 0 to the associated BRDYSTS.PIPEnBRDY bit through the software. In this case, 1s must be written to the PIPEBRDY bits for the other pipes.

In this mode, do not change the PIPECFG.BFRE bit setting until all data for a single transfer is processed. When it is necessary to change the PIPECFG.BFRE bit before completion of processing, all FIFO buffers for the pipe must be cleared using the PIPEnCTR.ACLRM bit.

**(3) When SOFCFG.BRDYM = 1 and PIPECFG.BFRE = 0**

With these settings, the BRDYSTS.PIPEnBRDY values are linked to the BSTS bit setting for each pipe. In other words, the BRDY interrupt status bits (PIPEBRDY) are set to 1 or 0 by the USB depending on the FIFO buffer status.

**For transmitting pipes**

The BRDY interrupt status bits are set to 1 when the FIFO buffer is ready for write access, and are set to 0 when it is not ready. The BRDY interrupt is not generated for the DCP in the transmitting direction even when it is ready for write access.

**For receiving pipes**

The BRDY interrupt status bits set to 1 when the FIFO buffer is ready for read access, and set to 0 when all data is read (not ready for read access).

When a zero-length packet is received while the FIFO buffer is empty, the associated bit is set to 1 and the BRDY interrupt is continuously generated until the software writes 1 to BCLR. With this setting, the PIPEnBRDY bit cannot be set to 0 by software.

When the SOFCFG.BRDYM bit is set to 1, set the PIPECFG.BFRE bit for all pipes to 0.

Figure 26.12 shows the timing of BRDY interrupt generation.

**(2) 当SOFCFG.BRDYM=0且PIPECFG.BFRE=1时**

使用这些设置，USBFS在完成使用接收管道读取单次传输的所有数据时生成BRDY中断，并将BRDYSTS中与管道关联的位设置为1。

在以下任何一种情况下，USBFS都会确定已接收到单次传输的最后一个数据。

- 收到包含零长度包的短包时
- 当使用PIPEn事务计数器寄存器(PIPEnTRN)并且完全接收到PIPEnTRN.TRCNT[15:0]位中指定的数据包数量时

当满足其中任何一个条件后数据被完全读取时，USBFS确定单次传输的所有数据都被完全读取。

当FIFO缓冲区为空时接收到零长度数据包时，当FIFO端口控制寄存器中的FRDY位为1且DTLN[8:0]位为0.在这种情况下，要开始下一次传输，通过软件向相关端口控制寄存器中的BCLR位写入1。使用这些设置，USBFS不会检测到传输管道的BRDY中断。

通过软件将0写入相关的BRDYSTS.PIPEnBRDY位，可以将管道的PIPEBRDY中断状态设置为0。在这种情况下，必须将1写入其他管道的PIPEBRDY位。

在此模式下，在处理完单次传输的所有数据之前，不要更改PIPECFG.BFRE位设置。当需要在处理完成之前更改PIPECFG.BFRE位时，必须使用PIPEnCTR.ACLRM位清除管道的所有FIFO缓冲区。

**(3) 当SOFCFG.BRDYM=1且PIPECFG.BFRE=0时**

通过这些设置，BRDYSTS.PIPEnBRDY值链接到每个管道的BSTS位设置。换句话说，BRDY中断状态位(PIPEBRDY)由USB设置为1或0，具体取决于FIFO缓冲区状态。

**用于传输管道**

当FIFO缓冲区准备好进行写访问时，BRDY中断状态位设置为1，当它未准备好时设置为0。发送方向上的DCP不会产生BRDY中断，即使它已准备好进行写访问。

**用于接收管道**

当FIFO缓冲区准备好进行读取访问时，BRDY中断状态位设置为1，并在读取所有数据（未准备好进行读取访问）时设置为0。

当FIFO缓冲区为空时接收到零长度数据包时，相关位设置为1，并且持续产生BRDY中断，直到软件将1写入BCLR。使用此设置，PIPEnBRDY位不能通过软件设置为0。

当SOFCFG.BRDYM位设置为1时，将所有管道的PIPECFG.BFRE位设置为0。

图26.12显示了BRDY中断产生的时序。

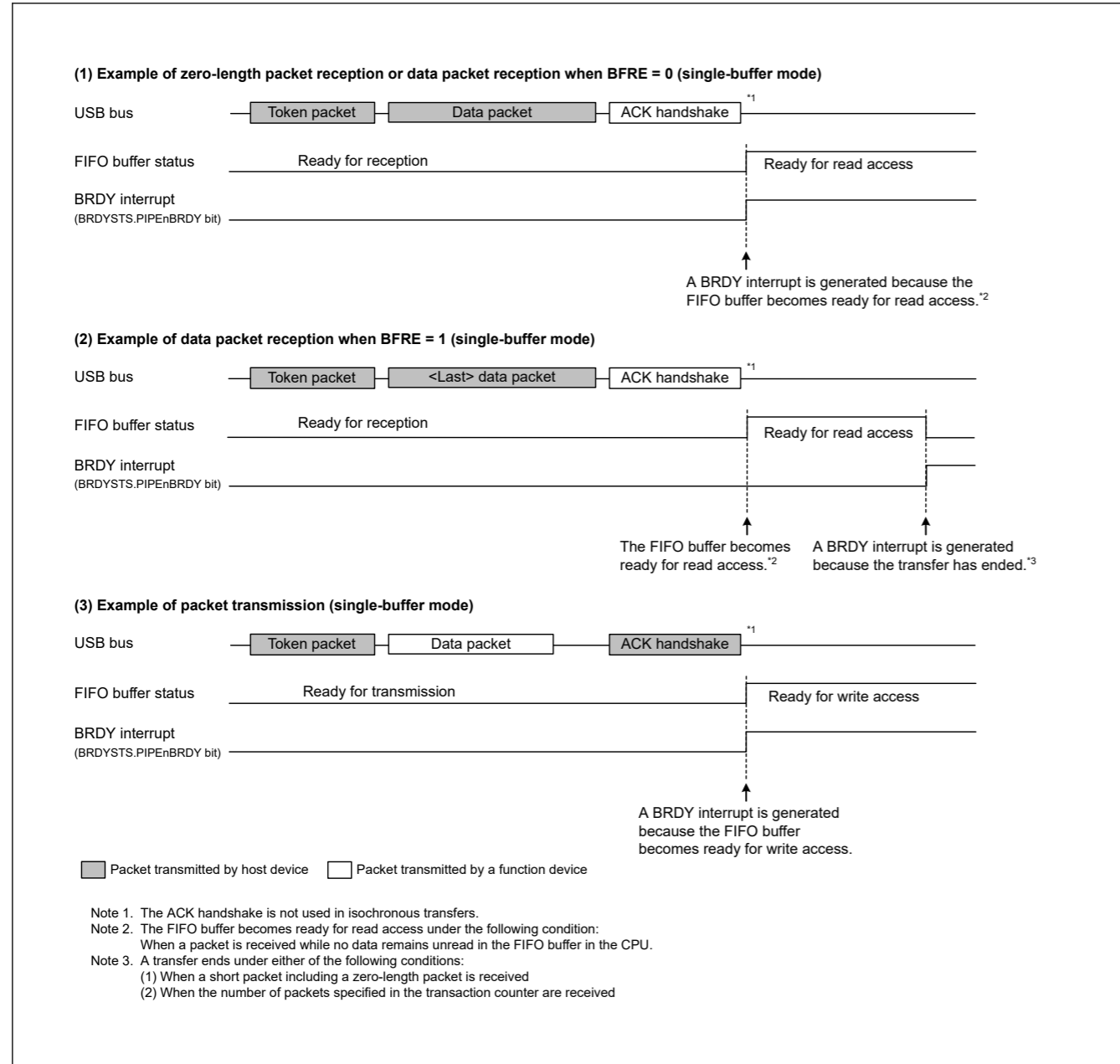


Figure 26.12 Timing of BRDY interrupt generation

The condition for clearing the INTSTS0.BRDY bit depends on the SOFCFG.BRDYM bit setting, as shown in Table 26.18.

Table 26.18 Conditions for clearing the BRDY bit

| BRDYM bit | Condition for clearing BRDY bit  |
|-----------|--|
| 0         | The USBFS clears the BRDY bit to 0 when all bits in BRDYSTS are set to 0 by software.  |
| 1         | The USBFS clears the BRDY bit to 0 when the BSTS bits for all pipes have cleared to 0. |

### 26.3.3.2 NRDY interrupt

On generating an internal NRDY interrupt request for the pipe whose PID bits are set to BUF by software, the USBFS sets the associated PIPEnNRDY bit in NRDYSTS to 1. If the associated bit in NRDYENB is set to 1 by software, the USBFS sets the INTSTS0.NRDY bit to 1 and generates a USBFS interrupt.

This section describes the conditions in which the USBFS generates the internal NRDY interrupt request for a given pipe.

The internal NRDY interrupt request is not generated during setup transaction execution in host controller mode. During setup transactions in host controller mode, the SACK or SIGN interrupt is detected.

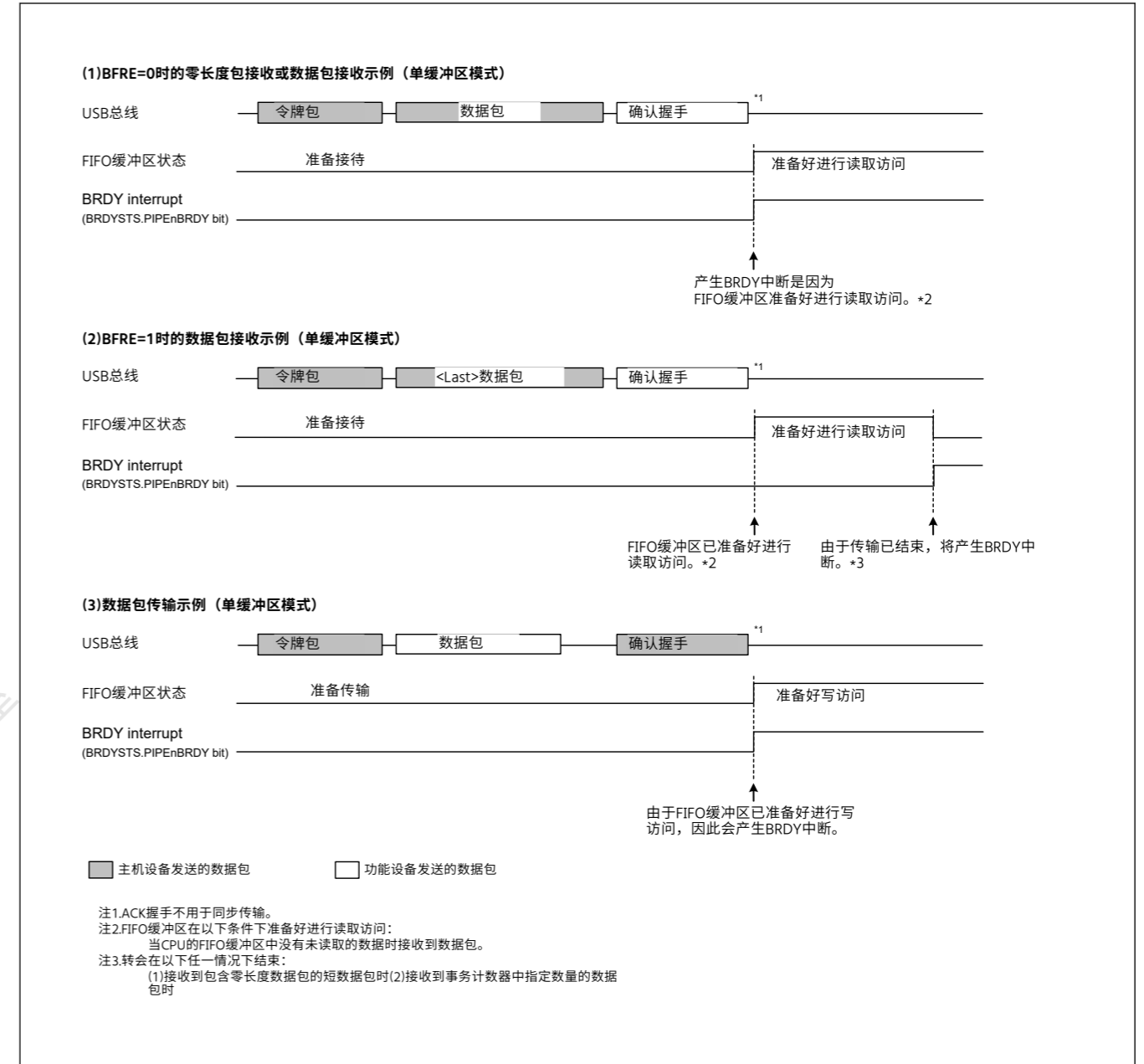


Figure 26.12 BRDY中断产生的时序

清除INTSTS0.BRDY位的条件取决于SOFCFG.BRDYM位设置, 如表26.18所示。

Table 26.18 清除BRDY位的条件

| BRDYM bit | 清除BRDY位的条件                            |
|-----------|---------------------------------------|
| 0         | 当BRDYSTS中的所有位被软件设置为0时, USBFS将BRDY位清零。 |
| 1         | 当所有管道的BSTS位已清零时, USBFS将BRDY位清零。       |

### 26.3.3.2 NRDY interrupt

在为PID位由软件设置为BUF的管道生成内部NRDY中断请求时, USBFS将NRDYSTS中的相关PIPEnNRDY位设置为1。如果NRDYENB中的相关位由软件设置为1, 则USBFS设置INTSTS0.NRDY位为1并产生USBFS中断。

本节描述USBFS为给定管道生成内部NRDY中断请求的条件。

内部NRDY中断请求在主控制器模式下的设置事务执行期间不会产生。在主控制器模式下的设置事务期间, 检测到SACK或SIGN中断。

The internal NRDY interrupt request is not generated during status stage execution of the control transfer in device controller mode.

### (1) In host controller mode

#### For transmitting pipes

On any of the following conditions, the USBFS detects an NRDY interrupt:

- For isochronous transfer pipes, when the time to issue an OUT token comes while there is no data to be transmitted in the FIFO buffer. In this case, the USBFS transmits a zero-length packet following the OUT token and sets the associated NRDYSTS.PIPEnNRDY bit and the FRMNUM.OVRN bit to 1.
- During communications other than setup transactions on pipes not used for isochronous transfers, when any combination of the following two cases occur three consecutive times:
  - No response is returned from the peripheral device (when timeout is detected before detection of the handshake packet from the peripheral device)
  - An error is detected in the packet from the peripheral device. In this case, the USBFS sets the associated PIPEnNRDY bit to 1 and changes the associated PID[1:0] setting for the pipe to NAK
- During communications other than setup transactions, when the STALL handshake is received from the peripheral device. In this case, the USBFS sets the associated PIPEnNRDY bit to 1 and changes the PID[1:0] setting for the associated pipe to STALL (11b).

#### For receiving pipes

- For isochronous transfer pipes, when the time to issue an IN token comes but there is no space available in the FIFO buffer. In this case, the USBFS discards the received data for the IN token and sets the PIPEnNRDY bit associated with the pipe and the OVRN bit to 1. When a packet error is detected in the received data for the IN token, the USBFS also sets the FRMNUM.CRCE bit to 1.
- For non-isochronous transfer pipes, when any combination of the following two cases occur three consecutive times:
  - No response is returned from the peripheral device for the IN token issued by the USBFS (when timeout is detected before detection of the DATA packet from the peripheral device)
  - An error is detected in the packet from the peripheral device. In this case, the USBFS sets the associated PIPEnNRDY bit to 1 and changes the associated PID[1:0] setting for the pipe to NAK
- For isochronous transfer pipes, when no response is returned from the peripheral device for the IN token (when timeout is detected before detection of the DATA packet from the peripheral device) or an error is detected in the packet from the peripheral device. In this case, the USBFS sets the PIPEnNRDY bit associated with the pipe to 1. The PID[1:0] setting for the pipe is not changed.
- For isochronous transfer pipes, when a CRC error or a bit stuffing error is detected in the received data packet. In this case, the USBFS sets the PIPEnNRDY bit associated with the pipe and the CRCE bit to 1.
- When the STALL handshake is received. In this case, the USBFS sets the PIPEnNRDY bit associated with the pipe to 1 and changes the PID[1:0] setting for the associated pipe to STALL.

### (2) In device controller mode

#### For transmitting pipes

- When an IN token is received while there is no data to be transmitted in the FIFO buffer. In this case, the USBFS generates a NRDY interrupt request on reception of the IN token and sets the NRDYSTS.PIPEnNRDY bit to 1. For an isochronous transfer pipe in which an interrupt is generated, the USBFS transmits a zero-length packet and sets the FRMNUM.OVRN bit to 1.

#### For receiving pipes

- When an OUT token is received but there is no space available in the FIFO buffer. For an isochronous transfer pipe in which an interrupt is generated, the USBFS generates a NRDY interrupt request on reception of the OUT token and sets the PIPEnNRDY bit to 1 and OVRN bit to 1. For a non-isochronous transfer pipe in which an interrupt is generated, the USBFS generates a NRDY interrupt request when a NAK handshake is transferred after the data following the OUT token is received, and sets the PIPEnNRDY bit to 1. The NRDY interrupt request is not generated during retransmission

在设备控制器模式下控制传输的状态阶段执行期间，不会产生内部NRDY中断请求。

### (1) 在主机控制器模式下

#### 用于传输管道

在以下任何一种情况下，USBFS都会检测到NRDY中断：

- 对于同步传输管道，当FIFO缓冲区中没有要传输的数据时发出OUT令牌的时间到来。在这种情况下，USBFS在OUT令牌之后发送一个长度为零的数据包，并将相关的NRDYSTS.PIPEnNRDY位和FRMNUM.OVRN位设置为1。
- 在不用于同步传输的管道上的设置事务以外的通信期间，当以下两种情况的任意组合连续发生3次时：
  - 外围设备没有返回响应（当在检测到来自外围设备的握手包之前检测到超时
  - 在来自外围设备的数据包中检测到错误。在这种情况下，USBFS将相关的PIPEnNRDY位设置为1，并将管道的相关PID[1:0]设置更改为NAK
- 在设置事务以外的通信期间，当从外围设备接收到STALL握手时。在这种情况下，USBFS将相关的PIPEnNRDY位设置为1，并将相关管道的PID[1:0]设置更改为STALL(11b)。

#### 用于接收管道

- 对于同步传输管道，当发出IN令牌的时间到来但FIFO中没有可用空间时缓冲。在这种情况下，USBFS丢弃接收到的IN令牌数据，并将与管道关联的PIPEnNRDY位和OVRN位设置为1。当在接收到的IN令牌数据中检测到数据包错误时，USBFS也会设置FRMNUM.CRCE位为1。
- 对于非等时传输管道，当以下两种情况的任意组合连续出现3次时：
  - USBFS发出的IN令牌没有从外围设备返回响应（当在检测到来自外围设备的DATA包之前检测到超时
  - 在来自外围设备的数据包中检测到错误。在这种情况下，USBFS将相关的PIPEnNRDY位设置为1，并将管道的相关PID[1:0]设置更改为NAK
- 对于同步传输管道，当外围设备没有返回对IN令牌的响应时（在检测到来自外围设备的DATA数据包之前检测到超时）或在外围设备的数据包中检测到错误。在这种情况下，USBFS将与管道关联的PIPEnNRDY位设置为1。管道的PID[1:0]设置不会更改。
- 对于同步传输管道，当在接收到的数据包中检测到CRC错误或比特填充错误时。在这种情况下，USBFS将与管道关联的PIPEnNRDY位和CRCE位设置为1。
- 收到STALL握手时。在这种情况下，USBFS将与管道关联的PIPEnNRDY位设置为1，并将关联管道的PID[1:0]设置更改为STALL。

### (2) 在设备控制器模式下

#### 用于传输管道

- 当接收到一个IN令牌而FIFO缓冲区中没有要传输的数据时。在这种情况下，USBFS在接收到IN令牌时生成NRDY中断请求并将NRDYSTS.PIPEnNRDY位设置为1。对于产生中断的同步传输管道，USBFS发送一个长度为零的数据包并将FRMNUM.OVRN位设置为1。

#### 用于接收管道

- 当接收到OUT令牌但FIFO缓冲区中没有可用空间时。对于产生中断的同步传输管道，USBFS在接收到OUT令牌时产生一个NRDY中断请求，并将PIPEnNRDY位设置为1，并将OVRN位设置为1。USBFS在接收到OUT令牌之后的数据后，在传输NAK握手时产生NRDY中断请求，并将PIPEnNRDY位设置为1。重传期间不产生NRDY中断请求



because of a DATA-PID mismatch. In addition, the NRDY interrupt request is not generated if an error occurs in the DATA packet.

- For isochronous transfer pipes, when a token is not received successfully within an interval frame. In this case, the USBFS generates an NRDY interrupt request when the SOF is received, and sets the PIPEnNRDY bit to 1.

Figure 26.13 shows the timing of NRDY interrupt generation in device controller mode.

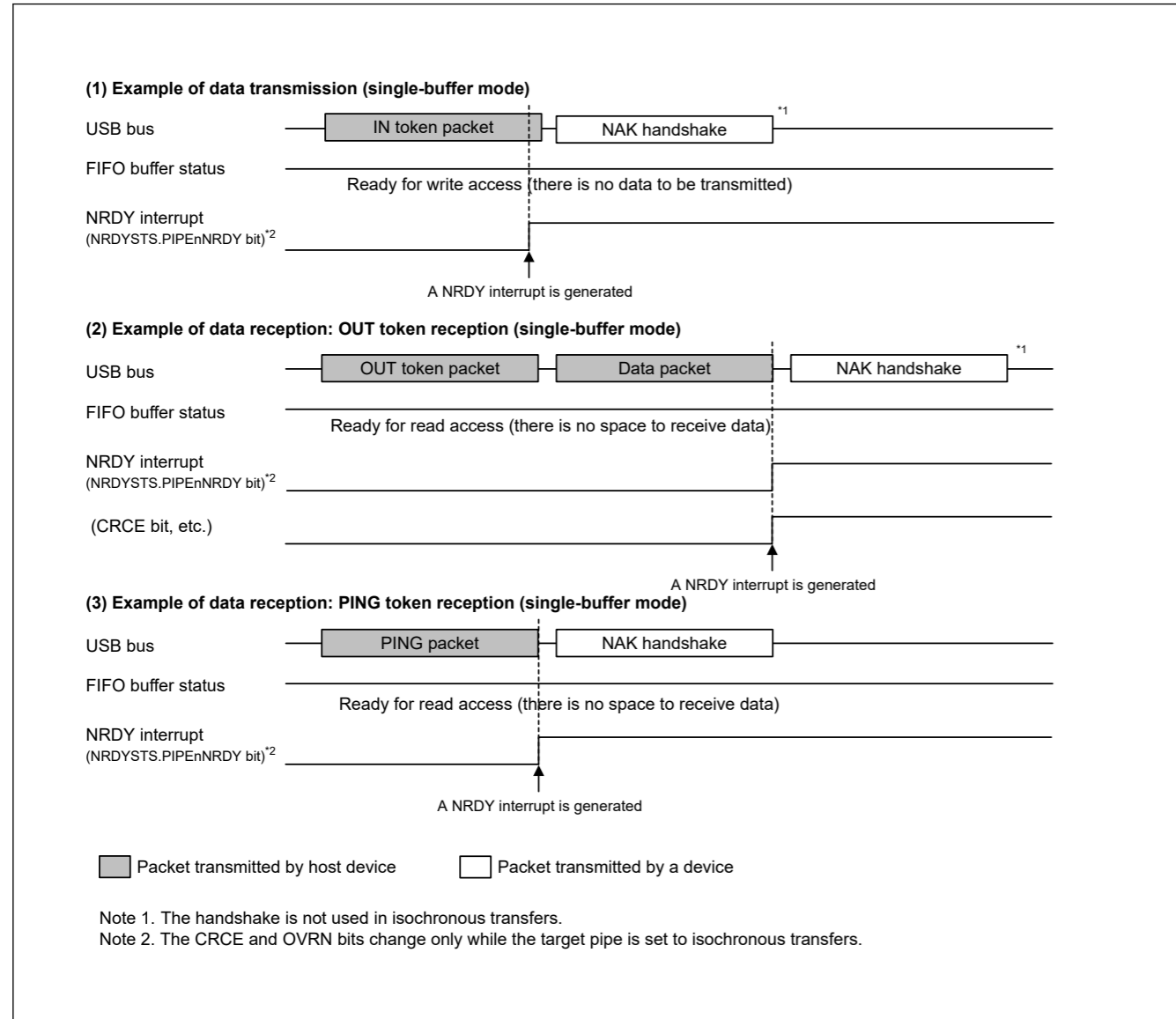


Figure 26.13 Timing of NRDY interrupt generation in device controller mode

### 26.3.3.3 BEMP interrupt

On detecting a BEMP interrupt for the pipe whose PID bits are set to BUF by software, the USBFS sets the associated BEMPSTS.PIPEnBEMP bit to 1. If the associated bit in BEMPENB is set to 1 by software, the USBFS sets the INTSTS0.BEMP bit to 1 and generates a USBFS interrupt. This section describes the conditions in which the USBFS generates an internal BEMP interrupt request.

#### (1) For transmitting pipes

When the FIFO buffer of the associated pipe is empty on completion of transmission, including zero-length packet transmission, and in single buffer mode, an internal BEMP interrupt request is generated simultaneously with the BRDY interrupt for a non-DCP pipe. The internal BEMP interrupt request is not generated in any of the following conditions:

因为DATA-PID不匹配。此外，如果DATA包发生错误，则不会产生NRDY中断请求。

- 对于同步传输管道，当在间隔帧内没有成功接收到令牌时。在这种情况下，USBFS在接收到SOF时产生一个NRDY中断请求，并将PIPEnNRDY位设置为1。

图26.13显示了设备控制器模式下NRDY中断产生的时序。

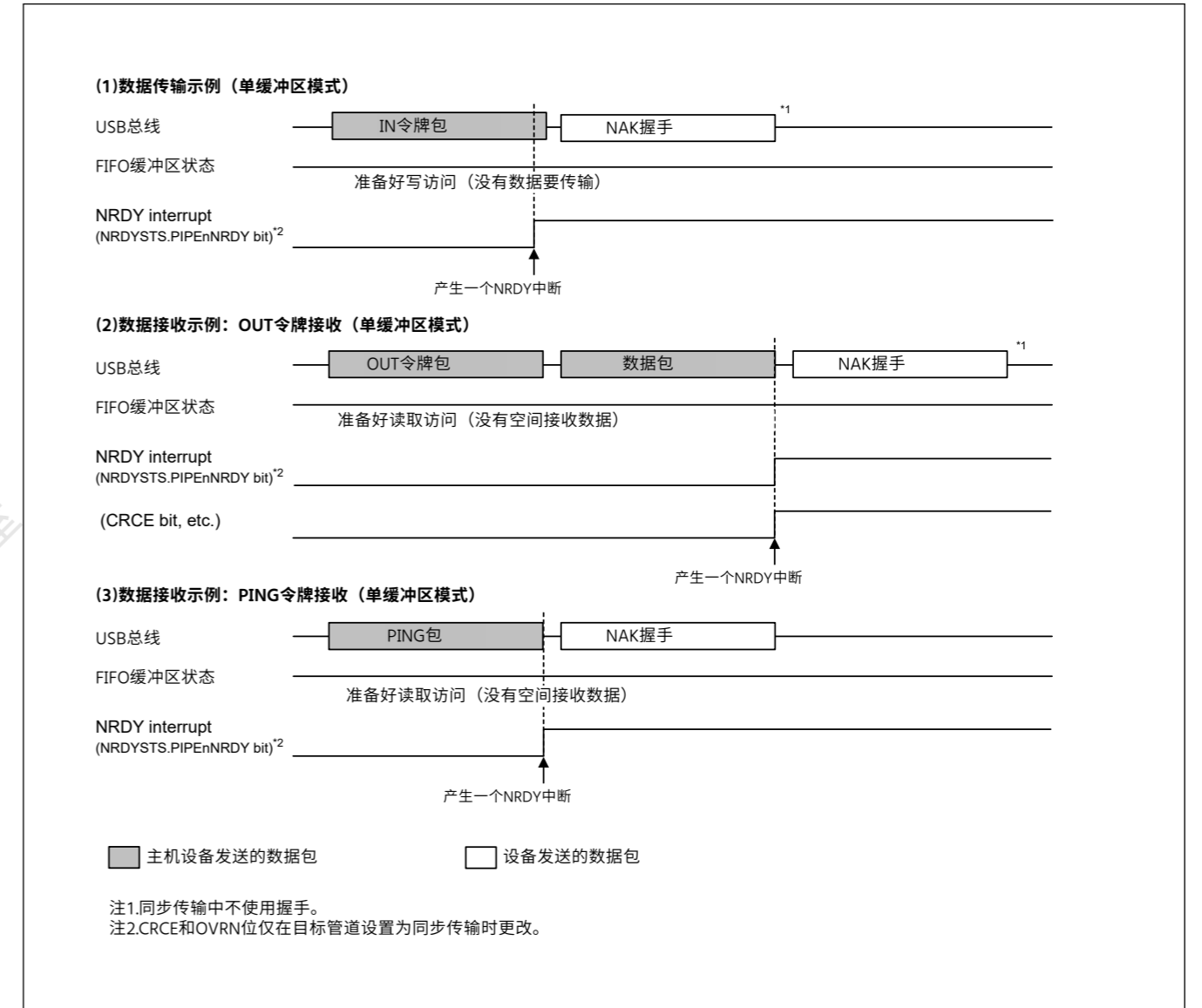


Figure 26.13 设备控制器模式下NRDY中断产生的时序

### 26.3.3.3 BEMP interrupt

在检测到PID位被软件设置为BUF的管道的BEMP中断时，USBFS将相关的BEMPSTS.PIPEnBEMP位设置为1。如果BEMPENB中的相关位被软件设置为1，USBFS将设置INTSTS0.BEMP位为1并产生USBFS中断。本节介绍USBFS产生内部BEMP中断请求的条件。

#### (1) 用于传输管道

当相关管道的FIFO缓冲区在传输完成时空时，包括零长度数据包传输，并且在单缓冲区模式下，内部BEMP中断请求与非DCP管道的BRDY中断同时生成。在以下任何一种情况下都不会产生内部BEMP中断请求：



- When the CPU or DMA/DTC has already started writing data to the FIFO buffer of the CPU on completion of transmitting data from one FIFO buffer in double buffer mode
- When the buffer is cleared (emptied) by setting the PIPEnCTR.ACLRM or the BCLR bit to 1 in the port control register
- When an IN transfer (zero-length packet transmission) is performed during the control transfer status stage in device controller mode

(2) For receiving pipes

When a successfully-received data packet size exceeds the specified maximum packet size. In this case, the USBFS generates a BEMP interrupt request, sets the associated BEMPSTS.PIPEnBEMP bit to 1, discards the received data, and changes the associated PID[1:0] setting for the pipe to STALL (11b). The USBFS returns no response in host controller mode, and returns STALL response in device controller mode.

The internal BEMP interrupt request is not generated in any of the following conditions:

- When a CRC error or a bit stuffing error is detected in the received data
- When a setup transaction is being performed:
  - Writing 0 to the BEMPSTS.PIPEnBEMP bit clears the status
  - Writing 1 to the BEMPSTS.PIPEnBEMP bit has no effect

Figure 26.14 shows the timing of BEMP interrupt generation in device controller mode.

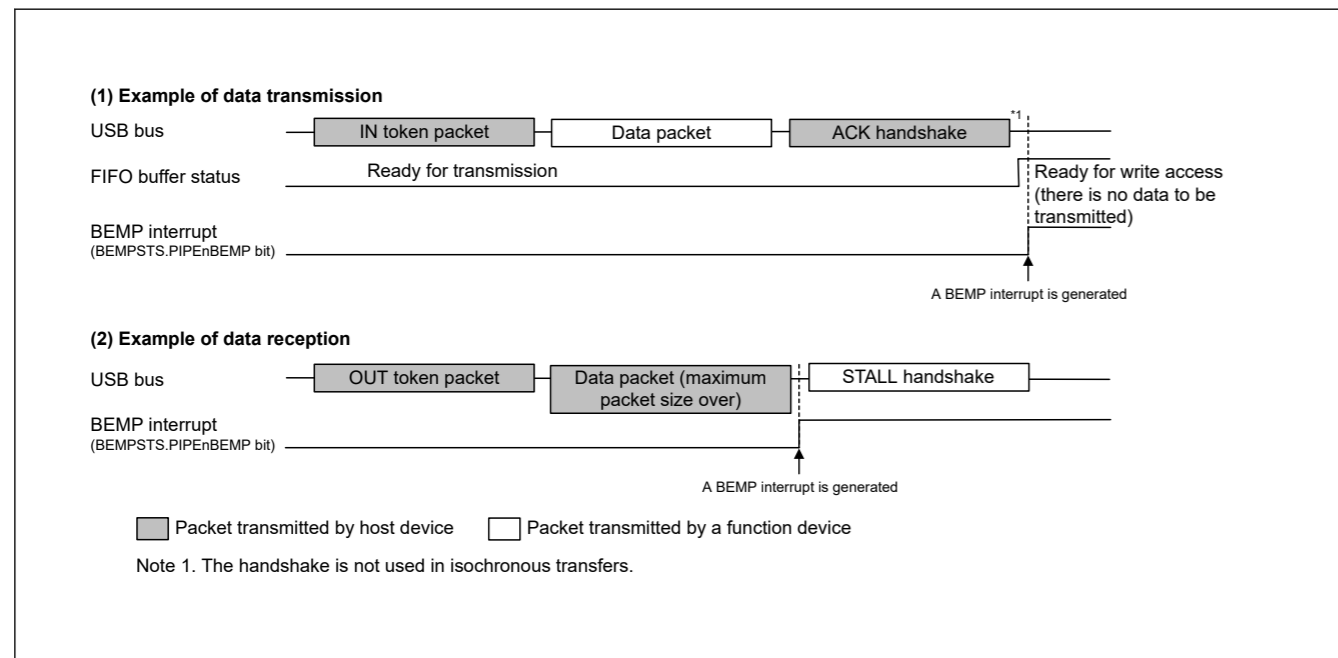


Figure 26.14 Timing of BEMP interrupt generation in device controller mode

26.3.3.4 Device state transition interrupt (device controller mode)

Figure 26.15 shows a diagram of the USBFS device state transitions. The USBFS controls device states and generates device state transition interrupts. However, recovery from the Suspend state (resume signal detection) is detected by means of the resume interrupt. Device state transition interrupts can be enabled or disabled independently in INTENB0. Devices whose states have changed can be checked in the INTSTS0.DVSQ[2:0] bits.

When a transition is made to the default state, a device state transition interrupt is generated after a USB bus reset is detected.

The USBFS controls device states, and device state transition interrupts can be generated, only in device controller mode.

- 当CPU或DMADTC在双缓冲模式下从一个FIFO缓冲区完成数据传输后已经开始向CPU的FIFO缓冲区写入数据时
- 通过将端口控制寄存器中的PIPEnCTR.ACLRM或BCLR位设置为1来清除 (清空) 缓冲区时
- 在设备控制器模式的控制传输状态阶段进行IN传输 (零长度包传输) 时

(2) 用于接收管道

当成功接收的数据包大小超过指定的最大包大小时。在这种情况下, USBFS生成一个BEMP中断请求, 将相关的BEMPSTS.PIPEnBEMP位设置为1, 丢弃接收到的数据, 并将管道的相关PID[1:0]设置更改为STALL(11b)。USBFS在主机控制器模式下不返回响应, 在设备控制器模式下返回STALL响应。

在以下任何一种情况下都不会产生内部BEMP中断请求:

- 在接收到的数据中检测到CRC错误或位填充错误时
- 执行设置事务时:
  - 将0写入BEMPSTS.PIPEnBEMP位可清除状态
  - 向BEMPSTS.PIPEnBEMP位写入1无效

图26.14显示了设备控制器模式下BEMP中断产生的时序。

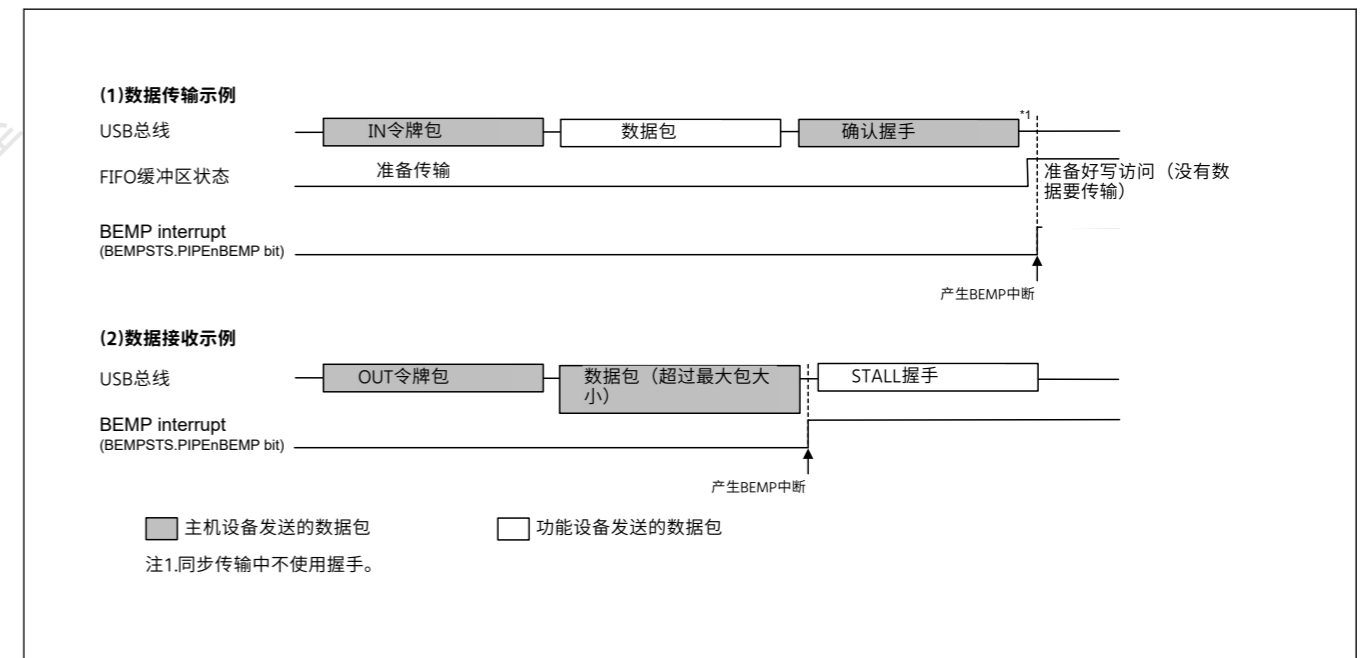


Figure 26.14 设备控制器模式下BEMP中断产生的时序

26.3.3.4 设备状态转换中断 (设备控制器模式)

图26.15显示了USBFS设备状态转换的示意图。USBFS控制设备状态并产生设备状态转换中断。但是, 从挂起状态的恢复 (恢复信号检测) 是通过恢复中断来检测的。可以在INTENB0中独立启用或禁用设备状态转换中断。可以在INTSTS0.DVSQ[2:0]位中检查状态已更改的设备。

当转换到默认状态时, 检测到USB总线复位后会产生设备状态转换中断。

USBFS控制设备状态, 并且只能在设备控制器模式下产生设备状态转换中断。

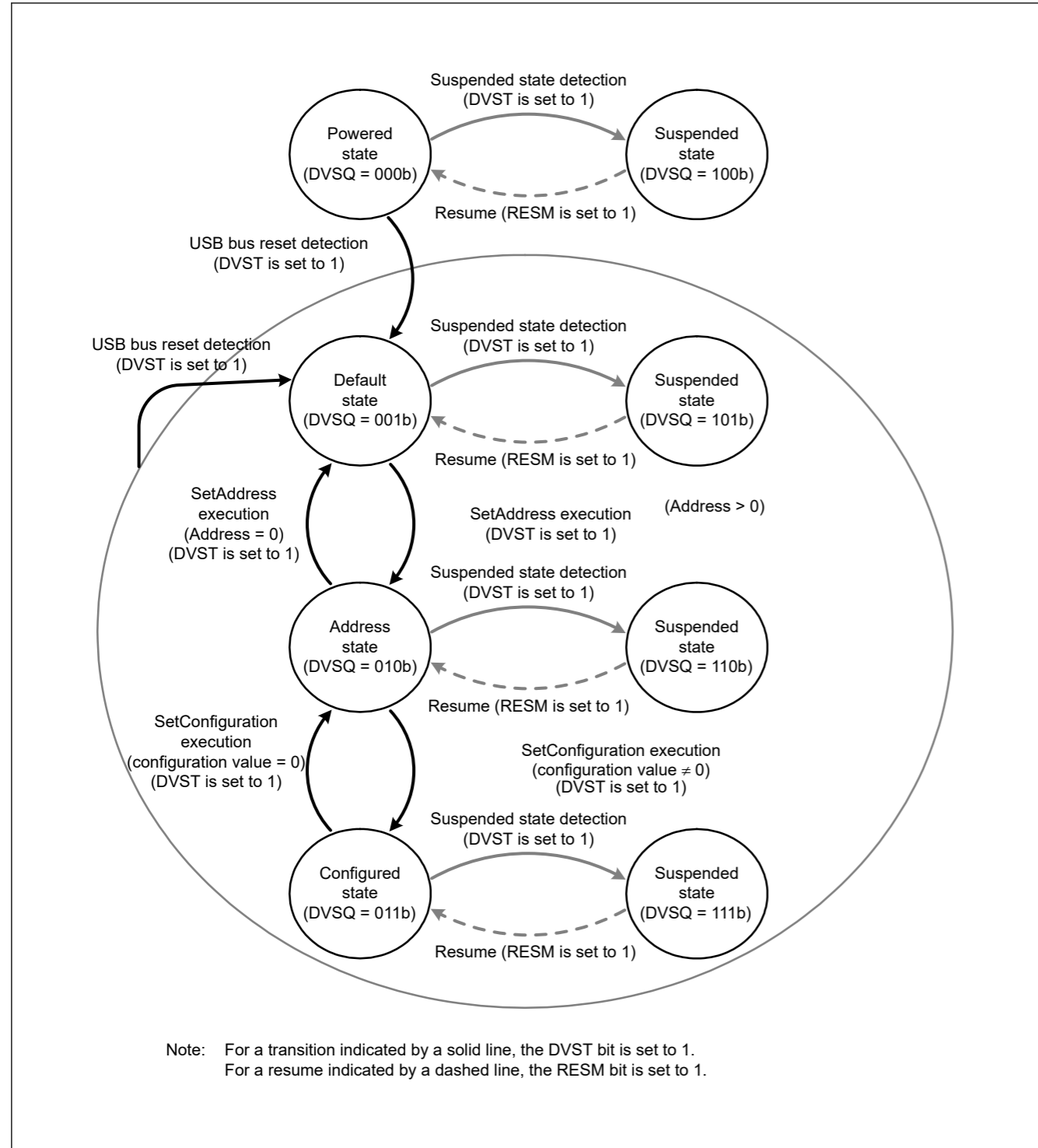


Figure 26.15 Device state transitions

26.3.3.5 Control transfer stage transition interrupt (device controller mode)

Figure 26.16 shows a diagram of the control transfer stage transitions of the USBFS. The USBFS controls the control transfer sequence and generates control transfer stage transition interrupts. Control transfer stage transition interrupts can be enabled or disabled independently in INTENB0. Transfer stages that have transitioned can be checked in the INTSTS0.CTSQ[2:0] bits.

Control transfer stage transition interrupts are generated only in device controller mode. This section describes control transfer sequence errors. If an error occurs, the DCPCTR.PID[1:0] bits are set to 1xb (STALL response).

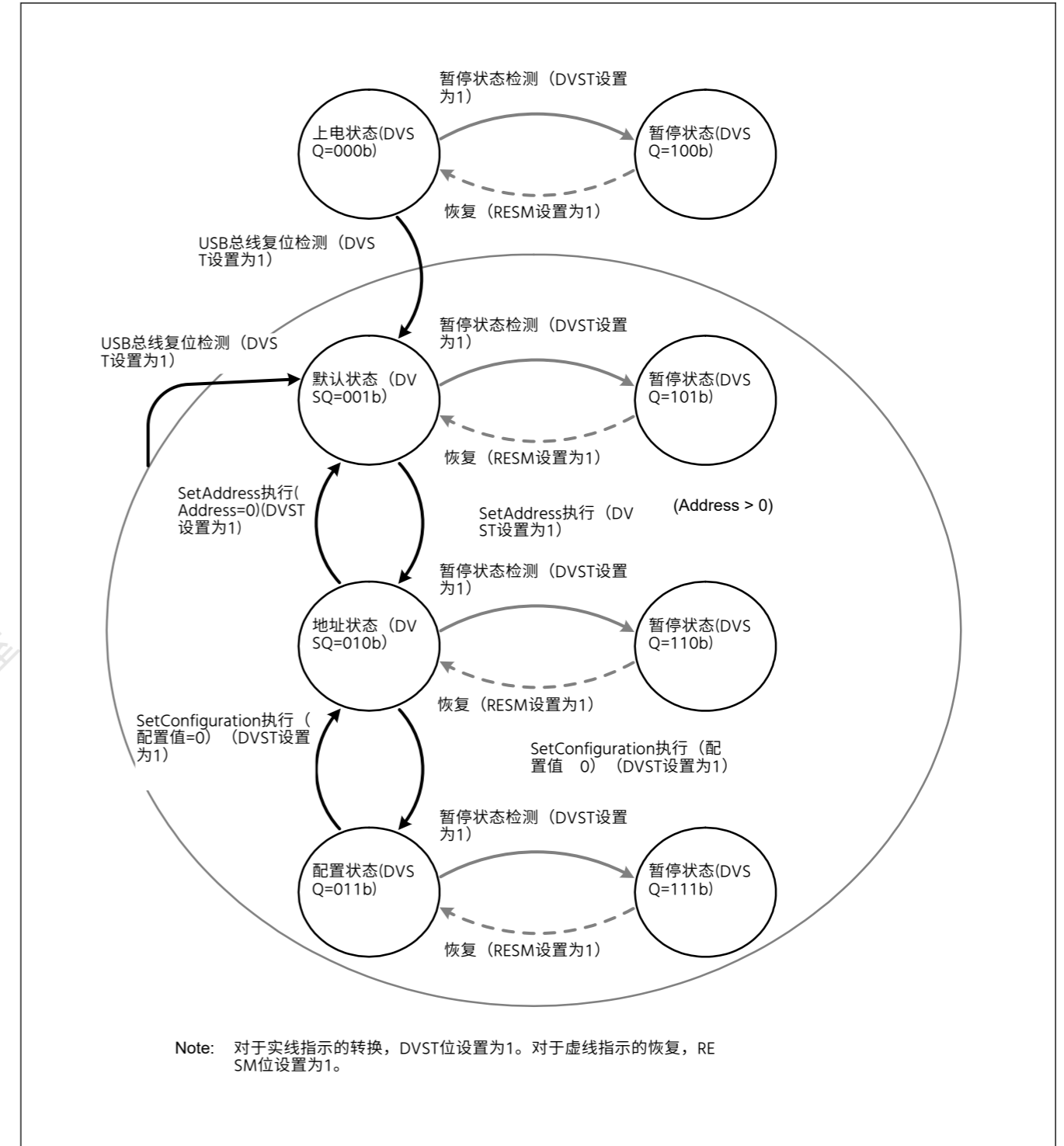


Figure 26.15 设备状态转换

26.3.3.5 控制转移阶段转换中断 (设备控制器模式)

图26.16显示了USBFS的控制传输阶段转换图。USBFS控制控制传输序列并产生控制传输阶段转换中断。控制转移阶段转换中断可以在INTENB0中独立启用或禁用。可以在INTSTS0.CTSQ[2:0]位中检查已转换的传输阶段。

控制转移阶段转换中断仅在设备控制器模式下产生。本节描述控制传输序列错误。如果发生错误, 则DCPCTR.PID[1:0]位设置为1xb (STALL响应)。

(1) Control read transfer errors

- An OUT token is received but no data is transferred in response to the IN token at the data stage
- An IN token is received at the status stage
- A data packet with DATAPID = DATA0 is received at the status stage

(2) Control write transfer errors

- An IN token is received but no ACK is returned in response to the OUT token at the data stage
- A data packet with DATAPID = DATA0 is received as the first data packet at the data stage
- An OUT token is received at the status stage

(3) Control write no data transfer errors

- An OUT token is received at the status stage

At the control write transfer data stage, if the receive data length exceeds the wLength value of the USB request, it is not recognized as a control transfer sequence error. At the control read transfer status stage, packets other than zero-length packets are received by an ACK response and the transfer ends normally.

When a CTRT interrupt occurs in response to a sequence error (INTSTS0.CTRT = 1), the CTSQ[2:0] = 110b value is saved until the CTRT bit is set to 0, clearing the interrupt status. While CTSQ[2:0] = 110b is being saved, no CTRT interrupt for ending the setup stage is generated, even if a new USB request is received. The USBFS saves the setup stage completion status, and it generates a CTRT interrupt after the interrupt status is cleared by software.

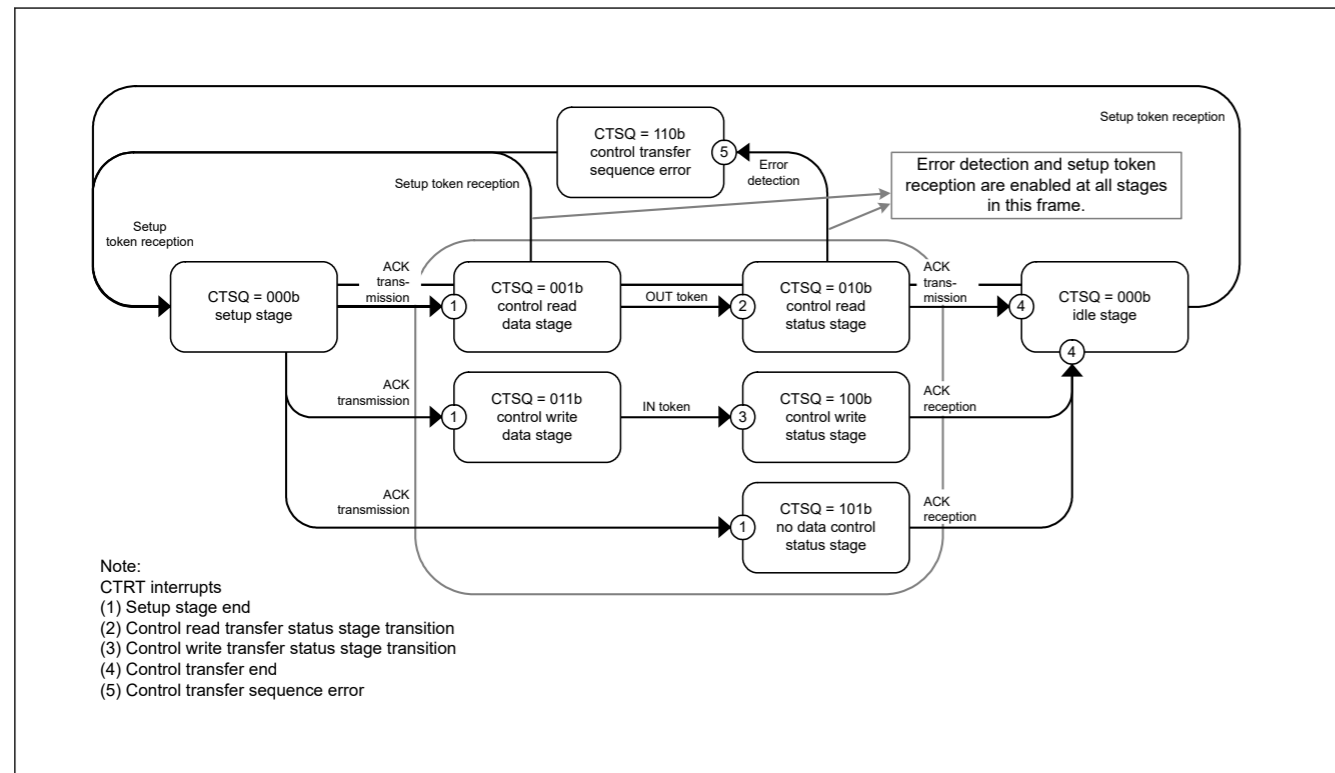


Figure 26.16 Control transfer stage transitions

26.3.3.6 Frame update interrupt

In host controller mode, an interrupt is generated when the frame number is updated.

In device controller mode, an SOFR interrupt is generated when the frame number is updated. The USBFS updates the frame number and generates an SOFR interrupt if it detects a new SOF packet during full-speed operation.

(1) 控制读取传输错误

- 在数据阶段收到一个OUT令牌，但没有传输数据以响应IN令牌
- 在状态阶段收到一个IN令牌
- 在状态阶段接收到DATAPID=DATA0的数据包

(2) 控制写入传输错误

- 在数据阶段收到一个IN令牌，但没有返回ACK响应OUT令牌
- DATAPID=DATA0的数据包作为数据阶段的第一个数据包被接收
- 在状态阶段收到一个OUT令牌

(3) 控制写入无数据传输错误

- 在状态阶段收到一个OUT令牌

在控制写入传输数据阶段，如果接收数据长度超过USB请求的wLength值，则不被识别为控制传输序列错误。在控制读取传输状态阶段，除了零长度数据包之外的数据包被一个ACK响应接收并且传输正常结束。

当响应序列错误 (INTSTS0.CTRT=1) 而发生CTRT中断时，将保存CTSQ[2:0]=110b值，直到CTRT位设置为0，清除中断状态。在保存CTSQ[2:0]=110b时，不会产生用于结束设置阶段的CTRT中断，即使收到新的USB请求也是如此。USBFS保存设置阶段完成状态，软件清除中断状态后产生CTRT中断。

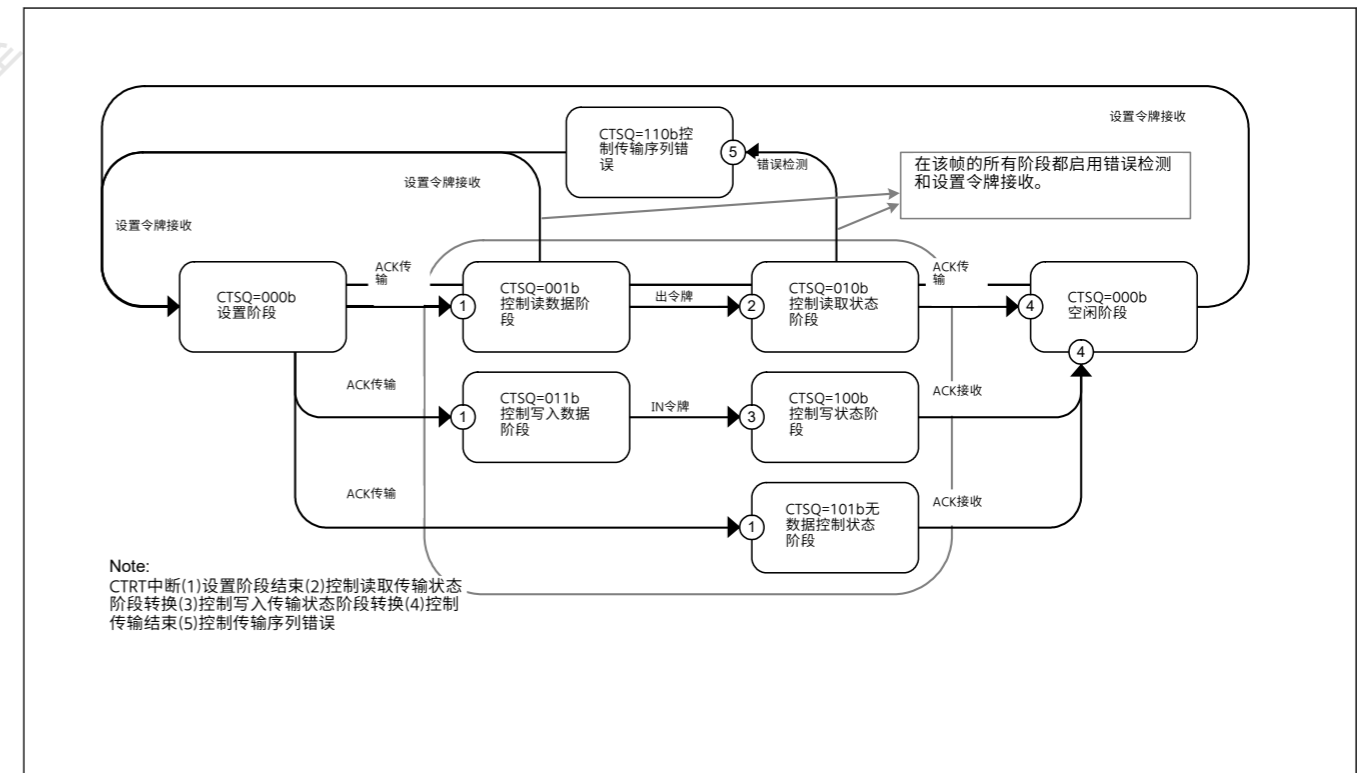


Figure 26.16 控制转移阶段转换

26.3.3.6 帧更新中断

在主机控制器模式下，更新帧号时会产生中断。

在设备控制器模式下，更新帧号时会产生SOFR中断。如果USBFS在全速运行期间检测到新的SOF数据包，则USBFS会更新帧号并生成SOFR中断。



### 26.3.3.7 VBUS interrupt

When the USB\_VBUS pin level changes, a VBUS interrupt is generated. The level of the USB\_VBUS pin can be checked with the INTSTS0.VBSTS bit. Whether the host controller is connected or disconnected can be confirmed using the VBUS interrupt. If the system is activated with the host controller connected, the first VBUS interrupt is not generated, because there is no change in the USB\_VBUS pin level.

### 26.3.3.8 Resume interrupt

In device controller mode, a resume interrupt is generated when the device state is the Suspend state and the USB bus state has changed (from J-state to K-state, or from J-state to SE0). Recovery from the Suspend state is detected by means of the resume interrupt.

In host controller mode, no resume interrupt is generated. Use the BCHG interrupt to detect a change in the USB bus state.

### 26.3.3.9 OVRCCR interrupt

An OVRCCR interrupt is generated when the USB\_OVRCURA or USB\_OVRCURB pin level has changed. The levels of the USB\_OVRCURA and USB\_OVRCURB pins can be checked in the SYSSTS0.OVCMON[1:0] flags. The external power supply IC can check whether overcurrent is detected using the OVRCCR interrupt.

For OTG connections, the OVRCCR interrupt allows you to check whether a change is detected in the VBUS comparator.

### 26.3.3.10 BCHG interrupt

A BCHG interrupt is generated when the USB bus state has changed. The BCHG interrupt can be used to detect whether a peripheral device is connected and can also be used to detect a remote wakeup in host controller mode. The BCHG interrupt is generated in both host and device controller modes.

### 26.3.3.11 DTCH interrupt

A DTCH interrupt occurs when a USB bus disconnect is detected in host controller mode. The USBFS detects bus disconnects in compliance with the USB 2.0 specification.

On interrupt detection, all pipes in which communications are being carried out for the relevant port must be terminated by software. The pipes enter the wait state for a bus connection to the port, waiting for an ATTCH interrupt to occur.

Regardless of the value set in the associated interrupt enable bit, the USBFS hardware:

- Sets the DVSTCTR0.UACT bit for the port in which the DTCH interrupt is detected to 0
- Puts the port in which the DTCH interrupt occurred into the idle state

### 26.3.3.12 SACK interrupt

A SACK interrupt is generated when an ACK response for the transmitted setup packet is received from the peripheral device in host controller mode. The SACK interrupt can be used to confirm that the setup transaction is successfully complete.

### 26.3.3.13 SIGN interrupt

A SIGN interrupt is generated when an ACK response for the transmitted setup packet is not correctly received from the peripheral device three consecutive times in host controller mode. The SIGN interrupt can be used to detect no ACK response transmitted from the peripheral device or corruption of an ACK packet.

### 26.3.3.14 ATTCH interrupt

An ATTCH interrupt is generated when J-state or K-state of the full-speed signal level is detected on the USB port for 2.5 μs in host controller mode. To be more specific, an ATTCH interrupt is detected on any of the following conditions:

- When K-state, SE0, or SE1 changes to J-state, and J-state continues 2.5 μs
- When J-state, SE0, or SE1 changes to K-state, and K-state continues 2.5 μs

### 26.3.3.7 VBUS interrupt

当USB\_VBUS引脚电平改变时,会产生VBUS中断。USB\_VBUS引脚的电平可以通过INTSTS0.VBSTS位检查。主控制器是连接还是断开可以使用VBUS中断来确认。如果系统在连接主机控制器的情况下激活,则不会产生第一个VBUS中断,因为USB\_VBUS引脚电平没有变化。

### 26.3.3.8 恢复中断

在设备控制器模式下,当设备状态为Suspend状态且USB总线状态发生变化(从J-state到K-state,或从J-state到SE0)时,会产生恢复中断。通过恢复中断检测从挂起状态的恢复。

在主机控制器模式下,不会产生恢复中断。使用BCHG中断来检测USB总线状态的变化。

### 26.3.3.9 OVRCCR interrupt

当USB\_OVRCURA或USB\_OVRCURB引脚电平发生变化时,会产生OVRCCR中断。的水平USB\_OVRCURA和USB\_OVRCURB引脚可以在SYSSTS0.OVCMON[1:0]标志中检查。外部电源IC可以使用OVRCCR中断检查是否检测到过电流。

对于OTG连接,OVRCCR中断允许您检查是否在VBUS比较器中检测到变化。

### 26.3.3.10 BCHG interrupt

当USB总线状态改变时会产生BCHG中断。BCHG中断可用于检测是否连接了外围设备,也可用于检测主机控制器模式下的远程唤醒。BCHG中断在主机和设备控制器模式下产生。

### 26.3.3.11 DTCH interrupt

当在主机控制器模式下检测到USB总线断开连接时,会发生DTCH中断。USBFS检测符合USB2.0规范的总线断开连接。

在检测到中断时,为相关端口执行通信的所有管道必须由软件终止。管道进入等待状态,等待总线连接到端口,等待ATTCH中断发生。无论相关中断使能位中设置的值如何,USBFS硬件:

- 将检测到DTCH中断的端口的DVSTCTR0.UACT位设置为0
- 将发生DTCH中断的端口置于空闲状态

### 26.3.3.12 SACK中断

当在主机控制器模式下从外围设备接收到对发送的设置数据包的ACK响应时,将产生SACK中断。SACK中断可用于确认设置事务成功完成。

### 26.3.3.13 标志中断

在主机控制器模式下,如果连续三次未从外围设备正确接收到已发送的设置数据包的ACK响应,则会产生SIGN中断。SIGN中断可用于检测没有从外围设备发送的ACK响应或ACK数据包的损坏。

### 26.3.3.14 ATTCH interrupt

在主机控制器模式下,当在USB端口上检测到全速信号电平的J状态或K状态持续2.5μs时,将产生ATTCH中断。更具体地说,在以下任何条件下都会检测到ATTCH中断:

- 当K-state、SE0或SE1变为J-state时,J-state持续2.5μs
- J-state、SE0或SE1变为K-state时,K-state持续2.5μs



### 26.3.3.15 EOFERR interrupt

An EOFERR interrupt occurs when the USBFS detects that communication is not complete at the EOF2 timing defined in the USB 2.0 specification.

On interrupt detection, all pipes in which communications are being carried out for the relevant port must be terminated by software, and the port must be re-enumerated. Regardless of the value set in the associated interrupt enable bit, the USBFS hardware:

- Sets the DVSTCTR0.UACT bit for the port in which the EOFERR interrupt is detected to 0
- Puts the port in which the EOFERR interrupt is generated into the idle state

### 26.3.3.16 Portable Device Detection Interrupt

The USBFS sets the INTSTS1.PDDETINT flag to 1 on detecting a portable device and generates the portable device detection interrupt. When the portable device detection interrupt is generated, use software to repeat reading the BCCTRL1.PDDETSTS flag until the same value is read three or more times, and perform debounce processing.

## 26.3.4 Pipe Control

Table 26.19 lists the pipe settings for the USBFS. USB data transfer is performed through logical pipes that the software associates with endpoints. The USBFS provides 10 pipes that are used for data transfer. Set up the pipes based on your system specifications.

Table 26.19 Pipe settings (1 of 2)

| Register name       | Bit name     | Setting  | Notes   |
|---------------------|--------------|--|---|
| DCPCFG<br>PIPECFG   | TYPE         | Transfer type                                      | Pipes 1 to 9: Settable  |
|                     | BFRE         | BRDY interrupt mode                                | Pipes 1 to 5: Settable  |
|                     | DBLB         | Double buffer select                               | Pipes 1 to 5: Settable  |
|                     | DIR          | Transfer direction select                          | IN or OUT settable  |
|                     | EPNUM        | Endpoint number                                    | Pipes 1 to 9: Settable<br>A value other than 0000b must be set when the pipe is used.   |
|                     | SHTNAK       | Selects disabled state for pipe when transfer ends | Pipes 1 and 2: Settable only for bulk transfers<br>Pipes 3 to 5: Settable   |
| DCPMAXP<br>PIPEMAXP | DEVSEL       | Device select                                      | Referenced only in host controller mode.  |
|                     | MXPS         | Maximum packet size                                | Compliant with the USB 2.0 specification.   |
| PIPEPERI            | IFIS         | Buffer flush                                       | Pipes 1 and 2: Settable only for isochronous transfers<br>Pipes 3 to 9: Setting disabled  |
|                     | IITV         | Interval counter                                   | Pipes 1 and 2: Settable only for isochronous transfers<br>Pipes 3 to 5: Setting disabled<br>Pipes 6 to 9: Settable only in host controller mode |
| DCPCTR<br>PIPECTR   | BSTS         | Buffer status                                      | For the DCP, receive buffer status and transmit buffer status are switched with the ISEL bit.   |
|                     | INBUFM       | IN buffer monitor                                  | Available only for pipes 1 to 5.  |
|                     | SUREQ        | Setup request                                      | Settable only for the DCP and controlled in host controller mode  |
|                     | SUREQCLR     | SUREQ clear  | Settable only for the DCP and controlled in host controller mode  |
|                     | ATREPM       | Auto response mode                                 | Pipes 1 to 5: Settable only in device controller mode   |
|                     | ACLRM        | Auto buffer clear                                  | Pipes 1 to 9: Settable  |
|                     | SQCLR        | Sequence clear                                     | Clears the data toggle bit  |
|                     | SQSET        | Sequence set                                       | Sets the data toggle bit  |
|                     | SQMON        | Sequence monitor                                   | Monitors the data toggle bit  |
|                     | PBUSY        | Pipe busy status                                   | —   |
| PID                 | Response PID | See section 26.3.4.6. Response PID.                |   |

### 26.3.3.15 EOFERR interrupt

当USBFS检测到在USB2.0规范中定义的EOF2时序未完成通信时，将发生EOFERR中断。

在检测到中断时，所有为相关端口执行通信的管道必须由软件终止，并且必须重新枚举该端口。无论相关中断使能位中设置的值如何，USBFS硬件：

- 将检测到EOFERR中断的端口的DVSTCTR0.UACT位设置为0
- 将产生EOFERR中断的端口置于空闲状态

### 26.3.3.16 便携式设备检测中断

USBFS在检测到便携式设备时将INTSTS1.PDDETINT标志设置为1，并生成便携式设备检测中断。当便携式设备检测中断产生时，使用软件重复读取BCCTRL1.PDDETSTS标志，直到读取相同的值3次或更多次，并进行抖动处理。

## 26.3.4 管道控制

表26.19列出了USBFS的管道设置。USB数据传输是通过软件与端点关联的逻辑管道执行的。USBFS提供了10个用于数据传输的管道。根据您的系统规格设置管道。

Table 26.19 管道设置(1of2)

| 注册名称                | 位名称      | Setting              | Notes   |
|---------------------|----------|----------------------|---|
| DCPCFG<br>PIPECFG   | TYPE     | 传输类型                 | 管道1至9：可设置   |
|                     | BFRE     | BRDY中断模式             | 管道1至5：可设置   |
|                     | DBLB     | 双缓冲选择                | 管道1至5：可设置   |
|                     | DIR      | 传输方向选择               | 输入或输出可设置  |
|                     | EPNUM    | 端点编号                 | 管道1至9：可设置<br>使用管道时，必须设置0000b以外的值。                     |
|                     | SHTNAK   | 传输结束时为管道选择禁用状态       | 管道1和2：仅可设置用于批量传输<br>管道3至5：可设置                         |
| DCPMAXP<br>PIPEMAXP | DEVSEL   | 设备选择                 | 仅在主机控制器模式下引用。   |
|                     | MXPS     | 最大数据包大小              | 符合USB2.0规范。   |
| PIPEPERI            | IFIS     | 缓冲区刷新                | 管道1和2：仅可设置用于同步传输<br>管道3到9：设置禁用                        |
|                     | IITV     | 间隔计数器                | 管道1和2：仅可设置用于同步传输<br>管道3到5：禁用设置<br>管道6到9：仅在主机控制器模式下可设置 |
| DCPCTR<br>PIPECTR   | BSTS     | 缓冲状态                 | 对于DCP，接收缓冲器状态和发送缓冲器状态通过ISEL位切换。                       |
|                     | INBUFM   | IN缓冲监视器              | 仅适用于管道1到5。  |
|                     | SUREQ    | 设置请求                 | 只能为DCP设置并在主机控制器模式下控制                                  |
|                     | SUREQCLR | SUREQ clear          | 只能为DCP设置并在主机控制器模式下控制                                  |
|                     | ATREPM   | 自动响应模式               | 管道1到5：仅在设备控制器模式下可设置                                   |
|                     | ACLRM    | 自动缓冲区清除              | 管道1至9：可设置   |
|                     | SQCLR    | 序列清除                 | 清除数据切换位   |
|                     | SQSET    | 序列集                  | 设置数据切换位   |
|                     | SQMON    | 序列监视器                | 监控数据切换位   |
|                     | PBUSY    | 管道繁忙状态               | —   |
| PID                 | 响应PID    | 请参阅第26.3.4.6节。响应PID。 |   |

Table 26.19 Pipe settings (2 of 2)

| Register name | Bit name | Setting                           | Notes                  |
|---------------|----------|-----------------------------------|------------------------|
| PIPEnTRE      | TRENB    | Transaction counter enable        | Pipes 1 to 5: Settable |
|               | TRCLR    | Current transaction counter clear | Pipes 1 to 5: Settable |
| PIPEnTRN      | TRNCNT   | Transaction counter               | Pipes 1 to 5: Settable |

### 26.3.4.1 Pipe control register switching procedures

The following bits in the pipe control registers can be changed only when USB communication is prohibited (PID = NAK).

Do not change the following registers and bits when USB communication is enabled (PID = BUF):

- Bits in DCPCFG and DCPMAXP
- SQCLR and SQSET bits in DCPCTR
- Bits in PIPECFG, PIPEMAXP, and PIPEPERI
- ATREPM, ACLRM, SQCLR, and SQSET bits in PIPEnCTR
- Bits in PIPEnTRE and PIPEnTRN

To set these bits when USB communication is enabled (PID = BUF):

1. A request to change the bits in the pipe control register occurs.
2. Set the PID[1:0] bits associated with the pipe to NAK.
3. Wait until the associated PBUSY bit clears to 0.
4. Set the bits in the pipe control register.

The following bits in the pipe control registers can be changed only when the selected pipe information is not set in the CURPIPE[3:0] bits in CFIFOSEL, D0FIFOSEL, and D1FIFOSEL.

Do not set the following registers when the CURPIPE[3:0] bits are set:

- Bits in DCPCFG and DCPMAXP
- Bits in PIPECFG, PIPEMAXP and PIPEPERI

To change pipe information, you must set the CURPIPE[3:0] bits in the port select registers to a pipe other than the one to be changed. For the DCP, the buffer must be cleared using the BCLR bit in the Port Control Register after the pipe information is changed.

### 26.3.4.2 Transfer types

The PIPECFG.TYPE[1:0] bits specify the following transfer types for each pipe:

- DCP: No setting is necessary (fixed at control transfer)
- Pipes 1 and 2: Set to bulk or isochronous transfer
- Pipes 3 to 5: Set to bulk transfer
- Pipes 6 to 9: Set to interrupt transfer

### 26.3.4.3 Endpoint number

The PIPECFG.EPNUM[3:0] bits are used to set the endpoint number for each pipe. The DCP is fixed at endpoint 0. The other pipes can be set from endpoint 1 to 15.

- DCP: No setting is necessary (fixed at endpoint 0)
- Pipes 1 to 9: Select and set the endpoint numbers from 1 to 15 so that the combination of the PIPECFG.DIR and EPNUM[3:0] bits is unique

Table 26.19 管道设置(2of2)

| 注册名称     | 位名称    | Setting  | Notes      |
|----------|--------|----------|------------|
| PIPEnTRE | TRENB  | 事务计数器启用  | 管道1至5: 可设置 |
|          | TRCLR  | 当前交易柜台清零 | 管道1至5: 可设置 |
| PIPEnTRN | TRNCNT | 交易柜台     | 管道1至5: 可设置 |

### 26.3.4.1 管道控制寄存器切换程序

只有当USB通信被禁止(PID=NAK)时, 管道控制寄存器中的以下位才能更改。

当启用USB通信(PID=BUF)时, 请勿更改以下寄存器和位:

- DCPCFG和DCPMAXP中的位
- DCPCTR中的SQCLR和SQSET位
- PIPECFG、PIPEMAXP和PIPEPERI中的位
- PIPEnCTR中的ATREPM、ACLRM、SQCLR和SQSET位
- PIPEnTRE和PIPEnTRN中的位

要在启用USB通信(PID=BUF)时设置这些位:

- 1.发生更改管道控制寄存器中的位的请求。
- 2.将与管道关联的PID[1:0]位设置为NAK。
- 3.等到相关的PBUSY位清除为0。
- 4.设置管道控制寄存器中的位。

管道控制寄存器中的以下位只有在所选管道信息未设置时才能更改CFIFOSEL、D0FIFOSEL和D1FIFOSEL中的CURPIPE[3:0]位。

设置CURPIPE[3:0]位时不要设置以下寄存器:

- DCPCFG和DCPMAXP中的位
- PIPECFG、PIPEMAXP和PIPEPERI中的位

要更改管道信息, 您必须将端口选择寄存器中的CURPIPE[3:0]位设置为要更改的管道以外的管道。对于DCP, 必须在管道信息更改后使用端口控制寄存器中的BCLR位清除缓冲区。

### 26.3.4.2 传输类型

PIPECFG.TYPE[1:0]位为每个管道指定以下传输类型:

- DCP: 无需设置 (控制转移时固定)
- 管道1和2: 设置为批量或同步传输
- 管道3到5: 设置为批量传输
- 管道6到9: 设置为中断传输

### 26.3.4.3 端点编号

PIPECFG.EPNUM[3:0]位用于设置每个管道的端点编号。DCP固定在端点0。其他管道可以设置从端点1到15。

- DCP: 无需设置 (固定在端点0)
- 管道1到9: 从1到15选择和设置端点编号, 以便PIPECFG.DIR和EPNUM[3:0]位的组合是唯一的

### 26.3.4.4 Maximum packet size setting

Specify the maximum packet size for each pipe in the DCPMAXP.MXPS[6:0] and PIPEMAXP.MXPS[9:0] bits. The DCP and pipes 1 to 5 can be set to any of the maximum pipe sizes defined in the USB 2.0 specification. For pipes 6 to 9, the maximum packet size is 64 bytes. Set the maximum packet size as follows before starting a transfer (PID = BUF):

- DCP: Set to 8, 16, 32, or 64
- Pipes 1 to 5: Set to 8, 16, 32, or 64 for bulk transfers
- Pipes 1 and 2: Set between 1 and 256 for isochronous transfers
- Pipes 6 to 9: Set between 1 and 64

### 26.3.4.5 Transaction counter for pipes 1 to 5 in the receiving direction

When the specified number of transactions is complete in the data packet receiving direction, the USBFS recognizes that the transfer ended. Two transaction counters are provided: one is the PIPEnTRN register, which specifies the number of transactions to be executed, and the other is the current counter, which internally counts the number of executed transactions. If the PIPECFG.SHTNAK bit is set to 1, when the current counter value matches the specified number of transactions, the associated PIPEnCTR.PID[1:0] bits are set to NAK and the subsequent transfer is disabled. The transactions can be counted again from the beginning by initializing the current counter of the transaction counter function through the PIPEnTRE.TRCLR bit. The data read from PIPEnTRN differs depending on the PIPEnTRE.TRENB setting as follows:

- The TRENB bit = 0: Specified transaction counter value can be read
- The TRENB bit = 1: Current counter value indicating the internally counted number of executed transactions can be read

The following constraints apply when working with the TRCLR bit:

- If the transactions are being counted and PID = BUF, the current counter cannot be cleared
- If there is any data left in the buffer, the current counter cannot be cleared

### 26.3.4.6 Response PID

Specify the response PID for each pipe in the PID[1:0] bits in DCPCTR and PIPEnCTR. This section describes the USBFS operation with different response PID settings.

#### (1) Software response PID settings in host controller mode

Select the response PID to specify the execution of transactions as follows:

- NAK setting: Using pipes is disabled and no transactions are executed
- BUF setting: Transactions are executed based on the FIFO buffer state:
  - OUT direction: An OUT token is issued if the FIFO buffer contains transmit data.
  - IN direction: An IN token is issued if the FIFO buffer is not full and can receive data.
- STALL setting: Using pipes is disabled and no transactions are executed

Note: Use the DCPCTR.SUREQ bit to execute setup transactions for the DCP.

#### (2) Software response PID settings in device controller mode

Select the response PID to respond as follows to transactions from the host:

- NAK setting: A NAK response is returned to all generated transactions
- BUF setting: A response is returned to transactions based on the FIFO buffer
- STALL setting: A STALL response is returned to all generated transactions

Note: For setup transactions, an ACK response is always returned, regardless of the PID[1:0] bits setting, and the USB request is stored in the register.

### 26.3.4.4 最大数据包大小设置

在DCPMAXP.MXPS[6:0]和PIPEMAXP.MXPS[9:0]位中指定每个管道的最大数据包大小。DCP和管道1到5可以设置为USB2.0规范中定义的任何最大管道尺寸。对于管道6到9，最大数据包大小为64字节。在开始传输之前设置最大数据包大小如下 (PID=BUF)：

- DCP：设置为8、16、32或64
- 管道1到5：设置为8、16、32或64以进行批量传输
- 管道1和2：设置在1和256之间，用于同步传输
- 管道6到9：设置在1到64之间

### 26.3.4.5 接收方向上管道1到5的事务计数器

当在数据包接收方向完成指定数量的事务时，USBFS识别传输结束。提供了两个事务计数器：一个是PIPEnTRN寄存器，指定要执行的事务数，另一个是当前计数器，内部统计执行的事务数。如果PIPECFG.SHTNAK位设置为1，则当当前计数器值与指定的事务数匹配时，相关的PIPEnCTR.PID[1:0]位将设置为NAK，并禁用后续传输。通过PIPEnTRE.TRCLR位初始化事务计数器功能的当前计数器，事务可以从头开始重新计数。从PIPEnTRN读取的数据因PIPEnTRE.TRENB设置而异，如下所示：

- TRENB位=0：可以读取指定的事务计数器值
- TRENB位=1：表示内部计数的已执行事务数的当前计数器值可被读取

使用TRCLR位时适用以下约束：

- 如果正在对事务进行计数且PID=BUF，则无法清除当前计数器
- 如果缓冲区中还有数据，则无法清除当前计数器

### 26.3.4.6 响应PID

在DCPCTR和PIPEnCTR的PID[1:0]位中指定每个管道的响应PID。本节介绍具有不同响应PID设置的USBFS操作。

#### (1) 主机控制器模式下的软件响应PID设置

选择响应PID来指定事务的执行，如下所示：

- NAK设置：禁用使用管道，不执行任何事务
- BUF设置：根据FIFO缓冲区状态执行事务：
  - OUT方向：如果FIFO缓冲区包含发送数据，则发出OUT令牌。
  - IN方向：如果FIFO缓冲区未充满并且可以接收数据，则发出IN令牌。
- STALL设置：禁止使用管道，不执行任何事务

Note: 使用DCPCTR.SUREQ位执行DCP的设置事务。

#### (2) 设备控制器模式下的软件响应PID设置

选择响应PID以对来自主机的事务进行如下响应：

- NAK设置：对所有生成的事务返回NAK响应
- BUF设置：根据FIFO缓冲区向事务返回响应
- STALL设置：向所有生成的事务返回STALL响应

Note: 对于设置事务，无论PID[1:0]位设置如何，始终返回ACK响应，并且USB请求存储在寄存器中。



Sections (3) and (4) describe situations in which the USBFS writes to the PID[1:0] bits because of specific transaction results.

### (3) Hardware response PID settings in host controller mode

- NAK setting: PID = NAK is set in the following cases, and issuing of tokens is automatically stopped:
  - When a non-isochronous transfer is performed and an NRDY interrupt is generated  
(For details, see [section 26.3.3.2. NRDY interrupt.](#))
  - If a short packet is received when the PIPECFG.SHTNAK bit is set to 1 for bulk transfers
  - If transaction counting ends when the SHTNAK bit is set to 1 for bulk transfers
- BUF setting: The USBFS does not write this setting.
- STALL setting: PID = STALL is set in the following cases, and issuing of tokens is automatically stopped:
  - When STALL is received in response to a transmitted token
  - When a received data packet exceeds the maximum packet size

### (4) Hardware response PID settings in device controller mode

- NAK setting: PID = NAK is set in the following cases, and a NAK response is returned to transactions:
  - When the setup token is received normally (DCP only)
  - If transaction counting ends or a short packet is received when the PIPECFG.SHTNAK bit is set to 1 for bulk transfers
- BUF setting: There is no BUF writing by the USBFS.
- STALL setting: PID = STALL is set in the following cases, and a STALL response is returned to transactions:
  - When a received data packet exceeds the maximum packet size
  - When a control transfer sequence error is detected (DCP only)

#### 26.3.4.7 Data PID sequence bit

The USBFS automatically toggles the sequence bit in the data PID when data is transferred successfully in the control transfer data stage, bulk transfer, and interrupt transfer. The sequence bit of the next data PID to be transmitted can be confirmed with the SQMON bit in DCPCTR and PIPEnCTR. When data is transmitted, the sequence bit toggles on ACK handshake reception. When data is received, the sequence bit toggles on ACK handshake transmission. The SQCLR bit in DCPCTR and the SQSET bit in PIPEnCTR can be used to change the data PID sequence bit.

In device controller mode when control transfers are used, the USBFS automatically sets the sequence bit for stage transitions. DATA1 is returned when the setup stage ends. The sequence bit is not referenced and PID = DATA1 is returned in the status stage. Therefore, no software settings are required. However, in host controller mode when control transfers are used, the sequence bit must be set by software for the stage transitions.

For ClearFeature requests for transmission or reception, the data PID sequence bit must be set by software in both host and device controller modes.

#### 26.3.4.8 Response PID = NAK function

The USBFS provides a function for disabling pipe operation (PID response = NAK) when the final data packet of a transaction is received. The USBFS automatically distinguishes this based on reception of a short packet or the transaction counter. Enable this function by setting the PIPECFG.SHTNAK bit to 1.

When the double buffer mode is being used for the FIFO buffer, using this function enables reception of data packets in transfer units. If pipe operation is disabled, the software must enable the pipe again (PID response = BUF).

The response PID = NAK function can be used only for bulk transfers.

第(3)和(4)节描述了USBFS由于特定事务结果而写入PID[1:0]位的情况。

### (3) 主机控制器模式下的硬件响应PID设置

- NAK设置: PID=NAK在以下情况下设置, 令牌自动停止发行:
  - 当执行非同步传输并产生NRDY中断时  
(有关详细信息, 请参阅第26.3.3.2节。NRDY中断。)
  - 如果在PIPECFG.SHTNAK位设置为1以进行批量传输时接收到短数据包
  - 如果在SHTNAK位设置为1以进行批量传输时事务计数结束
- BUF设置: USBFS不写入此设置。
- STALL设置: PID=STALL在以下情况下设置, 并且自动停止发行令牌:
  - 当接收到STALL以响应传输的令牌时
  - 当接收到的数据包超过最大包大小时

### (4) 设备控制器模式下的硬件响应PID设置

- NAK设置: PID=NAK在以下情况下设置, 并向事务返回NAK响应:
  - 正常接收到设置令牌时 (仅DCP)
  - 当PIPECFG.SHTNAK位设置为1以进行批量传输时, 如果事务计数结束或收到短数据包
- BUF设置: USBFS不写入BUF。
- STALL设置: PID=STALL在以下情况下设置, 并向事务返回STALL响应:
  - 当接收到的数据包超过最大包大小时
  - 当检测到控制传输序列错误时 (仅限DCP)

#### 26.3.4.7 数据PID序列位

当数据在控制传输数据阶段、批量传输和中断传输成功传输时, USBFS会自动切换数据PID中的序列位。下一个要发送的数据PID的序列位可以通过DCPCTR和PIPEnCTR中的SQMON位来确认。发送数据时, 序列位在ACK握手接收时切换。当接收到数据时, 序列位在ACK握手传输上切换。DCPCTR中的SQCLR位和PIPEnCTR中的SQSET位可用于更改数据PID序列位。

在使用控制传输的设备控制器模式下, USBFS自动设置阶段转换的序列位。DATA1在设置阶段结束时返回。不引用序列位, 在状态阶段返回PID=DATA1。因此, 不需要任何软件设置。但是, 在使用控制传输的主机控制器模式下, 必须由软件设置序列位以进行阶段转换。

对于发送或接收的ClearFeature请求, 数据PID序列位必须由软件在主机和设备控制器模式下设置。

#### 26.3.4.8 响应PID=NAK功能

USBFS提供了在接收到事务的最终数据包时禁用管道操作 (PID响应=NAK) 的功能。USBFS根据收到的短数据包或事务计数器自动区分这一点。通过将PIPECFG.SHTNAK位设置为1来启用此功能。

当FIFO缓冲区使用双缓冲区模式时, 使用此功能可以接收以传输为单位的数据包。如果管道操作被禁用, 软件必须再次启用管道 (PID响应=BUF)。

响应PID=NAK函数只能用于批量传输。



### 26.3.4.9 Auto response mode

For bulk transfer pipes (1 to 5), when the PIPEnCTR.ATREPM bit is set to 1, a transition is made to auto response mode. During an OUT transfer (PIPECFG.DIR = 0), OUT-NAK mode is invoked, and during an IN transfer (DIR = 1), null auto response mode is invoked.

### 26.3.4.10 OUT-NAK mode

For bulk OUT transfer pipes, NAK is returned in response to an OUT token, and an NRDY interrupt is output when the PIPEnCTR.ATREPM bit is set to 1. To transition from normal mode to OUT-NAK mode, specify OUT-NAK mode while pipe operation is disabled (PID[1:0] = 00b for NAK response). Next enable pipe operation (PID[1:0] = 01b for BUF response), on which OUT-NAK mode becomes valid. If an OUT token is received immediately before pipe operation is disabled, the token data is normally received, and an ACK is returned to the host.

To transition from OUT-NAK mode to normal mode, cancel OUT-NAK mode while pipe operation is disabled (NAK). Next enable pipe operation (BUF). In normal mode, reception of OUT data is enabled.

### 26.3.4.11 Null auto response mode

For bulk IN transfer pipes, zero-length packets are continuously transmitted when the PIPEnCTR.ATREPM bit is set to 1.

To transition from normal mode to null auto response mode, specify null auto response mode while pipe operation is disabled (response PID = NAK). Next enable pipe operation (response PID = BUF) on which null auto response mode becomes valid. Before setting null auto response mode, check that PIPEnCTR.INBUFM = 0, because the mode can be set only when the buffer is empty. If the INBUFM bit is 1, empty the buffer using the PIPEnCTR.ACLRM bit. Do not write data from the FIFO port while a transition to null auto response mode is being made.

To transition from null auto response mode to normal mode, keep pipe operation disabled (response PID = NAK) for the period of the zero-length packet transmission (about 10 μs) before canceling the null auto response mode. In normal mode, data can be written from the FIFO port, so packet transmission to the host is enabled by enabling pipe operation (response PID = BUF).

## 26.3.5 FIFO Buffer

The USBFS provides a FIFO buffer for data transfers, and it manages the memory area used for each pipe. The FIFO buffer has two states depending on whether the access right is assigned to the system (CPU side) or the USBFS (SIE side).

### (1) Buffer status

Table 26.20 and Table 26.21 show the buffer status in the USBFS. The FIFO buffer status can be confirmed using the DCPCTR.BSTS and PIPEnCTR.INBUFM bits. The transfer direction for the FIFO buffer can be specified in either the PIPECFG.DIR or CFIFOSEL.ISEL bit (when DCP is selected).

The INBUFM bit is valid for pipes 0 to 5 in the transmitting direction.

When a transmitting pipe uses double buffering, the software can read the BSTS bit to monitor the FIFO buffer status on the CPU side and the INBUFM bit to monitor the FIFO buffer status on the SIE side. When write access to the FIFO port by the CPU or DMA/DTC is slow and the buffer empty status cannot be determined using the BEMP interrupt, the software can use the INBUFM bit to confirm the end of transmission.

**Table 26.20 Buffer status indicated in the BSTS bit**

| ISEL or DIR                | BSTS | FIFO buffer status   |
|----------------------------|------|--|
| 0 (receiving direction)    | 0    | There is no received data, or data is being received.<br>Reading from the FIFO port is disabled.   |
| 0 (receiving direction)    | 1    | There is received data, or a zero-length packet is received.<br>Reading from the FIFO port is allowed.<br>When a zero-length packet is received, reading is not possible and the buffer must be cleared. |
| 1 (transmitting direction) | 0    | Transmission has not completed.<br>Writing to the FIFO port is disabled.   |
| 1 (transmitting direction) | 1    | Transmission is complete.<br>CPU write is allowed.   |

### 26.3.4.9 自动响应模式

对于批量传输管道（1到5），当PIPEnCTR.ATREPM位设置为1时，将转换到自动响应模式。在OUT传输期间(PIPECFG.DIR=0)，将调用OUT-NAK模式，在IN传输期间(DIR=1)，将调用空自动响应模式。

### 26.3.4.10 OUT-NAK mode

对于批量OUT传输管道，NAK响应OUT令牌返回，并且当PIPEnCTR.ATREPM位设置为1。要从正常模式转换到OUT-NAK模式，请在禁用管道操作时指定OUT-NAK模式（对于NAK响应，PID[1:0]=00b）。接下来启用管道操作（PID[1:0]=01b用于BUF响应），此时OUT-NAK模式变为有效。如果在禁用管道操作之前立即收到OUT令牌，则正常接收令牌数据，并向主机返回ACK。

要从OUT-NAK模式转换到正常模式，请在禁用管道操作(NAK)时取消OUT-NAK模式。接下来启用管道操作(BUF)。在正常模式下，可以接收OUT数据。

### 26.3.4.11 空自动响应模式

对于批量IN传输管道，当PIPEnCTR.ATREPM位设置为1时，将连续传输零长度数据包。

要从正常模式转换为空自动响应模式，请在禁用管道操作时指定空自动响应模式（响应PID=NAK）。接下来启用空自动响应模式有效的管道操作（响应PID=BUF）。在设置空自动响应模式之前，请检查PIPEnCTR.INBUFM=0，因为只有当缓冲区为空时才能设置模式。如果INBUFM位为1，则使用PIPEnCTR.ACLRM位清空缓冲区。在转换到空自动响应模式时，不要从FIFO端口写入数据。

要从空值自动响应模式转换到正常模式，在取消空值自动响应模式之前，在零长度数据包传输期间（约10μs）保持管道操作禁用（响应PID=NAK）。在正常模式下，可以从FIFO端口写入数据，因此通过启用管道操作（响应PID=BUF）来启用到主机的数据包传输。

## 26.3.5 FIFO Buffer

USBFS为数据传输提供FIFO缓冲区，并管理用于每个管道的内存区域。根据访问权限是分配给系统（CPU端）还是USBFS（SIE端），FIFO缓冲区有两种状态。

### (1) 缓冲状态

表26.20和表26.21显示了USBFS中的缓冲区状态。FIFO缓冲区状态可以使用确认DCPCTR.BSTS和PIPEnCTR.INBUFM位。FIFO缓冲区的传输方向可以在任一pipecfg.dir或cfifosel.isel位（选择DCP时）。

INBUFM位对传输方向的管道0到5有效。

当传输管道使用双缓冲时，软件可以读取BSTS位来监控CPU侧的FIFO缓冲区状态，以及读取INBUFM位来监控SIE侧的FIFO缓冲区状态。当写访问FIFO端口由

CPU或DMADTC较慢且无法使用BEMP中断确定缓冲区空状态，软件可以使用INBUFM位确认传输结束。

**Table 26.20 BSTS位中指示的缓冲区状态**

| ISEL或DIR                   | BSTS | FIFO缓冲区状态  |
|----------------------------|------|--|
| 0 (receiving direction)    | 0    | 没有接收到数据，或正在接收数据。<br>禁止从FIFO端口读取。                               |
| 0 (receiving direction)    | 1    | 有接收数据，或接收到零长度数据包。<br>允许从FIFO端口读取。<br>当接收到零长度数据包时，无法读取，必须清除缓冲区。 |
| 1 (transmitting direction) | 0    | 传输尚未完成。<br>禁止写入FIFO端口。   |
| 1 (transmitting direction) | 1    | 传输完成。<br>允许CPU写入。  |

Table 26.21 Buffer status indicated in the INBUFM bit

| DIR                        | INBUFM  | FIFO buffer status  |
|----------------------------|---------|---|
| 0 (receiving direction)    | Invalid | Invalid   |
| 1 (transmitting direction) | 0       | Transmission is complete.<br>There is no data waiting to be transmitted.          |
| 1 (transmitting direction) | 1       | The FIFO port has written data to the buffer.<br>There is data to be transmitted. |

### 26.3.6 FIFO Buffer Clearing

Table 26.22 shows the methods for clearing the FIFO buffer. The FIFO buffer can be cleared using BCLR bit in the port control register, DnFIFOSEL.DCLRM, or the PIPEnCTR.ACLRM bit.

Single or double buffering can be selected for pipes 1 to 5 in the PIPECFG.DBLB bit.

Table 26.22 Buffer clearing methods

| FIFO buffer clearing mode | Clearing FIFO buffer on the CPU side | Mode for automatically clearing the FIFO buffer after reading the specified pipe data | Auto buffer clear mode for discarding all received packets |
|---------------------------|--------------------------------------|---|--|
| Register used             | CFIFOCTR<br>DnFIFOCTR                | DnFIFOSEL   | PIPEnCTR   |
| Bit used                  | BCLR                                 | DCLRM   | ACLRM  |
| Clearing condition        | Cleared by writing 1                 | 1: Mode valid<br>0: Mode invalid  | 1: Mode valid<br>0: Mode invalid                           |

#### (1) Auto buffer clear mode function

The USBFS discards all received data packets if the PIPEnCTR.ACLRM bit is set to 1. If a correct data packet is received, the ACK response is returned to the host controller. The auto buffer clear mode function can only be set in the FIFO buffer reading direction.

Setting the ACLRM bit to 1 and then to 0 clears the FIFO buffer of the selected pipe regardless of the access direction. An access cycle of at least 100 ns is required for the internal hardware sequence processing between ACLRM = 1 and ACLRM = 0.

### 26.3.7 FIFO Port Functions

Table 26.23 shows the settings for the FIFO port functions. In write access, writing data until the maximum packet size is reached automatically enables transmission of the data. To enable transmission before the maximum packet size is reached, set the BVAL flag in the port control register to end writing. To send a zero-length packet, use the BCLR bit to clear the buffer, and then set the BVAL flag to end writing.

In reading, reception of new packets is automatically enabled when all data is read. Data cannot be read when a zero-length packet is received (DTLN[8:0] = 0), so the buffer must be cleared with the BCLR bit. The length of the receive data can be confirmed in the DTLN[8:0] bits in the port control register.

Table 26.23 FIFO port function settings (1 of 2)

| Register name                        | Bit name | Description   |
|--------------------------------------|----------|---|
| CFIFOSEL,<br>DnFIFOSEL<br>(n = 0, 1) | RCNT     | Selects DTLN[11:0] read mode  |
|                                      | REW      | FIFO buffer rewind (re-read, rewrite)   |
|                                      | DCLRM    | Automatically clears receive data for a specified pipe after the data is read (only for DnFIFO) |
|                                      | DREQE    | Enables DMA/DTC transfers (only for DnFIFO)   |
|                                      | MBW      | FIFO port access bit width  |
|                                      | BIGEND   | Selects FIFO port endian  |
|                                      | ISEL     | FIFO port access direction (only for DCP)   |
|                                      | CURPIPE  | Selects the current pipe  |

Table 26.21 INBUFM位中指示的缓冲区状态

| DIR                        | INBUFM  | FIFO缓冲区状态                   |
|----------------------------|---------|-----------------------------|
| 0 (receiving direction)    | Invalid | Invalid                     |
| 1 (transmitting direction) | 0       | 传输完成。<br>没有等待传输的数据。         |
| 1 (transmitting direction) | 1       | FIFO端口已将数据写入缓冲区。<br>有数据要传输。 |

### 26.3.6 FIFO缓冲区清除

表26.22显示了清除FIFO缓冲区的方法。可以使用端口控制寄存器中的BCLR位、DnFIFOSEL.DCLRM或PIPEnCTR.ACLRM位清除FIFO缓冲区。

可以在PIPECFG.DBLB位中为管道1到5选择单缓冲或双缓冲。

Table 26.22 缓冲区清除方法

| FIFO缓冲区清除模式 | 清除FIFO缓冲区CPU端         | 读取指定管道数据后自动清除FIFO缓冲区的模式 | 自动缓冲区清除模式，用于丢弃所有接收到的数据包 |
|-------------|-----------------------|-------------------------|-------------------------|
| 注册使用        | CFIFOCTR<br>DnFIFOCTR | DnFIFOSEL               | PIPEnCTR                |
| 使用的位        | BCLR                  | DCLRM                   | ACLRM                   |
| 清算条件        | 通过写1清除                | 1: 模式有效0<br>: 模式无效      | 1: 模式有效0<br>: 模式无效      |

#### (1) 自动缓冲清除模式功能

如果PIPEnCTR.ACLRM位设置为1，USBFS将丢弃所有接收到的数据包。如果接收到正确的数据包，则向主机控制器返回ACK响应。自动缓冲区清除模式功能只能在FIFO缓冲区读取方向设置。

无论访问方向如何，将ACLRM位设置为1，然后设置为0都会清除所选管道的FIFO缓冲区。ACLRM=1和ACLRM=0之间的内部硬件序列处理需要至少100ns的访问周期。

### 26.3.7 FIFO端口功能

表26.23显示了FIFO端口功能的设置。在写访问中，在达到最大数据包大小之前写入数据会自动启用数据传输。要在达到最大数据包大小之前启用传输，请设置端口控制寄存器中的BVAL标志以结束写入。要发送零长度数据包，请使用BCLR位清除缓冲区，然后设置BVAL标志以结束写入。

在读取中，当所有数据被读取时，自动启用新数据包的接收。接收到零长度数据包时 (DTLN[8:0]=0) 无法读取数据，因此必须使用BCLR位清除缓冲区。接收数据的长度可以在端口控制寄存器的DTLN[8:0]位中确认。

Table 26.23 FIFO端口功能设置(1of2)

| 注册名称                                 | 位名称     | Description                     |
|--------------------------------------|---------|---------------------------------|
| CFIFOSEL,<br>DnFIFOSEL<br>(n = 0, 1) | RCNT    | 选择DTLN[11:0]读取模式                |
|                                      | REW     | FIFO缓冲区倒带 (重新读取、重写)             |
|                                      | DCLRM   | 读取数据后自动清除指定管道的接收数据 (仅适用于DnFIFO) |
|                                      | DREQE   | 启用DMADTC传输 (仅适用于DnFIFO)         |
|                                      | MBW     | FIFO端口访问位宽                      |
|                                      | BIGEND  | 选择FIFO端口字节序                     |
|                                      | ISEL    | FIFO端口访问方向 (仅适用于DCP)            |
|                                      | CURPIPE | 选择当前管道                          |

Table 26.23 FIFO port function settings (2 of 2)

| Register name                        | Bit name | Description                            |
|--------------------------------------|----------|--|
| CFIFOCTR,<br>DnFIFOCTR<br>(n = 0, 1) | BVAL     | Ends writing to the FIFO buffer        |
|                                      | BCLR     | Clears the FIFO buffer on the CPU side |
|                                      | DTLN     | Checks the length of receive data      |

## (1) FIFO port selection

Table 26.24 shows the pipes that can be selected with the different FIFO ports. The pipe to be accessed must be selected in the CURPIPE[3:0] bits in the port select register. After the pipe is selected, the software must check whether the written value can be read correctly from the CURPIPE[3:0] bits. (If the previous pipe number is read, it indicates that the USBFS is modifying the pipe.) Next, the software checks that the FRDY bit in the port control register is 1.

In addition, the software must specify the bus width to be accessed in the MBW bit in the port select register. The FIFO buffer access direction conforms to the PIPECFG.DIR setting. For the DCP only, the ISEL bit in the port select register determines the direction.

Table 26.24 FIFO port access by pipe

| Pipe         | Access method  | Ports that can be used   |
|--------------|----------------|--|
| DCP          | CPU access     | CFIFO port register  |
| Pipes 1 to 9 | CPU access     | <ul style="list-style-type: none"> <li>CFIFO port register</li> <li>D0FIFO/D1FIFO port register</li> </ul> |
|              | DMA/DTC access | D0FIFO/D1FIFO port register  |

## (2) REW bit

It is possible to temporarily stop access to a pipe currently being accessed, access a different pipe, and then continue processing for the first pipe again. The REW bit in the port select register is used for this processing.

If a pipe is selected in the CURPIPE[3:0] bits in the port select register with the REW bit set to 1, the pointer used for reading from and writing to the FIFO buffer is reset, and reading or writing can be carried out from the first byte. If a pipe is selected with 0 set for the REW bit, data can be read and written in continuation from the previous selection, without the pointer being reset.

To access the FIFO port, the software must check that the FRDY bit in the port control register is 1 after selecting a pipe.

## 26.3.8 DMA Transfers (D0FIFO and D1FIFO Ports)

## (1) Overview of DMA transfers

For pipes 1 to 9, the FIFO port can be accessed using the DMAC. When buffer access for a pipe targeted for DMA transfer is enabled, a DMA transfer request is issued.

Select the unit of transfer to the FIFO port in the DnFIFOSEL.MBW bit, and select the pipe targeted for the DMA transfer in the DnFIFOSEL.CURPIPE[3:0] bits. Do not change the selected pipe during the DMA transfer.

## (2) DnFIFO auto clear mode (D0FIFO and D1FIFO port reading direction)

If 1 is set in the DnFIFOSEL.DCLRM bit, the USBFS automatically clears the FIFO buffer of the selected pipe when reading of data from the FIFO buffer is complete.

Table 26.25 shows the packet reception and FIFO buffer clearing processing by software for each of the settings. As shown in the table, the buffer clearing conditions depend on the value set in the PIPECFG.BFRE bit. Using the DnFIFOSEL.DCLRM bit eliminates the need for the buffer to be cleared by software in any situation that requires buffer clearing. This enables DMA transfers without involving software.

The DnFIFO auto clear mode can only be set in the FIFO buffer reading direction.

Table 26.23 FIFO端口功能设置(2of2)

| 注册名称                                 | 位名称  | Description    |
|--------------------------------------|------|----------------|
| CFIFOCTR,<br>DnFIFOCTR<br>(n = 0, 1) | BVAL | 结束写入FIFO缓冲区    |
|                                      | BCLR | 清除CPU端的FIFO缓冲区 |
|                                      | DTLN | 检查接收数据的长度      |

## (1) 先进先出端口选择

表26.24显示了可以使用不同FIFO端口选择的管道。必须在端口选择寄存器的CURPIPE[3:0]位中选择要访问的管道。选择管道后，软件必须检查是否可以从CURPIPE[3:0]位正确读取写入的值。（如果读取了之前的管道号，则表明USBFS正在修改管道。）接下来，软件检查端口控制寄存器中的FRDY位是否为1。

此外，软件必须在端口选择寄存器的MBW位中指定要访问的总线宽度。FIFO缓冲区访问方向符合PIPECFG.DIR设置。仅对于DCP，端口选择寄存器中的ISEL位决定方向。

Table 26.24 通过管道访问FIFO端口

| Pipe  | 访问方法           | 可以使用的端口  |
|-------|----------------|--|
| DCP   | CPU访问          | CFIFO端口寄存器   |
| 管道1至9 | CPU访问          | <ul style="list-style-type: none"> <li>CFIFO端口寄存器</li> <li>D0FIFO/D1FIFO端口寄存器</li> </ul> |
|       | DMA/DTC access | D0FIFO/D1FIFO端口寄存器   |

## (2) REW位

可以暂时停止对当前正在访问的管道的访问，访问不同的管道，然后再次继续处理第一个管道。端口选择寄存器中的REW位用于此处理。

如果在端口选择寄存器的CURPIPE[3:0]位中选择一个管道，并且REW位设置为1，则用于读取和写入FIFO缓冲区的指针复位，可以进行读取或写入从第一个字节开始。如果在REW位设置为0的情况下选择管道，则可以从先前的选择继续读取和写入数据，而无需重置指针。

要访问FIFO端口，软件必须在选择管道后检查端口控制寄存器中的FRDY位是否为1。

## 26.3.8 DMA传输 (D0FIFO和D1FIFO端口)

## (1) DMA传输概述

对于管道1到9，可以使用DMAC访问FIFO端口。当启用以DMA传输为目标的管道的缓冲区访问时，将发出DMA传输请求。

在DnFIFOSEL.MBW位中选择传输到FIFO端口的单位，并在DnFIFOSEL.CURPIPE[3:0]位中选择DMA传输的目标管道。在DMA传输期间不要更改选定的管道。

## (2) DnFIFO自动清除模式 (D0FIFO和D1FIFO端口读取方向)

如果DnFIFOSEL.DCLRM位设置为1，USBFS会在从FIFO缓冲区读取数据完成时自动清除所选管道的FIFO缓冲区。

表26.25显示了软件对每个设置的数据包接收和FIFO缓冲区清除处理。如表所示，缓冲区清除条件取决于PIPECFG.BFRE位中设置的值。使用DnFIFOSEL.DCLRM位无需在任何需要清除缓冲区的情况下通过软件清除缓冲区。这可以在不涉及软件的情况下实现DMA传输。

DnFIFO自动清除模式只能设置在FIFO缓冲区读取方向。



Table 26.25 Packet reception and FIFO buffer clearing processing by software

| Buffer status when packet is received | Register setting     |                      |                      |                      |
|---------------------------------------|----------------------|----------------------|----------------------|----------------------|
|                                       | DCLRM = 0            |                      | DCLRM = 1            |                      |
|                                       | BFRE = 0             | BFRE = 1             | BFRE = 0             | BFRE = 1             |
| Buffer full                           | No clearing required | No clearing required | No clearing required | No clearing required |
| Zero-length packet reception          | Clearing required    | Clearing required    | No clearing required | No clearing required |
| Normal short packet reception         | No clearing required | Clearing required    | No clearing required | No clearing required |
| Transaction count end                 | No clearing required | Clearing required    | No clearing required | No clearing required |

### 26.3.9 Control Transfers Using the DCP

The DCP is used for data transfers in the control transfer data stage. The FIFO buffer of the DCP is a 64-byte single buffer with a fixed area for both control reads and control writes. The FIFO buffer can be accessed only through the CFIFO port.

#### 26.3.9.1 Control transfers in host controller mode

##### (1) Setup stage

The USQREQ, USBVAL, USBINDX, and USBLENG registers are used to transmit USB requests for setup transactions. Writing the setup packet data to the registers and then writing 1 to the DCPCTR.SUREQ bit transmits the specified data for the setup transaction. On completion of the transaction, the SUREQ bit clears to 0. Do not change these USB request registers while SUREQ = 1.

When an attached function device is detected, the software must issue the first setup transaction for the device using this sequence with the DCPMAXP.DEVSEL[3:0] bits cleared to 0 and the DEVADD0.USBSPD[1:0] bits set appropriately.

When an attached function device is shifted to the Address state, the software must issue setup transactions using this sequence with the assigned USB address set in the DEVSEL[3:0] bits and the bits in DEVADDn corresponding to the specified USB address set appropriately. For example, when PIPEMAXP.DEVSEL[3:0] = 0010b, make appropriate settings in DEVADD2. When PIPEMAXP.DEVSEL[3:0] = 0101b, make appropriate settings in DEVADD5.

When the setup transaction data is sent, an interrupt request is generated based on the response from the peripheral device (SIGN or SACK bit in INTSTS1). This interrupt request allows the software to check the setup transaction result.

A DATA0 data packet (USB request) for the setup transaction is always transmitted regardless of the status of the DCPCTR.SQMON bit.

##### (2) Data stage

The data stage is used to transfer data using the DCP FIFO buffer.

Before accessing the DCP FIFO buffer, specify the access direction in the CFIFOSEL.ISEL bit. Specify the transfer direction in the DCPCFG.DIR bit.

For the first data packet of the data stage, the data PID must be transferred as DATA1. Set data PID = DATA1 in the DCPCTR.SQSET bit and set the PID bits = BUF. Completion of data transfer is detected using the BRDY or BEMP interrupt.

For control write transfers, when the number of data bytes to be sent is an integer multiple of the maximum packet size, the software must send a zero-length packet at the end.

##### (3) Status stage

The status stage is used for zero-length packet data transfers in the reverse direction of the data stage. As in the data stage, data is transferred using the DCP FIFO buffer. Transactions are executed using the same procedure as the data stage.

Data packets in the status stage must be transmitted and received with the data PID set to DATA1 using the DCPCTR.SQSET bit.

When a zero-length packet is received, check the receive-data length in the CFIFOCTR.DTLN[8:0] bits after a BRDY interrupt is generated, and then clear the FIFO buffer using the BCLR bit.

Table 26.25 通过软件进行数据包接收和FIFO缓冲区清除处理

| 收到数据包时的缓冲区状态 | 注册设置      |          |           |          |
|--------------|-----------|----------|-----------|----------|
|              | DCLRM = 0 |          | DCLRM = 1 |          |
|              | BFRE = 0  | BFRE = 1 | BFRE = 0  | BFRE = 1 |
| 缓冲区已满        | 无需清算      | 无需清算     | 无需清算      | 无需清算     |
| 零长度数据包接收     | 需要清算      | 需要清算     | 无需清算      | 无需清算     |
| 正常短包接收       | 无需清算      | 需要清算     | 无需清算      | 无需清算     |
| 交易计数结束       | 无需清算      | 需要清算     | 无需清算      | 无需清算     |

### 26.3.9 使用DCP进行控制传输

DCP用于控制传输数据阶段的数据传输。DCP的FIFO缓冲区是一个64字节的单缓冲区，具有用于控制读取和控制写入的固定区域。FIFO缓冲区只能通过CFIFO端口访问。

#### 26.3.9.1 主机控制器模式下的控制传输

##### (1) 设置阶段

USQREQ、USBVAL、USBINDX和USBLENG寄存器用于传输设置事务的USB请求。将设置数据包数据写入寄存器，然后向DCPCTR.SUREQ位写入1，以传输设置事务的指定数据。事务完成后，SUREQ位清除为0。在SUREQ=1时不要更改这些USB请求寄存器。

当检测到连接的功能器件时，软件必须使用此序列为器件发出第一个设置事务，其中DCPMAXP.DEVSEL[3:0]位清零，DEVADD0.USBSPD[1:0]位适当设置。

当连接的功能器件转移到地址状态时，软件必须使用此序列发出设置事务，其中指定的USB地址设置在DEVSEL[3:0]位中，并且DEVADDn中的位对应于指定的USB地址设置适当。例如，当PIPEMAXP.DEVSEL[3:0]=0010b时，在DEVADD2中进行适当的设置。当PIPEMAXP.DEVSEL[3:0]=0101b时，在DEVADD5中进行适当的设置。

发送设置事务数据时，根据外围设备的响应（INTSTS1中的SIGN或SACK位）生成中断请求。该中断请求允许软件检查设置事务结果。

一个DATA0数据包（USB请求）用于设置事务总是被传输，无论状态如何DCPCTR.SQMON bit。

##### (2) 数据阶段

数据级用于使用DCPFIFO缓冲区传输数据。

在访问DCPFIFO缓冲区之前，请在CFIFOSEL.ISEL位中指定访问方向。在DCPCFG.DIR位中指定传输方向。

对于数据阶段的第一个数据包，数据PID必须作为DATA1传输。在DCPCTR.SQSET位中设置数据PID=DATA1，并设置PID位=BUF。使用BRDY或BEMP中断检测数据传输的完成。

对于控制写传输，当要发送的数据字节数是最大数据包大小的整数倍时，软件必须在最后发送一个长度为零的数据包。

##### (3) 状态阶段

状态阶段用于在数据阶段的相反方向上进行零长度分组数据传输。与数据阶段一样，使用DCPFIFO缓冲区传输数据。事务使用与数据阶段相同的过程执行。

状态阶段的数据包必须在数据PID设置为DATA1的情况下使用DCPCTR.SQSET bit。

当接收到零长度数据包时，在产生BRDY中断后检查CFIFOCTR.DTLN[8:0]位中的接收数据长度，然后使用BCLR位清除FIFO缓冲区。



### 26.3.9.2 Control transfers in device controller mode

#### (1) Setup stage

The USBFS sends an ACK response to a normal setup packet for the USBFS. The USBFS operates in the setup stage as follows:

On receiving a new setup packet, the USBFS sets the following bits:

- Sets the INTSTS0.VALID bit to 1
- Sets the DCPCTR.PID[1:0] bits to NAK
- Sets the DCPCTR.CCPL bit to 0

When the USBFS receives a data packet following a setup packet, it stores the USB request parameters in USBREQ, USBVAL, USBINDX, and USBLENG.

Before performing the response processing for a control transfer, set the VALID flag to 0. When the VALID bit = 1, PID = BUF cannot be set, and the data stage cannot be terminated.

Using the VALID bit function, the USBFS can suspend a request being processed when it receives a new USB request during a control transfer and return a response to the latest request.

In addition, the USBFS automatically detects the direction bit (bmRequestType bit [8]) and the request data length (wLength) in the received USB request. It distinguishes between control read transfers, control write transfers, and no-data control transfers, and it controls stage transitions. For an incorrect sequence, a sequence error occurs in the control transfer stage transition interrupt, and the interrupt is reported to the software. For a diagram of the stage control by the USBFS, see Figure 26.16.

#### (2) Data stage

The DCP must be used to execute data transfers for received USB requests. Before accessing the DCP FIFO buffer, specify the access direction in the CFIFOSEL.ISEL bit.

If the transfer data is larger than the size of the DCP FIFO buffer, execute the data transfer using the BRDY interrupt for control write transfers and the BEMP interrupt for control read transfers.

#### (3) Status stage

Control transfers are terminated by setting the DCPCTR.CCPL bit to 1 while the DCPCTR.PID[1:0] bits are set to BUF.

After this setting is made, the USBFS automatically executes the status stage based on the data transfer direction determined at the setup stage. The procedure is as follows:

- For control read transfers  
The USBFS receives a zero-length packet from the USB host and transmits an ACK response.
- For control write transfers and no-data control transfers  
The USBFS transmits a zero-length packet and receives an ACK response from the USB host.

#### (4) Control transfer auto response function

The USBFS automatically responds to a correct SET\_ADDRESS request. If any of the following errors occurs in the SET\_ADDRESS request, a response from the software is necessary.

- bmRequestType is not 00h: Any transfer other than a control write transfer
- wIndex is not 00h: Request error
- wLength is not 00h: Any transfer other than a no-data control transfer
- wValue is larger than 7Fh: Request error
- INTSTS0.DVSQ[2:0] are 011b (Configured state): Control transfer of a device state error

For all requests other than the SET\_ADDRESS request, a response is required from the corresponding software.

### 26.3.9.2 设备控制器模式下的控制传输

#### (1) 设置阶段

USBFS向USBFS的正常设置数据包发送ACK响应。USBFS在设置阶段运行如下:

在接收到新的设置数据包时, USBFS设置以下位:

- 将INTSTS0.VALID位设置为1
- 将DCPCTR.PID[1:0]位设置为NAK
- 将DCPCTR.CCPL位设置为0

当USBFS在setup数据包之后接收到数据包时, 它会将USB请求参数存储在USBREQ中, USBVAL, USBINDX, and USBLENG.

在执行控制传输的响应处理之前, 将VALID标志设置为0。当VALID位=1时, PID=BUF不能设置, 数据阶段不能终止。

使用VALID位功能, USBFS可以在控制传输期间接收到新的USB请求时暂停正在处理的请求, 并返回对最新请求的响应。

此外, USBFS会自动检测接收到的USB请求中的方向位 (bmRequestTypebit[8]) 和请求数据长度 (wLength)。它区分控制读取传输、控制写入传输和无数据控制传输, 并控制阶段转换。对于不正确的序列, 在控制转移阶段转换中断中发生序列错误, 并将中断报告给软件。USBFS的阶段控制图见图26.16。

#### (2) 数据阶段

DCP必须用于执行接收到的USB请求的数据传输。在访问DCPFIFO缓冲区之前, 请在CFIFOSEL.ISEL位中指定访问方向。

如果传输数据大于DCPFIFO缓冲区的大小, 则使用控制写传输的BRDY中断和控制读传输的BEMP中断执行数据传输。

#### (3) 状态阶段

通过将DCPCTR.CCPL位设置为1而将DCPCTR.PID[1:0]位设置为BUF来终止控制传输。

完成此设置后, USBFS根据设置阶段确定的数据传输方向自动执行状态阶段。程序如下:

- 用于控制读取传输  
USBFS从USB主机接收零长度数据包并发送ACK响应。
- 用于控制写传输和无数据控制传输  
USBFS发送一个长度为零的数据包并接受来自USB主机的ACK响应。

#### (4) 控制转移自动响应功能

USBFS自动响应正确的SET\_ADDRESS请求。如果出现以下任何错误SET\_ADDRESS请求, 需要软件的响应。

- bmRequestType不是00h: 控制写入传输以外的任何传输
- wIndex不是00h: 请求错误
- wLength不是00h: 除无数据控制传输之外的任何传输
- wValue大于7Fh: 请求错误
- INTSTS0.DVSQ[2:0]为011b (已配置状态): 设备状态错误的控制传输

对于除SET\_ADDRESS请求之外的所有请求, 都需要相应软件的响应。

### 26.3.10 Bulk Transfers (Pipes 1 to 5)

The FIFO buffer usage (single/double buffer setting) is configurable for bulk transfers. The USBFS provides the following functions for bulk transfers:

- BRDY interrupt function (PIPECFG.BFRE bit), see [section 26.3.3.1. BRDY interrupt](#)
- Transaction count function (PIPEnTRE.TRENB, TRCLR, and PIPEnTRN.TRNCNT[15:0] bits), see [section 26.3.4.5. Transaction counter for pipes 1 to 5 in the receiving direction](#)
- Response PID = NAK function (PIPECFG.SHTNAK bit), see [section 26.3.4.8. Response PID = NAK function](#)
- Auto response mode (PIPEnCTR.ATREPM bit), see [section 26.3.4.9. Auto response mode](#)

### 26.3.11 Interrupt Transfers (Pipes 6 to 9)

In device controller mode, the USBFS performs interrupt transfers based on the timing dictated by the host controller.

In host controller mode, the software can set the timing for issuing tokens using the interval counter.

#### 26.3.11.1 Interval counter for interrupt transfers in host controller mode

Specify the transaction interval for interrupt transfers in the PIPEPERI.IITV[2:0] bits. The USBFS issues interrupt transfer tokens based on this interval.

##### (1) Counter initialization

The USBFS initializes the interval counter under the following conditions:

- Power-on reset  
This initializes the IITV[2:0] bits.
- FIFO buffer initialization using the PIPEnCTR.ACLRM bit:  
This does not initialize the IITV[2:0] bits, but does initialize the count value. Setting the PIPEnCTR.ACLRM bit to 0 starts counting from the value set in IITV[2:0].

The interval counter is not initialized in the following case:

- USB bus reset or USB suspended  
The IITV[2:0] bits are not initialized. Setting 1 to the DVSTCTR0.UACT bit starts counting from the value saved before entering the USB bus reset state or USB suspend state.

##### (2) Operation when tokens cannot be transmitted or received even on token generation

No token is generated in the following cases even at token generation time. In these cases, the USBFS tries to execute the transaction in the next interval.

- When the PID is set to NAK or STALL
- When the FIFO buffer is full at token transmit time in the receiving (IN) direction
- When there is no data to be transmitted in the FIFO buffer at token transmit time in the transmitting (OUT) direction

### 26.3.12 Isochronous Transfers (Pipes 1 and 2)

The USBFS provides the following functions for isochronous transfers:

- Notification of isochronous transfer error
- Interval counter specified in the PIPEPERI.IITV[2:0] bits
- Isochronous IN transfer data setup control (IDLY function)
- Isochronous IN transfer buffer flush function specified in the PIPEPERI.IFIS bit

### 26.3.10 批量传输 (管道1到5)

FIFO缓冲区使用 (单双缓冲区设置) 可配置为批量传输。USBFS为批量传输提供以下功能:

- BRDY中断功能 (PIPECFG.BFRE位), 见26.3.3.1节。BRDY中断
- 事务计数函数 (PIPEnTRE.TRENB、TRCLR和PIPEnTRN.TRNCNT[15:0]位), 参见第26.3.4.5节。接收方向上管道1到5的事务计数器
- 响应PID=NAK功能 (PIPECFG.SHTNAK位), 参见第26.3.4.8节。响应PID=NAK功能
- 自动响应模式 (PIPEnCTR.ATREPM位), 见第26.3.4.9节。自动响应模式

### 26.3.11 中断传输 (管道6到9)

在设备控制器模式下, USBFS根据主机控制器规定的时序执行中断传输。

在主机控制器模式下, 软件可以使用间隔计数器设置发布令牌的时间。

#### 26.3.11.1 主机控制器模式下中断传输的间隔计数器

在PIPEPERI.IITV[2:0]位中指定中断传输的事务间隔。USBFS基于此间隔发出中断传输令牌。

##### (1) 计数器初始化

USBFS在以下条件下初始化间隔计数器:

- Power-on reset  
这将初始化IITV[2:0]位。
- 使用PIPEnCTR.ACLRM位初始化FIFO缓冲区:  
这不会初始化IITV[2:0]位, 但会初始化计数值。将PIPEnCTR.ACLRM位设置为0从IITV[2:0]中设置的值开始计数。

在以下情况下不初始化间隔计数器:

- USB总线复位或USB挂起  
IITV[2:0]位未初始化。将DVSTCTR0.UACT位置1从进入USB总线复位状态或USB挂起状态之前保存的值开始计数。

##### (2) 即使在生成令牌时也无法发送或接收令牌时的操作

在以下情况下, 即使在生成令牌时也不会生成令牌。在这些情况下, USBFS会尝试在下一个时间间隔执行事务。

- 当PID设置为NAK或STALL时
- 接收(IN)方向的令牌发送时FIFO缓冲区已满时
- 在发送(OUT)方向的令牌发送时间, FIFO缓冲区中没有要发送的数据时

### 26.3.12 同步传输 (管道1和2)

USBFS为同步传输提供以下功能:

- 同步传输错误通知
- PIPEPERI.IITV[2:0]位中指定的间隔计数器
- 同步IN传输数据设置控制 (IDLY功能)
- PIPEPERI.IFIS位中指定的同步IN传输缓冲区刷新功能

### 26.3.12.1 Error detection in isochronous transfers

The USBFS provides a function for detecting the errors described in this section, so that when errors occur in isochronous transfers, they can be controlled by software. Table 26.26 and Table 26.27 show the priority order for errors detected by the USBFS and the associated interrupts.

#### PID errors

- The PID value of the received packet is invalid.

#### CRC errors and bit stuffing errors

- A CRC error is found in a received packet or the bit stuffing is illegal.

#### Maximum packet size exceeded

- The data size of the received packet exceeds the specified maximum packet size.

#### Overrun and underrun errors

In host controller mode:

- The FIFO buffer is full at token transmit time in the IN (receiving) direction
- There is no data to be sent in the FIFO buffer at token transmit time in the OUT (transmitting) direction

In device controller mode:

- There is no data to be sent in the FIFO buffer at token receive time in the IN (transmitting) direction
- The FIFO buffer is full at token receive time in the OUT (receiving) direction

#### Interval errors

In device controller mode, the following cases are treated as an interval error:

- Failure to receive an IN token in the interval frame during an isochronous IN transfer
- Failure to receive an OUT token in the interval frame during an isochronous OUT transfer

Table 26.26 Error detection for token transmission and reception

| Detection priority | Error                     | Generated interrupt and status  |
|--------------------|---------------------------|---|
| 1                  | PID error                 | No interrupts are generated in either host or device controller mode (ignored as a corrupted packet)  |
| 2                  | CRC or bit stuffing error | No interrupts are generated in either host or device controller mode (ignored as a corrupted packet)  |
| 3                  | Overrun or underrun error | An NRDY interrupt is generated to set the FRMNUM.OVRN bit to 1 in both host and device controller modes.<br>In device controller mode, a zero-length packet is transmitted in response to an IN token. No data packets are received in response to OUT token. |
| 4                  | Interval error            | An NRDY interrupt is generated in device controller mode. No interrupt is generated in host controller mode.  |

Table 26.27 Error detection for data packet reception

| Detection priority | Error                              | Generated interrupt and status  |
|--------------------|------------------------------------|---|
| 1                  | PID error                          | No interrupts are generated (ignored as a corrupted packet)   |
| 2                  | CRC or bit stuffing error          | An NRDY interrupt is generated and the FRMNUM.CRCE bit sets to 1 in both host and device controller modes |
| 3                  | Maximum packet size exceeded error | A BEMP interrupt is generated and the PID[1:0] bits set to STALL in both host and device controller modes |

### 26.3.12.1 同步传输中的错误检测

USBFS提供了检测本节所述的错误的功能，以便在同步传输中发生错误时，可以通过软件进行控制。表26.26和表26.27显示了USBFS检测到的错误和相关中断的优先级顺序。

#### PID错误

- 接收报文的PID值无效。

#### CRC错误和位填充错误

- 收到的报文发现CRC错误或比特填充不合法。

#### 超出最大数据包大小

- 接收到的数据包的数据大小超过了指定的最大数据包大小。

#### 溢出和欠载错误

在主机控制器模式下:

- 在IN（接收）方向发送令牌时，FIFO缓冲区已满
- 在OUT（发送）方向的令牌发送时间，FIFO缓冲区中没有要发送的数据

在设备控制器模式下:

- 在IN（发送）方向的令牌接收时间，FIFO缓冲区中没有要发送的数据
- 在OUT（接收）方向的令牌接收时间，FIFO缓冲区已满

#### 间隔错误

在设备控制器模式下，以下情况被视为间隔错误:

- 等时IN传输期间在间隔帧中接收IN令牌失败
- 在等时OUT传输期间未能在间隔帧中接收到OUT令牌

Table 26.26 令牌发送和接收的错误检测

| 检测优先级 | Error     | 产生的中断和状态  |
|-------|-----------|---|
| 1     | PID错误     | 在主机或设备控制器模式下都不会产生中断（被忽略为损坏的数据包）   |
| 2     | CRC或位填充错误 | 在主机或设备控制器模式下都不会产生中断（被忽略为损坏的数据包）   |
| 3     | 溢出或欠载错误   | 在主机和设备控制器模式下，都会产生一个NRDY中断来将FRMNUM.OVRN位设置为1。在设备控制器模式下，发送一个零长度数据包以响应IN令牌。<br>没有接收到响应OUT令牌的数据包。 |
| 4     | 间隔误差      | 在设备控制器模式下会产生一个NRDY中断。在主机控制器模式下不产生中断。  |

Table 26.27 数据包接收错误检测

| 检测优先级 | Error       | 产生的中断和状态                                   |
|-------|-------------|--|
| 1     | PID错误       | 不产生中断（作为损坏的数据包被忽略）                         |
| 2     | CRC或位填充错误   | 在主机和设备控制器模式下都会产生一个NRDY中断并且FRMNUM.CRCE位设置为1 |
| 3     | 超出最大数据包大小错误 | 在主机和设备控制器模式下都会产生BEMP中断并且PID[1:0]位设置为STALL  |



## 26.3.12.2 DATA-PID

In device controller mode, the USBFS responds to a received PID as follows:

## (1) IN direction

- DATA0: Transmitted as data packet PID
- DATA1: Not transmitted
- DATA2: Not transmitted
- mData: Not transmitted

## (2) OUT direction

- DATA0: Received normally as data packet PID
- DATA1: Received normally as data packet PID
- DATA2: Packets ignored
- mData: Packets ignored

## 26.3.12.3 Interval counter

The isochronous transfer interval can be set in the PIPEPERI.IITV[2:0] bits. In device controller mode, the interval counter enables the functions as shown in Table 26.28. In host controller mode, the USBFS generates the token issuance timing, and the interval counter operation is the same as that for interrupt transfers.

Table 26.28 Interval counter functions in device controller mode

| Transfer direction | Function                              | Conditions for detection   |
|--------------------|---------------------------------------|--|
| IN                 | Transmit buffer flush                 | Failure to receive an IN token successfully in the interval frame during an isochronous IN transfer.   |
| OUT                | Notification of no reception of token | Failure to receive an OUT token successfully in the interval frame during an isochronous OUT transfer. |

The interval count is performed when an SOF is received or for interpolated SOFs, so the isochronism can be maintained even if an SOF is corrupt. The frame interval can be set to  $2^{IITV}$  frames.

## (1) Counter initialization in device controller mode

The USBFS initializes the interval counter under the following conditions:

- Power-on reset  
This initializes the PIPEPERI.IITV[2:0] bits.
- FIFO buffer initialization using the ACLRM bit  
This does not initialize the IITV[2:0] bits, but does initialize the count value.

After the interval counter is initialized, the interval count starts under one of the following conditions when a packet is transferred successfully:

- An SOF is received after data is transmitted in response to an IN token when PID = BUF
- An SOF is received after data is received in response to an OUT token when PID = BUF

The interval counter is not initialized in the following conditions:

- When the PID[1:0] bits are set to NAK or STALL  
This does not stop the interval timer. The USBFS attempts the transaction in the next interval.
- When the USB bus is reset or USBFS is suspended  
This does not initialize the IITV[2:0] bits. When an SOF is received, the interval counter starts counting from the value set before SOF was received.

## 26.3.12.2 DATA-PID

在设备控制器模式下，USBFS响应接收到的PID如下：

## (1) 在方向

- DATA0：作为数据包PID发送
- DATA1：未发送
- DATA2：未传输
- mDATA：不传输

## (2) 出方向

- DATA0：作为数据包PID正常接收
- DATA1：作为数据包PID正常接收
- DATA2：忽略的数据包
- mDATA：忽略的数据包

## 26.3.12.3 间隔计数器

同步传输间隔可以在PIPEPERI.IITV[2:0]位中设置。在设备控制器模式下，间隔计数器启用如表26.28所示的功能。在主机控制器模式下，USBFS产生令牌发布时序，间隔计数器操作与中断传输相同。

Table 26.28 设备控制器模式下的间隔计数器功能

| 转移方向 | Function | 检测条件                        |
|------|----------|-----------------------------|
| IN   | 发送缓冲区刷新  | 在同步IN传输期间未能在间隔帧中成功接收IN令牌。   |
| OUT  | 未收到令牌的通知 | 在同步OUT传输期间未能在间隔帧中成功接收OUT令牌。 |

间隔计数在接收到SOF时执行或对插值SOF执行，因此即使SOF损坏也可以保持等时性。帧间隔可以设置为2个IITV帧。

## (1) 设备控制器模式下的计数器初始化

USBFS在以下条件下初始化间隔计数器：

- Power-on reset  
这将初始化PIPEPERI.IITV[2:0]位。
- 使用ACLRM位初始化FIFO缓冲区  
这不会初始化IITV[2:0]位，但会初始化计数值。

间隔计数器初始化后，当数据包传输成功时，间隔计数在以下条件之一开始：

- 当PID=BUF时，响应IN令牌传输数据后收到SOF
- 当PID=BUF时，接收到响应OUT令牌的数据后接收到SOF

间隔计数器在以下情况下不会初始化：

- 当PID[1:0]位设置为NAK或STALL时  
这不会停止间隔计时器。USBFS在下一个间隔尝试事务。
- USB总线复位或USBFS挂起时  
这不会初始化IITV[2:0]位。当接收到SOF时，间隔计数器从接收到SOF之前设置的值开始计数。



(2) Interval counting and transfer control in host controller mode

The USBFS controls the interval between token issuance operations based on the PIPEPERI.IITV[2:0] bits settings. Specifically, the USBFS issues a token for a selected pipe once every  $2^{IITV}$  frames.

The USBFS starts counting the token issuance interval at the frame following the frame in which the PID[1:0] bits are set to BUF by software.

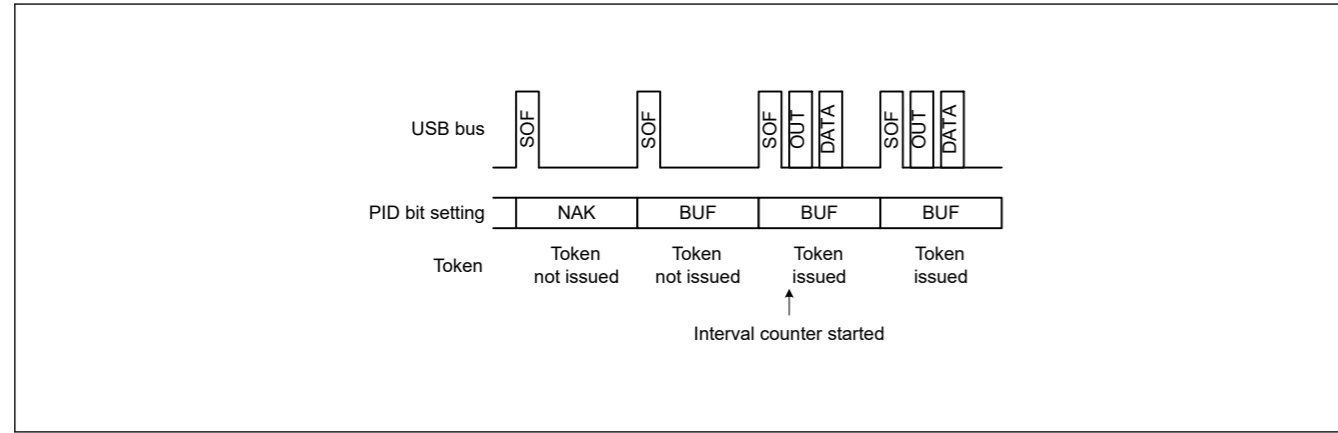


Figure 26.17 Token issuance when IITV = 0

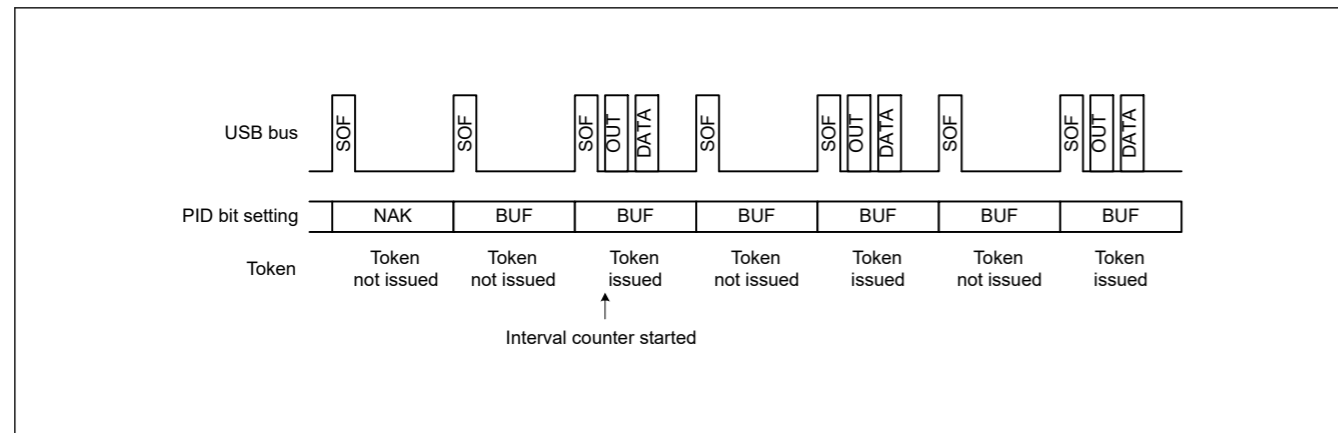


Figure 26.18 Token issuance when IITV = 1

When the selected pipe is set for isochronous transfers, the USBFS performs the following operation in addition to controlling the token issuance interval. The USBFS issues a token even when the NRDY interrupt generation condition is satisfied.

**When the selected pipe is for isochronous IN transfers**

The USBFS generates an NRDY interrupt when the USBFS issues an IN token but does not successfully receive a packet from a peripheral device (no response or packet error).

The USBFS sets the FRMNUM.OVRN bit to 1, generating an NRDY interrupt, when the time to issue an IN token occurs while the USBFS cannot receive data because the FIFO buffer is full, because the CPU or DMAC/DTC is too slow in reading data from the FIFO buffer.

**When the selected pipe is for isochronous OUT transfers**

The USBFS sets the OVRN bit to 1, generating an NRDY interrupt and transmitting a zero-length packet, when the time to issue an OUT token comes while there is no data to be transmitted in the FIFO buffer, or because the CPU or DMAC/DTC is too slow in writing data to the FIFO buffer.

The token issuance interval is reset on any of the following conditions:

- When the USBFS is reset through a reset pin  
This initializes the IITV[2:0] bits.

(2) 主机控制器模式下的间隔计数和传输控制

USBFS根据PIPEPERI.IITV[2:0]位设置控制令牌发布操作之间的间隔。具体来说，USBFS每2个IITV帧为所选管道发布一次令牌。

USBFS在PID[1:0]位设置为的帧之后的帧开始计算令牌发布间隔BUF通过软件。

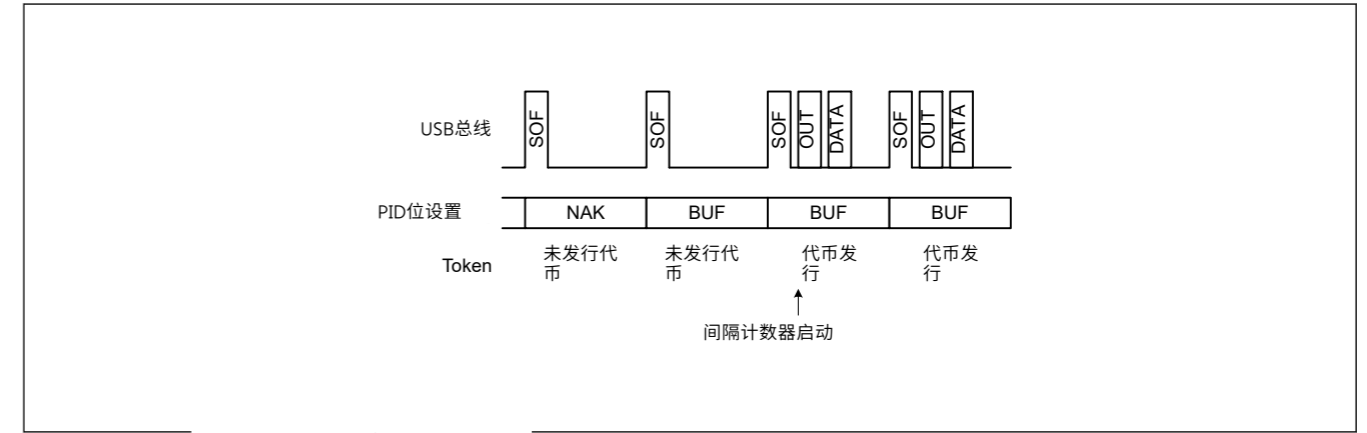


Figure 26.17 IITV=0时的代币发行

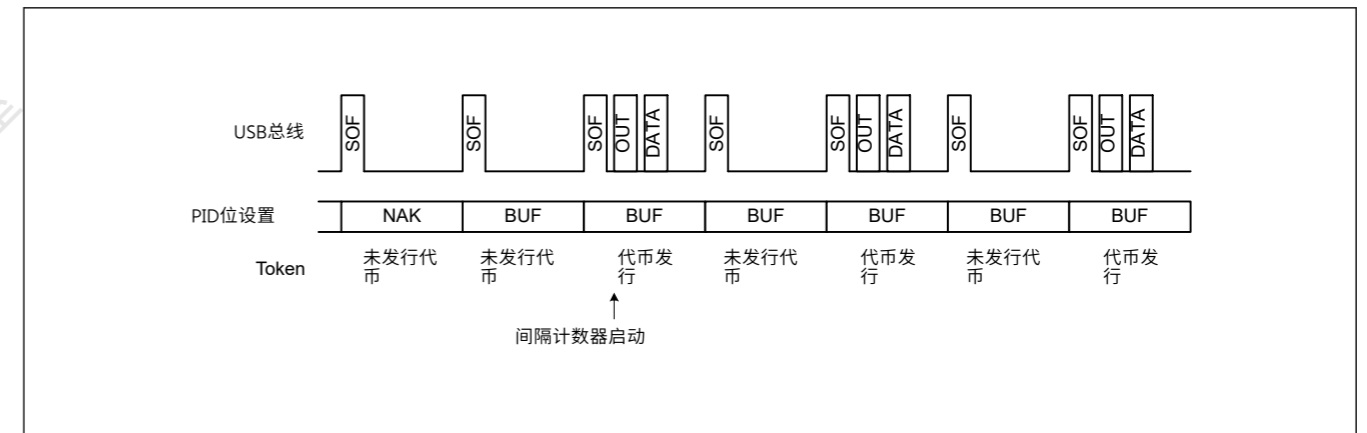


Figure 26.18 IITV=1时的代币发行

当所选管道设置为同步传输时，USBFS除了控制令牌发布间隔外，还执行以下操作。即使满足NRDY中断生成条件，USBFS也会发出令牌。

**当所选管道用于同步IN传输时**

当USBFS发出IN令牌但未成功接收到来自外围设备的数据包（无响应或数据包错误）时，USBFS会生成NRDY中断。

USBFS将FRMNUM.OVRN位设置为1，产生一个NRDY中断，此时发生发出IN令牌的时间，而USBFS无法接收数据，因为FIFO缓冲区已满，因为CPU或DMAC/DTC读取数据太慢从FIFO缓冲区。

**当所选管道用于同步OUT传输时**

USBFS将OVRN位设置为1，产生一个NRDY中断并发送一个长度为零的数据包，当发出OUT令牌的时间到来而FIFO缓冲区中没有要发送的数据时，或者因为CPU或DMAC/DTC将数据写入FIFO缓冲区太慢。

令牌发行间隔在以下任何条件下重置：

- USBFS通过复位引脚复位时  
这将初始化IITV[2:0]位。

- When the PIPEnCTR.ACLRM bit is set to 1 by software

(3) Interval counting and transfer control in device controller mode

**When the selected pipe is for isochronous OUT transfers**

The USBFS generates an NRDY interrupt when it fails to receive a data packet within the interval set in the PIPEPERI.IITV[2:0] bits.

The USBFS also generates an NRDY interrupt when it fails to receive data because of a CRC error or other errors contained in the data packet or because the FIFO buffer is full.

The NRDY interrupt is generated on SOF packet reception. Even if the SOF packet is corrupted, internal interpolation allows the interrupt to be generated when the SOF packet is received. However, when the IITV bits are set to a value other than 0, the USBFS generates an NRDY interrupt on receiving an SOF packet for every interval after interval counting starts.

When the PID[1:0] bits are set to NAK by software after starting the interval timer, the USBFS does not generate an NRDY interrupt on receiving an SOF packet.

The timing for starting interval counting depend on the IITV[2:0] setting as follows:

- When the IITV[2:0] bits = 0:
  - Interval counting starts at the next frame after the software changes the PID[1:0] bits of the selected pipe to BUF.
- When the IITV[2:0] bits ≠ 0:
  - Interval counting starts on completion of successful reception of the first data packet after the PID[1:0] bits for the selected pipe are changed to BUF.

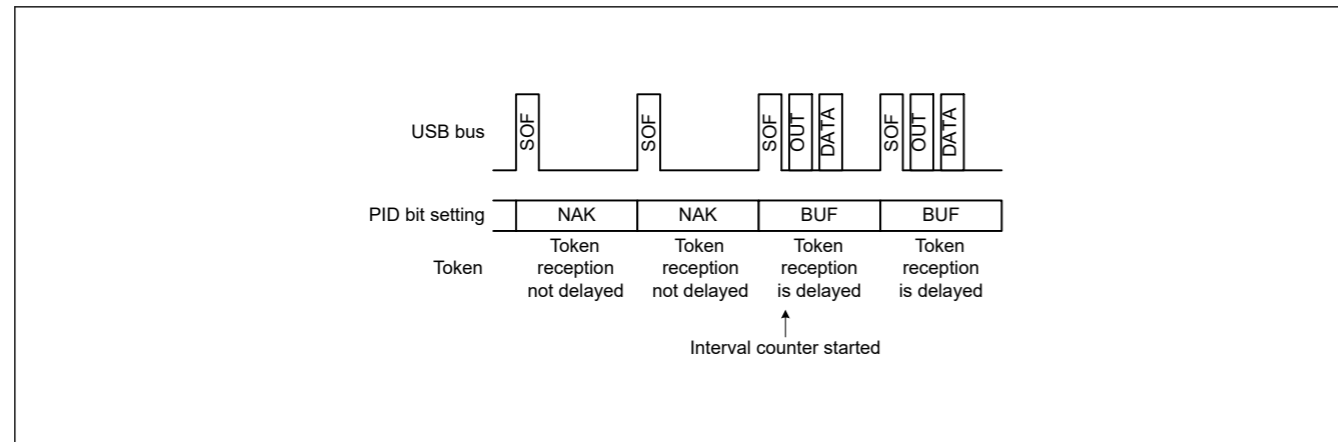


Figure 26.19 Relationship between frames and expected token reception when IITV[2:0] = 0

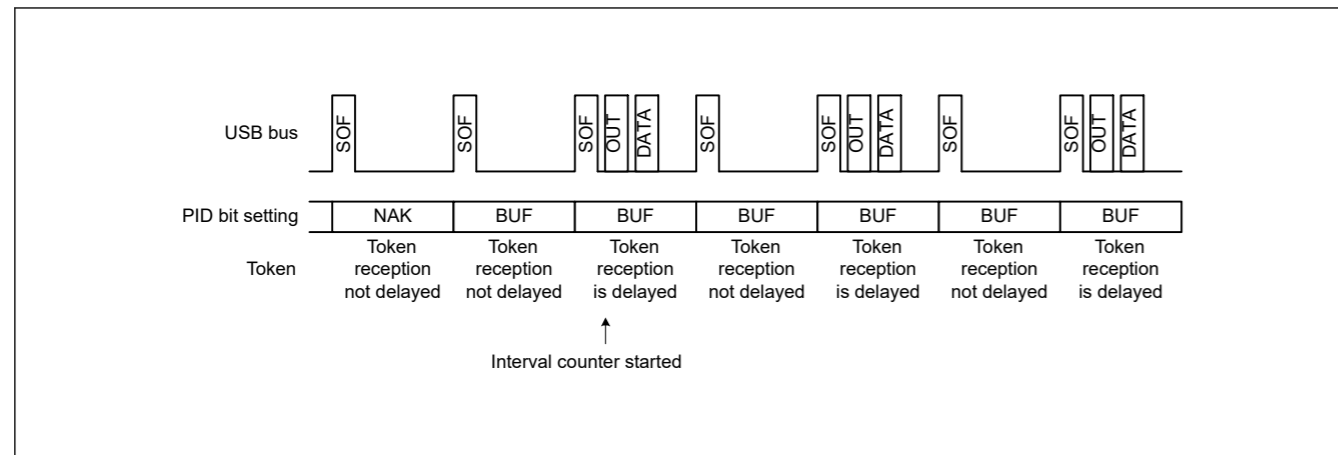


Figure 26.20 Relationship between frames and expected token reception when IITV[2:0] ≠ 0

- PIPEnCTR.ACLRM位由软件设置为1时

(3) 设备控制器模式下的间隔计数和传输控制

**当所选管道用于同步OUT传输时**

当USBFS在设置的时间间隔内没有接收到数据包时，会产生一个NRDY中断。PIPEPERI.IITV[2:0] bits.

当由于数据包中包含的CRC错误或其他错误或FIFO缓冲区已满而无法接收数据时，USBFS也会产生NRDY中断。

NRDY中断在SOF数据包接收时产生。即使SOF数据包损坏，内部插值也允许在接收到SOF数据包时产生中断。但是，当IITV位设置为0以外的值时，USBFS会在间隔计数开始后的每个间隔接收到SOF数据包时产生NRDY中断。

当PID[1:0]位在启动间隔定时器后被软件设置为NAK时，USBFS在接收到SOF数据包时不会产生NRDY中断。

开始间隔计数的时间取决于IITV[2:0]设置，如下所示：

- 当IITV[2:0]位=0时：
  - 软件将所选管道的PID[1:0]位更改为BUF后，间隔计数从下一帧开始。
- 当IITV[2:0]位≠0时：
  - 在所选管道的PID[1:0]位更改为BUF后，成功接收第一个数据包后，间隔计数开始。

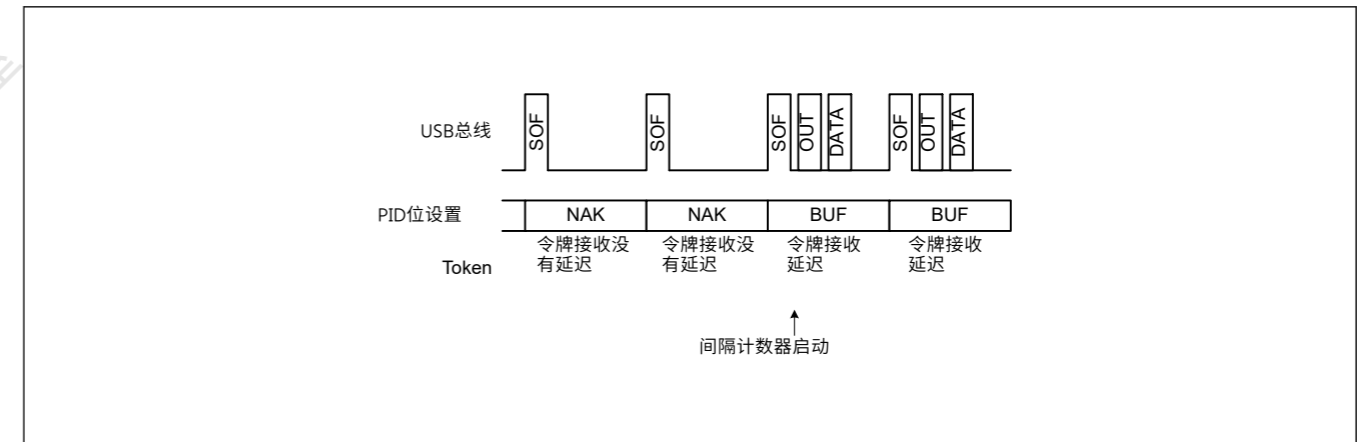


Figure 26.19 IITV[2:0]=0时帧与预期令牌接收之间的关系

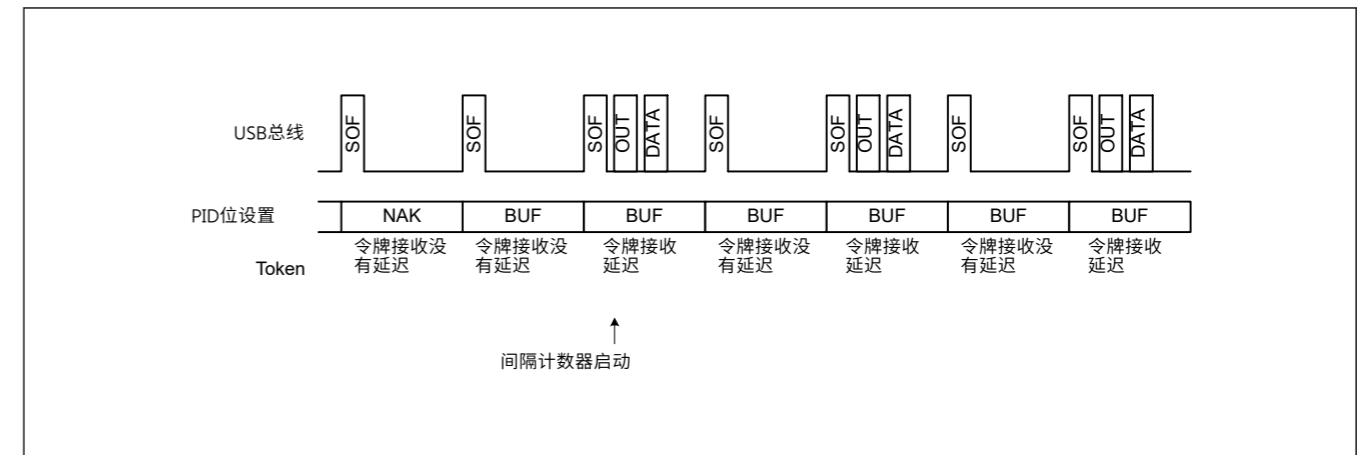


Figure 26.20 IITV[2:0]≠0时帧与预期令牌接收的关系

**When the selected pipe is for isochronous IN transfers**

The PIPEPERI.IFIS bit must be 1 for this use case. When IFIS = 0, the USBFS transmits a data packet in response to a received IN token regardless of the PIPEPERI.IITV[2:0] setting.

When IFIS is 1 and there is data to be transmitted in the FIFO buffer, the USBFS clears the FIFO buffer when it fails to receive an IN token in the frame at the interval set in the IITV[2:0] bits.

The USBFS also clears the FIFO buffer when it fails to receive an IN token successfully because of a bus error, such as a CRC error, contained in the IN token.

The FIFO buffer is cleared on SOF packet reception. Even if the SOF packet is corrupted, the internal interpolation allows the FIFO buffer to be cleared when the SOF packet is received.

The timing to start interval counting depends on the IITV[2:0] setting, as with OUT transfers.

The interval is counted on any of the following conditions in device controller mode:

- When a hardware reset is applied to the USBFS (which also sets the IITV[2:0] bits to 000b)
- When the PIPEnCTR.ACLRM bit is set to 1 by software
- When the USBFS detects a USB bus reset

**(4) Transmit data setup for isochronous transfers in device controller mode**

With isochronous data transmission using the USBFS in device controller mode, after data is written to the FIFO buffer, a data packet can be transmitted in the first frame after the SOF packet is detected. This isochronous transfer transmit data setup function can identify the frame that started transmission.

When the double buffering is used, transmission is only enabled for the buffer where data writing was completed first, even after the data write to both buffers is complete. Accordingly, even if multiple IN tokens are received, only the one packet of FIFO buffer data is transmitted.

When the FIFO buffer is ready to transmit data when an IN token is received, the data is transferred and a normal response is returned. However, if the FIFO buffer cannot transmit data, a zero-length packet is transmitted and an underrun error occurs.

Figure 26.21 shows an example transmission using the isochronous transfer transmission data setup function when IITV = 0 (every frame) is set.

**当所选管道用于同步IN传输时**

对于此用例，PIPEPERI.IFIS位必须为1。当IFIS=0时，无论PIPEPERI.IITV[2:0]设置如何，USBFS都会发送一个数据包以响应接收到的IN令牌。

当IFIS为1且FIFO缓冲区中有数据要发送时，如果USBFS在IITV[2:0]位设置的时间间隔内未能接收到帧中的IN令牌，则清除FIFO缓冲区。

当USBFS由于总线错误（例如CRC错误，包含在IN令牌中。

FIFO缓冲区在SOF数据包接收时被清除。即使SOF数据包损坏，内部插值也允许在接收到SOF数据包时清除FIFO缓冲区。

开始间隔计数的时间取决于IITV[2:0]设置，与OUT传输一样。

在设备控制器模式下，根据以下任何条件计算间隔：

- 当对USBFS应用硬件复位时（也将IITV[2:0]位设置为000b）
- PIPEnCTR.ACLRM位由软件设置为1时
- 当USBFS检测到USB总线复位时

**(4) 设备控制器模式下同步传输的传输数据设置**

在设备控制器模式下使用USBFS进行同步数据传输，数据写入FIFO缓冲区后，可在检测到SOF包后的第一帧发送数据包。此同步传输传输数据设置功能可以识别开始传输的帧。

使用双缓冲时，仅对先完成数据写入的缓冲区启用传输，即使在两个缓冲区的数据写入完成后也是如此。因此，即使接收到多个IN令牌，也仅发送一包FIFO缓冲器数据。

当接收到IN令牌时，当FIFO缓冲区准备好传输数据时，将传输数据并返回正常响应。但是，如果FIFO缓冲区无法传输数据，则会传输零长度数据包并发生欠载错误。

图26.21显示了在设置IITV=0（每帧）时使用同步传输传输数据设置功能的示例传输。

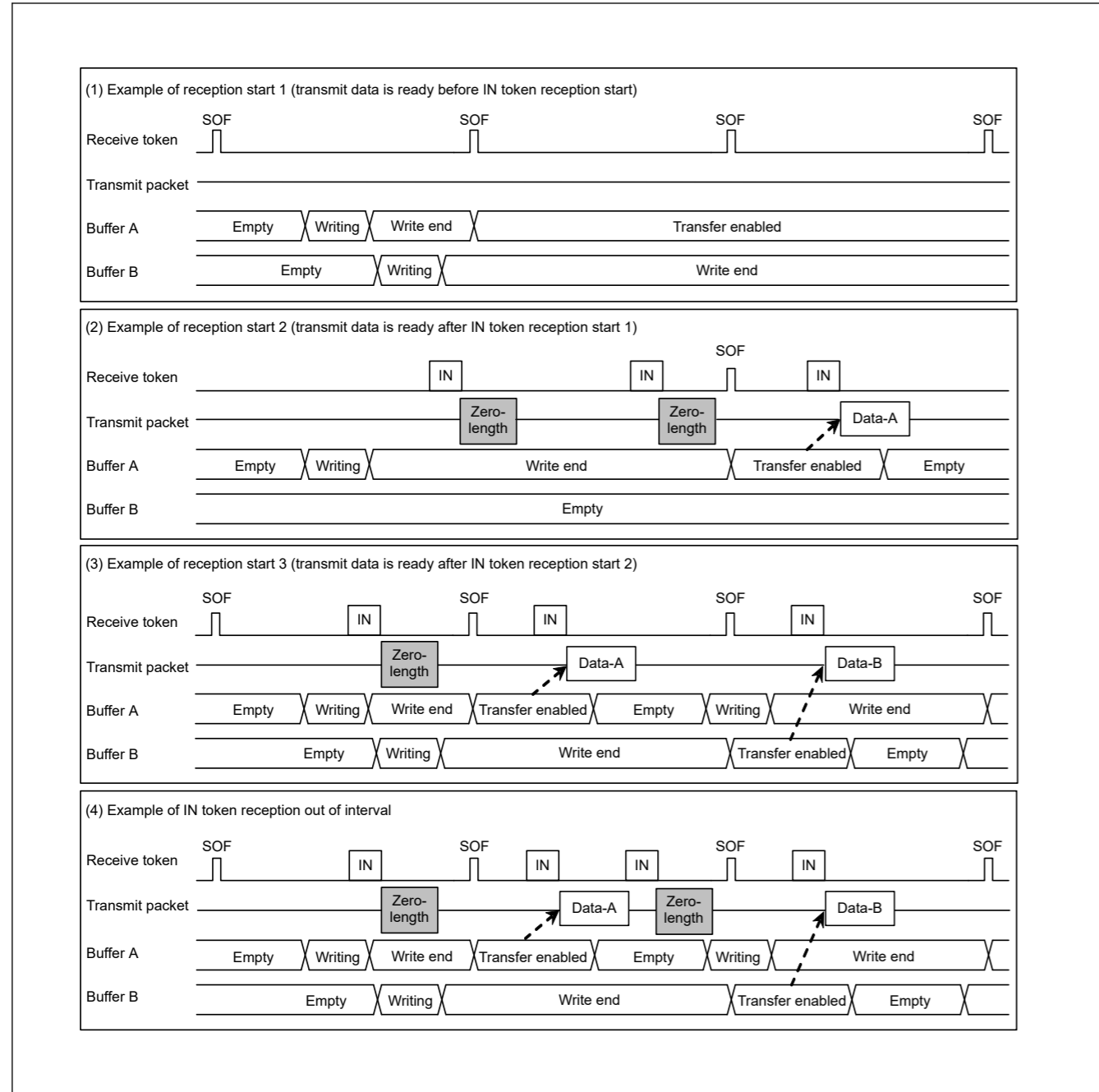


Figure 26.21 Example data setup operation

(5) Transmit buffer flush for isochronous transfers in device controller mode

In device controller mode during isochronous data transmission, if the USBFS receives an SOF packet for the next frame without receiving an IN token in the interval frame, it operates as if the IN token is corrupt and clears the buffer that is enabled for transmission, putting that buffer in the writing enabled state.

When double buffering is used and writing to both buffers is complete, the cleared FIFO buffer is assumed to be the one where the data was transmitted in the interval frame, and transmission is enabled for the FIFO buffer that was not cleared on SOF packet reception.

The timing of the buffer flush function depends on the PIPEPERL.IITV[2:0] setting as follows:

- When IITV = 0:  
The buffer flush operation starts from the first frame after the pipe is enabled.
- When IITV ≠ 0:  
The buffer flush operation starts after the first normal transaction.

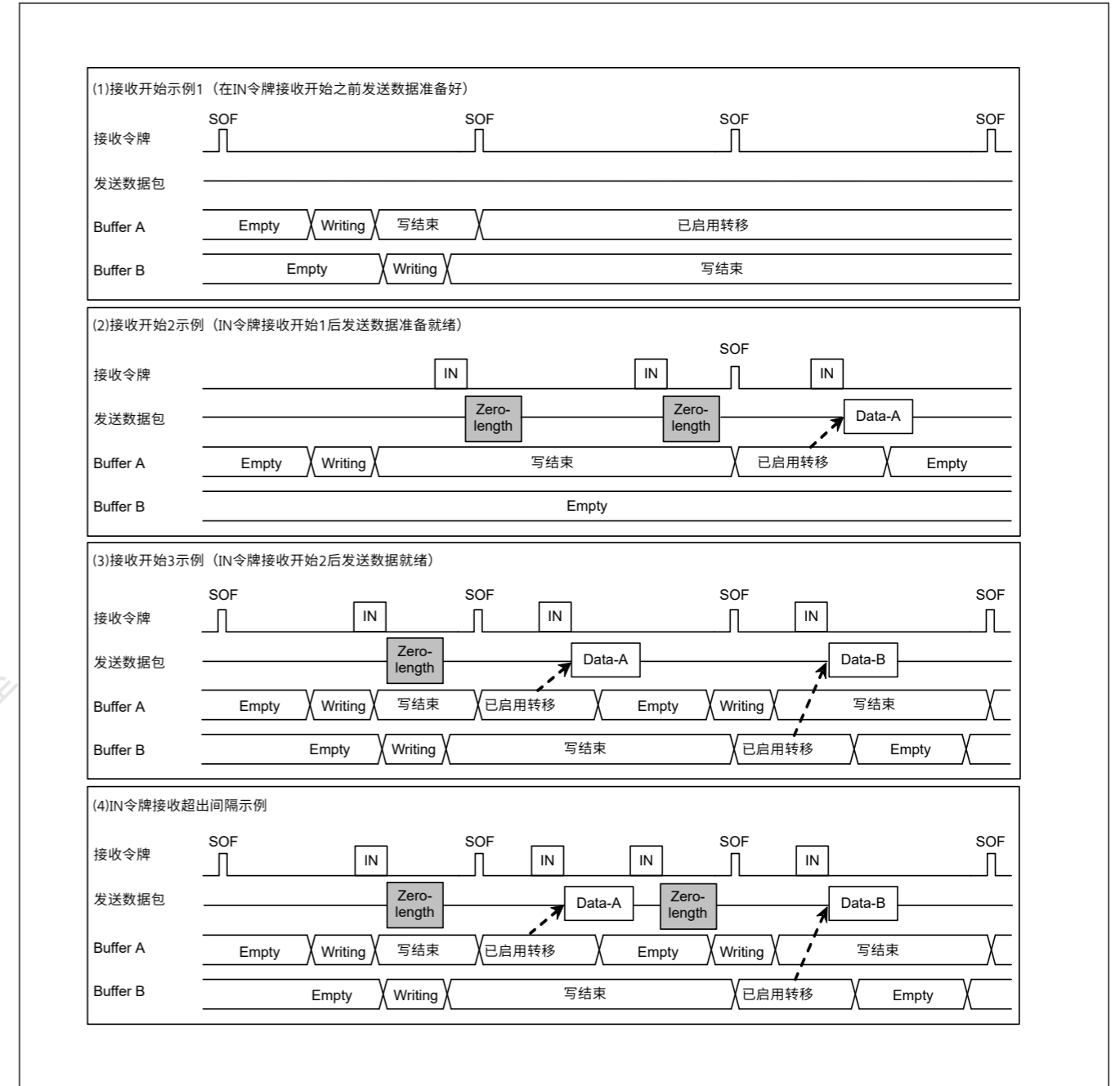


Figure 26.21 示例数据设置操作

(5) 设备控制器模式下同步传输的传输缓冲区刷新

在同步数据传输期间的设备控制器模式下，如果USBFS接收到下一帧的SOF数据包，而在间隔帧中没有接收到IN令牌，则它会像IN令牌损坏一样操作并清除启用传输的缓冲区，将该缓冲区处于写入启用状态。

当使用双缓冲并完成对两个缓冲区的写入时，已清除的FIFO缓冲区被假定为在间隔帧中传输数据的缓冲区，并为接收SOF数据包时未清除的FIFO缓冲区启用传输。

缓冲区刷新功能的时间取决于PIPEPERL.IITV[2:0]设置，如下所示：

- When IITV = 0:  
缓冲区刷新操作从启用管道后的第一帧开始。
- When IITV ≠ 0:  
缓冲区刷新操作在第一个正常事务之后开始。



Figure 26.22 shows an example buffer flush. When an unanticipated token is received before the interval frame, the USBFS sends the write data or a zero-length packet as an underrun error, depending on the data setup status.

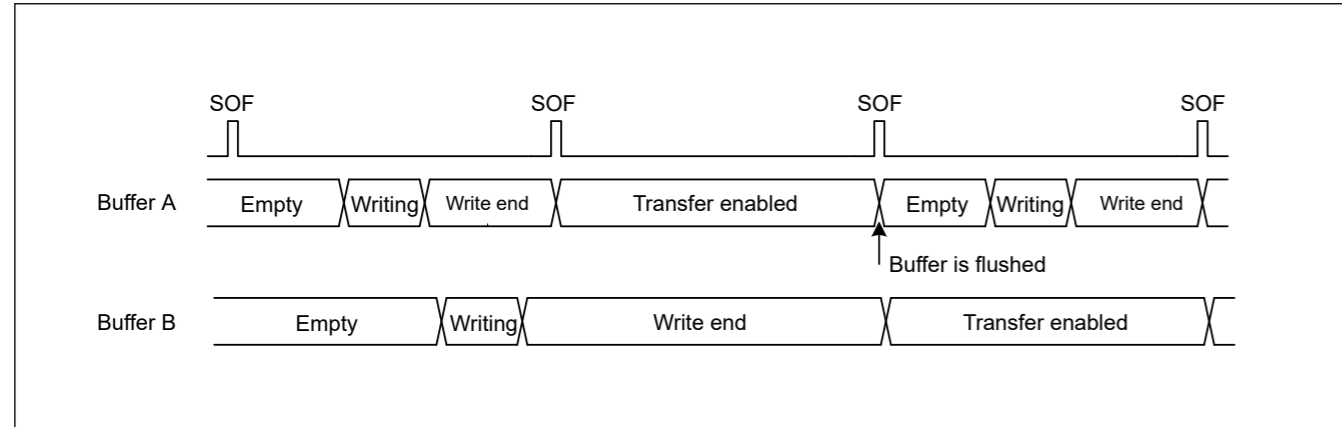


Figure 26.22 Example buffer flush operation

Figure 26.23 shows an example interval error occurrence. There are five types of interval errors, as shown in the figure. An interval error occurs at timing (A), and the buffer flush function is activated.

If an interval error occurs during an IN transfer, the buffer flush function is activated. If it occurs during an OUT transfer, an NRDY interrupt is generated. Use the FRMNUM.OVRN bit to distinguish between this and NRDY interrupts triggered by received packet errors and overrun errors.

For tokens that are shaded in the figure, responses are returned based on the FIFO buffer status.

- IN direction:
  - If the buffer is ready to transfer data, the data is transferred and a normal response is returned
  - If the buffer is not ready to transfer data, a zero-length packet is transmitted and an underrun error occurs
- OUT direction:
  - If the buffer is ready to receive data, the data is received and a normal response is returned
  - If the buffer is not ready to receive data, the received data is discarded and an overrun error occurs

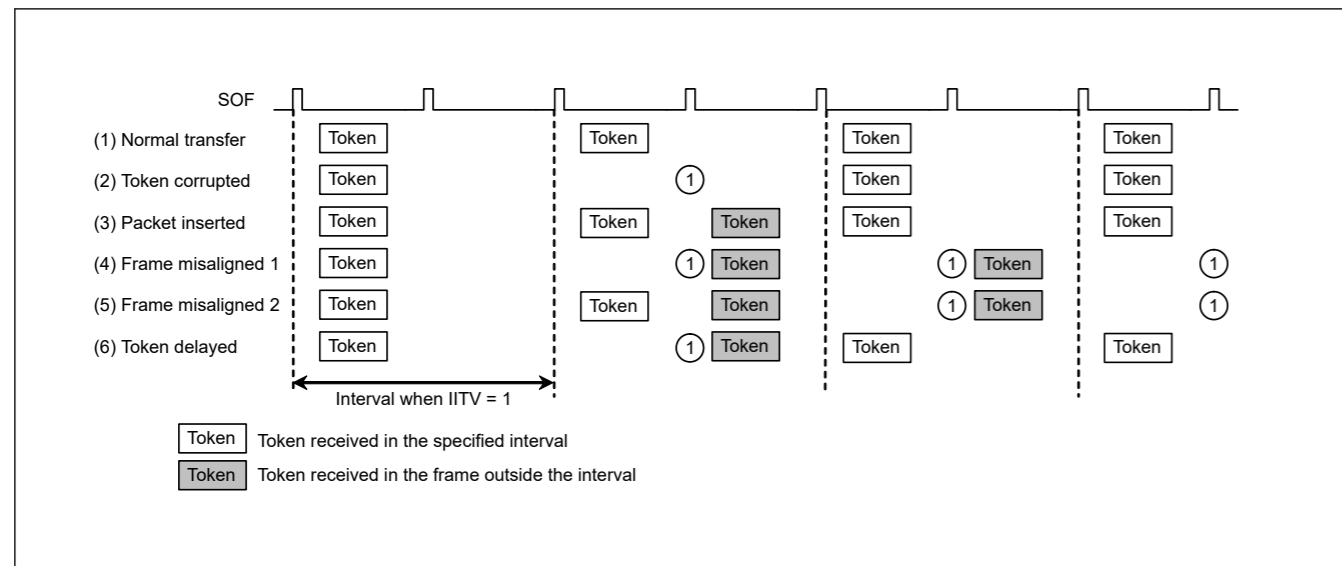


Figure 26.23 Example interval error occurrence when IITV = 1

### 26.3.13 SOF Interpolation Function

In device controller mode, if packet reception is disabled at intervals of 1 ms because the SOF packet is corrupted or missing, the USBFS interpolates the SOF. SOF interpolation begins when the USBE and SCKE bits in SYSCFG are set to 1 and an SOF packet is received.

图26.22显示了一个示例缓冲区刷新。当在间隔帧之前接收到意外令牌时，USBFS将根据数据设置状态发送写数据或零长度数据包作为欠载错误。

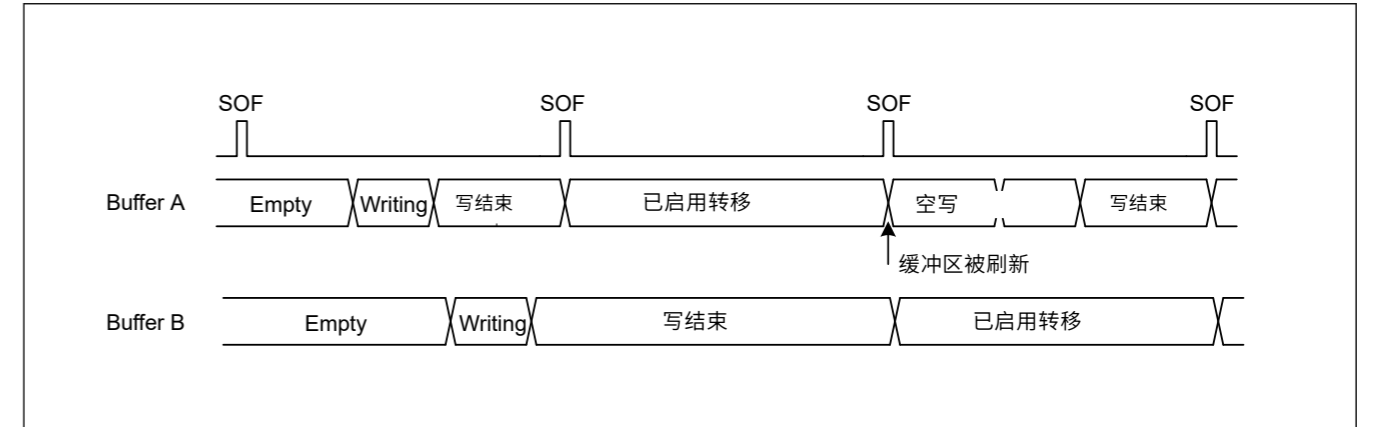


Figure 26.22 缓冲区刷新操作示例

图26.23显示了一个发生间隔错误的示例。如图所示，有五种区间误差。在时间 (A) 发生间隔错误，缓冲刷新功能被激活。

如果在IN传输期间发生间隔错误，则会激活缓冲区刷新功能。如果它发生在OUT传输期间，则NRDY中断产生。使用FRMNUM.OVRN位来区分此中断和由接收数据包错误和溢出错误触发的NRDY中断。

对于图中带阴影的令牌，根据FIFO缓冲区状态返回响应。

- IN direction:
  - 如果缓冲区准备好传输数据，则传输数据并返回正常响应
  - 如果缓冲区未准备好传输数据，则传输零长度数据包并发生欠载错误
- OUT direction:
  - 如果缓冲区准备好接收数据，则接收数据并返回正常响应
  - 如果缓冲区没有准备好接收数据，则丢弃接收到的数据并发生溢出错误

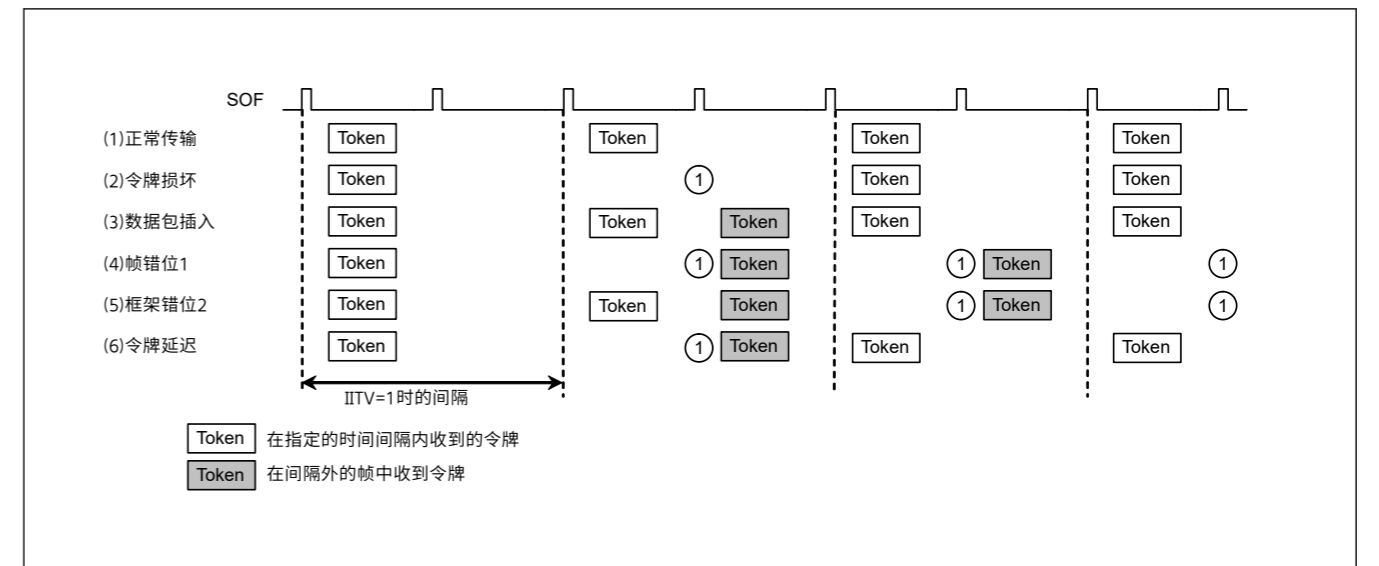


Figure 26.23 IITV=1时发生的示例间隔错误

### 26.3.13 SOF插值函数

在设备控制器模式下，如果由于SOF数据包损坏或丢失而每隔1ms禁用数据包接收，则USBFS会内插SOF。当SYSCFG中的USBE和SCKE位设置为1并且接收到SOF数据包时，SOF内插开始。

The interpolation function is initialized under the following conditions:

- MCU reset
- USB bus reset
- Suspend state detection

The SOF interpolation operates as follows:

- The interpolation function is not activated until an SOF packet is received
- When the first SOF packet is received, interpolation is performed by counting 1 ms on the 48-MHz internal clock
- When the second and subsequent SOF packets are received, interpolation is performed at the previous reception interval
- Interpolation is not performed in the Suspend state or on reception of a USB bus reset

The USBFS supports the following functions controlled by SOF packet reception. These functions operate normally with SOF interpolation if the SOF packet is missing:

- Updating of the frame number
- SOFR interrupt timing
- Isochronous transfer interval count

If an SOF packet is missing during full-speed operation, the FRMNUM.FRNM[10:0] bits are not updated.

### 26.3.14 Pipe Schedule

#### 26.3.14.1 Conditions for generating transactions

In host controller mode and when the DVSTCTR0.UACT bit is set to 1, the USBFS generates transactions under the conditions shown in Table 26.29.

Table 26.29 Conditions for generating transactions

| Transaction  | Conditions for generation |     |         |                      |           |
|--|---------------------------|-----|---------|----------------------|-----------|
|  | DIR                       | PID | IITV0   | Buffer state         | SUREQ     |
| Setup  | —*1                       | —*1 | —*1     | —*1                  | 1 setting |
| Control transfer data stage, status stage, bulk transfer | IN                        | BUF | Invalid | Receive area exists  | —*1       |
|  | OUT                       | BUF | Invalid | Transmit data exists | —*1       |
| Interrupt transfer                                       | IN                        | BUF | Valid   | Receive area exists  | —*1       |
|  | OUT                       | BUF | Valid   | Transmit data exists | —*1       |
| Isochronous transfer                                     | IN                        | BUF | Valid   | *2                   | —*1       |
|  | OUT                       | BUF | Valid   | *3                   | —*1       |

Note 1. An em dash (—) in the table indicates that the condition is unrelated to the generating of tokens. "Valid" indicates that, for interrupt transfers and isochronous transfers, a transaction is generated only in transfer frames that are based on the interval counter. "Invalid" indicates that a transaction is generated regardless of the interval counter.

Note 2. This indicates that a transaction is generated regardless of whether there is a receive area. If there is no receive area, however, the received data is discarded.

Note 3. This indicates that a transaction is generated regardless of whether there is any data to be transmitted. If there is no data to be transmitted, however, a zero-length packet is transmitted.

#### 26.3.14.2 Transfer schedule

This section describes the transfer scheduling within a frame of the USBFS. After the USBFS sends an SOF, the transfer is carried out in the following sequence:

1. Execution of periodic transfers:

插值函数在以下条件下初始化:

- MCU reset
- USB总线复位
- 暂停状态检测

SOF插值操作如下:

- 直到收到SOF数据包才激活插值功能
- 当接收到第一个SOF数据包时, 通过在48-MHz内部时钟上计数1ms执行插值
- 当接收到第二个和后续的SOF数据包时, 按照之前的接收间隔进行插值
- 在挂起状态或接收到USB总线复位时不执行插值

USBFS支持以下由SOF数据包接收控制的功能。这些功能正常运行如果SOF数据包丢失, 则SOF插值:

- 更新帧号
- SOFR中断时序
- 同步传输间隔计数

如果在全速运行期间丢失SOF数据包, 则不会更新FRMNUM.FRNM[10:0]位。

### 26.3.14 管道计划

#### 26.3.14.1 产生交易的条件

在主机控制器模式下, 当DVSTCTR0.UACT位设置为1时, USBFS在表26.29所示的条件下生成事务。

Table 26.29 产生交易的条件

| Transaction          | 生成条件 |     |         |        |           |
|----------------------|------|-----|---------|--------|-----------|
|                      | DIR  | PID | IITV0   | 缓冲状态   | SUREQ     |
| Setup                | —*1  | —*1 | —*1     | —*1    | 1 setting |
| 控制传输数据阶段、状态阶段、批量传输   | IN   | BUF | Invalid | 接收区存在  | —*1       |
|                      | OUT  | BUF | Invalid | 传输数据存在 | —*1       |
| 中断传输                 | IN   | BUF | Valid   | 接收区存在  | —*1       |
|                      | OUT  | BUF | Valid   | 传输数据存在 | —*1       |
| Isochronous transfer | IN   | BUF | Valid   | *2     | —*1       |
|                      | OUT  | BUF | Valid   | *3     | —*1       |

注1.表中的破折号(—)表示该条件与令牌的生成无关。“有效”表示, 对于中断传输和同步传输, 事务仅在基于间隔计数器的传输帧中生成。“无效”表示无论间隔计数器如何都生成事务。

注2.这表示无论是否有接收区域, 都会生成一个事务。但是, 如果没有接收区域, 则丢弃接收到的数据。

注3.这表示无论是否有任何数据要传输, 都会产生交易。然而, 如果没有要传输的数据, 则传输零长度数据包。

#### 26.3.14.2 转移时间表

本节介绍USBFS帧内的传输调度。USBFS发送SOF后, 按以下顺序进行传输:

- 1.定期转账的执行:

A pipe is searched for in the order of pipe 1 → pipe 2 → pipe 6 → pipe 7 → pipe 8 → pipe 9, and then if there is a pipe for which an isochronous or interrupt transfer transaction can be generated, the transaction is generated.

## 2. Setup transactions for control transfers:

The DCP is checked, and if a setup transaction is possible, it is sent.

## 3. Execution of bulk transfers, control transfer data stages, and control transfer status stages:

A pipe is searched for in the order of DCP → pipe 1 → pipe 2 → pipe 3 → pipe 4 → pipe 5, and then if there is a pipe for which a transaction for a bulk transfer, a control transfer data stage, or a control transfer status stage can be generated, the transaction is generated.

When a transaction is generated, processing moves to the next pipe transaction regardless of whether the response from the peripheral device is ACK or NAK. If there is time for transfer within the frame, step 3 is repeated.

### 26.3.14.3 Enabling USB communication

Setting the DVSTCR0.UACT bit to 1 initiates an SOF transmission, and transaction generation is enabled. Setting the UACT bit to 0 stops SOF transmission and the Suspend state is invoked. If the UACT setting is changed from 1 to 0, processing stops after the next SOF is sent.

### 26.3.15 Battery Charging Detection Processing

The USBFS provides control over the data contact detection processing (D+ line contact checking), primary detection processing (charger detection processing), and secondary detection processing (charger determination processing) as defined in the Battery Charging Specification.

#### 26.3.15.1 Processing in device controller mode

To operate a function device as a battery charging portable device:

1. Start primary detection processing after detecting contact with the D+ and D- lines. The Battery Charging Specification describes two processing methods for Data Contact Detection. The USBFS supports both methods as follows:
  - Software processing
 

After a VBINT interrupt or polling of the VBSTS flag indicates a change in the state of the USBFS\_VBUS input pin, software controls a wait from 300 to 900 ms. The BCCTRL1.VDPSRCE and CHGDETE bits are then both set to 1 to start primary detection processing.
  - Hardware Processing
 

Apply 7 to 13  $\mu$ A of current to the D+ line to hold the D+ line at the logical high level. This is done to detect the D+ and D- lines going to the logical low level because of pull-down resistors on the host device side when the D+ and D- lines come in contact with those of the host. Monitor the SYSSTS0.LNST[1:0] flags while the PHYSECTRL.CNEN bit, BCCTRL1.RPDME and IDPSRCE bit are set to 1 to see when the level on the D+ line changes from high to low. After detecting a low level on the D+ line, clear the PHYSECTRL.CNEN bit, BCCTRL1.RPDME and IDPSRCE bit to 0 and set both the BCCTRL1.VDPSRCE and CHGDETE bits to 1 to start primary detection processing. The VDPSRCE and CHGDETE bits must be set to 1 simultaneously.
2. After the start of primary detection processing followed by a software-controlled wait of 40 ms, check the BCCTRL1.CHGDETSTS flag. A value of 1 indicates detection of a charger, and secondary detection processing starts.\*1
3. To start secondary detection processing, clear the BCCTRL1.VDPSRCE bit to 0, then clear the BCCTRL1.CHGDETE bits to 0 after a software-controlled wait of 20 ms. Next, set both the BCCTRL1.VDMSRCE and PDDETE bits to 1.
4. After the start of secondary detection processing followed by a software-controlled wait of 40 ms, check the BCCTRL1.PDDETSTS flag, and determine the result of the secondary detection processing.

Note 1. In primary detection processing, detection of a voltage above the range from 0.25 to 0.4 V and below the range from 0.8 to 2.0 V on the D-Line indicates that the other device is a host device that supports battery charging (charging downstream port). The BCCTRL1.CHGDETSTS flag in the PHY block only indicates whether the voltage on the D-line is higher than the range from 0.25 to 0.4 V, so add processing as required to read the SYSSTS0.LNST[1:0] flags and confirm that the voltage on the D- line is also below the range from 0.8 to 2.0 V.

Figure 26.24 shows the process flow.

按照管道1→管道2→管道6→管道7→管道8→管道9的顺序查找管道，如果有管道可以生成等时或中断传输事务，则生成事务。

## 2.为控制转移设置交易:

DCP被检查，如果设置事务是可能的，它被发送。

## 3、批量传输、控制传输数据阶段、控制传输状态阶段的执行:

按照DCP→管道1→管道2→管道3→管道4→管道5的顺序搜索管道，然后如果有管道需要进行批量传输、控制传输数据阶段或可以生成控制转移状态阶段，生成事务。

生成事务时，无论来自外围设备的响应是ACK还是NAK，处理都会转移到下一个管道事务。如果帧内有时间进行传输，则重复步骤3。

### 26.3.14.3 启用USB通信

将DVSTCR0.UACT位设置为1启动SOF传输，并启用事务生成。设置UACT位为0停止SOF传输并调用暂停状态。如果UACT设置从1更改为0，则在发送下一个SOF后处理停止。

### 26.3.15 电池充电检测处理

USBFS提供对电池充电规范中定义的数据接触检测处理 (D+线路接触检查)、一次检测处理 (充电器检测处理) 和二次检测处理 (充电器确定处理) 的控制。

#### 26.3.15.1 设备控制器模式下的处理

将功能设备作为电池充电便携式设备操作:

1.检测到与D+和Dlines的接触后开始初级检测处理。电池充电规范描述了数据接触检测的两种处理方法。USBFS支持以下两种方法:

##### ●软件处理

在VBINT中断或VBSTS标志的轮询指示USBFS\_VBUS输入引脚的状态发生变化后，软件控制从300到900ms的等待。然后将BCCTRL1.VDPSRCE和CHGDETE位都设置为1以启动主要检测处理。

##### ●硬件处理

向D+线施加7到13 $\mu$ A的电流，以将D+线保持在逻辑高电平。这样做是为了检测D+和Dlines进入逻辑低电平，因为当D+和Dlines与主机的那些接触时，由于主机设备侧的下拉电阻器。在PHYSECTRL.CNEN位、BCCTRL1.RPDME和IDPSRCE位设置为1时监控SYSSTS0.LNST[1:0]标志，以查看D+线上的电平何时从高变为低。检测到D+线上的低电平后，将PHYSECTRL.CNEN位、BCCTRL1.RPDME和IDPSRCE位清除为0，并将BCCTRL1.VDPSRCE和CHGDETE位都设置为1，以启动初级检测处理。VDPSRCE和CHGDETE位必须同时设置为1。

2.主要检测处理开始后，软件控制等待40毫秒后，检查

BCCTRL1.CHGDETSTS标志。值为1表示检测到充电器，并开始二次检测处理。\*1

3.要启动二次检测处理，将BCCTRL1.VDPSRCE位清零，然后在软件控制的20ms等待后将BCCTRL1.CHGDETE位清零。接下来，将BCCTRL1.VDMSRCE和PDDETE位都设置为1。

4.二次检测处理开始后，软件控制等待40ms，检查BCCTRL1.PDDETSTS标志，确定二次检测处理的结果。

注1.在初级检测处理中，在D-Line上检测到高于0.25至0.4V范围且低于0.8至2.0V范围的电压表示其他设备是支持电池充电的主机设备 (充电下游港口)。PHY模块中的BCCTRL1.CHGDETSTS标志位仅指示Dline上的电压是否高于0.25到0.4V的范围，因此根据需要添加处理以读取SYSSTS0.LNST[1:0]标志位并确认电压Dline上的电压也低于0.8至2.0V的范围。

图26.24显示了处理流程。

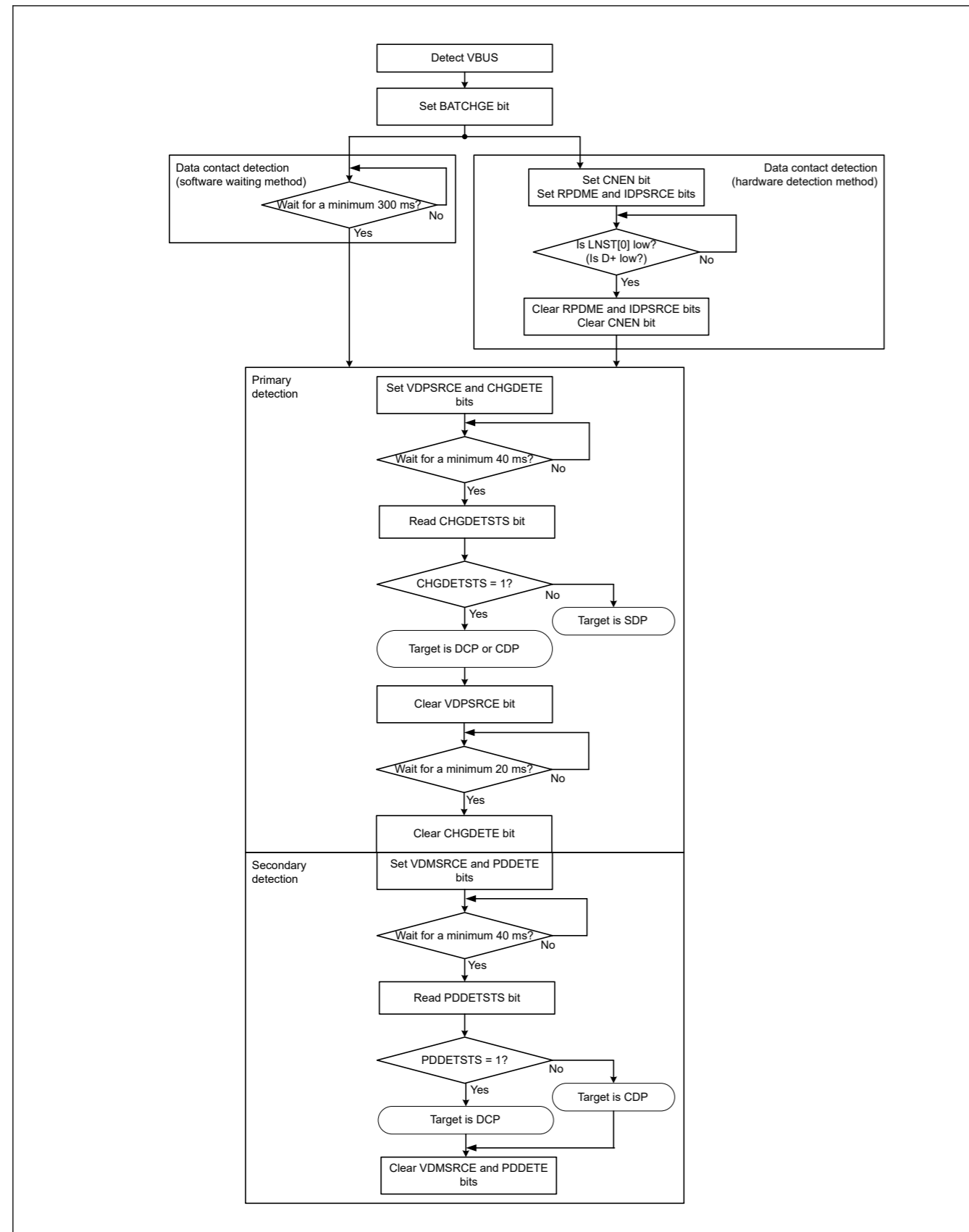


Figure 26.24 Processing flow as portable device

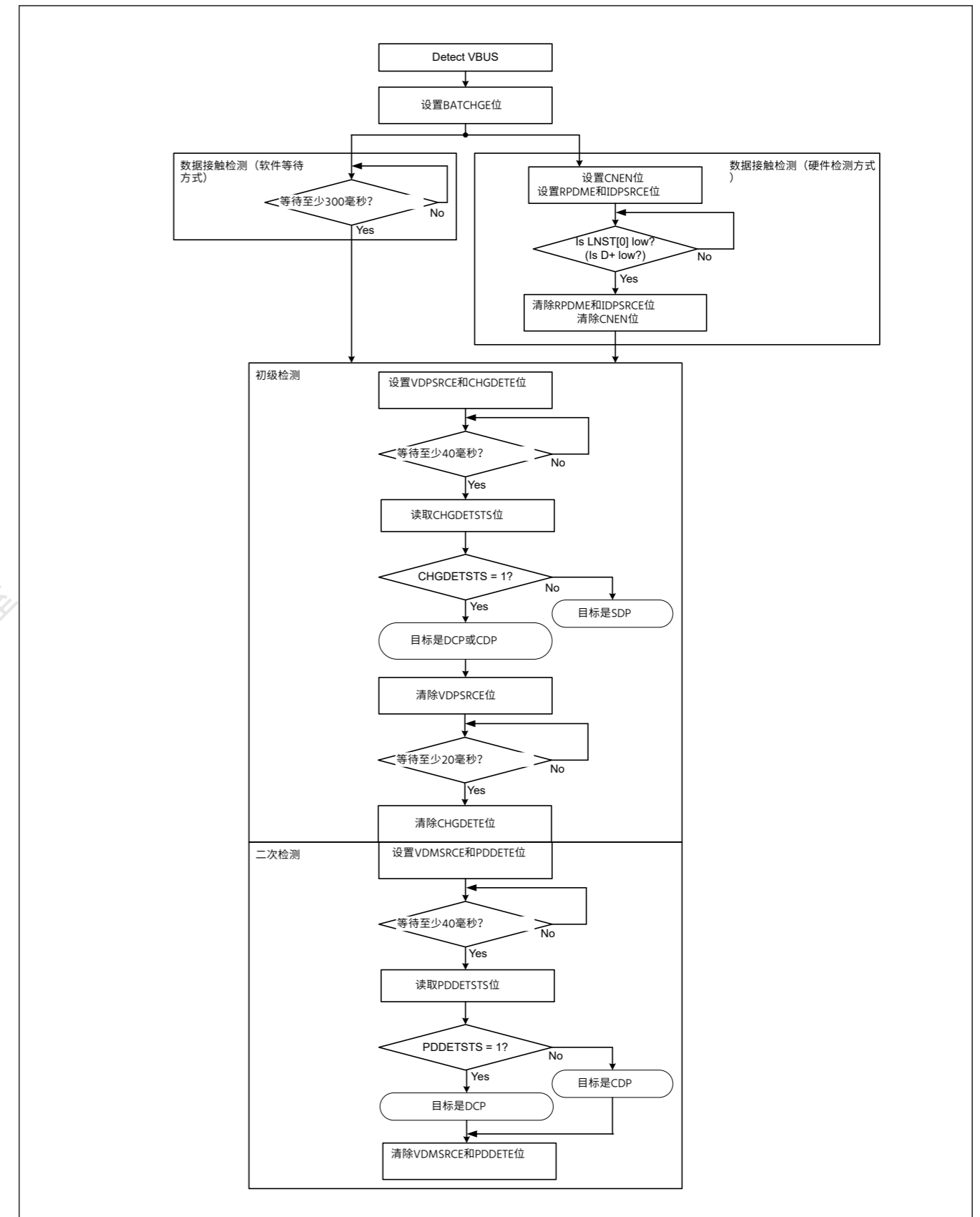


Figure 26.24 作为便携式设备的处理流程



### 26.3.15.2 Processing in host controller mode

In host controller mode, driving the D- line is required for a portable device to perform primary detection. The USBFS supports the following two primary detection methods:

#### When using the Portable Device detection function

The D- line is driven when a Portable Device is detected.

1. Start driving the VBUS.
2. Set the BCCTRL1.PDDETE bit to 1 to enable the portable device detection circuit.
3. Monitor the portable device detection signal and start driving the D- line when the level of the portable device detection signal is high.\*1
4. Stop driving the D- line when the portable device detection signal is at the low level.\*1

Note 1. The PDDTINT interrupt indicates a change in the level of the portable device detection signal, and the current level can be obtained by reading the PDDTSTS flag.

#### When not using the Portable Device detection function

Regardless of whether or not a Portable Device was detected, drive the D- line after device disconnection is detected, and leave the D- line open after connection is detected. Software handles the timing of a and b.

- a. After disconnection is detected, start driving the D- line within 200 ms.
- b. After connection is detected, stop driving the D- line within 10 ms.

Figure 26.25 shows the process flow for steps 1. to 4. and Figure 26.26 shows the process flow for steps a. and b., respectively.

### 26.3.15.2 主机控制器模式下的处理

在主机控制器模式下，便携式设备需要驱动Dline才能执行初级检测。USBFS支持以下两种主要检测方法：

#### 使用便携式设备检测功能时

当检测到便携式设备时驱动Dline。

- 1.开始驱动VBUS。
- 2.将BCCTRL1.PDDETE位设置为1以启用便携式设备检测电路。
- 3.监测便携设备检测信号，当便携设备检测信号为高电平时开始驱动Dline。\*1
- 4、当便携设备检测信号为低电平时，停止驱动Dline。\*1

注1.PDDTINT中断表示便携式设备检测信号电平的变化，当前电平可通过读取PDDTSTS标志获得。

#### 不使用便携设备检测功能时

无论是否检测到便携式设备，在检测到设备断开后驱动Dline，在检测到连接后保持Dline处于打开状态。软件处理a和b的时序。

- a. 检测到断线后，在200ms内开始驱动Dline。
- 湾。检测到连接后，请在10ms内停止驱动Dline。

图26.25显示了步骤1.到4.的处理流程，图26.26显示了步骤a.的处理流程。和b.，分别。

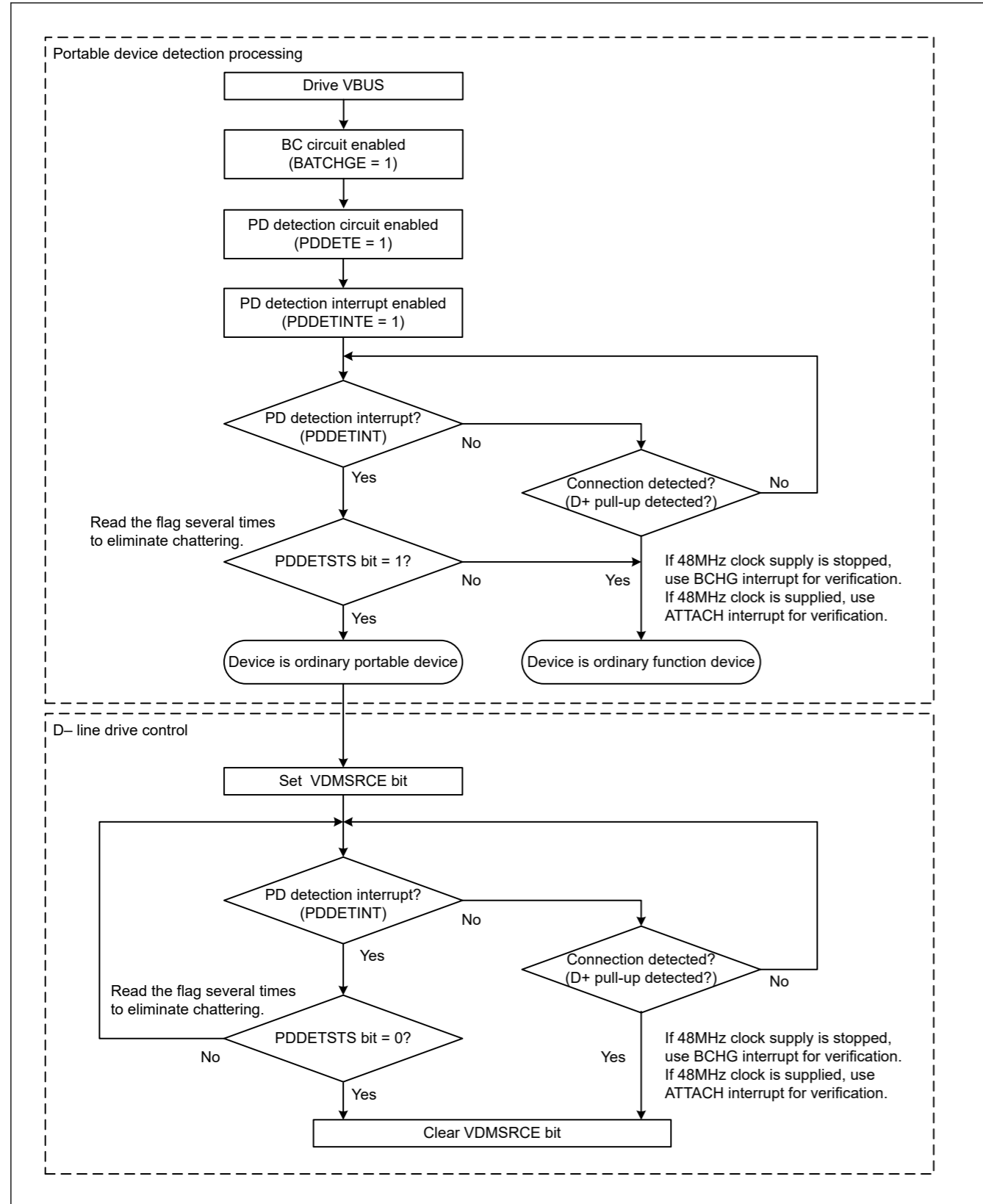


Figure 26.25 Processing flow when using the Portable Device detection function (steps 1. to 4.)

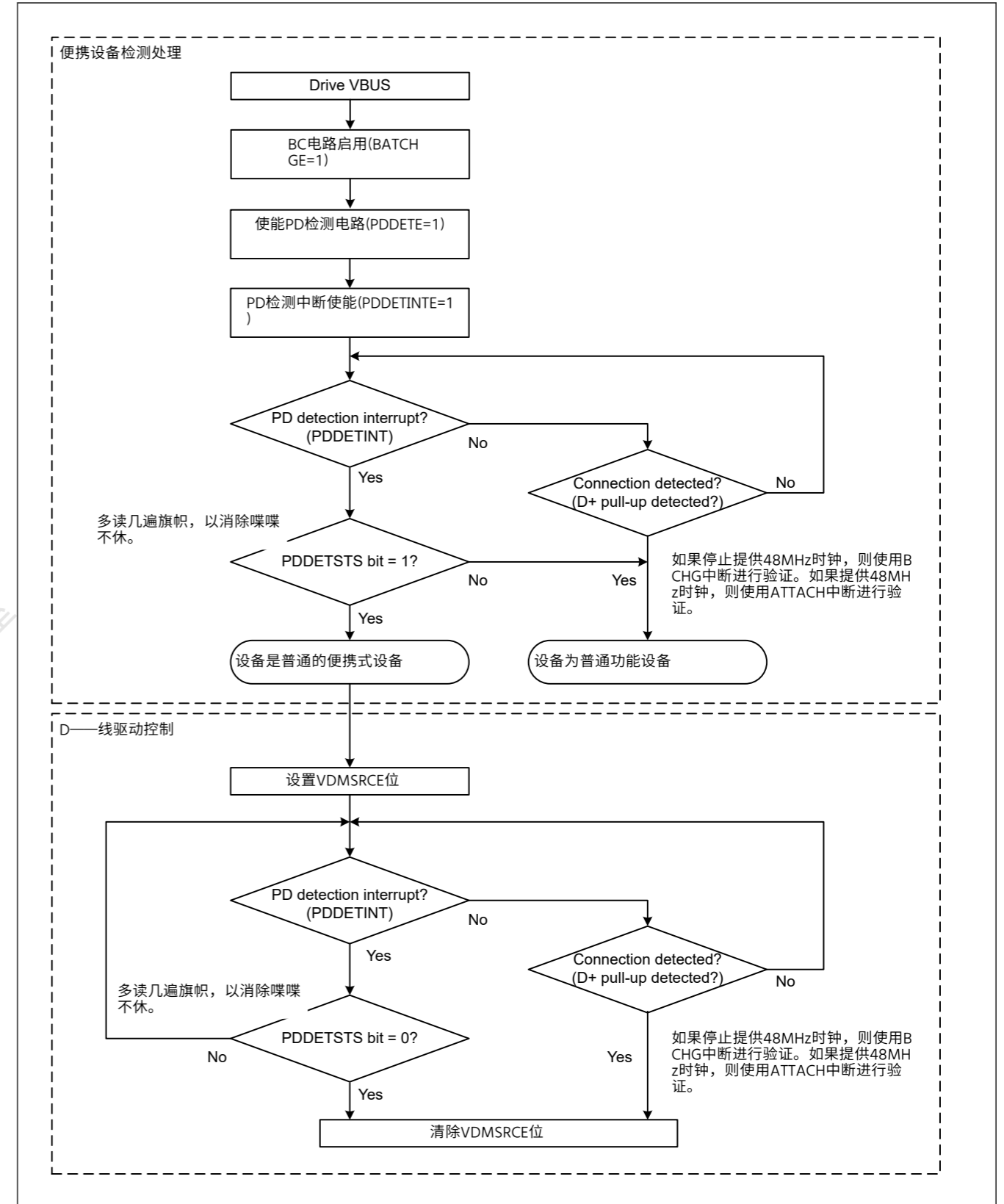


Figure 26.25 使用便携式设备检测功能时的处理流程 (步骤1.至4.)

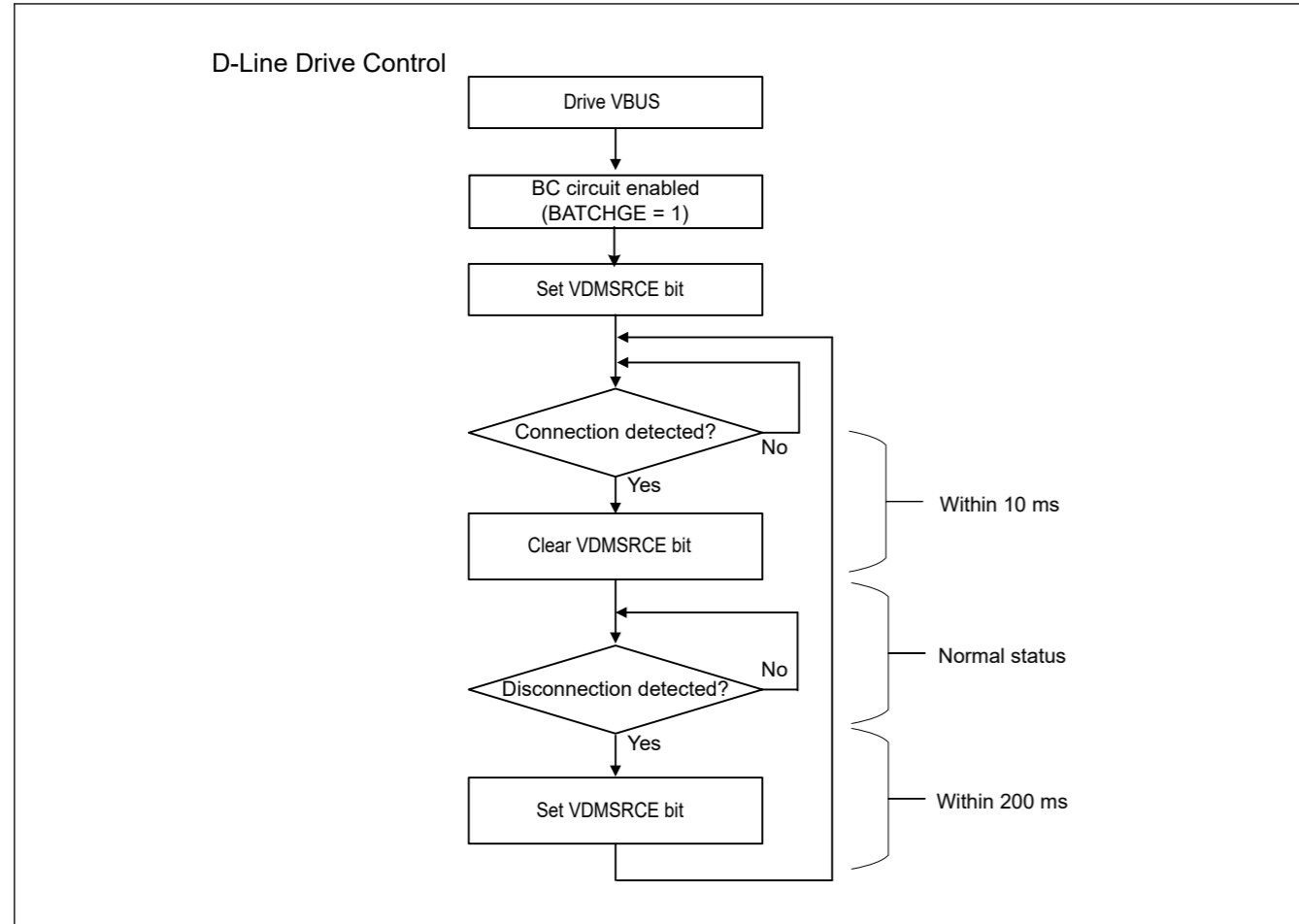


Figure 26.26 Processing flow when not using Portable Device detection function (steps a. and b.)

26.4 Usage Notes

26.4.1 Settings for the Module-Stop State

USBFS operation can be disabled or enabled using Module Stop Control Register B (MSTPCRB). The USBFS is initially stopped after reset. Releasing the module-stop state enables access to the registers. For details, see section 10, Low Power Modes.

26.4.2 Clearing the Interrupt Status Register on Exiting Software Standby Mode

Because the input buffer is always enabled in Software Standby mode, an unexpected interrupt might occur under the following conditions:

- When the interrupt is enabled in Normal mode
- When the interrupt is disabled in Software Standby mode
- When the input level of the pin that cancels software standby is changed in Software Standby mode

These conditions might cause the associated interrupt flag in the Interrupt Status Register to set unexpectedly. After the MCU exits the Software Standby mode, the unexpected interrupt might be sent to the interrupt controller. To avoid this, always clear the INTSTS0 and INTSTS1 registers in the canceling sequence.

26.4.3 Clearing the Interrupt Status Register after Setting Up the Port Function

The input buffer is disabled before the PmnPFS.PSEL and PmnPFS.PMR port is set up, so the internal signal is fixed high or low. The input buffer is enabled after the port is set so that the external pin state is propagated to the MCU. An unexpected interrupt might occur at this time, causing the VBINT and OVRCCR bits in INTSTS0 and INTSTS1, or other

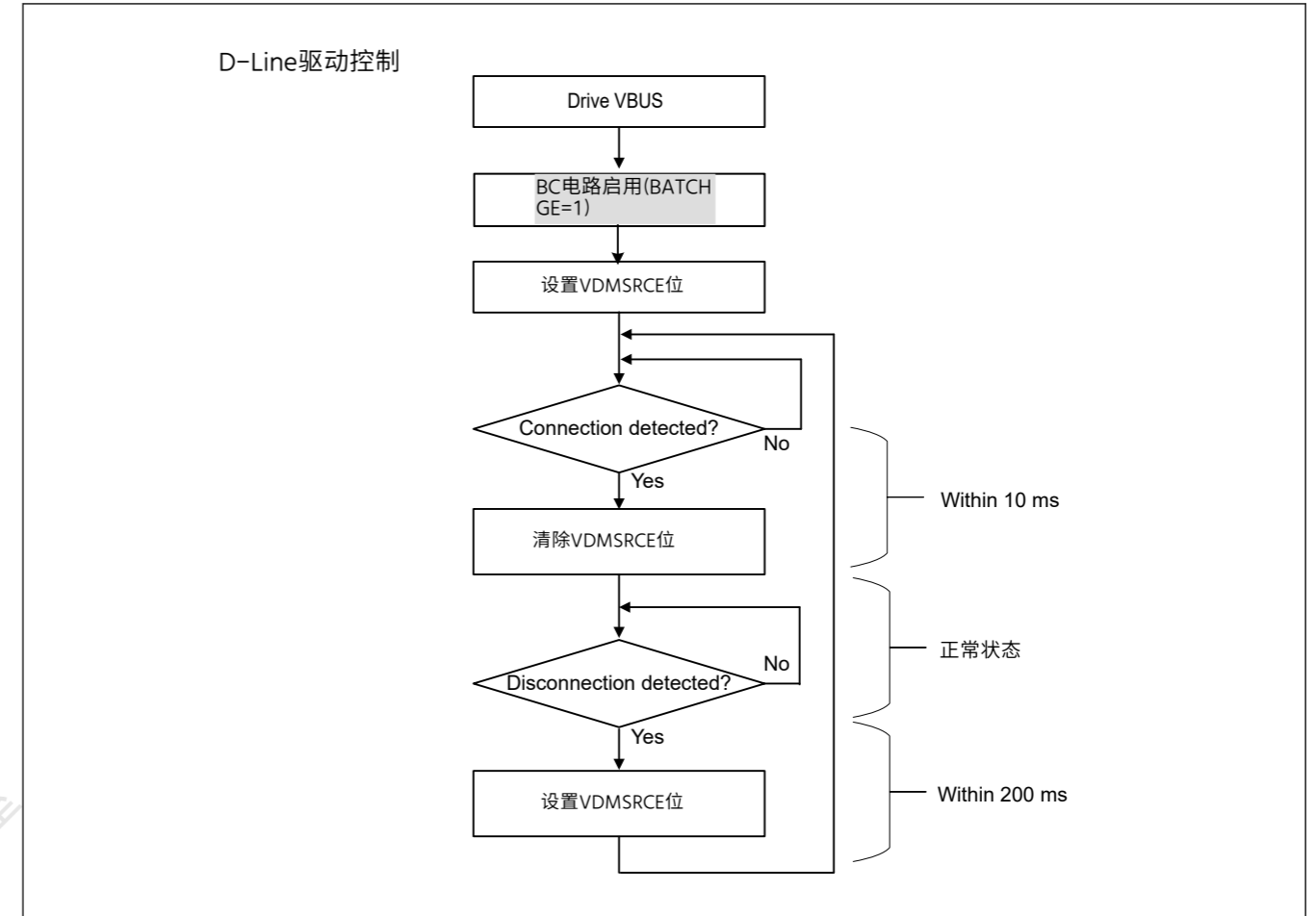


Figure 26.26 不使用便携设备检测功能时的处理流程 (步骤a.和b.)

26.4 使用说明

26.4.1 模块停止状态的设置

可以使用模块停止控制寄存器B(MSTPCRB)禁用或启用USBFS操作。USBFS在复位后最初停止。释放模块停止状态可以访问寄存器。有关详细信息，请参阅第10节，低功耗模式。

26.4.2 退出软件待机模式时清除中断状态寄存器

由于在软件待机模式下始终启用输入缓冲区，因此在以下情况下可能会发生意外中断：

- 在正常模式下使能中断时
- 在软件待机模式下禁用中断时
- 在软件待机模式下，取消软件待机的引脚的输入电平发生变化时

这些情况可能会导致中断状态寄存器中的相关中断标志意外设置。MCU退出软件待机模式后，可能会向中断控制器发送意外中断。为避免这种情况，请始终在取消序列中清除INTSTS0和INTSTS1寄存器。

26.4.3 设置端口功能后清除中断状态寄存器

在设置PmnPFS.PSEL和PmnPFS.PMR端口之前，输入缓冲器被禁用，因此内部信号固定为高电平或低电平。设置端口后启用输入缓冲器，以便将外部引脚状态传播到MCU。此时可能会发生意外中断，导致INTSTS0和INTSTS1中的VBINT和OVRCCR位，或其他

interrupt status flags to set to 1. To avoid a malfunction, always clear the INTSTS0 and INTSTS1 registers after setting up the port.

中断状态标志设置为1。为避免故障，请在设置端口后始终清除INTSTS0和INTSTS1寄存器。

RA生态工作室



## 27. Serial Communications Interface (SCI)

### 27.1 Overview

The Serial Communications Interface (SCI) × 6 channels have asynchronous and synchronous serial interfaces:

- Asynchronous interfaces (UART and Asynchronous Communications Interface Adapter (ACIA))
- 8-bit clock synchronous interface
- Simple IIC (master-only)
- Simple SPI
- Smart card interface
- Manchester interface
- Extended Serial interface

The smart card interface complies with the ISO/IEC 7816-3 standard for electronic signals and transmission protocol. SCIn (n = 0, 3, 4, 9) has FIFO buffers to enable continuous and full-duplex communication, and the data transfer speed can be configured independently using an on-chip baud rate generator.

In this section, PCLK refers to PCLKA.

Table 27.1 lists the SCI specifications, Figure 27.1 shows a block diagram of SCI, and Table 27.3 lists the I/O pins.

**Table 27.1 SCI specifications (1 of 3)**

| Parameter   | Specifications   |  |
|---|--|--|
| Number of modules                                 | 6 (SCIn (n = 0 to 4, 9))   |  |
| Serial communication modes                        | <ul style="list-style-type: none"> <li>● Asynchronous</li> <li>● Clock synchronous</li> <li>● Simple IIC</li> <li>● Simple SPI</li> <li>● Smart card interface</li> <li>● Manchester interface (SCIn (n = 3, 4))</li> <li>● Extended Serial interface (SCIn (n = 1, 2))</li> </ul> |  |
| Transfer speed                                    | Bit rate specifiable with the on-chip baud rate generator  |  |
| Full-duplex communications                        | <ul style="list-style-type: none"> <li>● Transmitter: Continuous transmission possible using double-buffering</li> <li>● Receiver: Continuous reception possible using double-buffering</li> </ul>   |  |
| Data transfer                                     | Selectable as LSB-first or MSB-first transfer  |  |
| Inverter for communication terminals (RXDn, TXDn) | Selectable inverter for each terminals (RXDn, TXDn) (SCIn (n = 0, 3, 4, 9))  |  |
| Interrupt sources                                 | Transmit data empty, receive data full, receive error, receive data ready*, address match*. (* SCIn (n = 0, 3, 4, 9) support)<br>Completion of generation of a start condition, restart condition, or stop condition (for simple IIC mode)   |  |
| Module-stop function                              | Module-stop state can be set for each channel  |  |
| Snooze end request                                | SCI0 address mismatch (SCI0_DCUF)  |  |
| Clock synchronous mode                            | Data length  | 8 bits   |
|   | Receive error detection  | Overflow error   |
|   | Clock source   | Selectable to internal clock (master mode) or external clock (slave mode)                  |
|   | Hardware flow control  | Transmission and reception controllable with CTSn_RTSn pins                                |
|   | Transmission and reception   | Selectable to 1-stage register or 16-stage FIFO (only SCIn (n = 0, 3, 4, 9) supports FIFO) |
| Asynchronous mode                                 | Data length  | 7, 8, or 9 bits  |
|   | Transmission stop bit  | 1 or 2 bits  |
|   | Adjustment of receive sampling timing  | Adjustable receive sampling timing before/after the default timing                         |

## 27. 串行通信接口(SCI)

### 27.1 Overview

串行通信接口(SCI)×6通道具有异步和同步串行接口:

- 异步接口 (UART和异步通信接口适配器(ACIA))
- 8位时钟同步接口
  - Simple IIC (master-only)
  - 简单的SPI
  - 智能卡接口
  - 曼彻斯特接口
  - 扩展串行接口

智能卡接口符合ISO/IEC7816-3电子信号和传输协议标准。SCIn(n=0 3 4 9)具有FIFO缓冲区以实现连续和全双工通信，并且可以使用片上波特率发生器独立配置数据传输速度。

在本节中，PCLK指的是PCLKA。

表27.1列出了SCI规格，图27.1显示了SCI的框图，表27.3列出了IO引脚。

**Table 27.1 SCI规范(1of3)**

| Parameter                  | Specifications  |  |
|----------------------------|---|--|
| 模块数量                       | 6 (SCIn (n = 0 to 4, 9))  |  |
| 串行通信模式                     | <ul style="list-style-type: none"> <li>● Asynchronous</li> <li>● 时钟同步</li> <li>● Simple IIC</li> <li>● 简单的SPI</li> <li>● 智能卡接口</li> <li>● 曼彻斯特接口(SCIn(n=3 4))</li> <li>● 扩展串行接口(SCIn(n=1 2))</li> </ul> |  |
| 传输速度                       | 可通过片上波特率发生器指定比特率  |  |
| Full-duplex communications | <ul style="list-style-type: none"> <li>● 发送器: 可使用双缓冲进行连续传输</li> <li>● 接收器: 使用双缓冲可以连续接收</li> </ul>   |  |
| 数据传输                       | 可选择LSB优先或MSB优先传输  |  |
| 通信终端用变频器 (RXDn, TXDn)      | 每个端子(RXDn TXDn)的可选逆变器(SCIn(n=0 3 4 9))  |  |
| 中断源                        | 发送数据空, 接收数据满, 接收错误, 接收数据就绪*, 地址匹配*。( *SCIn(n=0 3 4 9)support)完成启动条件、重启条件或停止条件的生成 (对于简单IIC模式)  |  |
| Module-stop function       | 每个通道可设置模块停止状态   |  |
| 暂停结束请求                     | SCI0地址不匹配(SCI0_DCUF)  |  |
| 时钟同步模式                     | 数据长度  | 8 bits   |
|                            | 接收错误检测  | 溢出错误   |
|                            | 时钟源   | 可选择内部时钟 (主模式) 或外部时钟 (从模式)                      |
|                            | 硬件流控制   | 可通过CTS <sub>n</sub> RTS <sub>n</sub> 引脚控制发送和接收 |
|                            | 传输和接收   | 可选择1级寄存器或16级FIFO (仅SCIn(n=0 3 4 9)支持FIFO)      |
| 异步模式                       | 数据长度  | 7、8或9位   |
|                            | 传输停止位   | 1或2位   |
|                            | 接收采样时序的调整   | 默认时序后可调接收采样时序                                  |

Table 27.1 SCI specifications (2 of 3)

| Parameter                                 | Specifications  |  |
|---|---|--|
| Adjustment of transmit timing             | Adjustable edge timing of transmit waveform controlled by the setting value of registers.   |  |
| Parity                                    | Even parity, odd parity, or no parity   |  |
| Receive error detection                   | <ul style="list-style-type: none"> <li>Parity error</li> <li>Overrun error</li> <li>Framing error</li> </ul>  |  |
| Hardware flow control                     | Transmission and reception controllable with CTSn_RTsn pins   |  |
| Transmission and reception                | Selectable to 1-stage register or 16-stage FIFO (SCIn (n = 0, 3, 4, 9) supports FIFO)   |  |
| Address match                             | Interrupt request/event output can be issued upon detecting a match between received data and the value in the compare match register (SCIn (n = 0, 3, 4, 9) support) |  |
| Address mismatch (SCIO only) receive data | Snooze end request can be issued when detecting a mismatch between the received data and the value in the compare match register                                      |  |
| Start-bit detection                       | Selectable to low level or falling edge detection   |  |
| Break detection                           | Breaks from framing errors detectable by read from SPTR register  |  |
| Clock source                              | Selectable to internal or external clock<br>Transfer rate clock input from the GPT can be used. (SCIn (n = 1, 2))   |  |
| Double-speed mode                         | Baud rate generator double-speed mode is selectable   |  |
| Multi-processor communications function   | Serial communication enabled among multiple processors  |  |
| Noise cancellation                        | Digital noise filters included on signal paths from the RXDn pin inputs   |  |
| Smart card interface mode                 | Error processing  | Error signal can be automatically transmitted upon detecting a parity error during reception<br>Data can be automatically retransmitted upon receiving an error signal during transmission |
|   | Data type   | Both direct and inverse convention supported   |
| Manchester mode                           | Communication format  | Manchester code with the preface and the Start Bit added   |
|   | Data length   | 7,8, or 9 bits   |
|   | Transmission stop bit   | 1 or 2 bits  |
|   | Parity function   | Even parity, odd parity, or no parity  |
|   | Receive error detection   | Parity, overrun, framing, Manchester errors  |
|   | Hardware flow control   | CTSn and RTSn pins can be used in controlling transmission   |
|   | Clock source  | Only internal clock can be used.   |
|   | Double-speed mode   | Baud rate generator double-speed mode is selectable  |
|   | Multi-processor communication function  | Serial communication among multiple processors   |
|   | Noise cancellation  | The signal paths from input on the RXDn pins incorporate digital noise filters   |
|   | Preface setting / detection function  | The function outputs the configured the preface pattern and detects it.  |
|   | Start Bit setting / detection function  | The function outputs the configured the Start Bit pattern and detects it.  |
|   | Reception retiming function   | Timing correction is performed for each bit of the received signal   |
| Simple IIC mode                           | Transfer format   | I <sup>2</sup> C bus format (MSB-first only)   |
|   | Operating mode  | Master (single-master operation only)  |

Table 27.1 SCI规范(2of3)

| Parameter           | Specifications   |   |
|---------------------|--|---|
| 发射时序的调整             | 由寄存器的设定值控制的发送波形边沿时序。   |   |
| Parity              | 偶校验、奇校验或无校验  |   |
| 接收错误检测              | <ul style="list-style-type: none"> <li>奇偶校验错误</li> <li>溢出错误</li> <li>构图错误</li> </ul> |   |
| 硬件流控制               | 可通过CTSn_RTsn引脚控制发送和接收  |   |
| 传输和接收               | 可选择1级寄存器或16级FIFO(SCIn(n=0 3 4 9)支持FIFO)  |   |
| 地址匹配                | 检测到接收数据与比较匹配寄存器中的值匹配时, 可以发出中断请求事件输出 (SCIn(n=0 3 4 9)支持)                              |   |
| 地址不匹配 (仅SCIO) 接收数据  | 当检测到接收到的数据与比较匹配寄存器中的值不匹配时, 可以发出贪睡结束请求  |   |
| Start-bit detection | 可选择低电平或下降沿检测   |   |
| 断线检测                | 通过从SPTR寄存器读取可检测到的帧错误中断   |   |
| 时钟源                 | 可选择内部或外部时钟<br>可以使用来自GPT的传输速率时钟输入。(SCIn(n=1 2))                                       |   |
| Double-speed mode   | 波特率发生器双速模式可选   |   |
| 多处理器通讯功能            | 在多个处理器之间启用串行通信   |   |
| 噪音消除                | 来自RXDn引脚输入的信号路径上包含数字噪声滤波器  |   |
| 智能卡接口方式             | 错误处理   | 在接收过程中检测到奇偶校验错误时可以自动发送错误信号<br>传输过程中接收到错误信号可自动重传数据 |
|                     | 数据类型   | 支持直接和反向约定   |
| 曼彻斯特模式              | 通讯格式   | 添加了前言和起始位的曼彻斯特代码                                  |
|                     | 数据长度   | 7 8或9位  |
|                     | 传输停止位  | 1或2位  |
|                     | 奇偶校验函数   | 偶校验、奇校验或无校验                                       |
|                     | 接收错误检测   | 奇偶校验、超限、成帧、曼彻斯特错误                                 |
|                     | 硬件流控制  | CTSn和RTSn引脚可用于控制传输                                |
|                     | 时钟源  | 只能使用内部时钟。   |
|                     | Double-speed mode  | 波特率发生器双速模式可选                                      |
|                     | 多处理器通讯功能   | 多个处理器之间的串行通信                                      |
|                     | 噪音消除   | 来自RXDn引脚输入的信号路径包含数字噪声滤波器                          |
|                     | 前言设定检测功能   | 该函数输出配置的序言模式并检测它。                                 |
|                     | 起始位设置检测功能  | 该函数输出配置的起始位模式并检测它。                                |
|                     | 接收重定时功能  | 对接收信号的每一位进行定时校正                                   |
| 简单IIC模式             | 传输格式   | I <sup>2</sup> C总线格式 (仅MSB优先)                     |
|                     | 操作模式   | 主机 (仅限单主机操作)                                      |

Table 27.1 SCI specifications (3 of 3)

| Parameter                    |                          | Specifications   |
|------------------------------|--------------------------|--|
|                              | Transfer rate            | Up to 400 kbps   |
|                              | Noise cancellation       | The signal paths from input on the SCLn and SDAn pins incorporate digital noise filters and provide an adjustable interval for noise cancellation  |
| Simple SPI mode              | Data length              | 8 bits   |
|                              | Error detection          | Overrun error  |
|                              | Clock source             | Selectable to internal clock (master mode) or external clock (slave mode)  |
|                              | SSn input pin function   | High impedance state can be invoked on the output pins by driving the SSn pin high.  |
|                              | Clock settings           | Configurable among four clock phase and clock polarity settings  |
| Extended serial mode         | Start Frame transmission | <ul style="list-style-type: none"> <li>Output of a low level as the Break Field over a specified width and generation of interrupts on completion</li> <li>Detection of bus collisions and the generation of interrupts on detection</li> </ul>  |
|                              | Start Frame reception    | <ul style="list-style-type: none"> <li>Detection of the Break Field low width and generation of an interrupt on detection</li> <li>Comparison of Control Fields 0 and 1 and generation of an interrupt when the two match</li> <li>Two kinds of data for comparison (primary and secondary) can be set in Control Field 1.</li> <li>A priority interrupt bit can be set in Control Field 1.</li> <li>Handling of Start Frames that do not include a Break Field</li> <li>Handling of Start Frames that do not include a Control Field 0</li> <li>Function for measuring bit rates</li> </ul> |
|                              | I/O control function     | <ul style="list-style-type: none"> <li>Selectable polarity for TXDXn and RXDXn signals</li> <li>Selection of a digital filter for the RXDXn signal</li> <li>Half-duplex operation employing RXDXn and TXDXn signals multiplexed on the same pin</li> <li>Selectable timing for the sampling of data received through RXDXn</li> <li>Signals received on RXDXn can be passed through to SCIn (n = 1, 2) when the extended serial mode control section is off.</li> </ul>  |
|                              | Timer function           | <ul style="list-style-type: none"> <li>Usable as a reloading timer</li> </ul>  |
| Bit rate modulation function |                          | Error reduction through correction of outputs from the on-chip baud rate generator   |
| Event link function          |                          | Error event output for receive error or error signal detection (SCIn_ERI) (n = 0 to 4, 9)<br>Receive data full event output (SCIn_RXI) (n = 0 to 4, 9)<br>Transmit data empty event output (SCIn_TXI) (n = 0 to 4, 9)<br>Address match event output (SCIn_AM) (n = 0, 3, 4, 9)<br>Transmit end event output (SCIn_TEI) (n = 0, 3, 4, 9)  |
| TrustZone Fileter            |                          | Security attribution can be set for each channels  |

Table 27.2 Functions of SCI Channel (1 of 2)

| Item                      | SCI0, SCI5 to SCI9 | SCI3, SCI4 | SCI1, SCI2    |
|---------------------------|--------------------|------------|---------------|
| Asynchronous mode         | Available          | Available  | Available     |
| Clock synchronous mode    | Available          | Available  | Available     |
| Smart card interface mode | Available          | Available  | Available     |
| Simple I2C mode           | Available          | Available  | Available     |
| Simple SPI mode           | Available          | Available  | Available     |
| FIFO mode                 | Available          | Available  | Not Available |
| Address match             | Available          | Available  | Not Available |

Table 27.1 SCI规范 (3个中的3个)

| Parameter         |           | Specifications  |
|-------------------|-----------|---|
|                   | 传输率       | 高达400kbps   |
|                   | 噪音消除      | 来自SCLn和SDAn引脚输入的信号路径包含数字噪声滤波器，并提供可调节的噪声消除间隔   |
| 简单SPI模式           | 数据长度      | 8 bits  |
|                   | 错误检测      | 溢出错误  |
|                   | 时钟源       | 可选择内部时钟（主模式）或外部时钟（从模式）  |
|                   | SSn输入引脚功能 | 通过将SSn引脚驱动为高电平，可以在输出引脚上调用高阻抗状态。   |
|                   | 时钟设置      | 可在四个时钟相位和时钟极性设置之间进行配置   |
| 扩展串行模式            | 开始帧传输     | <ul style="list-style-type: none"> <li>在指定宽度上输出低电平作为中断字段并在完成时生成中断</li> <li>检测总线冲突并在检测时产生中断</li> </ul>   |
|                   | 开始帧接收     | <ul style="list-style-type: none"> <li>检测中断字段低宽度并在检测时产生中断</li> <li>比较控制字段0和1并在两者匹配时产生中断</li> <li>可以设置两种比较数据（主要和次要）控制字段1。</li> <li>可以在控制字段1中设置优先级中断位。</li> <li>处理不包含中断字段的起始帧</li> <li>不包含控制字段0的起始帧的处理</li> <li>测量比特率的功能</li> </ul> |
|                   | IO控制功能    | <ul style="list-style-type: none"> <li>TXDXn和RXDXn信号的可选极性</li> <li>为RXDXn信号选择数字滤波器</li> <li>采用在同一引脚上复用的RXDXn和TXDXn信号的半双工操作</li> <li>通过RXDXn接收的数据采样的可选时序</li> <li>当扩展串行模式控制部分关闭时，RXDXn上接收的信号可以传递到SCIn(n=1, 2)。</li> </ul>          |
|                   | 定时器功能     | <ul style="list-style-type: none"> <li>可用作重新加载计时器</li> </ul>  |
| 比特率调制功能           |           | 通过校正片上波特率发生器的输出来减少错误  |
| 事件链接功能            |           | 接收错误或错误信号检测的错误事件输出(SCIn_ERI)(n=0到4, 9)<br>接收数据满事件输出(SCIn_RXI)(n=0到4, 9)<br>发送数据空事件输出(SCIn_TXI)(n=0到4, 9)<br>地址匹配事件输出(SCIn_AM)(n=0, 3, 4, 9)<br>发送结束事件输出(SCIn_TEI)(n=0, 3, 4, 9)   |
| TrustZone Fileter |           | 可以为每个通道设置安全属性   |

Table 27.2 SCI频道的功能(1of2)

| Item      | SCI0, SCI5 to SCI9 | SCI3, SCI4 | SCI1, SCI2 |
|-----------|--------------------|------------|------------|
| 异步模式      | Available          | Available  | Available  |
| 时钟同步模式    | Available          | Available  | Available  |
| 智能卡接口方式   | Available          | Available  | Available  |
| 简单I2C模式   | Available          | Available  | Available  |
| 简单SPI模式   | Available          | Available  | Available  |
| FIFO mode | Available          | Available  | 无法使用       |
| 地址匹配      | Available          | Available  | 无法使用       |

Table 27.2 Functions of SCI Channel (2 of 2)

| Item                 | SCI0, SCI5 to SCI9 | SCI3, SCI4    | SCI1, SCI2    |
|----------------------|--------------------|---------------|---------------|
| Manchester mode      | Not Available      | Available     | Not Available |
| Extended serial mode | Not Available      | Not Available | Available     |
| GPT clock input      | Not Available      | Not Available | Available     |

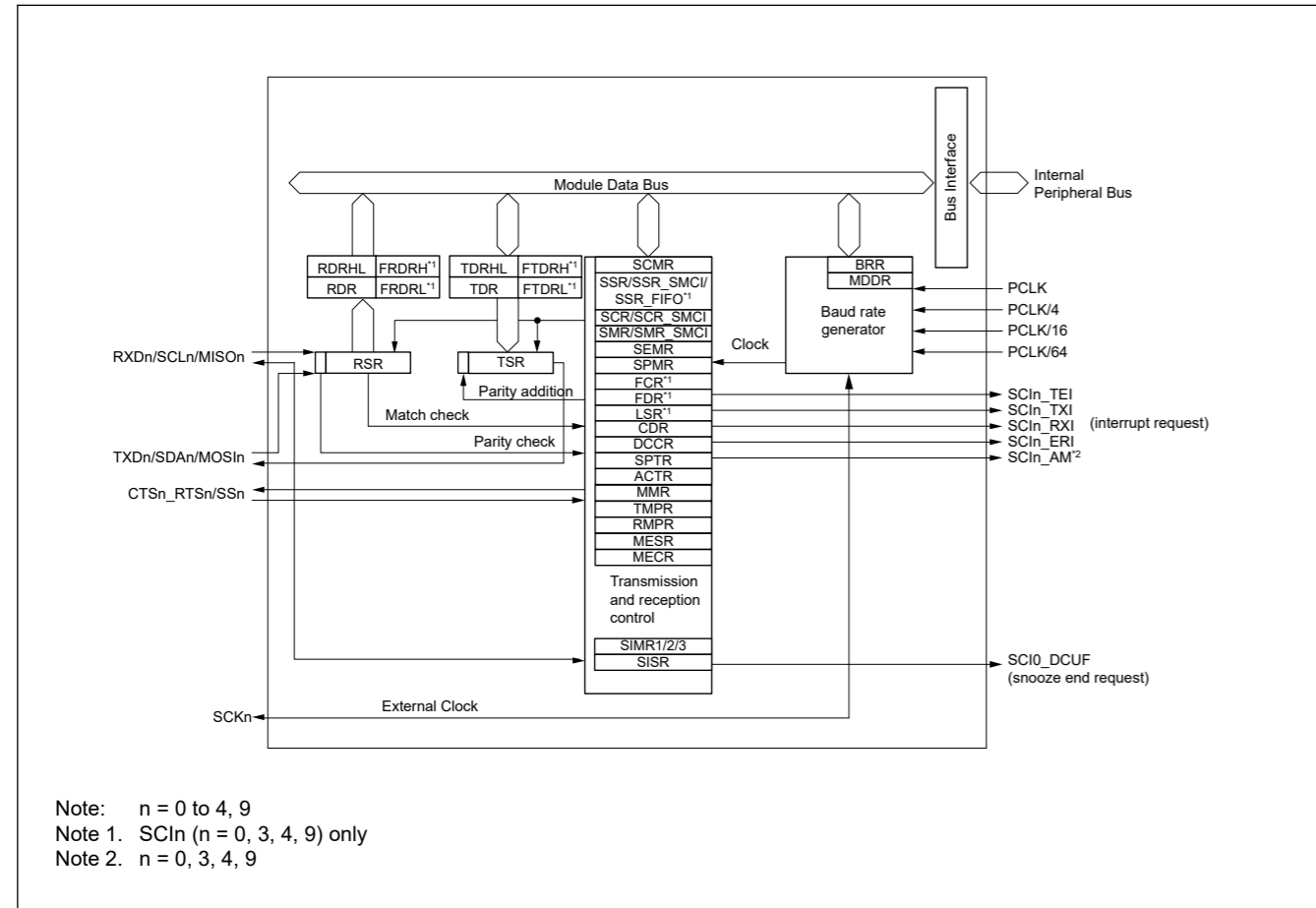


Figure 27.1 SCI block diagram

Table 27.2 SCI频道的功能(2of2)

| Item    | SCI0, SCI5 to SCI9 | SCI3, SCI4 | SCI1, SCI2 |
|---------|--------------------|------------|------------|
| 曼彻斯特模式  | 无法使用               | Available  | 无法使用       |
| 扩展串行模式  | 无法使用               | 无法使用       | Available  |
| GPT时钟输入 | 无法使用               | 无法使用       | Available  |

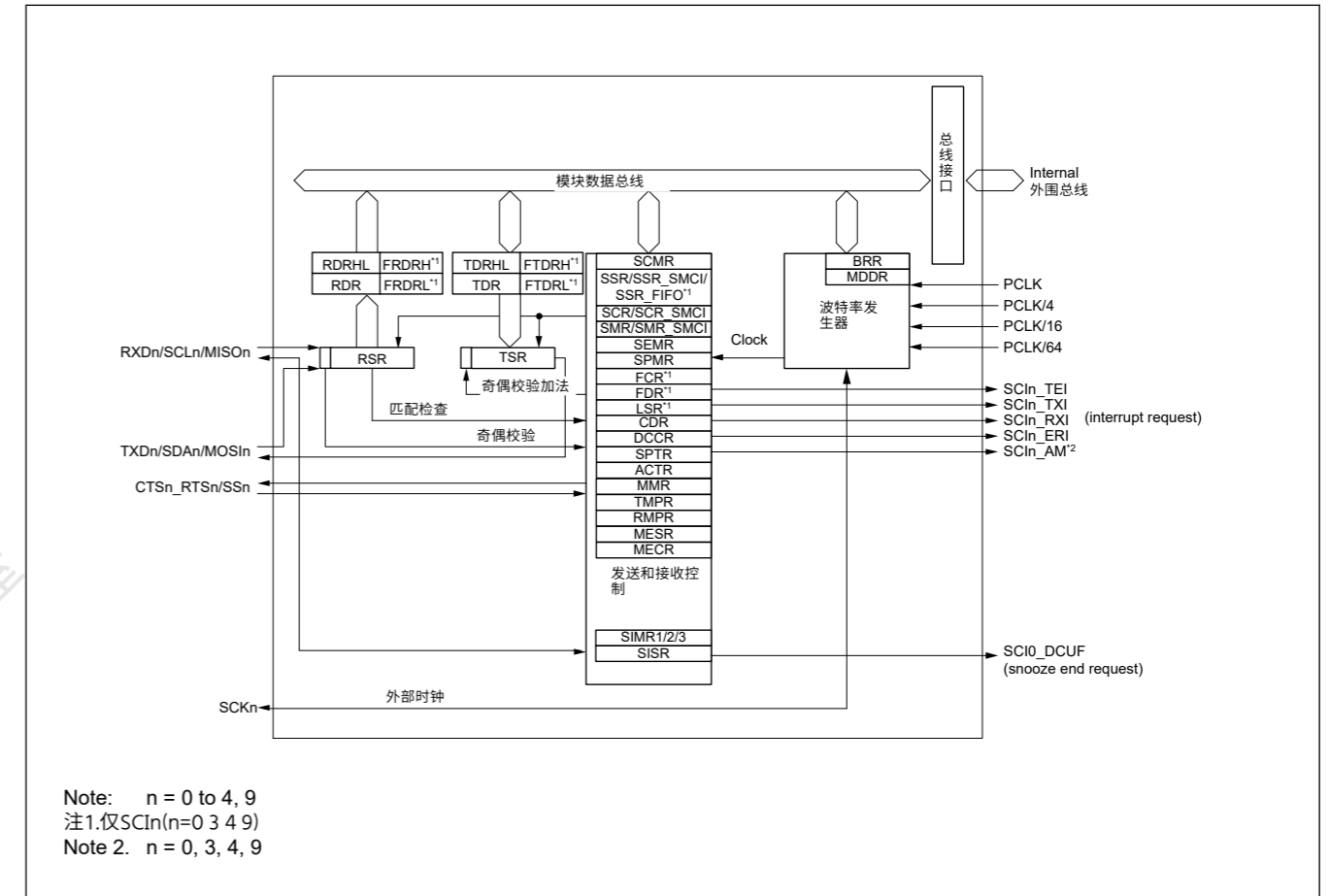


Figure 27.1 SCI框图



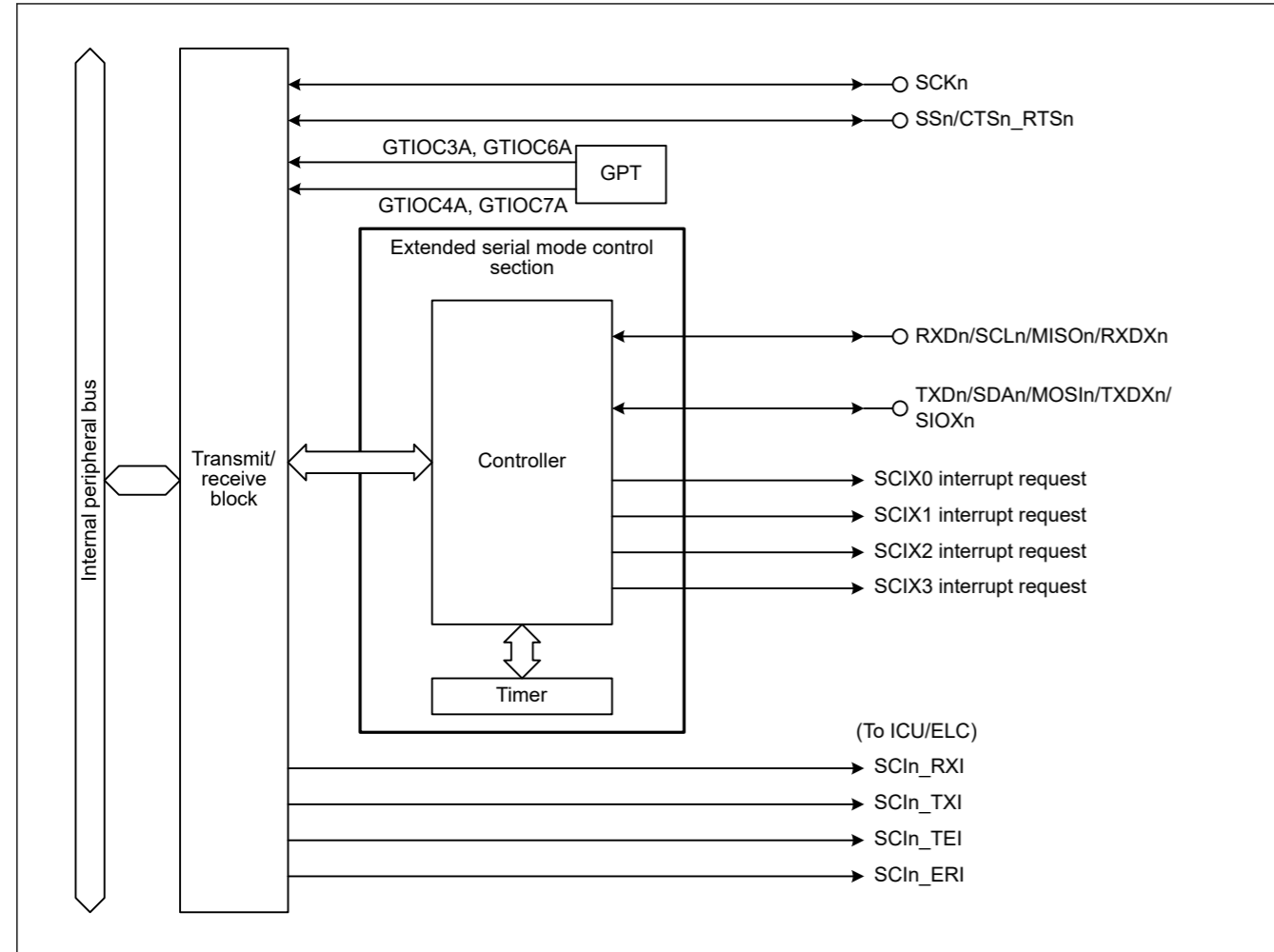


Figure 27.2 SCIn (n = 1, 2) extended serial mode controller block diagram

Table 27.3 SCI I/O pins

| Function             | Pin name        | Input/Output | Description  |
|----------------------|-----------------|--------------|--|
| SCIn (n = 0 to 4, 9) | SCKn            | Input/Output | SCIn clock input/output  |
|                      | RXDn/SCLn/MISOn | Input/Output | SCIn receive data input<br>SCIn I <sup>2</sup> C clock input/output<br>SCIn slave transmit data input/output   |
|                      | TXDn/SDAn/MOSIn | Input/Output | SCIn transmit data output<br>SCIn I <sup>2</sup> C data input/output<br>SCIn master transmit data input/output |
|                      | SSn/CTSn_RTSn   | Input/Output | SCIn chip select input, active-low<br>SCIn transfer start control input/output, active-low                     |
| SCIn (n = 0, 3 to 9) | CTSn            | Input        | SCIn transfer start control input, active-low  |
| SCIn (n = 1, 2)      | RXDn            | Input/Output | SCIn receive data input (Extended Serial Mode)   |
|                      | TXDn/SIOXn      | Input/Output | SCIn transmit data output (Extended Serial Mode)<br>SCIn transmit data input/output (Extended Serial Mode)     |

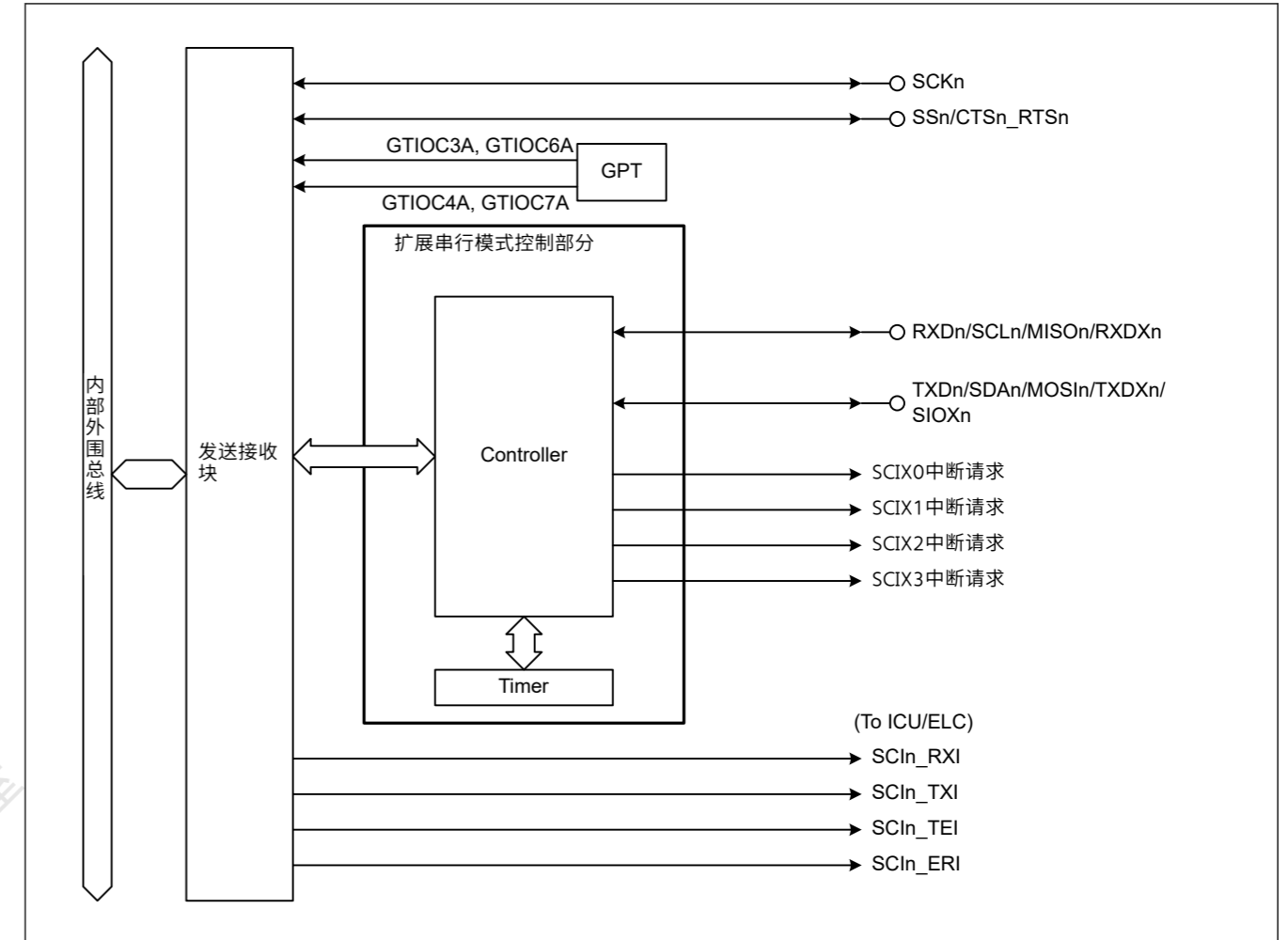


Figure 27.2 SCIn(n=1 2)扩展串行模式控制器框图

Table 27.3 SCII/O引脚

| Function             | 引脚名称            | Input/Output | Description  |
|----------------------|-----------------|--------------|--|
| SCIn (n = 0 to 4, 9) | SCKn            | Input/Output | SCIn clock input/output  |
|                      | RXDn/SCLn/MISOn | Input/Output | SCIn接收数据输入<br>SCIn I <sup>2</sup> C clock input/output<br>SCIn从机发送数据输入输出 |
|                      | TXDn/SDAn/MOSIn | Input/Output | SCIn发送数据输出<br>SCIn I <sup>2</sup> C数据输入输出<br>SCIn主机发送数据输入输出              |
|                      | SSn/CTSn_RTSn   | Input/Output | SCIn片选输入, 低电平有效<br>SCIn传输开始控制输入输出, 低电平有效                                 |
| SCIn (n = 0, 3 to 9) | CTSn            | Input        | SCIn传输开始控制输入, 低电平有效  |
| SCIn (n = 1, 2)      | RXDn            | Input/Output | SCIn接收数据输入 (扩展串行模式)  |
|                      | TXDn/SIOXn      | Input/Output | SCIn发送数据输出 (扩展串行模式)<br>SCIn传输数据输入输出 (扩展串行模式)                             |

## 27.2 Register Descriptions

### 27.2.1 RSR : Receive Shift Register

RSR is a shift register that receives serial data input from the RXDn pin and converts it into parallel data. When one frame of data is received, the data is automatically transferred to the RDR, RDRHL, or the receive FIFO register. The RSR register cannot be directly accessed by the CPU.

### 27.2.2 RDR : Receive Data Register

Base address: SCIn = 0x4011\_8000 + 0x0100 × n (n = 0, 3, 4, 9)  
 SCIm = 0x4011\_8000 + 0x0100 × m (m = 1, 2)

Offset address: 0x05



RDR is an 8-bit register that stores received data. When one frame of serial data is received, it is transferred from RSR to RDR, and the RSR register can receive more data. Because RSR and RDR function as a double buffer, continuous received operations can be performed.

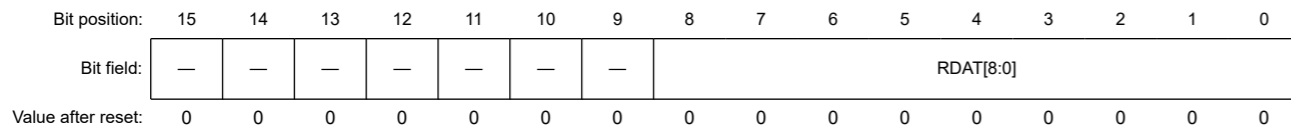
Read the RDR only once after a receive data full interrupt (SCIn\_RXI) occurs.

Note: If the next frame of data is received before reading the received data from RDR, an overrun error occurs. The CPU cannot write to the RDR.

### 27.2.3 RDRHL : Receive Data Register for Non-Manchester mode (MMR.MANEN = 0)

Base address: SCIn = 0x4011\_8000 + 0x0100 × n (n = 0, 3, 4, 9)  
 SCIm = 0x4011\_8000 + 0x0100 × m (m = 1, 2)

Offset address: 0x10



| Bit  | Symbol    | Function                  | R/W |
|------|-----------|---------------------------|-----|
| 8:0  | RDAT[8:0] | Serial Receive Data       | R   |
| 15:9 | —         | These bits are read as 0. | R   |

RDRHL is a 16-bit register that stores received data. Use this register when asynchronous mode and 9-bit data length are selected.

The lower 8 bits of RDRHL are the shadow register of RDR, so access to RDRHL affects the RDR register. Access to the RDRHL register is prohibited if 7-bit or 8-bit data length is selected.

After one frame of data is received, the received data is transferred from the RSR register to the RDR/RDRHL registers, allowing the RSR register to receive more data.

The RSR and RDRHL registers form a double-buffered structure to enable continuous reception. RDRHL should be read only when a receive data full interrupt (SCIn\_RXI) request is issued. An overrun error occurs when the next frame of data is received before the received data is read from RDRHL. The CPU cannot write to the RDRHL register.

## 27.2 注册说明

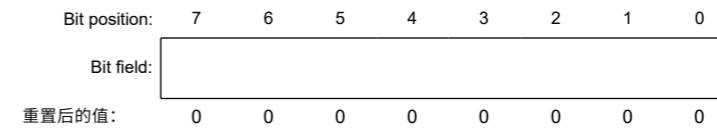
### 27.2.1 RSR:接收移位寄存器

RSR是一个移位寄存器，它接收从RXDn引脚输入的串行数据并将其转换为并行数据。当接收到一帧数据时，数据会自动传输到RDR、RDRHL或接收FIFO寄存器。CPU不能直接访问RSR寄存器。

### 27.2.2 RDR:接收数据寄存器

Base address: SCIn = 0x4011\_8000 + 0x0100 × n (n = 0, 3, 4, 9)  
 SCIm = 0x4011\_8000 + 0x0100 × m (m = 1, 2)

Offset address: 0x05



RDR是一个8位寄存器，用于存储接收到的数据。当接收到一帧串行数据时，将其从RSR传输到RDR，而RSR寄存器可以接收更多的数据。由于RSR和RDR用作双缓冲器，因此可以执行连续接收操作。

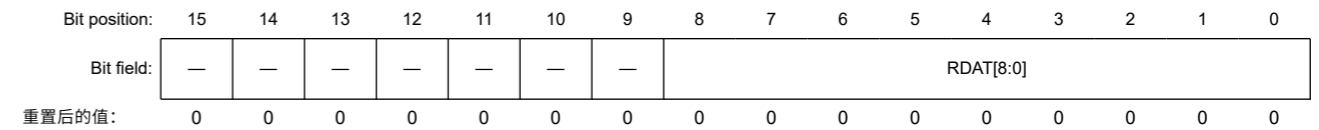
在接收数据完全中断(SCIn\_RXI)发生后，仅读取一次RDR。

Note: 如果在从RDR读取接收到的数据之前接收到下一帧数据，则会发生溢出错误。CPU无法写入RDR。

### 27.2.3 RDRHL:非曼彻斯特模式的接收数据寄存器(MMR.MANEN=0)

Base address: SCIn = 0x4011\_8000 + 0x0100 × n (n = 0, 3, 4, 9)  
 SCIm = 0x4011\_8000 + 0x0100 × m (m = 1, 2)

Offset address: 0x10



| Bit  | Symbol    | Function | R/W |
|------|-----------|----------|-----|
| 8:0  | RDAT[8:0] | 串行接收数据   | R   |
| 15:9 | —         | 这些位读为0。  | R   |

RDRHL是一个16位寄存器，用于存储接收到的数据。选择异步模式和9位数据长度时，请使用此寄存器。

RDRHL的低8位是RDR的影子寄存器，因此访问RDRHL会影响RDR寄存器。访问如果选择7位或8位数据长度，则禁止RDRHL寄存器。

接收到一帧数据后，将接收到的数据从RSR寄存器传送到RDR/RDRHL寄存器，使RSR寄存器可以接收更多数据。

RSR和RDRHL寄存器形成一个双缓冲结构以实现连续接收。只有在发出接收数据完全中断(SCIn\_RXI)请求时才应读取RDRHL。在从RDRHL读取接收到的数据之前接收到下一帧数据时，会发生溢出错误。CPU无法写入RDRHL寄存器。

## 27.2.4 RDRHL\_MAN : Receive Data Register for Manchester mode (MMR.MANEN = 1)

Base address: SCIn = 0x4011\_8000 + 0x0100 × n (n = 3, 4)

Offset address: 0x10



| Bit   | Symbol    | Function  | R/W |
|-------|-----------|---|-----|
| 8:0   | RDAT[8:0] | Serial receive data<br>It can read serial receive data  | R   |
| 9     | MPB       | Multi-processor bit<br>It can read multi-processor bit corresponded to serial receive data (RDAT[8:0])<br>0: Data transmission cycles<br>1: ID transmission cycles                              | R   |
| 11:10 | —         | These bits are read as 0. The write value should be 0.  | R   |
| 12    | RSYNC     | Receive SYNC data bit<br>It is valid when MMR.SBSEL = 1 in Manchester mode, 0 is read otherwise.<br>0: The received the Start Bit is DATA SYNC<br>1: The received the Start Bit is COMMAND SYNC | R   |
| 15:13 | —         | These bits are read as 0. The write value should be 0.  | R   |

RDRHL\_MAN is a 16-bit register that stores received data. Use this register when asynchronous mode and 9-bit data length are selected. The lower 8 bits of RDRHL\_MAN are the shadow register of RDR, so access to RDRHL\_MAN affects the RDR register. Access to the RDRHL\_MAN register is prohibited if 7-bit or 8-bit data length is selected.

After one frame of data is received, the received data is transferred from the RSR register to the RDR/RDRHL\_MAN registers, allowing the RSR register to receive more data.

The RSR and RDRHL\_MAN registers form a double-buffered structure to enable continuous reception.

RDRHL\_MAN should be read only when a receive data full interrupt (SCIn\_RXI) request is issued. An overrun error occurs when the next frame of data is received before the received data is read from RDRHL\_MAN.

The CPU cannot write to the RDRHL\_MAN register.

**RDAT[8:0] bit (Serial receive data)**

It can read serial receive data.

**MPB bit (Multi-processor bit)**

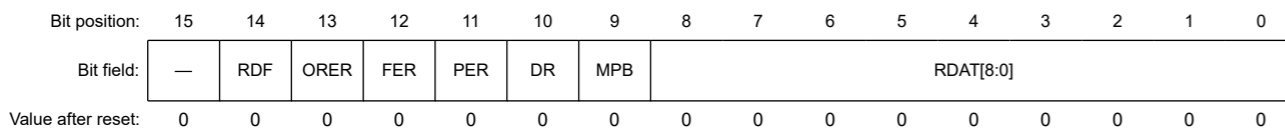
Holds the value of the multi-processor bit in the reception frame. This bit does not change when the SCR.RE bit is 0.

**RSYNC bit (Receive SYNC data bit)**

When Manchester mode and MMR.SBSEL = "1", this bit indicates the type of SYNC of the received the Start Bit. For other settings, it is fixed to 0.

## 27.2.5 FRDRHL/FRDRH/FRDRL : Receive FIFO Data Register

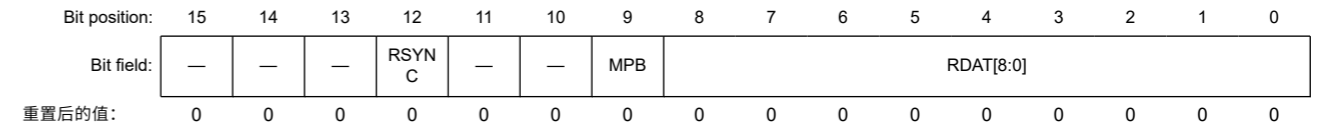
Base address: SCIn = 0x4011\_8000 + 0x0100 × n (n = 0, 3, 4, 9)

Offset address: 0x10 (FRDRHL/FRDRH)  
0x11 (FRDRL)

## 27.2.4 RDRHL\_MAN: 曼彻斯特模式的接收数据寄存器 (MMR.MANEN=1)

Base address: SCIn = 0x4011\_8000 + 0x0100 × n (n = 3, 4)

Offset address: 0x10



| Bit   | Symbol    | Function  | R/W |
|-------|-----------|---|-----|
| 8:0   | RDAT[8:0] | 串口接收数据<br>可读取串口接收数据   | R   |
| 9     | MPB       | Multi-processor bit<br>它可以读取对应于串行接收数据的多处理器位 (RDAT[8:0])<br>0: 数据传输周期1: ID传输周期       | R   |
| 11:10 | —         | 这些位被读取为0。写入值应为0。  | R   |
| 12    | RSYNC     | 接收同步数据位<br>曼彻斯特模式下MMR.SBSEL=1时有效, 否则读取0。<br>0: 接收的起始位为DATASYNC1: 接收的起始位为COMMANDSYNC | R   |
| 15:13 | —         | 这些位被读取为0。写入值应为0。  | R   |

RDRHL\_MAN是一个16位寄存器, 用于存储接收到的数据。选择异步模式和9位数据长度时, 请使用此寄存器。RDRHL\_MAN的低8位是RDR的影子寄存器, 因此访问RDRHL\_MAN会影响RDR寄存器。如果选择7位或8位数据长度, 则禁止访问RDRHL\_MAN寄存器。

接收到一帧数据后, 将接收到的数据从RSR寄存器传送到RDR/RDRHL\_MAN寄存器, 从而允许RSR寄存器接收更多数据。

RSR和RDRHL\_MAN寄存器形成一个双缓冲结构以实现连续接收。

只有在发出接收数据完全中断(SCIn\_RXI)请求时, 才应读取RDRHL\_MAN。在从RDRHL\_MAN读取接收到的数据之前接收到下一帧数据时, 会发生溢出错误。

CPU无法写入RDRHL\_MAN寄存器。

**RDAT[8:0]位 (串行接收数据)**

它可以读取串行接收数据。

**MPB bit (Multi-processor bit)**

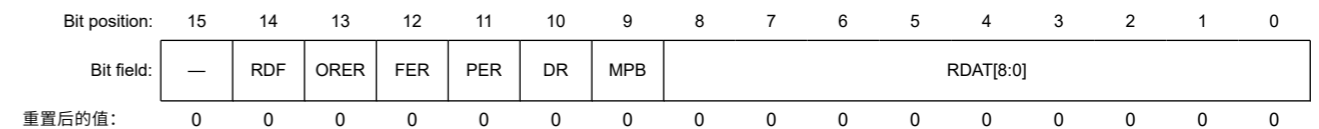
保存接收帧中多处理器位的值。当SCR.RE位为0时, 该位不变。

**RSYNC位 (接收SYNC数据位)**

当曼彻斯特模式和MMR.SBSEL="1"时, 该位指示接收到的StartBit的SYNC类型。对于其他设置, 它固定为0。

## 27.2.5 FRDRHL/FRDRH/FRDRL:接收FIFO数据寄存器

Base address: SCIn = 0x4011\_8000 + 0x0100 × n (n = 0, 3, 4, 9)

Offset address: 0x10 (FRDRHL/FRDRH)  
0x11 (FRDRL)

| Bit | Symbol    | Function   | R/W             |
|-----|-----------|--|-----------------|
| 8:0 | RDAT[8:0] | Serial receive data<br>Stores the serial receive data.<br>Valid only in asynchronous mode, including multi-processor mode, and clock synchronous mode, and with FIFO selected.   | R               |
| 9   | MPB       | Multi-Processor Bit Flag<br>Stores the value of the multi-processor bit in the serial receive data, RDAT[8:0]. Valid only in asynchronous mode with SMR.MP = 1, and with FIFO selected.<br>0: Data transmission cycle<br>1: ID transmission cycle  | R               |
| 10  | DR        | Receive Data Ready Flag<br>This flag is the same as SSR_FIFO.DR.<br>0: Receiving is in progress, or no received data remains in the FRDRH and FRDRL registers after successfully completed reception<br>1: Next receive data is not received for a period after successfully completed reception                       | R <sup>*1</sup> |
| 11  | PER       | Parity Error Flag<br>0: No parity error occurred in the first data of FRDRH and FRDRL<br>1: Parity error occurred in the first data of FRDRH and FRDRL   | R               |
| 12  | FER       | Framing Error Flag<br>0: No framing error occurred in the first data of FRDRH and FRDRL<br>1: Framing error occurred in the first data of FRDRH and FRDRL  | R               |
| 13  | ORER      | Overrun Error Flag<br>This flag is the same as SSR_FIFO.ORER.<br>0: No overrun error occurred<br>1: Overrun error occurred   | R <sup>*1</sup> |
| 14  | RDF       | Receive FIFO Data Full Flag<br>This flag is the same as SSR_FIFO.RDF.<br>0: The amount of receive data written in FRDRH and FRDRL is less than the specified receive triggering number<br>1: The amount of receive data written in FRDRH and FRDRL is equal to or greater than the specified receive triggering number | R <sup>*1</sup> |
| 15  | —         | This bit is read as 0.   | R               |

Note 1. If this flag is read, it indicates the same value as that read from the SSR\_FIFO register. Write 0 to the SSR\_FIFO register to clear the flag.

FRDRHL is a 16-bit register that consists of the 8-bit FRDRH and FRDRL registers. FRDRH is assigned to the FRDRHL[15:8] bits, and allocated to the same address as FRDRHL. FRDRL is assigned to the FRDRHL[7:0] bits, and allocated to (the address of FRDRHL + 1) address.

FRDRH and FRDRL constitute a 16-stage FIFO register that stores serial receive data and related status information readable by software. This register is only valid in asynchronous mode, including multi-processor mode, or clock synchronous mode.

The SCI completes reception of one frame of serial data by transferring the received data from the Receive Shift Register (RSR) into FRDRH and FRDRL for storage. Continuous reception is executed until 16 stages are stored. If data is read when there is no received data in FRDRH and FRDRL, the value is undefined. When FRDRH and FRDRL are full, subsequent serial receive data is lost. The CPU can read from the FRDRH and FRDRL registers but cannot write to them.

Reading 1 from the RDF, ORER, or DR flags of the FRDRH register is the same as reading from those bits in the SSR\_FIFO register. When writing 0 to clear a flag in the SSR\_FIFO register after reading the FRDRH register, write 0 only to the flag that is to be cleared and write 1 to the other flags.

When reading both the FRDRH and FRDRL registers, read in order from FRDRH to FRDRL. The FRDRHL register can be accessed in 16-bit units.

| Bit | Symbol    | Function  | R/W             |
|-----|-----------|---|-----------------|
| 8:0 | RDAT[8:0] | 串口接收数据<br>存储串行接收数据。仅在异步模式下有效，包括多处理器模式和时钟同步模式，并且选择了FIFO。   | R               |
| 9   | MPB       | 多处理器位标志<br>将多处理器位的值存储在串行接收数据RDAT[8:0]中。仅在SMR.MP=1且选择了FIFO的异步模式下有效。<br>0: 数据发送周期1: ID发送周期                      | R               |
| 10  | DR        | 接收数据就绪标志<br>该标志与SSR_FIFO.DR相同。<br>0: 接收中，或成功完成接收后，FRDRH和FRDRL寄存器中没有接收到的数据<br>1: 接收成功后一段时间内没有接收到下一个接收数据        | R <sup>*1</sup> |
| 11  | PER       | 奇偶校验错误标志<br>0: FRDRH和FRDRL的第一个数据没有发生奇偶校验错误1: FRDRH和FRDRL的第一个数据发生奇偶校验错误  | R               |
| 12  | FER       | 成帧错误标志<br>0: FRDRH和FRDRL的第一个数据没有发生帧错误1: FRDRH和FRDRL的第一个数据发生了帧错误   | R               |
| 13  | ORER      | 溢出错误标志<br>该标志与SSR_FIFO.ORER相同。<br>0: 未发生溢出错误1: 发生溢出错误   | R <sup>*1</sup> |
| 14  | RDF       | 接收FIFO数据满标志<br>该标志与SSR_FIFO.RDF相同。<br>0: FRDRH和FRDRL写入的接收数据量小于指定的接收触发数<br>1: 写入FRDRH和FRDRL的接收数据量等于或大于指定的接收触发数 | R <sup>*1</sup> |
| 15  | —         | 该位读为0。  | R               |

注1.如果读取该标志，则表示与从SSR\_FIFO寄存器读取的值相同。将0写入SSR\_FIFO寄存器以清除标志。

FRDRHL是一个16位寄存器，由8位FRDRH和FRDRL寄存器组成。FRDRH被分配到FRDRHL[15:8]位，并分配到与FRDRHL相同的地址。FRDRL分配给FRDRHL[7:0]位，并分配给(FRDRHL+1的地址)地址。

FRDRH和FRDRL构成一个16级FIFO寄存器，用于存储串行接收数据和软件可读的相关状态信息。该寄存器仅在异步模式下有效，包括多处理器模式或时钟同步模式。

SCI通过将接收到的数据从接收移位寄存器(RSR)传送到FRDRH和FRDRL中进行存储，从而完成一帧串行数据的接收。执行连续接收，直到存储16个阶段。如果在FRDRH和FRDRL中没有接收到数据时读取数据，则该值未定义。当FRDRH和FRDRL已满时，后续的串行接收数据会丢失。CPU可以读取FRDRH和FRDRL寄存器，但不能写入它们。

从FRDRH寄存器的RDF、ORER或DR标志读取1与从SSR\_FIFO寄存器。在读取FRDRH寄存器后写入0以清除SSR\_FIFO寄存器中的标志时，仅将0写入要清除的标志，将1写入其他标志。

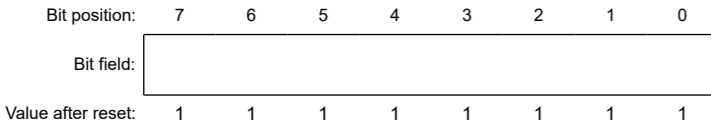
读取FRDRH和FRDRL寄存器时，按从FRDRH到FRDRL的顺序读取。FRDRHL寄存器可以以16位为单位进行访问。



## 27.2.6 TDR : Transmit Data Register

Base address: SCIn = 0x4011\_8000 + 0x0100 × n (n = 0, 3, 4, 9)  
SCIm = 0x4011\_8000 + 0x0100 × m (m = 1, 2)

Offset address: 0x03



| Bit | Symbol | Function             | R/W |
|-----|--------|----------------------|-----|
| 7:0 | n/a    | Serial Transmit Data | R/W |

TDR is an 8-bit register that stores transmit data.

When the SCI detects that the TSR register is empty, it transfers the transmit data written in the TDR register to the TSR register and starts transmission.

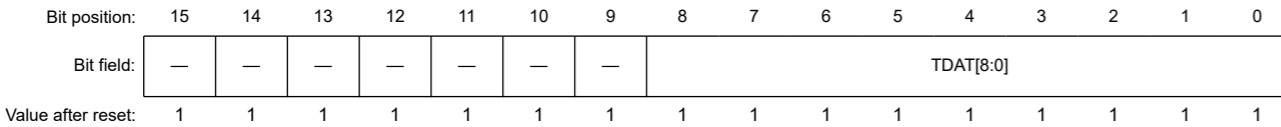
The double-buffered structure of the TDR and TSR registers enables continuous serial transmission. If the next transmit data is already written to TDR when one frame of data is transmitted, the SCI transfers the written data to the TSR register to continue transmission.

The CPU can read from or write to TDR at any time. Only write transmit data to TDR once after each instance of the transmit data empty interrupt (SCIn\_TXI).

## 27.2.7 TDRHL : Transmit Data Register for Non-Manchester mode (MMR.MANEN = 0)

Base address: SCIn = 0x4011\_8000 + 0x0100 × n (n = 0, 3, 4, 9)  
SCIm = 0x4011\_8000 + 0x0100 × m (m = 1, 2)

Offset address: 0x0E



| Bit  | Symbol    | Function  | R/W |
|------|-----------|---|-----|
| 8:0  | TDAT[8:0] | Serial Transmit Data                                | R/W |
| 15:9 | —         | This bit is read as 1. The write value should be 1. | R/W |

TDRHL is a 16-bit register that stores transmit data. Use this register when asynchronous mode and 9-bit data length are selected.

The lower 8 bits of TDRHL are the shadow register of TDR, so access to TDRHL affects the TDR register. Access to the TDRHL register is prohibited if 7-bit or 8-bit data length is selected.

When empty space is detected in the TSR register, the transmit data stored in the TDRHL registers is transferred to TSR and transmission starts.

The TSR and TDRHL registers have a double-buffered structure to support continuous transmission. When the next data to be transmitted is stored in TDRHL after one frame of data is transmitted, the transmitting operation continues by transferring the data to the TSR register.

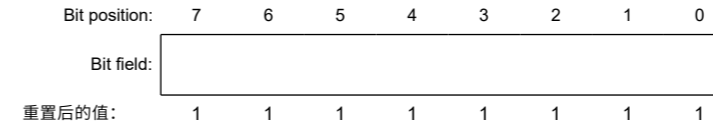
The CPU can read and write to the TDRHL register. Bits [15:9] in TDRHL are fixed to 1. These bits are read as 1. The write value should be 1.

Write transmit data to the TDRHL register only once when a transmit data empty interrupt (SCIn\_TXI) request is issued.

## 27.2.6 TDR: 发送数据寄存器

Base address: SCIn = 0x4011\_8000 + 0x0100 × n (n = 0, 3, 4, 9)  
SCIm = 0x4011\_8000 + 0x0100 × m (m = 1, 2)

Offset address: 0x03



| Bit | Symbol | Function | R/W |
|-----|--------|----------|-----|
| 7:0 | n/a    | 串行传输数据   | R/W |

TDR是一个8位寄存器，用于存储发送数据。

当SCI检测到TSR寄存器为空时，将写入TDR寄存器的发送数据传送到TSR寄存器并开始发送。

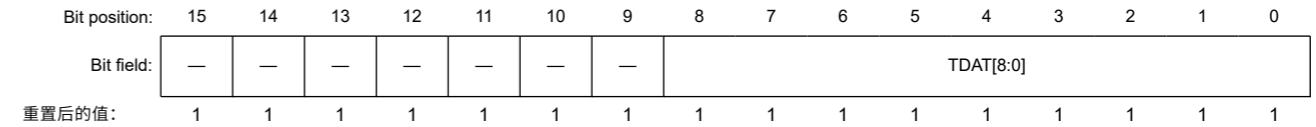
TDR和TSR寄存器的双缓冲结构可实现连续串行传输。如果在发送一帧数据时，下一个发送数据已经写入TDR，则SCI将写入的数据传输到TSR寄存器继续发送。

CPU可以随时读取或写入TDR。每次发送数据空中断(SCIn\_TXI)后，仅将发送数据写入TDR一次。

## 27.2.7 TDRHL: 非曼彻斯特模式的发送数据寄存器 (MMR.MANEN=0)

Base address: SCIn = 0x4011\_8000 + 0x0100 × n (n = 0, 3, 4, 9)  
SCIm = 0x4011\_8000 + 0x0100 × m (m = 1, 2)

Offset address: 0x0E



| Bit  | Symbol    | Function       | R/W |
|------|-----------|----------------|-----|
| 8:0  | TDAT[8:0] | 串行传输数据         | R/W |
| 15:9 | —         | 该位读取为1。写入值应为1。 | R/W |

TDRHL是一个16位寄存器，用于存储发送数据。选择异步模式和9位数据长度时，请使用此寄存器。

TDRHL的低8位是TDR的影子寄存器，因此访问TDRHL会影响TDR寄存器。访问如果选择7位或8位数据长度，则禁止TDRHL寄存器。

当在TSR寄存器中检测到空空间时，存储在TDRHL寄存器中的发送数据被传送到TSR并开始发送。

TSR和TDRHL寄存器具有双缓冲结构以支持连续传输。当发送完一帧数据后，下一个要发送的数据存储在TDRHL中时，通过将数据传输到TSR寄存器来继续发送操作。

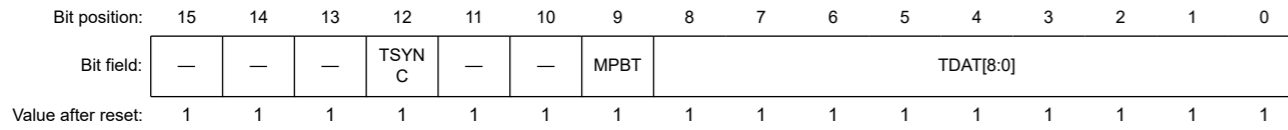
CPU可以读取和写入TDRHL寄存器。TDRHL中的位[15:9]固定为1。这些位被读取为1。写入值应为1。

当发送数据空中断(SCIn\_TXI)请求发出时，仅将发送数据写入TDRHL寄存器一次。

## 27.2.8 TDRHL\_MAN : Transmit Data Register for Manchester mode (MMR.MANEN = 1)

Base address: SCIn = 0x4011\_8000 + 0x0100 × n(n = 3, 4)

Offset address: 0x0E



| Bit   | Symbol    | Function   | R/W |
|-------|-----------|--|-----|
| 8:0   | TDAT[8:0] | Serial transmit data<br>It can set serial transmit data  | R/W |
| 9     | MPBT      | Multi-processor transfer bit flag<br>Value of the multi-processor bit in the transmission frame<br>0: Data transmission cycles<br>1: ID transmission cycles  | R/W |
| 11:10 | —         | The write value should be 1.   | R   |
| 12    | TSYNC     | Transmit SYNC data bit<br>It is valid when MMR.SBSEL = 1 and MMR.SYNSEL = 1 in Manchester mode.<br>0: The Start Bit is transmitted as DATA SYNC.<br>1: The Start Bit is transmitted as COMMAND SYNC. | R/W |
| 15:13 | —         | The write value should be 1.   | R   |

TDRHL\_MAN is a 16-bit register that stores transmit data. Use this register when asynchronous mode and 9-bit data length are selected.

The lower 8 bits of TDRHL\_MAN are the shadow register of TDR, so access to TDRHL\_MAN affects the TDR register. Access to the TDRHL\_MAN register is prohibited if 7-bit or 8-bit data length is selected.

When empty space is detected in the TSR register, the transmit data stored in the TDRHL\_MAN registers is transferred to TSR and transmission starts.

The TSR and TDRHL\_MAN registers have a double-buffered structure to support continuous transmission. When the next data to be transmitted is stored in TDRHL\_MAN after one frame of data is transmitted, the transmitting operation continues by transferring the data to the TSR register.

Write transmit data to the TDRHL\_MAN register only once when a transmit data empty interrupt (SCIn\_TXI) request is issued.

**TDAT[8:0] bit (Serial transmit data)**

This register sets serial transmission data.

**MPBT bit (Multi-processor transfer bit flag)**

Selects the multi processor bit of transmit frame.

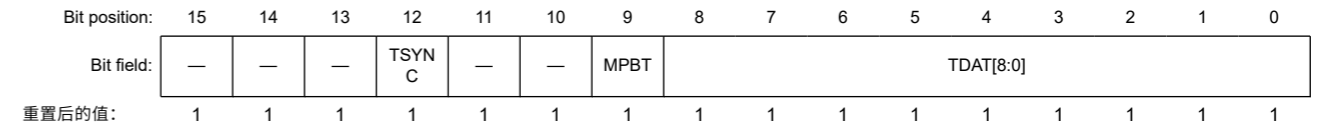
**TSYNC bit (Transmit SYNC data bit)**

When Manchester mode and MMR.SBSEL = "1" and MMR.SYNSEL = "1", the type of SYNC selected according to this bit becomes the Start Bit of the transmission frame.

## 27.2.8 TDRHL\_MAN: 曼彻斯特模式的发送数据寄存器 (MMR.MANEN=1)

Base address: SCIn = 0x4011\_8000 + 0x0100 × n(n = 3, 4)

Offset address: 0x0E



| Bit   | Symbol    | Function  | R/W |
|-------|-----------|---|-----|
| 8:0   | TDAT[8:0] | 串行传输数据<br>可设置串口发送数据   | R/W |
| 9     | MPBT      | 多处理器传输位标志<br>传输帧中多处理器位的值<br>0: 数据传输周期1: ID传输<br>周期  | R/W |
| 11:10 | —         | 写入值应为1。   | R   |
| 12    | TSYNC     | 发送SYNC数据位<br>在曼彻斯特模式下, 当MMR.SBSEL=1和MMR.SYNSEL=1时有效。<br>0: 起始位作为DATASYNC发送。1: 起始位作为COM<br>MANDSYNC发送。 | R/W |
| 15:13 | —         | 写入值应为1。   | R   |

TDRHL\_MAN是一个16位寄存器, 用于存储发送数据。选择异步模式和9位数据长度时, 请使用此寄存器。

TDRHL\_MAN的低8位是TDR的影子寄存器, 因此访问TDRHL\_MAN会影响TDR寄存器。如果选择7位或8位数据长度, 则禁止访问TDRHL\_MAN寄存器。

当在TSR寄存器中检测到空空间时, 存储在TDRHL\_MAN寄存器中的发送数据被传输到TSR和传输开始。

TSR和TDRHL\_MAN寄存器具有双缓冲结构以支持连续传输。当下一个要发送的数据在发送一帧数据后存储在TDRHL\_MAN中时, 通过将数据传输到TSR寄存器来继续发送操作。

当发出发送数据空中断(SCIn\_TXI)请求时, 仅将发送数据写入TDRHL\_MAN寄存器一次。

**TDAT[8:0]位 (串行发送数据)**

该寄存器设置串行传输数据。

**MPBT位 (多处理器传输位标志)**

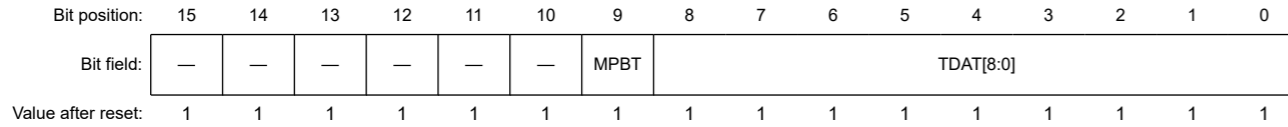
选择发送帧的多处理器位。

**TSYNC位 (发送SYNC数据位)**

当曼彻斯特模式和MMR.SBSEL="1"且MMR.SYNSEL="1"时, 根据该位选择的SYNC类型成为传输帧的起始位。

## 27.2.9 FTDRHL/FTDRH/FTDRL : Transmit FIFO Data Register

Base address: SCIn = 0x4011\_8000 + 0x0100 × n (n = 0, 3, 4, 9)

Offset address: 0x0E (FTDRHL/FTDRH)  
0x0F (FTDRL)

| Bit   | Symbol    | Function   | R/W |
|-------|-----------|--|-----|
| 8:0   | TDAT[8:0] | Serial transmit data<br>Specifies the serial transmit data.<br>Valid only in asynchronous mode, including multi-processor mode, and clock synchronous mode, and with FIFO selected.  | W   |
| 9     | MPBT      | Multi-Processor Transfer Bit Flag<br>Specifies the multi-processor bit in the transmission frame. Valid only in asynchronous mode and SMR.MP = 1, and with FIFO selected. Valid only in asynchronous mode, including multi-processor mode, and clock synchronous mode, and with FIFO selected.<br><br>0: Data transmission cycle<br>1: ID transmission cycle | W   |
| 15:10 | —         | The write value should be 1.   | W   |

FTDRHL is a 16-bit register that consists of the 8-bit FTDRH and FTDRL registers. FTDRH is assigned to the FTDRHL[15:8] bits, and allocated to the same address as FTDRHL. FTDRL is assigned to the FTDRHL[7:0] bits, and allocated to (the address of FTDRHL + 1) address.

FTDRH and FTDRL constitute a 16-stage FIFO register that stores data for serial transmission and a multi-processor transfer bit. This register is only valid in asynchronous mode, including multi-processor mode, or clock synchronous mode.

When the SCI detects that the Transmit Shift Register (TSR) is empty, it transfers data written in the FTDRH and FTDRL registers to the TSR register and starts serial transmission. Continuous serial transmission is executed until no transmit data is left in FTDRH and FTDRL. When FTDRHL is full of transmit data, no more data can be written. If writing new data is attempted, the data is ignored. The CPU can write to the FTDRH and FTDRL registers but cannot read them.

When writing to both the FTDRH and FTDRL registers, write in order from FTDRH to FTDRL.

**TDAT[8:0] bits (Serial transmit data)**

The TDAT[8:0] bits set the serial transmission data. This is valid only when FIFO is selected in asynchronous mode (including multiprocessor) or clock synchronous mode.

**MPBT flag (Multi-Processor Transfer Bit Flag)**

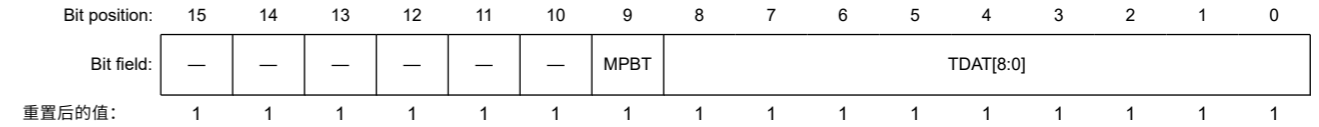
The MPBT flag specifies the value of the multi-processor bit of the transmit frame. When FCR.FM = 1, SSR.MPBT is invalid.

## 27.2.10 TSR : Transmit Shift Register

TSR is a shift register that transmits serial data. To perform serial data transmission, the SCI first automatically transfers transmit data from TDR, TDRHL, or transmit FIFO to TSR, then sends the data to the TXDn pin. The CPU cannot directly access the TSR.

## 27.2.9 FTDRHLFTDRHFTDRL:发送FIFO数据寄存器

Base address: SCIn = 0x4011\_8000 + 0x0100 × n (n = 0, 3, 4, 9)

Offset address: 0x0E (FTDRHL/FTDRH)  
0x0F (FTDRL)

| Bit   | Symbol    | Function   | R/W |
|-------|-----------|--|-----|
| 8:0   | TDAT[8:0] | 串行传输数据<br>指定串行传输数据。<br>仅在异步模式下有效，包括多处理器模式和时钟同步模式，并且选择了FIFO。  | W   |
| 9     | MPBT      | 多处理器传输位标志<br>指定传输帧中的多处理器位。仅在异步模式和SMR.MP=1且选择FIFO时有效。仅在异步模式下有效，包括多处理器模式和时钟同步模式，并选择FIFO。<br><br>0: 数据发送周期1: ID发送周期 | W   |
| 15:10 | —         | 写入值应为1。  | W   |

FTDRHL是一个16位寄存器，由8位FTDRH和FTDRL寄存器组成。FTDRH分配给FTDRHL[15:8]位，并分配到与FTDRHL相同的地址。FTDRL分配给FTDRHL[7:0]位，并分配给（FTDRHL的地址+1）地址。

FTDRH和FTDRL构成一个16级FIFO寄存器，用于存储串行传输的数据和一个多处理器传输位。该寄存器仅在异步模式下有效，包括多处理器模式或时钟同步模式。

当SCI检测到传输移位寄存器(TSR)为空时，它将写入FTDRH和FTDRL寄存器的数据传输到TSR寄存器并开始串行传输。执行连续串行传输，直到在FTDRH和FTDRL中没有剩余传输数据。当FTDRHL充满传输数据时，不能再写入数据。如果尝试写入新数据，则忽略该数据。CPU可以写入FTDRH和FTDRL寄存器，但不能读取它们。

当同时写入FTDRH和FTDRL寄存器时，按照从FTDRH到FTDRL的顺序写入。

**TDAT[8:0]位 (串行发送数据)**

TDAT[8:0]位设置串行传输数据。这仅在异步模式（包括多处理器）或时钟同步模式下选择FIFO时有效。

**MPBT标志 (多处理器传输位标志)**

MPBT标志指定发送帧的多处理器位的值。FCR.FM=1时，SSR.MPBT无效。

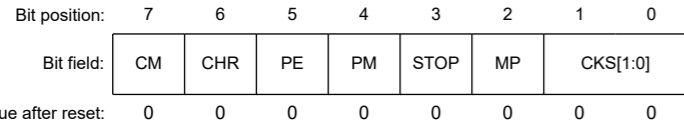
## 27.2.10 TSR: 发送移位寄存器

TSR是传送串行数据的移位寄存器。为了进行串行数据传输，SCI首先自动将发送数据从TDR、TDRHL或发送FIFO传输到TSR，然后将数据发送到TXDn引脚。CPU不能直接访问TSR。

27.2.11 SMR : Serial Mode Register for Non-Smart Card Interface Mode (SCMR.SMIF = 0)

Base address: SCIn = 0x4011\_8000 + 0x0100 × n (n = 0, 3, 4, 9)  
 SCIm = 0x4011\_8000 + 0x0100 × m (m = 1, 2)

Offset address: 0x00



| Bit | Symbol   | Function   | R/W              |
|-----|----------|--|------------------|
| 1:0 | CKS[1:0] | Clock Select<br>0 0: PCLK clock (n = 0) <sup>*1</sup><br>0 1: PCLK/4 clock (n = 1) <sup>*1</sup><br>1 0: PCLK/16 clock (n = 2) <sup>*1</sup><br>1 1: PCLK/64 clock (n = 3) <sup>*1</sup>   | R/W <sup>4</sup> |
| 2   | MP       | Multi-Processor Mode<br>Valid only in asynchronous mode.<br>0: Disable multi-processor communications function<br>1: Enable multi-processor communications function  | R/W <sup>4</sup> |
| 3   | STOP     | Stop Bit Length<br>Valid only in asynchronous mode.<br>0: 1 stop bit<br>1: 2 stop bits   | R/W <sup>4</sup> |
| 4   | PM       | Parity Mode<br>Valid only when the PE bit is 1.<br>0: Even parity<br>1: Odd parity   | R/W <sup>4</sup> |
| 5   | PE       | Parity Enable<br>Valid only in asynchronous mode.<br>0: When transmitting: Do not add parity bit<br>When receiving: Do not check parity bit<br>1: When transmitting: Add parity bit<br>When receiving: Check parity bit  | R/W <sup>4</sup> |
| 6   | CHR      | Character Length<br>Valid only in asynchronous mode. <sup>*2</sup><br>Selects the transmit/receive character length in combination with the SCMR.CHR1 bit.<br>0: SCMR.CHR1 = 0: Transmit/receive in 9-bit data length<br>SCMR.CHR1 = 1: Transmit/receive in 8-bit data length (initial value)<br>1: SCMR.CHR1 = 0: Transmit/receive in 9-bit data length<br>SCMR.CHR1 = 1: Transmit/receive in 7-bit data length <sup>*3</sup> | R/W <sup>4</sup> |
| 7   | CM       | Communication Mode<br>0: Asynchronous mode or simple IIC mode<br>1: Clock synchronous mode or simple SPI mode  | R/W <sup>4</sup> |

Note 1. n is the decimal notation of the value of n in the BRR register. See [section 27.2.20. BRR : Bit Rate Register](#).  
 Note 2. In any mode other than asynchronous mode, this bit setting is invalid and a fixed data length of 8 bits is used.  
 Note 3. LSB-first is fixed and the MSB (bit [7]) in the TDR register is not transmitted in transmit mode.  
 Note 4. Writable only when SCR.TE = 0 and SCR.RE = 0 (both serial transmission and reception are disabled).

The SMR register sets the communication format and clock source for the on-chip baud rate generator.

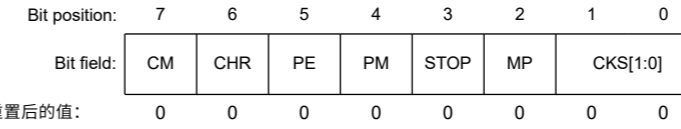
**CKS[1:0] bits (Clock Select)**

The CKS[1:0] bits select the clock source for the on-chip baud rate generator. For the relationship between the settings of these bits and the baud rate, see [section 27.2.20. BRR : Bit Rate Register](#).

27.2.11 SMR: 非智能卡接口模式的串行模式寄存器 (SCMR.SMIF=0)

Base address: SCIn = 0x4011\_8000 + 0x0100 × n (n = 0, 3, 4, 9)  
 SCIm = 0x4011\_8000 + 0x0100 × m (m = 1, 2)

Offset address: 0x00



| Bit | Symbol   | Function  | R/W              |
|-----|----------|---|------------------|
| 1:0 | CKS[1:0] | 时钟选择<br>0 0: PCLK clock (n = 0) <sup>*1</sup><br>0 1: PCLK/4 clock (n = 1) <sup>*1</sup><br>1 0: PCLK/16 clock (n = 2) <sup>*1</sup><br>1 1: PCLK/64 clock (n = 3) <sup>*1</sup>              | R/W <sup>4</sup> |
| 2   | MP       | Multi-Processor Mode<br>仅在异步模式下有效。<br>0: 禁用多机通讯功能1: 启用多机通讯功能  | R/W <sup>4</sup> |
| 3   | STOP     | 停止位长度<br>仅在异步模式下有效。<br>0: 1个停止位<br>1: 2个停止位   | R/W <sup>4</sup> |
| 4   | PM       | 奇偶校验模式<br>仅在PE位为1时有效。<br>0: 偶校验1: 奇校验   | R/W <sup>4</sup> |
| 5   | PE       | 奇偶校验使能<br>仅在异步模式下有效。<br>0: 发送时: 不加校验位接收时: 不校验校验位<br>1: 发送时: 添加校验位接收时: 校验校验位   | R/W <sup>4</sup> |
| 6   | CHR      | 字符长度<br>仅在异步模式下有效。 <sup>*2</sup><br>结合SCMR.CHR1位选择发送接收字符长度。<br>0: SCMR.CHR1=0: 发送接收9位数据长度<br>SCMR.CHR1=1: 发送接收8位数据长度 (初始值)<br>1: SCMR.CHR1=0: 发送接收9位数据长度SCMR.CHR1=1: 发送接收7位数据长度 <sup>*3</sup> | R/W <sup>4</sup> |
| 7   | CM       | 通讯方式<br>0: 异步模式或简单IIC模式1: 时钟同步模式或简单SPI模式  | R/W <sup>4</sup> |

注1.n是BRR寄存器中n值的十进制表示法。请参阅第27.2.20节。BRR: 比特率寄存器。  
 注2.在异步模式以外的任何模式下, 该位设置无效, 使用8位的固定数据长度。  
 注3.LSB-first是固定的, 并且TDR寄存器中的MSB (位[7]) 在发送模式下不发送。  
 注4.仅当SCR.TE=0且SCR.RE=0时可写 (串行发送和接收均禁用)。

SMR寄存器设置片内波特率发生器的通信格式和时钟源。

**CKS[1:0] bits (Clock Select)**

CKS[1:0]位选择片内波特率发生器的时钟源。关于这些位的设置与波特率之间的关系, 请参见第27.2.20节。BR: 比特率寄存器。



**MP bit (Multi-Processor Mode)**

The MP bit disables or enables the multi-processor communications function. The PE and PM bit settings are invalid in multi-processor mode.

**STOP bit (Stop Bit Length)**

The STOP bit selects the stop bit length in transmission.

In reception, only the first stop bit is checked regardless of this bit setting. If the second stop bit is 0, it is treated as the start bit of the next transmit frame.

**PM bit (Parity Mode)**

The PM bit selects the parity mode (even or odd) for transmission and reception. The PM bit setting is invalid in multiprocessor mode.

**PE bit (Parity Enable)**

When the PE bit is set to 1, the parity bit is added to transmit data, and the parity bit is checked in reception. Regardless of the PE bit setting, the parity bit is not added or checked in multi-processor format.

**CHR bit (Character Length)**

The CHR bit selects the data length for transmission and reception in combination with the SCMR.CHR1 bit. In modes other than asynchronous, a fixed data length of 8 bits is used.

**CM bit (Communication Mode)**

The CM bit selects the communication mode:

- Asynchronous mode or simple IIC mode
- Clock synchronous mode or simple SPI mode

**27.2.12 SMR\_SMCI : Serial Mode Register for Smart Card Interface Mode (SCMR.SMIF = 1)**

Base address: SCIn = 0x4011\_8000 + 0x0100 × n (n = 0, 3, 4, 9)  
SCIm = 0x4011\_8000 + 0x0100 × m (m = 1, 2)

Offset address: 0x00

|                    |    |     |    |    |          |          |   |   |
|--------------------|----|-----|----|----|----------|----------|---|---|
| Bit position:      | 7  | 6   | 5  | 4  | 3        | 2        | 1 | 0 |
| Bit field:         | GM | BLK | PE | PM | BCP[1:0] | CKS[1:0] |   |   |
| Value after reset: | 0  | 0   | 0  | 0  | 0        | 0        | 0 | 0 |

| Bit | Symbol   | Function   | R/W              |
|-----|----------|--|------------------|
| 1:0 | CKS[1:0] | Clock Select<br>0 0: PCLK clock (n = 0) <sup>*1</sup><br>0 1: PCLK/4 clock (n = 1) <sup>*1</sup><br>1 0: PCLK/16 clock (n = 2) <sup>*1</sup><br>1 1: PCLK/64 clock (n = 3) <sup>*1</sup> | R/W <sup>2</sup> |
| 3:2 | BCP[1:0] | Base Clock Pulse<br>Selects the number of base clock cycles in combination with the SCMR.BCP2 bit. Table 27.4 lists the combinations of the SCMR.BCP2 and SMR.BCP[1:0] bits.             | R/W <sup>2</sup> |
| 4   | PM       | Parity Mode<br>Valid only when the PE bit is 1.<br>0: Even parity<br>1: Odd parity   | R/W <sup>2</sup> |
| 5   | PE       | Parity Enable<br>When this bit is set to 1, a parity bit is added to transmit data, and the parity of received data is checked. Set this bit to 1 in smart card interface mode.          | R/W <sup>2</sup> |

**MP bit (Multi-Processor Mode)**

MP位禁用或启用多处理器通信功能。PE和PM位设置在多处理器模式下无效。

**停止位 (停止位长度)**

STOP位选择传输中的停止位长度。

在接收中, 无论该位设置如何, 都只检查第一个停止位。如果第二个停止位为0, 则将其视为下一个发送帧的起始位。

**PM bit (Parity Mode)**

PM位选择发送和接收的奇偶校验模式 (偶数或奇数)。PM位设置在多处理器模式下无效。

**PE位 (奇偶校验使能)**

当PE位设置为1时, 发送数据时添加奇偶校验位, 接收时检查奇偶校验位。无论PE位设置如何, 在多处理器格式中都不会添加或检查奇偶校验位。

**CHR bit (Character Length)**

CHR位与SCMR.CHR1位一起选择发送和接收的数据长度。在非异步模式下, 使用8位的固定数据长度。

**CM bit (Communication Mode)**

CM位选择通信模式:

- 异步模式或简单IIC模式
- 时钟同步模式或简单SPI模式

**27.2.12 SMR\_SMCI: 智能卡接口模式的串行模式寄存器(SCMR.SMIF=1)**

Base address: SCIn = 0x4011\_8000 + 0x0100 × n (n = 0, 3, 4, 9)  
SCIm = 0x4011\_8000 + 0x0100 × m (m = 1, 2)

Offset address: 0x00

|               |    |     |    |    |          |          |   |   |
|---------------|----|-----|----|----|----------|----------|---|---|
| Bit position: | 7  | 6   | 5  | 4  | 3        | 2        | 1 | 0 |
| Bit field:    | GM | BLK | PE | PM | BCP[1:0] | CKS[1:0] |   |   |
| 重置后的值:        | 0  | 0   | 0  | 0  | 0        | 0        | 0 | 0 |

| Bit | Symbol   | Function   | R/W              |
|-----|----------|--|------------------|
| 1:0 | CKS[1:0] | 时钟选择<br>0 0: PCLK clock (n = 0) <sup>*1</sup><br>0 1: PCLK/4 clock (n = 1) <sup>*1</sup><br>1 0: PCLK/16 clock (n = 2) <sup>*1</sup><br>1 1: PCLK/64 clock (n = 3) <sup>*1</sup> | R/W <sup>2</sup> |
| 3:2 | BCP[1:0] | 基本时钟脉冲<br>结合SCMR.BCP2位选择基本时钟周期数。表27.4列出了SCMR.BCP2和SMR.BCP[1:0]位的组合。  | R/W <sup>2</sup> |
| 4   | PM       | 奇偶校验模式<br>仅在PE位为1时有效。<br>0: 偶校验<br>1: 奇校验  | R/W <sup>2</sup> |
| 5   | PE       | 奇偶校验使能<br>当该位设置为1时, 发送数据时添加一个奇偶校验位, 并检查接收数据的奇偶校验。在智能卡接口模式下将此位设置为1。   | R/W <sup>2</sup> |

| Bit | Symbol | Function  | R/W              |
|-----|--------|---|------------------|
| 6   | BLK    | Block Transfer Mode<br>0: Normal mode operation<br>1: Block transfer mode operation | R/W <sup>2</sup> |
| 7   | GM     | GSM Mode<br>0: Normal mode operation<br>1: GSM mode operation                       | R/W <sup>2</sup> |

Note 1. n is the decimal notation of the value of n in the BRR register. See [section 27.2.20. BRR : Bit Rate Register](#).

Note 2. Writable only when SCR\_SMCI.TE = 0 and SCR\_SMCI.RE = 0 (both serial transmission and reception are disabled).

The SMR\_SMCI register sets the communication format and clock source for the on-chip baud rate generator.

#### CKS[1:0] bits (Clock Select)

The CKS[1:0] bits select the clock source for the on-chip baud rate generator. For the relationship between the settings of these bits and the baud rate, see [section 27.2.20. BRR : Bit Rate Register](#).

#### BCP[1:0] bits (Base Clock Pulse)

The BCP[1:0] bits select the number of base clock cycles in a 1-bit data transfer time in smart card interface mode. Set these bits in combination with the SCMR.BCP2 bit.

For details, see [section 27.7.4. Receive Data Sampling Timing and Reception Margin](#).

Table 27.4 Combinations of SCMR.BCP2 and SMR\_SMCI.BCP[1:0] bits

| SCMR.BCP2 bit | SMR_SMCI.BCP[1:0] bits | Number of base clock cycles for 1-bit transfer period <sup>*1</sup> |
|---------------|------------------------|---|
| 0             | 00b                    | 93 clock cycles (S = 93)  |
| 0             | 01b                    | 128 clock cycles (S = 128)  |
| 0             | 10b                    | 186 clock cycles (S = 186)  |
| 0             | 11b                    | 512 clock cycles (S = 512)  |
| 1             | 00b                    | 32 clock cycles (S = 32) (initial value)                            |
| 1             | 01b                    | 64 clock cycles (S = 64)  |
| 1             | 10b                    | 372 clock cycles (S = 372)  |
| 1             | 11b                    | 256 clock cycles (S = 256)  |

Note 1. S is the value of S in BRR (see [section 27.2.20. BRR : Bit Rate Register](#)).

#### PM bit (Parity Mode)

The PM bit selects the parity mode for transmission and reception (even or odd). For details on the usage of this bit in smart card interface mode, see [section 27.7.2. Data Format \(Except in Block Transfer Mode\)](#).

#### PE bit (Parity Enable)

Set the PE bit to 1. The parity bit is added to transmit data before transmission, and the parity bit is checked in reception.

#### BLK bit (Block Transfer Mode)

Setting the BLK bit to 1 enables block transfer mode operation. For details, see [section 27.7.3. Block Transfer Mode](#).

#### GM bit (GSM Mode)

Setting the GM bit to 1 enables GSM mode operation. In GSM mode, the SSR\_SMCI.TEND flag set timing is moved forward to 11.0 ETUs (elementary time unit = 1-bit transfer time) from the start bit, and clock output control is added. For details, see [section 27.7.6. Serial Data Transmission \(Except in Block Transfer Mode\)](#) and [section 27.7.8. Clock Output Control](#).

| Bit | Symbol | Function                        | R/W              |
|-----|--------|---------------------------------|------------------|
| 6   | BLK    | 块传输模式<br>0: 正常模式操作1: 块传输模式操作    | R/W <sup>2</sup> |
| 7   | GM     | GSM Mode<br>0: 正常模式操作1: GSM模式操作 | R/W <sup>2</sup> |

注1.n是BRR寄存器中n值的十进制表示法。请参阅第27.2.20节。BRR: 比特率寄存器。

注2.仅当SCR\_SMCI.TE=0且SCR\_SMCI.RE=0时可写(串行发送和接收均禁用)。

SMR\_SMCI寄存器设置片内波特率发生器的通信格式和时钟源。

#### CKS[1:0] bits (Clock Select)

CKS[1:0]位选择片内波特率发生器的时钟源。关于这些位的设置与波特率之间的关系, 请参见第27.2.20节。BR: 比特率寄存器。

#### BCP[1:0]位 (基本时钟脉冲)

BCP[1:0]位选择智能卡接口模式下1位数据传输时间内的基本时钟周期数。将这些位与SCMR.BCP2位一起设置。

有关详细信息, 请参阅第27.7.4节。接收数据采样时序和接收余量。

Table 27.4 SCMR.BCP2和SMR\_SMCI.BCP[1:0]位的组合

| SCMR.BCP2 bit | SMR_SMCI.BCP[1:0] bits | 1位传输周期的基本时钟周期数*1    |
|---------------|------------------------|---------------------|
| 0             | 00b                    | 93个时钟周期(S=93)       |
| 0             | 01b                    | 128个时钟周期(S=128)     |
| 0             | 10b                    | 186个时钟周期(S=186)     |
| 0             | 11b                    | 512个时钟周期(S=512)     |
| 1             | 00b                    | 32个时钟周期(S=32) (初始值) |
| 1             | 01b                    | 64个时钟周期(S=64)       |
| 1             | 10b                    | 372个时钟周期(S=372)     |
| 1             | 11b                    | 256个时钟周期(S=256)     |

注1.S是BRR中S的值(参见第27.2.20节。BRR: 比特率寄存器)。

#### PM bit (Parity Mode)

PM位选择发送和接收的奇偶校验模式(偶数或奇数)。关于智能卡接口模式下该位的使用详情, 请参见第27.7.2节。数据格式(块传输模式除外)。

#### PE位 (奇偶校验使能)

将PE位设置为1。发送数据前添加奇偶校验位, 接收时校验奇偶校验位。

#### BLK位 (块传输模式)

将BLK位设置为1可启用块传输模式操作。详见27.7.3节。块传输模式。

#### GM bit (GSM Mode)

将GM位设置为1启用GSM模式操作。在GSM模式下, SSR\_SMCI.TEND标志设置时序从起始位前移到11.0ETU(基本时间单位=1位传输时间), 并添加了时钟输出控制。详见27.7.6节。串行数据传输(块传输模式除外)和第27.7.8节。时钟输出控制。

27.2.13 SCR : Serial Control Register for Non-Smart Card Interface Mode (SCMR.SMIF = 0)

Base address: SCIn = 0x4011\_8000 + 0x0100 × n (n = 0, 3, 4, 9)  
 SCIm = 0x4011\_8000 + 0x0100 × m (m = 1, 2)

Offset address: 0x02

Bit position: 7 6 5 4 3 2 1 0

|            |     |     |    |    |      |      |          |
|------------|-----|-----|----|----|------|------|----------|
| Bit field: | TIE | RIE | TE | RE | MPIE | TEIE | CKE[1:0] |
|------------|-----|-----|----|----|------|------|----------|

Value after reset: 0 0 0 0 0 0 0 0

| Bit | Symbol   | Function  | R/W              |
|-----|----------|---|------------------|
| 1:0 | CKE[1:0] | Clock Enable<br>0 0: In asynchronous mode, the SCKn pin is available for use as an I/O port based on the I/O port settings.<br>In clock synchronous mode, the SCKn pin functions as the clock output pin.<br>0 1: In asynchronous mode, a clock with the same frequency as the bit rate is output from the SCKn pin.<br>In clock synchronous mode, the SCKn pin functions as the clock output pin.<br>Others: In asynchronous mode, input a clock with a frequency 16 times the bit rate from the SCKn pin when the SEMR.ABCS bit is 0. Input a clock signal with a frequency eight times the bit rate when the SEMR.ABCS bit is 1. The SCKn pin is available for use as an I/O port based on the I/O port settings when the GPT clock <sup>4</sup> is used.<br>In clock synchronous mode, the SCKn pin functions as the clock input pin. | R/W <sup>1</sup> |
| 2   | TEIE     | Transmit End Interrupt Enable<br>0: Disable SCIn_TEI interrupt requests<br>1: Enable SCIn_TEI interrupt requests  | R/W              |
| 3   | MPIE     | Multi-Processor Interrupt Enable<br>Valid in asynchronous mode when SMR.MP = 1.<br>0: Normal reception<br>1: When data with the multi-processor bit set to 0 is received, the data is not read, and setting the status flags RDRF, ORER, and FER in SSR to 1 and the status flags SYER, PFER, and SBER in MESR are disabled.<br>When data with the multi-processor bit set to 1 is received, the MPIE bit is automatically set to 0, and normal reception is resumed.   | R/W <sup>3</sup> |
| 4   | RE       | Receive Enable<br>0: Disable serial reception<br>1: Enable serial reception   | R/W <sup>2</sup> |
| 5   | TE       | Transmit Enable<br>0: Disable serial transmission<br>1: Enable serial transmission  | R/W <sup>2</sup> |
| 6   | RIE      | Receive Interrupt Enable<br>0: Disable SCIn_RXI and SCIn_ERI interrupt requests<br>1: Enable SCIn_RXI and SCIn_ERI interrupt requests   | R/W              |
| 7   | TIE      | Transmit Interrupt Enable<br>0: Disable SCIn_TXI interrupt requests<br>1: Enable SCIn_TXI interrupt requests  | R/W              |

- Note 1. Writable only when TE = 0 and RE = 0.  
 Note 2. 1 can be written only when TE = 0 and RE = 0, when the SMR.CM bit is 1. After setting TE or RE to 1, only 0 can be written to TE and RE. When the SMR.CM bit is 0 and the SIMR1.IICM bit is 0, writing is enabled under any condition.  
 Note 3. When writing a new value to a bit other than the MPIE bit of this register in multi-processor mode (SMR.MP bit = 1), write 0 to the MPIE bit using the store instruction to avoid accidentally setting the MPIE bit to 1 by a read-modify-write operation when using a bit manipulation instruction.  
 Note 4. GPT clock is selectable for SCI1 and SCI2.

The SCR register controls operation and clock source selection for transmission and reception.

**CKE[1:0] bits (Clock Enable)**

The CKE[1:0] bits select the clock source and the SCKn pin function.

27.2.13 SCR: 非智能卡接口模式的串行控制寄存器 (SCMR.SMIF=0)

Base address: SCIn = 0x4011\_8000 + 0x0100 × n (n = 0, 3, 4, 9)  
 SCIm = 0x4011\_8000 + 0x0100 × m (m = 1, 2)

Offset address: 0x02

Bit position: 7 6 5 4 3 2 1 0

|            |     |     |    |    |      |      |          |
|------------|-----|-----|----|----|------|------|----------|
| Bit field: | TIE | RIE | TE | RE | MPIE | TEIE | CKE[1:0] |
|------------|-----|-----|----|----|------|------|----------|

重置后的值: 0 0 0 0 0 0 0 0

| Bit | Symbol   | Function   | R/W              |
|-----|----------|--|------------------|
| 1:0 | CKE[1:0] | 时钟使能<br>00: 在异步模式下, SCKn引脚可根据IO端口设置用作IO端口。在时钟同步模式下, SCKn引脚用作时钟输出引脚。<br>01: 在异步模式下, 从SCKn引脚输出与比特率相同频率的时钟。在时钟同步模式下, SCKn引脚用作时钟输出引脚。<br>其他: 异步模式下, SEMR.ABCS位为0时, 从SCKn引脚输入16倍比特率的时钟。SEMR.ABCS位为1时, 输入8倍比特率的时钟信号。当使用GPT时钟 <sup>4</sup> 时, SCKn引脚可根据IO端口设置用作IO端口。在时钟同步模式下, SCKn引脚用作时钟输入引脚。 | R/W <sup>1</sup> |
| 2   | TEIE     | 发送结束中断使能<br>0: 禁用SCIn_TEI中断请求<br>1: 启用SCIn_TEI中断请求   | R/W              |
| 3   | MPIE     | 多处理器中断使能<br>当SMR.MP=1时在异步模式下有效。<br>0: 正常接收<br>1: 接收多处理器位设置为0的数据时, 不读取数据, 将SSR中的状态标志RDRF、ORER和FER设置为1, 并将状态标志SYER、PFER和MESR中的SBER被禁用。当接收到多处理器位设置为1的数据时, MPIE位自动设置为0, 并恢复正常接收。   | R/W <sup>3</sup> |
| 4   | RE       | 接收启用<br>0: 禁用串口接收<br>1: 启用串口接收   | R/W <sup>2</sup> |
| 5   | TE       | 发送启用<br>0: 禁用串口传输<br>1: 启用串口传输   | R/W <sup>2</sup> |
| 6   | RIE      | 接收中断使能<br>0: 禁用SCIn_RXI和SCIn_ERI中断请求<br>1: 启用SCIn_RXI和SCIn_ERI中断请求   | R/W              |
| 7   | TIE      | 发送中断使能<br>0: 禁用SCIn_TXI中断请求<br>1: 启用SCIn_TXI中断请求   | R/W              |

- 注1. 仅当TE=0且RE=0时可写。  
 注2. 只有当TE=0且RE=0时, 当SMR.CM位为1时, 才能写入1。将TE或RE设置为1后, TE和RE只能写入0。当SMR.CM位为0且SIMR1.IICM位为0时, 在任何情况下都可以写入。  
 注3. 在多处理器模式下 (SMR.MP位=1) 向该寄存器的MPIE位以外的位写入新值时, 将0写入MPIE位使用存储指令以避免在使用位操作指令时通过读-修改-写操作意外将MPIE位设置为1。  
 注4. GPT时钟可选择用于SCI1和SCI2。

SCR寄存器控制发送和接收的操作和时钟源选择。

**CKE[1:0] bits (Clock Enable)**

CKE[1:0]位选择时钟源和SCKn引脚功能。

**TEIE bit (Transmit End Interrupt Enable)**

The TEIE bit enables or disables SCIn\_TEI interrupt requests. Set TEIE to 0 to disable an SCIn\_TEI interrupt request.

In simple IIC mode, SCIn\_TEI is allocated to the interrupt on completion of issuing a start, restart, or stop condition (STIn). In this case, the TEIE bit can be used to enable or disable the STI.

**MPIE bit (Multi-Processor Interrupt Enable)**

When the MPIE bit is set to 1 and data with the multi-processor bit set to 0 is received, the data is not read and setting the status flags RDRF, ORER, FER, RDF, and DR in SSR/SSR\_FIFO to 1 is disabled. When data with the multi-processor bit set to 1 is received, the MPIE bit is automatically set to 0, and normal reception resumes. For details, see [section 27.4. Multi-Processor Communication Function](#).

**Multi-Processor Communication Function.**

When the MPB bit in the SSR register is 0, the receive data is not transferred from the RSR register to the RDR register, a receive error is not detected, and setting the flags ORER and FER to 1 is disabled.

When the MPB bit is set to 1, the MPIE bit is automatically set to 0, SCIn\_RXI and SCIn\_ERI interrupt requests are enabled (if the RIE bit in SCR is set to 1), and setting of the ORER and FER flags to 1 is enabled.

Set MPIE to 0 if the multi-processor communications function is not used.

**RE bit (Receive Enable)**

The RE bit enables or disables serial reception. When the RE bit is set to 1, serial reception starts by detecting the start bit in asynchronous mode or the synchronous clock input in clock synchronous mode. Set the reception format in the SMR register before setting the RE bit to 1.

In non-FIFO operation, when reception is halted by setting the RE bit to 0, the RDRF, ORER, FER, and PER flags in the SSR register are not affected, and the previous values are retained.

When FIFO operation is selected and reception is halted by setting the RE bit to 0, the RDF, ORER, FER, PER, and DR flags in SSR\_FIFO are not affected and the previous values are retained.

**TE bit (Transmit Enable)**

The TE bit enables or disables serial transmission.

When the TE bit is set to 1, serial transmission is started by writing transmit data to the TDR register. Set the transmission format in the SMR register before setting the TE bit to 1.

**RIE bit (Receive Interrupt Enable)**

The RIE bit enables or disables SCIn\_RXI and SCIn\_ERI interrupt requests.

SCIn\_RXI and SCIn\_ERI interrupt requests are disabled by setting the RIE bit to 0.

An SCIn\_ERI interrupt request can be canceled by reading 1 from the ORER, FER, or PER flag in SSR/SSR\_FIFO then setting the flag to 0, or by setting the RIE bit to 0.

**TIE bit (Transmit Interrupt Enable)**

The TIE bit enables or disables SCIn\_TXI interrupt requests. SCIn\_TXI interrupt requests are disabled by setting the TIE bit to 0.

Note: To switch the TIE bit value from 0 to 1 in FIFO mode, set the TIE and TE bits to 1 simultaneously or set the TIE bit to 1 when TE = 1. When TE = 0 in FIFO mode, setting the TIE bit to 1 is prohibited.

**TEIE位 (发送结束中断允许)**

TEIE位启用或禁用SCIn\_TEI中断请求。将TEIE设置为0以禁用SCIn\_TEI中断请求。

在简单IIC模式下，SCIn\_TEI在完成发出启动、重新启动或停止条件(STIn)时分配给中断。在这种情况下，TEIE位可用于启用或禁用STI。

**MPIE位 (多处理器中断允许)**

当MPIE位设置为1并且接收到多处理器位设置为0的数据时，不读取数据并且将SSR/SSR\_FIFO中的状态标志RDRF、ORER、FER、RDF和DR设置为1被禁用。当接收到多处理器位设置为1的数据时，MPIE位自动设置为0，并恢复正常接收。有关详细信息，请参阅第27.4节。多处理器通信功能。

当SSR寄存器的MPB位为0时，接收数据不会从RSR寄存器传送到RDR寄存器，不会检测到接收错误，并且将标志ORER和FER设置为1被禁止。

当MPB位设置为1时，MPIE位自动设置为0，允许SCIn\_RXI和SCIn\_ERI中断请求（如果SCR中的RIE位设置为1），并且允许设置ORER和FER标志为1。

如果不使用多处理器通信功能，则将MPIE设置为0。

**RE位 (接收使能)**

RE位启用或禁用串行接收。当RE位设置为1时，串行接收通过检测异步模式下的起始位或时钟同步模式下的同步时钟输入来启动。在将RE位设置为1之前，在SMR寄存器中设置接收格式。

在非FIFO操作中，当通过将RE位设置为0来停止接收时，RDRF、ORER、FER和PER标志SSR寄存器不受影响，保留之前的值。

When FIFO operation is selected and reception is halted by setting the RE bit to 0, the RDF, ORER, FER, PER, and DR flags in SSR\_FIFO are not affected and the previous values are retained.

**TE位 (发送使能)**

TE位启用或禁用串行传输。

当TE位设置为1时，通过将发送数据写入TDR寄存器开始串行发送。在将TE位设置为1之前，在SMR寄存器中设置传输格式。

**RIE位 (接收中断允许)**

RIE位启用或禁用SCIn\_RXI和SCIn\_ERI中断请求。

通过将RIE位设置为0来禁用SCIn\_RXI和SCIn\_ERI中断请求。

SCIn\_ERI中断请求可以通过从SSR/SSR\_FIFO中的ORER、FER或PER标志读取1然后将该标志设置为0或通过RIE位设置为0来取消。

**TIE位 (发送中断允许)**

TIE位启用或禁用SCIn\_TXI中断请求。通过将TIE位设置为0来禁用SCIn\_TXI中断请求。

Note: 要在FIFO模式下将TIE位值从0切换为1，请将TIE和TE位同时设置为1，或者在TE=1时将TIE位设置为1。在FIFO模式下，当TE=0时，将TIE位设置为1是禁止。



## 27.2.14 SCR\_SMCI : Serial Control Register for Smart Card Interface Mode (SCMR.SMIF = 1)

Base address: SCIn = 0x4011\_8000 + 0x0100 × n (n = 0, 3, 4, 9)  
SCIm = 0x4011\_8000 + 0x0100 × m (m = 1, 2)

Offset address: 0x02

Bit position: 7 6 5 4 3 2 1 0

|            |     |     |    |    |      |      |          |
|------------|-----|-----|----|----|------|------|----------|
| Bit field: | TIE | RIE | TE | RE | MPIE | TEIE | CKE[1:0] |
|------------|-----|-----|----|----|------|------|----------|

Value after reset: 0 0 0 0 0 0 0 0

| Bit | Symbol   | Function   | R/W              |
|-----|----------|--|------------------|
| 1:0 | CKE[1:0] | Clock Enable<br>0 0: When SMR_SMCI.GM = 0: Disable output<br>The SCKn pin is available for use as an I/O port if set up in the I/O port settings<br>When SMR_SMCI.GM = 1: Fix output low<br>0 1: When SMR_SMCI.GM = 0: Output clock<br>When SMR_SMCI.GM = 1: Output clock<br>1 0: When SMR_SMCI.GM = 0: Setting prohibited<br>When SMR_SMCI.GM = 1: Fix output high<br>1 1: When SMR_SMCI.GM = 0: Setting prohibited<br>When SMR_SMCI.GM = 1: Output clock | R/W <sup>1</sup> |
| 2   | TEIE     | Transmit End Interrupt Enable<br>Set this bit to 0 in smart card interface mode  | R/W              |
| 3   | MPIE     | Multi-Processor Interrupt Enable<br>Set this bit to 0 in smart card interface mode   | R/W              |
| 4   | RE       | Receive Enable<br>0: Disable serial reception<br>1: Enable serial reception  | R/W <sup>2</sup> |
| 5   | TE       | Transmit Enable<br>0: Disable serial transmission<br>1: Enable serial transmission   | R/W <sup>2</sup> |
| 6   | RIE      | Receive Interrupt Enable<br>0: Disable SCIn_RXI and SCIn_ERI interrupt requests<br>1: Enable SCIn_RXI and SCIn_ERI interrupt requests  | R/W              |
| 7   | TIE      | Transmit Interrupt Enable<br>0: Disable SCIn_TXI interrupt requests<br>1: Enable SCIn_TXI interrupt requests   | R/W              |

Note 1. Writable only when TE = 0 and RE = 0.

Note 2. 1 can be written only when TE = 0 and RE = 0. After setting TE or RE to 1, only 0 can be written to TE and RE.

The SCR\_SMCI register sets transmission and reception control, interrupt control, and clock source selection for transmission and reception.

For details on interrupt requests, see [section 27.12. Interrupt Sources](#).

### CKE[1:0] bits (Clock Enable)

The CKE[1:0] bits control the clock output from the SCKn pin. In GSM mode, clock output can be dynamically switched.

For details, see [section 27.7.8. Clock Output Control](#).

### TEIE bit (Transmit End Interrupt Enable)

Set the TEIE bit to 0 in smart card interface mode.

### MPIE bit (Multi-Processor Interrupt Enable)

Set the MPIE bit to 0 in smart card interface mode.

## 27.2.14 SCR\_SMCI: 智能卡接口模式的串行控制寄存器(SCMR.SMIF=1)

Base address: SCIn = 0x4011\_8000 + 0x0100 × n (n = 0, 3, 4, 9)  
SCIm = 0x4011\_8000 + 0x0100 × m (m = 1, 2)

Offset address: 0x02

Bit position: 7 6 5 4 3 2 1 0

|            |     |     |    |    |      |      |          |
|------------|-----|-----|----|----|------|------|----------|
| Bit field: | TIE | RIE | TE | RE | MPIE | TEIE | CKE[1:0] |
|------------|-----|-----|----|----|------|------|----------|

重置后的值: 0 0 0 0 0 0 0 0

| Bit | Symbol   | Function  | R/W              |
|-----|----------|---|------------------|
| 1:0 | CKE[1:0] | 时钟使能<br>00: 当SMR_SMCI.GM=0时: 禁用输出<br>如果在IO端口设置中设置SCKn引脚可用作IO端口<br>当SMR_SMCI.GM=1时: 固定输出低<br>01: 当SMR_SMCI.GM=0: 输出时钟当SMR_S<br>MCI.GM=1: 输出时钟<br>10: 当SMR_SMCI.GM=0时: 禁止设置当SMR_SMC<br>IGM=1时: 固定输出高<br>11: 当SMR_SMCI.GM=0时: 禁止设置当SMR_SMC<br>IGM=1时: 输出时钟 | R/W <sup>1</sup> |
| 2   | TEIE     | 发送结束中断使能<br>在智能卡接口模式下将此位设置为0  | R/W              |
| 3   | MPIE     | 多处理器中断使能<br>在智能卡接口模式下将此位设置为0  | R/W              |
| 4   | RE       | 接收启用<br>0: 禁用串口接收1: 启用<br>串口接收  | R/W <sup>2</sup> |
| 5   | TE       | 发送启用<br>0: 禁用串口传输1: 启用串口<br>传输  | R/W <sup>2</sup> |
| 6   | RIE      | 接收中断使能<br>0: 禁用SCIn_RXI和SCIn_ERI中断请求1: 启用SCIn_RXI<br>和SCIn_ERI中断请求  | R/W              |
| 7   | TIE      | 发送中断使能<br>0: 禁用SCIn_TXI中断请求1: 启用SCIn<br>_TXI中断请求  | R/W              |

注1. 仅当TE=0且RE=0时可写。

注2. 只有TE=0且RE=0时才能写入1。将TE或RE设置为1后, TE和RE只能写入0。

SCR\_SMCI寄存器设置发送和接收的发送和接收控制、中断控制以及发送和接收的时钟源选择。

有关中断请求的详细信息, 请参阅第27.12节。中断源。

### CKE[1:0] bits (Clock Enable)

CKE[1:0]位控制SCKn引脚的时钟输出。在GSM模式下, 时钟输出可以动态切换。

有关详细信息, 请参阅第27.7.8节。时钟输出控制。

### TEIE位 (发送结束中断允许)

在智能卡接口模式下将TEIE位设置为0。

### MPIE位 (多处理器中断允许)

在智能卡接口模式下将MPIE位设置为0。

**RE bit (Receive Enable)**

The RE bit enables or disables serial reception. When the RE bit is set to 1, serial reception starts by detecting the start bit. Set the reception format in the SMR\_SMCI register before setting the RE bit to 1.

If reception is halted by setting the RE bit to 0, the ORER, FER, and PER flags in SSR\_SMCI are not affected and the previous values are retained.

**TE bit (Transmit Enable)**

The TE bit enables or disables serial transmission. When the TE bit is set to 1, serial transmission is started by writing transmit data to TDR. Set the transmission format in the SMR\_SMCI register before setting the TE bit to 1.

**RIE bit (Receive Interrupt Enable)**

The RIE bit enables or disables SCIn\_RXI and SCIn\_ERI interrupt requests.

SCIn\_RXI and SCIn\_ERI interrupt requests are disabled by setting the RIE bit to 0.

An SCIn\_ERI interrupt request can be canceled by reading 1 from the ORER, FER, or PER flag in the SSR\_SMCI register, and then setting the flag to 0, or by setting the RIE bit to 0.

**TIE bit (Transmit Interrupt Enable)**

The TIE bit enables or disables SCIn\_TXI interrupt requests. SCIn\_TXI interrupt requests are disabled by setting the TIE bit to 0.

### 27.2.15 SSR : Serial Status Register for Non-Smart Card Interface and Non-FIFO Mode (SCMR.SMIF = 0, FCR.FM = 0, and MMR.MANEN = 0)

Base address: SCIn = 0x4011\_8000 + 0x0100 × n (n = 0, 3, 4, 9)  
SCIm = 0x4011\_8000 + 0x0100 × m (m = 1, 2)

Offset address: 0x04

|                    |      |      |      |     |     |      |     |      |
|--------------------|------|------|------|-----|-----|------|-----|------|
| Bit position:      | 7    | 6    | 5    | 4   | 3   | 2    | 1   | 0    |
| Bit field:         | TDRE | RDRF | ORER | FER | PER | TEND | MPB | MPBT |
| Value after reset: | 1    | 0    | 0    | 0   | 0   | 1    | 0   | 0    |

| Bit | Symbol | Function   | R/W                 |
|-----|--------|--|---------------------|
| 0   | MPBT   | Multi-Processor Bit Transfer<br>Sets the value of the multi-processor bit in the transmission frame.<br>0: Data transmission cycle<br>1: ID transmission cycle | R/W                 |
| 1   | MPB    | Multi-Processor<br>Value of the multi-processor bit in the reception frame.<br>0: Data transmission cycle<br>1: ID transmission cycle                          | R                   |
| 2   | TEND   | Transmit End Flag<br>0: A character is being transmitted<br>1: Character transfer is complete  | R                   |
| 3   | PER    | Parity Error Flag<br>0: No parity error occurred<br>1: Parity error occurred   | R/(W) <sup>*1</sup> |
| 4   | FER    | Framing Error Flag<br>0: No framing error occurred<br>1: Framing error occurred  | R/(W) <sup>*1</sup> |
| 5   | ORER   | Overrun Error Flag<br>0: No overrun error occurred<br>1: Overrun error occurred  | R/(W) <sup>*1</sup> |

**RE位 (接收使能)**

RE位启用或禁用串行接收。当RE位设置为1时，串行接收通过检测起始位开始。在将RE位设置为1之前，在SMR\_SMCI寄存器中设置接收格式。

如果通过将RE位设置为0来停止接收，则SSR\_SMCI中的ORER、FER和PER标志不受影响，并且保留以前的值。

**TE位 (发送使能)**

TE位启用或禁用串行传输。当TE位设置为1时，通过将发送数据写入TDR开始串行发送。在将TE位设置为1之前，在SMR\_SMCI寄存器中设置传输格式。

**RIE位 (接收中断允许)**

RIE位启用或禁用SCIn\_RXI和SCIn\_ERI中断请求。

通过将RIE位设置为0来禁用SCIn\_RXI和SCIn\_ERI中断请求。

通过从SSR\_SMCI寄存器中的ORER、FER或PER标志读取1，然后将该标志设置为0，或将RIE位设置为0，可以取消SCIn\_ERI中断请求。

**TIE位 (发送中断允许)**

TIE位启用或禁用SCIn\_TXI中断请求。通过将TIE位设置为0来禁用SCIn\_TXI中断请求。

### 27.2.15 SSR: 非智能卡接口和非FIFO模式的串行状态寄存器 (SCMR.SMIF=0、FCR.FM=0和MMR.MANEN=0)

Base address: SCIn = 0x4011\_8000 + 0x0100 × n (n = 0, 3, 4, 9)  
SCIm = 0x4011\_8000 + 0x0100 × m (m = 1, 2)

Offset address: 0x04

|               |      |      |      |     |     |      |     |      |
|---------------|------|------|------|-----|-----|------|-----|------|
| Bit position: | 7    | 6    | 5    | 4   | 3   | 2    | 1   | 0    |
| Bit field:    | TDRE | RDRF | ORER | FER | PER | TEND | MPB | MPBT |
| 重置后的值:        | 1    | 0    | 0    | 0   | 0   | 1    | 0   | 0    |

| Bit | Symbol | Function  | R/W                 |
|-----|--------|---|---------------------|
| 0   | MPBT   | 多处理器位传输<br>设置传输帧中多处理器位的值。<br>0: 数据发送周期1: ID发送周期       | R/W                 |
| 1   | MPB    | Multi-Processor<br>接收帧中多处理器位的值。<br>0: 数据发送周期1: ID发送周期 | R                   |
| 2   | TEND   | 发送结束标志<br>0: 字符传输中1: 字符传输完成                           | R                   |
| 3   | PER    | 奇偶校验错误标志<br>0: 未发生奇偶校验错误1: 发生奇偶校验错误                   | R/(W) <sup>*1</sup> |
| 4   | FER    | 成帧错误标志<br>0: 未发生帧错误1: 发生帧错误                           | R/(W) <sup>*1</sup> |
| 5   | ORER   | 溢出错误标志<br>0: 未发生溢出错误1: 发生溢出错误                         | R/(W) <sup>*1</sup> |

| Bit | Symbol | Function  | R/W     |
|-----|--------|---|---------|
| 6   | RDRF   | Receive Data Full Flag<br>0: No received data in RDR register<br>1: Received data in RDR register   | R/(W)*1 |
| 7   | TDRE   | Transmit Data Empty Flag<br>0: Transmit data in TDR register<br>1: No transmit data in TDR register | R/(W)*1 |

Note 1. Only 0 can be written to clear the flag after reading 1.

The SSR register provides SCI status flags and transmission and reception multi-processor bits.

#### MPBT bit (Multi-Processor Bit Transfer)

The MPBT bit sets the value of the multi-processor bit in the transmit frame.

#### MPB bit (Multi-Processor)

The MPB bit holds the value of the multi-processor bit in the reception frame. This bit does not change when the SCR.RE bit is 0.

#### TEND flag (Transmit End Flag)

The TEND flag indicates completion of transmission.

[Setting conditions]

- When the SCR.TE bit is set to 0 (serial transmission is disabled) and the FCR.FM bit is set to 0 (non-FIFO selected). When the SCR.TE bit is set to 1, the TEND flag is not affected and retains the value 1.
- When the TDR register is not updated on transmission of the tail-end bit of a character being transmitted.

[Clearing conditions]

- When transmit data is written to the TDR register while the SCR.TE bit is 1
- When 0 is written to TDRE after reading TDRE = 1 while the SCR.TE bit is 1

#### PER flag (Parity Error Flag)

The PER flag indicates that a parity error occurred during reception in asynchronous mode and the reception ended abnormally.

[Setting condition]

- When a parity error is detected during reception in asynchronous mode when the address match function is disabled (DCCR.DCME = 0).  
Although receive data is transferred to the RDR register when the parity error occurs, no SCIn\_RXI interrupt request occurs. When the PER flag is set to 1, the subsequent receive data is not transferred to the RDR register.

[Clearing condition]

- When 0 is written to PER after reading PER = 1. After writing 0 to the PER flag, read the PER flag to check that it is actually set to 0.

When the SCR.RE bit is set to 0 (serial reception is disabled), the PER flag is not affected and retains its previous value.

#### FER flag (Framing Error Flag)

The FER flag indicates that a framing error occurred during reception in asynchronous mode and the reception ended abnormally.

[Setting condition]

- When 0 is sampled as the stop bit during reception in asynchronous mode when the address match function is disabled (DCCR.DCME = 0).

In 2-stop-bit mode, only the first stop bit is checked. The second stop bit is not checked. Although receive data is transferred to the RDR register when the framing error occurs, no SCIn\_RXI interrupt request occurs. When the FER flag is to 1, the subsequent receive data is not transferred to the RDR register.

| Bit | Symbol | Function                                    | R/W     |
|-----|--------|---|---------|
| 6   | RDRF   | 接收数据满标志<br>0: RDR寄存器中没有接收到数据1: RDR寄存器中接收到数据 | R/(W)*1 |
| 7   | TDRE   | 传输数据空标志<br>0: 在TDR寄存器中发送数据1: 在TDR寄存器中不发送数据  | R/(W)*1 |

注1.读1后只能写0清除标志。

SSR寄存器提供SCI状态标志和发送和接收多处理器位。

#### MPBT bit (Multi-Processor Bit Transfer)

MPBT位设置发送帧中多处理器位的值。

#### MPB bit (Multi-Processor)

MPB位保存接收帧中多处理器位的值。当SCR.RE位为0时，该位不变。

#### TEND标志（发送结束标志）

TEND标志表示传输完成。

[Setting conditions]

- 当SCR.TE位设置为0（禁用串行传输）且FCR.FM位设置为0（选择非FIFO）时。当SCR.TE位设置为1时，TEND标志不受影响并保持值1。
- TDR寄存器未在发送字符的尾端位时更新时。

[Clearing conditions]

- 当SCR.TE位为1时将发送数据写入TDR寄存器
- 当SCR.TE位为1时，读取TDRE=1后向TDRE写入0

#### PER标志（奇偶校验错误标志）

PER标志表示在异步模式接收过程中发生奇偶校验错误，接收异常结束。

[Setting condition]

- 当地址匹配功能被禁用（DCCR.DCME=0）时，在异步模式接收期间检测到奇偶校验错误。

尽管发生奇偶校验错误时接收数据被传送到RDR寄存器，但不会发生SCIn\_RXI中断请求。当PER标志设置为1时，后续接收数据不会传送到RDR寄存器。

[Clearing condition]

- 读取PER=1后向PER写入0时。将0写入PER标志后，读取PER标志以检查它是否实际设置为0。

当SCR.RE位设置为0（禁用串行接收）时，PER标志不受影响并保留其先前的值。

#### FER标志（帧错误标志）

FER标志表示在异步模式下接收过程中发生了帧错误，并且接收异常结束。

[Setting condition]

- 当地址匹配功能被禁用（DCCR.DCME=0）时，在异步模式接收期间采样0作为停止位时。

在2停止位模式下，仅检查第一个停止位。不检查第二个停止位。虽然发生帧错误时接收数据被传输到RDR寄存器，但不会发生SCIn\_RXI中断请求。当FER标志为1时，后续接收数据不传送到RDR寄存器。

[Clearing condition]

- When 0 is written to FER after reading FER = 1. After writing 0 to the FER flag, read the FER flag to check that it is actually set to 0.

When the SCR.RE bit is set to 0 (serial reception is disabled), the FER flag is not affected and retains its previous value.

**ORER flag (Overrun Error Flag)**

The ORER flag indicates that an overrun error occurred during reception and the reception ended abnormally.

[Setting condition]

- When the next data is received before receive data that does not have a parity error and a framing error is read from the RDR register.

The data received before an overrun error occurred is saved in the RDR register, but data received after the error is lost. When the ORER flag is set to 1, receive data is not forwarded to the RDR register. In clock synchronous mode, serial transmission and reception are stopped.

[Clearing condition]

- When 0 is written to ORER after reading ORER = 1. After writing 0 to the ORER flag, read the ORER flag to check that it is actually set to 0.

When the SCR.RE bit is set to 0 (serial reception is disabled), the ORER flag is not affected and retains its previous value.

**RDRF flag (Receive Data Full Flag)**

The RDRF flag indicates the presence of receive data in the RDR register.

[Setting condition]

- When the reception ends normally, and receive data is forwarded from the RSR register to the RDR register.

[Clearing conditions]

- When 0 is written to RDRF after reading RDRF = 1
- When data is forwarded from the RDR register

**TDRE flag (Transmit Data Empty Flag)**

The TDRE flag indicates the presence of transmit data in the TDR register.

[Setting conditions]

- When the SCR.TE bit is 0
- When data is transmitted from the TDR register to the TSR register

[Clearing conditions]

- When 0 is written to TDRE after reading TDRE = 1
- When the SCR.TE bit is 1 and data is written to the TDR register

### 27.2.16 SSR\_FIFO : Serial Status Register for Non-Smart Card Interface and FIFO Mode (SCMR.SMIF = 0, FCR.FM = 1, and MMR.MANEN = 0)

Base address: SCIn = 0x4011\_8000 + 0x0100 × n (n = 0, 3, 4, 9)

Offset address: 0x04

|                    |      |     |      |     |     |      |   |    |
|--------------------|------|-----|------|-----|-----|------|---|----|
| Bit position:      | 7    | 6   | 5    | 4   | 3   | 2    | 1 | 0  |
| Bit field:         | TDFE | RDF | ORER | FER | PER | TEND | — | DR |
| Value after reset: | 1    | 0   | 0    | 0   | 0   | 0    | x | 0  |

[Clearing condition]

- 当读取FER=1后向FER写入0时。将0写入FER标志后，读取FER标志以检查它是否实际设置为0。

当SCR.RE位设置为0（禁用串行接收）时，FER标志不受影响并保留其先前的值。

**ORER标志（溢出错误标志）**

ORER标志表示接收期间发生溢出错误，接收异常结束。

[Setting condition]

- 在接收没有奇偶校验错误和帧错误的数据之前接收下一个数据时，从RDR寄存器中读取。

溢出错误发生前接收到的数据保存在RDR寄存器中，但错误发生后接收到的数据丢失。当ORER标志设置为1时，接收数据不转发到RDR寄存器。在时钟同步模式下，串行发送和接收停止。

[Clearing condition]

- 读取ORER=1后向ORER写入0时。向ORER标志写入0后，读取ORER标志以检查它是否实际设置为0。

当SCR.RE位设置为0（禁用串行接收）时，ORER标志不受影响并保留其先前的值。

**RDRF标志（接收数据满标志）**

RDRF标志指示RDR寄存器中存在接收数据。

[Setting condition]

- 接收正常结束时，接收数据从RSR寄存器转发到RDR寄存器。

[Clearing conditions]

- 读取RDRF=1后向RDRF写入0时
- 从RDR寄存器转发数据时

**TDRE标志（传输数据空标志）**

TDRE标志表示TDR寄存器中存在发送数据。

[Setting conditions]

- 当SCR.TE位为0时
- 当数据从TDR寄存器传送到TSR寄存器时

[Clearing conditions]

- 读取TDRE=1后写入0时
- 当SCR.TE位为1且数据写入TDR寄存器时

### 27.2.16 SSR\_FIFO：非智能卡接口和FIFO模式的串行状态寄存器（SCMR.SMIF=0、FCR.FM=1和MMR.MANEN=0）

Base address: SCIn = 0x4011\_8000 + 0x0100 × n (n = 0, 3, 4, 9)

Offset address: 0x04

|               |      |     |      |     |     |      |   |    |
|---------------|------|-----|------|-----|-----|------|---|----|
| Bit position: | 7    | 6   | 5    | 4   | 3   | 2    | 1 | 0  |
| Bit field:    | TDFE | RDF | ORER | FER | PER | TEND | — | DR |
| 重置后的值:        | 1    | 0   | 0    | 0   | 0   | 0    | x | 0  |



| Bit | Symbol | Function   | R/W              |
|-----|--------|--|------------------|
| 0   | DR     | Receive Data Ready Flag<br>0: Receiving is in progress, or no received data remains in FRDRHL after successfully completed reception (receive FIFO empty)<br>1: Next receive data is not received for a period after normal receiving is complete, when the amount of data stored in the FIFO is equal to or less than the receive triggering number | R/W <sup>1</sup> |
| 1   | —      | The read value is undefined. The write value should be 1.  | R/W              |
| 2   | TEND   | Transmit End Flag<br>0: A character is being transmitted<br>1: Character transfer is complete  | R/W <sup>1</sup> |
| 3   | PER    | Parity Error Flag<br>0: No parity error occurred<br>1: Parity error occurred   | R/W <sup>1</sup> |
| 4   | FER    | Framing Error Flag<br>0: No framing error occurred<br>1: Framing error occurred  | R/W <sup>1</sup> |
| 5   | ORER   | Overrun Error Flag<br>0: No overrun error occurred<br>1: Overrun error occurred  | R/W <sup>1</sup> |
| 6   | RDF    | Receive FIFO Data Full Flag<br>0: The amount of receive data written in FRDRHL is less than the specified receive triggering number<br>1: The amount of receive data written in FRDRHL is equal to or greater than the specified receive triggering number   | R/W <sup>1</sup> |
| 7   | TDFE   | Transmit FIFO Data Empty Flag<br>0: The amount of transmit data written in FTDRHL exceeds the specified transmit triggering number<br>1: The amount of transmit data written in FTDRHL is equal to or less than the specified transmit triggering number   | R/W <sup>1</sup> |

Note 1. Only 0 can be written, to clear the flag after reading 1.

The SSR\_FIFO register provides the SCI with FIFO mode status flags.

#### DR flag (Receive Data Ready Flag)

The DR flag indicates that the amount of data stored in the Receive FIFO Data Register (FRDRHL) falls below the specified receive triggering number, and that no next data is received after 15 ETUs (elementary time units) from the last stop bit in asynchronous mode. This flag is valid only in asynchronous mode, including multi-processor mode, when FIFO operation is selected.

In clock synchronous mode, the DR flag is not set to 1.

[Setting condition]

- When FRDRHL contains less data than the specified receive triggering number, and no next data is received after 15 ETUs<sup>1</sup> from the last stop bit, and the SSR\_FIFO.FER and SSR\_FIFO.PER flags are 0.

[Clearing conditions]

- When 1 is read from DR, after all received data is read
- When the FCR.FM bit is changed from 0 to 1

Note 1. This is equivalent to 1.5 frames in the 8-bit format with one stop bit.

The DR flag is only set to 1 when FIFO is selected in asynchronous mode, including multi-processor mode. It is not set to 1 in other operation modes.

#### TEND flag (Transmit End Flag)

The TEND flag indicates that FTDRHL does not contain valid data when transmitting the last bit of a serial character, so the transmission is halted.

[Setting condition]

| Bit | Symbol | Function  | R/W              |
|-----|--------|---|------------------|
| 0   | DR     | 接收数据就绪标志<br>0: 接收中, 或者接收成功后FRDRHL中没有接收到的数据 (接收FIFO为空)<br>1: 正常接收完成后一段时间内没有接收到下一个接收数据, 此时FIFO中存储的数据量等于或小于接收触发数 | R/W <sup>1</sup> |
| 1   | —      | 读取值未定义。写入值应为1。  | R/W              |
| 2   | TEND   | 发送结束标志<br>0: 字符传输中1: 字符传输完成   | R/W <sup>1</sup> |
| 3   | PER    | 奇偶校验错误标志<br>0: 未发生奇偶校验错误1<br>: 发生奇偶校验错误   | R/W <sup>1</sup> |
| 4   | FER    | 成帧错误标志<br>0: 未发生帧错误1: 发生帧错误   | R/W <sup>1</sup> |
| 5   | ORER   | 溢出错误标志<br>0: 未发生溢出错误1: 发生溢出错误   | R/W <sup>1</sup> |
| 6   | RDF    | 接收FIFO数据满标志<br>0: 写入FRDRHL的接收数据量小于指定的接收触发数<br>1: 写入FRDRHL的接收数据量等于或大于指定的接收触发数                                  | R/W <sup>1</sup> |
| 7   | TDFE   | 发送FIFO数据空标志<br>0: 写入FTDRHL的发送数据量超过指定的发送触发数<br>1: 写入FTDRHL的发送数据量等于或小于指定的发送触发数                                  | R/W <sup>1</sup> |

注1.只能写入0, 读取1后清除标志。

SSR\_FIFO寄存器为SCI提供FIFO模式状态标志。

#### DR标志 (接收数据就绪标志)

DR标志表示存储在接收FIFO数据寄存器(FRDRHL)中的数据量低于指定的接收触发数, 并且在异步模式下从最后一个停止位开始15个ETU (基本时间单位) 后没有接收到下一个数据.此标志仅在选择FIFO操作时在异步模式下有效, 包括多处理器模式。

在时钟同步模式下, DR标志不设置为1。

[Setting condition]

- 当FRDRHL包含的数据少于指定的接收触发数, 并且从最后一个停止位开始15个ETU\*1后没有接收到下一个数据, 并且SSR\_FIFO.FER和SSR\_FIFO.PER标志为0。

[Clearing conditions]

- 从DR读取1时, 在读取所有接收到的数据后
- 当FCR.FM位由0变为1时

注1.这相当于8位格式的1.5帧, 带有一位停止位。

只有在异步模式 (包括多处理器模式) 下选择FIFO时, DR标志才设置为1。在其他操作模式下不设置为1。

#### TEND标志 (发送结束标志)

TEND标志表明FTDRHL在发送串行字符的最后一位时不包含有效数据, 因此暂停发送。

[Setting condition]

- When FTDRHL does not contain transmit data when the last bit of a 1-byte serial character is transmitted.

[Clearing conditions]

- When transmit data is written to FTDRHL\*<sup>1</sup> while the SCR.TE bit is 1
- When 0 is written to TEND after 1 is read from TEND, when the SCR.TE bit is 1
- When the FCR.FM bit is changed from 0 to 1

Note 1. Do not use the TEND bit as a transmit end flag when the DTC writes data to FTDRHL in response to an SCIn\_TXI interrupt request.

#### PER flag (Parity Error Flag)

The PER flag indicates whether there is a parity error in the data read from the FRDRHL register in asynchronous mode when the address match function is disabled (DCCR.DCME = 0).

[Setting condition]

- When data is received and a parity error is detected, when the address match function is disabled (DCCR.DCME = 0).

[Clearing condition]

- When 0 is written to PER after reading PER = 1.

The reception operation is continuous, and the receive data is stored in the FRDRHL register, even when a parity error occurs during reception.

When the SCR.RE bit is set to 0 (serial reception is disabled), the PER flag is not affected and retains its previous value.

#### FER flag (Framing Error Flag)

The FER flag indicates whether there is a framing error in the data read from the FRDRHL register in asynchronous mode when the address match function is disabled (DCCR.DCME = 0).

[Setting condition]

- When 0 is sampled as the stop bit during reception when the address match function is disabled (DCCR.DCME = 0).

[Clearing condition]

- When 0 is written to FER after reading FER = 1.

The reception operation is continuous, and the receive data is stored in the FRDRHL register, even when a framing error occurs during reception.

When the SCR.RE bit is set to 0 (serial reception is disabled), the FER flag is not affected and retains its previous value.

#### ORER flag (Overrun Error Flag)

The ORER flag indicates that the receive operation stopped abnormally because an overrun error occurred.

[Setting condition]

- When the next serial reception completes while the receive FIFO is full with 16-byte receive data.

[Clearing condition]

- When 0 is written to ORER after reading ORER = 1.

When the SCR.RE bit is set to 0 (serial reception is disabled), the ORER flag is not affected and retains its previous value.

#### RDF flag (Receive FIFO Data Full Flag)

The RDF flag indicates that receive data was transferred to the FRDRHL register, and the amount of data in FRDRHL is equal to or exceeds the specified receive triggering number. When RTRG is set to 0, the RDF flag is not set even when the amount of data in the receive FIFO is equal to 0.

[Setting condition]

- When the amount of receive data equal to or greater than the specified receive triggering number is stored in FRDRHL,\*<sup>1</sup> and the FIFO is not empty.

- 当FTDRHL不包含发送数据时，发送1字节串行字符的最后一位。

[Clearing conditions]

- 当SCR.TE位为1时将发送数据写入FTDRHL\*<sup>1</sup>
- 从TEND读取1后，向TEND写入0时，SCR.TE位为1时
- 当FCR.FM位由0变为1时

注1.当DTC将数据写入FTDRHL以响应SCIn\_TXI中断请求时，请勿使用TEND位作为发送结束标志。

#### PER标志 (奇偶校验错误标志)

PER标志指示在禁用地址匹配功能 (DCCR.DCME=0) 时，异步模式下从FRDRHL寄存器读取的数据是否存在奇偶校验错误。

[Setting condition]

- 当接收到数据并检测到奇偶校验错误时，当地址匹配功能被禁用时 (DCCR.DCME=0)。

[Clearing condition]

- 读取PER=1后向PER写入0时。

接收操作是连续的，接收数据存储在FRDRHL寄存器中，即使在接收过程中发生奇偶校验错误。

当SCR.RE位设置为0 (禁用串行接收) 时，PER标志不受影响并保留其先前的值。

#### FER标志 (帧错误标志)

FER标志指示在禁用地址匹配功能 (DCCR.DCME=0) 时，异步模式下从FRDRHL寄存器读取的数据是否存在帧错误。

[Setting condition]

- 当地址匹配功能被禁用 (DCCR.DCME=0) 时，在接收期间采样0作为停止位时。

[Clearing condition]

- 读取FER=1后向FER写入0时。

接收操作是连续的，接收数据存储在FRDRHL寄存器中，即使在接收过程中发生帧错误。

当SCR.RE位设置为0 (禁用串行接收) 时，FER标志不受影响并保留其先前的值。

#### ORER标志 (溢出错误标志)

ORER标志指示接收操作由于发生溢出错误而异常停止。

[Setting condition]

- 当接收FIFO已满16字节接收数据时，下一次串行接收完成时。

[Clearing condition]

- 读取ORER=1后向ORER写入0时。

当SCR.RE位设置为0 (禁用串行接收) 时，ORER标志不受影响并保留其先前的值。

#### RDF标志 (接收FIFO数据满标志)

RDF标志表示接收数据已传送到FRDRHL寄存器，并且FRDRHL中的数据量等于或超过指定的接收触发数。当RTRG设置为0时，即使接收FIFO中的数据量等于0，RDF标志也不会设置。

[Setting condition]

- 当FRDRHL中存储了等于或大于指定接收触发数的接收数据量时，\*<sup>1</sup>且FIFO不为空。

[Clearing conditions]

- When 0 is written to RDF after reading RDF = 1
- When FRDRHL is read by the DTC, but only when the block transfer is the last transmission
- When the setting and clearing conditions occur at the same time, the RDF bit is set to 0. After that, when the amount of data stored in the FRDRHL register is the same as or greater than the RTRG value, RDF is set to 1 after 1 PCLK.

Note 1. Because FRDRHL is a 16-stage FIFO register, the maximum amount of data that can be read when RDF is 1 is equivalent to the specified receive triggering number. If an attempt is made to read after all the data in FRDRHL is read, the data is undefined.

**TDFE flag (Transmit FIFO Data Empty Flag)**

The TDFE flag indicates that data is transferred from the FTDRHL register into the TSR register, the amount of data in FTDRHL is below the specified transmit triggering number, and writing of transmit data to FTDRHL is enabled.

[Setting conditions]

- When the TE bit in SCR is 0
- When the amount of transmit data written in FTDRHL is equal to or less than the specified transmit triggering number\*1

[Clearing conditions]

- When writing to FTDRHL is executed on the last transmission while the DTC is activated
- When 0 is written to the TDFE flag after reading TDFE = 1.\*2  
The setting conditions are given priority when TE = 0. When the setting condition and clearing condition occur at the same time, the TDFE flag is set to 0. After that, when the amount of data stored in the FTDRHL register is equal to or less than the TTRG value, TDFE is set to 1 after 1 PCLK.

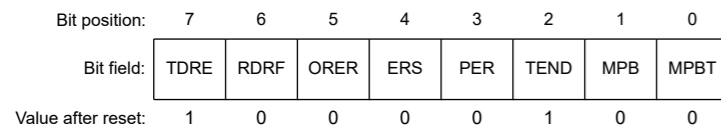
Note 1. Because the FTDRHL register is a 16-stage FIFO register, when the TDFE flag is 1, the maximum amount of data that can be written to the FTDRHL register is 16 minus FDR.T[4:0] bytes. If more data is written, data is discarded.

Note 2. Do not clear the TDFE flag during block transfer processing by the DTC.

**27.2.17 SSR\_SMCI : Serial Status Register for Smart Card Interface Mode (SCMR.SMIF = 1, and MMR.MANEN = 0)**

Base address: SCIn = 0x4011\_8000 + 0x0100 × n (n = 0, 3, 4, 9)  
SCIm = 0x4011\_8000 + 0x0100 × m (m = 1, 2)

Offset address: 0x04



| Bit | Symbol | Function   | R/W   |
|-----|--------|--|-------|
| 0   | MPBT   | Multi-Processor Bit Transfer<br>Set this bit to 0 in smart card interface mode                       | R/W   |
| 1   | MPB    | Multi-Processor<br>Set this bit to 0 in smart card interface mode                                    | R     |
| 2   | TEND   | Transmit End Flag<br>0: A character is being transmitted<br>1: Character transfer is complete        | R     |
| 3   | PER    | Parity Error Flag<br>0: No parity error occurred<br>1: Parity error occurred                         | R/W*1 |
| 4   | ERS    | Error Signal Status Flag<br>0: No low error signal response<br>1: Low error signal response occurred | R/W*1 |

[Clearing conditions]

- 读取RDF=1后向RDF写入0时
- 当DTC读取FRDRHL时，但仅当块传输是最后一次传输时
- 当设置和清除条件同时发生时，RDF位被设置为0。之后，当FRDRHL寄存器中存储的数据量等于或大于RTRG值时，RDF被设置为1在1个PCLK之后。

注1.因为FRDRHL是16级FIFO寄存器，所以当RDF为1时可以读取的最大数据量等于指定的接收触发数。如果在读取FRDRHL中的所有数据后尝试读取，则数据未定义。

**TDFE标志（发送FIFO数据空标志）**

TDFE标志表示数据从FTDRHL寄存器传送到TSR寄存器，在FTDRHL低于指定的发送触发数，并且允许将发送数据写入FTDRHL。

[Setting conditions]

- 当SCR的TE位为0时
- 当写入FTDRHL的发送数据量等于或小于指定的发送触发数时\*1

[Clearing conditions]

- 当DTC激活时，在最后一次传输上执行写入FTDRHL时
- 读取TDFE=1后向TDFE标志写入0时。\*2  
当TE=0时，设置条件优先。当设置条件和清除条件同时发生时，TDFE标志设置为0。之后，当FTDRHL寄存器中存储的数据量等于或小于比TTRG值，TDFE在1个PCLK后设置为1。

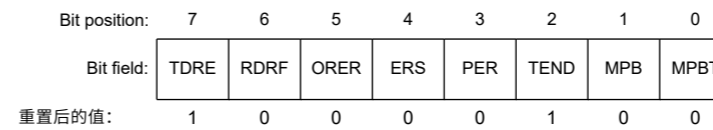
注1.由于FTDRHL寄存器为16级FIFO寄存器，因此当TDFE标志为1时，可写入FTDRHL寄存器的最大数据量为16减去FDR.T[4:0]字节。如果写入更多数据，则丢弃数据。

注2.在DTC的块传输处理过程中，不要清除TDFE标志。

**27.2.17 SSR\_SMCI: 智能卡接口模式的串行状态寄存器 (SCMR.SMIF=1, MMR.MANEN=0)**

Base address: SCIn = 0x4011\_8000 + 0x0100 × n (n = 0, 3, 4, 9)  
SCIm = 0x4011\_8000 + 0x0100 × m (m = 1, 2)

Offset address: 0x04



| Bit | Symbol | Function                                | R/W   |
|-----|--------|---|-------|
| 0   | MPBT   | 多处理器位传输<br>在智能卡接口模式下将此位设置为0             | R/W   |
| 1   | MPB    | Multi-Processor<br>在智能卡接口模式下将此位设置为0     | R     |
| 2   | TEND   | 发送结束标志<br>0: 字符传输中1: 字符传输完成             | R     |
| 3   | PER    | 奇偶校验错误标志<br>0: 未发生奇偶校验错误1<br>: 发生奇偶校验错误 | R/W*1 |
| 4   | ERS    | 错误信号状态标志<br>0: 无低位错误信号响应1: 发生低位错误信号响应   | R/W*1 |

| Bit | Symbol | Function  | R/W              |
|-----|--------|---|------------------|
| 5   | ORER   | Overrun Error Flag<br>0: No overrun error occurred<br>1: Overrun error occurred                     | R/W <sup>1</sup> |
| 6   | RDRF   | Receive Data Full Flag<br>0: No received data in RDR register<br>1: Received data in RDR register   | R/W <sup>1</sup> |
| 7   | TDRE   | Transmit Data Empty Flag<br>0: Transmit data in TDR register<br>1: No transmit data in TDR register | R/W <sup>1</sup> |

Note 1. Only 0 can be written, to clear the flag after reading 1.

The SSR\_SMCI register provides the SCI with smart card interface mode status flags.

#### TEND flag (Transmit End Flag)

When there is no error signal from the receiving side, the TEND flag is set to 1 when more data for transfer is ready to be transferred to the TDR register.

[Setting conditions]

- When the SCR\_SMCI.TE bit = 0 (serial transmission is disabled).  
When the SCR\_SMCI.TE bit is changed from 0 to 1, the TEND flag is not affected and retains the value 1.
- When a specified period elapses after the latest transmission of 1 byte, the ERS flag is 0, and the TDR register is not updated.

The set timing is determined by the following register settings:

- When SMR\_SMCI.GM = 0 and SMR\_SMCI.BLK = 0, 12.5 ETUs after the start of transmission
- When SMR\_SMCI.GM = 0 and SMR\_SMCI.BLK = 1, 11.5 ETUs after the start of transmission
- When SMR\_SMCI.GM = 1 and SMR\_SMCI.BLK = 0, 11.0 ETUs after the start of transmission
- When SMR\_SMCI.GM = 1 and SMR\_SMCI.BLK = 1, 11.0 ETUs after the start of transmission

[Clearing conditions]

- When transmit data is written to the TDR register while the SCR\_SMCI.TE bit is 1
- When 0 is written to TDRE after reading TDRE = 1 while the SCR\_SMCI.TE bit is 1

#### PER flag (Parity Error Flag)

The PER flag indicates that a parity error occurred during reception in asynchronous mode and the reception ended abnormally.

[Setting condition]

- When a parity error is detected during reception. Although receive data is transferred to RDR when a parity error occurs, no SCIn\_RXI interrupt request occurs. After the PER flag is set to 1, the subsequent receive data is not transferred to RDR.

[Clearing condition]

- When 0 is written to PER after reading PER = 1. After writing 0 to the PER flag, read the flag to check that it is actually set to 0.

When the RE bit in SCR\_SMCI is set to 0 (serial reception is disabled), the PER flag is not affected and retains its previous value.

#### ERS flag (Error Signal Status Flag)

[Setting condition]

- When a low error signal is sampled.

[Clearing condition]

| Bit | Symbol | Function                                    | R/W              |
|-----|--------|---|------------------|
| 5   | ORER   | 溢出错误标志<br>0: 未发生溢出错误1: 发生溢出错误               | R/W <sup>1</sup> |
| 6   | RDRF   | 接收数据满标志<br>0: RDR寄存器中没有接收到数据1: RDR寄存器中接收到数据 | R/W <sup>1</sup> |
| 7   | TDRE   | 传输数据空标志<br>0: 在TDR寄存器中发送数据1: 在TDR寄存器中不发送数据  | R/W <sup>1</sup> |

注1.只能写入0, 读取1后清除标志。

SSR\_SMCI寄存器为SCI提供智能卡接口模式状态标志。

#### TEND标志 (发送结束标志)

当接收端没有错误信号时, 当更多数据准备好传输到TDR寄存器时, TEND标志设置为1。

[Setting conditions]

- 当SCR\_SMCI.TE位=0时(禁用串行传输)。  
当SCR\_SMCI.TE位从0变为1时, TEND标志不受影响并保持值1。
- 在最后一次发送1个字节后经过指定时间后, ERS标志为0, 并且不更新TDR寄存器。

设置时序由以下寄存器设置确定:

- 当SMR\_SMCI.GM=0且SMR\_SMCI.BLK=0时, 传输开始后12.5ETU
- 当SMR\_SMCI.GM=0和SMR\_SMCI.BLK=1时, 传输开始后11.5ETU
- 当SMR\_SMCI.GM=1和SMR\_SMCI.BLK=0时, 传输开始后11.0ETU
- 当SMR\_SMCI.GM=1且SMR\_SMCI.BLK=1时, 传输开始后11.0ETU

[Clearing conditions]

- 当SCR\_SMCI.TE位为1时将发送数据写入TDR寄存器
- 当SCR\_SMCI.TE位为1时, 读取TDRE=1后向TDRE写入0

#### PER标志 (奇偶校验错误标志)

PER标志表示在异步模式接收过程中发生奇偶校验错误, 接收异常结束。

[Setting condition]

- 在接收过程中检测到奇偶校验错误时。尽管发生奇偶校验错误时将接收数据传输到RDR, 但不会发生SCIn\_RXI中断请求。PER标志设置为1后, 后续接收数据不会传输到RDR。

[Clearing condition]

- 读取PER=1后向PER写入0时。将0写入PER标志后, 读取该标志以检查它是否实际设置为0。

当SCR\_SMCI中的RE位设置为0(禁用串行接收)时, PER标志不受影响并保留其先前的值。

#### ERS标志 (错误信号状态标志)

[Setting condition]

- 采样低误差信号时。

[Clearing condition]



- When 0 is written to ERS after reading ERS = 1.

**ORER flag (Overrun Error Flag)**

The ORER flag indicates that an overrun error occurred during reception and the reception ended abnormally.

[Setting condition]

- When the next data is received before receive data that does not have a parity error is read from the RDR register. The data received before an overrun error occurred is saved in the RDR, but data received after the error is lost. When the ORER flag is set to 1, receive data is not forwarded to the RDR register.

[Clearing condition]

- When 0 is written to ORER after reading ORER = 1. After writing 0 to the ORER flag, read the flag to check that it is actually set to 0.

When the RE bit in SCR\_SMCI is set to 0, the ORER flag is not affected and retains its previous value.

**RDRF flag (Receive Data Full Flag)**

The RDRF flag indicates the presence of receive data in the RDR register.

[Setting condition]

- When the reception ends normally, and receive data is forwarded from the RSR register to the RDR register.

[Clearing conditions]

- When 0 is written to RDRF after reading RDRF = 1
- When data is forwarded from the RDR register

**TDRE flag (Transmit Data Empty Flag)**

The TDRE flag indicates the presence of transmit data in the TDR register.

[Setting conditions]

- When the SCR\_SMCLTE bit is 0
- When data is transmitted from the TDR register to the TSR register

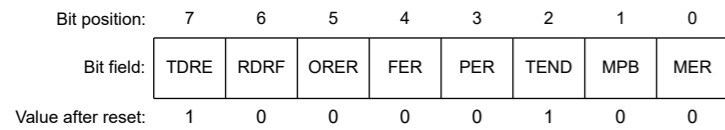
[Clearing conditions]

- When 0 is written to TDRE after reading TDRE = 1
- When the SCR\_SMCLTE bit is 1 and data is written to the TDR register

**27.2.18 SSR\_MANC : Serial Status Register for Manchester Mode (SCMR.SMIF = 0, and MMR.MANEN = 1)**

Base address: SCIn = 0x4011\_8000 + 0x0100 × n (n = 3, 4)

Offset address: 0x04



| Bit | Symbol | Function   | R/W                |
|-----|--------|--|--------------------|
| 0   | MER    | Manchester Error Flag<br>Valid for Manchester mode only<br>0: No Manchester error occurred<br>1: Manchester error has occurred | R/(W) <sup>1</sup> |

- 读取ERS =1后向ERS 写入0时。

**ORER标志 (溢出错误标志)**

ORER标志表示接收期间发生溢出错误，接收异常结束。

[Setting condition]

- 在从RDR寄存器读取没有奇偶校验错误的接收数据之前接收到下一个数据时。发生溢出错误前接收的数据保存在RDR中，但错误发生后接收的数据会丢失。当ORER标志设置为1时，接收数据不转发到RDR寄存器。

[Clearing condition]

- 读取ORER=1后向ORER写入0时。向ORER标志写入0后，读取该标志以检查它是否实际设置为0。

当SCR\_SMCI中的RE位设置为0时，ORER标志不受影响并保留其先前的值。

**RDRF标志 (接收数据满标志)**

RDRF标志指示RDR寄存器中存在接收数据。

[Setting condition]

- 接收正常结束时，接收数据从RSR寄存器转发到RDR寄存器。

[Clearing conditions]

- 读取RDRF=1后向RDRF写入0时
- 从RDR寄存器转发数据时

**TDRE标志 (传输数据空标志)**

TDRE标志表示TDR寄存器中存在发送数据。

[Setting conditions]

- 当SCR\_SMCLTE位为0时
- 当数据从TDR寄存器传送到TSR寄存器时

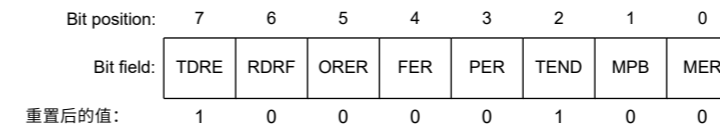
[Clearing conditions]

- 读取TDRE=1后写入0时
- 当SCR\_SMCLTE位为1且数据写入TDR寄存器时

**27.2.18 SSR\_MANC: 曼彻斯特模式的串行状态寄存器 (SCMR.SMIF=0, 并且 MMR.MANEN = 1)**

Base address: SCIn = 0x4011\_8000 + 0x0100 × n (n = 3, 4)

Offset address: 0x04



| Bit | Symbol | Function  | R/W                |
|-----|--------|---|--------------------|
| 0   | MER    | 曼彻斯特错误标志<br>仅适用于曼彻斯特模式<br>0: 未发生曼彻斯特错误<br>1: 发生曼彻斯特错误 | R/(W) <sup>1</sup> |

| Bit | Symbol | Function   | R/W     |
|-----|--------|--|---------|
| 1   | MPB    | Multi-Processor<br>Value of the multi-processor bit in the reception frame<br>0: Data transmission cycles<br>1: ID transmission cycles | R       |
| 2   | TEND   | Transmit End Flag<br>0: A character is being transmitted<br>1: Character transfer has been completed.                                  | R       |
| 3   | PER    | Parity Error Flag<br>0: No parity error occurred<br>1: A parity error has occurred   | R/(W)*1 |
| 4   | FER    | Framing Error Flag<br>0: No framing error occurred<br>1: A framing error has occurred  | R/(W)*1 |
| 5   | ORER   | Overrun Error Flag<br>0: No overrun error occurred<br>1: An overrun error has occurred   | R/(W)*1 |
| 6   | RDRF   | Receive Data Full Flag<br>0: No received data is in RDR register<br>1: Received data is in RDR register                                | R/(W)*1 |
| 7   | TDRE   | Transmit Data Empty Flag<br>0: Transmit data is in TDR register<br>1: No transmit data is in TDR register                              | R/(W)*1 |

Note 1. Only 0 can be written to this bit, to clear the flag after confirmed(read) the flag is set to 1.

SSR is constructed in the status flag of SCI and reception multi processor bits.

#### MER flag (Manchester Error Flag)

When data is received in Manchester mode, Manchester error is detected and it is displayed.

[Setting conditions]

- When receiving in Manchester mode and detecting Manchester code error in data area of received frame. Received data when an error occurs is transferred to the RDR register, but the RXI interrupt request is not generated and the ERI interrupt request is generated.  
When the Manchester error flag is set to "1", subsequent receive data is not transferred to the RDR register. For details on Manchester error, see [section 27.5.11. Errors in Manchester Mode](#).

[Clearing conditions]

- When 0 is written to MER after reading MER = 1 (after writing 0 to it, read the MER bit to check that it has actually been set to 0.)  
Even when the RE bit in SCR is set to 0 (serial reception is disabled), the MER flag is not affected and retains its previous value.

#### MPB flag (Multi-Processor)

Holds the value of the multi-processor bit in the reception frame. This bit does not change when the SCR.RE bit is 0.

#### TEND flag (Transmit End Flag)

Indicates completion of transmission.

[Setting conditions]

- When the SCR.TE bit is set to 0 (serial transmission is disabled) and FCR.FM bit is set to 0 (non-FIFO selected).  
When the SCR.TE bit is changed from 0 to 1, the TEND flag is not affected and retains the value 1.
- When the TDR register is not updated at the time of transmission of the tail-end bit of a character being transmitted

[Clearing conditions]

- When transmit data are written to the TDR register while the SCR.TE bit is 1.

| Bit | Symbol | Function   | R/W     |
|-----|--------|--|---------|
| 1   | MPB    | Multi-Processor<br>接收帧中多处理器位的值<br>0: 数据传输周期1: ID传输周期 | R       |
| 2   | TEND   | 发送结束标志<br>0: 正在传输字符1: 已完成字符传输。                       | R       |
| 3   | PER    | 奇偶校验错误标志<br>0: 未发生奇偶校验错误1: 发生奇偶校验错误                  | R/(W)*1 |
| 4   | FER    | 成帧错误标志<br>0: 未发生帧错误1: 发生帧错误                          | R/(W)*1 |
| 5   | ORER   | 溢出错误标志<br>0: 未发生溢出错误1: 发生溢出错误                        | R/(W)*1 |
| 6   | RDRF   | 接收数据满标志<br>0: RDR寄存器中没有接收到的数据1: RDR寄存器中接收到的数据        | R/(W)*1 |
| 7   | TDRE   | 传输数据空标志<br>0: 发送数据在TDR寄存器1: 没有发送数据在TDR寄存器            | R/(W)*1 |

注1.该位只能写入0,确认(读取)后清除标志,标志设置为1。

SSR由SCI的状态标志和接收多处理器位构成。

#### MER标志(曼彻斯特错误标志)

在曼彻斯特模式下接收数据时,检测到曼彻斯特错误并显示出来。

[Setting conditions]

- 曼彻斯特模式接收时,检测接收帧数据区的曼彻斯特码错误。  
发生错误时接收到的数据被传送到RDR寄存器,但不产生RXI中断请求,产生ERI中断请求。当曼彻斯特错误标志设置为"1"时,后续接收数据不会传输到RDR寄存器。

有关曼彻斯特错误的详细信息,请参阅第27.5.11节。曼彻斯特模式中的错误。

[Clearing conditions]

- 读MER=1后向MER写入0时(向其写入0后,读取MER位以检查它是否已实际设置为0。)即使SCR中的RE位设置为0(串行接收是禁用),MER标志不受影响并保留其先前的值。

#### MPB flag (Multi-Processor)

保存接收帧中多处理器位的值。当SCR.RE位为0时,该位不变。

#### TEND标志(发送结束标志)

表示传输完成。

[Setting conditions]

- 当SCR.TE位设置为0(禁用串行传输)且FCR.FM位设置为0(选择非FIFO)时。当SCR.TE位从0变为1时,TEND标志不受影响并保持值1。
- 发送字符尾端位时,TDR寄存器未更新时

[Clearing conditions]

- 当SCR.TE位为1时将发送数据写入TDR寄存器。

- When 0 is written to TDRE after reading TDRE = 1 while the SCR.TE bit is 1.

**PER flag (Parity Error Flag)**

Indicates that a parity error has occurred during reception in asynchronous mode and the reception ends abnormally.

[Setting condition]

- When a parity error is detected during reception in Asynchronous Mode and the state of Address Match function invalidity (DCCR.DCME = 0).  
Although receive data when the parity error occurs is transferred to RDR, no RXI interrupt request occurs. Note that when the PER flag is being set to 1, the subsequent receive data is not transferred to RDR.

[Clearing condition]

- When 0 is written to PER after reading PER = 1 (after writing 0 to it, read the PER bit to check that it has actually been set to 0.)

Even when the RE bit in SCR is set to 0 (serial reception is disabled), the PER flag is not affected and retains its previous value.

**FER flag (Framing Error Flag)**

Indicates that a framing error has occurred during reception in asynchronous mode and the reception ends abnormally.

[Setting condition]

- When "0" is sampled as the stop bit during reception in Asynchronous Mode and the state of Address Match function invalidity (DCCR.DCME = 0).  
In 2-stop-bit mode, only the first stop bit is checked whether it is 1 but the second stop bit is not checked. Note that although receive data when the framing error occurs is transferred to RDR, no RXI interrupt request occurs. In addition, when the FER flag is being set to 1, the subsequent receive data is not transferred to RDR.

[Clearing condition]

- When 0 is written to FER after reading FER = 1 (after writing 0 to it, read the FER bit to check that it has actually been set to 0.)

Even when the RE bit in SCR is set to 0, the FER flag is not affected and retains its previous value.

**ORER flag (Overrun Error Flag)**

Indicates that an overrun error has occurred during reception and the reception ends abnormally.

[Setting condition]

- When the next data is received before receive data is read from RDR which don't have any valid reception error.  
In RDR, receive data prior to an overrun error occurrence is retained, but data received after the overrun error occurrence is lost. When the ORER flag is set to 1, reception data isn't forwarded to RDR register. Note that, in clock synchronous mode, serial transmission and reception will be stop.

[Clearing condition]

- When 0 is written to ORER after reading ORER = 1 (after writing 0 to it, read the ORER bit to check that it has actually been set to 0.)

Even when the RE bit in SCR is set to 0, the ORER flag is not affected and retains its previous value.

**RDRF flag (Receive Data Full Flag)**

Indicates the presence of receive data in the RDR register.

[Setting condition]

- When the reception ends normally, and receive data is forwarded from the RSR register to the RDR register

[Clearing conditions]

- When it's written to "0" after the state of "1" is read

- 当SCR.TE位为1时，读取TDRE=1后向TDRE写入0。

**PER标志 (奇偶校验错误标志)**

表示异步接收时发生奇偶校验错误，接收异常结束。

[Setting condition]

- 在异步模式接收过程中检测到奇偶校验错误并且地址匹配功能无效状态 (DCCR.DCME=0)。虽然发生奇偶校验错误时的接收数据被传输到RDR，但没有发生RXI中断请求。请注意，当PER标志设置为1时，后续接收数据不会传输到RDR。

[Clearing condition]

- 读取PER=1后向PER写入0时 (写入0后，读取PER位以检查其是否已实际设置为0。)

即使SCR中的RE位设置为0 (禁用串行接收)，PER标志也不受影响并保持其先前的值。

**FER标志 (帧错误标志)**

表示异步模式接收时出现帧错误，接收异常结束。

[Setting condition]

- 当在异步模式接收期间采样"0"作为停止位和地址匹配功能无效状态 (DCCR.DCME=0)。在2-stop-bit模式下，只检查第一个停止位是否为1，不检查第二个停止位。请注意，虽然发生帧错误时的接收数据被传输到RDR，但不会发生RXI中断请求。此外，当FER标志设置为1时，后续接收数据不会传输到RDR。

[Clearing condition]

- 读取FER=1后向FER写入0时 (写入0后，读取FER位以检查其是否已实际设置为0。)

即使SCR中的RE位设置为0，FER标志也不受影响并保持其先前的值。

**ORER标志 (溢出错误标志)**

表示接收过程中发生溢出错误，接收异常结束。

[Setting condition]

- 在接收数据从没有任何有效接收错误的RDR读取之前接收到下一个数据时。在RDR中，保留发生溢出错误之前的接收数据，但发生溢出错误之后接收的数据会丢失。当ORER标志设置为1时，接收数据不转发到RDR寄存器。请注意，在时钟同步模式下，串行发送和接收将停止。

[Clearing condition]

- 读ORER=1后向ORER写入0时 (写入0后，读取ORER位以检查其是否已实际设置为0。)

即使SCR中的RE位设置为0，ORER标志也不受影响并保留其先前的值。

**RDRF标志 (接收数据满标志)**

指示RDR寄存器中存在接收数据。

[Setting condition]

- 接收正常结束时，接收数据从RSR寄存器转发到RDR寄存器

[Clearing conditions]

- 读取"1"状态后写入"0"时

- When it's read the data from the RDR register

**TDRE flag (Transmit Data Empty Flag)**

Indicates the presence of transmit data in the TDR register.

[Setting conditions]

- When the SCR.TE bit is "0"
- When data is transmitted from the TDR register to the TSR register

[Clearing conditions]

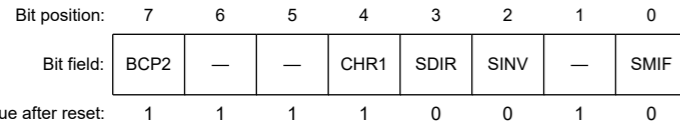
- When it's written to "0" after the state of "1" is read
- When the SCR.TE bit is 1, it's written to the TDR register

Note: RDRF and TDRE should not be cleared by SSR register access unless communication is interrupted.

**27.2.19 SCMR : Smart Card Mode Register**

Base address: SCIn = 0x4011\_8000 + 0x0100 × n (n = 0, 3, 4, 9)  
 SCIm = 0x4011\_8000 + 0x0100 × m (m = 1, 2)

Offset address: 0x06



| Bit | Symbol | Function   | R/W              |
|-----|--------|--|------------------|
| 0   | SMIF   | Smart Card Interface Mode Select<br>0: Non-smart card interface mode (asynchronous mode, clock synchronous mode, simple SPI mode, or simple IIC mode)<br>1: Smart card interface mode  | R/W <sup>1</sup> |
| 1   | —      | This bit is read as 1. The write value should be 1.  | R/W              |
| 2   | SINV   | Transmitted/Received Data Invert<br>Set the SINV bit to 0 for operation in simple IIC mode.<br>The level of communication terminals (RXD, TXD) are controlled by combination of this bit and SPTR.TINV/RINV. For details, see Figure 27.5.<br>The SINV bit can be used in the following modes:<br>• Smart card interface mode<br>• Asynchronous mode (including multi-processor mode)<br>• Clock synchronous mode<br>• Simple SPI mode<br>0: TDR contents are transmitted as they are. Received data is stored as received in the RDR register.<br>1: TDR register contents are inverted before transmission. Receive data is stored in inverted form in the RDR register. | R/W <sup>1</sup> |
| 3   | SDIR   | Transmitted/Received Data Transfer Direction<br>Set the SDIR bit to 1 for operation in simple IIC mode.<br>The SDIR bit can be used in the following modes:<br>• Smart card interface mode<br>• Asynchronous mode (including multi-processor mode)<br>• Clock synchronous mode<br>• Simple SPI mode<br>0: Transfer LSB-first<br>1: Transfer MSB-first  | R/W <sup>1</sup> |

- 从RDR寄存器读取数据时

**TDRE标志 (传输数据空标志)**

指示TDR寄存器中存在发送数据。

[Setting conditions]

- SCR.TE位为“0”时
- 当数据从TDR寄存器传送到TSR寄存器时

[Clearing conditions]

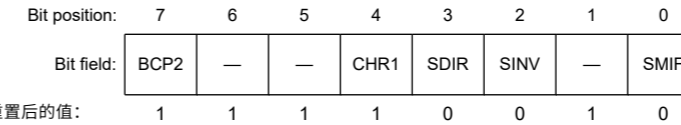
- 读取“1”状态后写入“0”时
- SCR.TE位为1时，写入TDR寄存器

Note: RDRF和TDRE不应被SSR寄存器访问清除，除非通信中断。

**27.2.19 SCMR:智能卡模式寄存器**

Base address: SCIn = 0x4011\_8000 + 0x0100 × n (n = 0, 3, 4, 9)  
 SCIm = 0x4011\_8000 + 0x0100 × m (m = 1, 2)

Offset address: 0x06



| Bit | Symbol | Function  | R/W              |
|-----|--------|---|------------------|
| 0   | SMIF   | 智能卡接口模式选择<br>0: 非智能卡接口模式 (异步模式、时钟同步模式、简单SPI模式或简单IIC模式)<br>1: 智能卡接口方式  | R/W <sup>1</sup> |
| 1   | —      | 该位读取为1。写入值应为1。  | R/W              |
| 2   | SINV   | 发送接收数据反转<br>将SINV位设置为0，以便在简单IIC模式下运行。<br>通信终端 (RXD, TXD) 的电平由该位和SPTR.TINV/RINV组合控制。详见图27.5。SINV位可用于以下模式: ●<br><br>智能卡接口方式<br>• 异步模式 (包括多处理器模式)<br>• 时钟同步模式<br>• 简单SPI模式<br>0: TDR内容按原样发送。接收到的数据按接收到的方式存储在RDR寄存器中。<br>1: TDR寄存器内容在发送前反转。接收数据以反转形式存储在RDR寄存器中。 | R/W <sup>1</sup> |
| 3   | SDIR   | 发送接收数据传输方向<br>将SDIR位设置为1以在简单IIC模式下运行。<br>SDIR位可用于以下模式: ●<br>智能卡接口方式<br>• 异步模式 (包括多处理器模式)<br>• 时钟同步模式<br>• 简单SPI模式<br>0: Transfer LSB-first<br>1: Transfer MSB-first   | R/W <sup>1</sup> |



| Bit | Symbol | Function   | R/W   |
|-----|--------|--|-------|
| 4   | CHR1   | Character Length 1<br>Valid only in asynchronous mode.*2<br>Selects the transmit/receive character length in combination with the SMR.CHR bit.<br>0: SMR.CHR = 0: Transmit/receive in 9-bit data length<br>SMR.CHR = 1: Transmit/receive in 9-bit data length<br>1: SMR.CHR = 0: Transmit/receive in 8-bit data length (initial value)<br>SMR.CHR = 1: Transmit/receive in 7-bit data length*3 | R/W*1 |
| 6:5 | —      | These bits are read as 1. The write value should be 1.   | R/W   |
| 7   | BCP2   | Base Clock Pulse 2<br>Selects the number of base clock cycles in combination with the SMR_SMCI.BCP[1:0] bits.<br>Table 27.5 lists the combinations of the SCMR.BCP2 and SMR_SMCI.BCP[1:0] bits.  | R/W*1 |

Note 1. Writable only when the TE and RE bits in SCR/SCR\_SMCI are 0 (both serial transmission and reception are disabled).

Note 2. The setting is invalid and a fixed data length of 8 bits is used in modes other than asynchronous mode.

Note 3. LSB-first must be selected and the value of the MSB (bit [7]) in TDR cannot be transmitted.

The SCMR register selects the smart card interface and communication format.

#### SMIF bit (Smart Card Interface Mode Select)

Setting the SMIF bit to 1 selects smart card interface mode. Setting it to 0 selects all other modes:

- Asynchronous mode, including multi-processor mode
- Clock synchronous mode
- Simple SPI mode
- Simple IIC mode

#### SINV bit (Transmitted/Received Data Invert)

The SINV bit inverts the transmit and receive data logic level. It does not affect the logic level of the parity bit. To invert the parity bit, invert the PM bit in SMR or SMR\_SMCI.

#### CHR1 bit (Character Length 1)

The CHR1 bit selects the data length of transmit and receive data in combination with the CHR bit in the SMR register. A fixed data length of 8 bits is used in modes other than asynchronous mode.

#### BCP2 bit (Base Clock Pulse 2)

The BCP2 bit selects the number of base clock cycles in a 1-bit data transfer time in smart card interface mode. Set this bit in combination with the SMR\_SMCI.BCP[1:0] bits.

Table 27.5 Combinations of the SCMR.BCP2 and SMR\_SMCI.BCP[1:0] bits

| SCMR.BCP2 bit | SMR_SMCI.BCP[1:0] bits | Number of base clock cycles for 1-bit transfer period |
|---------------|------------------------|---|
| 0             | 00b                    | 93 clock cycles (S = 93)*1                            |
| 0             | 01b                    | 128 clock cycles (S = 128)*1                          |
| 0             | 10b                    | 186 clock cycles (S = 186)*1                          |
| 0             | 11b                    | 512 clock cycles (S = 512)*1                          |
| 1             | 00b                    | 32 clock cycles (S = 32) (Initial Value)*1            |
| 1             | 01b                    | 64 clock cycles (S = 64)*1                            |
| 1             | 10b                    | 372 clock cycles (S = 372)*1                          |
| 1             | 11b                    | 256 clock cycles (S = 256)*1                          |

Note 1. S is the value of S in BRR : Bit Rate Register.

| Bit | Symbol | Function   | R/W   |
|-----|--------|--|-------|
| 4   | CHR1   | 字符长度1<br>仅在异步模式下有效。*2<br>结合SMR.CHR位选择发送接收字符长度。<br>0: SMR.CHR=0: 发送接收9位数据长度SMR.CHR=1:<br>发送接收9位数据长度<br>1: SMR.CHR=0: 发送接收以8位数据长度(初始值) SMR.CHR=1:<br>发送接收以7位数据长度*3 | R/W*1 |
| 6:5 | —      | 这些位被读取为1。写入值应为1。   | R/W   |
| 7   | BCP2   | 基本时钟脉冲2<br>结合SMR_SMCI.BCP[1:0]位选择基本时钟周期数。<br>表27.5列出了SCMR.BCP2和SMR_SMCI.BCP[1:0]位的组合。  | R/W*1 |

注1.仅当SCR/SCR\_SMCI中的TE和RE位为0时可写(串行发送和接收均禁用)。

注2.设置无效,异步模式以外的模式使用固定的8位数据长度。

注3.必须选择LSB-first并且不能传输TDR中MSB(位[7])的值。

SCMR寄存器选择智能卡接口和通信格式。

#### SMIF位(智能卡接口模式选择)

将SMIF位设置为1选择智能卡接口模式。将其设置为0会选择所有其他模式:

- 异步模式,包括多处理器模式
- 时钟同步模式
- 简单SPI模式
- 简单IIC模式

#### SINV位(发送接收数据反转)

SINV位反转发送和接收数据逻辑电平。它不影响奇偶校验位的逻辑电平。要反转奇偶校验位,请反转SMR或SMR\_SMCI中的PM位。

#### CHR1位(字符长度1)

CHR1位结合SMR寄存器中的CHR位选择发送和接收数据的数据长度。在异步模式以外的模式中使用8位的固定数据长度。

#### BCP2位(基本时钟脉冲2)

BCP2位选择智能卡接口模式下1位数据传输时间内的基本时钟周期数。将该位与SMR\_SMCI.BCP[1:0]位一起设置。

Table 27.5 SCMR.BCP2和SMR\_SMCI.BCP[1:0]位的组合

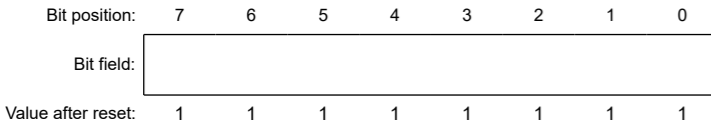
| SCMR.BCP2 bit | SMR_SMCI.BCP[1:0] bits | 1位传输周期的基本时钟周期数       |
|---------------|------------------------|----------------------|
| 0             | 00b                    | 93个时钟周期(S=93)*1      |
| 0             | 01b                    | 128个时钟周期(S=128)*1    |
| 0             | 10b                    | 186个时钟周期(S=186)*1    |
| 0             | 11b                    | 512个时钟周期(S=512)*1    |
| 1             | 00b                    | 32个时钟周期(S=32)(初始值)*1 |
| 1             | 01b                    | 64个时钟周期(S=64)*1      |
| 1             | 10b                    | 372个时钟周期(S=372)*1    |
| 1             | 11b                    | 256个时钟周期(S=256)*1    |

注1.S是BRR中S的值:比特率寄存器。

27.2.20 BRR : Bit Rate Register

Base address: SCIn = 0x4011\_8000 + 0x0100 × n (n = 0, 3, 4, 9)  
 SCIm = 0x4011\_8000 + 0x0100 × m (m = 1, 2)

Offset address: 0x01



BRR is an 8-bit register that adjusts the bit rate.

As each SCI channel has independent baud rate generator control, different bit rates can be set for each channel. Table 27.6 shows the relationship between the setting (N) in the BRR and the bit rate (B) for normal asynchronous mode, multi-processor transfer, clock synchronous mode, smart card interface mode, simple SPI mode, and simple IIC mode.

The initial value of the BRR register is 0xFF. The BRR register can be read by the CPU, but it can be written to only when the TE and RE bits in SCR/SCR\_SMCI are 0.

Table 27.6 Relationship between N setting in BRR and bit rate B

| Mode                                   | SEMR settings |            |            | BRR setting  | Error  |
|--|---------------|------------|------------|--|--|
|  | BGDM bit      | ABCS bit   | ABCS E bit |  |  |
| Asynchronous, multi-processor transfer | 0             | 0          | 0          | $N = \frac{PCLK \times 10^6}{64 \times 2^{2n-1} \times B} - 1$ | $Error (\%) = \left\{ \frac{PCLK \times 10^6}{B \times 64 \times 2^{2n-1} \times (N+1)} - 1 \right\} \times 100$ |
|  | 1             | 0          | 0          | $N = \frac{PCLK \times 10^6}{32 \times 2^{2n-1} \times B} - 1$ | $Error (\%) = \left\{ \frac{PCLK \times 10^6}{B \times 32 \times 2^{2n-1} \times (N+1)} - 1 \right\} \times 100$ |
|  | 0             | 1          | 0          | $N = \frac{PCLK \times 10^6}{16 \times 2^{2n-1} \times B} - 1$ | $Error (\%) = \left\{ \frac{PCLK \times 10^6}{B \times 16 \times 2^{2n-1} \times (N+1)} - 1 \right\} \times 100$ |
|  | 1             | 1          | 0          | $N = \frac{PCLK \times 10^6}{12 \times 2^{2n-1} \times B} - 1$ | $Error (\%) = \left\{ \frac{PCLK \times 10^6}{B \times 12 \times 2^{2n-1} \times (N+1)} - 1 \right\} \times 100$ |
|  | Don't care    | Don't care | 1          | $N = \frac{PCLK \times 10^6}{12 \times 2^{2n-1} \times B} - 1$ | $Error (\%) = \left\{ \frac{PCLK \times 10^6}{B \times 12 \times 2^{2n-1} \times (N+1)} - 1 \right\} \times 100$ |
| Clock synchronous, simple SPI          |               |            |            | $N = \frac{PCLK \times 10^6}{8 \times 2^{2n-1} \times B} - 1$  | —  |
| Smart card interface                   |               |            |            | $N = \frac{PCLK \times 10^6}{S \times 2^{2n+1} \times B} - 1$  | $Error (\%) = \left\{ \frac{PCLK \times 10^6}{B \times S \times 2^{2n+1} \times (N+1)} - 1 \right\} \times 100$  |
| Simple IIC <sup>1</sup>                |               |            |            | $N = \frac{PCLK \times 10^6}{64 \times 2^{2n-1} \times B} - 1$ | —  |

Note: B: Bit rate (bps)  
 N: BRR setting for on-chip baud rate generator (0 ≤ N ≤ 255)  
 PCLK: Operating frequency (MHz)  
 n and S: Determined by the SMR/SMR\_SMCI and SCMR register settings as listed in Table 27.8 and Table 27.9.  
 Note 1. Adjust the bit rate so that the widths of high and low level of the SCLn output in simple IIC mode satisfy the I<sup>2</sup>C bus standard.

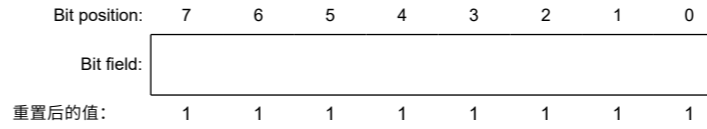
Table 27.7 Calculating widths of SCLn high and low levels

| Mode | SCLn                                | Formula (result in seconds)   |
|------|-------------------------------------|---|
| IIC  | Width at high level (minimum value) | $(N + 1) \times 4 \times 2^{2n-1} \times 7 \times \frac{1}{PCLK \times 10^6}$ |
|      | Width at low level (minimum value)  | $(N + 1) \times 4 \times 2^{2n-1} \times 8 \times \frac{1}{PCLK \times 10^6}$ |

27.2.20 BRR:比特率寄存器

Base address: SCIn = 0x4011\_8000 + 0x0100 × n (n = 0, 3, 4, 9)  
 SCIm = 0x4011\_8000 + 0x0100 × m (m = 1, 2)

Offset address: 0x01



BRR是一个8位寄存器，用于调整比特率。

由于每个SCI通道都有独立的波特率发生器控制，因此可以为每个通道设置不同的比特率。表27.6显示了BRR中的设置(N)与正常异步模式、多处理器传输、时钟同步模式、智能卡接口模式、简单SPI模式和简单IIC模式的比特率(B)之间的关系。

BRR寄存器的初始值为0xFF。BRR寄存器可以被CPU读取，但只有当SCR/SCR\_SMCI中的TE和RE位为0时才能写入。

Table 27.6 BRR中的N设置与比特率B的关系

| Mode                    | SEMR settings |            |         | BRR setting  | Error  |
|-------------------------|---------------|------------|---------|--|--|
|                         | BGDM bit      | ABCS 位     | ABCS E位 |  |  |
| 异步、多处理器传输               | 0             | 0          | 0       | $N = \frac{PCLK \times 10^6}{64 \times 2^{2n-1} \times B} - 1$ | $Error (\%) = \left\{ \frac{PCLK \times 10^6}{B \times 64 \times 2^{2n-1} \times (N+1)} - 1 \right\} \times 100$ |
|                         | 1             | 0          | 0       | $N = \frac{PCLK \times 10^6}{32 \times 2^{2n-1} \times B} - 1$ | $Error (\%) = \left\{ \frac{PCLK \times 10^6}{B \times 32 \times 2^{2n-1} \times (N+1)} - 1 \right\} \times 100$ |
|                         | 0             | 1          | 0       | $N = \frac{PCLK \times 10^6}{16 \times 2^{2n-1} \times B} - 1$ | $Error (\%) = \left\{ \frac{PCLK \times 10^6}{B \times 16 \times 2^{2n-1} \times (N+1)} - 1 \right\} \times 100$ |
|                         | 1             | 1          | 0       | $N = \frac{PCLK \times 10^6}{12 \times 2^{2n-1} \times B} - 1$ | $Error (\%) = \left\{ \frac{PCLK \times 10^6}{B \times 12 \times 2^{2n-1} \times (N+1)} - 1 \right\} \times 100$ |
|                         | Don't care    | Don't care | 1       | $N = \frac{PCLK \times 10^6}{12 \times 2^{2n-1} \times B} - 1$ | $Error (\%) = \left\{ \frac{PCLK \times 10^6}{B \times 12 \times 2^{2n-1} \times (N+1)} - 1 \right\} \times 100$ |
| 时钟同步，简单的SPI             |               |            |         | $N = \frac{PCLK \times 10^6}{8 \times 2^{2n-1} \times B} - 1$  | —  |
| 智能卡接口                   |               |            |         | $N = \frac{PCLK \times 10^6}{S \times 2^{2n+1} \times B} - 1$  | $Error (\%) = \left\{ \frac{PCLK \times 10^6}{B \times S \times 2^{2n+1} \times (N+1)} - 1 \right\} \times 100$  |
| Simple IIC <sup>1</sup> |               |            |         | $N = \frac{PCLK \times 10^6}{64 \times 2^{2n-1} \times B} - 1$ | —  |

Note: B: 比特率 (bps)  
 N: 片内波特率发生器的BRR设置 (0≤N≤255)  
 PCLK: 工作频率(MHz)n和S: 由表27.8和表27.9中列出的SMR/SMR\_SMCI和SCMR寄存器设置决定。

注1.调整比特率，使简单IIC模式下SCLn输出的高低电平宽度满足I2C总线标准。

Table 27.7 计算SCLn高低电平的宽度

| Mode | SCLn        | 公式 (以秒为单位的結果)   |
|------|-------------|---|
| IIC  | 高电平宽度 (最小值) | $(N + 1) \times 4 \times 2^{2n-1} \times 7 \times \frac{1}{PCLK \times 10^6}$ |
|      | 低电平宽度 (最小值) | $(N + 1) \times 4 \times 2^{2n-1} \times 8 \times \frac{1}{PCLK \times 10^6}$ |

Table 27.8 Clock source settings

| SMR or SMR_SMCI.CKS[1:0] bits setting | Clock source  | n |
|---------------------------------------|---------------|---|
| CKS[1:0] bits                         |               |   |
| 00b                                   | PCLK clock    | 0 |
| 01b                                   | PCLK/4 clock  | 1 |
| 10b                                   | PCLK/16 clock | 2 |
| 11b                                   | PCLK/64 clock | 3 |

Table 27.9 Base clock settings in smart card interface mode

| SCMR.BCP2 bit setting | SMR_SMCI.BCP[1:0] bits setting | Base clock cycles for 1-bit period | S   |
|-----------------------|--------------------------------|------------------------------------|-----|
| BCP2 bit              | BCP[1:0] bits                  |                                    |     |
| 0                     | 00b                            | 93 clock cycles                    | 93  |
| 0                     | 01b                            | 128 clock cycles                   | 128 |
| 0                     | 10b                            | 186 clock cycles                   | 186 |
| 0                     | 11b                            | 512 clock cycles                   | 512 |
| 1                     | 00b                            | 32 clock cycles                    | 32  |
| 1                     | 01b                            | 64 clock cycles                    | 64  |
| 1                     | 10b                            | 372 clock cycles                   | 372 |
| 1                     | 11b                            | 256 clock cycles                   | 256 |

Table 27.10 and Table 27.11 list examples of BRR (N) settings in normal asynchronous mode. Table 27.12 lists the maximum bit rate settable for each operating frequency. Table 27.16 lists examples of BRR (N) settings in smart card interface mode.

In smart card interface mode, the number of base clock cycles S in a 1-bit data transfer time can be selected. For details, see section 27.7.4. Receive Data Sampling Timing and Reception Margin. Table 27.13 and Table 27.15 list the maximum bit rates with external clock input.

When either the Asynchronous Mode Base Clock Select bit (ABCS) or the Baud Rate Generator Double-speed Mode Select bit (BGDM) in the Serial Extended Mode Register (SEMR) is set to 1 in asynchronous mode, the bit rate becomes twice the value listed in Table 27.17. When both of those registers are set to 1, the bit rate becomes four times the listed value.

Table 27.10 Examples of BRR settings for different bit rates in asynchronous mode (1) (1 of 2)

| Bit rate (bps) | Operating frequency PCLK (MHz) |     |           |        |     |           |    |     |           |    |     |           |        |     |           |
|----------------|--------------------------------|-----|-----------|--------|-----|-----------|----|-----|-----------|----|-----|-----------|--------|-----|-----------|
|                | 8                              |     |           | 9.8304 |     |           | 10 |     |           | 12 |     |           | 12.288 |     |           |
|                | n                              | N   | Error (%) | n      | N   | Error (%) | n  | N   | Error (%) | n  | N   | Error (%) | n      | N   | Error (%) |
| 110            | 2                              | 141 | 0.03      | 2      | 174 | -0.26     | 2  | 177 | -0.25     | 2  | 212 | 0.03      | 2      | 217 | 0.08      |
| 150            | 2                              | 103 | 0.16      | 2      | 127 | 0.00      | 2  | 129 | 0.16      | 2  | 155 | 0.16      | 2      | 159 | 0.00      |
| 300            | 1                              | 207 | 0.16      | 1      | 255 | 0.00      | 2  | 64  | 0.16      | 2  | 77  | 0.16      | 2      | 79  | 0.00      |
| 600            | 1                              | 103 | 0.16      | 1      | 127 | 0.00      | 1  | 129 | 0.16      | 1  | 155 | 0.16      | 1      | 159 | 0.00      |
| 1200           | 0                              | 207 | 0.16      | 0      | 255 | 0.00      | 1  | 64  | 0.16      | 1  | 77  | 0.16      | 1      | 79  | 0.00      |
| 2400           | 0                              | 103 | 0.16      | 0      | 127 | 0.00      | 0  | 129 | 0.16      | 0  | 155 | 0.16      | 0      | 159 | 0.00      |
| 4800           | 0                              | 51  | 0.16      | 0      | 63  | 0.00      | 0  | 64  | 0.16      | 0  | 77  | 0.16      | 0      | 79  | 0.00      |
| 9600           | 0                              | 25  | 0.16      | 0      | 31  | 0.00      | 0  | 32  | -1.36     | 0  | 38  | 0.16      | 0      | 39  | 0.00      |
| 19200          | 0                              | 12  | 0.16      | 0      | 15  | 0.00      | 0  | 15  | 1.73      | 0  | 19  | -2.34     | 0      | 19  | 0.00      |
| 31250          | 0                              | 7   | 0.00      | 0      | 9   | -1.70     | 0  | 9   | 0.00      | 0  | 11  | 0.00      | 0      | 11  | 2.40      |
| 38400          | —                              | —   | —         | 0      | 7   | 0.00      | 0  | 7   | 1.73      | 0  | 9   | -2.34     | 0      | 9   | 0.00      |

Table 27.8 时钟源设置

| SMR或SMR_SMCI.CKS[1:0]位设置 | 时钟源           | n |
|--------------------------|---------------|---|
| CKS[1:0] bits            |               |   |
| 00b                      | PCLK clock    | 0 |
| 01b                      | PCLK/4 clock  | 1 |
| 10b                      | PCLK/16 clock | 2 |
| 11b                      | PCLK/64 clock | 3 |

Table 27.9 智能卡接口模式下的基本时钟设置

| SCMR.BCP2位设置 | SMR_SMCI.BCP[1:0]位设置 | 1位周期的基本时钟周期 | S   |
|--------------|----------------------|-------------|-----|
| BCP2 bit     | BCP[1:0] bits        |             |     |
| 0            | 00b                  | 93个时钟周期     | 93  |
| 0            | 01b                  | 128个时钟周期    | 128 |
| 0            | 10b                  | 186个时钟周期    | 186 |
| 0            | 11b                  | 512个时钟周期    | 512 |
| 1            | 00b                  | 32个时钟周期     | 32  |
| 1            | 01b                  | 64个时钟周期     | 64  |
| 1            | 10b                  | 372个时钟周期    | 372 |
| 1            | 11b                  | 256个时钟周期    | 256 |

表27.10和表27.11列出了正常异步模式下的BRR(N)设置示例。表27.12列出了每个工作频率可设置的最大比特率。表27.16列出了智能卡接口模式下的BRR(N)设置示例。

在智能卡接口模式下，可以选择1位数据传输时间内的基本时钟周期数S。有关详细信息，请参阅第27.7.4节。接收数据采样时序和接收余量。表27.13和表27.15列出了外部时钟输入的最大比特率。

当串行扩展模式寄存器(SEMR)中的异步模式基本时钟选择位(ABCS)或波特率发生器双速模式选择位(BGDM)在异步模式下设置为1时，比特率变为该值的两倍列于表27.17中。当这两个寄存器都设置为1时，比特率变为所列值的四倍。

Table 27.10 异步模式下不同比特率的BRR设置示例(1)(1of2)

| 比特率 (bps) | 工作频率PCLK(MHz) |     |           |        |     |           |    |     |           |    |     |           |        |     |           |
|-----------|---------------|-----|-----------|--------|-----|-----------|----|-----|-----------|----|-----|-----------|--------|-----|-----------|
|           | 8             |     |           | 9.8304 |     |           | 10 |     |           | 12 |     |           | 12.288 |     |           |
|           | n             | N   | Error (%) | n      | N   | Error (%) | n  | N   | Error (%) | n  | N   | Error (%) | n      | N   | Error (%) |
| 110       | 2             | 141 | 0.03      | 2      | 174 | -0.26     | 2  | 177 | -0.25     | 2  | 212 | 0.03      | 2      | 217 | 0.08      |
| 150       | 2             | 103 | 0.16      | 2      | 127 | 0.00      | 2  | 129 | 0.16      | 2  | 155 | 0.16      | 2      | 159 | 0.00      |
| 300       | 1             | 207 | 0.16      | 1      | 255 | 0.00      | 2  | 64  | 0.16      | 2  | 77  | 0.16      | 2      | 79  | 0.00      |
| 600       | 1             | 103 | 0.16      | 1      | 127 | 0.00      | 1  | 129 | 0.16      | 1  | 155 | 0.16      | 1      | 159 | 0.00      |
| 1200      | 0             | 207 | 0.16      | 0      | 255 | 0.00      | 1  | 64  | 0.16      | 1  | 77  | 0.16      | 1      | 79  | 0.00      |
| 2400      | 0             | 103 | 0.16      | 0      | 127 | 0.00      | 0  | 129 | 0.16      | 0  | 155 | 0.16      | 0      | 159 | 0.00      |
| 4800      | 0             | 51  | 0.16      | 0      | 63  | 0.00      | 0  | 64  | 0.16      | 0  | 77  | 0.16      | 0      | 79  | 0.00      |
| 9600      | 0             | 25  | 0.16      | 0      | 31  | 0.00      | 0  | 32  | -1.36     | 0  | 38  | 0.16      | 0      | 39  | 0.00      |
| 19200     | 0             | 12  | 0.16      | 0      | 15  | 0.00      | 0  | 15  | 1.73      | 0  | 19  | -2.34     | 0      | 19  | 0.00      |
| 31250     | 0             | 7   | 0.00      | 0      | 9   | -1.70     | 0  | 9   | 0.00      | 0  | 11  | 0.00      | 0      | 11  | 2.40      |
| 38400     | —             | —   | —         | 0      | 7   | 0.00      | 0  | 7   | 1.73      | 0  | 9   | -2.34     | 0      | 9   | 0.00      |

Table 27.10 Examples of BRR settings for different bit rates in asynchronous mode (1) (2 of 2)

| Bit rate (bps) | Operating frequency PCLK (MHz) |     |           |    |     |           |         |     |           |    |     |           |         |     |           |
|----------------|--------------------------------|-----|-----------|----|-----|-----------|---------|-----|-----------|----|-----|-----------|---------|-----|-----------|
|                | 14                             |     |           | 16 |     |           | 17.2032 |     |           | 18 |     |           | 19.6608 |     |           |
|                | n                              | N   | Error (%) | n  | N   | Error (%) | n       | N   | Error (%) | n  | N   | Error (%) | n       | N   | Error (%) |
| 110            | 2                              | 248 | -0.17     | 3  | 70  | 0.03      | 3       | 75  | 0.48      | 3  | 79  | -0.12     | 3       | 86  | 0.31      |
| 150            | 2                              | 181 | 0.16      | 2  | 207 | 0.16      | 2       | 223 | 0.00      | 2  | 233 | 0.16      | 2       | 255 | 0.00      |
| 300            | 2                              | 90  | 0.16      | 2  | 103 | 0.16      | 2       | 111 | 0.00      | 2  | 116 | 0.16      | 2       | 127 | 0.00      |
| 600            | 1                              | 181 | 0.16      | 1  | 207 | 0.16      | 1       | 223 | 0.00      | 1  | 233 | 0.16      | 1       | 255 | 0.00      |
| 1200           | 1                              | 90  | 0.16      | 1  | 103 | 0.16      | 1       | 111 | 0.00      | 1  | 116 | 0.16      | 1       | 127 | 0.00      |
| 2400           | 0                              | 181 | 0.16      | 0  | 207 | 0.16      | 0       | 223 | 0.00      | 0  | 233 | 0.16      | 0       | 255 | 0.00      |
| 4800           | 0                              | 90  | 0.16      | 0  | 103 | 0.16      | 0       | 111 | 0.00      | 0  | 116 | 0.16      | 0       | 127 | 0.00      |
| 9600           | 0                              | 45  | -0.93     | 0  | 51  | 0.16      | 0       | 55  | 0.00      | 0  | 58  | -0.69     | 0       | 63  | 0.00      |
| 19200          | 0                              | 22  | -0.93     | 0  | 25  | 0.16      | 0       | 27  | 0.00      | 0  | 28  | 1.02      | 0       | 31  | 0.00      |
| 31250          | 0                              | 13  | 0.00      | 0  | 15  | 0.00      | 0       | 16  | 1.20      | 0  | 17  | 0.00      | 0       | 19  | -1.70     |
| 38400          | —                              | —   | —         | 0  | 12  | 0.16      | 0       | 13  | 0.00      | 0  | 14  | -2.34     | 0       | 15  | 0.00      |

Note: In this example, SEMR.ABCS = 0, SEMR.ABCSE = 0, and SEMR.BGDM = 0.  
When either the ABCS or BGDM bit is set to 1, the bit rate doubles.  
When both ABCS and BGDM are set to 1, the bit rate increases four times.

Table 27.11 Examples of BRR settings for different bit rates in asynchronous mode (2) (1 of 3)

| Bit rate (bps) | Operating frequency PCLK (MHz) |     |           |    |     |           |    |     |           |    |     |           |    |     |           |
|----------------|--------------------------------|-----|-----------|----|-----|-----------|----|-----|-----------|----|-----|-----------|----|-----|-----------|
|                | 20                             |     |           | 25 |     |           | 30 |     |           | 33 |     |           | 40 |     |           |
|                | n                              | N   | Error (%) | n  | N   | Error (%) | n  | N   | Error (%) | n  | N   | Error (%) | n  | N   | Error (%) |
| 110            | 3                              | 88  | -0.25     | 3  | 110 | -0.02     | 3  | 132 | 0.13      | 3  | 145 | 0.33      | 3  | 177 | -0.25     |
| 150            | 3                              | 64  | 0.16      | 3  | 80  | 0.47      | 3  | 97  | -0.35     | 3  | 106 | 0.39      | 3  | 129 | 0.16      |
| 300            | 2                              | 129 | 0.16      | 2  | 162 | -0.15     | 2  | 194 | 0.16      | 2  | 214 | -0.07     | 3  | 64  | 0.16      |
| 600            | 2                              | 64  | 0.16      | 2  | 80  | 0.47      | 2  | 97  | -0.35     | 2  | 106 | 0.39      | 2  | 129 | 0.16      |
| 1200           | 1                              | 129 | 0.16      | 1  | 162 | -0.15     | 1  | 194 | 0.16      | 1  | 214 | -0.07     | 2  | 64  | 0.16      |
| 2400           | 1                              | 64  | 0.16      | 1  | 80  | 0.47      | 1  | 97  | -0.35     | 1  | 106 | 0.39      | 1  | 129 | 0.16      |
| 4800           | 0                              | 129 | 0.16      | 0  | 162 | -0.15     | 0  | 194 | 0.16      | 0  | 214 | -0.07     | 1  | 64  | 0.16      |
| 9600           | 0                              | 64  | 0.16      | 0  | 80  | 0.47      | 0  | 97  | -0.35     | 0  | 106 | 0.39      | 0  | 129 | 0.16      |
| 19200          | 0                              | 32  | -1.36     | 0  | 40  | -0.76     | 0  | 48  | -0.35     | 0  | 53  | -0.54     | 0  | 64  | 0.16      |
| 31250          | 0                              | 19  | 0.00      | 0  | 24  | 0.00      | 0  | 29  | 0.00      | 0  | 32  | 0.00      | 0  | 39  | 0.00      |
| 38400          | 0                              | 15  | 1.73      | 0  | 19  | 1.73      | 0  | 23  | 1.73      | 0  | 26  | -0.54     | 0  | 32  | -1.36     |

Table 27.11 Examples of BRR settings for different bit rates in asynchronous mode (2) (2 of 3)

| Bit rate (bps) | Operating frequency PCLK (MHz) |     |           |    |     |           |     |     |           |
|----------------|--------------------------------|-----|-----------|----|-----|-----------|-----|-----|-----------|
|                | 50                             |     |           | 60 |     |           | 100 |     |           |
|                | n                              | N   | Error (%) | n  | N   | Error (%) | n   | N   | Error (%) |
| 110            | 3                              | 221 | -0.02     | —  | —   | —         | 3   | 255 | —         |
| 150            | 3                              | 162 | -0.15     | 3  | 194 | 0.16      | 3   | 255 | —         |
| 300            | 3                              | 80  | 0.47      | 3  | 97  | -0.35     | 3   | 162 | -0.15     |
| 600            | 2                              | 162 | -0.15     | 3  | 48  | -0.35     | 3   | 80  | 0.47      |
| 1200           | 2                              | 80  | 0.47      | 2  | 97  | -0.35     | 2   | 162 | -0.15     |
| 2400           | 1                              | 162 | -0.15     | 2  | 48  | -0.35     | 2   | 80  | 0.47      |

Table 27.10 异步模式下不同比特率的BRR设置示例(1)(2of2)

| 比特率 (bps) | 工作频率PCLK(MHz) |     |           |    |     |           |         |     |           |    |     |           |         |     |           |
|-----------|---------------|-----|-----------|----|-----|-----------|---------|-----|-----------|----|-----|-----------|---------|-----|-----------|
|           | 14            |     |           | 16 |     |           | 17.2032 |     |           | 18 |     |           | 19.6608 |     |           |
|           | n             | N   | Error (%) | n  | N   | Error (%) | n       | N   | Error (%) | n  | N   | Error (%) | n       | N   | Error (%) |
| 110       | 2             | 248 | -0.17     | 3  | 70  | 0.03      | 3       | 75  | 0.48      | 3  | 79  | -0.12     | 3       | 86  | 0.31      |
| 150       | 2             | 181 | 0.16      | 2  | 207 | 0.16      | 2       | 223 | 0.00      | 2  | 233 | 0.16      | 2       | 255 | 0.00      |
| 300       | 2             | 90  | 0.16      | 2  | 103 | 0.16      | 2       | 111 | 0.00      | 2  | 116 | 0.16      | 2       | 127 | 0.00      |
| 600       | 1             | 181 | 0.16      | 1  | 207 | 0.16      | 1       | 223 | 0.00      | 1  | 233 | 0.16      | 1       | 255 | 0.00      |
| 1200      | 1             | 90  | 0.16      | 1  | 103 | 0.16      | 1       | 111 | 0.00      | 1  | 116 | 0.16      | 1       | 127 | 0.00      |
| 2400      | 0             | 181 | 0.16      | 0  | 207 | 0.16      | 0       | 223 | 0.00      | 0  | 233 | 0.16      | 0       | 255 | 0.00      |
| 4800      | 0             | 90  | 0.16      | 0  | 103 | 0.16      | 0       | 111 | 0.00      | 0  | 116 | 0.16      | 0       | 127 | 0.00      |
| 9600      | 0             | 45  | -0.93     | 0  | 51  | 0.16      | 0       | 55  | 0.00      | 0  | 58  | -0.69     | 0       | 63  | 0.00      |
| 19200     | 0             | 22  | -0.93     | 0  | 25  | 0.16      | 0       | 27  | 0.00      | 0  | 28  | 1.02      | 0       | 31  | 0.00      |
| 31250     | 0             | 13  | 0.00      | 0  | 15  | 0.00      | 0       | 16  | 1.20      | 0  | 17  | 0.00      | 0       | 19  | -1.70     |
| 38400     | —             | —   | —         | 0  | 12  | 0.16      | 0       | 13  | 0.00      | 0  | 14  | -2.34     | 0       | 15  | 0.00      |

Note: 在此示例中, SEMR.ABCS=0、SEMR.ABCSE=0和SEMR.BGDM=0。  
当ABCS或BGDM位设置为1时, 比特率加倍。  
当ABCS和BGDM都设置为1时, 比特率增加四倍。

Table 27.11 异步模式下不同比特率的BRR设置示例(2)(1of3)

| 比特率 (bps) | 工作频率PCLK(MHz) |     |           |    |     |           |    |     |           |    |     |           |    |     |           |
|-----------|---------------|-----|-----------|----|-----|-----------|----|-----|-----------|----|-----|-----------|----|-----|-----------|
|           | 20            |     |           | 25 |     |           | 30 |     |           | 33 |     |           | 40 |     |           |
|           | n             | N   | Error (%) | n  | N   | Error (%) | n  | N   | Error (%) | n  | N   | Error (%) | n  | N   | Error (%) |
| 110       | 3             | 88  | -0.25     | 3  | 110 | -0.02     | 3  | 132 | 0.13      | 3  | 145 | 0.33      | 3  | 177 | -0.25     |
| 150       | 3             | 64  | 0.16      | 3  | 80  | 0.47      | 3  | 97  | -0.35     | 3  | 106 | 0.39      | 3  | 129 | 0.16      |
| 300       | 2             | 129 | 0.16      | 2  | 162 | -0.15     | 2  | 194 | 0.16      | 2  | 214 | -0.07     | 3  | 64  | 0.16      |
| 600       | 2             | 64  | 0.16      | 2  | 80  | 0.47      | 2  | 97  | -0.35     | 2  | 106 | 0.39      | 2  | 129 | 0.16      |
| 1200      | 1             | 129 | 0.16      | 1  | 162 | -0.15     | 1  | 194 | 0.16      | 1  | 214 | -0.07     | 2  | 64  | 0.16      |
| 2400      | 1             | 64  | 0.16      | 1  | 80  | 0.47      | 1  | 97  | -0.35     | 1  | 106 | 0.39      | 1  | 129 | 0.16      |
| 4800      | 0             | 129 | 0.16      | 0  | 162 | -0.15     | 0  | 194 | 0.16      | 0  | 214 | -0.07     | 1  | 64  | 0.16      |
| 9600      | 0             | 64  | 0.16      | 0  | 80  | 0.47      | 0  | 97  | -0.35     | 0  | 106 | 0.39      | 0  | 129 | 0.16      |
| 19200     | 0             | 32  | -1.36     | 0  | 40  | -0.76     | 0  | 48  | -0.35     | 0  | 53  | -0.54     | 0  | 64  | 0.16      |
| 31250     | 0             | 19  | 0.00      | 0  | 24  | 0.00      | 0  | 29  | 0.00      | 0  | 32  | 0.00      | 0  | 39  | 0.00      |
| 38400     | 0             | 15  | 1.73      | 0  | 19  | 1.73      | 0  | 23  | 1.73      | 0  | 26  | -0.54     | 0  | 32  | -1.36     |

Table 27.11 异步模式下不同比特率的BRR设置示例(2)(2of3)

| 比特率 (bps) | 工作频率PCLK(MHz) |     |           |    |     |           |     |     |           |
|-----------|---------------|-----|-----------|----|-----|-----------|-----|-----|-----------|
|           | 50            |     |           | 60 |     |           | 100 |     |           |
|           | n             | N   | Error (%) | n  | N   | Error (%) | n   | N   | Error (%) |
| 110       | 3             | 221 | -0.02     | —  | —   | —         | 3   | 255 | —         |
| 150       | 3             | 162 | -0.15     | 3  | 194 | 0.16      | 3   | 255 | —         |
| 300       | 3             | 80  | 0.47      | 3  | 97  | -0.35     | 3   | 162 | -0.15     |
| 600       | 2             | 162 | -0.15     | 3  | 48  | -0.35     | 3   | 80  | 0.47      |
| 1200      | 2             | 80  | 0.47      | 2  | 97  | -0.35     | 2   | 162 | -0.15     |
| 2400      | 1             | 162 | -0.15     | 2  | 48  | -0.35     | 2   | 80  | 0.47      |



Table 27.11 Examples of BRR settings for different bit rates in asynchronous mode (2) (3 of 3)

| Bit rate (bps) | Operating frequency PCLK (MHz) |     |           |    |    |           |     |     |           |
|----------------|--------------------------------|-----|-----------|----|----|-----------|-----|-----|-----------|
|                | 50                             |     |           | 60 |    |           | 100 |     |           |
|                | n                              | N   | Error (%) | n  | N  | Error (%) | n   | N   | Error (%) |
| 4800           | 1                              | 80  | 0.47      | 1  | 97 | -0.35     | 1   | 162 | -0.15     |
| 9600           | 0                              | 162 | -0.15     | 1  | 48 | -0.35     | 1   | 80  | 0.47      |
| 19200          | 0                              | 80  | 0.47      | 0  | 97 | -0.35     | 0   | 162 | -0.15     |
| 31250          | 0                              | 49  | 0.00      | 0  | 59 | 0.00      | 1   | 24  | 0.00      |
| 38400          | 0                              | 40  | -0.76     | 0  | 48 | -0.35     | 0   | 80  | 0.47      |

Note: In this example, SEMR.ABCS = 0, SEMR.ABCSE = 0, and SEMR.BGDM = 0.  
 When either the ABCS or BGDM bit is set to 1, the bit rate doubles.  
 When both ABCS = 1 and BGDM = 1, the bit rate quadruples.

Table 27.12 Maximum bit rate for each operating frequency in asynchronous mode (1 of 2)

| PCLK (MHz) | SEMR settings |          |           |   |           | Maximum bit rate (bps) | PCLK (MHz) | SEMR settings |          |           |           |         | Maximum bit rate (bps) |
|------------|---------------|----------|-----------|---|-----------|------------------------|------------|---------------|----------|-----------|-----------|---------|------------------------|
|            | BGDMbit       | ABCS bit | ABCSE bit | n | N         |                        |            | BGDMbit       | ABCS bit | ABCSE bit | n         | N       |                        |
| 8          | 0             | 0        | 0         | 0 | 0         | 250,000                | 16         | 0             | 0        | 0         | 0         | 500,000 |                        |
|            |               | 1        | 0         | 0 | 0         | 500,000                |            |               | 1        | 0         | 0         | 0       | 1,000,000              |
|            | 1             | 0        | 0         | 0 | 0         | 1,000,000              |            | 1             | 0        | 0         | 0         | 0       | 2,000,000              |
|            |               | 1        | 0         | 0 | 0         | 1,000,000              |            |               | 1        | 0         | 0         | 0       | 2,000,000              |
| Don'tcare  | Don'tcare     | 1        | 0         | 0 | 1,333,333 | Don'tcare              | Don'tcare  | 1             | 0        | 0         | 2,666,666 |         |                        |
| 9.8304     | 0             | 0        | 0         | 0 | 0         | 307,200                | 17.2032    | 0             | 0        | 0         | 0         | 537,600 |                        |
|            |               | 1        | 0         | 0 | 0         | 614,400                |            |               | 1        | 0         | 0         | 0       | 1,075,200              |
|            | 1             | 0        | 0         | 0 | 0         | 1,228,800              |            | 1             | 0        | 0         | 0         | 0       | 2,150,400              |
|            |               | 1        | 0         | 0 | 0         | 1,228,800              |            |               | 1        | 0         | 0         | 0       | 2,150,400              |
| Don'tcare  | Don'tcare     | 1        | 0         | 0 | 1,638,400 | Don'tcare              | Don'tcare  | 1             | 0        | 0         | 2,867,200 |         |                        |
| 10         | 0             | 0        | 0         | 0 | 0         | 312,500                | 18         | 0             | 0        | 0         | 0         | 562,500 |                        |
|            |               | 1        | 0         | 0 | 0         | 625,000                |            |               | 1        | 0         | 0         | 0       | 1,125,000              |
|            | 1             | 0        | 0         | 0 | 0         | 1,250,000              |            | 1             | 0        | 0         | 0         | 0       | 2,250,000              |
|            |               | 1        | 0         | 0 | 0         | 1,250,000              |            |               | 1        | 0         | 0         | 0       | 2,250,000              |
| Don'tcare  | Don'tcare     | 1        | 0         | 0 | 1,666,666 | Don'tcare              | Don'tcare  | 1             | 0        | 0         | 3,000,000 |         |                        |
| 12         | 0             | 0        | 0         | 0 | 0         | 375,000                | 19.6608    | 0             | 0        | 0         | 0         | 614,400 |                        |
|            |               | 1        | 0         | 0 | 0         | 750,000                |            |               | 1        | 0         | 0         | 0       | 1,228,800              |
|            | 1             | 0        | 0         | 0 | 0         | 1,500,000              |            | 1             | 0        | 0         | 0         | 0       | 2,457,600              |
|            |               | 1        | 0         | 0 | 0         | 1,500,000              |            |               | 1        | 0         | 0         | 0       | 2,457,600              |
| Don'tcare  | Don'tcare     | 1        | 0         | 0 | 2,000,000 | Don'tcare              | Don'tcare  | 1             | 0        | 0         | 3,276,800 |         |                        |
| 12.288     | 0             | 0        | 0         | 0 | 0         | 384,000                | 20         | 0             | 0        | 0         | 0         | 625,000 |                        |
|            |               | 1        | 0         | 0 | 0         | 768,000                |            |               | 1        | 0         | 0         | 0       | 1,250,000              |
|            | 1             | 0        | 0         | 0 | 0         | 1,536,000              |            | 1             | 0        | 0         | 0         | 0       | 2,500,000              |
|            |               | 1        | 0         | 0 | 0         | 1,536,000              |            |               | 1        | 0         | 0         | 0       | 2,500,000              |
| Don'tcare  | Don'tcare     | 1        | 0         | 0 | 2,048,000 | Don'tcare              | Don'tcare  | 1             | 0        | 0         | 3,333,333 |         |                        |

Table 27.11 异步模式下不同比特率的BRR设置示例(2)(3of3)

| 比特率(bps) | 工作频率PCLK(MHz) |     |           |    |    |           |     |     |           |
|----------|---------------|-----|-----------|----|----|-----------|-----|-----|-----------|
|          | 50            |     |           | 60 |    |           | 100 |     |           |
|          | n             | N   | Error (%) | n  | N  | Error (%) | n   | N   | Error (%) |
| 4800     | 1             | 80  | 0.47      | 1  | 97 | -0.35     | 1   | 162 | -0.15     |
| 9600     | 0             | 162 | -0.15     | 1  | 48 | -0.35     | 1   | 80  | 0.47      |
| 19200    | 0             | 80  | 0.47      | 0  | 97 | -0.35     | 0   | 162 | -0.15     |
| 31250    | 0             | 49  | 0.00      | 0  | 59 | 0.00      | 1   | 24  | 0.00      |
| 38400    | 0             | 40  | -0.76     | 0  | 48 | -0.35     | 0   | 80  | 0.47      |

Note: 在此示例中, SEMR.ABCS=0、SEMR.ABCSE=0和SEMR.BGDM=0。  
 当ABCS或BGDM位设置为1时, 比特率加倍。  
 当ABCS=1和BGDM=1时, 比特率翻四倍。

Table 27.12 异步模式下每个工作频率的最大比特率 (1of2)

| PCLK (MHz) | SEMR settings |          |           |   |           | Maximum bit rate (bps) | PCLK (MHz) | SEMR settings |          |           |           |         | Maximum bit rate (bps) |
|------------|---------------|----------|-----------|---|-----------|------------------------|------------|---------------|----------|-----------|-----------|---------|------------------------|
|            | BGDMbit       | ABCS bit | ABCSE bit | n | N         |                        |            | BGDMbit       | ABCS bit | ABCSE bit | n         | N       |                        |
| 8          | 0             | 0        | 0         | 0 | 0         | 250,000                | 16         | 0             | 0        | 0         | 0         | 500,000 |                        |
|            |               | 1        | 0         | 0 | 0         | 500,000                |            |               | 1        | 0         | 0         | 0       | 1,000,000              |
|            | 1             | 0        | 0         | 0 | 0         | 1,000,000              |            | 1             | 0        | 0         | 0         | 0       | 2,000,000              |
|            |               | 1        | 0         | 0 | 0         | 1,000,000              |            |               | 1        | 0         | 0         | 0       | 2,000,000              |
| Don'tcare  | Don'tcare     | 1        | 0         | 0 | 1,333,333 | Don'tcare              | Don'tcare  | 1             | 0        | 0         | 2,666,666 |         |                        |
| 9.8304     | 0             | 0        | 0         | 0 | 0         | 307,200                | 17.2032    | 0             | 0        | 0         | 0         | 537,600 |                        |
|            |               | 1        | 0         | 0 | 0         | 614,400                |            |               | 1        | 0         | 0         | 0       | 1,075,200              |
|            | 1             | 0        | 0         | 0 | 0         | 1,228,800              |            | 1             | 0        | 0         | 0         | 0       | 2,150,400              |
|            |               | 1        | 0         | 0 | 0         | 1,228,800              |            |               | 1        | 0         | 0         | 0       | 2,150,400              |
| Don'tcare  | Don'tcare     | 1        | 0         | 0 | 1,638,400 | Don'tcare              | Don'tcare  | 1             | 0        | 0         | 2,867,200 |         |                        |
| 10         | 0             | 0        | 0         | 0 | 0         | 312,500                | 18         | 0             | 0        | 0         | 0         | 562,500 |                        |
|            |               | 1        | 0         | 0 | 0         | 625,000                |            |               | 1        | 0         | 0         | 0       | 1,125,000              |
|            | 1             | 0        | 0         | 0 | 0         | 1,250,000              |            | 1             | 0        | 0         | 0         | 0       | 2,250,000              |
|            |               | 1        | 0         | 0 | 0         | 1,250,000              |            |               | 1        | 0         | 0         | 0       | 2,250,000              |
| Don'tcare  | Don'tcare     | 1        | 0         | 0 | 1,666,666 | Don'tcare              | Don'tcare  | 1             | 0        | 0         | 3,000,000 |         |                        |
| 12         | 0             | 0        | 0         | 0 | 0         | 375,000                | 19.6608    | 0             | 0        | 0         | 0         | 614,400 |                        |
|            |               | 1        | 0         | 0 | 0         | 750,000                |            |               | 1        | 0         | 0         | 0       | 1,228,800              |
|            | 1             | 0        | 0         | 0 | 0         | 1,500,000              |            | 1             | 0        | 0         | 0         | 0       | 2,457,600              |
|            |               | 1        | 0         | 0 | 0         | 1,500,000              |            |               | 1        | 0         | 0         | 0       | 2,457,600              |
| Don'tcare  | Don'tcare     | 1        | 0         | 0 | 2,000,000 | Don'tcare              | Don'tcare  | 1             | 0        | 0         | 3,276,800 |         |                        |
| 12.288     | 0             | 0        | 0         | 0 | 0         | 384,000                | 20         | 0             | 0        | 0         | 0         | 625,000 |                        |
|            |               | 1        | 0         | 0 | 0         | 768,000                |            |               | 1        | 0         | 0         | 0       | 1,250,000              |
|            | 1             | 0        | 0         | 0 | 0         | 1,536,000              |            | 1             | 0        | 0         | 0         | 0       | 2,500,000              |
|            |               | 1        | 0         | 0 | 0         | 1,536,000              |            |               | 1        | 0         | 0         | 0       | 2,500,000              |
| Don'tcare  | Don'tcare     | 1        | 0         | 0 | 2,048,000 | Don'tcare              | Don'tcare  | 1             | 0        | 0         | 3,333,333 |         |                        |

Table 27.12 Maximum bit rate for each operating frequency in asynchronous mode (2 of 2)

| PCLK (MHz) | SEMR settings |          |           |   |   | Maximum bit rate (bps) | PCLK (MHz) | SEMR settings |          |           |   |   | Maximum bit rate (bps) |
|------------|---------------|----------|-----------|---|---|------------------------|------------|---------------|----------|-----------|---|---|------------------------|
|            | BGDMbit       | ABCS bit | ABCSE bit | n | N |                        |            | BGDMbit       | ABCS bit | ABCSE bit | n | N |                        |
| 14         | 0             | 0        | 0         | 0 | 0 | 437,500                | 25         | 0             | 0        | 0         | 0 | 0 | 781,250                |
|            |               | 1        | 0         | 0 | 0 | 875,000                |            |               | 1        | 0         | 0 | 0 | 1,562,500              |
|            | 1             | 0        | 0         | 0 | 0 | 1,750,000              |            | 1             | 0        | 0         | 0 | 0 | 3,125,000              |
|            |               | 1        | 0         | 0 | 0 |                        |            |               | 0        | 0         | 0 | 0 |                        |
| 30         | 0             | 0        | 0         | 0 | 0 | 937,500                | 50         | 0             | 0        | 0         | 0 | 0 | 1,562,500              |
|            |               | 1        | 0         | 0 | 0 | 1,875,000              |            |               | 1        | 0         | 0 | 0 | 3,125,000              |
|            | 1             | 0        | 0         | 0 | 0 | 3,750,000              |            | 1             | 0        | 0         | 0 | 0 | 6,250,000              |
|            |               | 1        | 0         | 0 | 0 |                        |            |               | 0        | 0         | 0 | 0 |                        |
| 33         | 0             | 0        | 0         | 0 | 0 | 1,031,250              | 60         | 0             | 0        | 0         | 0 | 0 | 1,875,000              |
|            |               | 1        | 0         | 0 | 0 | 2,062,500              |            |               | 1        | 0         | 0 | 0 | 3,750,000              |
|            | 1             | 0        | 0         | 0 | 0 | 4,125,000              |            | 1             | 0        | 0         | 0 | 0 | 7,500,000              |
|            |               | 1        | 0         | 0 | 0 |                        |            |               | 0        | 0         | 0 | 0 |                        |
| 40         | 0             | 0        | 0         | 0 | 0 | 1,250,000              | 100        | 0             | 0        | 0         | 0 | 0 | 3,125,000              |
|            |               | 1        | 0         | 0 | 0 | 2,500,000              |            |               | 1        | 0         | 0 | 0 | 6,250,000              |
|            | 1             | 0        | 0         | 0 | 0 | 5,000,000              |            | 1             | 0        | 0         | 0 | 0 | 12,500,000             |
|            |               | 1        | 0         | 0 | 0 |                        |            |               | 0        | 0         | 0 | 0 |                        |
| 40         | 0             | 0        | 0         | 0 | 0 | 1,250,000              | 100        | 0             | 0        | 0         | 0 | 0 | 3,125,000              |
|            |               | 1        | 0         | 0 | 0 | 2,500,000              |            |               | 1        | 0         | 0 | 0 | 6,250,000              |
|            | 1             | 0        | 0         | 0 | 0 | 5,000,000              |            | 1             | 0        | 0         | 0 | 0 | 12,500,000             |
|            |               | 1        | 0         | 0 | 0 |                        |            |               | 0        | 0         | 0 | 0 |                        |

Table 27.13 Maximum bit rate with external clock input in asynchronous mode (1 of 2)

| Maximum bit rate (bps) |                           |                   |                   |
|------------------------|---------------------------|-------------------|-------------------|
| PCLK(MHz)              | External inputclock (MHz) | SEMR.ABCS bit = 0 | SEMR.ABCS bit = 1 |
| 8                      | 2.0000                    | 125,000           | 250,000           |
| 9.8304                 | 2.4576                    | 153,600           | 307,200           |
| 10                     | 2.5000                    | 156,250           | 312,500           |
| 12                     | 3.0000                    | 187,500           | 375,000           |
| 12.288                 | 3.0720                    | 192,000           | 384,000           |
| 14                     | 3.5000                    | 218,750           | 437,500           |
| 16                     | 4.0000                    | 250,000           | 500,000           |
| 17.2032                | 4.3008                    | 268,800           | 537,600           |
| 18                     | 4.5000                    | 281,250           | 562,500           |
| 19.6608                | 4.9152                    | 307,200           | 614,400           |
| 20                     | 5.0000                    | 312,500           | 625,000           |
| 25                     | 6.2500                    | 390,625           | 781,250           |
| 30                     | 7.5000                    | 468,750           | 937,500           |
| 33                     | 8.2500                    | 515,625           | 1,031,250         |
| 40                     | 10.0000                   | 625,000           | 1,250,000         |
| 50                     | 12.5000                   | 781,250           | 1,562,500         |

Table 27.12 异步模式下每个工作频率的最大比特率 (2之2)

| PCLK (MHz) | SEMR settings |       |        |   |   | Maximum bit rate (bps) | PCLK (MHz) | SEMR settings |       |        |   |   | Maximum bit rate (bps) |
|------------|---------------|-------|--------|---|---|------------------------|------------|---------------|-------|--------|---|---|------------------------|
|            | BGDMbit       | ABCS位 | ABCSE位 | n | N |                        |            | BGDMbit       | ABCS位 | ABCSE位 | n | N |                        |
| 14         | 0             | 0     | 0      | 0 | 0 | 437,500                | 25         | 0             | 0     | 0      | 0 | 0 | 781,250                |
|            |               | 1     | 0      | 0 | 0 | 875,000                |            |               | 1     | 0      | 0 | 0 | 1,562,500              |
|            | 1             | 0     | 0      | 0 | 0 | 1,750,000              |            | 1             | 0     | 0      | 0 | 0 | 3,125,000              |
|            |               | 1     | 0      | 0 | 0 |                        |            |               | 0     | 0      | 0 | 0 |                        |
| 30         | 0             | 0     | 0      | 0 | 0 | 937,500                | 50         | 0             | 0     | 0      | 0 | 0 | 1,562,500              |
|            |               | 1     | 0      | 0 | 0 | 1,875,000              |            |               | 1     | 0      | 0 | 0 | 3,125,000              |
|            | 1             | 0     | 0      | 0 | 0 | 3,750,000              |            | 1             | 0     | 0      | 0 | 0 | 6,250,000              |
|            |               | 1     | 0      | 0 | 0 |                        |            |               | 0     | 0      | 0 | 0 |                        |
| 33         | 0             | 0     | 0      | 0 | 0 | 1,031,250              | 60         | 0             | 0     | 0      | 0 | 0 | 1,875,000              |
|            |               | 1     | 0      | 0 | 0 | 2,062,500              |            |               | 1     | 0      | 0 | 0 | 3,750,000              |
|            | 1             | 0     | 0      | 0 | 0 | 4,125,000              |            | 1             | 0     | 0      | 0 | 0 | 7,500,000              |
|            |               | 1     | 0      | 0 | 0 |                        |            |               | 0     | 0      | 0 | 0 |                        |
| 40         | 0             | 0     | 0      | 0 | 0 | 1,250,000              | 100        | 0             | 0     | 0      | 0 | 0 | 3,125,000              |
|            |               | 1     | 0      | 0 | 0 | 2,500,000              |            |               | 1     | 0      | 0 | 0 | 6,250,000              |
|            | 1             | 0     | 0      | 0 | 0 | 5,000,000              |            | 1             | 0     | 0      | 0 | 0 | 12,500,000             |
|            |               | 1     | 0      | 0 | 0 |                        |            |               | 0     | 0      | 0 | 0 |                        |

Table 27.13 异步模式下外部时钟输入的最大比特率 (1 of 2)

| 最大比特率(bps) |                           |                   |                   |
|------------|---------------------------|-------------------|-------------------|
| PCLK(MHz)  | External inputclock (MHz) | SEMR.ABCS bit = 0 | SEMR.ABCS bit = 1 |
| 8          | 2.0000                    | 125,000           | 250,000           |
| 9.8304     | 2.4576                    | 153,600           | 307,200           |
| 10         | 2.5000                    | 156,250           | 312,500           |
| 12         | 3.0000                    | 187,500           | 375,000           |
| 12.288     | 3.0720                    | 192,000           | 384,000           |
| 14         | 3.5000                    | 218,750           | 437,500           |
| 16         | 4.0000                    | 250,000           | 500,000           |
| 17.2032    | 4.3008                    | 268,800           | 537,600           |
| 18         | 4.5000                    | 281,250           | 562,500           |
| 19.6608    | 4.9152                    | 307,200           | 614,400           |
| 20         | 5.0000                    | 312,500           | 625,000           |
| 25         | 6.2500                    | 390,625           | 781,250           |
| 30         | 7.5000                    | 468,750           | 937,500           |
| 33         | 8.2500                    | 515,625           | 1,031,250         |
| 40         | 10.0000                   | 625,000           | 1,250,000         |
| 50         | 12.5000                   | 781,250           | 1,562,500         |

Table 27.13 Maximum bit rate with external clock input in asynchronous mode (2 of 2)

| Maximum bit rate (bps) |                           |                   |                   |
|------------------------|---------------------------|-------------------|-------------------|
| PCLK(MHz)              | External inputclock (MHz) | SEMR.ABCS bit = 0 | SEMR.ABCS bit = 1 |
| 60                     | 15.0000                   | 937,500           | 1,875,000         |
| 100                    | 25.000                    | 1,562,500         | 3,125,000         |

Table 27.14 BRR settings for different bit rates in clock synchronous and simple SPI modes

| Bit rate (bps) | Operating frequency PCLK (MHz) |     |    |                 |    |     |    |                 |    |     |    |                 |    |     |    |     |    |     |    |                 |                 |     |  |
|----------------|--------------------------------|-----|----|-----------------|----|-----|----|-----------------|----|-----|----|-----------------|----|-----|----|-----|----|-----|----|-----------------|-----------------|-----|--|
|                | 8                              |     | 10 |                 | 16 |     | 20 |                 | 25 |     | 30 |                 | 33 |     | 40 |     | 50 |     | 60 |                 | 100             |     |  |
|                | n                              | N   | n  | N               | n  | N   | n  | N               | n  | N   | n  | N               | n  | N   | n  | N   | n  | N   | n  | N               | n               | N   |  |
| 110            |                                |     |    |                 |    |     |    |                 |    |     |    |                 |    |     |    |     |    |     |    |                 |                 |     |  |
| 250            | 3                              | 124 | —  | —               | 3  | 249 |    |                 |    |     |    |                 |    |     |    |     |    |     |    |                 |                 |     |  |
| 500            | 2                              | 249 | —  | —               | 3  | 124 | —  | —               |    |     | 3  | 233             |    |     |    |     |    |     |    |                 |                 |     |  |
| 1 k            | 2                              | 124 | —  | —               | 2  | 249 | —  | —               | 3  | 97  | 3  | 116             | 3  | 128 | 3  | 155 | 3  | 194 | 3  | 233             |                 |     |  |
| 2.5 k          | 1                              | 199 | 1  | 249             | 2  | 99  | 2  | 124             | 2  | 155 | 2  | 187             | 2  | 205 | 2  | 249 | 3  | 77  | 3  | 93              | 3               | 155 |  |
| 5 k            | 1                              | 99  | 1  | 124             | 1  | 199 | 1  | 249             | 2  | 77  | 2  | 93              | 2  | 102 | 2  | 124 | 2  | 155 | 3  | 46              | 3               | 77  |  |
| 10 k           | 0                              | 199 | 0  | 249             | 1  | 99  | 1  | 124             | 1  | 155 | 1  | 187             | 1  | 205 | 1  | 249 | 2  | 77  | 2  | 93              | 3               | 38  |  |
| 25 k           | 0                              | 79  | 0  | 99              | 0  | 159 | 0  | 199             | 0  | 249 | 1  | 74              | 1  | 82  | 1  | 99  | 1  | 124 | 1  | 149             | 1               | 249 |  |
| 50 k           | 0                              | 39  | 0  | 49              | 0  | 79  | 0  | 99              | 0  | 124 | 0  | 149             | 0  | 164 | 1  | 49  | 1  | 61  | 1  | 74              | 1               | 124 |  |
| 100 k          | 0                              | 19  | 0  | 24              | 0  | 39  | 0  | 49              | 0  | 62  | 0  | 74              | 0  | 82  | 0  | 99  | 0  | 124 | 0  | 149             | 0               | 249 |  |
| 250 k          | 0                              | 7   | 0  | 9               | 0  | 15  | 0  | 19              | 0  | 24  | 0  | 29              | 0  | 32  | 0  | 39  | 0  | 49  | 0  | 59              | 1               | 24  |  |
| 500 k          | 0                              | 3   | 0  | 4               | 0  | 7   | 0  | 9               | —  | —   | 0  | 14              | —  | —   | 0  | 19  | 0  | 24  | 0  | 29              | 0               | 49  |  |
| 1 M            | 0                              | 1   |    |                 | 0  | 3   | 0  | 4               | —  | —   | —  | —               | —  | 0   | 9  | —   | —  | 0   | 14 | 0               | 24              |     |  |
| 2.5 M          |                                |     | 0  | 0 <sup>*1</sup> |    |     | 0  | 1               | —  | —   | 0  | 2               | —  | —   | 0  | 3   | 0  | 4   | 0  | 5               | 0               | 9   |  |
| 5 M            |                                |     |    |                 |    |     | 0  | 0 <sup>*1</sup> | —  | —   | —  | —               | —  | 0   | 1  | —   | —  | 0   | 2  | 0               | 4               |     |  |
| 7.5 M          |                                |     |    |                 |    |     |    |                 |    |     | 0  | 0 <sup>*1</sup> |    |     |    |     |    |     | 0  | 1               |                 |     |  |
| 10 M           |                                |     |    |                 |    |     |    |                 |    |     |    |                 |    |     |    |     |    |     | 0  | 0 <sup>*1</sup> |                 |     |  |
| 15 M           |                                |     |    |                 |    |     |    |                 |    |     |    |                 |    |     |    |     |    |     |    | 0               | 0 <sup>*1</sup> |     |  |

Note: Space: Setting prohibited.

—: Can be set, but an error occurs.

Note 1. Continuous transmission or reception is not possible. After transmitting or receiving one frame of data, a 1-bit period elapses before starting to transmit or receive the next frame of data. The output of the synchronization clock is stopped for a 1-bit period. Therefore, it takes 9 bits worth of time to transfer one frame (8 bits) of data, and the average transfer rate is 8/9 times the bit rate. When the FIFO is selected, this setting (BRR = 00h and SMR.CKS[1:0] = 00b) is not available.

Table 27.15 Maximum bit rate with external clock input in clock synchronous and simple SPI modes (1 of 2)

| PCLK (MHz) | External input clock (MHz) | Maximum bit rate (Mbps) |
|------------|----------------------------|-------------------------|
| 8          | 1.3333                     | 1.3333333               |
| 10         | 1.6667                     | 1.6666667               |
| 12         | 2.0000                     | 2.0000000               |
| 14         | 2.3333                     | 2.3333333               |

Table 27.13 异步模式下外部时钟输入的最大比特率 (2之2)

| 最大比特率(bps) |                           |                   |                   |
|------------|---------------------------|-------------------|-------------------|
| PCLK(MHz)  | External inputclock (MHz) | SEMR.ABCS bit = 0 | SEMR.ABCS bit = 1 |
| 60         | 15.0000                   | 937,500           | 1,875,000         |
| 100        | 25.000                    | 1,562,500         | 3,125,000         |

Table 27.14 时钟同步和简单SPI模式下不同比特率的BRR设置

| 比特率 (bps) | 工作频率PCLK (MHz) |     |    |                 |    |     |    |                 |    |     |    |                 |    |     |    |     |    |     |    |     |                 |                 |  |
|-----------|----------------|-----|----|-----------------|----|-----|----|-----------------|----|-----|----|-----------------|----|-----|----|-----|----|-----|----|-----|-----------------|-----------------|--|
|           | 8              |     | 10 |                 | 16 |     | 20 |                 | 25 |     | 30 |                 | 33 |     | 40 |     | 50 |     | 60 |     | 100             |                 |  |
|           | n              | N   | n  | N               | n  | N   | n  | N               | n  | N   | n  | N               | n  | N   | n  | N   | n  | N   | n  | N   | n               | N               |  |
| 110       |                |     |    |                 |    |     |    |                 |    |     |    |                 |    |     |    |     |    |     |    |     |                 |                 |  |
| 250       | 3              | 124 | —  | —               | 3  | 249 |    |                 |    |     |    |                 |    |     |    |     |    |     |    |     |                 |                 |  |
| 500       | 2              | 249 | —  | —               | 3  | 124 | —  | —               |    |     | 3  | 233             |    |     |    |     |    |     |    |     |                 |                 |  |
| 1 k       | 2              | 124 | —  | —               | 2  | 249 | —  | —               | 3  | 97  | 3  | 116             | 3  | 128 | 3  | 155 | 3  | 194 | 3  | 233 |                 |                 |  |
| 2.5 k     | 1              | 199 | 1  | 249             | 2  | 99  | 2  | 124             | 2  | 155 | 2  | 187             | 2  | 205 | 2  | 249 | 3  | 77  | 3  | 93  | 3               | 155             |  |
| 5 k       | 1              | 99  | 1  | 124             | 1  | 199 | 1  | 249             | 2  | 77  | 2  | 93              | 2  | 102 | 2  | 124 | 2  | 155 | 3  | 46  | 3               | 77              |  |
| 10 k      | 0              | 199 | 0  | 249             | 1  | 99  | 1  | 124             | 1  | 155 | 1  | 187             | 1  | 205 | 1  | 249 | 2  | 77  | 2  | 93  | 3               | 38              |  |
| 25 k      | 0              | 79  | 0  | 99              | 0  | 159 | 0  | 199             | 0  | 249 | 1  | 74              | 1  | 82  | 1  | 99  | 1  | 124 | 1  | 149 | 1               | 249             |  |
| 50 k      | 0              | 39  | 0  | 49              | 0  | 79  | 0  | 99              | 0  | 124 | 0  | 149             | 0  | 164 | 1  | 49  | 1  | 61  | 1  | 74  | 1               | 124             |  |
| 100 k     | 0              | 19  | 0  | 24              | 0  | 39  | 0  | 49              | 0  | 62  | 0  | 74              | 0  | 82  | 0  | 99  | 0  | 124 | 0  | 149 | 0               | 249             |  |
| 250 k     | 0              | 7   | 0  | 9               | 0  | 15  | 0  | 19              | 0  | 24  | 0  | 29              | 0  | 32  | 0  | 39  | 0  | 49  | 0  | 59  | 1               | 24              |  |
| 500 k     | 0              | 3   | 0  | 4               | 0  | 7   | 0  | 9               | —  | —   | 0  | 14              | —  | —   | 0  | 19  | 0  | 24  | 0  | 29  | 0               | 49              |  |
| 1 M       | 0              | 1   |    |                 | 0  | 3   | 0  | 4               | —  | —   | —  | —               | —  | 0   | 9  | —   | —  | 0   | 14 | 0   | 24              |                 |  |
| 2.5 M     |                |     | 0  | 0 <sup>*1</sup> |    |     | 0  | 1               | —  | —   | 0  | 2               | —  | —   | 0  | 3   | 0  | 4   | 0  | 5   | 0               | 9               |  |
| 5 M       |                |     |    |                 |    |     | 0  | 0 <sup>*1</sup> | —  | —   | —  | —               | —  | 0   | 1  | —   | —  | 0   | 2  | 0   | 4               |                 |  |
| 7.5 M     |                |     |    |                 |    |     |    |                 |    |     | 0  | 0 <sup>*1</sup> |    |     |    |     |    |     |    | 0   | 1               |                 |  |
| 10 M      |                |     |    |                 |    |     |    |                 |    |     |    |                 |    |     |    |     |    |     |    | 0   | 0 <sup>*1</sup> |                 |  |
| 15 M      |                |     |    |                 |    |     |    |                 |    |     |    |                 |    |     |    |     |    |     |    |     | 0               | 0 <sup>*1</sup> |  |

Note: 空格: 禁止设置。—: 可以设置, 但发生错误。

注1.不能连续发送或接收。发送或接收一帧数据后, 经过1位周期后开始发送或接收下一帧数据。同步时钟的输出停止1位周期。因此, 传输一帧(8位)数据需要9位的时间, 平均传输速率为89倍的位速率。选择FIFO时, 此设置(BRR=00h且SMR.CKS[1:0]=00b)不可用。

Table 27.15 时钟同步和简单SPI模式下外部时钟输入的最大比特率 (1of2)

| PCLK (MHz) | 外部输入时钟(MHz) | 最大比特率(Mbps) |
|------------|-------------|-------------|
| 8          | 1.3333      | 1.3333333   |
| 10         | 1.6667      | 1.6666667   |
| 12         | 2.0000      | 2.0000000   |
| 14         | 2.3333      | 2.3333333   |

Table 27.15 Maximum bit rate with external clock input in clock synchronous and simple SPI modes (2 of 2)

| PCLK (MHz) | External input clock (MHz) | Maximum bit rate (Mbps) |
|------------|----------------------------|-------------------------|
| 16         | 2.6667                     | 2.6666667               |
| 18         | 3.0000                     | 3.0000000               |
| 20         | 3.3333                     | 3.3333333               |
| 25         | 4.1667                     | 4.1666667               |
| 30         | 5.0000                     | 5.0000000               |
| 33         | 5.5000                     | 5.5000000               |
| 40         | 6.6667                     | 6.6666667               |
| 50         | 8.3333                     | 8.3333333               |
| 60         | 10.0000                    | 10.0000000              |
| 100        | 16.6667                    | 16.6666667              |

Table 27.16 BRR settings for different bit rates in smart card interface mode, n = 0, S = 372 (1 of 4)

| Bit rate (bps) | Operating frequency PCLK (MHz) |   |           |       |   |           |         |   |           |       |   |           |
|----------------|--------------------------------|---|-----------|-------|---|-----------|---------|---|-----------|-------|---|-----------|
|                | 7.1424                         |   |           | 10.00 |   |           | 10.7136 |   |           | 13.00 |   |           |
|                | n                              | N | Error (%) | n     | N | Error (%) | n       | N | Error (%) | n     | N | Error (%) |
| 9600           | 0                              | 0 | 0.00      | 0     | 1 | 30        | 0       | 1 | 25        | 0     | 1 | 8.99      |

Table 27.16 BRR settings for different bit rates in smart card interface mode, n = 0, S = 372 (2 of 4)

| Bit rate (bps) | Operating frequency PCLK (MHz) |   |           |       |   |           |       |   |           |       |   |           |
|----------------|--------------------------------|---|-----------|-------|---|-----------|-------|---|-----------|-------|---|-----------|
|                | 14.2848                        |   |           | 16.00 |   |           | 18.00 |   |           | 20.00 |   |           |
|                | n                              | N | Error (%) | n     | N | Error (%) | n     | N | Error (%) | n     | N | Error (%) |
| 9600           | 0                              | 1 | 0.00      | 0     | 1 | 12.01     | 0     | 2 | 15.99     | 0     | 2 | 6.66      |

Table 27.16 BRR settings for different bit rates in smart card interface mode, n = 0, S = 372 (3 of 4)

| Bit rate (bps) | Operating frequency PCLK (MHz) |   |           |       |   |           |       |   |           |       |   |           |
|----------------|--------------------------------|---|-----------|-------|---|-----------|-------|---|-----------|-------|---|-----------|
|                | 25.00                          |   |           | 30.00 |   |           | 33.00 |   |           | 40.00 |   |           |
|                | n                              | N | Error (%) | n     | N | Error (%) | n     | N | Error (%) | n     | N | Error (%) |
| 9600           | 0                              | 3 | 12.49     | 0     | 3 | 5.01      | 0     | 4 | 7.59      | 0     | 5 | -6.66     |

Table 27.16 BRR settings for different bit rates in smart card interface mode, n = 0, S = 372 (4 of 4)

| Bit rate (bps) | Operating frequency PCLK (MHz) |   |           |       |   |           |        |    |           |   |   |           |
|----------------|--------------------------------|---|-----------|-------|---|-----------|--------|----|-----------|---|---|-----------|
|                | 50.00                          |   |           | 60.00 |   |           | 100.00 |    |           |   |   |           |
|                | n                              | N | Error (%) | n     | N | Error (%) | n      | N  | Error (%) | n | N | Error (%) |
| 9600           | 0                              | 6 | 0.01      | 0     | 7 | 5.01      | 0      | 13 | 0.01      |   |   |           |

Table 27.17 Maximum bit rate for each operating frequency in smart card interface mode (S = 32) (1 of 2)

| PCLK (MHz) | Maximum bit rate (bps) | n | N |
|------------|------------------------|---|---|
| 10.00      | 156,250                | 0 | 0 |
| 10.7136    | 167,400                | 0 | 0 |
| 13.00      | 203,125                | 0 | 0 |
| 16.00      | 250,000                | 0 | 0 |
| 18.00      | 281,250                | 0 | 0 |
| 20.00      | 312,500                | 0 | 0 |

Table 27.15 时钟同步和简单SPI模式下外部时钟输入的最大比特率(2of2)

| PCLK (MHz) | 外部输入时钟(MHz) | 最大比特率(Mbps) |
|------------|-------------|-------------|
| 16         | 2.6667      | 2.6666667   |
| 18         | 3.0000      | 3.0000000   |
| 20         | 3.3333      | 3.3333333   |
| 25         | 4.1667      | 4.1666667   |
| 30         | 5.0000      | 5.0000000   |
| 33         | 5.5000      | 5.5000000   |
| 40         | 6.6667      | 6.6666667   |
| 50         | 8.3333      | 8.3333333   |
| 60         | 10.0000     | 10.0000000  |
| 100        | 16.6667     | 16.6666667  |

Table 27.16 智能卡接口模式下不同比特率的BRR设置, n=0 S=372(1of4)

| 比特率(bps) | 工作频率PCLK(MHz) |   |           |       |   |           |         |   |           |       |   |           |
|----------|---------------|---|-----------|-------|---|-----------|---------|---|-----------|-------|---|-----------|
|          | 7.1424        |   |           | 10.00 |   |           | 10.7136 |   |           | 13.00 |   |           |
|          | n             | N | Error (%) | n     | N | Error (%) | n       | N | Error (%) | n     | N | Error (%) |
| 9600     | 0             | 0 | 0.00      | 0     | 1 | 30        | 0       | 1 | 25        | 0     | 1 | 8.99      |

Table 27.16 智能卡接口模式下不同比特率的BRR设置, n=0, S=372(2of4)

| 比特率(bps) | 工作频率PCLK(MHz) |   |           |       |   |           |       |   |           |       |   |           |
|----------|---------------|---|-----------|-------|---|-----------|-------|---|-----------|-------|---|-----------|
|          | 14.2848       |   |           | 16.00 |   |           | 18.00 |   |           | 20.00 |   |           |
|          | n             | N | Error (%) | n     | N | Error (%) | n     | N | Error (%) | n     | N | Error (%) |
| 9600     | 0             | 1 | 0.00      | 0     | 1 | 12.01     | 0     | 2 | 15.99     | 0     | 2 | 6.66      |

Table 27.16 智能卡接口模式下不同比特率的BRR设置, n=0 S=372(3of4)

| 比特率(bps) | 工作频率PCLK(MHz) |   |           |       |   |           |       |   |           |       |   |           |
|----------|---------------|---|-----------|-------|---|-----------|-------|---|-----------|-------|---|-----------|
|          | 25.00         |   |           | 30.00 |   |           | 33.00 |   |           | 40.00 |   |           |
|          | n             | N | Error (%) | n     | N | Error (%) | n     | N | Error (%) | n     | N | Error (%) |
| 9600     | 0             | 3 | 12.49     | 0     | 3 | 5.01      | 0     | 4 | 7.59      | 0     | 5 | -6.66     |

Table 27.16 智能卡接口模式下不同比特率的BRR设置, n=0 S=372(4of4)

| 比特率(bps) | 工作频率PCLK(MHz) |   |           |       |   |           |        |    |           |   |   |           |
|----------|---------------|---|-----------|-------|---|-----------|--------|----|-----------|---|---|-----------|
|          | 50.00         |   |           | 60.00 |   |           | 100.00 |    |           |   |   |           |
|          | n             | N | Error (%) | n     | N | Error (%) | n      | N  | Error (%) | n | N | Error (%) |
| 9600     | 0             | 6 | 0.01      | 0     | 7 | 5.01      | 0      | 13 | 0.01      |   |   |           |

Table 27.17 智能卡接口模式下每个工作频率的最大比特率(S=32)(1of2)

| PCLK (MHz) | 最大比特率(bps) | n | N |
|------------|------------|---|---|
| 10.00      | 156,250    | 0 | 0 |
| 10.7136    | 167,400    | 0 | 0 |
| 13.00      | 203,125    | 0 | 0 |
| 16.00      | 250,000    | 0 | 0 |
| 18.00      | 281,250    | 0 | 0 |
| 20.00      | 312,500    | 0 | 0 |



Table 27.17 Maximum bit rate for each operating frequency in smart card interface mode (S = 32) (2 of 2)

| PCLK (MHz) | Maximum bit rate (bps) | n | N |
|------------|------------------------|---|---|
| 25.00      | 390,625                | 0 | 0 |
| 30.00      | 468,750                | 0 | 0 |
| 33.00      | 515,625                | 0 | 0 |
| 40.00      | 625,000                | 0 | 0 |
| 50.00      | 781,250                | 0 | 0 |
| 60.00      | 937,500                | 0 | 0 |
| 100.00     | 1,562,500              | 0 | 0 |

Table 27.18 BRR settings for different bit rates in simple IIC mode (1 of 4)

| Bit rate (bps) | Operating frequency PCLK (MHz) |    |           |    |    |           |    |    |           |    |    |           |    |    |           |
|----------------|--------------------------------|----|-----------|----|----|-----------|----|----|-----------|----|----|-----------|----|----|-----------|
|                | 8                              |    |           | 10 |    |           | 16 |    |           | 20 |    |           | 25 |    |           |
|                | n                              | N  | Error (%) | n  | N  | Error (%) | n  | N  | Error (%) | n  | N  | Error (%) | n  | N  | Error (%) |
| 10 k           | 0                              | 24 | 0.0       | 0  | 31 | -2.3      | 1  | 12 | -3.8      | 1  | 15 | -2.3      | 1  | 19 | -2.3      |
| 25 k           | 0                              | 9  | 0.0       | 0  | 12 | -3.8      | 1  | 4  | 0.0       | 1  | 6  | -10.7     | 1  | 7  | -2.3      |
| 50 k           | 0                              | 4  | 0.0       | 0  | 6  | -10.7     | 1  | 2  | -16.7     | 1  | 3  | -21.9     | 1  | 3  | -2.3      |
| 100 k          | 0                              | 2  | -16.7     | 0  | 3  | -21.9     | 0  | 4  | 0.0       | 0  | 6  | -10.7     | 1  | 1  | -2.3      |
| 250 k          | 0                              | 0  | 0.0       | 0  | 1  | -37.5     | 0  | 1  | 0.0       | 0  | 2  | -16.7     | 0  | 3  | -21.9     |
| 350 k          |                                |    |           |    |    |           |    |    |           | 0  | 1  | -10.7     | 0  | 2  | -25.6     |
| 400 k          |                                |    |           |    |    |           |    |    |           | 0  | 1  | -21.9     | 0  | 1  | -2.3      |

Table 27.18 BRR settings for different bit rates in simple IIC mode (2 of 4)

| Bit rate (bps) | Operating frequency PCLK (MHz) |    |           |    |    |           |    |     |           |    |   |           |    |    |           |
|----------------|--------------------------------|----|-----------|----|----|-----------|----|-----|-----------|----|---|-----------|----|----|-----------|
|                | 30                             |    |           | 33 |    |           | 40 |     |           | 50 |   |           | 60 |    |           |
|                | n                              | N  | Error (%) | n  | N  | Error (%) | n  | N   | Error (%) | n  | N | Error (%) | n  | N  | Error (%) |
| 10 k           | 1                              | 23 | -2.3      | 1  | 25 | -0.8      | 0  | 124 | 0.00      | 2  | 9 | -2.3      | 1  | 46 | -0.27     |
| 25 k           | 1                              | 9  | -6.3      | 1  | 10 | -6.3      | 0  | 40  | 0.00      | 2  | 3 | -2.3      | 0  | 74 | 0.00      |
| 50 k           | 1                              | 4  | -6.3      | 1  | 5  | -14.1     | 0  | 24  | 0.00      | 2  | 1 | -2.3      | 0  | 37 | -1.32     |
| 100 k          | 1                              | 2  | -21.9     | 1  | 2  | -14.1     | 0  | 12  | -3.85     | 1  | 3 | -2.3      | 0  | 18 | -1.32     |
| 250 k          | 0                              | 3  | -6.3      | 0  | 4  | -17.5     | 0  | 4   | 0.00      | 0  | 6 | -10.7     | 0  | 7  | -6.25     |
| 350 k          | 0                              | 2  | -10.7     | 0  | 2  | -1.8      | 0  | 3   | -10.71    | 0  | 4 | -10.7     | 0  | 4  | 7.14      |
| 400 k          | 0                              | 1  | 17.2      | 0  | 2  | -14.1     | 0  | 2   | 4.17      | 0  | 3 | -2.34     | 0  | 4  | -6.25     |

Table 27.18 BRR settings for different bit rates in simple IIC mode (3 of 4)

| Bit rate (bps) | Operating frequency PCLK (MHz) |     |           |
|----------------|--------------------------------|-----|-----------|
|                | 100                            |     |           |
|                | n                              | N   | Error (%) |
| 10 k           | 1                              | 77  | 0.16      |
| 25 k           | 0                              | 124 | 0.00      |
| 50 k           | 0                              | 62  | -0.79     |
| 100 k          | 0                              | 30  | 0.81      |
| 250 k          | 0                              | 12  | -3.85     |

Table 27.17 智能卡接口模式下每个工作频率的最大比特率(S=32)(2of2)

| PCLK (MHz) | 最大比特率(bps) | n | N |
|------------|------------|---|---|
| 25.00      | 390,625    | 0 | 0 |
| 30.00      | 468,750    | 0 | 0 |
| 33.00      | 515,625    | 0 | 0 |
| 40.00      | 625,000    | 0 | 0 |
| 50.00      | 781,250    | 0 | 0 |
| 60.00      | 937,500    | 0 | 0 |
| 100.00     | 1,562,500  | 0 | 0 |

Table 27.18 简单IIC模式下不同比特率的BRR设置 (1of4)

| 比特率(bps) | 工作频率PCLK(MHz) |    |           |    |    |           |    |    |           |    |    |           |    |    |           |
|----------|---------------|----|-----------|----|----|-----------|----|----|-----------|----|----|-----------|----|----|-----------|
|          | 8             |    |           | 10 |    |           | 16 |    |           | 20 |    |           | 25 |    |           |
|          | n             | N  | Error (%) | n  | N  | Error (%) | n  | N  | Error (%) | n  | N  | Error (%) | n  | N  | Error (%) |
| 10 k     | 0             | 24 | 0.0       | 0  | 31 | -2.3      | 1  | 12 | -3.8      | 1  | 15 | -2.3      | 1  | 19 | -2.3      |
| 25 k     | 0             | 9  | 0.0       | 0  | 12 | -3.8      | 1  | 4  | 0.0       | 1  | 6  | -10.7     | 1  | 7  | -2.3      |
| 50 k     | 0             | 4  | 0.0       | 0  | 6  | -10.7     | 1  | 2  | -16.7     | 1  | 3  | -21.9     | 1  | 3  | -2.3      |
| 100 k    | 0             | 2  | -16.7     | 0  | 3  | -21.9     | 0  | 4  | 0.0       | 0  | 6  | -10.7     | 1  | 1  | -2.3      |
| 250 k    | 0             | 0  | 0.0       | 0  | 1  | -37.5     | 0  | 1  | 0.0       | 0  | 2  | -16.7     | 0  | 3  | -21.9     |
| 350 k    |               |    |           |    |    |           |    |    |           | 0  | 1  | -10.7     | 0  | 2  | -25.6     |
| 400 k    |               |    |           |    |    |           |    |    |           | 0  | 1  | -21.9     | 0  | 1  | -2.3      |

Table 27.18 简单IIC模式下不同比特率的BRR设置(2of4)

| 比特率(bps) | 工作频率PCLK(MHz) |    |           |    |    |           |    |     |           |    |   |           |    |    |           |
|----------|---------------|----|-----------|----|----|-----------|----|-----|-----------|----|---|-----------|----|----|-----------|
|          | 30            |    |           | 33 |    |           | 40 |     |           | 50 |   |           | 60 |    |           |
|          | n             | N  | Error (%) | n  | N  | Error (%) | n  | N   | Error (%) | n  | N | Error (%) | n  | N  | Error (%) |
| 10 k     | 1             | 23 | -2.3      | 1  | 25 | -0.8      | 0  | 124 | 0.00      | 2  | 9 | -2.3      | 1  | 46 | -0.27     |
| 25 k     | 1             | 9  | -6.3      | 1  | 10 | -6.3      | 0  | 40  | 0.00      | 2  | 3 | -2.3      | 0  | 74 | 0.00      |
| 50 k     | 1             | 4  | -6.3      | 1  | 5  | -14.1     | 0  | 24  | 0.00      | 2  | 1 | -2.3      | 0  | 37 | -1.32     |
| 100 k    | 1             | 2  | -21.9     | 1  | 2  | -14.1     | 0  | 12  | -3.85     | 1  | 3 | -2.3      | 0  | 18 | -1.32     |
| 250 k    | 0             | 3  | -6.3      | 0  | 4  | -17.5     | 0  | 4   | 0.00      | 0  | 6 | -10.7     | 0  | 7  | -6.25     |
| 350 k    | 0             | 2  | -10.7     | 0  | 2  | -1.8      | 0  | 3   | -10.71    | 0  | 4 | -10.7     | 0  | 4  | 7.14      |
| 400 k    | 0             | 1  | 17.2      | 0  | 2  | -14.1     | 0  | 2   | 4.17      | 0  | 3 | -2.34     | 0  | 4  | -6.25     |

Table 27.18 简单的不同比特率的BRR设置  
IIC模式 (4个中的3个)

| 比特率(bps) | 工作频率PCLK(MHz) |     |           |
|----------|---------------|-----|-----------|
|          | 100           |     |           |
|          | n             | N   | Error (%) |
| 10 k     | 1             | 77  | 0.16      |
| 25 k     | 0             | 124 | 0.00      |
| 50 k     | 0             | 62  | -0.79     |
| 100 k    | 0             | 30  | 0.81      |
| 250 k    | 0             | 12  | -3.85     |

**Table 27.18 BRR settings for different bit rates in simple IIC mode (4 of 4)**

| Bit rate (bps) | Operating frequency PCLK (MHz) |   |           |
|----------------|--------------------------------|---|-----------|
|                | 100                            |   |           |
|                | n                              | N | Error (%) |
| 350 k          | 0                              | 8 | -0.79     |
| 400 k          | 0                              | 8 | -13.19    |

**Table 27.19 Minimum widths at SCL high and low levels at multiple bit rates in simple IIC mode (1 of 4)**

| Bit rate (bps) | Operating frequency PCLK (MHz) |    |   |    |    |   |    |    |   |    |    |   |
|----------------|--------------------------------|----|---|----|----|---|----|----|---|----|----|---|
|                | 8                              |    |   | 10 |    |   | 16 |    |   | 20 |    |   |
|                | n                              | N  | Min. widths at SCL high/low levels (μs) | n  | N  | Min. widths at SCL high/low levels (μs) | n  | N  | Min. widths at SCL high/low levels (μs) | n  | N  | Min. widths at SCL high/low levels (μs) |
| 10 k           | 0                              | 24 | 43.75/50.00                             | 0  | 31 | 44.80/51.20                             | 1  | 12 | 45.5/52.00                              | 1  | 15 | 44.80/51.20                             |
| 25 k           | 0                              | 9  | 17.50/20.00                             | 0  | 12 | 18.2/20.80                              | 1  | 4  | 17.50/20.00                             | 1  | 6  | 19.60/22.40                             |
| 50 k           | 0                              | 4  | 8.75/10.00                              | 0  | 6  | 9.80/11.20                              | 1  | 2  | 10.50/12.00                             | 1  | 3  | 11.20/12.80                             |
| 100 k          | 0                              | 2  | 5.25/6.00                               | 0  | 3  | 5.60/6.40                               | 0  | 4  | 4.37/5.00                               | 0  | 6  | 4.90/5.60                               |
| 250 k          | 0                              | 0  | 1.75/2.00                               | 0  | 1  | 2.80/3.20                               | 0  | 1  | 1.75/2.00                               | 0  | 2  | 2.10/2.40                               |
| 350 k          |                                |    |   |    |    |   |    |    |   | 0  | 1  | 1.40/1.60                               |
| 400 k          |                                |    |   |    |    |   |    |    |   | 0  | 1  | 1.40/1.60                               |

**Table 27.19 Minimum widths at SCL high and low levels at multiple bit rates in simple IIC mode (2 of 4)**

| Bit rate (bps) | Operating frequency PCLK (MHz) |    |   |    |    |   |    |    |   |    |    |   |
|----------------|--------------------------------|----|---|----|----|---|----|----|---|----|----|---|
|                | 25                             |    |   | 30 |    |   | 33 |    |   | 40 |    |   |
|                | n                              | N  | Min. widths at SCL high/low levels (μs) | n  | N  | Min. widths at SCL high/low levels (μs) | n  | N  | Min. widths at SCL high/low levels (μs) | n  | N  | Min. widths at SCL high/low levels (μs) |
| 10 k           | 1                              | 19 | 44.80/51.20                             | 1  | 23 | 44.80/51.20                             | 1  | 25 | 44.12/50.42                             | 1  | 32 | 46.20/52.80                             |
| 25 k           | 1                              | 7  | 17.92/20.48                             | 1  | 9  | 18.66/21.33                             | 1  | 10 | 18.66/21.33                             | 1  | 12 | 18.20/20.80                             |
| 50 k           | 1                              | 3  | 8.96/10.24                              | 1  | 4  | 9.33/10.66                              | 1  | 5  | 10.18/11.63                             | 1  | 6  | 9.80/11.20                              |
| 100 k          | 1                              | 1  | 4.48/5.12                               | 1  | 2  | 5.60/6.40                               | 1  | 2  | 5.09/5.81                               | 0  | 13 | 4.90/5.60                               |
| 250 k          | 0                              | 3  | 2.24/2.56                               | 0  | 3  | 1.86/2.13                               | 0  | 4  | 2.12/2.42                               | 0  | 4  | 1.75/2.00                               |
| 350 k          | 0                              | 2  | 1.68/1.92                               | 0  | 2  | 1.40/1.60                               | 0  | 2  | 1.27/1.45                               | 0  | 3  | 1.40/1.60                               |
| 400 k          | 0                              | 1  | 1.12/1.28                               | 0  | 1  | 0.93/1.07                               | 0  | 2  | 1.27/1.45                               | 0  | 2  | 1.05/1.20                               |

**Table 27.19 Minimum widths at SCL high and low levels at multiple bit rates in simple IIC mode (3 of 4)**

| Bit rate (bps) | Operating frequency PCLK (MHz) |   |   |    |    |   |     |   |   |
|----------------|--------------------------------|---|---|----|----|---|-----|---|---|
|                | 50                             |   |   | 60 |    |   | 100 |   |   |
|                | n                              | N | Min. widths at SCL high/low levels (μs) | n  | N  | Min. widths at SCL high/low levels (μs) | n   | N | Min. widths at SCL high/low levels (μs) |
| 10 k           | 2                              | 9 | 44.80/51.20                             | 1  | 46 | 44.80/51.20                             | 0   | 0 | 43.68/49.92                             |

**Table 27.18 简单的不同比特率的BRR设置 IIC模式 (4个中的4个)**

| 比特率(bps) | 工作频率PCLK(MHz) |   |           |
|----------|---------------|---|-----------|
|          | 100           |   |           |
|          | n             | N | Error (%) |
| 350 k    | 0             | 8 | -0.79     |
| 400 k    | 0             | 8 | -13.19    |

**Table 27.19 简单IIC模式下多个比特率下SCL高电平和低电平的最小宽度 (4个中的1个)**

| 比特率(bps) | 工作频率PCLK(MHz) |    |                   |    |    |                   |    |    |                   |    |    |                   |
|----------|---------------|----|-------------------|----|----|-------------------|----|----|-------------------|----|----|-------------------|
|          | 8             |    |                   | 10 |    |                   | 16 |    |                   | 20 |    |                   |
|          | n             | N  | 分钟。SCL高低电平的宽度(μs) | n  | N  | 分钟。SCL高低电平的宽度(μs) | n  | N  | 分钟。SCL高低电平的宽度(μs) | n  | N  | 分钟。SCL高低电平的宽度(μs) |
| 10 k     | 0             | 24 | 43.75/50.00       | 0  | 31 | 44.80/51.20       | 1  | 12 | 45.5/52.00        | 1  | 15 | 44.80/51.20       |
| 25 k     | 0             | 9  | 17.50/20.00       | 0  | 12 | 18.2/20.80        | 1  | 4  | 17.50/20.00       | 1  | 6  | 19.60/22.40       |
| 50 k     | 0             | 4  | 8.75/10.00        | 0  | 6  | 9.80/11.20        | 1  | 2  | 10.50/12.00       | 1  | 3  | 11.20/12.80       |
| 100 k    | 0             | 2  | 5.25/6.00         | 0  | 3  | 5.60/6.40         | 0  | 4  | 4.37/5.00         | 0  | 6  | 4.90/5.60         |
| 250 k    | 0             | 0  | 1.75/2.00         | 0  | 1  | 2.80/3.20         | 0  | 1  | 1.75/2.00         | 0  | 2  | 2.10/2.40         |
| 350 k    |               |    |                   |    |    |                   |    |    |                   | 0  | 1  | 1.40/1.60         |
| 400 k    |               |    |                   |    |    |                   |    |    |                   | 0  | 1  | 1.40/1.60         |

**Table 27.19 简单IIC模式下多个比特率下SCL高电平和低电平的最小宽度 (4个中的2个)**

| 比特率(bps) | 工作频率PCLK(MHz) |    |                   |    |    |                   |    |    |                   |    |    |                   |
|----------|---------------|----|-------------------|----|----|-------------------|----|----|-------------------|----|----|-------------------|
|          | 25            |    |                   | 30 |    |                   | 33 |    |                   | 40 |    |                   |
|          | n             | N  | 分钟。SCL高低电平的宽度(μs) | n  | N  | 分钟。SCL高低电平的宽度(μs) | n  | N  | 分钟。SCL高低电平的宽度(μs) | n  | N  | 分钟。SCL高低电平的宽度(μs) |
| 10 k     | 1             | 19 | 44.80/51.20       | 1  | 23 | 44.80/51.20       | 1  | 25 | 44.12/50.42       | 1  | 32 | 46.20/52.80       |
| 25 k     | 1             | 7  | 17.92/20.48       | 1  | 9  | 18.66/21.33       | 1  | 10 | 18.66/21.33       | 1  | 12 | 18.20/20.80       |
| 50 k     | 1             | 3  | 8.96/10.24        | 1  | 4  | 9.33/10.66        | 1  | 5  | 10.18/11.63       | 1  | 6  | 9.80/11.20        |
| 100 k    | 1             | 1  | 4.48/5.12         | 1  | 2  | 5.60/6.40         | 1  | 2  | 5.09/5.81         | 0  | 13 | 4.90/5.60         |
| 250 k    | 0             | 3  | 2.24/2.56         | 0  | 3  | 1.86/2.13         | 0  | 4  | 2.12/2.42         | 0  | 4  | 1.75/2.00         |
| 350 k    | 0             | 2  | 1.68/1.92         | 0  | 2  | 1.40/1.60         | 0  | 2  | 1.27/1.45         | 0  | 3  | 1.40/1.60         |
| 400 k    | 0             | 1  | 1.12/1.28         | 0  | 1  | 0.93/1.07         | 0  | 2  | 1.27/1.45         | 0  | 2  | 1.05/1.20         |

**Table 27.19 简单IIC模式下多个比特率下SCL高电平和低电平的最小宽度 (3of4)**

| 比特率(bps) | 工作频率PCLK(MHz) |   |                   |    |    |                   |     |   |                   |
|----------|---------------|---|-------------------|----|----|-------------------|-----|---|-------------------|
|          | 50            |   |                   | 60 |    |                   | 100 |   |                   |
|          | n             | N | 分钟。SCL高低电平的宽度(μs) | n  | N  | 分钟。SCL高低电平的宽度(μs) | n   | N | 分钟。SCL高低电平的宽度(μs) |
| 10 k     | 2             | 9 | 44.80/51.20       | 1  | 46 | 44.80/51.20       | 0   | 0 | 43.68/49.92       |

Table 27.19 Minimum widths at SCL high and low levels at multiple bit rates in simple IIC mode (4 of 4)

| Bit rate (bps) | Operating frequency PCLK (MHz) |   |   |    |    |   |     |   |   |
|----------------|--------------------------------|---|---|----|----|---|-----|---|---|
|                | 50                             |   |   | 60 |    |   | 100 |   |   |
|                | n                              | N | Min. widths at SCL high/low levels (μs) | n  | N  | Min. widths at SCL high/low levels (μs) | n   | N | Min. widths at SCL high/low levels (μs) |
| 25 k           | 2                              | 3 | 17.92/20.48                             | 0  | 74 | 17.50/20.00                             | 0   | 0 | 17.50/20.00                             |
| 50 k           | 2                              | 1 | 8.96/10.24                              | 0  | 37 | 8.87/10.13                              | 0   | 0 | 8.82/10.08                              |
| 100 k          | 1                              | 3 | 4.48/5.12                               | 0  | 18 | 4.43/5.07                               | 0   | 0 | 4.34/4.96                               |
| 250 k          | 0                              | 6 | 1.96/2.24                               | 0  | 7  | 1.87/2.13                               | 0   | 0 | 1.82/2.08                               |
| 350 k          | 0                              | 4 | 1.40/1.60                               | 0  | 4  | 1.17/1.33                               | 0   | 0 | 1.26/1.44                               |
| 400 k          | 0                              | 3 | 1.12/1.28                               | 0  | 4  | 1.17/1.33                               | 0   | 0 | 1.26/1.44                               |

## 27.2.21 MDDR : Modulation Duty Register

Base address: SCIn = 0x4011\_8000 + 0x0100 × n (n = 0, 3, 4, 9)  
 SCIm = 0x4011\_8000 + 0x0100 × m (m = 1, 2)

Offset address: 0x12

| Bit position:      | 7                   | 6 | 5 | 4 | 3 | 2 | 1 | 0 |
|--------------------|---------------------|---|---|---|---|---|---|---|
| Bit field:         | [ 1 1 1 1 1 1 1 1 ] |   |   |   |   |   |   |   |
| Value after reset: | 1                   | 1 | 1 | 1 | 1 | 1 | 1 | 1 |

MDDR corrects the bit rate adjusted by the BRR register.

When the BRME bit in SEMR is set to 1, the bit rate generated by the on-chip baud rate generator is evenly corrected using the settings in MDDR (M/256). Table 27.20 shows the relationship between the MDDR setting (M) and the bit rate (B).

The initial value of MDDR is 0xFF. Bit [7] in this register is fixed to 1.

The CPU can read the MDDR register, but this register is only writable when the TE and RE bits in SCR/SCR\_SMCI are 0.

Table 27.19 简单IIC模式下多个比特率的SCL高电平和低电平的最小宽度 (4个中的4个)

| 比特率(bps) | 工作频率PCLK(MHz) |   |                           |    |    |                   |     |   |                           |
|----------|---------------|---|---------------------------|----|----|-------------------|-----|---|---------------------------|
|          | 50            |   |                           | 60 |    |                   | 100 |   |                           |
|          | n             | N | 最小值。在SCL高低的宽度 levels (μs) | n  | N  | 分钟。SCL高低电平的宽度(μs) | n   | N | 最小值。在SCL高低的宽度 levels (μs) |
| 25 k     | 2             | 3 | 17.92/20.48               | 0  | 74 | 17.50/20.00       | 0   | 0 | 17.50/20.00               |
| 50 k     | 2             | 1 | 8.96/10.24                | 0  | 37 | 8.87/10.13        | 0   | 0 | 8.82/10.08                |
| 100 k    | 1             | 3 | 4.48/5.12                 | 0  | 18 | 4.43/5.07         | 0   | 0 | 4.34/4.96                 |
| 250 k    | 0             | 6 | 1.96/2.24                 | 0  | 7  | 1.87/2.13         | 0   | 0 | 1.82/2.08                 |
| 350 k    | 0             | 4 | 1.40/1.60                 | 0  | 4  | 1.17/1.33         | 0   | 0 | 1.26/1.44                 |
| 400 k    | 0             | 3 | 1.12/1.28                 | 0  | 4  | 1.17/1.33         | 0   | 0 | 1.26/1.44                 |

## 27.2.21 MDDR: 调制占空比寄存器

Base address: SCIn = 0x4011\_8000 + 0x0100 × n (n = 0, 3, 4, 9)  
 SCIm = 0x4011\_8000 + 0x0100 × m (m = 1, 2)

Offset address: 0x12

| Bit position: | 7                   | 6 | 5 | 4 | 3 | 2 | 1 | 0 |
|---------------|---------------------|---|---|---|---|---|---|---|
| Bit field:    | [ 1 1 1 1 1 1 1 1 ] |   |   |   |   |   |   |   |
| 重置后的值:        | 1                   | 1 | 1 | 1 | 1 | 1 | 1 | 1 |

MDDR校正由BRR寄存器调整的比特率。

当SEMR中的BRME位设置为1时，片上波特率发生器生成的比特率使用MDDR(M256)中的设置进行均匀校正。表27.20显示了MDDR设置(M)和比特率(B)之间的关系。

MDDR的初始值为0xFF。该寄存器中的位[7]固定为1。

CPU可以读取MDDR寄存器，但该寄存器只有在SCR/SCR\_SMCI中的TE和RE位为0时才可写。

**Table 27.20 Relationship between MDDR setting (M) and bit rate (B) when bit rate modulation function is used**

B: Bit rate (bps)  
 M: MDDR setting (128 ≤ MDDR ≤ 256)  
 N: BRR setting for baud rate generator (0 ≤ N ≤ 255)  
 PCLK: Operating frequency (MHz)  
 n and S: Determined by the SMR/SMR\_SMCI and SCMR register settings as listed in Table 27.8 and Table 27.9 in section 27.2.20. BRR: Bit Rate Register.

| Mode                                 | SEMR settings |          |           | BRR setting   | Error  |
|--------------------------------------|---------------|----------|-----------|---|--|
|                                      | BGDM bit      | ABCS bit | ABCSE bit |   |  |
| Asynchronous multiprocessor transfer | 0             | 0        | 0         | $N = \frac{PCLK \times 10^6}{64 \times 2^{2n-1} \times (256/M) \times B} - 1$ | $Error(\%) = \left\{ \frac{PCLK \times 10^6}{B \times 64 \times 2^{2n-1} \times (256/M) \times (N+1)} - 1 \right\} \times 100$ |
|                                      | 1             | 0        | 0         | $N = \frac{PCLK \times 10^6}{32 \times 2^{2n-1} \times (256/M) \times B} - 1$ | $Error(\%) = \left\{ \frac{PCLK \times 10^6}{B \times 32 \times 2^{2n-1} \times (256/M) \times (N+1)} - 1 \right\} \times 100$ |
|                                      | 0             | 1        | 0         | $N = \frac{PCLK \times 10^6}{16 \times 2^{2n-1} \times (256/M) \times B} - 1$ | $Error(\%) = \left\{ \frac{PCLK \times 10^6}{B \times 16 \times 2^{2n-1} \times (256/M) \times (N+1)} - 1 \right\} \times 100$ |
|                                      | 1             | 1        | 0         | $N = \frac{PCLK \times 10^6}{12 \times 2^{2n-1} \times (256/M) \times B} - 1$ | $Error(\%) = \left\{ \frac{PCLK \times 10^6}{B \times 12 \times 2^{2n-1} \times (256/M) \times (N+1)} - 1 \right\} \times 100$ |
| Clock synchronous, simple SPI*1      | ×             | ×        | 1         | $N = \frac{PCLK \times 10^6}{8 \times 2^{2n-1} \times (256/M) \times B} - 1$  | —  |
| Smart card interface                 |               |          |           | $N = \frac{PCLK \times 10^6}{S \times 2^{2n+1} \times (256/M) \times B} - 1$  | $Error(\%) = \left\{ \frac{PCLK \times 10^6}{B \times S \times 2^{2n+1} \times (256/M) \times (N+1)} - 1 \right\} \times 100$  |
| Simple IIC*2                         |               |          |           | $N = \frac{PCLK \times 10^6}{64 \times 2^{2n-1} \times (256/M) \times B} - 1$ | —  |

Note 1. Do not use this function in clock synchronous mode or in the highest speed settings in simple SPI mode (SMR.CKS[1:0] = 00b, SCR.CKE[1] = 0, and BRR = 0).  
 Note 2. Adjust the bit rate so that the widths at high and low level of the SCLn output in simple IIC mode satisfy the IIC standard.

Table 27.21 and Table 27.22 list examples of N settings in BRR and M settings in MDDR in normal asynchronous mode.

**Table 27.21 Examples of the BRR and MDDR settings for different bit rates in asynchronous mode (1) (1 of 3)**

| Bit rate (bps) | Operating frequency PCLK (MHz) |   |     |          |           |        |   |         |          |           |    |    |     |          |           |
|----------------|--------------------------------|---|-----|----------|-----------|--------|---|---------|----------|-----------|----|----|-----|----------|-----------|
|                | 8                              |   |     |          |           | 9.8304 |   |         |          |           | 16 |    |     |          |           |
|                | n                              | N | M   | BGDM bit | Error (%) | n      | N | M       | BGDM bit | Error (%) | n  | N  | M   | BGDM bit | Error (%) |
| 38400          | 0                              | 5 | 236 | 0        | 0.03      | 0      | 7 | (256)*1 | 0        | 0.00      | 0  | 10 | 173 | 1        | -0.01     |
| 57600          | 0                              | 3 | 236 | 0        | 0.03      | 0      | 4 | 240     | 0        | 0.00      | 0  | 4  | 236 | 0        | 0.03      |
| 115200         | 0                              | 1 | 236 | 0        | 0.03      | 0      | 1 | 192     | 0        | 0.00      | 0  | 4  | 236 | 1        | 0.03      |
| 230400         | 0                              | 0 | 236 | 0        | 0.03      | 0      | 0 | 192     | 0        | 0.00      | 0  | 1  | 189 | 1        | 0.14      |
| 460800         | 0                              | 0 | 236 | 1        | 0.03      | 0      | 0 | 192     | 1        | 0.00      | 0  | 0  | 189 | 1        | 0.14      |

**Table 27.20 使用比特率调制功能时MDDR设置(M)和比特率(B)的关系**

B: 比特率 (bps)  
 M: MDDR setting (128 ≤ MDDR ≤ 256)  
 N: 波特率发生器的BRR设置 (0 ≤ N ≤ 255)  
 PCLK: 工作频率(MHz)n和S: 由SMRSMR\_SMCI和SCMR寄存器设置确定, 如第27.2.20节中的表27.8和表27.9中所列。BRR: 比特率寄存器。

| Mode          | SEMR settings |        |           | BRR setting   | Error  |
|---------------|---------------|--------|-----------|---|--|
|               | BGDM bit      | ABCS 位 | ABCSE bit |   |  |
| 异步多处理器传输      | 0             | 0      | 0         | $N = \frac{PCLK \times 10^6}{64 \times 2^{2n-1} \times (256/M) \times B} - 1$ | $Error(\%) = \left\{ \frac{PCLK \times 10^6}{B \times 64 \times 2^{2n-1} \times (256/M) \times (N+1)} - 1 \right\} \times 100$ |
|               | 1             | 0      | 0         | $N = \frac{PCLK \times 10^6}{32 \times 2^{2n-1} \times (256/M) \times B} - 1$ | $Error(\%) = \left\{ \frac{PCLK \times 10^6}{B \times 32 \times 2^{2n-1} \times (256/M) \times (N+1)} - 1 \right\} \times 100$ |
|               | 0             | 1      | 0         | $N = \frac{PCLK \times 10^6}{16 \times 2^{2n-1} \times (256/M) \times B} - 1$ | $Error(\%) = \left\{ \frac{PCLK \times 10^6}{B \times 16 \times 2^{2n-1} \times (256/M) \times (N+1)} - 1 \right\} \times 100$ |
|               | 1             | 1      | 0         | $N = \frac{PCLK \times 10^6}{12 \times 2^{2n-1} \times (256/M) \times B} - 1$ | $Error(\%) = \left\{ \frac{PCLK \times 10^6}{B \times 12 \times 2^{2n-1} \times (256/M) \times (N+1)} - 1 \right\} \times 100$ |
| 时钟同步, 简单SPI*1 | ×             | ×      | 1         | $N = \frac{PCLK \times 10^6}{8 \times 2^{2n-1} \times (256/M) \times B} - 1$  | —  |
| 智能卡接口         |               |        |           | $N = \frac{PCLK \times 10^6}{S \times 2^{2n+1} \times (256/M) \times B} - 1$  | $Error(\%) = \left\{ \frac{PCLK \times 10^6}{B \times S \times 2^{2n+1} \times (256/M) \times (N+1)} - 1 \right\} \times 100$  |
| Simple IIC*2  |               |        |           | $N = \frac{PCLK \times 10^6}{64 \times 2^{2n-1} \times (256/M) \times B} - 1$ | —  |

注1.不要在时钟同步模式或简单SPI模式的最高速度设置中使用此功能 (SMR.CKS[1:0]=00b, SCR.CKE[1] = 0, and BRR = 0).  
 注2.调整比特率, 使简单IIC模式下SCLn输出的高低电平宽度满足IIC标准。

表27.21和表27.22列出了正常异步模式下BRR中的N设置和MDDR中的M设置的示例。

**Table 27.21 异步模式下不同比特率的BRR和MDDR设置示例(1)(1of3)**

| 比特率 (bps) | 工作频率PCLK(MHz) |   |     |          |           |        |   |         |          |           |    |    |     |          |           |
|-----------|---------------|---|-----|----------|-----------|--------|---|---------|----------|-----------|----|----|-----|----------|-----------|
|           | 8             |   |     |          |           | 9.8304 |   |         |          |           | 16 |    |     |          |           |
|           | n             | N | M   | BGDM bit | Error (%) | n      | N | M       | BGDM bit | Error (%) | n  | N  | M   | BGDM bit | Error (%) |
| 38400     | 0             | 5 | 236 | 0        | 0.03      | 0      | 7 | (256)*1 | 0        | 0.00      | 0  | 10 | 173 | 1        | -0.01     |
| 57600     | 0             | 3 | 236 | 0        | 0.03      | 0      | 4 | 240     | 0        | 0.00      | 0  | 4  | 236 | 0        | 0.03      |
| 115200    | 0             | 1 | 236 | 0        | 0.03      | 0      | 1 | 192     | 0        | 0.00      | 0  | 4  | 236 | 1        | 0.03      |
| 230400    | 0             | 0 | 236 | 0        | 0.03      | 0      | 0 | 192     | 0        | 0.00      | 0  | 1  | 189 | 1        | 0.14      |
| 460800    | 0             | 0 | 236 | 1        | 0.03      | 0      | 0 | 192     | 1        | 0.00      | 0  | 0  | 189 | 1        | 0.14      |



Table 27.21 Examples of the BRR and MDDR settings for different bit rates in asynchronous mode (1) (2 of 3)

| Bit rate (bps) | Operating frequency PCLK (MHz) |   |     |          |           |        |   |         |          |           |    |    |     |          |           |
|----------------|--------------------------------|---|-----|----------|-----------|--------|---|---------|----------|-----------|----|----|-----|----------|-----------|
|                | 12                             |   |     |          |           | 12.288 |   |         |          |           | 14 |    |     |          |           |
|                | n                              | N | M   | BGDM bit | Error (%) | n      | N | M       | BGDM bit | Error (%) | n  | N  | M   | BGDM bit | Error (%) |
| 38400          | 0                              | 8 | 236 | 0        | 0.03      | 0      | 9 | (256)*1 | 0        | 0.00      | 0  | 16 | 191 | 1        | 0.00      |
| 57600          | 0                              | 5 | 236 | 0        | 0.03      | 0      | 4 | 192     | 0        | 0.00      | 0  | 13 | 236 | 1        | 0.03      |
| 115200         | 0                              | 2 | 236 | 0        | 0.03      | 0      | 4 | 192     | 1        | 0.00      | 0  | 6  | 236 | 1        | 0.03      |
| 230400         | 0                              | 2 | 236 | 1        | 0.03      | 0      | 2 | 230     | 1        | -0.17     | 0  | 2  | 202 | 1        | -0.11     |
| 460800         | 0                              | 0 | 157 | 1        | -0.18     | 0      | 0 | 154     | 1        | -0.26     | 0  | 0  | 135 | 1        | 0.14      |

Table 27.21 Examples of the BRR and MDDR settings for different bit rates in asynchronous mode (1) (3 of 3)

| Bit rate (bps) | Operating frequency PCLK (MHz) |    |     |          |           |         |    |         |          |           |    |    |     |          |           |
|----------------|--------------------------------|----|-----|----------|-----------|---------|----|---------|----------|-----------|----|----|-----|----------|-----------|
|                | 16                             |    |     |          |           | 17.2032 |    |         |          |           | 18 |    |     |          |           |
|                | n                              | N  | M   | BGDM bit | Error (%) | n       | N  | M       | BGDM bit | Error (%) | n  | N  | M   | BGDM bit | Error (%) |
| 38400          | 0                              | 11 | 236 | 0        | 0.03      | 0       | 13 | (256)*1 | 0        | 0.00      | 0  | 18 | 166 | 1        | -0.01     |
| 57600          | 0                              | 7  | 236 | 0        | 0.03      | 0       | 6  | 192     | 0        | 0.00      | 0  | 18 | 249 | 1        | -0.01     |
| 115200         | 0                              | 3  | 236 | 0        | 0.03      | 0       | 6  | 192     | 1        | 0.00      | 0  | 8  | 236 | 1        | 0.03      |
| 230400         | 0                              | 1  | 236 | 0        | 0.03      | 0       | 3  | 219     | 1        | -0.20     | 0  | 1  | 210 | 0        | 0.14      |
| 460800         | 0                              | 1  | 236 | 1        | 0.03      | 0       | 1  | 219     | 1        | -0.20     | 0  | 0  | 210 | 0        | 0.14      |

Note 1. In this example, the ABCS and ABCSE bits in the SEMR register are 0. SEMR.BRME = 0 (M = 256) disables the bit rate modulation function.

Table 27.22 Examples of BRR and MDDR settings for different bit rates in asynchronous mode (2) (1 of 3)

| Bit rate (bps) | Operating frequency PCLK (MHz) |    |         |          |           |    |    |     |          |           |    |    |     |          |           |
|----------------|--------------------------------|----|---------|----------|-----------|----|----|-----|----------|-----------|----|----|-----|----------|-----------|
|                | 19.6608                        |    |         |          |           | 20 |    |     |          |           | 25 |    |     |          |           |
|                | n                              | N  | M       | BGDM bit | Error (%) | n  | N  | M   | BGDM bit | Error (%) | n  | N  | M   | BGDM bit | Error (%) |
| 38400          | 0                              | 15 | (256)*1 | 0        | 0.00      | 0  | 10 | 173 | 0        | -0.01     | 0  | 11 | 151 | 0        | 0.00      |
| 57600          | 0                              | 9  | 240     | 0        | 0.00      | 0  | 9  | 236 | 0        | 0.03      | 0  | 7  | 151 | 0        | 0.00      |
| 115200         | 0                              | 4  | 240     | 0        | 0.00      | 0  | 4  | 236 | 0        | 0.03      | 0  | 3  | 151 | 0        | 0.00      |
| 230400         | 0                              | 1  | 192     | 0        | 0.00      | 0  | 4  | 236 | 1        | 0.03      | 0  | 1  | 151 | 0        | 0.00      |
| 460800         | 0                              | 0  | 192     | 0        | 0.00      | 0  | 0  | 189 | 0        | 0.14      | 0  | 0  | 151 | 0        | 0.00      |

Table 27.22 Examples of BRR and MDDR settings for different bit rates in asynchronous mode (2) (2 of 3)

| Bit rate (bps) | Operating frequency PCLK (MHz) |    |     |          |           |    |    |     |          |           |    |    |     |          |           |
|----------------|--------------------------------|----|-----|----------|-----------|----|----|-----|----------|-----------|----|----|-----|----------|-----------|
|                | 30                             |    |     |          |           | 33 |    |     |          |           | 40 |    |     |          |           |
|                | n                              | N  | M   | BGDM bit | Error (%) | n  | N  | M   | BGDM bit | Error (%) | n  | N  | M   | BGDM bit | Error (%) |
| 38400          | 0                              | 36 | 194 | 1        | 0.01      | 0  | 14 | 143 | 0        | 0.01      | 0  | 21 | 173 | 0        | -0.01     |
| 57600          | 0                              | 10 | 173 | 0        | -0.01     | 0  | 9  | 143 | 0        | 0.01      | 0  | 38 | 230 | 1        | -0.01     |
| 115200         | 0                              | 10 | 173 | 1        | -0.01     | 0  | 4  | 143 | 0        | 0.01      | 0  | 9  | 236 | 0        | 0.03      |
| 230400         | 0                              | 6  | 220 | 1        | -0.09     | 0  | 4  | 143 | 1        | 0.01      | 0  | 4  | 236 | 0        | 0.03      |
| 460800         | 0                              | 3  | 252 | 1        | 0.14      | 0  | 1  | 229 | 0        | 0.10      | 0  | 4  | 236 | 1        | 0.03      |

Table 27.21 异步模式下不同比特率的BRR和MDDR设置示例(1)(2of3)

| 比特率 (bps) | 工作频率PCLK(MHz) |   |     |          |           |        |   |         |          |           |    |    |     |          |           |
|-----------|---------------|---|-----|----------|-----------|--------|---|---------|----------|-----------|----|----|-----|----------|-----------|
|           | 12            |   |     |          |           | 12.288 |   |         |          |           | 14 |    |     |          |           |
|           | n             | N | M   | BGDM bit | Error (%) | n      | N | M       | BGDM bit | Error (%) | n  | N  | M   | BGDM bit | Error (%) |
| 38400     | 0             | 8 | 236 | 0        | 0.03      | 0      | 9 | (256)*1 | 0        | 0.00      | 0  | 16 | 191 | 1        | 0.00      |
| 57600     | 0             | 5 | 236 | 0        | 0.03      | 0      | 4 | 192     | 0        | 0.00      | 0  | 13 | 236 | 1        | 0.03      |
| 115200    | 0             | 2 | 236 | 0        | 0.03      | 0      | 4 | 192     | 1        | 0.00      | 0  | 6  | 236 | 1        | 0.03      |
| 230400    | 0             | 2 | 236 | 1        | 0.03      | 0      | 2 | 230     | 1        | -0.17     | 0  | 2  | 202 | 1        | -0.11     |
| 460800    | 0             | 0 | 157 | 1        | -0.18     | 0      | 0 | 154     | 1        | -0.26     | 0  | 0  | 135 | 1        | 0.14      |

Table 27.21 异步模式下不同比特率的BRR和MDDR设置示例(1)(3of3)

| 比特率 (bps) | 工作频率PCLK(MHz) |    |     |          |           |         |    |         |          |           |    |    |     |          |           |
|-----------|---------------|----|-----|----------|-----------|---------|----|---------|----------|-----------|----|----|-----|----------|-----------|
|           | 16            |    |     |          |           | 17.2032 |    |         |          |           | 18 |    |     |          |           |
|           | n             | N  | M   | BGDM bit | Error (%) | n       | N  | M       | BGDM bit | Error (%) | n  | N  | M   | BGDM bit | Error (%) |
| 38400     | 0             | 11 | 236 | 0        | 0.03      | 0       | 13 | (256)*1 | 0        | 0.00      | 0  | 18 | 166 | 1        | -0.01     |
| 57600     | 0             | 7  | 236 | 0        | 0.03      | 0       | 6  | 192     | 0        | 0.00      | 0  | 18 | 249 | 1        | -0.01     |
| 115200    | 0             | 3  | 236 | 0        | 0.03      | 0       | 6  | 192     | 1        | 0.00      | 0  | 8  | 236 | 1        | 0.03      |
| 230400    | 0             | 1  | 236 | 0        | 0.03      | 0       | 3  | 219     | 1        | -0.20     | 0  | 1  | 210 | 0        | 0.14      |
| 460800    | 0             | 1  | 236 | 1        | 0.03      | 0       | 1  | 219     | 1        | -0.20     | 0  | 0  | 210 | 0        | 0.14      |

注1.在本例中，SEMR寄存器中的ABCS和ABCSE位为0。SEMR.BRME=0(M=256)禁用比特率调制功能。

Table 27.22 异步模式下不同比特率的BRR和MDDR设置示例(2)(1of3)

| 比特率 (bps) | 工作频率PCLK(MHz) |    |         |          |           |    |    |     |          |           |    |    |     |          |           |
|-----------|---------------|----|---------|----------|-----------|----|----|-----|----------|-----------|----|----|-----|----------|-----------|
|           | 19.6608       |    |         |          |           | 20 |    |     |          |           | 25 |    |     |          |           |
|           | n             | N  | M       | BGDM bit | Error (%) | n  | N  | M   | BGDM bit | Error (%) | n  | N  | M   | BGDM bit | Error (%) |
| 38400     | 0             | 15 | (256)*1 | 0        | 0.00      | 0  | 10 | 173 | 0        | -0.01     | 0  | 11 | 151 | 0        | 0.00      |
| 57600     | 0             | 9  | 240     | 0        | 0.00      | 0  | 9  | 236 | 0        | 0.03      | 0  | 7  | 151 | 0        | 0.00      |
| 115200    | 0             | 4  | 240     | 0        | 0.00      | 0  | 4  | 236 | 0        | 0.03      | 0  | 3  | 151 | 0        | 0.00      |
| 230400    | 0             | 1  | 192     | 0        | 0.00      | 0  | 4  | 236 | 1        | 0.03      | 0  | 1  | 151 | 0        | 0.00      |
| 460800    | 0             | 0  | 192     | 0        | 0.00      | 0  | 0  | 189 | 0        | 0.14      | 0  | 0  | 151 | 0        | 0.00      |

Table 27.22 异步模式下不同比特率的BRR和MDDR设置示例(2)(2of3)

| 比特率 (bps) | 工作频率PCLK(MHz) |    |     |          |           |    |    |     |          |           |    |    |     |          |           |
|-----------|---------------|----|-----|----------|-----------|----|----|-----|----------|-----------|----|----|-----|----------|-----------|
|           | 30            |    |     |          |           | 33 |    |     |          |           | 40 |    |     |          |           |
|           | n             | N  | M   | BGDM bit | Error (%) | n  | N  | M   | BGDM bit | Error (%) | n  | N  | M   | BGDM bit | Error (%) |
| 38400     | 0             | 36 | 194 | 1        | 0.01      | 0  | 14 | 143 | 0        | 0.01      | 0  | 21 | 173 | 0        | -0.01     |
| 57600     | 0             | 10 | 173 | 0        | -0.01     | 0  | 9  | 143 | 0        | 0.01      | 0  | 38 | 230 | 1        | -0.01     |
| 115200    | 0             | 10 | 173 | 1        | -0.01     | 0  | 4  | 143 | 0        | 0.01      | 0  | 9  | 236 | 0        | 0.03      |
| 230400    | 0             | 6  | 220 | 1        | -0.09     | 0  | 4  | 143 | 1        | 0.01      | 0  | 4  | 236 | 0        | 0.03      |
| 460800    | 0             | 3  | 252 | 1        | 0.14      | 0  | 1  | 229 | 0        | 0.10      | 0  | 4  | 236 | 1        | 0.03      |

Table 27.22 Examples of BRR and MDDR settings for different bit rates in asynchronous mode (2) (3 of 3)

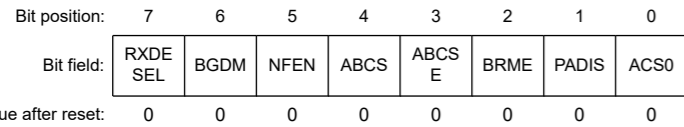
| Bit rate (bps) | Operating frequency PCLK (MHz) |    |     |          |           |    |    |     |          |           |     |    |     |          |           |
|----------------|--------------------------------|----|-----|----------|-----------|----|----|-----|----------|-----------|-----|----|-----|----------|-----------|
|                | 50                             |    |     |          |           | 60 |    |     |          |           | 120 |    |     |          |           |
|                | n                              | N  | M   | BGDM bit | Error (%) | n  | N  | M   | BGDM bit | Error (%) | n   | N  | M   | BGDM bit | Error (%) |
| 38400          | 0                              | 23 | 151 | 0        | 0.00      | 0  | 36 | 194 | 0        | 0.01      | 0   | 73 | 194 | 0        | 0.01      |
| 57600          | 0                              | 15 | 151 | 0        | 0.00      | 0  | 21 | 173 | 0        | -0.01     | 0   | 58 | 232 | 0        | 0.01      |
| 115200         | 0                              | 7  | 151 | 0        | 0.00      | 0  | 10 | 173 | 0        | -0.01     | 0   | 21 | 173 | 0        | -0.01     |
| 230400         | 0                              | 3  | 151 | 0        | 0.00      | 0  | 10 | 173 | 1        | -0.01     | 0   | 10 | 173 | 0        | -0.01     |
| 460800         | 0                              | 1  | 151 | 0        | 0.00      | 0  | 6  | 220 | 1        | -0.09     | 0   | 10 | 173 | 1        | -0.09     |

Note 1. In this example, the ABCS and ABCSE bits in the SEMR register are 0. SEMR.BRME = 0 (M = 256) disables the bit rate modulation function.

### 27.2.22 SEMR : Serial Extended Mode Register

Base address: SCIn = 0x4011\_8000 + 0x0100 × n (n = 0, 3, 4, 9)  
 SCIm = 0x4011\_8000 + 0x0100 × m (m = 1, 2)

Offset address: 0x07



| Bit | Symbol | Function   | R/W              |
|-----|--------|--|------------------|
| 0   | ACS0   | Asynchronous Mode Clock Source Select<br>Valid only in asynchronous mode<br>0: External clock input<br>1: Logical AND of compare matches output from the internal GPT.<br>These bit for the other SCI channels than SCIn (n = 1, 2) are reserved.  | R/W <sup>1</sup> |
| 1   | PADIS  | Preamble function Disable<br>Valid only in asynchronous mode<br>0: Preamble output function is enabled<br>1: Preamble output function is disabled<br>These bits for the other SCI channels than SCIn (n = 0, 3, 4, 9) are reserved.  | R/W              |
| 2   | BRME   | Bit Rate Modulation Enable<br>0: Disable bit rate modulation function<br>1: Enable bit rate modulation function  | R/W <sup>1</sup> |
| 3   | ABCSE  | Asynchronous Mode Extended Base Clock Select 1<br>Valid only in asynchronous mode with SCR.CKE[1] = 0.<br>0: Clock cycles for 1-bit period determined by combination of the BGDM and ABCS bits in the SEMR register<br>1: Baud rate is 6 base clock cycles for 1-bit period<br>These bits for the other SCI channels than SCIn (n = 0, 3, 4, 9) are reserved.  | R/W <sup>1</sup> |
| 4   | ABCS   | Asynchronous Mode Base Clock Select<br>Valid only in asynchronous mode.<br>0: Select 16 base clock cycles for 1-bit period<br>1: Select 8 base clock cycles for 1-bit period   | R/W <sup>1</sup> |
| 5   | NFEN   | Digital Noise Filter Function Enable<br>The NFEN bit must be 0 in all other modes.<br>0: In asynchronous mode: Disable noise cancellation function for RXDn input signal<br>In simple I <sup>2</sup> C mode: Disable noise cancellation function for SCLn and SDAn input signals<br>1: In asynchronous mode: Enable noise cancellation function for RXDn input signal<br>In simple I <sup>2</sup> C mode: Enable noise cancellation function for SCLn and SDAn input signals | R/W <sup>1</sup> |

Table 27.22 异步模式下不同比特率的BRR和MDDR设置示例(2)(3of3)

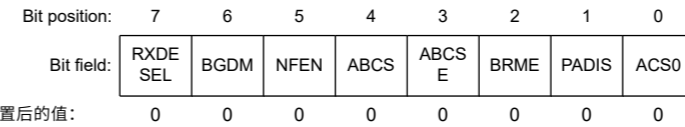
| 比特率(bps) | 工作频率PCLK(MHz) |    |     |          |           |    |    |     |          |           |     |    |     |          |           |
|----------|---------------|----|-----|----------|-----------|----|----|-----|----------|-----------|-----|----|-----|----------|-----------|
|          | 50            |    |     |          |           | 60 |    |     |          |           | 120 |    |     |          |           |
|          | n             | N  | M   | BGDM bit | Error (%) | n  | N  | M   | BGDM bit | Error (%) | n   | N  | M   | BGDM bit | Error (%) |
| 38400    | 0             | 23 | 151 | 0        | 0.00      | 0  | 36 | 194 | 0        | 0.01      | 0   | 73 | 194 | 0        | 0.01      |
| 57600    | 0             | 15 | 151 | 0        | 0.00      | 0  | 21 | 173 | 0        | -0.01     | 0   | 58 | 232 | 0        | 0.01      |
| 115200   | 0             | 7  | 151 | 0        | 0.00      | 0  | 10 | 173 | 0        | -0.01     | 0   | 21 | 173 | 0        | -0.01     |
| 230400   | 0             | 3  | 151 | 0        | 0.00      | 0  | 10 | 173 | 1        | -0.01     | 0   | 10 | 173 | 0        | -0.01     |
| 460800   | 0             | 1  | 151 | 0        | 0.00      | 0  | 6  | 220 | 1        | -0.09     | 0   | 10 | 173 | 1        | -0.09     |

注1.在本例中, SEMR寄存器中的ABCS和ABCSE位为0。 SEMR.BRME=0(M=256)禁用比特率调制功能。

### 27.2.22 SEMR:串行扩展模式寄存器

Base address: SCIn = 0x4011\_8000 + 0x0100 × n (n = 0, 3, 4, 9)  
 SCIm = 0x4011\_8000 + 0x0100 × m (m = 1, 2)

Offset address: 0x07



| Bit | Symbol | Function   | R/W              |
|-----|--------|--|------------------|
| 0   | ACS0   | 异步模式时钟源选择<br>仅在异步模式下有效<br>0: 外部时钟输入1: 比较的逻辑与匹配来自内部GPT的输出。<br>这些位用于除SCIn(n=1 2)之外的其他SCI通道。  | R/W <sup>1</sup> |
| 1   | PADIS  | 前导功能禁用<br>仅在异步模式下有效<br>0: 前导输出功能有效1: 前导输出功能无效<br>这些位用于除SCIn(n=0 3 4 9)之外的其他SCI通道。  | R/W              |
| 2   | BRME   | 比特率调制启用<br>0: 禁用码率调制功能1: 启用码率调制功能  | R/W <sup>1</sup> |
| 3   | ABCSE  | 异步模式扩展基本时钟选择1<br>仅在SCR.CKE[1]=0的异步模式下有效。<br>0: 1位周期的时钟周期由BGDM和ABCS组合确定 SEMR寄存器中的位<br>1: 波特率为1位周期的6个基本时钟周期<br>这些位用于除SCIn(n=0 3 4 9)之外的其他SCI通道。  | R/W <sup>1</sup> |
| 4   | ABCS   | 异步模式基本时钟选择<br>仅在异步模式下有效。<br>0: 为1位周期选择16个基本时钟周期1: 为1位周期选择8个基本时钟周期  | R/W <sup>1</sup> |
| 5   | NFEN   | 数字噪声滤波器功能启用<br>在所有其他模式下, NFEN位必须为0。<br>0: 异步模式: 禁用RXDn输入信号的噪声消除功能<br>在简单I <sup>2</sup> C模式下: 禁用SCLn和SDAn输入信号的噪声消除功能<br>1: 异步模式下: 使能RXDn输入信号的噪声消除功能<br>在简单I <sup>2</sup> C模式下: 启用SCLn和SDAn输入信号的噪声消除功能 | R/W <sup>1</sup> |

| Bit | Symbol  | Function  | R/W              |
|-----|---------|---|------------------|
| 6   | BGDM    | Baud Rate Generator Double-Speed Mode Select<br>Valid only in asynchronous mode with SCR.CKE[1] = 0.<br>0: Output clock from baud rate generator with normal frequency<br>1: Output clock from baud rate generator with doubled frequency | R/W <sup>1</sup> |
| 7   | RXDESEL | Asynchronous Start Bit Edge Detection Select<br>Valid only in asynchronous mode.<br>0: Detect low level on RXDn pin as start bit<br>1: Detect falling edge of RXDn pin as start bit   | R/W <sup>1</sup> |

Note 1. Writable only when the TE and RE bits in SCR/SCR\_SMCI are 0 (both serial transmission and reception are disabled).

The SEMR register selects the clock source for the 1-bit period in asynchronous mode.

#### ACS0 bit (Asynchronous Mode Clock Source Select)

Selects the clock source in the asynchronous mode.

The ACS0 bit is valid in asynchronous mode (SMR.CM bit = 0) and when an external clock input is selected (SCR.CKE[1:0] bits = 10b or 11b). This bit is used to select an external clock input or the logical AND of compare matches output from the internal GPT.

Set the ACS0 bit to 0 in other than asynchronous mode.

For SCI1 and SCI2, the GTIOCnA output (n = 3, 4, 6, 7) of GPT can be set as the serial transfer base clock. Refer to Table 27.23 for details.

These bits for the other SCI channels than SCI1 and SCI2 are reserved. The write values to these bits for other than SCI1 and SCI2 should be 0.

Table 27.23 Correspondence between SCI Channels and Compare Match Outputs

| SCI  | GPT  | Compare Match Output |
|------|------|----------------------|
| SCI1 | GPT3 | GTIOC3A              |
|      | GPT4 | GTIOC4A              |
| SCI2 | GPT6 | GTIOC6A              |
|      | GPT7 | GTIOC7A              |

Figure 27.3, Figure 27.4 show a setting example of when GTIOC3A and GTIOC4A are selected for output.

This figure shows an example when GPT clock is input to SCI1.

When generating 187.5 kbps of GPT average transfer rate for PCLKD = 32 MHz:

1. Generate a frequency of 4 MHz using GTIOC3A as the base clock.
2. Generate 3/4 clock enable of base clock to set an average transfer rate of  $3 \text{ MHz}/16 = 187.5 \text{ kbps}$  using GTIOC4A.

Setting examples of GPT and SCI

- GPT3.GTSSR = 0x80000000, GPT4.GTSSR = 0x80000000 (Enable software counter start)
- GPT3.GTPR = 0x00000007, GPT4.GTPR = 0x0000001F (Maximum count value of GTCNT)
- GPT3.GTCCRA = 0x00000003, GPT4.GTCCRA = 0x00000007 (Compare match value)
- GPT3.GTCR = 0x00000000, GPT4.GTCR = 0x00000000 (Saw-wave PWM mode, timer prescaler is PCLKD/1)
- GPT3.GTIOR = 0x00000306, GPT4.GTIOR = 0x00000306

(Initial output low, output high at GTCCRA compare match, output low at cycle end)

- SCR.SCK[1:0] = 10b (External clock input or GPT clock input is selected)
- SEMR = 0x01 (TMR clock input is selected with 16 base clock cycles for 1-bit period)
- GPT3.GTSTR = 0x00000018 (Software start GTCNT counter)

| Bit | Symbol  | Function  | R/W              |
|-----|---------|---|------------------|
| 6   | BGDM    | 波特率发生器双速模式选择<br>仅在SCR.CKE[1]=0的异步模式下有效。<br>0: 波特率发生器输出时钟, 正常频率<br>1: 波特率发生器输出时钟, 频率加倍 | R/W <sup>1</sup> |
| 7   | RXDESEL | 异步起始位边沿检测选择<br>仅在异步模式下有效。<br>0: 检测RXDn引脚的低电平作为起始位<br>1: 检测RXDn引脚的下降沿作为起始位             | R/W <sup>1</sup> |

注1.仅当SCR/SCR\_SMCI中的TE和RE位为0时可写(串行发送和接收均禁用)。

SEMR寄存器选择异步模式下1位周期的时钟源。

#### ACS0位(异步模式时钟源选择)

选择异步模式下的时钟源。

ACS0位在异步模式(SMR.CM位=0)和选择外部时钟输入时(SCR.CKE[1:0]位=10b或11b)有效。该位用于选择外部时钟输入或内部GPT的比较匹配输出的逻辑与。

在非异步模式下将ACS0位设置为0。

对于SCI1和SCI2, GPT的GTIOCnA输出(n=3 4 6 7)可以设置为串行传输基准时钟。详见表27.23。

这些位用于除SCI1和SCI2之外的其他SCI通道。SCI1和SCI2以外的这些位的写入值应为0。

Table 27.23 SCI通道和比较匹配输出之间的对应关系

| SCI  | GPT  | 比较匹配输出  |
|------|------|---------|
| SCI1 | GPT3 | GTIOC3A |
|      | GPT4 | GTIOC4A |
| SCI2 | GPT6 | GTIOC6A |
|      | GPT7 | GTIOC7A |

图27.3、图27.4显示了选择GTIOC3A和GTIOC4A进行输出时的设置示例。

此图显示了GPT时钟输入到SCI1时的示例。

当为PCLKD=32MHz生成187.5kbps的GPT平均传输速率时:

- 1.使用GTIOC3A作为基本时钟生成4MHz的频率。
- 2.使用GTIOC4A生成基本时钟的3/4时钟使能,以设置 $3 \text{ MHz}/16 = 187.5 \text{ kbps}$ 的平均传输速率。

GPT和SCI的树立榜样

- GPT3.GTSSR=0x80000000, GPT4.GTSSR=0x80000000 (启用软件计数器启动)
- GPT3.GTPR=0x00000007 GPT4.GTPR=0x0000001F (GTCNT的最大计数值)
- GPT3.GTCCRA = 0x00000003, GPT4.GTCCRA = 0x00000007 (Compare match value)
- GPT3.GTCR=0x00000000 GPT4.GTCR=0x00000000 (锯波PWM模式, 定时器预分频器为PCLKD1)
- GPT3.GTIOR = 0x00000306, GPT4.GTIOR = 0x00000306

(初始输出低, GTCCRA比较匹配时输出高, 循环结束时输出低)

- SCR.SCK[1:0]=10b (选择外部时钟输入或GPT时钟输入)
- SEMR=0x01 (TMR时钟输入选择16个基本时钟周期用于1位周期)
- GPT3.GTSTR = 0x00000018 (Software start GTCNT counter)

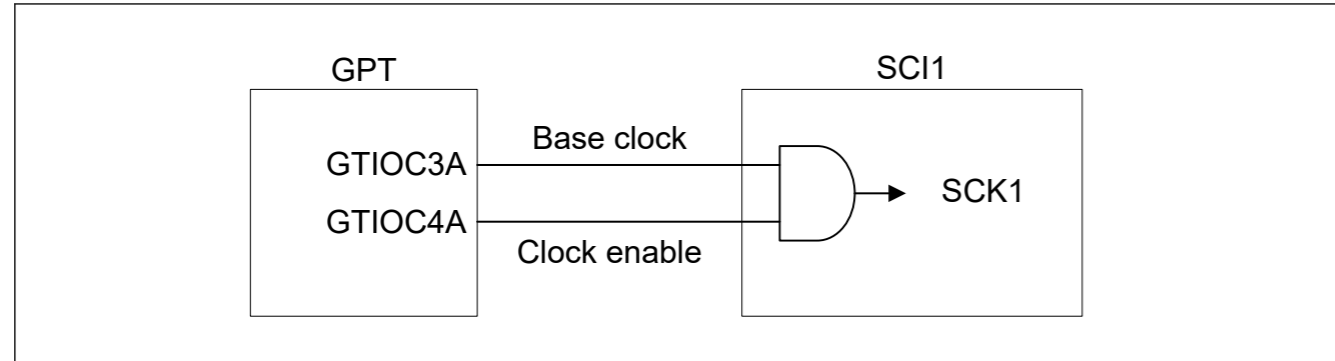


Figure 27.3 example of GPT and SCI connection

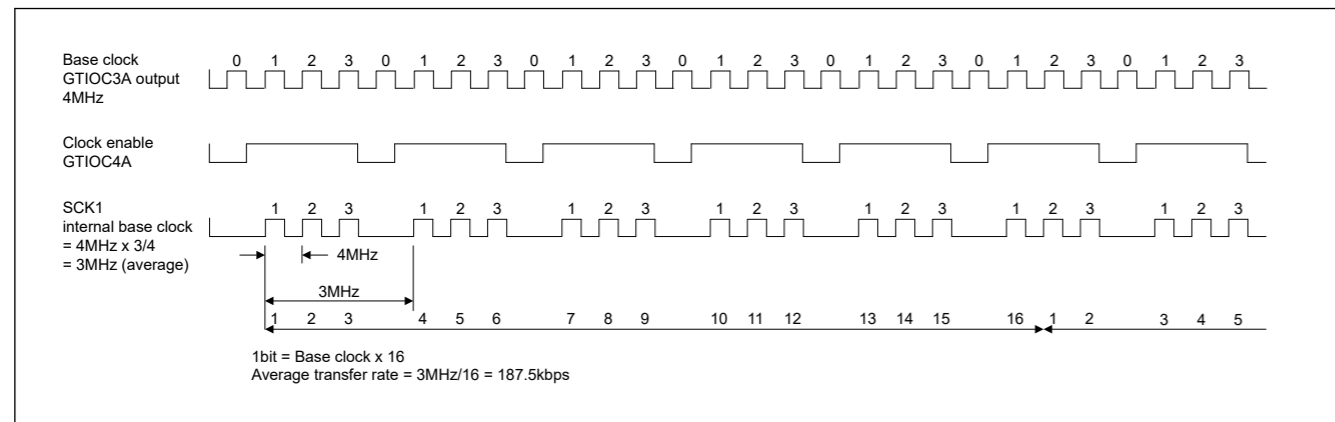


Figure 27.4 Example of Average Transfer Rate Setting When GPT Clock is Input

**PADIS bit (Preamble function Disable)**

In asynchronous mode, select enable / disable of preamble function. In Manchester mode, preamble is not output regardless of this bit setting

**BRME bit (Bit Rate Modulation Enable)**

The BRME bit enables or disables the bit rate modulation function. The bit rate generated by the on-chip baud rate generator is evenly corrected when this function is enabled. Set to 0 in Manchester mode.

**ABCSE bit (Asynchronous Mode Extended Base Clock Select 1)**

The ABCSE bit sets the pulse number for the base clock in a 1-bit period to 6, and the double-frequency clock is output from the baud rate generator. When the bit rate is set to 6 while dividing the bus clock frequency, use this bit and set SMR.CKS[1:0] = 00b and BRR = 0.

Set it to "0" in modes other than asynchronous mode. Even in asynchronous mode, set it to "0" when using external clock.

**ABCS bit (Asynchronous Mode Base Clock Select)**

The ABCS bit selects the number of clock cycles for a 1-bit period.

Set it to "0" in modes other than asynchronous mode and Manchester mode.

**NFEN bit (Digital Noise Filter Function Enable)**

The NFEN bit enables or disables the digital noise filter function.

When the digital noise filter function is enabled:

- Noise cancellation is applied to the RXDn input signal in asynchronous mode
- Noise cancellation is applied to the SDAn and SCLn input signals in simple I<sup>2</sup>C mode

In all other modes, set the NFEN bit to 0 to disable the digital noise filter function. When the function is disabled, input signals are transferred as received.

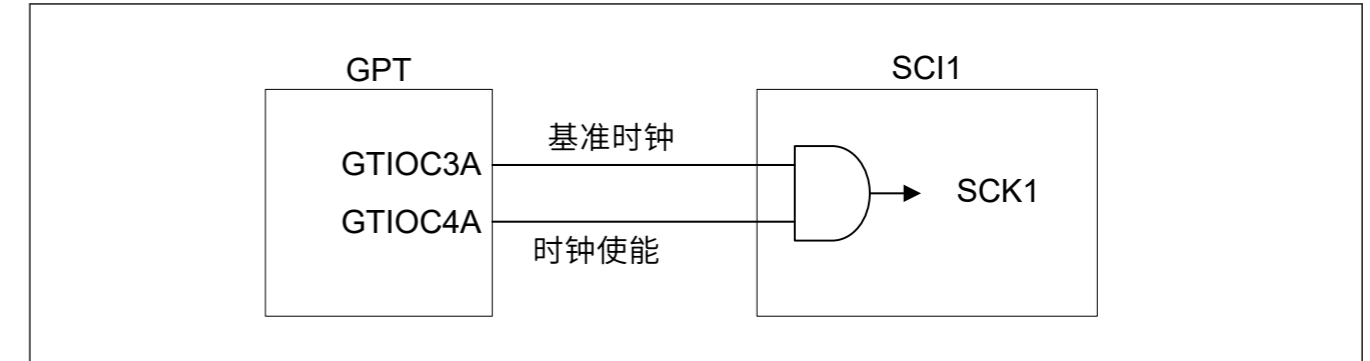


Figure 27.3 GPT和SCI连接示例

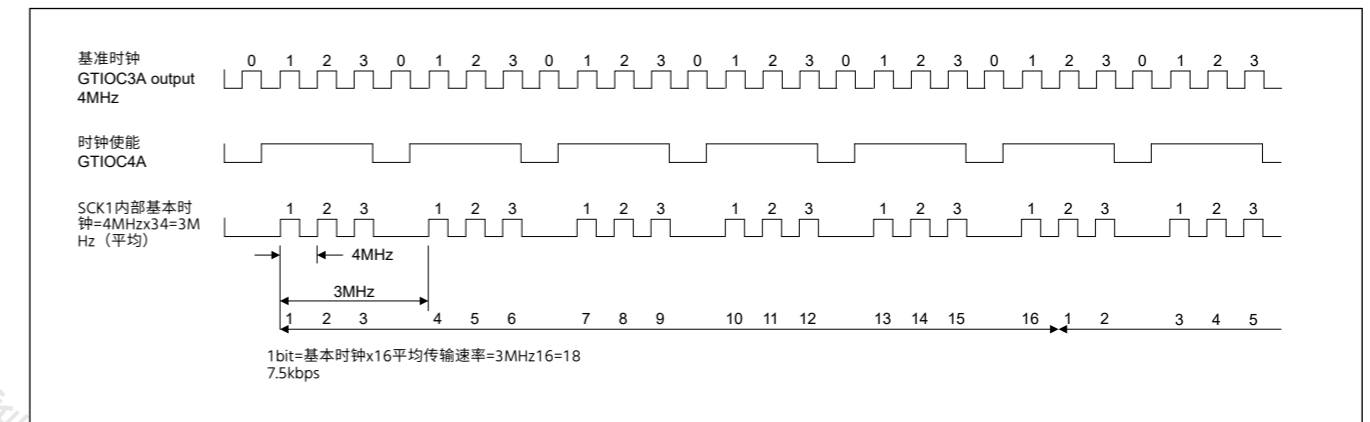


Figure 27.4 输入GPT时钟时的平均传输速率设置示例

**PADIS位（前导功能禁用）**

在异步模式下，选择enable/disable of preamble功能。在曼彻斯特模式下，无论该位设置如何，都不会输出前导码

**BRME位（比特率调制启用）**

BRME位启用或禁用比特率调制功能。该功能使能时，片内波特率发生器产生的比特率得到均匀校正。在曼彻斯特模式下设置为0。

**ABCSE位（异步模式扩展基本时钟选择1）**

ABCSE位将基本时钟在1位周期内的脉冲数设置为6，并从波特率发生器输出双频时钟。当比特率设置为6并同时分频总线时钟频率时，使用该位并设置SMR.CKS[1:0]=00b和BRR=0。

在异步模式以外的模式下将其设置为“0”。即使在异步模式下，使用外部时钟时也将其设置为“0”。

**ABCS位（异步模式基本时钟选择）**

ABCS位选择1位周期的时钟周期数。

在异步模式和曼彻斯特模式以外的模式下将其设置为“0”。

**NFEN位（数字噪声滤波器功能使能）**

NFEN位启用或禁用数字噪声滤波器功能。

启用数字噪声滤波器功能时：

- 在异步模式下对RXDn输入信号应用噪声消除
- 在简单I<sup>2</sup>C模式下，对SDAn和SCLn输入信号应用噪声消除

在所有其他模式下，将NFEN位设置为0以禁用数字噪声滤波器功能。禁用该功能时，输入信号按接收到的方式传输。



**BGDM bit (Baud Rate Generator Double-Speed Mode Select)**

The BGDM bit selects whether or not to double the base clock frequency output from the baud rate generator.

The BGDM bit is valid when the on-chip baud rate generator is selected as the clock source (SCR.CKE[1] = 0) in asynchronous mode (SMR.CM = 0) or Manchester mode (MMR.MANEN = 1). When external clock is selected (SCR.CKE[1] = 1), set it to 0. The base clock is generated by the clock output from the baud rate generator. When the BGDM bit is set to 1, the base clock cycle is halved and the bit rate is doubled.

Set this bit to 0 in modes other than asynchronous mode or Manchester mode.

**RXDESEL bit (Asynchronous Start Bit Edge Detection Select)**

The RXDESEL bit selects the detection method of the start bit for reception in asynchronous mode. When a break occurs, data reception operation depends on the setting of this bit. Set this bit to 1 when reception must be stopped while a break occurs or when reception must be started without keeping the RXDn pin input at the high level for the period of one data frame or longer after completion of the break.

Set this bit to 0 in modes other than asynchronous mode.

**27.2.23 SNFR : Noise Filter Setting Register**

Base address: SCIn = 0x4011\_8000 + 0x0100 × n (n = 0, 3, 4, 9)  
SCIm = 0x4011\_8000 + 0x0100 × m (m = 1, 2)

Offset address: 0x08

|                    |   |   |   |   |   |           |   |   |
|--------------------|---|---|---|---|---|-----------|---|---|
| Bit position:      | 7 | 6 | 5 | 4 | 3 | 2         | 1 | 0 |
| Bit field:         | — | — | — | — | — | NFCS[2:0] |   |   |
| Value after reset: | 0 | 0 | 0 | 0 | 0 | 0         | 0 | 0 |

| Bit | Symbol    | Function  | R/W              |
|-----|-----------|---|------------------|
| 2:0 | NFCS[2:0] | Noise Filter Clock Select<br>In asynchronous mode, selects the standard setting for the base clock.<br>In simple I <sup>2</sup> C mode, selects the standard settings for the clock source of the on-chip baud rate generator selected in the SMR.CKS[1:0] bits.<br>0 0 0: In asynchronous mode: Use clock signal divided by 1 with noise filter<br>In simple I <sup>2</sup> C mode: Setting prohibited<br>0 0 1: In asynchronous mode: Setting prohibited<br>In simple I <sup>2</sup> C mode: Use clock signal divided by 1 with noise filter<br>0 1 0: In asynchronous mode: Setting prohibited<br>In simple I <sup>2</sup> C mode: Use clock signal divided by 2 with noise filter<br>0 1 1: In asynchronous mode: Setting prohibited<br>In simple I <sup>2</sup> C mode: Use clock signal divided by 4 with noise filter<br>1 0 0: In asynchronous mode: Setting prohibited<br>In simple I <sup>2</sup> C mode: Use clock signal divided by 8 with noise filter<br>Others: Setting prohibited | R/W <sup>1</sup> |
| 7:3 | —         | These bits are read as 0. The write value should be 0.  | R/W              |

Note 1. Writing to these bits is only possible when the RE and TE bits in SCR/SCR\_SMCI are 0 (serial reception and transmission disabled).

The SNFR register sets the digital noise filter clock.

**NFCS[2:0] bits (Noise Filter Clock Select)**

The NFCS[2:0] bits select the sampling clock for the digital noise filter. To use the noise filter in asynchronous mode, set these bits to 000b. In simple I<sup>2</sup>C mode, when 32 clocks are selected as one bit period in the basic clock selection bits of the SEMR register, set the NFCS [2: 0] bits in the range from 001b to 100b. When any other value is selected for the basic clock selection bit, set the NFCS bit to 001b.

**BGDM位 (波特率发生器双速模式选择)**

BGDM位选择是否将波特率发生器输出的基本时钟频率加倍。

在异步模式(SMR.CM=0)或曼彻斯特模式(MMR.MANEN=1)选择片内波特率发生器作为时钟源(SCR.CKE[1]=0)时, BGDM位有效。选择外时钟(SCR.CKE[1]=1)时, 将其设置为0。基本时钟是由BaudRateGenerator的时钟输出生成的。当BGDM位设置为1时, 基本时钟周期减半, 比特率加倍。

在异步模式或曼彻斯特模式以外的模式下将此位设置为0。

**RXDESEL位 (异步起始位边沿检测选择)**

RXDESEL位选择异步模式下接收起始位的检测方法。发生中断时, 数据接收操作取决于该位的设置。如果在发生中断时必须停止接收, 或者在中断完成后, RXDn引脚输入在一个数据帧或更长时间内不保持高电平而必须开始接收时, 将该位设置为1。

在异步模式以外的模式下将此位设置为0。

**27.2.23 SNFR: 噪声滤波器设置寄存器**

Base address: SCIn = 0x4011\_8000 + 0x0100 × n (n = 0, 3, 4, 9)  
SCIm = 0x4011\_8000 + 0x0100 × m (m = 1, 2)

Offset address: 0x08

|               |   |   |   |   |   |           |   |   |
|---------------|---|---|---|---|---|-----------|---|---|
| Bit position: | 7 | 6 | 5 | 4 | 3 | 2         | 1 | 0 |
| Bit field:    | — | — | — | — | — | NFCS[2:0] |   |   |
| 重置后的值:        | 0 | 0 | 0 | 0 | 0 | 0         | 0 | 0 |

| Bit | Symbol    | Function  | R/W              |
|-----|-----------|---|------------------|
| 2:0 | NFCS[2:0] | 噪声滤波器时钟选择<br>在异步模式下, 选择基本时钟的标准设置。<br>在简单I <sup>2</sup> C模式下, 选择SMR.CKS[1:0]位中选择的片内波特率发生器时钟源的标准设置。<br><br>000: 在异步模式下: 使用时钟信号除以1和噪声滤波器在简单I <sup>2</sup> C模式下: 禁止设置<br>001: 异步模式下: 禁止设置<br>在简单I <sup>2</sup> C模式下: 使用时钟信号除以1和噪声滤波器<br>010: 异步模式下: 禁止设置<br>在简单I <sup>2</sup> C模式下: 使用时钟信号除以2和噪声滤波器<br>011: 异步模式下: 禁止设置<br>在简单I <sup>2</sup> C模式下: 使用时钟信号除以4和噪声滤波器<br>100: 异步模式下: 禁止设置<br>在简单I <sup>2</sup> C模式下: 使用时钟信号除以8和噪声滤波器<br>其他: 禁止设置 | R/W <sup>1</sup> |
| 7:3 | —         | 这些位被读取为0。写入值应为0。  | R/W              |

注1.只有当SCR/SCR\_SMCI中的RE和TE位为0(串行接收和发送禁用)时, 才能写入这些位。

SNFR寄存器设置数字噪声滤波器时钟。

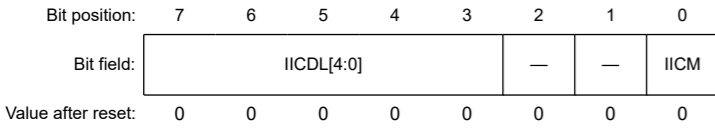
**NFCS[2:0]位 (噪声滤波器时钟选择)**

NFCS[2:0]位选择数字噪声滤波器的采样时钟。要在异步模式下使用噪声滤波器, 请将这些位设置为000b。在简单I<sup>2</sup>C模式下, 当在SEMR寄存器的基本时钟选择位中选择32个时钟作为一个位周期时, 将NFCS[2:0]位设置在001b到100b的范围内。当基本时钟选择位选择任何其他值时, 将NFCS位设置为001b。

27.2.24 SIMR1 : IIC Mode Register 1

Base address: SCIn = 0x4011\_8000 + 0x0100 × n (n = 0, 3, 4, 9)  
 SCLm = 0x4011\_8000 + 0x0100 × m (m = 1, 2)

Offset address: 0x09



| Bit | Symbol     | Function   | R/W              |
|-----|------------|--|------------------|
| 0   | IICM       | Simple IIC Mode Select<br>0: SCMR.SMIF = 0: Asynchronous mode (including multi-processor mode), clock synchronous mode, or simple SPI mode<br>SCMR.SMIF = 1: Smart card interface mode<br>1: SCMR.SMIF = 0: Simple IIC mode<br>SCMR.SMIF = 1: Setting prohibited | R/W <sup>1</sup> |
| 2:1 | —          | These bits are read as 0. The write value should be 0.   | R/W              |
| 7:3 | IICDL[4:0] | SDAn Delay Output Select<br>SDAn signal output delay in cycles of the clock signal from the on-chip baud rate generator.<br>0x00: No output delay<br>Others: (IICDL - 1) to (IICDL) cycles   | R/W <sup>1</sup> |

Note 1. Writing to these bits is only possible when the RE and TE bits in the SCR register are 0 (both serial transmission and reception are disabled).

SIMR1 selects simple IIC mode and the number of delay stages for the SDAn output.

**IICM bit (Simple IIC Mode Select)**

In combination with the SCMR.SMIF bit, the IICM bit selects the operating mode.

**IICDL[4:0] bits (SDAn Delay Output Select)**

The IICDL[4:0] bits specify an output delay on the SDAn pin relative to the falling edge of the output on the SCLn pin.

The available delay settings range from no delay to 31 cycles, with the clock signal from the on-chip baud rate generator as the base. The signal obtained by frequency-dividing PCLK by the divisor set in SMR.CKS[1:0] is supplied as the clock signal from the on-chip baud rate generator. Set 00000b to IICDL[4:0] bits unless operation is in simple IIC mode. In simple IIC mode, set the bits to a value in the range from 00001b to 11111b.

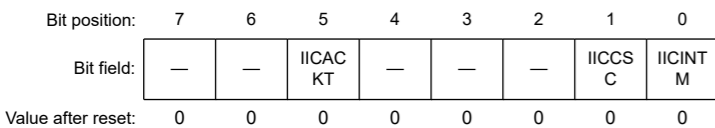
Table 27.24 Settable value of IICDL[4: 0] bits in each communication mode

| Communication mode         | ABCS       | Settable value of IICDL[4:0] bits |
|----------------------------|------------|-----------------------------------|
| Other than simple IIC mode | Don't care | 00000b                            |
| Simple IIC mode            | 0          | 00001b to 11111b                  |
|                            | 1          | 00001b to 00100b                  |

27.2.25 SIMR2 : IIC Mode Register 2

Base address: SCIn = 0x4011\_8000 + 0x0100 × n (n = 0, 3, 4, 9)  
 SCLm = 0x4011\_8000 + 0x0100 × m (m = 1, 2)

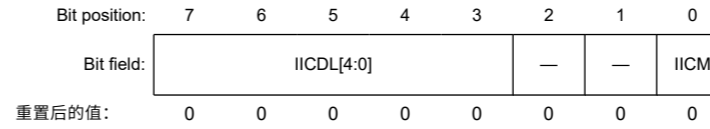
Offset address: 0x0A



27.2.24 SIMR1：IIC模式寄存器1

Base address: SCIn = 0x4011\_8000 + 0x0100 × n (n = 0, 3, 4, 9)  
 SCLm = 0x4011\_8000 + 0x0100 × m (m = 1, 2)

Offset address: 0x09



| Bit | Symbol     | Function   | R/W              |
|-----|------------|--|------------------|
| 0   | IICM       | 简单IIC模式选择<br>0: SCMR.SMIF=0: 异步模式（包括多处理器模式）、时钟同步模式或简单SPI模式<br>SCMR.SMIF=1: 智能卡接口模式<br>1: SCMR.SMIF=0: 简单IIC模式SCMR.SMIF=1: 禁止设置 | R/W <sup>1</sup> |
| 2:1 | —          | 这些位被读取为0。写入值应为0。   | R/W              |
| 7:3 | IICDL[4:0] | SDAn延迟输出选择<br>SDAn信号输出延迟来自片内波特率发生器的时钟信号周期。<br>0x00: 无输出延迟<br>其他: (IICDL1) 至 (IICDL) 周期   | R/W <sup>1</sup> |

注1.只有当SCR寄存器中的RE和TE位为0（串行发送和接收都被禁止）时，才能写入这些位。

SIMR1选择简单IIC模式和SDAn输出的延迟级数。

**IICM位（简单IIC模式选择）**

IICM位与SCMR.SMIF位一起选择工作模式。

**IICDL[4:0]位（SDAn延迟输出选择）**

IICDL[4:0]位指定SDAn引脚上相对于SCLn引脚输出下降沿的输出延迟。

可用的延迟设置范围从无延迟到31个周期，以来自片上波特率发生器的时钟信号为基准。通过在SMR.CKS[1:0]中设置的除数对PCLK进行分频获得的信号作为来自片上波特率发生器的时钟信号提供。除非在简单IIC模式下操作，否则将00000b设置为IICDL[4:0]位。在简单IIC模式下，将位设置为00001b到11111b范围内的值。

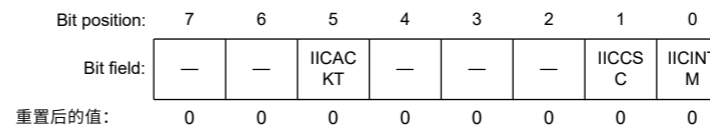
Table 27.24 每种通信模式下IICDL[4:0]位的可设置值

| 通讯方式       | ABCS | IICDL[4:0]位的可设置值 |
|------------|------|------------------|
| 除了简单的IIC模式 | 不在乎  | 00000b           |
| 简单IIC模式    | 0    | 00001b to 11111b |
|            | 1    | 00001b to 00100b |

27.2.25 SIMR2：IIC模式寄存器2

Base address: SCIn = 0x4011\_8000 + 0x0100 × n (n = 0, 3, 4, 9)  
 SCLm = 0x4011\_8000 + 0x0100 × m (m = 1, 2)

Offset address: 0x0A



| Bit | Symbol  | Function  | R/W              |
|-----|---------|---|------------------|
| 0   | IICINTM | IIC Interrupt Mode Select<br>0: Use ACK/NACK interrupts<br>1: Use reception and transmission interrupts | R/W <sup>1</sup> |
| 1   | IICCS   | Clock Synchronization<br>0: Do not synchronize with clock signal<br>1: Synchronize with clock signal    | R/W <sup>1</sup> |
| 4:2 | —       | These bits are read as 0. The write value should be 0.  | R/W              |
| 5   | IICACKT | ACK Transmission Data<br>0: ACK transmission<br>1: NACK transmission and ACK/NACK reception             | R/W              |
| 7:6 | —       | These bits are read as 0. The write value should be 0.  | R/W              |

Note 1. Writing to these bits is only possible when the RE and TE bits in the SCR register are 0 (serial reception and transmission disabled).

SIMR2 selects how reception and transmission are controlled in simple IIC mode.

#### IICINTM bit (IIC Interrupt Mode Select)

The IICINTM bit selects the sources of interrupt requests in simple IIC mode.

#### IICCS bit (Clock Synchronization)

Set the IICCS bit to 1 if the internally generated SCLn clock signal is to be synchronized when the SCLn pin is driven low because a wait was inserted by another other device.

The SCLn clock signal is not synchronized if the IICCS bit is 0. The SCLn clock signal is generated according to the rate selected in the BRR register regardless of the level being input on the SCLn pin.

Set the IICCS bit to 1 except during debugging.

#### IICACKT bit (ACK Transmission Data)

Transmitted data contains ACK bits. Set the IICACKT bit to 1 when ACK and NACK bits are received.

### 27.2.26 SIMR3 : IIC Mode Register 3

Base address: SCLn = 0x4011\_8000 + 0x0100 × n (n = 0, 3, 4, 9)  
SCLm = 0x4011\_8000 + 0x0100 × m (m = 1, 2)

Offset address: 0x0B

| Bit position: | 7            | 6            | 5       | 4         | 3            | 2         | 1         | 0         |
|---------------|--------------|--------------|---------|-----------|--------------|-----------|-----------|-----------|
| Bit field:    | IICSCLS[1:0] | IICSDAS[1:0] | IICSTIF | IICSTPREQ | IICRS TARE Q | IICSTAREQ | IICSTAREQ | IICSTAREQ |

Value after reset: 0 0 0 0 0 0 0 0 0

| Bit | Symbol     | Function   | R/W |
|-----|------------|--|-----|
| 0   | IICSTAREQ  | Start Condition Generation<br>0: Do not generate start condition<br>1: Generate start condition <sup>*1 *3 *5 *6</sup>       | R/W |
| 1   | IICRSTAREQ | Restart Condition Generation<br>0: Do not generate restart condition<br>1: Generate restart condition <sup>*2 *3 *5 *6</sup> | R/W |
| 2   | IICSTPREQ  | Stop Condition Generation<br>0: Do not generate stop condition<br>1: Generate stop condition <sup>*2 *3 *5 *6</sup>          | R/W |

| Bit | Symbol  | Function                                     | R/W              |
|-----|---------|--|------------------|
| 0   | IICINTM | IIC中断模式选择<br>0: 使用ACK/NACK中断<br>1: 使用接收和发送中断 | R/W <sup>1</sup> |
| 1   | IICCS   | 时钟同步<br>0: 不与时钟信号同步<br>1: 与时钟信号同步            | R/W <sup>1</sup> |
| 4:2 | —       | 这些位被读取为0。写入值应为0。                             | R/W              |
| 5   | IICACKT | ACK传输数据<br>0: ACK发送<br>1: NACK发送和ACK/NACK接收  | R/W              |
| 7:6 | —       | 这些位被读取为0。写入值应为0。                             | R/W              |

注1.只有当SCR寄存器中的RE和TE位为0（串行接收和发送禁用）时，才能写入这些位。

SIMR2选择在简单IIC模式下如何控制接收和发送。

#### IICINTM位 (IIC中断模式选择)

IICINTM位选择简单IIC模式下的中断请求源。

#### IICCS bit (Clock Synchronization)

如果在SCLn引脚被驱动为低电平时内部生成的SCLn时钟信号要同步，则将IICCS位设置为1，因为另一个其他设备插入了等待。

如果IICCS位为0，则SCLn时钟信号不同步。SCLn时钟信号根据BRR寄存器中选择的速率生成，与SCLn引脚上输入的电平无关。

除调试期间外，将IICCS位设置为1。

#### IICACKT位 (ACK传输数据)

传输的数据包含ACK位。当收到ACK和NACK位时，将IICACKT位设置为1。

### 27.2.26 SIMR3: IIC模式寄存器3

Base address: SCLn = 0x4011\_8000 + 0x0100 × n (n = 0, 3, 4, 9)  
SCLm = 0x4011\_8000 + 0x0100 × m (m = 1, 2)

Offset address: 0x0B

| Bit position: | 7            | 6            | 5       | 4         | 3            | 2         | 1         | 0         |
|---------------|--------------|--------------|---------|-----------|--------------|-----------|-----------|-----------|
| Bit field:    | IICSCLS[1:0] | IICSDAS[1:0] | IICSTIF | IICSTPREQ | IICRS TARE Q | IICSTAREQ | IICSTAREQ | IICSTAREQ |

重置后的值: 0 0 0 0 0 0 0 0 0

| Bit | Symbol     | Function   | R/W |
|-----|------------|--|-----|
| 0   | IICSTAREQ  | 开始条件生成<br>0: 不产生启动条件<br>1: 产生启动条件 <sup>*1 *3 *5 *6</sup> | R/W |
| 1   | IICRSTAREQ | 重启条件生成<br>0: 不产生重启条件<br>1: 产生重启条件 <sup>*2 *3 *5 *6</sup> | R/W |
| 2   | IICSTPREQ  | 停止条件生成<br>0: 不产生停止条件<br>1: 产生停止条件 <sup>*2 *3 *5 *6</sup> | R/W |

| Bit | Symbol       | Function  | R/W              |
|-----|--------------|---|------------------|
| 3   | IICSTIF      | Issuing of Start, Restart, or Stop Condition Completed Flag<br>0: No requests are being made for generating conditions, or a condition is being generated<br>1: Generation of start, restart, or stop condition is complete.<br>When 0 is written to IICSTIF, it is set to 0 <sup>4</sup> | R/W <sup>4</sup> |
| 5:4 | IICSDAS[1:0] | SDAn Output Select<br>00: Output serial data<br>01: Generate start, restart, or stop condition<br>10: Output low on SDAn pin<br>11: Drive SDAn pin to high-impedance state  | R/W              |
| 7:6 | IICSCLS[1:0] | SCLn Output Select<br>00: Output serial clock<br>01: Generate start, restart, or stop condition<br>10: Output low on SCLn pin<br>11: Drive SCLn pin to high-impedance state   | R/W              |

- Note 1. Only generate a start condition after checking the bus state and confirming that the bus is free.  
 Note 2. Generate a restart or stop condition after checking the bus state and confirming that the bus is busy.  
 Note 3. Do not set more than one of the IICSTAREQ, IICRSTAREQ, and IICSTPREQ bits to 1 at a given time.  
 Note 4. Write only 0. When 1 is written, the value is ignored.  
 Note 5. Execute the generation of a condition after the value of the IICSTIF flag is 0.  
 Note 6. Do not write 0 to this bit while it is 1. Generation of a condition is suspended by writing 0 to this bit while it is 1.

The SIMR3 register is used to control the start, restart, and stop conditions in the simple I<sup>2</sup>C mode, and to hold the SSDAn and SSCLn pins at fixed levels.

#### IICSTAREQ bit (Start Condition Generation)

When a start condition is to be generated, set both IICSDAS[1:0] and IICSCLS[1:0] to 01b in addition to setting the IICSTAREQ bit to 1.

[Setting condition]

- On writing 1 to the bit.

[Clearing condition]

- On completion of start condition generation.

#### IICRSTAREQ bit (Restart Condition Generation)

When a restart condition is to be generated, set both IICSDAS[1:0] and IICSCLS[1:0] to 01b in addition to setting the IICRSTAREQ bit to 1.

[Setting condition]

- On writing 1 to the bit.

[Clearing condition]

- On completion of restart condition generation.

#### IICSTPREQ bit (Stop Condition Generation)

When a stop condition is to be generated, set both IICSDAS[1:0] and IICSCLS[1:0] to 01b in addition to setting the IICSTPREQ bit to 1.

[Setting condition]

- On writing 1 to the bit.

[Clearing condition]

- On completion of stop condition generation.

| Bit | Symbol       | Function  | R/W              |
|-----|--------------|---|------------------|
| 3   | IICSTIF      | 发出启动、重启或停止条件完成标志<br>0: 没有请求生成条件, 或者正在生成条件<br>1: 启动、重启或停止条件的生成完成。0写入IICSTIF时, 设置为0*4 | R/W <sup>4</sup> |
| 5:4 | IICSDAS[1:0] | SDAn输出选择<br>00: 输出串行数据01: 产生启动、重启或停止条件10: SDAn引脚输出低电平11: 驱动SDAn引脚为高阻状态              | R/W              |
| 7:6 | IICSCLS[1:0] | SCLn输出选择<br>00: 输出串行时钟01: 产生启动、重启或停止条件10: SCLn引脚输出低电平11: 驱动SCLn引脚为高阻状态              | R/W              |

- 注1.仅在检查总线状态并确认总线空闲后才生成启动条件。  
 注2.检查总线状态并确认总线繁忙后, 生成重新启动或停止条件。  
 注3.在给定时间, 不要将IICSTAREQ、IICRSTAREQ和IICSTPREQ位中的一个以上设置为1。  
 注4.只写0。当写1时, 该值被忽略。  
 注5.在IICSTIF标志的值为0后执行条件生成。  
 注6.当该位为1时, 请勿向该位写入0。当该位为1时, 通过向该位写入0来暂停条件的产生。

SIMR3寄存器用于控制简单I<sup>2</sup>C模式下的启动、重启和停止条件, 并将SSDAn和SSCLn引脚保持在固定电平。

#### IICSTAREQ位 (开始条件生成)

当要产生一个开始条件时, 除了设置IICSDAS[1:0]和IICSCLS[1:0]为01b IICSTAREQ位为1。

[Setting condition]

- 向该位写入1。

[Clearing condition]

- 完成启动条件生成。

#### IICRSTAREQ位 (重启条件生成)

当要产生重启条件时, 除了设置IICSDAS[1:0]和IICSCLS[1:0]为01b IICRSTAREQ位为1。

[Setting condition]

- 向该位写入1。

[Clearing condition]

- 完成重启条件生成。

#### IICSTPREQ位 (停止条件生成)

当要产生停止条件时, 除了设置IICSDAS[1:0]和IICSCLS[1:0]为01b IICSTPREQ位为1。

[Setting condition]

- 向该位写入1。

[Clearing condition]

- 停止条件生成完成时。



**IICSTIF flag (Issuing of Start, Restart, or Stop Condition Completed Flag)**

After generating a condition, the IICSTIF flag indicates that the condition generation is complete. When using the IICSTAREQ, IICRSTAREQ, or IICSTPREQ bit to cause generation of a condition, do so after setting the IICSTIF flag to 0.

When the IICSTIF flag is 1 while an interrupt request is enabled by setting the SCR.TEIE bit, an STI request is output.

[Setting condition]

- On completion of a start, restart, or stop condition generation.

If the setting condition conflicts with any of the clearing conditions for the flag, the clearing condition takes precedence.

[Clearing conditions]

- On writing 0 to the bit. After writing 0 to the IICSTIF bit, read the bit to check that it is actually set to 0.
- On writing 0 to the SIMR1.IICM bit when operation is not in simple IIC mode.
- On writing 0 to the SCR.TE bit.

**IICSDAS[1:0] bits (SDAn Output Select)**

The IICSDAS[1:0] bits control output from the SDAn pin. Set IICSDAS[1:0] and IICSCLS[1:0] to the same value during normal operations.

**IICSCLS[1:0] bits (SCLn Output Select)**

The IICSCLS[1:0] bits control output from the SCLn pin. Set IICSDAS[1:0] and IICSCLS[1:0] to the same value during normal operations.

**27.2.27 SISR : IIC Status Register**

Base address: SCLn = 0x4011\_8000 + 0x0100 × n (n = 0, 3, 4, 9)  
SCLm = 0x4011\_8000 + 0x0100 × m (m = 1, 2)

Offset address: 0x0C

|                    |   |   |   |   |   |   |   |         |
|--------------------|---|---|---|---|---|---|---|---------|
| Bit position:      | 7 | 6 | 5 | 4 | 3 | 2 | 1 | 0       |
| Bit field:         | — | — | — | — | — | — | — | IICACKR |
| Value after reset: | 0 | 0 | x | x | 0 | x | 0 | 0       |

| Bit | Symbol  | Function   | R/W |
|-----|---------|--|-----|
| 0   | IICACKR | ACK Reception Data Flag<br>0: ACK received<br>1: NACK received | R   |
| 1   | —       | This bit is read as 0.   | R   |
| 2   | —       | The read value is undefined.                                   | R   |
| 3   | —       | This bit is read as 0.   | R   |
| 5:4 | —       | The read value is undefined.                                   | R   |
| 7:6 | —       | These bits are read as 0.                                      | R   |

SISR monitors the state in simple IIC mode.

**IICACKR flag (ACK Reception Data Flag)**

Received ACK and NACK bits can be read from the IICACKR flag. The IICACKR flag is updated on the rising edge of the SCLn clock for the received ACK/NACK bit.

**IICSTIF标志 (发出启动、重启或停止条件完成标志)**

生成条件后，IICSTIF标志指示条件生成完成。使用时IICSTAREQ、IICRSTAREQ或IICSTPREQ位会导致条件生成，请在将IICSTIF标志设置为0后执行此操作。

当IICSTIF标志为1且通过设置SCR.TEIE位使能中断请求时，输出STI请求。

[Setting condition]

- 完成启动、重新启动或停止条件生成时。

如果设置条件与标志的任何清除条件冲突，则清除条件优先。

[Clearing conditions]

- 向该位写入0。将0写入IICSTIF位后，读取该位以检查它是否实际设置为0。
- 在非简单IIC模式下向SIMR1.IICM位写入0。
- 将0写入SCR.TE位。

**IICSDAS[1:0]位 (SDAn输出选择)**

IICSDAS[1:0]位控制SDAn引脚的输出。在正常操作期间将IICSDAS[1:0]和IICSCLS[1:0]设置为相同的值。

**IICSCLS[1:0]位 (SCLn输出选择)**

IICSCLS[1:0]位控制SCLn引脚的输出。在正常操作期间将IICSDAS[1:0]和IICSCLS[1:0]设置为相同的值。

**27.2.27 SISR:IIC状态寄存器**

Base address: SCLn = 0x4011\_8000 + 0x0100 × n (n = 0, 3, 4, 9)  
SCLm = 0x4011\_8000 + 0x0100 × m (m = 1, 2)

Offset address: 0x0C

|               |   |   |   |   |   |   |   |         |
|---------------|---|---|---|---|---|---|---|---------|
| Bit position: | 7 | 6 | 5 | 4 | 3 | 2 | 1 | 0       |
| Bit field:    | — | — | — | — | — | — | — | IICACKR |
| 重置后的值:        | 0 | 0 | x | x | 0 | x | 0 | 0       |

| Bit | Symbol  | Function                       | R/W |
|-----|---------|--------------------------------|-----|
| 0   | IICACKR | ACK接收数据标志<br>0: 收到ACK1: 收到NACK | R   |
| 1   | —       | 该位读为0。                         | R   |
| 2   | —       | 读取值未定义。                        | R   |
| 3   | —       | 该位读为0。                         | R   |
| 5:4 | —       | 读取值未定义。                        | R   |
| 7:6 | —       | 这些位读为0。                        | R   |

SISR在简单IIC模式下监控状态。

**IICACKR标志 (ACK接收数据标志)**

接收到的ACK和NACK位可以从IICACKR标志中读取。IICACKR标志在上升沿更新接收到的ACK/NACK位的SCLn时钟。

## 27.2.28 SPMR : SPI Mode Register

Base address: SCIn = 0x4011\_8000 + 0x0100 × n (n = 0, 3, 4, 9)  
 SCIm = 0x4011\_8000 + 0x0100 × m (m = 1, 2)

Offset address: 0x0D

|                    |      |       |   |     |        |     |      |     |
|--------------------|------|-------|---|-----|--------|-----|------|-----|
| Bit position:      | 7    | 6     | 5 | 4   | 3      | 2   | 1    | 0   |
| Bit field:         | CKPH | CKPOL | — | MFF | CSTPEN | MSS | CTSE | SSE |
| Value after reset: | 0    | 0     | 0 | 0   | 0      | 0   | 0    | 0   |

| Bit | Symbol | Function  | R/W              |
|-----|--------|---|------------------|
| 0   | SSE    | SSn Pin Function Enable<br>0: Disable SSn pin function<br>1: Enable SSn pin function  | R/W <sup>1</sup> |
| 1   | CTSE   | CTS Enable<br>0: Disable CTS function (enable RTS output function)<br>1: Enable CTS function  | R/W <sup>1</sup> |
| 2   | MSS    | Master Slave Select<br>0: Transmit through TXDn pin and receive through RXDn pin (master mode)<br>1: Receive through TXDn pin and transmit through RXDn pin (slave mode)  | R/W <sup>1</sup> |
| 3   | CSTPEN | CTS external pin Enable<br>0: Alternate setting to use CTS and RTS functions as either one terminal<br>1: Dedicated setting for separately using CTS and RTS functions with 2 terminals<br>These bits for the other SCI channels than SCIn (n = 0, 3, 4, 9) are reserved. | R/W              |
| 4   | MFF    | Mode Fault Flag<br>0: No mode fault error<br>1: Mode fault error  | R/W <sup>2</sup> |
| 5   | —      | This bit is read as 0. The write value should be 0.   | R/W              |
| 6   | CKPOL  | Clock Polarity Select<br>0: Do not invert clock polarity<br>1: Invert clock polarity  | R/W <sup>1</sup> |
| 7   | CKPH   | Clock Phase Select<br>0: Do not delay clock<br>1: Delay clock   | R/W <sup>1</sup> |

Note 1. Writing to these bits is only possible when the RE and TE bits in the SCR register are 0 (both serial transmission and reception are disabled).

Note 2. Only 0 can be written to this bit, to clear the flag.

SPMR selects the extension settings in asynchronous and clock synchronous modes.

**SSE bit (SSn Pin Function Enable)**

Set the SSE bit to 1 to use the SSn pin to control transmission and reception in simple SPI mode. Set this bit to 0 in all other modes. In simple SPI mode, when master mode is selected (SCR.CKE[1:0] = 00b and SPMR.MSS = 0) and there is a single master, the SSn pin on the master side is not required to control reception and transmission. In such a case, set the SSE bit to 0. Do not set both the SSE and CTSE bits to 1. If this setting is made, operation is the same as that when these bits are set to 0.

**CTSE bit (CTS Enable)**

Set the CTSE bit to 1 if the SSn pin is to be used for inputting the CTS control signal to control transmission and reception. The RTS signal is output when this bit is set to 0. Set this bit to 0 in smart card interface mode, simple SPI mode, and simple IIC mode. Do not set both the CTSE and SSE bits to 1. If this setting is made, operation is the same as that when these bits are set to 0.

**MSS bit (Master Slave Select)**

The MSS bit selects master or slave operation in simple SPI mode. The functions of the TXDn and RXDn pins are reversed when this bit is set to 1, so that data is received through the TXDn pin and transmitted through the RXDn pin.

## 27.2.28 SPMR:SPI模式寄存器

Base address: SCIn = 0x4011\_8000 + 0x0100 × n (n = 0, 3, 4, 9)  
 SCIm = 0x4011\_8000 + 0x0100 × m (m = 1, 2)

Offset address: 0x0D

|               |      |       |   |     |        |     |      |     |
|---------------|------|-------|---|-----|--------|-----|------|-----|
| Bit position: | 7    | 6     | 5 | 4   | 3      | 2   | 1    | 0   |
| Bit field:    | CKPH | CKPOL | — | MFF | CSTPEN | MSS | CTSE | SSE |
| 重置后的值:        | 0    | 0     | 0 | 0   | 0      | 0   | 0    | 0   |

| Bit | Symbol | Function  | R/W              |
|-----|--------|---|------------------|
| 0   | SSE    | SSn引脚功能使能<br>0: 禁用SSn引脚功能<br>1: 启用SSn引脚功能   | R/W <sup>1</sup> |
| 1   | CTSE   | CTS Enable<br>0: 关闭CTS功能 (开启RTS输出功能)<br>1: 开启CTS功能  | R/W <sup>1</sup> |
| 2   | MSS    | 主从选择<br>0: 通过TXDn引脚发送并通过RXDn引脚接收 (主模式)<br>1: 通过TXDn引脚接收并通过RXDn引脚发送 (从模式)                                    | R/W <sup>1</sup> |
| 3   | CSTPEN | CTS外部引脚使能<br>0: 作为一个端子使用CTS和RTS功能的交替设置<br>1: 单独使用2个端子的CTS和RTS功能的专用设置<br>这些位用于SCIn以外的其他SCI通道 (n=0、3、4、9) 保留。 | R/W              |
| 4   | MFF    | 模式故障标志<br>0: 无模式故障错误<br>1: 模式故障错误   | R/W <sup>2</sup> |
| 5   | —      | 该位读取为0。写入值应为0。  | R/W              |
| 6   | CKPOL  | 时钟极性选择<br>0: 不反转时钟极性<br>1: 反转时钟极性   | R/W <sup>1</sup> |
| 7   | CKPH   | 时钟相位选择<br>0: 不延迟时钟<br>1: 延迟时钟   | R/W <sup>1</sup> |

注1.只有当SCR寄存器中的RE和TE位为0 (串行发送和接收都被禁止) 时,才能写入这些位。

注2.该位只能写入0,以清除标志。

SPMR在异步和时钟同步模式下选择扩展设置。

**SSE位 (SSn引脚功能使能)**

将SSE位设置为1以使用SSn引脚控制简单SPI模式下的发送和接收。在所有其他模式下将此位设置为0。在简单的SPI模式下,选择主模式 (SCR.CKE[1:0]=00B和SPMR.MSS=0),并且有一个主人,主侧不需要SSNPIN来控制接收和传输。在这种情况下,请将SSE位设置为0。不要将SSE和CTSE位都设置为1。如果进行此设置,则操作与将这些位设置为0时的操作相同。

**CTSE bit (CTS Enable)**

如果SSn引脚用于输入CTS控制信号以控制发送和接收,请将CTSE位设置为1。该位设置为0时输出RTS信号。在智能卡接口模式、简单SPI模式和简单模式下设置该位为0 IIC模式。不要将CTSE和SSE位都设置为1。如果进行此设置,则操作与将这些位设置为0时的操作相同。

**MSS位 (主从选择)**

MSS位选择简单SPI模式下的主机或从机操作。当该位设置为1时, TXDn和RXDn引脚的功能相反,因此数据通过TXDn引脚接收并通过RXDn引脚发送。

Set this bit to 0 in modes other than simple SPI mode.

**CSTPEN bit (CTS external pin Enable)**

Select the terminals usage method when using the CTS and RTS functions.

**MFF flag (Mode Fault Flag)**

The MFF flag indicates mode fault errors. In a multi-master configuration, determine the mode fault error occurrence by reading this flag.

[Setting condition]

- When input on the SSn pin is low during master operation in simple SPI mode (SSE bit = 1 and MSS bit = 0).

[Clearing condition]

- On writing 0 to the bit after it is read as 1.

**CKPOL bit (Clock Polarity Select)**

The CKPOL bit selects the polarity of the clock signal output through the SCKn pin. See Figure 27.99 for details. Set the CKPOL bit to 0 in all modes other than simple SPI mode and clock synchronous mode.

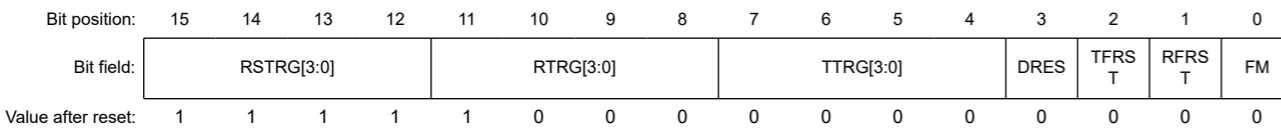
**CKPH bit (Clock Phase Select)**

The CKPH bit selects the phase of the clock signal output through the SCKn pin. See Figure 27.99 for details. Set the CKPH bit to 0 in all modes other than simple SPI mode and clock synchronous mode.

**27.2.29 FCR : FIFO Control Register**

Base address: SCIn = 0x4011\_8000 + 0x0100 × n (n = 0, 3, 4, 9)

Offset address: 0x14



| Bit | Symbol    | Function   | R/W              |
|-----|-----------|--|------------------|
| 0   | FM        | FIFO Mode Select<br>Valid only in asynchronous mode, including multi-processor mode, or clock synchronous mode.<br>0: Non-FIFO mode.<br>Selects TDR/RDR or TDRHL/RDRHL for communication.<br>1: FIFO mode.<br>Selects FTDRHL/FRDRHL for communication. | R/W <sup>1</sup> |
| 1   | RFRST     | Receive FIFO Data Register Reset<br>Valid only when FCR.FM = 1.<br>0: Do not reset FRDRHL<br>1: Reset FRDRHL   | R/W              |
| 2   | TFRST     | Transmit FIFO Data Register Reset<br>Valid only when FCR.FM = 1.<br>0: Do not reset FTDRHL<br>1: Reset FTDRHL  | R/W              |
| 3   | DRES      | Receive Data Ready Error Select<br>Selects the interrupt requested when detecting receive data ready.<br>0: Receive data full interrupt (SCIn_RXI)<br>1: Receive error interrupt (SCIn_ERI)  | R/W              |
| 7:4 | TTRG[3:0] | Transmit FIFO Data Trigger Number<br>Valid only in asynchronous mode, including multi-processor mode, or clock synchronous mode.<br>The trigger number is specified in the TTRG[3:0] bits.   | R/W              |

在简单SPI模式以外的模式下将此位设置为0。

**CSTPEN位 (CTS外部引脚使能)**

使用CTS和RTS功能时选择终端使用方法。

**MFF标志 (模式故障标志)**

MFF标志指示模式故障错误。在多主机配置中，通过读取该标志确定模式故障错误发生。

[Setting condition]

- 在简单SPI模式 (SSE位=1和MSS位=0) 的主机操作期间，SSn引脚上的输入为低电平。

[Clearing condition]

- 读为1后向该位写入0。

**CKPOL位 (时钟极性选择)**

CKPOL位选择通过SCKn引脚输出的时钟信号的极性。详见图27.99。设置在除简单SPI模式和时钟同步模式之外的所有模式中，CKPOL位为0。

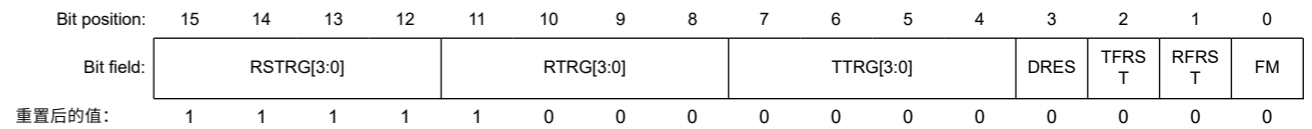
**CKPH位 (时钟相位选择)**

CKPH位选择通过SCKn引脚输出的时钟信号的相位。详见图27.99。设置CKPH位在除简单SPI模式和时钟同步模式之外的所有模式下为0。

**27.2.29 FCR：先进先出控制寄存器**

Base address: SCIn = 0x4011\_8000 + 0x0100 × n (n = 0, 3, 4, 9)

Offset address: 0x14



| Bit | Symbol    | Function  | R/W              |
|-----|-----------|---|------------------|
| 0   | FM        | 先进先出模式选择<br>仅在异步模式下有效，包括多处理器模式或时钟同步模式。<br>0: Non-FIFO mode.<br>选择TDRRDR或TDRHLRDRHL进行通信。<br>1: FIFO mode.<br>选择FTDRHLFRDRHL进行通信。 | R/W <sup>1</sup> |
| 1   | RFRST     | 接收FIFO数据寄存器复位<br>仅当FCR.FM=1时有效。<br>0: 不复位FRDRHL1: 复位FRDRHL  | R/W              |
| 2   | TFRST     | 发送FIFO数据寄存器复位<br>仅当FCR.FM=1时有效。<br>0: 不复位FTDRHL1: 复位FTDRHL  | R/W              |
| 3   | DRES      | 接收数据就绪错误选择<br>当检测到接收数据就绪时选择请求的中断。<br>0: 接收数据满中断 (SCIn_RXI) 1: 接收错误中断 (SCIn_ERI)   | R/W              |
| 7:4 | TTRG[3:0] | 发送FIFO数据触发数<br>仅在异步模式下有效，包括多处理器模式或时钟同步模式。触发编号在TTRG[3:0]位中指定。  | R/W              |

| Bit   | Symbol     | Function  | R/W |
|-------|------------|---|-----|
| 11:8  | RTRG[3:0]  | Receive FIFO Data Trigger Number<br>Valid only in asynchronous mode, including multi-processor mode, or clock synchronous mode.<br>The trigger number is specified in the RTRG[3:0] bits.   | R/W |
| 15:12 | RSTRG[3:0] | RTS Output Active Trigger Number Select<br>Valid only in asynchronous mode, including multi-processor mode, or clock synchronous mode, when FCR.FM = 1, SPMR.CTSE = 0, and SPMR.SSE = 0.<br>The trigger number is specified in the RSTRG[3:0] bits. | R/W |

Note 1. Writable only when TE = 0 and RE = 0.

FCR selects FIFO mode, resets FTDRHL and FRDRHL, selects the FIFO data trigger number for transmission or reception, and selects the RTS output active trigger number.

#### FM bit (FIFO Mode Select)

When the FM bit is set to 1, FTDRHL and FRDRHL are selected for communication. When the FM bit is set to 0, TDR and RDR, or TDRHL and RDRHL are selected for communication.

#### RFRST bit (Receive FIFO Data Register Reset)

When the RFRST bit is set to 1, the FRDRHL register is reset and the received data count resets to 0. When 1 is written to the RFRST bit, it clears to 0 after 1 PCLK.

#### TFRST bit (Transmit FIFO Data Register Reset)

When the TFRST bit is set to 1, the FTDRHL register is reset and the transmit data count resets to 0. When 1 is written to the TFRST bit, it clears to 0 after 1 PCLK.

#### DRES bit (Receive Data Ready Error Select)

When detecting a receive data ready error, the selection can be made from an SCIn\_RXI interrupt request or an SCIn\_ERI interrupt request. When starting DTC or DMAC and reading from the FRDRH and FRDRL registers, set the DRES bit to 1.

#### TTRG[3:0] bits (Transmit FIFO Data Trigger Number)

The TDFE flag is set to 1 when the amount of transmit data in FTDRHL is equal to or less than the transmit triggering number specified in the TTRG[3:0] bits, and software can write data to FTDRHL. If SCR.TIE = 1, an SCIn\_TXI interrupt request occurs.

#### RTRG[3:0] bits (Receive FIFO Data Trigger Number)

The RDF flag is set to 1 when the amount of receive data in FRDRHL is equal to or greater than the receive triggering number specified in the RTRG[3:0] bits, and software can read data from FRDRHL. If SCR.RIE = 1, an SCIn\_RXI interrupt request occurs.

When RTRG[3:0] is 0, the RDF flag is not set even when the amount of data in the receive FIFO is equal to 0, and an SCIn\_RXI interrupt does not occur.

#### RSTRG[3:0] bits (RTS Output Active Trigger Number Select)

When the amount of receive data stored in FRDRHL is equal to or greater than the receive triggering number specified in the RSTRG[3:0] bits, the RTS signal goes high.

When RSTRG[3:0] is 0, the RTS signal does not go high even when the amount of data in FRDRHL is equal to 0.

### 27.2.30 FDR : FIFO Data Count Register

Base address: SCIn = 0x4011\_8000 + 0x0100 × n (n = 0, 3, 4, 9)

Offset address: 0x16

|                    |    |    |    |        |    |    |   |   |   |   |        |   |   |   |   |   |
|--------------------|----|----|----|--------|----|----|---|---|---|---|--------|---|---|---|---|---|
| Bit position:      | 15 | 14 | 13 | 12     | 11 | 10 | 9 | 8 | 7 | 6 | 5      | 4 | 3 | 2 | 1 | 0 |
| Bit field:         | —  | —  | —  | T[4:0] |    |    |   | — | — | — | R[4:0] |   |   |   |   |   |
| Value after reset: | 0  | 0  | 0  | 0      | 0  | 0  | 0 | 0 | 0 | 0 | 0      | 0 | 0 | 0 | 0 | 0 |

| Bit   | Symbol     | Function   | R/W |
|-------|------------|--|-----|
| 11:8  | RTRG[3:0]  | 接收FIFO数据触发数<br>仅在异步模式下有效，包括多处理器模式或时钟同步模式。触发编号在RTRG[3:0]位中指定。                                   | R/W |
| 15:12 | RSTRG[3:0] | RTS输出有源触发数选择<br>仅在异步模式下有效，包括多处理器模式或时钟同步模式，当FCR.FM=1、SPMR.CTSE=0和SPMR.SSE=0时。触发数在RSTRG[3:0]中指定。 | R/W |

注1.仅当TE=0且RE=0时可写。

FCR选择FIFO模式，复位FTDRHL和FRDRHL，选择发送或接收的FIFO数据触发数，选择RTS输出激活触发数。

#### FM位 (FIFO模式选择)

当FM位设置为1时，选择FTDRHL和FRDRHL进行通信。当FM位设置为0时，TDR和选择RDR或TDRHL和RDRHL进行通信。

#### RFRST位 (接收FIFO数据寄存器复位)

当RFRST位设置为1时，FRDRHL寄存器复位，接收数据计数复位为0。当向RFRST位写入1时，它在1个PCLK后清除为0。

#### TFRST位 (发送FIFO数据寄存器复位)

当TFRST位设置为1时，FTDRHL寄存器复位并且发送数据计数复位为0。当1写入TFRST位时，它在1个PCLK后清除为0。

#### DRES位 (接收数据就绪错误选择)

当检测到接收数据就绪错误时，可以从SCIn\_RXI中断请求或SCIn\_ERI中断请求中进行选择。启动DTC或DMAC并读取FRDRH和FRDRL寄存器时，将DRES位设置为1。

#### TTRG[3:0]位 (发送FIFO数据触发编号)

当FTDRHL中的发送数据量等于或小于TTRG[3:0]位中指定的发送触发数时，TDFE标志设置为1，并且软件可以将数据写入FTDRHL。如果SCR.TIE=1，则发生SCIn\_TXI中断请求。

#### RTRG[3:0]位 (接收FIFO数据触发编号)

当FRDRHL中的接收数据量等于或大于RTRG[3:0]位中指定的接收触发数时，RDF标志设置为1，并且软件可以从FRDRHL中读取数据。如果SCR.RIE=1，则发生SCIn\_RXI中断请求。

当RTRG[3:0]为0时，即使接收FIFO中的数据量等于0，RDF标志也不置位，并且SCIn\_RXI中断不发生。

#### RSTRG[3:0]位 (RTS输出有效触发数选择)

当FRDRHL中存储的接收数据量等于或大于RSTRG[3:0]位中指定的接收触发数时，RTS信号变为高电平。

当RSTRG[3:0]为0时，即使FRDRHL中的数据量等于0，RTS信号也不会变高。

### 27.2.30 FDR:FIFO数据计数寄存器

Base address: SCIn = 0x4011\_8000 + 0x0100 × n (n = 0, 3, 4, 9)

Offset address: 0x16

|               |    |    |    |        |    |    |   |   |   |   |        |   |   |   |   |   |
|---------------|----|----|----|--------|----|----|---|---|---|---|--------|---|---|---|---|---|
| Bit position: | 15 | 14 | 13 | 12     | 11 | 10 | 9 | 8 | 7 | 6 | 5      | 4 | 3 | 2 | 1 | 0 |
| Bit field:    | —  | —  | —  | T[4:0] |    |    |   | — | — | — | R[4:0] |   |   |   |   |   |
| 重置后的值:        | 0  | 0  | 0  | 0      | 0  | 0  | 0 | 0 | 0 | 0 | 0      | 0 | 0 | 0 | 0 | 0 |



| Bit   | Symbol | Function   | R/W |
|-------|--------|--|-----|
| 4:0   | R[4:0] | Receive FIFO Data Count<br>Valid only in asynchronous mode, including multi-processor mode, or clock synchronous mode, when FCR.FM = 1.<br>Indicates the amount of receive data stored in FRDRHL.          | R   |
| 7:5   | —      | These bits are read as 0.  | R   |
| 12:8  | T[4:0] | Transmit FIFO Data Count<br>Valid only in asynchronous mode, including multi-processor mode, or clock synchronous mode, when FCR.FM = 1.<br>Indicates the amount of non-transmitted data stored in FTDRHL. | R   |
| 15:13 | —      | These bits are read as 0.  | R   |

The FDR register indicates the amount of data stored in FRDRHL and FTDRHL.

#### R[4:0] bits (Receive FIFO Data Count)

The R[4:0] bits indicate the amount of receive data stored in FRDRHL. 0x00 means no receive data, and 0x10 means that the maximum received data is stored in FRDRHL.

#### T[4:0] bits (Transmit FIFO Data Count)

The T[4:0] bits indicate the amount of non-transmitted data stored in FTDRHL. 0x00 means no transmit data, and 0x10 means that all (maximum amount) of the data to be transmitted is stored in FTDRHL.

### 27.2.31 LSR : Line Status Register

Base address: SCIn = 0x4011\_8000 + 0x0100 × n (n = 0, 3, 4, 9)

Offset address: 0x18

| Bit position:      | 15 | 14 | 13 | 12        | 11 | 10 | 9 | 8 | 7         | 6 | 5 | 4 | 3 | 2    | 1 | 0 |
|--------------------|----|----|----|-----------|----|----|---|---|-----------|---|---|---|---|------|---|---|
| Bit field:         | —  | —  | —  | PNUM[4:0] |    |    |   | — | FNUM[4:0] |   |   |   | — | ORER |   |   |
| Value after reset: | 0  | 0  | 0  | 0         | 0  | 0  | 0 | 0 | 0         | 0 | 0 | 0 | 0 | 0    | 0 | 0 |

| Bit   | Symbol    | Function  | R/W            |
|-------|-----------|---|----------------|
| 0     | ORER      | Overrun Error Flag<br>Valid only in asynchronous mode, including multi-processor mode, or clock synchronous mode, and when FIFO is selected.<br>0: No overrun error occurred<br>1: Overrun error occurred | R <sup>1</sup> |
| 1     | —         | This bit is read as 0.  | R              |
| 6:2   | FNUM[4:0] | Framing Error Count<br>Indicates the amount of data with a framing error in the receive data stored in FRDRHL.  | R              |
| 7     | —         | This bit is read as 0.  | R              |
| 12:8  | PNUM[4:0] | Parity Error Count<br>Indicates the amount of data with a parity error in the receive data stored in FRDRHL.  | R              |
| 15:13 | —         | These bits are read as 0.   | R              |

Note 1. Write 0 to SSR\_FIFO.ORER to clear the flag.

The LSR register indicates the receive error status.

#### ORER flag (Overrun Error Flag)

The ORER flag reflects the value in SSR\_FIFO.ORER.

#### FNUM[4:0] bits (Framing Error Count)

The FNUM[4:0] value indicates the amount of data with a framing error stored in the FRDRHL register.

| Bit   | Symbol | Function   | R/W |
|-------|--------|--|-----|
| 4:0   | R[4:0] | ReceiveFIFODataCount仅在异步模式下有效，包括多处理器模式，或时钟同步模式，当FCR.FM=1时。表示FRDRHL中存储的接收数据量。   | R   |
| 7:5   | —      | 这些位读为0。  | R   |
| 12:8  | T[4:0] | TransmitFIFODataCount仅在异步模式下有效，包括多处理器模式或时钟同步模式，当FCR.FM=1时。表示存储在FTDRHL中的未发送数据量。 | R   |
| 15:13 | —      | 这些位读为0。  | R   |

FDR寄存器指示存储在FRDRHL和FTDRHL中的数据量。

#### R[4:0]位（接收FIFO数据计数）

R[4:0]位指示存储在FRDRHL中的接收数据量。0x00表示没有接收数据，0x10表示最大接收数据存储在FRDRHL中。

#### T[4:0]位（发送FIFO数据计数）

T[4:0]位指示存储在FTDRHL中的未传输数据量。0x00表示没有传输数据，0x10表示所有（最大量）要传输的数据都存储在FTDRHL中。

### 27.2.31 LSR：线路状态寄存器

Base address: SCIn = 0x4011\_8000 + 0x0100 × n (n = 0, 3, 4, 9)

Offset address: 0x18

| Bit position: | 15 | 14 | 13 | 12        | 11 | 10 | 9 | 8 | 7         | 6 | 5 | 4 | 3 | 2    | 1 | 0 |
|---------------|----|----|----|-----------|----|----|---|---|-----------|---|---|---|---|------|---|---|
| Bit field:    | —  | —  | —  | PNUM[4:0] |    |    |   | — | FNUM[4:0] |   |   |   | — | ORER |   |   |
| 重置后的值:        | 0  | 0  | 0  | 0         | 0  | 0  | 0 | 0 | 0         | 0 | 0 | 0 | 0 | 0    | 0 | 0 |

| Bit   | Symbol    | Function  | R/W            |
|-------|-----------|---|----------------|
| 0     | ORER      | 溢出错误标志<br>仅在异步模式下有效，包括多处理器模式或时钟同步模式，以及选择FIFO时。<br>0: 未发生溢出错误1: 发生溢出错误 | R <sup>1</sup> |
| 1     | —         | 该位读为0。  | R              |
| 6:2   | FNUM[4:0] | 帧错误计数<br>表示FRDRHL中存储的接收数据中存在帧错误的数量。                                   | R              |
| 7     | —         | 该位读为0。  | R              |
| 12:8  | PNUM[4:0] | 奇偶错误计数<br>表示FRDRHL中存储的接收数据中有奇偶校验错误的数量。                                | R              |
| 15:13 | —         | 这些位读为0。   | R              |

注1.将0写入SSR\_FIFO.ORER以清除标志。

LSR寄存器指示接收错误状态。

#### ORER标志（溢出错误标志）

ORER标志反映了SSR\_FIFO.ORER中的值。

#### FNUM[4:0]位（帧错误计数）

FNUM[4:0]值表示存储在FRDRHL寄存器中的具有帧错误的数量。

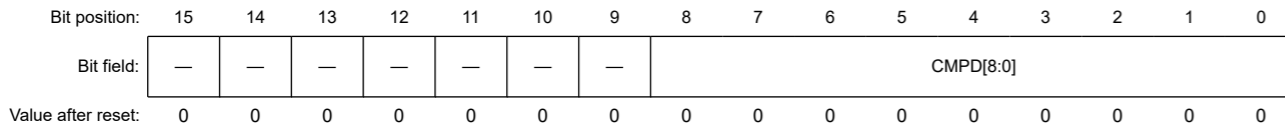
**PNUM[4:0] bits (Parity Error Count)**

The PNUM[4:0] value indicates the amount of data with a parity error stored in the FRDRHL register.

**27.2.32 CDR : Compare Match Data Register**

Base address: SCIn = 0x4011\_8000 + 0x0100 × n (n = 0, 3, 4, 9)

Offset address: 0x1A



| Bit  | Symbol    | Function  | R/W |
|------|-----------|---|-----|
| 8:0  | CMPD[8:0] | Compare Match Data<br>Holds compare data pattern for address match wakeup function. | R/W |
| 15:9 | —         | These bits are read as 0. The write value should be 0.                              | R/W |

The CDR register sets the compare data for the address match function.

**CMPD[8:0] bits (Compare Match Data)**

The CMPD[8:0] bits set the data to be compared to receive data for the address match function, when the address match function is enabled (DCCR.DCME = 1).

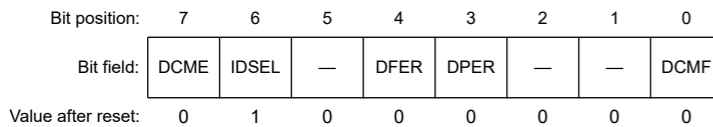
Three bit lengths are available:

- CMPD[6:0] with 7-bit length
- CMPD[7:0] with 8-bit length
- CMPD[8:0] with 9-bit length

**27.2.33 DCCR : Data Compare Match Control Register**

Base address: SCIn = 0x4011\_8000 + 0x0100 × n (n = 0, 3, 4, 9)

Offset address: 0x13



| Bit | Symbol | Function   | R/W     |
|-----|--------|--|---------|
| 0   | DCMF   | Data Compare Match Flag<br>0: Not matched<br>1: Matched  | R/(W)*1 |
| 2:1 | —      | These bits are read as 0. The write value should be 0.   | R/W     |
| 3   | DPER   | Data Compare Match Parity Error Flag<br>0: No parity error occurred<br>1: Parity error occurred    | R/(W)*1 |
| 4   | DFER   | Data Compare Match Framing Error Flag<br>0: No framing error occurred<br>1: Framing error occurred | R/(W)*1 |
| 5   | —      | This bit is read as 0. The write value should be 0.  | R/W     |

**PNUM[4:0]位 (奇偶校验错误计数)**

PNUM[4:0]值表示存储在FRDRHL寄存器中的具有奇偶校验错误的数量。

**27.2.32 CDR:比较匹配数据寄存器**

Base address: SCIn = 0x4011\_8000 + 0x0100 × n (n = 0, 3, 4, 9)

Offset address: 0x1A



| Bit  | Symbol    | Function                     | R/W |
|------|-----------|------------------------------|-----|
| 8:0  | CMPD[8:0] | 比较匹配数据<br>保存地址匹配唤醒功能的比较数据模式。 | R/W |
| 15:9 | —         | 这些位被读取为0。写入值应为0。             | R/W |

CDR寄存器设置地址匹配功能的比较数据。

**CMPD[8:0]位 (比较匹配数据)**

当地址匹配功能启用时 (DCCR.DCME=1)，CMPD[8:0]位设置要比较的数据以接收地址匹配功能的数据。

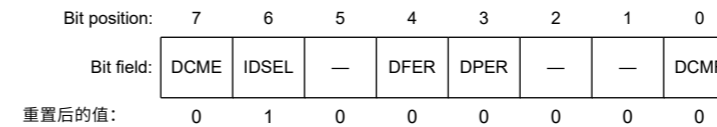
提供三种位长:

- CMPD[6:0], 7位长度
- CMPD[7:0] 8位长度
- CMPD[8:0], 9位长度

**27.2.33 DCCR:数据比较匹配控制寄存器**

Base address: SCIn = 0x4011\_8000 + 0x0100 × n (n = 0, 3, 4, 9)

Offset address: 0x13



| Bit | Symbol | Function                                      | R/W     |
|-----|--------|---|---------|
| 0   | DCMF   | 数据比较匹配标志<br>0: 不匹配 1: 匹配                      | R/(W)*1 |
| 2:1 | —      | 这些位被读取为0。写入值应为0。                              | R/W     |
| 3   | DPER   | 数据比较匹配奇偶校验错误标志<br>0: 未发生奇偶校验错误<br>1: 发生奇偶校验错误 | R/(W)*1 |
| 4   | DFER   | 数据比较匹配帧错误标志<br>0: 未发生帧错误 1: 发生帧错误             | R/(W)*1 |
| 5   | —      | 该位读取为0。写入值应为0。                                | R/W     |

| Bit | Symbol | Function  | R/W |
|-----|--------|---|-----|
| 6   | IDSEL  | ID Frame Select<br>Valid only in asynchronous mode, including multi-processor mode.<br>0: Always compare data regardless of the MPB bit value<br>1: Only compare data when MPB bit = 1 (ID frame) | R/W |
| 7   | DCME   | Data Compare Match Enable<br>Valid only in asynchronous mode, including multi-processor mode.<br>0: Disable address match function<br>1: Enable address match function                            | R/W |

Note 1. Only 0 can be written, to clear the flag after reading 1.

The DCCR register controls the address match function.

#### DCMF flag (Data Compare Match Flag)

The DCMF flag indicates that the SCI detected a receive data match with the comparison data (CDR.CMPD).

[Setting condition]

- On match of the comparison data (CDR.CMPD) with the receive data when DCCR.DCME = 1.

[Clearing condition]

- When 0 is written after 1 is read from DCMF.

Clearing the SCR.RE bit to 0 does not affect the DCMF flag, which retains its previous value.

#### DPER flag (Data Compare Match Parity Error Flag)

The DPER flag indicates that a parity error occurred on address match detection (receive data match detection).

[Setting condition]

- When a parity error is detected in a frame in which an address match is detected.

[Clearing conditions]

- When 0 is written after 1 is read from DPER.

When the SCR.RE bit is set to 0 (serial reception is disabled), the DPER flag is not affected and retains its previous value.

#### DFER flag (Data Compare Match Framing Error Flag)

The DFER flag indicates that a framing error occurred on address match detection (receive data match detection).

[Setting conditions]

- When a stop bit of a frame in which an address match is detected is 0.  
When in 2-stop-bit mode, only the first bit of the stop bits is checked for a value of 1 (the second stop bit is not checked).

[Clearing conditions]

- When 0 is written after 1 is read from DFER.

When the SCR.RE bit is set to 0 (serial reception is disabled), the DFER flag is not affected and retains its previous value.

#### IDSEL bit (ID Frame Select)

The IDSEL bit selects whether to compare data regardless of the MPB bit value or to compare data only when MPB = 1 (ID frame), when the address match function is enabled.

#### DCME bit (Data Compare Match Enable)

The DCME bit enables or disables the address match function (data compare match function).

If the SCI detects a match to the comparison data (CDR.CMPD) with the receive data, the DCME bit clears automatically, after which SCI operation mode is in normal receive mode. See [section 27.3.6. Address Match \(Receive Data Match Detection\) Function](#).

| Bit | Symbol | Function  | R/W |
|-----|--------|---|-----|
| 6   | IDSEL  | ID帧选择<br>仅在异步模式下有效，包括多处理器模式。<br>0: 无论MPB位值如何，始终比较数据1: 仅当MPB位=1时比较数据 (ID帧) | R/W |
| 7   | DCME   | 数据比较匹配启用<br>仅在异步模式下有效，包括多处理器模式。<br>0: 禁用地址匹配功能1: 启用地址匹配功能                 | R/W |

注1.只能写入0，读取1后清除标志。

DCCR寄存器控制地址匹配功能。

#### DCMF标志 (数据比较匹配标志)

DCMF标志表示SCI检测到接收数据与比较数据(CDR.CMPD)匹配。

[Setting condition]

- 当DCCR.DCME=1时，比较数据(CDR.CMPD)与接收数据匹配。

[Clearing condition]

- 从DCMF读取1后写入0时。

将SCR.RE位清除为0不会影响DCMF标志，它保留其先前的值。

#### DPER标志 (数据比较匹配奇偶校验错误标志)

DPER标志表示在地址匹配检测 (接收数据匹配检测) 时发生奇偶校验错误。

[Setting condition]

- 在检测到地址匹配的帧中检测到奇偶校验错误时。

[Clearing conditions]

- 从DPER读取1后写入0时。

当SCR.RE位设置为0 (禁用串行接收) 时，DPER标志不受影响并保留其先前的值。

#### DFER标志 (数据比较匹配帧错误标志)

DFER标志表示在地址匹配检测 (接收数据匹配检测) 时发生了帧错误。

[Setting conditions]

- 当检测到地址匹配的帧的停止位为0时。  
在2停止位模式下，仅检查停止位的第一位是否为1 (不检查第二个停止位)。

[Clearing conditions]

- 从DFER读取1后写入0时。

当SCR.RE位设置为0 (禁用串行接收) 时，DFER标志不受影响并保留其先前的值。

#### IDSEL位 (ID帧选择)

IDSEL位选择无论MPB位值如何比较数据，还是仅在MPB=1 (ID帧) 时比较数据，当地址匹配功能启用时。

#### DCME位 (数据比较匹配使能)

DCME位启用或禁用地址匹配功能 (数据比较匹配功能)。

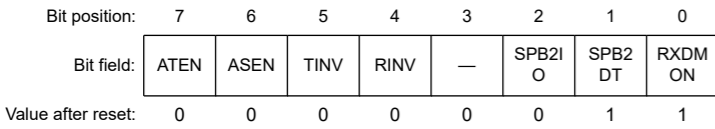
如果SCI检测到比较数据 (CDR.CMPD) 与接收数据匹配，则DCME位自动清零，此后SCI操作模式进入正常接收模式。请参见第27.3.6节。地址匹配 (接收数据匹配检测) 功能。

The write value must be 0 for all modes other than asynchronous mode.

### 27.2.34 SPTR : Serial Port Register

Base address: SCIn = 0x4011\_8000 + 0x0100 × n (n = 0, 3, 4, 9)

Offset address: 0x1C



| Bit | Symbol | Function   | R/W   |
|-----|--------|--|-------|
| 0   | RXDMON | Serial Input Data Monitor<br>Indicates the state of the RXDn pin.<br>0: When RINV is 1'b0, RXDn terminal is the low level.<br>When RINV is 1'b1, RXDn terminal is the High level.<br>1: When RINV is 1'b0, RXDn terminal is the High level.<br>When RINV is 1'b1, RXDn terminal is the Low level.  | R     |
| 1   | SPB2DT | Serial Port Break Data Select<br>Selects the output level of the TXDn pin when SCR.TE = 0.<br>0: When TINV is 1'b0, Low level is output in TXDn terminal.<br>When TINV is 1'b1, High level is output in TXDn terminal.<br>1: When TINV is 1'b0, High level is output in TXDn terminal.<br>When TINV is 1'b1, Low level is output in TXDn terminal.   | R/W   |
| 2   | SPB2IO | Serial Port Break I/O*1<br>Selects whether the value of SPB2DT is output to TXDn pin.<br>0: Do not output value of SPB2DT bit on TXDn pin<br>1: Output value of SPB2DT bit on TXDn pin   | R/W   |
| 3   | —      | These bits are read as 0. The write value should be 0.   | R/W   |
| 4   | RINV   | RXD invert bit<br>0: Received data from RXDn is not inverted and input.*2<br>1: Received data from RXDn is inverted and input.   | R/W*3 |
| 5   | TINV   | TXD invert bit<br>0: Transmit data is not inverted and output to TXDn.*2<br>1: Transmit data is inverted and output to TXDn.   | R/W*3 |
| 6   | ASEN   | Adjust receive sampling timing enable<br>(This bit enables in asynchronous mode using internal clock)<br>This function can adjust the receive sampling timing.<br>In asynchronous mode using internal clock, see <a href="#">section 27.3.10. The function of adjust receive sampling timing (Asynchronous Mode)</a> in detail.<br>0: Adjust sampling timing disable.<br>1: Adjust sampling timing enable. | R/W*3 |
| 7   | ATEN   | Adjust transmit timing enable<br>(This bit enables in asynchronous mode using internal clock)<br>This function can adjust the transmit edge of TXDn waveform. See <a href="#">section 27.3.11. The function of adjust transmit timing (Asynchronous Mode)</a> in detail.<br>0: Adjust transmit timing disable.<br>1: Adjust transmit timing enable.  | R/W*3 |

Note 1. Please use this bit in asynchronous mode and manchester mode. Movement by other mode isn't guaranteed.

Note 2. RINV/TINV should be set 1'b0 in smart card interface mode and simple I2C mode.

Note 3. Change the value of these bits only at SCR.TE = SCR.RE = 1'b0.

The SPTR register provides confirmation of the serial reception pin (RXDn pin) status and sets the transmission and receive pin status.

And SPTR register has enable bits for adjust functions of receive sampling timing and transmit timing.

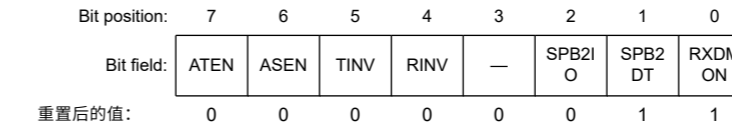
The TXDn pin status is determined by the combination of SCR.TE, SPTR.SPB2IO, and SPTR.SPB2DT settings, as shown in [Table 27.25](#).

对于异步模式以外的所有模式，写入值必须为0。

### 27.2.34 SPTR:串行端口寄存器

Base address: SCIn = 0x4011\_8000 + 0x0100 × n (n = 0, 3, 4, 9)

Offset address: 0x1C



| Bit | Symbol | Function  | R/W   |
|-----|--------|---|-------|
| 0   | RXDMON | 串行输入数据监视器<br>指示RXDn引脚的状态。<br>0: 当RINV为1'b0时, RXDn端为低电平。当RINV为1'b1时, RXDn端为高电平。<br>1: 当RINV为1'b0时, RXDn端为高电平。当RINV为1'b1时, RXDn端为低电平。                 | R     |
| 1   | SPB2DT | 串行端口中断数据选择<br>选择SCR.TE=0时TXDn引脚的输出电平。<br>0: 当TINV为1'b0时, TXDn端输出低电平。当TINV为1'b1时, TXDn端输出高电平。<br>1: 当TINV为1'b0时, TXDn端输出高电平。当TINV为1'b1时, TXDn端输出低电平。 | R/W   |
| 2   | SPB2IO | 串口中断IO*1<br>选择是否将SPB2DT的值输出到TXDn引脚。<br>0: 不输出TXDn引脚上SPB2DT位的值1: 输出TXDn引脚上SPB2DT位的值  | R/W   |
| 3   | —      | 这些位被读取为0。写入值应为0。  | R/W   |
| 4   | RINV   | RXD反转位<br>0: 从RXDn接收的数据不反相输入。*2<br>1: 从RXDn接收到的数据被反转并输入。  | R/W*3 |
| 5   | TINV   | TXD反转位<br>0: 发送数据不反相并输出到TXDn。*2<br>1: 发送数据反转并输出到TXDn。   | R/W*3 |
| 6   | ASEN   | 调整接收采样时序使能 (该位在使用内部时钟的异步模式下使能) 该功能可以调整接收采样时序。<br><br>在使用内部时钟的异步模式下, 请参阅第27.3.10节。详细调整接收采样时间(异步模式)的功能。<br>0: 调整采样时序禁用。1: 调整采样时序使能。                   | R/W*3 |
| 7   | ATEN   | 调整发送时序使能 (该位在使用内部时钟的异步模式下使能) 该功能可以调整TXDn波形的发送边沿。请参阅第27.3.11节。详细调整发送时间(异步模式)的功能。<br><br>0: 调整发送时序禁用。1: 调整发送时序使能。                                     | R/W*3 |

注1.请在异步模式和曼彻斯特模式下使用该位。不能保证通过其他模式移动。

注2.RINV/TINV在智能卡接口模式和简单I2C模式下应设置为1'b0。

注3.仅在SCR.TE=SCR.RE=1'b0时更改这些位的值。

SPTR寄存器提供串行接收引脚 (RXDn引脚) 状态的确认, 并设置发送和接收引脚状态。

SPTR寄存器具有调整接收采样时序和发送时序功能的使能位。

TXDn引脚状态由SCR.TE、SPTR.SPB2IO和SPTR.SPB2DT设置的组合决定, 如表27.25所示。



The data of RDR is controlled by RINV and SCMR.SINV. And the data from TXDn terminal is controlled by TINV and SCMR.SINV. The control by RINV/TINV are done to communication terminals(RXDn/TXDn), so they can control not only data-bits but also other bits (start bit, stop bit, parity bit). Please refer to Figure 27.5 in detail.

Table 27.25 TXDn pin status

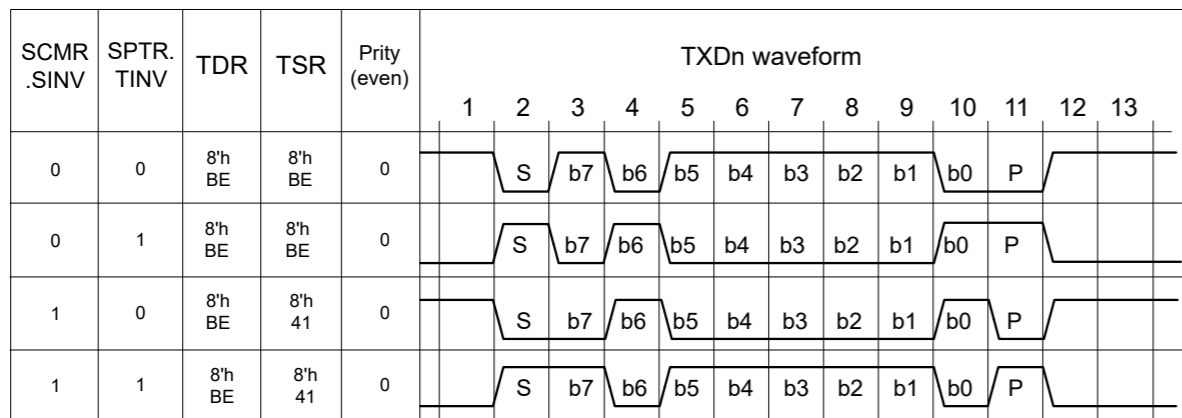
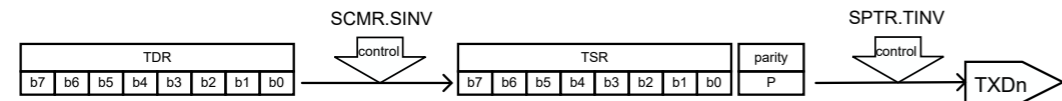
| Value of SCR.TE | Value of SPTR.SPB2IO | Value of SPTR.SPB2DT | TXDn pin status                |
|-----------------|----------------------|----------------------|--------------------------------|
| 0               | 0                    | —                    | Hi-Z (initial value)           |
| 0               | 1                    | 0                    | Low level output               |
| 0               | 1                    | 1                    | High level output              |
| 1               | —                    | —                    | Serial transmit data is output |

Note: —: Do not care.

Note: Use the SPTR register in asynchronous mode only. Using this register in any other mode is not guaranteed.

The receive/transmit data control (Data size=8bits, Even parity, MSB first)

The transmit data is controlled by SPTR.TINV and SCMR.SINV.



The received data is controlled by SPTR.RINV and SCMR.SINV.

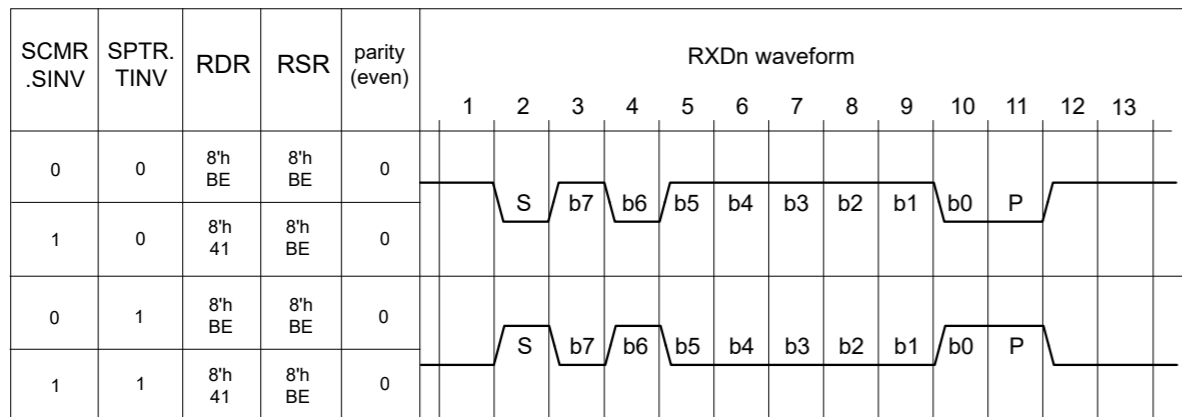
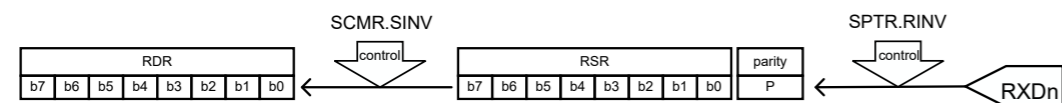


Figure 27.5 Example of the receive/transmit data control

RDR的数据由RINV和SCMR.SINV控制。来自TXDn终端的数据由TINV和SCMR.SINV。RINVTINV的控制是对通信终端 (RXDnTXDn) 进行的，因此它们不仅可以控制数据位，还可以控制其他位（起始位、停止位、奇偶校验位）。详细请参考图27.5。

Table 27.25 TXDn引脚状态

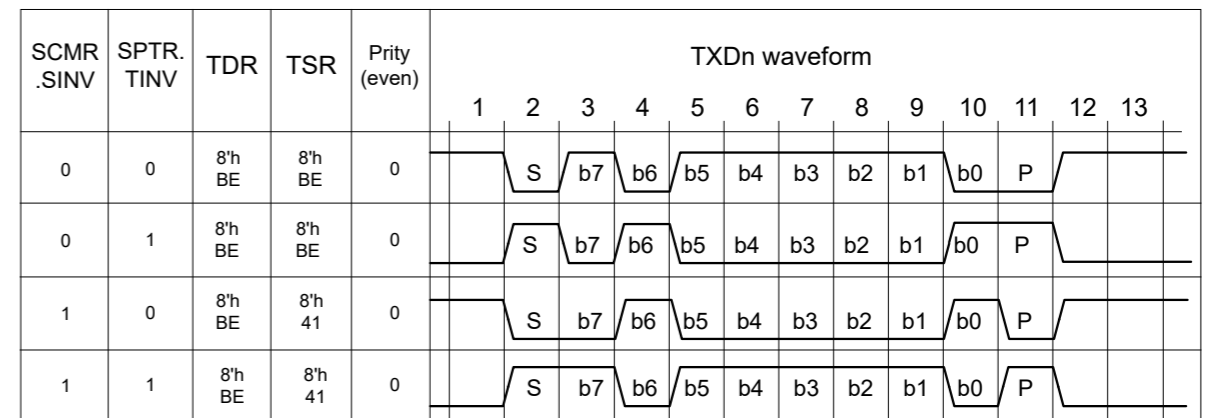
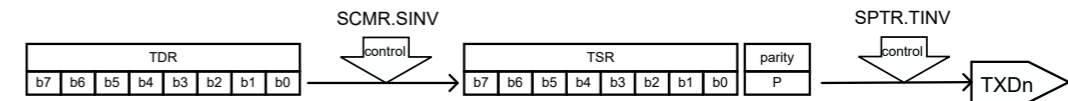
| SCR.TE的值 | SPTR.SPB2IO的值 | SPTR.SPB2DT的值 | TXDn引脚状态             |
|----------|---------------|---------------|----------------------|
| 0        | 0             | —             | Hi-Z (initial value) |
| 0        | 1             | 0             | 低电平输出                |
| 0        | 1             | 1             | 高电平输出                |
| 1        | —             | —             | 串行传输数据输出             |

Note: -: 不管。

Note: 仅在异步模式下使用SPTR寄存器。不保证在任何其他模式下使用该寄存器。

接收发送数据控制 (数据大小=8bits, 偶校验, MSB在前)

发送数据由SPTR.TINV和SCMR.SINV控制。



接收的数据由SPTR.RINV和SCMR.SINV控制。

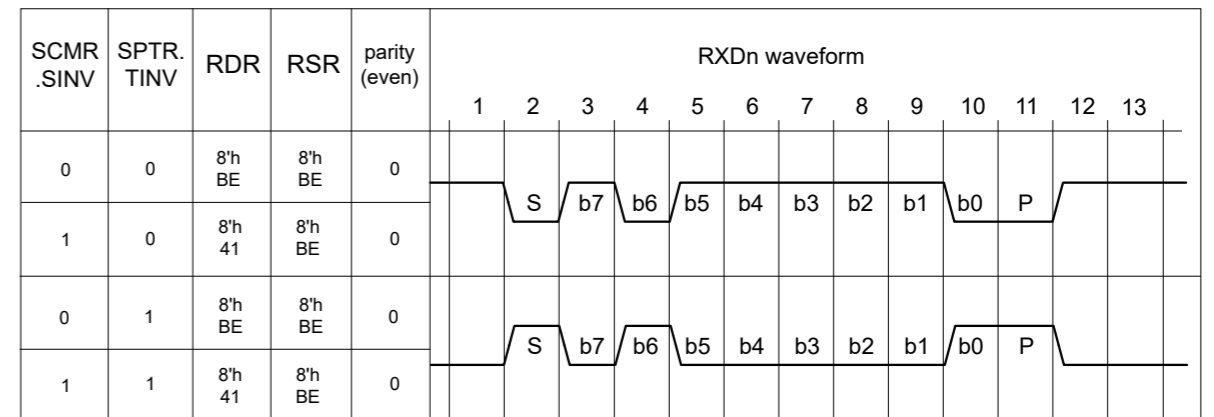
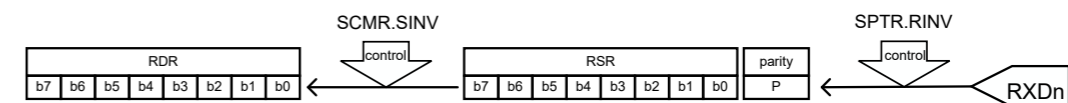
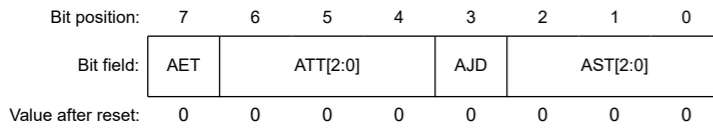


Figure 27.5 接收发送数据控制示例

## 27.2.35 ACTR : Adjustment Communication Timing Register

Base address: SCIn = 0x4011\_8000 + 0x0100 × n (n = 0, 3 to 5)

Offset address: 0x1D



| Bit | Symbol | Function  | R/W              |
|-----|--------|---|------------------|
| 2:0 | AST    | Adjustment value for receive Sampling Timing<br>The sampling timing of RXD terminal is adjusted from the middle of bit by the following formula.<br>Adjustment sampling timing = base clock * the setting value of AST[2:0].<br>This bit is effective only at SPTR.ASEN = 1. This setting timing is limited by setting the base clock cycles. Refer to <a href="#">section 27.3.10. The function of adjust receive sampling timing (Asynchronous Mode)</a> in detail. | R/W <sup>1</sup> |
| 3   | AJD    | Adjustment Direction for receive sampling timing<br>Adjustment direction for RXD receive sampling timing is determined by this bit.<br>0: The sampling timing is adjusted backward to the middle of bit.<br>1: The sampling timing is adjusted forward to the middle of bit.<br>This bit is effective only at SPTR.ASEN = 1. Refer to <a href="#">section 27.3.10. The function of adjust receive sampling timing (Asynchronous Mode)</a> in detail.                  | R/W <sup>1</sup> |
| 6:4 | ATT    | Adjustment value for Transmit timing<br>The selected edge timing of TXD is adjusted by the following formula.<br>Adjustment edge timing = base clock * the setting value of ATT[2:0].<br>This bit is effective only at SPTR.ATEN = 1. This setting timing is limited by setting the base clock cycles. Refer to <a href="#">section 27.3.11. The function of adjust transmit timing (Asynchronous Mode)</a> in detail.  | R/W <sup>2</sup> |
| 7   | AET    | Adjustment edge for transmit timing<br>The adjustable edge is set by this bit.<br>When SPTR.TINV is 1'b0,<br>0: Adjust the rising edge timing.<br>1: Adjust the falling edge timing.<br>When SPTR.TINV is 1'b1,<br>0: Adjust the falling edge timing.<br>1: Adjust the rising edge timing.<br>This bit is effective only at SPTR.ATEN = 1. Refer to <a href="#">section 27.3.11. The function of adjust transmit timing (Asynchronous Mode)</a> in detail.            | R/W <sup>2</sup> |

Note 1. Write this bit only when SPTR.ASEN = 0.

Note 2. Write this bit only when SPTR.ATEN = 0.

This register controls adjustment of receive sampling timing and transmit timing. This register is effective only when asynchronous mode using internal clock.

Refer to [section 27.3.10. The function of adjust receive sampling timing \(Asynchronous Mode\)](#) about adjustment receive sampling timing by this register.

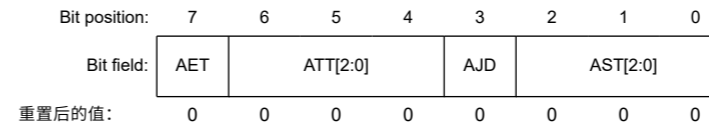
Refer to [section 27.3.11. The function of adjust transmit timing \(Asynchronous Mode\)](#) about adjustment transmit timing by this register.

Note: Sentences and a timing chart of the IP operation explanation (except [section 27.1. Overview](#), [section 27.2. Register Descriptions](#), [section 27.3.10. The function of adjust receive sampling timing \(Asynchronous Mode\)](#) and [section 27.3.11. The function of adjust transmit timing \(Asynchronous Mode\)](#)) are mentioned by the condition that the function added in SCIM-7 is off (SPTR.ASEN = 1'b0, SPTR.ATEN = 1'b0).

## 27.2.35 ACTR:调整通信时序寄存器

Base address: SCIn = 0x4011\_8000 + 0x0100 × n (n = 0, 3 to 5)

Offset address: 0x1D



| Bit | Symbol | Function   | R/W              |
|-----|--------|--|------------------|
| 2:0 | AST    | 接收采样时序的调整值<br>RXD端的采样时序由下式从位中间开始调整。调整采样时序=基准时钟*AST[2:0]的设置值。<br>该位仅在SPTR.ASEN=1时有效。此设置时序受设置基本时钟周期的限制。请参阅 <a href="#">第27.3.10节。详细调整接收采样时间（异步模式）的功能。</a>                                      | R/W <sup>1</sup> |
| 3   | AJD    | 接收采样时序调整方向<br>RXD接收采样时序的调整方向由该位决定。<br>0: 采样定时向后调整到位中间。1: 采样定时向前调整到位中间。<br>该位仅在SPTR.ASEN=1时有效。请参阅 <a href="#">第27.3.10节。详细调整接收采样时间（异步模式）的功能。</a>  | R/W <sup>1</sup> |
| 6:4 | ATT    | 发送时间的调整值<br>TXD的选定边沿时序通过以下公式进行调整。<br>调整边沿时序=基准时钟*ATT[2:0]的设置值。<br>该位仅在SPTR.ATEN=1时有效。此设置时序受设置基本时钟周期的限制。请参阅 <a href="#">第27.3.11节。详细调整发送时间（异步模式）的功能。</a>                                      | R/W <sup>2</sup> |
| 7   | AET    | 发送定时的调整边沿<br>可调边沿由该位设置。<br>当SPTR.TINV为1'b0时,<br>0: 调整上升沿时序。1: 调整下降沿时序。<br>当SPTR.TINV为1'b1时,<br>0: 调整下降沿时序。1: 调整上升沿时序。<br>该位仅在SPTR.ATEN=1时有效。请参阅 <a href="#">第27.3.11节。详细调整发送时间（异步模式）的功能。</a> | R/W <sup>2</sup> |

注1.仅当SPTR.ASEN=0时写入该位。注2.仅当SPTR.ATEN=0时写入该位。

该寄存器控制接收采样时序和发送时序的调整。该寄存器仅在异步模式使用内部时钟时有效。

请参阅[第27.3.10节。通过该寄存器调整接收采样时序的调整接收采样时序（异步模式）功能。](#)

请参阅[第27.3.11节。通过该寄存器调整发送时序的调整发送时序（异步模式）功能。](#)

Note: IP操作说明的语句和时序图（除了[第27.1节概述](#)，[第27.2节注册说明](#)，[第27.3.10节。调整接收采样时间（异步模式）的功能](#)和[第27.3.11节。调整发送时间（异步模式）的功能](#)是在SCIM-7中添加的功能关闭（SPTR.ASEN=1'b0, SPTR.ATEN=1'b0）的条件下提到的。

## 27.2.36 MMR : Manchester Mode Register

Base address: SCIn = 0x4011\_8000 + 0x0100 × n (n = 3, 4)

Offset address: 0x20

|                    |           |           |            |            |   |           |           |           |
|--------------------|-----------|-----------|------------|------------|---|-----------|-----------|-----------|
| Bit position:      | 7         | 6         | 5          | 4          | 3 | 2         | 1         | 0         |
| Bit field:         | MANE<br>N | SBSE<br>L | SYNS<br>EL | SYNV<br>AL | — | ERTE<br>N | TMPO<br>L | RMPO<br>L |
| Value after reset: | 0         | 0         | 0          | 0          | 0 | 0         | 0         | 0         |

| Bit | Symbol | Function  | R/W              |
|-----|--------|---|------------------|
| 0   | RMPOL  | Polarity of Received Manchester Code<br>Sets the polarity of the received Manchester code<br>0: Logic 0 is coded as a zero-to-one transition in Manchester code<br>Logic 1 is coded as a one-to-zero transition in Manchester code<br>1: Logic 0 is coded as a one-to-zero transition in Manchester code<br>Logic 1 is coded as a zero-to-one transition in Manchester code   | R/W <sup>1</sup> |
| 1   | TMPOL  | Polarity of Transmit Manchester Code<br>Sets the polarity of the transmit Manchester code<br>0: Logic 0 is coded as a zero-to-one transition in Manchester code<br>Logic 1 is coded as a one-to-zero transition in Manchester code<br>1: Logic 0 is coded as a one-to-zero transition in Manchester code<br>Logic 1 is coded as a zero-to-one transition in Manchester code   | R/W <sup>1</sup> |
| 2   | ERTEN  | Manchester Edge Retiming Enable<br>Sets the receive retiming function<br>0: Disables the receive retiming function<br>1: Enables the receive retiming function  | R/W <sup>1</sup> |
| 3   | —      | This bit is read as 0. The write value should be 0.   | R                |
| 4   | SYNVAL | SYNC value Setting<br>Sets the SYNC type of the start bit(s) in the Manchester code<br>When the start bit area consists of one bit.(SBSEL = "0") <ul style="list-style-type: none"> <li>when transmitting <ul style="list-style-type: none"> <li>0: The start bit is added as a zero-to-one transition.</li> <li>1: The start bit is added as a one-to-zero transition.</li> </ul> </li> <li>when receiving <ul style="list-style-type: none"> <li>0: Only when the start bit is a zero-to-one transition, the data is received. The other cases are judged as an error.</li> <li>1: Only when the start bit is a one-to-zero transition, the data is received. The other cases are judged as an error.</li> </ul> </li> </ul> When the start bit area consists of three bits.(SBSEL = "1") <ul style="list-style-type: none"> <li>when transmitting <ul style="list-style-type: none"> <li>0: The start bits are added as a zero-to-one transition. (DATA SYNC)</li> <li>1: The start bits are coded as a one-to-zero transition. (COMMAND SYNC)</li> </ul> </li> <li>when receiving <ul style="list-style-type: none"> <li>0: The start bits are added as a zero-to-one transition. (DATA SYNC)</li> <li>1: The start bits are coded as a one-to-zero transition. (COMMAND SYNC)</li> </ul> </li> </ul> When the start bit area consists of three bits, data is received regardless of the value of this bit. | R/W <sup>1</sup> |
| 5   | SYNSEL | SYNC Select<br>0: The start bit pattern is set with the SYNVAL bit<br>1: The start bit pattern is set with the TSYNC bit.   | R/W <sup>1</sup> |
| 6   | SBSEL  | Start Bit Select<br>0: The start bit area consists of one bit.<br>1: The start bit area consists of three bits (COMMAND SYNC or DATA SYNC)  | R/W <sup>1</sup> |
| 7   | MANEN  | Manchester Mode Enable<br>Sets the Manchester mode<br>0: Disables the Manchester mode<br>1: Enables the Manchester mode   | R/W <sup>1</sup> |

Note: Bits 6 to 0 in this register are valid only when the Manchester mode is enabled.(MANEN = "1") in bit 7.

Note 1. Writing to these bits is only possible when the RE and TE bits in SCR are 0 (both serial transmission and reception are disabled).

This register is used to enable or disable the Manchester mode, set the start bit area, and set the logic polarity.

## 27.2.36 MMR:曼彻斯特模式寄存器

Base address: SCIn = 0x4011\_8000 + 0x0100 × n (n = 3, 4)

Offset address: 0x20

|               |           |           |            |            |   |           |           |           |
|---------------|-----------|-----------|------------|------------|---|-----------|-----------|-----------|
| Bit position: | 7         | 6         | 5          | 4          | 3 | 2         | 1         | 0         |
| Bit field:    | MANE<br>N | SBSE<br>L | SYNS<br>EL | SYNV<br>AL | — | ERTE<br>N | TMPO<br>L | RMPO<br>L |
| 重置后的值:        | 0         | 0         | 0          | 0          | 0 | 0         | 0         | 0         |

| Bit | Symbol | Function   | R/W              |
|-----|--------|--|------------------|
| 0   | RMPOL  | 接收到的曼彻斯特码的极性<br>设置接收到的曼彻斯特码的极性<br>0: 逻辑0编码为曼彻斯特码中的零到一转换逻辑1编码为曼彻斯特码中的一到零转换<br>1: 逻辑0被编码为曼彻斯特码中的1到零转换逻辑1被编码为曼彻斯特码中的0到1转换   | R/W <sup>1</sup> |
| 1   | TMPOL  | 发送曼彻斯特码的极性<br>设置发送曼彻斯特码的极性<br>0: 逻辑0编码为曼彻斯特码中的零到一转换逻辑1编码为曼彻斯特码中的一到零转换<br>1: 逻辑0被编码为曼彻斯特码中的1到零转换逻辑1被编码为曼彻斯特码中的0到1转换   | R/W <sup>1</sup> |
| 2   | ERTEN  | 曼彻斯特边缘重定时启用<br>设置接收重定时功能<br>0: 关闭接收重定时功能1: 打开接收重定时功能   | R/W <sup>1</sup> |
| 3   | —      | 该位读取为0。写入值应为0。   | R                |
| 4   | SYNVAL | SYNC值设置<br>设置曼彻斯特代码中起始位的SYNC类型<br>起始位区域为1位时。(SBSEL="0")●<br>传输时<br>0: 添加起始位作为从零到一的转换。1: 添加起始位作为1到零的转换。<br>●接收时<br>0: 仅当起始位为0到1转换时,才接收数据。其他情况判断为错误。<br>1: 仅当起始位为1到零跳变时,才接收数据。其他情况判断为错误。<br>当起始位区域由三位组成时。(SBSEL="1")●<br>传输时<br>0: 添加起始位作为零到一的转换。(DATASYNC)1: 起始位被编码为一个从一到零的转换。(命令同步)<br>●接收时当起始位区域由三位组成时,无论该位的值如何,都将接收数据。 | R/W <sup>1</sup> |
| 5   | SYNSEL | 同步选择<br>0: 使用SYNVAL位设置起始位模式1: 使用TSYNC位设置起始位模式。   | R/W <sup>1</sup> |
| 6   | SBSEL  | 起始位选择<br>0: 起始位区域由一位组成。1: 起始位区域由三位组成 (COMMAND SYNC或DATASYNC)   | R/W <sup>1</sup> |
| 7   | MANEN  | ManchesterModeEnable设置曼彻斯特模式<br>0: 禁用曼彻斯特模式1: 启用曼彻斯特模式   | R/W <sup>1</sup> |

Note: 该寄存器中的位6到0仅在启用曼彻斯特模式时有效。(MANEN="1")在位7中。

注1.只有当SCR中的RE和TE位为0(串行发送和接收都被禁用)时,才能写入这些位。

该寄存器用于启用或禁用曼彻斯特模式、设置起始位区域和设置逻辑极性。

**RMPOL bit (Polarity of Received Manchester Code)**

This bit sets the polarity of the received Manchester code. For details, see [section 27.5.7. Serial Data Reception in Manchester Mode](#).

**TMPOL bit (Polarity of Transmit Manchester Code)**

This bit sets the polarity of the transmit Manchester code. For details, see [section 27.5.6. Serial data transmission in Manchester mode](#).

**ERTEN bit (Manchester Edge Retiming Enable)**

This bit sets the receive retiming function in Manchester mode.

For information on the receive retiming function, see [section 27.5.9. Receive Retiming](#).

**SYNVAL bit (SYNC value Setting)**

This bit is valid when the SYNSEL bit of this register is set to “0”.

The SYNC type can be set by combining this bit and the SBSEL bit.

For the start bit area determined by the combination of this bit and the SBSEL bit, see [Figure 27.52](#) and [Figure 27.53](#).

**SYNSEL bit (SYNC Select)**

This bit is valid when the SBSEL bit of this register is set to “1”. This bit determines the destination to be referred to for setting the SYNC type of the start bit area added to Manchester frames.

When this bit is set to “0”, the SYNVAL bit of this register is referred to.

When this bit is set to “1”, the TSYNC bit in the TDRH register is referred to.

For detail, see the bit table in [section 27.2.36. MMR : Manchester Mode Register](#).

**SBSEL bit (Start Bit Select)**

This bit sets the start bit area in Manchester frames.

When this bit is set to 1, the start bit area added to each frame consists of three bits, and the SYNSEL and SYNVAL bits in this register are valid.

When this bit is set to 0, the start bit area added to each frame consists of one bit.

**MANEN bit (Manchester Mode Enable)**

This bit sets the Manchester mode.

When this bit is set to 0, the Manchester mode is disabled.

When this bit is set to 1, the Manchester mode is enabled.

**27.2.37 Tmpr : Transmit Manchester Preface Setting Register**

Base address: SCIn = 0x4011\_8000 + 0x0100 × n (n = 3, 4)

Offset address: 0x22

|                    |   |   |            |            |   |   |   |   |
|--------------------|---|---|------------|------------|---|---|---|---|
| Bit position:      | 7 | 6 | 5          | 4          | 3 | 2 | 1 | 0 |
| Bit field:         | — | — | TPPAT[1:0] | TPLEN[3:0] |   |   |   |   |
| Value after reset: | 0 | 0 | 0          | 0          | 0 | 0 | 0 | 0 |

| Bit | Symbol | Function   | R/W              |
|-----|--------|--|------------------|
| 3:0 | TPLEN  | Transmit preface length<br>Set the preface length of the transmit data in Manchester mode<br>0x0: Disables the transmit preface generation<br>Others: Transmit preface length (bit length) | R/W <sup>1</sup> |

**RMPOL位 (接收曼彻斯特码的极性)**

该位设置接收到的曼彻斯特码的极性。有关详细信息，请参见第27.5.7节。串行数据接收曼彻斯特模式。

**TMPOL位 (发送曼彻斯特码的极性)**

该位设置发送曼彻斯特码的极性。详见27.5.6节。串行数据传输曼彻斯特模式。

**ERTEN位 (曼彻斯特边沿重定时使能)**

该位设置曼彻斯特模式下的接收重定时功能。

有关接收重定时功能的信息，请参见第27.5.9节。接收重定时。

**SYNVAL位 (SYNC值设置)**

当该寄存器的SYNSEL位设置为“0”时，该位有效。

SYNC类型可以通过组合该位和SBSEL位来设置。

由该位和SBSEL位组合决定的起始位区域，请参见图27.52和图27.53。

**SYNSEL位 (SYNC Select)**

当该寄存器的SBSEL位设置为“1”时，该位有效。该位确定要参考的目标，以设置添加到曼彻斯特帧的起始位区域的SYNC类型。

当该位设置为“0”时，参考该寄存器的SYNVAL位。

当该位设置为“1”时，参考TDRH寄存器中的TSYNC位。

详细请参见27.2.36节中的位表。MMR：曼彻斯特模式寄存器。

**SBSEL位 (Start Bit Select)**

该位设置曼彻斯特帧中的起始位区域。

当该位设置为1时，添加到每帧的起始位区域由3位组成，该寄存器中的SYNSEL和SYNVAL位有效。

当该位设置为0时，添加到每一帧的起始位区域由一位组成。

**MANEN位 (曼彻斯特模式使能)**

该位设置曼彻斯特模式。

当该位设置为0时，曼彻斯特模式被禁用。

当该位设置为1时，启用曼彻斯特模式。

**27.2.37 Tmpr : 发送曼彻斯特前言设置寄存器**

Base address: SCIn = 0x4011\_8000 + 0x0100 × n (n = 3, 4)

Offset address: 0x22

|               |   |   |            |            |   |   |   |   |
|---------------|---|---|------------|------------|---|---|---|---|
| Bit position: | 7 | 6 | 5          | 4          | 3 | 2 | 1 | 0 |
| Bit field:    | — | — | TPPAT[1:0] | TPLEN[3:0] |   |   |   |   |
| 重置后的值:        | 0 | 0 | 0          | 0          | 0 | 0 | 0 | 0 |

| Bit | Symbol | Function   | R/W              |
|-----|--------|--|------------------|
| 3:0 | TPLEN  | 传输前言长度<br>设置曼彻斯特模式下发送数据的前言长度<br>0x0: 禁用发送前言生成<br>其他: 传输前言长度 (位长) | R/W <sup>1</sup> |



| Bit | Symbol | Function  | R/W              |
|-----|--------|---|------------------|
| 5:4 | TPPAT  | Transmit preface pattern<br>Set the preface pattern of the transmit data<br>0 0: ALL ZERO<br>0 1: ZERO ONE<br>1 0: ONE ZERO<br>1 1: ALL ONE | R/W <sup>1</sup> |
| 7:6 | —      | The read value is undefined. The write value should be 0.   | R                |

Note: This register is valid only when the Manchester mode is enabled (MMR.MANEN = 1).

Note 1. Writing to these bits is only possible when the RE and TE bits in SCR are 0 (both serial transmission and reception are disabled).

This register is used to set the preface length and preface pattern of the transmit data in Manchester mode.

#### TPLEN bit (Transmit preface length)

These bits set the preface bit length of the transmit data in Manchester mode.

The settable range is 0h to Fh (0d to 15d). 0h disables the transmit preface, which is not added.

#### TPPAT bit (Transmit preface pattern)

These bits set one of the four preface patterns in Manchester mode.

When these bits are set to 00b, the preface area is set to all zeros.

When these bits are set to 01b, the preface area is set to the zero-one-zero-one pattern.

When these bits are set to 10b, the preface area is set to the one-zero-one-zero pattern.

When these bits are set to 11b, the preface area is set to all ones.

Note: For the transmit and receive data when the TPPAT bits are set, see Figure 27.51.

### 27.2.38 RMPR : Receive Manchester Preface Setting Register

Base address: SCIn = 0x4011\_8000 + 0x0100 × n (n = 3, 4)

Offset address: 0x23

|                    |   |   |            |   |            |   |   |   |
|--------------------|---|---|------------|---|------------|---|---|---|
| Bit position:      | 7 | 6 | 5          | 4 | 3          | 2 | 1 | 0 |
| Bit field:         | — | — | RPPAT[1:0] |   | RPLEN[3:0] |   |   |   |
| Value after reset: | 0 | 0 | 0          | 0 | 0          | 0 | 0 | 0 |

| Bit | Symbol | Function   | R/W              |
|-----|--------|--|------------------|
| 3:0 | RPLEN  | Receive Preface Length<br>Set the preface length in received frames when Manchester mode is enabled<br>0: Disables the receive preface generation<br>Others: Receive preface length (bit length) | R/W <sup>1</sup> |
| 5:4 | RPPAT  | Receive Preface Pattern<br>Set the preface pattern of received frames<br>0 0: ALL ZERO<br>0 1: ZERO ONE<br>1 0: ONE ZERO<br>1 1: ALL ONE   | R/W <sup>1</sup> |
| 7:6 | —      | These bits are read as 0. The write value should be 0.   | R                |

Note: This register is valid only when the Manchester mode is enabled (MMR.MANEN = 1).

Note 1. Writing to these bits is only possible when the RE and TE bits in SCR are 0 (both serial transmission and reception are disabled).

This register is used to set the preface length and preface pattern of the received frames in Manchester mode.

#### RPLEN bit (Receive Preface Length)

These bits set the preface bit length of the received frames in Manchester mode.

| Bit | Symbol | Function   | R/W              |
|-----|--------|--|------------------|
| 5:4 | TPPAT  | 传输前言模式<br>设置发送数据的前言模式<br>00: 全零01: 零<br>—10: 一个零11<br>: 全一 | R/W <sup>1</sup> |
| 7:6 | —      | 读取值未定义。写入值应为0。   | R                |

Note: 该寄存器仅在启用曼彻斯特模式 (MMR.MANEN=1) 时有效。

注1.只有当SCR中的RE和TE位为0 (串行发送和接收都被禁用) 时, 才能写入这些位。

该寄存器用于设置曼彻斯特模式下发送数据的前言长度和前言样式。

#### TPLEN位 (发送前言长度)

这些位设置曼彻斯特模式下发送数据的前言位长度。

可设置范围为0h到Fh (0d到15d)。0h禁用未添加的发送前言。

#### TPPAT位 (发送前言模式)

这些位设置曼彻斯特模式中的四个前言模式之一。

当这些位设置为00b时, 前言区域设置为全零。

当这些位设置为01b时, 前言区域设置为零—零—零—零模式。

当这些位设置为10b时, 前言区域设置为一零—零—零—零模式。

当这些位设置为11b时, 前言区域设置为全1。

Note: 对于设置TPPAT位时的发送和接收数据, 请参见图27.51。

### 27.2.38 RMPR:接收曼彻斯特前言设置寄存器

Base address: SCIn = 0x4011\_8000 + 0x0100 × n (n = 3, 4)

Offset address: 0x23

|               |   |   |            |   |            |   |   |   |
|---------------|---|---|------------|---|------------|---|---|---|
| Bit position: | 7 | 6 | 5          | 4 | 3          | 2 | 1 | 0 |
| Bit field:    | — | — | RPPAT[1:0] |   | RPLEN[3:0] |   |   |   |
| 重置后的值:        | 0 | 0 | 0          | 0 | 0          | 0 | 0 | 0 |

| Bit | Symbol | Function   | R/W              |
|-----|--------|--|------------------|
| 3:0 | RPLEN  | 接收序言长度<br>启用曼彻斯特模式时设置接收帧中的前言长度<br>0: 禁用接收前言生成<br>其他: 接收前言长度 (位长) | R/W <sup>1</sup> |
| 5:4 | RPPAT  | 接收前言模式<br>设置接收帧的前言模式<br>00: 全零01: 零<br>—10: 一个零11<br>: 全一        | R/W <sup>1</sup> |
| 7:6 | —      | 这些位被读取为0。写入值应为0。   | R                |

Note: 该寄存器仅在启用曼彻斯特模式 (MMR.MANEN=1) 时有效。

注1.只有当SCR中的RE和TE位为0 (串行发送和接收都被禁用) 时, 才能写入这些位。

该寄存器用于设置曼彻斯特模式下接收帧的序言长度和序言模式。

#### RPLEN位 (接收前言长度)

这些位设置曼彻斯特模式下接收帧的前言位长度。

The settable range is 0h to Fh (0d to 15d). 0h disables the receive preface, which is not added. When 1h to Fh is set, the set value is handled as the receive preface bit length.

#### RPPAT bit (Receive Preface Pattern)

These bits set one of the four preface patterns in Manchester mode.

When these bits are set to 00b, the preface area is handled as all zeros.

When these bits are set to 01b, the preface area is handled as the zero-one-zero-one pattern.

When these bits are set to 10b, the preface area is handled as the one-zero-one-zero pattern.

When these bits are set to 11b, the preface area is handled as all ones.

Note: For the transmit and receive data when the RPPAT bits are set, see Figure 27.51.

### 27.2.39 MESR : Manchester Extended Error Status Register

Base address: SCIn = 0x4011\_8000 + 0x0100 × n (n = 3, 4)

Offset address: 0x24

|                    |   |   |   |   |   |      |      |      |
|--------------------|---|---|---|---|---|------|------|------|
| Bit position:      | 7 | 6 | 5 | 4 | 3 | 2    | 1    | 0    |
| Bit field:         | — | — | — | — | — | SBER | SYER | PFER |
| Value after reset: | 0 | 0 | 0 | 0 | 0 | 0    | 0    | 0    |

| Bit | Symbol | Function   | R/W                 |
|-----|--------|--|---------------------|
| 0   | PFER   | Preface Error flag<br>This bit is set when a preface error (pattern mismatch) is detected<br>0: No preface error detected<br>1: Preface error detected                             | R/(W) <sup>*1</sup> |
| 1   | SYER   | SYNC Error flag<br>This bit is set when no edge is detected in the adjustable range during receive retiming<br>0: No receive SYNC error detected<br>1: Receive SYNC error detected | R/(W) <sup>*1</sup> |
| 2   | SBER   | Start Bit Error flag<br>This bit is set when a pattern mismatch in the start bit area is detected<br>0: No start bit error detected<br>1: Start bit error detected                 | R/(W) <sup>*1</sup> |
| 7:3 | —      | These bits are read as 0. The write value should be 0.   | R                   |

Note: This register is valid only when the Manchester mode is enabled (MMR.MANEN = 1).

Note 1. Only 0 can be written to this bit, to clear the flag. To clear the flag, confirm that the flag is 1 before setting it to 0.

This register indicates an error status when receiving frames in Manchester mode.

A preface error, receive SYNC error or start bit error was detected.

#### PFER bit (Preface Error flag)

This bit indicates that a preface error was detected when receiving frames in Manchester mode.

[Setting condition]

- When detecting a preface error when receiving frames in Manchester mode  
The following operations are performed when a preface error occurs.  
When MECR.PFEREN = 1  
The received data is not transferred to the RDR register and no RXI interrupt request occurs. Instead, an ERI interrupt request occurs. Note that when the PFER flag is being set to 1, the subsequently received data is not transferred to the RDR register.  
When MECR.PFEREN = 0  
The received data is transferred to the RDR register and an RXI interrupt request occurs. An ERI interrupt request is not generated. The subsequent receive operations are not affected even with the PFER flag being set to 1.

可设置范围为0h到Fh（0d到15d）。0h禁用接收前言，没有添加。当设置1h至Fh时，设置值作为接收前言位长度处理。

#### RPPAT位（接收前言模式）

这些位设置曼彻斯特模式中的四个前言模式之一。

当这些位设置为00b时，前言区域被处理为全零。

当这些位设置为01b时，前言区域作为零一零一模式处理。

当这些位设置为10b时，前言区域作为一零一零模式处理。

当这些位被设置为11b时，前言区域被当作全1处理。

Note: 对于设置RPPAT位时的发送和接收数据，请参见图27.51。

### 27.2.39 MESR: 曼彻斯特扩展错误状态寄存器

Base address: SCIn = 0x4011\_8000 + 0x0100 × n (n = 3, 4)

Offset address: 0x24

|               |   |   |   |   |   |      |      |      |
|---------------|---|---|---|---|---|------|------|------|
| Bit position: | 7 | 6 | 5 | 4 | 3 | 2    | 1    | 0    |
| Bit field:    | — | — | — | — | — | SBER | SYER | PFER |
| 重置后的值:        | 0 | 0 | 0 | 0 | 0 | 0    | 0    | 0    |

| Bit | Symbol | Function   | R/W                 |
|-----|--------|--|---------------------|
| 0   | PFER   | 前言错误标志<br>当检测到前言错误（模式不匹配）时设置该位<br>0: 未检测到前言错误<br>1: 检测到前言错误          | R/(W) <sup>*1</sup> |
| 1   | SYER   | 同步错误标志<br>当接收重定时期在可调范围内未检测到边沿时，该位置位<br>0: 未检测到接收同步错误<br>1: 检测到接收同步错误 | R/(W) <sup>*1</sup> |
| 2   | SBER   | 起始位错误标志<br>当检测到起始位区域中的模式不匹配时，设置该位<br>0: 未检测到起始位错误<br>1: 检测到起始位错误     | R/(W) <sup>*1</sup> |
| 7:3 | —      | 这些位被读取为0。写入值应为0。   | R                   |

Note: 该寄存器仅在启用曼彻斯特模式（MMR.MANEN=1）时有效。

注1.该位只能写入0，以清除标志。要清除标志，请先确认标志为1，然后再将其设置为0。

该寄存器指示在曼彻斯特模式下接收帧时的错误状态。

检测到前言错误、接收同步错误或起始位错误。

#### PFER位（前言错误标志）

该位表示在曼彻斯特模式下接收帧时检测到前言错误。

[Setting condition]

- 曼彻斯特模式接收帧时检测到前言错误出现前言错误时执行以下操作。
  - When MECR.PFEREN = 1  
接收到的数据不会传输到RDR寄存器，也不会发生RXI中断请求。相反，会发生ERI中断请求。请注意，当PFER标志设置为1时，随后接收到的数据不会传输到RDR寄存器。
  - When MECR.PFEREN = 0  
接收到的数据被传送到RDR寄存器并产生一个RXI中断请求。不产生ERI中断请求。即使PFER标志设置为1，后续接收操作也不受影响。

[Clearing condition]

- When 0 is written to the bit after it was read as 1

Even if the SCR.RE bit is cleared, the PFER flag is not affected, and the previous state is retained.

**SYER bit (SYNC Error flag)**

This bit indicates that a receive SYNC error was detected when receiving frames in Manchester mode with MMR.ERTEN = 1 (Manchester edge retiming enabled).

[Setting condition]

- When detecting a receive SYNC error when receiving frames in Manchester mode  
The following operations are performed when a receive SYNC error occurs.  
When MECR.SYEREN = 1  
Although the received data is transferred to the RDR register, no RXI interrupt request occurs. Instead, an ERI interrupt request occurs. Note that when the SYER flag is being set to 1, the subsequently received data is not transferred to the RDR register.  
When MECR.SYEREN = 0  
The received data is transferred to the RDR register and an RXI interrupt request occurs. An ERI interrupt request is not generated. The subsequent receive operations are not affected even with the SYER flag being set to 1.

[Clearing condition]

- When 0 is written to the bit after it was read as 1

Even if the SCR.RE bit is cleared, the SYER flag is not affected, and the previous state is retained.

**SBER bit (Start Bit Error flag)**

This bit indicates that a start bit error was detected when receiving frames in Manchester mode.

[Setting condition]

- When detecting a start bit error when receiving frames in Manchester mode  
The following operations are performed when a start bit error occurs.  
When MECR.SBEREN = 1  
The received data is not transferred to the RDR register and no RXI interrupt request occurs. Instead, an ERI interrupt request occurs. Note that when the SBER flag is being set to 1, the subsequently received data is not transferred to the RDR register.  
When MECR.SBEREN = 0  
The received data is transferred to the RDR register and an RXI interrupt request occurs. An ERI interrupt request is not generated. The subsequent receive operations are not affected even with the SBER flag being set to 1.

[Clearing condition]

- When 0 is written to the bit after it was read as 1

Even if the SCR.RE bit is cleared, the SBER flag is not affected, and the previous state is retained.

**27.2.40 MECR : Manchester Extended Error Control Register**

Base address: SCIn = 0x4011\_8000 + 0x0100 × n (n = 3, 4)

Offset address: 0x25

|                    |   |   |   |   |   |         |         |         |
|--------------------|---|---|---|---|---|---------|---------|---------|
| Bit position:      | 7 | 6 | 5 | 4 | 3 | 2       | 1       | 0       |
| Bit field:         | — | — | — | — | — | SBER EN | SYER EN | PFER EN |
| Value after reset: | 0 | 0 | 0 | 0 | 0 | 0       | 0       | 0       |

[Clearing condition]

- 读为1后写入0时

即使SCR.RE位被清除，PFER标志也不受影响，并且保持之前的状态。

**SYER位 (SYNC错误标志)**

该位表示在曼彻斯特模式下接收帧时检测到接收同步错误  
MMR.ERTEN=1（启用曼彻斯特边沿重定时）。

[Setting condition]

- 在曼彻斯特模式下接收帧时检测到接收SYNC错误发生接收SYNC错误时执行以下操作。  
When MECR.SYEREN = 1  
虽然接收到的数据被传送到RDR寄存器，但没有发生RXI中断请求。相反，会发生ERI中断请求。请注意，当SYER标志设置为1时，随后接收到的数据不会传输到RDR寄存器。  
When MECR.SYEREN = 0  
接收到的数据被传送到RDR寄存器并产生一个RXI中断请求。不产生ERI中断请求。即使SYER标志设置为1，后续接收操作也不受影响。

[Clearing condition]

- 读为1后写入0时

即使清除SCR.RE位，SYER标志也不受影响，并且保持之前的状态。

**SBER位 (起始位错误标志)**

该位表示在曼彻斯特模式下接收帧时检测到起始位错误。

[Setting condition]

- 在曼彻斯特模式下接收帧时检测到起始位错误发生起始位错误时执行以下操作。  
When MECR.SBEREN = 1  
接收到的数据不会传输到RDR寄存器，也不会发生RXI中断请求。相反，会发生ERI中断请求。请注意，当SBER标志设置为1时，随后接收到的数据不会传输到RDR寄存器。  
When MECR.SBEREN = 0  
接收到的数据被传送到RDR寄存器并产生一个RXI中断请求。不产生ERI中断请求。即使SBER标志设置为1，后续接收操作也不受影响。

[Clearing condition]

- 读为1后写入0时

即使SCR.RE位被清除，SBER标志也不受影响，并且保持之前的状态。

**27.2.40 MECR: 曼彻斯特扩展错误控制寄存器**

Base address: SCIn = 0x4011\_8000 + 0x0100 × n (n = 3, 4)

Offset address: 0x25

|               |   |   |   |   |   |         |         |         |
|---------------|---|---|---|---|---|---------|---------|---------|
| Bit position: | 7 | 6 | 5 | 4 | 3 | 2       | 1       | 0       |
| Bit field:    | — | — | — | — | — | SBER EN | SYER EN | PFER EN |
| 重置后的值:        | 0 | 0 | 0 | 0 | 0 | 0       | 0       | 0       |

| Bit | Symbol | Function   | R/W |
|-----|--------|--|-----|
| 0   | PFEREN | Preface Error Enable<br>Specifies whether to handle a preface error as an interrupt source<br>0: Does not handle a preface error as an interrupt source<br>1: Handles a preface error as an interrupt source                     | R/W |
| 1   | SYEREN | Receive SYNC Error Enable<br>Specifies whether to handle a receive SYNC error as an interrupt source<br>0: Does not handle a receive SYNC error as an interrupt source<br>1: Handles a receive SYNC error as an interrupt source | R/W |
| 2   | SBEREN | Start Bit Error Enable<br>Specifies whether to handle a start bit error as an interrupt source<br>0: Does not handle a start bit error as an interrupt source<br>1: Handles a start bit error as an interrupt source             | R/W |
| 7:3 | —      | These bits are read as 0. The write value should be 0.   | R   |

Note: This register is valid only when the Manchester mode is enabled (MMR.MANEN = 1).

This register is used to specify whether to handle a preface error, receive SYNC error, or a start bit error as an interrupt source in Manchester mode. If those errors are handled as interrupt sources, interrupt requests and event requests are generated at the occurrence of each error, and the next reception is not performed until the corresponding error flag is cleared.

Please set this register when MMR.MANEN = "0". And do not change this register during communication.

#### PFEREN bit (Preface Error Enable)

This bit specifies whether to handle a preface error as an interrupt source.

When it is set to 0, a preface error is not handled as an interrupt source. When it is set to 1, a preface error is handled as an interrupt source.

#### SYEREN bit (Receive SYNC Error Enable)

This bit specifies whether to handle a receive SYNC error as an interrupt source.

When it is set to 0, a receive SYNC error is not handled as an interrupt source. When it is set to 1, a receive SYNC error is handled as an interrupt source.

#### SBEREN bit (Start Bit Error Enable)

This bit specifies whether to handle a start bit error as an interrupt source.

When it is set to 0, a start bit error is not handled as an interrupt source. When it is set to 1, a start bit error is handled as an interrupt source.

### 27.2.41 ESMER : Extended Serial Module Enable Register

Base address: SCIm = 0x4011\_8000 + 0x0100 × m (m = 1, 2)

Offset address: 0x20

|                    |   |   |   |   |   |   |   |      |
|--------------------|---|---|---|---|---|---|---|------|
| Bit position:      | 7 | 6 | 5 | 4 | 3 | 2 | 1 | 0    |
| Bit field:         | — | — | — | — | — | — | — | ESME |
| Value after reset: | 0 | 0 | 0 | 0 | 0 | 0 | 0 | 0    |

| Bit | Symbol | Function   | R/W |
|-----|--------|--|-----|
| 0   | ESME   | Extended Serial Mode Enable<br>0: The extended serial mode is disabled.<br>1: The extended serial mode is enabled. | R/W |
| 7:1 | —      | These bits are read as 0. The write value should be 0.   | R/W |

#### ESME bit (Extended Serial Mode Enable)

When the ESME bit is 1, the facilities of the extended serial mode control section are enabled.

| Bit | Symbol | Function  | R/W |
|-----|--------|---|-----|
| 0   | PFEREN | 前言错误启用<br>指定是否将序言错误作为中断源处理<br>0: 不将序言错误作为中断源处理1: 将序言错误作为中断源处理           | R/W |
| 1   | SYEREN | 接收同步错误启用<br>指定是否将接收SYNC错误作为中断源处理<br>0: 不将接收同步错误作为中断源处理1: 将接收同步错误作为中断源处理 | R/W |
| 2   | SBEREN | 启动位错误启用<br>指定是否将起始位错误作为中断源处理<br>0: 不将起始位错误作为中断源处理1: 将起始位错误作为中断源处理       | R/W |
| 7:3 | —      | 这些位被读取为0。写入值应为0。  | R   |

Note: 该寄存器仅在启用曼彻斯特模式 (MMR.MANEN=1) 时有效。

该寄存器用于指定在曼彻斯特模式下是否处理序言错误、接收同步错误或起始位错误作为中断源。如果将这些错误作为中断源处理，则在每个错误发生时都会产生中断请求和事件请求，并且在相应的错误标志被清除之前不会执行下一次接收。

请在MMR.MANEN="0"时设置该寄存器。并且不要在通信过程中更改该寄存器。

#### PFEREN位 (前言错误使能)

该位指定是否将序言错误作为中断源处理。

当它设置为0时，前言错误不作为中断源处理。当它设置为1时，前言错误作为中断源处理。

#### SYEREN位 (接收同步错误使能)

该位指定是否将接收同步错误作为中断源处理。

当它设置为0时，接收SYNC错误不作为中断源处理。当它设置为1时，接收SYNC错误作为中断源处理。

#### SBEREN位 (启动位错误启用)

该位指定是否将起始位错误作为中断源处理。

当它设置为0时，起始位错误不作为中断源处理。当它设置为1时，起始位错误作为中断源处理。

### 27.2.41 ESMER:扩展串行模块使能寄存器

Base address: SCIm = 0x4011\_8000 + 0x0100 × m (m = 1, 2)

Offset address: 0x20

|               |   |   |   |   |   |   |   |      |
|---------------|---|---|---|---|---|---|---|------|
| Bit position: | 7 | 6 | 5 | 4 | 3 | 2 | 1 | 0    |
| Bit field:    | — | — | — | — | — | — | — | ESME |
| 重置后的值:        | 0 | 0 | 0 | 0 | 0 | 0 | 0 | 0    |

| Bit | Symbol | Function                             | R/W |
|-----|--------|--------------------------------------|-----|
| 0   | ESME   | 扩展串行模式启用<br>0: 禁用扩展串行模式。1: 使能扩展串行模式。 | R/W |
| 7:1 | —      | 这些位被读取为0。写入值应为0。                     | R/W |

#### ESME位 (扩展串行模式启用)

当ESME位为1时，启用扩展串行模式控制部分的功能。



When the ESME bit is 0, the extended serial mode control section is initialized.

**Table 27.26 Settings of the ESME Bit and Timer Operation Mode**

| ESME Bit | Timer Mode  | Break Field Low Width Determination Mode | Break Field Low Width Output Mode |
|----------|-------------|--|-----------------------------------|
| 0        | Available*1 | Not available                            | Not available                     |
| 1        | Available   | Available                                | Available                         |

Note 1. Operation is only possible with PCLK selected.

### 27.2.42 CR0 : Control Register 0

Base address: SCIm = 0x4011\_8000 + 0x0100 × m (m = 1, 2)

Offset address: 0x21

| Bit position:      | 7 | 6 | 5 | 4 | 3    | 2         | 1    | 0 |
|--------------------|---|---|---|---|------|-----------|------|---|
| Bit field:         | — | — | — | — | BRME | RXDS<br>F | SFSF | — |
| Value after reset: | 0 | 0 | 0 | 0 | 0    | 0         | 0    | 0 |

| Bit | Symbol | Function   | R/W |
|-----|--------|--|-----|
| 0   | —      | This bit is read as 0. The write value should be 0.  | R/W |
| 1   | SFSF   | Start Frame Status Flag<br>0: Start Frame detection function is disabled.<br>1: Start Frame detection function is enabled. | R   |
| 2   | RXDSF  | RXDn Input Status Flag<br>0: RXDn input is enabled.<br>1: RXDn input is disabled.  | R   |
| 3   | BRME   | Bit Rate Measurement Enable<br>0: Measurement of bit rate is disabled.<br>1: Measurement of bit rate is enabled.           | R/W |
| 7:4 | —      | These bits are read as 0. The write value should be 0.   | R/W |

### 27.2.43 CR1 : Control Register 1

Base address: SCIm = 0x4011\_8000 + 0x0100 × m (m = 1, 2)

Offset address: 0x22

| Bit position:      | 7         | 6 | 5    | 4          | 3         | 2   | 1 | 0 |
|--------------------|-----------|---|------|------------|-----------|-----|---|---|
| Bit field:         | PIBS[2:0] |   | PIBE | CF1DS[1:0] | CF0R<br>E | BFE |   |   |
| Value after reset: | 0         | 0 | 0    | 0          | 0         | 0   | 0 | 0 |

| Bit | Symbol     | Function  | R/W |
|-----|------------|---|-----|
| 0   | BFE        | Break Field Enable<br>0: Break Field detection is disabled.<br>1: Break Field detection is enabled.   | R/W |
| 1   | CF0RE      | Control Field 0 Reception Enable<br>0: Reception of Control Field 0 is disabled.<br>1: Reception of Control Field 0 is enabled.   | R/W |
| 3:2 | CF1DS[1:0] | Control Field 1 Data Register Select<br>00: Selects comparison with the value in PCF1DR.<br>01: Selects comparison with the value in SCF1DR.<br>10: Selects comparison with the values in PCF1DR and SCF1DR.<br>11: Setting prohibited. | R/W |

当ESME位为0时，扩展串行模式控制部分被初始化。

**Table 27.26 ESME位和定时器操作模式的设置**

| ESME钻头 | 定时器模式       | 断场低宽度测定模式 | 断场低宽度输出模式 |
|--------|-------------|-----------|-----------|
| 0      | Available*1 | 无法使用      | 无法使用      |
| 1      | Available   | Available | Available |

注1.只有在选择PCLK时才能进行操作。

### 27.2.42 CR0：控制寄存器0

Base address: SCIm = 0x4011\_8000 + 0x0100 × m (m = 1, 2)

Offset address: 0x21

| Bit position: | 7 | 6 | 5 | 4 | 3    | 2         | 1    | 0 |
|---------------|---|---|---|---|------|-----------|------|---|
| Bit field:    | — | — | — | — | BRME | RXDS<br>F | SFSF | — |
| 重置后的值:        | 0 | 0 | 0 | 0 | 0    | 0         | 0    | 0 |

| Bit | Symbol | Function                                | R/W |
|-----|--------|---|-----|
| 0   | —      | 该位读取为0。写入值应为0。                          | R/W |
| 1   | SFSF   | 开始帧状态标志<br>0: 禁止启动帧检测功能。1: 启动帧检测功能使能。   | R   |
| 2   | RXDSF  | RXDn输入状态标志<br>0: RXDn输入使能。1: RXDXn输入禁用。 | R   |
| 3   | BRME   | 比特率测量启用<br>0: 禁止比特率测量。1: 启用比特率测量。       | R/W |
| 7:4 | —      | 这些位被读取为0。写入值应为0。                        | R/W |

### 27.2.43 CR1：控制寄存器1

Base address: SCIm = 0x4011\_8000 + 0x0100 × m (m = 1, 2)

Offset address: 0x22

| Bit position: | 7         | 6 | 5    | 4          | 3         | 2   | 1 | 0 |
|---------------|-----------|---|------|------------|-----------|-----|---|---|
| Bit field:    | PIBS[2:0] |   | PIBE | CF1DS[1:0] | CF0R<br>E | BFE |   |   |
| 重置后的值:        | 0         | 0 | 0    | 0          | 0         | 0   | 0 | 0 |

| Bit | Symbol     | Function  | R/W |
|-----|------------|---|-----|
| 0   | BFE        | 中断字段启用<br>0: 中断场检测被禁用。1: 使能断场检测。  | R/W |
| 1   | CF0RE      | 控制字段0接收启用<br>0: 禁止接收控制字段0。1: 启用控制字段0的接收。  | R/W |
| 3:2 | CF1DS[1:0] | 控制字段1数据寄存器选择<br>00: 选择与PCF1DR中的值进行比较。01: 选择与SCF1DR中的值进行比较。10: 选择与PCF1DR和SCF1DR中的值进行比较。11: 禁止设置。 | R/W |

| Bit | Symbol    | Function  | R/W |
|-----|-----------|---|-----|
| 4   | PIBE      | Priority Interrupt Bit Enable<br>0: The priority interrupt bit is disabled.<br>1: The priority interrupt bit is enabled.  | R/W |
| 7:5 | PIBS[2:0] | Priority Interrupt Bit Select<br>0 0 0: 0th bit of Control Field 1<br>0 0 1: 1st bit of Control Field 1<br>0 1 0: 2nd bit of Control Field 1<br>0 1 1: 3rd bit of Control Field 1<br>1 0 0: 4th bit of Control Field 1<br>1 0 1: 5th bit of Control Field 1<br>1 1 0: 6th bit of Control Field 1<br>1 1 1: 7th bit of Control Field 1 | R/W |

27.2.44 CR2 : Control Register 2

Base address: SCIm = 0x4011\_8000 + 0x0100 × m (m = 1, 2)

Offset address: 0x23

Bit position: 7 6 5 4 3 2 1 0

|            |          |           |   |           |
|------------|----------|-----------|---|-----------|
| Bit field: | RTS[1:0] | BCCS[1:0] | — | DFCS[2:0] |
|------------|----------|-----------|---|-----------|

Value after reset: 0 0 0 0 0 0 0 0

| Bit | Symbol    | Function  | R/W |
|-----|-----------|---|-----|
| 2:0 | DFCS[2:0] | RXDXn Signal Digital Filter Clock Select<br>0 0 0: Filter is disabled.<br>0 0 1: Filter clock is SCI base clock <sup>*1 *2</sup><br>0 1 0: Filter clock is PCLK/8<br>0 1 1: Filter clock is PCLK/16<br>1 0 0: Filter clock is PCLK/32<br>1 0 1: Filter clock is PCLK/64<br>1 1 0: Filter clock is PCLK/128<br>1 1 1: Setting prohibited   | R/W |
| 3   | —         | This bit is read as 0. The write value should be 0.   | R/W |
| 5:4 | BCCS[1:0] | Bus Collision Detection Clock Select<br>• When SEMR.BGDM = 0 or SEMR.BGDM = 1 and SMR.CKS[1:0] = a value other than 00b<br>0 0: SCI base clock<br>0 1: SCI base clock frequency divided by 2<br>1 0: SCI base clock frequency divided by 4<br>1 1: Setting prohibited<br>• When SEMR.BGDM = 1 and SMR.CKS[1:0] = 00b<br>0 0: SCI base clock frequency divided by 2<br>0 1: SCI base clock frequency divided by 4<br>1 0: Setting prohibited<br>1 1: Setting prohibited  | R/W |
| 7:6 | RTS[1:0]  | RXDXn Reception Sampling Timing Select<br>• When SCIn.SEMR.ABCS = 0<br>0 0: Rising edge of the 8th cycle of SCI base clock<br>0 1: Rising edge of the 10th cycle of SCI base clock<br>1 0: Rising edge of the 12th cycle of SCI base clock<br>1 1: Rising edge of the 14th cycle of SCI base clock<br>• When SCIn.SEMR.ABCS = 1<br>0 0: Rising edge of the 4th cycle of SCI base clock<br>0 1: Rising edge of the 5th cycle of SCI base clock<br>1 0: Rising edge of the 6th cycle of SCI base clock<br>1 1: Rising edge of the 7th cycle of SCI base clock | R/W |

Note: The period of the SCI base clock is 1/16 of a single bit period when the SCIn.SEMR.ABCS is 0, and 1/8 of a single bit period when the SCIn.SEMR.ABCS is 1.

Note 1. To use the SCI base clock, set the SCIn.SCR.TE bit to 1.

| Bit | Symbol    | Function   | R/W |
|-----|-----------|--|-----|
| 4   | PIBE      | 优先中断位使能<br>0: 禁止优先中断位。1: 优先中断位使能。  | R/W |
| 7:5 | PIBS[2:0] | 优先中断位选择<br>000: 控制字段1的第0位001: 控制字段的第1位010: 控制字段的第2位011: 控制字段的第3位100: 控制字段的第4位101: 控制字段的第5位110: 控制字段的第6位111: 控制字段的第7位 | R/W |

27.2.44 CR2: 控制寄存器2

Base address: SCIm = 0x4011\_8000 + 0x0100 × m (m = 1, 2)

Offset address: 0x23

Bit position: 7 6 5 4 3 2 1 0

|            |          |           |   |           |
|------------|----------|-----------|---|-----------|
| Bit field: | RTS[1:0] | BCCS[1:0] | — | DFCS[2:0] |
|------------|----------|-----------|---|-----------|

重置后的值: 0 0 0 0 0 0 0 0

| Bit | Symbol    | Function  | R/W |
|-----|-----------|---|-----|
| 2:0 | DFCS[2:0] | RXDXn信号数字滤波器时钟选择<br>000: 过滤器被禁用。001: 滤波器时钟为SCI基本时钟*1*2<br>010: 滤波器时钟为PCLK8011: 滤波器时钟为PCLK16100: 滤波器时钟为PCLK32101: 滤波器时钟为PCLK64110: 滤波器时钟为PCLK128111: 设置禁止  | R/W |
| 3   | —         | 该位读取为0。写入值应为0。  | R/W |
| 5:4 | BCCS[1:0] | 总线冲突检测时钟选择●<br>当SEMR.BGDM=0或SEMR.BGDM=1且SMR.CKS[1:0]=00b以外的值时<br>00: SCI基准时钟01: SCI基准时钟频率除以210: SCI基准时钟频率除以411: 禁止设置<br>• 当SEMR.BGDM=1且SMR.CKS[1:0]=00b00: SCI基本时钟频率除以201: SCI基本时钟频率除以410: 禁止设置11: 禁止设置 | R/W |
| 7:6 | RTS[1:0]  | RXDXn接收采样时序选择●<br>00: SCI基准时钟第8周期上升沿01: SCI基准时钟第10周期上升沿10: SCI基准时钟第12周期上升沿11: SCI第14周期上升沿基准时钟<br>• 当SCIn.SEMR.ABCS=100: SCI基准时钟第4周期上升沿01: SCI基准时钟第5周期上升沿0: SCI基准时钟第6周期上升沿1: SCI基本时钟第7个周期的上升沿            | R/W |

Note: 当SCIn.SEMR.ABCS为0时, SCI基本时钟的周期为单位周期的116, 而当SCIn.SEMR.ABCS为1时, SCI基准时钟的周期为单位周期的18。

注1.要使用SCI基本时钟, 请将SCIn.SCR.TE位设置为1。

Note 2. The SCI base clock divided by 2 is the filter clock when the SEMR.BGDM bit is 1 and the SMR.CKS[1:0] bits are 00b.

### 27.2.45 CR3 : Control Register 3

Base address: SCIm = 0x4011\_8000 + 0x0100 × m (m = 1, 2)

Offset address: 0x24

|                    |   |   |   |   |   |   |   |      |
|--------------------|---|---|---|---|---|---|---|------|
| Bit position:      | 7 | 6 | 5 | 4 | 3 | 2 | 1 | 0    |
| Bit field:         | — | — | — | — | — | — | — | SDST |
| Value after reset: | 0 | 0 | 0 | 0 | 0 | 0 | 0 | 0    |

| Bit | Symbol | Function  | R/W |
|-----|--------|---|-----|
| 0   | SDST   | Start Frame Detection Start<br>0: Detection of Start Frame is not performed.<br>1: Detection of Start Frame is performed. | R/W |
| 7:1 | —      | These bits are read as 0. The write value should be 0.  | R/W |

#### SDST bit (Start Frame Detection Start)

Detection of a Start Frame begins when this bit is set to 1. The bit is read as 0.

### 27.2.46 PCR : Port Control Register

Base address: SCIm = 0x4011\_8000 + 0x0100 × m (m = 1, 2)

Offset address: 0x25

|                    |   |   |   |            |   |   |            |            |
|--------------------|---|---|---|------------|---|---|------------|------------|
| Bit position:      | 7 | 6 | 5 | 4          | 3 | 2 | 1          | 0          |
| Bit field:         | — | — | — | SHAR<br>PS | — | — | RXDX<br>PS | TXDX<br>PS |
| Value after reset: | 0 | 0 | 0 | 0          | 0 | 0 | 0          | 0          |

| Bit | Symbol | Function   | R/W |
|-----|--------|--|-----|
| 0   | TXDXPS | TXDXn Signal Polarity Select<br>0: The polarity of TXDXn signal is not inverted for output.<br>1: The polarity of TXDXn signal is inverted for output. | R/W |
| 1   | RXDXPS | RXDXn Signal Polarity Select<br>0: The polarity of RXDXn signal is not inverted for input.<br>1: The polarity of RXDXn signal is inverted for input.   | R/W |
| 3:2 | —      | These bits are read as 0. The write value should be 0.   | R/W |
| 4   | SHARPS | TXDXn/RXDXn Pin Multiplexing Select<br>0: The TXDXn and RXDXn pins are independent.<br>1: The TXDXn and RXDXn signals are multiplexed on the same pin. | R/W |
| 7:5 | —      | These bits are read as 0. The write value should be 0.   | R/W |

#### SHARPS bit (TXDXn/RXDXn Pin Multiplexing Select)

When this bit is set to 1, the TXDXn and RXDXn signals are multiplexed on the same pin so that half-duplex communications become possible.

注2.当SEMR.BGDM位为1且SMR.CKS[1:0]位为00b时，SCI基本时钟除以2为滤波器时钟。

### 27.2.45 CR3：控制寄存器3

Base address: SCIm = 0x4011\_8000 + 0x0100 × m (m = 1, 2)

Offset address: 0x24

|               |   |   |   |   |   |   |   |      |
|---------------|---|---|---|---|---|---|---|------|
| Bit position: | 7 | 6 | 5 | 4 | 3 | 2 | 1 | 0    |
| Bit field:    | — | — | — | — | — | — | — | SDST |
| 重置后的值:        | 0 | 0 | 0 | 0 | 0 | 0 | 0 | 0    |

| Bit | Symbol | Function                         | R/W |
|-----|--------|----------------------------------|-----|
| 0   | SDST   | 开始帧检测开始<br>0: 不检测起始帧。1: 执行起始帧检测。 | R/W |
| 7:1 | —      | 这些位被读取为0。写入值应为0。                 | R/W |

#### SDST位 (开始帧检测开始)

当该位设置为1时开始检测起始帧。该位被读取为0。

### 27.2.46 PCR：端口控制寄存器

Base address: SCIm = 0x4011\_8000 + 0x0100 × m (m = 1, 2)

Offset address: 0x25

|               |   |   |   |            |   |   |            |            |
|---------------|---|---|---|------------|---|---|------------|------------|
| Bit position: | 7 | 6 | 5 | 4          | 3 | 2 | 1          | 0          |
| Bit field:    | — | — | — | SHAR<br>PS | — | — | RXDX<br>PS | TXDX<br>PS |
| 重置后的值:        | 0 | 0 | 0 | 0          | 0 | 0 | 0          | 0          |

| Bit | Symbol | Function   | R/W |
|-----|--------|--|-----|
| 0   | TXDXPS | TXDXn信号极性选择<br>0: TXDXn信号的极性不反相输出。1: TXDXn信号极性反相输出。                | R/W |
| 1   | RXDXPS | RXDXn信号极性选择<br>0: RXDXn信号极性不反相输入。1: RXDXn信号极性反相输入。                 | R/W |
| 3:2 | —      | 这些位被读取为0。写入值应为0。   | R/W |
| 4   | SHARPS | TXDXn/RXDXn引脚复用选择<br>0: TXDXn和RXDXn引脚独立。1: TXDXn和RXDXn信号在同一个引脚上复用。 | R/W |
| 7:5 | —      | 这些位被读取为0。写入值应为0。   | R/W |

#### SHARPS位 (TXDXn/RXDXn引脚复用选择)

当该位设置为1时，TXDXn和RXDXn信号在同一引脚上复用，从而可以进行半双工通信。

## 27.2.47 ICR : Interrupt Control Register

Base address: SCIm = 0x4011\_8000 + 0x0100 × m (m = 1, 2)

Offset address: 0x26

|                    |   |   |       |       |        |        |        |       |
|--------------------|---|---|-------|-------|--------|--------|--------|-------|
| Bit position:      | 7 | 6 | 5     | 4     | 3      | 2      | 1      | 0     |
| Bit field:         | — | — | AEDIE | BCDIE | PIBDIE | CF1MIE | CF0MIE | BFDIE |
| Value after reset: | 0 | 0 | 0     | 0     | 0      | 0      | 0      | 0     |

| Bit | Symbol | Function   | R/W |
|-----|--------|--|-----|
| 0   | BFDIE  | Break Field Low Width Detected Interrupt Enable<br>0: Interrupts on detection of the low width for a Break Field are disabled.<br>1: Interrupts on detection of the low width for a Break Field are enabled. | R/W |
| 1   | CF0MIE | Control Field 0 Match Detected Interrupt Enable<br>0: Interrupts on detection of a match with Control Field 0 are disabled.<br>1: Interrupts on detection of a match with Control Field 0 are enabled.       | R/W |
| 2   | CF1MIE | Control Field 1 Match Detected Interrupt Enable<br>0: Interrupts on detection of a match with Control Field 1 are disabled.<br>1: Interrupts on detection of a match with Control Field 1 are enabled.       | R/W |
| 3   | PIBDIE | Priority Interrupt Bit Detected Interrupt Enable<br>0: Interrupts on detection of the priority interrupt bit are disabled.<br>1: Interrupts on detection of the priority interrupt bit are enabled.          | R/W |
| 4   | BCDIE  | Bus Collision Detected Interrupt Enable<br>0: Interrupts on detection of a bus collision are disabled.<br>1: Interrupts on detection of a bus collision are enabled.   | R/W |
| 5   | AEDIE  | Valid Edge Detected Interrupt Enable<br>0: Interrupts on detection of a valid edge are disabled.<br>1: Interrupts on detection of a valid edge are enabled.  | R/W |
| 7:6 | —      | These bits are read as 0. The write value should be 0.   | R/W |

## 27.2.48 STR : Status Register

Base address: SCIm = 0x4011\_8000 + 0x0100 × m (m = 1, 2)

Offset address: 0x27

|                    |   |   |      |      |       |       |       |     |
|--------------------|---|---|------|------|-------|-------|-------|-----|
| Bit position:      | 7 | 6 | 5    | 4    | 3     | 2     | 1     | 0   |
| Bit field:         | — | — | AEDF | BCDF | PIBDF | CF1MF | CF0MF | BDF |
| Value after reset: | 0 | 0 | 0    | 0    | 0     | 0     | 0     | 0   |

| Bit | Symbol | Function   | R/W |
|-----|--------|--|-----|
| 0   | BDF    | Break Field Low Width Detection Flag<br>[Setting conditions]<br><ul style="list-style-type: none"> <li>Detection of the low width for a Break Field</li> <li>Completion of the output of the low width for a Break Field</li> <li>Underflow of the timer</li> </ul> [Clearing condition]<br><ul style="list-style-type: none"> <li>Writing 1 to the BFDCL bit in STCR</li> </ul> | R   |
| 1   | CF0MF  | Control Field 0 Match Flag<br>[Setting conditions]<br><ul style="list-style-type: none"> <li>A match between the value received in Control Field 0 and the set value.</li> </ul> [Clearing condition]<br><ul style="list-style-type: none"> <li>Writing 1 to the CF0MCL bit in STCR</li> </ul>   | R   |

## 27.2.47 ICR: 中断控制寄存器

Base address: SCIm = 0x4011\_8000 + 0x0100 × m (m = 1, 2)

Offset address: 0x26

|               |   |   |       |       |        |        |        |       |
|---------------|---|---|-------|-------|--------|--------|--------|-------|
| Bit position: | 7 | 6 | 5     | 4     | 3      | 2      | 1      | 0     |
| Bit field:    | — | — | AEDIE | BCDIE | PIBDIE | CF1MIE | CF0MIE | BFDIE |
| 重置后的值:        | 0 | 0 | 0     | 0     | 0      | 0      | 0      | 0     |

| Bit | Symbol | Function  | R/W |
|-----|--------|---|-----|
| 0   | BFDIE  | 中断字段低宽度检测到中断使能<br>0: 禁止检测到中断字段的低宽度时的中断。1: 允许检测到中断字段的低宽度时的中断。  | R/W |
| 1   | CF0MIE | 控制字段0匹配检测到中断使能<br>0: 检测到与控制字段0匹配时的中断被禁用。1: 检测到与控制字段0匹配时的中断使能。 | R/W |
| 2   | CF1MIE | 控制字段1匹配检测到中断使能<br>0: 检测到与控制字段1匹配时的中断被禁用。1: 检测到与控制字段1匹配时的中断使能。 | R/W |
| 3   | PIBDIE | 优先中断位检测到中断使能<br>0: 禁止检测到优先中断位时的中断。1: 检测到优先中断位时的中断使能。          | R/W |
| 4   | BCDIE  | 总线冲突检测中断使能<br>0: 禁止检测到总线冲突时的中断。1: 使能检测到总线冲突时的中断。              | R/W |
| 5   | AEDIE  | 有效边沿检测中断使能<br>0: 禁止检测到有效边沿时的中断。1: 使能检测到有效边沿时的中断。              | R/W |
| 7:6 | —      | 这些位被读取为0。写入值应为0。  | R/W |

## 27.2.48 STR:状态寄存器

Base address: SCIm = 0x4011\_8000 + 0x0100 × m (m = 1, 2)

Offset address: 0x27

|               |   |   |      |      |       |       |       |     |
|---------------|---|---|------|------|-------|-------|-------|-----|
| Bit position: | 7 | 6 | 5    | 4    | 3     | 2     | 1     | 0   |
| Bit field:    | — | — | AEDF | BCDF | PIBDF | CF1MF | CF0MF | BDF |
| 重置后的值:        | 0 | 0 | 0    | 0    | 0     | 0     | 0     | 0   |

| Bit | Symbol | Function   | R/W |
|-----|--------|--|-----|
| 0   | BDF    | 中断字段低宽度检测标志[设置条件]●<br>检测中断字段的低宽度<br><ul style="list-style-type: none"> <li>完成中断字段的低宽度输出</li> </ul> ●定时器下溢[清除条件]●<br>将1写入STCR中的BFDCL位 | R   |
| 1   | CF0MF  | 控制字段0匹配标志[设置条件]●<br>控制字段0中接收的值与设定值之间的匹配。[结算条件]●<br>将1写入STCR中的CF0MCL位   | R   |

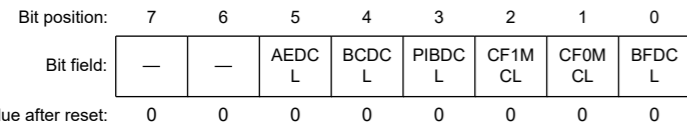


| Bit | Symbol | Function  | R/W |
|-----|--------|---|-----|
| 2   | CF1MF  | Control Field 1 Match Flag<br>[Setting conditions]<br>• A match between the data received in Control Field 1 and the set values.<br>[Clearing condition]<br>• Writing 1 to the CF1MCL bit in STCR | R   |
| 3   | PIBDF  | Priority Interrupt Bit Detection Flag<br>[Setting conditions]<br>• Detection of the priority interrupt bit<br>[Clearing condition]<br>• Writing 1 to the PIBDCL bit in STCR                       | R   |
| 4   | BCDF   | Bus Collision Detected Flag<br>[Setting conditions]<br>• Detection of the bus collision<br>[Clearing condition]<br>• Writing 1 to the BCDCL bit in STCR   | R   |
| 5   | AEDF   | Valid Edge Detection Flag<br>[Setting conditions]<br>• Detection of a valid edge<br>[Clearing condition]<br>• Writing 1 to the AEDCL bit in STCR  | R   |
| 7:6 | —      | These bits are read as 0. The write value should be 0.  | R   |

27.2.49 STCR : Status Clear Register

Base address: SCIm = 0x4011\_8000 + 0x0100 × m (m = 1, 2)

Offset address: 0x28



| Bit | Symbol | Function   | R/W |
|-----|--------|--|-----|
| 0   | BFDC L | BFDF Clear<br>Setting this bit to 1 clears the STR.BFDF flag. This bit is read as 0.   | R/W |
| 1   | CF0MCL | CF0MF Clear<br>Setting this bit to 1 clears the STR.CF0MF flag. This bit is read as 0. | R/W |
| 2   | CF1MCL | CF1MF Clear<br>Setting this bit to 1 clears the STR.CF1MF flag. This bit is read as 0. | R/W |
| 3   | PIBDCL | PIBDF Clear<br>Setting this bit to 1 clears the STR.PIBDF flag. This bit is read as 0. | R/W |
| 4   | BCDCL  | BCDF Clear<br>Setting this bit to 1 clears the STR.BCDF flag. This bit is read as 0.   | R/W |
| 5   | AEDCL  | AEDF Clear<br>Setting this bit to 1 clears the STR.AEDF flag. This bit is read as 0.   | R/W |
| 7:6 | —      | These bits are read as 0. The write value should be 0.                                 | R/W |

27.2.50 CF0DR : Control Field 0 Data Register

Base address: SCIm = 0x4011\_8000 + 0x0100 × m (m = 1, 2)

Offset address: 0x29

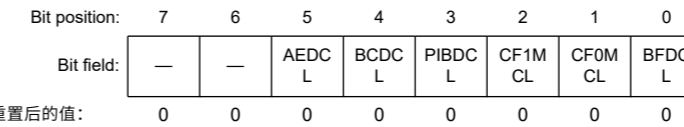


| Bit | Symbol | Function  | R/W |
|-----|--------|---|-----|
| 2   | CF1MF  | 控制字段1匹配标志[设置条件]●<br>控制字段1中接收的数据与设定值之间的匹配。[结算条件]●<br><br>将1写入STCR中的CF1MCL位 | R   |
| 3   | PIBDF  | 优先中断位检测标志[设置条件]●<br><br>检测优先中断位[清除条件]●<br><br>将1写入STCR中的PIBDCL位           | R   |
| 4   | BCDF   | BusCollisionDetectedFlag[设定条件]●<br>总线碰撞检测[清除条件]●<br><br>将1写入STCR中的BCDCL位  | R   |
| 5   | AEDF   | 有效边缘检测标志[设置条件]●<br>检测有效边沿[清除条件]●<br><br>将1写入STCR中的AEDCL位                  | R   |
| 7:6 | —      | 这些位被读取为0。写入值应为0。  | R   |

27.2.49 STCR:状态清除寄存器

Base address: SCIm = 0x4011\_8000 + 0x0100 × m (m = 1, 2)

Offset address: 0x28

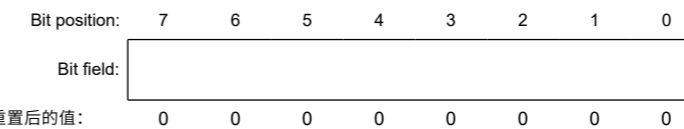


| Bit | Symbol | Function                                    | R/W |
|-----|--------|---|-----|
| 0   | BFDC L | BFDF Clear<br>将此位设置为1会清除STR.BFDF标志。该位读为0。   | R/W |
| 1   | CF0MCL | CF0MF Clear<br>将此位设置为1会清除STR.CF0MF标志。该位读为0。 | R/W |
| 2   | CF1MCL | CF1MF Clear<br>将此位设置为1会清除STR.CF1MF标志。该位读为0。 | R/W |
| 3   | PIBDCL | PIBDF Clear<br>将此位设置为1会清除STR.PIBDF标志。该位读为0。 | R/W |
| 4   | BCDCL  | BCDF Clear<br>将此位设置为1会清除STR.BCDF标志。该位读为0。   | R/W |
| 5   | AEDCL  | AEDF Clear<br>将此位设置为1会清除STR.AEDF标志。该位读为0。   | R/W |
| 7:6 | —      | 这些位被读取为0。写入值应为0。                            | R/W |

27.2.50 CF0DR: 控制字段0数据寄存器

Base address: SCIm = 0x4011\_8000 + 0x0100 × m (m = 1, 2)

Offset address: 0x29

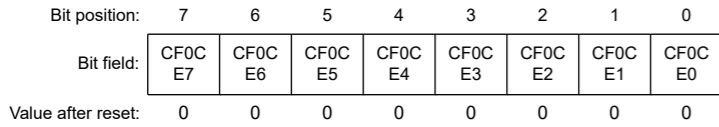


The CF0DR register is an 8-bit readable and writable register that holds a value for comparison with Control Field 0.

### 27.2.51 CF0CR : Control Field 0 Compare Enable Register

Base address: SCIm = 0x4011\_8000 + 0x0100 × m (m = 1, 2)

Offset address: 0x2A

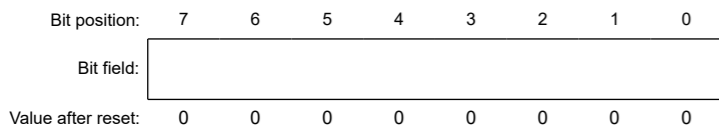


| Bit | Symbol | Function  | R/W |
|-----|--------|---|-----|
| 0   | CF0CE0 | Control Field 0 Bit 0 Compare Enable<br>0: Comparison with bit 0 of Control Field 0 is disabled.<br>1: Comparison with bit 0 of Control Field 0 is enabled. | R/W |
| 1   | CF0CE1 | Control Field 1 Bit 0 Compare Enable<br>0: Comparison with bit 1 of Control Field 0 is disabled.<br>1: Comparison with bit 1 of Control Field 0 is enabled. | R/W |
| 2   | CF0CE2 | Control Field 2 Bit 0 Compare Enable<br>0: Comparison with bit 2 of Control Field 0 is disabled.<br>1: Comparison with bit 2 of Control Field 0 is enabled. | R/W |
| 3   | CF0CE3 | Control Field 3 Bit 0 Compare Enable<br>0: Comparison with bit 3 of Control Field 0 is disabled.<br>1: Comparison with bit 3 of Control Field 0 is enabled. | R/W |
| 4   | CF0CE4 | Control Field 4 Bit 0 Compare Enable<br>0: Comparison with bit 4 of Control Field 0 is disabled.<br>1: Comparison with bit 4 of Control Field 0 is enabled. | R/W |
| 5   | CF0CE5 | Control Field 5 Bit 0 Compare Enable<br>0: Comparison with bit 5 of Control Field 0 is disabled.<br>1: Comparison with bit 5 of Control Field 0 is enabled. | R/W |
| 6   | CF0CE6 | Control Field 6 Bit 0 Compare Enable<br>0: Comparison with bit 6 of Control Field 0 is disabled.<br>1: Comparison with bit 6 of Control Field 0 is enabled. | R/W |
| 7   | CF0CE7 | Control Field 7 Bit 0 Compare Enable<br>0: Comparison with bit 7 of Control Field 0 is disabled.<br>1: Comparison with bit 7 of Control Field 0 is enabled. | R/W |

### 27.2.52 CF0RR : Control Field 0 Receive Data Register

Base address: SCIm = 0x4011\_8000 + 0x0100 × m (m = 1, 2)

Offset address: 0x2B



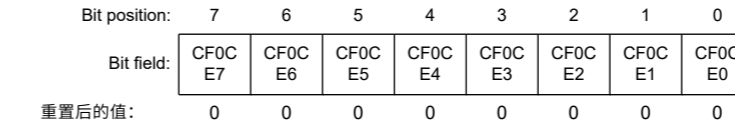
CF0RR is a readable register that holds the value received in Control Field 0.

CF0DR寄存器是一个8位可读写寄存器，它保存一个用于与控制字段0进行比较的值。

### 27.2.51 CF0CR：控制字段0比较使能寄存器

Base address: SCIm = 0x4011\_8000 + 0x0100 × m (m = 1, 2)

Offset address: 0x2A



| Bit | Symbol | Function   | R/W |
|-----|--------|--|-----|
| 0   | CF0CE0 | 控制字段0位0比较使能<br>0: 禁止与控制字段0的位0进行比较。1: 启用与控制字<br>段0的位0的比较。 | R/W |
| 1   | CF0CE1 | 控制字段1位0比较使能<br>0: 禁止与控制字段0的位1进行比较。1: 启用与控制字<br>段0的位1的比较。 | R/W |
| 2   | CF0CE2 | 控制字段2位0比较使能<br>0: 禁止与控制字段0的位2进行比较。1: 启用与控制字<br>段0的位2的比较。 | R/W |
| 3   | CF0CE3 | 控制字段3位0比较使能<br>0: 禁止与控制字段0的位3比较。1: 启用与控制字<br>段0的位3的比较。   | R/W |
| 4   | CF0CE4 | 控制字段4位0比较使能<br>0: 禁止与控制字段0的位4进行比较。1: 启用与控制字<br>段0的位4的比较。 | R/W |
| 5   | CF0CE5 | 控制字段5位0比较使能<br>0: 禁止与控制字段0的位5进行比较。1: 启用与控制字<br>段0的位5的比较。 | R/W |
| 6   | CF0CE6 | 控制字段6位0比较使能<br>0: 禁止与控制字段0的位6进行比较。1: 启用与控制字<br>段0的位6的比较。 | R/W |
| 7   | CF0CE7 | 控制字段7位0比较使能<br>0: 禁止与控制字段0的位7进行比较。1: 启用与控制字<br>段0的第7位比较。 | R/W |

### 27.2.52 CF0RR:控制字段0接收数据寄存器

Base address: SCIm = 0x4011\_8000 + 0x0100 × m (m = 1, 2)

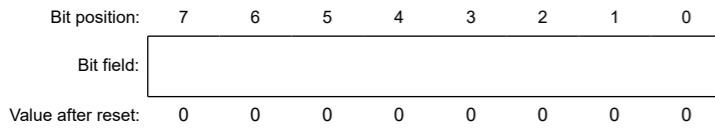
Offset address: 0x2B



CF0RR是一个可读寄存器，它保存在控制字段0中接收到的值。

27.2.53 PCF1DR : Primary Control Field 1 Data Register

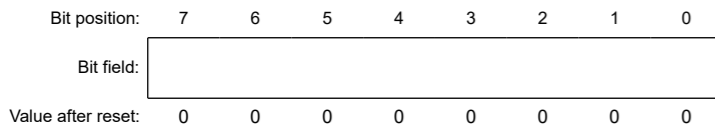
Base address: SCIm = 0x4011\_8000 + 0x0100 × m (m = 1, 2)  
 Offset address: 0x2C



PCF1DR is an 8-bit readable and writable register that holds the 8-bit primary value for comparison with Control Field 1.

27.2.54 SCF1DR : Secondary Control Field 1 Data Register

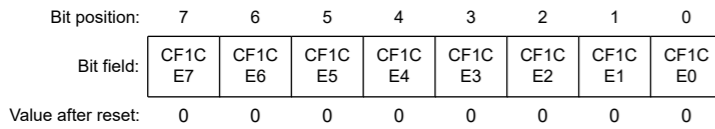
Base address: SCIm = 0x4011\_8000 + 0x0100 × m (m = 1, 2)  
 Offset address: 0x2D



SCF1DR is an 8-bit readable and writable register that holds the 8-bit secondary value for comparison with Control Field 1.

27.2.55 CF1CR : Control Field 1 Compare Enable Register

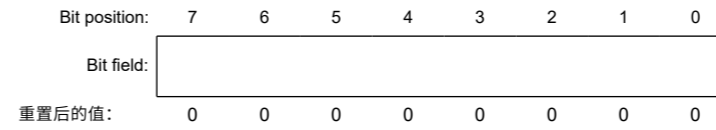
Base address: SCIm = 0x4011\_8000 + 0x0100 × m (m = 1, 2)  
 Offset address: 0x2E



| Bit | Symbol | Function  | R/W |
|-----|--------|---|-----|
| 0   | CF1CE0 | Control Field 1 Bit 0 Compare Enable<br>0: Comparison with bit 0 of Control Field 1 is disabled.<br>1: Comparison with bit 0 of Control Field 1 is enabled. | R/W |
| 1   | CF1CE1 | Control Field 1 Bit 1 Compare Enable<br>0: Comparison with bit 1 of Control Field 1 is disabled.<br>1: Comparison with bit 1 of Control Field 1 is enabled. | R/W |
| 2   | CF1CE2 | Control Field 1 Bit 2 Compare Enable<br>0: Comparison with bit 2 of Control Field 1 is disabled.<br>1: Comparison with bit 2 of Control Field 1 is enabled. | R/W |
| 3   | CF1CE3 | Control Field 1 Bit 3 Compare Enable<br>0: Comparison with bit 3 of Control Field 1 is disabled.<br>1: Comparison with bit 3 of Control Field 1 is enabled. | R/W |
| 4   | CF1CE4 | Control Field 1 Bit 4 Compare Enable<br>0: Comparison with bit 4 of Control Field 1 is disabled.<br>1: Comparison with bit 4 of Control Field 1 is enabled. | R/W |
| 5   | CF1CE5 | Control Field 1 Bit 5 Compare Enable<br>0: Comparison with bit 5 of Control Field 1 is disabled.<br>1: Comparison with bit 5 of Control Field 1 is enabled. | R/W |
| 6   | CF1CE6 | Control Field 1 Bit 6 Compare Enable<br>0: Comparison with bit 6 of Control Field 1 is disabled.<br>1: Comparison with bit 6 of Control Field 1 is enabled. | R/W |

27.2.53 PCF1DR: 主控制字段1数据寄存器

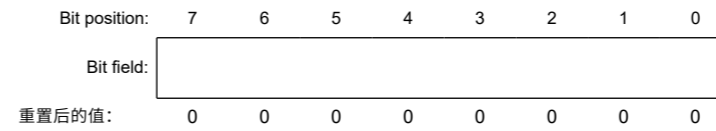
Base address: SCIm = 0x4011\_8000 + 0x0100 × m (m = 1, 2)  
 Offset address: 0x2C



PCF1DR是一个8位可读写寄存器，它保存8位主值，用于与控制字段1进行比较。

27.2.54 SCF1DR: 辅助控制字段1数据寄存器

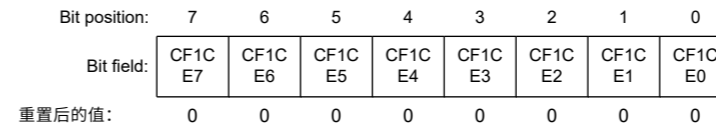
Base address: SCIm = 0x4011\_8000 + 0x0100 × m (m = 1, 2)  
 Offset address: 0x2D



SCF1DR是一个8位可读写寄存器，保存8位辅助值，用于与控制字段1进行比较。

27.2.55 CF1CR: 控制字段1比较使能寄存器

Base address: SCIm = 0x4011\_8000 + 0x0100 × m (m = 1, 2)  
 Offset address: 0x2E



| Bit | Symbol | Function   | R/W |
|-----|--------|--|-----|
| 0   | CF1CE0 | 控制字段1位0比较使能<br>0: 禁止与控制字段1的位0进行比较。1: 启用与控制字段1的位0的比较。 | R/W |
| 1   | CF1CE1 | 控制字段1位1比较使能<br>0: 禁止与控制字段1的位1比较。1: 启用与控制字段1的位1的比较。   | R/W |
| 2   | CF1CE2 | 控制字段1位2比较使能<br>0: 禁止与控制字段1的位2进行比较。1: 启用与控制字段1的位2的比较。 | R/W |
| 3   | CF1CE3 | 控制字段1位3比较使能<br>0: 禁止与控制字段1的位3比较。1: 启用与控制字段1的位3的比较。   | R/W |
| 4   | CF1CE4 | 控制字段1位4比较使能<br>0: 禁止与控制字段1的位4比较。1: 启用与控制字段1的位4的比较。   | R/W |
| 5   | CF1CE5 | 控制字段1位5比较使能<br>0: 禁止与控制字段1的位5进行比较。1: 启用与控制字段1的位5的比较。 | R/W |
| 6   | CF1CE6 | 控制字段1位6比较使能<br>0: 禁止与控制字段1的位6进行比较。1: 启用与控制字段1的位6的比较。 | R/W |

| Bit | Symbol | Function  | R/W |
|-----|--------|---|-----|
| 7   | CF1CE7 | Control Field 1 Bit 7 Compare Enable<br>0: Comparison with bit 7 of Control Field 1 is disabled.<br>1: Comparison with bit 7 of Control Field 1 is enabled. | R/W |

### 27.2.56 CF1RR : Control Field 1 Receive Data Register

Base address: SCIm = 0x4011\_8000 + 0x0100 × m (m = 1, 2)

Offset address: 0x2F

Bit position: 7 6 5 4 3 2 1 0

Bit field:

Value after reset: 0 0 0 0 0 0 0 0

CF1RR is a readable register that holds the value received in Control Field 1.

### 27.2.57 TCR : Timer Control Register

Base address: SCIm = 0x4011\_8000 + 0x0100 × m (m = 1, 2)

Offset address: 0x30

Bit position: 7 6 5 4 3 2 1 0

Bit field:  TCST

Value after reset: 0 0 0 0 0 0 0 0

| Bit | Symbol | Function   | R/W |
|-----|--------|--|-----|
| 0   | TCST   | Timer Count Start<br>0: Stops the timer counting<br>1: Starts the timer counting | R/W |
| 7:1 | —      | These bits are read as 0. The write value should be 0.                           | R/W |

### 27.2.58 TMR : Timer Mode Register

Base address: SCIm = 0x4011\_8000 + 0x0100 × m (m = 1, 2)

Offset address: 0x31

Bit position: 7 6 5 4 3 2 1 0

Bit field:  TCSS[2:0] TWRC  TOMS[1:0]

Value after reset: 0 0 0 0 0 0 0 0

| Bit | Symbol    | Function   | R/W |
|-----|-----------|--|-----|
| 1:0 | TOMS[1:0] | Timer Operating Mode Select*1<br>0 0: Timer mode<br>0 1: Break Field low width determination mode<br>1 0: Break Field low width output mode<br>1 1: Setting prohibited | R/W |
| 2   | —         | This bit is read as 0. The write value should be 0.  | R/W |
| 3   | TWRC      | Counter Write Control<br>0: Data is written to the reload register and counter<br>1: Data is written to the reload register only                                       | R/W |

| Bit | Symbol | Function  | R/W |
|-----|--------|---|-----|
| 7   | CF1CE7 | 控制字段1位7比较使能<br>0: 禁止与控制字段1的位7进行比较。1: 启用与控制字段1的位7比较。 | R/W |

### 27.2.56 CF1RR:控制字段1接收数据寄存器

Base address: SCIm = 0x4011\_8000 + 0x0100 × m (m = 1, 2)

Offset address: 0x2F

Bit position: 7 6 5 4 3 2 1 0

Bit field:

重置后的值: 0 0 0 0 0 0 0 0

CF1RR是一个可读寄存器，它保存在控制字段1中接收到的值。

### 27.2.57 TCR: 定时器控制寄存器

Base address: SCIm = 0x4011\_8000 + 0x0100 × m (m = 1, 2)

Offset address: 0x30

Bit position: 7 6 5 4 3 2 1 0

Bit field:  TCST

重置后的值: 0 0 0 0 0 0 0 0

| Bit | Symbol | Function                        | R/W |
|-----|--------|---------------------------------|-----|
| 0   | TCST   | 定时器计数开始<br>0: 停止定时器计数1: 开始定时器计数 | R/W |
| 7:1 | —      | 这些位被读取为0。写入值应为0。                | R/W |

### 27.2.58 TMR:定时器模式寄存器

Base address: SCIm = 0x4011\_8000 + 0x0100 × m (m = 1, 2)

Offset address: 0x31

Bit position: 7 6 5 4 3 2 1 0

Bit field:  TCSS[2:0] TWRC  TOMS[1:0]

重置后的值: 0 0 0 0 0 0 0 0

| Bit | Symbol    | Function   | R/W |
|-----|-----------|--|-----|
| 1:0 | TOMS[1:0] | 定时器工作模式选择*1<br>00: 定时器模式01: BreakField低宽度确定模式<br>10: BreakField低宽度输出模式11: 禁止设置 | R/W |
| 2   | —         | 该位读取为0。写入值应为0。   | R/W |
| 3   | TWRC      | 计数器写控制<br>0: 数据写入重载寄存器和计数器1: 数据仅写入重载寄存器  | R/W |



| Bit | Symbol    | Function   | R/W |
|-----|-----------|--|-----|
| 6:4 | TCSS[2:0] | Timer Count Clock Source Select*1<br>0 0 0: PCLK<br>0 0 1: PCLK/2<br>0 1 0: PCLK/4<br>0 1 1: PCLK/8<br>1 0 0: PCLK/16<br>1 0 1: PCLK/32<br>1 1 0: PCLK/64<br>1 1 1: PCLK/128 | R/W |
| 7   | —         | This bit is read as 0. The write value should be 0.  | R/W |

Note 1. Rewrite the TOMS[1:0] and TCSS[2:0] bits only when the timer is stopped (TCST = 0).

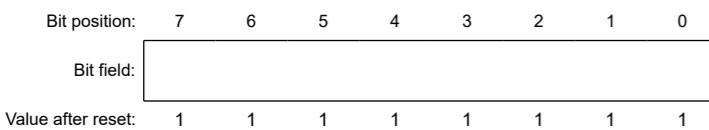
#### TWRC bit (Counter Write Control)

This bit determines whether a value written to TPRES or TCNT is written to the reload register only or is written to both the reload register and the counter.

#### 27.2.59 TPRES : Timer Prescaler Register

Base address: SCIm = 0x4011\_8000 + 0x0100 × m (m = 1, 2)

Offset address: 0x32



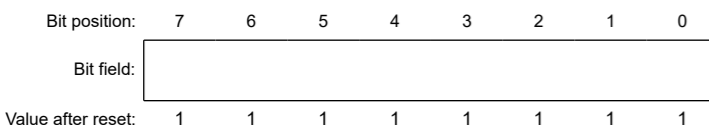
TPRES consists of an 8-bit reload register, a read buffer, and a counter, each of which has FFh as its initial value. The counter counts down in synchronization with the counter clock selected by the TMR.TCSS[2:0] bits, and is reloaded with the value in the reload register when it underflows. Underflows of this register provide the clock source to drive counting by the TCNT register. The reload register and read buffer are allocated to the same address. Data is written to the reload register in writing, and the counter value that has been transferred to the read buffer is returned in reading.

It takes one PCLK cycle to load a value from the reload register to the counter.

#### 27.2.60 TCNT : Timer Count Register

Base address: SCIm = 0x4011\_8000 + 0x0100 × m (m = 1, 2)

Offset address: 0x33



TCNT consists of an 8-bit reload register, a read buffer, and a counter, each of which has FFh as its initial value. This down-counter counts underflows of the TPRES register until the TCNT register underflows, and is then reloaded with the value from the reload register. The reload register and read buffer are allocated to the same address. Data is written to the reload register in writing, and the counter value that has been transferred to the read buffer is returned in reading.

It takes one PCLK cycle to load a value from the reload register to the counter.

### 27.3 Operation in Asynchronous Mode

Figure 27.6 shows the general format for asynchronous serial communications. One frame consists of a start bit (low level), transmit or receive data, a parity bit, and stop bits (high level). In asynchronous serial communications, the communications line is usually held in the mark state (high level).

| Bit | Symbol    | Function  | R/W |
|-----|-----------|---|-----|
| 6:4 | TCSS[2:0] | 定时器计数时钟源选择*1<br>0 0 0: PCLK<br>0 0 1: PCLK/2<br>0 1 0: PCLK/4<br>0 1 1: PCLK/8<br>1 0 0: PCLK/16<br>1 0 1: PCLK/32<br>1 1 0: PCLK/64<br>1 1 1: PCLK/128 | R/W |
| 7   | —         | 该位读取为0。写入值应为0。  | R/W |

注1.仅当定时器停止(TCST=0)时才重写TOMS[1:0]和TCSS[2:0]位。

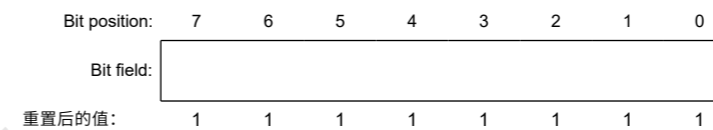
#### TWRC位 (计数器写控制)

该位确定写入TPRES或TCNT的值是仅写入重载寄存器还是同时写入重载寄存器和计数器。

#### 27.2.59 TPRES: 定时器预分频寄存器

Base address: SCIm = 0x4011\_8000 + 0x0100 × m (m = 1, 2)

Offset address: 0x32



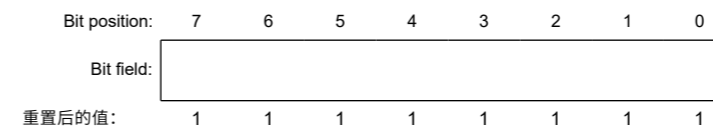
TPRES由一个8位重载寄存器、一个读缓冲区和一个计数器组成，每个计数器的初始值都为FFh。计数器与TMR.TCSS[2:0]位选择的计数器时钟同步递减计数，并在下溢时重新加载重载寄存器中的值。该寄存器的下溢提供时钟源来驱动TCNT寄存器的计数。重载寄存器和读缓冲区被分配到同一个地址。写入时数据被写入重载寄存器，读取时返回已传送到读缓冲区的计数器值。

将一个值从重载寄存器加载到计数器需要一个PCLK周期。

#### 27.2.60 TCNT: 定时器计数寄存器

Base address: SCIm = 0x4011\_8000 + 0x0100 × m (m = 1, 2)

Offset address: 0x33



TCNT由一个8位重载寄存器、一个读缓冲区和一个计数器组成，每个计数器的初始值都为FFh。该递减计数器对TPRES寄存器的下溢进行计数，直到TCNT寄存器下溢，然后用重新加载寄存器中的值重新加载。重载寄存器和读缓冲区被分配到同一个地址。写入时数据被写入重载寄存器，读取时返回已传送到读缓冲区的计数器值。

将一个值从重载寄存器加载到计数器需要一个PCLK周期。

### 27.3 异步模式下的操作

图27.6显示了异步串行通信的一般格式。一帧由起始位（低电平）、发送或接收数据、奇偶校验位和停止位（高电平）组成。在异步串行通信中，通信线路通常保持在标记状态（高电平）。

The SCI monitors the communications line. When the SCI detects a low, it regards that as a start bit and starts serial communication.

Inside the SCI, the transmitter and receiver are independent units, enabling full-duplex communications. Both the transmitter and receiver have a double-buffered structure in addition to FIFO mode, so that data can be read or written during transmission or reception, enabling continuous data transmission and reception.

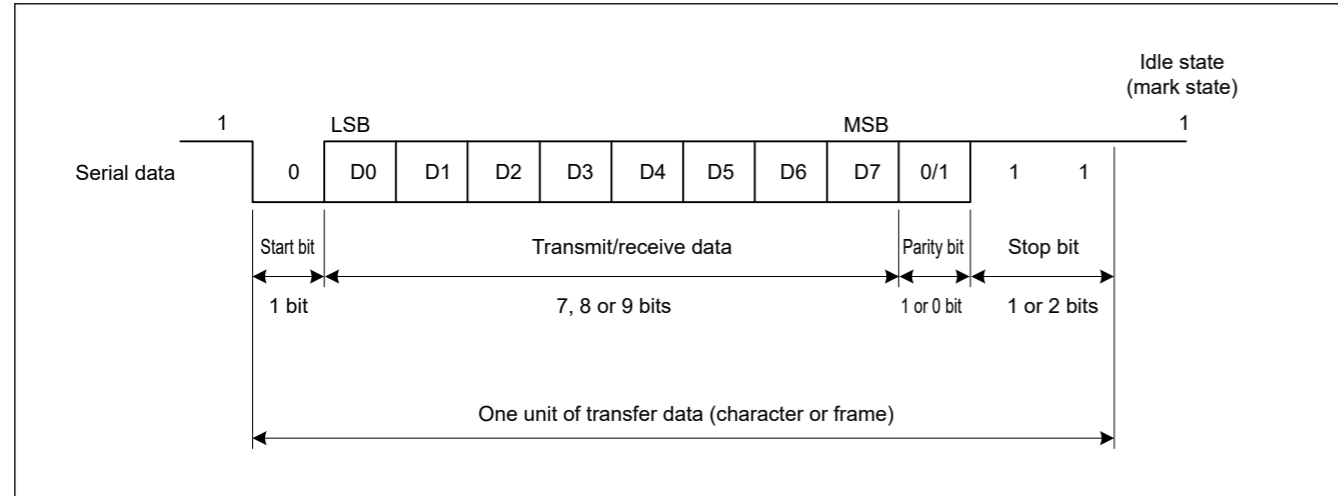


Figure 27.6 Data format in asynchronous serial communications with 8-bit data, parity bit, and 2 stop bits

### 27.3.1 Serial Data Transfer Format

Table 27.27 lists the serial data transfer formats that can be used in asynchronous mode. Any of 18 transfer formats can be selected with the SMR and SCMR settings. For details on the multi-processor function, see section 27.4. Multi-Processor Communication Function.

Table 27.27 Serial transfer formats in asynchronous mode (1 of 2)

| SCMR setting | SMR setting |     |    |    | Serial transfer format and frame length |    |            |   |   |   |   |   |    |    |    |    |    |    |  |
|--------------|-------------|-----|----|----|---|----|------------|---|---|---|---|---|----|----|----|----|----|----|--|
|              | CHR1        | CHR | PE | MP | STOP                                    | 1  | 2          | 3 | 4 | 5 | 6 | 7 | 8  | 9  | 10 | 11 | 12 | 13 |  |
| 0            | 0           | 0   | 0  | 0  | 0                                       | ST | 9-bit data |   |   |   |   |   |    |    | SP |    |    |    |  |
| 0            | 0           | 0   | 0  | 1  | 1                                       | ST | 9-bit data |   |   |   |   |   |    |    | SP | SP |    |    |  |
| 0            | 0           | 1   | 0  | 0  | 0                                       | ST | 9-bit data |   |   |   |   |   |    |    | P  | SP |    |    |  |
| 0            | 0           | 1   | 0  | 1  | 1                                       | ST | 9-bit data |   |   |   |   |   |    |    | P  | SP | SP |    |  |
| 1            | 0           | 0   | 0  | 0  | 0                                       | ST | 8-bit data |   |   |   |   |   |    | SP |    |    |    |    |  |
| 1            | 0           | 0   | 0  | 1  | 1                                       | ST | 8-bit data |   |   |   |   |   |    | SP | SP |    |    |    |  |
| 1            | 0           | 1   | 0  | 0  | 0                                       | ST | 8-bit data |   |   |   |   |   |    | P  | SP |    |    |    |  |
| 1            | 0           | 1   | 0  | 1  | 1                                       | ST | 8-bit data |   |   |   |   |   |    | P  | SP | SP |    |    |  |
| 1            | 1           | 0   | 0  | 0  | 0                                       | ST | 7-bit data |   |   |   |   |   | SP |    |    |    |    |    |  |

SCI监控通信线路。当SCI检测到低电平时，将其视为起始位并开始串行通信。

在SCI内部，发射器和接收器是独立的单元，可实现全双工通信。发送器和接收器除了FIFO模式外，都具有双缓冲结构，从而可以在发送或接收过程中读取或写入数据，从而实现数据的连续发送和接收。

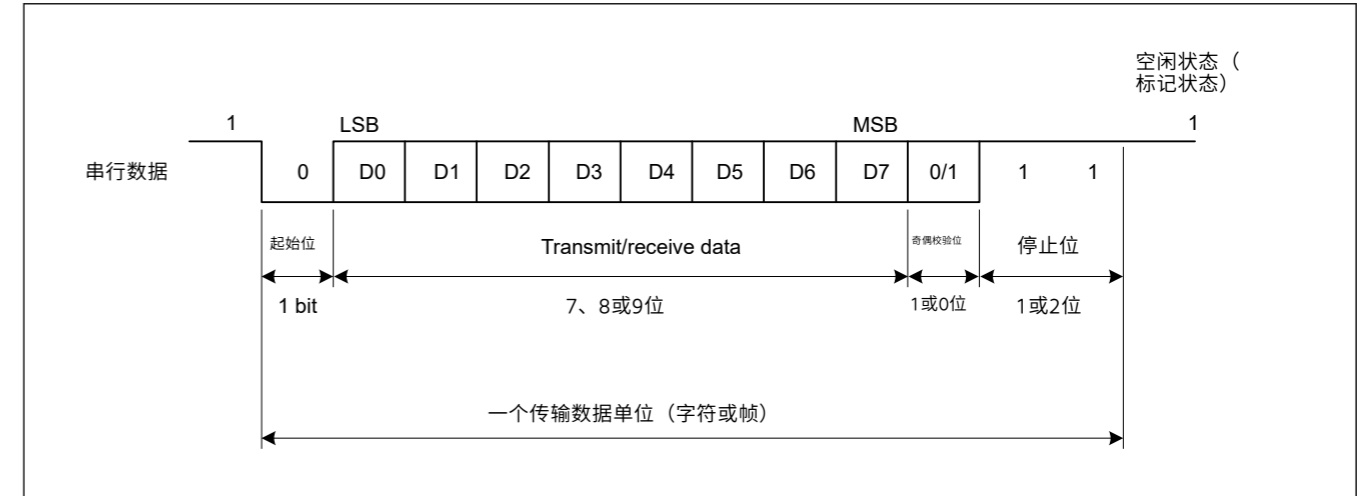


Figure 27.6 异步串行通信中的数据格式，包含8位数据、奇偶校验位和2个停止位

### 27.3.1 串行数据传输格式

表27.27列出了可以在异步模式下使用的串行数据传输格式。可以使用SMR和SCMR设置选择18种传输格式中的任何一种。关于多处理器功能的详细内容，请参阅27.4节。多处理器通信功能。

Table 27.27 异步模式下的串行传输格式 (1 of 2)

| SCMR setting | SMR setting |     |    |    | 串行传输格式和帧长 |    |            |   |   |   |   |   |    |    |    |    |    |    |  |
|--------------|-------------|-----|----|----|-----------|----|------------|---|---|---|---|---|----|----|----|----|----|----|--|
|              | CHR1        | CHR | PE | MP | STOP      | 1  | 2          | 3 | 4 | 5 | 6 | 7 | 8  | 9  | 10 | 11 | 12 | 13 |  |
| 0            | 0           | 0   | 0  | 0  | 0         | ST | 9-bit data |   |   |   |   |   |    |    | SP |    |    |    |  |
| 0            | 0           | 0   | 0  | 1  | 1         | ST | 9-bit data |   |   |   |   |   |    |    | SP | SP |    |    |  |
| 0            | 0           | 1   | 0  | 0  | 0         | ST | 9-bit data |   |   |   |   |   |    |    | P  | SP |    |    |  |
| 0            | 0           | 1   | 0  | 1  | 1         | ST | 9-bit data |   |   |   |   |   |    |    | P  | SP | SP |    |  |
| 1            | 0           | 0   | 0  | 0  | 0         | ST | 8-bit data |   |   |   |   |   |    | SP |    |    |    |    |  |
| 1            | 0           | 0   | 0  | 1  | 1         | ST | 8-bit data |   |   |   |   |   |    | SP | SP |    |    |    |  |
| 1            | 0           | 1   | 0  | 0  | 0         | ST | 8-bit data |   |   |   |   |   |    | P  | SP |    |    |    |  |
| 1            | 0           | 1   | 0  | 1  | 1         | ST | 8-bit data |   |   |   |   |   |    | P  | SP | SP |    |    |  |
| 1            | 1           | 0   | 0  | 0  | 0         | ST | 7-bit data |   |   |   |   |   | SP |    |    |    |    |    |  |

Table 27.27 Serial transfer formats in asynchronous mode (2 of 2)

| SCMR setting | SMR setting |     |    |    | Serial transfer format and frame length |               |   |   |   |   |   |   |     |     |    |    |    |    |  |
|--------------|-------------|-----|----|----|---|---------------|---|---|---|---|---|---|-----|-----|----|----|----|----|--|
|              | CHR1        | CHR | PE | MP | STOP                                    | 1             | 2 | 3 | 4 | 5 | 6 | 7 | 8   | 9   | 10 | 11 | 12 | 13 |  |
| 1            | 1           | 0   | 0  | 1  | 1                                       | ST 7-bit data |   |   |   |   |   |   | SP  | SP  |    |    |    |    |  |
| 1            | 1           | 1   | 0  | 0  | 1                                       | ST 7-bit data |   |   |   |   |   |   | P   | SP  |    |    |    |    |  |
| 1            | 1           | 1   | 0  | 1  | 1                                       | ST 7-bit data |   |   |   |   |   |   | P   | SP  | SP |    |    |    |  |
| 0            | 0           | —   | 1  | 0  | 1                                       | ST 9-bit data |   |   |   |   |   |   |     | MPB | SP |    |    |    |  |
| 0            | 0           | —   | 1  | 1  | 1                                       | ST 9-bit data |   |   |   |   |   |   |     | MPB | SP | SP |    |    |  |
| 1            | 0           | —   | 1  | 0  | 1                                       | ST 8-bit data |   |   |   |   |   |   | MPB | SP  |    |    |    |    |  |
| 1            | 0           | —   | 1  | 1  | 1                                       | ST 8-bit data |   |   |   |   |   |   | MPB | SP  | SP |    |    |    |  |
| 1            | 1           | —   | 1  | 0  | 1                                       | ST 7-bit data |   |   |   |   |   |   | MPB | SP  |    |    |    |    |  |
| 1            | 1           | —   | 1  | 1  | 1                                       | ST 7-bit data |   |   |   |   |   |   | MPB | SP  | SP |    |    |    |  |

ST: Start bit  
 SP: Stop bit  
 P: Parity bit  
 MPB: Multi-processor bit

27.3.2 Receive Data Sampling Timing and Reception Margin in Asynchronous Mode

In asynchronous mode, the SCI operates on a base clock with a frequency of 16 times\*1 the bit rate.

In reception, the SCI samples the falling edge of the start bit using the base clock, and performs internal synchronization.\*2

Because receive data is sampled on the rising edge of the 8th pulse\*1 of the base clock, data is latched at the middle of each bit (when sampling timing does not adjust (“SPTR.ASEN = 1'b0”)), as shown in Figure 27.7 The reception margin in asynchronous mode is determined by the following formula (1):

$$M = \left[ \left( 0.5 - \frac{1}{2N} \right) - (L - 0.5)F - \frac{|D - 0.5|}{N}(1 + F) \right] \times 100 [\%] \quad \dots \text{Formula (1)}$$

M: Reception margin

N: Ratio of bit rate to clock

(N = 16 when SEMR.ABCSE = 0 and SEMR.ABCS = 0. N = 8 when SEMR.ABCS = 1. N = 6 when SEMR.ABCSE = 1.)

D: Duty cycle of clock (D = 0.5 to 1.0)

L: Frame length (L = 9 to 13)

F: Absolute value of clock frequency deviation

Assuming values of F = 0 and D = 0.5 in formula (1), the reception margin is determined using the following formula:

$$M = \{0.5 - 1/(2 \times 16)\} \times 100 (\%) = 46.875 \%$$

This represents the computed value. Renesas recommends a margin of 20% to 30% in system design.

Note 1. In this example, the SEMR.ABCS bit is 0 and the SEMR.ABCSE is 0. When the ABCS bit is 1 and the ABCSE bit is 0, a frequency of 8 times the bit rate is used as a base clock, and receive data is sampled on the rising edge of the 4th pulse of the base clock.

Table 27.27 异步模式下的串行传输格式(2of2)

| SCMR setting | SMR setting |     |    |    | 串行传输格式和帧长 |               |   |   |   |   |   |   |     |     |    |    |    |    |  |
|--------------|-------------|-----|----|----|-----------|---------------|---|---|---|---|---|---|-----|-----|----|----|----|----|--|
|              | CHR1        | CHR | PE | MP | STOP      | 1             | 2 | 3 | 4 | 5 | 6 | 7 | 8   | 9   | 10 | 11 | 12 | 13 |  |
| 1            | 1           | 0   | 0  | 1  | 1         | ST 7-bit data |   |   |   |   |   |   | SP  | SP  |    |    |    |    |  |
| 1            | 1           | 1   | 0  | 0  | 1         | ST 7-bit data |   |   |   |   |   |   | P   | SP  |    |    |    |    |  |
| 1            | 1           | 1   | 0  | 1  | 1         | ST 7-bit data |   |   |   |   |   |   | P   | SP  | SP |    |    |    |  |
| 0            | 0           | —   | 1  | 0  | 1         | ST 9-bit data |   |   |   |   |   |   |     | MPB | SP |    |    |    |  |
| 0            | 0           | —   | 1  | 1  | 1         | ST 9-bit data |   |   |   |   |   |   |     | MPB | SP | SP |    |    |  |
| 1            | 0           | —   | 1  | 0  | 1         | ST 8-bit data |   |   |   |   |   |   | MPB | SP  |    |    |    |    |  |
| 1            | 0           | —   | 1  | 1  | 1         | ST 8-bit data |   |   |   |   |   |   | MPB | SP  | SP |    |    |    |  |
| 1            | 1           | —   | 1  | 0  | 1         | ST 7-bit data |   |   |   |   |   |   | MPB | SP  |    |    |    |    |  |
| 1            | 1           | —   | 1  | 1  | 1         | ST 7-bit data |   |   |   |   |   |   | MPB | SP  | SP |    |    |    |  |

ST: 起始位停  
 SP: 止位奇偶  
 P: 校验位  
 MPB: Multi-processor bit

27.3.2 异步模式下接收数据采样时序和接收余量

在异步模式下，SCI在频率为16倍\*1比特率的基本时钟上运行。

在接收时，SCI使用基本时钟对起始位的下降沿进行采样，并执行内部同步。\*2

因为接收数据在基本时钟的第8个脉冲\*1的上升沿采样，所以数据在每个位的中间锁存（当采样时序不调整时（“SPTR.ASEN=1'b0”）），如如图27.7所示，异步模式下的接收余量由下式（1）确定：

$$M = \left[ \left( 0.5 - \frac{1}{2N} \right) - (L - 0.5)F - \frac{|D - 0.5|}{N}(1 + F) \right] \times 100 [\%] \quad \dots \text{Formula (1)}$$

M: 接收余量

N: 比特率与时钟的比率（当SEMR.ABCSE=0和SEMR.ABCS=0时，N=16。当SEMR.ABCS=1时，N=8。当SEMR.ABCSE=1时，N=6。）D: 占空比时钟（D=0.5到1.0）

L: 帧长（L=9到13）

F: 时钟频率偏差的绝对值

假设公式（1）中的F=0和D=0.5的值，接收裕量使用以下公式确定：

$$M = \{0.5 - 1/(2 \times 16)\} \times 100 (\%) = 46.875 \%$$

这表示计算值。瑞萨建议在系统设计中留出20%到30%的余量。

注1.本例中，SEMR.ABCS位为0，SEMR.ABCSE位为0。当ABCS位为1，ABCSE位为0时，使用8倍比特率的频率作为基准时钟，并在基本时钟的第4个脉冲的上升沿对接收数据进行采样。

When the ABCSE bit is 1, a sextuple frequency of a bit rate is used as a base clock, and receive data is sampled on the rising edge of the 3rd pulse of the base clock.

Note 2. The determination condition of the start bit is as follows.

The function of adjust sampling timing is OFF (ASEN = 0):

The determination condition of a start bit is that Low beyond half bit length continues. It is same as the sampling timing. In Figure 27.7, Low period should be kept over 8-cycles to detect a start bit. If Low period does not keep over 8-cycles, the IP judges this as a noise. So, the IP does not start reception and wait start bit.

The function of adjust sampling timing is ON (ASEN = 1):

The determination condition of a start bit is that Low keeps up until the sampling timing. Adjusting the sampling timing forward (AJD = 1) increases the possibility of erroneously determining a noise as the start bit.

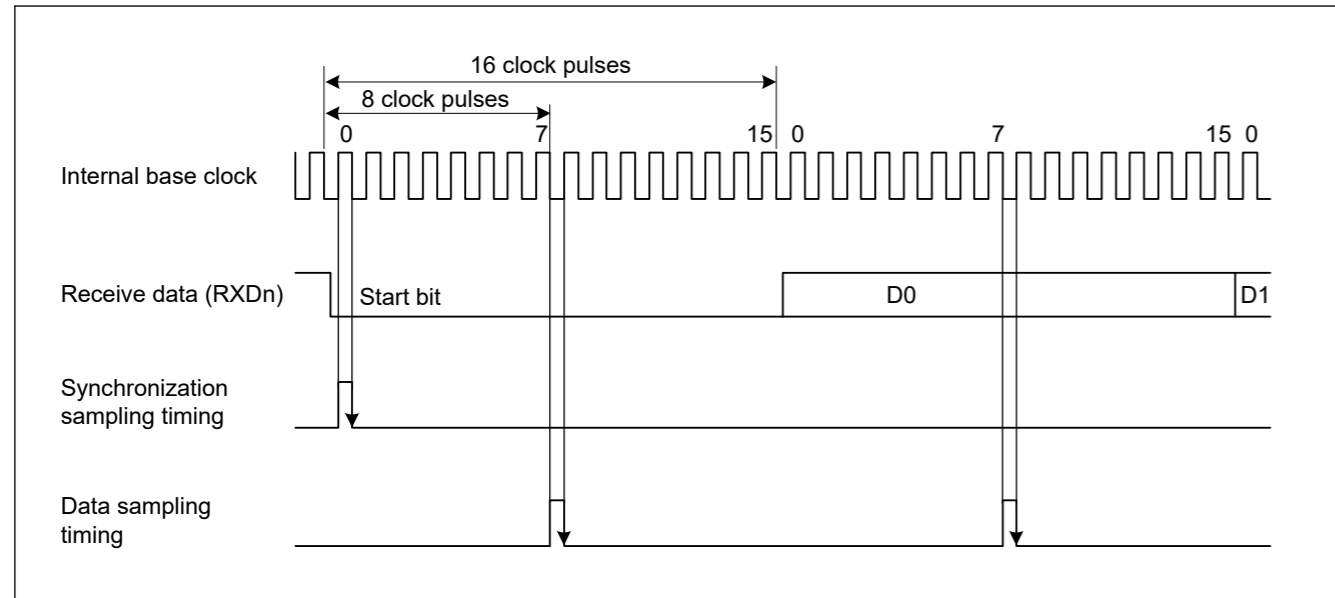


Figure 27.7 Receive data sampling timing in asynchronous mode

### 27.3.3 Clock

Either an internal clock generated by the on-chip baud rate generator or an external clock input to the SCKn pin can be selected as the transfer clock of the SCI, based on the SMR.CM and SCR.CKE[1:0] settings.

When an external clock is input to the SCKn pin, the clock frequency must be 16 times the bit rate (when SEMR.ABCS = 0) or 8 times the bit rate (when SEMR.ABCS = 1).

When the SCI uses its internal clock, the clock can be output from the SCKn pin. The frequency of the clock output in this case is equal to the bit rate, and the phase is configured so that the rising edge of the clock is in the middle of the transmit data, as shown in Figure 27.8.

When clock output is enabled, the clock is output after setting the SCR.TE or SCR.RE bit to 1.

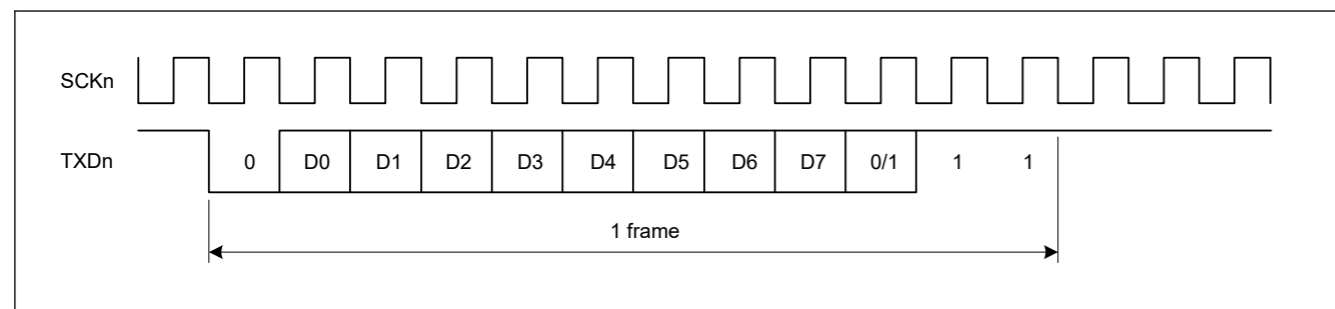


Figure 27.8 Phase relationship between output clock and transmit data in asynchronous mode when SMR.CHR = 0, PE = 1, MP = 0, and STOP = 1

当ABCSE位为1时，以比特率的六倍频为基准时钟，在基准时钟的第3个脉冲的上升沿对接收数据进行采样。

注2.起始位的判断条件如下。

调整采样定时功能关闭 (ASEN=0) :

起始位的确定条件是超过半位长度的Low继续。与采样时间相同。在图27.7中，低电平周期应保持超过8个周期以检测起始位。如果Low周期未保持超过8个周期，则IP将其判断为噪声。因此，IP不开始接收并等待起始位。

调整采样定时功能开启 (ASEN=1) :

起始位的确定条件是Low一直保持到采样定时。向前调整采样时序(AJD=1)会增加错误地将噪声确定为起始位的可能性。

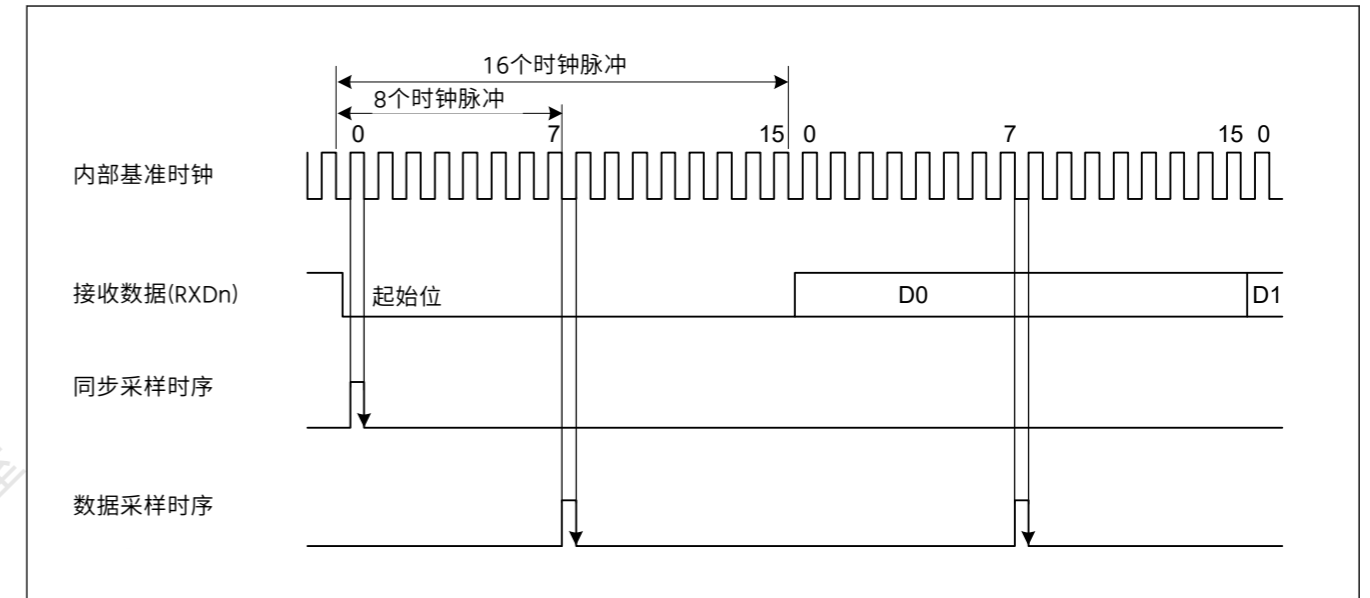


Figure 27.7 异步模式下接收数据采样时序

### 27.3.3 Clock

根据SMR.CM和SCR.CKE[1:0]设置，可以选择片内波特率发生器产生的内部时钟或输入到SCKn引脚的外部时钟作为SCI的传输时钟。

当外部时钟输入到SCKn引脚时，时钟频率必须为比特率的16倍 (SEMR.ABCS=0时) 或比特率的8倍 (SEMR.ABCS=1时)。

当SCI使用其内部时钟时，时钟可以从SCKn引脚输出。在这种情况下，时钟输出的频率等于比特率，并配置相位，使时钟的上升沿位于发送数据的中间，如图27.8所示。

时钟输出使能时，将SCR.TE或SCR.RE位设置为1后输出时钟。

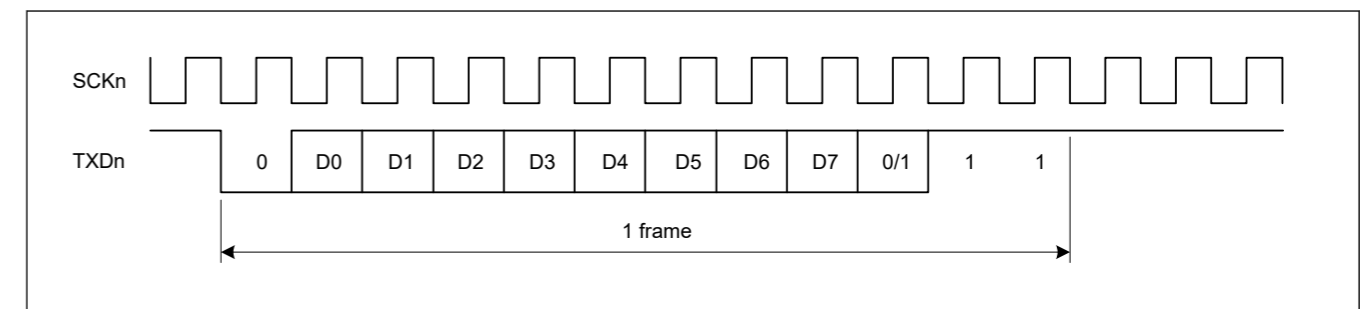


Figure 27.8 异步模式下输出时钟与传输数据的相位关系  
SMR.CHR=0, PE=1, MP=0, STOP=1



### 27.3.4 Double-Speed Operation and Frequency of 6 Times the Bit Rate

When the SEMR.ABCS bit is set to 1 and eight pulses of the base clock for a 1-bit period is selected, the SCI operates on the bit rate twice that of when ABCS is set to 0. When the SEMR.BGDM bit is set to 1, the cycle of the base clock is half and the bit rate is double that of when BGDM is set to 0. When the SCR.CKE[1] bit is set to 0 and the on-chip baud rate generator is selected, setting the ABCS and BGDM bits to 1 allows the SCI to operate at a bit rate four times that when the ABCS and BGDM bits are set to 0. When the SEMR.ABCSE bit is set to 1, the number of basic clock pulses is 6 during a period of 1 bit, and the SCI operates at a bit rate 16/3 times that when SEMR.ABCS = 0, SEMR.BGDM = 0, and SEMR.ABCSE = 0.

As shown by Formula (1) in [section 27.3.2. Receive Data Sampling Timing and Reception Margin in Asynchronous Mode](#), the reception margin decreases when the SEMR.ABCS or SEMR.ABCSE bit in SEMR is set to 1. Therefore, if the target bit rate can be obtained with ABCS or ABCSE set to 0, it is recommended that you use the SCI with ABCS and ABCSE set to 0.

### 27.3.5 CTS and RTS Functions

The CTS function uses input on the CTSn\_RTSn pin in transmission control. Setting the SPMR.CTSE bit to 1 enables the CTS function. For the functions of CTS and RTS, you can select the alternate setting that uses either function with one terminal and the dedicated setting that uses each function independently with two terminals. This setting is done with the SPMR.CTSPEN bit. When the CTS function is enabled, placing a low level on the CTSn\_RTSn pin causes transmission to start.

Driving the CTSn\_RTSn pin high while transmission is in progress does not affect transmission of the current frame.

In the RTS function, which uses output on the CTSn\_RTSn pin, a low level is output when reception becomes possible. Conditions for output of the low and high levels are shown in this section.

[Conditions for low level output]

Satisfaction of all conditions are listed in this section.

#### Non-FIFO selected

- The value of the SCR.RE bit is 1
- Reception is not in progress
- There is no received data yet to be read
- The ORER, FER, and PER flags in the SSR register are all 0

#### FIFO selected

- The value of the SCR.RE bit is 1
- The amount of receive data written in FRDRHL is equal to or less than the setting value of FCRH.RSTRG[3:0]
- The ORER flag in the SSR\_FIFO register (ORER in FRDRH) is 0

[Condition for high level output]

- The conditions for low-level output are not satisfied

### 27.3.6 Address Match (Receive Data Match Detection) Function

The address match function can be used only in asynchronous mode.

If the DCCR.DCME bit is set to 1, when one frame of data is received, the SCI compares that received data with the data set in CDR.CMPD. If the SCI detects a match to the comparison data (CDR.CMPD\*3) with the received data, the SCI can issue the SCIn\_RXI interrupt request.

If the SMR.MP bit is set to 0, comparison occurs only for valid data in receive format. In multi-processor mode (SMR.MP bit = 1), if the DCCR.IDSEL bit is set to 1, receive data where the MPB bit is 1 is subject to comparison for address match and receive data where the MPB bit is 0 is always treated as a non-match.

If the DCCR.IDSEL bit is set to 0, SCI performs address match detection regardless of the MPB bit value of the received data.

### 27.3.4 双倍速操作和6倍比特率的频率

当SEMR.ABCS位设置为1并选择1位周期的8个基本时钟脉冲时，SCI以ABCS设置为0时的两倍比特率运行。当SEMR.BGDM位设置为1，基本时钟的周期是BGDM设置为0时的一半，比特率是两倍。当SCR.CKE[1]位设置为0并且选择片内波特率发生器时，设置ABCS和BGDM位为1允许SCI以四倍于ABCS和BGDM位设置为0时的比特率运行。当SEMR.ABCSE位设置为1时，基本时钟脉冲数为6在1位周期内，SCI以16的比特率运行，是SEMR.ABCS=0、SEMR.BGDM=0和SEMR.ABCSE=0时的3倍。

如第27.3.2节中的公式(1)所示。异步模式下的接收数据采样时序和接收裕度，当SEMR中的SEMR.ABCS或SEMR.ABCSE位设置为1时，接收裕度减小。因此，如果将ABCS或ABCSE设置为0即可获得目标码率，建议您使用SCI，ABCSE和ABCSE设置为0。

### 27.3.5 CTS和RTS函数

CTS功能在传输控制中使用CTSn\_RTSn引脚上的输入。将SPMR.CTSE位设置为1可启用CTS功能。对于CTS和RTS的功能，您可以选择在一个端子上使用任一功能的交替设置和在两个端子上独立使用每个功能的专用设置。该设置通过SPMR.CTSPEN位完成。当CTS功能使能时，将CTSn\_RTSn引脚置于低电平会导致传输开始。

在传输过程中将CTSn\_RTSn引脚驱动为高电平不会影响当前帧的传输。

在使用CTSn\_RTSn引脚输出的RTS功能中，当可以接收时输出低电平。本节显示了低电平和高电平的输出条件。

【低电平输出的条件】

本节列出了所有条件的满足情况。

#### Non-FIFO selected

- SCR.RE位的值为1
- 接收未进行
- 没有接收到的数据尚未读取
- SSR寄存器中的ORER、FER、PER标志位均为0

#### FIFO selected

- SCR.RE位的值为1
- 写入FRDRHL的接收数据量等于或小于FCRH.RSTRG[3:0]的设定值
- SSR\_FIFO寄存器中的ORER标志（FRDRH中的ORER）为0

【高电平输出条件】

- 不满足低电平输出条件

### 27.3.6 地址匹配（接收数据匹配检测）功能

地址匹配功能只能在异步模式下使用。

如果DCCR.DCME位设置为1，当接收到一帧数据时，SCI会将接收到的数据与CDR.CMPD中设置的数据进行比较。如果SCI检测到比较数据(CDR.CMPD\*3)与接收到的数据匹配，则SCI可以发出SCIn\_RXI中断请求。

如果SMR.MP位设置为0，则仅对接收格式的有效数据进行比较。在多处理器模式下（SMR.MP位=1），如果DCCR.IDSEL位设置为1，则接收MPB位为1的数据进行地址匹配比较，接收MPB位为0的数据始终被视为不匹配。

如果DCCR.IDSEL位设置为0，SCI执行地址匹配检测，而不管接收数据的MPB位值如何。

Until SCI detects a match to the comparison data (CDR.CMPD\*<sup>3</sup>) with receive data, received data is skipped (discarded), and the SCI cannot detect a parity error or framing error.

When SCI detects a match, the DCCR.DCME bit is automatically cleared, and the DCCR.DCMF flag is set to 1. If the DCCR.IDSEL bit is set to 1, the SCR.MPIE bit is automatically cleared. If DCCR.IDSEL is set to 0, the value of the SCR.MPIE bit is retained. If the SCR.RIE bit is set to 1, the SCI issues an SCIn\_RXI interrupt request.

If the SCI detects a framing error in the receive data for which a match is detected, the DCCR.DFER flag is set to 1, and if the SCI detects a parity error in that frame, the DCCR.DPER flag is set to 1. The compared receive data is not stored in the RDR register\*<sup>1</sup>, and SSR.RDRF remains 0.\*<sup>2</sup>

After the SCI detects a match, and DCCR.DCME is automatically cleared, the SCI receives the next data continuously based on the current register setting.

When the DCCR.DFER or DCCR.DPER flag is set, the address match is not performed. Before enabling the address match function, set the DCCR.DFER and DCCR.DPER flags to 0.

Examples of the address match function are shown in [Figure 27.9](#) and [Figure 27.10](#).

Note 1. When FCR.FM = 1, this refers to the FRDRHL register.

Note 2. When FCR.FM = 1, this refers to the SSR\_FIFO.RDF flag.

Note 3. This comparative target can select one length of 3 types: CMPD[6:0] with 7-bit length, CMPD[7:0] with 8-bit length, and CMPD[8:0] with 9-bit length.

在SCI检测到与接收数据的比较数据(CDR.CMPD\*3)匹配之前, 会跳过(丢弃)接收到的数据, 并且SCI无法检测奇偶校验错误或帧错误。

当SCI检测到匹配时, 自动清除DCCR.DCME位, 并将DCCR.DCMF标志设置为1。如果DCCR.IDSEL位设置为1, SCR.MPIE位自动清零。如果DCCR.IDSEL设置为0, 则SCR.MPIE位被保留。如果SCR.RIE位设置为1, 则SCI发出SCIn\_RXI中断请求。

如果SCI在检测到匹配的接收数据中检测到帧错误, 则DCCR.DFER标志设置为1, 如果SCI在该帧中检测到奇偶校验错误, 则DCCR.DPER标志设置为1。比较后的接收数据不保存在RDR寄存器\*1中, SSR.RDRF保持为0。\*2

SCI检测到匹配后, DCCR.DCME自动清零, SCI根据当前寄存器设置连续接收下一个数据。

当设置DCCR.DFER或DCCR.DPER标志时, 不执行地址匹配。在启用地址匹配功能之前, 将DCCR.DFER和DCCR.DPER标志设置为0。

地址匹配函数的例子如图27.9和图27.10所示。

注1.当FCR.FM=1时, 指的是FRDRHL寄存器。

注2.当FCR.FM=1时, 这指的是SSR\_FIFO.RDF标志。

注3.此比较目标可以选择3种长度中的一种: 7位长度的CMPD[6:0]、8位长度的CMPD[7:0]和9位长度的CMPD[8:0]。

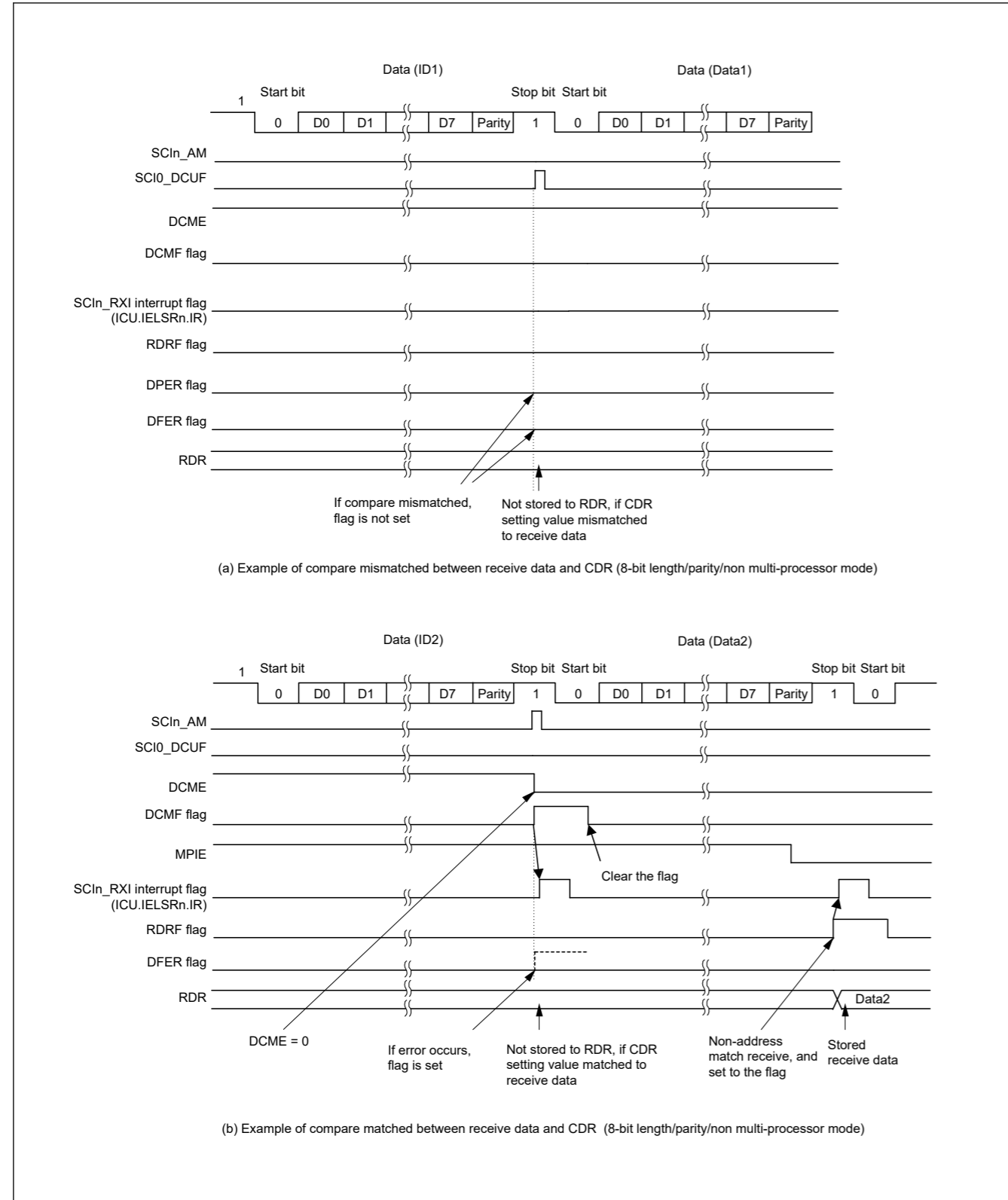


Figure 27.9 Example of address match (1) normal mode

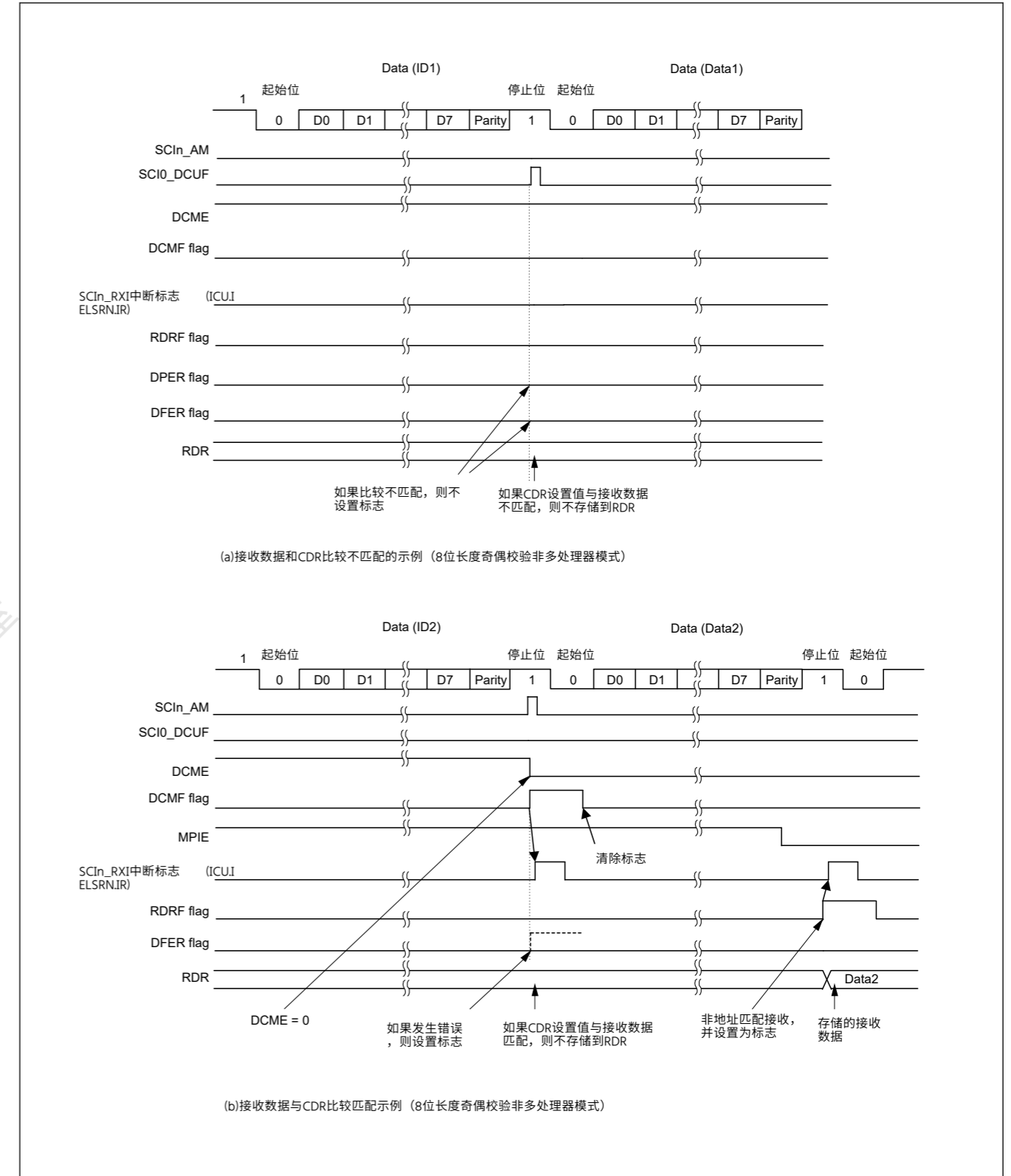


Figure 27.9 地址匹配示例 (一) 普通模式

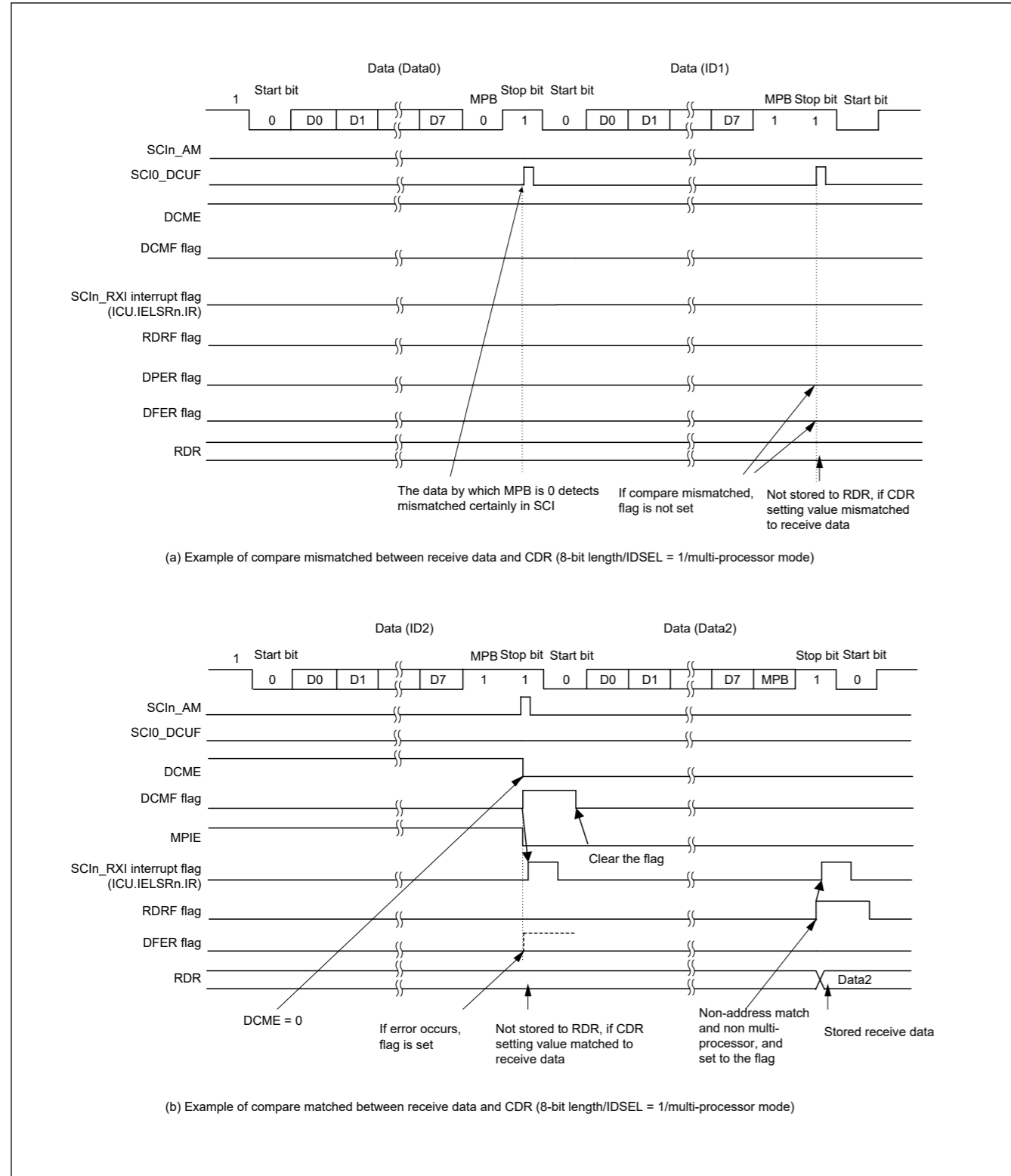


Figure 27.10 Example of address match (2) multi-processor mode

### 27.3.7 SCI Initialization in Asynchronous Mode

Before transmitting and receiving data, start by writing the initial value 0x00 to the SCR register, then continue through the SCI initialization procedure (select non-FIFO or FIFO) shown in Table 27.28 and Table 27.29. Whenever the operating mode or transfer format is to be changed, the SCR register must be initialized before the change is made.

When the external clock is used in asynchronous mode, ensure that the clock signal is supplied during initialization.

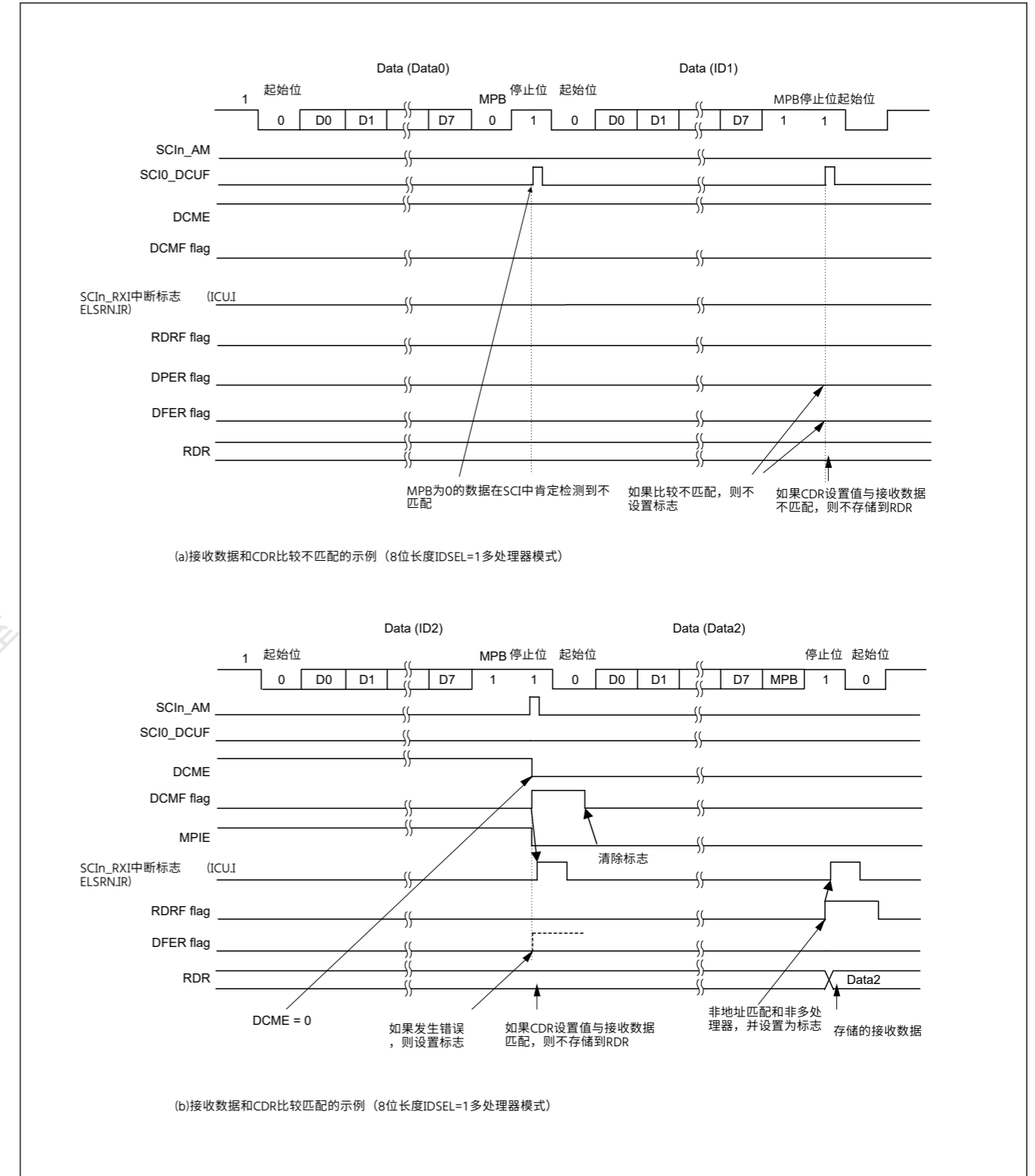


Figure 27.10 地址匹配示例 (二) 多处理器模式

### 27.3.7 异步模式下的SCI初始化

在发送和接收数据之前，首先将初始值0x00写入SCR寄存器，然后继续执行SCI初始化程序（选择非FIFO或FIFO）如表27.28和表27.29所示。每当要更改操作模式或传输格式时，必须在更改之前初始化SCR寄存器。

在异步模式下使用外部时钟时，请确保在初始化期间提供时钟信号。



Note: Setting the SCR.RE bit to 0 initializes neither the ORER, FER, RDRF, RDF, PER, and DR flags in SSR/SSR\_FIFO nor RDR and RDRHL. When the TE bit is set to 0, the TEND flag for the selected FIFO buffer is not initialized.

Note: In non-FIFO mode, switching the value of the SCR.TE bit from 1 to 0 or 0 to 1 while the SCR.TIE bit is 1 leads to the generation of an SCIn\_TXI interrupt request.

Table 27.28 Example flow of SCI initialization in asynchronous mode with non-FIFO selected

| No. | Step Name   | Description   |
|-----|---|---|
| 1   | Start initialization  |   |
| 2   | Set the SCR.TIE, RIE, TE, RE, and TEIE bits to 0                    |   |
| 3   | Set the FCR.FM bit to 0   | Set the FCR.FM bit to 0.  |
| 4   | Set the SCR.CKE[1:0] bits   | Set the clock selection in SCR.<br>When the clock output is selected in asynchronous mode, the clock is output immediately after SCR settings are made.       |
| 5   | Set the SIMR1.IICM bit to 0. Set the SPMR.CKPH and CKPOL bits to 0. | Set the SIMR1.IICM bit to 0.<br>Set the SPMR.CKPH and CKPOL bits to 0.<br>Step 5 can be skipped if the values have not been changed from the initial values.  |
| 6   | Set the data transmission/reception format in SMR, SCMR, and SEMR   | Set data transmission/reception format in SMR, SCMR, and SEMR.  |
| 7   | Set a value in SPTR and ACTR  | Set the communication terminals status in SPTR and adjustable sampling values in ACTR.  |
| 8   | Set a value in BRR  | Write a value corresponding to the bit rate to BRR.<br>This step is not necessary if an external clock is used.   |
| 9   | Set a value in MDDR   | Write the value obtained by correcting a bit rate error in MDDR. This step is not necessary if the BRME bit in SEMR is set to 0 or an external clock is used. |
| 10  | Set the I/O port functions  | Make I/O port settings to enable input and output functions as required for TXDn, RXDn, and SCKn pins.  |
| 11  | Set the SCR.TE or RE bit to 1, and set the SCR.TIE and RIE bits     | Set the SCR.TE or RE bit to 1. Also set the SCR.TIE and RIE bits.<br>Setting the TE and RE bits allows TXDn and RXDn to be used.                              |
| 12  | Initialization completion   |   |

Table 27.29 Example flow of SCI initialization in asynchronous mode with FIFO selected (1 of 2)

| No. | Step Name  | Description  |
|-----|--|--|
| 1   | Start initialization   |  |
| 2   | Set the SCR.TIE, RIE, TE, RE, and TEIE bits to 0   |  |
| 3   | Set the FCR.FM, TFRST, and RFRST bits to 1 (FIFO mode enabled, transmit/receive FIFOs empty). Set the FCR.TTRG[3:0], RTRG[3:0], and RSTRG[3:0] bits. | Set the FCR.FM, TFRST, and RFRST bits to 1 (FIFO mode enabled, transmit/receive FIFOs empty).<br>Set the FCR.TTRG[3:0], RTRG[3:0], and RSTRG[3:0] bits.      |
| 4   | Set the SCR.CKE[1:0] bits  | Set the clock selection in SCR.<br>When the clock output is selected in asynchronous mode, the clock is output immediately after SCR settings are made.      |
| 5   | Set the SIMR1.IICM bit to 0. Set the SPMR.CKPH and CKPOL bits to 0.  | Set the SIMR1.IICM bit to 0.<br>Set the SPMR.CKPH and CKPOL bits to 0.<br>Step 5 can be skipped if the values have not been changed from the initial values. |
| 6   | Set the data transmission/reception format in SMR, SCMR, and SEMR  | Set data transmission/reception format in SMR, SCMR, and SEMR.   |
| 7   | Set a value in SPTR and ACTR   | Set the communication terminals status in SPTR and adjustable sampling values in ACTR.   |
| 8   | Set a value in BRR   | Write a value corresponding to the bit rate to BRR.<br>This step is not necessary if an external clock is used.  |

Note: 将SCR.RE位设置为0既不会初始化SSR/SSR\_FIFO中的ORER、FER、RDRF、RDF、PER和DR标志，也不会初始化RDR和RDRHL。当TE位设置为0时，所选FIFO缓冲区的TEND标志未初始化。

Note: 在非FIFO模式下，当SCR.TIE位为1时，将SCR.TE位的值从1切换为0或从0切换为1会导致产生SCIn\_TXI中断请求。

Table 27.28 选择非FIFO的异步模式下SCI初始化示例流程

| No. | 步骤名称                                   | Description  |
|-----|--|--|
| 1   | 开始初始化                                  |  |
| 2   | 将SCR.TIE、RIE、TE、RE和TEIE位设置为0           |  |
| 3   | 将FCR.FM位设置为0                           | 将FCR.FM位设置为0。  |
| 4   | 设置SCR.CKE[1:0]位                        | 在SCR中设置时钟选择。<br>在异步模式下选择时钟输出时，时钟输出后立即进行SCR设置。                          |
| 5   | 将SIMR1.IICM位设置为0。设置SPMR.CKPH和CKPOL位为0。 | 将SIMR1.IICM位设置为0。<br>将SPMR.CKPH和CKPOL位设置为0。<br>如果这些值没有从初始值改变，则可以跳过第5步。 |
| 6   | 在SMR、SCMR和SEMR中设置数据发送接收格式              | 在SMR、SCMR、SEMR中设置数据发送接收格式。   |
| 7   | 在SPTR和ACTR中设置一个值                       | 在SPTR中设置通讯端子状态，在ACTR中设置可调采样值。  |
| 8   | 在BRR中设置一个值                             | 将与比特率对应的值写入BRR。<br>如果使用外部时钟，则不需要此步骤。                                   |
| 9   | 在MDDR中设置一个值                            | 在MDDR中写入通过纠正比特率错误获得的值。这一步是没有必要的，如果SEMR中的BRME位设置为0或使用外部时钟。              |
| 10  | 设置IO端口功能                               | 进行IO端口设置以启用TXDn、RXDn和所需的输入和输出功能SCKn pins。                              |
| 11  | 将SCR.TE或RE位设置为1，并设置SCR.TIE和RIE位        | 将SCR.TE或RE位设置为1。同时设置SCR.TIE和RIE位。<br>设置TE和RE位允许使用TXDn和RXDn。            |
| 12  | 初始化完成                                  |  |

Table 27.29 选择FIFO的异步模式下SCI初始化示例流程 (1of2)

| No. | 步骤名称   | Description  |
|-----|--|--|
| 1   | 开始初始化  |  |
| 2   | 将SCR.TIE、RIE、TE、RE和TEIE位设置为0                                   |  |
| 3   | 设置FCR.FM、TFRST和RFRST位为1。设置FCR.TTRG[3:0]、RTRG[3:0]和RSTRG[3:0]位。 | 将FCR.FM、TFRST和RFRST位设置为1（启用FIFO模式，发送接收FIFO为空）。设置FCR.TTRG[3:0]、RTRG[3:0]和RSTRG[3:0]位。 |
| 4   | 设置SCR.CKE[1:0]位  | 在SCR中设置时钟选择。<br>在异步模式下选择时钟输出时，时钟输出后立即进行SCR设置。  |
| 5   | 将SIMR1.IICM位设置为0。设置SPMR.CKPH和CKPOL位为0。                         | 将SIMR1.IICM位设置为0。<br>将SPMR.CKPH和CKPOL位设置为0。<br>如果这些值没有从初始值改变，则可以跳过第5步。               |
| 6   | 在SMR、SCMR和SEMR中设置数据发送接收格式                                      | 在SMR、SCMR、SEMR中设置数据发送接收格式。   |
| 7   | 在SPTR和ACTR中设置一个值   | 在SPTR中设置通讯端子状态，在ACTR中设置可调采样值。  |
| 8   | 在BRR中设置一个值   | 将与比特率对应的值写入BRR。<br>如果使用外部时钟，则不需要此步骤。   |

Table 27.29 Example flow of SCI initialization in asynchronous mode with FIFO selected (2 of 2)

| No. | Step Name   | Description   |
|-----|---|---|
| 9   | Set a value in MDDR   | Write the value obtained by correcting a bit rate error in MDDR. This step is not necessary if the BRME bit in SEMR is set to 0 or an external clock is used. |
| 10  | Set the FCR.TFRST and RFRST bits to 0                           | Set the FCR.TFRST and RFRST bits to 0.  |
| 11  | Set the I/O port functions                                      | Make I/O port settings to enable input and output functions as required for TXDn, RXDn, and SCKn pins.  |
| 12  | Set the SCR.TE or RE bit to 1, and set the SCR.TIE and RIE bits | Set the SCR.TE or RE bit to 1. Also set the SCR.TIE and RIE bits. Setting the TE and RE bits allows TXDn and RXDn to be used.                                 |
| 13  | Initialization completion                                       |   |

### 27.3.8 Serial Data Transmission in Asynchronous Mode

#### (1) Non-FIFO selected

Figure 27.11, Figure 27.12, and Figure 27.13 show examples of serial transmission in asynchronous mode.

In serial transmission, the SCI operates as described in this section. When the SCR.TE bit is set to 1, the high level is output to TXDn for one frame. However, when SEMR.PADIS is set to "1", this preamble will not be output. An example of operation when preamble is not output is shown in Figure 27.14.

- The SCI transfers data from the TDR\*1 register to the TSR register when data is written to TDR\*1 in the SCIn\_TXI interrupt handling routine.  
The SCIn\_TXI interrupt request at the beginning of transmission is generated when the SCR.TE and SCR.TIE bits are set to 1 simultaneously by a single instruction.
- Transmission starts after the SPMR.CTSE bit is set to 0 (CTS function is disabled) or a low level on the CTSn\_RTsn pin causes data transfer from the TDR\*1 register to the TSR register. If the SCR.TIE bit is 1, an SCIn\_TXI interrupt request is generated. Continuous transmission is possible by writing the next transmit data to the TDR\*1 register in the SCIn\_TXI interrupt handling routine before transmission of the current transmit data is complete. When SCIn\_TEI interrupt requests are in use, set the SCR.TIE bit to 0 (SCIn\_TXI interrupt requests are disabled) and the SCR.TEIE bit to 1 (an SCIn\_TEI interrupt request is enabled) after the last of the data to be transmitted is written to the TDR\*1 register from the handling routine for SCIn\_TXI requests.
- Data is sent from the TXDn pin in the following order:
  - Start bit
  - Transmit data
  - Parity bit or multi-processor bit (can be omitted depending on the format)
  - Stop bit
- The SCI checks for update of the TDR register on output of the stop bit.
- When the TDR register is updated, setting the SPMR.CTSE bit to 0 (CTS function is disabled) or a low level input on the CTSn\_RTsn pin causes transfer of the next transmit data from the TDR\*1 register to the TSR register and transmission of the stop bit, after which serial transmission of the next frame starts.
- If the TDR register is not updated, the SSR.TEND flag is set to 1, the stop bit is sent, and the mark state is entered, in which 1 is output. If the SCR.TEIE bit is 1, the SSR.TEND flag is set to 1 and an SCIn\_TEI interrupt request is generated.

Note 1. The TDRHL register when 9-bit data length is selected.

Figure 27.11, Figure 27.12, and Figure 27.13 show examples of serial transmission in asynchronous mode.

Table 27.29 选择FIFO的异步模式下SCI初始化示例流程 (2个中的2个)

| No. | 步骤名称                            | Description   |
|-----|---------------------------------|---|
| 9   | 在MDDR中设置一个值                     | 在MDDR中写入通过纠正比特率错误获得的值。这一步是没有必要的，如果SEMR中的BRME位设置为0或使用外部时钟。 |
| 10  | 设置FCR.TFRST和RFRST位为0            | 将FCR.TFRST和RFRST位设置为0。                                    |
| 11  | 设置IO端口功能                        | 进行IO端口设置以启用TXDn、RXDn和所需的输入和输出功能SCKn pins。                 |
| 12  | 将SCR.TE或RE位设置为1，并设置SCR.TIE和RIE位 | 将SCR.TE或RE位设置为1。同时设置SCR.TIE和RIE位。设置TE和RE位允许使用TXDn和RXDn。   |
| 13  | 初始化完成                           |   |

### 27.3.8 异步模式下的串行数据传输

(1)选择非FIFO图27.11、图27.12和图27.13显示了异步模式下串行传输的示例。

在串行传输中，SCI的操作如本节所述。当SCR.TE位设置为1时，高电平输出到TXDn一帧。但是，当SEMR.PADIS设置为"1"时，不会输出此前导码。图27.14显示了不输出前导码时的操作示例。

1.当在SCIn\_TXI中断处理程序中将数据写入TDR\*1时，SCI将数据从TDR\*1寄存器传输到TSR寄存器。当一条指令同时将SCR.TE和SCR.TIE位设置为1时，会在传输开始时产生SCIn\_TXI中断请求。

2.在SPMR.CTSE位设置为0（禁用CTS功能）或CTSn\_RTsn引脚上的低电平导致数据从TDR\*1寄存器传输到TSR寄存器后，传输开始。如果SCR.TIE位为1，则产生SCIn\_TXI中断请求。通过在当前发送数据的发送完成之前将下一个发送数据写入SCIn\_TXI中断处理程序中的TDR\*1寄存器，可以进行连续发送。使用SCIn\_TEI中断请求时，在写入最后一个要发送的数据后，将SCR.TIE位设置为0（禁止SCIn\_TXI中断请求）并将SCR.TEIE位设置为1（启用SCIn\_TEI中断请求）从SCIn\_TXI请求的处理例程到TDR\*1寄存器。

3.数据按以下顺序从TXDn引脚发送：

- 起始位
- 传输数据
- 奇偶校验位或多处理器位（可根据格式省略）
- 停止位

4.SCI在停止位输出时检查TDR寄存器的更新。

5.当TDR寄存器更新时，将SPMR.CTSE位设置为0（禁用CTS功能）或CTSn\_RTsn引脚上的低电平输入会导致下一个发送数据从TDR\*1寄存器传输到TSR寄存器，并且传输停止位，然后开始下一帧的串行传输。

6.如果TDR寄存器没有更新，则将SSR.TEND标志置1，发送停止位，进入标记状态，其中输出1。如果SCR.TEIE位为1，则SSR.TEND标志设置为1，并产生SCIn\_TEI中断请求。

注1.选择9位数据长度时的TDRHL寄存器。

图27.11、图27.12和图27.13显示了异步模式下的串行传输示例。

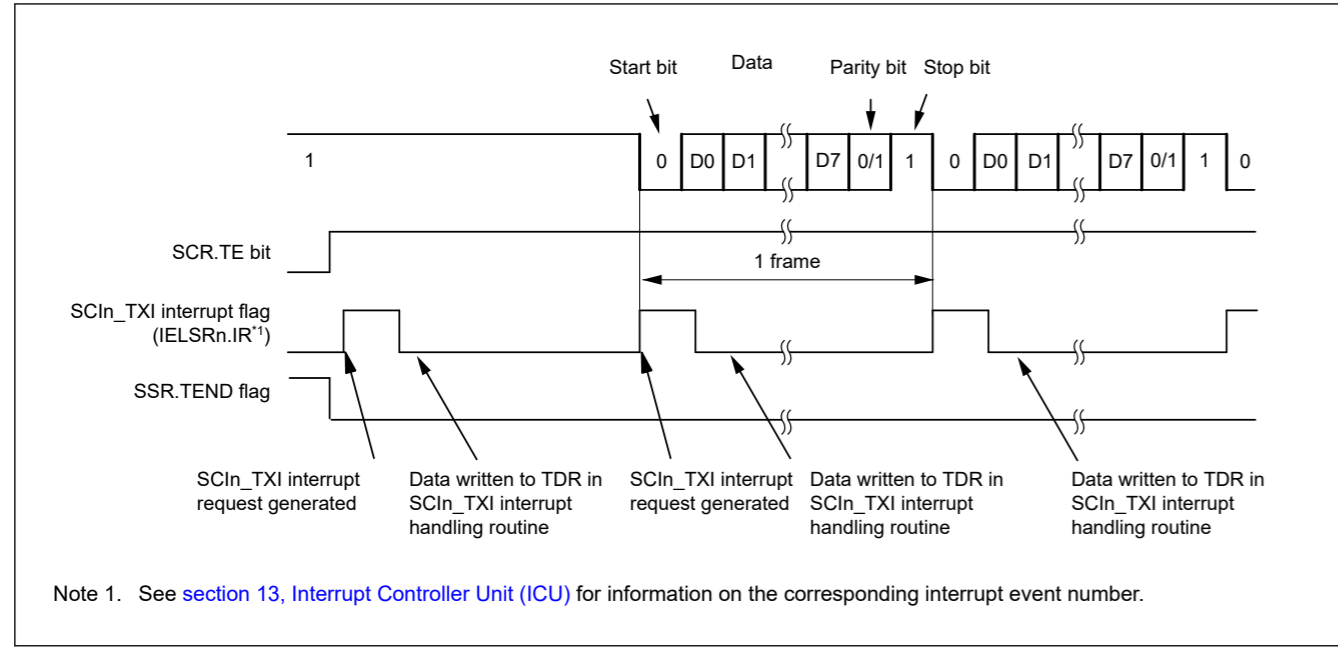


Figure 27.11 Example operation for serial transmission in asynchronous mode (1) with 8-bit data, parity bit, 1 stop bit, CTS function not used, and at the beginning of transmission

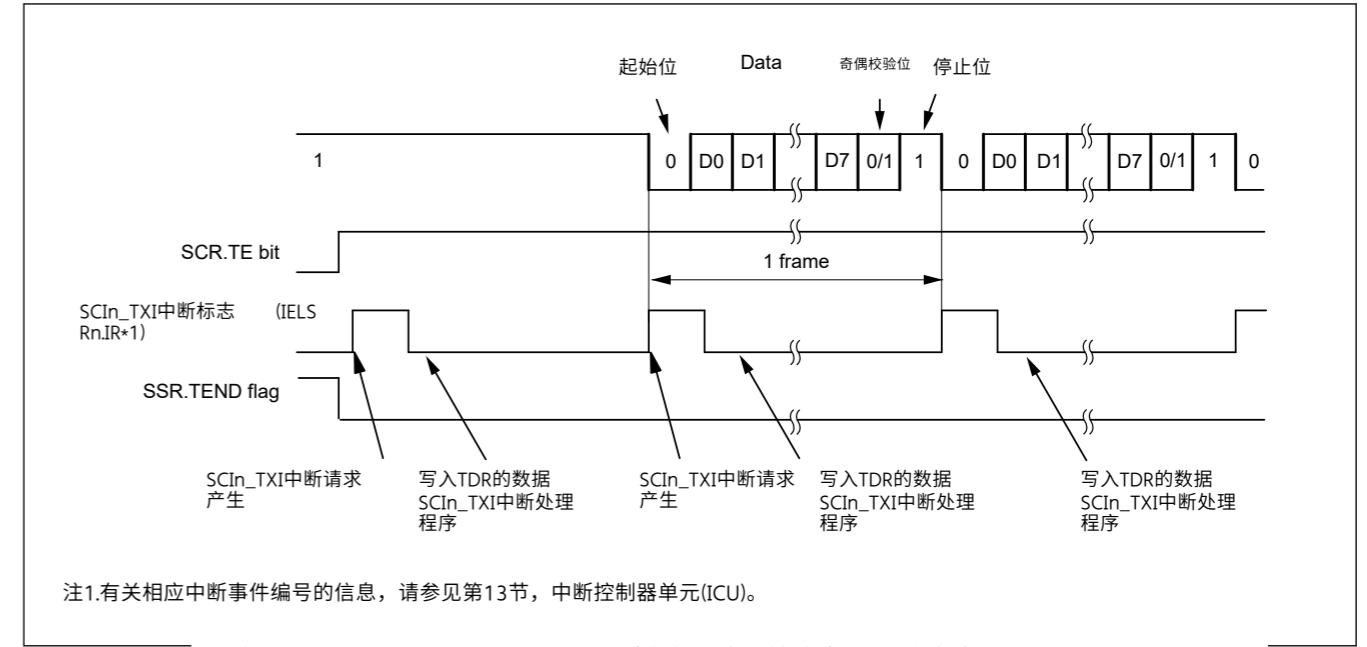


Figure 27.11 异步模式下串行传输的示例操作(1)使用8位数据、奇偶校验位、1个停止位、未使用CTS功能以及传输开始时

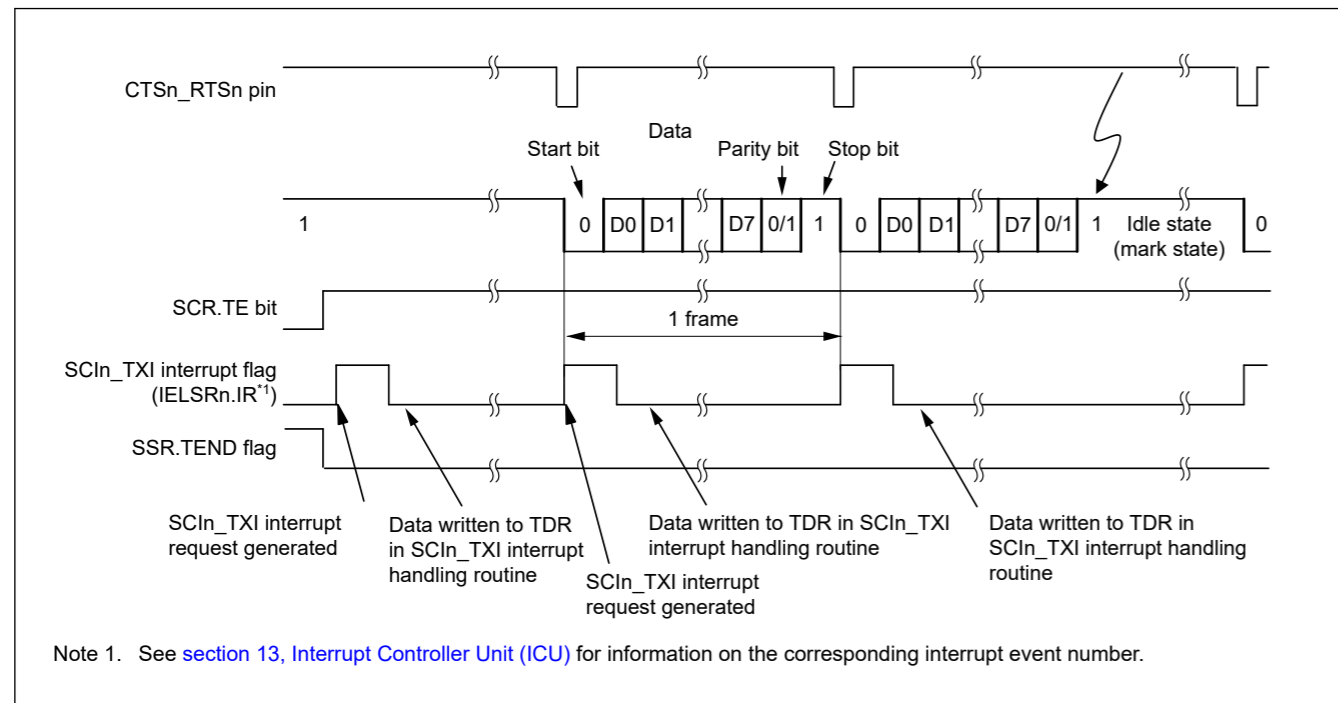


Figure 27.12 Example operation for serial transmission in asynchronous mode (2) with 8-bit data, parity bit, one stop bit, CTS function used, and at the beginning of transmission

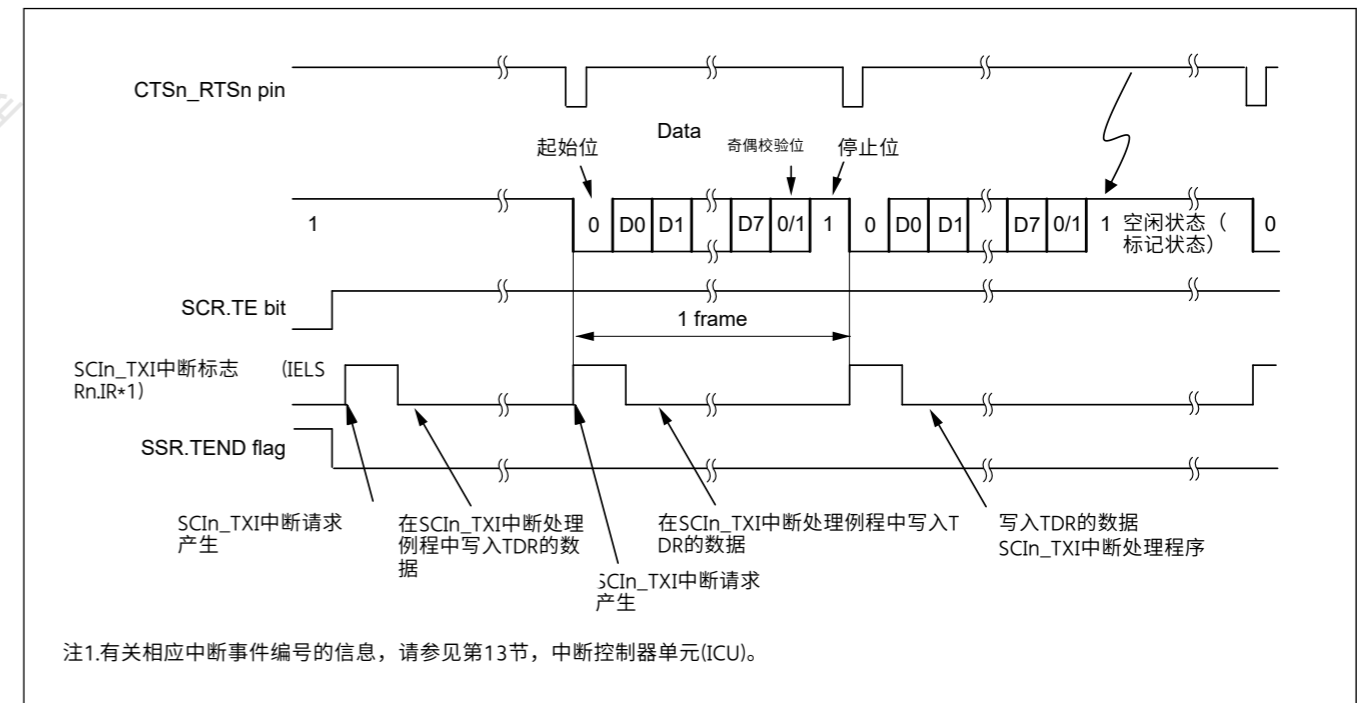


Figure 27.12 异步模式下串行传输的示例操作(2)使用8位数据、奇偶校验位、一个停止位、使用CTS功能以及在传输开始时

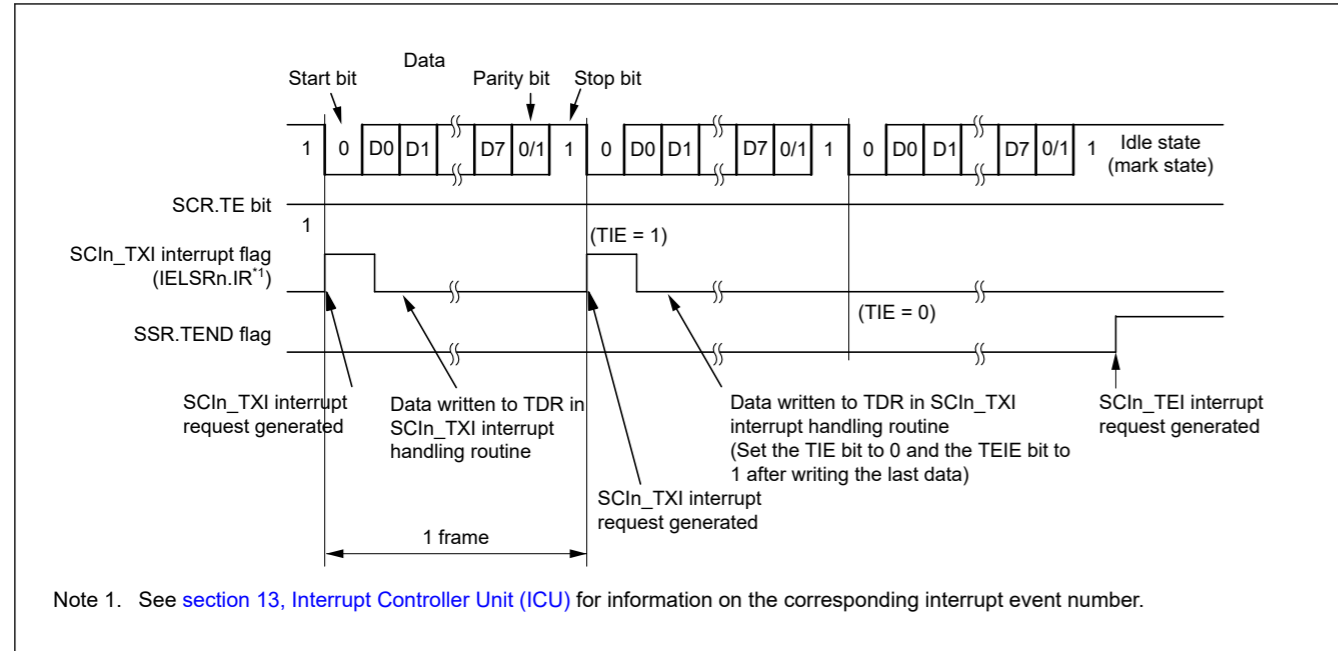


Figure 27.13 Example operation for serial transmission in asynchronous mode (3) with 8-bit data, parity bit, one stop bit, CTS function not used, and from the middle of transmission until transmission completion

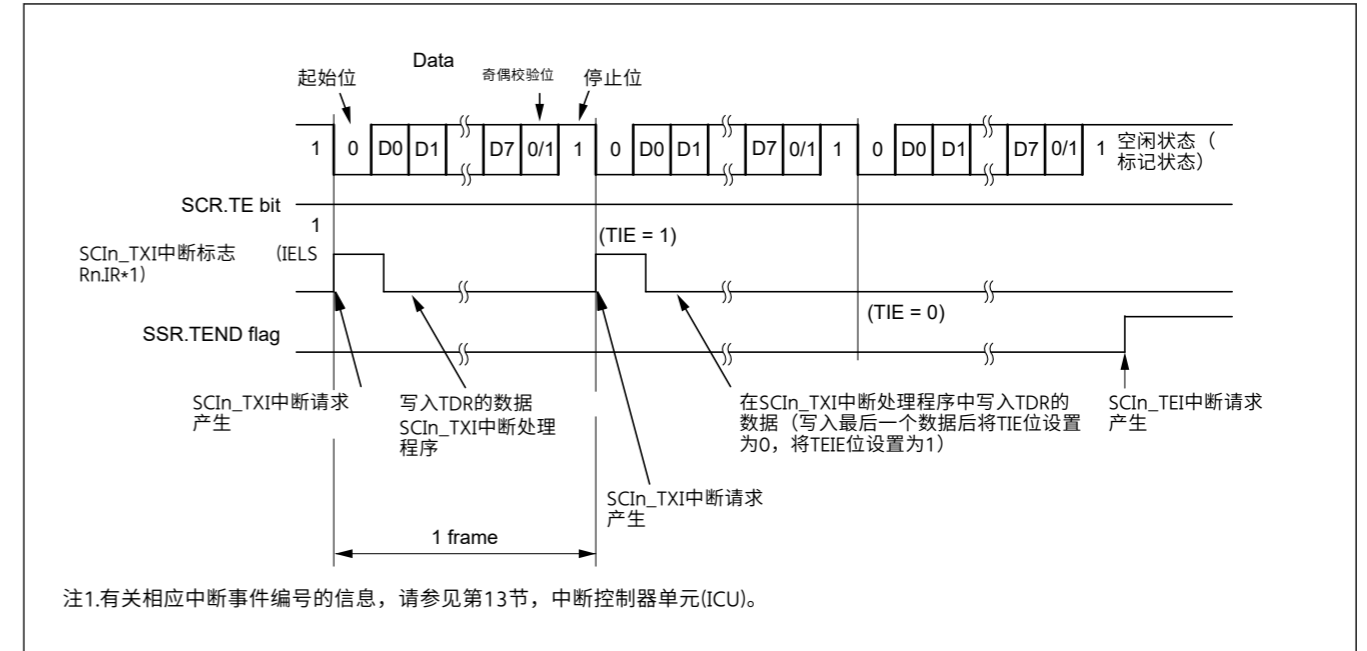


Figure 27.13 异步模式下串行传输的示例操作(3)使用8位数据、奇偶校验位、一个停止位、未使用CTS功能,以及从传输中间到传输完成

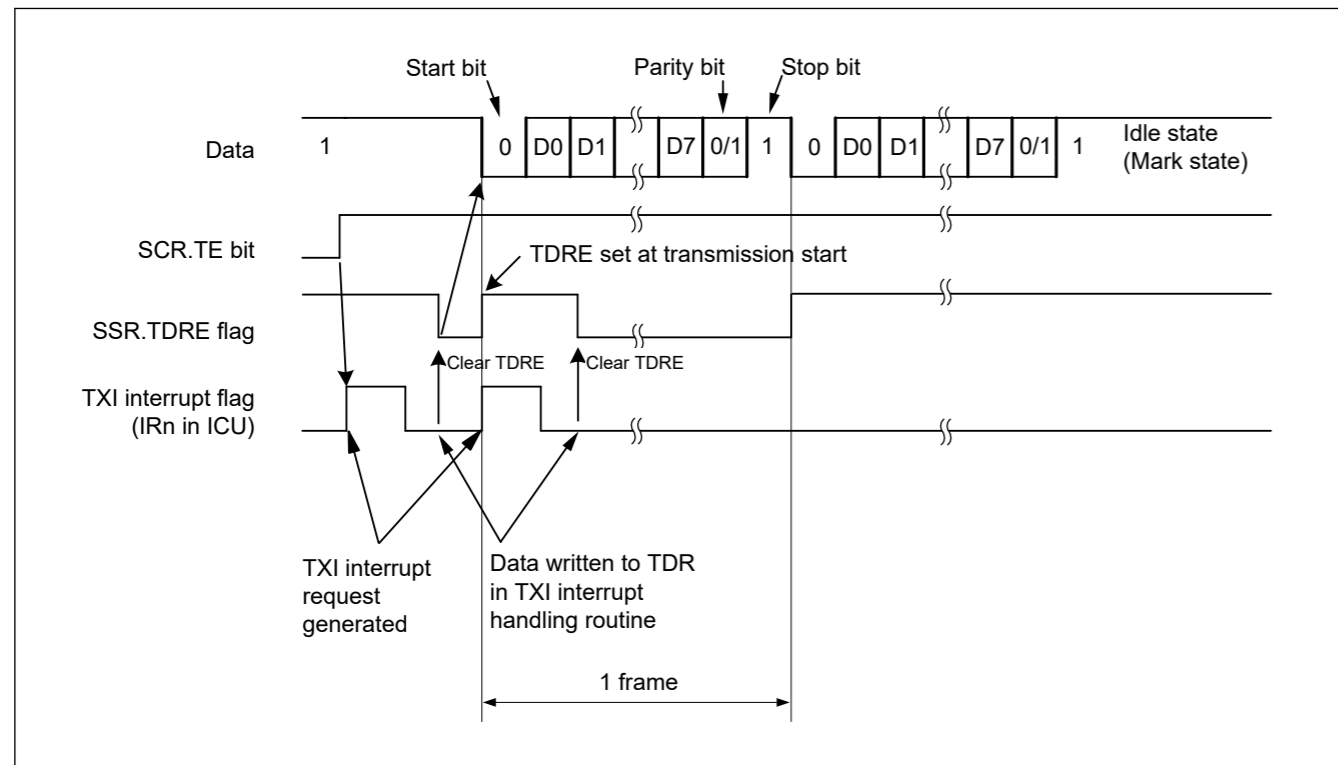


Figure 27.14 Example of Operation for Serial Transmission in Asynchronous Mode (4)(with 8-Bit Data, Parity, 1 Stop Bit, CTS Function Not Used, from the Middle of Transmission until Transmission Completion, stop preamble)

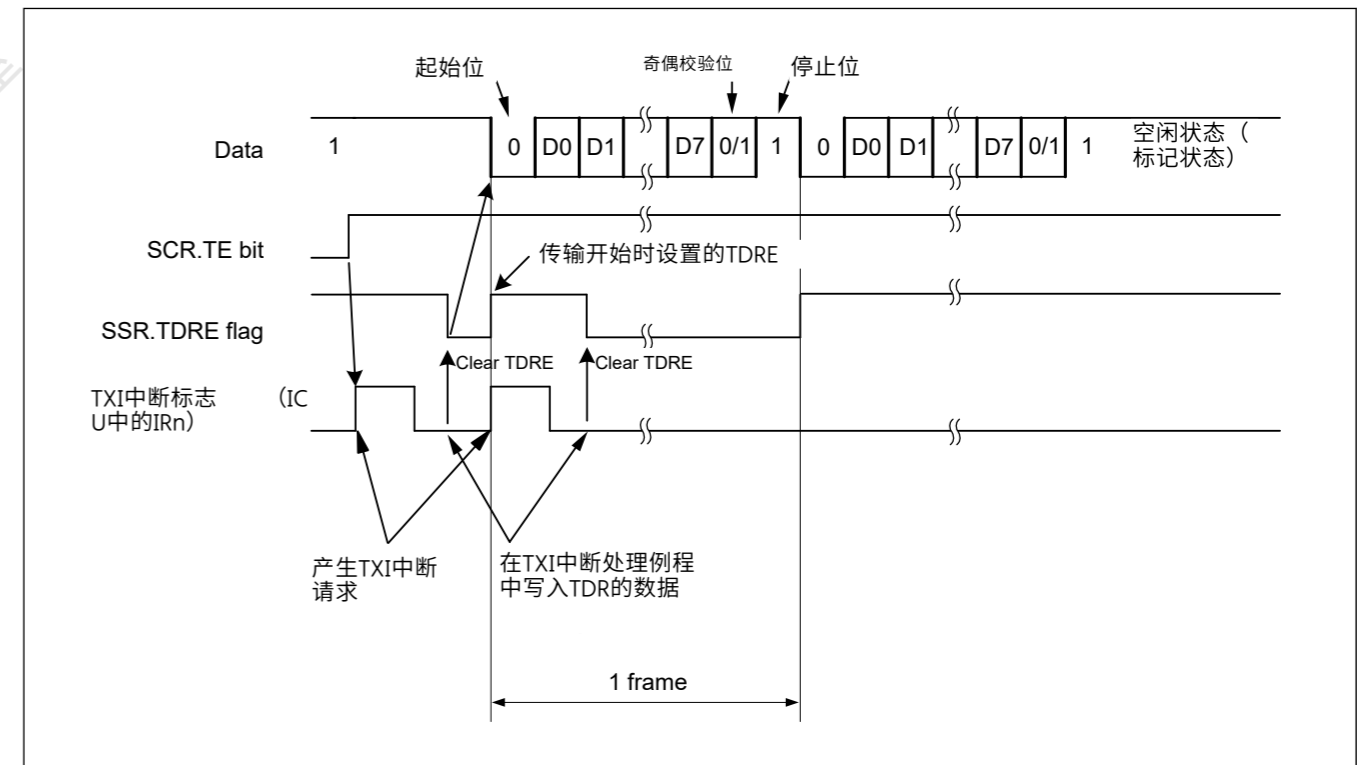


Figure 27.14 异步模式下串行传输的操作示例(4) (使用8位数据,奇偶校验,1个停止位,未使用CTS功能,从传输中间到传输完成,停止序言)



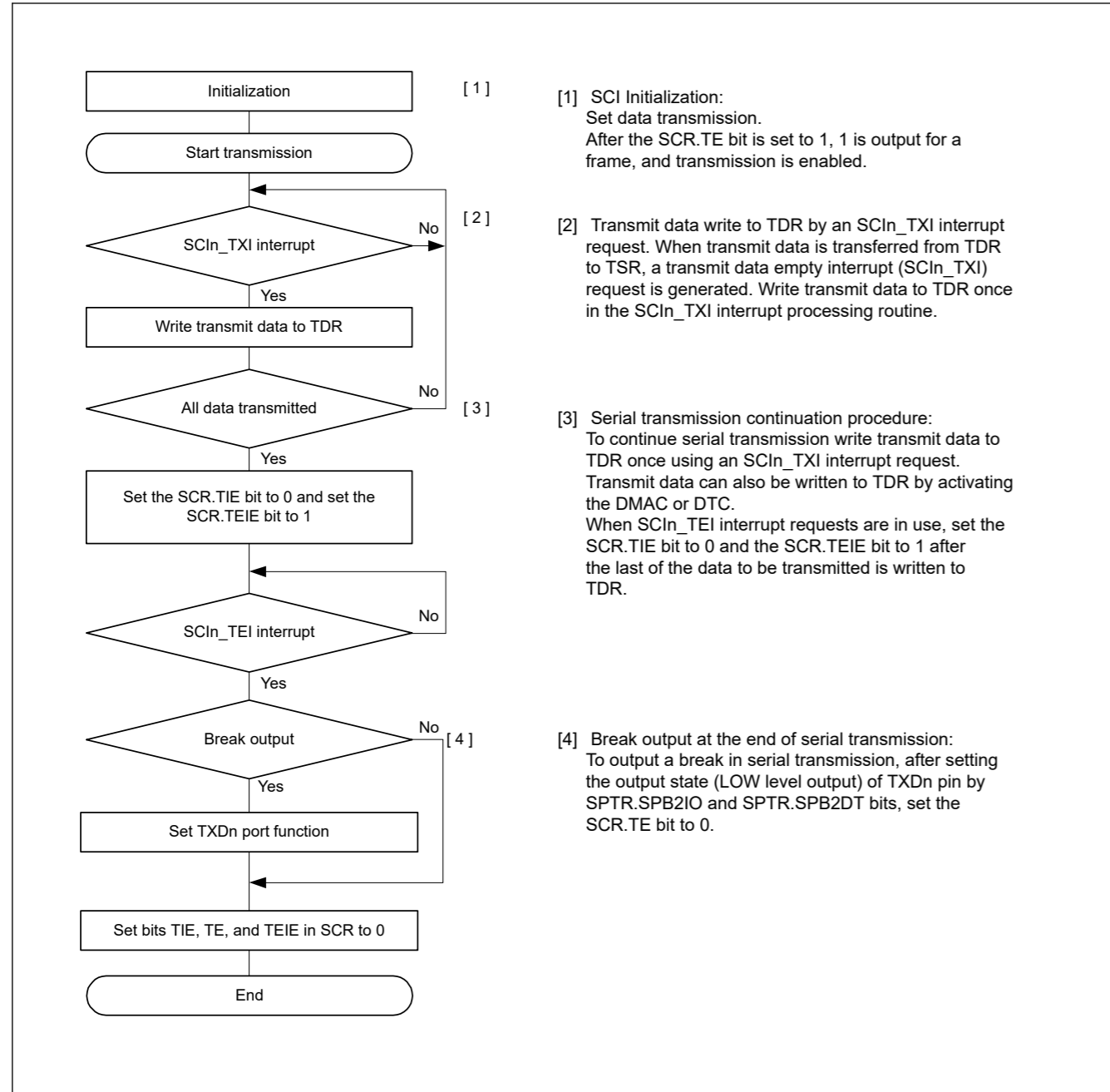


Figure 27.15 Example flow of serial transmission in asynchronous mode with non-FIFO selected

(2) FIFO selected

Figure 27.16 shows an example of a data format that is written to FTDRH and FTDRL in asynchronous mode.

Data corresponding to the data length is set to FTDRH and FTDRL. Write 0 for unused bits. Write in order from FTDRH to FTDRL.

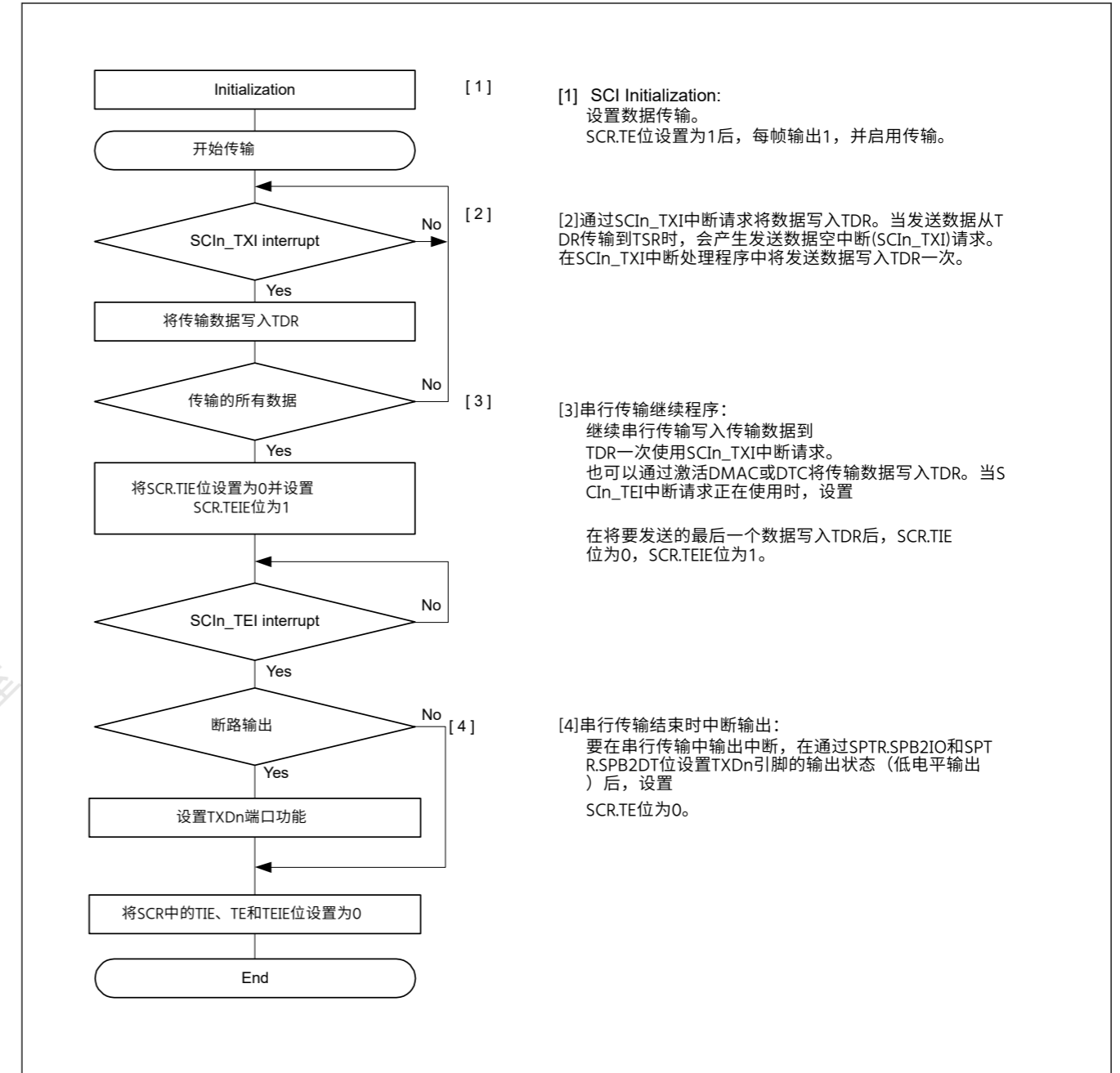


Figure 27.15 选择非FIFO的异步模式下串行传输示例流程

(2) FIFO selected

图27.16显示了以异步模式写入FTDRH和FTDRL的数据格式示例。

对应于数据长度的数据被设置为FTDRH和FTDRL。为未使用的位写入0。从FTDRH按顺序写到FTDRL。

| Data Length | Register Setting |            | Transmit data in FTDRH, FTDRL |    |    |    |    |    |    |    |       |    |    |    |    |    |    |                     |
|-------------|------------------|------------|-------------------------------|----|----|----|----|----|----|----|-------|----|----|----|----|----|----|---------------------|
|             | SCMR. CHR1       | SMR. CHR   | FTDRH                         |    |    |    |    |    |    |    | FTDRL |    |    |    |    |    |    |                     |
|             |                  |            | b7                            | b6 | b5 | b4 | b3 | b2 | b1 | b0 | b7    | b6 | b5 | b4 | b3 | b2 | b1 | b0                  |
| 7 bits      | 1                | 0          | -                             | -  | -  | -  | -  | -  | -  | -  | -     | -  | -  | -  | -  | -  | -  | 7-bit transmit data |
| 8 bits      | 1                | 1          | -                             | -  | -  | -  | -  | -  | -  | -  | -     | -  | -  | -  | -  | -  | -  | 8-bit transmit data |
| 9 bits      | 0                | Don't care | -                             | -  | -  | -  | -  | -  | -  | -  | -     | -  | -  | -  | -  | -  | -  | 9-bit transmit data |

Note: —: Invalid. The write value should be 0.

Figure 27.16 Data format written to FTDRH and FTDRL with FIFO selected

In serial transmission, the SCI operates as described in this section. When the TE bit is set to 1, the high level is output to TXDn for one frame (preamble).

- The SCI transfers data from the FTDRL\*1 register to the TSR register when data is written to FTDRL\*1 in the SCIn\_TXI interrupt handling routine. The amount of data that can be written to FTDRL is 16 minus FDR.T[4:0] bytes. The SCIn\_TXI interrupt request at the beginning of transmission is generated when the SCR.TE and SCR.TIE bits are set to 1 simultaneously by a single instruction.
- Transmission starts after the SPMR.CTSE bit is set to 0 (CTS function is disabled) or a low level on the CTSn\_RTsn pin causes data transfer from the FTDRL\*1 register to the TSR register. When the amount of transmit data written in FTDRL is equal to or less than the specified transmit triggering number, SSR\_FIFO.TDFE is set to 1. If the SCR.TIE bit is 1, an SCIn\_TXI interrupt request is generated. Continuous transmission is possible by writing the next transmit data to FTDRL\*1 in the SCIn\_TXI interrupt handling routine before transmission of the current transmit data is complete. When SCIn\_TEI interrupt requests are in use, set the SCR.TIE bit to 0 (SCIn\_TXI interrupt requests are disabled) and the SCR.TEIE bit to 1 (an SCIn\_TEI interrupt request is enabled) after the last of the data to be transmitted is written to the FTDRL\*1\*2 register from the handling routine for SCIn\_TXI requests.
- Data is sent from the TXDn pin in the following order:
  - Start bit
  - Transmit data
  - Parity bit or multi-processor bit (can be omitted depending on the format)
  - Stop bit
- On output of the stop bit, the SCI checks whether non-transmitted data remains in the FTDRL\*3 register.
- When data is set to FTDRL\*3, setting the SPMR.CTSE bit to 0 (CTS function is disabled) or a low level input on the CTSn\_RTsn pin causes transfer of the next transmit data from FTDRL\*1 to TSR and transmission of the stop bit, after which serial transmission of the next frame starts.
- If data is not set in FTDRL\*3, the TEND flag in SSR\_FIFO is set to 1, the stop bit is sent, and the mark state is entered in which 1 is output. If the SCR.TEIE bit is 1, the SSR\_FIFO.TEND flag is set to 1 and an SCIn\_TEI interrupt request is generated.

- Note 1. Write data not to FTDRL but to the FTDRH and FTDRL registers.  
 Note 2. Write data in order from FTDRH to FTDRL when 9-bit data length is selected.  
 Note 3. The SCI only checks for update to the FTDRL register and not the FTDRH register when 9-bit data length is selected.

Figure 27.17 shows an example flow of serial transmission in asynchronous mode with FIFO selected.

| 数据长度   | 寄存器设置      |            | 在FTDRH、FTDRL中传输数据 |    |    |    |    |    |    |    |       |    |    |    |    |    |    |        |
|--------|------------|------------|-------------------|----|----|----|----|----|----|----|-------|----|----|----|----|----|----|--------|
|        | SCMR. CHR1 | SMR. CHR   | FTDRH             |    |    |    |    |    |    |    | FTDRL |    |    |    |    |    |    |        |
|        |            |            | b7                | b6 | b5 | b4 | b3 | b2 | b1 | b0 | b7    | b6 | b5 | b4 | b3 | b2 | b1 | b0     |
| 7 bits | 1          | 0          | -                 | -  | -  | -  | -  | -  | -  | -  | -     | -  | -  | -  | -  | -  | -  | 7位传输数据 |
| 8 bits | 1          | 1          | -                 | -  | -  | -  | -  | -  | -  | -  | -     | -  | -  | -  | -  | -  | -  | 8位传输数据 |
| 9 bits | 0          | Don't care | -                 | -  | -  | -  | -  | -  | -  | -  | -     | -  | -  | -  | -  | -  | -  | 9位传输数据 |

Note: -: 无效的。写入值应为0。

Figure 27.16 选择FIFO写入FTDRH和FTDRL的数据格式

在串行传输中，SCI的操作如本节所述。当TE位设置为1时，高电平输出到TXDn一帧（前导码）。

- 当数据写入FTDRL\*1时，SCI将数据从FTDRL\*1寄存器传输到TSR寄存器  
 SCIn\_TXI中断处理程序。可写入FTDRL的数据量为16减去FDR.T[4:0]字节。当一条指令同时将SCR.TE和SCR.TIE位设置为1时，会在传输开始时产生SCIn\_TXI中断请求。
- 在SPMR.CTSE位设置为0（禁用CTS功能）或CTSn\_RTsn引脚上的低电平导致数据从FTDRL\*1寄存器传输到TSR寄存器后，传输开始。当写入FTDRL的发送数据量等于或小于指定的发送触发数时，SSR\_FIFO.TDFE设置为1。如果SCR.TIE位为1，则产生SCIn\_TXI中断请求。在当前发送数据的发送完成之前，通过在SCIn\_TXI中断处理例程中将下一个发送数据写入FTDRL\*1，可以进行连续发送。当使用SCIn\_TEI中断请求时，将SCR.TIE位设置为0（禁止SCIn\_TXI中断请求）并且  
 将要发送的最后一个数据写入到SCR.TEIE位为1（启用SCIn\_TEI中断请求）  
 FTDRL\*1\*2来自SCIn\_TXI请求处理例程的寄存器。
- 数据按以下顺序从TXDn引脚发送：
  - 起始位
  - 传输数据
  - 奇偶校验位或多处理器位（可根据格式省略）
  - 停止位
- 在停止位输出时，SCI检查未发送的数据是否保留在FTDRL\*3寄存器中。
- 当数据设置为FTDRL\*3时，将SPMR.CTSE位设置为0（禁用CTS功能）或CTSn\_RTsn引脚上的低电平输入会导致下一个传输数据从FTDRL\*1传输到TSR并传输停止位，之后开始下一帧的串行传输。
- 如果FTDRL\*3中没有设置数据，则将SSR\_FIFO中的TEND标志设置为1，发送停止位，并进入输出1的标记状态。如果SCR.TEIE位为1，则SSR\_FIFO.TEND标志设置为1，并产生SCIn\_TEI中断请求。

- 注1.不要将数据写入FTDRL，而是写入FTDRH和FTDRL寄存器。  
 注2.选择9位数据长度时，按从FTDRH到FTDRL的顺序写入数据。  
 注意3.SCI仅检查对FTDRL寄存器的更新，而不是选择9位数据长度时的FTDRH寄存器。

图27.17显示了选择FIFO的异步模式下串行传输的示例流程。

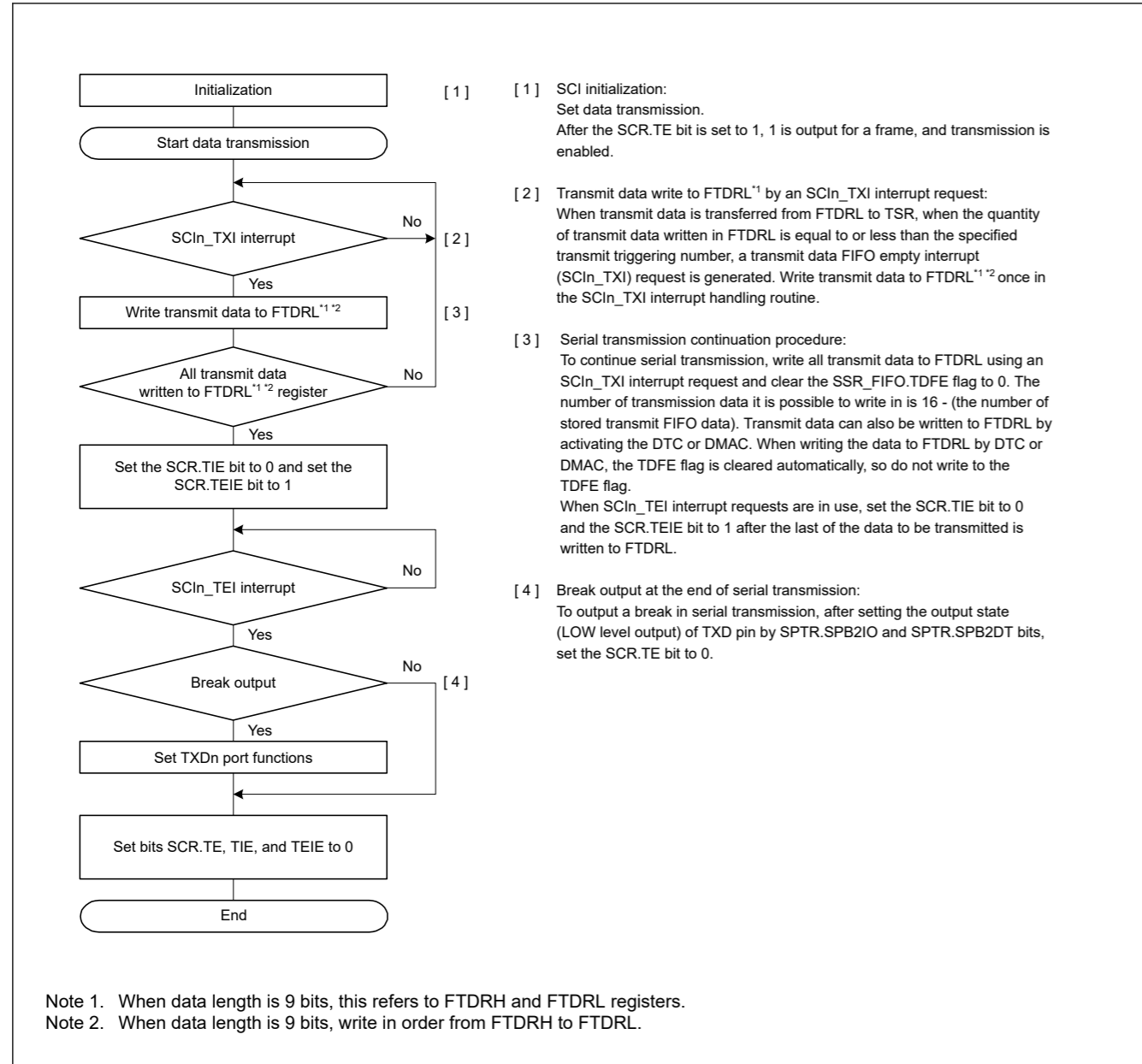


Figure 27.17 Example flow of serial transmission in asynchronous mode with FIFO selected

### 27.3.9 Serial Data Reception in Asynchronous Mode

(1) Non-FIFO selected

Figure 27.18 and Figure 27.19 show an example of the operation for serial data reception in asynchronous mode.

In serial data reception, the SCI operates as follows:

1. When the value of the SCR.RE bit becomes 1, the output signal on the CTSn\_RTsn pin goes low.
2. The SCI monitors the communications line and when it detects a start bit, the SCI performs internal synchronization, stores receive data in RSR.
3. If the multi-processor communication function is enabled (SMR.MP = 1), see section 27.4.2. Multi-Processor Serial Data Reception. If the address match function (data compare match function) is enabled (DCCR.DCME = 1), the SCI cannot detect a parity or framing error as receive data are skipped (discarded) until the SCI detects a match between the receive data and comparison data (CDR.CMPD<sup>\*1</sup>).
4. If the SCI detects an address match, the DCCR.DCME bit is automatically cleared, the DCCR.DCMF flag becomes 1, and an SCIn\_AM interrupt<sup>\*2</sup> request is generated. To enable the generation of an SCIn\_RXI interrupt request, set the SCR.RIE bit to 1. The compared receive data are not stored in the RDR register<sup>\*3</sup>. The SSR.RDRF flag remains 0.

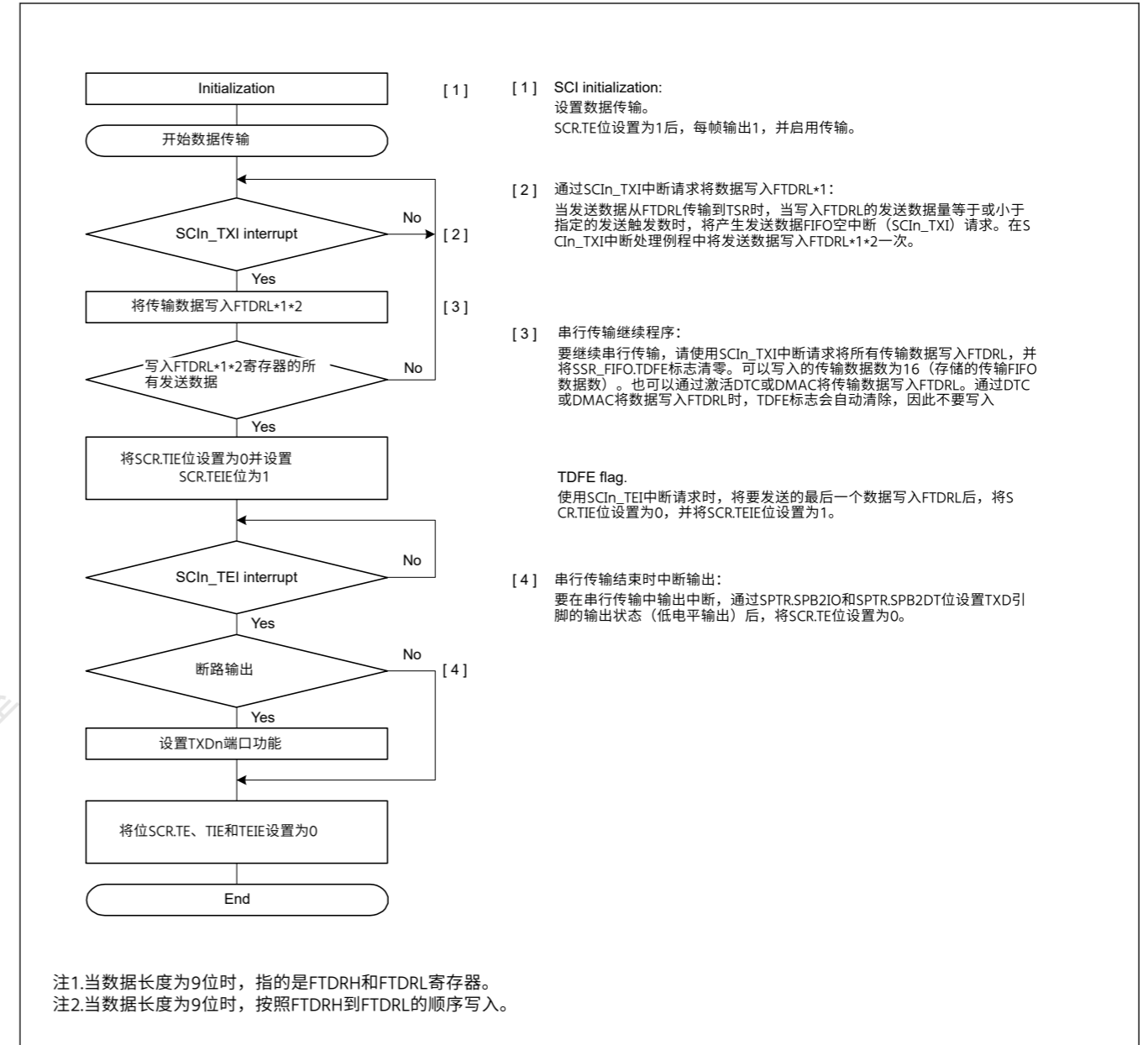


Figure 27.17 选择FIFO的异步模式下串行传输示例流程

### 27.3.9 异步模式下的串行数据接收

(1) Non-FIFO selected

图27.18和图27.19显示了异步模式下串行数据接收操作的示例。

在串行数据接收中，SCI操作如下：

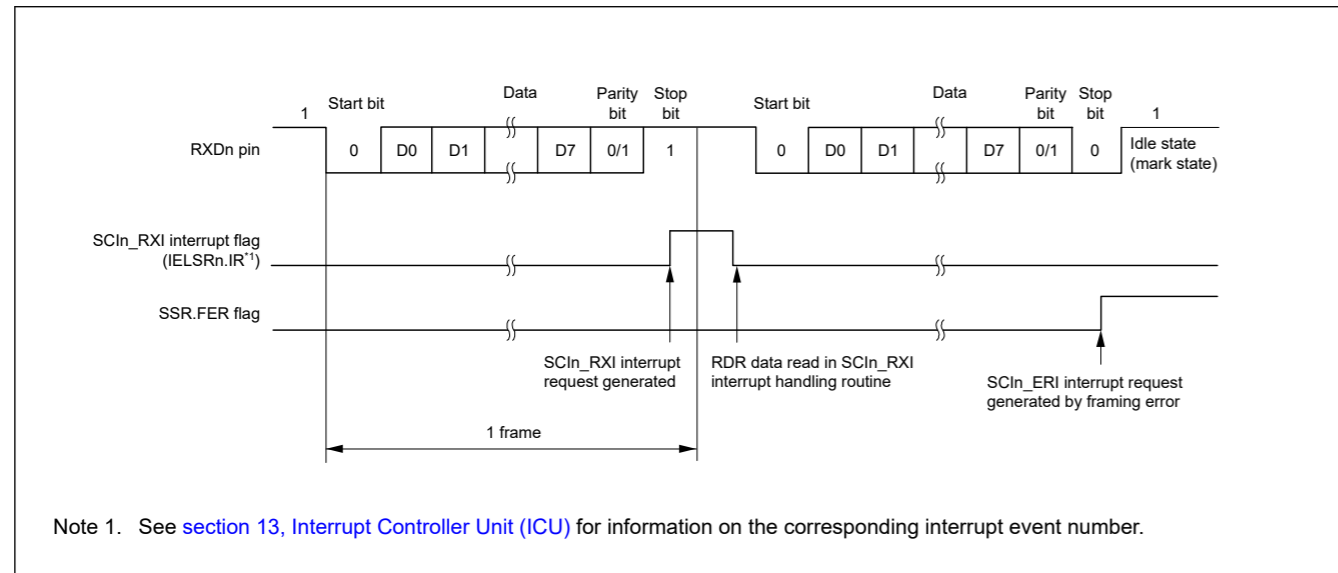
- 1.当SCR.RE位的值变为1时，CTSn\_RTsn引脚上的输出信号变为低电平。
- 2.SCI监控通信线路，当检测到起始位时，SCI执行内部同步，将接收数据存储存储在RSR中。
- 3.如果启用多处理器通信功能（SMR.MP=1），请参见第27.4.2节。多处理器串行数据接收。如果地址匹配功能（数据比较匹配功能）被启用（DCCR.DCME=1），SCI无法检测奇偶校验或帧错误，因为接收数据被跳过（丢弃），直到SCI检测到接收数据和比较之间的匹配数据（CDR.CMPD\*1）。
- 4.如果SCI检测到地址匹配，DCCR.DCME位自动清零，DCCR.DCMF标志变为1，并产生SCIn\_AM中断\*2请求。要启用SCIn\_RXI中断请求的生成，请将SCR.RIE位设置为1。比较的接收数据不存储在RDR寄存器\*3中。SSR.RDRF标志保持为0。

- If the SCI detects a framing error in the receive data for which an address match is detected, the DCCR.DFER flag is set to 1, and if the SCI detects a parity error in that frame, the DCCR.DPER flag becomes 1. To enable the generation of an SCIn\_ERI interrupt request, set the SCR.RIE bit to 1.
- If a framing or a parity error is detected (the DCCR.DFER flag or DCCR.DPER flag is 1) in the SCIn\_AM interrupt handling routine, set the DCCR.DFER and DCCR.DPER flags to 0 and set the DCCR.DCME bit to 1 to enable the address match function again. If neither a framing nor a parity error has been detected (the DCCR.DFER and DCCR.DPER flags are both 0), set the DCCR.DCMF flag to 0. See Figure 27.9.
- If an overrun error occurs, the SSR.ORER flag is set to 1. If the SCR.RIE bit is 1, an SCIn\_ERI interrupt request is generated. Receive data is not transferred to the RDR\*3 register.
- If a parity error is detected, the SSR.PER flag is set to 1 and receive data is transferred to the RDR\*3 register. If the SCR.RIE bit is 1, an SCIn\_ERI interrupt request is generated.
- If a framing error is detected, the SSR.FER flag is set to 1 and receive data is transferred to the RDR\*3 register. If the SCR.RIE bit is 1, an SCIn\_ERI interrupt request is generated.
- When reception finishes successfully, receive data is transferred to the RDR\*3 register. If the SCR.RIE bit is 1, an SCIn\_RXI interrupt request is generated. Continuous reception is enabled by reading the receive data transferred to the RDR register in the SCIn\_RXI interrupt handling routine before reception of the next receive data is complete. Reading the received data that was transferred to the RDR register causes the CTSn\_RTsn pin to output low.

Note 1. This scope of comparison is selectable as one of three lengths: CMPD[6:0] is for 7-bit length, CMPD[7:0] is for 8-bit length, and CMPD[8:0] is for 9-bit length.

Note 2. As no interrupt enable bit is assigned to the SCIn\_AM interrupt, an interrupt request is generated by setting the DCCR.DCMF to 1.

Note 3. Only read data in the RDRHL register when 9-bit data length is selected.



Note 1. See section 13, Interrupt Controller Unit (ICU) for information on the corresponding interrupt event number.

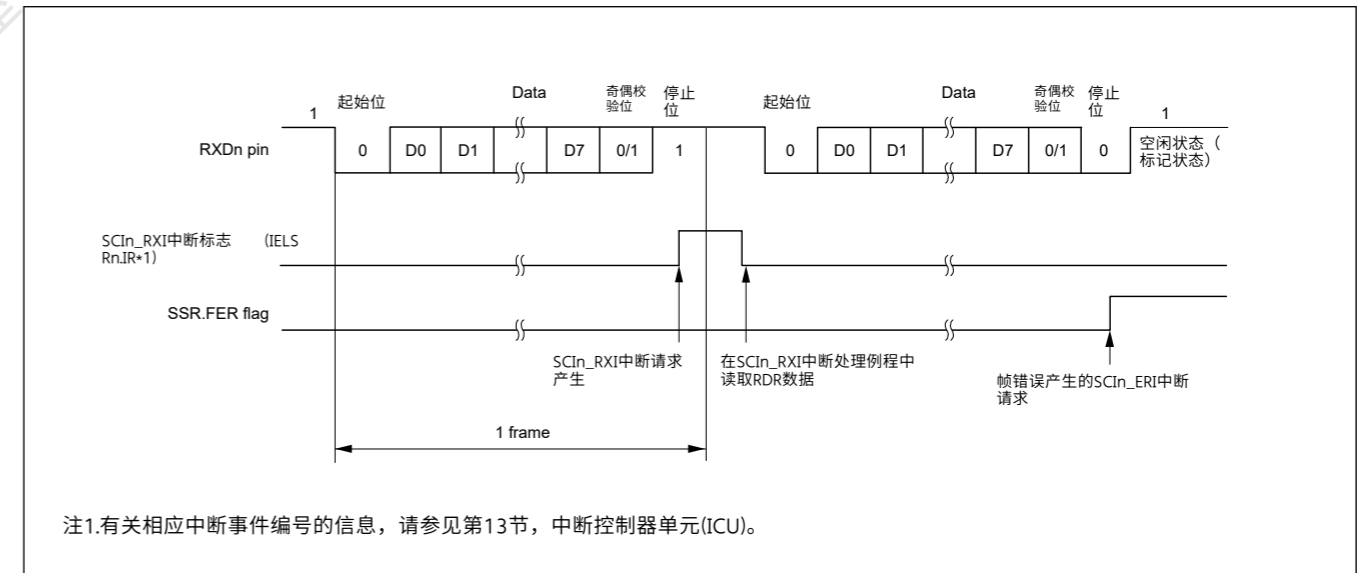
Figure 27.18 Example of SCI operation for serial reception in asynchronous mode (1) when the RTS function is not used, and with 8-bit data, parity bit, and 1 stop bit

- 如果SCI在检测到地址匹配的接收数据中检测到帧错误，则DCCR.DFER标志设置为1，如果SCI在该帧中检测到奇偶校验错误，则DCCR.DPER标志变为1。要启用SCIn\_ERI中断请求的生成，请将SCR.RIE位设置为1。
- 如果在SCIn\_AM中断处理例程中检测到成帧或奇偶校验错误（DCCR.DFER标志或DCCR.DPER标志为1），则将DCCR.DFER和DCCR.DPER标志设置为0，并设置DCCR.DCME位为1以再次启用地址匹配功能。如果既没有检测到成帧错误也没有检测到奇偶校验错误（DCCR.DFER和DCCR.DPER标志都为0），将DCCR.DCMF标志设置为0。参见图27.9。
- 如果发生溢出错误，则SSR.ORER标志设置为1。如果SCR.RIE位为1，则产生SCIn\_ERI中断请求。接收数据不传送到RDR\*3寄存器。
- 如果检测到奇偶校验错误，则将SSR.PER标志设置为1，并将接收数据传输到RDR\*3寄存器。如果SCR.RIE位为1，则产生SCIn\_ERI中断请求。
- 如果检测到帧错误，则将SSR.FER标志设置为1，并将接收数据传输到RDR\*3寄存器。如果SCR.RIE位为1，则产生SCIn\_ERI中断请求。
- 接收成功后，接收数据被传送到RDR\*3寄存器。如果SCR.RIE位为1，则SCIn\_RXI中断请求产生。通过读取传输到的接收数据启用连续接收。在接收下一个接收数据完成之前，SCIn\_RXI中断处理程序中的RDR寄存器。读取传输到RDR寄存器的接收数据会导致CTS<sub>n</sub>RTS<sub>n</sub>引脚输出低电平。

注1.此比较范围可选择以下三种长度之一：CMPD[6:0]用于7位长度，CMPD[7:0]用于8位长度，CMPD[8:0]用于9位长度。

注2.由于没有为SCIn\_AM中断分配中断使能位，因此通过设置DCCR.DCMF to 1.

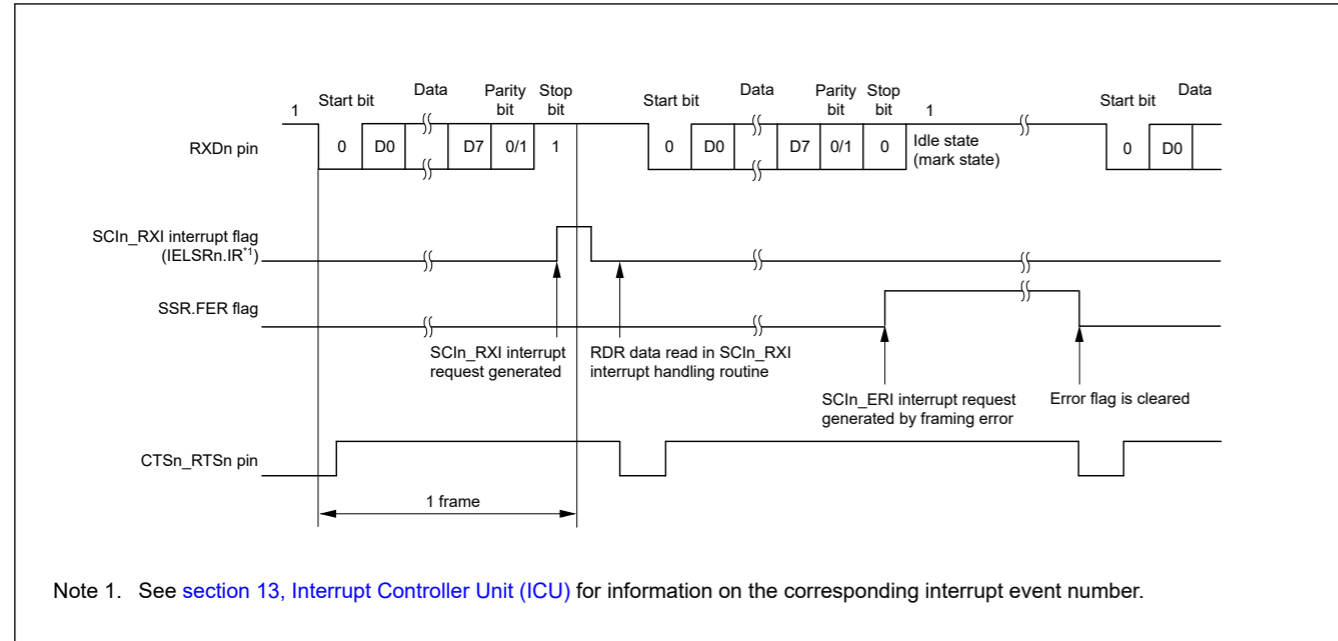
注3.选择9位数据长度时，仅读取RDRHL寄存器中的数据。



注1.有关相应中断事件编号的信息，请参见第13节，中断控制器单元(ICU)。

Figure 27.18 异步模式下串行接收的SCI操作示例(1)不使用RTS功能时，具有8位数据、奇偶校验位和1个停止位





Note 1. See section 13, Interrupt Controller Unit (ICU) for information on the corresponding interrupt event number.

Figure 27.19 Example of SCI operation for serial reception in asynchronous mode (2) when RTS function is used, and with 8-bit data, parity bit, and 1 stop bit

Table 27.30 lists the states of the flags in the SSR register and receive data handling when a receive error is detected.

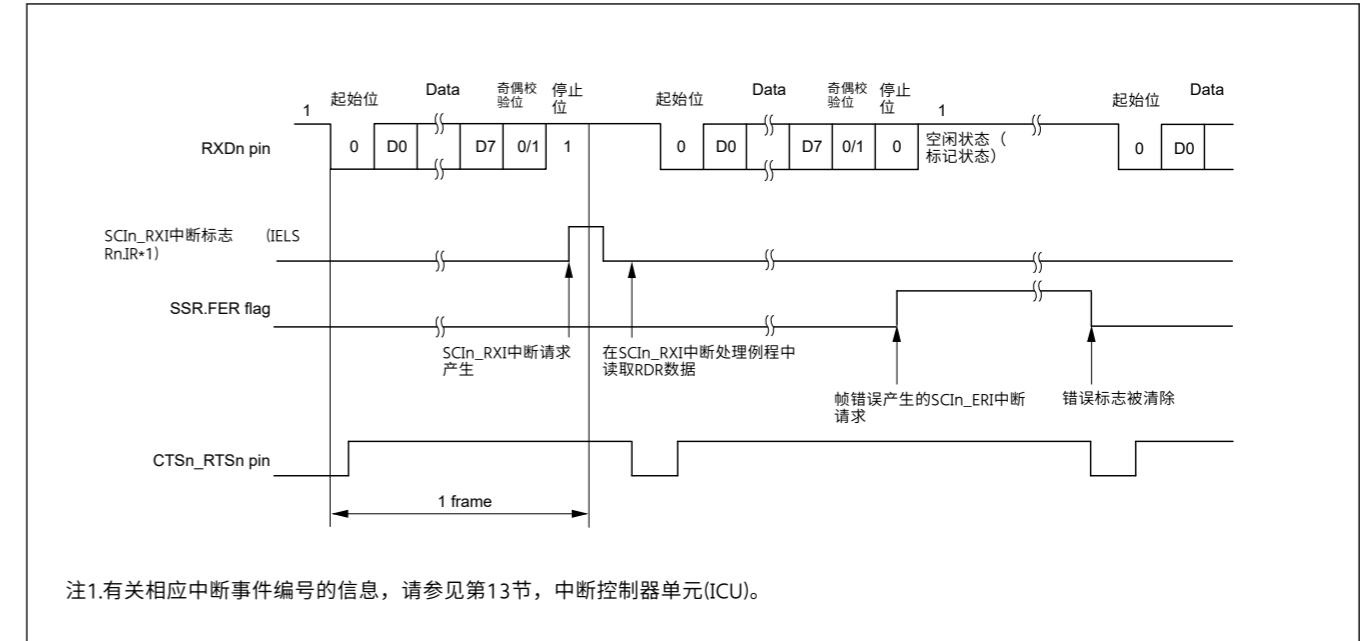
If a receive error is detected, an SCIn\_ERI interrupt request is generated but an SCIn\_RXI interrupt request is not generated. Data reception cannot be resumed while the receive error flag is 1. Accordingly, set the ORER, FER, and PER bits to 0 before resuming reception. In addition, be sure to read the RDR or RDRHL register during overrun error processing. When a reception is forced to terminate by setting the SCR.RE bit to 0 during operation, read the RDR or RDRHL register because received data that is not yet read might be left in the RDR or RDRHL.

Figure 27.20 and Figure 27.21 show example flows of serial data reception.

Table 27.30 Flags in SSR Status Register and receive data handling

| Flags in the SSR Status Register |     |     | Receive data         | Receive error type                           |
|----------------------------------|-----|-----|----------------------|--|
| ORER                             | FER | PER |                      |  |
| 1                                | 0   | 0   | Lost                 | Overrun error                                |
| 0                                | 1   | 0   | Transferred to RDR*1 | Framing error                                |
| 0                                | 0   | 1   | Transferred to RDR*1 | Parity error                                 |
| 1                                | 1   | 0   | Lost                 | Overrun error + framing error                |
| 1                                | 0   | 1   | Lost                 | Overrun error + parity error                 |
| 0                                | 1   | 1   | Transferred to RDR*1 | Framing error + parity error                 |
| 1                                | 1   | 1   | Lost                 | Overrun error + framing error + parity error |

Note 1. Only read data in the RDRHL register when 9-bit data length is selected.



注1.有关相应中断事件编号的信息,请参见第13节,中断控制器单元(ICU)。

Figure 27.19 使用RTS功能,8位数据、奇偶校验位和1个停止位时,异步模式下串行接收的SCI操作示例(2)

表27.30列出了SSR寄存器中标志的状态以及检测到接收错误时的接收数据处理。

如果检测到接收错误,则会产生SCIn\_ERI中断请求,但不会产生SCIn\_RXI中断请求。当接收错误标志为1时,无法恢复数据接收。因此,在恢复接收之前,请将ORER、FER和PER位设置为0。此外,请务必在溢出错误处理期间读取RDR或RDRHL寄存器。如果在操作期间通过将SCR.RE位设置为0来强制终止接收,请读取RDR或RDRHL寄存器,因为尚未读取的已接收数据可能留在RDR或RDRHL中。

图27.20和图27.21显示了串行数据接收的示例流程。

Table 27.30 SSR状态寄存器中的标志和接收数据处理

| SSR状态寄存器中的标志 |     |     | 接收数据     | 接收错误类型          |
|--------------|-----|-----|----------|-----------------|
| ORER         | FER | PER |          |                 |
| 1            | 0   | 0   | Lost     | 溢出错误            |
| 0            | 1   | 0   | 转移到RDR*1 | 构图错误            |
| 0            | 0   | 1   | 转移到RDR*1 | 奇偶校验错误          |
| 1            | 1   | 0   | Lost     | 溢出错误+成帧错误       |
| 1            | 0   | 1   | Lost     | 溢出错误+奇偶校验错误     |
| 0            | 1   | 1   | 转移到RDR*1 | 成帧错误+奇偶校验错误     |
| 1            | 1   | 1   | Lost     | 溢出错误+帧错误+奇偶校验错误 |

注1.选择9位数据长度时,仅读取RDRHL寄存器中的数据。

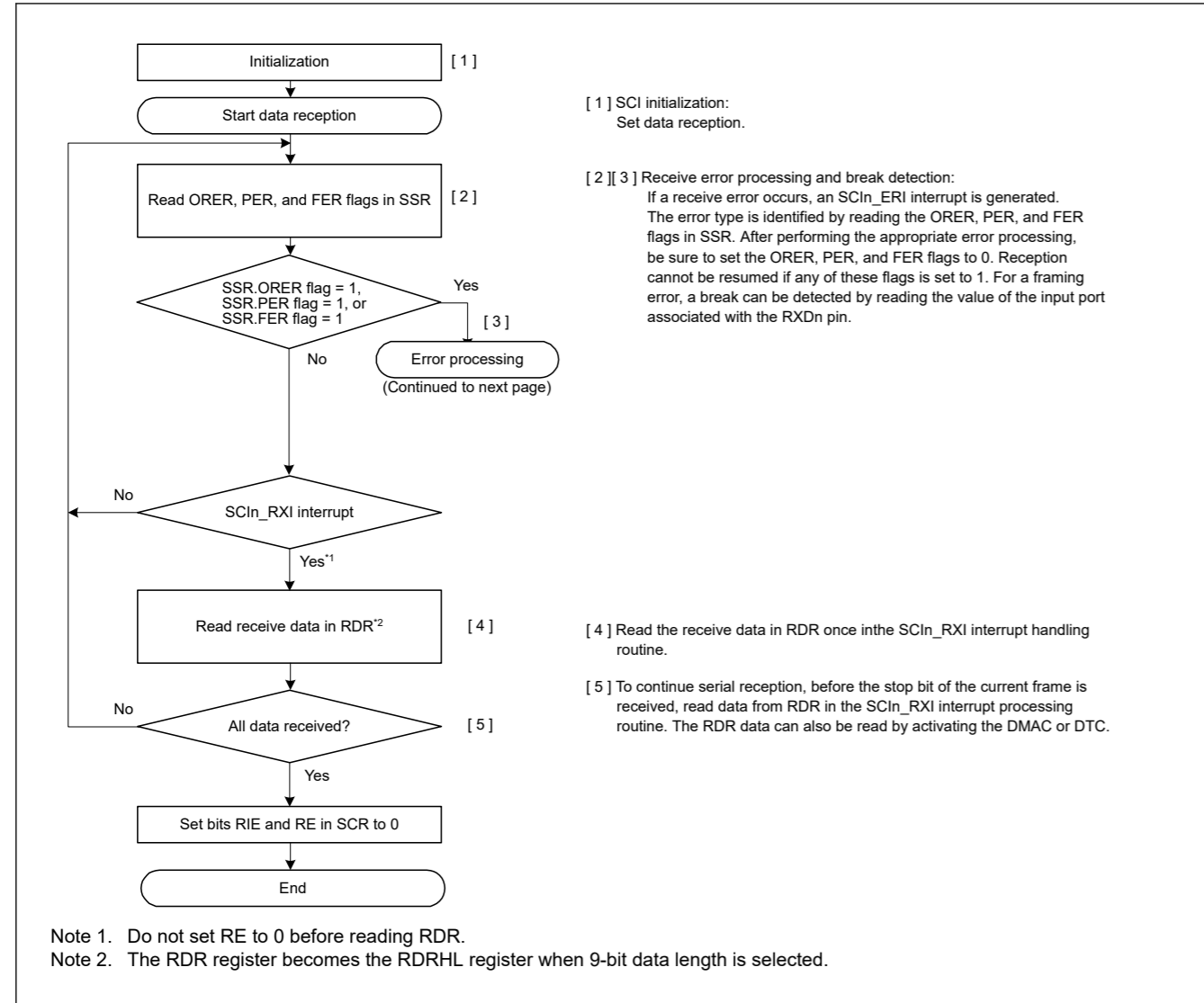


Figure 27.20 Example flow of serial reception in asynchronous mode with non-FIFO selected and Address Matching Disabled (1)

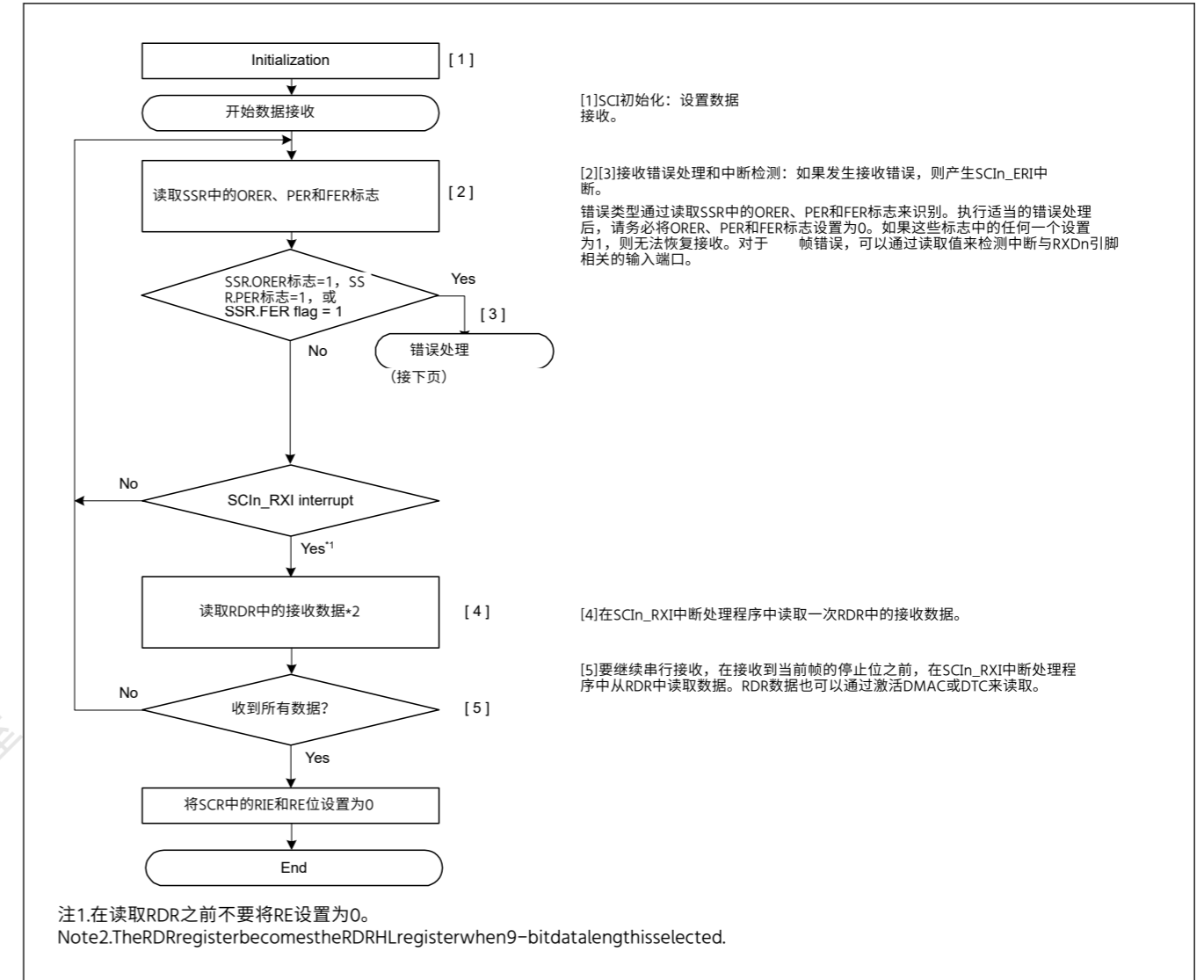


Figure 27.20 异步模式下串行接收的示例流程, 选择了非FIFO和地址匹配已禁用(1)

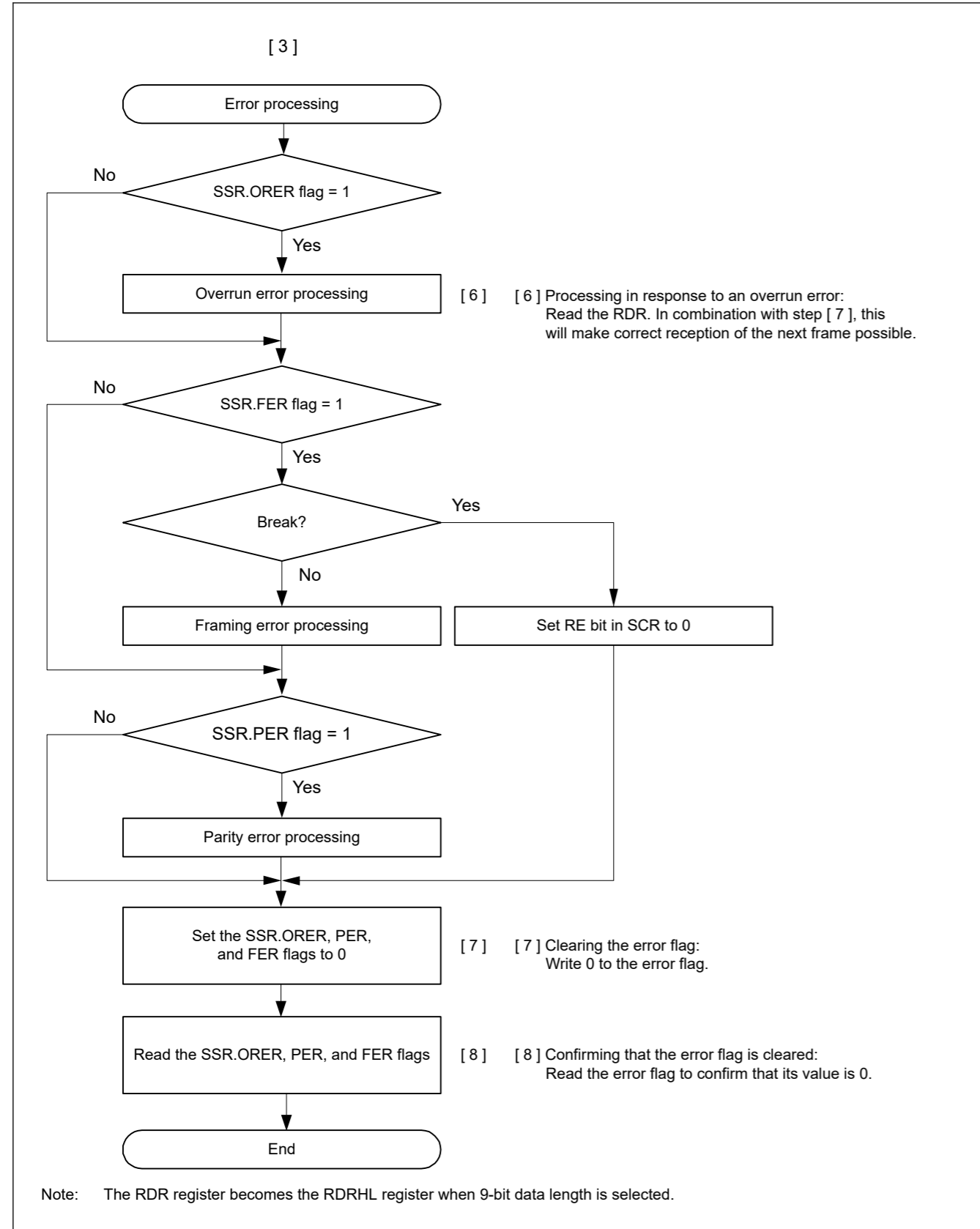


Figure 27.21 Example flow of serial reception in asynchronous mode with non-FIFO selected and Address Matching Disabled (2)

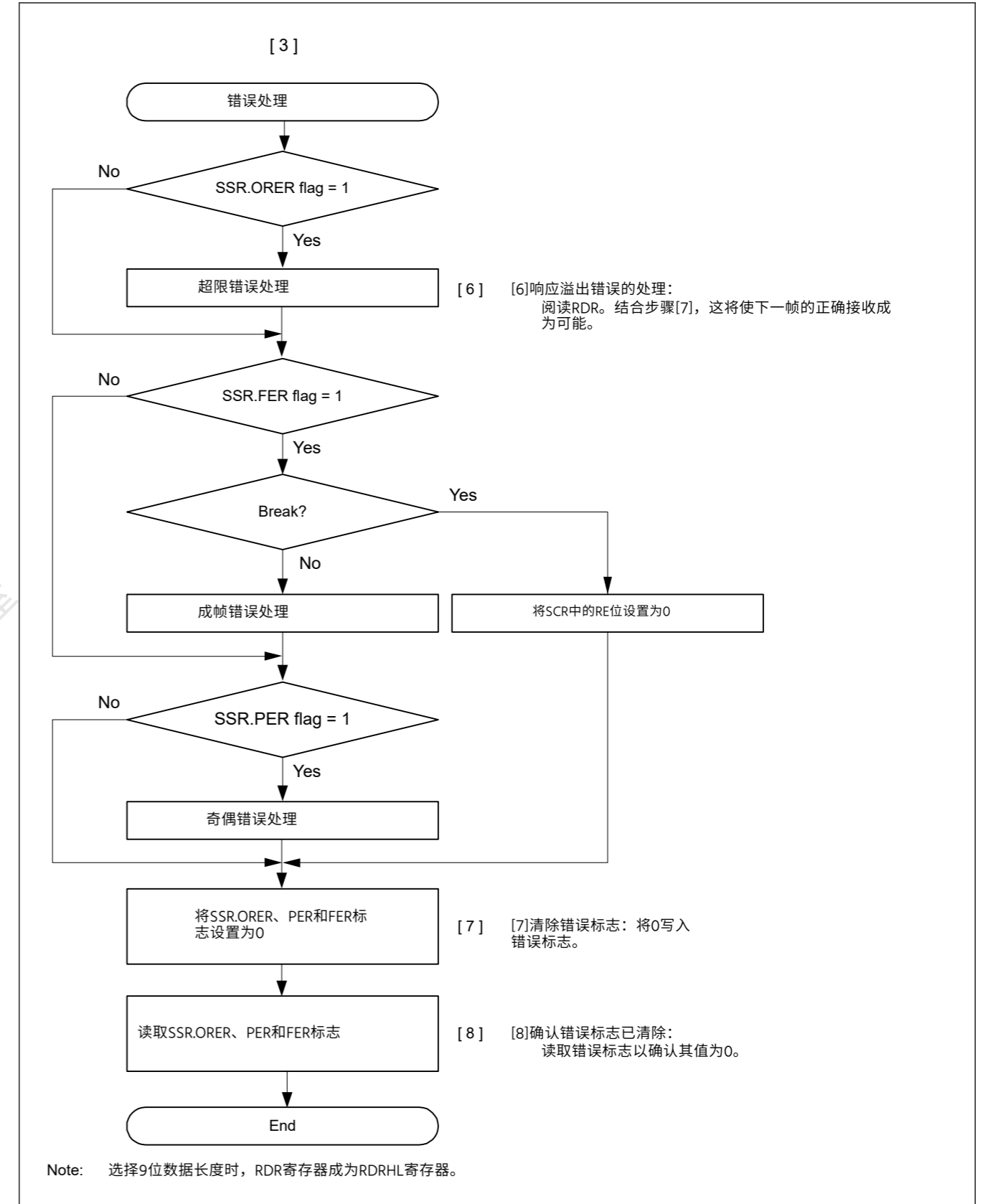


Figure 27.21 异步模式下串行接收的示例流程，选择了非FIFO和地址匹配已禁用(2)

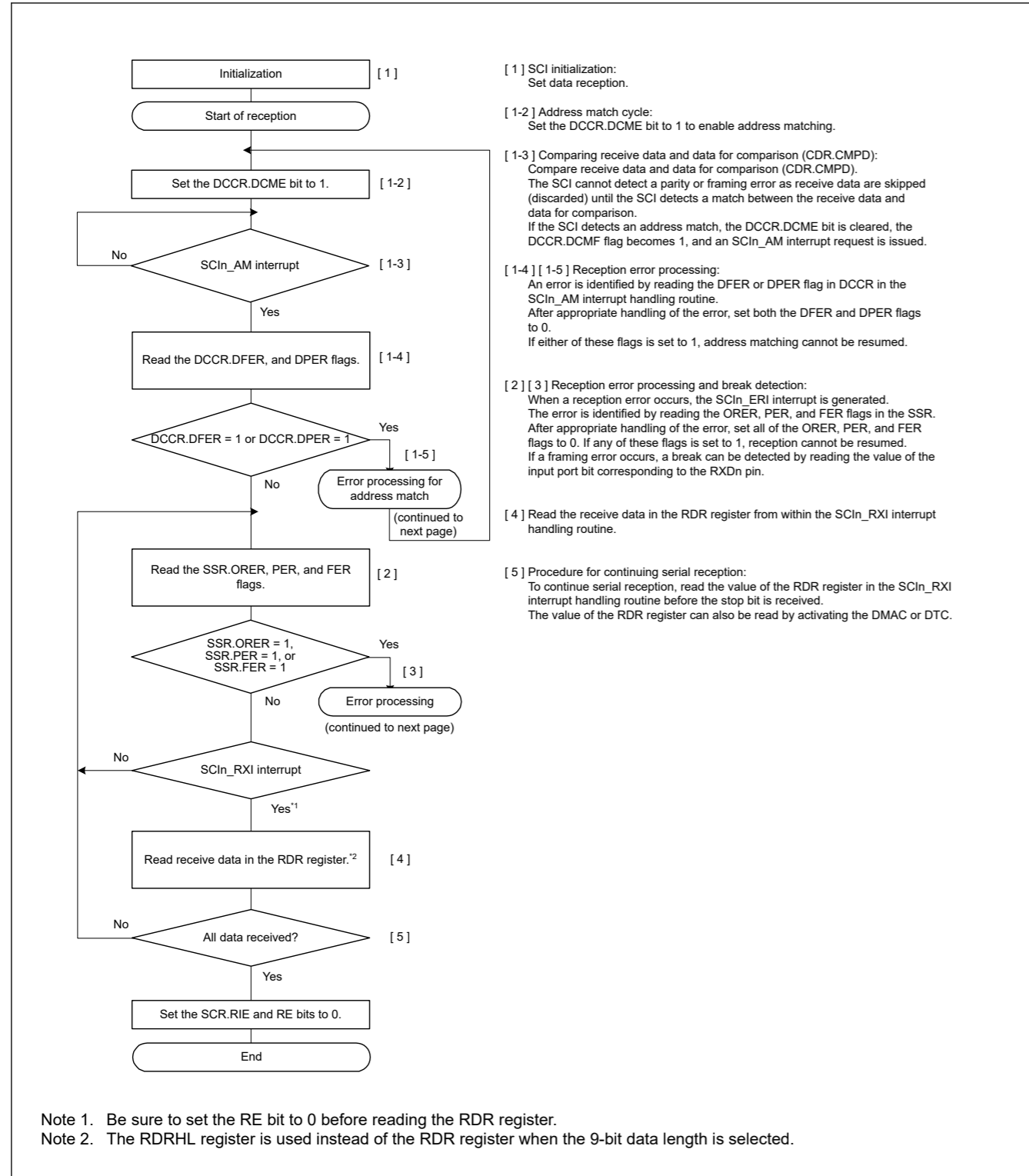


Figure 27.22 Example Flowchart of Serial Reception in Asynchronous Mode (FIFO not Selected and Address Matching Enabled) (1)

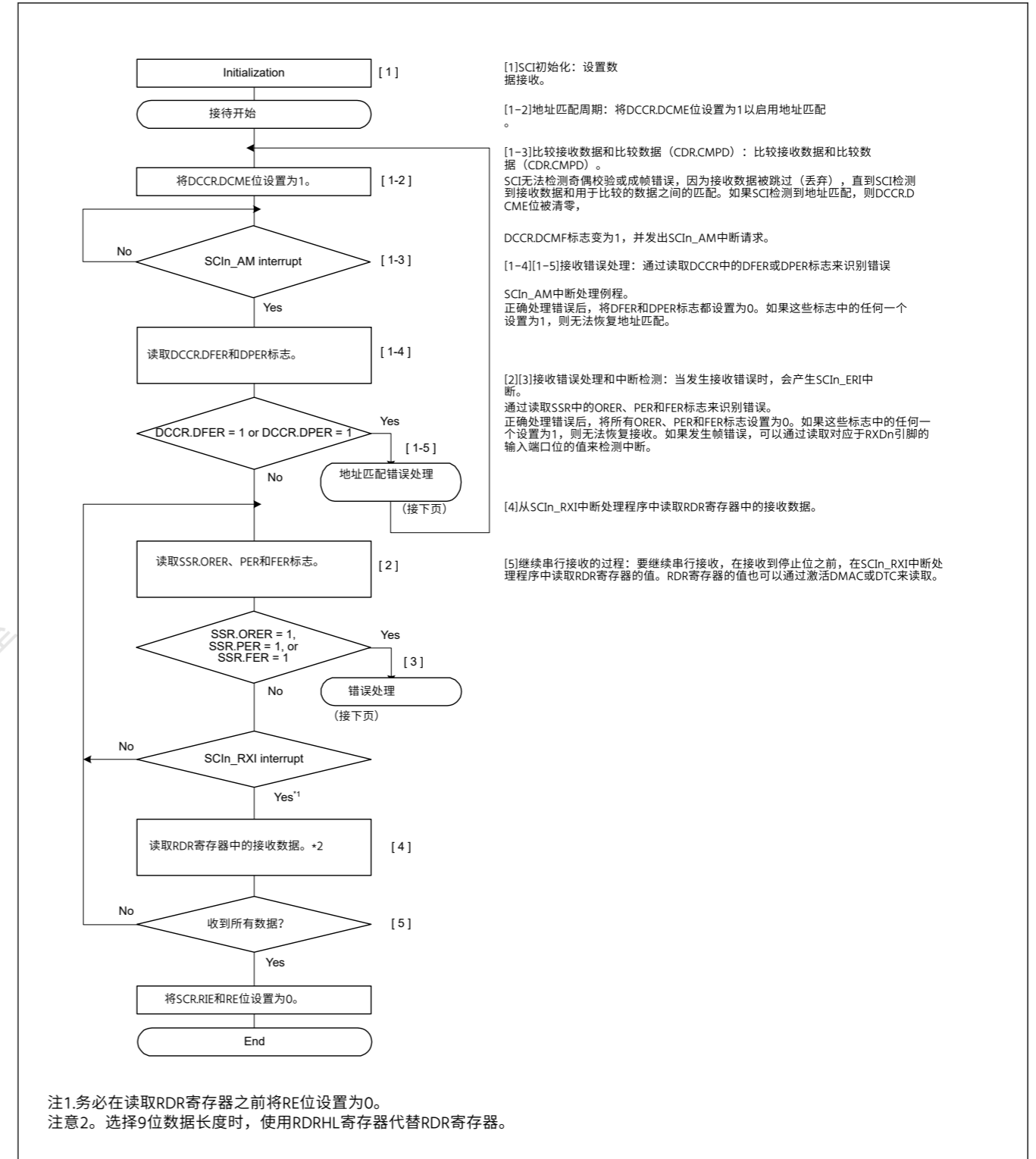


Figure 27.22 异步模式下串行接收的示例流程图 (未选择FIFO和地址匹配启用) (1)



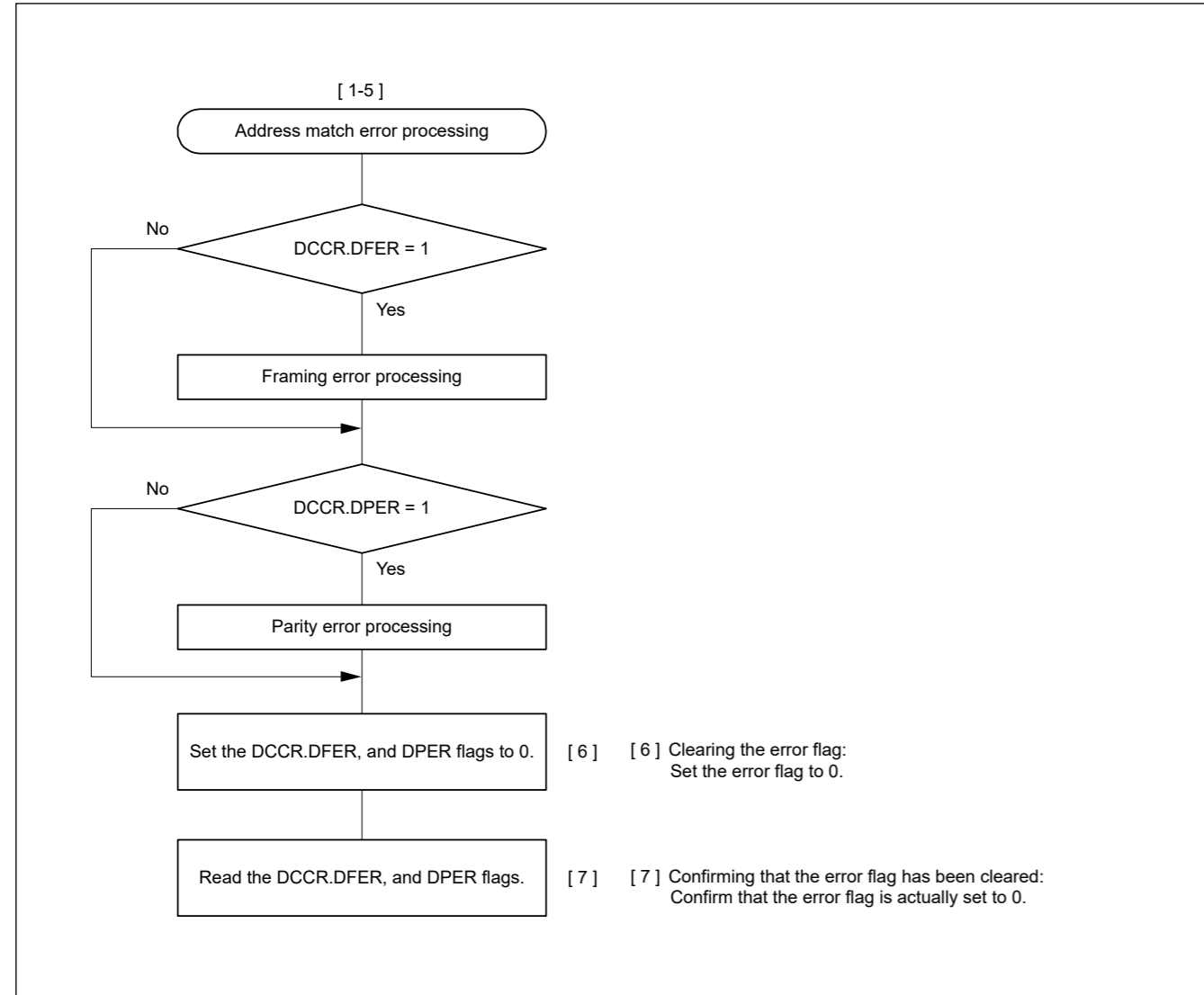


Figure 27.23 Example Flowchart of Serial Reception in Asynchronous Mode (FIFO not Selected and Address Matching Enabled) (2)

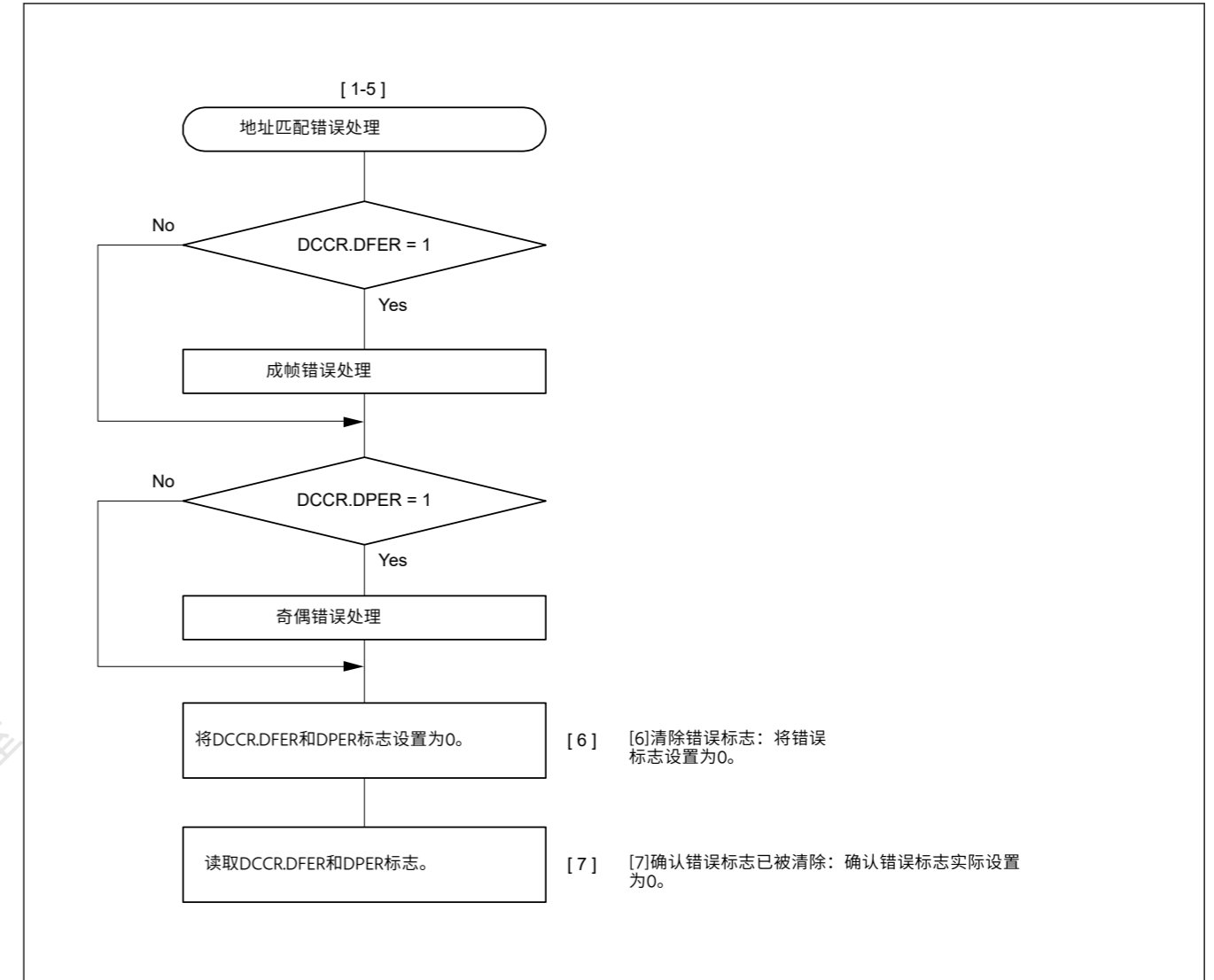


Figure 27.23 异步模式下串行接收的示例流程图 (未选择FIFO和地址 Matching Enabled) (2)

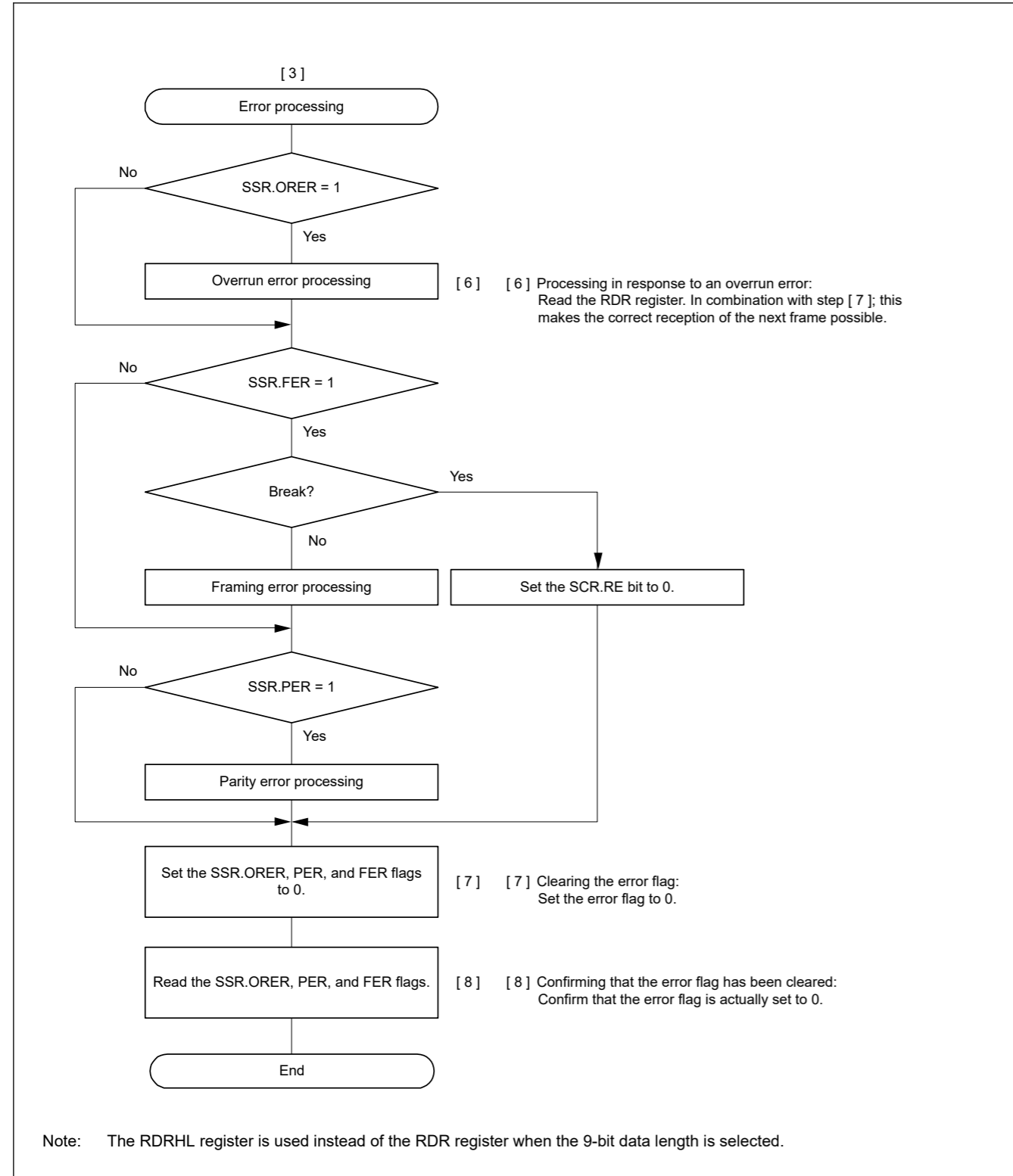


Figure 27.24 Example Flowchart of Serial Reception in Asynchronous Mode (FIFO not Selected and Address Matching Enabled) (3)

(2) FIFO selected

Figure 27.25 shows an example of a data format that is written to FRDRH register and FRDRL register in asynchronous mode.

In asynchronous mode, 0 is written to the MPB bit in the FRDRH register. Data that corresponds to the data length is written to FRDRH and FRDRL. Unused bits are written as 0. Read in order from FRDRH to FRDRL. If software reads FRDRL, the

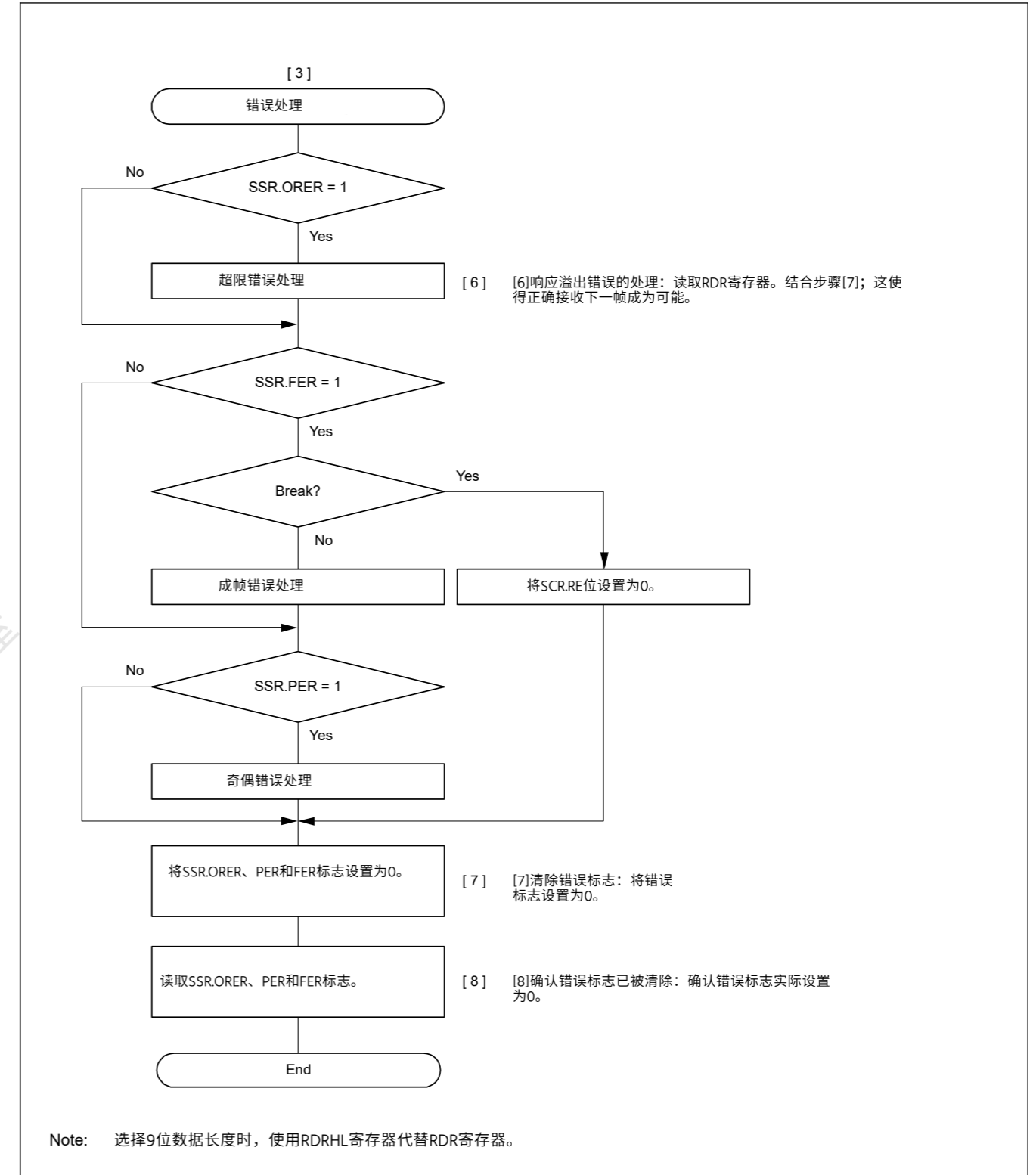


Figure 27.24 异步模式下串行接收的示例流程图 (未选择FIFO和地址 Matching Enabled) (3)

(2) FIFO selected

图27.25显示了在异步模式下写入FRDRH寄存器和FRDRL寄存器的数据格式示例。

在异步模式下，将0写入FRDRH寄存器的MPB位。对应于数据长度的数据被写入FRDRH和FRDRL。未使用的位写为0。按从FRDRH到FRDRL的顺序读取。如果软件读取FRDRL，则

SCI updates FER, PER, and receive data (RDAT[8:0]) in the FRDRL register with the next data. The flags RDF, ORER, and DR in the FRDRH register always reflect the associated flags in the SSR\_FIFO register.

| Data Length | Register Setting |            | Receive data in FRDRH, FRDRL |     |      |     |     |     |    |                    |                    |                    |    |    |    |    |    |    |
|-------------|------------------|------------|------------------------------|-----|------|-----|-----|-----|----|--------------------|--------------------|--------------------|----|----|----|----|----|----|
|             | SCMR. CHR1       | SMR. CHR   | FRDRH                        |     |      |     |     |     |    |                    |                    |                    |    |    |    |    |    |    |
|             |                  |            | b15                          | b14 | b13  | b12 | b11 | b10 | b9 | b8                 | b7                 | b6                 | b5 | b4 | b3 | b2 | b1 | b0 |
| 7 bits      | 1                | 0          | —                            | RDF | ORER | FER | PER | DR  | 0  | 0                  | 0                  | 7-bit receive data |    |    |    |    |    |    |
| 8 bits      | 1                | 1          | —                            | RDF | ORER | FER | PER | DR  | 0  | 0                  | 8-bit receive data |                    |    |    |    |    |    |    |
| 9 bits      | 0                | Don't care | —                            | RDF | ORER | FER | PER | DR  | 0  | 9-bit receive data |                    |                    |    |    |    |    |    |    |

Note: 0 is always read for MPB bit (FRDRH[1])  
When data length is 7 bits, 0 is always read for FRDRH[0] and FRDRL[7]  
When data length is 8 bits, 0 is always read for FRDRH[0]  
FRDRH[7] bit is read as an indefinite value

**Figure 27.25 Data format stored in FRDRH and FRDRL with FIFO selected**

In serial data reception, the SCI operates as follows:

- When the value of the SCR.RE bit becomes 1, the output signal on the CTSn\_RTSn pin goes low.
- The SCI monitors the communications line and, when it detects a start bit, the SCI performs internal synchronization, stores receive data in the RSR register.
- If the multi-processor communications function is enabled (SMR.MP = 1), see [section 27.4.2. Multi-Processor Serial Data Reception](#). If the address match function (data compare match function) is enabled (DCCR.DCME = 1), the SCI cannot detect a parity or framing error as receive data are skipped (discarded) until the SCI detects a match between the receive data and the data for comparison (CDR.CMPD\*1).
- If the SCI detects an address match, the DCCR.DCME bit is automatically cleared, the DCCR.DCMF flag becomes 1, and an SCIn\_AM interrupt\*2 request is generated. To enable the generation of an SCIn\_RXI interrupt request, set the SCR.RIE bit to 1. The compared receive data are not stored in the RDR register\*3. The SSR.RDRF flag remains 0.
- If the SCI detects a framing error in the receive data for which an address match was detected, the DCCR.DFER flag is set to 1, and if the SCI detects a parity error in that frame, the DCCR.DPER flag becomes 1. To enable the generation of an SCIn\_ERI interrupt request, set the SCR.RIE bit to 1.
- If a framing or a parity error is detected (the DCCR.DFER flag or DCCR.DPER flag is 1) in the SCIn\_AM interrupt handling routine, set the DCCR.DFER and DCCR.DPER flags to 0 and set the DCCR.DCME bit to 1 to enable the address match function again. If neither a framing nor a parity error has been detected (the DCCR.DFER and DCCR.DPER flags are 0), set the DCCR.DCMF flag to 0. See [Figure 27.9](#).
- If an overrun error occurs during normal communications, the SSR\_FIFO.ORER flag is set to 1. If the SCR.RIE bit in SCR is 1, an SCIn\_ERI interrupt request is generated. Receive data is not transferred to the FRDRL\*3 register.
- If a parity error is detected, the PER flag and receive data are transferred to the FRDRL\*3 register. If the SCR.RIE bit is set to 1, an SCIn\_ERI interrupt request is generated.
- If a framing error is detected, the FER flag and receive data are transferred to the FRDRL\*3 register. If the SCR.RIE bit is set to 1, an SCIn\_ERI interrupt request is generated.
- After a framing error is detected and when SCI detects that the continuous receive data is for one frame, reception stops.
- When the amount of data stored in the FRDRL register falls below the specified receive triggering number, and the next data is not received after 15 ETUs from the last stop bit in asynchronous mode, the SSR\_FIFO.DR flag is set to 1. When the SCR.RIE bit is 1 and the FCR.DRES bit is 0, the SCI generates an SCIn\_RXI interrupt request. When the FCR.DRES bit is 1, SCI generates an SCIn\_ERI interrupt request.
- When reception finishes successfully, receive data is transferred to the FRDRL\*3 register. The RDF bit is set to 1 when the amount of receive data written to FRDRHL is equal to or greater than the specified receive triggering number. If the

SCI使用下一个数据更新FRDRL寄存器中的FER、PER和接收数据(RDAT[8:0])。标志RDF、ORER和FRDRH寄存器中的DR始终反映SSR\_FIFO寄存器中的相关标志。

| 数据长度   | 寄存器设置      |            | 在FRDRH、FRDRL中接收数据 |     |      |     |     |     |    |        |        |        |    |    |    |    |    |    |
|--------|------------|------------|-------------------|-----|------|-----|-----|-----|----|--------|--------|--------|----|----|----|----|----|----|
|        | SCMR. CHR1 | SMR. CHR   | FRDRH             |     |      |     |     |     |    |        |        |        |    |    |    |    |    |    |
|        |            |            | b15               | b14 | b13  | b12 | b11 | b10 | b9 | b8     | b7     | b6     | b5 | b4 | b3 | b2 | b1 | b0 |
| 7 bits | 1          | 0          | —                 | RDF | ORER | FER | PER | DR  | 0  | 0      | 0      | 7位接收数据 |    |    |    |    |    |    |
| 8 bits | 1          | 1          | —                 | RDF | ORER | FER | PER | DR  | 0  | 0      | 8位接收数据 |        |    |    |    |    |    |    |
| 9 bits | 0          | Don't care | —                 | RDF | ORER | FER | PER | DR  | 0  | 9位接收数据 |        |        |    |    |    |    |    |    |

Note: MPB位(FRDRH[1])始终读取0当数据长度为7位时, FRDRH[0]和FRDRL[7]始终读取0  
当数据长度为8位时, FRDRH[0]总是读取0  
FRDRH[7]位被读取为不定值

**Figure 27.25 存储在FRDRH和FRDRL中的数据格式, 选择了FIFO**

在串行数据接收中, SCI操作如下:

- 当SCR.RE位的值变为1时, CTSn\_RTSn引脚上的输出信号变为低电平。
- SCI监视通信线路, 当它检测到一个起始位时, SCI执行内部同步, 将接收数据存储到RSR寄存器中。
- 如果启用多处理器通信功能 (SMR.MP=1), 请参见第27.4.2节。多处理器串行数据接收。如果地址匹配功能 (数据比较匹配功能) 被启用 (DCCR.DCME=1), SCI无法检测奇偶校验或帧错误, 因为接收数据被跳过 (丢弃), 直到SCI检测到接收数据与用于比较的数据 (CDR.CMPD\*1)。
- 如果SCI检测到地址匹配, DCCR.DCME位自动清零, DCCR.DCMF标志变为1, 并产生SCIn\_AM中断\*2请求。要启用SCIn\_RXI中断请求的生成, 请将SCR.RIE位设置为1。比较的接收数据不存储在RDR寄存器\*3中。SSR.RDRF标志保持为0。
- 如果SCI在检测到地址匹配的接收数据中检测到帧错误, 则DCCR.DFER标志设置为1, 如果SCI在该帧中检测到奇偶校验错误, 则DCCR.DPER标志变为1。要启用SCIn\_ERI中断请求的生成, 请将SCR.RIE位设置为1。
- 如果在SCIn\_AM中断处理例程中检测到成帧或奇偶校验错误 (DCCR.DFER标志或DCCR.DPER标志为1), 则将DCCR.DFER和DCCR.DPER标志设置为0, 并设置DCCR.DCME位为1以再次启用地址匹配功能。如果既没有检测到成帧错误也没有检测到奇偶校验错误 (DCCR.DFER和DCCR.DPER标志为0), 将DCCR.DCMF标志设置为0。参见图27.9。
- 如果在正常通信过程中发生溢出错误, 则SSR\_FIFO.ORER标志设置为1。如果SCR中的SCR.RIE位为1, 则产生SCIn\_ERI中断请求。接收数据不传送到FRDRL\*3寄存器。
- 如果检测到奇偶校验错误, 则将PER标志和接收数据传送到FRDRL\*3寄存器。如果SCR.RIE位设置为1, 则会产生SCIn\_ERI中断请求。
- 如果检测到帧错误, 则将FER标志和接收数据传送到FRDRL\*3寄存器。如果SCR.RIE位设置为1, 则会产生SCIn\_ERI中断请求。
- 检测到帧错误后, 当SCI检测到连续接收数据为一帧时, 停止接收。
- 当FRDRL寄存器中存储的数据量低于指定的接收触发数, 并且在异步模式下从最后一个停止位开始15个ETU后没有接收到下一个数据时, SSR\_FIFO.DR标志设置为1。SCR.RIE位为1, FCR.DRES位为0, SCI产生一个SCIn\_RXI中断请求。当FCR.DRES位为1时, SCI产生一个SCIn\_ERI中断请求。
- 接收成功后, 接收数据被传送到FRDRL\*3寄存器。当写入FRDRHL的接收数据量等于或大于指定的接收触发数时, RDF位设置为1。如果

SCR.RIE bit in SCR is 1, an SCIn\_RXI interrupt request is generated. Continuous reception is enabled by reading the receive data transferred to the FRDRL\*4 register in the SCIn\_RXI interrupt handling routine, before an overrun error occurs. If the received data that is transferred to FRDRL\*5 is less than the RTS trigger number, the CTSn\_RTsn pin outputs low.

- Note 1. One of three lengths is selected for the target for comparison: CMPD[6:0] is for 7-bit length, CMPD[7:0] is for 8-bit length, and CMPD[8:0] is for 9-bit length.
- Note 2. As no interrupt enable bit is assigned to the SCIn\_AM interrupt, an interrupt request is generated by setting the DCCR.DCMF to 1.
- Note 3. Only read data in the FRDRH and FRDRL registers when 9-bit data length is selected.
- Note 4. Read data in order from FRDRH to FRDRL when 9-bit data length is selected.
- Note 5. The SCI only checks for update to the FRDRL register and not to the FRDRH register when 9-bit data length is selected.

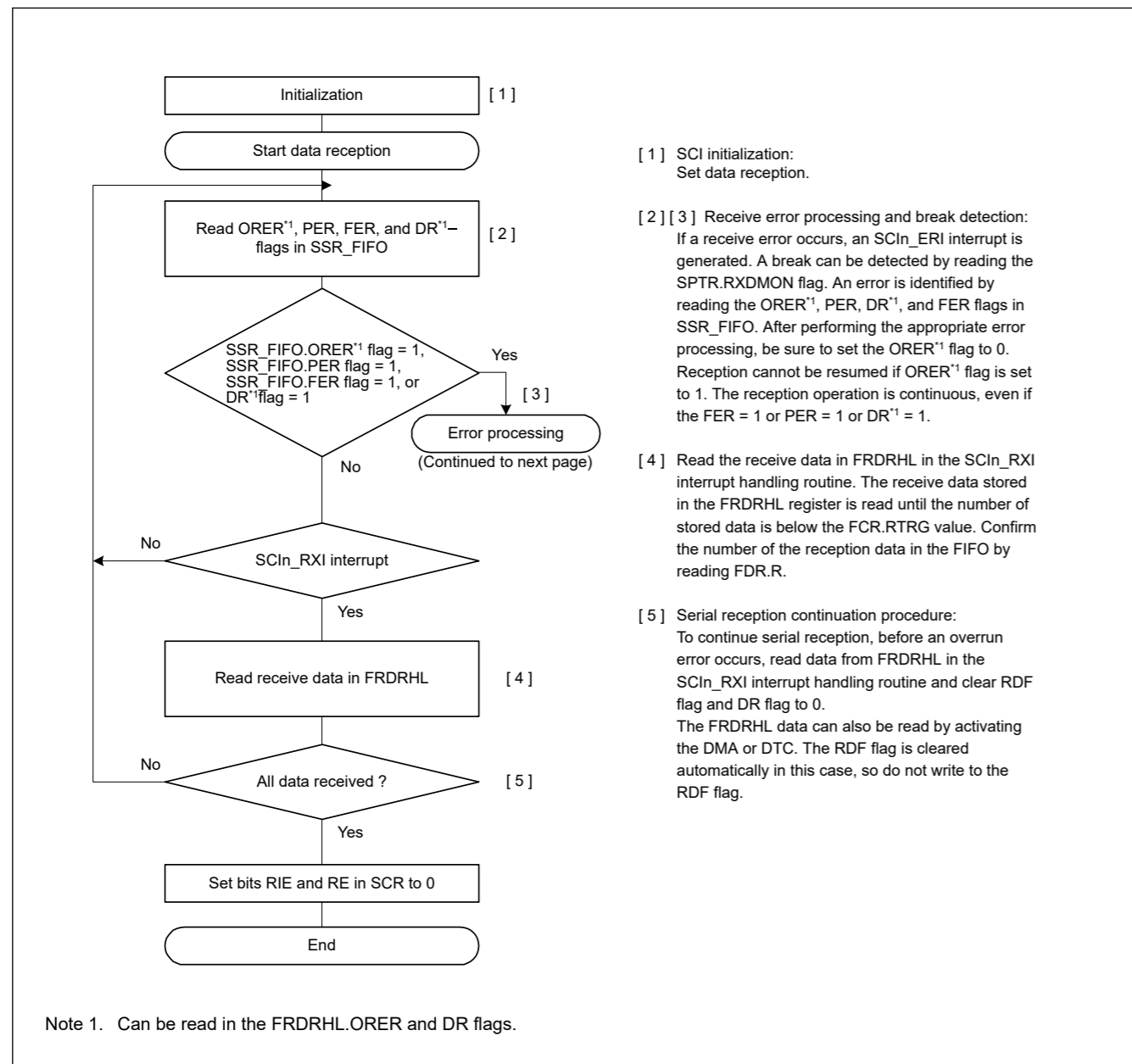


Figure 27.26 Example flow of serial reception in asynchronous mode with FIFO selected and Address Matching Enabled (1)

SCR中的SCR.RIE位为1, 产生SCIn\_RXI中断请求。在发生溢出错误之前, 通过在SCIn\_RXI中断处理程序中读取传输到FRDRL\*4寄存器的接收数据来启用连续接收。如果传送到FRDRL\*5的接收数据小于RTS触发数, CTSn\_RTsn引脚输出低电平。

- 注1.选择三个长度之一作为目标进行比较: CMPD[6:0]为7位长度, CMPD[7:0]为8位长度, CMPD[8:0]为9位长度。
- 注2.由于没有为SCIn\_AM中断分配中断使能位, 因此通过设置DCCR.DCMF to 1.
- 注3.选择9位数据长度时, 仅读取FRDRH和FRDRL寄存器中的数据。
- 注4.选择9位数据长度时, 按从FRDRH到FRDRL的顺序读取数据。
- Note5.TheSCIonlychecksforupdatetotheFRDRLregisterandnottotheFRDRHregisterwhen9-bitdatalengthisselected.

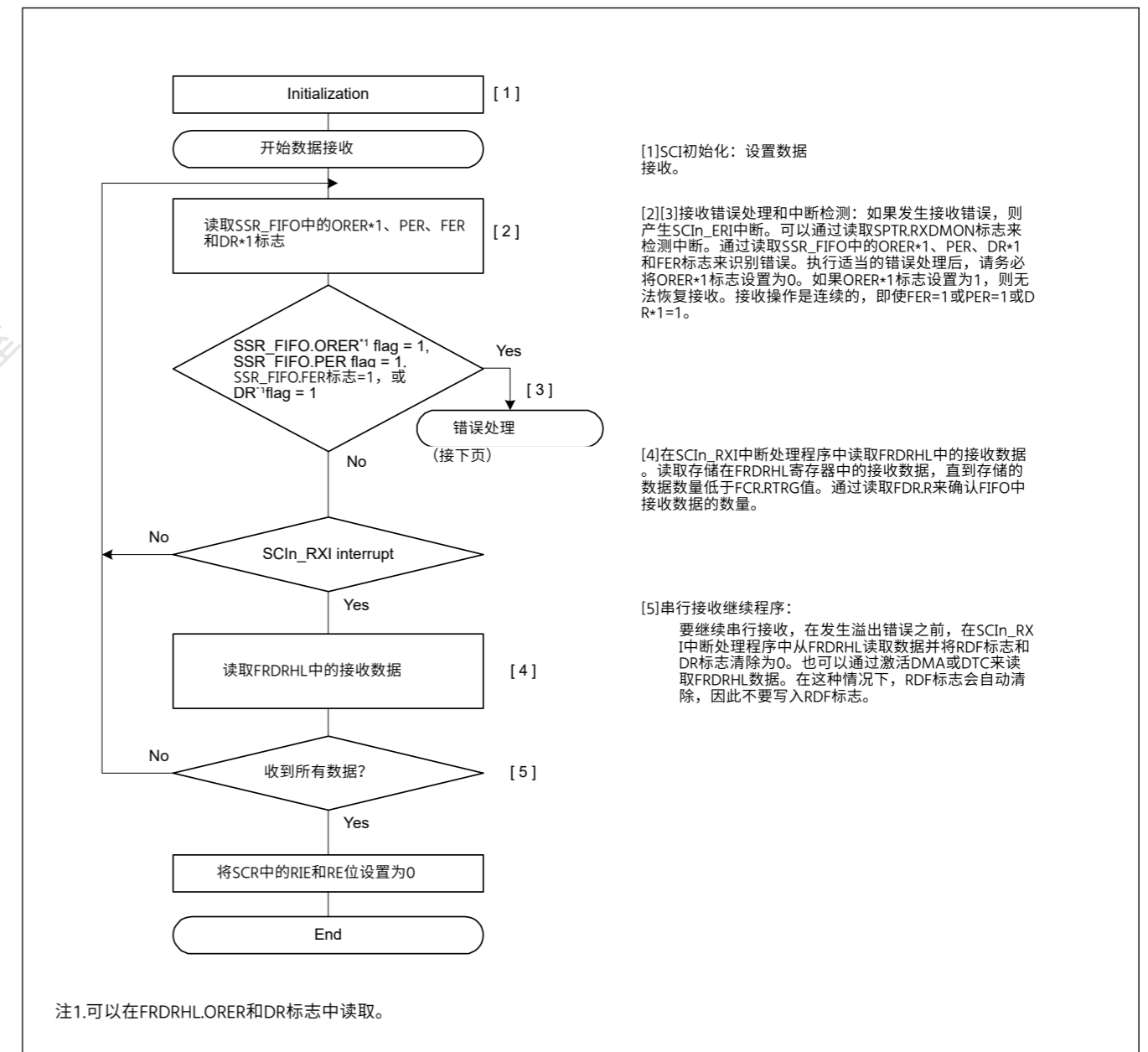


Figure 27.26 选择FIFO和地址的异步模式下串行接收示例流程匹配启用(1)



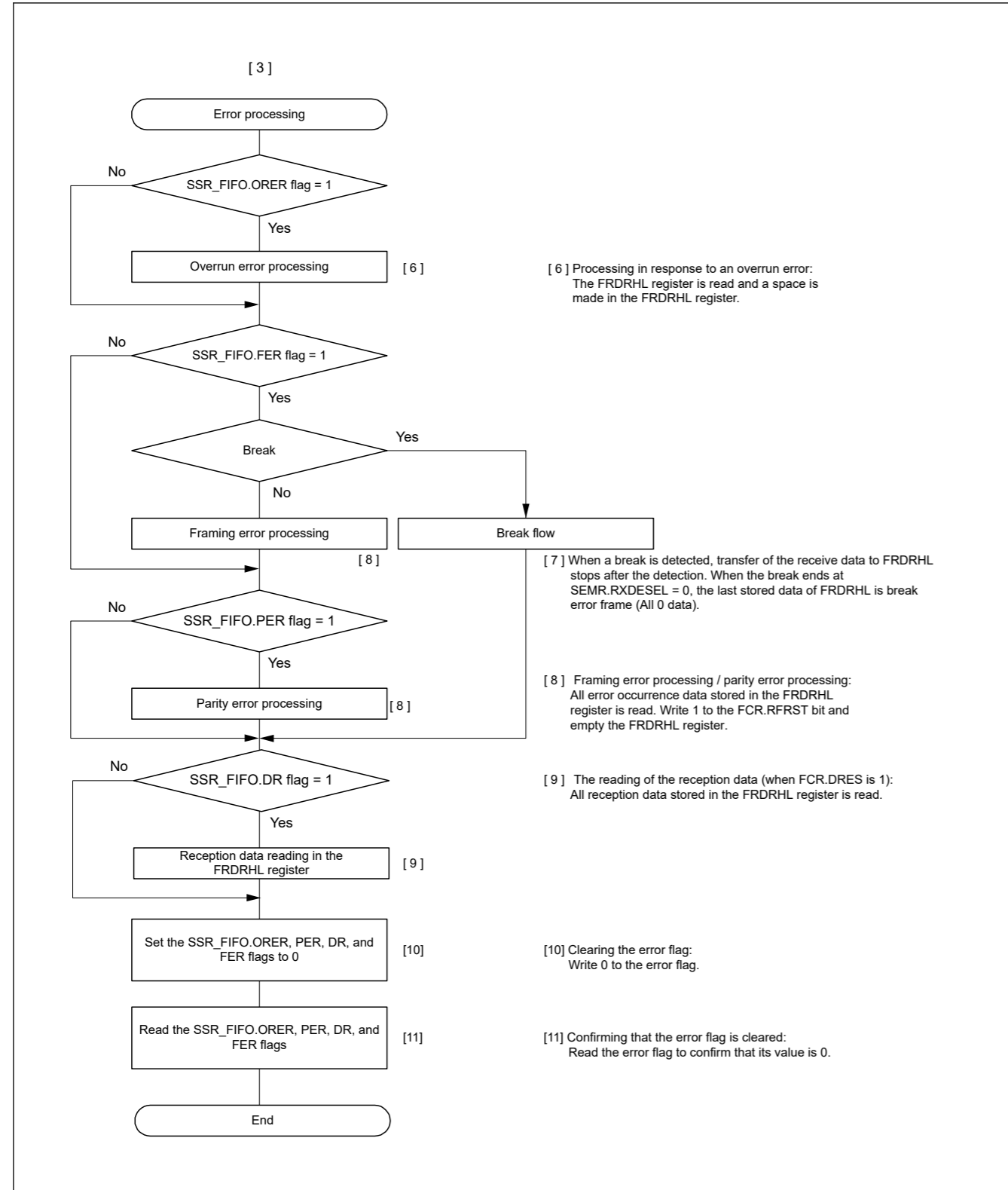


Figure 27.27 Example flow of serial reception in asynchronous mode with FIFO selected Address Matching Disabled (2)

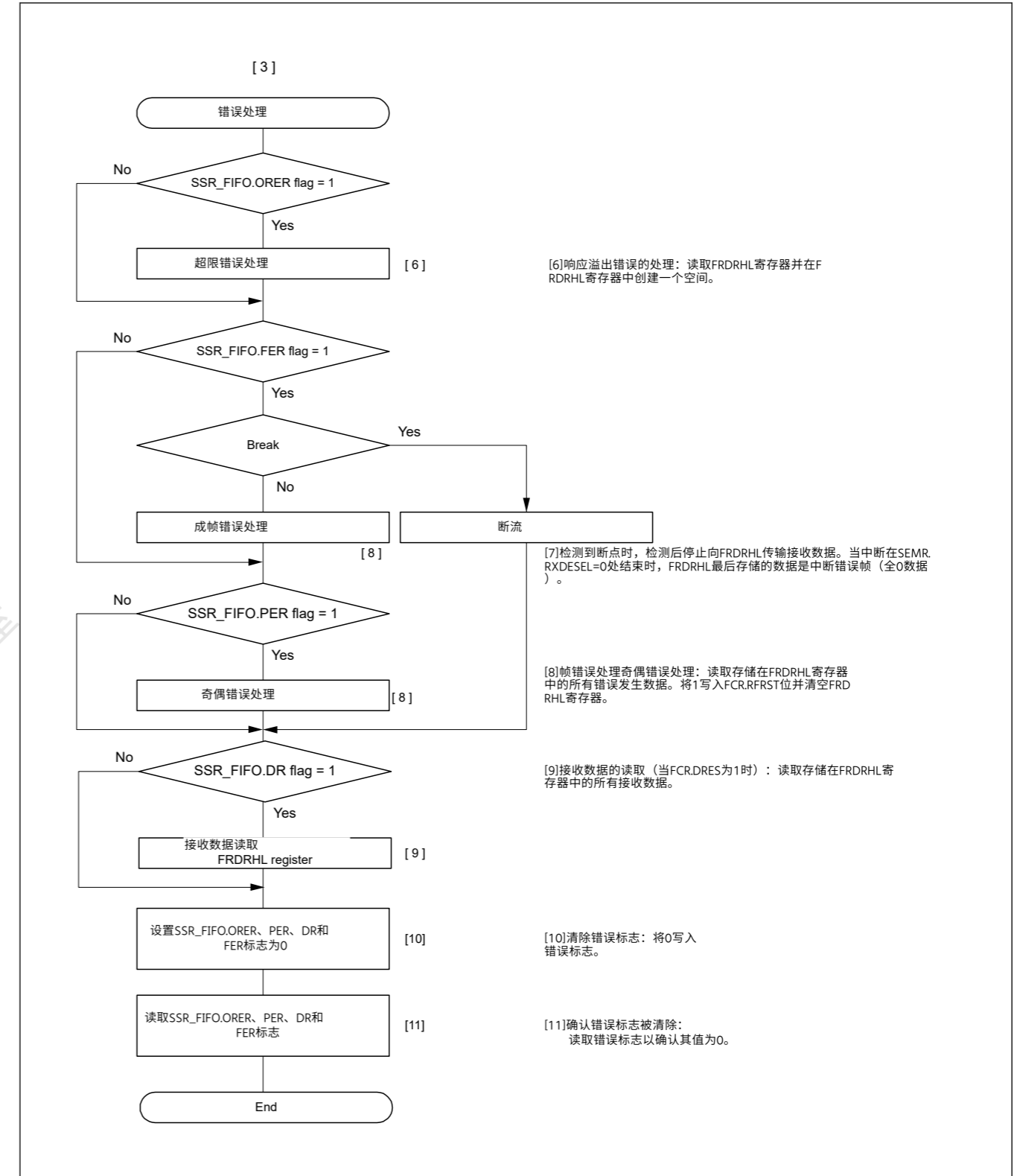


Figure 27.27 使用FIFO选择地址匹配的异步模式串行接收示例流程 Disabled (2)

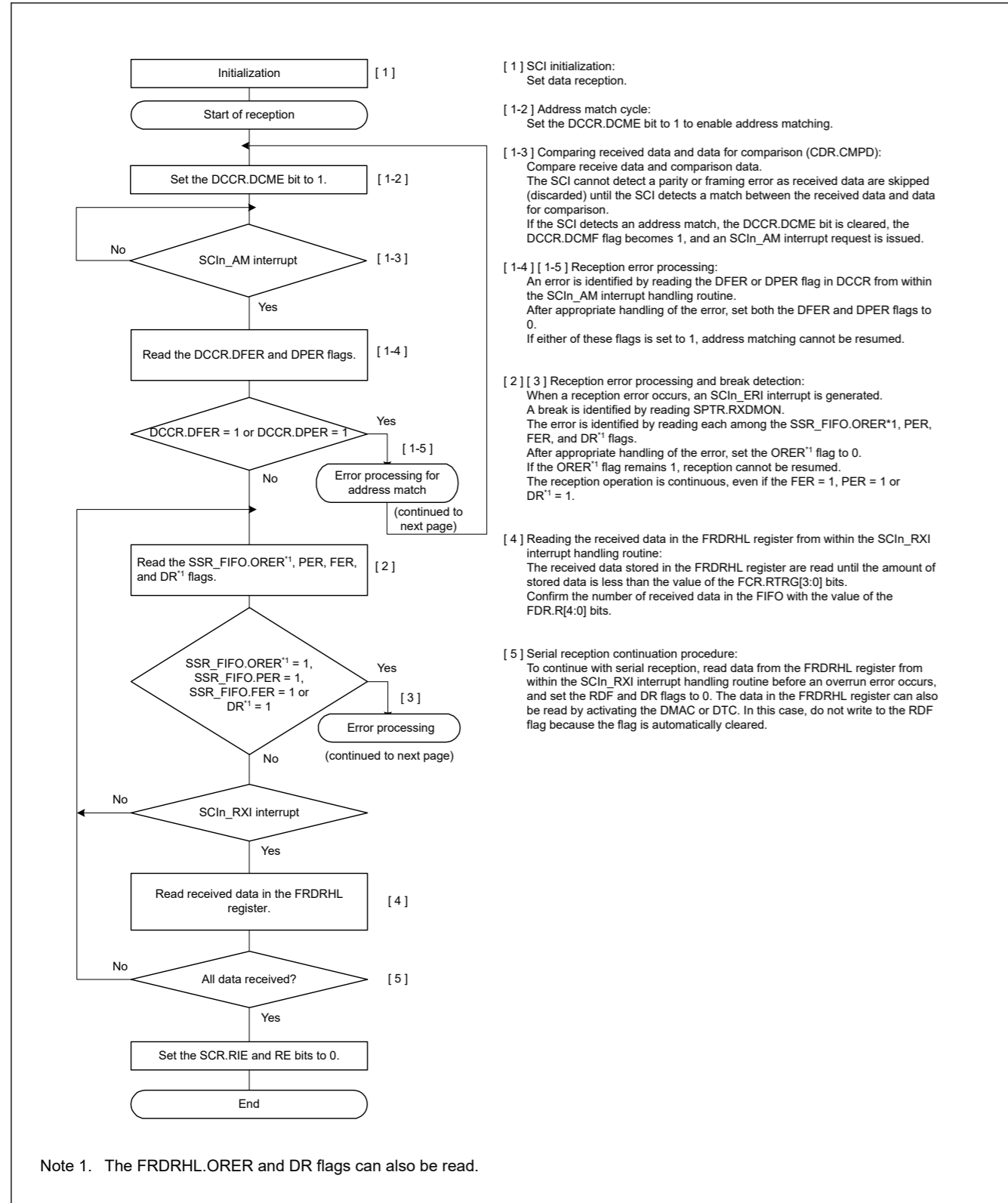


Figure 27.28 Example Flowchart of Serial Reception in Asynchronous Mode (FIFO Selected and Address Matching Enabled) (1)

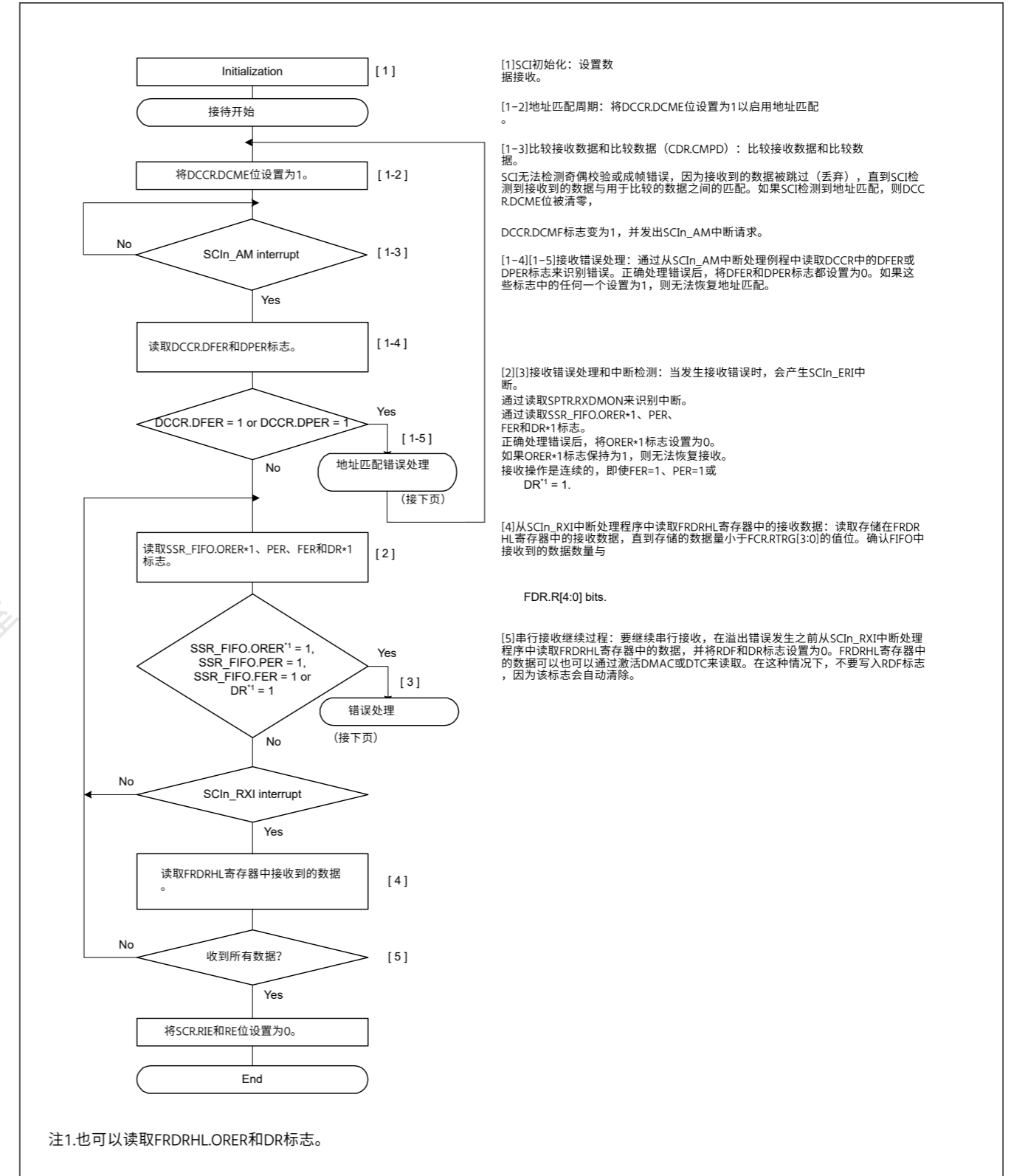


Figure 27.28 异步模式下串行接收的示例流程图（FIFO选择和地址 Matching Enabled）(1)

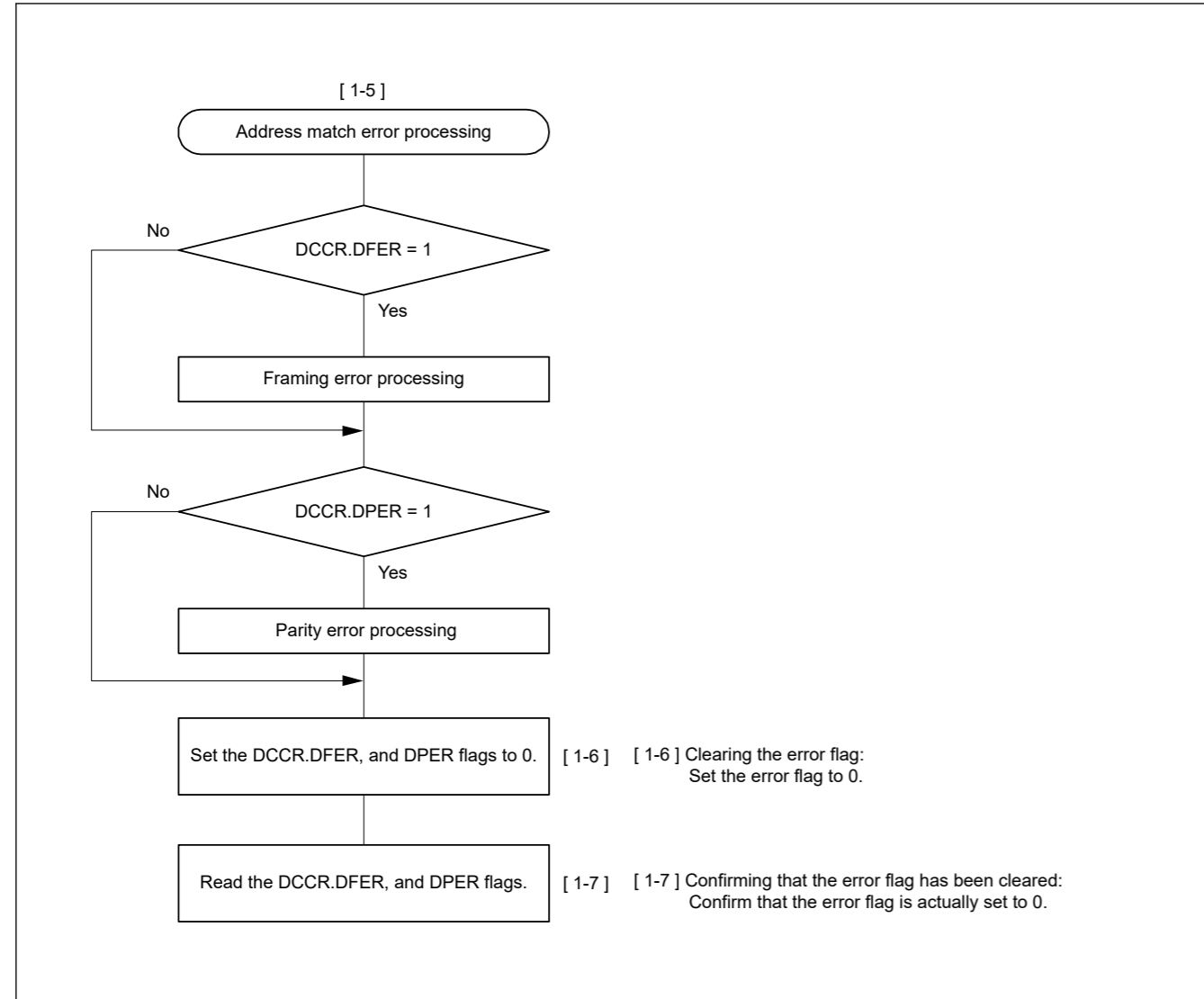


Figure 27.29 Example Flowchart of Serial Reception in Asynchronous Mode (FIFO Selected and Address Matching Enabled) (2)

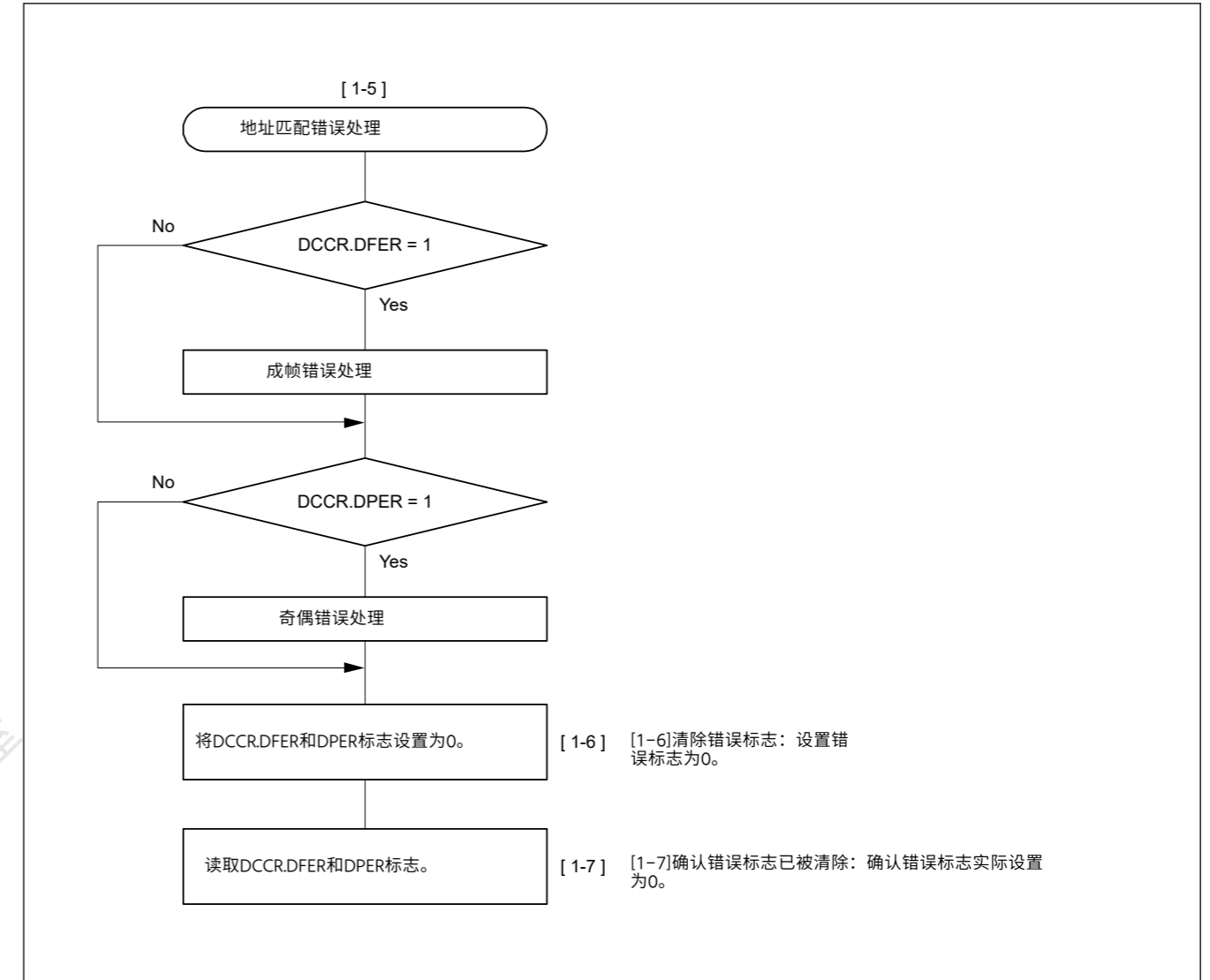


Figure 27.29 异步模式下串行接收的示例流程图 (FIFO选择和地址 Matching Enabled) (2)

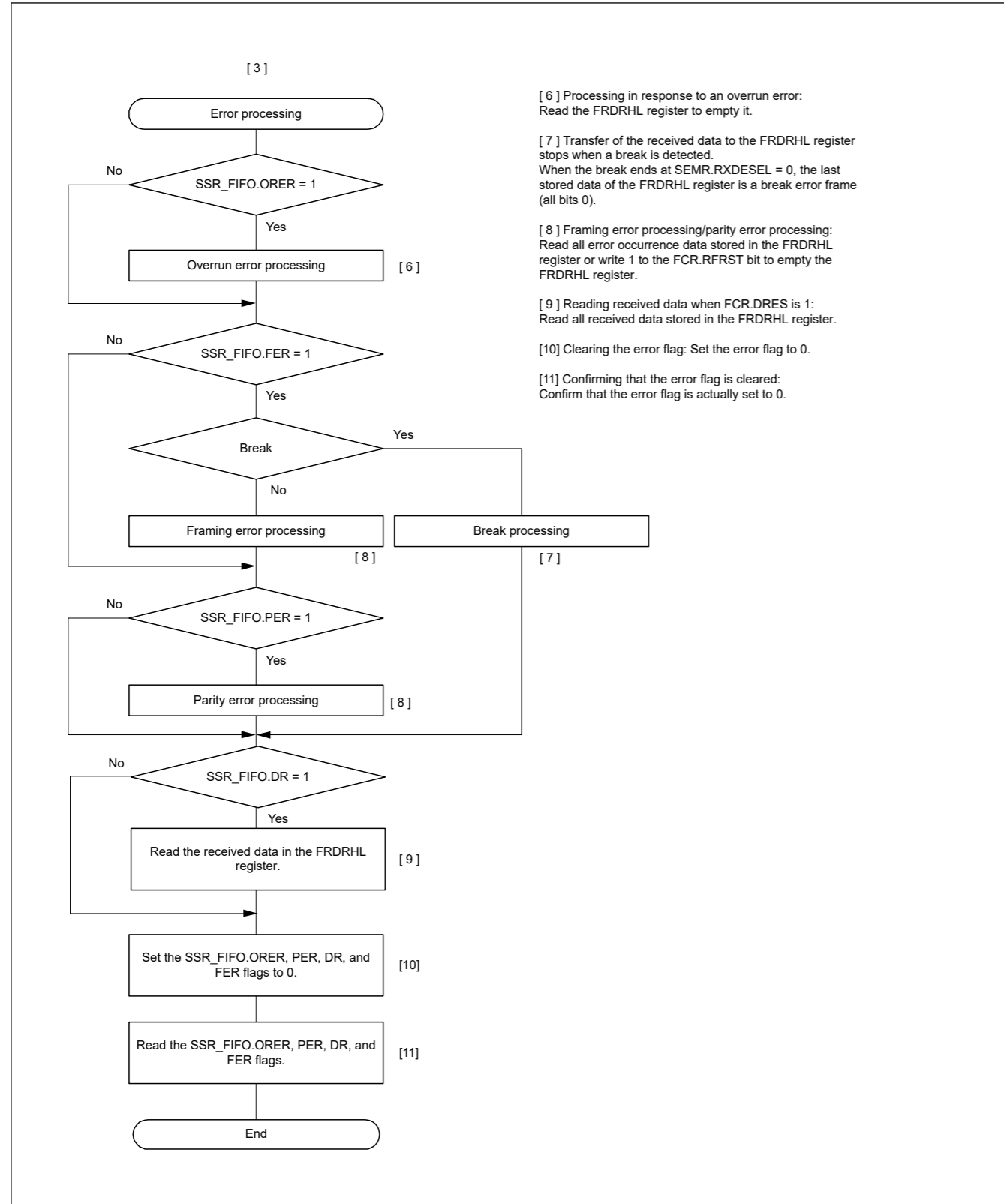


Figure 27.30 Example Flowchart of Serial Reception in Asynchronous Mode (FIFO Selected and Address Matching Enabled) (3)

27.3.10 The function of adjust receive sampling timing (Asynchronous Mode)

When there is the difference between the rising transfer time and the falling transfer time through a photo coupler, the receive sampling timing at middle of bit affects the reception margin. In this case, the receive sampling timing is able to adjust from the middle of bit to the optimum timing by using this function.

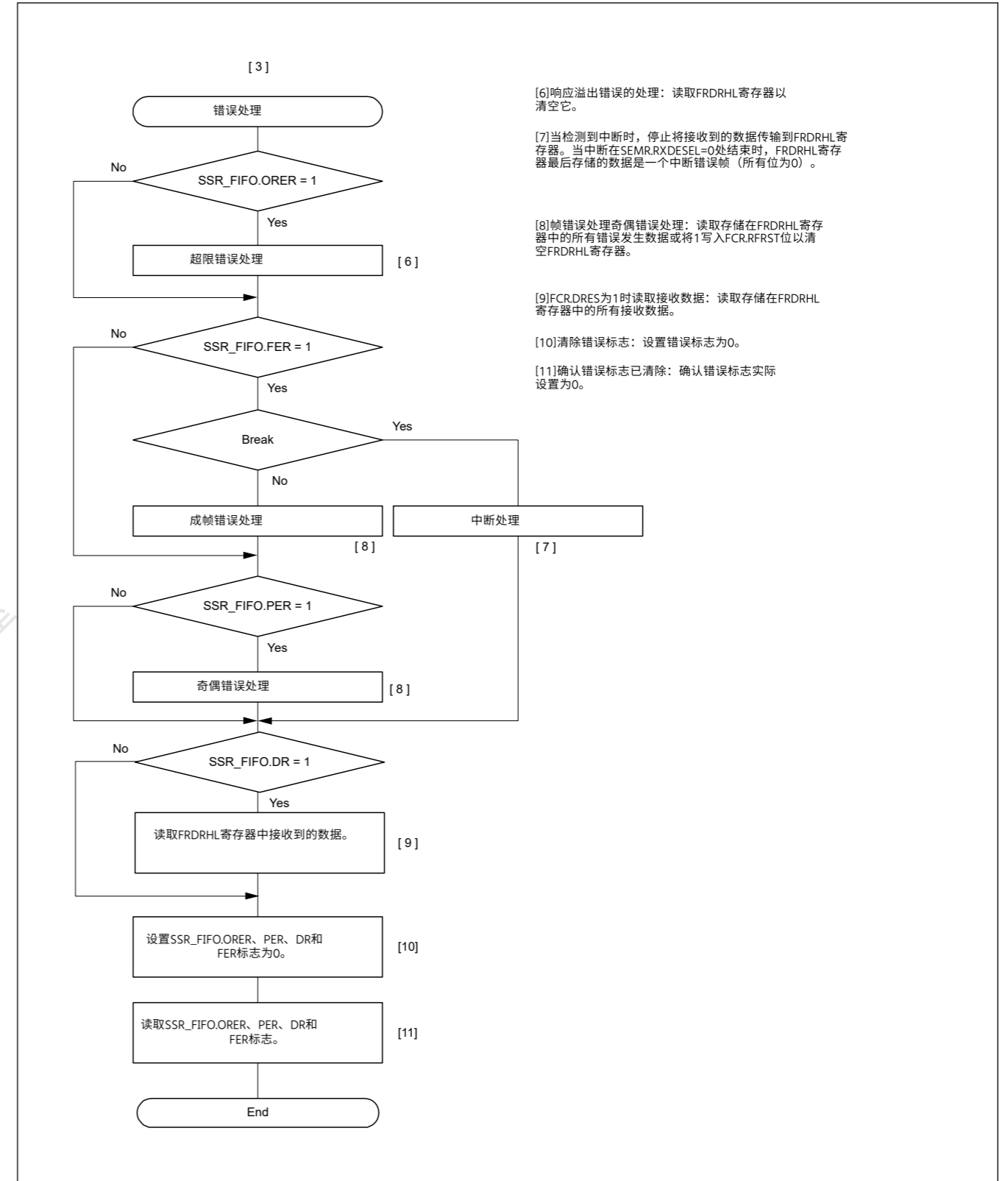


Figure 27.30 异步模式下串行接收的示例流程图（FIFO选择和地址匹配使能）(3)

27.3.10 调整接收采样定时功能（异步模式）

当通过光电耦合器的上升传输时间和下降传输时间之间存在差异时，位中间的接收采样时间会影响接收裕度。在这种情况下，接收采样时序可以通过使用该功能从比特中间调整到最佳时序。



The receive sampling timing is adjusted from the middle of bit by following formula. And the adjustable direction is set by ACTR.AJD. You can select forward or backward from the middle of bit. When adjusting backward (ACTR.AJD = 0), substitute AJD = +1 and substitute AJD = -1 when adjusting forward (ACTR.AJD = 1).

Adjusted sampling timing = the middle of bit + AJD \* (base clock \* the setting value of AST[2:0])

The setting timing is limited by base clock cycles per 1 bit. Please refer to Table 27.31 in detail.

A reception movement image figure of the communication through a photo coupler with this function is shown in Figure 27.31, Figure 27.32 and Figure 27.33, the movement explanation of this function is shown in Figure 27.34.

Please don't use this function when there is no difference between the rising transfer time and the falling transfer time, because there is a possibility of deteriorating the reception margin.

Table 27.31 The acceptable value of ACTR (asynchronous mode using internal clock)

| SEMR.ABCSE | SEMR.ABCS | The number of base clock cycles/1bit | The acceptable value of ACTR |                         |
|------------|-----------|--------------------------------------|------------------------------|-------------------------|
|            |           |                                      | ACTR.AJD                     | ACTR.AST                |
| 1          | x         | 6                                    | 0                            | 000 - 010 <sup>*1</sup> |
|            |           |                                      | 1                            |                         |
| 0          | 1         | 8                                    | 0                            | 000 - 011 <sup>*1</sup> |
|            |           |                                      | 1                            |                         |
| 0          | 0         | 16                                   | 0                            | 000 - 111               |
|            |           |                                      | 1                            |                         |

Note: x : Don't care

Note 1. When the value of ACTR.AST is over the acceptable value, sampling is done at default timing. (Adjustment of sampling is not done.)

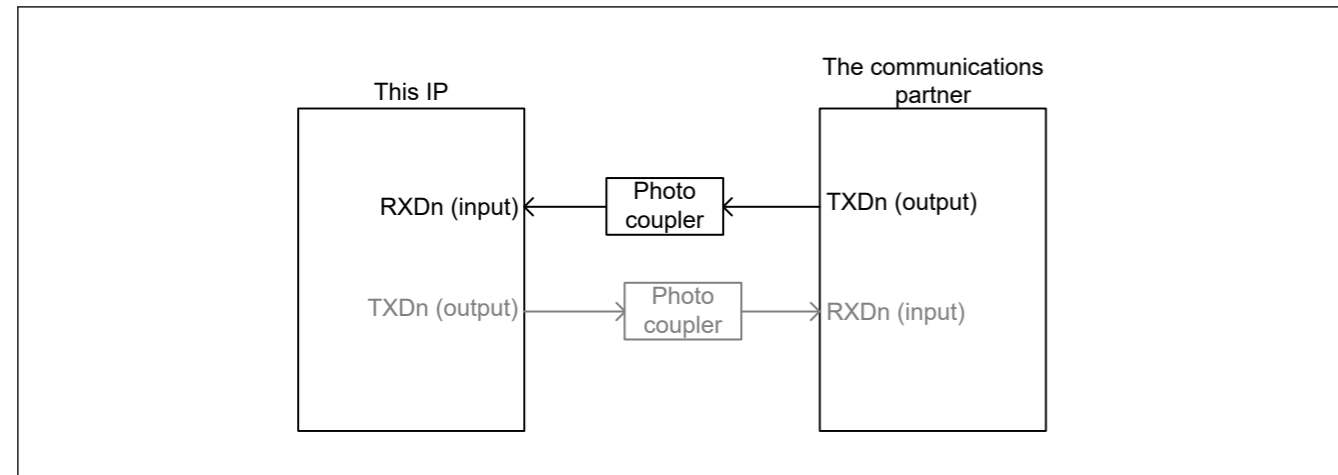


Figure 27.31 block diagram image of the reception through a photo coupler

接收采样定时通过以下公式从位中间调整。可调方向由 ACTR.AJD。您可以从位的中间选择向前或向后。向后调整时(ACTR.AJD=0)，代入AJD=+1，向前调整时代入AJD=-1(ACTR.AJD=1)。

调整后的采样时间=位中间值+AJD\*(基准时钟\*AST[2:0]的设置值)

设置时序受限于每1位的基本时钟周期。详见表27.31。

图27.31、图27.32、图27.33为具有该功能的光耦通信的接收动作图，该功能的动作说明如图27.34所示。

请不要在上升传输时间和下降传输时间没有差异时使用此功能，因为有可能恶化接收余量。

Table 27.31 ACTR的可接受值 (使用内部时钟的异步模式)

| SEMR.ABCSE | SEMR.ABCS | 基本时钟周期数1bit | ACTR的可接受值 |                         |
|------------|-----------|-------------|-----------|-------------------------|
|            |           |             | ACTR.AJD  | ACTR.AST                |
| 1          | x         | 6           | 0         | 000 - 010 <sup>*1</sup> |
|            |           |             | 1         |                         |
| 0          | 1         | 8           | 0         | 000 - 011 <sup>*1</sup> |
|            |           |             | 1         |                         |
| 0          | 0         | 16          | 0         | 000 - 111               |
|            |           |             | 1         |                         |

Note: x : Don't care

注1.当ACTR.AST的值超过可接受的值时，将在默认时间进行采样。(未进行采样调整。)

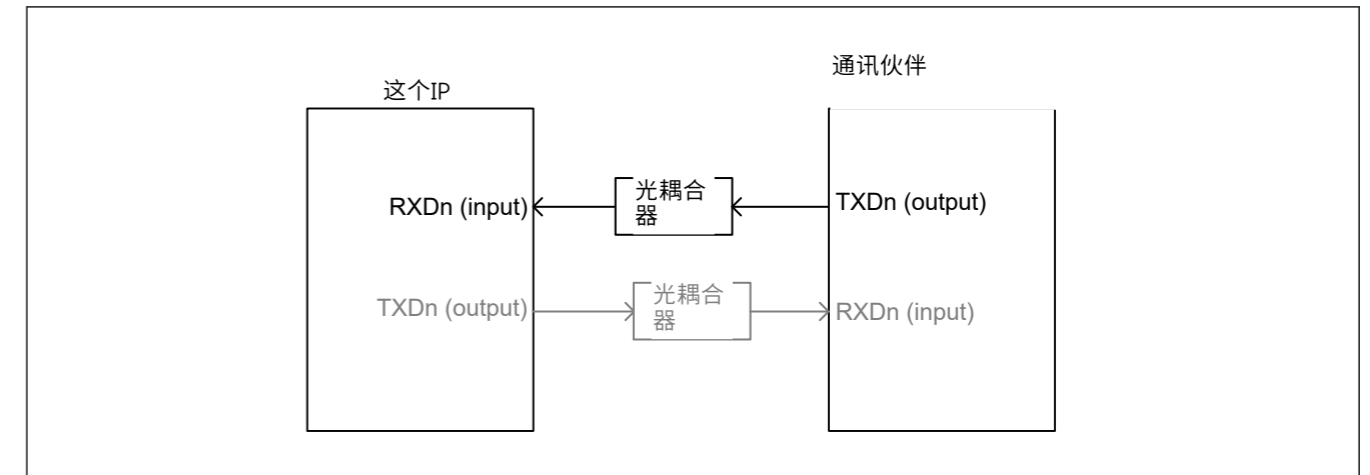


Figure 27.31 通过照片对接收的框图图像

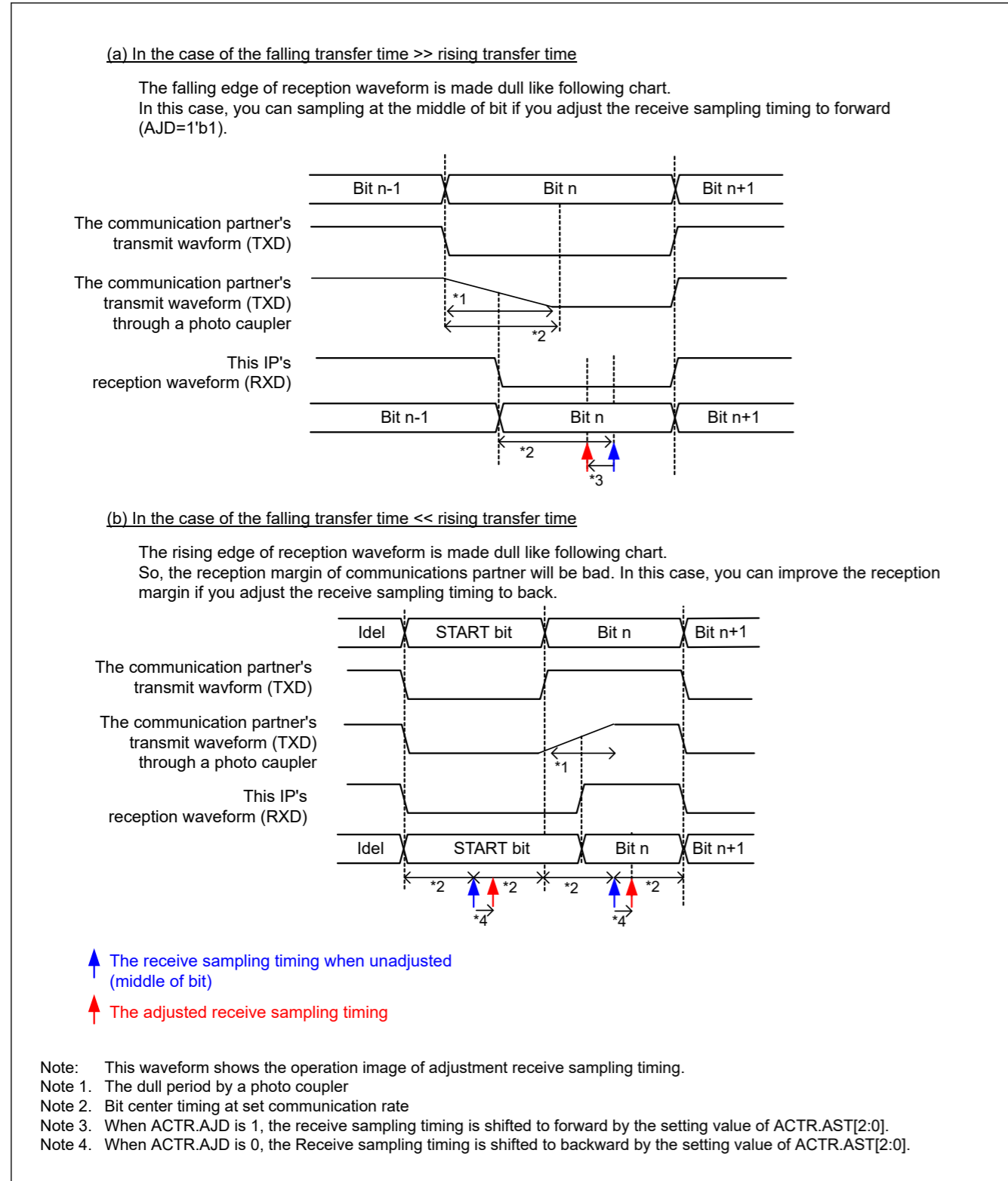


Figure 27.32 The reception movement image figure of the communication through a photo coupler

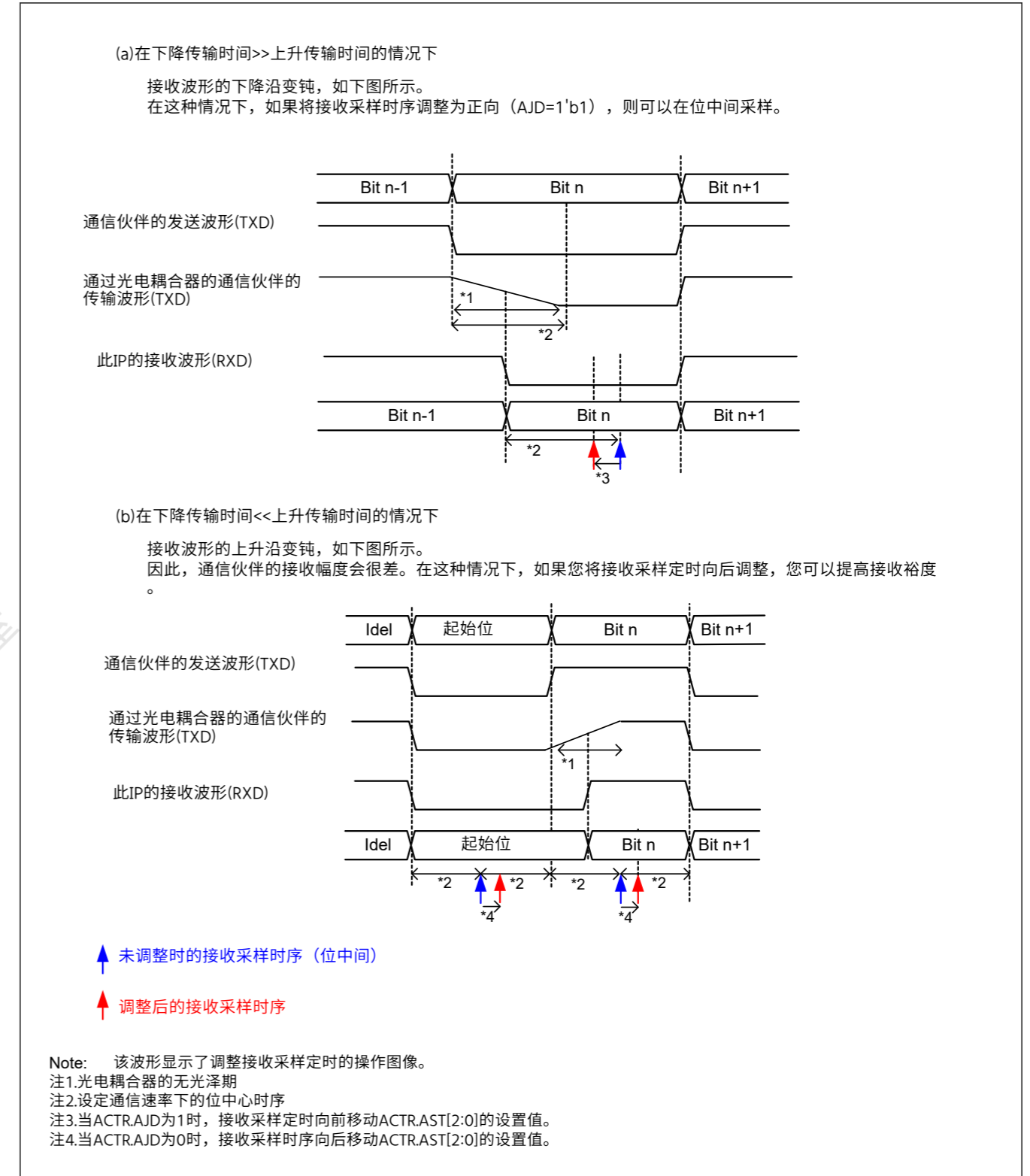


Figure 27.32 通过光电耦合器进行通信的接收运动图像图

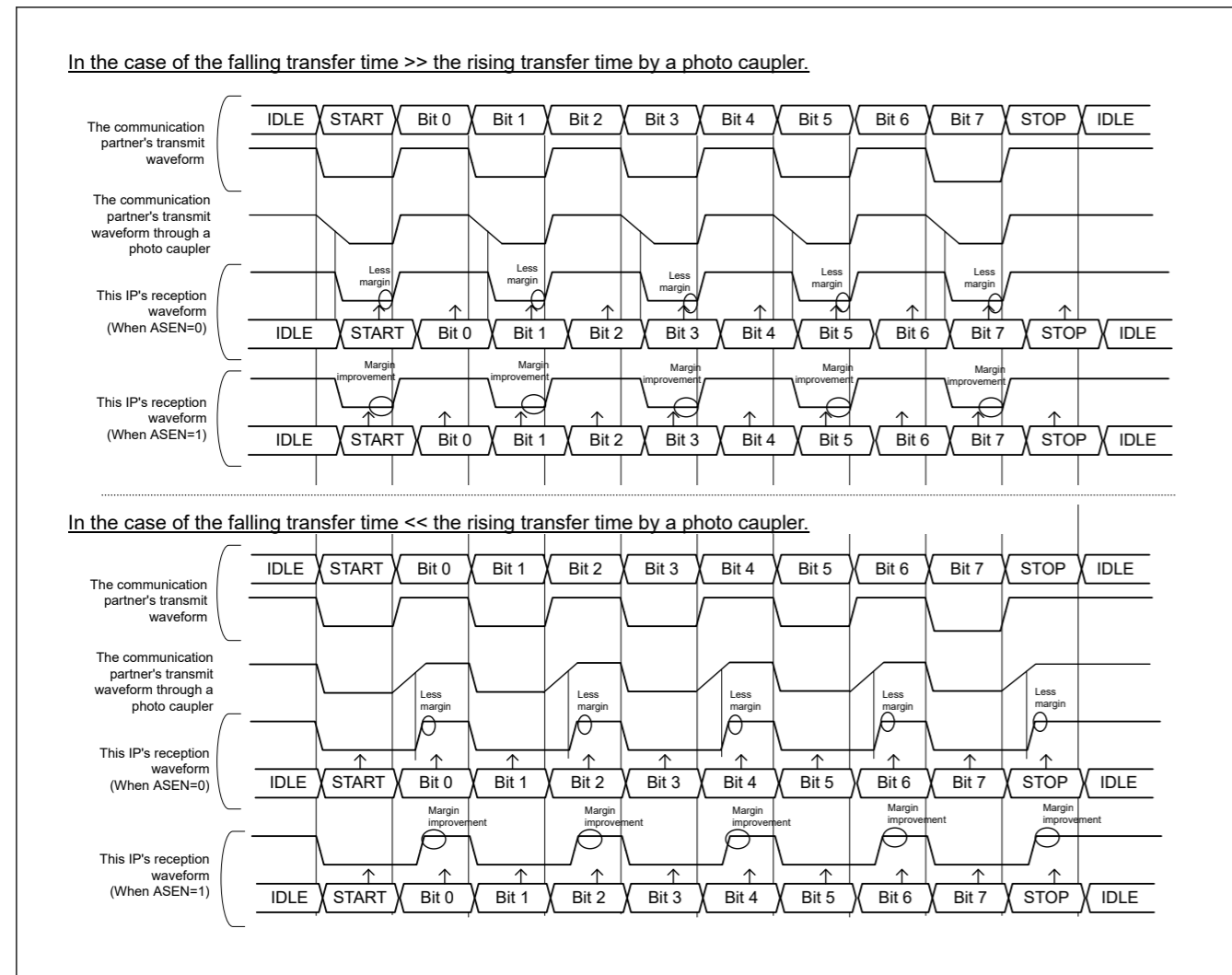


Figure 27.33 Improvement of reception margin when receive sampling timing adjustment function Image

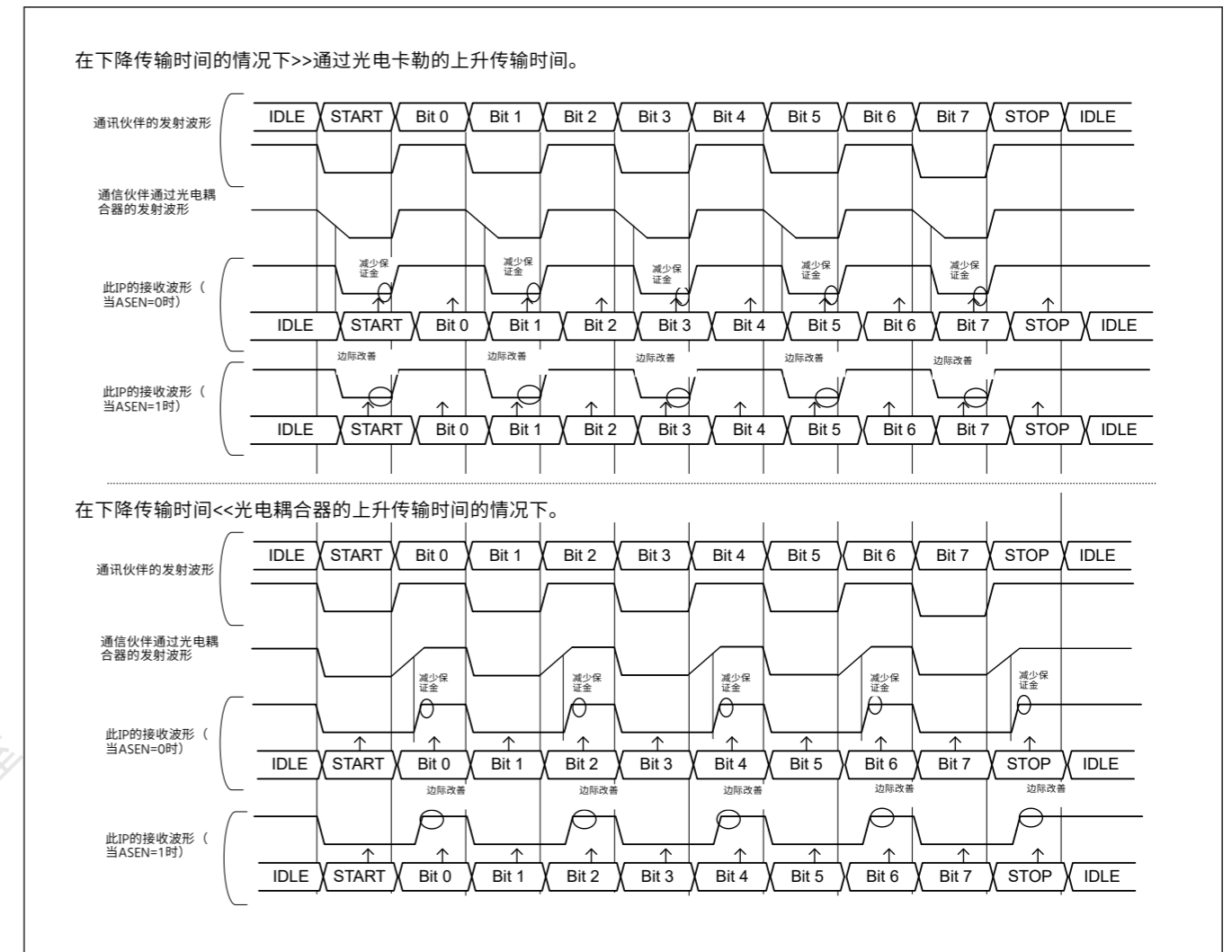


Figure 27.33 接收采样定时调整功能时的接收余量改善Image

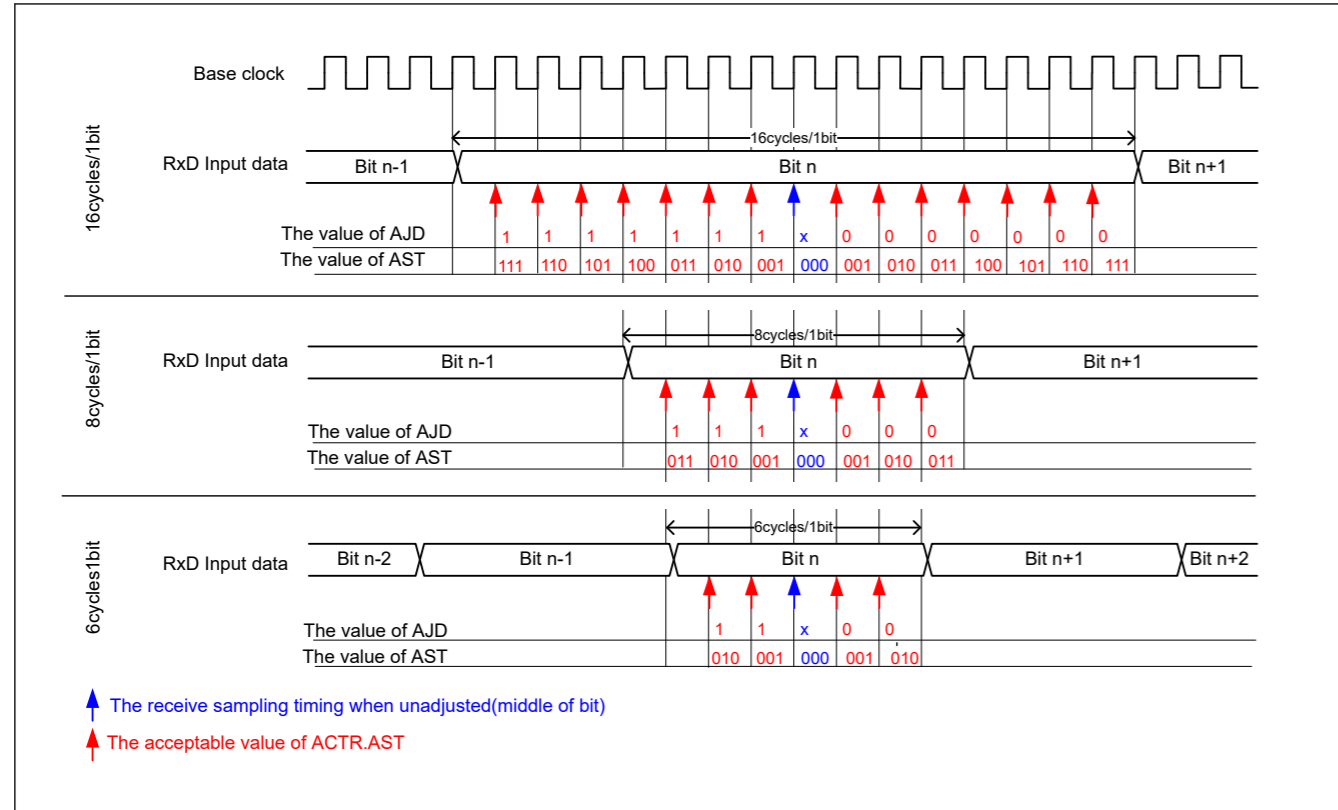


Figure 27.34 The adjustment operation explanation for the receive sampling timing (asynchronous mode using internal clock)

27.3.11 The function of adjust transmit timing (Asynchronous Mode)

In communication via a photo coupler or the like, when either the rising or falling transition time of the TXD output signal is long, then a communication partner receive dulled waveform. In this case, the reception margin may be affected.

In these cases, make a communication partner to be sampling at middle of bit using the function of adjust transmit timing.

When SPTR.ATEN is 1, this function can adjust the edge timing at the timing calculated by the following formula for the edge set with ACTR.AET.

$$\text{The adjustment edge timing} = \text{the base clock} * \text{ACTR.ATT}[2:0]$$

In addition, the upper limit of the adjustment edge timing is limited by setting the base clock cycles. Refer to Table 27.32 in details.

A transmission movement image figure of the communication through a photo coupler with this function is shown in Figure 27.35, Figure 27.36 and Figure 27.37, the movement explanation of this function is shown in Figure 27.38 and Figure 27.39.

Please don't use this function when there is not the difference between the rising transfer time and the falling transfer time, there is a possibility of deteriorating the reception margin of a communication partner.

Table 27.32 The acceptable value of ACTR.AET and ACTR.ATT (asynchronous mode using internal clock) (1 of 2)

| ABCSE | ABCS | The number of base clock cycles/1bit | The acceptable value of ACTR |           |
|-------|------|--------------------------------------|------------------------------|-----------|
|       |      |                                      | AET                          | ATT[2:0]  |
| 1     | x    | 6                                    | 0                            | 000 – 101 |
|       |      |                                      | 1                            |           |
| 0     | 1    | 8                                    | 0                            | 000 – 111 |
|       |      |                                      | 1                            |           |

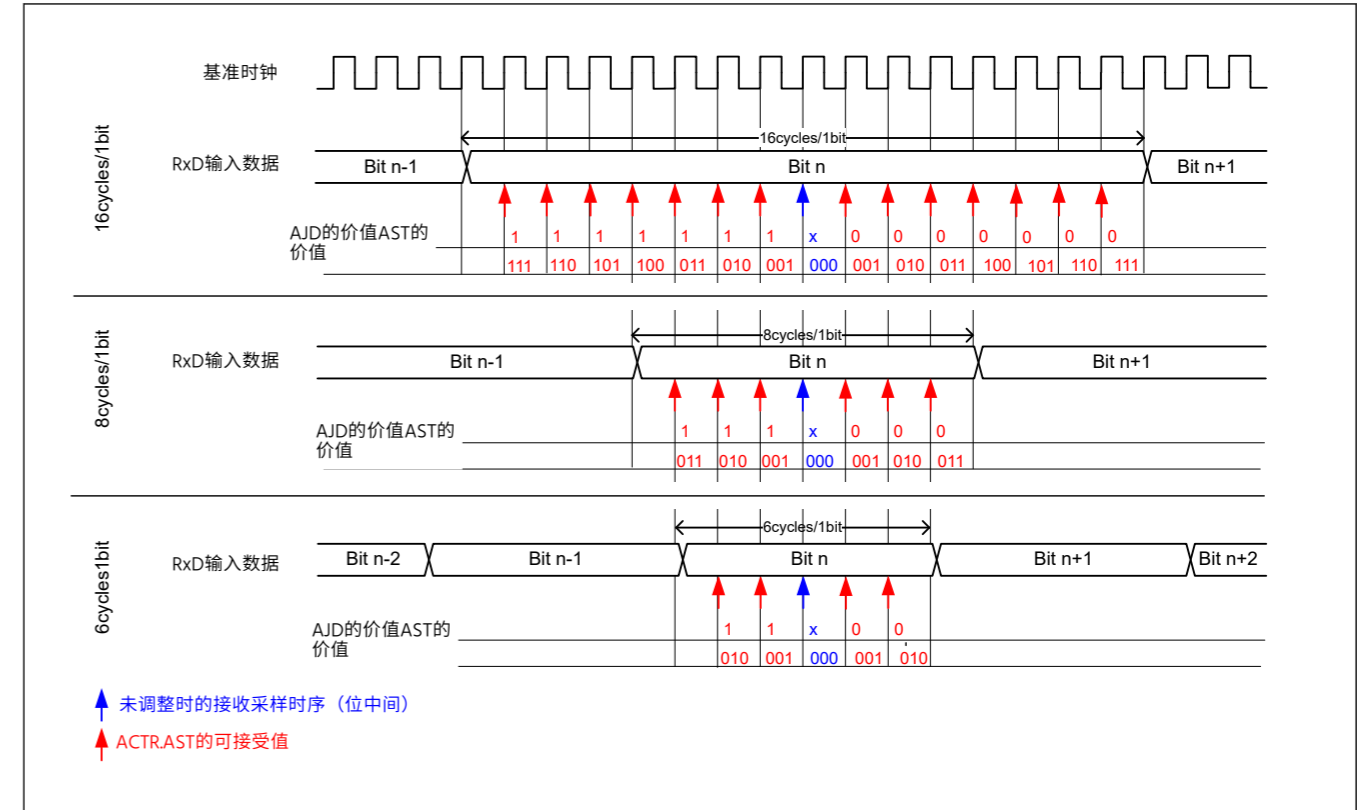


Figure 27.34 接收采样时序调整操作说明 (使用内部时钟的异步模式)

27.3.11 调整发送时间的功能 (异步模式)

在经由光电耦合器等的通信中，当TXD输出信号的上升或下降过渡时间较长时，通信伙伴接收到钝化的波形。在这种情况下，接收裕量可能会受到影响。

在这些情况下，使用调整发送时间的功能使通信伙伴在位中间进行采样。

当SPTR.ATEN为1时，该功能可以在ACTR.AET设置的边沿通过以下公式计算的时序调整边沿时序。

$$\text{调整边沿时序} = \text{基准时钟} * \text{ACTR.ATT}[2:0]$$

另外，调整边沿时序的上限是通过设置基本时钟周期来限制的。详见表27.32。

图27.35、图27.36和图27.37所示为具有该功能的光电耦合器通信的传输动作图，该功能的动作说明如图27.38和图27.39所示。

请不要在上升传输时间和下降传输时间之间没有差异时使用此功能，这可能会降低通信伙伴的接收裕度。

Table 27.32 ACTR.AET和ACTR.ATT的可接受值 (使用内部时钟的异步模式) (1of2)

| ABCSE | ABCS | 基本时钟周期数1bit | ACTR的可接受值 |           |
|-------|------|-------------|-----------|-----------|
|       |      |             | AET       | ATT[2:0]  |
| 1     | x    | 6           | 0         | 000 – 101 |
|       |      |             | 1         |           |
| 0     | 1    | 8           | 0         | 000 – 111 |
|       |      |             | 1         |           |



Table 27.32 The acceptable value of ACTR.AET and ACTR.ATT (asynchronous mode using internal clock) (2 of 2)

| ABCSE | ABCS | The number of base clock cycles/1bit | The acceptable value of ACTR |           |
|-------|------|--------------------------------------|------------------------------|-----------|
|       |      |                                      | AET                          | ATT[2:0]  |
| 0     | 0    | 16                                   | 0                            | 000 - 111 |
|       |      |                                      | 1                            |           |

Note: x : Don't care  
 Note: When the value of ACTR.AET/ATT is out of the acceptable value, this SCI module doesn't adjust transmit timing.

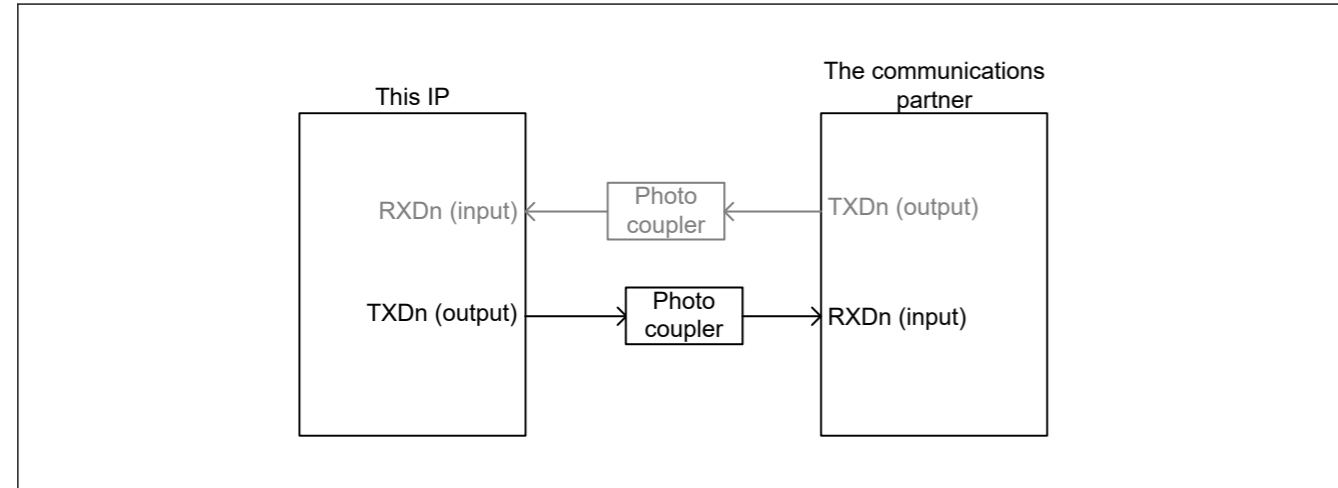


Figure 27.35 block diagram image of the transmission through a photo coupler

Table 27.32 ACTR.AET和ACTR.ATT的可接受值（使用内部时钟的异步模式）(2of2)

| ABCSE | ABCS | 基本时钟周期数1bit | ACTR的可接受值 |           |
|-------|------|-------------|-----------|-----------|
|       |      |             | AET       | ATT[2:0]  |
| 0     | 0    | 16          | 0         | 000 - 111 |
|       |      |             | 1         |           |

Note: x : Don't care  
 Note: 当ACTR.AET/ATT的值超出可接受的值时，该SCI模块不调整发送时序。

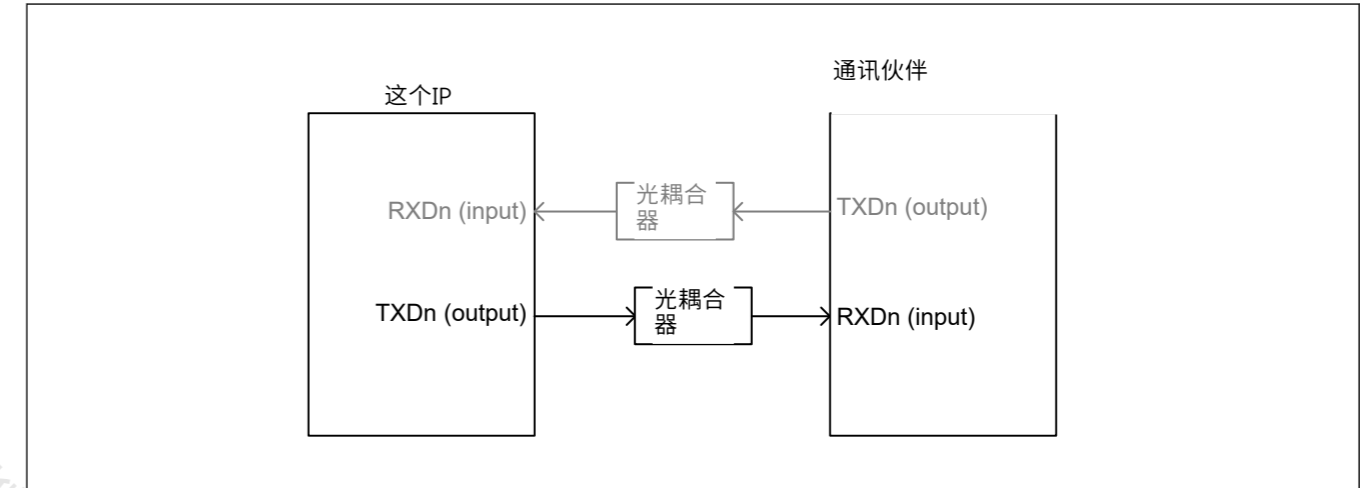


Figure 27.35 通过光耦合器传输的框图图像

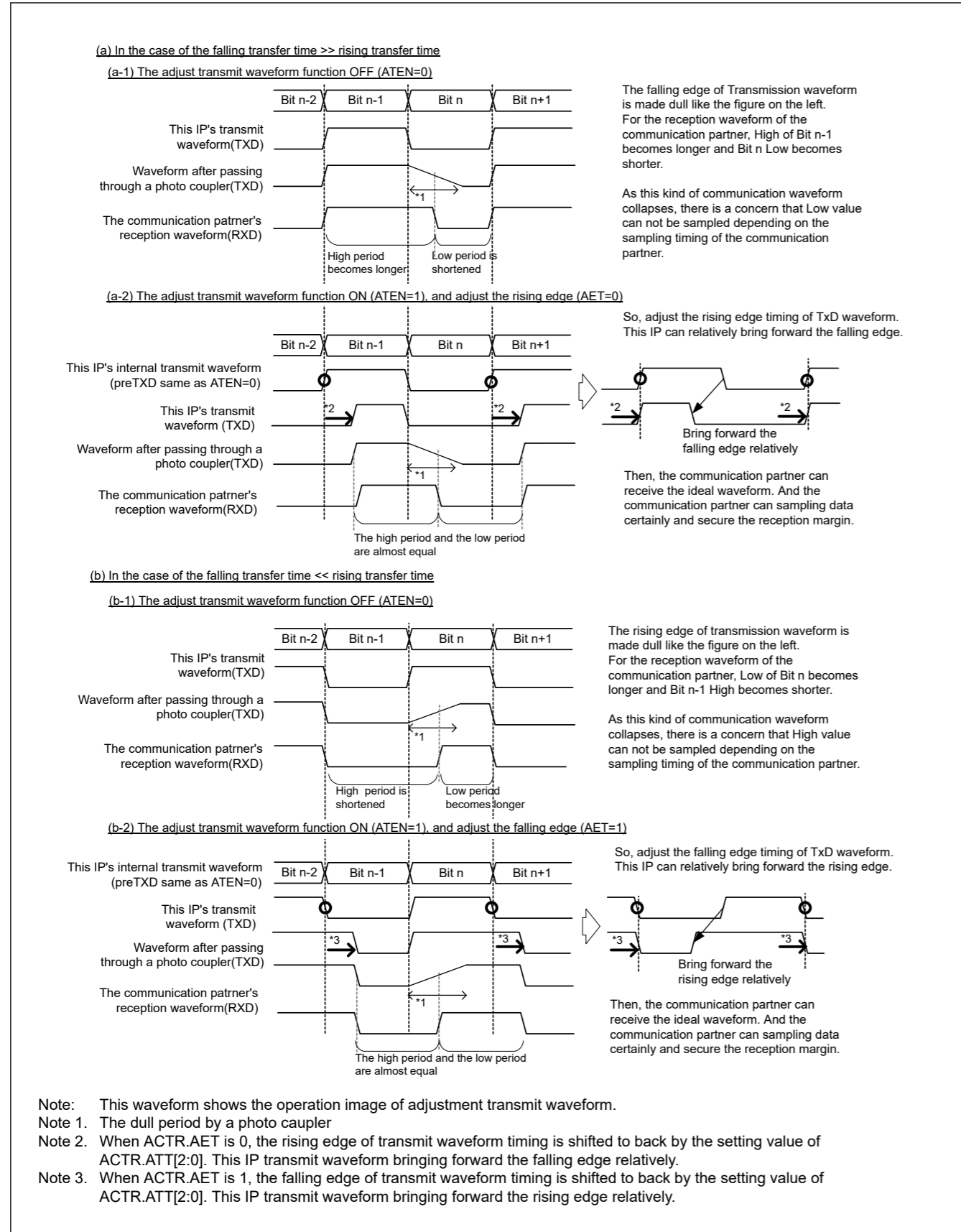


Figure 27.36 The transmission movement image figure of the communication through a photo coupler

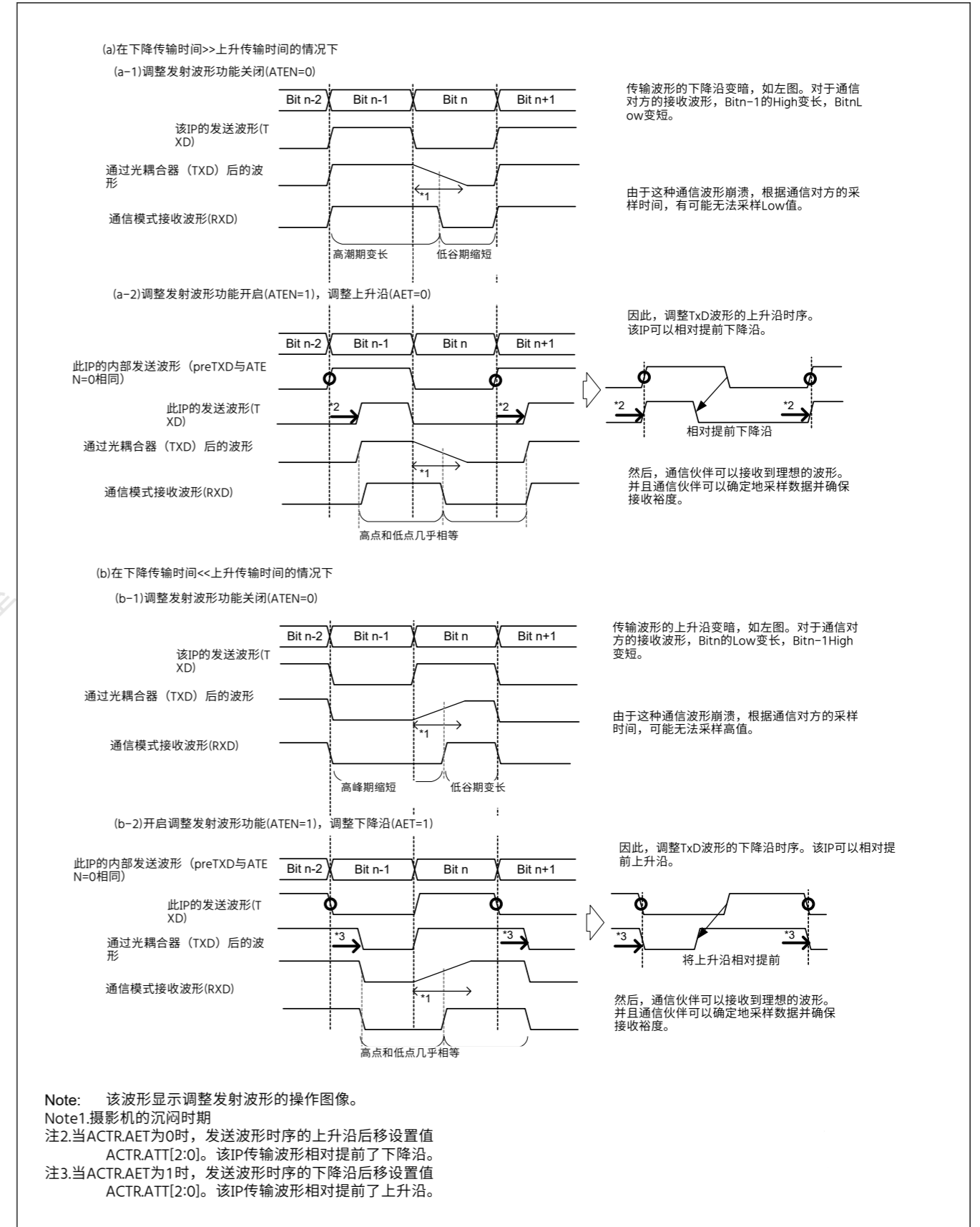


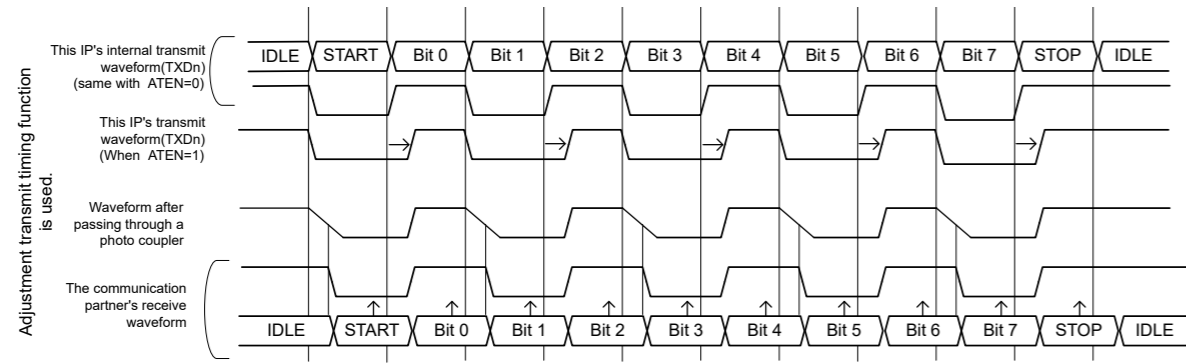
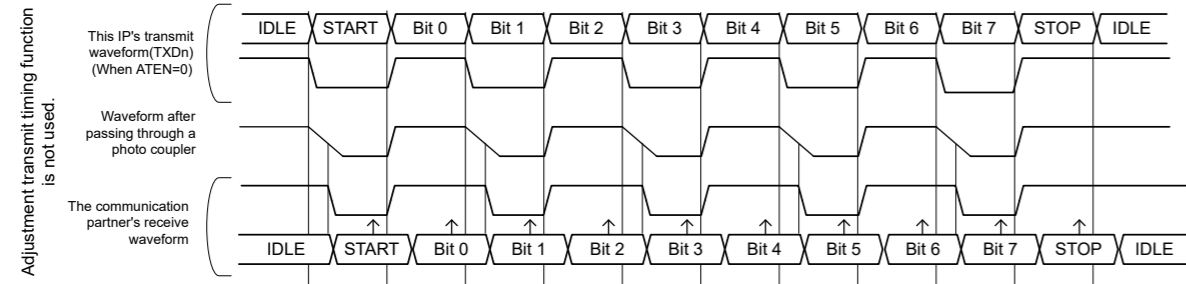
Figure 27.36 通过光电耦合器进行通信的传输运动图像图形

The explanation of transmit waveforms of the communication through a photo coupler using adjust transmit timing function

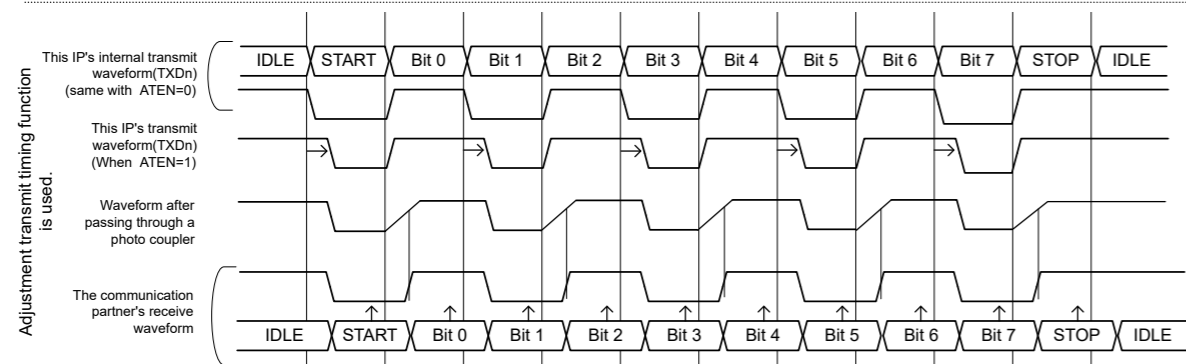
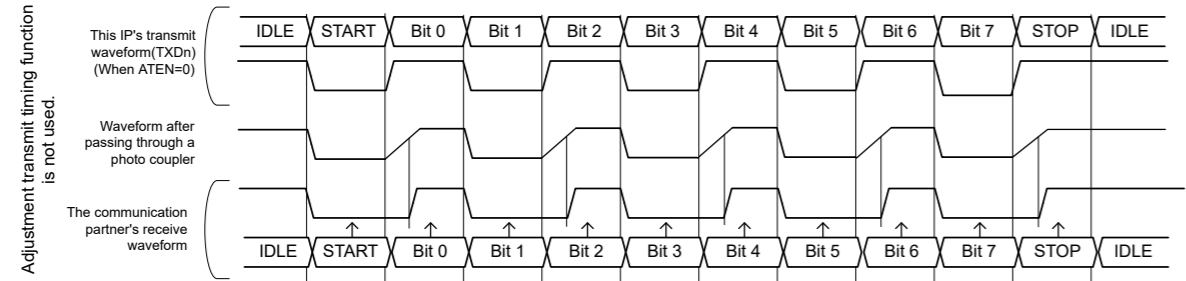
When using the transmission timing adjustment function, adjust the edge timing of the transmission waveform and correct the reception waveform of the communication partner

The following example is 8 bit long data.

(a) In the case of the falling edge transfer time >> the rising transfer time



(b) In the case of the falling edge transfer time << the rising transfer time



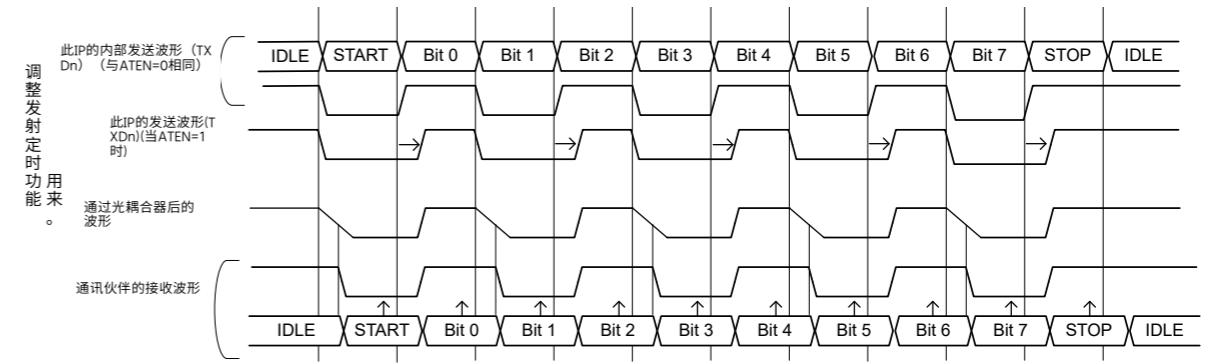
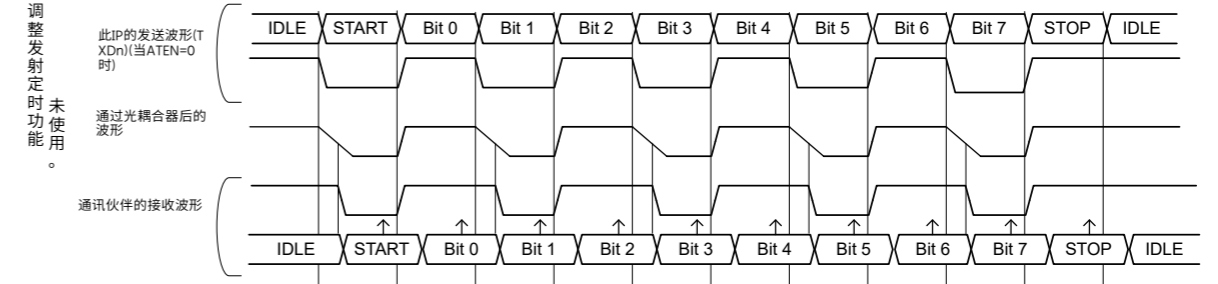
→ : The adjustment edge timing using this function    ↑ : A communication partner's sampling timing

Figure 27.37 The explanation for the transmit waveform through a photo coupler

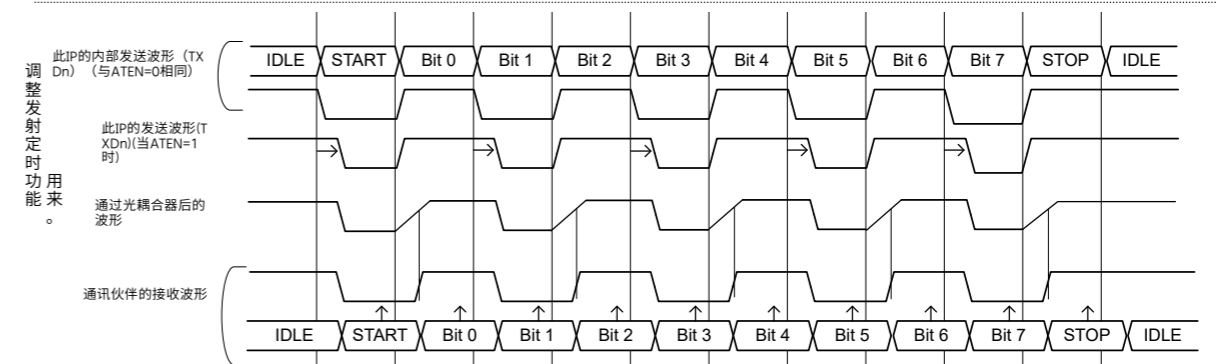
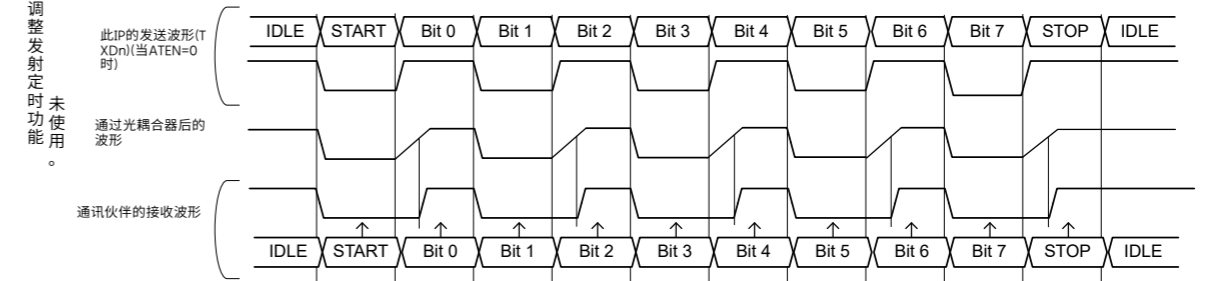
使用调整发射定时功能通过光电耦合器进行通信的发射波形说明

使用发送定时调整功能时，调整发送波形的边沿定时，修正通信对方的接收波形。下例为8位长的数据。

(a) 在下降沿传输时间>>上升沿传输时间的情况下



(b) 在下降沿传输时间<<上升沿传输时间的情况下



→ : 使用此功能的调整边沿时间    ↑ : 通信伙伴的采样时间

Figure 27.37 通过光电耦合器的发射波形的解释

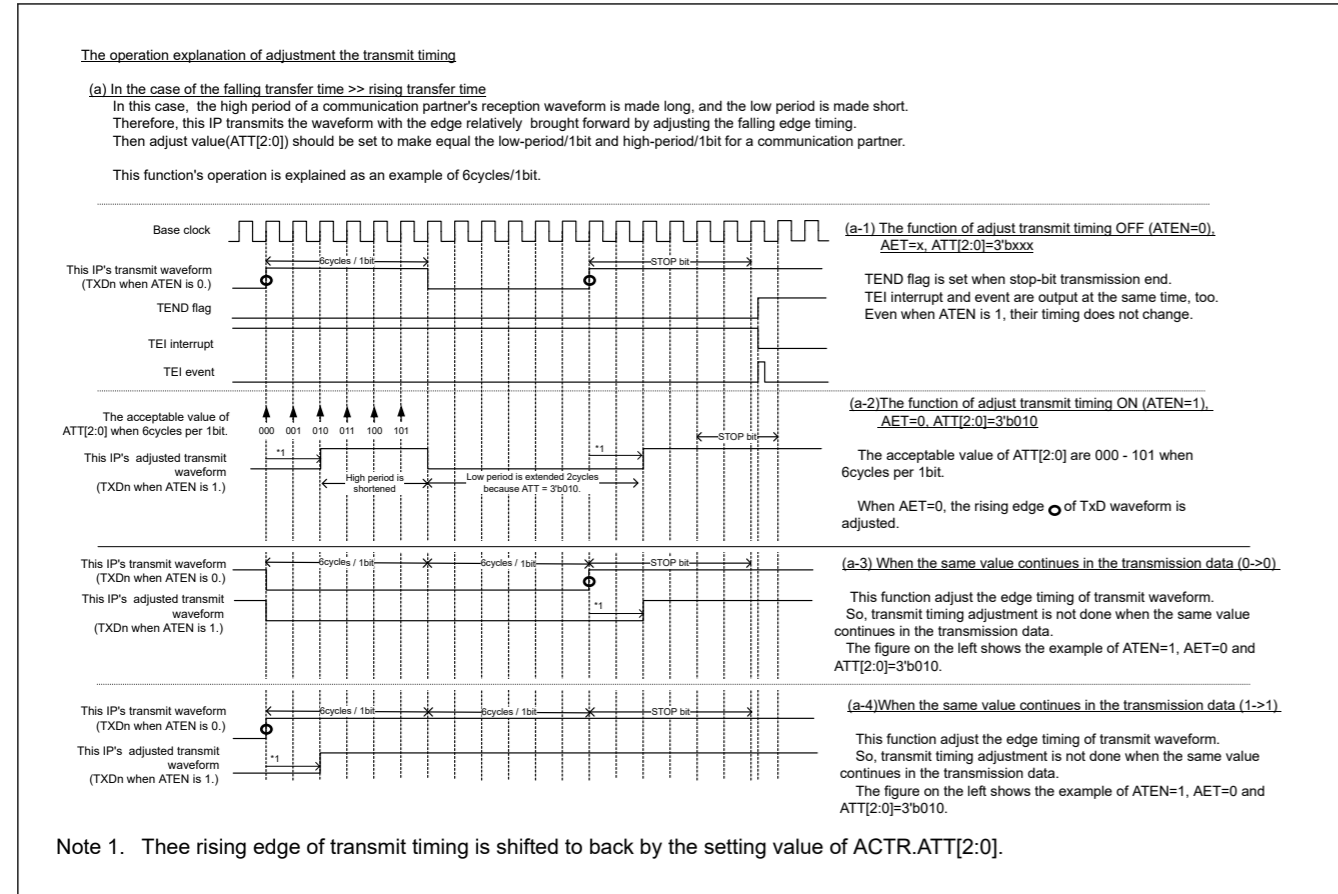


Figure 27.38 The adjustment operation explanation for the transmit timing when AET is 0

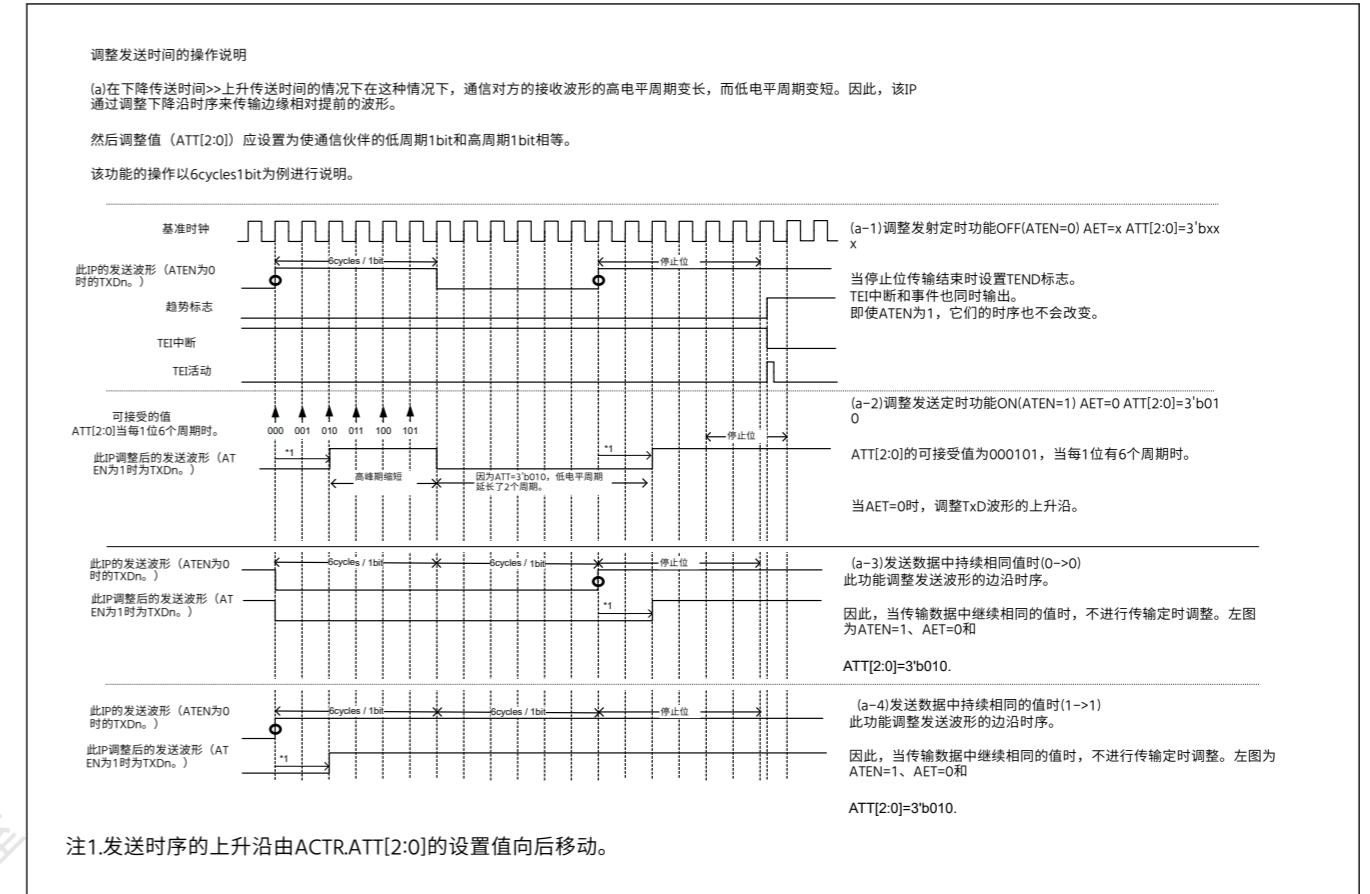


Figure 27.38 AET为0时发射时序调整操作说明



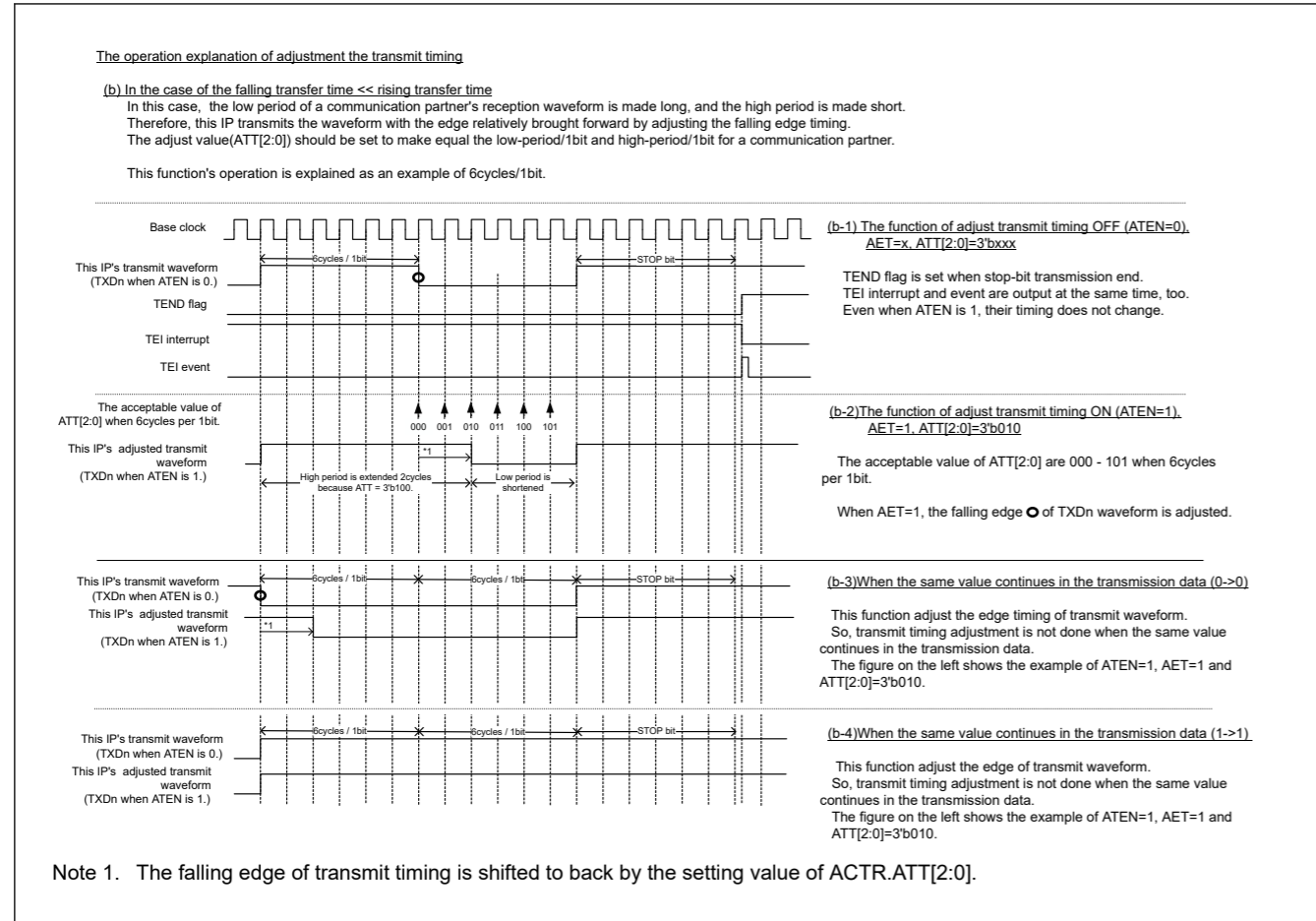


Figure 27.39 The adjustment operation explanation for the transmit timing when AET is 1

## 27.4 Multi-Processor Communication Function

The multi-processor communication function enables the SCI to transmit and receive data between multiple processors by sharing an asynchronous serial communication line that has an added multi-processor bit. In multi-processor communication, a unique ID code is allocated to each receiving station. Serial communication cycles consist of an ID transmission cycle to specify the receiving station and a data transmission cycle to transmit data to the specified receiving station.

The multi-processor bit is used to distinguish between the ID transmission cycle and the data transmission cycle:

- When the multi-processor bit is set to 1, the transmission cycle is the ID transmission cycle
- When the multi-processor bit is set to 0, the transmission cycle is the data transmission cycle

Figure 27.40 shows an example of communication between processors using a multi-processor format. First, a transmitting station transmits communication data in which the multi-processor bit set to 1 is added to the ID code of the receiving station. Next, the transmitting station transmits communication data in which the multi-processor bit set to 0 is added to the transmit data. After receiving communication data with the multi-processor bit set to 1, the receiving station compares the received ID with the ID of the receiving station itself. If the two match, the receiving station receives communication data that is subsequently transmitted. If the received ID does not match with the ID of the receiving station, the receiving station skips the communication data until it receives data in which the multi-processor bit is set to 1.

### (1) Non-FIFO selected

To support this function, the SCI provides the SCR.MPIE bit. When the MPIE bit is set to 1, the following operations are disabled until the reception of data in which the multi-processor bit is set to 1:

- Transfer of receive data from the RSR register to the RDR register (the RDRHL register when 9-bit data length is selected)
- Detection of a receive error

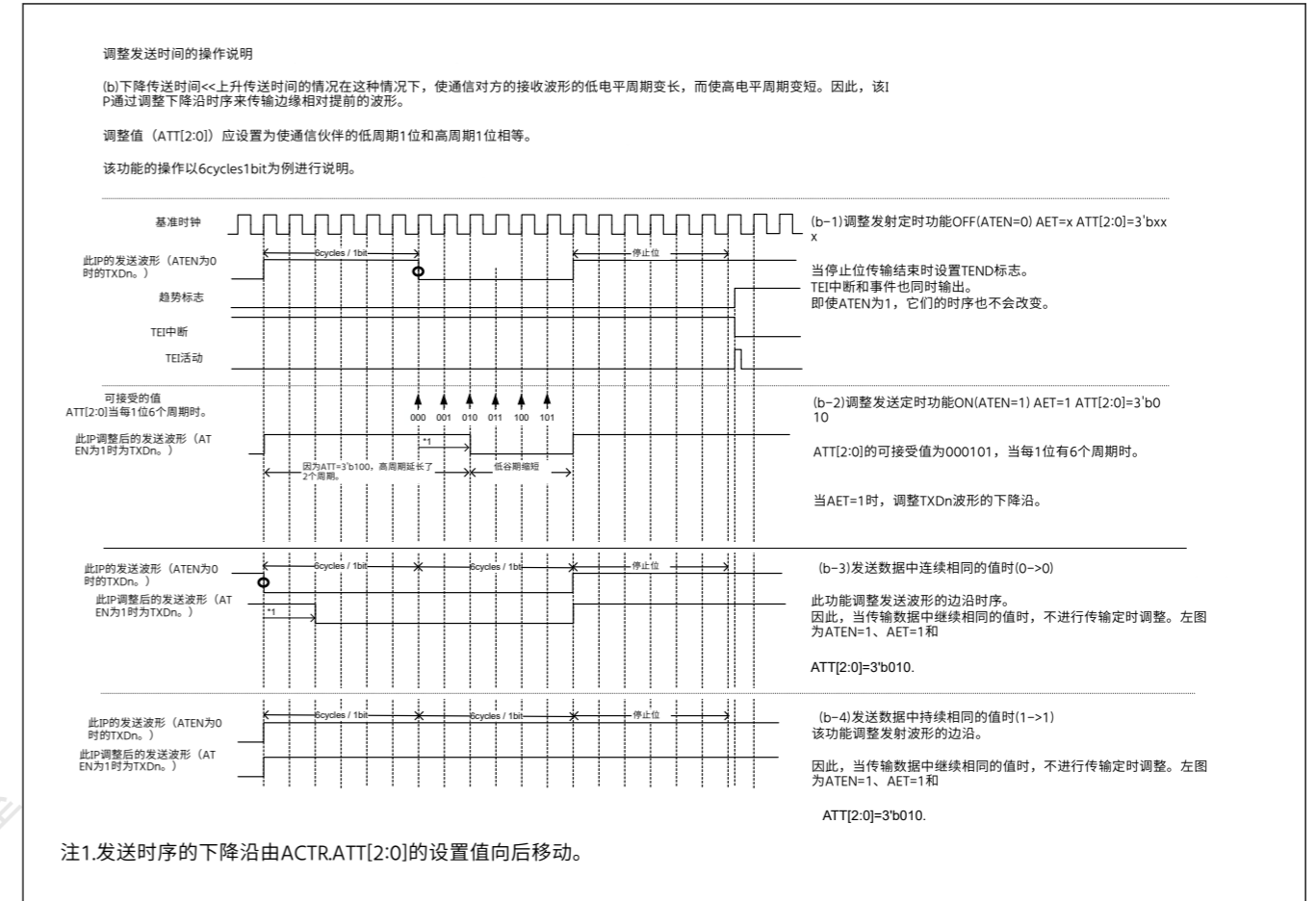


Figure 27.39 AET为1时发射时序调整操作说明

## 27.4 多处理器通信功能

多处理器通信功能使SCI能够通过共享一条增加了多处理器位的异步串行通信线路在多个处理器之间发送和接收数据。在多处理器通信中,为每个接收站分配一个唯一的ID代码。串行通信周期由指定接收站的ID传输周期和向指定接收站传输数据的数据传输周期组成。

多处理器位用于区分ID传输周期和数据传输周期:

- 当多处理器位设置为1时,传输周期为ID传输周期
- 当多处理器位设置为0时,传输周期为数据传输周期

图27.40显示了使用多处理器格式的处理器之间的通信示例。首先,发送站发送将设置为1的多处理器位添加到接收站的ID码的通信数据。接着,发送站发送在发送数据中附加了多处理器比特为0的通信数据。接收站接收到多处理器位设置为1的通信数据后,将接收到的ID与接收站自身的ID进行比较。如果两者匹配,则接收站接收随后发送的通信数据。如果接收到的ID与接收站的ID不匹配,则接收站跳过通信数据,直到接收到多处理器位设置为1的数据。

### (1) Non-FIFO selected

为了支持这个功能,SCI提供了SCR.MPIE位。当MPIE位设置为1时,以下操作被禁止,直到接收到多处理器位设置为1的数据:

- 将接收数据从RSR寄存器传送到RDR寄存器(选择9位数据长度时的RDRHL寄存器)
- 接收错误检测

- Setting of the respective RDRF, ORER, and FER status flags in the SSR register

When the SCI receives a character in which the multi-processor bit is set to 1, the SSR.MPBT bit is set to 1 and the SCR.MPIE bit is automatically cleared, returning the SCI to normal reception operation. If the SCR.RIE bit is set to 1, an SCIn\_RXI interrupt is generated.

When the multi-processor format is specified, the parity bit function is disabled. Apart from this, there is no difference from operation in normal asynchronous mode. The clock used for the multi-processor communication is the same as the clock used in normal asynchronous mode.

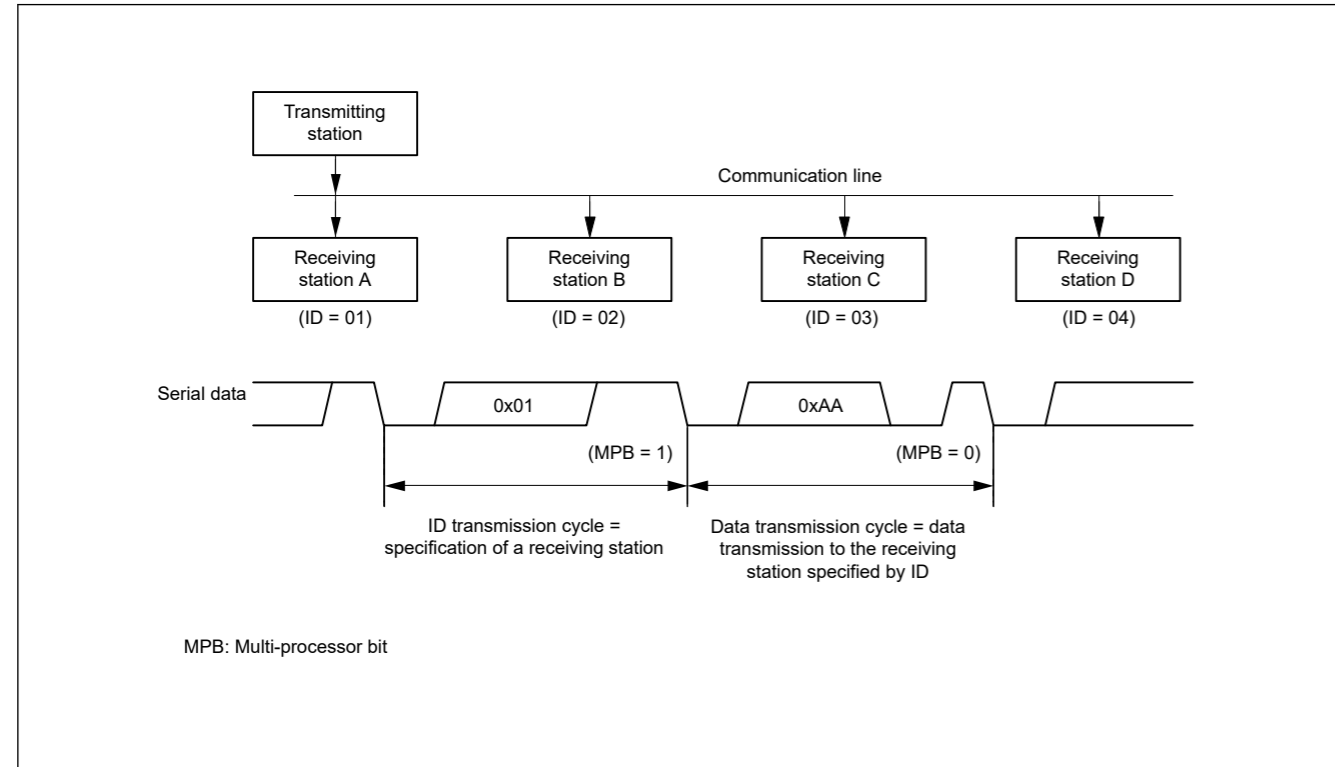


Figure 27.40 Example of communication using multi-processor format with transmission of data 0xAA to receiving station A

#### (2) FIFO selected

For data transmission, software must write data to FTDRHL.MPBT that corresponds to transmit data in FTDRHL.TDAT. For data reception, the multi-processor bit that is part of the receive data is written to FTDRHL.MPB and receive data is written to FRDRL.

When the MPIE bit is set to 1, the following operations are disabled until reception of data in which the multi-processor bit is set to 1:

- Transfer of receive data from the RSR register to the FRDRHL register
- Detection of a receive error
- Break
- Setting of the respective RDF, ORER, and FER status flags in the SSR\_FIFO register

When the SCI receives an 8-bit character in which the multi-processor bit is set to 1, the FTDRHL.MPB bit is set to 1 and receive data is written to FRDRHL.RDAT. The SCR.MPIE bit is automatically cleared, returning the SCI to normal reception operation. If the SCR.RIE bit is set to 1, an SCIn\_RXI interrupt is generated.

When the multi-processor format is specified, the parity bit function is disabled. Apart from this, there is no difference from operation in normal asynchronous mode with non-FIFO selected.

### 27.4.1 Multi-Processor Serial Data Transmission

#### (1) Non-FIFO selected

- 在SSR寄存器中设置相应的RDRF、ORER和FER状态标志

当SCI接收到多处理器位设置为1的字符时，SSR.MPBT位设置为1，并且SCR.MPIE位自动清零，使SCI恢复正常接收操作。如果SCR.RIE位设置为1，则SCIn\_RXI中断产生。

当指定多处理器格式时，奇偶校验位功能被禁用。除此之外，与正常异步模式下的操作没有区别。用于多处理器通信的时钟与正常异步模式下使用的时钟相同。

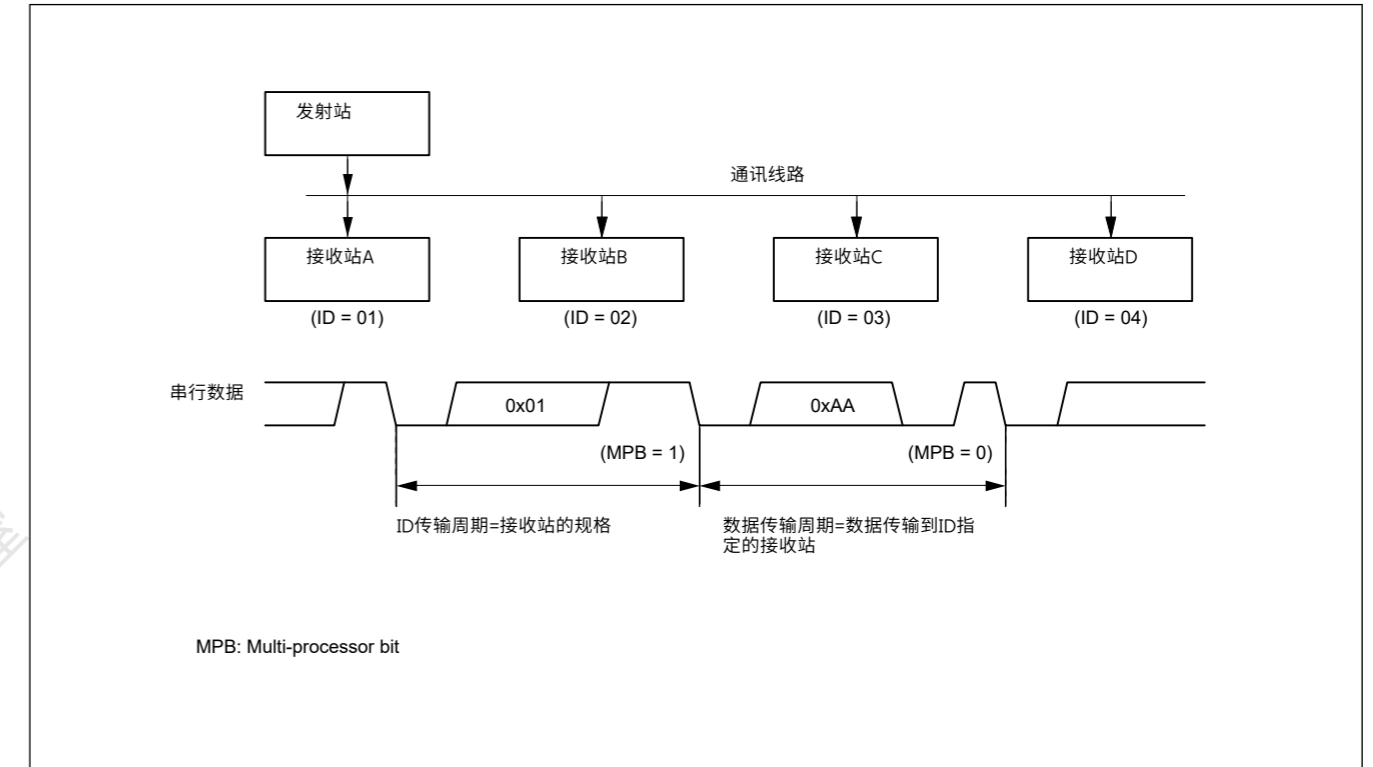


Figure 27.40 使用多处理器格式的通信示例，将数据0xAA传输到接收站A

#### (2) FIFO selected

对于数据传输，软件必须将数据写入与FTDRHL.TDAT中的传输数据相对应的FTDRHL.MPBT。对于数据接收，作为接收数据一部分的多处理器位被写入FTDRHL.MPB，接收数据被写入FRDRL。

当MPIE位设置为1时，以下操作被禁止，直到接收到多处理器位设置为1的数据：

- 将接收数据从RSR寄存器传送到FRDRHL寄存器
- 接收错误检测
- Break
- 在SSR\_FIFO寄存器中设置相应的RDF、ORER和FER状态标志

当SCI接收到多处理器位设置为1的8位字符时，FTDRHL.MPB位设置为1，接收数据写入FRDRHL.RDAT。SCR.MPIE位自动清零，使SCI恢复正常接收操作。如果SCR.RIE位设置为1，则会产生SCIn\_RXI中断。

当指定多处理器格式时，奇偶校验位功能被禁用。除此之外，与选择非FIFO的正常异步模式下的操作没有区别。

### 27.4.1 多处理器串行数据传输

#### (1) Non-FIFO selected

Figure 27.41 shows an example flow of multi-processor data transmission. In the ID transmission cycle, the ID must be transmitted with the SSR.MPBT bit set to 1. In the data transmission cycle, the data must be transmitted with the MPBT bit set to 0. The rest of the operations are the same as operations in asynchronous mode. Write the values in the order of the FTDRH register then the FTDRL register.

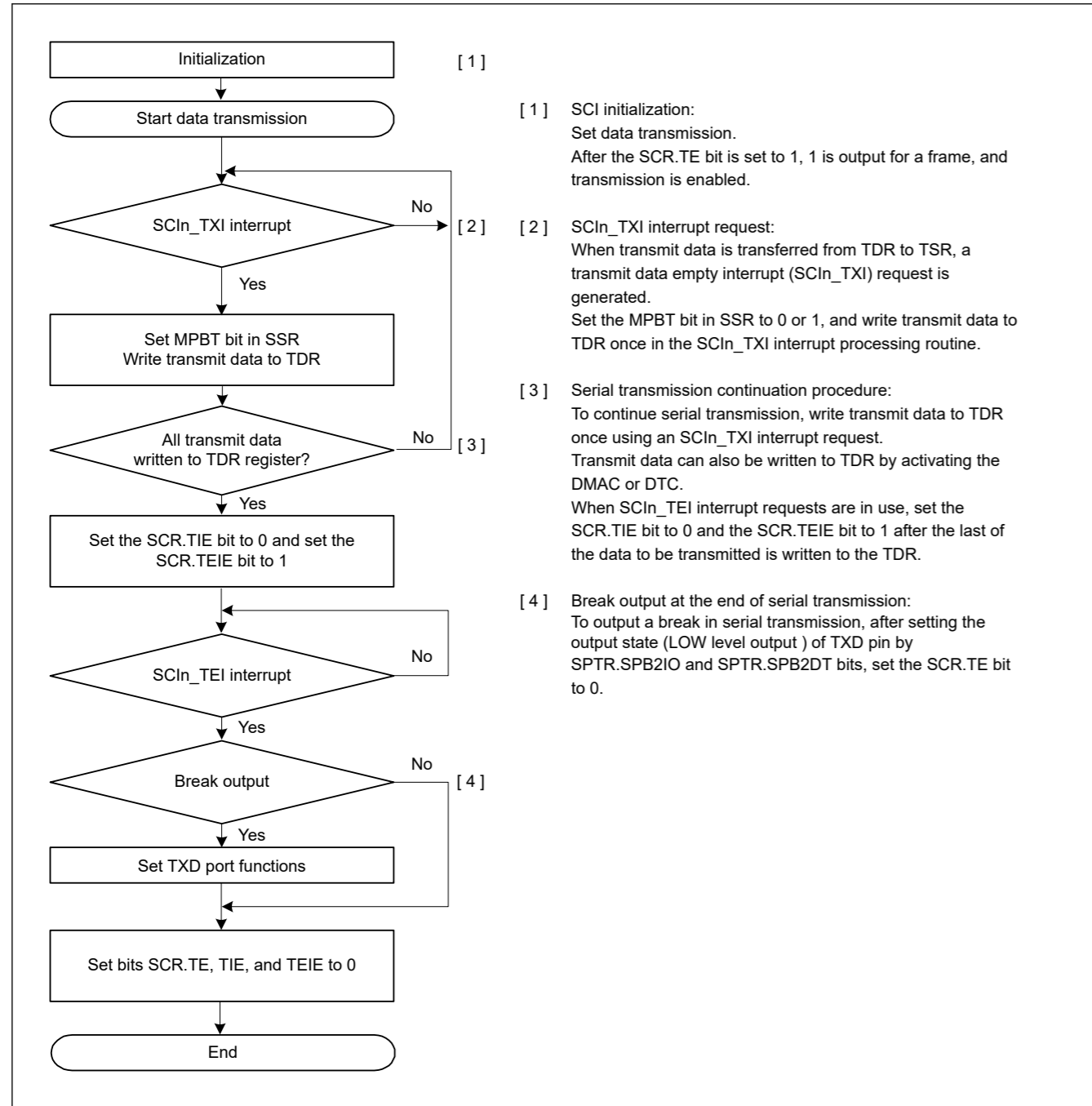


Figure 27.41 Example flow of multi-processor serial transmission with non-FIFO selected

(2) FIFO selected

Figure 27.42 shows an example of data format that is written to FTDRH and FTDRL in multi-processor mode. The FTDRH.MPBT bit is set to 1. Data is set to FTDRH and FTDRL with the correct data length. Write 0 for unused bits. Write in order from FTDRH to FTDRL.

图27.41显示了一个多处理器数据传输的示例流程。在ID传输周期，ID必须在SSR.MPBT位设置为1的情况下传输。在数据传输周期，数据必须在MPBT位设置为0的情况下传输。其余操作与操作相同在异步模式下。按照FTDRH寄存器然后FTDRL寄存器的顺序写入值。

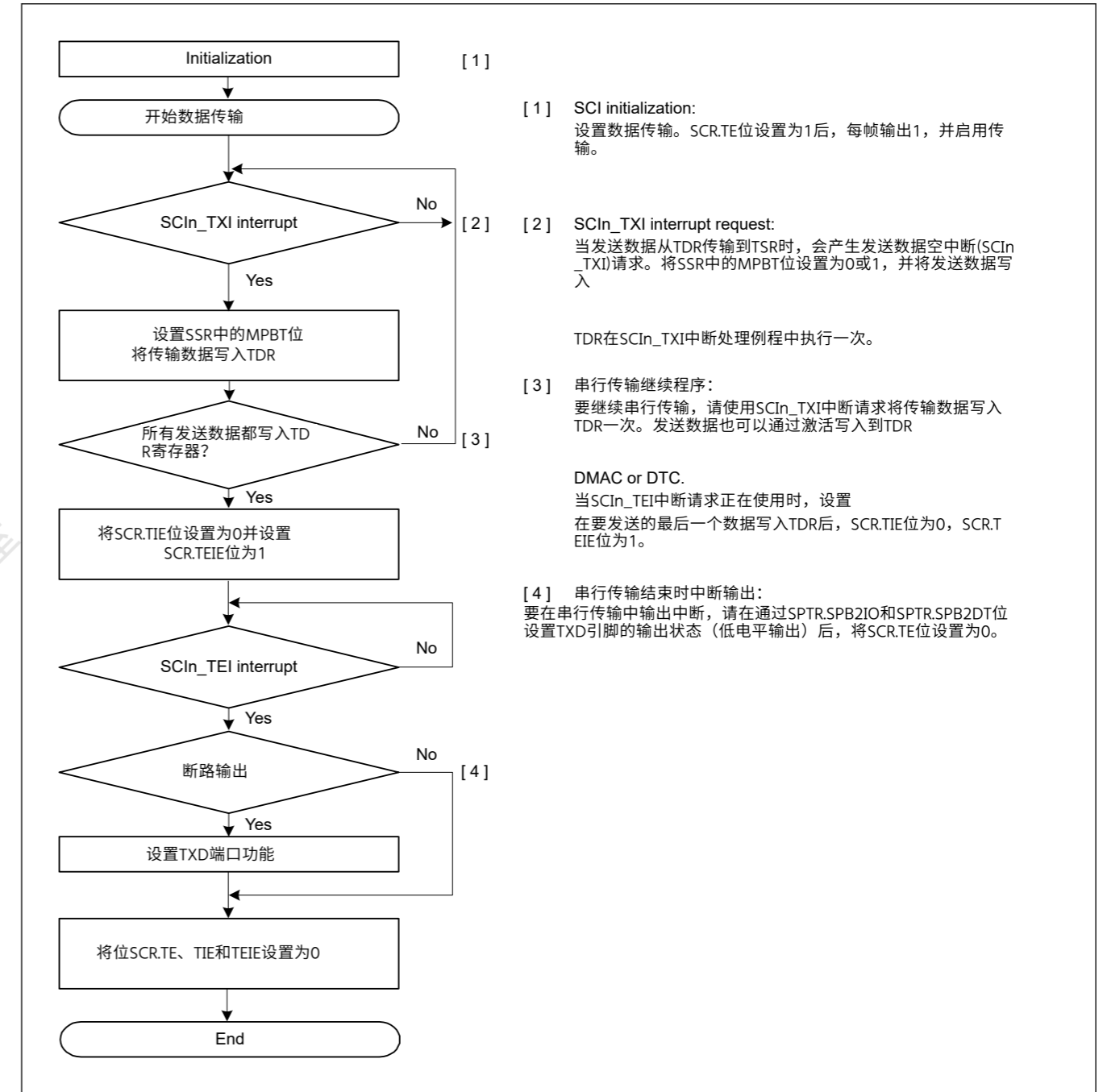


Figure 27.41 选择非FIFO的多处理器串行传输示例流程

(2) FIFO selected

图27.42显示了在多处理器模式下写入FTDRH和FTDRL的数据格式示例。这 FTDRH.MPBT位设置为1。数据设置为具有正确数据长度的FTDRH和FTDRL。为未使用的位写入0。从FTDRH到FTDR L的顺序写。

| Data Length | Register Setting |            | Transmit data in FTDRH, FTDRL |     |     |     |     |     |      |    |       |    |    |    |    |    |    |    |
|-------------|------------------|------------|-------------------------------|-----|-----|-----|-----|-----|------|----|-------|----|----|----|----|----|----|----|
|             | SCMR. CHR1       | SMR. CHR   | FTDRHL                        |     |     |     |     |     |      |    |       |    |    |    |    |    |    |    |
|             |                  |            | FTDRH                         |     |     |     |     |     |      |    | FTDRL |    |    |    |    |    |    |    |
|             |                  |            | b15                           | b14 | b13 | b12 | b11 | b10 | b9   | b8 | b7    | b6 | b5 | b4 | b3 | b2 | b1 | b0 |
| 7 bits      | 1                | 0          | -                             | -   | -   | -   | -   | -   | MPBT | -  | -     | -  | -  | -  | -  | -  | -  | -  |
| 8 bits      | 1                | 1          | -                             | -   | -   | -   | -   | -   | MPBT | -  | -     | -  | -  | -  | -  | -  | -  | -  |
| 9 bits      | 0                | Don't care | -                             | -   | -   | -   | -   | -   | MPBT | -  | -     | -  | -  | -  | -  | -  | -  | -  |

Note: -: Invalid. The write value should be 0.

Figure 27.42 Data format written to FTDRH and FTDRL in multi-processor mode with FIFO selected

Figure 27.43 shows an example flow of multi-processor serial transmission with FIFO selected. In the ID transmission cycle, the ID must be transmitted with the FTDRH.MPBT bit set to 1. In the data transmission cycle, the data must be transmitted with the MPBT bit set to 0. The rest of the operations are the same as operations in asynchronous mode with non-FIFO selected.

| 数据长度   | 寄存器设置      |            | 在FTDRH、FTDRL中传输数据 |     |     |     |     |     |      |    |       |    |    |    |    |    |    |    |
|--------|------------|------------|-------------------|-----|-----|-----|-----|-----|------|----|-------|----|----|----|----|----|----|----|
|        | SCMR. CHR1 | SMR. CHR   | FTDRHL            |     |     |     |     |     |      |    |       |    |    |    |    |    |    |    |
|        |            |            | FTDRH             |     |     |     |     |     |      |    | FTDRL |    |    |    |    |    |    |    |
|        |            |            | b15               | b14 | b13 | b12 | b11 | b10 | b9   | b8 | b7    | b6 | b5 | b4 | b3 | b2 | b1 | b0 |
| 7 bits | 1          | 0          | -                 | -   | -   | -   | -   | -   | MPBT | -  | -     | -  | -  | -  | -  | -  | -  | -  |
| 8 bits | 1          | 1          | -                 | -   | -   | -   | -   | -   | MPBT | -  | -     | -  | -  | -  | -  | -  | -  | -  |
| 9 bits | 0          | Don't care | -                 | -   | -   | -   | -   | -   | MPBT | -  | -     | -  | -  | -  | -  | -  | -  | -  |

Note: -: 无效的。写入值应为0。

Figure 27.42 在选择FIFO的多处理器模式下写入FTDRH和FTDRL的数据格式

图27.43显示了选择FIFO的多处理器串行传输示例流程。在ID传输周期中，必须在FTDRH.MPBT位设置为1的情况下传输ID。在数据传输周期中，必须在MPBT位设置为0的情况下传输数据。其余操作与操作相同在异步模式下选择非FIFO。



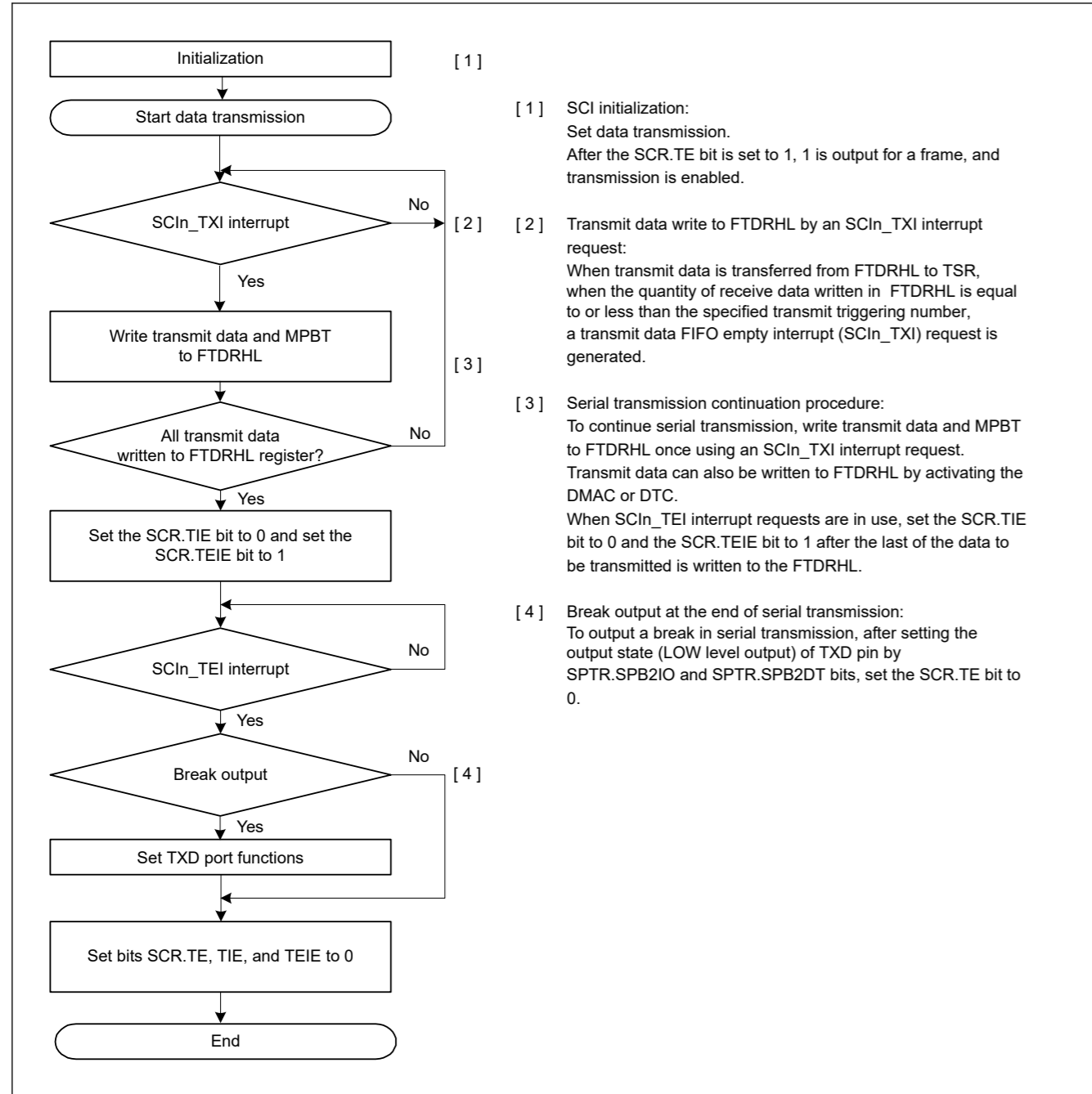


Figure 27.43 Example flow of serial transmission in multi-processor mode with FIFO selected

### 27.4.2 Multi-Processor Serial Data Reception

(1) Non-FIFO selected

Figure 27.45 and Figure 27.46 are example flows of multi-processor serial reception. When the SCR.MPIE bit is set to 1, reading communication data is skipped until reception of communication data in which the multi-processor bit is set to 1. When communication data in which the multi-processor bit is set to 1 is received, the received data is transferred to the RDR register (the RDRHL register when 9-bit data length is selected), and the SCIn\_RXI interrupt request is generated. The rest of the operations are the same as operations in asynchronous mode. Read the order from FRDRH to FRDRL.

Figure 27.44 shows an example operation for data reception.

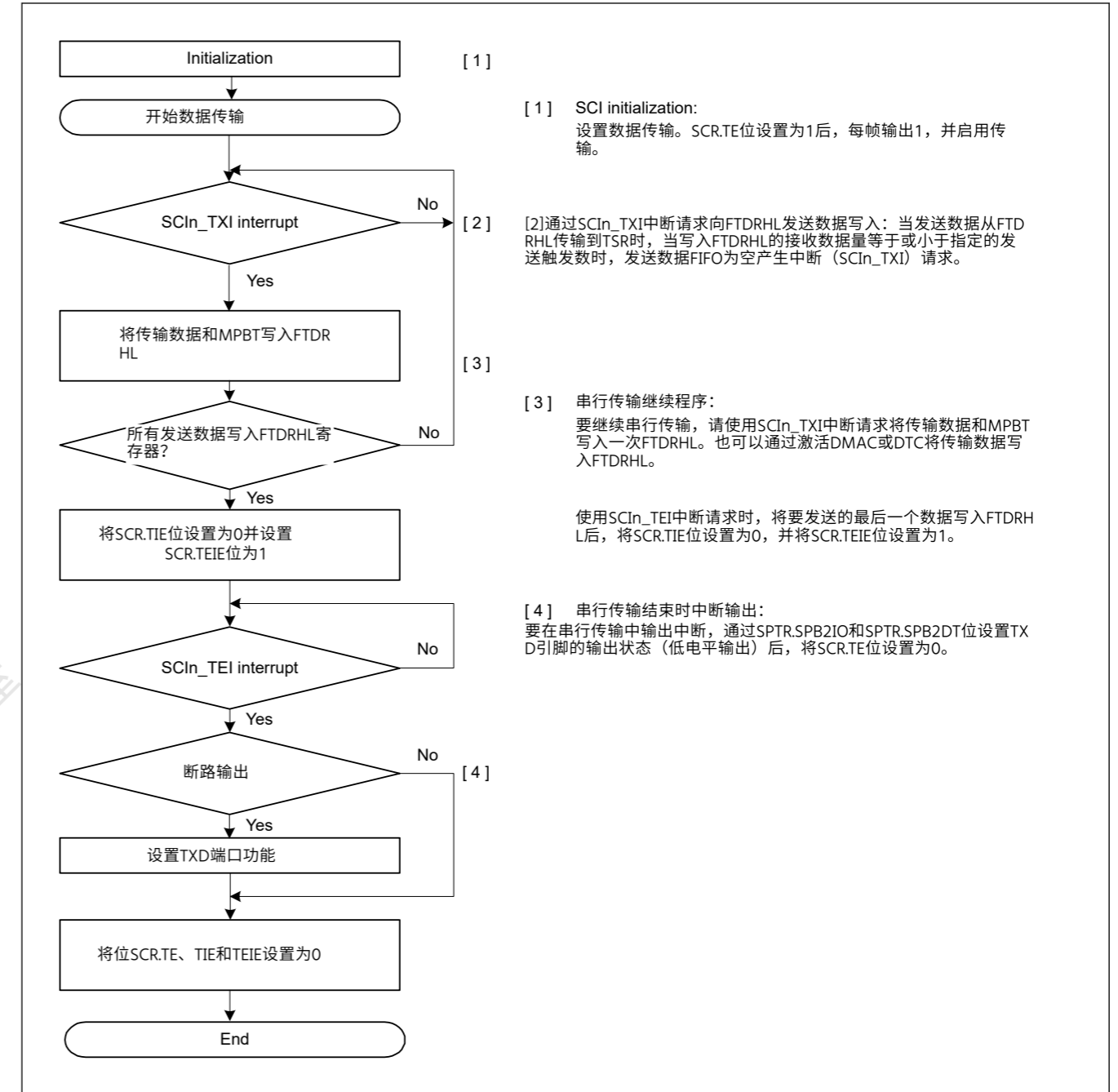


Figure 27.43 选择FIFO的多处理器模式下的串行传输示例流程

### 27.4.2 多处理器串行数据接收

(1) Non-FIFO selected

图27.45和图27.46是多处理器串行接收的示例流程。当SCR.MPIE位设置为1时，将跳过读取通信数据，直到接收到多处理器位设置为1的通信数据。当接收到多处理器位设置为1的通信数据时，接收到的数据被传输到

RDR寄存器（选择9位数据长度时的RDRHL寄存器），并产生SCIn\_RXI中断请求。其余操作与异步模式下的操作相同。读取从FRDRH到FRDRL的订单。

图27.44显示了数据接收的示例操作。

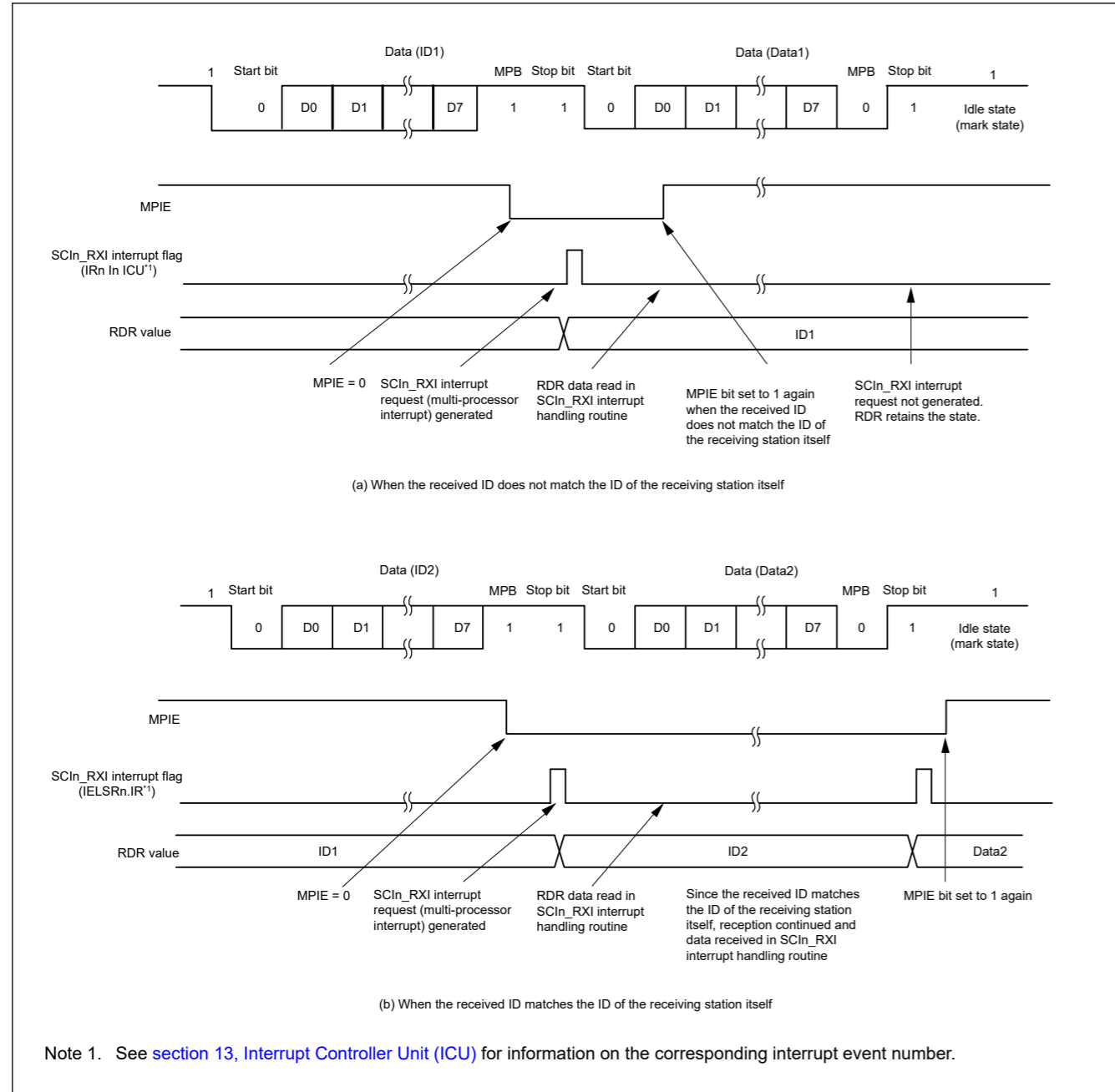


Figure 27.44 Example of SCI reception with 8-bit data, multi-processor bit, and 1 stop bit

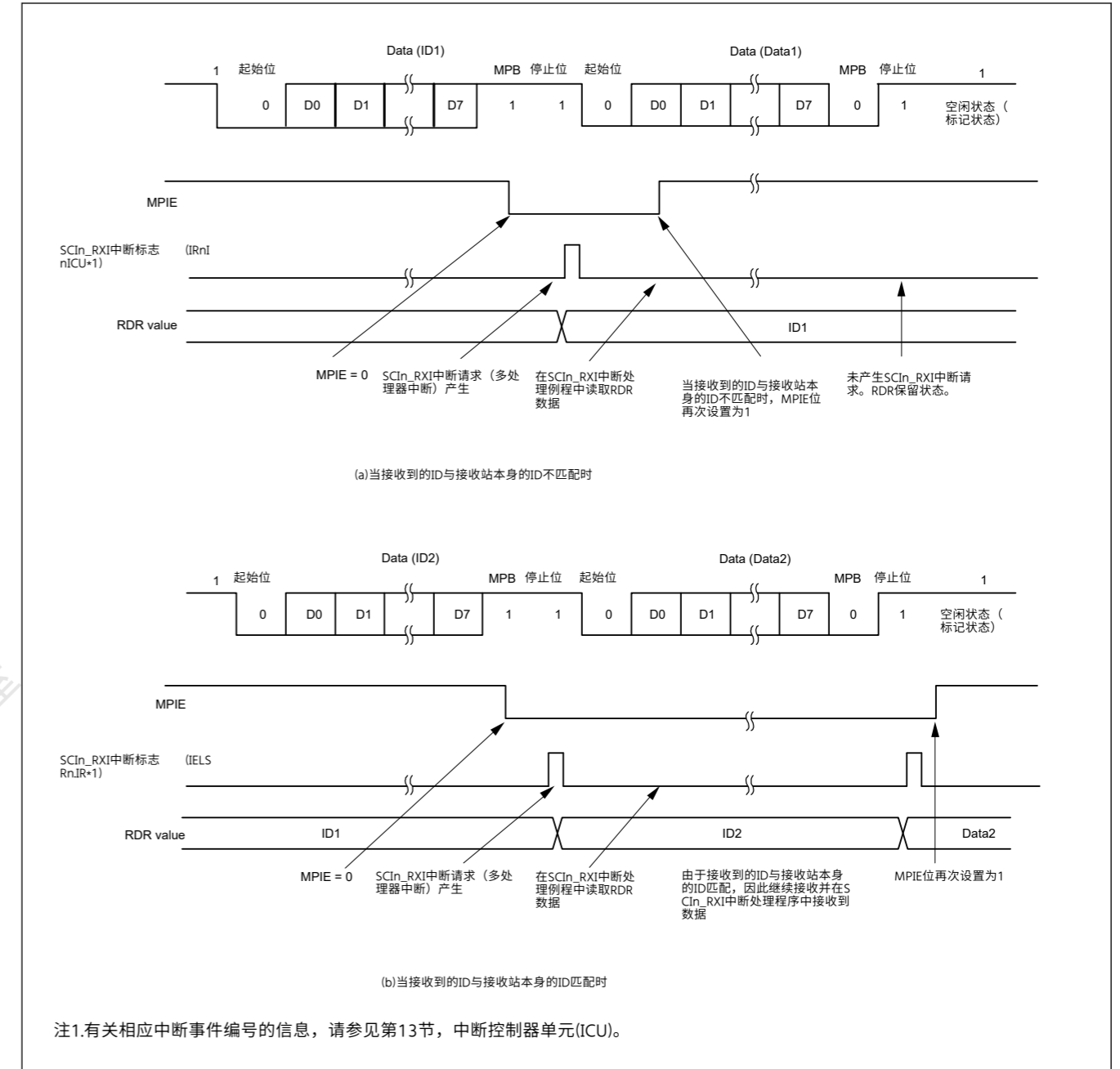


Figure 27.44 使用8位数据、多处理器位和1个停止位的SCI接收示例

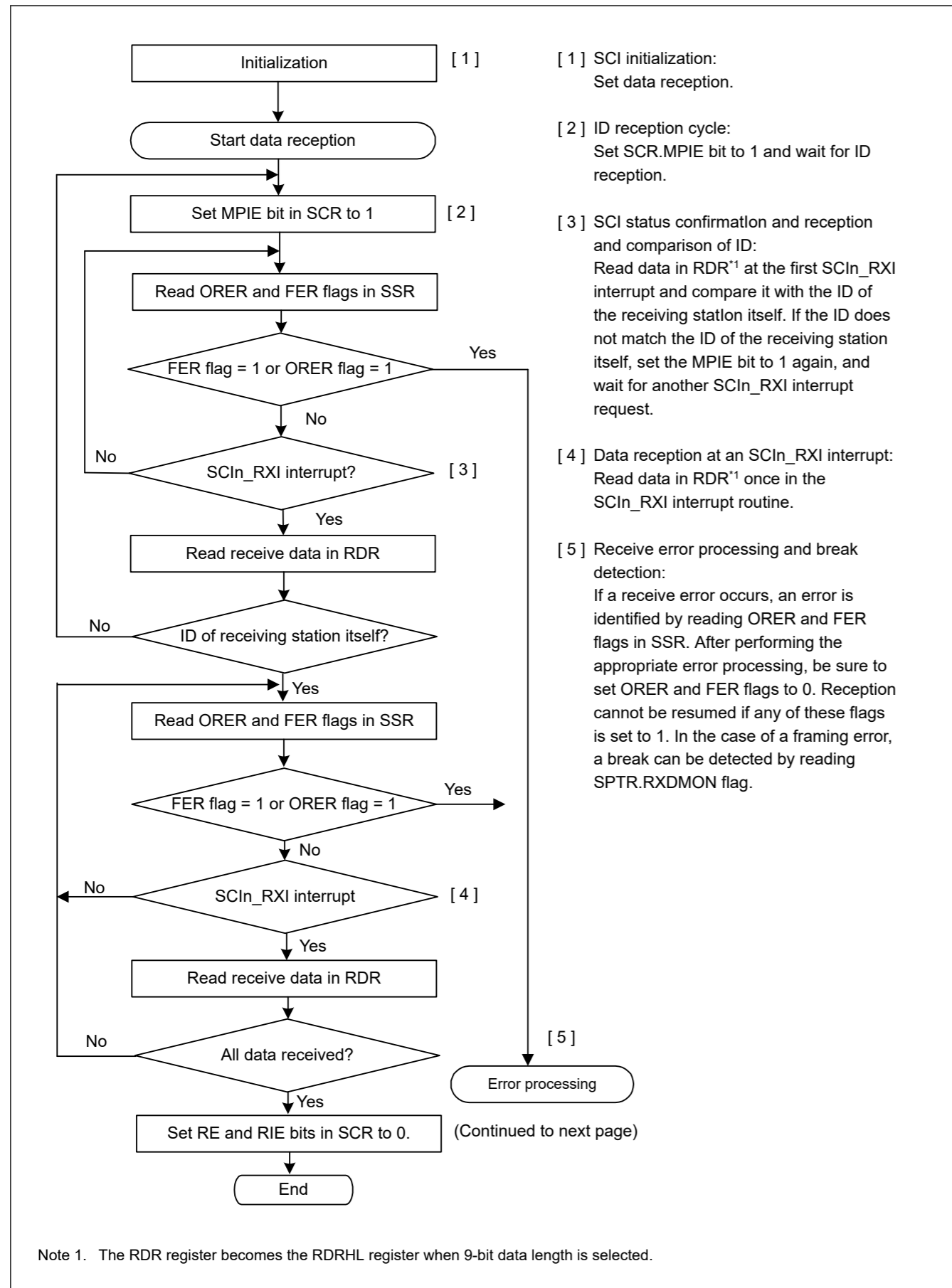


Figure 27.45 Example flow of multi-processor serial reception with non-FIFO selected (1)

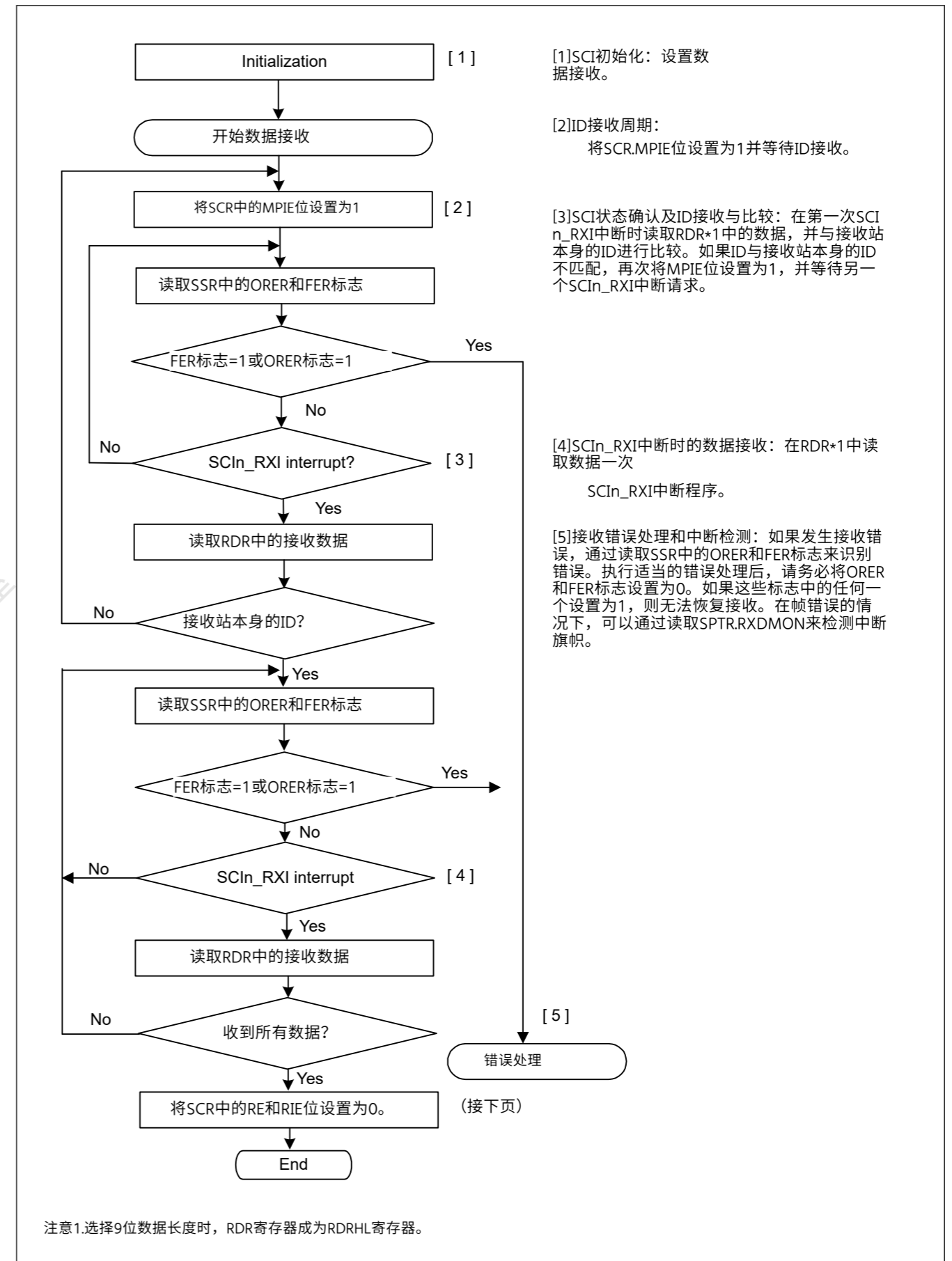


Figure 27.45 选择非FIFO的多处理器串行接收示例流程(1)

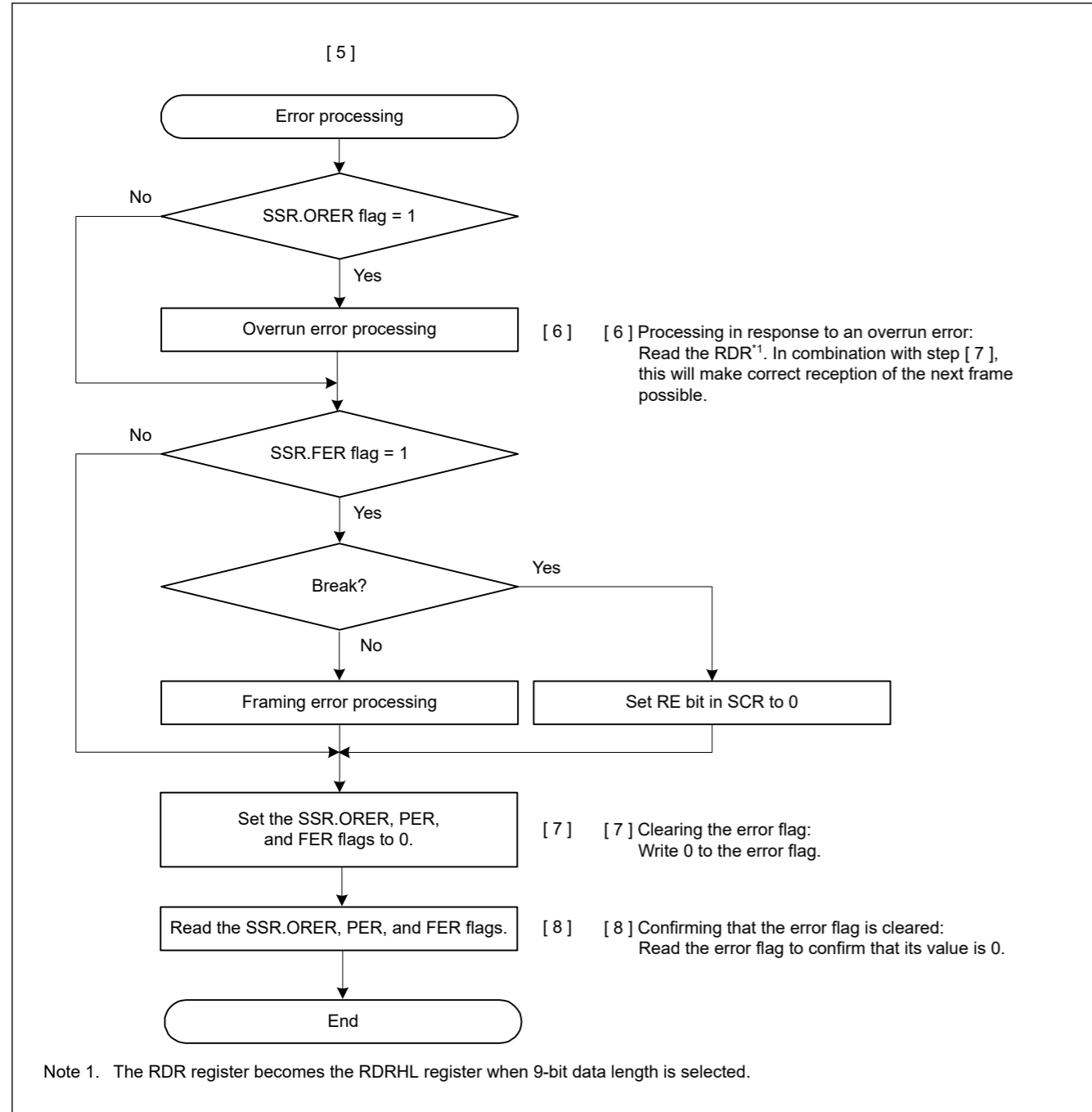


Figure 27.46 Example flow of multi-processor serial reception with non-FIFO selected (2)

(2) FIFO selected

Figure 27.47 shows an example of a data format that is written to FRDRH and FRDRL in multi-processor mode.

In multi-processor mode, the MPB value that is a part of the receive data is written to the FRDRH.MPB bit. A value of 0 is written to the FRDRH.PER flag. Data is written to FRDRH and FRDRL with the correct data length. Unused bits are written with 0. Read in order from FRDRH to FRDRL. When software reads the FRDRL register, the SCI updates FER, MPB, and receive data (RDAT[8:0]) in FRDRL with the next data. The RDF, ORER and DR flags in the FRDRH register always reflect the associated flags in the SSR\_FIFO register.

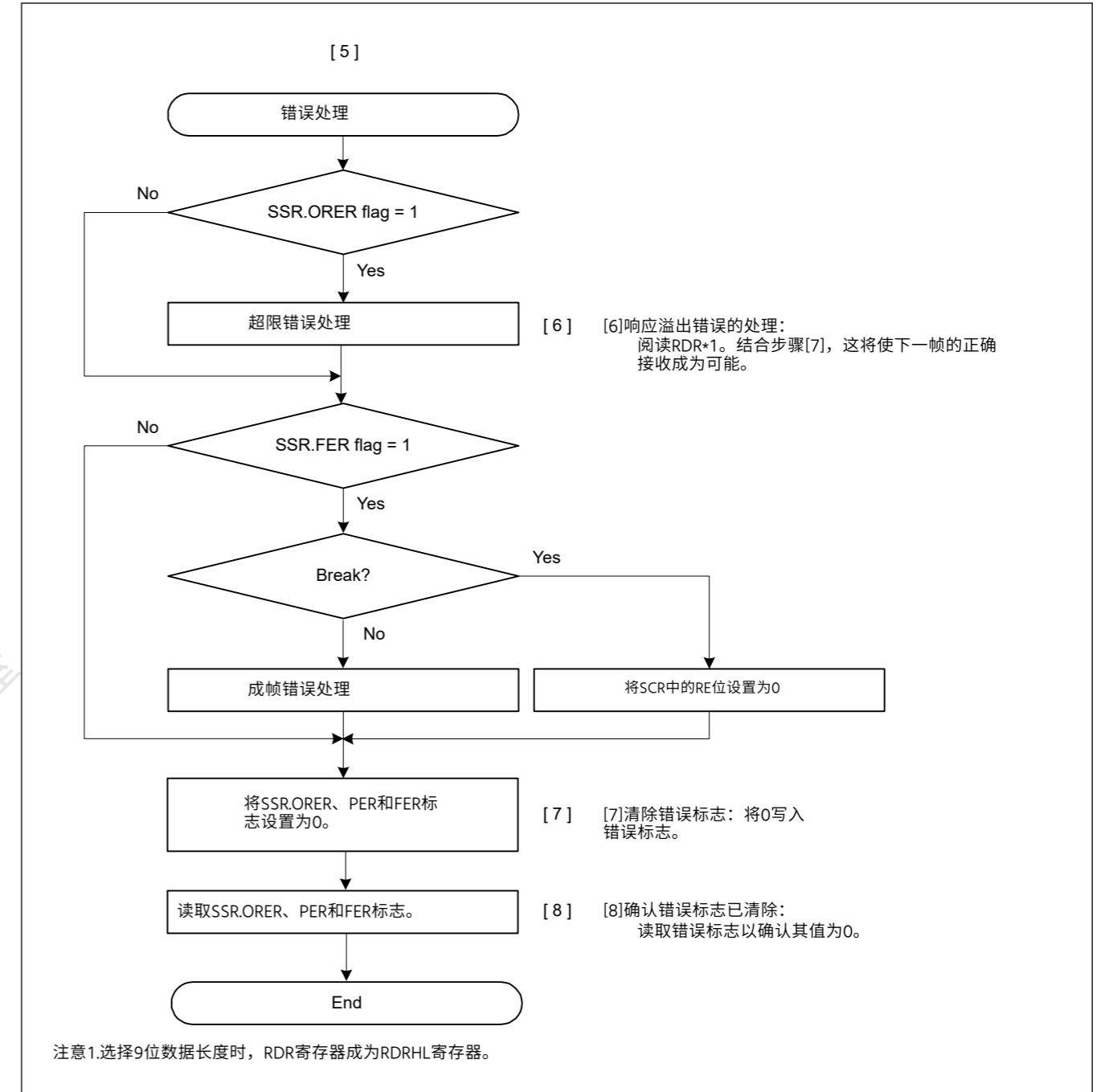


Figure 27.46 选择非FIFO的多处理器串行接收示例流程(2)

(2) FIFO selected

图27.47显示了在多处理器模式下写入FRDRH和FRDRL的数据格式示例。

在多处理器模式下，作为接收数据一部分的MPB值被写入FRDRH.MPB位。值0写入FRDRH.PER标志。数据以正确的数据长度写入FRDRH和FRDRL。未使用的位写入0。按从FRDRH到FRDRL的顺序读取。当软件读取FRDRL寄存器时，SCI用下一个数据更新FER、MPB和FRDRL中的接收数据 (RDAT[8:0])。FRDRH寄存器中的RDF、ORER和DR标志始终反映SSR\_FIFO寄存器中的相关标志。



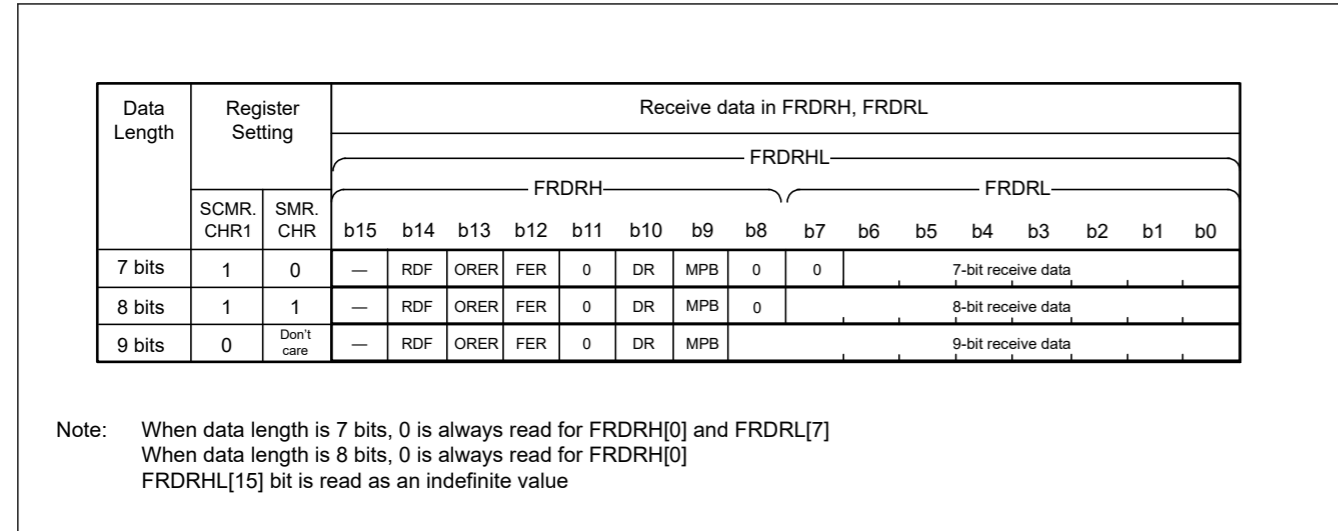


Figure 27.47 Data format stored in FRDRH and FRDRL in multi-processor mode with FIFO selected

Figure 27.48 shows an example flow of multi-processor data reception with FIFO selected. When the SCR.MPIE is set to 1, reading communication data is skipped until reception of communication data in which the multi-processor bit is set to 1. When communication data in which the multi-processor bit is set to 1 is received, the received data, MPB and associated errors are transferred to the FRDRHL register. The SCR.MPIE bit is automatically cleared and normal reception continues.

If a framing error occurs and the SSR\_FIFO.FER flag is set to 1, the SCI continues data reception. The rest of the operations are the same as operations in asynchronous mode with non-FIFO selected.

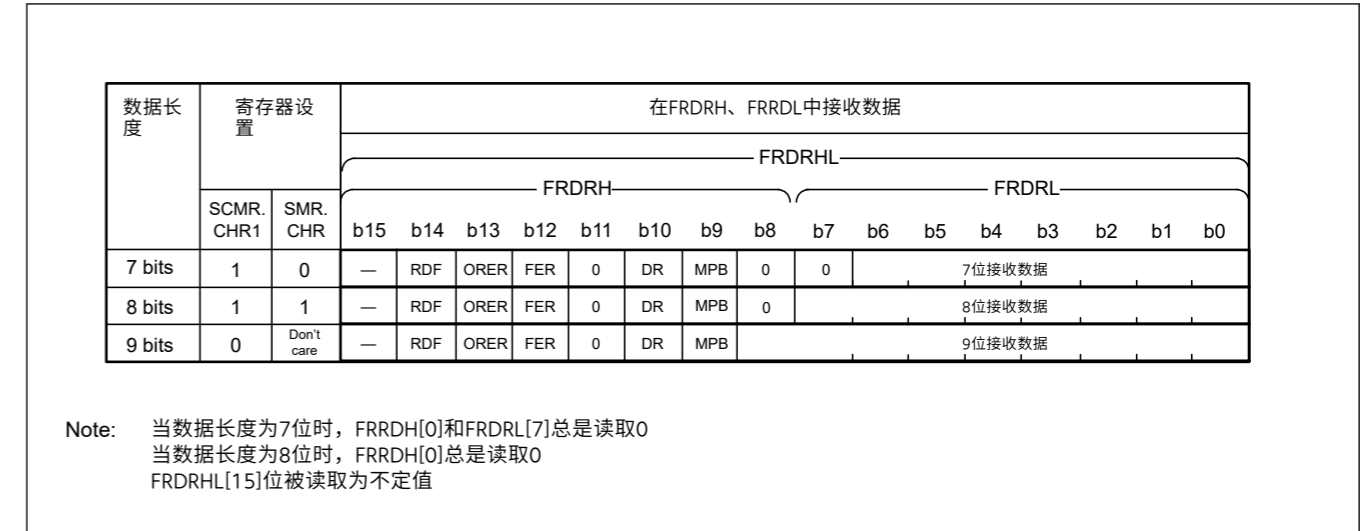


Figure 27.47 选择FIFO的多处理器模式下存储在FRDRH和FRDRL中的数据格式

图27.48显示了选择FIFO的多处理器数据接收示例流程。当SCR.MPIE设置为1时，将跳过读取通信数据，直到接收到多处理器位设置为1的通信数据。当接收到多处理器位设置为1的通信数据时，接收到的数据、MPB和相关错误被传送到FRDRHL寄存器。SCR.MPIE位自动清零并继续正常接收。

如果发生帧错误并且SSR\_FIFO.FER标志设置为1，则SCI继续数据接收。其余操作与选择非FIFO的异步模式中的操作相同。

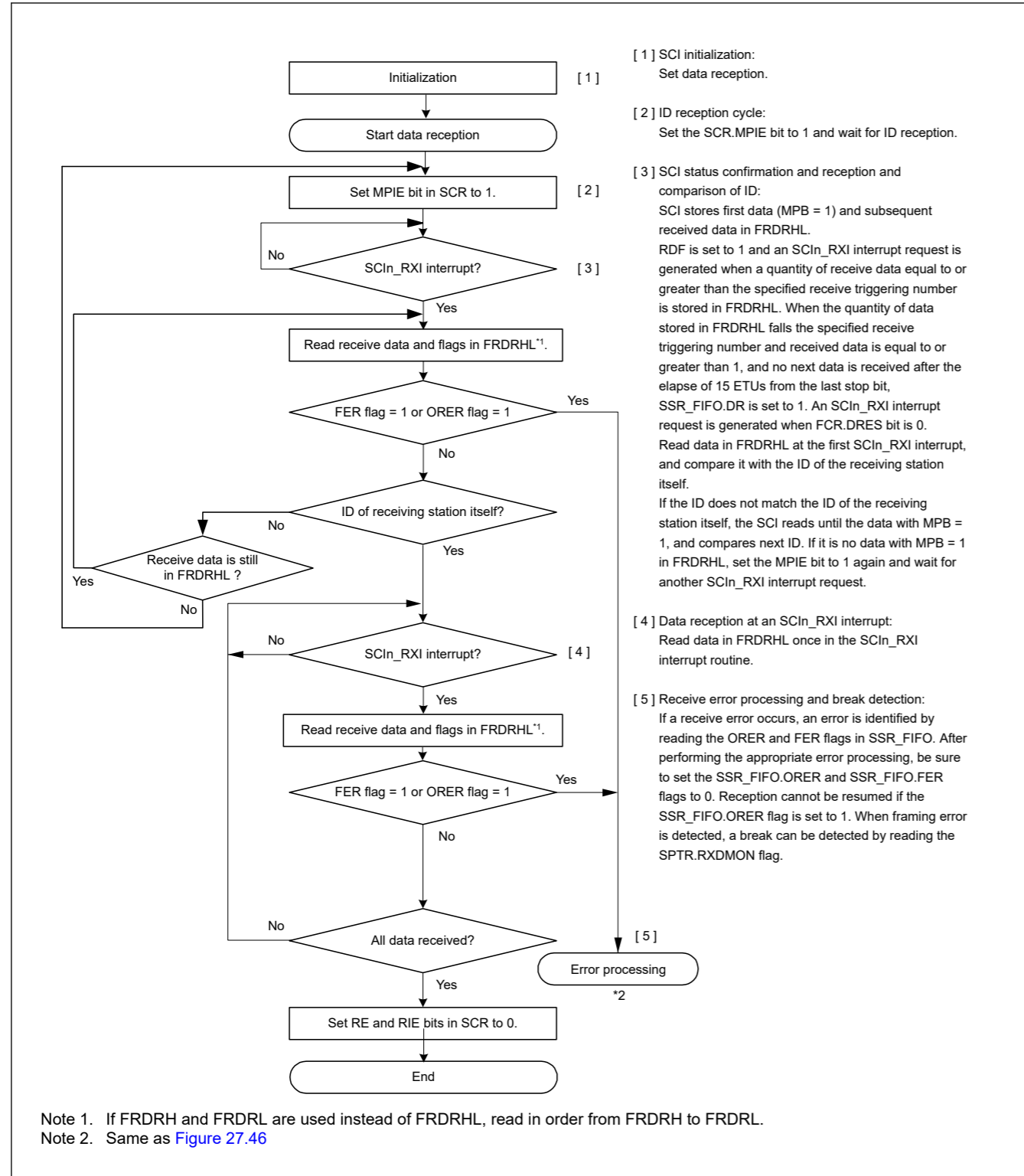


Figure 27.48 Example flow of serial ID reception in multi-processor mode with FIFO selected

### 27.5 Operation in Manchester mode

In Manchester mode, the transmit or receive serial data is coded in Manchester encoding.

Figure 27.49 shows the conceptual image of Manchester encoding.

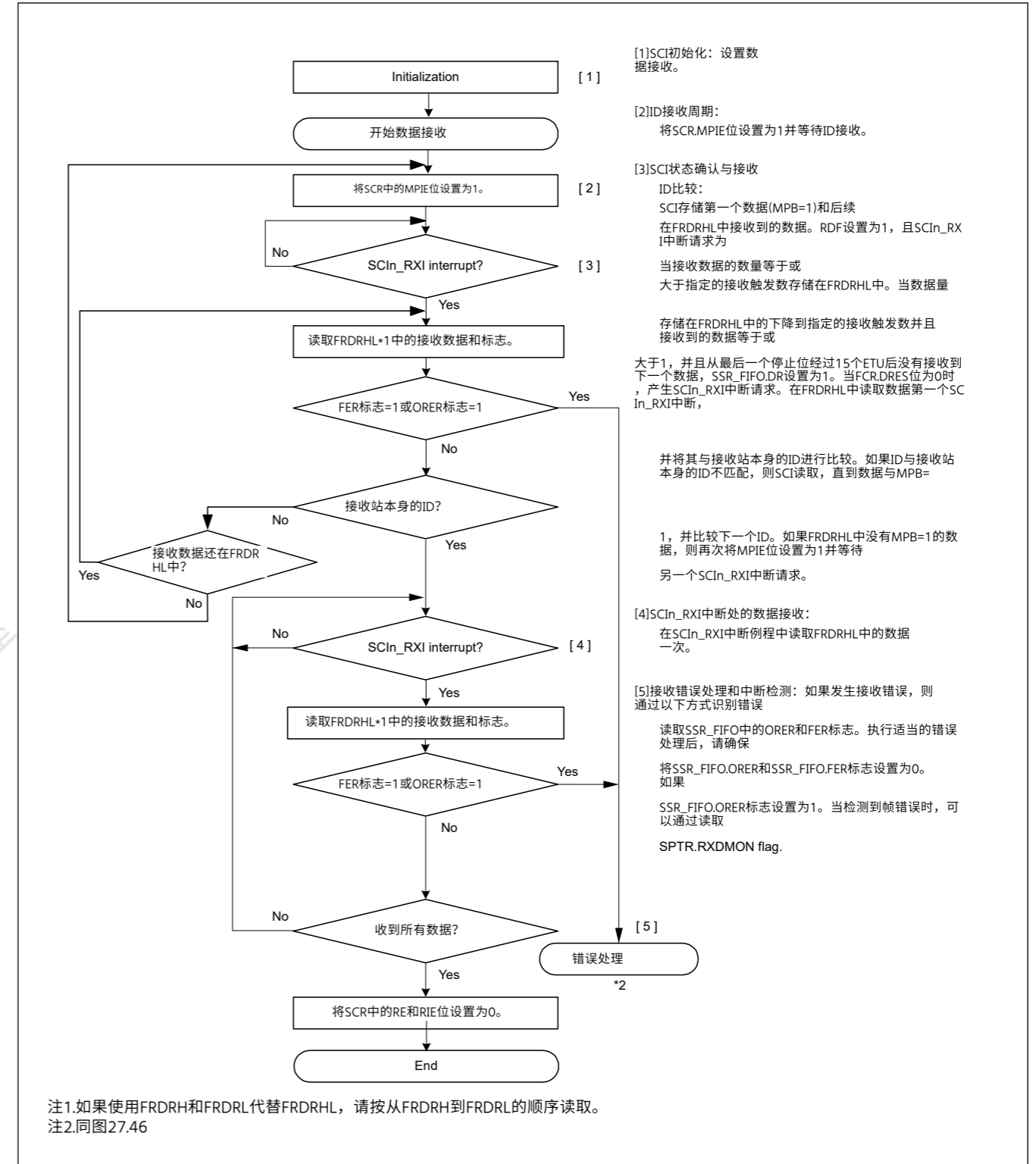


Figure 27.48 选择FIFO的多处理器模式下的串行接收示例流程

### 27.5 曼彻斯特模式下的操作

在曼彻斯特模式下,发送或接收串行数据以曼彻斯特编码进行编码。

图27.49显示了曼彻斯特编码的概念图。

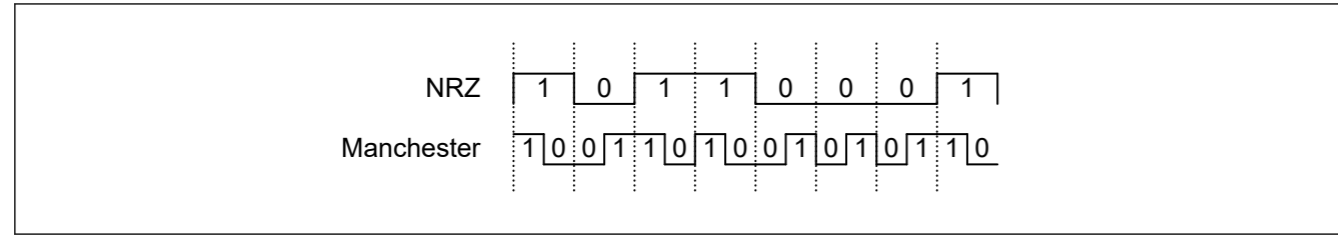


Figure 27.49 Example of Manchester Encoding

In Manchester mode, a preface and a start bit area are added to the transmit data in the register to configure a transmit frame. For transmission, data is encoded in Manchester encoding. When data is received, frames having the same format as transmitted frames are detected and Manchester decoding is performed.

For details on the frame format, see section 27.5.1. Frame Format.

### 27.5.1 Frame Format

Figure 27.50 shows the frame format in Manchester mode.

In the upper half of the figure, relevant setting registers are shown.

The preface area and the data area are encoded in Manchester encoding.

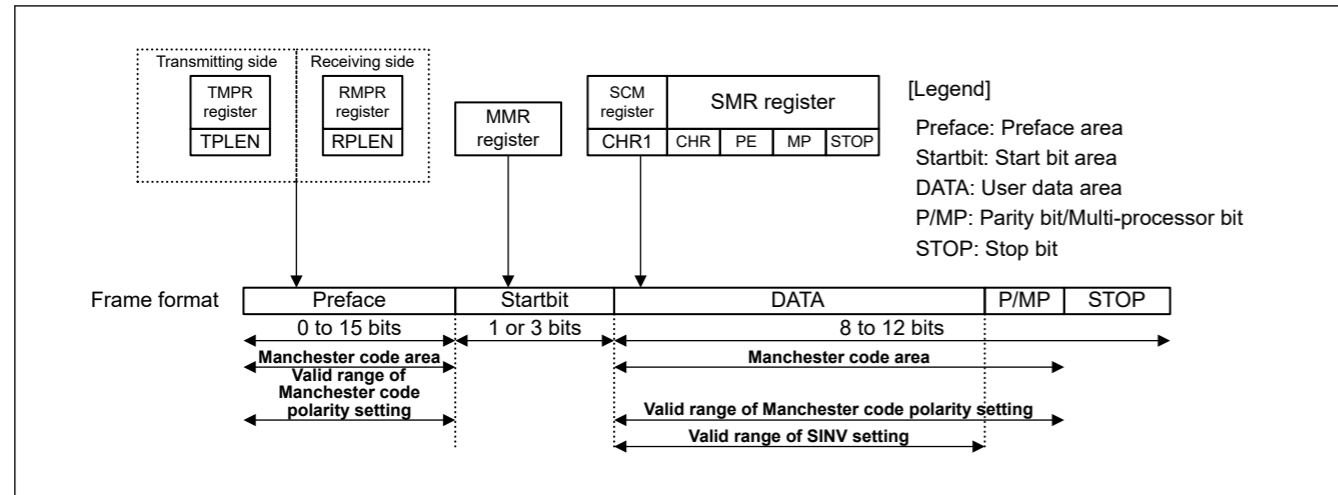


Figure 27.50 Frame Format in Manchester Mode

#### (1) Preface area

This is a fixed pattern area located at the beginning of each frame.

Different registers are used to set the preface area for transmission and reception. The preface length is determined by setting TMR.TPLEN[3:0] for transmission. It is determined by setting RMPR.RPLEN[3:0] for reception.

If it is set to 0, the transmit preface is disabled and is not added.

If it is set to 1d to 15d, a preface whose length is determined by this setting is added.

(For example, if it is set to 1d, a 1-bit preface is added. If it is set to 15d, a 15-bit preface is added.)

The preface pattern is set with TMR.TPPAT[1:0] for transmission and RMPR.RPPAT[1:0] for reception, and is selected from four types of patterns.

Figure 27.51 shows how the preface pattern is set. The preface area and the start bit area are added for each communication frame.

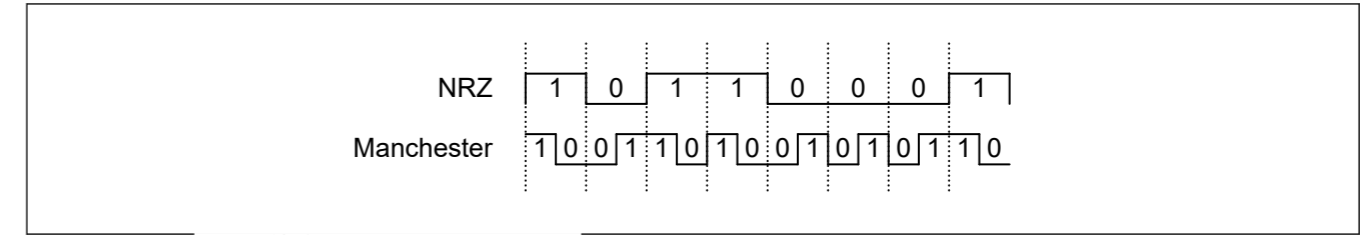


Figure 27.49 曼彻斯特编码示例

在曼彻斯特模式下，前言和起始位区域被添加到寄存器中的发送数据以配置发送帧。对于传输，数据以曼彻斯特编码进行编码。当接收到数据时，检测与传输帧格式相同的帧并执行曼彻斯特解码。

有关帧格式的详细信息，请参阅第27.5.1节。帧格式。

### 27.5.1 帧格式

图27.50显示了曼彻斯特模式下的帧格式。

在图的上半部分，显示了相关的设置寄存器。

前言区和数据区采用曼彻斯特编码。

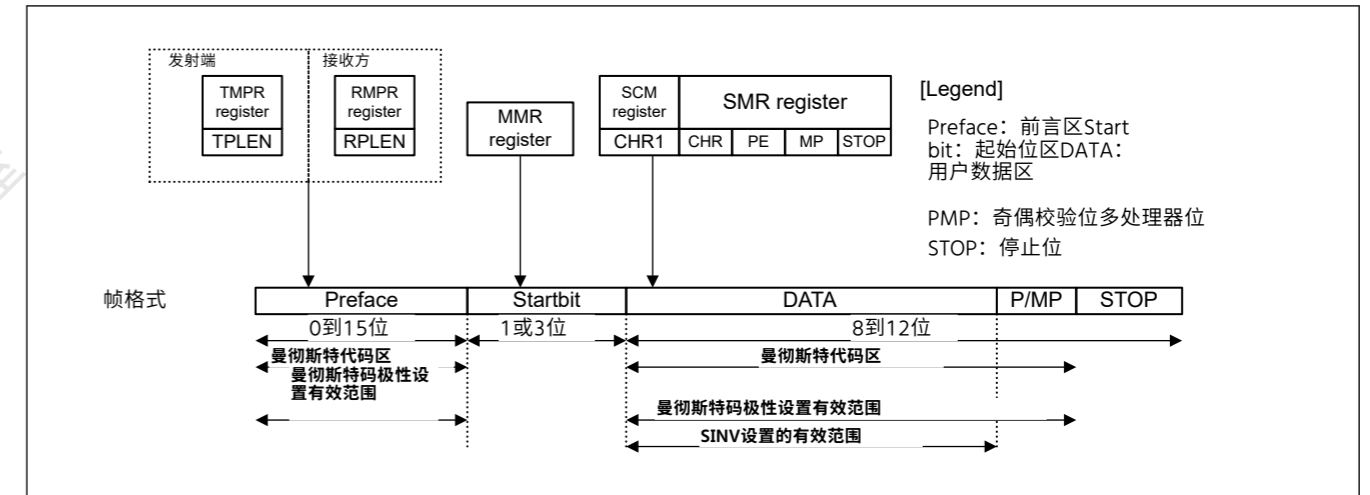


Figure 27.50 曼彻斯特模式下的帧格式

#### (1) 前言区

这是位于每帧开始处的固定模式区域。

不同的寄存器用于设置发送和接收的前言区域。前言长度通过设置TMR.TPLEN[3:0]来决定传输。通过设置RMPR.RPLEN[3:0]来确定接收。

如果设置为0，则发送前言被禁用且不添加。

如果设置为1d到15d，则添加一个长度由该设置确定的前言。

(例如，如果设置为1d，则添加1位前言。如果设置为15d，则添加15位前言。)

前言模式设置为发送用TMR.TPPAT[1:0]，接收用RMPR.RPPAT[1:0]，从四种模式中选择。

图27.51显示了如何设置前言模式。为每个通信帧添加前言区和起始位区。

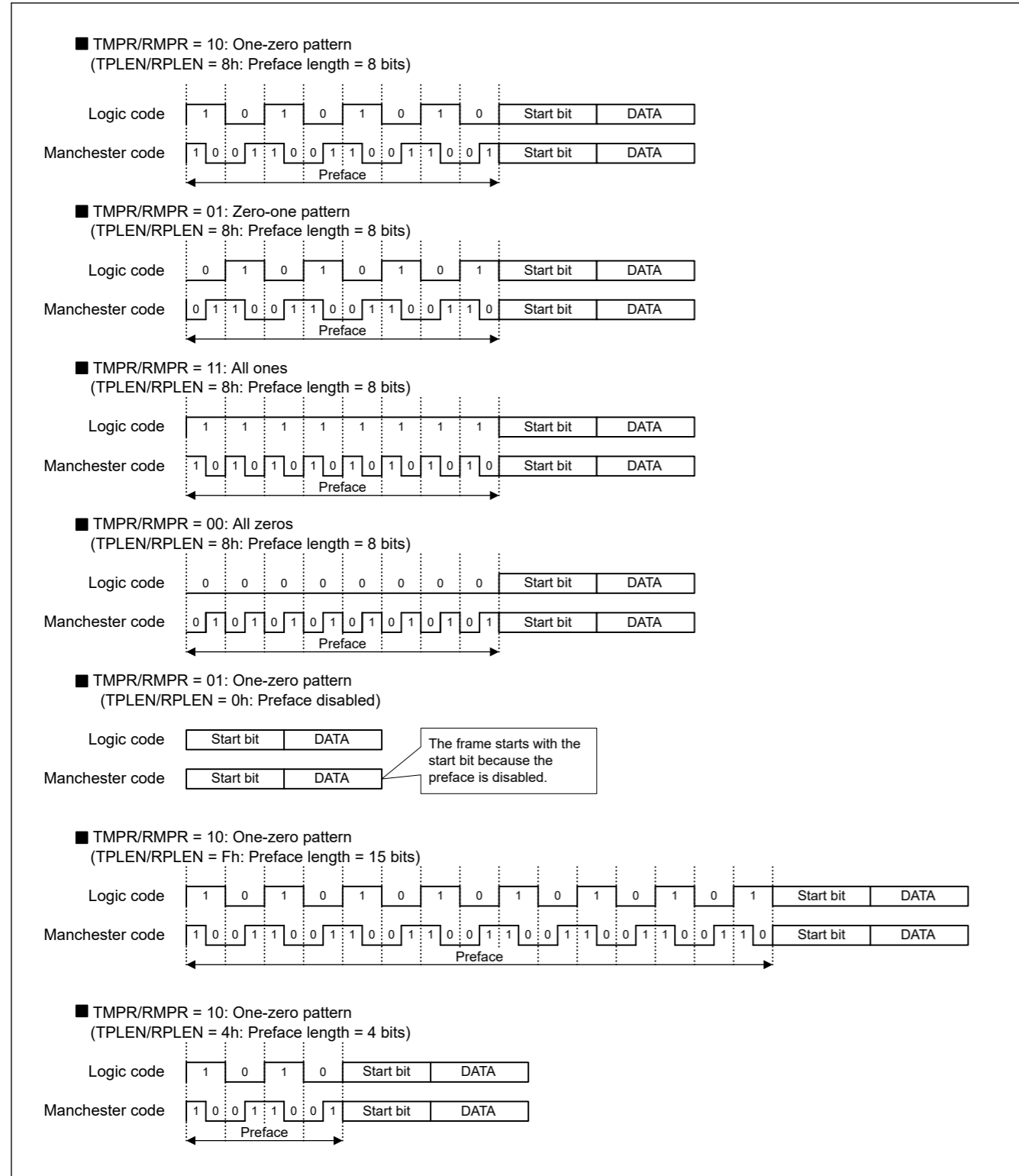


Figure 27.51 Preface Pattern Setting Example

(2) Start bit area

This is an area indicating the start of valid data in a frame. It is added after the preface area.

The start bit length is determined by MMR.SBSEL setting. When MMR.SBSEL = "0", the start bit length is 1 bit.

When MMR.SBSEL = "1", the start bit length is 3 bits.

When MMR.SBSEL = "1", the SYNC type can be selected from command SYNC and data SYNC.

Command SYNC means the three start bits are added as a one-to-zero transition.

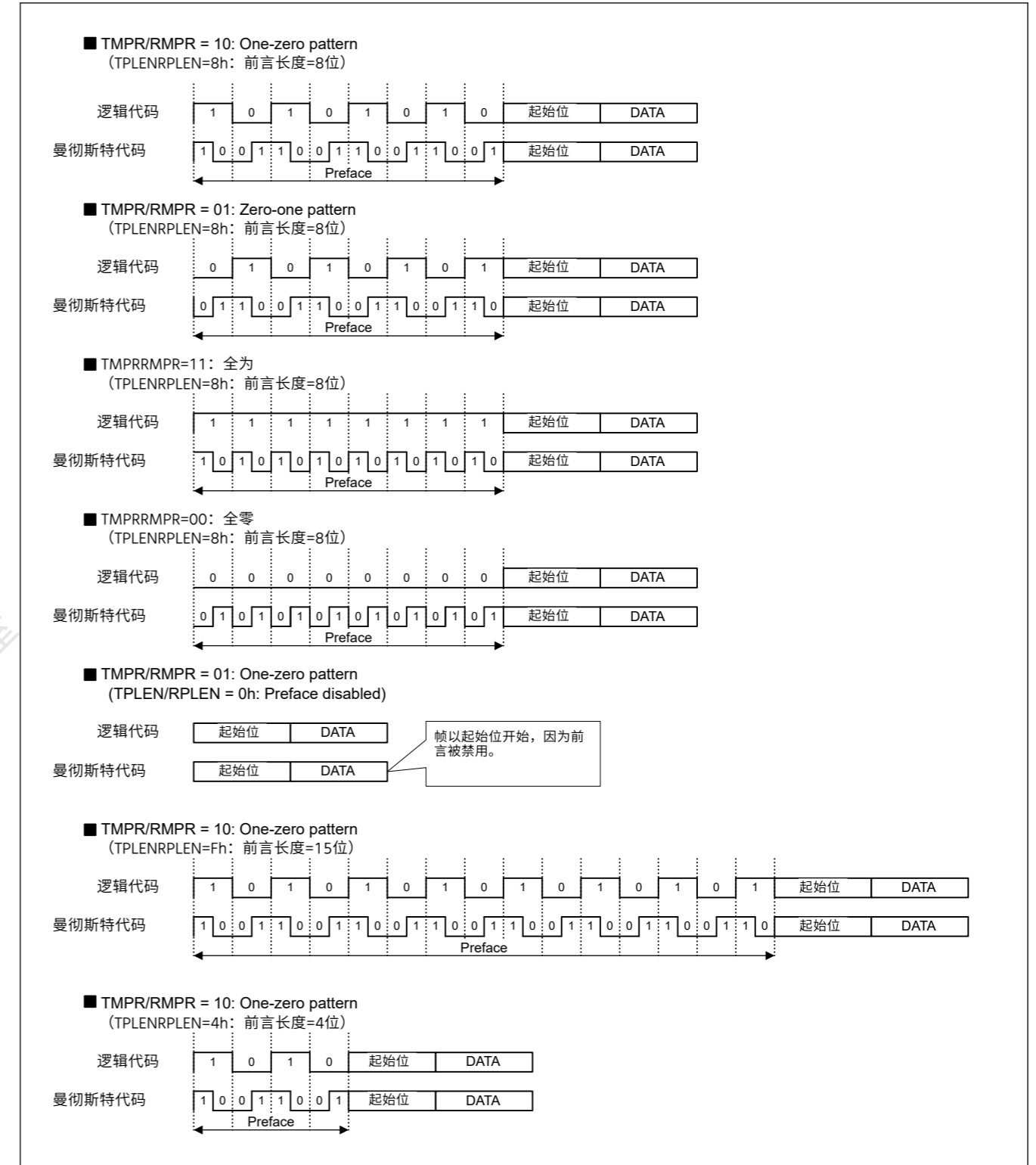


Figure 27.51 前言模式设置示例

(2) 起始位区

这是指示帧中有效数据开始的区域。它添加在前言区域之后。

起始位长度由MMR.SBSEL设置决定。当MMR.SBSEL="0"时，起始位长度为1位。

当MMR.SBSEL="1"时，起始位长度为3位。

当MMR.SBSEL="1"时，SYNC类型可以从命令SYNC和数据SYNC中选择。

命令SYNC意味着三个起始位被添加为一个从1到零的转换。



Data SYNC means the three start bits are added as a zero-to-one transition.

The SYNC type is determined by the MMR.SYNSEL, MMR.SYNVAL and TDRH.TSYNC settings.

(When receiving, the received result is applied to RDRH.RSYNC.)

When MMR.SBSEL = "0", the start bit is added as a zero-to-one or one-to-zero transition.

The selection is determined by the MMR.SYNVAL setting.

The MMR.SYNSEL bit specifies the destination to be referred to when setting for transmission.

When the MMR.SYNSEL bit is set to "1", the MMR.SYNVAL setting is referred to. When the MMR.SYNSEL bit is set to "0", the TDRH.TSYNC setting is referred to.

Figure 27.52 shows the state of the start bit area according to the settings in the MMR.SYNSEL, MMR.SYNVAL and TDRH.TSYNC registers in the case of transmission. Figure 27.53 shows that in the case of reception.

The start bit(s) is not affected by the MMR.TMPOL or MMR.RMPOL setting.

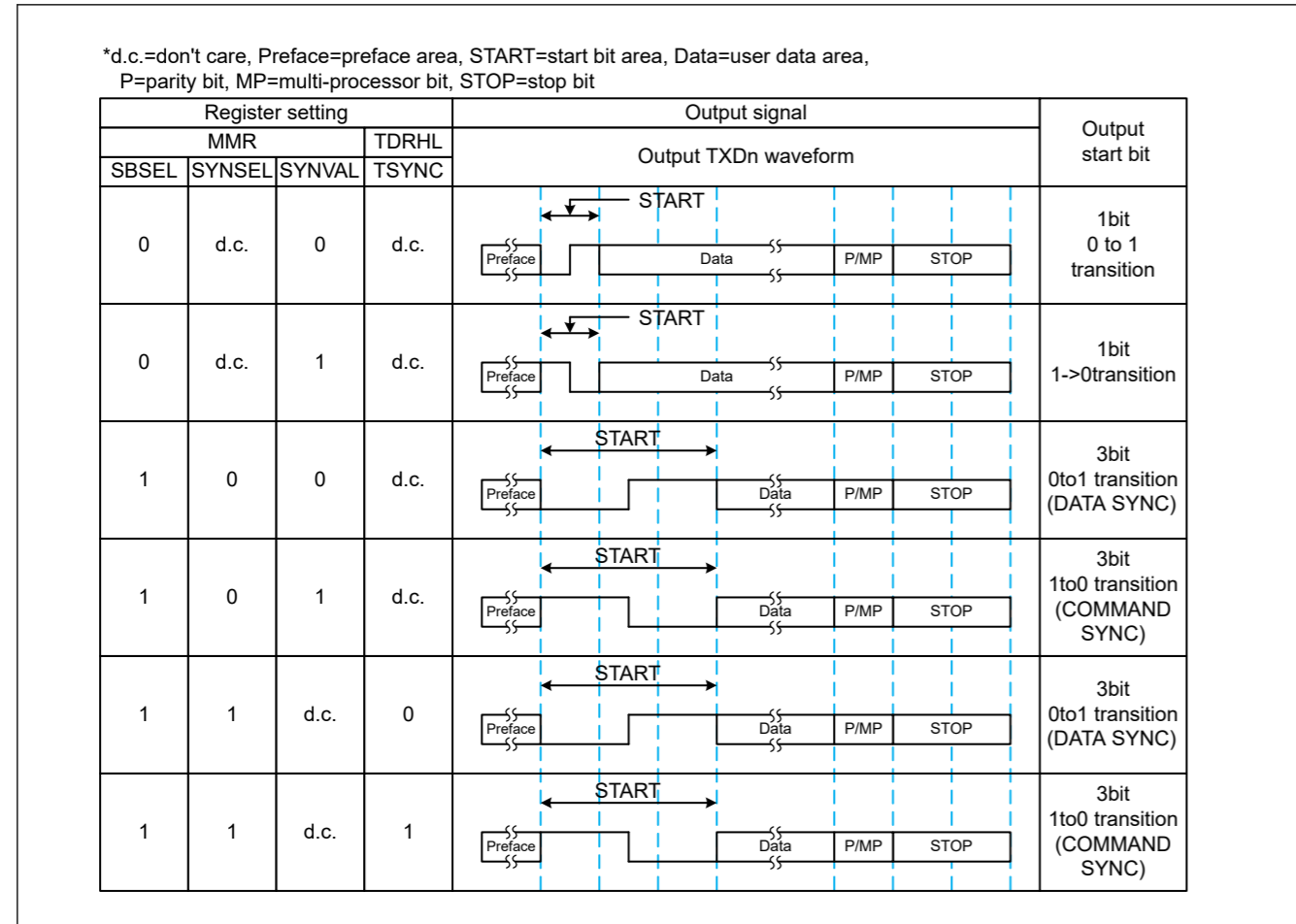


Figure 27.52 Settings Related to and Format of the Start Bit Area at Transmission

数据同步意味着三个起始位被添加为一个零到一的转换。

SYNC类型由MMR.SYNSEL、MMR.SYNVAL和TDRH.TSYNC设置确定。

(接收时，将接收到的结果应用到RDRH.RSYNC。)

当MMR.SBSEL="0"时，添加起始位作为零到一或一到零的转换。

选择由MMR.SYNVAL设置决定。

MMR.SYNSEL位指定发送设置时要参考的目标。

当MMR.SYNSEL位设置为"1"时，参考MMR.SYNVAL设置。当MMR.SYNSEL位设置为"0"时，参考TDRH.TSYNC设置。

图27.52显示了根据MMR.SYNSEL、MMR.SYNVAL和TDRH.TSYNC寄存器在传输的情况下。图27.53显示了在接收的情况下。

起始位不受MMR.TMPOL或MMR.RMPOL设置的影响。

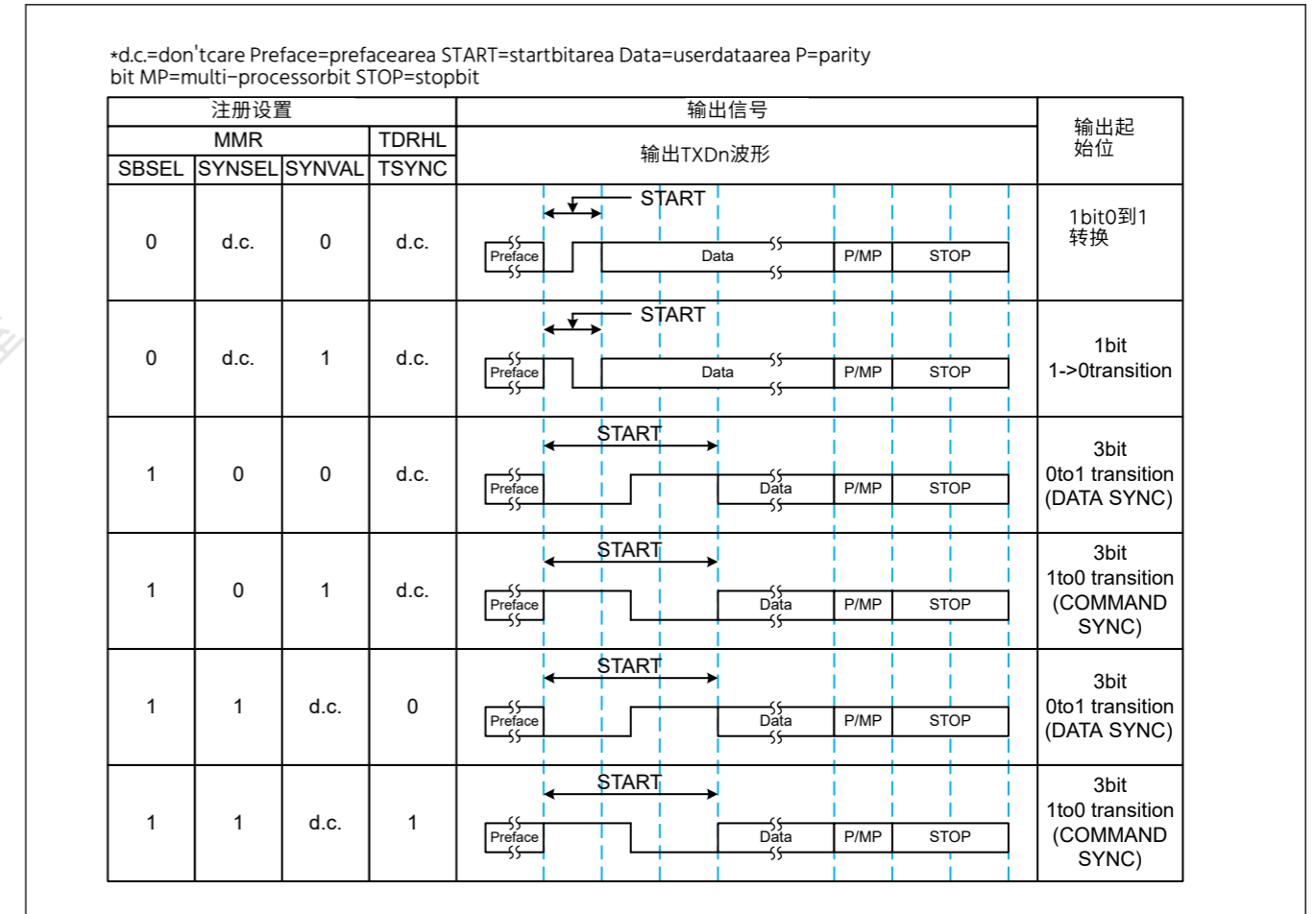


Figure 27.52 发送时起始位区域的相关设置和格式

When the start bit area is 3 bits long, SYNVAL is not referenced.  
 d.c. = don't care, Preface = Preface area, START = Start bit area, Data = Data area  
 P = Parity bit, MP = Multi-processor bit, STOP = Stop bit

| Register setting |        |        |       | Input signal<br>RXDn input waveform | Start bit detection result*1                | Register indication<br>RDRH.RSYNC |
|------------------|--------|--------|-------|-------------------------------------|---|-----------------------------------|
| MMR              |        | TDRH   |       |                                     |   |                                   |
| SBSEL            | SYNSEL | SYNVAL | TSYNC |                                     |   |                                   |
| 0                | d.c.   | 0      | d.c.  |                                     | Normal start bit (1 bit: 0-to-1 transition) | 0                                 |
|                  |        |        |       |                                     | Start bit error                             | 0                                 |
|                  |        |        |       |                                     | Start bit error                             | 0                                 |
|                  |        |        |       |                                     | Start bit error                             | 0                                 |
| 0                | d.c.   | 1      | d.c.  |                                     | Start bit error                             | 0                                 |
|                  |        |        |       |                                     | Normal start bit (1 bit: 1-to-0 transition) | 0                                 |
|                  |        |        |       |                                     | Start bit error                             | 0                                 |
|                  |        |        |       |                                     | Start bit error                             | 0                                 |
| 1                | d.c.   | d.c.   | d.c.  |                                     | Start bit error                             | 0                                 |
|                  |        |        |       |                                     | Start bit error                             | 0                                 |
|                  |        |        |       |                                     | Data SYNC                                   | 0                                 |
|                  |        |        |       |                                     | Command SYNC                                | 1                                 |

Note 1. Data other than the start bit is assumed to be normal.

Figure 27.53 Settings Related to and Judgment of the Start Bit Area at Reception

当起始位区域为3位长时，不引用SYNVAL。  
 直流电=don'tcare Preface=Prefacearea START=Startbitarea Data=DataareaP=Paritybit  
 MP=Multi-processorbit STOP=Stopbit

| 注册设置  |        |        |       | 输入信号<br>RXDn输入波形 | 起始位检测结果*1         | 登记指示<br>RDRH.RSYNC |
|-------|--------|--------|-------|------------------|-------------------|--------------------|
| MMR   |        | TDRH   |       |                  |                   |                    |
| SBSEL | SYNSEL | SYNVAL | TSYNC |                  |                   |                    |
| 0     | d.c.   | 0      | d.c.  |                  | 正常起始位 (1位: 0到1转换) | 0                  |
|       |        |        |       |                  | 起始位错误             | 0                  |
|       |        |        |       |                  | 起始位错误             | 0                  |
|       |        |        |       |                  | 起始位错误             | 0                  |
| 0     | d.c.   | 1      | d.c.  |                  | 起始位错误             | 0                  |
|       |        |        |       |                  | 正常起始位 (1位: 1到0转换) | 0                  |
|       |        |        |       |                  | 起始位错误             | 0                  |
|       |        |        |       |                  | 起始位错误             | 0                  |
| 1     | d.c.   | d.c.   | d.c.  |                  | 起始位错误             | 0                  |
|       |        |        |       |                  | 起始位错误             | 0                  |
|       |        |        |       |                  | 数据同步              | 0                  |
|       |        |        |       |                  | Command SYNC      | 1                  |

注1.假设起始位以外的数据正常。

Figure 27.53 接收时起始位区域的相关设置和判断

### (3) DATA

Since the format of the data area is the same as that of the asynchronous mode, see [section 27.3.1. Serial Data Transfer Format](#).

As shown in [Figure 27.49](#), Frame Format in Manchester Mode, the stop bit is not included in the Manchester encoding range.

#### 27.5.2 Clock

As the transfer clock in Manchester mode, the clock generated by the on-chip baud rate generator is used by setting the SMR.CKS[1:0] bit.

Also it is possible to set the oversampling (transfer rate of one-bit period) by SEMR.ABCS bit.

When the SMER.ABCS bit is set to 0, oversampling x16 is selected with the one-bit period being 16 cycles of the base clock. When the SMER.ABCS bit is set to 1, oversampling x8 is selected with the one-bit period being 8 cycles of the base clock.

#### 27.5.3 Initialization of the SCI in Manchester Mode

Before transferring data, write the initial value (00h) to the SCR register and initialize the SCI following the example of flowchart shown in [Figure 27.54](#).

Whenever the operating mode or transfer format is changed, the SCR register must be initialized before the change is made.

Note that setting the SCR.RE bit to 0 initializes none of: the ORER, FER, PER, MER, RDRF, and RDF flags in the SSR register, the SYER, PFER and SBER flags in the MESR register, and the RDR, RDRH, and RDRL registers.

Note also that switching the value of SCR.TE from “0” to “1” when SCR.TIE is “1” generates a TXI interrupt request.

### (3) DATA

由于数据区的格式与异步模式相同，见27.3.1节。串行数据传输 [Format](#)。

如图27.49，曼彻斯特模式下的帧格式，停止位不包含在曼彻斯特编码范围内。

#### 27.5.2 Clock

作为曼彻斯特模式下的传输时钟，片内波特率发生器产生的时钟用于设置 SMR.CKS[1:0] bit。

也可以通过SEMR.ABCS位设置过采样（一位周期的传输率）。

当SMER.ABCS位设置为0时，选择过采样x16，一位周期为基本时钟的16个周期。当SMER.ABCS位设置为1时，选择过采样x8，一位周期为基本时钟的8个周期。

#### 27.5.3 曼彻斯特模式下SCI的初始化

在传输数据之前，将初始值（00h）写入SCR寄存器并按照图27.54所示的流程图示例初始化SCI。

每当改变操作模式或传输格式时，必须在改变之前初始化SCR寄存器。

请注意，将SCR.RE位设置为0不会初始化以下各项：SSR寄存器中的ORER、FER、PER、MER、RDRF和RDF标志，MESR寄存器中的SYER、PFER和SBER标志，以及RDR、RDRH和RDRL寄存器。

另请注意，当SCR.TIE为“1”时，将SCR.TE的值从“0”切换为“1”会产生TXI中断请求。

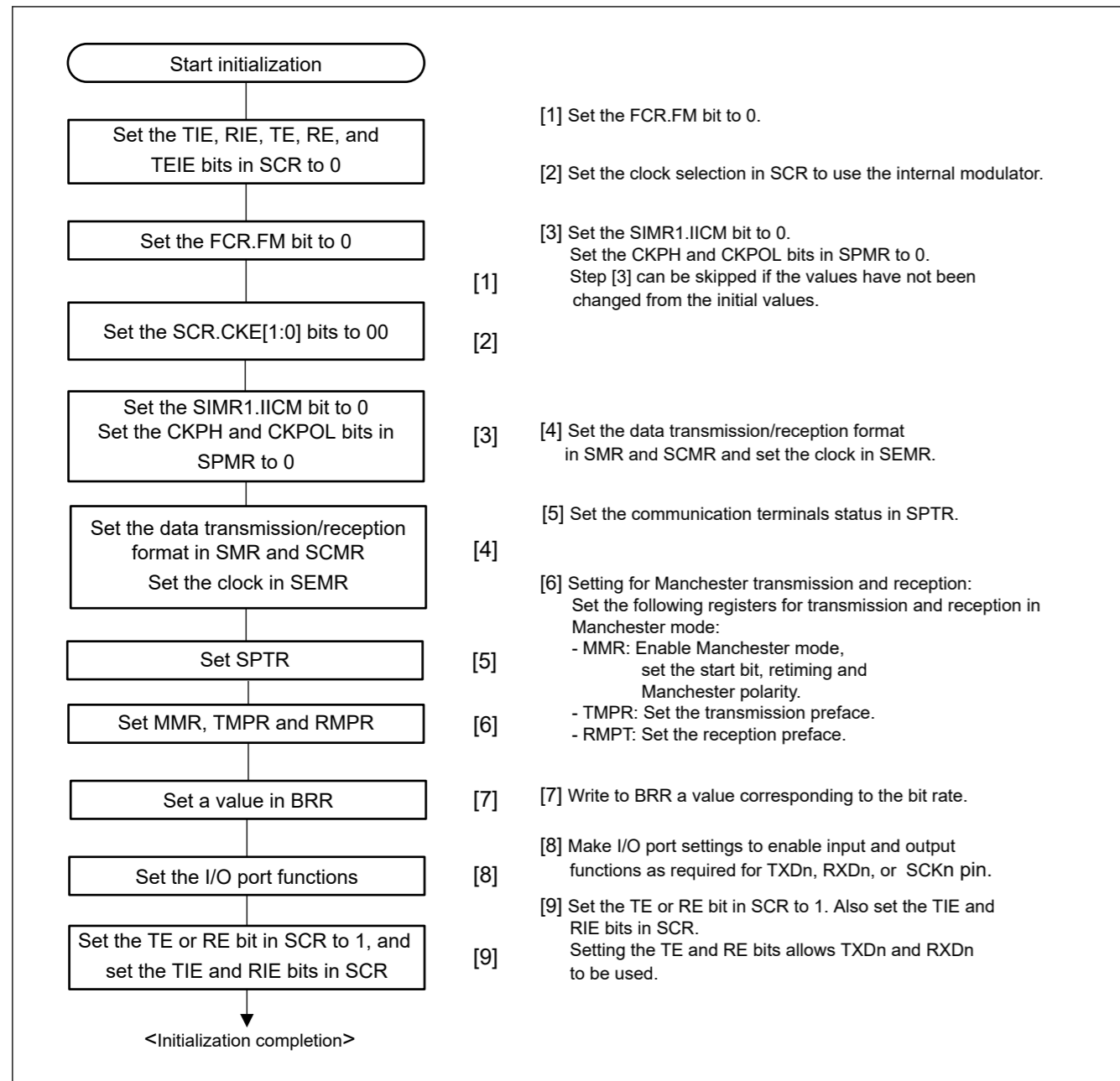


Figure 27.54 SCI Initialization Flow in Manchester Mode

27.5.4 Double-speed operation

When the ABCS bit in SEMR is set to “1” and eight pulses of the base clock for a 1-bit period is selected, the SCI operates on the bit rate twice that of when ABCS is set to “0”.

When the BGDM bit in SEMR is set to “1”, the cycle of the base clock is reduced to half and the SCI operates on the bit rate twice that of when ABCS is set to “0”.

When the ABCS bit in SEMR and the BGDM bit in SEMR are set to “1”, the SCI operates on the bit rate four times that of when the ABCS bit in SEMR and the BGDM bit in SEMR are set to “0”.

27.5.5 CTS and RTS functions

The CTS function uses input on the CTSn\_RTSn pin in transmission control. Setting the CTSE bit in SPMR to 1 enables the CTS function. The CTSn\_RTSn pin can be set as a multiplexed pin which allows one pin to be used for either function, or as dedicated pins with each pin for a single function. Use the CTSPEN bit in SPMR for this setting.

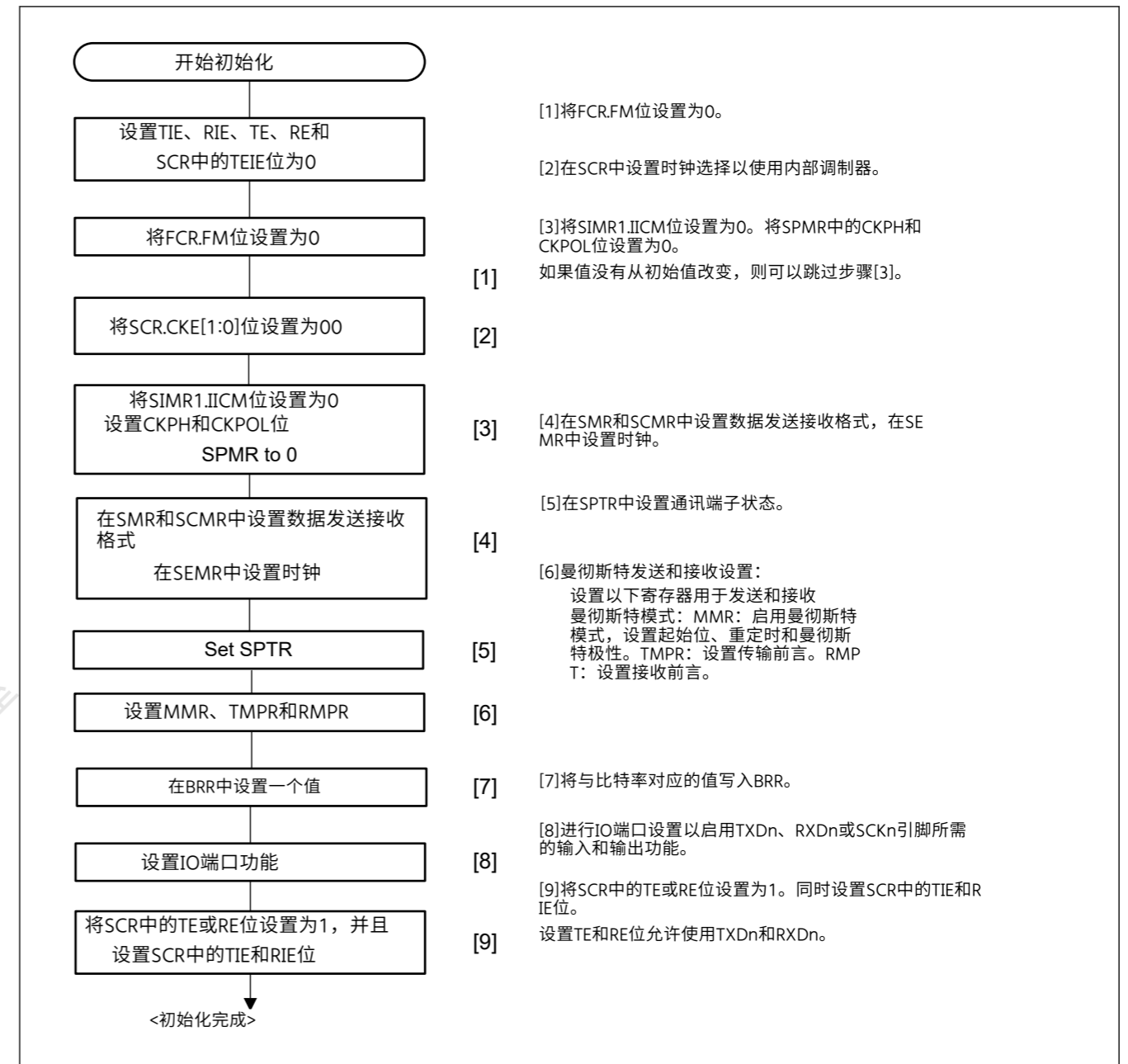


Figure 27.54 曼彻斯特模式下的SCI初始化流程

27.5.4 Double-speed operation

当SEMR中的ABCS位设置为“1”并选择1位周期的8个基本时钟脉冲时，SCI以ABCS设置为“0”时的两倍比特率运行。

当SEMR中的BGDM位设置为“1”时，基本时钟的周期减半，并且SCI以两倍于ABCS设置为“0”时的比特率运行。

当SEMR中的ABCS位和SEMR中的BGDM位设置为“1”时，SCI以SEMR中的ABCS位和SEMR中的BGDM位设置为“0”时的4倍比特率运行。

27.5.5 CTS和RTS功能

CTS功能在传输控制中使用CTSn\_RTSn引脚上的输入。将SPMR中的CTSE位设置为1使能CTS功能。CTSn\_RTSn管脚可以设置为多路复用管脚，允许一个管脚用于任一功能，或作为专用管脚，每个管脚用于单一功能。使用SPMR中的CTSPEN位进行此设置。



When the CTS function is enabled, reception starts only when the CTSn\_RTsn pin is at the low level.

Applying a high level to the CTSn\_RTsn pin after transmission starts does not affect transmission of the current frame, which continues.

The RTS function uses output on the CTSn\_RTsn pin to request transmission. When the SCI is ready to receive, it outputs a low level to the CTSn\_RTsn pin. Conditions for output of the low level and high level are as follows:

[Conditions for low-level output]

When all conditions listed below are satisfied:

- The value of the RE bit in SCR is 1.
- The SCI is ready to receive.
- There is no received data yet to be read.
- All of the following flags are set to 0: SSR.ORER, FER, PER and MER flags, and MESR.SYER (when SYEREN = 1), PFER (when PFEREN = 1) and SBER flags (when SBEREN = 1).

[Conditions for high-level output]

- When the conditions for low output are not satisfied

### 27.5.6 Serial data transmission in Manchester mode

The SCI encodes data in Manchester encoding and sends the resultant data in Manchester mode.

When the polarity setting (MR.TMPOL) set to 0, logic 0 is coded as a zero-to-one transition in Manchester code and logic 1 is coded as a one-to-zero transition in Manchester code.

When the polarity setting (MR.TMPOL) set to 1, logic 0 is coded as a one-to-zero transition in Manchester code and logic 1 is coded as a zero-to-one transition in Manchester code.

For this reason, a level transition occurs with the Manchester encoded data in the middle of individual logic data. (See [Figure 27.49](#)).

The transmitter constructs transmit frames in a specific format by adding a preface area to data and setting the start bit(s) according to the polarity setting and sends resultant serial data.

For details on the frame format, see [section 27.5.1. Frame Format](#).

[Figure 27.55](#) shows the flowchart in transmission. [Figure 27.56](#), [Figure 27.57](#), and [Figure 27.58](#) show examples of the operation for serial transmission in Manchester mode.

当CTS功能使能时，只有在CTSn\_RTsn引脚为低电平时才开始接收。

传输开始后将高电平应用到CTSn\_RTsn引脚不会影响当前帧的传输，当前帧会继续传输。

RTS功能使用CTSn\_RTsn引脚上的输出来请求传输。当SCI准备好接收时，向CTSn\_RTsn管脚输出一个低电平，输出低电平和高电平的条件如下：

[Conditions for low-level output]

当满足下列所有条件时：

- SCR中RE位的值为1。
- SCI已准备好接收。
- 没有接收到的数据尚未读取。
- 以下所有标志都设置为0：SSR.ORER、FER、PER和MER标志，以及MESR.SYER（当SYEREN=1时）、PFER（当PFEREN=1时）和SBER标志（当SBEREN=1时）。

[Conditions for high-level output]

- 不满足低输出条件时

### 27.5.6 曼彻斯特模式下的串行数据传输

SCI以曼彻斯特编码对数据进行编码，并以曼彻斯特模式发送结果数据。

当极性设置(MR.TMPOL)设置为0时，逻辑0被编码为曼彻斯特代码中的零到一转换，逻辑1被编码为曼彻斯特代码中的一到零转换。

当极性设置(MR.TMPOL)设置为1时，逻辑0被编码为曼彻斯特代码中的一对零转换，逻辑1被编码为曼彻斯特代码中的零到一转换。

出于这个原因，在各个逻辑数据中间的曼彻斯特编码数据会发生电平转换。（看 [Figure 27.49](#)）。

发送器通过向数据添加前言区域并根据极性设置设置起始位来构建特定格式的发送帧，并发送结果串行数据。

有关帧格式的详细信息，请参阅第27.5.1节。帧格式。

图27.55显示了传输的流程图。图27.56、图27.57和图27.58显示了曼彻斯特模式下串行传输的操作示例。

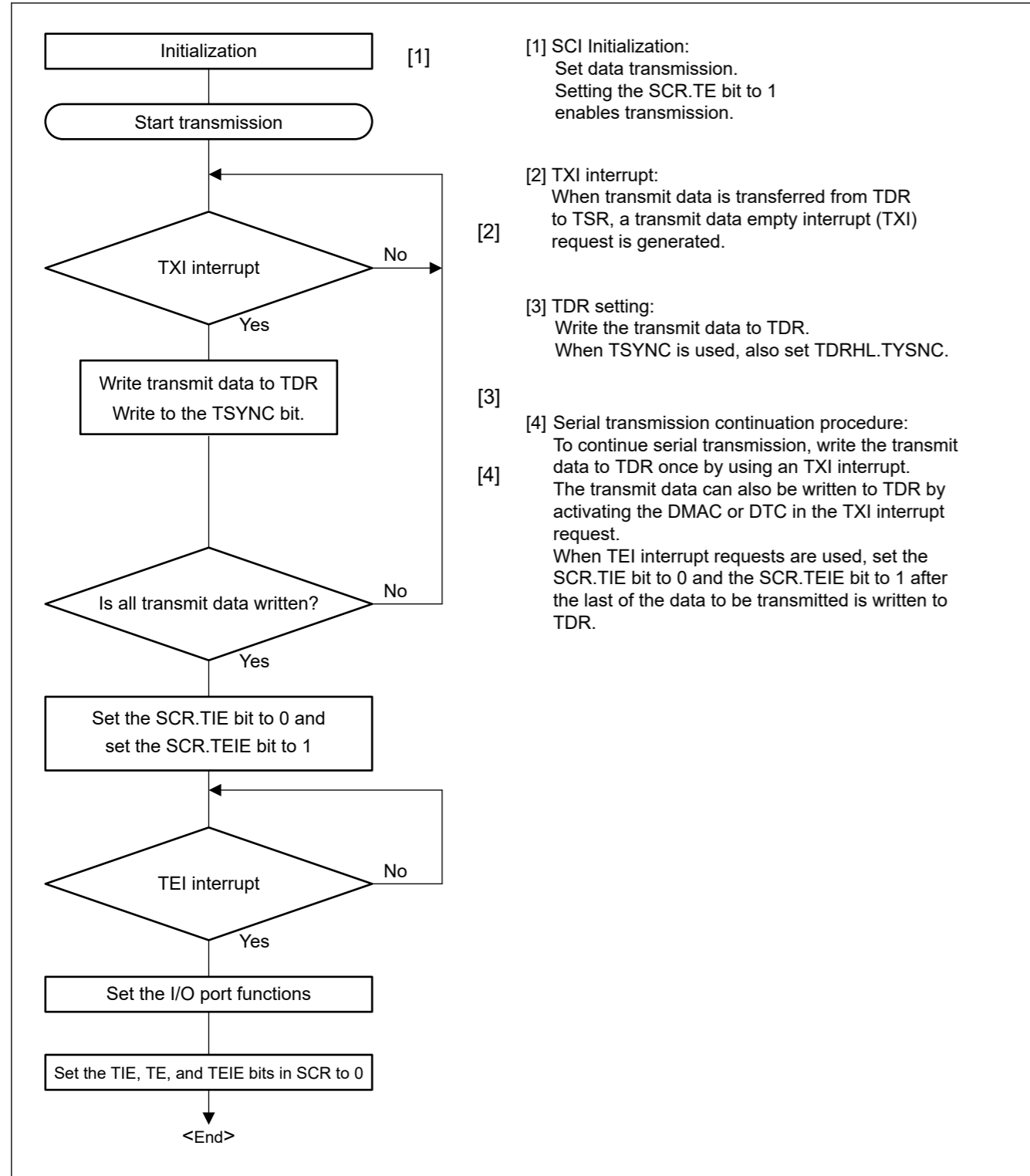


Figure 27.55 Example of Serial Transmission Flowchart in Manchester Mode

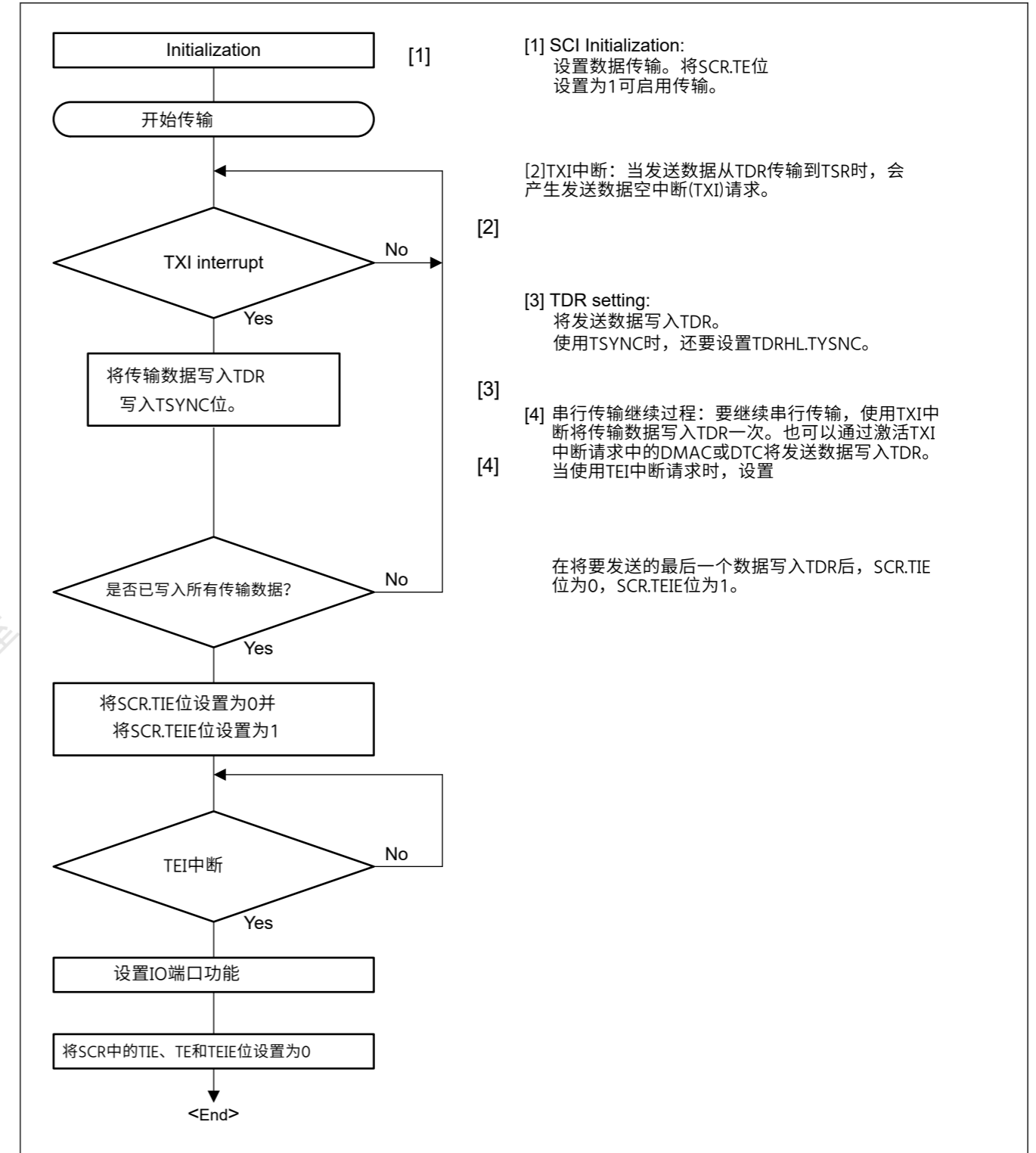


Figure 27.55 曼彻斯特模式下的串行传输流程图示例

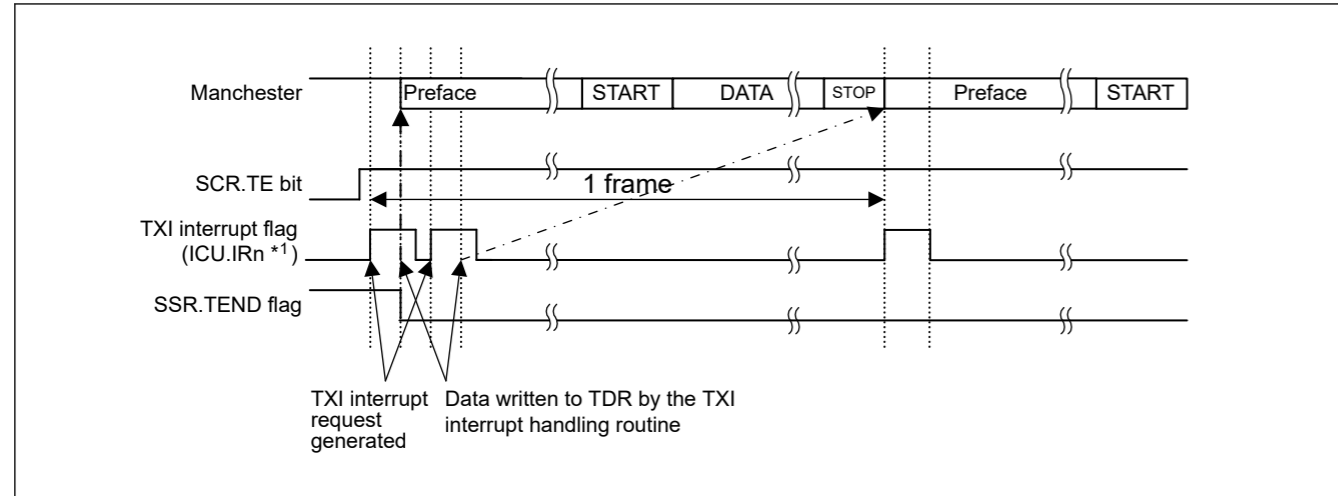


Figure 27.56 Example of Start-of-Transmission Operation for Serial Transmission in Manchester mode (with Preface but Without the CTS Function)

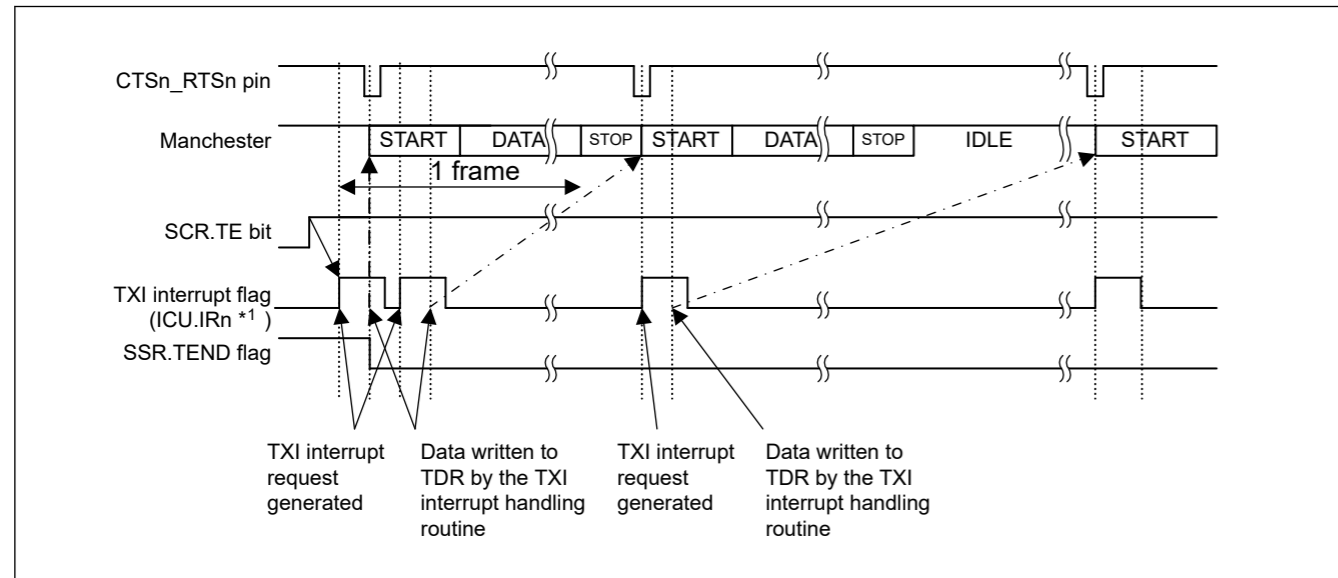


Figure 27.57 Example of Start-of-Transmission Operation for Serial Transmission in Manchester Mode (Without Preface but with the CTS Function)

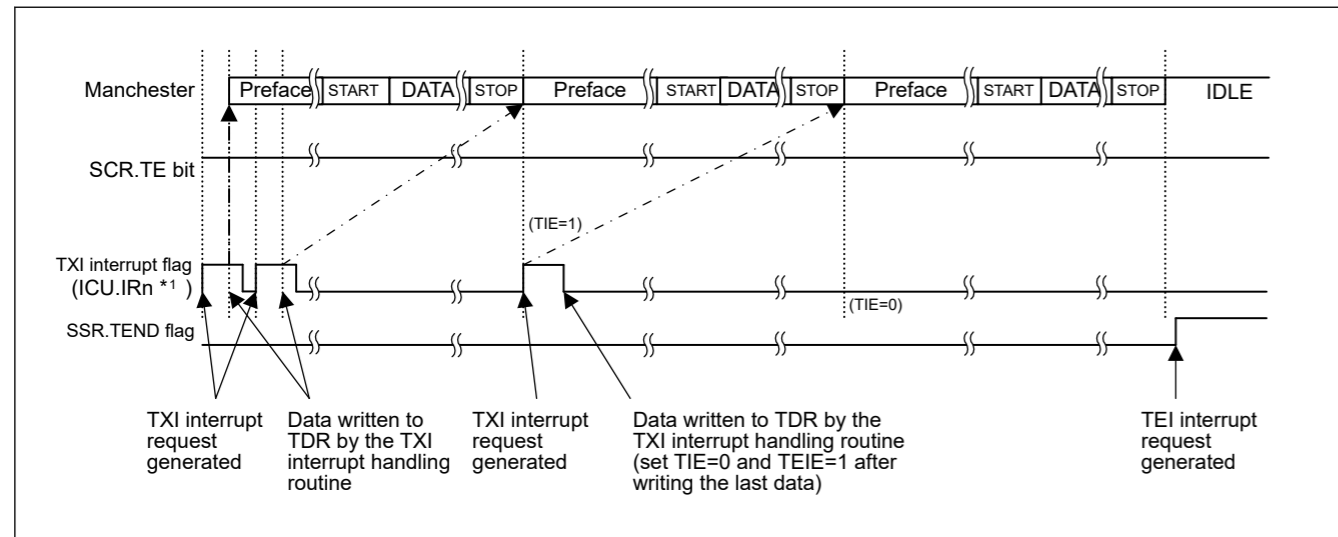


Figure 27.58 Example of End-of-Transmission Operation for Serial Transmission in Manchester Mode (with Preface but Without the CTS Function)

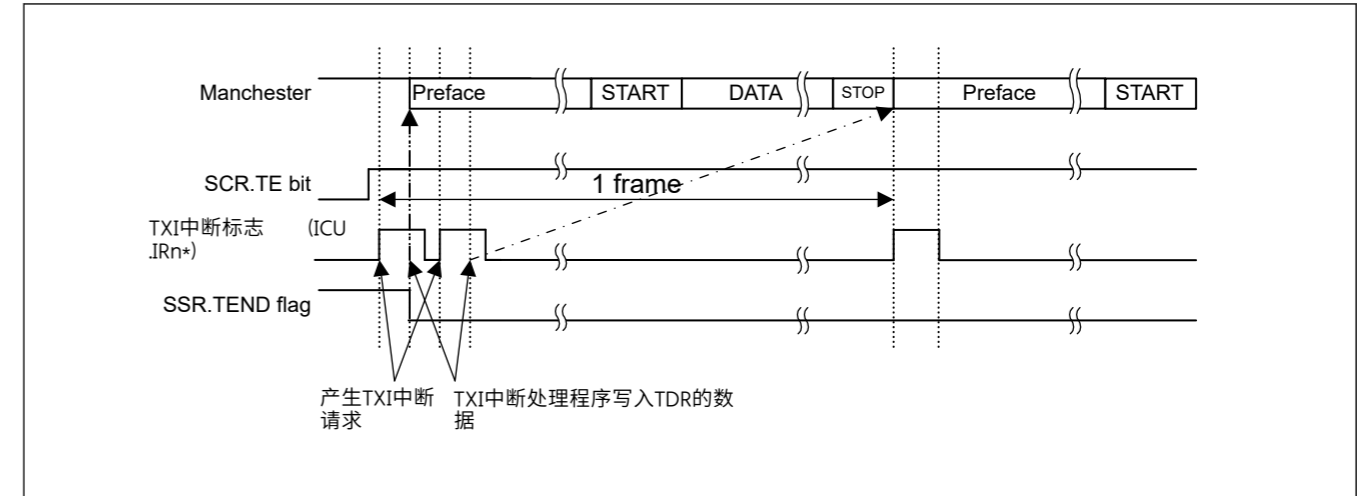


Figure 27.56 曼彻斯特模式下串行传输的传输开始操作示例 (使用前言但没有CTS功能)

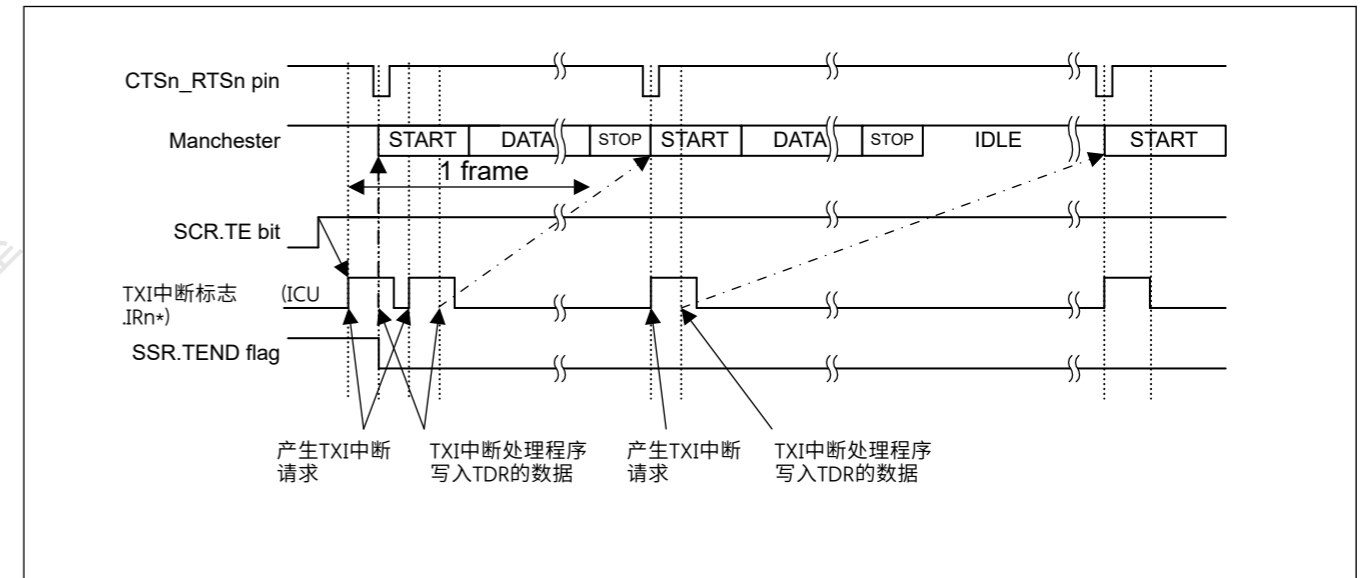


Figure 27.57 曼彻斯特模式下串行传输的传输开始操作示例 (无序但具有CTS功能)

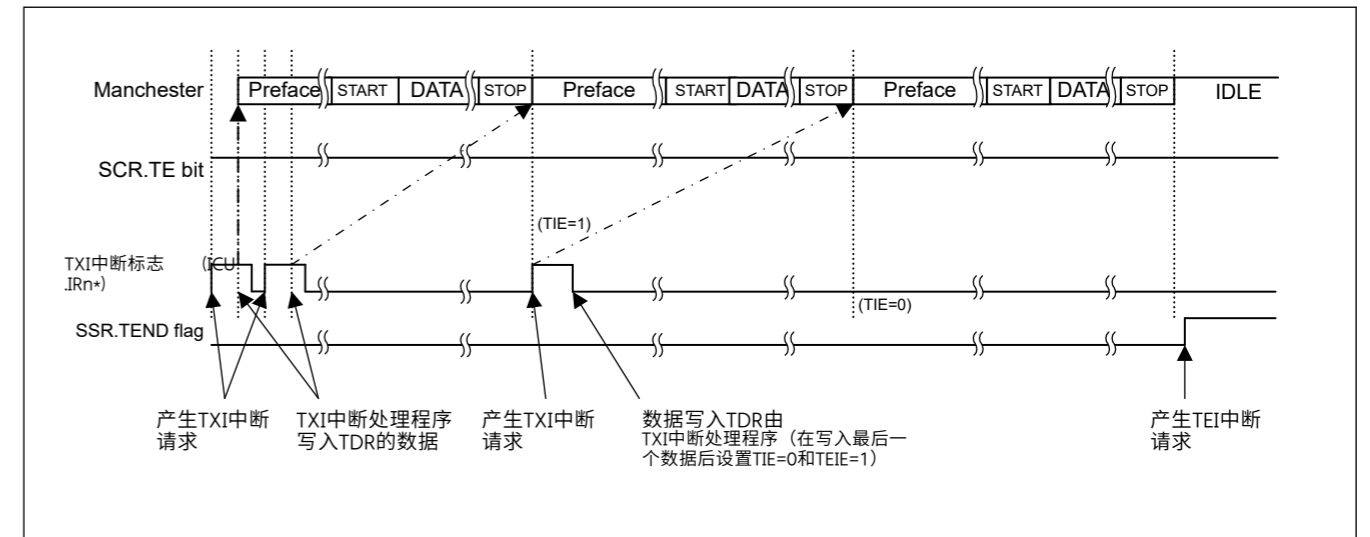


Figure 27.58 曼彻斯特模式下串行传输的传输结束操作示例 (使用前言但没有CTS功能)

## 27.5.7 Serial Data Reception in Manchester Mode

In Manchester mode, the SCI operates on a base clock with a frequency of 16 times<sup>\*1</sup> the bit rate. Reception starts by sampling the falling edges of received data at the base clock. As shown in Figure 27.59, reception starts at a falling edge of the received data and it continues if the received data keeps low for the duration of 1/4 bit. If the received data goes high within the duration of 1/4 bit, the SCI judges it as an error and waits for a falling edge again.

If a high level is expected in the first half of a bit in the received data, the SCI judges a low level that continues for one base clock cycle as an error and ignores the change to the low level.

Note 1. This is the case when SEMR.ABCS = 0. When SEMR.ABCS = 1, the SCI operates on a base clock with a frequency of 8 times the bit rate.

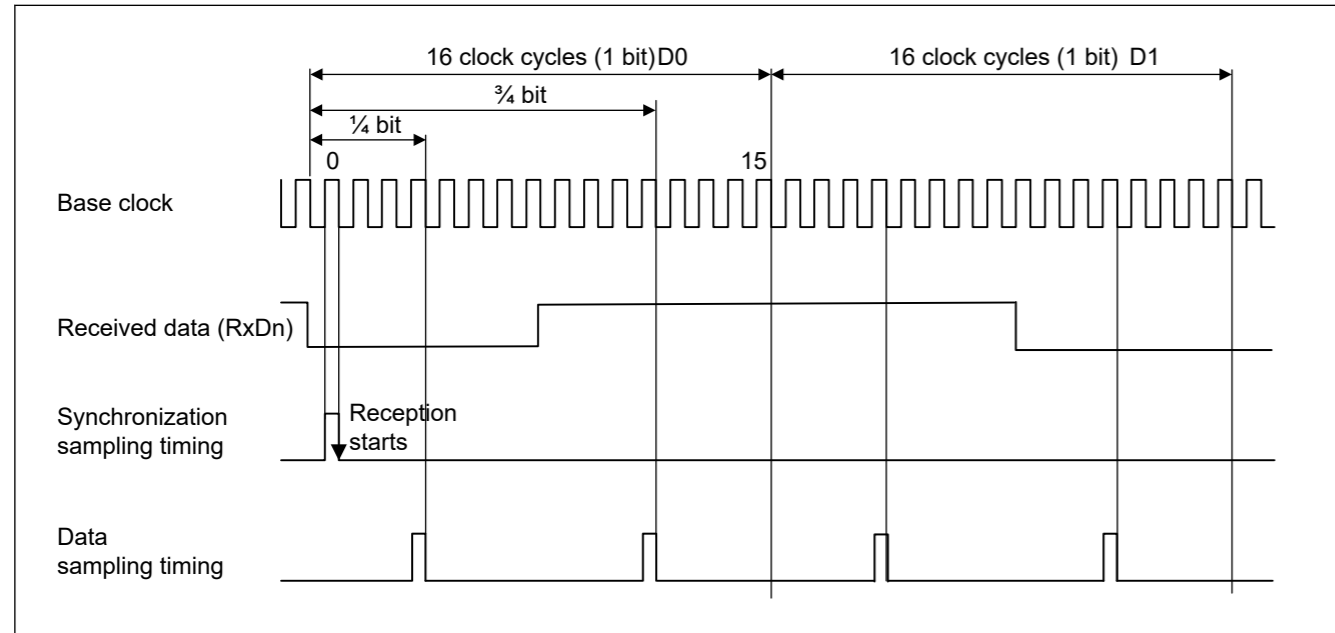


Figure 27.59 Data Reception Sampling Timing in Manchester Mode

In Manchester mode, data reception starts with detection of a preface and start bit area.

The SCI checks the input from the RXD pin to see whether a preface is added based on the value of RMPR.RPLEN.

If the preface is disabled (RMPR.RPLEN = 0), it moves on to the detection of a start bit area without detecting a preface.

When a preface is enabled, it identifies a preface pattern setting according to the set value in RMPR.RPPAT, and compares it with the RXD input for a pattern match to detect a preface pattern.

Upon detection of a preface pattern match, it judges it as a normal preface and moves on to the detection of a start bit area.

If detecting a preface pattern mismatch or a Manchester code error in the preface area, it judges it as a preface error and asserts a preface error (PFER).

For start bit detection, the SCI selects an expected value based on the register settings (MMR.SBSEL and SYNVAL), compares it with the RXD input for a pattern match to detect a start bit area. Upon detection of a start bit pattern match, it judges it as a normal start bit area and moves on to the data processing.

Only when a preface and a start bit area are detected normally, it moves on to the next phase of data reception.

Upon detection of a start bit pattern mismatch, it asserts a start bit error flag (SBER).

In data processing, the SCI shifts the data by the expected received data length based on the register settings (SCMR.CHR1 and SMR.CHR) through the RSR register. If two sampling points in a bit of the received data are identical, the SCI judges this as a Manchester code error.

For details, see para. (4) in section 27.5.11. Errors in Manchester Mode.

When the parity function is disabled (SMR.PE = 0), the SCI moves on to the next phase of stop bit detection. When the parity function is enabled (SMR.PE = 1), the SCI performs parity checking. If detecting a parity error, it asserts a parity error flag (PER), and then moves on to stop bit detection.

## 27.5.7 曼彻斯特模式下的串行数据接收

在曼彻斯特模式下，SCI在频率为16倍\*1比特率的基本时钟上运行。接收开始于在基本时钟处对接收到的数据的下降沿进行采样。如图27.59所示，接收在接收数据的下降沿开始，如果接收数据保持低电平持续14位，则继续接收。如果接收到的数据在14bit的时间内变高，则SCI判断为错误，再次等待下降沿。

如果在接收数据的前半个比特中预期为高电平，则SCI将持续一个基本时钟周期的低电平判断为错误，并忽略向低电平的变化。

注1.这是SEMR.ABCS=0时的情况。当SEMR.ABCS=1时，SCI在频率为比特率8倍的基本时钟上运行。

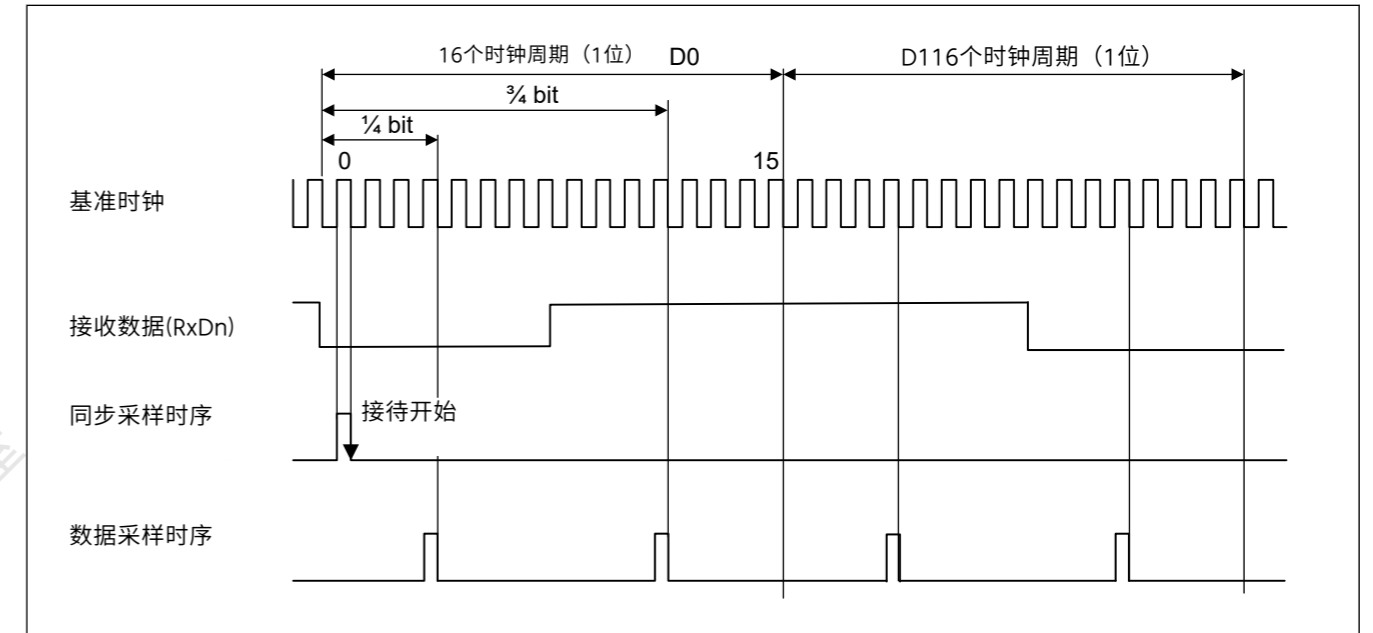


Figure 27.59 曼彻斯特模式下的数据接收采样时序

在曼彻斯特模式下，数据接收从检测前言和起始位区域开始。

SCI检查来自RXD引脚的输入，以查看是否根据RMPR.RPLEN的值添加了前言。

如果前言被禁用 (RMPR.RPLEN=0)，它会继续检测起始位区域而不检测前言。

启用前言时，它根据RMPR.RPPAT中的设置值识别前言模式设置，并将其与模式匹配的RXD输入进行比较，以检测前言模式。

在检测到前言模式匹配时，将其判断为正常前言并继续检测起始位区域。

如果在前言区域检测到前言模式不匹配或曼彻斯特码错误，则将其判断为前言错误并断言前言错误 (PFER)。

对于起始位检测，SCI根据寄存器设置 (MMR.SBSEL和SYNVAL) 选择预期值，将其与模式匹配的RXD输入进行比较，以检测起始位区域。在检测到起始位模式匹配时，将其判断为正常起始位区域并继续进行数据处理。

只有在正常检测到前言和起始位区域时，才进入下一个数据接收阶段。

在检测到起始位模式不匹配时，它会断言起始位错误标志(SBER)。

在数据处理中，SCI根据寄存器设置 (SCMR.CHR1和SMR.CHR) 通过RSR寄存器将数据移位预期的接收数据长度。如果接收到的数据位中的两个采样点相同，则SCI判断为曼彻斯特码错误。

有关详细信息，请参阅段落。(4)第27.5.11节。曼彻斯特模式中的错误。

当奇偶校验功能被禁用 (SMR.PE=0) 时，SCI进入下一个停止位检测阶段。当启用奇偶校验功能时 (SMR.PE=1)，SCI执行奇偶校验。如果检测到奇偶校验错误，它会置位奇偶校验错误标志(PER)，然后继续进行停止位检测。



In stop bit detection, the SCI checks the following in the stop bit area of the received frame:

It has two sampling points in a bit. If both points are at the high level, the bit is recognized as a normal stop bit and the data is stored in the RDR register. At least one low-level point is judged as an abnormal stop bit, causing a framing error flag (FER) to be set. Even when an error is detected, the received data is stored in the RDR register as abnormal data.

Figure 27.60 shows an example of the operation for serial data reception in Manchester mode.

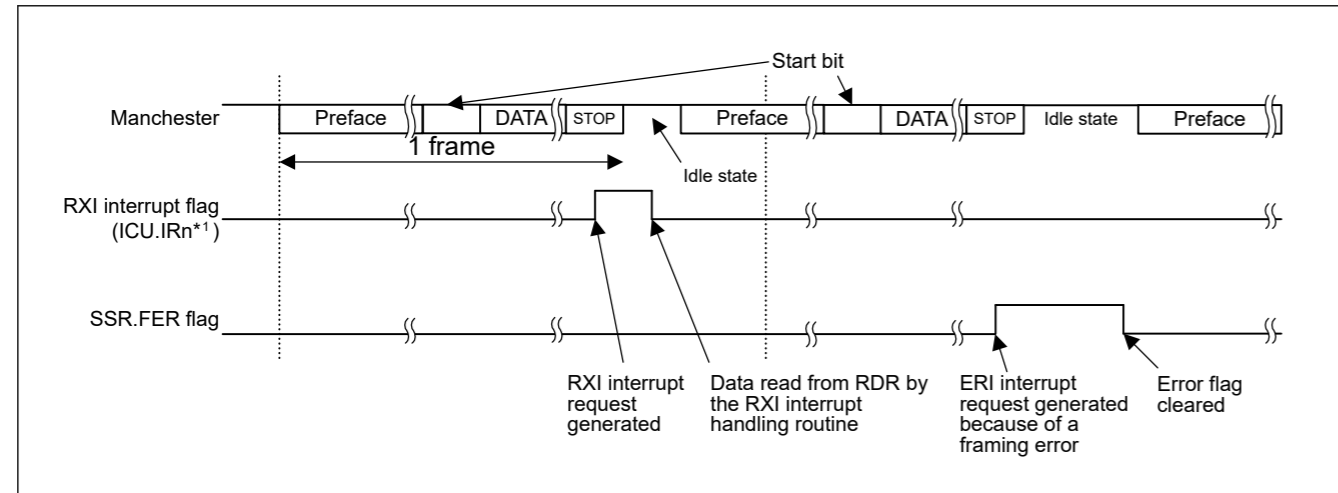


Figure 27.60 Example of Operation for Serial Data Reception in Manchester mode (with a Preface)

For the state of each status flag in the SSR register and RXD input processing when a receive error is detected, see section 27.5.11. Errors in Manchester Mode.

If a receive error is detected, an ERI interrupt request is generated but an RXI interrupt request is not generated.

Data reception cannot be resumed while the receive error flag is 1. Accordingly, set the ORER, FER, PER, MER, SYER\*1, PFER\*1, and SBER\*1 flags to 0 before resuming reception. Also, be sure to read the RDR (or RDRL) register during overrun error processing. When a reception is forcibly terminated by setting the SCR.RE bit to 0 during operation, read the RDR (or the RDRL) register because received data which has not yet been read may be left in the RDR (or the RDRL) register.

Figure 27.61 and Figure 27.62 show examples of serial data reception flowchart in Manchester mode.

Note 1. Effective when the corresponding bit is enabled.

在停止位检测中，SCI在接收帧的停止位区域中检查以下内容：

它有两个采样点。如果两个点都处于高电平，则该位被识别为正常停止位，数据存储在RDR寄存器中。至少有一个低电平点被判断为异常停止位，导致设置帧错误标志（FER）。即使检测到错误，接收到的数据也会作为异常数据存储在RDR寄存器中。

图27.60显示了曼彻斯特模式下串行数据接收操作的示例。

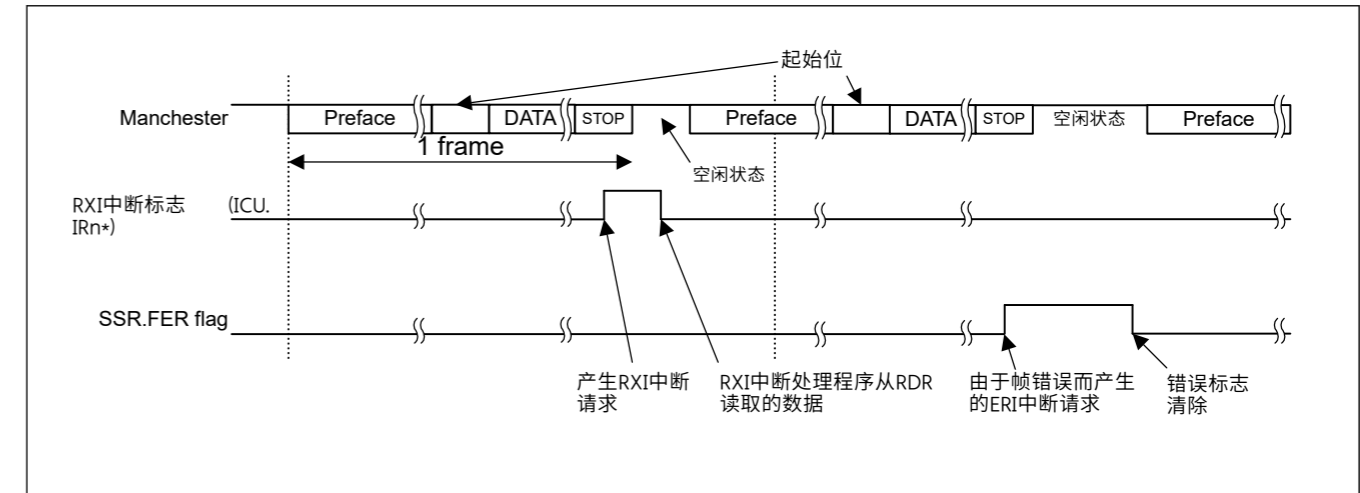


Figure 27.60 曼彻斯特模式下串行数据接收操作示例（附前言）

关于SSR寄存器中各状态标志的状态和检测到接收错误时的RXD输入处理，请参阅第27.5.11节。曼彻斯特模式中的错误。

如果检测到接收错误，则会产生ERI中断请求，但不会产生RXI中断请求。

当接收错误标志为1时，无法恢复数据接收。因此，在恢复接收之前将ORER、FER、PER、MER、SYER\*1、PFER\*1和SBER\*1标志设置为0。此外，请务必在溢出错误处理期间读取RDR（或RDRL）寄存器。如果在操作期间通过将SCR.RE位设置为0来强制终止接收，请读取RDR（或RDRL）寄存器，因为尚未读取的接收数据可能留在RDR（或RDRL）寄存器中。

图27.61和图27.62显示了曼彻斯特模式下的串行数据接收流程图示例。

注1.当相应位使能时有效。

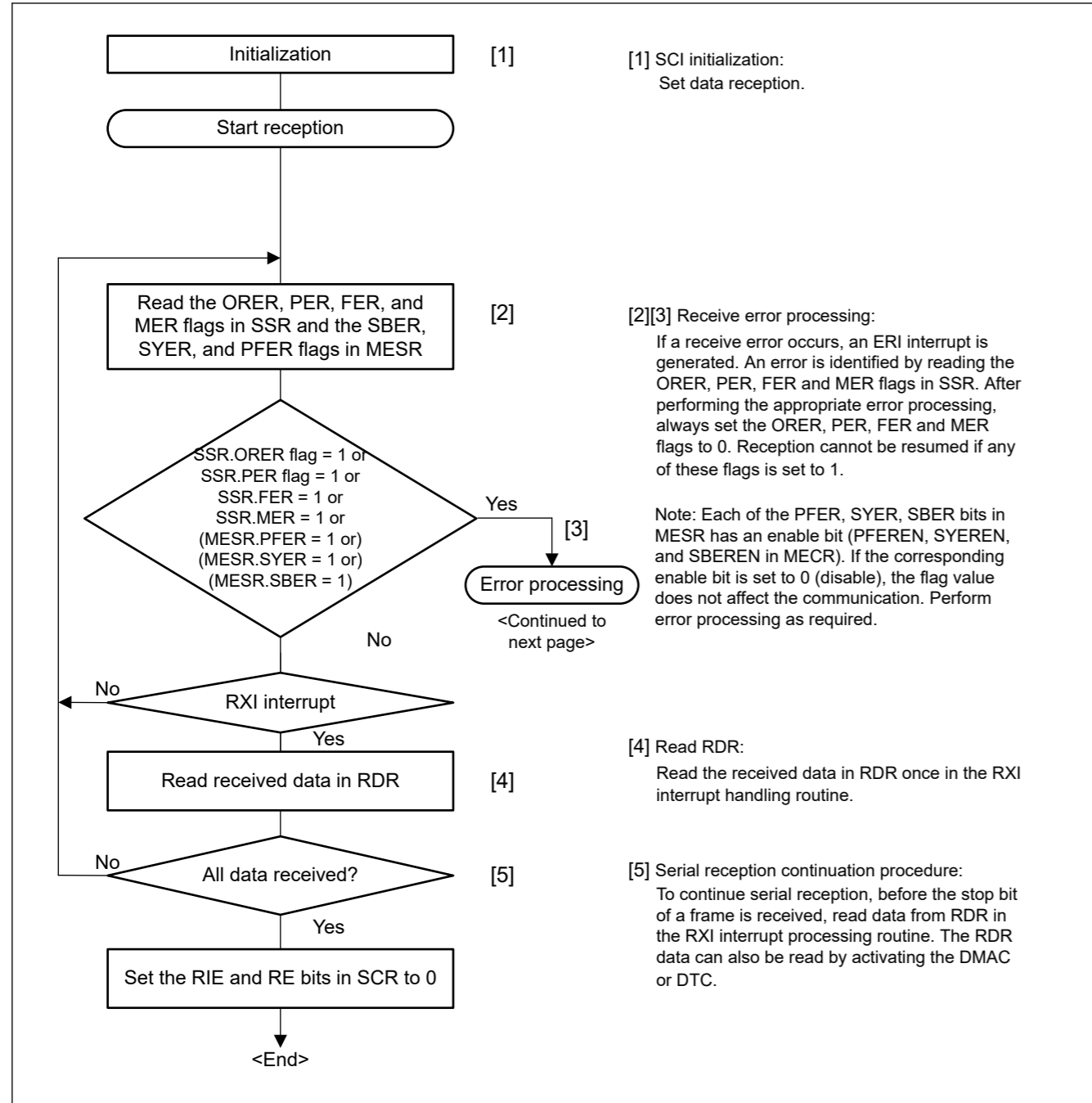


Figure 27.61 Example of Serial Data Reception Flowchart in Manchester Mode (Normal Reception)

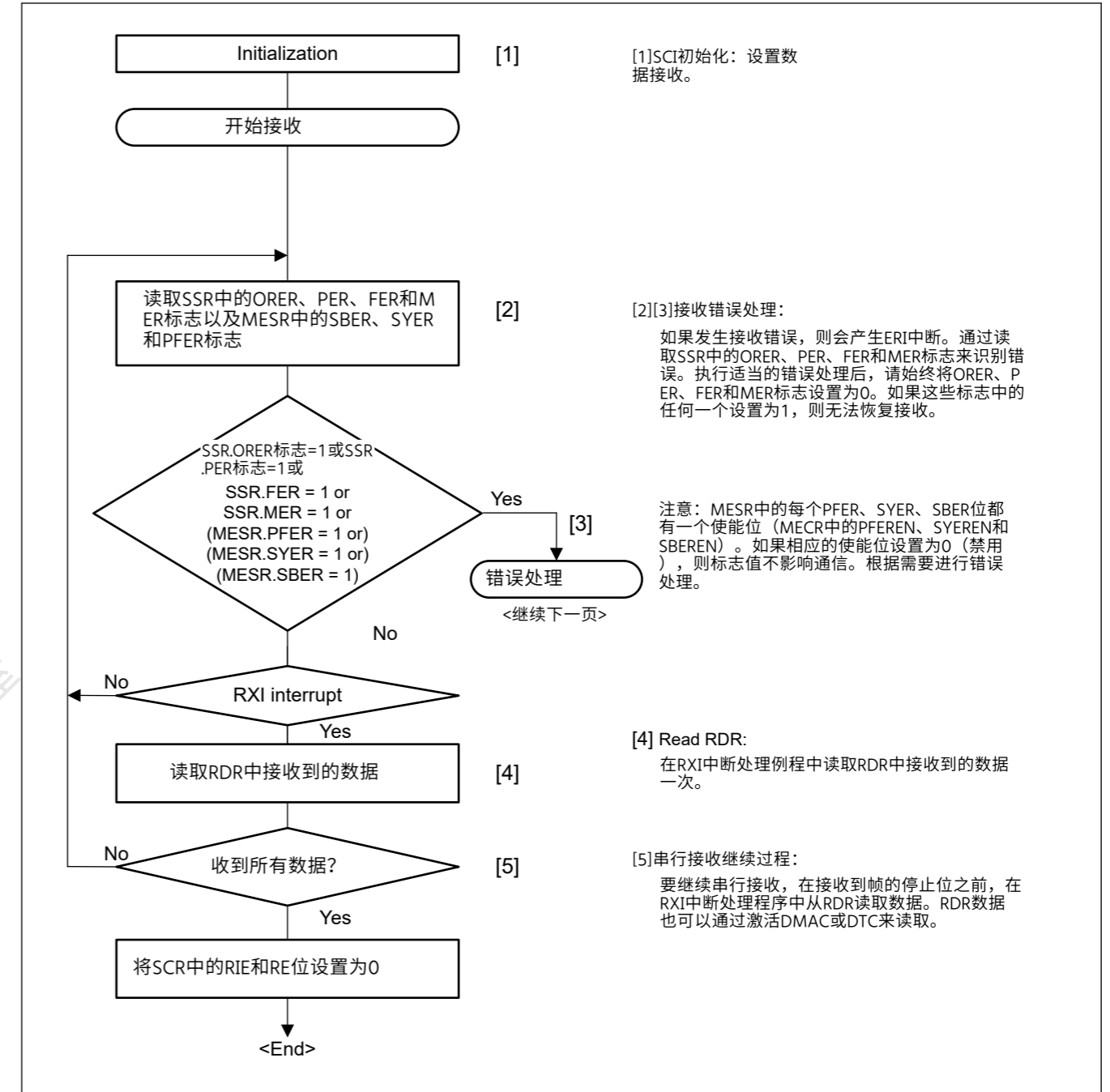


Figure 27.61 曼彻斯特模式下的串行数据接收流程图示例 (正常接收)

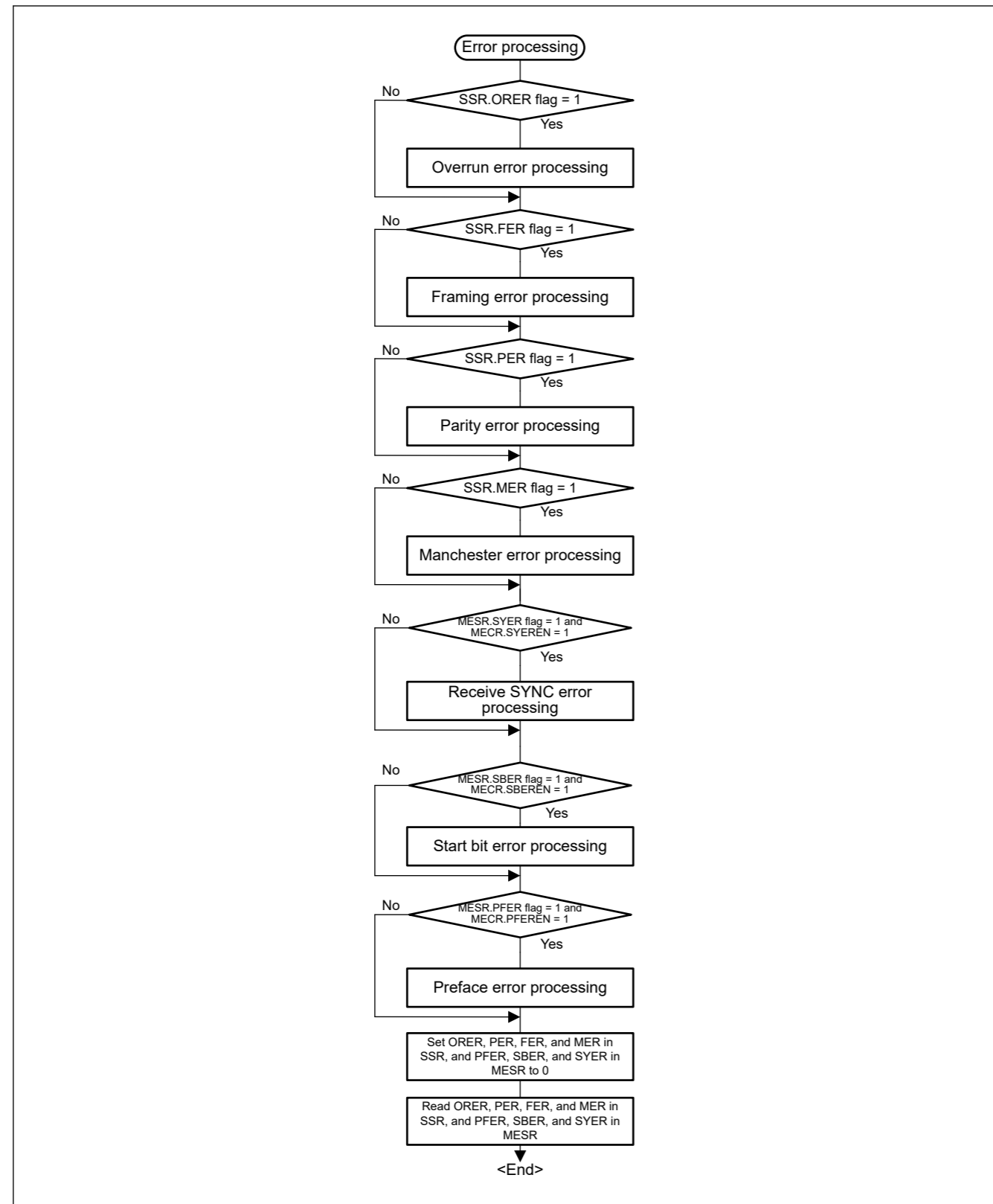


Figure 27.62 Example of Serial Reception Flowchart in Manchester Mode (Error Processing)

## 27.5.8 Operation When Multi-Processor Bit Is Used

See [section 27.4. Multi-Processor Communication Function \(1\)](#) for the operation in Manchester mode when using multi-processor mode because the operation is the same.

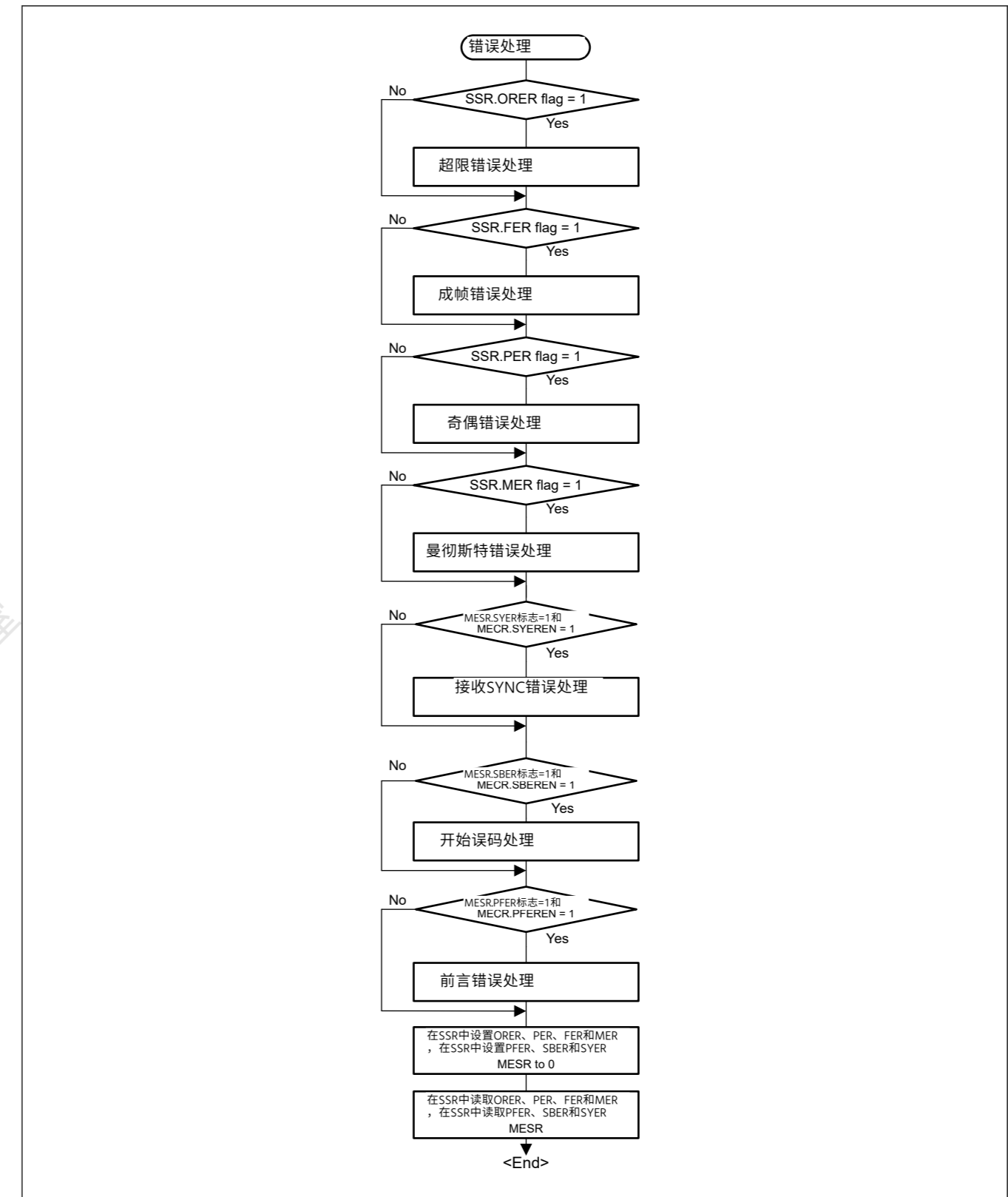


Figure 27.62 曼彻斯特模式下的串行接收流程图示例 (错误处理)

## 27.5.8 使用多处理器位时的操作

请参见第27.4节。多处理器通信功能(1)曼彻斯特模式下的操作在使用多处理器模式时因为操作是一样的。

A preface and a start bit area are added to the frame format in Manchester mode. See [Figure 27.62](#) for error processing in Manchester mode for the reception flowchart ([Figure 27.46](#)). Refer to [Table 27.35](#) for the operation status when detecting various errors.

### 27.5.9 Receive Retiming

This function corrects the timing for each central edge of the bit, taking advantage of the fact that each bit has an edge in the center in Manchester code.

The receive retiming function can be turned on or off by setting the ERTEN bit in the MMR register.

When the receive retiming function is turned off (MMR.ERTEN = 0), retiming is not performed, causing misalignment between the internal clock and the RXD input to be accumulated and the receive margin to be reduced.

When the receive retiming function is turned on (MMR.ERTEN = 1), retiming is performed for the preface area, the start bit area<sup>1</sup>, and the data area (excluding the stop bit).

Note 1. Retiming is not performed for the start bit area if the preface length is 0 and the start bit length is 3.

As an example, the receive retiming when oversampling x16 is selected is shown below.

When detecting an RXD input edge two to four cycles before the expected receive cycle, the receive processing is shortened by one sampling CLK cycle.

When detecting an RXD input edge two to three cycles after the expected receive cycle, the receive processing is extended by one sampling CLK cycle.

(Even if the clock is misaligned with the data by more than two cycles, one cycle is corrected for each bit.)

[Figure 27.63](#) shows the conceptual image of receive retiming range.

When detecting an edge in the tolerance area in the figure, data is received as is without making correction.

When detecting an edge in the SyncJump area in the figure, data is corrected for reception.

When detecting an edge in the SyncError area in the figure, data is received as abnormal data with no correction made.

For a Manchester code error (data matches at the 1/4-phase and 3/4-phase sampling points), the SCI reports a code error.

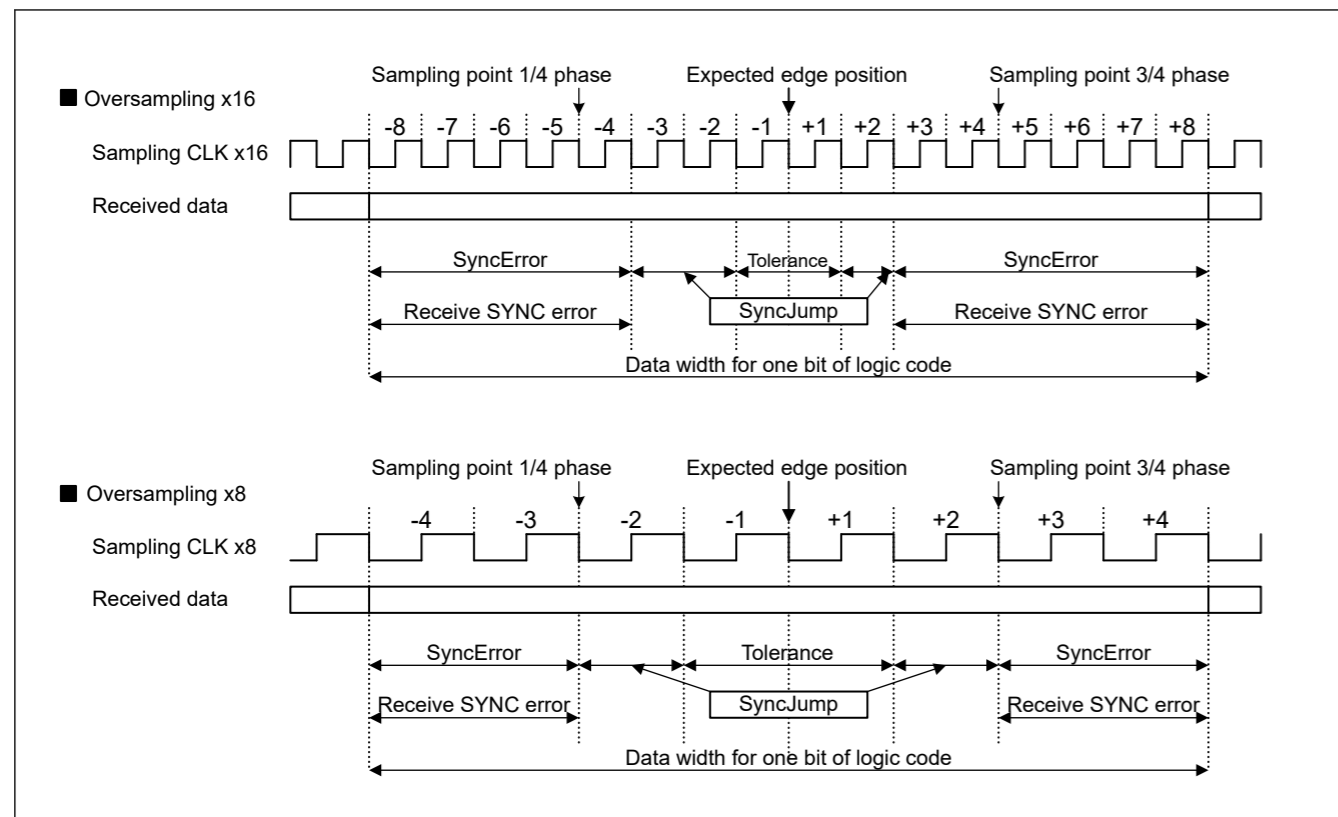


Figure 27.63 Conceptual Image of Reception Retiming Range

曼彻斯特模式的帧格式中添加了前言和起始位区域。接收流程图（图27.46）在曼彻斯特模式下的错误处理见图27.62。检测各种错误时的动作状态见表27.35。

### 27.5.9 接收重定时

该函数利用曼彻斯特码中每个位在中心的边缘这一事实，校正位的每个中心边沿的时序。

通过设置MMR寄存器中的ERTEN位可以打开或关闭接收重定时功能。

当接收重定时功能关闭（MMR.ERTEN=0）时，不执行重定时，导致内部时钟和RXD输入之间的错位被累积，接收裕量减少。

当接收重定时功能打开时（MMR.ERTEN=1），对前言区、起始位区\*1和数据区（不包括停止位）执行重定时。

注1.如果序言长度为0且起始位长度为3，则不对起始位区域执行重定时。

例如，选择过采样x16时的接收重定时如下所示。

当在预期接收周期前2到4个周期检测到RXD输入边沿时，接收处理将缩短1个采样CLK周期。

当在预期接收周期后两到三个周期检测到RXD输入边沿时，接收处理将延长一个采样CLK周期。

（即使时钟与数据的偏差超过两个周期，也会为每一位校正一个周期。）

图27.63显示了接收重定时范围的概念图。

在图中的公差范围内检测边缘时，直接接收数据而不进行校正。

当在图中的SyncJump区域检测到边缘时，数据被校正以进行接收。

当在图中的SyncError区域检测到边缘时，数据作为异常数据接收，没有进行校正。

对于曼彻斯特编码错误（数据在1个4相和3个4相采样点匹配），SCI报告编码错误。

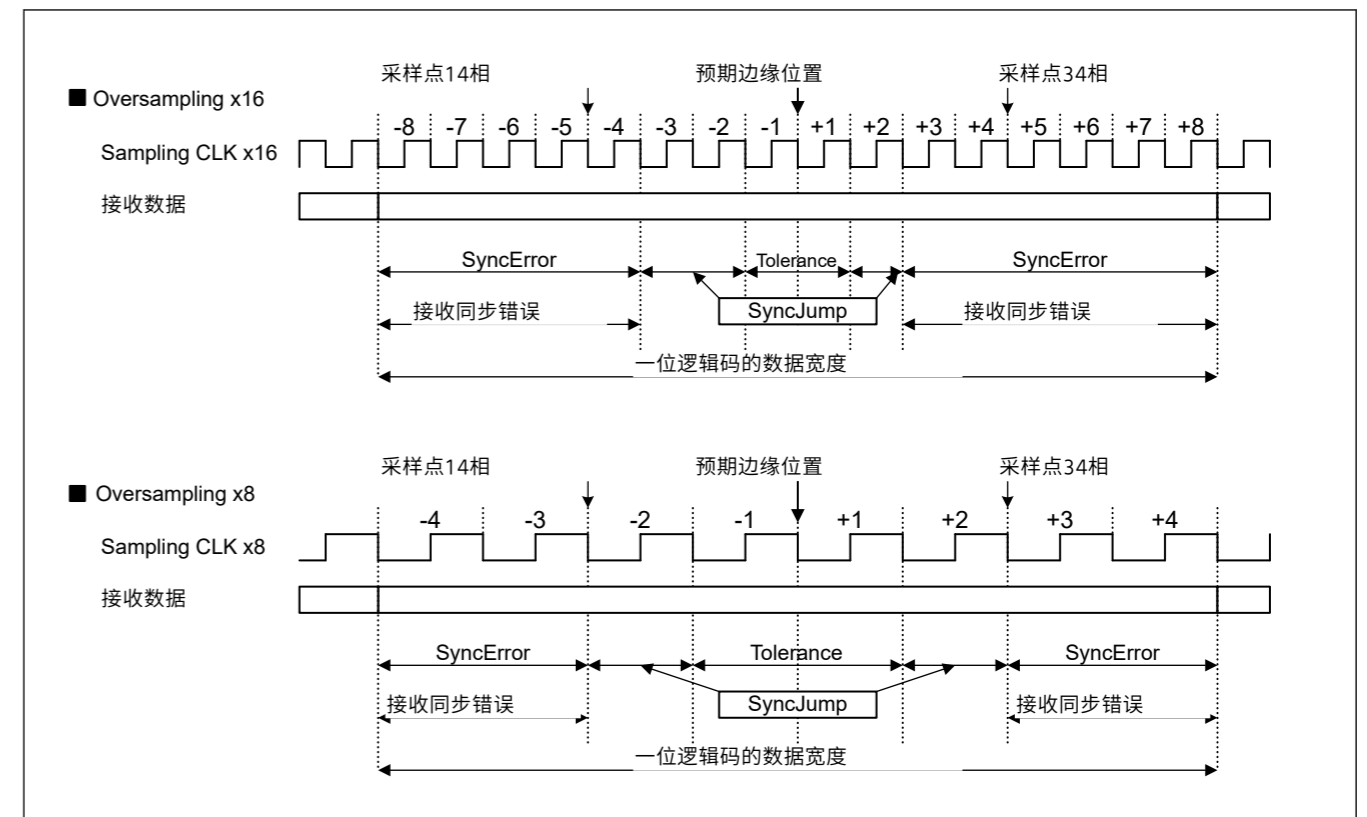


Figure 27.63 接收重定时范围的概念图



### 27.5.10 Polarity Setting for Manchester Code

The polarity of the Manchester code can be set with the Manchester Mode Register (MMR). It can be set separately for transmission and reception. Use the MMR.TMPOL bit to set the polarity for transmission and the MMR.RMPOL bit to set the polarity for reception.

The Manchester code polarity setting is valid for the preface area, the data area, and the parity or multi-processor area.

When the initial settings (TMPOL/RMPOL = 0) are used for the polarity of Manchester code, logic 0 is encoded as a zero-to-one transition in Manchester code and logic 1 is encoded as a one-to-zero transition in Manchester code. If the settings are changed to TMPOL/RMPOL = 1, logic 0 is encoded as a one-to-zero transition in Manchester code and logic 1 is encoded as a zero-to-one transition in Manchester code. Figure 27.64 shows the conceptual image of the settings and operation.

Separately from the function above, the transmitted and received data in the data area can be inverted by the transmitted/received data inversion function (SCMR.SINV). Since the polarity of Manchester code (MMR.TMPOL/RMPOL) can be set separately from the transmitted/received data invert function (SCMR.SINV), if both are set to inversion (MMR.TMPOL/RMPOL = 1 and SCMR.SINV = 1), the transmitted and received data are set to initial state (inversion + inversion = normal).

The polarity of the start bit area can be set by a register different from the ones mentioned above.

Since a different register is used, the polarity of the start bit area is not affected by the polarity setting for Manchester code mentioned above.

For details on the setting for the start bit area, see para. (2) in section 27.5.1. Frame Format.

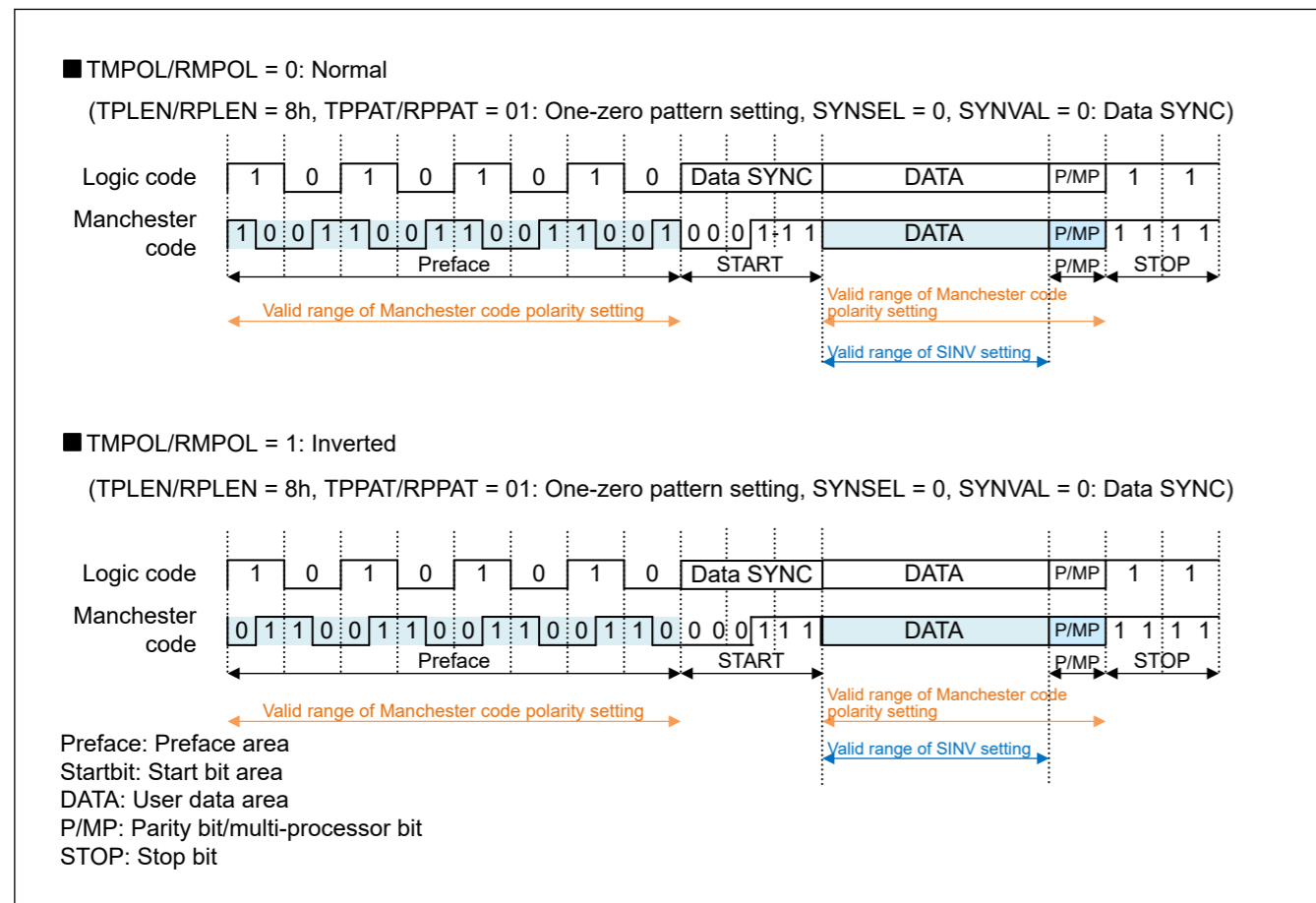


Figure 27.64 Valid Range of the Manchester Code Polarity Setting

### 27.5.11 Errors in Manchester Mode

There are the following errors in Manchester mode:

### 27.5.10 曼彻斯特码的极性设置

曼彻斯特码的极性可以通过曼彻斯特模式寄存器(MMR)设置。

可以分别设置发送和接收。使用MMR.TMPOL位设置传输的极性和MMR.RMPOL位设置接收极性。

曼彻斯特码极性设置对前言区、数据区、奇偶校验或多处理器区有效。

当初始设置(TMPOL/RMPOL=0)用于曼彻斯特代码的极性时，逻辑0被编码为曼彻斯特代码中的零到一转换，逻辑1被编码为曼彻斯特代码中的一对零转换。如果设置更改为TMPOL/RMPOL=1，则逻辑0被编码为曼彻斯特代码中的一对零转换，逻辑1被编码为曼彻斯特代码中的零到一转换。图27.64显示了设置和操作的概概念图。

与上述功能不同，数据区中的发送和接收数据可以通过发送接收数据反转功能(SCMR.SINV)反转。由于曼彻斯特码的极性(MMR.TMPOL/RMPOL)可以与发送的接收数据反转功能(SCMR.SINV)分开设置，如果两者都设置为反转(MMR.TMPOL/RMPOL=1和SCMR.SINV=1)，发送和接收的数据设置为初始状态(反转+反转=正常)。

起始位区域的极性可以通过与上述不同的寄存器来设置。

由于使用了不同的寄存器，因此起始位区域的极性不受上述曼彻斯特码极性设置的影响。

有关起始位区域设置的详细信息，请参见第1段。(2)在第27.5.1节中。帧格式。

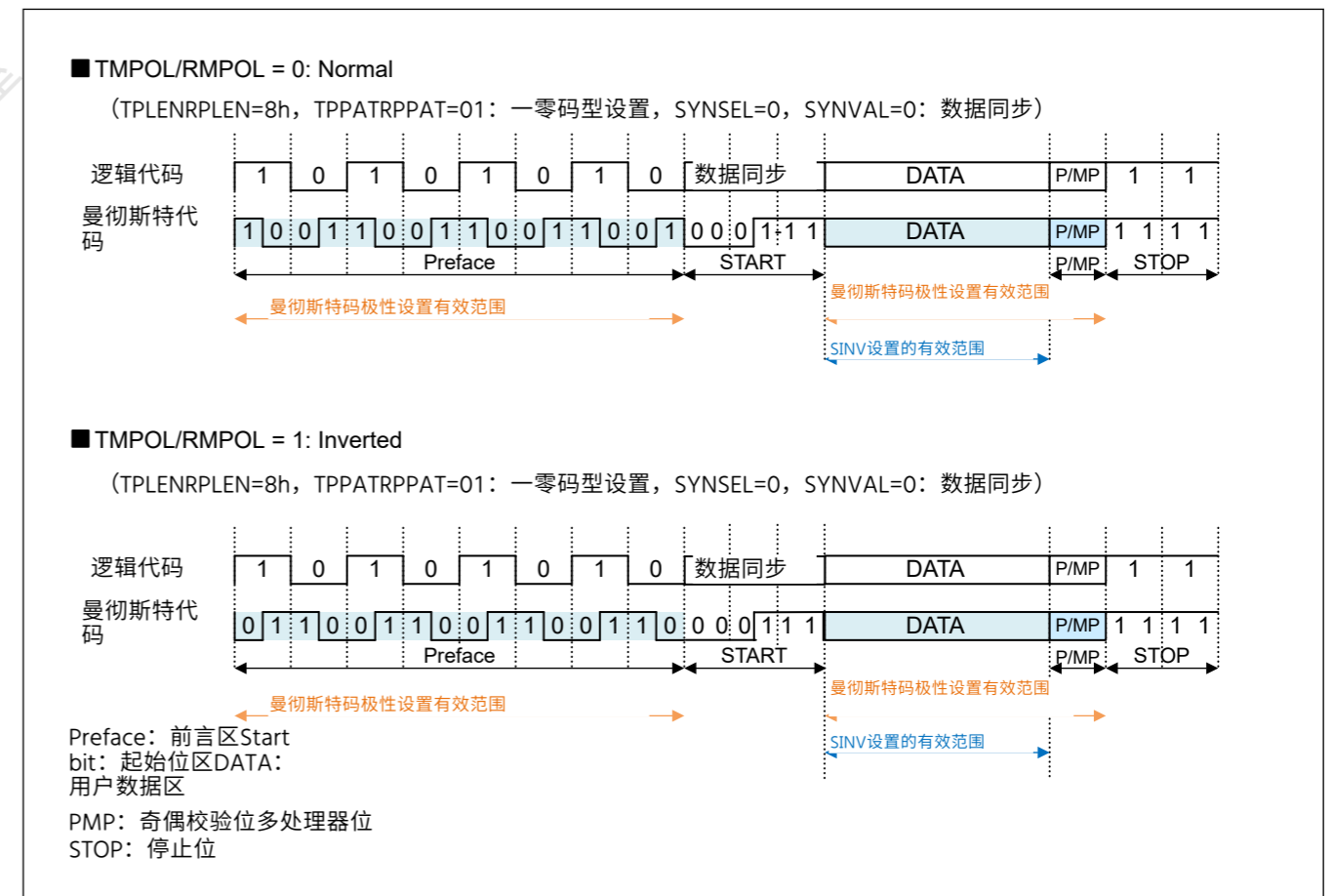


Figure 27.64 曼彻斯特码极性设置的有效范围

### 27.5.11 曼彻斯特模式中的错误

曼彻斯特模式有以下错误:

1. Parity error
2. Over run error
3. Framing error
4. Manchester error
5. Preface error
6. Start Bit error
7. Receive SYNC error

For errors (1) to (3), see [section 27.3.9. Serial Data Reception in Asynchronous Mode](#) (1) because they are the same as in asynchronous mode.

Each errors are judged in each area, but they are reflected on flags and operations at the timing of 3/4-bit sampling of the STOP bit area. If a preface error or start bit error is detected, subsequent data will not be received. Therefore, no other error detection is performed, and the error flag holds the previous information.

[Table 27.33](#) lists the states of the serial status register when detecting errors and judgment about whether to store data in the RDR.

[Table 27.34](#) lists the errors that can be detected in each area of a Manchester frame.

If a Preface error or Start bit error is detected, subsequent data will not be received. Therefore, no other error detection is performed, and the error flag holds the result of the previous frame reception. Also, if an error is detected in the previous frame, data will not be received, but errors in the pre-face area and start bit area will update that flag. [Table 27.35](#) shows the flags and actions in this case.

#### (4) Manchester error

A Manchester error is generated when a Manchester code error is detected.

In Manchester code, there must be an edge (transition) in the center of the bit.

In the data area of a received frame (including the parity/multi-processor bit), the values of the 1/4-bit and 3/4-bit sampling points are checked in each received 1-bit data, and a Manchester code error is determined if these two values match.

If a Manchester code error is detected, the Manchester error flag (SSR.MER) is asserted.

If a Manchester error occurs, it is handled as an interrupt source and event source. If a Manchester error is detected, the next reception is not performed until the corresponding error flag is cleared.

#### (5) Preface error

A preface error is generated when the preface pattern does not match or a Manchester code error is detected in the preface area. If a preface error is detected, the preface error flag (SSR.PFER) is asserted.

It is possible to set whether to use this error flag as an interrupt source with the setting of the MECCR register.

When MECCR.PFEREN = 1, a preface error is handled as an interrupt source or event source. If a preface error is detected, the next reception is not performed until the corresponding error flag is cleared.

When MECCR.PFEREN = 0, a preface error is not handled as an interrupt source or event source, and the next reception is not halted. However, a preface error is notified to MESR.PFER.

#### (6) Start bit error

A start bit error is generated when a mismatch is detected between the start bit area in the received frame and the preset start bit pattern. Upon detection of a start bit error, a start bit error flag (MESR.SBER) is asserted.

It is possible to set whether to use the start bit error as an interrupt source with the setting of the MECCR register.

When MECCR.SBEREN = 1, a start bit error is handled as an interrupt source or event source. If a start bit error is detected, the next reception is not performed until the corresponding error flag is cleared.

When MECCR.SBEREN = 0, a start bit error is not handled as an interrupt source or event source, and the next reception is not halted. However, a start bit error is notified to MESR.SBER.

#### (7) Receive SYNC error

When the receive retiming function described in [section 27.5.9. Receive Retiming](#) is enabled, the receive retiming operation is performed.

- 1.奇偶校验错误
- 2.溢出错误
- 3.构图错误
- 4.曼彻斯特错误
- 5.前言错误
- 6.起始位错误
- 7.收到SYNC错误

关于错误(1)至(3), 请参阅第27.3.9节。异步模式下的串行数据接收(1)因为它们与异步模式下相同。

在每个区域中判断每个错误, 但它们反映在标志和操作上, 在3个4位采样的时间停止位区域。如果检测到前言错误或起始位错误, 则不会接收后续数据。因此, 不进行其他错误检测, 错误标志保存先前的信息。

表27.33列出了串口状态寄存器在检测错误和判断是否存储数据时的状态RDR。

表27.34列出了可以在曼彻斯特帧的每个区域中检测到的错误。

如果检测到Preface错误或Startbit错误, 则不会接收后续数据。因此, 不进行其他错误检测, 错误标志保存前一帧接收的结果。此外, 如果在前一帧中检测到错误, 则不会接收数据, 但前脸区域和起始位区域中的错误将更新该标志。表27.35显示了这种情况下的标志和操作。

#### (4)曼彻斯特错误

当检测到曼彻斯特码错误时, 就会产生曼彻斯特错误。

在曼彻斯特码中, 位的中心必须有一个边(转换)。

在接收帧的数据区(包括奇偶校验多处理器位), 在每个接收的1位数据中检查1个4位和3个4位采样点的值, 确定曼彻斯特码错误如果这两个值匹配。

如果检测到曼彻斯特代码错误, 则曼彻斯特错误标志(SSR.MER)被置位。

如果发生曼彻斯特错误, 则将其作为中断源和事件源进行处理。如果检测到曼彻斯特错误, 则在清除相应错误标志之前不会执行下一次接收。

#### (5)前言错误

当前言模式不匹配或在前言区检测到曼彻斯特码错误时, 会产生前言错误。如果检测到前言错误, 则断言前言错误标志(SSR.PFER)。

可以通过MECCR寄存器的设置来设置是否使用该错误标志作为中断源。

当MECCR.PFEREN=1时, 前言错误作为中断源或事件源处理。如果检测到前言错误, 则在相应的错误标志被清除之前不会执行下一次接收。

当MECCR.PFEREN=0时, 前言错误不会作为中断源或事件源处理, 并且不会停止下一次接收。但是, 前言错误会通知给MESR.PFER。

#### (6)起始位错误

当检测到接收帧中的起始位区域与预设的起始位模式不匹配时, 会产生起始位错误。在检测到起始位错误时, 将置位起始位错误标志(MESR.SBER)。

可以通过MECCR寄存器的设置来设置是否使用起始位错误作为中断源。

当MECCR.SBEREN=1时, 起始位错误作为中断源或事件源处理。如果检测到起始位错误, 则在清除相应错误标志之前不会执行下一次接收。

当MECCR.SBEREN=0时, 不将起始位错误作为中断源或事件源处理, 并且不会停止下一次接收。但是, 将向MESR.SBER通知起始位错误。

#### (7)接收同步错误

当接收重定时功能在第27.5.9节中描述。启用接收重定时, 执行接收重定时操作。

If no edges are detected within the receive retiming range (SyncError area in Figure 27.63) when receive timing operation is being performed, a receive SYNC error is generated. Upon detection of a receive SYNC error, a receive SYNC error flag (MESR.SYER) is asserted. In areas not subject to retiming, receive SYNC errors are not detected.

The preface area\*1, the start bit area\*1,\*2, and the data area (excluding the stop bit) for which receive retiming operation is performed are checked.

It is possible to set whether to use the receive SYNC error as an interrupt source with the setting of the MECR register.

When MECR.SYEREN = 1, a receive SYNC error is handled as an interrupt source or event source. If a receive SYNC error is detected, the next reception is not performed until the corresponding error flag is cleared.

When MECR.SYEREN = 0, a receive SYNC error is not handled as an interrupt source or event source, and the next reception is not halted. However, a receive SYNC error is notified to MESR.SYER.

Note 1. In the case of a frame that starts with a pattern that expects the first half of the bit to be High, it is excluded from retiming.

Note 2. In the start bit area, when there is no preface length and 3 bit start bit is set, it is not subject to retiming.

Also, the 1st bit and the 2nd bit in the start bit area when 3 bit start bit is set are not subject to retiming.

Table 27.33 Flags in the SSR Register and Receive Data Handling in Manchester Mode

| Flag in the SSR register |                      |      |      | Flag in the MERS register |         |       | received data   | Received error status (ERI interrupt / event generation)         |
|--------------------------|----------------------|------|------|---------------------------|---------|-------|-----------------|--|
| ORE R                    | FER                  | PER  | MER  | SBE R*1                   | PFER *1 | SYE R |                 |  |
| 0                        | 0                    | 0    | 0    | 0                         | 0       | 0     | transfer to RDR | No error   |
| 0                        | 1                    | 0    | 0    | 0                         | 0       | 0     | transfer to RDR | Framin error   |
| 0                        | 0                    | 1    | 0    | 0                         | 0       | 0     | transfer to RDR | Parity error   |
| 0                        | 1                    | 1    | 0    | 0                         | 0       | 0     | transfer to RDR | Framing error + Parity error                                     |
| 0                        | 0                    | 0    | 1    | 0                         | 0       | 0     | transfer to RDR | Manchester error   |
| 0                        | 1                    | 0    | 1    | 0                         | 0       | 0     | transfer to RDR | Framing error + Manchester error                                 |
| 0                        | 0                    | 1    | 1    | 0                         | 0       | 0     | transfer to RDR | Parity error + Manchester error                                  |
| 0                        | 1                    | 1    | 1    | 0                         | 0       | 0     | transfer to RDR | Framing error + Parity error + Manchester error                  |
| 1                        | 0                    | 0    | 0    | 0                         | 0       | 0     | Lost            | Overflow error   |
| 1                        | 1                    | 0    | 0    | 0                         | 0       | 0     | Lost            | Overflow error + Framing error                                   |
| 1                        | 0                    | 1    | 0    | 0                         | 0       | 0     | Lost            | Overflow error + Parity error                                    |
| 1                        | 1                    | 1    | 0    | 0                         | 0       | 0     | Lost            | Overflow error + Framing error + Parity error                    |
| 1                        | 0                    | 0    | 1    | 0                         | 0       | 0     | Lost            | Overflow error + Manchester error                                |
| 1                        | 1                    | 0    | 1    | 0                         | 0       | 0     | Lost            | Overflow error + Framing error + Manchester error                |
| 1                        | 0                    | 1    | 1    | 0                         | 0       | 0     | Lost            | Overflow error + Parity error + Manchester error                 |
| 1                        | 1                    | 1    | 1    | 0                         | 0       | 0     | Lost            | Overflow error + Framing error + Parity error + Manchester error |
| 0                        | Combination of above |      |      | 0                         | 0       | 0     | transfer to RDR | Errors above + Receive SYNC error*2                              |
| 1                        |                      |      |      | 0                         | 0       | 0     | Lost            | Errors above + Receive SYNC error*2                              |
| hold                     | hold                 | hold | hold | 0                         | 1       | 0     | Lost            | Preface error*3  |
| hold                     | hold                 | hold | hold | 1                         | 0       | 0     | Lost            | Start bit error*3  |
| hold                     | hold                 | hold | hold | 0                         | 1       | 1     | Lost            | Preface error*3 + Receive SYNC error*2                           |
| hold                     | hold                 | hold | hold | 1                         | 0       | 1     | Lost            | Start bit error*3 + Receive SYNC error*2                         |

Note 1. Start bit error and Preface error never become "1" at the same time.

Note 2. When MECR.SYEREN = "1", ERI interrupt / event is generated by SYER factor.

Note 3. If MECR.PFEREN = "1" or MECR.SBEREN = "1", an ERI interrupt / event is generated when the corresponding flag is set.

如果在执行接收定时操作时在接收重定时范围内（图27.63中的SyncError区域）没有检测到边沿，则会产生接收SYNC错误。在检测到接收同步错误时，接收同步错误标志(MESR.SYER)被置位。在不受重定时限制的区域中，不会检测到接收同步错误。

检查执行接收重定时操作的前言区域\*1、起始位区域\*1、\*2和数据区域（不包括停止位）。

可以通过MECR寄存器的设置来设置是否使用接收SYNC错误作为中断源。

当MECR.SYEREN=1时，接收SYNC错误将作为中断源或事件源处理。如果检测到接收SYNC错误，则在清除相应错误标志之前不会执行下一次接收。

当MECR.SYEREN=0时，接收SYNC错误不会作为中断源或事件源处理，并且不会停止下一次接收。但是，接收同步错误会通知给MESR.SYER。

注1.对于以预期位的前半部分为高的模式开始的帧，它被排除在重定时之外。

注2.在起始位区域中，当没有序言长度且设置了3位起始位时，不进行重定时。

此外，当设置3位起始位时，起始位区域中的第1位和第2位不受重定时的影响。

Table 27.33 SSR寄存器中的标志和曼彻斯特模式下的接收数据处理

| SSR寄存器中的标志 |      |      |      | MERS寄存器中的标志 |         |       | 接收数据   | 接收错误状态 (ERI中断事件产生)      |
|------------|------|------|------|-------------|---------|-------|--------|-------------------------|
| ORE R      | FER  | PER  | MER  | SBE R*1     | PFER *1 | SYE R |        |                         |
| 0          | 0    | 0    | 0    | 0           | 0       | 0     | 转移到RDR | 没有错误                    |
| 0          | 1    | 0    | 0    | 0           | 0       | 0     | 转移到RDR | Framin error            |
| 0          | 0    | 1    | 0    | 0           | 0       | 0     | 转移到RDR | 奇偶校验错误                  |
| 0          | 1    | 1    | 0    | 0           | 0       | 0     | 转移到RDR | 成帧错误+奇偶校验错误             |
| 0          | 0    | 0    | 1    | 0           | 0       | 0     | 转移到RDR | 曼彻斯特错误                  |
| 0          | 1    | 0    | 1    | 0           | 0       | 0     | 转移到RDR | 帧错误+曼彻斯特错误              |
| 0          | 0    | 1    | 1    | 0           | 0       | 0     | 转移到RDR | 奇偶校验错误+曼彻斯特错误           |
| 0          | 1    | 1    | 1    | 0           | 0       | 0     | 转移到RDR | 成帧错误+奇偶校验错误+曼彻斯特错误      |
| 1          | 0    | 0    | 0    | 0           | 0       | 0     | Lost   | 溢出错误                    |
| 1          | 1    | 0    | 0    | 0           | 0       | 0     | Lost   | 溢出错误+成帧错误               |
| 1          | 0    | 1    | 0    | 0           | 0       | 0     | Lost   | 溢出错误+奇偶校验错误             |
| 1          | 1    | 1    | 0    | 0           | 0       | 0     | Lost   | 溢出错误+帧错误+奇偶校验错误         |
| 1          | 0    | 0    | 1    | 0           | 0       | 0     | Lost   | 超限错误+曼彻斯特错误             |
| 1          | 1    | 0    | 1    | 0           | 0       | 0     | Lost   | 溢出错误+帧错误+曼彻斯特错误         |
| 1          | 0    | 1    | 1    | 0           | 0       | 0     | Lost   | 溢出错误+奇偶校验错误+曼彻斯特错误      |
| 1          | 1    | 1    | 1    | 0           | 0       | 0     | Lost   | 溢出错误+成帧错误+奇偶校验错误+曼彻斯特错误 |
| 0          | 以上结合 |      |      | 0           | 0       | 0     | 转移到RDR | 上述错误+接收同步错误*2           |
| 1          |      |      |      | 0           | 0       | 0     | Lost   | 上述错误+接收同步错误*2           |
| hold       | hold | hold | hold | 0           | 1       | 0     | Lost   | 前言错误*3                  |
| hold       | hold | hold | hold | 1           | 0       | 0     | Lost   | 起始位错误*3                 |
| hold       | hold | hold | hold | 0           | 1       | 1     | Lost   | 前言错误*3+接收同步错误*2         |
| hold       | hold | hold | hold | 1           | 0       | 1     | Lost   | 起始位错误*3+接收同步错误*2        |

注1.起始位错误和序言错误永远不会同时变为"1"。

注2.当MECR.SYEREN="1"时，由SYER因素产生ERI中断事件。

注3.如果MECR.PFEREN="1"或MECR.SBEREN="1"，则在设置相应标志时产生ERI中断事件。



Table 27.34 Errors Detectable in Each Area

|                      | Preface error (PFER) | Start Bit error (SBER) | Manchester error (MER) | Receive SYNC error (SYER) | Parity error (PER) | Framing error (FER) |
|----------------------|----------------------|------------------------|------------------------|---------------------------|--------------------|---------------------|
| Preface area         | ✓                    | —                      | —*1                    | ✓*2                       | —                  | —                   |
| Start Bit area       | —                    | ✓                      | —                      | ✓*2                       | —                  | —                   |
| Data area            | —                    | —                      | ✓                      | ✓                         | —                  | —                   |
| Parity area          | —                    | —                      | ✓                      | ✓                         | ✓                  | —                   |
| Multi-processor area | —                    | —                      | ✓                      | ✓                         | —                  | —                   |
| Stop Bit area        | —                    | —                      | —                      | —                         | —                  | ✓                   |

Note: ✓: Detected, —: Not detected

Note 1. When an Manchester code error occurs in the preface area, it is defined as a preface error.

Note 2. It may not be subject to Receive SYNC error detection. For details see the text [section 27.5.11. Errors in Manchester Mode \(7\)](#)

Table 27.35 Operation status due to presence / absence of error in previous frame and operation status list in multiprocessor mode (1 of 2)

| Previous frame           | Each area of the Frame |            |            |            |            | PFER N     | SBER N     | SYER N     | received data   | Error flag       | Interrupt request | Event signal |
|--------------------------|------------------------|------------|------------|------------|------------|------------|------------|------------|-----------------|------------------|-------------------|--------------|
|                          | preface                | start bit  | data       | parity     | stop       |            |            |            |                 |                  |                   |              |
| No Error                 | PFER                   | No Error   | Don't Care | Don't Care | Don't Care | 0          | Don't Care | Don't Care | Lost            | set PFER*1       | not output        | not output   |
|                          | No SYER*1              |            |            |            |            | 1          |            |            |                 |                  | output            | output       |
| No Error                 | SBER                   | Don't Care | Don't Care | Don't Care | Don't Care | 0          | Don't Care | Don't Care | Lost            | set SBER*1       | not output        | not output   |
|                          | No SYER*1              |            |            |            |            | 1          |            |            |                 |                  | output            | output       |
| No Error                 | SYER                   | No Error   | Don't Care | Don't Care | Don't Care | Don't Care | Don't Care | 0          | transfer to RDR | set SYER         | not output        | not output   |
|                          | No PFER                |            |            |            |            | 1          |            | Lost       |                 |                  | output            | output       |
| No Error                 | SYER                   | Don't Care | Don't Care | Don't Care | Don't Care | Don't Care | Don't Care | 0          | transfer to RDR | set SYER         | not output        | not output   |
|                          | No SBER                |            |            |            |            | 1          |            | Lost       |                 |                  | output            | output       |
| No Error                 | No Error               | SYER       |            |            | No Error   | Don't Care | Don't Care | 0          | transfer to RDR | set SYER         | not output        | not output   |
|                          |                        |            |            |            |            | 1          |            | Lost       |                 |                  | output            | output       |
| No Error                 | No Error               | MER        |            |            | No Error   | Don't Care | Don't Care | Don't Care | transfer to RDR | set MER          | output            | output       |
| No Error                 | No Error               | Don't Care | PER        |            | No Error   | Don't Care | Don't Care | Don't Care | transfer to RDR | set PER          | output            | output       |
| No Error                 | No Error               | Don't Care | Don't Care | FER        |            | Don't Care | Don't Care | Don't Care | transfer to RDR | set FER          | output            | output       |
| There is some error ORER |                        |            |            |            |            | Don't Care | Don't Care | Don't Care | Lost            | set some flags*2 | output            | output       |
| No Error                 | No Error               | No Error   | No Error   | No Error   | ORER       | Don't Care | Don't Care | Don't Care | Lost            | set ORER         | output            | output       |

Table 27.34 每个区域可检测到的错误

|                      | 前言错误(PFER) | 起始位错误(SBER) | 曼彻斯特错误(MER) | 接收同步错误(SYER) | 奇偶校验错误(PER) | 成帧错误(FER) |
|----------------------|------------|-------------|-------------|--------------|-------------|-----------|
| 前言区                  | ✓          | —           | —*1         | ✓*2          | —           | —         |
| 起始位区域                | —          | ✓           | —           | ✓*2          | —           | —         |
| 数据区                  | —          | —           | ✓           | ✓            | —           | —         |
| 平价区                  | —          | —           | ✓           | ✓            | ✓           | —         |
| Multi-processor area | —          | —           | ✓           | ✓            | —           | —         |
| 停止位区域                | —          | —           | —           | —            | —           | ✓         |

Note: ✓: 检测到, —: 未检测到

注1.当序言区出现曼彻斯特码错误时, 定义为序言错误。

注2.它可能不受ReceiveSYNC错误检测的影响。有关详细信息, 请参阅文本部分27.5.11。曼彻斯特模式中的错误(7)

Table 27.35 由于前一帧中不存在错误而导致的操作状态和多处理器模式下的操作状态列表 (1of 2)

| Previous frame | 框架的每个区域   |            |            |            |            | PFER N     | SBER N     | SYER N     | 接收数据    | 错误标志       | Interrupt request | 事件信号   |
|----------------|-----------|------------|------------|------------|------------|------------|------------|------------|---------|------------|-------------------|--------|
|                | preface   | 起始位        | data       | parity     | stop       |            |            |            |         |            |                   |        |
| 没有错误           | PFER      | 没有错误       | 不在乎        | 不在乎        | 不在乎        | 0          | 不在乎        | 不在乎        | Lost    | set PFER*1 | 不输出               | 不输出    |
|                | No SYER*1 |            |            |            |            | 1          |            |            |         |            | output            | output |
| 没有错误           | SBER      | Don't Care | Don't Care | Don't Care | Don't Care | 0          | Don't Care | Don't Care | Lost    | set SBER*1 | 不输出               | 不输出    |
|                | No SYER*1 |            |            |            |            | 1          |            |            |         |            | output            | output |
| No Error       | SYER      | 没有错误       | 不在乎        | 不在乎        | 不在乎        | 不在乎        | 不在乎        | 0          | 转移到 RDR | set SYER   | 不输出               | 不输出    |
|                | No PFER   |            |            |            |            | 1          |            | Lost       |         |            | output            | output |
| 没有错误           | SYER      | Don't Care | Don't Care | Don't Care | Don't Care | Don't Care | Don't Care | 0          | 转移到 RDR | set SYER   | 不输出               | 不输出    |
|                | No SBER   |            |            |            |            | 1          |            | Lost       |         |            | output            | output |
| 没有错误           | 没有错误      | SYER       |            |            | 没有错误       | 不在乎        | 不在乎        | 0          | 转移到 RDR | set SYER   | 不输出               | 不输出    |
|                |           |            |            |            |            | 1          |            | Lost       |         |            | output            | output |
| 没有错误           | 没有错误      | MER        |            |            | 没有错误       | 不在乎        | 不在乎        | 不在乎        | 转移到 RDR | 设置MER      | output            | output |
| 没有错误           | 没有错误      | 不在乎        | PER        |            | 没有错误       | 不在乎        | 不在乎        | 不在乎        | 转移到 RDR | 设置PER      | output            | output |
| 没有错误           | 没有错误      | 不在乎        | 不在乎        | FER        |            | 不在乎        | 不在乎        | 不在乎        | 转移到 RDR | 设置FER      | output            | output |
| 有一些错误 ORER     |           |            |            |            |            | 不在乎        | 不在乎        | 不在乎        | Lost    | 设置一些标志*2   | output            | output |
| 没有错误           | 没有错误      | 没有错误       | 没有错误       | 没有错误       | ORER       | 不在乎        | 不在乎        | 不在乎        | Lost    | set ORER   | output            | output |



**Table 27.35 Operation status due to presence / absence of error in previous frame and operation status list in multiprocessor mode (2 of 2)**

| Previous frame           | Each area of the Frame |            |            |               |            | PFER N     | SBERE N    | SYERE N             | received data       | Error flag | Interrupt request | Event signal |            |          |          |                     |
|--------------------------|------------------------|------------|------------|---------------|------------|------------|------------|---------------------|---------------------|------------|-------------------|--------------|------------|----------|----------|---------------------|
|                          | preface                | start bit  | data       | parity        | stop       |            |            |                     |                     |            |                   |              |            |          |          |                     |
| some error*3*6           | PFER<br>No SYER*1      | No Error   | Don't Care | Don't Care    | Don't Care | 0          | Don't Care | Don't Care          | Lost                | set PFER*1 | output*4          | not output*5 |            |          |          |                     |
|                          |                        | No Error   | Don't Care | Don't Care    | Don't Care | 1          |            |                     |                     |            |                   |              |            |          |          |                     |
|                          | No Error<br>No SYER*1  | SBER       | Don't Care | Don't Care    | Don't Care | Don't Care | 0          | Don't Care          |                     |            |                   |              | set SBER*1 |          |          |                     |
|                          |                        | No Error   | Don't Care | Don't Care    | Don't Care | 1          |            |                     |                     |            |                   |              |            |          |          |                     |
|                          | SYER<br>No PFER        | No Error   | Don't Care | Don't Care    | Don't Care | Don't Care | Don't Care | Don't Care          |                     |            |                   |              |            | set SYER |          |                     |
|                          |                        | No Error   | Don't Care | Don't Care    | Don't Care | 1          |            |                     |                     |            |                   |              |            |          |          |                     |
|                          | No Error<br>No SBER    | SYER       | Don't Care | Don't Care    | Don't Care | Don't Care | Don't Care | Don't Care          |                     |            |                   |              |            |          | set SYER |                     |
|                          |                        | No Error   | Don't Care | Don't Care    | Don't Care | 1          |            |                     |                     |            |                   |              |            |          |          |                     |
|                          | No Error               | No Error   | SYER       |               | No Error   | Don't Care | Don't Care | Don't Care          |                     |            |                   |              |            |          |          | don't set any flags |
|                          |                        |            | MER        |               | No Error   | Don't Care |            |                     |                     |            |                   |              |            |          |          |                     |
| No Error                 | No Error               | Don't Care | PER        | No Error      | Don't Care | Don't Care | Don't Care | don't set any flags |                     |            |                   |              |            |          |          |                     |
|                          |                        | Don't Care | FER        | No Error      | Don't Care |            |            |                     |                     |            |                   |              |            |          |          |                     |
| There is some error ORER |                        |            |            |               | Don't Care | Don't Care | Don't Care |                     | don't set any flags |            |                   |              |            |          |          |                     |
| No Error                 | No Error               | No Error   | No Error   | No Error ORER | Don't Care | Don't Care | Don't Care |                     |                     |            |                   |              |            |          |          |                     |

- Note 1. If SYER is detected, the SYER flag is also set. Other operations are as shown in this table.
- Note 2. Other detected error flags including ORER are also set.
- Note 3. If all the error flags are cleared before the STOP bit is judged, the operation will be the same as the case where there is no error in the previous frame of this table.
- Note 4. Since the ERI interrupt request is level output, it remains active due to errors in the previous frame regardless of the presence or absence of error in the relevant frame.
- Note 5. Since the error cause is continuously detected, the ERI event is not newly output regardless of the presence or absence of errors in the relevant frame.
- Note 6. For PFER, SBER, and SYER, when each enable bit is set to disable, it is treated as no error.

**Table 27.36 Operation when MPIE = "1" in multi-processor mode (MPIE = "0")**

| MPB*1 | Each area of the frame |           |            |            |            | PFER N     | SBERE N    | SYERE N    | received data   | Error flag          | Interrupt request | Event signal |
|-------|------------------------|-----------|------------|------------|------------|------------|------------|------------|-----------------|---------------------|-------------------|--------------|
|       | preface                | start bit | data       | parity     | stop       |            |            |            |                 |                     |                   |              |
| 1     | No Error               | No Error  | Don't Care | Don't Care | Don't Care | Don't Care | Don't Care | Don't Care | transfer to RDR | set some flags      | output*2          | output*2     |
|       | No PFER                | No SBER   | Don't Care | Don't Care | Don't Care | Don't Care | Don't Care | 0          |                 |                     |                   |              |
|       | SYER*3                 | SYER*3    |            |            |            |            |            | 1          | Lost            | don't set any flags | not output        | not output   |
|       | PFER                   | No Error  | Don't Care | Don't Care | Don't Care | Don't Care | Don't Care | Don't Care |                 |                     |                   |              |
|       | No Error               | SBER      | Don't Care | Don't Care | Don't Care | Don't Care | Don't Care | Don't Care |                 |                     |                   |              |

- Note 1. If the received MPB bit is "0", it is not received the frame, and the operation is the same as lost of the reception data of this table.
- Note 2. If no error is detected, RXI interrupt request or event is output, and if it is detected, ERI interrupt request or event is output.

**Table 27.35 由于前一帧中不存在错误而导致的操作状态和多处理器模式下的操作状态列表 (2of2)**

| Previous frame | 框架的每个区域           |          |      |           |      | PFER N | SBERE N | SYERE N  | 接收数据     | 错误标志       | Interrupt request | 事件信号  |            |          |          |          |
|----------------|-------------------|----------|------|-----------|------|--------|---------|----------|----------|------------|-------------------|-------|------------|----------|----------|----------|
|                | preface           | 起始位      | data | parity    | stop |        |         |          |          |            |                   |       |            |          |          |          |
| 一些错误*3*6       | PFER<br>No SYER*1 | 没有错误     | 不在乎  | 不在乎       | 不在乎  | 0      | 不在乎     | 不在乎      | Lost     | set PFER*1 | output*4          | 不输出*5 |            |          |          |          |
|                |                   | 没有错误     | 不在乎  | 不在乎       | 不在乎  | 1      |         |          |          |            |                   |       |            |          |          |          |
|                | 没有错误<br>No SYER*1 | SBER     | 不在乎  | 不在乎       | 不在乎  | 不在乎    | 0       | 不在乎      |          |            |                   |       | set SBER*1 |          |          |          |
|                |                   | No Error | 不在乎  | 不在乎       | 不在乎  | 1      |         |          |          |            |                   |       |            |          |          |          |
|                | SYER<br>No PFER   | 没有错误     | 不在乎  | 不在乎       | 不在乎  | 不在乎    | 不在乎     | 0        |          |            |                   |       |            | set SYER |          |          |
|                |                   | No Error | 不在乎  | 不在乎       | 不在乎  | 1      |         |          |          |            |                   |       |            |          |          |          |
|                | 没有错误<br>No SBER   | SYER     | 不在乎  | 不在乎       | 不在乎  | 不在乎    | 不在乎     | 0        |          |            |                   |       |            |          | set SYER |          |
|                |                   | No Error | 不在乎  | 不在乎       | 不在乎  | 1      |         |          |          |            |                   |       |            |          |          |          |
|                | 没有错误              | 没有错误     | SYER |           | 没有错误 | 不在乎    | 不在乎     | 0        |          |            |                   |       |            |          |          | 不要设置任何标志 |
|                |                   |          | MER  |           | 没有错误 | 不在乎    |         |          |          |            |                   |       |            |          |          |          |
| 没有错误           | 没有错误              | 不在乎      | PER  | 没有错误      | 不在乎  | 不在乎    | 不在乎     | 不要设置任何标志 |          |            |                   |       |            |          |          |          |
|                |                   | 不在乎      | FER  | 没有错误      | 不在乎  |        |         |          |          |            |                   |       |            |          |          |          |
| 有一些错误 ORER     |                   |          |      |           | 不在乎  | 不在乎    | 不在乎     |          | 不要设置任何标志 |            |                   |       |            |          |          |          |
| 没有错误           | 没有错误              | 没有错误     | 没有错误 | 没有错误 ORER | 不在乎  | 不在乎    | 不在乎     |          |          |            |                   |       |            |          |          |          |

- 注1.如果SYER被检测到，SYER标志也被设置。其他操作如本表所示。
- 注2.还设置了其他检测到的错误标志，包括ORER。
- 注3.如果在判断STOP位之前清除所有错误标志，则操作将与该表的前一帧没有错误的情况相同。
- 注4.由于ERI中断请求是电平输出，因此无论相关帧中是否存在错误，它都会由于前一帧中的错误而保持有效。
- 注5.由于不断检测错误原因，因此无论相关帧中是否存在错误，都不会重新输出ERI事件。
- 注6.对于PFER、SBER和SYER，当每个使能位设置为禁用时，它被视为无错误。

**Table 27.36 多处理器模式下MPIE="1"时的操作(MPIE="0")**

| MPB*1 | 框架的每个区域 |         |      |        |      | PFER N | SBERE N | SYERE N | 接收数据   | 错误标志     | Interrupt request | 事件信号     |
|-------|---------|---------|------|--------|------|--------|---------|---------|--------|----------|-------------------|----------|
|       | preface | 起始位     | data | parity | stop |        |         |         |        |          |                   |          |
| 1     | 没有错误    | 没有错误    | 不在乎  | 不在乎    | 不在乎  | 不在乎    | 不在乎     | 不在乎     | 转移到RDR | 设置一些标志   | output*2          | output*2 |
|       | No PFER | No SBER | 不在乎  | 不在乎    | 不在乎  | 不在乎    | 不在乎     | 0       |        |          |                   |          |
|       | SYER*3  | SYER*3  |      |        |      |        |         | 1       | Lost   | 不要设置任何标志 | 不输出               | 不输出      |
|       | PFER    | 没有错误    | 不在乎  | 不在乎    | 不在乎  | 不在乎    | 不在乎     | 不在乎     |        |          |                   |          |
|       | 没有错误    | SBER    | 不在乎  | 不在乎    | 不在乎  | 不在乎    | 不在乎     | 不在乎     |        |          |                   |          |

- 注1.如果接收到的MPB位为"0"，则不接收帧，操作同本表接收数据丢失。
- 注2.如果没有检测到错误，则输出RXI中断请求或事件，如果检测到，则输出ERI中断请求或事件。

Note 3. When SYER is detected in the preface area or the start bit area, the behavior of handling as an error depending on the SYEREN bit changes.

## 27.6 Operation in Clock Synchronous Mode

Figure 27.65 shows the data format for clock synchronous serial data communications.

In clock synchronous mode, data is transmitted or received in synchronization with clock pulses. One character in transfer data consists of 8-bit data. In clock synchronous mode, no parity bit can be added.

In data transmission, the SCI outputs data from one falling edge of the synchronization clock to the next. In data reception, the SCI receives data in synchronization with the rising edge of the synchronization clock. After 8-bit data is output, the transmission line holds the last bit as output state. When the SPMR.CKPH bit is 1 in slave mode, the transmission line holds the first bit output state.

Within the SCI, the transmitter and receiver are independent units, enabling full-duplex communications by using a shared clock. Both the transmitter and the receiver also have a double-buffered structure, so that the next transmit data can be written during transmission or the previous receive data can be read during reception, enabling continuous data transfer.

However, it is not possible to perform continuous transfer in the fastest bit rate setting (BRR[7:0] = 0x00 and SMR.CKS[1:0] = 00b). Therefore, when the FIFO is selected, this setting (BRR[7:0] = 0x00 and SMR.CKS[1:0] = 00b) is not available.

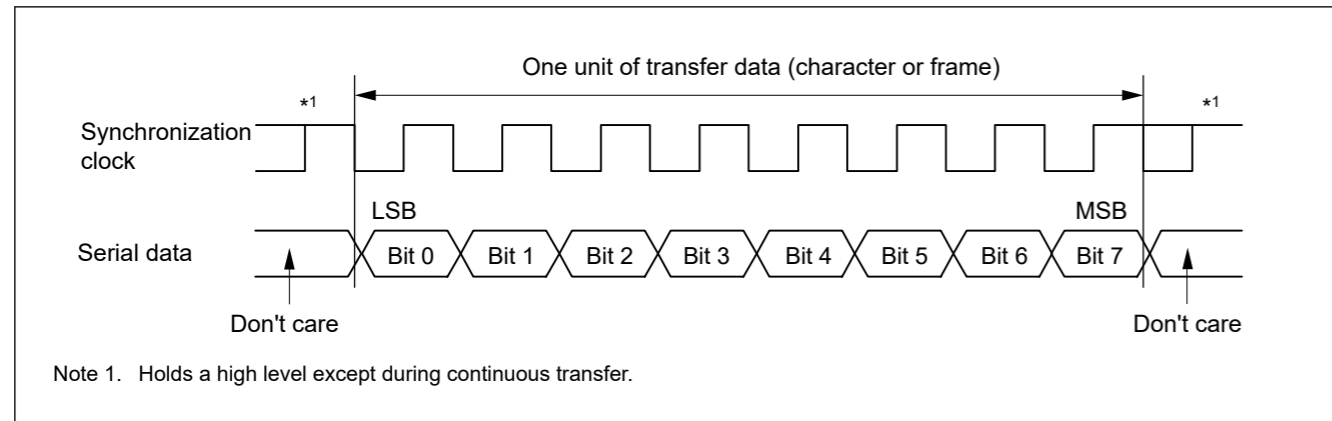


Figure 27.65 Data format in clock synchronous serial communications with LSB-first order

### 27.6.1 Clock

Either an internal clock generated by the on-chip baud rate generator or an external synchronization clock input at the SCKn pin can be selected based on the SCR.CKE[1:0] setting.

When the SCI operates on an internal clock, the synchronization clock is output from the SCKn pin. Eight synchronization clock pulses are output in the transfer of one character. When no transfer is performed, the clock is held high. However, when only data reception is performed while the CTS function is disabled, the synchronization clock output starts when the SCR.RE bit set to 1. The synchronization clock stops when it goes high\*1 and an overrun error occurs or the SCR.RE bit is set to 0.

When only data reception is performed and the CTS function is enabled, the clock output does not start when the SCR.RE bit set to 1 and the CTSn\_RTsn pin input is high. The synchronization clock output starts when the SCR.RE bit is set to 1 and the CTSn\_RTsn pin input is low. Following that, when the CTSn\_RTsn pin input is high on completion of the frame reception, the synchronization clock output stops when it goes high. If the CTSn\_RTsn pin input continues to be low, the synchronization clock stops when it goes high\*1 and an overrun error occurs or the SCR.RE bit is set to 0.

Note 1. The signal is held high while (SPMR.CKPH = 0 and SPMR.CKPOL = 1) or (SPMR.CKPH = 1 and SPMR.CKPOL = 1). It is held low while (SPMR.CKPH = 0 and SPMR.CKPOL = 0) or (SPMR.CKPH = 1 and SPMR.CKPOL = 0).

### 27.6.2 CTS and RTS Functions

In the CTS function, the CTSn\_RTsn pin input controls the start of data reception or transmission when the clock source is the internal clock. Setting the SPMR.CTSE bit to 1 enables the CTS function. When the CTS function is enabled, setting the CTSn\_RTsn pin low causes data reception or transmission to start.

注3.在序言区域或起始位区域中检测到SYER时,根据SYEREN位作为错误处理的行为会发生变化。

## 27.6 时钟同步模式下的操作

图27.65显示了时钟同步串行数据通信的数据格式。

在时钟同步模式下,数据的发送或接收与时钟脉冲同步。传输数据中的一个字符由8位数据组成。在时钟同步模式下,不能添加奇偶校验位。

在数据传输中,SCI从同步时钟的一个下降沿输出数据到下一个下降沿。在数据接收中,SCI与同步时钟的上升沿同步接收数据。8位数据输出后,传输线保持最后一位作为输出状态。当SPMR.CKPH位在从机模式下为1时,传输线保持第一位输出状态。

在SCI中,发送器和接收器是独立的单元,通过使用共享时钟实现全双工通信。发送端和接收端都具有双缓冲结构,可以在发送时写入下一个发送数据,或者在接收时读取前一个接收数据,实现数据的连续传输。

但是,不可能以最快的比特率设置(BRR[7:0]=0x00和SMR.CKS[1:0]=00b)。因此,当FIFO被选中时,此设置(BRR[7:0]=0x00和SMR.CKS[1:0]=00b)不可用。

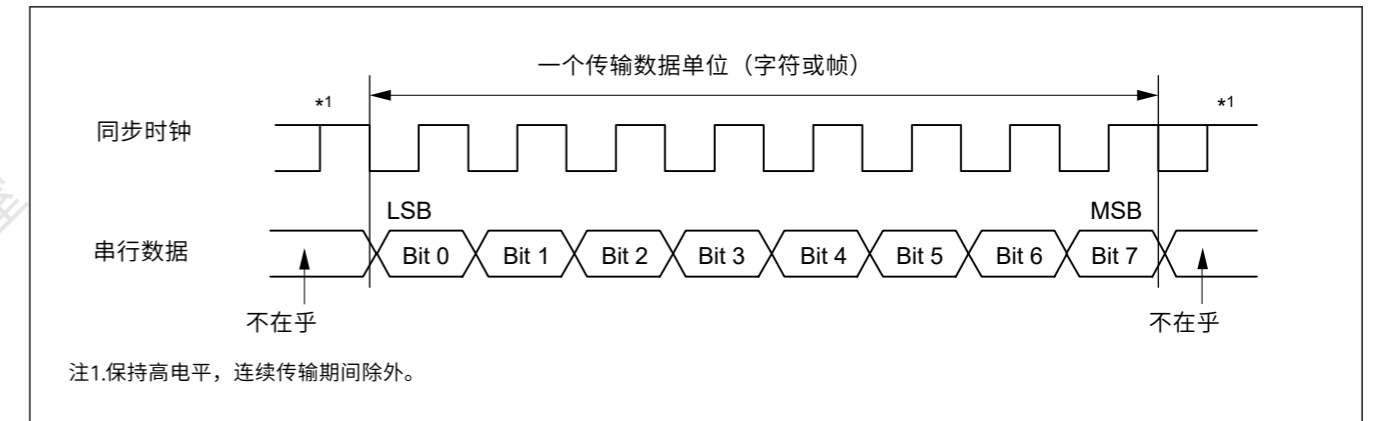


Figure 27.65 具有LSB优先顺序的时钟同步串行通信中的数据格式

### 27.6.1 Clock

可以根据SCR.CKE[1:0]设置选择由片内波特率发生器生成的内部时钟或SCKn引脚上的外部同步时钟输入。

当SCI在内部时钟上运行时,同步时钟从SCKn引脚输出。在一个字符的传输中输出八个同步时钟脉冲。当不执行传输时,时钟保持高电平。但是,当CTS功能禁用时仅执行数据接收时,同步时钟输出会在SCR.RE位设置为1时开始。同步时钟在变为高电平时停止\*1并且发生溢出错误或SCR.RE位设置为0。

仅执行数据接收且启用CTS功能时,当SCR.RE位设置为1且CTSn\_RTsn引脚输入为高电平时,时钟输出不会启动。当SCR.RE位设置为1且CTSn\_RTsn引脚输入为低电平时,同步时钟输出开始。之后,当CTSn\_RTsn引脚输入在帧接收完成时为高电平时,同步时钟输出在其变为高电平时停止。如果CTSn\_RTsn引脚输入持续为低电平,则同步时钟在变为高电平时停止\*1并发生溢出错误或SCR.RE位设置为0。

注1.当(SPMR.CKPH=0且SPMR.CKPOL=1)或(SPMR.CKPH=1且SPMR.CKPOL=1)时,信号保持高电平。它在(SPMR.CKPH=0和SPMR.CKPOL=0)或(SPMR.CKPH=1和SPMR.CKPOL=0)时保持低电平。

### 27.6.2 CTS和RTS函数

在CTS功能中,当时钟源为内部时钟时,CTSn\_RTsn引脚输入控制数据接收或发送的开始。将SPMR.CTSE位设置为1可启用CTS功能。当CTS功能使能时,将CTSn\_RTsn引脚设置为低电平会导致数据接收或发送开始。

Setting the CTSn\_RTsn pin high while the data transmission or reception is in progress does not affect transmission or reception of the current frame.

In the RTS function, the CTSn\_RTsn pin output is used to request the start of data reception or transmission when the clock source is an external synchronizing clock. The CTSn\_RTsn output goes low when serial communication becomes possible. Conditions for output of the CTSn\_RTsn low and high are shown as follows:

[Conditions for low output]

Satisfaction of all the following conditions:

#### Non-FIFO selected when all of the following conditions are satisfied

- The value of the SCR.RE bit or the SCR.TE bit is 1
- Neither transmission nor reception is in progress
- There is no received data available to be read when the SCR.RE bit is 1
- Transmit data is written when the SCR.TE bit is 1 and SCR.CKE[1] bit is 0
- Data is available for transmission in the TSR register when SCR.TE bit is 1 and SCR.CKE[1] bit is 1
- The SSR.ORER flag is 0

#### FIFO selected when all of the following conditions are satisfied

- The value of the SCR.RE bit or the SCR.TE bit is 1
- Neither transmission nor reception is in progress
- The amount of receive data written in FRDRHL is less than the setting value of FCRH.RSTRG[3:0] when SCR.RE = 1
- Data that has not been transmitted is available in FTDRHL when SCR.TE bit is 1 and SCR.CKE[1] bit is 0
- Data is available for transmission in the TSR register when SCR.TE bit is 1 and SCR.CKE[1] bit is 1
- The SSR\_FIFO.ORER flag is 0

[Condition for high output]

- The conditions for low output are not satisfied

### 27.6.3 SCI Initialization in Clock Synchronous Mode

Before transmitting and receiving data, start by writing the initial value 0x00 to the SCR register, then continue through the SCI initialization procedure given in the sections describing non-FIFO and FIFO selection in [section 27.6.2. CTS and RTS Functions](#). Anytime the operating mode or transfer format is to be changed, the SCR register must be initialized before the change can be made.

Note: Setting the SCR.RE bit to 0 initializes neither the ORER, FER, and PER flags in SSR/SSR\_FIFO nor the RDR register. When the TE bit is set to 0, the TEND flag for the selected FIFO buffer is not initialized.

Note: In non-FIFO mode, switching the value of the SCR.TE bit from 1 to 0 or 0 to 1 when the SCR.TIE bit is 1 generates an SCIn\_TXI interrupt request.

Table 27.37 Example flow of SCI initialization in clock synchronous mode with non-FIFO selected (1 of 2)

| No. | Step Name  | Description   |
|-----|--|---|
| 1   | Start initialization   |   |
| 2   | Set the SCR.TIE, RIE, TE, RE, and TEIE bits to 0               |   |
| 3   | Set the FCR.FM bit to 0  | Set the FCR.FM bit to 0.  |
| 4   | Set the SCR.CKE[1:0] bits                                      | Set the clock selection in SCR.   |
| 5   | Set the SIMR1.IICM bit to 0. Set the SPMR.CKPH and CKPOL bits. | Set the SIMR1.IICM bit to 0. Set the SPMR.CKPH and CKPOL bits. Step 5 can be skipped if the values have not been changed from the initial values. |

在数据发送或接收过程中将CTSn\_RTsn引脚设置为高电平不会影响当前帧的发送或接收。

在RTS功能中，当时钟源为外部同步时钟时，CTSn\_RTsn引脚输出用于请求开始数据接收或发送。当串行通信成为可能时，CTSn\_RTsn输出变为低电平。CTSn\_RTsn低电平和高电平的输出条件如下所示：

[低输出的条件]

满足以下所有条件：

#### 满足以下所有条件时选择非FIFO

- SCR.RE位或SCR.TE位的值为1
- 发送和接收都没有进行
- 当SCR.RE位为1时，没有可读取的接收数据
- 当SCR.TE位为1且SCR.CKE[1]位为0时写入发送数据
- 当SCR.TE位为1且SCR.CKE[1]位为1时，TSR寄存器中的数据可用于传输
- SSR.ORER标志为0

#### 满足以下所有条件时选择FIFO

- SCR.RE位或SCR.TE位的值为1
- 发送和接收都没有进行
- SCR.RE=1时，FRDRHL写入的接收数据量小于FCRH.RSTRG[3:0]的设定值
- 当SCR.TE位为1且SCR.CKE[1]位为0时，FTDRHL中未发送的数据可用
- 当SCR.TE位为1且SCR.CKE[1]位为1时，TSR寄存器中的数据可用于传输
- SSR\_FIFO.ORER标志为0

【高输出条件】

- 不满足低输出条件

### 27.6.3 时钟同步模式下的SCI初始化

在发送和接收数据之前，首先将初始值0x00写入SCR寄存器，然后继续执行第27.6.2节中描述非FIFO和FIFO选择的部分中给出的SCI初始化过程。CTS和RTS功能。任何时候要更改操作模式或传输格式，必须先初始化SCR寄存器，然后才能进行更改。

Note: 将SCR.RE位设置为0既不会初始化SSR/SSR\_FIFO中的ORER、FER和PER标志，也不会初始化RDR寄存器。当TE位设置为0时，所选FIFO缓冲区的TEND标志未初始化。

Note: 在非FIFO模式下，当SCR.TIE位为1时，将SCR.TE位的值从1切换为0或从0切换为1会产生SCIn\_TXI中断请求。

Table 27.37 在时钟同步模式下选择非FIFO的SCI初始化示例流程 (1 of 2)

| No. | 步骤名称                                 | Description   |
|-----|--------------------------------------|---|
| 1   | 开始初始化                                |   |
| 2   | 将SCR.TIE、RIE、TE、RE和TEIE位设置为0         |   |
| 3   | 将FCR.FM位设置为0                         | 将FCR.FM位设置为0。   |
| 4   | 设置SCR.CKE[1:0]位                      | 在SCR中设置时钟选择。  |
| 5   | 将SIMR1.IICM位设置为0。设置SPMR.CKPH和CKPOL位。 | 将SIMR1.IICM位设置为0。设置SPMR.CKPH和CKPOL位。如果这些值没有从初始值改变，则可以跳过第5步。 |



Table 27.37 Example flow of SCI initialization in clock synchronous mode with non-FIFO selected (2 of 2)

| No. | Step Name   | Description   |
|-----|---|---|
| 6   | Set the data transmission/reception format in SMR, SCMR, and SEMR | Set data transmission/reception format in SMR, SCMR, and SEMR.  |
| 7   | Set a value in SPTR   | Set the communication terminals status in SPTR.   |
| 8   | Set a value in BRR  | Write a value corresponding to the bit rate to BRR. This step is not necessary if an external clock is used.  |
| 9   | Set a value in MDDR   | Write the value obtained by correcting a bit rate error in MDDR. This step is not necessary if the BRME bit in SEMR is set to 0 or an external clock is used. |
| 10  | Set the I/O port functions  | Make I/O port settings to enable input and output functions as required for TXDn, RXDn, and SCKn pins.  |
| 11  | Set the SCR.TE or RE bit to 1, and set the SCR.TIE and RIE bits   | Set the SCR.TE or RE bit to 1. Also set the SCR.TIE and RIE bits. Setting the TE and RE bits allows TXDn and RXDn pins to be used.                            |
| 12  | Initialization completion   |   |

Note: In simultaneous transmit and receive operations, the TE and RE bits in SCR must both be set to 0 or set to 1 simultaneously

Table 27.38 Example flow of SCI initialization in clock synchronous mode with FIFO selected

| No. | Step Name  | Description   |
|-----|--|---|
| 1   | Start initialization   |   |
| 2   | Set the SCR.TIE, RIE, TE, RE, and TEIE bits to 0   |   |
| 3   | Set the FCR.FM, TFRST, and RFRST bits to 1. Set the FCR.TTRG[3:0], RTRG[3:0], and RSTRG[3:0] bits. | Set the FCR.FM, TFRST, and RFRST bits to 1 (FIFO mode enabled, transmit/receive FIFOs empty). Set the FCR.TTRG[3:0], RTRG[3:0], and RSTRG[3:0] bits.          |
| 4   | Set the SCR.CKE[1:0] bits  | Set the clock selection in SCR.   |
| 5   | Set the SIMR1.IICM bit to 0. Set the SPMR.CKPH and CKPOL bits.                                     | Set the SIMR1.IICM bit to 0. Set the SPMR.CKPH and CKPOL bits. Step 5 can be skipped if the values have not been changed from the initial values.             |
| 6   | Set the data transmission/reception format in SMR, SCMR, and SEMR                                  | Set data transmission/reception format in SMR, SCMR, and SEMR.  |
| 7   | Set a value in SPTR  | Set the communication terminals status in SPTR.   |
| 8   | Set a value in BRR   | Write a value corresponding to the bit rate to BRR. This step is not necessary if an external clock is used.  |
| 9   | Set a value in MDDR  | Write the value obtained by correcting a bit rate error in MDDR. This step is not necessary if the BRME bit in SEMR is set to 0 or an external clock is used. |
| 10  | Set the FCR.TFRST and RFRST bits to 0  | Set the FCR.TFRST and RFRST bits to 0.  |
| 11  | Set the I/O port functions   | Make I/O port settings to enable input and output functions as required for TXDn, RXDn, and SCKn pins.  |
| 12  | Set the SCR.TE or RE bit to 1, and set the SCR.TIE and RIE bits                                    | Set the SCR.TE or RE bit to 1. Also set the SCR.TIE and RIE bits. Setting the TE and RE bits allows TXDn and RXDn pins to be used.                            |
| 13  | Initialization completion  |   |

Note: In simultaneous transmit and receive operations, the TE and RE bits in SCR must both be set to 0 or set to 1 simultaneously.

## 27.6.4 Serial Data Transmission in Clock Synchronous Mode

### (1) Non-FIFO selected

Figure 27.66, Figure 27.67, and Figure 27.68 show examples of serial transmission in clock synchronous mode.

Table 27.37 在时钟同步模式下选择非FIFO的SCI初始化示例流程 (2个中的2个)

| No. | 步骤名称                            | Description   |
|-----|---------------------------------|---|
| 6   | 在SMR、SCMR和SEMR中设置数据发送接收格式       | 在SMR、SCMR、SEMR中设置数据发送接收格式。                                |
| 7   | 在SPTR中设置一个值                     | 在SPTR中设置通讯终端状态。   |
| 8   | 在BRR中设置一个值                      | 将与比特率对应的值写入BRR。如果使用外部时钟,则不需要此步骤。                          |
| 9   | 在MDDR中设置一个值                     | 在MDDR中写入通过纠正比特率错误获得的值。这一步是没有必要的,如果SEMR中的BRME位设置为0或使用外部时钟。 |
| 10  | 设置IO端口功能                        | 进行IO端口设置以启用TXDn、RXDn和所需的输入和输出功能SCKn pins。                 |
| 11  | 将SCR.TE或RE位设置为1,并设置SCR.TIE和RIE位 | 将SCR.TE或RE位设置为1。同时设置SCR.TIE和RIE位。设置TE和RE位允许使用TXDn和RXDn引脚。 |
| 12  | 初始化完成                           |   |

Note: 在同时发送和接收操作中,SCR中的TE和RE位必须都设置为0或同时设置为1

Table 27.38 选择FIFO的时钟同步模式下的SCI初始化示例流程

| No. | 步骤名称  | Description  |
|-----|---|--|
| 1   | 开始初始化   |  |
| 2   | 将SCR.TIE、RIE、TE、RE和TEIE位设置为0                                    |  |
| 3   | 设置FCR.FM、TFRST和RFRST位为1。设置FCR.TTRG[3:0], RTRG[3:0]和RSTRG[3:0]位。 | 将FCR.FM、TFRST和RFRST位设置为1(启用FIFO模式,发送接收FIFO为空)。设置FCR.TTRG[3:0]、RTRG[3:0]和RSTRG[3:0]位。 |
| 4   | 设置SCR.CKE[1:0]位   | 在SCR中设置时钟选择。   |
| 5   | 将SIMR1.IICM位设置为0。设置SPMR.CKPH和CKPOL bits。                        | 将SIMR1.IICM位设置为0。设置SPMR.CKPH和CKPOL位。如果这些值没有从初始值改变,则可以跳过第5步。                          |
| 6   | 在SMR、SCMR和SEMR中设置数据发送接收格式                                       | 在SMR、SCMR、SEMR中设置数据发送接收格式。   |
| 7   | 在SPTR中设置一个值   | 在SPTR中设置通讯终端状态。  |
| 8   | 在BRR中设置一个值  | 将与比特率对应的值写入BRR。如果使用外部时钟,则不需要此步骤。   |
| 9   | 在MDDR中设置一个值   | 在MDDR中写入通过纠正比特率错误获得的值。这一步是没有必要的,如果SEMR中的BRME位设置为0或使用外部时钟。                            |
| 10  | 设置FCR.TFRST和RFRST位为0  | 将FCR.TFRST和RFRST位设置为0。   |
| 11  | 设置IO端口功能  | 进行IO端口设置以启用TXDn、RXDn和所需的输入和输出功能SCKn pins。  |
| 12  | 将SCR.TE或RE位设置为1,并设置SCR.TIE和RIE位                                 | 将SCR.TE或RE位设置为1。同时设置SCR.TIE和RIE位。设置TE和RE位允许使用TXDn和RXDn引脚。                            |
| 13  | 初始化完成   |  |

Note: 在同时发送和接收操作中,SCR中的TE和RE位必须都设置为0或同时设置为1。

## 27.6.4 时钟同步模式下的串行数据传输

### (1) Non-FIFO selected

图27.66、图27.67和图27.68显示了时钟同步模式下的串行传输示例。



In serial data transmission, the SCI operates as follows:

1. The SCI transfers data from the TDR register to the TSR register when data is written to TDR in the SCIn\_TXI interrupt handling routine. The SCIn\_TXI interrupt request at the beginning of transmission is generated when the TE bit is set to 1 but only after the TIE bit in the SCR is also set to 1 or when these two bits are set to 1 simultaneously by a single instruction.
2. After transferring data from TDR to TSR, the SCI starts transmission. When the SCR.TIE bit is set to 1, an SCIn\_TXI interrupt request is generated. Continuous transmission is enabled by writing the next transmit data to TDR in the SCIn\_TXI interrupt handling routine before transmission of the current transmit data finishes. When SCIn\_TEI interrupt requests are in use, set the SCR.TIE bit to 0 and the SCR.TEIE bit to 1 after the last of the data to be transmitted is written to the TDR register from the handling routine for SCIn\_TXI requests.
3. 8-bit data is sent from the TXDn pin in synchronization with the output clock when the clock output mode is specified and in synchronization with the input clock when the use of an external clock is specified. Output of the clock signal is suspended until the input CTS signal is low when the SPMR.CTSE bit is 1.
4. The SCI checks for update to the TDR register on output of the last bit.
5. When the TDR register is updated, the next transmit data is transferred from TDR to TSR, and serial transmission of the next frame starts.
6. If TDR is not updated, the SSR.TEND flag is set to 1. The TXDn pin retains the output state of the last bit. If the SCR.TEIE bit is 1, an SCIn\_TEI interrupt request is generated and the SCKn pin is held high.

Figure 27.66, Figure 27.67, and Figure 27.68 show examples of serial data transmission.

Transmission does not start while a receive error flag (ORER, FER, or PER in SSR) is set to 1. Always set the receive error flags to 0 before starting transmission.

Note: Setting the SCR.RE bit to 0 does not clear the receive error flags.

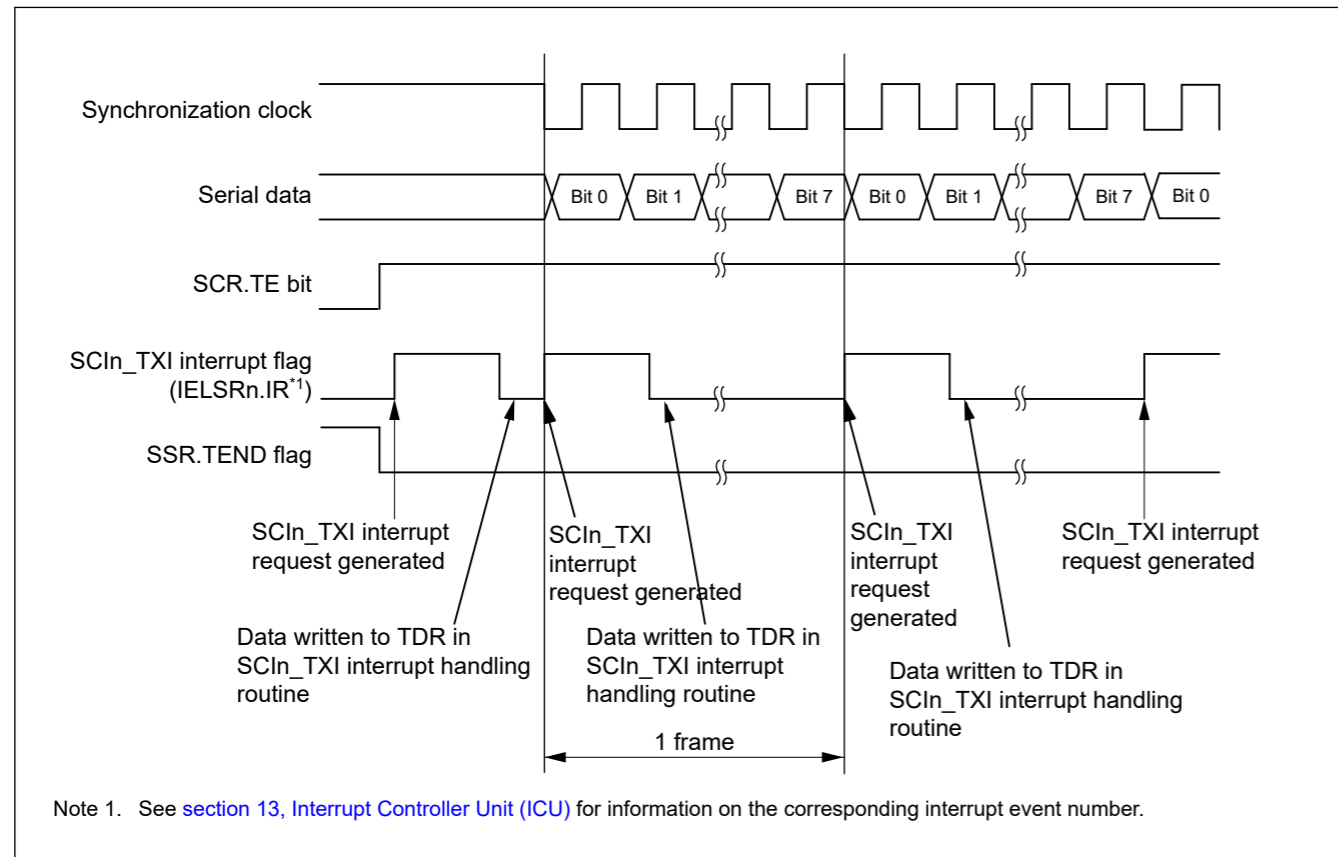


Figure 27.66 Example of serial data transmission in clock synchronous mode when the CTS function is not used at the beginning of transmission

在串行数据传输中，SCI操作如下：

- 1.当数据在SCIn\_TXI中断处理程序中写入TDR时，SCI将数据从TDR寄存器传输到TSR寄存器。发送开始时的SCIn\_TXI中断请求在TE位设置为1且仅在SCR中的TIE位也设置为1或当这两个位通过一条指令同时设置为1时产生。
- 2.将数据从TDR传输到TSR后，SCI开始传输。当SCR.TIE位设置为1时，会产生SCIn\_TXI中断请求。在当前发送数据发送完成之前，通过在SCIn\_TXI中断处理例程中将下一个发送数据写入TDR来启用连续发送。使用SCIn\_TEI中断请求时，在SCIn\_TXI请求的处理例程中将要发送的最后一个数据写入TDR寄存器后，将SCR.TIE位设置为0，并将SCR.TEIE位设置为1。
- 3.指定时钟输出模式时，与输出时钟同步，指定使用外部时钟时，与输入时钟同步，从TXDn引脚发送8位数据。当SPMR.CTSE位为1时，时钟信号的输出被暂停，直到输入CTS信号为低电平。
- 4.SCI在最后一位输出时检查对TDR寄存器的更新。
- 5.TDR寄存器更新后，下一个发送数据从TDR传送到TSR，开始下一帧的串行发送。
- 6.如果TDR未更新，则SSR.TEND标志设置为1。TXDn引脚保持最后一位的输出状态。如果SCR.TEIE位为1，则产生SCIn\_TEI中断请求并且SCKn引脚保持高电平。

图27.66、图27.67和图27.68显示了串行数据传输的示例。

当接收错误标志（SSR中的ORER、FER或PER）设置为1时，发送不会开始。在开始发送之前，请务必将接收错误标志设置为0。

Note: 将SCR.RE位设置为0不会清除接收错误标志。

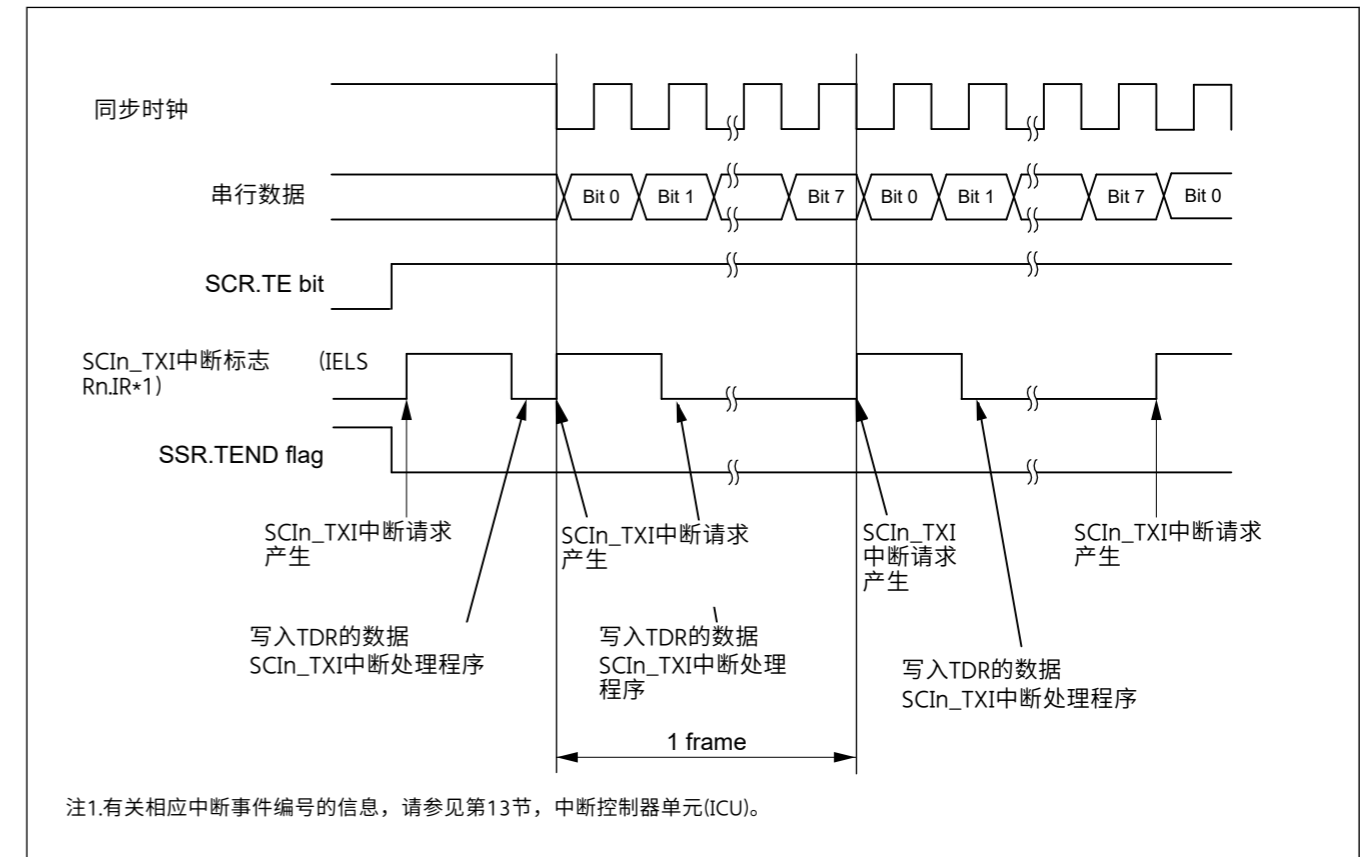


Figure 27.66 传输开始时未使用CTS功能时时钟同步模式下的串行数据传输示例

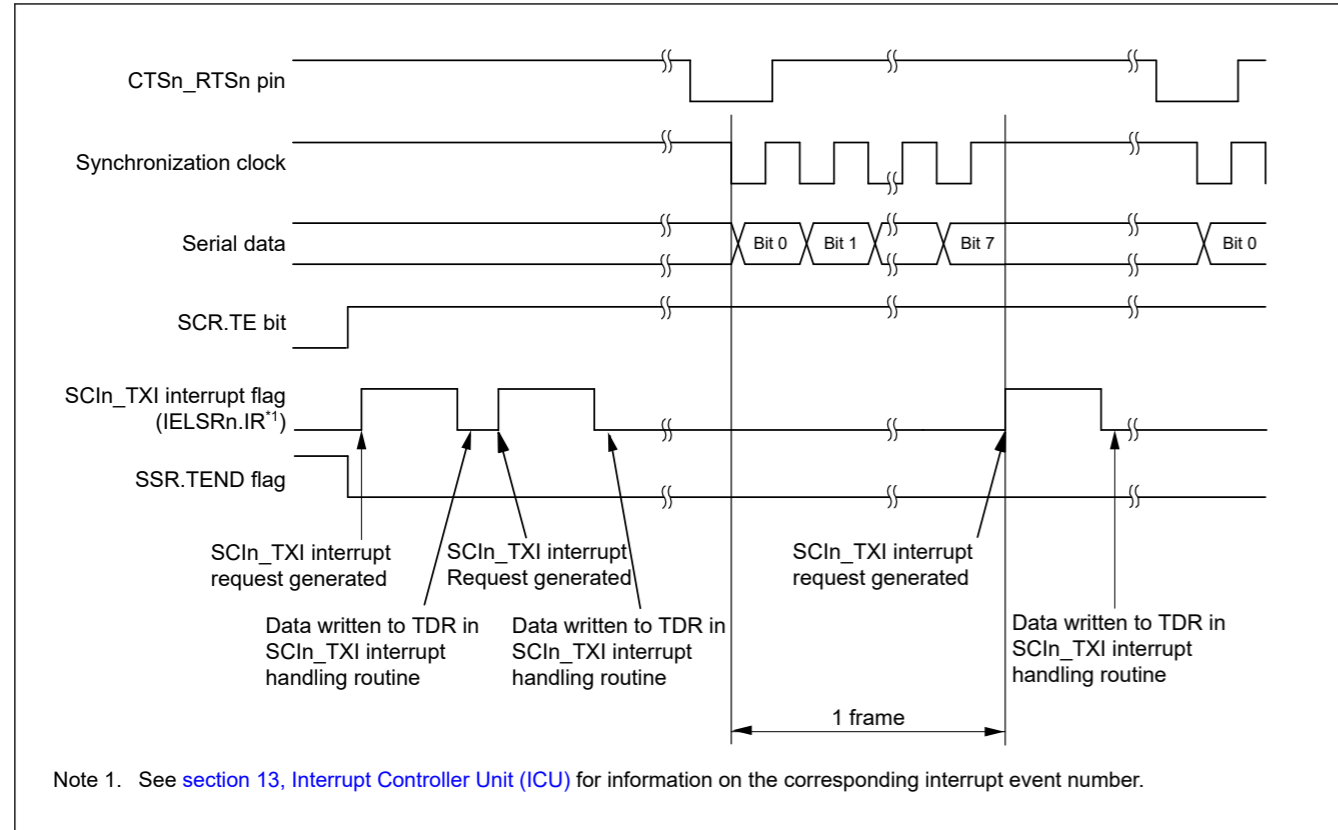


Figure 27.67 Example of serial data transmission in clock synchronous mode when the CTS function is used at the beginning of transmission

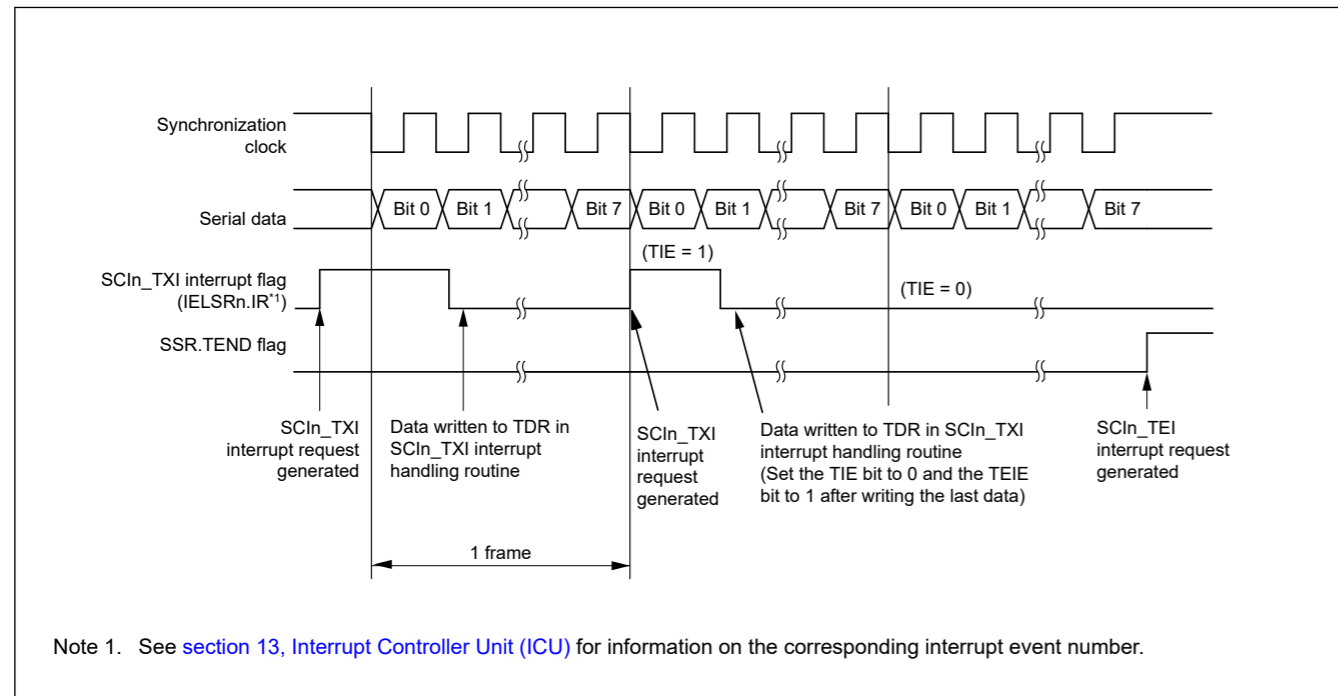


Figure 27.68 Example of serial data transmission in clock synchronous mode from the middle of transmission until transmission completion

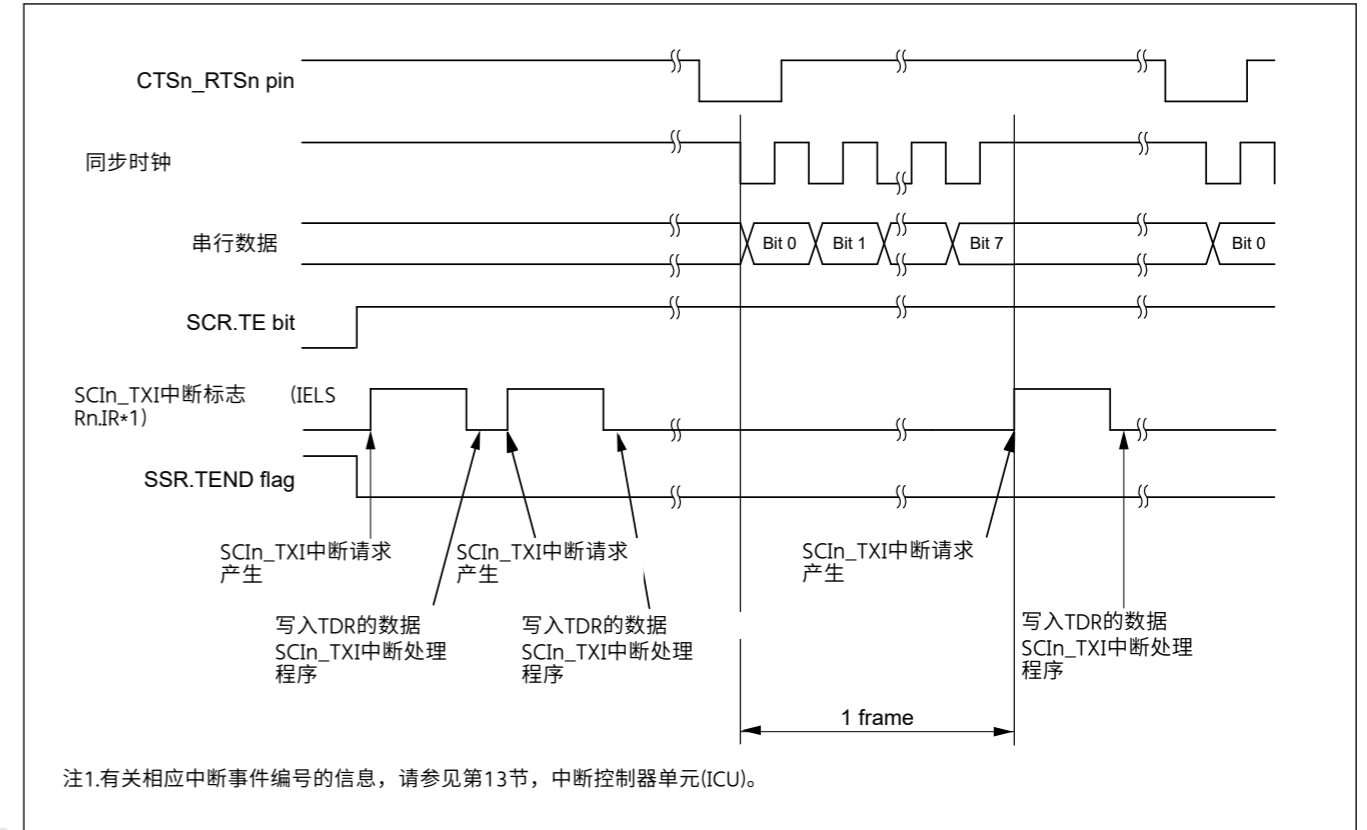


Figure 27.67 传输开始时使用CTS功能时时钟同步模式下的串行数据传输示例

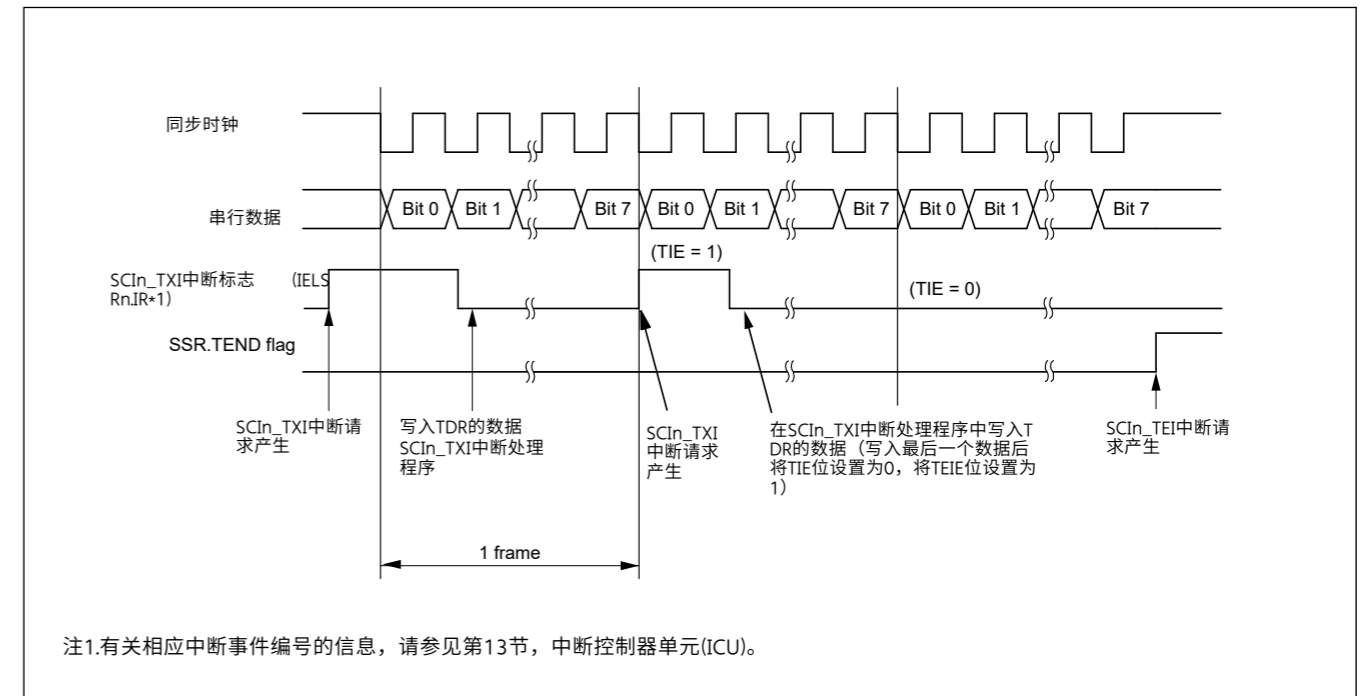


Figure 27.68 从传输中间到传输完成的时钟同步模式下的串行数据传输示例

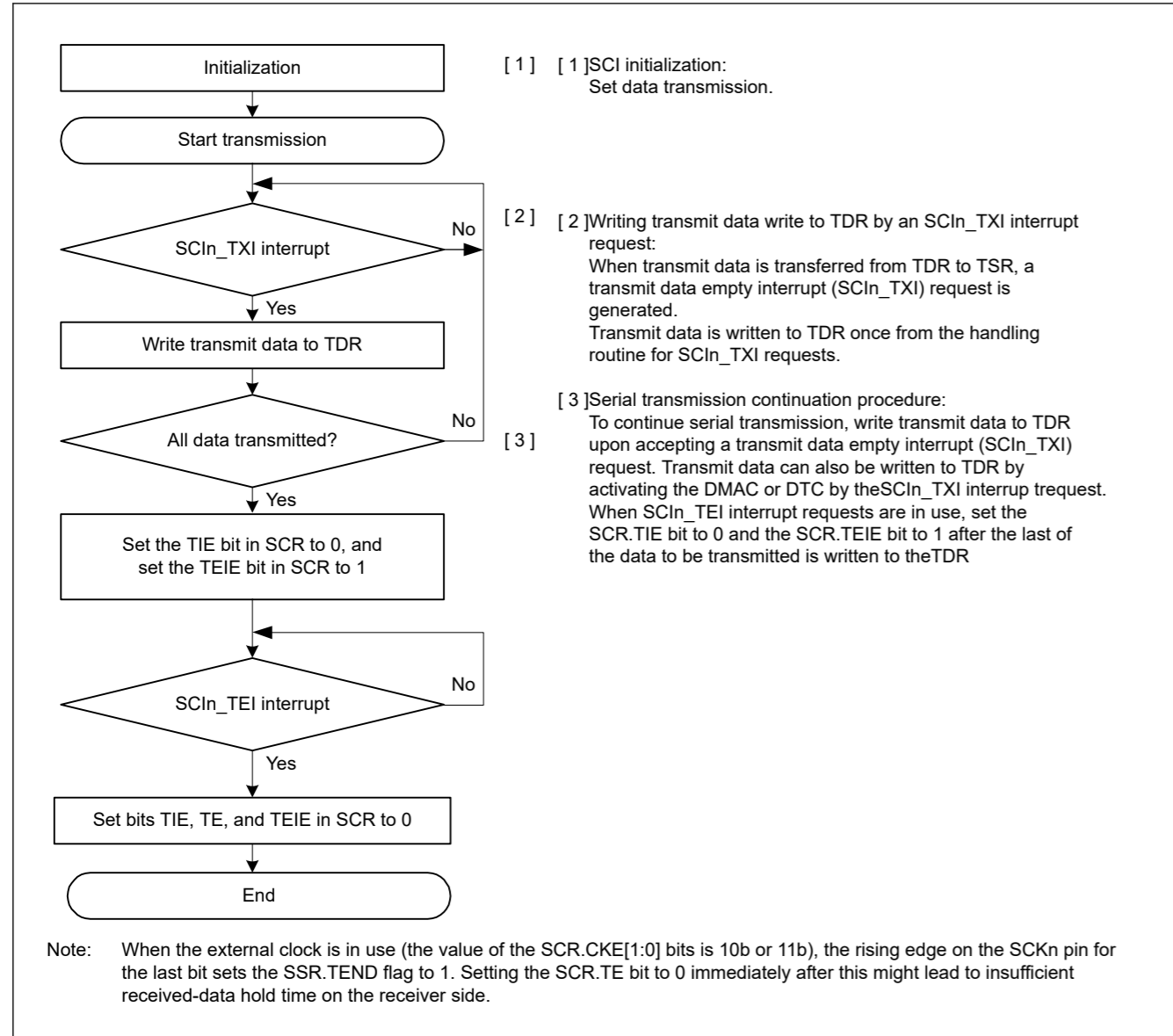


Figure 27.69 Example flow of serial transmission in clock synchronous mode with non-FIFO selected

(2) FIFO selected

Figure 27.70 shows an example of serial transmission in clock synchronous mode with FIFO selected.

In serial data transmission, the SCI operates as follows:

1. The SCI transfers data from the FTDRL\*1 register to the TSR register when data is written to FTDRL\*1 in the SCIn\_TXI interrupt handling routine. The amount of data that can be written to FTDRL is 16 minus FDR.T[4:0] bytes. The SCIn\_TXI interrupt request at the beginning of transmission is generated when the SCR.TE bit is set to 1 but only after the SCR.TIE bit is also set to 1 or when these two bits are set to 1 simultaneously by a single instruction.
2. After transferring data from FTDRL to TSR, the SCI starts transmission. When the amount of transmit data written in FTDRL is equal to or less than the specified transmit triggering number, the SSR\_FIFO.TDFE is set to 1. When the SCR.TIE bit is set to 1, an SCIn\_TXI interrupt request is generated. Continuous transmission is enabled by writing the next transmit data to FTDRL in the SCIn\_TXI interrupt handling routine before transmission of the current transmit data has finished. When SCIn\_TEI interrupt requests are in use, set the SCR.TIE bit to 0 and the SCR.TEIE bit to 1 after the last of the data to be transmitted is written to the FTDRL from the handling routine for SCIn\_TXI requests.
3. 8-bit data is sent from the TXDn pin in synchronization with the output clock when the clock output mode is specified and in synchronization with the input clock when the use of an external clock is specified. Output of the clock signal is suspended until the input CTS signal is low when the SPMR.CTSE bit is 1.
4. The SCI checks whether non-transmitted data remains in FTDRL on output of the stop bit.

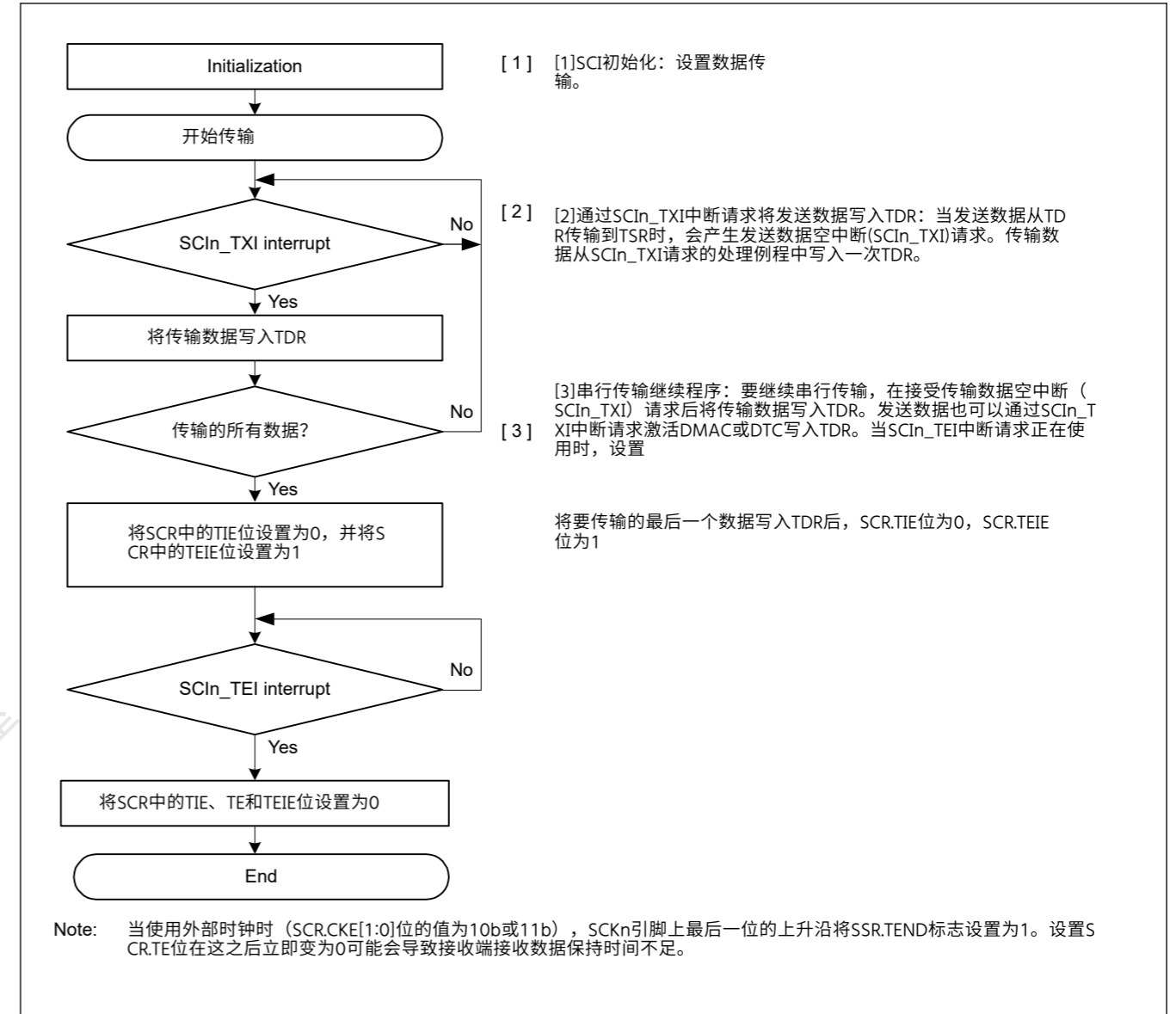


Figure 27.69 选择非FIFO的时钟同步模式下的串行传输示例流程

(2)选择FIFO图27.70显示了在时钟同步模式下选择FIFO的串行传输示例。

在串行数据传输中，SCI操作如下：

- 1.当数据写入FTDRL\*1时，SCI将数据从FTDRL\*1寄存器传输到TSR寄存器  
SCIn\_TXI中断处理程序。可写入FTDRL的数据量为16减去FDR.T[4:0]字节。发送开始时的SCIn\_TXI中断请求在SCR.TE位设置为1时产生，但仅在SCR.TIE位也设置为1或当这两个位通过一条指令同时设置为1时产生。
- 2.将数据从FTDRL传输到TSR后，SCI开始传输。当写入FTDRL的发送数据量等于或小于指定的发送触发数时，SSR\_FIFO.TDFE设置为1。当  
SCR.TIE位设置为1，产生SCIn\_TXI中断请求。在当前发送数据的发送完成之前，通过在SCIn\_TXI中断处理例程中将下一个发送数据写入FTDRL来启用连续发送。当使用SCIn\_TEI中断请求时，在SCIn\_TXI请求的处理例程中将要发送的最后一个数据写入FTDRL后，将SCR.TIE位设置为0，并将SCR.TEIE位设置为1。
- 3.指定时钟输出模式时，与输出时钟同步，指定使用外部时钟时，与输入时钟同步，从TXDn引脚发送8位数据。当SPMR.CTSE位为1时，时钟信号的输出被暂停，直到输入CTS信号为低电平。
- 4.SCI在停止位输出时检查未传输的数据是否保留在FTDRL中。

- When FTDRL is updated, the next transmit data is transferred from FTDRL to TSR and serial transmission of the next frame starts.
- If FTDRL is not updated, the SSR\_FIFO.TEND flag is set to 1. The TXDn pin retains the output state of the last bit. If the SCR.TEIE bit is 1, an SCIn\_TEI interrupt request is generated and the SCKn pin is held high.

Note 1. In clock synchronous mode, FTDRH is not used.

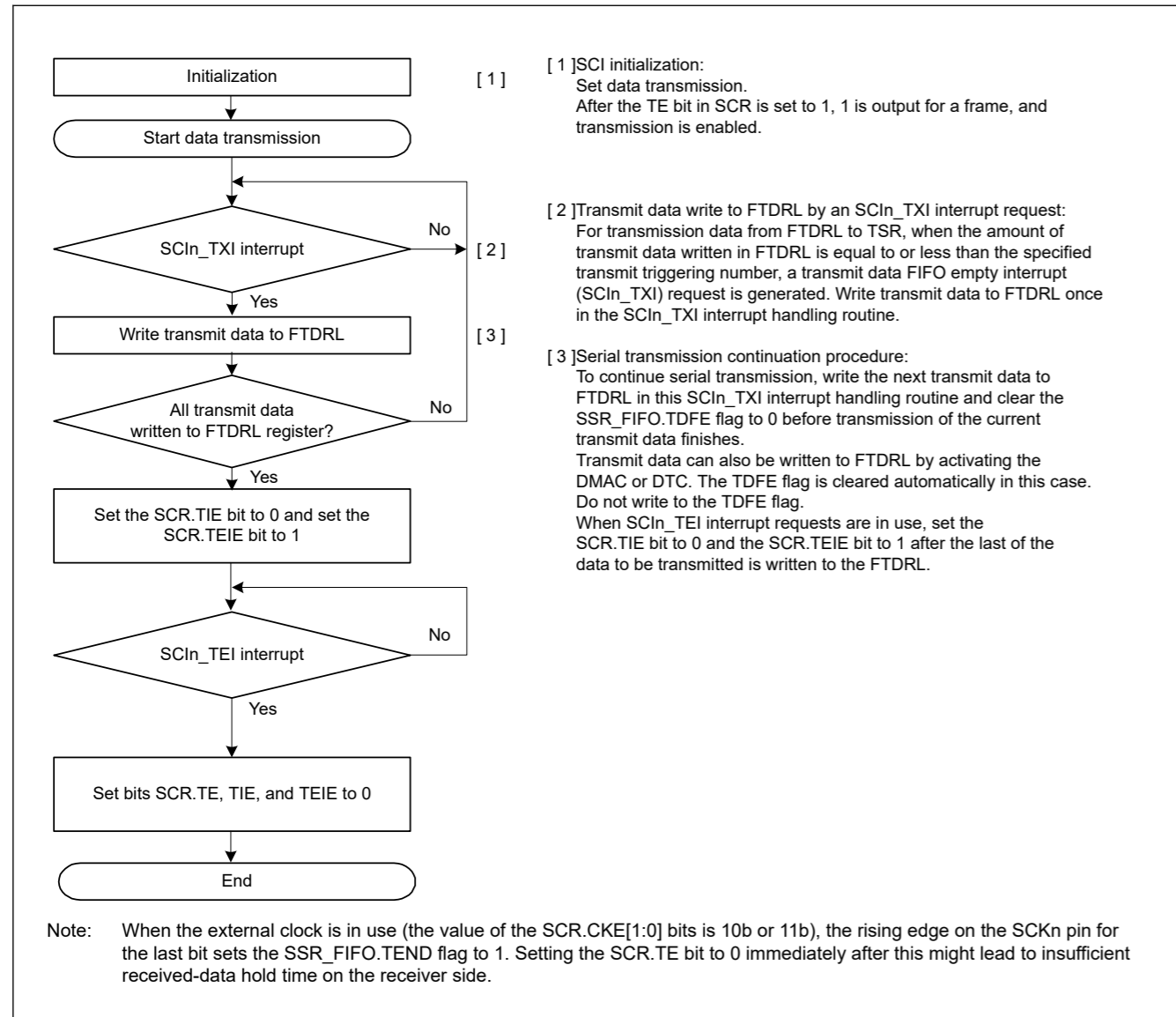


Figure 27.70 Example flow of serial transmission in clock synchronous mode with FIFO selected

### 27.6.5 Serial Data Reception in Clock Synchronous Mode

(1) Non-FIFO selected

Figure 27.71 and Figure 27.72 show examples of SCI operation for serial reception in clock synchronous mode.

In serial data reception, the SCI operates as follows:

- When the value of the SCR.RE bit becomes 1, the CTSn\_RTsn pin goes low.
- The SCI performs internal initialization and starts receiving data in synchronization with a synchronization clock input or output, and stores the receive data in the RSR register.
- If an overrun error occurs, the SSR.ORER flag is set to 1. If the SCR.RIE bit is 1, an SCIn\_ERI interrupt request is generated. Receive data is not transferred to the RDR register.

- 当FTDRL更新时，下一个传输数据从FTDRL传输到TSR并开始下一帧的串行传输。
- 如果FTDRL未更新，则SSR\_FIFO.TEND标志设置为1。TXDn引脚保持最后一位的输出状态。如果SCR.TEIE位为1，则产生SCIn\_TEI中断请求并且SCKn引脚保持高电平。

注1.在时钟同步模式下，不使用FTDRH。

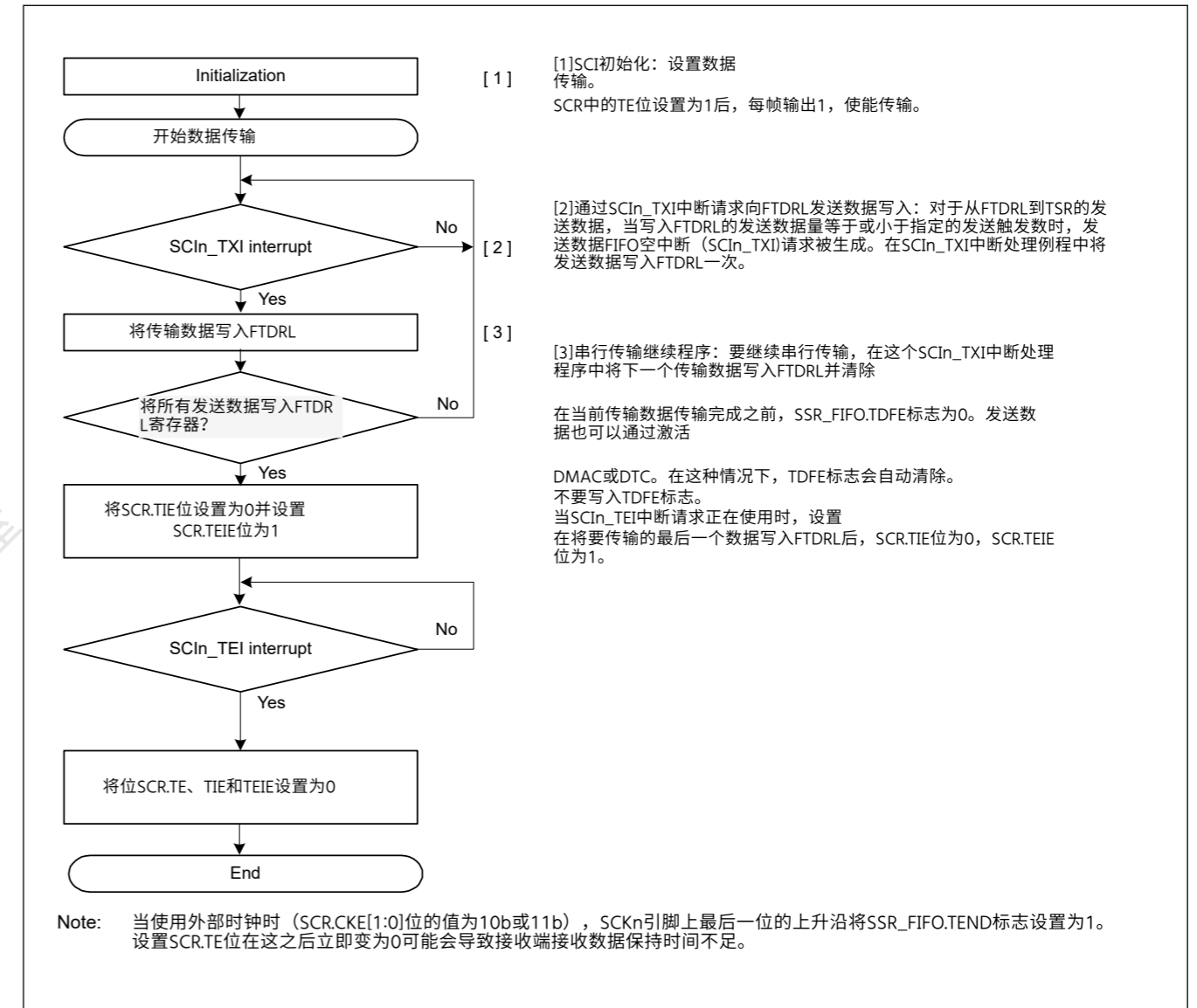


Figure 27.70 选择FIFO的时钟同步模式下的串行传输示例流程

### 27.6.5 时钟同步模式下的串行数据接收

(1) Non-FIFO selected

图27.71和图27.72显示了时钟同步模式下串行接收的SCI操作示例。

在串行数据接收中，SCI操作如下：

- 当SCR.RE位的值变为1时，CTSn\_RTsn引脚变为低电平。
- SCI执行内部初始化，并与同步时钟输入或输出同步开始接收数据，并将接收数据存储存储在RSR寄存器中。
- 如果发生溢出错误，则SSR.ORER标志设置为1。如果SCR.RIE位为1，则产生SCIn\_ERI中断请求。接收数据不传送到RDR寄存器。



4. When reception completes successfully, receive data is transferred to the RDR register. If the SCR.RIE bit is 1, an SCIn\_RXI interrupt request is generated. Continuous reception is enabled by reading the received data transferred to the RDR register in the SCIn\_RXI interrupt handling routine before reception of the next receive data completes. Reading the received data that is transferred to RDR causes the CTSn\_RTSn pin to output low.

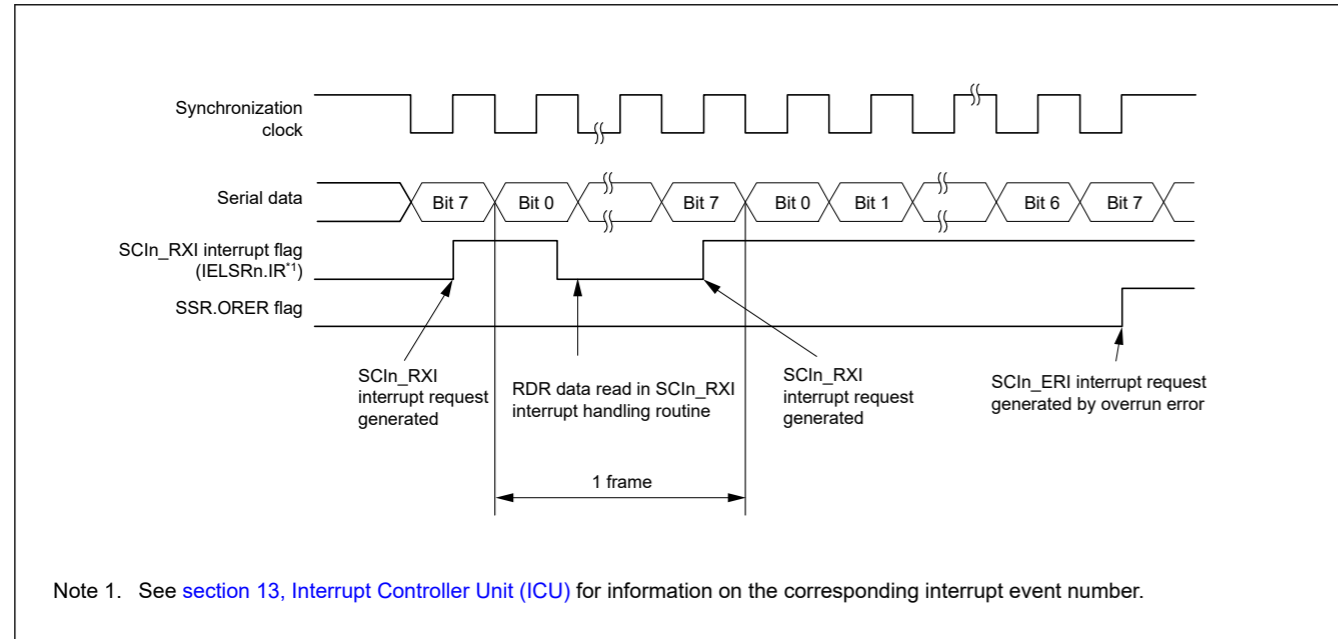


Figure 27.71 Example operation for serial reception in clock synchronous mode (1) when the RTS function is not used

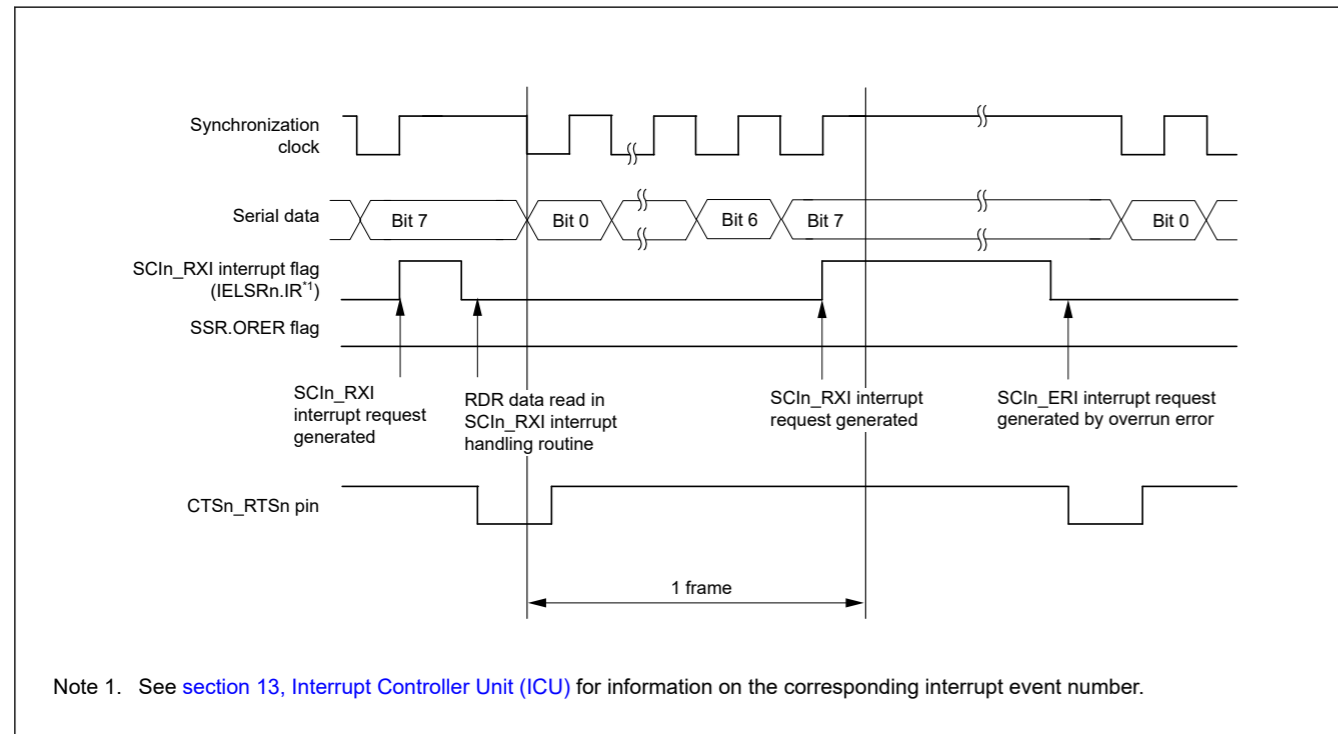


Figure 27.72 Example operation for serial reception in clock synchronous mode (2) when RTS function is used

Data transfer cannot resume while the receive error flag is 1. Therefore, clear the ORER, FER, and PER flags in the SSR register to 0 before resuming data reception. Additionally, always read the RDR register during overrun error processing. When a data reception is forced to terminate by a 0 write to the SCR.RE bit during operation, read the RDR register because received data that is not yet read might be left in the RDR register.

- 4.当接收成功完成时，接收数据被传送到RDR寄存器。如果SCR.RIE位为1，则SCIn\_RXI中断请求产生。连续接收是通过读取接收到的数据传输到RDR寄存器在接收下一个接收数据完成之前，SCIn\_RXI中断处理程序中的RDR寄存器。读取传输到RDR的接收数据会导致CTS<sub>n</sub>RTSn引脚输出低电平。

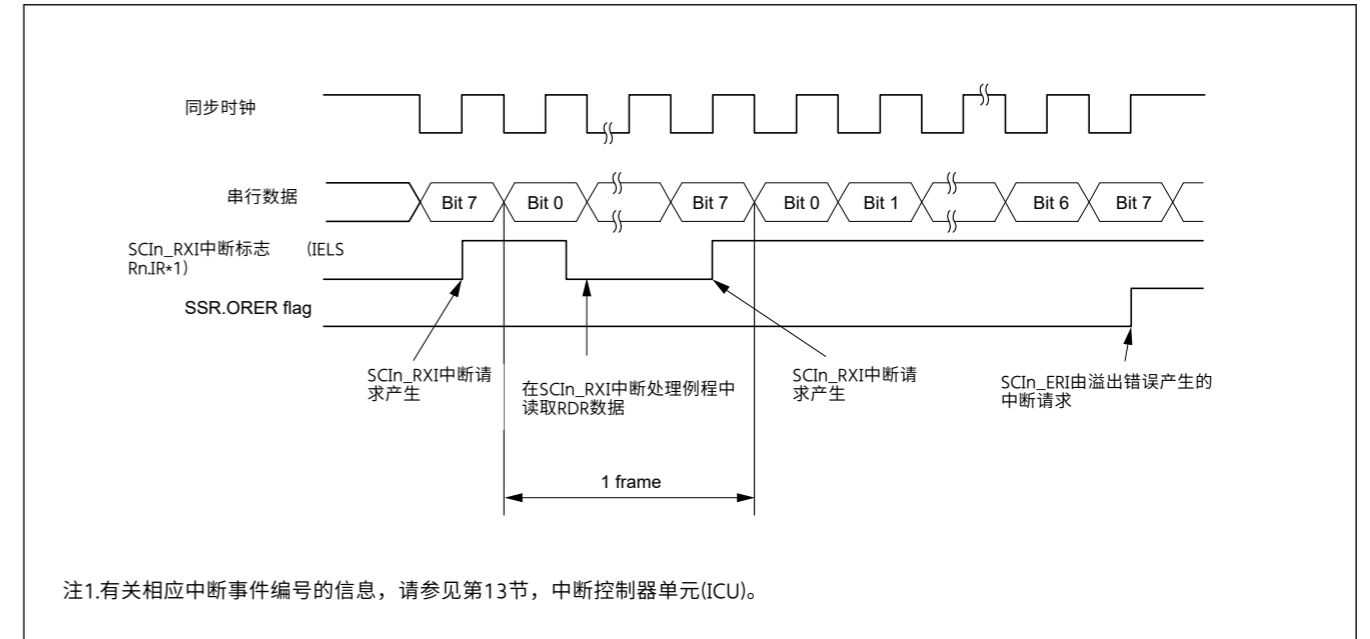


Figure 27.71 不使用RTS功能时时钟同步模式下串行接收的示例操作(1)

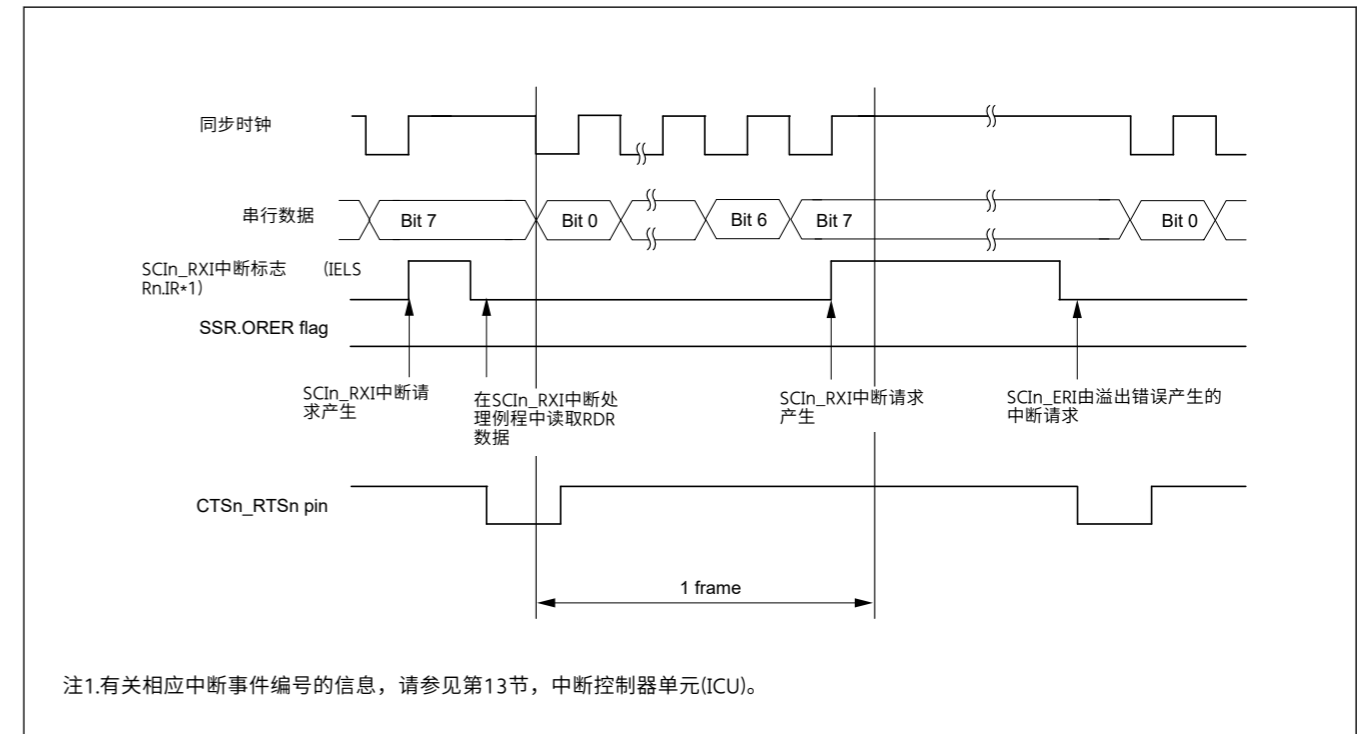


Figure 27.72 使用RTS功能时时钟同步模式下串行接收的示例操作(2)

接收错误标志为1时无法恢复数据传输。因此，在恢复数据接收之前，将SSR寄存器中的ORER、FER和PER标志清除为0。此外，在溢出错误处理期间始终读取RDR寄存器。如果在操作期间通过向SCR.RE位写入0来强制终止数据接收，请读取RDR寄存器，因为尚未读取的已接收数据可能会留在RDR寄存器中。

Figure 27.73 shows an example flow of serial data reception.

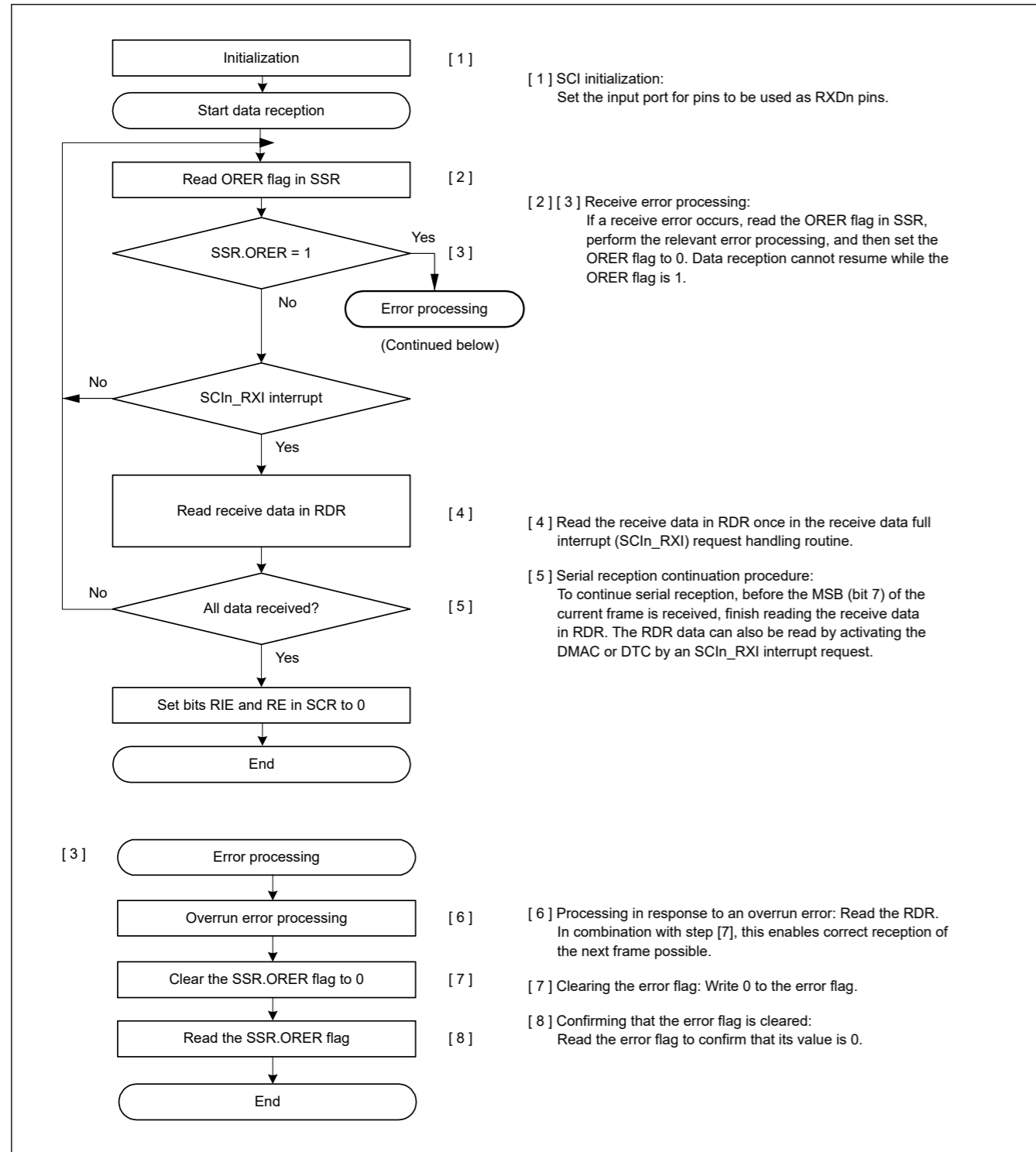


Figure 27.73 Example flow of serial reception in clock synchronous mode with non-FIFO selected

(2) FIFO selected

Figure 27.74 shows an example of serial reception in clock synchronous mode with FIFO selected.

In serial data reception, the SCI operates as follows:

1. When the value of the SCR.RE bit becomes 1, the CTSn\_RTSn pin goes low.
2. The SCI performs internal initialization and starts receiving data in synchronization with a synchronization clock input or output, and stores the receive data in the RSR register.

图27.73显示了串行数据接收的示例流程。

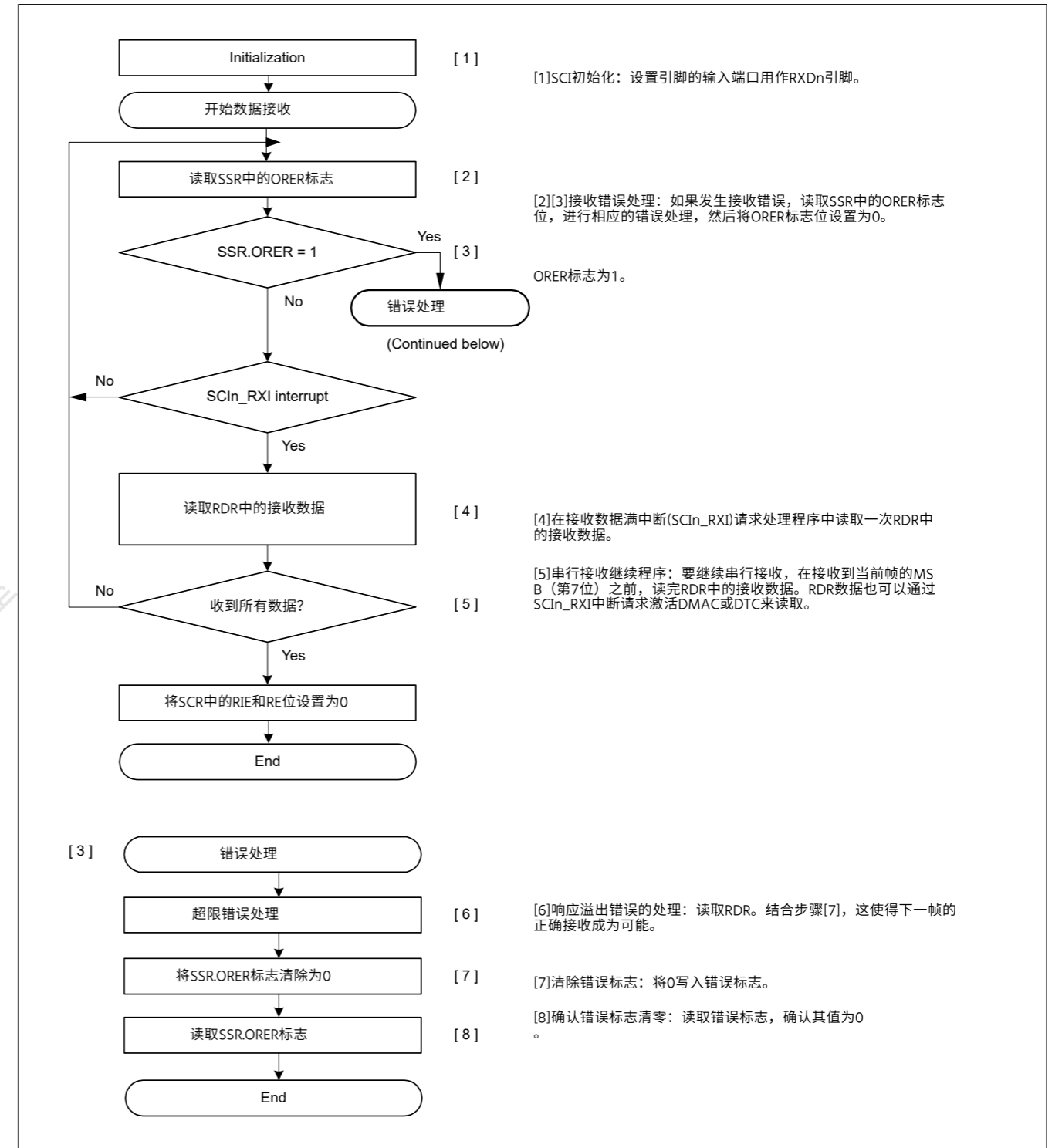


Figure 27.73 选择非FIFO的时钟同步模式下的串行接收示例流程

(2)选择FIFO图27.74显示了在时钟同步模式下选择FIFO的串行接收示例。

在串行数据接收中，SCI操作如下：

- 1.当SCR.RE位的值变为1时，CTSn\_RTSn引脚变为低电平。
- 2.SCI执行内部初始化，并与同步时钟输入或输出同步开始接收数据，并将接收数据存储在RSR寄存器中。

3. If an overrun error occurs, the SSR\_FIFO.Over flag is set to 1. If the SCR.RIE bit is 1, an SCIn\_ERI interrupt request is generated. Received data is not transferred to the FRDRL\*1 register.
4. When data reception completes successfully, the receive data is transferred to the FRDRL\*1 register. The RDF flag is set to 1 when the amount of the receive data stored in FRDRL is equal to or greater than the specified receive triggering number. If the SCR.RIE bit is 1, an SCIn\_RXI interrupt request is generated. Continuous data reception is enabled by reading the receive data transferred to FRDRL\*2 in the SCIn\_RXI interrupt handling routine before an overrun error occurs. If the amount of received data that is transferred to FRDRL is less than the RTS trigger number, the CTSn\_RTsn pin goes low.

Note 1. In clock synchronous mode, FRDRH is not used.

Note 2. Read data in order from FRDRH to FRDRL when RDF and ORER are read with receive data.

- 3.如果发生溢出错误,则SSR\_FIFO.Over标志设置为1。如果SCR.RIE位为1,则产生SCIn\_ERI中断请求。接收到的数据不传送到FRDRL\*1寄存器。
- 4.当数据接收成功完成时,接收数据被传送到FRDRL\*1寄存器。当存储在FRDRL中的接收数据量等于或大于指定的接收触发数时,RDF标志设置为1。如果SCR.RIE位为1,则产生SCIn\_RXI中断请求。在发生溢出错误之前,通过在SCIn\_RXI中断处理程序中读取传输到FRDRL\*2的接收数据来启用连续数据接收。如果传输到FRDRL的接收数据量小于RTS触发数,则CTSn\_RTsn引脚变为低电平。

注1.在时钟同步模式下,不使用FRDRH。

注2.RDF和ORER与接收数据一起读取时,按FRDRH到FRDRL的顺序读取数据。

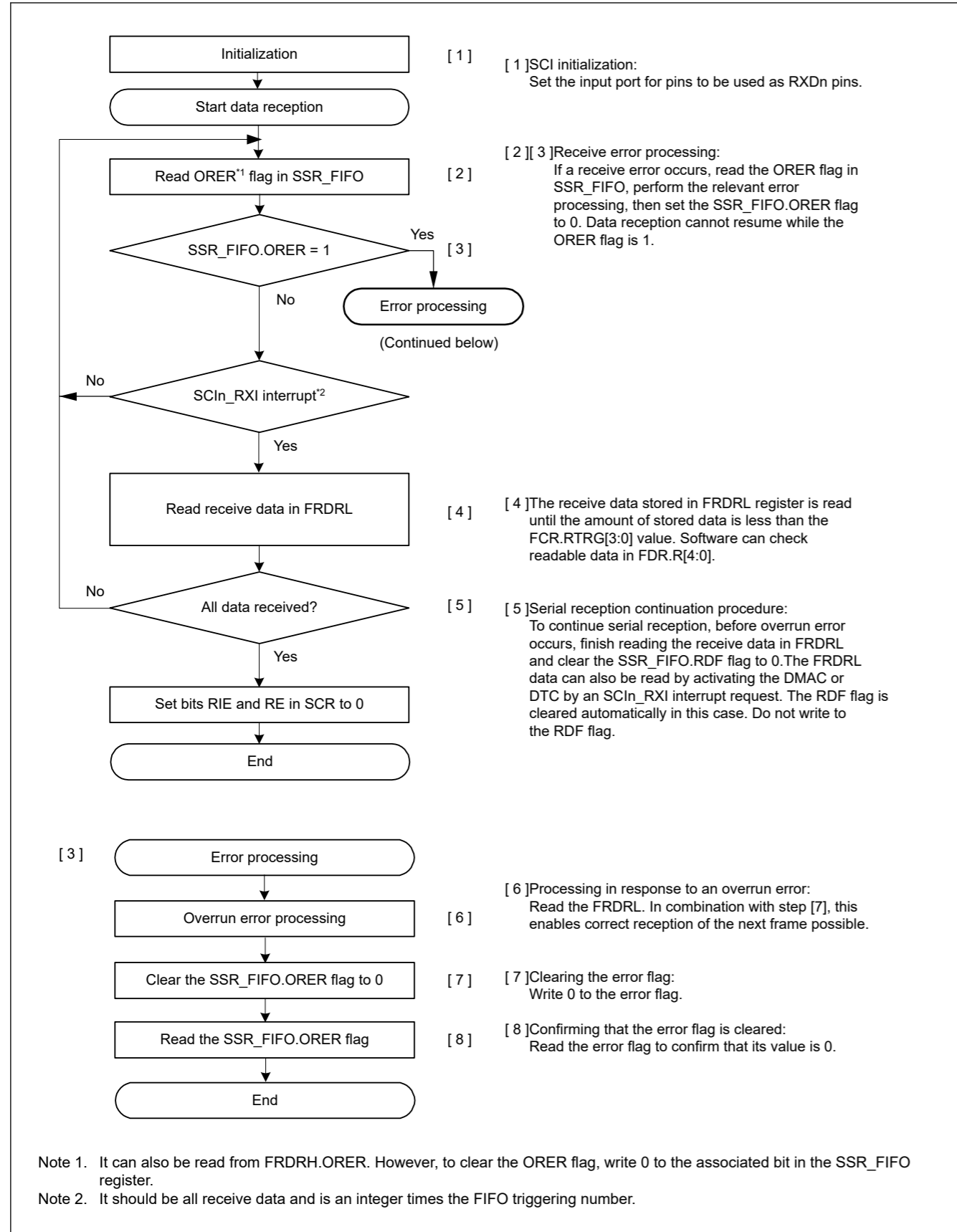


Figure 27.74 Example flow of serial reception in clock synchronous mode with FIFO selected

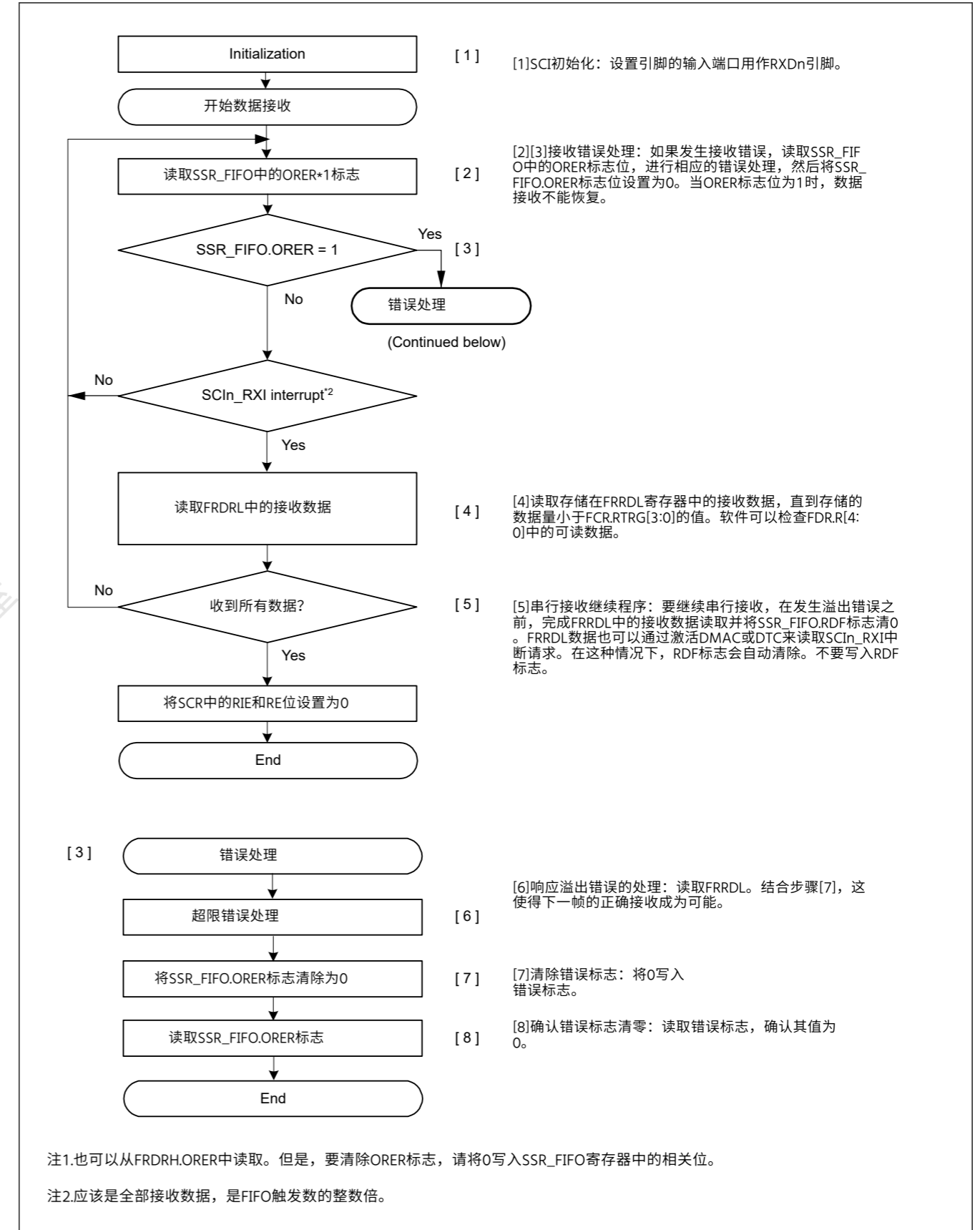


Figure 27.74 选择FIFO的时钟同步模式下的串行接收示例流程



### 27.6.6 Simultaneous Serial Data Transmission and Reception in Clock Synchronous Mode

(1) Non-FIFO selected

Figure 27.75 shows an example flow of simultaneous serial transmit and receive operations in clock synchronous mode. After initializing the SCI, use the following procedure for simultaneous serial data transmit and receive operations.

To switch from transmit mode to simultaneous transmit and receive mode:

1. Check that the SCI completes the data transmission by verifying that the SSR.TEND flag is set to 1.
2. Initialize the SCR register, and then set the TIE, RIE, TE, and RE bits in the SCR register to 1 simultaneously by a single instruction.

To switch from receive mode to simultaneous transmit and receive mode:

1. Check that the SCI completes the data reception.
2. Set the RIE and RE bits to 0, and then check that the receive error flag ORER in the SSR register is 0.
3. Set the TIE, RIE, TE, and RE bits in the SCR register to 1 simultaneously by a single instruction.

### 27.6.6 时钟同步的同时串行数据发送和接收 Mode

(1) Non-FIFO selected

图27.75显示了时钟同步模式下同时串行发送和接收操作的示例流程。初始化SCI后，使用以下程序同时进行串行数据发送和接收操作。

从发送模式切换到同时发送和接收模式：

- 1.通过验证SSR.TEND标志是否设置为1来检查SCI是否完成数据传输。
- 2.初始化SCR寄存器，然后通过一条指令同时将SCR寄存器中的TIE、RIE、TE和RE位设置为1。

从接收模式切换到同时发送和接收模式：

- 1.检查SCI是否完成数据接收。
- 2.将RIE和RE位设置为0，然后检查SSR寄存器中的接收错误标志ORER是否为0。
- 3.通过一条指令同时将SCR寄存器中的TIE、RIE、TE和RE位设置为1。

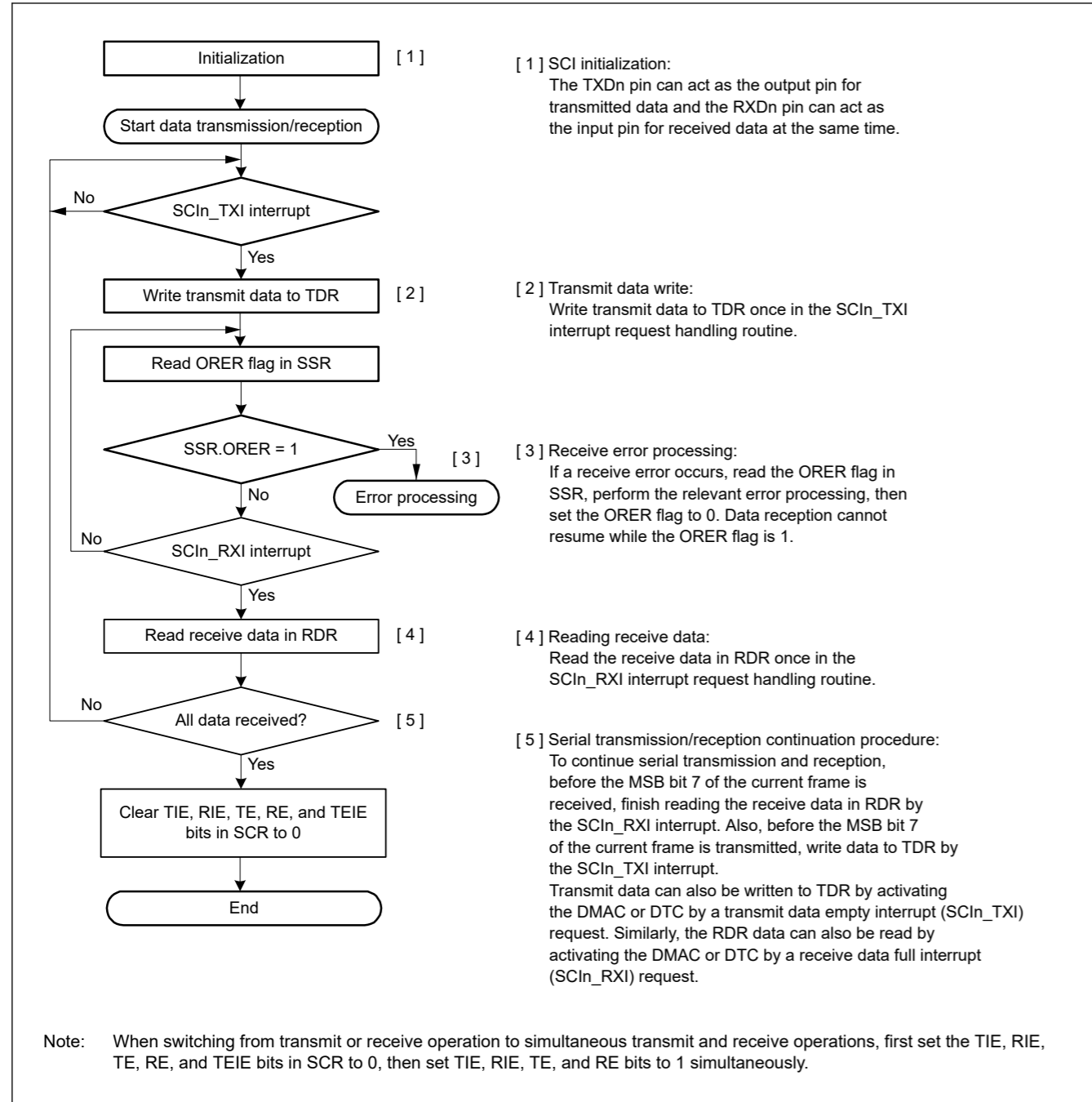


Figure 27.75 Example flow of simultaneous serial transmission and reception in clock synchronous mode with non-FIFO selected

(2) FIFO selected

Figure 27.76 shows an example flow of simultaneous serial transmit and receive operations in clock synchronous mode with FIFO selected.

After initializing the SCI, use the following procedure for simultaneous serial data transmit and receive operations.

To switch from transmit mode to simultaneous transmit and receive mode:

1. Check that the SCI completes the transmission by verifying that the SSR\_FIFO.TEND flag is set to 1.
2. Initialize the SCR register, then set the TIE, RIE, TE, and RE bits in the SCR register to 1 simultaneously by a single instruction.

To switch from receive mode to simultaneous transmit and receive mode:

1. Check that the SCI completes the reception.

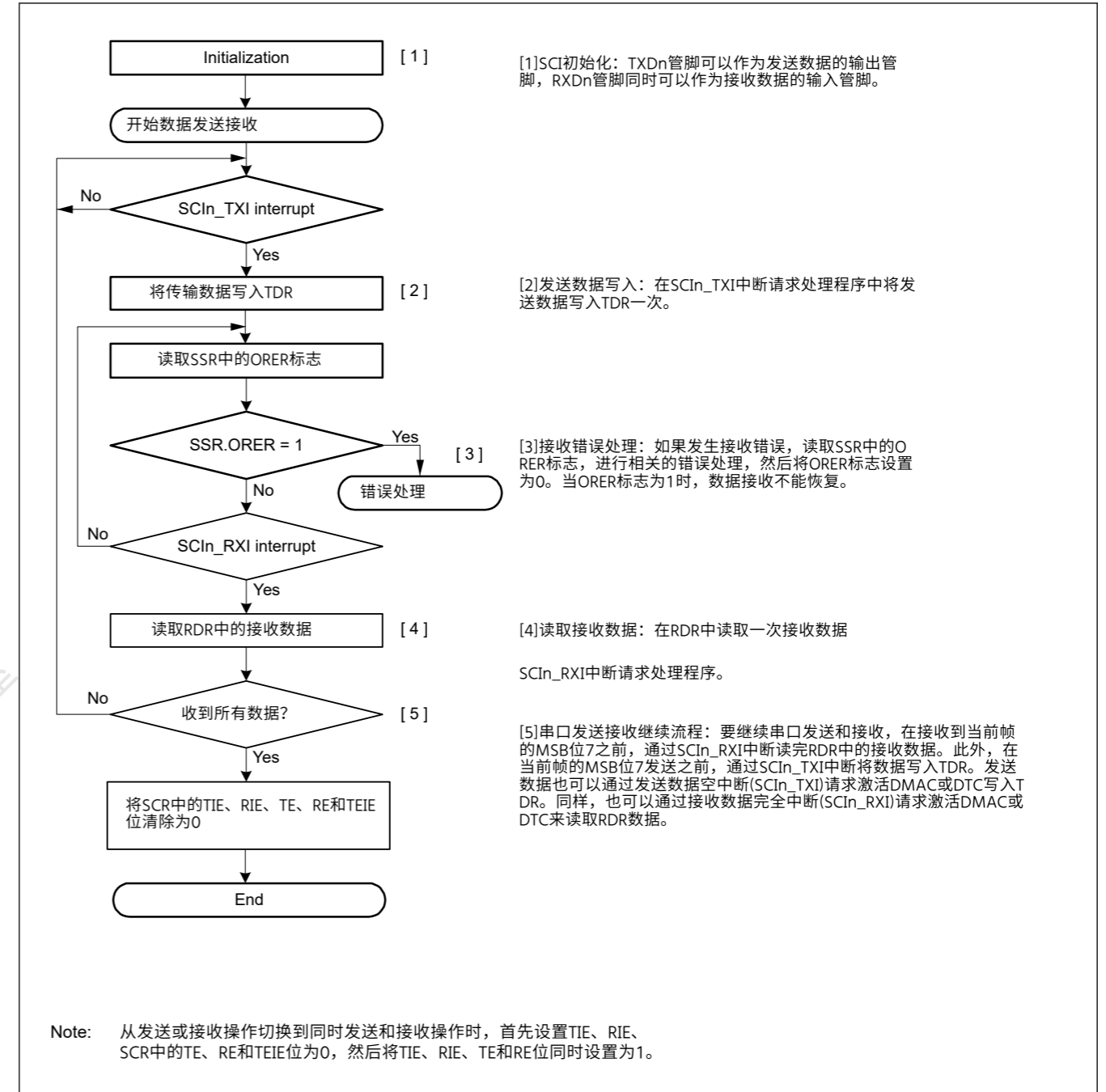


Figure 27.75 选择非FIFO的时钟同步模式下同时串行发送和接收的示例流程

(2) FIFO selected

图27.76显示了在时钟同步模式下同时串行发送和接收操作的示例流程, 其中FIFO selected.

初始化SCI后, 使用以下程序同时进行串行数据发送和接收操作。

从发送模式切换到同时发送和接收模式:

- 1.通过验证SSR\_FIFO.TEND标志设置为1来检查SCI是否完成传输。
- 2.初始化SCR寄存器, 然后通过一条指令同时将SCR寄存器中的TIE、RIE、TE和RE位设置为1。

从接收模式切换到同时发送和接收模式:

- 1.检查SCI是否完成接收。

- Set the RIE and RE bits to 0.
- Check that the receive error flags ORER in the SSR\_FIFO register are 0, and then set the TIE, RIE, TE, and RE bits in the SCR register to 1 simultaneously by a single instruction.

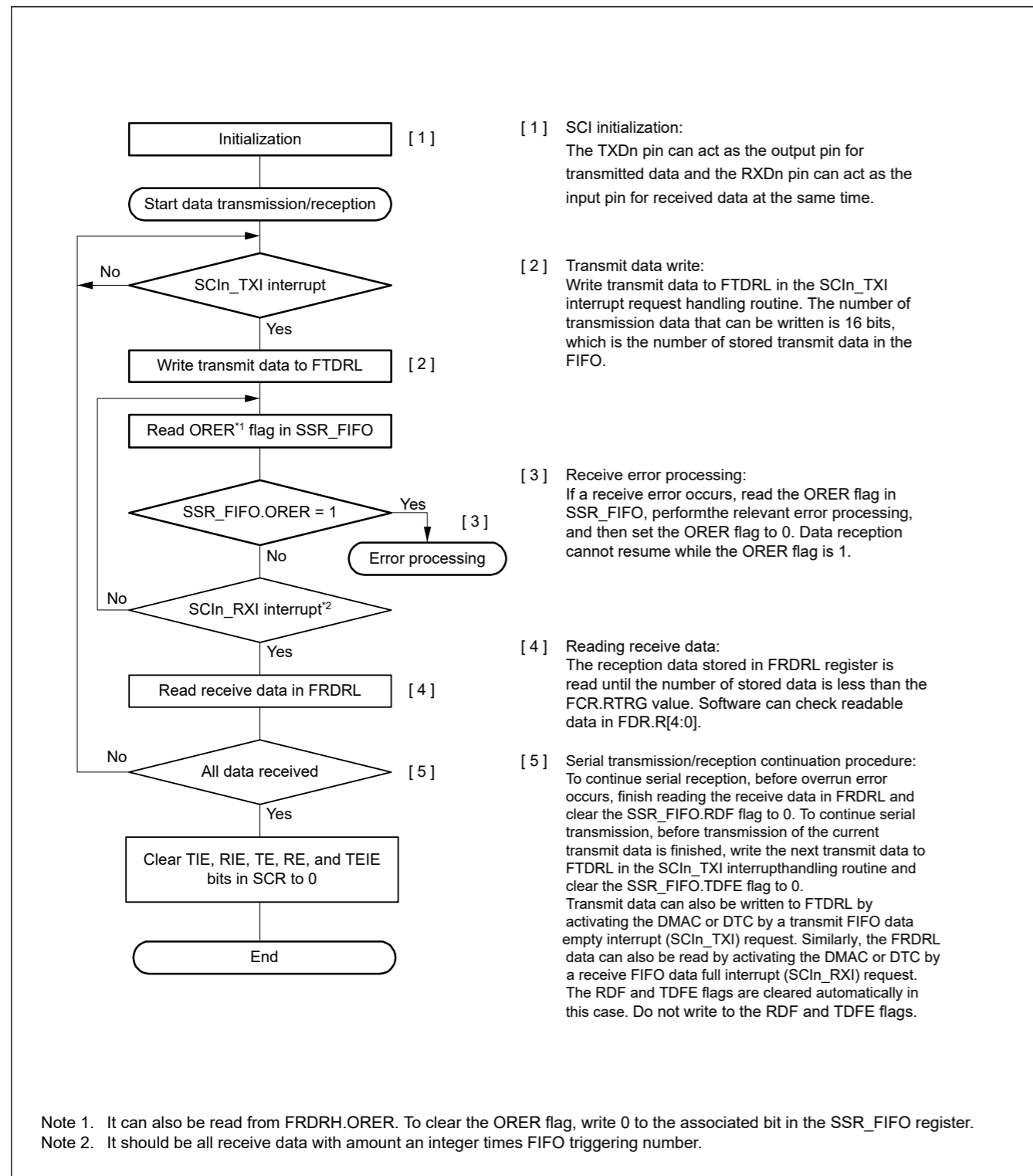


Figure 27.76 Example flow of simultaneous serial transmission and reception in clock synchronous mode with FIFO selected

- 将RIE和RE位设置为0。
- 检查SSR\_FIFO寄存器中的接收错误标志ORER是否为0，然后通过一条指令将SCR寄存器中的TIE、RIE、TE和RE位同时设置为1。

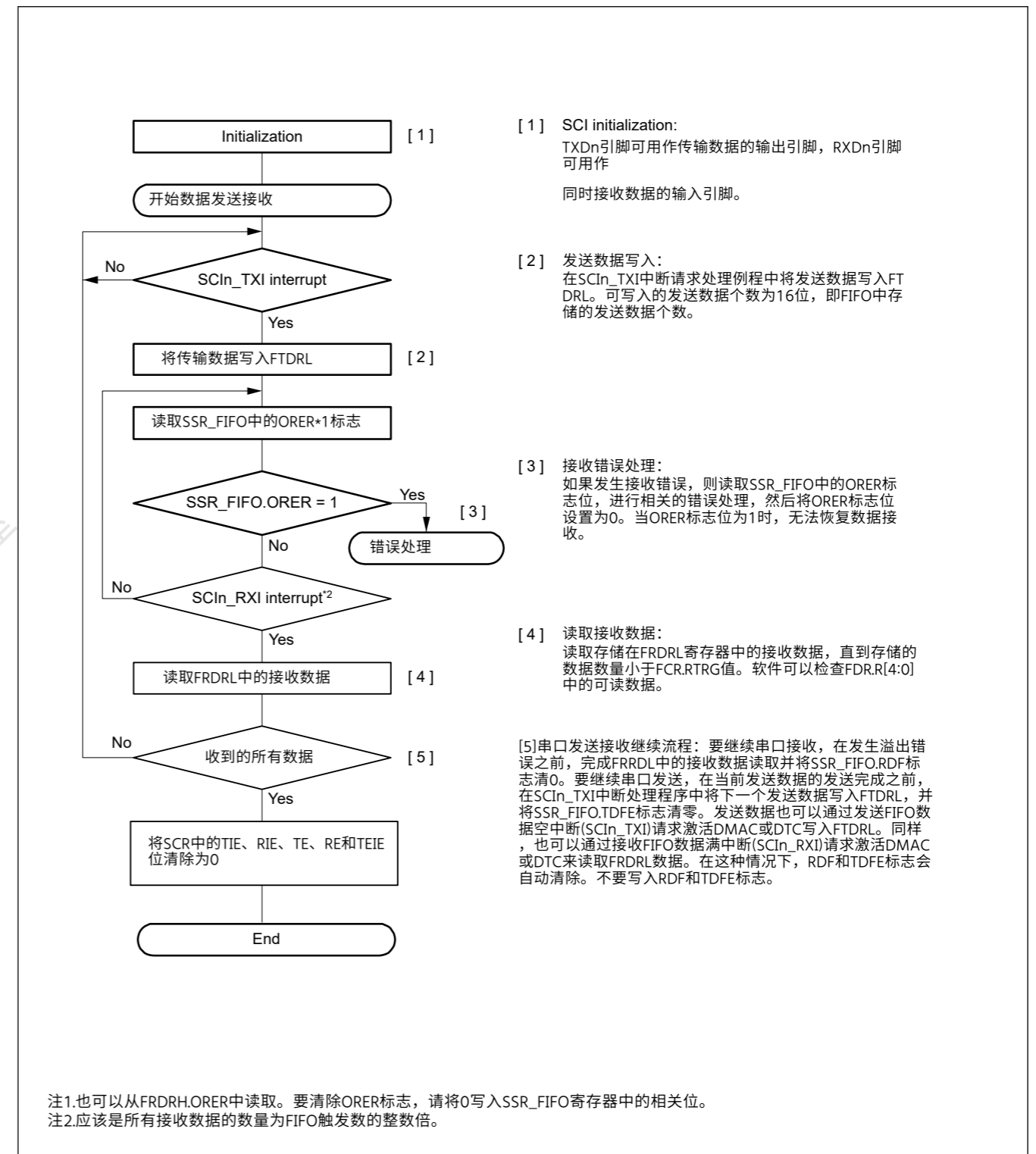


Figure 27.76 选择FIFO的时钟同步模式下同时串行发送和接收的示例流程

## 27.7 Operation in Smart Card Interface Mode

The SCI supports smart card (IC card) interfaces conforming to ISO/IEC 7816-3 (standard for Identification Cards), as an extended function of the SCI.

Smart card interface mode can be selected using the appropriate register.

### 27.7.1 Example Connection

Figure 27.77 shows an example connection between a smart card (IC card) and the MCU. As shown in Figure 27.77, because the MCU communicates with an IC card using a single transmission line, interconnect the TXDn and RXDn pins and pull up the data transmission line to VCC using a resistor.

Setting the SCR\_SMCI.TE and SCR\_SMCI.RE bits to 1 with an IC card disconnected enables closed-loop transmission or reception, allowing self-diagnosis. To supply an IC card with the clock pulses generated by the SCI, input the SCKn pin output to the CLK pin of an IC card.

An output port of the MCU can be used to output a reset signal.

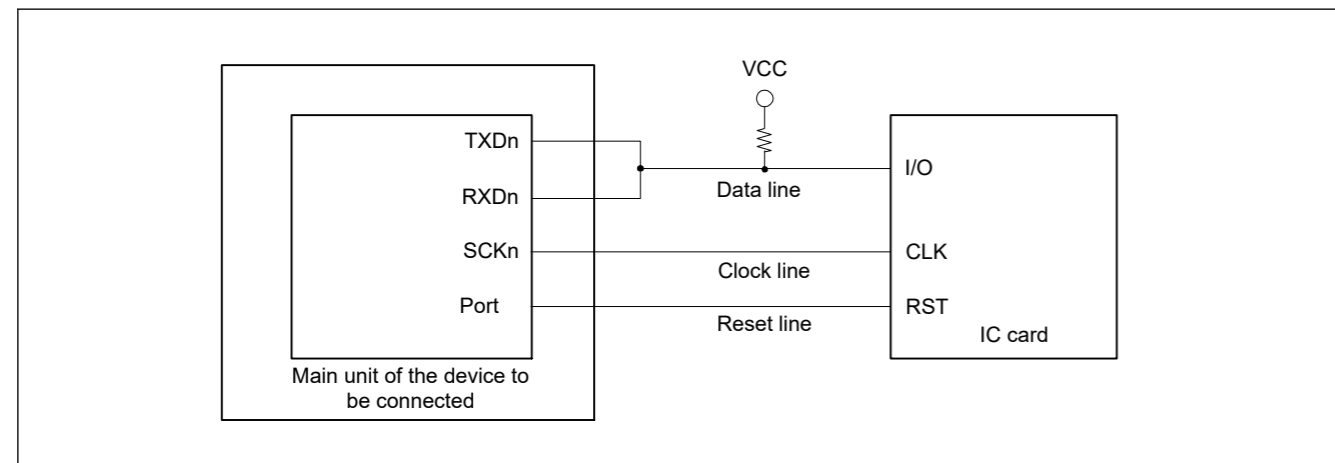


Figure 27.77 Example connection with a smart card (IC card)

### 27.7.2 Data Format (Except in Block Transfer Mode)

Figure 27.78 shows the data transfer formats in smart card interface mode:

- One frame consists of 8-bit data and a parity bit in asynchronous mode.
- During transmission, at least 2 ETUs (elementary time unit – the time required for transferring 1 bit) is set as a guard time from the end of the parity bit until the start of the next frame.
- If a parity error is detected during reception, a low error signal is output for 1 ETU after 10.5 ETUs elapse from the start bit.
- If an error signal is sampled during transmission, the same data is automatically retransmitted after at least 2 ETUs.

## 27.7 智能卡接口模式下的操作

SCI支持符合ISO/IEC7816-3（识别卡标准）的智能卡（IC卡）接口，作为SCI的扩展功能。

可以使用适当的寄存器选择智能卡接口模式。

### 27.7.1 示例连接

图27.77显示了智能卡（IC卡）和MCU之间的示例连接。如图27.77所示，由于MCU使用单条传输线与IC卡通信，因此将TXDn和RXDn引脚互连，并使用电阻将数据传输线上拉到VCC。

在断开IC卡的情况下将SCR\_SMCI.TE和SCR\_SMCI.RE位设置为1可启用闭环发送或接收，从而实现自诊断。要将SCI产生的时钟脉冲提供给IC卡，请将SCKn引脚输出输入到IC卡的CLK引脚。

MCU的输出端口可用于输出复位信号。

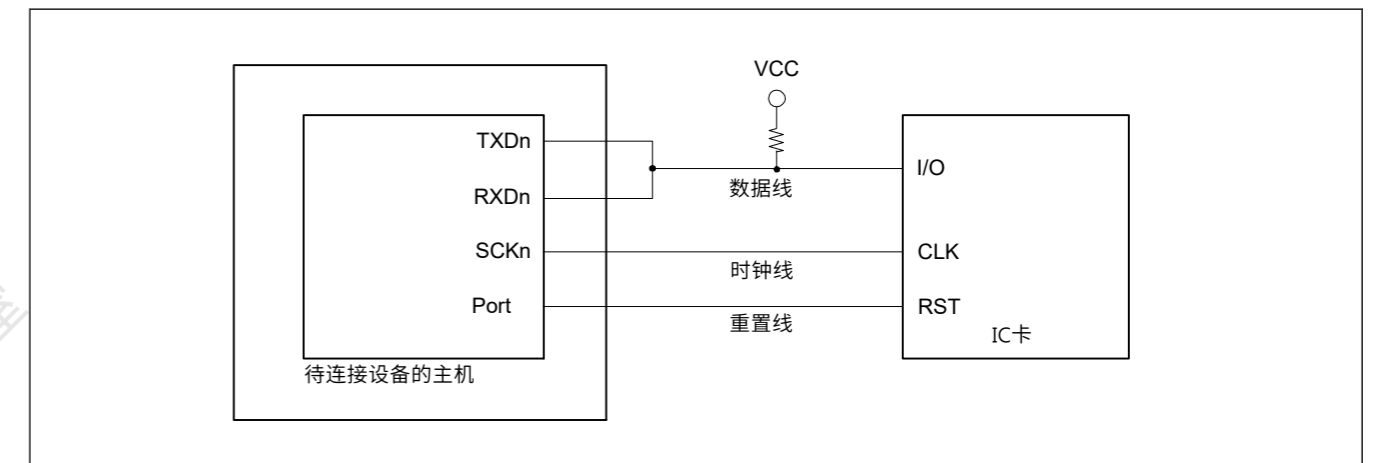


Figure 27.77 与智能卡（IC卡）的连接示例

### 27.7.2 数据格式（块传输模式除外）

图27.78显示了智能卡接口模式下的数据传输格式：

- 一帧由8位数据和一个异步模式的奇偶校验位组成。
- 在传输过程中，至少设置2个ETU（基本时间单位——传输1位所需的时间）作为从奇偶校验位结束到下一帧开始的保护时间。
- 如果在接收过程中检测到奇偶校验错误，则在从起始位经过10.5ETU后输出1ETU的低错误信号。
- 如果在传输过程中对错误信号进行采样，相同的数据会在至少2个ETU后自动重传。



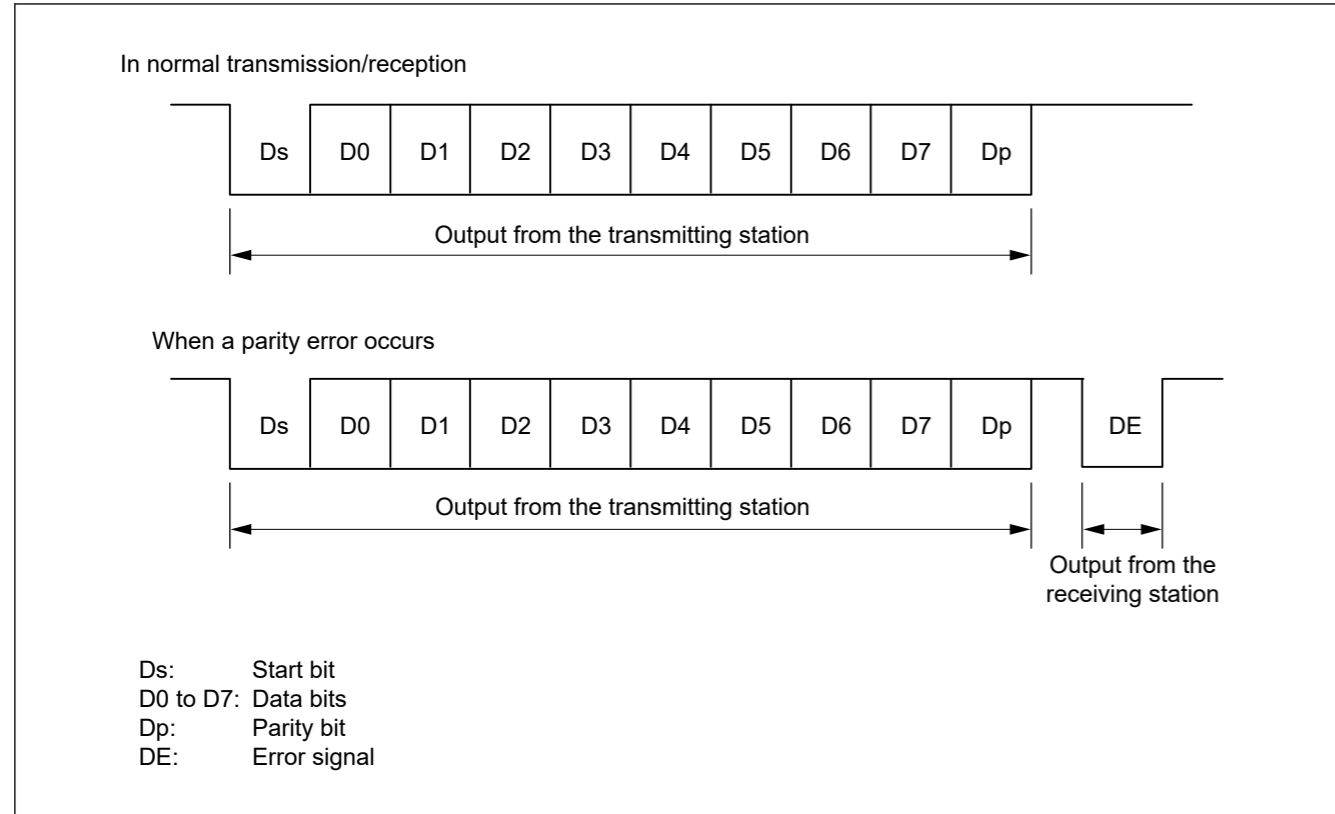


Figure 27.78 Data formats in smart card interface mode

For communications with IC cards of the direct convention type and inverse convention type, follow the procedures in this section.

(1) Direct Convention Type

For the direct convention type, logic levels 1 and 0 indicate the Z and A states, respectively, and data is transferred with LSB-first for the start character, as shown in Figure 27.79. Therefore, data in the start character in the figure is 0x3B.

When using the direct convention type, write 0 to both the SCMR.SDIR and SCMR.SINV bits. Write 0 to the SMR\_SMCI.PM bit to use even parity, which is prescribed by the smart card standard.

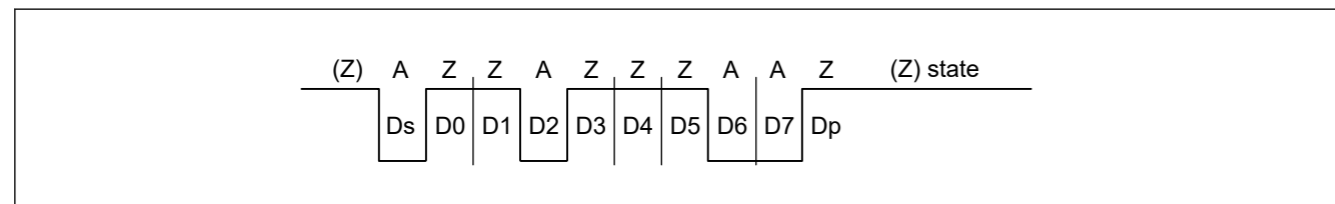


Figure 27.79 Direct convention with SDIR in SCMR = 0, SINV in SCMR = 0, and PM in SMR\_SMCI = 0

(2) Inverse Convention Type

For the inverse convention type, logic levels 1 and 0 indicate the A and Z states, respectively, and data is transferred with MSB-first for the start character, as shown in Figure 27.80. Therefore, data in the start character in the figure is 0x3F.

When using the inverse convention type, write 1 to both the SCMR.SDIR and SCMR.SINV bits. The parity bit is logic level 0 to produce even parity, which is prescribed by the smart card standard, and corresponds to the Z state. Because the SINV bit of the MCU only inverts data bits D7 to D0, write 1 to the PM bit in SMR\_SMCI to invert the parity bit for both transmission and reception.

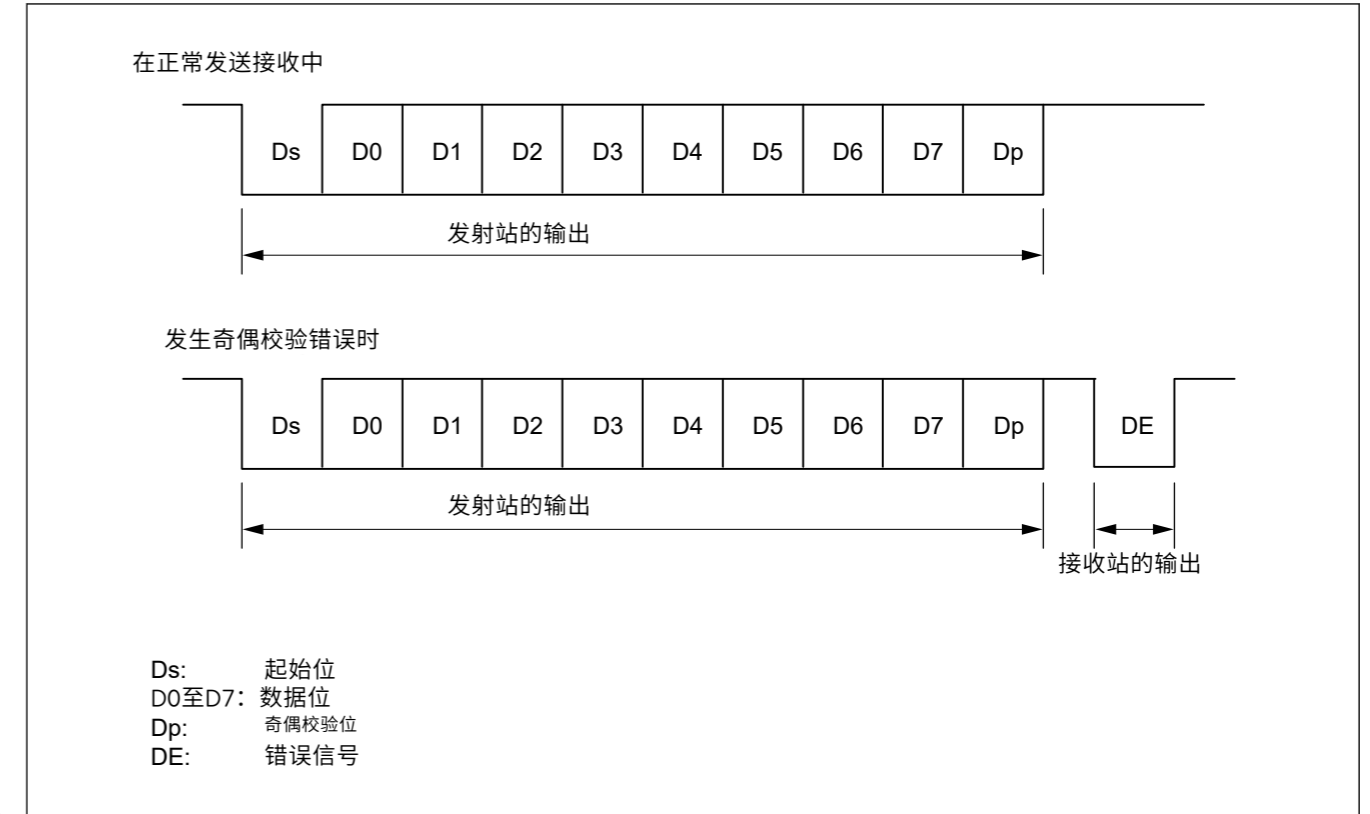


Figure 27.78 智能卡接口模式下的数据格式

与直接约定型和逆约定型IC卡进行通信时，请按照本节的步骤进行。

(1) 直接约定型

对于直接约定类型，逻辑电平1和0分别表示Z和A状态，数据通过 LSB-first为起始字符，如图27.79所示。因此，图中起始字符中的数据为0x3B。

使用直接约定类型时，将0写入SCMR.SDIR和SCMR.SINV位。将0写入 SMR\_SMCI.PM位使用智能卡标准规定的偶校验。

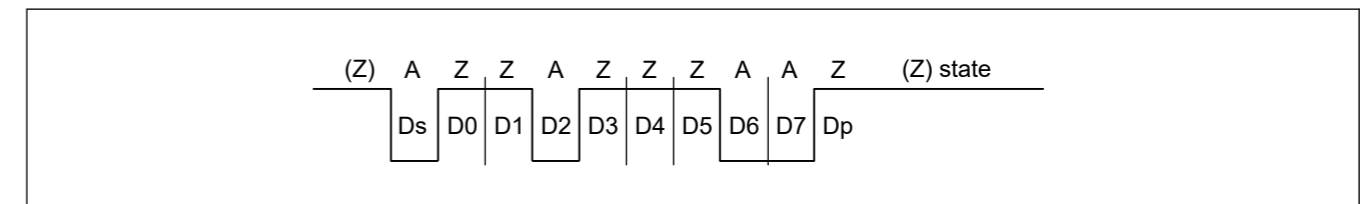


Figure 27.79 与SCMR=0中的SDIR、SCMR=0中的SINV和SMR\_SMCI=0中的PM的直接约定

(2) 逆约定型

对于逆约定类型，逻辑电平1和0分别表示A和Z状态，数据通过 MSB-first为起始字符，如图27.80所示。因此，图中起始字符中的数据为0x3F。

使用逆约定类型时，将1写入SCMR.SDIR和SCMR.SINV位。奇偶校验位为逻辑电平0，产生偶校验，这是智能卡标准规定的，对应于Z状态。由于MCU的SINV位仅将数据位D7反转为D0，因此向SMR\_SMCI中的PM位写入1以反转发送和接收的奇偶校验位。

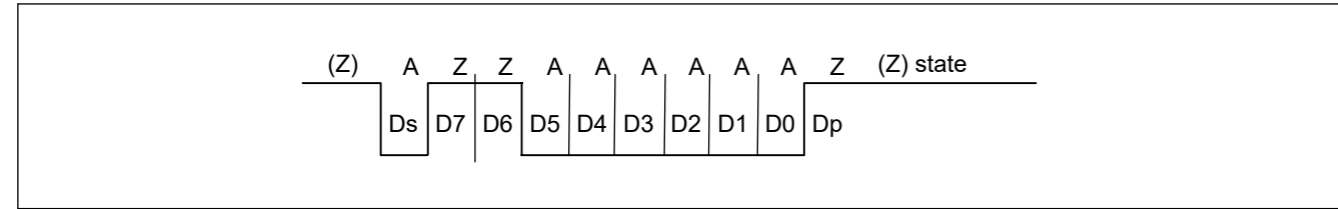


Figure 27.80 Inverse convention with SDIR in SCMR = 1, SINV in SCMR = 1, and PM in SMR\_SMCI = 1

### 27.7.3 Block Transfer Mode

Block transfer mode differs from normal smart card interface mode as follows:

- Even if a parity error is detected during reception, no error signal is output. Because the PER flag in SSR\_SMCI is set by error detection, clear the PER flag before receiving the parity bit of the next frame.
- During transmission, at least 1 ETU is set as a guard time from the end of the parity bit until the start of the next frame.
- Because the same data is not retransmitted, the TEND flag in SSR\_SMCI is set to 11.5 ETUs after transmission starts.
- In block transfer mode, the ERS flag in SSR\_SMCI indicates the error signal status as in normal smart card interface mode, but the flag is read as 0 because no error signal is transferred.

### 27.7.4 Receive Data Sampling Timing and Reception Margin

Only the internal clock generated by the on-chip baud rate generator can be used as a transfer clock in smart card interface mode.

In this mode, the SCI can operate on a base clock with a frequency of 32, 64, 372, 256, 93, 128, 186, or 512 times the bit rate set up in the SCMR.BCP2 and the SMR\_SMCI.BCP[1:0] bits. The frequency is always 16 times the bit rate in normal asynchronous mode.

For data reception, the falling edge of the start bit is sampled with the base clock to perform internal synchronization.

Receive data is sampled on the 16th, 32nd, 186th, 128th, 46th, 64th, 93rd, and 256th rising edges of the base clock so that it can be latched at the middle of each bit as shown in Figure 27.81. The reception margin is determined by the following formula:

$$M = \left| \left( 0.5 - \frac{1}{2N} \right) - (L - 0.5)F - \frac{|D - 0.5|}{N}(1 + F) \right| \times 100 \text{ [%]}$$

M: Reception margin (%)

N: Ratio of bit rate to clock (N = 32, 64, 372, 256)

D: Duty cycle of clock (D = 0 to 1.0)

L: Frame length (L = 10)

F: Absolute value of clock frequency deviation

Assuming values of F = 0, D = 0.5, and N = 372 in the specified formula, the reception margin is determined using the following formula:

$$M = \{0.5 - 1/(2 \times 372)\} \times 100 \text{ [%]} = 49.866 \text{ %}$$

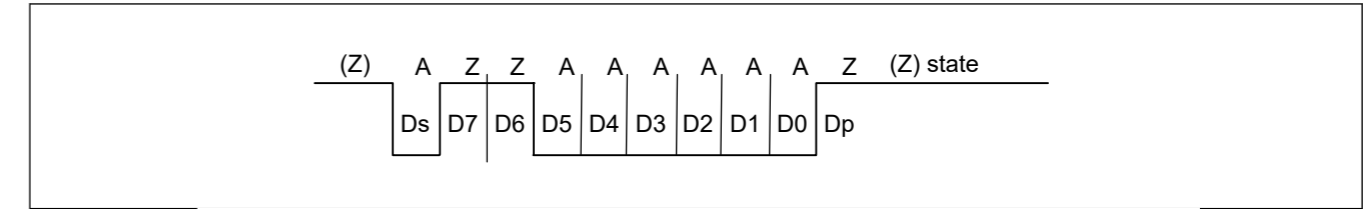


Figure 27.80 SCMR=1中的SDIR、SCMR=1中的SINV和SMR\_SMCI=1中的PM的逆约定

### 27.7.3 块传输模式

块传输模式与普通智能卡接口模式的区别如下:

- 即使在接收过程中检测到奇偶校验错误,也不会输出错误信号。因为SSR\_SMCI中的PER标志是由错误检测设置的,所以在接收下一帧的奇偶校验位之前清除PER标志。
- 在传输过程中,从奇偶校验位结束到下一帧开始至少设置1个ETU作为保护时间
- 由于没有重传相同的数据,所以在传输开始后,SSR\_SMCI中的TEND标志设置为11.5ETU
- 在块传输模式下,SSR\_SMCI中的ERS标志指示错误信号状态,与普通智能卡接口模式一样,但该标志被读取为0,因为没有传输错误信号

### 27.7.4 接收数据采样时序和接收裕量

只有片内波特率发生器产生的内部时钟可以用作智能卡接口模式下的传输时钟。

在这种模式下,SCI可以在频率为SCMR.BCP2和SMR\_SMCI.BCP[1:0]位。在正常异步模式下,频率始终是比特率的16倍。

对于数据接收,起始位的下降沿用基准时钟进行采样,以进行内部同步。

接收数据在基本时钟的第16、32、186、128、46、64、93和256个上升沿进行采样,以便在每个位的中间锁存,如图27.81所示。接收余量由以下公式确定:

$$M = \left| \left( 0.5 - \frac{1}{2N} \right) - (L - 0.5)F - \frac{|D - 0.5|}{N}(1 + F) \right| \times 100 \text{ [%]}$$

M: 接收余量 (%)

N: 比特率与时钟的比率 (N=32、64、372、256)

D: 时钟的占空比 (D=0到1.0)

L: 帧长 (L=10)

F: 时钟频率偏差的绝对值

假设指定公式中的F=0、D=0.5和N=372的值,则使用以下公式确定接收余量:

$$M = \{0.5 - 1/(2 \times 372)\} \times 100 \text{ [%]} = 49.866 \text{ %}$$

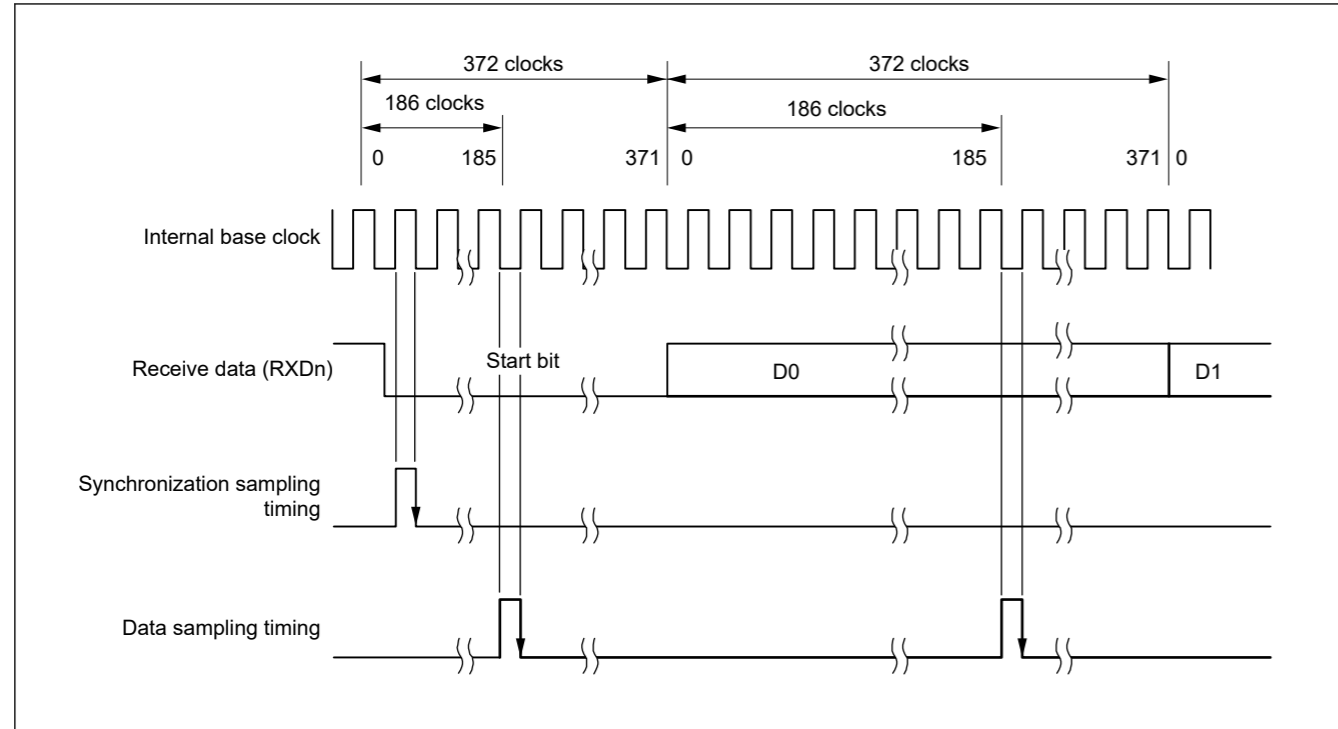


Figure 27.81 Receive data sampling timing in smart card interface mode when the clock frequency is 372 times the bit rate

27.7.5 SCI Initialization (Smart Card Interface Mode)

Before transmitting and receiving data, write the initial value 0x00 in the SCR\_SMCI register and initialize the SCI following the example flow shown in Table 27.39.

Always set the initial value in the TIE, RIE, TE, RE, TEIE bits in the SCR\_SMCI register before switching from transmission to reception mode or from reception to transmission mode. When SCR\_SMCI.RE is set to 0, the RDR register is not initialized.

To change from reception mode to transmission mode, first check that reception has completed, then initialize the SCI. At the end of initialization, set SCR\_SMCI.TE = 1 and SCR\_SMCI.RE = 0. Reception completion can be verified by reading the SCIn\_RXI request, ORER, or PER flag in SSR\_SMCI.

To change transmission mode to reception mode, first check that transmission has completed, then initialize the SCI. At the end of initialization, set SCR\_SMCI.TE = 0 and SCR\_SMCI.RE = 1. Transmission completion can be verified by reading the TEND flag in SSR\_SMCI.

Table 27.39 Example flow of SCI initialization in smart card interface mode (1 of 2)

| No. | Step Name  | Description  |
|-----|--|--|
| 1   | Start initialization   |  |
| 2   | Set SCR_SMCI.TIE, RIE, TE, RE, TEIE, and CKE[1:0] to 0                 | Stop the communication and initialize SKE[1:0].                              |
| 3   | Set SIMR1.IICM bit to 0. Set SCMR.SMIF to 1.                           | Set to smart card interface mode.  |
| 4   | Set SSR_SMCI.ORER, ERS, PER to 0                                       | Write to SSR_SMCI after reading SSR_SMCI.                                    |
| 5   | Set SPMR.CKPH, CKPOL   | Set the transmission or reception format in SPMR.                            |
| 6   | Set SMR_SMCI.GM, BLK, PM, BCP[1:0], CKS[1:0], and set SMR_SMCI.PE to 1 | Set the operation mode and the transmission or reception format in SMR_SMCI. |
| 7   | Set SCMR.BCP2, SDIR, SINV  | Set the transmission or reception format in SCMR.                            |
| 8   | Set SPTR to the initial value.   | Set the Initial value to SPTR.   |

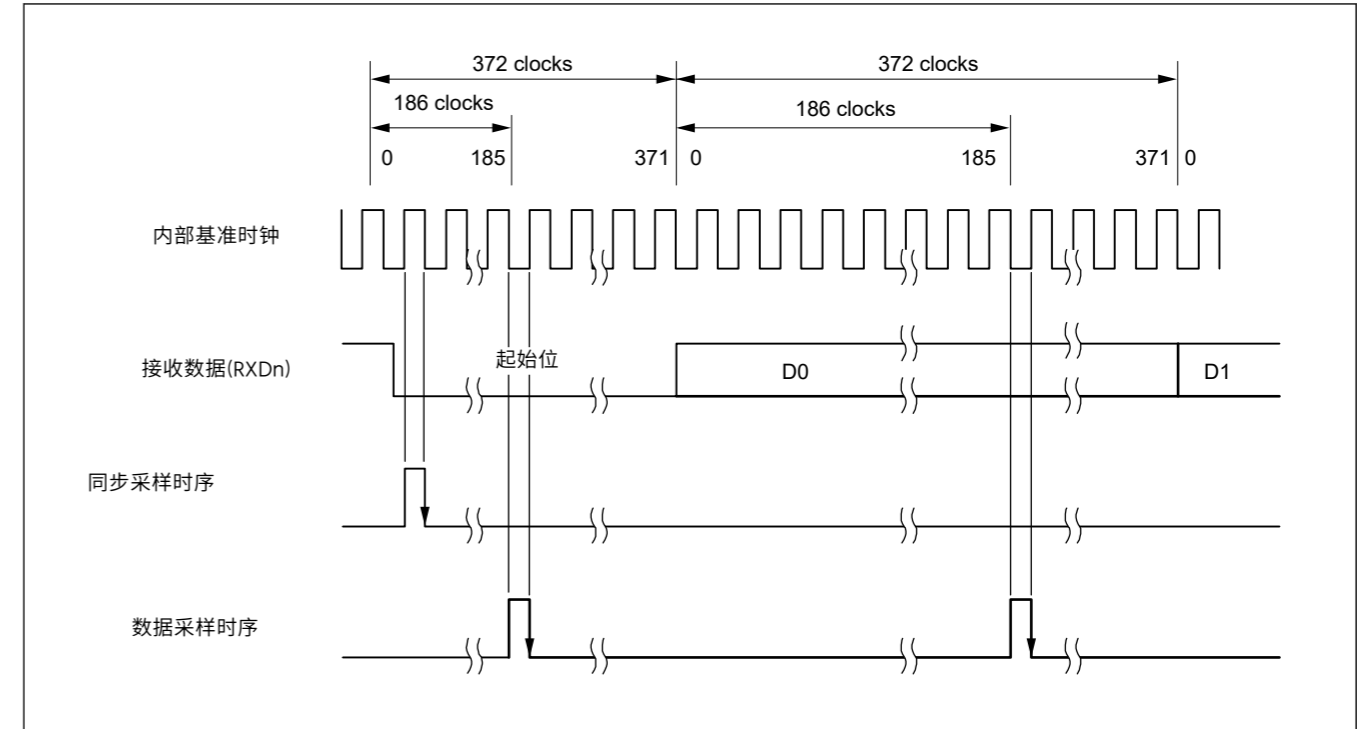


Figure 27.81 时钟频率为372倍比特率时智能卡接口模式下接收数据采样时序

27.7.5 SCI初始化 (智能卡接口模式)

在发送和接收数据之前，将初始值0x00写入SCR\_SMCI寄存器并按照表27.39所示的示例流程初始化SCI。

在从发送模式切换到接收模式或从接收模式切换到发送模式之前，请务必在SCR\_SMCI寄存器中的TIE、RIE、TE、RE、TEIE位中设置初始值。当SCR\_SMCI.RE设置为0时，RDR寄存器未初始化。

要从接收模式更改为发送模式，首先检查接收是否完成，然后初始化SCI。在初始化结束时，设置SCR\_SMCI.TE=1和SCR\_SMCI.RE=0。可以通过读取SSR\_SMCI中的SCIn\_RXI请求、ORER或PER标志来验证接收完成。

要将传输模式更改为接收模式，首先检查传输是否完成，然后初始化SCI。在初始化结束时，设置SCR\_SMCI.TE=0和SCR\_SMCI.RE=1。可以通过读取SSR\_SMCI中的TEND标志来验证传输完成。

Table 27.39 智能卡接口模式下SCI初始化示例流程 (1of2)

| No. | 步骤名称  | Description               |
|-----|---|---------------------------|
| 1   | 开始初始化   |                           |
| 2   | 将SCR_SMCI.TIE、RIE、TE、RE、TEIE和CKE[1:0]设置为0                         | 停止通信并初始化SKE[1:0]。         |
| 3   | 将SIMR1.IICM位设置为0。将SCMR.SMIF设置为1。                                  | 设置为智能卡接口模式。               |
| 4   | 设置SSR_SMCI.ORER、ERS、PER到0   | 读取SSR_SMCI后写入SSR_SMCI。    |
| 5   | Set SPMR.CKPH, CKPOL  | 在SPMR中设置发送或接收格式。          |
| 6   | Set SMR_SMCI.GM, BLK, PM, BCP[1:0], CKS[1:0], 并设置SMR_SMCI.PE to 1 | 在SMR_SMCI中设置操作模式和发送或接收格式。 |
| 7   | Set SCMR.BCP2, SDIR, SINV   | 在SCMR中设置发送或接收格式。          |
| 8   | 将SPTR设置为初始值。  | 将初始值设置为SPTR。              |

Table 27.39 Example flow of SCI initialization in smart card interface mode (2 of 2)

| No. | Step Name   | Description  |
|-----|---|--|
| 9   | Set SEMR.BRME and SEMR.RXDESEL to 0                   | Set SEMR.BRME and SEMR.RXDESEL to 0.   |
| 10  | Set a value in BRR                                    | Write the value for the bit rate in BRR.   |
| 11  | Set the I/O port functions                            | Set the I/O port functions for TXDn, RXDn, and SCKn.   |
| 12  | Set a value in SCR_SMCI.CKE[1:0]                      | Set the SCR_SMCI.CKE[1:0]. Even though the function depends on SMR_SMCI.GM, when the CKE[0] bit is set to 1, the clock is output from the SCKn pin.                |
| 13  | Set SCR_SMCI.TE or RE to 1, and set SCR_SMCI.TIE, RIE | Set the TE or RE bit in SCR_SMCI to 1, then set the TIE and RIE bits in SCR_SMCI. Do not simultaneously set the TE and RE bits to 1 if self-diagnosis is not used. |
| 14  | Initialization completed                              |  |

### 27.7.6 Serial Data Transmission (Except in Block Transfer Mode)

Serial data transmission in smart card interface mode (except in block transfer mode) is different from that in non-smart card interface mode, in that an error signal is sampled and data can be re-transmitted in smart card mode. Figure 27.82 shows the data re-transfer operation during transmission.

- When an error signal from the receiver end is sampled after 1-frame data is transmitted, the SSR\_SMCI.ERS flag is set to 1. If the SCR\_SMCI.RIE bit is 1, an SCIn\_ERI interrupt request is generated. Clear the ERS flag to 0 before the next parity bit is sampled.
- For a frame in which an error signal is received, the SSR\_SMCI.TEND flag is not set. Data is re-transferred from TDR to TSR, allowing automatic data retransmission.
- If no error signal is returned from the receiver, the ERS flag is not set to 1.
- In this case, the SCI determines that transmission of 1-frame data, including the re-transfer, is complete, and the TEND flag is set. If the SCR\_SMCI.TIE bit is 1, an SCIn\_TXI interrupt request is generated. Write transmit data to the TDR to start transmission of the next data.

Figure 27.84 shows an example flow of serial transmission. All the processing steps are automatically performed using an SCIn\_TXI interrupt request to activate the DTC or DMAC.

When the SSR\_SMCI.TEND flag is set to 1 in transmission and when the SCR\_SMCI.TIE bit is 1, an SCIn\_TXI interrupt request is generated.

The DTC or DMAC is activated by an SCIn\_TXI interrupt request if the SCIn\_TXI interrupt request is previously specified as a source of DTC or DMAC activation, allowing the transfer of transmit data. The TEND flag is automatically set to 0 when the DTC or DMAC transfers the data.

If an error occurs, the SCI automatically retransmits the same data. During this retransmission, the TEND flag is kept at 0 and the DTC or DMAC is not activated. Therefore, the SCI and DTC or DMAC automatically transmit the specified number of bytes, including retransmission when an error occurs. Because the ERS flag is not automatically cleared, set the RIE bit to 1 before enabling an SCIn\_ERI interrupt request to be generated if an error occurs, and clear the ERS flag to 0.

When transmitting or receiving data using the DTC or DMAC, always enable the DTC or DMAC before making the SCI settings.

For DTC or DMAC settings, see section 17, Data Transfer Controller (DTC), section 16, DMA Controller (DMAC).

Table 27.39 智能卡接口模式下SCI初始化流程示例 (2之2)

| No. | 步骤名称                                     | Description  |
|-----|--|--|
| 9   | 将SEMR.BRME和SEMR.RXDESEL设置为0              | 将SEMR.BRME和SEMR.RXDESEL设置为0。   |
| 10  | 在BRR中设置一个值                               | 在BRR中写入比特率的值。  |
| 11  | 设置IO端口功能                                 | 设置TXDn、RXDn和SCKn的IO端口功能。   |
| 12  | 在中设置一个值 SCR_SMCI.CKE[1:0]                | 设置SCR_SMCI.CKE[1:0]。即使函数依赖于SMR_SMCI.GM, 当CKE[0]位设置为1, 时钟从SCKn引脚输出。       |
| 13  | 将SCR_SMCI.TE或RE设置为1, 并设置SCR_SMCI.TIE、RIE | 将SCR_SMCI中的TE或RE位设置为1, 然后设置SCR_SMCI中的TIE和RIE位。如果不使用自诊断, 请勿同时将TE和RE位设置为1。 |
| 14  | 初始化完成                                    |  |

### 27.7.6 串行数据传输 (块传输模式除外)

智能卡接口模式下的串行数据传输 (块传输模式除外) 与非智能卡接口模式下的串行数据传输不同之处在于, 在智能卡模式下对错误信号进行采样, 数据可以重新传输。图27.82显示了传输过程中的数据重传操作。

- 发送1帧数据后, 在接收端采样到错误信号时, SSR\_SMCI.ERS标志置1。如果SCR\_SMCI.RIE位为1, 则产生SCIn\_ERI中断请求。在采样下一个奇偶校验位之前将ERS标志清零。
- 对于接收到错误信号的帧, 不设置SSR\_SMCI.TEND标志。数据从TDR重新传输到TSR, 允许自动数据重新传输。
- 如果接收器没有返回错误信号, 则ERS标志不设置为1。
- 在这种情况下, SCI确定1帧数据的传输 (包括重新传输) 已完成, 并设置TEND标志。如果SCR\_SMCI.TIE位为1, 则产生SCIn\_TXI中断请求。将传输数据写入TDR以开始传输下一个数据。

图27.84显示了串行传输的示例流程。所有处理步骤都使用一个自动执行SCIn\_TXI中断请求以激活DTC或DMAC。

当发送中SSR\_SMCI.TEND标志设置为1且SCR\_SMCI.TIE位为1时, 将产生SCIn\_TXI中断请求。

如果先前将SCIn\_TXI中断请求指定为DTC或DMAC激活源, 则DTC或DMAC由SCIn\_TXI中断请求激活, 从而允许传输数据。当DTC或DMAC传输数据时, TEND标志自动设置为0。

如果发生错误, SCI会自动重新传输相同的数据。在此重传期间, TEND标志保持为0, 并且DTC或DMAC未激活。因此, SCI和DTC或DMAC会自动传输指定的字节数, 包括发生错误时的重传。因为ERS标志不会自动清零, 所以如果发生错误, 在使能SCIn\_ERI中断请求之前将RIE位设置为1, 并将ERS标志清零。

使用DTC或DMAC发送或接收数据时, 请务必在进行SCI设置之前启用DTC或DMAC。

对于DTC或DMAC设置, 请参阅第17节, 数据传输控制器(DTC), 第16节, DMA控制器(DMAC)。



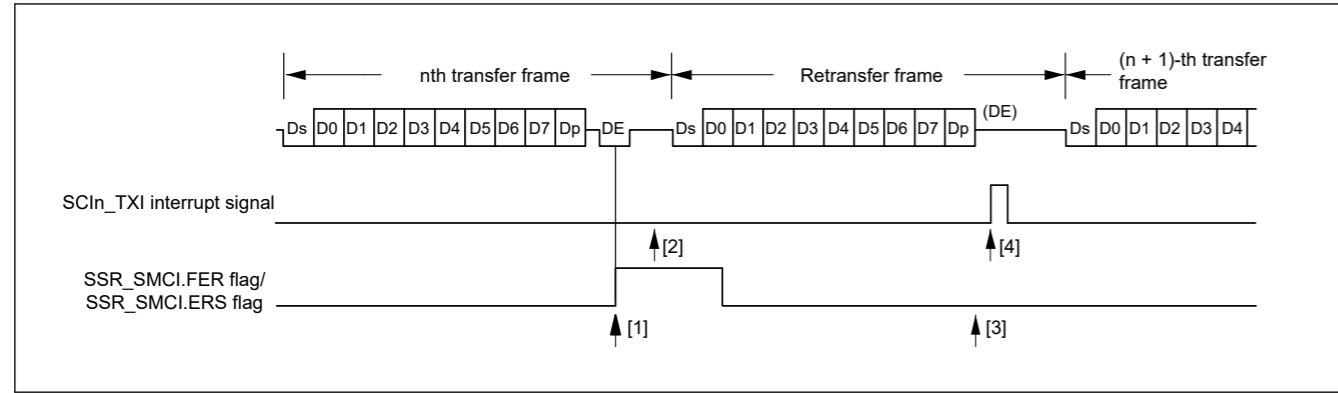


Figure 27.82 Data re-transfer operation in smart card interface transmission mode

The SSR\_SMCI.TEND flag is set at different timings depending on the SMR\_SMCI.GM bit setting. Figure 27.83 shows the TEND flag generation timing.

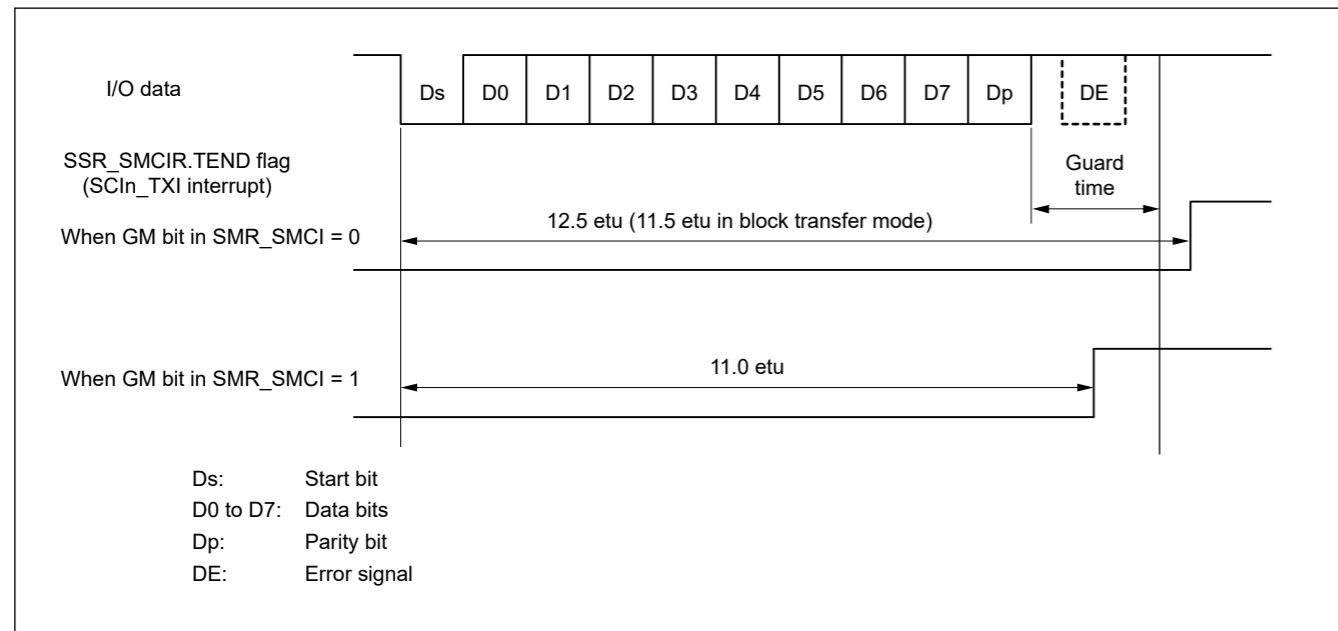


Figure 27.83 SSR.TEND flag generation timing during transmission

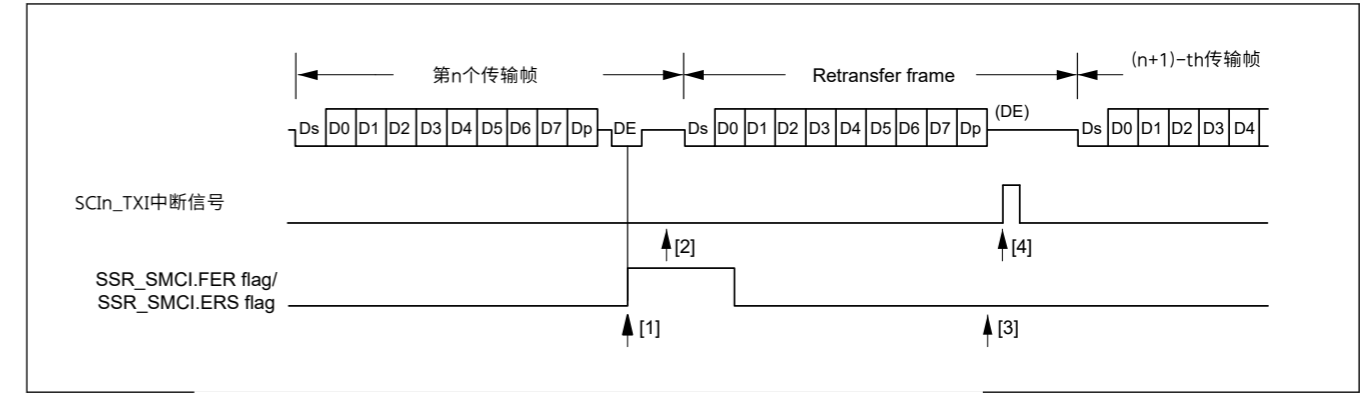


Figure 27.82 智能卡接口传输模式下的数据重传操作

SSR\_SMCI.TEND标志根据SMR\_SMCI.GM位设置在不同的时间设置。图27.83显示了TEND标志生成时序。

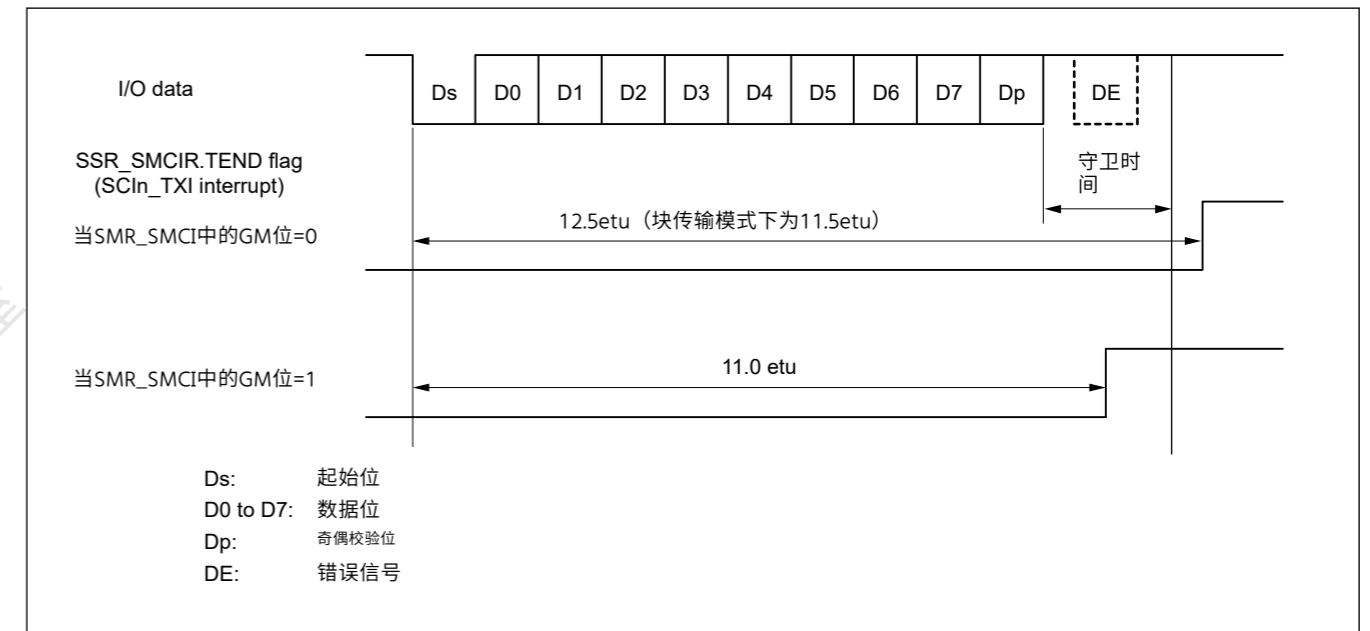


Figure 27.83 发送期间的SSR.TEND标志生成时序

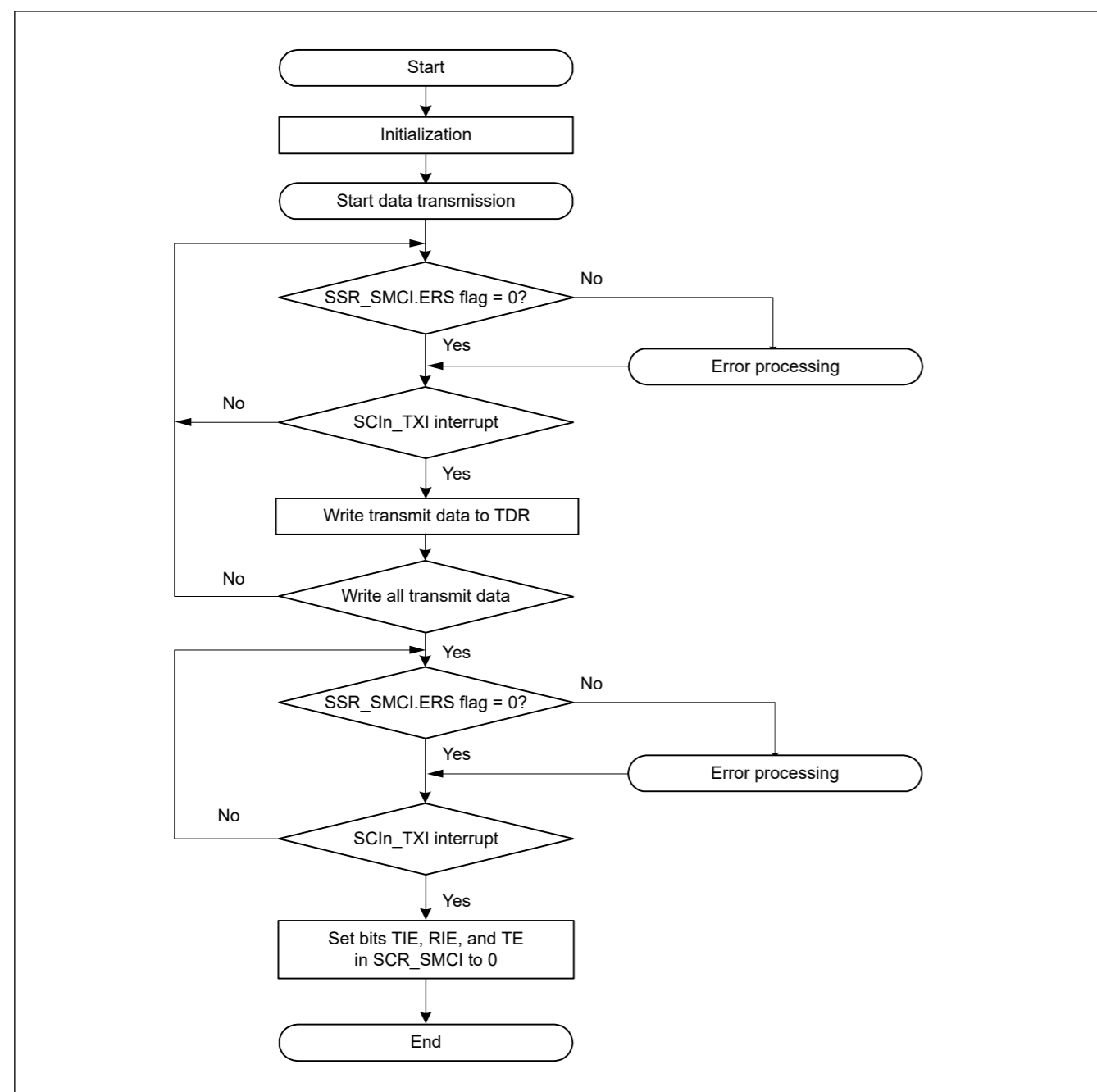


Figure 27.84 Example flow of smart card interface transmission

### 27.7.7 Serial Data Reception (Except in Block Transfer Mode)

Serial data reception in smart card interface mode is similar to that in non-smart card interface mode. Figure 27.85 shows the data re-transfer operation in reception mode.

1. If a parity error is detected in the receive data, the SSR\_SMCI.PER flag is set to 1. When the SCR\_SMCI.RIE bit is 1, an SCIn\_ERI interrupt request is generated. Clear the PER flag to 0 before the next parity bit is sampled.
2. For a frame in which a parity error is detected, no SCIn\_RXI interrupt is generated.
3. When no parity error is detected, the SCR\_SMCI.PER flag is not set to 1.
4. In this case, data is determined to be received successfully. When the SCR\_SMCI.RIE bit is 1, an SCIn\_RXI interrupt request is generated.

Figure 27.86 shows an example flow of serial data reception. All the processing steps are automatically performed using an SCIn\_RXI interrupt request to activate the DTC or DMAC.

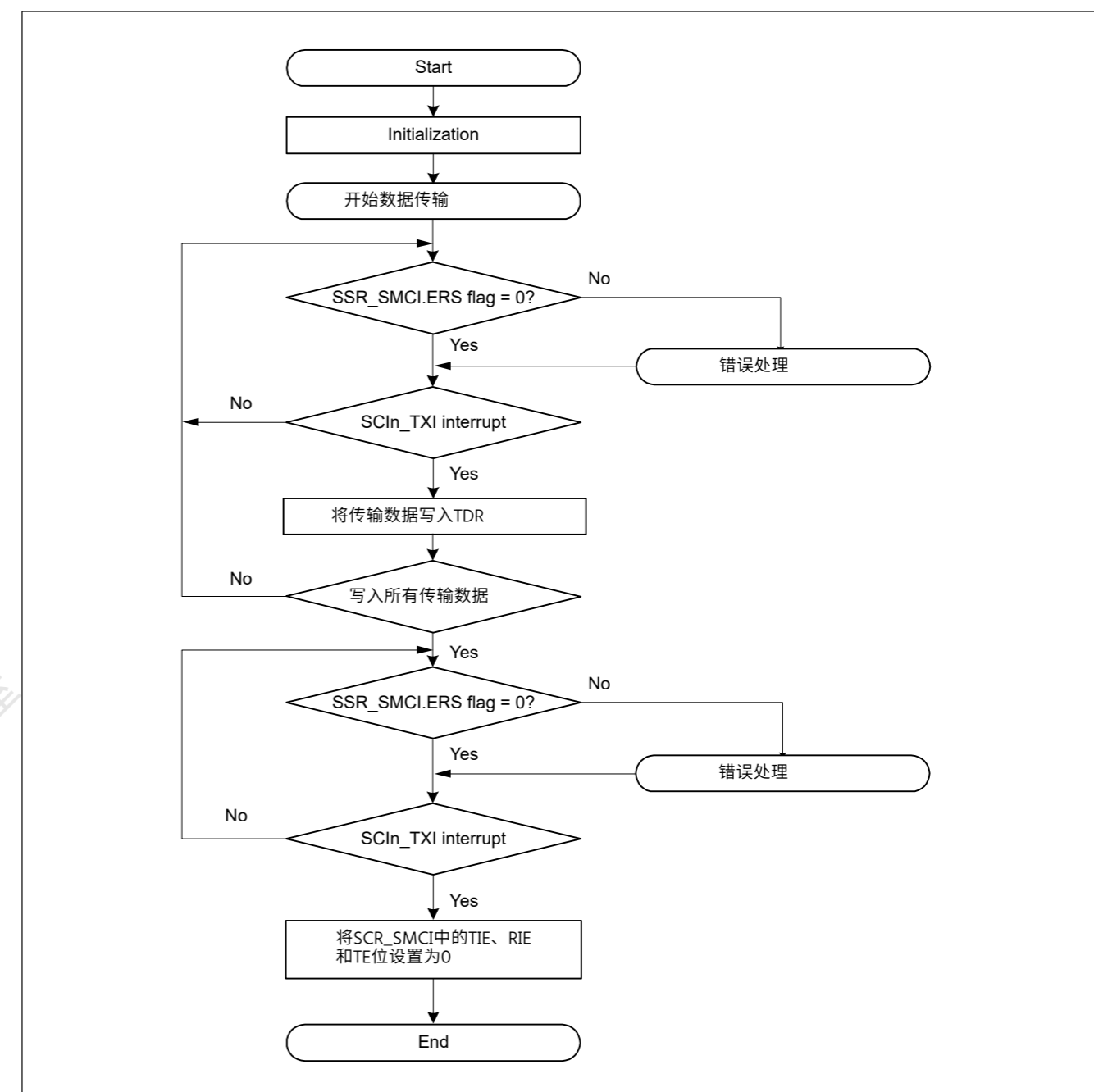


Figure 27.84 智能卡接口传输示例流程

### 27.7.7 串行数据接收（块传输模式除外）

智能卡接口模式下的串行数据接收与非智能卡接口模式下的串行数据接收类似。图27.85显示了接收模式下的数据重传操作。

- 1.如果在接收数据中检测到奇偶校验错误，则SSR\_SMCI.PER标志设置为1。当SCR\_SMCI.RIE位为1时，产生SCIn\_ERI中断请求。在采样下一个奇偶校验位之前将PER标志清零。
- 2.对于检测到奇偶校验错误的帧，不产生SCIn\_RXI中断。
- 3.未检测到奇偶校验错误时，SCR\_SMCI.PER标志不设置为1。
- 4.在这种情况下，确定数据接收成功。当SCR\_SMCI.RIE位为1时，产生SCIn\_RXI中断请求。

图27.86显示了串行数据接收的示例流程。所有处理步骤都使用一个自动执行SCIn\_RXI中断请求以激活DTC或DMAC。

In reception, setting the RIE bit to 1 allows an SCIn\_RXI interrupt request to be generated. The DTC or DMAC is activated by an SCIn\_RXI interrupt request if the SCIn\_RXI interrupt request is previously specified as a source of DTC or DMAC activation, allowing the transfer of receive data.

If an error occurs during reception and either the ORER or PER flag in SSR\_SMCI is set to 1, a receive error interrupt (SCIn\_ERI) request is generated. Clear the error flag after the error occurrence. If an error occurs, the DTC or DMAC is not activated and receive data is skipped. Therefore, the number of bytes of receive data specified in the DTC or DMAC is transferred.

If a parity error occurs and the PER flag is set to 1 during reception, the receive data is transferred to RDR, allowing the data to be read.

When a reception is forced to terminate by setting SCR\_SMCI.RE to 0 during operation, read the RDR register because the received data that is not yet read might be left in the RDR.

Note: For operations in block transfer mode, see [section 27.3.9. Serial Data Reception in Asynchronous Mode](#).

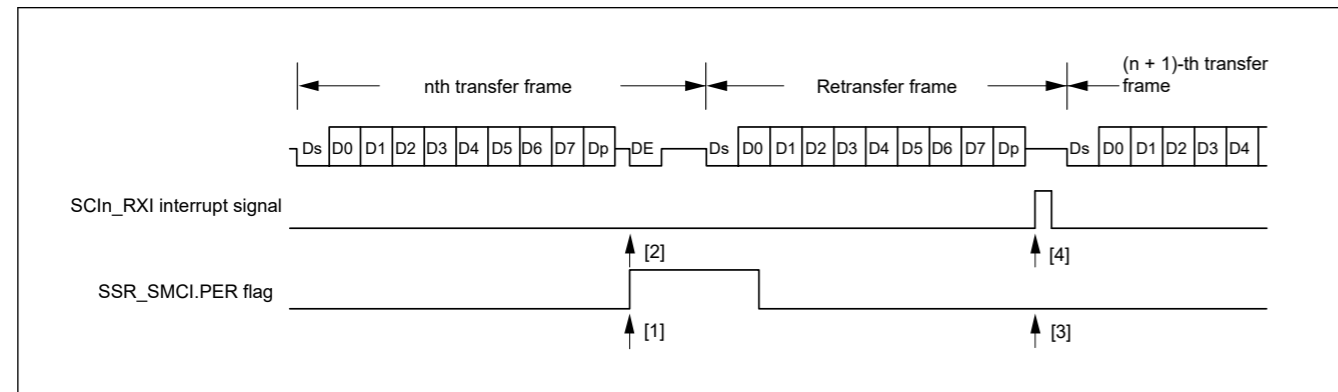


Figure 27.85 Data re-transfer operation in smart card interface reception mode

在接收时，将RIE位设置为1允许产生SCIn\_RXI中断请求。如果先前将SCIn\_RXI中断请求指定为DTC或DMAC激活源，则DTC或DMAC由SCIn\_RXI中断请求激活，从而允许传输接收数据。

如果接收期间发生错误并且SSR\_SMCI中的ORER或PER标志设置为1，则会生成接收错误中断(SCIn\_ERI)请求。错误发生后清除错误标志。如果发生错误，则不会激活DTC或DMAC并跳过接收数据。因此，将传输DTC或DMAC中指定的接收数据字节数。

如果在接收过程中发生奇偶校验错误并且PER标志设置为1，则接收数据将传输到RDR，从而可以读取数据。

如果在操作期间通过将SCR\_SMCI.RE设置为0来强制终止接收，请读取RDR寄存器，因为尚未读取的已接收数据可能留在RDR中。

Note: 关于块传输模式下的操作，请参见第27.3.9节。异步模式下的串行数据接收。

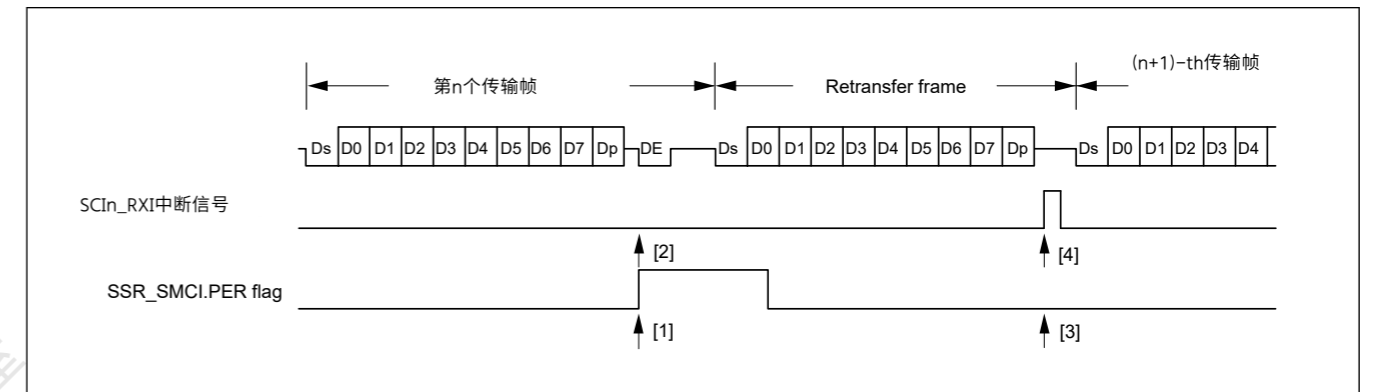


Figure 27.85 智能卡接口接收模式下的数据重传操作

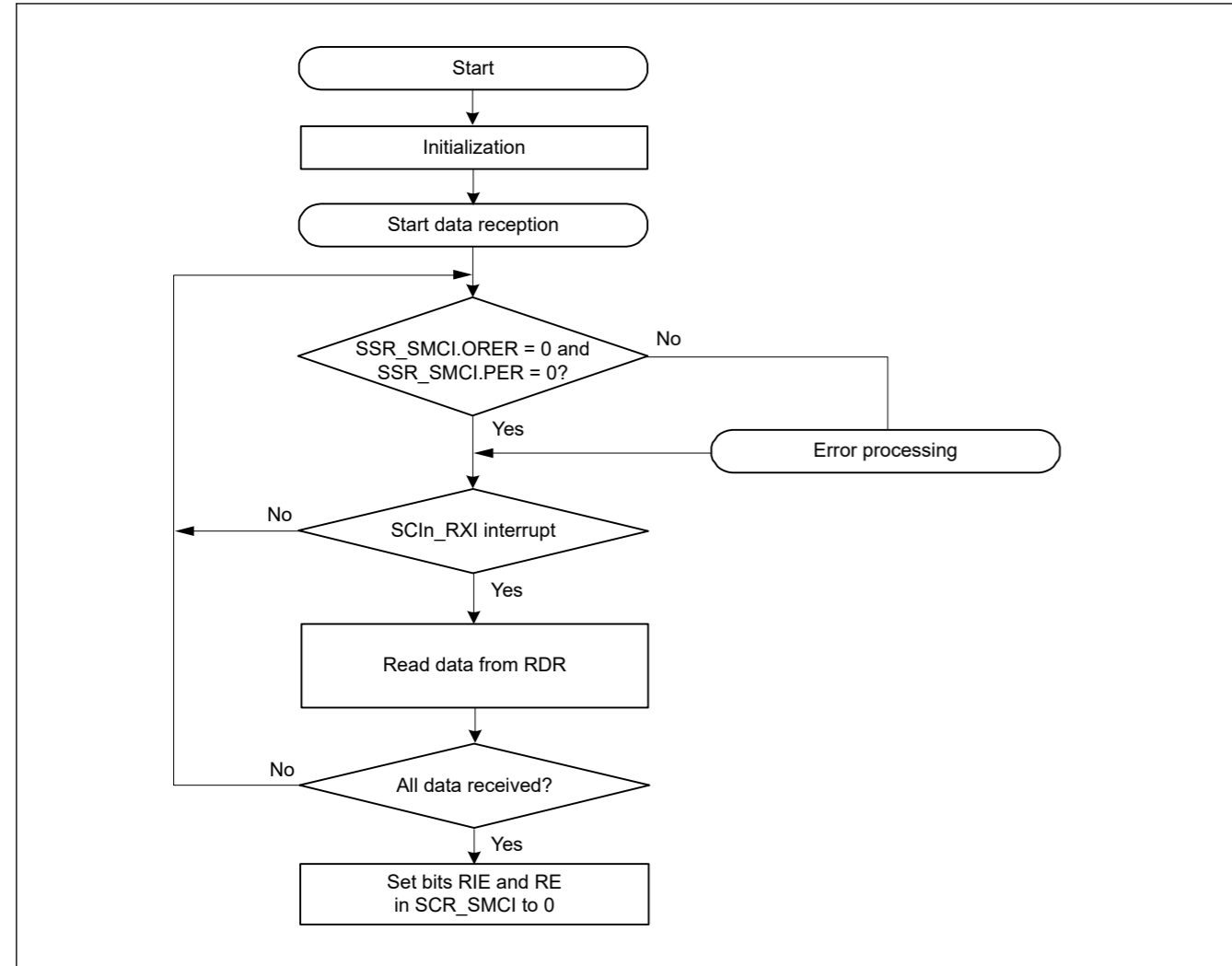


Figure 27.86 Example flow of smart card interface reception

### 27.7.8 Clock Output Control

When the GM bit in SMR\_SMCI is set to 1, the clock output can be controlled by the CKE[1:0] bits in SCR\_SMCI. For details on the CKE[1:0] bits, see [section 27.2.14. SCR\\_SMCI: Serial Control Register for Smart Card Interface Mode \(SCMR.SMIF = 1\)](#). When setting the clock output, the base clock described in [section 27.7.4. Receive Data Sampling Timing and Reception Margin](#).

[Figure 27.87](#) shows an example timing for the clock output control when the CKE[1] bit in SCR\_SMCI is set to 0 and the CKE[0] bit in SCR\_SMCI is controlled.

When the GM bit in SMR\_SMCI is 0, output control by the CKE[0] bit in SCR\_SMCI is immediately reflected on the SCKn pin, so there is a possibility that pulses with an unintended width may be output from the SCKn pin.

When the GM bit in SMR\_SMCI is 1, the clock with the same pulse width as the base clock is output even if the CKE[0] bit in SCR\_SMCI is changed.

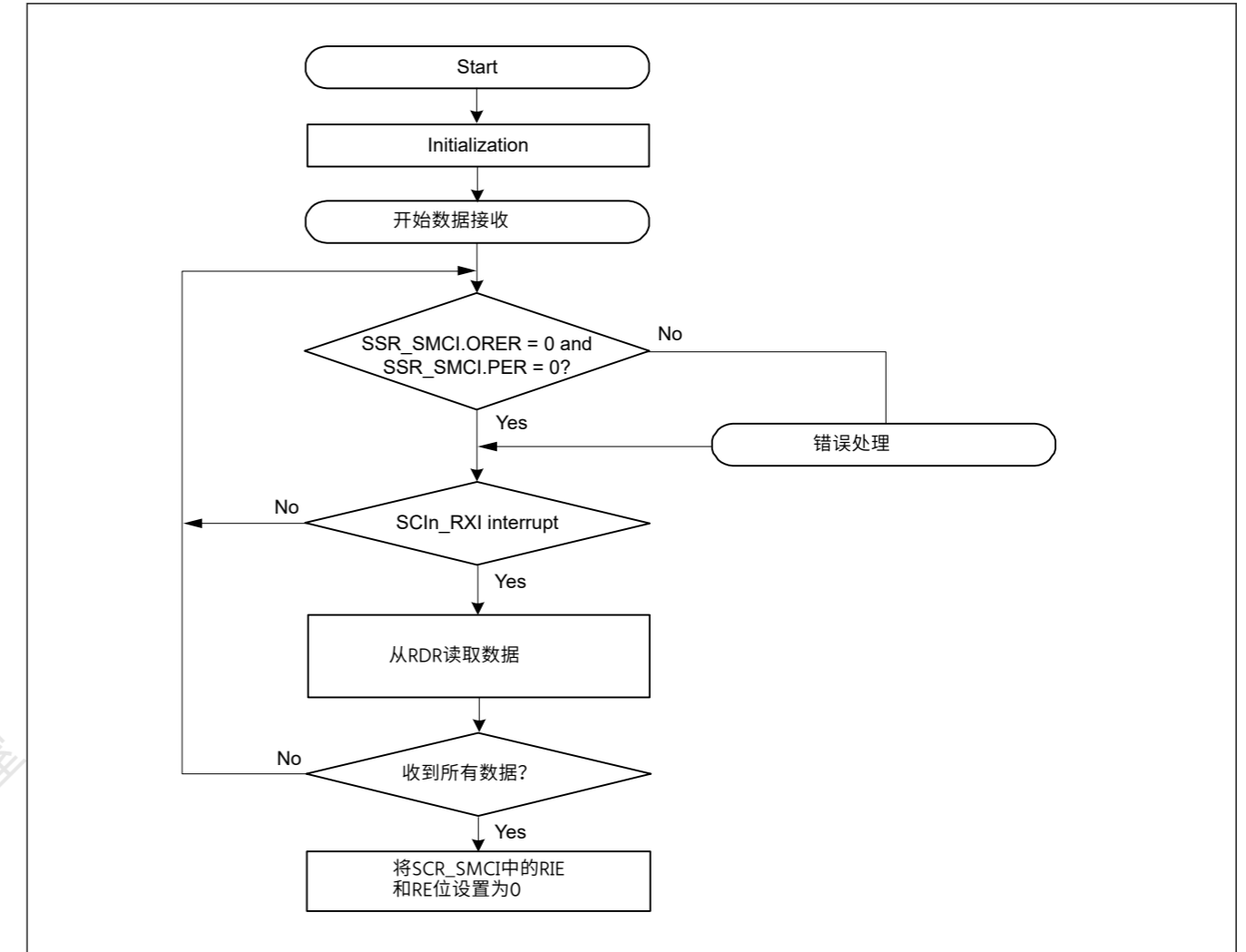


Figure 27.86 智能卡接口接收示例流程

### 27.7.8 时钟输出控制

当SMR\_SMCI中的GM位设置为1时，时钟输出可以由SCR\_SMCI中的CKE[1:0]位控制。有关CKE[1:0]位的详细信息，请参见第27.2.14节。SCR\_SMCI：智能卡接口模式的串行控制寄存器(SCMR.SMIF=1)。设置时钟输出时，使用第27.7.4节中描述的基本时钟。接收数据采样时序和接收余量。

图27.87显示了当SCR\_SMCI中的CKE[1]位设置为0且控制SCR\_SMCI中的CKE[0]位。

当SMR\_SMCI中的GM位为0时，SCR\_SMCI中CKE[0]位的输出控制立即反映在SCKn引脚，因此有可能会从SCKn引脚输出具有意外宽度的脉冲。

当SMR\_SMCI中的GM位为1时，即使SCR\_SMCI中的CKE[0]位发生变化，也会输出与基本时钟脉冲宽度相同的时钟。



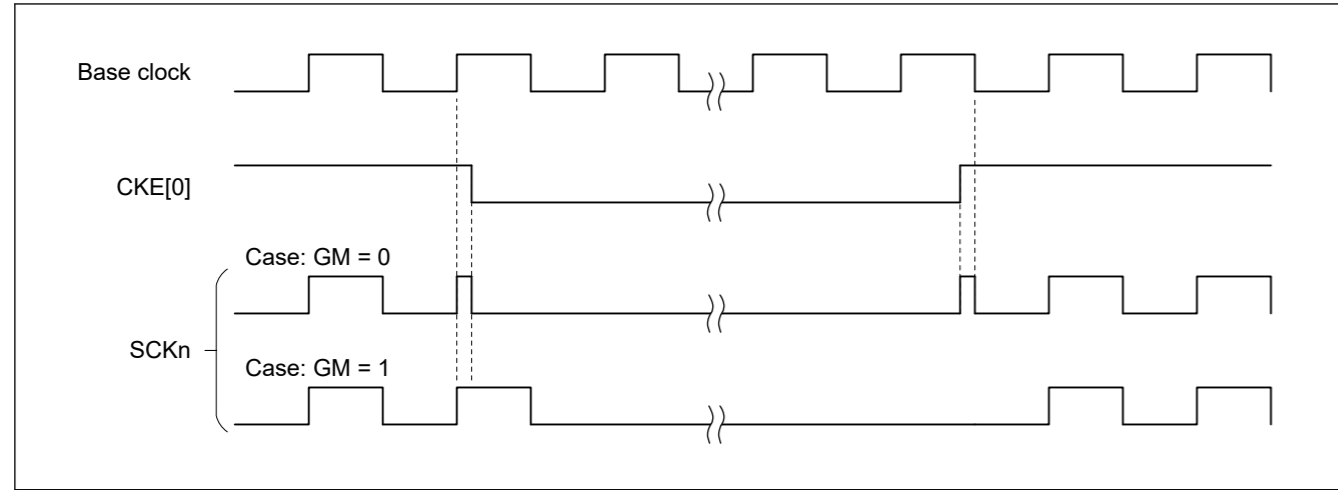


Figure 27.87 Clock Output timing

### 27.8 Operation in Simple IIC Mode

Simple IIC mode format is composed of 8 data bits and an acknowledge bit. By continuing into a slave-address frame after a start condition or restart condition, a master device can specify a slave device as the partner for communications. The currently specified slave device remains valid until a new slave device is specified or a stop condition is satisfied. The 8 data bits in all frames are transmitted in order from the MSB.

The I<sup>2</sup>C bus format and timing of the I<sup>2</sup>C bus are shown in Figure 27.88 and Figure 27.89.

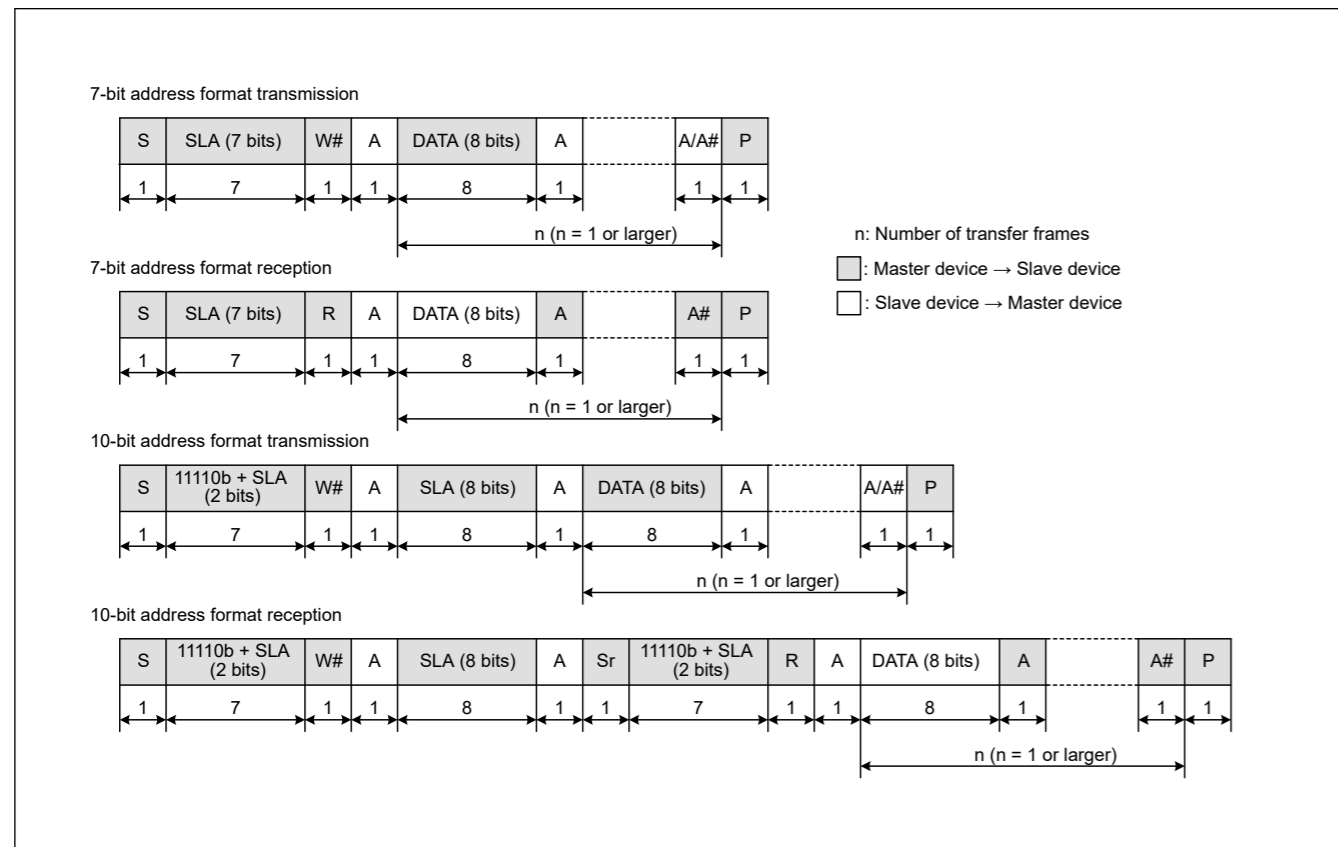


Figure 27.88 I<sup>2</sup>C bus format

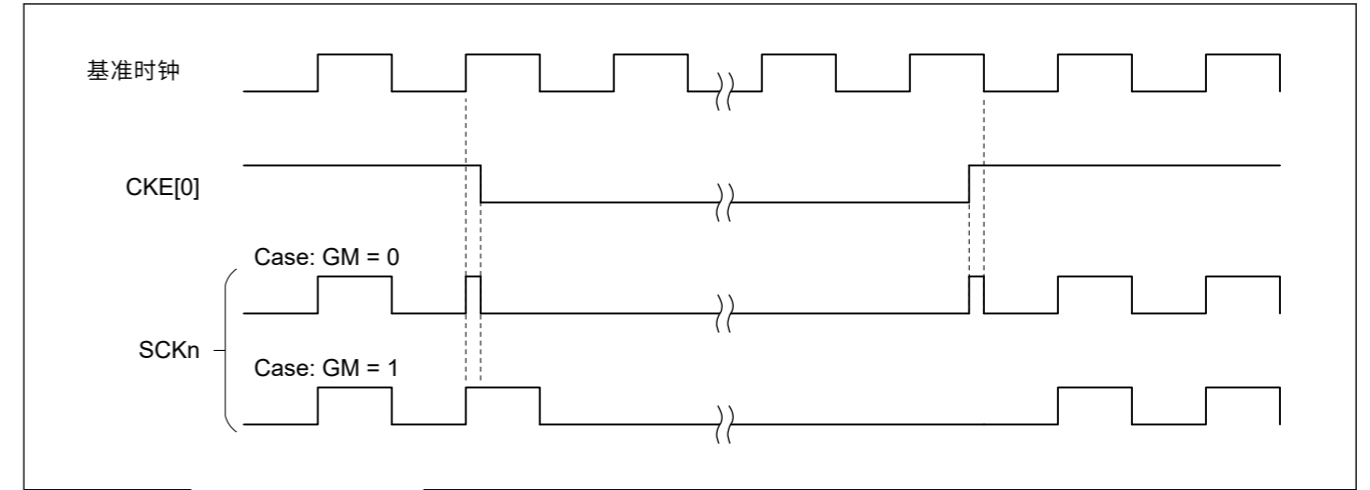


Figure 27.87 时钟输出时序

### 27.8 简单IIC模式下的操作

简单IIC模式格式由8个数据位和一个确认位组成。通过在启动条件或重新启动条件之后继续进入从地址帧，主设备可以指定从设备作为通信伙伴。当前指定的从设备保持有效，直到指定新的从设备或满足停止条件。所有帧中的8个数据位从MSB开始按顺序传输。

I<sup>2</sup>C总线格式和I<sup>2</sup>C总线时序如图27.88和图27.89所示。

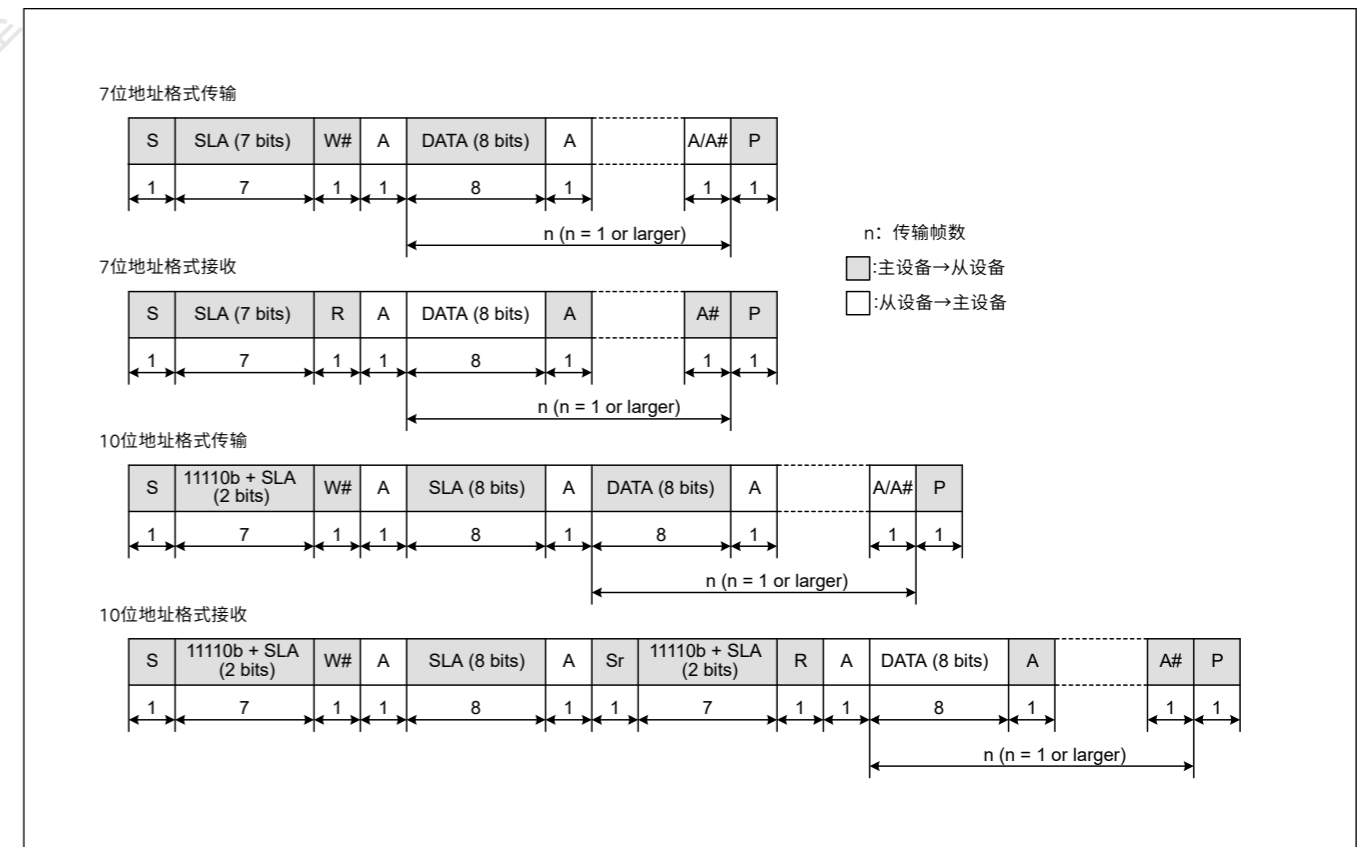
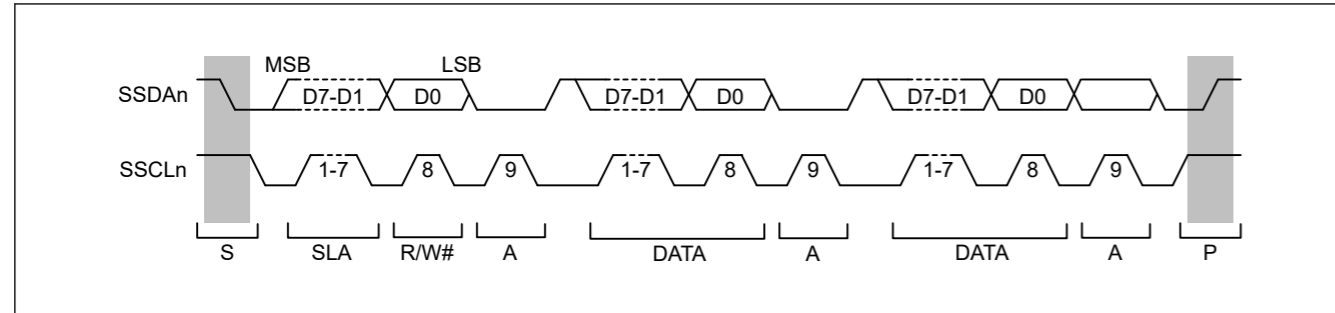


Figure 27.88 I<sup>2</sup>C总线格式

Figure 27.89 I<sup>2</sup>C bus timing when SLA is 7 bits

- S: Indicates a start condition, when the master device changes the level on the SDA<sub>n</sub> line from high to low while the SCL<sub>n</sub> line is high
- SLA: Indicates a slave address, by which the master device selects a slave device
- R/W#: Indicates the direction of transfer (reception or transmission). The value 1 indicates transfer from the slave device to the master device and 0 indicates transfer from the master device to the slave device.
- A/A#: Indicates an acknowledge bit. This is returned by the slave device for master transmission and by the master device for master reception. Return low indicates ACK and return high indicates NACK.
- Sr: Indicates a restart condition, when the master device changes the level on the SDA<sub>n</sub> line from high to low while the SCL<sub>n</sub> line is high and after the setup time elapses
- DATA: Indicates the data being received or transmitted
- P: Indicates a stop condition, when the master device changes the level on the SDA<sub>n</sub> line from low to high while the SCL<sub>n</sub> line is high

### 27.8.1 Generation of Start, Restart, and Stop Conditions

Writing 1 to the SIMR3.IICSTAREQ bit causes the generation of a start condition. The generation of a start condition proceeds through the following operations:

- The level on the SDA<sub>n</sub> line falls (from the high level to the low level) and the SCL<sub>n</sub> line is kept in the released state
- The hold time for the start condition is set as half of a bit period at the bit rate determined by the BRR setting
- The level on the SCL<sub>n</sub> line falls (from the high level to the low level), the IICSTAREQ bit in SIMR3 is set to 0, and a start-condition generated interrupt is output

Writing 1 to the IICRSTAREQ bit in SIMR3 causes the generation of a restart condition. The generation of a restart condition proceeds through the following operations:

- The SDA<sub>n</sub> line is released and the SCL<sub>n</sub> line is kept at the low level
- The period at low level for the SCL<sub>n</sub> line is set as half of a bit period at the bit rate determined by the BRR setting
- The SCL<sub>n</sub> line is released (transition from the low to the high level)
- When a high level is detected on the SCL<sub>n</sub> line, the setup time for the restart condition is set as half of a bit period at the bit rate determined by the BRR setting
- The level on the SDA<sub>n</sub> line falls (from the high level to the low level)
- The hold time for the restart condition is set as half of a bit period at the bit rate determined by the BRR setting
- The level on the SCL<sub>n</sub> line falls (from the high level to the low level), the SIMR3.IICRSTAREQ bit is set to 0, and a restart-condition generated interrupt is output

Writing 1 to the SIMR3.IICSTPREQ bit causes the generation of a stop condition. The generation of a stop condition proceeds through the following operations:

- The level on the SDA<sub>n</sub> line falls (from the high level to the low level) and the SCL<sub>n</sub> line is kept at the low level
- The period at low level for the SCL<sub>n</sub> line is set as half of a bit period at the bit rate determined by the BRR setting
- The SCL<sub>n</sub> line is released (transition from the low to the high level)

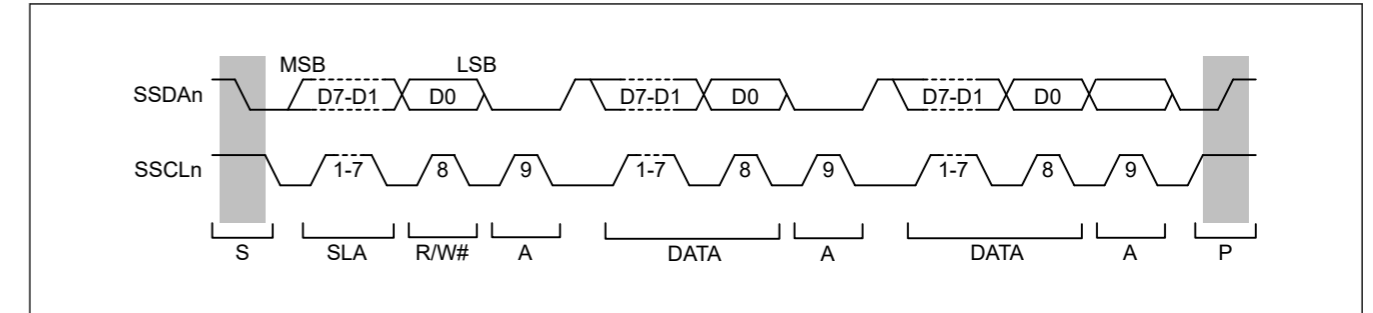


Figure 27.89 SLA为7位时的I2C总线时序

- S: 表示启动条件，当主设备在SCL<sub>n</sub>线为高时将SDA<sub>n</sub>线上的电平从高电平变为低电平
- SLA: 表示从地址，主设备通过该地址选择从设备
- RW#: 指示传输方向（接收或传输）。值1表示从从设备传输到主设备，0表示从主设备传输到从设备。
- AA#: 表示确认位。这由从设备返回用于主传输，并由主设备返回用于主接收。返回低电平表示ACK，返回高电平表示NACK。
- Sr: 表示重启条件，当主设备将SDA<sub>n</sub>线上的电平从高电平变为低电平，而SCL<sub>n</sub>线为高电平且经过设置时间后
- DATA: 表示正在接收或发送的数据
- P: 表示停止条件，当主设备将SDA<sub>n</sub>线上的电平从低电平变为高电平而SCL<sub>n</sub>线为高电平时

### 27.8.1 启动、重启和停止条件的生成

将1写入SIMR3.IICSTAREQ位会导致产生启动条件。开始条件的生成通过以下操作进行:

- SDA<sub>n</sub>线上的电平下降（从高电平到低电平），SCL<sub>n</sub>线保持在释放状态
- 开始条件的保持时间设置为比特周期的一半，比特率由BRR设置确定
- SCL<sub>n</sub>线上的电平下降（从高电平到低电平），SIMR3中的IICSTAREQ位设置为0，并输出一个起始条件产生的中断

将1写入SIMR3中的IICRSTAREQ位会导致产生重启条件。重新启动条件的生成通过以下操作进行:

- SDA<sub>n</sub>线释放，SCL<sub>n</sub>线保持低电平
- SCL<sub>n</sub>线的低电平周期设置为比特周期的一半，比特率由BRR设置确定
- SCL<sub>n</sub>线被释放（由低电平转变为高电平）
- 当在SCL<sub>n</sub>线上检测到高电平时，重新启动条件的建立时间设置为BRR设置确定的比特率的半个比特周期
- SDA<sub>n</sub>线上的电平下降（从高电平到低电平）
- 重启条件的保持时间设置为比特周期的一半，比特率由BRR设置确定
- SCL<sub>n</sub>线上的电平下降（从高电平变为低电平），SIMR3.IICRSTAREQ位设置为0，并输出重启条件产生的中断

将1写入SIMR3.IICSTPREQ位会导致产生停止条件。停止条件的生成通过以下操作进行:

- SDA<sub>n</sub>线上的电平下降（从高电平到低电平），SCL<sub>n</sub>线保持在低电平
- SCL<sub>n</sub>线的低电平周期设置为比特周期的一半，比特率由BRR设置确定
- SCL<sub>n</sub>线被释放（由低电平转变为高电平）

- When a high level is detected on the SCLn line, the setup time for the stop condition is set as half of a bit period at the bit rate determined by the BRR setting
- The SDA<sub>n</sub> line is released (transition from the low to the high level), the SIMR3.IICSTPREQ bit is set to 0, and a stop-condition generated interrupt is output

Figure 27.90 shows the timing of operations in the generation of start, restart, and stop conditions.

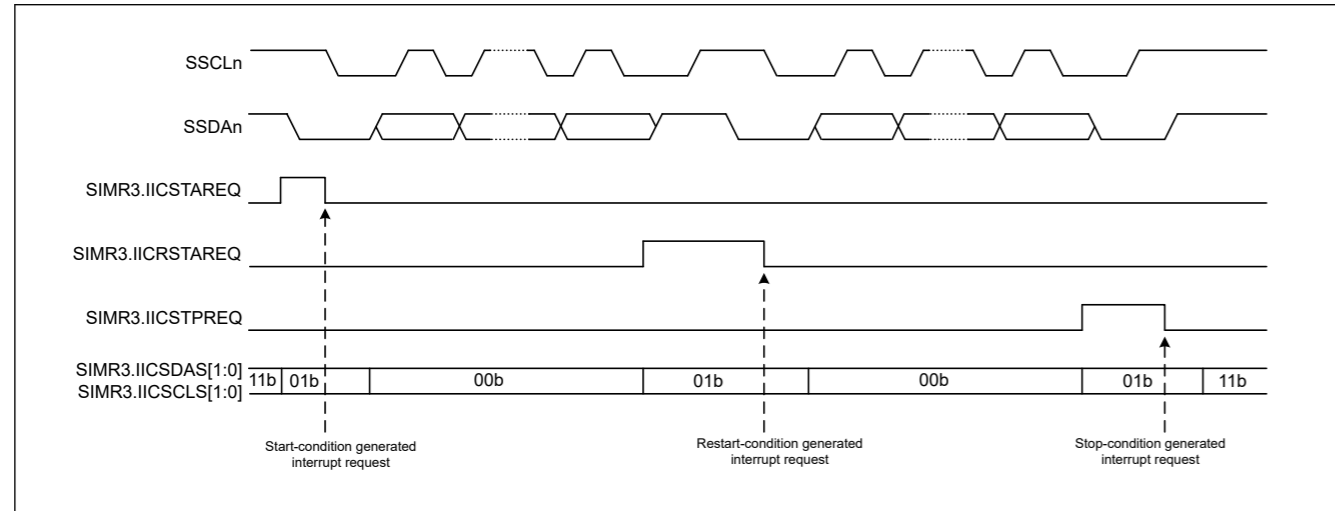


Figure 27.90 Timing of operations in generation of start, restart, and stop conditions

### 27.8.2 Clock Synchronization

The SCLn line can be driven low if a wait is inserted by a slave device at the other side of the transfer. Setting the SIMR2.IICCSC bit to 1 applies control to obtain synchronization when a difference arises between the levels of the internal SCLn clock signal and the level being input on the SCLn pin.

When the SIMR2.IICCSC bit is set to 1, the level of the internal SCLn clock signal changes from low to high. Counting to determine the period at a high level stops while the low level is being input on the SCLn pin. Counting to determine the period at a high level starts after the transition of the input on the SCLn pin to the high level.

The interval from this time until counting to determine the period at high level starts on the transition of the SCLn pin to the high level, is the total of the delay of SCLn output, delay for noise filtering of the input on the SCLn pin (2 or 3 cycles of sampling clock for the noise filter), and delay for internal processing (1 or 2 cycles of PCLK). The period at high level of the internal SCLn clock is extended even when other devices do not place the low level on the SCLn line.

If the SIMR2.IICCSC bit is 1, synchronization is obtained for the transmission and reception of data by taking the logical AND of the input on the SCLn pin and the internal SCLn clock. If the SIMR2.IICCSC bit is 0, synchronization with the internal SCLn clock is obtained for the transmission and reception of data.

If a slave device inserts a wait period into the interval until the transition of the internal SCLn clock signal from the low to the high level after a request for the generation of a start, restart, or stop condition is issued, the time until generation is prolonged by that period.

If a slave device inserts a wait period after the transition of the internal SCLn clock signal from the low to the high level, although the generation-completed interrupt is issued without stopping the waiting period, generation of the condition itself is not guaranteed. Figure 27.91 shows an example operation for synchronizing the clocks.

- 当在SCLn线上检测到高电平时，停止条件的建立时间设置为比特周期的一半，比特率由BRR设置确定
- SDA<sub>n</sub>线被释放（从低电平转换为高电平），SIMR3.IICSTPREQ位设置为0，并输出停止条件生成中断

图27.90显示了生成启动、重新启动和停止条件的操作时序。

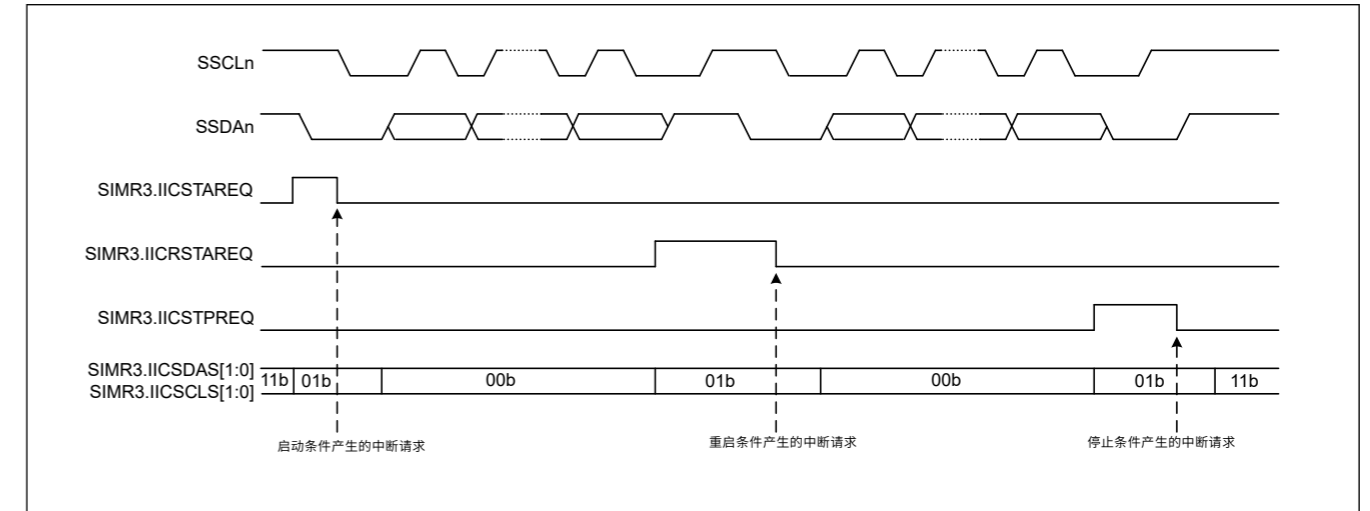


Figure 27.90 生成启动、重启和停止条件时的操作时序

### 27.8.2 时钟同步

如果从设备在传输的另一侧插入等待，则可以将SCLn线驱动为低电平。设置当内部电平之间出现差异时，SIMR2.IICCSC位为1应用控制以获得同步SCLn时钟信号和输入到SCLn引脚的电平。

当SIMR2.IICCSC位设置为1时，内部SCLn时钟信号的电平由低变为高。当SCLn引脚输入低电平时，停止计数以确定高电平周期。在SCLn引脚上的输入转换为高电平后，开始计数以确定高电平的周期。

从这个时间到从SCLn引脚转变为高电平开始计数确定高电平周期的时间间隔是SCLn输出延迟的总和，SCLn引脚上输入的噪声过滤延迟（2或3个周期的采样时钟用于噪声滤波器），以及延迟用于内部处理（1或2个PCLK周期）。即使其他设备没有将低电平置于SCLn线上，内部SCLn时钟的高电平周期也会延长。

如果SIMR2.IICCSC位为1，则通过取逻辑数据的发送和接收来获得同步SCLn引脚上的输入与内部SCLn时钟的与。如果SIMR2.IICCSC位为0，则与内部SCLn时钟同步以进行数据的发送和接收。

如果从设备在发出启动、重启或停止条件的生成请求后，在内部SCLn时钟信号从低电平转变为高电平之前的间隔中插入一个等待周期，则直到生成的时间为延长了那个时期。

如果从设备在内部SCLn时钟信号从低电平转变为高电平之后插入等待周期，尽管在不停止等待周期的情况下发出生成完成中断，但不能保证条件本身的生成。图27.91显示了同步时钟的示例操作。

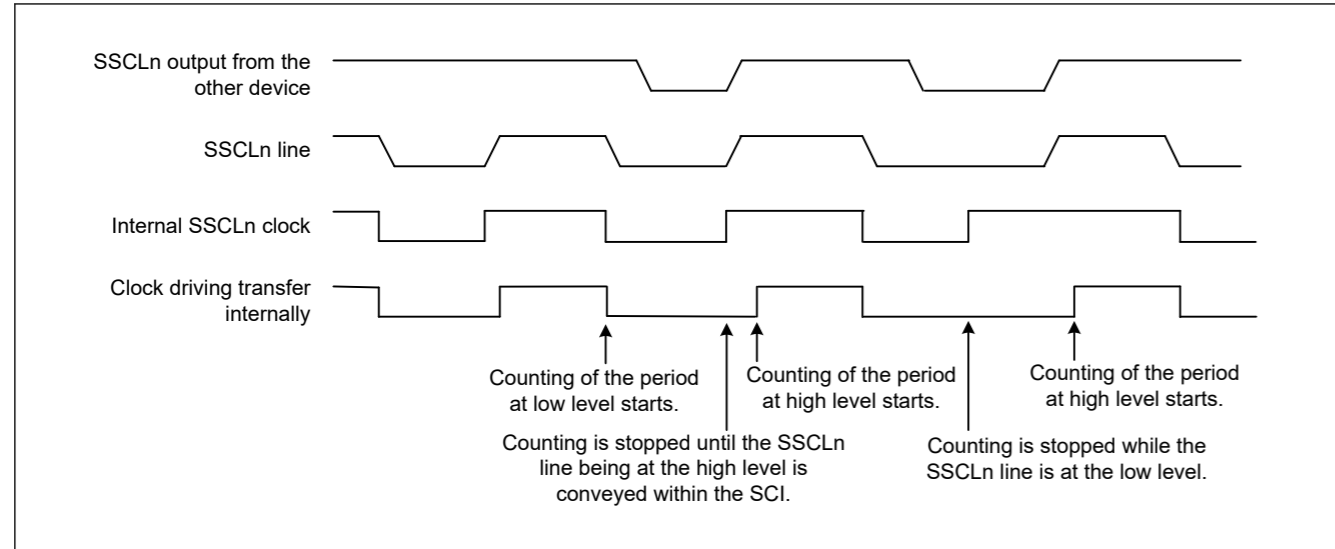


Figure 27.91 Example operations for clock synchronization

### 27.8.3 SDAn Output Delay

The SIMR1.IICDL[4:0] bits can be used to set a delay for output on the SDAn pin relative to falling edges of output on the SCLn pin. Delay settings from 0 to 31 are selectable, representing periods of the corresponding numbers of cycles of the clock signal from the on-chip baud rate generator (derived by frequency-dividing the base clock, PCLK, by the divisor selected in the SMR.CKS[1:0] bits). A delay for output on the SDAn pin applies to the start condition/restart condition/stop condition signal, 8-bit transmit data, and acknowledge bit.

If the SDAn output delay is shorter than the time for the level on the SCLn pin to fall, the change of the output on the SDAn pin starts while the output level on the SCLn pin is falling, creating a possibility of erroneous operation for slave devices. Ensure that settings for the delay of output on the SDAn pin specify times greater than the time output on the SCLn pin takes to fall (300 ns for IIC in normal mode and fast mode).

Figure 27.92 shows the timing of delays in SDAn output.

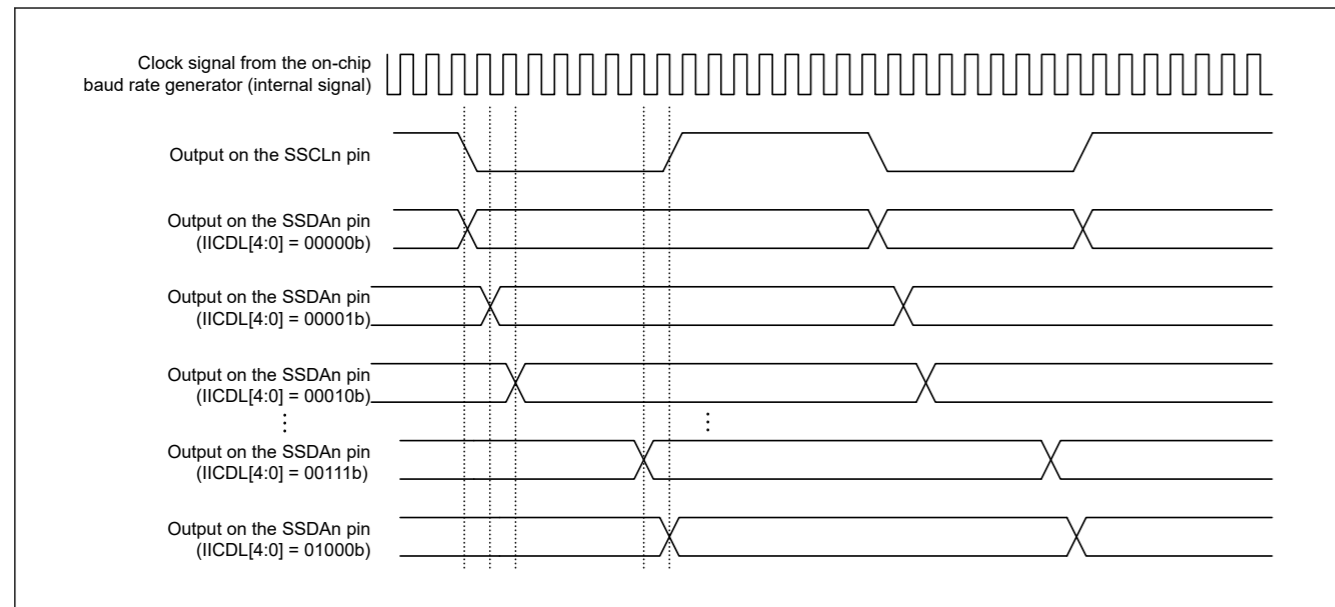


Figure 27.92 Timing of delays in SDAn output

### 27.8.4 SCI Initialization in Simple IIC Mode

Before transferring data, write the initial value 0x00 to SCR and initialize the interface following the example shown in Table 27.40.

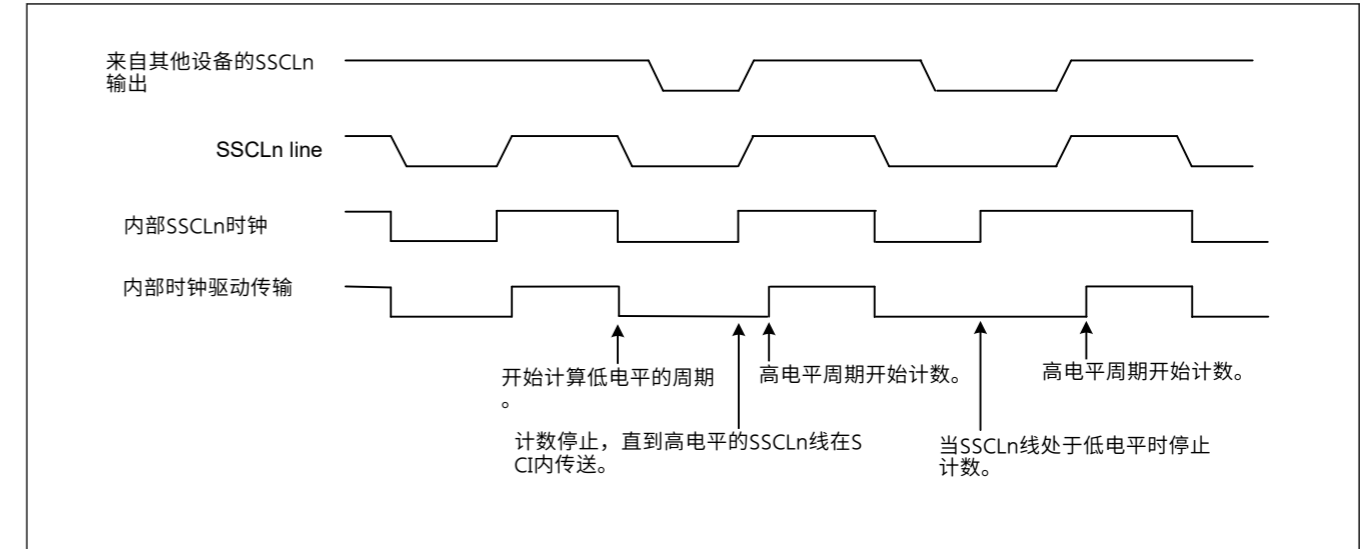


Figure 27.91 时钟同步的示例操作

### 27.8.3 SDAn输出延迟

SIMR1.IICDL[4:0]位可用于设置SDAn引脚输出相对于输出下降沿的延迟。SCLn引脚。从0到31的延迟设置是可选的，表示来自片上波特率发生器的时钟信号的相应周期数的周期（通过在SMR.CKS中选择的除数对基本时钟PCLK进行分频得出[1:0]位）。SDAn引脚上的输出延迟适用于启动条件/重启条件/停止条件信号、8位发送数据和确认位。

如果SDAn输出延迟小于SCLn引脚电平下降的时间，则SDAn引脚上的输出变化会在SCLn引脚上的输出电平下降时开始，从而产生从设备错误操作的可能性。确保SDAn引脚上的输出延迟设置指定的时间大于SCLn引脚上输出的下降时间（IIC在正常模式和快速模式下为300ns）。

图27.92显示了SDAn输出中的延迟时间。

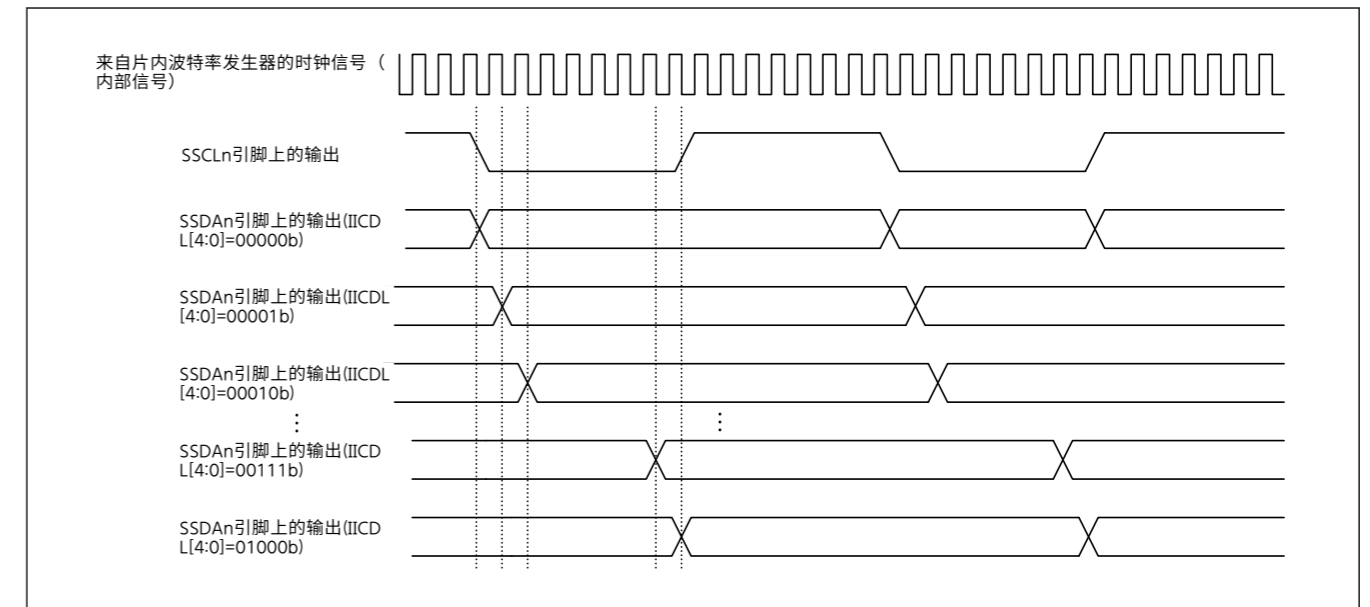


Figure 27.92 SDAn输出中的延迟时间

### 27.8.4 简单IIC模式下的SCI初始化

在传输数据之前，将初始值0x00写入SCR并按照中所示的示例初始化接口 Table 27.40.



Before making any changes to the operating mode or transfer format, be sure to set SCR to its initial value. In simple IIC mode, the open-drain setting for the communication ports should be made on the port side.

**Table 27.40 Example flow of SCI initialization in simple IIC mode**

| No. | Step Name   | Description   |
|-----|---|---|
| 1   | Start of initialization   |   |
| 2   | Set the TIE, RIE, TE, RE, TEIE and CKE[1:0] bits in SCR to 0          |   |
| 3   | Set the I/O port functions  | Set the I/O port to allow use (on N-channel open-drain output pins) of the SSCLn and SSDAn pin functions.   |
| 4   | Set the IICSDAS[1:0] and IICSCLS[1:0] bits in SIMR3 to 11b            | Place the SSCLn and SSDAn pins in the high-impedance state until a start condition is to be generated.  |
| 5   | Set up the transfer or reception format in SMR and SCMR               | Set the format for transmission and reception in SMR and SCMR. In SMR, set the CKS[1:0] bits to the target value and set the other bits to 0. In SCMR, set the SDIR bit to 1 and the SINV and SMIF bits to 0.   |
| 6   | Set the initial value to SPTR.  | Set the Initial value to SPTR.  |
| 7   | Set the value in BRR  | Write the value for the targeted bit rate to BRR.   |
| 8   | Set a value in MDDR   | Write the value obtained by correcting a bit rate error in MDDR. This step is not required if the BRME bit in SEMR is set to 0.   |
| 9   | Set the values in SEMR, SNFR, SIMR1, SIMR2, and SPMR                  | Set the values in SEMR, SNFR, SIMR1, SIMR2, and SPMR. Set the NFEN and BRME bits in SEMR. In SNFR, set the NFCS[2:0] bits. In SIMR1, set the IICM bit to 1 and the IICDL[4:0] bits as required. In SIMR2, set the IICACKT and IICCS bits to 1 and the IICINTM bits as required. In SPMR, set all the bits to 0. |
| 10  | Set the SCR.RE and TE bit to 1 and set the SCR.TIE, RIE and TEIE bits | Set the RE and TE bits in the SCR to 1. Then, set the SCR.TIE, RIE, and TEIE bits (for transmission and when the SIMR2.IICINTM bit is 1, set the RIE bit to 0). Setting the TE and RE bits to 1 enables the SSCLn and SSDAn pin functions.  |
| 11  | Start of transmission or reception                                    |   |

### 27.8.5 Operation in Master Transmission in Simple IIC Mode

Figure 27.93 and Figure 27.94 show examples of master transmission and Figure 27.95 shows an example flow of data transmission. The value of the SIMR2.IICINTM bit is assumed to be 1 (use reception and transmission interrupts) and the value of the SCR.RIE bit is assumed to be 0 (SCIn\_RXI and SCIn\_ERI interrupt requests are disabled). See Table 27.45 for more information on the STI interrupt.

When 10-bit slave addresses are in use, steps [3] and [4] in Figure 27.95 are repeated twice.

In simple IIC mode, the transmit data empty interrupt (SCIn\_TXI) is generated when communication of one frame is complete, unlike the SCIn\_TXI interrupt request generation timing during clock synchronous transmission.

在对操作模式或传输格式进行任何更改之前，请务必将SCR设置为其初始值。在简单IIC模式下，通信端口的开漏设置应在端口侧进行。

**Table 27.40 简单IIC模式下SCI初始化示例流程**

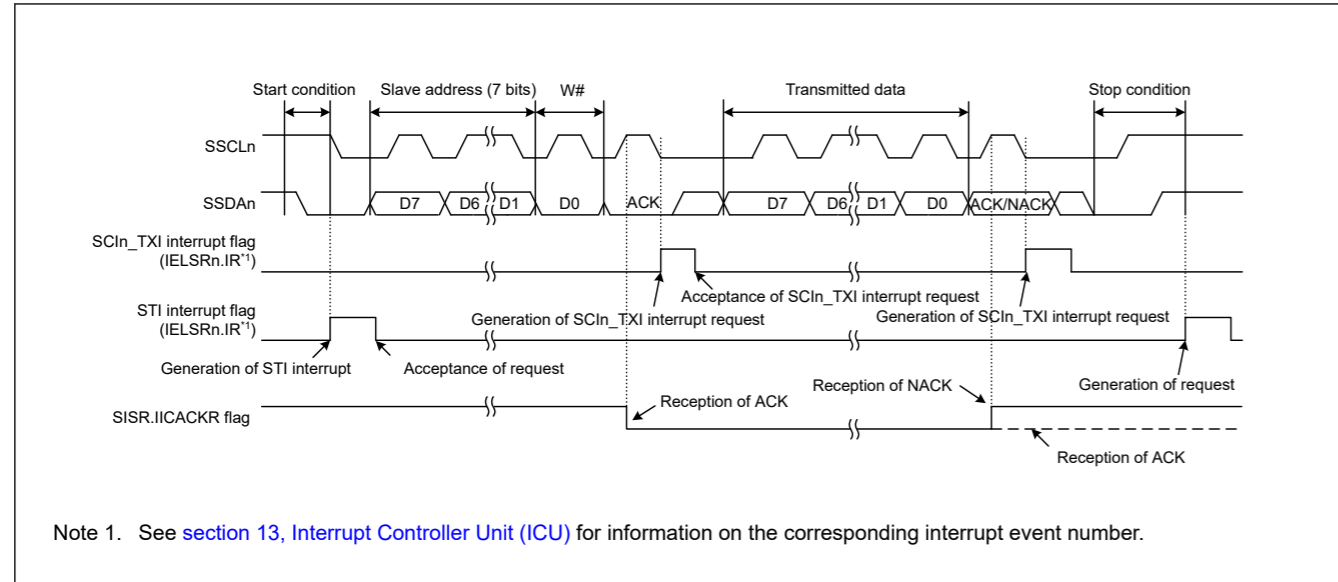
| No. | 步骤名称                                    | Description   |
|-----|---|---|
| 1   | 初始化开始                                   |   |
| 2   | 将SCR中的TIE、RIE、TE、RE、TEIE和CKE[1:0]位设置为0  |   |
| 3   | 设置IO端口功能                                | 设置IO端口以允许使用（在N通道开漏输出引脚上）SSCLn和SSDAn引脚功能。  |
| 4   | 设置IICSDAS[1:0]和SIMR3至11b中的IICSCLS[1:0]位 | 将SSCLn和SSDAn引脚置于高阻抗状态，直到产生启动条件。   |
| 5   | 在SMR和SCMR中设置传输或接收格式                     | 在SMR和SCMR中设置发送和接收的格式。在SMR中，将CKS[1:0]位设置为目标值，并将其他位设置为0。在SCMR中，将SDIR位设置为1，将SINV和SMIF位设置为0。  |
| 6   | 将初始值设置为SPTR。                            | 将初始值设置为SPTR。  |
| 7   | 设置BRR中的值                                | 将目标比特率的值写入BRR。  |
| 8   | 在MDDR中设置一个值                             | 在MDDR中写入通过纠正比特率错误获得的值。此步骤不是必需的，如果SEMR中的BRME位设置为0。   |
| 9   | 设置SEMR中的值，SNFR, SIMR1, SIMR2, and SPMR  | 设置SEMR、SNFR、SIMR1、SIMR2和SPMR中的值。设置SEMR中的NFEN和BRME位。在SNFR中，设置NFCS[2:0]位。在SIMR1中，根据需要将IICM位和IICDL[4:0]位设置为1。在SIMR2中，根据需要将IICACKT和IICCS位设置为1，并将IICINTM位设置为1。在SPMR中，将所有位设置为0。 |
| 10  | 将SCR.RE和TE位设置为1，并设置SCR.TIE、RIE和TEIE位    | 将SCR中的RE和TE位设置为1。然后，设置SCR.TIE、RIE和TEIE位（用于传输且当SIMR2.IICINTM位为1时，将RIE位设置为0）。将TE和RE位设置为1启用SSCLn和SSDAn引脚功能。  |
| 11  | 开始发送或接收                                 |   |

### 27.8.5 简单IIC模式下的主传输操作

图27.93和图27.94显示了主机传输的示例，图27.95显示了数据传输的示例流程。SIMR2.IICINTM位的值假定为1（使用接收和发送中断），SCR.RIE位的值假定为0（SCIn\_RXI和SCIn\_ERI中断请求被禁用）。有关STI中断的更多信息，请参见表27.45。

当使用10位从地址时，图27.95中的步骤[3]和[4]重复两次。

在简单IIC模式下，与时钟同步传输期间的SCIn\_TXI中断请求产生时序不同，当一帧的通信完成时产生发送数据空中断（SCIn\_TXI）。



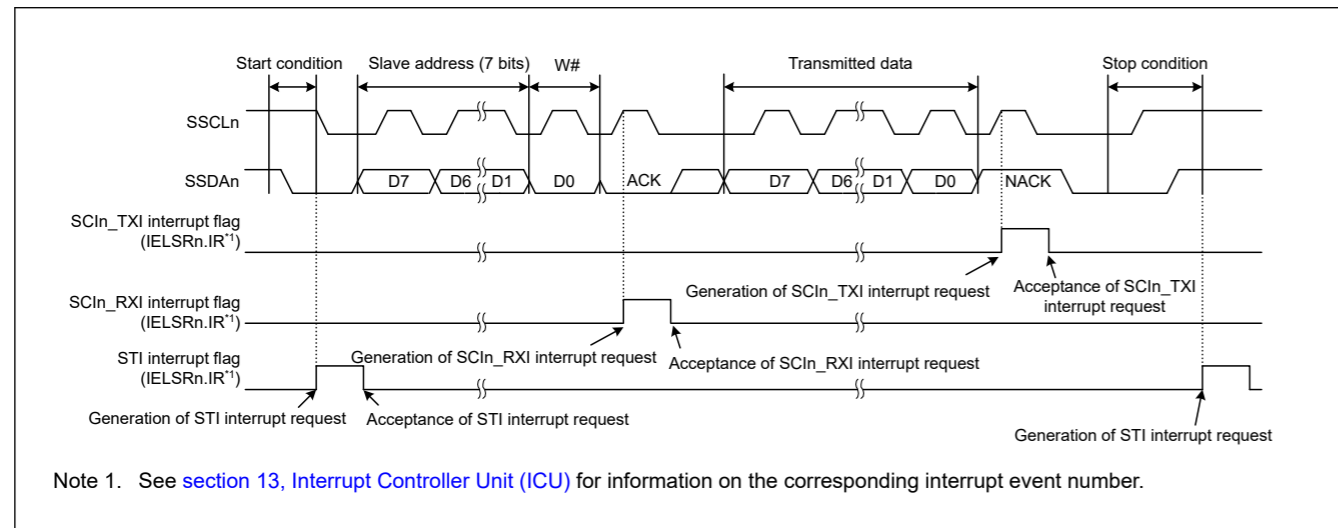
Note 1. See section 13, Interrupt Controller Unit (ICU) for information on the corresponding interrupt event number.

Figure 27.93 Example 1 of operations for master transmission in simple IIC mode with 7-bit slave addresses, transmission interrupts, and reception interrupts

When the SIMR2.IICINTM bit is set to 0 (use ACK/NACK interrupts) during master transmission, the DTC or DMAC is activated by the ACK interrupt as the trigger and required number of data bytes are transmitted. When the NACK is received, error processing such as transmission stop and retransmission is performed using the NACK interrupt as the trigger.

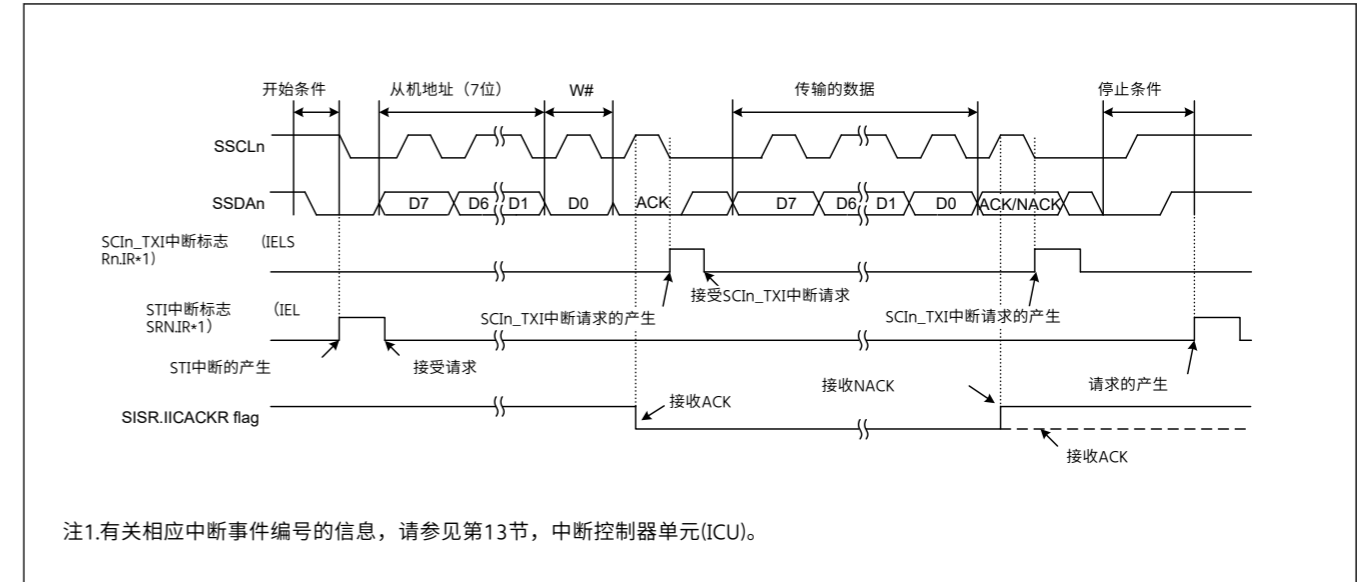
To restart communication for some reason after writing data in the TDR register, use the following procedure:

1. Set the TE and RE bits in the SCR register to 0 to stop communication.
2. Set 0xF0 in the SIMR3 register, release the I<sup>2</sup>C bus, and clear the generation of a condition.
3. If the RDRF flag in the SSR register is set, clear it.
4. Set the TE and RE bits in the SCR register to 1 and start the next communication.



Note 1. See section 13, Interrupt Controller Unit (ICU) for information on the corresponding interrupt event number.

Figure 27.94 Example 2 of operations for master transmission in simple IIC mode with 7-bit slave addresses, ACK interrupts, and NACK interrupts



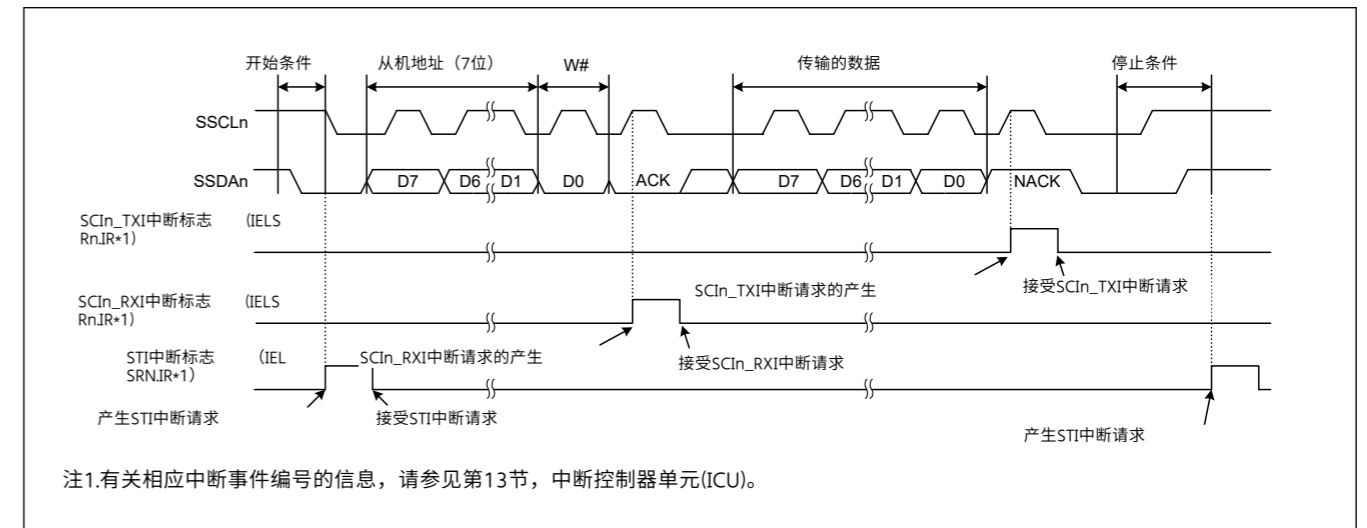
注1.有关相应中断事件编号的信息，请参见第13节，中断控制器单元(ICU)。

Figure 27.93 简单IIC模式下主机发送操作示例1，具有7位从机地址、发送中断和接收中断

当SIMR2.IICINTM位在主机传输期间设置为0（使用ACK/NACK中断）时，DTC或DMAC由ACK中断作为触发器激活并传输所需的数据字节数。接收到NACK时，以NACK中断为触发进行发送停止、重发等错误处理。

要在将数据写入TDR寄存器后出于某种原因重新启动通信，请使用以下过程：

- 1.将SCR寄存器中的TE和RE位设置为0以停止通信。
- 2.设置SIMR3寄存器中的0xF0，释放I<sup>2</sup>C总线，并清除条件的产生。
- 3.如果SSR寄存器中的RDRF标志被设置，则清除它。
- 4.将SCR寄存器中的TE和RE位设置为1，开始下一次通信。



注1.有关相应中断事件编号的信息，请参见第13节，中断控制器单元(ICU)。

Figure 27.94 使用7位从机地址、ACK中断和NACK中断的简单IIC模式下主机传输操作示例2

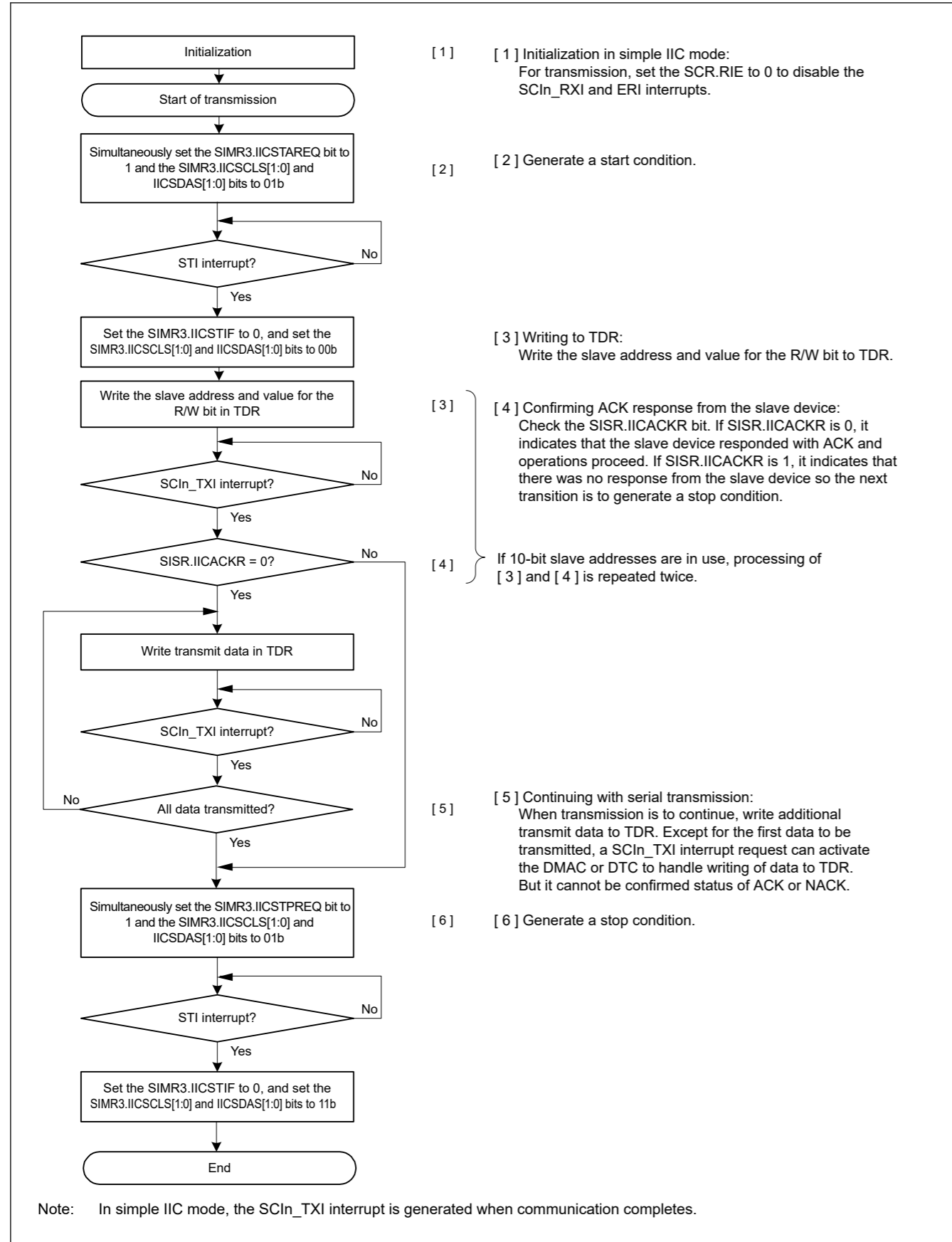


Figure 27.95 Example flow of master transmission in simple IIC mode with transmission interrupts and reception interrupts

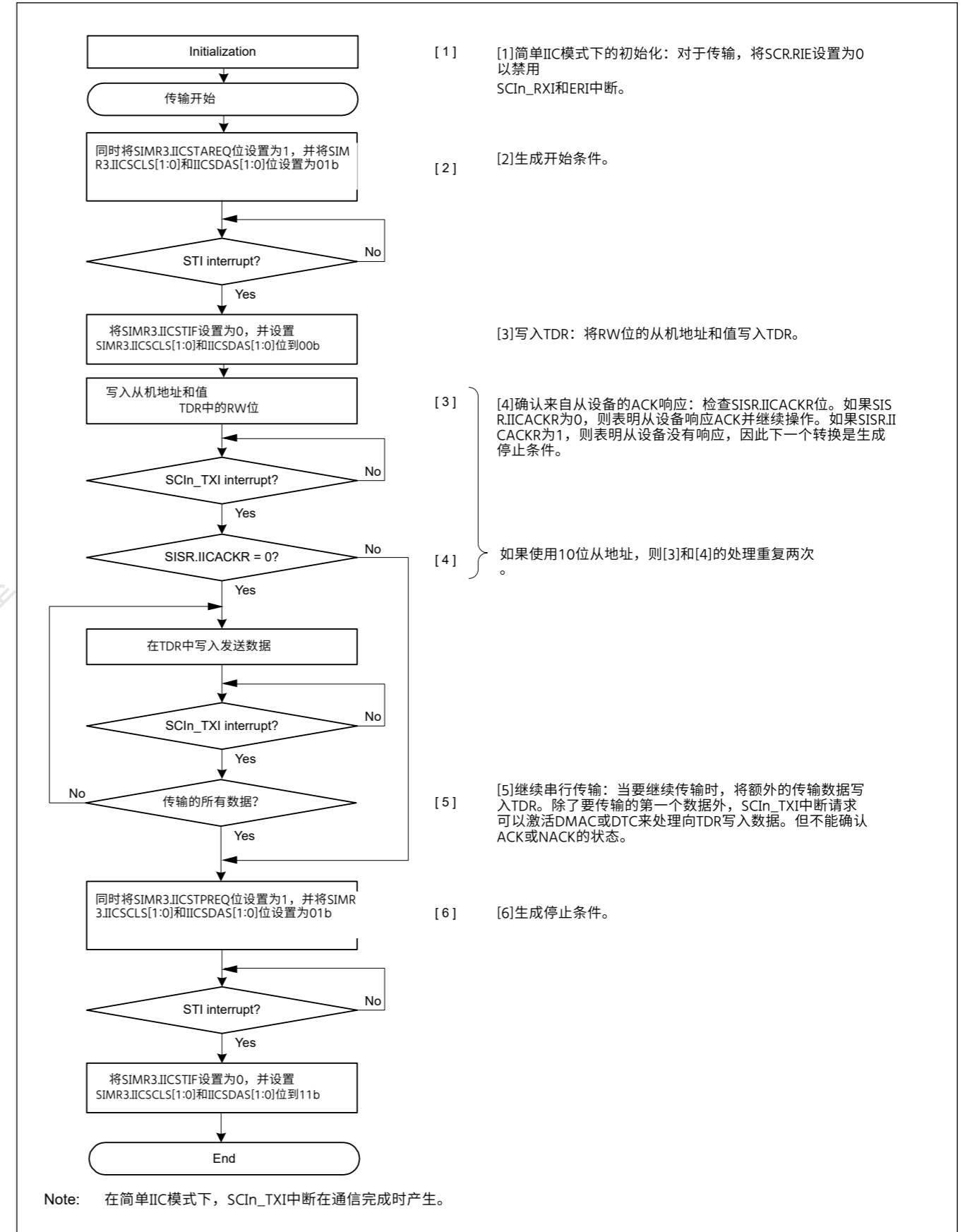


Figure 27.95 带有发送中断和接收中断的简单IIC模式下的主机发送示例流程

27.8.6 Master Reception in Simple IIC Mode

Figure 27.96 shows an example operation in simple IIC mode master reception and Figure 27.97 shows an example flow of master reception.

The value of the SIMR2.IICINTM bit is assumed to be 1 (use reception and transmission interrupts).

In simple IIC mode, the transmit data empty interrupt (SCIn\_TXI) is generated when communication of one frame is complete, unlike the SCIn\_TXI interrupt request generation timing during clock synchronous transmission.

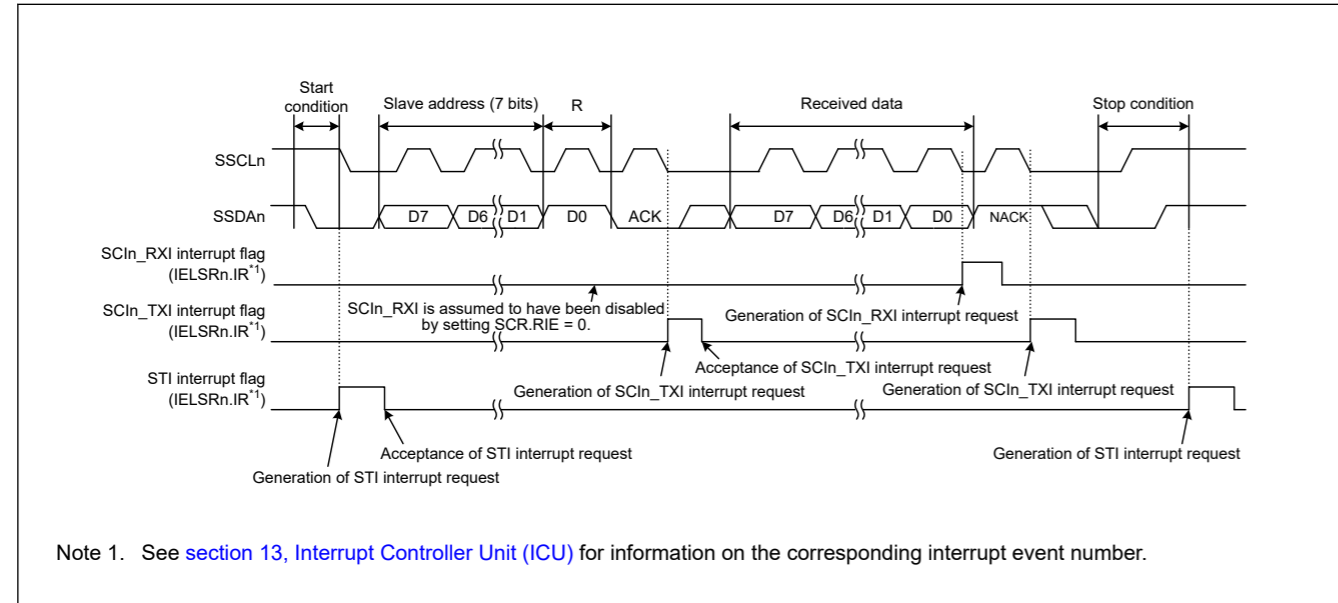


Figure 27.96 Example operations for master reception in simple IIC mode with 7-bit slave addresses, transmission interrupts, and reception interrupts

27.8.6 简单IIC模式下的主接收

图27.96显示了简单IIC模式主机接收的示例操作，图27.97显示了主机接收的示例流程。

SIMR2.IICINTM位的值假定为1（使用接收和发送中断）。

在简单IIC模式下，与时钟同步传输期间的SCIn\_TXI中断请求产生时序不同，当一帧的通信完成时产生发送数据空中断（SCIn\_TXI）。

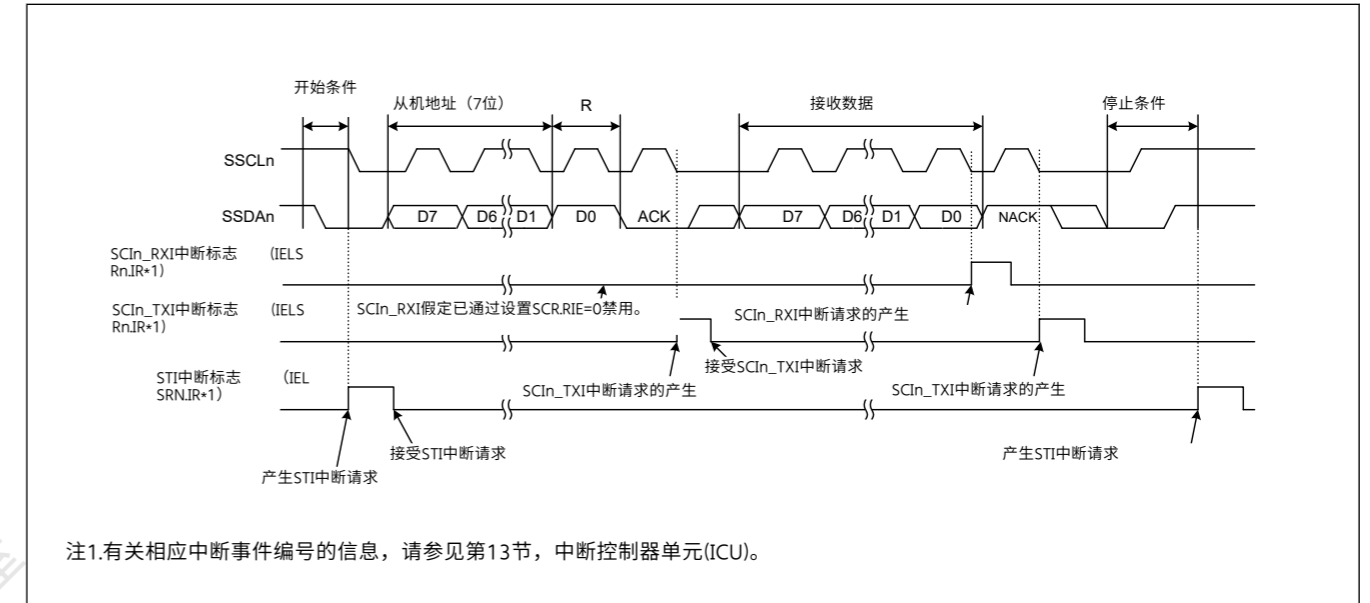


Figure 27.96 使用7位从地址、发送中断和接收中断的简单IIC模式下的主机接收示例操作



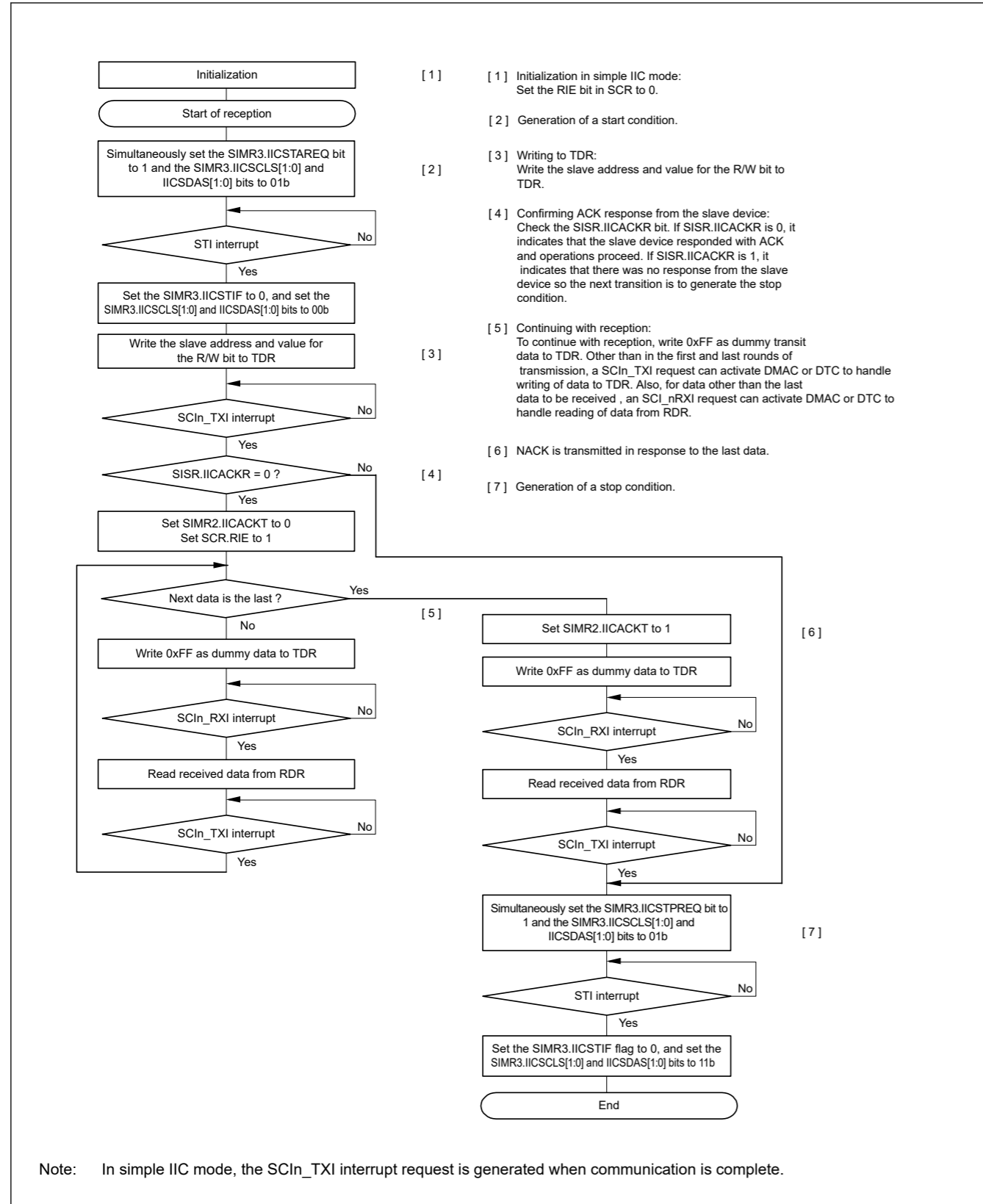


Figure 27.97 Example flow of master reception in simple IIC mode with transmission interrupts and reception interrupts

27.9 Operation in Simple SPI Mode

As an extended function, the SCI supports a simple SPI mode that handles transfer among one or multiple master devices and multiple slave devices.

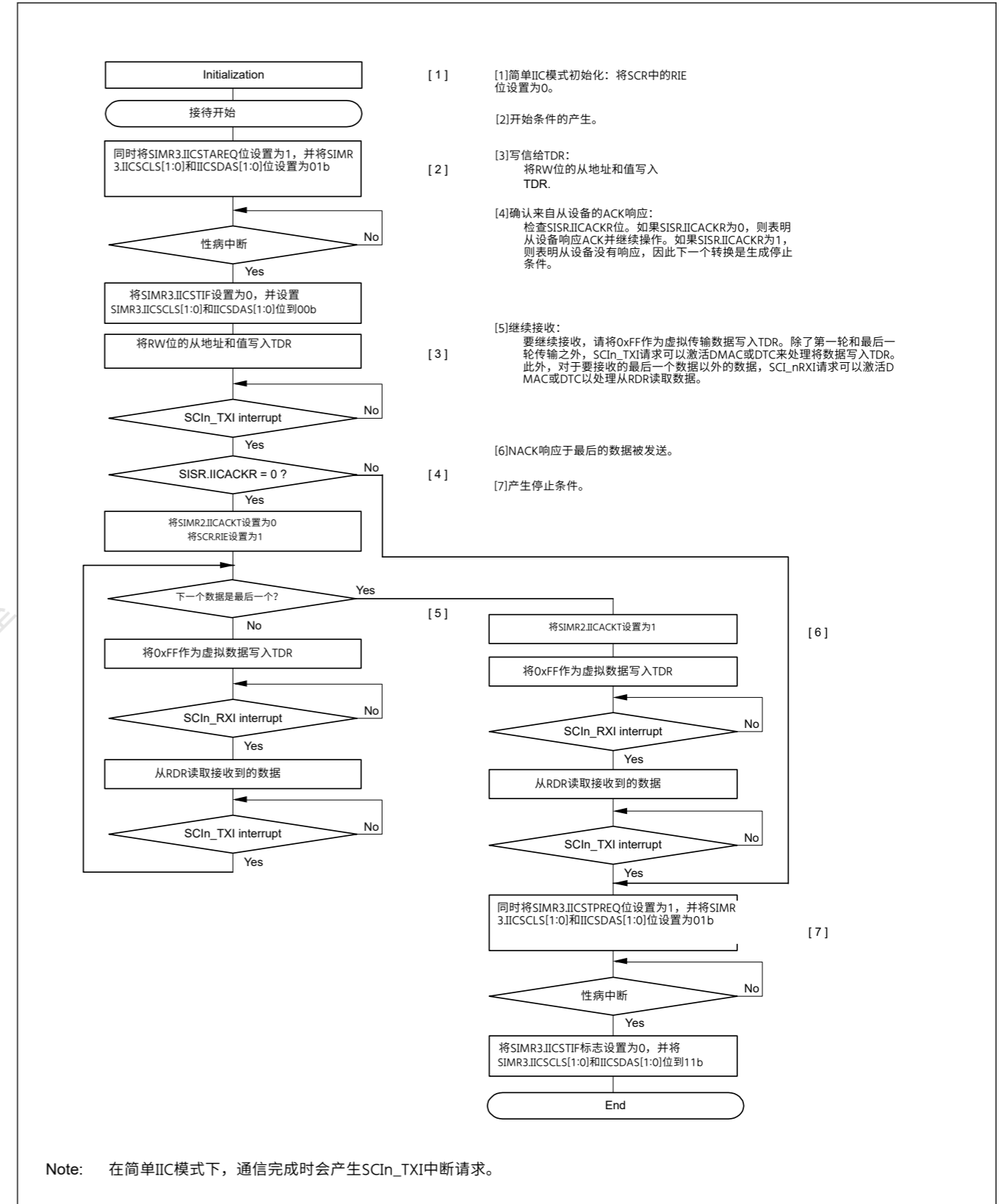


Figure 27.97 带有发送中断和接收中断的简单IIC模式下的主机接收示例流程

27.9 简单SPI模式下的操作

作为一项扩展功能, SCI支持简单的SPI模式, 可处理一个或多个主设备与多个从设备之间的传输。

Using the settings for clock synchronous mode (SCMR.SMIF = 0, SIMR1.IICM = 0, SMR.CM = 1) and setting the SPMR.SSE bit to 1 places the SCI in simple SPI mode. However, the SSn pin function on the master side is not required for connection of the device used as the master in simple SPI mode when the configuration only has a single master. Therefore, set the SPMR.SSE bit to 0 in such cases.

Figure 27.98 shows an example of connections for simple SPI mode. Control a general port pin to produce the SSn output signal from the master.

In simple SPI mode, data is transferred in synchronization with clock pulses in the same way as in clock synchronous mode. One character of data for transfer consists of 8 bits of data, and parity bits cannot be appended. The data can be inverted by setting the SCMR.SINV bit to 1.

Because the receiver and transmitter are independent of each other within the SCI module, full-duplex communications are possible, with a shared clock signal. Additionally, because both the transmitter and receiver have a buffered structure, writing the next transmit data while transmission is in progress and reading previously received data while reception is in progress are both possible. This enables continuous transfer.

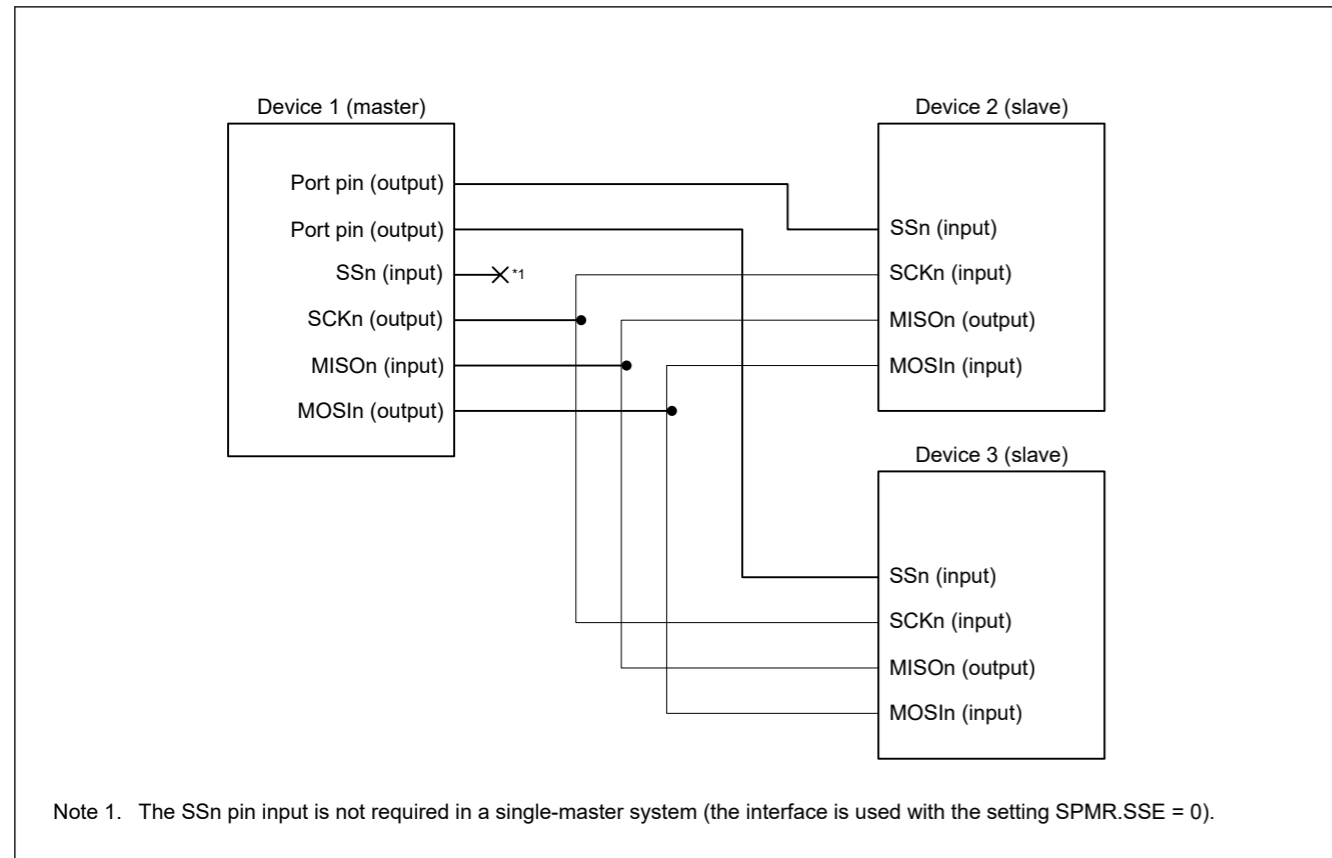


Figure 27.98 Example connections using simple SPI mode in single master mode with SPMR.SSE bit = 0

### 27.9.1 States of Pins in Master and Slave Modes

The direction (input or output) of pins for the simple SPI mode interface differs according to whether the device is a master (SCR.CKE[1:0] = 00b or 01b and SPMR.MSS = 0) or slave (SCR.CKE[1:0] = 10b or 11b and SPMR.MSS = 1).

Table 27.41 lists the relationship between the pin states, mode, and level on the SSn pin.

Table 27.41 States of pins by mode and input level on SSn pin (1 of 2)

| Mode          | Input on SSn pin                    | State of MOSI pin              | State of MISO pin                      | State of SCKn pin |
|---------------|-------------------------------------|--------------------------------|--|-------------------|
| Master mode*1 | High level (transfer can proceed)   | Output for data transmission*2 | Input for received data                | Clock output*3    |
|               | Low level (transfer cannot proceed) | High-impedance                 | Input for received data (but disabled) | High-impedance    |

使用时钟同步模式的设置(SCMR.SMIF=0 SIMR1.IICM=0 SMR.CM=1)并设置 SPMR.SSE位为1将SCI置于简单SPI模式。但是，当配置只有一个主控时，在简单SPI模式下连接用作主控的设备不需要主控侧的SSn引脚功能。因此，在这种情况下，将SPMR.SSE位设置为0。

图27.98显示了简单SPI模式的连接示例。控制一个通用端口引脚以产生来自主机的SSn输出信号。

在简单SPI模式下，数据与时钟脉冲同步传输，方式与时钟同步模式相同。1个字符的传输数据由8位数据组成，不能附加奇偶校验位。可以通过将SCMR.SINV位设置为1来反转数据。

由于接收器和发送器在SCI模块中彼此独立，因此可以使用共享时钟信号进行全双工通信。此外，由于发送器和接收器都具有缓冲结构，因此在发送过程中写入下一个发送数据和在接收过程中读取先前接收到的数据都是可能的。这使得连续传输成为可能。

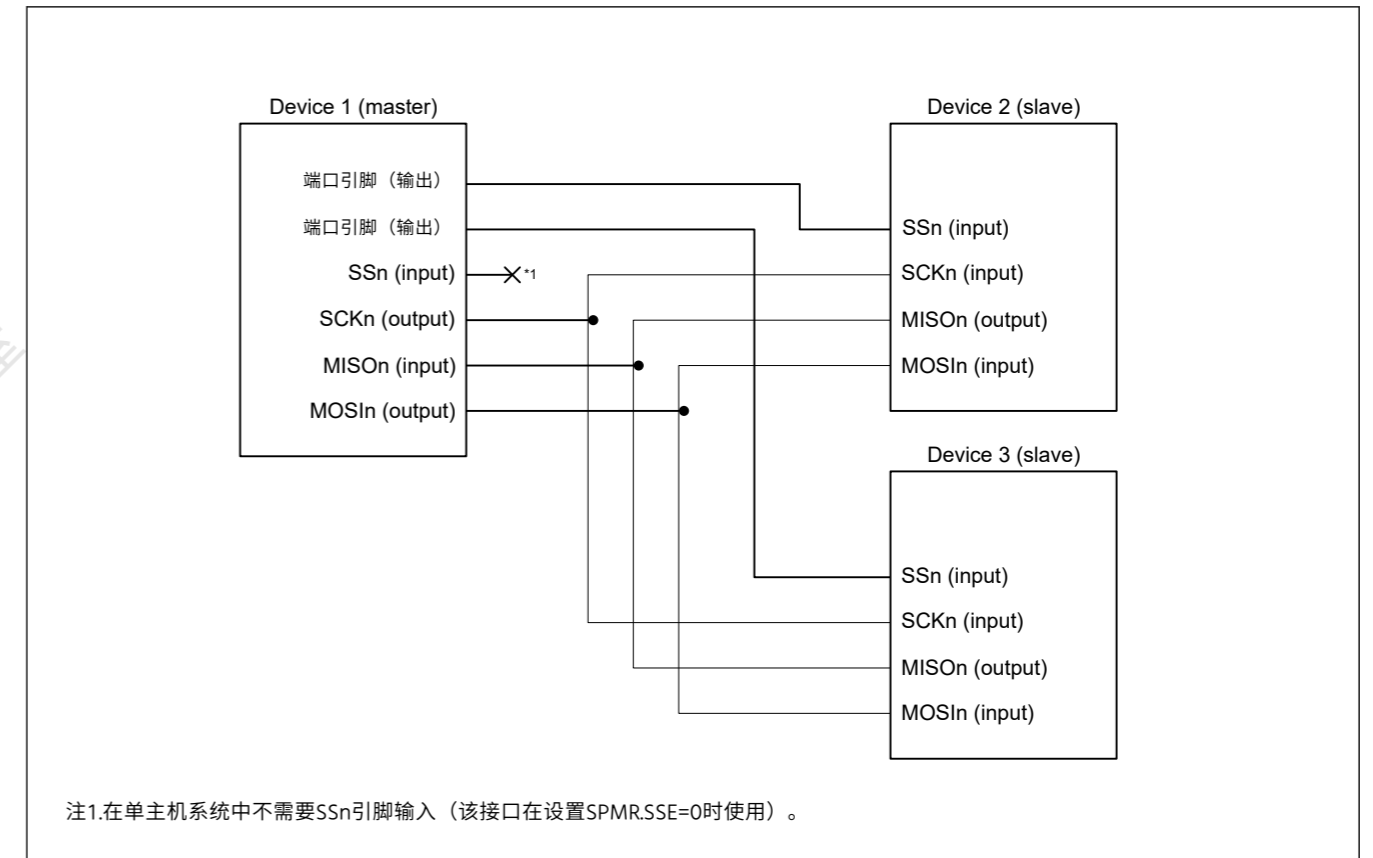


Figure 27.98 在SPMR.SSE位=0的单主模式下使用简单SPI模式的示例连接

### 27.9.1 主从模式下的引脚状态

简单SPI模式接口的引脚方向（输入或输出）根据设备是主设备（SCR.CKE[1:0]=00b或01b且SPMR.MSS=0）还是从设备（SCR.CKE[1:0]=10b或11b且SPMR.MSS=1）而不同。

表27.41列出了SSn引脚上的引脚状态、模式和电平之间的关系。

Table 27.41 SSn引脚上的模式和输入电平的引脚状态（2个中的1个）

| Mode  | SSn引脚上的输入   | MOSI引脚状态       | MISO引脚的状态    | SCKn引脚状态       |
|-------|-------------|----------------|--------------|----------------|
| 主模式*1 | 高电平（可以进行转移） | 数据传输用输出*2      | 接收数据的输入      | 时钟输出*3         |
|       | 低电平（传输无法进行） | High-impedance | 接收数据的输入（但禁用） | High-impedance |

Table 27.41 States of pins by mode and input level on SSn pin (2 of 2)

| Mode       | Input on SSn pin                     | State of MOSIn pin                     | State of MISOn pin           | State of SCKn pin          |
|------------|--------------------------------------|--|------------------------------|----------------------------|
| Slave mode | High level (transfer cannot proceed) | Input for received data (but disabled) | High-impedance               | Clock input (but disabled) |
|            | Low level (transfer can proceed)     | Input for received data                | Output for data transmission | Clock input                |

Note 1. When there is only a single master (SPMR.SSE = 0), transfer is possible regardless of the input level on the SSn pin. This is equivalent to input of a high level on the SSn pin.

Note 2. The MOSIn pin output is in the high-impedance state when serial transmission is disabled (SCR.TE bit = 0).

Note 3. The SCKn pin output is in the high-impedance state when serial transmission is disabled (SCR.TE and RE bits = 00b) in a multi-master configuration (SPMR.SSE = 1).

### 27.9.2 SS Function in Master Mode

Setting the CKE[1:0] bits in the SCR to 00b and the MSS bit in the SPMR to 0 selects master operation. The SSn pin is not used in single-master configurations (SPMR.SSE = 0), so transmission or reception can proceed regardless of the value of the SSn pin.

When the level on the SSn pin is high in a multi-master configuration (SPMR.SSE = 1), a master device outputs clock signals from the SCKn pin before starting transmission or reception to indicate that there are no other masters or another master is performing reception or transmission.

When the level on the SSn pin is low in a multi-master configuration (SPMR.SSE = 1), there are other masters, and a transmission or reception is in progress. The MOSIn output and SCKn pins are placed in the high-impedance state and starting transmission or reception is not possible. In addition, the value of the SPMR.MFF bit is 1, indicating a mode fault error. In a multi-master configuration, start error processing by reading SPMR.MFF flag. If a mode fault error occurs while transmission or reception is in progress, transmission or reception does not stop, but the MOSIn and SCKn outputs are in the high-impedance state after completion of the transfer. Use a general port pin to produce the SS output signal from the master.

### 27.9.3 SS Function in Slave Mode

Setting the SCR.CKE[1:0] bits to 10b and the SPMR.MSS bit to 1 selects slave operation. When the SSn pin is high, the MISOn output pin is in the high-impedance state and clock input through the SCKn pin is ignored. When the SSn pin is low, clock input through the SCKn pin is valid and transmission or reception can proceed.

If the input on the SSn pin changes from low to high during transmission or reception, the MISOn output pin is placed in the high-impedance state. Meanwhile, the internal processing for transmission or reception continues at the rate of the clock input through the SCKn pin until processing for the character being transmitted or received is complete, after which it stops, and the appropriate interrupt (SCIn\_TXI, SCIn\_RXI, or SCIn\_TEI) is generated.

### 27.9.4 Relationship between Clock and Transmit/Receive Data

The CKPOL and CKPH bits in the SPMR register can be used to set up the clock for use in transmission and reception in four different ways. The relation between the clock signal and the transmission and reception of data is shown in Figure 27.99. The relation is the same for both master and slave operation. This is the same as when the level on the SSn pin is high.

Table 27.41 SSn引脚上的模式和输入电平的引脚状态 (2个中的2个)

| Mode | SSn引脚上的输入    | MOSIn管脚状态     | MISOn引脚的状态     | SCKn引脚状态   |
|------|--------------|---------------|----------------|------------|
| 从机模式 | 高电平 (传输无法进行) | 接收数据的输入 (但禁用) | High-impedance | 时钟输入 (但禁用) |
|      | 低电平 (可以继续传输) | 接收数据的输入       | 数据传输输出         | 时钟输入       |

注1.当只有一个主机(SPMR.SSE=0)时,无论SSn引脚上的输入电平如何,都可以进行传输。这相当于在SSn引脚上输入高电平。

注2.当串行传输被禁用(SCR.TE位=0)时,MOSIn引脚输出处于高阻抗状态。

注3.在多主机配置(SPMR.SSE=1)中禁用串行传输(SCR.TE和RE位=00b)时,SCKn引脚输出处于高阻抗状态。

### 27.9.2 主控模式下的SS功能

将SCR中的CKE[1:0]位设置为00b并将SPMR中的MSS位设置为0来选择主机操作。SSn引脚不用于单主机配置(SPMR.SSE=0),因此无论SSn引脚的值如何,都可以进行发送或接收。

在多主机配置(SPMR.SSE=1)中,当SSn引脚上的电平为高电平时,主机设备在开始发送或接收之前从SCKn引脚输出时钟信号,以指示没有其他主机或另一个主机在进行接收或发送。

在多主机配置(SPMR.SSE=1)中,当SSn引脚上的电平为低电平时,存在其他主机,并且正在进行发送或接收。MOSIn输出和SCKn引脚处于高阻状态,无法开始发送或接收。此外,SPMR.MFF位的值为1,表示模式故障错误。在多主机配置中,通过读取SPMR.MFF标志开始错误处理。如果在发送或接收过程中发生模式故障错误,则发送或接收不会停止,但MOSIn和SCKn输出在传输完成后处于高阻抗状态。使用通用端口引脚从主机产生SS输出信号。

### 27.9.3 从模式下的SS功能

将SCR.CKE[1:0]位设置为10b并将SPMR.MSS位设置为1选择从机操作。当SSn引脚为高电平时,MISOn输出引脚处于高阻抗状态,通过SCKn引脚输入的时钟被忽略。当SSn引脚为低电平时,通过SCKn引脚输入的时钟有效,可以进行发送或接收。

如果SSn引脚上的输入在发送或接收期间从低电平变为高电平,则MISOn输出引脚处于高阻抗状态。同时,发送或接收的内部处理以通过SCKn引脚输入的时钟速率继续进行,直到对正在发送或接收的字符的处理完成,之后它停止,并出现适当的中断(SCIn\_TXI、SCIn\_RXI或SCIn\_TEI)生成。

### 27.9.4 时钟与发送接收数据的关系

SPMR寄存器中的CKPOL和CKPH位可用于以四种不同的方式设置用于发送和接收的时钟。时钟信号与数据收发发的关系如图27.99所示。主从操作的关系是相同的。这与SSn引脚上的电平为高电平时相同。

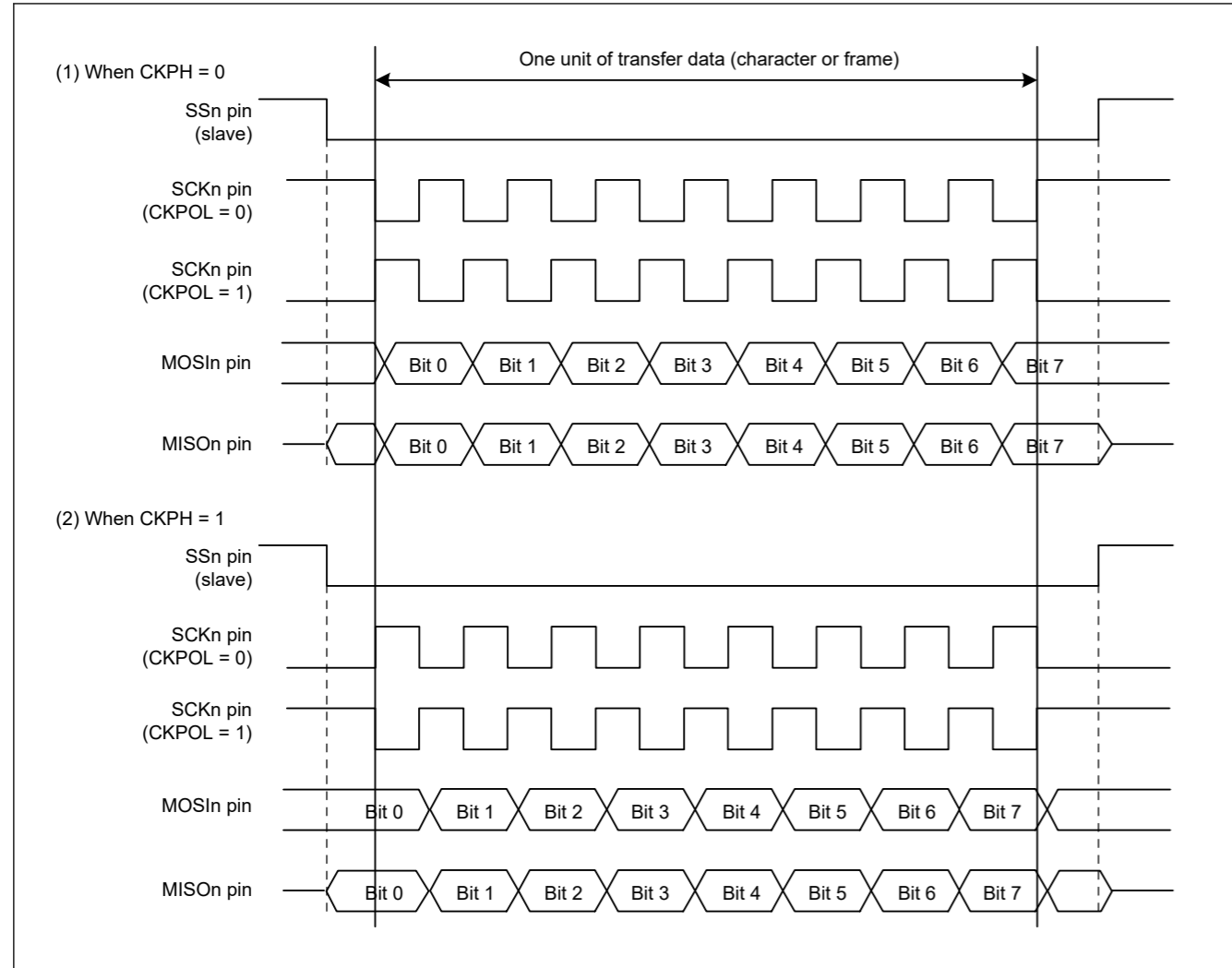


Figure 27.99 Relation between clock signal and transmit or receive data in simple SPI mode

### 27.9.5 SCI Initialization in Simple SPI Mode

Initialization in simple SPI mode is the same as in clock synchronous mode. See [section 27.6.3. SCI Initialization in Clock Synchronous Mode](#) for an example initialization flow. The CKPOL and CKPH bits in the SPMR register must be set to ensure that the clock signal is suitable for both master and slave devices.

Always initialize the SCR register before making any changes to the operating mode or transfer format.

Note: Only the RE bit is set to 0. The SSR.ORER, FER, PER, and RDR flags are not initialized.

Changing the value of the TE bit from 1 to 0 or from 0 to 1 when the TIE bit in the SCR register is 1 at the same time, leads to the generation of a transmit data empty interrupt (SCIn\_TXI).

### 27.9.6 Transmission and Reception of Serial Data in Simple SPI Mode

In master operation, ensure that the SSn pin of the slave device on the other side of the transfer is at the low level before starting the transfer and at the high level on completion of the transfer. Otherwise, the procedures are the same as in clock synchronous mode.

### 27.10 Bit Rate Modulation Function

Using the bit rate modulation function, the bit rate can be evenly corrected using the number specified in the MDDR register when the PCLK is selected in the CKS[1:0] bits in SMR/SMR\_SMCI.

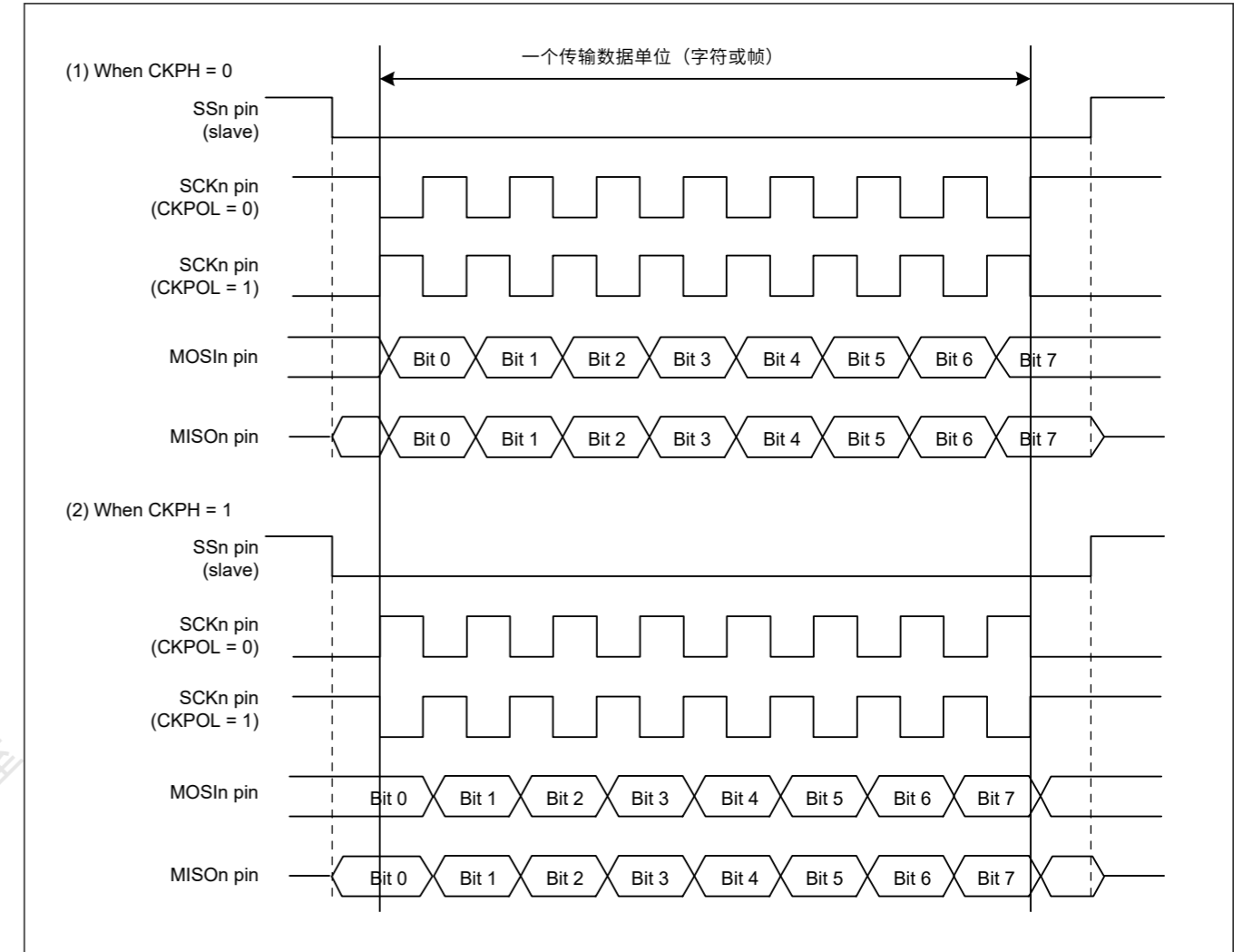


Figure 27.99 简单SPI模式下时钟信号与发送或接收数据的关系

### 27.9.5 简单SPI模式下的SCI初始化

简单SPI模式的初始化与时钟同步模式相同。请参见第27.6.3节。时钟中的SCI初始化示例初始化流程的同步模式。必须设置SPMR寄存器中的CKPOL和CKPH位，以确保时钟信号适用于主设备和从设备。

在对操作模式或传输格式进行任何更改之前，始终初始化SCR寄存器。

Note: 只有RE位设置为0。SSR.ORER、FER、PER和RDR标志未初始化。

当SCR寄存器中的TIE位同时为1时，将TE位的值从1更改为0或从0更改为1，会导致产生发送数据空中断（SCIn\_TXI）。

### 27.9.6 简单SPI模式下串行数据的发送和接收

在主机操作中，确保传输另一侧的从设备的SSn管脚在开始传输前为低电平，在传输完成时为高电平。否则，过程与时钟同步模式相同。

### 27.10 比特率调制功能

使用比特率调制功能，当在SMRSMR\_SMCI的CKS[1:0]位中选择PCLK时，可以使用MDDR寄存器中指定的数字均匀地校正比特率。



Figure 27.100 shows an example where the PCLK is selected in the CKS[1:0] bits in SMR/SMR\_SMCI, the BRR bit is set to 0, and the MDDR is set to 160 in asynchronous mode. In this example, the cycle of the base clock is evenly corrected (256/160) and the bit rate is also corrected (160/256).

Note: Enabling an internal clock causes bias, and expansion and contraction are generated in the pulse width of the internal base clock.

Do not use this function in clock synchronous mode and in the highest speed settings in simple SPI mode (SMR.CKS[1:0] = 00b, SCR.CKE[1] = 0, and BRR = 0).

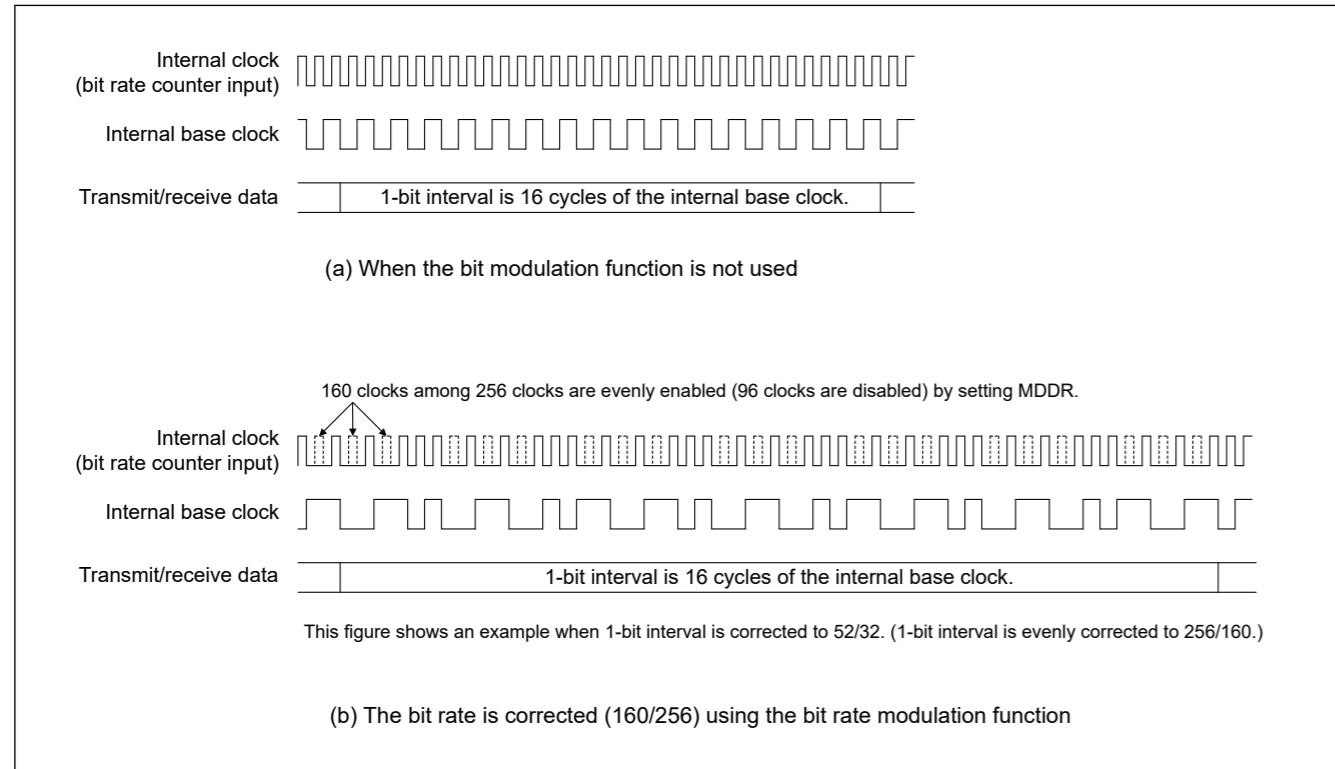


Figure 27.100 Example internal base clock when bit rate modulation function is used

## 27.11 Extended Serial Mode Control Section: Description of Operation

### 27.11.1 Serial Transfer Protocol

In conjunction with the SCIG module, the extended serial mode control section of the SCIH module can realize the serial transfer protocol composed of Start Frames and Information Frames that is shown in Figure 27.101.

A Start Frame is composed of a Break Field, Control Field 0, and Control Field 1. An Information Frame is composed of a number of Data Fields, a CRC16 Upper Field, and a CRC16 Lower Field.

图27.100显示了一个示例，其中在SMRSMR\_SMCI的CKS[1:0]位中选择PCLK，BRR位设置为0，异步模式下MDDR设置为160。在这个例子中，基本时钟的周期被均匀地校正（256/160）并且比特率也被校正（160/256）。

Note: 启用内部时钟会导致偏差，并且会在内部基本时钟的脉冲宽度中产生扩展和收缩。

不要在时钟同步模式和简单SPI模式的最高速度设置（SMR.CKS[1:0]=00b，SCR.CKE[1]=0和BRR=0）中使用此功能。

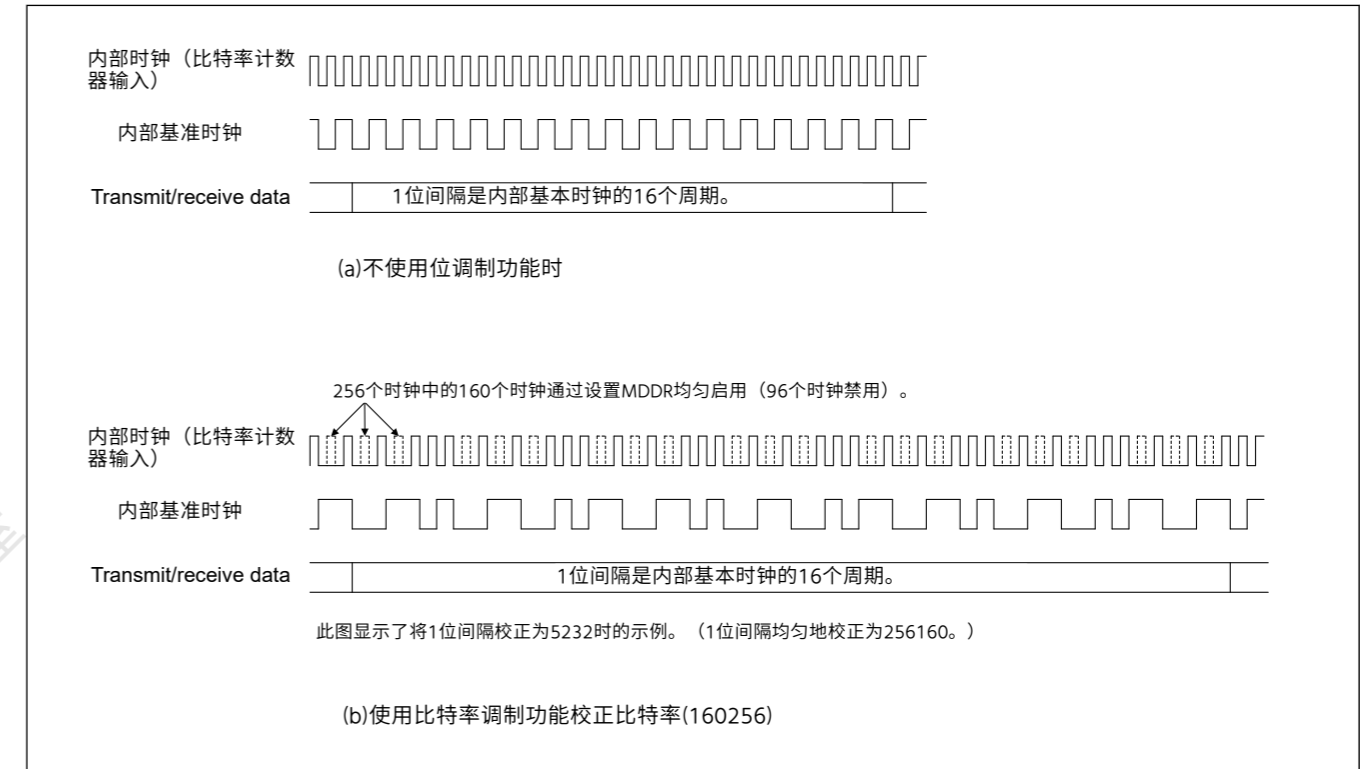


图27.100使用比特率调制功能时的内部基准时钟示例

## 27.11 扩展串行模式控制部分：操作说明

### 27.11.1 串行传输协议

结合SCIG模块，SCIH模块的扩展串行模式控制部分可以实现由StartFrames和信息帧组成的串行传输协议，如图27.101所示。

起始帧由中断字段、控制字段0和控制字段1组成。信息帧由多个数据字段、CRC16上字段和CRC16下字段组成。

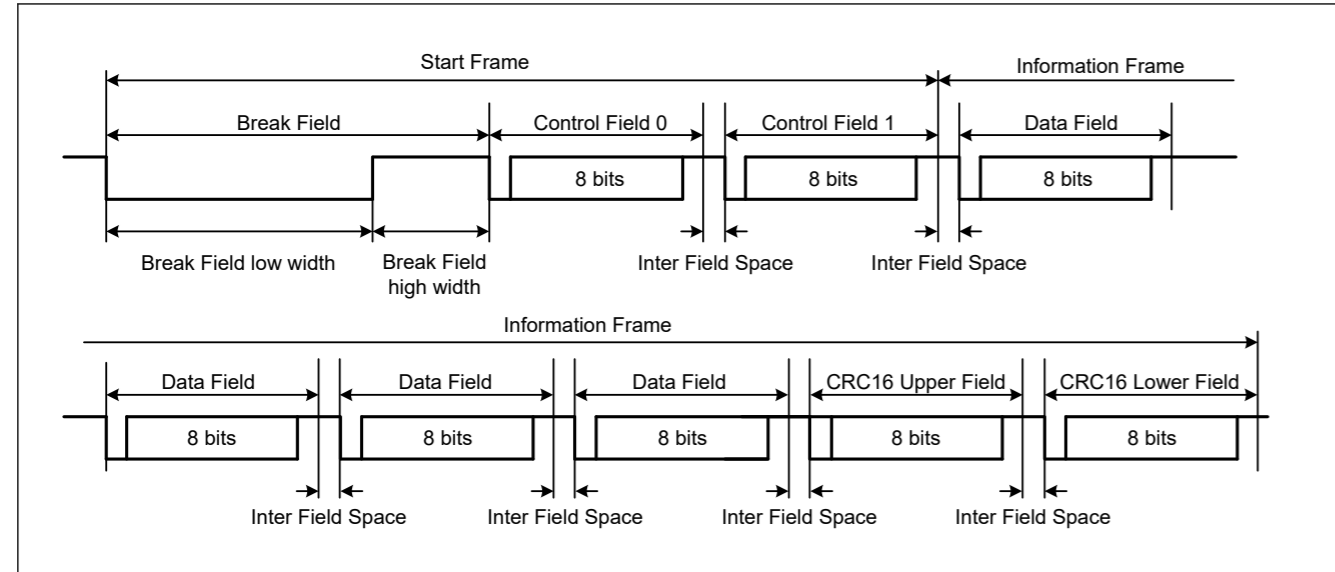


Figure 27.101 Protocol for Serial Transfer by the Extended Serial Mode Control Section

### 27.11.2 Transmitting a Start Frame

Figure 27.102 shows an example of operations to transmit a Start Frame, which is composed of the Break Field low width, Control Field 0, and Control Field 1. Figure 27.103 and Figure 27.104 are flowcharts for the transmission of a Start Frame.

Operations when the extended serial mode control section is to be used to transmit a Start Frame are as listed below. Be sure to use the SCIn (n = 1, 2) in asynchronous mode.

1. With Break Field low width output mode as the operating mode for the timer, writing 1 to the TCR.TCST bit starts counting by the timer, and the low level will be output from the TXDXn (n = 1, 2) pin over the period corresponding to registers TCNT and TPRE settings.
2. The output on the TXDXn pin is inverted when the timer counter underflows, and the STR.BFDF flag is set to 1. An SCIX0 interrupt is also generated if the value of the ICR.BFDIE bit is 1.
3. Write 0 to the TCR.TCST bit to stop counting by the timer, and send the data for Control Field 0 by using SCIn. After the Break Field low width output, stop counting before the next underflow occurs.
4. When the data for Control Field 0 have been transmitted, send the data for Control Field 1.
5. When the data for Control Field 1 have been transmitted, send an Information Frame.

Omit the Break Field and Control Field 0 to suit the structure of the Start Frame.

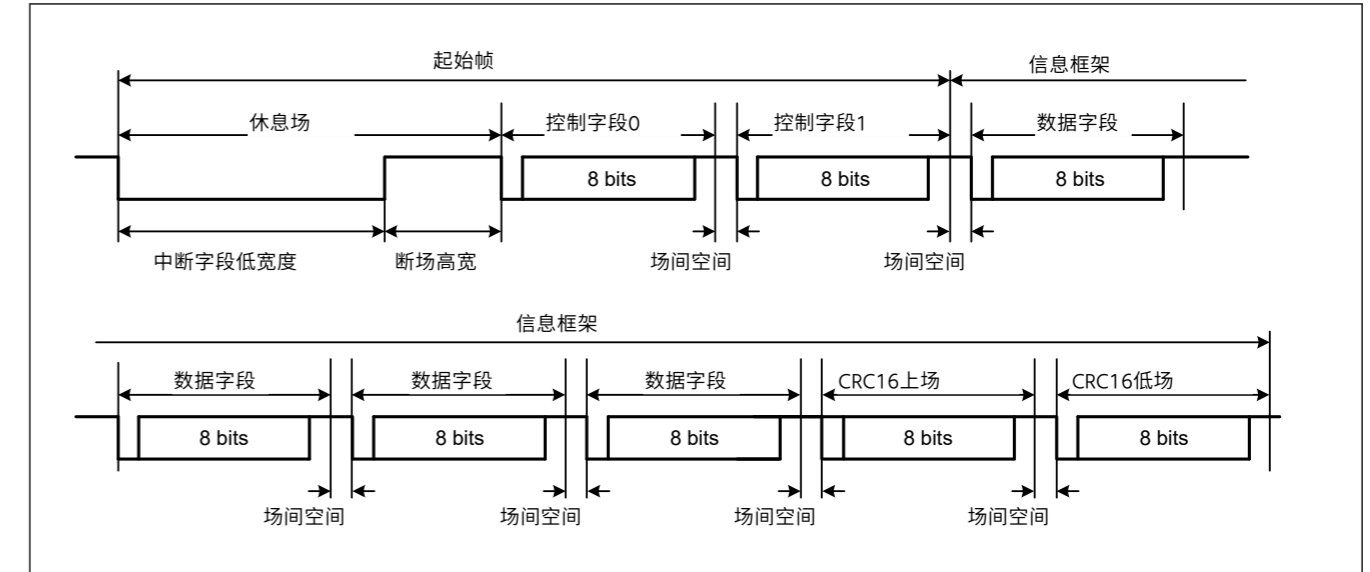


图27.101扩展串行模式控制部分的串行传输协议

### 27.11.2 发送起始帧

图27.102显示了发送起始帧的操作示例，起始帧由中断字段低宽度、控制字段0和控制字段1组成。图27.103和图27.104是发送起始帧的流程图。

使用扩展串行模式控制部分发送起始帧时的操作如下所列。请务必在异步模式下使用SCIn(n=1, 2)。

- 1.以中断场低宽度输出模式作为定时器的工作模式，开始向TCR.TCST位写入1  
通过定时器计数，在对应于寄存器TCNT和TPRE设置的周期内，低电平将从TXDXn(n=1, 2)引脚输出。
- 2.当定时器计数器下溢时，TXDXn引脚的输出反相，STR.BFDF标志设置为1。如果ICR.BFDIE位的值为1，也会产生SCIX0中断。
- 3.将0写入TCR.TCST位以停止定时器计数，并使用SCIn发送控制字段0的数据。在BreakField低宽度输出之后，在下次下溢发生之前停止计数。
- 4.当控制字段0的数据传输完毕后，发送控制字段1的数据。
- 5.当控制字段1的数据传输完毕后，发送一个信息帧。

省略BreakField和控制Field0以适应起始帧的结构。

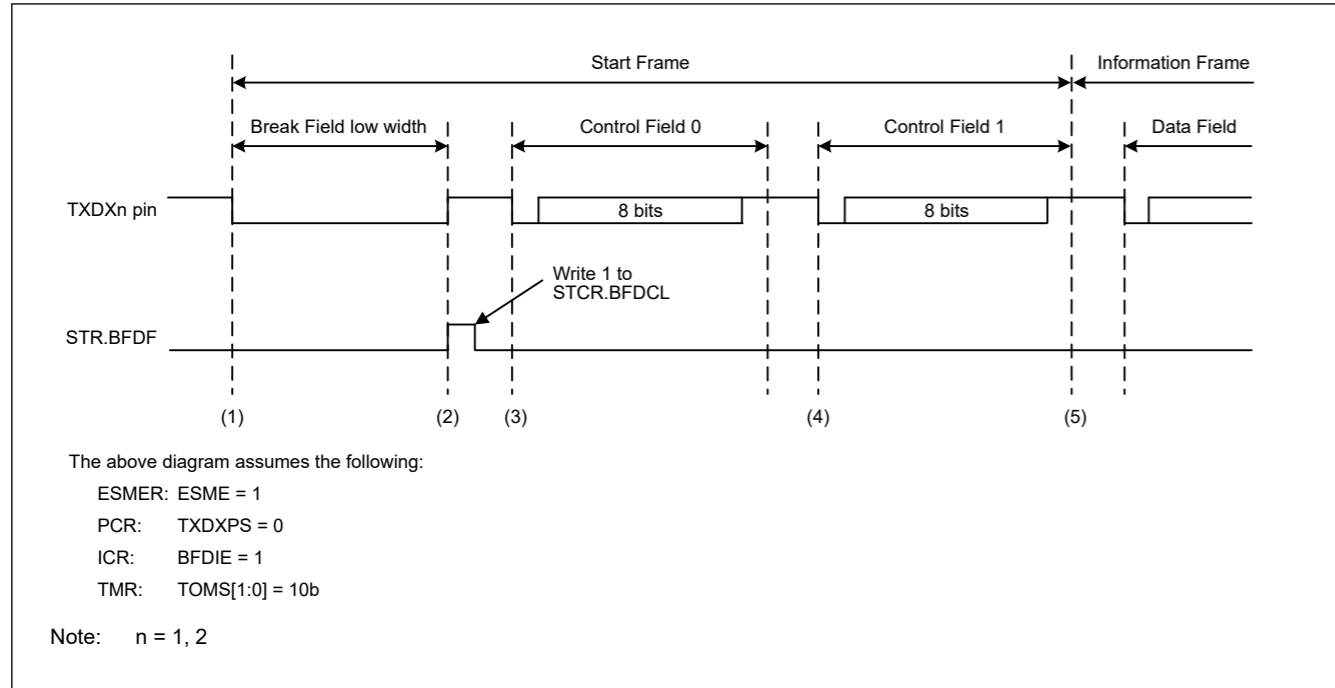


Figure 27.102 Example of Operations When Transmitting a Start Frame

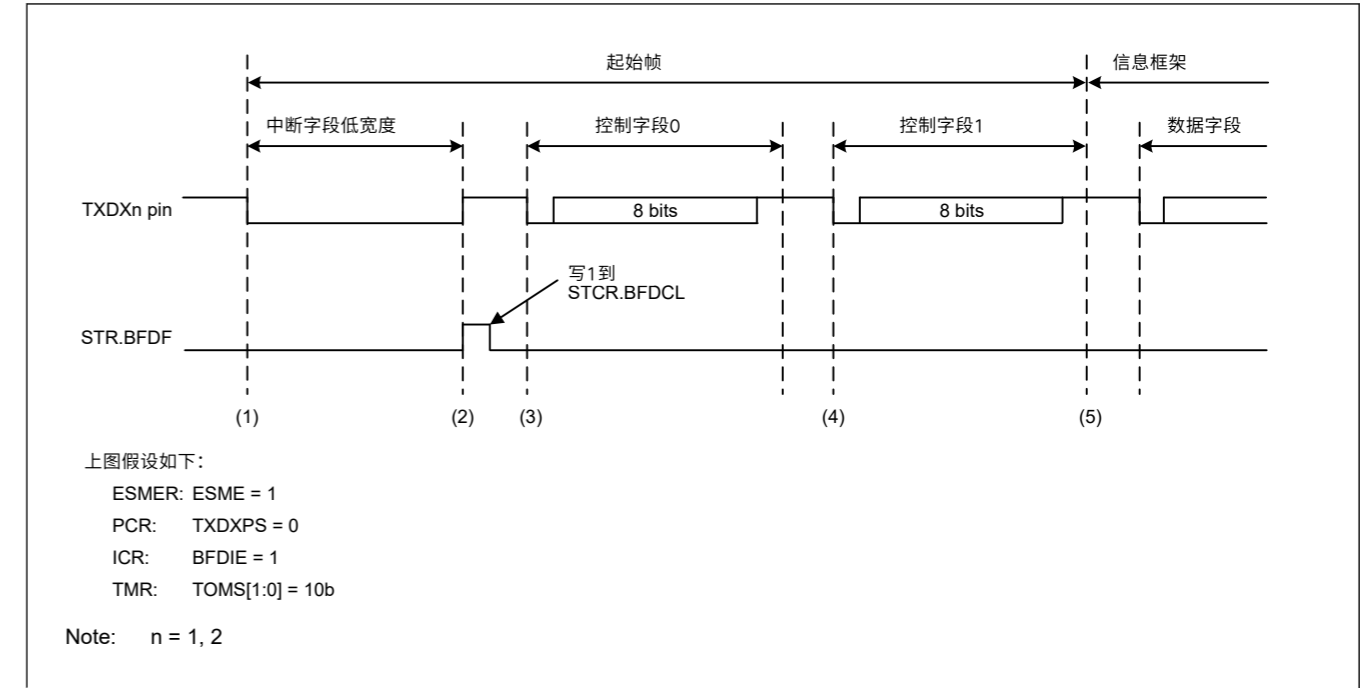


图27.102发送起始帧时的操作示例

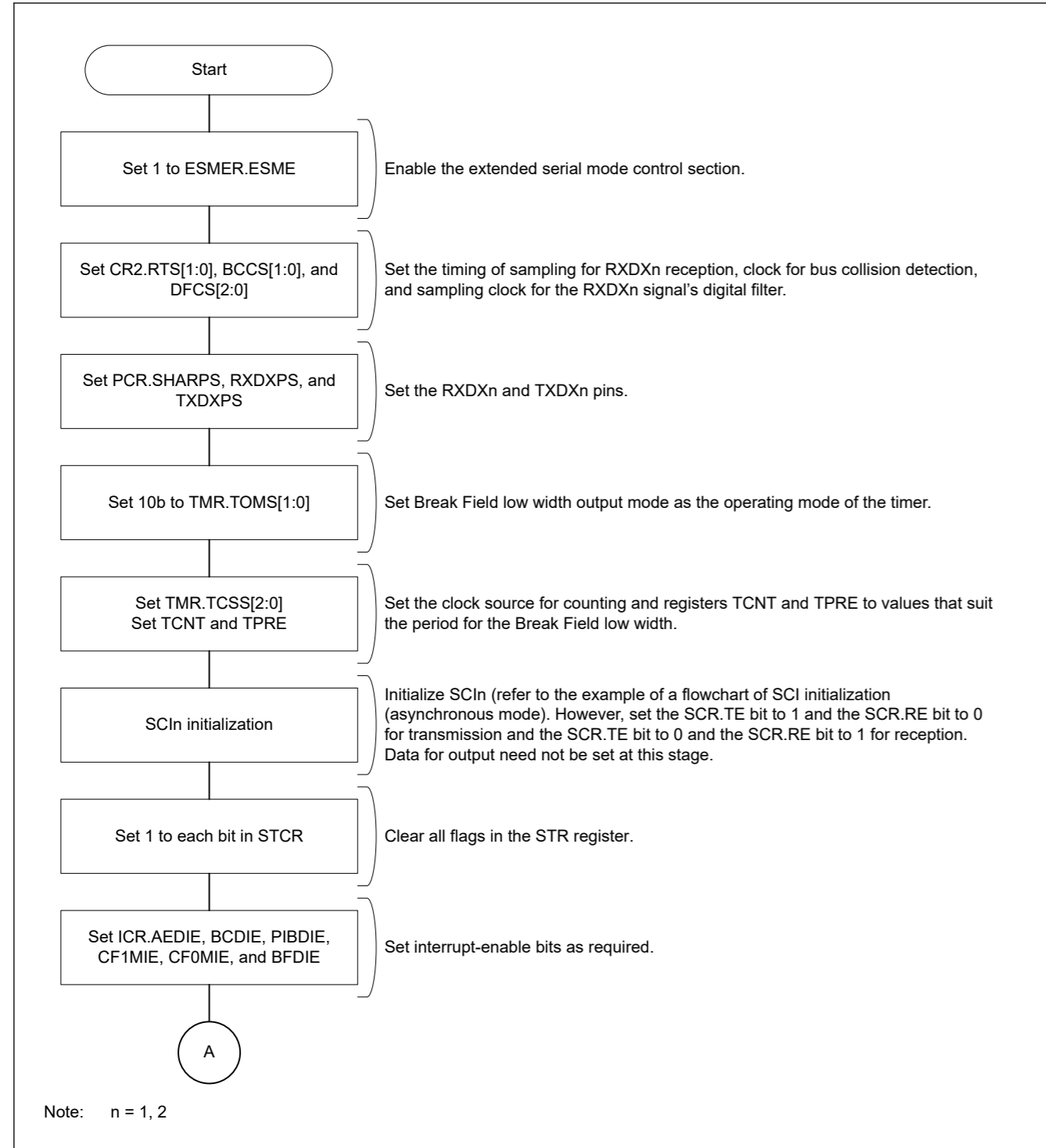


Figure 27.103 Example of Start Frame Transmission (1/2)

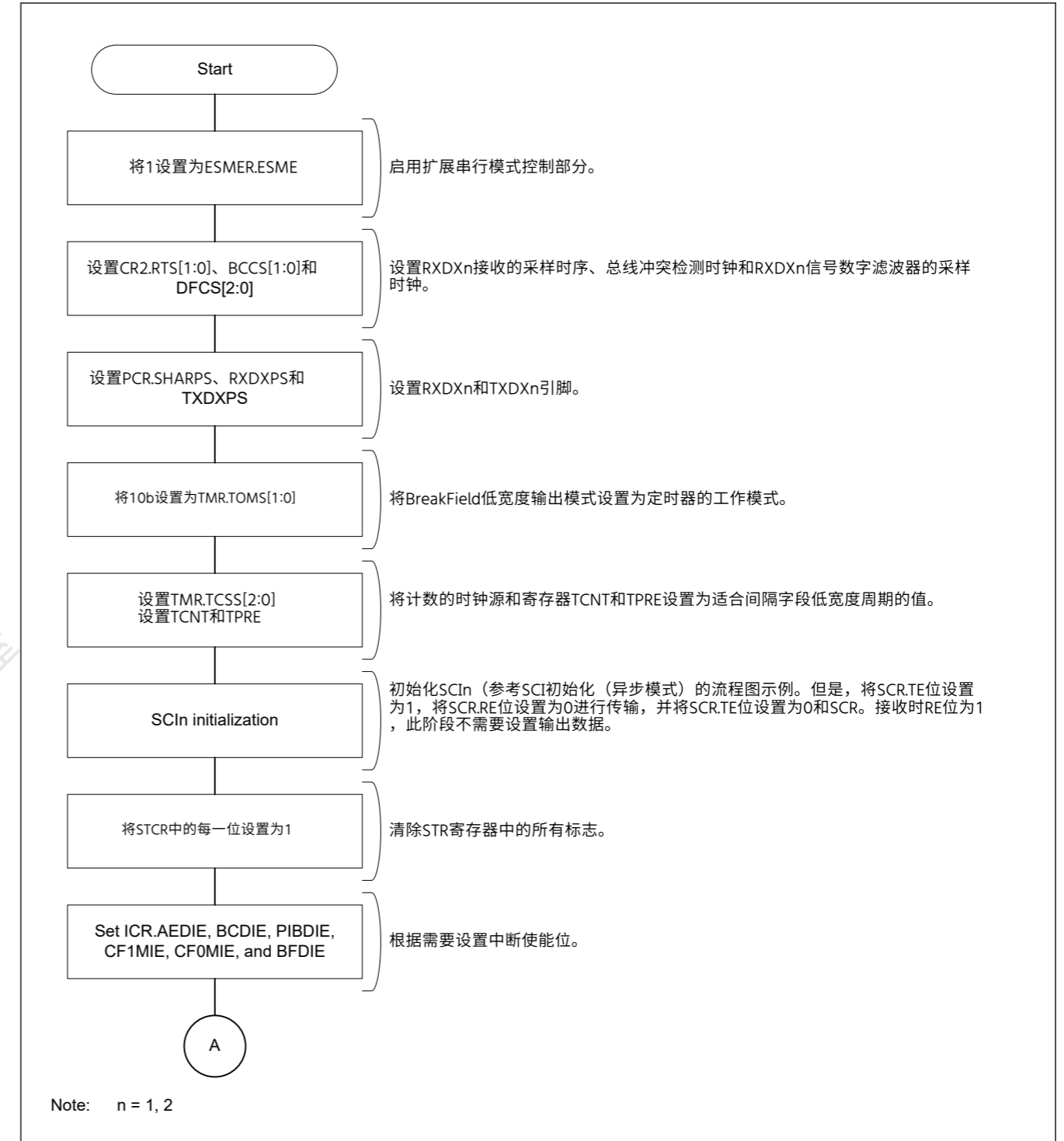


图27.103起始帧传输示例(1/2)



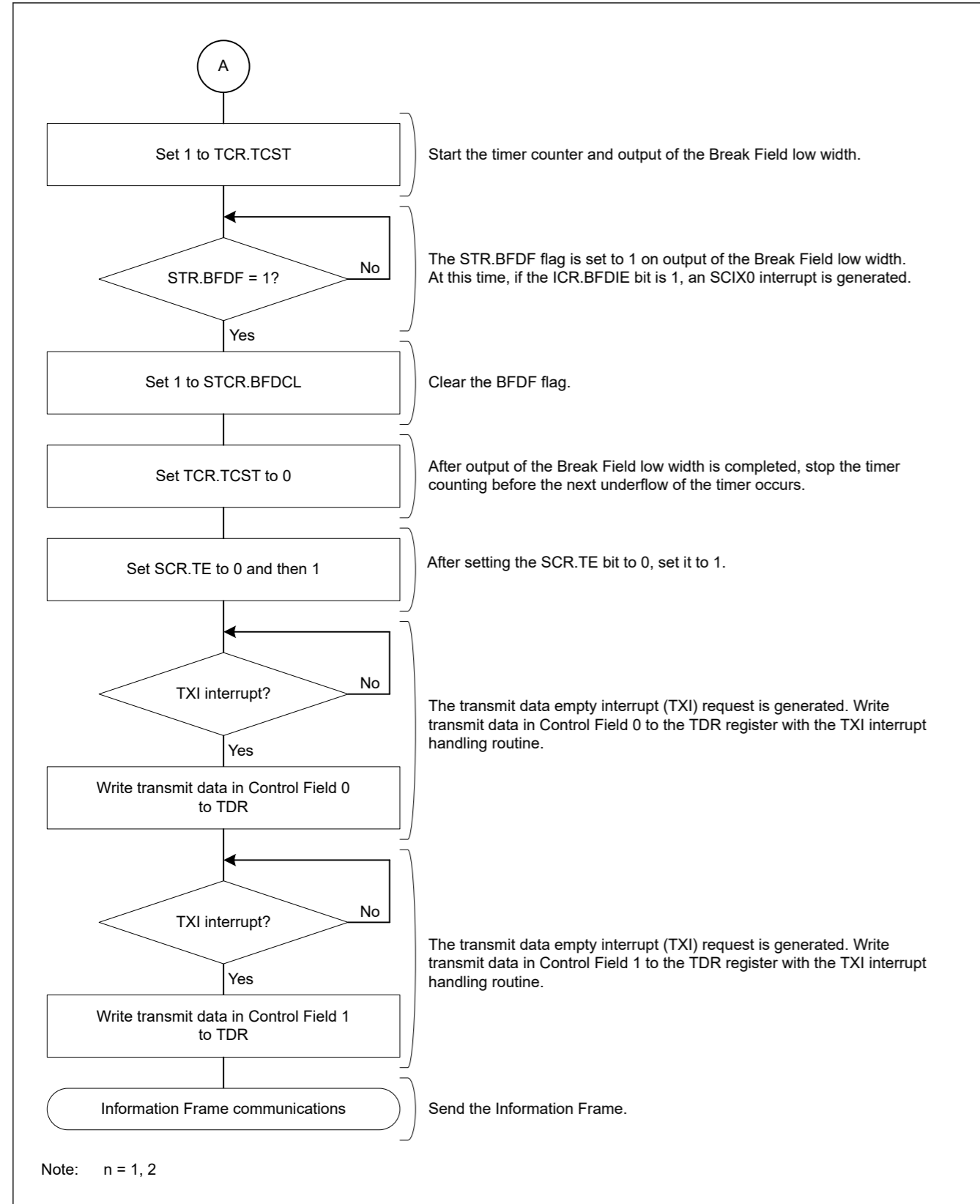


Figure 27.104 Example of Start Frame Transmission (2/2)

27.11.3 Receiving a Start Frame

The extended serial mode control section is capable of receiving Start Frames with the structures listed in Figure 27.105.

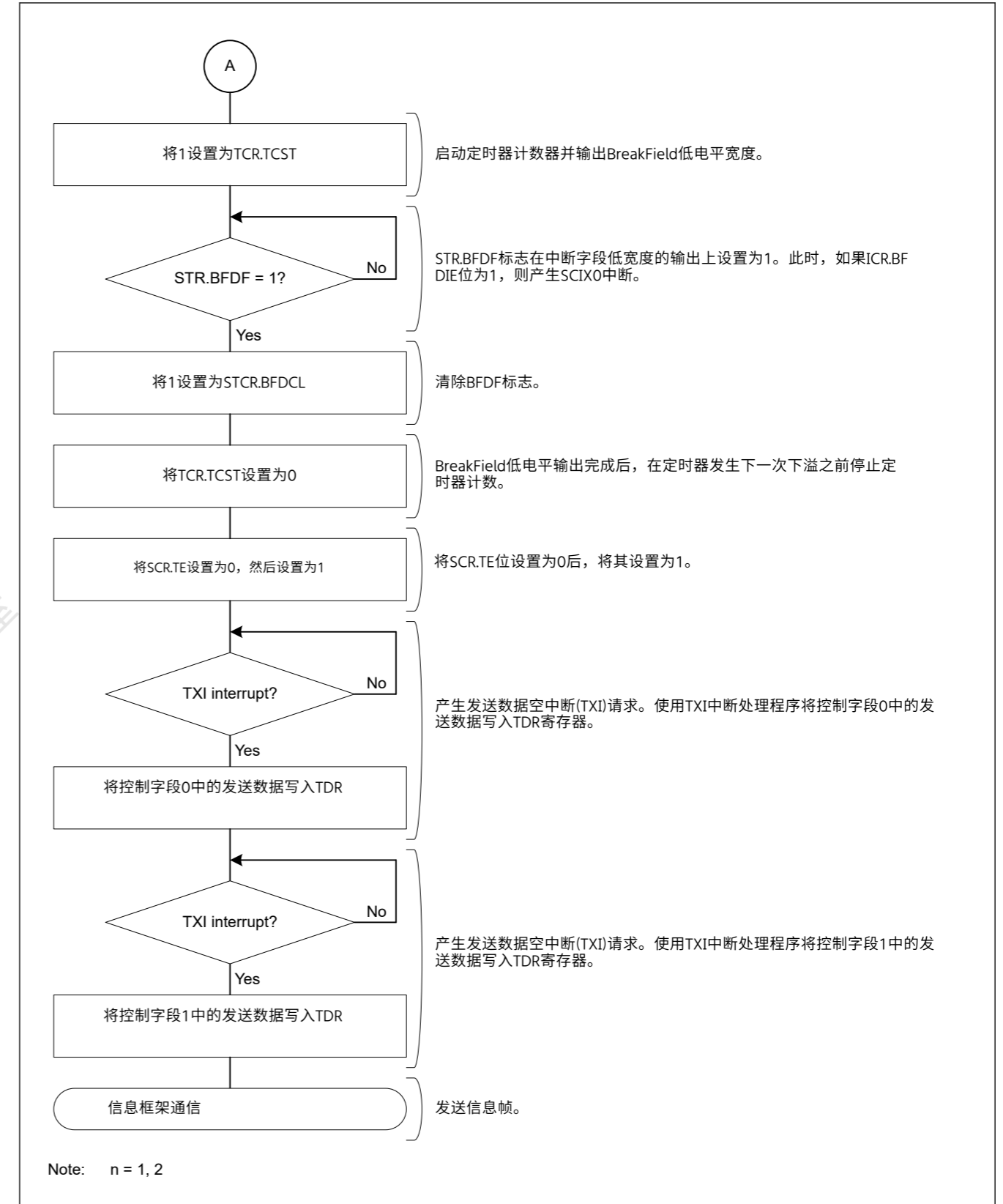


图27.104起始帧传输示例(2/2)

27.11.3 接收起始帧

扩展串行模式控制部分能够接收具有图27.105中列出的结构的起始帧。

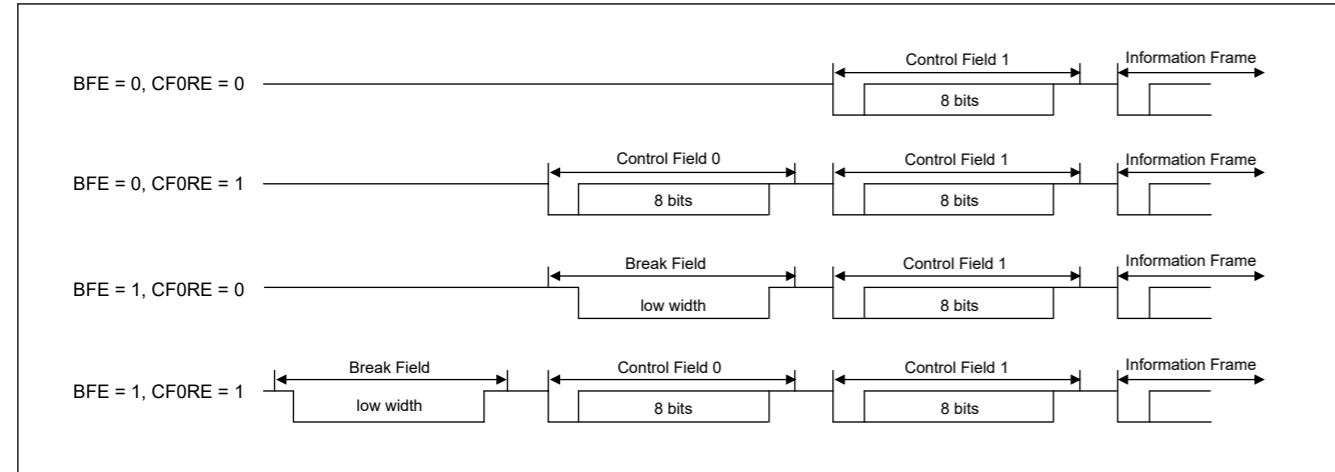


Figure 27.105 Structures of Start Frames

Figure 27.106 shows an example of operations to receive a Start Frame, which is composed of the Break Field low width, Control Field 0, and Control Field 1. Figure 27.107 and Figure 27.108 are flowcharts for the reception of a Start Frame, and Figure 27.109 is a state transition diagram for the extended serial mode control section.

Operations when the extended serial mode control section is to be used to receive a Start Frame are as listed below. Be sure to use the SCIn (n = 1, 2) in asynchronous mode.

1. With Break Field low width detection mode as the operating mode for the timer, writing 1 to the CR3.SDST bit enables detection of the Break Field low width. RXDXn input to the SCIn is disabled at this time.
2. Low-level input on the RXDXn pin continuing over a period longer than that corresponding to the settings of registers TCNT and TPRES is detected as the Break Field low width. At this time, the STR.BFDF flag is set to 1. An SCIX0 interrupt is also generated if the value of the ICR.BFDIE bit is 1.
3. When the input from the RXDXn pin goes high after the Break Field low width, the CR0.RXDSF flag becomes 0 and reception of Control Field 0 by the SCIn starts.
4. If the data received in Control Field 0 match the data set in the CF0DR register, the STR.CF0MF flag is set to 1. An SCIX1 interrupt is also generated if the value of the ICR.CF0MIE bit is 1. Reception of Control Field 1 by the SCIn starts after that. If the data received in Control Field 0 do not match the data set in the CF0DR register, a transition to the state prior to Break Field low width detection proceeds.
5. If the data received in Control Field 1 match the data set in registers PCF1DR and SCF1DR, the STR.CF1MF flag is set to 1. An SCIX1 interrupt is also generated if the value of the ICR.CF1MIE bit is 1. Transfer of the Information Frame by the SCIn starts after that. If the data received in Control Field 1 do not match the data set in either or both of registers PCF1DR and SCF1DR, a transition to the state prior to Break Field low width detection proceeds.

Omit the Break Field and Control Field 0 to suit the structure of the Start Frame.

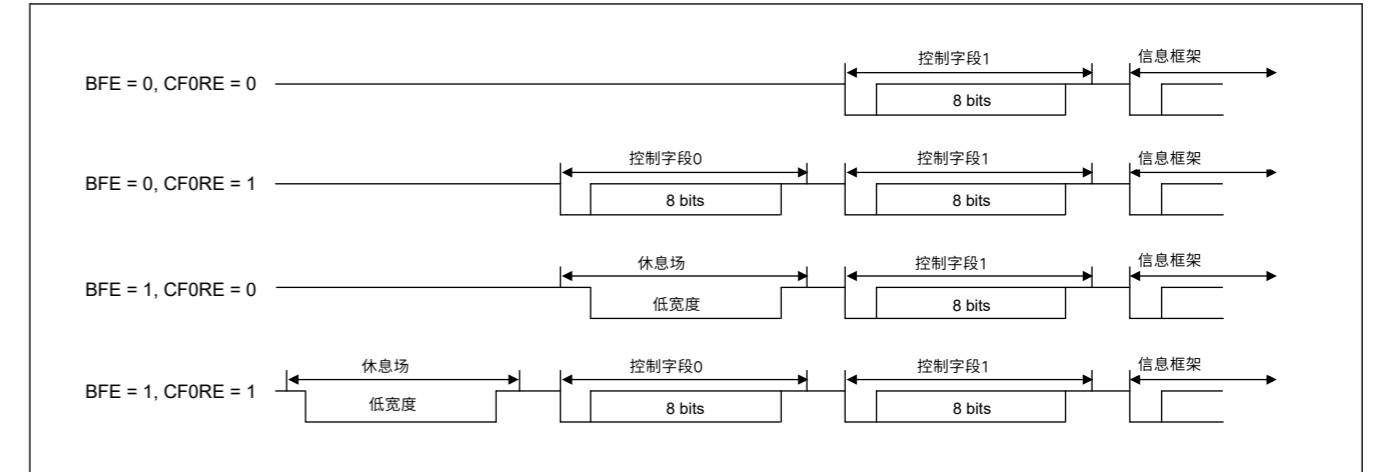


图27.105起始帧的结构

图27.106显示了接收起始帧的操作示例，起始帧由中断字段低宽度组成，控制字段0和控制字段1。图27.107和图27.108是接收起始帧的流程图，以及图27.109是扩展串行模式控制部分的状态转换图。

使用扩展串行模式控制部分接收起始帧时的操作如下所列。请务必在异步模式下使用SCIn(n=1, 2)。

- 1.使用间隔场低宽度检测模式作为定时器的操作模式，向CR3.SDST位写入1可启用间隔场低宽度检测。此时SCIn的RXDXn输入被禁用。
- 2.RXDXn引脚上的低电平输入持续时间长于对应寄存器TCNT和TPRES的设置的时间被检测为中断场低电平宽度。此时，STR.BFDF标志置1。如果ICR.BFDIE位的值为1，也会产生SCIX0中断。
- 3.当来自RXDXn引脚的输入在BreakField低电平宽度之后变为高电平时，CR0.RXDSF标志变为0，并且SCIn开始接收ControlField0。
- 4.如果控制域0中接收的数据与CF0DR寄存器中设置的数据匹配，则STR.CF0MF标志设置为1。如果ICR.CF0MIE位的值为1，也会产生SCIX1中断。接收控制SCIn的字段1在那之后开始。如果在控制字段0中接收到的数据与CF0DR寄存器中设置的数据不匹配，则转换到中断字段低宽度检测之前的状态。
- 5.如果控制字段1中接收的数据与寄存器PCF1DR和SCF1DR中设置的数据匹配，则STR.CF1MF标志设置为1。如果ICR.CF1MIE位的值为1，也会产生SCIX1中断。SCIn的信息帧在此之后开始。如果在控制字段1中接收到的数据与寄存器PCF1DR和SCF1DR中的一个或两个中设置的数据不匹配，则转换到中断字段低宽度检测之前的状态。

省略BreakField和ControlField0以适应起始帧的结构。

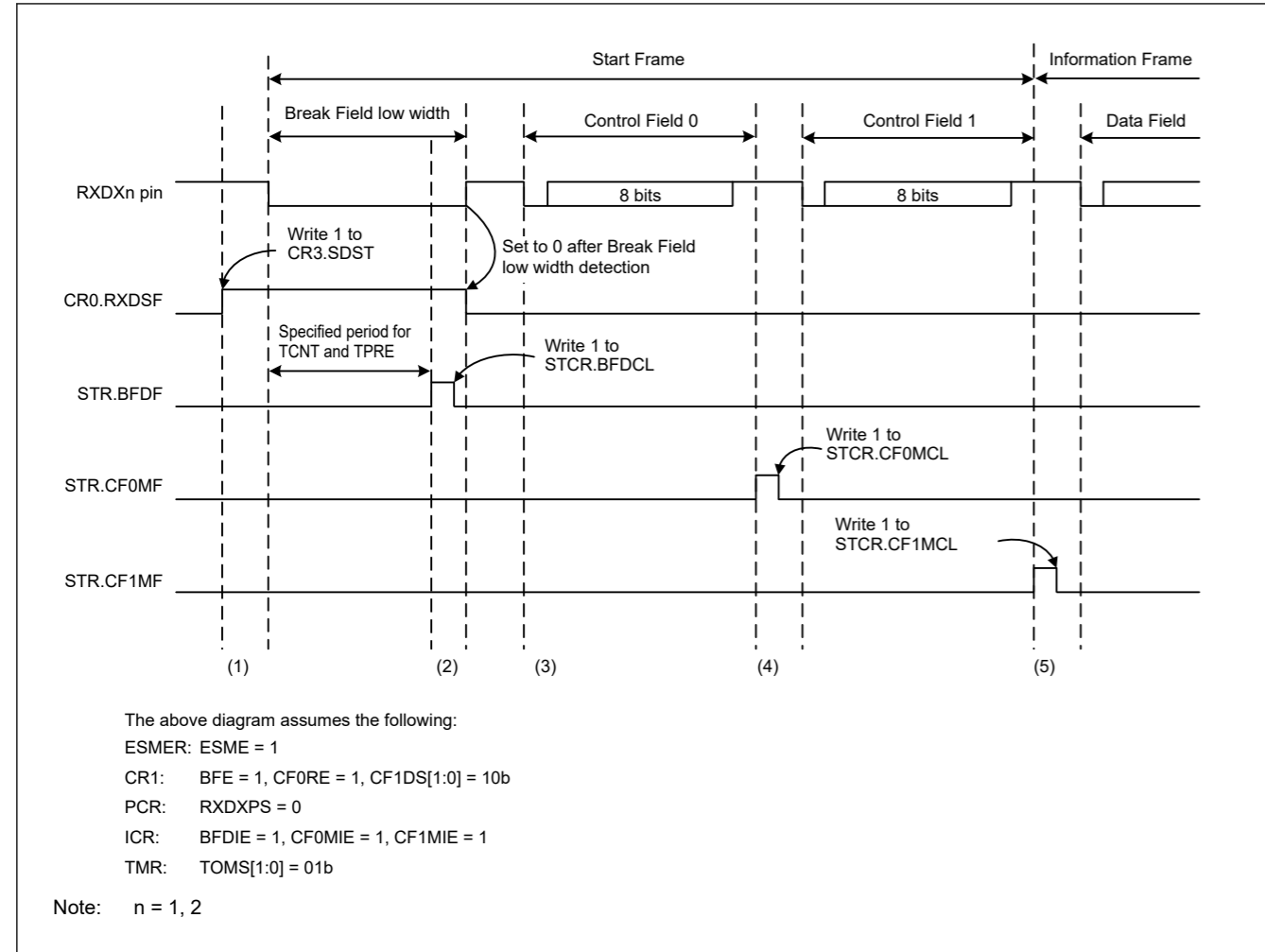


Figure 27.106 Example of Operations at the Time of Start Frame Reception

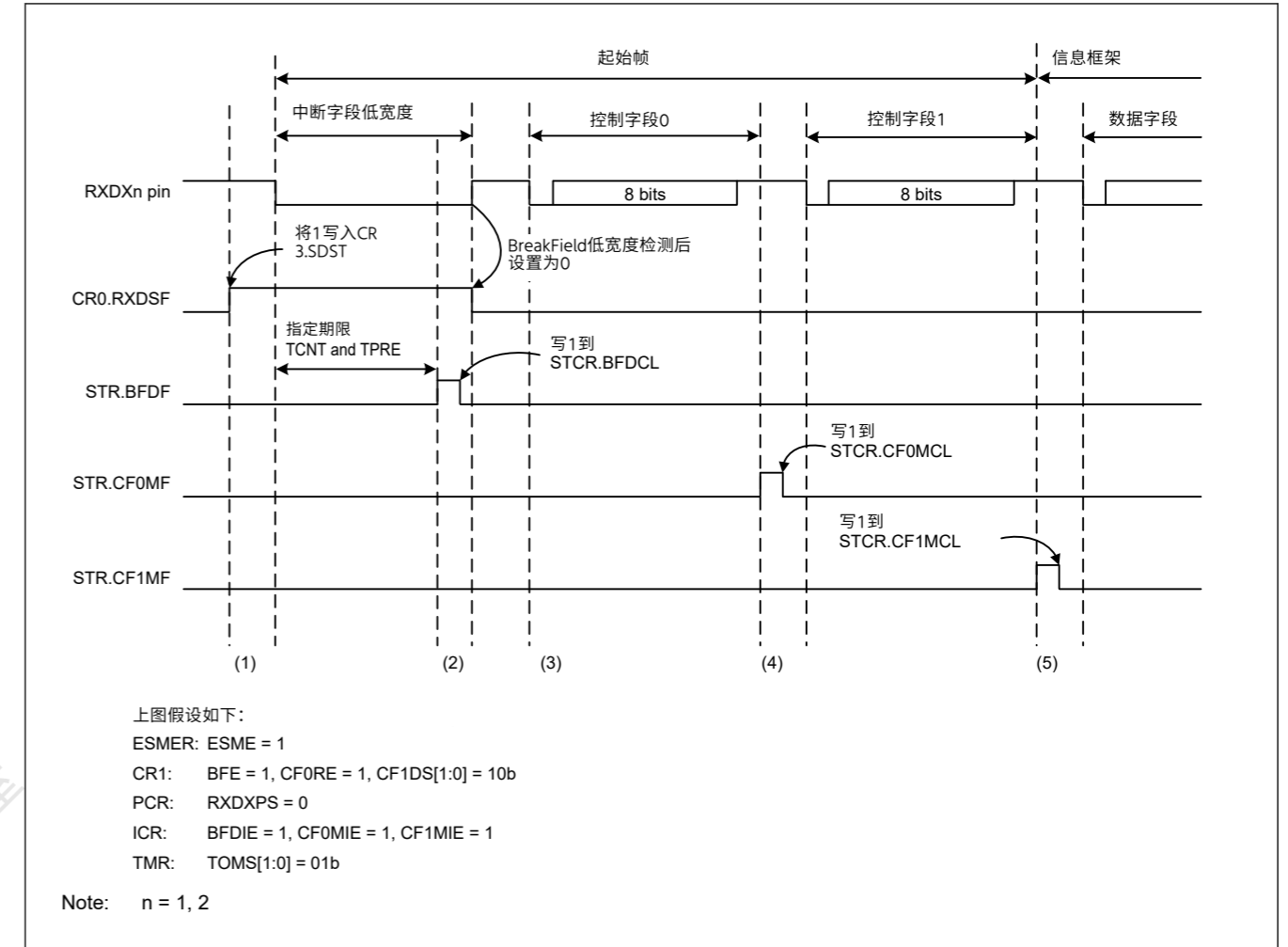


图27.106开始帧接收时的操作示例

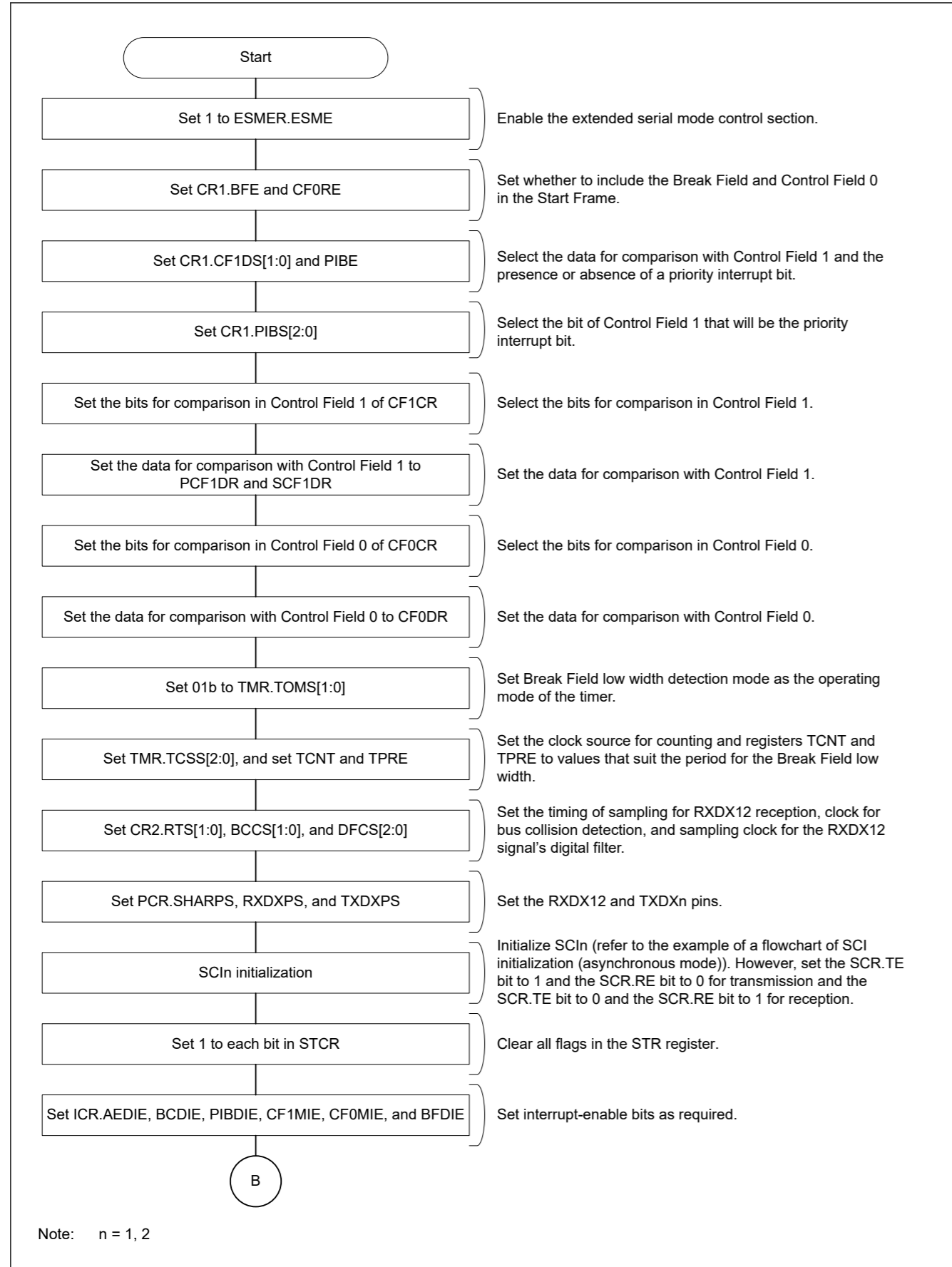


Figure 27.107 Sample Flowchart for Reception of a Start Frame (1)



图27.107接收起始帧的示例流程图(1)



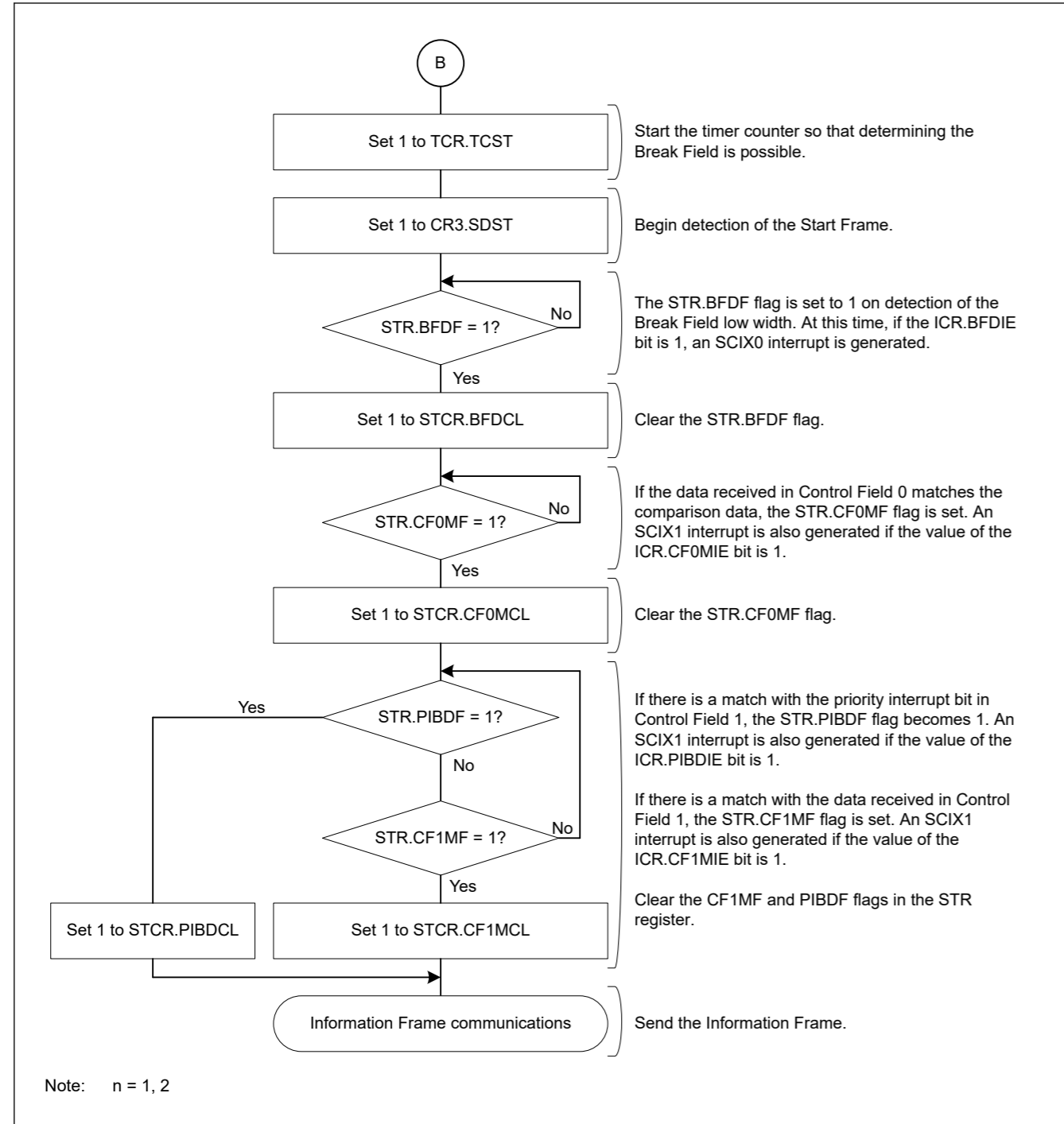


Figure 27.108 Sample Flowchart for Reception of a Start Frame (2)

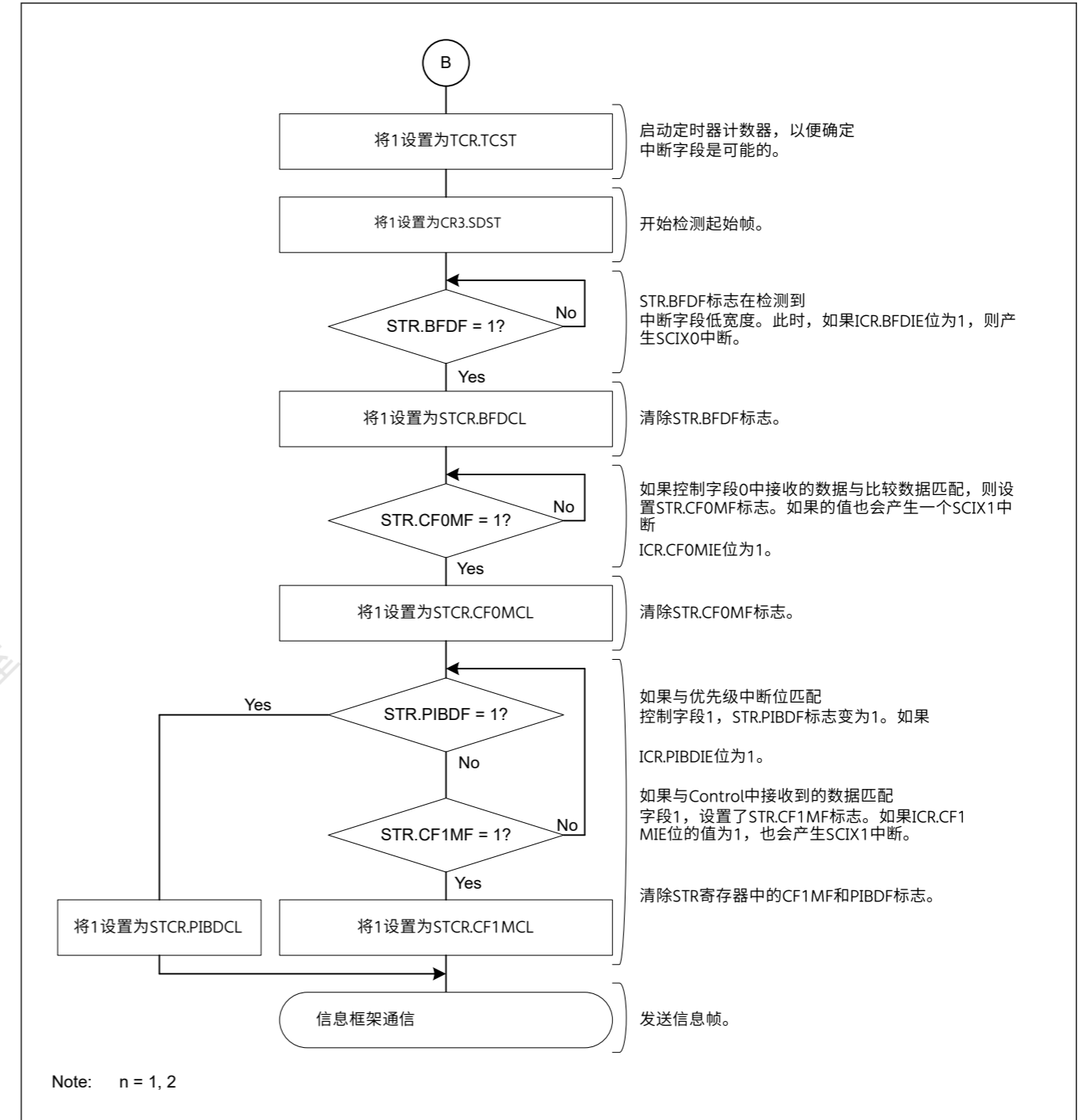


图27.108接收起始帧的示例流程图(2)

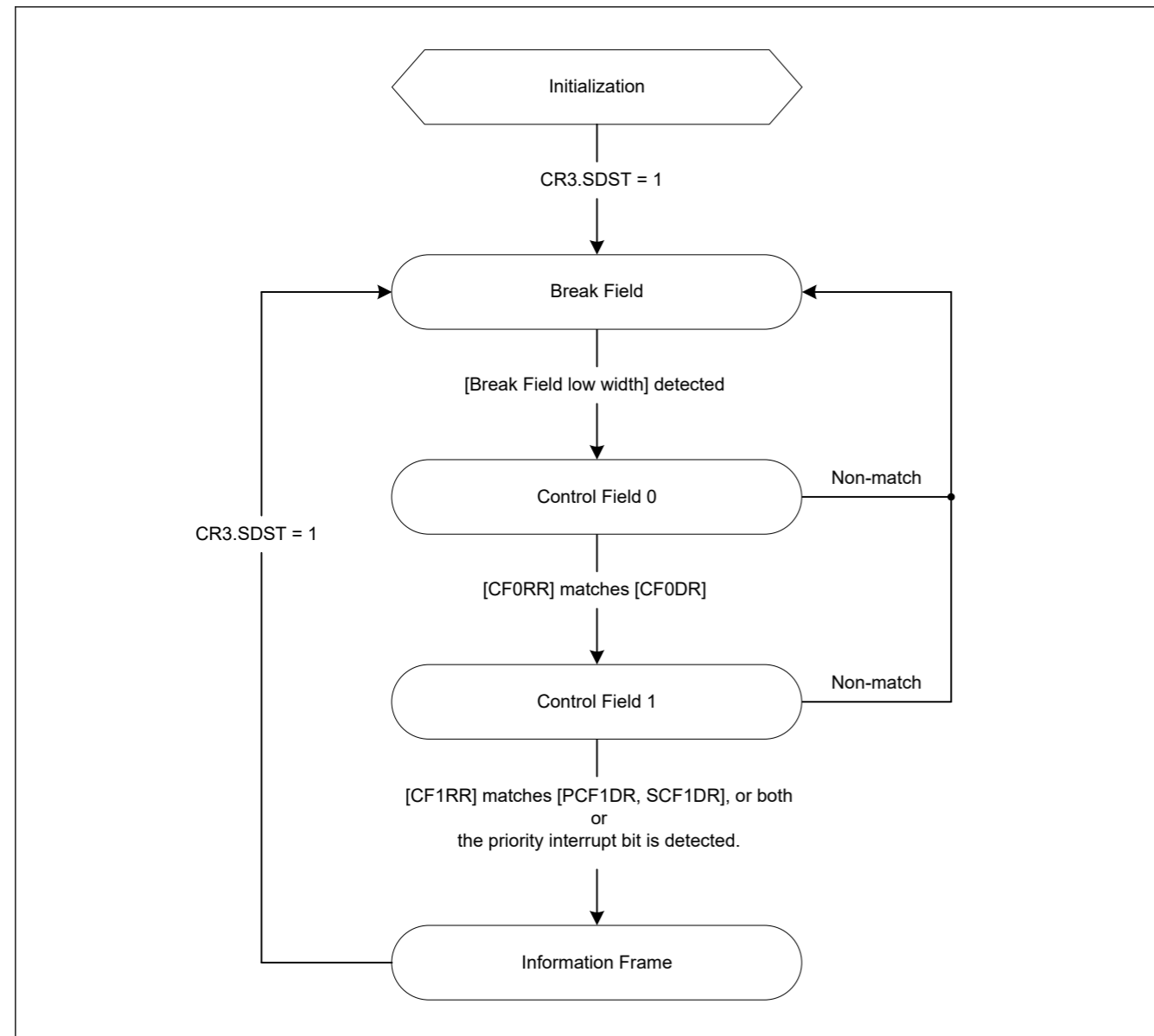


Figure 27.109 State Transitions When Receiving a Start Frame

### 27.11.3.1 Priority Interrupt Bit

Figure 27.110 shows an example of operation in Start Frame reception where a priority interrupt bit is in use. Setting the CR1.PIBDF bit to 1 enables the use of a priority interrupt bit.

Operations of the extended serial mode control section in start Frame reception where a priority interrupt bit is in use are as described below.

Steps (1) to (4) are the same as in Figure 27.106, for Start Frame reception.

(5) If the value of the bit selected by the CR1.PIBS[2:0] bits matches the corresponding bit in the PCF1DR register, the STR.PIBDF flag is set to 1. An SCIX1 interrupt is also generated if the value of the ICR.PIBDIE bit is 1. Transfer of the Information Frame by the SCIn (n = 1, 2) starts after that. If the data received in Control Field 1 do not match the data set in either or both of registers PCF1DR and SCF1DR and the priority interrupt bit is not detected, a transition to the state prior to Break Field low width detection proceeds.

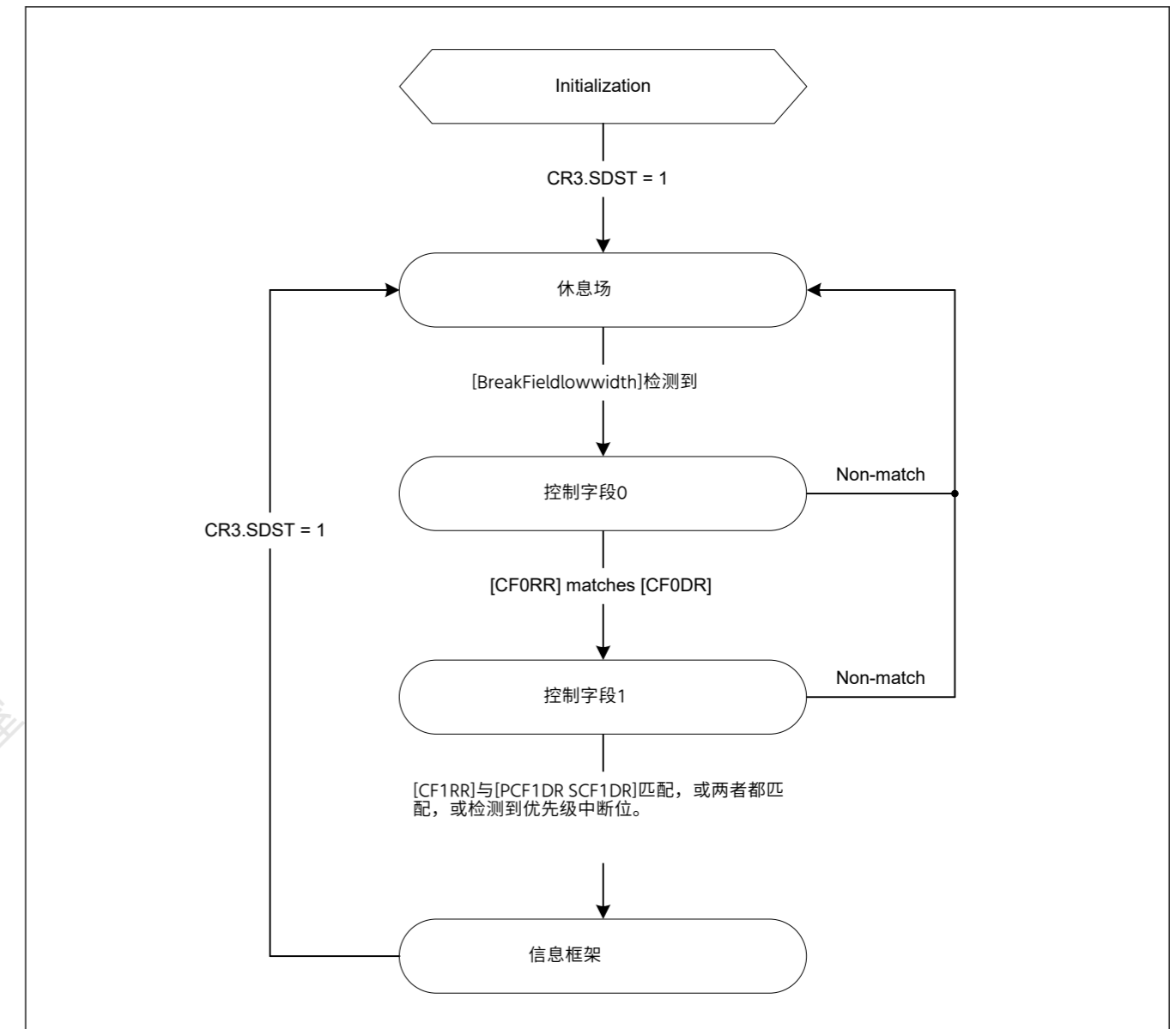


图27.109接收起始帧时的状态转换

### 27.11.3.1 优先中断位

图27.110显示了使用优先中断位的起始帧接收操作示例。设置CR1.PIBDF位为1启用优先级中断位。

在使用优先中断位的开始帧接收中扩展串行模式控制部分的操作如下所述。

步骤(1)到(4)与图27.106中的相同，用于接收起始帧。

(5)如果CR1.PIBS[2:0]位选择的位的值与PCF1DR寄存器中的相应位相匹配，则STR.PIBDF标志设置为1。如果ICR.PIBDIE位为1。

SCIn(n=1, 2)的信息帧在此之后开始。如果在控制字段1中接收的数据与寄存器PCF1DR和SCF1DR中的一个或两个中设置的数据不匹配，并且未检测到优先级中断位，则转换到中断字段低宽度检测之前的状态。

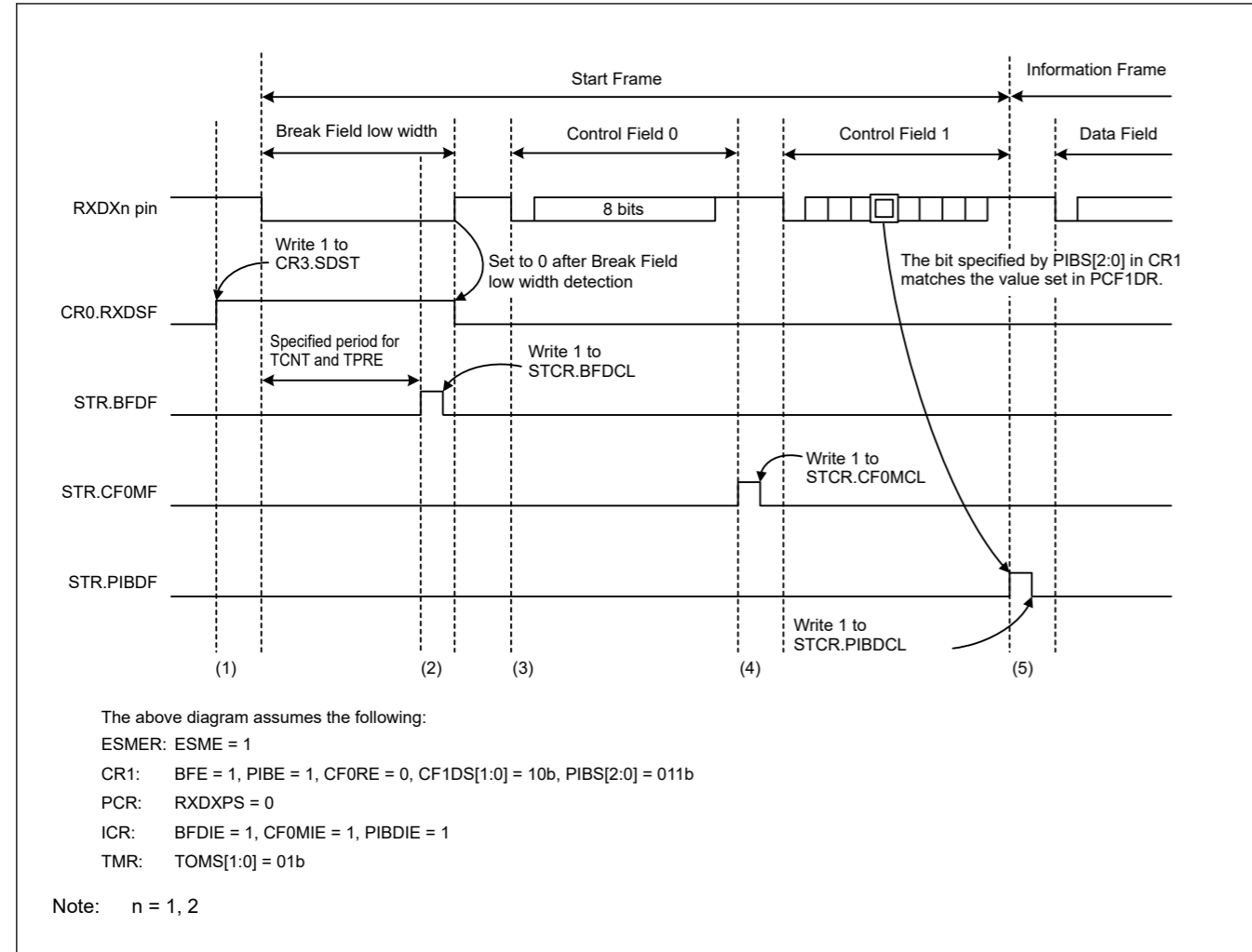


Figure 27.110 Example of Operations When Receiving a Start Frame While the CR1.PIBE Bit is 1

### 27.11.4 Detection of Bus Collisions

Detection of bus collisions operate for cases where output of the Break Field low width and transmission of data by the SCIn (n = 1, 2) are in progress when the ESMER.ESME bit and the SCIn.SCI.TE bit are set to 1.

Figure 27.111 shows an example of operations with bus collision detection. Signals output through TXDXn and input through RXDXn are sampled with the bus collision detection clock set with the CR2.BCCS[1:0] bits as the sampling clock, and the STR.BCDF flag is set to 1 if the signals fail to match three times in a row. An SCIX2 interrupt is also generated if the value of the ICR.BCDIE bit is 1.

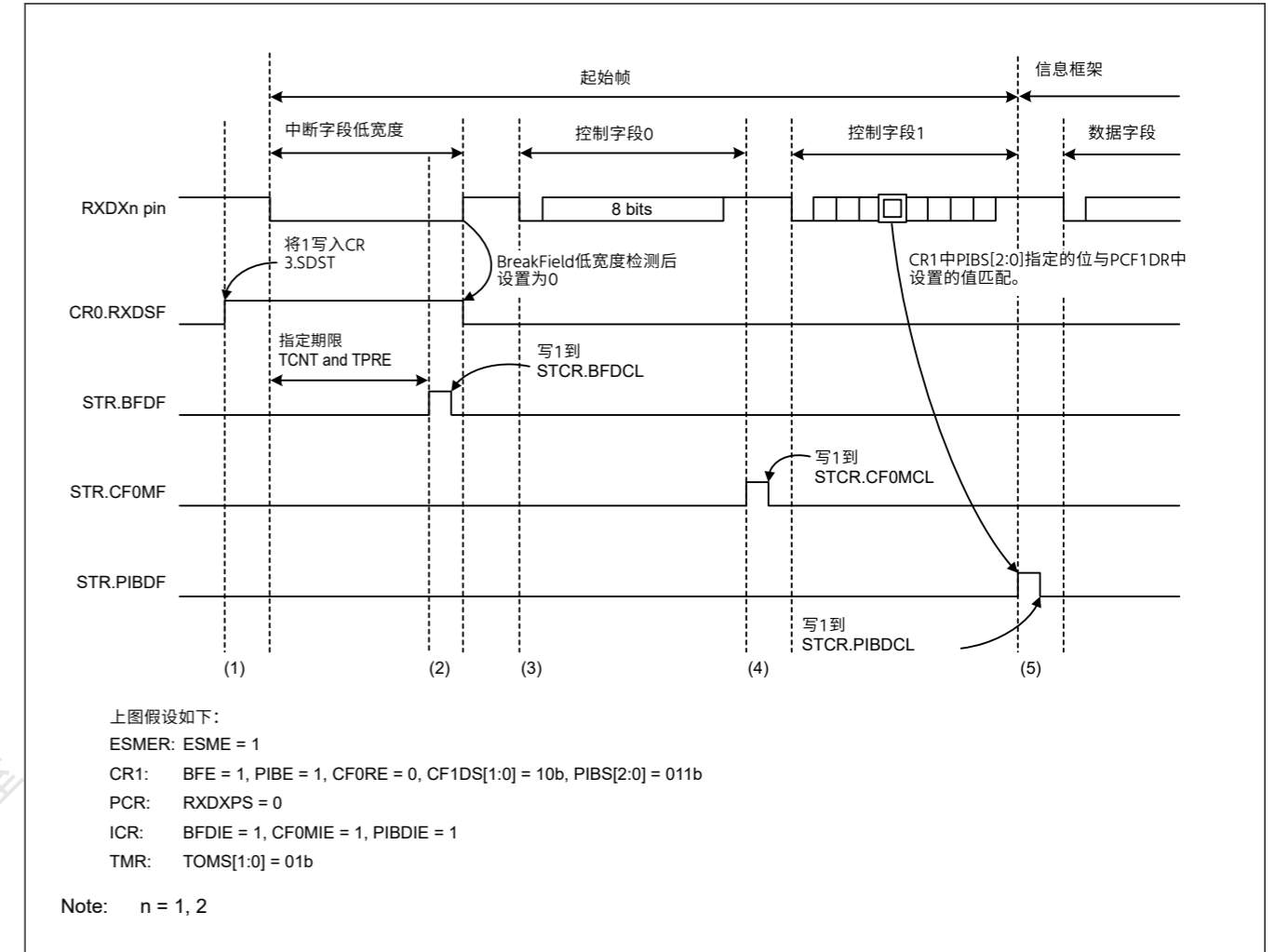


图27.110 CR1.PIBE位为1时接收起始帧时的操作示例

### 27.11.4 总线碰撞检测

总线冲突检测适用于中断字段低宽度的输出和数据传输的情况当ESMER.ESME位和SCIn.SCI.TE位设置为1时，SCIn(n=1,2)正在进行。

图27.111显示了带有总线冲突检测的操作示例。通过TXDXn输出和通过RXDXn输入的信号以CR2.BCCS[1:0]位设置的总线冲突检测时钟作为采样时钟进行采样，如果信号不匹配三个，则STR.BCDF标志设置为1连续几次。如果ICR.BCDIE位的值为1，也会产生SCIX2中断。

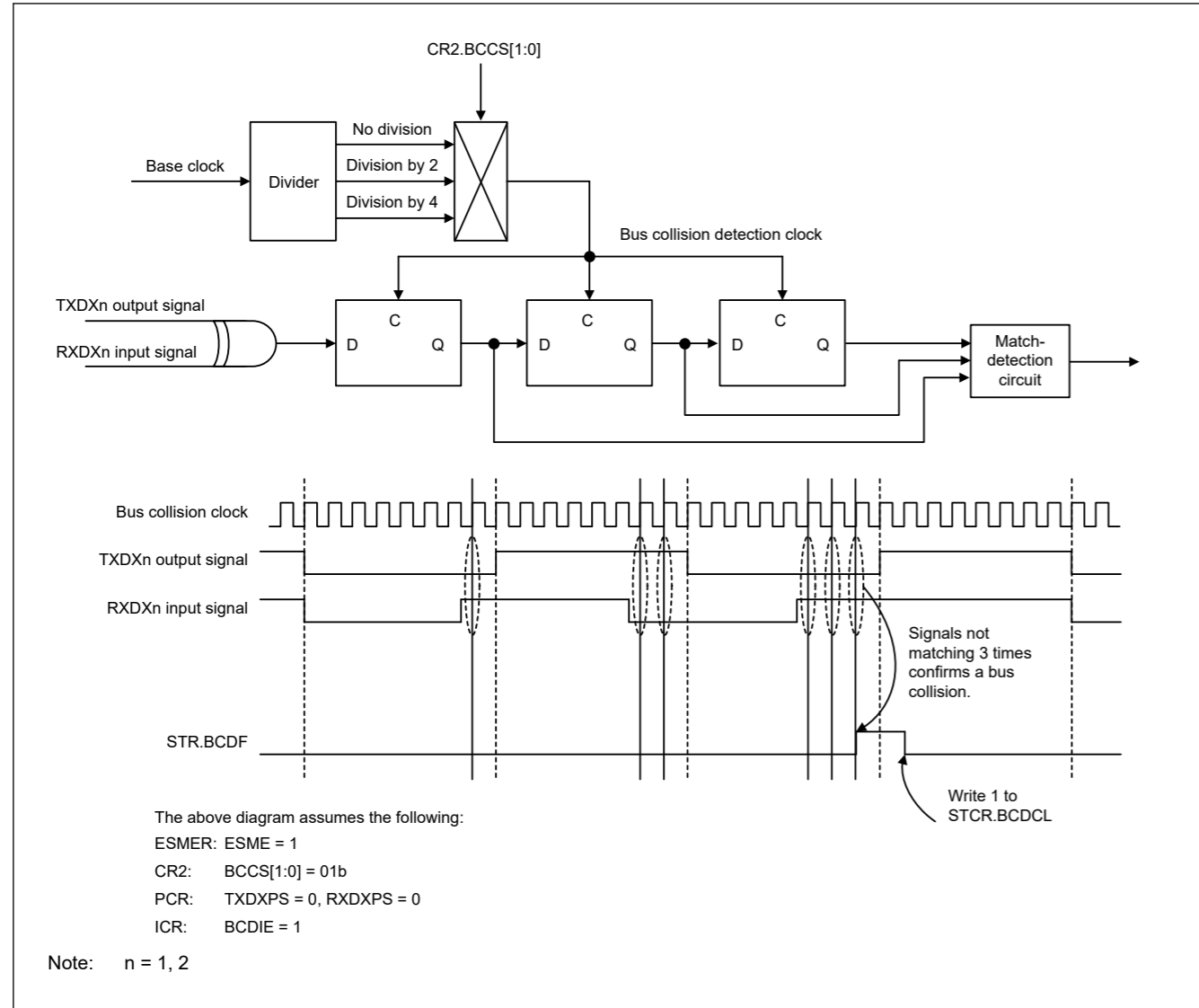


Figure 27.111 Example of Operations with Bus Collision Detection

27.11.5 Digital Filter for Input on the RXDXn (n = 1, 2) Pin

Signals input through the RXDXn pin can be passed through a digital filter before they are conveyed to the internal circuits. The digital filter consists of three flip-flop circuit stages connected in series and a match-detecting circuit. The CR2.DFCS[2:0] bits select the sampling clock for the RXDXn pin input signals. If the outputs of all three latches match, the given level is conveyed to subsequent circuits. If the levels do not match, the previous value is retained. In other words, levels are confirmed as being the signal if they are retained for at least three cycles of the sampling clock but judged to be noise rather than changes in the signal level if they change within three cycles of the sampling clock. Figure 27.112 shows an example of operations with the digital filter.

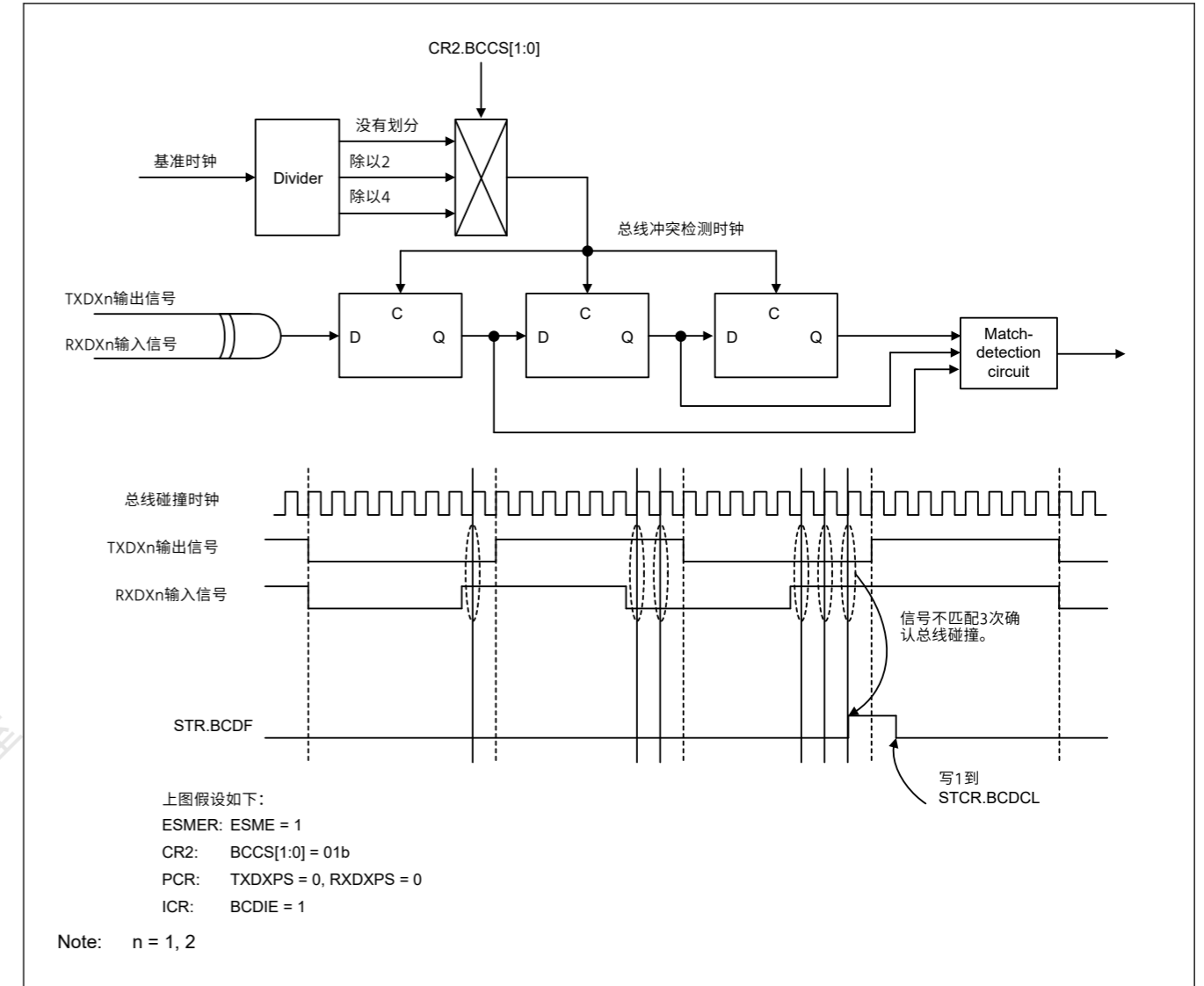


图27.111 带有总线冲突检测的操作示例

27.11.5 RXDXn(n=1 2)引脚上的输入数字滤波器

通过RXDXn引脚输入的信号在传送到内部电路之前可以通过数字滤波器。数字滤波器由三个串联的触发器电路级和一个匹配检测电路组成。这 CR2.DFCS[2:0]位选择RXDXn引脚输入信号的采样时钟。如果所有三个锁存器的输出都匹配，则将给定电平传送到后续电路。如果级别不匹配，则保留先前的值。换言之，如果电平在采样时钟的至少三个周期内保持，则确认电平为信号，但如果在采样时钟的三个周期内变化，则判断为噪声而不是信号电平的变化的。图27.112显示了使用数字滤波器的操作示例。



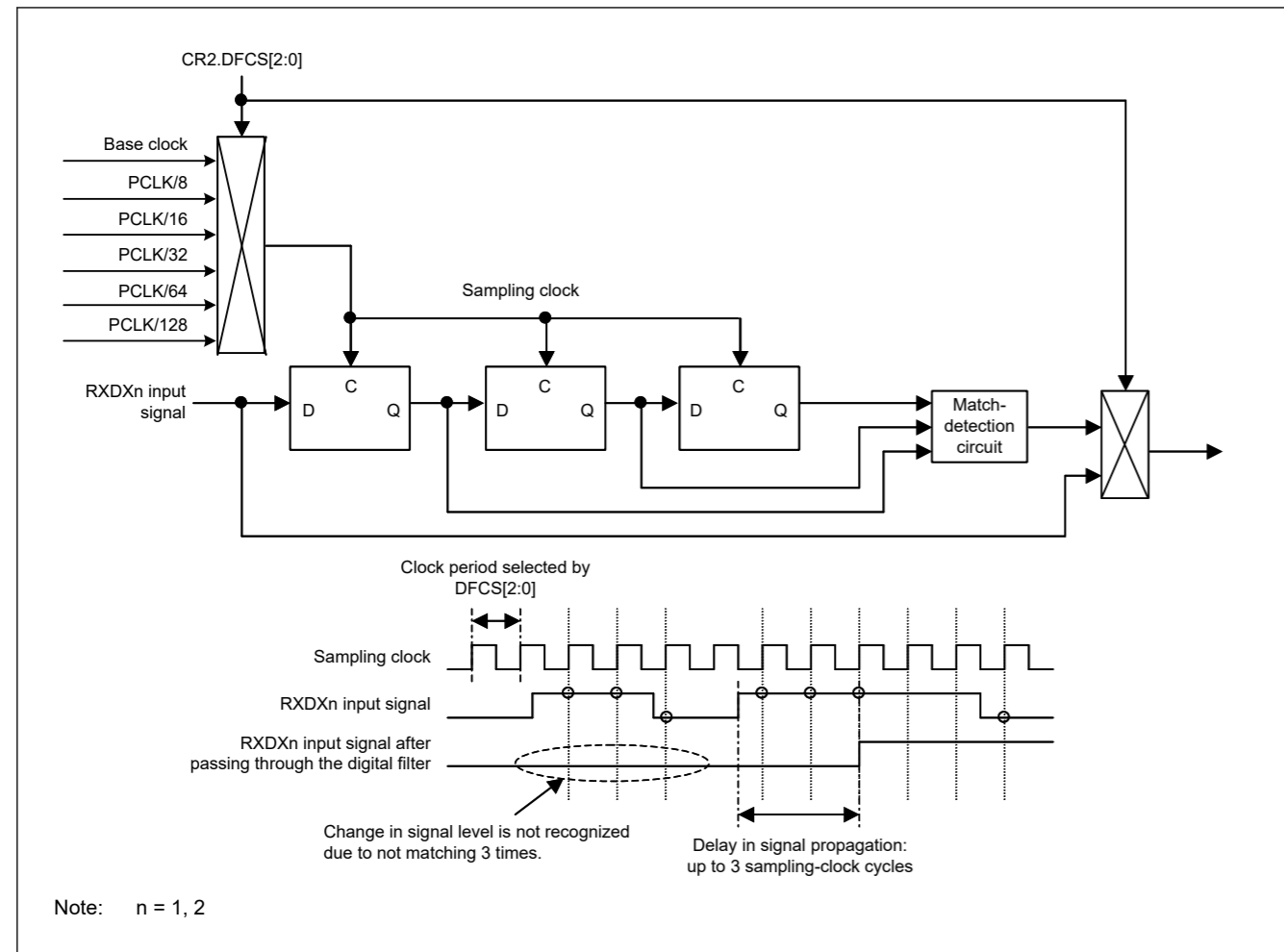


Figure 27.112 Example of Operations with the Digital Filter

### 27.11.6 Bit Rate Measurement

The bit rate measurement function measures the intervals between rising and falling edges and between falling and rising edges of the signal input from the RXDXn (n = 1, 2) pin. Figure 27.113 shows an example of operations for bit rate measurement.

1. Writing 1 to the CR0.BRME bit enables bit rate measurement. Only set the BRME bit to 1 when you wish to proceed with bit rate measurement. Furthermore, bit rate measurement will not proceed during a Break Field, even if the BRME bit is set to 1.
2. After detection of the Break Field low width, bit rate measurement starts when the level input on the RXDXn pin becomes high.
3. Once bit rate measurement has started, counter values from the timer are retained in the read buffers on the input of valid edges from the RXDXn pin (rising and falling edges) and the counter is reloaded. An SCIX3 interrupt is also generated if the value of the ICR.AEDIE bit is 1. Retention by registers TCNT and TPRE is released by reading these registers.
4. The bit rate as calculated from the values counted during intervals between valid edges can be used for adjusting the rate by changing the settings of the SCIn. To disable the bit rate measurement after a match with Control Field 1, write 0 to the CR0.BRME bit.

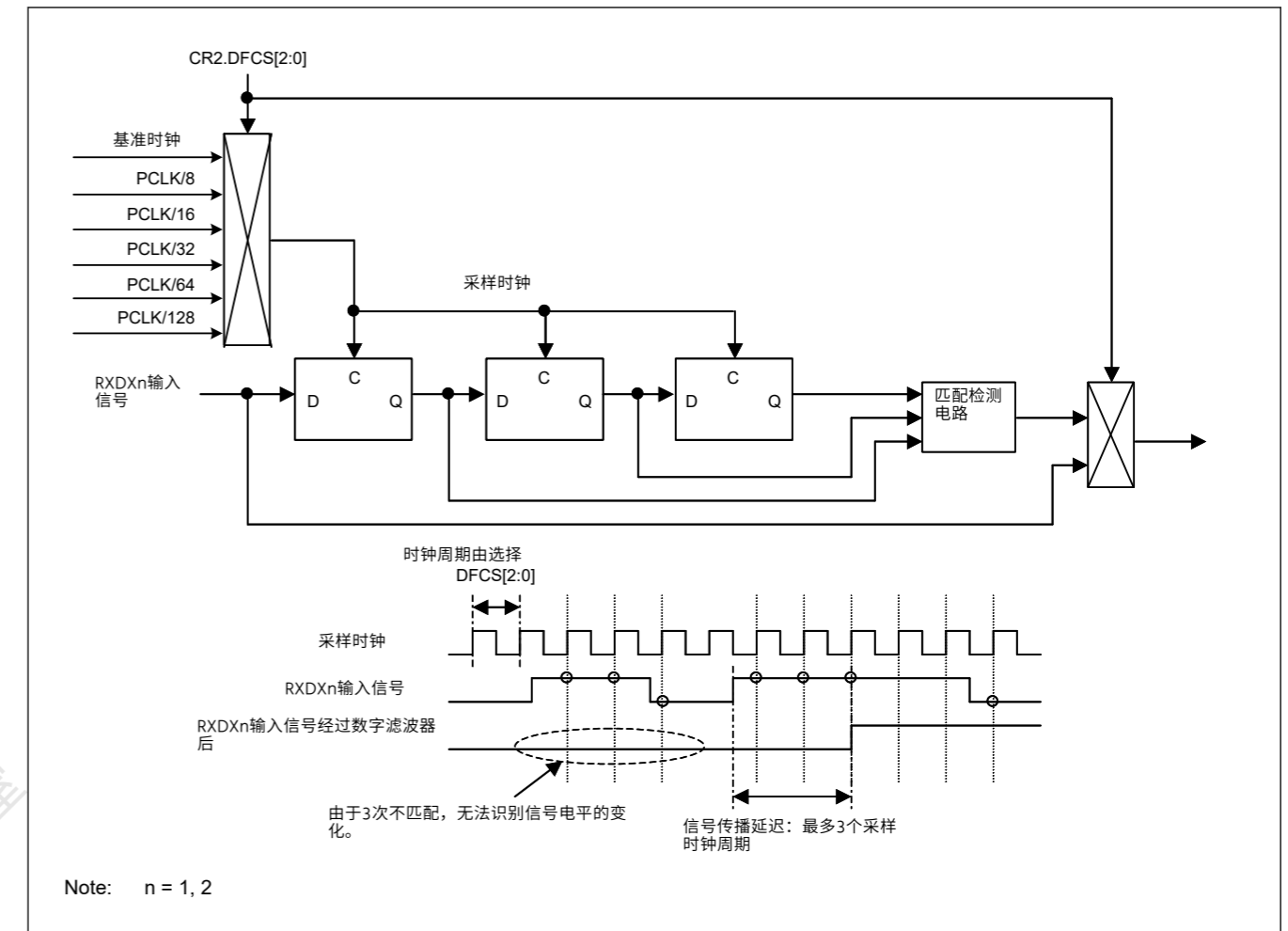


图27.112使用数字滤波器的操作示例

### 27.11.6 比特率测量

比特率测量功能测量从RXDXn(n=1,2)引脚输入的信号的上升沿和下降沿之间以及下降沿和上升沿之间的间隔。图27.113显示了比特率测量的操作示例。

- 1.将1写入CR0.BRME位启用比特率测量。仅当您希望继续进行比特率测量时，才将BRME位设置为1。此外，即使BRME位设置为1，在中断字段期间也不会进行比特率测量。
- 2.检测到BreakField低电平宽度后，当RXDXn引脚上的电平输入变为高电平时开始比特率测量。
- 3.一旦比特率测量开始，来自定时器的计数器值在来自RXDXn引脚的有效边沿（上升沿和下降沿）的输入上保留在读缓冲器中，并且计数器被重新加载。如果ICR.AEDIE位的值为1，也会产生SCIX3中断。寄存器TCNT和TPRE的保留通过读取这些寄存器来释放。
- 4.根据有效边沿之间的间隔期间计数的值计算的比特率可用于通过更改SCIn的设置来调整速率。要在与控制字段1匹配后禁用比特率测量，请将0写入CR0.BRME位。

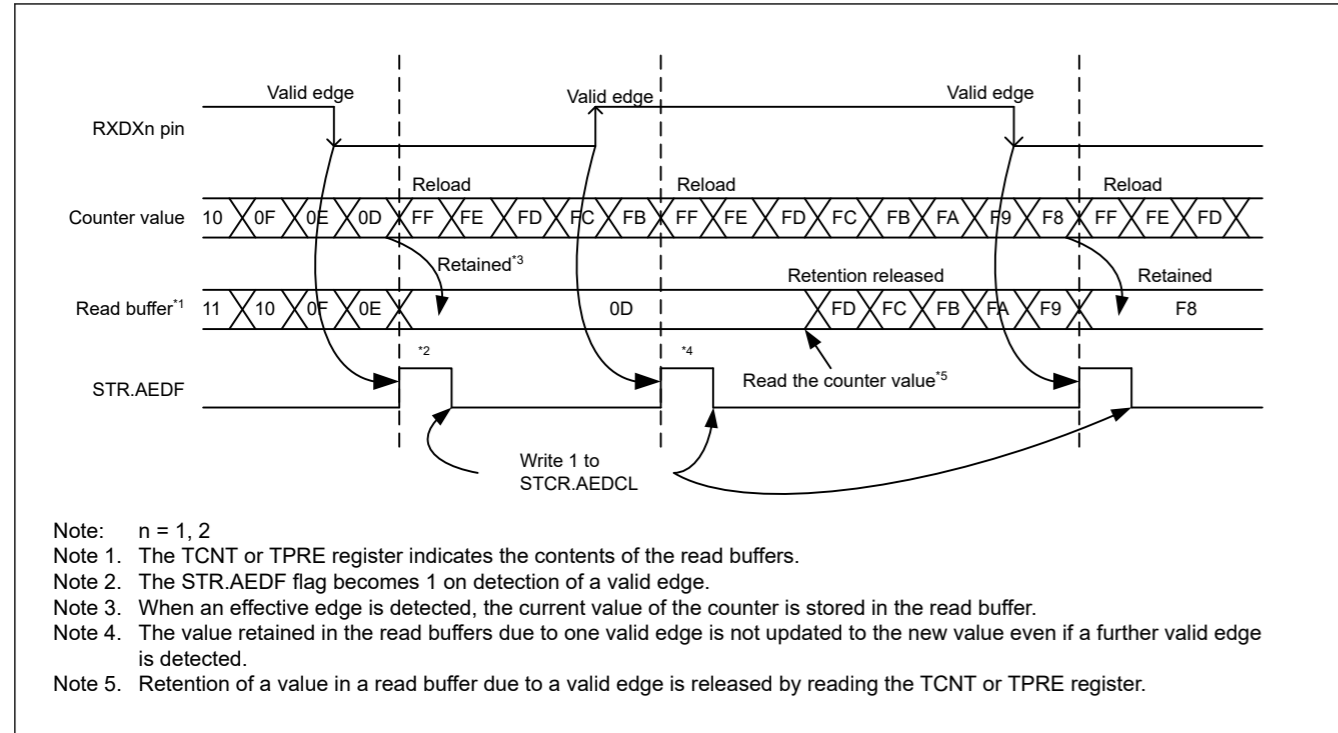


Figure 27.113 Example of Operations for Bit Rate Measurement

### 27.11.7 Selectable Timing for Sampling Data Received through RXDXn (n = 1, 2)

The extended serial mode control section provides a way of adjusting the timing for the sampling of data received through the RXDXn pin of an SCIn by setting the CR2.RTS[1:0] bits to select the rising edges of 8th, 10th, 12th, or 14th cycle of the SCI base clock. If the value of the SEMR.ABCS bit is 1, the bits select the rising edges of 4th, 5th, 6th, or 7th cycle of the PCLK clock of the SCIn. Figure 27.114 shows timing for the sampling of data received through RXDXn.

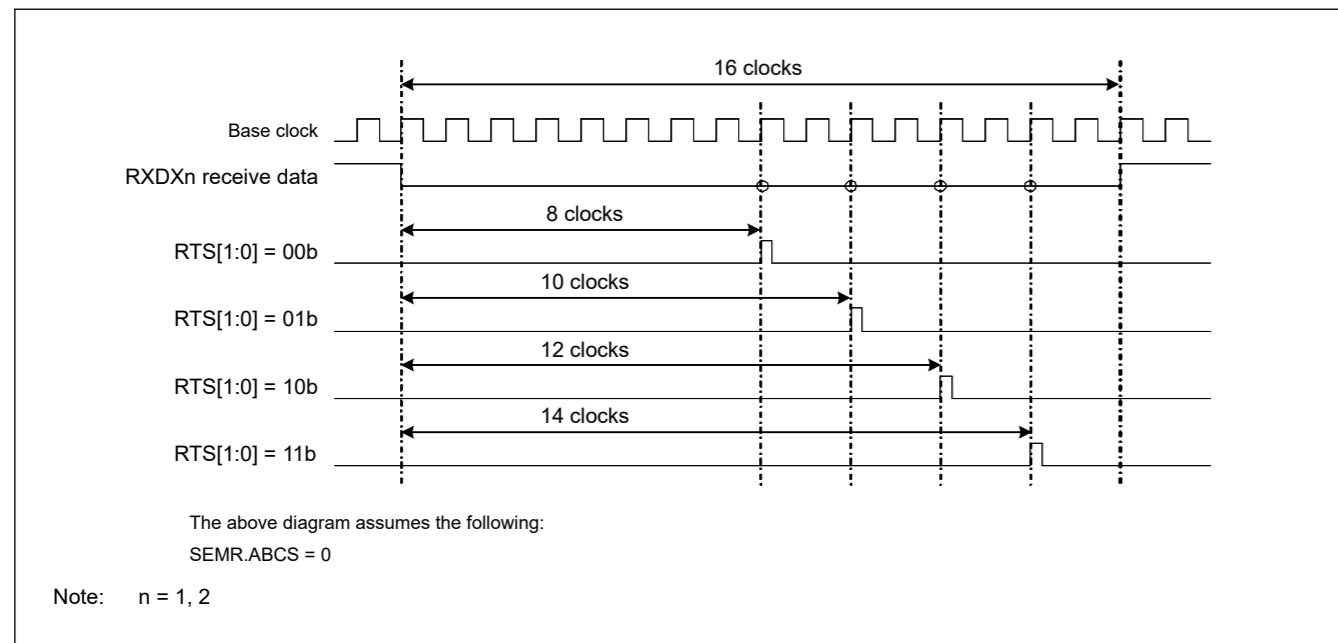


Figure 27.114 Timing for Sampling of Data Received through RXDXn

### 27.11.8 Timer

The timer has the following operating modes.

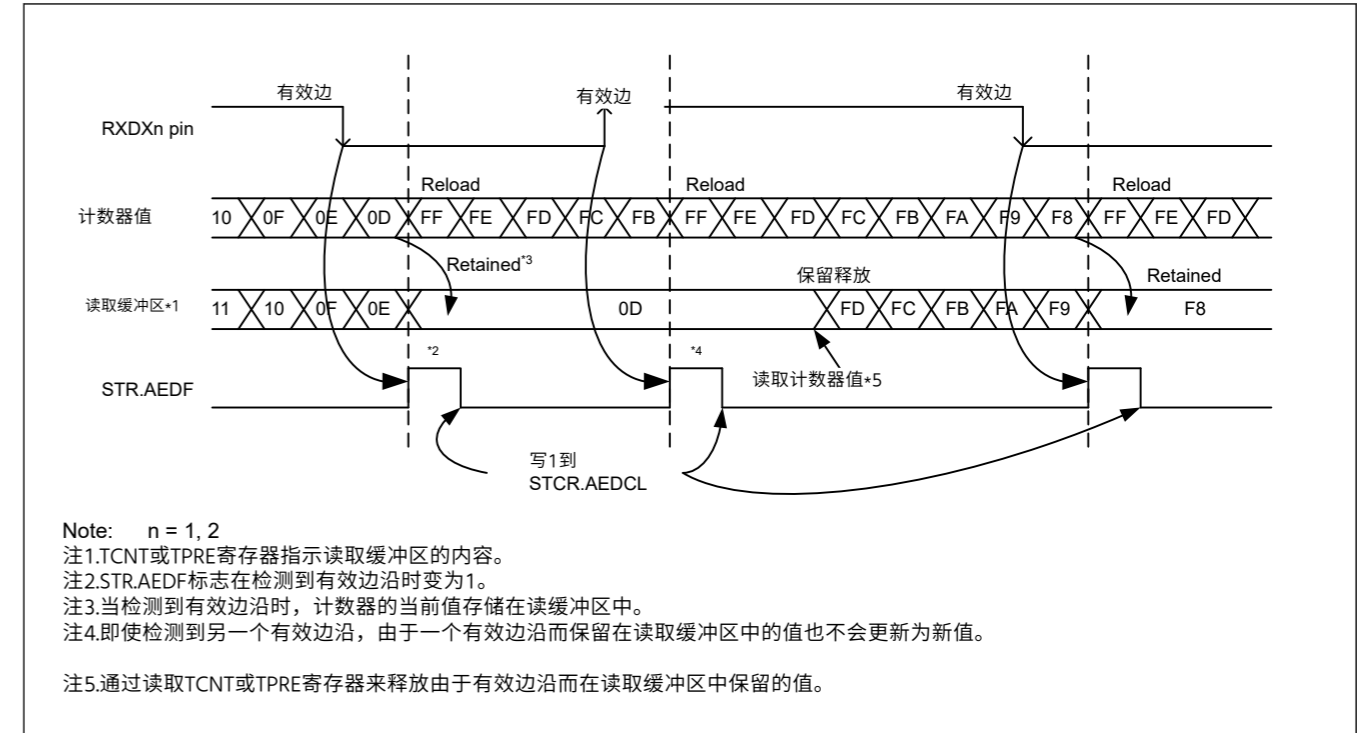


图27.113比特率测量操作示例

### 27.11.7 对通过RXDXn(n=1,2)接收的数据进行采样的可选时序

扩展串行模式控制部分通过设置CR2.RTS[1:0]位来选择第8、10、12、或SCI基本时钟的第14个周期。如果SEMR.ABCS位的值为1，则这些位选择第4、第5、第6或第7个周期的上升沿。SCIn的PCLK时钟。图27.114显示了对通过RXDXn接收的数据进行采样的时序。

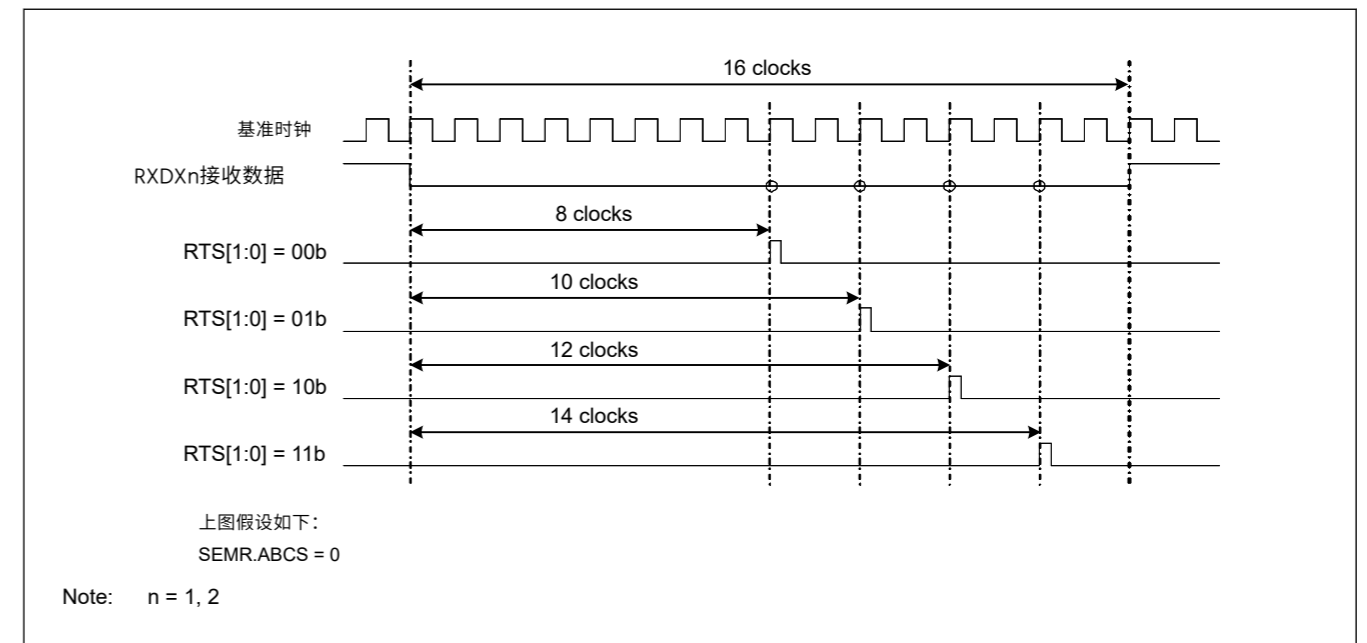


图27.114对通过RXDXn接收的数据进行采样的时序

### 27.11.8 Timer

定时器具有以下操作模式。

(1) Break Field Low Width Output Mode

This mode is for output through the TXDXn (n = 1, 2) pin of the low level over the Break Field low width at the transmission of a Start Frame. Setting the TMR.TOMS[1:0] bits to 10b switches operation to Break Field low width output mode. The TMR.TCSS[2:0] bits select the clock source for the counter. When the TCR.TCST bit is set to 1, the output on the TXDXn pin goes to the low level and counting starts. When the timer underflows, the output on the TXDXn pin goes to the high level and the STR.BFDF flag is set to 1. An SCIX0 interrupt is also generated if the value of the ICR.BFDIE bit is 1. When 0 is written to the TCR.TCST bit, counting stops after reloading of registers TPRES and TCNT. After output of the Break Field low width is completed, stop the timer before it underflows again. Figure 27.115 shows an example of operations in Break Field low width output mode.

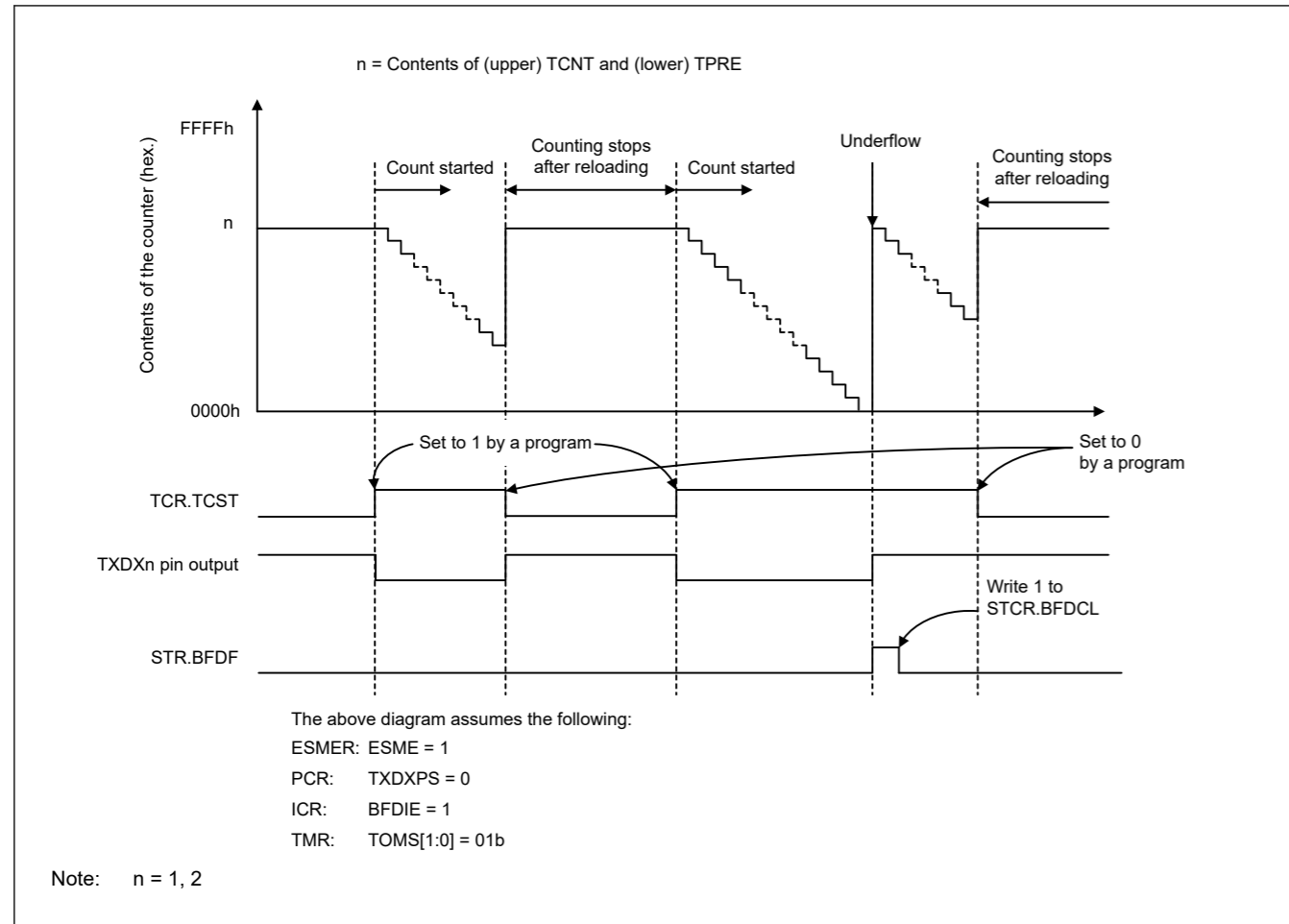


Figure 27.115 Example of Operations in Break Field Low Width Output Mode

(2) Break Field Low Width Determination Mode

This mode is for determining the Break Field low width in the input signal on the RXDXn (n = 1, 2) pin at the reception of a Start Frame. Setting the TMR.TOMS[1:0] bits to 01b switches operation to Break Field low width determination mode. The TMR.TCSS[2:0] bits select the clock source for the counter. When the TCR.TCST bit is set to 1, the interface enters the Break Field low width determinable state. Determination starts when a low level is input from the RXDXn pin. When a high level is then input on the RXDXn pin, registers TPRES and TCNT are reloaded and the interface enters the Break Field low width determinable state. When the timer underflows during Break Field low width determination, the STR.BFDF flag is set to 1. An SCIX0 interrupt is also generated if the value of the ICR.BFDIE bit is 1. If an underflow of the timer during data transfer cause a problem in the form of interrupt generation, stop the timer after Break Field low width determination. Figure 27.116 shows an example of operations in Break Field low width output mode.

(1) 断场低宽度输出模式

此模式用于在传输起始帧时通过中断字段低电平宽度上的低电平TXDXn(n=1,2)引脚输出。将TMR.TOMS[1:0]位设置为10b会将操作切换到BreakField低宽度输出模式。TMR.TCSS[2:0]位选择计数器的时钟源。当TCR.TCST位设置为1时，TXDXn引脚上的输出变为低电平并开始计数。当定时器下溢时，TXDXn引脚上的输出变为高电平，STR.BFDF标志设置为1。如果ICR.BFDIE位的值为1，也会产生SCIX0中断。当写入0时TCR.TCST位，重新加载寄存器TPRES和TCNT后计数停止。BreakField低宽度输出完成后，在定时器再次下溢之前停止定时器。图27.115显示了中断场低宽度输出模式下的操作示例。

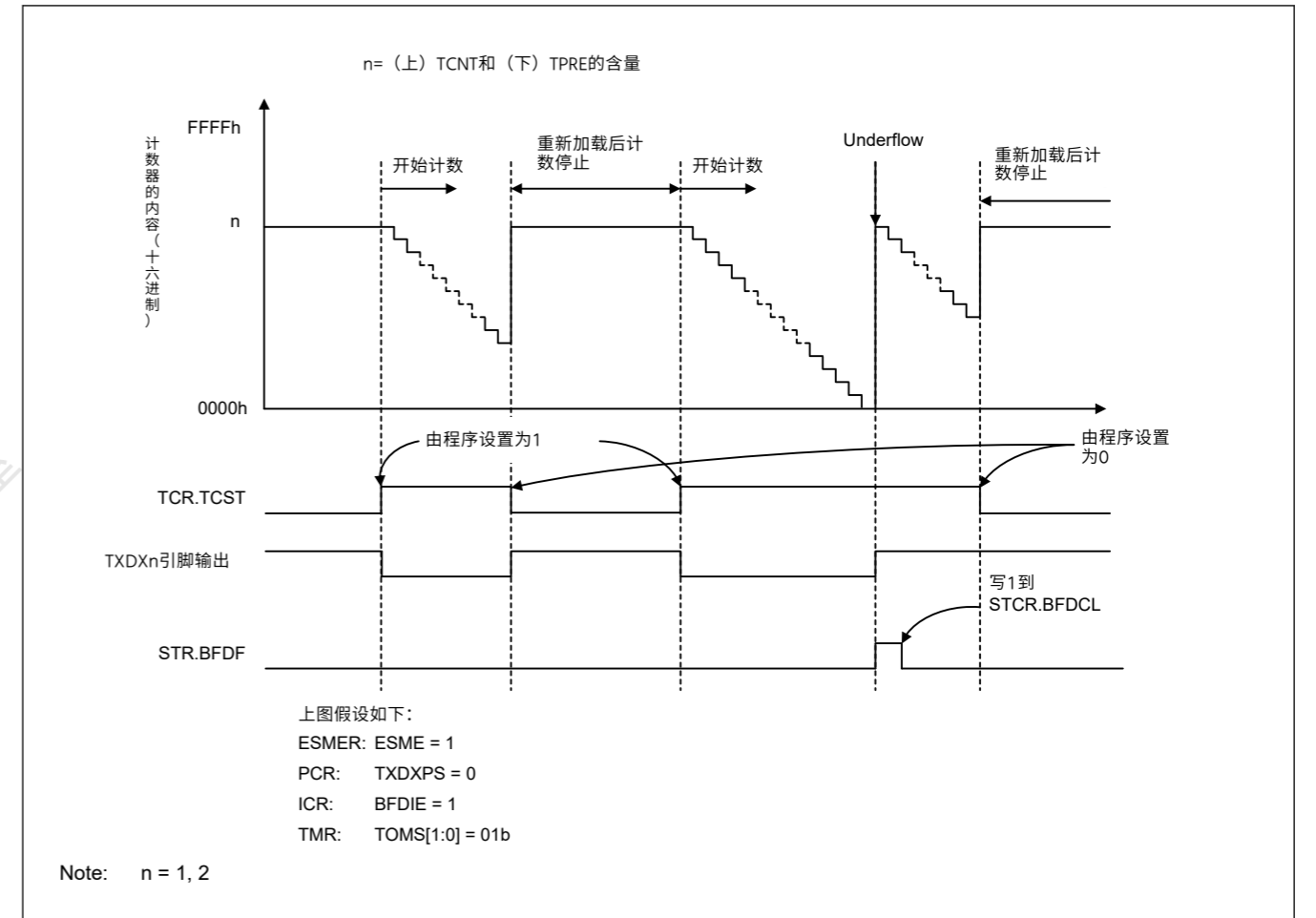


图27.115中断场低宽度输出模式下的操作示例

(2) 断场低宽度测定模式

该模式用于在接收起始帧时确定RXDXn(n=1,2)引脚上的输入信号中的中断场低电平宽度。将TMR.TOMS[1:0]位设置为01b会将操作切换到中断字段低宽度确定模式。TMR.TCSS[2:0]位选择计数器的时钟源。当TCR.TCST位设置为1时，接口进入BreakField低宽度可确定状态。当从RXDXn引脚输入低电平时开始确定。当RXDXn引脚输入高电平时，寄存器TPRES和TCNT被重新加载，接口进入中断字段低宽度可确定状态。在中断字段低宽度确定期间定时器下溢时，STR.BFDF标志设置为1。如果ICR.BFDIE位的值为1，也会产生SCIX0中断。如果在数据传输期间定时器下溢导致中断产生形式的问题，在BreakField低宽度确定后停止定时器。图27.116显示了中断场低宽度输出模式下的操作示例。

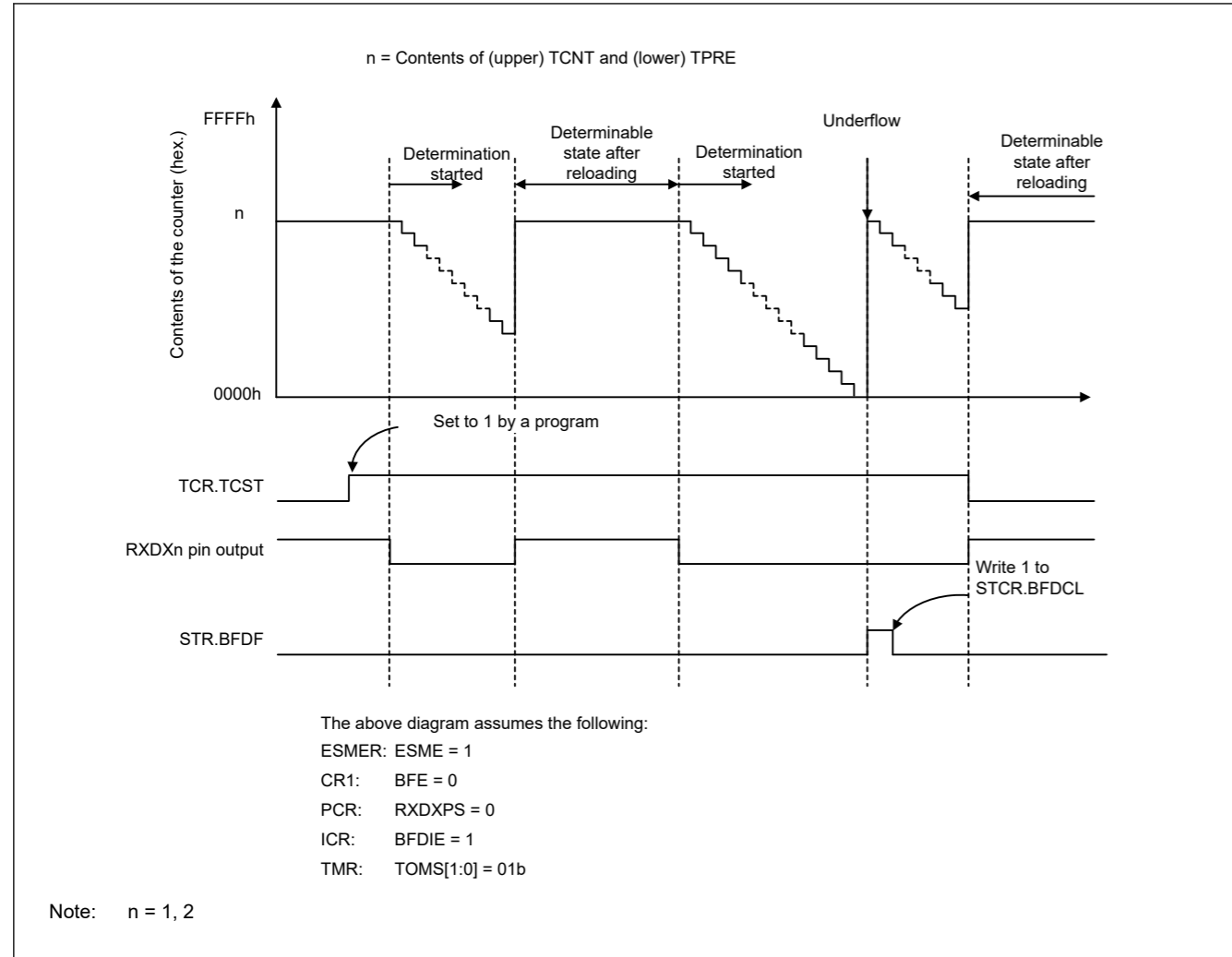


Figure 27.116 Example of Operations in Break Field Low Width Determination Mode

(3) Timer Mode

This mode is for counting cycles of the internal clock as the clock source. Setting the TMR.TOMS[1:0] bits to 00b switches operation to timer mode. The TMR.TCSS[2:0] bits select the clock source for the counter. Counting starts when 1 is written to the TCR.TCST bit and stops when 0 is written to the TCST bit. Registers TPRE and TCNT both count down. The TPRE register counts cycles of the clock source for counting, and underflows of the TPRE register provide the clock source for counting by the TCNT register. When the timer underflows, the STR.BFDF flag is set to 1. An SCIX0 interrupt is also generated if the value of the ICR.BFDIE bit is 1.

27.12 Interrupt Sources

27.12.1 Buffer Operation for SCIn\_TXI and SCIn\_RXI Interrupts (non-FIFO selected)

If the conditions for an SCIn\_TXI and SCIn\_RXI interrupt are satisfied while the interrupt status flag in the ICU is 1, the ICU does not output the interrupt request but saves it internally with a capacity for retention of one request per source.

When the interrupt status flag in the ICU is set to 0, the interrupt request retained within the ICU is output. The internally retained interrupt request is automatically discarded when the actual interrupt is output. Clearing of the associated interrupt enable bit (the TIE or RIE bit in the SCR/SCR\_SMCI) can also be used to discard an internally retained interrupt request.

27.12.2 Buffer Operation for SCIn\_TXI and SCIn\_RXI Interrupts (FIFO selected)

When an interrupt status flag in the ICU is set to 1, the SCIn\_TXI and SCIn\_RXI interrupts do not output interrupt requests to the ICU. When an interrupt status flag of the ICU is set to 0, and if the conditions for an SCIn\_TXI and SCIn\_RXI interrupts are satisfied, an interrupt request is generated.

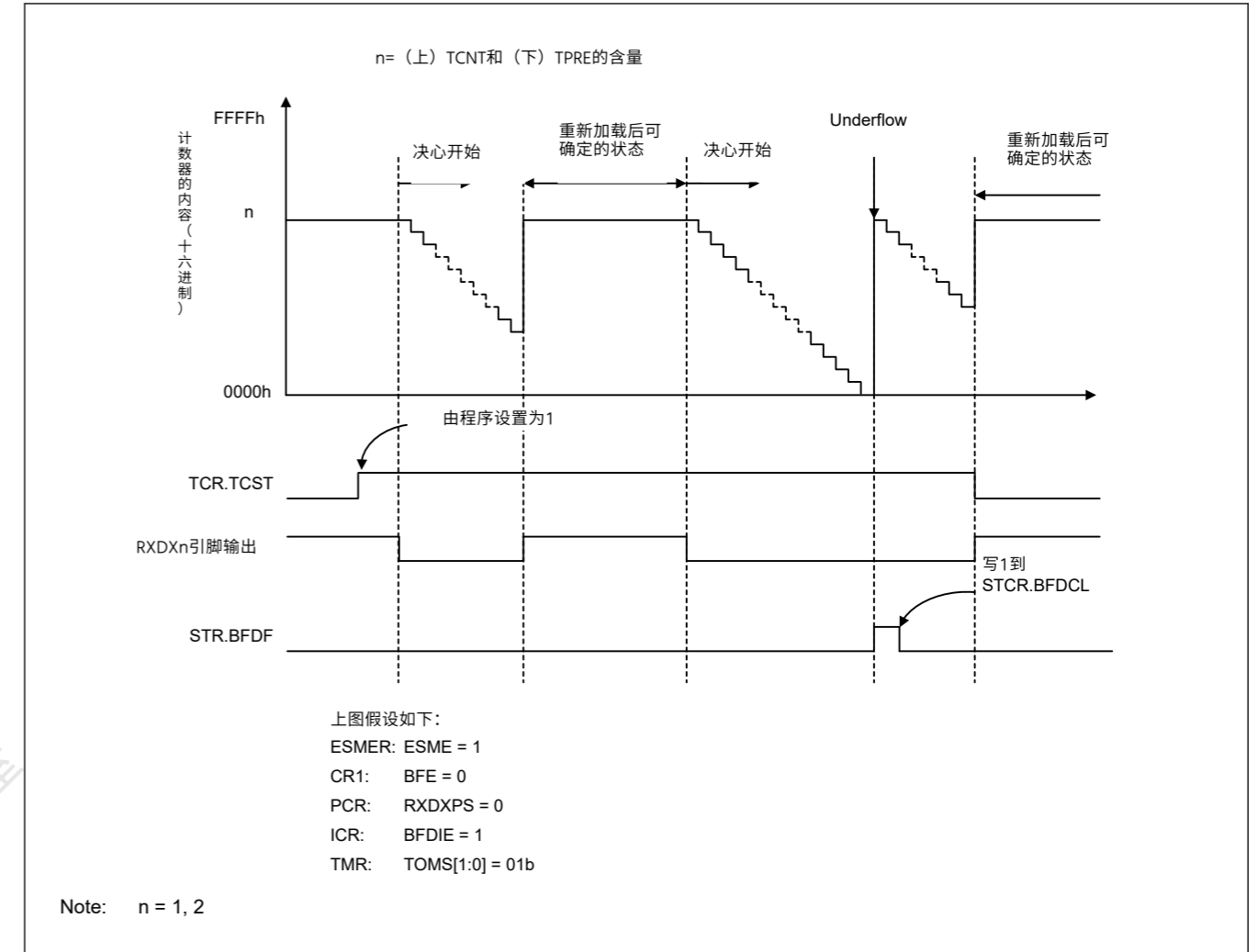


图27.116中断场低宽度确定模式下的操作示例

(3) 定时器模式

该模式用于计数内部时钟作为时钟源的周期。将TMR.TOMS[1:0]位设置为00b会将操作切换到定时器模式。TMR.TCSS[2:0]位选择计数器的时钟源。将1写入TCR.TCST位时开始计数，将0写入TCST位时停止计数。寄存器TPRE和TCNT都倒计时。TPRE寄存器对时钟源的周期计数进行计数，TPRE寄存器的下溢为TCNT寄存器的计数提供时钟源。当定时器下溢时，STR.BFDF标志设置为1。如果ICR.BFDIE位的值为1，也会产生SCIX0中断。

27.12 中断源

27.12.1 SCIn\_TXI和SCIn\_RXI中断的缓冲区操作（选择非FIFO）

如果在ICU中的中断状态标志为1时满足SCIn\_TXI和SCIn\_RXI中断的条件，则ICU不输出中断请求，而是将其保存在内部，每个源可以保留一个请求。

当ICU中的中断状态标志设置为0时，输出ICU中保留的中断请求。当实际中断输出时，内部保留的中断请求会被自动丢弃。清除相关中断使能位（SCR/SCR\_SMCI中的TIE或RIE位）也可用于丢弃内部保留的中断请求。

27.12.2 SCIn\_TXI和SCIn\_RXI中断的缓冲区操作（选择FIFO）

当ICU中的中断状态标志设置为1时，SCIn\_TXI和SCIn\_RXI中断不会向ICU输出中断请求。当ICU的中断状态标志设置为0，并且满足SCIn\_TXI和SCIn\_RXI中断的条件时，将产生中断请求。



### 27.12.3 Interrupts in Asynchronous, Manchester, Clock Synchronous, and Simple SPI Modes

#### (1) Non-FIFO selected

Table 27.42 lists interrupt sources in asynchronous mode, Manchester mode, clock synchronous mode, and simple SPI mode. A different interrupt vector can be assigned to each interrupt source. Individual interrupt sources can be enabled or disabled with the enable bits in the SCR register.

If the SCR.TIE bit is 1, an SCIn\_TXI interrupt request is generated when transmit data is transferred from the TDR or TDRHL register\*1 to the TSR register. An SCIn\_TXI interrupt request can also be generated by using a single instruction to set the SCR.TE and SCR.TIE bits to 1 at the same time. An SCIn\_TXI interrupt request can activate the DTC or DMAC to handle data transfer.

An SCIn\_TXI interrupt request is not generated by setting the SCR.TE bit to 1 when SCR.TIE is 0 or by setting the SCR.TIE bit to 1 when the SCR.TE is 1.\*2

When new data is not written by the time of transmission of the last bit of the current transmit data and SCR.TEIE is 1, the SSR.TEND flag is set to 1 and an SCIn\_TEI interrupt request is generated. Additionally, when SCR.TE is 1, the SSR.TEND flag retains the value 1 until more transmit data is written to the TDR or TDRHL register\*1, and setting SCR.TEIE to 1 leads to the generation of an SCIn\_TEI interrupt request.

Writing data to the TDR or TDRHL register\*1 leads to clearing of the SSR.TEND flag and, after a certain time, discarding of the SCIn\_TEI interrupt request.

If the SCR.RIE bit is 1, an SCIn\_RXI interrupt request is generated when received data is stored in the RDR register. An SCIn\_RXI interrupt request can activate the DTC or DMAC to handle data transfer.

Setting any of the SSR.ORER, FER, PER and MER\*3 flags to 1 when the SCR.RIE bit is 1 leads to the generation of an SCIn\_ERI interrupt request. An SCIn\_RXI interrupt request is not generated in this case. Clearing all these flags (ORER, FER, PER, MER\*3, SYER\*3, PFER\*3 and SBER\*3) leads to discarding of the SCIn\_ERI interrupt request.

Note 1. When asynchronous mode and 9-bit data length are selected.

Note 2. To temporarily prohibit SCIn\_TXI interrupts on transmission of the last of the data when a new round of transmission is to be started, after handling the transmission-completed interrupt, control activation of the interrupt by using the interrupt request enable bit in the ICU rather than using the SCR.TIE bit. This approach can prevent the suppression of SCIn\_TXI interrupt requests in the transfer of new data.

Note 3. MER, SYER, PFER, and SBER work as a factor of ERI interrupt only in Manchester mode. SYER, PFER, and SBER also only work if its enable bits (SYEREN, PFEREN, SBEREN in MECCR) are set to "1".

#### (2) FIFO selected

Table 27.43 lists interrupt sources in FIFO selected mode.

If the SCR.TIE bit is 1, an SCIn\_TXI interrupt request is generated when the stored amount of data in the FTDRL register becomes the threshold value indicated in FCR.TTRG or below. An SCIn\_TXI interrupt request can also be generated by using a single instruction to set the SCR.TIE and SCR.TE bits to 1 simultaneously or by setting SCR.TIE to 1 when SCR.TE is 1.

An SCIn\_TXI interrupt request is not generated by setting SCR.TE to 1 when SCR.TIE is 0.

If SCR.TEIE is 1 and if the next data is not written to the FTDRL register by the time the last bit of the transmit data is sent, the SSR\_FIFO.TEND flag is set to 1 and the SCIn\_TEI interrupt request is generated.

If SCR.RIE is 1, the SCIn\_RXI interrupt request is generated when the stored amount of data in the FRDRL register is equal to or greater than the threshold value indicated in FCR.RTRG. When RTRG is 0, an SCIn\_RXI interrupt does not occur even when the amount of data in the receive FIFO is equal to 0.

If the SCR.RIE bit is 1, when the SSR\_FIFO.ORER flag is set to 1 or data with a framing error or a parity error is stored in the FRDRL register, the SCIn\_ERI interrupt request is generated. When the amount of data stored in the FRDRL register is at the threshold value or above, the SCIn\_RXI interrupt request is also generated. The SCIn\_ERI interrupt request can be canceled, in which case SSR\_FIFO.ORER, FER, and PER flags are all cleared.

### 27.12.3 异步、曼彻斯特、时钟同步和简单SPI中的中断 Modes

#### (1) Non-FIFO selected

表27.42列出了异步模式、曼彻斯特模式、时钟同步模式和简单SPI模式下的中断源。可以为每个中断源分配不同的中断向量。可以使用SCR寄存器中的启用位启用或禁用各个中断源。

如果SCR.TIE位为1，则当发送数据从TDR传输或TDRHL寄存器\*1到TSR寄存器。也可以使用一条指令同时将SCR.TE和SCR.TIE位设置为1，从而产生SCIn\_TXI中断请求。SCIn\_TXI中断请求可以激活DTC或DMAC来处理数据传输。

当SCR.TIE为0时将SCR.TE位设置为1或通过设置当SCR.TE为1时，SCR.TIE位为1。\*2

当当前发送数据的最后一位发送时尚未写入新数据且SCR.TEIE为1，则SSR.TEND标志设置为1并产生SCIn\_TEI中断请求。此外，当SCR.TE为1时，SSR.TEND标志保持值1，直到更多的发送数据写入TDR或TDRHL寄存器\*1，并且将SCR.TEIE设置为1会导致产生SCIn\_TEI中断请求。

将数据写入TDR或TDRHL寄存器\*1会导致SSR.TEND标志清零，并在一定时间后丢弃SCIn\_TEI中断请求。

如果SCR.RIE位为1，则当接收到的数据存储在RDR寄存器中时会产生SCIn\_RXI中断请求。一个SCIn\_RXI中断请求可以激活DTC或DMAC来处理数据传输。

当SCR.RIE位为1时，将任何SSR.ORER、FER、PER和MER\*3标志设置为1会导致生成SCIn\_ERI中断请求。在这种情况下不会产生SCIn\_RXI中断请求。清除所有这些标志（ORER，FER PER MER\*3 SYER\*3 PFER\*3 and SBER\*3）导致丢弃SCIn\_ERI中断请求。

注意1.选择异步模式和9位数据长度时。

注2.为了在新一轮传输开始时，在传输最后一个数据时暂时禁止SCIn\_TXI中断，在处理完传输完成中断后，使用ICU中的中断请求使能位控制中断的激活而不是使用SCR.TIE位。这种方法可以防止在传输新数据时抑制SCIn\_TXI中断请求。

注3.MER、SYER、PFER和SBER仅在曼彻斯特模式下作为ERI中断的一个因素起作用。SYER、PFER和SBER也仅在其启用位（MECCR中的SYEREN、PFEREN、SBEREN）设置为“1”时才起作用。

#### (2) FIFO selected

表27.43列出了FIFO选择模式下的中断源。

如果SCR.TIE位为1，当FTDRL寄存器中存储的数据量变为FCR.TTRG中指示的阈值或更低时，将产生SCIn\_TXI中断请求。SCIn\_TXI中断请求也可以通过使用一条指令同时将SCR.TIE和SCR.TE位设置为1或在SCR.TE为1时将SCR.TIE设置为1来生成。

当SCR.TIE为0时，将SCR.TE设置为1不会产生SCIn\_TXI中断请求。

如果SCR.TEIE为1，并且在发送数据的最后一位时下一个数据未写入FTDRL寄存器，则SSR\_FIFO.TEND标志设置为1，并产生SCIn\_TEI中断请求。

如果SCR.RIE为1，则当FRDRL寄存器中存储的数据量等于或大于FCR.RTRG中指示的阈值时，将产生SCIn\_RXI中断请求。当RTRG为0时，即使接收FIFO中的数据量等于0，也不会发生SCIn\_RXI中断。

如果SCR.RIE位为1，当SSR\_FIFO.ORER标志设置为1或帧错误或奇偶校验错误的的数据存储在FRDRL寄存器中时，将产生SCIn\_ERI中断请求。当FRDRL寄存器中存储的数据量在阈值或以上时，也会产生SCIn\_RXI中断请求。SCIn\_ERI中断请求可以被取消，在这种情况下SSR\_FIFO.ORER、FER和PER标志都被清除。

Table 27.42 SCI interrupt sources with non-FIFO selected

| Name                     | Interrupt source    | Interrupt flag   | Interrupt enable | DTC or DMAC activation |
|--------------------------|---------------------|--|------------------|------------------------|
| SCIn_ERI (n = 0 to 4, 9) | Receive error*1     | SSR.ORER, SSR.FER, SSR.PER, DCCR.DFER, DCCR.DPER, (SSR.MER, MESR.SYER, MESR.PFER, MESR.SBER)*2 | SCR.RIE          | Not possible           |
| SCIn_RXI (n = 0 to 4, 9) | Receive data full   | SSR.RDRF   | SCR.RIE          | Possible               |
|                          | Address match       | DCCR.DCMF  | SCR.RIE          | Possible               |
| SCIn_AM (n = 0, 3, 4, 9) | Address match       | DCCR.DCMF  | —                | Not possible           |
| SCIn_TXI (n = 0 to 4, 9) | Transmit data empty | SSR.TDRE   | SCR.TIE          | Possible               |
| SCIn_TEI (n = 0 to 4, 9) | Transmit end        | SSR.TEND   | SCR.TEIE         | Not possible           |

Note 1. The interrupt flag is only ORER when in clock synchronous and simple SPI mode.  
 Note 2. MER, SYER, PFER, and SBER work as a factor of ERI interrupt only in Manchester mode. SYER, PFER, and SBER also only work if its enable bits (SYEREN, PFEREN, SBEREN in MECR) are set to "1".

Table 27.43 SCI interrupt sources with FIFO selected

| Name                     | Interrupt source    | Interrupt flag  | Interrupt enable | DTC or DMAC activation |
|--------------------------|---------------------|---|------------------|------------------------|
| SCIn_ERI (n = 0 to 4, 9) | Receive error*1     | SSR_FIFO.ORER, SSR_FIFO.FER, SSR_FIFO.PER, DCCR.DFER, DCCR.DPER | SCR.RIE          | Not possible           |
|                          |                     | SSR_FIFO.DR (when FCR.DRES = 1)                                 | SCR.RIE          | Not possible           |
| SCIn_RXI (n = 0 to 4, 9) | Receive data full   | SSR_FIFO.RDF  | SCR.RIE          | Possible               |
|                          | Receive data ready  | SSR_FIFO.DR (when FCR.DRES = 0)                                 | SCR.RIE          | Possible               |
|                          | Address match       | DCCR.DCMF   | SCR.RIE          | Possible               |
| SCIn_AM (n = 0, 3, 4, 9) | Address match       | DCCR.DCMF   | —                | Not possible           |
| SCIn_TXI (n = 0 to 4, 9) | Transmit data empty | SSR_FIFO.TDFE   | SCR.TIE          | Possible               |
| SCIn_TEI (n = 0 to 4, 9) | Transmit end        | SSR_FIFO.TEND   | SCR.TEIE         | Not possible           |

Note 1. The interrupt flag is only ORER when in clock synchronous and simple SPI mode.

### 27.12.4 Interrupts in Smart Card Interface Mode

Table 27.44 lists interrupt sources in smart card interface mode. A transmit end interrupt (SCIn\_TEI) request and an address match (SCIn\_AM) request cannot be used in this mode.

Table 27.44 SCI Interrupt sources

| Name                     | Interrupt source                        | Interrupt flag                            | Interrupt enable | DTC or DMAC activation |
|--------------------------|---|---|------------------|------------------------|
| SCIn_ERI (n = 0 to 4, 9) | Receive error or error signal detection | SSR_SMCI.ORER, SSR_SMCI.PER, SSR_SMCI.ERS | SCR_SMCI.RIE     | Not possible           |
| SCIn_RXI (n = 0 to 4, 9) | Receive data full                       | SSR_SMCI.RDRF                             | SCR_SMCI.RIE     | Possible               |
| SCIn_TXI (n = 0 to 4, 9) | Transmit data empty                     | SSR_SMCI.TEND                             | SCR_SMCI.TIE     | Possible               |

Data transmission or reception using the DTC or DMAC is also possible in smart card interface mode, similar to normal SCI mode. In transmission, when the SSR\_SMCI.TEND flag is set to 1, an SCIn\_TXI interrupt request is generated. This

Table 27.42 选择了非FIFO的SCI中断源

| Name                     | 中断源    | 中断标志   | 中断使能     | DTC或DMAC激活 |
|--------------------------|--------|--|----------|------------|
| SCIn_ERI (n = 0 to 4, 9) | 接收错误*1 | SSR.ORER, SSR.FER, SSR.PER, DCCR.DFER, DCCR.DPER, (SSR.MER, MESR.SYER, MESR.PFER, MESR.SBER)*2 | SCR.RIE  | 不可能        |
| SCIn_RXI (n = 0 to 4, 9) | 接收数据已满 | SSR.RDRF   | SCR.RIE  | Possible   |
|                          | 地址匹配   | DCCR.DCMF  | SCR.RIE  | Possible   |
| SCIn_AM (n = 0, 3, 4, 9) | 地址匹配   | DCCR.DCMF  | —        | 不可能        |
| SCIn_TXI (n = 0 to 4, 9) | 传输数据为空 | SSR.TDRE   | SCR.TIE  | Possible   |
| SCIn_TEI (n = 0 to 4, 9) | 发射端    | SSR.TEND   | SCR.TEIE | 不可能        |

注1.中断标志 仅在时钟同步和简单SPI模式下为ORER。  
 注2.MER、SYER、PFER和SBER仅在曼彻斯特模式下作为ERI中断的一个因素起作用。SYER、PFER和SBER也仅在其启用位（MECR中的SYEREN、PFEREN、SBEREN）设置为“1”时才起作用。

Table 27.43 选择了FIFO的SCI中断源

| Name                     | 中断源    | 中断标志  | 中断使能     | DTC或DMAC激活 |
|--------------------------|--------|---|----------|------------|
| SCIn_ERI (n = 0 to 4, 9) | 接收错误*1 | SSR_FIFO.ORER, SSR_FIFO.FER, SSR_FIFO.PER, DCCR.DFER, DCCR.DPER | SCR.RIE  | 不可能        |
|                          |        | SSR_FIFO.DR (when FCR.DRES = 1)                                 | SCR.RIE  | 不可能        |
| SCIn_RXI (n = 0 to 4, 9) | 接收数据已满 | SSR_FIFO.RDF  | SCR.RIE  | Possible   |
|                          | 接收数据就绪 | SSR_FIFO.DR (when FCR.DRES = 0)                                 | SCR.RIE  | Possible   |
|                          | 地址匹配   | DCCR.DCMF   | SCR.RIE  | Possible   |
| SCIn_AM (n = 0, 3, 4, 9) | 地址匹配   | DCCR.DCMF   | —        | 不可能        |
| SCIn_TXI (n = 0 to 4, 9) | 传输数据为空 | SSR_FIFO.TDFE   | SCR.TIE  | Possible   |
| SCIn_TEI (n = 0 to 4, 9) | 发射端    | SSR_FIFO.TEND   | SCR.TEIE | 不可能        |

注1.中断标志 仅在时钟同步和简单SPI模式下为ORER。

### 27.12.4 智能卡接口模式中的中断

表27.44列出了智能卡接口模式下的中断源。在此模式下不能使用发送结束中断(SCIn\_TEI)请求和地址匹配(SCIn\_AM)请求。

Table 27.44 SCI中断源

| Name                     | 中断源         | 中断标志                                      | 中断使能         | DTC或DMAC激活 |
|--------------------------|-------------|---|--------------|------------|
| SCIn_ERI (n = 0 to 4, 9) | 接收错误或错误信号检测 | SSR_SMCI.ORER, SSR_SMCI.PER, SSR_SMCI.ERS | SCR_SMCI.RIE | 不可能        |
| SCIn_RXI (n = 0 to 4, 9) | 接收数据已满      | SSR_SMCI.RDRF                             | SCR_SMCI.RIE | Possible   |
| SCIn_TXI (n = 0 to 4, 9) | 传输数据为空      | SSR_SMCI.TEND                             | SCR_SMCI.TIE | Possible   |

在智能卡接口模式下也可以使用DTC或DMAC进行数据传输或接收，类似于正常SCI模式。在发送过程中，当SSR\_SMCI.TEND标志设置为1时，会产生一个SCIn\_TXI中断请求。这个

SCIn\_TXI interrupt request activates the DTC or DMAC, allowing transfer of transmit data if the SCIn\_TXI request is previously specified as a source of DTC or DMAC activation. The TEND flag is automatically set to 0 when the DTC or DMAC transfers the data.

If an error occurs, the SCI automatically retransmits the same data. During the retransmission, the TEND flag is kept at 0 and the DTC or DMAC is not activated. Therefore, the SCI and DTC or DMAC automatically transmit the specified number of bytes, including retransmission after an error occurrence. However, the SSR\_SMCLERS flag is not automatically set to 0 at error occurrence. Therefore, the ERS flag must be cleared by previously setting the SCR\_SMCLRIE bit to 1 to enable an SCIn\_ERI interrupt request to be generated at error occurrence.

When transmitting or receiving data using the DTC or DMAC, always enable the DTC or DMAC before making the SCI settings. For DTC or DMAC settings, see [section 17, Data Transfer Controller \(DTC\)](#), [section 16, DMA Controller \(DMAC\)](#).

In reception, an SCIn\_RXI interrupt request is generated when receive data is set to the RDR register. This SCIn\_RXI interrupt request activates the DTC or DMAC, allowing transfer of the receive data if the SCIn\_RXI request is previously specified as a source of DTC or DMAC activation. If an error occurs, the error flag is set. Therefore, the DTC or DMAC is not activated and an SCIn\_ERI interrupt request is issued to the CPU instead. The error flag must be cleared.

### 27.12.5 Interrupts in Simple IIC Mode

[Table 27.45](#) lists the interrupt sources in simple IIC mode. The STI interrupt is allocated to the transmit end interrupt (SCIn\_TEI) request. The receive error interrupt (SCIn\_ERI) and the address match (SCIn\_AM) request cannot be used.

The DTC or DMAC can also be used to handle transfer in simple IIC mode.

When the SIMR2.IICINTM bit is 1:

- An SCIn\_RXI request is generated on the falling edge of the SCLn signal for the 8<sup>th</sup> bit. If SCIn\_RXI is previously set up as an activation source for the DTC or DMAC, the SCIn\_RXI request activates the DTC or DMAC to handle transfer of the received data.
- An SCIn\_TXI request is generated on the falling edge of the SCLn signal for the 9<sup>th</sup> bit (acknowledge bit). If SCIn\_TXI is previously set up as an activation source for the DTC or DMAC, the SCIn\_TXI request activates the DTC or DMAC to handle transfer of the transmit data.

When the SIMR2.IICINTM bit is 0:

- An SCIn\_RXI request (ACK detection) is generated if the input on the SDAn pin is low on the rising edge of the SCLn signal for the 9<sup>th</sup> bit (acknowledge bit)
- An SCIn\_TXI request (NACK detection) is generated if the input on the SDAn pin is high on the rising edge of the SCLn signal for the 9<sup>th</sup> bit (acknowledge bit)
- If SCIn\_RXI is previously set up as an activation source for the DTC or DMAC, the SCIn\_RXI request activates the DTC or DMAC to handle transfer of the received data.

If the DTC or DMAC is used for data transfer in reception or transmission, always set up and enable the DTC or DMAC before setting up the SCI.

When the IICSTAREQ, IICRSTAREQ, and IICSTPREQ bits in SIMR3 are used to generate a start condition, restart condition, or stop condition, the STI request is issued when generation is complete.

**Table 27.45 SCI interrupt sources**

| Name                           | Interrupt source  | Interrupt flag | Interrupt enable | DTC or DMAC activation |
|--------------------------------|---|----------------|------------------|------------------------|
| SCIn_RXI (n = 0 to 4, 9)       | Reception, ACK detection  | —              | SCMR.RIE         | Possible*1             |
| SCIn_TXI (n = 0 to 4, 9)       | Transmission, NACK detection                                    | —              | SCMR.TIE         | Possible               |
| SCIn_TEI(STIn) (n = 0 to 4, 9) | Completion of generation of a start, restart, or stop condition | SIMR3.IICSTIF  | SCMR.TEIE        | Not possible           |

Note 1. Activation of the DTC or DMAC is only possible when the SIMR2.IICINTM bit is 1 (use reception and transmission interrupts)

SCIn\_TXI中断请求激活DTC或DMAC，如果之前将SCIn\_TXI请求指定为DTC或DMAC激活源，则允许传输数据。当DTC或DMAC传输数据时，TEND标志自动设置为0。

如果发生错误，SCI会自动重新传输相同的数据。在重传期间，TEND标志保持为0，并且DTC或DMAC不被激活。因此，SCI和DTC或DMAC会自动传输指定的字节数，包括发生错误后的重传。但是，发生错误时，SSR\_SMCLERS标志不会自动设置为0。因此，必须通过预先将SCR\_SMCLRIE位设置为1来清除ERS标志，以在发生错误时启用SCIn\_ERI中断请求。

使用DTC或DMAC发送或接收数据时，请务必在进行SCI设置之前启用DTC或DMAC。对于DTC或DMAC设置，请参阅第17节，数据传输控制器(DTC)，第16节，DMA控制器(DMAC)。

在接收中，当接收数据设置到RDR寄存器时，会产生SCIn\_RXI中断请求。该SCIn\_RXI中断请求激活DTC或DMAC，如果先前将SCIn\_RXI请求指定为DTC或DMAC激活源，则允许传输接收数据。如果发生错误，则设置错误标志。因此，不会激活DTC或DMAC，而是向CPU发出SCIn\_ERI中断请求。必须清除错误标志。

### 27.12.5 简单IIC模式下的中断

表27.45列出了简单IIC模式下的中断源。STI中断分配给发送结束中断(SCIn\_TEI)请求。不能使用接收错误中断(SCIn\_ERI)和地址匹配(SCIn\_AM)请求。

DTC或DMAC也可用于处理简单IIC模式下的传输。

当SIMR2.IICINTM位为1时：

- SCIn\_RXI请求在第8位的SCLn信号下降沿产生。如果SCIn\_RXI先前设置为DTC或DMAC的激活源，则SCIn\_RXI请求将激活DTC或DMAC以处理接收数据的传输。
- SCIn\_TXI请求在第9位（确认位）的SCLn信号的下降沿产生。如果SCIn\_TXI先前设置为DTC或DMAC的激活源，则SCIn\_TXI请求将激活DTC或DMAC以处理传输数据的传输。

当SIMR2.IICINTM位为0时：

- 如果SDAn引脚上的输入在第9位（确认位）的SCLn信号的上升沿为低电平，则生成SCIn\_RXI请求（ACK检测）
- 如果SDAn引脚上的输入在第9位（确认位）的SCLn信号的上升沿为高电平，则生成SCIn\_TXI请求（NACK检测）
- 如果先前将SCIn\_RXI设置为DTC或DMAC的激活源，则SCIn\_RXI请求将激活DTC或DMAC以处理接收数据的传输。

如果DTC或DMAC用于接收或传输中的数据，请务必在设置SCI之前设置并启用DTC或DMAC。

当SIMR3中的IICSTAREQ、IICRSTAREQ和IICSTPREQ位用于生成开始条件、重新启动条件或停止条件时，生成完成时会发出STI请求。

**Table 27.45 SCI中断源**

| Name                           | 中断源               | 中断标志          | 中断使能      | DTC或DMAC激活 |
|--------------------------------|-------------------|---------------|-----------|------------|
| SCIn_RXI (n = 0 to 4, 9)       | 接收、ACK检测          | —             | SCMR.RIE  | Possible*1 |
| SCIn_TXI (n = 0 to 4, 9)       | 传输、NACK检测         | —             | SCMR.TIE  | Possible   |
| SCIn_TEI(STIn) (n = 0 to 4, 9) | 完成启动、重新启动或停止条件的生成 | SIMR3.IICSTIF | SCMR.TEIE | 不可能        |

注1.仅当SIMR2.IICINTM位为1时才可能激活DTC或DMAC（使用接收和发送中断）



### 27.12.6 Interrupt Requests from the Extended Serial Mode Control Section

The extended serial mode control section has a total of six types of interrupt request for generating the SCIX0 interrupt (Break Field low width detected), SCIX1 interrupt (Control Field 0 match, Control Field 1 match, priority interrupt bit detected), SCIX2 interrupt (bus collision detected), and SCIX3 interrupt (valid edge detected). When any of the interrupt factors is generated, the corresponding status flag is set to 1. Details of all of the interrupt requests are listed in Table 27.46.

**Table 27.46 Interrupt Sources of the Extended Serial Mode Control Section**

| Interrupt Request                                 | Status Flag | Interrupt Factors  |
|---|-------------|--|
| SCIX0 interrupt (Break Field low width detected)  | BDFD        | <ul style="list-style-type: none"> <li>Detection of a Break Field low width longer than the interval corresponding to the timer setting</li> <li>Completion of the output of a Break Field low width over the interval corresponding to the timer setting</li> <li>Underflow of the timer</li> </ul> |
| SCIX1 interrupt (Control Field 0 match)           | CF0MF       | The data received in Control Field 0 matching the value set in CF0DR   |
| SCIX1 interrupt (Control Field 1 match)           | CF1MF       | The data received in Control Field 1 matching the value set in PCF1DR or SCF1DR  |
| SCIX1 interrupt (priority interrupt bit detected) | PIBDF       | The value of the bit specified as the priority interrupt bit matching the value set in PCF1DR  |
| SCIX2 interrupt (bus collision detected)          | BCDF        | The output level on the RXDXn (n = 1, 2) pin and the input level on the RXDXn pin not matching on three consecutive cycles of the bus collision detection clock  |
| SCIX3 interrupt (valid edge detected)             | AEDF        | Detection of a valid edge during bit rate measurement  |

### 27.13 Event Linking

By using interrupt request signals as event signals, the SCIn can provide linked operation through the ELC for modules selected in advance.

Event signals can be output regardless of the values of the associated interrupt request enable bits.

#### (1) Error event output (receive error or error signal detected) (SCIn\_ERI, n = 0 to 4, 9)

- Indicates abnormal termination because of a parity error during reception in asynchronous mode
- Indicates abnormal termination because of a framing error during reception in asynchronous mode
- Indicates abnormal termination because of an overrun error during reception
- Indicates detection of the error signal during transmission in smart card interface mode
- The SSR\_FIFO.FER and PER flags are 0, and receive data less than the receive FIFO data trigger number is set in a reception FIFO buffer, and it indicates that 15 ETUs elapse when FIFO is selected and the FCR.DRES bit is 1

#### (2) Receive data full event output (SCIn\_RXI, n = 0 to 4, 9)

- Indicates that ACK is detected if the SIMR2.IICINTM bit is 0 in simple IIC mode
- Indicates that the 8th-bit SCLn falling edge is detected if the SIMR2.IICINTM bit is 1 in simple IIC mode
- When the SIMR2.IICINTM bit is 1 during master transmission in simple IIC mode, set the ELC so that receive data full events are not used

#### Non-FIFO selected

- Indicates that received data is set in the Receive Data Register (RDR or RDRHL).

#### FIFO selected

- Using this event output is prohibited.

#### (3) Transmit data empty event output (SCIn\_TXI, n = 0 to 4, 9)

- Indicates that the SCR/SCR\_SMCI.TE bit is changed from 0 to 1

### 27.12.6 来自扩展串行模式控制部分的中断请求

扩展串行模式控制部分共有六种中断请求，用于产生SCIX0中断（BreakFieldlowwidthdetected）、SCIX1中断（ControlField0match、ControlField1match、优先级中断位检测）、SCIX2中断（检测到总线冲突）和SCIX3中断（检测到有效边沿）。当产生任何中断因素时，相应的状态标志设置为1。所有中断请求的详细信息如表27.46所示。

**Table 27.46 扩展串行模式控制部分的中断源**

| 中断请求              | 状态标志  | 中断因素   |
|-------------------|-------|--|
| SCIX0中断（检测到断场低宽度） | BDFD  | <ul style="list-style-type: none"> <li>检测到比定时器设置对应的间隔长的中断字段低宽度</li> <li>在与定时器设置相对应的时间间隔内完成中断字段低宽度的输出</li> <li>定时器下溢</li> </ul> |
| SCIX1中断（控制字段0匹配）  | CF0MF | 在控制字段0中接收到的数据与设置的值匹配 CF0DR   |
| SCIX1中断（控制字段1匹配）  | CF1MF | 控制字段1中接收到的数据与设置的值匹配 PCF1DR or SCF1DR   |
| SCIX1中断（检测到优先中断位） | PIBDF | 指定为优先级中断位的位的值与PCF1DR中设置的值匹配  |
| SCIX2中断（检测到总线冲突）  | BCDF  | RXDXn(n=1,2)引脚上的输出电平和RXDXn引脚上的输入电平在总线冲突检测时钟的三个连续周期上不匹配   |
| SCIX3中断（检测到有效边沿）  | AEDF  | 在比特率测量期间检测有效边沿   |

### 27.13 事件链接

通过使用中断请求信号作为事件信号，SCIn可以通过ELC为预先选择的模块提供链接操作。

无论相关中断请求使能位的值如何，都可以输出事件信号。

#### (1) 错误事件输出（接收错误或检测到错误信号）(SCIn\_ERI, n=0到4、9)

- 表示异步模式接收时奇偶校验错误导致异常终止
- 表示异步模式接收时因帧错误而异常终止
- 表示接收过程中由于溢出错误而异常终止
- 指示在智能卡接口模式下传输过程中检测到错误信号
- ssr\_fifo.fer和每个标志为0，并且接收数据少于接收FIFO缓冲区中的接收FIFO数据触发号码，它表明选择FIFO时15ETUSETALESE，而FCR.DRES位置为1。

#### (2) 接收数据满事件输出(SCIn\_RXI n=0to4 9)

- 简单IIC模式下SIMR2.IICINTM位为0表示检测到ACK
- 如果SIMR2.IICINTM位在simpleIIC模式下为1，则表示检测到第8位SCLn下降沿
- 当SIMR2.IICINTM位在simpleIIC模式下主机发送期间为1时，设置ELC以便不使用接收数据满事件

#### Non-FIFO selected

- 表示接收数据设置在接收数据寄存器（RDR或RDRHL）中。

#### FIFO selected

- 禁止使用该事件输出。

#### (3) 发送数据空事件输出 (SCIn\_TXI n=0to4 9)

- 表示SCR/SCR\_SMCI.TE位由0变为1



- Indicates that transmission is complete in smart card interface mode
- Indicates that NACK is detected if the SIMR2.IICINTM bit is 0 in simple IIC mode
- Indicates that the 9th-bit SCLn falling edge is detected if the SIMR2.IICINTM bit is 1 in simple IIC mode

**Non-FIFO selected**

- Indicates that transmit data is transferred from the Transmit Data Register (TDR or TDRHL) to the Transmit Shift Register (TSR).

**FIFO selected**

- Using this event output is prohibited.

**(4) Transmit end event output (SCIn\_TEI, n = 0 to 4, 9)**

- Indicates the completion of transmission
- Indicates that the starting condition, resumption condition, or termination condition is generated in simple IIC mode

Note: When FIFO is selected, using this event output is prohibited

**(5) Address match event output (SCIn\_AM, n = 0, 3, 4, 9)**

- Indicates a match of the comparison data (CDR.CMPD) with one frame of receive data when DCCR.DCME is set to 1 in asynchronous mode, including multi-processor mode.

**27.14 Address Non-match Event Output (SCIO\_DCUF)**

SCIO\_DCUF indicates the non-match of comparison data (CDR.CMPD) with receive data that is one frame of the data that is received when DCCR.DCME is set to 1 in asynchronous mode, including multi-processor mode. This event can be used for Snooze end request only. In detail, see [section 10, Low Power Modes](#).

**27.15 Noise Cancellation Function**

Figure 27.117 shows the configuration of the noise filter used for noise cancellation. The noise filter consists of a 2-stage flip-flop circuit and a match detection circuit. When the input signals of the noise filter and the output signals of the 2-stage flip-flop circuits completely match, the matched level is conveyed as an internal signal. Unless otherwise matched, the previous value is retained. When the same level is retained for 3 cycles or longer on the sampling clock of the noise filter, it is considered as a valid receive signal. A change in pulse for 3 cycles or shorter is considered as noise, not as a receive signal.

When SEMR.ABCS = 0 and SEMR.ABCSE = 0, the cycle is 1/16 of a 1-bit period.

When SEMR.ABCS = 1 and SEMR.ABCSE = 0, the cycle is 1/8 of a 1-bit period.

When SEMR.ABCSE = 1, the cycle is 1/6 of a 1-bit period.

In asynchronous mode, the noise cancellation function can be applied to the receive signal input to the RXDn pin. The receive level of the RXDn is taken in the flip-flop circuit of the noise filter on the base clock of asynchronous mode.

In simple IIC mode, this function can be used for each input on SDAn and SCLn. The sampling clock is selected from four baud rate generator settings (1, 2, 4, and PCLK divided by 4) in SNFR.NFCS.

If the base clock is stopped once with the noise filter enabled and then the base clock input is restarted again, the noise filter operation resumes from the state where the clock was stopped. When SCR.TE and SCR.RE are set to 0 during base clock input, all of the noise filter flip-flop values are initialized to 1. Accordingly, if the input data is 1 when reception operation resumes, the function determines that a level match is detected and the result is conveyed as an internal signal. When the level being input corresponds to 0, the initial output of the noise filter is retained until the level matches in three consecutive sampling cycles.

- 表示在智能卡接口模式下传输完成
- SIMR2.IICINTM位在simpleIIC模式下为0表示检测到NACK
- 如果SIMR2.IICINTM位在simpleIIC模式下为1，则表示检测到第9位SCLn下降沿

**Non-FIFO selected**

- 表示发送数据从发送数据寄存器（TDR或TDRHL）传送到发送移位寄存器（TSR）。

**FIFO selected**

- 禁止使用该事件输出。

**(4) 发送结束事件输出(SCIn\_TEI n=0to4 9)**

- 表示传输完成
- 表示在简单IIC模式下产生启动条件、恢复条件或终止条件

Note: 选择FIFO时，禁止使用该事件输出

**(5) 地址匹配事件输出(SCIn\_AM n=0 3 4 9)**

- 在异步模式下，包括多处理器模式，当DCCR.DCME置1时，表示比较数据（CDR.CMPD）与一帧接收数据匹配。

**27.14 地址不匹配事件输出(SCIO\_DCUF)**

SCIO\_DCUF表示比较数据(CDR.CMPD)与接收数据不匹配，接收数据是在异步模式（包括多处理器模式）下DCCR.DCME设置为1时接收到的数据的一帧。此事件仅可用于贪睡结束请求。详细信息，请参见第10节，低功耗模式。

**27.15 降噪功能**

图27.117显示了用于噪声消除的噪声滤波器的配置。噪声滤波器由一个2级触发器电路和一个匹配检测电路组成。当噪声滤波器的输入信号和2级触发器电路的输出信号完全匹配时，匹配的电平作为内部信号传送。除非另有匹配，否则将保留先前的值。当相同电平在噪声滤波器的采样时钟上保持3个周期或更长时间时，它被认为是有效的接收信号。3个周期或更短的脉冲变化被认为是噪声，而不是接收信号。

当SEMR.ABCS=0和SEMR.ABCSE=0时，周期为1位周期的116。

当SEMR.ABCS=1且SEMR.ABCSE=0时，周期为1位周期的18。

当SEMR.ABCSE=1时，周期为1位周期的16。

在异步模式下，可以对输入到RXDn引脚的接收信号应用噪声消除功能。RXDn的接收电平是在异步模式的基本时钟上的噪声滤波器的触发器电路中获取的。

在简单IIC模式下，该功能可用于SDAn和SCLn上的每个输入。采样时钟从SNFR.NFCS中的四个波特率发生器设置（1、2、4和PCLK除以4）中选择。

如果在启用噪声滤波器的情况下基准时钟停止一次，然后再次重新启动基准时钟输入，则噪声滤波器操作将从时钟停止的状态恢复。当SCR.TE和SCR.RE在基本时钟输入期间设置为0时，所有噪声滤波器触发器值都被初始化为1。因此，如果在接收操作恢复时输入数据为1，则该函数确定一个电平检测到匹配并将结果作为内部信号传送。当输入的电平对应于0时，保留噪声滤波器的初始输出，直到电平在三个连续的采样周期中匹配。



## (2) Reception

**When address match function is not used as wake-up condition**

Before specifying the module-stop state or making a transition to Software Standby mode, stop the receive operations (RE = 0 in SCR/SCR\_SMCI). If transition is made during data reception, the received data is invalid.

Figure 27.121 shows an example flow of transition to Software Standby mode during reception.

**When address match function is used as wake-up condition**

Before specifying the module-stop state or making a transition to Software Standby mode:

1. Set the operations after cancellation of the low power state.
2. Set CDR.CMPD and DCCR.DCME to 1.
3. Set the receive operations (RE = 1 in SCR/SCR\_SMCI).
4. Set the module-stop state or Software Standby mode.

When SCI transfers to low power mode, if the receive data pin (RXD) is at the low level, set SEMR.RXDESEL = 0.

When setting SEMR.RXDESEL = 1, there is a possibility that a start bit (falling edge of RXD pin) cannot be detected on release of the low power mode.

Figure 27.122 shows an example flow of transition to Software Standby mode during reception with address match.

**When using SCI0 in Snooze mode**

When using SCI0 in Snooze mode, some restrictions apply, including maximum bit rates. For details, see [section 10, Low Power Modes](#).

## (2) Reception

**地址匹配功能不用作唤醒条件时**

在指定模块停止状态或转换到软件待机模式之前，停止接收操作（SCR/SCR\_SMCI中的RE=0）。如果在数据接收期间进行转换，则接收到的数据无效。

图27.121显示了接收期间转换到软件待机模式的示例流程。

**当地址匹配功能用作唤醒条件时**

在指定模块停止状态或转换到软件待机模式之前：

- 1.设置取消低功耗状态后的操作。
- 2.将CDR.CMPD和DCCR.DCME设置为1。
- 3.设置接收操作（在SCR/SCR\_SMCI中RE=1）。
- 4.设置模块停止状态或软件待机模式。

当SCI转移到低功耗模式时，如果接收数据引脚(RXD)为低电平，则设置SEMR.RXDESEL=0。

当设置SEMR.RXDESEL=1时，有可能在解除低功耗模式时无法检测到起始位（RXD引脚的下降沿）。

图27.122显示了在地址匹配的接收期间转换到软件待机模式的示例流程。

**在贪睡模式下使用SCI0时**

在贪睡模式下使用SCI0时，有一些限制，包括最大比特率。有关详细信息，请参阅第10节，[低电源模式](#)。

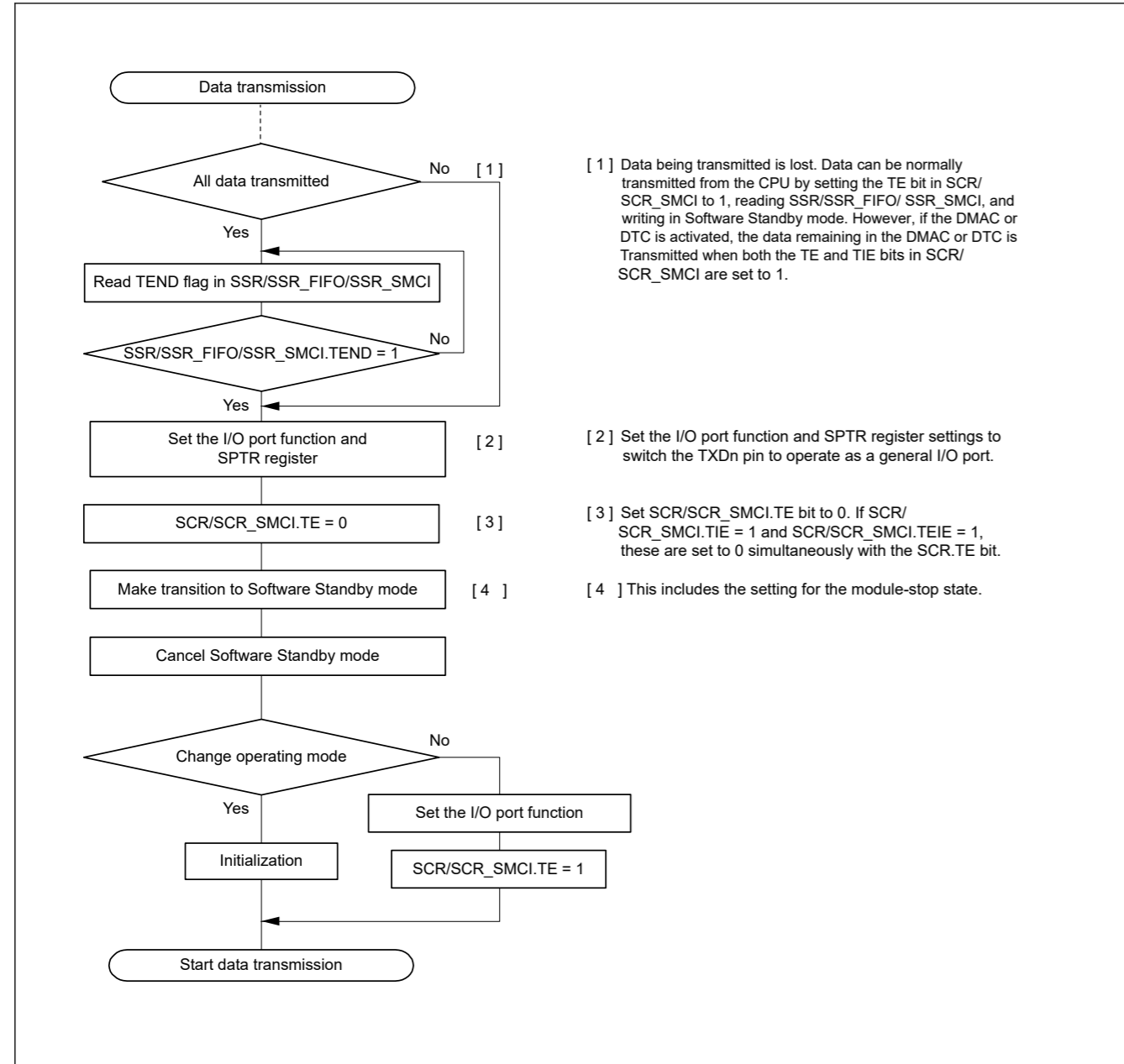


Figure 27.118 Example flow of transition to Software Standby mode during transmission

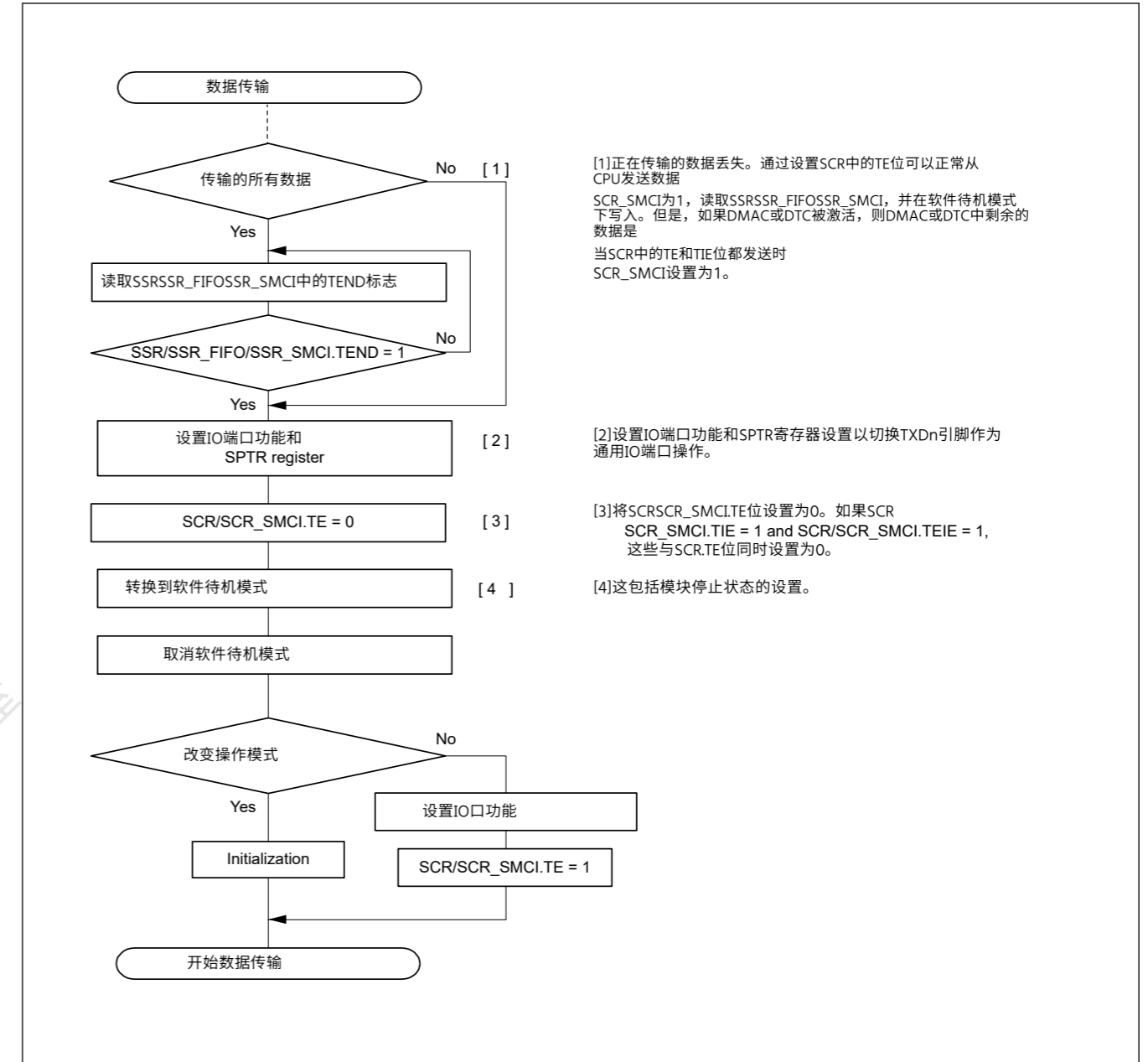


图27.118在传输期间切换到软件待机模式的示例流程



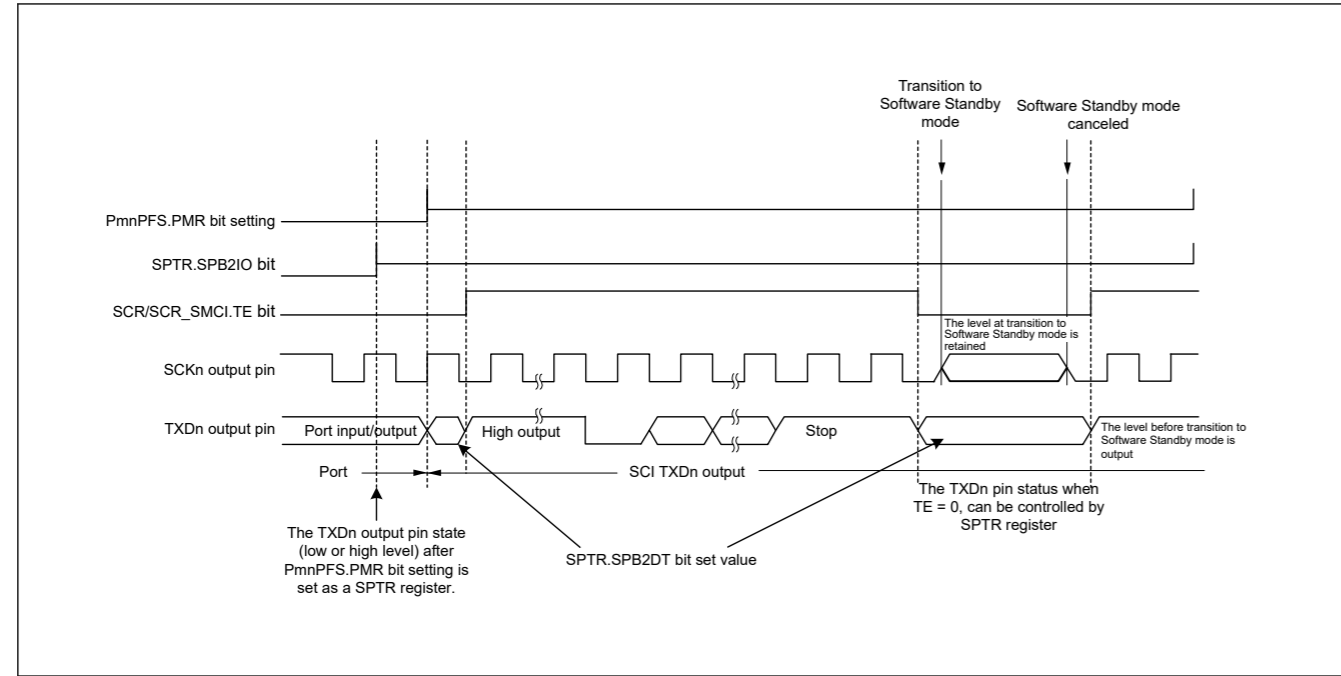


Figure 27.119 Port pin states during transition to Software Standby mode with internal clock and asynchronous transmission

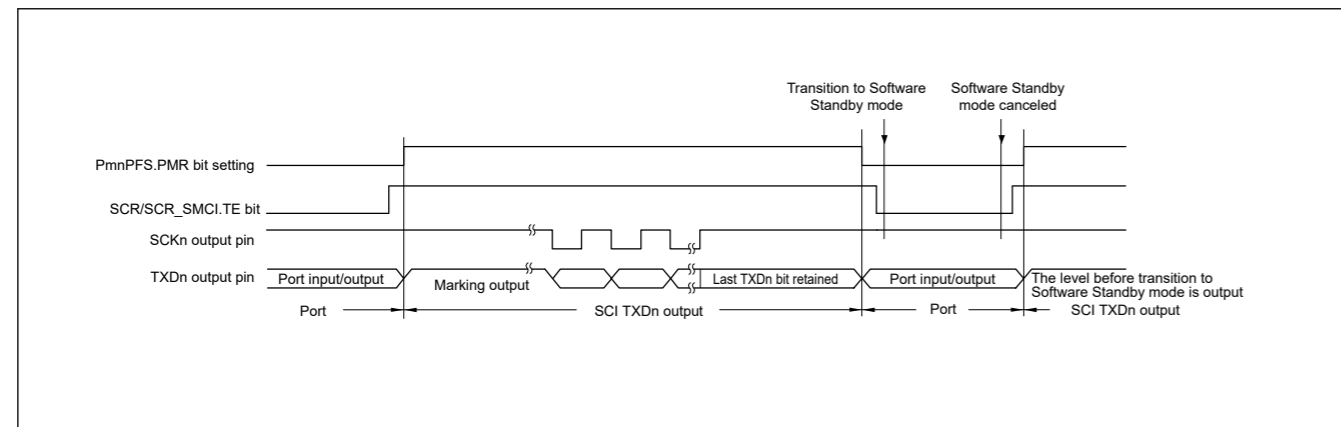


Figure 27.120 Port pin states during transition to Software Standby mode with internal clock and clock synchronous transmission

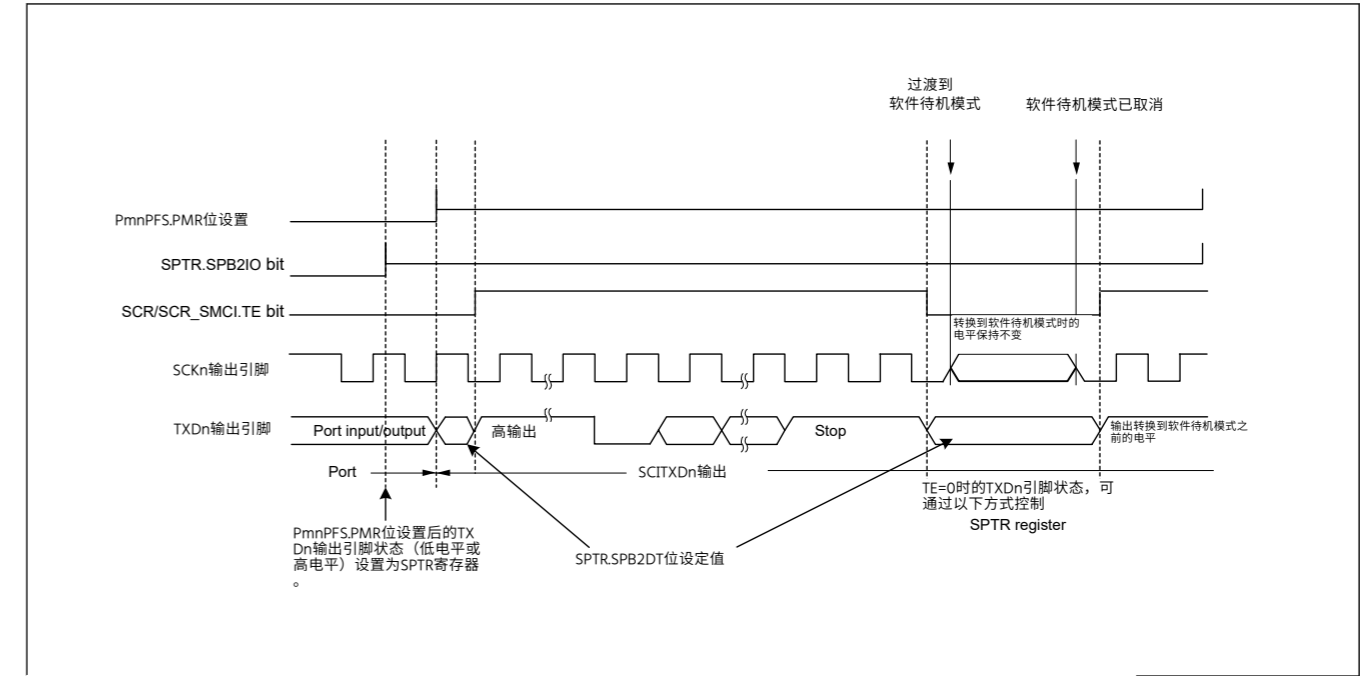


图27.119 转换到内部时钟和异步传输的软件待机模式期间的端口引脚状态

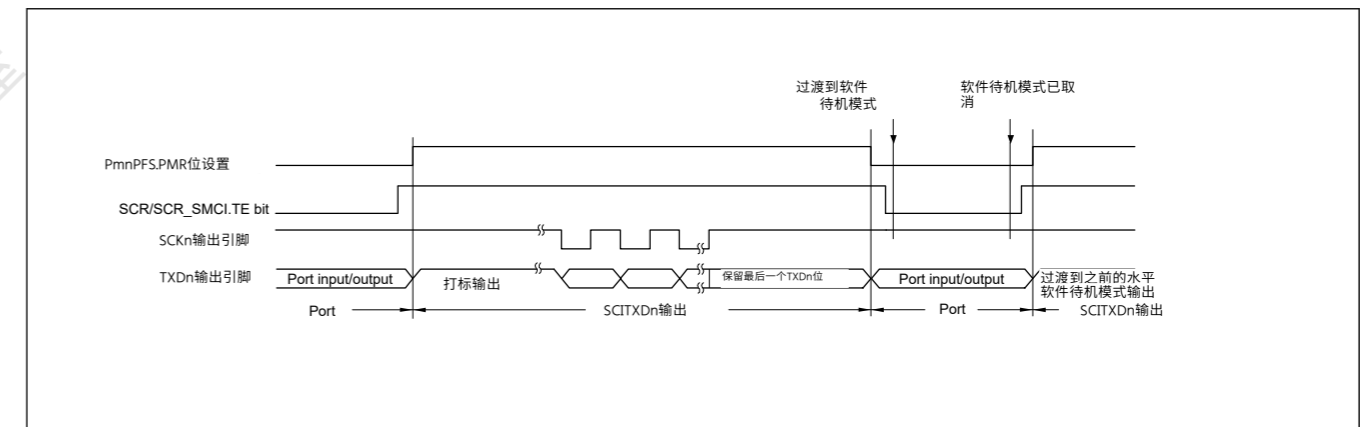


图27.120 转换到内部时钟和时钟同步传输的软件待机模式期间的端口引脚状态

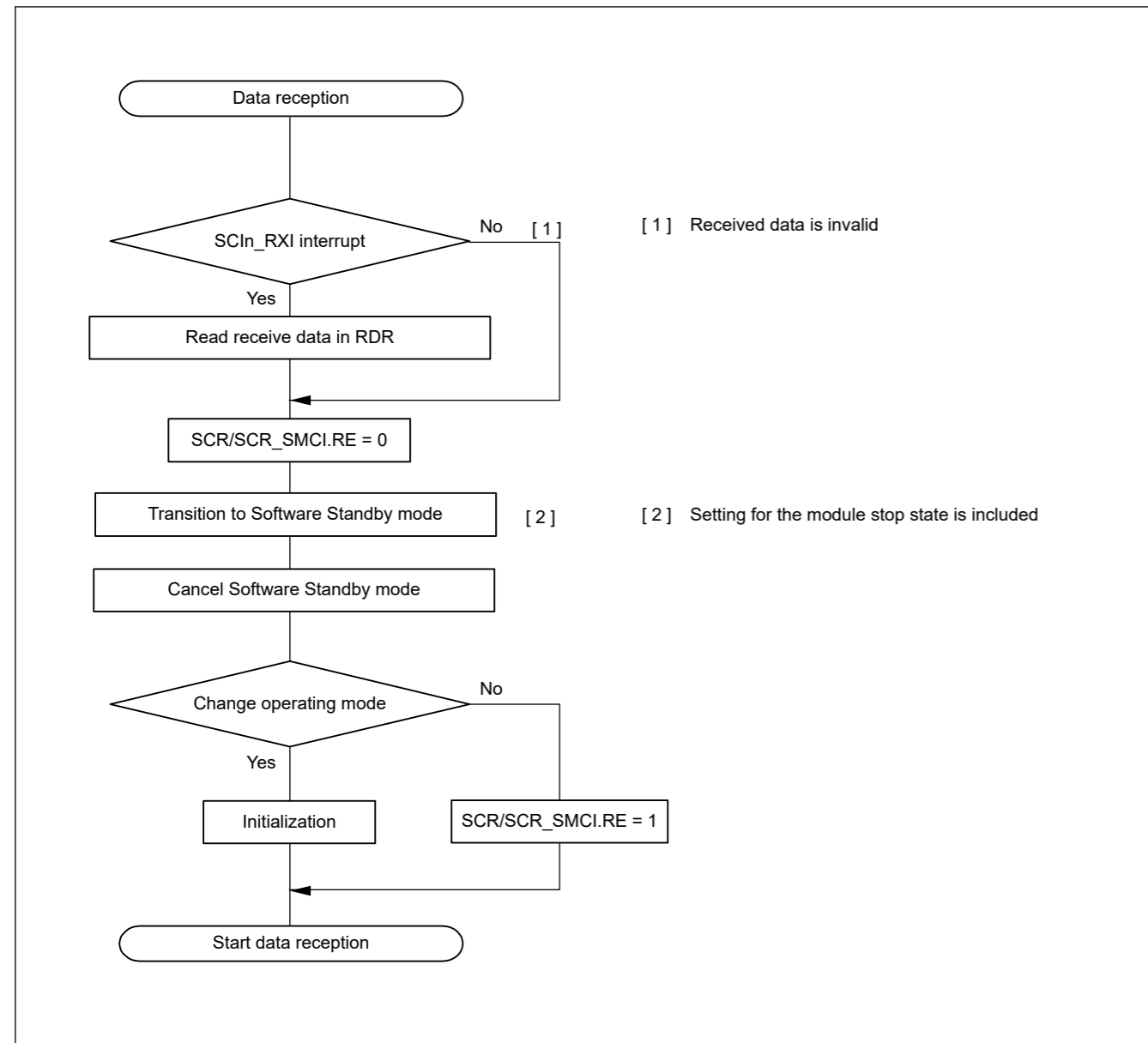


Figure 27.121 Example flow of transition to Software Standby mode during reception

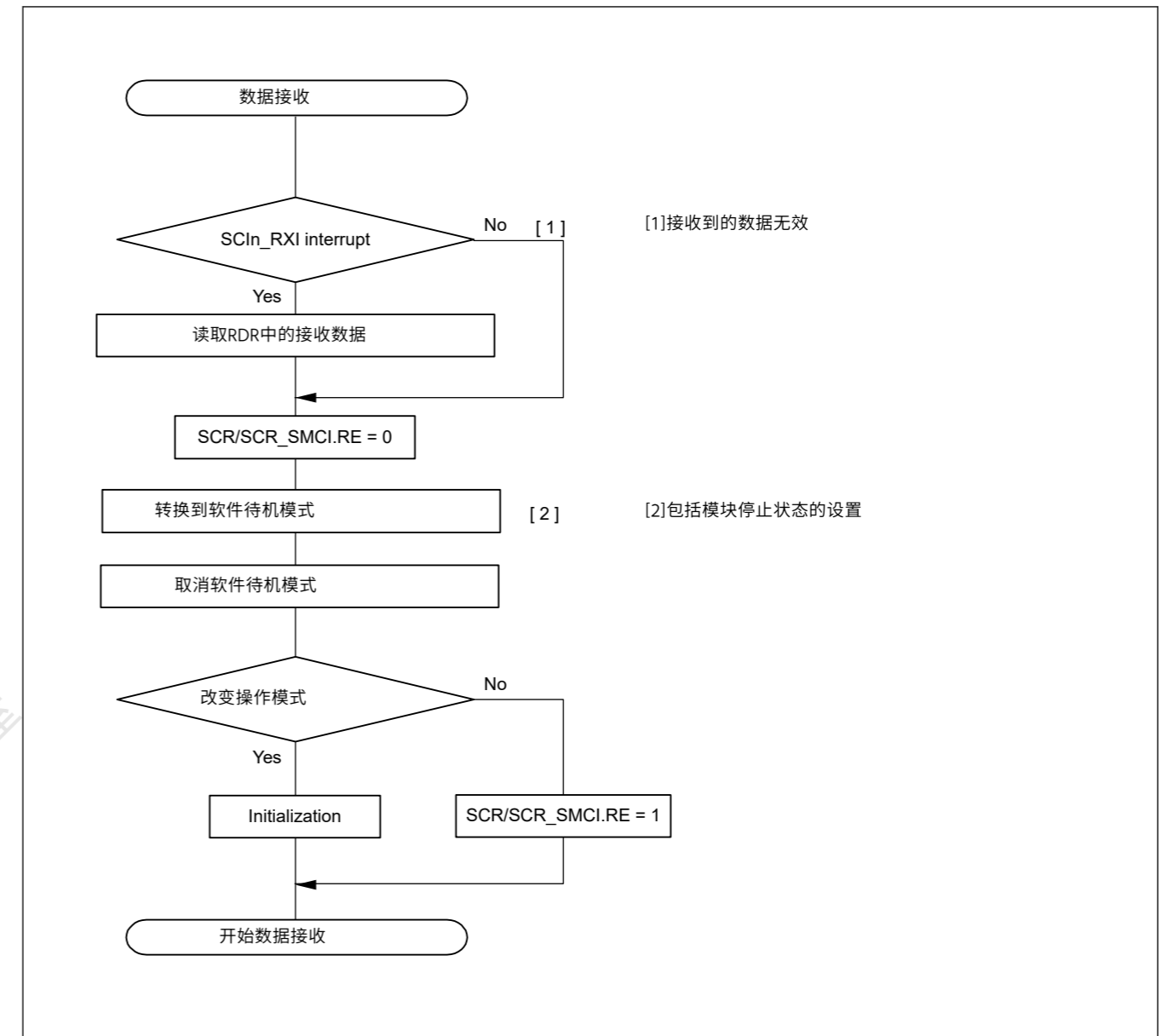


图27.121在接收期间转换到软件待机模式的示例流程

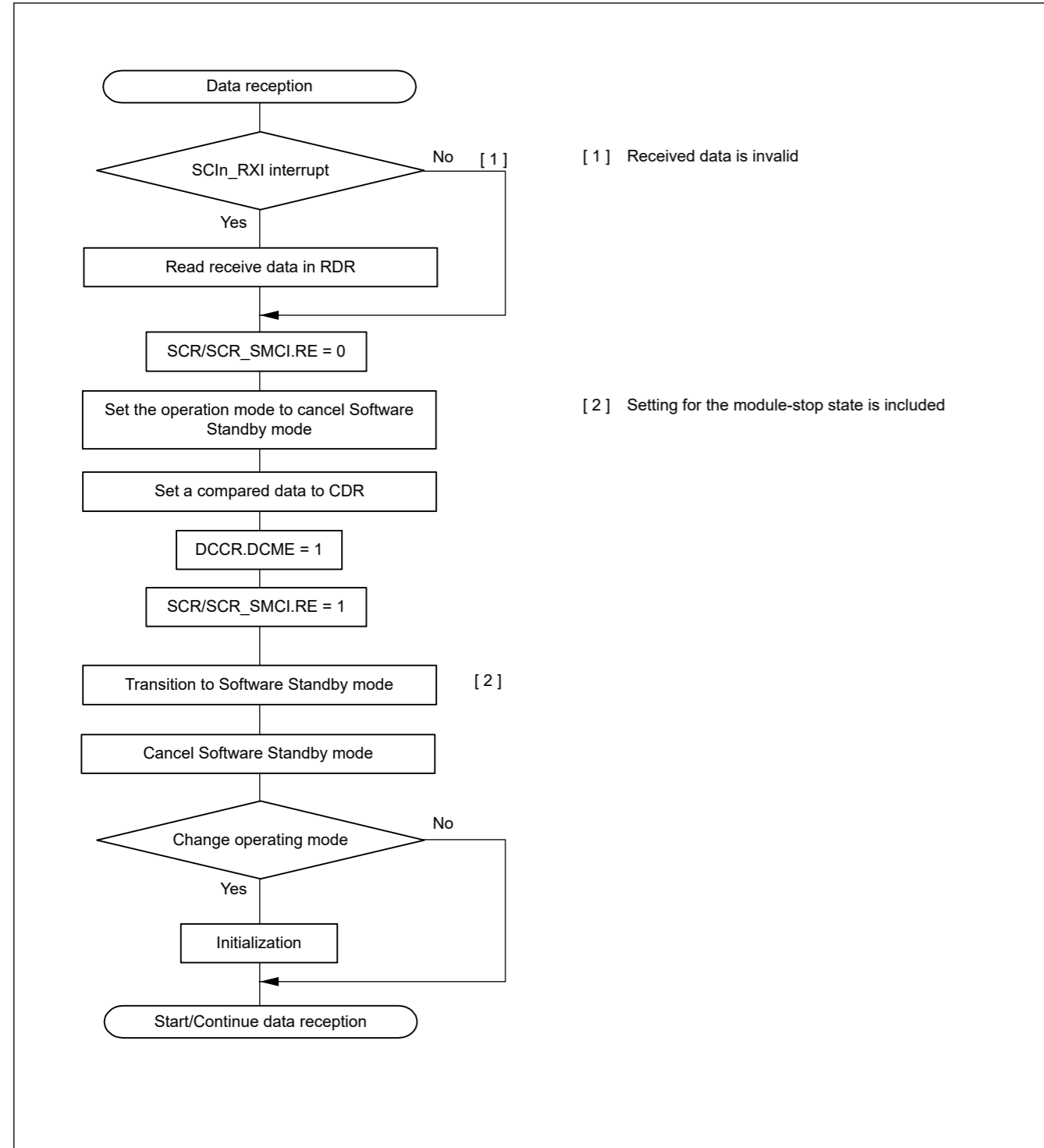


Figure 27.122 Example flow of transition to Software Standby mode during reception with address match

### 27.16.3 Break Detection and Processing

(1) Non-FIFO selected

When a framing error is detected, a break can be detected by reading the RXDn pin value directly. In a break, the input from the RXDn pin becomes all 0s, and the SSR.FER flag is set to 1 to indicate a framing error, and the SSR.PER flag might also be set to 1 to indicate a parity error. The SCI continues the receive operation even after a break is received. Therefore, even if the FER flag is 0, indicating that no framing error occurred, it is set to 1 again. When the SEMR.RXDESEL bit is 1, the SCI sets the SSR.FER flag to 1 and stops receiving operations until a start bit of the next data frame is detected. If the SSR.FER flag is set to 0, the SSR.FER flag retains 0 during the break.

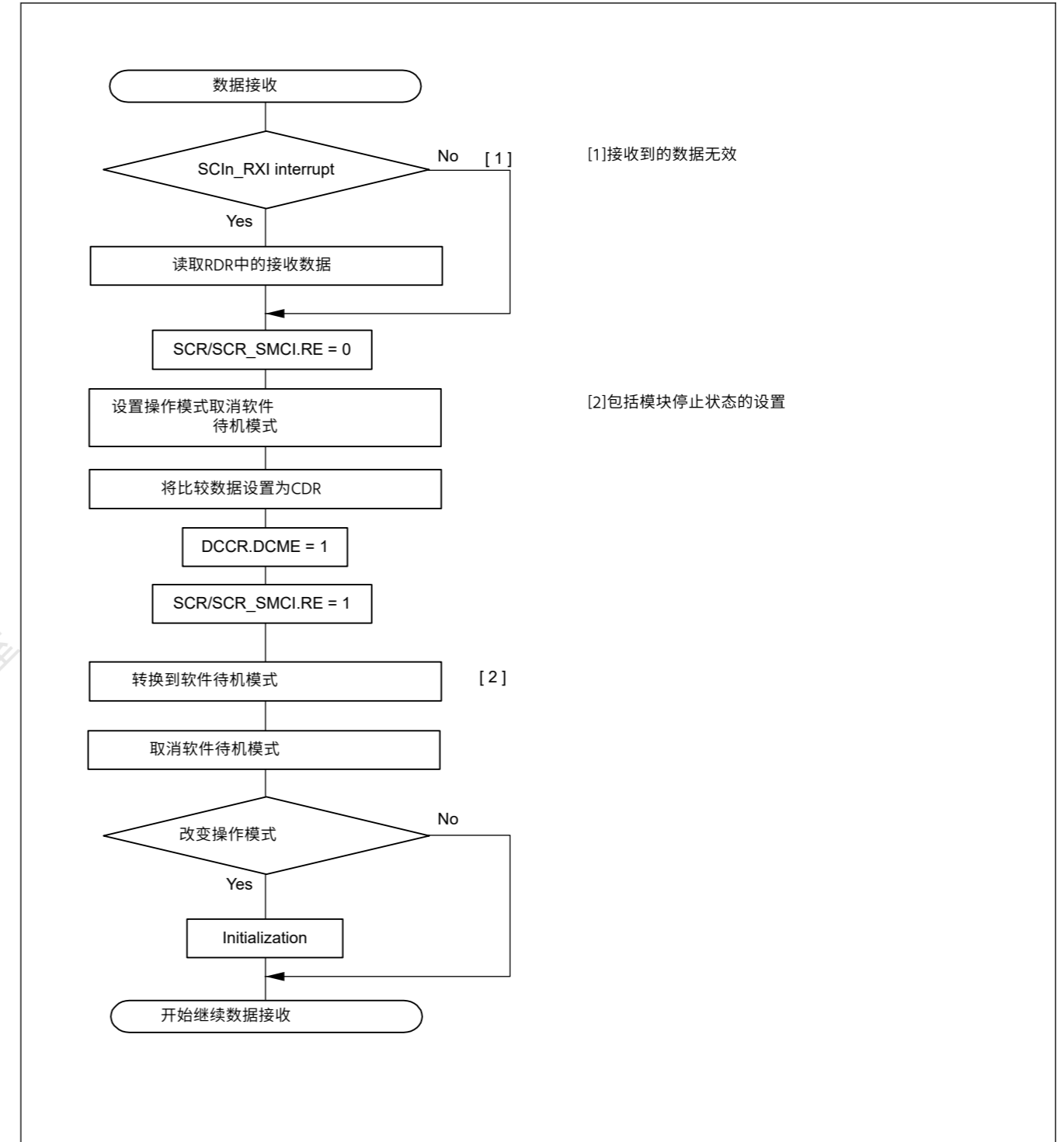


图27.122在地址匹配的接收期间转换到软件待机模式的示例流程

### 27.16.3 断裂检测和处理

(1) Non-FIFO selected

当检测到帧错误时，可以通过直接读取RXDn引脚值来检测中断。在中断时，来自RXDn引脚的输入变为全0，并且SSR.FER标志设置为1表示帧错误，SSR.PER标志也可能设置为1表示奇偶校验错误。即使在收到中断后，SCI仍继续接收操作。因此，即使FER标志为0，表示没有发生帧错误，它也会再次设置为1。当SEMR.RXDESEL位为1时，SCI将SSR.FER标志设置为1并停止接收操作，直到检测到下一个数据帧的起始位。如果

SSR.FER标志设置为0，SSR.FER标志在中断期间保持0。

When the RXDn pin is set to 1 and the break ends, detecting the beginning of the start bit on the first falling edge of the RXDn pin allows the SCI to start the receiving operation.

#### (2) FIFO selected

After a framing error is detected and when the SCI detects that continuous receive data is 0 for 1 frame, reception stops. When a framing error is detected, a break can be detected by reading the SPTR.RXDMON flag value. After the RXD signal is in high and the break is finished, data reception to the FRDRHL register resumes.

### 27.16.4 Mark State and Production of Breaks

When the SCR/SCR\_SMCI.TE bit is 0, disabling serial transmission, the state of the TXDn pin can be set using the SPTR.SPB2IO and SPTR.SPB2DT bits. With this approach, a TXDn pin can be placed in the mark state to transmit a break.

Before setting the SCR/SCR\_SMCI.TE bit to 1, enabling serial transmission, set the SPB2IO and SPB2DT bits to put the communication line in the mark state (the state of 1), and change the TXDn pin using I/O port function. To output a break on data transmission, after setting the TXDn pin to output 0 by setting the SPB2IO and SPB2DT bits, change the TXDn pin using the I/O port function and set the SCR/SCR\_SMCI.TE bit to 0. When the SCR/SCR\_SMCI.TE bit is set to 0, the transmitter is initialized regardless of the current state of transmission.

### 27.16.5 Receive Error Flags and Transmit Operation in Clock Synchronous Mode and Simple SPI Mode

Transmission cannot start when a receive error flag (ORER) in SSR/SSR\_FIFO is set to 1, even when data is written to TDR or FTDR\*1. Always set the receive error flags to 0 before starting transmission.

Note: The receive error flags cannot be set to 0 when the RE bit in SCR/SCR\_SMCI is set to 0 (serial reception is disabled).

Note 1. Do not use the FTDRH register in simple SPI mode.

### 27.16.6 Restrictions on Clock Synchronous Transmission in Clock Synchronous Mode and Simple SPI Mode

When the external clock source is used as a synchronization clock, the following restrictions apply.

#### (1) Start of transmission

Wait at least the following time from writing transmit data to TDR to the start of the external clock input:

1 PCLK cycle + data output delay time for the slave ( $t_{DO}$ ) + setup time for the master ( $t_{SU}$ ). See [Figure 27.123](#).

#### (2) Continuous transmission

Write the next transmit data to TDR or TDRHL before the falling edge of the transmit clock for bit [7]. See [Figure 27.123](#).

When updating TDR after bit [7] has started to transmit, update TDR while the synchronization clock is in the low-level period, and set the high-level width of the transmit clock (bit [7]) to 4 PCLK cycles or longer. See [Figure 27.123](#).

当RXDn引脚设置为1且中断结束时，在第一个下降沿检测起始位的开始RXDn引脚允许SCI开始接收操作。

#### (2) FIFO selected

检测到帧错误后，当SCI检测到1帧连续接收数据为0时，接收停止。当检测到帧错误时，可以通过读取SPTR.RXDMON标志值来检测中断。在RXD信号为高电平且中断完成后，FRDRHL寄存器的数据接收恢复。

### 27.16.4 标记状态和产生的中断

当SCRSCR\_SMCI.TE位为0时，禁用串行传输，TXDn引脚的状态可以使用SPTR.SPB2IO和SPTR.SPB2DT位。使用这种方法，可以将TXDn引脚置于标记状态以发送中断。

在设置SCRSCR\_SMCI.TE位为1，使能串行传输之前，设置SPB2IO和SPB2DT位使通信线处于标记状态（状态为1），并使用IO端口功能改变TXDn引脚。要输出数据传输中断，通过设置SPB2IO和SPB2DT位将TXDn引脚设置为输出0后，使用IO端口功能更改TXDn引脚并将SCRSCR\_SMCI.TE位设置为0。当SCRSCR\_SMCI.TE位设置为0，无论当前的传输状态如何，都初始化发送器。

### 27.16.5 在时钟同步模式下接收错误标志和发送操作和简单SPI模式

当SSRSSR\_FIFO中的接收错误标志(ORER)设置为1时，传输无法开始，即使数据已写入TDR或FTDR\*1。在开始传输之前，始终将接收错误标志设置为0。

Note: 当SCRSCR\_SMCI中的RE位设置为0（禁用串行接收）时，接收错误标志不能设置为0。

注1.不要在简单SPI模式下使用FTDRH寄存器。

### 27.16.6 时钟同步模式和简单SPI模式下时钟同步传输的限制

当外部时钟源用作同步时钟时，有以下限制。

#### (1) 传输开始

从将发送数据写入TDR到外部时钟输入开始，至少等待以下时间：

1个PCLK周期+从机的数据输出延迟时间( $t_{DO}$ )+主机的建立时间( $t_{SU}$ )。请参见图27.123。

#### (2) 连续传输

在位[7]的发送时钟下降沿之前将下一个发送数据写入TDR或TDRHL。请参见图27.123。

在bit[7]开始发送后更新TDR时，在同步时钟处于低电平期间更新TDR，并将发送时钟（bit[7]）的高电平宽度设置为4个PCLK周期或更长。请参见图27.123。



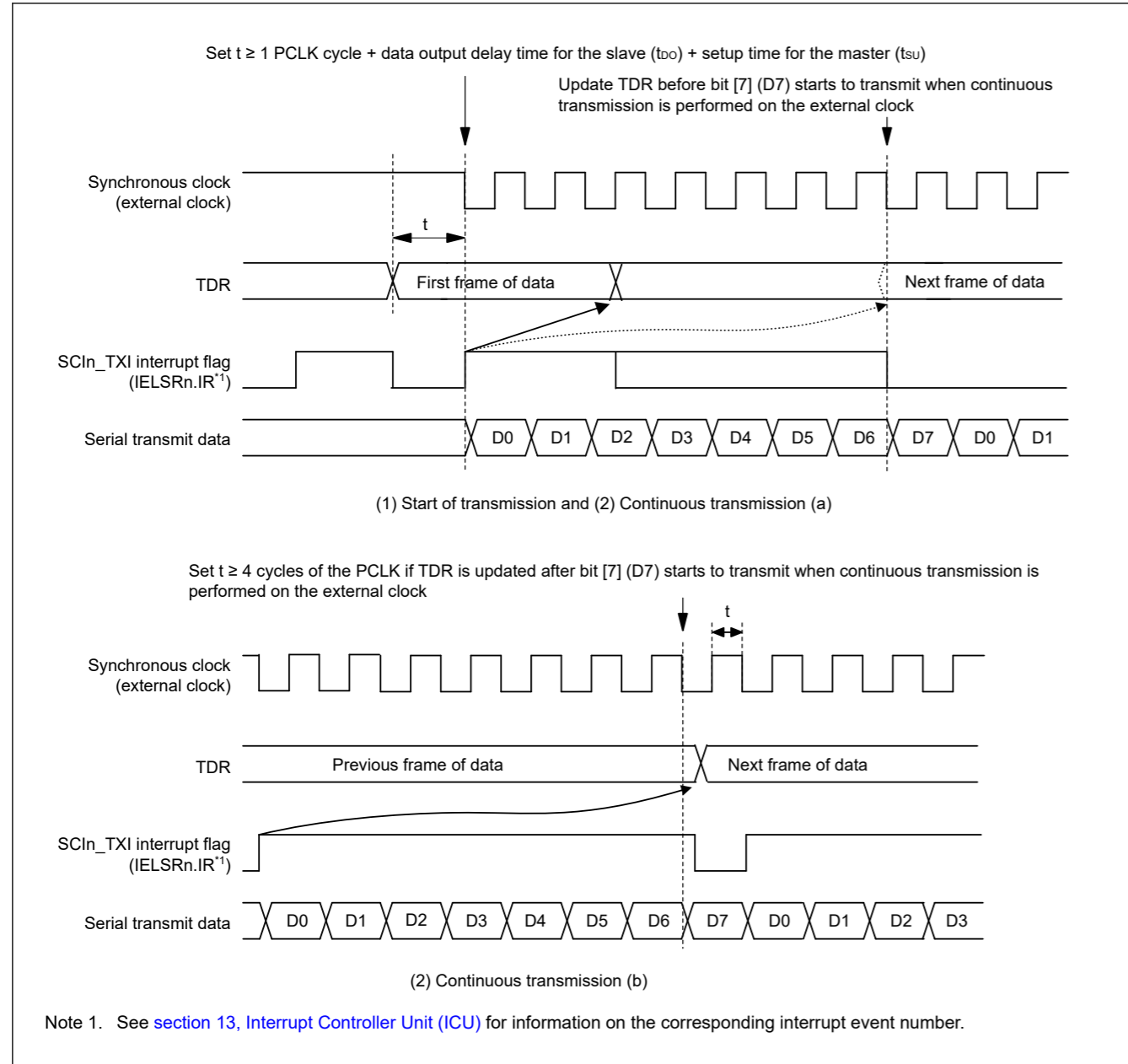


Figure 27.123 Restraints on use of external clock in clock synchronous transmission

### 27.16.7 Restrictions on Using DTC or DMAC

During transmission or reception operations using the DTC or DMAC, do not set transfer data for the DTC or DMAC.

#### (1) Writing data to TDR (FTDRHL)

##### Non-FIFO selected

Data can be written to TDR and TDRHL. However, if new data is written to TDR or TDRHL when transmit data remains in TDR or TDRHL, the previous data in TDR and TDRHL is lost because it was not transferred to TSR yet. When using DTC or DMAC, always write transmit data to TDR or TDRHL in the SCIn\_TXI interrupt request handling routine.

##### FIFO selected

It is possible to write data to the FTDRH and FTDRL registers when SCR.TE is 1. Confirm the amount of writable data using the FDR.T[4:0] bits.

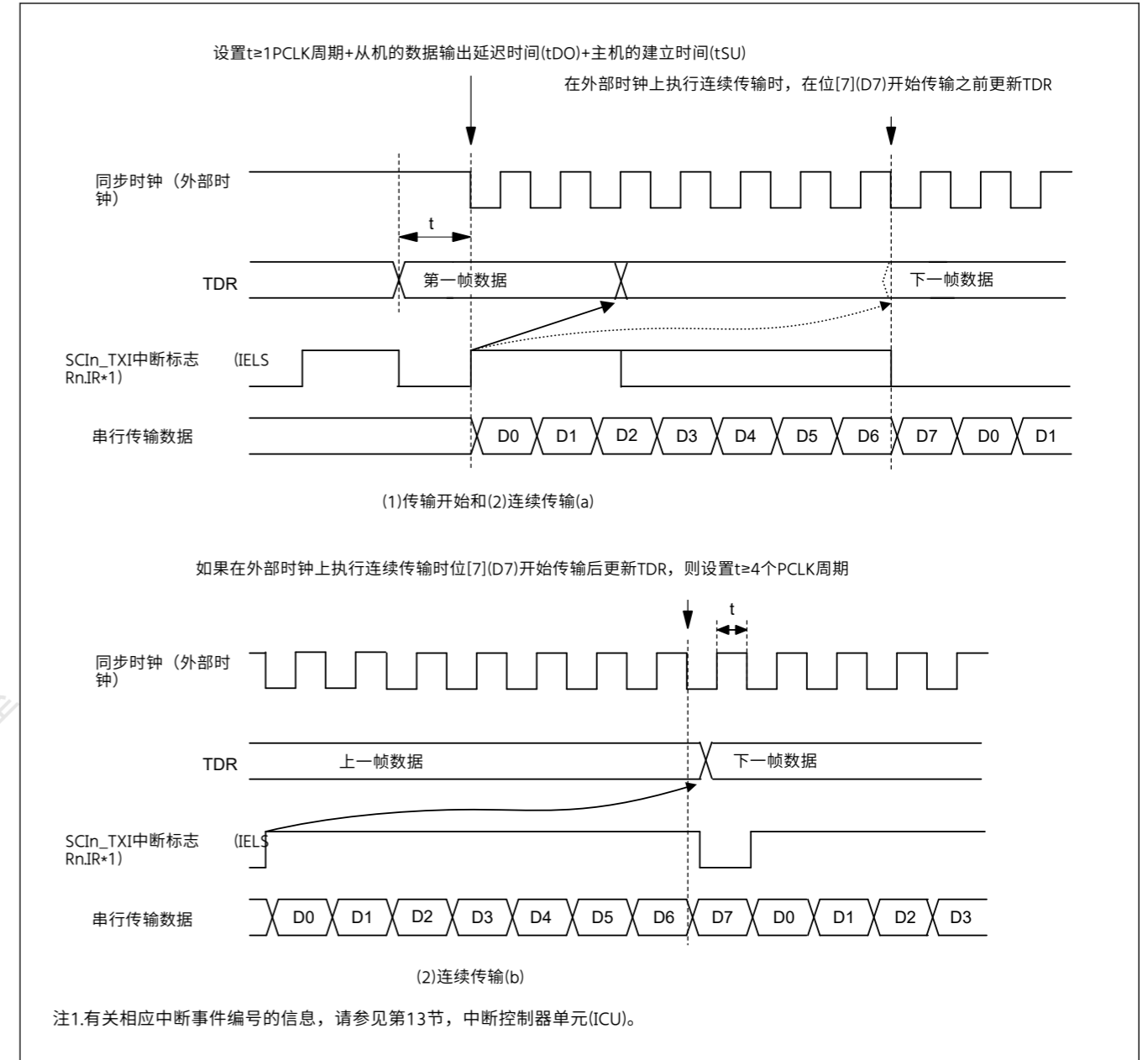


图27.123时钟同步传输中使用外部时钟的限制

### 27.16.7 使用DTC或DMAC的限制

在使用DTC或DMAC进行发送或接收操作期间, 请勿为DTC或DMAC设置传输数据。

#### (1) 将数据写入TDR(FTDRHL)

##### Non-FIFO selected

数据可以写入TDR和TDRHL。但是, 如果在发送数据保留在TDR或TDRHL中将新数据写入TDR或TDRHL, 则TDR和TDRHL中的先前数据将丢失, 因为它尚未传输到TSR。使用DTC或DMAC时, 始终在SCIn\_TXI中断请求处理程序中将发送数据写入TDR或TDRHL。

##### FIFO selected

当SCR.TE为1时, 可以将数据写入FTDRH和FTDRL寄存器。使用FDR.T[4:0]位确认可写入的数据量。

## (2) Reading data from RDR (FRDRHL)

When using the DTC or DMAC to read RDR and RDRHL, always set the receive data full interrupt (SCIn\_RXI) as the activation source of the relevant SCI.

### 27.16.8 Notes on Starting Transfer

At the point where transfer starts when the interrupt status flag (IELSRn.IR flag) in the ICU is 1, follow the procedure in this section to clear interrupt requests before permitting operations (by setting the SCR/SCR\_SMCI.TE or SCR/SCR\_SMCI.RE bit to 1). For details on the interrupt status flag, see [section 13, Interrupt Controller Unit \(ICU\)](#).

1. Confirm that transfer has stopped (the SCR/SCR\_SMCI.TE or SCR/SCR\_SMCI.RE bit is 0)
2. Set the associated interrupt enable bit (SCR/SCR\_SMCI.TIE or SCR/SCR\_SMCI.RIE) to 0
3. Read the associated interrupt enable bit (SCR/SCR\_SMCI.TIE or SCR/SCR\_SMCI.RIE bit) to check that it actually becomes 0
4. Set the interrupt status flag, IELSRn.IR, in the ICU to 0

### 27.16.9 External Clock Input in Clock Synchronous Mode and Simple SPI Mode

In clock synchronous mode and simple SPI mode, the external clock SCKn must be input as follows:

High-pulse period, low-pulse period = 2 PCLK cycles or more, period = 6 PCLK cycles or more.

### 27.16.10 Limitations on Simple SPI Mode

#### (1) Master mode

- Use a resistor to pull up or pull down the clock line matching the initial settings for the transfer clock set in the SPMR.CKPH and CKPOL bits when the SPMR.SSE bit is 1.

This prevents the clock line from being placed in the high-impedance state when the SCR.TE bit is set to 0 or unexpected edges from being generated on the clock line when the SCR.TE bit changes from 0 to 1. When the SPMR.SSE bit is 0 in single master mode, pulling up or pulling down the clock line is not required because the clock line is not placed in the high-impedance state even when the SCR.TE bit is set to 0.

- For the clock delay setting (SPMR.CKPH bit is 1), the receive data full interrupt (SCIn\_RXI) is generated before the final clock edge on the SCKn pin as indicated in [Figure 27.124](#). If the TE and RE bits in the SCR register become 0 before the final edge of the clock signal on the SCKn pin, the SCKn pin is placed in the high-impedance state, so the width of the last clock pulse of the transfer clock is shortened. Additionally, an SCIn\_RXI interrupt might lead to the input signal on the SSn pin of a connected slave going to the high level before the final edge of the clock signal on the SCKn pin, leading to incorrect operation of the slave.
- In a multi-master configuration, the SCKn pin output goes to high-impedance while the input on the SSn pin is at the low level if a mode fault error occurs while a character is being transferred, stopping supply of the clock signal to the connected slave. Reset the connected slave to avoid misaligned bits when transfer is restarted.

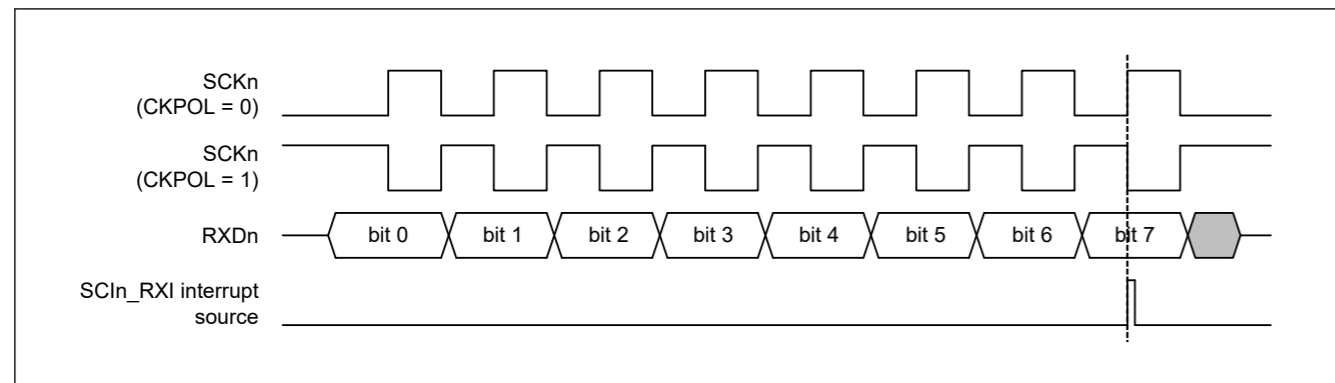


Figure 27.124 Timing of SCIn\_RXI interrupt in simple SPI mode with clock delay

## (2) 从RDR(FRDRHL)读取数据

使用DTC或DMAC读取RDR和RDRHL时，始终将接收数据满中断（SCIn\_RXI）设置为相关SCI的激活源。

### 27.16.8 开始转移注意事项

在ICU中的中断状态标志（IELSRn.IR标志）为1时开始传输的点，按照本节中的步骤在允许操作之前清除中断请求（通过设置SCRSCR\_SMCI.TE或SCRSCR\_SMCI.RE位到1）。有关中断状态标志的详细信息，请参见第13节，中断控制器单元(ICU)。

- 1.确认传输已停止（SCRSCR\_SMCI.TE或SCRSCR\_SMCI.RE位为0）
- 2.将相关的中断使能位（SCRSCR\_SMCI.TIE或SCRSCR\_SMCI.RIE）设置为0
- 3.读取相关的中断使能位（SCRSCR\_SMCI.TIE或SCRSCR\_SMCI.RIE位），检查它是否实际变为0
- 4.将ICU中的中断状态标志IELSRn.IR设置为0

### 27.16.9 时钟同步模式和简单SPI模式下的外部时钟输入

在时钟同步模式和简单SPI模式下，外部时钟SCKn必须输入如下：

高脉冲周期，低脉冲周期=2个PCLK周期或更多，周期=6个PCLK周期或更多。

### 27.16.10 简单SPI模式的限制

#### (1) 主模式

- 当SPMR.SSE位为1时，使用电阻上拉或下拉与SPMR.CKPH和CKPOL位中设置的传输时钟的初始设置相匹配的时钟线。

这可以防止当SCR.TE位设置为0时时钟线处于高阻抗状态，或者当SCR.TE位从0变为1时在时钟线上产生意外边沿。SSE位在单主机模式下为0，不需要上拉或下拉时钟线，因为即使SCR.TE位设置为0，时钟线也不会处于高阻抗状态。

- 对于时钟延迟设置（SPMR.CKPH位为1），接收数据满中断（SCIn\_RXI）在SCKn引脚的最后一个时钟沿之前产生，如图27.124所示。如果SCR寄存器中的TE和RE位在SCKn引脚上的时钟信号的最后一个边沿之前变为0，则SCKn引脚处于高阻状态，因此传输时钟的最后一个时钟脉冲的宽度为缩短。此外，SCIn\_RXI中断可能会导致所连接从机的SSn引脚上的输入信号在SCKn引脚上的时钟信号的最后一个边沿之前变为高电平，从而导致从机的错误操作。

- 在多主机配置中，如果在传输字符时发生模式故障错误，则SCKn引脚输出变为高阻态，而SSn引脚上的输入处于低电平，从而停止向主机提供时钟信号。连接的奴隶。重新启动传输时，重置连接的从机以避免未对齐的位。

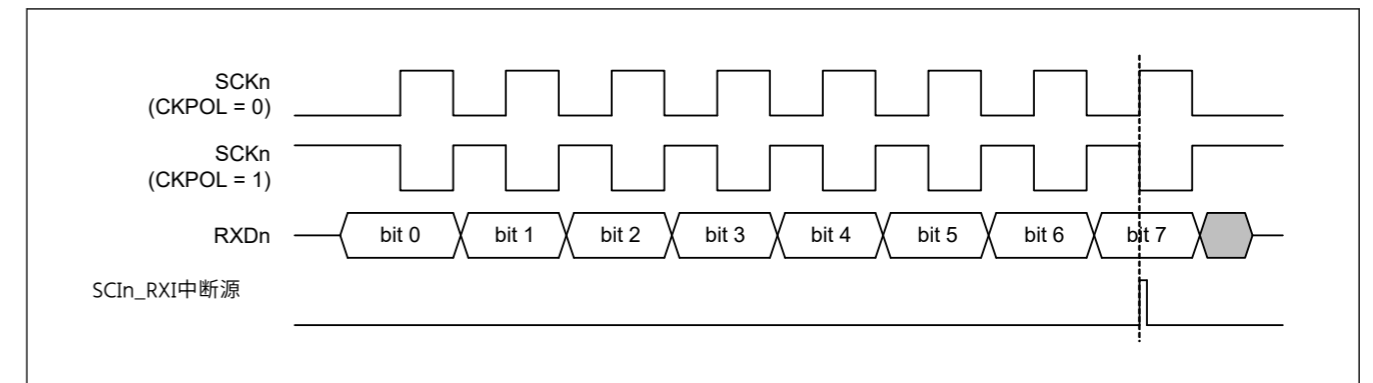


图27.124带时钟延迟的简单SPI模式下SCIn\_RXI中断的时序

## (2) Slave mode

- Wait at least the following time from writing transmit data in the TDR register to the start of the external clock input.  
1 PCLK cycle + data output delay for the slave ( $t_{DO}$ ) + setup time for the master ( $t_{SU}$ )  
Also wait at least 5 PCLK cycles from the input of the low level on the SSn pin to the start of the external clock input.
- Provide an external clock signal to the master the same as the data length for transfer
- Control the input on the SSn pin before the start and after the end of data transfer
- When the input level on the SSn pin is to be changed from low to high while a character is being transferred, set the TE and RE bits in the SCR register to 0 and, after restoring the settings, restart transfer of the first byte

## 27.16.11 Notes on Transmitt Enable bit (SCR.TE)

In initial register value, when SCR.TE bit is "0", the terminal as "TXDn" outputs high impedance.

So please make sure that the TXDn line won't be high impedance by the following one of ways.

1. The pull-up resistance is connected to the TXDn line.
2. Before SCR.TE bit is "0", the function of the terminal is changed to general-purpose input port or output port. And after SCR.TE bit is "1", the function of the terminal is changed to "TXDn".
3. In asynchronous mode, you can set SPTR and decided level of TXDn terminal during SCR.TE is "0".

In the Simple SPI mode slave operation, the RXDn terminal operates in the same way as the above TXDn terminal, so please deal with 1 or 2 in the same way. (3 can not be used.)

## 27.16.12 Limitation 1 on Usage of the Extended Serial Mode Control Section

When the PCR.SHARPS bit is set to 1, output on the TXDXn/RXDXn ( $n = 1, 2$ ) pin is only possible when the following conditions apply.

- The timer of the SCIH module is in Break Field low width output mode and the value of the TCR.TCST bit is 1 (when the TCST bit is set to 1, the high level continues to be output for up to one cycle of the clock source for counting by the timer counter before output of the low level)
- The value of the SCIn.SCR.TE bit is 1.

## 27.16.13 Limitation 2 on Usage of the Extended Serial Mode Control Section

An SCIG interrupt request is generated even if the extended serial mode is enabled. However, the SCIG interrupt should not be used during reception of a Start Frame because SCIH uses an SCIG interrupt request.

The two ways of dealing with this are described below. When a receive error is detected, clear the error flag of the SCIG and initialize the control section of the SCIH.

1. Set the SCR.RIE bit of the SCIG to 0 to disable the output of interrupt requests. Check the error flags in the SSR register for SCIG on completion of the reception of a Start Frame, because an ERI interrupt is not generated if a receive error occurs. After reception of the Start Frame is completed, set the SCR.RIE bit of the SCIG to 1 by the time the first byte of the Information Frame is received.
2. Set the SCR.RIE bit of the SCIG to 1 to disable RXI interrupts and enable ERI interrupts for ICU. Clear the IRn.IR flag to enable the acceptance of RXI interrupts by ICU by the time the first byte of the Information Frame is received after the completion of Start Frame reception.

## (2) 从机模式

- 从将发送数据写入TDR寄存器到外部时钟输入开始，至少等待以下时间。  
1个PCLK周期+从机的数据输出延迟( $t_{DO}$ )+主机的建立时间( $t_{SU}$ )  
还要等待至少5个PCLK周期，从SSn引脚上的低电平输入到外部时钟输入开始。
- 向主机提供与传输数据长度相同的外部时钟信号
- 在数据传输开始前和结束后控制SSn引脚上的输入
- 当在字符传输过程中SSn引脚的输入电平由低变为高时，将SCR寄存器中的TE和RE位设置为0，并在恢复设置后重新开始传输第一个字节

## 27.16.11 发送使能位(SCR.TE)的注意事项

在初始寄存器值中，当SCR.TE位为"0"时，"TXDn"端输出高阻抗。

所以请通过以下方式之一确保TXDn线不会高阻。

- 1.上拉电阻连接到TXDn线。
- 2.SCR.TE位为"0"之前，端子功能变为通用输入端口或输出端口。并且在SCR.TE位为"1"后，终端的thr功能变为"TXDn"。
- 3.在异步模式下，可以设置SPTR和SCR.TE期间TXDn端子的决定电平为"0"。

在SimpleSPI模式从机操作中，RXDn端子与上述TXDn端子的操作方式相同，因此请按相同方式处理1或2。（3个不能用。）

## 27.16.12 使用扩展串行模式控制部分的限制1

当PCR.SHARPS位设置为1时，TXDXn/RXDXn( $n=1, 2$ )引脚上的输出只有在以下条件适用时才可能。

- SCIH模块的定时器处于BreakField低宽度输出模式，TCR.TCST位的值为1（当TCST位设置为1时，最多持续输出高电平一个周期）低电平输出前由定时器计数器计数的时钟源）
- SCIn.SCR.TE位的值为1。

## 27.16.13 使用扩展串行模式控制部分的限制2

即使启用了扩展串行模式，也会产生SCIG中断请求。但是，在接收起始帧期间不应使用SCIG中断，因为SCIH使用SCIG中断请求。

下面介绍两种处理方法。当检测到接收错误时，清除SCIG的错误标志并初始化SCIH的控制部分。

- 1.将SCIG的SCR.RIE位设置为0，以禁用中断请求的输出。在完成接收起始帧时检查SSR寄存器中的错误标志是否有SCIG，因为如果发生接收错误，则不会产生ERI中断。开始帧接收完成后，在接收到信息帧的第一个字节时将SCIG的SCR.RIE位设置为1。
- 2.将SCIG的SCR.RIE位设置为1，以禁用RXI中断并启用ICU的ERI中断。  
清除IRn.IR标志以使ICU在信息的第一个字节之前接受RXI中断  
开始帧接收完成后接收帧。

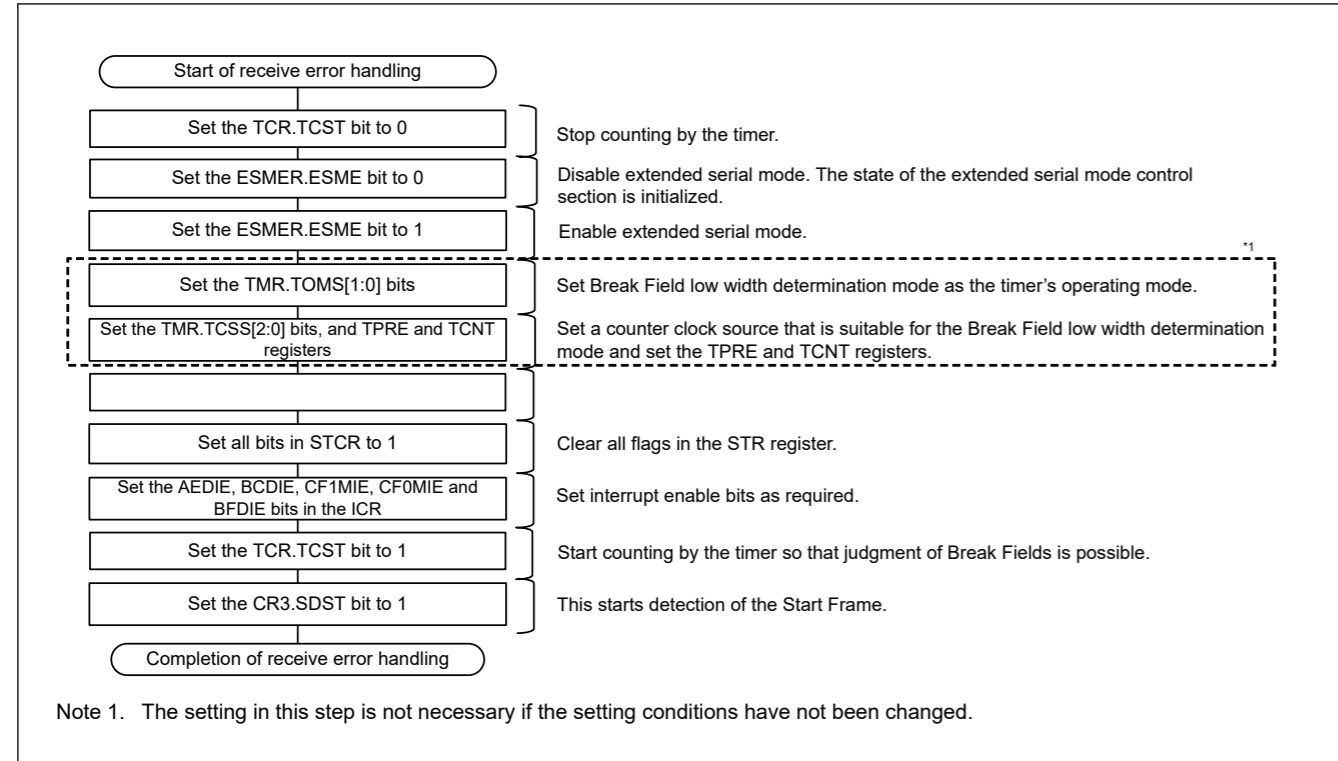


Figure 27.125 Example of Flowchart for Receive Error Handling (during Reception of the Start Frame)

27.16.14 Note on Stopping Reception When Using the RTS Function in Asynchronous Mode

One clock cycle of PCLK is required for the time from setting the SCR.RE bit to 0 to stopping the RTS signal generator in asynchronous mode.

When reading the RDR (or RDRL) register after setting the SCR.RE bit to 0, confirm that the RE bit has been set to 0 before reading the RDR (or RDRL) register to prevent these two processes from being performed consecutively.

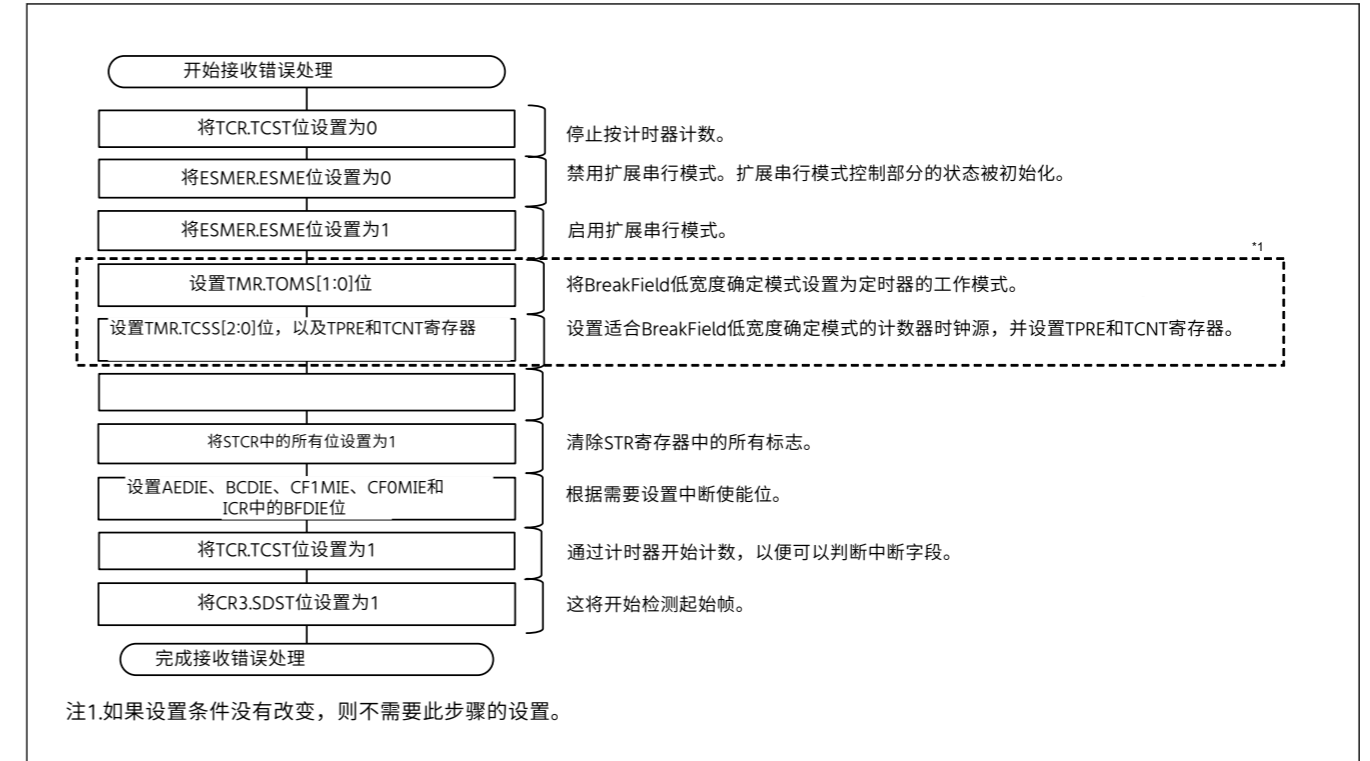


图27.125接收错误处理流程图示例 (接收起始帧期间)

27.16.14 异步使用RTS函数时停止接收的注意事项

从将SCR.RE位设置为0到在异步模式下停止RTS信号发生器,需要一个PCLK时钟周期。

在将SCR.RE位设置为0后读取RDR (或RDRL) 寄存器时,请在读取RDR (或RDRL) 寄存器之前确认RE位已设置为0,以防止这两个过程连续执行。



## 28. I<sup>2</sup>C Bus Interface (IIC)

### 28.1 Overview

The I<sup>2</sup>C bus interface (IIC) has 2 channels. The IIC module conforms with and provides a subset of the NXP I<sup>2</sup>C (Inter-Integrated Circuit) bus interface functions.

Table 28.1 lists the IIC specifications, Figure 28.1 shows a block diagram, and Figure 28.2 shows an example of I/O pin connections to external circuits, with an I<sup>2</sup>C bus configuration. Table 28.2 lists the I/O pins.

Table 28.1 IIC specifications (1 of 2)

| Parameter                        | Specifications  |
|----------------------------------|---|
| Communications format            | <ul style="list-style-type: none"> <li>I<sup>2</sup>C-bus format or SMBus format</li> <li>Master or slave mode selectable</li> <li>Automatic securing of the setup times, hold times, and bus-free times for the transfer rate</li> </ul>   |
| Transfer rate                    | <ul style="list-style-type: none"> <li>Fast-mode Plus supported, up to 1 Mbps</li> </ul>  |
| SCL clock                        | For master operation, the duty cycle of the SCL clock is selectable in the range from 4% to 96%   |
| Issuing and detecting conditions | <ul style="list-style-type: none"> <li>Start, restart, and stop conditions are automatically generated</li> <li>Start conditions (including restart conditions) and stop conditions are detectable</li> </ul>   |
| Slave address                    | <ul style="list-style-type: none"> <li>Configurable for up to three different slave addresses</li> <li>7- and 10-bit address formats supported, including simultaneous use</li> <li>General call addresses, device ID addresses, and SMBus host addresses detectable</li> </ul>   |
| Acknowledgment                   | <ul style="list-style-type: none"> <li>For transmission, automatic loading of the acknowledge bit<br/>Transfer of the next transmit data can be automatically suspended on detection of a not-acknowledge bit.</li> <li>For reception, automatic transmission of the acknowledge bit<br/>If a wait between the 8th and 9th clock cycles is selected, the software can control the value in the acknowledge field in response to the received value.</li> </ul>  |
| Wait function                    | During reception, the following wait periods are available by holding the SCL clock low: <ul style="list-style-type: none"> <li>Waiting between the eighth and ninth clock cycles</li> <li>Waiting between the ninth clock cycle and the 1st clock cycle of the next transfer</li> </ul>  |
| SDA output delay function        | Output timing of transmitted data, including the acknowledge bit, can be delayed  |
| Arbitration                      | <ul style="list-style-type: none"> <li>For multi-master operation: <ul style="list-style-type: none"> <li>SCL clock synchronization is possible when conflict occurs with the SCL signal from another master</li> <li>When issuing the start condition creates conflict on the bus, loss of arbitration is detected by testing for a mismatch between the internal signal for the SDA line and the level on the SDA line</li> <li>In master operation, loss of arbitration is detected by testing for non-matching between the signal on the SDA line and the internal signal for the SDA line</li> </ul> </li> <li>Loss of arbitration because the start condition occurs while the bus is busy is detectable, to prevent the issuing of double start conditions</li> <li>Loss of arbitration is detectable on transfer of a not-acknowledge bit because the internal signal for the SDA line and the level on the SDA line do not match</li> <li>Loss of arbitration because a mismatch of internal and line levels for data is detectable in slave transmission</li> </ul> |
| Timeout function                 | Internal detection of long-interval stops of the SCL clock  |
| Noise cancellation               | <ul style="list-style-type: none"> <li>Digital noise filters for both the SCL and SDA signals</li> <li>Programmable window for noise cancellation by the filters</li> </ul>   |
| Interrupt sources                | <ul style="list-style-type: none"> <li>Transfer error or event occurrence (arbitration-lost, NACK, timeout, start or restart condition, or stop condition)</li> <li>Receive data full, including matching with a slave address</li> <li>Transmit data empty, including matching with a slave address</li> <li>Transmit end</li> </ul>   |
| Module-stop function             | Module-stop state can be set  |
| IIC operating modes              | <ul style="list-style-type: none"> <li>Master transmit</li> <li>Master receive</li> <li>Slave transmit</li> <li>Slave receive</li> </ul>  |

## 28. I2C总线接口(IIC)

### 28.1 Overview

I2C总线接口(IIC)有2个通道。IIC模块符合并提供NXP I2C(Inter-Integrated Circuit)总线接口功能。

表28.1列出了IIC规范，图28.1显示了框图，图28.2显示了IO引脚连接到外部电路的示例，具有I2C总线配置。表28.2列出了IO引脚。

Table 28.1 IIC规格(1of2)

| Parameter            | Specifications   |
|----------------------|--|
| 通讯格式                 | <ul style="list-style-type: none"> <li>I2C-bus格式或SMBus格式</li> <li>可选择主从模式</li> <li>自动保护传输速率的设置时间、保持时间和无总线时间</li> </ul>   |
| 传输率                  | <ul style="list-style-type: none"> <li>支持快速模式Plus, 最高1Mbps</li> </ul>  |
| SCL clock            | 对于主机操作, SCL时钟的占空比可在4%至96%的范围内选择  |
| 发布和检测条件              | <ul style="list-style-type: none"> <li>自动生成启动、重启和停止条件</li> <li>可检测启动条件(包括重启条件)和停止条件</li> </ul>   |
| 从机地址                 | <ul style="list-style-type: none"> <li>最多可配置三个不同的从地址</li> <li>支持7位和10位地址格式, 包括同时使用</li> <li>可检测到广播呼叫地址、设备ID地址和SMBus主机地址</li> </ul>   |
| Acknowledgment       | <ul style="list-style-type: none"> <li>对于传输, 自动加载确认位<br/>检测到未确认位时, 可以自动暂停下一个发送数据的传输。</li> <li>对于接收, 确认位的自动传输<br/>如果选择了第8和第9个时钟周期之间的等待, 软件可以控制确认字段中的值以响应接收到的值。</li> </ul>   |
| 等待功能                 | 在接收期间, 将SCL时钟保持为低电平可获得以下等待周期: ● <ul style="list-style-type: none"> <li>在第八和第九个时钟周期之间等待</li> <li>在第9个时钟周期和下一次传输的第1个时钟周期之间等待</li> </ul>  |
| SDA输出延迟功能            | 传输数据的输出时序, 包括确认位, 可以延迟   |
| Arbitration          | <ul style="list-style-type: none"> <li>For multi-master operation: <ul style="list-style-type: none"> <li>当与来自另一个主机的SCL信号发生冲突时, 可以进行SCL时钟同步</li> <li>当发出启动条件在总线上产生冲突时, 通过测试SDA线的内部信号和SDA线上的电平之间的不匹配来检测仲裁丢失</li> <li>在主机操作中, 通过测试SDA线路上的信号与SDA线路的内部信号之间的不匹配来检测仲裁丢失</li> </ul> </li> <li>可检测到由于在总线繁忙时出现启动条件而导致的仲裁丢失, 以防止发出双启动条件</li> <li>由于SDA线的内部信号和SDA线上的电平不匹配, 在传输未确认位时可检测到仲裁丢失</li> <li>在从传输中可检测到数据的内部电平和线路电平不匹配而导致仲裁丢失</li> </ul> |
| 超时功能                 | 内部检测SCL时钟的长间隔停止  |
| 噪音消除                 | <ul style="list-style-type: none"> <li>SCL和SDA信号的数字噪声滤波器</li> <li>通过滤波器消除噪声的可编程窗口</li> </ul>   |
| 中断源                  | <ul style="list-style-type: none"> <li>传输错误或事件发生(仲裁丢失、NACK、超时、启动或重启条件或停止条件)</li> <li>接收数据已满, 包括与从地址匹配</li> <li>发送数据为空, 包括匹配从机地址</li> <li>发射端</li> </ul>  |
| Module-stop function | 模块停止状态可设置  |
| IIC操作模式              | <ul style="list-style-type: none"> <li>主传输</li> <li>主接收</li> <li>从机发送</li> <li>从机接收</li> </ul>   |

Table 28.1 IIC specifications (2 of 2)

| Parameter                    | Specifications  |
|------------------------------|---|
| Event link function (output) | <ul style="list-style-type: none"> <li>Transfer error or event occurrence (arbitration-lost, NACK, timeout, start or restart condition, or stop condition)</li> <li>Receive data full, including matching with a slave address</li> <li>Transmit data empty, including matching with a slave address</li> <li>Transmit end</li> </ul> |
| Wakeup function*1            | CPU can return from Software Standby mode using a wakeup event  |
| TrustZone Filter             | Security attribution can be set for each channels   |

Note 1. This function is only available for IIC channel IIC0. IIC1 is not supported.

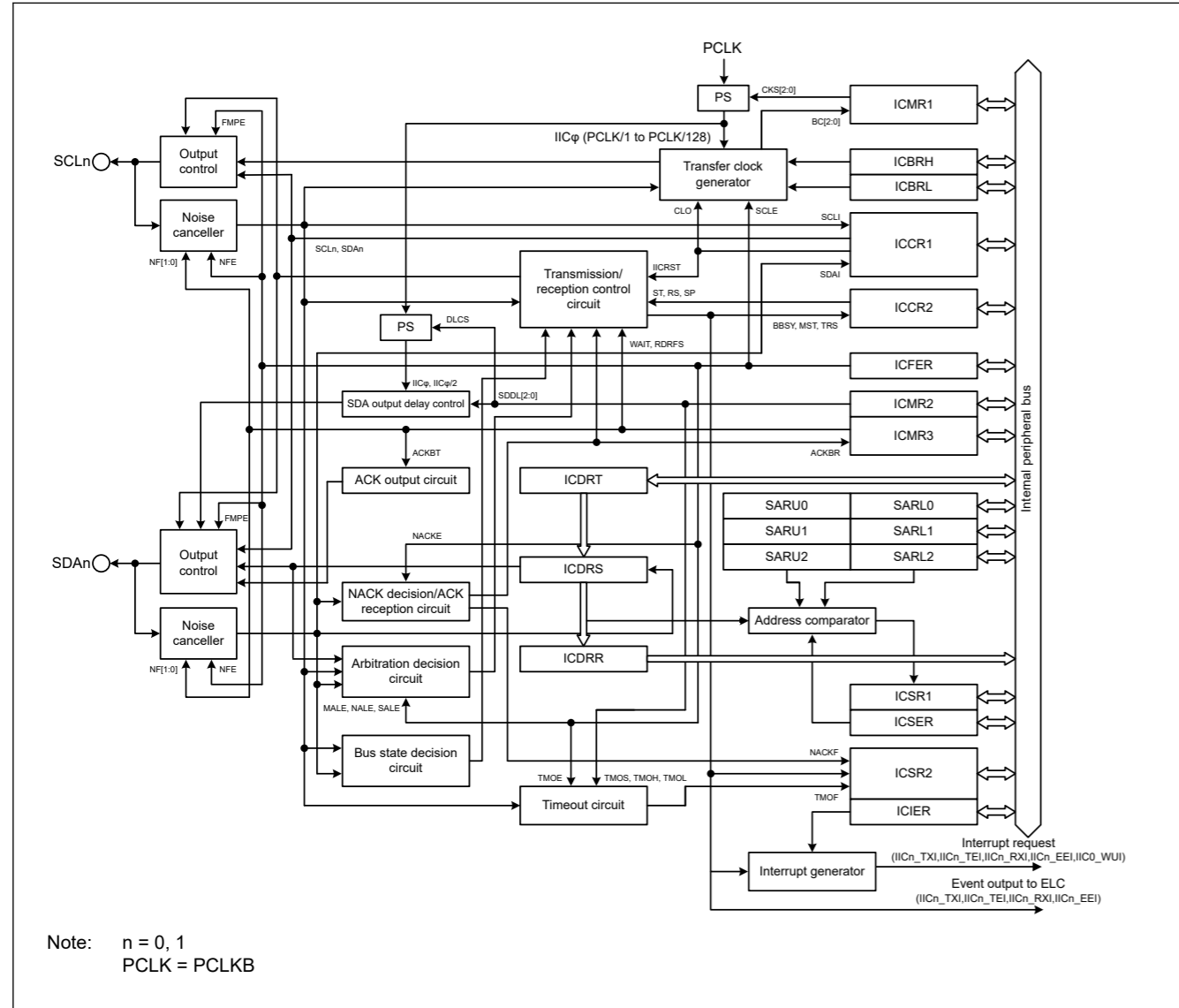


Figure 28.1 IIC block diagram

Table 28.1 IIC规格 (2个中的2个)

| Parameter        | Specifications   |
|------------------|--|
| 事件链接功能 (输出)      | <ul style="list-style-type: none"> <li>传输错误或事件发生 (仲裁丢失、NACK、超时、启动或重启条件或停止条件)</li> <li>接收数据已满, 包括与从地址匹配</li> <li>发送数据为空, 包括匹配从机地址</li> <li>发射端</li> </ul> |
| 唤醒功能*1           | CPU可以使用唤醒事件从软件待机模式返回   |
| TrustZone Filter | 可以为每个通道设置安全属性  |

注1.此功能仅适用于IIC通道IIC0。不支持IIC1。

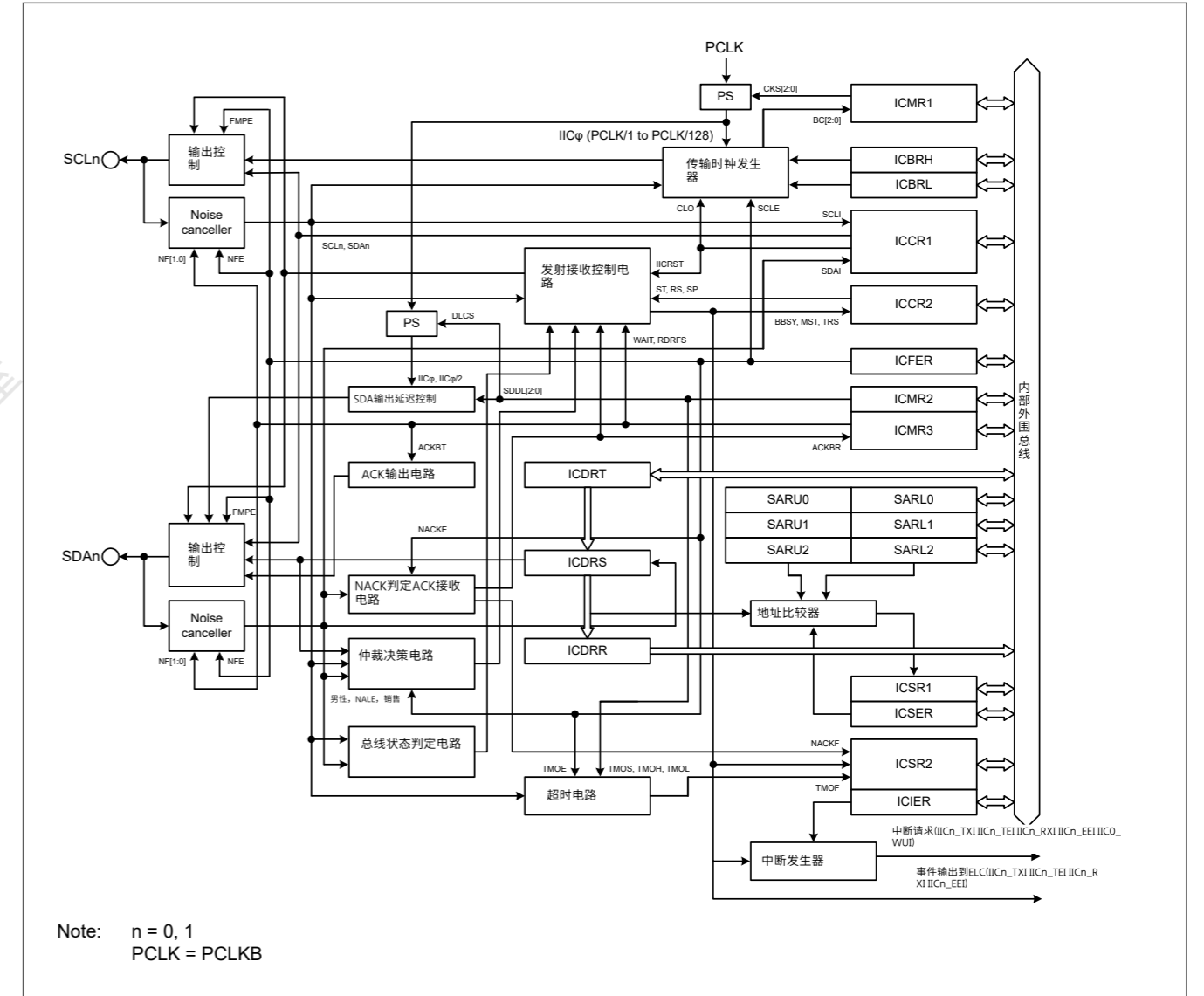


Figure 28.1 IIC框图

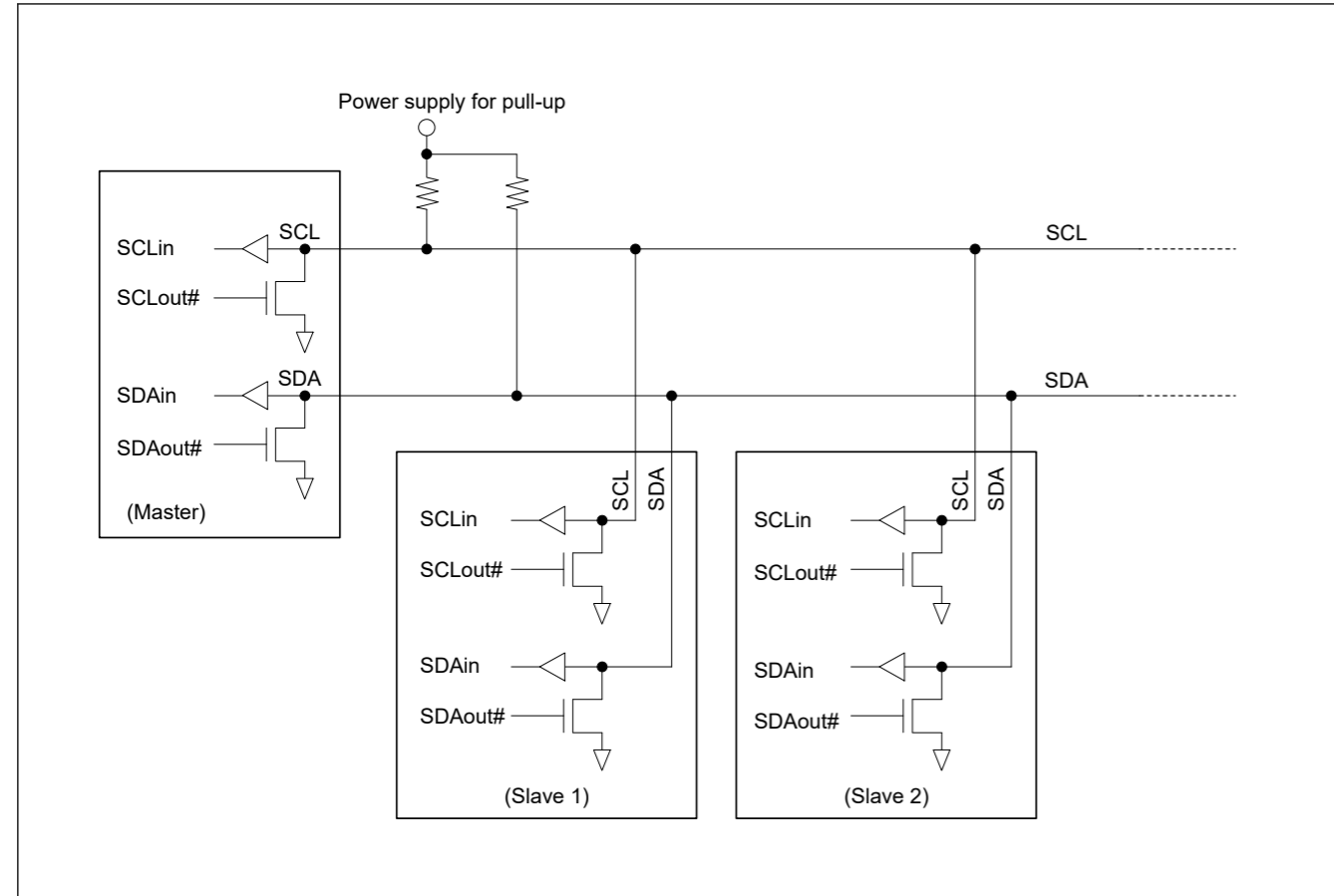


Figure 28.2 I/O pin connection to an external circuit (I<sup>2</sup>C bus configuration example)

The input level of the signals for IIC is CMOS when I<sup>2</sup>C bus is selected (ICMR3.SMBS = 0), or TTL when SMBus is selected (ICMR3.SMBS = 1).

Table 28.2 IIC I/O pins

| Channel | Pin name | I/O | Function                  |
|---------|----------|-----|---------------------------|
| IICn    | SCLn     | I/O | IICn serial clock I/O pin |
|         | SDAn     | I/O | IICn serial data I/O pin  |

Note: n = 0, 1

## 28.2 Register Descriptions

### 28.2.1 ICCR1 : I<sup>2</sup>C Bus Control Register 1

Base address: IICn = 0x4009\_F000 + 0x0100 × n (n = 0, 1)

Offset address: 0x00

|                    |     |                    |     |      |      |      |      |      |
|--------------------|-----|--------------------|-----|------|------|------|------|------|
| Bit position:      | 7   | 6                  | 5   | 4    | 3    | 2    | 1    | 0    |
| Bit field:         | ICE | IICRS <sub>T</sub> | CLO | SOWP | SCLO | SDAO | SCLI | SDAI |
| Value after reset: | 0   | 0                  | 0   | 1    | 1    | 1    | 1    | 1    |

| Bit | Symbol | Function  | R/W |
|-----|--------|---|-----|
| 0   | SDAI   | SDA Line Monitor<br>0: SDAn line is low<br>1: SDAn line is high | R   |

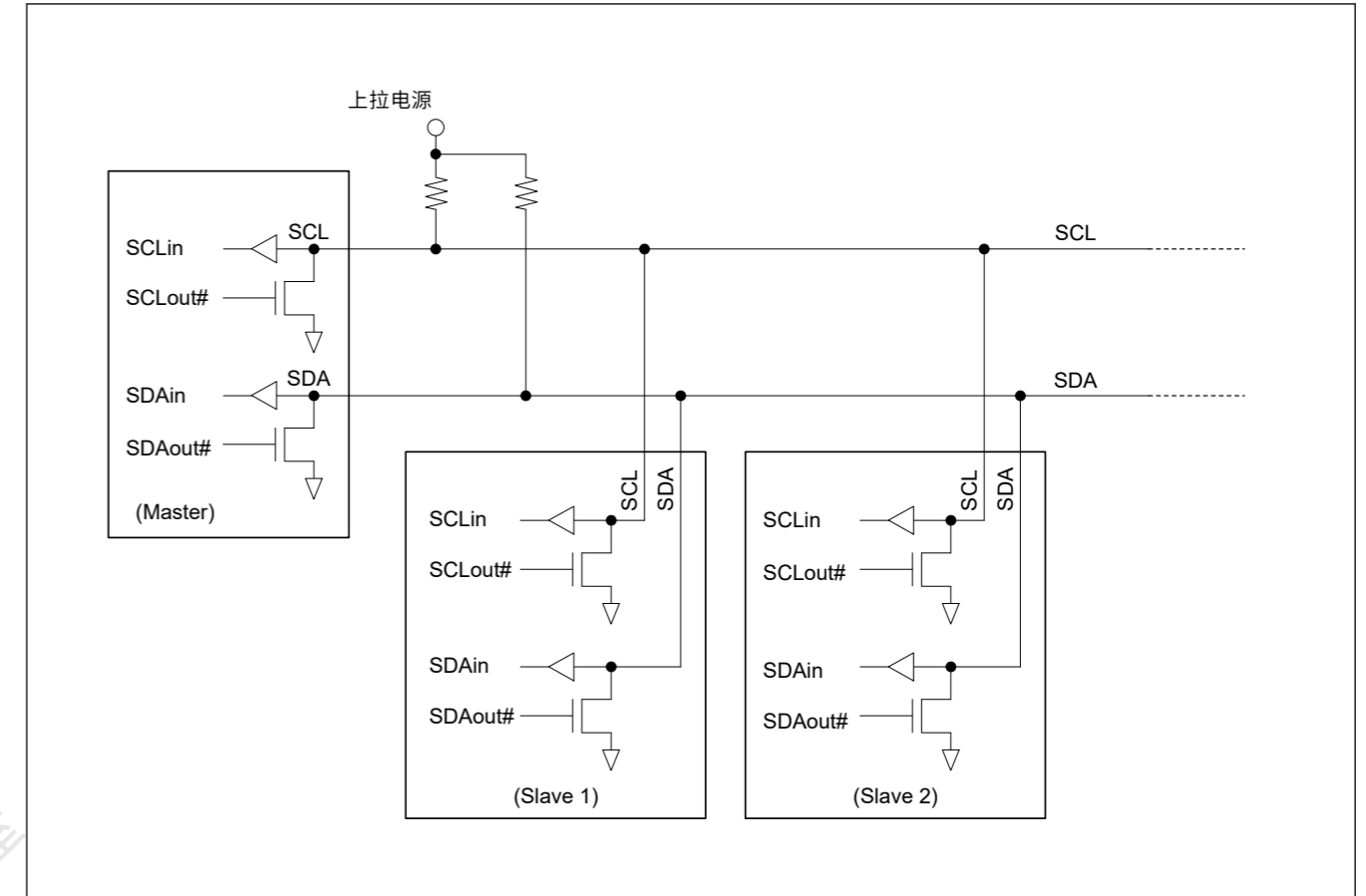


Figure 28.2 IO引脚连接到外部电路 (I2C总线配置示例)

The input level of the signals for IIC is CMOS when I<sup>2</sup>C bus is selected (ICMR3.SMBS=0) or TTL when SMBus is selected (ICMR3.SMBS=1).

Table 28.2 IIC I/O pins

| Channel | 引脚名称 | I/O | Function     |
|---------|------|-----|--------------|
| IICn    | SCLn | I/O | IICn串行时钟IO引脚 |
|         | SDAn | I/O | IICn串行数据IO引脚 |

Note: n = 0, 1

## 28.2 注册说明

### 28.2.1 ICCR1:I2C总线控制寄存器1

Base address: IICn = 0x4009\_F000 + 0x0100 × n (n = 0, 1)

Offset address: 0x00

|               |     |                    |     |      |      |      |      |      |
|---------------|-----|--------------------|-----|------|------|------|------|------|
| Bit position: | 7   | 6                  | 5   | 4    | 3    | 2    | 1    | 0    |
| Bit field:    | ICE | IICRS <sub>T</sub> | CLO | SOWP | SCLO | SDAO | SCLI | SDAI |
| 重置后的值:        | 0   | 0                  | 0   | 1    | 1    | 1    | 1    | 1    |

| Bit | Symbol | Function                       | R/W |
|-----|--------|--------------------------------|-----|
| 0   | SDAI   | SDA线路监视器<br>0: SDAn线低1: SDAn线高 | R   |

| Bit | Symbol | Function   | R/W |
|-----|--------|--|-----|
| 1   | SCLI   | SCL Line Monitor<br>0: SCLn line is low<br>1: SCLn line is high  | R   |
| 2   | SDAO   | SDA Output Control/Monitor<br>0: Read: IIC drives SDA pin low<br>Write: IIC drives SDA pin low<br>1: Read: IIC releases SDA pin<br>Write: IIC releases SDA pin   | R/W |
| 3   | SCLO   | SCL Output Control/Monitor<br>Use an external pull-up resistor to drive the signal high.<br>0: Read: IIC drives SCLn pin low<br>Write: IIC drives SCLn pin low<br>1: Read: IIC releases SCLn pin<br>Write: IIC releases SCLn pin | R/W |
| 4   | SOWP   | SCLO/SDAO Write Protect<br>This bit is read as 1.<br>0: Write enable SCLO and SDAO bits<br>1: Write protect SCLO and SDAO bits   | W   |
| 5   | CLO    | Extra SCL Clock Cycle Output<br>This bit clears automatically after 1 clock cycle is output.<br>0: Do not output extra SCL clock cycle (default)<br>1: Output extra SCL clock cycle  | R/W |
| 6   | IICRST | I <sup>2</sup> C Bus Interface Internal Reset<br>This setting clears the bit counter and the SCLn/SDAn output latch.<br>0: Release IIC reset or internal reset<br>1: Initiate IIC reset or internal reset                        | R/W |
| 7   | ICE    | I <sup>2</sup> C Bus Interface Enable<br>Used in combination with the IICRST bit to select either IIC or internal reset.<br>0: Disable (SCLn and SDA pins in inactive state)<br>1: Enable (SCLn and SDA pins in active state)    | R/W |

#### SDAO bit (SDA Output Control/Monitor) and SCLO bit (SCL Output Control/Monitor)

The SDAO and SCLO bits directly control the SDA pin and SCLn signals output from the IIC. When writing to these bits, also write 0 to the SOWP bit. Setting these bits results in input to the IIC by the input buffer. When slave mode is selected, a start condition might be detected and the bus might be released, depending on the bit settings.

Do not rewrite these bits during a start condition, stop condition, restart condition, transmission, or reception. Operation after rewriting under these conditions is not guaranteed. When reading these bits, the state of signals output from the IIC can be read.

#### CLO bit (Extra SCL Clock Cycle Output)

The CLO bit allows output of an extra SCL clock cycle for debugging or error processing. Normally, set this bit to 0. Setting the bit to 1 in a normal communication state causes a communication error. For details on this function, see [section 28.12.2. Extra SCL Clock Cycle Output Function](#).

#### IICRST bit (I<sup>2</sup>C Bus Interface Internal Reset)

The IICRST bit initiates an internal state reset of the IIC. Setting this bit to 1 initiates an IIC reset or internal reset. Whether an IIC reset or internal reset is initiated is determined by the settings of this bit in combination with the ICE bit. [Table 28.3](#) lists the IIC resets.

The IIC reset initializes all registers except ICCR1.ICE and ICCR1.IICRST bits and internal states of the IIC. In addition to the internal states of the IIC, the internal reset initializes the following:

- Bit counter (ICMR1.BC[2:0] bits)
- I<sup>2</sup>C Bus Shift Register (ICDRS)
- I<sup>2</sup>C Bus Status Registers (ICSR1 and ICSR2)
- SDAO and SCLO Output Control/Monitor (ICCR1.SDAO and ICCR1.SCLO bits)

| Bit | Symbol | Function   | R/W |
|-----|--------|--|-----|
| 1   | SCLI   | SCL线路监视器<br>0: SCLn线低1: SC<br>Ln线高   | R   |
| 2   | SDAO   | SDA Output Control/Monitor<br>0: 读: IIC将SDAn引脚驱动为低电平<br>写: IIC将SDAn引脚驱动为低电平<br>1: 读: IIC释放SDAn引脚写: I<br>C释放SDAn引脚                        | R/W |
| 3   | SCLO   | SCL Output Control/Monitor<br>使用外部上拉电阻将信号驱动为高电平。<br>0: 读: IIC将SCLn引脚驱动为低电平写<br>: IIC将SCLn引脚驱动为低电平<br>1: 读: IIC释放SCLn引脚写: IIC<br>释放SCLn引脚 | R/W |
| 4   | SOWP   | SCLO/SDAO写保护<br>该位读为1。<br>0: 写使能SCLO和SDAO位1: 写保护S<br>CLO和SDAO位   | W   |
| 5   | CLO    | 额外的SCL时钟周期输出<br>该位在输出1个时钟周期后自动清零。<br>0: 不输出额外的SCL时钟周期(默认) 1: 输出<br>额外的SCL时钟周期  | R/W |
| 6   | IICRST | I2C总线接口内部复位<br>该设置清除位计数器和SCLn/SDAn输出锁存器。<br>0: 释放IIC复位或内部复位1: 启动IIC<br>复位或内部复位   | R/W |
| 7   | ICE    | I2C总线接口使能<br>与IICRST位结合使用来选择IIC或内部复位。<br>0: 禁用(SCLn和SDAn引脚处于非活动状态) 1:<br>启用(SCLn和SDAn引脚处于活动状态)   | R/W |

#### SDAO位(SDA输出控制监视器)和SCLO位(SCL输出控制监视器)

SDAO和SCLO位直接控制IIC输出的SDAn和SCLn信号。写入这些位时,还要向SOWP位写入0。设置这些位会导致输入缓冲器向IIC输入。选择从模式时,可能会检测到启动条件并释放总线,具体取决于位设置。

不要在开始条件、停止条件、重启条件、发送或接收期间重写这些位。不保证在这些条件下重写后的操作。读取这些位时,可以读取IIC输出的信号状态。

#### CLO位(额外SCL时钟周期输出)

CLO位允许输出额外的SCL时钟周期用于调试或错误处理。通常,将此位设置为0。在正常通信状态下将此位设置为1会导致通信错误。有关此功能的详细信息,请参阅第28.12.2节。额外的SCL时钟周期输出功能。

#### IICRST位(I2C总线接口内部复位)

IICRST位启动IIC的内部状态复位。将此位设置为1会启动IIC复位或内部复位。是IIC复位还是内部复位由该位的设置和ICE位共同决定。表28.3列出了IIC复位。

IIC复位初始化除ICCR1.ICE和ICCR1.IICRST位和IIC内部状态之外的所有寄存器。除了IIC的内部状态之外,内部复位还会初始化以下内容:

- 位计数器(ICMR1.BC[2:0]位)
- I2C总线移位寄存器(ICDRS)
- I2C总线状态寄存器(ICSR1和ICSR2)
- SDAO和SCLO输出控制监视器(ICCR1.SDAO和ICCR1.SCLO位)



- I<sup>2</sup>C Bus Control Register 2 (except ICCR2.BBSY bit)

For the reset conditions for each register, see [section 28.15. State of Registers When Issuing Each Condition](#).

An internal reset initiated with the IICRST bit set to 1 during operation (with the ICE bit set to 1) resets the internal states of the IIC without initializing the port settings and the control and setting registers of the IIC. If the IIC hangs in a low-level output state, resetting the internal states cancels the low-level output state and releases the bus with the SCLn pin and SDAn pin at high impedance.

**Note:** If an internal reset is initiated using the IICRST bit for a bus hang-up that occurs during communication with the master device in slave mode, the slave and master devices might enter different states, because the bit counter information differs. For this reason, do not initiate an internal reset in slave mode. Initiate recovery processing from the master device. If an internal reset is required because the IIC hangs with the SCLn line in a low-level output state in slave mode, initiate an internal reset, then issue a restart condition from the master device, or issue a stop condition and resume communication from the start condition. If communication is restarted by initiating a reset solely in the slave device without issuing a start or restart condition from the master device, synchronization is lost because the master and slave devices operate asynchronously.

**Table 28.3 IIC resets**

| IICRST | ICE | State          | Specifications   |
|--------|-----|----------------|--|
| 1      | 0   | IIC reset      | Resets all registers except ICCR1.IICRST and ICCR1.ICE bits, and the internal states of the IIC  |
|        | 1   | Internal reset | Reset the following: <ul style="list-style-type: none"> <li>● ICMR1.BC[2:0] bits</li> <li>● ICSR1, ICSR2, ICDRS registers</li> <li>● SDAO and SCLO Output Control/Monitor (ICCR1.SDAO and ICCR1.SCLO bits)</li> <li>● I<sup>2</sup>C Bus Control Register 2 (except ICCR2.BBSY bit)</li> <li>● Internal states of the IIC</li> </ul> |

**ICE bit (I<sup>2</sup>C Bus Interface Enable)**

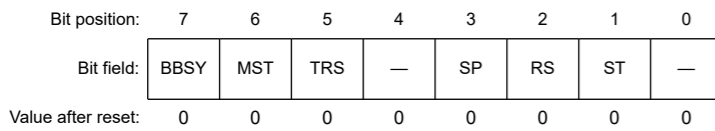
The ICE bit selects the active or inactive state of the SCLn and SDAn pins. It can also be combined with the IICRST bit to initiate two types of resets. See [Table 28.3](#) for the reset descriptions.

Set the ICE bit to 1 when using the IIC. The SCLn and SDAn pins are placed in the active state when the ICE bit is set to 1. Set the ICE bit to 0 when the IIC is not used. The SCLn and SDAn pins are placed in the inactive state when the ICE bit is set to 0. Do not assign the SCLn or SDAn pin to the IIC when setting up the pin function control. Slave address comparison is performed if the pins are assigned to the IIC.

**28.2.2 ICCR2 : I<sup>2</sup>C Bus Control Register 2**

Base address: IICn = 0x4009\_F000 + 0x0100 × n (n = 0, 1)

Offset address: 0x01



| Bit | Symbol | Function  | R/W |
|-----|--------|---|-----|
| 0   | —      | This bit is read as 0. The write value should be 0.   | R/W |
| 1   | ST     | Start Condition Issuance Request<br>0: Do not issue a start condition request<br>1: Issue a start condition request       | R/W |
| 2   | RS     | Restart Condition Issuance Request<br>0: Do not issue a restart condition request<br>1: Issue a restart condition request | R/W |

- I2C总线控制寄存器2 (ICCR2.BBSY位除外)

关于各寄存器的复位条件，请参阅第28.15节。发出每个条件时的寄存器状态。

在操作期间将IICRST位设置为1（ICE位设置为1）启动的内部复位会复位IIC的内部状态，而无需初始化IIC的端口设置以及控制和设置寄存器。如果IIC在低电平输出状态下挂起，复位内部状态会取消低电平输出状态并释放总线，同时SCLn引脚和SDAn引脚处于高阻抗状态。

**Note:** 如果在从模式下与主设备通信期间发生的总线挂断使用IICRST位启动内部复位，则从设备和主设备可能会进入不同的状态，因为位计数器信息不同。因此，不要在从模式下启动内部复位。从主设备启动恢复处理。如果由于IIC在从模式下挂起且SCLn线处于低电平输出状态而需要内部复位，则启动内部复位，然后从主设备发出重新启动条件，或者发出停止条件并从主设备恢复通信开始条件。如果通过仅在从设备中启动复位来重新启动通信，而没有从主设备发出启动或重启条件，则由于主设备和从设备异步操作而失去同步。

**Table 28.3 IIC resets**

| IICRST | ICE | State     | Specifications  |
|--------|-----|-----------|---|
| 1      | 0   | IIC reset | 复位除ICCR1.IICRST和ICCR1.ICE位之外的所有寄存器，以及IIC的内部状态   |
|        | 1   | 内部复位      | 重置以下内容： <ul style="list-style-type: none"> <li>● bits</li> <li>● ICSR1, ICSR2, ICDRS registers</li> <li>● SDAO和SCLO输出控制监视器 (ICCR1.SDAO和ICCR1.SCLO bits)</li> <li>● I2C总线控制寄存器2 (ICCR2.BBSY位除外)</li> <li>● IIC的内部状态</li> </ul> |

**ICE位 (I2C总线接口使能)**

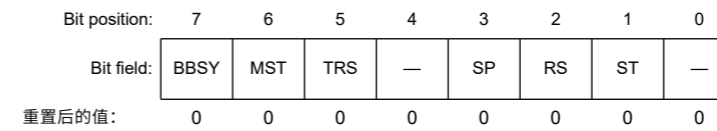
ICE位选择SCLn和SDAn引脚的有效或无效状态。它也可以与IICRST位组合来启动两种类型的复位。复位说明见表28.3。

使用IIC时将ICE位设置为1。当ICE位设置为1时，SCLn和SDAn引脚处于活动状态。不使用IIC时，将ICE位设置为0。当ICE位设置为0时，SCLn和SDAn引脚处于非活动状态。在设置引脚功能控制时，不要将SCLn或SDAn引脚分配给IIC。如果引脚分配给IIC，则执行从地址比较。

**28.2.2 ICCR2:I2C总线控制寄存器2**

Base address: IICn = 0x4009\_F000 + 0x0100 × n (n = 0, 1)

Offset address: 0x01



| Bit | Symbol | Function                                | R/W |
|-----|--------|---|-----|
| 0   | —      | 该位读取为0。写入值应为0。                          | R/W |
| 1   | ST     | 开始条件发布请求<br>0: 不发出启动条件请求<br>1: 发出启动条件请求 | R/W |
| 2   | RS     | 重启条件发布请求<br>0: 不发出重启条件请求<br>1: 发出重启条件请求 | R/W |

| Bit | Symbol | Function  | R/W              |
|-----|--------|---|------------------|
| 3   | SP     | Stop Condition Issuance Request<br>0: Do not issue a stop condition request<br>1: Issue a stop condition request                  | R/W              |
| 4   | —      | This bit is read as 0. The write value should be 0.   | R/W              |
| 5   | TRS    | Transmit/Receive Mode<br>0: Receive mode<br>1: Transmit mode  | R/W <sup>1</sup> |
| 6   | MST    | Master/Slave Mode<br>0: Slave mode<br>1: Master mode  | R/W <sup>1</sup> |
| 7   | BBSY   | Bus Busy Detection Flag<br>0: I <sup>2</sup> C bus released (bus free state)<br>1: I <sup>2</sup> C bus occupied (bus busy state) | R                |

Note 1. The MST and TRS bits can be written to when the ICMR1.MTWP bit is set to 1.

### ST bit (Start Condition Issuance Request)

The ST bit requests transition to master mode and triggers a start condition. When this bit is set to 1, a start condition is issued when the BBSY flag is set to 0 (bus free state). For details on this function, see [section 28.11. Start, Restart, and Stop Condition Issuing Function](#).

[Setting condition]

- When 1 is written to the ST bit.

[Clearing conditions]

- When 0 is written to the ST bit
- When a start condition is issued (a start condition is detected)
- When the AL (arbitration-lost) flag in ICSR2 is set to 1
- When 1 is written to the IICRST bit in ICCR1 to apply an IIC reset or an internal reset.

Note: Only set the ST bit to 1 (start condition request) when the BBSY flag is set to 0 (bus free state). Arbitration might be lost if the ST bit is set to 1 (start condition request) when the BBSY flag is 1 (bus busy state).

### RS bit (Restart Condition Issuance Request)

The RS bit requests that a restart condition be issued in master mode. When this bit is set to 1 to request a restart condition, a restart condition is issued when the BBSY flag is set to 1 (bus busy state) and the MST bit is set to 1 (master mode). For details on this function, see [section 28.11. Start, Restart, and Stop Condition Issuing Function](#).

[Setting condition]

- When 1 is written to the RS bit with the BBSY flag in ICCR2 set to 1.

[Clearing conditions]

- When 0 is written to the RS bit
- When a restart condition is issued (a start condition is detected)
- When the AL (arbitration-lost) flag in ICSR2 is set to 1
- When 1 is written to the IICRST bit in ICCR1 to apply an IIC reset or an internal reset.

Note: Do not set the RS bit to 1 while issuing a stop condition.

Note: If 1 (restart condition request) is written to the RS bit in slave mode, the restart condition is not issued, but the RS bit remains set to 1. If the operating mode changes to master mode without the bit being cleared, a restart condition might be issued.

| Bit | Symbol | Function   | R/W              |
|-----|--------|--|------------------|
| 3   | SP     | 停止条件发出请求<br>0: 不发出停止条件请求<br>1: 发出停止条件请求              | R/W              |
| 4   | —      | 该位读取为0。写入值应为0。                                       | R/W              |
| 5   | TRS    | Transmit/Receive Mode<br>0: 接收模式<br>1: 发送模式          | R/W <sup>1</sup> |
| 6   | MST    | Master/Slave Mode<br>0: 从模式<br>1: 主模式                | R/W <sup>1</sup> |
| 7   | BBSY   | 总线忙检测标志<br>0: I2C总线释放 (总线空闲状态)<br>1: I2C总线占用 (总线忙状态) | R                |

注1.当ICMR1.MTWP位设置为1时，可以写入MST和TRS位。

### ST位 (开始条件发布请求)

ST位请求切换到主模式并触发启动条件。当该位设置为1时，当BBSY标志设置为0 (总线空闲状态) 时发出启动条件。有关此功能的详细信息，请参阅第28.11节。启动、重启和停止条件发布功能。

[Setting condition]

- ST位写入1时。

[Clearing conditions]

- ST位写入0时
- 发出启动条件时 (检测到启动条件)
- ICSR2中的AL (仲裁失败) 标志设置为1时
- 当ICCR1的IICRST位写入1时，应用IIC复位或内部复位。

Note: 仅当BBSY标志设置为0 (总线空闲状态) 时，才将ST位设置为1 (启动条件请求)。如果在BBSY标志为1 (总线繁忙状态) 时将ST位设置为1 (开始条件请求)，则仲裁可能会丢失。

### RS位 (重启条件发布请求)

RS位请求在主机模式下发出重启条件。当该位设置为1以请求重新启动条件时，当BBSY标志设置为1 (总线繁忙状态) 且MST位设置为1 (主模式) 时，发出重新启动条件。有关此功能的详细信息，请参阅第28.11节。启动、重启和停止条件发布功能。

[Setting condition]

- 当ICCR2中的BBSY标志设置为1时，将1写入RS位。

[Clearing conditions]

- 向RS位写入0时
- 发出重新启动条件时 (检测到启动条件)
- ICSR2中的AL (仲裁失败) 标志设置为1时
- 当ICCR1的IICRST位写入1时，应用IIC复位或内部复位。

Note: 发出停止条件时不要将RS位设置为1。

Note: 如果在从模式下将1 (重新启动条件请求) 写入RS位，则不会发出重新启动条件，但RS位保持设置为1。如果操作模式更改为主模式而未清除该位，则重新启动条件可能会发出。

**SP bit (Stop Condition Issuance Request)**

The SP bit requests that a stop condition be issued in master mode. When this bit is set to 1, a stop condition is issued when the BBSY flag is set to 1 (bus busy state) and the MST bit is set to 1 (master mode). For details on this function, see [section 28.11. Start, Restart, and Stop Condition Issuing Function](#).

[Setting condition]

- When 1 is written to the SP bit with both the BBSY flag and the MST bit in ICCR2 set to 1.

[Clearing conditions]

- When 0 is written to the SP bit
- When a stop condition is issued (a stop condition is detected)
- When the AL (arbitration-lost) flag in ICSR2 is set to 1
- When a start condition and a restart condition are detected
- When 1 is written to the IICRST bit in ICCR1 to apply an IIC reset or an internal reset.

Note: Writing to the SP bit is not possible while the BBSY flag is 0 (bus free state).

Note: Do not set the SP bit to 1 while a restart condition is being issued.

**TRS bit (Transmit/Receive Mode)**

The TRS bit indicates transmit or receive mode. The IIC is in receive mode when the TRS bit is 0 and in transmit mode when the bit is 1. The combination of this bit and the MST bit indicates the IIC operating mode.

The value of the TRS bit automatically changes to 1 for transmit mode or 0 for receive mode when a start condition is issued or detected and the R/W# bit is set. Although writing to the TRS bit is possible when the MTWP bit in ICMR1 is set to 1, writing to this bit is not required during normal usage.

[Setting conditions]

- When a start condition is issued normally because of a start condition request (when a start condition is detected with the ST bit set to 1)
- When a restart condition is issued normally because of a restart condition request (when a restart condition is detected with the RS bit set to 1)
- When the R/W# bit appended to the slave address is set to 0 in master mode
- When the address received in slave mode matches the address enabled in ICSEER, with the R/W# bit set to 1
- When 1 is written to the TRS bit with the MTWP bit in ICMR1 set to 1.

[Clearing conditions]

- When a stop condition is detected
- When the AL (arbitration-lost) flag in ICSR2 is set to 1
- When the R/W# bit appended to the slave address is set to 1 in master mode
- In slave mode, on a match between the received address and the address enabled in ICSEER when the value of the received R/W# bit is 0, including when the received address is the general call address
- In slave mode, when a restart condition is detected (a restart condition is detected with ICCR2.BBSY = 1 and ICCR2.MST = 0)
- When 0 is written to the TRS bit with the MTWP bit in ICMR1 set to 1
- When 1 is written to the IICRST bit in ICCR1 to apply an IIC reset or an internal reset.

**MST bit (Master/Slave Mode)**

The MST bit indicates master or slave mode. The IIC is in slave mode when the MST bit is 0 and is in master mode when the bit is 1. The combination of this bit and the TRS bit indicates the IIC operating mode.

The value of the MST bit automatically changes to 1 for master mode or 0 for slave mode when a start condition is issued or a stop condition is issued or detected. Although writing to the MST bit is possible when the MTWP bit in ICMR1 is set to 1, writing to this bit is not required during normal usage.

**SP位 (停止条件发布请求)**

SP位请求在主机模式下发出停止条件。当该位设置为1时，当BBSY标志设置为1（总线繁忙状态）且MST位设置为1（主模式）时，发出停止条件。有关此功能的详细信息，请参阅第28.11节。启动、重启和停止条件发布功能。

[Setting condition]

- 当ICCR2中的BBSY标志和MST位都设置为1时，将1写入SP位。

[Clearing conditions]

- SP位写入0时
- 发出停止条件时（检测到停止条件）
- ICSR2中的AL（仲裁失败）标志设置为1时
- 检测到启动条件和重启条件时
- 当ICCR1的IICRST位写入1时，应用IIC复位或内部复位。

Note: 当BBSY标志为0（总线空闲状态）时，不能写入SP位。

Note: 发出重启条件时不要将SP位设置为1。

**TRS bit (Transmit/Receive Mode)**

TRS位指示发送或接收模式。TRS位为0时IIC处于接收模式，该位为1时IIC处于发送模式。该位和MST位的组合表示IIC工作模式。

当发出或检测到启动条件并且设置RW#位时，TRS位的值自动更改为1（发送模式）或0（接收模式）。虽然当ICMR1的MTWP位设置为1时可以写入TRS位，但在正常使用期间不需要写入该位。

[Setting conditions]

- 因启动条件请求而正常发出启动条件时（ST位设置为1时检测到启动条件时）
- 因重新启动条件请求而正常发出重新启动条件时（在RS位设置为1的情况下检测到重新启动条件时）
- 在主机模式下，附加在从机地址上的RW#位设置为0时
- 从机模式接收到的地址与ICSEER中使能的地址匹配时，RW#位设置为1
- 当ICMR1中的MTWP位设置为1时将1写入TRS位。

[Clearing conditions]

- 检测到停止条件时
- ICSR2中的AL（仲裁失败）标志设置为1时
- 在主机模式下，附加在从机地址上的RW#位设置为1时
- 从机模式下，当接收到的RW#位的值为0时，接收到的地址与ICSEER中使能的地址匹配，包括当接收到的地址是广播地址时
- 在从模式下，检测到重启条件时（检测到重启条件时ICCR2.BBSY=1和ICCR2.MST=0）
- 当ICMR1中的MTWP位设置为1时，将0写入TRS位时
- 当ICCR1的IICRST位写入1时，应用IIC复位或内部复位。

**MST bit (Master/Slave Mode)**

MST位指示主机或从机模式。当MST位为0时，IIC处于从机模式，当该位为1时，IIC处于主机模式。该位和TRS位的组合表示IIC工作模式。

当发出启动条件或发出或检测到停止条件时，MST位的值自动变为1（主机模式）或0（从机模式）。虽然当ICMR1中的MTWP位设置为1时可以写入MST位，但在正常使用期间不需要写入该位。



[Setting conditions]

- When a start condition is issued normally because of a start condition request (when a start condition is detected with the ST bit set to 1)
- When 1 is written to the MST bit with the MTWP bit in ICMR1 set to 1.

[Clearing conditions]

- When a stop condition is detected
- When the AL (arbitration-lost) flag in ICSR2 is set to 1
- When 0 is written to the MST bit with the MTWP bit in ICMR1 set to 1
- When 1 is written to the IICRST bit in ICCR1 to apply an IIC reset or an internal reset.

**BBSY flag (Bus Busy Detection Flag)**

The BBSY flag indicates whether the I<sup>2</sup>C bus is occupied (bus busy state) or released (bus free state). The flag is set to 1 when the SDAn line changes from high to low when the SCLn line is high, assuming that a start condition was issued. The flag is set to 0 if a start condition is not detected for the bus free time (ICBRL setting), assuming that a stop condition was issued.

[Setting condition]

- When a start condition is detected.

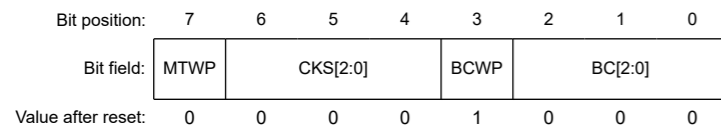
[Clearing conditions]

- When a start condition is not detected for the bus free time (ICBRL setting) after detecting a stop condition
- When 1 is written to the IICRST bit in ICCR1 with the ICE bit in ICCR1 set to 0 (IIC reset).

28.2.3 ICMR1 : I<sup>2</sup>C Bus Mode Register 1

Base address: IICn = 0x4009\_F000 + 0x0100 × n (n = 0, 1)

Offset address: 0x02



| Bit | Symbol   | Function  | R/W              |
|-----|----------|---|------------------|
| 2:0 | BC[2:0]  | Bit Counter<br>0 0 0: 9 bits<br>0 0 1: 2 bits<br>0 1 0: 3 bits<br>0 1 1: 4 bits<br>1 0 0: 5 bits<br>1 0 1: 6 bits<br>1 1 0: 7 bits<br>1 1 1: 8 bits | R/W <sup>1</sup> |
| 3   | BCWP     | BC Write Protect<br>This bit is read as 1.<br>0: Write enable BC[2:0] bits<br>1: Write protect BC[2:0] bits   | W <sup>1</sup>   |
| 6:4 | CKS[2:0] | Internal Reference Clock Select<br>Select the internal reference clock source (IICφ) for the IIC.<br>IICφ = (PCLKB / 2 <sup>CKS[2:0]</sup> ) clock  | R/W              |
| 7   | MTWP     | MST/TRS Write Protect<br>0: Write protect MST and TRS bits in ICCR2<br>1: Write enable MST and TRS bits in ICCR2                                    | R/W              |

Note 1. Rewrite the BC[2:0] bits and set the BCWP bit to 0 at the same time.

[Setting conditions]

- 因启动条件请求而正常发出启动条件时 (ST位设置为1时检测到启动条件时)
- 当ICMR1中的MTWP位设置为1时将1写入MST位。

[Clearing conditions]

- 检测到停止条件时
- ICSR2中的AL (仲裁失败) 标志设置为1时
- 当ICMR1中的MTWP位设置为1时, 将0写入MST位时
- 当ICCR1的IICRST位写入1时, 应用IIC复位或内部复位。

**BBSY标志 (总线忙检测标志)**

BBSY标志指示I2C总线是被占用 (总线繁忙状态) 还是被释放 (总线空闲状态)。当SCLn线为高时SDAn线从高变为低时, 该标志设置为1, 假设发出了启动条件。如果在总线空闲时间 (ICBRL设置) 没有检测到启动条件, 则该标志设置为0, 假设发出了停止条件。

[Setting condition]

- 检测到启动条件时。

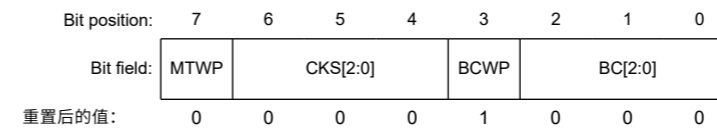
[Clearing conditions]

- 检测到停止条件后, 在总线空闲时间 (ICBRL设置) 内未检测到启动条件时
- 当ICCR1的IICRST位写入1且ICCR1的ICE位设置为0时 (IIC复位)。

28.2.3 ICMR1:I2C总线模式寄存器1

Base address: IICn = 0x4009\_F000 + 0x0100 × n (n = 0, 1)

Offset address: 0x02



| Bit | Symbol   | Function   | R/W              |
|-----|----------|--|------------------|
| 2:0 | BC[2:0]  | 位计数器<br>0 0 0: 9 bits<br>0 0 1: 2 bits<br>0 1 0: 3 bits<br>0 1 1: 4 bits<br>1 0 0: 5 bits<br>1 0 1: 6 bits<br>1 1 0: 7 bits<br>1 1 1: 8 bits | R/W <sup>1</sup> |
| 3   | BCWP     | BC写保护<br>该位读为1。<br>0: 写使能BC[2:0]位<br>1: 写保护BC[2:0]位  | W <sup>1</sup>   |
| 6:4 | CKS[2:0] | 内部参考时钟选择<br>选择IIC的内部参考时钟源(IICφ)。<br>IICφ = (PCLKB / 2 <sup>CKS[2:0]</sup> ) clock  | R/W              |
| 7   | MTWP     | MSTTRS写保护<br>0: 写保护ICCR2中的MST和TRS位<br>1: 写使能ICCR2中的MST和TRS位  | R/W              |

注1.重写BC[2:0]位, 同时将BCWP位设置为0。



**BC[2:0] bits (Bit Counter)**

The BC[2:0] bits function as a counter indicating the number of bits remaining to be transferred on detection of a rising edge on the SCLn line. Although BC[2:0] are read/write bits, it is not required to access these bits under normal conditions.

To write to these bits, specify the number of bits to be transferred plus one, for an additional acknowledge bit, between transferred frames when the SCLn line is at a low level. The value in the BC[2:0] bits returns to 000b at the end of a data transfer, including the acknowledge bit, or when a start or restart condition is detected.

**28.2.4 ICMR2 : I<sup>2</sup>C Bus Mode Register 2**

Base address: IICn = 0x4009\_F000 + 0x0100 × n (n = 0, 1)

Offset address: 0x03

|                    |      |           |   |   |   |      |      |      |
|--------------------|------|-----------|---|---|---|------|------|------|
| Bit position:      | 7    | 6         | 5 | 4 | 3 | 2    | 1    | 0    |
| Bit field:         | DLCS | SDDL[2:0] |   |   | — | TMOH | TMOL | TMOS |
| Value after reset: | 0    | 0         | 0 | 0 | 0 | 1    | 1    | 0    |

| Bit | Symbol    | Function   | R/W |
|-----|-----------|--|-----|
| 0   | TMOS      | Timeout Detection Time Select<br>0: Select long mode<br>1: Select short mode   | R/W |
| 1   | TMOL      | Timeout L Count Control<br>0: Disable count while SCLn line is low<br>1: Enable count while SCLn line is low   | R/W |
| 2   | TMOH      | Timeout H Count Control<br>0: Disable count while SCLn line is high<br>1: Enable count while SCLn line is high   | R/W |
| 3   | —         | This bit is read as 0. The write value should be 0.  | R/W |
| 6:4 | SDDL[2:0] | SDA Output Delay Counter<br>0 0 0: No output delay<br>0 0 1: 1 IICφ cycle (When ICMR2.DLCS = 0 (IICφ))<br>1 or 2 IICφ cycles (When ICMR2.DLCS = 1 (IICφ/2))<br>0 1 0: 2 IICφ cycles (When ICMR2.DLCS = 0 (IICφ))<br>3 or 4 IICφ cycles (When ICMR2.DLCS = 1 (IICφ/2))<br>0 1 1: 3 IICφ cycles (When ICMR2.DLCS = 0 (IICφ))<br>5 or 6 IICφ cycles (When ICMR2.DLCS = 1 (IICφ/2))<br>1 0 0: 4 IICφ cycles (When ICMR2.DLCS = 0 (IICφ))<br>7 or 8 IICφ cycles (When ICMR2.DLCS = 1 (IICφ/2))<br>1 0 1: 5 IICφ cycles (When ICMR2.DLCS = 0 (IICφ))<br>9 or 10 IICφ cycles (When ICMR2.DLCS = 1 (IICφ/2))<br>1 1 0: 6 IICφ cycles (When ICMR2.DLCS = 0 (IICφ))<br>11 or 12 IICφ cycles (When ICMR2.DLCS = 1 (IICφ/2))<br>1 1 1: 7 IICφ cycles (When ICMR2.DLCS = 0 (IICφ))<br>13 or 14 IICφ cycles (When ICMR2.DLCS = 1 (IICφ/2)) | R/W |
| 7   | DLCS      | SDA Output Delay Clock Source Select<br>0: Select internal reference clock (IICφ) as the clock source for SDA output delay counter<br>1: Select internal reference clock divided by 2 (IICφ/2) as the clock source for SDA output delay counter*1  | R/W |

Note 1. The setting DLCS = 1 (IICφ/2) is only valid when SCL is low. When SCL is high, the DLCS = 1 setting becomes invalid and the clock source becomes the internal reference clock (IICφ).

**TMOS bit (Timeout Detection Time Select)**

The TMOS bit selects long or short mode for the timeout detection time when the timeout function is enabled (ICFER.TMOE = 1). When this bit is set to 0, long mode is selected. When it is set to 1, short mode is selected. In long mode, the timeout detection internal counter functions as a 16 bit-counter. In short mode, the counter functions as a 14-bit counter. While the SCLn line is in the state that enables this counter as specified in the TMOH and TMOL bits, the counter

**BC[2:0] bits (Bit Counter)**

BC[2:0]位用作计数器，指示在检测到SCLn线上的上升沿时要传输的剩余位数。虽然BC[2:0]是读写位，但在正常情况下不需要访问这些位。

要写入这些位，在SCLn线处于低电平时，指定要传输的位数加1，作为附加确认位，在传输的帧之间。BC[2:0]位中的值在数据传输结束时返回到000b，包括确认位，或者当检测到启动或重启条件时。

**28.2.4 ICMR2:I2C总线模式寄存器2**

Base address: IICn = 0x4009\_F000 + 0x0100 × n (n = 0, 1)

Offset address: 0x03

|               |      |           |   |   |   |      |      |      |
|---------------|------|-----------|---|---|---|------|------|------|
| Bit position: | 7    | 6         | 5 | 4 | 3 | 2    | 1    | 0    |
| Bit field:    | DLCS | SDDL[2:0] |   |   | — | TMOH | TMOL | TMOS |
| 重置后的值:        | 0    | 0         | 0 | 0 | 0 | 1    | 1    | 0    |

| Bit | Symbol    | Function   | R/W |
|-----|-----------|--|-----|
| 0   | TMOS      | 超时检测时间选择<br>0: 选择长模式1: 选择短模式   | R/W |
| 1   | TMOL      | 超时L计数控制<br>0: SCLn线为低电平时禁止计数1: SCLn线为低电平时使能计数  | R/W |
| 2   | TMOH      | 超时H计数控制<br>0: SCLn线为高电平时禁止计数1: SCLn线为高电平时使能计数  | R/W |
| 3   | —         | 该位读取为0。写入值应为0。   | R/W |
| 6:4 | SDDL[2:0] | SDA输出延迟计数器<br>000: 无输出延迟001: 1个IICφ周期 (当ICMR2.DLCS=0(IICφ)时)<br>1或2个IICφ周期 (当ICMR2.DLCS=1(IICφ/2)时)<br>0 1 0: 2 IICφ cycles (When ICMR2.DLCS = 0 (IICφ))<br>3或4个IICφ周期 (当ICMR2.DLCS=1(IICφ/2)时)<br>0 1 1: 3 IICφ cycles (When ICMR2.DLCS = 0 (IICφ))<br>5或6个IICφ周期 (当ICMR2.DLCS=1(IICφ/2)时)<br>1 0 0: 4 IICφ cycles (When ICMR2.DLCS = 0 (IICφ))<br>7或8个IICφ周期 (当ICMR2.DLCS=1(IICφ/2)时)<br>1 0 1: 5 IICφ cycles (When ICMR2.DLCS = 0 (IICφ))<br>9或10个IICφ周期 (当ICMR2.DLCS=1(IICφ/2)时)<br>1 1 0: 6 IICφ cycles (When ICMR2.DLCS = 0 (IICφ))<br>11或12个IICφ周期 (当ICMR2.DLCS=1(IICφ/2)时)<br>1 1 1: 7 IICφ cycles (When ICMR2.DLCS = 0 (IICφ))<br>13或14个IICφ周期 (当ICMR2.DLCS=1(IICφ/2)时) | R/W |
| 7   | DLCS      | SDA输出延迟时钟源选择<br>0: 选择内部参考时钟 (IICφ) 作为SDA输出延迟计数器的时钟源<br>1: 选择内部参考时钟除以2(IICφ/2)作为SDA输出延迟计数器的时钟源*1  | R/W |

注1.设置DLCS=1(IICφ/2)仅在SCL为低电平时有效。当SCL为高电平时，DLCS=1设置无效，时钟源变为内部参考时钟(IICφ)。

**TMOS位 (超时检测时间选择)**

当使能超时功能 (ICFER.TMOE=1) 时，TMOS位为超时检测时间选择长模式或短模式。当该位设置为0时，选择长模式。当设置为1时，选择短模式。在长模式下，超时检测内部计数器用作16位计数器。在短模式下，计数器用作14位计数器。当SCLn线处于启用TMOH和TMOL位中指定的计数器的状态时，计数器

counts up in synchronization with the internal reference clock (IICφ) as a count source. For details on this function, see [section 28.12.1. Timeout Function](#).

**TMOL bit (Timeout L Count Control)**

The TMOL bit enables or disables up-counting on the internal counter of the timeout function while the SCLn line is held low and the timeout function is enabled (ICFER.TMOE = 1).

**TMOH bit (Timeout H Count Control)**

The TMOH bit enables or disables up-counting on the internal counter of the timeout function while the SCLn line is held high and the timeout function is enabled (ICFER.TMOE = 1).

**SDDL[2:0] bits (SDA Output Delay Counter)**

The SDDL[2:0] bits can be used to delay the SDA output. This counter works with the clock source selected in the DLCS bit. This setting can be used for all types of SDA output, including transmission of the acknowledge bit.

Set the SDA output delay to meet the I<sup>2</sup>C bus standard for the data enable time/acknowledge enable time,\*1 or the SMBus standard, within [data hold time (300 ns or more + the SCL clock low-level period) - the data setup time (250 ns)]. If a value outside the standard is set, communication between devices might malfunction or falsely indicate a start or stop condition, depending on the bus state.

For details on this function, see [section 28.5. SDA Output Delay Function](#).

Note 1. Data enable time/acknowledge enable time.

- 3,450 ns for up to 100 kbps: Standard mode (Sm)
- 900 ns for up to 400 kbps: Fast mode (Fm)
- 450 ns for up to 1 Mbps: Fast-mode Plus (Fm+)

**28.2.5 ICMR3 : I<sup>2</sup>C Bus Mode Register 3**

Base address: IICn = 0x4009\_F000 + 0x0100 × n (n = 0, 1)

Offset address: 0x04

|                    |      |      |           |           |           |           |         |   |
|--------------------|------|------|-----------|-----------|-----------|-----------|---------|---|
| Bit position:      | 7    | 6    | 5         | 4         | 3         | 2         | 1       | 0 |
| Bit field:         | SMBS | WAIT | RDRF<br>S | ACKW<br>P | ACKB<br>T | ACKB<br>R | NF[1:0] |   |
| Value after reset: | 0    | 0    | 0         | 0         | 0         | 0         | 0       | 0 |

| Bit | Symbol  | Function   | R/W   |
|-----|---------|--|-------|
| 1:0 | NF[1:0] | Noise Filter Stage Select<br>0 0: Filter out noise of up to 1 IICφ cycle (single-stage filter)<br>0 1: Filter out noise of up to 2 IICφ cycles (2-stage filter)<br>1 0: Filter out noise of up to 3 IICφ cycles (3-stage filter)<br>1 1: Filter out noise of up to 4 IICφ cycles (4-stage filter)  | R/W   |
| 2   | ACKBR   | Receive Acknowledge<br>0: 0 received as the acknowledge bit (ACK reception)<br>1: 1 received as the acknowledge bit (NACK reception)   | R     |
| 3   | ACKBT   | Transmit Acknowledge<br>0: Send 0 as the acknowledge bit (ACK transmission)<br>1: Send 1 as the acknowledge bit (NACK transmission)  | R/W*1 |
| 4   | ACKWP   | ACKBT Write Protect<br>0: Write protect ACKBT bit<br>1: Write enable ACKBT bit   | R/W   |
| 5   | RDRFS   | RDRF Flag Set Timing Select<br>Low-hold is released by writing to ACKBT.<br>0: Set the RDRF flag on the rising edge of the 9th SCL clock cycle. The SCLn line is not held low on the falling edge of the 8th clock cycle.<br>1: Set the RDRF flag on the rising edge of the 8th SCL clock cycle. The SCLn line is held low on the falling edge of the 8th clock cycle. | R/W*2 |

与作为计数源的内部参考时钟(IICφ)同步计数。有关此功能的详细信息，请参阅第28.12.1节。超时功能。

**TMOL位 (超时L计数控制)**

TMOL位启用或禁用超时功能内部计数器的递增计数，同时SCLn线保持低电平且启用超时功能(ICFER.TMOE=1)。

**TMOH位 (超时H计数控制)**

TMOH位启用或禁用超时功能内部计数器的递增计数，同时SCLn线保持高电平且启用超时功能(ICFER.TMOE=1)。

**SDDL[2:0]位 (SDA输出延迟计数器)**

SDDL[2:0]位可用于延迟SDA输出。该计数器与在DLCS位中选择的时钟源一起工作。该设置可用于所有类型的SDA输出，包括确认位的传输。

将SDA输出延迟设置为满足I2C总线标准的数据使能时间确认使能时间，\*1或SMBus标准，在[数据保持时间(300 ns或更长+SCL时钟低电平周期) - 数据建立时间(250ns)]。如果设置了超出标准的值，则设备之间的通信可能会发生故障或错误地指示开始或停止条件，具体取决于总线状态。

有关此功能的详细信息，请参阅第28.5节。SDA输出延迟功能。

注1.数据使能时间确认使能时间。

- 3 450ns, 最高100kbps: 标准模式(Sm)
- 900ns, 最高400kbps: 快速模式(Fm)
- 高达1Mbps时为450ns: Fast-modePlus(Fm+)

**28.2.5 ICMR3:I2C总线模式寄存器3**

Base address: IICn = 0x4009\_F000 + 0x0100 × n (n = 0, 1)

Offset address: 0x04

|               |      |      |           |           |           |           |         |   |
|---------------|------|------|-----------|-----------|-----------|-----------|---------|---|
| Bit position: | 7    | 6    | 5         | 4         | 3         | 2         | 1       | 0 |
| Bit field:    | SMBS | WAIT | RDRF<br>S | ACKW<br>P | ACKB<br>T | ACKB<br>R | NF[1:0] |   |
| 重置后的值:        | 0    | 0    | 0         | 0         | 0         | 0         | 0       | 0 |

| Bit | Symbol  | Function   | R/W   |
|-----|---------|--|-------|
| 1:0 | NF[1:0] | 噪声过滤级选择<br>00: 最多过滤1个IICφ周期的噪声 (单级滤波器) 01: 最多过滤2个IICφ周期的噪声 (2级滤波器) 10: 最多过滤3个IICφ周期的噪声 (3级滤波器) 11: 过滤掉最多4个IICφ周期的噪声 (4级滤波器)                  | R/W   |
| 2   | ACKBR   | 接收确认<br>0: 0作为确认位接收 (ACK接收) 1: 1作为确认位接收 (NACK接收)   | R     |
| 3   | ACKBT   | 发送确认<br>0: 发送0作为确认位 (ACK发送) 1: 发送1作为确认位 (NACK发送)   | R/W*1 |
| 4   | ACKWP   | ACKBT写保护<br>0: 写保护ACKBT位 1: 写使能ACKBT位  | R/W   |
| 5   | RDRFS   | RDRF标志设置时序选择<br>通过写入ACKBT释放低保持。<br>0: 在第9个SCL时钟周期的上升沿设置RDRF标志。SCLn线在第8个时钟周期的下降沿不保持低电平。<br>1: 在第8个SCL时钟周期的上升沿设置RDRF标志。SCLn线在第8个时钟周期的下降沿保持低电平。 | R/W*2 |

| Bit | Symbol | Function  | R/W              |
|-----|--------|---|------------------|
| 6   | WAIT   | Low-hold is released by reading ICDRR.<br>0: No wait (The SCLn line is not held low during the period between the 9th clock cycle and the 1st clock cycle.)<br>1: Wait (The SCLn line is held low during the period between the 9th clock cycle and the 1st clock cycle.) | R/W <sup>2</sup> |
| 7   | SMBS   | SMBus/I <sup>2</sup> C Bus Select<br>0: Select I <sup>2</sup> C Bus<br>1: Select SMBus  | R/W              |

Note 1. Write to the ACKBT bit only while the ACKWP bit is already 1. If the application writes 1 to the ACKWP and ACKBT bits at the same time, the ACKBT bit is not set to 1.

Note 2. The WAIT and RDRFS bits are only valid in receive mode (invalid in transmit mode).

### NF[1:0] bits (Noise Filter Stage Select)

The NF[1:0] bits select the number of stages in the digital noise filter. For details on this function, see [section 28.6. Digital Noise Filter Circuits](#)

Note: Set the noise range to be filtered within a range less than the SCLn line high- or low-level period. If the noise range is set to a value of [SCL clock width: high- or low-level period, whichever is shorter] - [1.5 internal reference clock (IICφ) cycles + analog noise filter: 120 ns (reference values)] or more, the SCL clock is regarded as noise, which might prevent the IIC from operating normally.

### ACKBR bit (Receive Acknowledge)

The ACKBR bit stores the acknowledge bit information received from the receive device in transmit mode.

[Setting condition]

- When 1 is received as the acknowledge bit with the TRS bit in ICCR2 set to 1.

[Clearing conditions]

- When 0 is received as the acknowledge bit with the TRS bit in ICCR2 set to 1
- When 1 is written to the IICRST bit in ICCR1 while the ICE bit in ICCR1 is 0 (IIC reset).

### ACKBT bit (Transmit Acknowledge)

The ACKBT bit sets the acknowledge bit to be sent in receive mode

[Setting condition]

- When 1 is written to this bit with the ACKWP bit set to 1.

[Clearing conditions]

- When 0 is written to this bit with the ACKWP bit set to 1
- When stop condition request is detected with the SP bit in ICCR2 set to 1
- When 1 is written to the IICRST bit in ICCR1 while the ICE bit in ICCR1 is 0 (IIC reset).

### ACKWP bit (ACKBT Write Protect)

The ACKWP bit controls write enabling of the ACKBT bit.

### RDRFS bit (RDRF Flag Set Timing Select)

The RDRFS bit selects the RDRF flag set timing in receive mode and also selects whether to hold the SCLn line low on the falling edge of the 8th SCL clock cycle.

When the RDRFS bit is 0, the SCLn line is not held low on the falling edge of the 8th SCL clock cycle, and the RDRF flag is set to 1 on the rising edge of the 9th SCL clock cycle.

When the RDRFS bit is 1, the RDRF flag is set to 1 on the rising edge of the 8th SCL clock cycle, and the SCLn line is held low on the falling edge of the 8th SCL clock cycle. The low-hold of the SCLn line is released by a write to the ACKBT bit.

After data is received with this setting, the SCLn line is automatically held low before the acknowledge bit is sent. This enables processing to send ACK (ACKBT = 0) or NACK (ACKBT = 1), based on the receive data.

| Bit | Symbol | Function   | R/W              |
|-----|--------|--|------------------|
| 6   | WAIT   | 通过读取ICDRR释放低保持。<br>0: 无等待 (在第9个时钟周期和第1个时钟周期之间的时间段内, SCLn线不保持低电平。)<br>1: 等待 (SCLn线在第9个时钟周期和第1个时钟周期之间保持低电平。) | R/W <sup>2</sup> |
| 7   | SMBS   | SMBusI2C总线选择<br>0: 选择I2C总线1<br>1: 选择SMBus  | R/W              |

注1.仅当ACKWP位已经为1时才写入ACKBT位。如果应用程序同时向ACKWP和ACKBT位写入1,则ACKBT位不会设置为1。

注2.WAIT和RDRFS位仅在接收模式下有效 (在发送模式下无效)。

### NF[1:0]位 (噪声滤波器级选择)

NF[1:0]位选择数字噪声滤波器的级数。关于此功能的详细信息,请参阅第28.6节。数字的噪声滤波电路

Note: 将要过滤的噪声范围设置在小于SCLn线高电平或低电平周期的范围内。如果噪声范围设置为[SCL时钟宽度: 高电平或低电平周期,以较短者为准][1.5内部参考时钟(IICφ)周期+模拟噪声滤波器: 120ns (参考值)]或更大的值,则SCL时钟被视为噪声,可能会妨碍IIC正常工作。

### ACKBR bit (Receive Acknowledge)

ACKBR位存储在发送模式下从接收设备接收到的确认位信息。

[Setting condition]

- 当ICCR2中的TRS位设置为1接收到1作为确认位时。

[Clearing conditions]

- 当ICCR2中的TRS位设置为1接收到0作为确认位时
- 当ICCR1中的IICRST位写入1而ICCR1中的ICE位为0时 (IIC复位)。

### ACKBT bit (Transmit Acknowledge)

ACKBT位设置要在接收模式下发送的确认位

[Setting condition]

- 当1写入该位且ACKWP位设置为1时。

[Clearing conditions]

- 当0写入该位且ACKWP位设置为1时
- ICCR2的SP位设置为1时检测到停止条件请求时
- 当ICCR1中的IICRST位写入1而ICCR1中的ICE位为0时 (IIC复位)。

### ACKWP位 (ACKBT写保护)

ACKWP位控制ACKBT位的写使能。

### RDRFS位 (RDRF标志设置时序选择)

RDRFS位选择接收模式下的RDRF标志设置时序,并选择是否在第8个SCL时钟周期的下降沿保持SCLn线为低电平。

当RDRFS位为0时,SCLn线在第8个SCL时钟周期的下降沿不保持低电平,并且RDRF标志在第9个SCL时钟周期的上升沿设置为1。

当RDRFS位为1时,RDRF标志在第8个SCL时钟周期的上升沿设置为1,并且SCLn线在第8个SCL时钟周期的下降沿保持低电平。SCLn线的低保持通过写ACKBT位来释放。

使用此设置接收数据后,SCLn线在发送确认位之前自动保持低电平。这使处理能够根据接收数据发送ACK(ACKBT=0)或NACK(ACKBT=1)。



**WAIT bit (WAIT)**

The WAIT bit controls whether to force a low-hold between the ninth SCL clock cycle and the first SCL clock cycle, until the receive data buffer (ICDRR) is completely read each time single-byte data is received in receive mode.

When the WAIT bit is 0, the receive operation continues without a low-hold between the ninth and the first SCL clock cycle. When both the RDRFS and WAIT bits are 0, continuous receive operation is enabled with the double buffer.

When the WAIT bit is 1, the SCLn line is held low from the falling edge of the ninth clock cycle until the ICDRR value is read each time single-byte data is received. This enables receive operation in byte units.

Note: When the value of the WAIT bit is to be read, always read ICDRR first.

**SMBS bit (SMBus/I<sup>2</sup>C Bus Select)**

Setting the SMBS bit to 1 selects the SMBus and enables the HOAE bit in ICSEER.

**28.2.6 ICFER : I<sup>2</sup>C Bus Function Enable Register**

Base address: IICn = 0x4009\_F000 + 0x0100 × n (n = 0, 1)

Offset address: 0x05

|                    |      |      |     |        |      |      |      |      |
|--------------------|------|------|-----|--------|------|------|------|------|
| Bit position:      | 7    | 6    | 5   | 4      | 3    | 2    | 1    | 0    |
| Bit field:         | FMPE | SCLE | NFE | NACK E | SALE | NALE | MALE | TMOE |
| Value after reset: | 0    | 1    | 1   | 1      | 0    | 0    | 1    | 0    |

| Bit | Symbol            | Function   | R/W |
|-----|-------------------|--|-----|
| 0   | TMOE              | Timeout Function Enable<br>0: Disable<br>1: Enable   | R/W |
| 1   | MALE              | Master Arbitration-Lost Detection Enable<br>0: Disable the arbitration-lost detection function and disable automatic clearing of the MST and TRS bits in ICCR2 when arbitration is lost<br>1: Enable the arbitration-lost detection function and enable automatic clearing of the MST and TRS bits in ICCR2 when arbitration is lost | R/W |
| 2   | NALE              | NACK Transmission Arbitration-Lost Detection Enable<br>0: Disable<br>1: Enable   | R/W |
| 3   | SALE              | Slave Arbitration-Lost Detection Enable<br>0: Disable<br>1: Enable   | R/W |
| 4   | NACKE             | NACK Reception Transfer Suspension Enable<br>0: Do not suspend transfer operation during NACK reception (disable transfer suspension)<br>1: Suspend transfer operation during NACK reception (enable transfer suspension)  | R/W |
| 5   | NFE               | Digital Noise Filter Circuit Enable<br>0: Do not use the digital noise filter circuit<br>1: Use the digital noise filter circuit   | R/W |
| 6   | SCLE              | SCL Synchronous Circuit Enable<br>0: Do not use the SCL synchronous circuit<br>1: Use the SCL synchronous circuit  | R/W |
| 7   | FMPE <sup>1</sup> | Fast-Mode Plus Enable<br>0: Do not use the Fm+ slope control circuit for the SCLn and SDA n pins<br>1: Use the Fm+ slope control circuit for the SCLn and SDA n pins.  | R/W |

Note 1. The Fast-mode Plus enable bit (FMPE) is supported by IIC0 (SCL0\_A, SDA0\_A). Bit [7] is the reserved bit in the not supported channel.

**TMOE bit (Timeout Function Enable)**

The TMOE bit enables or disables the timeout function. For details on this function, see [section 28.12.1. Timeout Function](#).

**等待位 (等待)**

WAIT位控制是否在第9个SCL时钟周期和第一个SCL时钟周期之间强制保持低电平，直到每次在接收模式下接收到单字节数据时完全读取接收数据缓冲区(ICDRR)。

当WAIT位为0时，接收操作继续，在第9个和第一个SCL时钟周期之间没有低电平保持。当RDRFS和WAIT位都为0时，双缓冲器使能连续接收操作。

当WAIT位为1时，SCLn线从第9个时钟周期的下降沿保持低电平，直到每次接收到单字节数据时读取ICDRR值。这启用了以字节为单位的接收操作。

Note: 当要读取WAIT位的值时，总是先读取ICDRR。

**SMBS位 (SMBus/I<sup>2</sup>C总线选择)**

将SMBS位设置为1可选择SMBus并启用ICSEER中的HOAE位。

**28.2.6 ICFER:I2C总线功能使能寄存器**

Base address: IICn = 0x4009\_F000 + 0x0100 × n (n = 0, 1)

Offset address: 0x05

|               |      |      |     |        |      |      |      |      |
|---------------|------|------|-----|--------|------|------|------|------|
| Bit position: | 7    | 6    | 5   | 4      | 3    | 2    | 1    | 0    |
| Bit field:    | FMPE | SCLE | NFE | NACK E | SALE | NALE | MALE | TMOE |
| 重置后的值:        | 0    | 1    | 1   | 1      | 0    | 0    | 1    | 0    |

| Bit | Symbol            | Function  | R/W |
|-----|-------------------|---|-----|
| 0   | TMOE              | 超时功能启用<br>0: 禁用1<br>: 启用  | R/W |
| 1   | MALE              | 主仲裁丢失检测启用<br>0: 禁止仲裁丢失检测功能，禁止仲裁丢失时自动清除ICCR2中的MST和TRS位<br>1: 使能仲裁丢失检测功能，并在仲裁丢失时自动清除ICCR2中的MST和TRS位 | R/W |
| 2   | NALE              | NACK传输仲裁丢失检测使能<br>0: 禁用1<br>: 启用  | R/W |
| 3   | SALE              | 从设备仲裁丢失检测使能<br>0: 禁用1<br>: 启用   | R/W |
| 4   | NACKE             | NACK接收传输暂停使能<br>0: 在NACK接收期间不停传输操作（禁用传输暂停）<br>1: 在NACK接收期间暂停传输操作（启用传输暂停）                          | R/W |
| 5   | NFE               | 数字噪声滤波器电路使能<br>0: 不使用数字噪声滤波电路1: 使用数字噪声滤波电路  | R/W |
| 6   | SCLE              | SCL同步电路使能<br>0: 不使用SCL同步电路1: 使用SCL同步电路  | R/W |
| 7   | FMPE <sup>1</sup> | 快速模式加启用<br>0: SCLn和SDAn引脚不使用Fm+斜率控制电路1: SCLn和SDAn引脚使用Fm+斜率控制电路。                                   | R/W |

注1.IIC0(SCL0\_A SDA0\_A)支持Fast-modePlus使能位(FMPE)。位[7]是不支持通道中的保留位。

**TMOE位 (超时功能使能)**

TMOE位启用或禁用超时功能。有关此功能的详细信息，请参阅第28.12.1节。超时功能。



**MALE bit (Master Arbitration-Lost Detection Enable)**

The MALE bit specifies whether to use the arbitration-lost detection function in master mode. Normally, set this bit to 1.

**NALE bit (NACK Transmission Arbitration-Lost Detection Enable)**

The NALE bit specifies whether to cause arbitration to be lost when ACK is detected during transmission of NACK in receive mode, for example when slaves with the same address exist on the bus or when two or more masters select the same slave device simultaneously with a different number of receive bytes.

**SALE bit (Slave Arbitration-Lost Detection Enable)**

The SALE bit specifies whether to cause arbitration to be lost when a value different from the value being transmitted is detected on the bus in slave transmit mode, for example when slaves with the same address exist on the bus or when a mismatch with the transmit data occurs because of noise.

**NACKE bit (NACK Reception Transfer Suspension Enable)**

The NACKE bit specifies whether to continue or discontinue the transfer operation when NACK is received in transmit mode. Normally, set this bit to 1.

When NACK is received with the NACKE bit set to 1, the next transfer operation is suspended. When the NACKE bit is 0, the next transfer operation continues regardless of the received acknowledge content.

For details, see [section 28.9.2. NACK Reception Transfer Suspension Function](#).

**SCLE bit (SCL Synchronous Circuit Enable)**

The SCLE bit specifies whether to synchronize the SCL clock with the SCL input clock. Normally, set this bit to 1.

When the SCLE bit is set to 0 (no SCL synchronous circuit used), the IIC does not synchronize the SCL clock with the SCL input clock. With this setting, the IIC outputs the SCL clock at the transfer rate set in ICBRH and ICBRL, regardless of the SCLn line state. For this reason, if the bus load of the I<sup>2</sup>C bus line is much larger than the specification value, or if the SCL clock output overlaps in multiple masters, a short-cycle SCL clock that does not meet the specification might be output. When no SCL synchronous circuit is used, it also affects the issuing of the start, restart, and stop conditions, and the continuous output of extra SCL clock cycles.

Do not set this bit to 0 except when checking the output of the set transfer rate.

**FMPE bit (Fast-Mode Plus Enable)**

The FMPE bit specifies whether to use a slope control circuit for Fast-mode Plus (Fm+).

When this bit is set to 1, a slope control circuit conforming to the I<sup>2</sup>C bus Fast-mode Plus (Fm+) standard (tof) is selected. When this bit is set to 0, a slope control circuit conforming to the I<sup>2</sup>C bus Standard-mode (Sm) and Fast-mode (Fm) standards (tof) is selected.

Set this bit to 1 when using transmission rates up to 1 Mbps (Fast-mode Plus (Fm+) standard). Set it to 0 when using other transmission rates (up to 100 kbps (Sm) or up to 400 kbps (Fm)) or for SMBus (10 to 100 kbps).

**28.2.7 IC SER : I<sup>2</sup>C Bus Status Enable Register**

Base address: IICn = 0x4009\_F000 + 0x0100 × n (n = 0, 1)

Offset address: 0x06

|                    |      |   |      |   |      |           |           |           |
|--------------------|------|---|------|---|------|-----------|-----------|-----------|
| Bit position:      | 7    | 6 | 5    | 4 | 3    | 2         | 1         | 0         |
| Bit field:         | HOAE | — | DIDE | — | GCAE | SAR2<br>E | SAR1<br>E | SAR0<br>E |
| Value after reset: | 0    | 0 | 0    | 0 | 1    | 0         | 0         | 1         |

| Bit | Symbol | Function   | R/W |
|-----|--------|--|-----|
| 0   | SAR0E  | Slave Address Register 0 Enable<br>0: Disable slave address in SARL0 and SARU0<br>1: Enable slave address in SARL0 and SARU0 | R/W |

**MALE位 (主仲裁丢失检测使能)**

MALE位指定是否在主机模式下使用仲裁丢失检测功能。通常，将此位设置为1。

**NALE位 (NACK传输仲裁丢失检测使能)**

NALE位指定在接收模式下发送NACK期间检测到ACK时是否导致仲裁丢失，例如，当总线上存在具有相同地址的从设备时，或者当两个或多个主设备同时选择相同的从设备时接收字节数。

**SALE位 (从设备仲裁丢失检测使能)**

SALE位指定当在从发送模式下在总线上检测到与正在发送的值不同的值时，是否导致仲裁丢失，例如，当总线上存在具有相同地址的从机或与发送数据不匹配时由于噪音而发生。

**NACKE位 (NACK接收传输暂停使能)**

NACKE位指定在发送模式下接收到NACK时是继续还是停止传输操作。通常，将此位设置为1。

当在NACKE位设置为1的情况下接收到NACK时，暂停下一个传输操作。当NACKE位为0时，无论接收到的确认内容如何，下一次传输操作都会继续进行。

有关详细信息，请参阅第28.9.2节。NACK接收传输暂停功能。

**SCLE位 (SCL同步电路使能)**

SCLE位指定是否将SCL时钟与SCL输入时钟同步。通常，将此位设置为1。

当SCLE位设置为0 (不使用SCL同步电路) 时，IIC不会将SCL时钟与SCL输入时钟同步。使用此设置，无论SCLn线路状态如何，IIC都以ICBRH和ICBRL中设置的传输速率输出SCL时钟。因此，如果I2C总线的总线负载远大于规格值，或者多个主机的SCL时钟输出重叠，则可能会输出不符合规格的短周期SCL时钟。当不使用SCL同步电路时，也会影响启动、重启和停止条件的发出，以及额外SCL时钟周期的连续输出。

除非检查设置传输速率的输出，否则不要将此位设置为0。

**FMPE位 (Fast-Mode Plus Enable)**

FMPE位指定是否对Fast-mode Plus (Fm+) 使用斜率控制电路。

当该位设置为1时，选择符合I2C总线快速模式加(Fm+)标准(tof)的斜率控制电路。

当该位设置为0时，选择符合I2C总线标准模式(Sm)和快速模式(Fm)标准(tof)的斜率控制电路。

当使用高达1Mbps的传输速率 (Fast-mode Plus (Fm+) 标准) 时，将此位设置为1。当使用其他传输速率 (最高100kbps(Sm)或最高400kbps(Fm)) 或SMBus (10至100kbps) 时，将其设置为0。

**28.2.7 IC SER: I2C总线状态使能寄存器**

Base address: IICn = 0x4009\_F000 + 0x0100 × n (n = 0, 1)

Offset address: 0x06

|               |      |   |      |   |      |           |           |           |
|---------------|------|---|------|---|------|-----------|-----------|-----------|
| Bit position: | 7    | 6 | 5    | 4 | 3    | 2         | 1         | 0         |
| Bit field:    | HOAE | — | DIDE | — | GCAE | SAR2<br>E | SAR1<br>E | SAR0<br>E |
| 重置后的值:        | 0    | 0 | 0    | 0 | 1    | 0         | 0         | 1         |

| Bit | Symbol | Function  | R/W |
|-----|--------|---|-----|
| 0   | SAR0E  | 从地址寄存器0使能<br>0: 禁用SARL0和SARU0中的从地址1: 启用SARL0和SARU0中的从地址 | R/W |

| Bit | Symbol | Function   | R/W |
|-----|--------|--|-----|
| 1   | SAR1E  | Slave Address Register 1 Enable<br>0: Disable slave address in SARL1 and SARU1<br>1: Enable slave address in SARL1 and SARU1 | R/W |
| 2   | SAR2E  | Slave Address Register 2 Enable<br>0: Disable slave address in SARL2 and SARU2<br>1: Enable slave address in SARL2 and SARU2 | R/W |
| 3   | GCAE   | General Call Address Enable<br>0: Disable general call address detection<br>1: Enable general call address detection         | R/W |
| 4   | —      | This bit is read as 0. The write value should be 0.  | R/W |
| 5   | DIDE   | Device-ID Address Detection Enable<br>0: Disable device-ID address detection<br>1: Enable device-ID address detection        | R/W |
| 6   | —      | This bit is read as 0. The write value should be 0.  | R/W |
| 7   | HOAE   | Host Address Enable<br>0: Disable host address detection<br>1: Enable host address detection                                 | R/W |

**SARyE bit (Slave Address Register y Enable) (y = 0 to 2)**

The SARyE bit enables or disables the received slave address and the slave address set in SARLy and SARUy.

When this bit is set to 1, the slave address set in SARLy and SARUy is enabled and is compared with the received slave address. When this bit is set to 0, the slave address set in SARLy and SARUy is disabled and is ignored even if it matches the received slave address.

**GCAE bit (General Call Address Enable)**

The GCAE bit specifies whether to ignore the general call address (0000 000b + 0 [W]: All 0) when it is received.

When this bit is set to 1, if the received slave address matches the general call address, the IIC recognizes the received slave address as the general call address independently of the slave addresses set in SARLy and SARUy (y = 0 to 2) and performs the data receive operation. When this bit is set to 0, the received slave address is ignored even if it matches the general call address.

**DIDE bit (Device-ID Address Detection Enable)**

The DIDE bit specifies whether to recognize and execute the device-ID address when a device ID (1111 100b) is received in the first frame after a start or restart condition is detected.

When this bit is set to 1, if the received first frame matches the device ID, the IIC recognizes that the device-ID address was received. When the next R/W# bit is 0 (W), the IIC recognizes the second and the subsequent frames as slave addresses and continues the receive operation. When this bit is set to 0, the IIC ignores the received first frame even if it matches the device-ID address, and it recognizes the first frame as a normal slave address.

For details on this function, see [section 28.7.3. Device-ID Address Detection](#).

**HOAE bit (Host Address Enable)**

The HOAE bit specifies whether to ignore the received host address (0001 000b) when the SMBS bit in ICMR3 is 1.

When this bit is set to 1 while the SMBS bit in ICMR3 is 1, if the received slave address matches the host address, the IIC recognizes the received slave address as the host address independently of the slave addresses set in SARLy and SARUy (y = 0 to 2) and performs the receive operation.

When the SMBS bit in ICMR3 or the HOAE bit is set to 0, the received slave address is ignored even if it matches the host address.

| Bit | Symbol | Function  | R/W |
|-----|--------|---|-----|
| 1   | SAR1E  | 从地址寄存器1使能<br>0: 禁用SARL1和SARU1中的从地址1: 启用SARL1和SARU1中的从地址 | R/W |
| 2   | SAR2E  | 从地址寄存器2使能<br>0: 禁用SARL2和SARU2中的从地址1: 启用SARL2和SARU2中的从地址 | R/W |
| 3   | GCAE   | 广播呼叫地址启用<br>0: 禁用广播地址检测1: 启用广播地址检测                      | R/W |
| 4   | —      | 该位读取为0。写入值应为0。  | R/W |
| 5   | DIDE   | 设备ID地址检测启用<br>0: 禁用设备ID地址检测1: 启用设备ID地址检测                | R/W |
| 6   | —      | 该位读取为0。写入值应为0。  | R/W |
| 7   | HOAE   | 主机地址启用<br>0: 禁用主机地址检测1: 启用主机地址检测                        | R/W |

**SARyE位（从地址寄存器y使能）（y=0到2）**

SARyE位启用或禁用接收到的从机地址和设置在SARLy和SARUy中的从机地址。

当该位设置为1时，设置在SARLy和SARUy中的从机地址被启用，并与接收到的从机地址进行比较。当该位设置为0时，设置在SARLy和SARUy中的从机地址被禁用并被忽略，即使它与接收到的从机地址匹配。

**GCAE位（广播呼叫地址使能）**

GCAE位指定接收到的广播调用地址（0000000b+0[W]：全0）是否忽略。

当该位设置为1时，如果接收到的从机地址与广播呼叫地址匹配，则IIC将接收到的从机地址识别为广播呼叫地址，而与在SARLy和SARUy中设置的从机地址（y=0到2）无关，并执行数据接收操作。当该位设置为0时，即使接收到的从机地址与广播呼叫地址匹配，也会忽略它。

**DIDE位（设备ID地址检测使能）**

DIDE位指定在检测到启动或重新启动条件后的第一帧中接收到设备ID(1111100b)时是否识别和执行设备ID地址。

当该位设置为1时，如果接收到的第一个帧与设备ID匹配，则IIC识别出设备ID地址已被接收。当下一个RW#位为0 (W)时，IIC将第二个和后续帧识别为从地址并继续接收操作。当该位设置为0时，IIC忽略接收到的第一帧，即使它与设备ID地址匹配，并将第一帧识别为正常的从地址。

有关此功能的详细信息，请参阅[第28.7.3节。设备ID地址检测](#)。

**HOAE位（主机地址使能）**

HOAE位指定当ICMR3中的SMBS位为1时是否忽略接收到的主机地址（0001000b）。

当该位设置为1而ICMR3中的SMBS位为1时，如果接收到的从机地址与主机地址匹配，则IIC将接收到的从机地址识别为主机地址，而与SARLy和SARUy中设置的从机地址无关（y=0到2）并执行接收操作。

当ICMR3中的SMBS位或HOAE位设置为0时，即使接收到的从机地址与主机地址匹配，也会忽略它。

28.2.8 ICIER : I<sup>2</sup>C Bus Interrupt Enable Register

Base address: IICn = 0x4009\_F000 + 0x0100 × n (n = 0, 1)

Offset address: 0x07

|                    |     |      |     |       |      |      |      |       |
|--------------------|-----|------|-----|-------|------|------|------|-------|
| Bit position:      | 7   | 6    | 5   | 4     | 3    | 2    | 1    | 0     |
| Bit field:         | TIE | TEIE | RIE | NAKIE | SPIE | STIE | ALIE | TMOIE |
| Value after reset: | 0   | 0    | 0   | 0     | 0    | 0    | 0    | 0     |

| Bit | Symbol | Function  | R/W |
|-----|--------|---|-----|
| 0   | TMOIE  | Timeout Interrupt Request Enable<br>0: Disable timeout interrupt (TMOI) request<br>1: Enable timeout interrupt (TMOI) request   | R/W |
| 1   | ALIE   | Arbitration-Lost Interrupt Request Enable<br>0: Disable arbitration-lost interrupt (ALI) request<br>1: Enable arbitration-lost interrupt (ALI) request                            | R/W |
| 2   | STIE   | Start Condition Detection Interrupt Request Enable<br>0: Disable start condition detection interrupt (STI) request<br>1: Enable start condition detection interrupt (STI) request | R/W |
| 3   | SPIE   | Stop Condition Detection Interrupt Request Enable<br>0: Disable stop condition detection interrupt (SPI) request<br>1: Enable stop condition detection interrupt (SPI) request    | R/W |
| 4   | NAKIE  | NACK Reception Interrupt Request Enable<br>0: Disable NACK reception interrupt (NAKI) request<br>1: Enable NACK reception interrupt (NAKI) request                                | R/W |
| 5   | RIE    | Receive Data Full Interrupt Request Enable<br>0: Disable receive data full interrupt (IICn_RXI) request<br>1: Enable receive data full interrupt (IICn_RXI) request               | R/W |
| 6   | TEIE   | Transmit End Interrupt Request Enable<br>0: Disable transmit end interrupt (IICn_TEI) request<br>1: Enable transmit end interrupt (IICn_TEI) request                              | R/W |
| 7   | TIE    | Transmit Data Empty Interrupt Request Enable<br>0: Disable transmit data empty interrupt (IICn_TXI) request<br>1: Enable transmit data empty interrupt (IICn_TXI) request         | R/W |

**TMOIE bit (Timeout Interrupt Request Enable)**

The TMOIE bit enables or disables timeout interrupt (TMOI) requests when the TMOF flag in ICSR2 is 1. To cancel a TMOI interrupt request, set the TMOF flag or the TMOIE bit to 0.

**ALIE bit (Arbitration-Lost Interrupt Request Enable)**

The ALIE bit enables or disables arbitration-lost interrupt (ALI) requests when the AL flag in ICSR2 is 1. To cancel an ALI interrupt request, set the AL flag or the ALIE bit to 0.

**STIE bit (Start Condition Detection Interrupt Request Enable)**

The STIE bit enables or disables start condition detection interrupt (STI) requests when the START flag in ICSR2 is 1. To cancel an STI interrupt request, set the START flag or the STIE bit to 0.

**SPIE bit (Stop Condition Detection Interrupt Request Enable)**

The SPIE bit enables or disables stop condition detection interrupt (SPI) requests when the STOP flag in ICSR2 is 1. To cancel an SPI interrupt request, set the STOP flag or the SPIE bit to 0.

**NAKIE bit (NACK Reception Interrupt Request Enable)**

The NAKIE bit enables or disables NACK reception interrupt (NAKI) requests when the NACKF flag in ICSR2 is 1. To cancel a NAKI interrupt request, set the NACKF flag or the NAKIE bit to 0.

## 28.2.8 ICIER:I2C总线中断使能寄存器

Base address: IICn = 0x4009\_F000 + 0x0100 × n (n = 0, 1)

Offset address: 0x07

|               |     |      |     |       |      |      |      |       |
|---------------|-----|------|-----|-------|------|------|------|-------|
| Bit position: | 7   | 6    | 5   | 4     | 3    | 2    | 1    | 0     |
| Bit field:    | TIE | TEIE | RIE | NAKIE | SPIE | STIE | ALIE | TMOIE |
| 重置后的值:        | 0   | 0    | 0   | 0     | 0    | 0    | 0    | 0     |

| Bit | Symbol | Function  | R/W |
|-----|--------|---|-----|
| 0   | TMOIE  | 超时中断请求使能<br>0: 禁用超时中断 (TMOI) 请求<br>1: 启用超时中断 (TMOI) 请求                  | R/W |
| 1   | ALIE   | 仲裁丢失中断请求使能<br>0: 禁用仲裁丢失中断 (ALI) 请求<br>1: 启用仲裁丢失中断 (ALI) 请求              | R/W |
| 2   | STIE   | 启动条件检测中断请求使能<br>0: 禁止启动条件检测中断 (STI) 请求<br>1: 允许启动条件检测中断 (STI) 请求        | R/W |
| 3   | SPIE   | 停止条件检测中断请求使能<br>0: 禁止停止条件检测中断 (SPI) 请求<br>1: 使能停止条件检测中断 (SPI) 请求        | R/W |
| 4   | NAKIE  | NACK接收中断请求使能<br>0: 禁止NACK接收中断 (NAKI) 请求<br>1: 允许NACK接收中断 (NAKI) 请求      | R/W |
| 5   | RIE    | 接收数据满中断请求使能<br>0: 禁止接收数据满中断 (IICn_RXI) 请求<br>1: 使能接收数据满中断 (IICn_RXI) 请求 | R/W |
| 6   | TEIE   | 发送结束中断请求使能<br>0: 禁止发送结束中断 (IICn_TEI) 请求<br>1: 允许发送结束中断 (IICn_TEI) 请求    | R/W |
| 7   | TIE    | 发送数据空中断请求使能<br>0: 禁止发送数据空中断 (IICn_TXI) 请求<br>1: 使能发送数据空中断 (IICn_TXI) 请求 | R/W |

**TMOIE位 (超时中断请求使能)**

当ICSR2中的TMOF标志为1时，TMOIE位启用或禁用超时中断(TMOI)请求。取消一个TMOI中断请求，设置TMOF标志或TMOIE位为0。

**ALIE位 (仲裁失败中断请求使能)**

当ICSR2中的AL标志为1时，ALIE位启用或禁用仲裁丢失中断(ALI)请求。要取消ALI中断请求，请将AL标志或ALIE位设置为0。

**STIE位 (启动条件检测中断请求使能)**

当ICSR2中的START标志为1时，STIE位启用或禁用启动条件检测中断(STI)请求。要取消STI中断请求，请将START标志或STIE位设置为0。

**SPIE位 (停止条件检测中断请求使能)**

当ICSR2中的STOP标志为1时，SPIE位启用或禁用停止条件检测中断(SPI)请求。要取消SPI中断请求，请将STOP标志或SPIE位设置为0。

**NAKIE位 (NACK接收中断请求使能)**

当ICSR2中的NACKF标志为1时，NAKIE位启用或禁用NACK接收中断(NAKI)请求。要取消NAKI中断请求，请将NACKF标志或NAKIE位设置为0。



**RIE bit (Receive Data Full Interrupt Request Enable)**

The RIE bit enables or disables receive data full interrupt (IICn\_RXI) requests when the RDRF flag in ICSR2 is 1.

**TEIE bit (Transmit End Interrupt Request Enable)**

The TEIE bit enables or disables transmit end interrupt (IICn\_TEI) requests when the TEND flag in ICSR2 is 1. To cancel an IICn\_TEI interrupt request, set the TEND flag or the TEIE bit to 0.

**TIE bit (Transmit Data Empty Interrupt Request Enable)**

The TIE bit enables or disables transmit data empty interrupt (IICn\_TXI) requests when the TDRE flag in ICSR2 is 1.

**28.2.9 ICSR1 : I<sup>2</sup>C Bus Status Register 1**

Base address: IICn = 0x4009\_F000 + 0x0100 × n (n = 0, 1)

Offset address: 0x08

|                    |     |   |     |   |     |      |      |      |
|--------------------|-----|---|-----|---|-----|------|------|------|
| Bit position:      | 7   | 6 | 5   | 4 | 3   | 2    | 1    | 0    |
| Bit field:         | HOA | — | DID | — | GCA | AAS2 | AAS1 | AAS0 |
| Value after reset: | 0   | 0 | 0   | 0 | 0   | 0    | 0    | 0    |

| Bit | Symbol | Function  | R/W                 |
|-----|--------|---|---------------------|
| 0   | AAS0   | Slave Address 0 Detection Flag<br>0: Slave address 0 not detected<br>1: Slave address 0 detected  | R/(W) <sup>*1</sup> |
| 1   | AAS1   | Slave Address 1 Detection Flag<br>0: Slave address 1 not detected<br>1: Slave address 1 detected  | R/(W) <sup>*1</sup> |
| 2   | AAS2   | Slave Address 2 Detection Flag<br>0: Slave address 2 not detected<br>1: Slave address 2 detected  | R/(W) <sup>*1</sup> |
| 3   | GCA    | General Call Address Detection Flag<br>0: General call address not detected<br>1: General call address detected   | R/(W) <sup>*1</sup> |
| 4   | —      | This bit is read as 0. The write value should be 0.   | R/W                 |
| 5   | DID    | Device-ID Address Detection Flag<br>This bit is set to 1 when the first frame received immediately after a start condition is detected matches a value of (device ID (1111 100b) + 0[W]).<br>0: Device-ID command not detected<br>1: Device-ID command detected | R/(W) <sup>*1</sup> |
| 6   | —      | This bit is read as 0. The write value should be 0.   | R/W                 |
| 7   | HOA    | Host Address Detection Flag<br>This bit is set to 1 when the received slave address matches the host address (0001 000b).<br>0: Host address not detected<br>1: Host address detected   | R/(W) <sup>*1</sup> |

Note 1. Only 0 can be written to clear the flag.

**AASy flag (Slave Address y Detection flag) (y = 0 to 2)**

The AASy flag indicates whether slave address y was detected.

[Setting conditions]

For 7-bit address format (SARUy.FS = 0):

- When the received slave address matches the SVA[6:0] value in SARLy, with the SARyE bit in ICSEY set to 1 (slave address y detection enabled).  
The AASy flag is set to 1 on the rising edge of the ninth SCL clock cycle in the frame.

For 10-bit address format: (SARUy.FS = 1):

**RIE位 (接收数据满中断请求使能)**

当ICSR2中的RDRF标志为1时, RIE位启用或禁用接收数据完整中断(IICn\_RXI)请求。

**TEIE位 (发送结束中断请求使能)**

当ICSR2中的TEND标志为1时, TEIE位启用或禁用发送结束中断(IICn\_TEI)请求。要取消IICn\_TEI中断请求, 请将TEND标志或TEIE位设置为0。

**TIE位 (发送数据空中断请求使能)**

当ICSR2中的TDRE标志为1时, TIE位启用或禁用发送数据空中断 (IICn\_TXI) 请求。

**28.2.9 ICSR1:I2C总线状态寄存器1**

Base address: IICn = 0x4009\_F000 + 0x0100 × n (n = 0, 1)

Offset address: 0x08

|               |     |   |     |   |     |      |      |      |
|---------------|-----|---|-----|---|-----|------|------|------|
| Bit position: | 7   | 6 | 5   | 4 | 3   | 2    | 1    | 0    |
| Bit field:    | HOA | — | DID | — | GCA | AAS2 | AAS1 | AAS0 |
| 重置后的值:        | 0   | 0 | 0   | 0 | 0   | 0    | 0    | 0    |

| Bit | Symbol | Function   | R/W                 |
|-----|--------|--|---------------------|
| 0   | AAS0   | 从地址0检测标志<br>0: 未检测到从地址01: 检测到从地址0  | R/(W) <sup>*1</sup> |
| 1   | AAS1   | 从地址1检测标志<br>0: 未检测到从地址11: 检测到从地址1  | R/(W) <sup>*1</sup> |
| 2   | AAS2   | 从地址2检测标志<br>0: 未检测到从地址21: 检测到从地址2  | R/(W) <sup>*1</sup> |
| 3   | GCA    | 广播呼叫地址检测标志<br>0: 未检测到广播呼叫地址1: 检测到广播呼叫地址  | R/(W) <sup>*1</sup> |
| 4   | —      | 该位读取为0。写入值应为0。   | R/W                 |
| 5   | DID    | 设备ID地址检测标志<br>当检测到开始条件后立即接收到的第一个帧与(设备ID(1111100b)+0[W])的值匹配时, 该位设置为1。<br>0: 未检测到设备ID命令1: 检测到设备ID命令 | R/(W) <sup>*1</sup> |
| 6   | —      | 该位读取为0。写入值应为0。   | R/W                 |
| 7   | HOA    | 主机地址检测标志<br>当接收到的从机地址与主机地址(0001000b)匹配时, 该位设置为1。<br>0: 未检测到主机地址1: 检测到主机地址                          | R/(W) <sup>*1</sup> |

注1.只能写入0来清除标志。

**AASy标志 (从机地址y检测标志) (y=0到2)**

AASy标志指示是否检测到从地址y。

[Setting conditions]

对于7位地址格式(SARUy.FS=0):

- 当接收到的从地址与SARLy中的SVA[6:0]值匹配时, ICSEY中的SARyE位设置为1 (从地址y检测使能)。AASy标志在帧中第9个SCL时钟周期的上升沿设置为1。

对于10位地址格式: (SARUy.FS=1):



- When the received slave address matches a value of (11110b + SVA[1:0] in SARUy), and the subsequent address matches the SARLy value, with the SARyE bit in ICSEr set to 1 (slave address y detection enabled). The AASy flag is set to 1 on the rising edge of the ninth SCL clock cycle in the frame.

[Clearing conditions]

- When 0 is written to the AASy flag after reading AASy = 1
- When a stop condition is detected
- When 1 is written to the IICRST bit in ICCR1 to apply an IIC reset or an internal reset.

For 7-bit address format (SARUy.FS = 0):

- When the received slave address does not match the SVA[6:0] value in SARLy, with the SARyE bit in ICSEr set to 1 (slave address y detection enabled). The AASy flag is set to 0 on the rising edge of the ninth SCL clock cycle in the frame.

For 10-bit address format (SARUy.FS = 1):

- When the received slave address does not match a value of (11110b + SVA[1:0] in SARUy), with the SARyE bit in ICSEr set to 1 (slave address y detection enabled). The AASy flag is set to 0 on the rising edge of the ninth SCL clock cycle in the frame.
- When the received slave address matches a value of (11110b + SVA[1:0] in SARUy), and the subsequent address does not match the SARLy value, with the SARyE bit in ICSEr set to 1 (slave address y detection enabled). The AASy flag is set to 0 on the rising edge of the ninth SCL clock cycle in the frame.

#### GCA flag (General Call Address Detection Flag)

The GCA flag indicates whether the general call address was detected.

[Setting condition]

- When the received slave address matches the general call address (0000 000b + 0 [W]), with the GCAE bit in ICSEr set to 1 (general call address detection enabled). The GCA flag is set to 1 on the rising edge of the ninth SCL clock cycle in the frame.

[Clearing conditions]

- When 0 is written to the GCA flag after reading GCA = 1
- When a stop condition is detected
- When the received slave address does not match the general call address (0000 000b + 0 [W]), with the GCAE bit in ICSEr set to 1 (general call address detection enabled). The GCA flag is set to 0 on the rising edge of the ninth SCL clock cycle in the frame.
- When 1 is written to the IICRST bit in ICCR1 to apply an IIC reset or an internal reset.

#### DID flag (Device-ID Address Detection Flag)

The DID flag indicates whether the device-ID address was detected.

[Setting condition]

- When the first frame received immediately after a start or restart condition is detected matches a value of (device ID (1111 100b) + 0 [W]), with the DIDE bit in ICSEr set to 1 (device-ID address detection enabled). The DID flag is set to 1 on the rising edge of the ninth SCL clock cycle in the frame.

[Clearing conditions]

- When 0 is written to the DID flag after reading DID = 1
- When a stop condition is detected
- When the first frame received immediately after a start or restart condition is detected does not match a value of (device ID (1111 100b)), with the DIDE bit in ICSEr set to 1 (device-ID address detection enabled). The DID flag is set to 0 on the rising edge of the ninth SCL clock cycle in the frame.

- 当接收到的从地址与 (SARUy中的11110b+SVA[1:0]) 值匹配, 并且后续地址与SARLy值匹配时, ICSEr中的SARyE位设置为1 (启用从地址y检测)。AASy标志在帧中第9个SCL时钟周期的上升沿设置为1。

[Clearing conditions]

- 读取AASy=1后向AASy标志写入0时
- 检测到停止条件时
- 当ICCR1的IICRST位写入1时, 应用IIC复位或内部复位。

对于7位地址格式(SARUy.FS=0):

- 当接收到的从地址与SARLy中的SVA[6:0]值不匹配时, 将ICSEr中的SARyE位设置为1 (启用从地址y检测)。AASy标志在帧中第9个SCL时钟周期的上升沿设置为0。

对于10位地址格式(SARUy.FS=1):

- 当接收到的从地址与 (SARUy中的11110b+SVA[1:0]) 的值不匹配时, ICSEr中的SARyE位设置为1 (启用从地址y检测)。AASy标志在帧中第9个SCL时钟周期的上升沿设置为0。
- 当接收到的从地址与 (SARUy中的11110b+SVA[1:0]) 值匹配, 且后续地址与SARLy值不匹配时, ICSEr中的SARyE位设置为1 (启用从地址y检测)。AASy标志在帧中第9个SCL时钟周期的上升沿设置为0。

#### GCA标志 (广播呼叫地址检测标志)

GCA标志指示是否检测到广播呼叫地址。

[Setting condition]

- 当接收到的从机地址与广播呼叫地址 (0000000b+0[W]) 匹配时, ICSEr中的GCAE位设置为1 (启用广播呼叫地址检测)。GCA标志在帧中第9个SCL时钟周期的上升沿设置为1。

[Clearing conditions]

- 读取GCA=1后将0写入GCA标志时
- 检测到停止条件时
- 当接收到的从机地址与广播呼叫地址 (0000000b+0[W]) 不匹配时, 将ICSEr中的GCAE位设置为1 (启用广播呼叫地址检测)。GCA标志在帧中第9个SCL时钟周期的上升沿设置为0。
- 当ICCR1的IICRST位写入1时, 应用IIC复位或内部复位。

#### DID标志 (设备ID地址检测标志)

DID标志指示是否检测到设备ID地址。

[Setting condition]

- 当检测到启动或重启条件后立即接收到的第一帧与 (设备ID(1111100b)+0[W]) 的值匹配, 且ICSEr中的DIDE位设置为1 (启用设备ID地址检测)。DID标志在帧中第9个SCL时钟周期的上升沿设置为1。

[Clearing conditions]

- 读取DID=1后向DID标志写入0时
- 检测到停止条件时
- 当检测到启动或重启条件后立即接收到的第一帧与 (设备ID (1111100b)) 的值不匹配时, ICSEr中的DIDE位设置为1 (启用设备ID地址检测)。DID标志在帧中第9个SCL时钟周期的上升沿设置为0。

- When the first frame received immediately after a start or restart condition is detected matches a value of (device ID (1111 100b) + 0 [W]), and the second frame does not match any slave address from 0 to 2, with the DIDE bit in IC SER set to 1 (device-ID address detection enabled)  
The DID flag is set to 0 on the rising edge of the ninth SCL clock cycle in the frame.
- When 1 is written to the IICRST bit in ICCR1 to apply an IIC reset or an internal reset.

**HOA flag (Host Address Detection Flag)**

The HOA flag indicates whether the host address was detected.

[Setting condition]

- When the received slave address matches the host address (0001 000b), with the HOAE bit in IC SER set to 1 (host address detection enabled).  
The HOA flag is set to 1 on the rising edge of the ninth SCL clock cycle in the frame.

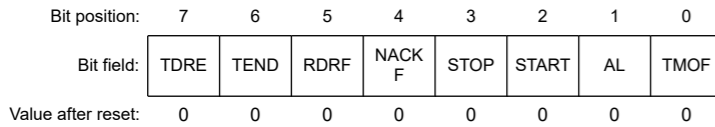
[Clearing conditions]

- When 0 is written to the HOA flag after reading HOA = 1
- When a stop condition is detected
- When the received slave address does not match the host address (0001 000b), with the HOAE bit in IC SER set to 1 (host address detection enabled)  
The HOA flag is set to 0 on the rising edge of the ninth SCL clock cycle in the frame.
- When 1 is written to the IICRST bit in ICCR1 to apply an IIC reset or an internal reset.

**28.2.10 ICSR2 : I<sup>2</sup>C Bus Status Register 2**

Base address: IICn = 0x4009\_F000 + 0x0100 × n (n = 0, 1)

Offset address: 0x09



| Bit | Symbol | Function   | R/W                 |
|-----|--------|--|---------------------|
| 0   | TMOF   | Timeout Detection Flag<br>0: Timeout not detected<br>1: Timeout detected                         | R/(W) <sup>*1</sup> |
| 1   | AL     | Arbitration-Lost Flag<br>0: Arbitration not lost<br>1: Arbitration lost                          | R/(W) <sup>*1</sup> |
| 2   | START  | Start Condition Detection Flag<br>0: Start condition not detected<br>1: Start condition detected | R/(W) <sup>*1</sup> |
| 3   | STOP   | Stop Condition Detection Flag<br>0: Stop condition not detected<br>1: Stop condition detected    | R/(W) <sup>*1</sup> |
| 4   | NACKF  | NACK Detection Flag<br>0: NACK not detected<br>1: NACK detected                                  | R/(W) <sup>*1</sup> |
| 5   | RDRF   | Receive Data Full Flag<br>0: ICDRR contains no receive data<br>1: ICDRR contains receive data    | R/(W) <sup>*1</sup> |
| 6   | TEND   | Transmit End Flag<br>0: Data being transmitted<br>1: Data transmit complete                      | R/(W) <sup>*1</sup> |

- 当检测到启动或重启条件后立即接收到的第一帧与（设备ID）的值匹配时（1111100b)+0[W]，并且第二帧不匹配从0到2的任何从机地址，且ICSER中的DIDE位设置为1（启用设备ID地址检测）DID标志设置为0在帧的第9个SCL时钟周期的上升沿。

- 当ICCR1的IICRST位写入1时，应用IIC复位或内部复位。

**HOA标志（主机地址检测标志）**

HOA标志指示是否检测到主机地址。

[Setting condition]

- 当接收到的从机地址与主机地址（0001000b）匹配时，ICSER中的HOAE位设置为1（主机地址检测使能）。HOA标志在帧中第9个SCL时钟周期的上升沿设置为1。

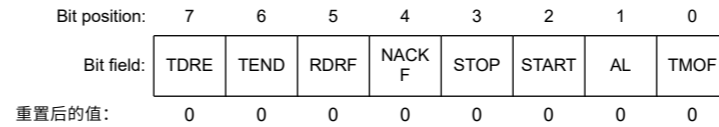
[Clearing conditions]

- 读取HOA=1后向HOA标志写入0时
- 检测到停止条件时
- 当接收到的从机地址与主机地址（0001000b）不匹配时，ICSER中的HOAE位设置为1（主机地址检测使能）在第9个SCL时钟周期的上升沿将HOA标志设置为0框架。
- 当ICCR1的IICRST位写入1时，应用IIC复位或内部复位。

**28.2.10 ICSR2: I2C总线状态寄存器2**

Base address: IICn = 0x4009\_F000 + 0x0100 × n (n = 0, 1)

Offset address: 0x09



| Bit | Symbol | Function                                 | R/W                 |
|-----|--------|--|---------------------|
| 0   | TMOF   | 超时检测标志<br>0: 未检测到超时1: 检测到超时              | R/(W) <sup>*1</sup> |
| 1   | AL     | Arbitration-Lost Flag<br>0: 仲裁未丢失1: 仲裁丢失 | R/(W) <sup>*1</sup> |
| 2   | START  | 启动条件检测标志<br>0: 未检测到启动条件1: 检测到启动条件        | R/(W) <sup>*1</sup> |
| 3   | STOP   | 停止条件检测标志<br>0: 未检测到停止条件1: 检测到停止条件        | R/(W) <sup>*1</sup> |
| 4   | NACKF  | NACK检测标志<br>0: 未检测到NACK1: 检测到NACK        | R/(W) <sup>*1</sup> |
| 5   | RDRF   | 接收数据满标志<br>0: ICDRR不包含接收数据1: ICDRR包含接收数据 | R/(W) <sup>*1</sup> |
| 6   | TEND   | 发送结束标志<br>0: 数据发送中1: 数据发送完成              | R/(W) <sup>*1</sup> |

| Bit | Symbol | Function  | R/W |
|-----|--------|---|-----|
| 7   | TDRE   | Transmit Data Empty Flag<br>0: ICDRT contains transmit data<br>1: ICDRT contains no transmit data | R   |

Note 1. Only 0 can be written, to clear the flag.

### TMOF flag (Timeout Detection Flag)

The TMOF flag is set to 1 when the IIC detects a timeout because the SCLn line state remains unchanged for the set period.

[Setting condition]

- When the SCLn line state remains unchanged for the period specified in the ICMR2.TMOH, TMOL, and TMOS bits while the ICFER.TMOE bit is 1 (timeout function enabled) in master or in slave mode and the received slave address matches.

[Clearing conditions]

- When 0 is written to the TMOF flag after reading TMOF = 1
- When 1 is written to the IICRST bit in ICCR1 to apply an IIC reset or an internal reset.

### AL flag (Arbitration-Lost Flag)

The AL flag indicates that bus mastership was lost in arbitration because of a bus conflict or some other reason when a start condition was issued or an address and data was transmitted. The IIC monitors the level on the SDAn line during transmission and, if the level on the line does not match the value of the bit being output, is set the value of the AL flag to 1 to indicate that the bus is occupied by another device.

The IIC can also set the AL flag to indicate the detection of arbitration loss during NACK transmission or during data transmission.

[Setting conditions]

When master arbitration-lost detection is enabled (ICFER.MALE = 1):

- When the internal SDA output state does not match the SDAn line level on the rising edge of the SCL clock except for the ACK period during data transmission in master transmit mode
- When a start condition is detected while the ST bit in ICCR2 is 1 (start condition requested) or the internal SDA output state does not match the SDAn line level
- When the ST bit in ICCR2 is 1 (start condition requested), with the BBSY flag in ICCR2 set to 1.

When NACK arbitration-lost detection is enabled (ICFER.NALE = 1):

- When the internal SDA output state does not match the SDAn line level on the rising edge of the SCL clock in the ACK period during NACK transmission in receive mode.

When slave arbitration-lost detection is enabled (ICFER.SALE = 1):

- When the internal SDA output state does not match the SDAn line level on the rising edge of the SCL clock, except for the ACK period during data transmission in slave transmit mode.

[Clearing conditions]

- When 0 is written to the AL flag after reading AL = 1
- When 1 is written to the IICRST bit in ICCR1 to apply an IIC reset or an internal reset.

| Bit | Symbol | Function                                 | R/W |
|-----|--------|--|-----|
| 7   | TDRE   | 传输数据空标志<br>0: ICDRT包含发送数据1: ICDRT不包含发送数据 | R   |

注1.只能写入0,清除标志。

### TMOF标志 (超时检测标志)

当IIC检测到超时时, TMOF标志设置为1, 因为SCLn线路状态在设置的周期内保持不变。

[Setting condition]

- SCLn线路状态在ICMR2.TMOH、TMOL和TMOS位指定的时间段内保持不变, 而ICFER.TMOE位在主机或从机模式下为1 (使能超时功能) 并且接收到的从机地址匹配。

[Clearing conditions]

- 读取TMOF=1后向TMOF标志写入0时
- 当ICCR1的IICRST位写入1时, 应用IIC复位或内部复位。

### AL标志 (仲裁失败标志)

AL标志表明在发出启动条件或传输地址和数据时, 由于总线冲突或其他原因, 总线控制权在仲裁中丢失。IIC在传输过程中监视SDAn线上的电平, 如果线上的电平与正在输出的位的值不匹配, 则将AL标志的值设置为1, 以指示总线被另一个设备占用。

IIC还可以设置AL标志以指示在NACK传输或数据传输期间检测到仲裁丢失。

[Setting conditions]

当启用主机仲裁丢失检测时(ICFER.MALE=1):

- 主机传输模式下数据传输期间, 除了ACK周期外, 当内部SDA输出状态在SCL时钟的上升沿与SDAn线电平不匹配时
- 当ICCR2的ST位为1 (请求启动条件) 或内部SDA输出状态与SDAn线电平不匹配时检测到启动条件
- ICCR2中的ST位为1 (请求启动条件) 时, ICCR2中的BBSY标志设置为1。

当启用NACK仲裁丢失检测时(ICFER.NALE=1):

- 在接收模式下的NACK传输过程中, 当内部SDA输出状态在ACK周期的SCL时钟上升沿与SDAn线电平不匹配时。

当启用从设备仲裁丢失检测时(ICFER.SALE=1):

- 当内部SDA输出状态在SCL时钟的上升沿与SDAn线电平不匹配时, 除了在从机传输模式下数据传输期间的ACK周期。

[Clearing conditions]

- 读取AL=1后向AL标志写入0时
- 当ICCR1的IICRST位写入1时, 应用IIC复位或内部复位。

Table 28.4 Relationship between arbitration-lost generation sources and arbitration-lost enable functions

| ICFER |      |      | ICSR2 |  | Error                          | Arbitration-lost generation source   |
|-------|------|------|-------|--|--------------------------------|--|
| MALE  | NALE | SALE | AL    |  |                                |  |
| 1     | x    | x    | 1     |  | Start condition issuance error | When internal SDA output state does not match SDA line level when a start condition is detected, while the ST bit in ICCR2 is 1<br>When ST in ICCR2 is set to 1 while BBSY in ICCR2 is 1 |
|       |      |      | 1     |  | Transmit data mismatch         | When transmit data (including slave address) does not match the bus state in master transmit mode  |
| x     | 1    | x    | 1     |  | NACK transmission mismatch     | When ACK is detected during transmission of NACK in master or slave receive mode   |
| x     | x    | 1    | 1     |  | Transmit data mismatch         | When transmit data does not match the bus state in slave transmit mode   |

x: Don't care

#### START flag (Start Condition Detection Flag)

The START flag indicates whether a start or restart condition was detected.

[Setting condition]

- When a start or restart condition is detected.

[Clearing conditions]

- When 0 is written to the START flag after reading START = 1
- When a stop condition is detected
- When 1 is written to the IICRST bit in ICCR1 to apply an IIC reset or an internal reset.

#### STOP flag (Stop Condition Detection Flag)

The STOP flag indicates whether a stop condition was detected.

[Setting condition]

- When a stop condition is detected.

[Clearing conditions]

- When 0 is written to the STOP flag after reading STOP = 1
- When 1 is written to the IICRST bit in ICCR1 to apply an IIC reset or an internal reset.

#### NACKF flag (NACK Detection Flag)

The NACKF flag indicates whether a NACK was detected.

[Setting condition]

- When acknowledge is not received (NACK received) from the receive device in transmit mode, with the NACKE bit in ICFER set to 1 (transfer suspension enabled).

[Clearing conditions]

- When 0 is written to the NACKF flag after reading NACKF = 1
- When 1 is written to the IICRST bit in ICCR1 to apply an IIC reset or an internal reset.

Note: When the NACKF flag is set to 1, the IIC suspends data transmission and reception. Writing to ICDRT in transmit mode or reading from ICDRR in receive mode with the NACKF flag set to 1 does not enable data transmit or receive operation. To restart data transmission or reception, set the NACKF flag to 0.

#### RDRF flag (Receive Data Full Flag)

The RDRF flag indicates whether the ICDRR contains receive data.

Table 28.4 仲裁丢失生成源和仲裁丢失使能函数之间的关系

| ICFER |      |      | ICSR2 |  | Error     | 仲裁失败的生成源   |
|-------|------|------|-------|--|-----------|--|
| MALE  | NALE | SALE | AL    |  |           |  |
| 1     | x    | x    | 1     |  | 开始条件发布错误  | 当检测到启动条件时内部SDA输出状态与SDAn线电平不匹配, 而ICCR2中的ST位为1<br>ICCR2中的ST设置为1而ICCR2中的BBSY为1时 |
|       |      |      | 1     |  | 传输数据不匹配   | 当发送数据(包括从地址)与主发送模式下的总线状态不匹配时   |
| x     | 1    | x    | 1     |  | NACK传输不匹配 | 在主机或从机接收模式下发送NACK期间检测到ACK时   |
| x     | x    | 1    | 1     |  | 传输数据不匹配   | 当发送数据与从发送模式下的总线状态不匹配时  |

x: Don't care

#### START标志(开始条件检测标志)

START标志指示是否检测到启动或重新启动条件。

[Setting condition]

- 检测到启动或重启条件时。

[Clearing conditions]

- 读取START=1后向START标志写入0时
- 检测到停止条件时
- 当ICCR1的IICRST位写入1时, 应用IIC复位或内部复位。

#### STOP标志(停止条件检测标志)

STOP标志指示是否检测到停止条件。

[Setting condition]

- 检测到停止条件时。

[Clearing conditions]

- 读取STOP=1后向STOP标志写入0时
- 当ICCR1的IICRST位写入1时, 应用IIC复位或内部复位。

#### NACKF标志(NACK检测标志)

NACKF标志指示是否检测到NACK。

[Setting condition]

- 当在发送模式下未从接收设备接收到确认(NACK接收)时, ICFER中的NACKE位设置为1(启用传输暂停)。

[Clearing conditions]

- 读取NACKF=1后向NACKF标志写入0时
- 当ICCR1的IICRST位写入1时, 应用IIC复位或内部复位。

Note: 当NACKF标志设置为1时, IIC暂停数据发送和接收。在NACKF标志设置为1的情况下, 在发送模式下写入ICDRT或在接收模式下从ICDRR读取不会启用数据发送或接收操作。要重新开始数据发送或接收, 请将NACKF标志设置为0。

#### RDRF标志(接收数据满标志)

RDRF标志指示ICDRR是否包含接收数据。



## [Setting conditions]

- When receive data is transferred from ICDRS to ICDRR  
The RDRF flag is set to 1 on the rising edge of the eighth or ninth SCL clock cycle (selected in the RDRFS bit in ICMR3).
- When the received slave address matches after a start or restart condition is detected with the TRS bit in ICCR2 set to 0.

## [Clearing conditions]

- When 0 is written to the RDRF flag after reading RDRF = 1
- When data is read from ICDRR
- When 1 is written to the IICRST bit in ICCR1 to apply an IIC reset or an internal reset.

**TEND flag (Transmit End Flag)**

The TEND flag indicates completion of transmission.

## [Setting condition]

- On the rising edge of the ninth SCL clock cycle while the TDRE flag is 1.

## [Clearing conditions]

- When 0 is written to the TEND flag after reading TEND = 1
- When data is written to ICDRT
- When a stop condition is detected
- When 1 is written to the IICRST bit in ICCR1 to apply an IIC reset or an internal reset.

**TDRE flag (Transmit Data Empty Flag)**

The TDRE flag indicates whether the ICDRT contains transmit data.

## [Setting conditions]

- When data is transferred from ICDRT to ICDRS and ICDRT becomes empty
- When the TRS bit in ICCR2 is set to 1
- When the received slave address matches while the TRS bit is 1.

## [Clearing conditions]

- When data is written to ICDRT
- When the TRS bit in ICCR2 is set to 0
- When 1 is written to the IICRST bit in ICCR1 to apply an IIC reset or an internal reset.

Note: When the NACKF flag is set to 1 while the NACKIE bit in ICFER is 1, the IIC suspends data transmission and reception. In this case, if the TDRE flag is 0 (next transmit data written), data is transferred to the ICDRS register and the ICDRT register becomes empty on the rising edge of the 9th clock cycle, but the TDRE flag does not set to 1.

**28.2.11 ICWUR : I<sup>2</sup>C Bus Wakeup Unit Register**

Base address: IIC0WU = 0x4009\_F014

Offset address: 0x02

|                    |     |      |     |           |   |   |   |           |
|--------------------|-----|------|-----|-----------|---|---|---|-----------|
| Bit position:      | 7   | 6    | 5   | 4         | 3 | 2 | 1 | 0         |
| Bit field:         | WUE | WUIE | WUF | WUAC<br>K | — | — | — | WUAF<br>A |
| Value after reset: | 0   | 0    | 0   | 1         | 0 | 0 | 0 | 0         |

## [Setting conditions]

- 接收数据从ICDRS传输到ICDRR时  
RDRF标志在第8个或第9个SCL时钟周期的上升沿设置为1（在RDRFS位中选择ICMR3）。
- 当ICCR2中的TRS位设置为0检测到启动或重启条件后接收到的从机地址匹配时。

## [Clearing conditions]

- 读取RDRF=1后向RDRF标志写入0时
- 从ICDRR读取数据时
- 当ICCR1的IICRST位写入1时，应用IIC复位或内部复位。

**TEND标志（发送结束标志）**

TEND标志表示传输完成。

## [Setting condition]

- 在第9个SCL时钟周期的上升沿，同时TDRE标志为1。

## [Clearing conditions]

- 读取TEND=1后向TEND标志写入0时
- 数据写入ICDRT时
- 检测到停止条件时
- 当ICCR1的IICRST位写入1时，应用IIC复位或内部复位。

**TDRE标志（传输数据空标志）**

TDRE标志指示ICDRT是否包含发送数据。

## [Setting conditions]

- 当数据从ICDRT传输到ICDRS并且ICDRT变为空时
- ICCR2的TRS位为1时
- TRS位为1时接收到的从机地址匹配时。

## [Clearing conditions]

- 数据写入ICDRT时
- ICCR2的TRS位设置为0时
- 当ICCR1的IICRST位写入1时，应用IIC复位或内部复位。

Note: 当ICFER的NACKIE位为1时NACKF标志设置为1，IIC暂停数据发送和接收。在这种情况下，如果TDRE标志为0（写入下一个发送数据），则数据被传送到ICDRS寄存器，并且ICDRT寄存器在第9个时钟周期的上升沿变为空，但TDRE标志不设置为1。

**28.2.11 ICWUR:I2C总线唤醒单元寄存器**

Base address: IIC0WU = 0x4009\_F014

Offset address: 0x02

|               |     |      |     |           |   |   |   |           |
|---------------|-----|------|-----|-----------|---|---|---|-----------|
| Bit position: | 7   | 6    | 5   | 4         | 3 | 2 | 1 | 0         |
| Bit field:    | WUE | WUIE | WUF | WUAC<br>K | — | — | — | WUAF<br>A |
| 重置后的值:        | 0   | 0    | 0   | 1         | 0 | 0 | 0 | 0         |

| Bit | Symbol | Function   | R/W |
|-----|--------|--|-----|
| 0   | WUAFA  | Wakeup Analog Filter Additional Selection<br>0: Do not add the wakeup analog filter<br>1: Add the wakeup analog filter             | R/W |
| 3:1 | —      | These bits are read as 0. The write value should be 0.   | R/W |
| 4   | WUACK  | ACK Bit for Wakeup Mode<br>Choice of four response modes in combination with ICCR1.IICRST and WUACK. See Table 28.5.               | R/W |
| 5   | WUF    | Wakeup Event Occurrence Flag<br>0: Slave address not matching during wakeup<br>1: Slave address matching during wakeup             | R/W |
| 6   | WUIE   | Wakeup Interrupt Request Enable<br>0: Disable wakeup interrupt request (IIC0_WUI)<br>1: Enable wakeup interrupt request (IIC0_WUI) | R/W |
| 7   | WUE    | Wakeup Function Enable<br>0: Disable wakeup function<br>1: Enable wakeup function  | R/W |

Table 28.5 Wakeup mode

| IICRST | WUACK | Operation mode        | Description   |
|--------|-------|-----------------------|---|
| 0      | 0     | Normal wakeup mode 1  | ACK response on 9th SCL, and SCL low-hold after 9th SCL.  |
| 0      | 1     | Normal wakeup mode 2  | No ACK response immediately and SCL low-hold between 8th and 9th SCL. SCL low-hold release and ACK response on 9th SCL. |
| 1      | 0     | Command recovery mode | ACK response on 9th SCL and no SCL low-hold.  |
| 1      | 1     | EOP response mode     | NACK response on 9th SCL and no SCL low-hold.   |

**WUF flag (Wakeup Event Occurrence Flag)**

The WUF flag indicates whether the slave address is matching during wakeup.

[Setting condition]

- When PCLKB is supplied after a slave-address match in the first 8th SCL low during wakeup mode.

[Clearing conditions]

- When 0 is written to the WUF flag after reading WUF = 1
- When ICE = 0 and IICRST = 1.

**28.2.12 ICWUR2 : I<sup>2</sup>C Bus Wakeup Unit Register 2**

Base address: IIC0WU = 0x4009\_F014

Offset address: 0x03

| Bit position:      | 7 | 6 | 5 | 4 | 3 | 2         | 1          | 0         |
|--------------------|---|---|---|---|---|-----------|------------|-----------|
| Bit field:         | — | — | — | — | — | WUSY<br>F | WUAS<br>YF | WUSE<br>N |
| Value after reset: | 1 | 1 | 1 | 1 | 1 | 1         | 0          | 1         |

| Bit | Symbol | Function  | R/W |
|-----|--------|---|-----|
| 0   | WUSEN  | Wakeup Function Synchronous Enable<br>0: IIC asynchronous circuit enable<br>1: IIC synchronous circuit enable                                     | R/W |
| 1   | WUASYF | Wakeup Function Asynchronous Operation Status Flag<br>0: IIC synchronous circuit enable condition<br>1: IIC asynchronous circuit enable condition | R   |

| Bit | Symbol | Function  | R/W |
|-----|--------|---|-----|
| 0   | WUAFA  | 唤醒模拟滤波器附加选择<br>0: 不加唤醒模拟滤波器1: 加唤醒模拟滤波器                    | R/W |
| 3:1 | —      | 这些位被读取为0。写入值应为0。  | R/W |
| 4   | WUACK  | 唤醒模式的ACK位<br>结合ICCR1.IICRST和WUACK可选择四种响应模式。见表28.5。        | R/W |
| 5   | WUF    | 唤醒事件发生标志<br>0: 唤醒期间从机地址不匹配1: 唤醒期间从机地址匹配                   | R/W |
| 6   | WUIE   | 唤醒中断请求使能<br>0: 禁用唤醒中断请求 (IIC0_WUI) 1: 启用唤醒中断请求 (IIC0_WUI) | R/W |
| 7   | WUE    | 唤醒功能启用<br>0: 禁用唤醒功能1: 启用唤醒功能                              | R/W |

Table 28.5 唤醒模式

| IICRST | WUACK | 操作模式    | Description  |
|--------|-------|---------|--|
| 0      | 0     | 正常唤醒模式1 | 第9个SCL的ACK响应，以及第9个SCL之后的SCL低保持。                        |
| 0      | 1     | 正常唤醒模式2 | 在第8和第9个SCL之间没有立即ACK响应并且SCL保持低电平。SCL低保持释放和第9个SCL的ACK响应。 |
| 1      | 0     | 命令恢复模式  | 第9个SCL的ACK响应且没有SCL低保持。                                 |
| 1      | 1     | EOP响应模式 | 第9个SCL的NACK响应且没有SCL低保持。                                |

**WUF标志 (唤醒事件发生标志)**

WUF标志指示在唤醒期间从地址是否匹配。

[Setting condition]

- 在唤醒模式期间，在第一个第8个SCL低电平的从机地址匹配后提供PCLKB时。

[Clearing conditions]

- 读取WUF=1后向WUF标志写入0时
- 当ICE=0且IICRST=1时。

**28.2.12 ICWUR2:I2C总线唤醒单元寄存器2**

Base address: IIC0WU = 0x4009\_F014

Offset address: 0x03

| Bit position: | 7 | 6 | 5 | 4 | 3 | 2         | 1          | 0         |
|---------------|---|---|---|---|---|-----------|------------|-----------|
| Bit field:    | — | — | — | — | — | WUSY<br>F | WUAS<br>YF | WUSE<br>N |
| 重置后的值:        | 1 | 1 | 1 | 1 | 1 | 1         | 0          | 1         |

| Bit | Symbol | Function                                     | R/W |
|-----|--------|--|-----|
| 0   | WUSEN  | 唤醒功能同步使能<br>0: IIC异步电路使能1: IIC同步电路使能         | R/W |
| 1   | WUASYF | 唤醒功能异步操作状态标志<br>0: IIC同步电路使能条件1: IIC异步电路使能条件 | R   |

| Bit | Symbol | Function   | R/W |
|-----|--------|--|-----|
| 2   | WUSYF  | Wakeup Function Synchronous Operation Status Flag<br>0: IIC asynchronous circuit enable condition<br>1: IIC synchronous circuit enable condition | R   |
| 7:3 | —      | These bits are read as 1. The write value should be 1.   | R/W |

**WUSEN bit (Wakeup Function Synchronous Enable)**

The WUSEN bit is used in combination with the WUASYF flag (or WUSYF flag) to switch between the PCLKB synchronous and asynchronous operation, when the wakeup effective function is enabled (ICWUR.WUE = 1).

The PCLKB operation switches from synchronous to asynchronous operation:

When the ICCR2.BBSY flag is 0, if 0 is written to the WUSEN bit while the WUASYF flag is 0. The reception occurs independently of the operation of PCLKB (with PCLKB stopped) after it switches to the PCLKB asynchronous operation, on wakeup event detection.

The PCLKB operation switches from asynchronous to synchronous operation:

- When 1 is written to the WUSEN bit, with the WUASYF flag at 1, when a wakeup event is detected. After writing 1, the WUASYF flag immediately becomes 0.
- When the stop condition is detected with a wakeup event undetected.

**WUASYF flag (Wakeup Function Asynchronous Operation Status Flag)**

The WUASYF flag can place the IIC in PCLKB asynchronous operation when the wakeup effective function is enabled (ICWUR.WUE = 1).

[Setting condition]

- When the ICCR2.BBSY flag is 0, and the WUSEN bit is set to 0 with the ICWUR.WUE bit set to 1.

[Clearing conditions]

- When 1 is written to the WUSEN bit after detecting the wake-up event with ICWUR.WUE bit set to 1.
- When a stop condition is detected with WUSEN bit set to 1 before detecting the wake-up event with WUASY flag set to 1 with ICWUR.WUE bit set to 1.
- When you write 1 in the WUSEN bit with the WUASYF flag detected 1 and the wake-up event in the state of ICWUR.WUE = 1.
- ICCR1.ICE = 0 and ICCRST = 1 (ICC reset)
- ICWUR.WUE = 0.

**WUSYF flag (Wakeup Function Synchronous Operation Status Flag)**

It is shown that IIC is in the PCLKB synchronous operation at wake-up effective function (ICWUR.WUE = 1). This flag is a value in which the WUASYF flag is always reserved.

[Setting conditions]

- When 1 is written to the WUSEN bit after detecting the wake-up event with ICWUR.WUE bit set to 1 with WUSYF flag set to 0 with ICWUR.WUE bit set to 1.
- When a stop condition is detected with WUSEN bit set to 1 before detecting the wake-up event with WUSYF flag set to 0 with ICWUR.WUE bit set to 1.
- ICCR1.ICE = 0 and ICCRST = 1 (ICC reset)
- ICWUR.WUE = 0.

[Clearing condition]

- When the ICCR2.BBSY flag is 0 with the ICWUR.WUE bit set to 1 after writing 0 to the WUSEN bit.

| Bit | Symbol | Function                                     | R/W |
|-----|--------|--|-----|
| 2   | WUSYF  | 唤醒功能同步操作状态标志<br>0: IIC异步电路使能条件1: IIC同步电路使能条件 | R   |
| 7:3 | —      | 这些位被读取为1。写入值应为1。                             | R/W |

**WUSEN位 (唤醒功能同步使能)**

WUSEN位与WUASYF标志 (或WUSYF标志) 结合使用, 在启用唤醒有效功能 (ICWUR.WUE=1) 时在PCLKB同步和异步操作之间切换。

PCLKB操作从同步操作切换到异步操作:

当ICCR2.BBSY标志为0时, 如果在WUASYF标志为0时将0写入WUSEN位。在唤醒事件切换到PCLKB异步操作后, 接收发生独立于PCLKB的操作 (PCLKB停止) 检测。

PCLKB操作从异步操作切换到同步操作:

- 当WUSEN位写入1且WUASYF标志为1时, 检测到唤醒事件。写入1后, WUASYF标志立即变为0。
- 当检测到停止条件且未检测到唤醒事件时。

**WUASYF标志 (唤醒功能异步操作状态标志)**

WUASYF标志可以在启用唤醒有效功能 (ICWUR.WUE=1) 时将IIC置于PCLKB异步操作中。

[Setting condition]

- ICCR2.BBSY标志为0且WUSEN位设置为0且ICWUR.WUE位设置为1时。

[Clearing conditions]

- 当检测到唤醒事件后将1写入WUSEN位, 且ICWUR.WUE位设置为1。
- 在检测到WUASY标志设置为1且ICWUR.WUE位设置为1的唤醒事件之前检测到WUSEN位设置为1的停止条件时。
- 当您在WUSEN位写入1时, 检测到WUASYF标志为1, 并且唤醒事件处于ICWUR.WUE=1的状态。
- ICCR1.ICE = 0 and ICCRST = 1 (ICC reset)
- ICWUR.WUE = 0.

**WUSYF标志 (唤醒功能同步操作状态标志)**

表明IIC在唤醒有效功能(ICWUR.WUE=1)时处于PCLKB同步操作。此标志是WUASYF标志始终保留的值。

[Setting conditions]

- 当检测到唤醒事件后将1写入WUSEN位时, 将ICWUR.WUE位设置为1, 将WUSYF标志设置为0, 并将ICWUR.WUE位设置为1。
- 在检测到WUSYF标志设置为0且ICWUR.WUE位设置为1的唤醒事件之前检测到WUSEN位设置为1的停止条件时。
- ICCR1.ICE = 0 and ICCRST = 1 (ICC reset)
- ICWUR.WUE = 0.

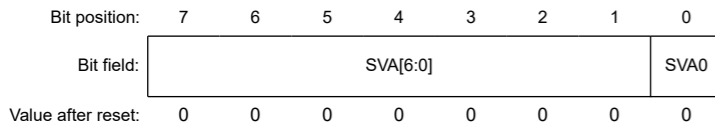
[Clearing condition]

- 当ICCR2.BBSY标志为0且ICWUR.WUE位在WUSEN位写入0后设置为1时。

## 28.2.13 SARLy : Slave Address Register Ly (y = 0 to 2)

Base address: IICn = 0x4009\_F000 + 0x0100 × n (n = 0, 1)

Offset address: 0x0A + 0x02 × y



| Bit | Symbol   | Function   | R/W |
|-----|----------|--|-----|
| 0   | SVA0     | 10-bit Address LSB Slave address setting.                      | R/W |
| 7:1 | SVA[6:0] | 7-bit Address/10-bit Address Lower Bits Slave address setting. | R/W |

**SVA0 bit (10-bit Address LSB)**

When the 10-bit address format is selected (SARUy.FS = 1), the SVA0 bit functions as the LSB of a 10-bit address and is combined with the SVA[6:0] bits to form the lower 8 bits of a 10-bit address.

This bit is valid when the SARyE bit in ICSEr is set to 1 (SARLy and SARUy enabled) and the SARUy.FS bit is 1. When the SARUy.FS or SARyE bit is 0, the setting in this bit is ignored.

**SVA[6:0] bits (7-bit Address/10-bit Address Lower Bits)**

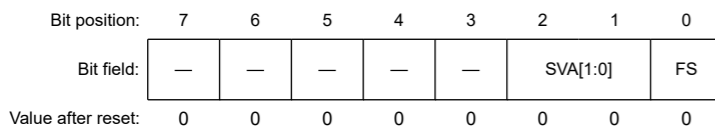
When the 7-bit address format is selected (SARUy.FS = 0), the SVA[6:0] bits function as a 7-bit address. When the 10-bit address format is selected (SARUy.FS = 1), these bits combine with the SVA0 bit to form the lower 8 bits of a 10-bit address.

When the SARyE bit in ICSEr is 0, the setting in these bits is ignored.

## 28.2.14 SARUy : Slave Address Register Uy (y = 0 to 2)

Base address: IICn = 0x4009\_F000 + 0x0100 × n (n = 0, 1)

Offset address: 0x0B + 0x02 × y



| Bit | Symbol   | Function  | R/W |
|-----|----------|---|-----|
| 0   | FS       | 7-bit/10-bit Address Format Select<br>0: Select 7-bit address format<br>1: Select 10-bit address format | R/W |
| 2:1 | SVA[1:0] | 10-bit Address Upper Bits Slave address setting.  | R/W |
| 7:3 | —        | These bits are read as 0. The write value should be 0.  | R/W |

**FS bit (7-bit/10-bit Address Format Select)**

The FS bit selects 7- or 10-bit format for slave address y (in SARLy and SARUy).

When the SARyE bit in ICSEr is set to 1 (SARLy and SARUy enabled) and the SARUy.FS bit is 0, the 7-bit address format is selected for slave address y, the SVA[6:0] setting in SARLy is valid, and the SVA[1:0] and SVA0 settings in SARLy are ignored.

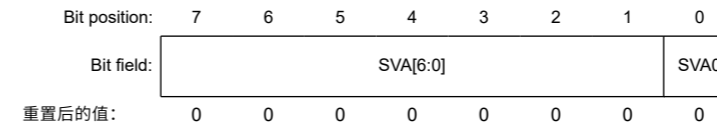
When the SARyE bit in ICSEr is set to 1 (SARLy and SARUy enabled) and the SARUy.FS bit is 1, the 10-bit address format is selected for slave address y and the SVA[1:0] and SARLy settings are valid.

When the SARyE bit in ICSEr is 0 (SARLy and SARUy disabled), the SARUy.FS setting is invalid.

## 28.2.13 SARLy: 从地址寄存器Ly (y=0到2)

Base address: IICn = 0x4009\_F000 + 0x0100 × n (n = 0, 1)

Offset address: 0x0A + 0x02 × y



| Bit | Symbol   | Function           | R/W |
|-----|----------|--------------------|-----|
| 0   | SVA0     | 10位地址LSB从机地址设置。    | R/W |
| 7:1 | SVA[6:0] | 7位地址10位地址低位从机地址设置。 | R/W |

**SVA0位 (10位地址LSB)**

When the 10-bit address format is selected (SARUy.FS=1) the SVA0 bit functions as the LSB of a 10-bit address and is combined with the SVA[6:0] bits to form the lower 8 bits of a 10-bit address.

当ICSEr中的SARyE位设置为1 (启用SARLy和SARUy) 且SARUy.FS位为1时, 该位有效。当SARUy.FS或SARyE位为0时, 忽略该位的设置。

**SVA[6:0]位 (7位地址10位地址低位)**

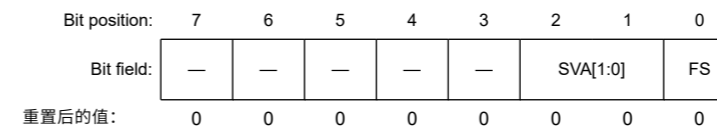
When the 7-bit address format is selected (SARUy.FS=0) the SVA[6:0] bits function as a 7-bit address. When the 10-bit address format is selected (SARUy.FS=1) these bits combine with the SVA0 bit to form the lower 8 bits of a 10-bit address.

当ICSEr中的SARyE位为0时, 这些位中的设置将被忽略。

## 28.2.14 SARUy: 从地址寄存器Uy (y=0到2)

Base address: IICn = 0x4009\_F000 + 0x0100 × n (n = 0, 1)

Offset address: 0x0B + 0x02 × y



| Bit | Symbol   | Function                               | R/W |
|-----|----------|--|-----|
| 0   | FS       | 7位10位地址格式选择<br>0: 选择7位地址格式1: 选择10位地址格式 | R/W |
| 2:1 | SVA[1:0] | 10位地址高位从机地址设置。                         | R/W |
| 7:3 | —        | 这些位被读取为0。写入值应为0。                       | R/W |

**FS位 (7位10位地址格式选择)**

FS位为从地址y选择7位或10位格式 (在SARLy和SARUy中)。

当ICSEr中的SARyE位设置为1 (启用SARLy和SARUy) 且SARUy.FS位为0时, 从机地址y选择7位地址格式, SARLy中的SVA[6:0]设置有效 并且忽略SARLy中的SVA[1:0]和SVA0设置。

当ICSEr中的SARyE位设置为1 (启用SARLy和SARUy) 且SARUy.FS位为1时, 从机地址y选择10位地址格式且SVA[1:0]和SARLy设置有效。

当ICSEr中的SARyE位为0 (SARLy和SARUy禁用) 时, SARUy.FS设置无效。



**SVA[1:0] bits (10-bit Address Upper Bits)**

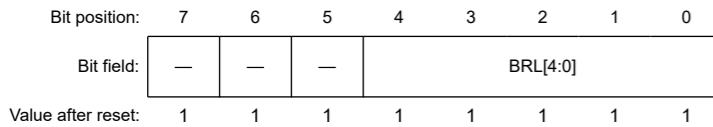
When the 10-bit address format is selected (FS = 1), the SVA[1:0] bits function as the upper 2 bits of a 10-bit address.

These bits are valid when the SARyE bit in ICSEr is set to 1 (SARLy and SARUy enabled) and the SARUy.FS bit is 1. When the SARUy.FS or SARyE bit is 0, the setting in these bits is ignored.

**28.2.15 ICBRL : I2C Bus Bit Rate Low-Level Register**

Base address: IICn = 0x4009\_F000 + 0x0100 × n (n = 0, 1)

Offset address: 0x10



| Bit | Symbol   | Function  | R/W |
|-----|----------|---|-----|
| 4:0 | BRL[4:0] | Bit Rate Low-Level Period<br>Low-level period of SCL clock. | R/W |
| 7:5 | —        | These bits are read as 1. The write value should be 1.      | R/W |

**BRL[4:0] bits (Bit Rate Low-Level Period)**

The BRL[4:0] bits set the low-level period of the SCL clock. ICBRL counts the low-level period with the internal reference clock source (IICφ) specified by the CKS[2:0] bits in ICMR1. ICBRL also generates the data setup time for automatic SCL low-hold operation, see [section 28.9. Automatic Low-Hold Function for SCL](#). When the IIC is used in slave mode, the BRL[4:0] bits must be set to a value longer than the data setup time\*1.

If the digital noise filter is enabled (NFE bit in ICFER is 1), set the BRL[4:0] bits to a value at least one greater than the number of stages in the noise filter. For details on the number of stages, see the description of the NF[1:0] bits in [section 28.2.5. ICMR3 : I2C Bus Mode Register 3](#).

Note 1. Data setup time (t<sub>SU</sub>: DAT)

- 250 ns for up to 100 kbps: Standard-mode (Sm)
- 100 ns for up to 400 kbps: Fast-mode (Fm)
- 50 ns for up to 1 Mbps: Fast-mode Plus (Fm+)

**28.2.16 ICBRH : I2C Bus Bit Rate High-Level Register**

Base address: IICn = 0x4009\_F000 + 0x0100 × n (n = 0, 1)

Offset address: 0x11



| Bit | Symbol   | Function  | R/W |
|-----|----------|---|-----|
| 4:0 | BRH[4:0] | Bit Rate High-Level Period<br>High-level period of SCL clock. | R/W |
| 7:5 | —        | These bits are read as 1. The write value should be 1.        | R/W |

**BRH[4:0] bits (Bit Rate High-Level Period)**

The BRH[4:0] bits set the high-level period of SCL clock. BRH[4:0] bits are valid in master mode. If the IIC is used only in slave mode, do not set the BRH[4:0] bits.

**SVA[1:0]位 (10位地址高位)**

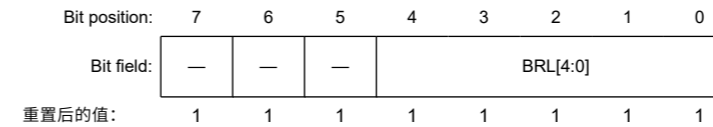
When the 10-bit address format is selected (FS = 1) the SVA[1:0] bits function as the upper 2 bits of a 10-bit address.

当ICSEr中的SARyE位设置为1 (启用SARLy和SARUy) 且SARUy.FS位为1时, 这些位有效。当SARUy.FS或SARyE位为0时, 这些位中的设置将被忽略。

**28.2.15 ICBRL: I2C总线比特率低电平寄存器**

Base address: IICn = 0x4009\_F000 + 0x0100 × n (n = 0, 1)

Offset address: 0x10



| Bit | Symbol   | Function                 | R/W |
|-----|----------|--------------------------|-----|
| 4:0 | BRL[4:0] | 比特率低电平周期<br>SCL时钟的低电平周期。 | R/W |
| 7:5 | —        | 这些位被读取为1。写入值应为1。         | R/W |

**BRL[4:0]位 (比特率低电平周期)**

BRL[4:0]位设置SCL时钟的低电平周期。ICBRL使用由ICMR1中的CKS[2:0]位指定的内部参考时钟源(IICφ)对低电平周期进行计数。ICBRL还为自动SCL低保持操作生成数据建立时间, 请参见第28.9节。SCL的自动低保持功能。当IIC在从机模式下使用时, BRL[4:0]位必须设置为比数据建立时间\*1更长的值。

如果启用了数字噪声滤波器 (ICFER中的NFE位为1), 请将BRL[4:0]位设置为至少比噪声滤波器中的级数大1的值。关于阶段数的详细信息, 请参见第28.2.5节中对NF[1:0]位的描述。ICMR3: I2C总线模式寄存器3。

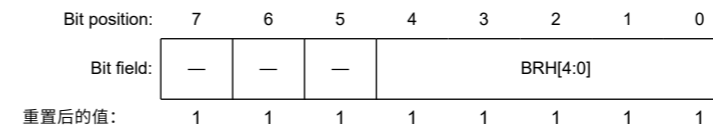
注1.数据建立时间(t<sub>SU</sub>:DAT)

- 250ns, 最高100kbps: 标准模式(Sm)
- 100ns, 最高400kbps: 快速模式(Fm)
- 高达1Mbps时为50ns: Fast-modePlus(Fm+)

**28.2.16 ICBRH: I2C总线比特率高级寄存器**

Base address: IICn = 0x4009\_F000 + 0x0100 × n (n = 0, 1)

Offset address: 0x11



| Bit | Symbol   | Function               | R/W |
|-----|----------|------------------------|-----|
| 4:0 | BRH[4:0] | 比特率高级期<br>SCL时钟的高电平周期。 | R/W |
| 7:5 | —        | 这些位被读取为1。写入值应为1。       | R/W |

**BRH[4:0]位 (比特率高电平周期)**

BRH[4:0]位设置SCL时钟的高电平周期。BRH[4:0]位在主机模式下有效。如果IIC仅用于从机模式, 则不要设置BRH[4:0]位。

ICBRH counts the high-level period with the internal reference clock source (IIC $\phi$ ) specified in the CKS[2:0] bits in ICMR1.

If the digital noise filter is enabled (the NFE bit in ICFER is 1), set these bits to a value at least one greater than the number of stages in the noise filter. For the number of stages in the noise filter, see the description of the NF[1:0] bits in [section 28.2.5. ICMR3 : I<sup>2</sup>C Bus Mode Register 3](#).

The IIC transfer rate and the SCL clock duty are calculated using the following expressions (1) to (5):

- ICFER.SCLE = 0  
Transfer rate =  $1 / [ \{ (BRH + 1) + (BRL + 1) \} / IIC\phi * 1 + tr * 2 + tf * 2 ]$   
Duty cycle =  $[ tr + \{ (BRH + 1) / IIC\phi \} ] / [ tr + tf + \{ (BRH + 1) + (BRL + 1) \} / IIC\phi ]$
- ICFER.SCLE = 1 and ICFER.NFE = 0 and CKS[2:0] = 000b (IIC $\phi$  = PCLKB)  
Transfer rate =  $1 / [ \{ (BRH + 3) + (BRL + 3) \} / IIC\phi + tr + tf ]$   
Duty cycle =  $[ tr + \{ (BRH + 3) / IIC\phi \} ] / [ tr + tf + \{ (BRH + 3) + (BRL + 3) \} / IIC\phi ]$
- ICFER.SCLE = 1 and ICFER.NFE = 1 and CKS[2:0] = 000b (IIC $\phi$  = PCLKB)  
Transfer rate =  $1 / [ \{ (BRH + 3 + nf * 3) + (BRL + 3 + nf) \} / IIC\phi + tr + tf ]$   
Duty cycle =  $[ tr + \{ (BRH + 3 + nf) / IIC\phi \} ] / [ tr + tf + \{ (BRH + 3 + nf) + (BRL + 3 + nf) \} / IIC\phi ]$
- ICFER.SCLE = 1 and ICFER.NFE = 0 and CKS[2:0]  $\neq$  000b  
Transfer rate =  $1 / [ \{ (BRH + 2) + (BRL + 2) \} / IIC\phi + tr + tf ]$   
Duty cycle =  $[ tr + \{ (BRH + 2) / IIC\phi \} ] / [ tr + tf + \{ (BRH + 2) + (BRL + 2) \} / IIC\phi ]$
- ICFER.SCLE = 1 and ICFER.NFE = 1 and CKS[2:0]  $\neq$  000b  
Transfer rate =  $1 / [ \{ (BRH + 2 + nf) + (BRL + 2 + nf) \} / IIC\phi + tr + tf ]$   
Duty cycle =  $[ tr + \{ (BRH + 2 + nf) / IIC\phi \} ] / [ tr + tf + \{ (BRH + 2 + nf) + (BRL + 2 + nf) \} / IIC\phi ]$

Note 1. IIC $\phi$  = PCLKB  $\times$  division ratio

Note 2. The SCLn line rise time (tr) and SCLn line fall time (tf) depend on the total bus line capacitance (Cb) and the pull-up resistor (Rp). For details, see the I<sup>2</sup>C bus standard from NXP Semiconductors.

Note 3. nf = Number of digital noise filters selected in the ICMR3.NF bit.

**Table 28.6 Example of ICBRH/ICBRL Settings for Transfer Rate IIC when SCLE = 0**

| Transfer rate (kbps) | CKS[2:0] (ICMR1) | BRH[4:0] (ICBRH) | BRL[4:0] (ICBRL) | PCLKB (MHz) | NF[1:0] | Computation expression |
|----------------------|------------------|------------------|------------------|-------------|---------|------------------------|
| 100                  | 011b             | 24 (0xF8)        | 30 (0xFE)        | 50          | —       | (1)                    |
| 400                  | 010b             | 7 (0xE7)         | 15 (0xEF)        | 50          | —       | (1)                    |
| 1000                 | 000b             | 12 (0xEC)        | 24 (0xF8)        | 50          | —       | (1)                    |

**Table 28.7 Example of ICBRH/ICBRL Settings for Transfer Rate when SCLE = 1 and NFE = 0**

| Transfer rate (kbps) | CKS[2:0] (ICMR1) | BRH[4:0] (ICBRH) | BRL[4:0] (ICBRL) | PCLKB (MHz) | NF[1:0] | Computation expression |
|----------------------|------------------|------------------|------------------|-------------|---------|------------------------|
| 100                  | 100b             | 11 (0xEB)        | 13 (0xED)        | 50          | —       | (4)                    |
| 400                  | 001b             | 13 (0xED)        | 31 (0xFF)        | 50          | —       | (4)                    |
| 1000                 | 000b             | 10 (0xEA)        | 22 (0xF6)        | 50          | —       | (2)                    |

**Table 28.8 Example of ICBRH/ICBRL Settings for Transfer Rate when SCLE = 1 and NFE = 1**

| Transfer rate (kbps) | CKS[2:0] (ICMR1) | BRH[4:0] (ICBRH) | BRL[4:0] (ICBRL) | PCLKB (MHz) | NF[1:0] | Computation expression |
|----------------------|------------------|------------------|------------------|-------------|---------|------------------------|
| 100                  | 011b             | 21 (0xF5)        | 26 (0xFA)        | 50          | 01b     | (5)                    |
| 400                  | 001b             | 11 (0xEB)        | 29 (0xFD)        | 50          | 01b     | (5)                    |
| 1000                 | 000b             | 8 (0xE8)         | 20 (0xF4)        | 50          | 01b     | (3)                    |

ICBRH使用CKS[2:0]位中指定的内部参考时钟源(IIC $\phi$ )计算高电平周期ICMR1。

如果启用了数字噪声滤波器 (ICFER中的NFE位为1)，请将这些位设置为至少比噪声滤波器中的级数大1的值。关于噪声滤波器的级数，请参见第28.2.5节中对NF[1:0]位的说明。ICMR3：I2C总线模式寄存器3。

IIC传输速率和SCL时钟占空比使用以下表达式(1)到(5)计算：

- ICFER.SCLE = 0  
传输率 =  $1 / [ \{ (BRH + 1) + (BRL + 1) \} / IIC\phi * 1 + tr * 2 + tf * 2 ]$   
占空比 =  $[ tr + \{ (BRH + 1) / IIC\phi \} ] / [ tr + tf + \{ (BRH + 1) + (BRL + 1) \} / IIC\phi ]$
- ICFER.SCLE = 1且ICFER.NFE = 0且CKS[2:0] = 000b (IIC $\phi$  = PCLKB) 传输速率 =  $1 / [ \{ (BRH + 3) + (BRL + 3) \} / IIC\phi + tr + tf ]$   
占空比 =  $[ tr + \{ (BRH + 3) / IIC\phi \} ] / [ tr + tf + \{ (BRH + 3) + (BRL + 3) \} / IIC\phi ]$
- ICFER.SCLE = 1且ICFER.NFE = 1且CKS[2:0] = 000b (IIC $\phi$  = PCLKB) 传输速率 =  $1 / [ \{ (BRH + 3 + nf * 3) + (BRL + 3 + nf) \} / IIC\phi + tr + tf ]$   
占空比 =  $[ tr + \{ (BRH + 3 + nf) / IIC\phi \} ] / [ tr + tf + \{ (BRH + 3 + nf) + (BRL + 3 + nf) \} / IIC\phi ]$
- ICFER.SCLE = 1且ICFER.NFE = 0且CKS[2:0]  $\neq$  000b 传输率 =  $1 / [ \{ (BRH + 2) + (BRL + 2) \} / IIC\phi + tr + tf ]$   
占空比 =  $[ tr + \{ (BRH + 2) / IIC\phi \} ] / [ tr + tf + \{ (BRH + 2) + (BRL + 2) \} / IIC\phi ]$
- ICFER.SCLE = 1且ICFER.NFE = 1且CKS[2:0]  $\neq$  000b 传输率 =  $1 / [ \{ (BRH + 2 + nf) + (BRL + 2 + nf) \} / IIC\phi + tr + tf ]$   
占空比 =  $[ tr + \{ (BRH + 2 + nf) / IIC\phi \} ] / [ tr + tf + \{ (BRH + 2 + nf) + (BRL + 2 + nf) \} / IIC\phi ]$

注1.IIC $\phi$ =PCLKB $\times$ 分频比

注2.SCLn线路上升时间(tr)和SCLn线路下降时间(tf)取决于总线电容(Cb)和上拉电阻(Rp)。有关详细信息，请参阅NXP Semiconductors的I2C总线标准。

注3.nf=在ICMR3.NF位中选择的数字噪声滤波器的数量。

**Table 28.6 SCLE=0时传输速率IIC的ICBRHICBRL设置示例**

| 传输速率(kbps) | CKS[2:0] (ICMR1) | BRH[4:0] (ICBRH) | BRL[4:0] (ICBRL) | PCLKB (MHz) | NF[1:0] | 计算表达式 |
|------------|------------------|------------------|------------------|-------------|---------|-------|
| 100        | 011b             | 24 (0xF8)        | 30 (0xFE)        | 50          | —       | (1)   |
| 400        | 010b             | 7 (0xE7)         | 15 (0xEF)        | 50          | —       | (1)   |
| 1000       | 000b             | 12 (0xEC)        | 24 (0xF8)        | 50          | —       | (1)   |

**Table 28.7 SCLE=1和NFE=0时传输速率的ICBRHICBRL设置示例**

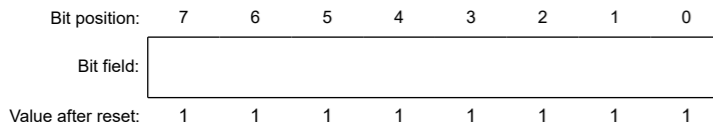
| 传输速率(kbps) | CKS[2:0] (ICMR1) | BRH[4:0] (ICBRH) | BRL[4:0] (ICBRL) | PCLKB (MHz) | NF[1:0] | 计算表达式 |
|------------|------------------|------------------|------------------|-------------|---------|-------|
| 100        | 100b             | 11 (0xEB)        | 13 (0xED)        | 50          | —       | (4)   |
| 400        | 001b             | 13 (0xED)        | 31 (0xFF)        | 50          | —       | (4)   |
| 1000       | 000b             | 10 (0xEA)        | 22 (0xF6)        | 50          | —       | (2)   |

**Table 28.8 SCLE=1和NFE=1时传输速率的ICBRHICBRL设置示例**

| 传输速率(kbps) | CKS[2:0] (ICMR1) | BRH[4:0] (ICBRH) | BRL[4:0] (ICBRL) | PCLKB (MHz) | NF[1:0] | 计算表达式 |
|------------|------------------|------------------|------------------|-------------|---------|-------|
| 100        | 011b             | 21 (0xF5)        | 26 (0xFA)        | 50          | 01b     | (5)   |
| 400        | 001b             | 11 (0xEB)        | 29 (0xFD)        | 50          | 01b     | (5)   |
| 1000       | 000b             | 8 (0xE8)         | 20 (0xF4)        | 50          | 01b     | (3)   |

### 28.2.17 ICDRT : I<sup>2</sup>C Bus Transmit Data Register

Base address: IICn = 0x4009\_F000 + 0x0100 × n (n = 0, 1)  
Offset address: 0x12



When ICDRT detects a space in the I<sup>2</sup>C Bus Shift Register (ICDRS), it transfers the transmit data that was written to ICDRT to ICDRS and starts transmitting data in transmit mode. The double-buffer structure of ICDRT and ICDRS allows continuous transmit operation if the next transmit data is written to ICDRT while the ICDRS data is being transmitted.

ICDRT can always be read and written to. Write transmit data to ICDRT once when a transmit data empty interrupt (IICn\_TXI) request is generated.

### 28.2.18 ICDRR : I<sup>2</sup>C Bus Receive Data Register

Base address: IICn = 0x4009\_F000 + 0x0100 × n (n = 0, 1)  
Offset address: 0x13

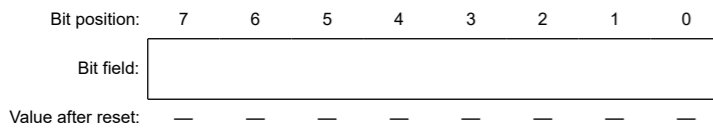


When 1 byte of data is received, the received data is transferred from the I<sup>2</sup>C Bus Shift Register (ICDRS) to ICDRR to enable the next data to be received. The double-buffer structure of ICDRS and ICDRR allows continuous receive operation if the received data is read from ICDRR while ICDRS is receiving data. ICDRR cannot be written to. Read data from ICDRR once when a receive data full interrupt (IICn\_RXI) request is generated.

If ICDRR receives the next receive data before the current data is read from ICDRR (while the RDRF flag in ICSR2 is 1), the IIC automatically holds the SCL clock low 1 cycle before the RDRF flag is set to 1 next.

### 28.2.19 ICDRS : I<sup>2</sup>C Bus Shift Register

Base address: n/a  
Offset address: n/a



ICDRS is an 8-bit shift register for data transmit and receive. During transmission, transmit data is transferred from ICDRT to ICDRS and is transmitted from the SDAn pin. During reception, data is transferred from ICDRS to ICDRR after 1 byte of data is received. ICDRS cannot be accessed directly.

## 28.3 Operation

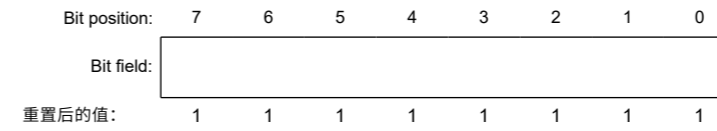
### 28.3.1 Communication Data Format

The I<sup>2</sup>C bus format consists of 8-bit data and 1-bit acknowledge. The frame following a start or restart condition is an address frame that specifies a slave device with which the master device communicates. The specified slave is valid until a new slave is specified or a stop condition is issued.

Figure 28.3 shows the I<sup>2</sup>C bus format, and Figure 28.4 shows the I<sup>2</sup>C bus timing.

### 28.2.17 ICDRT: I2C总线发送数据寄存器

Base address: IICn = 0x4009\_F000 + 0x0100 × n (n = 0, 1)  
Offset address: 0x12

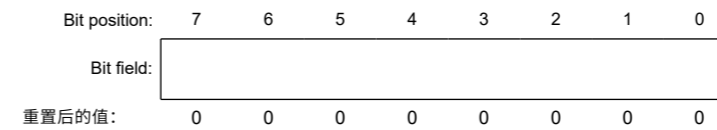


当ICDRT检测到I2C总线移位寄存器(ICDRS)中有空间时，它将写入ICDRT的发送数据传输到ICDRS，并开始在发送模式下发送数据。ICDRT和ICDRS的双缓冲结构允许在传输ICDRS数据的同时将下一个传输数据写入ICDRT的连续传输操作。

ICDRT始终可以被读取和写入。当产生发送数据空中断 (IICn\_TXI) 请求时，将发送数据写入ICDRT。

### 28.2.18 ICDRR:I2C总线接收数据寄存器

Base address: IICn = 0x4009\_F000 + 0x0100 × n (n = 0, 1)  
Offset address: 0x13

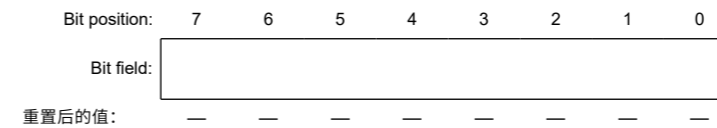


当接收到1个字节的数据时，接收到的数据会从I2C总线移位寄存器(ICDRS)传输到ICDRR，以便接收下一个数据。如果在ICDRS正在接收数据时从ICDRR读取接收到的数据，ICDRS和ICDRR的双缓冲结构允许连续接收操作。无法写入ICDRR。当产生接收数据完全中断(IICn\_RXI)请求时，从ICDRR读取数据一次。

如果ICDRR在从ICDRR读取当前数据之前接收到下一个接收数据（此时ICSR2中的RDRF标志为1），则IIC在下一个RDRF标志设置为1之前自动将SCL时钟保持低1个周期。

### 28.2.19 ICDRS:I2C总线移位寄存器

Base address: n/a  
Offset address: n/a



ICDRS是一个用于数据发送和接收的8位移位寄存器。在传输期间，传输数据从ICDRT传输到ICDRS，并从SDAn引脚传输。在接收过程中，接收到1个字节的数据后，数据从ICDRS传输到ICDRR。ICDRS不能直接访问。

## 28.3 Operation

### 28.3.1 通讯数据格式

I2C总线格式由8位数据和1位确认组成。开始或重启条件之后的帧是地址帧，它指定与主设备通信的从设备。指定的从站有效，直到指定新的从站或发出停止条件。

图28.3显示了I2C总线格式，图28.4显示了I2C总线时序。

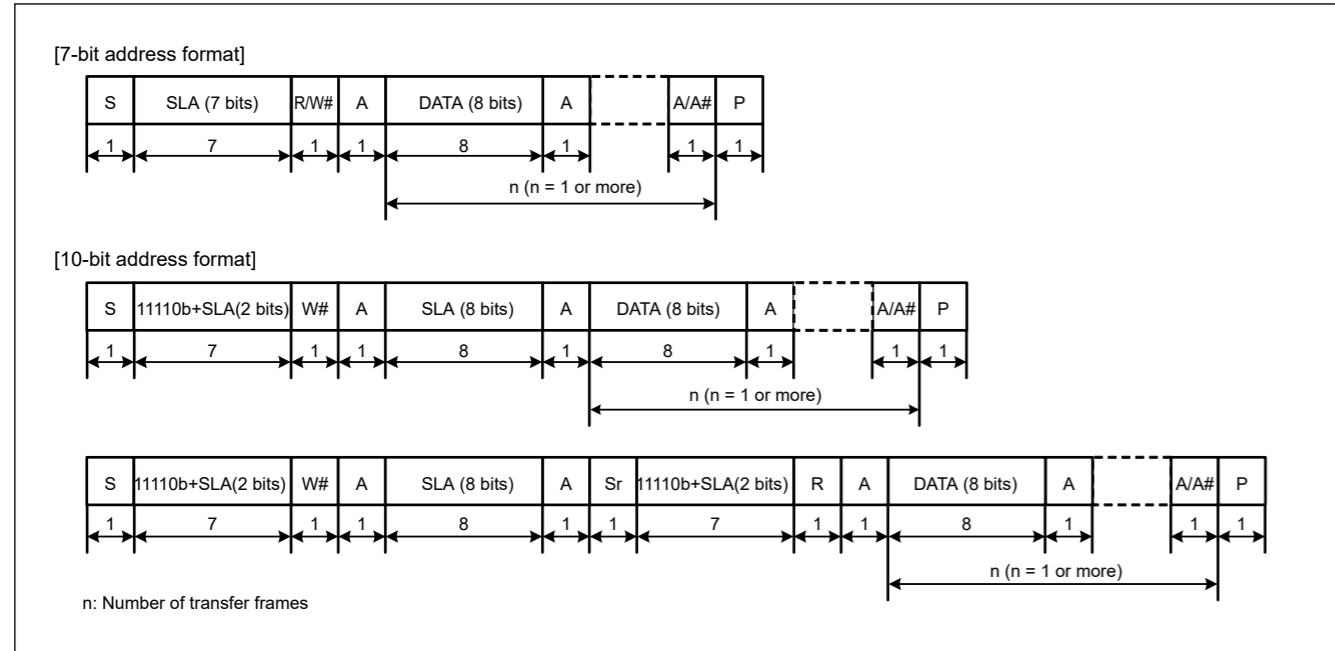


Figure 28.3 I2C bus format

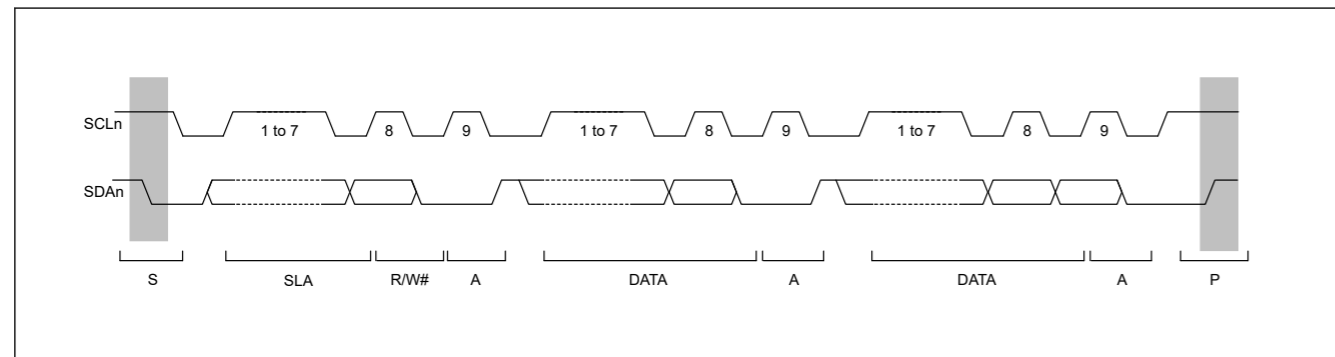


Figure 28.4 I2C bus timing when the SLA setting = 7 bits

- S: Start condition. The master device drives the SDAn line low from high while the SCLn line is high.
- SLA: Slave address, by which the master device selects a slave device.
- R/W#: Indicates the direction of data transfer: from the slave device to the master device when R/W# is 1, or from the master device to the slave device when R/W# is 0.
- A: Acknowledge. The receive device drives the SDAn line low. In master transmit mode, the slave device returns acknowledge. In master receive mode, the master device returns acknowledge.
- A#: Not Acknowledge. The receive device drives the SDAn line high.
- Sr: Restart condition. The master device drives the SDAn line low from the high level after the setup time has elapsed with the SCLn line high.
- DATA: Transmitted or received data.
- P: Stop condition. The master device drives the SDAn line high from low while the SCLn line is high.

### 28.3.2 Initial Settings

Before starting data transmission or reception, initialize the IIC using the procedure shown in Figure 28.5.

1. Set the ICCR1.ICE bit to 0 to set the SCLn and SDAn pins to the inactive state.
2. Set the ICCR1.IICRST bit to 1 to initiate IIC reset.
3. Set the ICCR1.ICE bit to 1 to initiate internal reset.
4. Set the SARLy, SARUy, ICSEr, ICMR1, ICBRH, and ICBRL registers (y = 0 to 2), and set the other registers as required. For initial settings of the IIC, see Figure 28.5.

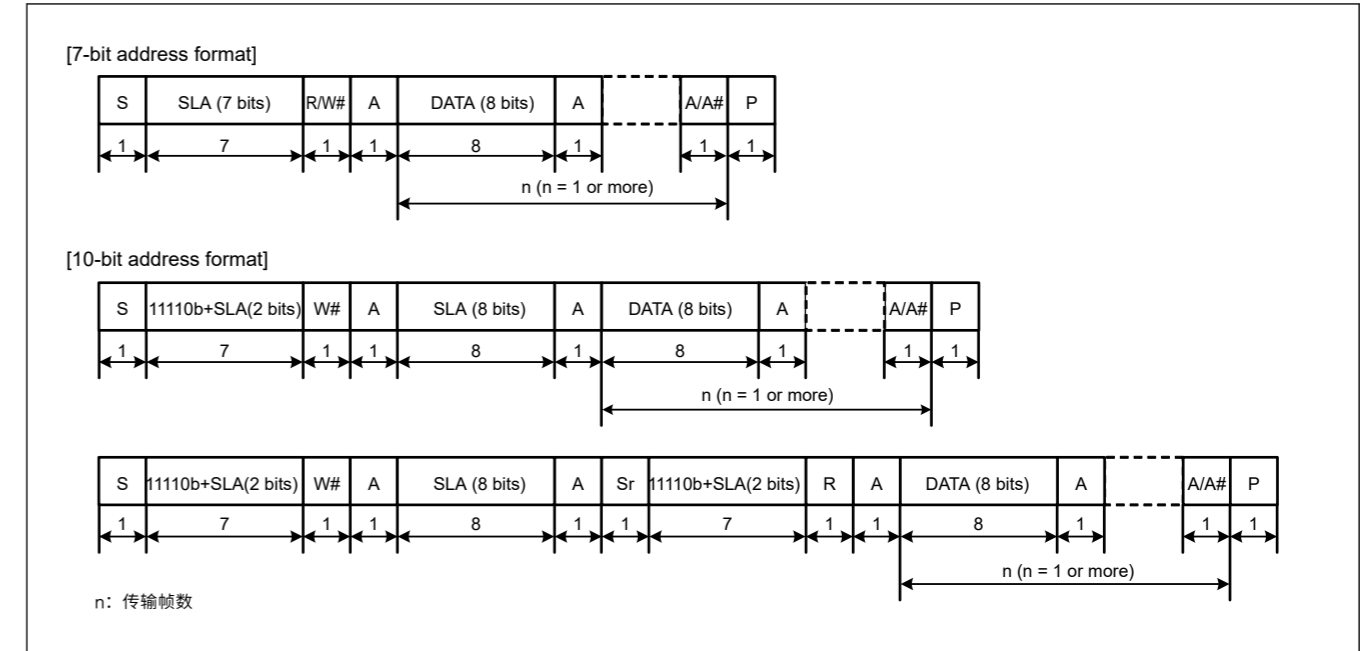


Figure 28.3 I2C总线格式

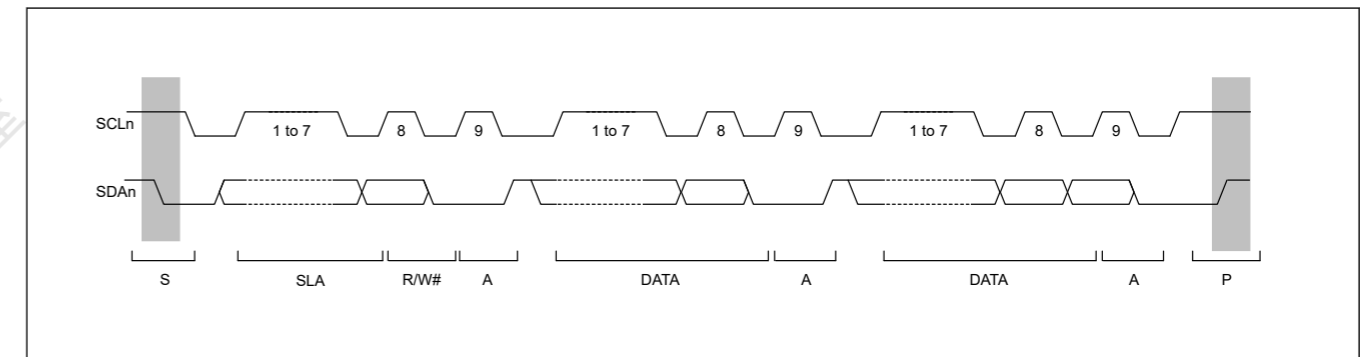


Figure 28.4 SLA设置=7位时的I2C总线时序

- S: 启动条件。主设备将SDAn线从高电平驱动为低电平，而SCLn线为高电平。
- SLA: 从地址，主设备通过该地址选择从设备。
- R/W#: 指示数据传输的方向：当RW#为1时从从设备到主设备，或者当RW#为0时从主设备到从设备。
- A: 承认。接收设备将SDAn线驱动为低电平。在主发送模式下，从设备返回确认。在主接收模式下，主设备返回确认。
- A#: 不承认。接收设备将SDAn线驱动为高电平。
- Sr: 重启条件。建立时间过后，主设备将SDAn线从高电平驱动为低电平 SCLn线高。
- DATA: 传输或接收的数据。
- P: 停止条件。主设备将SDAn线从低电平驱动至高电平，而SCLn线为高电平。

### 28.3.2 初始设置

在开始数据发送或接收之前，使用图28.5所示的过程初始化IIC。

1. 将ICCR1.ICE位设置为0，将SCLn和SDAn引脚设置为无效状态。
2. 将ICCR1.IICRST位设置为1以启动IIC复位。
3. 将ICCR1.ICE位设置为1以启动内部复位。
4. 设置SARLy、SARUy、ICSEr、ICMR1、ICBRH和ICBRL寄存器 (y=0到2)，并根据需要设置其他寄存器。IIC的初始设置见图28.5。



5. When the required register settings are complete, set the ICCR1.IICRST bit to 0 to release the IIC reset.

This procedure is not required if the IIC initialization is already complete.

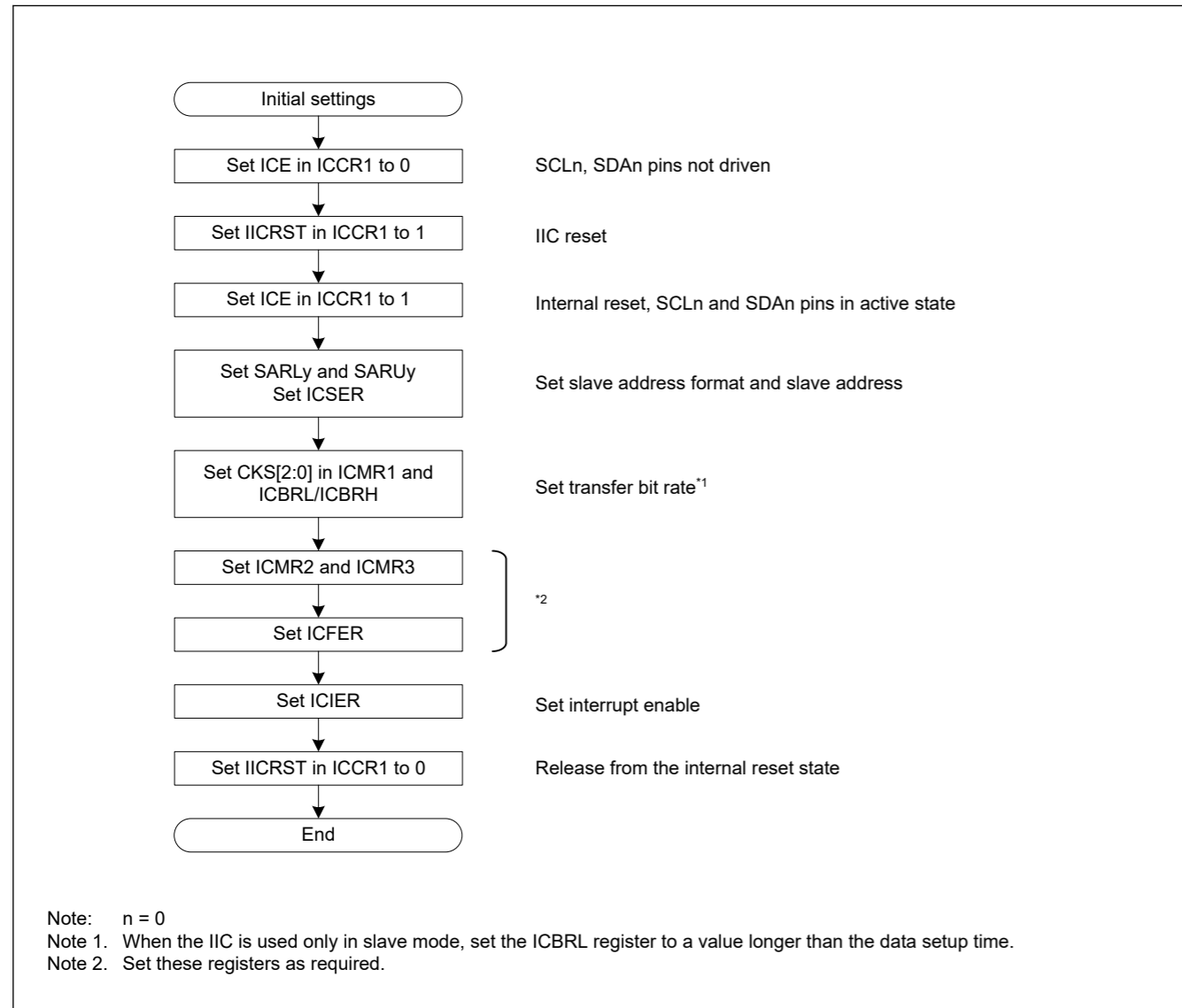


Figure 28.5 Example IIC initialization flow

### 28.3.3 Master Transmit Operation

In master transmit operation, the IIC outputs the SCL clock and transmitted data signals as the master device, and the slave device returns acknowledgments. Figure 28.6 shows an example of master transmission, and Figure 28.7 to Figure 28.9 show the operation timing in master transmission.

To set up and perform master transmission:

1. Process initial settings. For details, see section 28.3.2. Initial Settings.
2. Read the BBSY flag in ICCR2 to check that the bus is free, and then set the ST bit in ICCR2 to 1 (start condition request). On receiving the request, the IIC issues a start condition. At the same time, the BBSY and START flags in ICSR2 automatically set to 1 and the ST bit automatically is set to 0. At this time, if the start condition is detected and the internal levels for the SDA output state and the levels on the SDAn line match while the ST bit is 1, the IIC recognizes that issuance of the start condition as requested by the ST bit is successfully complete, and the MST and TRS bits in ICCR2 automatically set to 1, placing the IIC in master transmit mode. The TDRE flag in ICSR2 also automatically is set to 1 in response to the setting of the TRS bit to 1.

5.完成所需的寄存器设置后，将ICCR1.IICRST位设置为0以释放IIC复位。

如果IIC初始化已经完成，则不需要此过程。

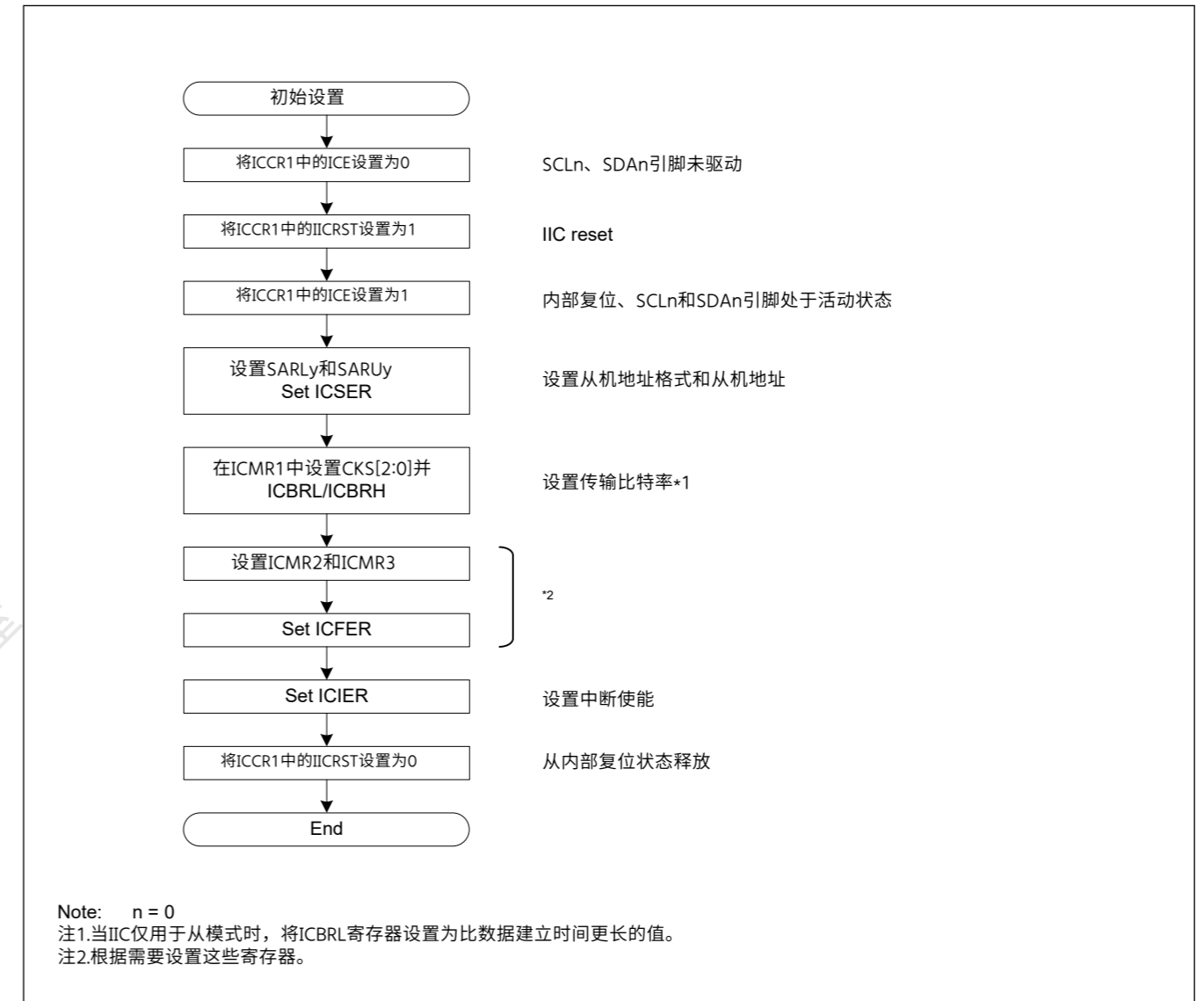


Figure 28.5 示例IIC初始化流程

### 28.3.3 主发送操作

在主设备发送操作中，IIC作为主设备输出SCL时钟和发送的数据信号，从设备返回确认。图28.6显示了主传输的示例，图28.7至图28.9显示了主传输中的操作时序。

设置和执行主传输：

- 1.处理初始设置。详见28.3.2节。初始设置。
- 2.读取ICCR2中的BBSY标志，检查总线是否空闲，然后将ICCR2中的ST位设置为1（启动条件要求）。收到请求后，IIC发出一个开始条件。同时，ICSR2中的BBSY和START标志位自动置1，ST位自动置0。此时，如果检测到启动条件，内部电平为SDA输出状态和当ST位为1时SDAn线匹配，IIC识别出ST位请求的启动条件的发布已成功完成，并且ICCR2中的MST和TRS位自动设置为1，将IIC置于主机发送模式。ICSR2中的TDRE标志也自动设置为1，以响应TRS位设置为1。

3. Check that the TDRE flag in ICSR2 is 1, and then write the value for transmission (the slave address and the R/W# bit) to ICDRT. When the transmit data is written to ICDRT, the TDRE flag automatically is set to 0, the data is transferred from ICDRT to ICDRS, and the TDRE flag again is set to 1. After the byte containing the slave address and R/W# bit is transmitted, the value of the TRS bit automatically updates to select master transmit or master receive mode based on the value of the transmitted R/W# bit. If the value of the R/W# bit was 0, the IIC continues in master transmit mode. Because the ICSR2.NACKF flag being 1 at this time indicates that no slave device recognized the address or there was an error in communications, write 1 to the ICCR2.SP bit to issue a stop condition. For data transmission with an address in the 10-bit format, start by writing 11110b, the 2 higher-order bits of the slave address, and W to ICDRT as the first address transmission. For the second address transmission, write the 8 lower-order bits of the slave address to ICDRT.
4. Check that the TDRE flag in ICSR2 is 1, and then write the transmit data to the ICDRT register. The IIC automatically holds the SCLn line low until the transmit data is ready or a stop condition is issued.
5. After all bytes of transmit data are written to the ICDRT register, wait until the value in the TEND flag in ICSR2 returns to 1, and then set the SP bit in ICCR2 to 1 (stop condition requested). On receiving a stop condition request, the IIC issues the stop condition. Regarding issuing a stop condition, see [section 28.11.3. Issuing a Stop Condition](#).
6. On detecting the stop condition, the IIC automatically sets the MST and TRS bits in ICCR2 to 00b and enters slave receive mode. Additionally, it automatically sets the TDRE and TEND flags to 0, and sets the STOP flag in ICSR2 to 1.
7. Check that the ICSR2.STOP flag is 1, and then set the ICSR2.NACKF and STOP flags to 0 for the next transfer operation.

3.检查ICSR2中的TDRE标志是否为1,然后将要发送的值(从机地址和RW#位)写入ICDRT。当发送数据写入ICDRT时,TDRE标志自动设置为0,数据从ICDRT传输到ICDRS,TDRE标志再次设置为1。在发送包含从机地址和RW#位的字节后,TRS位的值会自动更新,以根据发送的RW#位的值选择主机发送或主机接收模式。如果RW#位的值为0,则IIC继续处于主机发送模式。因为此时ICSR2.NACKF标志为1表示没有从设备识别该地址或通信中有错误,所以向ICCR2.SP位写入1以发出停止条件。对于地址为10位格式的数据传输,首先将11110b、从机地址的高2位和W写入ICDRT作为第一个地址传输。对于第二次地址传输,将从地址的低8位写入ICDRT。

4.检查ICSR2中的TDRE标志是否为1,然后将发送数据写入ICDRT寄存器。IIC自动将SCLn线保持为低电平,直到发送数据准备好或发出停止条件。

5.将发送数据的所有字节写入ICDRT寄存器后,等待ICSR2中的TEND标志中的值返回1,然后将ICCR2中的SP位设置为1(请求停止条件)。在收到停止条件请求时,IIC发出停止条件。关于发出停止条件,请参阅第28.11.3节。发出停止条件。

6.在检测到停止条件时,IIC自动将ICCR2中的MST和TRS位设置为00b并进入从机接收模式。此外,它自动将TDRE和TEND标志设置为0,并将ICSR2中的STOP标志设置为1。

7.检查ICSR2.STOP标志是否为1,然后将ICSR2.NACKF和STOP标志设置为0以进行下一次传输操作。

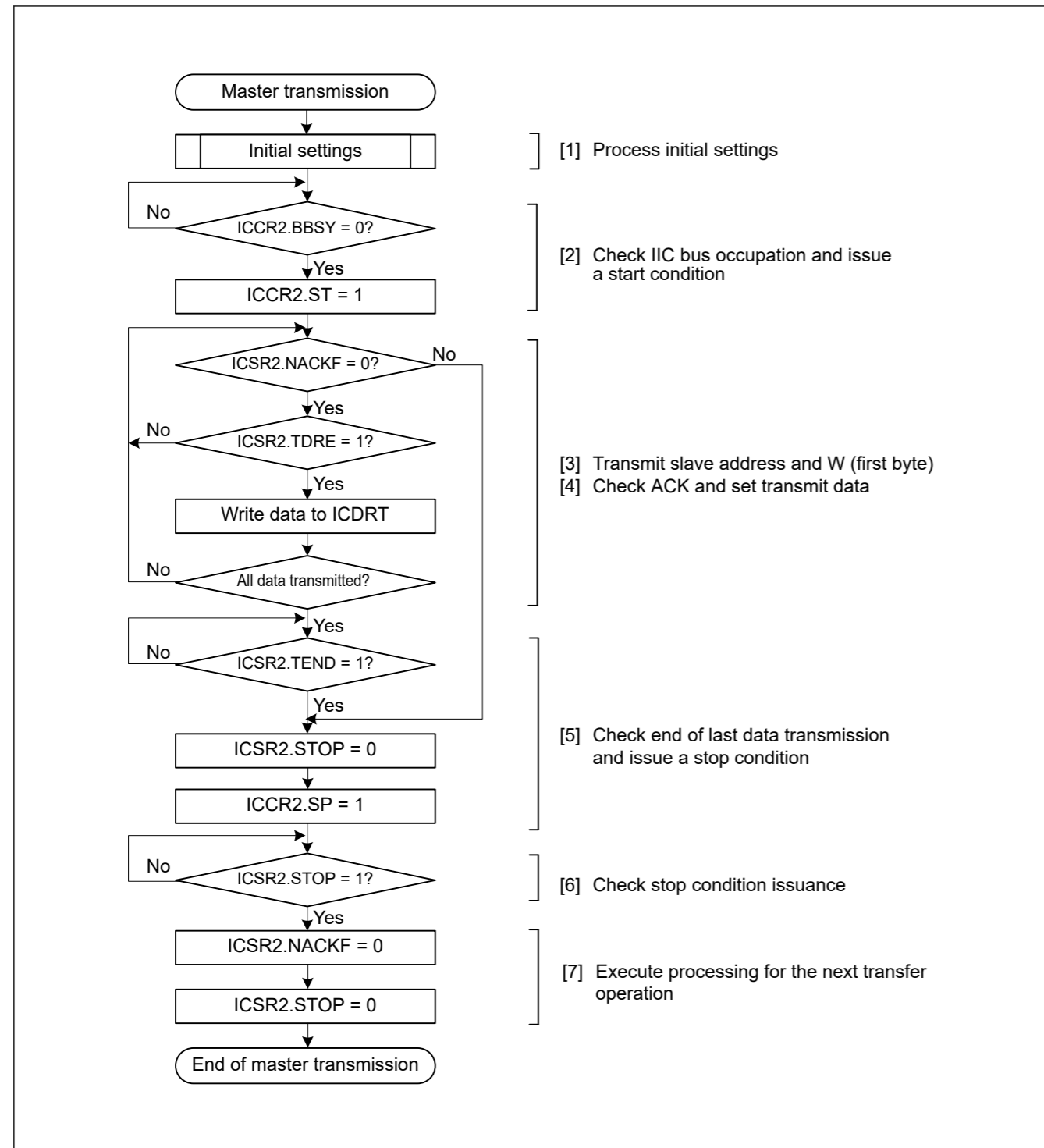


Figure 28.6 Example master transmission flow

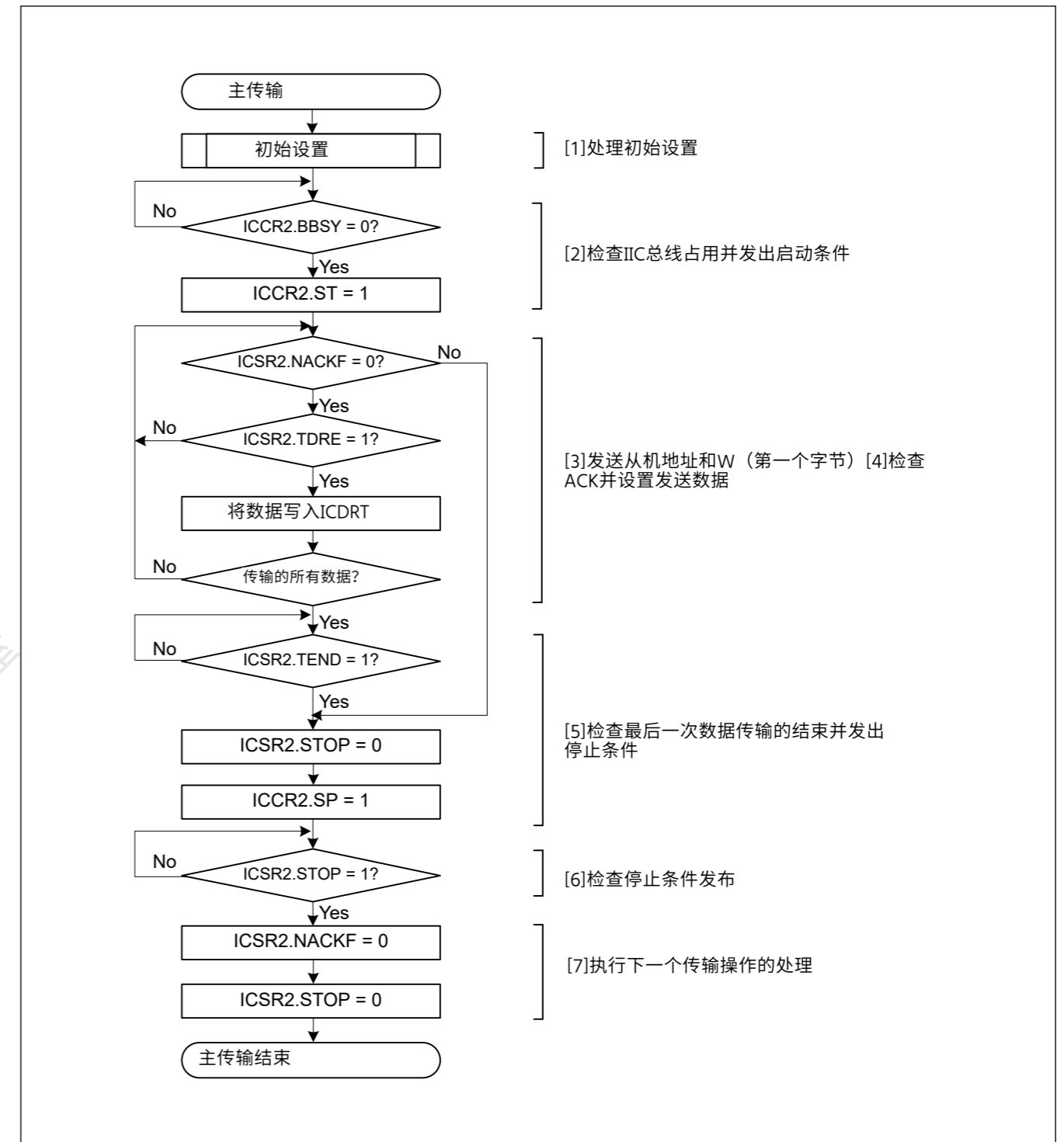


Figure 28.6 示例主传输流程

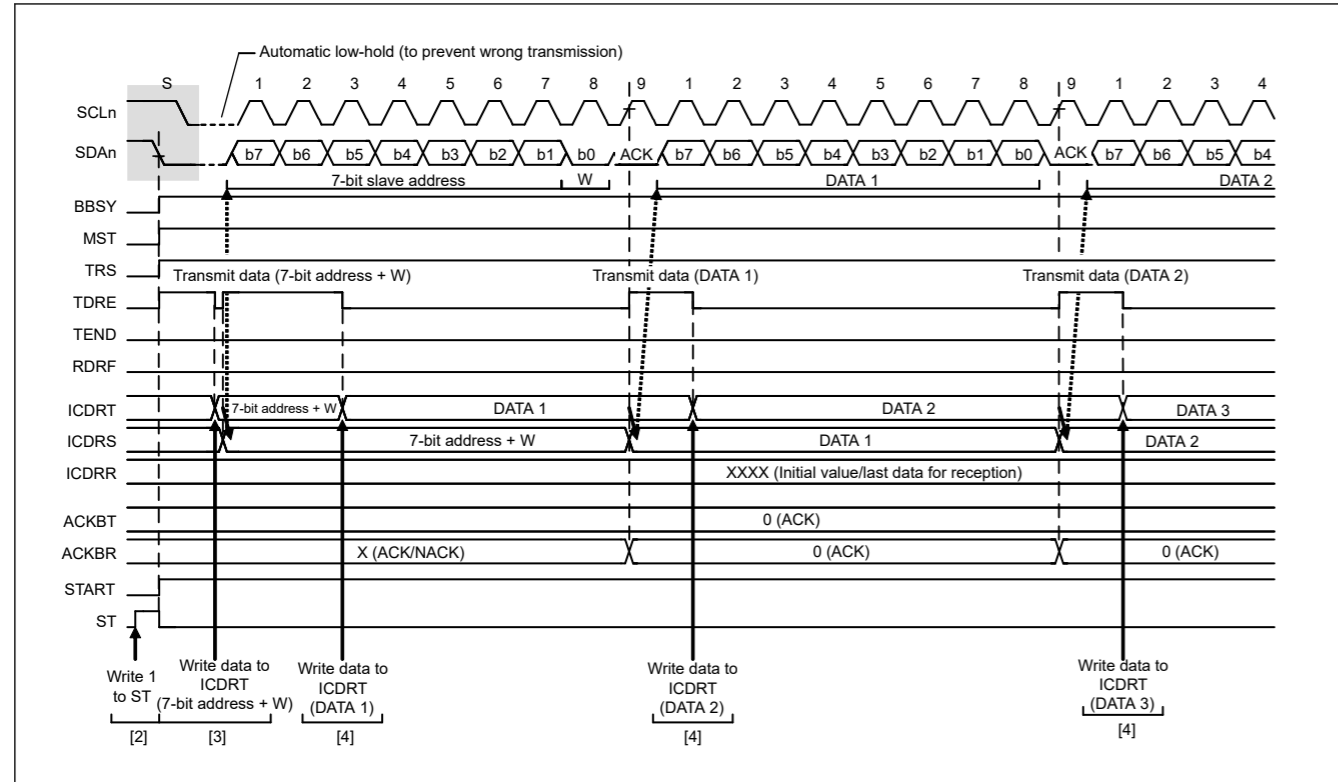


Figure 28.7 Master transmit operation timing (1) with 7-bit address format

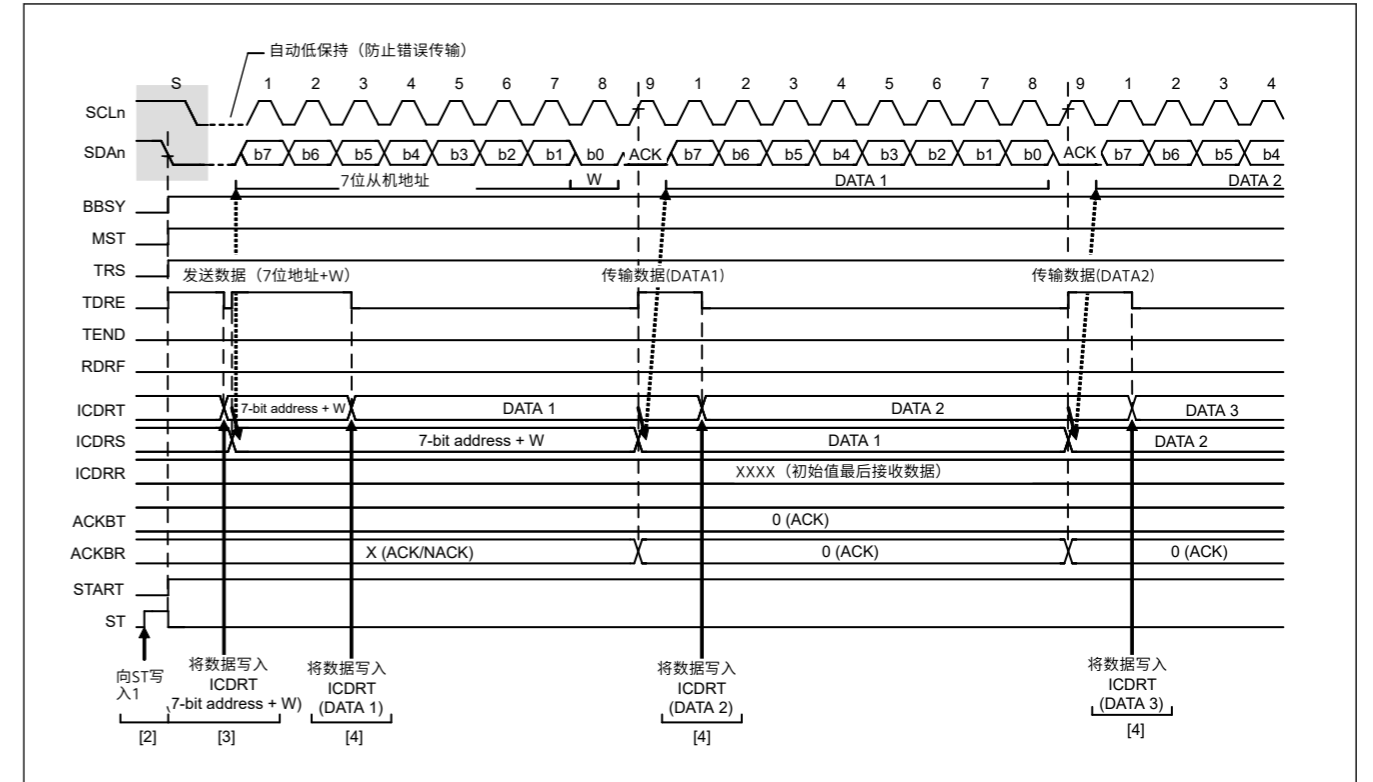


Figure 28.7 7位地址格式的主机发送操作时序(1)

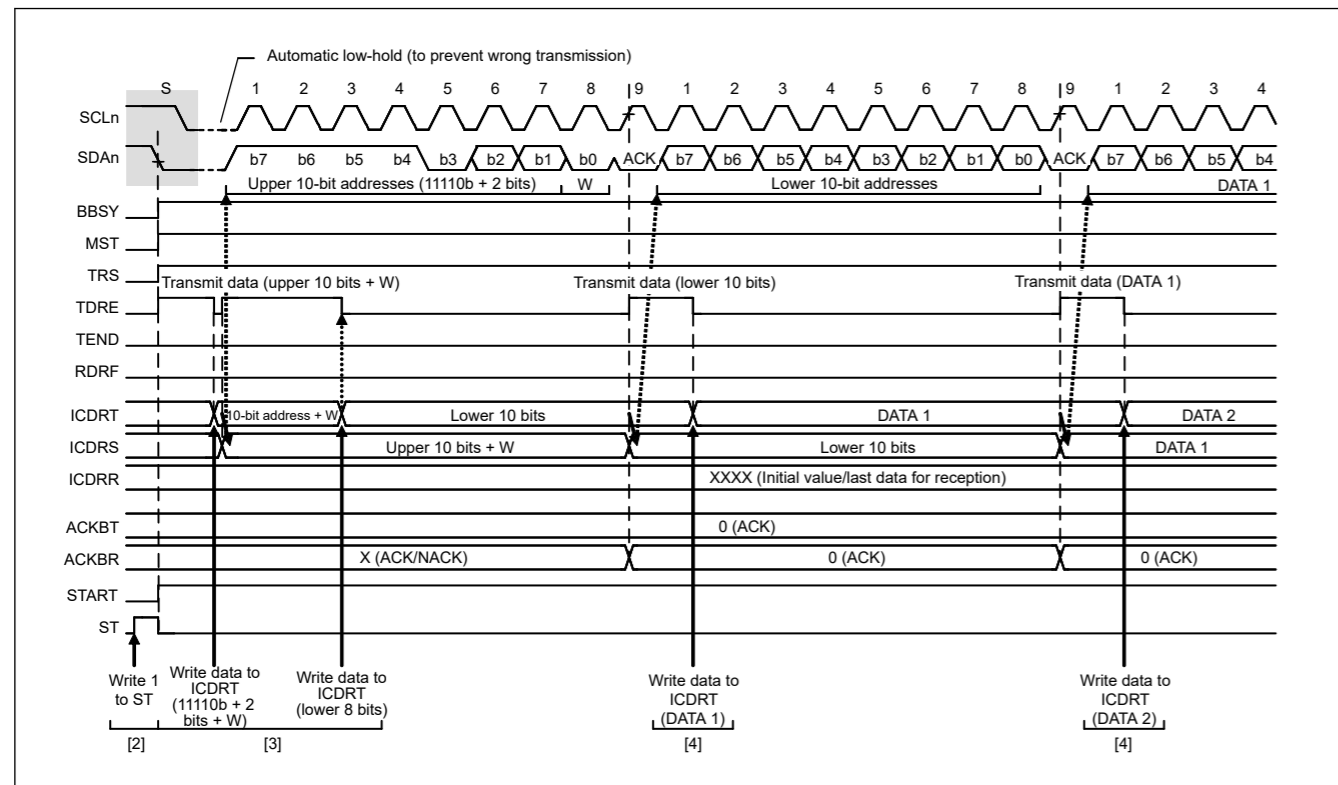


Figure 28.8 Master transmit operation timing (2) with 10-bit address format

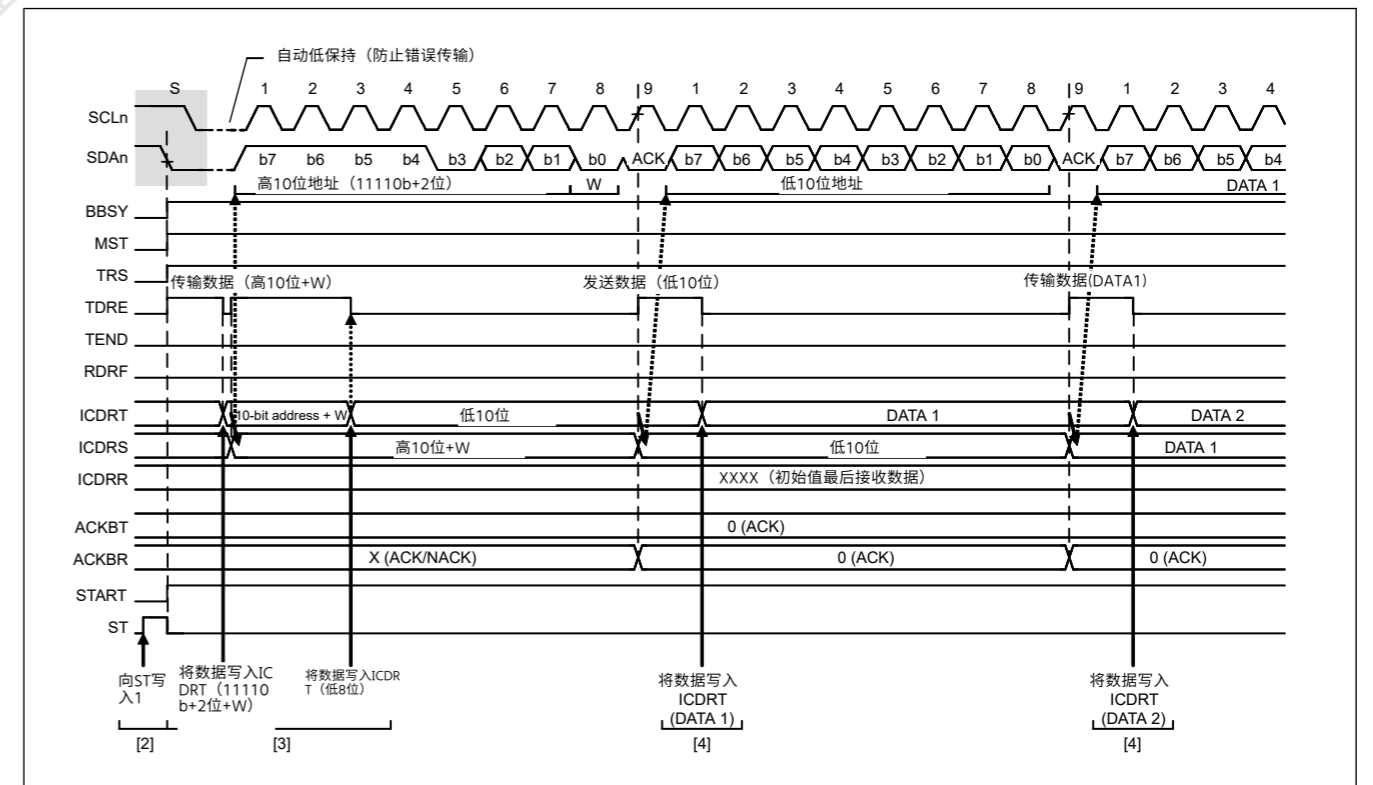


Figure 28.8 10位地址格式的主机发送操作时序(2)



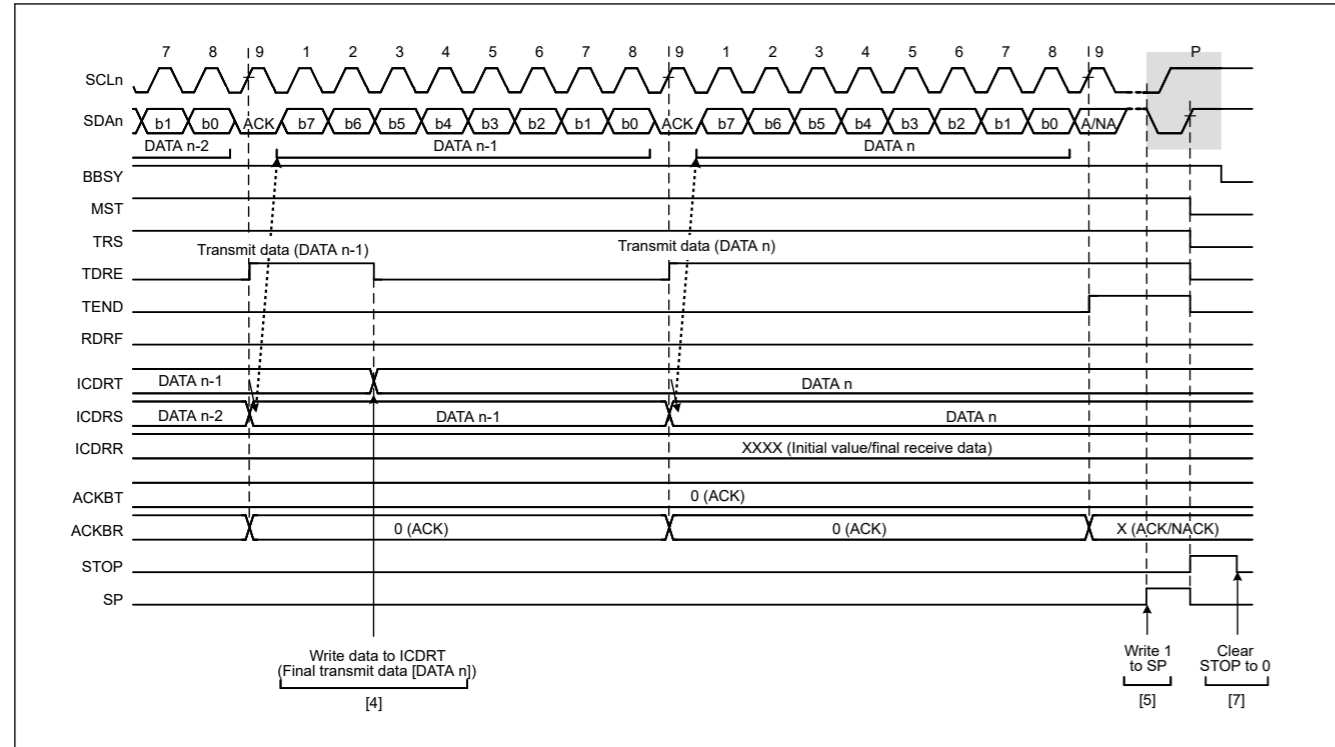


Figure 28.9 Master transmit operation timing (3)

### 28.3.4 Master Receive Operation

In master receive operation, the IIC as a master device outputs the SCL clock, receives data from the slave device, and returns acknowledgments. Because the IIC must start by sending a slave address to the associated slave device, this part of the procedure is performed in master transmit mode, but the subsequent steps are in master receive mode.

Figure 28.10 and Figure 28.11 show examples of master reception (7-bit address format), and Figure 28.12 to Figure 28.14 show the operation timing in master reception.

To set up and perform master reception:

1. Process initial settings. For details, see [section 28.3.2. Initial Settings](#).
2. Read the BBSY flag in ICCR2 to check that the bus is free, and then set the ST bit in ICCR2 to 1 (start condition request). On receiving the request, the IIC issues a start condition. When the IIC detects the start condition, the BBSY and START flags in ICSR2 automatically set to 1, and the ST bit automatically is set to 0. At this time, if the start condition is detected and the levels for the SDA output and the levels on the SDA<sub>n</sub> line match while the ST bit is 1, the IIC recognizes that issuance of the start condition as requested by the ST bit is successfully complete, and the MST and TRS bits in ICCR2 automatically set to 1, placing the IIC in master transmit mode. The TDRE flag in ICSR2 also automatically is set to 1 in response to the setting of the TRS bit to 1.
3. Check that the TDRE flag in ICSR2 is 1, and then write the value for transmission (the first byte indicates the slave address and value of the R/W# bit) to ICDRT. When the transmit data is written to ICDRT, the TDRE flag automatically is set to 0, the data is transferred from ICDRT to ICDRS, and the TDRE flag again is set to 1. When the byte containing the slave address and R/W# bit is transmitted, the value of the ICCR2.TRS bit automatically updates to select transmit or receive mode based on the value of the transmitted R/W# bit. If the value of the R/W# bit is 1, the TRS bit is set to 0 on the rising edge of the ninth cycle of the SCL clock, placing the IIC in master receive mode. At this time, the TDRE flag is set to 0 and the ICSR2.RDRF flag automatically is set to 1. Because the ICSR2.NACKF flag being 1 at this time indicates that no slave device recognized the address or there was an error in communications, write 1 to the ICCR2.SP bit to issue a stop condition. For master reception from a device with a 10-bit address, start by using master transmission to issue the 10-bit address, and then issue a restart condition. After that, transmitting 11110b, the two higher-order bits of the slave address, and the R bit places the IIC in master receive mode.
4. Dummy read ICDRR after confirming that the RDRF flag in ICSR2 is 1. This makes the IIC start output of the SCL clock and start data reception.

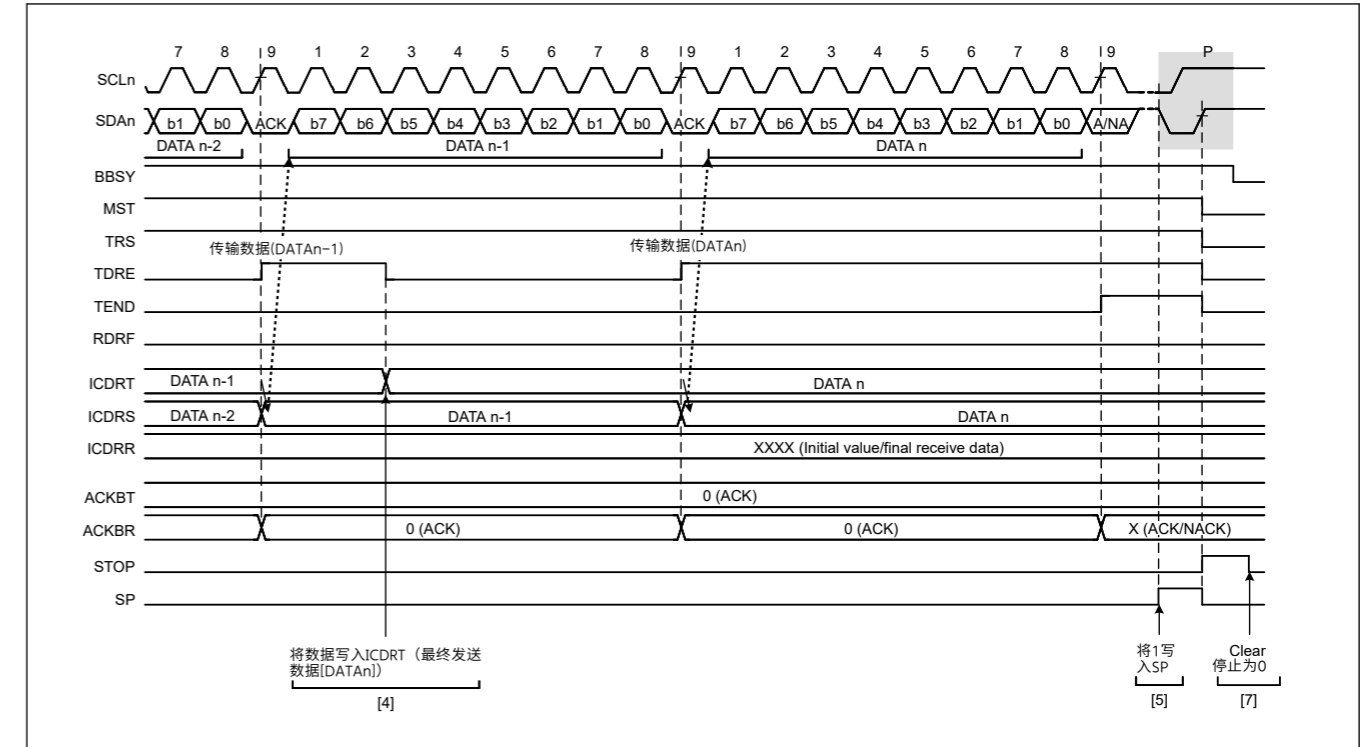


Figure 28.9 主机发送操作时序 (3)

### 28.3.4 主接收操作

在主设备接收操作中，作为主设备的IIC输出SCL时钟，从从设备接收数据，并返回确认。因为IIC必须首先向相关的从设备发送一个从地址，所以这部分程序在主发送模式下执行，但后续步骤在主接收模式下执行。

图28.10和图28.11显示了主机接收示例（7位地址格式），图28.12至图28.14显示了主机接收中的操作时序。

设置和执行主接收：

- 1.处理初始设置。详见28.3.2节。初始设置。
- 2.读取ICCR2中的BBSY标志，检查总线是否空闲，然后将ICCR2中的ST位设置为1（启动条件要求）。收到请求后，IIC发出一个开始条件。当IIC检测到启动条件时，ICSR2中的BBSY和START标志位自动置1，ST位自动置0。此时，如果检测到启动条件，则SDA输出的电平和平在ST位为1时SDA<sub>n</sub>线匹配时，IIC识别出由ST位请求的启动条件的发布已成功完成，并且MST和TRC2中的TRS位自动设置为1，将IIC置于主机发送模式。ICSR2中的TDRE标志也自动设置为1，以响应TRC2.S位设置为1。
- 3、检查ICSR2中的TDRE标志为1，然后写入值进行发送（第一个字节表示从机RW#位的地址和值）到ICDRT。当发送数据写入ICDRT时，TDRE标志自动设置为0，数据从ICDRT传输到ICDRS，TDRE标志再次设置为1。当发送包含从机地址和RW#位的字节时，ICCR2.TRS位的值自动更新以根据发送的RW#位的值选择发送或接收模式。如果RW#位的值为1，则在SCL时钟的第9个周期的上升沿将TRS位设置为0，将IIC置于主机接收模式。此时TDRE标志置0，ICSR2.RDRF标志自动置1。因为此时ICSR2.NACKF标志为1表示没有从设备识别该地址或通信出现错误，向ICCR2.SP位写入1以发出停止条件。对于来自具有10位地址的设备的主机接收，首先使用主机发送来发出10位地址，然后发出重启条件。之后，发送11110b、从机地址的两个高阶位和R位将IIC置于主机接收模式。
- 4.确认ICSR2中的RDRF标志为1后伪读ICDRR。这使得IIC开始输出SCL时钟并开始数据接收。

5. After 1 byte of data is received, the RDRF flag in ICSR2 is set to 1 on the rising edge of the 8th or 9th cycle of the SCL clock, as selected in the RDRFS bit in ICMR3. Reading ICDRR at this time produces the received data, and the RDRF flag is automatically set to 0 at the same time. Additionally, the value of the acknowledgment field received during the ninth cycle of the SCL clock is returned as the value set in the ICMR3.ACKBT bit. If the next byte to be received is the second-to-last byte, set the ICMR3.WAIT bit to 1 for wait insertion before reading ICDRR, containing the second-to-last byte. In addition to enabling NACK output, even when interrupts or other operations result in delays in setting the ICMR3.ACKBT bit to 1 (NACK) in step (6), this fixes the SCLn line to the low level on the rising edge of the ninth clock cycle in reception of the last byte, which enables the issuing of a stop condition.
6. When the ICMR3.RDRFS bit is 0, and the slave device must be notified that it is to end transfer for data reception after transfer of the next and final byte, set the ICMR3.ACKBT bit to 1 (NACK).
7. After reading the second-to-last byte from the ICDRR register, if the value of the ICSR2.RDRF flag is 1, write 1 to the SP bit in ICCR2 (stop condition requested), and then read the last byte from ICDRR. When ICDRR is read, the IIC is released from the wait state and issues the stop condition after low-level output in the ninth clock cycle is complete or the SCLn line is released from the low-hold state.
8. On detecting the stop condition, the IIC automatically sets the MST and TRS bits in ICCR2 to 00b and enters slave receive mode. Additionally, detection of the stop condition sets the ICSR2.STOP flag to 1.
9. Check that the ICSR2.STOP flag is 1, then set the ICSR2.NACKF and STOP flags to 0 for the next transfer operation.

5. 接收到1个字节的數據后，在SCL时钟的第8或第9个周期的上升沿将ICSR2中的RDRF标志设置为1，这由ICMR3中的RDRFS位选择。此时读取ICDRR产生接收数据，同时RDRF标志位自动置0。此外，在SCL时钟的第9个周期内接收到的确认字段的值作为ICMR3.ACKBT位中设置的值返回。如果要接收的下一个字节是倒数第二个字节，则在读取包含倒数第二个字节的ICDRR之前将ICMR3.WAIT位设置为1以等待插入。除了使能NACK输出外，即使在中断或其他操作导致在步骤(6)中将ICMR3.ACKBT位设置为1(NACK)时出现延迟，这也会在第9次的上升沿将SCLn线固定为低电平接收最后一个字节的时钟周期，它可以发出停止条件。
6. 当ICMR3.RDRFS位为0时，必须通知从设备在传输下一个和最后一个字节后结束传输以进行数据接收，将ICMR3.ACKBT位设置为1(NACK)。
7. 从ICDRR寄存器中读取倒数第二个字节后，如果ICSR2.RDRF标志的值为1，则将1写入ICCR2中的SP位（请求停止条件），然后从ICDRR中读取最后一个字节。当读取ICDRR时，IIC从等待状态中释放，并在第9个时钟周期的低电平输出完成或SCLn线从低保持状态释放后发出停止条件。
8. 在检测到停止条件时，IIC自动将ICCR2中的MST和TRS位设置为00b并进入从机接收模式。此外，检测到停止条件会将ICSR2.STOP标志设置为1。
9. 检查ICSR2.STOP标志是否为1，然后将ICSR2.NACKF和STOP标志设置为0以进行下一次传输操作。

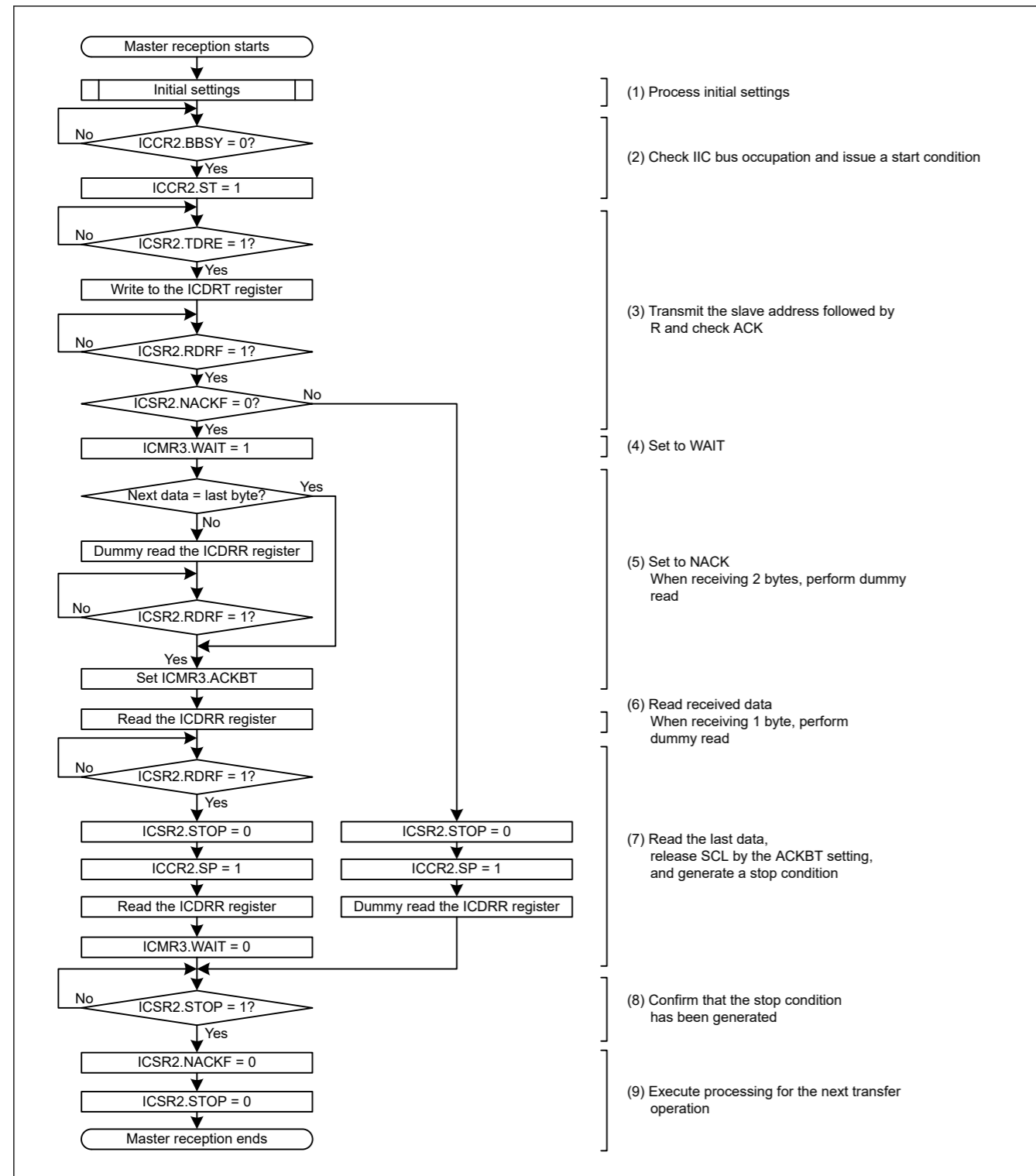


Figure 28.10 Example master reception flow with 7-bit address format of 1 byte or 2 bytes

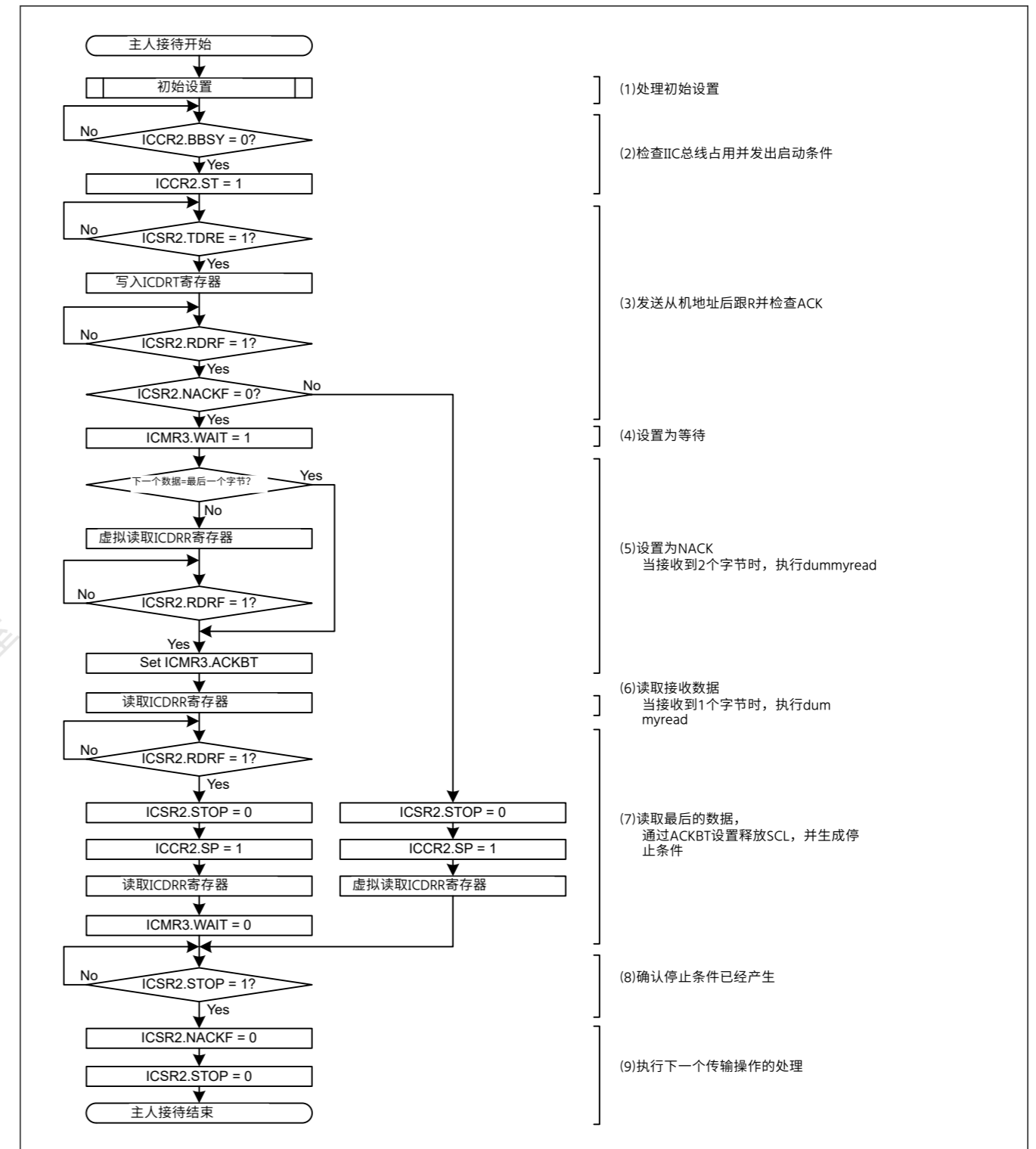


Figure 28.10 具有1字节或2字节的7位地址格式的主机接收流程示例

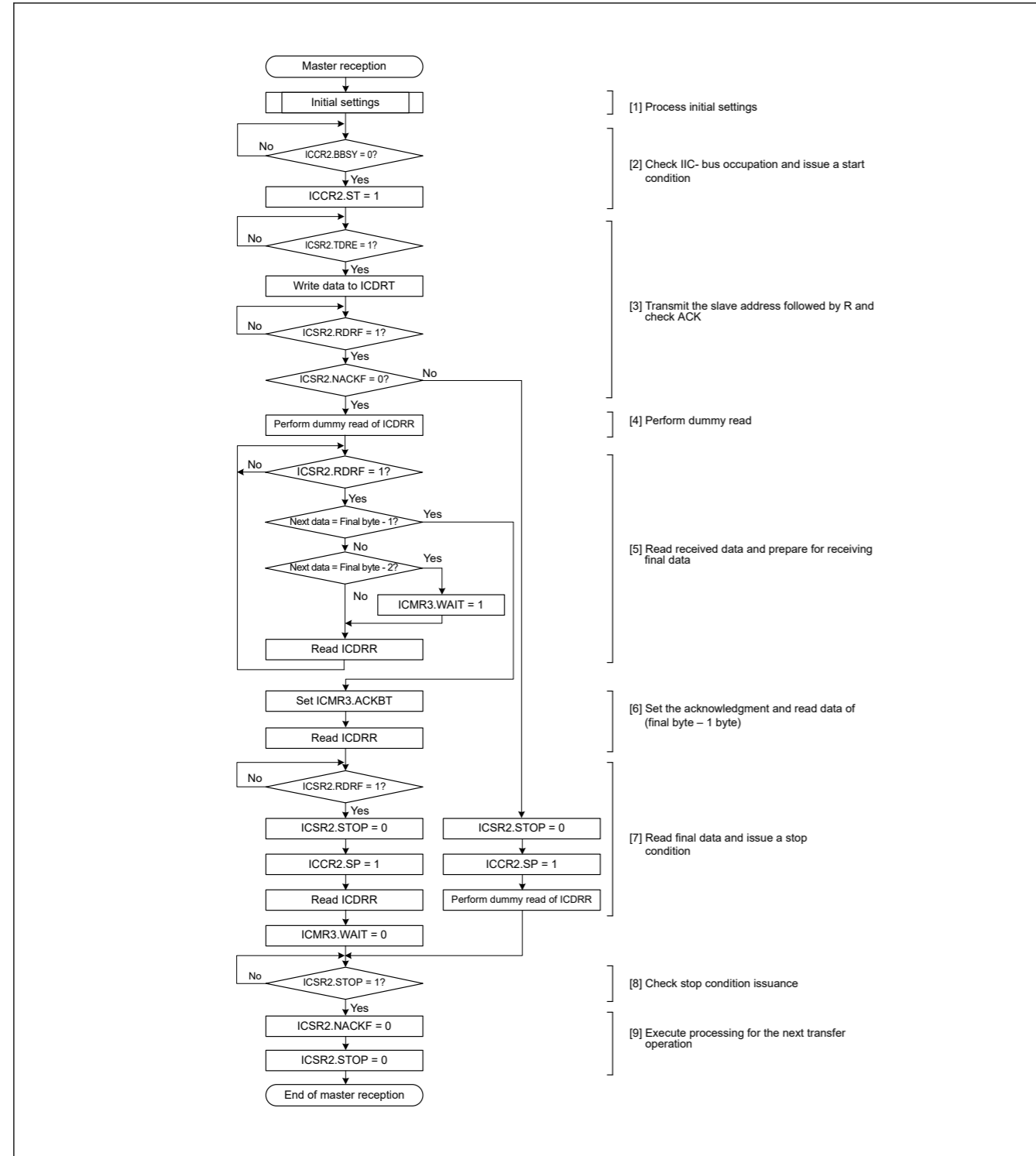


Figure 28.11 Example master reception flow with 7-bit address format of 3 or more bytes

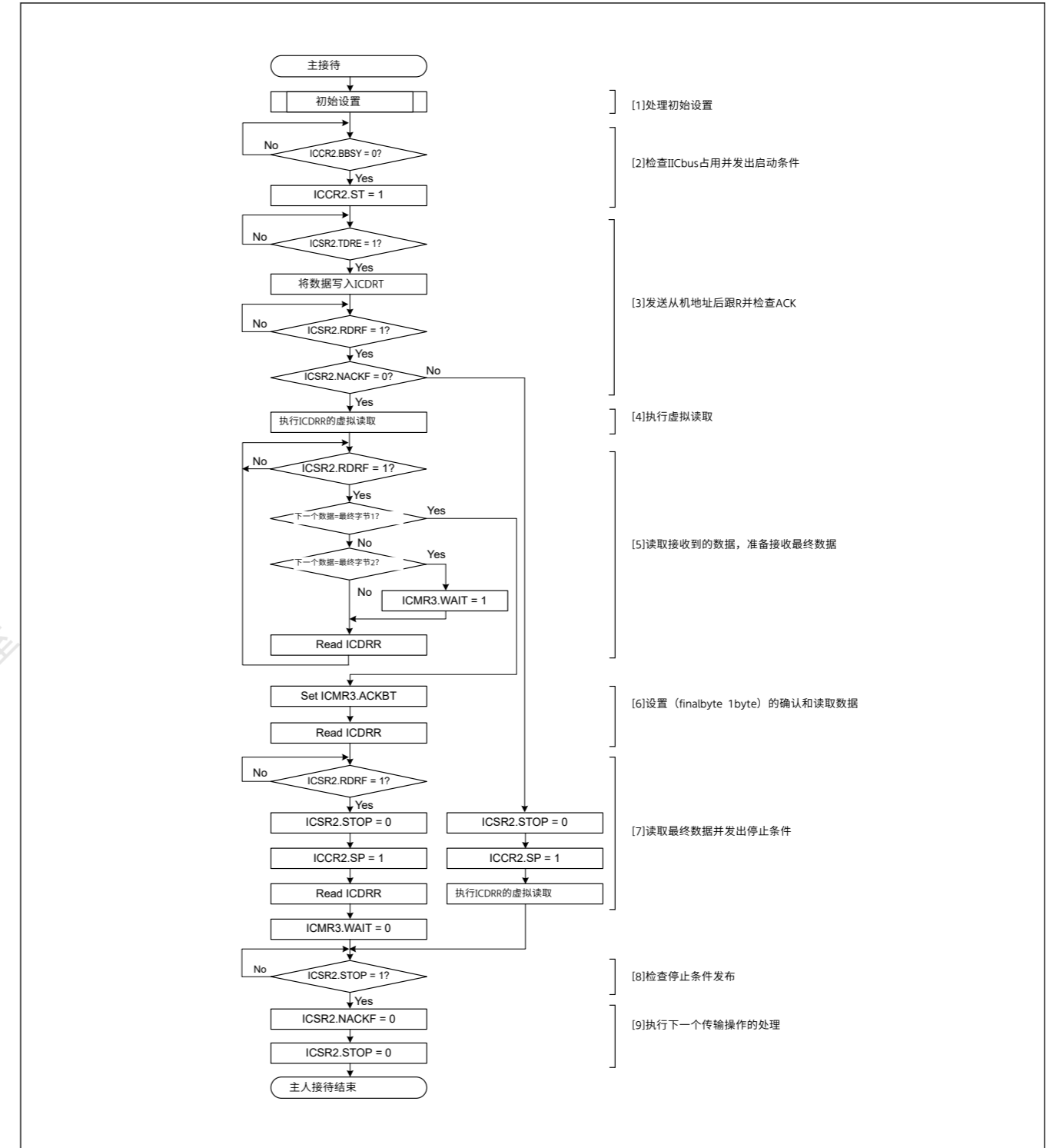


Figure 28.11 具有3个或更多字节的7位地址格式的示例主机接收流程



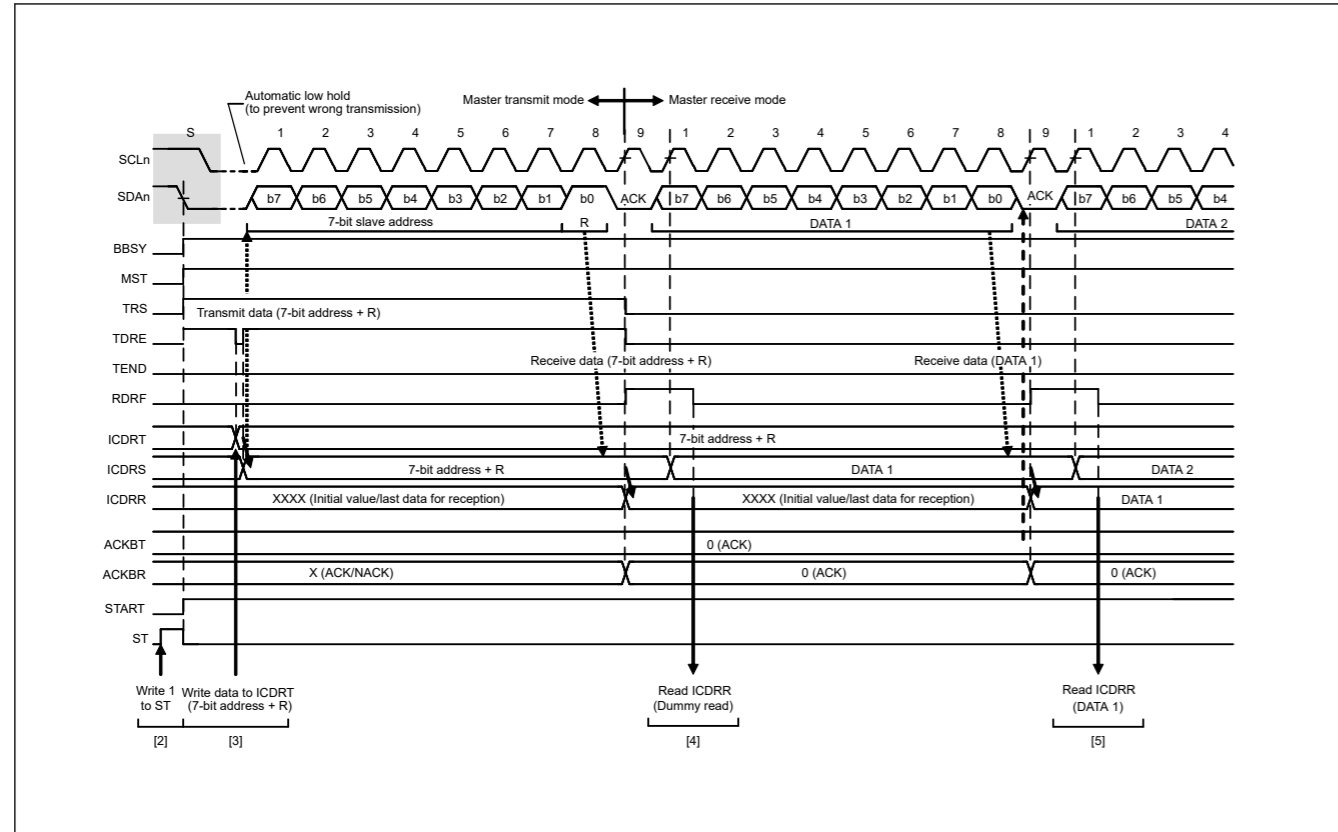


Figure 28.12 Master receive operation timing (1) with 7-bit address format when RDRFS = 0

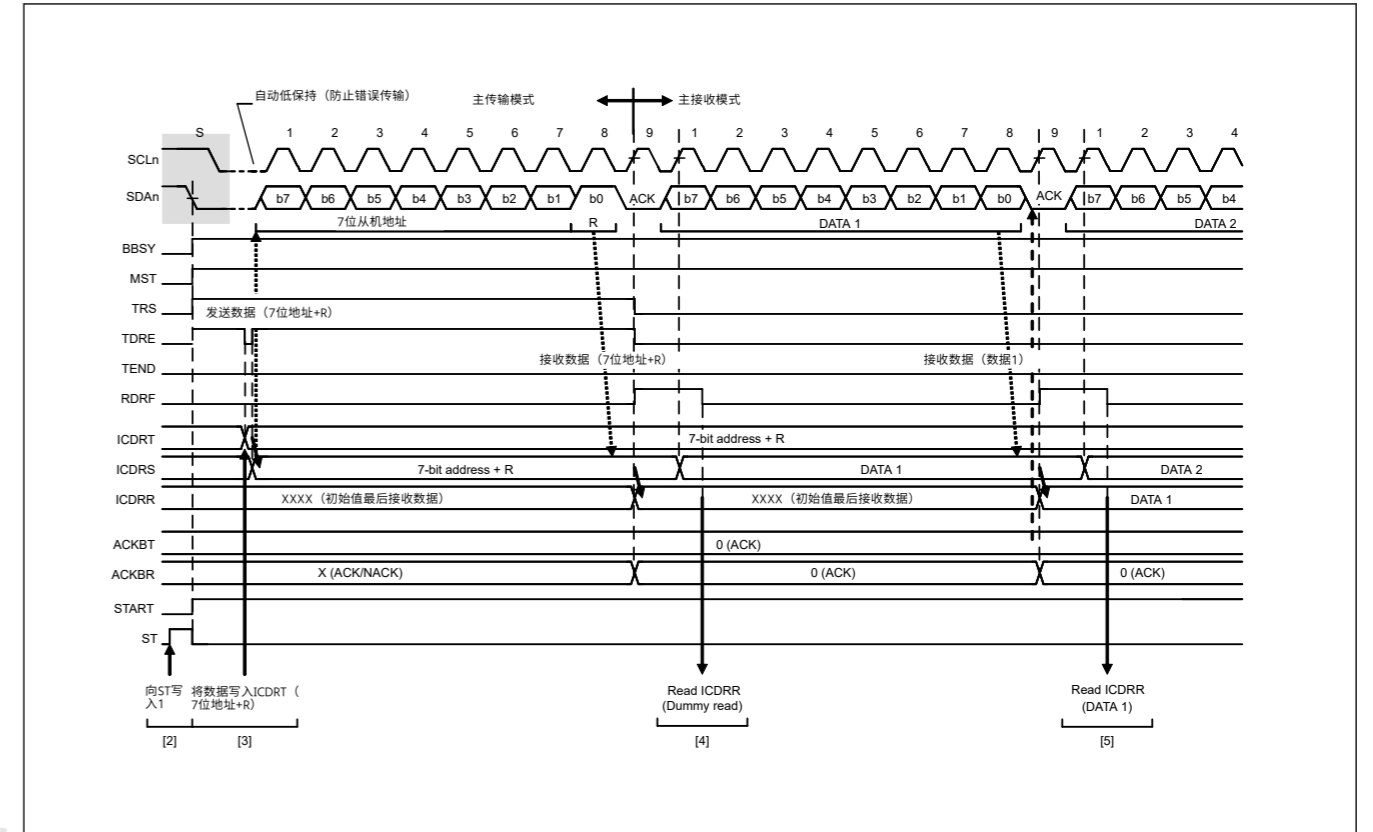


Figure 28.12 RDRFS=0时采用7位地址格式的主机接收操作时序(1)

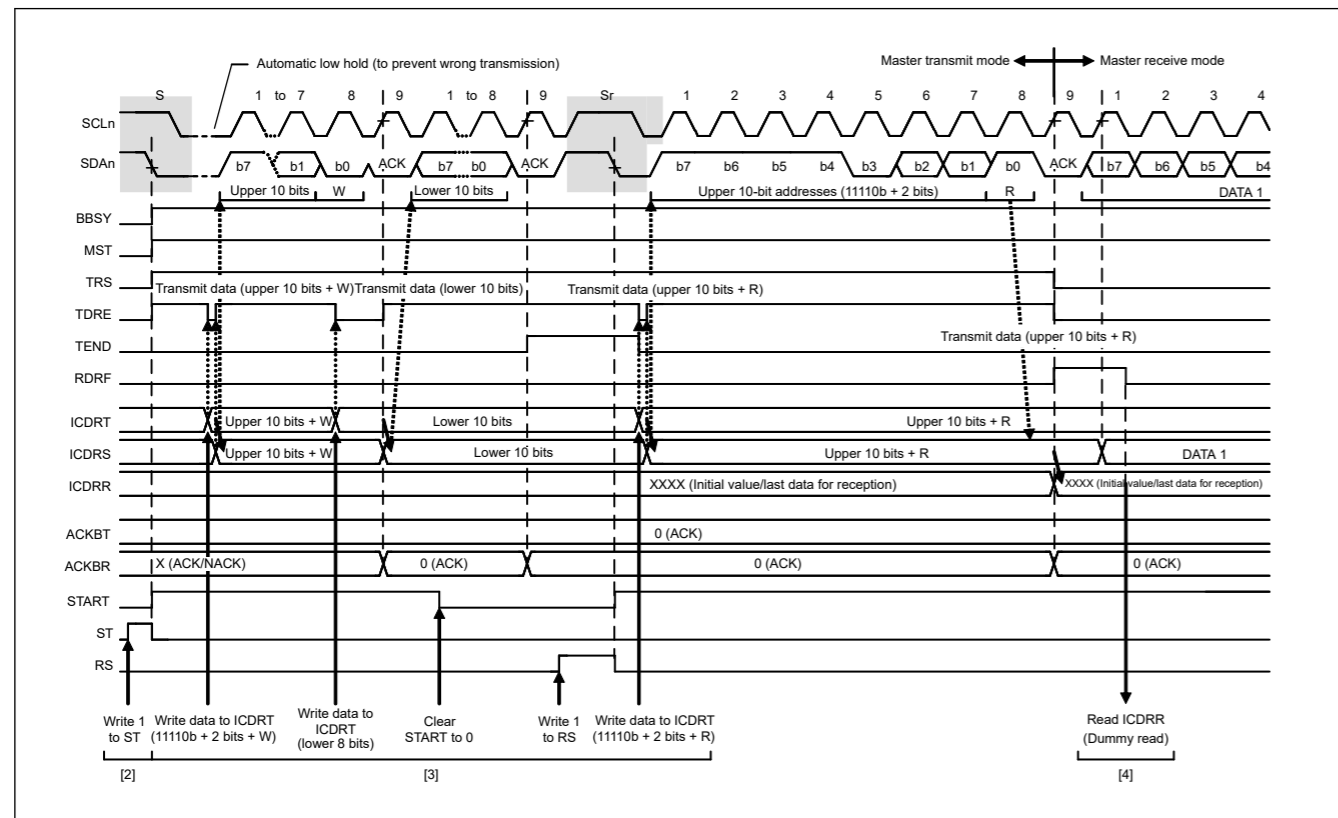


Figure 28.13 Master receive operation timing (2) with 10-bit address format when RDRFS = 0

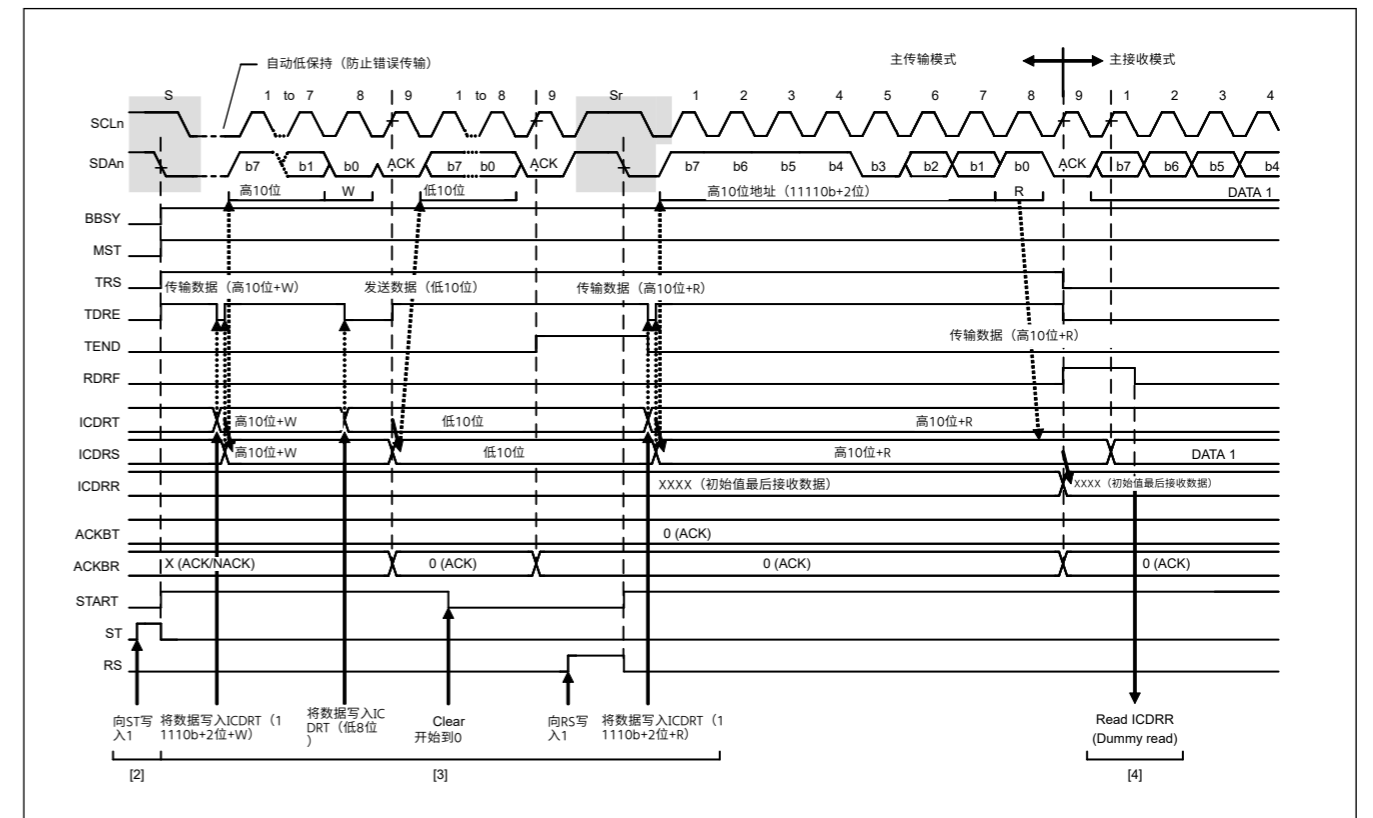


Figure 28.13 RDRFS=0时10位地址格式的主机接收操作时序(2)

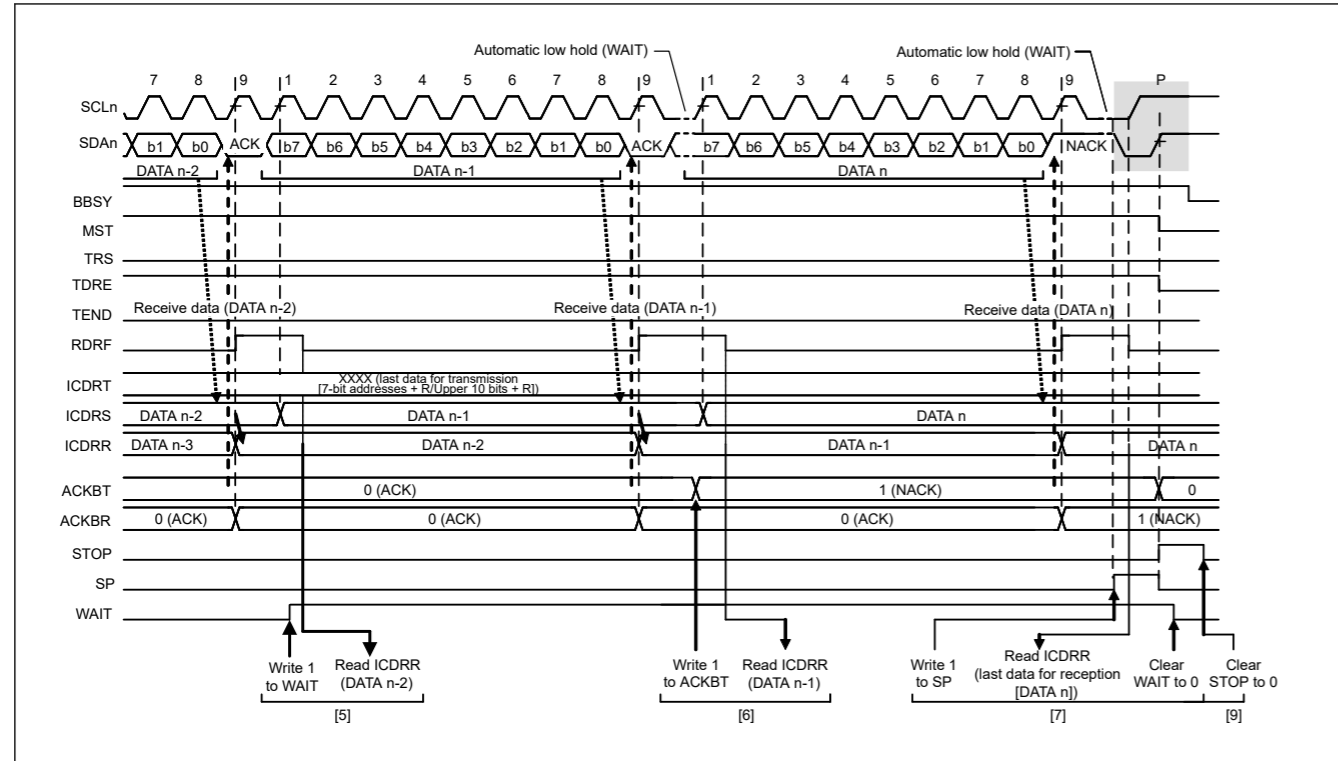


Figure 28.14 Master receive operation timing (3) when RDRFS = 0

### 28.3.5 Slave Transmit Operation

In slave transmit operation, the master device outputs the SCL clock, the IIC transmits data as a slave device, and the master device returns acknowledgments.

Figure 28.15 shows an example of slave transmission, and Figure 28.16 and Figure 28.17 show the operation timing in slave transmission.

To set up and perform slave transmission:

1. Initialize the IIC using the procedure in section 28.3.2. Initial Settings.  
After initialization, the IIC stays in the standby state until it receives a slave address that matches.
2. After receiving a matching slave address, the IIC sets one of the associated ICSR1.HOA, GCA, and AASy flags (y = 0 to 2) to 1 on the rising edge of the ninth cycle of the SCL clock and outputs the value set in the ICMR3.ACKBT bit to the acknowledge bit on the ninth cycle of the SCL clock. If the value of the R/W# bit is 1, the IIC automatically places itself in slave transmit mode by setting both the ICCR2.TRS bit and the ICSR2.TDRE flag to 1.
3. Check that the ICSR2.TDRE flag is 1, then write the transmit data to the ICDRT register. If the IIC receives no acknowledge from the master device (receives an NACK signal) while the ICFER.NACKF bit is 1, the IIC suspends transfer of the next data.
4. Wait until the ICSR2.TEND flag is set to 1 while the ICSR2.TDRE flag is 1, after the ICSR2.NACKF flag is set to 1 or the last byte for transmission is written to the ICDRT register. When the ICSR2.NACKF flag or the TEND flag is 1, the IIC drives the SCLn line low on the ninth falling edge of the SCL clock.
5. When the ICSR2.NACKF or ICSR2.TEND flag is 1, dummy read ICDRR to complete the processing. This releases the SCLn line.
6. On detecting the stop condition, the IIC automatically sets the ICSR1.HOA, GCA, and AASy flags (y = 0 to 2), the ICSR2.TDRE and TEND flags, and the ICCR2.TRS bit to 0, and enters slave receive mode.
7. Check that the ICSR2.STOP flag is 1, then set the ICSR2.NACKF and STOP flags to 0 for the next transfer operation.

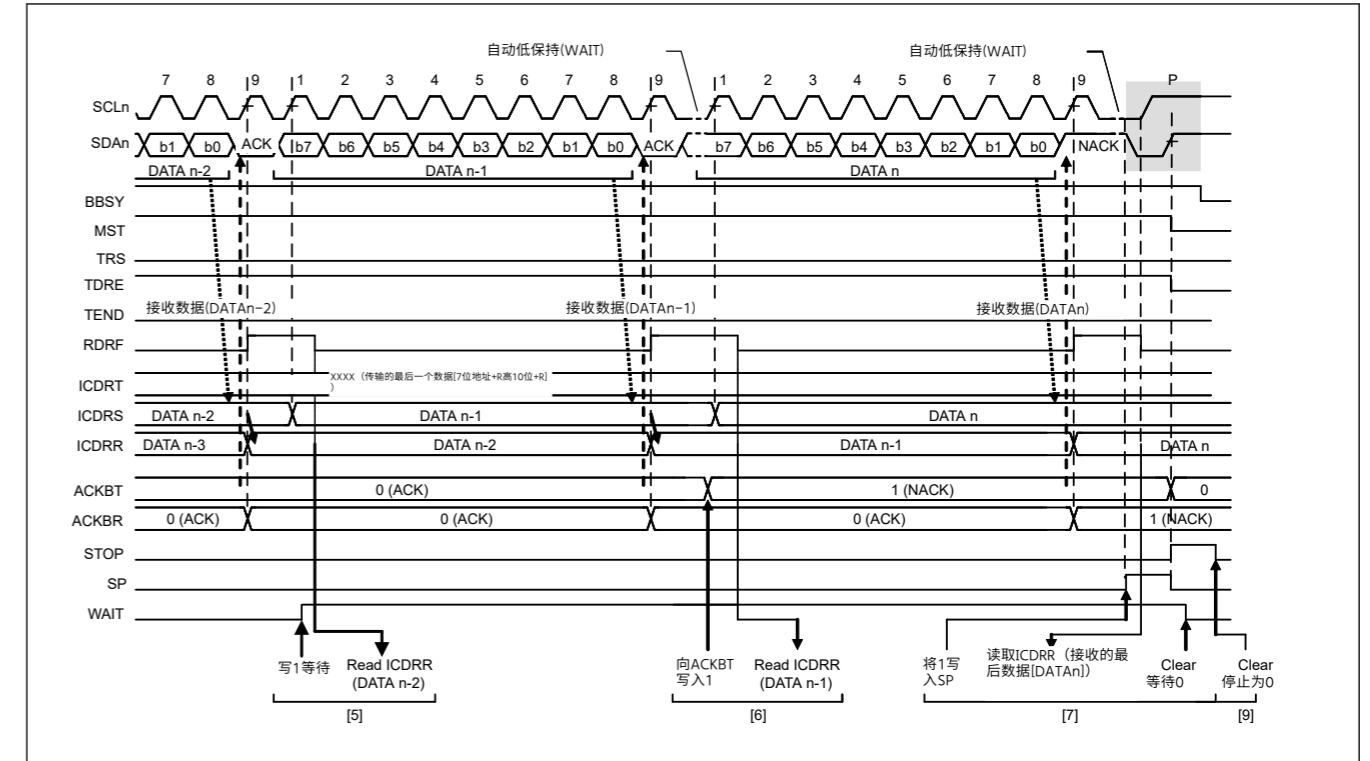


Figure 28.14 RDRFS=0时的主机接收操作时序(3)

### 28.3.5 从机发送操作

在从发送操作中，主设备输出SCL时钟，IIC作为从设备发送数据，主设备返回确认。

图28.15显示了从机传输的示例，图28.16和图28.17显示了从机传输的操作时序。

设置和执行从属传输：

- 1.使用第28.3.2节中的过程初始化IIC。初始设置。  
初始化后，IIC一直处于待机状态，直到收到匹配的从机地址。
- 2.接收到匹配的从地址后，IIC在SCL时钟的第9个周期的上升沿将相关的ICSR1.HOA、GCA和AASy标志之一（y=0到2）设置为1，并输出该值在SCL时钟的第9个周期将ICMR3.ACKBT位设置为确认位。如果RW#位的值为1，则IIC通过将ICCR2.TRS位和ICSR2.TDRE标志都设置为1自动将自身置于从发送模式。
- 3.检查ICSR2.TDRE标志是否为1，然后将发送数据写入ICDRT寄存器。如果IIC没有收到当ICFER.NACKF位为1时，来自主设备的确认（接收NACK信号），IIC暂停下一个数据的传输。
- 4.等到ICSR2.TEND标志设置为1，而ICSR2.TDRE标志为1，在ICSR2.NACKF标志设置为1或将要发送的最后一个字节写入ICDRT寄存器之后。当ICSR2.NACKF标志或TEND标志为1时，IIC在SCL时钟的第九个下降沿将SCLn线驱动为低电平。
- 5.当ICSR2.NACKF或ICSR2.TEND标志为1时，假读ICDRR完成处理。这将释放SCLn线。
- 6.在检测到停止条件时，IIC自动将ICSR1.HOA、GCA和AASy标志（y=0到2）、ICSR2.TDRE和TEND标志以及ICCR2.TRS位设置为0，并进入从机接收模式。
- 7.检查ICSR2.STOP标志是否为1，然后将ICSR2.NACKF和STOP标志设置为0以进行下一次传输操作。

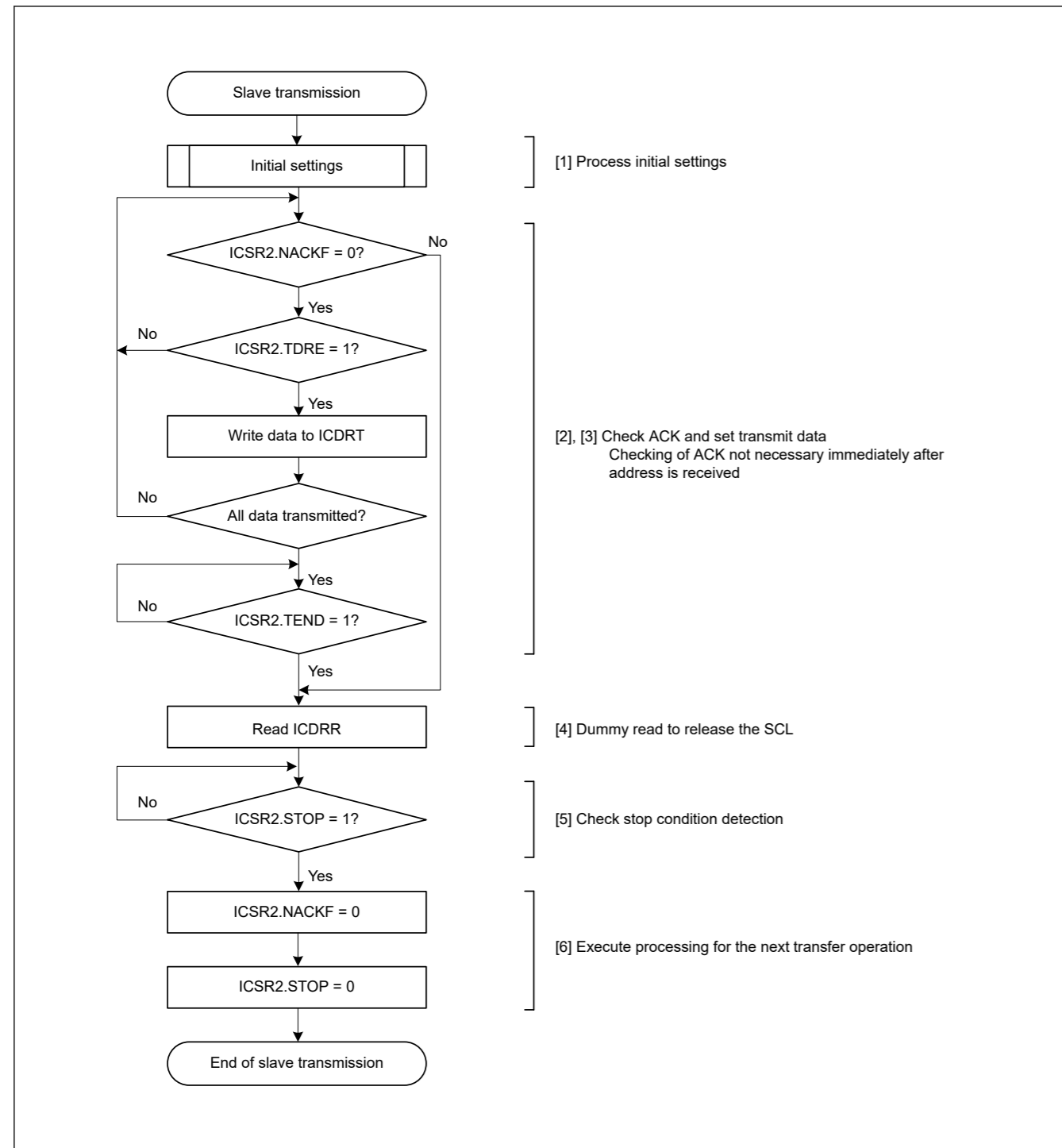


Figure 28.15 Example slave transmission flow

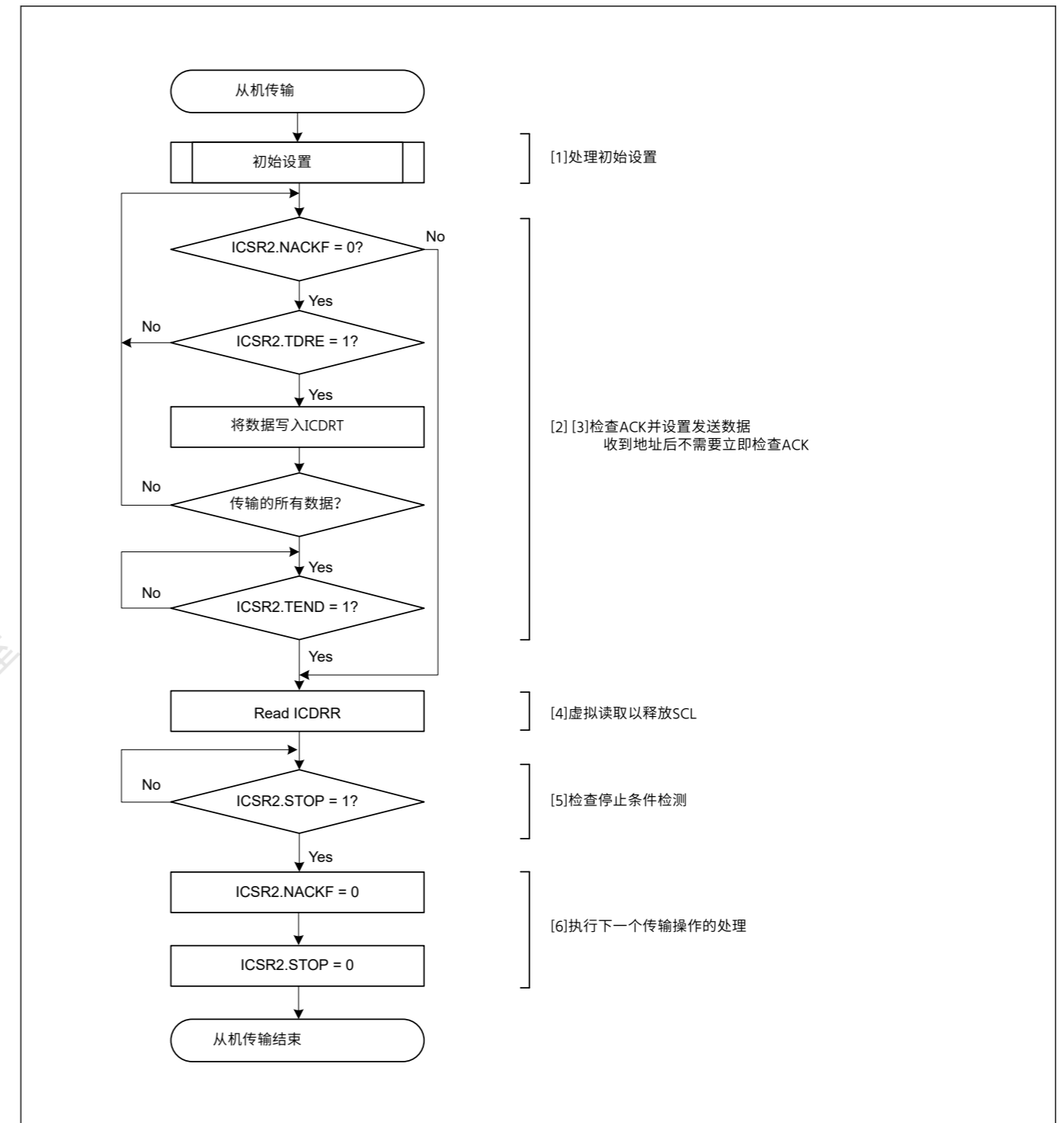


Figure 28.15 从机传输流程示例

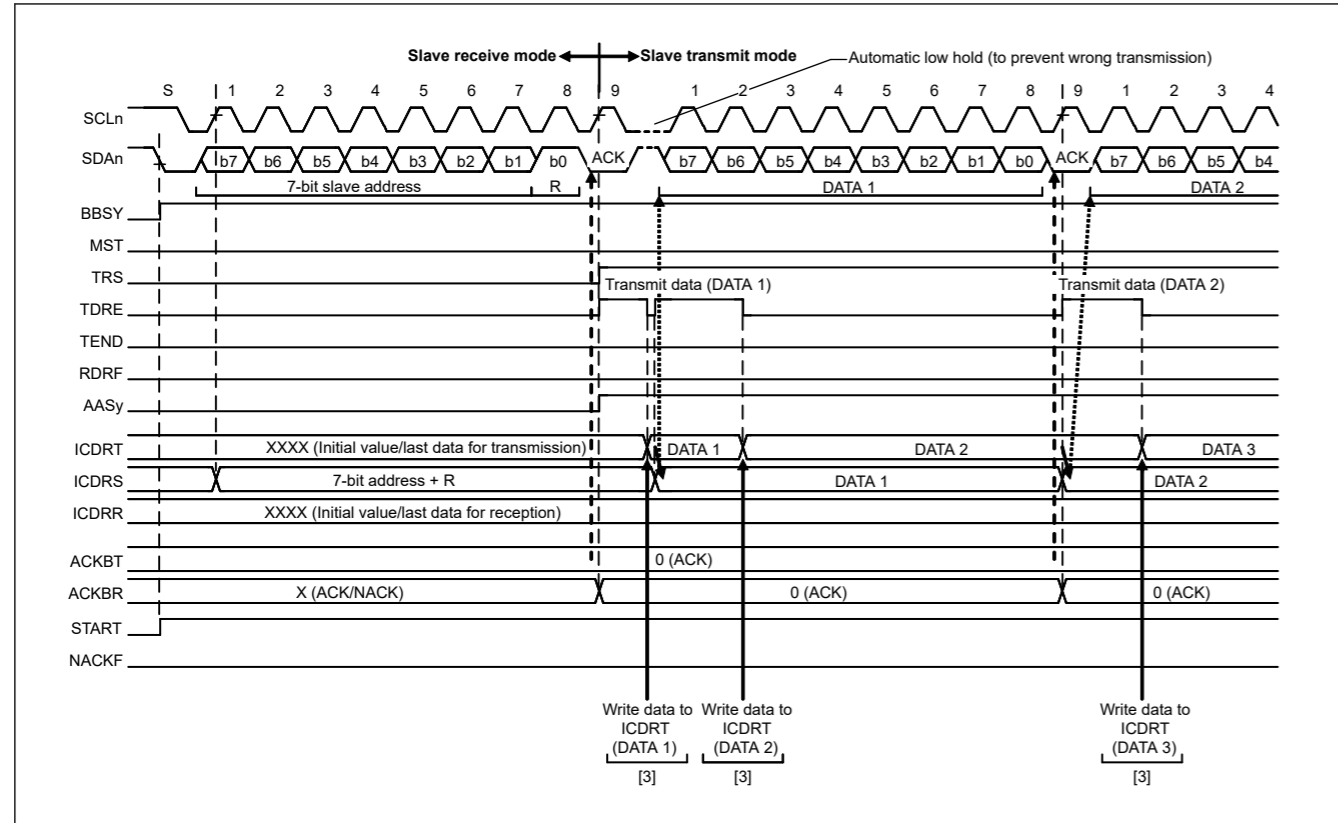


Figure 28.16 Slave transmit operation timing (1) with 7-bit address format

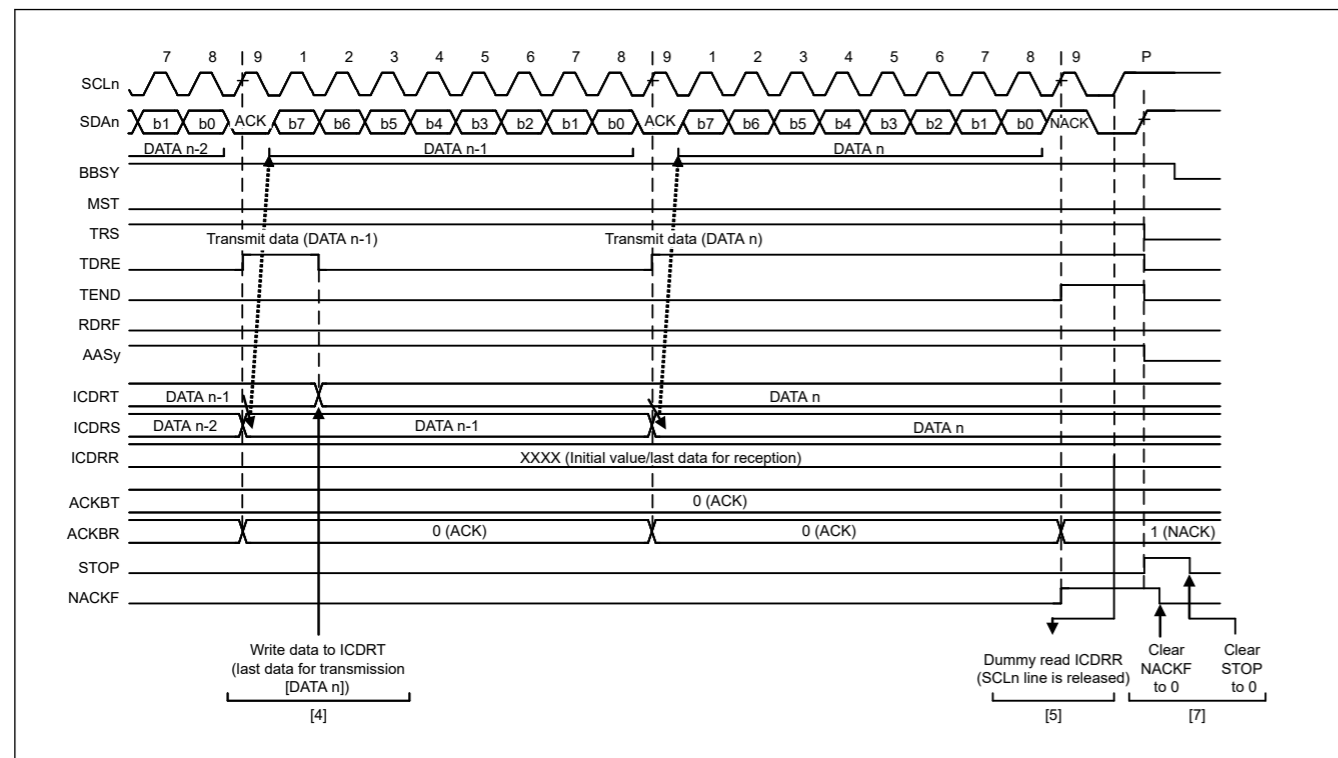


Figure 28.17 Slave transmit operation timing (2)

### 28.3.6 Slave Receive Operation

In slave receive operation, the master device outputs the SCL clock and transmit data, and the IIC returns acknowledgments as a slave device.

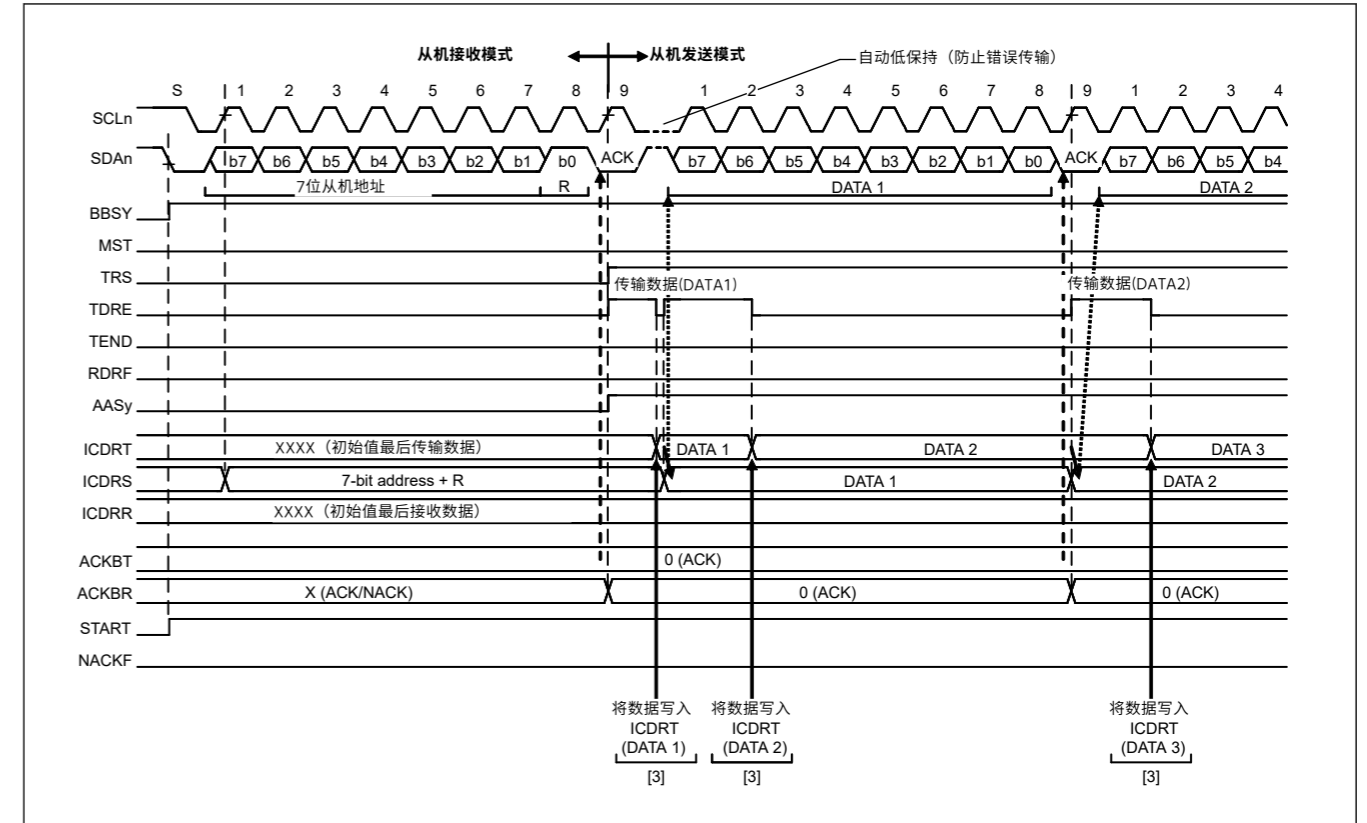


Figure 28.16 7位地址格式的从机发送操作时序(1)

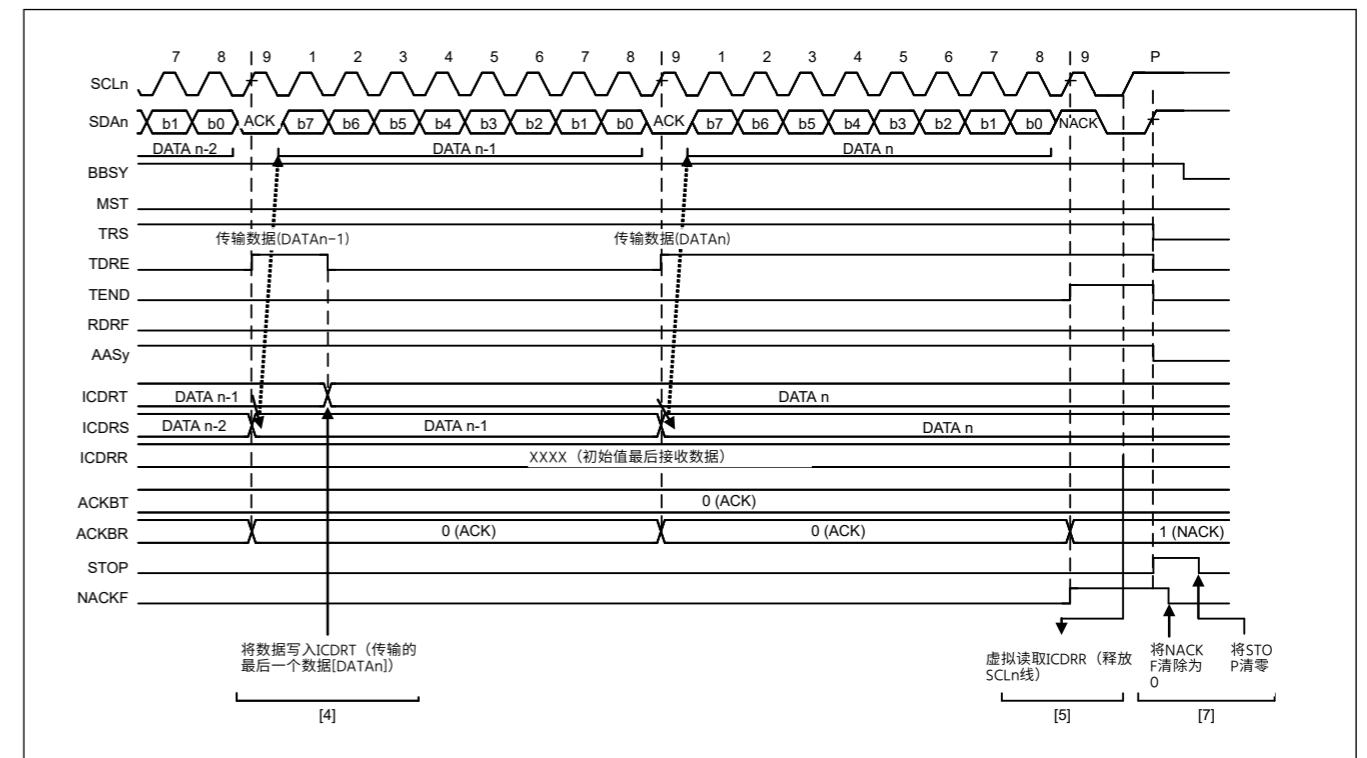


Figure 28.17 从机发送操作时序 (2)

### 28.3.6 从机接收操作

在从机接收操作中，主设备输出SCL时钟并发送数据，IIC作为从设备返回确认。



Figure 28.18 shows an example of slave reception, and Figure 28.19 and Figure 28.20 show the operation timing in slave reception.

To set up and perform slave reception:

1. Initialize the IIC using the procedure in section 28.3.2. Initial Settings.  
After initialization, the IIC stays in the standby state until it receives a slave address that matches.
2. After receiving a matching slave address, the IIC sets one of the associated ICSR1.HOA, GCA, and AASy flags (y = 0 to 2) to 1 on the rising edge of the ninth cycle of the SCL clock and outputs the value set in the ICMR3.ACKBT bit to the acknowledge bit on the ninth cycle of the SCL clock. If the value of the R/W# bit is 0, the IIC continues to place itself in slave receive mode and sets the RDRF flag in ICSR2 to 1.
3. Check that the ICSR2.STOP flag is 0 and the ICSR2.RDRF flag is 1, then dummy read ICDRR. The dummy value consists of the slave address and R/W# bit when the 7-bit address format is selected, or the lower 8 bits when the 10-bit address format is selected.
4. When ICDRR is read, the IIC automatically sets the ICSR2.RDRF flag to 0. If reading of ICDRR is delayed and a next byte is received while the RDRF flag is still set to 1, the IIC holds the SCLn line low until 1 SCL cycle before the point where RDRF must be set. In this case, reading ICDRR releases the SCLn line from being held low. When the ICSR2.STOP flag is 1 and the ICSR2.RDRF flag is also 1, read ICDRR until all the data is completely received.
5. On detecting the stop condition, the IIC automatically clears the ICSR1.HOA, GCA, and AASy flags (y = 0 to 2) to 0.
6. Check that the ICSR2.STOP flag is 1, then set the ICSR2.STOP flag to 0 for the next transfer operation.

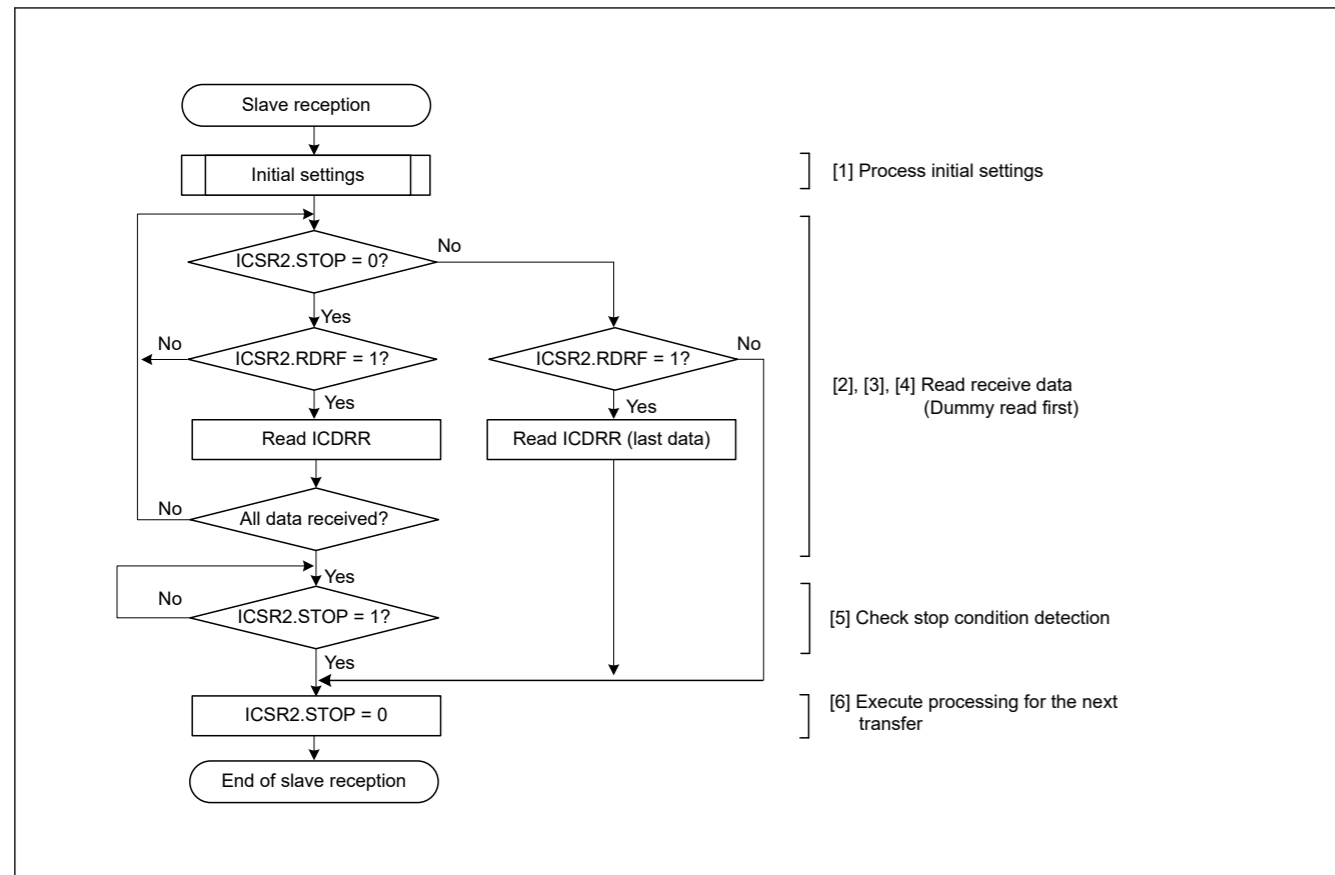


Figure 28.18 Example slave reception flow

图28.18显示了从机接收的示例，图28.19和图28.20显示了从机接收的操作时序。

设置和执行从属接收：

- 1.使用第28.3.2节中的过程初始化IIC。初始设置。  
初始化后，IIC一直处于待机状态，直到收到匹配的从机地址。
- 2.接收到匹配的从地址后，IIC在SCL时钟的第9个周期的上升沿将相关的ICSR1.HOA、GCA和AASy标志之一（y=0到2）设置为1，并输出该值在SCL时钟的第9个周期将ICMR3.ACKBT位设置为确认位。如果RW#位的值为0，则IIC继续将自身置于从机接收模式并将ICSR2中的RDRF标志设置为1。
- 3.检查ICSR2.STOP标志为0且ICSR2.RDRF标志为1，然后虚拟读取ICDRR。虚拟值选择7位地址格式时由从机地址和RW#位组成，选择10位地址格式时由低8位组成。
- 4.读取ICDRR时，IIC自动将ICSR2.RDRF标志设置为0。如果ICDRR的读取延迟并且在RDRF标志仍设置为1时接收到下一个字节，则IIC将SCLn线保持为低电平直到1SCL在必须设置RDRF的点之前循环。在这种情况下，读取ICDRR会释放SCLn线的低电平。当ICSR2.STOP标志为1且ICSR2.RDRF标志也为1时，读取ICDRR直到完全接收到所有数据。
- 5.在检测到停止条件时，IIC自动将ICSR1.HOA、GCA和AASy标志（y=0到2）清除为0。
- 6.检查ICSR2.STOP标志是否为1，然后将ICSR2.STOP标志设置为0以进行下一次传输操作。

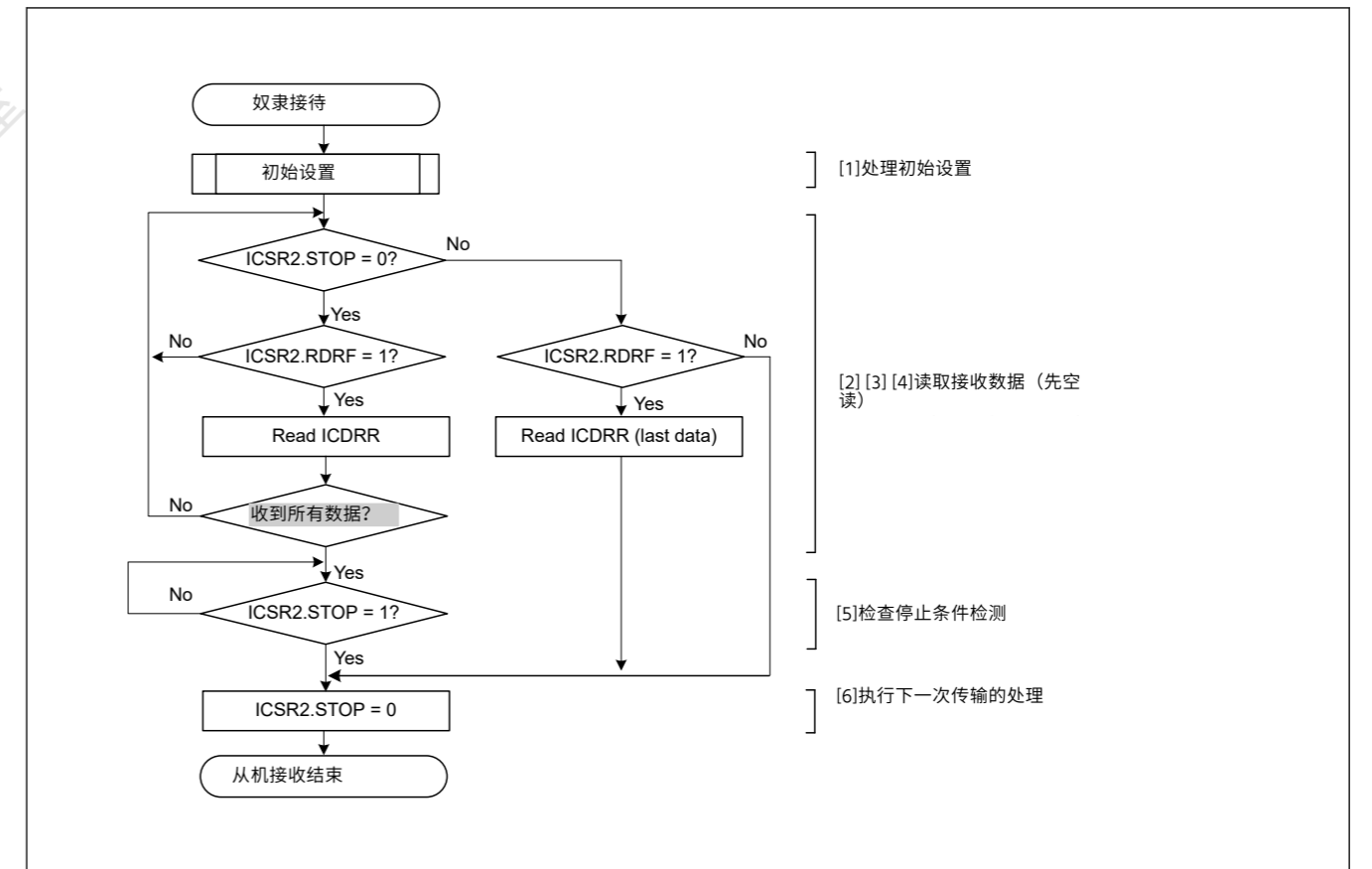


Figure 28.18 从机接收流程示例

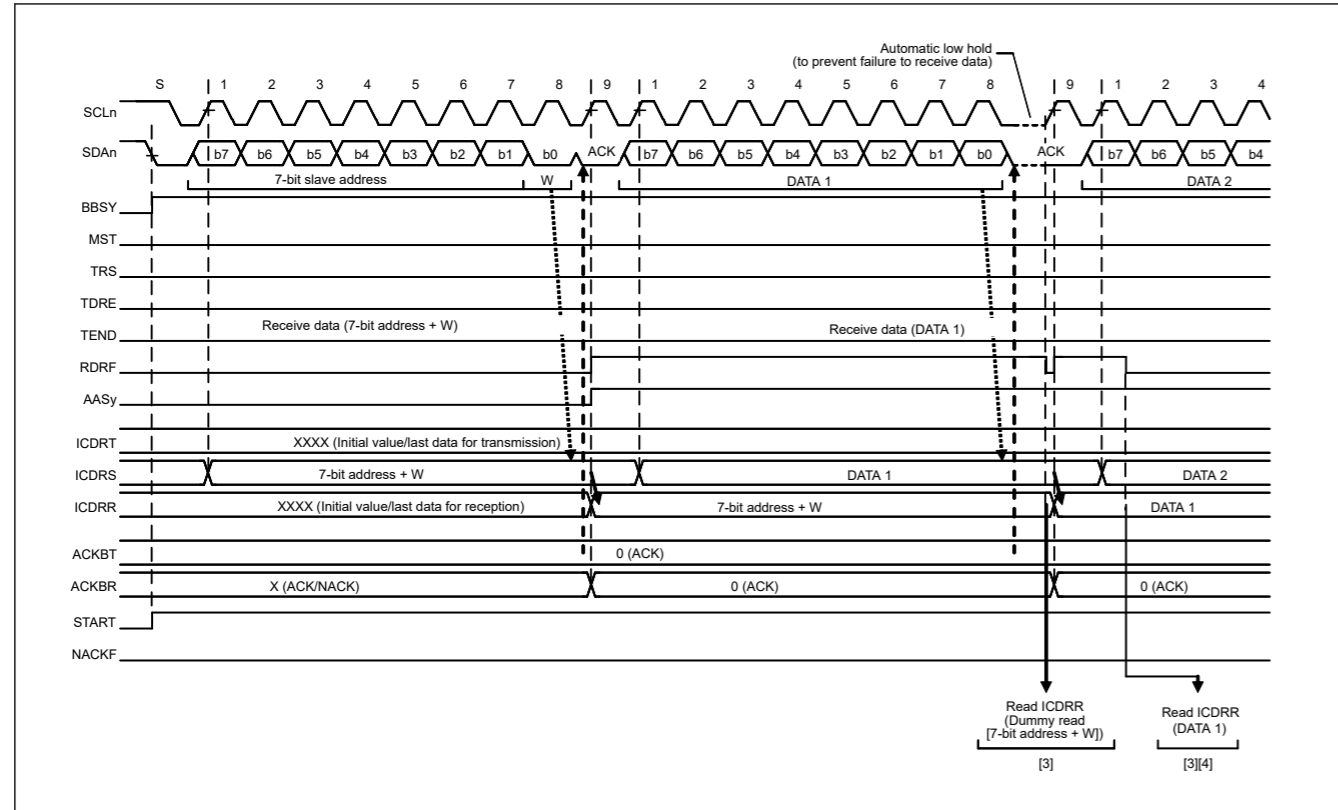


Figure 28.19 Slave receive operation timing (1) with 7-bit address format when RDRFS = 0

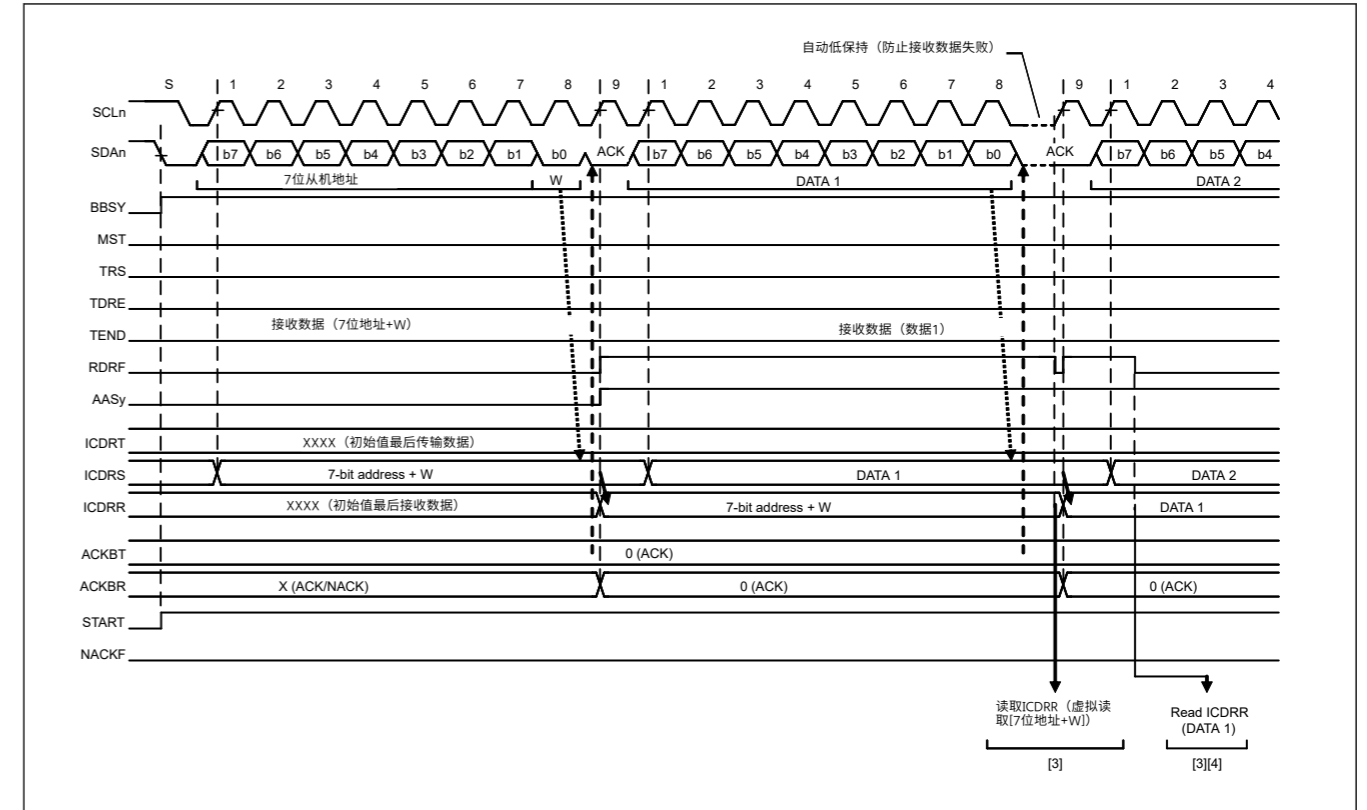


Figure 28.19 RDRFS=0时7位地址格式的从机接收操作时序(1)

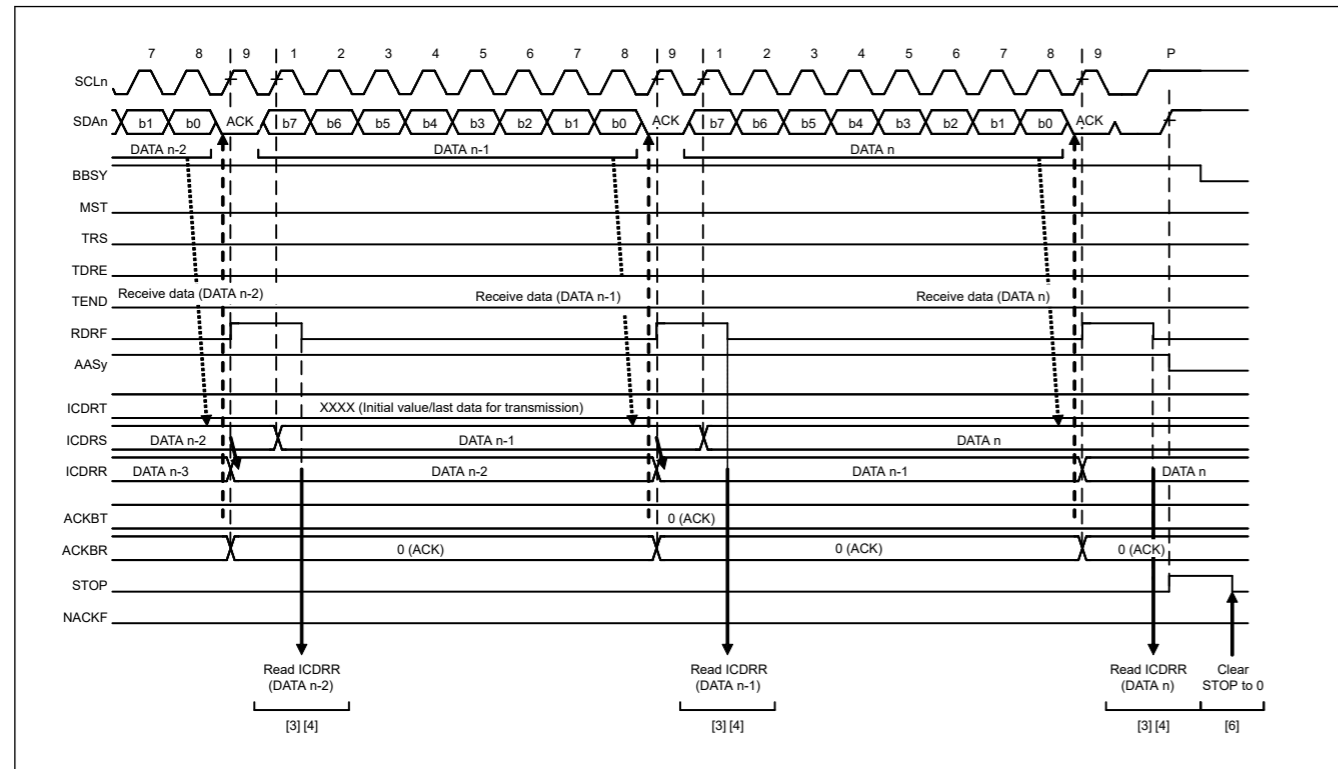


Figure 28.20 Slave receive operation timing (2) when RDRFS = 0

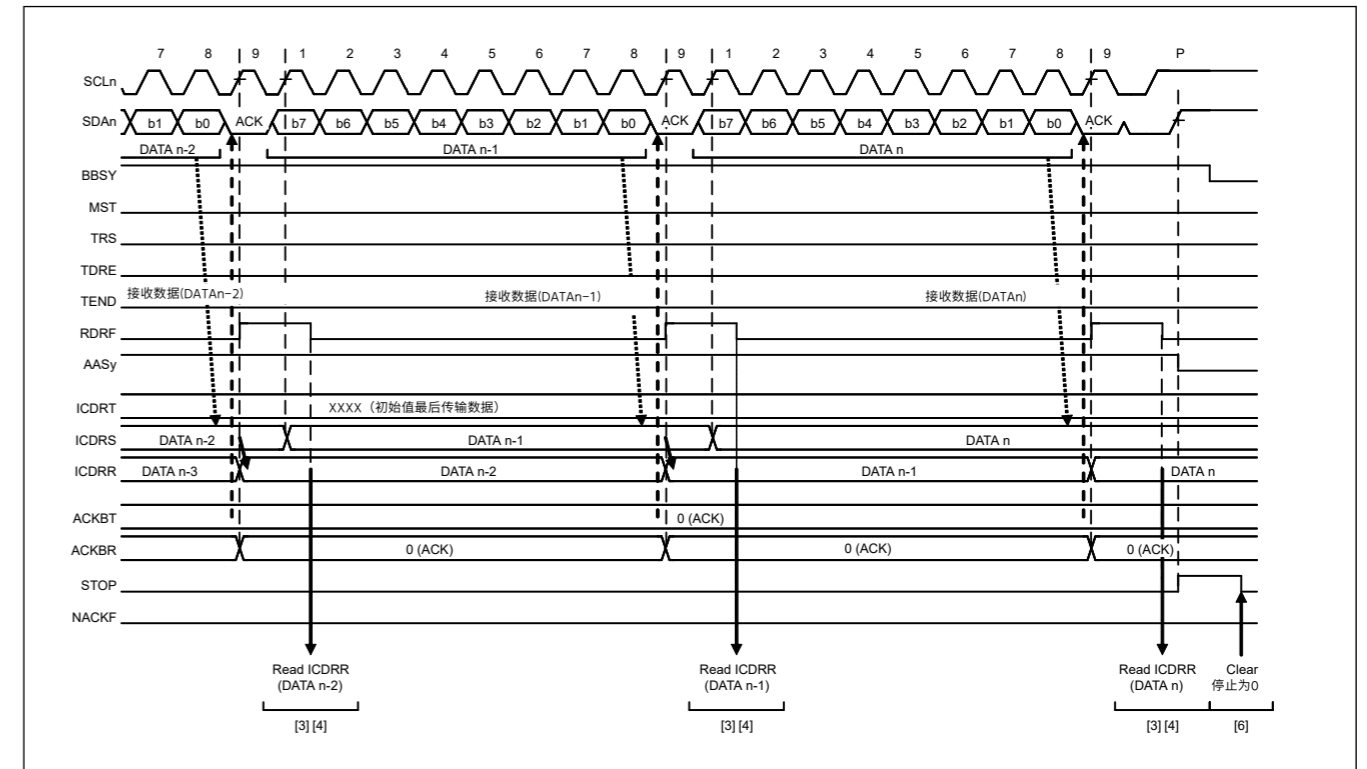


Figure 28.20 RDRFS=0时的从机接收操作时序(2)

### 28.4 SCL Synchronization Circuit

For generation of the SCL clock, the IIC starts counting the value for the high-level period specified in ICBRH when it detects a rising edge on the SCLn line, and it drives the SCLn line low when it completes counting. When the IIC detects the falling edge of the SCLn line, it starts counting the value for the low-level period specified in ICBRL, and then it stops

### 28.4 SCL同步电路

为了生成SCL时钟，IIC在检测到SCLn线上的上升沿时开始对ICBRH中指定的高电平周期的值进行计数，并在完成计数时将SCLn线驱动为低电平。当IIC检测到SCLn线的下降沿时，它开始计数ICBRL中指定的低电平周期的值，然后停止

driving the SCLn line, releasing the line, when it completes counting. The IIC repeats this process to generate the SCL clock.

If multiple master devices are connected to the I<sup>2</sup>C bus, a collision of SCL signals might arise because of contention with another master device. In such cases, the master devices must synchronize their SCL signals. Because this synchronization of SCL signals must be bit-by-bit, the IIC is equipped with an SCL synchronization circuit to obtain bit-by-bit synchronization of the SCL clock signals by monitoring the SCLn line while in master mode.

When the IIC detects a rising edge on the SCLn line and starts counting the high-level period specified in ICBRH.BRH[4:0], and the level on the SCLn line falls because an SCL signal is being generated by another master device, the IIC performs the following:

1. Stops counting when it detects the falling edge.
2. Drives the level on the SCLn line low.
3. Starts counting the low-level period specified in ICBRL.BRL[4:0].

When the IIC finishes counting the low-level period, it stops driving the SCLn line low to release the line. If the low-level period of the SCL clock signal from the other master device is longer than the low-level period set in the IIC, the low-level period of the SCL signal is extended. When the low-level period for the other master device ends, the SCL signal rises because the SCLn line is released.

When the IIC finishes outputting the low-level period of the SCL clock, the SCLn line is released and the SCL clock rises. That is, when SCL signals from more than one master are contending, the high-level period of the SCL signal is synchronized with that of the clock with the narrower period, and the low-level period of the SCL signal is synchronized with that of the clock with the broader period. However, such synchronization of the SCL signal is only enabled when the SCLE bit in ICFER is set to 1.

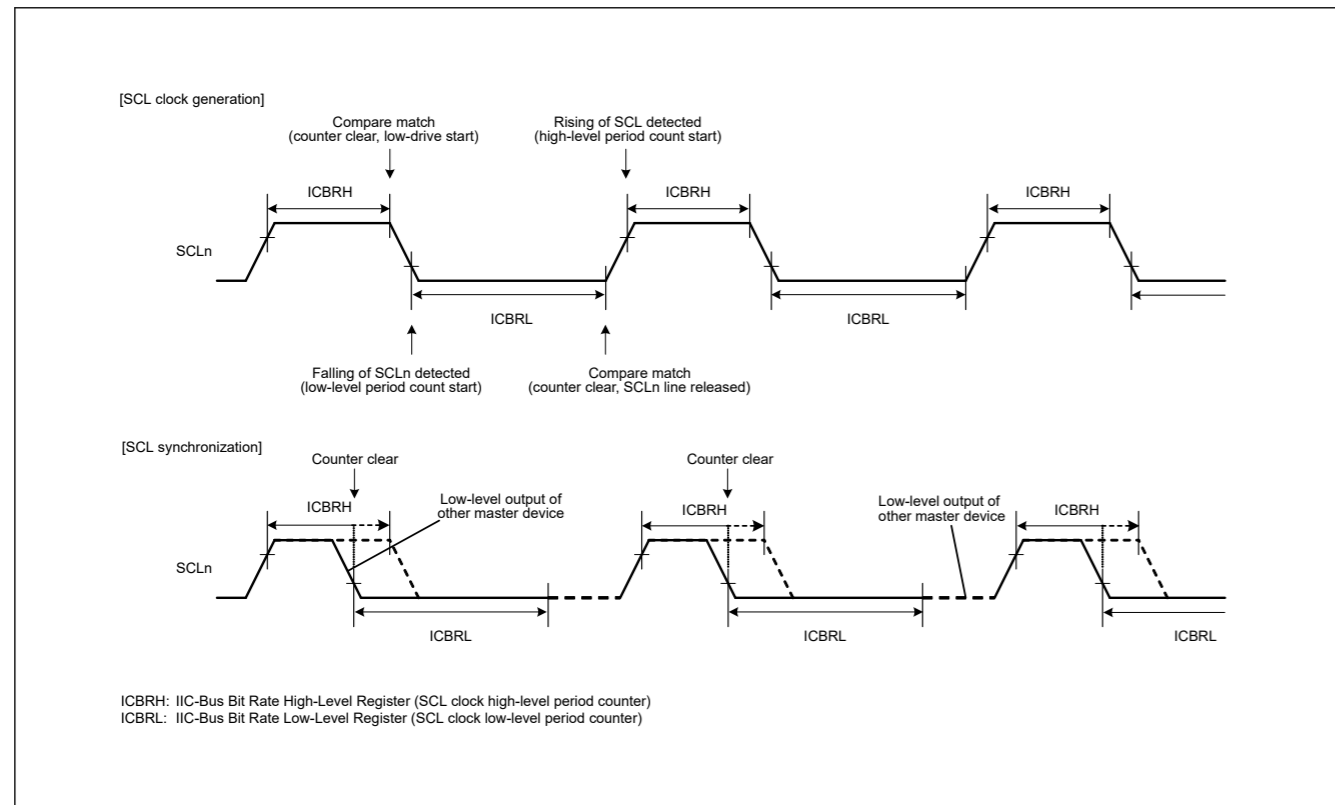


Figure 28.21 Generation and synchronization of SCL signal from IIC

### 28.5 SDA Output Delay Function

The IIC module incorporates a function for delaying output on the SDA line. The delay can be applied to all output on the SDA line, including issuing of the start, restart, and stop conditions, data, and the ACK and NACK signals.

完成计数后，驱动SCLn线，释放线。IIC重复此过程以生成SCL时钟。

如果多个主设备连接到I2C总线，由于与另一个主设备争用，可能会出现SCL信号冲突。在这种情况下，主设备必须同步它们的SCL信号。因为SCL信号的这种同步必须是逐位的，所以IIC配备了一个SCL同步电路，通过在主机模式下监视SCLn线来获得SCL时钟信号的逐位同步。

当IIC检测到SCLn线上的上升沿并开始计数指定的高电平周期时 ICBRH.BRH[4:0]，并且SCLn线上的电平下降，因为另一个主设备正在生成SCL信号，IIC执行以下操作：

- 1.检测到下降沿停止计数。
- 2.将SCLn线上的电平拉低。
- 3.开始计算ICBRL.BRL[4:0]中指定的低电平周期。

当IIC完成对低电平周期的计数时，它停止将SCLn线驱动为低电平以释放该线。如果来自其他主设备的SCL时钟信号的低电平周期长于IIC中设置的低电平周期，则延长SCL信号的低电平周期。当另一个主设备的低电平周期结束时，SCL信号上升，因为SCLn线被释放。

当IIC输出完SCL时钟的低电平周期后，SCLn线被释放，SCL时钟上升。即当来自多个主控的SCL信号竞争时，SCL信号的高电平周期与周期较窄的时钟同步，SCL信号的低电平周期与主控的低电平周期同步。具有更广泛周期的时钟。但是，只有当ICFER中的SCLE位设置为1时，才会启用SCL信号的这种同步。

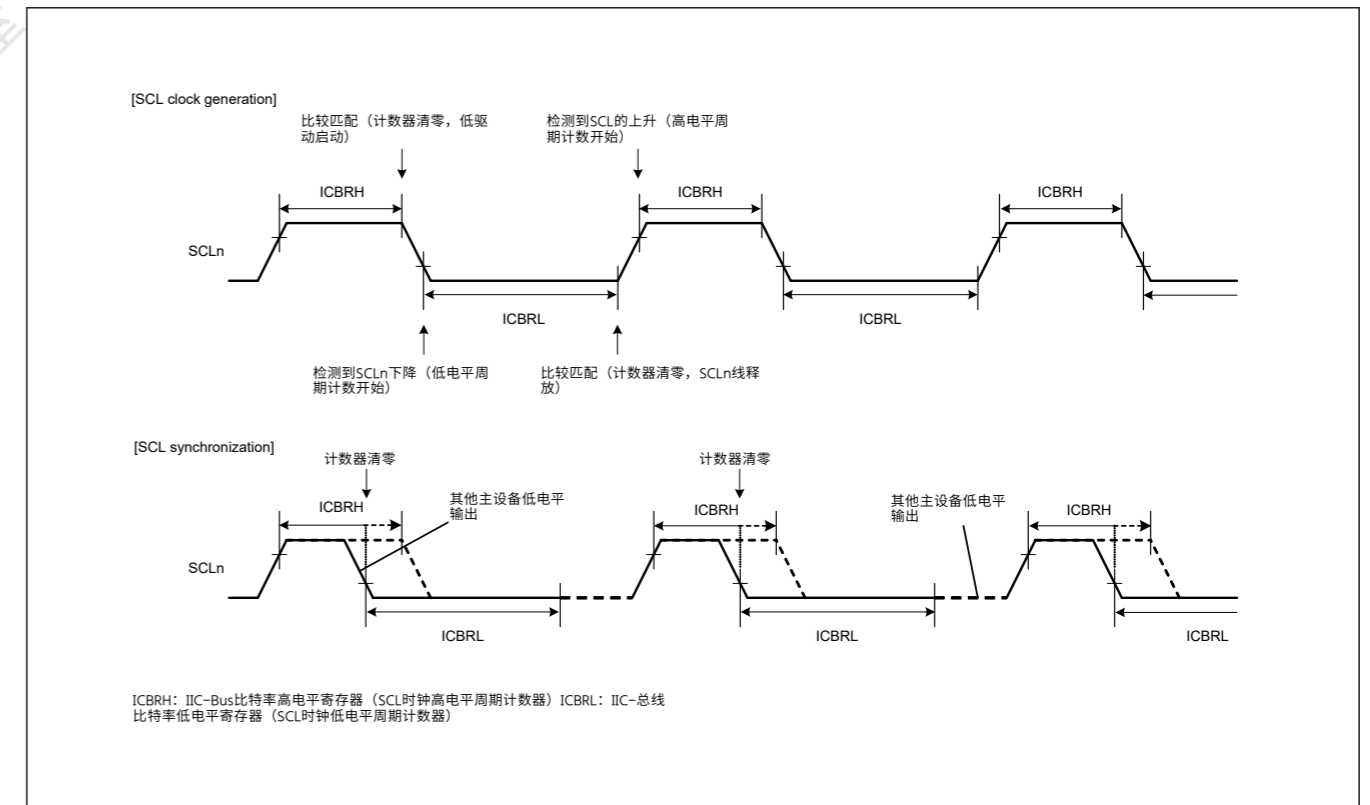


Figure 28.21 从IIC生成和同步SCL信号

### 28.5 SDA输出延迟功能

IIC模块包含延迟SDA线上输出的功能。延迟可以应用于所有输出SDA线，包括发出启动、重新启动和停止条件、数据以及ACK和NACK信号。

With this function, SDA output is delayed from the detection of a falling edge of the SCL signal to ensure that the SDA signal is output within the interval during which the SCL clock is low. This approach helps prevent erroneous operation of communications devices, with the aim of satisfying the 300-ns minimum data-hold time requirement of the SMBus specification. The output delay function is enabled by setting the SDDL[2:0] bits in ICMR2 to a value other than 000b, and disabled by setting the same bits to 000b.

When the SDA output delay function is enabled, for example, the DLCS bit in ICMR2 selects the clock source for the SDA output delay counter, either as the internal base clock (IICφ) for the IIC module or as the internal base clock divided by 2 (IICφ/2). The counter counts the number of cycles set in the SDDL[2:0] bits in ICMR2. When the delay cycles count is reached, the IIC module places the required output (start, restart, or stop condition, data, or an ACK or NACK signal) on the SDA line.

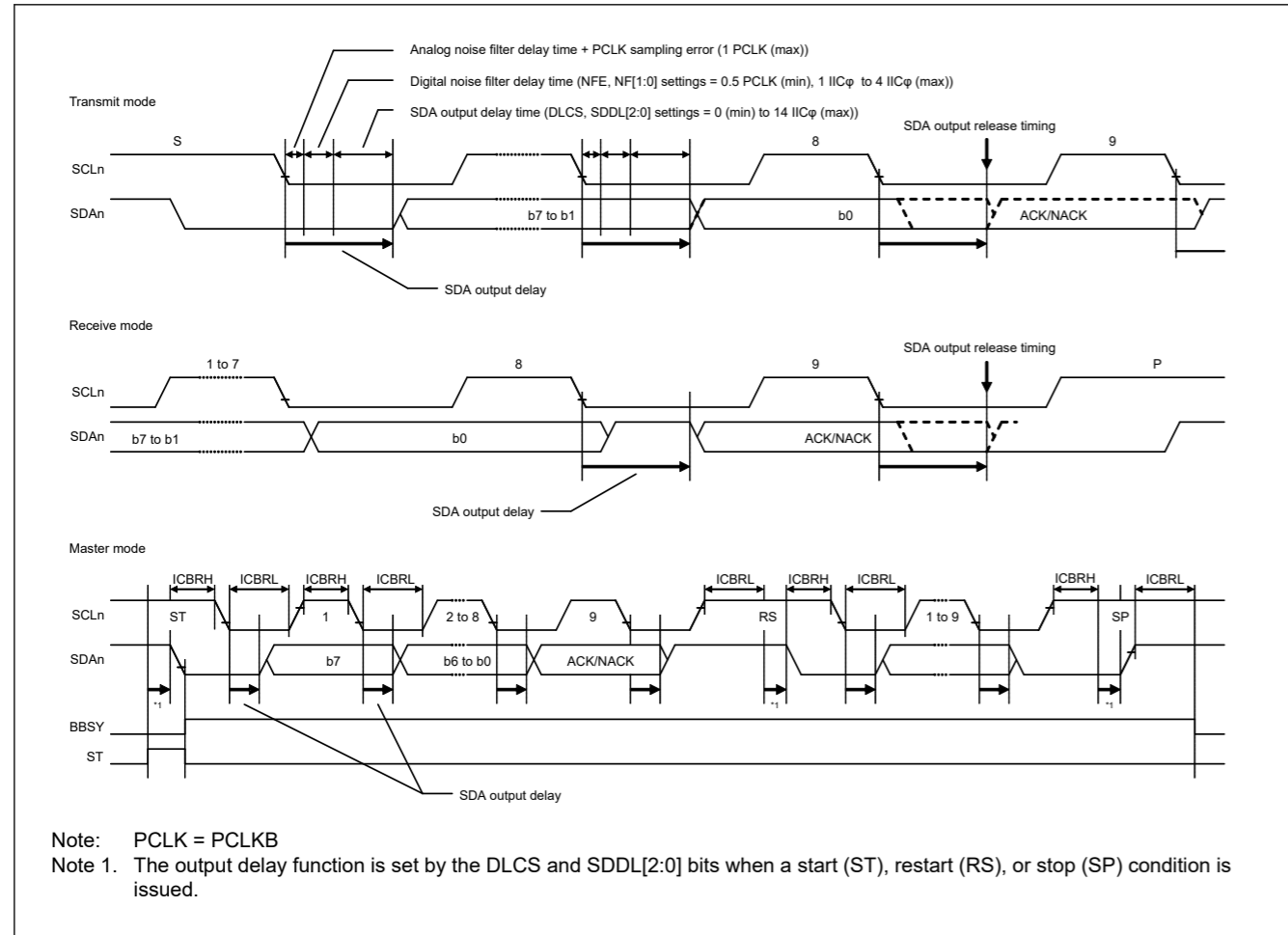


Figure 28.22 SDA output delay function

### 28.6 Digital Noise Filter Circuits

The internal circuitry sees the states of the SCLn and SDA n pins through analog and digital noise-filter circuits. Figure 28.23 shows a block diagram of the digital noise-filter circuit.

The on-chip digital noise-filter circuit of the IIC consists of four flip-flop circuit stages connected in series and a match-detection circuit. The number of valid stages in the digital noise filter is selected in the NF[1:0] bits in ICMR3. The selected number of valid stages determines the noise-filtering capability as a period from 1 to 4 IICφ cycles.

The input signal to the SCLn pin (or SDA n pin) is sampled on falling edges of the IICφ signal. When the input signal level matches the output level of the number of valid flip-flop circuit stages as selected in the NF[1:0] bits in ICMR3, the signal level is seen in the the subsequent stage. If the signal levels do not match, the previous value is saved.

If the ratio between the frequency of the internal operating clock (PCLKB) and the transfer rate is small, for example, if data transfer is 400 kbps with PCLKB = 4 MHz, the characteristics of the digital noise filter might lead to the elimination of

使用此功能，SDA输出从检测到SCL信号的下沿开始延迟，以确保在SCL时钟为低电平的时间间隔内输出SDA信号。这种方法有助于防止通信设备的错误操作，旨在满足SMBus规范的300ns最小数据保持时间要求。通过将ICMR2中的SDDL[2:0]位设置为000b以外的值来启用输出延迟功能，通过将相同位设置为000b来禁用输出延迟功能。

例如，当SDA输出延迟功能使能时，ICMR2中的DLCS位选择SDA输出延迟计数器的时钟源，或者作为IIC模块的内部基准时钟(IICφ)，或者作为内部基准时钟除以2(IICφ/2)。计数器计算ICMR2中SDDL[2:0]位中设置的周期数。当达到延迟周期计数时，IIC模块将所需的输出（启动、重启或停止条件、数据或ACK或NACK信号）放在SDA线上。

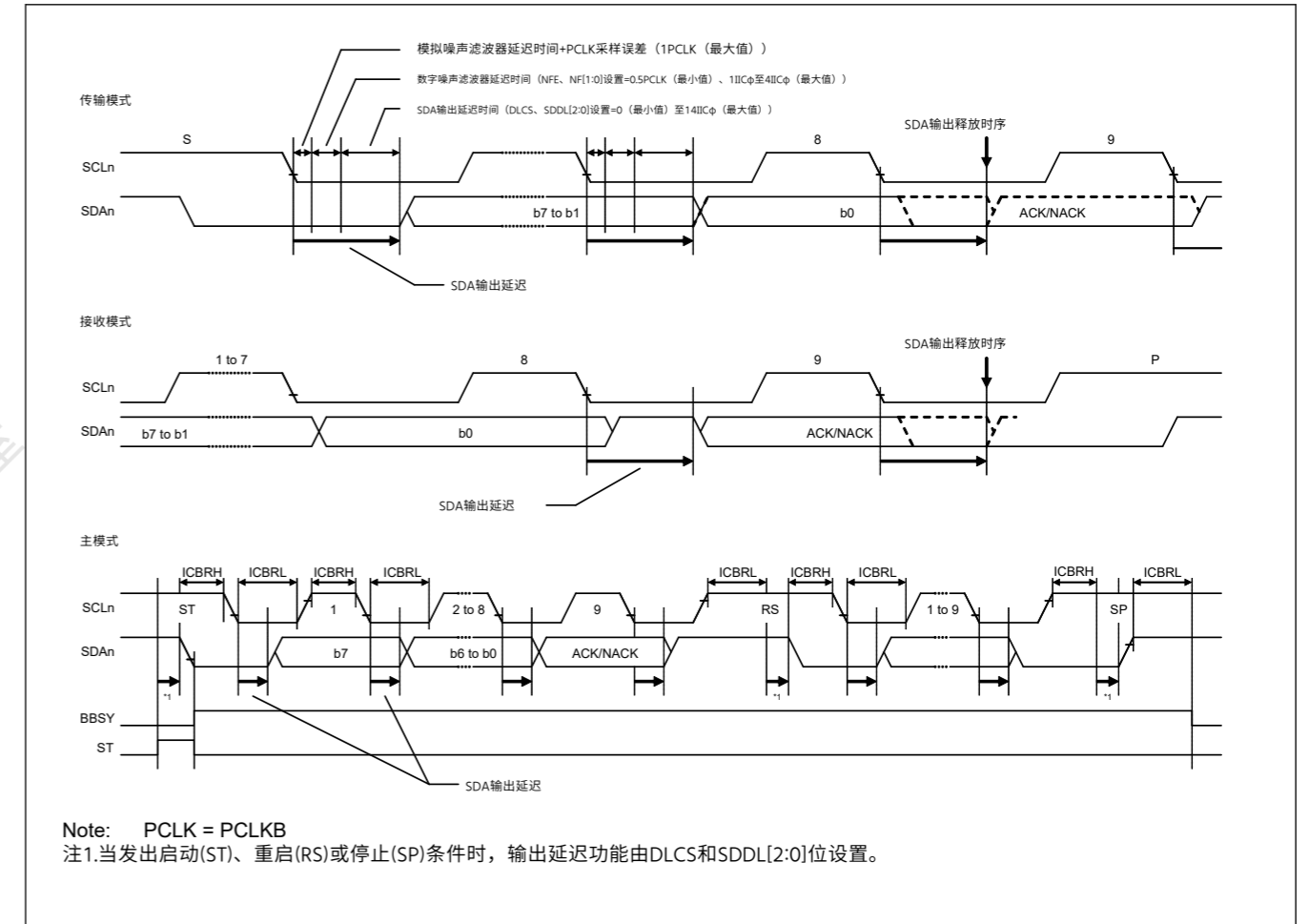


Figure 28.22 SDA输出延迟功能

### 28.6 数字噪声滤波器电路

内部电路通过模拟和数字噪声滤波器电路查看SCLn和SDA n引脚的状态。图28.23显示了数字噪声滤波器电路的框图。

IIC的片上数字噪声滤波器电路由四个串联的触发器电路级和一个匹配检测电路组成。数字噪声滤波器的有效级数在ICMR3的NF[1:0]位中选择。选定的有效级数决定了噪声过滤能力，周期为1到4个IICφ周期。

SCLn引脚（或SDA n引脚）的输入信号在IICφ信号的下沿采样。当输入信号电平与在ICMR3的NF[1:0]位中选择的有效触发器电路级数的输出电平相匹配时，将在后续级中看到信号电平。如果信号电平不匹配，则保存先前的值。

如果内部工作时钟(PCLKB)的频率与传输速率之间的比率很小，例如，如果数据传输为400kbps，PCLKB=4MHz，则数字噪声滤波器的特性可能会导致消除



required signals as noise. In such cases, it is possible to disable the digital noise-filter circuit by setting the ICFER.NFE bit to 0, and use only the analog noise filter circuit.

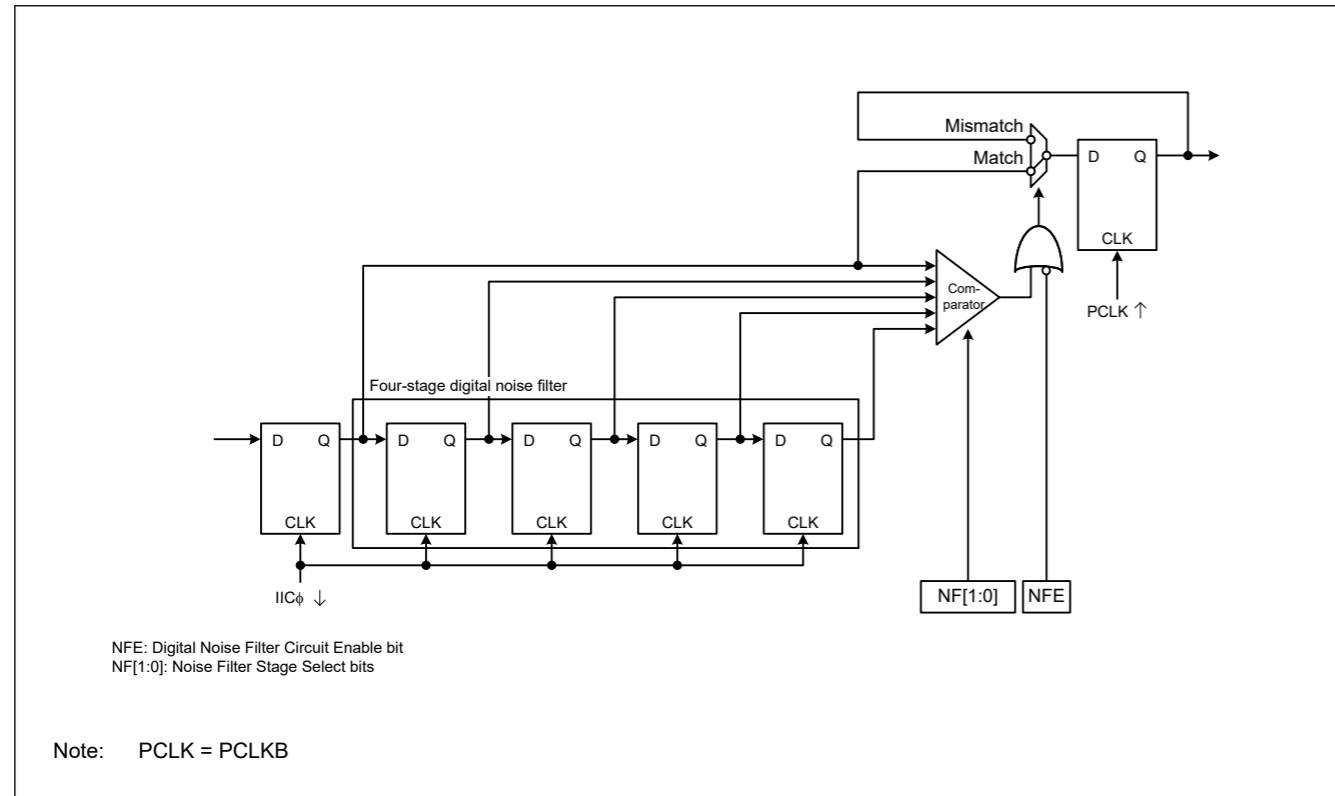


Figure 28.23 Digital noise filter circuit block diagram

## 28.7 Address Match Detection

The IIC can set three unique slave addresses in addition to the general call address and host address. The slave addresses can be 7-bit or 10-bit slave addresses.

### 28.7.1 Slave-Address Match Detection

The IIC can set three unique slave addresses and has a slave address detection function for each unique slave address. When the SARyE bit ( $y = 0$  to 2) in ICSER is set to 1, the slave addresses set in SARUy and SARLy ( $y = 0$  to 2) can be detected.

When the IIC detects a match of the set slave address, the associated AASy flag ( $y = 0$  to 2) in ICSR1 is set to 1 on the rising edge of the ninth SCL clock cycle, and the RDRF flag in ICSR2 or the TDRE flag in ICSR2 is set to 1 by the subsequent R/W# bit. This causes a receive data full interrupt (IICn\_RXI) or transmit data empty interrupt (IICn\_TXI) to be generated. The AASy flag identifies which slave address is specified.

Figure 28.24 to Figure 28.26 show the AASy flag set timing in three cases.

所需的信号作为噪声。在这种情况下，可以通过将ICFER.NFE位设置为0来禁用数字噪声滤波器电路，并仅使用模拟噪声滤波器电路。

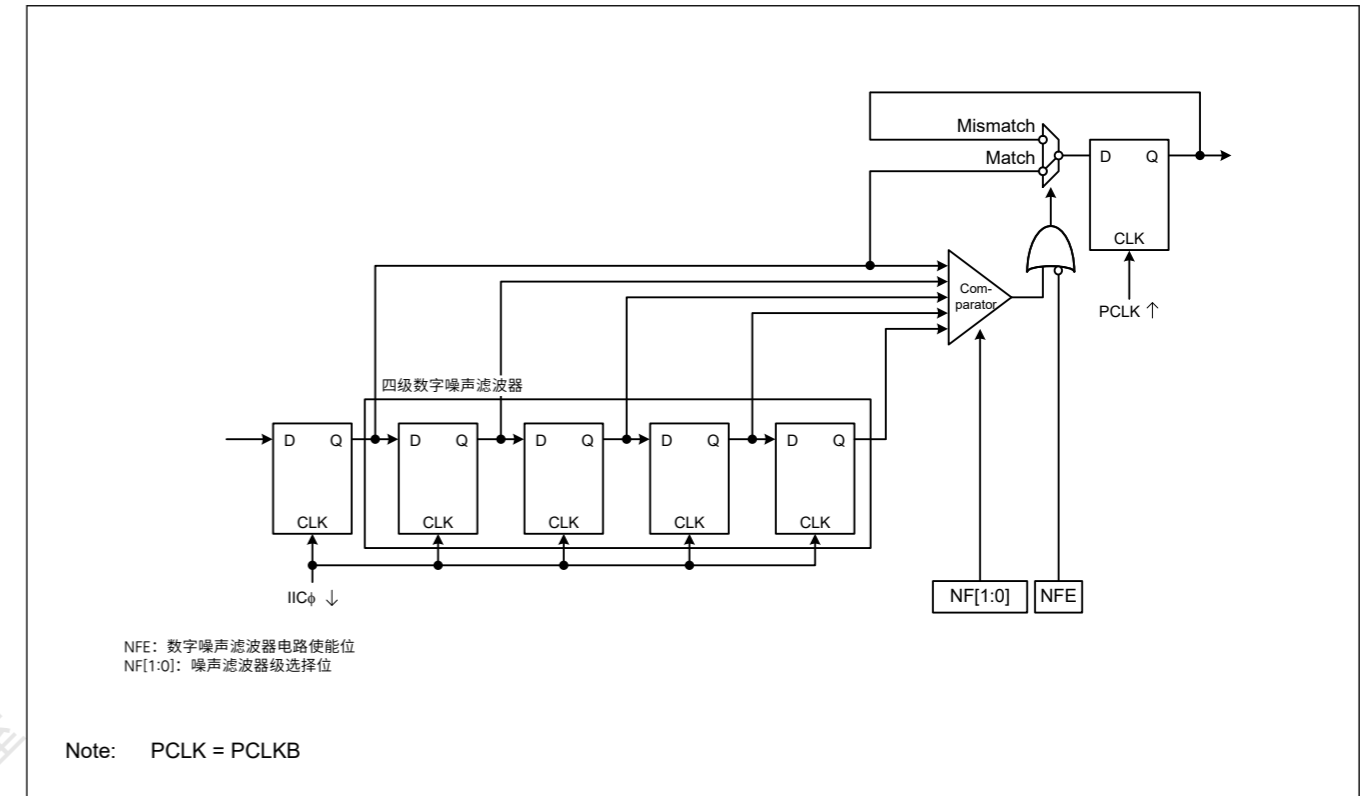


Figure 28.23 数字噪声滤波器电路框图

## 28.7 地址匹配检测

IIC除了广播地址和主机地址外，还可以设置三个唯一的从机地址。从地址可以是7位或10位从地址。

### 28.7.1 从地址匹配检测

IIC可以设置三个唯一的从机地址，并对每个唯一的从机地址具有从机地址检测功能。当ICSER中的SARyE位（ $y=0$ 到2）设置为1时，可以检测到设置在SARUy和SARLy（ $y=0$ 到2）中的从机地址。

当IIC检测到与设置的从地址匹配时，ICSR1中相关的AASy标志（ $y=0$ 到2）在第9个SCL时钟周期的上升沿设置为1，并且ICSR2中的RDRF标志或TDRE标志ICSR2中的1由随后的RW#位设置为1。这会导致产生接收数据满中断（IICn\_RXI）或发送数据空中断（IICn\_TXI）。AASy标志标识指定了哪个从地址。

图28.24到图28.26显示了三种情况下的AASy标志设置时序。

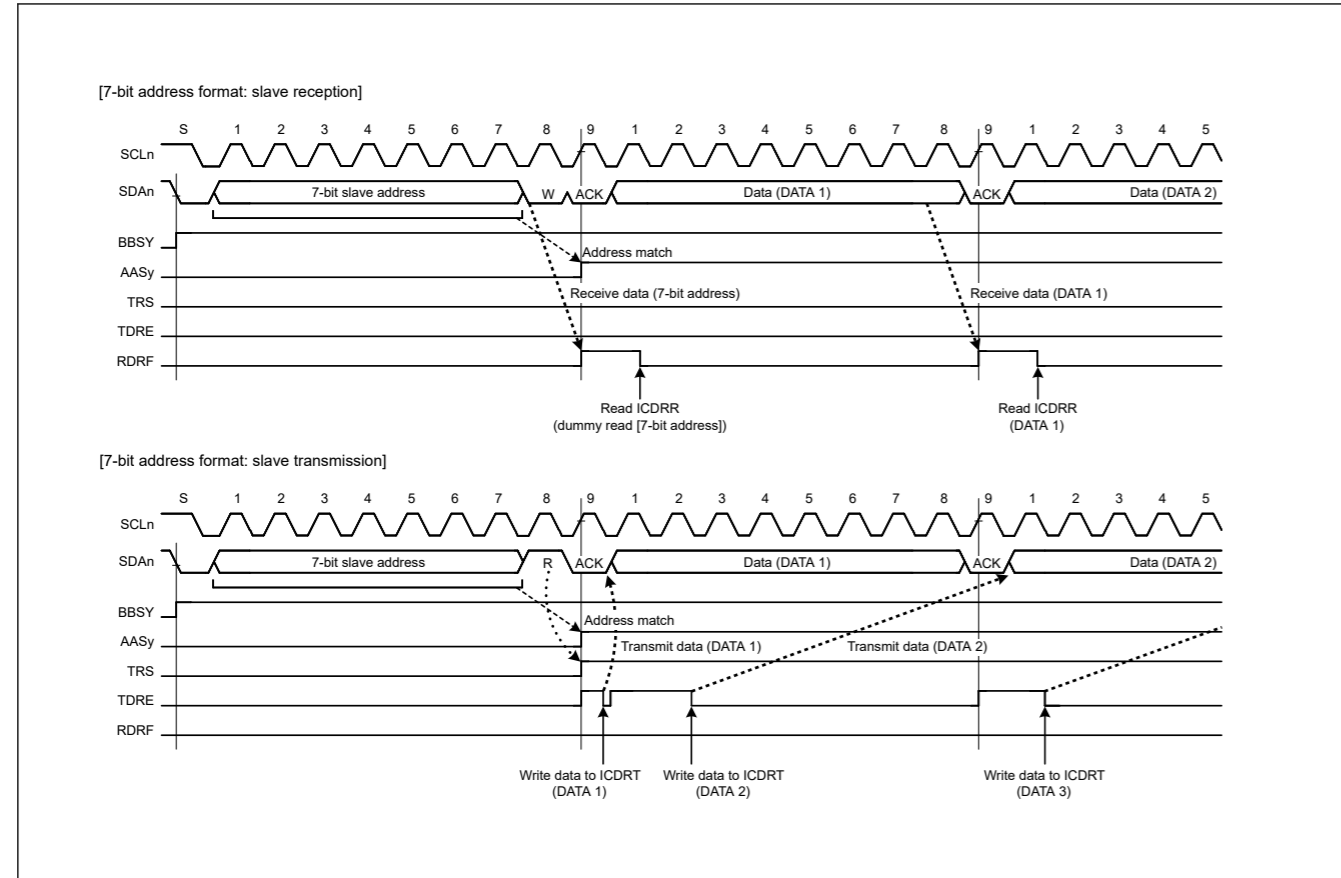


Figure 28.24 AASy flag set timing with 7-bit address format

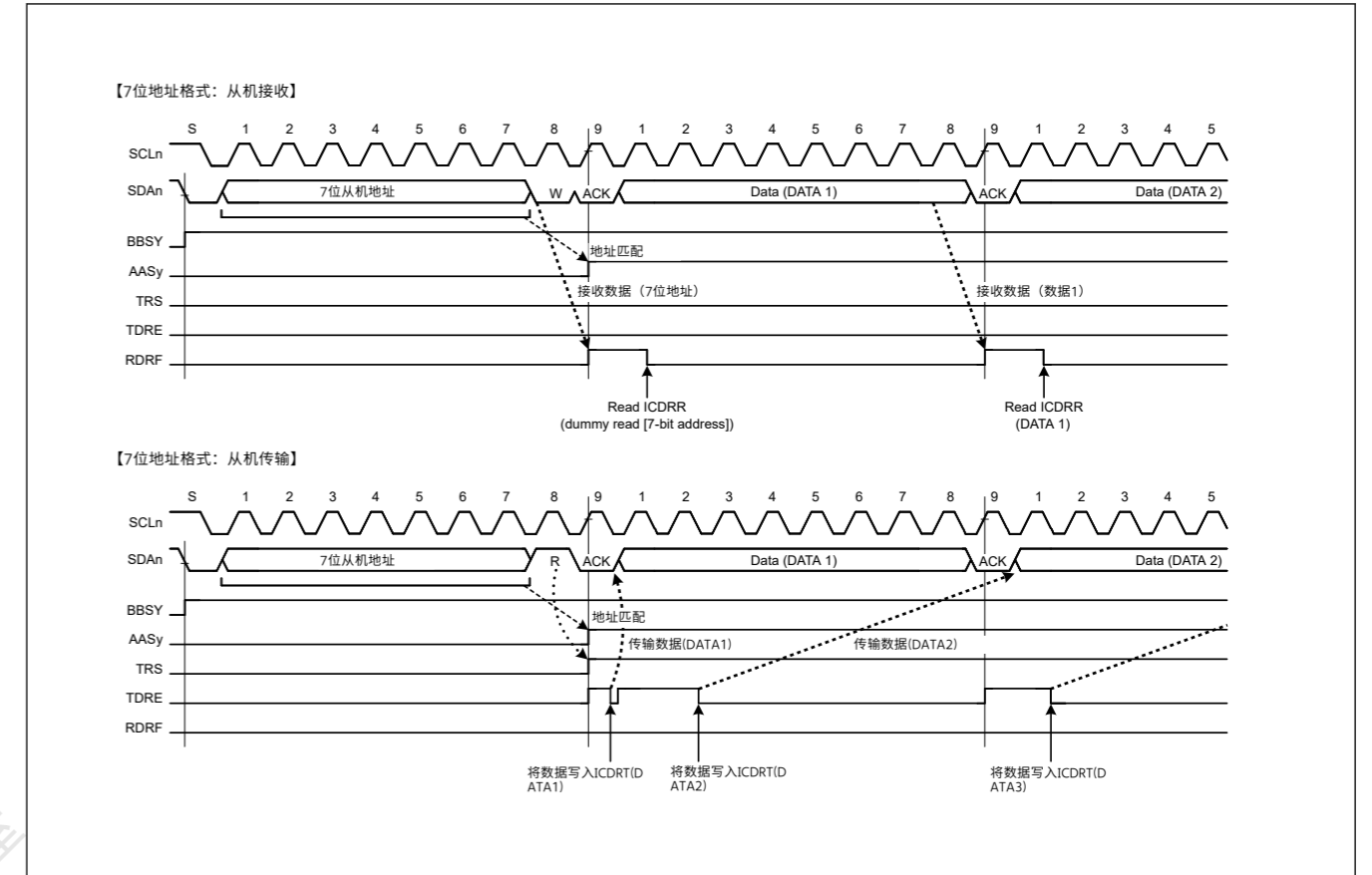


Figure 28.24 7位地址格式的AASy标志设置时序

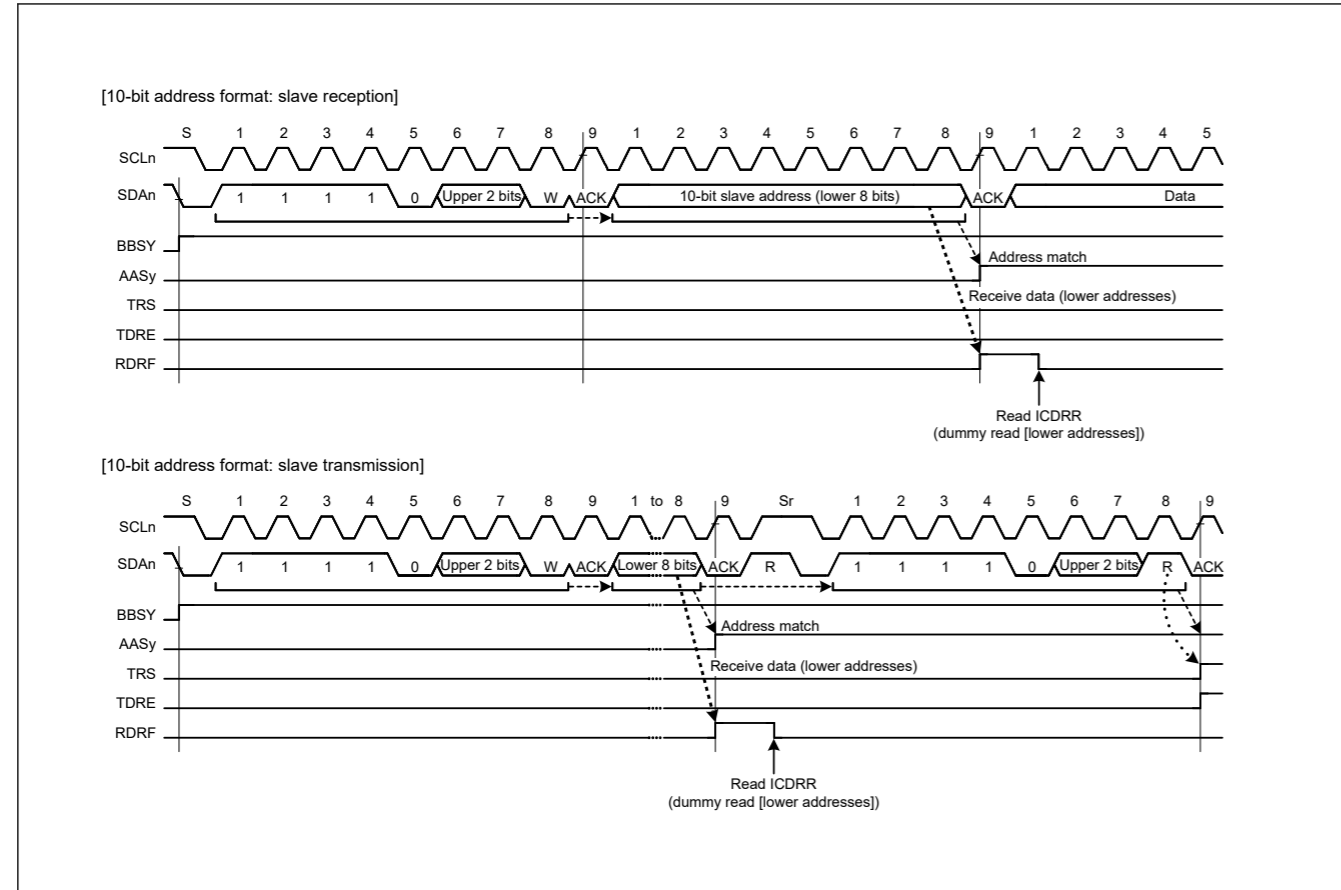


Figure 28.25 AASy flag set timing with 10-bit address format

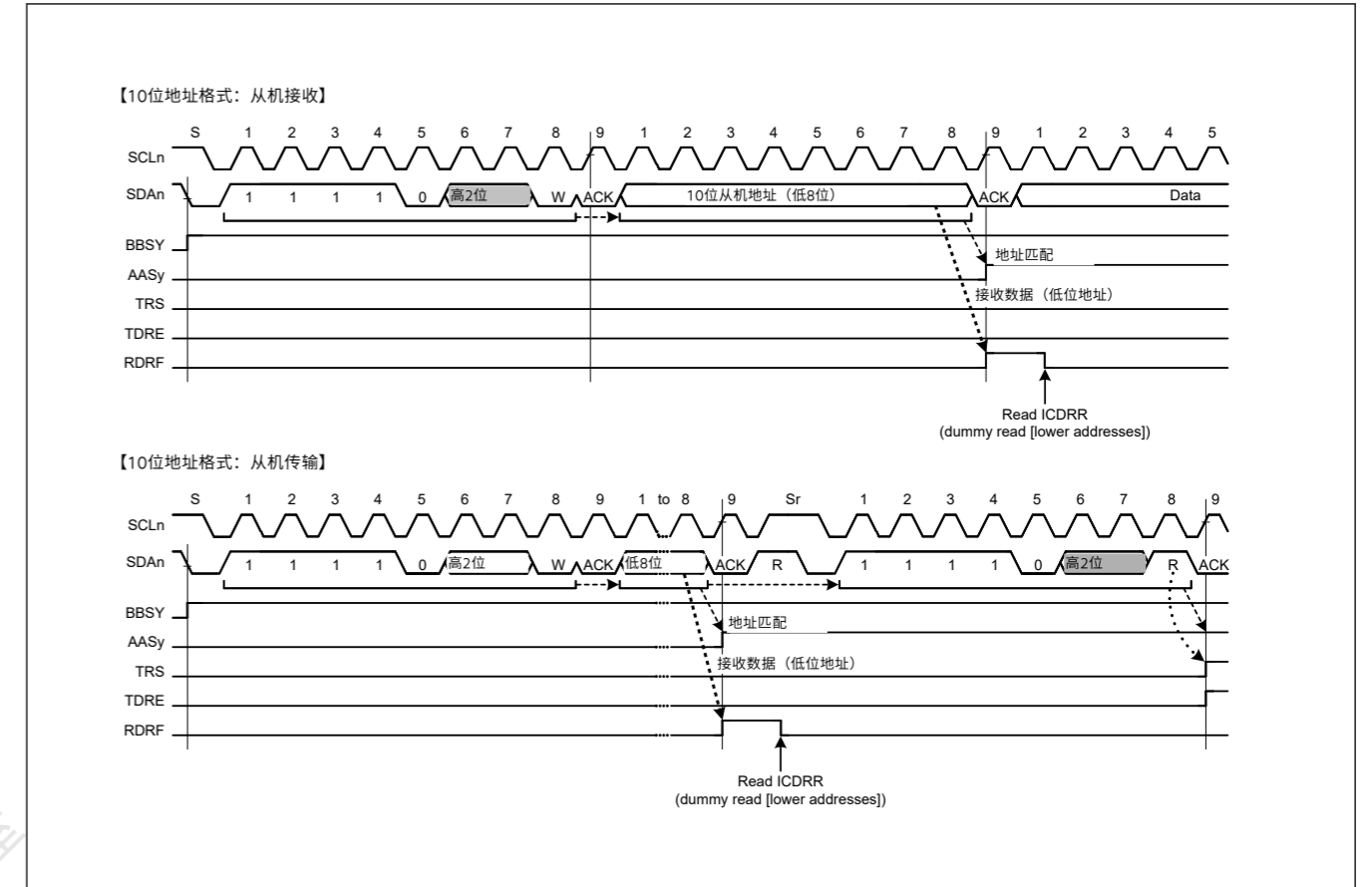


Figure 28.25 10位地址格式的AASy标志设置时序

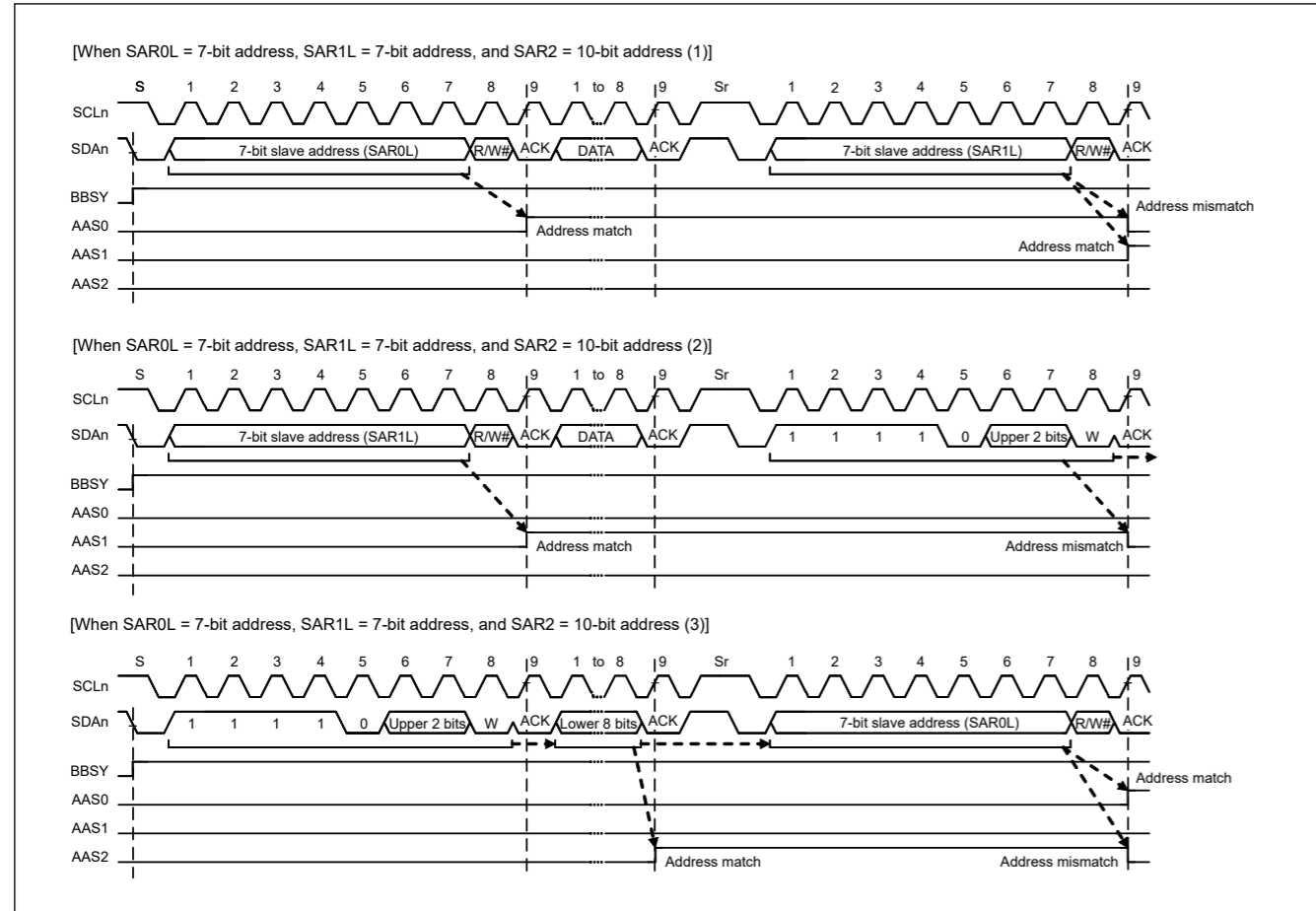


Figure 28.26 AASy flag set and clear timing with mixed 7-bit and 10-bit address formats

28.7.2 Detection of General Call Address

The IIC provides detection of the general call address (0000 000b + 0 [W]). This is enabled by setting the GCAE bit in IC SER to 1.

If the address received after a start or restart condition is issued is 0000 000b + 1[R] (start byte), the IIC recognizes this as the address of a slave device with an all-zero address, but not as the general call address.

When the IIC detects the general call address, both the GCA flag in ICSR1 and the RDRF flag in ICSR2 set to 1 on the rising edge of the ninth cycle of the SCL clock. This leads to the generation of a receive data full interrupt (IICn\_RXI). The value of the GCA flag can be checked to confirm that the general call address was transmitted.

Operation after detection of the general call address is the same as normal slave receive operation.

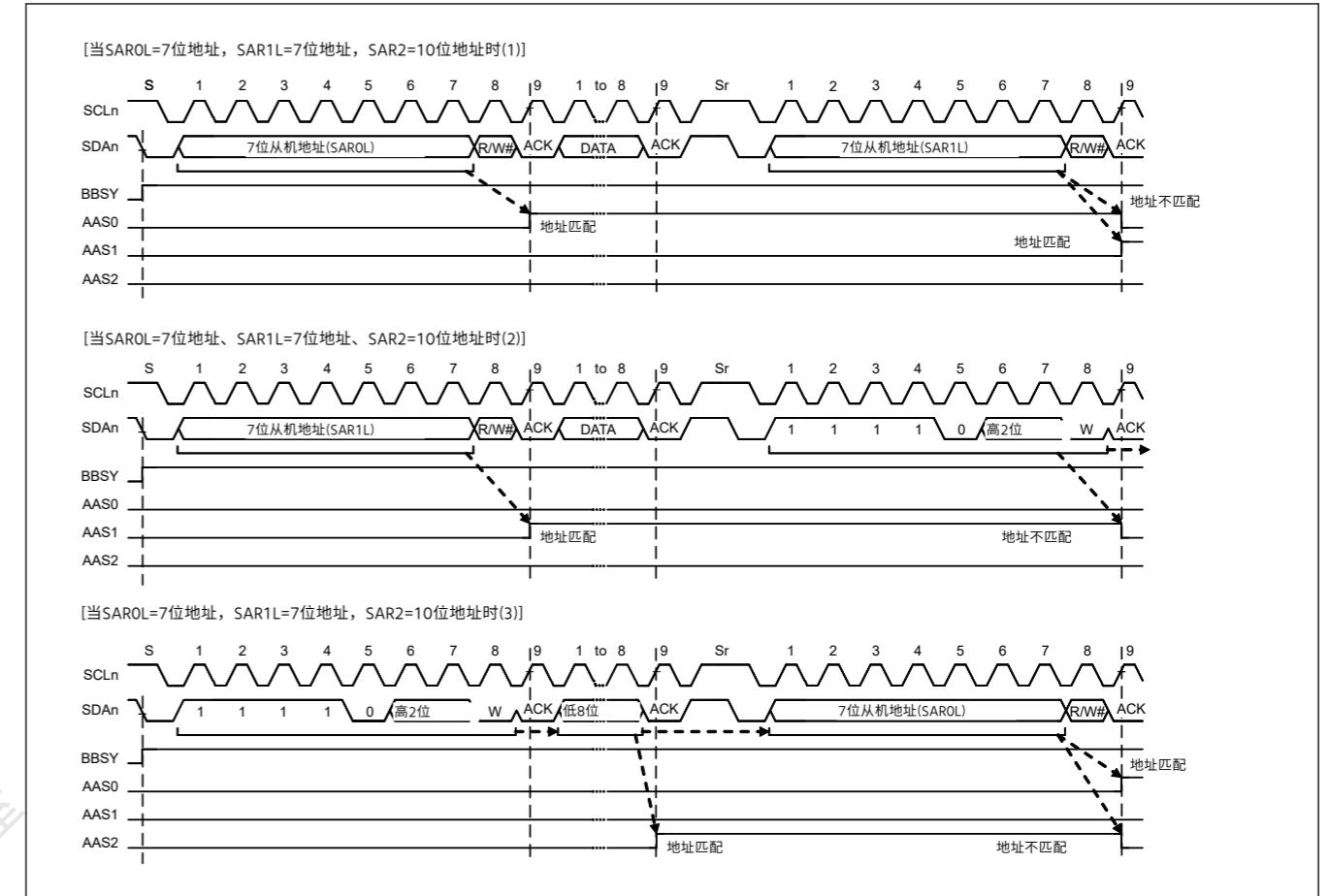


Figure 28.26 混合7位和10位地址格式的AASy标志设置和清除时序

28.7.2 广播呼叫地址检测

IIC提供对广播呼叫地址(0000000b+0[W])的检测。这是通过设置GCAE位启用 IC SER to 1。

如果在发出启动或重新启动条件后接收到的地址是0000000b+1[R] (起始字节)，则IIC将其识别为具有全零地址的从设备的地址，但不是广播地址。

当IIC检测到广播呼叫地址时，ICSR1中的GCA标志和ICSR2中的RDRF标志都在SCL时钟的第9个周期的上升沿设置为1。这会导致接收数据完全中断(IICn\_RXI)的产生。可以检查GCA标志的值以确认广播呼叫地址已被传输。

检测到广播呼叫地址后的操作与正常的从机接收操作相同。



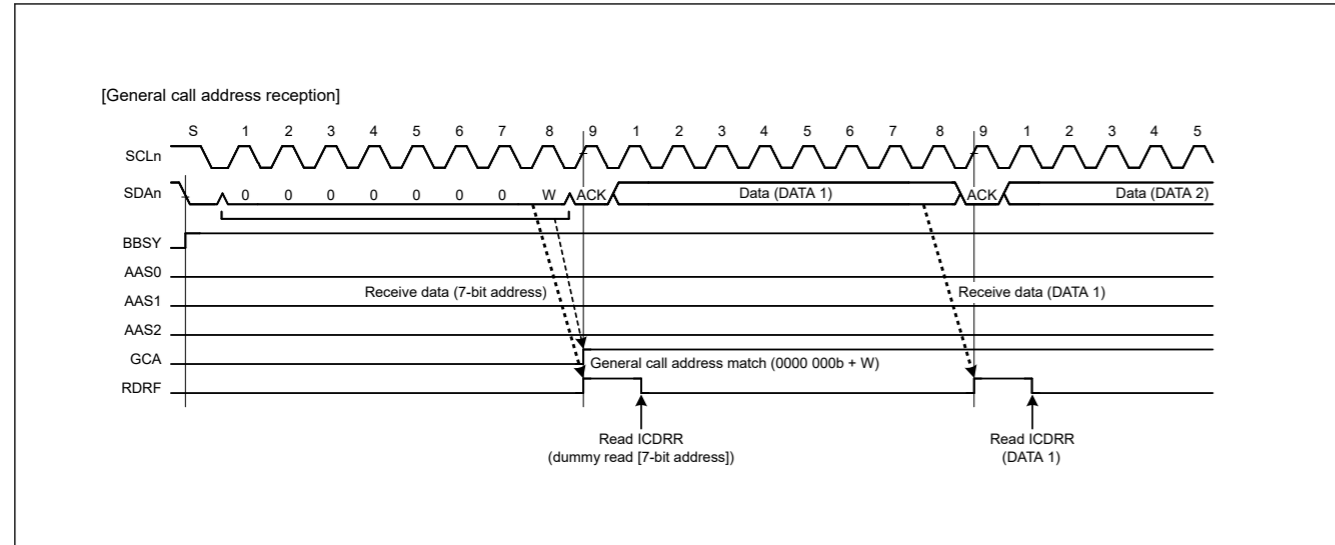


Figure 28.27 Timing of GCA flag setting during reception of general call address

### 28.7.3 Device-ID Address Detection

The IIC module provides detection of device-ID address compliant with the I<sup>2</sup>C bus specification (revision 03). When the IIC receives 1111 100b as the first byte after a start or restart condition is issued with the DIDE bit in ICSER set to 1, it recognizes the address as a device ID, sets the DID flag in ICSR1 to 1 on the rising edge of the ninth SCL clock cycle when the subsequent R/W# bit is 0, then compares the second and subsequent bytes with its own slave address. If the address matches the value in the slave address register, the IIC sets the associated AASy flag (y = 0 to 2) in ICSR1 to 1.

When the first byte received after the issue of a start or restart condition matches the device ID address (1111 100b) again and the subsequent R/W# bit is 1, the IIC does not compare the second and subsequent bytes and sets the ICSR2.TDRE flag to 1.

In the device ID address detection function, the IIC sets the DID flag to 0 if a match with the IIC slave address is not obtained or a match with the device ID address is not obtained after a match with the IIC slave address and a restart condition is not detected. If the first byte after detection of a start or restart condition matches the device ID address (1111 100b), and the R/W# bit is 0, the IIC sets the DID flag to 1 and compares the second and subsequent bytes with the slave address of the IIC. If the R/W# bit is 1, the DID flag holds the previous value and the IIC does not compare the second and subsequent bytes. Therefore, the reception of a device ID address can be checked by reading the DID flag after confirming that TDRE = 1.

Additionally, prepare the device ID fields (3 bytes: 12 bits indicating the manufacturer + 9 bits identifying the part + 3 bits indicating the revision) that must be sent to the host after reception of a continuous device-ID field as normal transmit data. For details on the information that must be included in device ID fields, contact NXP Semiconductors.

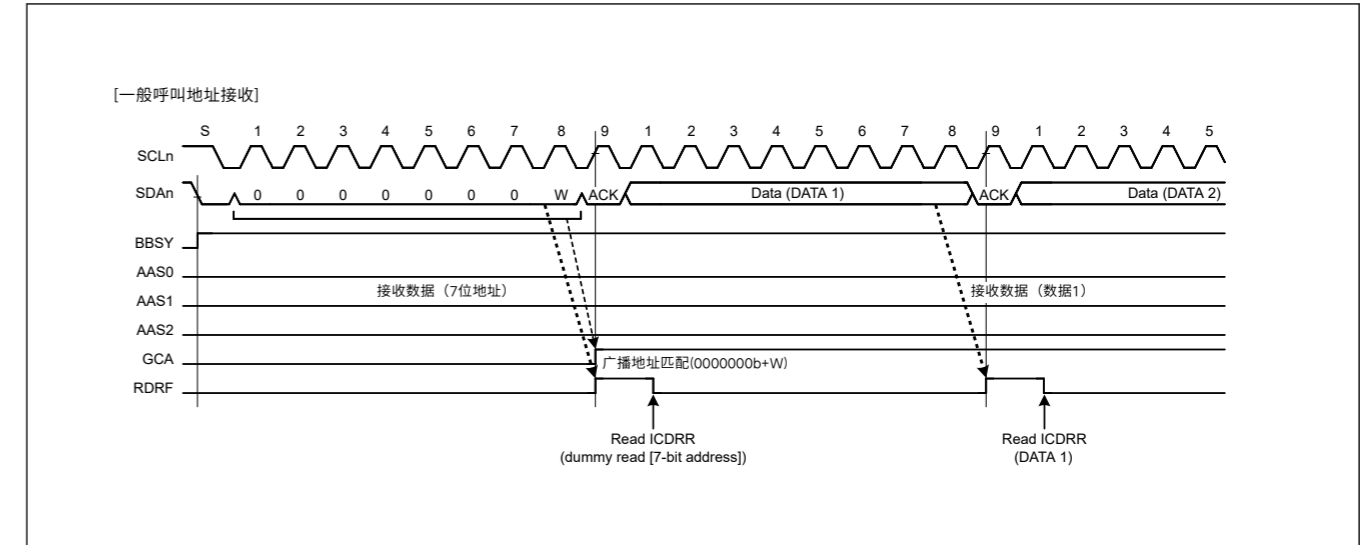


Figure 28.27 在接收广播呼叫地址期间设置GCA标志的时机

### 28.7.3 设备ID地址检测

IIC模块提供符合I2C总线规范（修订版03）的设备ID地址检测。当。。。的时候 IIC在ICSER中的DIDE位设置为1的情况下，在发出启动或重启条件后接收1111100b作为第一个字节，它将地址识别为设备ID，在第9个上升沿将ICSR1中的DID标志设置为1当后续RW#位为0时，SCL时钟周期，然后将第二个和后续字节与其自己的从地址进行比较。如果地址与从地址寄存器中的值匹配，则IIC将ICSR1中相关的AASy标志（y=0到2）设置为1。

当发出启动或重启条件后接收到的第一个字节再次与设备ID地址(1111100b)匹配且后续RW#位为1时，IIC不比较第二个和后续字节并设置ICSR2.TDRE标志为1。

在设备ID地址检测功能中，如果没有获得与IIC从机地址匹配或在与IIC从机地址匹配和重启条件后未获得与设备ID地址匹配，则IIC将DID标志设置为0未检测到。如果检测到启动或重启条件后的第一个字节与设备ID地址(1111100b)匹配，并且RW#位为0，则IIC将DID标志设置为1，并将第二个和后续字节与从机地址进行比较IIC。如果RW#位为1，则DID标志保持前一个值，并且IIC不比较第二个和后续字节。因此，在确认TDRE=1后，可以通过读取DID标志来检查设备ID地址的接收。

此外，准备设备ID字段（3个字节：12位表示制造商+9位表示部件+3位表示版本）在接收到连续的设备ID字段作为正常发送数据后必须发送到主机。有关必须包含在设备ID字段中的信息的详细信息，请联系NXP Semiconductors。

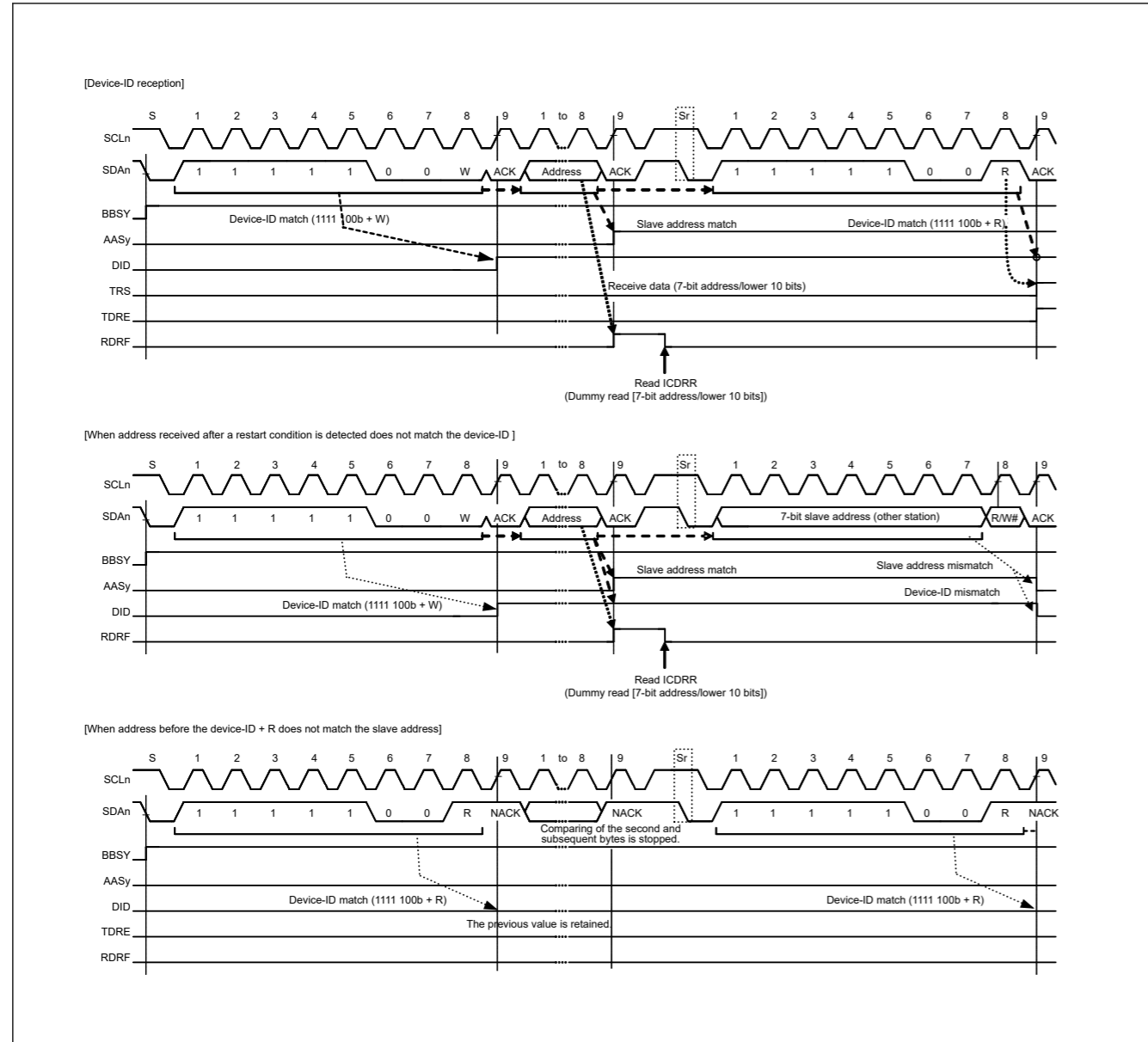


Figure 28.28 AASy and DID flag set and clear timing during reception of device ID

### 28.7.4 Host Address Detection

The IIC provides host address detection when operating in SMBus. When the HOAE bit in IC SER is set to 1 while the SMBS bit in ICMR3 is 1, the IIC can detect the host address (0001 000b) in slave receive mode (MST and TRS bits = 00b in ICCR2).

When the IIC detects the host address, the HOA flag in ICSR1 is set to 1 on the rising edge of the 9th SCL clock cycle, and at the same time, the RDRF flag in ICSR2 is set to 1 when the R/W# bit is 0 (Wr bit). This causes a receive data full interrupt (IICn\_RXI) to be generated. The HOA flag indicates that the host address was sent from another device.

If the bit following the host address (0001 000b) is an Rd bit (R/W# bit = 1), the IIC can also detect the host address. After the host address is detected, the IIC operates in the same manner as in normal slave operation.

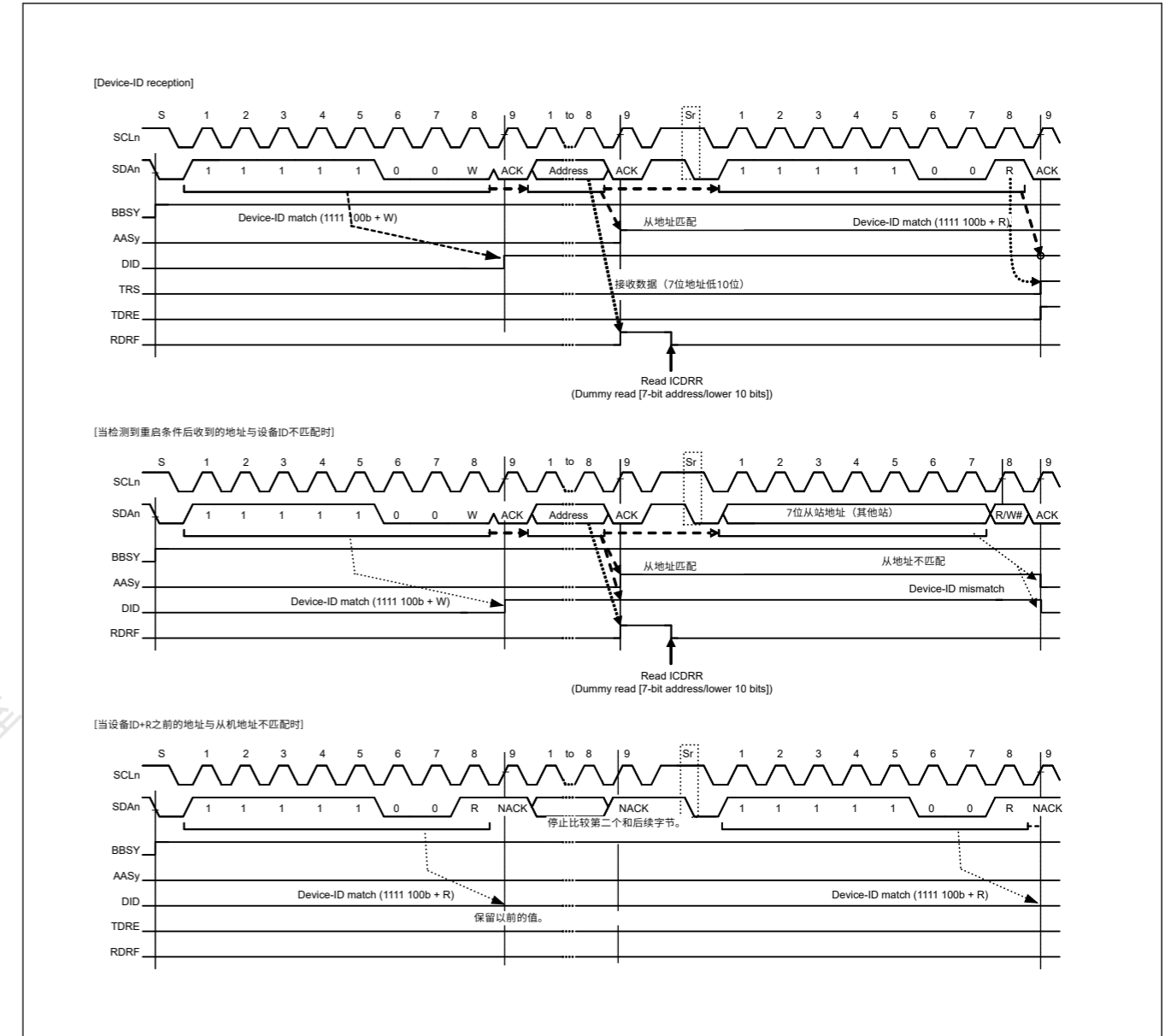


Figure 28.28 在接收设备ID期间设置AASy和DID标志并清除时序

### 28.7.4 主机地址检测

IIC在SMBus中运行时提供主机地址检测。当ICSER中的HOAE位设置为1而ICMR3中的SMBS位为1，IIC可以在从机接收模式下检测主机地址（0001000b）（ICCR2中的MST和TRS位=00b）。

当IIC检测到主机地址时，ICSR1中的HOA标志在第9个SCL时钟周期的上升沿置1，同时ICSR2中的RDRF标志在RW#位为0时置1（写位）。这会导致产生接收数据完全中断（IICn\_RXI）。HOA标志表明主机地址是从另一个设备发送的。

如果主机地址（0001000b）后面的位是Rd位（RW#位=1），则IIC也可以检测主机地址。检测到主机地址后，IIC以与正常从机操作相同的方式运行。

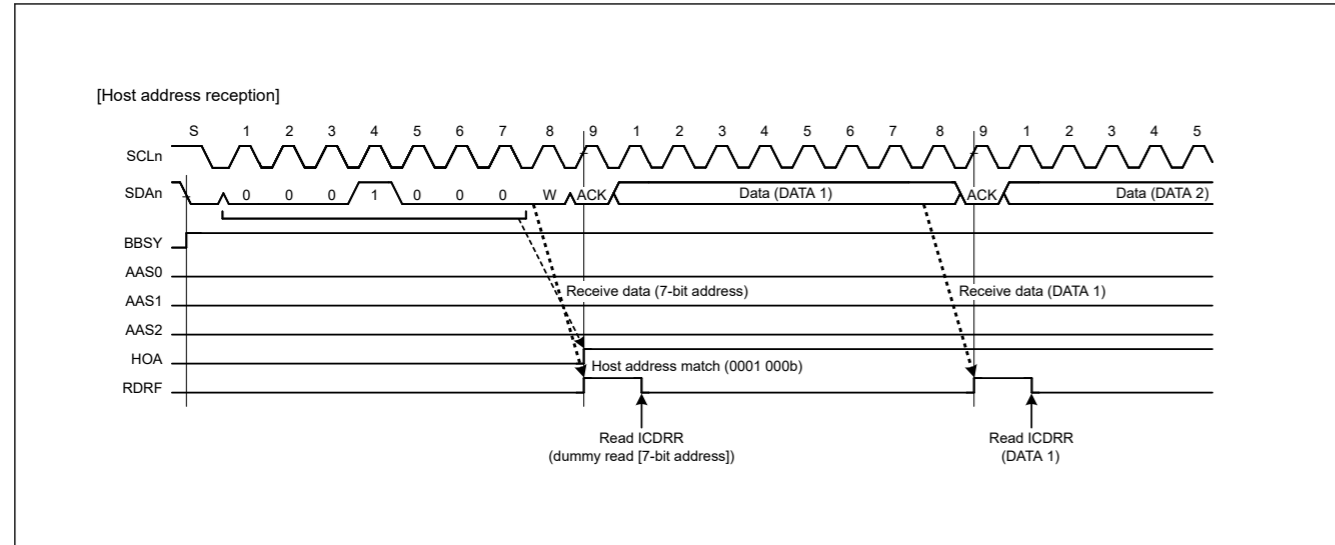


Figure 28.29 HOA flag set timing during reception of host address

### 28.8 Wakeup Function

The IIC provides a wakeup function that causes the MCU to transition from Software Standby mode or Snooze mode to normal operation. The wakeup function enables the reception of data when the system clock (PCLKB) is stopped, and generates a wakeup interrupt signal on a match of the slave address of the received data. This wakeup interrupt signal triggers the return to normal operation. After the wakeup interrupt occurs, switch the IIC to PCLKB synchronous operation so that communication can continue.

The wakeup function has four operation modes:

- Normal wakeup mode 1
- Normal wakeup mode 2
- Command recovery mode
- EEP response mode

Table 28.9 describes the behavior in these modes.

Table 28.9 Wakeup operation modes

| Operation mode        | ACK response timing  | ACK response before wakeup to PCLKB synchronous operation                      | SCL state during wakeup to PCLKB synchronous operation |
|-----------------------|--|--|--|
| Normal wakeup mode 1  | Before wakeup to PCLKB synchronous operation <sup>*1</sup>   | ACK  | Fixed low  |
| Normal wakeup mode 2  | After wakeup to PCLKB synchronous operation <sup>*2</sup>    | Before wakeup: no response (NACK level retained)<br>After wakeup: ACK response | Fixed low  |
| Command recovery mode | Before wakeup to PCLKB synchronous operation <sup>*1</sup>   | ACK  | Open   |
| EEP response mode     | Before recovery to PCLKB synchronous operation <sup>*1</sup> | NACK   | Open   |

Note 1. Switching timing from PCLKB asynchronous operation to PCLKB synchronous operation is the falling edge of the 9th clock of the SCL.

Note 2. Switching timing from PCLKB asynchronous operation to PCLKB synchronous operation is the falling edge of the 8th clock of the SCL.

The following can be selected as wakeup interrupt sources:

- Host address detection (valid when IC SER.HOAE = 1)
- General call address detection (valid when IC SER.GCAE = 1)
- Slave address 0<sup>\*1</sup> detection (valid when IC SER.SAR0E = 1)

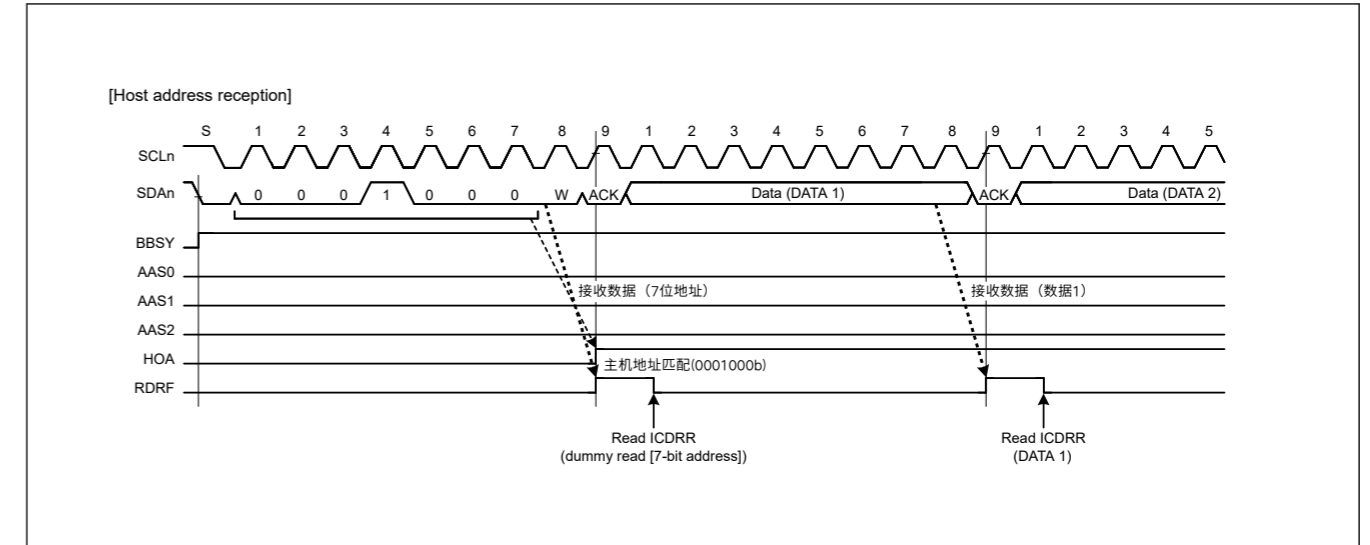


Figure 28.29 接收主机地址期间的HOA标志设置时序

### 28.8 唤醒功能

IIC提供唤醒功能，使MCU从软件待机模式或贪睡模式转换到正常操作。唤醒功能在系统时钟（PCLKB）停止时启用数据接收，并在接收到的数据的从地址匹配时产生唤醒中断信号。该唤醒中断信号触发恢复正常操作。唤醒中断发生后，将IIC切换为PCLKB同步操作，以便继续通信。

唤醒功能有四种操作模式：

- 正常唤醒模式1
- 正常唤醒模式2
- 命令恢复模式
- EEP响应方式

表28.9描述了这些模式下的行为。

Table 28.9 唤醒操作模式

| 操作模式    | ACK响应时间          | 唤醒前的ACK响应到PCLKB同步操作            | 唤醒到PCLKB同步操作期间的SCL状态 |
|---------|------------------|--------------------------------|----------------------|
| 正常唤醒模式1 | 唤醒到PCLKB同步操作之前*1 | ACK                            | 固定低                  |
| 正常唤醒模式2 | 唤醒到PCLKB同步操作后*2  | 唤醒前：无响应（保留NACK电平）<br>唤醒后：ACK响应 | 固定低                  |
| 命令恢复模式  | 唤醒到PCLKB同步操作之前*1 | ACK                            | Open                 |
| EEP响应模式 | 恢复到PCLKB同步操作之前*1 | NACK                           | Open                 |

注1.从PCLKB异步操作切换到PCLKB同步操作的时序是第9个时钟的下降沿SCL。

注2.从PCLKB异步操作切换到PCLKB同步操作的时序是第8个时钟的下降沿SCL。

可以选择以下作为唤醒中断源：

- 主机地址检测（当IC SER.HOAE=1时有效）
- 广播地址检测（IC SER.GCAE=1时有效）
- 从机地址0\*1检测（在IC SER.SAR0E=1时有效）

- Slave address 1<sup>\*1</sup> detection (valid when IC SER.SAR1E = 1)
- Slave address 2<sup>\*1</sup> detection (valid when IC SER.SAR2E = 1)

Note 1. Only 7-bit address can be set. Set the FS bit in SARUy (y = 0 to 2) to 0.

### Precautions on the use of the wakeup function

- Do not change the content of the IIC registers except the WUSEN bit in ICWUR2 while the WUASYF flag in ICWUR2 is 1 (during PCLKB asynchronous operation).
- Set ICWUR.WUE and ICWUR.WUIE to 1, and ICCR2.MST and ICCR2.TRS to 0 (slave reception mode) before switching to PCLKB asynchronous mode.
- The device ID and the 10-bit slave address cannot be selected for the wakeup interrupt source. Set the DIDE bit in IC SER and FS bit in SARUy (y = 0 to 2) to 0.
- Set bits TIE, TEIE, RIE, NAKIE, SPIE, STIE, ALIE, and TMOIE in the ICIER register to 0 (interrupt disabled) before switching to the asynchronous operation.
- When the wakeup function is enabled, do not use the timeout function (ICWUR.WUE = 1)
- Even when a wakeup interrupt is generated during PCLKB asynchronous operation (when ICWUR2.WUASYF = 1), if the slave addresses match in PCLKB synchronous mode (ICWUR2.WUASYF = 0), the wakeup interrupt does not occur and the WUF flag is not set.
- If the timing of writing 0 to the ICWUR2.WUSEN bit and the timing of detecting a start condition conflict, the IIC might start the next reception in PCLKB synchronous operation mode. In this case, ICWUR2.WUASYF flag becomes 1 (switch to PCLKB asynchronous mode) when data communication is complete, a stop condition is detected, and detection of a wakeup event starts.
- After writing 0 to the WUSEN bit in ICWUR2, do not change registers relate to the IIC operation mode setting (ICMR3, IC SER, and SARLy) until the mode is switched to PCLKB asynchronous operation from PCLKB synchronous operation (while the ICWUR2.WUASYF flag is 1). If the register value changes during this period by an interrupt handling or another factor, the IIC might malfunction before switching to the asynchronous operation.

#### 28.8.1 Normal Wakeup Mode 1

This section describes the behavior, the timing, and an example operation of normal wakeup mode 1.

In normal wakeup mode 1, a wakeup interrupt triggered by the match of the slave address initiates the transition to normal operation as follows:

Before wakeup: ACK is sent in response to the data received with its own slave address of the IIC.  
 During wakeup: ACK response is made on the 9th clock cycle of SCL, after which SCL is held low<sup>\*1</sup>.  
 After wakeup: Normal operation continues.

Note 1. Between the 9th clock cycle and 1st clock cycle during wakeup, WAIT = 1 is invalid.

If the slave address does not match, the SCL line is not held low after the 9th clock cycle of SCL, and the slave operation continues. Figure 28.30 shows an operation example, and Figure 28.32 shows the detailed timing.

If the transition from Software Standby mode or Snooze mode is triggered by an interrupt other than a wakeup interrupt, for example the IRQn, the WUF flag is not set to 1. Figure 28.31 shows an operation example.

- 从机地址1\*1检测（当IC SER.SAR1E=1时有效）
- 从机地址2\*1检测（当IC SER.SAR2E=1时有效）

注1.只能设置7位地址。将SARUy (y=0到2) 中的FS位设置为0。

### 唤醒功能使用注意事项

- 当ICWUR2的WUASYF标志为1时（PCLKB异步操作期间），不要改变ICWUR2中除WUSEN位以外的IIC寄存器的内容。
- 在切换到PCLKB异步模式之前，将ICWUR.WUE和ICWUR.WUIE设置为1，并将ICCR2.MST和ICCR2.TRS设置为0（从接收模式）。
- 唤醒中断源不能选择设备ID和10位从机地址。将IC SER中的DIDE位和SARUy (y=0到2) 中的FS位设置为0。
- 在切换到异步操作之前，将ICIER寄存器中的TIE、TEIE、RIE、NAKIE、SPIE、STIE、ALIE和TMOIE位设置为0（禁止中断）。
- 启用唤醒功能时，不要使用超时功能（ICWUR.WUE=1）
- 即使在PCLKB异步操作期间（ICWUR2.WUASYF=1）产生唤醒中断，如果在PCLKB同步模式下从机地址匹配（ICWUR2.WUASYF=0），唤醒中断不会发生并且WUF标志不放。
- 如果向ICWUR2.WUSEN位写入0的时序与检测启动条件的时序冲突，则IIC可能会在PCLKB同步操作模式下开始下一次接收。在这种情况下，当数据通信完成时，ICWUR2.WUASYF标志变为1（切换到PCLKB异步模式），检测到停止条件，并开始检测唤醒事件。
- 在ICWUR2的WUSEN位写入0后，不要更改与IIC操作模式设置相关的寄存器（ICMR3、IC SER和SARLy），直到模式从PCLKB同步操作切换到PCLKB异步操作（同时ICWUR2.WUASYF标志是1）。如果在此期间寄存器值因中断处理或其他因素而发生变化，则IIC可能会在切换到异步操作之前发生故障。

#### 28.8.1 正常唤醒模式1

本节介绍正常唤醒模式1的行为、时序和示例操作。

在正常唤醒模式1中，由匹配从机地址触发的唤醒中断启动到正常操作的转换，如下所示：

Before wakeup: ACK是响应接收到的带有IIC从机地址的数据而发送的。  
 During wakeup: 在SCL的第9个时钟周期做出ACK响应，之后SCL保持低电平\*1。  
 After wakeup: 正常操作继续。

注1.在唤醒期间的第9个时钟周期和第1个时钟周期之间，WAIT=1无效。

如果从机地址不匹配，则SCL线在SCL的第9个时钟周期后不保持低电平，从机操作继续。图28.30显示了一个操作示例，图28.32显示了详细的时序。

如果从软件待机模式或贪睡模式的转换是由唤醒中断以外的中断触发的，例如IRQn，则WUF标志不设置为1。图28.31显示了一个操作示例。



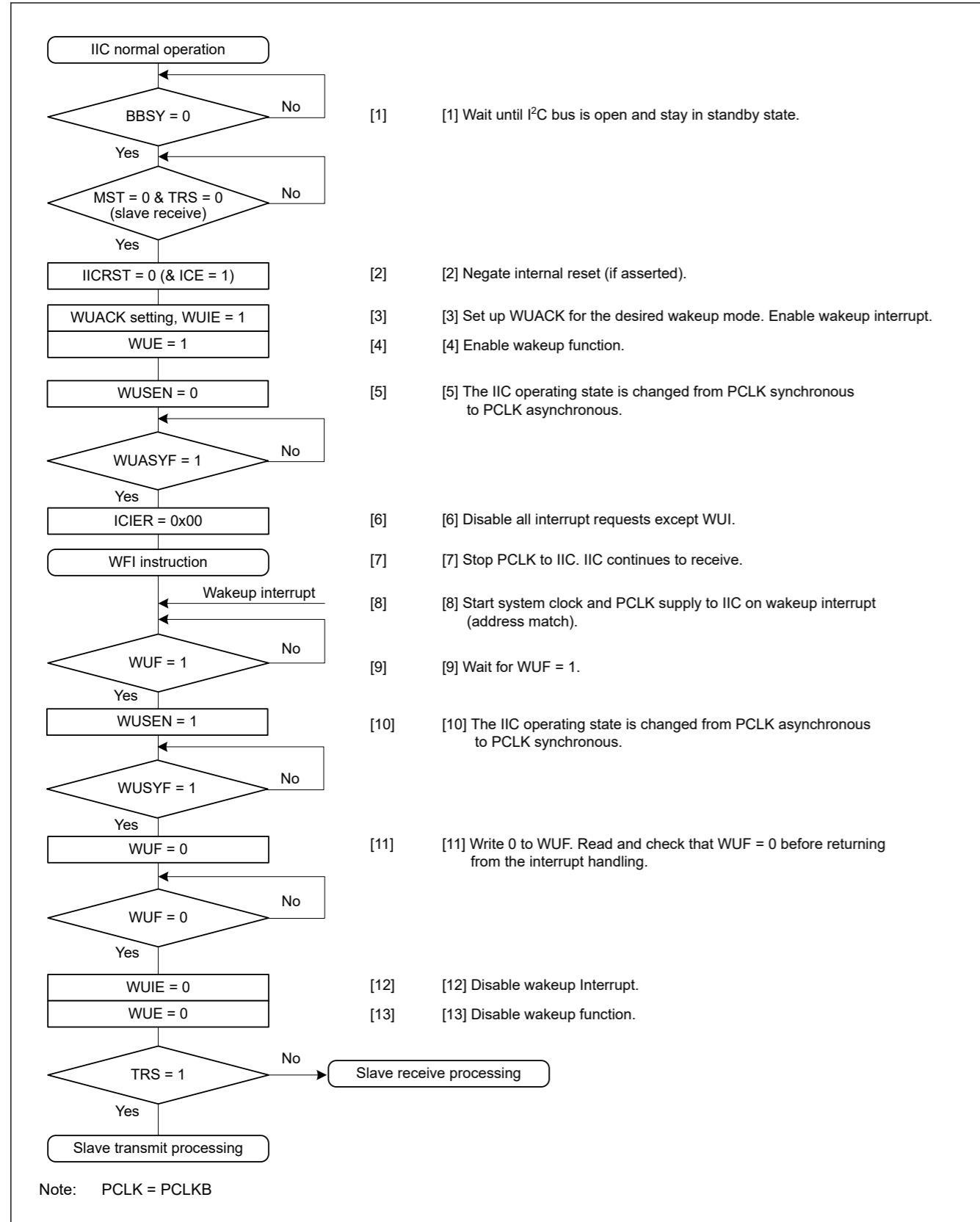


Figure 28.30 Example operation of normal wakeup mode 1 when wakeup is triggered by a wakeup interrupt on match of the slave address

Note: See [Precautions on the use of the wakeup function](#).

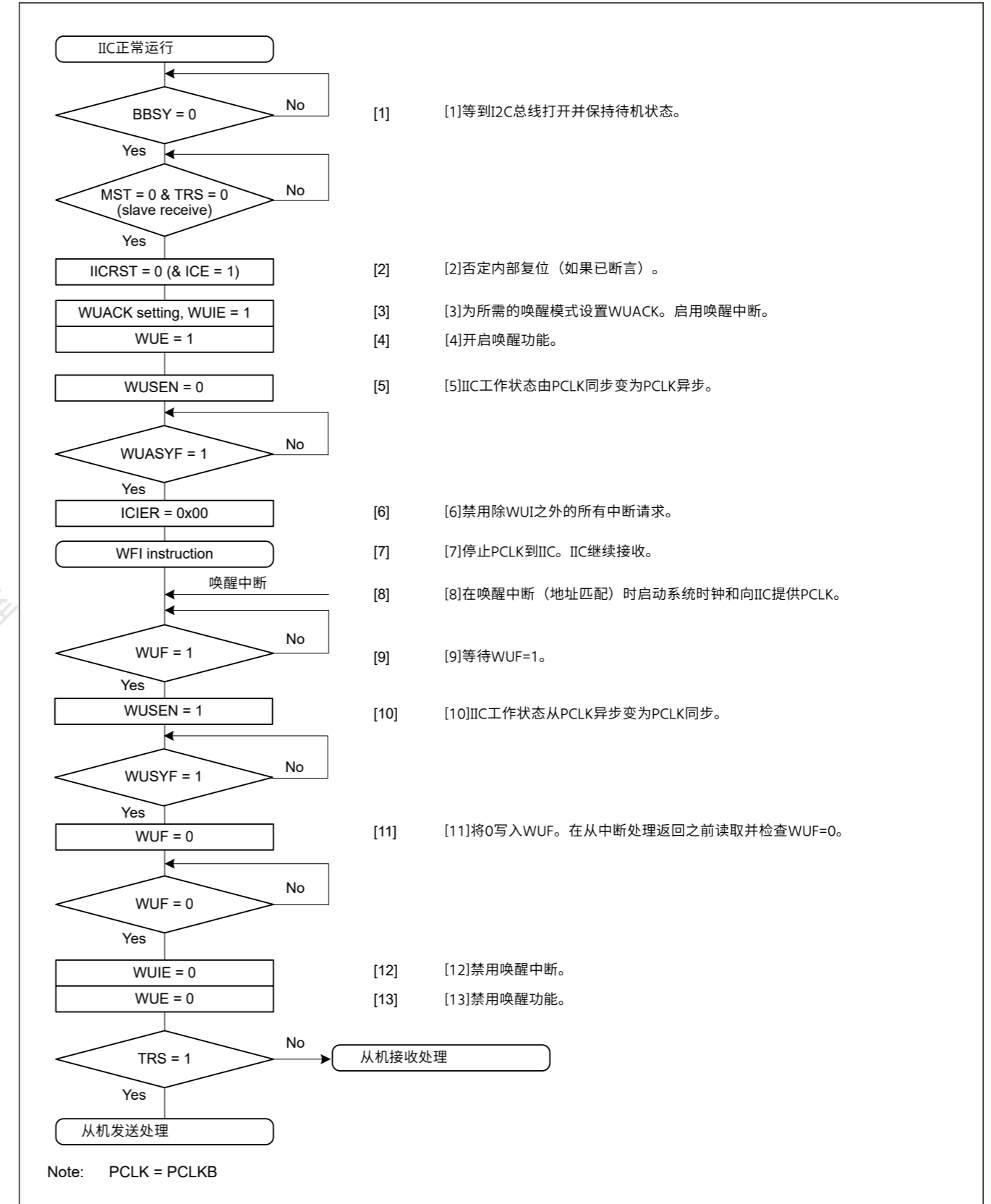


Figure 28.30 正常唤醒模式1的示例操作，当唤醒由从地址匹配时的唤醒中断触发时

Note: 请参阅[唤醒功能使用注意事项](#)。

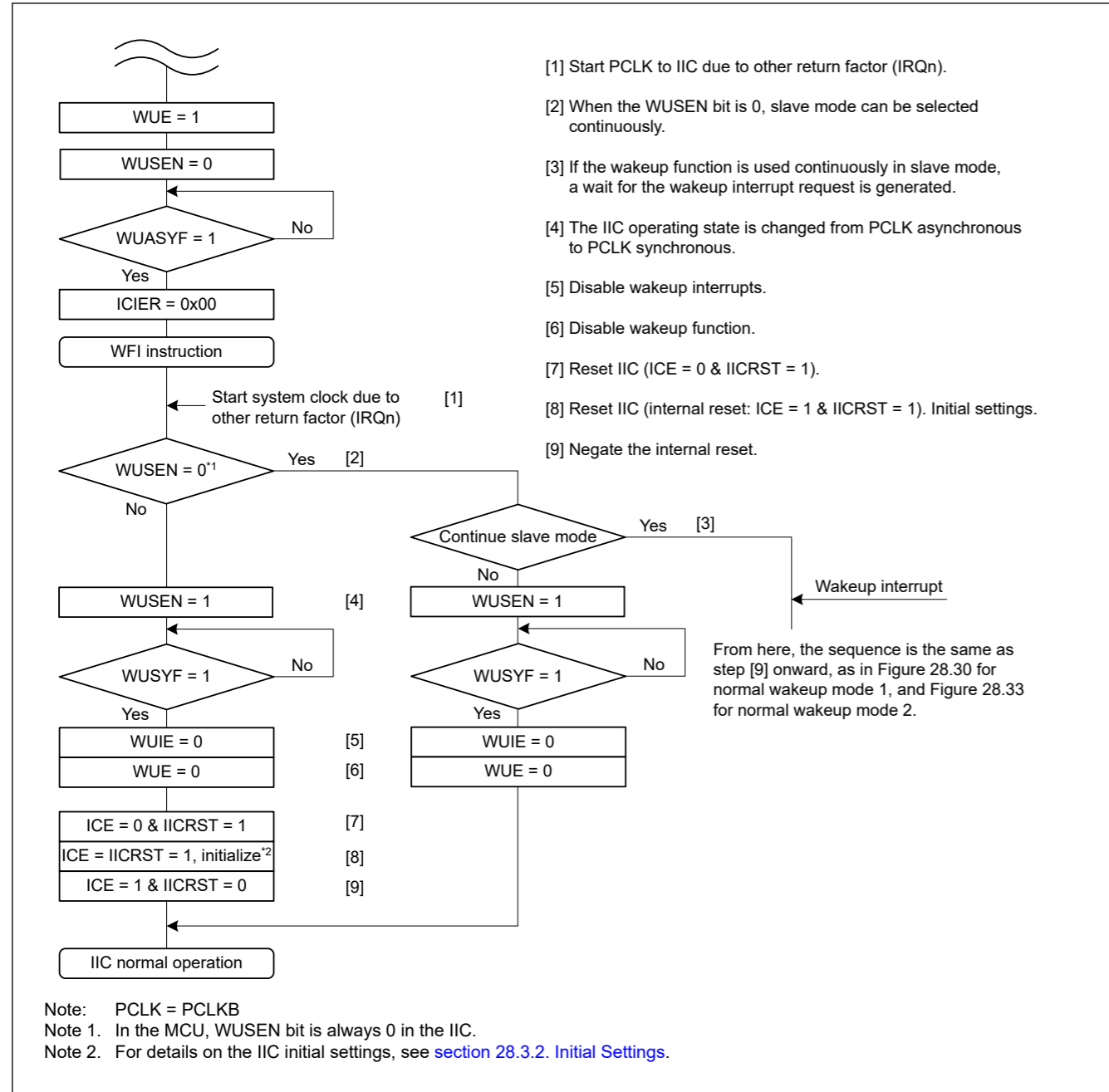


Figure 28.31 Example operation of normal wakeup modes 1 and 2 when wakeup is triggered by an interrupt other than IIC wakeup interrupt, for example, the IRQn

Note: For details on the IIC initial settings, see section 28.3.2. Initial Settings.

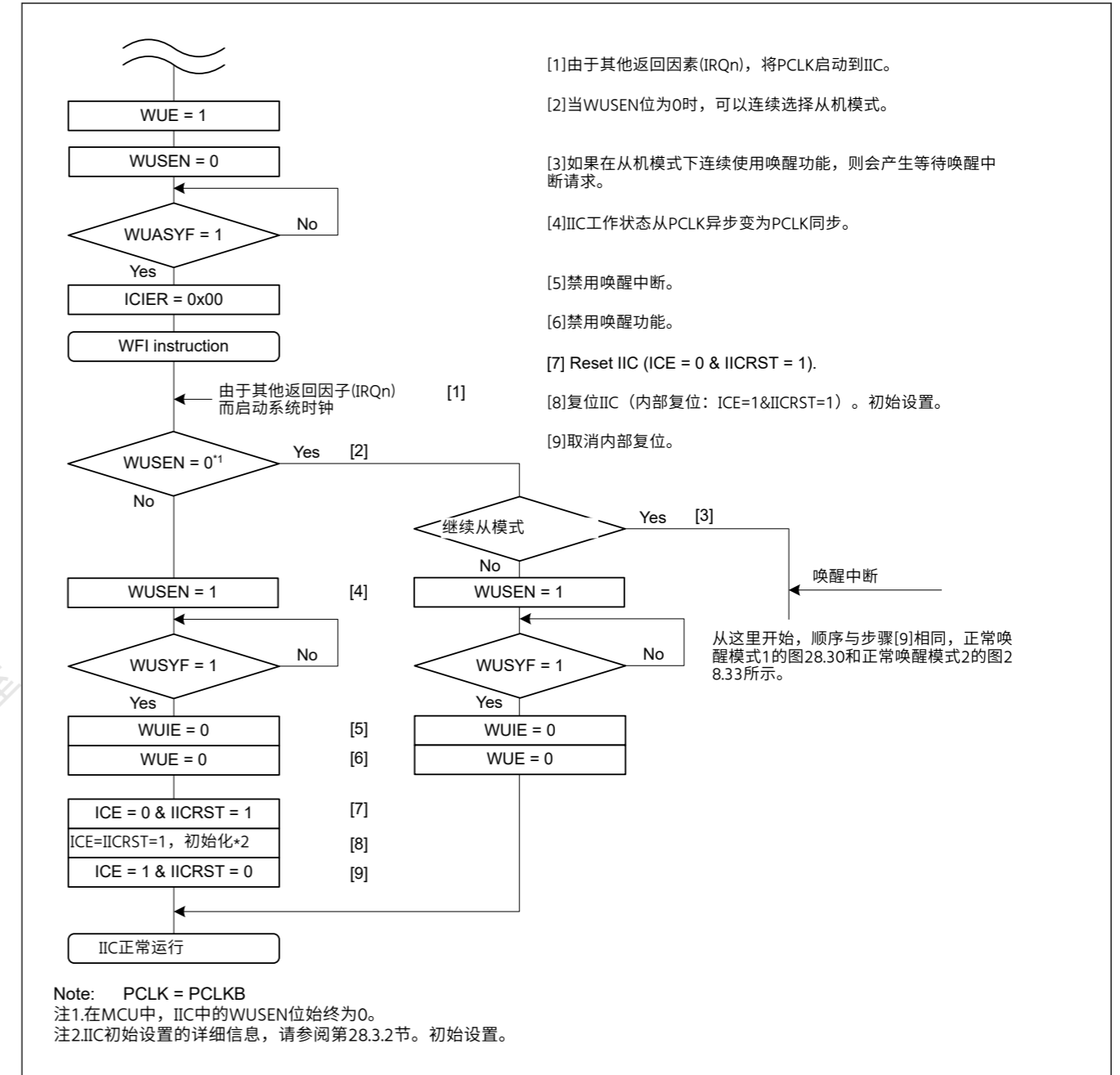


Figure 28.31 当唤醒由IIC唤醒中断以外的中断（例如IRQn）触发时，正常唤醒模式1和2的示例操作

Note: 有关IIC初始设置的详细信息，请参阅第28.3.2节。初始设置。

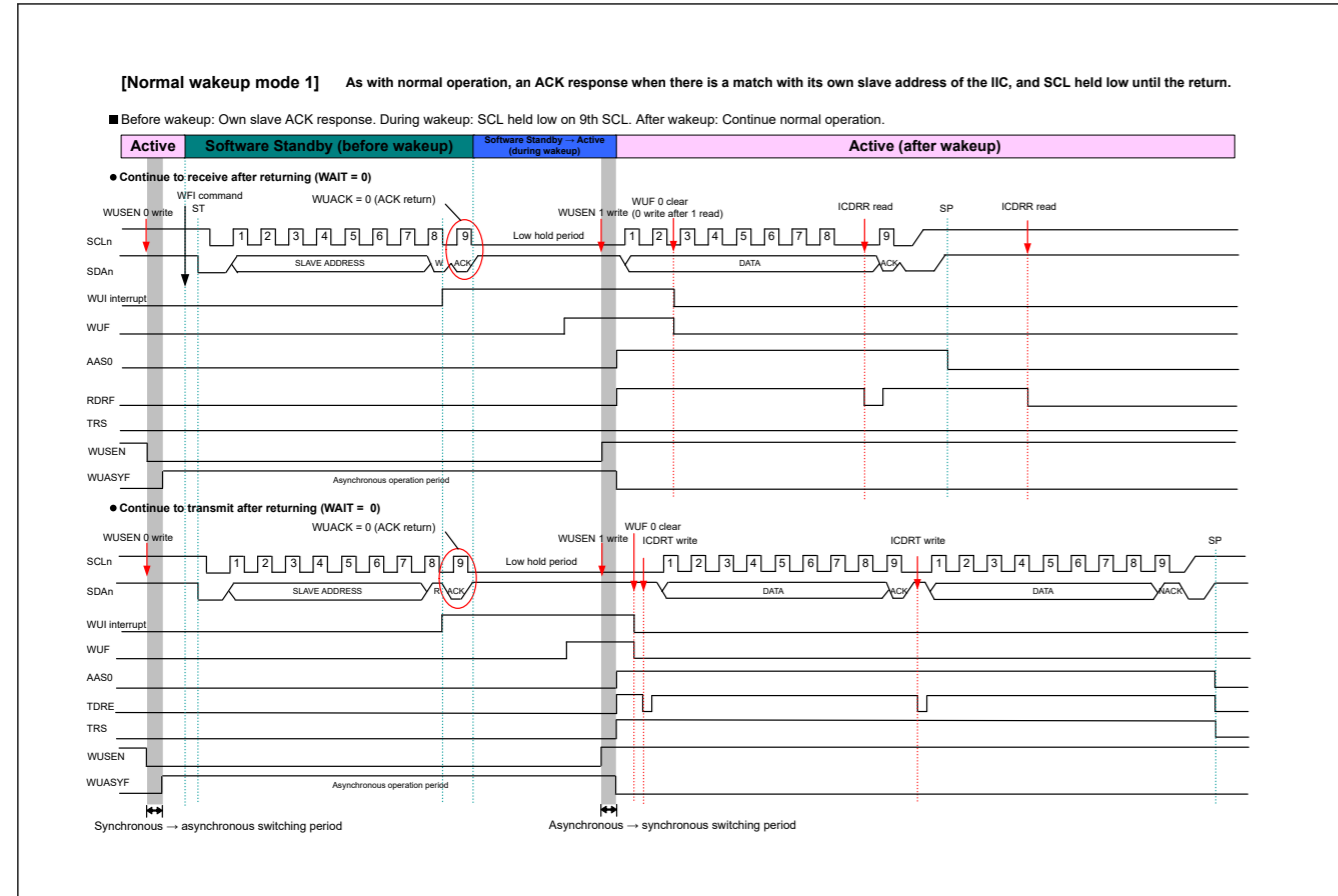


Figure 28.32 Timing of normal wakeup mode 1

### 28.8.2 Normal Wakeup Mode 2

This section describes the behavior, the timing, and an example operation of normal wakeup mode 2.

In normal wakeup mode 2, a wakeup interrupt triggered by a match of the slave address initiates the transition to normal operation as follows:

- Before wakeup: No response to data received with its own slave address until the end of the 8th SCL cycle.
- During wakeup: SCL line held low during the 8th and 9th clock cycles.
- After wakeup: ACK returns on the 9th clock cycle of SCL, and normal operation continues.

If the slave address does not match, the SCL line is not held low after the 8th SCL clock cycle, and the slave operation continues. Figure 28.33 shows an example operation, and Figure 28.34 shows the detailed timing.

If the transition from Software Standby mode or Snooze mode is triggered by an interrupt other than a wakeup interrupt, such as the IRQn, for example, the WUF flag is not set to 1. Figure 28.31 shows an operation example.

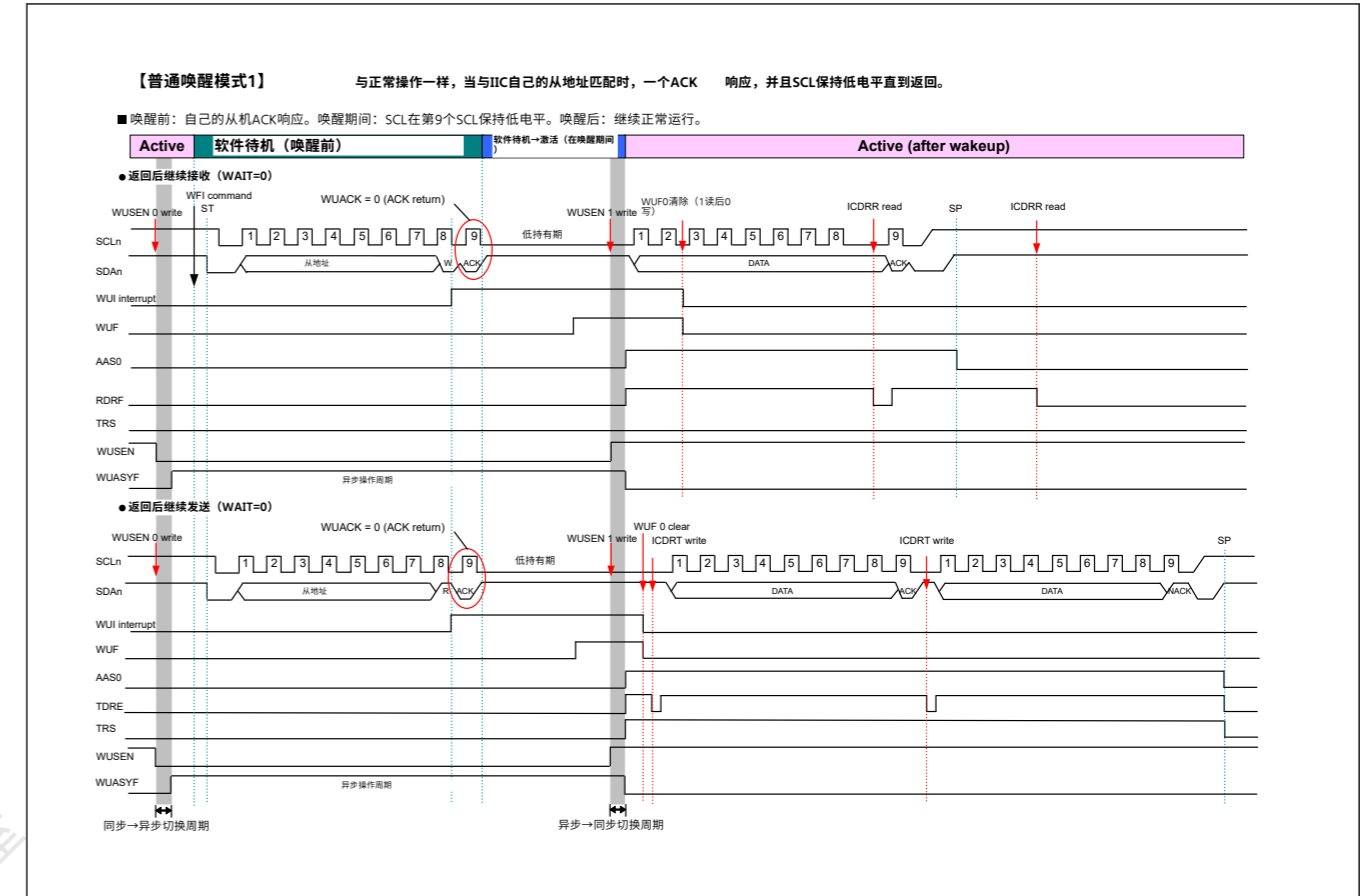


Figure 28.32 正常唤醒模式1的时序

### 28.8.2 正常唤醒模式2

本节介绍正常唤醒模式2的行为、时序和示例操作。

在正常唤醒模式2中，由匹配从机地址触发的唤醒中断会启动到正常操作的转换，如下所示：

- Before wakeup: 直到第8个SCL周期结束，才对接收到的带有自己的从地址的数据作出响应。
- During wakeup: SCL线在第8和第9个时钟周期内保持低电平。
- After wakeup: ACK在SCL的第9个时钟周期返回，并继续正常操作。

如果从机地址不匹配，则SCL线在第8个SCL时钟周期后不会保持低电平，从机操作继续。图28.33显示了一个示例操作，图28.34显示了详细的时序。

如果从软件待机模式或贪睡模式的转换是由唤醒中断以外的中断触发的，例如IRQn，则WUF标志不设置为1。图28.31显示了一个操作示例。

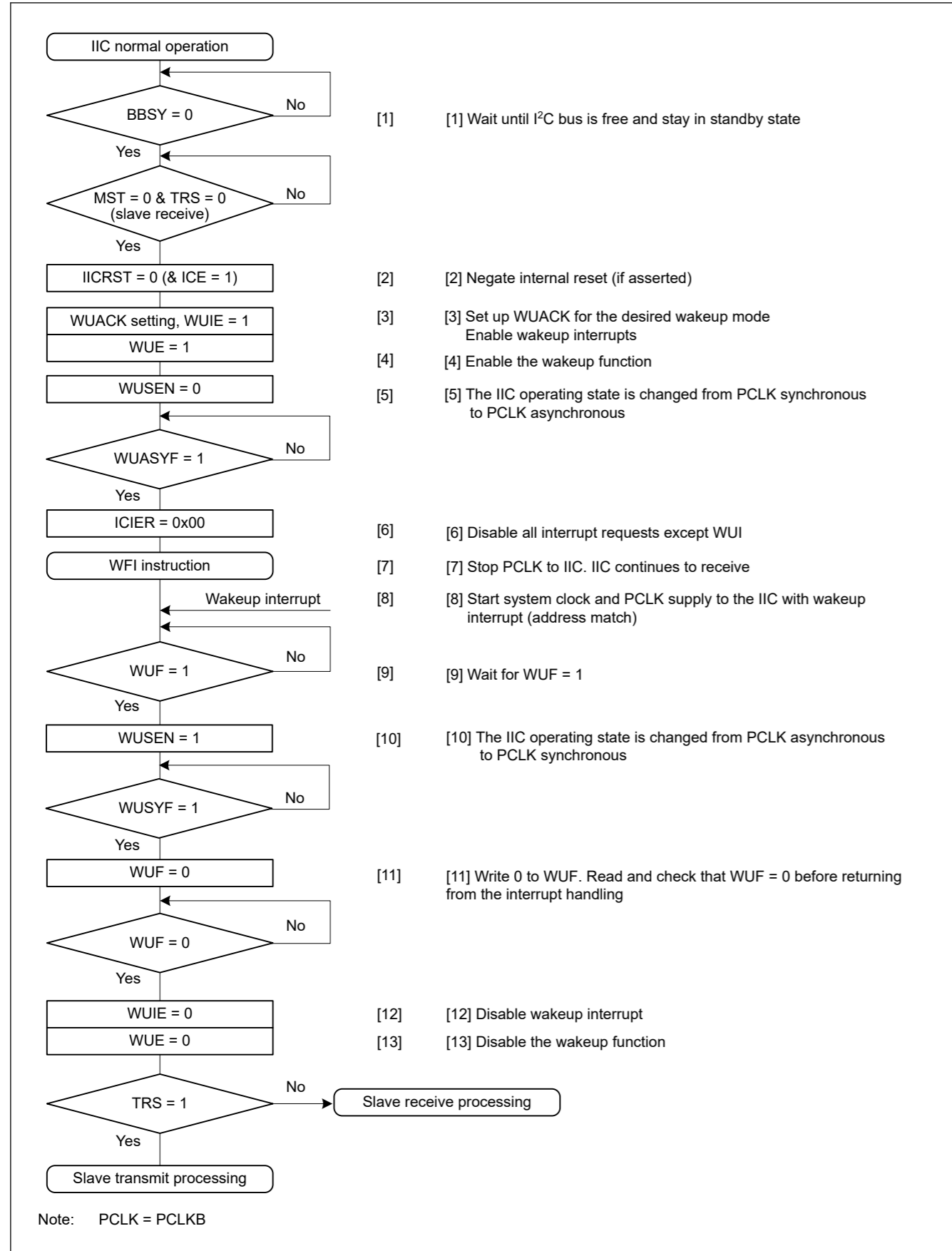


Figure 28.33 Example operation of normal wakeup mode 2 when wakeup is triggered by a wakeup interrupt on match of the slave address

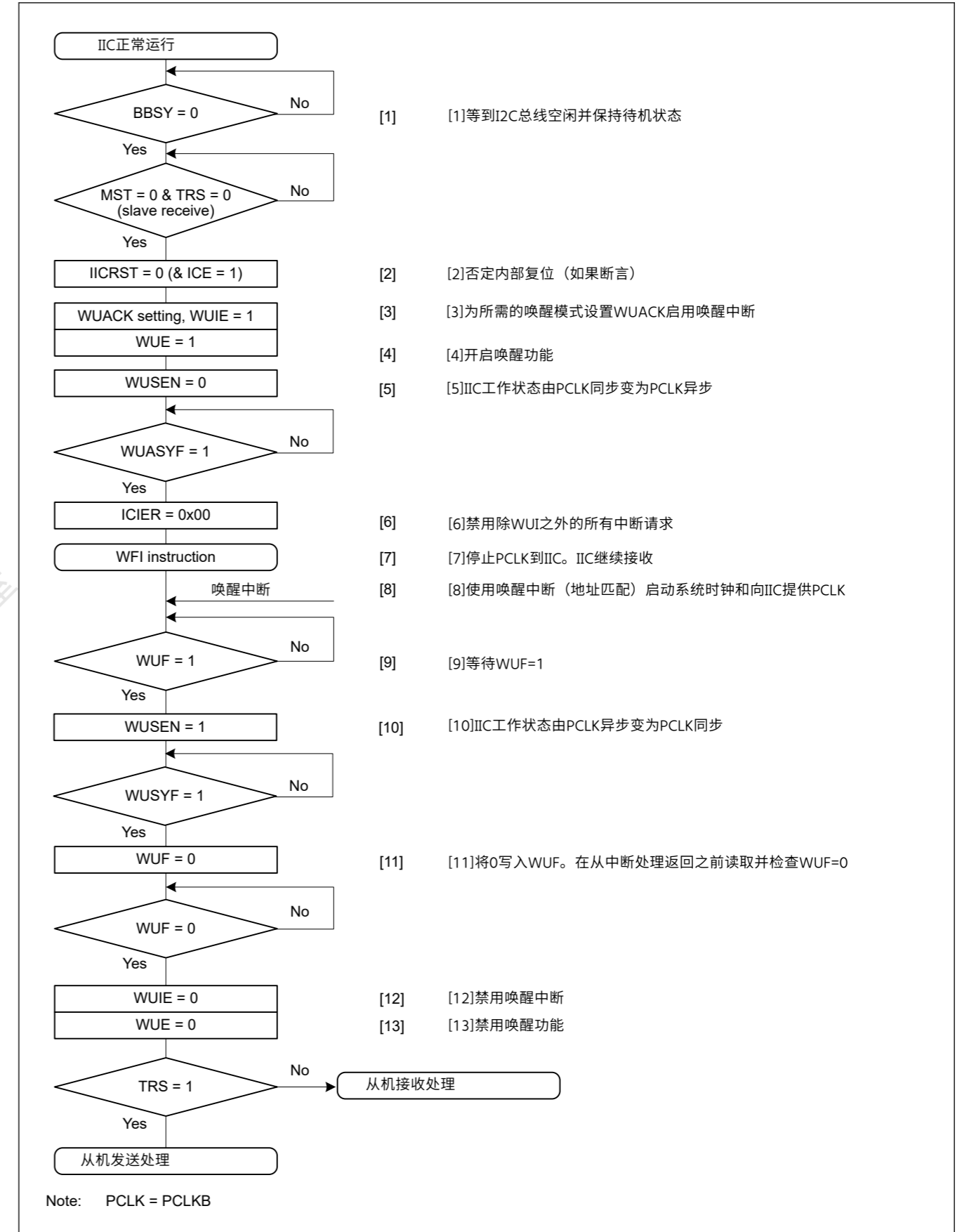


Figure 28.33 正常唤醒模式2的示例操作，当唤醒由从地址匹配时的唤醒中断触发时



Note: See [Precautions on the use of the wakeup function](#).

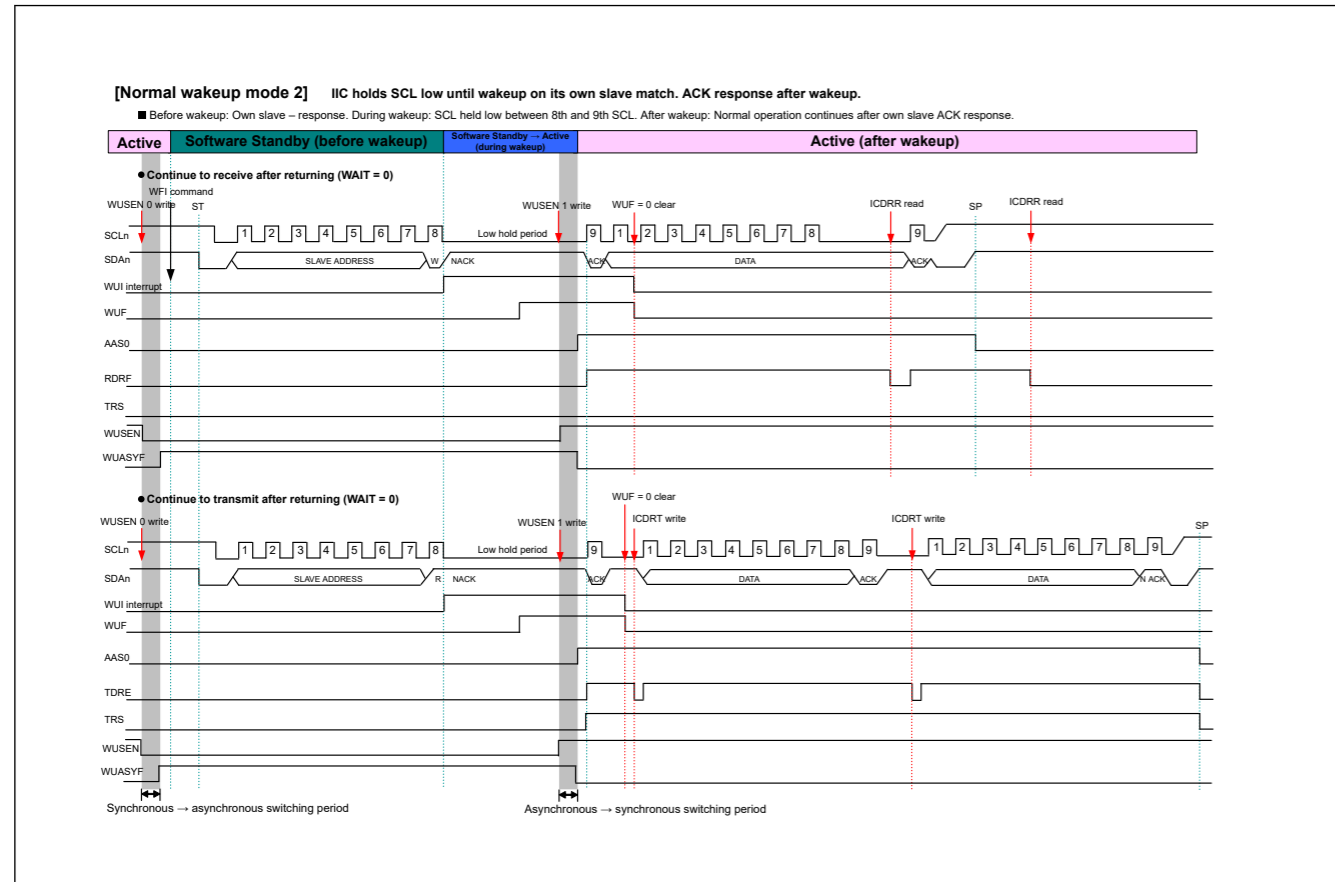


Figure 28.34 Timing of normal wakeup mode 2

### 28.8.3 Command Recovery Mode and EEP Response Mode (Special Wakeup Modes)

This section describes the behavior, the timing, and example operations of the command recovery and EEP response modes.

In the command recovery and EEP response modes, the SCL line is not held low during the wakeup period (after the rise of the 9th clock cycle of SCL). Therefore, other IIC devices can use the I<sup>2</sup>C bus during this period.

A wakeup interrupt triggered by a match of the slave address initiates the transition to normal operation as follows:

- Before wakeup: In response to the data received with its own slave address, the IIC returns ACK (command recovery mode) or NACK (EEP response mode).
- During wakeup: The SCL line is not held low.
- After wakeup: Normal operation continues after IIC initialization.

If the slave address does not match, the slave operation continues.

Note: Because the SCL line is not held low during wakeup, transmission or reception of the data that follows the slave address is not possible.

Note: The command recovery and EEP response modes are internal reset states (ICE = IICRST = 1). Therefore, the match of the slave address does not set the flags, HOA, GCA, ASS0, ASS1, and ASS2 in the ICSR1 register.

Figure 28.35 shows an example operation in recovery and EEP response modes. Figure 28.37 shows the detailed timing.

If the transition from Software Standby mode or Snooze mode is triggered by an interrupt other than a wakeup interrupt, such as IRQn for example, the WUF flag is not set to 1. Follow the processing shown in Figure 28.36.

Note: 请参阅[唤醒功能使用注意事项](#)。

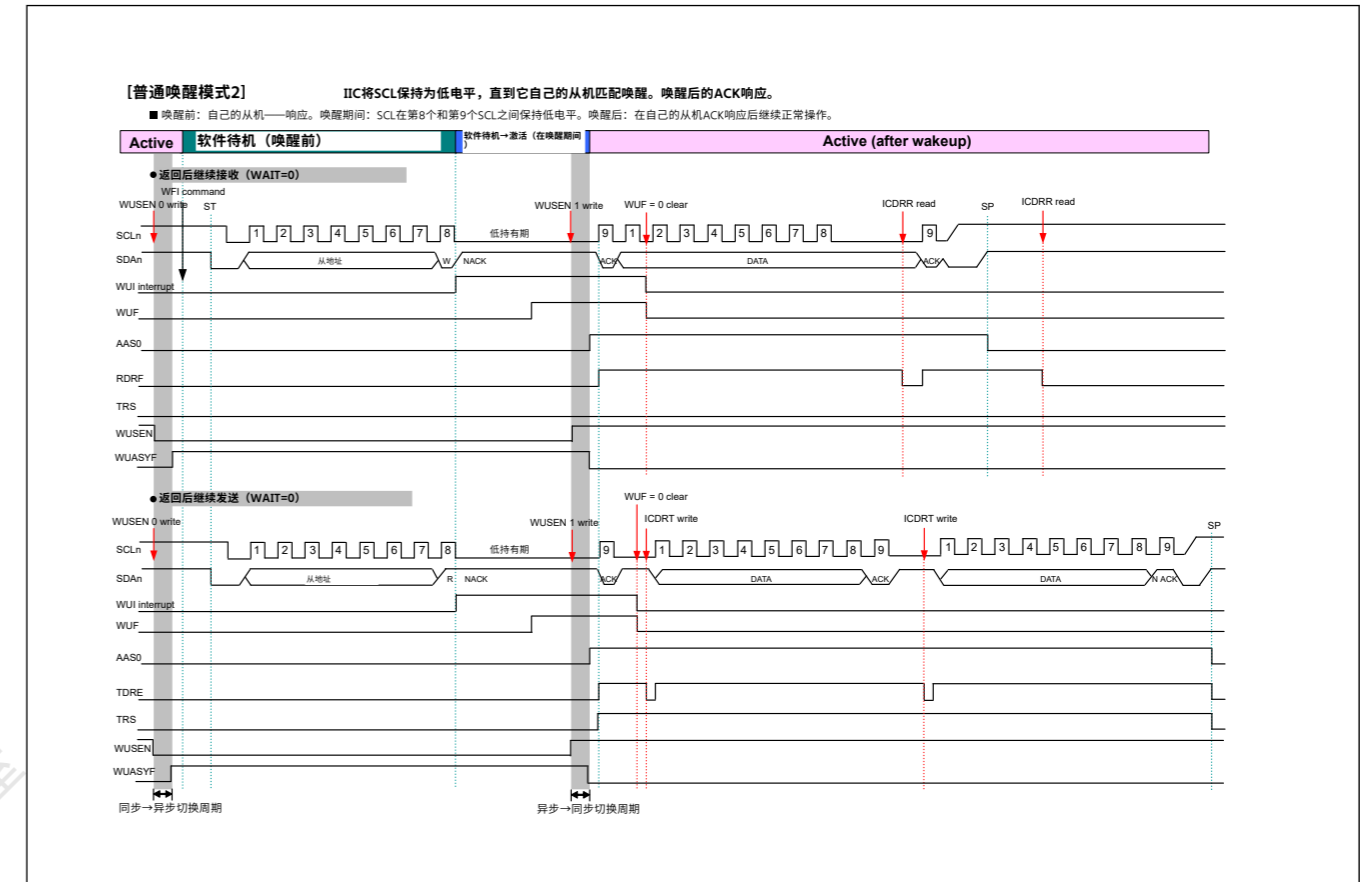


Figure 28.34 正常唤醒模式2的时序

### 28.8.3 命令恢复模式和EEP响应模式（特殊唤醒模式）

本节介绍命令恢复和EEP响应模式的行为、时序和示例操作。

在命令恢复和EEP响应模式下，SCL线在唤醒期间（在SCL的第9个时钟周期上升之后）不保持低电平。因此，其他IIC设备在此期间可以使用I2C总线。

由匹配从地址触发的唤醒中断会启动到正常操作的转换，如下所示：

- Before wakeup: IIC响应使用自己的从机地址接收到的数据，返回ACK（命令恢复模式）或NACK（EEP响应模式）。
- During wakeup: SCL线没有保持低电平。
- After wakeup: IIC初始化后继续正常操作。

如果从机地址不匹配，从机操作继续。

Note: 因为SCL线在唤醒期间没有保持低电平，所以无法发送或接收跟随从地址的数据。

Note: 命令恢复和EEP响应模式是内部复位状态(ICE=IICRST=1)。因此，从地址的匹配不会设置ICSR1寄存器中的标志位HOA、GCA、ASS0、ASS1和ASS2。

图28.35显示了恢复和EEP响应模式下的示例操作。图28.37显示了详细的时序。

如果从软件待机模式或贪睡模式的转换是由唤醒中断以外的中断触发的，例如IRQn，则WUF标志不设置为1。按照图28.36中所示的处理。

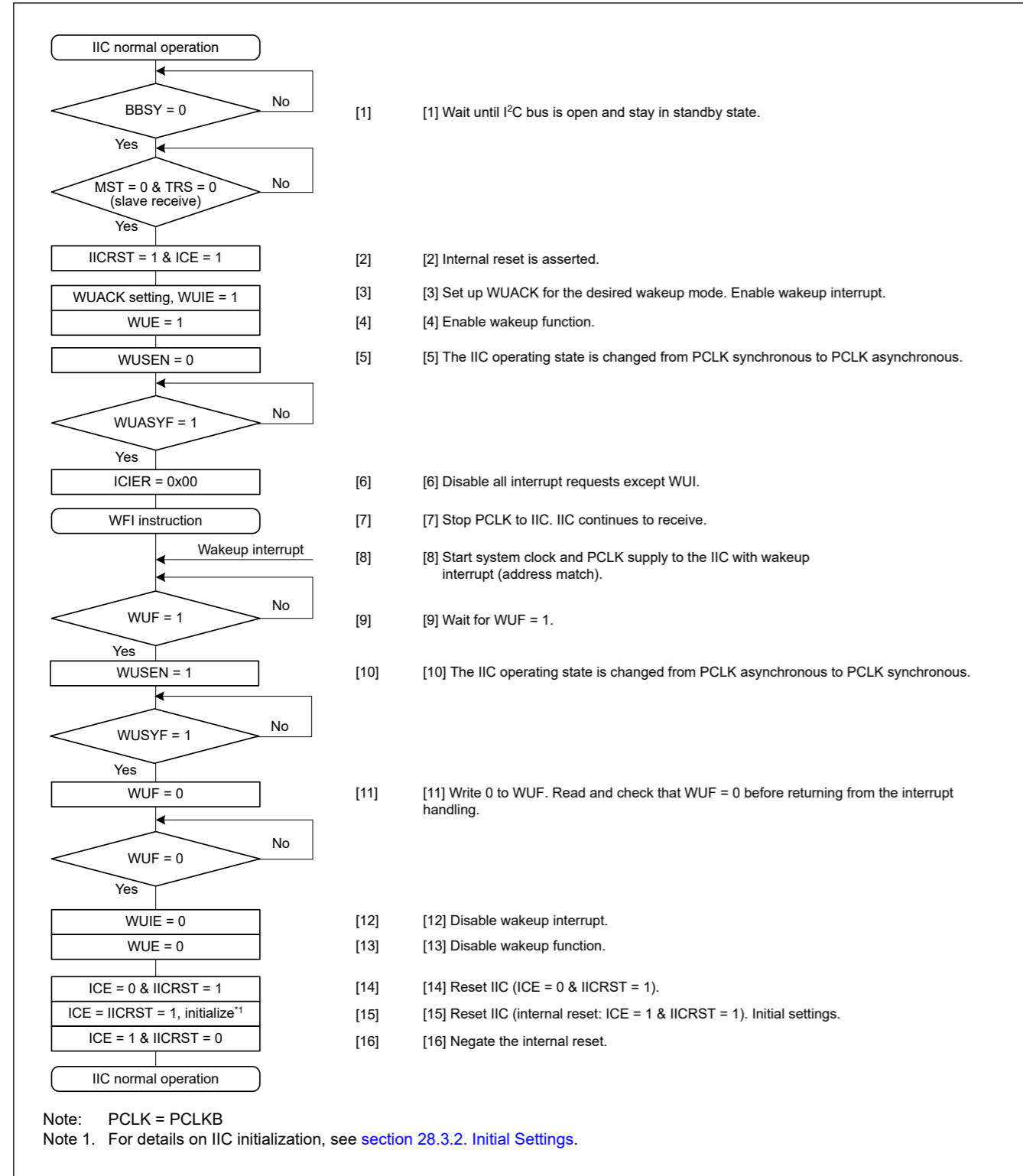


Figure 28.35 Example operation of command recovery mode and EEP response mode when wakeup is triggered by a wakeup interrupt on match of the slave address

Note: See [Precautions on the use of the wakeup function.](#)

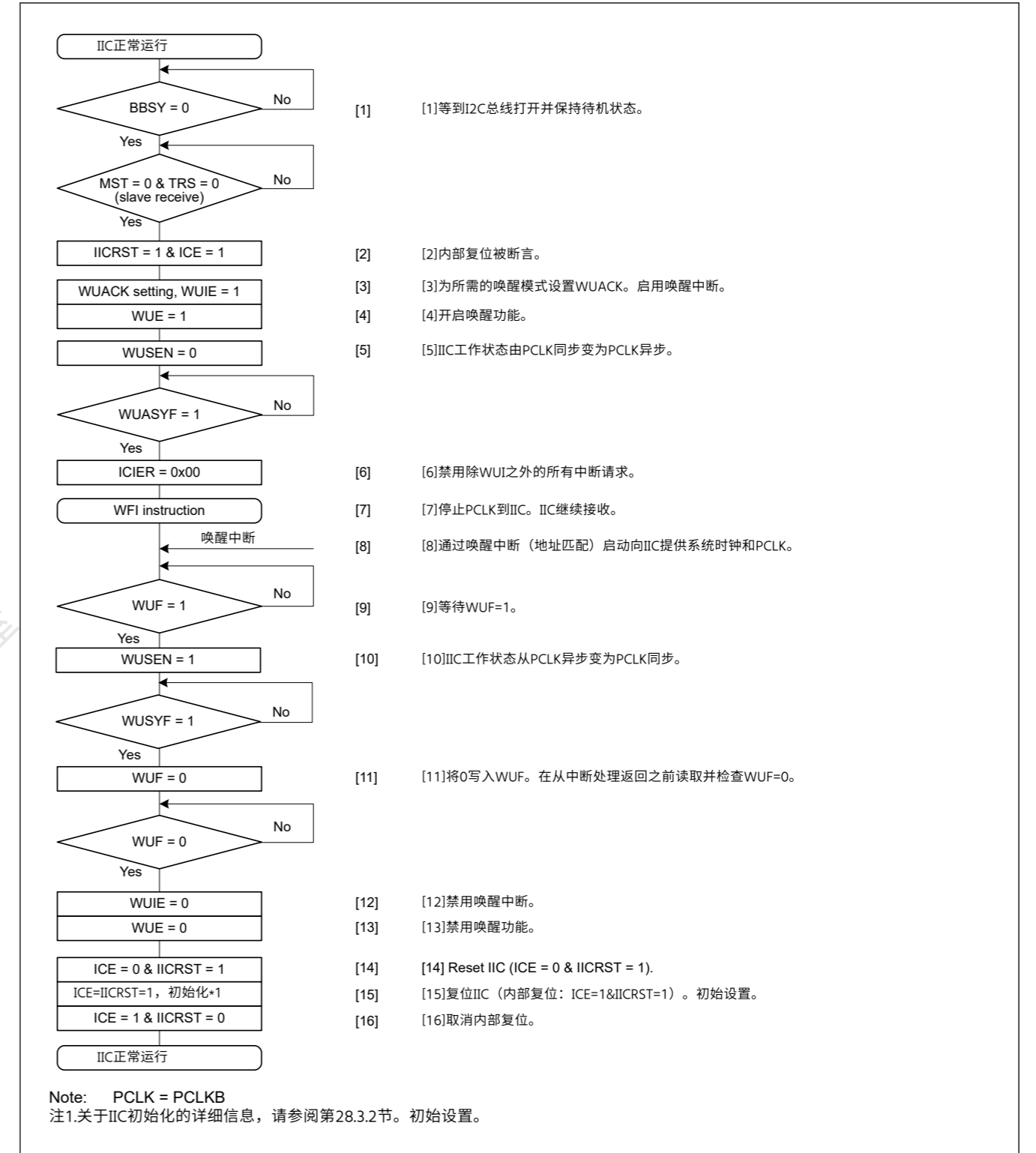


Figure 28.35 从地址匹配时唤醒中断触发唤醒时命令恢复模式和EEP响应模式的示例操作

Note: [请参阅唤醒功能使用注意事项。](#)

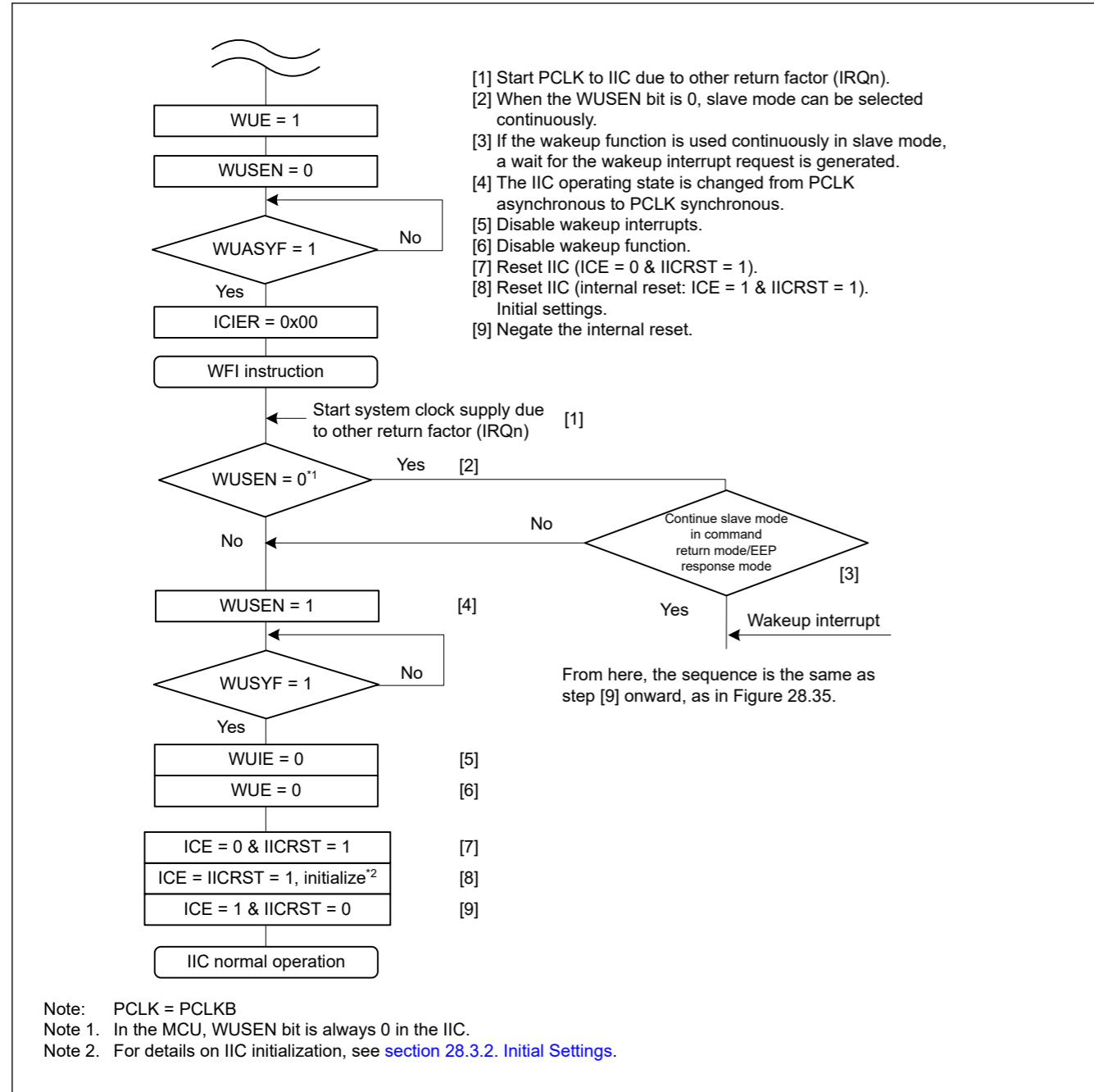


Figure 28.36 Example operation of command recovery and EEP response modes when wakeup is triggered by an interrupt other than IIC wakeup interrupt, for example, the IRQn

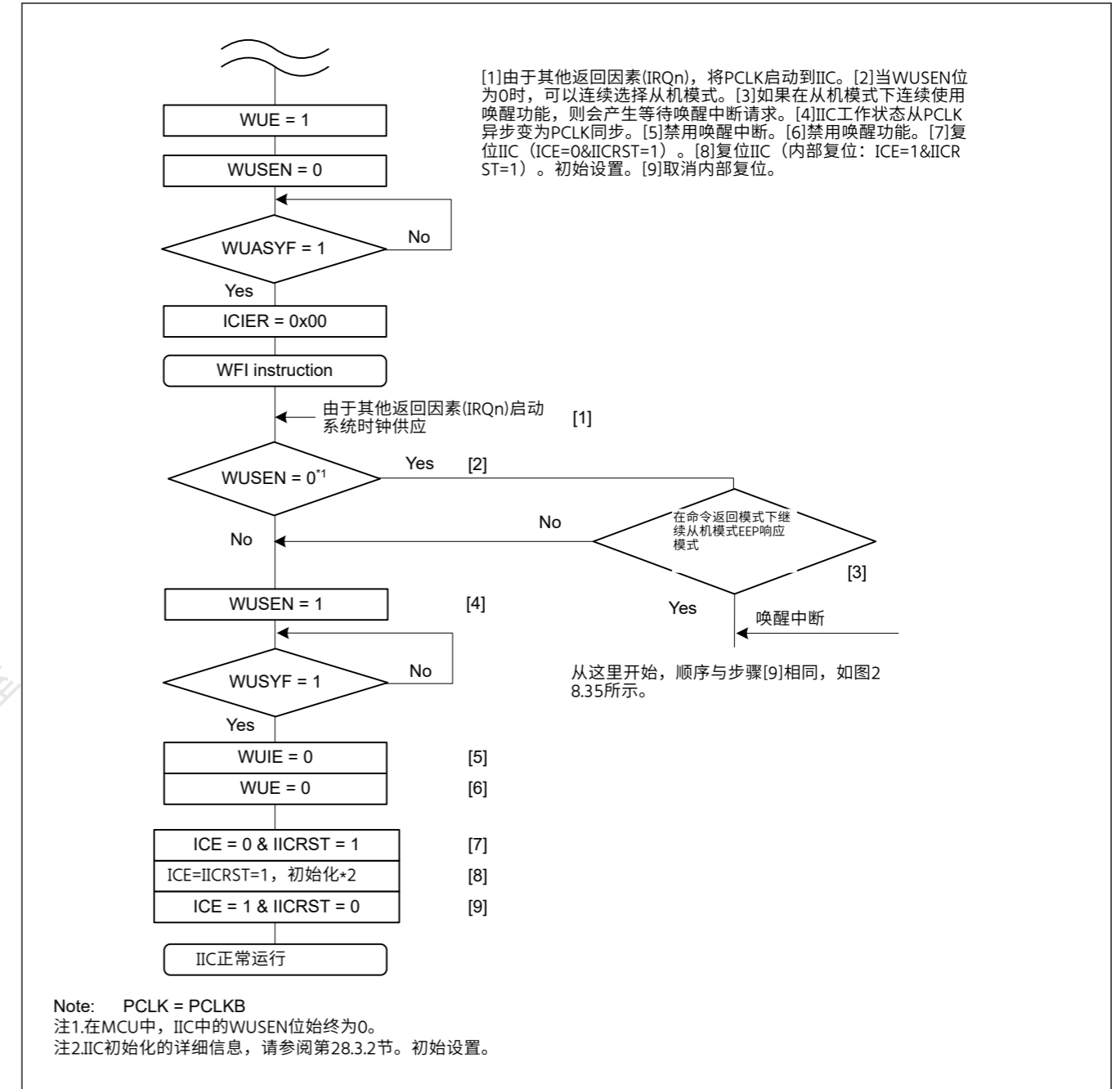


Figure 28.36 由IIC唤醒中断以外的中断（例如IRQn）触发唤醒时的命令恢复和EEP响应模式的示例操作

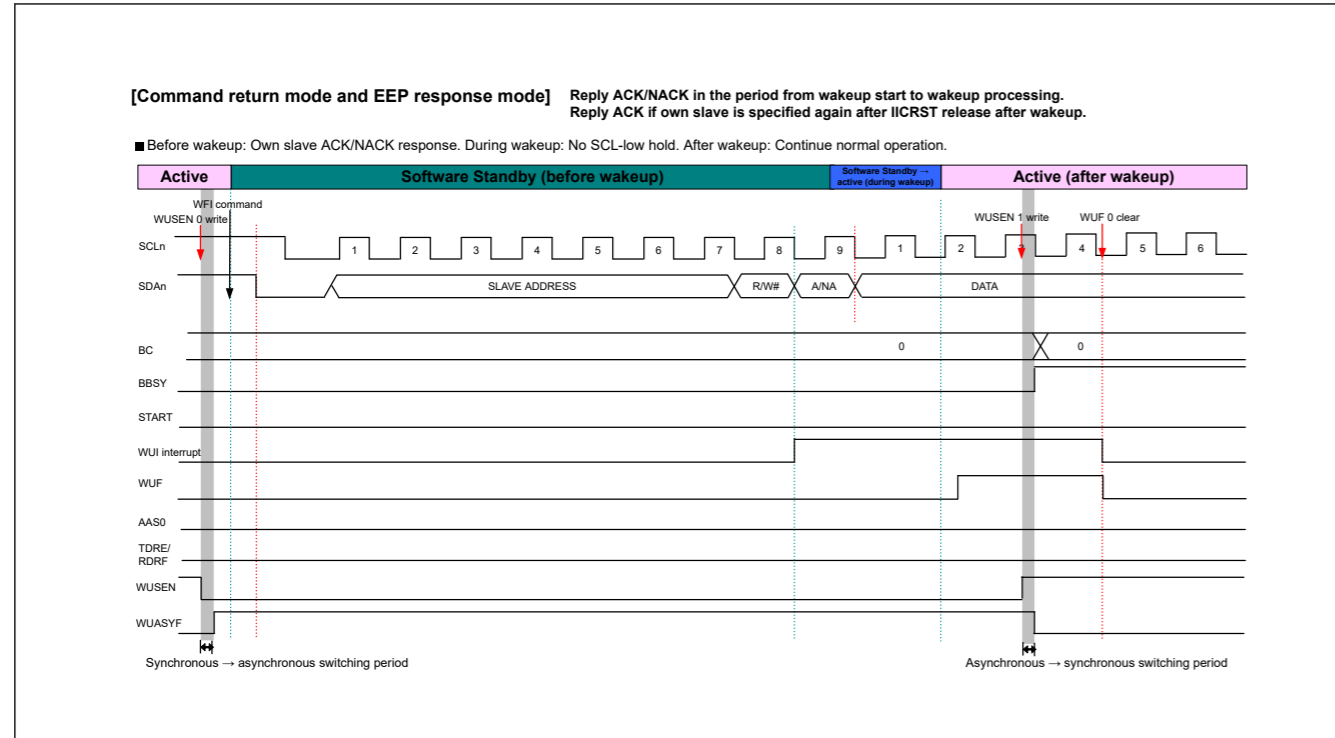


Figure 28.37 Timing of command recovery and EEP response modes

## 28.9 Automatic Low-Hold Function for SCL

### 28.9.1 Function to Prevent Wrong Transmission of Transmit Data

If the I<sup>2</sup>C Bus Shift Register (ICDRS) is empty and data has not been written to the I<sup>2</sup>C Bus Transmit Data Register (ICDRT) with the IIC in transmission mode (TRS bit = 1 in ICCR2), the SCLn line is automatically held low over the subsequent intervals. This low-hold period is extended until the transmit data is written, which prevents the unintended transmission of erroneous data.

Master transmit mode:

- Low-level interval after a start or restart condition is issued
- Low-level interval between the 9th clock cycle of one transfer and the 1st clock cycle of the next.

Slave transmit mode:

- Low-level interval between the 9th clock cycle of one transfer and the 1st clock cycle of the next.

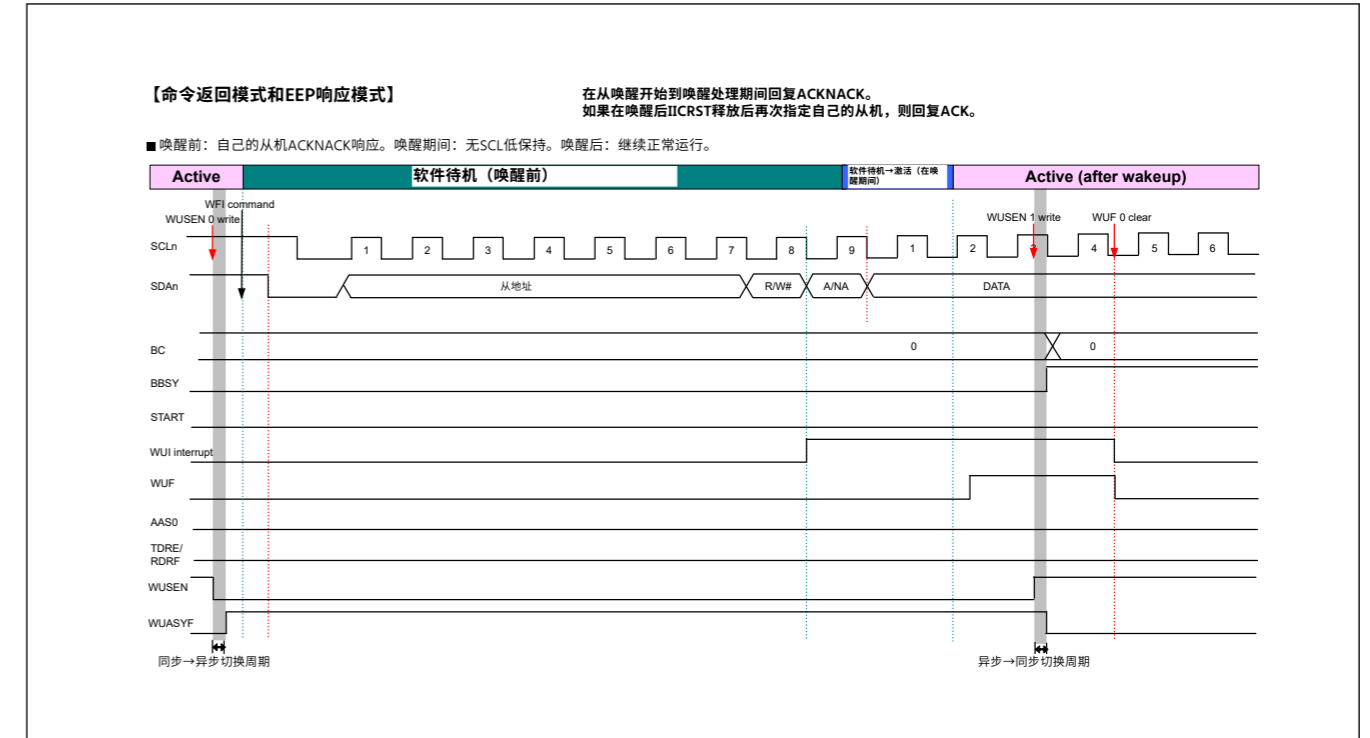


Figure 28.37 命令恢复和EEP响应模式的时序

## 28.9 SCL的自动低保持功能

### 28.9.1 防止传输数据错误传输的功能

如果I2C总线移位寄存器(ICDRS)为空且数据尚未写入I2C总线发送数据寄存器(ICDRT)且IIC处于传输模式 (TRS位=ICCR2中的1)，则SCLn线为在随后的时间间隔内自动保持低电平。这个低保持期一直延长到发送数据被写入，这样可以防止错误数据的意外传输。

主传输模式:

- 发出启动或重启条件后的低电平间隔
- 一次传输的第9个时钟周期和下一次传输的第1个时钟周期之间的低电平间隔。

从机发送模式:

- 一次传输的第9个时钟周期和下一次传输的第1个时钟周期之间的低电平间隔。



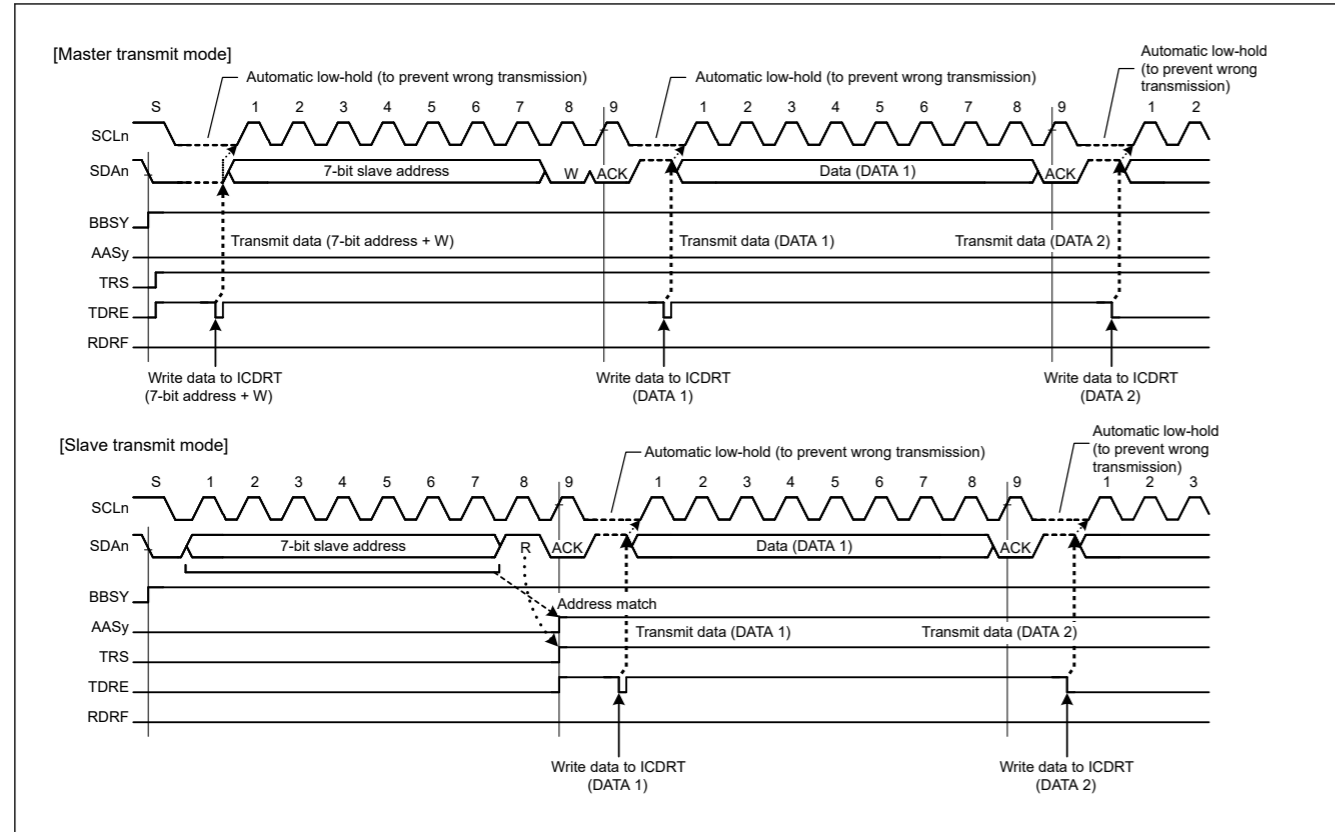


Figure 28.38 Automatic low-hold operation in transmit mode

### 28.9.2 NACK Reception Transfer Suspension Function

This function suspends transfer operation when NACK is received in transmit mode (TRS bit = 1 in ICCR2). This function is enabled when the NACKEN bit in ICFER is set to 1. If the next transmit data is already written (TDRE flag = 0 in ICSR2) when NACK is received, the next data transmission on the falling edge of the 9th SCL clock cycle is automatically suspended. This prevents the SDAn line output level from being held low when the MSB of the next transmit data is 0.

If the transfer operation is suspended by this function (NACKF flag = 1 in ICSR2), transmit and receive operations are discontinued. To restore transmit or receive operation, after issuing the restart condition, you need to set the NACKF flag to 0 and try again, or set the NACKF flag to 0 after issuing the stop condition and then start again from issuing the start condition..

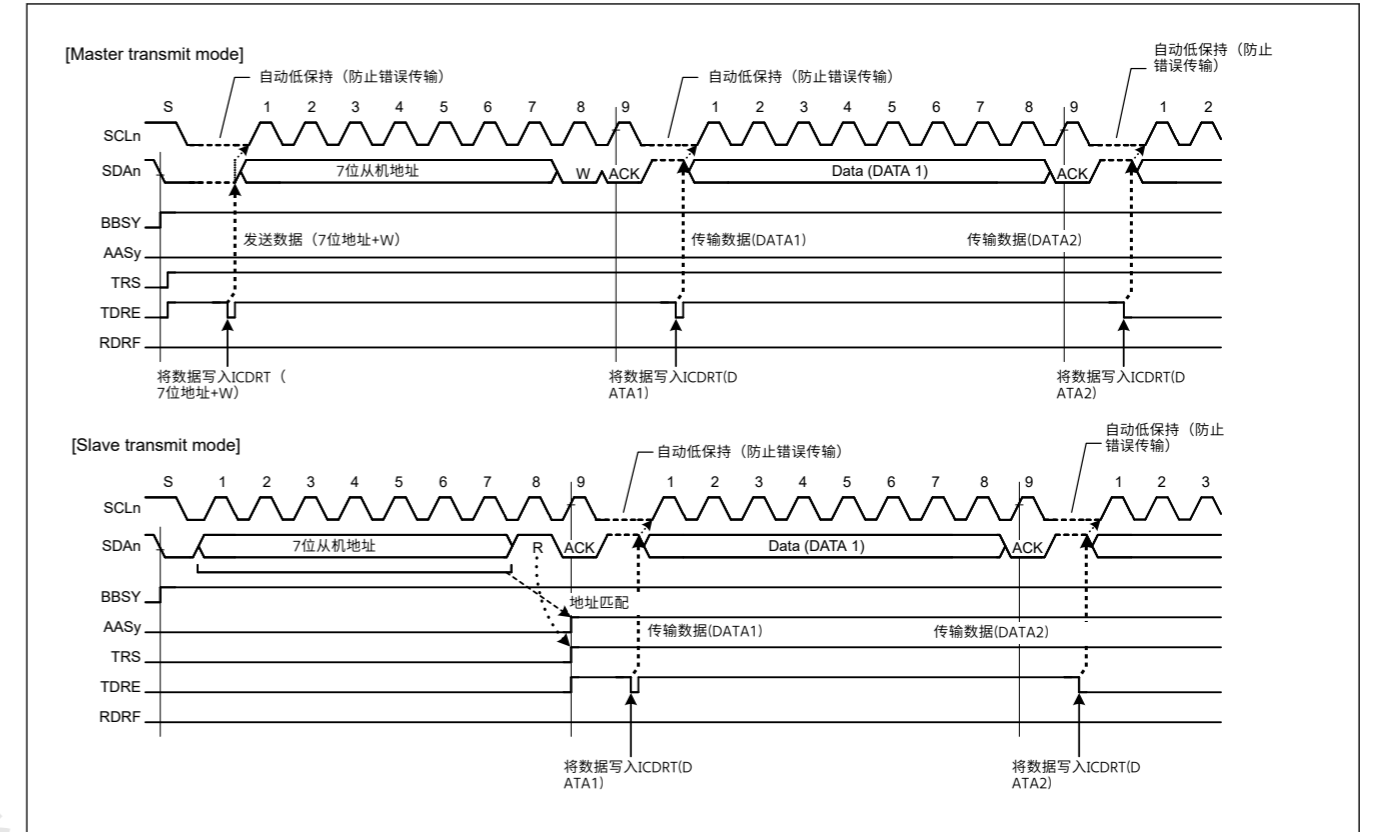


Figure 28.38 发送模式下的自动低保持操作

### 28.9.2 NACK接收传输暂停功能

当在发送模式下接收到NACK (ICCR2中的TRS位=1) 时, 该函数暂停传输操作。当ICFER中的NACKEN位设置为1时, 此功能使能。如果在收到NACK时已经写入下一个发送数据 (ICSR2中的TDRE标志=0), 则在第9个SCL时钟周期的下降沿进行下一个数据发送被自动挂起。这可以防止SDAn线路输出电平在下一个发送数据的MSB为0时保持低电平。

如果传输操作被该函数挂起 (ICSR2中的NACKF标志=1), 发送和接收操作将中断。要恢复发送或接收操作, 在发出重启条件后, 您需要将NACKF标志设置为0并重试, 或者在发出停止条件后将NACKF标志设置为0, 然后从发出启动条件重新开始。

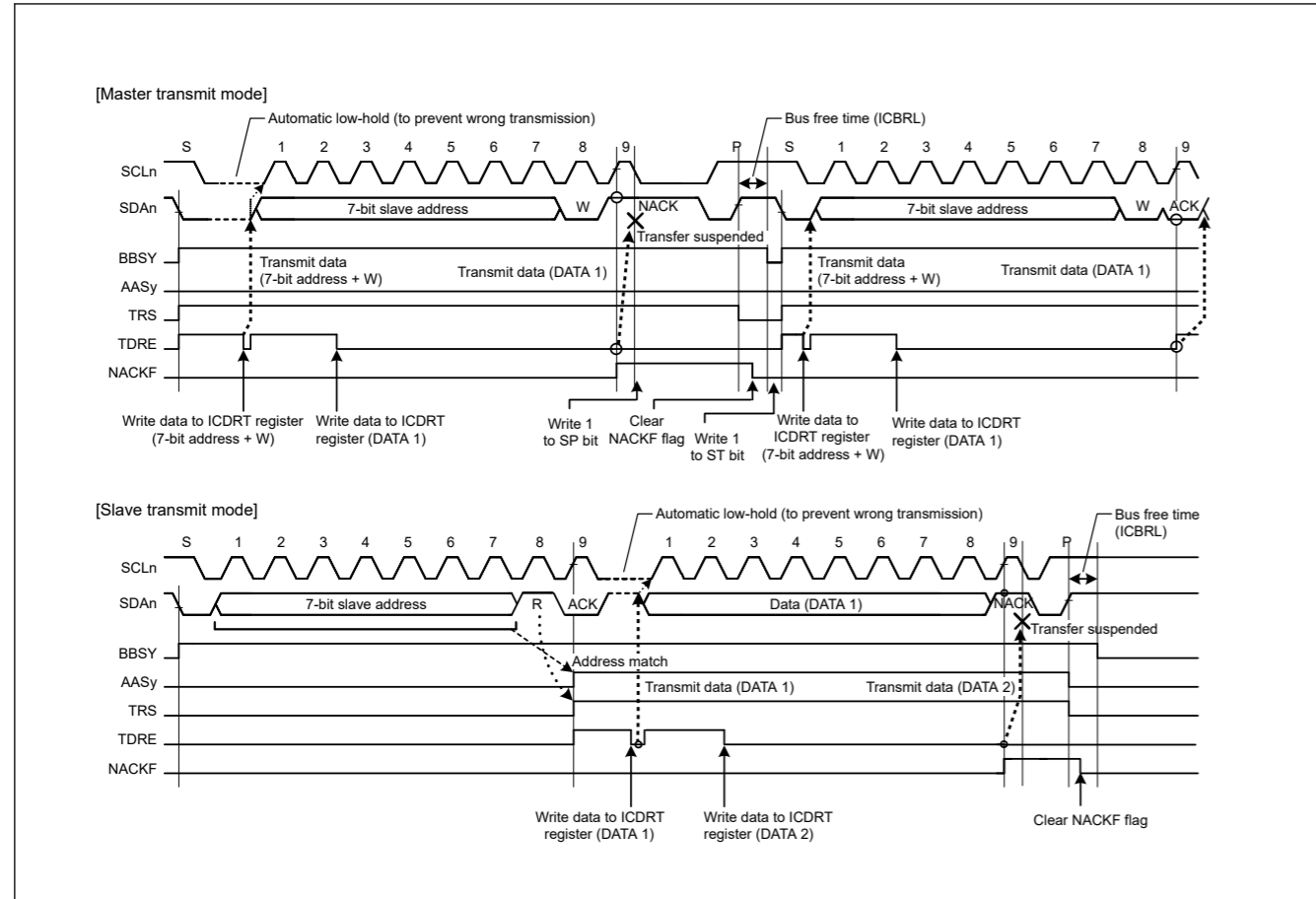


Figure 28.39 Suspension of data transfer when NACK is received, when NACKCE = 1

### 28.9.3 Function to Prevent Failure to Receive Data

If response processing is delayed when receive data (ICDRR) read is delayed for a period of one transfer frame or more with receive data full (RDRF flag = 1 in ICSR2) in receive mode (TRS = 0 in ICCR2), the IIC holds the SCLn line low automatically immediately before the next data is received to prevent a failure to receive data.

This function is enabled even if the read processing of the final receive data is delayed and, in the meantime, the IIC slave address is designated after a stop condition is issued. This function does not interfere with other communication because the IIC does not hold the SCLn line low when a mismatch with its own slave address occurs after a stop condition is issued.

Periods in which the SCLn line is held low can be selected with a combination of the WAIT and RDRFS bits in ICMR3.

#### (1) 1-byte receive operation and automatic low-hold function using the WAIT bit

When the WAIT bit in ICMR3 is set to 1, the IIC performs a 1-byte receive operation using the WAIT bit function. Additionally, when the ICMR3.RDRFS bit is 0, the IIC automatically sends the ACKBT bit value in ICMR3 for the acknowledge bit in the period from the falling edge of the 8th SCL clock cycle to the falling edge of the 9th SCL clock cycle, and automatically holds the SCLn line low on the falling edge of the 9th SCL clock cycle using the WAIT bit function. This low-hold is released by reading data from ICDRR, which enables byte-wise receive operation.

The WAIT bit function is enabled for receive frames after a match with the IIC slave address, including the general call address and host address, is obtained in master or slave receive mode.

#### (2) 1-byte receive operation (ACK/NACK transmission control) and automatic low-hold function using the RDRFS bit

When the RDRFS bit in ICMR3 is set to 1, the IIC performs a 1-byte receive operation using the RDRFS bit function. When the RDRFS bit is set to 1, the RDRF flag in ICSR2 is set to 1 (receive data full) on the rising edge of the eighth SCL clock cycle, and the SCLn line is automatically held low on the falling edge of the eighth SCL clock cycle. This low-hold is released by writing a value to the ACKBT bit in ICMR3, but cannot be released by reading data from ICDRR, which enables receive operation through the ACK or NACK transmission control based on the data received in byte units.

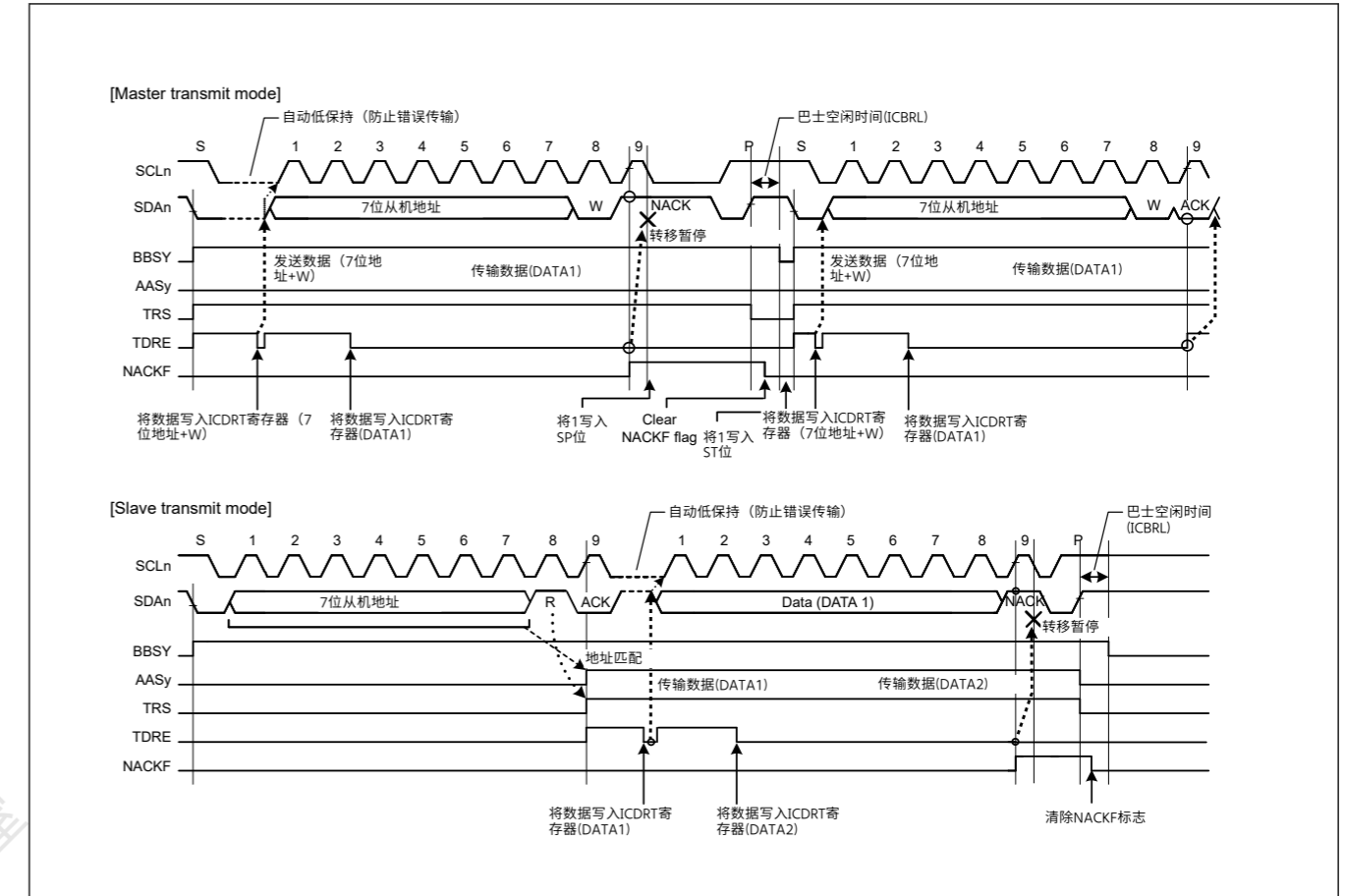


Figure 28.39 接收到NACK时暂停数据传输, 当NACKCE=1

### 28.9.3 防止数据接收失败的功能

如果在接收模式 (ICCR2中的TRS=0) 下接收数据 (ICDRR) 读取延迟一个传输帧或更长时间且接收数据已满 (ICSR2中的RDRF标志=1) 时响应处理延迟, 则IIC保持在接收到下一个数据之前, SCLn线自动变为低电平, 以防止接收数据失败。

即使最终接收数据的读取处理延迟, 该功能也有效, 同时, 在发出停止条件后指定IIC从机地址。此功能不会干扰其他通信, 因为在发出停止条件后发生与其自己的从地址不匹配时, IIC不会将SCLn线保持为低电平。

SCLn线保持低电平的周期可以通过ICMR3中的WAIT和RDRFS位的组合来选择。

#### (1) 使用WAIT位的1字节接收操作和自动低保持功能

当ICMR3中的WAIT位设置为1时, IIC使用WAIT位功能执行1字节接收操作。此外, 当ICMR3.RDRFS位为0时, IIC会在第8个SCL时钟周期的下降沿到第9个SCL时钟周期的下降沿期间自动发送ICMR3中的ACKBT位值作为确认位, 并且使用WAIT位功能在第9个SCL时钟周期的下降沿自动将SCLn线保持为低电平。该低保持通过从ICDRR读取数据来释放, 从而启用逐字节接收操作。

在主机或从机接收模式下获得与IIC从机地址 (包括广播地址和主机地址) 匹配后的接收帧启用WAIT位功能。

#### (2) 1字节接收操作 (ACK/NACK传输控制) 和使用RDRFS位的自动低保持功能

当ICMR3中的RDRFS位设置为1时, IIC使用RDRFS位功能执行1字节接收操作。当RDRFS位为1时, ICSR2中的RDRF标志位在第8个SCL时钟周期的上升沿置1 (接收数据满), 并且SCLn线在第8个SCL的下降沿自动保持为低电平。该低保持通过向ICMR3中的ACKBT位写入值来释放, 但不能通过从ICDRR读取数据来释放, ICDRR可以根据以字节为单位接收的数据通过ACK或NACK传输控制进行接收操作。

The RDRFS bit function is enabled for receive frames after a match with the IIC slave address, including the general call address and host address, is obtained in master or slave receive mode.

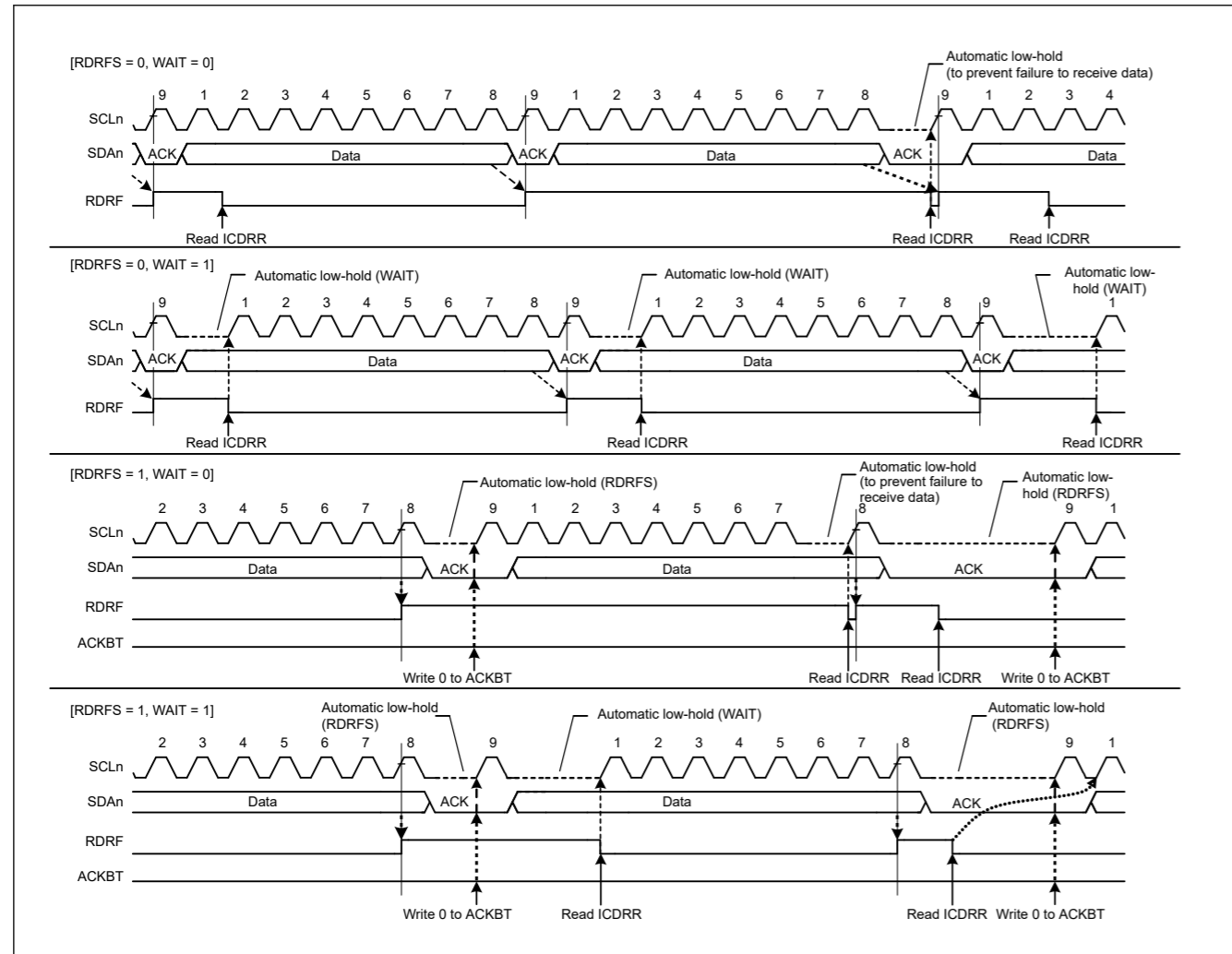


Figure 28.40 Automatic low-hold operation in receive mode using the RDRFS and WAIT bits

### 28.10 Arbitration-Lost Detection Functions

In addition to the normal arbitration-lost detection function defined by the I<sup>2</sup>C bus standard, the IIC provides functions to prevent double-issue of a start condition, detect arbitration-lost during transmission of NACK, and detect arbitration-lost in slave transmit mode.

#### 28.10.1 Master Arbitration-Lost Detection (MALE Bit)

The IIC drives the SDA<sub>n</sub> line low to issue a start condition. However, if the SDA<sub>n</sub> line was already driven low by another master device issuing a start condition, the IIC regards its own start condition as an error and considers this a loss in arbitration. Priority is given to transfer by the other master device. Similarly, if a request to issue a start condition is made by setting the ST bit in ICCR2 to 1 while the bus is busy (BBSY flag = 1 in ICCR2), the IIC regards this as a double-issuing-of-start-condition error and considers itself to have lost in arbitration. This prevents a failure of transfer resulting from a start condition being issued while transfer is in progress.

When a start condition is issued successfully, if the transmit data including the address bits (internal SDA output level) and the level on the SDA<sub>n</sub> line do not match (high output as the internal SDA output, meaning the SDA<sub>n</sub> pin is in the high-impedance state) and a low level is detected on the SDA<sub>n</sub> line, the IIC loses in arbitration.

After a loss in arbitration of mastership, the IIC immediately enters slave receive mode. If a slave address, including the general call address, matches its own address at this time, the IIC continues in slave operation.

在主机或从机接收模式下获得与IIC从机地址（包括广播地址和主机地址）匹配后的接收帧启用RDRFS位功能。

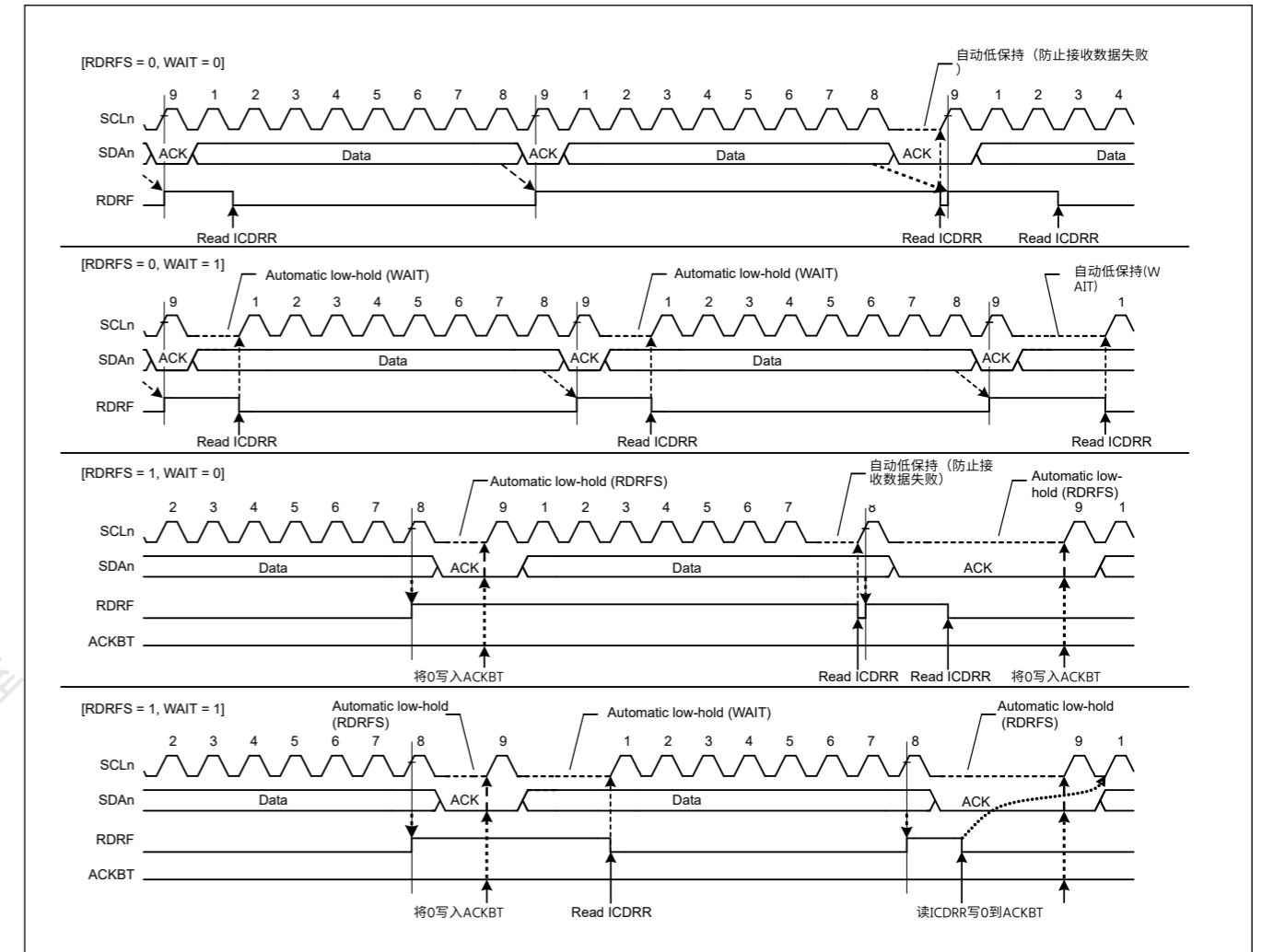


Figure 28.40 使用RDRFS和WAIT位在接收模式下自动保持低电平操作

### 28.10 仲裁丢失检测功能

除了I2C总线标准定义的正常仲裁丢失检测功能外，IIC还提供防止重复发出启动条件、在NACK传输期间检测仲裁丢失以及在从机发送中检测仲裁丢失的功能模式。

#### 28.10.1 主仲裁丢失检测 (MALE位)

IIC将SDA<sub>n</sub>线驱动为低电平以发出启动条件。但是，如果SDA<sub>n</sub>线已经被另一个发出启动条件的主设备驱动为低电平，则IIC将其自己的启动条件视为错误，并认为这是仲裁失败。其他主设备优先传输。类似地，如果在总线繁忙时通过将ICCR2中的ST位设置为1来请求发出启动条件（ICCR2中的BBSY标志=1），则IIC将此视为双重发出启动条件错误，并且认为自己在仲裁中败诉。这可以防止由于在传输过程中发出启动条件而导致传输失败。

当启动条件成功发出时，如果发送数据包括地址位（内部SDA输出电平）与SDA<sub>n</sub>线上的电平不匹配（高输出作为内部SDA输出，意味着SDA<sub>n</sub>引脚处于高阻抗状态）并且在SDA<sub>n</sub>线上检测到低电平，则IIC在仲裁中失败。

在主仲裁失败后，IIC立即进入从机接收模式。如果此时从机地址（包括广播地址）与自己的地址匹配，则IIC继续从机操作。

A loss in arbitration of mastership is detected when the following conditions are met while the MALE bit in ICFER is 1 (master arbitration-lost detection enabled).

[Master arbitration-lost conditions]

- Mismatching of the internal level for output on SDA and the level on the SDA<sub>n</sub> line after a start condition was issued by setting the ST bit in ICCR2 to 1 while the BBSY flag in ICCR2 is set to 0 (erroneous issuing of a start condition)
- Setting of the ST bit in ICCR2 to 1 (start condition double-issue error) while the BBSY flag is 1
- When the transmit data excluding acknowledge (internal SDA output level) does not match the level on the SDA<sub>n</sub> line in master transmit mode (MST and TRS bits = 11b in ICCR2).

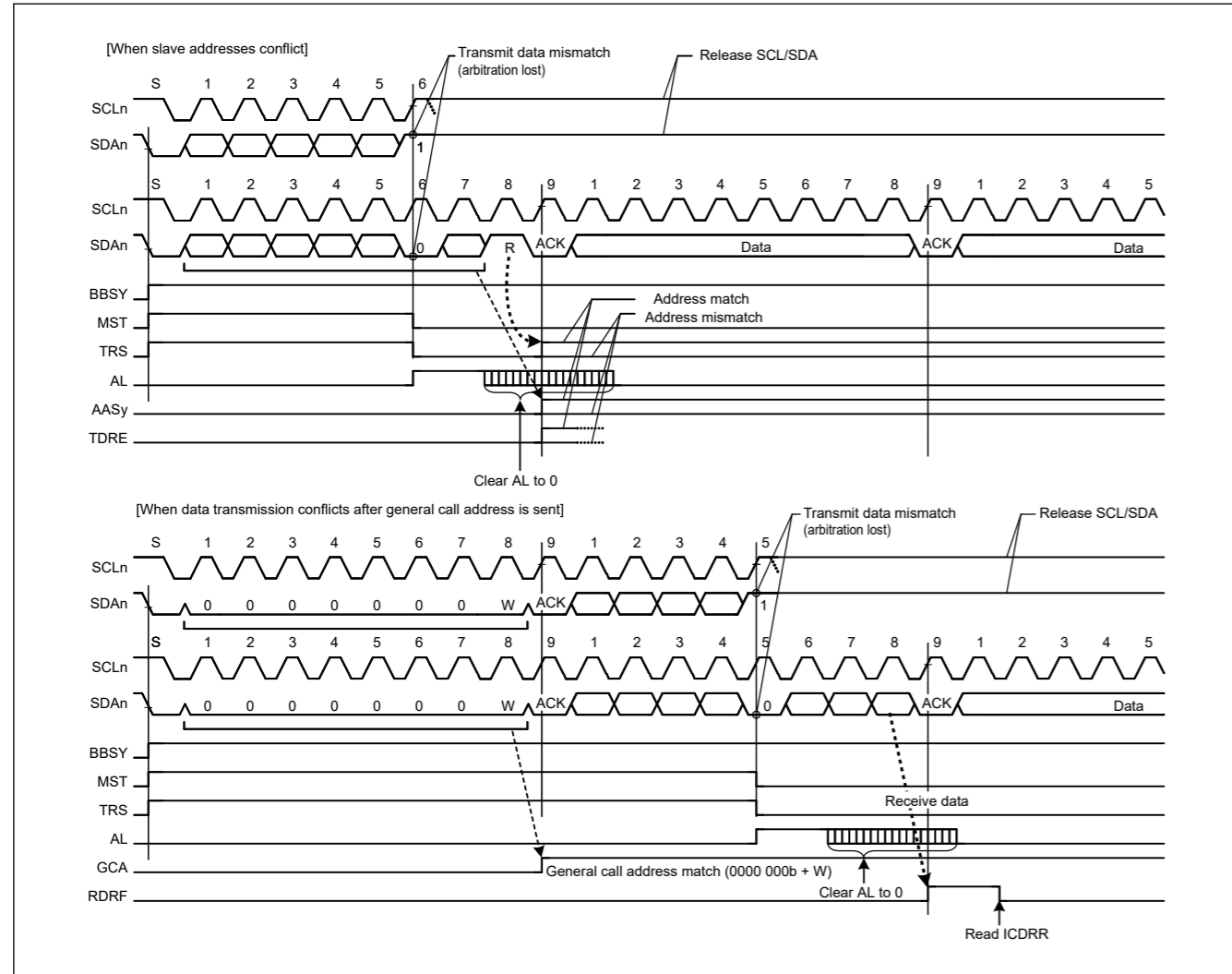


Figure 28.41 Examples of master arbitration-lost detection when MALE = 1

当ICFER中的MALE位为1（启用主仲裁丢失检测）时满足以下条件时，检测到主控仲裁丢失。

[Master arbitration-lost conditions]

- 通过将ICCR2中的ST位设置为1，同时将ICCR2中的BBSY标志设置为0，发出启动条件后，SDA输出的内部电平与SDA<sub>n</sub>线上的电平不匹配（错误发出启动条件）
- 在BBSY标志为1时将ICCR2中的ST位设置为1（启动条件双发错误）
- 当发送数据不包括确认（内部SDA输出电平）与主发送模式下SDA<sub>n</sub>线上的电平不匹配时（ICCR2中的MST和TRS位=11b）。

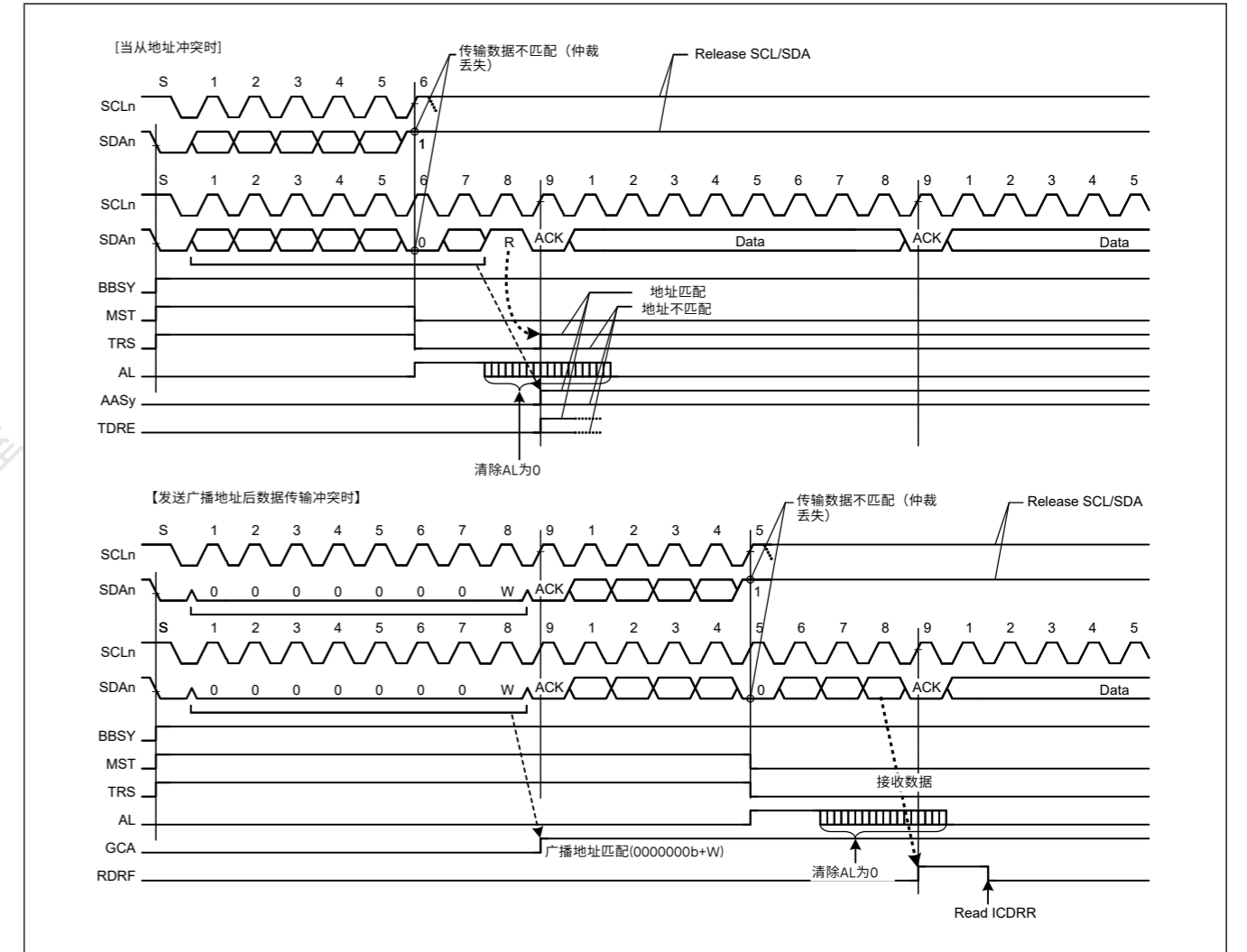


Figure 28.41 MALE=1时的主仲裁丢失检测示例



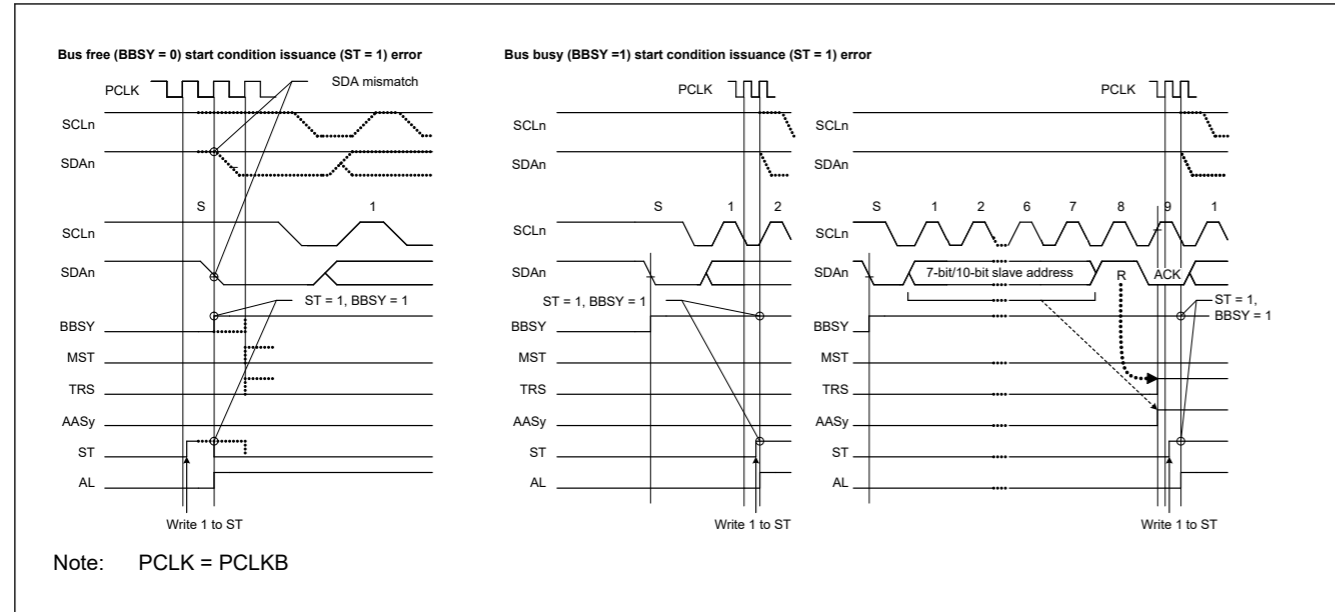


Figure 28.42 Arbitration-lost when start condition is issued when MALE = 1

28.10.2 Function to Detect Loss of Arbitration during NACK Transmission (NALE Bit)

This function causes arbitration to be lost if the internal SDA output level does not match the level on the SDAAn line (high output as the internal SDA output, meaning the SDAAn pin is in the high-impedance state) and the low level is detected on the SDAAn line during transmission of NACK in receive mode. Arbitration is lost because of a conflict between NACK and ACK transmissions when two or more master devices receive data from the same slave device simultaneously in a multi-master system. Such a conflict occurs when multiple master devices send or receive the same information through a single slave device. Figure 28.43 shows an example of arbitration-lost detection during transmission of NACK.

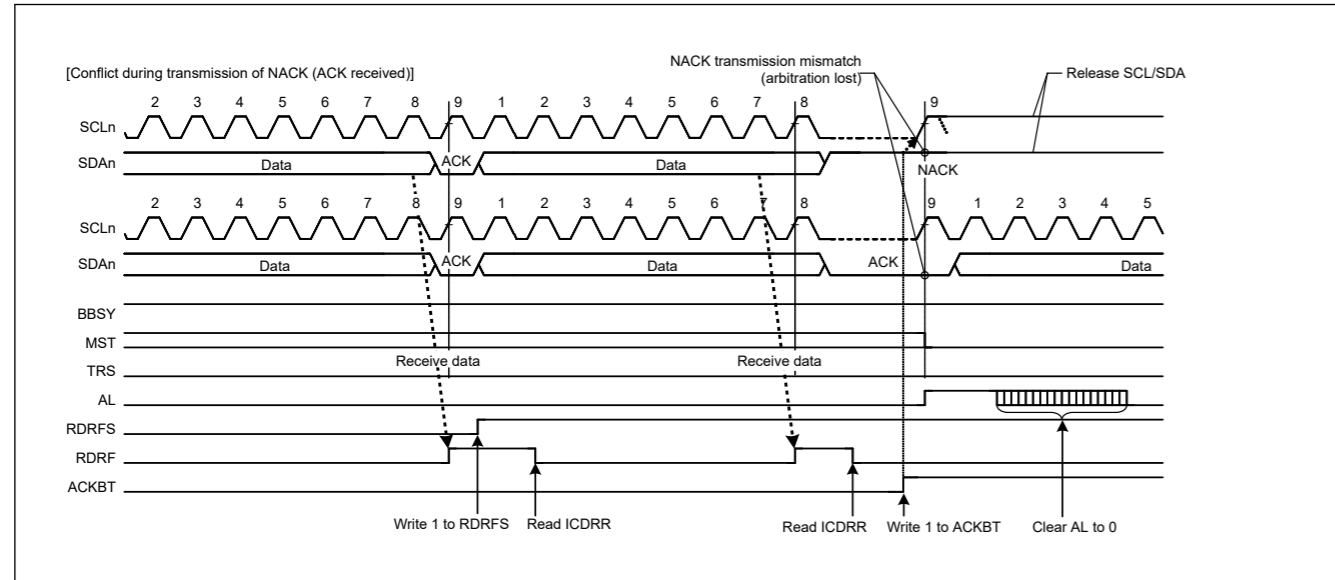


Figure 28.43 Example of arbitration-lost detection during transmission of NACK when NALE = 1

The following explains arbitration-lost detection using an example in which two master devices (master A and master B) and a single slave device are connected through the bus. In this example, master A receives 2 bytes of data from the slave device, and master B receives 4 bytes of data from the slave device.

If master A and master B access the slave device simultaneously, because the slave address is identical, arbitration is not lost in either master A or master B during access to the slave device. Therefore, both master A and master B recognize that they have obtained the bus mastership and operate as such. Master A sends NACK when it has received 2 final bytes of data from the slave device. Meanwhile, master B sends ACK because it has not received the required 4 bytes of data. At this time, the NACK transmission from master A and the ACK transmission from master B conflict. In general, if a conflict like

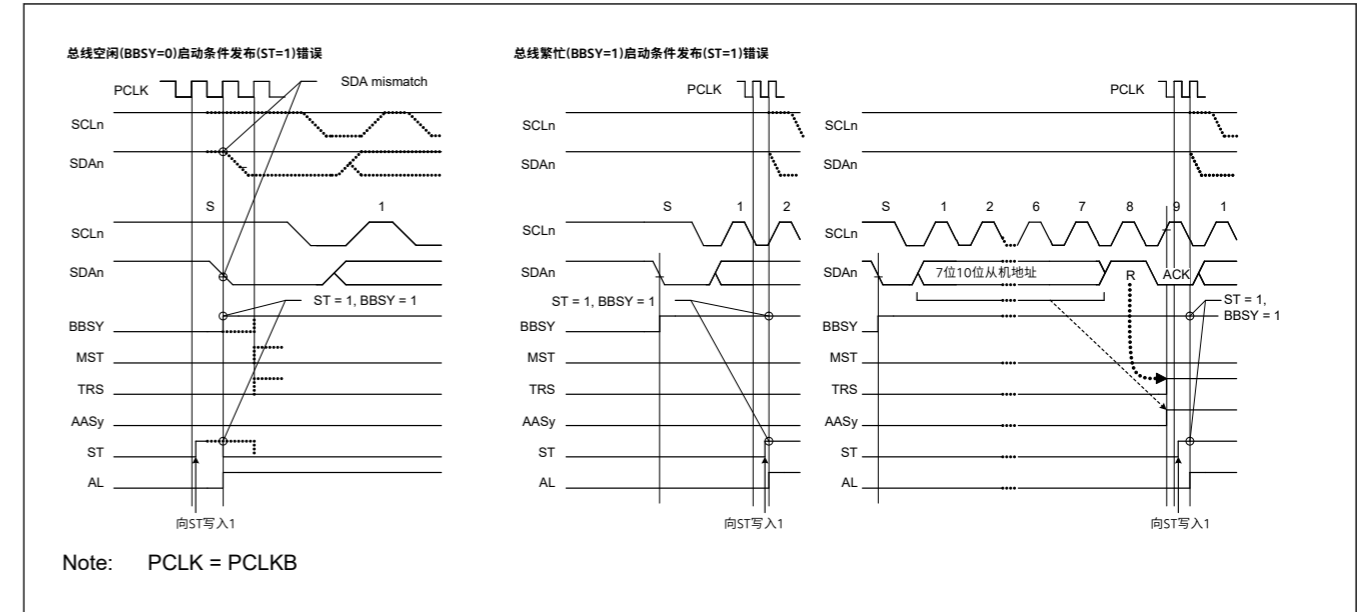


Figure 28.42 MALE=1时发出启动条件时仲裁失败

28.10.2 在NACK传输期间检测仲裁丢失的功能 (NALE位)

如果内部SDA输出电平与SDAAn线上的电平不匹配 (高输出作为内部SDA输出, 意味着SDAAn引脚处于高阻抗状态) 并且在上检测到低电平, 此功能会导致仲裁丢失在接收模式下发送NACK期间的SDAAn线。当多主控系统中两个或多个主控设备同时从同一从属设备接收数据时, 由于NACK和ACK传输之间的冲突, 仲裁会丢失。当多个主设备通过单个从设备发送或接收相同的信息时, 就会发生这种冲突。图28.43显示了在NACK传输期间检测仲裁丢失的示例。

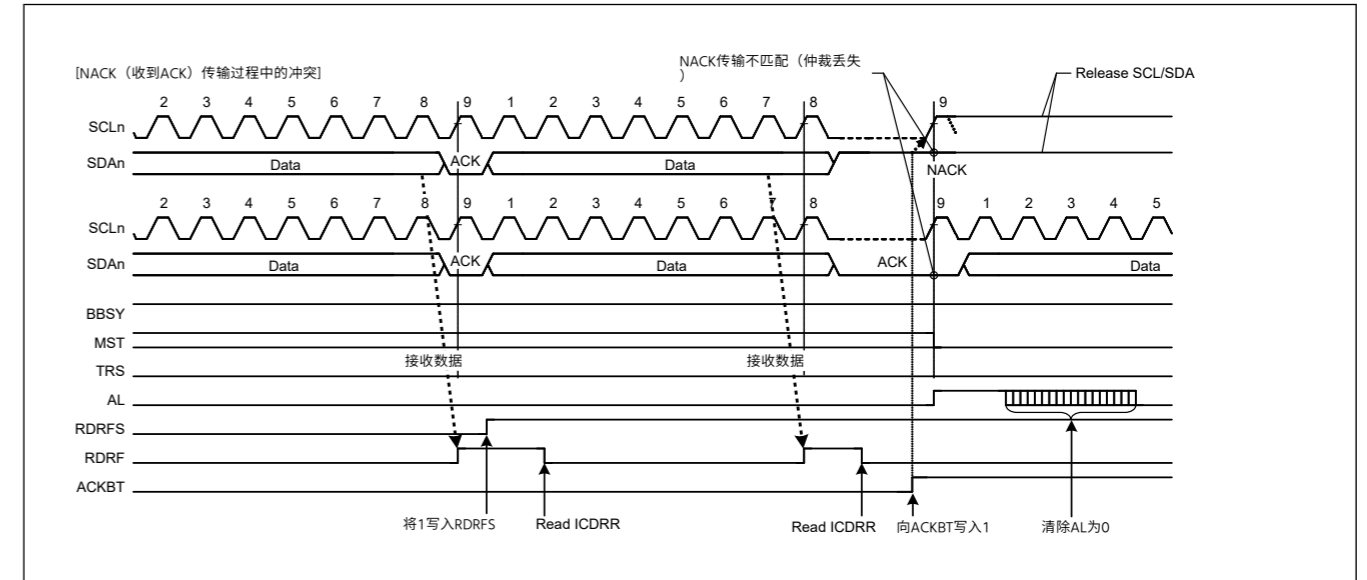


Figure 28.43 NALE=1时NACK传输期间仲裁丢失检测的示例

下面以两个主设备 (主设备A和主设备B) 和一个从设备通过总线连接的示例来说明仲裁丢失检测。在本例中, 主设备A从从设备接收2个字节的数据, 主设备B从从设备接收4个字节的数据。

如果主设备A和主设备B同时访问从设备, 因为从设备地址相同, 在访问从设备期间, 主设备A或主设备B都不会丢失仲裁。因此, 主机A和主机B都承认他们已经获得了总线控制权并照此运行。主设备A在从从设备接收到2个最终字节的数据时发送NACK。同时, masterB发送ACK, 因为它没有收到所需的4字节数据。此时, 来自masterA的NACK传输和来自masterB的ACK传输冲突。一般来说, 如果像这样的冲突

this occurs, master A cannot detect the ACK transmitted by master B and issues a stop condition. The stop condition issue conflicts with the SCL clock output of master B, which disrupts communication.

When the IIC receives ACK during transmission of NACK, it detects a defeat in conflict with other master devices and causes arbitration to be lost. If arbitration is lost during transmission of NACK, the IIC immediately cancels the slave match condition and enters slave receive mode. This prevents a stop condition from being issued, preventing a communication failure on the bus.

Similarly, in the ARP command processing of SMBus, the function to detect loss of arbitration during transmission of NACK is also available for eliminating the extra clock cycle processing, such as 0xFF transmission processing, which is required if the UDID (Unique Device Identifier) of the assigned address does not match in the Get UDID general processing after the Assign Address command.

The IIC detects arbitration-lost during transmission of NACK when the following condition is met with the NALE bit in ICFER set to 1 (arbitration-lost detection during NACK transmission enabled).

[Condition for arbitration-lost during NACK transmission]

- When the internal SDA output level does not match the SDA<sub>n</sub> line (ACK is received) during transmission of NACK (ACKBT bit = 1 in ICMR3).

### 28.10.3 Slave Arbitration-Lost Detection (SALE Bit)

This function causes arbitration to be lost if the transmit data (internal SDA output level) and the level on the SDA<sub>n</sub> line do not match (high output as the internal SDA output, meaning the SDA<sub>n</sub> pin is in the high-impedance state), and the low level is detected on the SDA<sub>n</sub> line in slave transmit mode. This arbitration-lost detection function is mainly used when transmitting a UDID (Unique Device Identifier) over an SMBus.

When the IIC loses slave arbitration, the IIC is immediately released from the slave-matched state and enters slave receive mode. This function can detect conflicts of data during transmission of UDIDs over an SMBus and eliminates subsequent redundant processing for the transmission of 0xFF.

The IIC detects slave arbitration-lost when the following condition is met with the SALE bit in ICFER set to 1 (slave arbitration-lost detection enabled).

[Condition for slave arbitration-lost]

- When transmit data excluding acknowledge (internal SDA output level) does not match the SDA<sub>n</sub> line in slave transmit mode (MST and TRS bits = 01b in ICCR2).

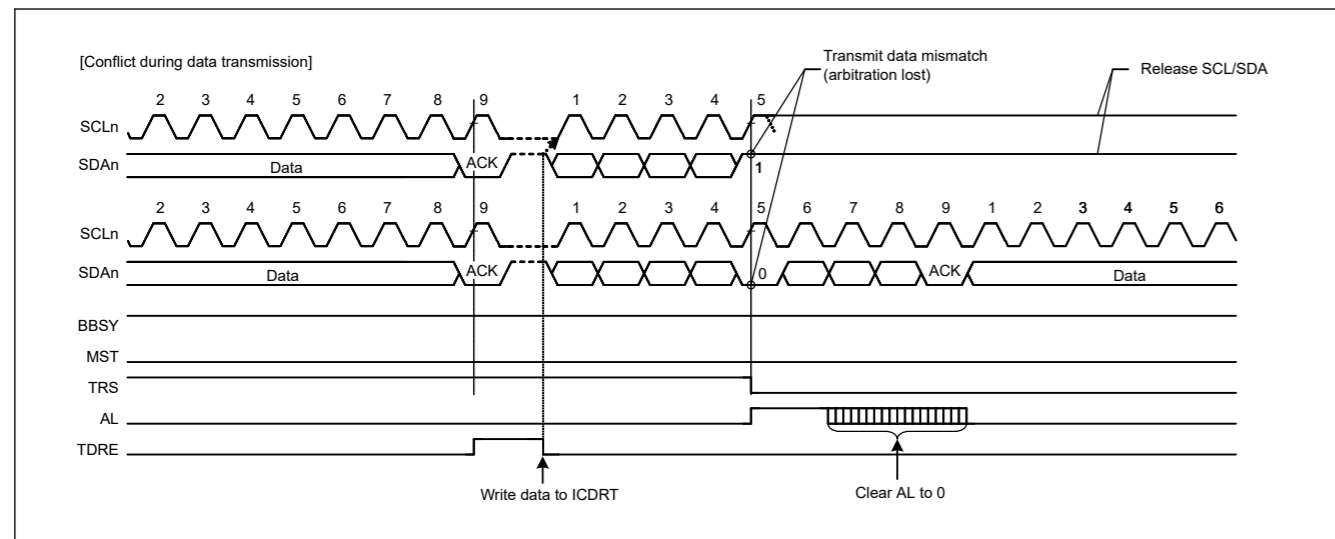


Figure 28.44 Example of slave arbitration-lost detection when SALE = 1

发生这种情况时，主机A无法检测到主机B发送的ACK并发出停止条件。停止条件问题与主B的SCL时钟输出冲突，从而中断通信。

当IIC在NACK传输过程中收到ACK时，它会检测到与其他主设备冲突的失败并导致仲裁丢失。如果在NACK传输过程中仲裁丢失，IIC立即取消从机匹配条件并进入从机接收模式。这可以防止发出停止条件，从而防止总线上的通信故障。

同样，在SMBus的ARP命令处理中，检测传输过程中仲裁丢失的功能NACK也可用于消除额外的时钟周期处理，例如0xFF传输处理，如果分配地址的UDID（唯一设备标识符）在分配地址命令后的获取UDID常规处理中不匹配，则需要此处理。

IIC在NACK传输期间检测到仲裁丢失，当满足以下条件时ICFER设置为1（启用NACK传输期间的仲裁丢失检测）。

[在NACK传输期间仲裁丢失的条件]

- 在发送NACK（ICMR3中的ACKBT位=1）期间，当内部SDA输出电平与SDA<sub>n</sub>线不匹配时（接收到ACK）。

### 28.10.3 从设备仲裁丢失检测（SALE位）

如果发送数据（内部SDA输出电平）与SDA<sub>n</sub>线上的电平不匹配（高输出作为内部SDA输出，意味着SDA<sub>n</sub>引脚处于高阻状态），此功能会导致仲裁丢失，并且在从机发送模式下，SDA<sub>n</sub>线上检测到低电平。这种仲裁丢失检测功能主要用于通过SMBus传输UDID（唯一设备标识符）时。

当IIC失去从机仲裁时，IIC立即从从机匹配状态中释放并进入从机接收模式。该功能可以检测通过SMBus传输UDID期间的数据冲突，并消除后续对0xFF传输的冗余处理。

当ICFER中的SALE位设置为1（启用从设备仲裁丢失检测）满足以下条件时，IIC检测从设备仲裁丢失。

[从机仲裁失败的条件]

- 当发送数据不包括确认（内部SDA输出电平）与从发送模式下的SDA<sub>n</sub>线不匹配时（MST和TRS位=ICCR2中的01b）。

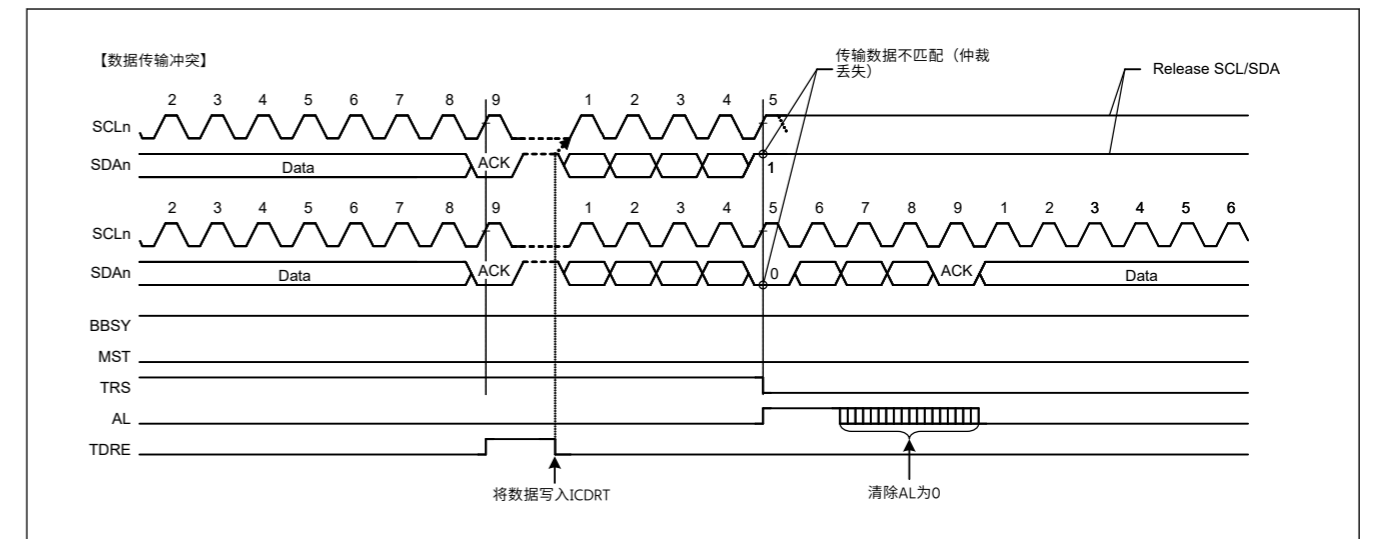


Figure 28.44 SALE=1时从设备仲裁丢失检测示例

## 28.11 Start, Restart, and Stop Condition Issuing Function

### 28.11.1 Issuing a Start Condition

The IIC issues a start condition when the ST bit in ICCR2 is set to 1. When the ST bit is set to 1, a start condition request is made, and the IIC issues a start condition when the BBSY flag in ICCR2 is 0 (bus free state). When a start condition is issued normally, the IIC automatically shifts to the master transmit mode.

To issue a start condition:

1. Drive the SDA<sub>n</sub> line low (high level to low level).
2. Ensure that the time set in ICBRH and the start condition hold time elapse.
3. Drive the SCL<sub>n</sub> line low (high level to low level).
4. Detect low level on the SCL<sub>n</sub> line and ensure the low-level period of the SCL<sub>n</sub> line set in ICBRL elapses.

### 28.11.2 Issuing a Restart Condition

The IIC issues a restart condition when the RS bit in ICCR2 is set to 1. When the RS bit is set to 1, a restart condition request is made, and the IIC issues a restart condition when the BBSY flag in ICCR2 is 1 (bus busy state) and the MST bit in ICCR2 is 1 (master mode).

To issue a restart condition:

1. Release the SDA<sub>n</sub> line.
2. Ensure the low-level period of the SCL<sub>n</sub> line set in ICBRL elapses.
3. Release the SCL<sub>n</sub> line (low level to high level).
4. Detect a high level on the SCL<sub>n</sub> line and ensure the time set in ICBRL and the restart condition setup time elapse.
5. Drive the SDA<sub>n</sub> line low (high level to low level).
6. Ensure the time set in ICBRH and the restart condition hold time elapse.
7. Drive the SCL<sub>n</sub> line low (high level to low level).
8. Detect a low level on the SCL<sub>n</sub> line and ensure the low-level period of the SCL<sub>n</sub> line set in ICBRL elapses.

Note: When issuing restart condition requests, write the slave address to ICDRT after confirming that ICCR2.RS = 0. Data written while ICCR2.RS = 1 is not forwarded because of the retransmission condition before the occurrence.

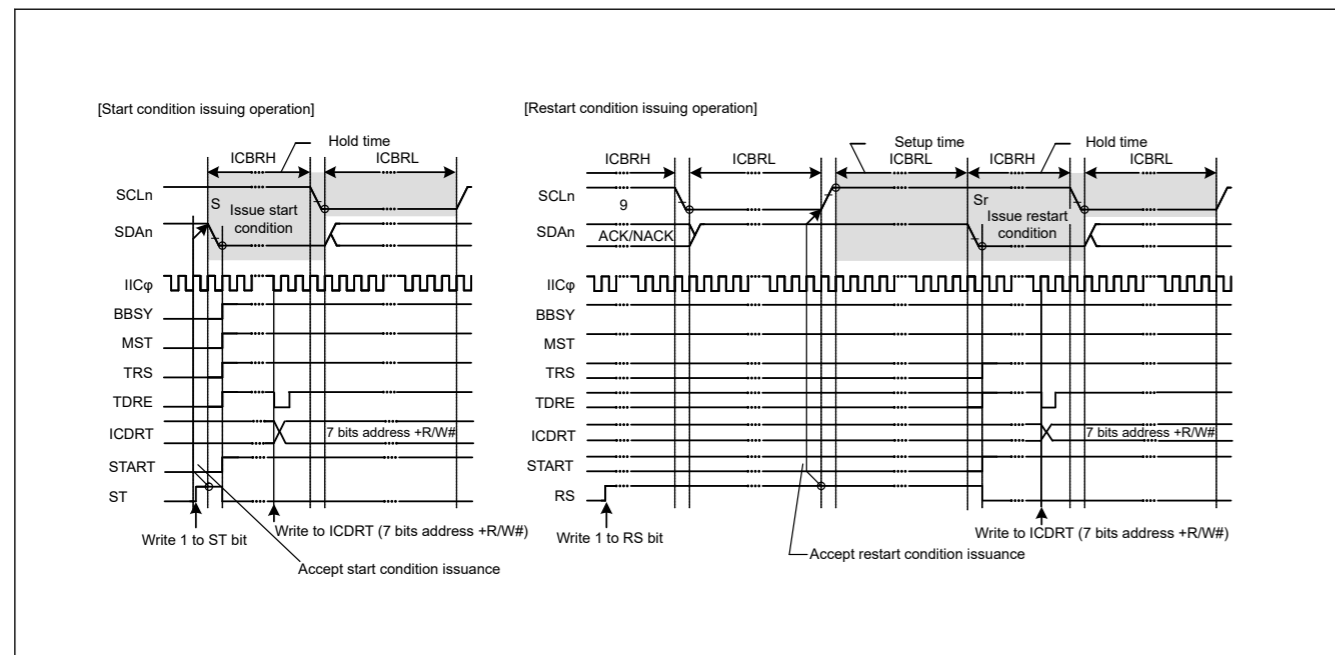


Figure 28.45 Start and restart condition issue timing using the ST and RS bits

## 28.11 启动、重启和停止条件发布功能

### 28.11.1 发出开始条件

当ICCR2中的ST位设置为1时，IIC发出启动条件。当ST位设置为1时，发出启动条件请求，当ICCR2中的BBSY标志为0时，IIC发出启动条件（总线自由状态）。当启动条件正常发出时，IIC自动切换到主机发送模式。

发出开始条件：

- 1.将SDAn线拉低（高电平转低电平）。
- 2.确保ICBRH中设置的时间和启动条件保持时间已过。
- 3.将SCLn线拉低（高电平转低电平）。
- 4.检测SCLn线的低电平，确保ICBRL中设置的SCLn线的低电平周期过去。

### 28.11.2 发出重启条件

当ICCR2中的RS位设置为1时，IIC发出重启条件。当RS位设置为1时，发出重启条件请求，当ICCR2中的BBSY标志为1时，IIC发出重启条件（总线忙状态）并且ICCR2中的MST位为1（主模式）。

发出重启条件：

- 1.释放SDAn线。
- 2.确保ICBRL中设置的SCLn线的低电平周期已过。
- 3.释放SCLn线（低电平到高电平）。
- 4.检测SCLn线上的高电平并确保ICBRL中设置的时间和重启条件设置时间已过。
- 5.将SDAn线拉低（高电平转低电平）。
- 6.确保ICBRH中设置的时间和重启条件保持时间已过。
- 7.将SCLn线拉低（从高电平到低电平）。
- 8.检测SCLn线上的低电平，确保ICBRL中设置的SCLn线的低电平周期过去。

Note: 发出重启条件请求时，确认ICCR2.RS=0后，将从机地址写入ICDRT。在ICCR2.RS=1时写入的数据由于发生前的重传条件而不会转发。

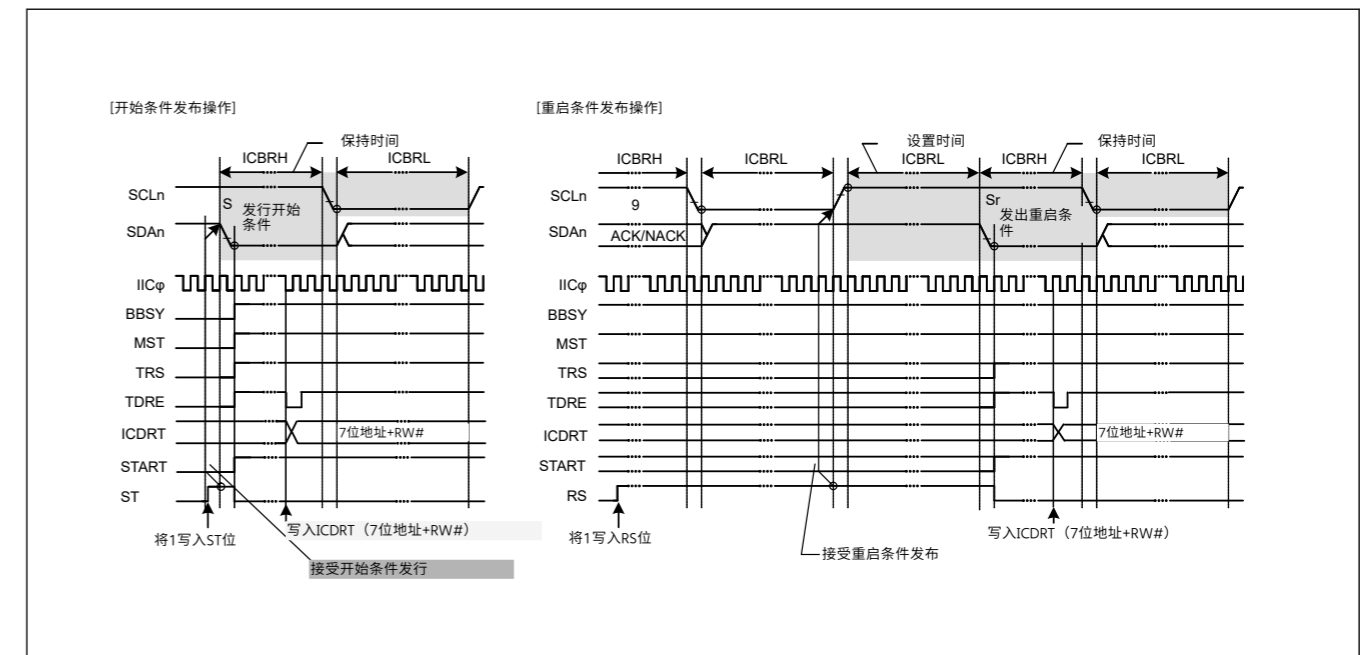


Figure 28.45 使用ST和RS位的启动和重启条件发出时序



Figure 28.46 shows the operation timing when a restart condition is issued after the master transmission.

[To issue a restart condition after the master transmission:]

1. Initialize the IIC using the procedure in section 28.3.2. Initial Settings.
2. Read the BBSY flag in ICCR2 to check that the bus is open, then set the ST bit in ICCR2 to 1 (start condition issuance request). On receiving the request, the IIC issues a start condition. At the same time, the BBSY and the START flags in ICSR2 are automatically set to 1 and the ST bit is automatically set to 0. If the start condition is detected and the internal levels for the SDA output state and the levels on the SDA line match while the ST bit is 1, the IIC recognizes that a start condition is successfully issued as requested by the ST bit has been successfully completed. The MST and TRS bits in ICCR2 are automatically set to 1, placing the IIC in master transmit mode. The TDRE flag in ICSR2 is also automatically set to 1 when the TRS bit is set to 1.
3. Check that the TDRE flag in ICSR2 is 1, and then write the value for transmission (the slave address and the R/W# bit) to ICDRT. After the data for transmission is written to ICDRT, the TDRE flag is automatically set to 0, data is transferred from ICDRT to ICDRS, and the TDRE flag is again set to 1. After the byte containing the slave address and R/W# bit has been transmitted, the value of the TRS bit is automatically updated to select master transmit or master receive mode according to the value of the transmitted R/W# bit. If the value of the R/W# bit is 0, the IIC continues in master transmit mode. If the ICSR2.NACKF flag is 1 at this time, indicating that no slave device recognized the address or that there was an error in communications, write 1 to ICCR2.SP bit to issue a stop condition. To transmit data with an address in the 10-bit format, start by writing 1111 0b, the 2 upper bits of the slave address, and W to ICDRT as the first address transmission. Then, as the second address transmission, write the 8 lower bits of the slave address to ICDRT.
4. After confirming that the TDRE flag in ICSR2 is 1, write data for transmission to the ICDRT register. The IIC automatically holds the SCLn line low until data for transmission is ready, a restart condition is issued or a stop condition is issued.
5. After all bytes of data for transmission are written to the ICDRT register, wait until the value of the TEND flag in ICSR2 returns to 1. Then after checking that the START flag in ICSR2 is 1, set the START flag in ICSR2 to 0.
6. Set the RS bit in ICCR2 to 1 (restart condition issue request). On receiving the request, the IIC issues a restart condition.
7. After checking that the START flag in ICSR2 is 1, write the value for transmission (the slave address and the R/W# bit) to ICDRT.

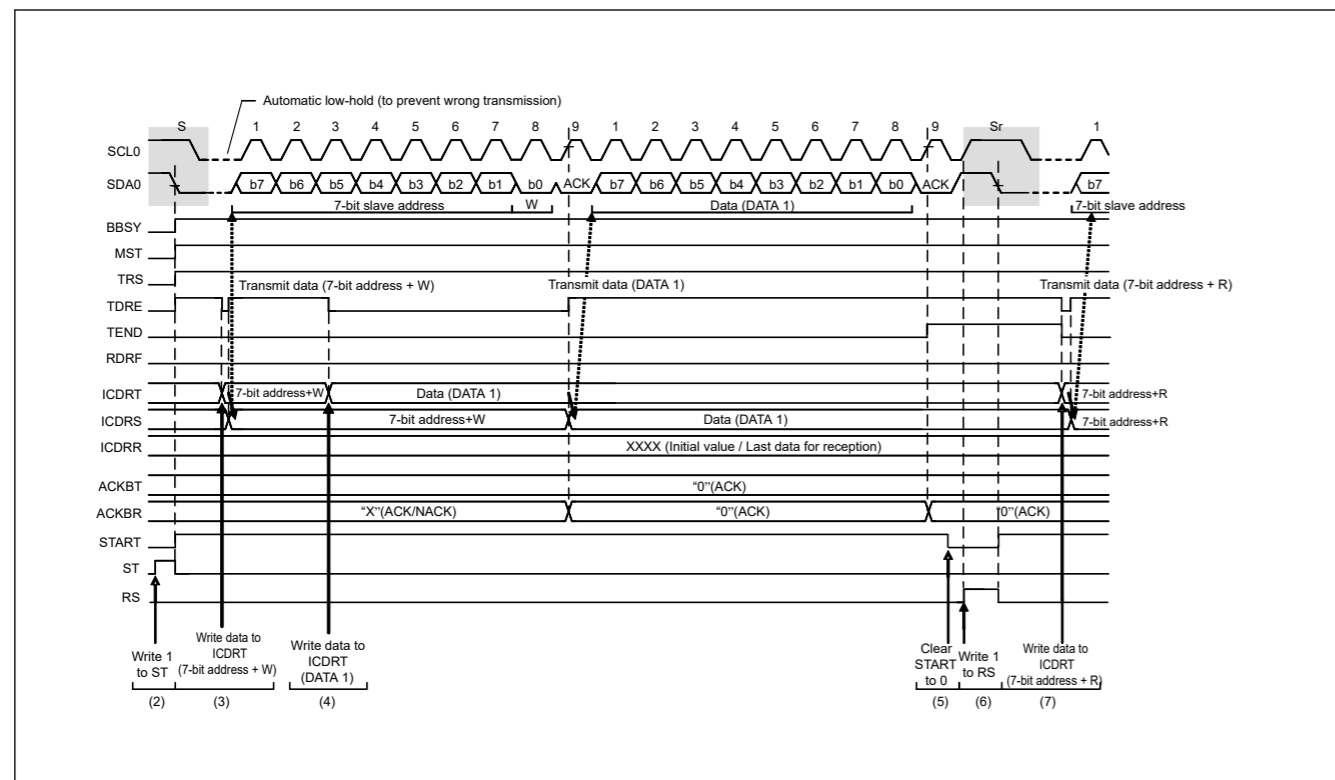


Figure 28.46 Restart condition issue timing after master transmission.

图28.46显示了在主机发送后发出重新启动条件时的操作时序。

[在主传输后发出重启条件:]

- 1.使用第28.3.2节中的过程初始化IIC。初始设置。
- 2.读取ICCR2中的BBSY标志以检查总线是否打开，然后将ICCR2中的ST位设置为1（开始条件发出请求）。收到请求后，IIC发出一个开始条件。同时，ICSR2中的BBSY和START标志位自动设置为1，ST位自动设置为0。如果检测到启动条件，则内部电平为SDA输出状态和SDAn线上的电平当ST位为1时匹配，IIC识别成功发出启动条件，因为ST位请求已成功完成。ICCR2中的MST和TRS位自动设置为1，将IIC置于主机发送模式。当TRS位设置为1时，ICSR2中的TDRE标志也自动设置为1。
- 3.检查ICSR2中的TDRE标志是否为1，然后将要发送的值（从机地址和RW#位）写入ICDRT。待传输数据写入ICDRT后，TDRE标志自动置0，数据从ICDRT传输到ICDRS，TDRE标志再次置1。发送时，TRS位的值会根据发送的RW#位的值自动更新以选择主机发送或主机接收模式。如果RW#位的值为0，则IIC继续处于主机发送模式。如果此时ICSR2.NACKF标志位为1，表示没有从设备识别该地址或通信出现错误，向ICCR2.SP位写入1发出停止条件。要使用10位格式的的地址传输数据，首先将11110b、从机地址的高2位和W写入ICDRT作为第一个地址传输。然后，作为第二次地址传输，将从地址的低8位写入ICDRT。
- 4.确认ICSR2中的TDRE标志为1后，将要发送的数据写入ICDRT寄存器。IIC自动将SCLn线保持为低电平，直到传输数据准备好、发出重启条件或发出停止条件。
- 5.待发送的所有字节数据写入ICDRT寄存器后，等待ICSR2中的TEND标志的值返回1。然后检查ICSR2中的START标志为1后，将ICSR2中的START标志设置为0。
- 6.将ICCR2中的RS位设置为1（重新启动条件发出请求）。收到请求后，IIC发出重启条件。
- 7.检查ICSR2中的START标志为1后，将要发送的值（从机地址和RW#位）写入ICDRT。

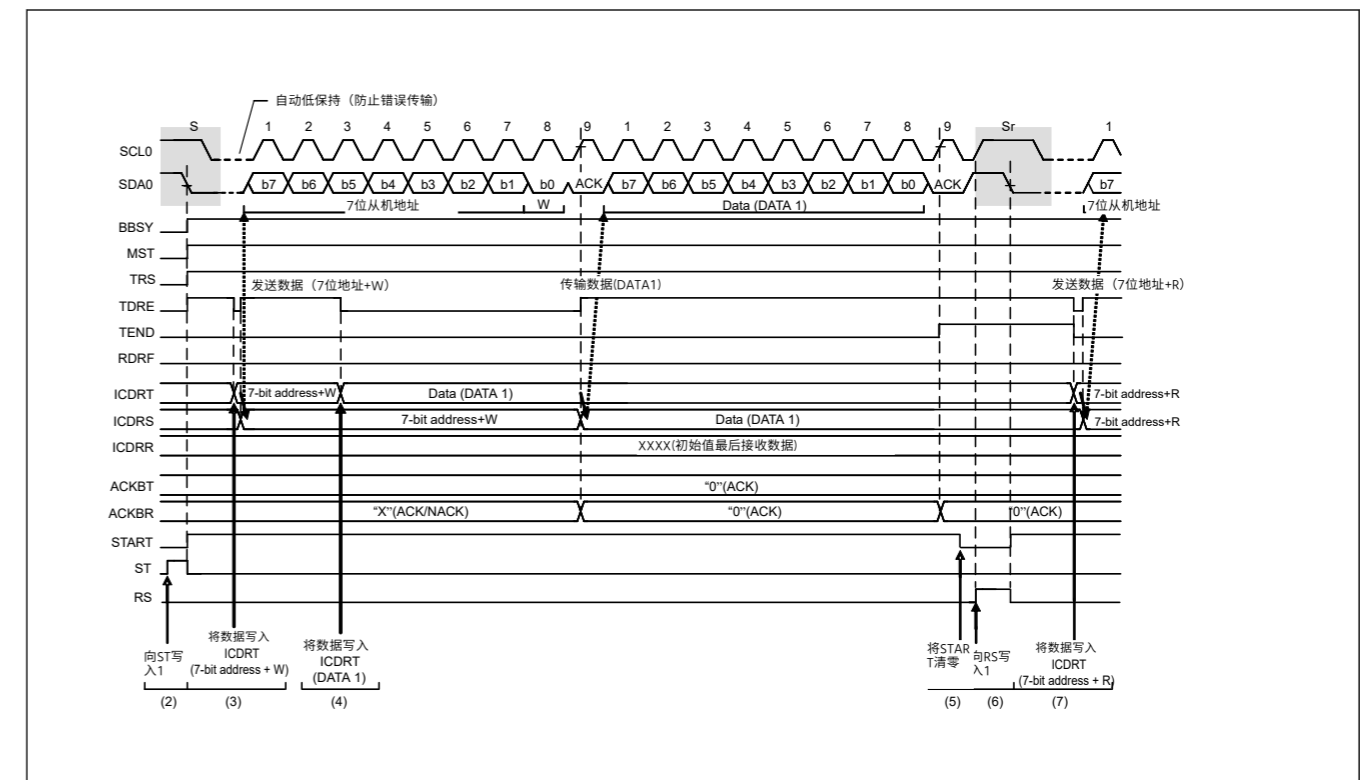


Figure 28.46 主传输后重启条件发出时序。



### 28.11.3 Issuing a Stop Condition

The IIC issues a stop condition when the SP bit in ICCR2 is set to 1. When the SP bit is set to 1, a stop condition request is made, and the IIC issues a stop condition when the BBSY flag in ICCR2 is 1 (bus busy state) and the MST bit in ICCR2 is 1 (master mode).

To issue a stop condition:

1. Drive the SDA<sub>n</sub> line low (high level to low level).
2. Ensure the low-level period of the SCL<sub>n</sub> line set in ICBRL elapses.
3. Release the SCL<sub>n</sub> line (low level to high level).
4. Detect a high level on the SCL<sub>n</sub> line and ensure the time set in ICBRH and the stop condition setup time elapse.
5. Release the SDA<sub>n</sub> line (low level to high level).
6. Ensure the time set in ICBRL and the bus free time elapse.
7. Clear the BBSY flag to 0 to release the bus mastership.

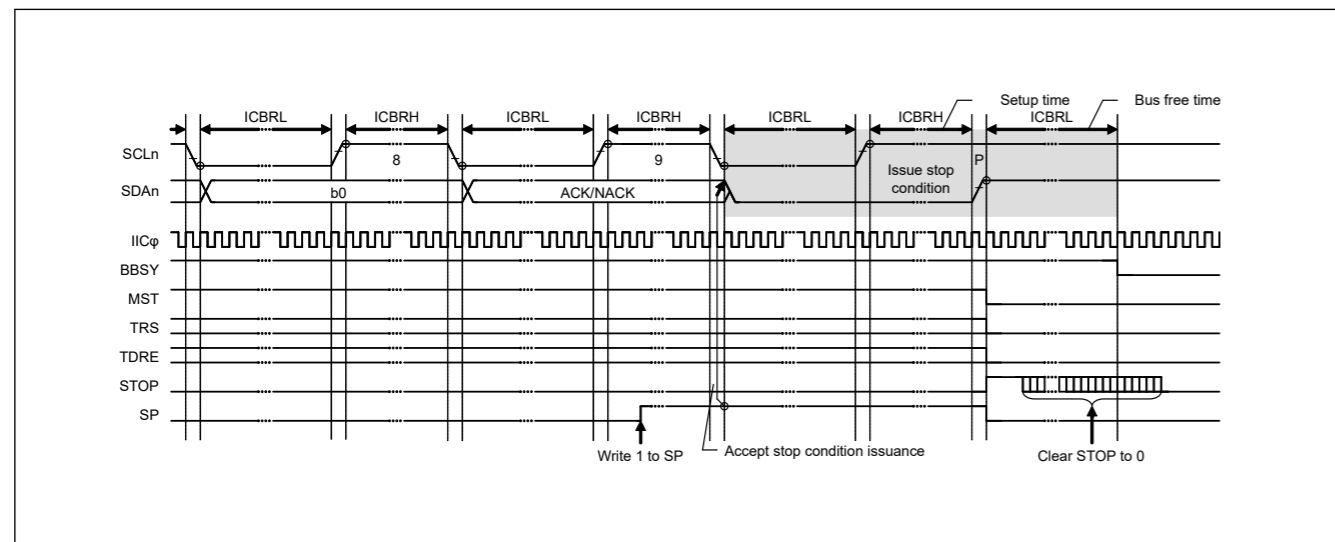


Figure 28.47 Stop condition issue timing using the SP bit

### 28.12 Bus Hanging

If the clock signals from the master and slave devices are out of synchronization because of noise or other factors, the I<sup>2</sup>C bus might hang with a fixed level on the SCL<sub>n</sub> line or SDA<sub>n</sub> line.

To manage bus hanging, the IIC has a timeout function to detect hanging by monitoring the SCL<sub>n</sub> line, and a function for outputting an extra SCL clock cycle to release the bus from:

- A timeout function to detect hanging by monitoring the SCL<sub>n</sub> line
- The IIC reset function
- An internal reset function.

By checking the SCLO, SDAO, SCLI, and SDAI bits in ICCR1, it is possible to see whether the IIC or its communicating partner is placing the low level on the SCL<sub>n</sub> or SDA<sub>n</sub> line.

#### 28.12.1 Timeout Function

The timeout function can detect when the SCL<sub>n</sub> line is stuck longer than the predetermined time. The IIC can detect an abnormal bus state by monitoring that the SCL<sub>n</sub> line is stuck low or high for a predetermined time.

The timeout function monitors the SCL<sub>n</sub> line state and counts the low- or high-level period using the internal counter. The timeout function resets the internal counter each time the SCL<sub>n</sub> line changes (rises or falls), but continues to count unless the SCL<sub>n</sub> line changes. If the internal counter overflows because no SCL<sub>n</sub> line changes, the IIC can detect the timeout and report the bus hung state.

### 28.11.3 发出停止条件

当ICCR2中的SP位设置为1时，IIC发出停止条件。当SP位设置为1时，发出停止条件请求，当ICCR2中的BBSY标志为1时，IIC发出停止条件（总线忙状态）并且ICCR2中的MST位为1（主模式）。

发出停止条件：

- 1.将SDAn线拉低（高电平转低电平）。
- 2.确保ICBRL中设置的SCLn线的低电平周期已过。
- 3.释放SCLn线（低电平到高电平）。
- 4.检测SCLn线上的高电平并确保ICBRH中设置的时间和停止条件设置时间已过。
- 5.释放SDAn线（低电平到高电平）。
- 6.确保ICBRL中设置的时间和巴士空闲时间已过。
- 7.将BBSY标志清为0以释放总线控制权。

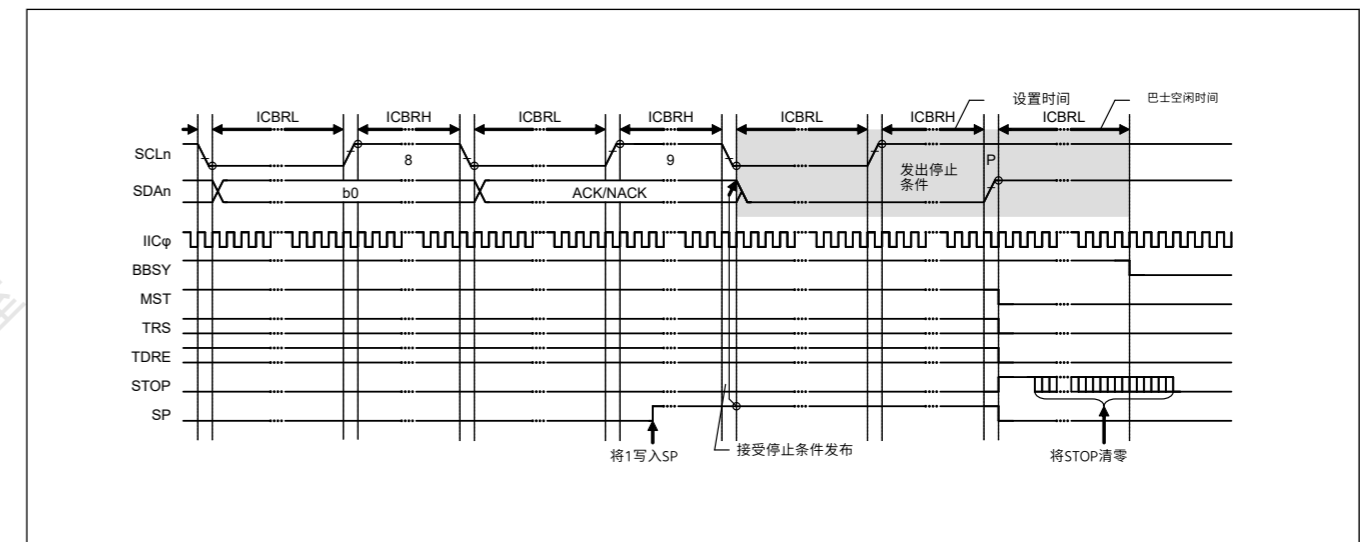


Figure 28.47 使用SP位的停止条件发出时序

### 28.12 巴士挂

如果来自主设备的时钟信号由于噪声或其他因素不同步，则I2C总线可能会在SCL<sub>n</sub>线或SDA<sub>n</sub>线上以固定电平挂起。

为了管理总线挂起，IIC具有通过监视SCL<sub>n</sub>线检测挂起的超时功能，以及输出额外SCL时钟周期以释放总线的功能：

- 通过监控SCL<sub>n</sub>线路来检测挂起的超时功能
- IIC复位功能
- 内部复位功能。

通过检查ICCR1中的SCLO、SDAO、SCLI和SDAI位，可以查看IIC或其通信伙伴是否将SCL<sub>n</sub>或SDA<sub>n</sub>线置于低电平。

#### 28.12.1 超时功能

超时功能可以检测SCL<sub>n</sub>线路何时卡住超过预定时间。IIC可以通过监视SCL<sub>n</sub>线在预定时间内保持低电平或高电平来检测异常总线状态。

超时功能监控SCL<sub>n</sub>线路状态并使用内部计数器计算低电平或高电平周期。每次SCL<sub>n</sub>线改变（上升或下降）时，超时功能都会复位内部计数器，但除非SCL<sub>n</sub>线改变，否则会继续计数。如果内部计数器因为SCL<sub>n</sub>线没有变化而溢出，IIC可以检测到超时并报告总线挂起状态。

This timeout function is enabled when the ICFER.TMOE bit is 1. It detects a hung state when the SCLn line is stuck low or high during the following conditions:

- The bus is busy (ICCR2.BBSY flag is 1) in master mode (ICCR2.MST bit is 1)
- The IIC slave address is detected (ICSR1 register is not 0x00) and the bus is busy (ICCR2.BBSY flag is 1) in slave mode (ICCR2.MST bit is 0)
- The bus is open (ICCR2.BBSY flag is 0) while a start condition is requested (ICCR2.ST bit is 1).

The internal counter of the timeout function uses the internal reference clock (IIC $\phi$ ) set in the CKS[2:0] bits in ICMR1 as a count source. It functions as a 16-bit counter when long mode is selected (TMOS bit = 0 in ICMR2) or a 14-bit counter when short mode is selected (TMOS bit = 1).

The SCLn line level (low, high, or both levels) during which this counter is activated can be selected in the TMOH and TMOL bits in ICMR2. If both TMOL and TMOH bits are set to 0, the internal counter is disabled.

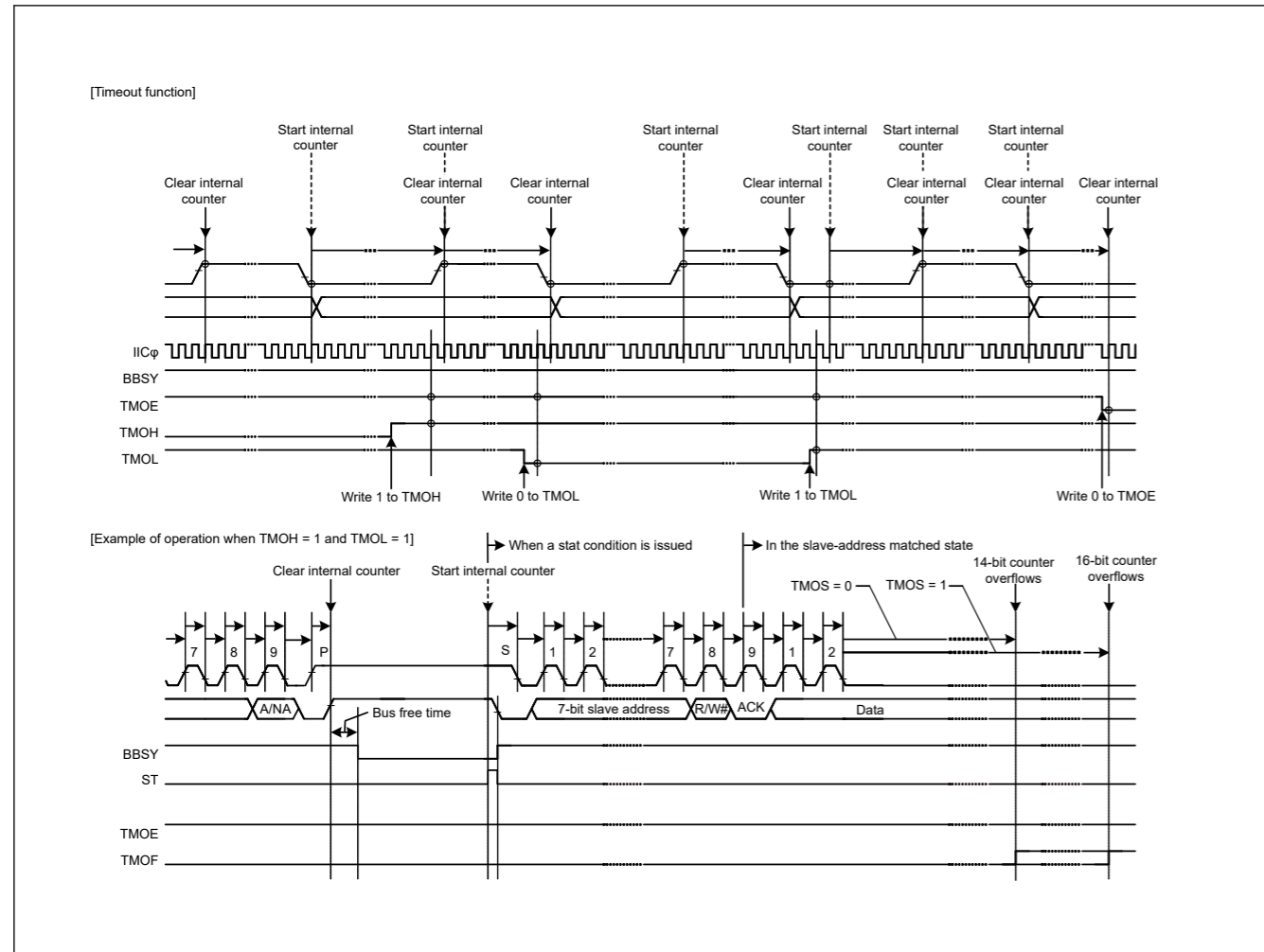


Figure 28.48 Timeout function using the TMOE, TMOS, TMOH, and TMOL bits

### 28.12.2 Extra SCL Clock Cycle Output Function

In master mode, this function outputs extra SCL clock cycles to release the SDAn line of the slave device from being held low because the master is out of synchronization with the slave device. This function is mainly used in master mode to release the SDAn line of the slave device from being fixed low by including extra cycles of SCL output from the IIC. It uses single cycles of the SCL clock for a bus error where the IIC cannot issue a stop condition because the slave device is holding the SDAn line at the low level. Do not use this function in normal situations. Using it when communications are proceeding correctly leads to malfunctions.

When the CLO bit in ICCR1 is set to 1 in master mode, a single cycle of the SCL clock at the frequency specified in the CKS[2:0] bits in ICMR1, and in the ICBRH and ICBRL registers, is output as an extra clock cycle. After output of this

此超时功能在ICFER.TMOE位为1时启用。在以下情况下，当SCLn线卡在低电平或高电平时，它会检测到挂起状态：

- 总线繁忙 (ICCR2.BBSY标志为1) 在主机模式 (ICCR2.MST位为1)
- 检测到IIC从机地址 (ICSR1寄存器不是0x00) 并且在从机模式下总线忙 (ICCR2.BBSY标志为1) (ICCR2.MST位为0)
- 请求启动条件时 (ICCR2.ST位为1)，总线打开 (ICCR2.BBSY标志为0)。

超时功能的内部计数器使用ICMR1的CKS[2:0]位中设置的内部参考时钟(IIC $\phi$ )作为计数源。It functions as a 16-bit counter when long mode is selected (TMOS bit = 0 in ICMR2) or a 14-bit counter when short mode is selected (TMOS bit = 1).

可以在TMOH和ICMR2中的TMOL位。如果TMOL和TMOH位都设置为0，则内部计数器被禁用。

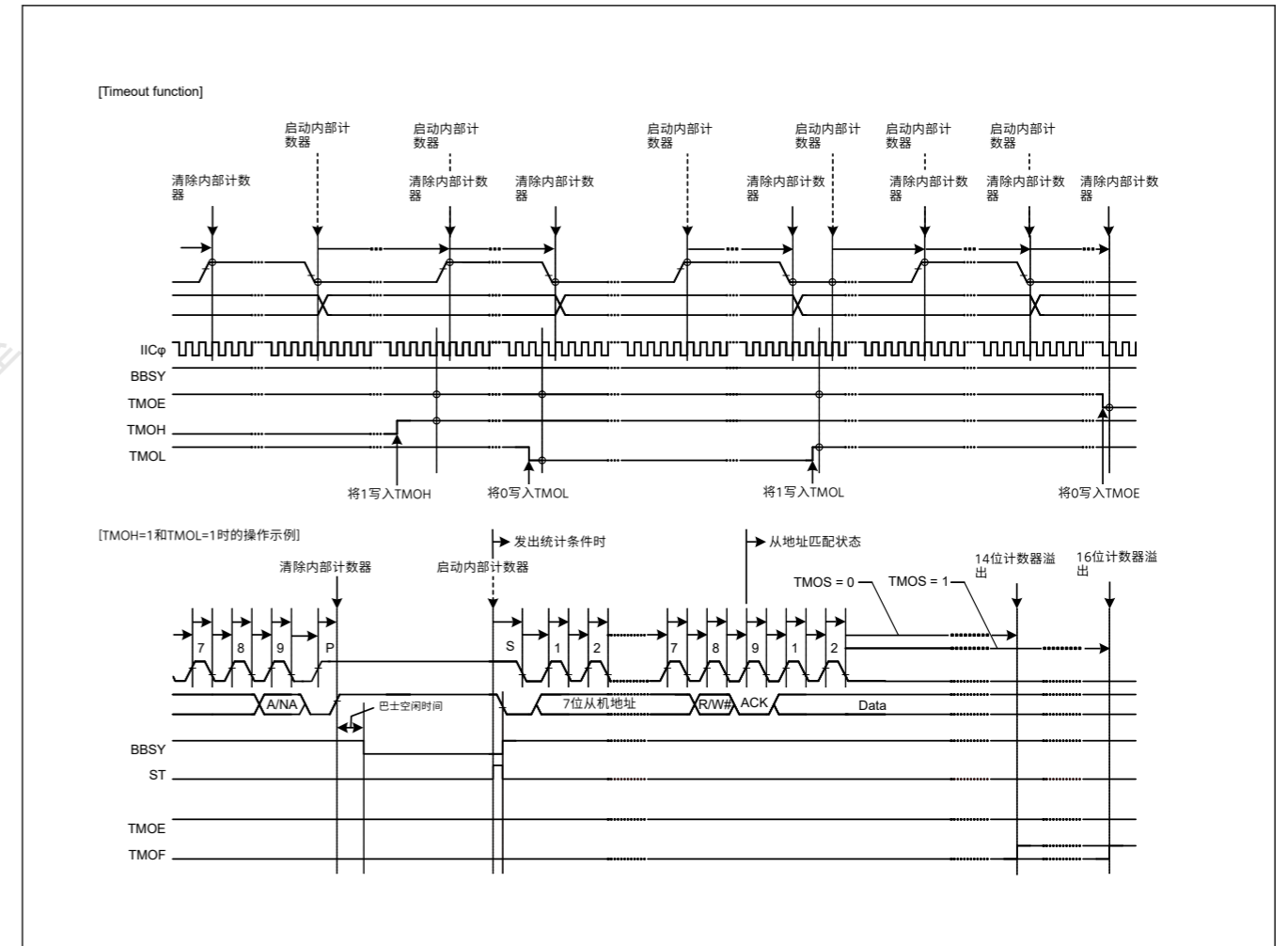


Figure 28.48 使用TMOE、TMOS、TMOH和TMOL位的超时功能

### 28.12.2 额外的SCL时钟周期输出功能

在主模式下，该函数输出额外的SCL时钟周期，以释放从设备的SDAn线保持低电平，因为主设备与从设备不同步。该功能主要用于主机模式，通过包含IIC的额外SCL输出周期来释放从机设备的SDAn线固定为低电平。它使用SCL时钟的单个周期来处理IIC无法发出停止条件的总线错误，因为从设备将SDAn线保持在低电平。在正常情况下不要使用此功能。在通信正常进行时使用它会导致故障。

当ICCR1中的CLO位在主机模式下设置为1时，以ICMR1中的CKS[2:0]位以及ICBRH和ICBRL寄存器中指定的频率的SCL时钟的单个周期作为额外输出输出时钟周期。这个输出后

single cycle of the SCL clock, the CLO bit is automatically set to 0. At this time, if ICCR2.BBSY = 1, the SCL pin goes low, and when ICCR2.BBSY = 0, the SCL pin goes high. After confirming that the CLO bit is 0 by software, write 1 to the CLO bit to output the additional clock continuously.

When the IIC module is in master mode and the slave device is holding the SDA<sub>n</sub> line low because synchronization with the slave device is lost because of effects like noise, the output of a stop condition is not possible. This function can be used to output extra cycles of SCL one by one to make the slave device release the SDA<sub>n</sub> line from being held low, and so recover the bus from an unusable state. Release of the SDA<sub>n</sub> line by the slave device can be monitored by reading the SDAI bit in ICCR1. After confirming the release of the SDA<sub>n</sub> line by the slave device, complete communications by reissuing the stop condition.

[Output conditions for using the CLO bit in ICCR1]

- When the bus is open (BBSY flag in ICCR2 = 0) or in master mode (MST bit = 1 and BBSY flag = 1 in ICCR2)
- When the communication device does not hold the SCL<sub>n</sub> line low.

Figure 28.49 shows the operation timing of the extra SCL clock cycle output function (CLO bit).

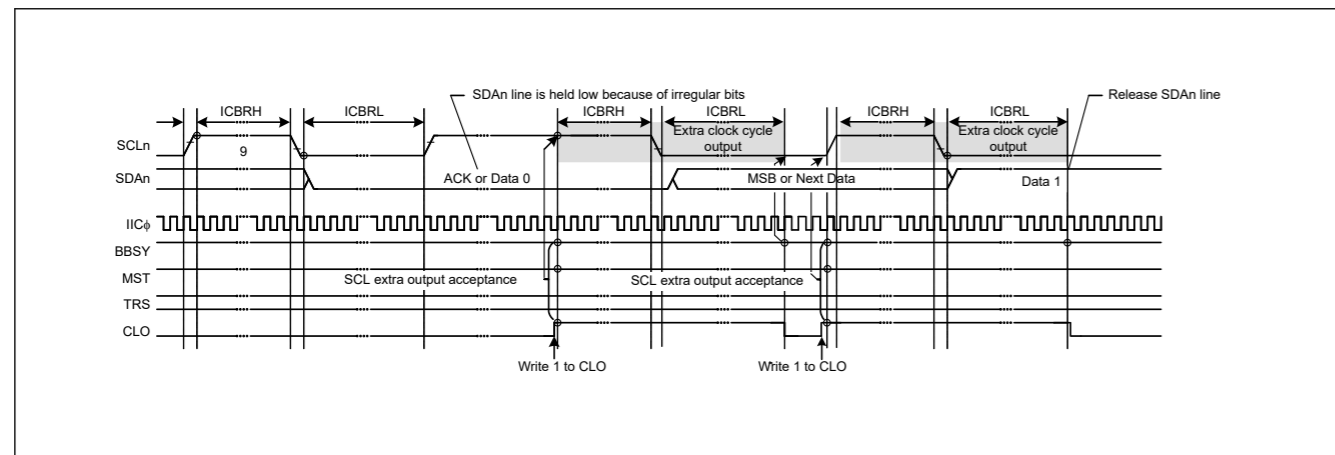


Figure 28.49 Extra SCL clock cycle output function using the CLO bit

### 28.12.3 IIC Reset and Internal Reset

The IIC module incorporates a function for resetting itself. It uses two types of resets:

- An IIC reset, which initializes all registers, including the BBSY flag in ICCR2.
- An internal reset, which releases the IIC from the slave-address matched state and initializes the internal counter while saving other settings.

After issuing a reset, always set the IICRST bit in ICCR1 to 0. Both types of resets are valid for release from bus-hung states, because both restore the output state of the SCL<sub>n</sub> and SDA<sub>n</sub> pins to the high-impedance state.

Issuing a reset during slave operation might lead to a loss of synchronization between the master device clock and the slave device clock, so avoid this when possible. In addition, monitoring of the bus state, such as for the presence of a start condition, is not possible during an IIC reset (ICE and IICRST bits = 01b in ICCR1).

For a detailed description of the IIC and internal resets, see [section 28.15. State of Registers When Issuing Each Condition](#).

### 28.13 SMBus Operation

The IIC supports data communication conforming to the SMBus Specification (version 2.0). To perform SMBus communication, set the SMBS bit in ICMR3 to 1. To use the transfer rate within a range of 10 to 100 kbps of the SMBus standard, set the CKS[2:0] bits in ICMR1, the ICBRH, and ICBRL registers. In addition, specify the values in the DLCS bit in ICMR2 and the SDDL[2:0] bits in ICMR2 to meet the data hold time specification of 300 ns or more. When the IIC is used only as a slave device, the transfer rate setting is not required, but ICBRL must be set to a value longer than the data setup time (250 ns).

For the SMBus device default address (1100 001b), use one of the slave address registers L0 to L2 (SARL0, SARL1, and SARL2), and set the associated FS bit (7- or 10-bit address format select) in SARU<sub>y</sub> (y = 0 to 2) to 0 (7-bit address format).

在SCL时钟的一个周期内，CLO位自动设置为0。此时，如果ICCR2.BBSY=1，SCL引脚变为低电平，当ICCR2.BBSY=0时，SCL引脚变为高电平。通过软件确认CLO位为0后，向CLO位写入1以连续输出附加时钟。

当IIC模块处于主模式且从设备保持SDA<sub>n</sub>线为低电平时，由于噪声等影响与从设备失去同步，因此无法输出停止条件。该功能可用于逐个输出额外的SCL周期，使从设备释放SDA<sub>n</sub>线的低电平状态，从而将总线从不可用状态恢复。从设备释放SDA<sub>n</sub>线可以通过读取ICCR1中的SDAI位来监控。从设备确认SDA<sub>n</sub>线的释放后，通过重新发出停止条件完成通信。

[使用ICCR1中CLO位的输出条件]

- 当总线打开（ICCR2中的BBSY标志=0）或主机模式（ICCR2中的MST位=1和BBSY标志=1）时
- 当通信设备不保持SCL<sub>n</sub>线为低电平时。

图28.49显示了额外SCL时钟周期输出功能（CLO位）的操作时序。

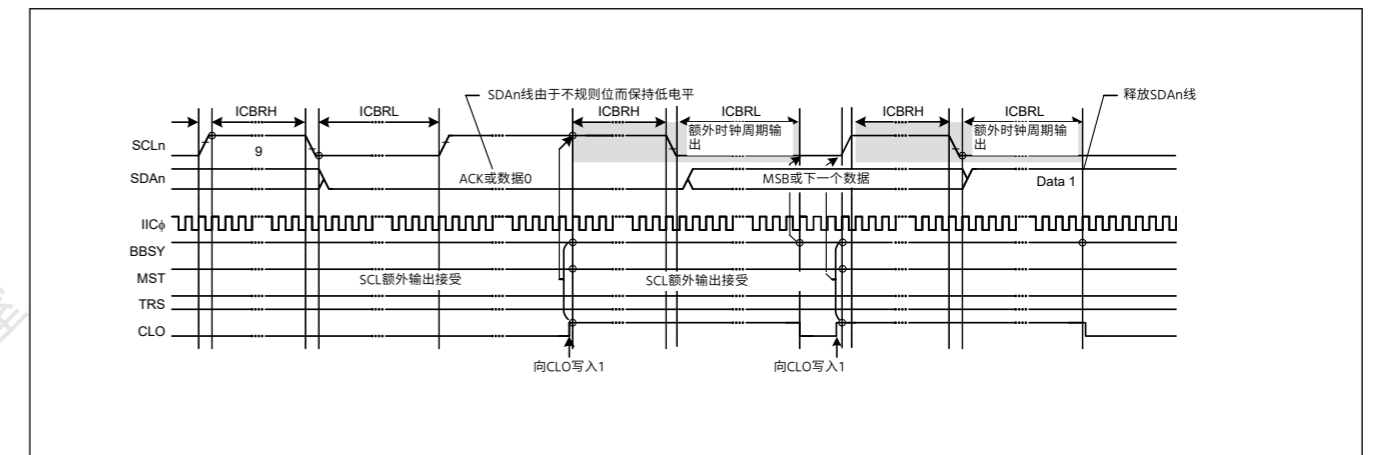


Figure 28.49 使用CLO位的额外SCL时钟周期输出功能

### 28.12.3 IIC复位和内部复位

IIC模块包含一个自我复位功能。它使用两种类型的重置：

- IIC复位，初始化所有寄存器，包括ICCR2中的BBSY标志。
- 内部复位，将IIC从从地址匹配状态释放并初始化内部计数器，同时保存其他设置。

发出复位后，始终将ICCR1中的IICRST位设置为0。两种类型的复位都对从总线挂起状态释放有效，因为两者都将SCL<sub>n</sub>和SDA<sub>n</sub>引脚的输出状态恢复为高阻状态。

在从机操作期间发出复位可能会导致主设备时钟和从设备时钟之间失去同步，因此请尽可能避免这种情况。此外，在IIC复位（ICE和IICRST位=ICCR1中的01b）期间无法监控总线状态，例如是否存在启动条件。

有关IIC和内部复位的详细说明，请参见第28.15节。发出每个条件时的寄存器状态。

### 28.13 SMBus Operation

IIC支持符合SMBus规范（2.0版）的数据通信。要执行SMBus通信，请将ICMR3中的SMBS位设置为1。要使用SMBus标准的10至100kbps范围内的传输速率，请设置ICMR1、ICBRH和ICBRL寄存器中的CKS[2:0]位。此外，请指定ICMR2中的DLCS位和ICMR2中的SDDL[2:0]位中的值，以满足300ns或更长的数据保持时间规范。当IIC仅用作从设备时，不需要设置传输速率，但必须将ICBRL设置为比数据建立时间（250ns）更长的值。

对于SMBus器件默认地址(1100001b)，使用从地址寄存器L0到L2之一（SARL0、SARL1和SARL2），并将SARU<sub>y</sub>(y=0到2)中相关的FS位（7位或10位地址格式选择）设置为0（7位地址格式）。



When transmitting the UDID (Unique Device Identifier), set the SALE bit in ICFER to 1 to enable the slave arbitration-lost detection function.

### 28.13.1 SMBus Timeout Measurement

#### (1) Measuring slave device timeout

The following period (timeout interval:  $T_{LOW:SEXT}$ ) must be measured for slave devices in SMBus communication:

- From start condition to stop condition.

To measure timeout for slave devices, measure the period from start condition detection to stop condition detection with the GPT using the IIC start condition detection interrupt (STIn) and stop condition detection interrupt (SPIn). The measured timeout period must be within the total clock low-level period [slave device]  $T_{LOW:SEXT}$ : 25 ms (maximum) of the SMBus standard.

If the time measured with the GPT exceeds the clock low-level detection timeout  $T_{TIMEOUT}$ : 25 ms (minimum) of the SMBus standard, the slave device must release the bus by writing 1 to the IICRST bit in ICCR1 to issue an internal reset of the IIC. When an internal reset is issued, the IIC stops driving the bus for the SCLn and SDA n pins, making them output high-impedance, which releases the bus.

#### (2) Measuring master device timeout

The following periods (timeout interval:  $T_{LOW:MEXT}$ ) must be measured for master devices in SMBus communication:

- From start condition to acknowledge bit
- Between acknowledge bits
- From acknowledge bit to stop condition.

To measure timeout for master devices, measure these periods with the GPT using the IIC start condition detection interrupt (STIn), stop condition detection interrupt (SPIn), transmit end interrupt (IICn\_TEI), or receive data full interrupt (IICn\_RXI). The measured timeout period must be within the total clock low-level extended period (master device)  $T_{LOW:MEXT}$ : 10 ms (maximum) of the SMBus standard, and the total of all  $T_{LOW:MEXT}$  values from start condition to stop condition must be within  $T_{LOW:SEXT}$ : 25 ms (maximum).

For the ACK receive timing (rising edge of the 9th SCL clock cycle), monitor the TEND flag in ICSR2 in master transmit mode (master transmitter) and the RDRF flag in ICSR2 in master receive mode (master receiver). Perform byte-wise transmit operations in master transmit mode, and hold the RDRFS bit in ICMR3 at 0 until the byte immediately before reception of the final byte in master receive mode. While the RDRFS bit is 0, the RDRF flag is set to 1 on the rising edge of the 9th SCL clock cycle.

If the period measured with the GPT exceeds the total clock low-level extended period (master device)  $T_{LOW:MEXT}$ : 10 ms (maximum) of the SMBus standard or the total of measured periods exceeds the clock low-level detection timeout  $T_{TIMEOUT}$ : 25 ms (minimum) of the SMBus standard, the master device must stop the transaction by issuing a stop condition. In master transmit mode, immediately stop the transmit operation (stop writing data to ICDRT).

发送UDID (UniqueDeviceIdentifier) 时, 将ICFER中的SALE位设置为1, 以能从机仲裁丢失检测功能。

### 28.13.1 SMBus超时测量

#### (1) 测量从设备超时

对于SMBus通信中的从设备, 必须测量以下周期 (超时间隔:  $T_{LOW:SEXT}$ ):

- 从开始条件到停止条件。

要测量从设备的超时, 请使用GPT使用IIC启动条件检测中断(STIn)和停止条件检测中断(SPIn)测量从启动条件检测到停止条件检测的周期。测得的超时周期必须在总时钟低电平周期[从设备] $T_{LOW:SEXT}$ :SMBus标准的25ms (最大值) 内。

如果用GPT测量的时间超过时钟低电平检测超时 $T_{TIMEOUT}$ :25ms (最小值) SMBus标准, 从设备必须通过向ICCR1中的IICRST位写入1来释放总线, 以发出IIC的内部复位。当发出内部复位时, IIC停止驱动SCLn和SDAn引脚的总线, 使它们输出高阻抗, 从而释放总线。

#### (2) 测量主设备超时

对于SMBus通信中的主设备, 必须测量以下周期 (超时间隔:  $T_{LOW:MEXT}$ ):

- 从开始条件到确认位
- 确认位之间
- 从确认位到停止条件。

要测量主设备的超时, 请使用GPT使用IIC开始条件检测中断(STIn)、停止条件检测中断(SPIn)、发送结束中断(IICn\_TEI)或接收数据完整中断(IICn\_RXI)来测量这些周期。测量的超时周期必须在总时钟低电平扩展周期 (主设备)  $T_{LOW:MEXT}$ : 10ms (最大值) 内。

$T_{LOW:MEXT}$ : SMBus标准的10毫秒 (最大值), 从开始条件到停止条件的所有 $T_{LOW:MEXT}$ 值的总和必须在 $T_{LOW:SEXT}$ : 25毫秒 (最大值) 内。

对于ACK接收时序 (第9个SCL时钟周期的上升沿), 在主机发送模式 (主机发送器) 下监控ICSR2中的TEND标志, 在主机接收模式 (主机接收器) 下监控ICSR2中的RDRF标志。在主机发送模式下执行逐字节发送操作, 并将ICMR3中的RDRFS位保持为0, 直到在主机接收模式下接收到最后一个字节之前的字节。当RDRFS位为0时, RDRF标志在第9个SCL时钟周期的上升沿设置为1。

如果用GPT测量的周期超过总时钟低电平延长周期 (主设备)  $T_{LOW:MEXT}$ :SMBus标准的10ms (最大值) 或总测量周期超过时钟低电平检测超时 $T_{TIMEOUT}$ : SMBus标准的25ms (最小值), 主设备必须通过发出停止条件来停止事务。在主机发送模式下, 立即停止发送操作 (停止向ICDRT写入数据)。



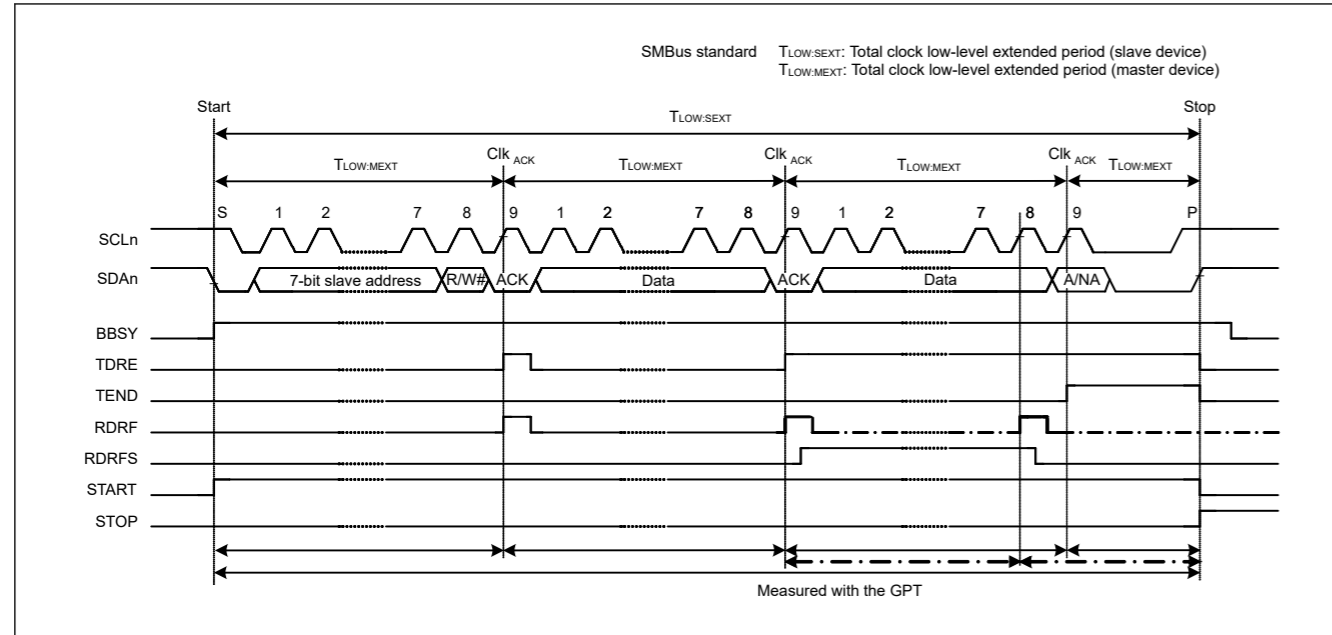


Figure 28.50 SMBus timeout measurement

### 28.13.2 Packet Error Code (PEC)

The MCU provides a CRC calculator that enables transmission of a Packet Error Code (PEC) or allows checking of the received data in SMBus data communication for the IIC. For the CRC-generating polynomials of the CRC calculator, see [section 34, Cyclic Redundancy Check \(CRC\) Calculator](#).

In master transmit mode, the PEC data can be generated by writing all transmit data to the CRC Data Input Register (CRCDIR) in the CRC calculator.

In master receive mode, the PEC data can be checked by writing all receive data to CRCDIR in the CRC calculator and comparing the obtained value in the CRC Data Output Register (CRCDOR) with the received PEC data.

To send ACK or NACK based on the match or mismatch result when the final byte is received as a result of the PEC code check, set the RDRFS bit in ICMR3 to 1 before the rising edge of the 8th SCL clock cycle during reception of the final byte, and hold the SCLn line low on the falling edge of the 8th clock cycle.

### 28.13.3 SMBus Host Notification Protocol (Notify ARP Master Command)

In communicating over an SMBus, a slave device can temporarily act as a master device to notify the SMBus host (or ARP master) of its own slave address, or to request its own slave address from the SMBus host.

For a product using the MCU to operate as an SMBus host or ARP master, the host address (0001 000b) sent from the slave device must be detected as a slave address, and so the IIC provides a function for detecting the host address. To detect the host address as a slave address, set the SMBS bit in ICMR3 and the HOAE bit in ICSEB to 1. Operation after the host address is detected is the same as normal slave operation.

## 28.14 Interrupt Sources

The IIC issues five types of interrupt requests:

- Transfer error or event generation (arbitration-lost, NACK detection, timeout detection, start condition detection, and stop condition detection)
- Receive data full
- Transmit data empty
- Transmit end
- Address match during wakeup function

[Table 28.10](#) lists details about the interrupt requests. The receive data full and transmit data empty interrupts can activate data transfer by the DTC or DMAC.

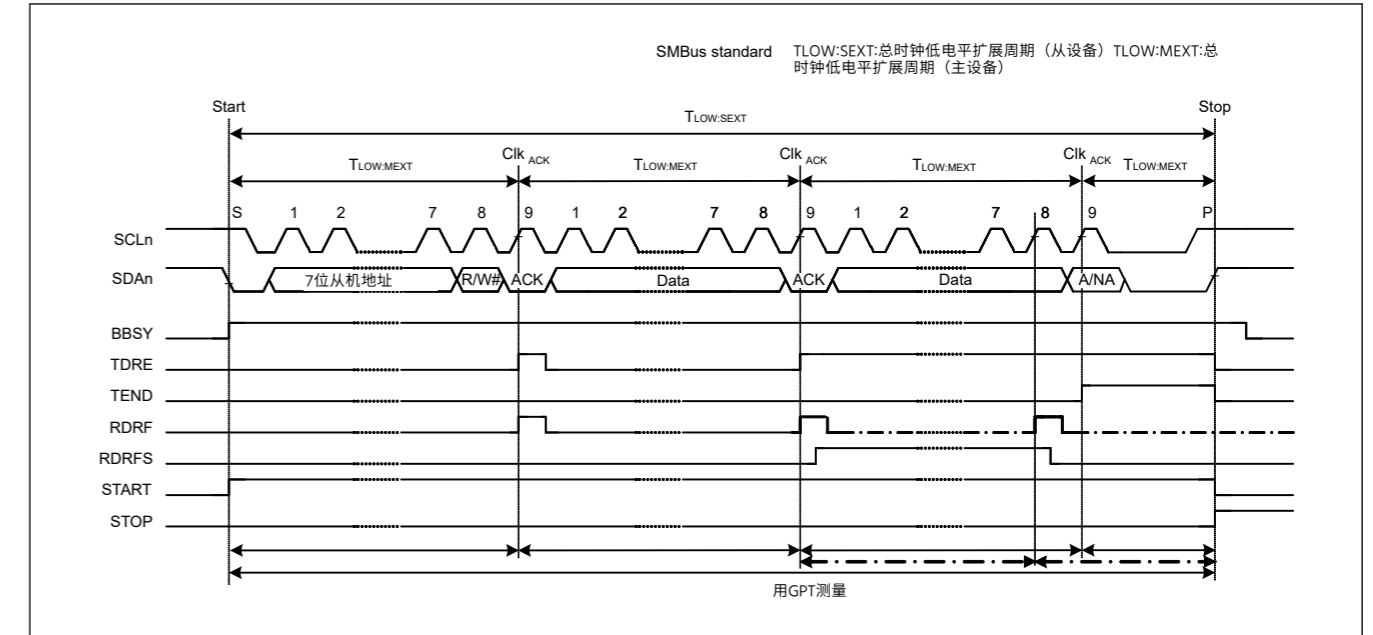


Figure 28.50 SMBus超时测量

### 28.13.2 数据包错误代码(PEC)

MCU提供了一个CRC计算器，可以传输数据包错误代码(PEC)或检查IIC的SMBus数据通信中接收到的数据。有关CRC计算器的CRC生成多项式，请参阅第34节，循环冗余校验(CRC)计算器。

在主机发送模式下，可以通过将所有发送数据写入CRC计算器中的CRC数据输入寄存器(CRCDIR)来生成PEC数据。

在主机接收模式下，可以通过将所有接收数据写入CRC计算器中的CRCDIR并将获得的CRC数据输出寄存器(CRCDOR)中的值与接收到的PEC数据进行比较来检查PEC数据。

当作为PEC代码检查的结果接收到最后一个字节时，要根据匹配或不匹配结果发送ACK或NACK，请在接收最后一个字节期间的第8个SCL时钟周期的上升沿之前将ICMR3中的RDRFS位设置为1字节，并在第8个时钟周期的下降沿保持SCLn线为低电平。

### 28.13.3 SMBus主机通知协议（通知ARP主机命令）

在通过SMBus进行通信时，从设备可以临时充当主设备来通知SMBus主机（或ARP主机）它自己的从地址，或者从SMBus主机请求它自己的从地址。

对于使用MCU作为SMBus主机或ARP主机的产品，从机发送的主机地址（0001000b）必须被检测为从机地址，因此IIC提供了主机地址检测功能。要将主机地址检测为从机地址，请将ICMR3中的SMBS位和ICSEB中的HOAE位设置为1。检测到主机地址后的操作与正常从机操作相同。

## 28.14 中断源

IIC发出五种类型的中断请求：

- 传输错误或事件发生（仲裁丢失、NACK检测、超时检测、开始条件检测和停止条件检测）
- 接收数据已满
- 传输数据为空
- 发送端
- 唤醒功能期间的地址匹配

表28.10列出了有关中断请求的详细信息。接收数据满和发送数据空中断可以通过DTC或DMAC激活数据传输。

Table 28.10 Interrupt sources

| Symbol                    | Interrupt source                           | Interrupt flag | DTC or DMAC activation | Interrupt condition  |
|---------------------------|--|----------------|------------------------|--|
| IICn_EEI <sup>*5</sup>    | Transfer error or event occurrence         | AL             | Not possible           | AL = 1, ALIE = 1   |
|                           |  | NACKF          |                        | NACKF = 1, NAKIE = 1   |
|                           |  | TMOF           |                        | TMOF = 1, TMOIE = 1  |
|                           |  | START          |                        | START = 1, STIE = 1  |
|                           |  | STOP           |                        | STOP = 1, SPIE = 1   |
| IICn_RXI <sup>*2 *5</sup> | Receive data full                          | RDRF           | Possible               | RDRF = 1, RIE = 1  |
| IICn_TXI <sup>*1 *5</sup> | Transmit data empty                        | RDRF           | Possible               | TDRE = 1, TIE = 1  |
| IICn_TEI <sup>*3 *5</sup> | Transmit end                               | TEND           | Not possible           | TEND = 1, TEIE = 1   |
| IIC0_WUI <sup>*4</sup>    | Slave address match during wakeup function | WUF            | Not possible           | Slave address match<br>Slave receive complete<br>RWAK operation ASY0 = 1<br>WUIE = 1 |

Note: There is a delay between the execution of a write instruction for a peripheral module by the CPU and the actual writing to the module. When an interrupt flag is cleared or masked, read the relevant flag again to check whether clearing or masking is complete, then return from interrupt handling. Not doing so creates the possibility of repeated processing of the same interrupt.

Note 1. Because IICn\_TXI is edge-detected, it does not require clearing. Additionally, the TDRE flag in ICSR2 (condition for IICn\_TXI) is automatically set to 0 when transmit data is written to the ICDRT register or a stop condition is detected (STOP flag = 1 in ICSR2).

Note 2. Because IICn\_RXI is edge-detected, it does not require clearing. Additionally, the RDRF flag in ICSR2 (condition for IICn\_RXI) is automatically set to 0 when data is read from ICDRR.

Note 3. When using the IICn\_TEI interrupt, clear the TEND flag in ICSR2 in the IICn\_TEI interrupt handling. The TEND flag in ICSR2 automatically is set to 0 when transmit data is written to the ICDRT register or a stop condition is detected (STOP flag = 1 in ICSR2).

Note 4. Only channel 0 has a wakeup function, so IIC0\_WUI is for channel 0 only.

Note 5. Channel number (n = 0, 1).

Clear or mask each flag during interrupt handling.

### 28.14.1 Buffer Operation for IICn\_TXI and IICn\_RXI Interrupts

If the conditions for generating an IICn\_TXI or IICn\_RXI interrupt are satisfied while the associated IR flag is 1, the interrupt request is not output for the ICU but is saved internally. One request per source can be saved internally.

An interrupt request that is saved in the ICU is output when the ICU.IELSRn.IR flag becomes 0. Internally saved interrupt requests are automatically cleared under normal conditions. They can also be cleared by writing 0 to the interrupt enable bit within the associated peripheral module.

### 28.15 State of Registers When Issuing Each Condition

The IIC has two dedicated resets, IIC reset and Internal reset. Table 28.11 lists the registers states when issuing each condition.

Table 28.11 Register states when issuing each condition (1 of 2)

| Registers | Reset       | IIC reset (ICE = 0, IICRST = 1) | Internal reset (ICE = 1, IICRST = 1) | Start or restart condition detection | Stop condition detection |          |
|-----------|-------------|---------------------------------|--------------------------------------|--------------------------------------|--------------------------|----------|
| ICCR1     | ICE, IICRST | In reset                        | Saved                                | Saved                                | Saved                    |          |
|           | SCLO, SDAO  | In reset                        | In reset                             |                                      |                          |          |
|           | Others      |                                 | Saved                                |                                      |                          |          |
| ICCR2     | BBSY        | In reset                        | In reset                             | Set                                  | In reset                 |          |
|           | ST, RS      |                                 |                                      | In reset                             | Saved                    |          |
|           | SP          |                                 |                                      |                                      | Set or saved             | In reset |
|           | TRS         |                                 |                                      | In reset                             |                          | Saved    |
|           | MST         |                                 |                                      |                                      |                          | Saved    |

Table 28.10 中断源

| Symbol                    | 中断源           | 中断标志  | DTC或DMAC激活 | 中断条件   |
|---------------------------|---------------|-------|------------|--|
| IICn_EEI <sup>*5</sup>    | 传输错误或事件发生     | AL    | 不可能        | AL = 1, ALIE = 1                                       |
|                           |               | NACKF |            | NACKF = 1, NAKIE = 1                                   |
|                           |               | TMOF  |            | TMOF = 1, TMOIE = 1                                    |
|                           |               | START |            | START = 1, STIE = 1                                    |
|                           |               | STOP  |            | STOP = 1, SPIE = 1                                     |
| IICn_RXI <sup>*2 *5</sup> | 接收数据已满        | RDRF  | Possible   | RDRF = 1, RIE = 1                                      |
| IICn_TXI <sup>*1 *5</sup> | 传输数据为空        | RDRF  | Possible   | TDRE = 1, TIE = 1                                      |
| IICn_TEI <sup>*3 *5</sup> | 发射端           | TEND  | 不可能        | TEND = 1, TEIE = 1                                     |
| IIC0_WUI <sup>*4</sup>    | 唤醒功能期间的从机地址匹配 | WUF   | 不可能        | 从地址匹配<br>从机接收完成<br>RWAK operation ASY0 = 1<br>WUIE = 1 |

Note: CPU执行外围模块的写指令与实际写入模块之间存在延迟。当一个中断标志被清除或屏蔽时，再次读取相关标志，检查清除或屏蔽是否完成，然后从中断处理返回。不这样做会产生重复处理同一中断的可能性。

注1.因为IICn\_TXI是边沿检测，所以不需要清零。此外，当发送数据写入ICDRT寄存器或检测到停止条件（ICSR2中的STOP标志=1）时，ICSR2中的TDRE标志（IICn\_TXI的条件）自动设置为0。

注2.因为IICn\_RXI是边沿检测，所以不需要清零。此外，从ICDRR读取数据时，ICSR2中的RDRF标志（IICn\_RXI的条件）自动设置为0。

注3.使用IICn\_TEI中断时，在IICn\_TEI中断处理中清除ICSR2中的TEND标志。当发送数据写入ICDRT寄存器或检测到停止条件（ICSR2中的STOP标志=1）时，ICSR2中的TEND标志自动设置为0。

注4.只有通道0有唤醒功能，所以IIC0\_WUI仅适用于通道0。

注5.通道编号(n=0 1)。

在中断处理期间清除或屏蔽每个标志。

### 28.14.1 IICn\_TXI和IICn\_RXI中断的缓冲区操作

如果在相关的IR标志为1时满足产生IICn\_TXI或IICn\_RXI中断的条件，则中断请求不会输出给ICU，而是在内部保存。每个源的一个请求可以在内部保存。

当ICU.IELSRn.IR标志变为0时，输出ICU中保存的中断请求。在正常情况下，内部保存的中断请求会自动清除。它们也可以通过向相关外围模块中的中断使能位写入0来清除。

### 28.15 发布每个条件时的寄存器状态

IIC有两个专用复位，IIC复位和内部复位。表28.11列出了发出每个条件时的寄存器状态。

Table 28.11 发出每个条件时注册状态 (2个中的1个)

| Registers | Reset       | IIC reset (ICE = 0, IICRST = 1) | 内部复位 (ICE=1, IICRST=1) | 启动或重启条件检测 | 停止条件检测 |          |       |          |
|-----------|-------------|---------------------------------|------------------------|-----------|--------|----------|-------|----------|
| ICCR1     | ICE, IICRST | 复位中                             | Saved                  | Saved     | Saved  |          |       |          |
|           | SCLO, SDAO  |                                 |                        |           |        | 复位中      |       |          |
|           | Others      |                                 |                        |           |        | Saved    |       |          |
| ICCR2     | BBSY        | 复位中                             | 复位中                    | Saved     | Set    |          |       |          |
|           | ST, RS      |                                 |                        |           |        | 复位中      | Saved |          |
|           | SP          |                                 |                        |           |        |          | 设置或保存 | In reset |
|           | TRS         |                                 |                        |           |        | In reset |       | Saved    |
|           | MST         |                                 |                        |           |        |          |       | Saved    |

Table 28.11 Register states when issuing each condition (2 of 2)

| Registers                                  | Reset    | IIC reset<br>(ICE = 0, IICRST = 1) | Internal reset<br>(ICE = 1, IICRST = 1) | Start or restart<br>condition detection | Stop condition<br>detection |
|--|----------|------------------------------------|---|---|-----------------------------|
| ICMR1                                      | BC[2:0]  | In reset                           | In reset                                | In reset                                | Saved                       |
|  | Others   |                                    |   | Saved                                   | Saved                       |
| ICMR2                                      | In reset | In reset                           | Saved                                   | Saved                                   | Saved                       |
| ICMR3                                      | ACKBT    | In reset                           | In reset                                | Saved                                   | In reset                    |
|  | Others   |                                    |   |   | Saved                       |
| ICFER                                      | In reset | In reset                           | Saved                                   | Saved                                   | Saved                       |
| ICSER                                      | In reset | In reset                           | Saved                                   | Saved                                   | Saved                       |
| ICIER                                      | In reset | In reset                           | Saved                                   | Saved                                   | Saved                       |
| ICSR1                                      | In reset | In reset                           | In reset                                | Saved                                   | In reset                    |
| ICSR2                                      | TEND     | In reset                           | In reset                                | In reset                                | In reset                    |
|  | TDRE     |                                    |   | Set or saved                            |                             |
|  | START    |                                    |   | Set                                     |                             |
|  | STOP     |                                    |   | Saved                                   | Set                         |
|  | Others   |                                    |   | Saved                                   | Saved                       |
| ICWUR                                      | In reset | In reset                           | Saved                                   | Saved                                   | Saved                       |
| SARL0, SARL1, SARL2<br>SARU0, SARU1, SARU2 | In reset | In reset                           | Saved                                   | Saved                                   | Saved                       |
| ICBRH, ICBRL                               | In reset | In reset                           | Saved                                   | Saved                                   | Saved                       |
| ICDRT                                      | In reset | In reset                           | Saved                                   | Saved                                   | Saved                       |
| ICDRR                                      | In reset | In reset                           | Saved                                   | Saved                                   | Saved                       |
| ICDRS                                      | In reset | In reset                           | In reset                                | Saved                                   | Saved                       |
| Timeout function                           | In reset | In reset                           | In reset                                | Operating                               | Operating                   |
| Bus free time measurement                  | In reset | In reset                           | Operating                               | Operating                               | Operating                   |
| ICWUR2                                     | WUSEN    | In reset                           | In reset                                | Saved                                   | Saved                       |
|  | Others   |                                    |   |   | Saved or set or reset       |

## 28.16 Event Link Output

The IIC0 module handles the event output for the Event Link Controller (ELC) for the following sources:

### (1) Transfer error event

When a transfer error event occurs, the associated event signal can be output to another module by the ELC.

### (2) Receive data full

When a receive data register becomes full, the associated event signal can be output to another module by the ELC.

### (3) Transmit data empty

When a transmit data register becomes empty, the associated event signal can be output to another module by the ELC.

### (4) Transmit end

On completion of the transfer, the associated event signal can be output to another module by the ELC.

## 28.16.1 Interrupt Handling and Event Linking

Each of the IIC interrupt types (see Table 28.10) has an enable bit to control enabling and disabling of the associated interrupt signal. An interrupt request signal is output to the CPU when an interrupt source condition is satisfied while the associated enable bit is set.

Table 28.11 发布每个条件时注册状态 (2个中的2个)

| Registers                                  | Reset   | IIC reset<br>(ICE = 0, IICRST = 1) | 内部复位 (ICE=1, IICRST=1) | 启动或重启条件检测 | 停止条件检测    |
|--|---------|------------------------------------|------------------------|-----------|-----------|
| ICMR1                                      | BC[2:0] | 复位中                                | 复位中                    | 复位中       | Saved     |
|  | Others  |                                    |                        | Saved     | Saved     |
| ICMR2                                      | 复位中     | 复位中                                | Saved                  | Saved     | Saved     |
| ICMR3                                      | ACKBT   | 复位中                                | 复位中                    | Saved     | 复位中       |
|  | Others  |                                    |                        |           | Saved     |
| ICFER                                      | 复位中     | 复位中                                | Saved                  | Saved     | Saved     |
| ICSER                                      | 复位中     | 复位中                                | Saved                  | Saved     | Saved     |
| ICIER                                      | 复位中     | 复位中                                | Saved                  | Saved     | Saved     |
| ICSR1                                      | 复位中     | 复位中                                | 复位中                    | Saved     | 复位中       |
| ICSR2                                      | TEND    | 复位中                                | 复位中                    | 复位中       | 复位中       |
|  | TDRE    |                                    |                        | 设置或保存     |           |
|  | START   |                                    |                        | Set       |           |
|  | STOP    |                                    |                        | Saved     | Set       |
|  | Others  |                                    |                        | Saved     | Saved     |
| ICWUR                                      | 复位中     | 复位中                                | Saved                  | Saved     | Saved     |
| SARL0, SARL1, SARL2<br>SARU0, SARU1, SARU2 | 复位中     | 复位中                                | Saved                  | Saved     | Saved     |
| ICBRH, ICBRL                               | 复位中     | 复位中                                | Saved                  | Saved     | Saved     |
| ICDRT                                      | 复位中     | 复位中                                | Saved                  | Saved     | Saved     |
| ICDRR                                      | 复位中     | 复位中                                | Saved                  | Saved     | Saved     |
| ICDRS                                      | 复位中     | 复位中                                | 复位中                    | Saved     | Saved     |
| 超时功能                                       | 复位中     | 复位中                                | 复位中                    | Operating | Operating |
| 公交车空闲时间测量                                  | 复位中     | 复位中                                | Operating              | Operating | Operating |
| ICWUR2                                     | WUSEN   | 复位中                                | 复位中                    | Saved     | Saved     |
|  | Others  |                                    |                        |           | 保存或设置或重置  |

## 28.16 事件链接输出

IIC0模块为以下源处理事件链接控制器(ELC)的事件输出:

### (1) 传输错误事件

当发生传输错误事件时, ELC可以将相关事件信号输出到另一个模块。

### (2) 接收数据已满

当接收数据寄存器变满时, ELC可以将相关的事件信号输出到另一个模块。

### (3) 传输数据为空

当发送数据寄存器变为空时, ELC可以将相关的事件信号输出到另一个模块。

### (4) 发射端

传输完成后, ELC可以将相关的事件信号输出到另一个模块。

## 28.16.1 中断处理和事件链接

每种IIC中断类型(见表28.10)都有一个启用位来控制相关中断信号的启用和禁用。当相关的使能位设置时, 中断源条件成立时, 将向CPU输出中断请求信号。

The associated event link output signals are sent to other modules as event signals by the ELC when the interrupt source conditions are satisfied, regardless of the interrupt enable bit settings. For details on interrupt sources, see [Table 28.10](#).

## 28.17 Usage Notes

### 28.17.1 Settings for the Module-Stop Function

The Module Stop Control Register B (MSTPCRB) can enable or disable IIC operation. The IIC is initially stopped after reset. Releasing the module-stop state enables access to the registers. For details, see [section 10, Low Power Modes](#).

### 28.17.2 Notes on Starting Transfer

If the IR flag associated with the IIC interrupt is 1 when transfer is started (ICCR1.ICE bit = 1), follow the procedure in this section to clear the interrupts before enabling operations. Starting transfer with the IR flag set to 1 while the ICCR1.ICE bit is 1 leads to an interrupt request being internally saved after transfer starts, and this can lead to unexpected behavior of the IR flag.

To clear interrupts before starting transfer operation:

1. Confirm that the ICCR1.ICE bit is 0.
2. Set the relevant interrupt enable bits, such as ICIER.TIE to 0.
3. Read the relevant interrupt enable bits, such as ICIER.TIE, and confirm that the value is 0.
4. Set the IR flag to 0.

当满足中断源条件时，ELC将关联的事件链接输出信号作为事件信号发送到其他模块，而不管中断使能位设置如何。有关中断源的详细信息，请参见表28.10。

## 28.17 使用说明

### 28.17.1 模块停止功能的设置

模块停止控制寄存器B(MSTPCRB)可以启用或禁用IIC操作。IIC在复位后最初停止。释放模块停止状态可以访问寄存器。有关详细信息，请参阅第10节，低功耗模式。

### 28.17.2 开始转移注意事项

如果在传输开始时与IIC中断相关的IR标志为1（ICCR1.ICE位=1），请按照本节中的步骤在使能操作之前清除中断。在ICCR1.ICE位为1时将IR标志设置为1开始传输会导致在传输开始后内部保存中断请求，这可能导致IR标志的意外行为。

在开始传输操作之前清除中断：

- 1.确认ICCR1.ICE位为0。
- 2.设置相关的中断使能位，如ICIER.TIE为0。
- 3、读取相关的中断使能位，如ICIER.TIE，确认值为0。
- 4.将IR标志设置为0。



## 29. Controller Area Network (CAN) Module

### 29.1 Overview

The Controller Area Network (CAN) module uses a message-based protocol to receive and transmit data between multiple slaves and masters in electromagnetically noisy applications. The module complies with the ISO 11898-1 (CAN 2.0A/CAN 2.0B) standard and supports up to 32 mailboxes, which can be configured for transmission or reception in normal mailbox and FIFO modes. Both standard (11-bit) and extended (29-bit) messaging formats are supported. The CAN module requires an additional external CAN transceiver.

Table 29.1 lists the CAN specifications and Figure 29.1 shows a block diagram.

**Table 29.1 CAN specifications (1 of 2)**

| Parameter                            | Specifications   |
|--------------------------------------|--|
| Data transfer rate                   | ISO11898-1-compliant for standard and extended frames  |
| Bit rate                             | Data transfer rate programmable up to 1 Mbps (fCAN ≥ 8 MHz)<br>fCAN: CAN clock source  |
| Message box                          | 32 mailboxes, with two selectable mailbox modes <ul style="list-style-type: none"> <li>Normal mode: 32 mailboxes independently configurable for either transmission or reception</li> <li>FIFO mode: 24 mailboxes independently configurable for either transmission or reception, with remaining mailboxes used for receive (RX) and transmit (TX) 4-stage FIFOs</li> </ul>   |
| Reception                            | <ul style="list-style-type: none"> <li>Support for data frame and remote frame reception</li> <li>Reception ID format selectable to only standard ID, only extended ID, or mixed IDs</li> <li>Programmable one-shot reception function</li> <li>Selectable between overwrite mode (unread message overwritten) and overrun mode (unread message saved)</li> <li>Reception complete interrupt independently enabled or disabled for each mailbox</li> </ul>   |
| Acceptance filter                    | <ul style="list-style-type: none"> <li>Eight acceptance masks (one for every four mailboxes)</li> <li>Masks independently enabled or disabled for each mailbox</li> </ul>  |
| Transmission                         | <ul style="list-style-type: none"> <li>Support for data frame and remote frame transmission</li> <li>Transmission ID format selectable to only standard ID, only extended ID, or mixed IDs</li> <li>Programmable one-shot transmission function</li> <li>Broadcast messaging function</li> <li>Priority mode selectable based on message ID or mailbox number</li> <li>Support for transmission request abort, with abort completion confirmed in status flag</li> <li>Transmission complete interrupt independently enabled or disabled for each mailbox</li> </ul> |
| Mode transition for bus-off recovery | Mode transition for the recovery from the bus-off state selectable to: <ul style="list-style-type: none"> <li>ISO11898-1 specification-compliant</li> <li>Automatic invoking of CAN halt mode on bus-off entry</li> <li>Automatic invoking of CAN halt mode on bus-off end</li> <li>Invoking of CAN halt mode through the software</li> <li>Transition to error-active state through the software</li> </ul>   |
| Error status monitoring              | <ul style="list-style-type: none"> <li>Monitoring of CAN bus errors, including stuff error, form error, ACK error, 15-bit CRC error, bit error, and ACK delimiter error</li> <li>Detection of transition to error states, including error-warning, error-passive, bus-off entry, and bus-off recovery</li> <li>Supports reading of error counters</li> </ul>   |
| Time stamping                        | <ul style="list-style-type: none"> <li>Time stamp function using a 16-bit counter</li> <li>Reference clock selectable to 1-bit, 2-bit, 4-bit, and 8-bit time periods</li> </ul>  |
| Interrupt function                   | Support for five interrupt sources: <ul style="list-style-type: none"> <li>Reception complete</li> <li>Transmission complete</li> <li>Receive FIFO</li> <li>Transmit FIFO</li> <li>Error interrupts</li> </ul>   |
| CAN sleep mode                       | CAN clock stopped to reduce power consumption  |

## 29. 控制器局域网(CAN)模块

### 29.1 Overview

控制器局域网(CAN)模块使用基于消息的协议在电磁噪声应用中的多个从机和主机之间接收和传输数据。该模块符合ISO11898-1(CAN2.0A/CAN2.0B)标准,最多支持32个邮箱,可配置为普通邮箱和FIFO模式下的发送或接收。支持标准(11位)和扩展(29位)消息格式。CAN模块需要额外的外部CAN收发器。

表29.1列出了CAN规范,图29.1显示了框图。

**Table 29.1 CAN规格(1of2)**

| Parameter    | Specifications  |
|--------------|---|
| 数据传输率        | 标准和扩展框架符合ISO11898-1   |
| 比特率          | 数据传输速率可编程高达1Mbps(fCAN≥8MHz)fCAN: CAN时钟源   |
| 消息框          | 32个邮箱,两种邮箱模式可选● <ul style="list-style-type: none"> <li>正常模式: 32个邮箱可独立配置用于发送或接收</li> <li>FIFO模式: 24个邮箱可独立配置用于发送或接收,其余邮箱用于接收(RX)和发送(TX)4级FIFO</li> </ul>  |
| Reception    | <ul style="list-style-type: none"> <li>支持数据帧和远程帧接收</li> <li>接收ID格式可选择仅标准ID、仅扩展ID或混合ID</li> <li>可编程一次性接收功能</li> <li>在覆盖模式(覆盖未读消息)和溢出模式(保存未读消息)之间选择</li> </ul> <ul style="list-style-type: none"> <li>为每个邮箱独立启用或禁用接收完成中断</li> </ul> |
| 验收过滤器        | <ul style="list-style-type: none"> <li>八个接受面具(每四个邮箱一个)</li> <li>为每个邮箱独立启用或禁用掩码</li> </ul>   |
| Transmission | <ul style="list-style-type: none"> <li>支持数据帧和远程帧传输</li> <li>传输ID格式可选择仅标准ID、仅扩展ID或混合ID</li> <li>可编程一次性传输功能</li> <li>广播消息功能</li> <li>可根据消息ID或邮箱号码选择优先模式</li> <li>支持传输请求中止,在状态标志中确认中止完成</li> <li>为每个邮箱独立启用或禁用传输完成中断</li> </ul>       |
| 总线关闭恢复的模式转换  | 从总线关闭状态恢复的模式转换可选择: ● <ul style="list-style-type: none"> <li>在总线关闭进入时自动调用CAN停止模式</li> <li>总线关闭端自动调用CAN停机模式</li> <li>通过软件调用CAN停机模式</li> <li>通过软件转换到错误激活状态</li> </ul>  |
| 错误状态监控       | <ul style="list-style-type: none"> <li>监控CAN总线错误,包括填充错误、格式错误、ACK错误、15位CRC错误、位错误和ACK分隔符错误</li> <li>检测到错误状态的转换,包括错误警告、错误被动、总线关闭进入和总线关闭恢复</li> <li>支持读取错误计数器</li> </ul>  |
| 时间戳          | <ul style="list-style-type: none"> <li>使用16位计数器的时间戳功能</li> <li>可选择1位、2位、4位和8位时间周期的参考时钟</li> </ul>   |
| 中断功能         | 支持五个中断源: ● <ul style="list-style-type: none"> <li>接待完成</li> <li>传输完成</li> <li>Receive FIFO</li> <li>Transmit FIFO</li> <li>错误中断</li> </ul>  |
| CAN睡眠模式      | CAN时钟停止以降低功耗  |

Table 29.1 CAN specifications (2 of 2)

| Parameter             | Specifications  |
|-----------------------|---|
| Software support unit | Three software support units: <ul style="list-style-type: none"> <li>● Acceptance filter support</li> <li>● Mailbox search support, including receive mailbox search, transmit mailbox search, and message lost search</li> <li>● Channel search support</li> </ul> |
| CAN clock source      | CANMCLK or PCLKB  |
| Test mode             | Three test modes available for evaluation purposes: <ul style="list-style-type: none"> <li>● Listen-only mode</li> <li>● Self-test mode 0 (external loopback)</li> <li>● Self-test mode 1 (internal loopback)</li> </ul>  |
| TrustZone Filte       | Security attribution can be set   |

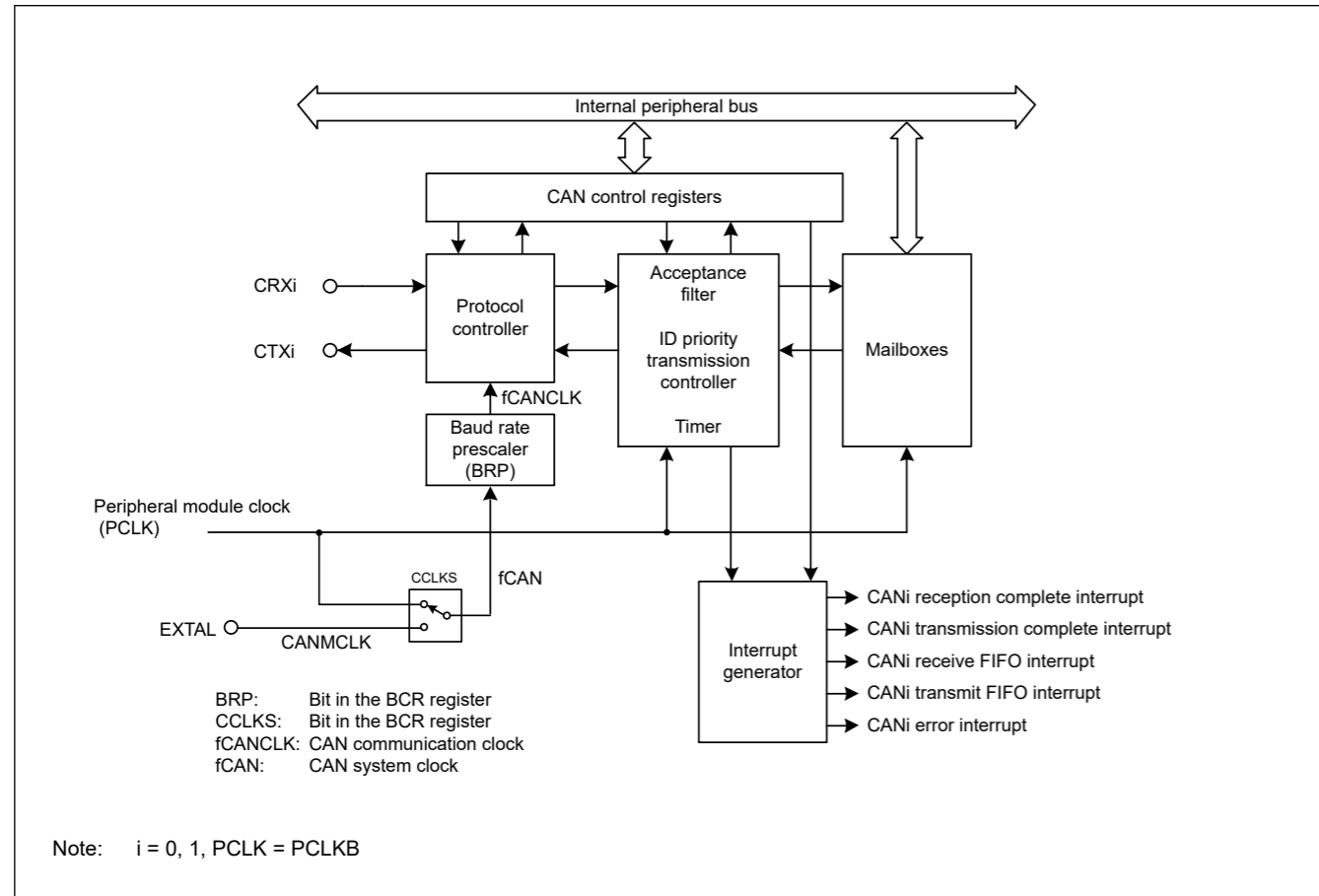


Figure 29.1 CAN module block diagram

The CAN module includes the following blocks:

- CAN input and output pins  
CRXi and CTXi (i = 0, 1)
- Protocol controller  
Handles CAN protocol processing such as bus arbitration, bit timing during transmission and reception, stuffing, and error handling.
- Mailboxes  
Consists of 32 mailboxes, which can be configured as either transmit or receive. Each mailbox has an individual ID, data length code (DLC), data field (8 bytes), and a time stamp.

Table 29.1 CAN规格 (2个中的2个)

| Parameter       | Specifications  |
|-----------------|---|
| 软件支持单位          | 三个软件支持单元: ●<br>接受过滤器支持<br>● 邮箱搜索支持, 包括接收邮箱搜索、发送邮箱搜索、邮件丢失搜索<br>● 频道搜索支持                                |
| CAN时钟源          | CANMCLK or PCLKB  |
| 测试模式            | 三种可用于评估目的的测试模式: ●<br>● Self-test mode 0 (external loopback)<br>● Self-test mode 1 (internal loopback) |
| TrustZone Filte | 可设置安全属性   |

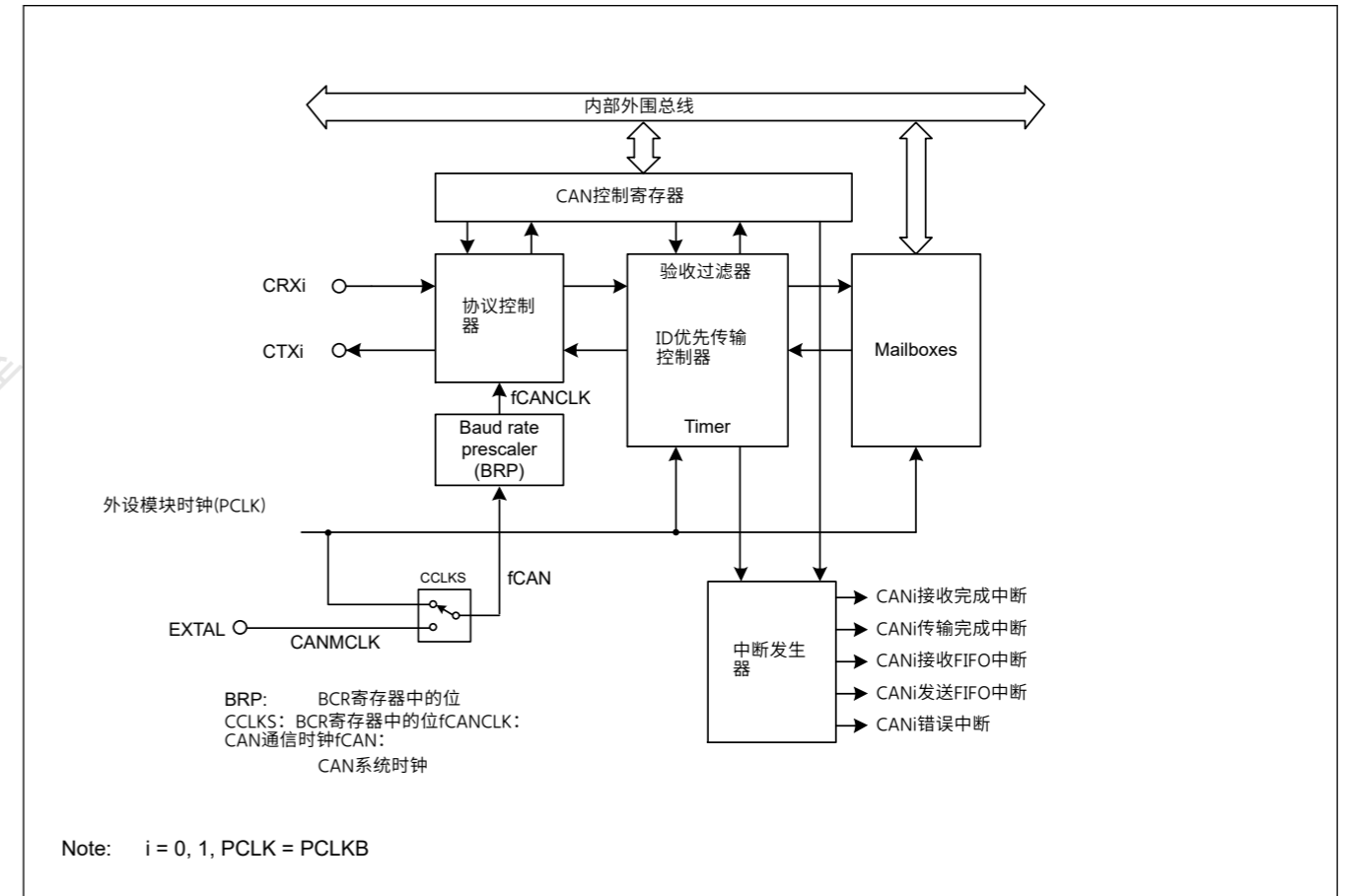


Figure 29.1 CAN模块框图

CAN模块包括以下模块:

- CAN输入输出引脚  
CRXi and CTXi (i = 0, 1)
- 协议控制器  
处理CAN协议处理, 例如总线仲裁、发送和接收期间的位时序、填充和错误处理。
- Mailboxes  
包含32个邮箱, 可配置为发送或接收。每个邮箱都有一个单独的ID、数据长度代码(DLC)、数据字段 (8个字节) 和一个时间戳。

- Acceptance filter  
Performs filtering of received messages. MKR0 to MKR7 are used for the filtering process.
- Timer  
Used for the time stamp function. The timer value when a message is stored in the mailbox is written as the time stamp value.
- Interrupt generator for five types of interrupts:
  - CANi reception complete interrupt
  - CANi transmission complete interrupt
  - CANi receive FIFO interrupt
  - CANi transmit FIFO interrupt
  - CANi error interrupt

Table 29.2 lists the CAN module pins. These pins are multiplexed with other signals on the MCU. For details, see section 19, I/O Ports.

Table 29.2 CAN module I/O pins (i = 0, 1)

| Pin name | I/O    | Function      |
|----------|--------|---------------|
| CRXi     | Input  | Data receive  |
| CTXi     | Output | Data transmit |

## 29.2 Register Descriptions

### 29.2.1 CTLR : Control Register

Base address: CANn = 0x400A\_8000 + 0x1000 × n (n = 0, 1)

Offset address: 0x840

|                    |    |    |      |          |      |           |           |      |     |     |           |     |   |   |   |   |
|--------------------|----|----|------|----------|------|-----------|-----------|------|-----|-----|-----------|-----|---|---|---|---|
| Bit position:      | 15 | 14 | 13   | 12       | 11   | 10        | 9         | 8    | 7   | 6   | 5         | 4   | 3 | 2 | 1 | 0 |
| Bit field:         | —  | —  | RBOC | BOM[1:0] | SLPM | CANM[1:0] | TSPS[1:0] | TSRC | TPM | MLM | IDFM[1:0] | MBM |   |   |   |   |
| Value after reset: | 0  | 0  | 0    | 0        | 0    | 1         | 0         | 1    | 0   | 0   | 0         | 0   | 0 | 0 | 0 | 0 |

| Bit | Symbol    | Function  | R/W |
|-----|-----------|---|-----|
| 0   | MBM       | CAN Mailbox Mode Select*1<br>0: Normal mailbox mode<br>1: FIFO mailbox mode   | R/W |
| 2:1 | IDFM[1:0] | ID Format Mode Select*1<br>00: Standard ID mode<br>All mailboxes, including FIFO mailboxes, handle only standard IDs<br>01: Extended ID mode<br>All mailboxes, including FIFO mailboxes, handle only extended IDs<br>10: Mixed ID mode<br>All mailboxes, including FIFO mailboxes, handle both standard and extended IDs. In normal mailbox mode, use the associated IDE bit to differentiate standard and extended IDs. In FIFO mailbox mode, the associated IDE bits are used for mailboxes 0 to 23, the IDE bits in FIDCR0 and FIDCR1 are used for the receive FIFO, and the IDE bit associated with mailbox 24 is used for the transmit FIFO.<br>11: Setting prohibited | R/W |
| 3   | MLM       | Message Lost Mode Select*1<br>0: Overwrite mode<br>1: Overrun mode  | R/W |

- 验收过滤器  
对收到的消息执行过滤。MKR0到MKR7用于过滤过程。
- Timer  
用于时间戳功能。将消息存储在邮箱中的计时器值作为时间戳值写入。
- 用于五种中断的中断发生器:
  - CANi接收完成中断
  - CANi传输完成中断
  - CANi接收FIFO中断
  - CANi发送FIFO中断
  - CANi错误中断

表29.2列出了CAN模块引脚。这些引脚与MCU上的其他信号复用。有关详细信息，请参阅第19节，IO端口。

Table 29.2 CAN模块IO引脚(i=0 1)

| 引脚名称 | I/O    | Function |
|------|--------|----------|
| CRXi | Input  | 数据接收     |
| CTXi | Output | 数据传输     |

## 29.2 注册说明

### 29.2.1 CTLR:控制寄存器

Base address: CANn = 0x400A\_8000 + 0x1000 × n (n = 0, 1)

Offset address: 0x840

|               |    |    |      |          |      |           |           |      |     |     |           |     |   |   |   |   |
|---------------|----|----|------|----------|------|-----------|-----------|------|-----|-----|-----------|-----|---|---|---|---|
| Bit position: | 15 | 14 | 13   | 12       | 11   | 10        | 9         | 8    | 7   | 6   | 5         | 4   | 3 | 2 | 1 | 0 |
| Bit field:    | —  | —  | RBOC | BOM[1:0] | SLPM | CANM[1:0] | TSPS[1:0] | TSRC | TPM | MLM | IDFM[1:0] | MBM |   |   |   |   |
| 重置后的值:        | 0  | 0  | 0    | 0        | 0    | 1         | 0         | 1    | 0   | 0   | 0         | 0   | 0 | 0 | 0 | 0 |

| Bit | Symbol    | Function   | R/W |
|-----|-----------|--|-----|
| 0   | MBM       | CAN邮箱模式选择*1<br>0: 普通邮箱模式1: FIFO邮箱模式  | R/W |
| 2:1 | IDFM[1:0] | ID格式模式选择*1<br>00: 标准ID模式<br>所有邮箱，包括FIFO邮箱，只处理标准ID<br>01: 扩展ID模式<br>所有邮箱，包括FIFO邮箱，只处理扩展ID<br>10: 混合ID模式<br>所有邮箱，包括FIFO邮箱，都处理标准ID和扩展ID。在普通邮箱模式下，使用相关的IDE位来区分标准ID和扩展ID。在FIFO邮箱模式下，相关的IDE位用于邮箱0到23，FIDCR0和FIDCR1中的IDE位用于接收FIFO，与邮箱24相关的IDE位用于发送FIFO。<br>11: 禁止设定 | R/W |
| 3   | MLM       | 信息丢失模式选择*1<br>0: 覆盖模式1: 溢出模式   | R/W |

| Bit   | Symbol    | Function   | R/W |
|-------|-----------|--|-----|
| 4     | TPM       | Transmission Priority Mode Select*1<br>0: ID priority transmit mode<br>1: Mailbox number priority transmit mode  | R/W |
| 5     | TSRC      | Time Stamp Counter Reset Command*4<br>0: Do not reset time stamp counter<br>1: Reset time stamp counter*3  | R/W |
| 7:6   | TSPS[1:0] | Time Stamp Prescaler Select*1<br>00: Every 1-bit time<br>01: Every 2-bit time<br>10: Every 4-bit time<br>11: Every 8-bit time  | R/W |
| 9:8   | CANM[1:0] | CAN Operating Mode Select*5<br>00: CAN operation mode<br>01: CAN reset mode<br>10: CAN halt mode<br>11: CAN reset mode (forced transition)   | R/W |
| 10    | SLPM      | CAN Sleep Mode*5 *6<br>0: All other modes<br>1: CAN sleep mode   | R/W |
| 12:11 | BOM[1:0]  | Bus-Off Recovery Mode*1<br>00: Normal mode (ISO11898-1-compliant)<br>01: Enter CAN halt mode automatically on entering bus-off state<br>10: Enter CAN halt mode automatically at the end of bus-off state<br>11: Enter CAN halt mode during bus-off recovery period through a software request | R/W |
| 13    | RBOC      | Forcible Return from Bus-Off*2<br>0: No return occurred<br>1: Forced return from bus-off state*3   | R/W |
| 15:14 | —         | These bits are read as 0. The write value should be 0.   | R/W |

Note 1. Write to the BOM[1:0], TSPS[1:0], TPM, MLM, IDFM[1:0], and MBM bits in CAN reset mode.

Note 2. Set the RBOC bit to 1 in the bus-off state.

Note 3. This bit is automatically set to 0 after being set to 1. It should read as 0.

Note 4. Set the TSRC bit to 1 in CAN operation mode.

Note 5. When the CANM[1:0] and SLPM bits are changed, check STR to ensure that the mode is switched. Do not change the CANM[1:0] bits or SLPM bit until the mode is switched.

Note 6. Write to the SLPM bit in CAN reset mode or CAN halt mode. When changing the SLPM bit, write 0 or 1 only to the SLPM bit.

#### MBM bit (CAN Mailbox Mode Select)

When the MBM bit is 0 (normal mailbox mode), mailboxes 0 to 31 are configured as transmit or receive mailboxes. When the MBM bit is 1 (FIFO mailbox mode):

- Mailboxes 0 to 23 are configured as transmit or receive mailboxes
- Mailboxes 24 to 27 are configured as transmit FIFO
- Mailboxes 28 to 31 are configured as receive FIFO

Transmit data is written into mailbox 24, a window mailbox for the transmit FIFO. Receive data is read from mailbox 28, a window mailbox for the receive FIFO.

Table 29.3 lists the mailbox configuration.

#### IDFM[1:0] bits (ID Format Mode Select)

The IDFM[1:0] bits specify the ID format.

#### MLM bit (Message Lost Mode Select)

The MLM bit specifies the operation when a new message is captured in an unread mailbox. Overwrite mode or overrun mode can be selected. In both cases, the mode applies to all mailboxes, including the receive FIFO.

When the MLM bit is 0, all mailboxes are set to overwrite mode. Any new message received overwrites the pre-existing message.

| Bit   | Symbol    | Function   | R/W |
|-------|-----------|--|-----|
| 4     | TPM       | 传输优先模式选择*1<br>0: ID优先传输模式1: 邮箱号码优先传输模式   | R/W |
| 5     | TSRC      | 时间戳计数器复位命令*4<br>0: 不复位时间戳计数器1: 复位时间戳计数器*3  | R/W |
| 7:6   | TSPS[1:0] | 时间戳预分频器选择*1<br>00: 每1位时间01: 每2位时间10: 每4位时间11: 每8位时间  | R/W |
| 9:8   | CANM[1:0] | CAN操作模式选择*5<br>00: CAN操作模式01: CAN复位模式10: CAN暂停模式11: CAN复位模式(强制转换)  | R/W |
| 10    | SLPM      | CAN睡眠模式*5*6<br>0: 所有其他模式1: CAN睡眠模式   | R/W |
| 12:11 | BOM[1:0]  | 总线关闭恢复模式*1<br>00: 正常模式(符合ISO11898-1) 01: 进入总线关闭状态时自动进入CAN停止模式1<br>0: 在总线关闭状态结束时自动进入CAN停止模式11: 在总线关闭状态下自动进入CAN停止模式通过软件请求的总线关闭恢复 | R/W |
| 13    | RBOC      | Bus-Off强制返回*2<br>0: 未发生返回1: 从总线关闭状态强制返回*3  | R/W |
| 15:14 | —         | 这些位被读取为0。写入值应为0。   | R/W |

注1.在CAN复位模式下写入BOM[1:0]、TSPS[1:0]、TPM、MLM、IDFM[1:0]和MBM位。

注2.在总线关闭状态下将RBOC位设置为1。

注3.该位设置为1后自动设置为0，应读为0。

注4.在CAN操作模式下，将TSRC位设置为1。

注5.当CANM[1:0]和SLPM位改变时，检查STR以确保模式切换。在切换模式之前不要更改CANM[1:0]位或SLPM位。

注6.在CAN复位模式或CAN暂停模式下写入SLPM位。更改SLPM位时，仅向SLPM位写入0或1。

#### MBM位 (CAN邮箱模式选择)

当MBM位为0 (正常邮箱模式) 时，邮箱0到31被配置为发送或接收邮箱。当MBM位为1 (FIFO邮箱模式) 时:

- 邮箱0到23被配置为发送或接收邮箱
- 邮箱24到27被配置为发送FIFO
- 邮箱28到31配置为接收FIFO

发送数据写入邮箱24，这是发送FIFO的窗口邮箱。接收数据从邮箱28中读取，该邮箱是接收FIFO的窗口邮箱。

表29.3列出了邮箱配置。

#### IDFM[1:0]位 (ID格式模式选择)

IDFM[1:0]位指定ID格式。

#### MLM位 (消息丢失模式选择)

MLM位指定在未读邮箱中捕获新消息时的操作。可以选择覆盖模式或溢出模式。在这两种情况下，该模式都适用于所有邮箱，包括接收FIFO。

当MLM位为0时，所有邮箱都设置为覆盖模式。收到的任何新消息都会覆盖先前存在的消息。



When the MLM bit is 1, all mailboxes are set to overrun mode. Any new message received does not overwrite the preexisting message, and it is discarded.

#### TPM bit (Transmission Priority Mode Select)

The TPM bit specifies the priority when transmitting messages. ID priority transmit mode or mailbox number transmit mode can be selected. All mailboxes are set for either ID priority transmission or mailbox number priority transmission.

When TPM is 0, ID priority transmit mode is selected and transmission priority is arbitrated as defined in the ISO11898-1 CAN specification. In ID priority transmit mode, mailboxes 0 to 31 (in normal mailbox mode), and mailboxes 0 to 23 (in FIFO mailbox mode), and the transmit FIFO are compared for the IDs of mailboxes configured for transmission. If two or more mailbox IDs are the same, the mailbox with the smaller number has higher priority.

Only the next message to be transmitted from the transmit FIFO is included in the transmission arbitration. If a FIFO message is being transmitted, the next pending message within the transmit FIFO is included in the transmission arbitration.

When TPM is 1, mailbox number transmit mode is selected and the transmit mailbox with the smallest mailbox number has the highest priority. In FIFO mailbox mode, the transmit FIFO has lower priority than normal mailboxes (0 to 23).

#### TSRC bit (Time Stamp Counter Reset Command)

The TSRC bit resets the time stamp counter. When it is set to 1, TSR is set to 0x0000. TSRC is set to 0 automatically.

#### TSPS[1:0] bits (Time Stamp Prescaler Select)

The TSPS[1:0] bits select the prescaler for the time stamp. The reference clock for the time stamp can be selected to 1-bit, 2-bit, 4-bit, or 8-bit time periods.

#### CANM[1:0] bits (CAN Operating Mode Select)

The CANM[1:0] bits select one of the following modes for the CAN module:

- CAN operation mode
- CAN reset mode
- CAN halt mode

The CAN sleep mode is set in the SLPM bit. For details, see [section 29.3. Operation Modes](#).

When the CAN module enters CAN halt mode based on the BOM[1:0] setting, the CANM[1:0] bits are automatically set to 10b.

#### SLPM bit (CAN Sleep Mode)

When the SLPM bit is set to 1, the CAN module enters CAN sleep mode. When the SLPM bit is set to 0, the CAN module exits CAN sleep mode. For details, see [section 29.3. Operation Modes](#).

#### BOM[1:0] bits (Bus-Off Recovery Mode)

The BOM[1:0] bits select bus-off recovery mode for the CAN module.

When the BOM[1:0] bits are 00b, the recovery from bus-off is compliant with the ISO11898-1 CAN specification. The CAN module recovers CAN communication (error-active state) after detecting 11 consecutive recessive bits 128 times. A bus-off recovery interrupt request occurs when recovering from bus-off.

When the BOM[1:0] bits are 01b and the CAN module reaches the bus-off state, the CANM[1:0] bits in CTRLR are set to 10b to enter CAN halt mode. No bus-off recovery interrupt request occurs when recovering from bus-off, and TECR and RECR are set to 0x00.

When the BOM[1:0] bits are 10b, the CANM[1:0] bits are set to 10b as soon as the CAN module reaches the bus-off state. The CAN module enters CAN halt mode after the recovery from the bus-off state, and after detecting 11 consecutive recessive bits 128 times. A bus-off recovery interrupt request occurs when recovering from bus-off, and TECR and RECR are set to 0x00.

When the BOM[1:0] bits are 11b, the CAN module enters CAN halt mode by setting the CANM[1:0] bits to 10b while the CAN module is still in the bus-off state. No bus-off recovery interrupt request occurs when recovering from bus-off, and TECR and RECR are set to 0x00. However, if the CAN module recovers from bus-off after detecting 11 consecutive recessive bits 128 times before the CANM[1:0] bits are set to 10b, a bus-off recovery interrupt request is generated.

当MLM位为1时，所有邮箱都设置为溢出模式。收到的任何新消息都不会覆盖先前存在的消息，并且会被丢弃。

#### TPM位 (传输优先模式选择)

TPM位指定传输消息时的优先级。可选择ID优先传输模式或邮箱号码传输模式。所有信箱都设置为ID优先传输或信箱号码优先传输。

当TPM为0时，选择ID优先传输模式，传输优先级按照ISO11898-1CAN规范中的定义进行仲裁。在ID优先传输模式下，邮箱0到31（在普通邮箱模式下）和邮箱0到23（在FIFO邮箱模式下）和传输FIFO会针对配置为传输的邮箱ID进行比较。如果两个或多个邮箱ID相同，则编号较小的邮箱优先级较高。

只有从发送FIFO发送的下一条消息包含在发送仲裁中。如果正在发送FIFO消息，则发送FIFO中的下一个待处理消息将包含在发送仲裁中。

当TPM为1时，选择邮箱号发送模式，邮箱号最小的发送邮箱优先级最高。在FIFO邮箱模式下，发送FIFO的优先级低于普通邮箱（0到23）。

#### TSRC位 (时间戳计数器复位命令)

TSRC位复位时间戳计数器。当它设置为1时，TSR设置为0x0000。TSRC自动设置为0。

#### TSPS[1:0]位 (时间戳预分频器选择)

TSPS[1:0]位选择时间戳的预分频器。时间戳的参考时钟可以选择为1位、2位、4位或8位时间段。

#### CANM[1:0]位 (CAN操作模式选择)

CANM[1:0]位为CAN模块选择以下模式之一：

- CAN操作模式
- CAN复位模式
- CAN停机模式

CAN睡眠模式在SLPM位中设置。有关详细信息，请参阅第29.3节。操作模式。

当CAN模块根据BOM[1:0]设置进入CAN暂停模式时，CANM[1:0]位自动设置为10b。

#### SLPM位 (CAN休眠模式)

当SLPM位设置为1时，CAN模块进入CAN睡眠模式。当SLPM位设置为0时，CAN模块退出CAN睡眠模式。有关详细信息，请参阅第29.3节。操作模式。

#### BOM[1:0]位 (总线关闭恢复模式)

BOM[1:0]位选择CAN模块的总线关闭恢复模式。

当BOM[1:0]位为00b时，总线关闭恢复符合ISO11898-1CAN规范。这CAN模块在检测到11个连续隐性位128次后恢复CAN通信（错误激活状态）。从总线关闭中恢复时会出现总线关闭恢复中断请求。

当BOM[1:0]位为01b且CAN模块达到总线关闭状态时，CTRLR中的CANM[1:0]位设置为10b以进入CAN停止模式。总线关闭恢复时不产生总线关闭恢复中断请求，TECR和RECR设置为0x00。

当BOM[1:0]位为10b时，CAN模块一到达总线关闭状态，CANM[1:0]位就会设置为10b。CAN模块从总线关闭状态恢复后，并在检测到11个连续的隐性位128次后进入CAN停止模式。从总线关闭恢复时产生总线关闭恢复中断请求，TECR和RECR设置为0x00。

当BOM[1:0]位为11b时，CAN模块通过将CANM[1:0]位设置为10b进入CAN暂停模式，而CAN模块仍处于总线关闭状态。从总线关闭恢复时没有总线关闭恢复中断请求发生，并且TECR和RECR设置为0x00。但是，如果CAN模块在CANM[1:0]位设置为10b之前128次检测到11个连续隐性位后从总线关闭中恢复，则会产生总线关闭恢复中断请求。

If the CPU requests an entry to CAN reset mode at the same time as the CAN module attempts to enter CAN halt mode (at bus-off entry when the BOM[1:0] bits are 01b, or at bus-off end when the BOM[1:0] bits are 10b), then the CPU request has higher priority.

**RBOC bit (Forcible Return from Bus-Off)**

When the RBOC bit is set to 1 in the bus-off state, the CAN module forcibly exits the bus-off state. It is set to 0 automatically, and the error state changes from bus-off to error-active. When the RBOC bit is set to 1, RECR and TECR are set to 0x00 and the BOST bit in STR is set to 0, indicating that the CAN module is not in bus-off state. The other registers remain unchanged when RBOC is set to 1. No bus-off recovery interrupt request occurs by this recovery from the bus-off state. Use the RBOC bit only when the BOM[1:0] bits are 00b (normal mode).

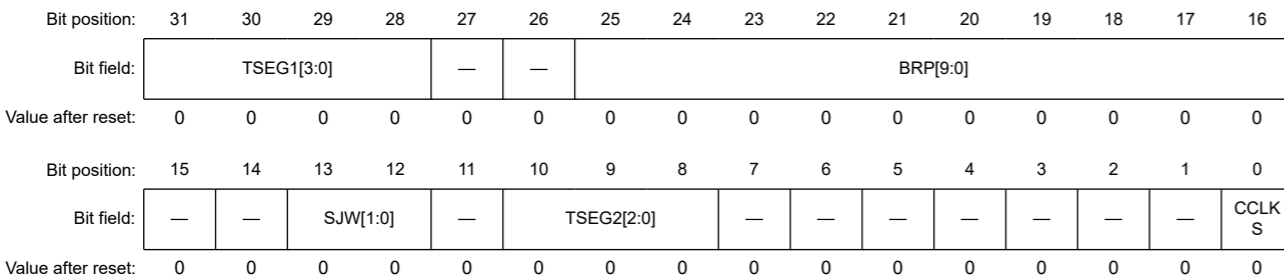
**Table 29.3 Mailbox configuration**

| Mailbox            | MBM bit = 0 (normal mailbox mode) | MBM bit = 1 (FIFO mailbox mode)*1 to *5 |
|--------------------|-----------------------------------|---|
| Mailboxes 0 to 23  | Normal mailbox                    | Normal mailbox                          |
| Mailboxes 24 to 27 |                                   | Transmit FIFO                           |
| Mailboxes 28 to 31 |                                   | Receive FIFO                            |

- Note 1. The transmit FIFO is controlled by TFCR. The MCTL\_TX[j] registers associated with mailboxes 24 to 27 are disabled. MCTL\_TX[24] to MCTL\_TX[27] cannot be used by the transmit FIFO.
- Note 2. The receive FIFO is controlled by RFCR. The MCTL\_RX[j] registers associated with mailboxes 28 to 31 are disabled. MCTL\_RX[28] to MCTL\_RX[31] cannot be used by the receive FIFO.
- Note 3. See the MIER\_FIFO description for information on the FIFO interrupts.
- Note 4. The bits in MKIVLR associated with mailboxes 24 to 31 are disabled. Set these bits to 0.
- Note 5. The transmit and receive FIFOs can be used for both data frames and remote frames.

**29.2.2 BCR : Bit Configuration Register**

Base address: CANn = 0x400A\_8000 + 0x1000 × n (n = 0, 1)  
 Offset address: 0x844



| Bit  | Symbol     | Function   | R/W |
|------|------------|--|-----|
| 0    | CCLKS      | CAN Clock Source Selection<br>0: PCLKB (generated by the PLL clock)<br>1: CANMCLK (generated by the main clock oscillator)                                   | R/W |
| 7:1  | —          | These bits are read as 0. The write value should be 0.   | R/W |
| 10:8 | TSEG2[2:0] | Time Segment 2 Control<br>0 0 0: Setting prohibited<br>0 0 1: 2 Tq<br>0 1 0: 3 Tq<br>0 1 1: 4 Tq<br>1 0 0: 5 Tq<br>1 0 1: 6 Tq<br>1 1 0: 7 Tq<br>1 1 1: 8 Tq | R/W |
| 11   | —          | This bit is read as 0. The write value should be 0.  | R/W |

如果CPU在CAN模块尝试进入CAN暂停模式的同时请求进入CAN复位模式（当BOM[1:0]位为01b时在总线关闭进入，或者当BOM[1:0]位为10b），则CPU请求具有更高的优先级。

**RBOC位（从总线关闭强制返回）**

当RBOC位在总线关闭状态下设置为1时，CAN模块强制退出总线关闭状态。它自动设置为0，错误状态从总线关闭变为错误激活。当RBOC位设置为1时，RECR和TECR设置为0x00，STR中的BOST位设置为0，表示CAN模块不处于总线关闭状态。当RBOC设置为1时，其他寄存器保持不变。从总线关闭状态恢复不会产生总线关闭恢复中断请求。仅当BOM[1:0]位为00b（正常模式）时才使用RBOC位。

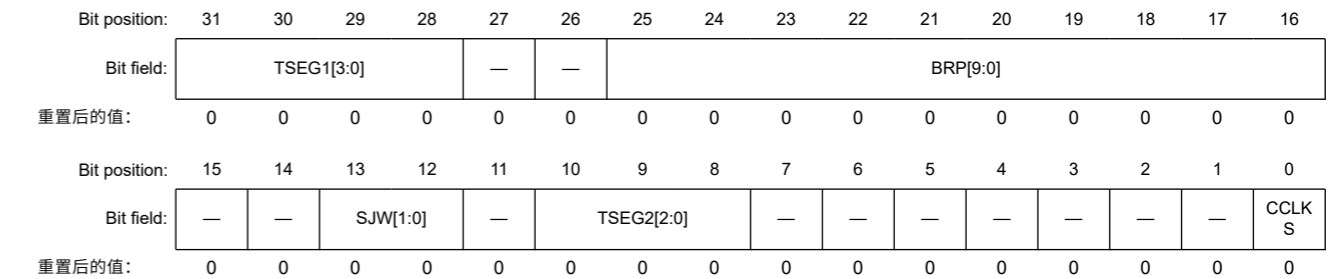
**Table 29.3 邮箱配置**

| Mailbox | MBM位=0（正常邮箱模式） | MBM位=1（FIFO邮箱模式）*1至*5 |
|---------|----------------|-----------------------|
| 邮箱0到23  | 普通邮箱           | 普通邮箱                  |
| 邮箱24至27 |                | Transmit FIFO         |
| 邮箱28至31 |                | Receive FIFO          |

- 注1.发送FIFO由TFCR控制。与邮箱24到27关联的MCTL\_TX[j]寄存器被禁用。发送FIFO不能使用MCTL\_TX[24]到MCTL\_TX[27]。
- 注2.接收FIFO由RFCR控制。与邮箱28到31关联的MCTL\_RX[j]寄存器被禁用。MCTL\_RX[28]到MCTL\_RX[31]不能被接收FIFO使用。
- 注3.有关FIFO中断的信息，请参见MIER\_FIFO描述。
- 注4.MKIVLR中与邮箱24到31相关的位被禁用。将这些位设置为0。
- 注5.发送和接收FIFO可用于数据帧和远程帧。

**29.2.2 BCR：位配置寄存器**

Base address: CANn = 0x400A\_8000 + 0x1000 × n (n = 0, 1)  
 Offset address: 0x844



| Bit  | Symbol     | Function  | R/W |
|------|------------|---|-----|
| 0    | CCLKS      | CAN时钟源选择<br>0: PCLKB (由PLL时钟产生) 1: CANMCLK (由主时钟振荡器产生)                                  | R/W |
| 7:1  | —          | 这些位被读取为0。写入值应为0。  | R/W |
| 10:8 | TSEG2[2:0] | 时间段2控制<br>000: 禁止设置001: 2Tq<br>010: 3Tq011: 4Tq10<br>0: 5Tq101: 6Tq110: 7Tq<br>111: 8Tq | R/W |
| 11   | —          | 该位读取为0。写入值应为0。  | R/W |

| Bit   | Symbol     | Function   | R/W |
|-------|------------|--|-----|
| 13:12 | SJW[1:0]   | Synchronization Jump Width Control<br>0 0: 1 Tq<br>0 1: 2 Tq<br>1 0: 3 Tq<br>1 1: 4 Tq   | R/W |
| 15:14 | —          | These bits are read as 0. The write value should be 0.   | R/W |
| 25:16 | BRP[9:0]   | Baud Rate Prescaler Select*1<br>These bits set the frequency of the CAN communication clock (fCANCLK).   | R/W |
| 27:26 | —          | These bits are read as 0. The write value should be 0.   | R/W |
| 31:28 | TSEG1[3:0] | Time Segment 1 Control<br>0x3: 4 Tq<br>0x4: 5 Tq<br>0x5: 6 Tq<br>0x6: 7 Tq<br>0x7: 8 Tq<br>0x8: 9 Tq<br>0x9: 10 Tq<br>0xA: 11 Tq<br>0xB: 12 Tq<br>0xC: 13 Tq<br>0xD: 14 Tq<br>0xE: 15 Tq<br>0xF: 16 Tq<br>Others: Setting prohibited | R/W |

Note: Tq: Time Quantum

Note 1. Do not select a value less than or equal to 1 while the SCKSCR.CKSEL[2:0] bits are 011b (selecting the main clock oscillator).

For details about setting the bit timing, see [section 29.4. Data Transfer Rate Configuration](#). Set BCR before entering CAN halt or CAN operation mode from CAN reset mode. After the setting is made once, this register can be written to in CAN reset or CAN halt mode. A 32-bit read/write accesses must be performed carefully so as not to change bits [7:0].

#### CCLKS bit (CAN Clock Source Selection)

The CCLKS bit selects CAN clock source. When the CCLKS bit is 0, the peripheral module clock (PCLKB) produced by the PLL frequency synthesizer is used as the CAN clock source (fCAN). When the CCLKS bit is 1, CANMCLK produced externally by the EXTAL pins is used as the CAN clock source (fCAN).

#### TSEG2[2:0] bits (Time Segment 2 Control)

The TSEG2[2:0] bits specify the length of the phase buffer segment 2 (PHASE\_SEG2) with a Tq value. A value from 2 to 8 Tq can be set. Set a value smaller than that in the TSEG1[3:0] bits.

#### SJW[1:0] bits (Synchronization Jump Width Control)

The SJW[1:0] bits specify the synchronization jump width with a Tq value. A value from 1 to 4 Tq can be set. Set a value smaller than or equal to that in the TSEG2[2:0] bits.

#### BRP[9:0] bits (Baud Rate Prescaler Select)

The BRP[9:0] bits set the frequency of the CAN communication clock (fCANCLK). The fCANCLK cycle is 1 Tq. If the setting is P (0 to 1023), the baud rate prescaler divides fCAN by P + 1.

#### TSEG1[3:0] bits (Time Segment 1 Control)

The TSEG1[3:0] bits specify the total length of the propagation time segment (PROP\_SEG) and phase buffer segment 1 (PHASE\_SEG1) with a time quantum (Tq) value. A value from 4 to 16 Tq can be set.

| Bit   | Symbol     | Function   | R/W |
|-------|------------|--|-----|
| 13:12 | SJW[1:0]   | 同步跳转宽度控制<br>0 0: 1 Tq<br>0 1: 2 Tq<br>1 0: 3 Tq<br>1 1: 4 Tq   | R/W |
| 15:14 | —          | 这些位被读取为0。写入值应为0。   | R/W |
| 25:16 | BRP[9:0]   | 波特率预分频器选择*1<br>这些位设置CAN通信时钟(fCANCLK)的频率。   | R/W |
| 27:26 | —          | 这些位被读取为0。写入值应为0。   | R/W |
| 31:28 | TSEG1[3:0] | 时间段1控制<br>0x3: 4 Tq<br>0x4: 5 Tq<br>0x5: 6 Tq<br>0x6: 7 Tq<br>0x7: 8 Tq<br>0x8: 9 Tq<br>0x9: 10 Tq<br>0xA: 11 Tq<br>0xB: 12 Tq<br>0xC: 13 Tq<br>0xD: 14 Tq<br>0xE: 15 Tq<br>0xF: 16 Tq<br>其他: 禁止设置 | R/W |

Note: Tq: 时间量子

注1.当SCKSCR.CKSEL[2:0]位为011b (选择主时钟振荡器)时, 请勿选择小于或等于1的值。

有关设置位时序的详细信息, 请参阅第29.4节。数据传输率配置。在从CAN复位模式进入CAN停止或CAN操作模式之前设置BCR。设置一次后, 可在CAN复位或CAN停止模式下写入该寄存器。必须小心执行32位读写访问, 以免更改位[7:0]。

#### CCLKS位 (CAN时钟源选择)

CCLKS位选择CAN时钟源。当CCLKS位为0时, PLL频率合成器产生的外设模块时钟 (PCLKB) 用作CAN时钟源 (fCAN)。当CCLKS位为1时, 由EXTAL引脚从外部产生的CANMCLK用作CAN时钟源(fCAN)。

#### TSEG2[2:0]位 (时间段2控制)

TSEG2[2:0]位用Tq值指定相位缓冲段2(PHASE\_SEG2)的长度。一个从2到8的值可以设置Tq。设置一个小于TSEG1[3:0]位的值。

#### SJW[1:0]位 (同步跳转宽度控制)

SJW[1:0]位用Tq值指定同步跳转宽度。可以设置1到4Tq的值。设置一个小于或等于TSEG2[2:0]位的值。

#### BRP[9:0]位 (波特率预分频器选择)

BRP[9:0]位设置CAN通信时钟(fCANCLK)的频率。fCANCLK周期为1Tq。如果设置为P (0到1023), 则波特率预分频器将fCAN除以P+1。

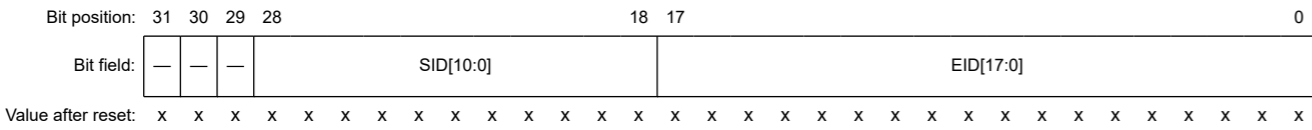
#### TSEG1[3:0]位 (时间段1控制)

TSEG1[3:0]位用时间量子(Tq)值指定传播时间段(PROP\_SEG)和相位缓冲段1(PHASE\_SEG1)的总长度。可以设置4到16Tq的值。



29.2.3 MKR[k] : Mask Register k (k = 0 to 7)

Base address: CANn = 0x400A\_8000 + 0x1000 × n (n = 0, 1)  
 Offset address: 0x400 + 0x04 × k



| Bit   | Symbol    | Function   | R/W |
|-------|-----------|--|-----|
| 17:0  | EID[17:0] | Extended ID<br>0: Do not compare associated EID[17:0] bits<br>1: Compare associated EID[17:0] bits | R/W |
| 28:18 | SID[10:0] | Standard ID<br>0: Do not compare associated SID[10:0] bits<br>1: Compare associated SID[10:0] bits | R/W |
| 31:29 | —         | The read values are undefined. The write value should be 0.  | R/W |

For the mask function in FIFO mailbox mode, see section 29.6. Acceptance Filtering and Masking Functions.

Write to MKR0 to MKR7 in CAN reset mode or CAN halt mode.

EID[17:0] bits (Extended ID)

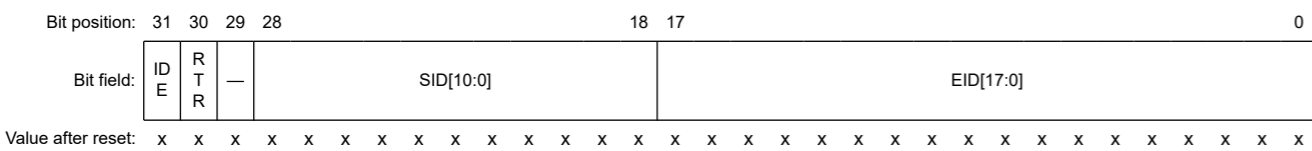
The EID[17:0] bits are the filter mask bits associated with the CAN extended ID bits. They are used to receive extended ID messages. When an EID[17:0] bit is set to 0, the received ID is not compared with the associated mailbox ID. When an EID[17:0] bit is set to 1, the received ID is compared with the associated mailbox ID.

SID[10:0] bits (Standard ID)

The SID[10:0] bits are the filter mask bits associated with the CAN standard ID bits. They are used to receive both standard ID and extended ID messages. When an SID[10:0] bit is set to 0, the received ID is not compared with the associated mailbox ID. When an SID[10:0] bit is set to 1, the received ID is compared with the associated mailbox ID.

29.2.4 FIDCRk : FIFO Received ID Compare Register k (k = 0, 1)

Base address: CANn = 0x400A\_8000 + 0x1000 × n (n = 0, 1)  
 Offset address: 0x420 + 0x04 × k

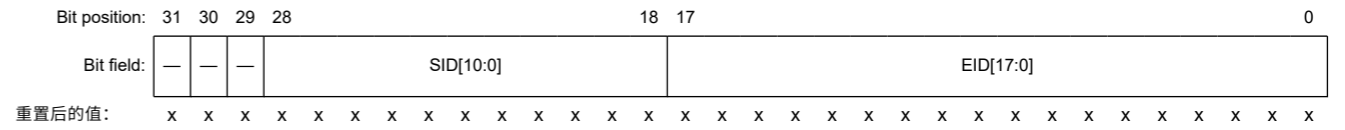


| Bit   | Symbol    | Function  | R/W |
|-------|-----------|---|-----|
| 17:0  | EID[17:0] | Extended ID of data and remote frames                           | R/W |
| 28:18 | SID[10:0] | Standard ID of data and remote frames                           | R/W |
| 29    | —         | The read value is undefined. The write value should be 0.       | R/W |
| 30    | RTR       | Remote Transmission Request<br>0: Data frame<br>1: Remote frame | R/W |
| 31    | IDE       | ID Extension*1<br>0: Standard ID<br>1: Extended ID              | R/W |

Note 1. The IDE bit is enabled when the CTLR.IDFM[1:0] bits are 10b (mixed ID mode). When the IDFM[1:0] bits are not 10b, only write 0 to IDE. It reads as 0.

29.2.3 MKR[k]:掩码寄存器k(k=0to7)

Base address: CANn = 0x400A\_8000 + 0x1000 × n (n = 0, 1)  
 Offset address: 0x400 + 0x04 × k



| Bit   | Symbol    | Function  | R/W |
|-------|-----------|---|-----|
| 17:0  | EID[17:0] | 扩展ID<br>0: 不比较关联的EID[17:0]位<br>1: 比较关联的EID[17:0]位 | R/W |
| 28:18 | SID[10:0] | 标准标识<br>0: 不比较关联的SID[10:0]位<br>1: 比较关联的SID[10:0]位 | R/W |
| 31:29 | —         | 读取的值未定义。写入值应为0。                                   | R/W |

关于FIFO邮箱模式下的屏蔽功能，请参见第29.6节。接受过滤和屏蔽功能。

在CAN复位模式或CAN暂停模式下写入MKR0至MKR7。

EID[17:0] bits (Extended ID)

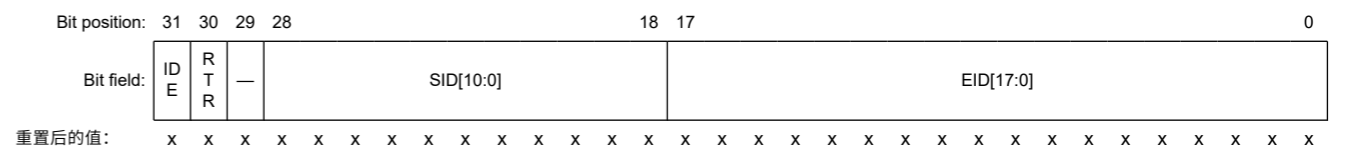
EID[17:0]位是与CAN扩展ID位相关的过滤器掩码位。它们用于接收扩展ID消息。当EID[17:0]位设置为0时，接收到的ID不会与关联的邮箱ID进行比较。当EID[17:0]位设置为1时，接收到的ID将与关联的邮箱ID进行比较。

SID[10:0] bits (Standard ID)

SID[10:0]位是与CAN标准ID位相关的过滤器掩码位。它们用于接收两个标准ID和扩展ID消息。当SID[10:0]位设置为0时，接收到的ID不会与关联的邮箱ID进行比较。当SID[10:0]位设置为1时，接收到的ID将与关联的邮箱ID进行比较。

29.2.4 FIDCRk:FIFO接收ID比较寄存器k(k=0 1)

Base address: CANn = 0x400A\_8000 + 0x1000 × n (n = 0, 1)  
 Offset address: 0x420 + 0x04 × k



| Bit   | Symbol    | Function                      | R/W |
|-------|-----------|-------------------------------|-----|
| 17:0  | EID[17:0] | 数据和远程帧的扩展ID                   | R/W |
| 28:18 | SID[10:0] | 数据和远程帧的标准ID                   | R/W |
| 29    | —         | 读取值未定义。写入值应为0。                | R/W |
| 30    | RTR       | 远程传输请求<br>0: 数据帧<br>1: 远程帧    | R/W |
| 31    | IDE       | 身份证扩展*1<br>0: 标准ID<br>1: 扩展ID | R/W |

注1.当CTLR.IDFM[1:0]位为10b（混合ID模式）时，IDE位被使能。当IDFM[1:0]位不是10b时，只写0到IDE。它读作0。



FIDCR0 and FIDCR1 are enabled when the MBM bit in CTRL is set to 1 (FIFO mailbox mode). In this mode, the EID[17:0], SID[10:0], RTR, and IDE bits in mailboxes 28 to 31 are disabled. Write to FIDCR0 and FIDCR1 in CAN reset mode or CAN halt mode. For information on using FIDCR0 and FIDCR1, see [section 29.6. Acceptance Filtering and Masking Functions](#).

#### EID[17:0] bits (Extended ID of data and remote frames)

The EID[17:0] bits set the extended ID of data frames and remote frames. These bits are used to receive extended ID messages.

#### SID[10:0] bits (Standard ID of data and remote frames)

The SID[10:0] bits set the standard ID of data frames and remote frames. These bits are used to receive both standard ID and extended ID messages.

#### RTR bit (Remote Transmission Request)

The RTR bit sets the frame format to data frames or remote frames:

- When the RTR bits in both FIDCR0 and FIDCR1 registers are set to 0, only data frames are received
- When the RTR bits in both FIDCR0 and FIDCR1 registers are set to 1, only remote frames are received
- When the RTR bits in both FIDCR0 and FIDCR1 registers are set to different values, both data frames and remote frames are received

#### IDE bit (ID Extension)

The IDE bit sets the ID format to standard ID or extended ID. The IDE bit is enabled when the IDFM[1:0] bits in CTRL are 10b (mixed ID mode):

- When the IDE bits in both FIDCR0 and FIDCR1 registers are set to 0, only standard ID frames are received
- When the IDE bits in both FIDCR0 and FIDCR1 registers are set to 1, only extended ID frames are received
- When the IDE bits in both FIDCR0 and FIDCR1 registers are set to different values, both standard ID and extended ID frames are received

### 29.2.5 MKIVLR : Mask Invalid Register

Base address: CANn = 0x400A\_8000 + 0x1000 × n (n = 0, 1)

Offset address: 0x428

|                    |      |      |      |      |      |      |      |      |      |      |      |      |      |      |      |      |
|--------------------|------|------|------|------|------|------|------|------|------|------|------|------|------|------|------|------|
| Bit position:      | 31   | 30   | 29   | 28   | 27   | 26   | 25   | 24   | 23   | 22   | 21   | 20   | 19   | 18   | 17   | 16   |
| Bit field:         | MB31 | MB30 | MB29 | MB28 | MB27 | MB26 | MB25 | MB24 | MB23 | MB22 | MB21 | MB20 | MB19 | MB18 | MB17 | MB16 |
| Value after reset: | x    | x    | x    | x    | x    | x    | x    | x    | x    | x    | x    | x    | x    | x    | x    | x    |
| Bit position:      | 15   | 14   | 13   | 12   | 11   | 10   | 9    | 8    | 7    | 6    | 5    | 4    | 3    | 2    | 1    | 0    |
| Bit field:         | MB15 | MB14 | MB13 | MB12 | MB11 | MB10 | MB9  | MB8  | MB7  | MB6  | MB5  | MB4  | MB3  | MB2  | MB1  | MB0  |
| Value after reset: | x    | x    | x    | x    | x    | x    | x    | x    | x    | x    | x    | x    | x    | x    | x    | x    |

| Bit  | Symbol      | Function   | R/W |
|------|-------------|--|-----|
| 31:0 | MB31 to MB0 | Mask Invalid<br>0: Mask valid<br>1: Mask invalid | R/W |

Each bit in MKIVLR is associated with a mailbox of the same number. Bit [0] in MKIVLR corresponds to mailbox 0 (MB0), and bit [31] corresponds to mailbox 31 (MB31).\*1

When a bit is set to 1, the associated acceptance mask register becomes invalid for the associated mailbox. When a mask invalid bit is set to 1, a message is received by the associated mailbox only if the receive message ID matches the mailbox ID exactly.

Write to MKIVLR in CAN reset or halt mode.

当CTRL中的MBM位设置为1 (FIFO邮箱模式) 时, FIDCR0和FIDCR1被使能。在这种模式下, 邮箱28到31中的EID[17:0]、SID[10:0]、RTR和IDE位被禁用。在CAN复位模式或CAN暂停模式下写入FIDCR0和FIDCR1。有关使用FIDCR0和FIDCR1的信息, 请参阅第29.6节。接受过滤和屏蔽功能。

#### EID[17:0]位 (数据和远程帧的扩展ID)

EID[17:0]位设置数据帧和远程帧的扩展ID。这些位用于接收扩展ID消息。

#### SID[10:0]位 (数据和远程帧的标准ID)

SID[10:0]位设置数据帧和远程帧的标准ID。这些位用于接收标准ID和扩展ID消息。

#### RTR位 (远程传输请求)

RTR位将帧格式设置为数据帧或远程帧:

- 当FIDCR0和FIDCR1寄存器的RTR位都设置为0时, 只接收数据帧
- 当FIDCR0和FIDCR1寄存器的RTR位都设置为1时, 只接收远程帧
- 当FIDCR0和FIDCR1寄存器的RTR位设置为不同的值时, 数据帧和远程帧都被接收

#### IDE位 (ID扩展)

IDE位将ID格式设置为标准ID或扩展ID。当CTRL中的IDFM[1:0]位为10b (混合ID模式) 时, IDE位被使能:

- 当FIDCR0和FIDCR1寄存器中的IDE位都设置为0时, 只接收标准ID帧
- 当FIDCR0和FIDCR1寄存器中的IDE位都设置为1时, 只接收扩展ID帧
- 当FIDCR0和FIDCR1寄存器中的IDE位设置为不同的值时, 标准ID和扩展ID帧都被接收

### 29.2.5 MKIVLR:屏蔽无效寄存器

Base address: CANn = 0x400A\_8000 + 0x1000 × n (n = 0, 1)

Offset address: 0x428

|               |      |      |      |      |      |      |      |      |      |      |      |      |      |      |      |      |
|---------------|------|------|------|------|------|------|------|------|------|------|------|------|------|------|------|------|
| Bit position: | 31   | 30   | 29   | 28   | 27   | 26   | 25   | 24   | 23   | 22   | 21   | 20   | 19   | 18   | 17   | 16   |
| Bit field:    | MB31 | MB30 | MB29 | MB28 | MB27 | MB26 | MB25 | MB24 | MB23 | MB22 | MB21 | MB20 | MB19 | MB18 | MB17 | MB16 |
| 重置后的值:        | x    | x    | x    | x    | x    | x    | x    | x    | x    | x    | x    | x    | x    | x    | x    | x    |
| Bit position: | 15   | 14   | 13   | 12   | 11   | 10   | 9    | 8    | 7    | 6    | 5    | 4    | 3    | 2    | 1    | 0    |
| Bit field:    | MB15 | MB14 | MB13 | MB12 | MB11 | MB10 | MB9  | MB8  | MB7  | MB6  | MB5  | MB4  | MB3  | MB2  | MB1  | MB0  |
| 重置后的值:        | x    | x    | x    | x    | x    | x    | x    | x    | x    | x    | x    | x    | x    | x    | x    | x    |

| Bit  | Symbol      | Function                   | R/W |
|------|-------------|----------------------------|-----|
| 31:0 | MB31 to MB0 | 掩码无效<br>0: 屏蔽有效<br>1: 屏蔽无效 | R/W |

MKIVLR中的每个位都与一个相同号码的邮箱相关联。MKIVLR中的位[0]对应邮箱0(MB0), 位[31]对应邮箱31(MB31)。\*1

当某个位设置为1时, 相关联的接受屏蔽寄存器对于相关联的邮箱变得无效。当掩码无效位设置为1时, 只有当接收消息ID与邮箱ID完全匹配时, 相关邮箱才会接收消息。

在CAN复位或暂停模式下写入MKIVLR。

Note 1. Set bits [31:24] to 0 in FIFO mailbox mode.

### 29.2.6 Mailbox Registers

Table 29.4 lists the CANi mailbox memory mapping, and Table 29.5 lists the CAN data frame configuration.

The value of the CANi mailbox after reset is undefined.

Write to MBj\_ID, MBj\_DL, MBj\_Dm, and MBj\_TS only when the related MCTL\_TX[j] or MCTL\_RX[j] register (j = 0 to 31) is 0x00 and the associated mailbox is not processing an abort request.

See Table 29.4 for detailed on register addresses.

**Table 29.4 CANi mailbox memory mapping (i = 0, 1)**

| Address                              | Message content             |
|--------------------------------------|-----------------------------|
| <b>CANn (n = 0, 1)</b>               | <b>Memory mapping</b>       |
| 0x4005_0200 + 1000 × n + 16 × j + 0  | IDE, RTR, SID10 to SID6     |
| 0x4005_0200 + 1000 × n + 16 × j + 1  | SID5 to SID0, EID17, EID16  |
| 0x4005_0200 + 1000 × n + 16 × j + 2  | EID15 to EID8               |
| 0x4005_0200 + 1000 × n + 16 × j + 3  | EID7 to EID0                |
| 0x4005_0200 + 1000 × n + 16 × j + 4  | —                           |
| 0x4005_0200 + 1000 × n + 16 × j + 5  | Data length code (DLC[3:0]) |
| 0x4005_0200 + 1000 × n + 16 × j + 6  | Data byte 0                 |
| 0x4005_0200 + 1000 × n + 16 × j + 7  | Data byte 1                 |
| 0x4005_0200 + 1000 × n + 16 × j + 8  | Data byte 2                 |
| 0x4005_0200 + 1000 × n + 16 × j + 9  | Data byte 3                 |
| 0x4005_0200 + 1000 × n + 16 × j + 10 | Data byte 4                 |
| 0x4005_0200 + 1000 × n + 16 × j + 11 | Data byte 5                 |
| 0x4005_0200 + 1000 × n + 16 × j + 12 | Data byte 6                 |
| 0x4005_0200 + 1000 × n + 16 × j + 13 | Data byte 7                 |
| 0x4005_0200 + 1000 × n + 16 × j + 14 | Time stamp upper byte       |
| 0x4005_0200 + 1000 × n + 16 × j + 15 | Time stamp lower byte       |

**Table 29.5 CAN data frame configuration**

|               |              |                |               |              |              |       |       |     |       |
|---------------|--------------|----------------|---------------|--------------|--------------|-------|-------|-----|-------|
| SID10 to SID6 | SID5 to SID0 | EID17 to EID16 | EID15 to EID8 | EID7 to EID0 | DLC3 to DLC1 | DATA0 | DATA1 | ... | DATA7 |
|---------------|--------------|----------------|---------------|--------------|--------------|-------|-------|-----|-------|

The previous value of each mailbox is retained unless a new message is received.

#### 29.2.6.1 MBj\_ID : Mailbox ID Register j (j = 0 to 31)

Base address: CANn = 0x400A\_8000 + 0x1000 × n (n = 0, 1)

Offset address: 0x200 + 0x10 × j

|                    |           |     |    |           |    |    |    |    |    |    |    |    |    |    |    |           |
|--------------------|-----------|-----|----|-----------|----|----|----|----|----|----|----|----|----|----|----|-----------|
| Bit position:      | 31        | 30  | 29 | 28        | 27 | 26 | 25 | 24 | 23 | 22 | 21 | 20 | 19 | 18 | 17 | 16        |
| Bit field:         | IDE       | RTR | —  | SID[10:0] |    |    |    |    |    |    |    |    |    |    |    | EID[17:0] |
| Value after reset: | x         | x   | x  | x         | x  | x  | x  | x  | x  | x  | x  | x  | x  | x  | x  | x         |
| Bit position:      | 15        | 14  | 13 | 12        | 11 | 10 | 9  | 8  | 7  | 6  | 5  | 4  | 3  | 2  | 1  | 0         |
| Bit field:         | EID[17:0] |     |    |           |    |    |    |    |    |    |    |    |    |    |    |           |
| Value after reset: | x         | x   | x  | x         | x  | x  | x  | x  | x  | x  | x  | x  | x  | x  | x  | 0         |

注1.在FIFO邮箱模式下将位[31:24]设置为0。

### 29.2.6 邮箱寄存器

表29.4列出了CANi邮箱内存映射，表29.5列出了CAN数据帧配置。

复位后CANi邮箱的值未定义。

仅当相关的MCTL\_TX[j]或MCTL\_RX[j]寄存器 (j=0到31) 为0x00且相关邮箱未处理中止请求时，才写入MBj\_ID、MBj\_DL、MBj\_Dm和MBj\_TS。

有关寄存器地址的详细信息，请参见表29.4。

**Table 29.4 CANi邮箱内存映射(i=0 1)**

| Address                              | 留言内容                       |
|--------------------------------------|----------------------------|
| <b>CANn (n = 0, 1)</b>               | <b>内存映射</b>                |
| 0x4005_0200 + 1000 × n + 16 × j + 0  | IDE、RTR、SID10到SID6         |
| 0x4005_0200 + 1000 × n + 16 × j + 1  | SID5 to SID0, EID17, EID16 |
| 0x4005_0200 + 1000 × n + 16 × j + 2  | EID15 to EID8              |
| 0x4005_0200 + 1000 × n + 16 × j + 3  | EID7 to EID0               |
| 0x4005_0200 + 1000 × n + 16 × j + 4  | —                          |
| 0x4005_0200 + 1000 × n + 16 × j + 5  | 数据长度码 (DLC[3:0])           |
| 0x4005_0200 + 1000 × n + 16 × j + 6  | 数据字节0                      |
| 0x4005_0200 + 1000 × n + 16 × j + 7  | 数据字节1                      |
| 0x4005_0200 + 1000 × n + 16 × j + 8  | 数据字节2                      |
| 0x4005_0200 + 1000 × n + 16 × j + 9  | 数据字节3                      |
| 0x4005_0200 + 1000 × n + 16 × j + 10 | 数据字节4                      |
| 0x4005_0200 + 1000 × n + 16 × j + 11 | 数据字节5                      |
| 0x4005_0200 + 1000 × n + 16 × j + 12 | 数据字节6                      |
| 0x4005_0200 + 1000 × n + 16 × j + 13 | 数据字节7                      |
| 0x4005_0200 + 1000 × n + 16 × j + 14 | 时间戳高字节                     |
| 0x4005_0200 + 1000 × n + 16 × j + 15 | 时间戳低字节                     |

**Table 29.5 CAN数据帧配置**

|               |              |                |               |              |              |       |       |     |       |
|---------------|--------------|----------------|---------------|--------------|--------------|-------|-------|-----|-------|
| SID10 to SID6 | SID5 to SID0 | EID17 to EID16 | EID15 to EID8 | EID7 to EID0 | DLC3 to DLC1 | DATA0 | DATA1 | ... | DATA7 |
|---------------|--------------|----------------|---------------|--------------|--------------|-------|-------|-----|-------|

除非收到新邮件，否则保留每个邮箱的先前值。

#### 29.2.6.1 MBj\_ID:邮箱ID寄存器j(j=0到31)

Base address: CANn = 0x400A\_8000 + 0x1000 × n (n = 0, 1)

Offset address: 0x200 + 0x10 × j

|               |           |     |    |           |    |    |    |    |    |    |    |    |    |    |    |           |
|---------------|-----------|-----|----|-----------|----|----|----|----|----|----|----|----|----|----|----|-----------|
| Bit position: | 31        | 30  | 29 | 28        | 27 | 26 | 25 | 24 | 23 | 22 | 21 | 20 | 19 | 18 | 17 | 16        |
| Bit field:    | IDE       | RTR | —  | SID[10:0] |    |    |    |    |    |    |    |    |    |    |    | EID[17:0] |
| 重置后的值:        | x         | x   | x  | x         | x  | x  | x  | x  | x  | x  | x  | x  | x  | x  | x  | x         |
| Bit position: | 15        | 14  | 13 | 12        | 11 | 10 | 9  | 8  | 7  | 6  | 5  | 4  | 3  | 2  | 1  | 0         |
| Bit field:    | EID[17:0] |     |    |           |    |    |    |    |    |    |    |    |    |    |    |           |
| 重置后的值:        | x         | x   | x  | x         | x  | x  | x  | x  | x  | x  | x  | x  | x  | x  | x  | 0         |

| Bit   | Symbol    | Function  | R/W |
|-------|-----------|---|-----|
| 17:0  | EID[17:0] | Extended ID of data and remote frames*1                         | R/W |
| 28:18 | SID[10:0] | Standard ID of data and remote frames                           | R/W |
| 29    | —         | The read value is undefined. The write value should be 0.       | R/W |
| 30    | RTR       | Remote Transmission Request<br>0: Data frame<br>1: Remote frame | R/W |
| 31    | IDE       | ID Extension*2<br>0: Standard ID<br>1: Extended ID              | R/W |

Note 1. If the mailbox receives a standard ID message, the EID bits in the mailbox are undefined.

Note 2. The IDE bit is enabled when the CTLR.IDFM[1:0] bits are 10b (mixed ID mode). When the IDFM[1:0] bits are not 10b, only write 0 to IDE. It reads as 0.

**EID[17:0] bits (Extended ID of data and remote frames)**

The EID[17:0] bits set the extended ID of data frames and remote frames. They are used to transmit or receive extended ID messages.

**SID[10:0] bits (Standard ID of data and remote frames)**

The SID[10:0] bits set the standard ID of data frames and remote frames. They are used to transmit or receive both standard ID and extended ID messages.

**RTR bit (Remote Transmission Request)**

The RTR bit sets the frame format of data frames or remote frames.

- The receive mailbox only receives frames with the format specified in the RTR bit
- The transmit mailbox transmits with the frame format specified in the RTR bit
- The receive FIFO mailbox receives the data frame, remote frame, or both frames specified in the RTR bit in FIDCR0 and FIDCR1
- The transmit FIFO mailbox transmits the data frame or remote frame specified in the RTR bit in the transmit message

**IDE bit (ID Extension)**

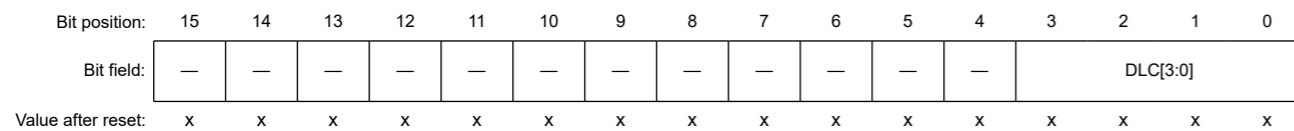
The IDE bit sets the ID format to standard IDs or extended IDs. The IDE bit is enabled when the IDFM[1:0] bits in CTLR are 10b (mixed ID mode).

- The receive mailbox only receives the ID format specified in the IDE bit
- The transmit mailbox transmits with the ID format specified in the IDE bit
- The receive FIFO mailbox receives messages with the standard ID and extended ID settings specified in the IDE bit in FIDCR0 and FIDCR1
- The transmit FIFO mailbox transmits messages with the standard ID or extended ID settings specified in the IDE bit in the transmit message

**29.2.6.2 MB<sub>j</sub>\_DL : Mailbox Data Length Register j (j = 0 to 31)**

Base address: CANn = 0x400A\_8000 + 0x1000 × n (n = 0, 1)

Offset address: 0x204 + 0x10 × j



| Bit   | Symbol    | Function                   | R/W |
|-------|-----------|----------------------------|-----|
| 17:0  | EID[17:0] | 数据和远程帧的扩展ID*1              | R/W |
| 28:18 | SID[10:0] | 数据和远程帧的标准ID                | R/W |
| 29    | —         | 读取值未定义。写入值应为0。             | R/W |
| 30    | RTR       | 远程传输请求<br>0: 数据帧1: 远程帧     | R/W |
| 31    | IDE       | 身份证扩展名*2<br>0: 标准ID1: 扩展ID | R/W |

注1.如果邮箱接收到标准ID消息，则邮箱中的EID位未定义。

注2.当CTLR.IDFM[1:0]位为10b（混合ID模式）时，IDE位被使能。当IDFM[1:0]位不是10b时，只写0到IDE。它读作0。

**EID[17:0]位（数据和远程帧的扩展ID）**

EID[17:0]位设置数据帧和远程帧的扩展ID。它们用于传输或接收扩展ID消息。

**SID[10:0]位（数据和远程帧的标准ID）**

SID[10:0]位设置数据帧和远程帧的标准ID。它们用于传输或接收这两种标准ID和扩展ID消息。

**RTR位（远程传输请求）**

RTR位设置数据帧或远程帧的帧格式。

- 接收邮箱只接收RTR位指定格式的帧
- 发送邮箱以RTR位指定的帧格式发送
- 接收FIFO邮箱接收FIDCR0和FIDCR1中的RTR位指定的数据帧、远程帧或同时接收这两个帧
- 发送FIFO邮箱发送发送报文中RTR位指定的数据帧或远程帧

**IDE位（ID扩展）**

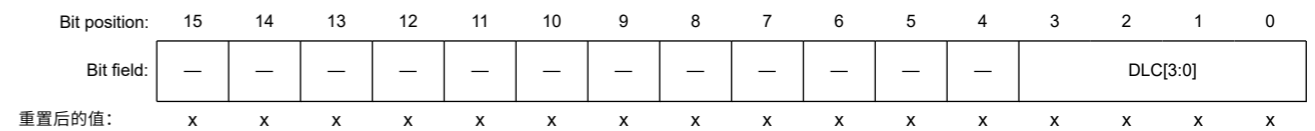
IDE位将ID格式设置为标准ID或扩展ID。当CTLR中的IDFM[1:0]位为10b（混合ID模式）时，IDE位被使能。

- 接收邮箱只接收IDE位指定的ID格式
- 发送邮箱以IDE位指定的ID格式发送
- 接收FIFO邮箱接收具有标准ID和扩展ID设置的消息，这些设置在FIDCR0和FIDCR1的IDE位中指定
- 发送FIFO邮箱使用发送消息中IDE位指定的标准ID或扩展ID设置发送消息

**29.2.6.2 MB<sub>j</sub>\_DL：邮箱数据长度寄存器j（j=0到31）**

Base address: CANn = 0x400A\_8000 + 0x1000 × n (n = 0, 1)

Offset address: 0x204 + 0x10 × j



| Bit  | Symbol   | Function  | R/W |
|------|----------|---|-----|
| 3:0  | DLC[3:0] | Data Length Code*1<br>0x0: Data length = 0 byte<br>0x1: Data length = 1 byte<br>0x2: Data length = 2 bytes<br>0x3: Data length = 3 bytes<br>0x4: Data length = 4 bytes<br>0x5: Data length = 5 bytes<br>0x6: Data length = 6 bytes<br>0x7: Data length = 7 bytes<br>Others: Data length = 8 bytes | R/W |
| 15:4 | —        | The read values are undefined. The write value should be 0.   | R/W |

Note 1. If the mailbox receives a message with data length (set in DLC[3:0]) of n bytes, where n is less than 8, the data in DATAn to DATA7 registers in the mailbox is undefined. DATA0 to DATA7 are data registers for this mailbox. For example, if data length is 6 bytes (DLC[3:0] = 0x6), the data in DATA6 and DATA7 registers is undefined.

**DLC[3:0] bits (Data Length Code)**

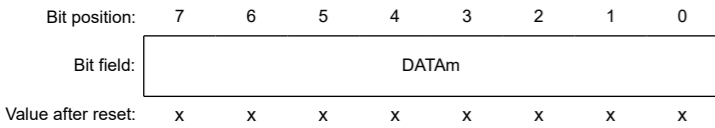
The DLC[3:0] bits specify the data length to be transmitted in data frames. When a remote frame is used to request data, this field specifies the requested data length.

When a data frame is received, the received data length is stored in this field. When a remote frame is received, this field stores the requested data length.

**29.2.6.3 MBj\_Dm : Mailbox Data Register j (j = 0 to 31, m = 0 to 7)**

Base address: CANn = 0x400A\_8000 + 0x1000 × n (n = 0, 1)

Offset address: (0x206 + m) + 0x10 × j



| Bit | Symbol         | Function   | R/W |
|-----|----------------|--|-----|
| 7:0 | DATA0 to DATA7 | Data Bytes 0 to 7*1*2<br>DATA0 to DATA7 store the transmitted or received CAN message data. Transmission or reception starts from DATA0. The bit order on the CAN bus is MSB-first, and transmission or reception starts from bit [7]. | R/W |

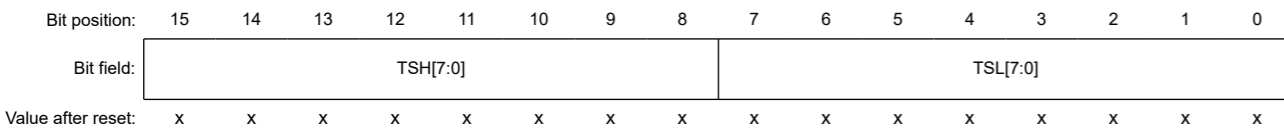
Note 1. If the mailbox receives a message with n bytes, where n is less than 8 bytes, the values of DATAn to DATA7 in the mailbox are undefined.

Note 2. If the mailbox receives a remote frame, the previous values of DATA0 to DATA7 in the mailbox are saved.

**29.2.6.4 MBj\_TS : Mailbox Time Stamp Register j (j = 0 to 31)**

Base address: CANn = 0x400A\_8000 + 0x1000 × n (n = 0, 1)

Offset address: 0x20E + 0x10 × j



| Bit | Symbol   | Function  | R/W |
|-----|----------|---|-----|
| 7:0 | TSL[7:0] | Time Stamp Lower Byte<br>The TSH[7:0] and TSL[7:0] bits store the counter value of the time stamp when received messages are stored in the mailbox. | R/W |

| Bit  | Symbol   | Function  | R/W |
|------|----------|---|-----|
| 3:0  | DLC[3:0] | 数据长度代码*1<br>0x0: 数据长度=0字节0x1: 数据长度=1字节0x2: 数据长度=2字节0x3: 数据长度=3字节0x4: 数据长度=4字节0x5: 数据长度=5字节0x6: 数据长度=6字节0x7: 数据长度=7个字节<br>其他: 数据长度=8字节 | R/W |
| 15:4 | —        | 读取的值未定义。写入值应为0。   | R/W |

注1.如果邮箱接收到数据长度（在DLC[3:0]中设置）为n字节的消息，其中n小于8，则邮箱中DATAn到DATA7寄存器中的数据未定义。DATA0到DATA7是该邮箱的数据寄存器。例如，如果数据长度为6字节（DLC[3:0]=0x6），则DATA6和DATA7寄存器中的数据未定义。

**DLC[3:0]位（数据长度代码）**

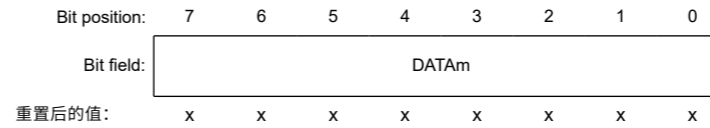
DLC[3:0]位指定要在数据帧中传输的数据长度。当使用远程帧请求数据时，该字段指定请求的数据长度。

当接收到一个数据帧时，接收到的数据长度存储在该字段中。当接收到远程帧时，该字段存储请求的数据长度。

**29.2.6.3 MBj\_Dm: 邮箱数据寄存器j (j=0到31, m=0到7)**

Base address: CANn = 0x400A\_8000 + 0x1000 × n (n = 0, 1)

Offset address: (0x206 + m) + 0x10 × j



| Bit | Symbol         | Function   | R/W |
|-----|----------------|--|-----|
| 7:0 | DATA0 to DATA7 | 数据字节0到7*1*2<br>DATA0到DATA7存储发送或接收的CAN报文数据。发送或接收从DATA0开始。CAN总线上的位顺序是MSB优先，发送或接收从位[7]开始。 | R/W |

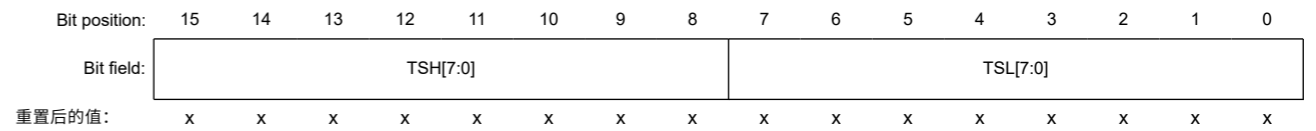
注1.如果邮箱收到n字节的消息，其中n小于8字节，邮箱中的DATAn到DATA7的值是未定义的。

注2: 如果邮箱接收到远程帧，邮箱中的DATA0到DATA7之前的值将被保存。

**29.2.6.4 MBj\_TS: 邮箱时间戳寄存器j (j=0到31)**

Base address: CANn = 0x400A\_8000 + 0x1000 × n (n = 0, 1)

Offset address: 0x20E + 0x10 × j



| Bit | Symbol   | Function  | R/W |
|-----|----------|---|-----|
| 7:0 | TSL[7:0] | 时间戳低字节<br>当收到的消息存储在邮箱中时，TSH[7:0]和TSL[7:0]位存储时间戳的计数器值。 | R/W |



| Bit  | Symbol   | Function   | R/W |
|------|----------|--|-----|
| 15:8 | TSH[7:0] | Time Stamp Higher Byte<br>The TSH[7:0] and TSL[7:0] bits store the counter value of the time stamp when received messages are stored in the mailbox. | R/W |

### 29.2.7 MIER : Mailbox Interrupt Enable Register

Base address: CANn = 0x400A\_8000 + 0x1000 × n (n = 0, 1)

Offset address: 0x42C

|                    |      |      |      |      |      |      |      |      |      |      |      |      |      |      |      |      |
|--------------------|------|------|------|------|------|------|------|------|------|------|------|------|------|------|------|------|
| Bit position:      | 31   | 30   | 29   | 28   | 27   | 26   | 25   | 24   | 23   | 22   | 21   | 20   | 19   | 18   | 17   | 16   |
| Bit field:         | MB31 | MB30 | MB29 | MB28 | MB27 | MB26 | MB25 | MB24 | MB23 | MB22 | MB21 | MB20 | MB19 | MB18 | MB17 | MB16 |
| Value after reset: | x    | x    | x    | x    | x    | x    | x    | x    | x    | x    | x    | x    | x    | x    | x    | x    |
| Bit position:      | 15   | 14   | 13   | 12   | 11   | 10   | 9    | 8    | 7    | 6    | 5    | 4    | 3    | 2    | 1    | 0    |
| Bit field:         | MB15 | MB14 | MB13 | MB12 | MB11 | MB10 | MB9  | MB8  | MB7  | MB6  | MB5  | MB4  | MB3  | MB2  | MB1  | MB0  |
| Value after reset: | x    | x    | x    | x    | x    | x    | x    | x    | x    | x    | x    | x    | x    | x    | x    | x    |

| Bit  | Symbol      | Function  | R/W |
|------|-------------|---|-----|
| 31:0 | MB31 to MB0 | Interrupt Enable<br>Bit [31] is associated with mailbox 31 (MB31), and bit [0] with mailbox 0 (MB0).<br>0: Disable interrupt<br>1: Enable interrupt | R/W |

MIER can enable interrupts for each mailbox independently. This register is available in normal mailbox mode. Do not access this register in FIFO mailbox mode.

Each bit is associated with the mailbox having the same number. These bits enable or disable transmission and reception complete interrupts for the associated mailboxes as follows:

- Bit [0] in MIER corresponds to mailbox 0 (MB0)
- Bit [31] in MIER corresponds to mailbox 31 (MB31)

Write to MIER only when the associated MCTL\_TX[j] or MCTL\_RX[j] register (j = 0 to 31) is 0x00 and the associated mailbox is not processing a transmission or reception abort request.

### 29.2.8 MIER\_FIFO : Mailbox Interrupt Enable Register for FIFO Mailbox Mode

Base address: CANn = 0x400A\_8000 + 0x1000 × n (n = 0, 1)

Offset address: 0x42C

|                    |      |      |      |      |      |      |      |      |      |      |      |      |      |      |      |      |
|--------------------|------|------|------|------|------|------|------|------|------|------|------|------|------|------|------|------|
| Bit position:      | 31   | 30   | 29   | 28   | 27   | 26   | 25   | 24   | 23   | 22   | 21   | 20   | 19   | 18   | 17   | 16   |
| Bit field:         | —    | —    | MB29 | MB28 | —    | —    | MB25 | MB24 | MB23 | MB22 | MB21 | MB20 | MB19 | MB18 | MB17 | MB16 |
| Value after reset: | x    | x    | x    | x    | x    | x    | x    | x    | x    | x    | x    | x    | x    | x    | x    | x    |
| Bit position:      | 15   | 14   | 13   | 12   | 11   | 10   | 9    | 8    | 7    | 6    | 5    | 4    | 3    | 2    | 1    | 0    |
| Bit field:         | MB15 | MB14 | MB13 | MB12 | MB11 | MB10 | MB9  | MB8  | MB7  | MB6  | MB5  | MB4  | MB3  | MB2  | MB1  | MB0  |
| Value after reset: | x    | x    | x    | x    | x    | x    | x    | x    | x    | x    | x    | x    | x    | x    | x    | x    |

| Bit  | Symbol      | Function  | R/W |
|------|-------------|---|-----|
| 23:0 | MB23 to MB0 | Interrupt Enable<br>Bit [23] is associated with mailbox 23 (MB23), and bit [0] with mailbox 0 (MB0).<br>0: Disable interrupt<br>1: Enable interrupt | R/W |

| Bit  | Symbol   | Function  | R/W |
|------|----------|---|-----|
| 15:8 | TSH[7:0] | 时间戳高字节<br>当收到的消息存储在邮箱中时，TSH[7:0]和TSL[7:0]位存储时间戳的计数器值。 | R/W |

### 29.2.7 MIER:邮箱中断使能寄存器

Base address: CANn = 0x400A\_8000 + 0x1000 × n (n = 0, 1)

Offset address: 0x42C

|               |      |      |      |      |      |      |      |      |      |      |      |      |      |      |      |      |
|---------------|------|------|------|------|------|------|------|------|------|------|------|------|------|------|------|------|
| Bit position: | 31   | 30   | 29   | 28   | 27   | 26   | 25   | 24   | 23   | 22   | 21   | 20   | 19   | 18   | 17   | 16   |
| Bit field:    | MB31 | MB30 | MB29 | MB28 | MB27 | MB26 | MB25 | MB24 | MB23 | MB22 | MB21 | MB20 | MB19 | MB18 | MB17 | MB16 |
| 重置后的值:        | x    | x    | x    | x    | x    | x    | x    | x    | x    | x    | x    | x    | x    | x    | x    | x    |
| Bit position: | 15   | 14   | 13   | 12   | 11   | 10   | 9    | 8    | 7    | 6    | 5    | 4    | 3    | 2    | 1    | 0    |
| Bit field:    | MB15 | MB14 | MB13 | MB12 | MB11 | MB10 | MB9  | MB8  | MB7  | MB6  | MB5  | MB4  | MB3  | MB2  | MB1  | MB0  |
| 重置后的值:        | x    | x    | x    | x    | x    | x    | x    | x    | x    | x    | x    | x    | x    | x    | x    | x    |

| Bit  | Symbol      | Function  | R/W |
|------|-------------|---|-----|
| 31:0 | MB31 to MB0 | 中断使能<br>位[31]与邮箱31(MB31)相关联，位[0]与邮箱0(MB0)相关联。<br>0: 禁用中断1: 启用中断 | R/W |

MIER可以独立为每个邮箱启用中断。该寄存器在正常邮箱模式下可用。不要在FIFO邮箱模式下访问该寄存器。

每个位与具有相同编号的邮箱相关联。这些位启用或禁用相关邮箱的发送和接收完成中断，如下所示：

- MIER中的位[0]对应邮箱0(MB0)
- MIER中的位[31]对应邮箱31(MB31)

仅当关联的MCTL\_TX[j]或MCTL\_RX[j]寄存器 (j=0到31) 为0x00并且关联的邮箱未处理发送或接收中止请求时才写入MIER。

### 29.2.8 MIER\_FIFO:FIFO邮箱模式的邮箱中断使能寄存器

Base address: CANn = 0x400A\_8000 + 0x1000 × n (n = 0, 1)

Offset address: 0x42C

|               |      |      |      |      |      |      |      |      |      |      |      |      |      |      |      |      |
|---------------|------|------|------|------|------|------|------|------|------|------|------|------|------|------|------|------|
| Bit position: | 31   | 30   | 29   | 28   | 27   | 26   | 25   | 24   | 23   | 22   | 21   | 20   | 19   | 18   | 17   | 16   |
| Bit field:    | —    | —    | MB29 | MB28 | —    | —    | MB25 | MB24 | MB23 | MB22 | MB21 | MB20 | MB19 | MB18 | MB17 | MB16 |
| 重置后的值:        | x    | x    | x    | x    | x    | x    | x    | x    | x    | x    | x    | x    | x    | x    | x    | x    |
| Bit position: | 15   | 14   | 13   | 12   | 11   | 10   | 9    | 8    | 7    | 6    | 5    | 4    | 3    | 2    | 1    | 0    |
| Bit field:    | MB15 | MB14 | MB13 | MB12 | MB11 | MB10 | MB9  | MB8  | MB7  | MB6  | MB5  | MB4  | MB3  | MB2  | MB1  | MB0  |
| 重置后的值:        | x    | x    | x    | x    | x    | x    | x    | x    | x    | x    | x    | x    | x    | x    | x    | x    |

| Bit  | Symbol      | Function  | R/W |
|------|-------------|---|-----|
| 23:0 | MB23 to MB0 | 中断使能<br>位[23]与邮箱23(MB23)相关联，位[0]与邮箱0(MB0)相关联。<br>0: 禁用中断1: 启用中断 | R/W |

| Bit   | Symbol | Function   | R/W |
|-------|--------|--|-----|
| 24    | MB24   | Transmit FIFO Interrupt Enable<br>0: Disable interrupt<br>1: Enable interrupt  | R/W |
| 25    | MB25   | Transmit FIFO Interrupt Generation Timing Control<br>0: Generate every time transmission completes<br>1: Generate when the transmit FIFO empties on transmission completion              | R/W |
| 27:26 | —      | The read values are undefined. The write value should be 0.  | R/W |
| 28    | MB28   | Receive FIFO Interrupt Enable<br>0: Disable interrupt<br>1: Enable interrupt   | R/W |
| 29    | MB29   | Receive FIFO Interrupt Generation Timing Control*1<br>0: Generate every time reception completes<br>1: Generate when the receive FIFO becomes a buffer warning*2 on reception completion | R/W |
| 31:30 | —      | The read values are undefined. The write value should be 0.  | R/W |

Note 1. No interrupt request occurs when the receive FIFO becomes buffer warning because it is full.  
Note 2. Buffer warning indicates a state in which the third message is stored in the receive FIFO.

MIER\_FIFO can independently enable interrupts for each mailbox and FIFO. This register is available in FIFO mailbox mode. Do not access it in normal mailbox mode.

The MB0 to MB23 bits are associated with the mailbox of the same number. These bits enable or disable transmission and reception complete interrupts for the associated mailboxes:

- Bit [0] in MIER\_FIFO is associated with mailbox 0 (MB0)
- Bit [23] in MIER\_FIFO is associated with mailbox 23 (MB23)

MB24, MB25, MB28, and MB29 specify whether transmit and receive FIFO interrupts are enabled or disabled, and the timing of interrupt requests.

Write to MIER\_FIFO only when the associated MCTL\_TX[j] or MCTL\_RX[j] register (j = 0 to 31) is 0x00 and the associated mailbox is not processing a transmission or reception abort request. In addition, change the bits in MIER\_FIFO for the associated FIFO only when all of the following conditions are true:

- The TFE bit in TFCR is 0 and the TFEST bit is 1.
- The RFE bit in RFCR is 0 and the RFEST bit in RFCR is 1.

### 29.2.9 MCTL\_TX[j] : Message Control Register for Transmit (j = 0 to 31)

Base address: CANn = 0x400A\_8000 + 0x1000 × n (n = 0, 1)

Offset address: 0x820 + 0x01 × j

|                    |            |            |   |             |   |            |               |              |
|--------------------|------------|------------|---|-------------|---|------------|---------------|--------------|
| Bit position:      | 7          | 6          | 5 | 4           | 3 | 2          | 1             | 0            |
| Bit field:         | TRMR<br>EQ | RECR<br>EQ | — | ONES<br>HOT | — | TRMA<br>BT | TRMA<br>CTIVE | SENT<br>DATA |
| Value after reset: | 0          | 0          | 0 | 0           | 0 | 0          | 0             | 0            |

| Bit | Symbol    | Function  | R/W |
|-----|-----------|---|-----|
| 0   | SENTDATA  | Transmission Complete Flag*1 *2<br>0: Transmission not complete<br>1: Transmission complete                     | R/W |
| 1   | TRMACTIVE | Transmission-in-Progress Status Flag<br>0: Transmission pending or not requested<br>1: Transmission in progress | R   |

| Bit   | Symbol | Function  | R/W |
|-------|--------|---|-----|
| 24    | MB24   | 发送FIFO中断使能<br>0: 禁用中断1: 启用中断                                | R/W |
| 25    | MB25   | 发送FIFO中断产生时序控制<br>0: 每次发送完成时生成1: 发送完成时发送FIFO清空时生成           | R/W |
| 27:26 | —      | 读取的值未定义。写入值应为0。   | R/W |
| 28    | MB28   | 接收FIFO中断使能<br>0: 禁用中断1: 启用中断                                | R/W |
| 29    | MB29   | 接收FIFO中断发生时序控制*1<br>0: 每次接收完成时产生1: 当接收FIFO变为缓冲区警告时产生*2接收完成时 | R/W |
| 31:30 | —      | 读取的值未定义。写入值应为0。   | R/W |

注1.当接收FIFO已满而变为缓冲区警告时，不会发生中断请求。  
注2.缓冲区警告表示第三条消息存储在接收FIFO中的状态。

MIER\_FIFO可以独立启用每个邮箱和FIFO的中断。该寄存器在FIFO邮箱模式下可用。不要在普通邮箱模式下访问它。

MB0到MB23位与相同编号的邮箱相关联。这些位启用或禁用相关邮箱的发送和接收完成中断:

- MIER\_FIFO中的位[0]与邮箱0(MB0)相关联
- MIER\_FIFO中的位[23]与邮箱23(MB23)相关联

MB24、MB25、MB28和MB29指定是启用还是禁用发送和接收FIFO中断，以及中断请求的时序。

仅当关联的MCTL\_TX[j]或MCTL\_RX[j]寄存器 (j=0到31) 为0x00并且关联的邮箱未处理发送或接收中止请求时才写入MIER\_FIFO。此外，仅当以下所有条件都为真时，才更改关联FIFO的MIER\_FIFO中的位:

- TFCR中的TFE位为0，TFEST位为1。
- RFCR中的RFE位为0，RFCR中的RFEST位为1。

### 29.2.9 MCTL\_TX[j] : 用于发送的消息控制寄存器 (j=0到31)

Base address: CANn = 0x400A\_8000 + 0x1000 × n (n = 0, 1)

Offset address: 0x820 + 0x01 × j

|               |            |            |   |    |   |            |               |          |
|---------------|------------|------------|---|----|---|------------|---------------|----------|
| Bit position: | 7          | 6          | 5 | 4  | 3 | 2          | 1             | 0        |
| Bit field:    | TRMR<br>EQ | RECR<br>EQ | — | 热门 | — | TRMA<br>BT | TRMA<br>CTIVE | 发送<br>数据 |
| 重置后的值:        | 0          | 0          | 0 | 0  | 0 | 0          | 0             | 0        |

| Bit | Symbol    | Function                      | R/W |
|-----|-----------|-------------------------------|-----|
| 0   | SENTDATA  | 传输完成标志*1*2<br>0: 传输未完成1: 传输完成 | R/W |
| 1   | TRMACTIVE | 传输中状态标志<br>0: 传输未决或未请求1: 传输中  | R   |

| Bit | Symbol  | Function  | R/W |
|-----|---------|---|-----|
| 2   | TRMABT  | Transmission Abort Complete Flag <sup>*1 *2</sup><br>0: Transmission started, transmission abort failed because transmission completed, or transmission abort not requested<br>1: Transmission abort complete | R/W |
| 3   | —       | This bit is read as 0. The write value should be 0.   | R/W |
| 4   | ONESHOT | One-Shot Enable <sup>*2 *3</sup><br>0: Disable one-shot transmission<br>1: Enable one-shot transmission   | R/W |
| 5   | —       | This bit is read as 0. The write value should be 0.   | R/W |
| 6   | RECREQ  | Receive Mailbox Request <sup>*2 *3 *4 *5</sup><br>0: Do not configure for reception<br>1: Configure for reception   | R/W |
| 7   | TRMREQ  | Transmit Mailbox Request <sup>*2 *4</sup><br>0: Do not configure for transmission<br>1: Configure for transmission  | R/W |

Note 1. Write 0 only. Writing 1 has no effect.

Note 2. When writing to bits of this register, write 1 to SENTDATA and TRMABT flags if these bits are not the write target.

Note 3. To enter one-shot transmit mode, write 1 to the ONESHOT bit at the same time as setting the TRMREQ bit to 1. To exit one-shot transmit mode, write 0 to the ONESHOT bit after the message is transmitted or aborted.

Note 4. Do not set both the RECREQ and TRMREQ bits to 1.

Note 5. When setting the RECREQ bit to 0, set the SENTDATA, TRMACTIVE, and TRMABT flags to 0 simultaneously.

MCTL\_TX[j] sets mailbox j to transmit mode or receive mode. In transmit mode, MCTL\_TX[j] also controls and indicates the transmission status. Do not access MCTL\_TX[j] if mailbox j is in receive mode. Only write to MCTL\_TX[j] in CAN operation or halt mode. Do not use MCTL\_TX24 to MCTL\_TX31 in FIFO mailbox mode.

#### SENTDATA flag (Transmission Complete Flag)

The SENTDATA flag is set to 1 when data transmission from the associated mailbox is complete. This flag is set to 0 through a software write. To set this flag to 0, first set the TRMREQ bit to 0. The SENTDATA flag and the TRMREQ bit cannot be set to 0 simultaneously. To transmit a new message from the associated mailbox, set the SENTDATA flag to 0.

#### TRMACTIVE flag (Transmission-in-Progress Status Flag)

The TRMACTIVE flag is set to 1 when the associated mailbox of the CAN module begins to transmit a message. It is set to 0 when the CAN module loses the CAN bus arbitration, when a CAN bus error occurs, or when data transmission completes.

#### TRMABT flag (Transmission Abort Complete Flag)

The TRMABT flag is set to 1 in the following cases:

- Following a transmission abort request, when the transmission abort is complete before starting transmission
- Following a transmission abort request, when the CAN module detects CAN bus arbitration-lost or a CAN bus error
- In one-shot transmission mode (RECREQ = 0, TRMREQ = 1, and ONESHOT = 1), when the CAN module detects a CAN bus arbitration-lost or a CAN bus error.

The TRMABT flag is not set to 1 when data transmission is complete. The SENTDATA flag is set to 1, and the TRMABT flag is set to 0 through a software write.

#### ONESHOT bit (One-Shot Enable)

When the ONESHOT bit is set to 1 in transmit mode (RECREQ = 0 and TRMREQ = 1), the CAN module transmits a message only one time. The CAN module does not transmit the message again if a CAN bus error or CAN bus arbitration-lost occurs. When transmission is complete, the SENTDATA flag is set to 1. If transmission does not complete because of a CAN bus error or CAN bus arbitration-lost error, the TRMABT flag is set to 1. Set the ONESHOT bit to 0 after the SENTDATA or TRMABT flag is set to 1.

#### RECREQ bit (Receive Mailbox Request)

The RECREQ bit selects the receive modes listed in [Table 29.10](#).

| Bit | Symbol  | Function   | R/W |
|-----|---------|--|-----|
| 2   | TRMABT  | 传输中止完成标志*1*2<br>0: 传输开始, 传输中止失败, 因为传输完成, 或者没有请求传输中止<br>1: 传输中止完成 | R/W |
| 3   | —       | 该位读取为0。写入值应为0。   | R/W |
| 4   | ONESHOT | One-Shot Enable <sup>*2 *3</sup><br>0: 禁止一次性发送<br>1: 允许一次性发送     | R/W |
| 5   | —       | 该位读取为0。写入值应为0。   | R/W |
| 6   | RECREQ  | 接收邮箱请求*2*3*4*5<br>0: 不配置接收<br>1: 配置接收                            | R/W |
| 7   | TRMREQ  | 发送邮箱请求*2*4<br>0: 不配置传输<br>1: 配置传输                                | R/W |

注1.只写0。写1无效。

注2.当写入该寄存器的位时, 如果这些位不是写入目标, 则将1写入SENTDATA和TRMABT标志。

注3.要进入一次性发送模式, 请在将TRMREQ位设置为1的同时将1写入ONESHOT位。要退出一次性发送模式, 请在发送或中止消息后向ONESHOT位写入0。

注4.不要将RECREQ和TRMREQ位都设置为1。

注5.将RECREQ位设置为0时, 同时将SENTDATA、TRMACTIVE和TRMABT标志设置为0。

MCTL\_TX[j]将邮箱j设置为发送模式或接收模式。在传输模式下, MCTL\_TX[j]也控制和指示传输状态。如果邮箱j处于接收模式, 则不要访问MCTL\_TX[j]。仅在CAN操作或暂停模式下写入MCTL\_TX[j]。不要在FIFO邮箱模式下使用MCTL\_TX24到MCTL\_TX31。

#### SENTDATA标志 (传输完成标志)

当来自相关邮箱的数据传输完成时, SENTDATA标志设置为1。该标志通过软件写入设置为0。要将此标志设置为0, 首先将TRMREQ位设置为0。SENTDATA标志和TRMREQ位不能同时设置为0。要从关联邮箱发送新消息, 请将SENTDATA标志设置为0。

#### TRMACTIVE标志 (传输中状态标志)

当CAN模块的相关邮箱开始发送消息时, TRMACTIVE标志设置为1。当CAN模块失去CAN总线仲裁、发生CAN总线错误或数据传输完成时, 它设置为0。

#### TRMABT标志 (传输中止完成标志)

在以下情况下, TRMABT标志设置为1:

- 在发送中止请求之后, 在开始发送前完成发送中止时
- 在发送中止请求后, CAN模块检测到CAN总线仲裁丢失或CAN总线错误
- 单次传输模式 (RECREQ=0, TRMREQ=1, ONESHOT=1), 当CAN模块检测到CAN总线仲裁失败或CAN总线错误时。

当数据传输完成时, TRMABT标志不设置为1。SENTDATA标志设置为1, TRMABT标志通过软件写入设置为0。

#### ONESHOT bit (One-Shot Enable)

在发送模式下 (RECREQ=0且TRMREQ=1) 将ONESHOT位设置为1时, CAN模块仅发送一次报文。如果发生CAN总线错误或CAN总线仲裁丢失, CAN模块不会再次发送消息。传输完成时, SENTDATA标志设置为1。如果由于CAN总线错误或CAN总线仲裁丢失导致传输未完成, 则TRMABT标志设置为1。在发送后将ONESHOT位设置为0

SENTDATA或TRMABT标志设置为1。

#### RECREQ位 (接收邮箱请求)

RECREQ位选择表29.10中列出的接收模式。



When the RECREQ bit is set to 1, the associated mailbox is configured for reception of a data or remote frame.

When the RECREQ bit is set to 0, the associated mailbox is not configured for reception of a data or remote frame.

Due to hardware protection, the RECREQ bit cannot be set to 0 through a software write during the following period:

- Hardware protection is started from the acceptance filter processing (the beginning of the CRC field)
- Hardware protection is released:
  - For the mailbox that is specified to receive the incoming message, after the received data is stored in the mailbox or a CAN bus error occurs. This means that the maximum period of hardware protection is from the beginning of CRC field to the end of the 7th bit of EOF.
  - For the other mailboxes, after acceptance filter processing
  - If no mailbox is specified to receive the message, after acceptance filter processing.

When setting the RECREQ bit to 1, do not set the TRMREQ bit to 1. To change the configuration of a mailbox from transmission to reception, first abort the transmission, then set the SENTDATA and TRMABT flags to 0 before changing to reception.

Note: MCTL\_TX[j].RECREQ is the mirror bit of MCTL\_RX[j].RECREQ.

**TRMREQ bit (Transmit Mailbox Request)**

The TRMREQ bit selects the transmit modes listed in Table 29.10.

When the TRMREQ bit is set to 1, the associated mailbox is configured for transmission of a data or remote frame.

When the TRMREQ bit is set to 0, the associated mailbox is not configured for transmission of a data or remote frame.

If the TRMREQ bit is changed from 1 to 0 to cancel the associated transmission request, either the TRMABT or SENTDATA flag is set to 1. When setting the TRMREQ bit to 1, do not set the RECREQ bit to 1. To change the configuration of a mailbox from reception to transmission, first abort the reception, then set the NEWDATA and MSGLOST flags to 0 before changing to transmission.

Note: MCTL\_TX[j].TRMREQ is the mirror bit of MCTL\_RX[j].TRMREQ.

**29.2.10 MCTL\_RX[j] : Message Control Register for Receive (j = 0 to 31)**

Base address: CANn = 0x400A\_8000 + 0x1000 × n (n = 0, 1)

Offset address: 0x820 + 0x01 × j

|                    |         |         |   |          |   |          |            |          |
|--------------------|---------|---------|---|----------|---|----------|------------|----------|
| Bit position:      | 7       | 6       | 5 | 4        | 3 | 2        | 1          | 0        |
| Bit field:         | TRMR EQ | RECR EQ | — | ONES HOT | — | MSGL OST | INVAL DATA | NEWD ATA |
| Value after reset: | 0       | 0       | 0 | 0        | 0 | 0        | 0          | 0        |

| Bit | Symbol    | Function  | R/W |
|-----|-----------|---|-----|
| 0   | NEWDATA   | Reception Complete Flag*1 *2<br>0: No data received, or 0 was written to the flag<br>1: New message being stored or was stored in the mailbox | R/W |
| 1   | INVALDATA | Reception-in-Progress Status Flag<br>0: Message valid<br>1: Message being updated   | R   |
| 2   | MSGLOST   | Message Lost Flag*1 *2<br>0: Message not overwritten or overrun<br>1: Message overwritten or overrun  | R/W |
| 3   | —         | This bit is read as 0. The write value should be 0.   | R/W |
| 4   | ONESHOT   | One-Shot Enable*2 *3<br>0: Disable one-shot reception<br>1: Enable one-shot reception   | R/W |

当RECREQ位设置为1时，相关邮箱配置为接收数据或远程帧。

当RECREQ位设置为0时，相关邮箱未配置为接收数据或远程帧。

由于硬件保护，RECREQ位在以下期间不能通过软件写入设置为0:

- 硬件保护从验收过滤处理开始 (CRC字段的开始)
- 硬件保护解除:
  - 对于指定接收传入消息的邮箱，在接收到的数据存储于邮箱中或发生CAN总线错误后。这意味着硬件保护的周期是从CRC字段的开始到EOF的第7位结束。

对于其他邮箱，接受过滤处理后  
如果没有指定邮箱接收消息，则在接受过滤处理之后。

将RECREQ位设置为1时，不要将TRMREQ位设置为1。要将邮箱配置从发送更改为接收，首先中止发送，然后在更改为接收之前将SENTDATA和TRMABT标志设置为0。

Note: MCTL\_TX[j].RECREQ是MCTL\_RX[j].RECREQ的镜像位。

**TRMREQ位 (发送邮箱请求)**

TRMREQ位选择表29.10中列出的发送模式。

当TRMREQ位设置为1时，相关邮箱配置为传输数据或远程帧。

当TRMREQ位设置为0时，相关邮箱未配置为传输数据或远程帧。

如果TRMREQ位从1更改为0以取消相关的发送请求，则TRMABT或SENTDATA标志设置为1。将TRMREQ位设置为1时，不要将RECREQ位设置为1。要更改邮箱从接收到发送，首先中止接收，然后将NEWDATA和MSGLOST标志设置为0，然后再更改为发送。

Note: MCTL\_TX[j].TRMREQ是MCTL\_RX[j].TRMREQ的镜像位。

**29.2.10 MCTL\_RX[j]:接收消息控制寄存器(j=0to31)**

Base address: CANn = 0x400A\_8000 + 0x1000 × n (n = 0, 1)

Offset address: 0x820 + 0x01 × j

|               |         |         |   |    |   |          |            |          |
|---------------|---------|---------|---|----|---|----------|------------|----------|
| Bit position: | 7       | 6       | 5 | 4  | 3 | 2        | 1          | 0        |
| Bit field:    | TRMR EQ | RECR EQ | — | 热门 | — | MSGL OST | INVAL DATA | NEWD ATA |
| 重置后的值:        | 0       | 0       | 0 | 0  | 0 | 0        | 0          | 0        |

| Bit | Symbol    | Function   | R/W |
|-----|-----------|--|-----|
| 0   | NEWDATA   | 接收完成标志*1*2<br>0: 未接收到数据，或标志位已写入0<br>1: 新消息正在存储或已存储在邮箱中 | R/W |
| 1   | INVALDATA | 接收中状态标志<br>0: 消息有效<br>1: 消息正在更新                        | R   |
| 2   | MSGLOST   | 消息丢失标志*1*2<br>0: 信息未被覆盖或溢出<br>1: 信息被覆盖或溢出              | R/W |
| 3   | —         | 该位读取为0。写入值应为0。   | R/W |
| 4   | ONESHOT   | One-Shot Enable*2 *3<br>0: 关闭一键接收<br>1: 打开一键接收         | R/W |



| Bit | Symbol | Function   | R/W |
|-----|--------|--|-----|
| 5   | —      | This bit is read as 0. The write value should be 0.  | R/W |
| 6   | RECREQ | Receive Mailbox Request*2 *3 *4 *5<br>0: Do not configure for reception<br>1: Configure for reception  | R/W |
| 7   | TRMREQ | Transmit Mailbox Request*2 *4<br>0: Do not configure for transmission<br>1: Configure for transmission | R/W |

Note 1. Write 0 only. Writing 1 has no effect.

Note 2. When writing to bits of this register, write 1 to the NEWDATA and MSGLOST flags if they are not the write target.

Note 3. To enter one-shot receive mode, write 1 to the ONESHOT bit at the same time as setting the RECREQ bit to 1. To exit one-shot receive mode, write 0 to the ONESHOT bit after writing 0 to the RECREQ bit and confirming that it is 0.

Note 4. Do not set both the RECREQ and TRMREQ bits to 1.

Note 5. When setting the RECREQ bit to 0, set MSGLOST, NEWDATA, and RECREQ to 0 simultaneously.

MCTL\_RX[j] sets mailbox j to transmit or receive mode. In receive mode, MCTL\_RX[j] also controls and indicates the reception status. Do not access MCTL\_RX[j] if mailbox j is in transmit mode. Only write to the MCTL\_RX[j] in CAN operation or halt mode. Do not use MCTL\_RX24 to MCTL\_RX31 in FIFO mailbox mode.

#### NEWDATA flag (Reception Complete Flag)

The NEWDATA flag is set to 1 when a new message is being stored or was stored in the mailbox. Always set this bit to 1 simultaneously with the INVALIDDATA flag. The NEWDATA flag is set to 0 through a software write. The NEWDATA flag cannot be set to 0 through a software write while the associated INVALIDDATA flag is 1.

#### INVALIDDATA flag (Reception-in-Progress Status Flag)

After the completion of a message reception, the INVALIDDATA flag is set to 1 while the received message is updated in the associated mailbox. The INVALIDDATA flag is set to 0 immediately after the message is stored. If the mailbox is read while the INVALIDDATA flag is 1, the data is undefined.

#### MSGLOST flag (Message Lost Flag)

The MSGLOST flag is set to 1 when the mailbox is overwritten or overrun by a new received message while the NEWDATA flag is 1. The MSGLOST flag is set to 1 at the end of the 6th bit of EOF. The MSGLOST flag is set to 0 through a software write.

In both overwrite and overrun modes, the MSGLOST flag cannot be set to 0 through a software write during the 5 PCLKB cycles following the 6th bit of EOF.

#### ONESHOT bit (One-Shot Enable)

When the ONESHOT bit is set to 1 in receive mode (RECREQ = 1 and TRMREQ = 0), the mailbox receives a message only one time. The mailbox does not behave as a receive mailbox after having received a message one time. The behavior of the NEWDATA and INVALIDDATA flags is the same as in normal receive mode. In one-shot receive mode, the MSGLOST flag is not set to 1. To set the ONESHOT bit to 0, first write 0 to the RECREQ bit and ensure that it is 0.

#### RECREQ bit (Receive Mailbox Request)

The RECREQ bit selects receive modes listed in Table 29.10.

When the RECREQ bit is set to 1, the associated mailbox is configured for reception of a data or remote frame.

When the RECREQ bit is set to 0, the associated mailbox is not configured for reception of a data or remote frame.

Due to hardware protection, the RECREQ bit cannot be set to 0 through a software write during the following period:

- Hardware protection is started from the acceptance filter processing (the beginning of the CRC field)
- Hardware protection is released:
  - For the mailbox that is specified to receive the incoming message, after the received data is stored in the mailbox or a CAN bus error occurs. This means that the maximum period of hardware protection is from the beginning of the CRC field to the end of the 7th bit of EOF.
  - For the other mailboxes, after acceptance filter processing
  - If no mailbox is specified to receive the message, after acceptance filter processing.

| Bit | Symbol | Function                          | R/W |
|-----|--------|-----------------------------------|-----|
| 5   | —      | 该位读取为0。写入值应为0。                    | R/W |
| 6   | RECREQ | 接收邮箱请求*2*3*4*5<br>0: 不配置接收1: 配置接收 | R/W |
| 7   | TRMREQ | 发送邮箱请求*2*4<br>0: 不配置传输1: 配置传输     | R/W |

注1.只写0。写1无效。

注2.当写入该寄存器的位时，如果NEWDATA和MSGLOST标志不是写入目标，则向它们写入1。

注3.要进入一次性接收模式，请在将RECREQ位设置为1的同时向ONESHOT位写入1。要退出一次性接收模式，请在向RECREQ位写入0后向ONESHOT位写入0并确认它是0。

注4.不要将RECREQ和TRMREQ位都设置为1。

注5.将RECREQ位设置为0时，同时将MSGLOST、NEWDATA和RECREQ设置为0。

MCTL\_RX[j]将邮箱j设置为发送或接收模式。在接收模式下，MCTL\_RX[j]也控制和指示接收状态。如果邮箱j处于发送模式，则不要访问MCTL\_RX[j]。仅在CAN操作或暂停模式下写入MCTL\_RX[j]。不要在FIFO邮箱模式下使用MCTL\_RX24到MCTL\_RX31。

#### NEWDATA标志 (接收完成标志)

当新消息正在存储或已存储在邮箱中时，NEWDATA标志设置为1。始终将此位与INVALIDDATA标志同时设置为1。NEWDATA标志通过软件写入设置为0。当相关的INVALIDDATA标志为1时，不能通过软件写入将NEWDATA标志设置为0。

#### INVALIDDATA标志 (接收进行中状态标志)

消息接收完成后，INVALIDDATA标志设置为1，同时在相关邮箱中更新接收到的消息。INVALIDDATA标志在消息存储后立即设置为0。如果在INVALIDDATA标志为1时读取邮箱，则数据未定义。

#### MSGLOST标志 (消息丢失标志)

当邮箱被新收到的消息覆盖或溢出时，MSGLOST标志设置为1，而NEWDATA标志为1。MSGLOST标志在EOF的第6位末尾设置为1。MSGLOST标志通过软件写入设置为0。

在覆盖和溢出模式下，MSGLOST标志不能在EOF第6位之后的5个PCLKB周期内通过软件写入设置为0。

#### ONESHOT bit (One-Shot Enable)

在接收模式下 (RECREQ=1和TRMREQ=0) 将ONESHOT位设置为1时，邮箱只接收一次消息。邮箱在收到一次消息后不再充当接收邮箱。NEWDATA和INVALIDDATA标志的行为与正常接收模式相同。在单次接收模式下，MSGLOST标志不设置为1。要将ONESHOT位设置为0，首先将0写入RECREQ位并确保其为0。

#### RECREQ位 (接收邮箱请求)

RECREQ位选择表29.10中列出的接收模式。

当RECREQ位设置为1时，相关邮箱配置为接收数据或远程帧。

当RECREQ位设置为0时，相关邮箱未配置为接收数据或远程帧。

由于硬件保护，RECREQ位在以下期间不能通过软件写入设置为0:

- 硬件保护从验收过滤处理开始 (CRC字段的开始)
- 硬件保护解除:

对于指定接收传入消息的邮箱，在接收到的数据存储于邮箱中或发生CAN总线错误后。这意味着硬件保护的周期是从CRC字段的开始到EOF的第7位结束。

对于其他邮箱，接受过滤处理后

如果没有指定邮箱接收消息，则在接受过滤处理之后。

When setting the RECREQ bit to 1, do not set the TRMREQ bit to 1. To change the configuration of a mailbox from transmission to reception, first abort the transmission, then set the SENTDATA and TRMABT flags to 0 before changing to reception.

Note: MCTL\_RX[j].RECREQ is the mirror bit of MCTL\_TX[j].RECREQ.

**TRMREQ bit (Transmit Mailbox Request)**

The TRMREQ bit selects the transmit modes listed in Table 29.10.

When the TRMREQ bit is set to 1, the associated mailbox is configured for transmission of a data or remote frame.

When the TRMREQ bit is set to 0, the associated mailbox is not configured for transmission of a data or remote frame.

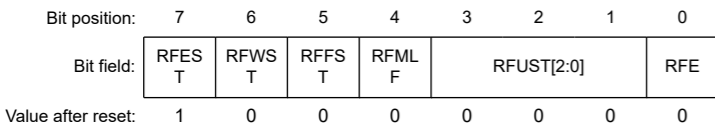
If the TRMREQ bit is changed from 1 to 0 to cancel the associated transmission request, either the TRMABT or SENTDATA flag is set to 1. When setting the TRMREQ bit to 1, do not set the RECREQ bit to 1. To change the configuration of a mailbox from reception to transmission, first abort the reception, then set the NEWDATA and MSGLOST flags to 0 before changing to transmission.

Note: MCTL\_RX[j].TRMREQ is the mirror bit of MCTL\_TX[j].TRMREQ.

**29.2.11 RFCR : Receive FIFO Control Register**

Base address: CANn = 0x400A\_8000 + 0x1000 × n (n = 0, 1)

Offset address: 0x848



| Bit | Symbol     | Function  | R/W |
|-----|------------|---|-----|
| 0   | RFE        | Receive FIFO Enable<br>0: Disable receive FIFO<br>1: Enable receive FIFO  | R/W |
| 3:1 | RFUST[2:0] | Receive FIFO Unread Message Number Status<br>0 0 0: No unread message<br>0 0 1: 1 unread message<br>0 1 0: 2 unread messages<br>0 1 1: 3 unread messages<br>1 0 0: 4 unread messages<br>1 0 1: Reserved<br>1 1 0: Reserved<br>1 1 1: Reserved | R   |
| 4   | RFMLF      | Receive FIFO Message Lost Flag<br>0: Receive FIFO message not lost<br>1: Receive FIFO message lost  | R/W |
| 5   | RFFST      | Receive FIFO Full Status Flag<br>0: Receive FIFO not full<br>1: Receive FIFO full (4 unread messages)   | R   |
| 6   | RFWST      | Receive FIFO Buffer Warning Status Flag<br>0: Receive FIFO is not buffer warning<br>1: Receive FIFO is buffer warning (3 unread messages)   | R   |
| 7   | RFEST      | Receive FIFO Empty Status Flag<br>0: Unread message in receive FIFO<br>1: No unread message in receive FIFO   | R   |

Write to RFCR in CAN operation or halt mode.

**RFE bit (Receive FIFO Enable)**

When the RFE bit is set to 1, the receive FIFO is enabled.

将RECREQ位设置为1时，不要将TRMREQ位设置为1。要将邮箱配置从发送更改为接收，首先中止发送，然后在更改为接收之前将SENTDATA和TRMABT标志设置为0。

Note: MCTL\_RX[j].RECREQ是MCTL\_TX[j].RECREQ的镜像位。

**TRMREQ位 (发送邮箱请求)**

TRMREQ位选择表29.10中列出的发送模式。

当TRMREQ位设置为1时，相关邮箱配置为传输数据或远程帧。

当TRMREQ位设置为0时，相关邮箱未配置为传输数据或远程帧。

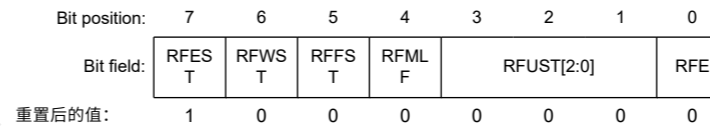
如果TRMREQ位从1更改为0以取消相关的发送请求，则TRMABT或SENTDATA标志设置为1。将TRMREQ位设置为1时，不要将RECREQ位设置为1。要更改邮箱从接收到发送，首先中止接收，然后将NEWDATA和MSGLOST标志设置为0，然后再更改为发送。

Note: MCTL\_RX[j].TRMREQ是MCTL\_TX[j].TRMREQ的镜像位。

**29.2.11 RFCR：接收FIFO控制寄存器**

Base address: CANn = 0x400A\_8000 + 0x1000 × n (n = 0, 1)

Offset address: 0x848



| Bit | Symbol     | Function   | R/W |
|-----|------------|--|-----|
| 0   | RFE        | 接收FIFO使能<br>0: 禁用接收FIFO1: 启用接收FIFO   | R/W |
| 3:1 | RFUST[2:0] | 接收FIFO未读消息编号状态<br>000: 没有未读消息001: 1条未读消息010: 2条未读消息011: 3条未读消息100: 4条未读消息101: 保留110: 保留111: 保留 | R   |
| 4   | RFMLF      | 接收FIFO消息丢失标志<br>0: 接收FIFO报文不丢失1: 接收FIFO报文丢失  | R/W |
| 5   | RFFST      | 接收FIFO满状态标志<br>0: 接收FIFO未读满1: 接收FIFO已读满 (4个未读消息)   | R   |
| 6   | RFWST      | 接收FIFO缓冲区警告状态标志<br>0: 接收FIFO不是缓冲区警告1: 接收FIFO是缓冲区警告 (3个未读消息)                                    | R   |
| 7   | RFEST      | 接收FIFO空状态标志<br>0: 接收FIFO中有未读报文1: 接收FIFO中没有未读报文   | R   |

在CAN操作或暂停模式下写入RFCR。

**RFE bit (Receive FIFO Enable)**

当RFE位设置为1时，启用接收FIFO。

When the RFE bit is set to 0, the receive FIFO is disabled for reception and becomes empty (RFEST bit = 1). Write 0 to the RFE bit simultaneously with the RFMLF flag setting.

Do not set this bit to 1 in normal mailbox mode (MBM bit in CTLR = 0). Due to hardware protection, the RFE bit cannot be set to 0 through a software write during the following period:

- Hardware protection is started from acceptance filter processing (the beginning of the CRC field)
- When hardware protection is released:
  - If the receive FIFO is specified to receive the incoming message, after the received data is stored in the receive FIFO or a CAN bus error occurs. This means that the maximum period of hardware protection is from the beginning of the CRC field to the end of the 7th bit of EOF.
  - If the receive FIFO is not specified to receive the message, after acceptance filter processing.

#### RFUST[2:0] bits (Receive FIFO Unread Message Number Status)

The RFUST[2:0] bits indicate the number of unread messages in the receive FIFO. The value of the RFUST[2:0] bits are initialized to 000b when the RFE bit is set to 0.

#### RFMLF flag (Receive FIFO Message Lost Flag)

The RFMLF flag is set to 1 (receive FIFO message lost) when the receive FIFO receives a new message and is full. It is set to 1 at the end of the 6th bit of EOF.

The RFMLF flag is set to 0 through a software write. Writing 1 has no effect. In both overwrite and overrun modes, if the receive FIFO is full and determined to have received a message, the RFMLF flag cannot be set to 0 (no receive FIFO message lost) through a software write during the 5 PCLKB cycles following the 6th bit of EOF.

#### RFFST flag (Receive FIFO Full Status Flag)

The RFFST flag is set to 1 (receive FIFO is full) when the number of unread messages in the receive FIFO is 4. The flag is 0 (receive FIFO is not full) when the number of unread messages in the receive FIFO is less than 4. The flag is set to 0 when the RFE bit is 0.

#### RFWST flag (Receive FIFO Buffer Warning Status Flag)

The RFWST flag is set to 1 (receive FIFO is a buffer warning) when the number of unread messages in the receive FIFO is 3. The flag is 0 (receive FIFO is not a buffer warning) when the number of unread messages in the receive FIFO is less than 3 or equal to 4. The RFWST flag is set to 0 when the RFE bit is 0.

#### RFEST flag (Receive FIFO Empty Status Flag)

The RFEST flag is set to 1 (no unread message in receive FIFO) when the number of unread messages in the receive FIFO is 0. The flag is set to 1 when the RFE bit is set to 0. The flag is set to 0 (unread message in receive FIFO) when the number of unread messages in the receive FIFO is one or more.

Figure 29.2 shows the receive FIFO mailbox operation.

当RFE位设置为0时，接收FIFO禁止接收并变为空（RFEST位=1）。将0写入RFE位与RFMLF标志设置同时进行。

在正常邮箱模式下不要将此位设置为1（CTLR中的MBM位=0）。由于硬件保护，RFE位在以下期间不能通过软件写入设置为0：

- 硬件保护从验收过滤处理开始（CRC字段的开始）
- 硬件保护解除时：
  - 如果指定接收FIFO接收传入报文，则在接收到的数据存储在接收FIFO中或发生CAN总线错误后。这意味着硬件保护的最大周期是从CRC字段的开始到EOF的第7位结束。

如果接收FIFO未指定接收报文，则在接受过滤处理之后。

#### RFUST[2:0]位（接收FIFO未读消息编号状态）

RFUST[2:0]位指示接收FIFO中未读消息的数量。当RFE位设置为0时，RFUST[2:0]位的值被初始化为000b。

#### RFMLF标志（接收FIFO消息丢失标志）

当接收FIFO接收到新消息并已满时，RFMLF标志设置为1（接收FIFO消息丢失）。它在EOF的第6位末尾设置为1。

RFMLF标志通过软件写入设置为0。写1无效。在覆盖和溢出模式下，如果接收FIFO已满并确定已接收到消息，则RFMLF标志不能通过软件在第6位之后的5个PCLKB周期内通过软件写入设置为0（没有接收FIFO消息丢失）。EOF。

#### RFFST标志（接收FIFO满状态标志）

当接收FIFO中未读消息数为4时，RFFST标志设置为1（接收FIFO已满）。当接收FIFO中未读消息数小于4。当RFE位为0时，标志设置为0。

#### RFWST标志（接收FIFO缓冲区警告状态标志）

当接收FIFO中的未读报文数为3时，RFWST标志设置为1（接收FIFO为缓冲区警告）。当接收中未读报文数为0时，该标志为0（接收FIFO不是缓冲区警告）FIFO小于3或等于4。当RFE位为0时，RFWST标志设置为0。

#### RFEST标志（接收FIFO空状态标志）

当接收FIFO中的未读报文数为0时，RFEST标志设置为1（接收FIFO中没有未读报文）。当RFE位设置为0时，该标志设置为1。该标志设置为0（接收FIFO中的未读消息）当接收FIFO中的未读消息数为1或多个时。

图29.2显示了接收FIFO邮箱操作。

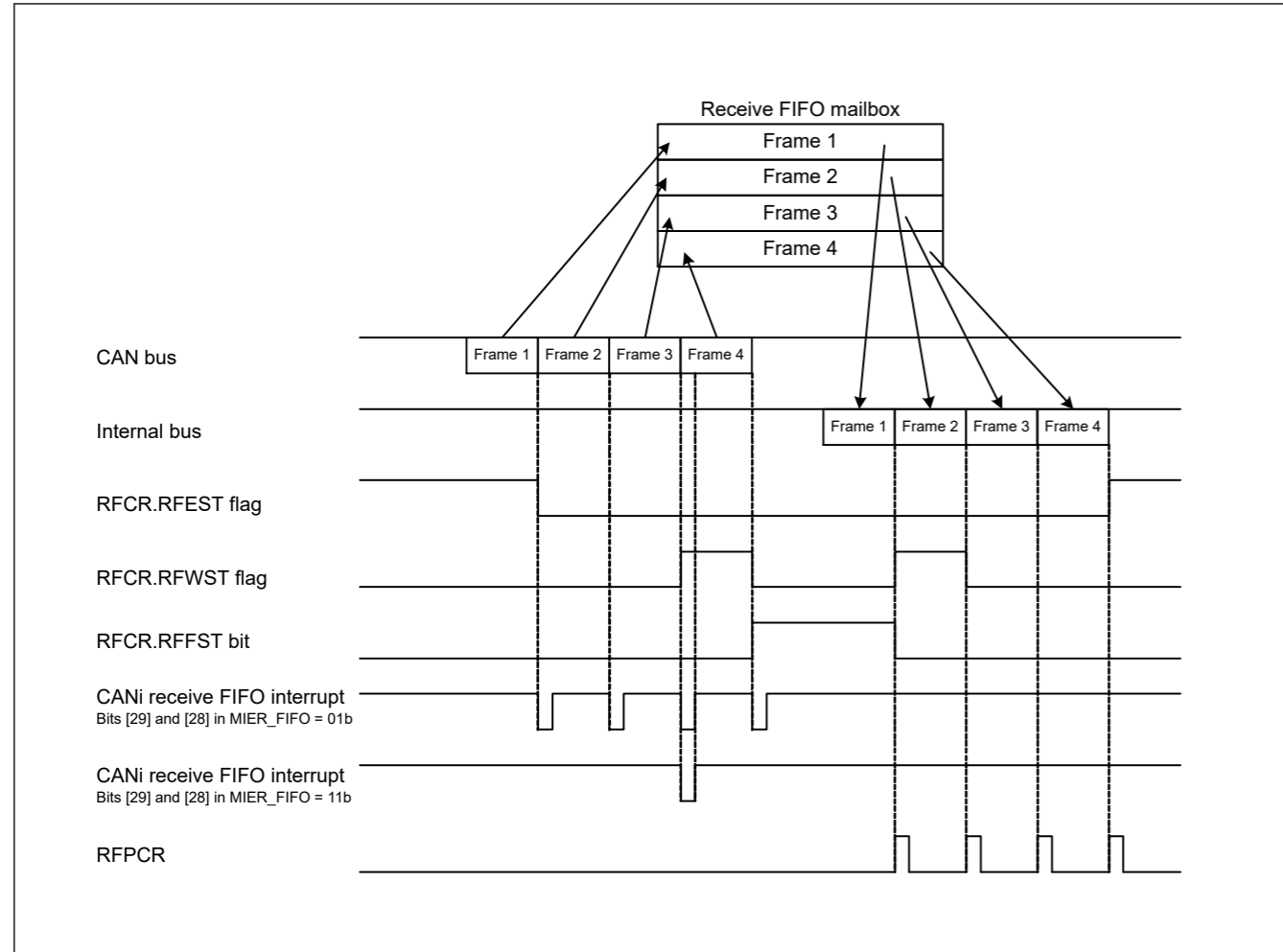
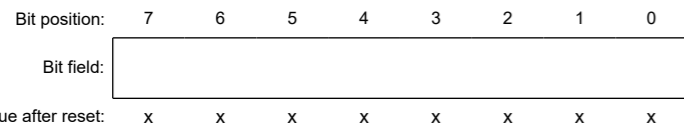


Figure 29.2 Receive FIFO mailbox operation when bits [29] and [28] in MIER\_FIFO = 01b or 11b

29.2.12 RFPCR : Receive FIFO Pointer Control Register

Base address: CANn = 0x400A\_8000 + 0x1000 × n (n = 0, 1)

Offset address: 0x849



| Bit | Symbol | Function  | R/W |
|-----|--------|---|-----|
| 7:0 | n/a    | The CPU pointer for the receive FIFO is incremented by writing 0xFF to RFPCR. | W   |

When the receive FIFO is not empty, write 0xFF to RFPCR through software to increment the CPU pointer to the next mailbox location. Do not write to RFPCR when the RFE bit in RFCR is 0 (receive FIFO disabled).

Both the CAN and CPU pointers are incremented when a new message is received and the RFFST flag is 1 (receive FIFO is full) in overwrite mode. When the RFMLF flag is 1 in this condition, the CPU pointer does not increment on a software write to RFPCR.

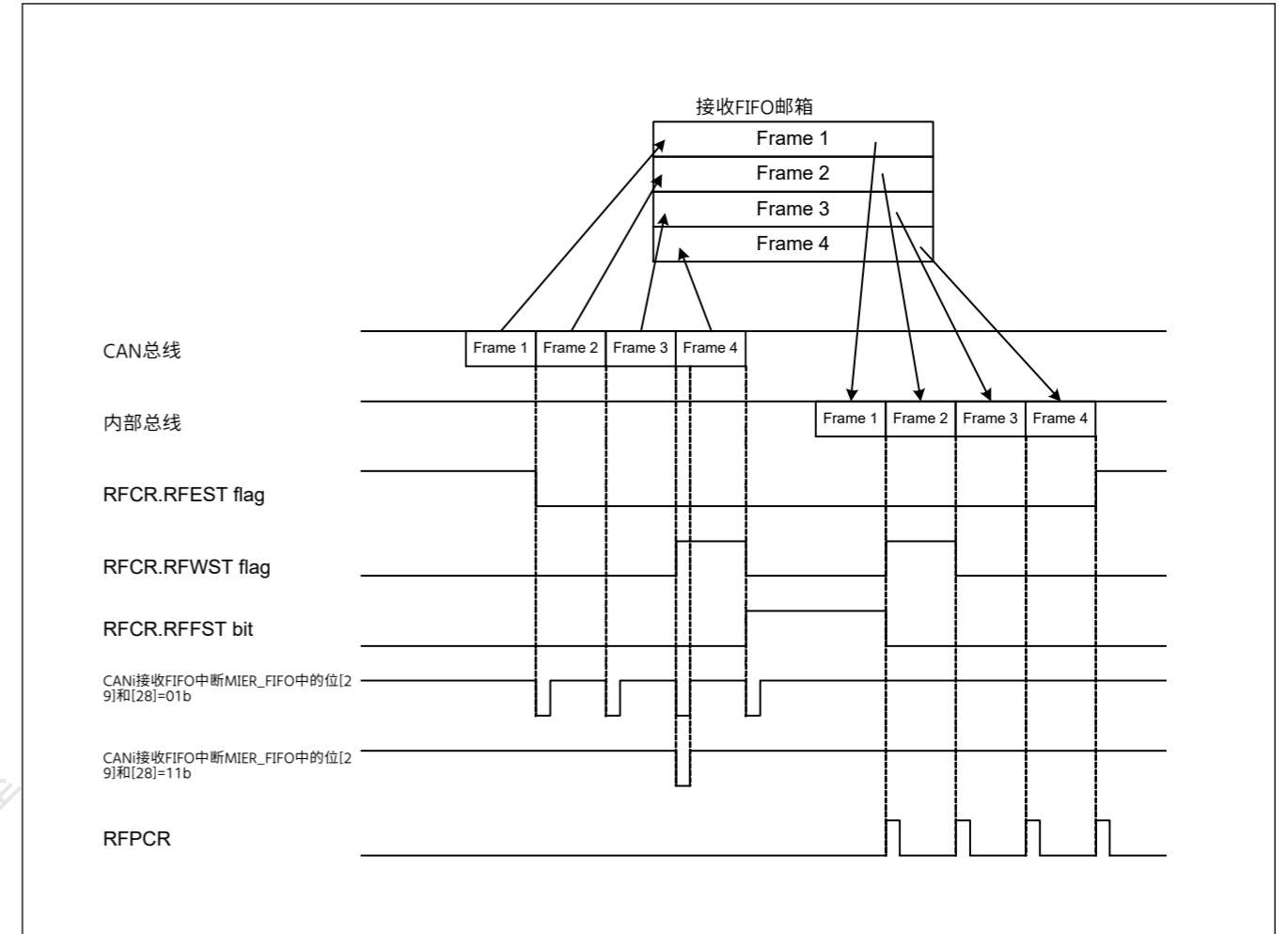
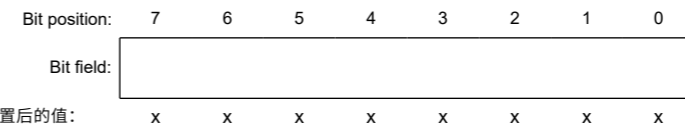


Figure 29.2 当MIER\_FIFO中的位[29]和[28]=01b或11b时接收FIFO邮箱操作

29.2.12 RFPCR：接收FIFO指针控制寄存器

Base address: CANn = 0x400A\_8000 + 0x1000 × n (n = 0, 1)

Offset address: 0x849



| Bit | Symbol | Function                       | R/W |
|-----|--------|--------------------------------|-----|
| 7:0 | n/a    | 通过将0xFF写入RFPCR，接收FIFO的CPU指针递增。 | W   |

当接收FIFO不为空时，通过软件向RFPCR写入0xFF以使CPU指针递增到下一个邮箱位置。当RFCR中的RFE位为0（禁用接收FIFO）时，不要写入RFPCR。

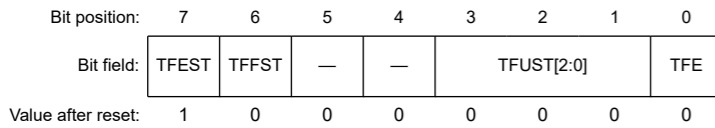
当接收到新消息并且在覆盖模式下RFFST标志为1（接收FIFO已满）时，CAN和CPU指针都会递增。在这种情况下，当RFMLF标志为1时，CPU指针不会在软件写入RFPCR时递增。



## 29.2.13 TFCR : Transmit FIFO Control Register

Base address: CANn = 0x400A\_8000 + 0x1000 × n (n = 0, 1)

Offset address: 0x84A



| Bit | Symbol     | Function   | R/W |
|-----|------------|--|-----|
| 0   | TFE        | Transmit FIFO Enable<br>0: Disable transmit FIFO<br>1: Enable transmit FIFO  | R/W |
| 3:1 | TFUST[2:0] | Transmit FIFO Unsent Message Number Status<br>0 0 0: 0 unsent messages<br>0 0 1: 1 unsent message<br>0 1 0: 2 unsent messages<br>0 1 1: 3 unread messages<br>1 0 0: 4 unread messages<br>1 0 1: Reserved<br>1 1 0: Reserved<br>1 1 1: Reserved | R   |
| 5:4 | —          | These bits are read as 0. The write value should be 0.   | R/W |
| 6   | TFFST      | Transmit FIFO Full Status<br>0: Transmit FIFO not full<br>1: Transmit FIFO full (4 unsent messages)  | R   |
| 7   | TFEST      | Transmit FIFO Empty Status<br>0: Unsent message in transmit FIFO<br>1: No unsent message in transmit FIFO  | R   |

Write to TFCR in CAN operation or halt mode.

**TFE bit (Transmit FIFO Enable)**

Setting the TFE bit set to 1 enables the transmit FIFO. Setting the TFE bit to 0 empties the transmit FIFO (TFEST bit = 1), and unsent messages in the transmit FIFO are lost in the following ways:

- Immediately if a message from the transmit FIFO is not scheduled for the next transmission or is already in transmission
- On completion of transmission, on a CAN bus error, CAN bus arbitration-lost, or entry to CAN halt mode, if a message from the transmit FIFO is scheduled for the next transmission or is already in transmission.

Before setting the TFE bit to 1 again, ensure that the TFEST bit is set to 1. After setting the TFE bit to 1, write transmit data to mailbox 24.

Do not set the TFE bit to 1 in normal mailbox mode (MBM bit in CTRL = 0).

**TFUST[2:0] bits (Transmit FIFO Unsent Message Number Status)**

The TFUST[2:0] bits indicate the number of unsent messages in the transmit FIFO. These bits are set to 000b after the TFE bit is set to 0 and transmission is aborted or completes.

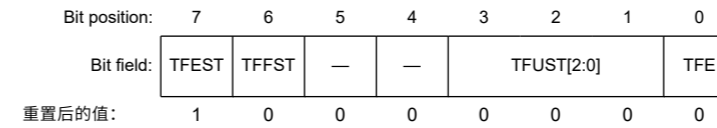
**TFFST bit (Transmit FIFO Full Status)**

The TFFST bit is set to 1 (transmit FIFO is full) when the number of unsent messages in the transmit FIFO is 4. The TFFST bit is set to 0 (transmit FIFO is not full) when the number of unsent messages in the transmit FIFO is less than 4. The TFFST bit is set to 0 when transmission from the transmit FIFO is aborted.

## 29.2.13 TFCR:发送FIFO控制寄存器

Base address: CANn = 0x400A\_8000 + 0x1000 × n (n = 0, 1)

Offset address: 0x84A



| Bit | Symbol     | Function   | R/W |
|-----|------------|--|-----|
| 0   | TFE        | 发送FIFO使能<br>0: 禁用发送FIFO<br>1: 启用发送FIFO   | R/W |
| 3:1 | TFUST[2:0] | 发送FIFO未发送消息编号状态<br>000: 0条未发送消息<br>001: 1条未发送消息<br>010: 2条未发送消息<br>011: 3条未读消息<br>100: 4条未读消息<br>101: 保留<br>110: 保留<br>111: 保留 | R   |
| 5:4 | —          | 这些位被读取为0。写入值应为0。   | R/W |
| 6   | TFFST      | 发送FIFO满状态<br>0: 发送FIFO未满<br>1: 发送FIFO已满 (4个未发送消息)  | R   |
| 7   | TFEST      | 发送FIFO空状态<br>0: 发送FIFO中未发送消息<br>1: 发送FIFO中没有未发送消息  | R   |

在CAN操作或暂停模式下写入TFCR。

**TFE bit (Transmit FIFO Enable)**

将TFE位设置为1会启用发送FIFO。将TFE位设置为0会清空发送FIFO (TFEST位=1)，发送FIFO中未发送的消息会通过以下方式丢失:

- 如果来自发送FIFO的消息未安排下一次发送或已在发送中，则立即发送
- 在传输完成、CAN总线错误、CAN总线仲裁丢失或进入CAN暂停模式时，如果来自传输FIFO的消息被安排用于下一次传输或已经在传输中。

再次将TFE位设置为1之前，请确保TFEST位设置为1。将TFE位设置为1后，将发送数据写入邮箱24。

不要在正常邮箱模式下将TFE位设置为1 (CTRL中的MBM位=0)。

**TFUST[2:0]位 (发送FIFO未发送消息编号状态)**

TFUST[2:0]位指示发送FIFO中未发送消息的数量。在TFE位设置为0并且传输被中止或完成后，这些位设置为000b。

**TFFST位 (发送FIFO满状态)**

当发送FIFO中未发送消息的数量为4时，TFFST位设置为1 (发送FIFO已满)。当发送FIFO中未发送消息的数量为4时，TFFST位设置为0 (发送FIFO未满) 小于4。当来自发送FIFO的发送被中止时，TFFST位设置为0。

**TFEST bit (Transmit FIFO Empty Status)**

The TFEST bit is set to 1 (no message in transmit FIFO) when the number of unsent messages in the transmit FIFO is 0. The TFEST bit is set to 1 when transmission from the transmit FIFO is aborted. The TFEST bit is set to 0 (message in transmit FIFO) when the number of unsent messages in the transmit FIFO is not 0.

Figure 29.3 shows the transmit FIFO mailbox operation.

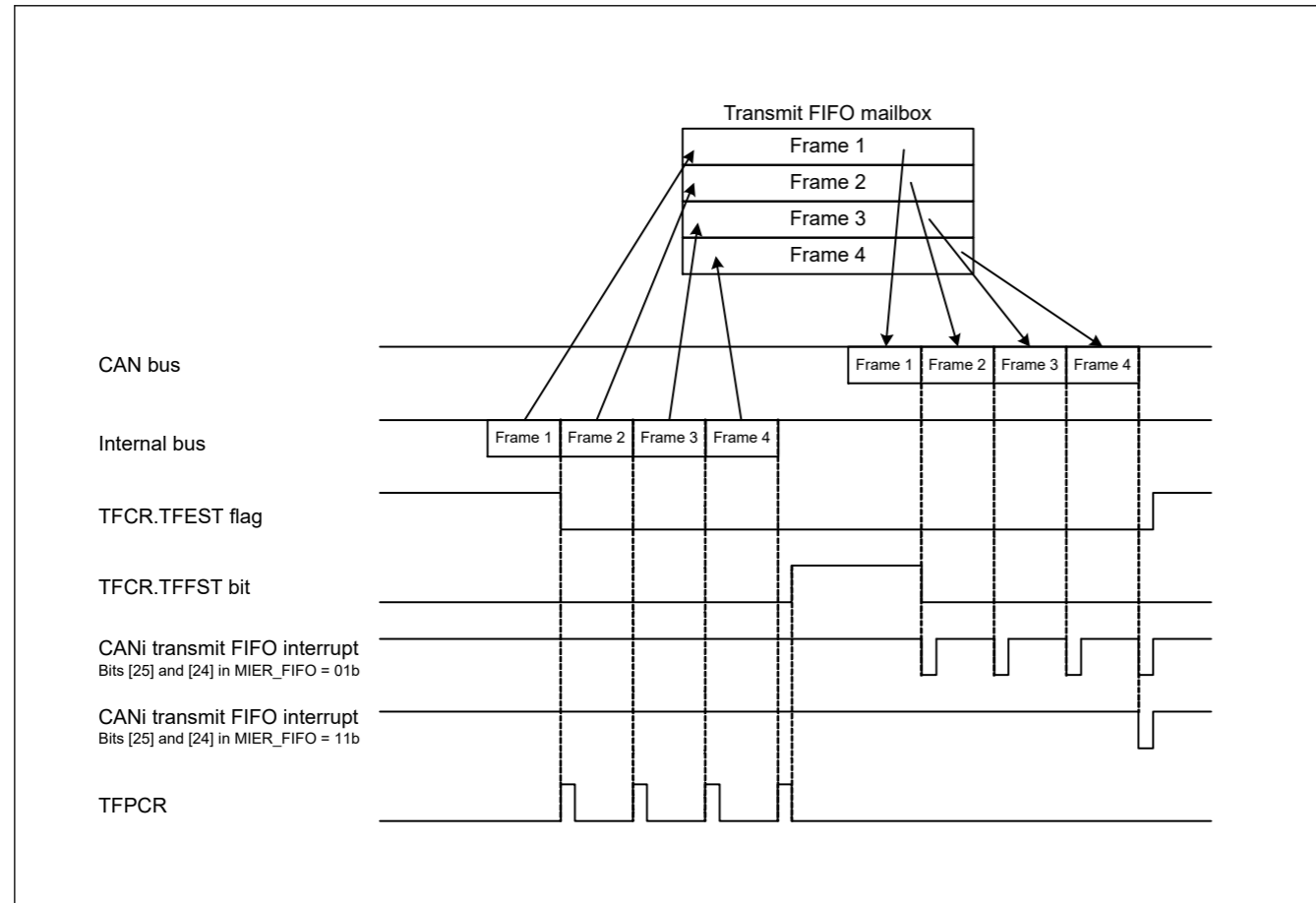
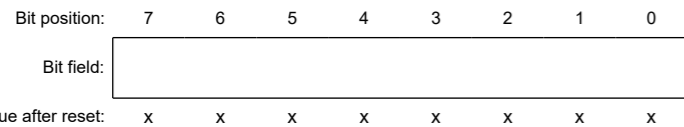


Figure 29.3 Transmit FIFO mailbox operation when bits [25] and [24] in MIER\_FIFO = 01b or 11b

**29.2.14 TFPCR : Transmit FIFO Pointer Control Register**

Base address: CANn = 0x400A\_8000 + 0x1000 × n (n = 0, 1)

Offset address: 0x84B



| Bit | Symbol | Function   | R/W |
|-----|--------|--|-----|
| 7:0 | n/a    | The CPU pointer for the transmit FIFO is incremented by writing 0xFF to TFPCR. | W   |

When the transmit FIFO is not full, write 0xFF to TFPCR through software to increment the CPU pointer for the transmit FIFO to the next mailbox location.

Do not write to TFPCR when the TFE bit in TFCR is 0 (transmit FIFO disabled).

**TFEST位 (发送FIFO空状态)**

当发送FIFO中未发送消息的数量为0时，TFEST位设置为1（发送FIFO中没有消息）。当来自发送FIFO的发送被中止时，TFEST位设置为1。当发送FIFO中未发送消息的数量不为0时，TFEST位设置为0（发送FIFO中的消息）。

图29.3显示了发送FIFO邮箱操作。

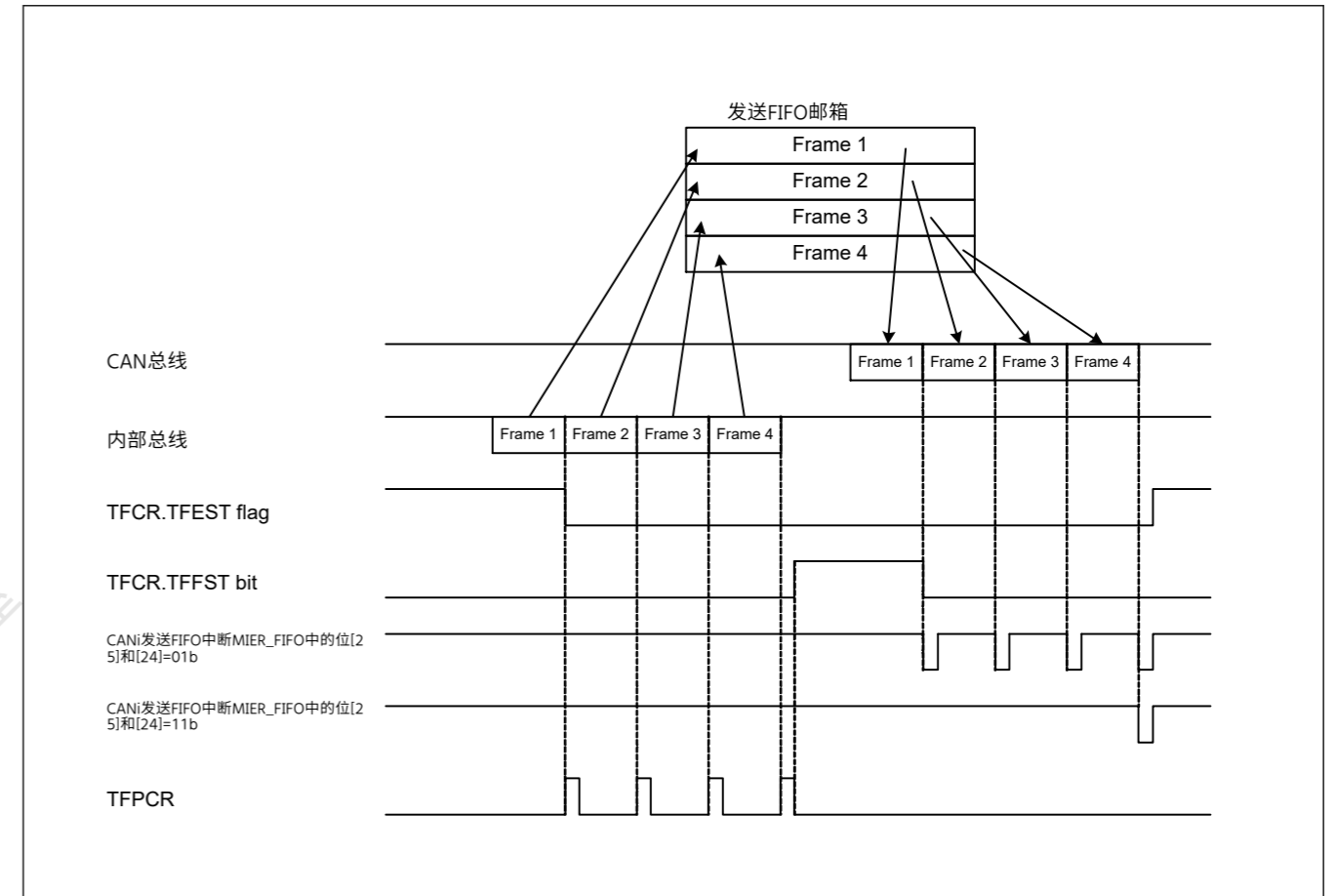
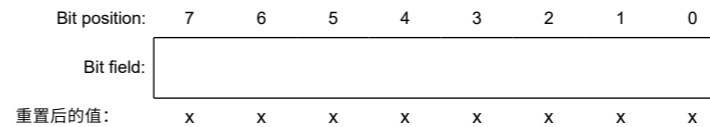


Figure 29.3 当MIER\_FIFO中的位[25]和[24]=01b或11b时发送FIFO邮箱操作

**29.2.14 TFPCR: 发送FIFO指针控制寄存器**

Base address: CANn = 0x400A\_8000 + 0x1000 × n (n = 0, 1)

Offset address: 0x84B



| Bit | Symbol | Function                       | R/W |
|-----|--------|--------------------------------|-----|
| 7:0 | n/a    | 通过将0xFF写入TFPCR，发送FIFO的CPU指针递增。 | W   |

当发送FIFO未满载时，通过软件向TFPCR写入0xFF以增加发送的CPU指针FIFO到下一个邮箱位置。

当TFCR中的TFE位为0（禁用发送FIFO）时，不要写入TFPCR。

## 29.2.15 STR : Status Register

Base address: CANn = 0x400A\_8000 + 0x1000 × n (n = 0, 1)

Offset address: 0x842

|                    |    |           |           |      |      |       |       |           |     |       |           |           |      |      |      |      |
|--------------------|----|-----------|-----------|------|------|-------|-------|-----------|-----|-------|-----------|-----------|------|------|------|------|
| Bit position:      | 15 | 14        | 13        | 12   | 11   | 10    | 9     | 8         | 7   | 6     | 5         | 4         | 3    | 2    | 1    | 0    |
| Bit field:         | —  | RECS<br>T | TRMS<br>T | BOST | EPST | SLPST | HLTST | RSTS<br>T | EST | TABST | FMLS<br>T | NMLS<br>T | TFST | RFST | SDST | NDST |
| Value after reset: | 0  | 0         | 0         | 0    | 0    | 1     | 0     | 1         | 0   | 0     | 0         | 0         | 0    | 0    | 0    | 0    |

| Bit | Symbol | Function   | R/W |
|-----|--------|--|-----|
| 0   | NDST   | NEWDATA Status Flag<br>0: No mailbox with NEWDATA = 1<br>1: One or more mailboxes with NEWDATA = 1                     | R   |
| 1   | SDST   | SENTDATA Status Flag<br>0: No mailbox with SENTDATA = 1<br>1: One or more mailboxes with SENTDATA = 1                  | R   |
| 2   | RFST   | Receive FIFO Status Flag<br>0: Receive FIFO empty<br>1: Message in receive FIFO  | R   |
| 3   | TFST   | Transmit FIFO Status Flag<br>0: Transmit FIFO is full<br>1: Transmit FIFO is not full                                  | R   |
| 4   | NMLST  | Normal Mailbox Message Lost Status Flag<br>0: No mailbox with MSGLOST = 1<br>1: One or more mailboxes with MSGLOST = 1 | R   |
| 5   | FMLST  | FIFO Mailbox Message Lost Status Flag<br>0: RFMLF = 0<br>1: RFMLF = 1  | R   |
| 6   | TABST  | Transmission Abort Status Flag<br>0: No mailbox with TRMABT = 1<br>1: One or more mailboxes with TRMABT = 1            | R   |
| 7   | EST    | Error Status Flag<br>0: No error occurred<br>1: Error occurred   | R   |
| 8   | RSTST  | CAN Reset Status Flag<br>0: Not in CAN reset mode<br>1: In CAN reset mode  | R   |
| 9   | HLTST  | CAN Halt Status Flag<br>0: Not in CAN halt mode<br>1: In CAN halt mode   | R   |
| 10  | SLPST  | CAN Sleep Status Flag<br>0: Not in CAN sleep mode<br>1: In CAN sleep mode  | R   |
| 11  | EPST   | Error-Passive Status Flag<br>0: Not in error-passive state<br>1: In error-passive state                                | R   |
| 12  | BOST   | Bus-Off Status Flag<br>0: Not in bus-off state<br>1: In bus-off state  | R   |
| 13  | TRMST  | Transmit Status Flag<br>0: Bus idle or reception in progress<br>1: Transmission in progress or module in bus-off state | R   |
| 14  | RECST  | Receive Status Flag<br>0: Bus idle or transmission in progress<br>1: Reception in progress                             | R   |

## 29.2.15 STR:状态寄存器

Base address: CANn = 0x400A\_8000 + 0x1000 × n (n = 0, 1)

Offset address: 0x842

|               |    |           |           |      |      |       |       |           |     |       |           |           |      |      |      |      |
|---------------|----|-----------|-----------|------|------|-------|-------|-----------|-----|-------|-----------|-----------|------|------|------|------|
| Bit position: | 15 | 14        | 13        | 12   | 11   | 10    | 9     | 8         | 7   | 6     | 5         | 4         | 3    | 2    | 1    | 0    |
| Bit field:    | —  | RECS<br>T | TRMS<br>T | BOST | EPST | SLPST | HLTST | RSTS<br>T | EST | TABST | FMLS<br>T | NMLS<br>T | TFST | RFST | SDST | NDST |
| 重置后的值:        | 0  | 0         | 0         | 0    | 0    | 1     | 0     | 1         | 0   | 0     | 0         | 0         | 0    | 0    | 0    | 0    |

| Bit | Symbol | Function  | R/W |
|-----|--------|---|-----|
| 0   | NDST   | NEWDATA状态标志<br>0: 没有NEWDATA=1的邮箱1: 一个或多个NEWDATA=1的邮箱    | R   |
| 1   | SDST   | SENTDATA状态标志<br>0: 没有SENTDATA=1的邮箱1: 一个或多个SENTDATA=1的邮箱 | R   |
| 2   | RFST   | 接收FIFO状态标志<br>0: 接收FIFO为空1: 接收FIFO中的报文                  | R   |
| 3   | TFST   | 发送FIFO状态标志<br>0: 发送FIFO已满1: 发送FIFO未满                    | R   |
| 4   | NMLST  | 正常邮箱消息丢失状态标志<br>0: 没有MSGLOST=1的邮箱1: 一个或多个MSGLOST=1的邮箱   | R   |
| 5   | FMLST  | FIFO邮箱消息丢失状态标志<br>0: RFMLF = 0<br>1: RFMLF = 1          | R   |
| 6   | TABST  | 传输中止状态标志<br>0: 没有TRMABT=1的邮箱1: 一个或多个TRMABT=1的邮箱         | R   |
| 7   | EST    | 错误状态标志<br>0: 未发生错误1: 发生错误                               | R   |
| 8   | RSTST  | CAN复位状态标志<br>0: 不处于CAN复位模式1: 处于CAN复位模式                  | R   |
| 9   | HLTST  | CAN停止状态标志<br>0: 不处于CAN停止模式1: 处于CAN停止模式                  | R   |
| 10  | SLPST  | CAN睡眠状态标志<br>0: 不处于CAN休眠模式1: 处于CAN休眠模式                  | R   |
| 11  | EPST   | 错误被动状态标志<br>0: 不处于被动错误状态1: 处于被动错误状态                     | R   |
| 12  | BOST   | 总线关闭状态标志<br>0: 不处于总线关闭状态1: 处于总线关闭状态                     | R   |
| 13  | TRMST  | 发送状态标志<br>0: 总线空闲或接收中1: 传输中或模块处于总线关闭状态                  | R   |
| 14  | RECST  | 接收状态标志<br>0: 总线空闲或发送中1: 接收中                             | R   |

| Bit | Symbol | Function               | R/W |
|-----|--------|------------------------|-----|
| 15  | —      | This bit is read as 0. | R   |

**NDST flag (NEWDATA Status Flag)**

The NDST flag is set to 1 when at least one NEWDATA flag in MCTL\_RX[j] (j = 0 to 31) is 1, regardless of the value of MIER or MIER\_FIFO. The NDST flag is set to 0 when all NEWDATA flags are 0.

**SDST flag (SENTDATA Status Flag)**

The SDST flag is set to 1 when at least one SENTDATA flag in MCTL\_TX[j] (j = 0 to 31) is 1, regardless of the value of MIER or MIER\_FIFO. The SDST flag is set to 0 when all SENTDATA flags are 0.

**RFST flag (Receive FIFO Status Flag)**

The RFST flag is set to 1 when the receive FIFO is not empty. The RFST flag is set to 0 when the receive FIFO is empty or normal mailbox mode is selected.

**TFST flag (Transmit FIFO Status Flag)**

The TFST flag is set to 1 when the transmit FIFO is not full. The TFST flag is set to 0 when the transmit FIFO is full or normal mailbox mode is selected.

**NMLST flag (Normal Mailbox Message Lost Status Flag)**

The NMLST flag is set to 1 when at least one MSGLOST flag in MCTL\_RX[j] (j = 0 to 31) is 1, regardless of the value of MIER or MIER\_FIFO. The NMLST flag is set to 0 when all MSGLOST flags are 0.

**FMLST flag (FIFO Mailbox Message Lost Status Flag)**

The FMLST flag is set to 1 when the RFMLF flag in RFCR is 1, regardless of the value of MIER\_FIFO. The FMLST flag is set to 0 when the RFMLF flag is 0.

**TABST flag (Transmission Abort Status Flag)**

The TABST flag is set to 1 when at least one TRMABT flag in MCTL\_TX[j] (j = 0 to 31) is 1, regardless of the value of MIER or MIER\_FIFO. The TABST flag is set to 0 when all TRMABT flags are 0.

**EST flag (Error Status Flag)**

The EST flag is set to 1 when at least one error is detected by EIFR, regardless of the value of EIER. The EST flag is set to 0 when no error is detected by EIFR.

**RSTST flag (CAN Reset Status Flag)**

The RSTST flag is set to 1 when the CAN module is in CAN reset mode. The RSTST flag is 0 when the CAN module is not in CAN reset mode. Even when the state changes from CAN reset mode to CAN sleep mode, the flag remains 1.

**HLTST flag (CAN Halt Status Flag)**

The HLTST flag is set to 1 when the CAN module is in CAN halt mode. The HLTST is set to 0 when the CAN module is not in CAN halt mode. Even when the state changes from CAN halt mode to CAN sleep mode, the flag remains 1.

**SLPST flag (CAN Sleep Status Flag)**

The SLPST flag is set to 1 when the CAN module is in CAN sleep mode. The SLPST flag is set to 0 when the CAN module is not in CAN sleep mode.

**EPST flag (Error-Passive Status Flag)**

The EPST flag is set to 1 when the value of TECR or RECR exceeds 127 and the CAN module is in the error-passive state ( $128 \leq \text{TEC} < 256$  or  $128 \leq \text{REC} < 256$ ). The EPST flag is set to 0 when the CAN module is not in the error-passive state.

**BOST flag (Bus-Off Status Flag)**

The BOST flag is set to 1 when the value of TECR exceeds 255 and the CAN module is in the bus-off state ( $\text{TEC} \geq 256$ ). The BOST flag is set to 0 when the CAN module is not in the bus-off state.

| Bit | Symbol | Function | R/W |
|-----|--------|----------|-----|
| 15  | —      | 该位读为0。   | R   |

**NDST标志 (NEWDATA状态标志)**

当MCTL\_RX[j](j=0到31)中的至少一个NEWDATA标志为1时，NDST标志设置为1，无论MIER或MIER\_FIFO。当所有NEWDATA标志为0时，NDST标志设置为0。

**SDST标志 (SENTDATA状态标志)**

当MCTL\_TX[j](j=0到31)中的至少一个SENTDATA标志为1时，SDST标志设置为1，无论MIER或MIER\_FIFO。当所有SENTDATA标志为0时，SDST标志设置为0。

**RFST标志 (接收FIFO状态标志)**

当接收FIFO不为空时，RFST标志设置为1。当接收FIFO为空或选择正常邮箱模式时，RFST标志设置为0。

**TFST标志 (发送FIFO状态标志)**

当发送FIFO未滿时，TFST标志设置为1。当发送FIFO已滿或选择正常邮箱模式时，TFST标志设置为0。

**NMLST标志 (普通邮箱消息丢失状态标志)**

当MCTL\_RX[j](j=0到31)中的至少一个MSGLOST标志为1时，NMLST标志设置为1，无论MIER或MIER\_FIFO。当所有MSGLOST标志为0时，NMLST标志设置为0。

**FMLST标志 (FIFO邮箱消息丢失状态标志)**

当RFCR中的RFMLF标志为1时，无论MIER\_FIFO的值如何，FMLST标志都设置为1。当RFMLF标志为0时，FMLST标志设置为0。

**TABST标志 (传输中止状态标志)**

当MCTL\_TX[j](j=0到31)中的至少一个TRMABT标志为1时，TABST标志设置为1，无论MIER或MIER\_FIFO。当所有TRMABT标志为0时，TABST标志设置为0。

**EST标志 (错误状态标志)**

当EIFR检测到至少一个错误时，无论EIER的值如何，EST标志设置为1。当EIFR未检测到错误时，EST标志设置为0。

**RSTST标志 (CAN复位状态标志)**

当CAN模块处于CAN复位模式时，RSTST标志设置为1。当CAN模块未处于CAN复位模式时，RSTST标志为0。即使状态从CAN复位模式更改为CAN睡眠模式，该标志仍保持为1。

**HLTST标志 (CAN停止状态标志)**

当CAN模块处于CAN暂停模式时，HLTST标志设置为1。当CAN模块未处于CAN暂停模式时，HLTST设置为0。即使状态从CAN停止模式更改为CAN睡眠模式，该标志仍保持为1。

**SLPST标志 (CAN睡眠状态标志)**

当CAN模块处于CAN睡眠模式时，SLPST标志设置为1。当CAN模块未处于CAN睡眠模式时，SLPST标志设置为0。

**EPST标志 (错误被动状态标志)**

当TECR或RECR的值超过127并且CAN模块处于错误被动状态 ( $128 \leq \text{TEC} < 256$  或  $128 \leq \text{REC} < 256$ ) 时，EPST标志设置为1。当CAN模块不处于被动错误状态时，EPST标志设置为0。

**BOST标志 (总线关闭状态标志)**

当TECR的值超过255并且CAN模块处于总线关闭状态 ( $\text{TEC} \geq 256$ ) 时，BOST标志设置为1。当CAN模块不处于总线关闭状态时，BOST标志设置为0。



**TRMST flag (Transmit Status Flag)**

The TRMST flag is set to 1 when the CAN module performs as a transmitter node or is in the bus-off state. The TRMST flag is set to 0 when the CAN module performs as a receiver node or is in the bus-idle state.

**RECST flag (Receive Status Flag)**

The RECST flag is set to 1 when the CAN module performs as a receiver node. The RECST flag is set to 0 when the CAN module performs as a transmitter node or is in the bus-idle state.

**29.2.16 MSMR : Mailbox Search Mode Register**

Base address: CANn = 0x400A\_8000 + 0x1000 × n (n = 0, 1)

Offset address: 0x853

|                    |   |   |   |   |   |   |           |   |
|--------------------|---|---|---|---|---|---|-----------|---|
| Bit position:      | 7 | 6 | 5 | 4 | 3 | 2 | 1         | 0 |
| Bit field:         | — | — | — | — | — | — | MBSM[1:0] |   |
| Value after reset: | 0 | 0 | 0 | 0 | 0 | 0 | 0         | 0 |

| Bit | Symbol    | Function   | R/W |
|-----|-----------|--|-----|
| 1:0 | MBSM[1:0] | Mailbox Search Mode Select<br>0 0: Receive mailbox search mode<br>0 1: Transmit mailbox search mode<br>1 0: Message lost search mode<br>1 1: Channel search mode | R/W |
| 7:2 | —         | These bits are read as 0. The write value should be 0.   | R/W |

Write to MSMR in CAN operation or halt mode.

**MBSM[1:0] bits (Mailbox Search Mode Select)**

The MBSM[1:0] bits select the search mode for the mailbox search function.

When the MBSM[1:0] bits are 00b, receive mailbox search mode is selected. In this mode, the search targets are the NEWDATA flag in MCTL\_RX[j] (j = 0 to 31) for the normal mailbox and the RFEST flag in RFCR.

When the MBSM[1:0] bits are 01b, transmit mailbox search mode is selected. In this mode, the search target is the SENTDATA flag in MCTL\_TX[j].

When the MBSM[1:0] bits are 10b, message lost search mode is selected. In this mode, the search targets are the MSGLOST flag in MCTL\_RX[j] for the normal mailbox and the RFMLF flag in RFCR.

When the MBSM[1:0] bits are 11b, channel search mode is selected. In this mode, the search target is CSSR. See [section 29.2.18. CSSR : Channel Search Support Register](#).

**29.2.17 MSSR : Mailbox Search Status Register**

Base address: CANn = 0x400A\_8000 + 0x1000 × n (n = 0, 1)

Offset address: 0x852

|                    |      |   |   |            |   |   |   |   |
|--------------------|------|---|---|------------|---|---|---|---|
| Bit position:      | 7    | 6 | 5 | 4          | 3 | 2 | 1 | 0 |
| Bit field:         | SEST | — | — | MBNST[4:0] |   |   |   |   |
| Value after reset: | 1    | 0 | 0 | 0          | 0 | 0 | 0 | 0 |

| Bit | Symbol     | Function   | R/W |
|-----|------------|--|-----|
| 4:0 | MBNST[4:0] | Search Result Mailbox Number Status<br>These bits output the smallest mailbox number that is found in each search mode selected in the MSMR. | R   |
| 6:5 | —          | These bits are read as 0.  | R   |

**TRMST标志 (发送状态标志)**

当CAN模块作为发送器节点运行或处于总线关闭状态时，TRMST标志设置为1。当CAN模块作为接收器节点运行或处于总线空闲状态时，TRMST标志设置为0。

**RECST标志 (接收状态标志)**

当CAN模块作为接收器节点运行时，RECST标志设置为1。当CAN模块作为发送器节点运行或处于总线空闲状态时，RECST标志设置为0。

**29.2.16 MSMR: 邮箱搜索模式寄存器**

Base address: CANn = 0x400A\_8000 + 0x1000 × n (n = 0, 1)

Offset address: 0x853

|               |   |   |   |   |   |   |           |   |
|---------------|---|---|---|---|---|---|-----------|---|
| Bit position: | 7 | 6 | 5 | 4 | 3 | 2 | 1         | 0 |
| Bit field:    | — | — | — | — | — | — | MBSM[1:0] |   |
| 重置后的值:        | 0 | 0 | 0 | 0 | 0 | 0 | 0         | 0 |

| Bit | Symbol    | Function   | R/W |
|-----|-----------|--|-----|
| 1:0 | MBSM[1:0] | 邮箱搜索模式选择<br>00: 接收邮箱搜索模式01: 发送邮箱搜索模式10: 消息丢失搜索模式11: 频道搜索模式 | R/W |
| 7:2 | —         | 这些位被读取为0。写入值应为0。   | R/W |

在CAN操作或暂停模式下写入MSMR。

**MBSM[1:0]位 (邮箱搜索模式选择)**

MBSM[1:0]位选择邮箱搜索功能的搜索模式。

当MBSM[1:0]位为00b时，选择接收邮箱搜索模式。在这种模式下，搜索目标是MCTL\_RX[j]中的NEWDATA标志 (j=0到31) 用于普通邮箱和RFCR中的RFEST标志。

当MBSM[1:0]位为01b时，选择发送邮箱搜索模式。在这种模式下，搜索目标是MCTL\_TX[j]中的SENTDATA标志。

当MBSM[1:0]位为10b时，选择消息丢失搜索模式。在这种模式下，搜索目标是正常邮箱的MCTL\_RX[j]中的MSGLOST标志和RFCR中的RFMLF标志。

当MBSM[1:0]位为11b时，选择频道搜索模式。在这种模式下，搜索目标是CSSR。请参阅第29.2.18节。CSSR：频道搜索支持寄存器。

**29.2.17 MSSR: 邮箱搜索状态寄存器**

Base address: CANn = 0x400A\_8000 + 0x1000 × n (n = 0, 1)

Offset address: 0x852

|               |      |   |   |            |   |   |   |   |
|---------------|------|---|---|------------|---|---|---|---|
| Bit position: | 7    | 6 | 5 | 4          | 3 | 2 | 1 | 0 |
| Bit field:    | SEST | — | — | MBNST[4:0] |   |   |   |   |
| 重置后的值:        | 1    | 0 | 0 | 0          | 0 | 0 | 0 | 0 |

| Bit | Symbol     | Function                                     | R/W |
|-----|------------|--|-----|
| 4:0 | MBNST[4:0] | 搜索结果邮箱号码状态<br>这些位输出在MSMR中选择的每个搜索模式中找到的最小邮箱号。 | R   |
| 6:5 | —          | 这些位读为0。                                      | R   |

| Bit | Symbol | Function  | R/W |
|-----|--------|---|-----|
| 7   | SEST   | Search Result Status<br>0: Search result found<br>1: No search result | R   |

**MBNST[4:0] bits (Search Result Mailbox Number Status)**

In all mailbox search modes, the MBNST[4:0] bits output the smallest found mailbox number. In receive mailbox search mode, transmit mailbox search mode, and message lost search mode, the value of the mailbox (the search result to be output) is updated under the following conditions:

- When the associated NEWDATA, SENTDATA, or MSGLOST flag is set to 0 for a mailbox output by MBNST[4:0]
- When the associated NEWDATA, SENTDATA, or MSGLOST flag is set to 1 for a mailbox with a smaller number than that in MBNST[4:0]

If the MBSM[1:0] bits are set to 00b (receive mailbox search mode) or 10b (message lost search mode), the receive FIFO (mailbox 28) is output when it is not empty and there are no unread received messages and no lost messages in any of the normal mailboxes 0 to 23. If the MBSM[1:0] bits are set to 01b (transmit mailbox search mode), the transmit FIFO (mailbox 24) is not output. Table 29.6 lists the behavior of the MBNST[4:0] bits in FIFO mailbox mode.

In channel search mode, the MBNST[4:0] bits output the associated channel number. After MSSR is read by software, the next target channel number is output.

**SEST bit (Search Result Status)**

The SEST bit is set to 1 (no search result) when no associated mailbox is found after searching all mailboxes. For example, in transmit mailbox search mode, the SEST bit is set to 1 when no SENTDATA flag is 1 for any mailbox. The SEST bit is set to 0 when at least one SENTDATA flag is 1. When the SEST bit is 1, the value of the MBNST[4:0] bits is undefined.

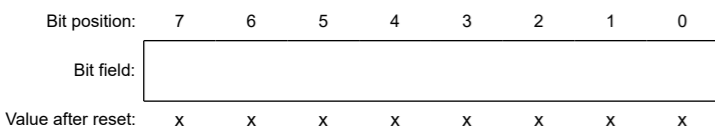
**Table 29.6 Behavior of MBNST[4:0] bits in FIFO mailbox mode**

| MBSM[1:0] bits | Mailbox 24 (transmit FIFO) | Mailbox 28 (receive FIFO)  |
|----------------|----------------------------|--|
| 00b            | Mailbox 24 is not output.  | Mailbox 28 is output when no MCTL_RX[j].NEWDATA flag for the normal mailboxes is set to 1 (new message is being stored or was stored in the mailbox) and the receive FIFO is not empty.                            |
| 01b            |                            | Mailbox 28 is not output.  |
| 10b            |                            | Mailbox 28 is output when no MCTL_RX[j].MSGLOST flag for the normal mailboxes is set to 1 (message is overwritten or overrun) and the RFCR.RFMLF flag is set to 1 (receive FIFO message lost) in the receive FIFO. |
| 11b            |                            | Mailbox 28 is not output.  |

**29.2.18 CSSR : Channel Search Support Register**

Base address: CANn = 0x400A\_8000 + 0x1000 × n (n = 0, 1)

Offset address: 0x851



| Bit | Symbol | Function  | R/W |
|-----|--------|---|-----|
| 7:0 | n/a    | When the value for the channel search is input, the channel number is output to MSSR. | R/W |

The bits that are set to 1 in CSSR, are encoded by an 8/3 encoder (the LSB position has the higher priority) and output to the MBNST[4:0] bits in MSSR. MSSR outputs the updated value whenever it is read by software.

Write to CSSR only when the MSRM.MBSM[1:0] bits are 11b (channel search mode). Write to CSSR in CAN operation mode or CAN halt mode.

Figure 29.4 shows the write and read operations of the CSSR and MSSR registers.

| Bit | Symbol | Function                         | R/W |
|-----|--------|----------------------------------|-----|
| 7   | SEST   | 搜索结果状态<br>0: 找到搜索结果<br>1: 没有搜索结果 | R   |

**MBNST[4:0]位 (搜索结果邮箱号码状态)**

在所有邮箱搜索模式中，MBNST[4:0]位输出找到的最小邮箱号。在接收邮箱搜索模式、发送邮箱搜索模式和消息丢失搜索模式下，邮箱的值（要输出的搜索结果）在以下条件下更新：

- 当MBNST[4:0]为邮箱输出的相关NEWDATA、SENTDATA或MSGLOST标志设置为0时
- 当邮箱的相关NEWDATA、SENTDATA或MSGLOST标志设置为1时，邮箱的编号小于MBNST[4:0]中的编号

如果MBSM[1:0]位设置为00b（接收邮箱搜索模式）或10b（邮件丢失搜索模式），则在接收FIFO（邮箱28）不为空且没有未读接收到的消息时输出在任何正常邮箱0到23中都没有丢失消息。如果MBSM[1:0]位设置为01b（发送邮箱搜索模式），则不输出发送FIFO（邮箱24）。表29.6列出了MBNST[4:0]位在FIFO邮箱模式下的行为。

在频道搜索模式下，MBNST[4:0]位输出相关的频道号。软件读取MSSR后，输出下一个目标通道号。

**SEST位 (搜索结果状态)**

当搜索所有邮箱后未找到相关邮箱时，SEST位设置为1（无搜索结果）。例如，在发送邮箱搜索模式中，当没有任何邮箱的SENTDATA标志为1时，SEST位设置为1。当至少一个SENTDATA标志为1时，SEST位设置为0。当SEST位为1时，MBNST[4:0]位的值未定义。

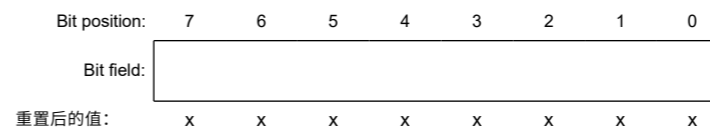
**Table 29.6 FIFO邮箱模式下MBNST[4:0]位的行为**

| MBSM[1:0] bits | Mailbox 24 (transmit FIFO) | Mailbox 28 (receive FIFO)   |
|----------------|----------------------------|---|
| 00b            | 邮箱24不输出。                   | 当正常邮箱的MCTL_RX[j].NEWDATA标志未设置为1（新消息正在存储或已存储在邮箱中）且接收FIFO不为空时，输出邮箱28。                     |
| 01b            |                            | 邮箱28不输出。  |
| 10b            |                            | 当正常邮箱的MCTL_RX[j].MSGLOST标志未设置为1（消息被覆盖或溢出）且接收FIFO中的RFCR.RFMLF标志设置为1（接收FIFO消息丢失）时，输出邮箱28。 |
| 11b            |                            | 邮箱28不输出。  |

**29.2.18 CSSR: 频道搜索支持注册**

Base address: CANn = 0x400A\_8000 + 0x1000 × n (n = 0, 1)

Offset address: 0x851



| Bit | Symbol | Function               | R/W |
|-----|--------|------------------------|-----|
| 7:0 | n/a    | 输入频道搜索的值时，频道号将输出到MSSR。 | R/W |

CSSR中设置为1的位由8/3编码器（LSB位置具有较高优先级）编码并输出到MSSR中的MBNST[4:0]位。每当软件读取时，MSSR就会输出更新的值。

仅当MSRM.MBSM[1:0]位为11b（通道搜索模式）时才写入CSSR。在CAN操作模式或CAN暂停模式下写入CSSR。

图29.4显示了CSSR和MSSR寄存器的写和读操作。

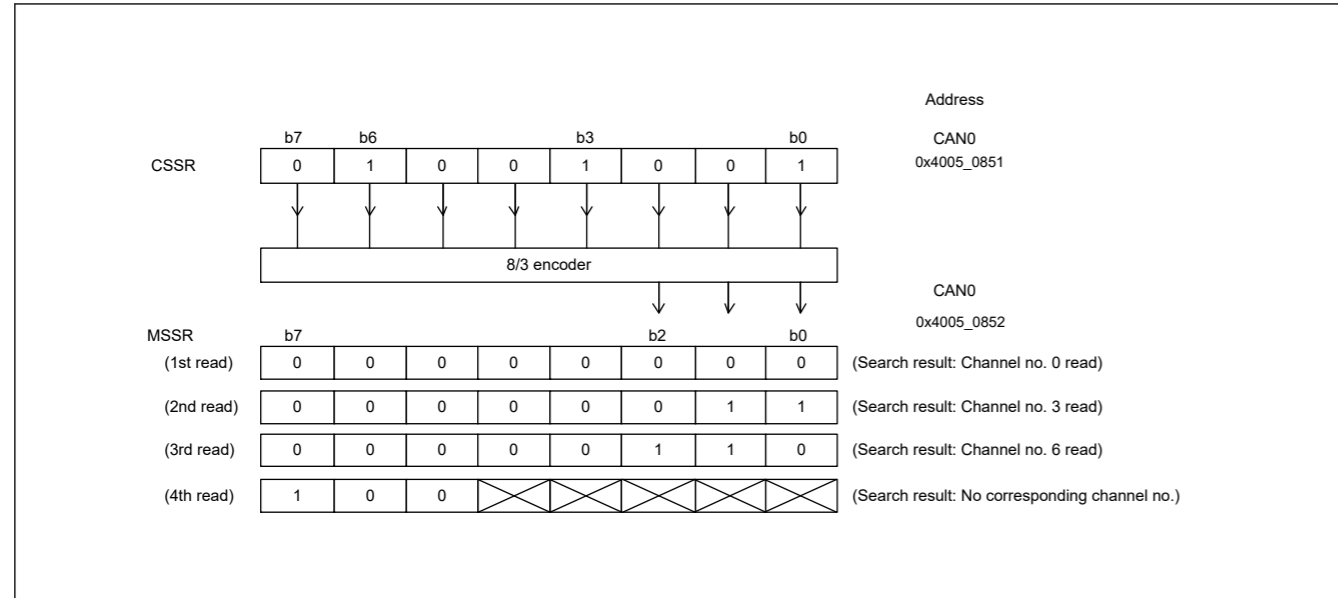


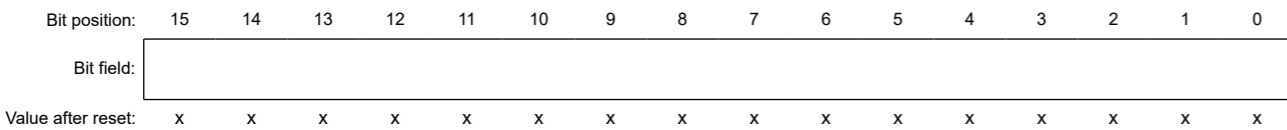
Figure 29.4 Write and read operations of the CSSR and MSSR registers

The value of CSSR is also updated whenever MSSR is read. On this read, the value prior to conversion by the 8/3 encoder can be read.

29.2.19 AFSR : Acceptance Filter Support Register

Base address: CANn = 0x400A\_8000 + 0x1000 × n (n = 0, 1)

Offset address: 0x856



| Bit  | Symbol | Function   | R/W |
|------|--------|--|-----|
| 15:0 | n/a    | After the standard ID of a received message is written, the value converted for data table search can be read. | R/W |

Note: Write to AFSR in CAN operation mode or CAN halt mode.

The acceptance filter support unit (ASU) can be used for data table (8 bits × 256) searches. In the data table, all standard IDs that are created are set as valid or invalid in bit units. When AFSR is written with data in 16-bit units including the SID[10:0] bits in MBj\_ID (j = 0 to 31), in which a received standard ID is stored, a decoded row (byte offset) position and column (bit) position for data table search can be read. The ASU can be used for standard (11-bit) IDs only.

The ASU is enabled in the following cases:

- When the ID to be received cannot be masked by the acceptance filter. For example, if IDs to be received are 0x078, 0x087, and 0x111.
- When there are too many IDs to receive, and the software filtering time is expected to be shortened.

Note: AFSR cannot be set in CAN reset mode.

Figure 29.5 shows the write and read operations in the AFSR register.

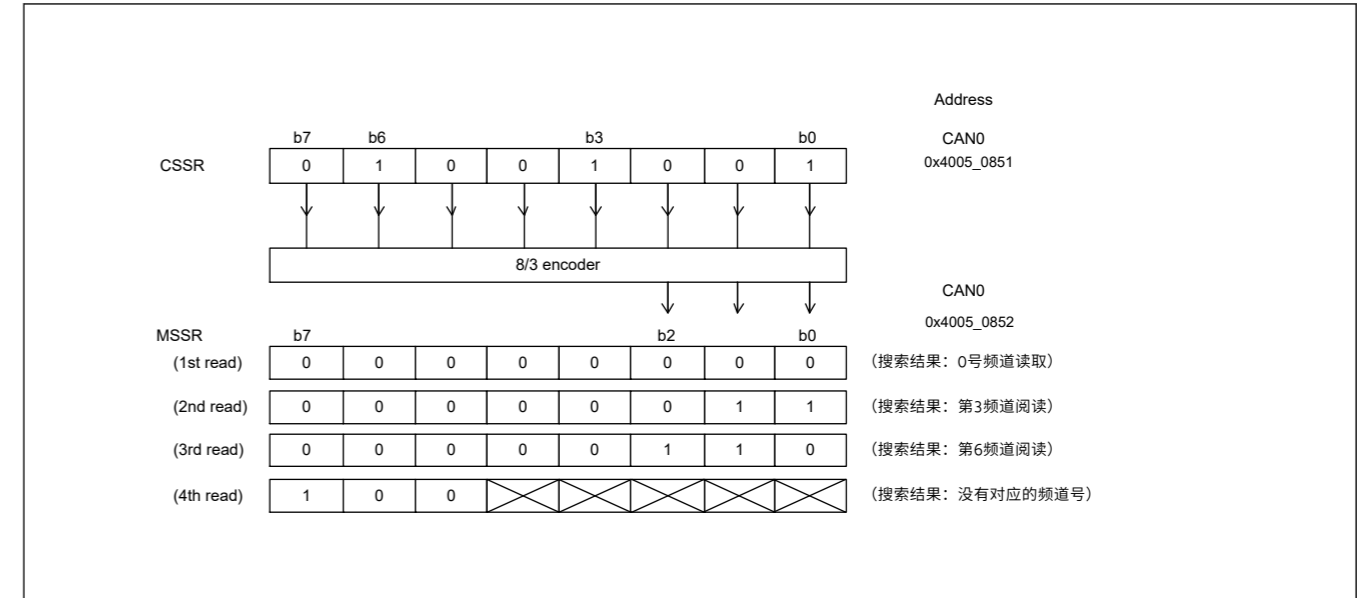


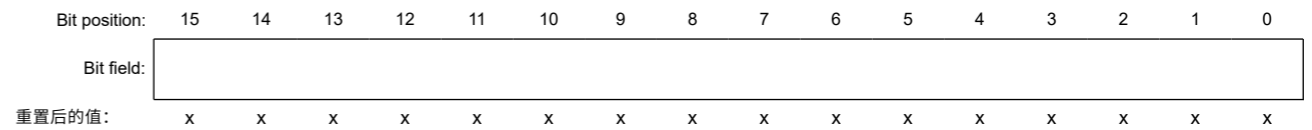
Figure 29.4 CSSR和MSSR寄存器的写和读操作

每当读取MSSR时，CSSR的值也会更新。在此读取中，可以读取83编码器转换之前的值。

29.2.19 AFSR：接受过滤器支持寄存器

Base address: CANn = 0x400A\_8000 + 0x1000 × n (n = 0, 1)

Offset address: 0x856



| Bit  | Symbol | Function                         | R/W |
|------|--------|----------------------------------|-----|
| 15:0 | n/a    | 将接收到的消息的标准ID写入后，就可以读取为数据查表转换的值了。 | R/W |

Note: 在CAN操作模式或CAN暂停模式下写入AFSR。

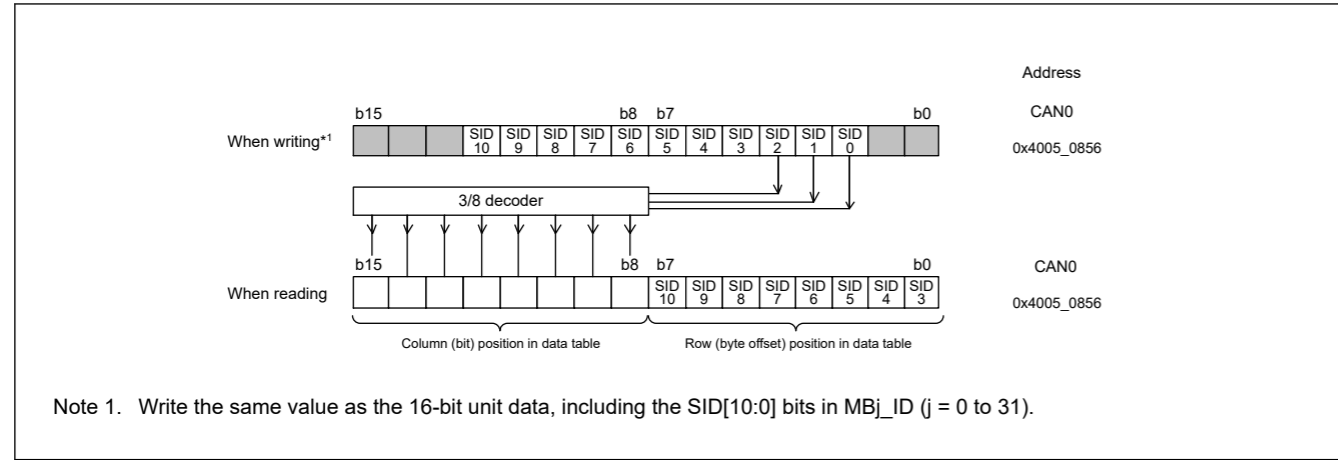
验收滤波器支持单元(ASU)可用于数据表 (8位×256) 搜索。在数据表中，所有创建的标准ID都以位为单位设置为有效或无效。当AFSR以16位单元写入数据时，包括MBj\_ID(j=0到31)中的SID[10:0]位，其中存储了接收到的标准ID，解码的行 (字节偏移) 位置和列 (位) 数据表搜索的位置可以被读取。ASU只能用于标准 (11位) ID。

ASU在以下情况下启用：

- 当接收的ID不能被接受过滤器屏蔽时。例如，如果要接收的ID是0x078、0x087和0x111。
- 接收的ID过多，预计软件过滤时间会缩短。

Note: CAN复位模式下不能设置AFSR。

图29.5显示了AFSR寄存器中的写和读操作。



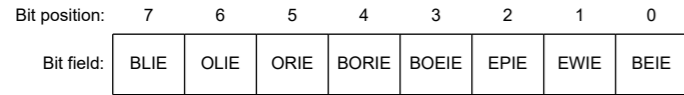
Note 1. Write the same value as the 16-bit unit data, including the SID[10:0] bits in MBj\_ID (j = 0 to 31).

Figure 29.5 Write and read operations in the AFSR register

29.2.20 EIER : Error Interrupt Enable Register

Base address: CANn = 0x400A\_8000 + 0x1000 × n (n = 0, 1)

Offset address: 0x84C



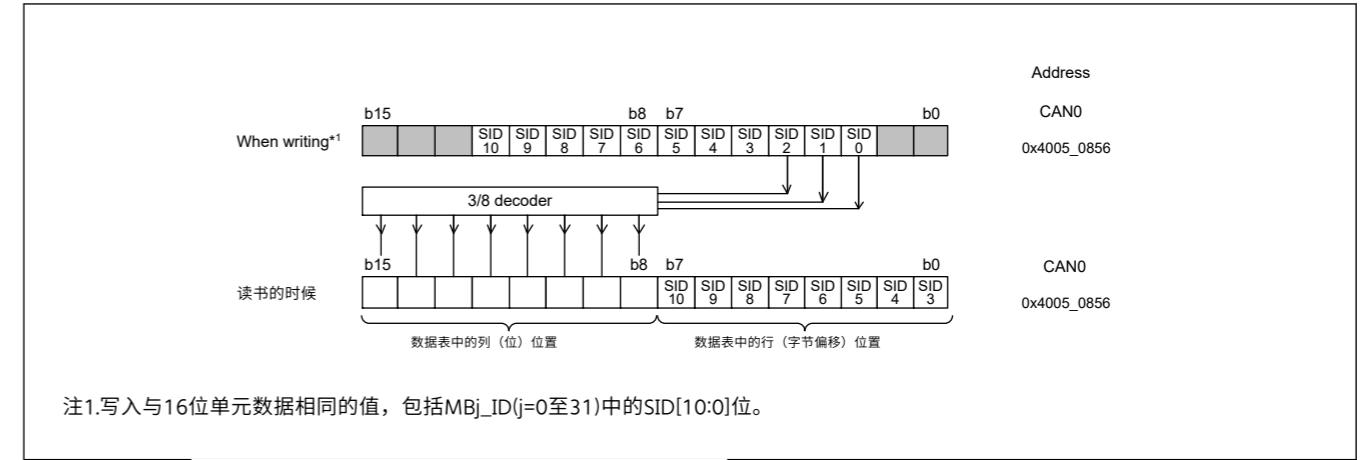
Value after reset: 0 0 0 0 0 0 0 0

| Bit | Symbol | Function  | R/W |
|-----|--------|---|-----|
| 0   | BEIE   | Bus Error Interrupt Enable<br>0: Disable interrupt<br>1: Enable interrupt               | R/W |
| 1   | EWIE   | Error-Warning Interrupt Enable<br>0: Disable interrupt<br>1: Enable interrupt           | R/W |
| 2   | EPIE   | Error-Passive Interrupt Enable<br>0: Disable interrupt<br>1: Enable interrupt           | R/W |
| 3   | BOEIE  | Bus-Off Entry Interrupt Enable<br>0: Disable interrupt<br>1: Enable interrupt           | R/W |
| 4   | BORIE  | Bus-Off Recovery Interrupt Enable<br>0: Disable interrupt<br>1: Enable interrupt        | R/W |
| 5   | ORIE   | Overrun Interrupt Enable<br>0: Disable interrupt<br>1: Enable interrupt                 | R/W |
| 6   | OLIE   | Overload Frame Transmit Interrupt Enable<br>0: Disable interrupt<br>1: Enable interrupt | R/W |
| 7   | BLIE   | Bus Lock Interrupt Enable<br>0: Disable interrupt<br>1: Enable interrupt                | R/W |

The EIER register enables or disables each error interrupt source independently in EIFR. Write to EIER in CAN reset mode.

**BEIE bit (Bus Error Interrupt Enable)**

When the BEIE bit is 0, no error interrupt request occurs even if the BEIF flag in EIFR is 1. When the BEIE bit is 1, an error interrupt request occurs if the BEIF flag is set to 1.



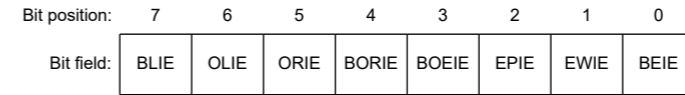
注1.写入与16位单元数据相同的值，包括MBj\_ID(j=0至31)中的SID[10:0]位。

Figure 29.5 AFSR寄存器中的写和读操作

29.2.20 EIER:错误中断使能寄存器

Base address: CANn = 0x400A\_8000 + 0x1000 × n (n = 0, 1)

Offset address: 0x84C



重置后的值: 0 0 0 0 0 0 0 0

| Bit | Symbol | Function                     | R/W |
|-----|--------|------------------------------|-----|
| 0   | BEIE   | 总线错误中断使能<br>0: 禁用中断1: 启用中断   | R/W |
| 1   | EWIE   | 错误警告中断使能<br>0: 禁用中断1: 启用中断   | R/W |
| 2   | EPIE   | 错误被动中断使能<br>0: 禁用中断1: 启用中断   | R/W |
| 3   | BOEIE  | 总线关闭进入中断使能<br>0: 禁用中断1: 启用中断 | R/W |
| 4   | BORIE  | 总线关闭恢复中断使能<br>0: 禁用中断1: 启用中断 | R/W |
| 5   | ORIE   | 溢出中断使能<br>0: 禁用中断1: 启用中断     | R/W |
| 6   | OLIE   | 过载帧发送中断使能<br>0: 禁用中断1: 启用中断  | R/W |
| 7   | BLIE   | 总线锁定中断使能<br>0: 禁用中断1: 启用中断   | R/W |

EIER寄存器在EIFR中独立启用或禁用每个错误中断源。在CAN复位模式下写入EIER。

**BEIE位 (总线错误中断使能)**

当BEIE位为0时，即使EIFR中的BEIF标志为1，也不会发生错误中断请求。当BEIE位为1时，如果BEIF标志位设置为1，则发生错误中断请求。



**EWIE bit (Error-Warning Interrupt Enable)**

When the EWIE bit is 0, no error interrupt request occurs even if the EWIF flag in EIFR is 1. When the EWIE bit is 1, an error interrupt request is generated if the EWIF flag is set to 1.

**EPIE bit (Error-Passive Interrupt Enable)**

When the EPIE bit is 0, no error interrupt request occurs even if the EPIF flag in EIFR is 1. When the EPIE bit is 1, an error interrupt request occurs if the EPIF flag is set to 1.

**BOEIE bit (Bus-Off Entry Interrupt Enable)**

When the BOEIE bit is 0, no error interrupt request occurs even if the BOEIF flag in EIFR is 1. When the BOEIE bit is 1, an error interrupt request occurs if the BOEIF flag is set to 1.

**BORIE bit (Bus-Off Recovery Interrupt Enable)**

When the BORIE bit is 0, no error interrupt request occurs even if the BORIF flag in EIFR is 1. When the BORIE bit is 1, an error interrupt request occurs if the BORIF flag is set to 1.

**ORIE bit (Overrun Interrupt Enable)**

When the ORIE bit is 0, no error interrupt request occurs even if the ORIF flag in EIFR is 1. When the ORIE bit is 1, an error interrupt request occurs if the ORIF flag is set to 1.

**OLIE bit (Overload Frame Transmit Interrupt Enable)**

When the OLIE bit is 0, no error interrupt request occurs even if the OLIF flag in EIFR is 1. When the OLIE bit is 1, an error interrupt request occurs if the OLIF flag is set to 1.

**BLIE bit (Bus Lock Interrupt Enable)**

When the BLIE bit is 0, no error interrupt request occurs even if the BLIF flag in EIFR is 1. When the BLIE bit is 1, an error interrupt request occurs if the BLIF flag is set to 1.

**29.2.21 EIFR : Error Interrupt Factor Judge Register**

Base address: CANn = 0x400A\_8000 + 0x1000 × n (n = 0, 1)

Offset address: 0x84D

|                    |      |      |      |       |       |      |      |      |
|--------------------|------|------|------|-------|-------|------|------|------|
| Bit position:      | 7    | 6    | 5    | 4     | 3     | 2    | 1    | 0    |
| Bit field:         | BLIF | OLIF | ORIF | BORIF | BOEIF | EPIF | EWIF | BEIF |
| Value after reset: | 0    | 0    | 0    | 0     | 0     | 0    | 0    | 0    |

| Bit | Symbol | Function  | R/W |
|-----|--------|---|-----|
| 0   | BEIF   | Bus Error Detect Flag<br>0: No bus error detected<br>1: Bus error detected                      | R/W |
| 1   | EWIF   | Error-Warning Detect Flag<br>0: No error-warning detected<br>1: Error-warning detected          | R/W |
| 2   | EPIF   | Error-Passive Detect Flag<br>0: No error-passive detected<br>1: Error-passive detected          | R/W |
| 3   | BOEIF  | Bus-Off Entry Detect Flag<br>0: No bus-off entry detected<br>1: Bus-off entry detected          | R/W |
| 4   | BORIF  | Bus-Off Recovery Detect Flag<br>0: No bus-off recovery detected<br>1: Bus-off recovery detected | R/W |

**EWIE位 (错误警告中断使能)**

当EWIE位为0时, 即使EIFR中的EWIF标志为1, 也不会产生错误中断请求。当EWIE位为1时, 如果EWIF标志位设置为1, 则产生错误中断请求。

**EPIE位 (错误被动中断使能)**

当EPIE位为0时, 即使EIFR中的EPIF标志为1, 也不会发生错误中断请求。当EPIE位为1时, 如果EPIF标志位设置为1, 则会发生错误中断请求。

**BOEIE位 (总线关闭进入中断允许)**

当BOEIE位为0时, 即使EIFR中的BOEIF标志为1, 也不会产生错误中断请求。当BOEIE位为1时, 如果将BOEIF标志设置为1, 则会产生错误中断请求。

**BORIE位 (总线关闭恢复中断使能)**

当BORIE位为0时, 即使EIFR中的BORIF标志为1, 也不会产生错误中断请求。当BORIE位为1时, 如果将BORIF标志设置为1, 则会产生错误中断请求。

**ORIE位 (溢出中断使能)**

当ORIE位为0时, 即使EIFR中的ORIF标志为1, 也不会发生错误中断请求。当ORIE位为1时, 如果将ORIF标志设置为1, 则会发生错误中断请求。

**OLIE位 (过载帧发送中断使能)**

当OLIE位为0时, 即使EIFR中的OLIF标志为1, 也不会产生错误中断请求。当OLIE位为1时, 如果OLIF标志被设置为1, 则产生错误中断请求。

**BLIE位 (总线锁定中断使能)**

当BLIE位为0时, 即使EIFR中的BLIF标志为1, 也不会发生错误中断请求。当BLIE位为1时, 如果BLIF标志位设置为1, 则会发生错误中断请求。

**29.2.21 EIFR:错误中断因素判断寄存器**

Base address: CANn = 0x400A\_8000 + 0x1000 × n (n = 0, 1)

Offset address: 0x84D

|               |      |      |      |       |       |      |      |      |
|---------------|------|------|------|-------|-------|------|------|------|
| Bit position: | 7    | 6    | 5    | 4     | 3     | 2    | 1    | 0    |
| Bit field:    | BLIF | OLIF | ORIF | BORIF | BOEIF | EPIF | EWIF | BEIF |
| 重置后的值:        | 0    | 0    | 0    | 0     | 0     | 0    | 0    | 0    |

| Bit | Symbol | Function                                   | R/W |
|-----|--------|--|-----|
| 0   | BEIF   | 总线错误检测标志<br>0: 未检测到总线错误1:<br>检测到总线错误       | R/W |
| 1   | EWIF   | 错误警告检测标志<br>0: 未检测到错误警告1: 检测到错误警告          | R/W |
| 2   | EPIF   | 错误被动检测标志<br>0: 未检测到被动错误1: 检测到被动错误          | R/W |
| 3   | BOEIF  | 总线关闭进入检测标志<br>0: 未检测到总线关闭条目1:<br>检测到总线关闭条目 | R/W |
| 4   | BORIF  | 总线关闭恢复检测标志<br>0: 未检测到总线关闭恢复1: 检测到总线关闭恢复    | R/W |

| Bit | Symbol | Function   | R/W |
|-----|--------|--|-----|
| 5   | ORIF   | Receive Overrun Detect Flag<br>0: No receive overrun detected<br>1: Receive overrun detected                                     | R/W |
| 6   | OLIF   | Overload Frame Transmission Detect Flag<br>0: No overload frame transmission detected<br>1: Overload frame transmission detected | R/W |
| 7   | BLIF   | Bus Lock Detect Flag<br>0: No bus lock detected<br>1: Bus lock detected  | R/W |

If an event associated with an EIFR flag occurs, the associated bit in EIFR is set to 1, regardless of the setting of EIER.

Clear the bits to 0 through a software write. If a bit is set to 1 at the same time that the software clears it, it becomes 1. When setting a single bit to 0 in software, use the transfer instruction (MOV) to ensure that only the specified bit is set to 0 and the other bits are set to 1. Writing 1 has no effect to these bit values.

#### BEIF flag (Bus Error Detect Flag)

The BEIF flag is set to 1 when a bus error is detected.

#### EWIF flag (Error-Warning Detect Flag)

The EWIF flag is set to 1 when the value of the receive error counter (REC) or transmit error counter (TEC) exceeds 95. The EWIF flag is set to 1 only when REC or TEC initially exceeds 95. If software writes 0 to this flag while the REC or TEC value remains greater than 95, the EWIF flag does not set to 1 until the REC or TEC value goes below 95, and then exceeds 95 again.

#### EPIF flag (Error-Passive Detect Flag)

The EPIF flag is set to 1 when the CAN error state becomes error-passive, when the REC or TEC value exceeds 127. The EPIF flag is set to 1 only when the REC or TEC value initially exceeds 127. If software writes 0 to this flag while REC or TEC remains greater than 127, the EPIF flag is not set to 1 until REC or TEC goes below 127, and then exceeds 127 again.

#### BOEIF flag (Bus-Off Entry Detect Flag)

The BOEIF flag is set to 1 when the CAN error state becomes bus-off, when the TEC value exceeds 255. The BOEIF flag is also set to 1 when the BOM[1:0] bits in CTRLR are 01b (automatic entry to CAN halt mode on bus-off entry) and the CAN module becomes the bus-off state.

#### BORIF flag (Bus-Off Recovery Detect Flag)

The BORIF flag is set to 1 when the CAN module recovers from the bus-off state normally by detecting 11 consecutive bits 128 times in the following conditions:

- When the BOM[1:0] bits in CTRLR are 00b
- When the BOM[1:0] bits in CTRLR are 10b
- When the BOM[1:0] bits in CTRLR are 11b

The BORIF flag is not set to 1 if the CAN module recovers from the bus-off state in the following conditions:

- When the CANM[1:0] bits in CTRLR are set to 01b or 11b (CAN reset mode)
- When the RBOC bit in CTRLR is set to 1 (forced return from bus-off)
- When the BOM[1:0] bits in CTRLR are set to 01b
- When the BOM[1:0] bits in CTRLR are set to 11b and the CANM[1:0] bits in CTRLR are set to 10b (CAN halt mode) before normal recovery occurs

Table 29.7 lists the behavior of the BOEIF and BORIF flags for each CTRLR.BOM[1:0] bits setting.

| Bit | Symbol | Function                                 | R/W |
|-----|--------|--|-----|
| 5   | ORIF   | 接收溢出检测标志<br>0: 未检测到接收溢出<br>1: 检测到接收溢出    | R/W |
| 6   | OLIF   | 过载帧传输检测标志<br>0: 未检测到过载帧传输<br>1: 检测到过载帧传输 | R/W |
| 7   | BLIF   | 总线锁定检测标志<br>0: 未检测到总线锁定<br>1: 检测到总线锁定    | R/W |

如果发生与EIFR标志相关的事件，则EIFR中的相关位设置为1，而与EIER的设置无关。

通过软件写入将这些位清除为0。如果在软件清零的同时将某个位设置为1，则该位变为1。在软件中设置单个位为0时，使用传输指令(MOV)确保只有指定位设置为0，其他位设置为1。写1对这些位值没有影响。

#### BEIF标志 (总线错误检测标志)

当检测到总线错误时，BEIF标志设置为1。

#### EWIF标志 (错误警告检测标志)

当接收错误计数器(REC)或发送错误计数器(TEC)的值超过95时，EWIF标志设置为1。仅当REC或TEC最初超过95时，EWIF标志才设置为1。如果软件将0写入此当REC或TEC值保持大于95时，EWIF标志不会设置为1，直到REC或TEC值低于95，然后再次超过95。

#### EPIF标志 (错误被动检测标志)

当CAN错误状态变为被动错误时，当REC或TEC值超过127时，EPIF标志设置为1。仅当REC或TEC值最初超过127时，EPIF标志才设置为1。如果软件将0写入此当REC或TEC保持大于127时，EPIF标志不会设置为1，直到REC或TEC低于127，然后再次超过127。

#### BOEIF标志 (总线关闭进入检测标志)

当CAN错误状态变为总线关闭时，当TEC值超过255时，BOEIF标志设置为1。当CTRLR中的BOM[1:0]位为01b (自动进入CAN进入总线关闭时的停止模式) 并且CAN模块变为总线关闭状态。

#### BORIF标志 (总线关闭恢复检测标志)

当CAN模块通过检测11个连续位128次从总线关闭状态正常恢复时，BORIF标志设置为1，条件如下：

- CTRLR的BOM[1:0]位为00b时
- CTRLR的BOM[1:0]位为10b时
- CTRLR的BOM[1:0]位为11b时

如果CAN模块在以下情况下从总线关闭状态恢复，则BORIF标志不设置为1：

- CTRLR中的CANM[1:0]位设置为01b或11b时 (CAN复位模式)
- CTRLR的RBOC位设置为1时 (强制从总线关闭返回)
- 当CTRLR的BOM[1:0]位设置为01b时
- CTRLR中的BOM[1:0]位设置为11b且CTRLR中的CANM[1:0]位设置为10b时 (CAN停止模式) 在正常恢复发生之前

表29.7列出了每个CTRLR.BOM[1:0]位设置的BOEIF和BORIF标志的行为。

Table 29.7 Behavior of BOEIF and BORIF flags for each CTRL.BOM[1:0] setting

| BOM[1:0] bits | BOEIF flag                             | BORIF flag  |
|---------------|--|---|
| 00b           | Set to 1 on entry to the bus-off state | Sets to 1 on exit from the bus-off state  |
| 01b           |  | Do not set to 1   |
| 10b           |  | Set to 1 on exit from the bus-off state   |
| 11b           |  | Set to 1 if normal bus-off recovery occurs before the CANM[1:0] bits are set to 10b (CAN halt mode) |

**ORIF flag (Receive Overrun Detect Flag)**

The ORIF flag is set to 1 when a receive overrun occurs. This flag is not set to 1 in overwrite mode.

In overwrite mode, a reception complete interrupt request occurs if an overwrite condition occurs and the ORIF flag is not set to 1.

In overrun mode with normal mailbox mode, if an overrun occurs in any of mailboxes 0 to 31, the ORIF flag is set to 1. In overrun mode with FIFO mailbox mode, if an overrun occurs in any of mailboxes 0 to 23 or the receive FIFO, this flag is set to 1.

**OLIF flag (Overload Frame Transmission Detect Flag)**

The OLIF flag is set to 1 if the transmitting condition of an overload frame is detected when the CAN module is transmitting or receiving.

**BLIF flag (Bus Lock Detect Flag)**

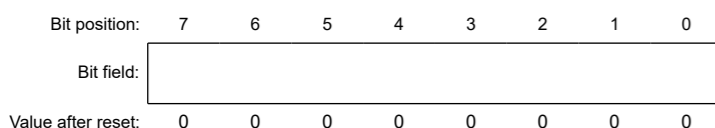
The BLIF flag is set to 1 if 32 consecutive dominant bits are detected on the CAN bus while the CAN module is in CAN operation mode. After the BLIF flag is set to 1, 32 consecutive dominant bits are detected again in either of the following conditions:

- Recessive bits are detected after the BLIF flag changes to 0 from 1
- The CAN module enters CAN reset or halt mode and then enters CAN operation mode again after the BLIF flag changes to 0 from 1

## 29.2.22 RECR : Receive Error Count Register

Base address: CANn = 0x400A\_8000 + 0x1000 × n (n = 0, 1)

Offset address: 0x84E



| Bit | Symbol | Function  | R/W |
|-----|--------|---|-----|
| 7:0 | n/a    | Receive error count function. RECR increments or decrements the counter value based on the error status of the CAN module during reception. | R   |

RECR indicates the value of the receive error counter. See the CAN specification (ISO11898-1) for information on the increment and decrement conditions of the receive error counter.

The value of RECR in the bus-off state is undefined.

Table 29.7 每个CTRL.BOM[1:0]设置的BOEIF和BORIF标志的行为

| BOM[1:0] bits | BOEIF flag    | BORIF flag   |
|---------------|---------------|--|
| 00b           | 进入总线关闭状态时设置为1 | 退出总线关闭状态时设置为1                                      |
| 01b           |               | 不要设置为1   |
| 10b           |               | 退出总线关闭状态时设置为1                                      |
| 11b           |               | 如果在CANM[1:0]位设置为10b (CAN停止模式) 之前发生正常的总线关闭恢复, 则设置为1 |

**ORIF标志 (接收溢出检测标志)**

当发生接收溢出时, ORIF标志设置为1。此标志在覆盖模式下不设置为1。

在覆盖模式下, 如果出现覆盖条件且ORIF标志未设置为1, 则会产生接收完成中断请求。

在具有正常邮箱模式的溢出模式中, 如果在任何邮箱0到31中发生溢出, 则ORIF标志设置为1。在具有FIFO邮箱模式的溢出模式中, 如果在任何邮箱0到23或接收中发生溢出FIFO, 此标志设置为1。

**OLIF标志 (过载帧传输检测标志)**

如果在CAN模块发送或接收时检测到过载帧的发送条件, 则OLIF标志设置为1。

**BLIF标志 (总线锁定检测标志)**

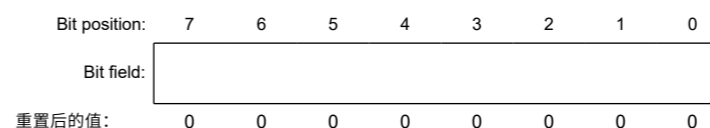
如果在CAN模块处于CAN操作模式时在CAN总线上检测到32个连续显性位, 则BLIF标志设置为1。将BLIF标志设置为1后, 在以下任一条件下再次检测到32个连续的显性位:

- BLIF标志由1变为0后检测隐性位
- CAN模块进入CAN复位或停止模式, 待BLIF标志位由1变为0后再次进入CAN工作模式

## 29.2.22 RECR:接收错误计数寄存器

Base address: CANn = 0x400A\_8000 + 0x1000 × n (n = 0, 1)

Offset address: 0x84E



| Bit | Symbol | Function                                | R/W |
|-----|--------|---|-----|
| 7:0 | n/a    | 接收错误计数功能。RECR根据接收期间CAN模块的错误状态递增或递减计数器值。 | R   |

RECR指示接收错误计数器的值。有关接收错误计数器的递增和递减条件的信息, 请参见CAN规范(ISO11898-1)。

总线关闭状态下RECR的值未定义。

29.2.23 TECR : Transmit Error Count Register

Base address: CANn = 0x400A\_8000 + 0x1000 × n (n = 0, 1)  
 Offset address: 0x84F



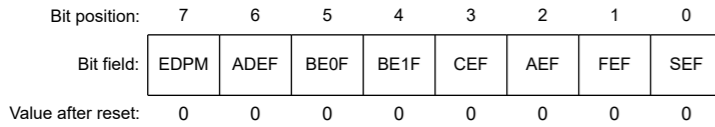
| Bit | Symbol | Function  | R/W |
|-----|--------|---|-----|
| 7:0 | n/a    | Transmit error count function. TECR increments or decrements the counter value based on the error status of the CAN module during transmission. | R   |

TECR indicates the value of the transmit error counter. See the CAN specification (ISO11898-1) for information on the increment and decrement conditions of the transmit error counter.

The value of TECR in the bus-off state is undefined.

29.2.24 ECSR : Error Code Store Register

Base address: CANn = 0x400A\_8000 + 0x1000 × n (n = 0, 1)  
 Offset address: 0x850

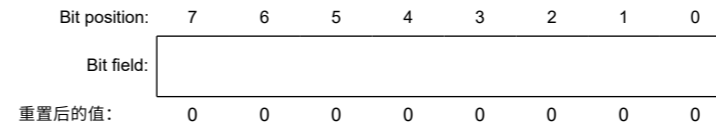


| Bit | Symbol | Function   | R/W |
|-----|--------|--|-----|
| 0   | SEF    | Stuff Error Flag*1 *2<br>0: No stuff error detected<br>1: Stuff error detected                               | R/W |
| 1   | FEF    | Form Error Flag*1 *2<br>0: No form error detected<br>1: Form error detected                                  | R/W |
| 2   | AEF    | ACK Error Flag*1 *2<br>0: No ACK error detected<br>1: ACK error detected                                     | R/W |
| 3   | CEF    | CRC Error Flag*1 *2<br>0: No CRC error detected<br>1: CRC error detected                                     | R/W |
| 4   | BE1F   | Bit Error (recessive) Flag*1 *2<br>0: No bit error (recessive) detected<br>1: Bit error (recessive) detected | R/W |
| 5   | BE0F   | Bit Error (dominant) Flag*1 *2<br>0: No bit error (dominant) detected<br>1: Bit error (dominant) detected    | R/W |
| 6   | ADEF   | ACK Delimiter Error Flag*1 *2<br>0: No ACK delimiter error detected<br>1: ACK delimiter error detected       | R/W |
| 7   | EDPM   | Error Display Mode Select*3 *4<br>0: Output first detected error code<br>1: Output accumulated error code    | R/W |

Note 1. Writing 1 has no effect on these bit values.

29.2.23 TECR: 发送错误计数寄存器

Base address: CANn = 0x400A\_8000 + 0x1000 × n (n = 0, 1)  
 Offset address: 0x84F



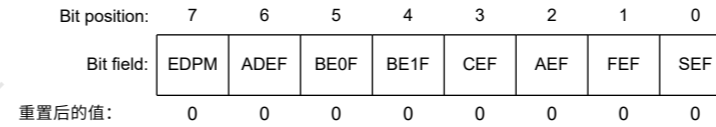
| Bit | Symbol | Function                                  | R/W |
|-----|--------|---|-----|
| 7:0 | n/a    | 发送错误计数功能。TECR根据CAN模块在传输过程中的错误状态递增或递减计数器值。 | R   |

TECR指示发送错误计数器的值。有关发送错误计数器的递增和递减条件的信息，请参见CAN规范(ISO11898-1)。

总线关闭状态下的TECR值未定义。

29.2.24 ECSR: 错误代码存储寄存器

Base address: CANn = 0x400A\_8000 + 0x1000 × n (n = 0, 1)  
 Offset address: 0x850



| Bit | Symbol | Function  | R/W |
|-----|--------|---|-----|
| 0   | SEF    | 填充错误标志*1*2<br>0: 未检测到填充错误1:<br>检测到填充错误                | R/W |
| 1   | FEF    | 表格错误标志*1*2<br>0: 未检测到表单错误1:<br>检测到表单错误                | R/W |
| 2   | AEF    | ACK错误标志*1*2<br>0: 未检测到ACK错误1:<br>检测到ACK错误             | R/W |
| 3   | CEF    | CRC错误标志*1*2<br>0: 未检测到CRC错误1:<br>检测到CRC错误             | R/W |
| 4   | BE1F   | 位错误 (隐性) 标志*1*2<br>0: 未检测到位错误 (隐性) 1: 检<br>测到位错误 (隐性) | R/W |
| 5   | BE0F   | 位错误 (显性) 标志*1*2<br>0: 未检测到位错误 (显性) 1: 检<br>测到位错误 (显性) | R/W |
| 6   | ADEF   | ACK分隔符错误标志*1*2<br>0: 未检测到ACK分隔符错误1: 检<br>检测到ACK分隔符错误  | R/W |
| 7   | EDPM   | 错误显示模式选择*3*4<br>0: 输出第一个检测到的错误代码1<br>: 输出累积错误代码       | R/W |

注1.写1对这些位值没有影响。



Note 2. To write 0 to the SEF, FEF, AEF, CEF, BE1F, BE0F, and ADEF bits, use the transfer (MOV) instruction to ensure that only the specified bit is set to 0 and the other bits are set to 1.

Note 3. Write to the EDPM bit in CAN reset or halt mode.

Note 4. If more than one error condition is detected simultaneously, all related bits are set to 1.

ECSR indicates whether an error occurs on the CAN bus. See the CAN specification (ISO11898-1) for the conditions when each error occurs.

Clear all of the bits, except for the EDPM bit, to 0 through a software write. If the ECSR bit is set to 1 at the same time that software writes 0 to it, the bit becomes 1.

#### SEF flag (Stuff Error Flag)

The SEF flag is set to 1 when a stuff error is detected.

#### FEF flag (Form Error Flag)

The FEF flag is set to 1 when a form error is detected.

#### AEF flag (ACK Error Flag)

The AEF flag is set to 1 when an ACK error is detected.

#### CEF flag (CRC Error Flag)

The CEF flag is set to 1 when a CRC error is detected.

#### BE1F flag (Bit Error (recessive) Flag)

The BE1F flag is set to 1 when a recessive bit error is detected.

#### BE0F flag (Bit Error (dominant) Flag)

The BE0F flag is set to 1 when a dominant bit error is detected.

#### ADEF flag (ACK Delimiter Error Flag)

The ADEF flag is set to 1 when a form error is detected with the ACK delimiter during transmission.

#### EDPM bit (Error Display Mode Select)

The EDPM bit selects the output mode of ECSR. When the EDPM bit is set to 0, ECSR outputs the first error code. When the EDPM bit is set to 1, ECSR outputs the accumulated error code.

### 29.2.25 TSR : Time Stamp Register

Base address: CANn = 0x400A\_8000 + 0x1000 × n (n = 0, 1)

Offset address: 0x854

|                    |             |    |    |    |    |    |   |   |   |   |   |   |   |   |   |   |
|--------------------|-------------|----|----|----|----|----|---|---|---|---|---|---|---|---|---|---|
| Bit position:      | 15          | 14 | 13 | 12 | 11 | 10 | 9 | 8 | 7 | 6 | 5 | 4 | 3 | 2 | 1 | 0 |
| Bit field:         | [Empty box] |    |    |    |    |    |   |   |   |   |   |   |   |   |   |   |
| Value after reset: | 0           | 0  | 0  | 0  | 0  | 0  | 0 | 0 | 0 | 0 | 0 | 0 | 0 | 0 | 0 | 0 |

| Bit  | Symbol | Function   | R/W |
|------|--------|--|-----|
| 15:0 | n/a    | Free-running counter value for the time stamp function | R   |

Note: Read TSR in 16-bit units.

Reading the TSR register returns the current value of the 16-bit free-running time stamp counter. The time stamp counter reference clock is configured in the TSPS[1:0] bits in CTLR. The counter stops in CAN sleep mode and CAN halt mode, and is initialized in CAN reset mode. The time stamp counter value is stored in the TSL[7:0] and TSH[7:0] bits in MBj\_TS when a received message is stored in a receive mailbox.

注2.要将0写入SEF、FEF、AEF、CEF、BE1F、BE0F和ADEF位,请使用传输(MOV)指令确保只有指定位设置为0,其他位设置为1。

注3.在CAN复位或暂停模式下写入EDPM位。

注4.如果同时检测到多个错误条件,则所有相关位都设置为1。

ECSR指示CAN总线上是否发生错误。有关每个错误发生的条件,请参见CAN规范(ISO11898-1)。

通过软件写入将除EDPM位之外的所有位清零。如果ECSR位在软件写入0的同时设置为1,则该位变为1。

#### SEF标志 (填充错误标志)

当检测到填充错误时,SEF标志设置为1。

#### FEF标志 (表格错误标志)

当检测到表单错误时,FEF标志设置为1。

#### AEF标志 (ACK错误标志)

当检测到ACK错误时,AEF标志设置为1。

#### CEF标志 (CRC错误标志)

当检测到CRC错误时,CEF标志设置为1。

#### BE1F标志 (位错误 (隐性) 标志)

当检测到隐性位错误时,BE1F标志设置为1。

#### BE0F标志 (位错误 (显性) 标志)

当检测到显性位错误时,BE0F标志设置为1。

#### ADEF标志 (ACK分隔符错误标志)

当在传输过程中使用ACK定界符检测到格式错误时,ADEF标志设置为1。

#### EDP M位 (错误显示模式选择)

EDP M位选择ECSR的输出模式。当EDPM位设置为0时,ECSR输出第一个错误代码。当EDPM位设置为1时,ECSR输出累积的错误代码。

### 29.2.25 TSR:时间戳寄存器

Base address: CANn = 0x400A\_8000 + 0x1000 × n (n = 0, 1)

Offset address: 0x854

|               |             |    |    |    |    |    |   |   |   |   |   |   |   |   |   |   |
|---------------|-------------|----|----|----|----|----|---|---|---|---|---|---|---|---|---|---|
| Bit position: | 15          | 14 | 13 | 12 | 11 | 10 | 9 | 8 | 7 | 6 | 5 | 4 | 3 | 2 | 1 | 0 |
| Bit field:    | [Empty box] |    |    |    |    |    |   |   |   |   |   |   |   |   |   |   |
| 重置后的值:        | 0           | 0  | 0  | 0  | 0  | 0  | 0 | 0 | 0 | 0 | 0 | 0 | 0 | 0 | 0 | 0 |

| Bit  | Symbol | Function       | R/W |
|------|--------|----------------|-----|
| 15:0 | n/a    | 时间戳功能的自由运行计数器值 | R   |

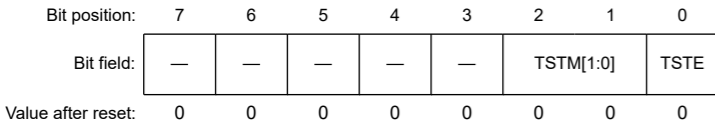
Note: 以16位为单位读取TSR。

读取TSR寄存器返回16位自由运行时间戳计数器的当前值。时间戳计数器参考时钟在CTLR的TSPS[1:0]位中配置。计数器在CAN睡眠模式和CAN暂停模式下停止,并在CAN复位模式下初始化。当收到的消息存储在接收邮箱中时,时间戳计数器值存储在MBj\_TS中的TSL[7:0]和TSH[7:0]位中。

29.2.26 TCR : Test Control Register

Base address: CANn = 0x400A\_8000 + 0x1000 × n (n = 0, 1)

Offset address: 0x858



| Bit | Symbol    | Function  | R/W |
|-----|-----------|---|-----|
| 0   | TSTE      | CAN Test Mode Enable<br>0: Disable CAN test mode<br>1: Enable CAN test mode   | R/W |
| 2:1 | TSTM[1:0] | CAN Test Mode Select<br>00: Not CAN test mode<br>01: Listen-only mode<br>10: Self-test mode 0 (external loopback)<br>11: Self-test mode 1 (internal loopback) | R/W |
| 7:3 | —         | These bits are read as 0. The write value should be 0.  | R/W |

TCR controls the CAN test mode. Write to TCR in CAN halt mode only.

(1) Listen-only mode

The CAN specification (ISO11898-1) recommends an optional bus monitoring mode. In listen-only mode, valid data frames and valid remote frames can be received. However, only recessive bits can be sent on the CAN bus. The ACK bit, overload flag, and active error flag cannot be sent.

Listen-only mode can be used for baud rate detection. Do not request transmission from any mailboxes in listen-only mode.

Figure 29.6 shows the connection when listen-only mode is selected.

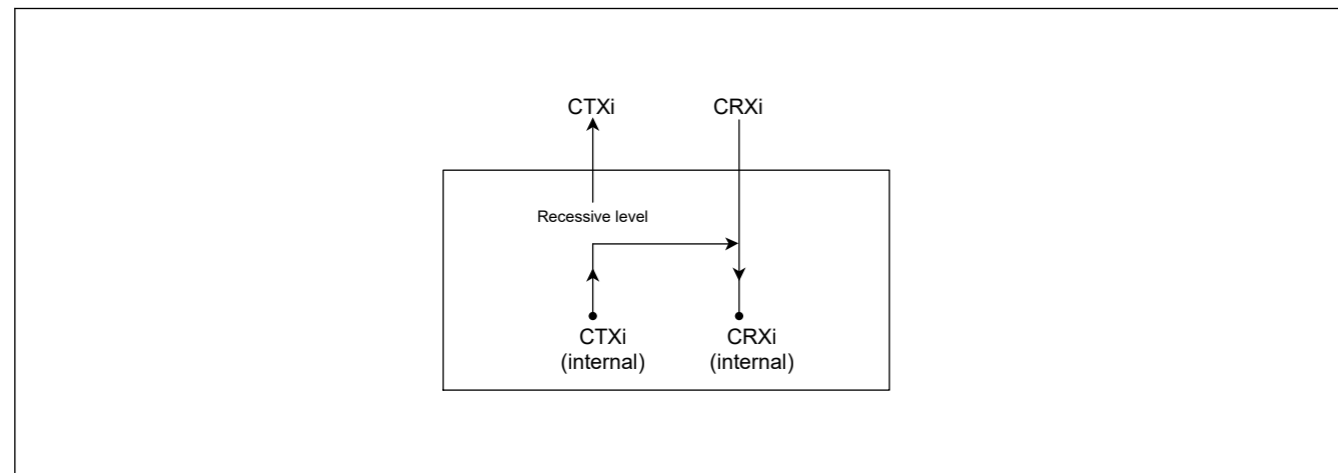


Figure 29.6 Connection when listen-only mode is selected (i = 0, 1)

(2) Self-test mode 0 (external loopback)

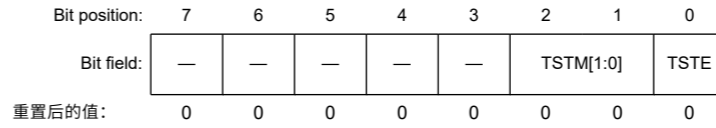
Self-test mode 0 is provided for CAN transceiver tests. In this mode, the protocol module treats its own transmitted messages as those received by the CAN transceiver and stores them into the receive mailbox. To be independent from external stimulation, the protocol module generates the ACK bit. Connect the CTXi and CRXi pins to the transceiver.

Figure 29.7 shows the connection when self-test mode 0 is selected.

29.2.26 TCR:测试控制寄存器

Base address: CANn = 0x400A\_8000 + 0x1000 × n (n = 0, 1)

Offset address: 0x858



| Bit | Symbol    | Function  | R/W |
|-----|-----------|---|-----|
| 0   | TSTE      | CAN测试模式启用<br>0: 禁用CAN测试模式1:<br>启用CAN测试模式                              | R/W |
| 2:1 | TSTM[1:0] | CAN测试模式选择<br>00: 非CAN测试模式01: 只听模式10:<br>自测模式0 (外部环回) 11: 自测模式1 (内部环回) | R/W |
| 7:3 | —         | 这些位被读取为0。写入值应为0。  | R/W |

TCR控制CAN测试模式。仅在CAN停止模式下写入TCR。

(1) Listen-only mode

CAN规范(ISO11898-1)推荐一种可选的总线监控模式。在只听模式下，可以接收到有效的数据帧和有效的远程帧。但是，只能在CAN总线上发送隐性位。不能发送ACK位、过载标志和活动错误标志。

只听模式可用于波特率检测。不要在只听模式下从任何邮箱请求传输。

图29.6显示了选择只听模式时的连接。

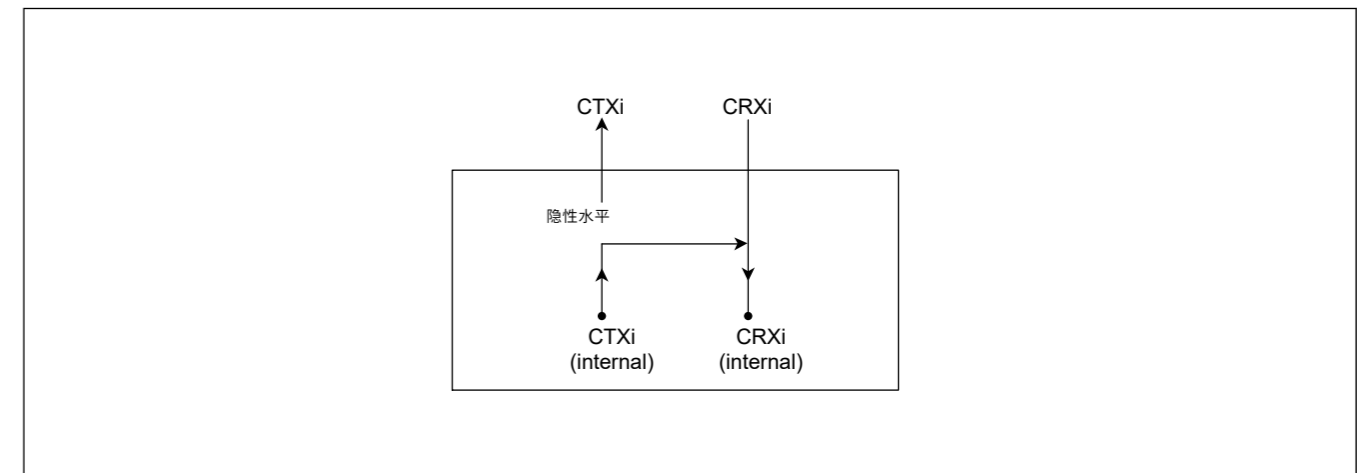


Figure 29.6 选择只听模式时的连接(i=0 1)

(2) Self-test mode 0 (external loopback)

自测模式0用于CAN收发器测试。在该模式下，协议模块将自己发送的报文视为CAN收发器接收到的报文，并将其存储到接收邮箱中。为独立于外部刺激，协议模块生成ACK位。将CTXi和CRXi引脚连接到收发器。

图29.7显示了选择自检模式0时的连接。

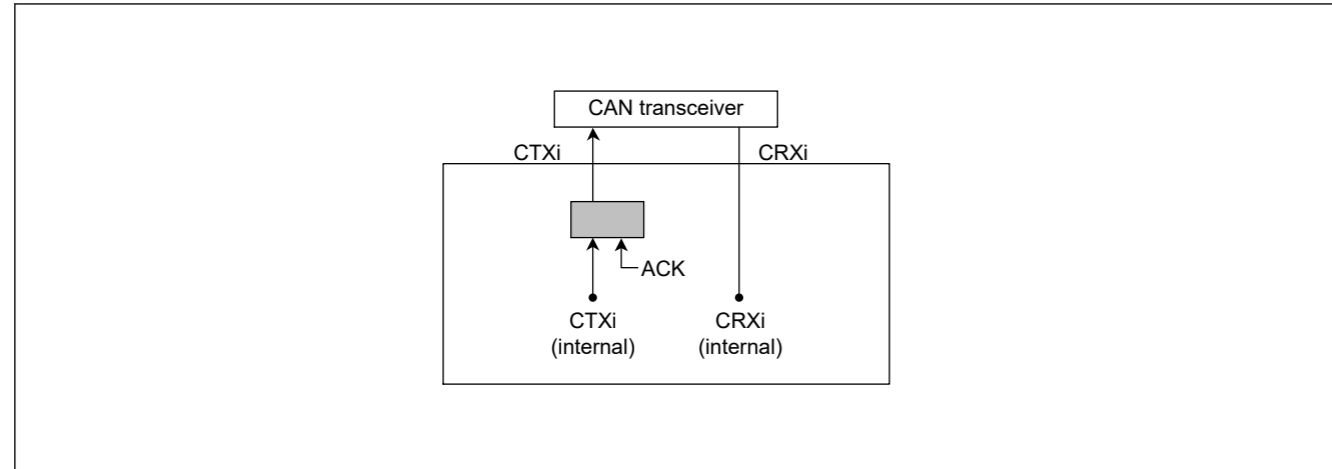


Figure 29.7 Connection when self-test mode 0 is selected (i = 0, 1)

### (3) Self-test mode 1 (internal loopback)

Self-test mode 1 is provided for self-test functions. In this mode, the protocol controller treats its transmitted messages as received messages and stores them into the receive mailbox. To be independent from external stimulation, the protocol controller generates the ACK bit.

In self-test mode 1, the protocol controller performs an internal feedback from the internal CTXi pin to the internal CRXi pin. The input value of the external CRXi pin is ignored. The external CTXi pin outputs only recessive bits. The CTXi and CRXi pins are not required to be connected to the CAN bus or any external device.

Figure 29.8 shows the connection when self-test mode 1 is selected.

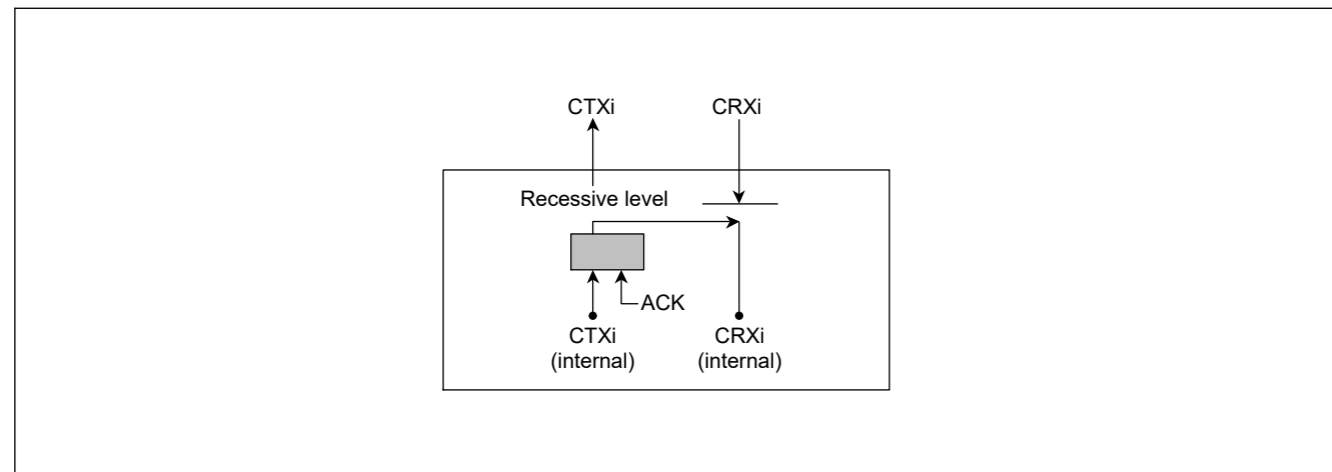


Figure 29.8 Connection when self-test mode 1 is selected (i = 0, 1)

## 29.3 Operation Modes

The CAN module operation includes the following modes:

- CAN reset mode
- CAN halt mode
- CAN operation mode
- CAN sleep mode

Figure 29.9 shows the transitions between different operation modes.

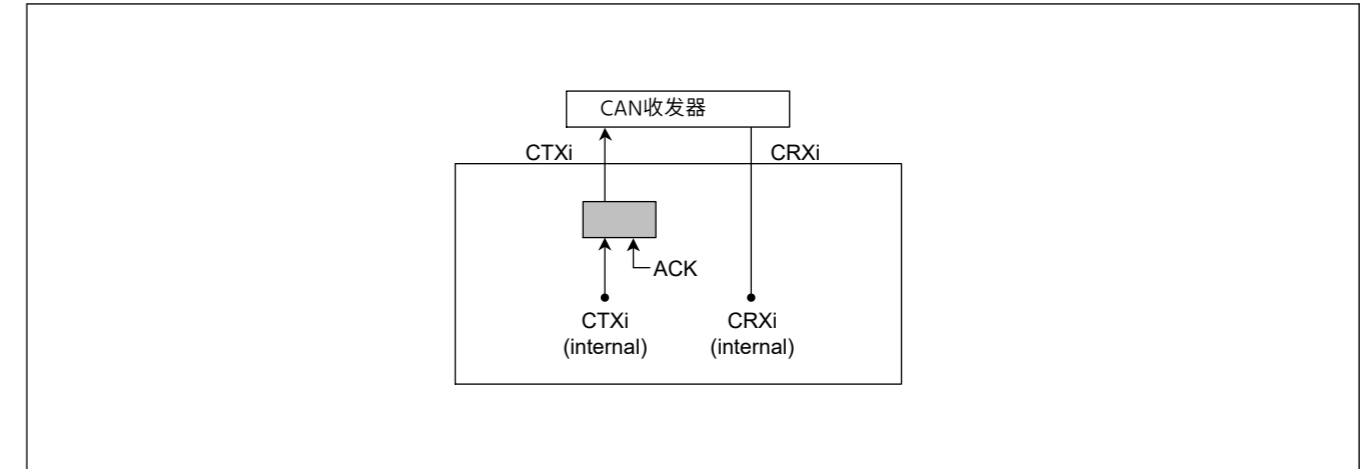


Figure 29.7 选择自检模式0时的连接(i=0 1)

### (3) Self-test mode 1 (internal loopback)

自检模式1用于自检功能。在这种模式下，协议控制器将其发送的消息视为接收的消息，并将它们存储到接收邮箱中。为了独立于外部刺激，协议控制器生成ACK位。

在自检模式1中，协议控制器执行从内部CTXi引脚到内部CRXi引脚的内部反馈。外部CRXi引脚的输入值被忽略。外部CTXi引脚仅输出隐性位。CTXi和CRXi引脚不需要连接到CAN总线或任何外部设备。

图29.8显示了选择自检模式1时的连接。

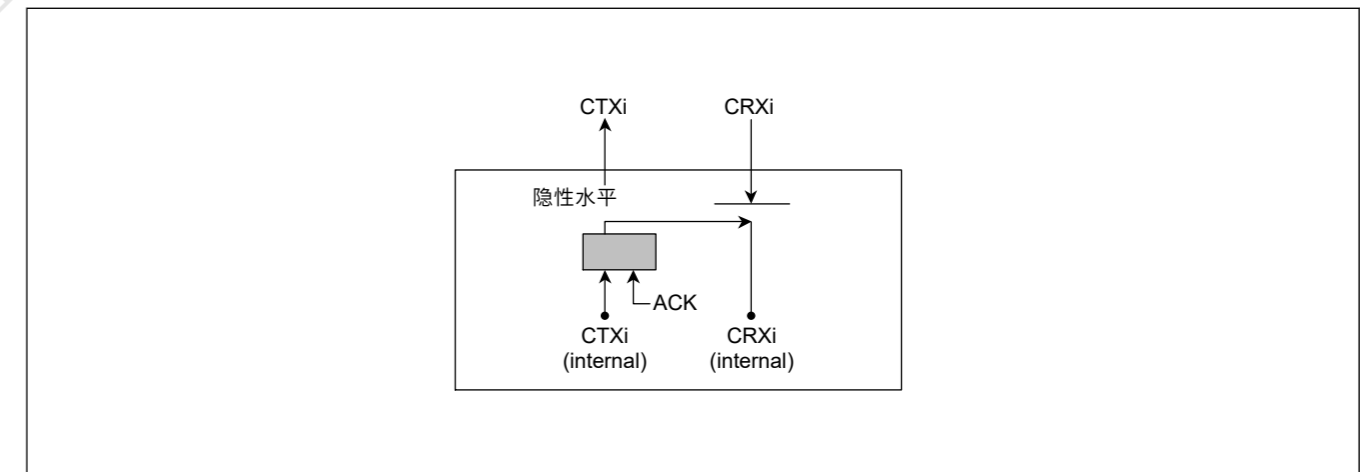


Figure 29.8 选择自检模式1时的连接(i=0 1)

## 29.3 操作模式

CAN模块操作包括以下模式：

- CAN复位模式
- CAN停机模式
- CAN操作模式
- CAN休眠模式

图29.9显示了不同操作模式之间的转换。





- MIER and MIER\_FIFO
- EIER
- BCR
- CSSR
- ECSR (only the EDPM bit)
- MBj\_ID, MBj\_DL, MBj\_Dm and MBj\_TS
- MKRk
- FIDCR0 and FIDCR1
- MKIVLR
- AFSR
- RFPCR
- TFPCR

### 29.3.2 CAN Halt Mode

CAN halt mode is used for mailbox configuration and test mode setting.

When the CTRL.CANM[1:0] bits are set to 10b, CAN halt mode is selected, and the STR.HLTST bit is set to 1. Do not change the CTRL.CANM[1:0] bits until the HLTST bit is 1.

See Table 29.8 for the state transition conditions when transmitting or receiving.

All registers except for the RSTST, HLTST, and SLPST bits in STR remain unchanged when the CAN enters CAN halt mode. Do not change CTRL (except for the CANM[1:0] and SLPM bits) and EIER in CAN halt mode. BCR can be changed in CAN halt mode only when listen-only mode is selected for automatic baud rate detection.

Table 29.8 Operation in CAN reset mode and CAN halt mode

| Operation mode                                     | Receiver   | Transmitter  | Bus-off  |
|--|--|--|--|
| CAN reset mode (forced transition) CANM[1:0] = 11b | CAN module enters CAN reset mode without waiting for the end of message reception.   | CAN module enters CAN reset mode without waiting for the end of message transmission.    | CAN module enters CAN reset mode without waiting for the end of bus-off recovery.  |
| CAN reset mode CANM[1:0] = 01b                     | CAN module enters CAN reset mode without waiting for the end of message reception.   | CAN module enters CAN reset mode after waiting for the end of message transmission.*1 *4 | CAN module enters CAN reset mode without waiting for the end of bus-off recovery.  |
| CAN halt mode                                      | CAN module enters CAN halt mode after waiting for the end of message reception.*2 *3 | CAN module enters CAN halt mode after waiting for the end of message transmission.*1 *4  | <ul style="list-style-type: none"> <li>• When the BOM[1:0] bits are 00b: A halt request from software is accepted only after bus-off recovery.</li> <li>• When the BOM[1:0] bits are 01b: CAN module automatically enters CAN halt mode without waiting for the end of bus-off recovery, regardless of a halt request from the software.</li> <li>• When the BOM[1:0] bits are 10b: CAN module automatically enters CAN halt mode after waiting for the end of bus-off recovery, regardless of a halt request from software.</li> <li>• When the BOM[1:0] bits are 11b: CAN module enters CAN halt mode without waiting for the end of bus-off recovery, if a halt is requested by software during bus-off.</li> </ul> |

Note: BOM[1:0] bits: Bits in CTRL.

Note 1. If transmission of multiple messages is requested, a mode transition occurs on completion of the first transmission. If the CAN reset mode is being requested during suspend transmission, mode transition occurs when the bus is idle, the next transmission ends, or the CAN module becomes a receiver.

Note 2. If the CAN bus is locked at the dominant level, the program can detect this state by monitoring the BLIF flag in EIFR.

Note 3. If a CAN bus error occurs during reception after CAN halt mode is requested, the CAN module transitions to CAN halt mode.

- MIER and MIER\_FIFO
- EIER
- BCR
- CSSR
- ECSR (only the EDPM bit)
- MBj\_ID, MBj\_DL, MBj\_Dm and MBj\_TS
- MKRk
- FIDCR0 and FIDCR1
- MKIVLR
- AFSR
- RFPCR
- TFPCR

### 29.3.2 CAN暂停模式

CAN暂停模式用于邮箱配置和测试模式设置。

当CTRL.CANM[1:0]位设置为10b时，选择CAN停止模式，并且STR.HLTST位设置为1。在HLTST位之前不要更改CTRL.CANM[1:0]位是1。

发送或接收时的状态转换条件见表29.8。

当CAN进入CAN暂停模式时，除STR中的RSTST、HLTST和SLPST位之外的所有寄存器都保持不变。不要在CAN暂停模式下更改CTRL（CANM[1:0]和SLPM位除外）和EIER。只有在为自动波特率检测选择只听模式时，才能在CAN暂停模式下更改BCR。

Table 29.8 CAN复位模式和CAN暂停模式下的操作

| 操作模式                       | Receiver                      | Transmitter                   | Bus-off  |
|----------------------------|-------------------------------|-------------------------------|--|
| CAN复位模式（强制转换）CANM[1:0]=11b | CAN模块无需等待报文接收结束即可进入CAN复位模式。   | CAN模块无需等待报文传输结束就进入CAN复位模式。    | CAN模块无需等待总线关闭恢复结束即可进入CAN复位模式。  |
| CAN复位模式CANM[1:0]=01b       | CAN模块无需等待报文接收结束即可进入CAN复位模式。   | CAN模块等待报文传输结束后进入CAN复位模式。*1*4  | CAN模块无需等待总线关闭恢复结束即可进入CAN复位模式。  |
| CAN暂停模式                    | CAN模块在等待报文接收结束后进入CAN停止模式。*2*3 | CAN模块在等待报文传输结束后进入CAN停止模式。*1*4 | <ul style="list-style-type: none"> <li>• 当BOM[1:0]位为00b时：仅在总线关闭恢复后才接受来自软件的暂停请求。</li> <li>• 当BOM[1:0]位为01b时：CAN模块自动进入CAN停止模式，无需等待总线关闭恢复结束，无论来自软件的停止请求如何。</li> <li>• 当BOM[1:0]位为10b时：CAN模块在等待总线关闭恢复结束后自动进入CAN停止模式，无论软件是否有停止请求。</li> <li>• 当BOM[1:0]位为11b时：如果在总线关闭期间软件请求停止，CAN模块无需等待总线关闭恢复结束即可进入CAN停止模式。</li> </ul> |

Note: BOM[1:0]位: CTRL中的位。

注1.如果请求发送多个消息，则在第一次发送完成时发生模式转换。如果在暂停传输期间请求CAN复位模式，则在总线空闲、下一次传输结束或CAN模块成为接收器时发生模式转换。

注2.如果CAN总线被锁定在显性电平，程序可以通过监控EIFR中的BLIF标志来检测该状态。

注3.如果在请求CAN暂停模式后接收期间发生CAN总线错误，CAN模块将转换到CAN暂停模式。

Note 4. If a CAN bus error or arbitration-lost occurs during transmission after CAN reset mode or CAN halt mode is requested, the CAN module transitions to the requested CAN mode.

### 29.3.3 CAN Sleep Mode

CAN sleep mode reduces power consumption by stopping the clock supply to the CAN module. After a reset from an MCU pin or a software reset, the CAN module starts from CAN sleep mode.

When the SLPB bit in CTRL is set to 1, the CAN module enters CAN sleep mode, and the SLPST bit in STR is set to 1. Do not change the value of the SLPB bit until the SLPST bit is 1. The other registers remain unchanged when the CAN module enters CAN sleep mode.

Write to the SLPB bit in CAN reset mode and CAN halt mode. Do not change any registers (except for the SLPB bit) during CAN sleep mode. Read operation is still allowed.

When the SLPB bit is set to 0, the CAN module is released from CAN sleep mode. When the CAN module exits CAN sleep mode, the other registers remain unchanged.

### 29.3.4 CAN Operation Mode (Excluding Bus-Off State)

CAN operation mode is used for CAN communication.

When the CANM[1:0] bits in CTRL are set to 00b, the CAN module enters CAN operation mode. The RSTST and HLTST bits in STR are set to 0. Do not change the value of the CANM[1:0] bits until the RSTST and HLTST bits are 0.

If 11 consecutive recessive bits are detected after entering CAN operation mode:

- The CAN module becomes an active node on the network, which enables transmission and reception of CAN messages.
- Error monitoring of the CAN bus, such as receive and transmit error counters, is performed.

During CAN operation mode, the CAN module might be in one of the following three sub-modes, depending on the status of the CAN bus:

- Idle mode: No transmission or reception occurs.
- Receive mode: A CAN message sent by another node is being received.
- Transmit mode: A CAN message is being transmitted. The CAN module receives a message transmitted by the local node simultaneously when self-test mode 0 (TSTM[1:0] bits in TCR = 10b) or self-test mode 1 (TSTM[1:0] bits = 11b) is selected.

Figure 29.10 shows the sub-modes of CAN operation mode.

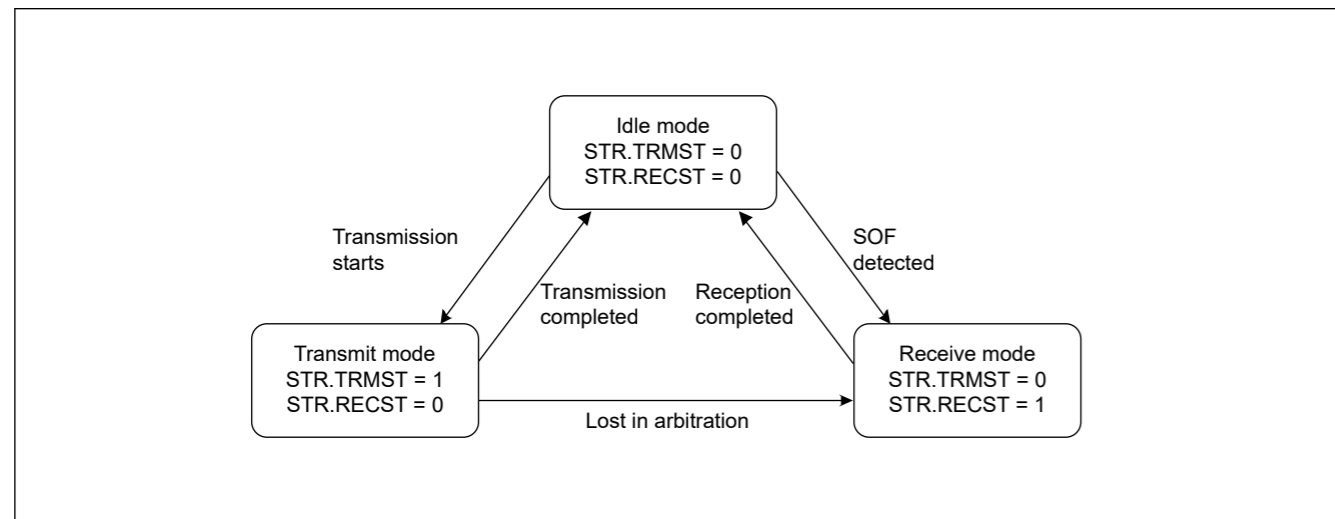


Figure 29.10 Sub-modes of CAN operation mode

注4.如果在请求CAN复位模式或CAN暂停模式后的传输过程中发生CAN总线错误或仲裁丢失，则CAN模块将转换到请求的CAN模式。

### 29.3.3 CAN睡眠模式

CAN睡眠模式通过停止向CAN模块提供时钟来降低功耗。在从MCU引脚复位或软件复位后，CAN模块从CAN睡眠模式启动。

当CTRL中的SLPB位为1时，CAN模块进入CAN休眠模式，同时STR中的SLPST位为1。在SLPST位为1之前不要改变SLPB位的值。其他寄存器保持不变CAN模块进入CAN休眠模式时不变。

在CAN复位模式和CAN暂停模式下写入SLPB位。在CAN睡眠模式期间不要更改任何寄存器（SLPB位除外）。仍然允许读取操作。

当SLPB位设置为0时，CAN模块从CAN睡眠模式中释放。当CAN模块退出CAN休眠模式时，其他寄存器保持不变。

### 29.3.4 CAN操作模式（不包括总线关闭状态）

CAN操作模式用于CAN通信。

当CTRL中的CANM[1:0]位设置为00b时，CAN模块进入CAN操作模式。STR中的RSTST和HLTST位设置为0。在RSTST和HLTST位为0之前，不要更改CANM[1:0]位的值。

如果进入CAN操作模式后检测到11个连续的隐性位：

- CAN模块成为网络上的一个活动节点，实现CAN报文的发送和接收。
- 执行CAN总线的错误监控，例如接收和发送错误计数器。

在CAN操作模式期间，CAN模块可能处于以下三种子模式之一，具体取决于CAN总线的状态：

- 空闲模式：不发送或接收。
- 接收模式：正在接收另一个节点发送的CAN报文。
- 传输模式：正在传输CAN报文。CAN模块接收本地发送的报文  
nodesimultaneouslywhenself-testmode0(TSTM[1:0]bitsinTCR=10b)orself-testmode1(TSTM[1:0]bits=11b)is elected.

图29.10显示了CAN操作模式的子模式。

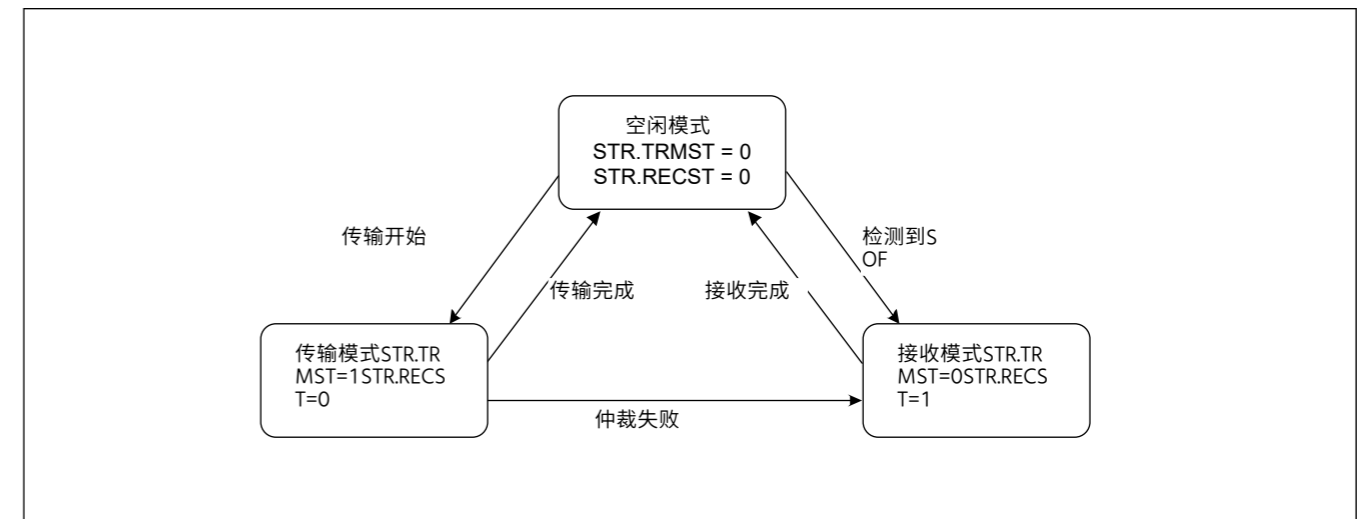


Figure 29.10 CAN操作模式的子模式

### 29.3.5 CAN Operation Mode (Bus-Off State)

The CAN module enters the bus-off state based on the incrementing or decrementing rules for the transmit and error counters defined in the CAN specifications.

The following cases apply when the CAN module is recovering from the bus-off state. When the CAN module is in the bus-off state, the values of the CAN module registers remain unchanged, except for those in STR, EIFR, RECR, TECR, and TSR.

#### (1) When CTLR.BOM[1:0] = 00b (normal mode)

The CAN module enters the error-active state after it completes recovery from the bus-off state and CAN communication is enabled. The BORIF flag in EIFR is set to 1 (bus-off recovery detected).

#### (2) When CTLR.RBOC = 1 (forced return from bus-off)

The CAN module enters the error-active state when it is in the bus-off state and the RBOC bit is 1. CAN communication is enabled again after 11b consecutive recessive bits are detected. The BORIF flag is not set to 1.

#### (3) When CTLR.BOM[1:0] = 01b (automatic transition to CAN halt mode on bus-off entry)

The CAN module enters CAN halt mode when it reaches the bus-off state. The BORIF flag is not set to 1.

#### (4) When CTLR.BOM[1:0] = 10b (automatic transition to CAN halt mode on bus-off end)

The CAN module enters CAN halt mode when it completes recovery from bus-off. The BORIF flag is set to 1.

#### (5) When CTLR.BOM[1:0] = 11b (automatic transition to CAN halt mode through software) and CTLR.CANM[1:0] = 10b (CAN halt mode) during bus-off state

The CAN module enters CAN halt mode when it is in the bus-off state and the CANM[1:0] bits are set to 10b (CAN halt mode). The BORIF flag is not set to 1.

If the CANM[1:0] bits are not set to 10b during bus-off, the same behavior as (1) applies.

## 29.4 Data Transfer Rate Configuration

This section describes how to configure the data transfer rate.

### 29.4.1 Clock Setting

The CAN module provides a CAN clock generator. The CAN clock can be set in the CCLKS and BRP[9:0] bits in BCR. Figure 29.11 shows a block diagram of the CAN clock generator.

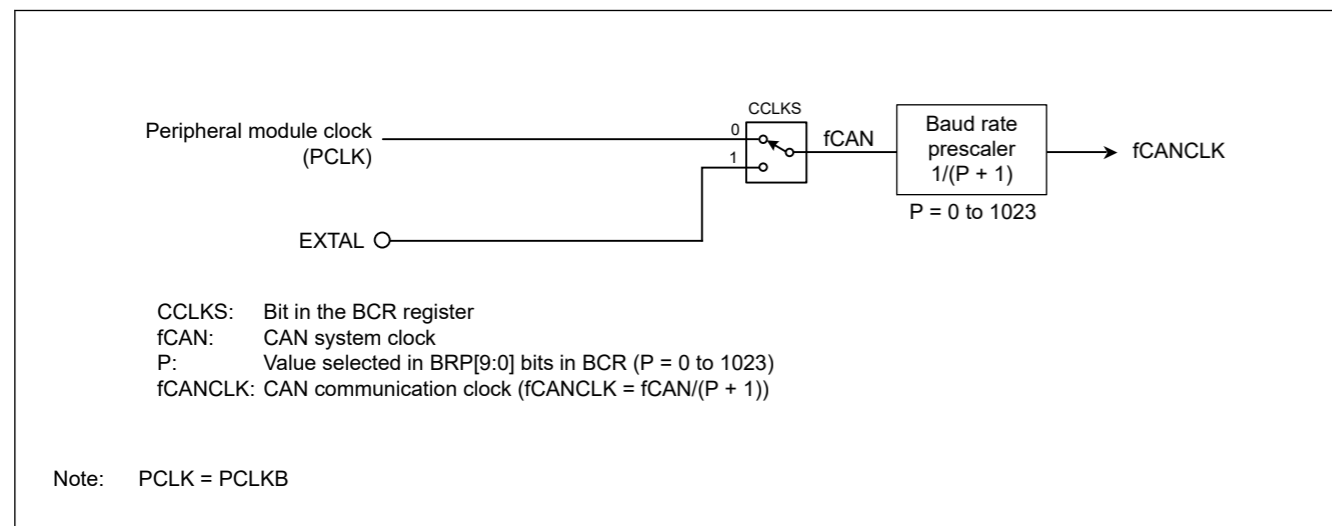


Figure 29.11 Block diagram of CAN clock generator

### 29.3.5 CAN操作模式 (总线关闭状态)

CAN模块根据CAN规范中定义的发送和错误计数器的递增或递减规则进入总线关闭状态。

以下情况适用于CAN模块从总线关闭状态恢复时。当CAN模块处于busoff状态时，CAN模块寄存器的值保持不变，除了STR、EIFR、RECR、TECR和TSR中的值。

#### (1) When CTLR.BOM[1:0] = 00b (normal mode)

CAN模块在完成从总线关闭状态恢复并启用CAN通信后进入错误激活状态。EIFR中的BORIF标志设置为1 (检测到总线关闭恢复)。

#### (2) 当CTLR.RBOC=1时 (从总线关闭强制返回)

当CAN模块处于总线关闭状态且RBOC位为1时，进入错误激活状态。在检测到11b个连续的隐性位后再次启用CAN通信。BORIF标志未设置为1。

#### (3) 当CTLR.BOM[1:0]=01b时 (在总线关闭进入时自动转换到CAN暂停模式)

CAN模块在达到总线关闭状态时进入CAN停止模式。BORIF标志未设置为1。

#### (4) 当CTLR.BOM[1:0]=10b时 (在总线关闭结束时自动转换到CAN暂停模式)

CAN模块在完成总线关闭恢复后进入CAN暂停模式。BORIF标志设置为1。

#### (5) 当CTLR.BOM[1:0]=11b (通过软件自动转换到CAN暂停模式) 并且总线关闭状态期间CTLR.CANM[1:0]=10b (CAN停止模式)

CAN模块在总线关闭状态且CANM[1:0]位设置为10b (CAN停止模式) 时进入CAN停止模式。BORIF标志未设置为1。

如果在总线关闭期间CANM[1:0]位未设置为10b，则适用与(1)相同的行为。

## 29.4 数据传输率配置

本节介绍如何配置数据传输速率。

### 29.4.1 时钟设置

CAN模块提供一个CAN时钟发生器。CAN时钟可以在BCR的CCLKS和BRP[9:0]位中设置。图29.11显示了CAN时钟发生器的框图。

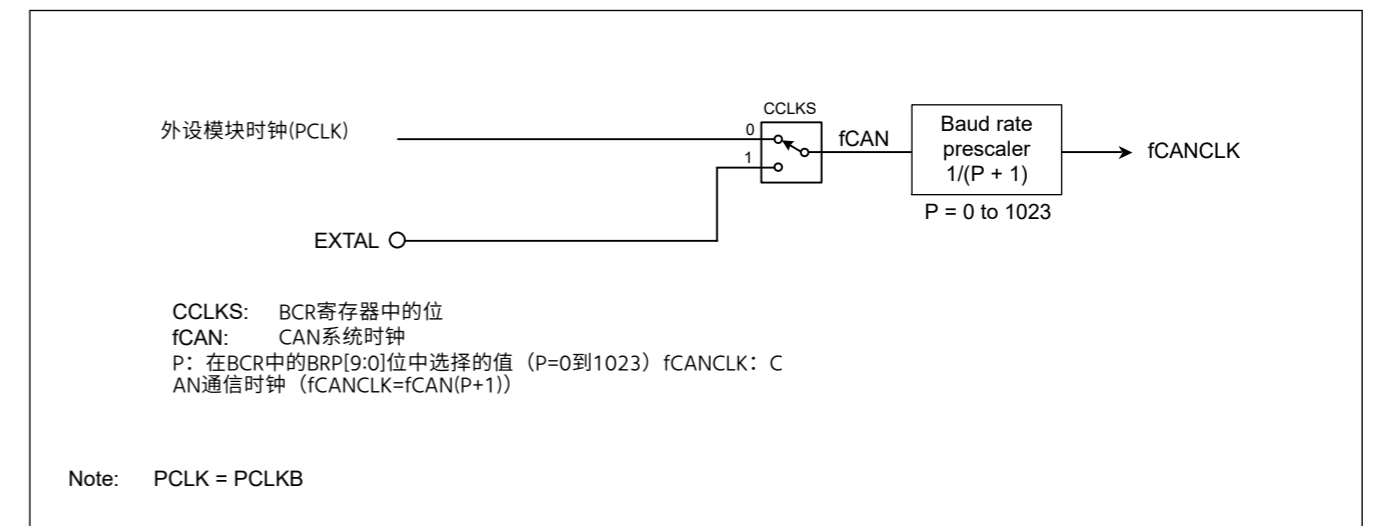


Figure 29.11 CAN时钟发生器框图

### 29.4.2 Bit Timing Setting

The bit timing consists of three segments as shown in Figure 29.12.

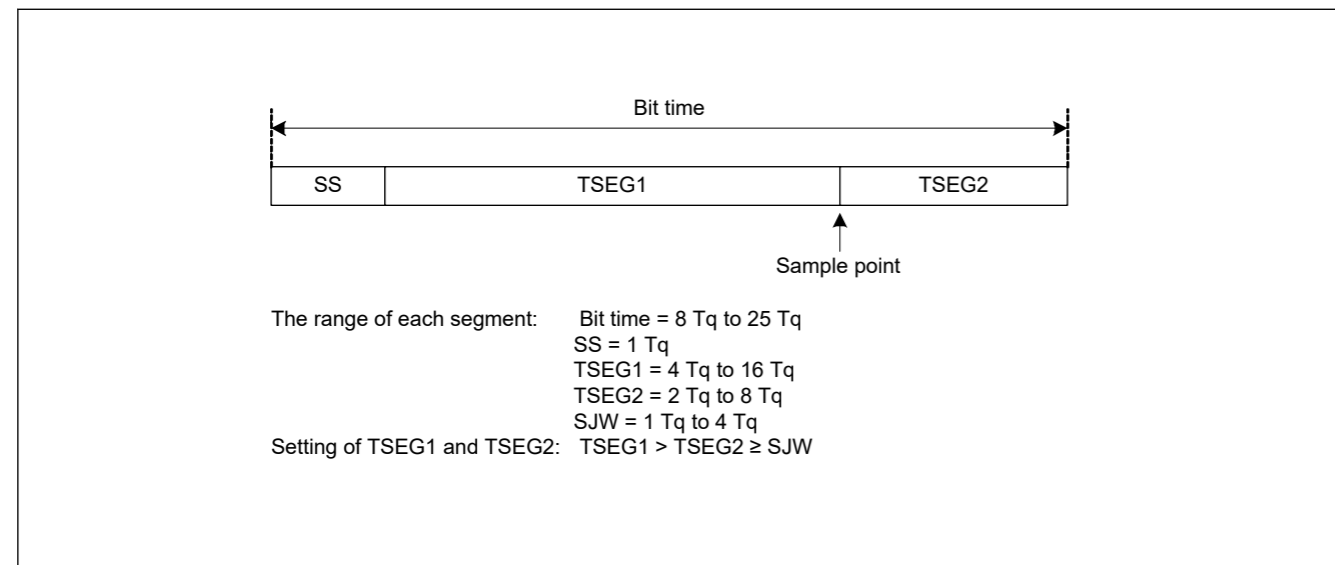


Figure 29.12 Bit timing

### 29.4.3 Data Transfer Rate

The data transfer rate depends on the division value of fCAN (CAN system clock), the division value of the baud rate prescaler, and the Tq count for 1 bit time.

The division value of baud rate prescaler = P + 1 (P: 0 to 1023), where P is the BRP[9:0] setting in BCR.

$$\text{Data transfer rate (bps)} = \frac{f_{CAN}}{\text{Baud rate prescaler division value} \times \text{Tq count for 1 bit time}} = \frac{f_{CANCLK}}{\text{Tq count for 1 bit time}}$$

Table 29.9 lists data transfer rate examples.

Table 29.9 Data transfer rate examples

| fCAN               | 20 MHz   |       |
|--------------------|----------|-------|
| Data transfer rate | Tq count | P + 1 |
| 1 Mbps             | 5 Tq     | 4     |
|                    | 10 Tq    | 2     |
| 500 kbps           | 5 Tq     | 8     |
|                    | 10 Tq    | 4     |
| 250 kbps           | 5 Tq     | 16    |
|                    | 10 Tq    | 8     |
| 125 kbps           | 5 Tq     | 32    |
|                    | 10 Tq    | 16    |
| 83.3 kbps          | 5 Tq     | 48    |
|                    | 10 Tq    | 24    |
| 33.3 kbps          | 5 Tq     | 120   |
|                    | 8 Tq     | 75    |
|                    | 10 Tq    | 60    |

### 29.5 Mailbox and Mask Register Structure

Figure 29.13 shows the structure of the 32 mailbox registers: MBj\_ID, MBj\_DL, MBj\_Dm, and MBj\_TS.

### 29.4.2 位时序设置

位时序由三个部分组成，如图29.12所示。

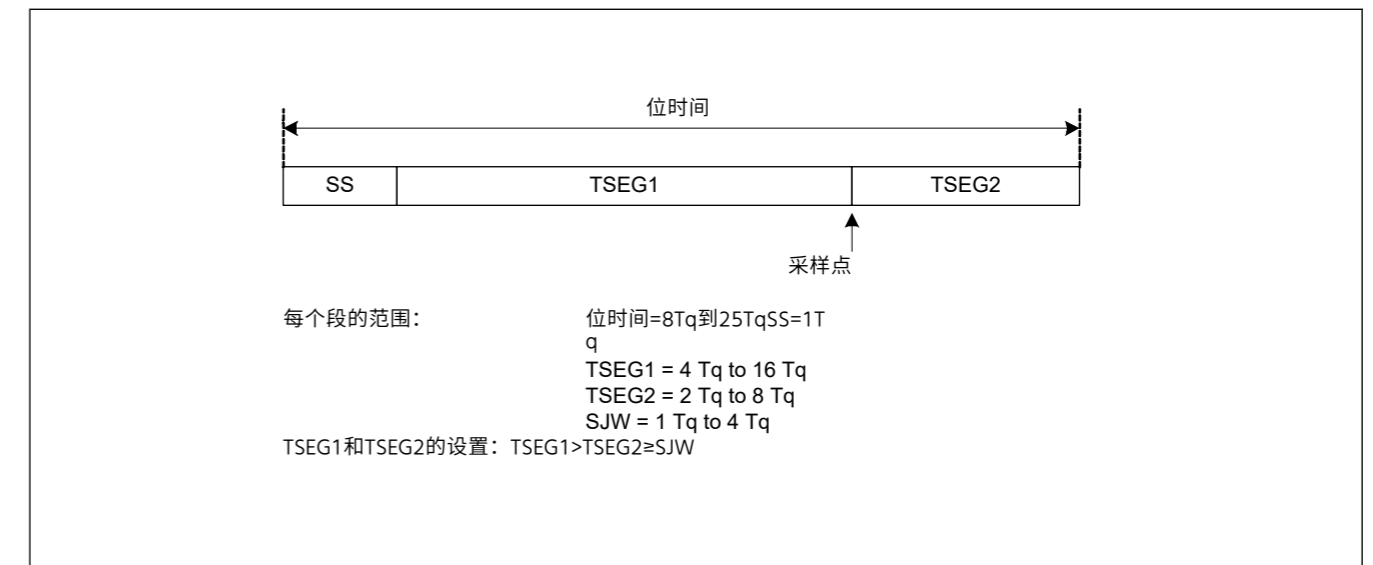


Figure 29.12 位时序

### 29.4.3 数据传输率

数据传输率取决于fCAN (CAN系统时钟) 的分频值、波特率预分频器的分频值和1位时间的Tq计数。

波特率预分频器的分频值=P+1(P:0到1023)，其中P是BCR中的BRP[9:0]设置。

$$\text{数据传输率(bps)} = \frac{f_{CAN}}{\text{波特率预分频器分频值} \times \text{1位时间的Tq计数}} = \frac{\text{1位时间的} f_{CANCLK} \text{Tq计数}}{\text{计数}}$$

表29.9列出了数据传输率示例。

Table 29.9 数据传输率示例

| fCAN      | 20 MHz   |       |
|-----------|----------|-------|
| 数据传输率     | Tq count | P + 1 |
| 1 Mbps    | 5 Tq     | 4     |
|           | 10 Tq    | 2     |
| 500 kbps  | 5 Tq     | 8     |
|           | 10 Tq    | 4     |
| 250 kbps  | 5 Tq     | 16    |
|           | 10 Tq    | 8     |
| 125 kbps  | 5 Tq     | 32    |
|           | 10 Tq    | 16    |
| 83.3 kbps | 5 Tq     | 48    |
|           | 10 Tq    | 24    |
| 33.3 kbps | 5 Tq     | 120   |
|           | 8 Tq     | 75    |
|           | 10 Tq    | 60    |

### 29.5 邮箱和掩码寄存器结构

图29.13显示了32个邮箱寄存器的结构：MBj\_ID、MBj\_DL、MBj\_Dm和MBj\_TS。





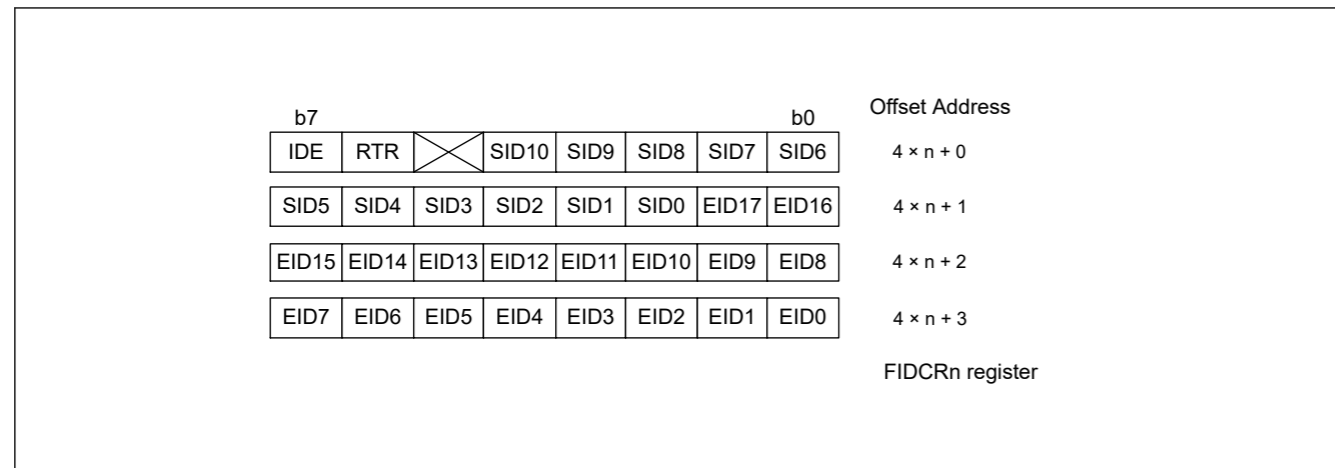


Figure 29.15 Structure of the FIDCRn registers (n = 0, 1)

## 29.6 Acceptance Filtering and Masking Functions

The acceptance filtering and masking functions allow you to select and receive messages with multiple IDs for mailboxes within a specified range.

The MKRk registers can mask the standard ID and the extended ID of 29 bits.

- MKR0 controls mailboxes 0 to 3
- MKR1 controls mailboxes 4 to 7
- MKR2 controls mailboxes 8 to 11
- MKR3 controls mailboxes 12 to 15
- MKR4 controls mailboxes 16 to 19
- MKR5 controls mailboxes 20 to 23
- MKR6 controls mailboxes 24 to 27 in normal mailbox mode and the receive FIFO mailboxes 28 to 31 in FIFO mailbox mode
- MKR7 controls mailboxes 28 to 31 in normal mailbox mode and the receive FIFO mailboxes 28 to 31 in FIFO mailbox mode

MKIVLR disables acceptance filtering independently for each mailbox.

The IDE bit in MBj\_ID is valid when the IDFM[1:0] bits in CTRL are 10b (mixed ID mode).

The RTR bit in MBj\_ID selects a data or remote frame.

In FIFO mailbox mode, normal mailboxes 0 to 23 use one associated register from MKR0 to MKR5 for acceptance filtering. The receive FIFO mailboxes 28 to 31 use two registers, MKR6 and MKR7, for acceptance filtering.

The receive FIFO also uses two registers, FIDCR0 and FIDCR1, for ID comparison. The EID[17:0], SID[10:0], RTR, and IDE bits in MB28 to MB31 for the receive FIFO are disabled. As acceptance filtering depends on the result of two logic AND operations, two ranges of IDs can be received into the receive FIFO. MKIVLR is disabled for the receive FIFO.

If different standard ID and extended ID values are set in the IDE bits in FIDCR0 and FIDCR1, both ID formats are received.

If different data frame and remote frame values are set in the RTR bits in FIDCR0 and FIDCR1, both data and remote frames are received.

When a combination of two ranges of IDs is not required, set the same mask value and the same ID into both the FIFO ID and mask registers.

Figure 29.16 shows the associations between the mask registers and mailboxes. Figure 29.17 shows the acceptance filtering.

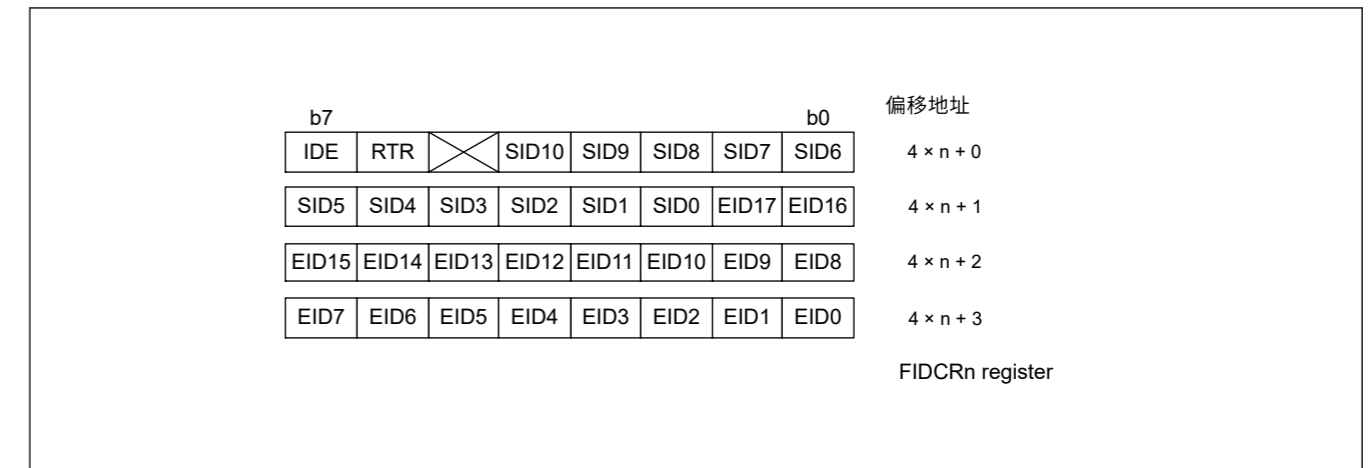


Figure 29.15 FIDCRn寄存器的结构(n=0 1)

## 29.6 接受过滤和屏蔽功能

接受过滤和屏蔽功能允许您为指定范围内的邮箱选择和接收具有多个ID的消息。

MKRk寄存器可以屏蔽标准ID和29位扩展ID。

- MKR0控制邮箱0到3
- MKR1控制邮箱4到7
- MKR2控制邮箱8到11
- MKR3控制邮箱12到15
- MKR4控制邮箱16到19
- MKR5控制邮箱20到23
- MKR6在普通邮箱模式下控制邮箱24到27，在FIFO邮箱模式下控制接收FIFO邮箱28到31
- MKR7在普通邮箱模式下控制邮箱28到31，在FIFO邮箱模式下控制接收FIFO邮箱28到31

MKIVLR为每个邮箱单独禁用接受过滤。

当CTRL中的IDFM[1:0]位为10b（混合ID模式）时，MBj\_ID中的IDE位有效。

MBj\_ID中的RTR位选择数据或远程帧。

在FIFO邮箱模式下，普通邮箱0到23使用一个从MKR0到MKR5的关联寄存器用于接受过滤。接收FIFO邮箱28到31使用两个寄存器，MKR6和MKR7，用于接受过滤。

接收FIFO还使用两个寄存器FIDCR0和FIDCR1进行ID比较。EID[17:0]、SID[10:0]、RTR和MB28到MB31中用于接收FIFO的IDE位被禁用。由于验收过滤取决于两个逻辑的结果AND操作，可以将两个范围的ID接收到接收FIFO中。MKIVLR对接收FIFO禁用。

如果在FIDCR0和FIDCR1的IDE位中设置了不同的标准ID和扩展ID值，则会接收两种ID格式。

如果在FIDCR0和FIDCR1的RTR位中设置了不同的数据帧和远程帧值，则数据帧和远程帧都被接收。

当不需要两个ID范围的组合时，将相同的掩码值和相同的ID设置到FIFOID和掩码寄存器中。

图29.16显示了掩码寄存器和邮箱之间的关联。图29.17显示了接受过滤。

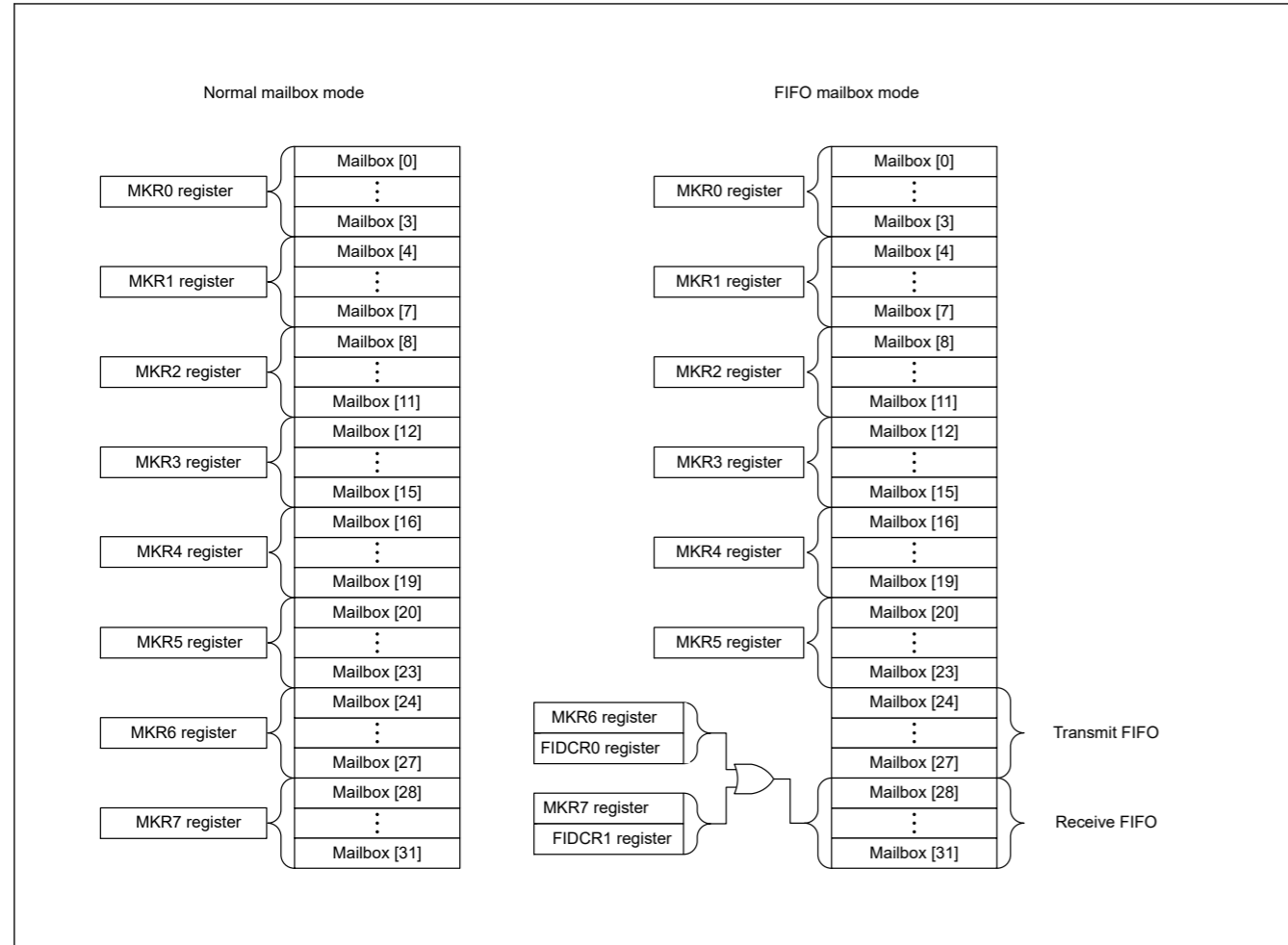


Figure 29.16 Associations between mask registers and mailboxes

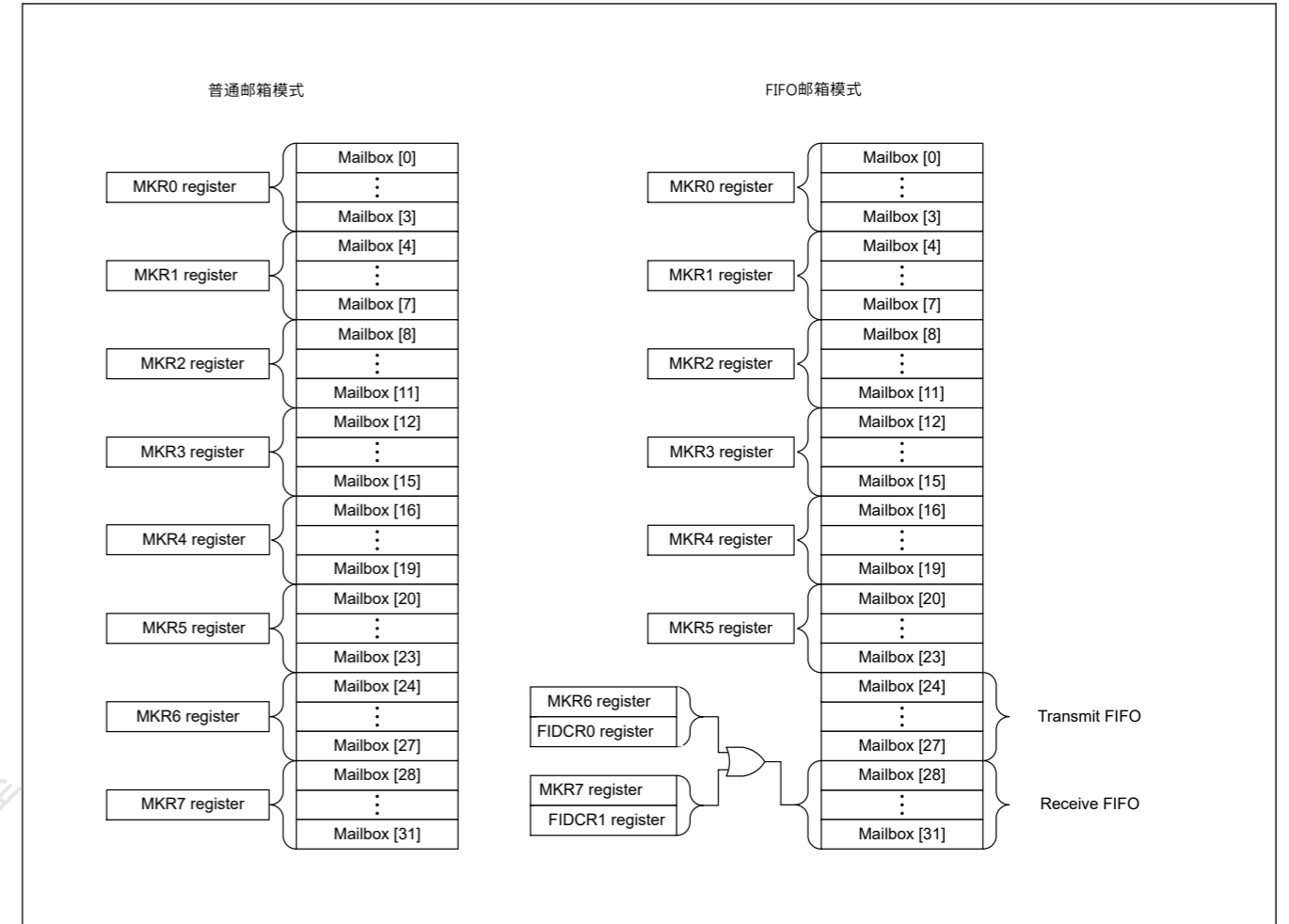


Figure 29.16 掩码寄存器和邮箱之间的关联

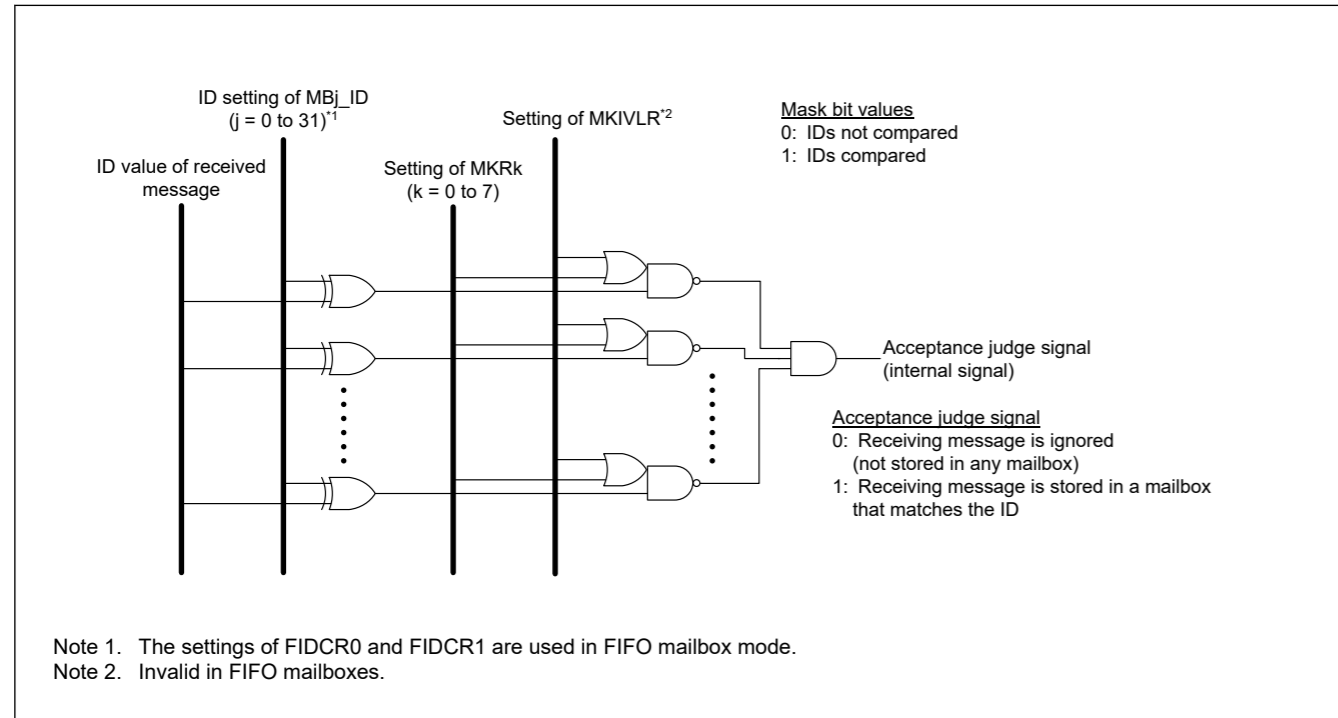


Figure 29.17 Acceptance filtering

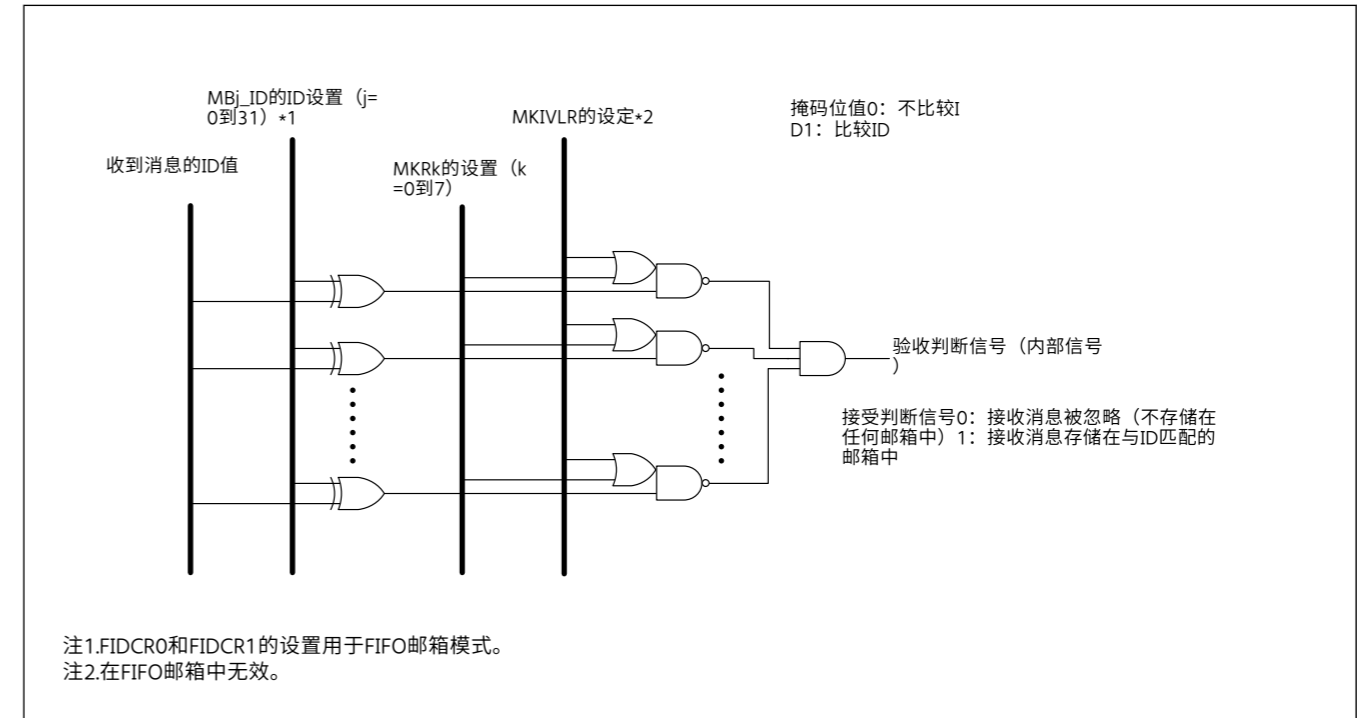


Figure 29.17 验收过滤

## 29.7 Reception and Transmission

Table 29.10 lists the CAN communication mode settings.

Table 29.10 Settings for CAN receive and transmit modes

| MCTL_TX[j].TRMREQ<br>and<br>MCTL_RX[j].TRMREQ | MCTL_TX[j].RECREQ<br>and<br>MCTL_RX[j].RECREQ | MCTL_TX[j].ONESHOT<br>and<br>MCTL_RX[j].ONESHOT | Mailbox communication mode  |
|---|---|---|---|
| 0   | 0   | 0   | Mailbox disabled or transmission being aborted  |
| 0   | 0   | 1   | Can be configured only when transmission or reception from a mailbox programmed in one-shot mode is aborted |
| 0   | 1   | 0   | Configured as a receive mailbox for a data or remote frame  |
| 0   | 1   | 1   | Configured as a one-shot receive mailbox for a data or remote frame.  |
| 1   | 0   | 0   | Configured as a transmit mailbox for a data or remote frame.  |
| 1   | 0   | 1   | Configured as a one-shot transmit mailbox for a data or remote frame.                                       |
| 1   | 1   | 0   | Do not set.   |
| 1   | 1   | 1   | Do not set.   |

Note: j = 0 to 31

When a mailbox is configured as a receive mailbox or a one-shot receive mailbox, the following restrictions apply:

- Before configuring the mailbox, set MCTL\_RX[j] to 0x00.
- A received message is stored in the first mailbox that matches the condition resulting from the receive mode settings and acceptance filtering. The matching mailbox with the smallest number takes priority for storing the received message.
- In CAN operation mode, the CAN module does not receive its own transmitted data even when the ID is a match. In self-test mode, however, the CAN module receives its own transmitted data and returns ACK.

When configuring a mailbox as a transmit mailbox or a one-shot transmit mailbox, the following constraint applies:

- Before configuring a mailbox, ensure that MCTL\_TX[j] is 0x00 and that there is no pending abort process.

### 29.7.1 Reception

Figure 29.18 shows an operation example of data frame reception in overwrite mode. The example shows the overwriting of the first message when the CAN module receives two consecutive CAN messages that match the receiving conditions in MCTL\_RX[j] (j = 0 to 31).

## 29.7 接收和传输

表29.10列出了CAN通信模式设置。

Table 29.10 CAN接收和发送模式的设置

| MCTL_TX[j].TRMREQ<br>and<br>MCTL_RX[j].TRMREQ | MCTL_TX[j].RECREQ<br>and<br>MCTL_RX[j].RECREQ | MCTL_TX[j].ONESHOT<br>and<br>MCTL_RX[j].ONESHOT | 邮箱通讯方式                        |
|---|---|---|-------------------------------|
| 0   | 0   | 0   | 邮箱禁用或传输被中止                    |
| 0   | 0   | 1   | 只有在一次性模式中编程的邮箱的发送或接收被中止时才可以配置 |
| 0   | 1   | 0   | 配置为数据或远程帧的接收邮箱                |
| 0   | 1   | 1   | 配置为数据或远程帧的一次性接收邮箱。            |
| 1   | 0   | 0   | 配置为数据或远程帧的传输邮箱。               |
| 1   | 0   | 1   | 配置为数据或远程帧的一次性发送邮箱。            |
| 1   | 1   | 0   | 不要设置。                         |
| 1   | 1   | 1   | 不要设置。                         |

Note: j = 0 to 31

当邮箱配置为接收邮箱或一次性接收邮箱时，以下限制适用：

- 配置邮箱前，将MCTL\_RX[j]设置为0x00。
- 收到的消息存储在第一个符合接收模式设置和接受过滤条件的邮箱中。编号最小的匹配邮箱优先存储收到的消息。
- 在CAN操作模式下，即使ID匹配，CAN模块也不会接收到自己发送的数据。然而，在自检模式下，CAN模块接收自己发送的数据并返回ACK。

将邮箱配置为传输邮箱或一次性传输邮箱时，适用以下约束：

- 在配置邮箱之前，请确保MCTL\_TX[j]为0x00，并且没有挂起的中止进程。

### 29.7.1 Reception

图29.18显示了覆盖模式下数据帧接收的操作示例。该示例显示当CAN模块接收到与MCTL\_RX[j] (j=0到31) 中的接收条件匹配的两个连续CAN报文时，第一条报文的覆盖。



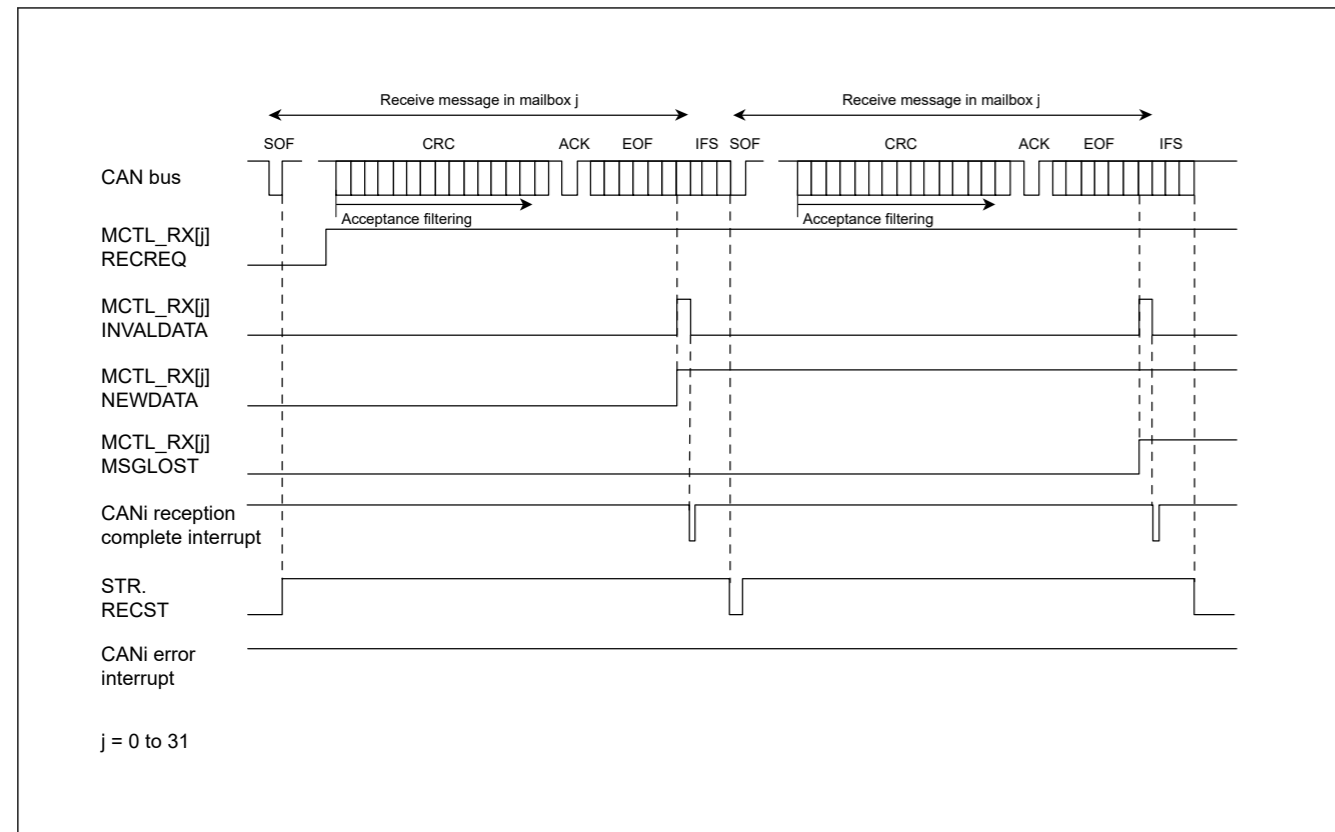


Figure 29.18 Operation example of data frame reception in overwrite mode

1. When an SOF is detected on the CAN bus, the RECST bit in STR is set to 1 (reception in progress) if the CAN module has no message ready to start transmission.
2. Acceptance filtering starts at the beginning of the CRC field to select the receive mailbox.
3. After a message is received, the NEWDATA flag in MCTL\_RX[j] for the receive mailbox is set to 1 (new message is being stored or was stored in the mailbox). The INVALIDDATA flag in MCTL\_RX[j] is set to 1 (message is being updated) at the same time, and then the INVALIDDATA flag is set to 0 (message valid) again after the complete message is transferred to the mailbox.
4. When the interrupt enable bit in MIER for the receive mailbox is 1 (interrupt enabled), the INVALIDDATA flag is set to 0, which triggers a CAN0 reception complete interrupt request.
5. After reading the message from the mailbox, the NEWDATA flag must be set to 0 by software.
6. In overwrite mode, if the next CAN message is received before the NEWDATA flag in MCTL\_RX[j] is set to 1, the MSGLOST flag in MCTL\_RX[j] is set to 1 (message was overwritten). The new received message is transferred to the mailbox. The CAN0 reception complete interrupt request occurs the same as in step 4.

Figure 29.19 shows an operation example of data frame reception in overrun mode. The example shows the overrun of the second message when the CAN module receives two consecutive CAN messages that match the receiving conditions in MCTL\_RX[j] (j = 0 to 31).

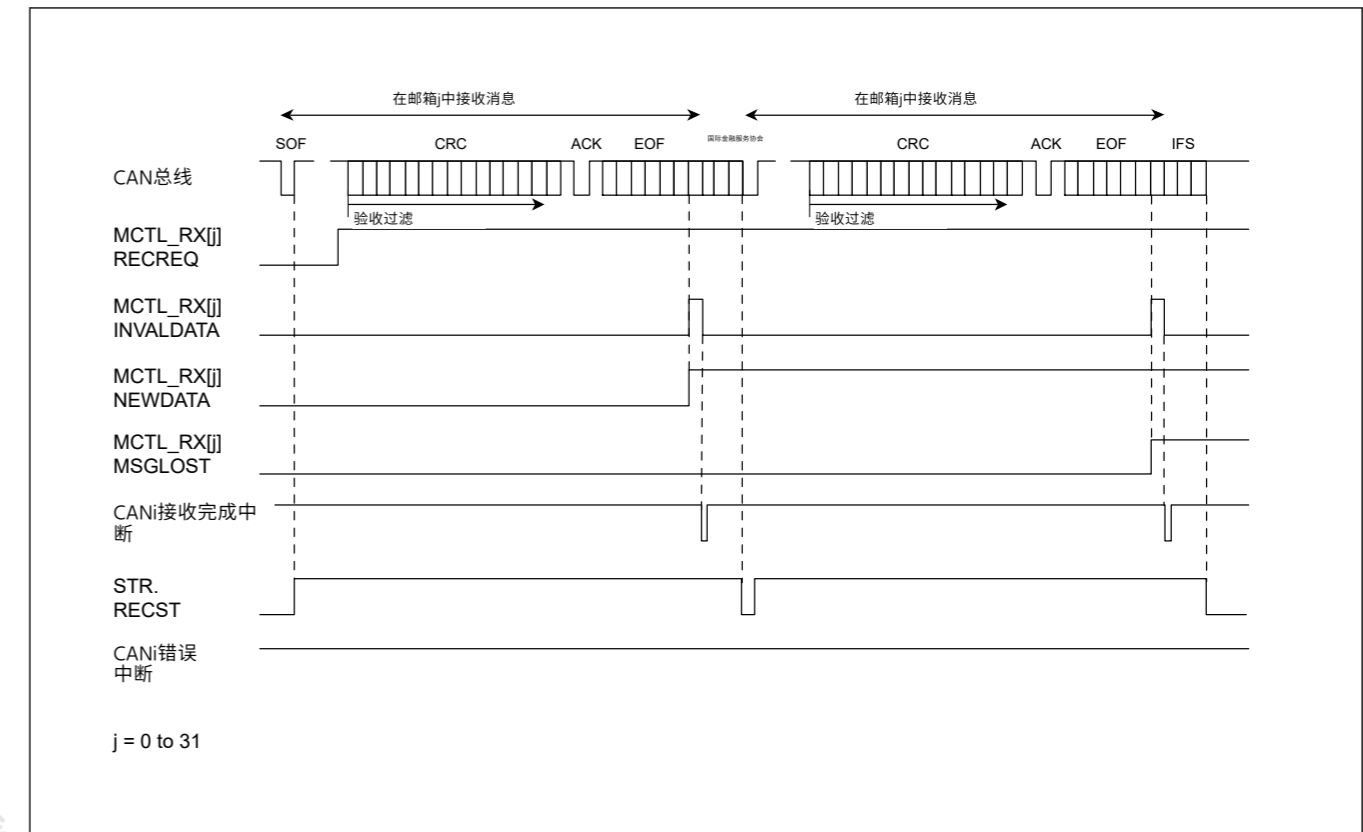


Figure 29.18 覆盖模式下数据帧接收的操作示例

1. 当CAN总线上检测到SOF时，如果CAN模块没有准备好开始发送的消息，则STR中的RECST位设置为1（正在接收）。
2. 接受过滤从CRC字段的开头开始，以选择接收邮箱。
3. 收到消息后，接收邮箱的MCTL\_RX[j]中的NEWDATA标志设置为1（新消息正在存储或已存储在邮箱中）。MCTL\_RX[j]中的INVALIDDATA标志同时设置为1（消息正在更新），然后在完整的消息传送到邮箱后再次将INVALIDDATA标志设置为0（消息有效）。
4. 当接收邮箱的MIER中的中断使能位为1（中断使能）时，INVALIDDATA标志设置为0，触发CAN0接收完成中断请求。
5. 从邮箱读取消息后，NEWDATA标志必须由软件设置为0。
6. 在覆盖模式下，如果在MCTL\_RX[j]中的NEWDATA标志设置为1之前接收到下一个CAN报文，则MCTL\_RX[j]中的MSGLOST标志设置为1（消息被覆盖）。新收到的消息被传送到邮箱。CAN0接收完成中断请求的发生与步骤4相同。

图29.19显示了溢出模式下数据帧接收的操作示例。该示例显示当CAN模块接收到与MCTL\_RX[j] (j=0到31) 中的接收条件匹配的两个连续CAN报文时，第二条报文的溢出。

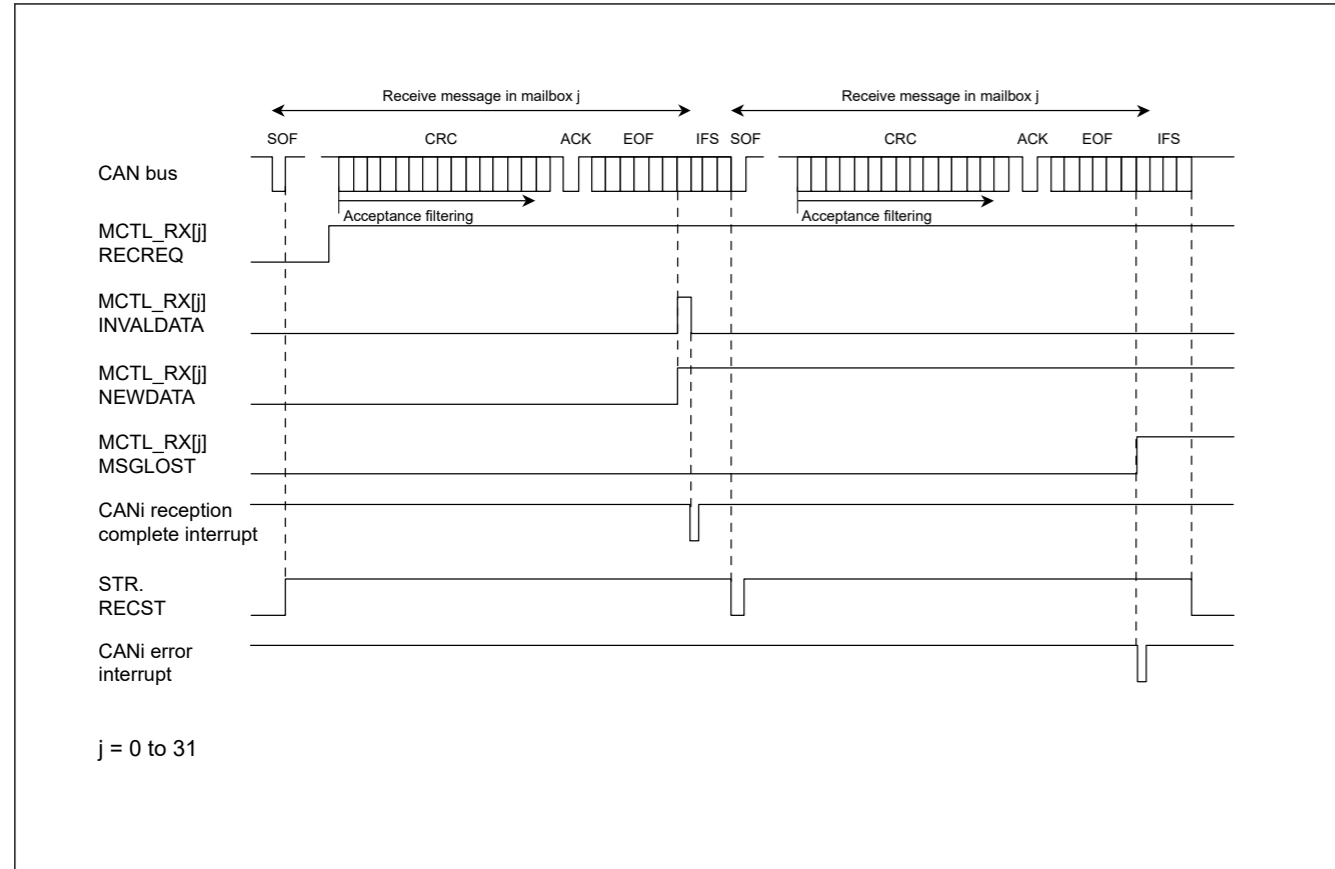


Figure 29.19 Operation example of data frame reception in overrun mode

1. When an SOF is detected on the CAN bus, the RECST bit in STR is set to 1 (reception in progress) if the CAN module has no message ready to start transmission.
2. Acceptance filtering starts at the beginning of the CRC field to select the receive mailbox.
3. After a message is received, the NEWDATA flag in MCTL\_RX[j] for the receive mailbox is set to 1 (new message is being stored or was stored in the mailbox). The INVALIDDATA flag in MCTL\_RX[j] is set to 1 (message is being updated) at the same time, and then the INVALIDDATA flag is set to 0 (message valid) again after the complete message is transferred to the mailbox.
4. When the interrupt enable bit in MIER for the receive mailbox is 1 (interrupt enabled), the INVALIDDATA flag is set to 0, which triggers a CAN0 reception complete interrupt request.
5. After reading the message from the mailbox, the NEWDATA flag must be set to 0 by software.
6. In overrun mode, if the next CAN message is received before the NEWDATA flag in MCTL\_RX[j] is set to 0, the MSGLOST flag in MCTL\_RX[j] is set to 1 (message was saved). The new received message is discarded and a CANi error interrupt request occurs if the associated interrupt enable bit in EIER is set to 1 (interrupt enabled).

### 29.7.2 Transmission

Figure 29.20 shows an operation example of data frame transmission.

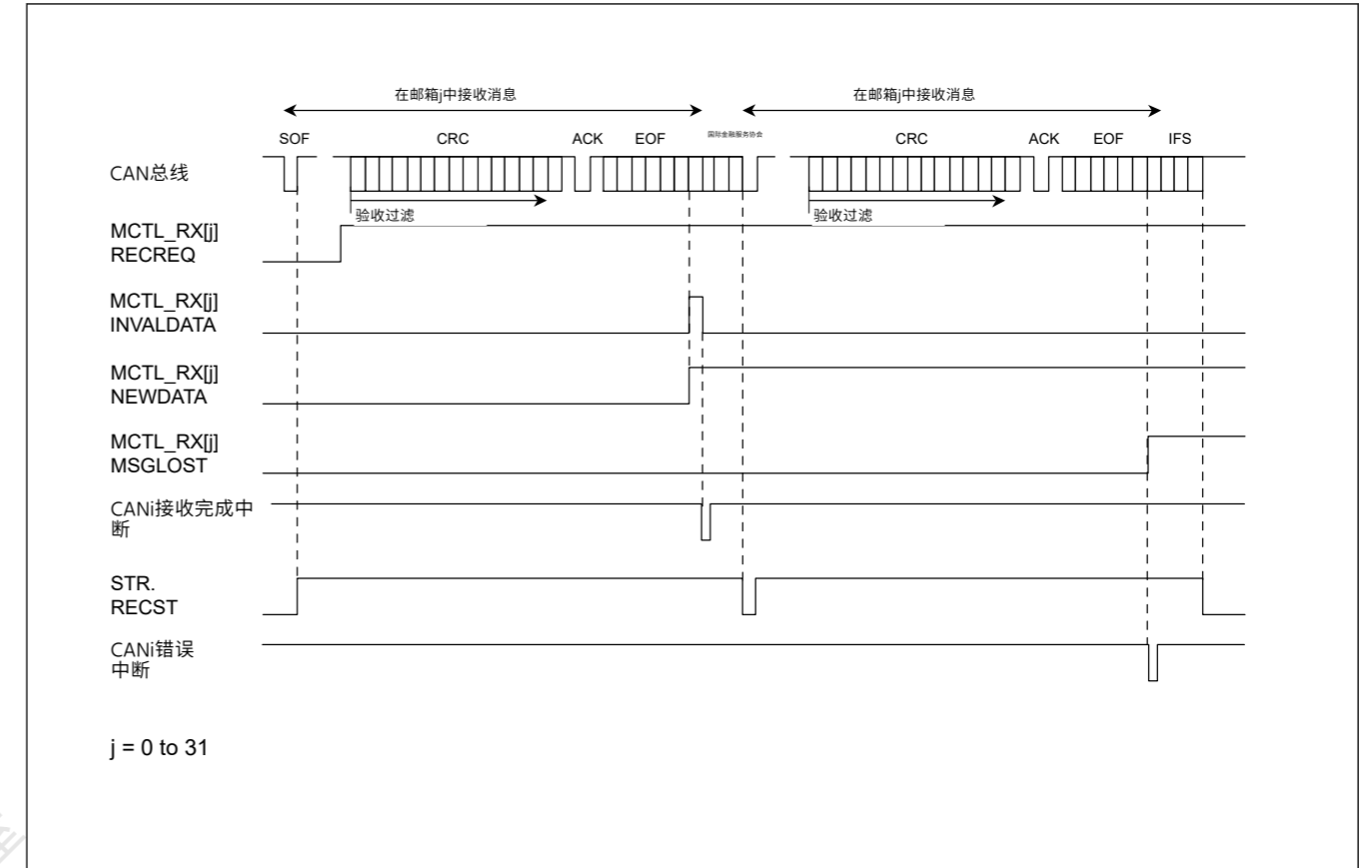


Figure 29.19 溢出模式下数据帧接收的操作示例

1. 当CAN总线上检测到SOF时，如果CAN模块没有准备好开始发送的消息，则STR中的RECST位设置为1（正在接收）。
2. 接受过滤从CRC字段的开头开始，以选择接收邮箱。
3. 收到消息后，接收邮箱的MCTL\_RX[j]中的NEWDATA标志设置为1（新消息正在存储或已存储在邮箱中）。MCTL\_RX[j]中的INVALIDDATA标志同时设置为1（消息正在更新），然后在完整的消息传送到邮箱后再次将INVALIDDATA标志设置为0（消息有效）。
4. 当接收邮箱的MIER中的中断使能位为1（中断使能）时，INVALIDDATA标志设置为0，触发CAN0接收完成中断请求。
5. 从邮箱读取消息后，NEWDATA标志必须由软件设置为0。
6. 在溢出模式下，如果在MCTL\_RX[j]中的NEWDATA标志设置为0之前接收到下一个CAN报文，则MCTL\_RX[j]中的MSGLOST标志设置为1（消息已保存）。如果EIER中的相关中断使能位设置为1（中断使能），则丢弃新接收到的消息并产生CANi错误中断请求。

### 29.7.2 Transmission

图29.20显示了数据帧传输的操作示例。

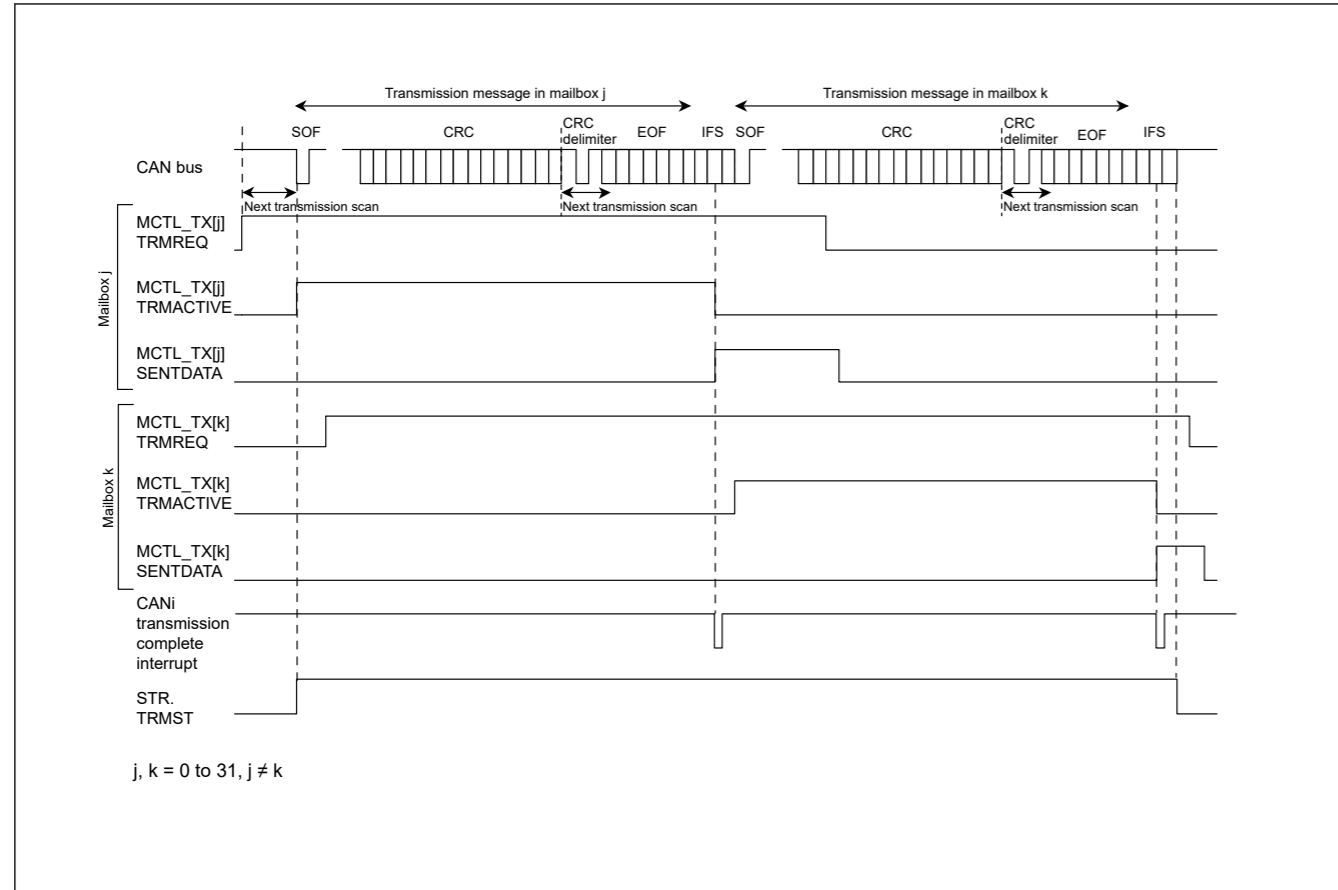


Figure 29.20 Operation example of data frame transmission

1. When a TRMREQ bit in MCTL\_TX[j] (j = 0 to 31) is set to 1 (transmit mailbox) in the bus-idle state, mailbox scanning starts to decide the highest-priority mailbox for transmission. When the transmit mailbox is decided, the TRMACTIVE flag in MCTL\_TX[j] is set to 1 (from acceptance of transmission request to completion of transmission, or error or arbitration-lost), the TRMST bit in STR is set to 1 (transmission in progress), and the CAN module starts transmission.\*1
2. If other TRMREQ bits are set, the transmission scanning starts with the CRC delimiter for the next transmission.
3. If transmission is complete without losing arbitration, the SENTDATA flag in MCTL\_TX[j] is set to 1 (transmission complete) and the TRMACTIVE flag is set to 0 (transmission is pending or transmission is not requested). If the interrupt enable bit in MIER is 1 (interrupt enabled), the CANi transmission complete interrupt request is generated.
4. When requesting the next transmission from the same mailbox, set the SENTDATA flag and TRMREQ bit to 0, and then set the TRMREQ bit to 1 after checking that the SENTDATA flag and TRMREQ bit are set to 0.

Note 1. If arbitration is lost after the CAN module starts transmission, the TRMACTIVE flag is set to 0. Transmission scanning is performed again to search for the highest-priority transmit mailbox from the beginning of the CRC delimiter. If an error occurs either during transmission or following arbitration-lost, transmission scanning is performed again to search for the highest-priority transmit mailbox from the start of the error delimiter.

### 29.8 Interrupts

The CAN module provides the following interrupts for each channel. Table 29.11 lists the CAN interrupts.

- CANi reception complete interrupt for mailboxes 0 to 31 (CANi\_RXM)
- CANi transmission complete interrupt for mailboxes 0 to 31 (CANi\_TXM)
- CANi receive FIFO interrupt (CANi\_RXF)
- CANi transmit FIFO interrupt (CANi\_TXF)
- CANi error interrupt (CANi\_ERS)

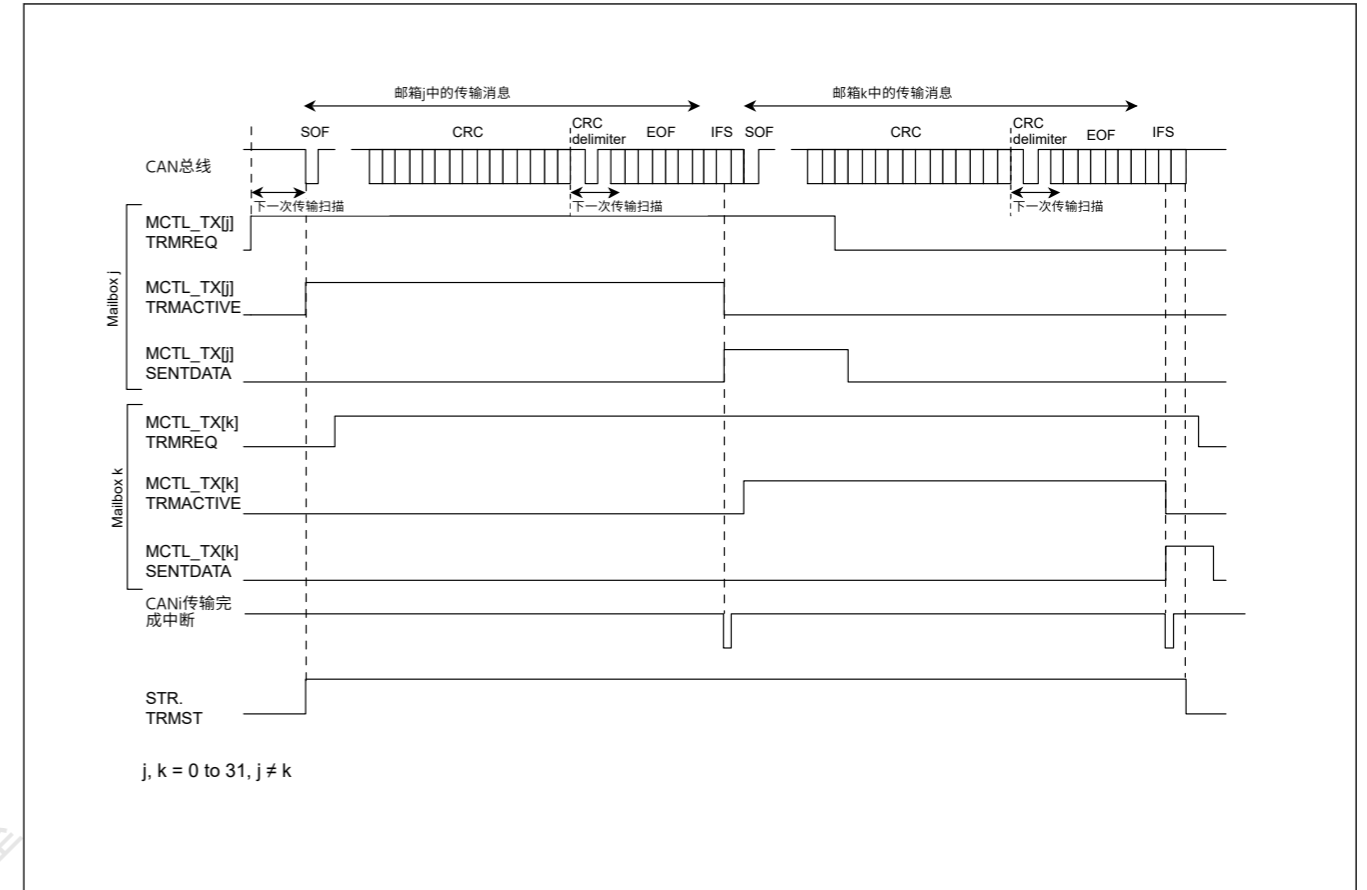


Figure 29.20 数据帧传输的操作示例

- 1.当MCTL\_TX[j] (j=0到31) 中的TRMREQ位在总线空闲状态下设置为1 (发送邮箱) 时, 邮箱扫描开始决定发送的最高优先级邮箱。当确定发送邮箱时, MCTL\_TX[j]中的TRMACTIVE标志置1 (从接受发送请求到发送完成, 或错误或仲裁丢失), STR中的TRMST位设置为1 (发送进度), CAN模块开始传输。\*1
- 2.如果设置了其他TRMREQ位, 则传输扫描以CRC定界符开始, 以进行下一次传输。
- 3.如果传输完成且没有丢失仲裁, 则MCTL\_TX[j]中的SENTDATA标志设置为1 (传输完成) 并且TRMACTIVE标志设置为0 (传输未决或未请求传输)。如果MIER中的中断使能位为1 (中断使能), 则产生CANi传输完成中断请求。
- 4.从同一邮箱请求下一次发送时, 将SENTDATA标志和TRMREQ位设置为0, 然后在检查SENTDATA标志和TRMREQ位设置为0后将TRMREQ位设置为1。

注1.如果CAN模块开始发送后仲裁丢失, 则TRMACTIVE标志设置为0。再次执行发送扫描以从CRC分隔符的开头搜索优先级最高的发送邮箱。如果在传输过程中或仲裁丢失后发生错误, 则再次执行传输扫描以从错误分隔符的开头搜索最高优先级的传输邮箱。

### 29.8 Interrupts

CAN模块为每个通道提供以下中断。表29.11列出了CAN中断。

- 邮箱0到31(CANi\_RXM)的CANi接收完成中断
- 邮箱0到31(CANi\_TXM)的CANi传输完成中断
- CANi接收FIFO中断 (CANi\_RXF)
- CANi发送FIFO中断(CANi\_TXF)
- CANi错误中断(CANi\_ERS)

Eight interrupt sources are available for CANi error interrupts. Check EIFR to determine the interrupt sources:

- Bus error
- Error-warning
- Error-passive
- Bus-off entry
- Bus-off recovery
- Receive overrun
- Overload frame transmission
- Bus lock

Table 29.11 CAN interrupts

| Module          | Interrupt name | Interrupt source  | Source flag                             |
|-----------------|----------------|---|---|
| CANi (i = 0, 1) | CANi_ERS       | Bus lock detected   | EIFR.BLIF                               |
|                 |                | Overload frame transmission detected                              | EIFR.OLIF                               |
|                 |                | Overrun detected  | EIFR.ORIF                               |
|                 |                | Bus-off recovery detected   | EIFR.BORIF                              |
|                 |                | Bus-off entry detected  | EIFR.BOEIF                              |
|                 |                | Error-passive detected  | EIFR.EPIF                               |
|                 |                | Error-warning detected  | EIFR.EWIF                               |
|                 |                | Bus error detected  | EIFR.BEIF                               |
|                 | CANi_RXF       | Receive FIFO message received (MIER_FIFO.MB29 = 0)                | RFCR.RFUST[2:0]                         |
|                 |                | Receive FIFO warning (MIER_FIFO.MB29 = 1)                         |   |
|                 | CANi_TXF       | Transmit FIFO message transmission completed (MIER_FIFO.MB25 = 0) | TFCR.TFUST[2:0]                         |
|                 |                | FIFO last message transmission completed (MIER_FIFO.MB25 = 1)     |   |
|                 | CANi_RXM       | Mailbox 0 to 31 message received                                  | MCTL_RX0.NEWDATA to MCTL_RX31.NEWDATA   |
|                 | CANi_TXM       | Mailbox 0 to 31 message transmission completed                    | MCTL_TX0.SENTDATA to MCTL_TX31.SENTDATA |

## 29.9 Usage Notes

### 29.9.1 Settings for the Module-Stop State

The MSTPCRB can enable or disable CAN operation. The CAN module is initially stopped after reset. Releasing the module-stop state enables access to the registers. For details, see [section 10, Low Power Modes](#).

### 29.9.2 Settings for the Operating Clock

The settings for the operating clock can be made as follows:

- The following clock constraint must be satisfied for the CAN module:
 
$$PCLKB \geq CANMCLK$$
- The peripheral module clock source must be PLL for the CAN module when the CCLKS bit is 0.

八个中断源可用于CANi错误中断。检查EIFR以确定中断源：

- 总线错误
- Error-warning
- Error-passive
- Bus-off entry
- Bus-off recovery
- 接收溢出
- 超载帧传输
- 巴士锁

Table 29.11 CAN中断

| Module          | 中断名称     | 中断源                              | 源标志                                     |
|-----------------|----------|----------------------------------|---|
| CANi (i = 0, 1) | CANi_ERS | 检测到总线锁                           | EIFR.BLIF                               |
|                 |          | 检测到超载帧传输                         | EIFR.OLIF                               |
|                 |          | 检测到溢出                            | EIFR.ORIF                               |
|                 |          | 检测到总线关闭恢复                        | EIFR.BORIF                              |
|                 |          | 检测到总线关闭条目                        | EIFR.BOEIF                              |
|                 |          | Error-passive detected           | EIFR.EPIF                               |
|                 |          | Error-warning detected           | EIFR.EWIF                               |
|                 |          | 检测到总线错误                          | EIFR.BEIF                               |
|                 | CANi_RXF | 接收接收到的FIFO消息(MIER_FIFO.MB29=0)   | RFCR.RFUST[2:0]                         |
|                 |          | 接收FIFO警告(MIER_FIFO.MB29=1)       |   |
|                 | CANi_TXF | 传输FIFO消息传输完成(MIER_FIFO.MB25=0)   | TFCR.TFUST[2:0]                         |
|                 |          | FIFO最后一条消息传输完成(MIER_FIFO.MB25=1) |   |
|                 | CANi_RXM | 邮箱0到31收到消息                       | MCTL_RX0.NEWDATA to MCTL_RX31.NEWDATA   |
|                 | CANi_TXM | 邮箱0到31消息传输完成                     | MCTL_TX0.SENTDATA to MCTL_TX31.SENTDATA |

## 29.9 使用说明

### 29.9.1 模块停止状态的设置

MSTPCRB可以启用或禁用CAN操作。CAN模块在复位后最初停止。释放模块停止状态可以访问寄存器。有关详细信息，请参阅第10节，低功耗模式。

### 29.9.2 工作时钟设置

工作时钟的设置可按如下方式进行：

- CAN模块必须满足以下时钟约束：
 
$$PCLKB \geq CANMCLK$$
- 当CCLKS位为0时，外围模块时钟源必须为CAN模块的PLL。



## 30. Serial Peripheral Interface (SPI)

### 30.1 Overview

The Serial Peripheral Interface (SPI) provides high-speed full-duplex synchronous serial communications with multiple processors and peripheral devices. Table 30.1 lists the SPI specifications, Figure 30.1 shows a block diagram, and Table 30.2 lists the I/O pins.

Table 30.1 SPI specifications (1 of 2)

| Parameter                  | Specifications   |
|----------------------------|--|
| Number of channels         | One channel  |
| SPI transfer functions     | <ul style="list-style-type: none"> <li>Use of MOSI (master out/slave in), MISO (master in/slave out), SSL (slave select), and RSPCK (SPI clock) signals allows serial communications through SPI operation (4-wire method) or clock synchronous operation (3-wire method)</li> <li>Transmit-only operation available</li> <li>Receive-only operation is available (Slave mode only)</li> <li>Communication mode selectable to full-duplex or transmit-only</li> <li>RSPCK polarity switching</li> <li>RSPCK phase switching</li> </ul>   |
| Data format                | <ul style="list-style-type: none"> <li>MSB-first or LSB-first selectable</li> <li>Transfer bit length selectable to 8, 9, 10, 11, 12, 13, 14, 15, 16, 20, 24, or 32 bits</li> <li>128-bit transmit and receive buffers</li> <li>Up to four frames transferable in one round of transmission or reception (each frame consisting of up to 32 bits)</li> <li>Byte swap operating function</li> <li>Transmit/receive data can be inverted.</li> </ul>   |
| Bit rate                   | <ul style="list-style-type: none"> <li>In master mode, the on-chip baud rate generator generates RSPCK by frequency-dividing PCLKA (the division ratio ranges from divided by 2 to divided by 4096)</li> <li>In slave mode, the minimum PCLKA clock divided by 4 can be input as RSPCK (PCLKA divided by 4 is the maximum RSPCK frequency)</li> <li>Width at high level: 2 PCLKA cycles; width at low level: 2 PCLKA cycles</li> </ul>   |
| Buffer configuration       | <ul style="list-style-type: none"> <li>Double buffer configuration for the transmit and receive buffers</li> <li>128 bits for the transmit and receive buffers</li> </ul>  |
| Error detection            | <ul style="list-style-type: none"> <li>Mode fault error detection</li> <li>Underrun error detection</li> <li>Overrun error detection*1</li> <li>Parity error detection</li> </ul>  |
| SSL control function       | <ul style="list-style-type: none"> <li>Four SSL pins (SSLn: SSLn0 to SSLn3) (n = A, B) for each channel</li> <li>In single-master mode, SSLn0 to SSLn3 pins are output</li> <li>In multi-master mode, SSLn0 pin for input, and SSLn1 to SSLn3 pins either for output or unused</li> <li>In slave mode, SSLn0 pin for input</li> <li>Controllable delay from SSL output assertion to RSPCK operation (RSPCK delay)<br/>Range: 1 to 8 RSPCK cycles (set in RSPCK-cycle units)</li> <li>Controllable delay from RSPCK stop to SSL output negation (SSL negation delay)<br/>Range: 1 to 8 RSPCK cycles (set in RSPCK-cycle units)</li> <li>Controllable wait for next-access SSL output assertion (next-access delay)<br/>Range: 1 to 8 RSPCK cycles (set in RSPCK-cycle units)</li> <li>Function for changing SSL polarity</li> <li>Delay between frames in burst transfer is settable, and SSLn1 to SSLn3 pins unused</li> </ul> |
| Control in master transfer | <ul style="list-style-type: none"> <li>Transfers of up to eight commands each can be executed sequentially in looped execution</li> <li>For each command, the following can be set:<br/>SSL signal value, bit rate, RSPCK polarity and phase, transfer data length, MSB- or LSB-first, burst, RSPCK delay, SSL negation delay, and next-access delay</li> <li>Transfers can be initiated by writing to the transmit buffer</li> <li>MOSI signal value specifiable in SSL negation</li> <li>RSPCK auto-stop function</li> </ul>   |

## 30. 串行外设接口(SPI)

### 30.1 Overview

串行外围接口(SPI)提供与多个处理器和外围设备的高速全双工同步串行通信。表30.1列出了SPI规格，图30.1显示了框图，表30.2列出了IO引脚。

Table 30.1 SPI规格 (2个中的1个)

| Parameter | Specifications  |
|-----------|---|
| 通道数       | 一个频道  |
| SPI传输函数   | <ul style="list-style-type: none"> <li>使用MOSI (主输出从输入)、MISO (主输入从输出)、SSL (从选择) 和RSPCK (SPI时钟) 信号允许通过SPI操作 (4线方法) 或时钟同步操作 (3-线法)</li> <li>仅传输操作可用</li> <li>仅接收操作可用 (仅从模式)</li> <li>通信模式可选择全双工或仅传输</li> <li>RSPCK极性切换</li> <li>RSPCK相位切换</li> </ul>   |
| 数据格式      | <ul style="list-style-type: none"> <li>可选择MSB优先或LSB优先</li> <li>传输位长度可选择为8、9、10、11、12、13、14、15、16、20、24或32位</li> <li>128位发送和接收缓冲器</li> <li>在一轮发送或接收中最多可传输四帧 (每帧最多包含32位)</li> <li>字节交换操作功能</li> <li>发送接收数据可以反转。</li> </ul>  |
| 比特率       | <ul style="list-style-type: none"> <li>在主机模式下, 片内波特率发生器通过分频产生RSPCK<br/>PCLKA (分频比范围从2分频到4096分频)</li> <li>在从机模式下, 可以输入最小PCLKA时钟4分频作为RSPCK (PCLKA4分频为最大RSPCK频率)<br/>高电平宽度: 2个PCLKA周期; 低电平宽度: 2个PCLKA周期</li> </ul>   |
| 缓冲区配置     | <ul style="list-style-type: none"> <li>发送和接收缓冲区的双缓冲区配置</li> <li>128位用于发送和接收缓冲区</li> </ul>   |
| 错误检测      | <ul style="list-style-type: none"> <li>模式故障错误检测</li> <li>欠载错误检测</li> <li>溢出错误检测*1</li> <li>奇偶校验错误检测</li> </ul>  |
| SSL控制功能   | <ul style="list-style-type: none"> <li>每个通道有四个SSL引脚 (SSLn: SSLn0到SSLn3) (n=A、B)</li> <li>在单主模式下, 输出SSLn0到SSLn3引脚</li> <li>在多主模式下, SSLn0引脚用于输入, SSLn1至SSLn3引脚用于输出或未使用</li> <li>在从机模式下, SSLn0引脚用于输入</li> <li>从SSL输出断言到RSPCK操作的可控延迟 (RSPCK延迟)<br/>范围: 1到8个RSPCK循环 (以RSPCK循环为单位设置)</li> <li>从RSPCK停止到SSL输出否定的可控延迟 (SSL否定延迟)<br/>范围: 1到8个RSPCK循环 (以RSPCK循环为单位设置)</li> <li>下一次访问SSL输出断言的可控等待 (下一次访问延迟)<br/>范围: 1到8个RSPCK循环 (以RSPCK循环为单位设置)</li> <li>更改SSL极性的功能</li> <li>突发传输中帧之间的延迟是可设置的, 并且SSLn1到SSLn3引脚未使用</li> </ul> |
| 主传输中的控制   | <ul style="list-style-type: none"> <li>最多可传输8个命令, 每个命令可以在循环执行中顺序执行</li> <li>对于每个命令, 可以设置以下内容:<br/>SSL信号值、比特率、RSPCK极性和相位、传输数据长度、MSB或LSB在前、突发、RSPCK延迟、SSL否定延迟和下一次访问延迟</li> <li>可以通过写入发送缓冲区来启动传输</li> <li>在SSL否定中可指定的MOSI信号值</li> <li>RSPCK auto-stop function</li> </ul>  |

Table 30.1 SPI specifications (2 of 2)

| Parameter            | Specifications  |
|----------------------|---|
| Interrupt sources    | Interrupt sources: <ul style="list-style-type: none"> <li>• Receive buffer full interrupt</li> <li>• Transmit buffer empty interrupt</li> <li>• SPI error interrupt (mode fault error, overrun error, parity error)</li> <li>• SPI idle interrupt (SPI idle)</li> <li>• Transmission-complete interrupt</li> </ul>            |
| Event link function  | The following events can be output to the Event Link Controller (ELC): <ul style="list-style-type: none"> <li>• Receive buffer full signal</li> <li>• Transmit buffer empty signal</li> <li>• Mode fault, underrun, overrun, or parity error signal</li> <li>• SPI idle signal</li> <li>• Communication end signal</li> </ul> |
| Other functions      | <ul style="list-style-type: none"> <li>• Switching between CMOS output and open-drain output</li> <li>• SPI initialization function</li> <li>• Loopback mode</li> </ul>   |
| Module-stop function | Module-stop state can be set to reduce power consumption.   |
| TrustZone Filter     | Security attribution can be set   |

Note 1. In master reception and when the RSPCK auto-stop function is enabled, an overrun error does not occur because the transfer clock is stopped on overrun error detection.

Table 30.1 SPI规范 (2个中的2个)

| Parameter            | Specifications  |
|----------------------|---|
| 中断源                  | Interrupt sources: <ul style="list-style-type: none"> <li>• 接收缓冲区满中断</li> <li>• 发送缓冲区空中断</li> <li>• SPI错误中断 (模式错误错误、溢出错误、奇偶校验错误)</li> <li>• SPI空闲中断 (SPI空闲)</li> <li>• Transmission-complete interrupt</li> </ul> |
| 事件链接功能               | 以下事件可以输出到事件链接控制器(ELC): ● <ul style="list-style-type: none"> <li>• 接收缓冲区满信号</li> <li>• 发送缓冲区空信号</li> <li>• 模式故障、欠载、溢出或奇偶校验错误信号</li> <li>• SPI空闲信号</li> <li>• 通讯结束信号</li> </ul>                                     |
| 其他功能                 | <ul style="list-style-type: none"> <li>• 在CMOS输出和开漏输出之间切换</li> <li>• SPI初始化函数</li> <li>• Loopback mode</li> </ul>   |
| Module-stop function | 可设置模块停止状态以降低功耗。   |
| TrustZone Filter     | 可设置安全属性   |

注1.在主机接收和启用RSPCK自动停止功能时,不会发生溢出错误,因为在检测到溢出错误时会停止传输时钟。

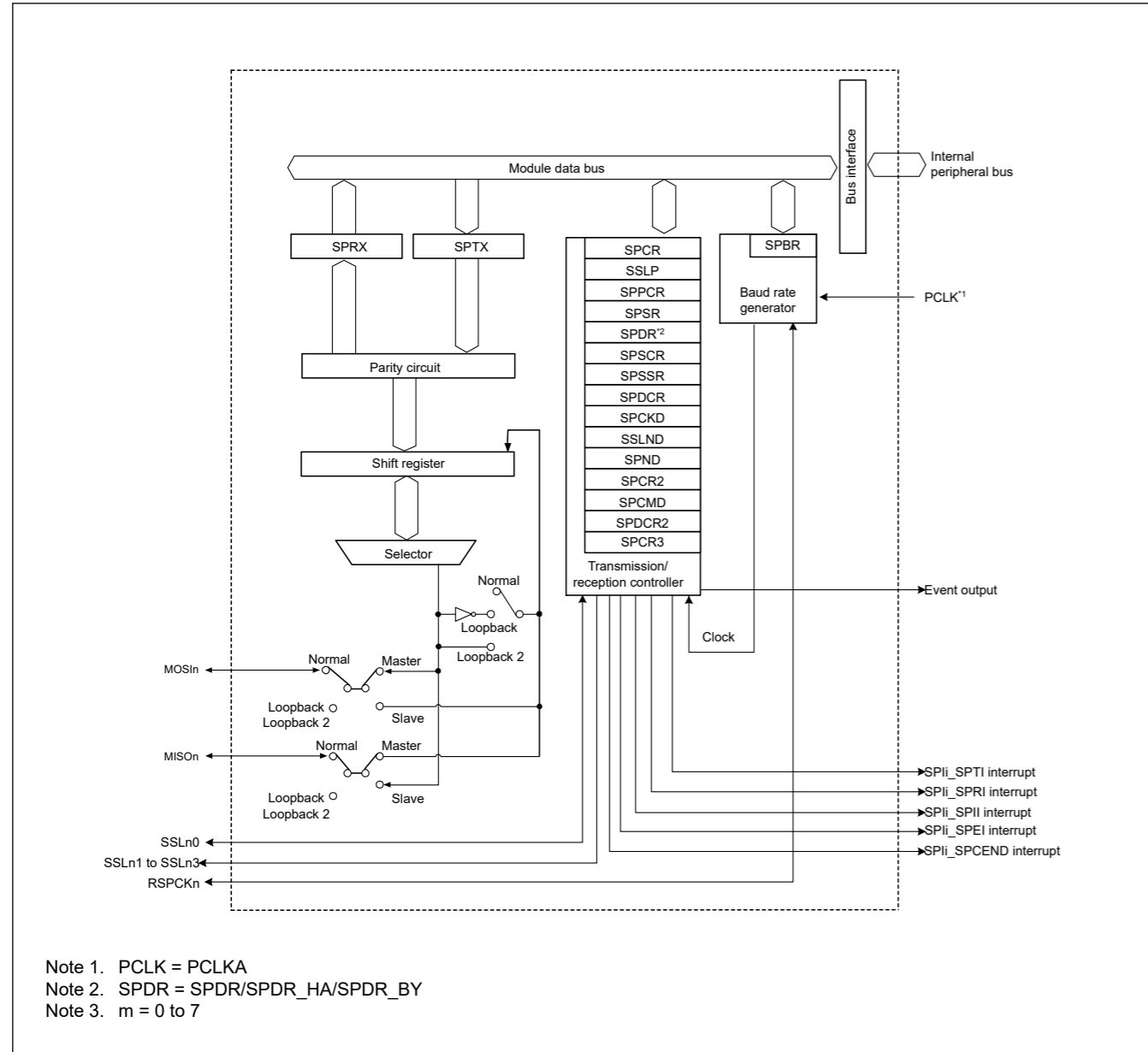


Figure 30.1 SPI block diagram

The SPI automatically switches the I/O direction of the SSLn0 pin. SSLn0 is set as an output when the SPI is a single master, and as an input when the SPI is a multi-master or a slave. The RSPCKn, MOSIn, and MISOIn pins are automatically set as inputs or outputs based on the master or slave setting and the level input on the SSLn0 pin. For details, see [section 30.3.2. Controlling the SPI Pins](#).

Table 30.2 SPI I/O pins

| Channel | Pin name       | I/O    | Description                       |
|---------|----------------|--------|-----------------------------------|
| SPI0    | RSPCKA         | I/O    | Clock input/output pin            |
|         | SSLA0          | I/O    | Slave selection input/output      |
|         | SSLA1 to SSLA3 | Output | Slave selection output            |
|         | MOSIA          | I/O    | Master transmit data input/output |
|         | MISOA          | I/O    | Slave transmit data input/output  |

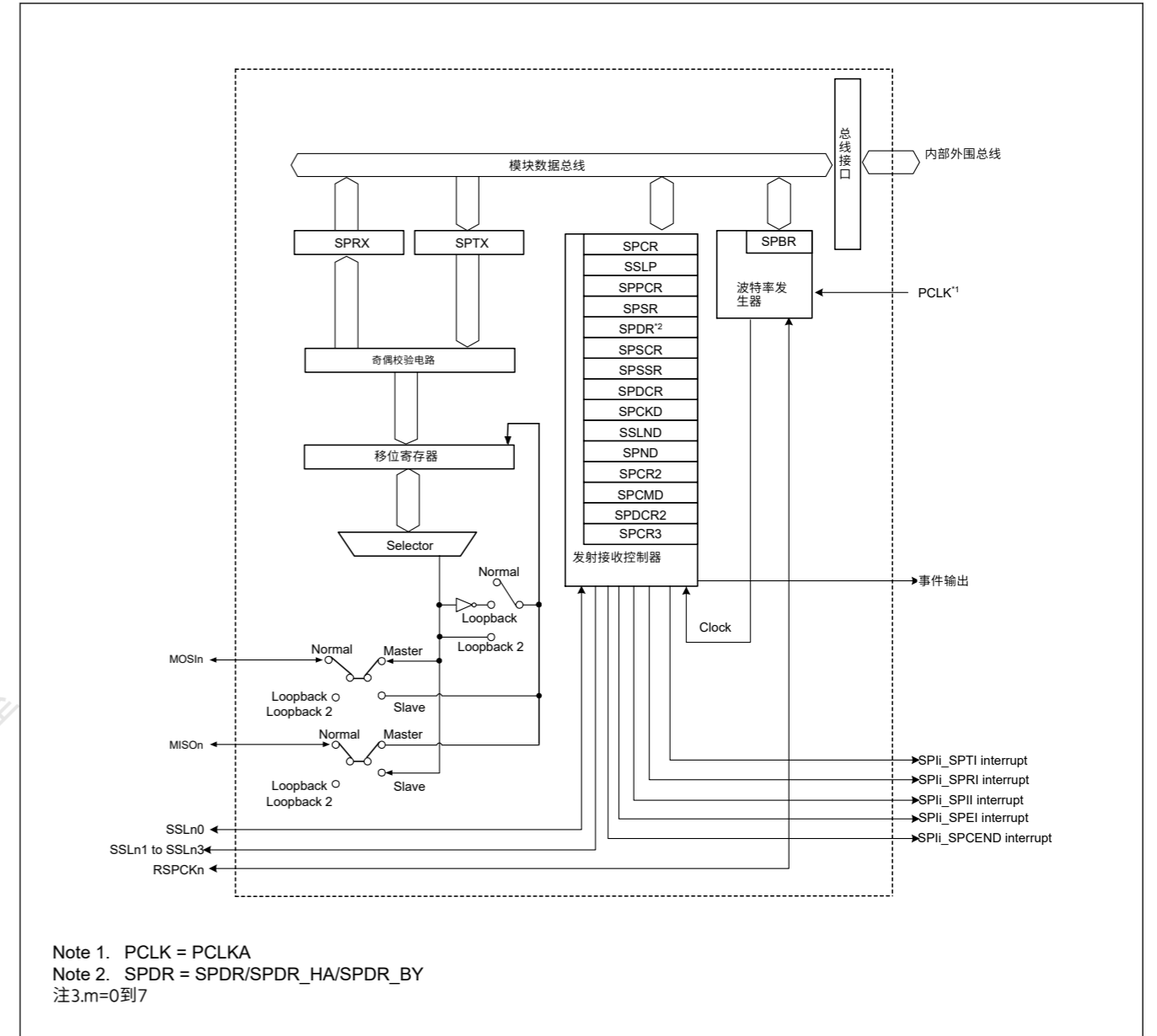


Figure 30.1 SPI框图

SPI自动切换SSLn0引脚的IO方向。当SPI为单主机时SSLn0设置为输出，当SPI为多主机或从机时设置为输入。RSPCKn、MOSIn和MISOIn引脚会根据主机或从机设置以及SSLn0引脚上的电平输入自动设置为输入或输出。有关详细信息，请参阅第30.3.2节。控制SPI引脚。

Table 30.2 SPIIO引脚

| Channel | 引脚名称           | I/O    | Description |
|---------|----------------|--------|-------------|
| SPI0    | RSPCKA         | I/O    | 时钟输入输出引脚    |
|         | SSLA0          | I/O    | 从机选择输入输出    |
|         | SSLA1 to SSLA3 | Output | 从机选择输出      |
|         | MOSIA          | I/O    | 主机发送数据输入输出  |
|         | MISOA          | I/O    | 从机发送数据输入输出  |

## 30.2 Register Descriptions

## 30.2.1 SPCR : SPI Control Register

Base address: SPI0 = 0x4011\_A000

Offset address: 0x00

|                    |       |     |       |       |      |         |      |      |
|--------------------|-------|-----|-------|-------|------|---------|------|------|
| Bit position:      | 7     | 6   | 5     | 4     | 3    | 2       | 1    | 0    |
| Bit field:         | SPRIE | SPE | SPTIE | SPEIE | MSTR | MODF EN | TXMD | SPMS |
| Value after reset: | 0     | 0   | 0     | 0     | 0    | 0       | 0    | 0    |

| Bit | Symbol | Function  | R/W |
|-----|--------|---|-----|
| 0   | SPMS   | SPI Mode Select<br>0: Select SPI operation (4-wire method)<br>1: Select clock synchronous operation (3-wire method)                                       | R/W |
| 1   | TXMD   | Communications Operating Mode Select<br>0: Select full-duplex synchronous serial communications<br>1: Select serial communications with transmit-only     | R/W |
| 2   | MODFEN | Mode Fault Error Detection Enable<br>0: Disable detection of mode fault errors<br>1: Enable detection of mode fault errors                                | R/W |
| 3   | MSTR   | SPI Master/Slave Mode Select<br>0: Select slave mode<br>1: Select master mode   | R/W |
| 4   | SPEIE  | SPI Error Interrupt Enable<br>0: Disable SPI error interrupt requests<br>1: Enable SPI error interrupt requests   | R/W |
| 5   | SPTIE  | Transmit Buffer Empty Interrupt Enable<br>0: Disable transmit buffer empty interrupt requests<br>1: Enable transmit buffer empty interrupt requests       | R/W |
| 6   | SPE    | SPI Function Enable<br>0: Disable SPI function<br>1: Enable SPI function  | R/W |
| 7   | SPRIE  | SPI Receive Buffer Full Interrupt Enable<br>0: Disable SPI receive buffer full interrupt requests<br>1: Enable SPI receive buffer full interrupt requests | R/W |

**SPMS bit (SPI Mode Select)**

The SPMS bit selects SPI operation (4-wire method) or clock synchronous operation (3-wire method).

The SSLn0 to SSLn3 pins are not used in clock synchronous operation. The RSPCKn, MOSIn, and MISON pins handle communications. For clock synchronous operation in master mode (MSTR = 1), the SPCMDm.CPHA bit can be set to either 0 or 1. For clock synchronous operation in slave mode (MSTR = 0), always set the CPHA bit to 1. Do not perform operations if the CPHA bit is set to 0 for clock synchronous operation in slave mode (MSTR = 0).

**TXMD bit (Communications Operating Mode Select)**

The TXMD bit selects full-duplex synchronous serial communications or transmit-only operations. When this bit is set to 1, the SPI only performs transmit operations and not receive operations (see [section 30.3.6. Data Transfer Modes](#)), and receive buffer full interrupt requests cannot be used.

TXMD setting is invalid in receive only slave mode.

**MODFEN bit (Mode Fault Error Detection Enable)**

The MODFEN bit enables or disables the detection of mode fault errors (see [section 30.3.9. Error Detection](#)). In addition, the SPI determines the I/O direction of the SSLni pins based on combination of the MODFEN and MSTR bits (see [section 30.3.2. Controlling the SPI Pins](#)).

## 30.2 注册说明

## 30.2.1 SPCR:SPI控制寄存器

Base address: SPI0 = 0x4011\_A000

Offset address: 0x00

|               |       |     |       |       |      |         |      |      |
|---------------|-------|-----|-------|-------|------|---------|------|------|
| Bit position: | 7     | 6   | 5     | 4     | 3    | 2       | 1    | 0    |
| Bit field:    | SPRIE | SPE | SPTIE | SPEIE | MSTR | MODF EN | TXMD | SPMS |
| 重置后的值:        | 0     | 0   | 0     | 0     | 0    | 0       | 0    | 0    |

| Bit | Symbol | Function  | R/W |
|-----|--------|---|-----|
| 0   | SPMS   | SPI模式选择<br>0: 选择SPI操作（4线方式）1: 选择时钟同步操作（3线方式）          | R/W |
| 1   | TXMD   | 通讯操作模式选择<br>0: 选择全双工同步串行通信1: 选择只发送串行通信                | R/W |
| 2   | MODFEN | 模式故障错误检测启用<br>0: 禁用模式故障错误检测1: 启用模式故障错误检测              | R/W |
| 3   | MSTR   | SPI主从模式选择<br>0: 选择从模式1: 选择主模式                         | R/W |
| 4   | SPEIE  | SPI错误中断使能<br>0: 禁用SPI错误中断请求1: 启用SPI错误中断请求             | R/W |
| 5   | SPTIE  | 发送缓冲区空中断使能<br>0: 禁止发送缓冲区空中断请求1: 允许发送缓冲区空中断请求          | R/W |
| 6   | SPE    | SPI功能使能<br>0: 禁用SPI功能1: 启用SPI功能                       | R/W |
| 7   | SPRIE  | SPI接收缓冲器满中断使能<br>0: 禁止SPI接收缓冲器满中断请求1: 使能SPI接收缓冲器满中断请求 | R/W |

**SPMS位 (SPI模式选择)**

SPMS位选择SPI操作（4线方法）或时钟同步操作（3线方法）。

SSLn0到SSLn3引脚不用于时钟同步操作。RSPCKn、MOSIn和MION引脚处理通信。对于主机模式下的时钟同步操作(MSTR=1)，SPCMDm.CPHA位可以设置为0或1。对于从机模式下的时钟同步操作(MSTR=0)，始终将CPHA位设置为1。不要如果CPHA位设置为0以在从机模式下进行时钟同步操作（MSTR=0），则执行操作。

**TXMD位 (通信操作模式选择)**

TXMD位选择全双工同步串行通信或仅发送操作。当该位设置为1时，SPI只执行发送操作而不执行接收操作（参见第30.3.6节。数据传输模式），并且不能使用接收缓冲器满中断请求。

TXMD设置在只接收从机模式下无效。

**MODFEN位 (模式故障错误检测使能)**

MODFEN位启用或禁用模式故障错误检测（请参阅第30.3.9节。错误检测）。此外，SPI根据MODFEN和MSTR位的组合确定SSLni引脚的IO方向（参见第30.3.2节。控制SPI引脚）。



**MSTR bit (SPI Master/Slave Mode Select)**

The MSTR bit selects master or slave mode for the SPI. Based on the MSTR bit settings, the SPI determines the direction of the RSPCKn, MOSIn, MISOOn, and SSLn pins.

**SPEIE bit (SPI Error Interrupt Enable)**

The SPEIE bit enables or disables the generation of SPI error interrupt requests when one of the following occurs:

- The SPI detects a mode fault error or underrun error and sets the SPSR.MODF flag to 1
- The SPI detects an overrun error and sets the SPSR.OVRF flag to 1
- The SPI detects a parity error and sets the SPSR.PERF flag to 1

For details, see [section 30.3.9. Error Detection](#).

**SPTIE bit (Transmit Buffer Empty Interrupt Enable)**

The SPTIE bit enables or disables the generation of transmit buffer empty interrupt requests when the SPI detects that the transmit buffer is empty. To generate a transmit buffer empty interrupt request when transmission starts, set the SPE and SPTIE bits to 1 at the same time or set the SPE bit to 1 after setting the SPTIE bit to 1.

When the SPTIE bit is 1, transmit buffer interrupts are generated even when the SPI function is disabled (when the SPE bit is changed to 0).

**SPE bit (SPI Function Enable)**

The SPE bit enables or disables the SPI function. The SPE bit cannot be set to 1 when the SPSR.MODF flag is 1. For details, see [section 30.3.9. Error Detection](#).

Setting the SPE bit to 0 disables the SPI function and initializes a part of the module function. For details, see [section 30.3.10. Initializing the SPI](#). In addition, a transmit buffer empty interrupt request is generated when the SPE bit is changed from 0 to 1 or from 1 to 0.

**SPRIE bit (SPI Receive Buffer Full Interrupt Enable)**

The SPRIE bit enables or disables the generation of an SPI receive buffer full interrupt request when the SPI detects a receive buffer full write after completion of a serial transfer.

**30.2.2 SSLP : SPI Slave Select Polarity Register**

Base address: SPI0 = 0x4011\_A000

Offset address: 0x01

|                    |   |   |   |   |       |       |       |       |
|--------------------|---|---|---|---|-------|-------|-------|-------|
| Bit position:      | 7 | 6 | 5 | 4 | 3     | 2     | 1     | 0     |
| Bit field:         | — | — | — | — | SSL3P | SSL2P | SSL1P | SSL0P |
| Value after reset: | 0 | 0 | 0 | 0 | 0     | 0     | 0     | 0     |

| Bit | Symbol | Function   | R/W |
|-----|--------|--|-----|
| 0   | SSL0P  | SSLn0 Signal Polarity Setting<br>0: Set SSLn0 signal to active-low<br>1: Set SSLn0 signal to active-high | R/W |
| 1   | SSL1P  | SSLn1 Signal Polarity Setting<br>0: Set SSLn1 signal to active-low<br>1: Set SSLn1 signal to active-high | R/W |
| 2   | SSL2P  | SSLn2 Signal Polarity Setting<br>0: Set SSLn2 signal to active-low<br>1: Set SSLn2 signal to active-high | R/W |
| 3   | SSL3P  | SSLn3 Signal Polarity Setting<br>0: Set SSLn3 signal to active-low<br>1: Set SSLn3 signal to active-high | R/W |
| 7:4 | —      | These bits are read as 0. The write value should be 0.   | R/W |

**MSTR位 (SPI主从模式选择)**

MSTR位选择SPI的主模式或从模式。根据MSTR位设置，SPI确定RSPCKn、MOSIn、MISOOn和SSLn引脚的方向。

**SPEIE位 (SPI错误中断使能)**

当发生以下情况之一时，SPEIE位启用或禁用SPI错误中断请求的生成：

- SPI检测到模式故障错误或欠载错误并将SPSR.MODF标志设置为1
- SPI检测到溢出错误并将SPSR.OVRF标志设置为1
- SPI检测到奇偶校验错误并将SPSR.PERF标志设置为1

有关详细信息，请参阅[第30.3.9节。错误检测](#)。

**SPTIE位 (发送缓冲区空中断允许)**

当SPI检测到发送缓冲区为空时，SPTIE位使能或禁止生成发送缓冲区空中断请求。要在发送开始时产生发送缓冲区空中断请求，请将SPE和SPTIE位同时设置为1，或在将SPTIE位设置为1后将SPE位设置为1。

当SPTIE位为1时，即使禁用SPI功能（当SPE位变为0时）也会产生发送缓冲区中断。

**SPE位 (SPI功能使能)**

SPE位启用或禁用SPI功能。当SPSR.MODF标志为1时，SPE位不能设置为1。详情请参见[30.3.9节。错误检测](#)。

将SPE位设置为0将禁用SPI功能并初始化部分模块功能。有关详细信息，请参阅[第30.3.10节。初始化SPI](#)。此外，当SPE位从0变为1或从1变为0时，会产生发送缓冲区空中断请求。

**SPRIE位 (SPI接收缓冲器满中断使能)**

当SPI在串行传输完成后检测到接收缓冲区已满写入时，SPRIE位启用或禁用SPI接收缓冲区已满中断请求的生成。

**30.2.2 SSLP: SPI从机选择极性寄存器**

Base address: SPI0 = 0x4011\_A000

Offset address: 0x01

|               |   |   |   |   |       |       |       |       |
|---------------|---|---|---|---|-------|-------|-------|-------|
| Bit position: | 7 | 6 | 5 | 4 | 3     | 2     | 1     | 0     |
| Bit field:    | — | — | — | — | SSL3P | SSL2P | SSL1P | SSL0P |
| 重置后的值:        | 0 | 0 | 0 | 0 | 0     | 0     | 0     | 0     |

| Bit | Symbol | Function  | R/W |
|-----|--------|---|-----|
| 0   | SSL0P  | SSLn0信号极性设置<br>0: 将SSLn0信号设置为低电平有效<br>1: 将SSLn0信号设置为高电平有效 | R/W |
| 1   | SSL1P  | SSLn1信号极性设置<br>0: 将SSLn1信号设置为低电平有效<br>1: 将SSLn1信号设置为高电平有效 | R/W |
| 2   | SSL2P  | SSLn2信号极性设置<br>0: 将SSLn2信号设置为低电平有效<br>1: 将SSLn2信号设置为高电平有效 | R/W |
| 3   | SSL3P  | SSLn3信号极性设置<br>0: 设置SSLn3信号为低电平有效<br>1: 设置SSLn3信号为高电平有效   | R/W |
| 7:4 | —      | 这些位被读取为0。写入值应为0。  | R/W |

## 30.2.3 SPPCR : SPI Pin Control Register

Base address: SPI0 = 0x4011\_A000

Offset address: 0x02

|                    |   |   |       |       |   |   |       |      |
|--------------------|---|---|-------|-------|---|---|-------|------|
| Bit position:      | 7 | 6 | 5     | 4     | 3 | 2 | 1     | 0    |
| Bit field:         | — | — | MOIFE | MOIFV | — | — | SPLP2 | SPLP |
| Value after reset: | 0 | 0 | 0     | 0     | 0 | 0 | 0     | 0    |

| Bit | Symbol | Function   | R/W |
|-----|--------|--|-----|
| 0   | SPLP   | SPI Loopback<br>0: Normal mode<br>1: Loopback mode (receive data = inverted transmit data)   | R/W |
| 1   | SPLP2  | SPI Loopback 2<br>0: Normal mode<br>1: Loopback mode (receive data = transmit data)  | R/W |
| 3:2 | —      | These bits are read as 0. The write value should be 0.   | R/W |
| 4   | MOIFV  | MOSI Idle Fixed Value<br>0: Set level output on MOSIn pin during MOSI idling to low<br>1: Set level output on MOSIn pin during MOSI idling to high                   | R/W |
| 5   | MOIFE  | MOSI Idle Value Fixing Enable<br>0: Set MOSI output value to equal final data from previous transfer<br>1: Set MOSI output value to equal value set in the MOIFV bit | R/W |
| 7:6 | —      | These bits are read as 0. The write value should be 0.   | R/W |

**SPLP bit (SPI Loopback)**

The SPLP bit selects the mode of the SPI pins. When this bit is set to 1, the SPI shuts off the path between the MISO pin and the shift register if the SPCR.MSTR bit is 1, and between the MOSIn pin and the shift register if the SPCR.MSTR bit is 0. The SPI then inverts the value of the input path for the shift register and connects it to the output path (loopback mode). For more information, see [section 30.3.13. Loopback Mode](#).

**SPLP2 bit (SPI Loopback 2)**

The SPLP2 bit selects the mode of the SPI pins. When this bit is set to 1, the SPI shuts off the path between the MISO pin and the shift register if the SPCR.MSTR bit is 1, and between the MOSIn pin and the shift register if the SPCR.MSTR bit is 0. The SPI then connects the value of the input path for the shift register to the output path (loopback mode) without inverting the value. For more information, see [section 30.3.13. Loopback Mode](#).

**MOIFV bit (MOSI Idle Fixed Value)**

The MOIFV bit determines the MOSIn pin output value during the SSL negation period (including the SSL retention period during a burst transfer) when the MOIFE bit is 1 in master mode.

**MOIFE bit (MOSI Idle Value Fixing Enable)**

The MOIFE bit fixes the MOSIn output value when the SPI is in master mode and in an SSL negation period (including the SSL retention period during a burst transfer). When the MOIFE bit is 0, the SPI outputs the last data from the previous serial transfer during the SSL negation period to the MOSIn pin. When the MOIFE bit is 1, the SPI outputs the fixed value set in the MOIFV bit to the MOSIn pin.

## 30.2.3 SPPCR:SPI引脚控制寄存器

Base address: SPI0 = 0x4011\_A000

Offset address: 0x02

|               |   |   |       |       |   |   |       |      |
|---------------|---|---|-------|-------|---|---|-------|------|
| Bit position: | 7 | 6 | 5     | 4     | 3 | 2 | 1     | 0    |
| Bit field:    | — | — | MOIFE | MOIFV | — | — | SPLP2 | SPLP |
| 重置后的值:        | 0 | 0 | 0     | 0     | 0 | 0 | 0     | 0    |

| Bit | Symbol | Function  | R/W |
|-----|--------|---|-----|
| 0   | SPLP   | SPI Loopback<br>0: 正常模式1: 环回模式 (接收数据=反转发送数据)                            | R/W |
| 1   | SPLP2  | SPI Loopback 2<br>0: 正常模式1: 环回模式 (接收数据=发送数据)                            | R/W |
| 3:2 | —      | 这些位被读取为0。写入值应为0。  | R/W |
| 4   | MOIFV  | MOSI空闲固定值<br>0: 在MOSI空闲期间将MOSIn引脚的电平输出设置为低1: 在MOSI空闲期间将MOSIn引脚的电平输出设置为高 | R/W |
| 5   | MOIFE  | MOSI空闲值固定启用<br>0: 设置MOSI输出值等于上次传输的最终数据1: 设置MOSI输出值等于MOIFV位中设置的值         | R/W |
| 7:6 | —      | 这些位被读取为0。写入值应为0。  | R/W |

**SPLP bit (SPI Loopback)**

SPLP位选择SPI引脚的模式。当该位设置为1时，如果SPCR.MSTR位为1，则SPI关闭MISO引脚和移位寄存器之间的路径，如果SPCR.MSTR位为0，则关闭MOSIn引脚和移位寄存器之间的路径。SPI然后反转移寄存器的输入路径的值并将其连接到输出路径（环回模式）。有关详细信息，请参阅第30.3.13节。环回模式。

**SPLP2 bit (SPI Loopback 2)**

SPLP2位选择SPI引脚的模式。当该位设置为1时，如果SPCR.MSTR位为1，则SPI关闭MISO引脚和移位寄存器之间的路径，如果SPCR.MSTR位为0，则关闭MOSIn引脚和移位寄存器之间的路径。然后SPI将移位寄存器的输入路径的值连接到输出路径（环回模式），而不反转该值。有关详细信息，请参阅第30.3.13节。环回模式。

**MOIFV位 (MOSI空闲固定值)**

MOIFV位决定主模式下MOIFE位为1时SSL否定期间（包括突发传输期间的SSL保持期间）的MOSIn引脚输出值。

**MOIFE位 (MOSI空闲值固定启用)**

MOIFE位固定SPI处于主机模式和SSL否定周期（包括突发传输期间的SSL保持周期）时的MOSIn输出值。当MOIFE位为0时，SPI输出上一个串行的最后一个数据在SSL否定期间传输到MOSIn引脚。当MOIFE位为1时，SPI将MOIFV位中设置的固定值输出到MOSIn引脚。

## 30.2.4 SPSR : SPI Status Register

Base address: SPI0 = 0x4011\_A000

Offset address: 0x03

|                    |      |           |           |      |      |      |       |      |
|--------------------|------|-----------|-----------|------|------|------|-------|------|
| Bit position:      | 7    | 6         | 5         | 4    | 3    | 2    | 1     | 0    |
| Bit field:         | SPRF | CEND<br>F | SPTE<br>F | UDRF | PERF | MODF | IDLNF | OVRF |
| Value after reset: | 0    | 0         | 1         | 0    | 0    | 0    | 0     | 0    |

| Bit | Symbol | Function  | R/W                 |
|-----|--------|---|---------------------|
| 0   | OVRF   | Overrun Error Flag<br>0: No overrun error occurred<br>1: Overrun error occurred   | R/W <sup>1</sup>    |
| 1   | IDLNF  | SPI Idle Flag<br>0: SPI is in the idle state<br>1: SPI is in the transfer state   | R                   |
| 2   | MODF   | Mode Fault Error Flag<br>0: No mode fault or underrun error occurred<br>1: Mode fault error or underrun error occurred                                | R/W <sup>1</sup>    |
| 3   | PERF   | Parity Error Flag<br>0: No parity error occurred<br>1: Parity error occurred  | R/W <sup>1</sup>    |
| 4   | UDRF   | Underrun Error Flag<br>The UDRF bit is valid when MODF flag is 1.<br>0: Mode fault error occurred (MODF = 1)<br>1: Underrun error occurred (MODF = 1) | R/W <sup>1</sup> *2 |
| 5   | SPTEF  | SPI Transmit Buffer Empty Flag<br>0: Data is in the transmit buffer<br>1: No data is in the transmit buffer   | R/W <sup>3</sup>    |
| 6   | CENDF  | Communication End Flag<br>0: Not communicating or communicating<br>1: Communication completed   | R/W <sup>1</sup>    |
| 7   | SPRF   | SPI Receive Buffer Full Flag<br>0: No valid data is in SPDR/SPDR_HA<br>1: Valid data is in SPDR/SPDR_HA   | R/W <sup>3</sup>    |

Note 1. Only 0 can be written to clear the flag after reading 1.

Note 2. Clear the UDRF flag at the same time as the MODF flag.

Note 3. The write value should be 1.

**OVRF flag (Overrun Error Flag)**

The OVRF flag indicates the occurrence of an overrun error. In master mode (SPCR.MSTR bit = 1) and when the RSPCK clock auto-stop function is enabled (SPCR1.SCKASE bit = 1), overrun errors do not occur. This flag does not set to 1. For details, see [section 30.3.9.1. Overrun errors](#).

[Setting condition]

When the next serial transfer ends and the receive buffer is full, and satisfy one of following.

- The SPCR.TXMD bit = 0. (transmit-receive master mode or transmit-receive slave mode or receive only slave mode)
- The SPCR.MSTR bit = 0, and the SPCR3.ETXMD bit = 1. (receive only slave mode)

[Clearing condition]

- When 0 is written to the OVRF flag after the OVRF flag is confirmed to be 1 by a read of SPSR.

**IDLNF flag (SPI Idle Flag)**

The IDLNF flag indicates the transfer status of the SPI.

[Setting conditions]

## 30.2.4 SPSR: SPI状态寄存器

Base address: SPI0 = 0x4011\_A000

Offset address: 0x03

|               |      |           |           |      |      |      |       |      |
|---------------|------|-----------|-----------|------|------|------|-------|------|
| Bit position: | 7    | 6         | 5         | 4    | 3    | 2    | 1     | 0    |
| Bit field:    | SPRF | CEND<br>F | SPTE<br>F | UDRF | PERF | MODF | IDLNF | OVRF |
| 重置后的值:        | 0    | 0         | 1         | 0    | 0    | 0    | 0     | 0    |

| Bit | Symbol | Function  | R/W                 |
|-----|--------|---|---------------------|
| 0   | OVRF   | 溢出错误标志<br>0: 未发生溢出错误1: 发生溢出错误   | R/W <sup>1</sup>    |
| 1   | IDLNF  | SPI空闲标志<br>0: SPI处于空闲状态1: SPI处于传输状态                                       | R                   |
| 2   | MODF   | 模式故障错误标志<br>0: 未发生模式故障或欠载错误1: 发生模式故障错误或欠载错误                               | R/W <sup>1</sup>    |
| 3   | PERF   | 奇偶校验错误标志<br>0: 未发生奇偶校验错误1: 发生奇偶校验错误                                       | R/W <sup>1</sup>    |
| 4   | UDRF   | 欠载错误标志<br>当MODF标志为1时, UDRF位有效。<br>0: 发生模式故障错误 (MODF=1) 1: 发生欠载错误 (MODF=1) | R/W <sup>1</sup> *2 |
| 5   | SPTEF  | SPI发送缓冲区空标志<br>0: 发送缓冲区中有数据1: 发送缓冲区中没有数据                                  | R/W <sup>3</sup>    |
| 6   | CENDF  | 通讯结束标志<br>0: 不通讯或通讯1: 通讯完成  | R/W <sup>1</sup>    |
| 7   | SPRF   | SPI接收缓冲区满标志<br>0: SPDRSPDR_HA中没有有效数据1: SPDRSPDR_HA中有有效数据                  | R/W <sup>3</sup>    |

注1.读1后只能写0清除标志。

注2.在清除MODF标志的同时清除UDRF标志。

注3.写入值应为1。

**OVRF标志 (溢出错误标志)**

OVRF标志指示发生溢出错误。在主机模式 (SPCR.MSTR位=1) 和启用RSPCK时钟自动停止功能 (SPCR1.SCKASE位=1) 时, 不会发生溢出错误。此标志不设置为1。有关详细信息, 请参阅第30.3.9.1节。溢出错误。

[Setting condition]

当下一次串行传输结束且接收缓冲区已满时, 满足以下条件之一。

- SPCR.TXMD位=0。(发送-接收主模式或发送-接收从模式或仅接收从模式)
- SPCR.MSTR位=0, SPCR3.ETXMD位=1。(仅接收从机模式)

[Clearing condition]

- 在通过读取SPSR确认OVRF标志为1后, 向OVRF标志写入0时。

**IDLNF标志 (SPI空闲标志)**

IDLNF标志指示SPI的传输状态。

[Setting conditions]

## Master mode

- When none of the conditions in the master mode [Clearing condition] is met.

## Slave mode

- When the SPE bit in SPCR is 1, enabling the SPI function.

## [Clearing conditions]

## Master mode

When condition 1 or all other conditions are satisfied.

Condition 1: The SPE bit in SPCR is 0, indicating that the SPI is initialized.

Condition 2: The transmit buffer (SPTX) is empty, indicating that data for the next transfer is not set.

Condition 3: The SPI internal sequencer is in the idle state, indicating that operation up to next-access delay is complete.

Condition 4: The SPCP[2:0] bits in SPSSR are 000 (at the beginning of sequence control)

## Slave mode

- When condition 1 is satisfied.

**MODF flag (Mode Fault Error Flag)**

The MODF flag indicates the occurrence of a mode fault error or an underrun error. The UDRF flag indicates which error occurred.

## [Setting conditions]

## Multi-master mode

- When the input level of the SSLni pin changes to the active level while the SPCR.MSTR bit is 1 (master mode) and the SPCR.MODFEN bit is 1 (mode fault error detection is enabled), triggering a mode fault error.

## Slave mode

- When condition 1 or 2 is satisfied.

Condition 1: The SSLni pin is negated before the RSPCK cycle required for data transfer ends while the SPCR.MSTR bit is 0 (slave mode) and the SPCR.MODFEN bit is 1 (mode fault error detection is enabled), triggering a mode fault error.

Condition 2: The serial transfer begins with the SPCR.MSTR bit is set to 0 (slave mode), the SPCR.SPE bit is set to 1, and the transmission data not prepared, triggering an underrun error.

The active level of the SSLni signal is determined by the SSLP.SSLiP bit (SSLi signal polarity setting).

## [Clearing condition]

- When SPSR is read while this flag is 1, and then 0 is written to this flag.

**PERF flag (Parity Error Flag)**

The PERF flag indicates the occurrence of a parity error.

## [Setting condition]

When a serial transfer ends while the SPCR2.SPPE bit is 1, triggering a parity error, and satisfy one of following.

- The SPCR.TXMD bit = 0. (transmit-receive master mode or transmit-receive slave mode or receive only slave mode)
- The SPCR.MSTR bit = 0, and the SPCR3.ETXMD bit = 1. (receive only slave mode)

## [Clearing condition]

- When SPSR is read while this flag is 1, and then 0 is written to this flag.

**UDRF flag (Underrun Error Flag)**

The UDRF flag indicates the occurrence of an underrun error.

## [Setting condition]

## 主模式

- 当主模式[清除条件]中的条件均不满足时。

## 从机模式

- 当SPCR的SPE位为1时，使能SPI功能。

## [Clearing conditions]

## 主模式

当满足条件1或所有其他条件时。

条件1: SPCR中的SPE位为0，表示SPI已初始化。

条件2: 发送缓冲区 (SPTX) 为空，表示未设置下一次传输的数据。

条件3: SPI内部定序器处于空闲状态，表示到next-accessdelay的操作已完成。

条件4: SPSSR中的SPCP[2:0]位为000 (在序列控制开始时)

## 从机模式

- 满足条件1时。

**MODF标志 (模式故障错误标志)**

MODF标志指示发生模式故障错误或欠载错误。UDRF标志指示发生了哪个错误。

## [Setting conditions]

## Multi-master mode

- 当SPCR.MSTR位为1 (主模式) 且SPCR.MODFEN位为1 (使能模式故障错误检测) 时，SSLni管脚的输入电平变为有效电平时，触发模式故障错误。

## 从机模式

- 满足条件1或2时。

条件1: 当SPCR.MSTR位为0 (从模式) 且SPCR.MODFEN位为1 (启用模式故障错误检测) 时，SSLni引脚在数据传输所需的RSPCK周期结束前被取反，触发模式故障错误。

条件2: 串行传输开始时SPCR.MSTR位设置为0 (从模式)，SPCR.SPE位设置为1，传输数据未准备好，触发欠载错误。

SSLni信号的有效电平由SSLP.SSLiP位 (SSLi信号极性设置) 确定。

## [Clearing condition]

- 当此标志为1时读取SPSR，然后将0写入此标志。

**PERF标志 (奇偶校验错误标志)**

PERF标志指示奇偶校验错误的发生。

## [Setting condition]

当SPCR2.SPPE位为1时串行传输结束，触发奇偶校验错误，并满足以下之一。

- SPCR.TXMD位=0。(发送-接收主模式或发送-接收从模式或仅接收从模式)
- SPCR.MSTR位=0，SPCR3.ETXMD位=1。(仅接收从机模式)

## [Clearing condition]

- 当此标志为1时读取SPSR，然后将0写入此标志。

**UDRF标志 (欠载错误标志)**

UDRF标志指示发生了欠载错误。

## [Setting condition]



- When the serial transfer begins with the SPCR.MSTR bit is set to 0 (slave mode), the SPCR3.ETXMD bit =0 (transmit-receive slave mode or transmit slave mode) the SPCR.SPE bit is set to 1, and the transmission data not prepared, triggering an underrun error.

[Clearing condition]

- When SPSR is read while this flag is 1, and then 0 is written to this flag.

#### SPTEF flag (SPI Transmit Buffer Empty Flag)

The SPTEF flag indicates the status of the transmit buffer for the SPI Data Register (SPDR/SPDR\_HA).

[Setting conditions]

- When condition 1. or 2. is satisfied.
  1. The SPCR.SPE bit is 0, indicating that the SPI is initialized.
  2. Transmit data (the frame size specified by the SPDCR.SPFC[1:0]) is transferred from the transmit buffer to the shift register.

[Clearing condition]

- When data is written to SPDR/SPDR\_HA/SPDR\_BY equals the number of frames set in the SPFC[1:0] bits in the SPI Data Control Register (SPDCR).

Data can only be written to SPDR/SPDR\_HA/SPDR\_BY when the SPTEF flag is 1. If data is written to the transmit buffer of SPDR/SPDR\_HA when the SPTEF flag is 0, data in the transmit buffer is not updated.

#### CENDF flag (Communication End Flag)

This flag indicates communication end status of RSPI. It turns 1 at communication end, and turns 0 at starting next communication.

[Setting condition]

##### Mastar mode

The following 3 conditions are met.

- The transmit buffer(SPTX) is empty. (There is no next transmission data.)
- The SPSSR.SPCP[2:0] are 000b. (It means the head of the sequential control.)
- The state of RSPI internal sequencer transferred to the idle state. (It means the next access delay has been completed.)

##### Transmit-receive / transmit only slave mode in SPI serial communication (4-wire: the SPCR.SPMS bit is 0)

The following 3 conditions are met.

- The transmit buffer(SPTX) is empty. (There is no next transmission data.)
- The transmission shift register is empty. (It means RSPI does not do serial transfer.)
- SSL0 was negated.

##### Transmit-receive / transmit only slave mode in clock synchronous (3-wire: the SPCR.SPMS bit is 1)

The following 3 conditions are met.

- The transmit buffer(SPTX) is empty. (There is no next transmission data.)
- The transmission shift register is empty. (It means RSPI does not do serial transfer.)
- The last even edge of RSPCK of the last data was detected. (When the SPCMD.CPHA bit is "1".)

##### Receive only slave mode in SPI serial communication (4-wire: the SPCR.SPMS bit is 0)

The following condition is met.

- SSL0 was negated after the last data was written in the received buffer.

##### Receive only slave mode in clock synchronous (3-wire: the SPCR.SPMS bit is 1)

The following condition is met.

- 当串行传输开始时SPCR.MSTR位设置为0（从机模式），SPCR3.ETXMD位=0（发送接收从机模式或发送从机模式）SPCR.SPE位设置为1，发送数据未准备好，触发欠载错误。

[Clearing condition]

- 当此标志为1时读取SPSR，然后将0写入此标志。

#### SPTEF标志（SPI发送缓冲区空标志）

SPTEF标志指示SPI数据寄存器(SPDRSPDR\_HA)的发送缓冲区的状态。

[Setting conditions]

- 满足条件1.或2.时。
  - 1.SPCR.SPE位为0，表示SPI初始化。
  - 2.发送数据（由SPDCR.SPFC[1:0]指定的帧大小）从发送缓冲器传送到移位寄存器。

[Clearing condition]

- 当数据写入SPDRSPDR\_HASPCR\_BY等于SPI数据控制寄存器(SPDCR)的SPFC[1:0]位中设置的帧数。

数据只能在SPTEF标志为1时写入SPDRSPDR\_HASPCR\_BY。如果在SPTEF标志为0时将数据写入SPDRSPDR\_HA的发送缓冲区，则发送缓冲区中的数据不会更新。

#### CENDF标志（通信结束标志）

该标志指示RSPI的通信结束状态。通讯结束时变为1，开始下一次通讯时变为0。

[Setting condition]

##### Mastar mode

满足以下3个条件。

- 发送缓冲区(SPTX)为空。（没有下一个传输数据。）
- SPSSR.SPCP[2:0]为000b。（表示顺序控制的头部。）
- RSPI内部定序器的状态转为空闲状态。（表示下一次访问延迟已经完成。）

##### SPI串行通信中的发送-接收仅发送从机模式（4线：SPCR.SPMS位为0）

满足以下3个条件。

- 发送缓冲区(SPTX)为空。（没有下一个传输数据。）
- 传输移位寄存器为空。（这意味着RSPI不进行串行传输。）
- SSL0被否定。

##### 时钟同步中的发送-接收仅发送从模式（3线：SPCR.SPMS位为1）

满足以下3个条件。

- 发送缓冲区(SPTX)为空。（没有下一个传输数据。）
- 传输移位寄存器为空。（这意味着RSPI不进行串行传输。）
- 检测到最后一个数据的RSPCK的最后一个偶边沿。（当SPCMD.CPHA位为"1"时。）

##### SPI串行通信中仅接收从机模式（4线：SPCR.SPMS位为0）

满足以下条件。

- 最后一个数据写入接收缓冲区后，SSL0被否定。

##### 在时钟同步下仅接收从模式（3线：SPCR.SPMS位为1）

满足以下条件。

- The last even edge of RSPCK of the last data was detected. (When the SPCMD.CPHA bit is 1.)

[Clearing condition]

Master mode

Satisfy one of following.

- The next transmit data was written to the transmit buffer (SPTX).
- The CENDF flag was written 0 after reading the SPSR when the CENDF flag was 1

Transmit-receive / transmit only slave mode

Satisfy one of following.

- The next transmit data was written to the transmit buffer(SPTX).
- The CENDF flag was written 0 after reading the SPSR when the CENDF flag was 1.

Receive only slave mode in SPI serial communication (4-wire: the SPCR.SPMS bit is 0)

Satisfy one of following.

- SSL0 assertion of next data was detected.
- The CENDF flag was written 0 after reading the SPSR when the CENDF flag was 1.

Receive only slave mode in clock synchronous (3-wire: the SPCR.SPMS bit is 1)

Satisfy one of following.

- The first edge of RSPCK of the next data was detected.
- The CENDF flag was written 0 after reading the SPSR when the CENDF flag was 1.

**SPRF flag (SPI Receive Buffer Full Flag)**

The SPRF flag indicates the status of the receive buffer for the SPI Data Register (SPDR/SPDR\_HA).

[Setting condition]

- Received data with the frame size specified by the SPDCR.SPFC[1:0] bits have been transferred to the SPDR from the shift register while the SPRF flag is 0. And satisfy one of following. However, the SPRF flag does not change from 0 to 1 while the OVRF flag = 1.
  - The SPCR.TXMD bit is 0 (transmit-receive master mode, transmit-receive slave mode, or receive only slave mode)
  - The SPCR.MSTR bit is 0 and the SPCR3.ETXMD bit is 1 (receive only slave mode)

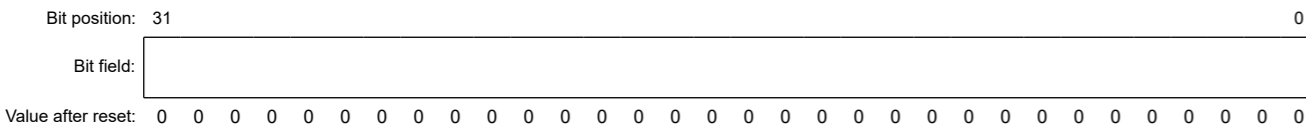
[Clearing condition]

- When received data is read from the SPDR/SPDR\_HA.

**30.2.5 SPDR/SPDR\_HA/SPDR\_BY : SPI Data Register**

Base address: SPI0 = 0x4011\_A000

Offset address: 0x04



| Bit  | Symbol | Function | R/W |
|------|--------|----------|-----|
| 31:0 | n/a    | SPI Data | R/W |

SPDR/SPDR\_HA/SPDR\_BY is the interface with the buffers that hold data for transmission and reception by the SPI. When accessing this register in words (the SPDCR.SPLW bit is 1), access SPDR. When accessing it in halfwords (the SPLW bit is 0), access SPDR\_HA. When accessing it in byte (the SPDCR.SPBYT bit is 1), access SPDR\_BY.

- 检测到最后一个数据的RSPCK的最后一个偶边沿。（当SPCMD.CPHA位为1时。）

[Clearing condition]

主模式

满足以下之一。

- 下一个发送数据被写入发送缓冲区(SPTX)。
- 当CENDF标志为1时，读取SPSR后CENDF标志被写入0

发送-接收仅发送从模式

满足以下之一。

- 下一个发送数据被写入发送缓冲区(SPTX)。
- 当CENDF标志为1时，读取SPSR后CENDF标志被写入0。

SPI串行通信中仅接收从机模式（4线：SPCR.SPMS位为0）

满足以下之一。

- 检测到下一个数据的SSL0断言。
- 当CENDF标志为1时，读取SPSR后CENDF标志被写入0。

在时钟同步下仅接收从模式（3线：SPCR.SPMS位为1）

满足以下之一。

- 检测到下一个数据的RSPCK的第一个边沿。
- 当CENDF标志为1时，读取SPSR后CENDF标志被写入0。

**SPRF标志（SPI接收缓冲区满标志）**

SPRF标志指示SPI数据寄存器(SPDR/SPDR\_HA)的接收缓冲区的状态。

[Setting condition]

- 在SPRF标志为0时，接收到的具有SPDCR.SPFC[1:0]位指定的帧大小的数据已从移位寄存器传送到SPDR。并且满足以下之一。但是，当OVRF标志=1时，SPRF标志不会从0变为1。

SPCR.TXMD位为0（发送-接收主机模式、发送-接收从机模式或仅接收从机模式）

SPCR.MSTR位为0，SPCR3.ETXMD位为1（仅接收从模式）

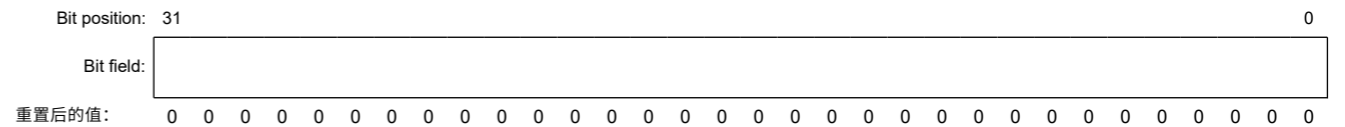
[Clearing condition]

- 从SPDR/SPDR\_HA读取接收数据时。

**30.2.5 SPDR/SPDR\_HA/SPDR\_BY:SPI数据寄存器**

Base address: SPI0 = 0x4011\_A000

Offset address: 0x04



| Bit  | Symbol | Function | R/W |
|------|--------|----------|-----|
| 31:0 | n/a    | SPI数据    | R/W |

SPDR/SPDR\_HA/SPDR\_BY是与缓冲区的接口，缓冲区保存数据以供SPI发送和接收。以字访问该寄存器时（SPDCR.SPLW位为1），访问SPDR。当以半字访问它时（SPLW位为0），访问SPDR\_HA。当按字节访问时（SPDCR.SPBYT位为1），访问SPDR\_BY。

The transmit buffer (SPTX) and receive buffer (SPRX) are independent but are both mapped to SPDR/SPDR\_HA. Figure 30.2 shows the configuration of the SPDR/SPDR\_HA register.

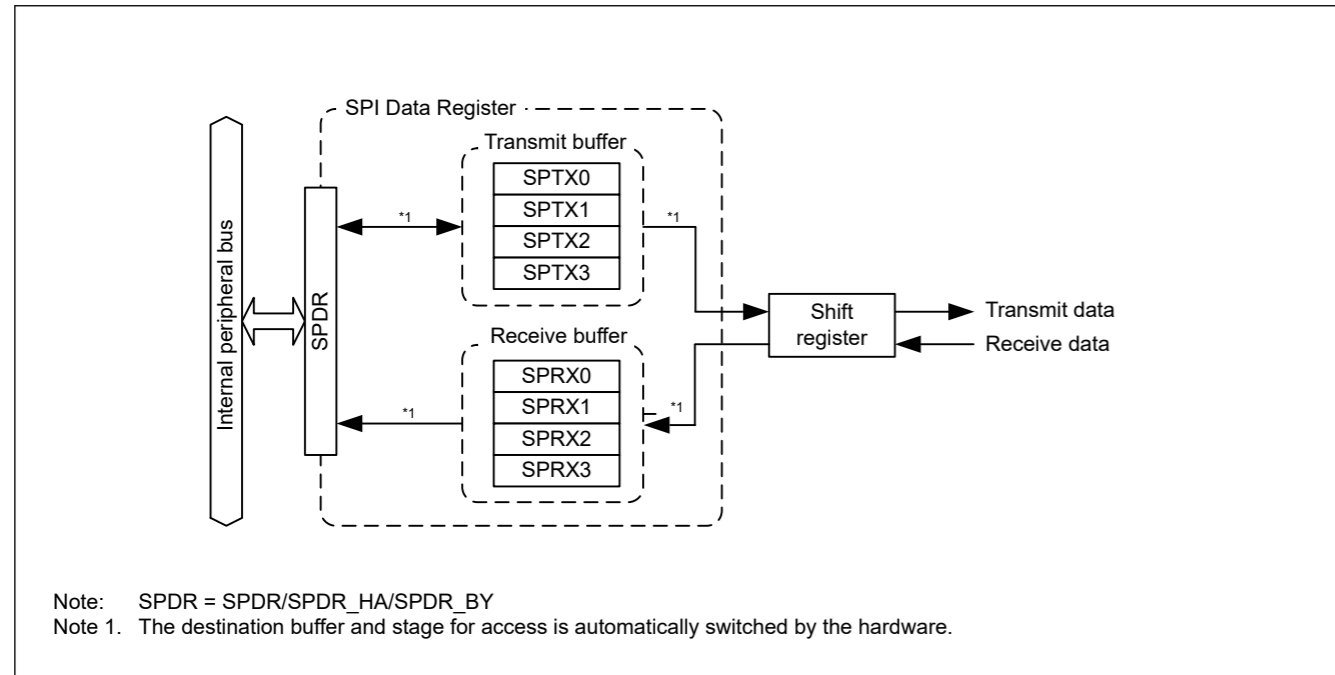


Figure 30.2 Configuration of SPDR/SPDR\_HA/SPDR\_BY

The transmit and receive buffers each have one stages. The four stages of the buffer are all mapped to the single address of SPDR/SPDR\_HA/SPDR\_BY.

Data written to SPDR/SPDR\_HA/SPDR\_BY is written to a transmit-buffer stage (SPTX<sub>n</sub>) (n = 0 to 3), and then transmitted from the buffer. The receive buffer holds received data on completion of reception. The receive buffer is not updated if an overrun is generated.

Additionally, if the data length is not 32 bits, bits not referred to in SPTX<sub>n</sub> (n = 0 to 3) are stored in the associated bits in SPRX<sub>n</sub> (n = 0 to 3). For example, if the data length is 9 bits, the received data is stored in the SPRX<sub>n</sub>[8:0] bits, and the SPTX<sub>n</sub>[31:9] bits are stored in the SPRX<sub>n</sub>[31:9] bits.

#### (1) Bus interface

SPDR/SPDR\_HA/SPDR\_BY is an interface with 32-bit wide transmit and receive buffers, each of which has one stages, for a total of 32 bytes. The 32 bytes are mapped to the 4-byte address space for SPDR/SPDR\_HA/SPDR\_BY. Additionally, the unit of access for SPDR/SPDR\_HA/SPDR\_BY is selected by the SPI Word Access/Halfword Access Specification bit in the SPI Data Control Register (SPDCR.SPLW). SPDR can also be accessed with the access size specified by the SPI Byte Access bit in the SPI Data Control Register (SPDCR.SPBYT).

Flush the transmission data at the LSB end of the register, and store the received data at the LSB end.

The following sections describe the operations involved in writing to and reading from SPDR/SPDR\_HA/SPDR\_BY.

#### Writing

Data written to SPDR/SPDR\_HA/SPDR\_BY is written to a transmit buffer (SPTX<sub>n</sub>). This is not affected by the value of the SPDCR.SPRDTD bit, unlike when reading from SPDR/SPDR\_HA/SPDR\_BY. The transmit buffer includes a transmit buffer write pointer that is automatically updated to reference the next stage each time data is written to SPDR/SPDR\_HA/SPDR\_BY.

Figure 30.3 shows the configuration of the bus interface with the transmit buffer when writing to SPDR/SPDR\_HA/SPDR\_BY.

发送缓冲区(SPTX)和接收缓冲区(SPRX)是独立的，但都映射到SPDR/SPDR\_HA。图30.2显示了SPDR/SPDR\_HA寄存器的配置。

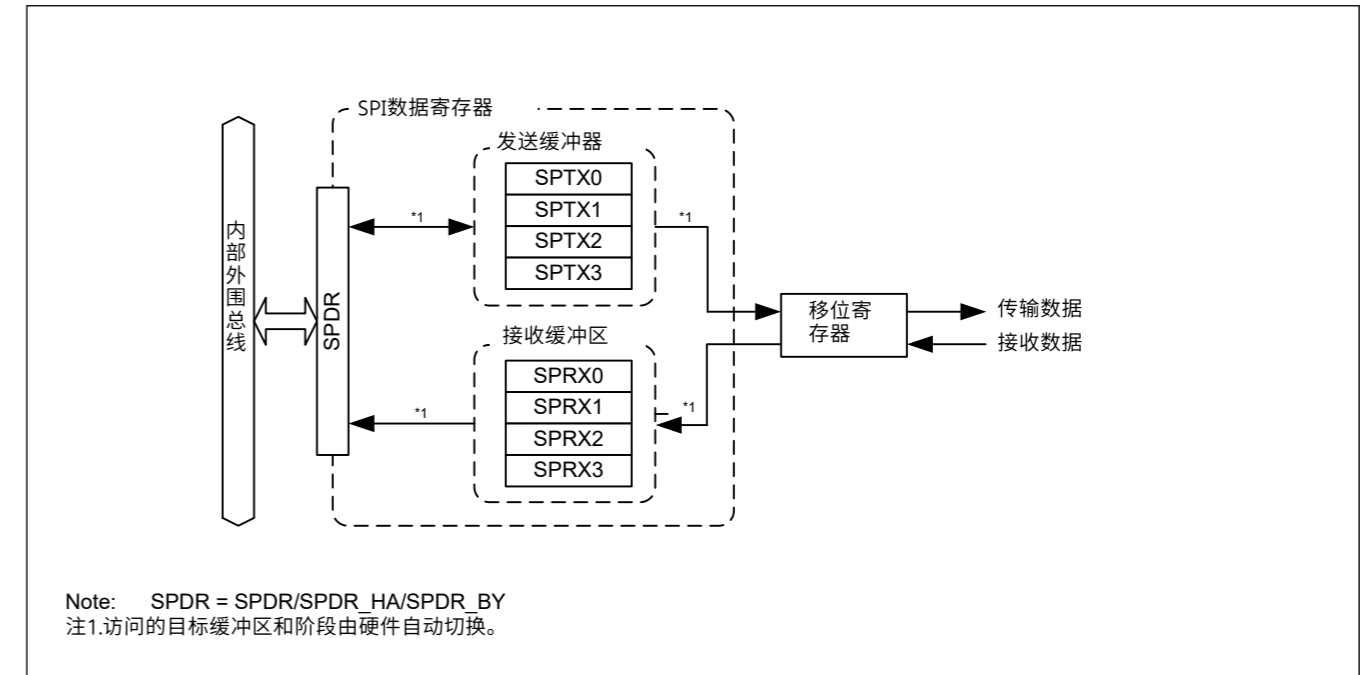


Figure 30.2 SPDR/SPDR\_HA/SPDR\_BY的配置

发送和接收缓冲器各有一级。缓冲区的四个阶段都映射到单个地址 SPDR/SPDR\_HA/SPDR\_BY。

写入SPDR/SPDR\_HA/SPDR\_BY的数据被写入发送缓冲区级(SPTX<sub>n</sub>)(n=0到3)，然后从缓冲区发送。接收缓冲器在接收完成时保存接收到的数据。如果产生溢出，接收缓冲器不会更新。

此外，如果数据长度不是32位，SPTX<sub>n</sub>(n=0到3)中未提及的位将存储在 SPRX<sub>n</sub> (n=0到3)。例如，如果数据长度为9位，则接收到的数据存储在SPRX<sub>n</sub>[8:0]位中，而 SPTX<sub>n</sub>[31:9]位存储在SPRX<sub>n</sub>[31:9]位中。

#### (1) 总线接口

SPDR/SPDR\_HA/SPDR\_BY是一个具有32位宽的发送和接收缓冲区的接口，每个缓冲区都有一个阶段，总共32个字节。32个字节映射到SPDR/SPDR\_HA/SPDR\_BY的4字节地址空间。此外，SPDR/SPDR\_HA/SPDR\_BY的访问单元由SPI数据控制寄存器(SPDCR.SPLW)中的SPI字访问半字访问规范位选择。SPDR也可以通过SPI字节指定的访问大小进行访问。

SPI数据控制寄存器(SPDCR.SPBYT)中的访问位。

在寄存器的LSB端刷新发送数据，在LSB端存储接收到的数据。

以下部分描述了写入和读取SPDR/SPDR\_HA/SPDR\_BY所涉及的操作。

#### Writing

写入SPDR/SPDR\_HA/SPDR\_BY的数据被写入发送缓冲区(SPTX<sub>n</sub>)。这不受SPDCR.SPRDTD位的影响，与从SPDR/SPDR\_HA/SPDR\_BY读取时不同。发送缓冲区包括一个发送缓冲区写指针，每次将数据写入SPDR/SPDR\_HA/SPDR\_BY时，该指针会自动更新以引用下一阶段。

图30.3显示了写入SPDR/SPDR\_HA时带有发送缓冲区的总线接口的配置 SPDR\_BY。

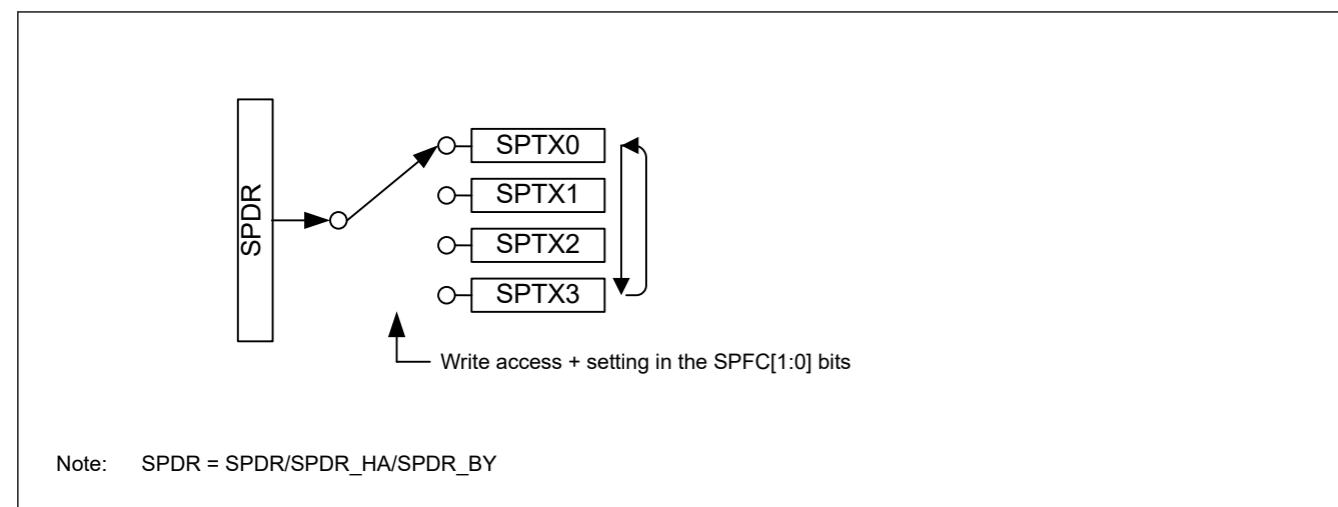


Figure 30.3 Configuration of SPDR/SPDR\_HA/SPDR\_BY for write access

The sequence for switching the transmit buffer write pointer differs with the setting of the number of frames specification bits in the SPI Data Control Register (SPDCR.SPFC[1:0]). The relationship of the SPFC[1:0] setting and the sequence of pointer switching from SPTX0 to SPTX3 is as follows:

- When SPFC[1:0] = 00b: SPTX0 → SPTX0 → SPTX0 → ...
- When SPFC[1:0] = 01b: SPTX0 → SPTX1 → SPTX0 → SPTX1 → ...
- When SPFC[1:0] = 10b: SPTX0 → SPTX1 → SPTX2 → SPTX0 → SPTX1 → ...
- When SPFC[1:0] = 11b: SPTX0 → SPTX1 → SPTX2 → SPTX3 → SPTX0 → SPTX1 → ...

When 1 is written to the SPI Function Enable bit in the SPI Control Register (SPCR.SPE) while the bit is 0, SPTX0 is the destination for the next write.

When writing to the transmit buffer (SPTXn) after generating the transmit buffer empty interrupt (when SPSR.SPTEF is 1), write the number of frames set in SPFC[1:0] in the SPI Data Control Register (SPDCR). Even when the specified number of frames is written to the transmit buffer (SPTXn), the value of the buffer is not updated after completion of the writing and before generation of the next transmit buffer empty interrupt (when SPTEF is 0).

#### Reading

SPDR/SPDR\_HA/SPDR\_BY can be accessed to read the value of a receive buffer (SPRXn) or a transmit buffer (SPTXn). The setting in the SPI Receive/Transmit Data Select bit in the SPI Data Control Register (SPDCR.SPRDTD) selects whether reading is of the receive or transmit buffer. The sequence of reading the SPDR/SPDR\_HA/SPDR\_BY register is controlled by the independent receive buffer and transmit buffer read pointers.

Figure 30.4 shows the configuration of the bus interface with the receive and transmit buffers for reading from SPDR/SPDR\_HA/SPDR\_BY.

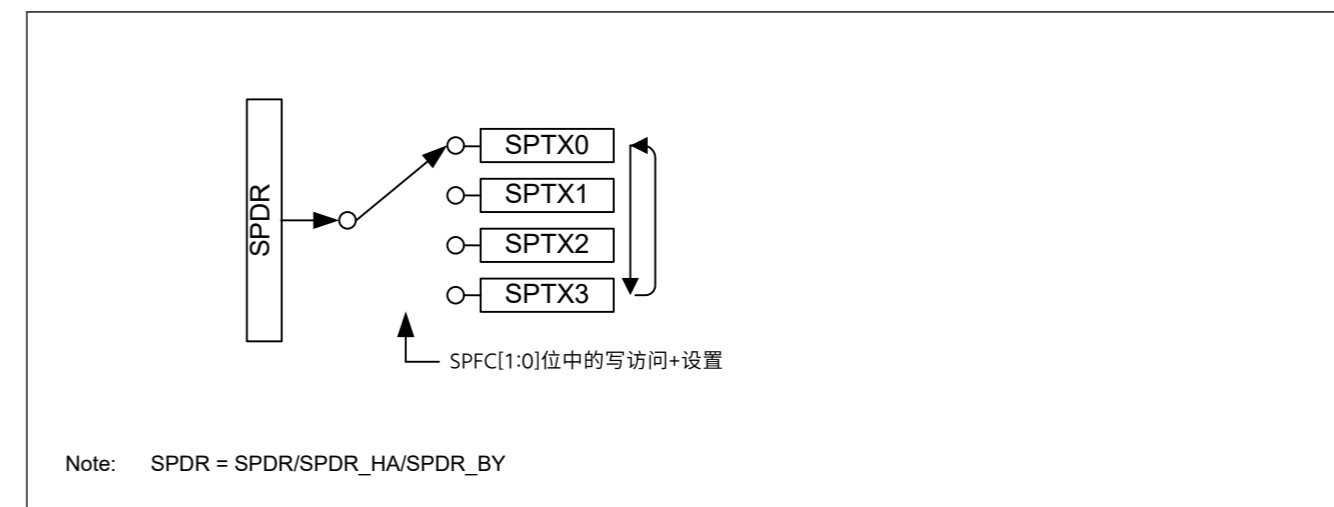


Figure 30.3 为写访问配置SPDR/SPDR\_HA/SPDR\_BY

发送缓冲区写指针的切换顺序因SPI数据控制寄存器(SPDCR.SPFC[1:0])中帧数规范位的设置而异。SPFC[1:0]设置与指针从SPTX0切换到SPTX3的顺序关系如下:

- When SPFC[1:0] = 00b: SPTX0 → SPTX0 → SPTX0 → ...
- When SPFC[1:0] = 01b: SPTX0 → SPTX1 → SPTX0 → SPTX1 → ...
- When SPFC[1:0] = 10b: SPTX0 → SPTX1 → SPTX2 → SPTX0 → SPTX1 → ...
- When SPFC[1:0] = 11b: SPTX0 → SPTX1 → SPTX2 → SPTX3 → SPTX0 → SPTX1 → ...

当1写入SPI控制寄存器(SPCR.SPE)中的SPI功能使能位且该位为0时，SPTX0是下一次写入的目标。

在产生发送缓冲区空中断后写入发送缓冲区(SPTXn)时(当SPSR.SPTEF为1时)，将SPFC[1:0]中设置的帧数写入SPI数据控制寄存器(SPDCR)。即使指定的帧数被写入发送缓冲区(SPTXn)，缓冲区的值在写入完成后和下一个发送缓冲区空中断发生之前(SPTEF为0时)也不会更新。

#### Reading

SPDR/SPDR\_HA可以访问SPDR\_BY以读取接收缓冲区(SPRXn)或发送缓冲区(SPTXn)的值。SPI数据控制寄存器(SPDCR.SPRDTD)的SPI接收发送数据选择位中的设置选择读取接收缓冲区还是发送缓冲区。读取SPDR/SPDR\_HA/SPDR\_BY寄存器的顺序由独立的接收缓冲区和发送缓冲区读取指针控制。

图30.4显示了带有用于从SPDR读取的接收和发送缓冲区的总线接口配置SPDR\_HA/SPDR\_BY。



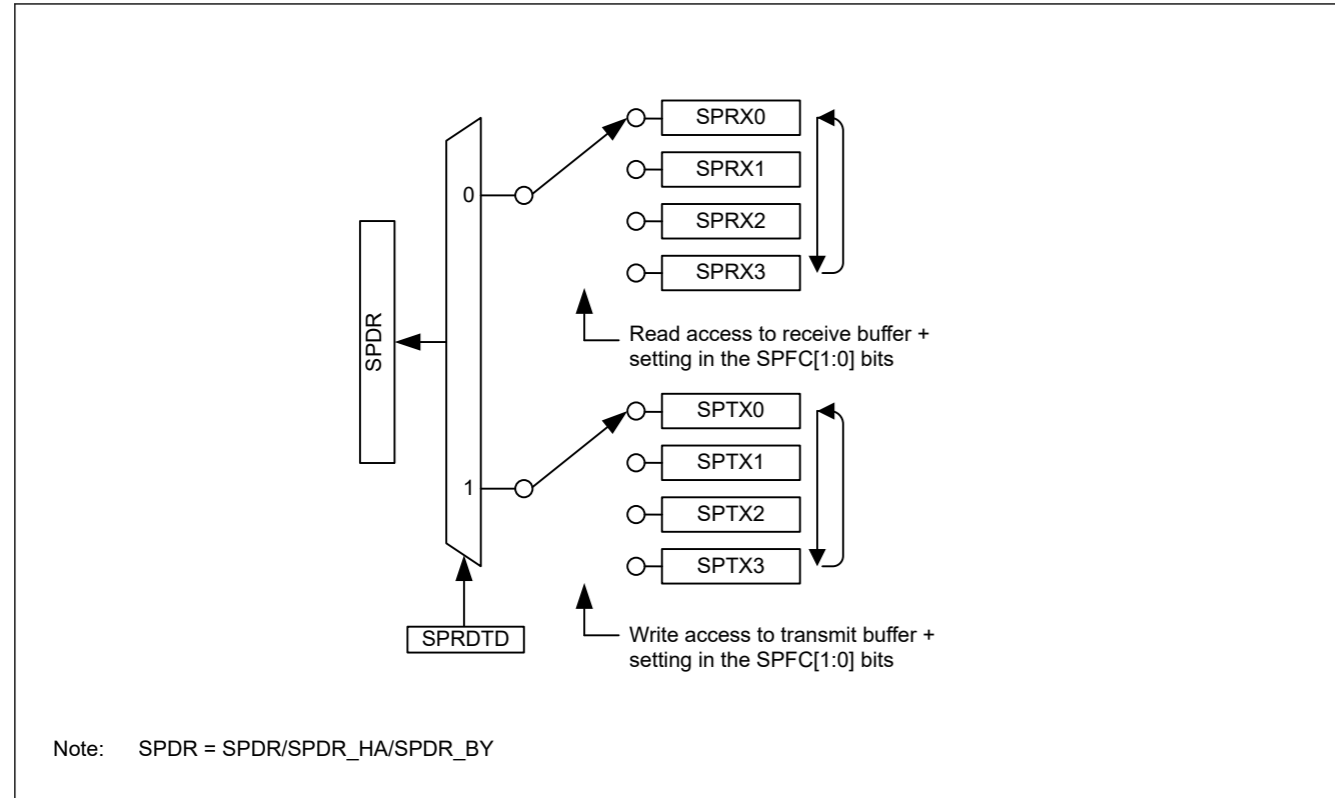


Figure 30.4 Configuration of SPDR/SPDR\_HA/SPDR\_BY for read access

Reading the receive buffer switches the receive buffer read pointer to the next buffer automatically. The switching sequence for the receive buffer read pointer is the same as that for the transmit buffer write pointer. However, when 1 is written to the SPI Function Enable bit in the SPI Control Register (SPCR.SPE) while the value of the bit is 1, SPRX0 is referenced by the buffer read pointer for the next read.

The transmit buffer read pointer is updated when writing to SPDR/SPDR\_HA/SPDR\_BY, but not updated when reading from the transmit buffer. When reading from the transmit buffer, the value most recently written to SPDR/SPDR\_HA/SPDR\_BY is read.

After a transmit buffer empty interrupt is generated, reading from the transmit buffer returns all 0s after the completion of writing the number of frames of data specified in the SPDCR.SPFC[1:0] bits, until the next buffer empty interrupt is generated (when SPTEF is 0).

### 30.2.6 SPSCR : SPI Sequence Control Register

Base address: SPI0 = 0x4011\_A000

Offset address: 0x08

|                    |   |   |   |   |   |            |   |   |
|--------------------|---|---|---|---|---|------------|---|---|
| Bit position:      | 7 | 6 | 5 | 4 | 3 | 2          | 1 | 0 |
| Bit field:         | — | — | — | — | — | SPSLN[2:0] |   |   |
| Value after reset: | 0 | 0 | 0 | 0 | 0 | 0          | 0 | 0 |

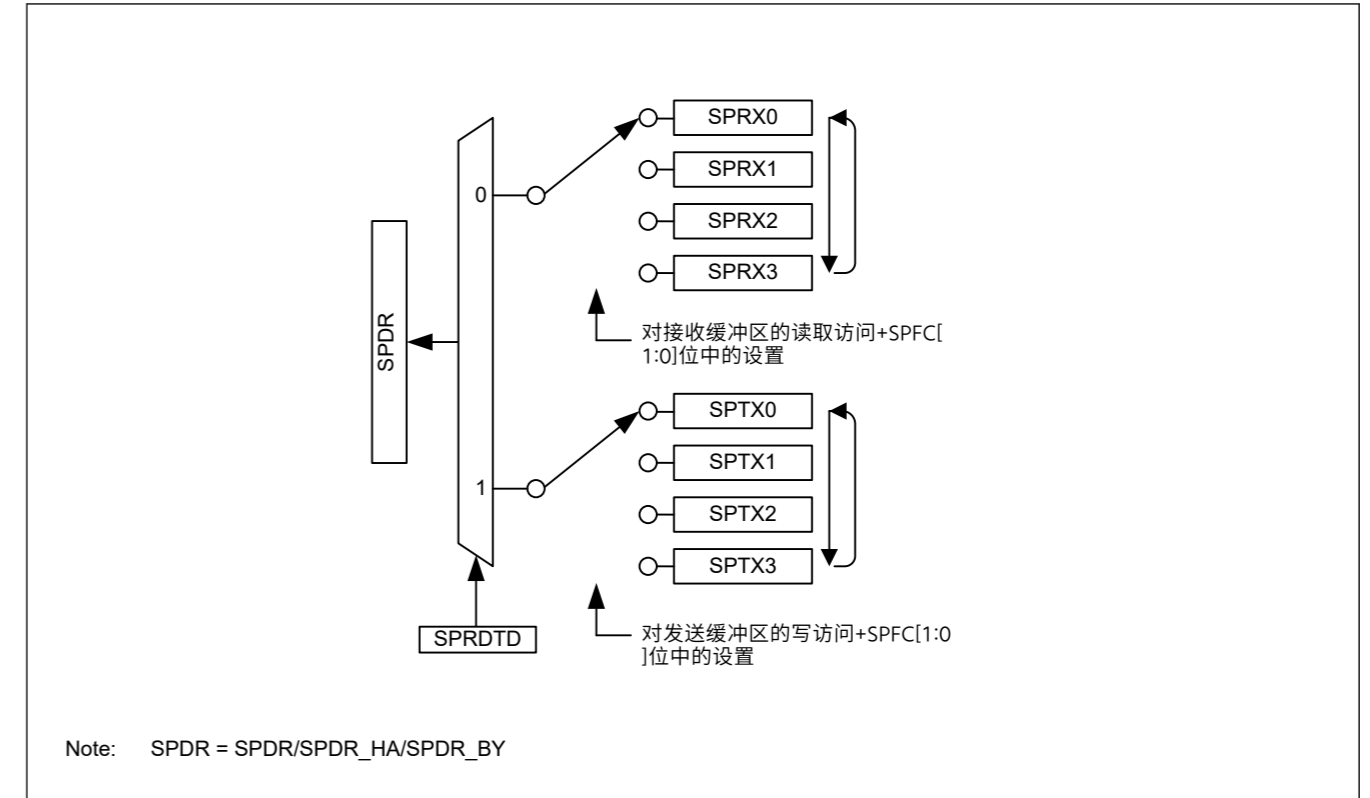


Figure 30.4 为读取访问配置SPDR/SPDR\_HA/SPDR\_BY

读取接收缓冲区会自动将接收缓冲区读取指针切换到下一个缓冲区。接收缓冲区读指针的切换顺序与发送缓冲区写指针的切换顺序相同。但是，当1写入SPI控制寄存器(SPCR.SPE)中的SPI功能使能位且该位的值为1时，缓冲区读取指针将引用SPRX0以进行下一次读取。

发送缓冲区读指针在写入SPDR/SPDR\_HA/SPDR\_BY时更新，但在从发送缓冲区读取时不更新。从发送缓冲区读取时，会读取最近写入SPDR/SPDR\_HA/SPDR\_BY的值。

产生发送缓冲区空中断后，在完成写入SPDCR.SPFC[1:0]位中指定的数据帧数后，从发送缓冲区读取返回全0，直到产生下一个缓冲区空中断（当SPTEF为0时）。

### 30.2.6 SPSCR:SPI序列控制寄存器

Base address: SPI0 = 0x4011\_A000

Offset address: 0x08

|               |   |   |   |   |   |            |   |   |
|---------------|---|---|---|---|---|------------|---|---|
| Bit position: | 7 | 6 | 5 | 4 | 3 | 2          | 1 | 0 |
| Bit field:    | — | — | — | — | — | SPSLN[2:0] |   |   |
| 重置后的值:        | 0 | 0 | 0 | 0 | 0 | 0          | 0 | 0 |

| Bit | Symbol     | Function   | R/W |
|-----|------------|--|-----|
| 2:0 | SPSLN[2:0] | <p>SPI Sequence Length Specification</p> <p>The sequence length that is set in these bits determines the order in which the SPCMD0 to SPCMD07 registers are referenced. The setting defines the relationship between the sequence length and the SPCMD0 to SPCMD7 registers referenced by the SPI. In slave mode, the SPI references SPCMD0.</p> <p>0 0 0: Sequence Length is 1 (Referenced SPCMDn, n = 0→0→...)<br/>                     0 0 1: Sequence Length is 2 (Referenced SPCMDn, n = 0→1→0→...)<br/>                     0 1 0: Sequence Length is 3 (Referenced SPCMDn, n = 0→1→2→0→...)<br/>                     0 1 1: Sequence Length is 4 (Referenced SPCMDn, n = 0→1→2→3→0→...)<br/>                     1 0 0: Sequence Length is 5 (Referenced SPCMDn, n = 0→1→2→3→4→0→...)<br/>                     1 0 1: Sequence Length is 6 (Referenced SPCMDn, n = 0→1→2→3→4→5→0→...)<br/>                     1 1 0: Sequence Length is 7 (Referenced SPCMDn, n = 0→1→2→3→4→5→6→0→...)<br/>                     1 1 1: Sequence Length is 8 (Referenced SPCMDn, n = 0→1→2→3→4→5→6→7→0→...)</p> | R/W |
| 7:3 | —          | These bits are read as 0. The write value should be 0.   | R/W |

SPSCR specifies the sequence length when the SPI operates in master mode. Before changing the SPSLN[2:0] bits while both the SPCR.MSTR and SPCR.SPE bits are 1, check that the SPSR.IDLNF flag is 0.

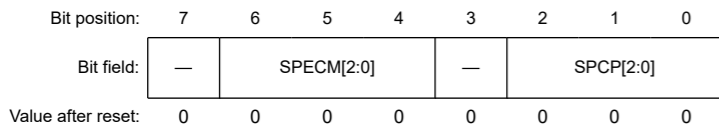
**SPSLN[2:0] bits (SPI Sequence Length Specification)**

The SPSLN[2:0] bits specify the sequence length when the SPI in master mode performs sequential operations. The SPI in master mode changes the SPCMD0 to SPCMD7 registers to be referenced, and the order in which they are referenced is based on this sequence length setting. In slave mode, SPCMD0 is referenced.

**30.2.7 SPSSR : SPI Sequence Status Register**

Base address: SPI0 = 0x4011\_A000

Offset address: 0x09



| Bit | Symbol     | Function   | R/W |
|-----|------------|--|-----|
| 2:0 | SPCP[2:0]  | <p>SPI Command Pointer</p> <p>0 0 0: SPCMD0<br/>                     0 0 1: SPCMD1<br/>                     0 1 0: SPCMD2<br/>                     0 1 1: SPCMD3<br/>                     1 0 0: SPCMD4<br/>                     1 0 1: SPCMD5<br/>                     1 1 0: SPCMD6<br/>                     1 1 1: SPCMD7</p> | R   |
| 3   | —          | This bit is read as 0.   | R   |
| 6:4 | SPECM[2:0] | <p>SPI Error Command</p> <p>0 0 0: SPCMD0<br/>                     0 0 1: SPCMD1<br/>                     0 1 0: SPCMD2<br/>                     0 1 1: SPCMD3<br/>                     1 0 0: SPCMD4<br/>                     1 0 1: SPCMD5<br/>                     1 1 0: SPCMD6<br/>                     1 1 1: SPCMD7</p>   | R   |
| 7   | —          | This bit is read as 0.   | R   |

SPSSR indicates the sequence control status when the SPI operates in master mode. Any writes to SPSSR are ignored.

| Bit | Symbol     | Function  | R/W |
|-----|------------|---|-----|
| 2:0 | SPSLN[2:0] | <p>SPI序列长度规范</p> <p>在这些位中设置的序列长度决定了SPCMD0到SPCMD7寄存器。该设置定义了序列长度与SPI引用的SPCMD0到SPCMD7寄存器之间的关系。在从机模式下，SPI参考SPCMD0。</p> <p>000: 序列长度为1 (参考SPCMDn, n=0→0→...) 001: 序列长度为2 (参考SPCMDn, n=0→1→0→...) 010: 序列长度为3 (参考SPCMDn, n=0→1→2→0→...) 011: 序列长度为4 (参考SPCMDn, n=0→1→2→3→0→...) 100: 序列长度为5 (参考SPCMDn, n=0→1→2→3→4→0→...) 101: 序列长度为6 (参考SPCMDn, n=0→1→2→3→4→5→0→...) 110: 序列长度为7 (参考SPCMDn, n=0→1→2→3→4→5→6→0→...) 111: 序列长度为8 (参考SPCMDn, n=0→1→2→3→4→5→6→7→0→...)</p> | R/W |
| 7:3 | —          | 这些位被读取为0。写入值应为0。  | R/W |

SPSCR指定SPI在主模式下工作时的序列长度。在SPCR.MSTR和SPCR.SPE位均为1时更改SPSLN[2:0]位之前，请检查SPSR.IDLNF标志是否为0。

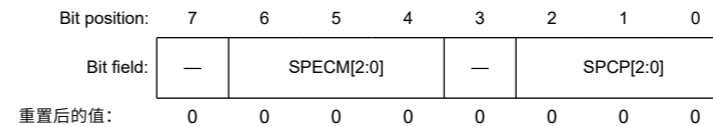
**SPSLN[2:0]位 (SPI序列长度规范)**

SPSLN[2:0]位指定SPI在主模式下执行顺序操作时的序列长度。主机模式下的SPI将SPCMD0到SPCMD7寄存器更改为被引用，它们被引用的顺序基于此序列长度设置。在从模式下，以SPMD0为参考。

**30.2.7 SPSSR: SPI序列状态寄存器**

Base address: SPI0 = 0x4011\_A000

Offset address: 0x09



| Bit | Symbol     | Function   | R/W |
|-----|------------|--|-----|
| 2:0 | SPCP[2:0]  | <p>SPI命令指针</p> <p>0 0 0: SPCMD0<br/>                     0 0 1: SPCMD1<br/>                     0 1 0: SPCMD2<br/>                     0 1 1: SPCMD3<br/>                     1 0 0: SPCMD4<br/>                     1 0 1: SPCMD5<br/>                     1 1 0: SPCMD6<br/>                     1 1 1: SPCMD7</p> | R   |
| 3   | —          | 该位读为0。   | R   |
| 6:4 | SPECM[2:0] | <p>SPI错误命令</p> <p>0 0 0: SPCMD0<br/>                     0 0 1: SPCMD1<br/>                     0 1 0: SPCMD2<br/>                     0 1 1: SPCMD3<br/>                     1 0 0: SPCMD4<br/>                     1 0 1: SPCMD5<br/>                     1 1 0: SPCMD6<br/>                     1 1 1: SPCMD7</p> | R   |
| 7   | —          | 该位读为0。   | R   |

SPSSR指示SPI在主模式下工作时的序列控制状态。对SPSSR的任何写入都将被忽略。

**SPCP[2:0] bits (SPI Command Pointer)**

The SPCP[2:0] bits indicate the SPCMDm register that is referenced to by the pointer during sequence control by the SPI. For the SPI sequence control, see [section 30.3.11.1. Master mode operation](#).

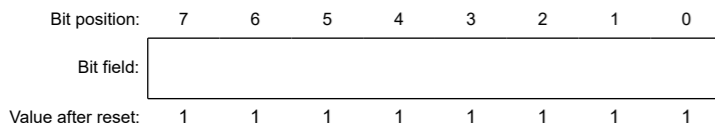
**SPECM[2:0] bits (SPI Error Command)**

The SPECM[2:0] bits indicate the SPCMDm register that is specified in the SPCP[2:0] bits when an error is detected during sequence control by the SPI. The SPI updates the SPECM[2:0] bits only when an error is detected. If both the SPSR.OVRF and SPSR.MODF flags are 0 and there is no error, the values of the SPECM[2:0] bits have no meaning.

For the SPI error detection function, see [section 30.3.9. Error Detection](#). For the SPI sequence control, see [section 30.3.11.1. Master mode operation](#).

**30.2.8 SPBR : SPI Bit Rate Register**

Base address: SPI0 = 0x4011\_A000  
Offset address: 0x0A



| Bit | Symbol | Function | R/W |
|-----|--------|----------|-----|
| 7:0 | n/a    | Bit rate | R/W |

SPBR sets the bit rate in master mode.

When the SPI is in slave mode, the bit rate depends on the bit rate of the input clock, regardless of the settings in SPBR and the SPCMDm.BRDV[1:0] bits (bit rate division setting). Use bit rates that satisfy the electrical characteristics of the device.

The bit rate is determined by combinations of the SPBR and SPCMDm.BRDV[1:0] settings in the SPI Command Register. The equation for calculating the bit rate is given as follows:

$$\text{Bit rate} = \frac{f(\text{PCLK})}{2 \times (n + 1) \times 2^N}$$

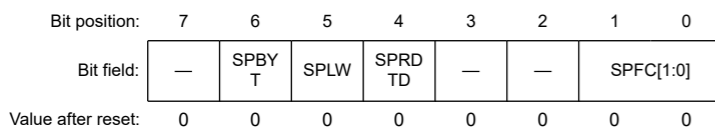
( PCLK = PCLKA )

In the equation, n denotes an SPBR setting (0, 1, 2, ..., 255), and N denotes a BRDV[1:0] setting (0, 1, 2, 3).

[section 30.2.8. SPBR : SPI Bit Rate Register](#) lists examples of the relationship between the SPBR settings, the BRDV[1:0] settings, and bit rates.

**30.2.9 SPDCR : SPI Data Control Register**

Base address: SPI0 = 0x4011\_A000  
Offset address: 0x0B



| Bit | Symbol    | Function  | R/W |
|-----|-----------|---|-----|
| 1:0 | SPFC[1:0] | Number of Frames Specification<br>0 0: 1 frame<br>0 1: 2 frames<br>1 0: 3 frames<br>1 1: 4 frames | R/W |
| 3:2 | —         | These bits are read as 0. The write value should be 0.  | R/W |

**SPCP[2:0]位 (SPI命令指针)**

SPCP[2:0]位指示在SPI序列控制期间指针所引用的SPCMDm寄存器。有关SPI序列控制，请参阅第30.3.11.1节。主模式操作。

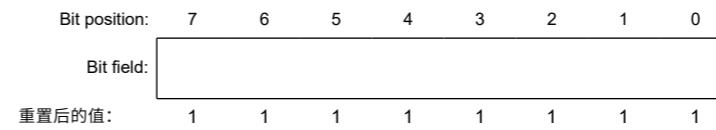
**SPECM[2:0]位 (SPI错误命令)**

SPECM[2:0]位指示在SPI序列控制期间检测到错误时在SPCP[2:0]位中指定的SPCMDm寄存器。SPI仅在检测到错误时更新SPECM[2:0]位。如果SPSR.OVRF和SPSR.MODF标志均为0且没有错误，则SPECM[2:0]位的值没有意义。

关于SPI错误检测功能，请参见第30.3.9节。错误检测。有关SPI序列控制，请参阅第30.3.11.1节。主模式操作。

**30.2.8 SPBR:SPI比特率寄存器**

Base address: SPI0 = 0x4011\_A000  
Offset address: 0x0A



| Bit | Symbol | Function | R/W |
|-----|--------|----------|-----|
| 7:0 | n/a    | 比特率      | R/W |

SPBR在主模式下设置比特率。

当SPI处于从机模式时，比特率取决于输入时钟的比特率，与SPBR和SPMDm.BRDV[1:0]位（比特率分频设置）的设置无关。使用满足设备电气特性的比特率。

比特率由SPI命令寄存器中的SPBR和SPMDm.BRDV[1:0]设置的组合确定。计算比特率的公式如下：

$$\text{比特率} = \frac{f(\text{PCLK})}{2 \times (n + 1) \times 2^N}$$

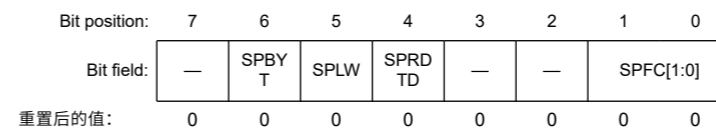
( PCLK = PCLKA )

在等式中，n表示SPBR设置(0 1 2 ... 255)，N表示BRDV[1:0]设置(0 1 2 3)。

第30.2.8节。SPBR:SPI比特率寄存器列出了SPBR设置、BRDV[1:0]设置和比特率之间的关系示例。

**30.2.9 SPDCR:SPI数据控制寄存器**

Base address: SPI0 = 0x4011\_A000  
Offset address: 0x0B



| Bit | Symbol    | Function                                | R/W |
|-----|-----------|---|-----|
| 1:0 | SPFC[1:0] | 帧数规格<br>00: 1帧01:<br>2帧10: 3帧1<br>1: 4帧 | R/W |
| 3:2 | —         | 这些位被读取为0。写入值应为0。                        | R/W |

| Bit | Symbol | Function  | R/W |
|-----|--------|---|-----|
| 4   | SPRDTD | SPI Receive/Transmit Data Select<br>0: Read SPDR/SPDR_HA values from receive buffer<br>1: Read SPDR/SPDR_HA values from transmit buffer, but only if the transmit buffer is empty | R/W |
| 5   | SPLW   | SPI Word Access/Halfword Access Specification<br>0: Set SPDR_HA to valid for halfword access<br>1: Set SPDR to valid for word access  | R/W |
| 6   | SPBYT  | SPI Byte Access Specification<br>0: SPDR/SPDR_HA is accessed in halfword or word (SPLW is valid)<br>1: SPDR_BY is accessed in byte (SPLW is invalid)                              | R/W |
| 7   | —      | This bit is read as 0. The write value should be 0.   | R/W |

The SPI Data Control Register (SPDCR) is used to read the number of frames that can be stored in the SPDR register, read the SPDR register, and to set the access width for the SPDR register to word access, halfword access, or byte access. Up to four frames can be transmitted or received in one round of transmission or reception. The amount of data in each transfer is controlled by the combination of the SPCMDm.SP3[3:0] bits, the SPSCR.SP3SLN[2:0] bits, and the SPFC[1:0] bits.

When changing the SPFC[1:0] bits while the SPCR.SPE bit is 1, check that the SPSR.IDLNF flag is 0.

#### SPFC[1:0] bits (Number of Frames Specification)

The SPFC[1:0] bits specify the number of frames that can be stored in SPDR/SPDR\_HA per transfer activation. Up to four frames can be transmitted or received in one round of transmission or reception.

When the number of transmission data frames specified in the SPFC[1:0] bits is written to the SPDR/SPDR\_HA register, SPI clears the SPSR.SPTEF flag to 0 and begins transmitting. After that, when the number of transmission data frames specified in the SPFC[1:0] bits is transmitted to the shift register, the SPI generates the transmit buffer empty interrupt (SPSR.SPTEF sets to 1).

When the number of data frames specified in the SPFC[1:0] bits is received, the SPI generates the receive buffer full interrupt (SPSR.SPRF sets to 1).

**Table 30.3** Settable combinations of the SP3SLN[2:0] and SPFC[1:0] bits

| Setting | SP3SLN[2:0] | SPFC[1:0] | Number of frames in a single sequence | Number of frames at which transmission or receive buffer is filled |
|---------|-------------|-----------|---------------------------------------|--|
| 1-1     | 000b        | 00b       | 1                                     | 1  |
| 1-2     | 000b        | 01b       | 2                                     | 2  |
| 1-3     | 000b        | 10b       | 3                                     | 3  |
| 1-4     | 000b        | 11b       | 4                                     | 4  |
| 2-1     | 001b        | 01b       | 2                                     | 2  |
| 2-2     | 001b        | 11b       | 4                                     | 4  |
| 3       | 010b        | 10b       | 3                                     | 3  |
| 4       | 011b        | 11b       | 4                                     | 4  |
| 5       | 100b        | 00b       | 5                                     | 1  |
| 6       | 101b        | 00b       | 6                                     | 1  |
| 7       | 110b        | 00b       | 7                                     | 1  |
| 8       | 111b        | 00b       | 8                                     | 1  |

#### SPRDTD bit (SPI Receive/Transmit Data Select)

The SPRDTD bit selects whether the SPDR/SPDR\_HA reads values from the receive buffer or from the transmit buffer. If reading is from the transmit buffer, the last value written to SPDR/SPDR\_HA register is read. Read the transmit buffer after an SPI transmit buffer empty interrupt is generated until data of frames specified by SPFC[1:0] has been written (while the SPSR.SPTEF flag is 1).

For details, see [section 30.2.5. SPDR/SPDR\\_HA/SPDR\\_BY : SPI Data Register](#).

| Bit | Symbol | Function   | R/W |
|-----|--------|--|-----|
| 4   | SPRDTD | SPI接收发送数据选择<br>0: 从接收缓冲区读取SPDRSPDR_HA值1: 从发送缓冲区读取SPDRSPDR_HA值, 但前提是发送缓冲区为空 | R/W |
| 5   | SPLW   | SPI字访问半字访问规范<br>0: 将SPDR_HA设置为对半字访问有效1: 将SPDR设置为对字访问有效                     | R/W |
| 6   | SPBYT  | SPI字节访问规范<br>0: SPDRSPDR_HA以半字或字访问 (SPLW有效) 1: SPDR_BY以字节访问 (SPLW无效)       | R/W |
| 7   | —      | 该位读取为0。写入值应为0。   | R/W |

SPI数据控制寄存器(SPDCR)用于读取SPDR寄存器中可存储的帧数, 读取SPDR寄存器, 并将SPDR寄存器的访问宽度设置为字访问、半字访问或字节访问。在一轮发送或接收中最多可以发送或接收四帧。每次传输中的数据量由SPCMDm.SP3[3:0]位、SPSCR.SP3SLN[2:0]位和SPFC[1:0]位的组合控制。

在SPCR.SPE位为1时更改SPFC[1:0]位时, 检查SPSR.IDLNF标志是否为0。

#### SPFC[1:0]位 (帧数规范)

SPFC[1:0]位指定每次传输激活时可以存储在SPDRSPDR\_HA中的帧数。在一轮发送或接收中最多可以发送或接收四帧。

当SPFC[1:0]位中指定的传输数据帧数写入SPDRSPDR\_HA寄存器时, SPI将SPSR.SPTEF标志清除为0并开始发送。之后, 当SPFC[1:0]位中指定的发送数据帧数被发送到移位寄存器时, SPI产生发送缓冲区空中断 (SPSR.SPTEF设置为1)。

当接收到SPFC[1:0]位中指定的数据帧数时, SPI产生接收缓冲区满中断 (SPSR.SPRF设置为1)。

**Table 30.3** SP3SLN[2:0]和SPFC[1:0]位的可设置组合

| Setting | SP3SLN[2:0] | SPFC[1:0] | 单个序列中的帧数 | 填充传输或接收缓冲区的帧数 |
|---------|-------------|-----------|----------|---------------|
| 1-1     | 000b        | 00b       | 1        | 1             |
| 1-2     | 000b        | 01b       | 2        | 2             |
| 1-3     | 000b        | 10b       | 3        | 3             |
| 1-4     | 000b        | 11b       | 4        | 4             |
| 2-1     | 001b        | 01b       | 2        | 2             |
| 2-2     | 001b        | 11b       | 4        | 4             |
| 3       | 010b        | 10b       | 3        | 3             |
| 4       | 011b        | 11b       | 4        | 4             |
| 5       | 100b        | 00b       | 5        | 1             |
| 6       | 101b        | 00b       | 6        | 1             |
| 7       | 110b        | 00b       | 7        | 1             |
| 8       | 111b        | 00b       | 8        | 1             |

#### SPRDTD位 (SPI接收发送数据选择)

SPRDTD位选择SPDRSPDR\_HA是从接收缓冲区还是从发送缓冲区读取值。如果从发送缓冲区读取, 则读取写入SPDRSPDR\_HA寄存器的最后一个值。在产生SPI发送缓冲区空中断后读取发送缓冲区, 直到SPFC[1:0]指定的帧数据被写入 (此时SPSR.SPTEF标志为1)。

有关详细信息, 请参阅[第30.2.5节. SPDRSPDR\\_HASPD\\_BY: SPI数据寄存器](#)。



**SPLW bit (SPI Word Access/Halfword Access Specification)**

The SPLW bit specifies the access width for SPDR. Access to SPDR\_HA in halfwords is valid when the SPLW bit is 0 and access to SPDR in words is valid when the SPLW bit is 1. Also, when this bit is 0, set the SPI data length setting bits, SPCMDm.SPB[3:0], from 8 to 16 bits. Do not perform any operations when a data length of 20, 24, or 32 bits is specified.

**SPBYT bit (SPI Byte Access Specification)**

The SPBYT bit is used to set the data width of access to the SPI Data Register (SPDR). When SPBYT = 0, use word or half word access to SPDR/SPDR\_HA. When SPBYT = 1 (in that case, SPLW is invalid), use byte access to SPDR\_BY.

When SPBYT = 1, set the SPI data length bits (SPB[3:0]) in the SPI Command Register m (SPCMDm) to 8 bits. If SPB[3:0] are set to 9 to 16, 20, 24, or 32 bit, subsequent operation is not guaranteed.

**30.2.10 SPCKD : SPI Clock Delay Register**

Base address: SPI0 = 0x4011\_A000

Offset address: 0x0C

|                    |   |   |   |   |   |            |   |   |
|--------------------|---|---|---|---|---|------------|---|---|
| Bit position:      | 7 | 6 | 5 | 4 | 3 | 2          | 1 | 0 |
| Bit field:         | — | — | — | — | — | SCKDL[2:0] |   |   |
| Value after reset: | 0 | 0 | 0 | 0 | 0 | 0          | 0 | 0 |

| Bit | Symbol     | Function  | R/W |
|-----|------------|---|-----|
| 2:0 | SCKDL[2:0] | RSPCK Delay Setting<br>0 0 0: 1 RSPCK<br>0 0 1: 2 RSPCK<br>0 1 0: 3 RSPCK<br>0 1 1: 4 RSPCK<br>1 0 0: 5 RSPCK<br>1 0 1: 6 RSPCK<br>1 1 0: 7 RSPCK<br>1 1 1: 8 RSPCK | R/W |
| 7:3 | —          | These bits are read as 0. The write value should be 0.  | R/W |

SPCKD specifies the RSPCK delay, the period from the beginning of SSLni signal assertion to RSPCK oscillation, when the SPCMDm.SCKDEN bit is 1.

**SCKDL[2:0] bits (RSPCK Delay Setting)**

The SCKDL[2:0] bits specify an RSPCK delay value when the SPCMDm.SCKDEN bit is 1. When using the SPI in slave mode, set the SCKDL[2:0] bits to 000b.

**30.2.11 SSLND : SPI Slave Select Negation Delay Register**

Base address: SPI0 = 0x4011\_A000

Offset address: 0x0D

|                    |   |   |   |   |   |            |   |   |
|--------------------|---|---|---|---|---|------------|---|---|
| Bit position:      | 7 | 6 | 5 | 4 | 3 | 2          | 1 | 0 |
| Bit field:         | — | — | — | — | — | SLNDL[2:0] |   |   |
| Value after reset: | 0 | 0 | 0 | 0 | 0 | 0          | 0 | 0 |

**SPLW位 (SPI字访问半字访问规范)**

SPLW位指定SPDR的访问宽度。当SPLW位为0时，以半字访问SPDR\_HA有效，当SPLW位为1时，以字访问SPDR有效。此外，当该位为0时，设置SPI数据长度设置位SPMDm.SPB[3:0]，从8到16位。当指定数据长度为20、24或32位时，请勿执行任何操作。

**SPBYT位 (SPI字节访问规范)**

SPBYT位用于设置访问SPI数据寄存器(SPDR)的数据宽度。当SPBYT=0时，使用字或半字访问SPDR/SPDR\_HA。当SPBYT=1时（在这种情况下，SPLW无效），使用对SPDR\_BY的字节访问。

当SPBYT=1时，将SPI命令寄存器m(SPCMDm)中的SPI数据长度位(SPB[3:0])设置为8位。如果SPB[3:0]设置为9至16、20、24或32位，不保证后续操作。

**30.2.10 SPCKD:SPI时钟延迟寄存器**

Base address: SPI0 = 0x4011\_A000

Offset address: 0x0C

|               |   |   |   |   |   |            |   |   |
|---------------|---|---|---|---|---|------------|---|---|
| Bit position: | 7 | 6 | 5 | 4 | 3 | 2          | 1 | 0 |
| Bit field:    | — | — | — | — | — | SCKDL[2:0] |   |   |
| 重置后的值:        | 0 | 0 | 0 | 0 | 0 | 0          | 0 | 0 |

| Bit | Symbol     | Function  | R/W |
|-----|------------|---|-----|
| 2:0 | SCKDL[2:0] | RSPCK延迟设置<br>0 0 0: 1 RSPCK<br>0 0 1: 2 RSPCK<br>0 1 0: 3 RSPCK<br>0 1 1: 4 RSPCK<br>1 0 0: 5 RSPCK<br>1 0 1: 6 RSPCK<br>1 1 0: 7 RSPCK<br>1 1 1: 8 RSPCK | R/W |
| 7:3 | —          | 这些位被读取为0。写入值应为0。  | R/W |

SPCKD指定RSPCK延迟，即从SSLni信号断言开始到RSPCK振荡的周期，当SPCMDm.SCKDEN位为1时。

**SCKDL[2:0]位 (RSPCK延迟设置)**

当SPCMDm.SCKDEN位为1时，SCKDL[2:0]位指定RSPCK延迟值。在从机模式下使用SPI时，将SCKDL[2:0]位设置为000b。

**30.2.11 SSLND:SPI从机选择否定延迟寄存器**

Base address: SPI0 = 0x4011\_A000

Offset address: 0x0D

|               |   |   |   |   |   |            |   |   |
|---------------|---|---|---|---|---|------------|---|---|
| Bit position: | 7 | 6 | 5 | 4 | 3 | 2          | 1 | 0 |
| Bit field:    | — | — | — | — | — | SLNDL[2:0] |   |   |
| 重置后的值:        | 0 | 0 | 0 | 0 | 0 | 0          | 0 | 0 |

| Bit | Symbol     | Function   | R/W |
|-----|------------|--|-----|
| 2:0 | SLNDL[2:0] | SSL Negation Delay Setting<br>0 0 0: 1 RSPCK<br>0 0 1: 2 RSPCK<br>0 1 0: 3 RSPCK<br>0 1 1: 4 RSPCK<br>1 0 0: 5 RSPCK<br>1 0 1: 6 RSPCK<br>1 1 0: 7 RSPCK<br>1 1 1: 8 RSPCK | R/W |
| 7:3 | —          | These bits are read as 0. The write value should be 0.   | R/W |

SSLND specifies the SSL negation delay, the period from the transmission of a final RSPCK edge to the negation of the SSLni signal during a serial transfer by the SPI in master mode. If the contents of SSLND are changed while both the SPCR.MSTR and SPCR.SPE bits are 1, do not perform subsequent operations.

#### SLNDL[2:0] bits (SSL Negation Delay Setting)

The SLNDL[2:0] bits specify an SSL negation delay value when the SLNDEN bit in SPCMDn is 1 and the SPI is in master mode. When using the SPI in slave mode, set the SLNDL[2:0] bits to 000b.

### 30.2.12 SPND : SPI Next-Access Delay Register

Base address: SPI0 = 0x4011\_A000

Offset address: 0x0E

|                    |   |   |   |   |   |            |   |   |
|--------------------|---|---|---|---|---|------------|---|---|
| Bit position:      | 7 | 6 | 5 | 4 | 3 | 2          | 1 | 0 |
| Bit field:         | — | — | — | — | — | SPNDL[2:0] |   |   |
| Value after reset: | 0 | 0 | 0 | 0 | 0 | 0          | 0 | 0 |

| Bit | Symbol     | Function  | R/W |
|-----|------------|---|-----|
| 2:0 | SPNDL[2:0] | SPI Next-Access Delay Setting<br>0 0 0: 1 RSPCK + 2 PCLKA<br>0 0 1: 2 RSPCK + 2 PCLKA<br>0 1 0: 3 RSPCK + 2 PCLKA<br>0 1 1: 4 RSPCK + 2 PCLKA<br>1 0 0: 5 RSPCK + 2 PCLKA<br>1 0 1: 6 RSPCK + 2 PCLKA<br>1 1 0: 7 RSPCK + 2 PCLKA<br>1 1 1: 8 RSPCK + 2 PCLKA | R/W |
| 7:3 | —          | These bits are read as 0. The write value should be 0.  | R/W |

SPND specifies the next-access delay, the non-active period of the SSLni signal after termination of a serial transfer, when the SPCMDm.SPNDEN bit is 1.

#### SPNDL[2:0] bits (SPI Next-Access Delay Setting)

The SPNDL[2:0] bits specify a next-access delay when the SPCMDm.SPNDEN bit is 1. When using the SPI in slave mode, set the SPNDL[2:0] bits to 000b.

### 30.2.13 SPCR2 : SPI Control Register 2

Base address: SPI0 = 0x4011\_A000

Offset address: 0x0F

|                    |   |   |   |            |     |      |      |      |
|--------------------|---|---|---|------------|-----|------|------|------|
| Bit position:      | 7 | 6 | 5 | 4          | 3   | 2    | 1    | 0    |
| Bit field:         | — | — | — | SCKA<br>SE | PTE | SPIE | SPOE | SPPE |
| Value after reset: | 0 | 0 | 0 | 0          | 0   | 0    | 0    | 0    |

| Bit | Symbol     | Function  | R/W |
|-----|------------|---|-----|
| 2:0 | SLNDL[2:0] | SSL否定延迟设置<br>0 0 0: 1 RSPCK<br>0 0 1: 2 RSPCK<br>0 1 0: 3 RSPCK<br>0 1 1: 4 RSPCK<br>1 0 0: 5 RSPCK<br>1 0 1: 6 RSPCK<br>1 1 0: 7 RSPCK<br>1 1 1: 8 RSPCK | R/W |
| 7:3 | —          | 这些位被读取为0。写入值应为0。  | R/W |

SSLND指定SSL否定延迟，从传输最终RSPCK边缘到否定SPI在主模式下进行串行传输期间的SSLni信号。如果SSLND的内容发生更改，而SPCR.MSTR和SPCR.SPE位为1，不执行后续操作。

#### SLNDL[2:0]位 (SSL否定延迟设置)

当SPCMDn中的SLNDEN位为1且SPI处于主模式时，SLNDL[2:0]位指定SSL否定延迟值。在从机模式下使用SPI时，将SLNDL[2:0]位设置为000b。

### 30.2.12 SPND:SPI下一次访问延迟寄存器

Base address: SPI0 = 0x4011\_A000

Offset address: 0x0E

|               |   |   |   |   |   |            |   |   |
|---------------|---|---|---|---|---|------------|---|---|
| Bit position: | 7 | 6 | 5 | 4 | 3 | 2          | 1 | 0 |
| Bit field:    | — | — | — | — | — | SPNDL[2:0] |   |   |
| 重置后的值:        | 0 | 0 | 0 | 0 | 0 | 0          | 0 | 0 |

| Bit | Symbol     | Function   | R/W |
|-----|------------|--|-----|
| 2:0 | SPNDL[2:0] | SPI下一次访问延迟设置<br>0 0 0: 1 RSPCK + 2 PCLKA<br>0 0 1: 2 RSPCK + 2 PCLKA<br>0 1 0: 3 RSPCK + 2 PCLKA<br>0 1 1: 4 RSPCK + 2 PCLKA<br>1 0 0: 5 RSPCK + 2 PCLKA<br>1 0 1: 6 RSPCK + 2 PCLKA<br>1 1 0: 7 RSPCK + 2 PCLKA<br>1 1 1: 8 RSPCK + 2 PCLKA | R/W |
| 7:3 | —          | 这些位被读取为0。写入值应为0。   | R/W |

当SPMDm.SPNDEN位为1时，SPND指定下一次访问延迟，即串行传输终止后SSLni信号的非活动期。

#### SPNDL[2:0]位 (SPI下一次访问延迟设置)

当SPMDm.SPNDEN位为1时，SPNDL[2:0]位指定下一次访问延迟。在从机模式下使用SPI时，将SPNDL[2:0]位设置为000b。

### 30.2.13 SPCR2: SPI控制寄存器2

Base address: SPI0 = 0x4011\_A000

Offset address: 0x0F

|               |   |   |   |            |     |      |      |      |
|---------------|---|---|---|------------|-----|------|------|------|
| Bit position: | 7 | 6 | 5 | 4          | 3   | 2    | 1    | 0    |
| Bit field:    | — | — | — | SCKA<br>SE | PTE | SPIE | SPOE | SPPE |
| 重置后的值:        | 0 | 0 | 0 | 0          | 0   | 0    | 0    | 0    |

| Bit | Symbol | Function   | R/W |
|-----|--------|--|-----|
| 0   | SPPE   | Parity Enable<br>0: Do not add parity bit to transmit data and do not check parity bit of receive data<br>1: When SPCR.TXMD = 0: Add parity bit to transmit data and check parity bit of receive data<br>When SPCR.TXMD = 1: Add parity bit to transmit data but do not check parity bit of receive data | R/W |
| 1   | SPOE   | Parity Mode<br>0: Select even parity for transmission and reception<br>1: Select odd parity for transmission and reception   | R/W |
| 2   | SPIIE  | SPI Idle Interrupt Enable<br>0: Disable idle interrupt requests<br>1: Enable idle interrupt requests   | R/W |
| 3   | PTE    | Parity Self-Testing<br>0: Disable self-diagnosis function of the parity circuit<br>1: Enable self-diagnosis function of the parity circuit   | R/W |
| 4   | SCKASE | RSPCK Auto-Stop Function Enable<br>0: Disable RSPCK auto-stop function<br>1: Enable RSPCK auto-stop function   | R/W |
| 7:5 | —      | These bits are read as 0. The write value should be 0.   | R/W |

**SPPE bit (Parity Enable)**

The SPPE bit enables or disables the parity function.

When the SPCR.TXMD bit is 0 and this bit is 1, the parity bit is added to transmit data and parity checking is performed for receive data.

When the SPCR.TXMD bit is 1 and this bit is 1, the parity bit is added to transmit data but parity checking is not performed for receive data.

**SPOE bit (Parity Mode)**

The SPOE bit specifies odd or even parity.

When even parity is set, parity bit addition is performed so that the total number of bits whose value is 1 in the transmit or receive character plus the parity bit is even. Similarly, when odd parity is set, parity bit addition is performed so that the total number of bits whose value is 1 in the transmit or receive character plus the parity bit is odd.

The SPOE bit is only valid when the SPPE bit is 1.

**SPIIE bit (SPI Idle Interrupt Enable)**

The SPIIE bit enables or disables the generation of SPI idle interrupt requests when an idle state is detected in the SPI and the SPSR.IDLNF flag clears is set to 0.

**PTE bit (Parity Self-Testing)**

The PTE bit enables self-diagnosis of the parity circuit to check whether the parity function is operating correctly.

**SCKASE bit (RSPCK Auto-Stop Function Enable)**

The SCKASE bit enables or disables the RSPCK auto-stop function. When this function is enabled, the RSPCK clock is stopped before an overrun error occurs, when data is received in master mode. For details, see [section 30.3.9.1. Overrun errors](#).

| Bit | Symbol | Function  | R/W |
|-----|--------|---|-----|
| 0   | SPPE   | 奇偶校验使能<br>0: 发送数据不添加奇偶校验位, 接收数据不校验校验位<br>1: 当SPCR.TXMD=0: 发送数据添加校验位, 接收数据校验校验位<br>当SPCR.TXMD=1: 添加校验位发送数据但不检查接收数据的奇偶校验位 | R/W |
| 1   | SPOE   | 奇偶校验模式<br>0: 发送和接收选择偶校验<br>1: 发送和接收选择奇校验  | R/W |
| 2   | SPIIE  | SPI空闲中断使能<br>0: 禁用空闲中断请求<br>1: 启用空闲中断请求   | R/W |
| 3   | PTE    | Parity Self-Testing<br>0: 禁用奇偶电路自诊断功能<br>1: 启用奇偶电路自诊断功能   | R/W |
| 4   | SCKASE | RSPCK自动停止功能启用<br>0: 禁用RSPCK自动停止功能<br>1: 启用RSPCK自动停止功能   | R/W |
| 7:5 | —      | 这些位被读取为0。写入值应为0。  | R/W |

**SPPE bit (Parity Enable)**

SPPE位启用或禁用奇偶校验功能。

当SPCR.TXMD位为0且该位为1时, 发送数据添加奇偶校验位, 接收数据执行奇偶校验。

当SPCR.TXMD位为1且该位为1时, 发送数据添加奇偶校验位, 但接收数据不执行奇偶校验。

**SPOE bit (Parity Mode)**

SPOE位指定奇校验或偶校验。

当设置了偶校验时, 执行奇偶校验位相加, 以使发送或接收字符中值为1的总位数加上奇偶校验位为偶数。类似地, 当设置奇校验时, 执行校验位相加, 使得发送或接收字符中值为1的位加上奇偶校验位的总数为奇数。

SPOE位仅在SPPE位为1时有效。

**SPIIE位 (SPI空闲中断允许)**

当在SPI中检测到空闲状态并且SPSR.IDLNF标志清除设置为0时, SPIIE位启用或禁用SPI空闲中断请求的生成。

**PTE bit (Parity Self-Testing)**

PTE位启用奇偶校验电路的自诊断, 以检查奇偶校验功能是否正常运行。

**SCKASE位 (RSPCK自动停止功能使能)**

SCKASE位启用或禁用RSPCK自动停止功能。启用此功能后, 在主机模式下接收数据时, RSPCK时钟会在发生溢出错误之前停止。有关详细信息, 请参见第30.3.9.1节。溢出错误。

## 30.2.14 SPCMDm : SPI Command Register m (m = 0 to 7)

Base address: SPI0 = 0x4011\_A000

Offset address: 0x10 + 0x02 × m

|                    |            |            |            |      |          |    |   |           |           |   |   |           |   |      |      |   |
|--------------------|------------|------------|------------|------|----------|----|---|-----------|-----------|---|---|-----------|---|------|------|---|
| Bit position:      | 15         | 14         | 13         | 12   | 11       | 10 | 9 | 8         | 7         | 6 | 5 | 4         | 3 | 2    | 1    | 0 |
| Bit field:         | SCKD<br>EN | SLND<br>EN | SPND<br>EN | LSBF | SPB[3:0] |    |   | SSLK<br>P | SSLA[2:0] |   |   | BRDV[1:0] |   | CPOL | CPHA |   |
| Value after reset: | 0          | 0          | 0          | 0    | 0        | 1  | 1 | 1         | 0         | 0 | 0 | 0         | 1 | 1    | 0    | 1 |

| Bit  | Symbol    | Function   | R/W |
|------|-----------|--|-----|
| 0    | CPHA      | RSPCK Phase Setting<br>0: Select data sampling on leading edge, data change on trailing edge<br>1: Select data change on leading edge, data sampling on trailing edge  | R/W |
| 1    | CPOL      | RSPCK Polarity Setting<br>0: Set RSPCK low during idle<br>1: Set RSPCK high during idle  | R/W |
| 3:2  | BRDV[1:0] | Bit Rate Division Setting<br>0 0: Base bit rate<br>0 1: Base bit rate divided by 2<br>1 0: Base bit rate divided by 4<br>1 1: Base bit rate divided by 8   | R/W |
| 6:4  | SSLA[2:0] | SSL Signal Assertion Setting<br>0 0 0: SSL0<br>0 0 1: SSL1<br>0 1 0: SSL2<br>0 1 1: SSL3<br>Others: Setting prohibited   | R/W |
| 7    | SSLKP     | SSL Signal Level Keeping<br>0: Negate all SSL signals on completion of transfer<br>1: Keep SSL signal level from the end of transfer until the beginning of the next access  | R/W |
| 11:8 | SPB[3:0]  | SPI Data Length Setting<br>0x0: 20 bits<br>0x1: 24 bits<br>0x2: 32 bits<br>0x3: 32 bits<br>0x8: 9 bits<br>0x9: 10 bits<br>0xA: 11 bits<br>0xB: 12 bits<br>0xC: 13 bits<br>0xD: 14 bits<br>0xE: 15 bits<br>0xF: 16 bits<br>Others: 8 bits | R/W |
| 12   | LSBF      | SPI LSB First<br>0: MSB-first<br>1: LSB-first  | R/W |
| 13   | SPNDEN    | SPI Next-Access Delay Enable<br>0: Select next-access delay of 1 RSPCK + 2 PCLKA<br>1: Select next-access delay equal to the setting in the SPI Next-Access Delay Register (SPND)  | R/W |
| 14   | SLNDEN    | SSL Negation Delay Setting Enable<br>0: Select SSL negation delay of 1 RSPCK<br>1: Select SSL negation delay equal to the setting in the SPI Slave Select Negation Delay Register (SSLND)  | R/W |

## 30.2.14 SPCMDm: SPI命令寄存器m (m=0到7)

Base address: SPI0 = 0x4011\_A000

Offset address: 0x10 + 0x02 × m

|               |            |            |            |      |          |    |   |           |           |   |   |           |   |      |      |   |
|---------------|------------|------------|------------|------|----------|----|---|-----------|-----------|---|---|-----------|---|------|------|---|
| Bit position: | 15         | 14         | 13         | 12   | 11       | 10 | 9 | 8         | 7         | 6 | 5 | 4         | 3 | 2    | 1    | 0 |
| Bit field:    | SCKD<br>EN | SLND<br>EN | SPND<br>EN | LSBF | SPB[3:0] |    |   | SSLK<br>P | SSLA[2:0] |   |   | BRDV[1:0] |   | CPOL | CPHA |   |
| 重置后的值:        | 0          | 0          | 0          | 0    | 0        | 1  | 1 | 1         | 0         | 0 | 0 | 0         | 1 | 1    | 0    | 1 |

| Bit  | Symbol    | Function   | R/W |
|------|-----------|--|-----|
| 0    | CPHA      | RSPCK相位设置<br>0: 选择前沿数据采样, 后沿数据变化<br>1: 选择前沿数据变化, 后沿数据采样  | R/W |
| 1    | CPOL      | RSPCK极性设置<br>0: 空闲时将RSPCK设置为低<br>1: 空闲时将RSPCK设置为高  | R/W |
| 3:2  | BRDV[1:0] | 比特率划分设置<br>00: 基本比特率<br>01: 基本比特率除以2<br>10: 基本比特率除以4<br>11: 基本比特率除以8   | R/W |
| 6:4  | SSLA[2:0] | SSL信号断言设置<br>0 0 0: SSL0<br>0 0 1: SSL1<br>0 1 0: SSL2<br>0 1 1: SSL3<br>其他: 禁止设置  | R/W |
| 7    | SSLKP     | SSL信号电平保持<br>0: 在传输完成时否定所有SSL信号<br>1: 从传输结束到下一次访问开始时保持SSL信号电平  | R/W |
| 11:8 | SPB[3:0]  | SPI数据长度设置<br>0x0: 20 bits<br>0x1: 24 bits<br>0x2: 32 bits<br>0x3: 32 bits<br>0x8: 9 bits<br>0x9: 10 bits<br>0xA: 11 bits<br>0xB: 12 bits<br>0xC: 13 bits<br>0xD: 14 bits<br>0xE: 15 bits<br>0xF: 16 bits<br>Others: 8 bits | R/W |
| 12   | LSBF      | SPI LSB优先<br>0: MSB-first<br>1: LSB-first  | R/W |
| 13   | SPNDEN    | SPI下一次访问延迟使能<br>0: 选择下一次访问延迟1RSPCK+2PCLKA<br>1: 选择下一次访问延迟等于SPI下一次访问延迟寄存器(SPND)中的设置   | R/W |
| 14   | SLNDEN    | SSL否定延迟设置启用<br>0: 选择SSL否定延迟1RSPCK<br>1: 选择SSL否定延迟等于SPI从选择否定延迟寄存器(SSLND)中的设置  | R/W |



| Bit | Symbol | Function   | R/W |
|-----|--------|--|-----|
| 15  | SCKDEN | RSPCK Delay Setting Enable<br>0: Select RSPCK delay of 1 RSPCK<br>1: Select RSPCK delay equal to the setting in the SPI Clock Delay Register (SPCKD) | R/W |

The SPCMDm registers specify the transfer format for the SPI in master mode. Each channel has eight SPCMDm (m = 0 to 7). Some of the bits in the SPCMD0 registers are used to set the transfer mode for the SPI in slave mode. The SPI in master mode sequentially references the SPCMDm registers based on the settings in the SPSCR.SPSSLN[2:0] bits and executes the serial transfer that is set in the referenced SPCMDm registers.

Set the SPCMDm registers while the transmit buffer is empty (SPSR.SPTEF is 1 and data for the next transfer is not set) and before the setting of the data to be transmitted when that SPCMDm registers is referenced.

The SPCMDm registers referenced by the SPI in master mode can be checked by means of the SPSSR.SPCP[2:0] bits.

#### CPHA bit (RSPCK Phase Setting)

The CPHA bit selects the RSPCK phase of the SPI in master or slave mode. Data communications between SPI modules require the same RSPCK phase setting between the modules.

#### CPOL bit (RSPCK Polarity Setting)

The CPOL bit selects the RSPCK polarity of the SPI in master or slave mode. Data communications between SPI modules require the same RSPCK polarity setting between the modules.

#### BRDV[1:0] bits (Bit Rate Division Setting)

The BRDV[1:0] bits determine the bit rate in combination with the settings in the SPBR register. (see [section 30.2.8. SPBR : SPI Bit Rate Register](#)). The SPBR settings determine the base bit rate. The BRDV[1:0] setting selects the bit rate obtained by dividing the base bit rate by 1, 2, 4, or 8. Different BRDV[1:0] bit settings can be specified in the SPCMD0 register. This enables execution of serial transfers at different bit rates for each command.

#### SSLA[2:0] bits (SSL Signal Assertion Setting)

The SSLA[2:0] bits control the SSLni signal assertion when the SPI performs serial transfers in master mode. When an SSLni signal is asserted, its polarity is determined by the value set in the associated SSLP. When the SSLA[2:0] bits are set to 000b in multi-master mode, serial transfers are performed with all the SSL signals in the negated state (as the SSLn0 pin acts as input).

When using the SPI in slave mode, set the SSLA[2:0] bits to 000b.

#### SSLKP bit (SSL Signal Level Keeping)

When the SPI in master mode performs a serial transfer, the SSLKP bit specifies whether the SSLni signal level for the current command is to be kept or negated between the SSL negation associated with the current command and the SSL assertion associated with the next command. Setting the SSLKP bit to 1 enables a burst transfer. For details, see [section 30.3.11.1. Master mode operation](#). When using the SPI in slave mode, set the SSLKP bit to 0.

#### SPB[3:0] bits (SPI Data Length Setting)

The SPB[3:0] bits specify the transfer data length for the SPI in master or slave mode.

#### LSBF bit (SPI LSB First)

The LSBF bit specifies the data format of the SPI in master or slave mode to MSB-first or LSB-first.

#### SPNDEN bit (SPI Next-Access Delay Enable)

The SPNDEN bit specifies the next-access delay, the period from the time the SPI in master mode terminates a serial transfer and sets the SSLni signal inactive until the SPI enables the SSLni signal assertion for the next access. If the SPNDEN bit is 0, the SPI sets the next-access delay to 1 RSPCK + 2 PCLKA. If the SPNDEN bit is 1, the SPI inserts a next-access delay according to the SPND setting.

When using the SPI in slave mode, set the SPNDEN bit to 0.

| Bit | Symbol | Function  | R/W |
|-----|--------|---|-----|
| 15  | SCKDEN | RSPCK延迟设置启用<br>0: 选择RSPCK延迟为1RSPCK1: 选择RSPCK延迟等于SPI时钟延迟寄存器(SPCKD)中的设置 | R/W |

SPCMDm寄存器指定主模式下SPI的传输格式。每个通道有8个SPCMDm (m=0到7)。SPCMD0寄存器中的一些位用于设置SPI在从机模式下的传输模式。主机模式下的SPI根据SPSCR.SPSSLN[2:0]位中的设置顺序引用SPCMDm寄存器，并执行在引用的SPCMDm寄存器中设置的串行传输。

在发送缓冲区为空时 (SPSR.SPTEF为1且未设置下一次传输的数据) 和设置要发送的数据之前，当引用该SPCMDm寄存器时设置SPCMDm寄存器。

SPI在主模式下引用的SPCMDm寄存器可以通过SPSSR.SPCP[2:0]位进行检查。

#### CPHA位 (RSPCK相位设置)

CPHA位在主模式或从模式下选择SPI的RSPCK相位。SPI模块之间的数据通信需要模块之间相同的RSPCK相位设置。

#### CPOL位 (RSPCK极性设置)

CPOL位在主模式或从模式下选择SPI的RSPCK极性。SPI模块之间的数据通信要求模块之间的RSPCK极性设置相同。

#### BRDV[1:0]位 (比特率划分设置)

BRDV[1:0]位结合SPBR寄存器中的设置确定比特率。(参见第30.2.8节。SPBR: SPI比特率寄存器)。SPBR设置决定了基本比特率。BRDV[1:0]设置选择通过将基本比特率除以1、2、4或8获得的比特率。可以在SPCMD0寄存器中指定不同的BRDV[1:0]位设置。这使得每个命令能够以不同的比特率执行串行传输。

#### SSLA[2:0]位 (SSL信号断言设置)

当SPI在主模式下执行串行传输时，SSLA[2:0]位控制SSLni信号断言。当一个SSLni信号被置位，其极性由相关SSLP中设置的值确定。当SSLA[2:0]位在多主机模式下设置为000b时，串行传输在所有SSL信号处于否定状态时执行 (因为SSLn0引脚用作输入)。

在从机模式下使用SPI时，将SSLA[2:0]位设置为000b。

#### SSLKP位 (SSL信号电平保持)

当主模式的SPI执行串行传输时，SSLKP位指定当前命令的SSLni信号电平是在与当前命令关联的SSL否定和与下一个命令关联的SSL断言之间保持还是否定。将SSLKP位设置为1可启用突发传输。有关详细信息，请参阅第30.3.11.1节。主模式操作。在从机模式下使用SPI时，将SSLKP位设置为0。

#### SPB[3:0]位 (SPI数据长度设置)

SPB[3:0]位指定SPI在主模式或从模式下的传输数据长度。

#### LSBF bit (SPI LSB First)

LSBF位指定SPI在主模式或从模式下的数据格式为MSB优先或LSB优先。

#### SPNDEN位 (SPI下一次访问延迟使能)

SPNDEN位指定下一次访问延迟，即从主模式下的SPI终止串行传输并将SSLni信号设置为无效到SPI为下一次访问启用SSLni信号断言的时间段。如果SPNDEN位为0，则SPI将下一次访问延迟设置为1RSPCK+2PCLKA。如果SPNDEN位为1，则SPI根据SPND设置插入下一次访问延迟。

在从机模式下使用SPI时，将SPNDEN位设置为0。

**SLNDEN bit (SSL Negation Delay Setting Enable)**

The SLNDEN bit specifies the SSL negation delay, the period from the time the SPI in master mode stops RSPCK oscillation until the SPI sets the SSLni signal to inactive. If the SLNDEN bit is 0, the SPI sets the SSL negation delay to 1 RSPCK. If the SLNDEN bit is 1, the SPI negates the SSL signal at the SSL negation delay according to the SSLND setting.

When using the SPI in slave mode, set the SLNDEN bit to 0.

**SCKDEN bit (RSPCK Delay Setting Enable)**

The SCKDEN bit specifies the SPI clock delay, the period from the point when the SPI in master mode asserts the SSLni signal until the RSPCK starts oscillation. If the SCKDEN bit is 0, the SPI sets the RSPCK delay to 1 RSPCK. If the SCKDEN bit is 1, the SPI starts the oscillation of RSPCK at an RSPCK delay according to the SPCKD setting.

When using the SPI in slave mode, set the SCKDEN bit to 0.

**30.2.15 SPDCR2 : SPI Data Control Register 2**

Base address: SPI0 = 0x4011\_A000

Offset address: 0x20

|                    |   |   |   |   |   |   |      |      |
|--------------------|---|---|---|---|---|---|------|------|
| Bit position:      | 7 | 6 | 5 | 4 | 3 | 2 | 1    | 0    |
| Bit field:         | — | — | — | — | — | — | SINV | BYSW |
| Value after reset: | 0 | 0 | 0 | 0 | 0 | 0 | 0    | 0    |

| Bit | Symbol | Function   | R/W |
|-----|--------|--|-----|
| 0   | BYSW   | Byte Swap Operating Mode Select<br>0: Byte Swap OFF<br>1: Byte Swap ON       | R/W |
| 1   | SINV   | Serial Data Invert Bit<br>0: Not invert serial data<br>1: Invert serial data | R/W |
| 7:2 | —      | These bits are read as 0. The write value should be 0.                       | R/W |

SPI Data Control Register 2 (SPDCR2) is the setting register, that is to swap a transmit/receive data in byte units and to invert serial data. If these bits are modified while the SPI in slave mode is enabled (SPCR.SPE = 1), subsequent operation is not guaranteed.

**BYSW bit (Byte Swap Operating Mode Select)**

It is a setting bit, that is to swap a transmit/receive data in byte units. When byte access is valid (SPDCR.SPBYT = 1), byte swap is invalid. When byte swap is valid, parity function must be invalid (SPCR2.SPPE bit = 0). Setting change of BYSW bit must be SPCR.SPE bit = 0.

A data after byte swap is different by a data length (setting of SPCMD.SPB[3:0]).

When byte swap, A data length (setting of SPB[3:0]) must be set to 32 bit or 16bit. Other case of data length (that is 8 to 15, 20, 24 bit length), byte swap is not guaranteed. Before swap and after swap are shown below (length data (32 bit/16 bit)).

- Length data 32 bits (SPB[3:0] = 0010b or 0011b)  
Before swap: [31:24] [23:16] [15:8] [7:0]  
After swap: [7:0] [15:8] [23:16] [31:24]
- Length data 16 bit (SPB[3:0] = 1111b)  
Before swap: [31:24] [23:16]  
After swap: [23:16] [31:24]

When byte access mode (SPDCR.SPBT = 1), byte swap setting is invalid.

When byte swap is valid, set parity function to invalid (SPCR2.SPPE = 0). When the parity function set to valid, the behavior is not guaranteed.

**SLNDEN位 (SSL否定延迟设置启用)**

SLNDEN位指定SSL否定延迟，即从主模式下的SPI停止RSPCK振荡到SPI将SSLni信号设置为无效的时间段。如果SLNDEN位为0，则SPI将SSL否定延迟设置为1RSPCK。如果SLNDEN位为1，则SPI根据SSLND设置在SSL否定延迟时否定SSL信号。

在从机模式下使用SPI时，将SLNDEN位设置为0。

**SCKDEN位 (RSPCK延迟设置使能)**

SCKDEN位指定SPI时钟延迟，即从主模式下的SPI断言SSLni信号到RSPCK开始振荡的周期。如果SCKDEN位为0，则SPI将RSPCK延迟设置为1RSPCK。如果SCKDEN位为1，则SPI根据SPCKD设置以RSPCK延迟启动RSPCK的振荡。

在从机模式下使用SPI时，将SCKDEN位设置为0。

**30.2.15 SPDCR2:SPI数据控制寄存器2**

Base address: SPI0 = 0x4011\_A000

Offset address: 0x20

|               |   |   |   |   |   |   |      |      |
|---------------|---|---|---|---|---|---|------|------|
| Bit position: | 7 | 6 | 5 | 4 | 3 | 2 | 1    | 0    |
| Bit field:    | — | — | — | — | — | — | SINV | BYSW |
| 重置后的值:        | 0 | 0 | 0 | 0 | 0 | 0 | 0    | 0    |

| Bit | Symbol | Function                              | R/W |
|-----|--------|---------------------------------------|-----|
| 0   | BYSW   | 字节交换操作模式选择<br>0: 字节交换关闭1<br>1: 字节交换开启 | R/W |
| 1   | SINV   | 串行数据反转位<br>0: 不反转串行数据1:<br>反转串行数据     | R/W |
| 7:2 | —      | 这些位被读取为0。写入值应为0。                      | R/W |

SPI数据控制寄存器2(SPDCR2)是设置寄存器，即以字节为单位交换发送接收数据和反转串行数据。如果在使能从模式下的SPI(SPCR.SPE=1)时修改这些位，则无法保证后续操作。

**BYSW位 (字节交换操作模式选择)**

它是一个设置位，即以字节为单位交换一个发送接收数据。当字节访问有效时 (SPDCR.SPBYT=1)，字节交换无效。当字节交换有效时，奇偶校验功能必须无效 (SPCR2.SPPE位=0)。BYSW位的设置更改必须是SPCR.SPE位=0。

字节交换后的数据因数据长度不同 (SPCMD.SPB[3:0]的设置)。

字节交换时，A数据长度 (SPB[3:0]的设置) 必须设置为32位或16位。其他数据长度情况 (即8到15、20、24位长度)，不保证字节交换。交换前和交换后如下所示 (长度数据 (32位16位))。

- 长度数据32位 (SPB[3:0]=0010b或0011b)  
Before swap: [31:24] [23:16] [15:8] [7:0]  
After swap: [7:0] [15:8] [23:16] [31:24]
- 长度数据16位 (SPB[3:0]=1111b)  
Before swap: [31:24] [23:16]  
After swap: [23:16] [31:24]

当字节访问模式 (SPDCR.SPBT=1) 时，字节交换设置无效。

当字节交换有效时，将奇偶校验功能设置为无效 (SPCR2.SPPE=0)。当奇偶校验函数设置为有效时，行为不被保证。

**SINV bit (Serial Data Invert Bit)**

This bit is used to invert transmit data and receive data.

When the SINV bit is set to 1, transmit buffer (SPTX) data is inverted to invert transmit data and receive data, and then the inverted data is stored in the receive buffer (SPRX). The parity bit is the value corresponding to the inverted transmission/reception data.

**30.2.16 SPCR3 : SPI Control Register 3**

Base address: SPI0 = 0x4011\_A000

Offset address: 0x21

|                    |   |   |   |            |   |   |      |       |
|--------------------|---|---|---|------------|---|---|------|-------|
| Bit position:      | 7 | 6 | 5 | 4          | 3 | 2 | 1    | 0     |
| Bit field:         | — | — | — | CENDI<br>E | — | — | BFDS | ETXMD |
| Value after reset: | 0 | 0 | 0 | 0          | 0 | 0 | 0    | 0     |

| Bit | Symbol | Function   | R/W |
|-----|--------|--|-----|
| 0   | ETXMD  | Extended Communication Mode Select<br>0: Full-duplex synchronous or transmit-only serial communications. [the SPCR.TXMD bit is enabled]<br>1: Receive-only serial communications in slave mode (SPCR.MSTR bit = 0). [the SPCR.TXMD bit is disabled]<br>Setting is prohibited in master mode (SPCR.MSTR bit = 1). | R/W |
| 1   | BFDS   | Between Burst Transfer Frames Delay Select<br>0: Delay (RSPCK delay, SSL negation delay and next-access delay) between frames is inserted in burst transfer.<br>1: Delay between frames is not inserted in burst transfer.   | R/W |
| 3:2 | —      | These bits are read as 0. The write value should be 0.   | R/W |
| 4   | CENDIE | RSPI Communication End Interrupt Enable<br>0: Communication end interrupt request is disabled.<br>1: Communication end interrupt request is enabled.   | R/W |
| 7:5 | —      | These bits are read as 0. The write value should be 0.   | R/W |

SPI control register 3 (SPCR3) is control register for operation mode. If you change the value of ETXMD and BFDS when the SPCR.SPE bit is 1, the SPI operation does not guarantee.

**ETXMD bit (Extended Communication Mode Select)**

This bit is valid on slave mode only (the SPCR.MSTR bit is 0). This bit select receive only operation. When the ETXMD bit is 1 on slave mode, the communication is only received not transmit (see [section 30.3.6. Data Transfer Modes](#)). When the ETXMD is 1, transmit data empty interrupt can not be used.

The communication state by each mode (master mode, slave mode) is shown as below. It is controlled by the ETXMD bit, the SPCR.MSTR bit and the TXMD bit.

**Table 30.4 RSPI communication state (master/slave mode)**

| SPCR.MSTR bit | SPCR3.ETXMD bit | SPCR.TXMD bit | Communication state                   |
|---------------|-----------------|---------------|---------------------------------------|
| 1             | 0               | 0             | Transmit-receive master mode          |
| 1             | 0               | 1             | Transmit master mode                  |
| 0             | 0               | 0             | Transmit-receive slave mode (default) |
| 0             | 0               | 1             | Transmit slave mode                   |
| 0             | 1               | —             | Receive slave mode                    |

**BFDS bit (Between Burst Transfer Frames Delay Select)**

This bit controls whether insert the delay time between the burst transfer frames.

This bit is valid when the SPCMD.SSLKP bit is 1 in master mode (the SPCR.MSTR bit is 1).

**SINV位 (串行数据反转位)**

该位用于反转发送数据和接收数据。

当SINV位设置为1时，发送缓冲器(SPTX)数据反转以反转发送数据和接收数据，然后将反转的数据存储在接收缓冲器(SPRX)中。奇偶校验位是对应于反转的发送接收数据的值。

**30.2.16 SPCR3：SPI控制寄存器3**

Base address: SPI0 = 0x4011\_A000

Offset address: 0x21

|               |   |   |   |            |   |   |      |       |
|---------------|---|---|---|------------|---|---|------|-------|
| Bit position: | 7 | 6 | 5 | 4          | 3 | 2 | 1    | 0     |
| Bit field:    | — | — | — | CENDI<br>E | — | — | BFDS | ETXMD |
| 重置后的值:        | 0 | 0 | 0 | 0          | 0 | 0 | 0    | 0     |

| Bit | Symbol | Function  | R/W |
|-----|--------|---|-----|
| 0   | ETXMD  | 扩展通信模式选择<br>0: 全双工同步或仅传输串行通信。[启用SPCR.TXMD位]<br>1: 从机模式下仅接收串行通信 (SPCR.MSTR位=0)。[SPCR.TXMD位禁用]主机模式下禁止设置 (SPCR.MSTR位=1)。 | R/W |
| 1   | BFDS   | 突发传输帧之间延迟选择<br>0: 在突发传输中插入帧之间的延迟 (RSPCK延迟、SSL否定延迟和下一次访问延迟)。<br>1: 突发传输中不插入帧间延迟。                                       | R/W |
| 3:2 | —      | 这些位被读取为0。写入值应为0。  | R/W |
| 4   | CENDIE | RSPI通信结束中断使能<br>0: 禁止通讯结束中断请求。1: 使能通信结束中断请求。  | R/W |
| 7:5 | —      | 这些位被读取为0。写入值应为0。  | R/W |

SPI控制寄存器3(SPCR3)是操作模式的控制寄存器。如果在SPCR.SPE位为1时更改ETXMD和BFDS的值，则SPI操作不保证。

**ETXMD位 (扩展通信模式选择)**

该位仅在从模式下有效 (SPCR.MSTR位为0)。该位选择只接收操作。当ETXMD位在从机模式下为1时，通信只接收不发送 (参见第30.3.6节。数据传输模式)。当ETXMD为1时，不能使用发送数据空中断。

各模式 (主模式、从模式) 的通信状态如下所示。它由ETXMD位、SPCR.MSTR位和TXMD位控制。

**Table 30.4 RSPI通信状态 (主从模式)**

| SPCR.MSTR bit | SPCR3.ETXMD bit | SPCR.TXMD bit | 通讯状态         |
|---------------|-----------------|---------------|--------------|
| 1             | 0               | 0             | 收发主模式        |
| 1             | 0               | 1             | 传输主模式        |
| 0             | 0               | 0             | 发送接收从模式 (默认) |
| 0             | 0               | 1             | 传输从模式        |
| 0             | 1               | —             | 接收从机模式       |

**BFDS位 (突发传输帧之间延迟选择)**

该位控制是否在突发传输帧之间插入延迟时间。

当SPCMD.SSLKP位在主机模式下为1 (SPCR.MSTR位为1) 时，该位有效。



This bit should be set to 0 in slave mode. The usage of SSL delay control between transfer frames is shown as below. See (4)Burst transfers in detail.

**Table 30.5 Usage of SSL delay control between transfer frames (Master mode)**

| Transmit                                    |   | SPCMD.SSLK P bit | SPCR3.BFDS bit | SSL delay control register*1 (RSPCK clock delay, SSL negation delay, next access delay)   |
|---|---|------------------|----------------|---|
| Non-burst transmit                          |   | 0                | 0              | Any given value. You can control each delay value according to setting for RSPCK clock delay, SSL negation delay and next access delay.   |
| Burst transmit with delay between frames    | From the 1st frame to the last previous frame | 1                | 0              |   |
|   | The last frame                                | 0                | 0              |   |
| Burst transmit with no delay between frames | From the 1st frame to the last previous frame | 1                | 1              | Any given value. But delay is inserted only below. <ul style="list-style-type: none"> <li>RSPCK clock delay of the 1st frame</li> <li>SSL negation delay and next access delay of the last frame</li> </ul> |
|   | The last frame                                | 0                | 1              |   |

Note 1. Whether the setting value of following bits are valid or not depends on the setting value of the SPCMD.SPNDEN bit (see section 30.2.14. SPCMDm : SPI Command Register m (m = 0 to 7)).  
The SPCKD.SCKDL[2:0] bits: RSPCK delay  
The SSLND.SLNDL[2:0] bits: SSL negate delay  
The SPND.SPNDL[2:0] bits: Next access delay

#### CENDIE bit (RSPI Communication End Interrupt Enable)

This bit controls generation of a communication end interrupt request.

### 30.3 Operation

In this section, the serial transfer period refers to the period from the beginning of driving valid data to the fetching of the final valid data.

#### 30.3.1 Overview of SPI Operation

The SPI is capable of synchronous serial transfers in the following modes:

- Slave mode (SPI operation)
- Single master mode (SPI operation)
- Multi-master mode (SPI operation)
- Slave mode (clock synchronous operation)
- Master mode (clock synchronous operation)

The SPI mode can be selected by using the MSTR, MODFEN, and SPMS bits in SPCR. Table 30.6 lists the relationship between SPI modes and SPCR settings, and a description of each mode.

**Table 30.6 Relationship between SPCR settings and SPI modes (1 of 2)**

| Mode               | Slave (SPI operation) | Single-master (SPI operation) | Multi-master (SPI operation) | Slave (clock synchronous operation) | Master (clock synchronous operation) |
|--------------------|-----------------------|-------------------------------|------------------------------|-------------------------------------|--------------------------------------|
| MSTR bit setting   | 0                     | 1                             | 1                            | 0                                   | 1                                    |
| MODFEN bit setting | 0 or 1                | 0                             | 1                            | 0                                   | 0                                    |
| SPMS bit setting   | 0                     | 0                             | 0                            | 1                                   | 1                                    |
| RSPCKn pins        | Input                 | Output                        | Output/Hi-Z                  | Input                               | Output                               |
| MOSIn pin          | Input                 | Output                        | Output/Hi-Z                  | Input                               | Output                               |
| MISOOn pin         | Output/Hi-Z           | Input                         | Input                        | Output                              | Input                                |

在从机模式下，该位应设置为0。传输帧之间的SSL延迟控制的使用如下所示。详见(4)突发传输。

**Table 30.5 传输帧之间使用SSL延迟控制（主模式）**

| Transmit           |           | SPCMD.SSLK P bit | SPCR3.BFDS bit | SSL延迟控制寄存器*1 (RSPCK时钟延迟、SSL否定延迟、下一次访问延迟)                       |
|--------------------|-----------|------------------|----------------|--|
| Non-burst transmit |           | 0                | 0              | 任何给定的值。您可以根据对RSPCK时钟延迟、SSL否定延迟和下一次访问延迟的设置来控制每个延迟值。             |
| 帧之间有延迟的突发传输        | 从第一帧到最后一帧 | 1                | 0              |  |
|                    | 最后一帧      | 0                | 0              |  |
| 帧间无延迟的突发传输         | 从第一帧到最后一帧 | 1                | 1              | 任何给定的值。但是延迟只在下面插入。●<br>第一帧的RSPCK时钟延迟<br>● 最后一帧的SSL否定延迟和下一次访问延迟 |
|                    | 最后一帧      | 0                | 1              |  |

注1.以下位的设置值是否有效取决于SPCMD.SPNDEN位的设置值（参见第30.2.14节。SPCMDm：SPI命令寄存器m（m=0至7））。SPCKD.SCKDL[2:0]位：RSPCK延迟

SSLND.SLNDL[2:0]位：SSL否定延迟SPND.SPNDL[2:0]位：下一次访问延迟

#### CENDIE位（RSPI通信结束中断使能）

该位控制通信结束中断请求的产生。

### 30.3 Operation

在本节中，串行传输周期是指从开始驱动有效数据到获取最终有效数据的周期。

#### 30.3.1 SPI操作概述

SPI能够在以下模式下进行同步串行传输：

- 从机模式（SPI操作）
- 单主模式（SPI操作）
  - Multi-master mode (SPI operation)
- 从机模式（时钟同步操作）
- 主模式（时钟同步操作）

可以使用SPCR中的MSTR、MODFEN和SPMS位选择SPI模式。表30.6列出了SPI模式和SPCR设置之间的关系，以及每种模式的说明。

**Table 30.6 SPCR设置和SPI模式之间的关系(1 of 2)**

| Mode        | Slave (SPI operation) | Single-master (SPI operation) | Multi-master (SPI operation) | 从机（时钟同步操作） | 主控（时钟同步操作） |
|-------------|-----------------------|-------------------------------|------------------------------|------------|------------|
| MSTR位设置     | 0                     | 1                             | 1                            | 0          | 1          |
| MODFEN位设置   | 0 or 1                | 0                             | 1                            | 0          | 0          |
| SPMS位设置     | 0                     | 0                             | 0                            | 1          | 1          |
| RSPCKn pins | Input                 | Output                        | Output/Hi-Z                  | Input      | Output     |
| MOSIn pin   | Input                 | Output                        | Output/Hi-Z                  | Input      | Output     |
| MISOOn pin  | Output/Hi-Z           | Input                         | Input                        | Output     | Input      |



Table 30.6 Relationship between SPCR settings and SPI modes (2 of 2)

| Mode                            | Slave (SPI operation)                 | Single-master (SPI operation)   | Multi-master (SPI operation)  | Slave (clock synchronous operation) | Master (clock synchronous operation)  |
|---------------------------------|---------------------------------------|---|---|-------------------------------------|---|
| SSLn0 pins                      | Input                                 | Output  | Input   | Hi-Z <sup>1</sup>                   | Hi-Z <sup>1</sup>   |
| SSLn1 to SSLn3 pins             | Hi-Z <sup>1</sup>                     | Output  | Output/Hi-Z   | Hi-Z <sup>1</sup>                   | Hi-Z <sup>1</sup>   |
| SSL polarity change function    | Supported                             | Supported   | Supported   | —                                   | —   |
| Max transfer rate               | PCLKA/4                               | PCLKA/2   | PCLKA/2   | PCLKA/4                             | PCLKA/2   |
| Clock source                    | RSPCK input                           | On-chip baud rate generator   | On-chip baud rate generator   | RSPCK input                         | On-chip baud rate generator   |
| Clock polarity                  | Two                                   |   |   |                                     |   |
| Clock phase                     | Two                                   | Two   | Two   | One (CPHA = 1)                      | Two   |
| First transfer bit              | MSB/LSB                               |   |   |                                     |   |
| Transfer data length            | 8 to 16, 20, 24, 32 bits              |   |   |                                     |   |
| Burst transfer                  | Possible (CPHA = 1)                   | Possible (CPHA = 0, 1)  | Possible (CPHA = 0, 1)  | —                                   | —   |
| RSPCK delay control             | Not supported                         | Supported   | Supported   | Not supported                       | Supported   |
| SSL negation delay control      | Not supported                         | Supported   | Supported   | Not supported                       | Supported   |
| Next-access delay control       | Not supported                         | Supported   | Supported   | Not supported                       | Supported   |
| Transfer trigger                | SSL input active or RSPCK oscillation | Write to transmit buffer on generation of transmit buffer empty interrupt request (SPTEF = 1) | Write to transmit buffer on generation of transmit buffer empty interrupt request (SPTEF = 1) | RSPCK oscillation                   | Write to transmit buffer on generation of transmit buffer empty interrupt request (SPTEF = 1) |
| Sequence control                | Not supported                         | Supported   | Supported   | Not supported                       | Supported   |
| Transmit buffer empty detection | Supported <sup>5</sup>                |   |   |                                     |   |
| Receive buffer full detection   | Supported <sup>2</sup>                |   |   |                                     |   |
| Overrun error detection         | Supported <sup>2</sup>                | Supported <sup>2*4</sup>  | Supported <sup>2*4</sup>  | Supported <sup>2</sup>              | Supported <sup>2</sup>  |
| Parity error detection          | Supported <sup>3*2</sup>              |   |   |                                     |   |
| Mode fault error detection      | Supported (MODFEN = 1)                | Not supported   | Supported   | Not supported                       | Not supported   |
| Underrun error detection        | Supported <sup>5</sup>                | Not supported   | Not supported   | Supported <sup>5</sup>              | Not supported   |

Note 1. This function is not supported in this mode.

Note 2. When the SPCR.TXMD bit is 1, detection of receiver buffer full, overrun error, and parity error are not performed.

Note 3. When the SPCR2.SPPE bit is 0, parity error detection is not performed.

Note 4. When the SPCR2.SCKASE bit is 1, overrun error detection does not proceed.

Note 5. When SPI is receive only slave mode, none of transmit buffer empty and underrun error is detected.

### 30.3.2 Controlling the SPI Pins

Based on the settings of the MSTR, MODFEN, and SPMS bits in SPCR and the PmnPFS.NCODR bit for I/O Ports, the SPI can switch pin states. Table 30.7 lists the relationship between pin states and bit settings. Setting the PmnPFS.NCODR bit for an I/O port to 0 selects the CMOS output. Setting it to 1 selects the open-drain output. The I/O port settings must follow this relationship.

Table 30.6 SPCR设置和SPI模式之间的关系(2of2)

| Mode          | Slave (SPI operation)    | Single-master (SPI operation)    | Multi-master (SPI operation)     | 从机 (时钟同步操作)            | 主控 (时钟同步操作)                      |
|---------------|--------------------------|----------------------------------|----------------------------------|------------------------|----------------------------------|
| SSLn0 pins    | Input                    | Output                           | Input                            | Hi-Z <sup>1</sup>      | Hi-Z <sup>1</sup>                |
| SSLn1到SSLn3引脚 | Hi-Z <sup>1</sup>        | Output                           | Output/Hi-Z                      | Hi-Z <sup>1</sup>      | Hi-Z <sup>1</sup>                |
| SSL极性改变功能     | Supported                | Supported                        | Supported                        | —                      | —                                |
| 最大传输率         | PCLKA/4                  | PCLKA/2                          | PCLKA/2                          | PCLKA/4                | PCLKA/2                          |
| 时钟源           | RSPCK input              | 片上波特率发生器                         | 片上波特率发生器                         | RSPCK input            | 片上波特率发生器                         |
| 时钟极性          | Two                      |                                  |                                  |                        |                                  |
| 时钟相位          | Two                      | Two                              | Two                              | One (CPHA = 1)         | Two                              |
| 第一个传输位        | MSB/LSB                  |                                  |                                  |                        |                                  |
| 传输数据长度        | 8至16、20、24、32位           |                                  |                                  |                        |                                  |
| 突发传输          | Possible (CPHA = 1)      | Possible (CPHA = 0, 1)           | Possible (CPHA = 0, 1)           | —                      | —                                |
| RSPCK延迟控制     | 不支持                      | Supported                        | Supported                        | 不支持                    | Supported                        |
| SSL否定延迟控制     | 不支持                      | Supported                        | Supported                        | 不支持                    | Supported                        |
| 下一次访问延迟控制     | 不支持                      | Supported                        | Supported                        | 不支持                    | Supported                        |
| 转移触发          | SSL输入有效或RSPCK振荡          | 在产生发送缓冲区空中断请求时写入发送缓冲区(SPTEF = 1) | 在产生发送缓冲区空中断请求时写入发送缓冲区(SPTEF = 1) | RSPCK oscillation      | 在产生发送缓冲区空中断请求时写入发送缓冲区(SPTEF = 1) |
| 顺序控制          | 不支持                      | Supported                        | Supported                        | 不支持                    | Supported                        |
| 发送缓冲区空检测      | Supported <sup>5</sup>   |                                  |                                  |                        |                                  |
| 接收缓冲区满检测      | Supported <sup>2</sup>   |                                  |                                  |                        |                                  |
| 溢出错误检测        | Supported <sup>2</sup>   | Supported <sup>2*4</sup>         | Supported <sup>2*4</sup>         | Supported <sup>2</sup> | Supported <sup>2</sup>           |
| 奇偶校验错误检测      | Supported <sup>3*2</sup> |                                  |                                  |                        |                                  |
| 模式故障错误检测      | Supported (MODFEN = 1)   | 不支持                              | Supported                        | 不支持                    | 不支持                              |
| 欠载错误检测        | Supported <sup>5</sup>   | 不支持                              | 不支持                              | Supported <sup>5</sup> | 不支持                              |

注1.此模式不支持此功能。

注2.当SPCR.TXMD位为1时,不执行接收缓冲区满、溢出错误和奇偶校验错误的检测。

注3.当SPCR2.SPPE位为0时,不执行奇偶校验错误检测。

注4.当SPCR2.SCKASE位为1时,不进行溢出错误检测。

注5.当SPI为仅接收从机模式时,不会检测到发送缓冲区为空和欠载错误。

### 30.3.2 控制SPI引脚

根据SPCR中的MSTR、MODFEN和SPMS位以及IO端口的PmnPFS.NCODR位的设置, SPI可以切换引脚状态。表30.7列出了引脚状态和位设置之间的关系。将IO端口的PmnPFS.NCODR位设置为0可选择CMOS输出。将其设置为1选择开漏输出。IO端口设置必须遵循这种关系。

Table 30.7 Relationship between pin states and bit settings

| Mode   | Pin                            | Pin state*2                        |                                    |
|--|--------------------------------|------------------------------------|------------------------------------|
|  |                                | PmnPFS.NCODR bit for I/O ports = 0 | PmnPFS.NCODR bit for I/O ports = 1 |
| Single-master mode (SPI operation)<br>(MSTR = 1, MODFEN = 0, SPMS = 0)           | RSPCKn                         | CMOS output                        | Open-drain output                  |
|  | SSLn0 to SSLn3                 | CMOS output                        | Open-drain output                  |
|  | MOSIn                          | CMOS output                        | Open-drain output                  |
|  | MISO <sub>n</sub>              | Input                              | Input                              |
| Multi-master mode (SPI operation)<br>(MSTR = 1, MODFEN = 1, SPMS = 0)            | RSPCKn <sup>3</sup>            | CMOS output/Hi-Z                   | Open-drain output/Hi-Z             |
|  | SSLn0                          | Input                              | Input                              |
|  | SSLn1 to SSLn3 <sup>3</sup>    | CMOS output/Hi-Z                   | Open-drain output/Hi-Z             |
|  | MOSIn <sup>3</sup>             | CMOS output/Hi-Z                   | Open-drain output/Hi-Z             |
|  | MISO <sub>n</sub>              | Input                              | Input                              |
| Slave mode (SPI operation)<br>(MSTR = 0, SPMS = 0)                               | RSPCKn                         | Input                              | Input                              |
|  | SSLn0                          | Input                              | Input                              |
|  | SSLn1 to SSLn3 <sup>5</sup>    | Hi-Z <sup>1</sup>                  | Hi-Z <sup>1</sup>                  |
|  | MOSIn                          | Input                              | Input                              |
|  | MISO <sub>n</sub> <sup>4</sup> | CMOS output/Hi-Z                   | Open-drain output/Hi-Z             |
| Master mode<br>(clock synchronous operation)<br>(MSTR = 1, MODFEN = 0, SPMS = 1) | RSPCKn                         | CMOS output                        | Open-drain output                  |
|  | SSLn0 to SSLn3 <sup>5</sup>    | Hi-Z <sup>1</sup>                  | Hi-Z <sup>1</sup>                  |
|  | MOSIn                          | CMOS output                        | Open-drain output                  |
|  | MISO <sub>n</sub>              | Input                              | Input                              |
| Slave mode<br>(clock synchronous operation)<br>(MSTR = 0, SPMS = 1)              | RSPCKn                         | Input                              | Input                              |
|  | SSLn0 to SSLn3 <sup>5</sup>    | Hi-Z <sup>1</sup>                  | Hi-Z <sup>1</sup>                  |
|  | MOSIn                          | Input                              | Input                              |
|  | MISO <sub>n</sub>              | CMOS output                        | Open-drain output                  |

Note 1. This function is not supported in this mode.

Note 2. SPI settings are not reflected in multiplexed pins for which the SPI function is not selected.

Note 3. When SSLn0 is at the active level, the pin state is Hi-Z. Whether or not the input signal is at the active level determines the setting of the SSLP.SSL0P bit.

Note 4. When SSLn0 is at the non-active level or the SPCR.SPE bit is 0, the pin state is Hi-Z. Whether or not the input signal is at the active level determines the setting of the SSLP.SSL0P bit.

Note 5. These pins are available for use as I/O port pins.

The SPI in single-master mode (SPI operation) or multi-master mode (SPI operation) determines the MOSI signal values during the SSL negation period (including the SSL retention period during a burst transfer) based on the MOIFE and MOIFV bit settings in SPPCR, as listed in Table 30.8.

Table 30.8 MOSI signal value determination during SSL negation

| MOIFE bit | MOIFV bit | MOSIn signal value during SSL negation |
|-----------|-----------|--|
| 0         | 0, 1      | Final data from previous transfer      |
| 1         | 0         | Low                                    |
| 1         | 1         | High                                   |

Table 30.7 引脚状态和位设置之间的关系

| Mode   | Pin                            | 引脚状态*2               |                        |
|--|--------------------------------|----------------------|------------------------|
|  |                                | IO端口的PmnPFS.NCODR位=0 | IO端口的PmnPFS.NCODR位=1   |
| Single-master mode (SPI operation)<br>(MSTR = 1, MODFEN = 0, SPMS = 0) | RSPCKn                         | CMOS output          | Open-drain output      |
|  | SSLn0 to SSLn3                 | CMOS output          | Open-drain output      |
|  | MOSIn                          | CMOS output          | Open-drain output      |
|  | MISO <sub>n</sub>              | Input                | Input                  |
| Multi-master mode (SPI operation)<br>(MSTR = 1, MODFEN = 1, SPMS = 0)  | RSPCKn <sup>3</sup>            | CMOS output/Hi-Z     | Open-drain output/Hi-Z |
|  | SSLn0                          | Input                | Input                  |
|  | SSLn1 to SSLn3 <sup>3</sup>    | CMOS output/Hi-Z     | Open-drain output/Hi-Z |
|  | MOSIn <sup>3</sup>             | CMOS output/Hi-Z     | Open-drain output/Hi-Z |
|  | MISO <sub>n</sub>              | Input                | Input                  |
| 从机模式 (SPI操作) (MSTR=0, SPMS=0)  | RSPCKn                         | Input                | Input                  |
|  | SSLn0                          | Input                | Input                  |
|  | SSLn1 to SSLn3 <sup>5</sup>    | Hi-Z <sup>1</sup>    | Hi-Z <sup>1</sup>      |
|  | MOSIn                          | Input                | Input                  |
|  | MISO <sub>n</sub> <sup>4</sup> | CMOS output/Hi-Z     | Open-drain output/Hi-Z |
| 主模式 (时钟同步操作) (MSTR=1, MODFEN=0, SPMS=1)                                | RSPCKn                         | CMOS output          | Open-drain output      |
|  | SSLn0 to SSLn3 <sup>5</sup>    | Hi-Z <sup>1</sup>    | Hi-Z <sup>1</sup>      |
|  | MOSIn                          | CMOS output          | Open-drain output      |
|  | MISO <sub>n</sub>              | Input                | Input                  |
| 从机模式 (时钟同步操作) (MSTR=0, SPMS=1)   | RSPCKn                         | Input                | Input                  |
|  | SSLn0 to SSLn3 <sup>5</sup>    | Hi-Z <sup>1</sup>    | Hi-Z <sup>1</sup>      |
|  | MOSIn                          | Input                | Input                  |
|  | MISO <sub>n</sub>              | CMOS output          | Open-drain output      |

注1.此模式不支持此功能。

注2.SPI设置不反映在未选择SPI功能的复用引脚中。

注3.当SSLn0处于有效电平时，引脚状态为Hi-Z。输入信号是否处于活动电平决定SSLP.SSL0P位的设置。

注4.当SSLn0处于无效电平或SPCR.SPE位为0时，引脚状态为Hi-Z。输入信号是否处于活动电平决定SSLP.SSL0P位的设置。

注5.这些引脚可用作IO端口引脚。

单主机模式 (SPI操作) 或多主机模式 (SPI操作) 下的SPI根据中的MOIFE和MOIFV位设置确定SSL否定期间 (包括突发传输期间的SSL保留期间) 的MOSI信号值SPPCR, 如表30.8中所列。

Table 30.8 SSL否定期间的MOSI信号值确定

| MOIFE bit | MOIFV bit | SSL否定期间的MOSIn信号值 |
|-----------|-----------|------------------|
| 0         | 0, 1      | 上次传输的最终数据        |
| 1         | 0         | Low              |
| 1         | 1         | High             |

### 30.3.3 SPI System Configuration Examples

#### 30.3.3.1 Single-master/single-slave with the MCU as a master

Figure 30.5 shows a single-master/single-slave SPI system configuration example where the MCU is used as a master. In the single-master/single-slave configuration, the SSLn<sub>i</sub> outputs of the MCU (master) are not used. The SSL input of the SPI slave is fixed to the low level, and the SPI slave is maintained in the selected state.\*1

Note 1. In the transfer format configured when the SPCMDm.CPHA bit is 0, the SSL signal for some slave devices cannot be fixed to an active level. In this case, always connect the SSLn<sub>i</sub> output of the MCU to the SSL input of the slave device.

The MCU (master) drives the RSPCKn and MOSIn signals. The SPI slave drives the MISO signal.

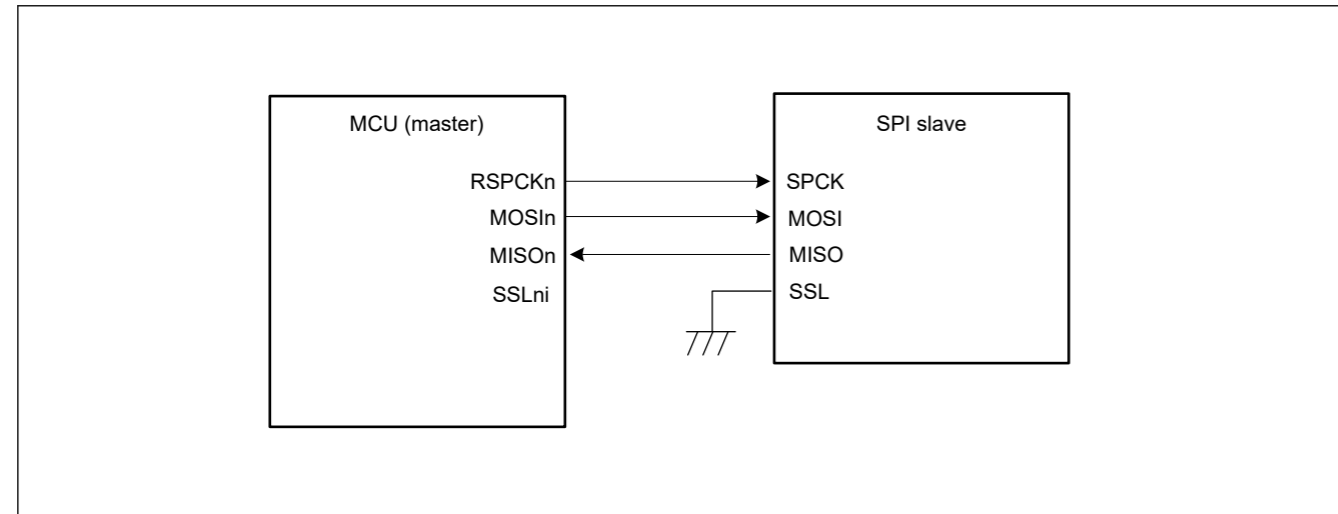


Figure 30.5 Single-master/single-slave configuration example with the MCU as a master

#### 30.3.3.2 Single-master/single-slave with the MCU as a slave

Figure 30.6 shows a single-master/single-slave SPI system configuration example where the MCU is used as a slave. When the MCU operates as a slave, the SSLn<sub>0</sub> pin is used as SSL input. The SPI master drives the RSPCK and MOSI signals. The MCU (slave) drives the MISO signal.\*1

Note 1. When SSLn<sub>0</sub> is at a non-active level, the pin state is Hi-Z.

In the single-slave configuration when the SPCMDm.CPHA bit is set to 1, the SSLn<sub>0</sub> input of the MCU (slave) is fixed to the low level and the MCU (slave) is maintained in the selected state. This enables serial transfer execution (Figure 30.7). However, the communication end interrupt does not output when SSL<sub>0</sub> input is fixed as Figure 30.7.

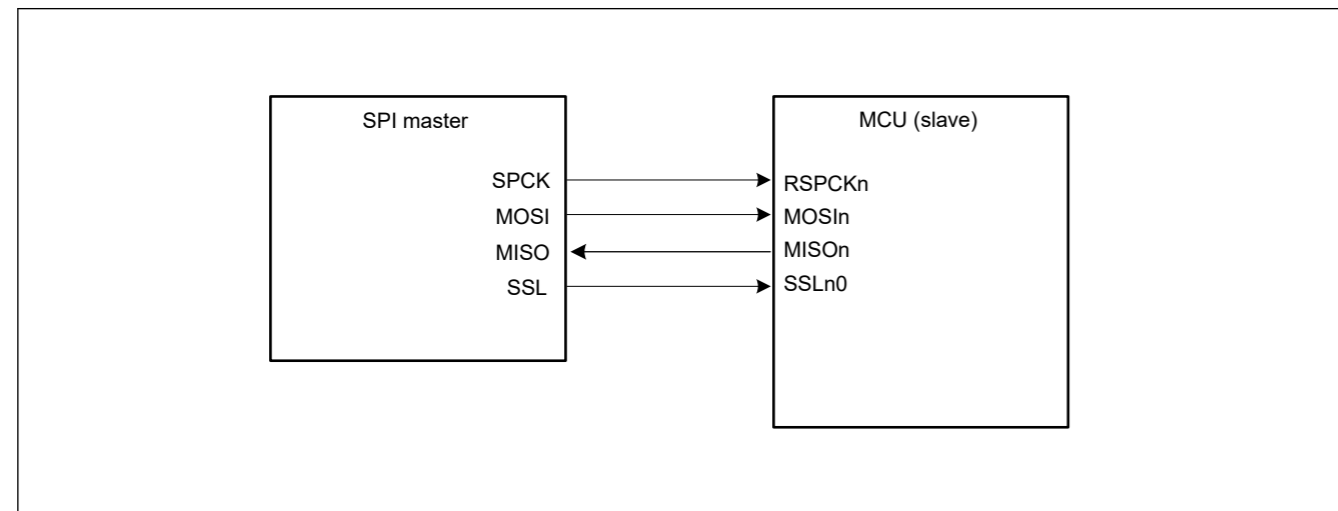


Figure 30.6 Single-master/single-slave configuration example with the MCU as a slave and CPHA = 0

### 30.3.3 SPI系统配置示例

#### 30.3.3.1 单主单从单片机为主

图30.5显示了单主单从SPI系统配置示例，其中MCU用作主机。在单主单从配置中，不使用MCU（主）的SSLn<sub>i</sub>输出。SPI从机的SSL输入固定为低电平，SPI从机保持在选中状态。\*1

注1.在SPCMDm.CPHA位为0时配置的传输格式中，某些从设备的SSL信号不能固定为有效电平。在这种情况下，请始终将MCU的SSLn<sub>i</sub>输出连接到从设备的SSL输入。

MCU（主控）驱动RSPCKn和MOSIn信号。SPI从机驱动MISO信号。

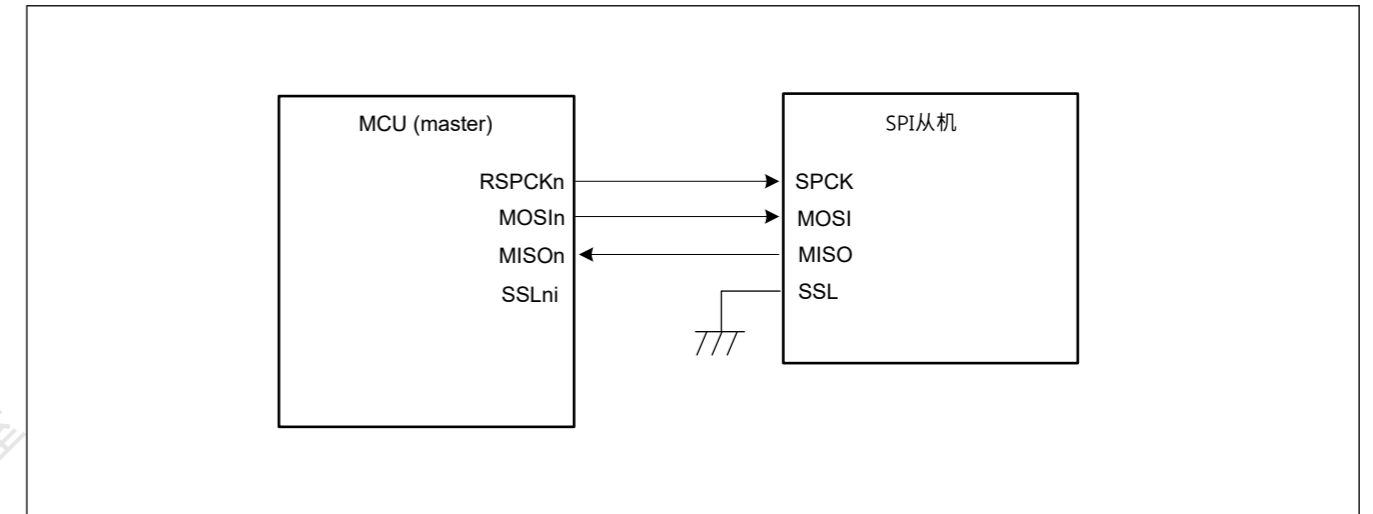


Figure 30.5 MCU为主的单主单从配置示例

#### 30.3.3.2 单主单从单片机作为从机

图30.6显示了单主单从SPI系统配置示例，其中MCU用作从机。当MCU作为从机运行时，SSLn<sub>0</sub>引脚用作SSL输入。SPI主机驱动RSPCK和MOSI信号。MCU（从机）驱动MISO信号。\*1

注1.当SSLn<sub>0</sub>处于非活动电平时，引脚状态为Hi-Z。

在单从机配置中，当SPCMDm.CPHA位设置为1时，MCU（从机）的SSLn<sub>0</sub>输入固定为低电平，MCU（从机）保持在选中状态。这将启用串行传输执行（图30.7）。但是，如图30.7那样固定SSL<sub>0</sub>输入时，不输出通信结束中断。

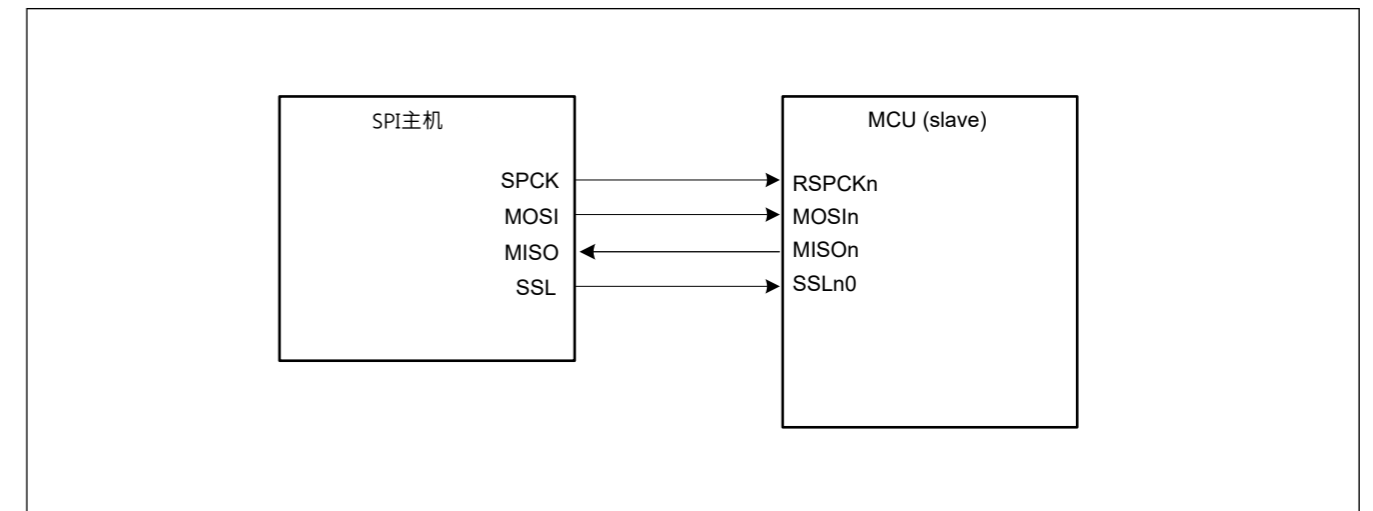


Figure 30.6 单主单从配置示例，单片机作为从机，CPHA=0

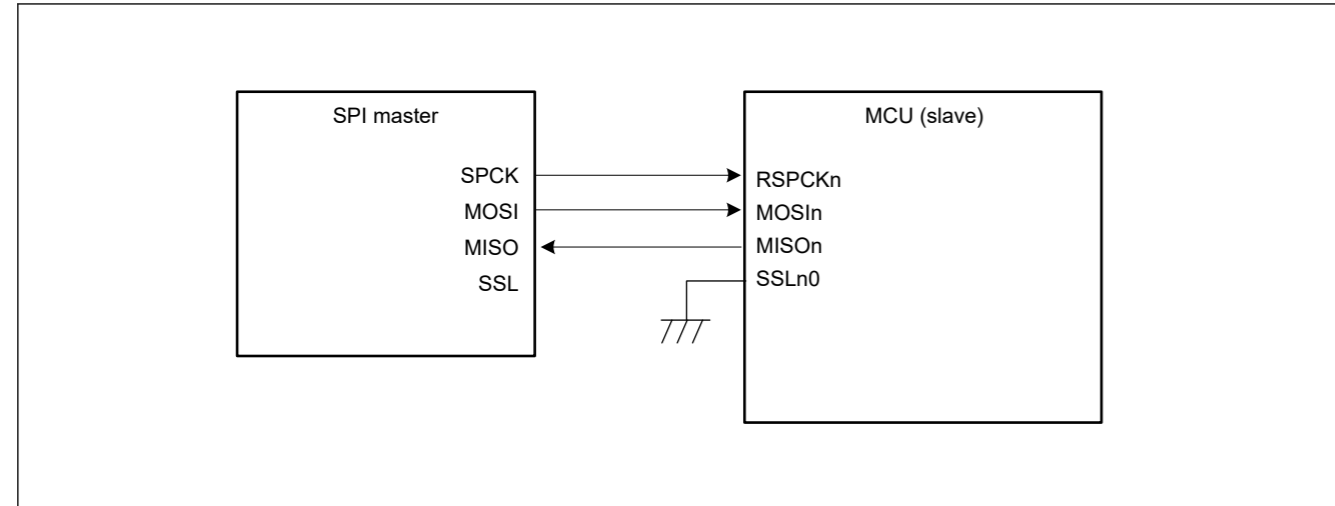


Figure 30.7 Single-master/single-slave configuration example with the MCU as a slave and CPHA = 1

### 30.3.3.3 Single-master/multi-slave with the MCU as a master

Figure 30.8 shows a single-master/multi-slave SPI system configuration example where the MCU is used as a master. In this example, the SPI system includes the MCU (master) and four slaves (SPI slave 0 to SPI slave 3).

The RSPCKn and MOSIn outputs of the MCU (master) are connected to the RSPCK and MOSI inputs of SPI slaves 0 to 3. The MISO outputs of SPI slaves 0 to 3 are all connected to the MISO input of the MCU (master). The SSLn0 to SSLn3 outputs of the MCU (master) are connected to the SSL inputs of SPI slaves 0 to 3, respectively.

The MCU (master) drives the RSPCKn, MOSIn, and SSLn0 to SSLn3 signals. Of the SPI slaves 0 to 3, the slave that receives low-level input into the SSL input drives the MISO signal.

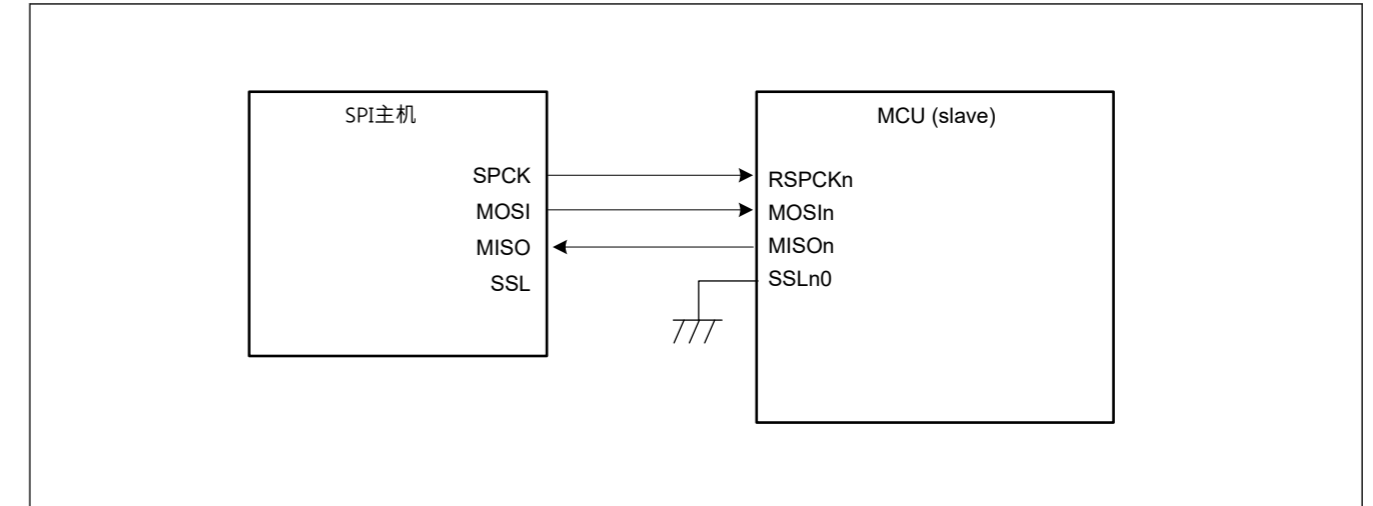


Figure 30.7 MCU作为从机且CPHA=1的单主单从配置示例

### 30.3.3.3 单主多从，单片机为主

图30.8显示了单主多从SPI系统配置示例，其中MCU用作主控。在本例中，SPI系统包括MCU（主机）和四个从机（SPI从机0到SPI从机3）。

MCU（主机）的RSPCKn和MOSIn输出连接到SPI从机0到3的RSPCK和MOSI输入。SPI从机0到3的MISO输出都连接到MCU（主机）的MISO输入。MCU（主机）的SSLn0到SSLn3输出分别连接到SPI从机0到3的SSL输入。

MCU（主控）驱动RSPCKn、MOSIn和SSLn0到SSLn3信号。在SPI从机0到3中，接收到SSL输入的低电平输入的从机驱动MISO信号。



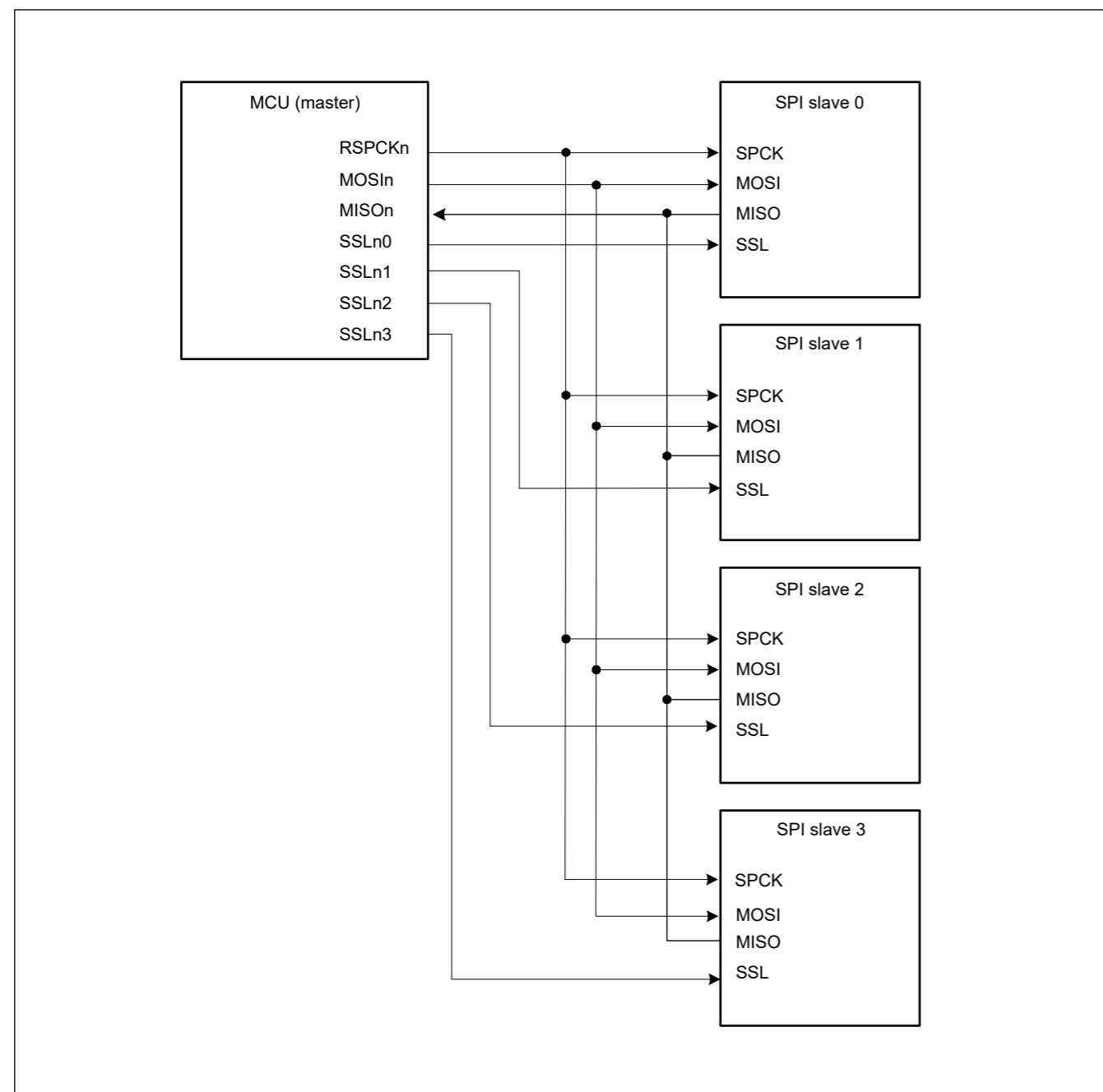


Figure 30.8 Single-master/multi-slave configuration example with the MCU as a master

30.3.3.4 Single-master/multi-slave with the MCU as a slave

Figure 30.9 shows a single-master/multi-slave SPI system configuration example where the MCU is used as a slave. In this example, the SPI system includes an SPI master and two MCUs (slaves X and Y).

The SPCK and MOSI outputs of the SPI master are connected to the RSPCKn and MOSIn inputs of the MCUs (slaves X and Y). The MISO outputs of the MCUs (slaves X and Y) are all connected to the MISO input of the SPI master. The SSLX and SSLY outputs of the SPI master are connected to the SSLn0 inputs of the MCUs (slaves X and Y, respectively).

The SPI master drives the SPCK, MOSI, SSLX, and SSLY signals. Of the MCUs (slaves X and Y), the slave that receives low-level input into the SSLn0 input drives the MISO signal.

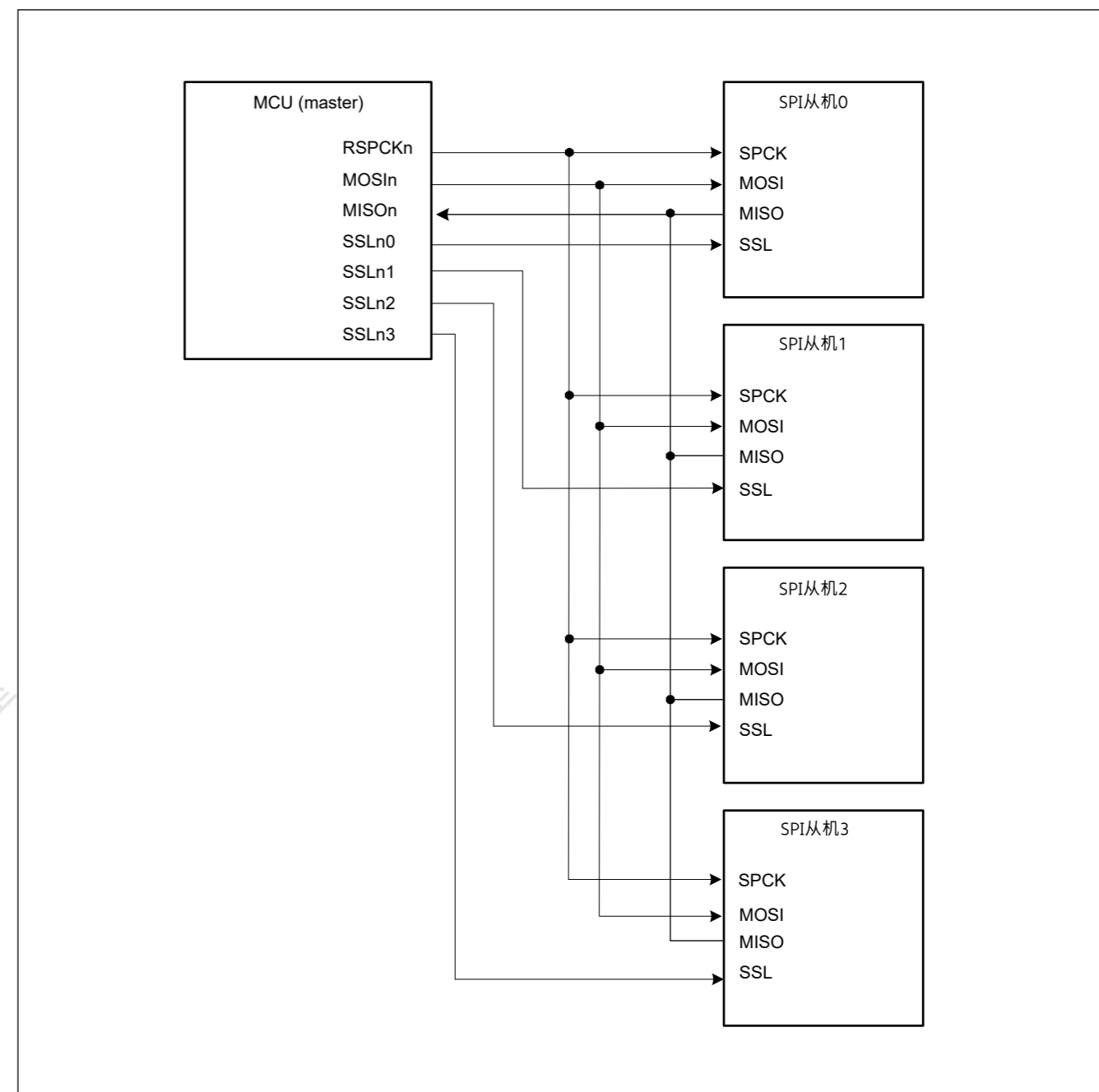


Figure 30.8 MCU为主的单主多从配置示例

30.3.3.4 单主多从，单片机作为从机

图30.9显示了单主多从SPI系统配置示例，其中MCU用作从设备。在本例中，SPI系统包括一个SPI主控和两个MCU（从属X和Y）。

SPI主机的SPCK和MOSI输出连接到MCU（从机X和Y）的RSPCKn和MOSIn输入。MCU（从机X和Y）的MISO输出都连接到SPI主机的MISO输入。SPI主机的SSLX和SSLY输出连接到MCU的SSLn0输入（分别为从机X和Y）。

SPI主机驱动SPCK、MOSI、SSLX和SSLY信号。在MCU（从机X和Y）中，接收到SSLn0输入的低电平输入的从机驱动MISO信号。

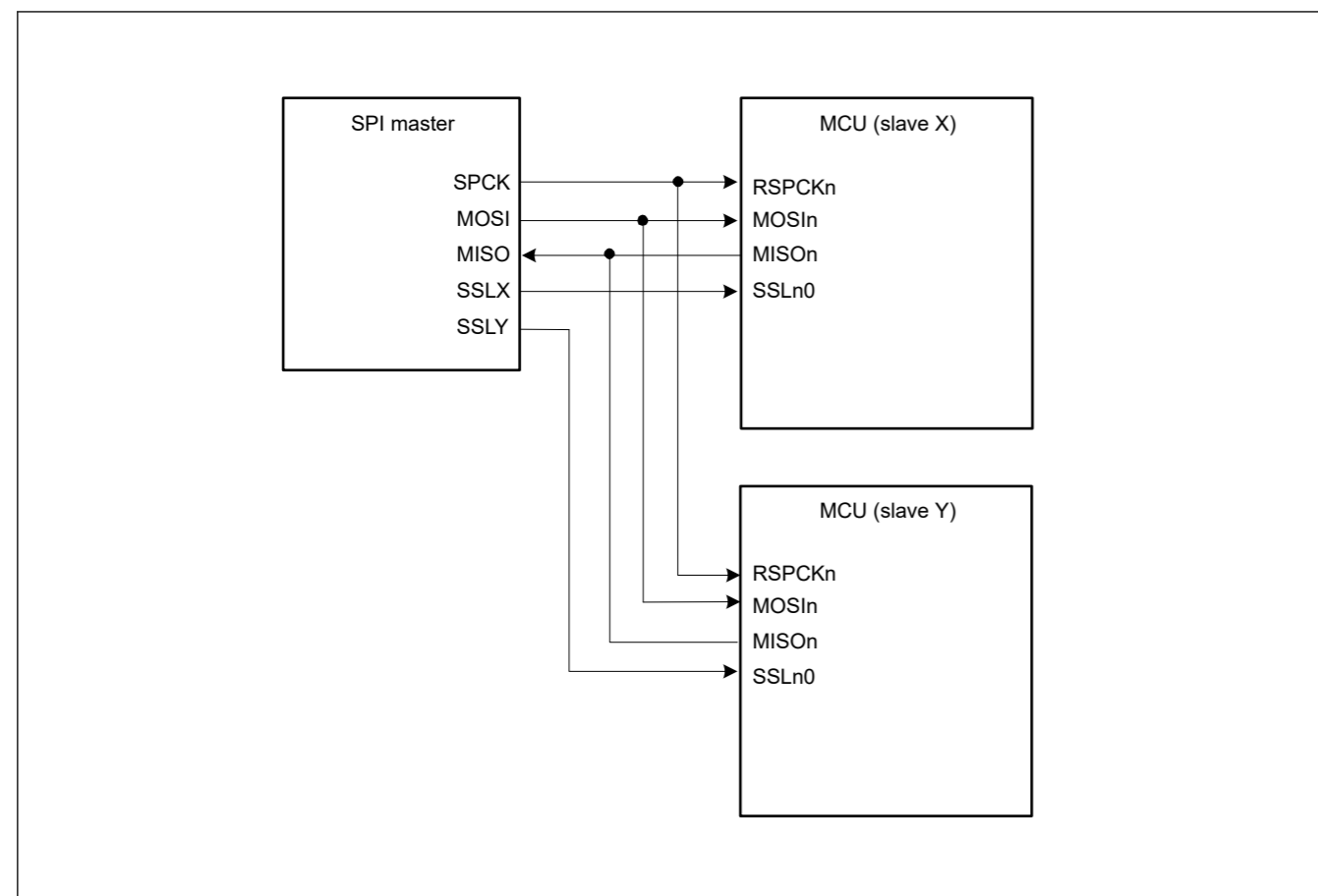


Figure 30.9 Single-master/multi-slave configuration example with the MCU as a slave

### 30.3.3.5 Multi-master/multi-slave with the MCU as a master

Figure 30.10 shows a multi-master/multi-slave SPI system configuration example where the MCU is used as a master. In this example, the SPI system includes two MCUs (masters X and Y) and two SPI slaves (SPI slaves 1 and 2).

The RSPCKn and MOSIn outputs of the MCUs (masters X and Y) are connected to the RSPCK and MOSI inputs of SPI slaves 1 and 2. The MISO outputs of SPI slaves 1 and 2 are connected to the MISOOn inputs of the MCUs (masters X and Y). Any generic port Y output from the MCU (master X) is connected to the SSLn0 input of the MCU (master Y). Any generic port X output of the MCU (master Y) is connected to the SSLn0 input of the MCU (master X). The SSLn1 and SSLn2 outputs of the MCUs (masters X and Y) are connected to the SSL inputs of the SPI slaves 1 and 2. In this configuration example, because the system can be comprised solely of SSLn0 input, and SSLn1 and SSLn2 outputs for slave connections, the SSLn3 output of the MCU is not required.

The MCU drives the RSPCKn, MOSIn, SSLn1, and SSLn2 signals when the SSLn0 input level is high. When the SSLn0 input level is low, the MCU detects a mode fault error, sets RSPCKn, MOSIn, SSLn1, and SSLn2 to Hi-Z, and releases the SPI bus directly to the other master. Of the SPI slaves 1 and 2, the slave that receives low-level input into the SSL input drives the MISO signal.

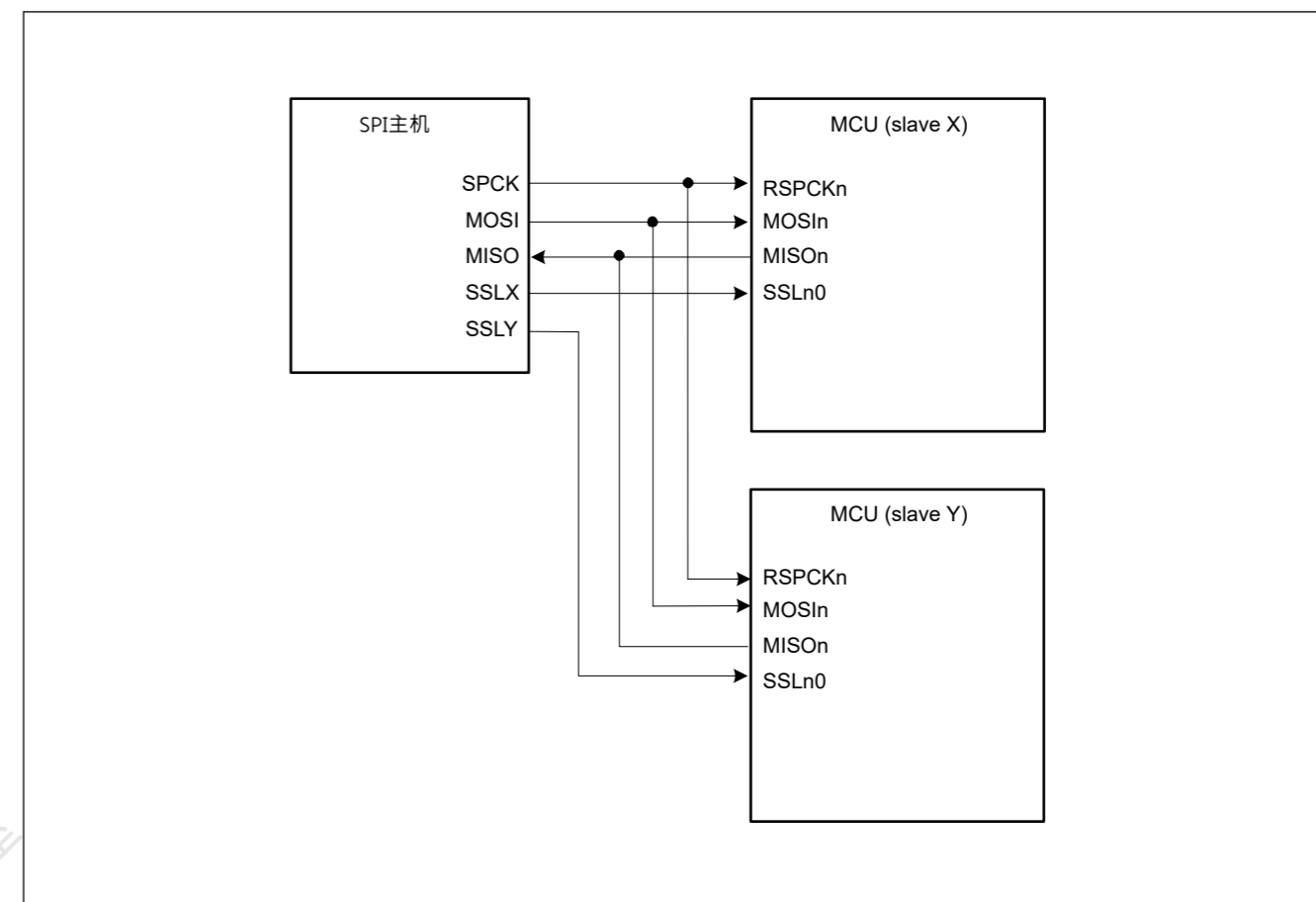


Figure 30.9 MCU作为从机的单主多从配置示例

### 30.3.3.5 以单片机为主的多主多从

图30.10显示了一个多主机多从机SPI系统配置示例，其中MCU用作主机。在此示例中，SPI系统包括两个MCU（主X和Y）和两个SPI从机（SPI从机1和2）。

MCU（主机X和Y）的RSPCKn和MOSIn输出连接到SPI从机1和2的RSPCK和MOSI输入。SPI从机1和2的MISO输出连接到MCU（主机X）的MISOOn输入和Y）。来自MCU（主X）的任何通用端口Y输出都连接到MCU（主Y）的SSLn0输入。MCU（主设备Y）的任何通用端口X输出都连接到MCU（主设备X）的SSLn0输入。MCU（主机X和Y）的SSLn1和SSLn2输出连接到SPI从机1和2的SSL输入。在此配置示例中，因为系统可以仅由SSLn0输入和SSLn1和SSLn2输出组成从连接，不需要MCU的SSLn3输出。

当SSLn0输入电平为高电平时，MCU驱动RSPCKn、MOSIn、SSLn1和SSLn2信号。当SSLn0输入电平为低时，MCU检测到模式故障错误，将RSPCKn、MOSIn、SSLn1和SSLn2设置为Hi-Z，并将SPI总线直接释放到另一个主控。在SPI从机1和2中，接收到SSL输入的低电平输入的从机驱动MISO信号。

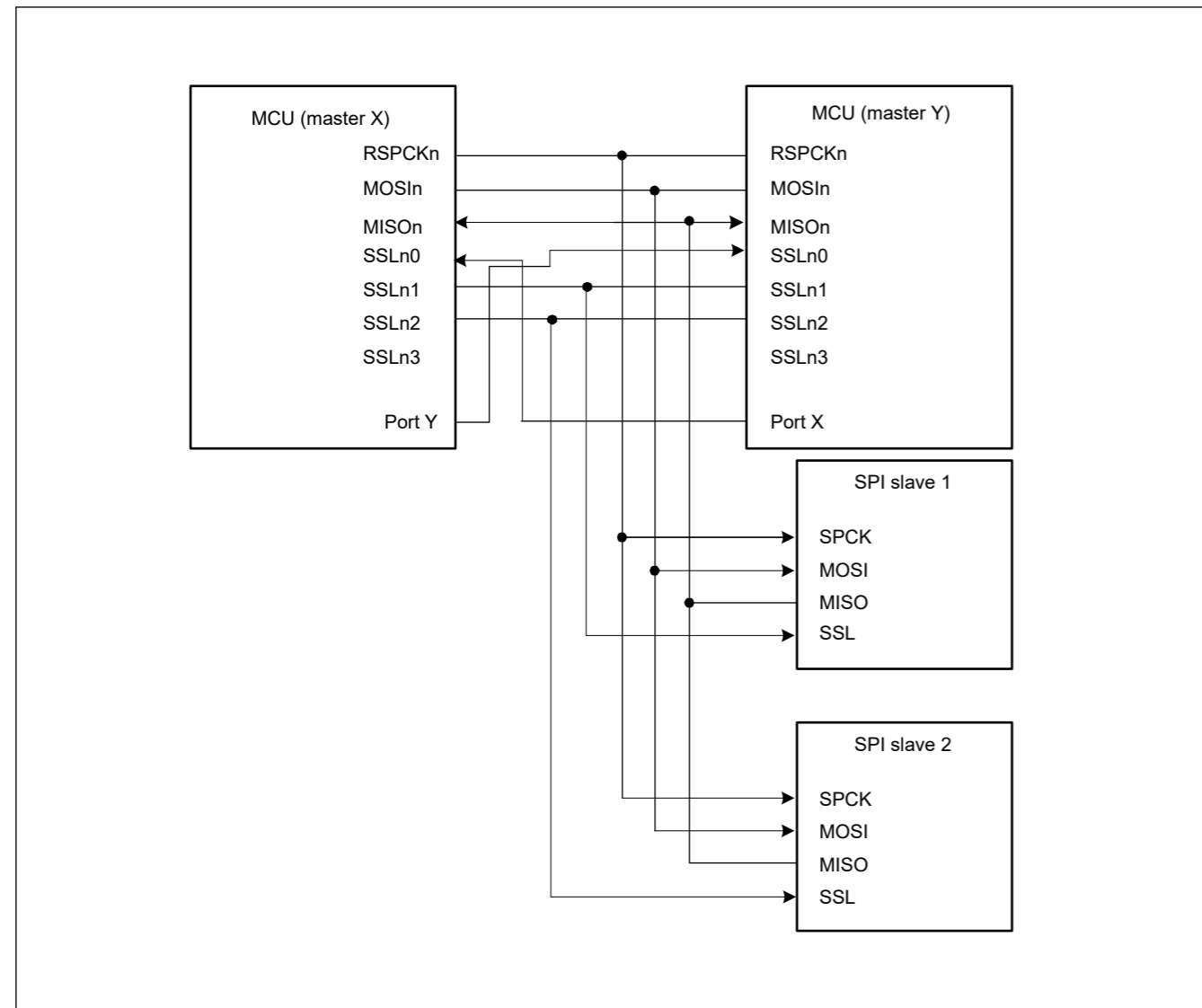


Figure 30.10 Multi-master/multi-slave configuration example with the MCU as a master

30.3.3.6 Master and slave in clock synchronous mode with the MCU configured as a master

Figure 30.11 shows a master and slave in clock synchronous mode configuration example where the MCU is used as a master. In this configuration, SSLni of the MCU (master) are not used.

The MCU (master) drives the RSPCKn and MOSIn signals. The SPI slave drives the MISO signal.

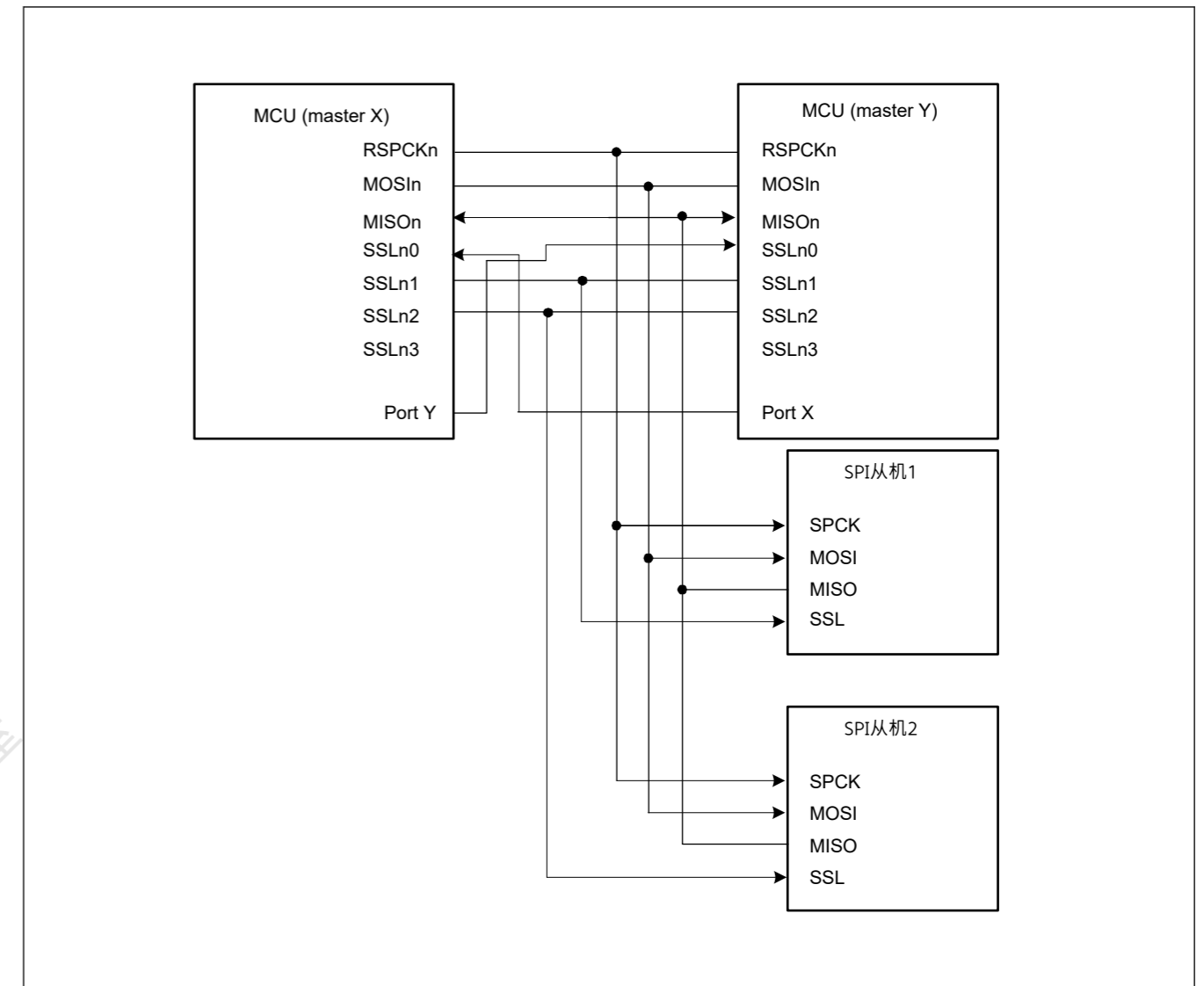


Figure 30.10 MCU为主的多主多从配置示例

30.3.3.6 主从时钟同步模式，MCU配置为主

图30.11显示了时钟同步模式下的主从配置示例，其中MCU用作主控。在此配置中，不使用MCU（主）的SSLni。

MCU（主控）驱动RSPCKn和MOSIn信号。SPI从机驱动MISO信号。

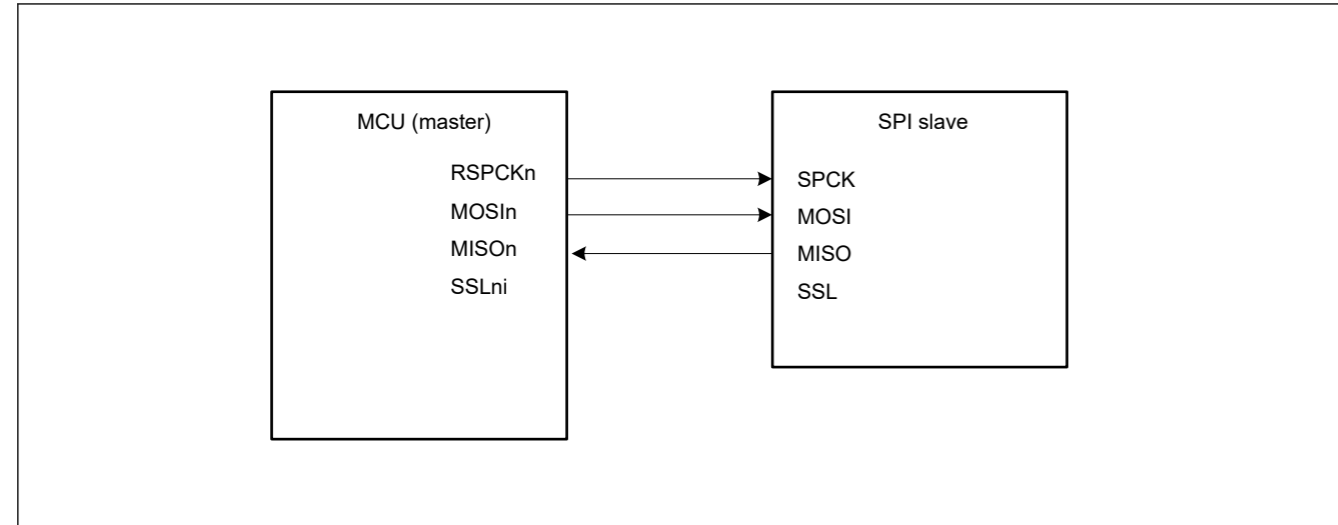


Figure 30.11 Clock synchronous master/slave configuration example with the MCU as a master

### 30.3.3.7 Master and slave in clock synchronous mode with the MCU as a slave

Figure 30.12 shows a master and slave in clock synchronous mode configuration example where the MCU is used as a slave. When the MCU operates as a slave (clock synchronous operation), the MCU (slave) drives the MISO signal and the SPI master drives the SPCK and MOSI signals. In addition, SSLn0 to SSLn3 of the MCU (slave) are not used.

The MCU (slave) can only execute serial transfers in the single-slave configuration when the SPCMDm.CPHA bit is set to 1.

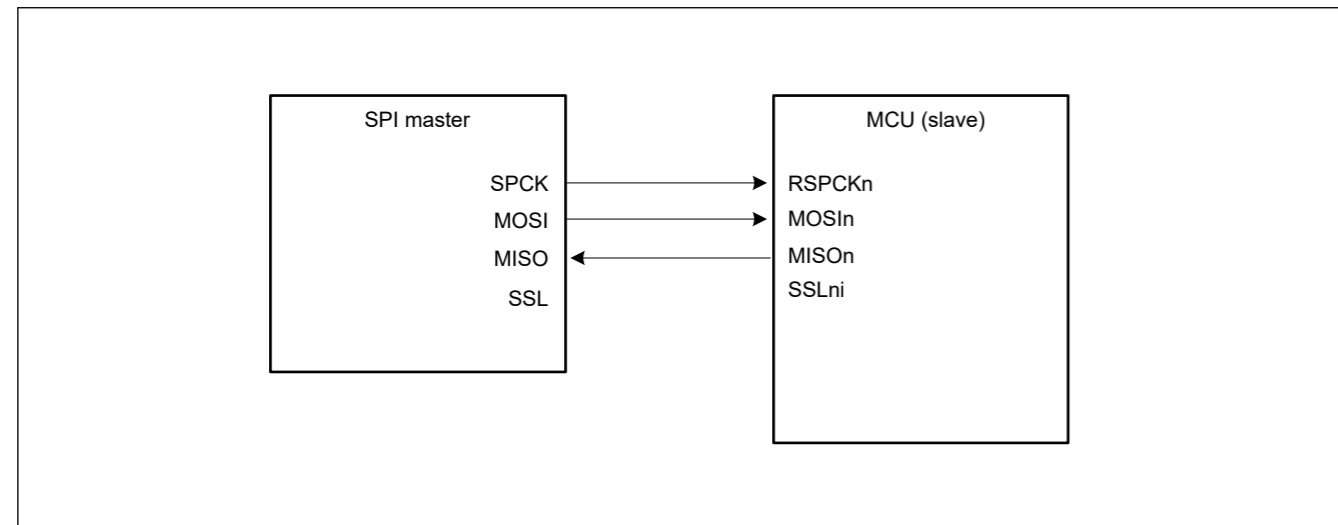


Figure 30.12 Clock synchronous master/slave configuration example with the MCU as a slave and CPHA = 1

### 30.3.4 Data Formats

The data format of the SPI depends on the settings in SPI Command Register m (SPCMDm) and the parity enable bit in SPI Control Register 2 (SPCR2.SPPE). Regardless of whether the MSB or LSB is first, the SPI treats the range from the LSB bit in the SPI Data Register (SPDR/SPDR\_HA) to the bit associated with the selected data length, as transfer data.

This section shows the format of one frame of data before or after transfer.

#### Data format with parity disabled

When parity is disabled, transmission or reception of data proceeds with the length in bits selected in the SPI data length setting in SPI Command Register m (SPCMDm.SPB[3:0]).

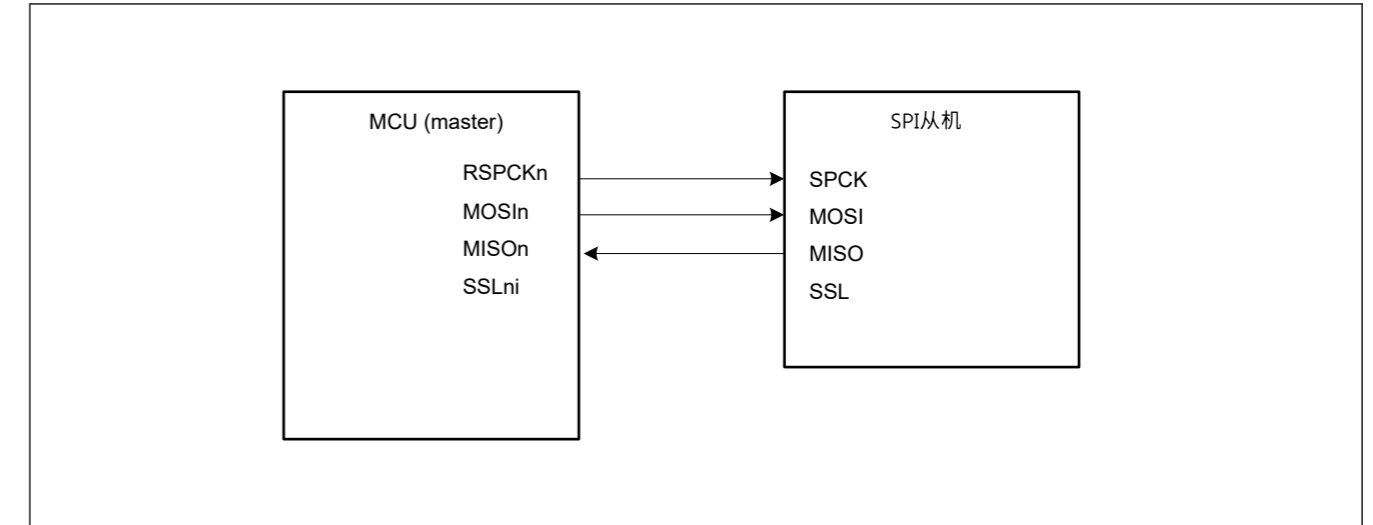


Figure 30.11 以MCU为主的时钟同步主从配置示例

### 30.3.3.7 主从时钟同步模式，单片机作为从机

图30.12显示了时钟同步模式下的主机和从机配置示例，其中MCU用作从机。当MCU作为从机运行时（时钟同步操作），MCU（从机）驱动MIO信号，SPI主机驱动SPCK和MOSI信号。此外，不使用MCU（从机）的SSLn0到SSLn3。

当SPCMDm.CPHA位设置为1时，MCU（从机）只能在单从机配置中执行串行传输。

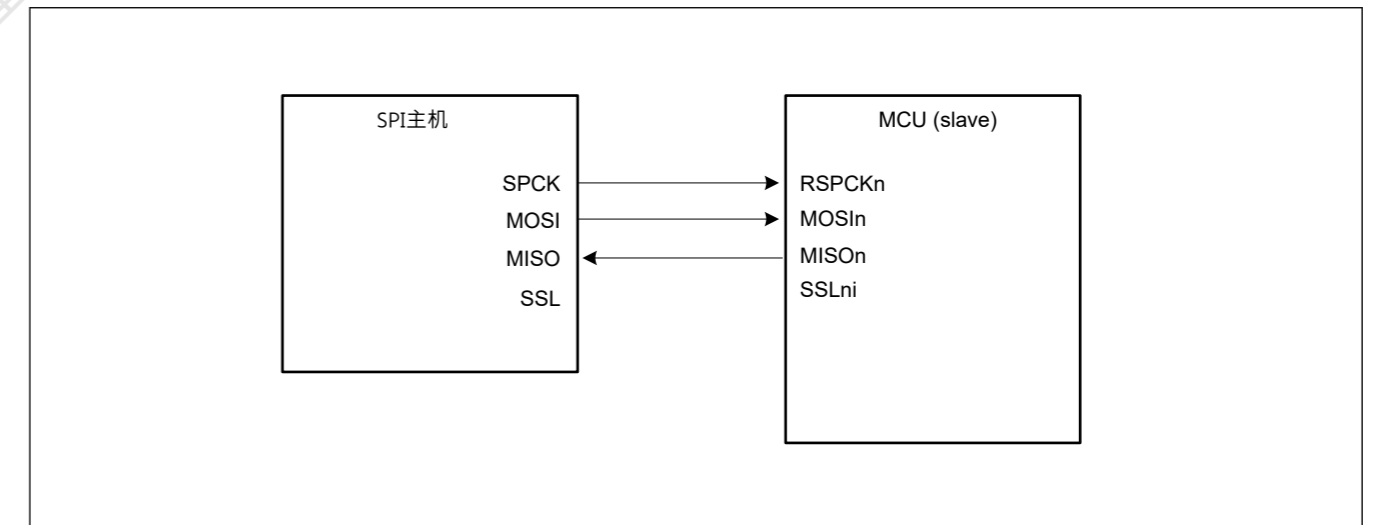


Figure 30.12 以MCU作为从机且CPHA=1的时钟同步主从配置示例

### 30.3.4 数据格式

SPI的数据格式取决于SPI命令寄存器m (SPCMDm)中的设置和SPI控制寄存器2 (SPCR2.SPPE)中的奇偶校验使能位。无论MSB还是LSB在前，SPI都会将SPI数据寄存器 (SPDR/SPDR\_HA)中的LSB位到与所选数据长度相关的位的范围视为传输数据。

本节显示传输前后一帧数据的格式。

#### 禁用奇偶校验的数据格式

当奇偶校验被禁用时，数据的发送或接收将按照在SPI命令寄存器m (SPCMDm.SPB[3:0])的SPI数据长度设置中选择的位长度进行。



**Data format with parity enabled**

When parity is enabled, transmission or reception of data proceeds with the length in bits selected in the SPI data length setting in SPI Command Register m (SPCMDm.SPB[3:0]). In this case, however, the last bit is a parity bit.

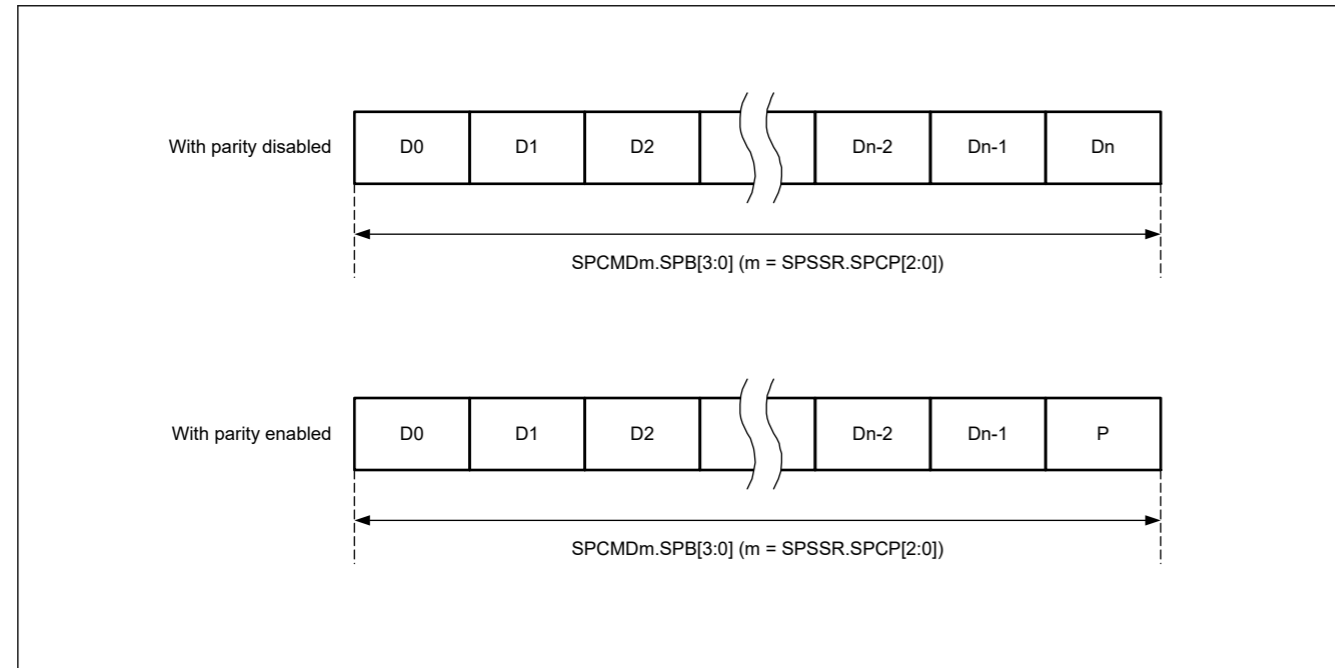


Figure 30.13 Data format with parity disabled and enabled

**30.3.4.1 Operation when parity is disabled (SPCR2.SPPE = 0)**

When parity is disabled, data for transmission is copied to the shift register with no pre-processing. This section describes the connection between the SPI Data Register (SPDR/SPDR\_HA) and the shift register in terms of the combination of MSB- or LSB-first order and data length.

**(1) MSB-first transfer with 32-bit data**

Figure 30.14 shows the operation of the SPI Data Register (SPDR) and the shift register in a transfer with parity disabled, a SPI data length of 32 bits, and MSB-first selected.

In transmission, bits T31 to T00 from the current stage of the transmit buffer are copied to the shift register. Data for transmission is shifted out from the shift register from T31 to T30, and continuing to T00.

In reception, received data is shifted in bit-by-bit through bit[0] of the shift register. When the R31 to R00 bits are collected after input of the required number of RSPCK cycles, the value in the shift register is copied to the receive buffer.

**启用奇偶校验的数据格式**

当奇偶校验使能时，数据的发送或接收按照在SPI命令寄存器m(SPCMDm.SPB[3:0])的SPI数据长度设置中选择的位长度进行。然而，在这种情况下，最后一位是奇偶校验位。

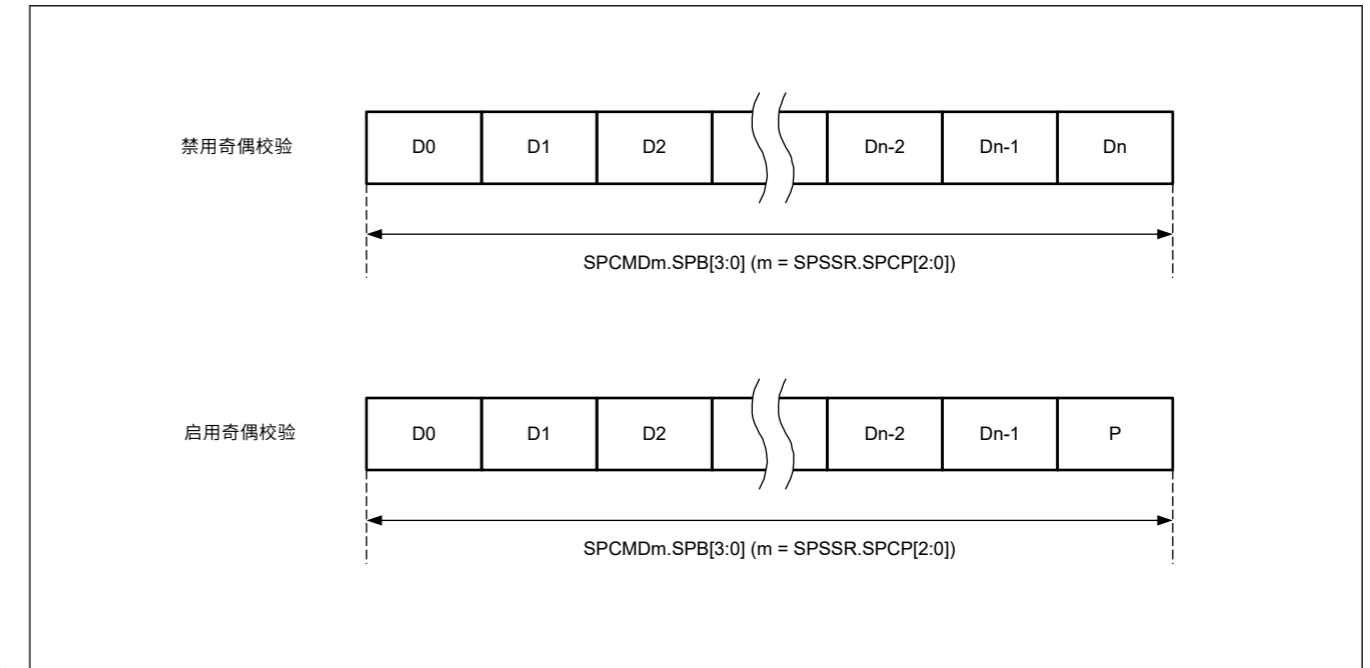


Figure 30.13 禁用和启用奇偶校验的数据格式

**30.3.4.1 禁用奇偶校验时的操作(SPCR2.SPPE=0)**

当奇偶校验被禁用时，用于传输的数据被复制到移位寄存器而不进行预处理。本节从MSB或LSB-first order和数据长度的组合来描述SPI数据寄存器(SPDR/SPDR\_HA)和移位寄存器之间的连接。

**(1) 32位数据的MSB优先传输**

图30.14显示了SPI数据寄存器(SPDR)和移位寄存器在奇偶校验禁用的传输中的操作，a SPI数据长度为32位，且MSB优先选择。

在发送过程中，发送缓冲器当前级的T31到T00位被复制到移位寄存器。发送数据从移位寄存器从T31移出到T30，并继续到T00。

在接收中，接收到的数据通过移位寄存器的bit[0]逐位移位。在输入所需的RSPCK周期数后收集R31至R00位时，将移位寄存器中的值复制到接收缓冲区。

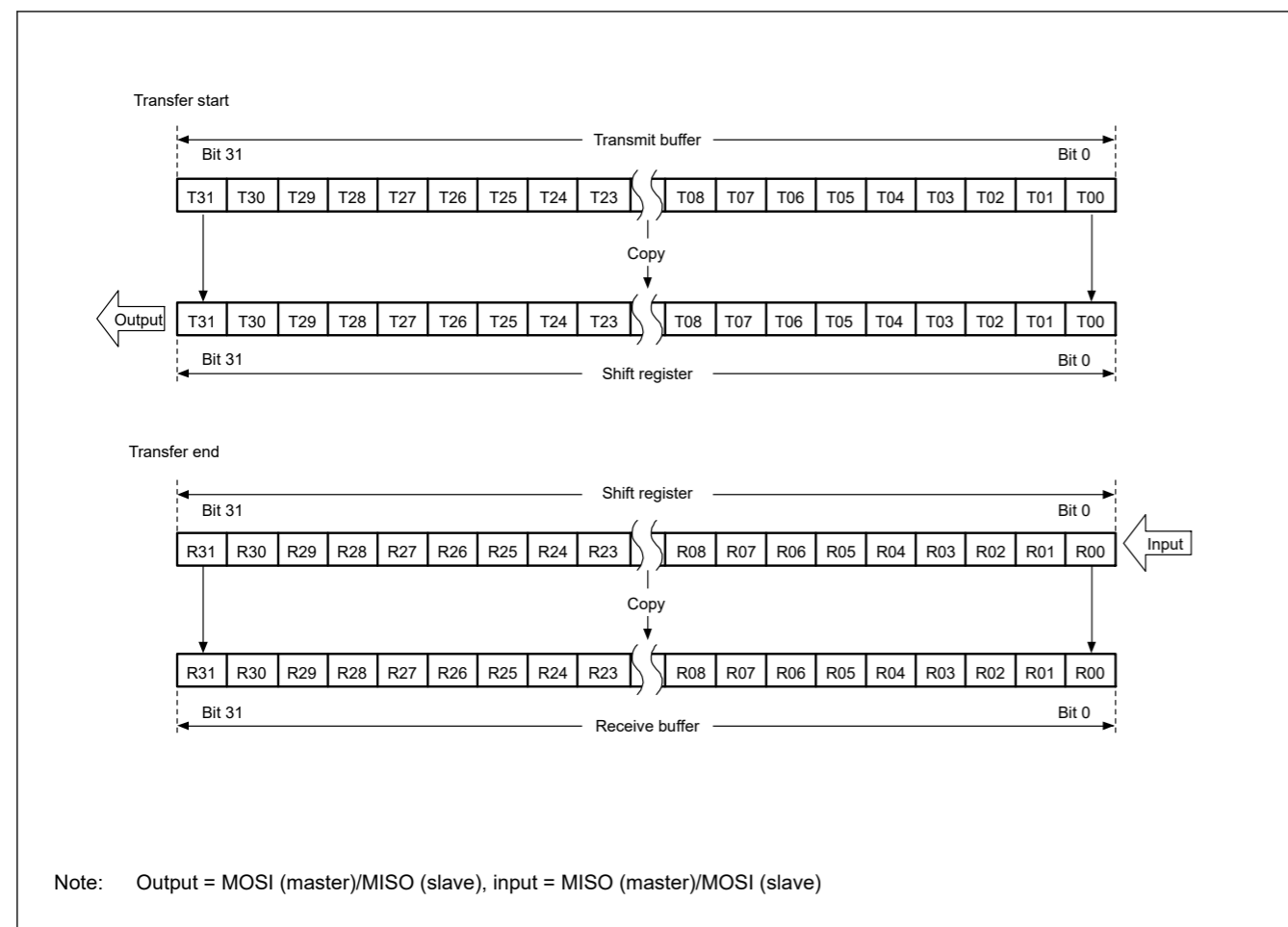


Figure 30.14 MSB-first transfer with 32-bit data and parity disabled

## (2) MSB-first transfer with 24-bit data

Figure 30.15 shows the operation of the SPI Data Register (SPDR) and the shift register in a transfer with parity disabled, an SPI data length of 24 bits for an example that is not 32 bits, and MSB-first selected.

In transmission, the lower 24 bits (T23 to T00) from the current stage of the transmit buffer are copied to the shift register. Data for transmission is shifted out from the shift register from T23 to T22, and continuing to T00.

In reception, received data is shifted in bit-by-bit through bit[0] of the shift register. When the R23 to R00 bits are collected after input of the required number of RSPCK cycles, the value in the shift register is copied to the receive buffer. The upper 8 bits of the transmit buffer are stored in the upper 8 bits of the receive buffer in case of transmit-receive operation. Writing 0 to bits T31 to T24 during transmission leads to 0 being inserted in the upper 8 bits of the receive buffer. On the other hand, the upper 8-bits of the receive buffer is written 0 in case of receive only operation.

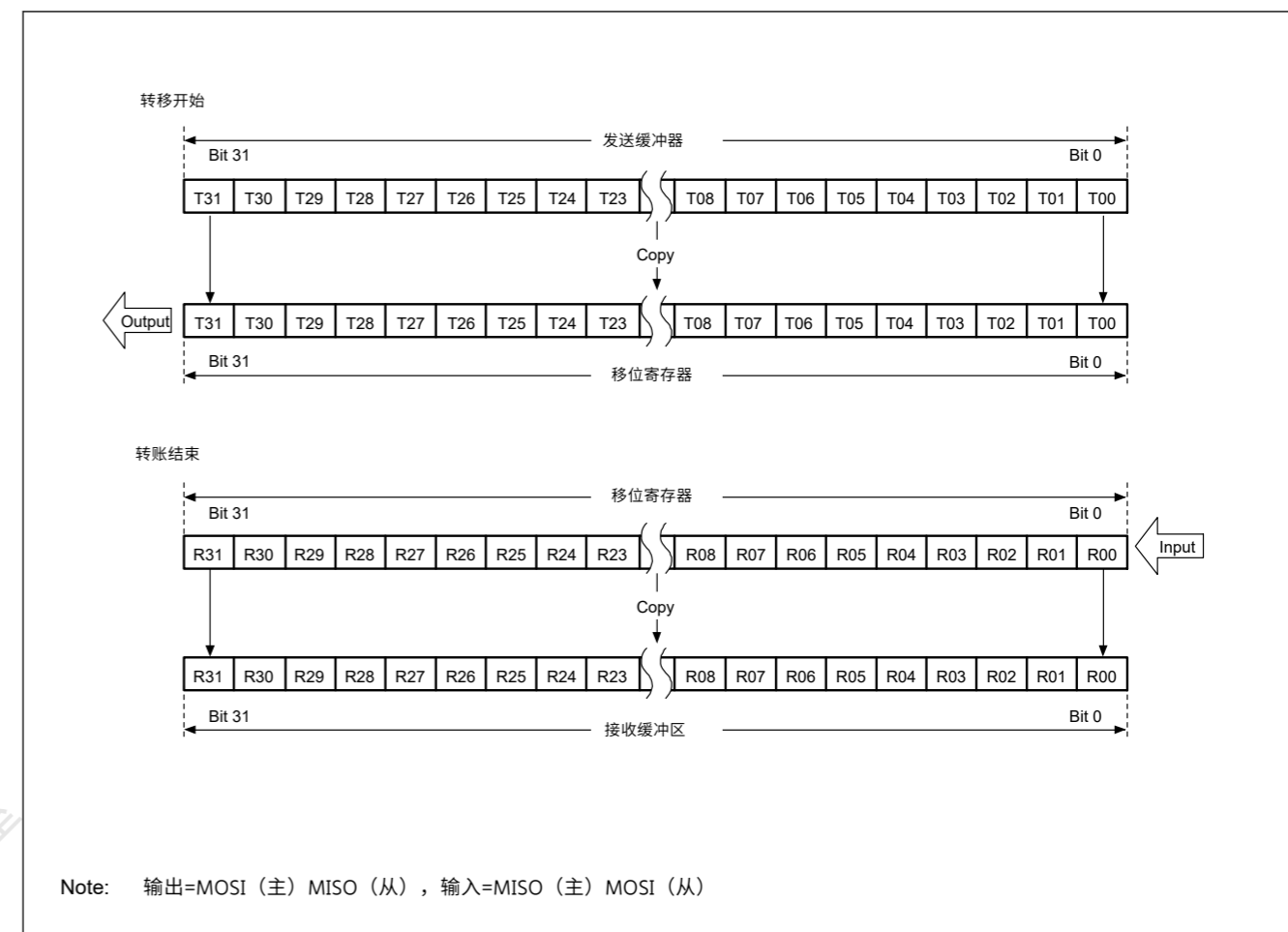


Figure 30.14 禁用32位数据和奇偶校验的MSB优先传输

## (2) 24位数据的MSB优先传输

图30.15显示了SPI数据寄存器(SPDR)和移位寄存器在奇偶校验禁用的传输中的操作，以24位SPI数据长度为例，即不是32位，并且选择MSB优先。

在发送过程中，来自发送缓冲器当前阶段的低24位（T23到T00）被复制到移位寄存器。发送的数据从移位寄存器从T23移出到T22，并继续到T00。

在接收中，接收到的数据通过移位寄存器的bit[0]逐位移位。在输入所需数量的RSPCK周期后，当R23到R00位被收集时，移位寄存器中的值被复制到接收缓冲区。在发送-接收操作的情况下，发送缓冲区的高8位存储在接收缓冲区的高8位中。在传输过程中将0写入位T31到T24会导致将0插入接收缓冲区的高8位。另一方面，在只接收操作的情况下，接收缓冲区的高8位被写入0。

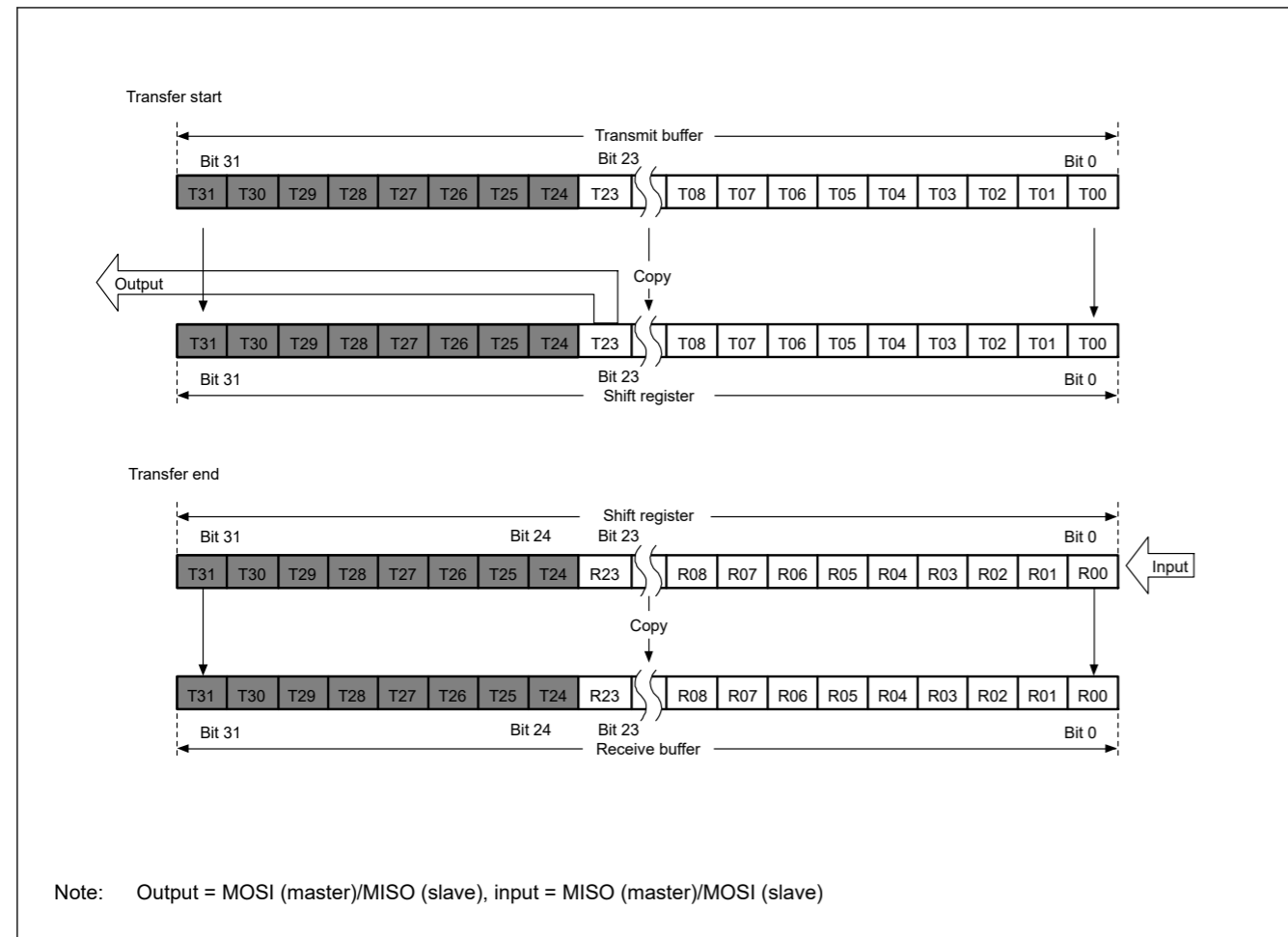


Figure 30.15 MSB-first transfer with 24-bit data and parity disabled

## (3) LSB-first transfer with 32-bit data

Figure 30.16 shows the operation of the SPI Data Register (SPDR) and the shift register in a transfer with parity disabled, an SPI data length of 32 bits, and LSB-first selected.

In transmission, bits T31 to T00 from the current stage of the transmit buffer are reordered bit-by-bit to obtain the order T00 to T31 for copying to the shift register. Data for transmission is shifted out from the shift register in order from T00 to T01, and continuing to T31.

In reception, received data is shifted in bit-by-bit through bit[0] of the shift register. When the R00 to R31 bits are collected after input of the required number of RSPCK cycles, the value in the shift register is copied to the receive buffer.

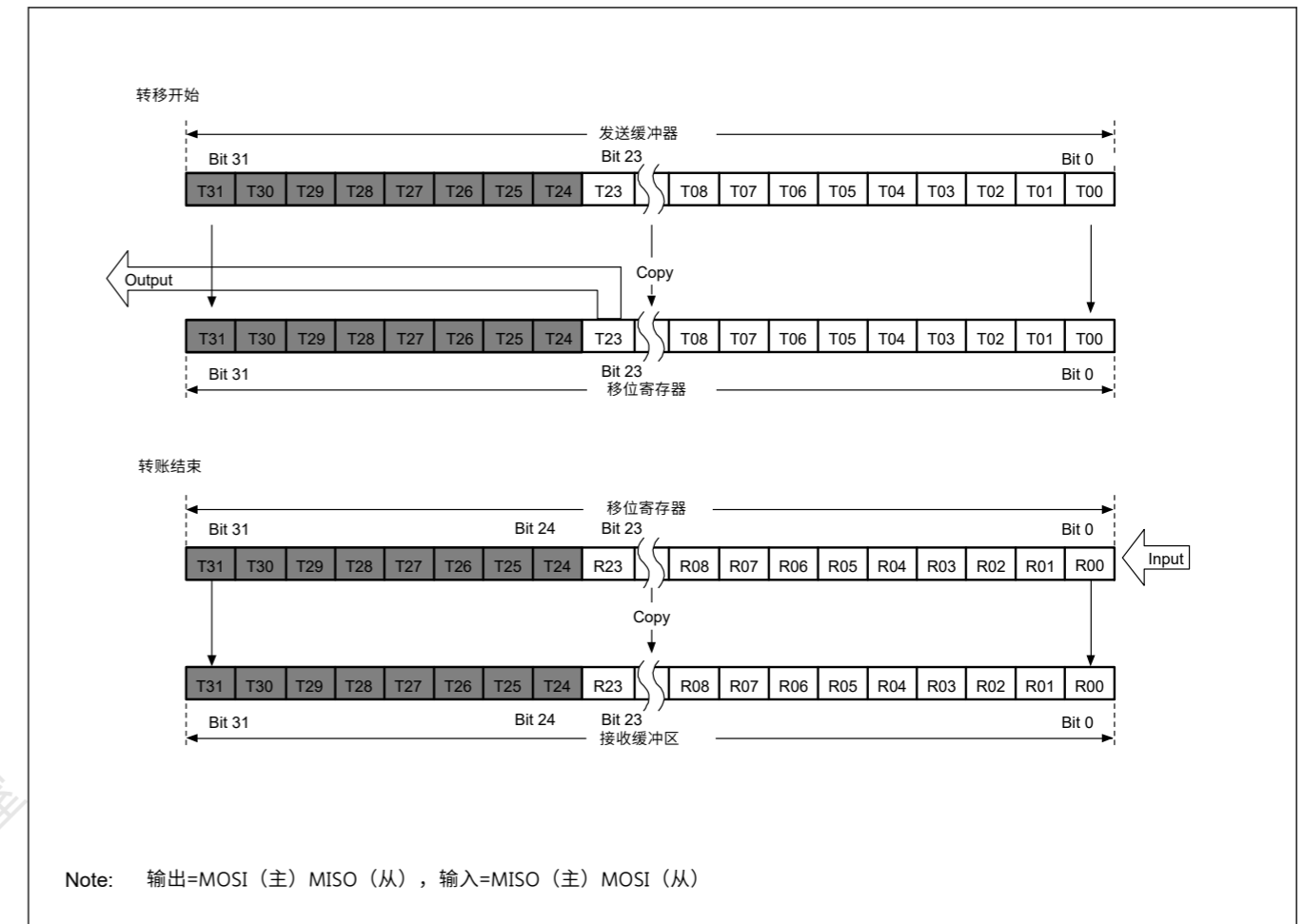


Figure 30.15 禁用24位数据和奇偶校验的MSB优先传输

## (3) 32位数据的LSB优先传输

图30.16显示了SPI数据寄存器(SPDR)和移位寄存器在奇偶校验禁用的传输中的操作，SPI数据长度为32位，并选择LSB-first。

在传输过程中，传输缓冲器当前级的位T31到T00被逐位重新排序，以获得用于复制到移位寄存器的顺序T00到T31。传输的数据从移位寄存器中按顺序从T00移出到T01，并继续到T31。

在接收中，接收到的数据通过移位寄存器的bit[0]逐位移位。在输入所需数量的RSPCK周期后收集R00至R31位时，将移位寄存器中的值复制到接收缓冲区。

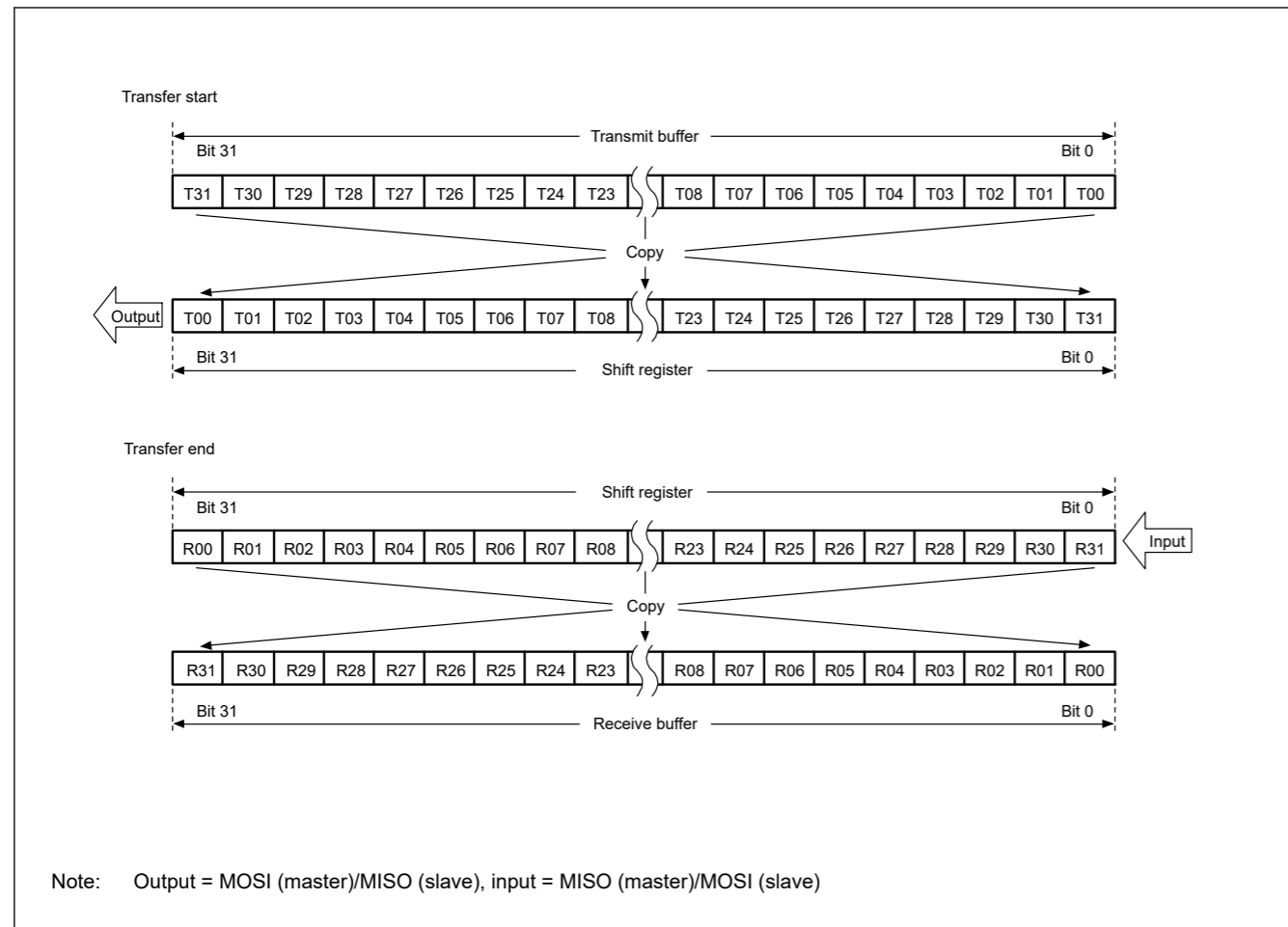


Figure 30.16 LSB-first transfer with 32-bit data and parity disabled

## (4) LSB-first transfer with 24-bit data

Figure 30.17 shows the operation of the SPI Data Register (SPDR) and the shift register in transfers with parity disabled, an SPI data length of 24 bits for an example that is not 32, and LSB-first selected.

In transmission, the lower 24 bits (T23 to T00) from the current stage of the transmit buffer are reordered bit-by-bit to obtain the order T00 to T23 for copying to the shift register. Data for transmission is shifted out from the shift register from T00 to T01, and continuing to T23.

In reception, received data is shifted in bit-by-bit through bit[8] of the shift register. When the R00 to R23 bits are collected after input of the required number of RSPCK cycles, the value in the shift register is copied to the receive buffer.

The upper 8 bits of the transmit buffer are stored in the upper 8 bits of the receive buffer in case of transmit-receive operation. Writing 0 to T31 to T24 during transmission leads to 0 being inserted in the upper 8 bits of the receive buffer. On the other hand, the upper 8-bits of the receive buffer is written 0 in case of receive only operation.

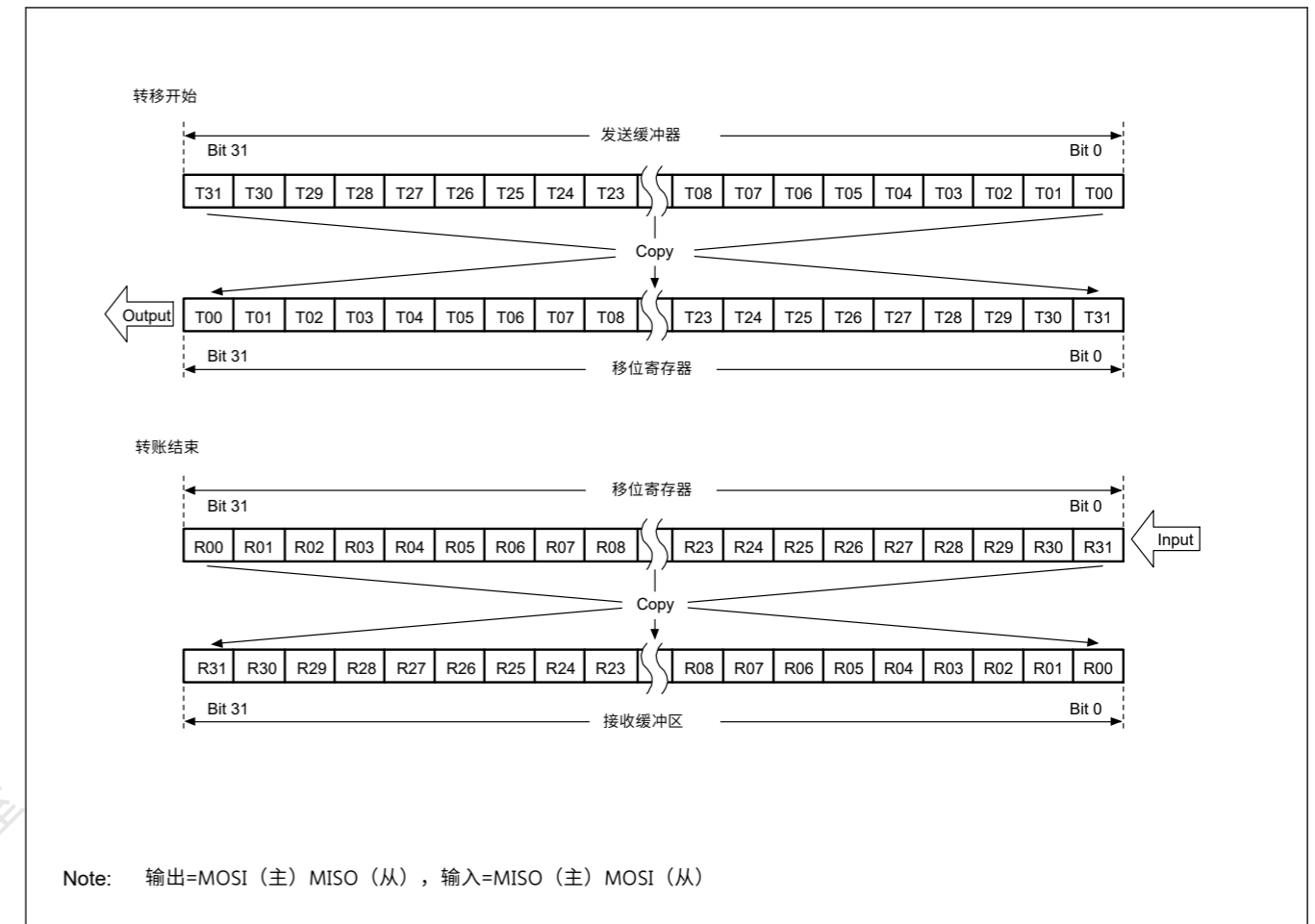


Figure 30.16 LSB优先传输，32位数据和奇偶校验禁用

## (4) 24位数据的LSB优先传输

图30.17显示了SPI数据寄存器(SPDR)和移位寄存器在奇偶校验禁用的传输中的操作，一个SPI数据长度为24位，例如不是32位，并且选择LSB优先。

发送时，将发送缓冲区当前级的低24位（T23到T00）逐位重新排序，得到T00到T23的顺序，用于复制到移位寄存器。发送的数据从移位寄存器从T00移出到T01，并继续到T23。

在接收中，接收到的数据通过移位寄存器的bit[8]逐位移位。在输入所需的RSPCK周期数后收集R00至R23位时，将移位寄存器中的值复制到接收缓冲区。

在发送-接收操作的情况下，发送缓冲区的高8位存储在接收缓冲区的高8位中。在发送过程中将0写入T31到T24会导致将0插入接收缓冲区的高8位。另一方面，在只接收操作的情况下，接收缓冲区的高8位被写入0。



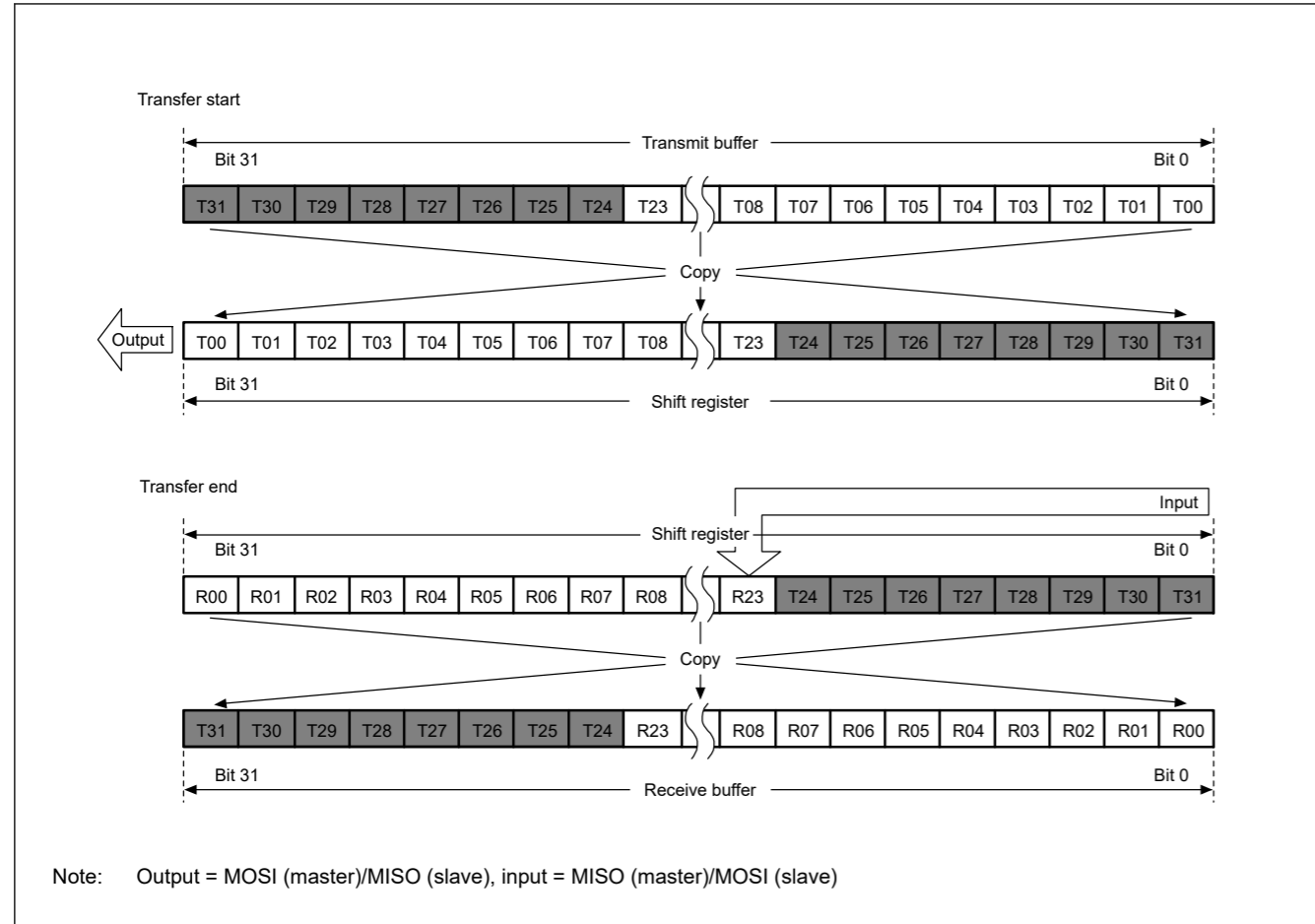


Figure 30.17 LSB-first transfer with 24-bit data and parity disabled

30.3.4.2 Operation when parity is enabled (SPCR2.SPPE = 1)

When parity is enabled, the lowest-order bit of the data for transmission becomes a parity bit. Hardware calculates the value of the parity bit.

(1) MSB-first transfer with 32-bit data

Figure 30.18 shows the operation of the SPI Data Register (SPDR) and the shift register in a transfer with parity enabled, an SPI data length of 32 bits, and MSB-first selected.

In transmission, the value of the parity bit (P) is calculated from bits T31 to T01. This replaces the final bit, T00, and the whole value is copied to the shift register. Data is transmitted in the order T31, T30, ..., T01, and P.

In reception, received data is shifted in bit-by-bit through bit[0] of the shift register. When the R31 to P bits are collected after input of the required number of RSPCK cycles, the value in the shift register is copied to the receive buffer. On copying of data to the shift register, the data from R31 to P is checked for parity.

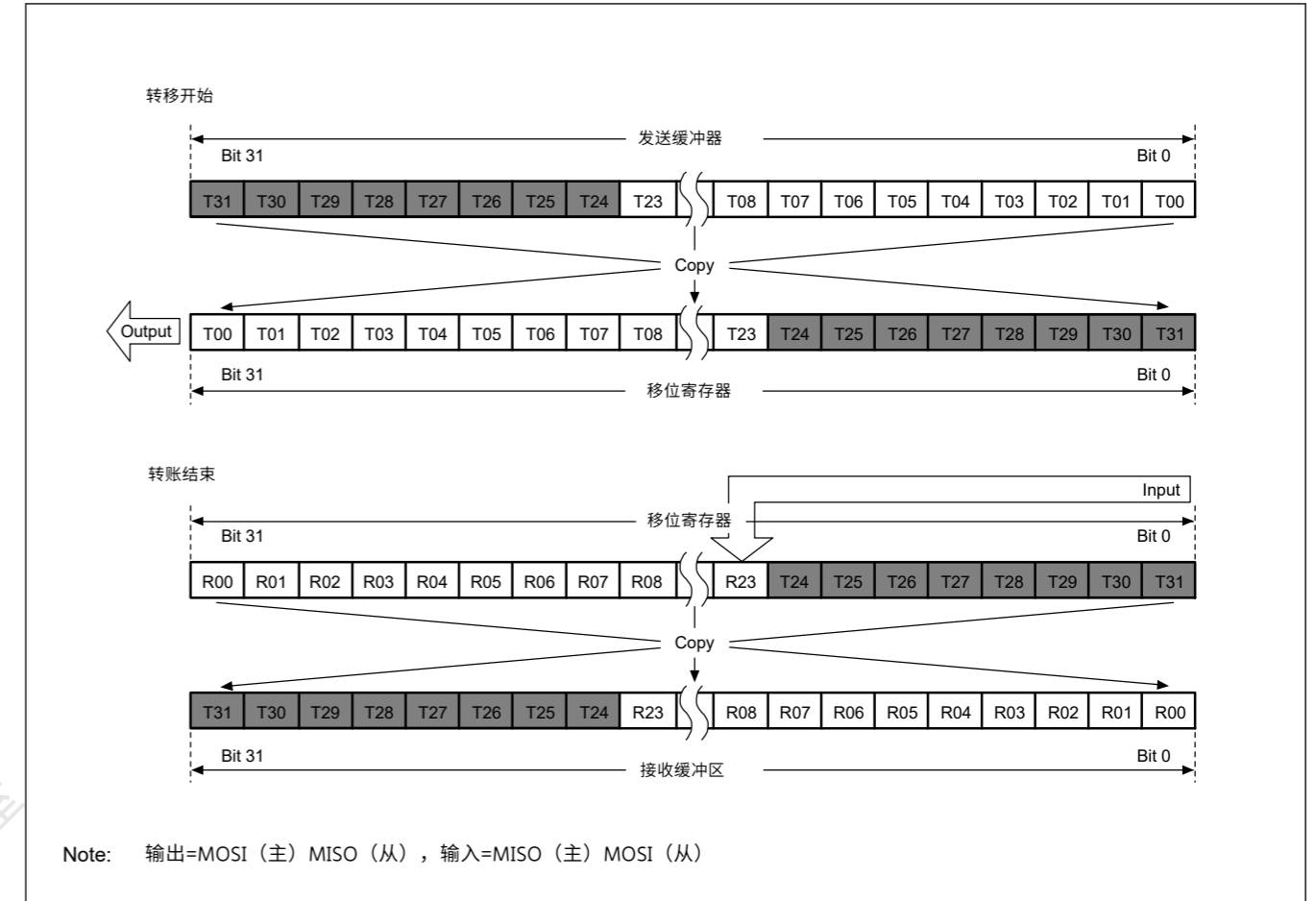


Figure 30.17 LSB优先传输，24位数据和奇偶校验禁用

30.3.4.2 启用奇偶校验时的操作(SPCR2.SPPE=1)

启用奇偶校验时，传输数据的最低位变为奇偶校验位。硬件计算奇偶校验位的值。

(1) 32位数据的MSB优先传输

图30.18显示了SPI数据寄存器(SPDR)和移位寄存器在启用奇偶校验的传输中的操作，SPI数据长度为32位，且MSB优先选择。

在传输中，奇偶校验位(P)的值是从位T31到T01计算的。这将替换最后一位T00，并将整个值复制到移位寄存器。数据按T31、T30、……、T01和P的顺序传输。

在接收中，接收到的数据通过移位寄存器的bit[0]逐位移位。在输入所需数量的RSPCK周期后收集R31至P位时，将移位寄存器中的值复制到接收缓冲区。在将数据复制到移位寄存器时，会检查从R31到P的数据的奇偶性。

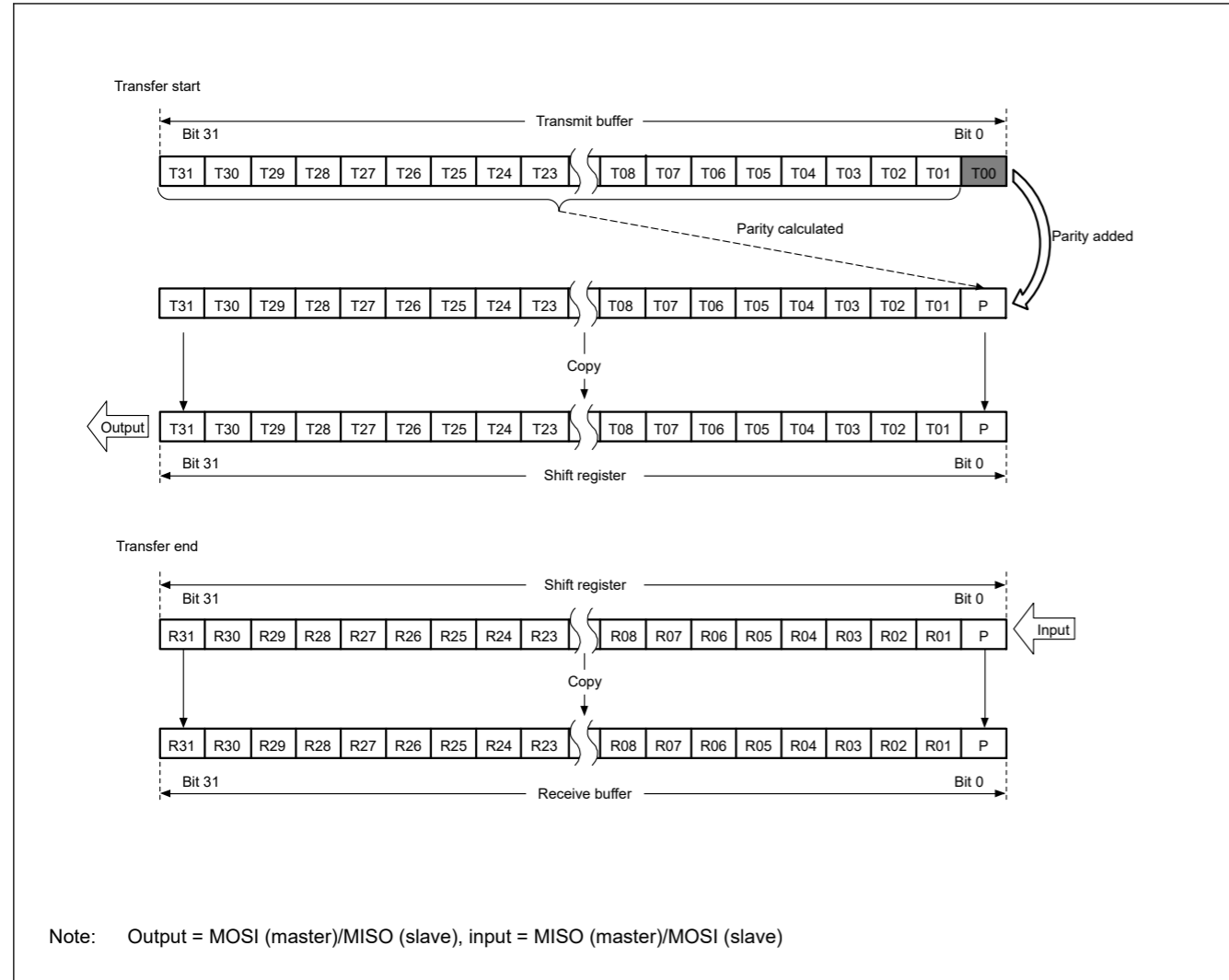


Figure 30.18 MSB-first transfer with 32-bit data and parity enabled

## (2) MSB-first transfer with 24-bit data

Figure 30.19 shows the operation of the SPI Data Register (SPDR) and the shift register in a transfer with parity enabled, a SPI data length of 24 bits, and MSB-first selected.

In transmission, the value of the parity bit (P) is calculated from bits T23 to T01. This replaces the final bit, T00, and the whole value is copied to the shift register. Data is transmitted in the order T23, T22, ..., T01, and P.

In reception, received data is shifted in bit-by-bit through bit[0] of the shift register. When the R23 to P bits are collected after input of the required number of RSPCK cycles, the value in the shift register is copied to the receive buffer. On copying of data to the shift register, the data from R23 to P is checked for parity. The upper 8 bits of the transmit buffer is stored in the upper 8 bits of the receive buffer in case of transmit-receive operation. Writing 0 to T31 to T24 during transmission leads to 0 being inserted in the upper 8 bits of the receive buffer. On the other hand, the upper 8-bits of the receive buffer is written 0 in case of receive only operation.

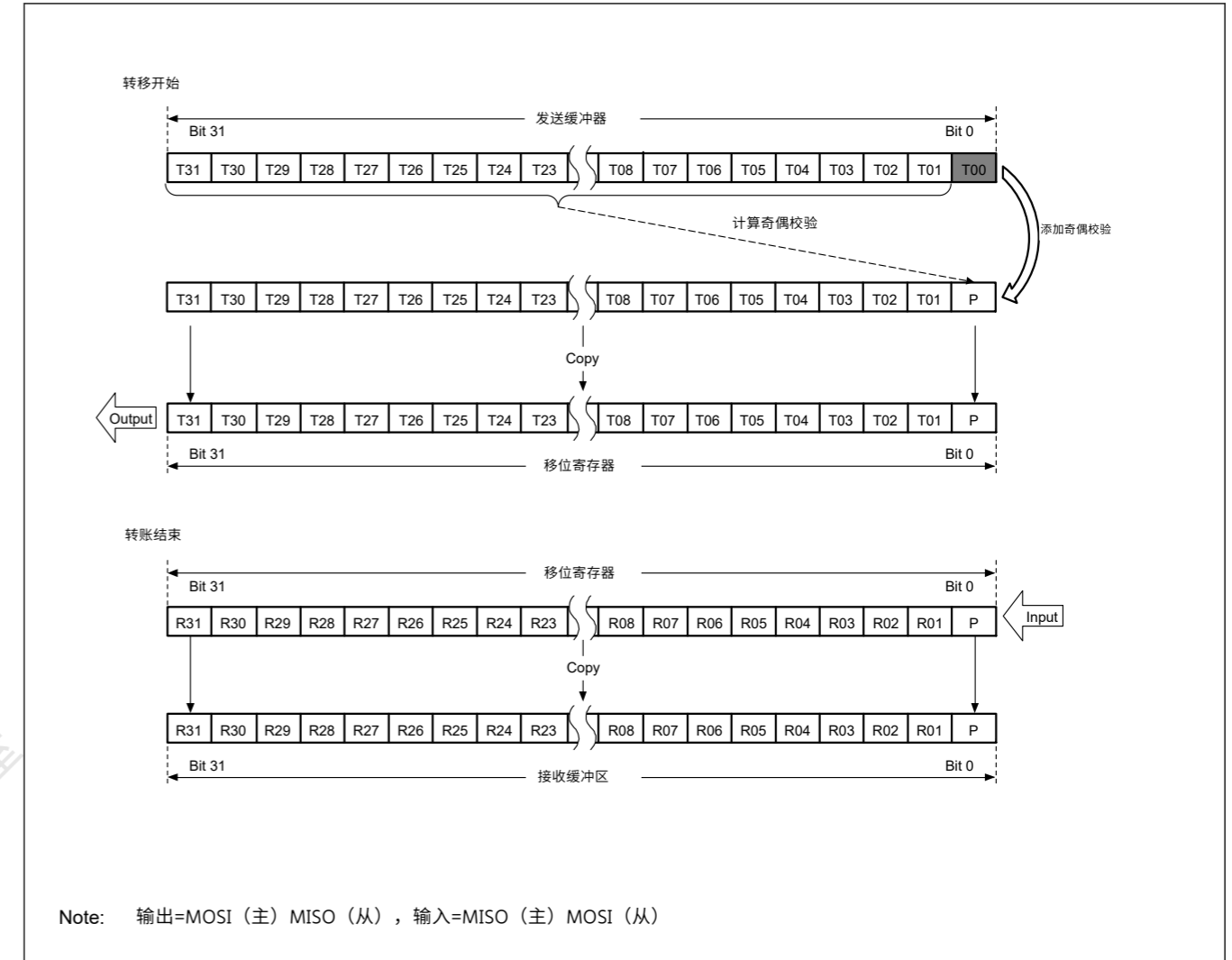


Figure 30.18 启用32位数据和奇偶校验的MSB优先传输

## (2) 24位数据的MSB优先传输

图30.19显示了SPI数据寄存器(SPDR)和移位寄存器在启用奇偶校验的传输中的操作，a SPI数据长度为24位，且MSB优先选择。

在传输中，奇偶校验位(P)的值是从位T23到T01计算的。这将替换最后一位T00，并将整个值复制到移位寄存器。数据按T23、T22、……、T01和P的顺序传输。

在接收中，接收到的数据通过移位寄存器的bit[0]逐位移位。在输入所需数量的RSPCK周期后收集R23至P位时，将移位寄存器中的值复制到接收缓冲区。在将数据复制到移位寄存器时，会检查从R23到P的数据的奇偶性。在发送-接收操作的情况下，发送缓冲区的高8位存储在接收缓冲区的高8位中。在发送过程中将0写入T31到T24会导致将0插入接收缓冲区的高8位。另一方面，在只接收操作的情况下，接收缓冲区的高8位被写入0。

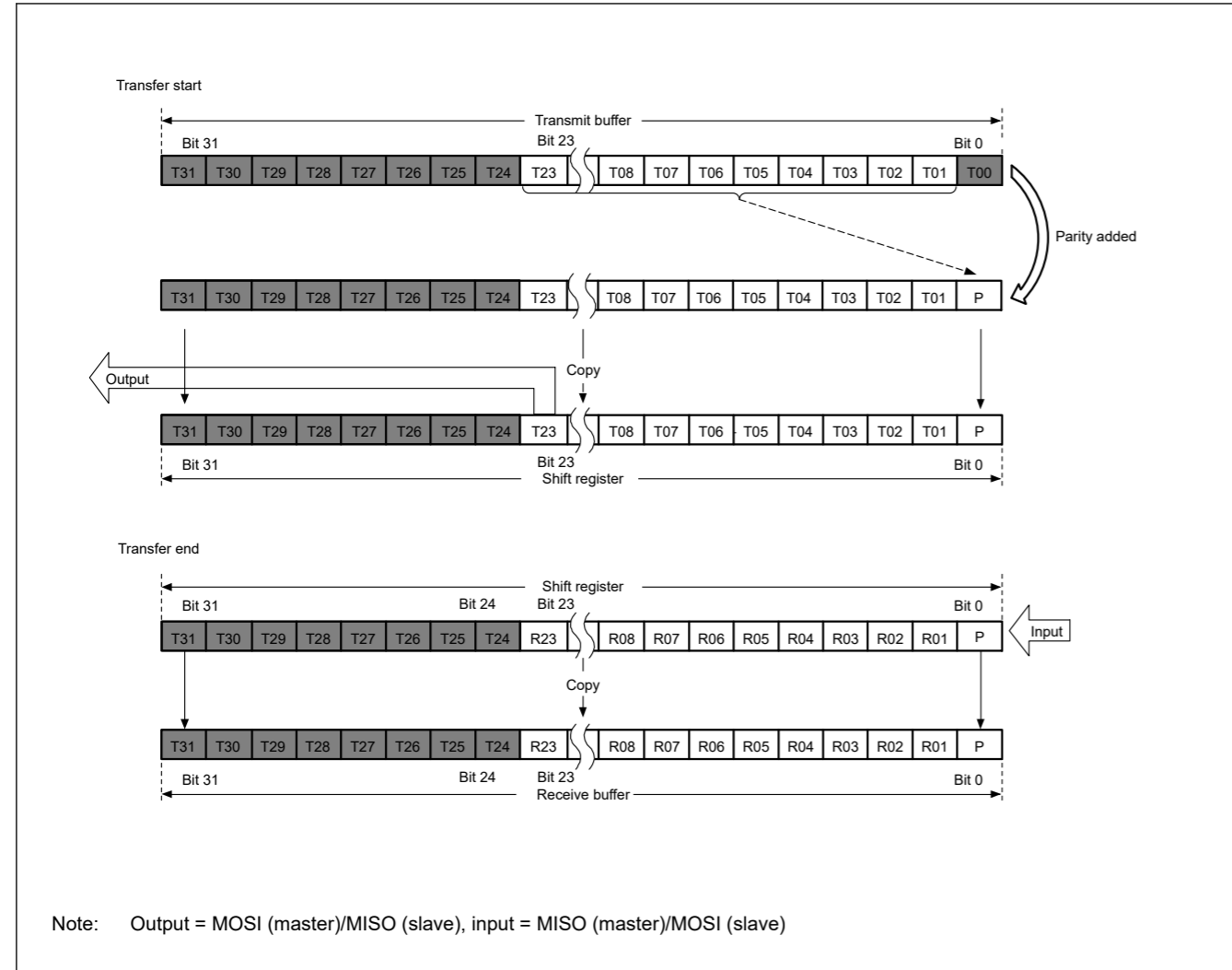


Figure 30.19 MSB-first transfer with 24-bit data and parity enabled

(3) LSB-first transfer with 32-bit data

Figure 30.20 shows the operation of the SPI Data Register (SPDR) and the shift register in a transfer with parity enabled, an SPI data length of 32 bits, and LSB-first selected.

In transmission, the value of the parity bit (P) is calculated from bits T30 to T00. This replaces the final bit, T31, and the whole value is copied to the shift register. Data is transmitted in the order T00, T01, ..., T30, and P.

In reception, received data is shifted in bit-by-bit through bit[0] of the shift register. When the R00 to P bits are collected after input of the required number of RSPCK cycles, the value in the shift register is copied to the receive buffer. On copying of data to the shift register, the data from R00 to P is checked for parity.

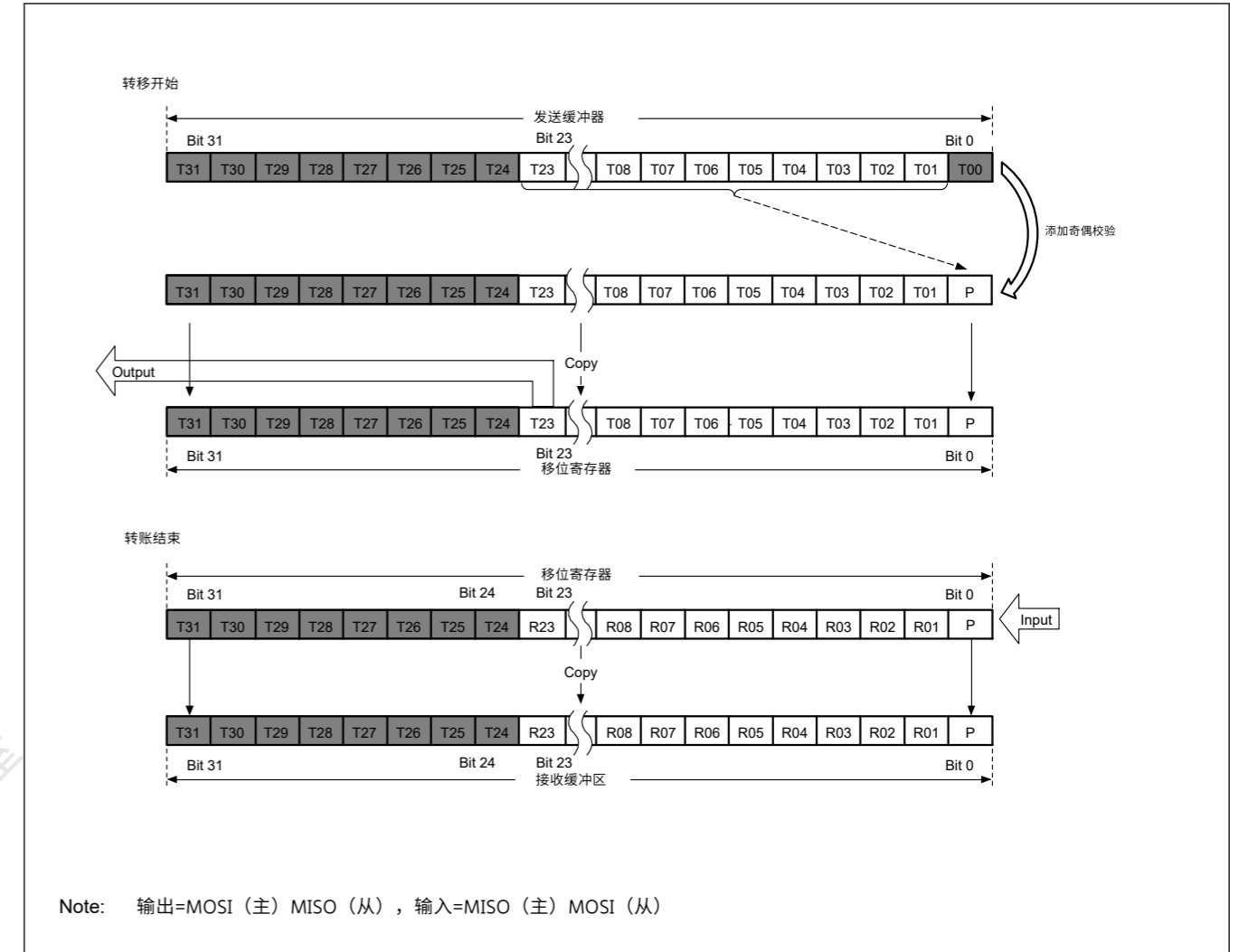


Figure 30.19 启用24位数据和奇偶校验的MSB优先传输

(3) 32位数据的LSB优先传输

图30.20显示了SPI数据寄存器(SPDR)和移位寄存器在启用奇偶校验的传输中的操作，SPI数据长度为32位，并选择LSB-first。

在传输中，奇偶校验位(P)的值是从位T30到T00计算的。这将替换最后一位T31，并将整个值复制到移位寄存器。数据按T00、T01、……、T30和P的顺序传输。

在接收中，接收到的数据通过移位寄存器的bit[0]逐位移位。在输入所需数量的RSPCK周期后收集R00至P位时，将移位寄存器中的值复制到接收缓冲区。在将数据复制到移位寄存器时，会检查从R00到P的数据的奇偶性。

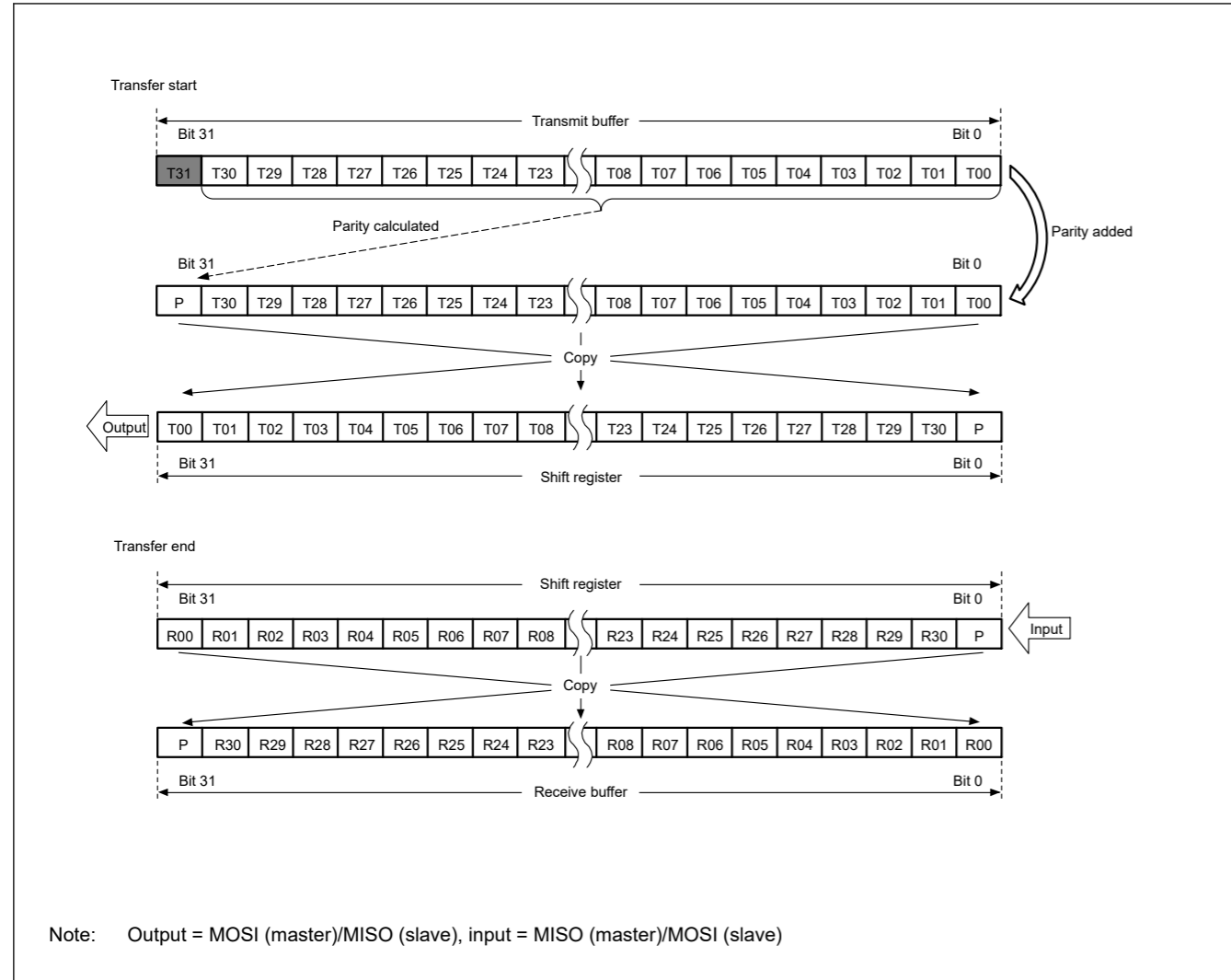


Figure 30.20 LSB-first transfer with 32-bit data and parity enabled

(4) LSB-first transfer with 24-bit data

Figure 30.21 shows the operation of the SPI Data Register (SPDR) and the shift register in a transfer with parity enabled, a SPI data length of 24 bits, and LSB-first selected.

In transmission, the value of the parity bit (P) is calculated from bits T22 to T00. This replaces the final bit, T23, and the whole value is copied to the shift register. Data is transmitted in the order T00, T01, ..., T22, and P.

In reception, received data is shifted in bit-by-bit through bit[8] of the shift register. When the R00 to P bits are collected after input of the required number of RSPCK cycles, the value in the shift register is copied to the receive buffer. On copying of data to the shift register, the data from R00 to P is checked for parity. The upper 8 bits of the transmit buffer is stored in the upper 8 bits of the receive buffer in case of transmit-receive operation. Writing 0 to T31 to T24 during transmission leads to 0 being inserted in the upper 8 bits of the receive buffer. On the other hand, the upper 8-bits of the receive buffer is written 0 in case of receive only operation.

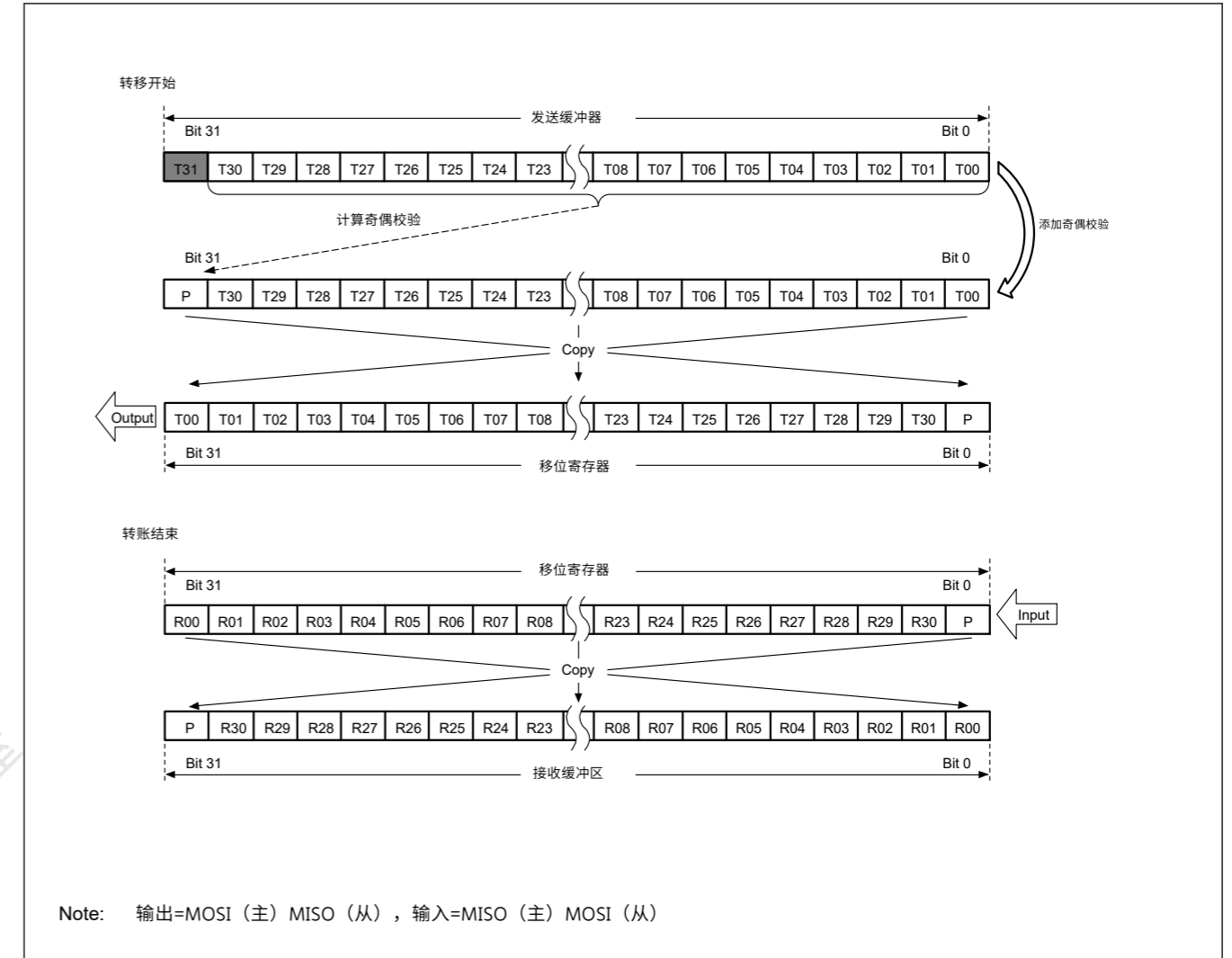


Figure 30.20 启用32位数据和奇偶校验的LSB优先传输

(4) 24位数据的LSB优先传输

图30.21显示了SPI数据寄存器(SPDR)和移位寄存器在启用奇偶校验的传输中的操作，a SPI数据长度为24位，并选择LSB优先。

在传输中，奇偶校验位(P)的值是从位T22到T00计算的。这将替换最后一位T23，并将整个值复制到移位寄存器。数据按T00、T01、……、T22和P的顺序传输。

在接收中，接收到的数据通过移位寄存器的bit[8]逐位移位。在输入所需数量的RSPCK周期后收集R00至P位时，将移位寄存器中的值复制到接收缓冲区。在将数据复制到移位寄存器时，会检查从R00到P的数据的奇偶性。在发送-接收操作的情况下，发送缓冲区的高8位存储在接收缓冲区的高8位中。在发送过程中将0写入T31到T24会导致将0插入接收缓冲区的高8位。另一方面，在只接收操作的情况下，接收缓冲区的高8位被写入0。



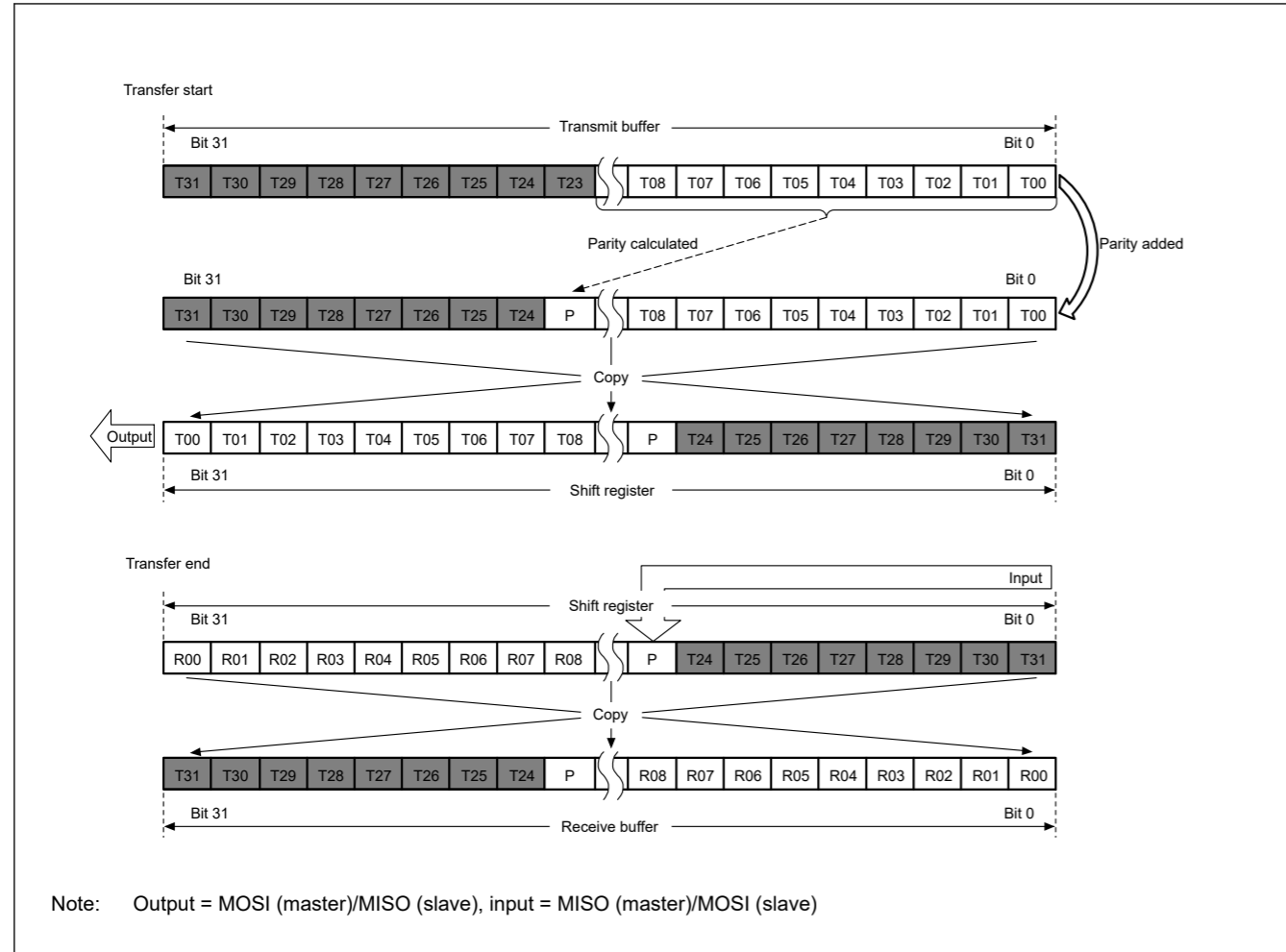


Figure 30.21 LSB-first transfer with 24-bit data and parity enabled

### 30.3.4.3 Byte Swap Transmission

#### (1) MSB-first transfer. (When the byte swap is disabled.)

Data (Byte0 [T31 to T24] to Byte3 [T07 to T00]) in the transmit buffer are copied to the shift register.

Bit values in the shift register are shifted and transmitted in the order of T31 → T30 → ... → T00 as transmit data.

#### (2) MSB-first transfer. (When the byte swap is enabled.)

Byte values of the transmit buffer (Byte0 [T31 to T24] to Byte3 [T07 to T00]) are reversed in byte units and are copied to the shift register in the order of Byte3 [T07 to T00] to Byte0 [T31 to T24].

Bit values in the shift register are shifted and transmitted in the order of T07 → T06 → ... → T00 → T15 → T14 → ... → T08 → T23 → T22 → ... → T16 → T31 → T30 → ... → T24 as transmit data.

#### (3) LSB-first transfer. (When the byte swap is disabled.)

Bit values of the transmit buffer (Byte0 [T31 to T24] to Byte3 [T07 to T00]) are reversed in bit units and are copied to the shift register in the order of Byte3 [T00 to T07] to Byte0 [T24 to T31].

Bit values in the shift register are shifted and transmitted in the order of T00 → T01 → ... → T31 as transmit data.

#### (4) LSB-first transfer. (When the byte swap is enabled.)

Bit values of each byte of the transmit buffer (Byte0 [T31 to T24] to Byte3 [T07 to T00]) are reversed in bit units and are copied to the shift register in the order of Byte0 [T24 to T31] to Byte3 [T00 to T07].

Bit values in the shift register are shifted and transmitted in the order of T24 → T25 → ... → T31 → T16 → T17 → ... → T23 → T08 → T09 → ... → T15 → T00 → T01 → ... → T07 as transmit data.

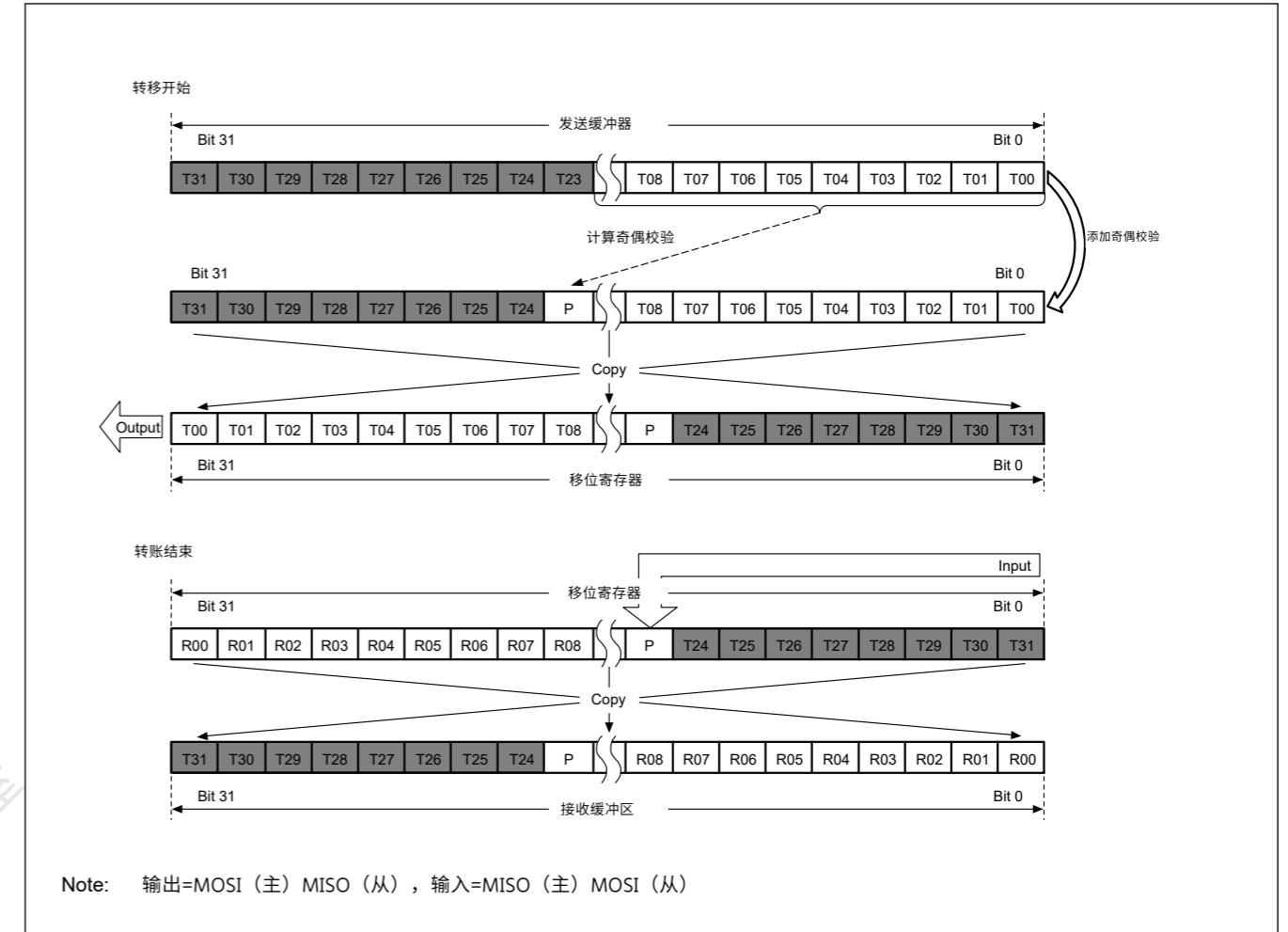


Figure 30.21 启用24位数据和奇偶校验的LSB优先传输

### 30.3.4.3 字节交换传输

#### (1) MSB优先传输。(禁用字节交换时。)

发送缓冲器中的数据 (Byte0[T31到T24]到Byte3[T07到T00]) 被复制到移位寄存器。

移位寄存器中的位值按照T31→T30→...→T00的顺序移位和传输，作为传输数据。

#### (2) MSB优先传输。(启用字节交换时。)

发送缓冲区的字节值 (Byte0[T31到T24]到Byte3[T07到T00]) 以字节为单位反转，并按照Byte3[T07到T00]到Byte0[T31到T24]的顺序复制到移位寄存器。

移位寄存器中的位值按照T07→T06→...→T00→T15→T14→...→T08→T23→T22→...→T16→T31→T30→...→T24作为传输数据。

#### (3) LSB优先传输。(禁用字节交换时。)

发送缓冲区的位值 (Byte0[T31到T24]到Byte3[T07到T00]) 以位为单位反转，并按照Byte3[T00到T07]到Byte0[T24到T31]的顺序复制到移位寄存器。

移位寄存器中的位值按照T00→T01→...→T31的顺序移位和发送，作为发送数据。

#### (4) LSB优先传输。(启用字节交换时。)

发送缓冲区 (Byte0[T31到T24]到Byte3[T07到T00]) 的每个字节的位值以位为单位反转，并按照Byte0[T24到T31]到Byte3[T00]的顺序复制到移位寄存器到T07。

移位寄存器中的位值按照T24→T25→...→T31→T16→T17→...→T23→T08→T09→...→T15→T00→T01→...→T07作为传输数据。

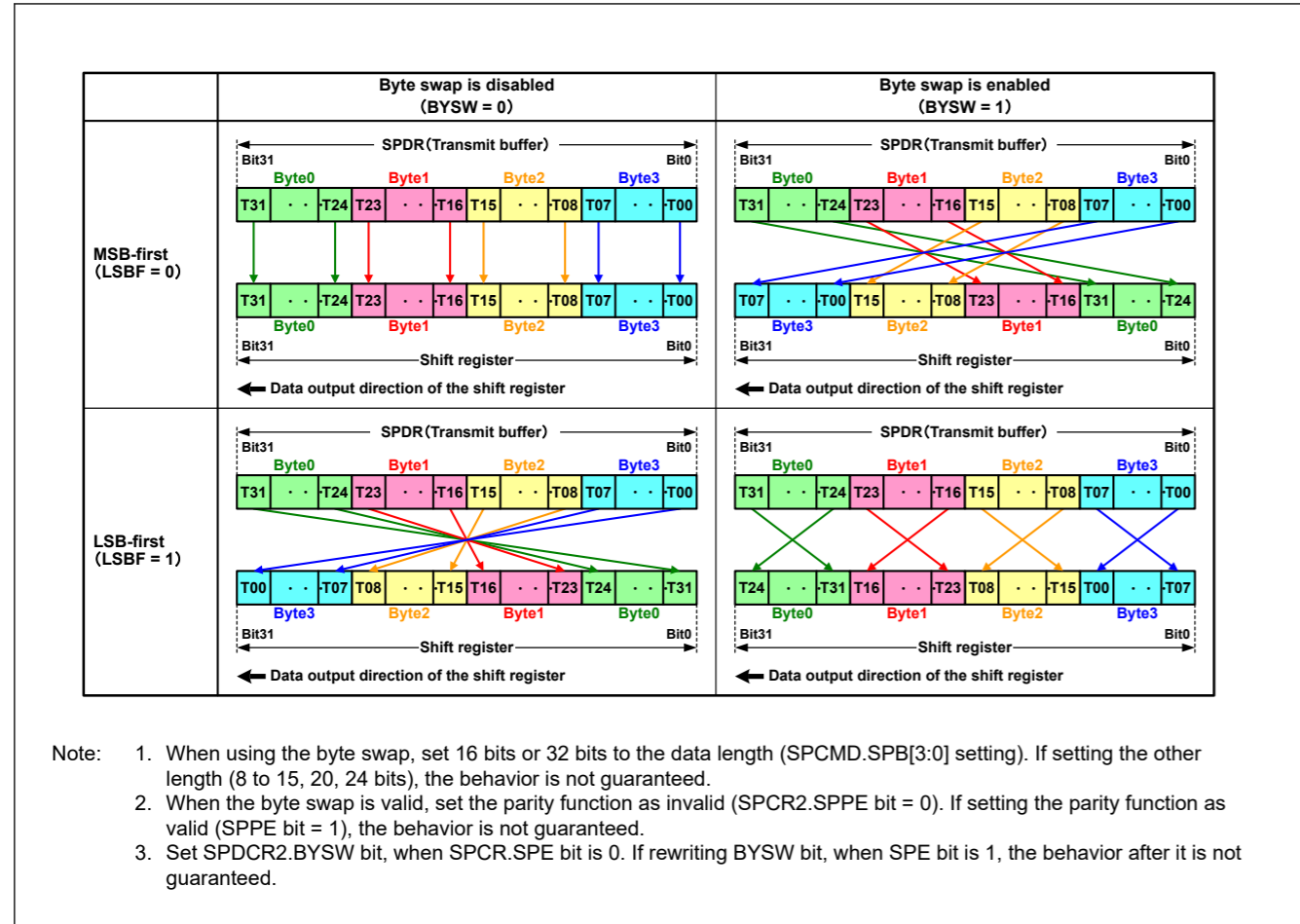


Figure 30.22 Byte swap with MSB/LSB transfer

### 30.3.4.4 Byte Swap Reception

#### (1) MSB-first transfer. (When the byte swap is disabled.)

The first received data (R31) is stored in bit 0 of the shift register, and received data is shifted in the order of R31 → R30 → ... → R00.

When necessary RSPCK cycles are input and data is stored from Byte0 [R31 to R24] to Byte3 [R07 to R00], the shift register value is copied to the receive buffer.

#### (2) MSB-first transfer. (When the byte swap is enabled.)

The first received data (R07) is stored in bit 0 of the shift register, and received data is shifted in the order of R07 → R06 → ... → R00 → R15 → R14 → ... → R08 → R23 → R22 → ... → R16 → R31 → R30 → ... → R24.

When necessary RSPCK cycles are input and data is stored from Byte3 [R07 to R00] to Byte0 [R31 to R24], byte values in the shift register are reversed in byte units and are copied to the receive buffer in the order of Byte0 [R31 to R24] to Byte3 [R07 to R00].

#### (3) LSB-first transfer. (When the byte swap is disabled.)

The first received data (R00) is stored in bit 0 of the shift register, and received data is shifted in the order of R00 → R01 → ... → R31.

When necessary RSPCK cycles are input and data is stored from Byte3 [R00 to R07] to Byte0 [R24 to R31], bit values in the shift register are reversed in bit units and are copied to the receive buffer in the order of Byte0 [R31 to R24] to Byte3 [R07 to R00].

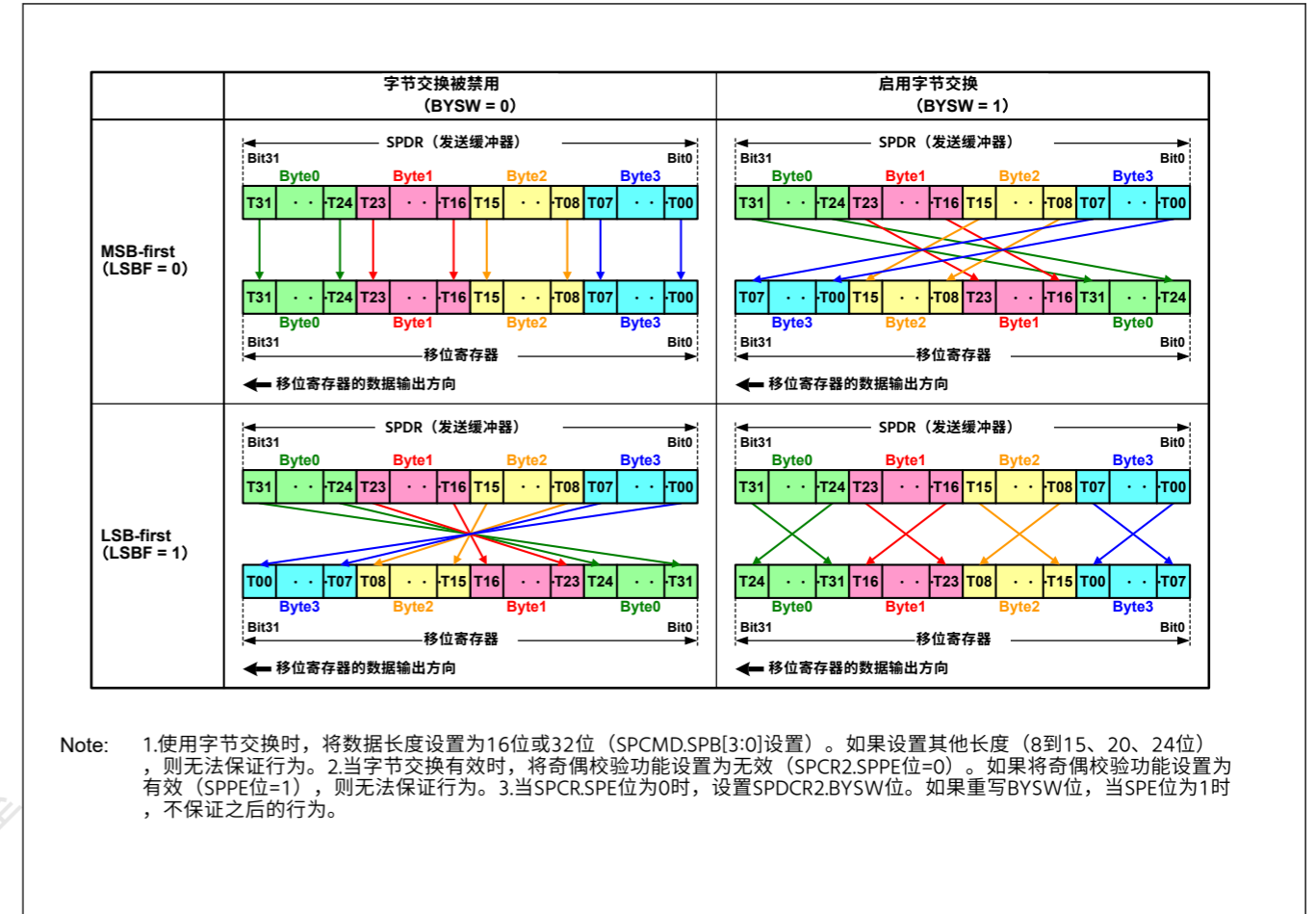


Figure 30.22 带MSBLSB传输的字节交换

### 30.3.4.4 字节交换接收

#### (1) MSB优先传输。（禁用字节交换时。）

第一个接收到的数据（R31）存储在移位寄存器的第0位，接收到的数据按照R31→R30→...→R00的顺序进行移位。

当输入必要的RSPCK周期并将数据从Byte0[R31到R24]存储到Byte3[R07到R00]时，移位寄存器值被复制到接收缓冲区。

#### (2) MSB优先传输。（启用字节交换时。）

第一个接收到的数据（R07）存放在移位寄存器的第0位，接收到的数据按照R07→R06→...→R00→R15→R14→...→R08→R23→R22→...→R16→R31→R30→...→R24的顺序移位。

当输入必要的RSPCK周期并将数据从Byte3[R07到R00]存储到Byte0[R31到R24]时，移位寄存器中的字节值以字节为单位进行反转，并按Byte0[R31的顺序复制到接收缓冲区到R24]到字节3[R07到R00]。

#### (3) LSB优先传输。（禁用字节交换时。）

第一个接收到的数据（R00）存放在移位寄存器的第0位，接收到的数据按照R00→R01→...→R31的顺序移位。

当输入必要的RSPCK周期并将数据从Byte3[R00到R07]存储到Byte0[R24到R31]时，移位寄存器中的位值以位为单位反转，并按Byte0[R31的顺序复制到接收缓冲区到R24]到字节3[R07到R00]。

(4) LSB-first transfer. (When the byte swap is enabled.)

The first received data (R24) is stored in bit 0 of the shift register, and received data is shifted in the order of R24 → R25 → ... → R31 → R16 → R17 → ... → R23 → R08 → R09 → ... → R15 → R00 → R01 → ... → R07.

When necessary RSPCK cycles are input and data is stored from Byte0 [R24 to R31] to Byte3 [R00 to R07], bit values of each byte in the shift register are reversed in bit units and are copied to the receive buffer in the order of Byte0 [R31 to R24] to Byte3 [R07 to R00].

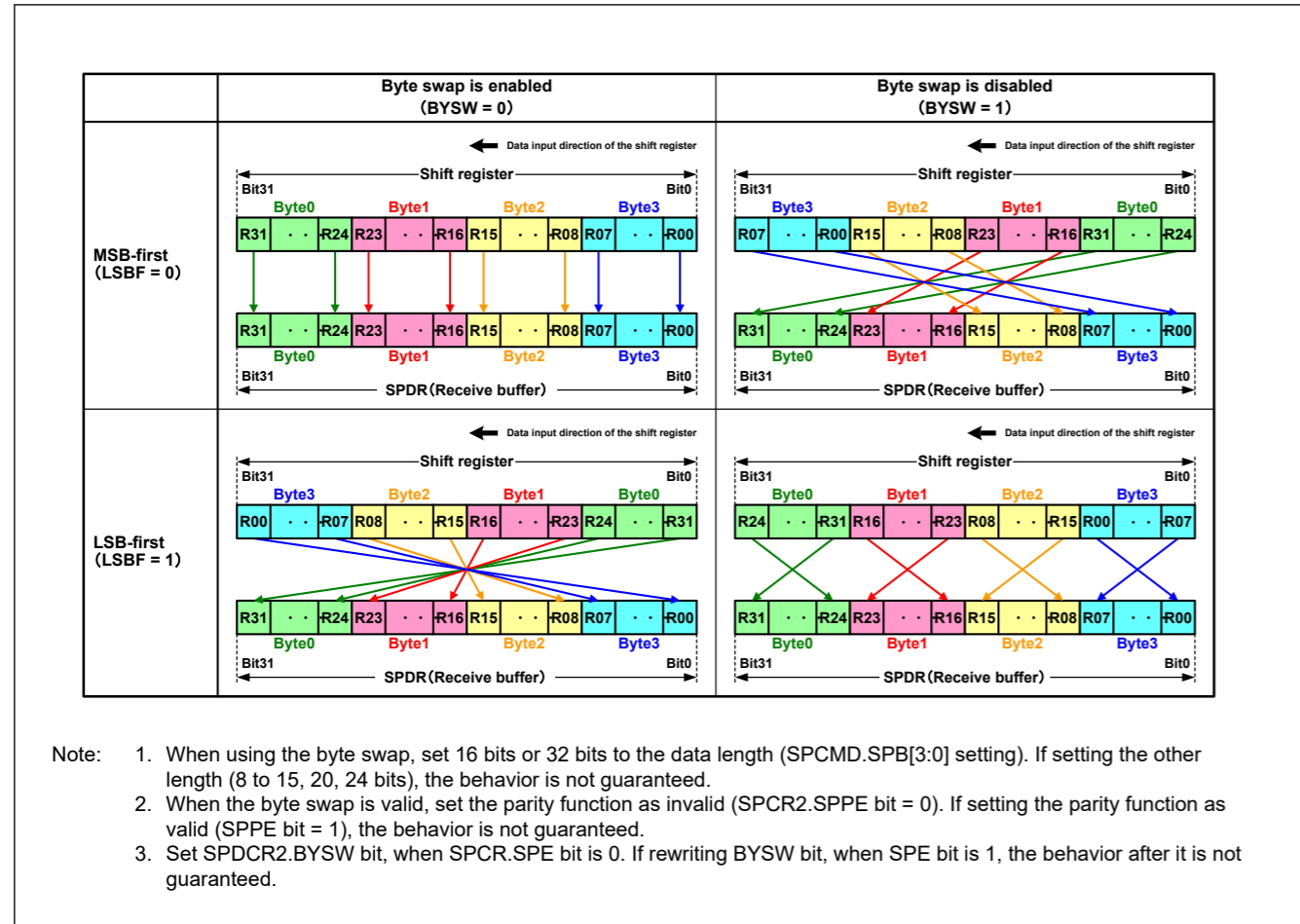


Figure 30.23 Byte swap with MSB/LSB transfer

30.3.5 Transfer Formats

30.3.5.1 When CPHA = 0

Figure 30.24 shows an example transfer format for the serial transfer of 8-bit data when the SPCMDm.CPHA bit is 0. Do not perform clock synchronous operation (SPCR.SPMS = 1) when the SPI operates in slave mode (SPCR.MSTR = 0) and the CPHA bit is 0. In Figure 30.24, RSPCKn (CPOL = 0) indicates the RSPCKn signal waveform when the SPCMDm.CPOL bit is 0, and RSPCKn (CPOL = 1) indicates the RSPCKn signal waveform when the CPOL bit is 1. The sampling timing represents the timing at which the SPI fetches serial transfer data into the shift register. The I/O directions of the signals depend on the SPI settings. For details, see section 30.3.2. Controlling the SPI Pins.

When the SPCMDm.CPHA bit is 0, the driving of valid data to the MOSIn and MISOOn signals begins at an SSLni signal assertion. The first RSPCKn signal change that occurs after the SSLni signal assertion becomes the first transfer data fetch. After this, data is sampled every 1 RSPCK cycle. The change timing for MOSIn and MISOOn signals is 1/2 RSPCK cycles after the transfer data fetch timing. The CPOL bit setting does not affect the RSPCK signal operation timing as it only affects the signal polarity.

t1 denotes the RSPCK delay, the period from an SSLni signal assertion to RSPCKn oscillation. t2 denotes the SSL negation delay, the period from the termination of RSPCKn oscillation to an SSLni signal negation. t3 denotes the next-access delay,

(4) LSB优先传输。(启用字节交换时。)

第一个接收到的数据 (R24) 存放在移位寄存器的第0位, 接收到的数据按R24→R25→...→R31→R16→R17→...→R23→R08→R09→...→R15→的顺序移位R00→R01→...→R07。

当输入必要的RSPCK周期并将数据从Byte0[R24到R31]到Byte3[R00到R07]存储时, 移位寄存器中每个字节的位值以位为单位反转, 并按顺序复制到接收缓冲区Byte0[R31到R24]到Byte3[R07到R00]。

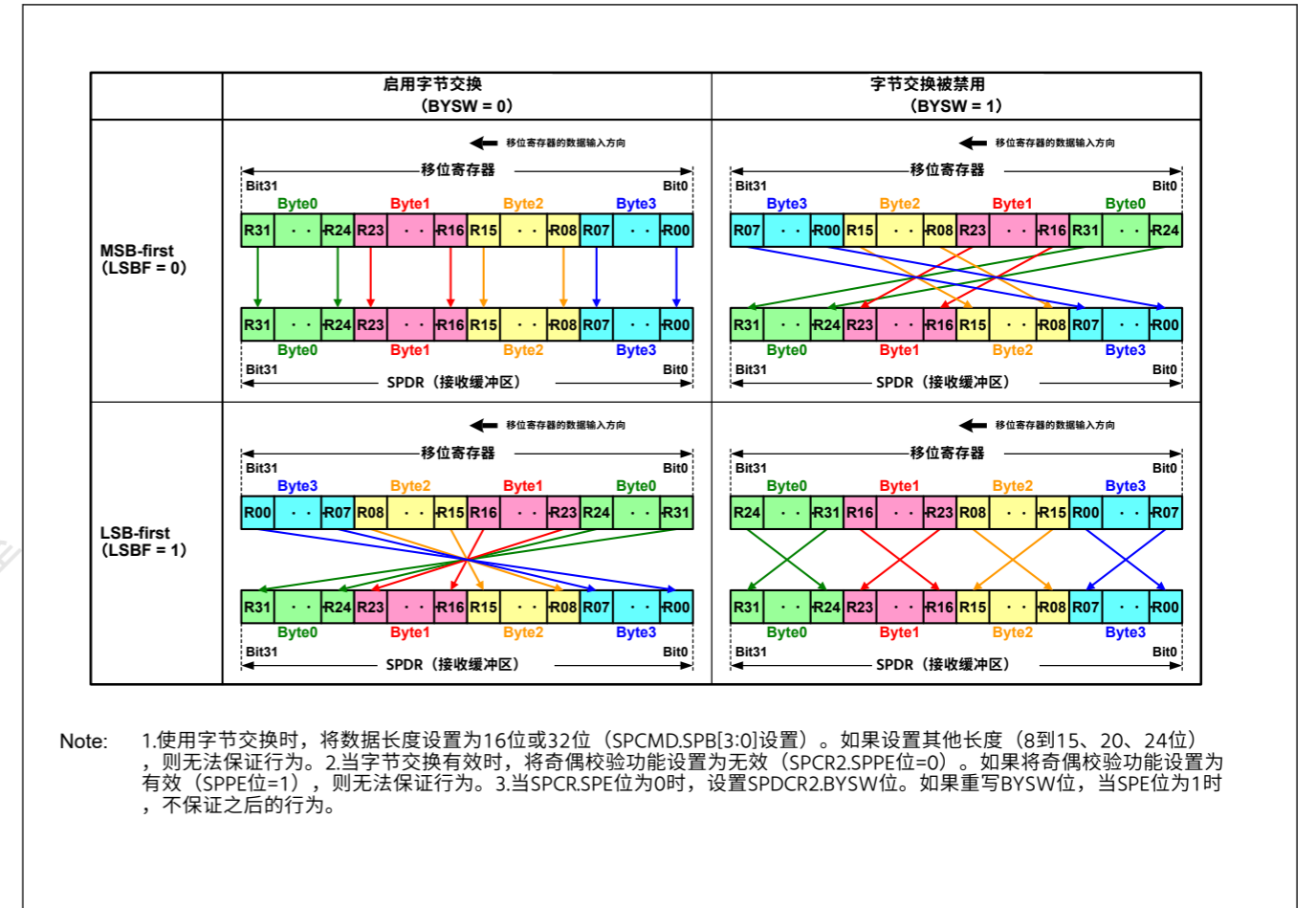


Figure 30.23 带MSB/LSB传输的字节交换

30.3.5 传输格式

30.3.5.1 When CPHA = 0

图30.24显示了当SPCMDm.CPHA位为0时串行传输8位数据的示例传输格式。当SPI在从机模式下运行时 (SPCR.MSTR=0)且CPHA位为0。在图30.24中, RSPCKn(CPOL=0)表示SPCMDm.CPOL位为0时的RSPCKn信号波形, RSPCKn(CPOL=1)表示CPOL位为1时的RSPCKn信号波形。采样时序表示SPI将串行传输数据取入移位寄存器的时序。信号的IO方向取决于SPI设置。有关详细信息, 请参阅第30.3.2节。控制SPI引脚。

当SPCMDm.CPHA位为0时, 将有效数据驱动到MOSIn和MISOOn信号开始于SSLni信号断言。在SSLni信号断言之后发生的第一个RSPCKn信号变化成为第一次传输数据获取。此后, 每1个RSPCK周期对数据进行采样。MOSIn和MISOOn信号的变化时序是传输数据获取时序之后的1/2 RSPCK周期。CPOL位设置不影响RSPCK信号操作时序, 因为它只影响信号极性。

t1表示RSPCK延迟, 即从SSLni信号断言到RSPCKn振荡的周期。t2表示SSL否定延迟, 即从RSPCKn振荡终止到SSLni信号否定的周期。t3表示下一次访问延迟,



the period in which SSLni signal assertion is suppressed for the next transfer after the end of serial transfer. t1, t2, and t3 are controlled by a master device running on the SPI system. For a description of t1, t2, and t3 when the SPI is in master mode, see [section 30.3.11.1. Master mode operation](#).

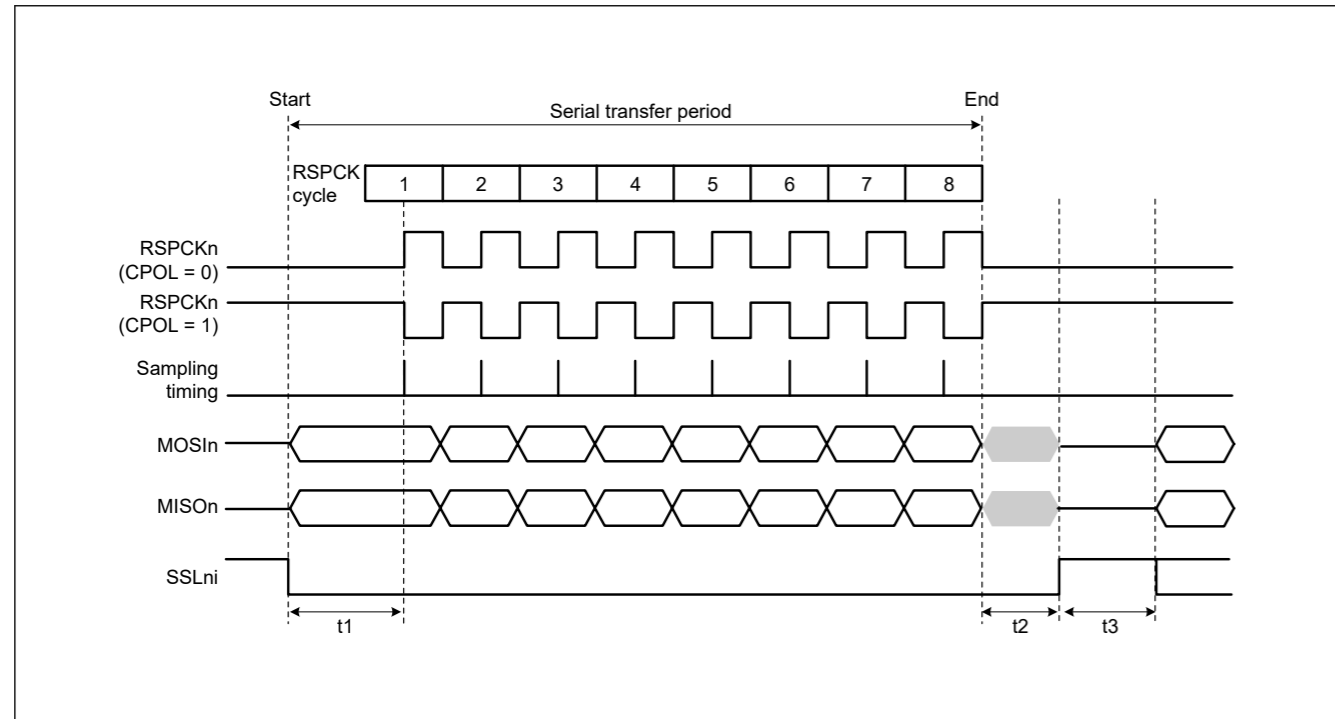


Figure 30.24 SPI transfer format when CPHA = 0

### 30.3.5.2 When CPHA = 1

Figure 30.25 shows an example transfer format for the serial transfer of 8-bit data when the SPCMDm.CPHA bit is 1. However, when the SPCR.SPMS bit is 1, the SSLni signals are not used, and only the three signals RSPCKn, MOSIn, and MISOOn handle communications. In Figure 30.25, RSPCK (CPOL = 0) indicates the RSPCKn signal waveform when the SPCMDm.CPOL bit is 0 and RSPCK (CPOL = 1) indicates the RSPCKn signal waveform when the CPOL bit is 1. The sampling timing represents the timing at which the SPI fetches serial transfer data into the shift register. The I/O directions of the signals depend on the SPI mode (master or slave mode). For details, see [section 30.3.2. Controlling the SPI Pins](#).

When the SPCMDm.CPHA bit is 1, the driving of invalid data to the MISOOn signal begins at an SSLni signal assertion. The output of valid data to the MOSIn and MISOOn signals begins at the first RSPCKn signal change that occurs after the SSLni signal assertion. After this, data is updated every 1 RSPCK cycle. The transfer data fetch timing is 1/2 RSPCK cycles after the data update timing. The SPCMDm.CPOL bit setting does not affect the RSPCKn signal operation timing. It only affects the signal polarity.

t1, t2, and t3 are the same as those when CPHA = 0. For a description of t1, t2, and t3 when the SPI of the MCU is in master mode, see [section 30.3.11.1. Master mode operation](#).

在串行传输结束后，为下一次传输抑制SSLni信号断言的时间段。t1、t2和t3由在SPI系统上运行的主设备控制。有关SPI处于主模式时的t1、t2和t3的说明，请参见第30.3.11.1节。主模式操作。

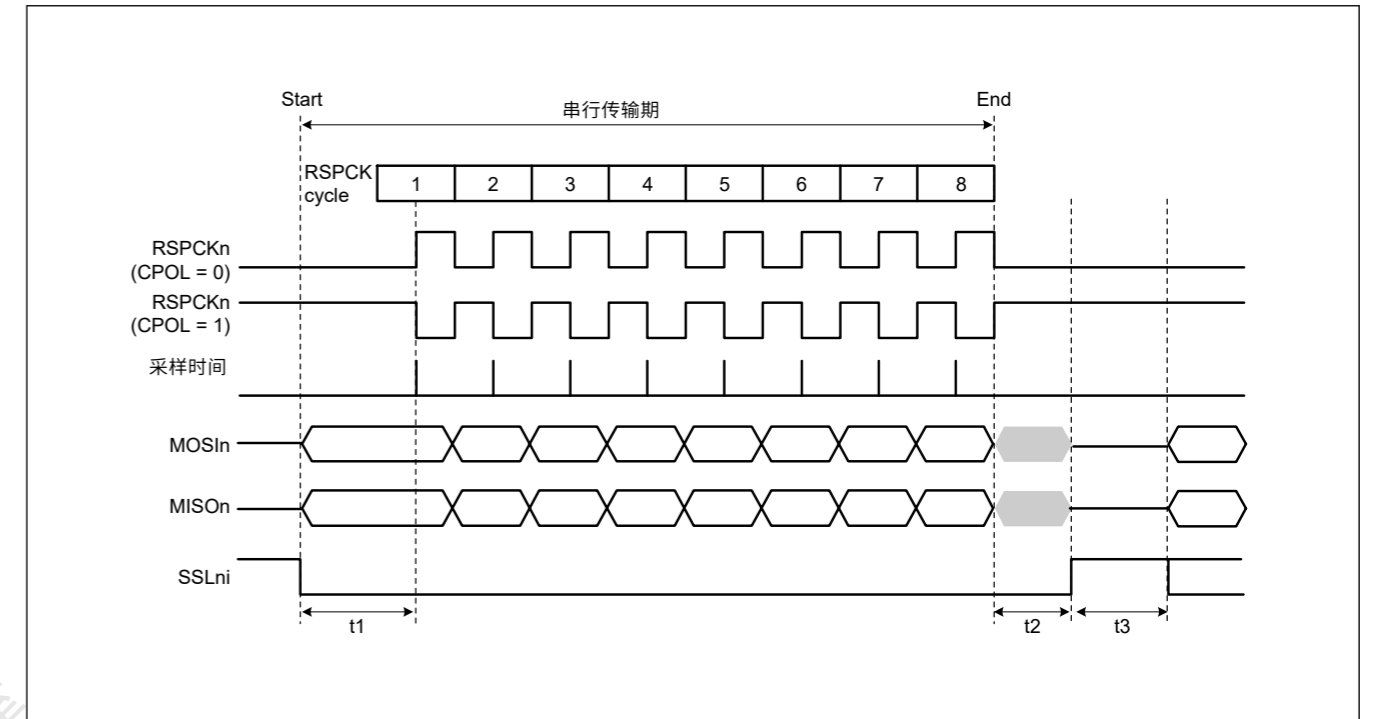


Figure 30.24 CPHA=0时的SPI传输格式

### 30.3.5.2 When CPHA = 1

图30.25显示了当SPCMDm.CPHA位为1时串行传输8位数据的示例传输格式。但是，当SPCR.SPMS位为1时，不使用SSLni信号，只有RSPCKn、MOSIn和MISOOn处理通信。在图30.25中，RSPCK(CPOL=0)表示SPCMDm.CPOL位为0时的RSPCKn信号波形，RSPCK(CPOL=1)表示CPOL位为1时的RSPCKn信号波形。SPI将串行传输数据提取到移位寄存器中。信号的IO方向取决于SPI模式（主模式或从模式）。有关详细信息，请参阅第30.3.2节。控制SPI引脚。

当SPCMDm.CPHA位为1时，将无效数据驱动到MISOOn信号开始于SSLni信号断言。在SSLni信号置位后发生的第一个RSPCKn信号变化时，开始向MOSIn和MISOOn信号输出有效数据。此后，每1个RSPCK周期更新一次数据。传输数据获取时序是数据更新时序之后的1/2个RSPCK周期。SPCMDm.CPOL位设置不影响RSPCKn信号操作时序。它只影响信号极性。

t1、t2、t3与CPHA=0时相同。MCU的SPI为主机模式时t1、t2、t3的说明见30.3.11.1节。主模式操作。



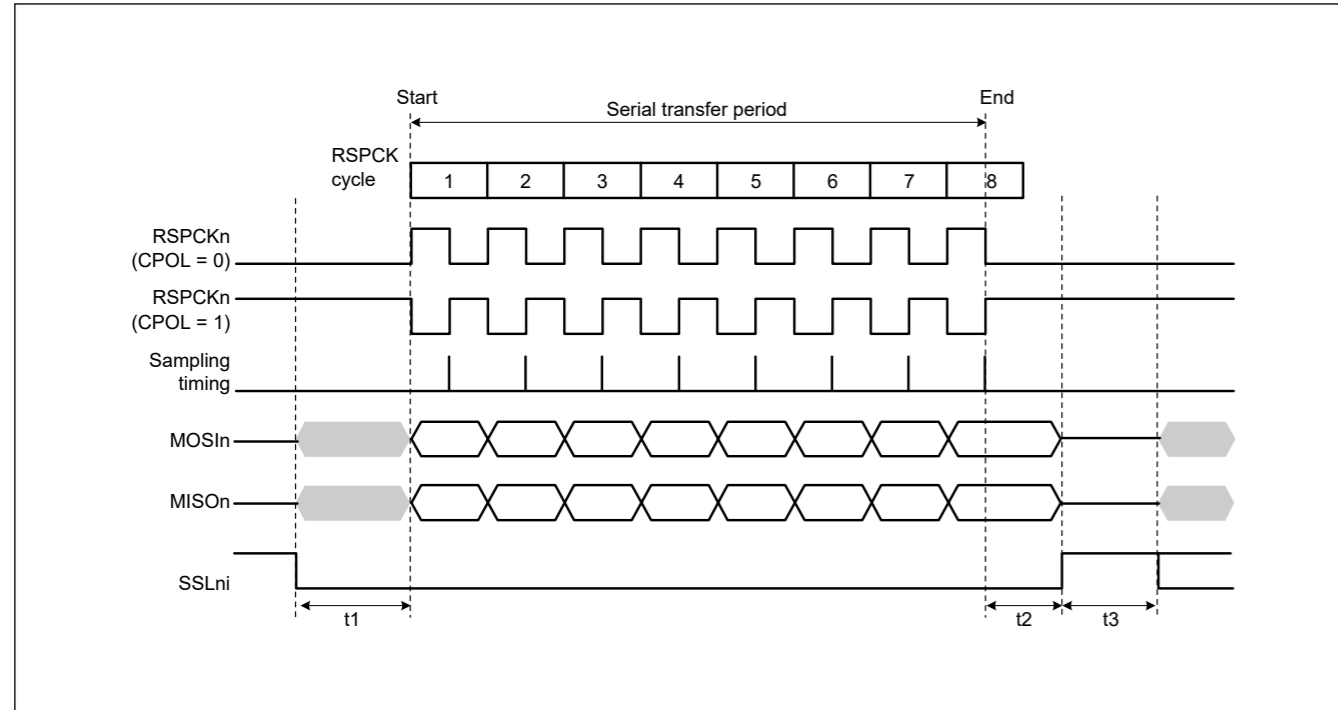


Figure 30.25 SPI transfer format when CPHA = 1

### 30.3.6 Data Transfer Modes

Full-duplex synchronous serial communications or transmit operations can only be selected in the Communications Operating Mode Select bit (SPCR.TXMD) when the extended communication mode select bit (ETXMD) in the SPI control register 3 (SPCR3) is 0. The SPI operation is receive only in slave mode (SPCR.MSTR = 0) when the SPCR3.ETXMD bit is 1, because SPCR.TXMD bit does not affect the SPI operation. The register accesses shown in Figure 30.26, Figure 30.27, and Figure 30.28 indicate the condition of access to the SPDR/SPDR\_HA register, where W denotes a write cycle.

#### 30.3.6.1 Full-duplex synchronous serial communications (SPCR3.ETXMD = 0, SPCR.TXMD = 0)

Figure 30.26 shows an example of operation when the extended communication mode select bit (ETXMD) in the SPI control register 3 (SPCR3) is set to 0 and the Communications Operating Mode Select bit (SPCR.TXMD) is set to 0. In this example, the SPI performs an 8-bit serial transfer when SPDCR.SPFC[1:0] bits are 00b, the SPCMDm.CPHA bit is 1, and the SPCMDm.CPOL bit is 0. The numbers given for RSPCKn in the waveform represent the number of RSPCK cycles, such as the number of transferred bits.

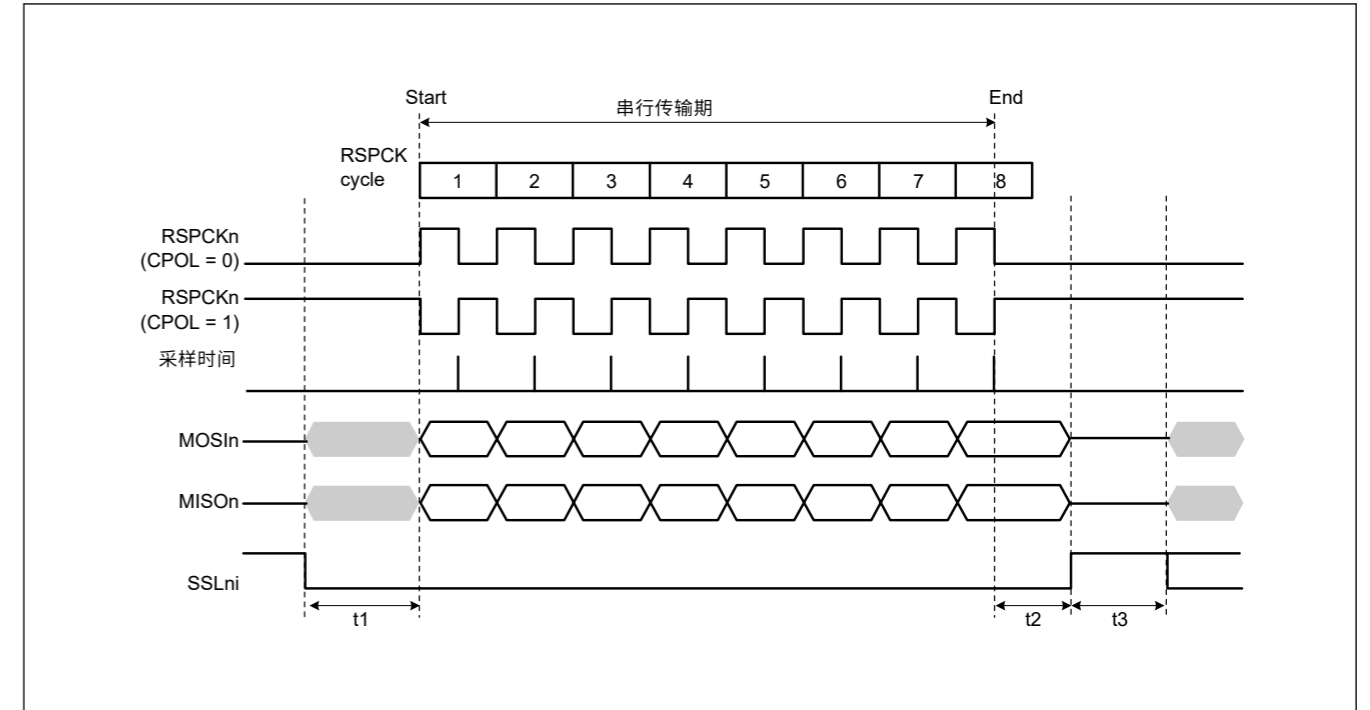


Figure 30.25 CPHA=1时的SPI传输格式

### 30.3.6 数据传输模式

全双工同步串行通信或传输操作只能在通信中选择  
当SPI控制寄存器3(SPCR3)中的扩展通信模式选择位(ETXMD)为0时，工作模式选择位(SPCR.TXMD)。当SPCR3.ETXMD位为1，因为SPCR.TXMD位不影响SPI操作。图30.26、图30.27和图30.28所示的寄存器访问表示访问SPDR/SPDR\_HA寄存器的条件，其中W表示写周期。

#### 30.3.6.1 全双工同步串行通信 (SPCR3.ETXMD=0, SPCR.TXMD = 0)

图30.26显示了当SPI控制寄存器3(SPCR3)中的扩展通信模式选择位(ETXMD)设置为0并且通信操作模式选择位(SPCR.TXMD)设置为0时的操作示例。在此示例中，当SPDCR.SPFC[1:0]位为00b、SPCMDm.CPHA位为1、SPCMDm.CPOL位为0时，SPI执行8位串行传输。波形中为RSPCKn给出的数字表示RSPCK周期数，例如传输的位数。

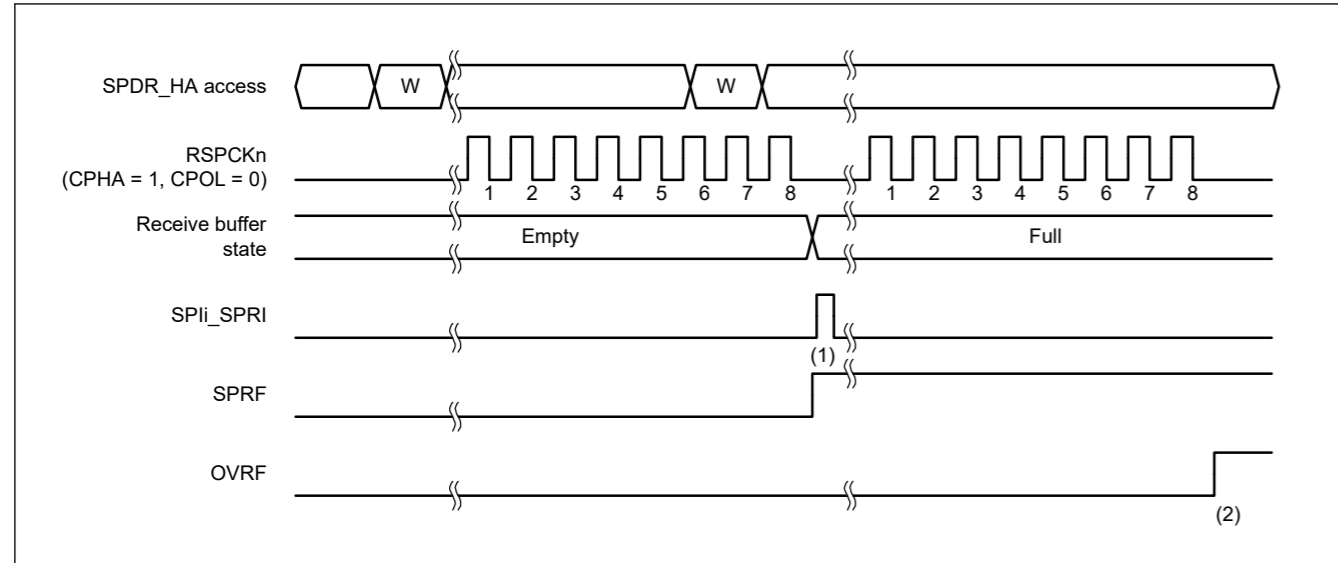


Figure 30.26 Operation example when SPCR3.ETXMD = 0 and SPCR.TXMD = 0

The operation of the flags at timings (1) and (2) in Figure 30.26 is as follows:

1. When a serial transfer ends with the receive buffer of SPDR\_HA empty, the SPI generates a receive buffer full interrupt request (SPIi\_SPRI), the SPI sets the SPSR.SPRF flag to 1, and copies the received data in the shift register to the receive buffer.
2. When a serial transfer ends with the receive buffer of SPDR\_HA holding data that was received in the previous serial transfer, the SPI sets the SPSR.OVRF flag to 1, and discards the received data in the shift register. For details about the operation of the SPSR.OVRF flag, see section 30.3.9.1. Overrun errors.

### 30.3.6.2 Transmit-Only Serial Communications (SPCR3.ETXMD = 0, SPCR.TXMD = 1)

Figure 30.27 shows an example of operation when the extended communication mode select bit (ETXMD) in the SPI control register 3 (SPCR3) is set to 0 and the Communications Operating Mode Select bit (SPCR.TXMD) is set to 1. In this example, the SPI performs an 8-bit serial transfer when SPDCR.SPFC[1:0] bits are 00b, the SPCMDm.CPHA bit is 1, and the SPCMDm.CPOL bit is 0. The numbers given for RSPCKn in the waveform represent the number of RSPCK cycles, such as the number of transferred bits.

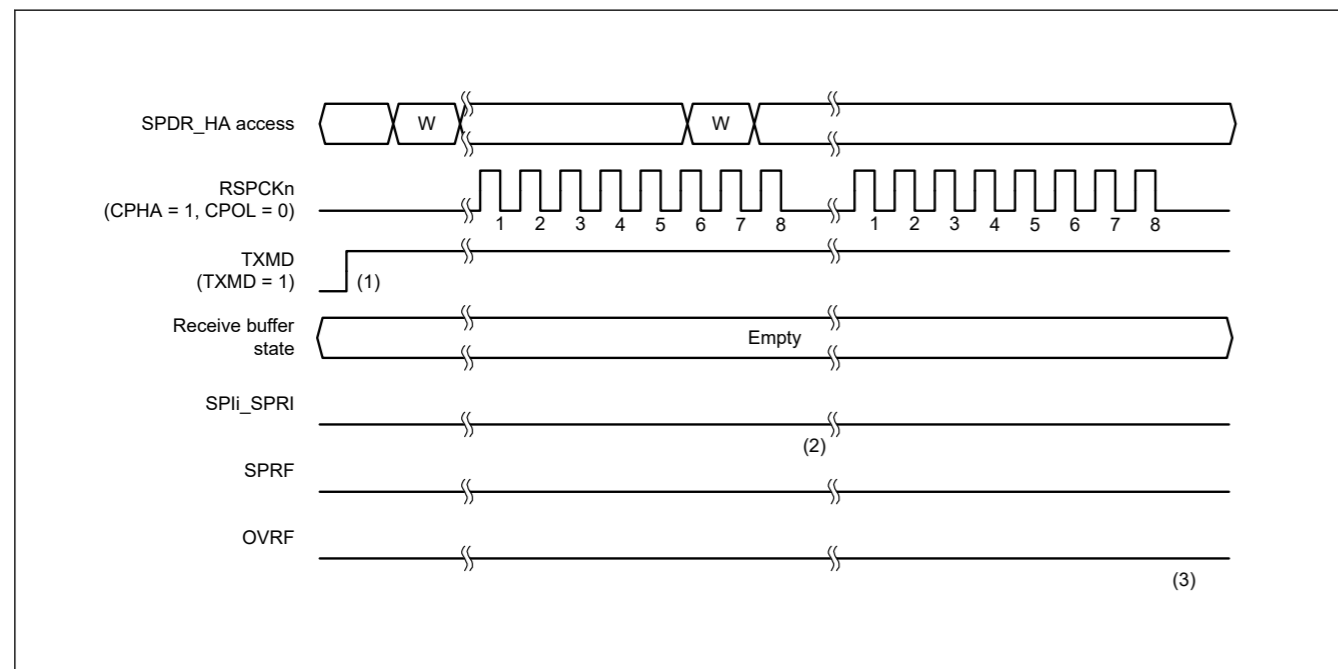


Figure 30.27 Operation example when SPCR3.ETXMD = 0 and SPCR.TXMD = 1

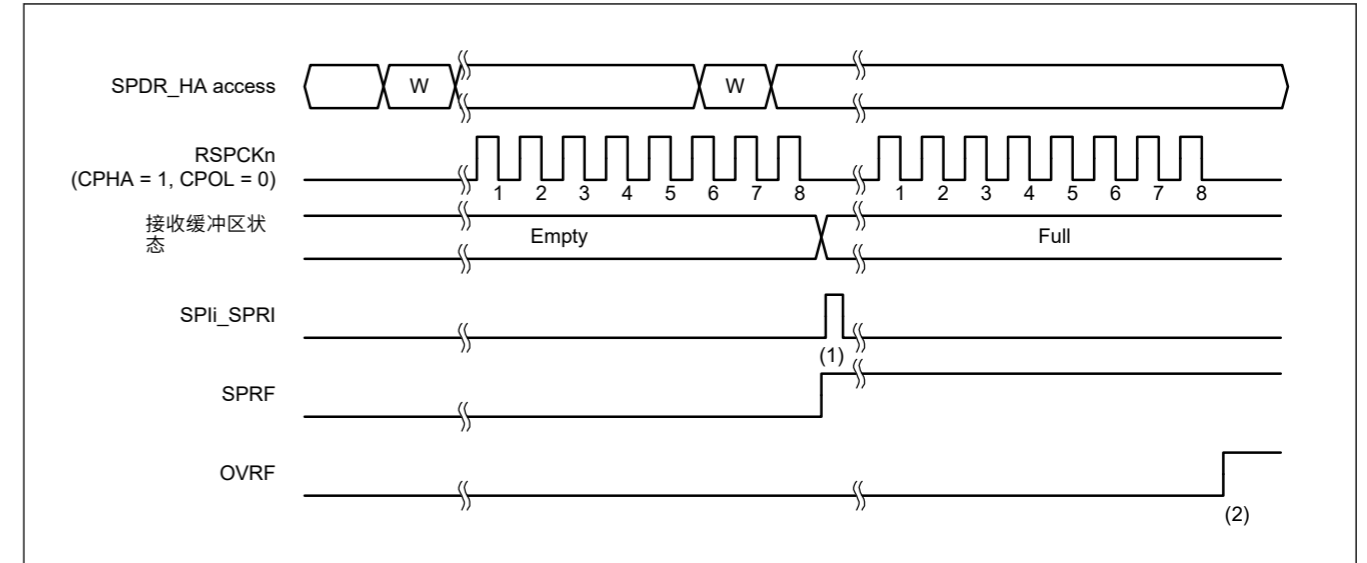


Figure 30.26 SPCR3.ETXMD=0和SPCR.TXMD=0时的操作示例

图30.26中时序(1)和(2)的标志操作如下:

- 1.当串行传输结束且SPDR\_HA的接收缓冲区为空时，SPI产生接收缓冲区满中断请求（SPIi\_SPRI），SPI将SPSR.SPRF标志设置为1，并将接收到的移位寄存器中的数据复制到接收缓冲区。
- 2.当串行传输结束时，SPDR\_HA的接收缓冲区保存了前一次串行传输中接收到的数据，SPI将SPSR.OVRF标志设置为1，并丢弃移位寄存器中接收到的数据。有关SPSR.OVRF标志操作的详细信息，请参见第30.3.9.1节。溢出错误。

### 30.3.6.2 仅发送串行通信 (SPCR3.ETXMD=0, SPCR.TXMD=1)

图30.27显示了当SPI控制寄存器3 (SPCR3) 中的扩展通信模式选择位 (ETXMD) 设置为0并且通信操作模式选择位 (SPCR.TXMD) 设置为1时的操作示例。在此示例中，当SPDCR.SPFC[1:0]位为00b、SPCMDm.CPHA位为1、SPCMDm.CPOL位为0时，SPI执行8位串行传输。波形中为RSPCKn给出的数字表示RSPCK周期数，例如传输的位数。

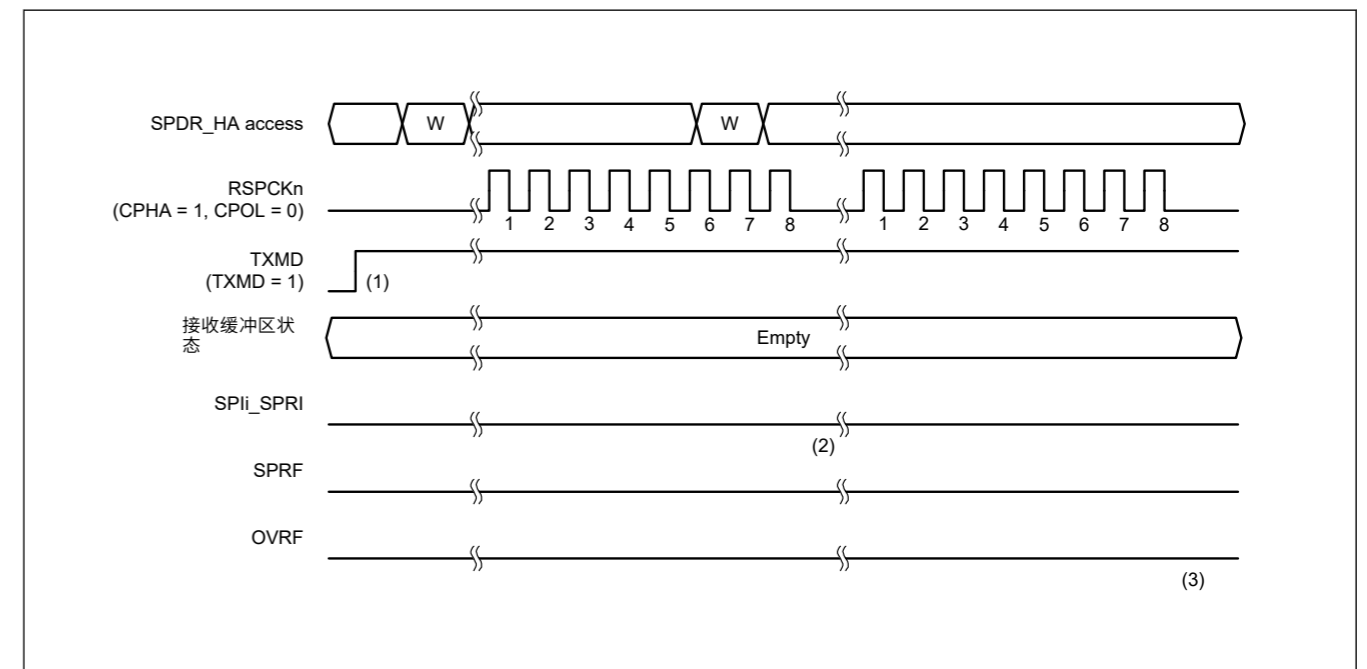


Figure 30.27 SPCR3.ETXMD=0和SPCR.TXMD=1时的操作示例

The operation of the flags at timings (1) to (3) in Figure 30.27 is as follows:

1. Make sure there is no data left in the receive buffer (the SPSR.SPRF flag is 0) and the SPSR.OVRF flag is 0 before entering transmit-only mode (SPCR3.ETXMD = 0, SPCR.TXMD = 1).
2. When a serial transfer ends with the receive buffer of SPDR\_HA empty, if the transmit-only mode is selected (SPCR3.ETXMD = 0, SPCR.TXMD = 1), the SPSR.SPRF flag retains the value of 0, and the SPI does not copy the data in the shift register to the receive buffer.
3. Because the receive buffer of SPDR\_HA does not hold data that was received in the previous serial transfer, even when a serial transfer ends, the SPSR.OVRF flag retains the value of 0, and the data in the shift register is not copied to the receive buffer.

In transmit-only mode (SPCR3.ETXMD = 0, SPCR.TXMD = 1), the SPI transmits data but does not receive data. Therefore, the SPSR.SPRF and SPSR.OVRF flags remain 0 at timings (1) to (3).

### 30.3.6.3 Receive-Only Serial Communication (MSTR = 0, ETXMD = 1)

Figure 30.28 shows an example of operation when the SPI master/slave mode select bit (MSTR) in the SPI control register (SPCR) is set to 0 and the extended communication mode select bit (ETXMD) in the SPI control register 3 (SPCR3) is set to 1. In the example in Figure 30.28, the SPI performs 8-bit data serial transfer with the settings of SPFC[1:0] in the SPI data control register (SPDCR) = 00b, CPHA in the SPI command register (SPCMD) = 1, and CPOL in SPCMD = 0. Numbers under the RSPCK waveform show the number of RSPCK cycles (number of transfer bits).

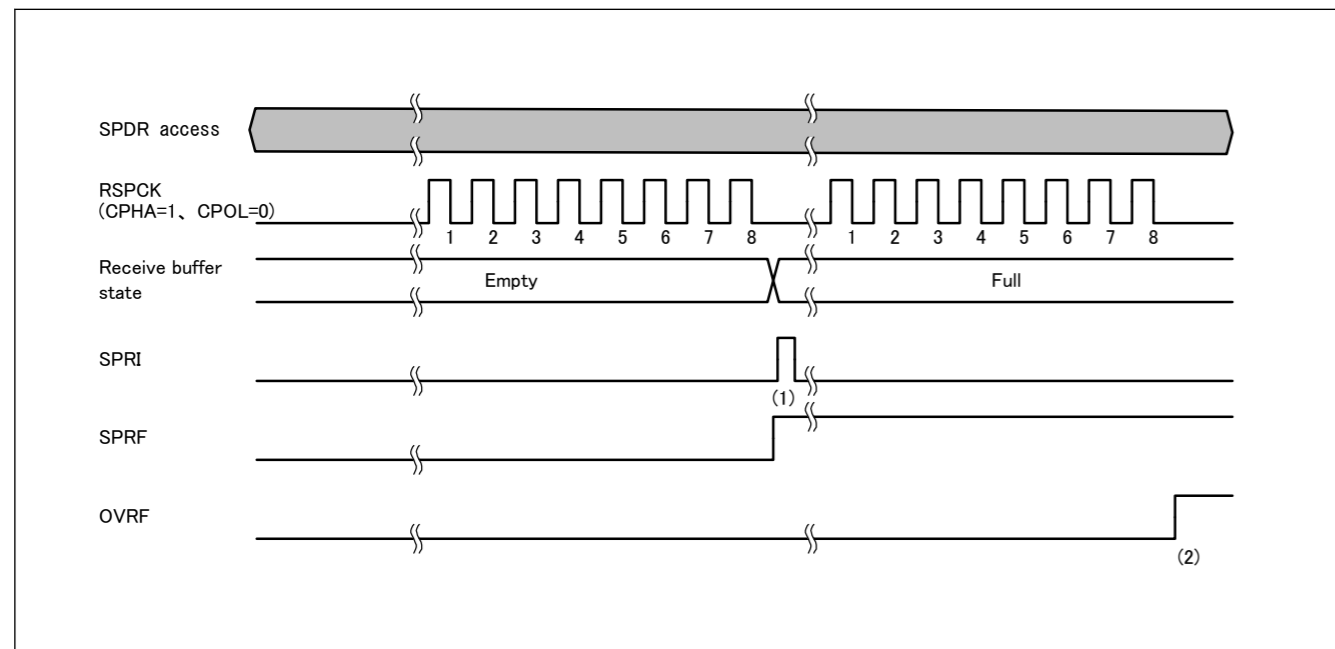


Figure 30.28 Example of Operation when MSTR = 0 and ETXMD = 1

The following describes operation of flags at timings (1) and (2) in the figure above.

- (1) When serial transfer ends while the SPDR's receive buffer is empty, the SPI generates a receive buffer full interrupt request SPRI (setting the SPSR.SPRF flag to 1) and copies the received data in the shift register to the receive buffer
- (2) When serial transfer ends while previously received data is remaining in the SPDR's receive buffer, the SPI sets the OVRF flag in the SPI status register (SPSR) to 1 and discards the received data in the shift register.

### 30.3.7 Transmit Buffer Empty and Receive Buffer Full Interrupts

Figure 30.29 and Figure 30.30 show examples of operation of the transmit buffer empty interrupt (SPIi\_SPTI) and the receive buffer full interrupt (SPIi\_SPRI). The SPDR\_HA register accesses shown in these figures indicate the conditions of access to the register, where W denotes a write cycle and R a read cycle. In Figure 30.29, the SPI performs an 8-bit serial transfer when SPCR.TXMD bit is 0, the SPDCR.SPFC[1:0] bits are 00b, the SPCMDm.CPHA bit is 0, and the SPCMDm.CPOL bit is 0. In Figure 30.30, the SPI performs an 8-bit serial transfer when SPCR.TXMD bit is 0, the

图30.27中时间(1)到(3)的标志操作如下:

- 1.在进入仅发送模式 (SPCR3.ETXMD=0, SPCR.TXMD=1) 之前, 确保接收缓冲区中没有剩余数据 (SPSR.SPRF标志为0) 且SPSR.OVRF标志为0。
- 2.当串行传输结束且SPDR\_HA的接收缓冲区为空时, 如果选择了仅传输模式 (SPCR3.ETXMD=0 SPCR.TXMD=1), SPSR.SPRF标志保持0的值, SPI不将移位寄存器中的数据复制到接收缓冲区。
- 3.因为SPDR\_HA的接收缓冲区中没有保存上一次串行传输接收到的数据, 所以即使一次串行传输结束, SPSR.OVRF标志保持值0, 移位寄存器中的数据不会被复制到接收缓冲区。

在仅发送模式下 (SPCR3.ETXMD=0, SPCR.TXMD=1), SPI发送数据但不接收数据。因此, SPSR.SPRF和SPSR.OVRF标志在时间(1)到(3)保持0。

### 30.3.6.3 仅接收串行通信 (MSTR=0, ETXMD=1)

图30.28显示了当SPI控制寄存器(SPCR)中的SPI主从模式选择位(MSTR)设置为0并且SPI控制寄存器3(SPCR3)中的扩展通信模式选择位(ETXMD)为设置为1。在图30.28的示例中, SPI执行8位数据串行传输, 设置SPI数据控制寄存器 (SPDCR) 中的SPFC[1:0]=00b, SPI命令寄存器中的CPHA (SPCMD)=1, SPCMD中的CPOL=0。RSPCK波形下的数字表示RSPCK周期数 (传输位数)。

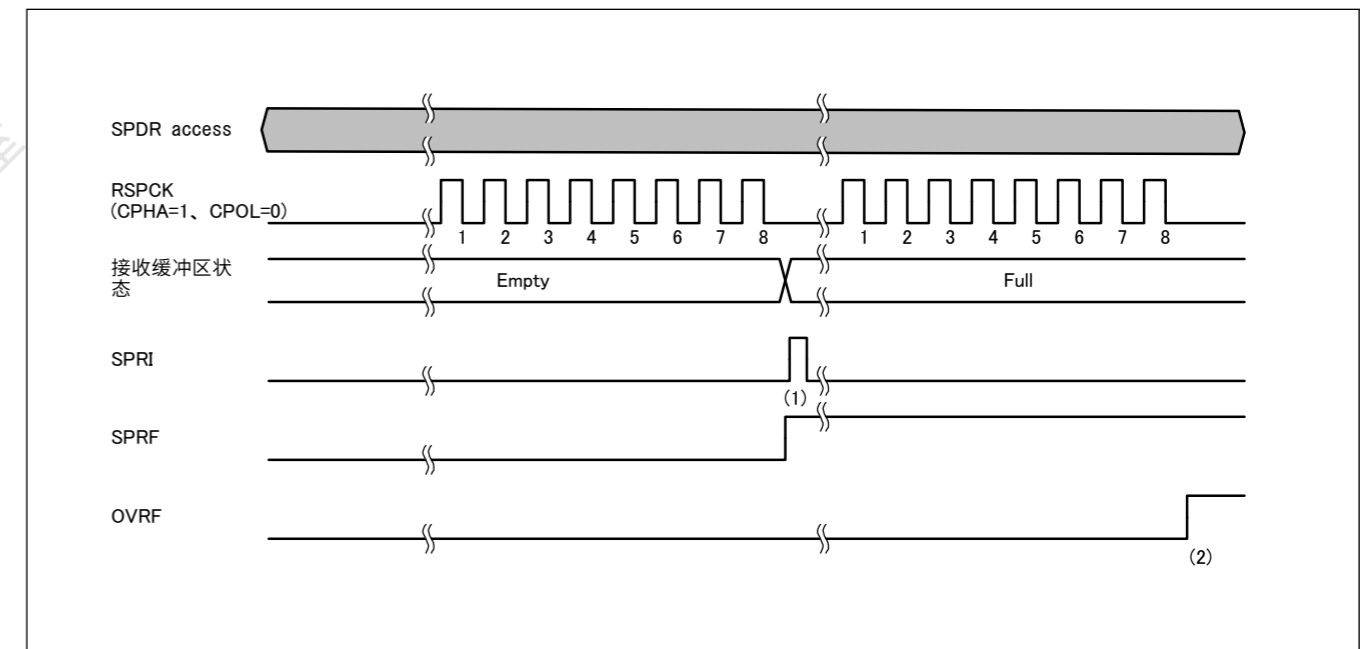


Figure 30.28 MSTR=0和ETXMD=1时的操作示例

下面描述在上图中的时间(1)和(2)的标志的操作。

- (1)当串行传输结束而SPDR的接收缓冲区为空时, SPI产生接收缓冲区满中断请求SPRI (将SPSR.SPRF标志设置为1) 并将接收到的移位寄存器中的数据复制到接收缓冲区
- (2)当串行传输结束而先前接收的数据仍留在SPDR的接收缓冲区中时, SPI将SPI状态寄存器(SPSR)中的OVRF标志设置为1, 并丢弃移位寄存器中的接收数据。

### 30.3.7 发送缓冲区空和接收缓冲区满中断

图30.29和图30.30显示了发送缓冲区空中断(SPIi\_SPTI)和接收缓冲区满中断(SPIi\_SPRI)的操作示例。这些图中显示的SPDR\_HA寄存器访问表示访问寄存器的条件, 其中W表示写周期, R表示读周期。在图30.29中, 当SPCR.TXMD位为0、SPDCR.SPFC[1:0]位为00b、SPCMDm.CPHA位为0、SPCMDm.CPOL位为0时, SPI执行8位串行传输。在图30.30中, 当SPCR.TXMD位为0时, SPI执行8位串行传输,

SPDCR.SPFC[1:0] bits are 00b, the SPCMDm.CPHA bit is 1, and the SPCMDm.CPOL bit is 0. The numbers given for RSPCKn in the waveform represent the number of RSPCK cycles, such as the number of transferred bits.

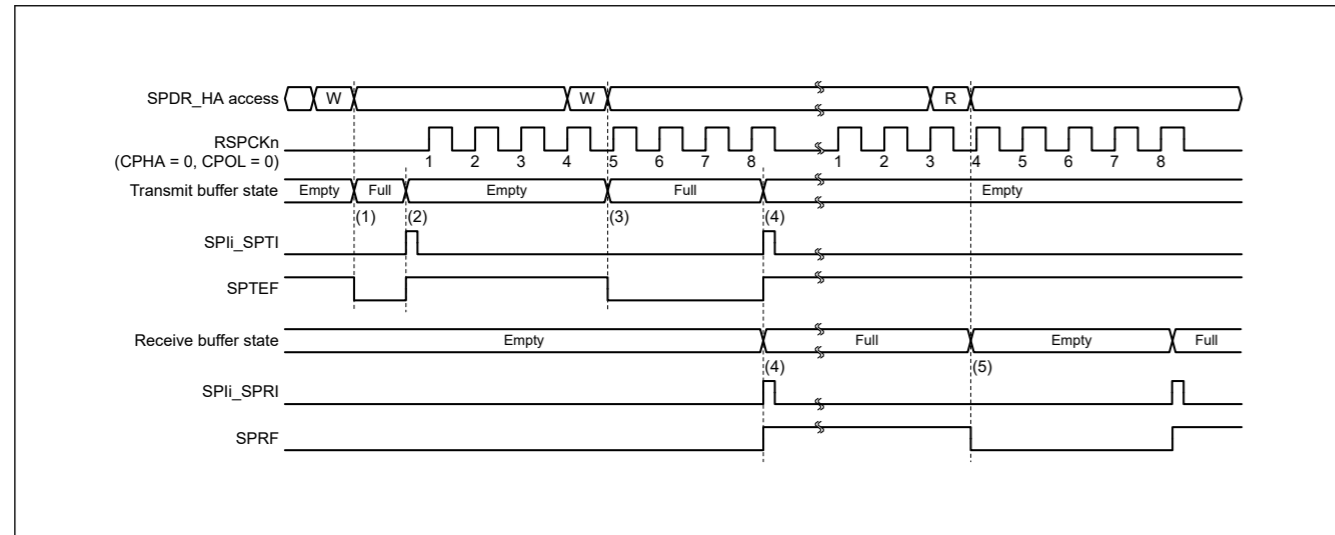


Figure 30.29 Operation example of the SPIi\_SPTI and SPIi\_SPRI interrupts when CPHA = 0 and CPOL = 0 in master mode

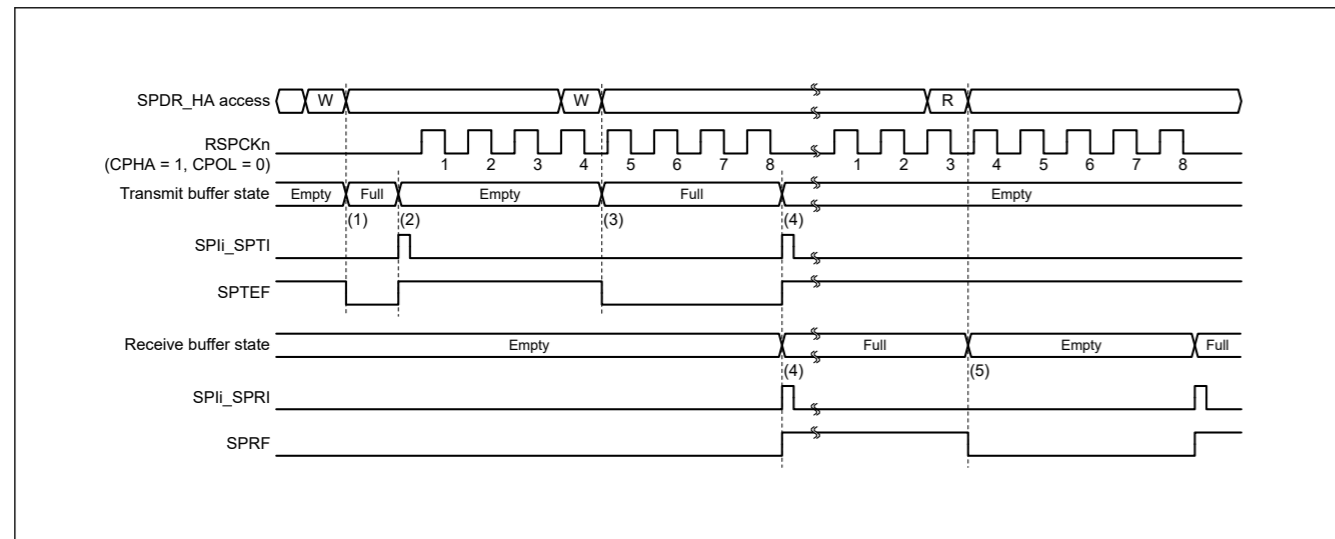


Figure 30.30 Operation example of the SPIi\_SPTI and SPIi\_SPRI interrupts when CPHA = 1 and CPOL = 0 in master mode

The operation of the SPI at timings (1) to (5) in Figure 30.29 and Figure 30.30 is as follows:

1. When transmit data is written to SPDR\_HA with the transmit buffer of SPDR\_HA is empty and data for the next transfer is not set, the SPI writes data to the transmit buffer and clears the SPSR.SPTEF flag to 0.
2. If the shift register is empty, the SPI copies the data in the transmit buffer to the shift register, generates a transmit buffer empty interrupt request (SPIi\_SPTI), and sets the SPSR.SPTEF flag to 1. How a serial transfer is started depends on the SPI mode. For details, see [section 30.3. Operation](#), and [section 30.3.12. Clock Synchronous Operation](#).
3. When transmit data is written to SPDR\_HA either by the transmit buffer empty interrupt routine, or by the processing of the transmit buffer empty using the SPTEF flag, the SPI writes data to the transmit buffer and clears the SPTEF flag to 0. Because the data being transferred serially is stored in the shift register, the SPI does not copy the data in the transmit buffer to the shift register.
4. When the serial transfer ends with the receive buffer of SPDR\_HA empty, the SPI copies the receive data in the shift register to the receive buffer, generates a receive buffer full interrupt request (SPIi\_SPRI), and sets the SPRF flag to 1. Because the shift register becomes empty on completion of the serial transfer, if the transmit buffer is full before the serial transfer ended, the SPI sets the SPTEF flag to 1 and copies data in the transmit buffer to the shift register. Even

SPDCR.SPFC[1:0]位为00b, SPCMDm.CPHA位为1, SPCMDm.CPOL位为0。波形中的RSPCKn表示RSPCK周期数, 例如传输的位数。

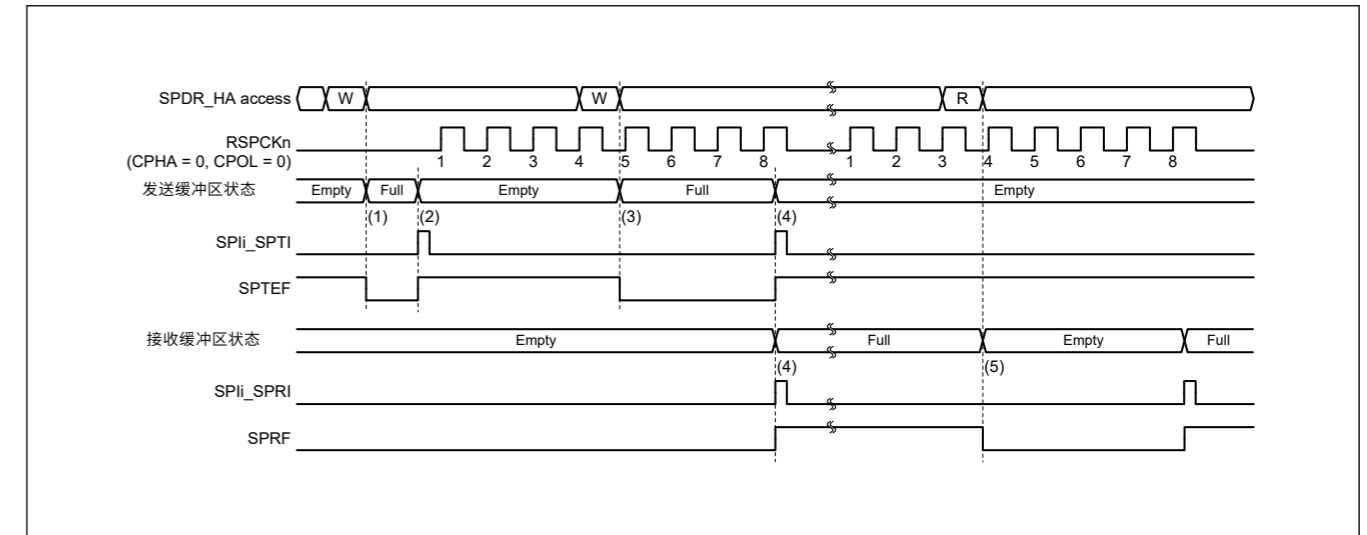


Figure 30.29 主机模式下CPHA=0和CPOL=0时SPIi\_SPTI和SPIi\_SPRI中断的操作示例

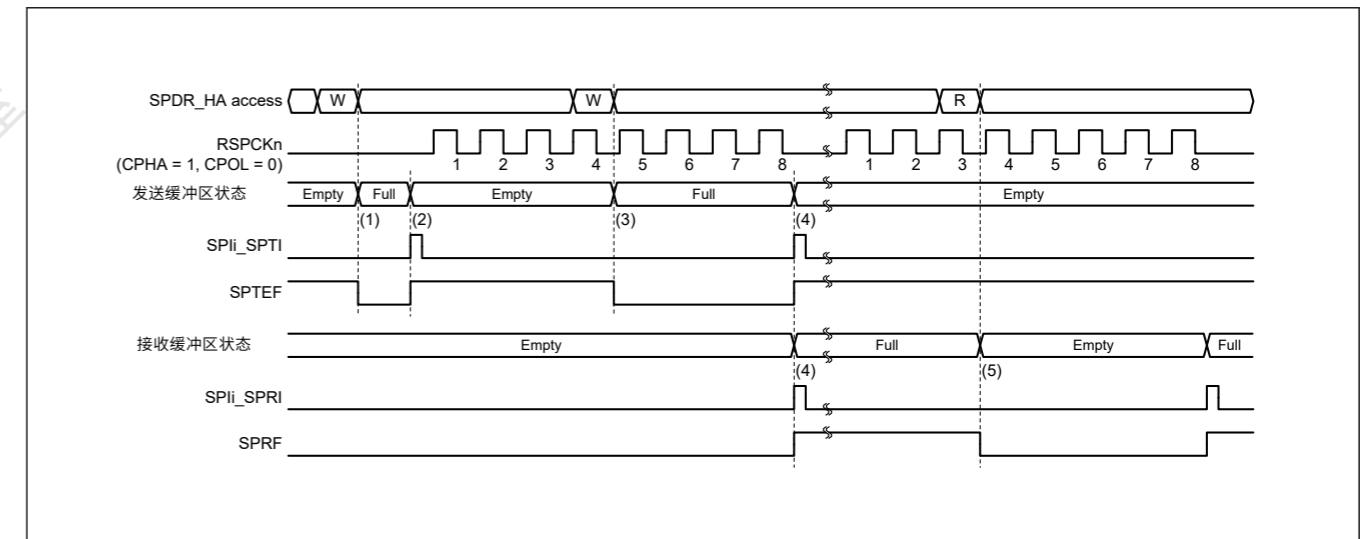


Figure 30.30 主机模式下CPHA=1和CPOL=0时SPIi\_SPTI和SPIi\_SPRI中断的操作示例

SPI在图30.29和图30.30中时序(1)到(5)的操作如下:

- 1.当发送数据写入SPDR\_HA且SPDR\_HA的发送缓冲区为空且未设置下一次传输的数据时, SPI将数据写入发送缓冲区并将SPSR.SPTEF标志清除为0。
- 2.如果移位寄存器为空, SPI将发送缓冲区中的数据复制到移位寄存器, 产生发送缓冲区空中断请求(SPIi\_SPTI), 并将SPSR.SPTEF标志设置为1。如何启动串行传输取决于SPI模式。有关详细信息, 请参阅第30.3节。操作和第30.3.12节。时钟同步操作。
- 3.当发送数据被发送缓冲区空中断程序写入SPDR\_HA时, 或者通过使用SPTEF标志处理发送缓冲区空时, SPI将数据写入发送缓冲区并将SPTEF标志清除为0。因为串行传输的数据存储在移位寄存器中, SPI不会将发送缓冲区中的数据复制到移位寄存器中。
- 4.当串行传输结束且SPDR\_HA的接收缓冲区为空时, SPI将移位寄存器中的接收数据复制到接收缓冲区, 产生接收缓冲区满中断请求(SPIi\_SPRI), 并将SPRF标志设置为1。因为串行传输完成后移位寄存器变为空, 如果在串行传输结束前发送缓冲区已满, SPI将SPTEF标志设置为1, 并将发送缓冲区中的数据复制到移位寄存器。甚至



when received data is not copied from the shift register to the receive buffer in an overrun error status, on completion of the serial transfer, the SPI determines that the shift register is empty, so data transfer from the transmit buffer to the shift register is enabled.

- When SPDR\_HA is read either by the receive buffer full interrupt routine or processing of the receive buffer full interrupt using the SPRF flag, the receive data can be read.

If SPDR\_HA is written to when the transmit buffer holds data that is not yet transmitted (the SPTEF flag is 0), the SPI does not update data in the transmit buffer. When writing to SPDR\_HA, always use either a transmit buffer empty interrupt request or processing of the transmit buffer empty interrupt using the SPTEF flag. To use a transmit buffer empty interrupt, set the SPTIE bit in SPCR to 1. If the SPI function is disabled (the SPCR.SPE bit is 0), set the SPTIE bit to 0.

When serial transfer ends and the receive buffer is full (the SPRF flag is 1), the SPI does not copy data from the shift register to the receive buffer, and it detects an overrun error (see [section 30.3.9. Error Detection](#)). To prevent a receive data overrun error, read the received data using a receive buffer full interrupt request before the next serial transfer ends. To use an SPI receive buffer full interrupt, set the SPCR.SPRIE bit to 1.

Transmission and reception interrupts or the associated IELSRn.IR flags (where n is the interrupt vector number) in the ICU can be used to confirm the states of the transmit and receive buffers.

Similarly, the SPTEF and SPRF flags can be used to confirm the states of the transmit and receive buffers. See [section 13, Interrupt Controller Unit \(ICU\)](#) for the interrupt vector numbers.

### 30.3.8 Communication End Interrupt

#### 30.3.8.1 Transmit-Receive/Transmit in Master Mode

The communication end interrupt (SPCI) is made and the CENDF flag is set to 1, when following conditions are satisfied in transmit-receive master mode and transmit master mode. The set timing of the CENDF flag is same as IDLNF flag. The communication end interrupt (SPCI) is one PCLKUSCIX width and low active.

- When the value of the SPSSR.SPCP[2:0] bits are same as the SPSCR.SPSSLN[2:0] bits.
- When there is no next transmission data.

The CENDF flag will not be cleared even if the SPCR.SPE bit is cleared after CENDF = 1. The CENDF flag will be cleared in one of following tow conditions.

- When the next transmission data is written to the transmit buffer (SPTX).
- The CENDF flag was written 0 after reading the SPSR when the CENDF flag was 1.

[Figure 30.31](#) shows an example of communication end interrupt operation during transmit-receive/transmit master mode.

当接收到的数据在溢出错误状态下没有从移位寄存器复制到接收缓冲区时，在串行传输完成时，SPI确定移位寄存器为空，因此从发送缓冲区到移位寄存器的数据传输被启用。

- 当接收缓冲区满中断程序或使用SPRF标志处理接收缓冲区满中断读取SPDR\_HA时，可以读取接收数据。

如果在发送缓冲区保存尚未发送的数据时写入SPDR\_HA（SPTEF标志为0），则SPI不会更新发送缓冲区中的数据。写入SPDR\_HA时，始终使用发送缓冲区空中断请求或使用SPTEF标志处理发送缓冲区空中断。要使用发送缓冲区空中断，请将SPCR中的SPTIE位设置为1。如果禁用SPI功能（SPCR.SPE位为0），请将SPTIE位设置为0。

当串行传输结束且接收缓冲区已满（SPRF标志为1）时，SPI不会将数据从移位寄存器复制到接收缓冲区，它会检测到溢出错误（参见第30.3.9节。错误检测）。为防止接收数据溢出错误，请在下一次串行传输结束前使用接收缓冲区满中断请求读取接收数据。要使用SPI接收缓冲区满中断，请将SPCR.SPRIE位设置为1。

ICU中的发送和接收中断或相关的IELSRn.IR标志（其中n是中断向量号）可用于确认发送和接收缓冲区的状态。

类似地，SPTEF和SPRF标志可用于确认发送和接收缓冲区的状态。见第13节，用于中断向量编号的中断控制器单元(ICU)。

### 30.3.8 通讯结束中断

#### 30.3.8.1 主控模式下的发送-接收发送

在发送-接收主机模式和发送主机模式下满足以下条件时，将产生通信结束中断(SPCI)并将CENDF标志设置为1。CENDF标志的设置时序与IDLNF标志相同。通信结束中断(SPCI)是一个PCLKUSCIX宽度和低电平有效。

- 当SPSSR.SPCP[2:0]位的值与SPSCR.SPSSLN[2:0]位的值相同时。
- 当没有下一个传输数据时。

即使在CENDF=1后清除SPCR.SPE位，CENDF标志也不会被清除。CENDF标志将在以下两种情况之一被清除。

- 下一个发送数据写入发送缓冲区（SPTX）时。
- 当CENDF标志为1时，读取SPSR后CENDF标志被写入0。

图30.31显示了发送-接收发送主机模式下的通信结束中断操作示例。

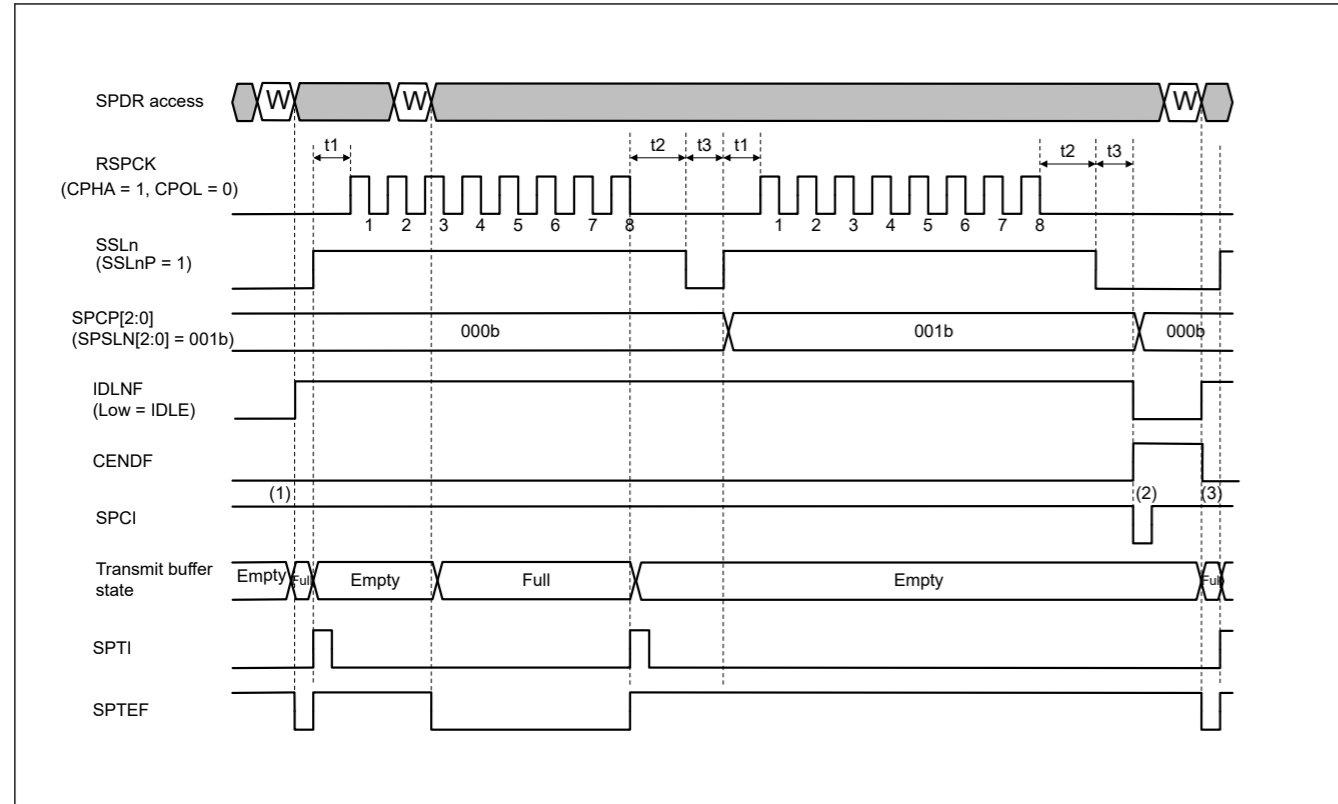


Figure 30.31 Example of Communication End Interrupt Operation (Transmit-Receive/Transmit Master mode)

1. The CENDF flag is 0 and the level of SPCI is 1 before communication start, and these have kept during communication.
2. The CENDF flag will be 1 (Communication End) at the end of t3 cycle, because the next command is 000b and there is no next transmit data, and then the SPCI interrupt output when the CENDIE bit is 1.
3. The CENDF flag is cleared when the next transmission data is written to the transmit buffer (SPTX). Or the CENDF flag is cleared if the CENDF flag was written 0 after reading the SPCR when the CENDF flag was 1.

In slave mode operation, the output timing of the communication end interrupt is deferent due to the value of the SPCR.SPMS bit (RSPI mode select bit), and the clear timing of the communication end interrupt is deferent due to the communication mode (transmit-receive or transmit-only or receive-only).

### 30.3.8.2 Transmit-Receive/Transmit in Slave Mode on SPI Operation (4-wire)

The communication end interrupt (SPCI) is made and the CENDF flag is set to 1, when both SPTX buffer and transmit shift buffer are empty in transmit-receive/transmit slave mode on SPI Operation (4-wire). The set timing of the CENDF flag is same as SSL0 negate timing. The communication end interrupt (SPCI) is one PCLKUSCIx width and low active.

The CENDF flag will not be cleared even if the SPCR.SPE bit is cleared after CENDF = 1. The CENDF flag will be cleared in one of following tow conditions.

- When the next transmission data is written to the transmit buffer (SPTX).
- The CENDF flag was written 0 after reading the SPSR when the CENDF flag was 1.

Figure 30.32 shows an example of communication end interrupt operation during transmit-receive/transmit slave mode on SPI operation.

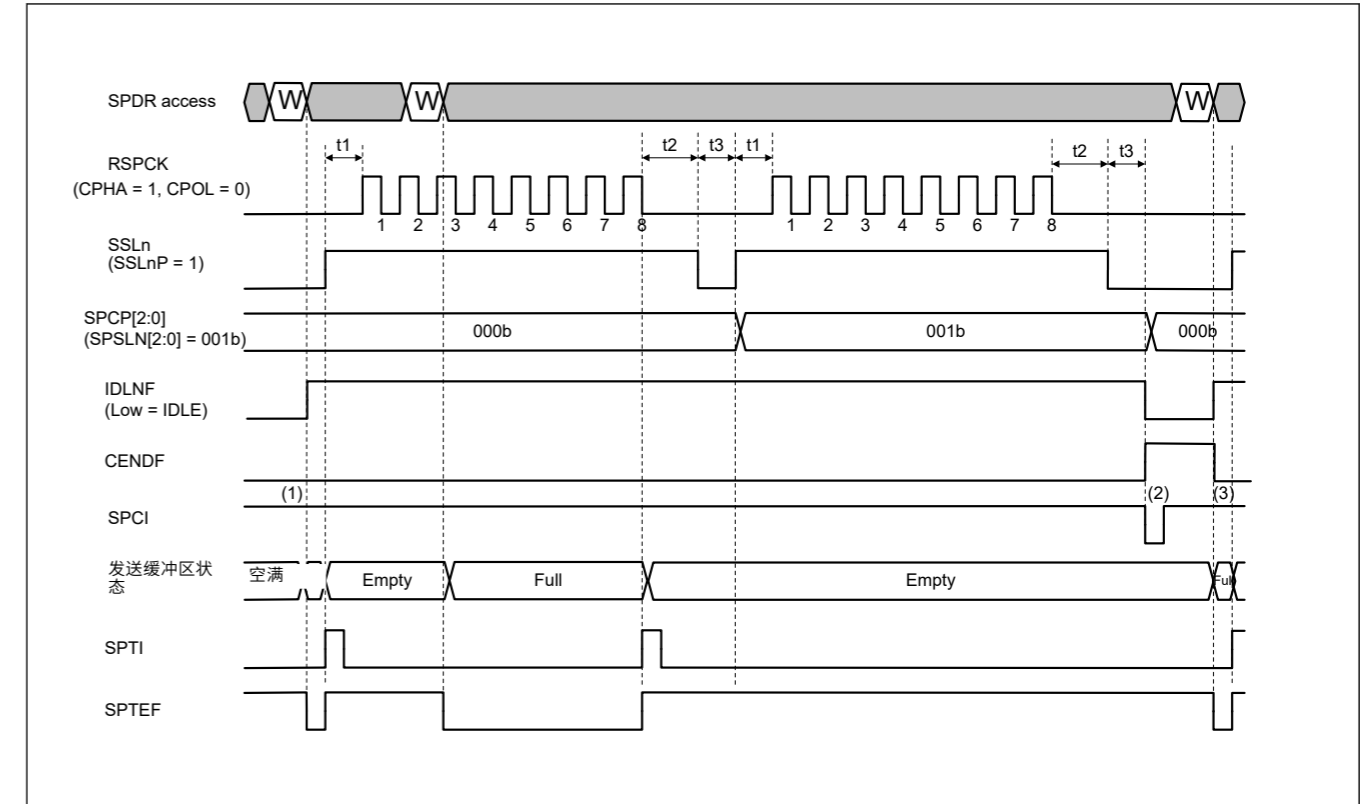


Figure 30.31 通信结束中断操作示例（发送-接收发送主机模式）

- 1、通信开始前CENDF标志为0，SPCI的电平为1，在通信过程中一直保持。
- 2.CENDF标志在t3周期结束时为1（通讯结束），因为下一条指令为000b，没有下一条发送数据，当CENDIE位为1时SPCI中断输出。
- 3.CENDF标志在下一个发送数据写入发送缓冲区（SPTX）时被清除。或者，当CENDF标志为1时，如果在读取SPCR后将CENDF标志写入0，则清除CENDF标志。

在从模式操作中，通信结束中断的输出时序是不同的，因为SPCR.SPMS位（RSPI模式选择位），通信结束中断的清除时序因通信模式（发送-接收或仅发送或仅接收）而异。

### 30.3.8.2 SPI操作（4线）从模式下的发送-接收发送

在SPI操作（4线）的发送-接收发送从模式下，当SPTX缓冲区和发送移位缓冲区都为空时，将产生通信结束中断(SPCI)并将CENDF标志设置为1。CENDF标志的设置时序与SSL0否定时序相同。通信结束中断(SPCI)是一个PCLKUSCIx宽度和低电平有效。

即使在CENDF=1后清除SPCR.SPE位，CENDF标志也不会被清除。CENDF标志将在以下两种情况之一被清除。

- 下一个发送数据写入发送缓冲区（SPTX）时。
- 当CENDF标志为1时，读取SPSR后CENDF标志被写入0。

图30.32显示了在发送-接收发送从模式开启期间的通信结束中断操作示例SPI操作。

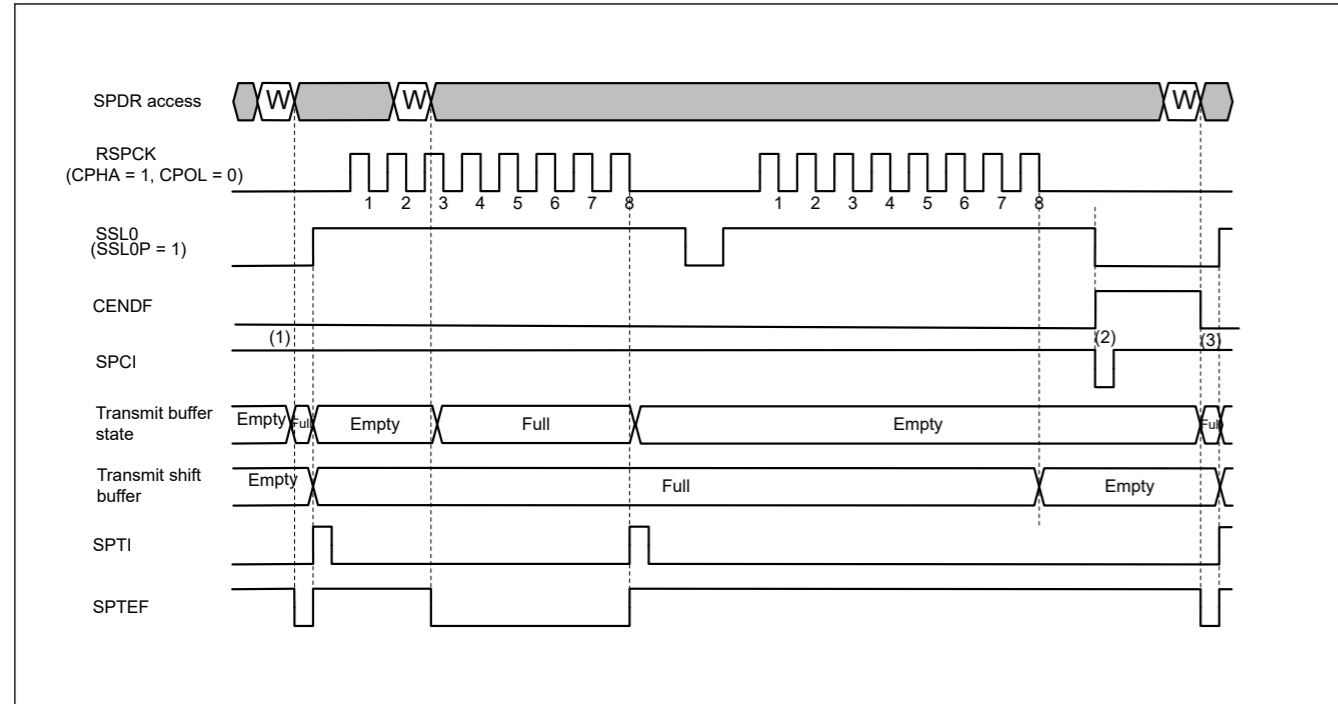


Figure 30.32 Example of Communication End Interrupt Operation (Transmit-Receive/Transmit Slave mode on SPI Operation)

1. The CENDF flag is 0 and the level of SPCI is 1 before communication start, and these have kept during communication.
2. The CENDF flag will be 1 (Communication End) at the timing of SSL0 negate, when both SPTX buffer and transmit shift buffer are empty, and then the SPCI interrupt output when the CENDIE bit is 1.
3. The CENDF flag is cleared when the next transmission data is written to the transmit buffer (SPTX). Or the CENDF flag is cleared if the CENDF flag was written 0 after reading the SPCR when the CENDF flag was 1.

### 30.3.8.3 Receive Only in Slave Mode on SPI Operation (4-wire)

The communication end interrupt (SPCI) is made and the CENDF flag is set to 1 at the SSL0 negate timing in receive only slave mode on SPI operation (4-wire). The number of transmission frame is set by the SPDCR.SPFC[1:0]. Then the SSL0 is negated at the last frame transmission end. The communication end interrupt (SPCI) is one PCLKUSCix width and low active.

The CENDF flag will not be cleared even if the SPCR.SPE bit is cleared after CENDF = 1. The CENDF flag will be cleared in one of following tow conditions.

- The SSL0 assert timing of next transmission.
- The CENDF flag was written 0 after reading the SPSR when the CENDF flag was 1.

Figure 30.33 shows an example of communication end interrupt operation during receive only slave mode on SPI operation (4-wire).

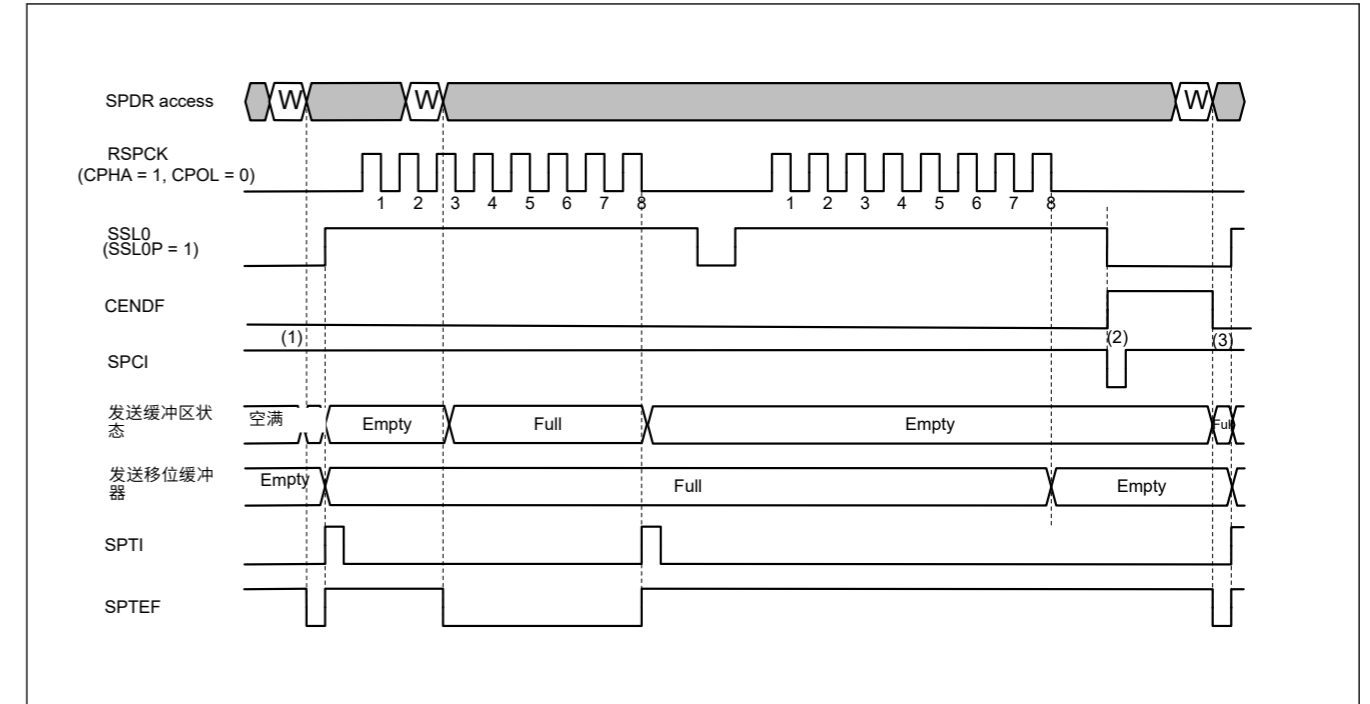


Figure 30.32 通信结束中断操作示例 (SPI操作上的发送-接收发送从模式)

- 1、通信开始前CENDF标志为0，SPCI的电平为1，在通信过程中一直保持。
- 2.在SSL0否定的时刻，当SPTX缓冲区和发送移位缓冲区都为空时，CENDF标志将为1（通信结束），然后当CENDIE位为1时输出SPCI中断。
- 3.CENDF标志在下一个发送数据写入发送缓冲区（SPTX）时被清除。或者，当CENDF标志为1时，如果在读取SPCR后将CENDF标志写入0，则清除CENDF标志。

### 30.3.8.3 SPI操作时仅在从模式下接收（4线）

在SPI操作（4线）上仅接收从机模式下，在SSL0否定时序产生通信结束中断(SPCI)并将CENDF标志设置为1。传输帧数由SPDCR.SPFC[1:0]设置。然后在最后一帧传输结束时对SSL0取反。通信结束中断(SPCI)是一个PCLKUSCix宽度和低电平有效。

即使在CENDF=1后清除SPCR.SPE位，CENDF标志也不会被清除。CENDF标志将在以下两种情况之一被清除。

- SSL0断言下一次传输的时序。
- 当CENDF标志为1时，读取SPSR后CENDF标志被写入0。

图30.33显示了SPI操作（4线）上仅接收从机模式期间的通信结束中断操作示例。

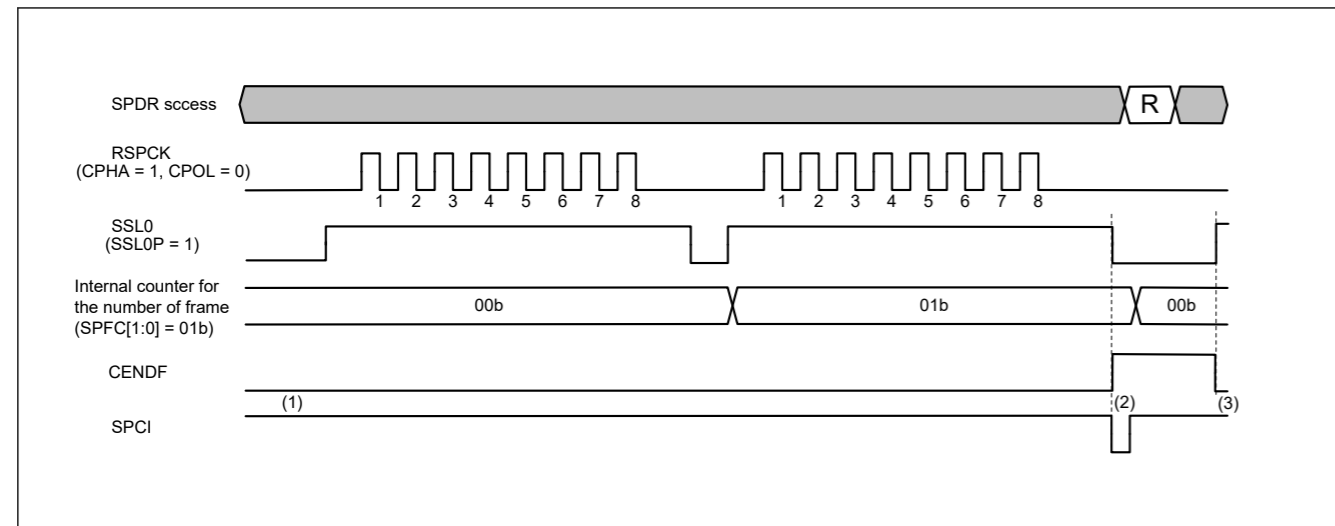


Figure 30.33 Example of Communication End Interrupt Operation (Receive only Slave mode on SPI Operation)

1. The CENDF flag is 0 and the level of SPCI is 1 before communication start, and these have kept during communication.
2. The CENDF flag will be 1 (Communication End) at the timing of SSL0 negate, when the last frame transmission ends, and then the SPCI interrupt output when the CENDIE bit is 1.
3. The CENDF flag is cleared at the SSL0 assert when the next transmission start. Or the CENDF flag is cleared if the CENDF flag was written 0 after reading the SPCR when the CENDF flag was 1.

#### 30.3.8.4 Transmit-Receive/Transmit in Slave Mode on Clock Synchronous Operation (3-wire)

The communication end interrupt (SPCI) is made and the CENDF flag is set to 1 when both SPTX buffer and transmit shift register are empty in transmit-receive/transmit slave mode on clock synchronous operation (3-wire). The set timing of CENDF flag is same as the last data sampling of the RSPCK (the last odd edge of RSPCK when the SPCMD0.CPHA bit is 0, the last even edge of RSPCK when the SPCMD0.CPHA bit is 1). The communication end interrupt (SPCI) is one PCLKUSCix width and low active.

The CENDF flag will not be cleared even if the SPCR.SPE bit is cleared after CENDF = 1. The CENDF flag will be cleared in one of following tow conditions.

- The SSL0 assert timing of next transmission.
- The CENDF flag was written 0 after reading the SPSR when the CENDF flag was 1.

Figure 30.34 shows an example of communication end interrupt operation during transmig-receive/transmit slave mode on clock synchronous operation (3-wire).

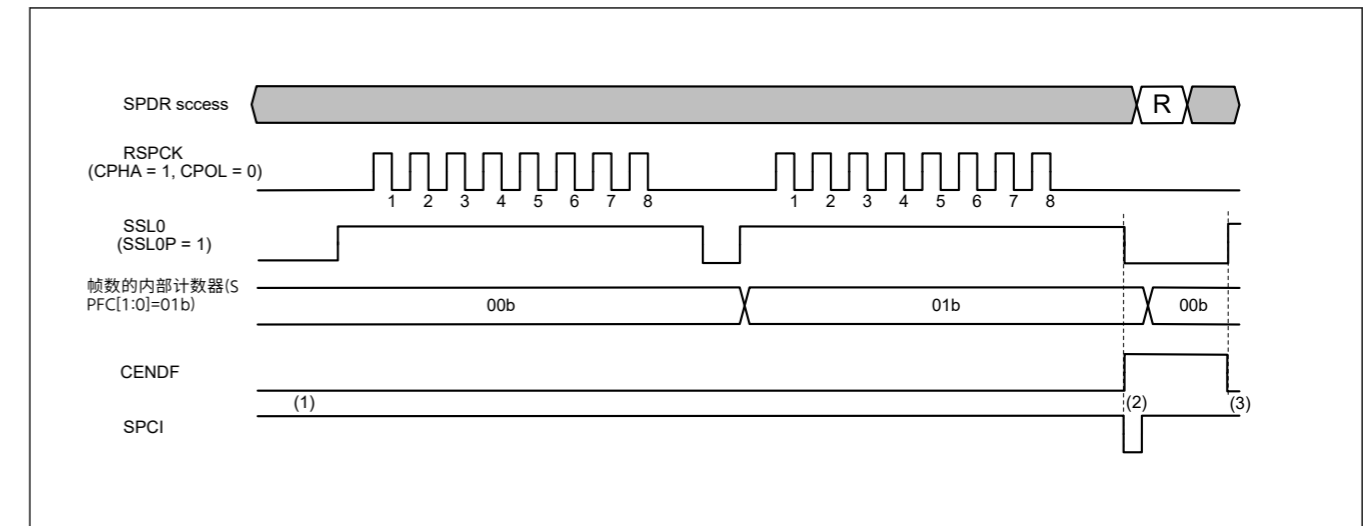


Figure 30.33 通信结束中断操作示例 (SPI上仅接收从模式 Operation)

- 1、通信开始前CENDF标志为0，SPCI的电平为1，在通信过程中一直保持。
- 2.CENDF标志位在SSL0否定的时刻，即最后一帧传输结束时为1（通信结束），然后当CENDIE位为1时输出SPCI中断。
- 3.CENDF标志在下次传输开始时在SSL0断言处被清除。或者，当CENDF标志为1时，如果在读取SPCR后将CENDF标志写入0，则清除CENDF标志。

#### 30.3.8.4 在时钟同步操作（3线）的从模式下发送-接收发送

在时钟同步操作（3线）的发送-接收发送从模式下，当SPTX缓冲器和发送移位寄存器都为空时，产生通信结束中断(SPCI)并将CENDF标志设置为1。CENDF标志的设置时序与RSPCK的最后一次数据采样相同（SPCMD0.CPHA位为0时RSPCK的最后一个奇边沿，SPCMD0.CPHA位为1时RSPCK的最后一个偶边沿）。通信结束中断(SPCI)是一个PCLKUSCix宽度和低电平有效。

即使在CENDF=1后清除SPCR.SPE位，CENDF标志也不会被清除。CENDF标志将在以下两种情况之一被清除。

- SSL0断言下一次传输的时序。
- 当CENDF标志为1时，读取SPSR后CENDF标志被写入0。

图30.34显示了在时钟同步操作（3线）下发送接收发送从模式期间的通信结束中断操作示例。



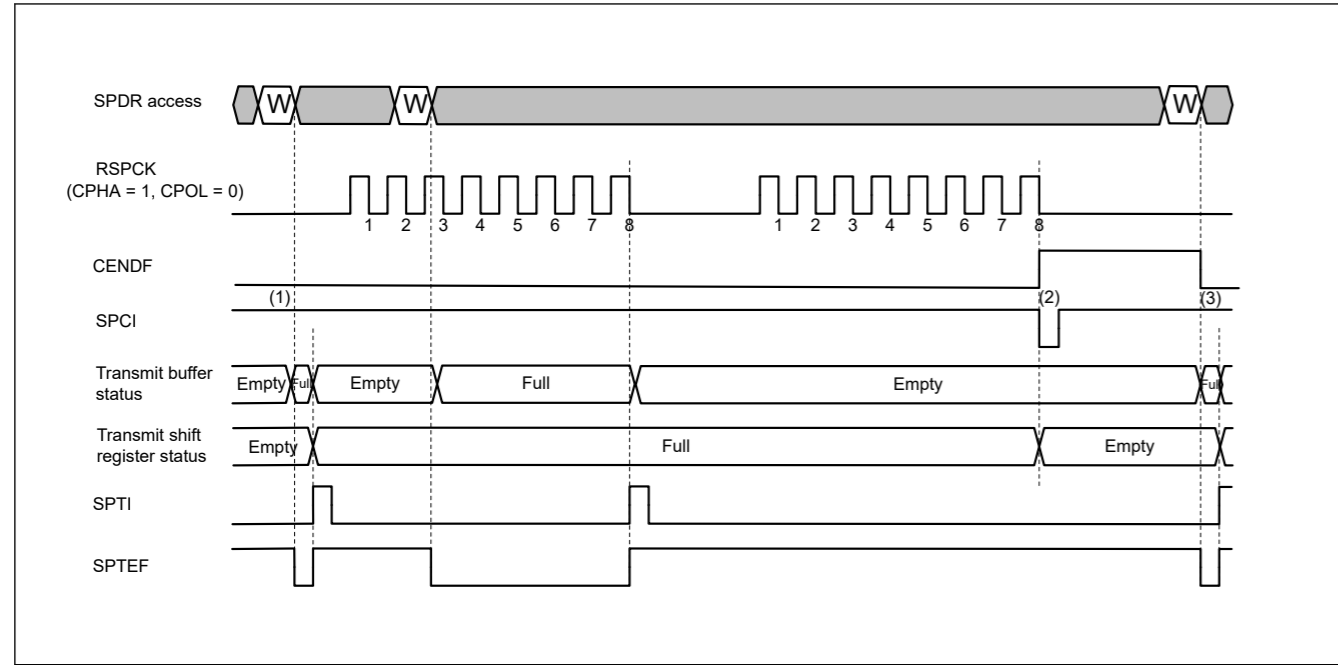


Figure 30.34 Example of Communication End Interrupt Operation (Transmit-Receive/Transmit Slave mode on Clock Synchronous Operation)

1. The CENDF flag is 0 and the level of SPCI is 1 before communication start, and these have kept during communication.
2. The CENDF flag will be 1 (Communication End) at the last data sampling timing of RSPCK, when both SPTX buffer and transmit shift buffer are empty, and then the SPCI interrupt output when the CENDIE bit is 1.
3. The CENDF flag is cleared when the next transmission data is written to the transmit buffer (SPTX). Or the CENDF flag is cleared if the CENDF flag was written 0 after reading the SPCR when the CENDF flag was 1.

### 30.3.8.5 Receive Only in Slave Mode on Clock Synchronous Operation (3-wire)

The communication end interrupt (SPCI) is made and the CENDF flag is set to 1 at the last data sampling of the last transmission frame in receive only slave mode on clock synchronous operation (3-wire). The sampling timing is the last odd edge of RSPCK when the SPCMD0.CPHA bit is 0, the last even edge of RSPCK when the SPCMD0.CPHA bit is 1. The number of transmission frame is set by the SPDCR.SPFC[1:0]. The communication end interrupt (SPCI) is one PCLKUSCIX width and low active.

The CENDF flag will not be cleared even if the SPCR.SPE bit is cleared after CENDF = 1. The CENDF flag will be cleared in one of following two conditions.

- The first edge of RSPCK for next transmission.
- The CENDF flag was written 0 after reading the SPSR when the CENDF flag was 1.

Figure 30.35 shows an example of communication end interrupt operation during receive only slave mode on clock synchronous operation.

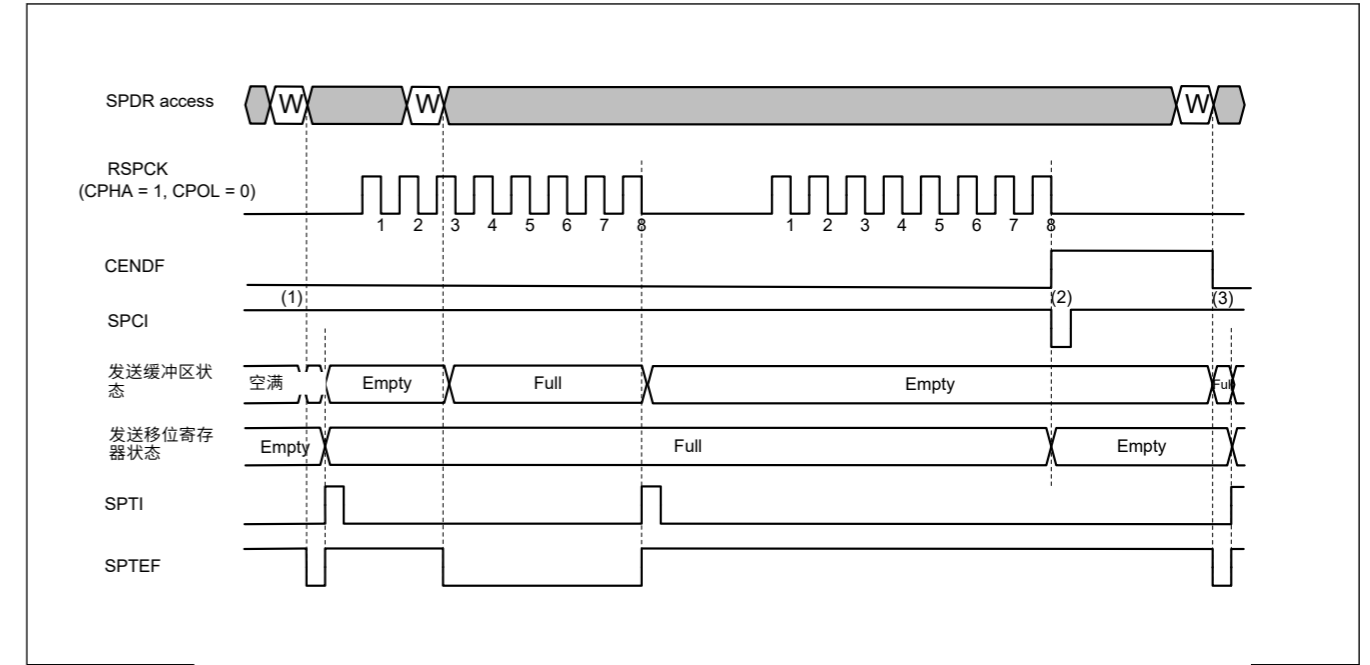


Figure 30.34 通信结束中断操作示例 (时钟同步操作的发送-接收发送从模式)

- 1、通信开始前CENDF标志为0，SPCI的电平为1，在通信过程中一直保持。
- 2.在RSPCK的最后一个数据采样时序，当SPTX缓冲区和发送移位缓冲区都为空时，CENDF标志为1（通信结束），然后当CENDIE位为1时输出SPCI中断。
- 3.CENDF标志在下一个发送数据写入发送缓冲区（SPTX）时被清除。或者，当CENDF标志为1时，如果在读取SPCR后将CENDF标志写入0，则清除CENDF标志。

### 30.3.8.5 在时钟同步操作（3线）上仅在从模式下接收

在时钟同步操作（3线）仅接收从机模式下，在最后一个传输帧的最后一个数据采样时产生通信结束中断(SPCI)并将CENDF标志设置为1。采样时序在SPCMD0.CPHA位为0时为RSPCK的最后一个奇边沿，当SPCMD0.CPHA位为1时为RSPCK的最后一个偶边沿。发送帧数由SPDCR.SPFC[1:0]设置。通信结束中断(SPCI)是一个PCLKUSCIX宽度和低电平有效。

即使在CENDF=1后清除SPCR.SPE位，CENDF标志也不会被清除。CENDF标志将在以下两种情况之一被清除。

- RSPCK的第一个边沿用于下一次传输。
- 当CENDF标志为1时，读取SPSR后CENDF标志被写入0。

图30.35显示了时钟同步操作下仅接收从机模式期间的通信结束中断操作示例。

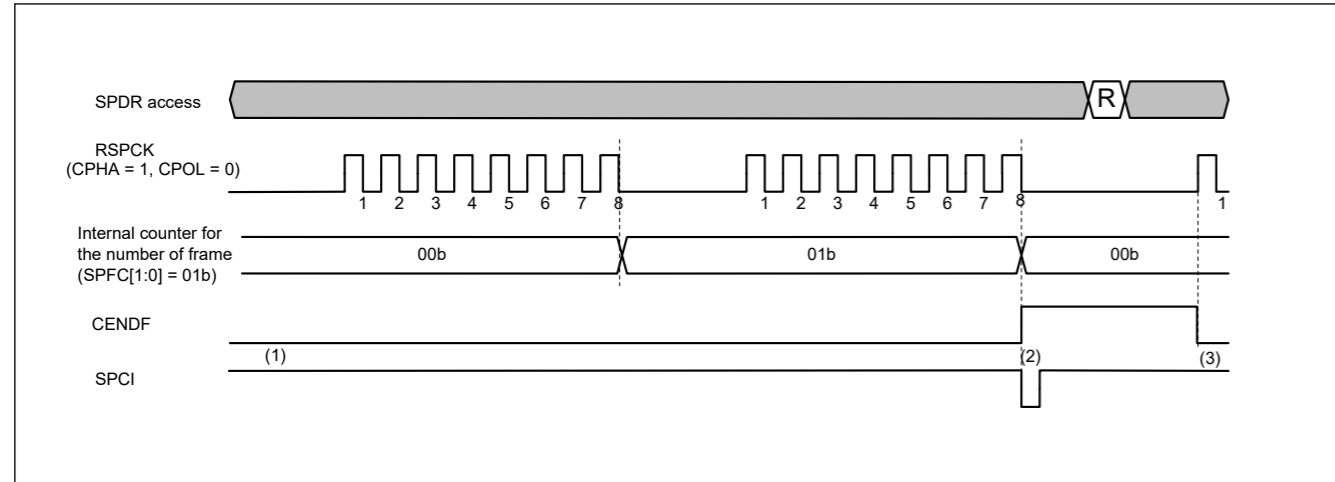


Figure 30.35 Example of Communication End Interrupt Operation (Receive-only Slave mode on Clock Synchronous Operation)

1. The CENDF flag is 0 and the level of SPCI is 1 before communication start, and these have kept during communication.
2. The CENDF flag will be 1 (Communication End) at the last data sampling timing of RSPCK, when the last frame transmission end. The number of transmission frame is set by the SPDCR.SPFC[1:0]. And then the SPCI interrupt output when the CENDIE bit is 1.
3. The CENDF flag is cleared at the first edge of RSPCK for the next transmission. Or the CENDF flag is cleared if the CENDF flag was written 0 after reading the SPCR when the CENDF flag was 1.

### 30.3.8.6 Common Operation

In this chapter, the operation common to each mode / area option communication in section 30.3.8.1. Transmit-Receive/ Transmit in Master Mode to section 30.3.8.5. Receive Only in Slave Mode on Clock Synchronous Operation (3-wire) is explained. When the enable of RSPI communication end interrupt (CENDIE) is 0, at the time of communication completion, a flag of communication end (CENDF) is set and an event of communication end (sp\_elccend) is output, but no interrupt is output. However, if the enable of communication end interrupt (CENDIE) is set to 1 before clearing the flag of communication end (CENDF) while the enable of RSPI function (SPE) is 1, the communication end interrupt is output.

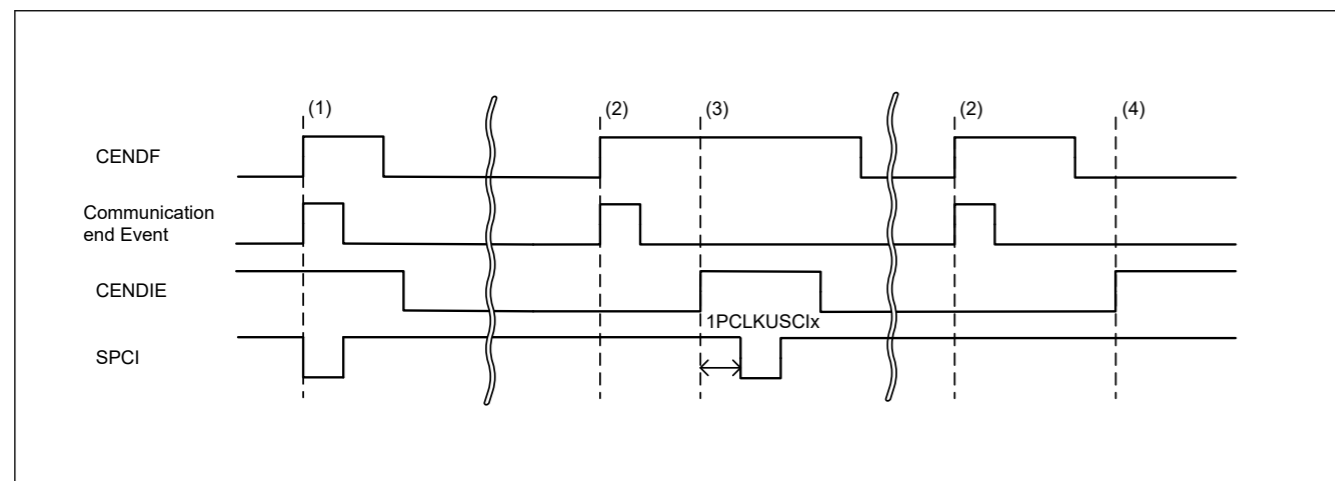


Figure 30.36 Example of Communication End Interrupt Operation (Enable control)

1. When the enable of RSPI communication end interrupt (CENDIE) is 1, at the time of communication completion, the following three are the same timing.
  - A flag of communication end (CENDF)
  - An event of communication end (sp\_elccend)
  - The communication end interrupt

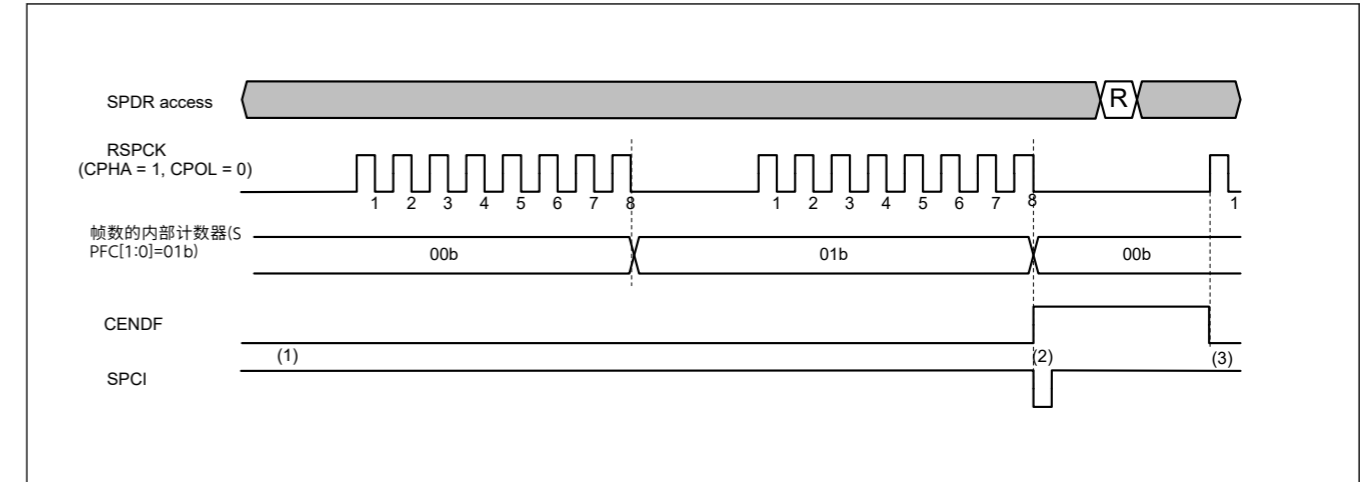


Figure 30.35 通信结束中断操作示例 (时钟上的仅接收从模式) Synchronous Operation)

- 1、通信开始前CENDF标志为0，SPCI的电平为1，在通信过程中一直保持。
- 2.CENDF标志位在RSPCK的最后一个数据采样定时为1（通信结束），即最后一帧传输结束。传输帧数由SPDCR.SPFC[1:0]设置。然后在CENDIE位为1时输出SPCI中断。
- 3.CENDF标志在RSPCK的第一个边沿被清除以进行下一次传输。或者，当CENDF标志为1时，如果在读取SPCR后将CENDF标志写入0，则清除CENDF标志。

### 30.3.8.6 常用操作

在本章中，30.3.8.1节中的每个模式区域选项通信的通用操作。发送-接收在主模式下发送到第30.3.8.5节。解释了时钟同步操作（3线）时仅在从模式下接收。当RSPI通信结束中断（CENDIE）使能为0时，通信完成时，设置通信结束标志（CENDF）并输出通信结束事件（sp\_elccend），但不输出中断。但是，如果在清除通信结束标志（CENDF）之前将通信结束中断（CENDIE）的使能设置为1，而RSPI功能（SPE）的使能为1，则输出通信结束中断。

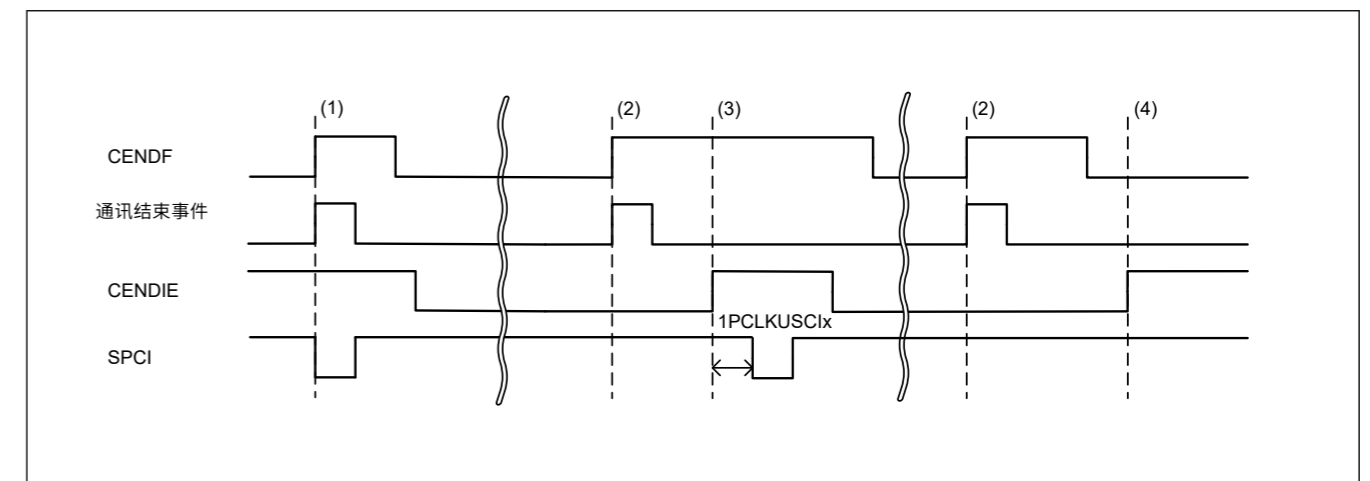


Figure 30.36 通信结束中断操作示例 (启用控制)

- 1、当RSPI通讯结束中断（CENDIE）使能为1时，通讯完成时，以下三个是相同的时序。
  - 通讯结束标志（CENDF）
  - 通信结束事件（sp\_elccend）
  - 通讯结束中断

- When the enable of RSPI communication end interrupt (CENDIE) is 0, at the time of communication completion, the following two are the same timing, but no interrupt.
  - A flag of communication end (CENDF)
  - An event of communication end (sp\_elccend)
- After (2), if the enable of communication end interrupt (CENDIE) is set when the enable of RSPI function (SPE) and the flag of communication end (CENDF) are 1, the communication end interrupt is output after 1 PCLKUSCIX.
- After (2), even if the enable of communication end interrupt (CENDIE) is set when the enable of RSPI function (SPE) or the flag of communication end (CENDF) is 0, the communication end interrupt is not output.

### 30.3.9 Error Detection

In normal SPI serial transfers, data written to the transmit buffer of SPDR/SPDR\_HA is transmitted, and received data can be read from the receive buffer of SPDR/SPDR\_HA. If access is made to SPDR/SPDR\_HA, an abnormal transfer might occur, depending on the status of the transmit or receive buffer or the status of the SPI at the beginning or end of serial transfer.

If an abnormal transfer occurs, the SPI detects the event as an underrun error, overrun error, parity error, or mode fault error. Table 30.9 lists the relationship between non-normal transfer operations and the SPI error detection function.

Table 30.9 Relationship between non-normal transfer operations and SPI error detection

| Operation | Occurrence condition   | SPI operation   | Error detection  |
|-----------|--|---|------------------|
| 1         | SPDR/SPDR_HA is written when the transmit buffer is full.  | <ul style="list-style-type: none"> <li>The contents of the transmit buffer are kept</li> <li>Write data is missing</li> </ul>   | None             |
| 2         | SPDR/SPDR_HA is read when the receive buffer is empty.   | The contents of the receive buffer and previously received data are output.   | None             |
| 3         | Serial transfer is started in slave mode when the SPI is not able to transmit data.  | <ul style="list-style-type: none"> <li>Serial transfer is suspended</li> <li>Transmit or receive data is missing</li> <li>Driving of the MISO output signal is stopped</li> <li>SPI function is disabled</li> </ul>                           | Underrun error   |
| 4         | Serial transfer terminates when the receive buffer is full.  | <ul style="list-style-type: none"> <li>Keeps the contents of the receive buffer</li> <li>Missing receive data</li> </ul>  | Overrun error    |
| 5         | An incorrect parity bit is received during full-duplex synchronous serial communication with the parity function enabled in following mode: <ul style="list-style-type: none"> <li>Transmit-receive master mode</li> <li>Transmit-receive slave mode</li> <li>Receive-only slave mode</li> </ul> | The parity error flag is asserted   | Parity error     |
| 6         | The SSLn0 input signal is asserted when the serial transfer is idle in multi-master mode.  | <ul style="list-style-type: none"> <li>Driving of the RSPCKn, MOSIn, SSLn1 to SSLn3 output signals is stopped</li> <li>SPI function is disabled</li> </ul>  | Mode fault error |
| 7         | The SSLn0 input signal is asserted during serial transfer in multi-master mode.  | <ul style="list-style-type: none"> <li>Serial transfer is suspended</li> <li>Transmit or receive data is missing</li> <li>Driving of the RSPCKn, MOSIn, SSLn1 to SSLn3 output signals is stopped</li> <li>SPI function is disabled</li> </ul> | Mode fault error |
| 8         | The SSLn0 input signal is negated during serial transfer in slave mode.  | <ul style="list-style-type: none"> <li>Serial transfer is suspended</li> <li>Transmit or receive data is missing</li> <li>Driving of the MISO output signal is stopped</li> <li>SPI function is disabled</li> </ul>                           | Mode fault error |

In operation 1 described in Table 30.9, the SPI does not detect an error. To prevent data omission during writes to SPDR/SPDR\_HA, the writes to SPDR/SPDR\_HA must be executed using a transmit buffer empty interrupt request (when the SPSR.SPTEF flag is 1).

Similarly, the SPI does not detect an error in operation 2. To prevent extraneous data from being read, SPDR/SPDR\_HA read must be executed with an SPI receive buffer full interrupt request (when the SPSR.SPRF flag is 1).

For information on the other errors, see the following sections:

- 当RSPI通讯结束中断 (CENDIE) 使能为0时, 通讯完成时, 以下两者时序相同, 但无中断。
  - 通讯结束标志 (CENDF)
  - 通信结束事件 (sp\_elccend)

3. (2) 之后, 如果在RSPI功能 (SPE) 使能和通信结束标志 (CENDF) 为1的情况下设置通信结束中断 (CENDIE) 使能, 则在1个PCLKUSCIX后输出通信结束中断。

4.(2)后, 即使在RSPI功能(SPE)使能或通信结束标志(CENDF)为0时设置通信结束中断(CENDIE)使能, 也不输出通信结束中断。

### 30.3.9 错误检测

在正常的SPI串行传输中, 写入到SPDRSPDR\_HA的发送缓冲区的数据被发送, 接收到的数据可以从SPDRSPDR\_HA的接收缓冲区中读取。如果访问SPDRSPDR\_HA, 可能会发生异常传输, 具体取决于发送或接收缓冲区的状态或串行传输开始或结束时SPI的状态。

如果发生异常传输, SPI会将事件检测为欠载错误、溢出错误、奇偶校验错误或模式故障错误。表30.9列出了非正常传输操作和SPI错误检测功能之间的关系。

Table 30.9 非正常传输操作与SPI错误检测的关系

| Operation | 发生条件   | SPI操作   | 错误检测           |
|-----------|--|---|----------------|
| 1         | SPDRSPDR_HA在发送缓冲区已满时写入。  | <ul style="list-style-type: none"> <li>发送缓冲区的内容被保留</li> <li>写入数据丢失</li> </ul>   | None           |
| 2         | SPDRSPDR_HA在接收缓冲区为空时读取。  | 输出接收缓冲区的内容和先前接收的数据。   | None           |
| 3         | 当SPI无法传输数据时, 串行传输在从模式下启动。  | <ul style="list-style-type: none"> <li>串行传输被暂停</li> <li>发送或接收数据丢失</li> <li>MIO输出信号的驱动停止</li> </ul> <ul style="list-style-type: none"> <li>SPI功能被禁用</li> </ul> | Underrun error |
| 4         | 当接收缓冲区已满时, 串行传输终止。   | <ul style="list-style-type: none"> <li>保留接收缓冲区的内容</li> <li>缺少接收数据</li> </ul>  | 溢出错误           |
| 5         | 全双工同步串行通信时接收到错误的奇偶校验位, 并在以下模式下启用奇偶校验功能: ● <ul style="list-style-type: none"> <li>收发主模式</li> <li>收发从模式</li> <li>只接收从模式</li> </ul> | 奇偶错误标志被置位   | 奇偶校验错误         |
| 6         | 当串行传输在多主模式下空闲时, SSLn0输入信号被置位。  | <ul style="list-style-type: none"> <li>将RSPCKn、MOSIn、SSLn1驱动到SSLn3输出信号停止</li> <li>SPI功能被禁用</li> </ul>   | 模式故障错误         |
| 7         | SSLn0输入信号在多主机模式下的串行传输期间被置位。  | <ul style="list-style-type: none"> <li>串行传输被暂停</li> <li>发送或接收数据丢失</li> <li>将RSPCKn、MOSIn、SSLn1驱动到SSLn3输出信号停止</li> <li>SPI功能被禁用</li> </ul>                     | 模式故障错误         |
| 8         | SSLn0输入信号在从模式下的串行传输期间被否定。  | <ul style="list-style-type: none"> <li>串行传输被暂停</li> <li>发送或接收数据丢失</li> <li>MIO输出信号的驱动停止</li> </ul> <ul style="list-style-type: none"> <li>SPI功能被禁用</li> </ul> | 模式故障错误         |

在表30.9中描述的操作1中, SPI未检测到错误。防止写入SPDR期间的数据遗漏 SPDR\_HA, 对SPDRSPDR\_HA的写入必须使用发送缓冲区空中断请求 (当 SPSR.SPTEF标志为1)。

同样, SPI不会检测到操作2中的错误。为防止读取无关数据, 必须使用SPI接收缓冲区满中断请求 (当 SPSR.SPRF标志为1时) 执行SPDRSPDR\_HA读取。

有关其他错误的信息, 请参阅以下部分:



- Underrun error, indicated in operation 3, see [section 30.3.9.4. Underrun errors](#)
- Overrun error, indicated in operation 4, see [section 30.3.9.1. Overrun errors](#)
- Parity error, indicated in operation 5, see [section 30.3.9.2. Parity errors](#)
- Mode fault error, indicated in operations 6 to 8, see [section 30.3.9.3. Mode fault errors](#)
- For the transmit and receive interrupts, see [section 30.3.7. Transmit Buffer Empty and Receive Buffer Full Interrupts](#).

### 30.3.9.1 Overrun errors

If a serial transfer ends when the receive buffer of SPDR/SPDR\_HA is full, the SPI detects an overrun error and sets the SPSR.OVRF flag to 1. When the OVRF flag is 1, the SPI does not copy data from the shift register to the receive buffer, so the data prior to the error occurrence is retained in the receive buffer. To set the OVRF flag to 0, write 0 to the OVRF flag after the CPU reads SPSR with the OVRF flag set to 1.

Figure 30.37 shows an example of operation of the OVRF and SPRF flags. The SPSR and SPDR\_HA accesses shown in Figure 30.37 indicate the condition of accesses to the SPSR and SPDR\_HA register, where W denotes a write cycle, and R a read cycle. In this example, the SPI performs an 8-bit serial transfer when SPCMDm.CPHA bit is 1 and the SPCMDm.CPOL bit is 0. The numbers given for RSPCKn in the waveform represent the number of RSPCK cycles, such as the number of transferred bits.

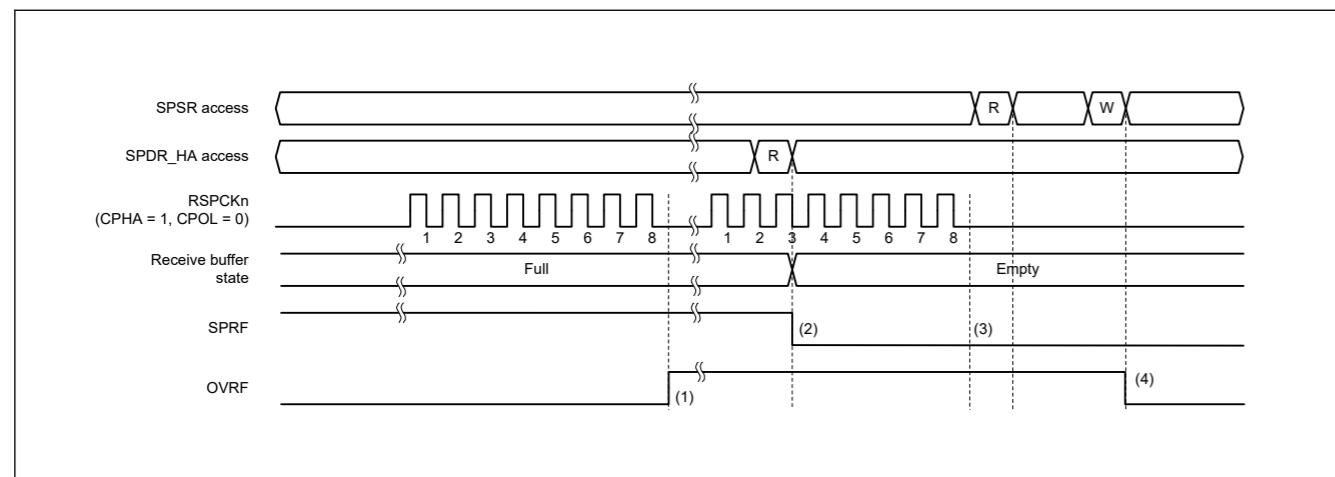


Figure 30.37 Operation example of the OVRF and SPRF flags

The operation of the flags at timings (1) to (4) in Figure 30.37 is as follows:

1. If a serial transfer terminates with the SPRF flag set to 1 (receive buffer full), the SPI detects an overrun error, and sets the OVRF flag to 1. The SPI does not copy the data in the shift register to the receive buffer. Even when the SPPE bit is 1, parity errors are not detected.
2. When SPDR/SPDR\_HA is read, the SPI outputs the data in the receive buffer. The SPRF flag is then set to 0. The receive buffer becoming empty does not set the OVRF flag to 0.
3. If the serial transfer ends with the OVRF flag set to 1 (overrun error occurred), the SPI does not copy data in the shift register to the receive buffer (the SPRF flag does not set to 1). A receive buffer full interrupt is not generated. Even when the SPPE bit is 1, parity errors are not detected. In an overrun error state when the SPI does not copy the received data from the shift register to the receive buffer, on termination of the serial transfer, the SPI determines that the shift register is empty. This enables data transfer from the transmit buffer to the shift register.
4. If 0 is written to the OVRF flag after SPSR is read when the OVRF flag is 1, the OVRF flag clears is set to 0.

The occurrence of an overrun can be checked either by reading SPSR or by using an SPI error interrupt and reading SPSR. When executing a serial transfer, you must ensure that overrun errors are detected early, for example by reading SPSR immediately after SPDR/SPDR\_HA/SPDR\_BY is read.

If an overrun error occurs and the OVRF flag sets to 1, normal reception operations cannot be performed until the OVRF flag is set to 0.

- 欠载错误，在操作3中指示，参见第30.3.9.4节。欠载错误
- 超限错误，在操作4中显示，参见第30.3.9.1节。溢出错误
- 奇偶校验错误，在操作5中指示，参见第30.3.9.2节。奇偶校验错误
- 模式故障错误，在操作6到8中指示，参见第30.3.9.3节。模式故障错误
- 关于发送和接收中断，参见30.3.7节。发送缓冲区空和接收缓冲区满中断。

### 30.3.9.1 溢出错误

如果在SPDR/SPDR\_HA的接收缓冲区已满时串行传输结束，则SPI检测到溢出错误并设置SPSR.OVRF标志为1。当OVRF标志为1时，SPI不会将数据从移位寄存器复制到接收缓冲区，因此错误发生之前的数据会保留在接收缓冲区中。要将OVRF标志设置为0，请在CPU读取OVRF标志设置为1的SPSR后将0写入OVRF标志。

图30.37显示了OVRF和SPRF标志的操作示例。SPSR和SPDR\_HA访问显示在图30.37表示访问SPSR和SPDR\_HA寄存器的条件，其中W表示写周期，R表示读周期。在本例中，当SPCMDm.CPHA位为1且SPCMDm.CPOL位为0时，SPI执行8位串行传输。波形中为RSPCKn给出的数字表示RSPCK周期数，例如传输的位数。

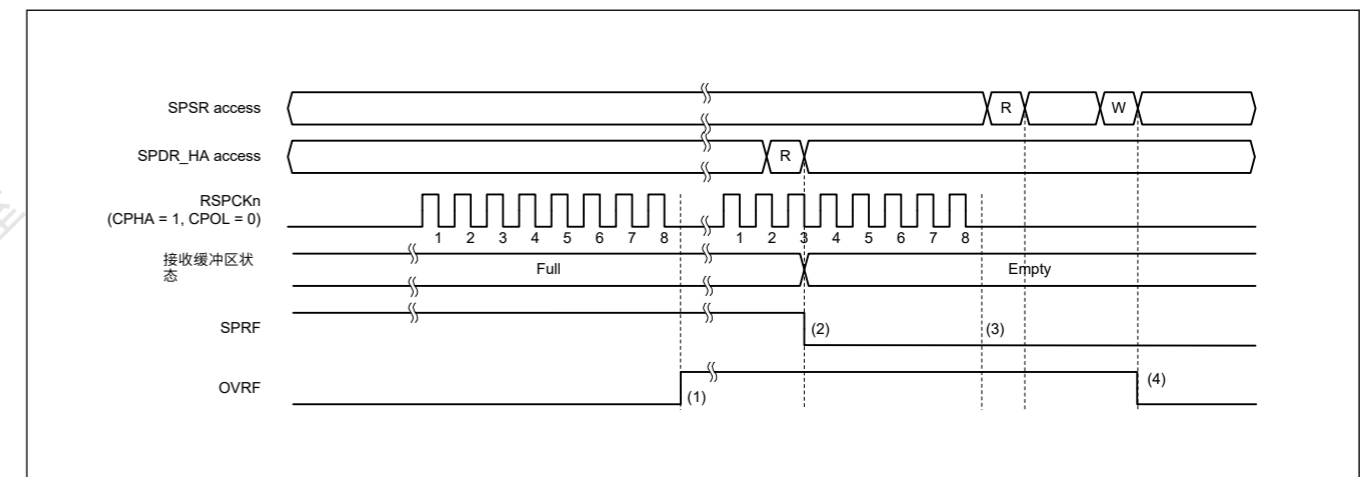


Figure 30.37 OVRF和SPRF标志的操作示例

图30.37中时间(1)到(4)的标志操作如下：

- 1.如果串行传输终止且SPRF标志设置为1（接收缓冲区已满），则SPI检测到溢出错误，并将OVRF标志设置为1。SPI不会将移位寄存器中的数据复制到接收缓冲区。即使SPPE位为1，也不会检测到奇偶校验错误。
- 2.读取SPDR/SPDR\_HA时，SPI输出接收缓冲区中的数据。然后SPRF标志设置为0。接收缓冲区变空不会将OVRF标志设置为0。
- 3.如果串行传输结束时OVRF标志设置为1（发生溢出错误），则SPI不会将移位寄存器中的数据复制到接收缓冲区（SPRF标志不设置为1）。不产生接收缓冲区满中断。即使SPPE位为1，也不会检测到奇偶校验错误。在SPI未将接收到的数据从移位寄存器复制到接收缓冲区的溢出错误状态下，在串行传输终止时，SPI确定移位寄存器为空。这使数据能够从发送缓冲器传输到移位寄存器。
- 4.如果在OVRF标志为1时读取SPSR后向OVRF标志写入0，则OVRF标志清除设置为0。

可以通过读取SPSR或使用SPI错误中断并读取SPSR来检查溢出的发生。执行串行传输时，必须确保及早检测到溢出错误，例如在读取SPDR/SPDR\_HA/SPDR\_BY后立即读取SPSR。

如果发生溢出错误并且OVRF标志设置为1，则在OVRF标志设置为0之前无法执行正常接收操作。



When the RSPCK auto-stop function is enabled (SPCR2.SCKASE = 1) in master mode, an overrun error does not occur. Figure 30.38 and Figure 30.39 show the clock stop waveform when a serial transfer continues while the receive buffer is full in master mode.

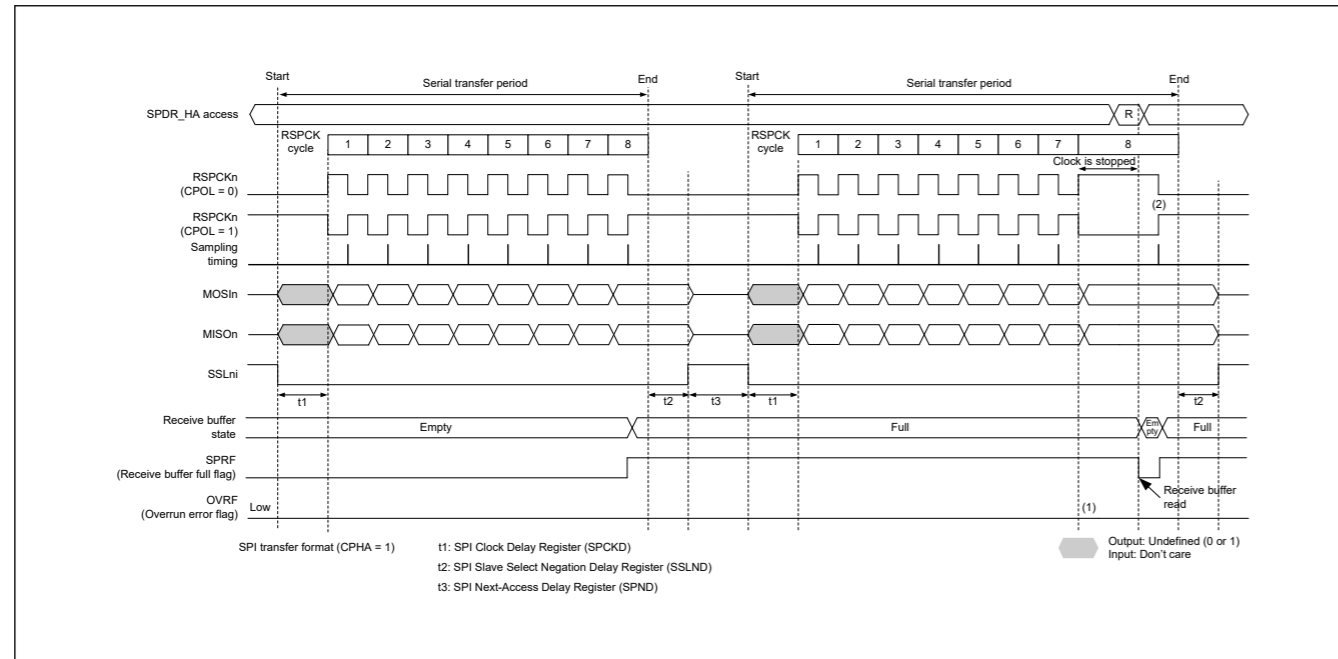


Figure 30.38 Clock stop waveform when serial transfer continues while receive buffer is full in master mode (CPHA = 1)

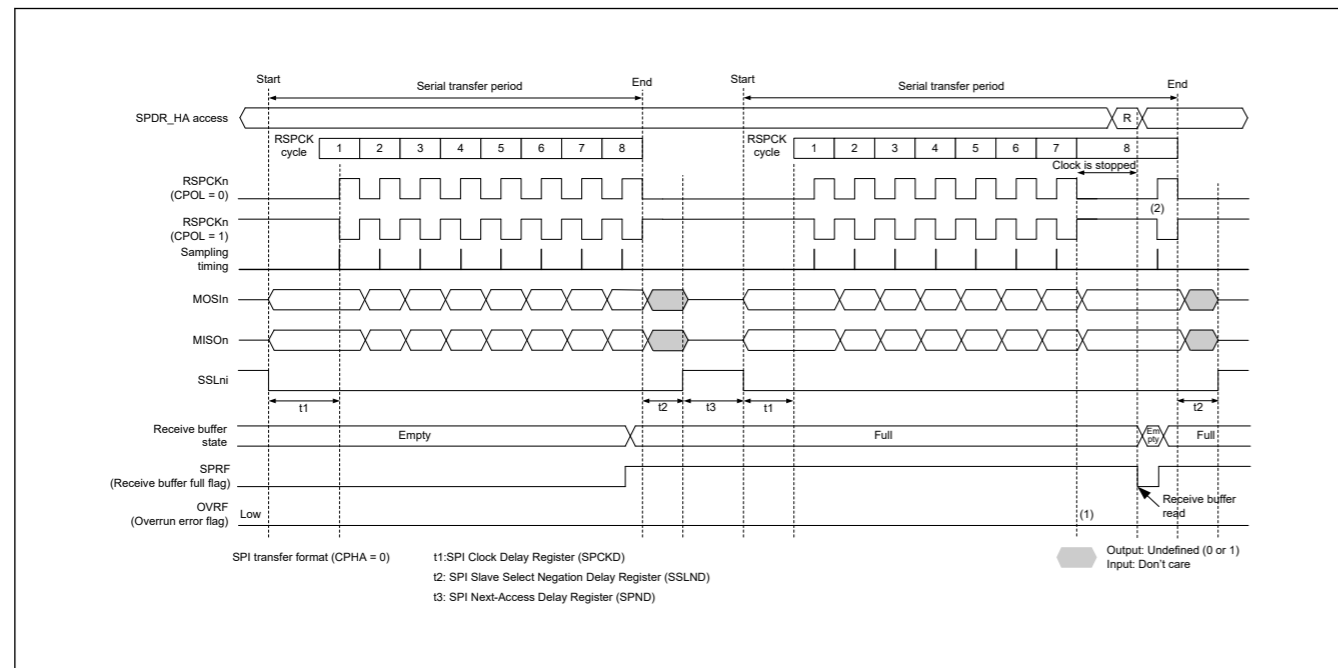


Figure 30.39 Clock stop waveform when serial transfer continues while receive buffer is full in master mode (CPHA = 0)

The operation of the flags at timings (1) and (2) in Figure 30.38 and Figure 30.39 is as follows:

1. When the receive buffer is full, an overrun error does not occur because the RSPCK clock is stopped.
2. If SPDR/SPDR\_HA is read while the clock is stopped, data in the receive buffer can be read. The RSPCK clock restarts after reading the receive buffer (after the SPSR.SPRF is set to 0).

在主机模式下启用RSPCK自动停止功能 (SPCR2.SCKASE=1) 时, 不会发生溢出错误。图30.38和图30.39显示了在主机模式下接收缓冲器已满时串行传输继续时的时钟停止波形。

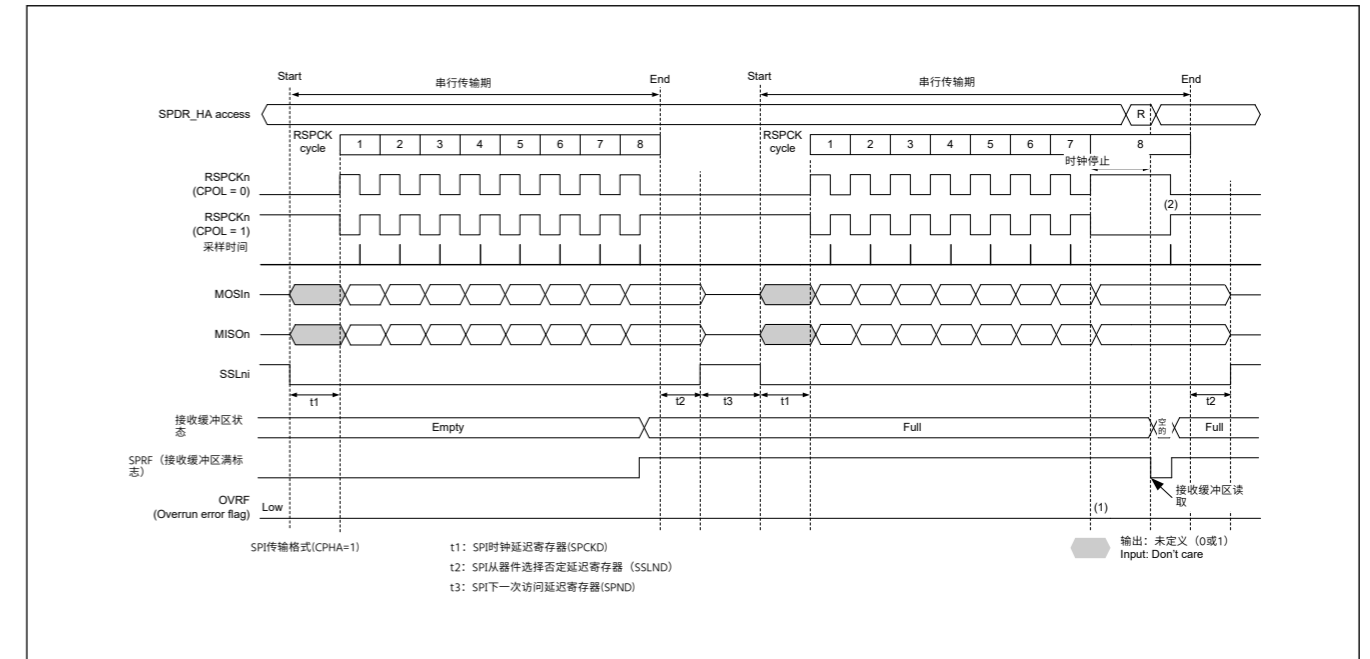


Figure 30.38 主机模式下接收缓冲器满时串行传输继续时的时钟停止波形(CPHA=1)

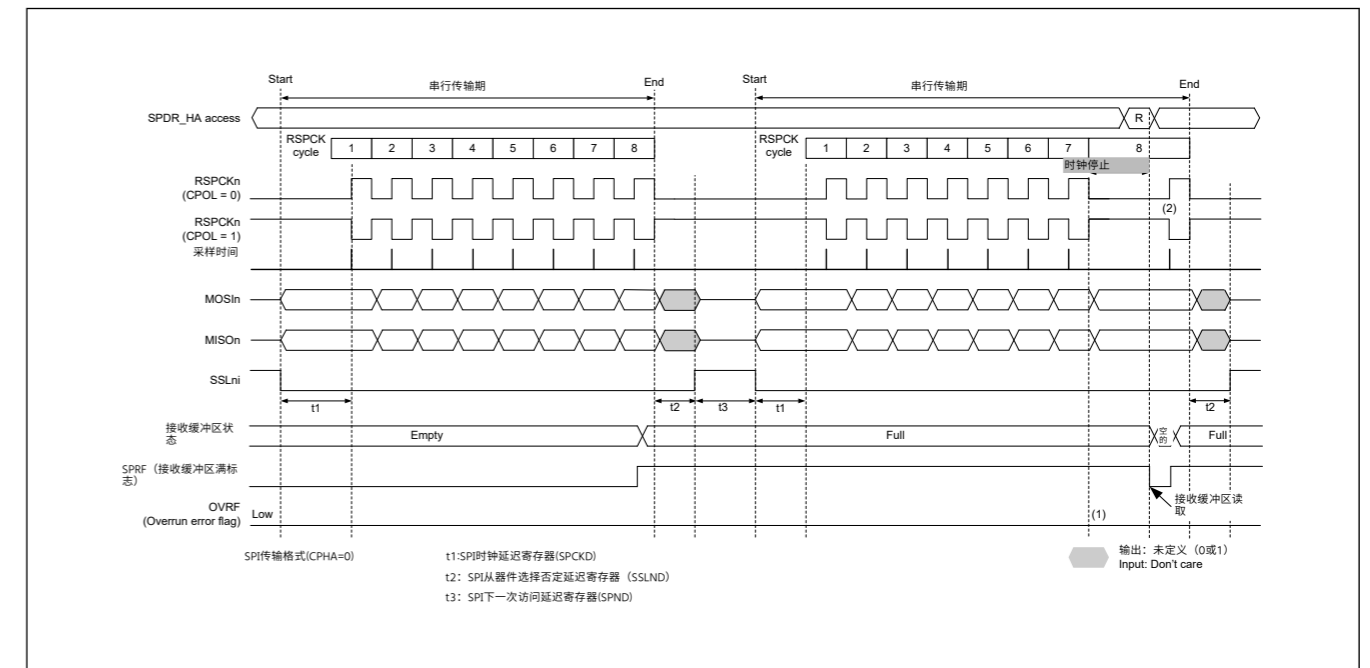


Figure 30.39 主机模式下接收缓冲器满时串行传输继续时的时钟停止波形(CPHA=0)

图30.38和图30.39中时序 (1) 和 (2) 的标志操作如下:

- 1.当接收缓冲区已满时, 不会发生溢出错误, 因为RSPCK时钟已停止。
- 2.如果在时钟停止时读取SPDR/SPDR\_HA, 则可以读取接收缓冲区中的数据。RSPCK时钟在读取接收缓冲区后重新启动 (在SPSR.SPRF标志设置为0后)。

Overrun error does not occur when RSPCK automatic stop function is enabled for transfer with no delay of between frames during burst transfer in master mode. Figure 30.40 and Figure 30.41 show the clock stop waveform, when there is no delay between frames at burst transfer and the serial transfer continues in the reception buffer full state.

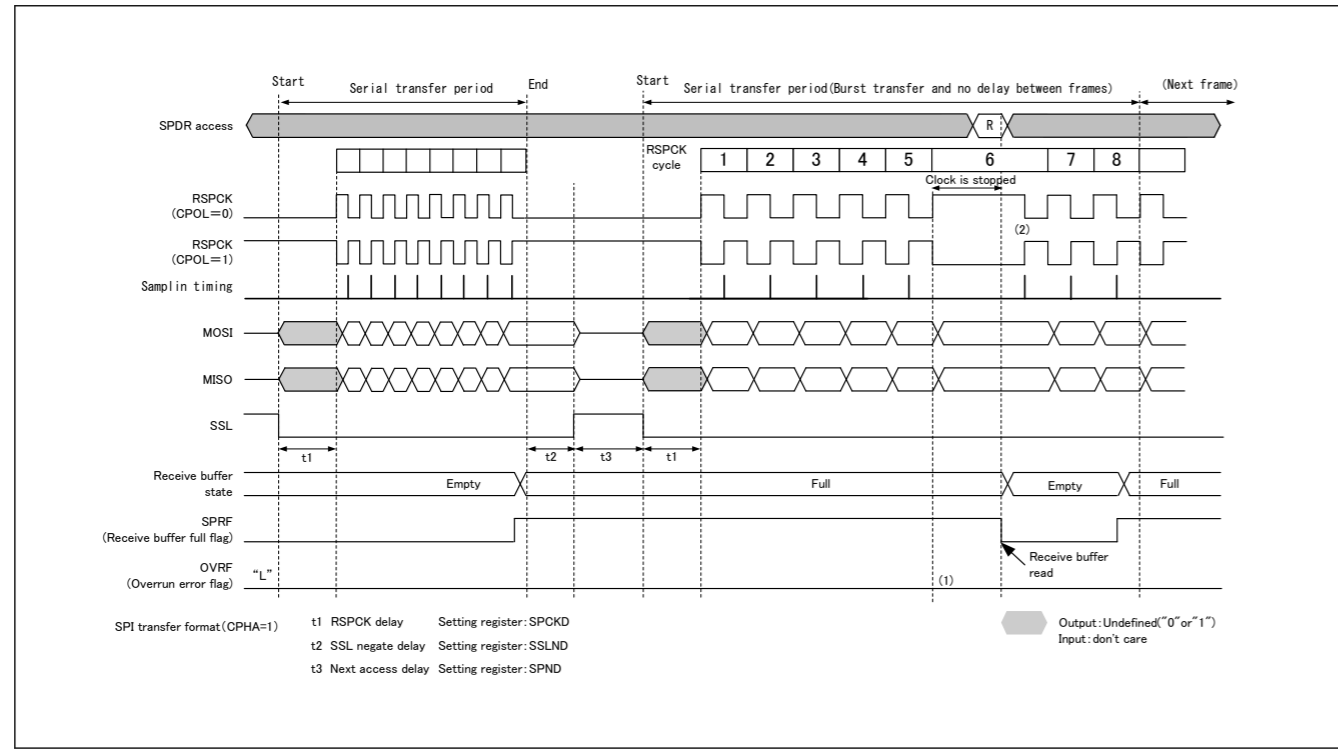


Figure 30.40 Clock Stop Waveform when Serial Transfer Continues in the Receive Buffer Full in Master Mode (at burst transfer and no delay between frames CPHA = 1)

在主模式下的突发传输期间，如果传输启用RSPCK自动停止功能且帧之间没有延迟，则不会发生溢出错误。图30.40和图30.41显示了时钟停止波形，当突发传输的帧之间没有延迟并且串行传输在接收缓冲器满状态下继续时。

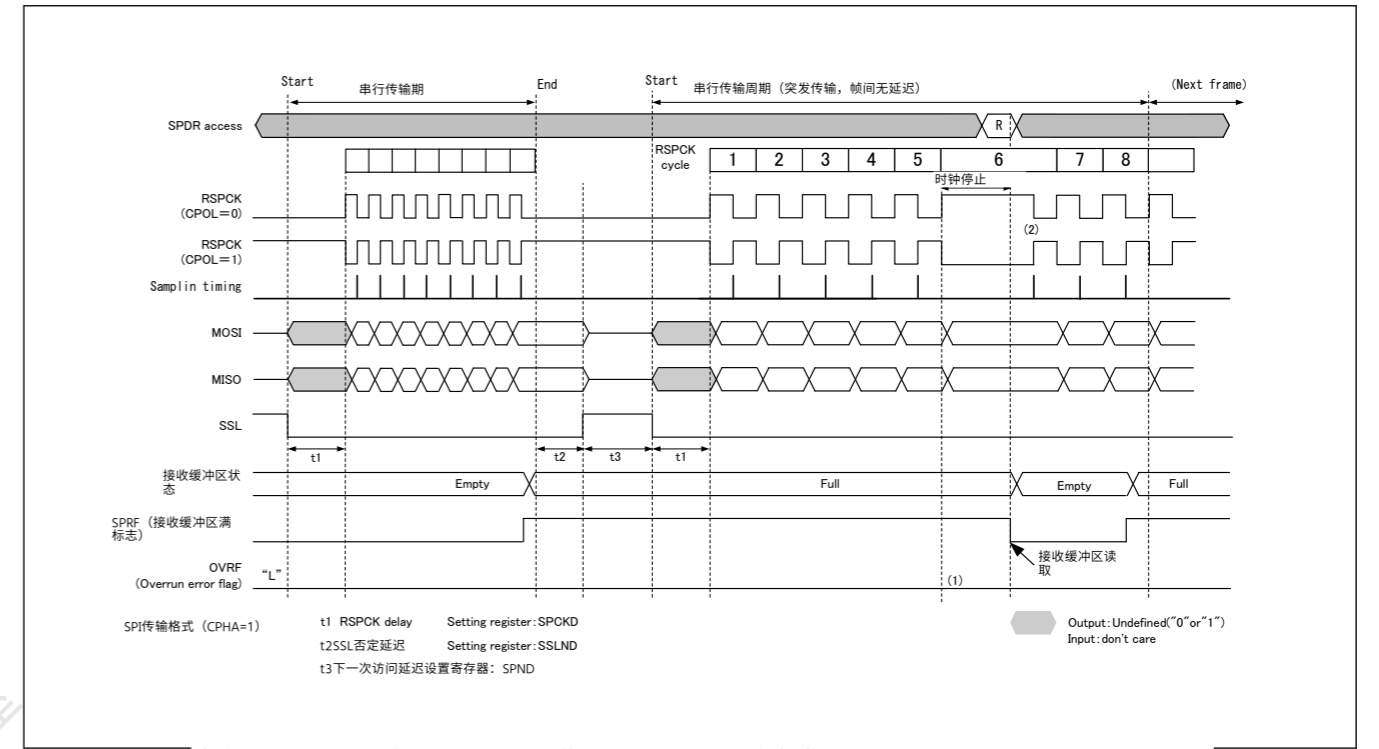


Figure 30.40 当串行传输在主机中的接收缓冲器满时继续时的时钟停止波形模式 (突发传输且帧之间无延迟CPHA=1)

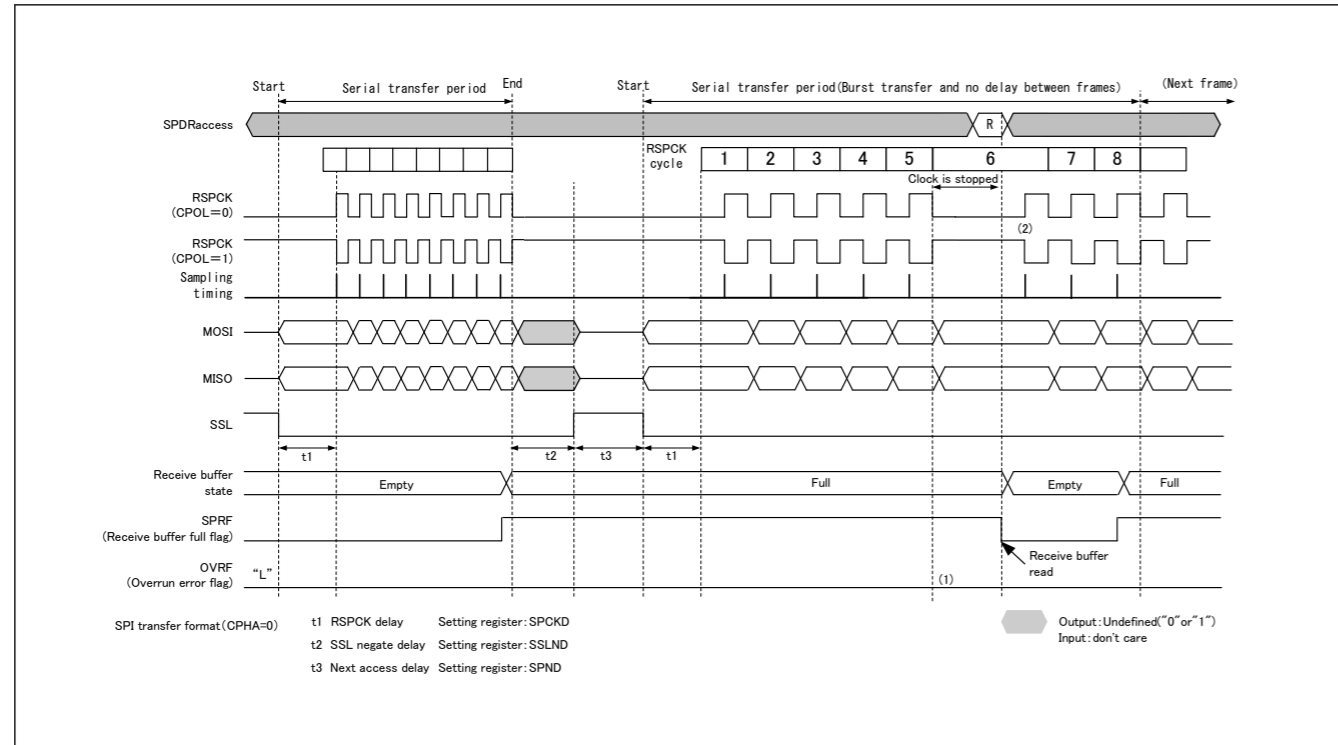


Figure 30.41 Clock Stop Waveform when Serial Transfer Continues in the Receive Buffer Full in Master Mode (at burst transfer and no delay between frames CPHA = 0)

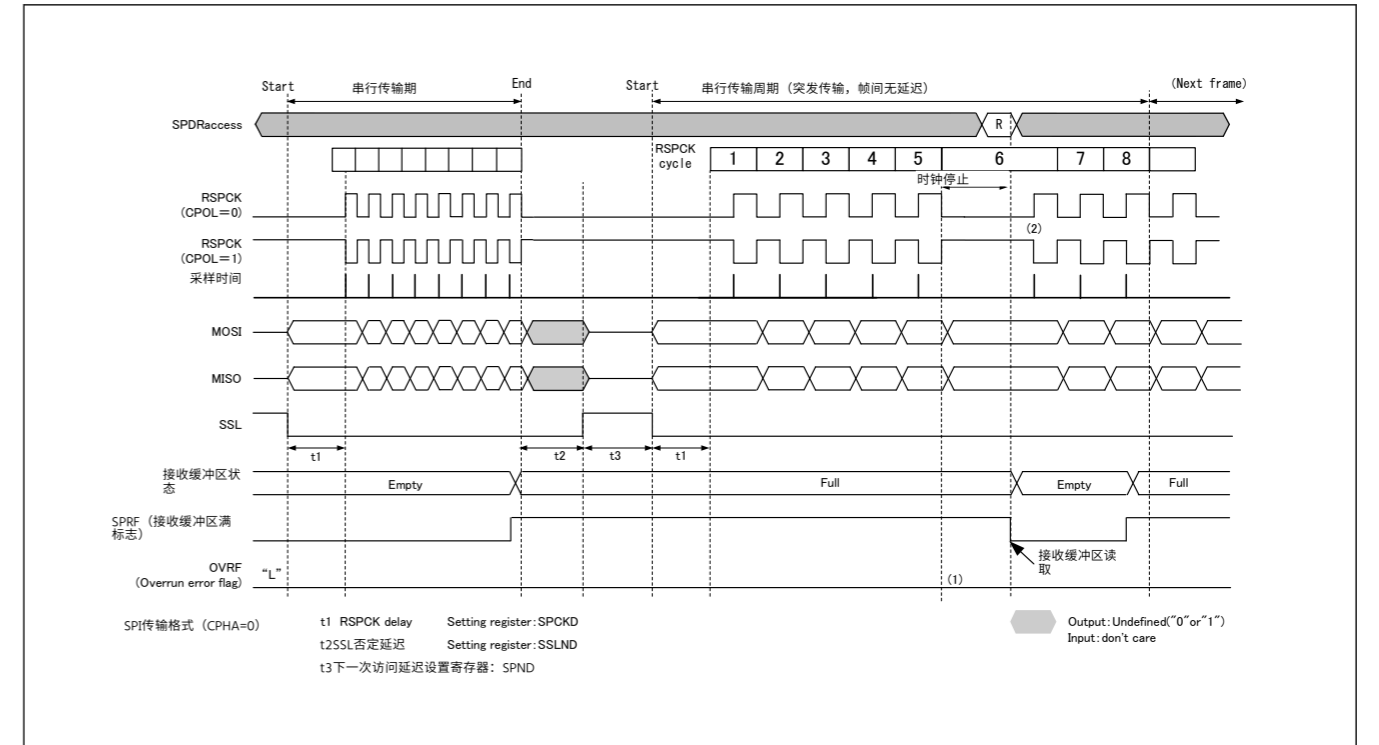


Figure 30.41 当串行传输在主机中的接收缓冲器满时继续时的时钟停止波形模式 (突发传输且帧之间无延迟CPHA=0)

The following describes operation of flags at timings (1) and (2) in the figure above.

下面描述在上图中的时间(1)和(2)的标志的操作。

1. While the receive buffer is full, the RSPCK clock is deactivated and no overrun error occurs.
2. Receive buffer data can be read by reading SPDR during clock stop. After the receive buffer data has been read (after the SPSR.SPRF flag has been cleared to 0), the RSPCK clock restarts.

### 30.3.9.2 Parity errors

When full-duplex synchronous serial communications is performed with the SPCR.TXMD bit set to 0 and the SPCR2.SPPE bit set to 1, when serial transfer ends, the SPI checks whether there are parity errors. On detecting a parity error in the received data, the SPI sets the SPSR.PERF flag to 1. Because the SPI does not copy data in the shift register to the receive buffer when the SPSR.OVRF flag is set to 1, parity error detection is not performed for the received data. To set the PERF flag to 0, write 0 to the PERF flag after the SPSR register is read with the PERF flag set to 1.

Figure 30.42 shows an example of operation of the OVRF and PERF flags. The SPSR access shown in Figure 30.42 indicates the condition of access to the register, where W denotes a write cycle, and R a read cycle. In this example, full-duplex serial communication is performed while the SPCR2.SPPE bit is 1. The SPI performs an 8-bit serial transfer when SPCMDm.CPHA bit is 1 and the SPCMDm.CPOL bit is 0. The numbers given for RSPCKn in the waveform represent the number of RSPCK cycles, such as the number of transferred bits.

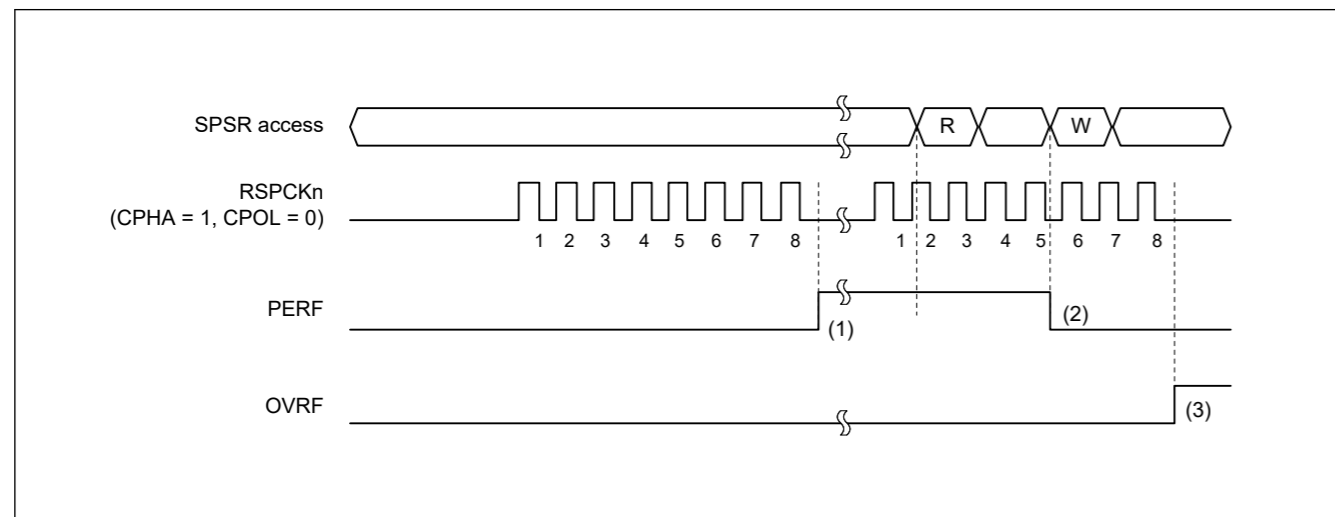


Figure 30.42 Operation example of the PERF flag

The operation of the flags at timings (1) to (3) in Figure 30.42 is as follows:

1. If a serial transfer terminates with the SPI not detecting an overrun error, the SPI copies the data in the shift register to the receive buffer. The SPI checks the received data at this time and sets the PERF flag to 1 if a parity error is detected.
2. If 0 is written to the PERF flag after the SPSR register is read when the PERF flag is 1, the PERF flag is set to 0.
3. When the SPI detects an overrun error and serial transfer is terminated, the data in the shift register is not copied to the receive buffer. The SPI does not perform parity error detection at this time.

Parity errors can be checked for by either reading the SPSR register or using an SPI error interrupt and reading the SPSR register. When executing a serial transfer, such checks are required to ensure early detection of parity errors. When the SPI is used in master mode, the pointer value to the SPCMDm register at the occurrence of the error can be checked by reading the SPSR.SPECM[2:0] bits (Only SPI0).

### 30.3.9.3 Mode fault errors

The SPI operates in multi-master mode when the SPCR.MSTR bit is 1, the SPCR.SPMS bit is 0, and the SPCR.MODFEN bit is 1. If the active level is input for the SSLn0 input signal of the SPI in multi-master mode, the SPI detects a mode fault error regardless of the status of the serial transfer, and sets the SPSR.MODF flag to 1. On detecting the mode fault error, the SPI copies the value of the pointer to SPCMDm to the SPDCR.SPFC[1:0] bits. The active level of the SSLn0 signal is determined by the SSLP.SSL0P bit.

When the MSTR bit is 0, the SPI operates in slave mode. The SPI detects a mode fault error if the MODFEN bit of the SPI in slave mode is 1, and the SPMS bit is 0, and if the SSLn0 input signal is negated during the serial transfer period (from the time the driving of valid data is started to the time the final valid data is fetched).

- 1.当接收缓冲器已满时，RSPCK时钟被停用，不会发生溢出错误。
- 2.在时钟停止时，可以通过读取SPDR来读取接收缓冲数据。读取接收缓冲区数据后（在SPSR.SPRF标志被清除为0后），RSPCK时钟重新启动。

### 30.3.9.2 奇偶校验错误

当SPCR.TXMD位设置为0且SPCR2.SPPE位设置为1进行全双工同步串行通信时，串行传输结束时，SPI会检查是否有奇偶校验错误。在检测到接收数据中的奇偶校验错误时，SPI将SPSR.PERF标志设置为1。因为当SPSR.OVRF标志设置为1时，SPI不会将移位寄存器中的数据复制到接收缓冲区，所以奇偶校验错误检测不针对接收到的数据执行。要将PERF标志设置为0，请在读取SPSR寄存器并将PERF标志设置为1后将0写入PERF标志。

图30.42显示了OVRF和PERF标志的操作示例。图30.42所示的SPSR访问表示访问寄存器的条件，其中W表示写周期，R表示读周期。在本例中，当SPCR2.SPPE位为1时执行全双工串行通信。当SPCMDm.CPHA位为1且SPCMDm.CPOL位为0时，SPI执行8位串行传输。波形表示RSPCK周期数，例如传输的位数。

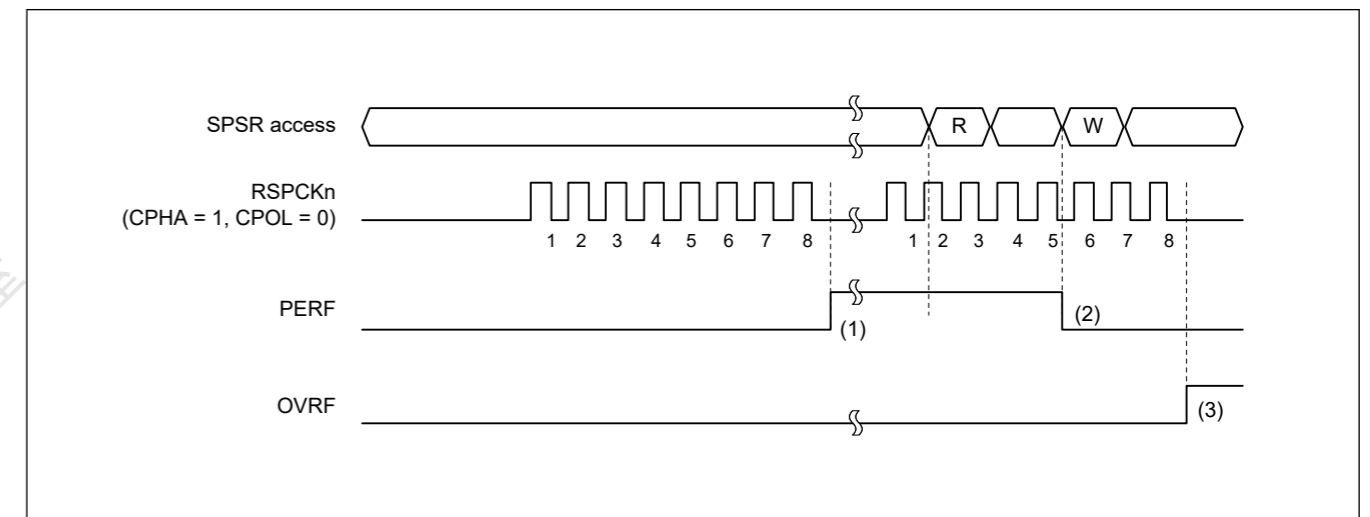


Figure 30.42 PERF标志的操作示例

图30.42中时间(1)到(3)的标志操作如下:

- 1.如果串行传输终止且SPI未检测到溢出错误，则SPI将移位寄存器中的数据复制到接收缓冲区。此时SPI会检查接收到的数据，如果检测到奇偶校验错误，则将PERF标志设置为1。
- 2.如果在PERF标志为1时读取SPSR寄存器后将0写入PERF标志，则将PERF标志设置为0。
- 3.当SPI检测到溢出错误并终止串行传输时，移位寄存器中的数据不会复制到接收缓冲区。此时SPI不执行奇偶校验错误检测。

可以通过读取SPSR寄存器或使用SPI错误中断并读取SPSR寄存器来检查奇偶校验错误。在执行串行传输时，需要进行此类检查以确保及早发现奇偶校验错误。当SPI用于主机模式时，可以通过读取SPSSR.SPECM[2:0]位（仅SPI0）来检查发生错误时指向SPCMDm寄存器的指针值。

### 30.3.9.3 模式故障错误

当SPCR.MSTR位为1、SPCR.SPMS位为0、SPCR.MODFEN位为1时，SPI工作在多主机模式。如果在多主机模式下SPI的SSLn0输入信号输入有效电平-主模式，无论串行传输的状态如何，SPI都会检测到模式故障错误，并将SPSR.MODF标志设置为1。在检测到模式故障错误时，SPI将指向SPCMDm的指针的值复制到SPDCR.SPFC[1:0]位。SSLn0信号的有效电平由SSLP.SSL0P位决定。

当MSTR位为0时，SPI工作在从机模式。如果从机模式下SPI的MODFEN位为1，SPMS位为0，并且在串行传输期间（从驱动有效数据开始到获取最终有效数据的时间）。



On detecting a mode fault error, the SPI stops the driving of the output signals and clears the SPCR.SPE bit to 0 (see [section 30.3.10. Initializing the SPI](#)). For multi-master configuration, detection of a mode fault error is used to stop the driving of output signals and the SPI function, which allows the master to be released.

The occurrence of a mode fault error can be checked either by reading SPSR or by using an SPI error interrupt and reading SPSR. Detecting mode-fault errors without using the SPI error interrupt requires polling of SPSR. When using the SPI in master mode, the value of the pointer to the SPCMDm register at the occurrence of the error can be checked by reading the SPSSR.SPECM[2:0] bits.

When the MODF flag is 1, writing 1 to the SPE bit is ignored by the SPI. To enable the SPI function after the detection of a mode fault error, the MODF flag must be set to 0.

#### 30.3.9.4 Underrun errors

While the SPI is operating in slave mode (SPCR.MSTR bit = 0) and the Extended Communication Mode Select bit (ETXMD) in the SPI Control Register 3 (SPCR3) is set to 0, if serial transfer is started before transmit data output is ready with the SPCR.SPE bit set to 1 (SPI function enabled), the SPI detects an underrun error and sets the SPSR.MODF and SPSR.UDRF flags to 1.

On detecting an underrun error, the SPI stops the driving of output signals and clears the SPCR.SPE bit to 0 (see [section 30.3.10. Initializing the SPI](#)).

The occurrence of underrun errors can be checked either by reading SPSR or by using an SPI error interrupt and reading SPSR. Detecting underrun errors without using the SPI error interrupt requires polling of SPSR.

When the MODF flag is 1, writing 1 to the SPE bit is ignored by the SPI. To enable the SPI function after the detection of an underrun error, the MODF flag must be set to 0.

### 30.3.10 Initializing the SPI

If 0 is written to the SPCR.SPE bit or if the SPI sets the SPE bit to 0 because it detected a mode fault error or an underrun error, the SPI disables the SPI function and initializes some of the module functions. When a system reset is generated, the SPI initializes all of the module functions. This section describes initialization by clearing of the SPCR.SPE bit and by a system reset.

#### 30.3.10.1 Initialization by clearing of the SPCR.SPE bit

When the SPCR.SPE bit is set to 0, the SPI initializes by:

- Suspending any serial transfer that is being executed
- Stopping the driving of output signals (Hi-Z) in slave mode
- Initializing the internal state of the SPI
- Initializing the transmit buffer of the SPI (the SPSR.STEF flag sets to 1)

Initialization by clearing of the SPE bit does not initialize the control bits of the SPI. For this reason, the SPI can be started in the same transfer mode in use prior to initialization when the SPE bit is set to 1 again.

The SPSR.CENDF, SPSR.SPRF, SPSR.OVRF, SPSR.MODF, SPSR.PERF, and SPSR.UDRF flags are not initialized, and the value of the SPI Sequence Status Register (SPSSR) is not initialized. Therefore, even after the SPI is initialized, data from the receive buffer can be read to check the communication completion status and the error status during an SPI transfer.

The transmit buffer is initialized to an empty state (the SPSR.SPTEF flag sets to 1). Therefore, if the SPCR.SPTIE bit is set to 1 after SPI initialization, a transmit buffer empty interrupt is generated. To disable any transmit buffer empty interrupts when the SPI is initialized, write 0 to the SPTIE bit simultaneously while writing 0 to the SPE bit.

#### 30.3.10.2 Initialization by system reset

A system reset completely initializes the SPI by initializing all SPI control bits, status bits, and data registers, in addition to meeting the requirements described in [section 30.3.10.1. Initialization by clearing of the SPCR.SPE bit](#).

在检测到模式故障错误时，SPI停止驱动输出信号并将SPCR.SPE位清零（参见第30.3.10节。初始化SPI）。对于多主机配置，检测到模式故障错误用于停止驱动输出信号和SPI功能，从而释放主机。

可以通过读取SPSR或使用SPI错误中断并读取SPSR来检查模式故障错误的发生。在不使用SPI错误中断的情况下检测模式错误需要轮询SPSR。在主模式下使用SPI时，可以通过读取SPSSR.SPECM[2:0]位来检查发生错误时指向SPCMDm寄存器的指针的值。

当MODF标志为1时，向SPE位写入1会被SPI忽略。要在检测到模式故障错误后启用SPI功能，MODF标志必须设置为0。

#### 30.3.9.4 Underrun errors

当SPI工作在从机模式（SPCR.MSTR位=0）并且SPI控制寄存器3（SPCR3）中的扩展通信模式选择位（ETXMD）设置为0时，如果串行传输在发送数据输出之前开始准备好将SPCR.SPE位设置为1（启用SPI功能），SPI检测到欠载错误并将SPSR.MODF和SPSR.UDRF标志设置为1。

检测到欠载错误时，SPI停止驱动输出信号并将SPCR.SPE位清零（参见第30.3.10节。初始化SPI）。

可以通过读取SPSR或使用SPI错误中断并读取SPSR。在不使用SPI错误中断的情况下检测欠载错误需要轮询SPSR。

当MODF标志为1时，向SPE位写入1会被SPI忽略。要在检测到欠载错误后启用SPI功能，MODF标志必须设置为0。

### 30.3.10 初始化SPI

如果将0写入SPCR.SPE位，或者如果SPI由于检测到模式故障错误或欠载错误而将SPE位设置为0，则SPI将禁用SPI功能并初始化一些模块功能。当产生系统复位时，SPI初始化所有模块功能。本节介绍通过清除SPCR.SPE位和系统复位进行的初始化。

#### 30.3.10.1 通过清除SPCR.SPE位进行初始化

当SPCR.SPE位设置为0时，SPI通过以下方式初始化：

- 暂停任何正在执行的串行传输
- 从机模式下停止驱动输出信号（Hi-Z）
- 初始化SPI的内部状态
- 初始化SPI的发送缓冲区（SPSR.STEF标志设置为1）

通过清除SPE位进行的初始化不会初始化SPI的控制位。因此，当SPE位再次设置为1时，SPI可以在初始化之前以相同的传输模式启动。

SPSR.CENDF、SPSR.SPRF、SPSR.OVRF、SPSR.MODF、SPSR.PERF和SPSR.UDRF标志未初始化，SPI序列状态寄存器（SPSSR）的值未初始化。因此，即使在SPI初始化之后，也可以从接收缓冲区读取数据，以检查SPI传输期间的通信完成状态和错误状态。

发送缓冲区初始化为空状态（SPSR.SPTEF标志设置为1）。因此，如果SPCR.SPTIE位在SPI初始化后设置为1，则会产生发送缓冲区空中断。要在SPI初始化时禁用任何发送缓冲区空中断，请同时将0写入SPTIE位，同时将0写入SPE位。

#### 30.3.10.2 通过系统复位初始化

除了满足第30.3.10.1节中描述的要求外，系统复位还通过初始化所有SPI控制位、状态位和数据寄存器来完全初始化SPI。通过清除SPCR.SPE位进行初始化。



### 30.3.11 SPI Operation

#### 30.3.11.1 Master mode operation

The only difference between single- and multi-master mode operation is the use of mode fault error detection (see [section 30.3.9. Error Detection](#)). In single-master mode, the SPI does not detect mode fault errors whereas in multi-master mode, it does. This section explains operations that are common to both modes.

##### (1) Starting a serial transfer

The SPI updates the data in the transmit buffer (SPTX) when data is written to the SPI Data Register (SPDR/SPDR\_HA) with the SPI transmit buffer empty, data for the next transfer is not set, and the SPSR.STEF flag is 0. When the shift register is empty after the number of frames set in the SPDCR.SPFC[1:0] bits are written to the SPDR/SPDR\_HA/SPDR\_BY, the SPI copies data from the transmit buffer to the shift register and starts serial transfer. On copying transmit data to the shift register, the SPI changes the status of the shift register to full. On termination of the serial transfer, it changes the status of the shift register to empty. The status of the shift register cannot be referenced.

The polarity of the SSLni output pins depends on the SSLP register settings. For details on the SPI transfer format, see [section 30.3.5. Transfer Formats](#).

##### (2) Terminating a serial transfer

Regardless of the SPCMDm.CPHA bit setting, the SPI terminates the serial transfer after transmitting an RSPCKn edge associated with the final sampling timing. If free space is available in the receive buffer (SPRX) (the SPSR.SPRF flag is 0), on termination of the serial transfer, the SPI copies data from the shift register to the receive buffer of the SPDR/SPDR\_HA register.

The final sampling timing varies depending on the bit length of transfer data. In master mode, the SPI data length depends on the SPCMDm.SPB[3:0] bit settings. The polarity of the SSLni output pin depends on the SSLP register settings. For details on the SPI transfer format, see [section 30.3.5. Transfer Formats](#).

##### (3) Sequence control

The transfer format used in master mode is determined by the SPSCR, SPCMDm, SPBR, SPCKD, SSLND, and SPND registers.

The SPSCR register determines the sequence configuration for serial transfers that are executed by the SPI in master mode. The following items are set in the SPCMDm register:

- SSLni pin output signal value
- MSB- or LSB-first
- Data length
- Some of the bit rate settings
- RSPCK polarity and phase
- Whether SPCKD is to be referenced
- Whether SSLND is to be referenced
- Whether SPND is to be referenced

SPBR holds some of the bit rate settings, including SPCKD (SPI clock delay), SSLND (SSL negation delay), and SPND (next-access delay).

Based on the sequence length assigned in SPSCR, the SPI makes up a sequence comprised of a part or all of the SPCMDm register. The SPI contains a pointer to the SPCMDm register that makes up the sequence. The value of this pointer can be checked by reading the SPSSR.SPCP[2:0] bits. When the SPCR.SPE bit is set to 1 and the SPI function is enabled, the SPI loads the pointer to the commands in SPCMD0, and incorporates the SPCMD0 settings into the transfer format at the beginning of serial transfer. The SPI increments the pointer each time the next-access delay period for a data transfer ends. On completion of the serial transfer that corresponds to the final command in the sequence, the SPI sets the pointer to SPCMD0, and in this way the sequence is executed repeatedly.

### 30.3.11 SPI操作

#### 30.3.11.1 主模式操作

单主机模式和多主机模式操作之间的唯一区别是使用模式故障错误检测（请参阅第30.3.9节。错误检测）。在单主机模式下，SPI不检测模式故障错误，而在多主机模式下，它可以。本节介绍两种模式共有的操作。

##### (1) 开始串行传输

当数据写入SPI数据寄存器(SPDRSPDR\_HA)且SPI发送缓冲区为空、未设置下一次传输的数据且SPSR.STEF标志为0时，SPI更新发送缓冲区(SPTX)中的数据。当SPDCR.SPFC[1:0]位设置的帧数写入SPDRSPDR\_HASPDR\_BY后移位寄存器为空时，SPI将数据从发送缓冲区复制到移位寄存器并开始串行传输。在将发送数据复制到移位寄存器时，SPI将移位寄存器的状态更改为已满。在串行传输终止时，它将移位寄存器的状态更改为空。无法引用移位寄存器的状态。

SSLni输出引脚的极性取决于SSLP寄存器设置。有关SPI传输格式的详细信息，请参见第30.3.5节。传输格式。

##### (2) 终止串行传输

无论SPMDm.CPHA位设置如何，SPI在发送与最终采样时序相关的RSPCKn边沿后终止串行传输。如果接收缓冲区(SPRX)中有可用空间(SPSR.SPRF标志为0)，则在串行传输终止时，SPI将数据从移位寄存器复制到SPDRSPDR\_HA寄存器的接收缓冲区。

最终的采样时序根据传输数据的位长而变化。在主模式下，SPI数据长度取决于SPMDm.SPB[3:0]位设置。SSLni输出引脚的极性取决于SSLP寄存器设置。有关SPI传输格式的详细信息，请参见第30.3.5节。传输格式。

##### (3) 顺序控制

主机模式中使用的传输格式由SPSCR、SPCMDm、SPBR、SPCKD、SSLND和SPND寄存器确定。

SPSCR寄存器确定由SPI在主模式下执行的串行传输的序列配置。在SPCMDm寄存器中设置以下项目：

- SSLni管脚输出信号值
- MSB- or LSB-first
- 数据长度
- 一些比特率设置
- RSPCK极性和相位
- 是否引用SPCKD
- 是否引用SSLND
- 是否引用SPND

SPBR保存一些比特率设置，包括SPCKD（SPI时钟延迟）、SSLND（SSL否定延迟）和SPND（下一次访问延迟）。

根据在SPSCR中分配的序列长度，SPI组成一个由部分或全部SPMDm寄存器组成的序列。SPI包含一个指向构成序列的SPCMDm寄存器的指针。该指针的值可以通过读取SPSSR.SPCP[2:0]位来检查。当SPCR.SPE位设置为1且SPI功能使能时，SPI加载指向SPCMD0中命令的指针，并在串行传输开始时将SPCMD0设置合并到传输格式中。每次数据传输的下一个访问延迟周期结束时，SPI都会递增指针。在完成对应于序列中最终命令的串行传输后，SPI将指针设置为

SPCMD0，并以这种方式重复执行序列。

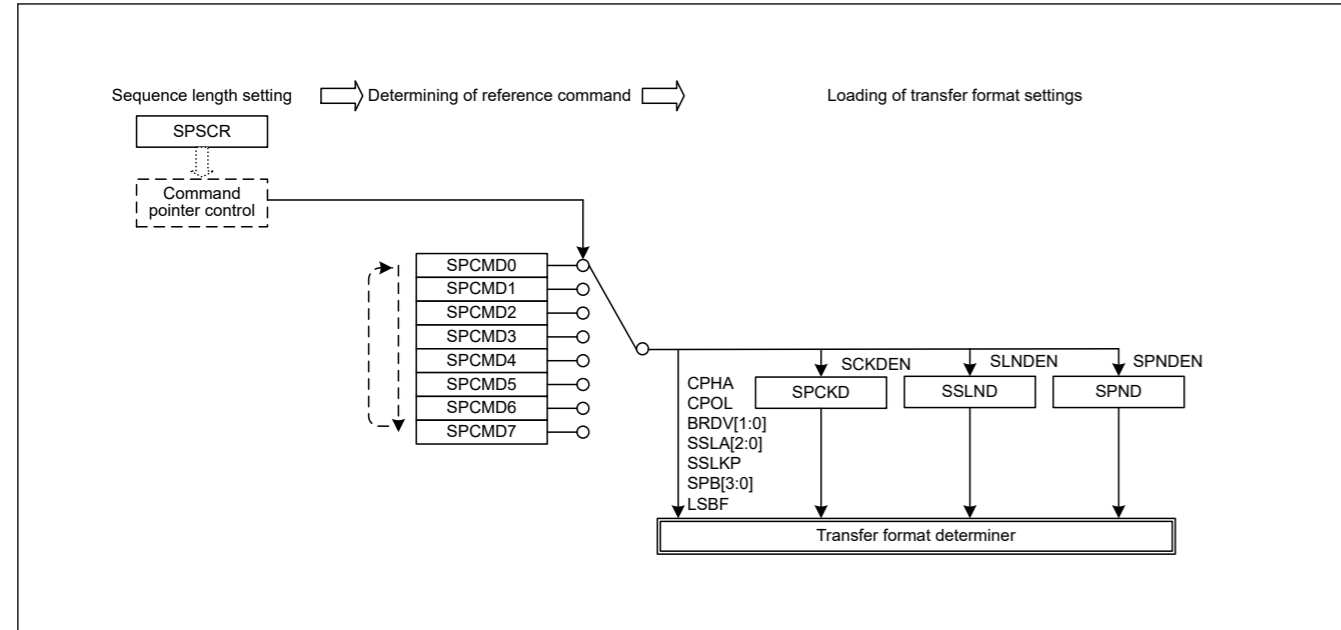


Figure 30.43 Procedure for determining the form of a serial transfer in master mode

In this section, a frame is the combination of the data in SPDR/SPDR\_HA and the settings in SPCMDm.

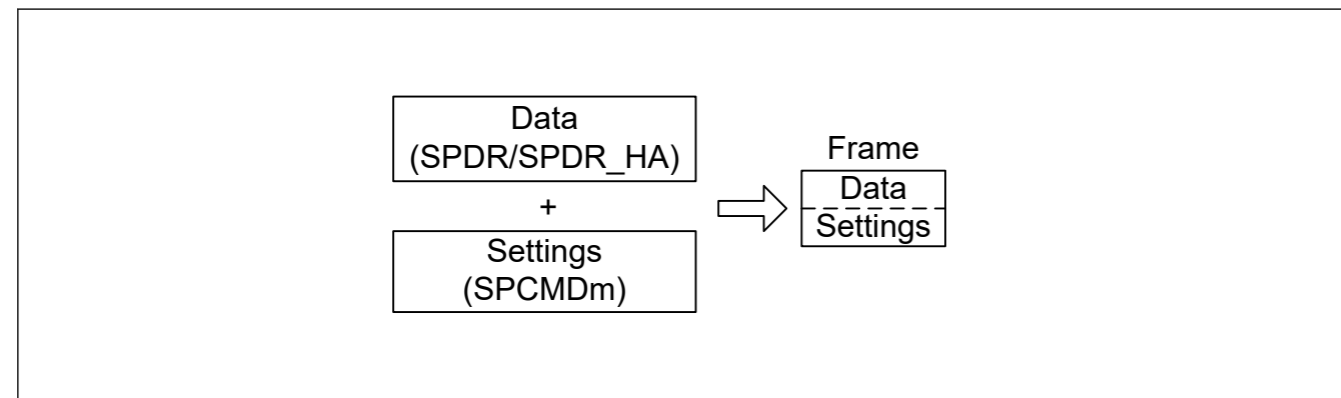


Figure 30.44 Conceptual diagram of frames

Figure 30.45 shows the correspondence between the commands and the transmit and receive buffers in the sequence of operations specified by the settings in Table 30.3.

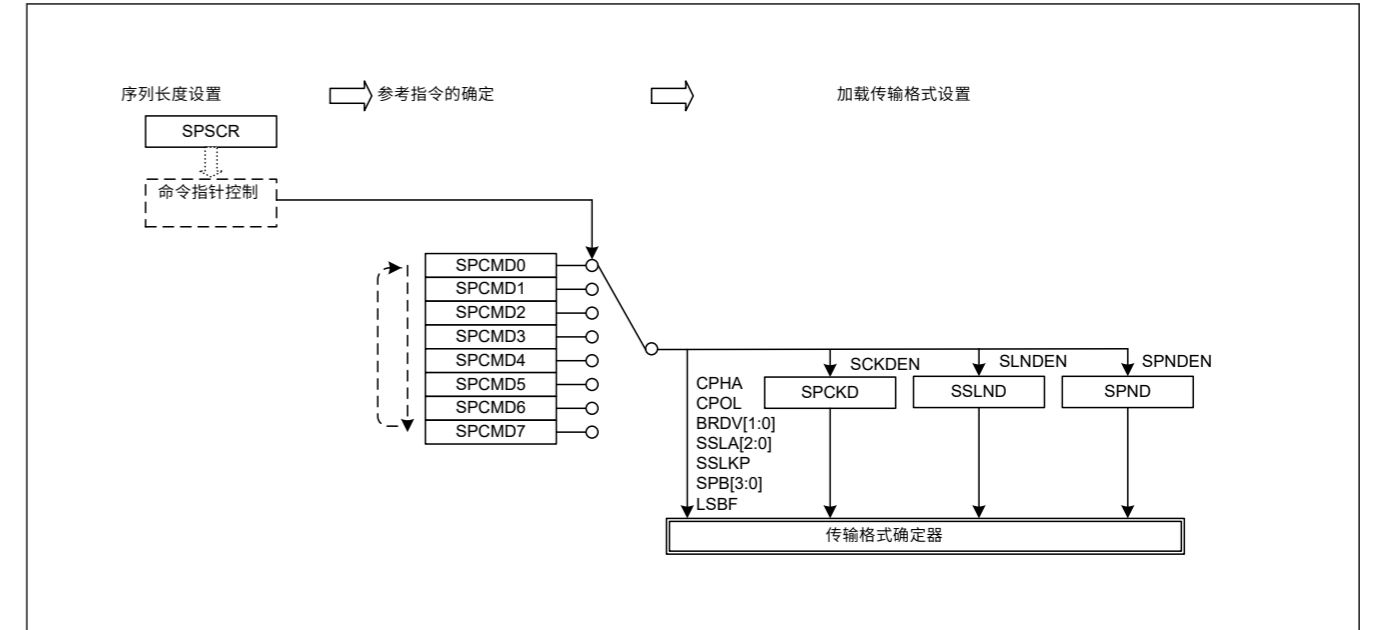


Figure 30.43 确定主模式下串行传输形式的过程

在本节中，帧是SPDR/SPDR\_HA中的数据和SPCMDm中的设置的组合。

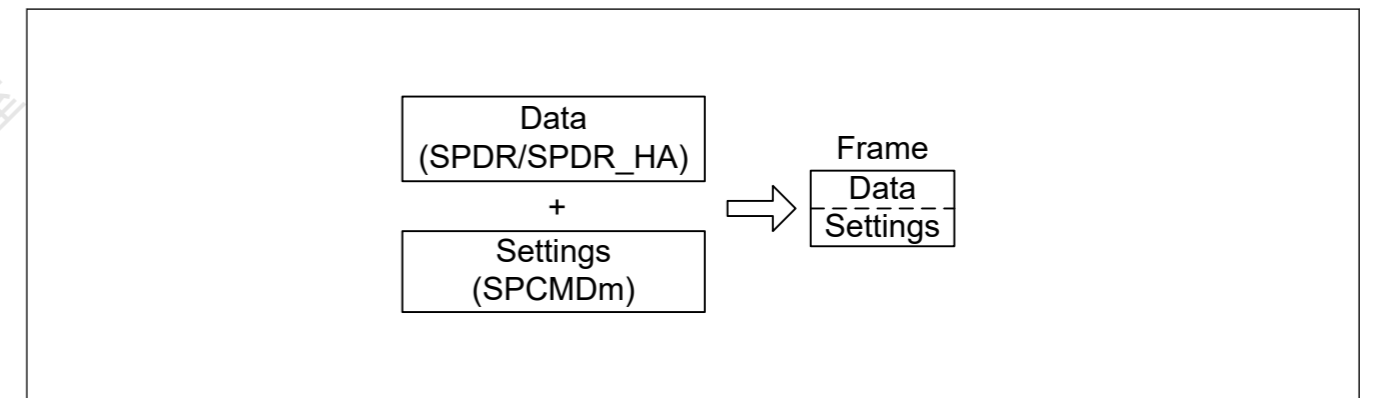


Figure 30.44 框架的概念图

图30.45显示了在表30.3中设置指定的操作顺序中命令与发送和接收缓冲区之间的对应关系。

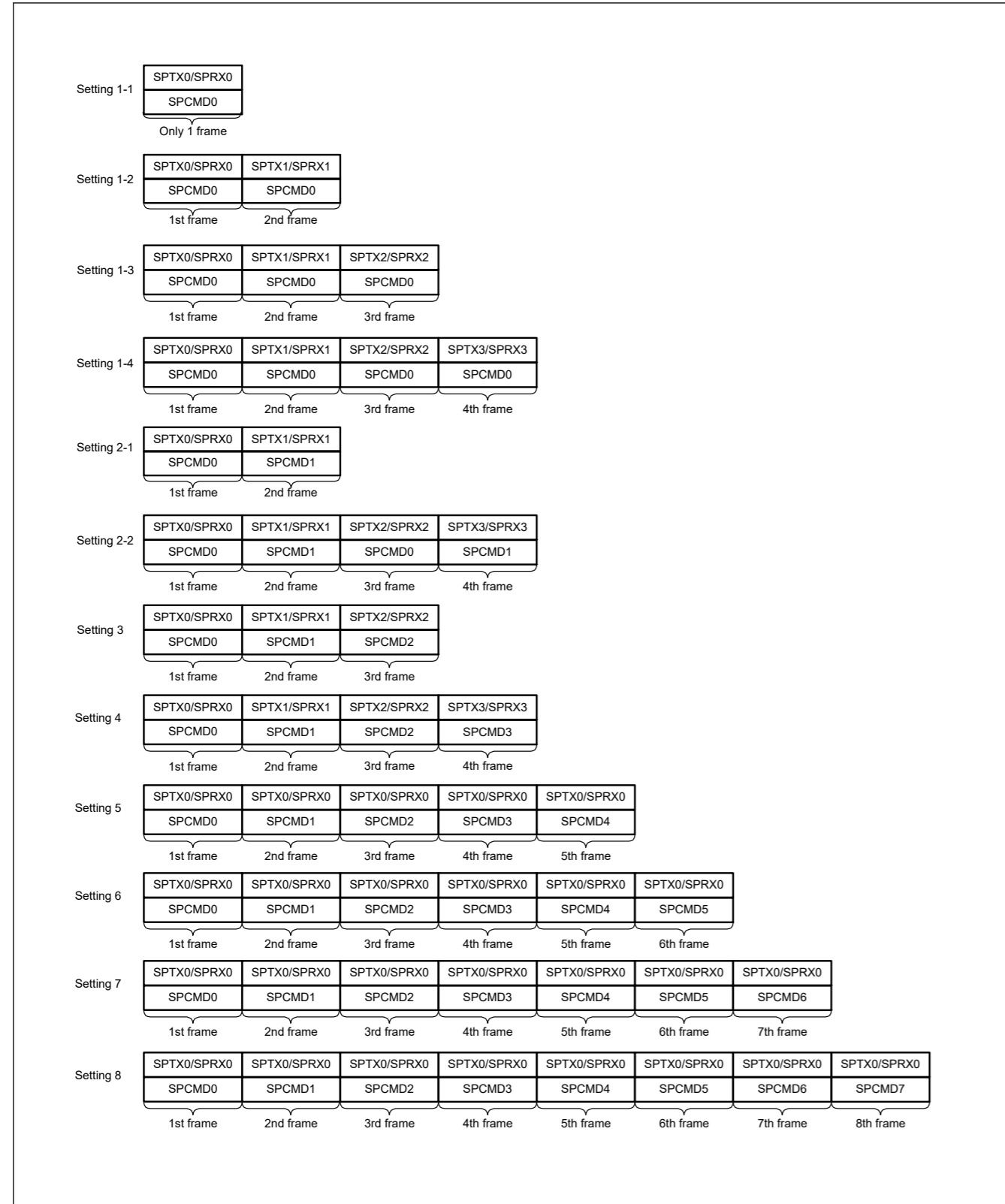


Figure 30.45 Correspondence between SPI Command Register and transmit and receive buffers in sequence operations

(4) Burst transfers

If the SPCMDm.SSLKP bit that the SPI references during the current serial transfer is 1, the SPI maintains the SSLni signal level during the serial transfer until the beginning of the SSLni signal assertion for the next serial transfer. If the SSLni

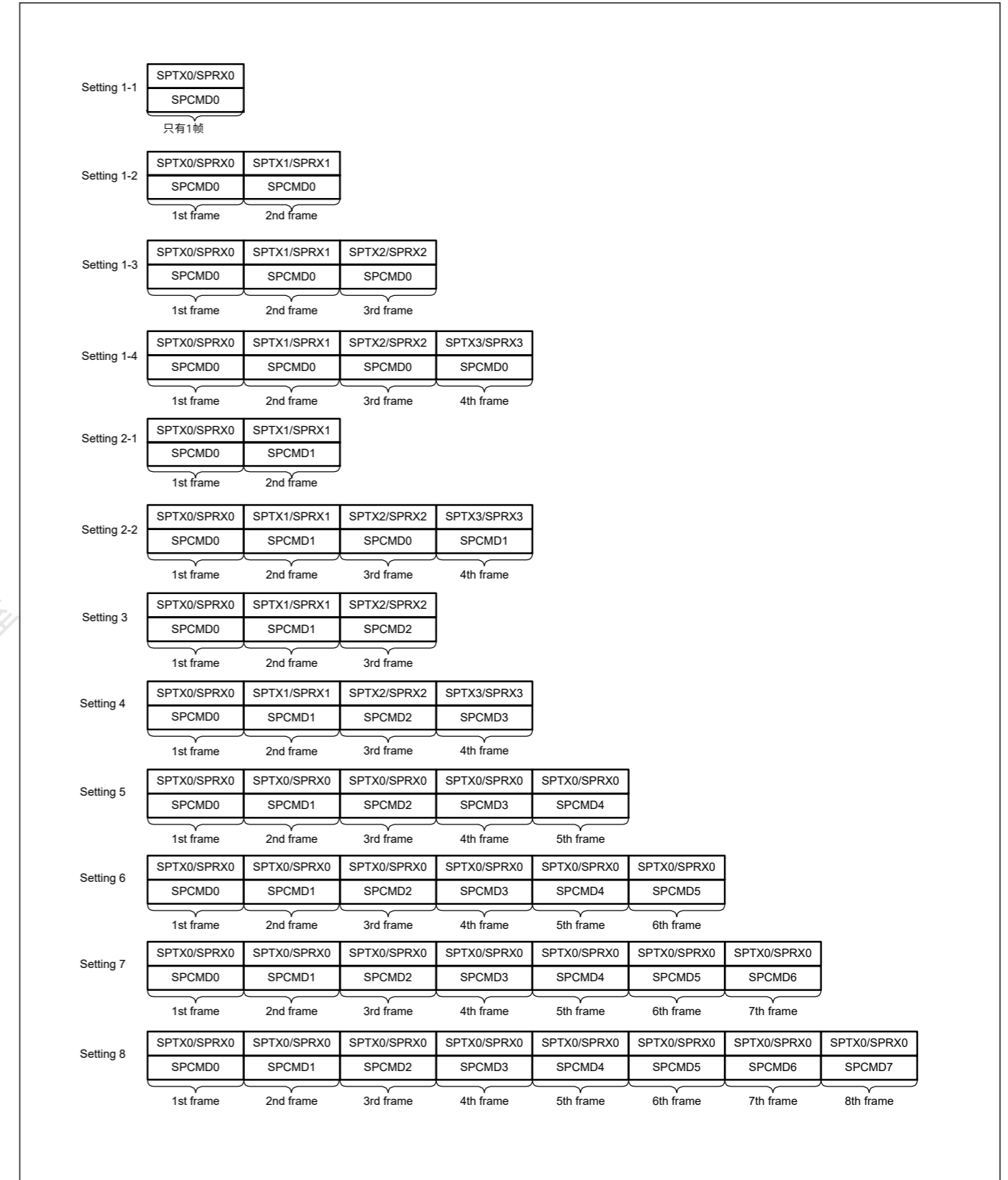


Figure 30.45 顺序操作中SPI命令寄存器与发送接收缓冲区的对应关系

(4) 突发传输

如果SPI在当前串行传输期间引用的SPCMDm.SSLKP位为1，则SPI在串行传输期间保持SSLni信号电平，直到下一次串行传输的SSLni信号断言开始。如果SSLni

signal level for the next serial transfer is the same as the SSLni signal level for the current serial transfer, the SPI can execute continuous serial transfers while keeping the SSLni signal assertion status (burst transfer).

- When Between Burst Transfer Frames Delay Select bit (BFDS) of SPI control register 3 (SPCR3) is 0.

Figure 30.46 shows an example of an SSLni signal operation for a burst transfer that is implemented using the SPCMD0 and SPCMD1 register settings. This section describes SPI operations (1) to (8) shown in Figure 30.46.

Note: The polarity of the SSLni output signal depends on the SSLP register settings.

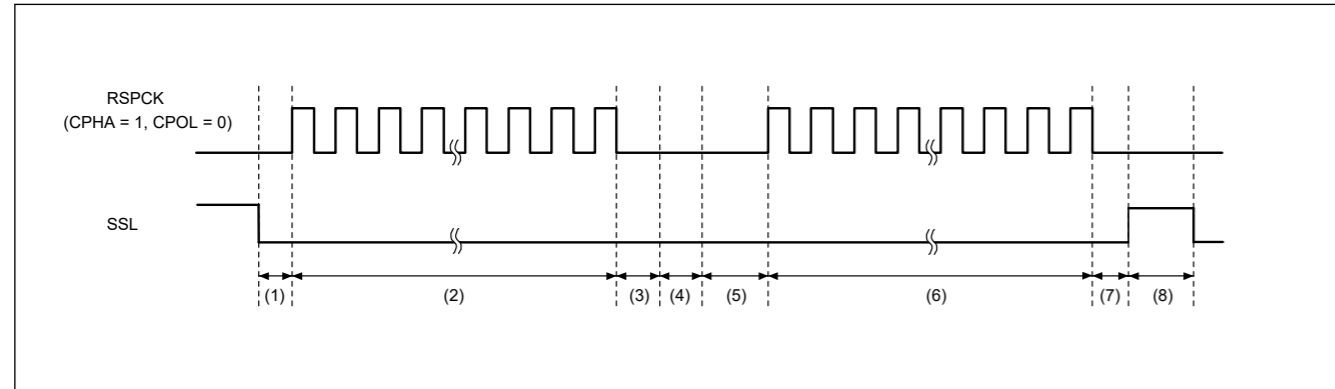


Figure 30.46 Example of burst transfer operation using the SSLKP bit (BFDS = 0)

The SPI operation at times (1) to (8) in the figure is as follows:

- Based on the SPCMD0 settings, the SPI asserts the SSLni signal and inserts RSPCK delays.
- The SPI executes serial transfers in accordance with the SPCMD0 settings.
- The SPI inserts an SSL negation delay.
- Because the SPCMD0.SSLKP bit is 1, the SPI keeps the SSLni signal value specified in SPCMD0. This period is sustained at a minimum for a period equal to the next-access delay in SPCMD0. If the shift register is empty after the passage of the minimum period, this period is sustained until the transmit data is stored in the shift register for the next transfer.
- Based on the SPCMD1 settings, the SPI asserts the SSLni signal and inserts RSPCK delays.
- The SPI executes serial transfers in accordance with the SPCMD1 settings.
- Insert SSL negate delay.
- Because the SPCMD1.SSLKP bit is 0, the SPI negates the SSLni signal. In addition, a next-access delay is inserted in accordance with SPCMD1.

If the SSLni signal output settings in the SPCMDm register where 1 is assigned to the SSLKP bit are different from the SSLni signal output settings in the SPCMDm register to be used in the next transfer, the SPI switches the SSLni signal status to SSLni signal assertion as shown in (5) in Figure 30.46. This corresponds to the command for the next transfer.

Note: If such an SSLni signal switching occurs, the slaves that drive the MISO signal compete, and collision of signal levels might occur.

The SPI in master mode references the SSLni signal operation within the module when the SSLKP bit is not used. When the SPCMDm.CPHA bit is 0, the SPI can accurately start serial transfers by using the SSLni signal assertion for the next transfer that is detected internally.

- When Between Burst Transfer Frames Delay Select bit (BFDS) of SPI control register 3 (SPCR3) is 1.

Figure 30.47 shows an example of SSL signal operation when burst transfer is achieved by using the settings of SPCMD0 and SPCMD1. The following describes SPI operations of (1) to (6) shown in Figure 30.47. The SSL output signal polarity depends on the set SPI slave select polarity register (SSLP) value.

下一次串行传输的信号电平与当前串行传输的SSLni信号电平相同，SPI可以在保持SSLni信号断言状态（突发传输）的同时执行连续串行传输。

- 当SPI控制寄存器3(SPCR3)的突发传输帧之间延迟选择位(BFDS)为0时。

图30.46显示了使用SPCMD0和SPCMD1寄存器设置实现的突发传输的SSLni信号操作示例。本节介绍图30.46所示的SPI操作(1)至(8)。

Note: SSLni输出信号的极性取决于SSLP寄存器设置。

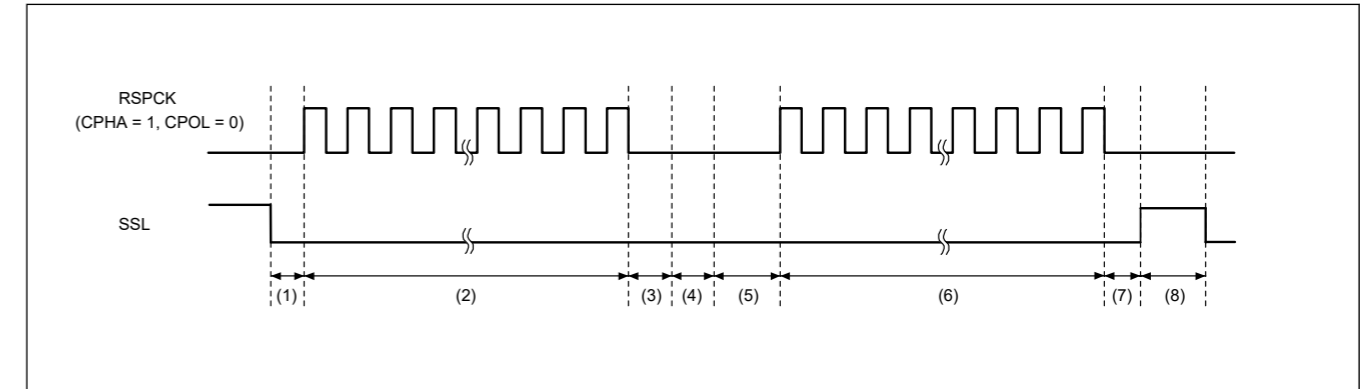


Figure 30.46 使用SSLKP位(BFDS=0)的突发传输操作示例

图中(1)到(8)时刻的SPI操作如下:

- 基于SPCMD0设置，SPI断言SSLni信号并插入RSPCK延迟。
- SPI根据SPMD0设置执行串行传输。
- SPI插入SSL否定延迟。
- 由于SPCMD0.SSLKP位为1，SPI保持SPCMD0中指定的SSLni信号值。这个时期是至少持续一段时间等于SPMD0中的下一次访问延迟。如果在经过最小周期后移位寄存器为空，则该周期一直持续到发送数据存储到移位寄存器中以供下一次传输。
- 基于SPCMD1设置，SPI断言SSLni信号并插入RSPCK延迟。
- SPI根据SPMD1设置执行串行传输。
- 插入SSL否定延迟。
- 由于SPCMD1.SSLKP位为0，SPI否定SSLni信号。此外，根据SPMD1插入下一个访问延迟。

如果SPCMDm寄存器中的SSLni信号输出设置（其中1分配给SSLKP位）与SPCMDm寄存器中用于下一次传输的SSLni信号输出设置不同，则SPI将SSLni信号状态切换为SSLni信号断言，如下所示如图30.46（5）所示。这对应于下一次传输的命令。

Note: 如果发生这种SSLni信号切换，驱动MISO信号的从机竞争，可能会发生信号电平冲突。

当不使用SSLKP位时，主模式下的SPI参考模块内的SSLni信号操作。当。。。的时候 SPCMDm.CPHA位为0，SPI可以通过使用SSLni信号断言来准确启动串行传输，以进行内部检测到的下一次传输。

- 当SPI控制寄存器3(SPCR3)的突发传输帧之间延迟选择位(BFDS)为1时。

图30.47显示了使用SPCMD0和SPCMD1的设置实现突发传输时SSL信号操作的示例。下面描述图30.47所示的(1)到(6)的SPI操作。SSL输出信号极性取决于设置的SPI从机选择极性寄存器(SSLP)值。



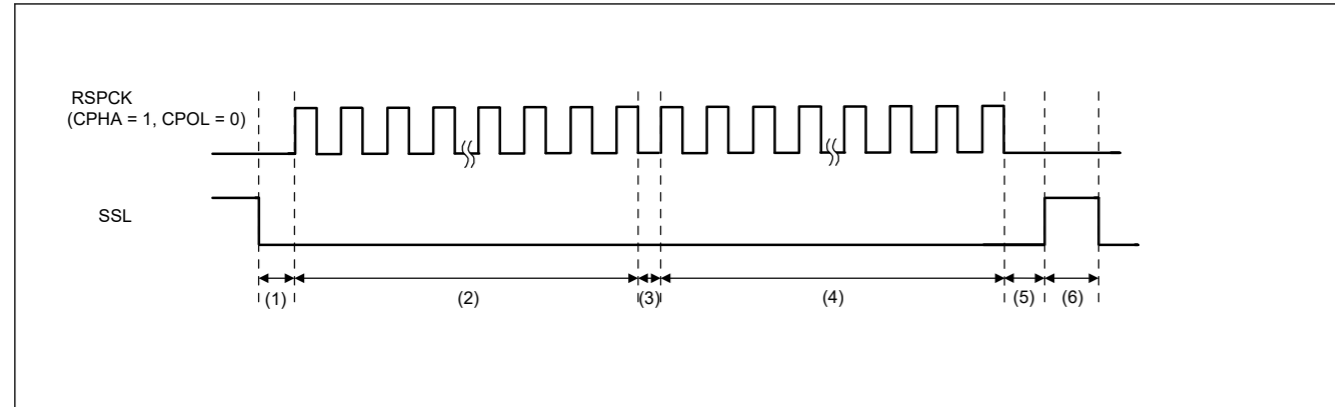


Figure 30.47 Example of Burst Transfer Operation Using SSLKP Bit (BFDS = 1)

1. Assert the SSL signal and insert an RSPCK delay according to SPCMD0. The RSPCK delay is inserted only the first frame of burst transmission.
2. Perform serial transfer according to SPCMD0. Wait last clock until the next transmit data is stored in the shift register, if the shift register is empty during RSPCK negate period between frames.
3. The value of SSL signal according to SPCMD0 is hold, because the SPCMD0.SSLKP bit is 1. RSPCK negate period between frames is 0.5RSPCK, if the shift register is not empty.
4. Perform serial transfer according to SPCMD1.
5. Insert SSL negate delay for the last frame.
6. The SSL signal is negated because the SSLKP bit in SPCMD1 is 0. Furthermore, the next-access delay is inserted according to SPCMD1.

(5) RSPCK delay (t1)

The RSPCK delay value of the SPI in master mode depends on the SPCMDm.SCKDEN bit setting and the SPCKD.SCKDL[2:0] bits setting. The SPI determines the SPCMDm register to be referenced during a serial transfer by pointer control, and determines an RSPCK delay using the SPCMDm.SCKDEN bit and SPCKD.SCKDL[2:0] bits, as listed in Table 30.10. For a definition of RSPCK delay, see section 30.3.5. Transfer Formats.

RSPCK delay insert to only the first frame of burst transmission, when transmit without “Between Burst Transfer Frames Delay”. (The SPCMD.SSLKP bit is 1 and the SPCR3.BFDS bit is 1.)

Table 30.10 Relationship between the SPCMDm.SCKDEN bit, SPCKD.SCKDL[2:0] bits, and RSPCK delay

| SPCMDm.SCKDEN bit | SPCKD.SCKDL[2:0] bits | RSPCK delay |
|-------------------|-----------------------|-------------|
| 0                 | 000b to 111b          | 1 RSPCK     |
| 1                 | 000b                  | 1 RSPCK     |
|                   | 001b                  | 2 RSPCK     |
|                   | 010b                  | 3 RSPCK     |
|                   | 011b                  | 4 RSPCK     |
|                   | 100b                  | 5 RSPCK     |
|                   | 101b                  | 6 RSPCK     |
|                   | 110b                  | 7 RSPCK     |
|                   | 111b                  | 8 RSPCK     |

(6) SSL negation delay (t2)

The SSL negation delay value of the SPI in master mode depends on the SPCMDm.SLNDEN bit setting and the SSLND.SLNDL[2:0] bits setting. The SPI determines the SPCMDm register to be referenced by pointer control during a serial transfer, and determines an SSL negation delay using the SPCMDm.SLNDEN bit and SSLND.SLNDL[2:0] bits, as listed in Table 30.11. For a definition of SSL negation delay, see section 30.3.5. Transfer Formats.

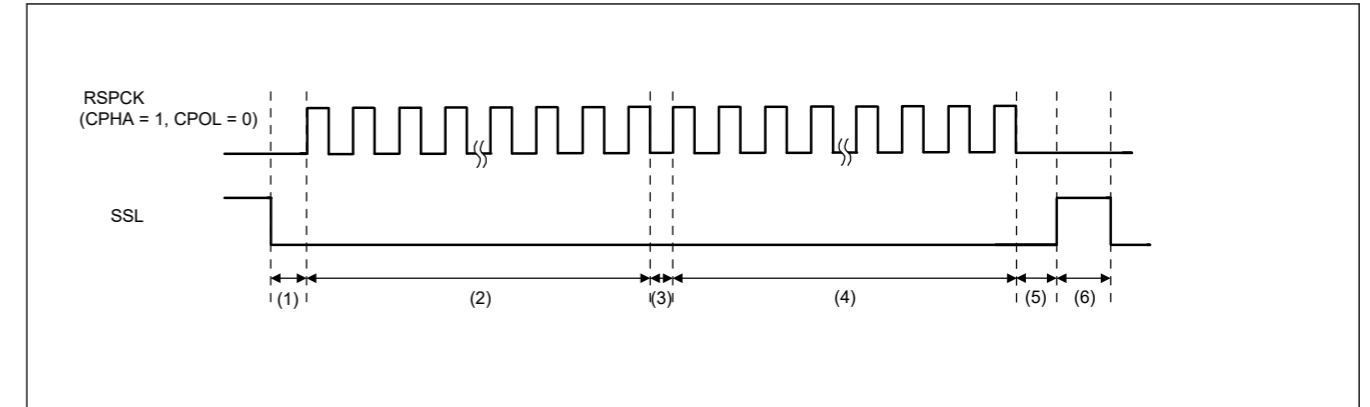


Figure 30.47 使用SSLKP位(BFDS=1)的突发传输操作示例

1. 置位SSL信号并根据SPMD0插入一个RSPCK延迟。RSPCK延迟仅插入突发传输的第一帧。
2. 根据SPMD0进行串行传输。如果在帧之间的RSPCK否定周期内移位寄存器为空，则等待最后一个时钟，直到下一个发送数据存储在移位寄存器中。
3. SPCMD0的SSL信号值被保持，因为SPCMD0.SSLKP位为1。如果移位寄存器不为空，则帧之间的RSPCK否定周期为0.5RSPCK。
4. 根据SPMD1进行串行传输。
5. 为最后一帧插入SSL否定延迟。
6. SSL信号被取反，因为SPCMD1中的SSLKP位为0。另外，根据SPCMD1插入下一个访问延迟。

(5) RSPCK delay (t1)

主机模式下SPI的RSPCK延迟值取决于SPMDm.SCKDEN位设置和SPCKD.SCKDL[2:0]位设置。SPI通过指针控制确定串行传输期间要引用的SPCMDm寄存器，并使用SPCMDm.SCKDEN位和SPCKD.SCKDL[2:0]位确定RSPCK延迟，如表30.10中所列。有关RSPCK延迟的定义，请参见第30.3.5节。传输格式。

当没有“BetweenBurstTransferFrames”传输时，RSPCK延迟仅插入到突发传输的第一帧延迟”。(SPCMD.SSLKP位为1，SPCR3.BFDS位为1。)

Table 30.10 SPCMDm.SCKDEN位、SPCKD.SCKDL[2:0]位和RSPCK延迟之间的关系

| SPCMDm.SCKDEN bit | SPCKD.SCKDL[2:0] bits | RSPCK delay |
|-------------------|-----------------------|-------------|
| 0                 | 000b to 111b          | 1 RSPCK     |
| 1                 | 000b                  | 1 RSPCK     |
|                   | 001b                  | 2 RSPCK     |
|                   | 010b                  | 3 RSPCK     |
|                   | 011b                  | 4 RSPCK     |
|                   | 100b                  | 5 RSPCK     |
|                   | 101b                  | 6 RSPCK     |
|                   | 110b                  | 7 RSPCK     |
|                   | 111b                  | 8 RSPCK     |

(6) SSL否定延迟(t2)

主模式下SPI的SSL否定延迟值取决于SPMDm.SLNDEN位设置和SSLND.SLNDL[2:0]位设置。SPI确定串行传输期间指针控制要引用的SPCMDm寄存器，并使用SPCMDm.SLNDEN位和SSLND.SLNDL[2:0]位确定SSL否定延迟，如表30.11中所列。有关SSL否定延迟的定义，请参见第30.3.5节。传输格式。

An SSL negation delay is inserted to only the last frame of the burst transmission, that is, transmit without “between burst transfer frames delay”. (SPCMD.SSLKP bit is 1 and SPCR3.BFDS bit is 1).

**Table 30.11 Relationship between the SPCMDm.SLNDEN bit, SSLND.SLNDL[2:0] bits, and SSL negation delay**

| SPCMDm.SLNDEN bit | SSLND.SLNDL[2:0] bits | SSL negation delay |
|-------------------|-----------------------|--------------------|
| 0                 | 000b to 111b          | 1 RSPCK            |
| 1                 | 000b                  | 1 RSPCK            |
|                   | 001b                  | 2 RSPCK            |
|                   | 010b                  | 3 RSPCK            |
|                   | 011b                  | 4 RSPCK            |
|                   | 100b                  | 5 RSPCK            |
|                   | 101b                  | 6 RSPCK            |
|                   | 110b                  | 7 RSPCK            |
|                   | 111b                  | 8 RSPCK            |

#### (7) Next-access delay (t3)

The next-access delay value of the SPI in master mode depends on the SPCMDm.SPNDEN bit setting and the SPND.SPNDL[2:0] bits setting. The SPI determines the SPCMDm register to be referenced during serial transfer by pointer control, and then determines a next-access delay during serial transfer using the SPCMDm.SPNDEN bit and SPND.SPNDL[2:0] bits, as listed in [Table 30.12](#). For a definition of next-access delay, see [section 30.3.5. Transfer Formats](#).

A next-Access delay is inserted to only the last frame of the burst transmission, that is, transmit without “between burst transfer frames delay”. (SPCMD.SSLKP bit is 1 and SPCR3.BFDS bit is 1).

**Table 30.12 Relationship between the SPCMDm.SPNDEN bit, SPND.SPNDL[2:0] bits, and next-access delay**

| SPCMDm.SPNDEN bit | SPND.SPNDL[2:0] bits | Next-access delay |
|-------------------|----------------------|-------------------|
| 0                 | 000b to 111b         | 1 RSPCK + 2 PCLKA |
| 1                 | 000b                 | 1 RSPCK + 2 PCLKA |
|                   | 001b                 | 2 RSPCK + 2 PCLKA |
|                   | 010b                 | 3 RSPCK + 2 PCLKA |
|                   | 011b                 | 4 RSPCK + 2 PCLKA |
|                   | 100b                 | 5 RSPCK + 2 PCLKA |
|                   | 101b                 | 6 RSPCK + 2 PCLKA |
|                   | 110b                 | 7 RSPCK + 2 PCLKA |
|                   | 111b                 | 8 RSPCK + 2 PCLKA |

#### (8) Initialization flow

[Figure 30.48](#) shows an example of SPI initialization flow when the SPI is in master mode. For information on how to set up the Interrupt Controller Unit (ICU), DMAC and I/O ports, see the descriptions given in the individual blocks.

SSL否定延迟仅插入到突发传输的最后一帧，即没有“突发传输帧之间延迟”的传输。（SPCMD.SSLKP位为1，SPCR3.BFDS位为1）。

**Table 30.11 SPCMDm.SLNDEN位、SSLND.SLNDL[2:0]位和SSL否定延迟之间的关系**

| SPCMDm.SLNDEN bit | SSLND.SLNDL[2:0] bits | SSL否定延迟 |
|-------------------|-----------------------|---------|
| 0                 | 000b to 111b          | 1 RSPCK |
| 1                 | 000b                  | 1 RSPCK |
|                   | 001b                  | 2 RSPCK |
|                   | 010b                  | 3 RSPCK |
|                   | 011b                  | 4 RSPCK |
|                   | 100b                  | 5 RSPCK |
|                   | 101b                  | 6 RSPCK |
|                   | 110b                  | 7 RSPCK |
|                   | 111b                  | 8 RSPCK |

#### (7) Next-access delay (t3)

主机模式下SPI的下次访问延迟值取决于SPMDm.SPNDEN位设置和SPND.SPNDL[2:0]位设置。SPI通过指针控制确定串行传输期间要引用的SPCMDm寄存器，然后使用SPCMDm.SPNDEN位和SPND.SPNDL[2:0]位确定串行传输期间的下次访问延迟，如表30.12中所列。有关下次访问延迟的定义，请参见第30.3.5节。传输格式。

仅在突发传输的最后一帧中插入下一个访问延迟，即，在没有“突发传输帧之间延迟”的情况下进行传输。（SPCMD.SSLKP位为1，SPCR3.BFDS位为1）。

**Table 30.12 SPMDm.SPNDEN位、SPND.SPNDL[2:0]位和下次访问延迟之间的关系**

| SPCMDm.SPNDEN bit | SPND.SPNDL[2:0] bits | Next-access delay |
|-------------------|----------------------|-------------------|
| 0                 | 000b to 111b         | 1 RSPCK + 2 PCLKA |
| 1                 | 000b                 | 1 RSPCK + 2 PCLKA |
|                   | 001b                 | 2 RSPCK + 2 PCLKA |
|                   | 010b                 | 3 RSPCK + 2 PCLKA |
|                   | 011b                 | 4 RSPCK + 2 PCLKA |
|                   | 100b                 | 5 RSPCK + 2 PCLKA |
|                   | 101b                 | 6 RSPCK + 2 PCLKA |
|                   | 110b                 | 7 RSPCK + 2 PCLKA |
|                   | 111b                 | 8 RSPCK + 2 PCLKA |

#### (8) 初始化流程

图30.48显示了SPI处于主机模式时的SPI初始化流程示例。有关如何设置中断控制器单元(ICU)、DMAC和IO端口的信息，请参见各个块中给出的说明。

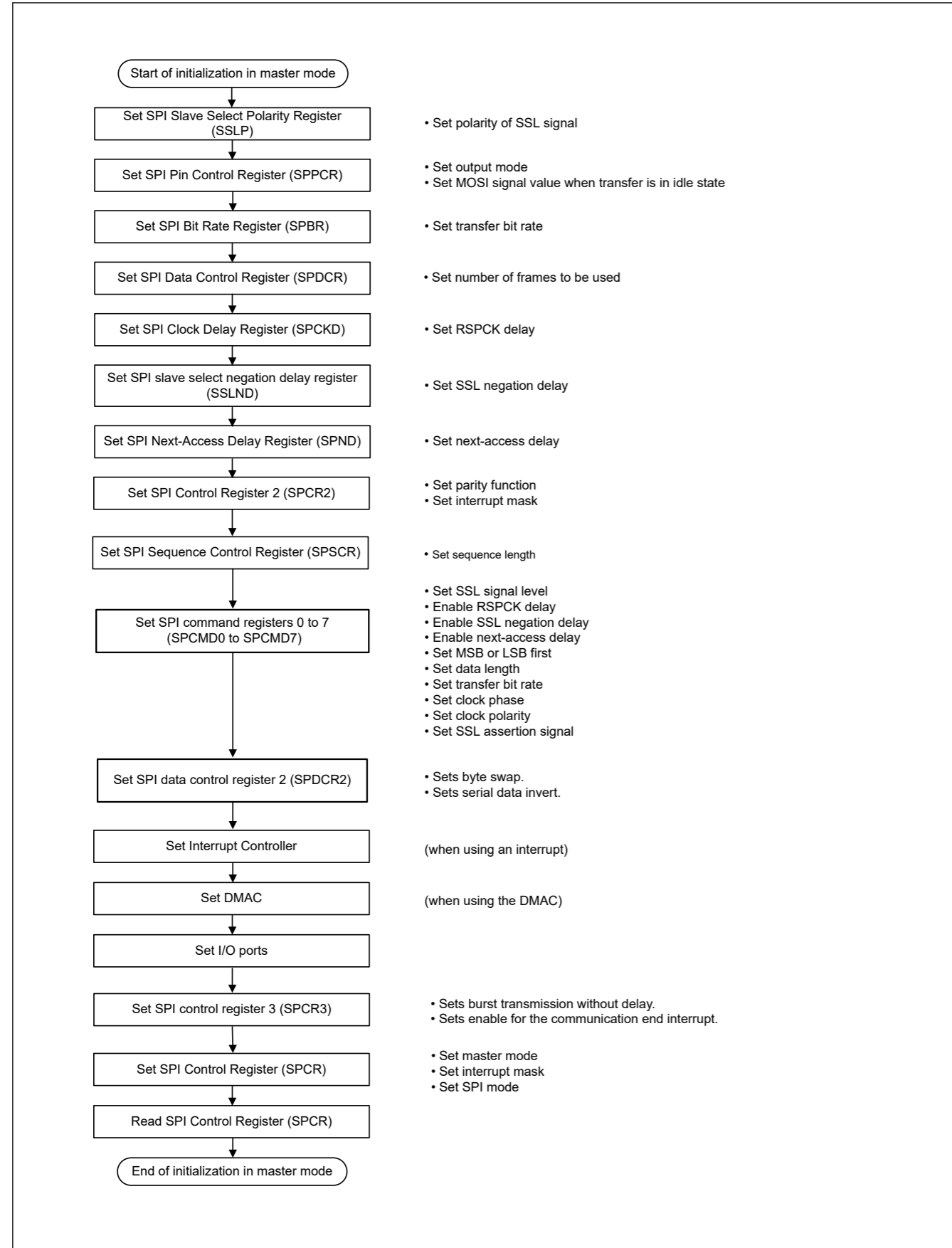


Figure 30.48 Example of initialization flow in master mode for SPI operation

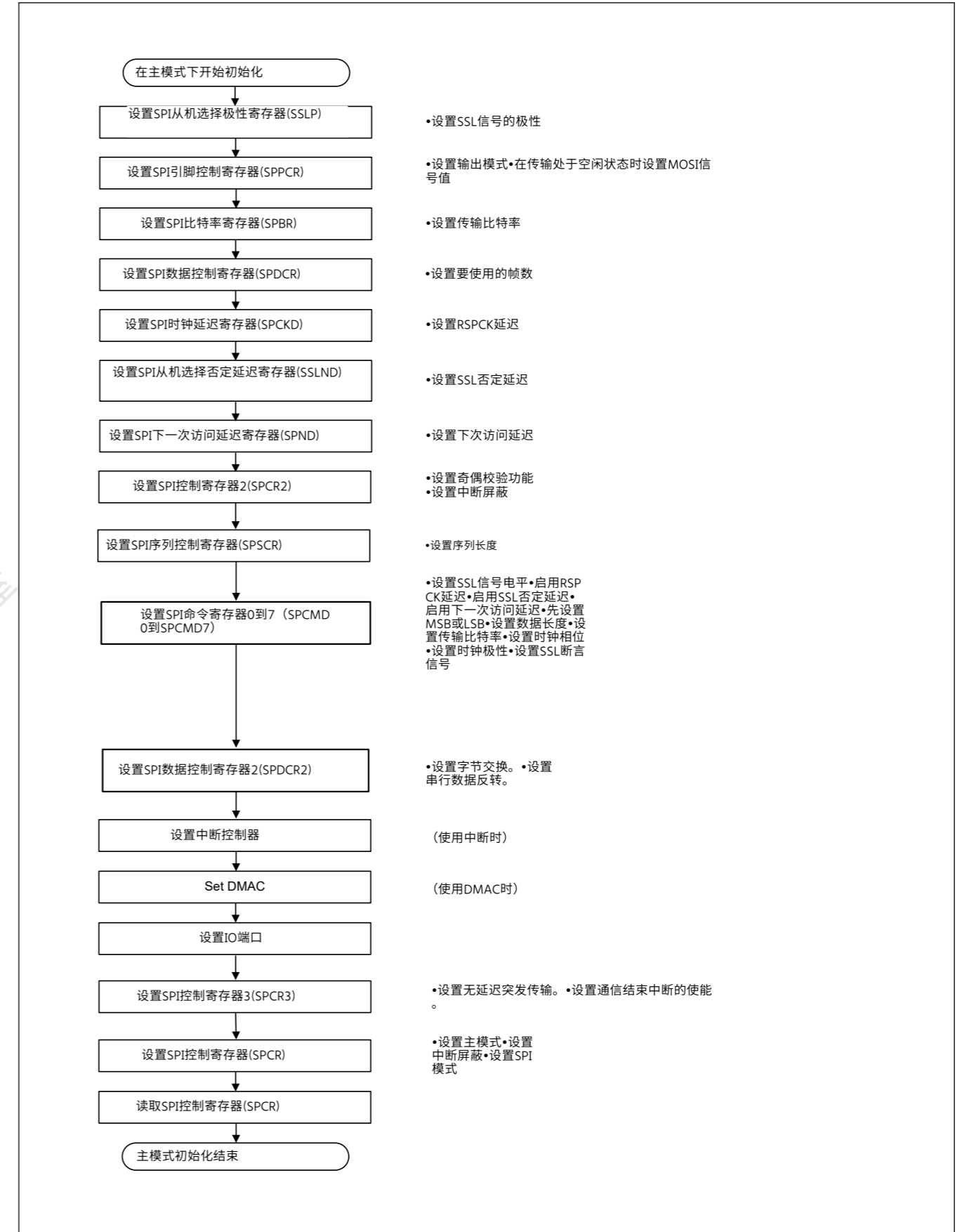


Figure 30.48 SPI操作的主模式初始化流程示例

(9) Software processing flow

Figure 30.49 to Figure 30.51 show examples of the software processing flow.

Transmit processing flow

When transmitting data, with the SPI<sub>i</sub> SPII interrupt enabled, the CPU is notified of the completion of data transmission after the last data write for transmission.

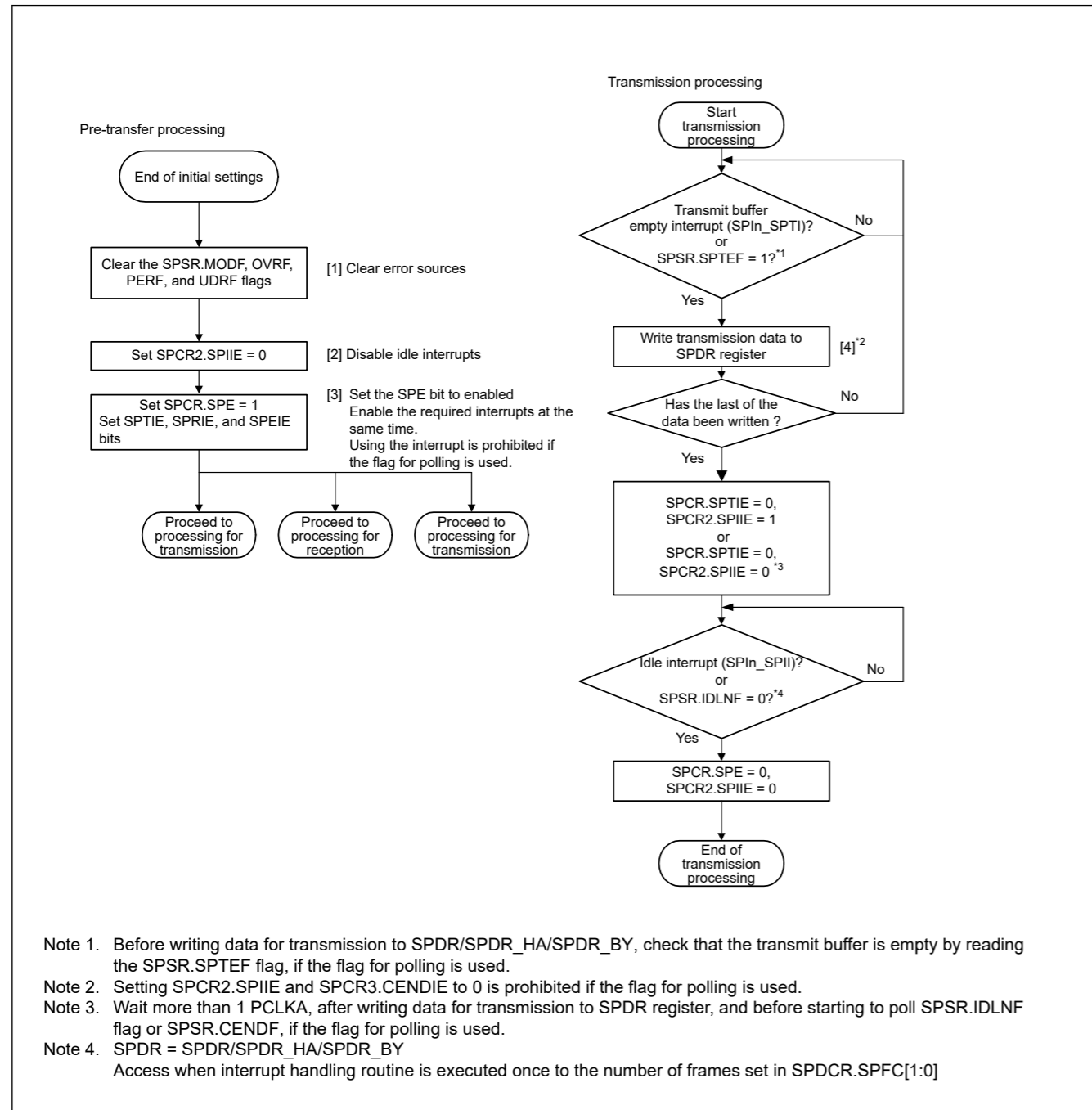


Figure 30.49 Transmission flow in master mode

Receive processing flow

The SPI has receive only operation in slave mode.

(9) 软件处理流程

图30.49至图30.51显示了软件处理流程的示例。

传输处理流程

发送数据时，SPI<sub>i</sub> SPII中断使能，在最后一次数据写入发送后通知CPU数据发送完成。

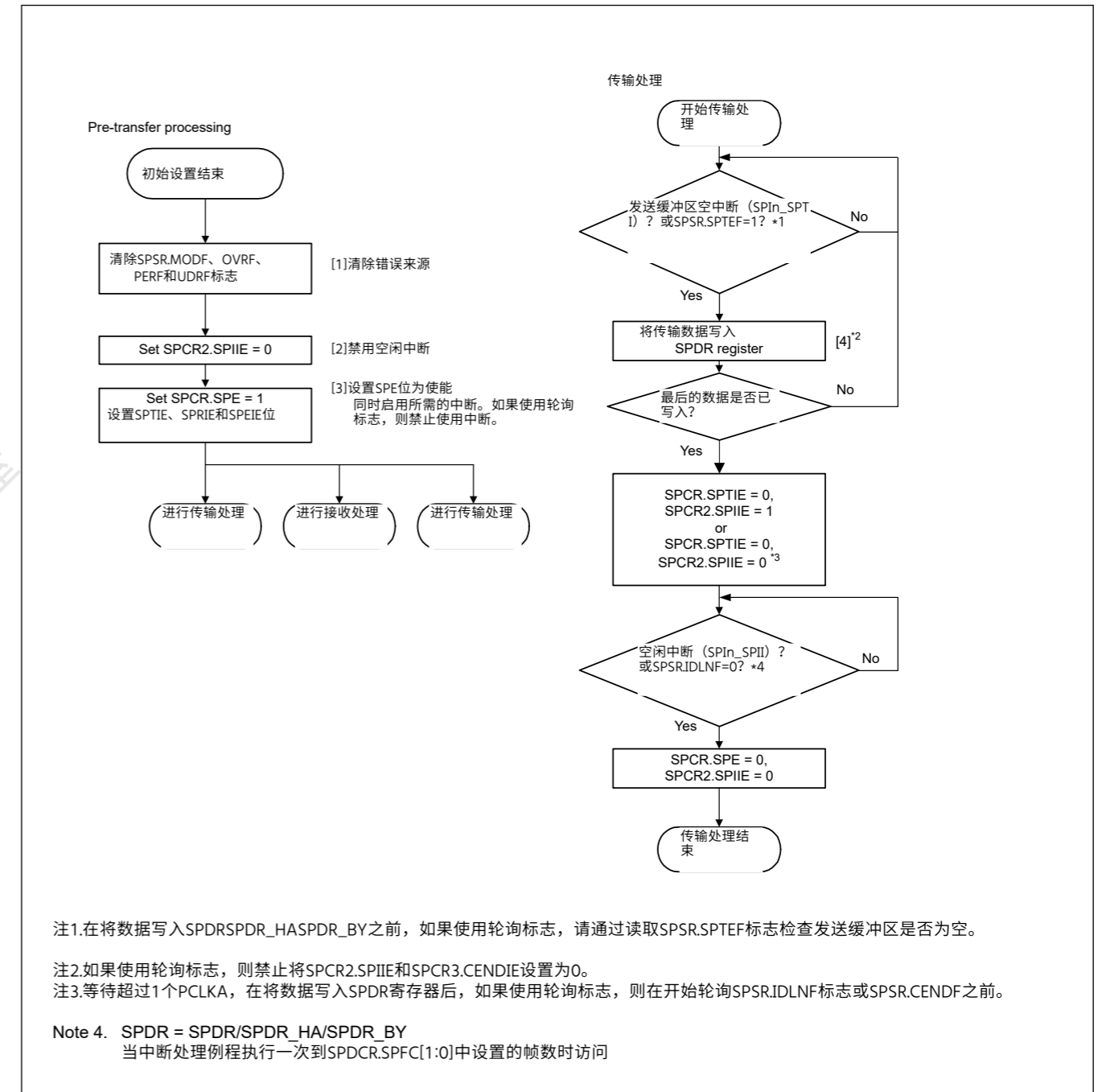


Figure 30.49 主模式下的传输流

接收处理流程

SPI在从机模式下仅接收操作。



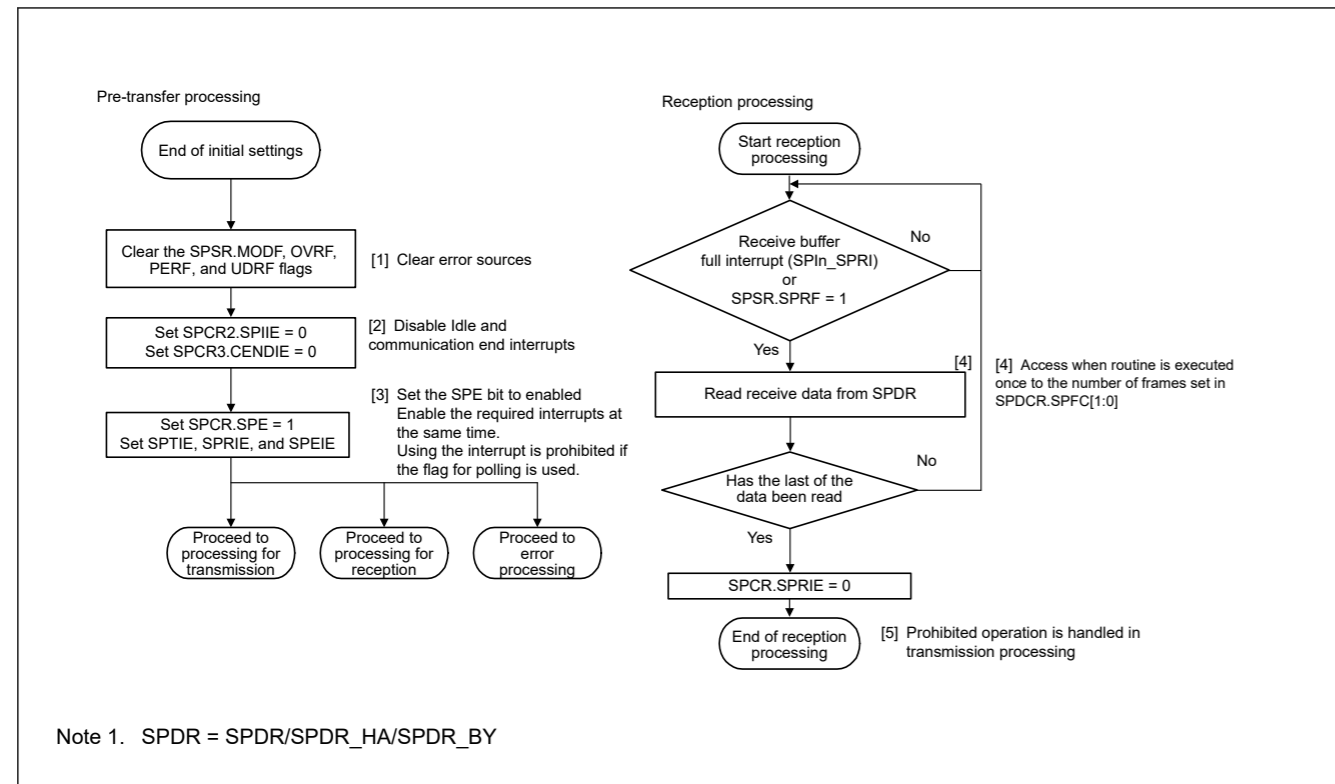


Figure 30.50 Reception flow in master mode

**Error processing flow**

The SPI detects the following errors:

- Mode fault error
- Underrun error
- Overrun error
- Parity error

When a mode fault error is generated, the SPCR.SPE bit is automatically cleared, stopping operations for transmission and reception. For errors from other sources, the SPCR.SPE bit is not cleared and operations for transmission and reception continue. Therefore, Renesas recommends clearing the SPCR.SPE bit to stop operations for errors other than mode fault errors. Not doing so leads to updating of the SPSSR.SPECM[2:0] bits.

When an error is detected using an interrupt, clear the ICU.IELSRn.IR flag in the error processing routine. If this is not done, the ICU.IELSRn.IR flag might continue to indicate the SPIi\_SPTI or SPIi\_SPRI interrupt request. If the SPIi\_SPRI interrupt request is indicated, read the receive buffer and initialize the sequencer in the SPI.

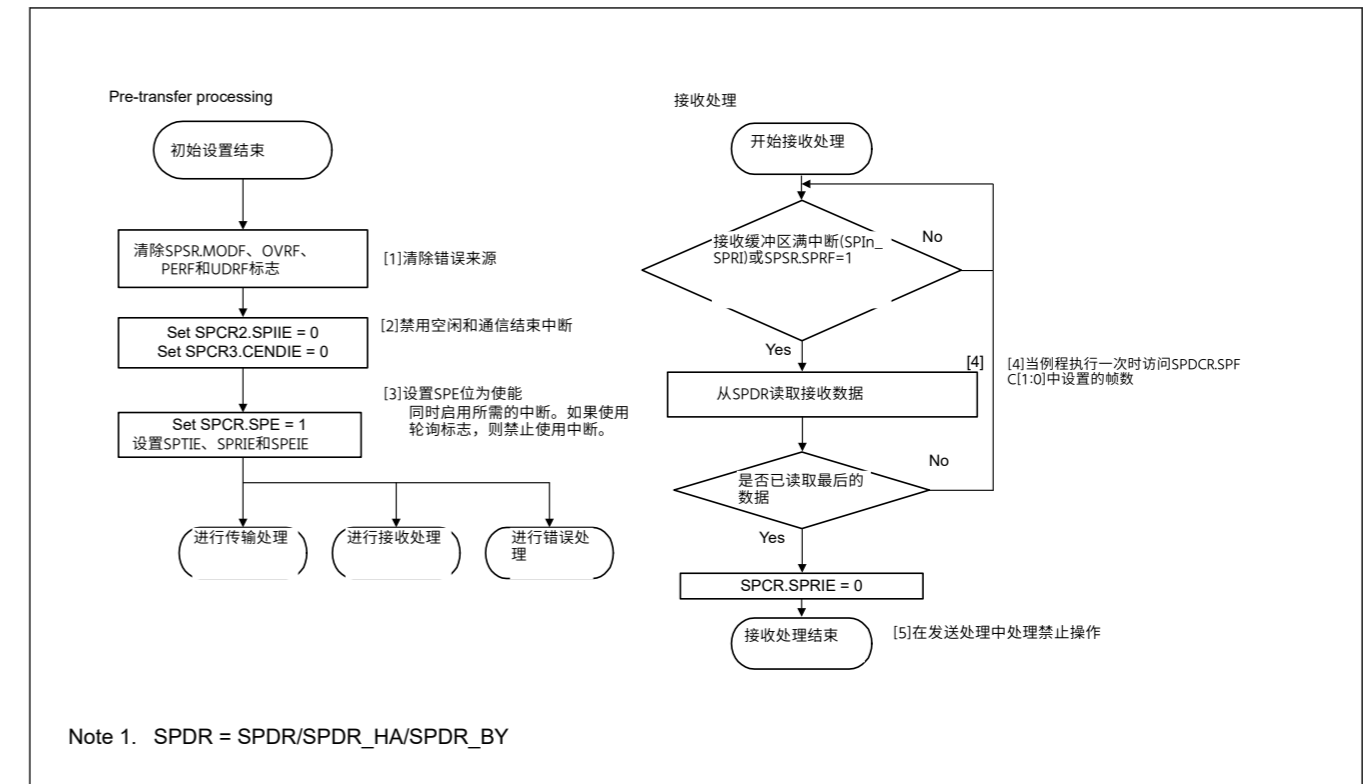


Figure 30.50 主模式下的接收流程

**错误处理流程**

SPI检测到以下错误:

- 模式故障错误
- Underrun error
- 超限错误
- 奇偶校验错误

当产生模式故障错误时，SPCR.SPE位自动清零，停止发送和接收操作。对于其他来源的错误，SPCR.SPE位不会被清除，发送和接收操作会继续。因此，瑞萨建议清除SPCR.SPE位以停止除模式故障错误以外的错误操作。不这样做会导致更新SPSSR.SPECM[2:0]位。

当使用中断检测到错误时，清除错误处理例程中的ICU.IELSRn.IR标志。如果不这样做，ICU.IELSRn.IR标志可能会继续指示SPIi\_SPTI或SPIi\_SPRI中断请求。如果指示了SPIi\_SPRI中断请求，则读取接收缓冲区并初始化SPI中的定序器。

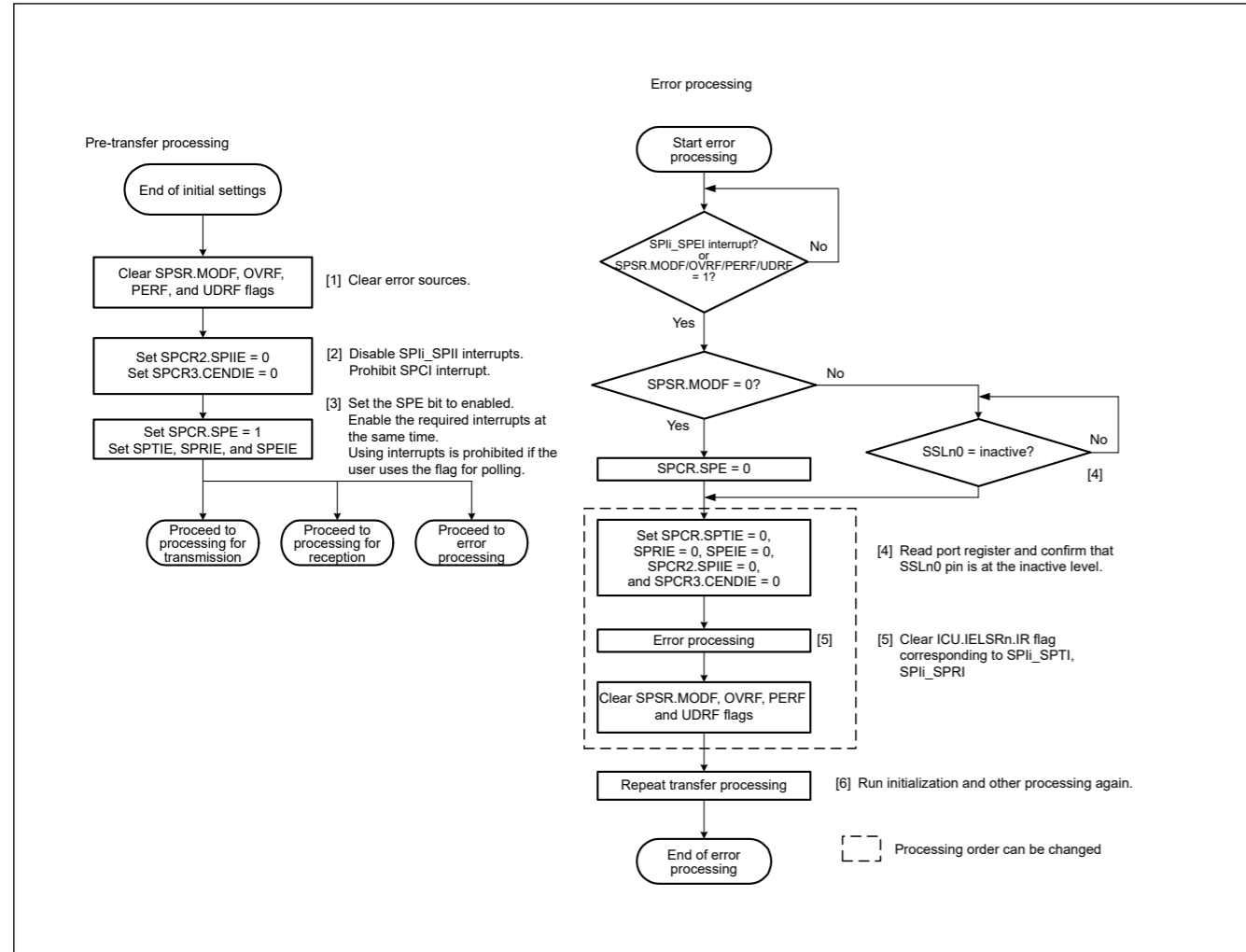


Figure 30.51 Error processing flow in master mode

30.3.11.2 Slave mode operation

(1) Starting a serial transfer

When the SPCMD0.CPHA bit is 0, if the SPI detects an SSLn0 input signal assertion, it must drive valid data to the MISO<sub>n</sub> output signal. For this reason, when the CPHA bit is 0, the assertion of the SSLn0 input signal triggers the start of a serial transfer.

When the CPHA bit is 1, if the SPI detects the first RSPCK<sub>n</sub> edge in an SSLn0 signal asserted condition, it must drive valid data to the MISO<sub>n</sub> output signal. For this reason, when the CPHA bit is 1, the first RSPCK<sub>n</sub> edge in an SSLn0 signal asserted condition triggers the start of a serial transfer.

Regardless of the CPHA bit setting, the SPI drives the MISO<sub>n</sub> output signal on SSLn0 signal assertion. The data that is output by the SPI is either valid or invalid, depending on the CPHA bit setting.

For details on the SPI transfer format, see section 30.3.5. Transfer Formats. The polarity of the SSLn0 input signal depends on the SSLP.SSL0P setting.

(2) Terminating a serial transfer

Regardless of the SPCMD0.CPHA bit setting, the SPI terminates the serial transfer after detecting an RSPCK<sub>n</sub> edge corresponding to the final sampling timing. When free space is available in the receive buffer (the SPSR.SPRF flag is 0), on termination of serial transfer, the SPI copies received data from the shift register to the receive buffer of the SPDR/SPDR\_HA register. On termination of a serial transfer, the SPI changes the status of the shift register to empty, regardless of the receive buffer state. A mode fault error occurs if the SPI detects an SSLn0 input signal negation from the beginning of serial transfer to the end of serial transfer (see section 30.3.9. Error Detection).

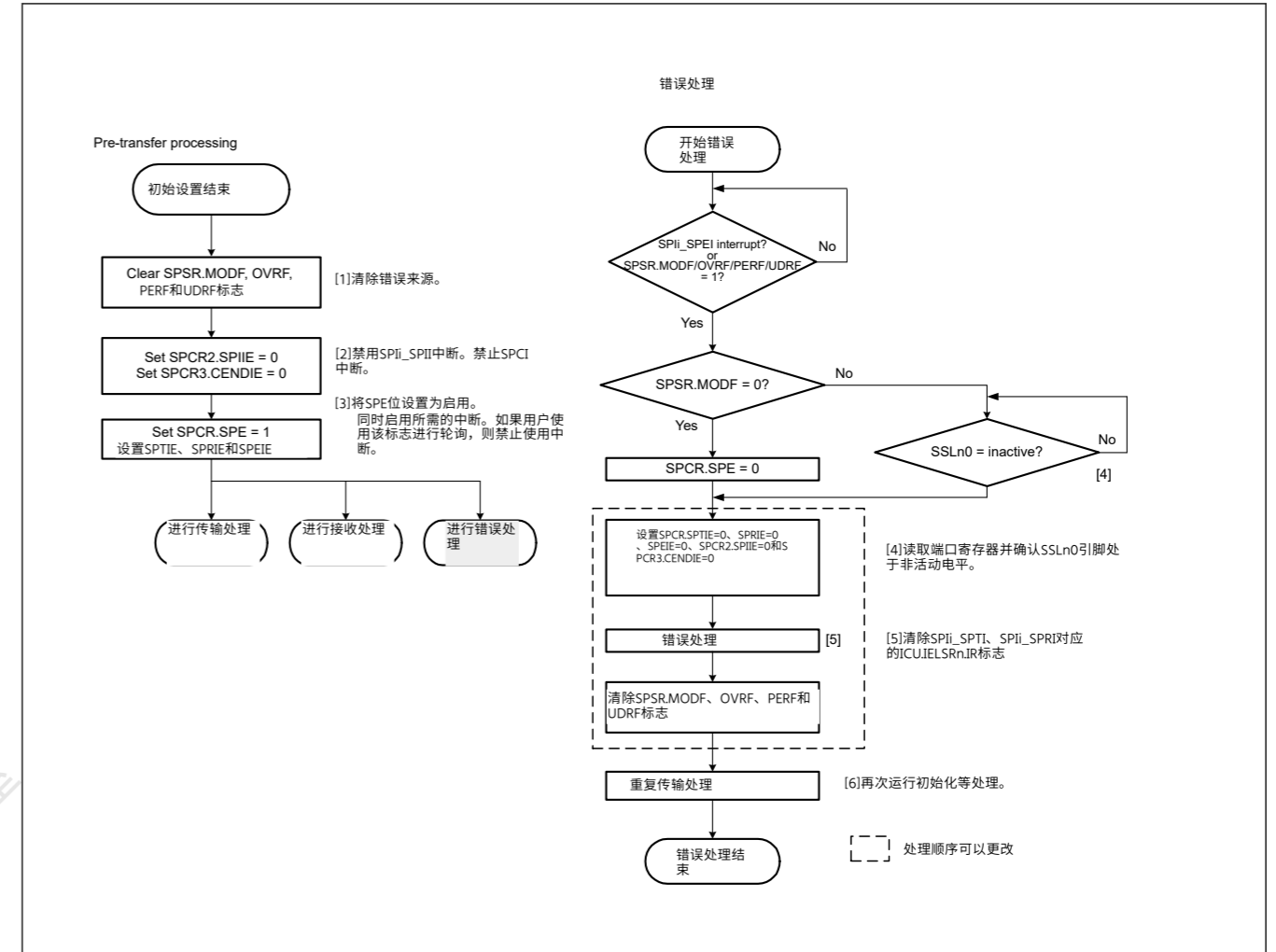


Figure 30.51 主模式下的错误处理流程

30.3.11.2 从模式操作

(1) 开始串行传输

当SPCMD0.CPHA位为0时，如果SPI检测到SSLn0输入信号断言，它必须将有效数据驱动到MISO<sub>n</sub>输出信号。因此，当CPHA位为0时，SSLn0输入信号的断言触发串行传输的开始。

当CPHA位为1时，如果SPI在SSLn0信号置位条件下检测到第一个RSPCK<sub>n</sub>边沿，它必须将有效数据驱动到MISO<sub>n</sub>输出信号。因此，当CPHA位为1时，SSLn0信号断言条件中的第一个RSPCK<sub>n</sub>边沿触发串行传输的开始。

无论CPHA位设置如何，SPI都会在SSLn0信号置位时驱动MISO<sub>n</sub>输出信号。SPI输出的数据是有效还是无效，取决于CPHA位设置。

有关SPI传输格式的详细信息，请参见第30.3.5节。传输格式。SSLn0输入信号的极性取决于SSLP.SSL0P设置。

(2) 终止串行传输

无论SPCMD0.CPHA位设置如何，SPI在检测到对应于最终采样时序的RSPCK<sub>n</sub>边沿后终止串行传输。当接收缓冲区中有可用空间时（SPSR.SPRF标志为0），在串行传输终止时，SPI将接收到的数据从移位寄存器复制到SPDR/SPDR\_HA寄存器的接收缓冲区。在串行传输终止时，SPI将移位寄存器的状态更改为空，而与接收缓冲区状态无关。如果SPI从串行传输开始到串行传输结束检测到SSLn0输入信号取反，则会发生模式故障错误（请参阅第30.3.9节。错误检测）。

The final sampling timing changes depending on the bit length of transfer data. In slave mode, the SPI data length is determined by the SPCMD0.SPB[3:0] bits setting. The polarity of the SSLn0 input signal is determined by the SSLP.SSLOP bit setting. For details on the SPI transfer format, see [section 30.3.5. Transfer Formats](#).

### (3) Notes on single-slave operations

If the SPCMD0.CPHA bit is 0, the SPI starts serial transfers when it detects the assertion edge for an SSLn0 input signal. In the configuration shown in [Figure 30.7](#), if the SPI is used in single-slave mode, the SSLn0 signal is fixed at an active state. Therefore, when the CPHA bit is set to 0, the SPI cannot correctly start a serial transfer. For the SPI to correctly execute transmit and receive operations in slave mode when the SSLn0 input signal is fixed at an active state, the CPHA bit must be set to 1. Do not fix the SSLn0 input signal if there is a requirement for setting the CPHA bit to 0.

### (4) Burst transfer

If the SPCMD0.CPHA bit is 1, continuous serial transfer (burst transfer) can be executed while retaining the assertion state for the SSLn0 input signal. When the CPHA bit is 1, the serial transfer period is the period from the first RSPCKn edge to the sampling timing for the reception of the final bit in an SSLn0 signal active state. Even when the SSLn0 input signal remains at the active level, the SPI can accommodate burst transfers, because it can detect the start of an access.

When the CPHA bit is 0, the second and subsequent serial transfers during burst transfer cannot be executed correctly.

### (5) Initialization flow

[Figure 30.52](#) shows an example of initialization flow for SPI operation when the SPI is in slave mode. For a description of how to set up the ICU, DTC, and I/O ports, see the descriptions given in the individual blocks.

最终的采样时序根据传输数据的位长而变化。在从机模式下，SPI数据长度由SPCMD0.SPB[3:0]位设置决定。SSLn0输入信号的极性由SSLP.SSLOP位设置决定。有关SPI传输格式的详细信息，请参见第30.3.5节。传输格式。

### (3) 单从操作注意事项

如果SPCMD0.CPHA位为0，则SPI在检测到SSLn0输入信号的断言边沿时开始串行传输。在图30.7所示的配置中，如果SPI用于单从模式，则SSLn0信号固定在激活状态。因此，当CPHA位设置为0时，SPI无法正确启动串行传输。为使SPI在SSLn0输入信号固定为活动状态时正确执行从模式下的发送和接收操作，CPHA位必须设置为1。如果需要设置CPHA，请不要固定SSLn0输入信号位为0。

### (4) 突发传输

如果SPCMD0.CPHA位为1，则可以执行连续串行传输（突发传输），同时保持SSLn0输入信号的断言状态。当CPHA位为1时，串行传输周期是从第一个RSPCKn边沿到SSLn0信号有效状态下接收最后一个位的采样时序的周期。即使SSLn0输入信号保持在有效电平，SPI也可以适应突发传输，因为它可以检测访问的开始。

当CPHA位为0时，突发传输期间的第二次和后续串行传输无法正确执行。

### (5) 初始化流程

图30.52显示了SPI处于从机模式时SPI操作的初始化流程示例。有关如何设置ICU、DTC和IO端口的说明，请参见各个块中给出的说明。

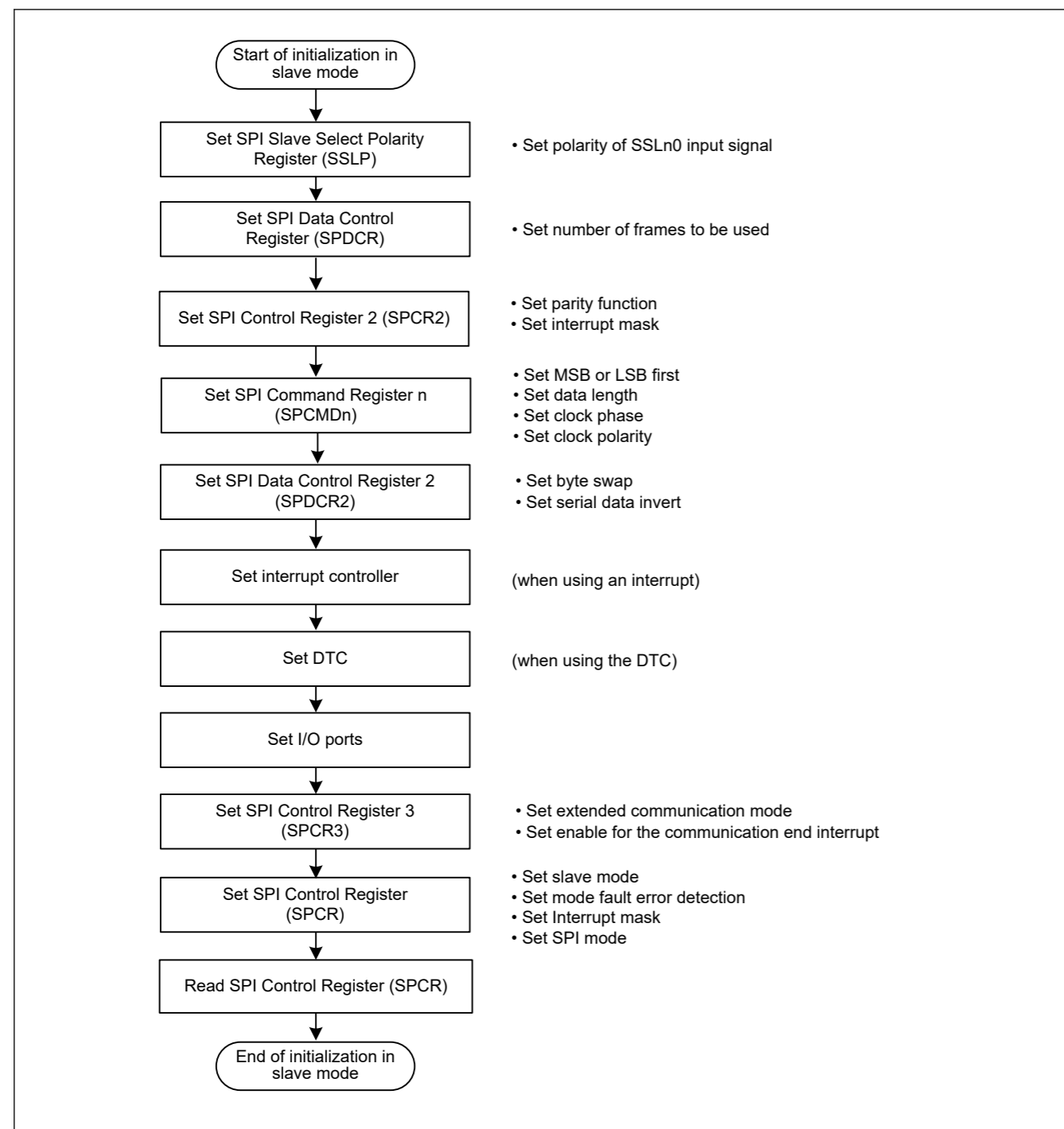


Figure 30.52 Example initialization flow in slave mode for SPI operation

(6) Software processing flow

Figure 30.53 to Figure 30.55 show examples of the flow of software processing.

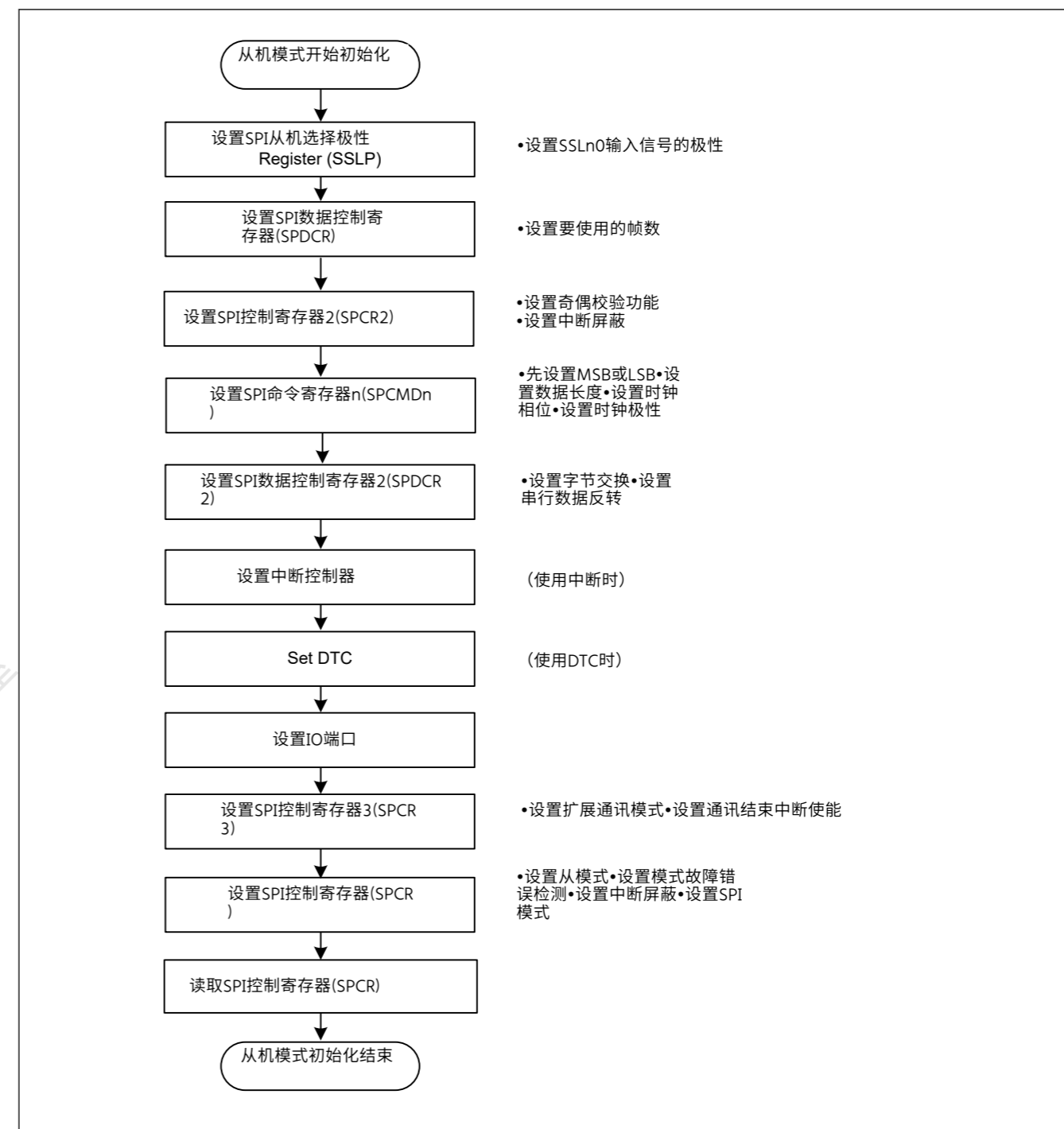


Figure 30.52 SPI操作的从模式初始化流程示例

(6) 软件处理流程

图30.53至图30.55显示了软件处理流程的示例。



Transmit processing flow

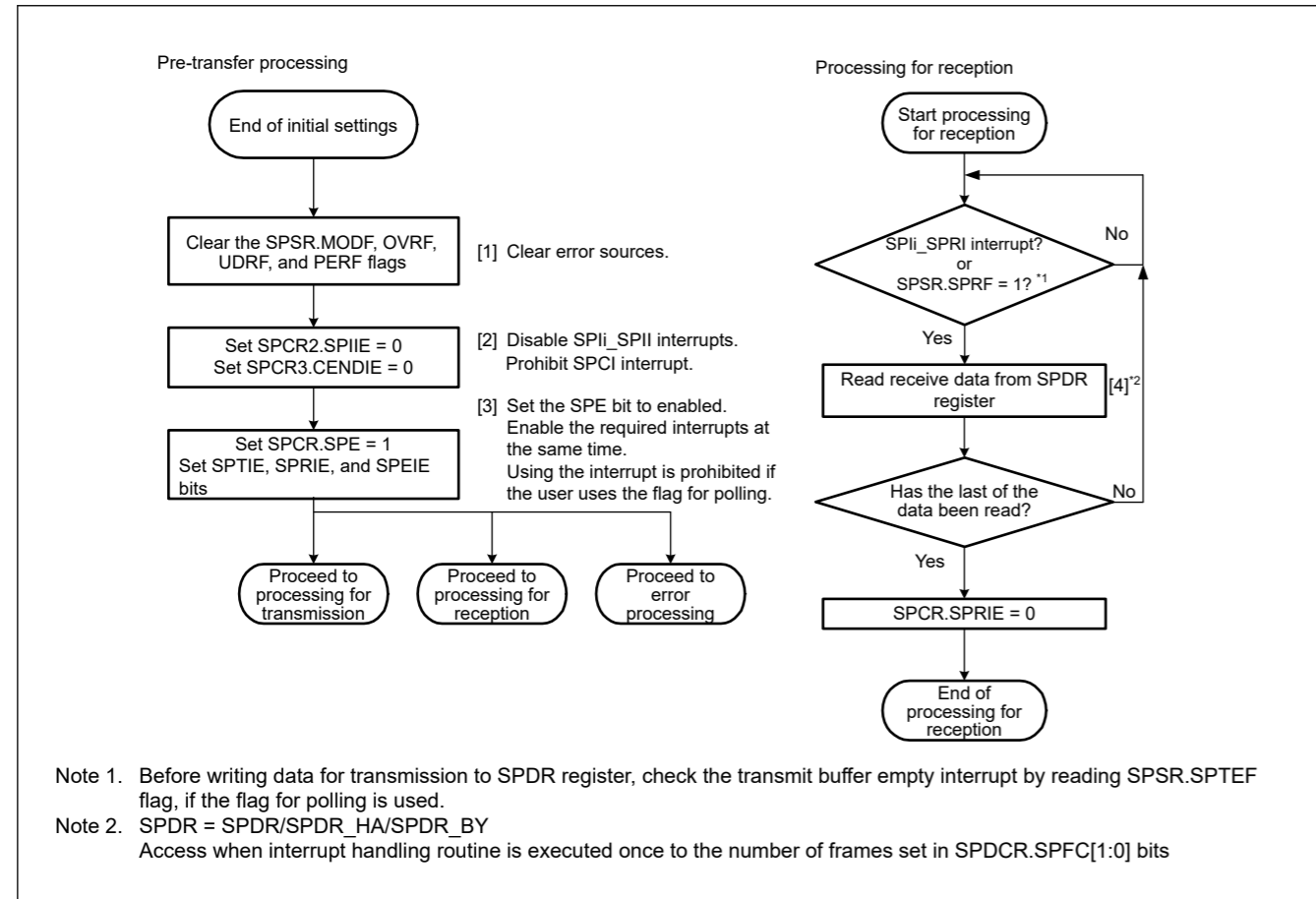


Figure 30.53 Transmission flow in slave mode

Receive processing flow

The SPI does not handle receive-only operation, so processing for transmission is required.

传输处理流程

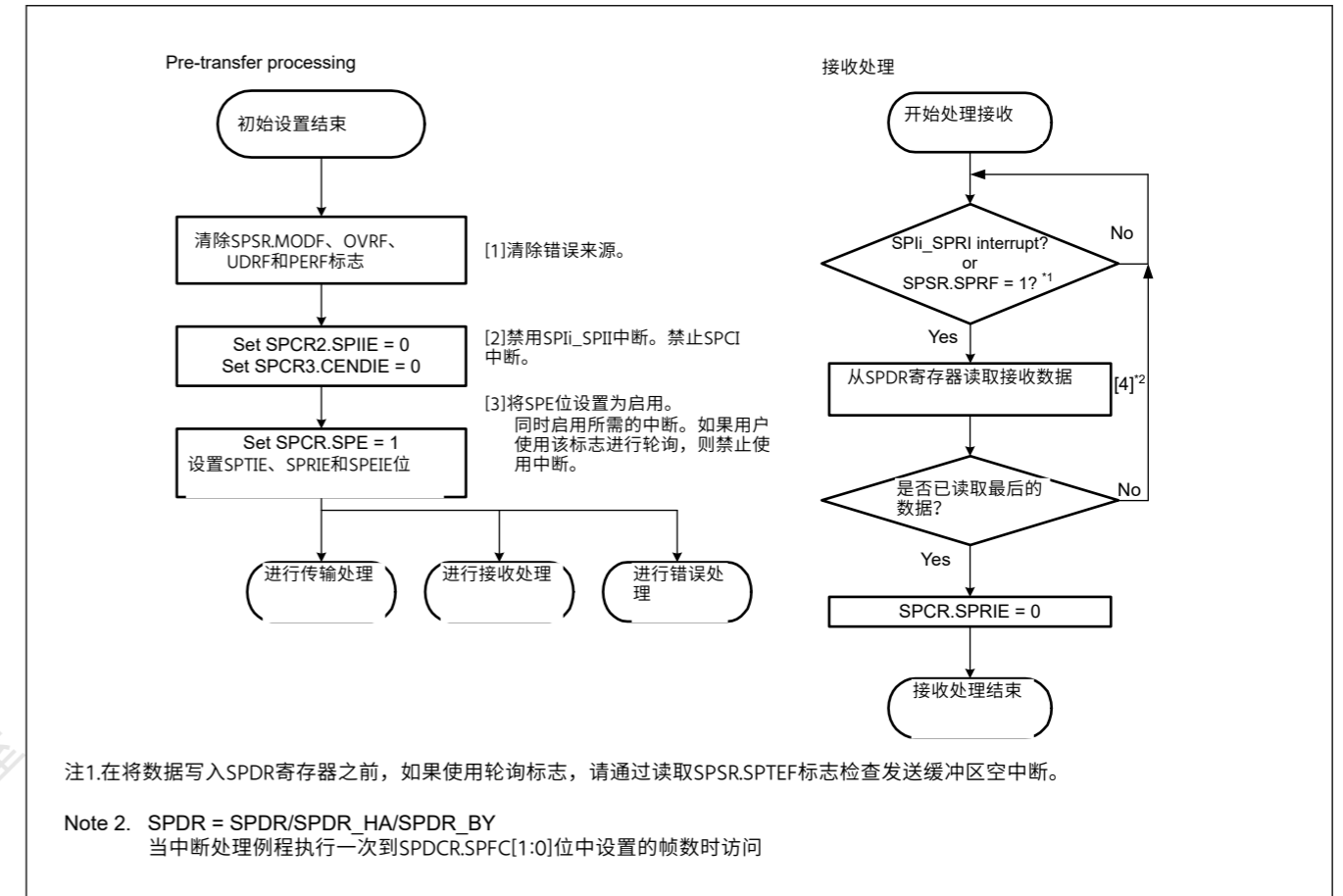


Figure 30.53 从模式下的传输流

接收处理流程

SPI不处理只接收操作，因此需要处理传输。

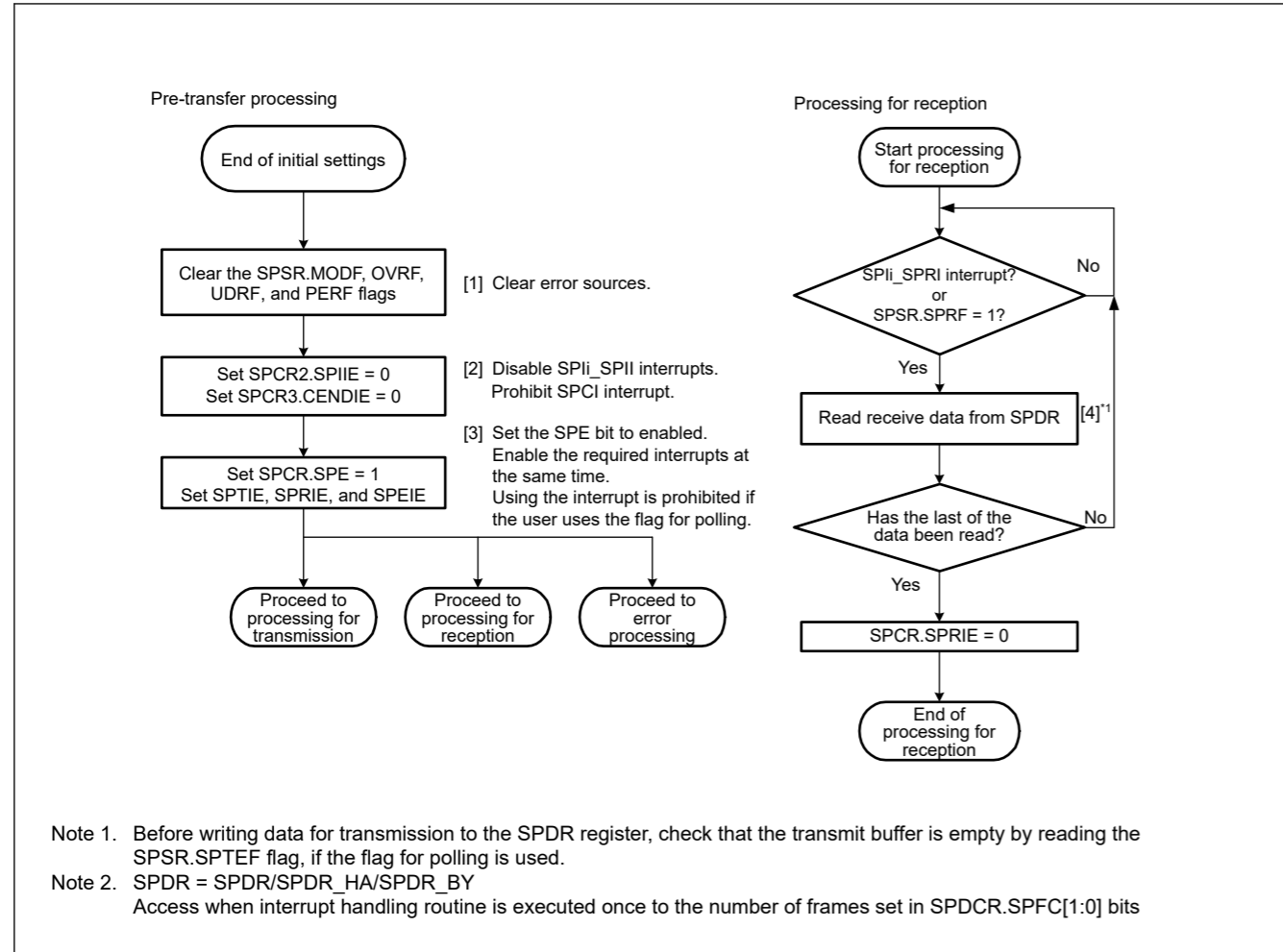


Figure 30.54 Reception flow in slave mode

**Error processing flow**

In slave mode operation, even when a mode fault error is generated, the SPSR.MODF flag can be cleared regardless of the state of the SSLn0 pin.

When an error is detected by using an interrupt, clear the ICU.IELSRn.IR flag in the error processing routine. If this is not done, the ICU.IELSRn.IR flag might continue to indicate the SPIi\_SPTI or SPIi\_SPRI interrupt request. If the SPIi\_SPRI interrupt request is indicated, read the receive buffer and initialize the sequencer in the SPI.

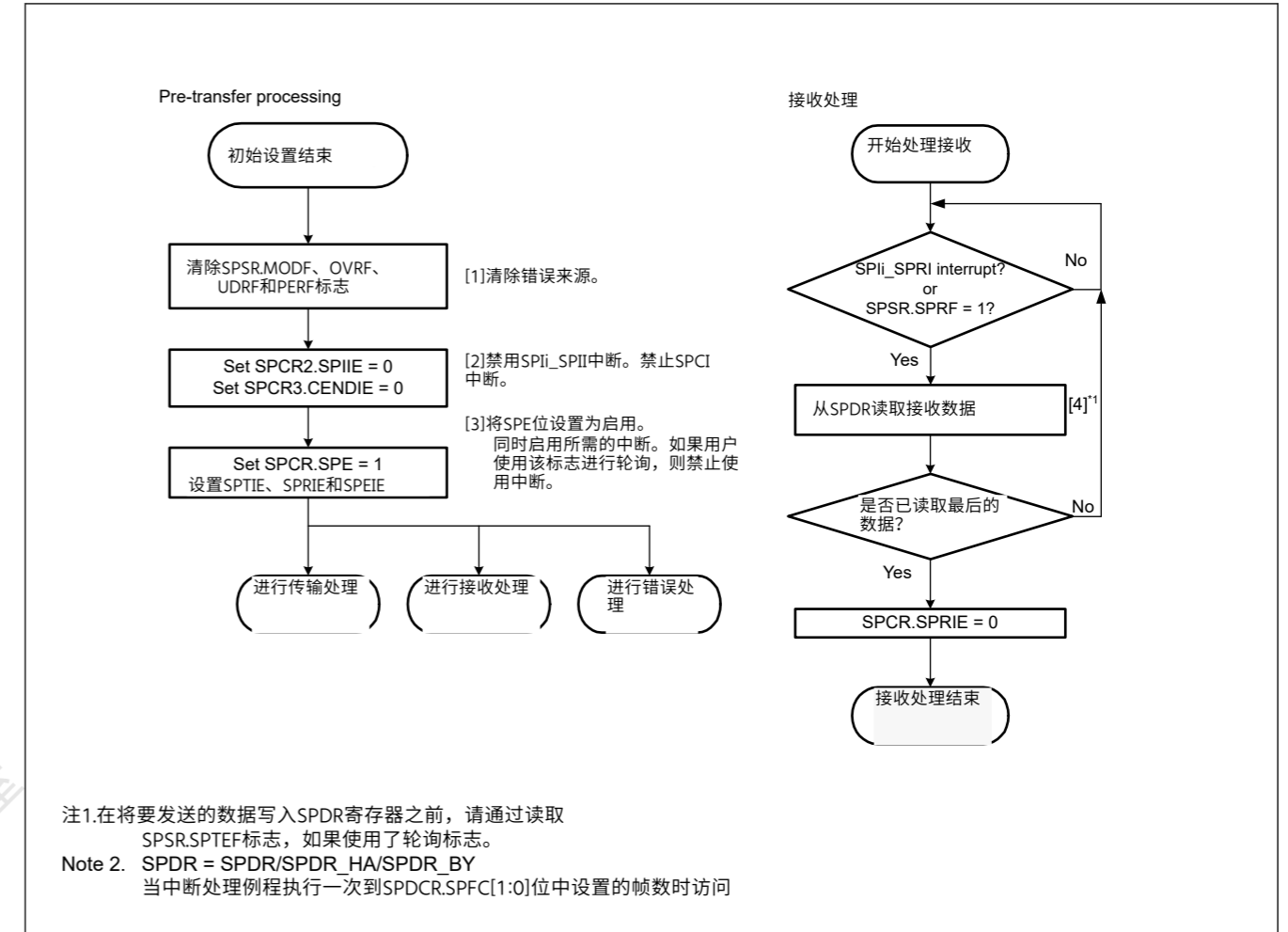


Figure 30.54 从机模式下的接收流程

**错误处理流程**

在从模式操作中，即使产生了模式故障错误，SPSR.MODF标志也可以被清除，而与SSLn0引脚的状态无关。

当使用中断检测到错误时，清除错误处理例程中的ICU.IELSRn.IR标志。如果不这样做，ICU.IELSRn.IR标志可能会继续指示SPIi\_SPTI或SPIi\_SPRI中断请求。如果指示了SPIi\_SPRI中断请求，则读取接收缓冲区并初始化SPI中的定序器。

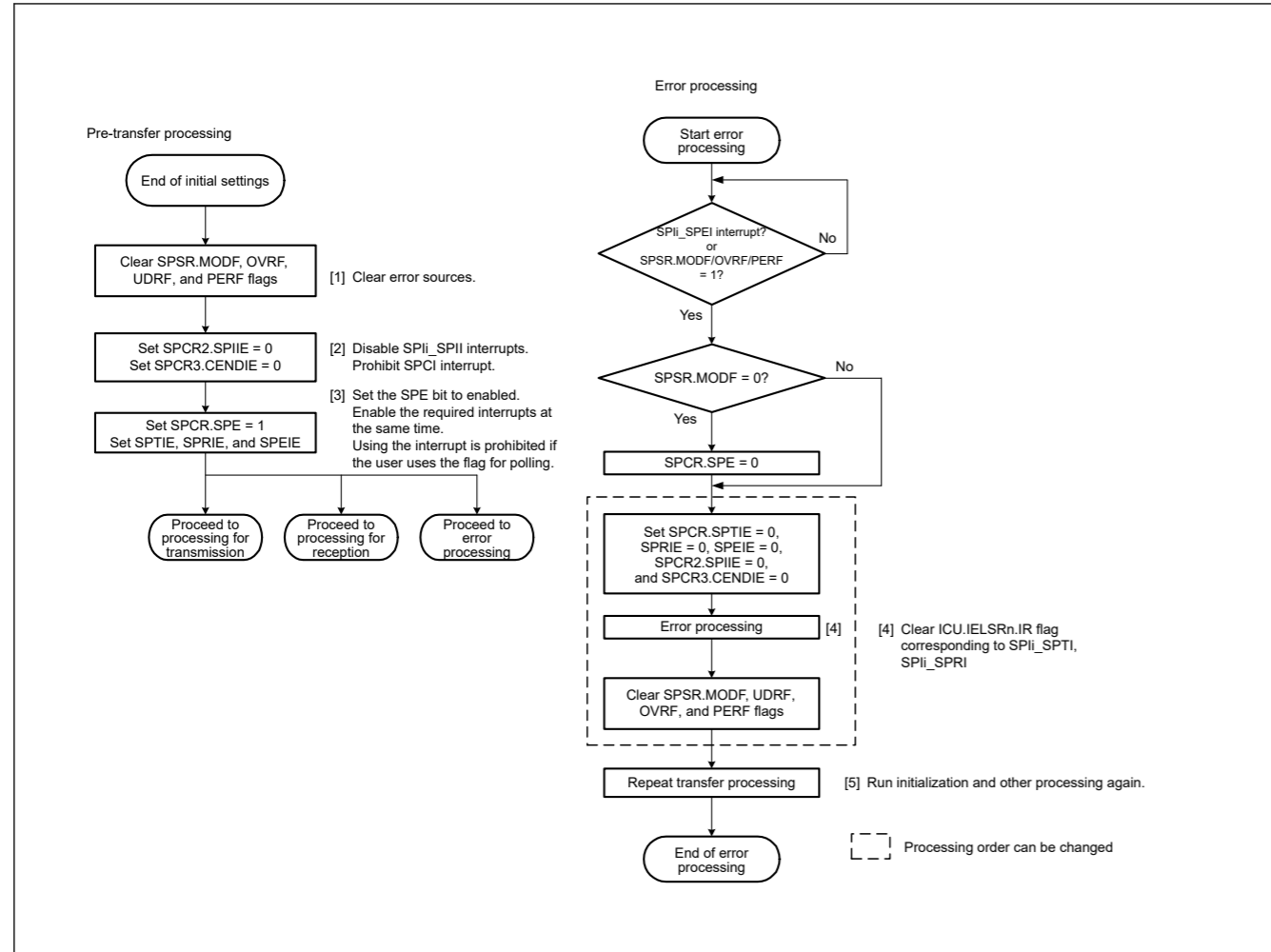


Figure 30.55 Error processing flow for slave mode

### 30.3.12 Clock Synchronous Operation

Setting the SPCR.SPMS bit to 1 selects clock synchronous operation of the SPI. In clock synchronous operation, the SSLnI pin is not used, and the RSPCKn, MOSIn, and MISON pins handle communications. All SSLnI pins are available as I/O port pins.

Although clock synchronous operation does not require the use of the SSLnI pin, operation of the module is the same as in SPI operation. In both master mode and slave mode operations, communications can be performed with the same flow as in SPI operation. However, mode fault errors are not detected, because the SSLnI pin is not used.

Additionally, do not perform operation if clock synchronous operation is enabled when the SPCMDm.CPHA bit is set to 0 in slave mode (SPCR.MSTR = 0).

#### 30.3.12.1 Master mode operation

##### (1) Starting serial transfer

The SPI updates the data in the transmit buffer (SPTX) of SPDR/SPDR\_HA when data is written to the SPDR/SPDR\_HA register with the transmit buffer empty, the data for the next transfer not set and the SPSR.SPTEF flag is 1. When the shift register is empty after the number of frames set in the SPDCR.SPFC[1:0] bits are written to the SPDR/SPDR\_HA, the SPI copies data from the transmit buffer to the shift register and starts serial transmission. On copying transmit data to the shift register, the SPI changes the status of the shift register to full, and on termination of serial transfer, it changes the status of the shift register to empty. The status of the shift register cannot be referenced.

Transfer in clock synchronous operation is conducted without the SSLn0 output signal. For details on the SPI transfer format, see section 30.3.5. Transfer Formats.

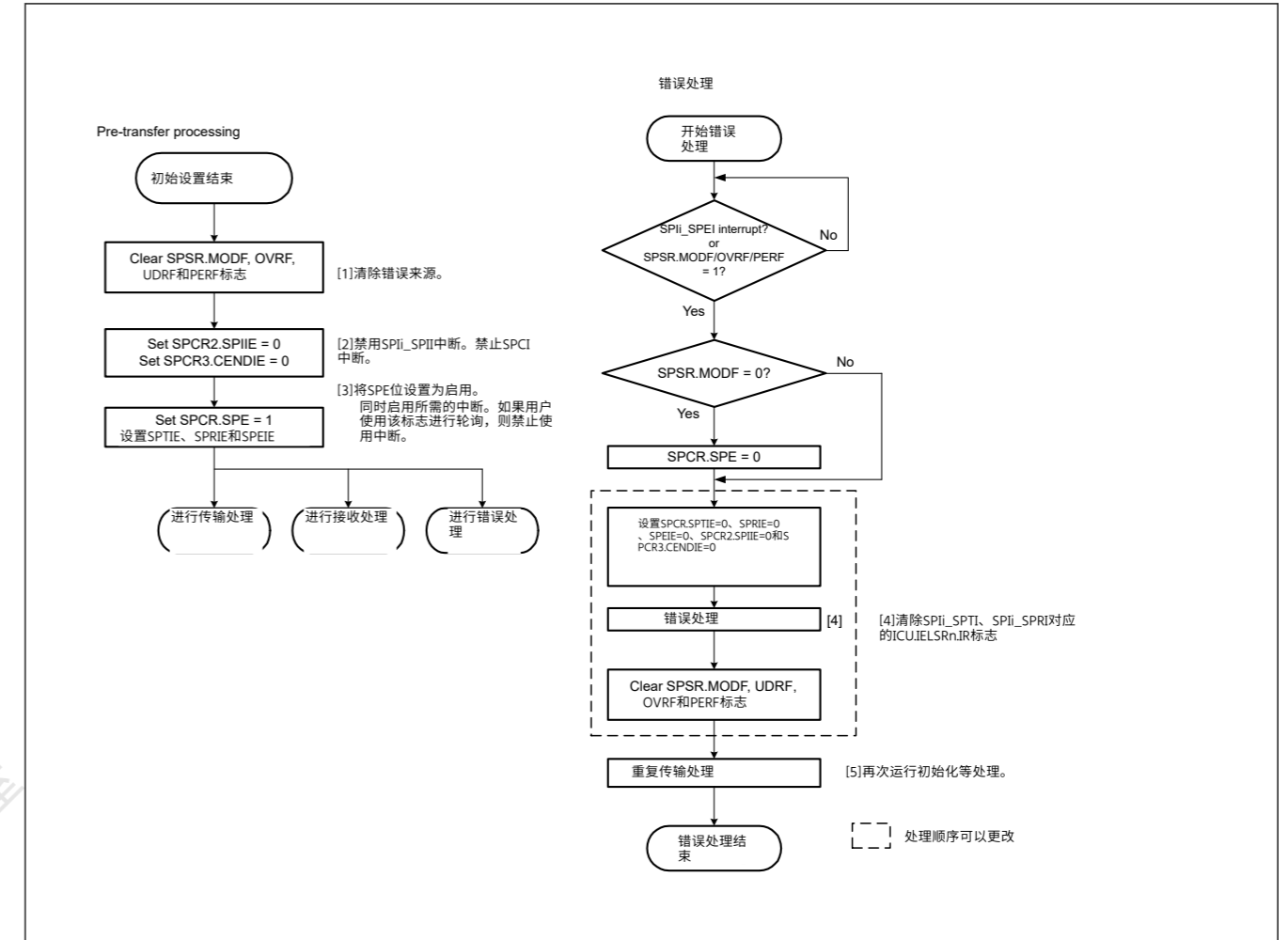


Figure 30.55 从机模式的错误处理流程

### 30.3.12 时钟同步操作

将 SPCR.SPMS 位设置为 1 可选择 SPI 的时钟同步操作。在时钟同步操作中，不使用 SSLnI 引脚，而 RSPCKn、MOSIn 和 MISON 引脚处理通信。所有 SSLnI 引脚都可用作 IO 端口引脚。

虽然时钟同步操作不需要使用 SSLnI 引脚，但模块的操作与 SPI 操作相同。在主模式和从模式操作中，可以使用与在相同的流程中执行通信 SPI 操作。但是，未检测到模式故障错误，因为未使用 SSLnI 引脚。

此外，如果在从模式 (SPCR.MSTR=0) 下 SPCMDm.CPHA 位设置为 0 时使能时钟同步操作，则不要执行操作。

此外，如果在从模式 (SPCR.MSTR=0) 下 SPCMDm.CPHA 位设置为 0 时使能时钟同步操作，则不要执行操作。

#### 30.3.12.1 主模式操作

##### (1) 开始串行传输

当数据写入 SPDR/SPDR\_HA 寄存器且发送缓冲区为空、未设置下一次传输的数据且 SPSR.SPTEF 标志为 1 时，SPI 更新 SPDR/SPDR\_HA 的发送缓冲区 (SPTX) 中的数据。将 SPDCR.SPFC[1:0] 位中设置的帧数写入 SPDR/SPDR\_HA 后，寄存器为空，SPI 将数据从发送缓冲区复制到移位寄存器并开始串行传输。将发送数据复制到移位寄存器时，SPI 将移位寄存器的状态更改为满，而在串行传输终止时，它将移位寄存器的状态更改为空。无法引用移位寄存器的状态。

在没有 SSLn0 输出信号的情况下进行时钟同步操作的传输。有关 SPI 传输格式的详细信息，请参见第 30.3.5 节。传输格式。

## (2) Terminating serial transfer

The SPI terminates the serial transfer after transmitting an RSPCKn edge corresponding to the sampling timing. If free space is available in the receive buffer (the SPSR.SPRF flag is 0), on termination of serial transfer, the SPI copies data from the shift register to the receive buffer of the SPI Data Register (SPDR/SPDR\_HA).

The final sampling timing varies depending on the bit length of transfer data. In master mode, the SPI data length depends on the SPCMDm.SPB[3:0] bits setting. Transfer in clock synchronous operation is conducted without the SSLn0 output signal. For details on the SPI transfer format, see [section 30.3.5. Transfer Formats](#).

## (3) Sequence control

The transfer format used in master mode is determined by the SPSCR, SPCMDm, SPBR, SPCKD, SSLND, and SPND registers. Although the SSLni signals are not output in clock synchronous operation, these settings are valid.

The SPSCR register determines the sequence configuration for serial transfers that are executed by the SPI in master mode. The following parameters are specified in the SPCMDm register:

- SSLni output signal value
- MSB or LSB first
- Data length
- Some of the bit rate settings
- RSPCKn polarity and phase
- Whether SPCKD is to be referenced
- Whether SSLND is to be referenced
- Whether SPND is to be referenced

SPBR holds some of the bit rate settings such as SPCKD, an SPI clock delay value, SSLND, an SSL negation delay, and SPND, a next-access delay value.

Based on the sequence length that is assigned to SPSCR, the SPI makes up a sequence comprised of a part or all of SPCMDm register. The SPI contains a pointer to the SPCMDm register that makes up the sequence. The value of this pointer can be checked by reading the SPSSR.SPCP[2:0] bits. When the SPCR.SPE bit is set to 1 and the SPI function is enabled, the SPI loads the pointer to the commands in SPCMD0 register, and incorporates the SPCMD0 register setting into the transfer format at the beginning of serial transfer. The SPI increments the pointer each time the next-access delay period for a data transfer ends. On completion of the serial transfer that corresponds to the final command comprising the sequence, the SPI sets the pointer to the SPCMD0 register, and in this manner the sequence is executed repeatedly.

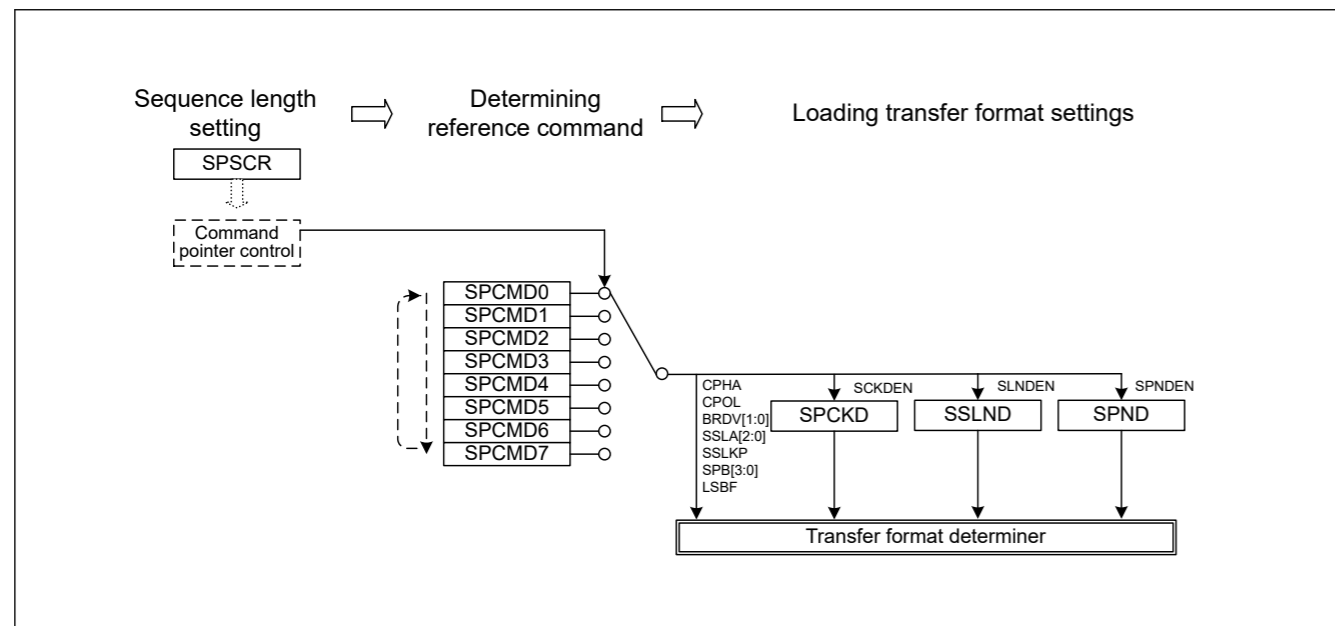


Figure 30.56 Procedure for determining the form of serial transmission in master mode

## (2) 终止串行传输

SPI在发送对应于采样时序的RSPCKn边沿后终止串行传输。如果接收缓冲区中有可用空间 (SPSR.SPRF标志为0)，则在串行传输终止时，SPI将数据从移位寄存器复制到SPI数据寄存器(SPDR/SPDR\_HA)的接收缓冲区。

最终的采样时序根据传输数据的位长而变化。在主机模式下，SPI数据长度取决于SPMDm.SPB[3:0]位设置。在没有SSLn0输出信号的情况下进行时钟同步操作的传输。有关SPI传输格式的详细信息，请参见第30.3.5节。传输格式。

## (3) 顺序控制

主机模式中使用的传输格式由SPSCR、SPCMDm、SPBR、SPCKD、SSLND和SPND寄存器确定。虽然在时钟同步操作中不输出SSLni信号，但这些设置是有效的。

SPSCR寄存器确定由SPI在主模式下执行的串行传输的序列配置。SPCMDm寄存器中指定了以下参数：

- SSLni输出信号值
- MSB或LSB在前
- 数据长度
- 一些比特率设置
- RSPCKn极性和相位
- 是否引用SPCKD
- 是否引用SSLND
- 是否引用SPND

SPBR保存一些比特率设置，例如SPCKD、SPI时钟延迟值、SSLND、SSL否定延迟和SPND，下一次访问延迟值。

根据分配给SPSCR的序列长度，SPI组成一个序列，该序列由部分或全部SPMDm寄存器。SPI包含一个指向构成序列的SPCMDm寄存器的指针。该指针的值可以通过读取SPSSR.SPCP[2:0]位来检查。当SPCR.SPE位设置为1且SPI功能使能时，SPI将指针加载到SPCMD0寄存器中的命令，并在串行传输开始时将SPCMD0寄存器设置合并到传输格式中。每次数据传输的下一个访问延迟周期结束时，SPI都会递增指针。在完成对应于包含序列的最终命令的串行传输后，SPI将指针设置为SPMD0寄存器，并以这种方式重复执行序列。

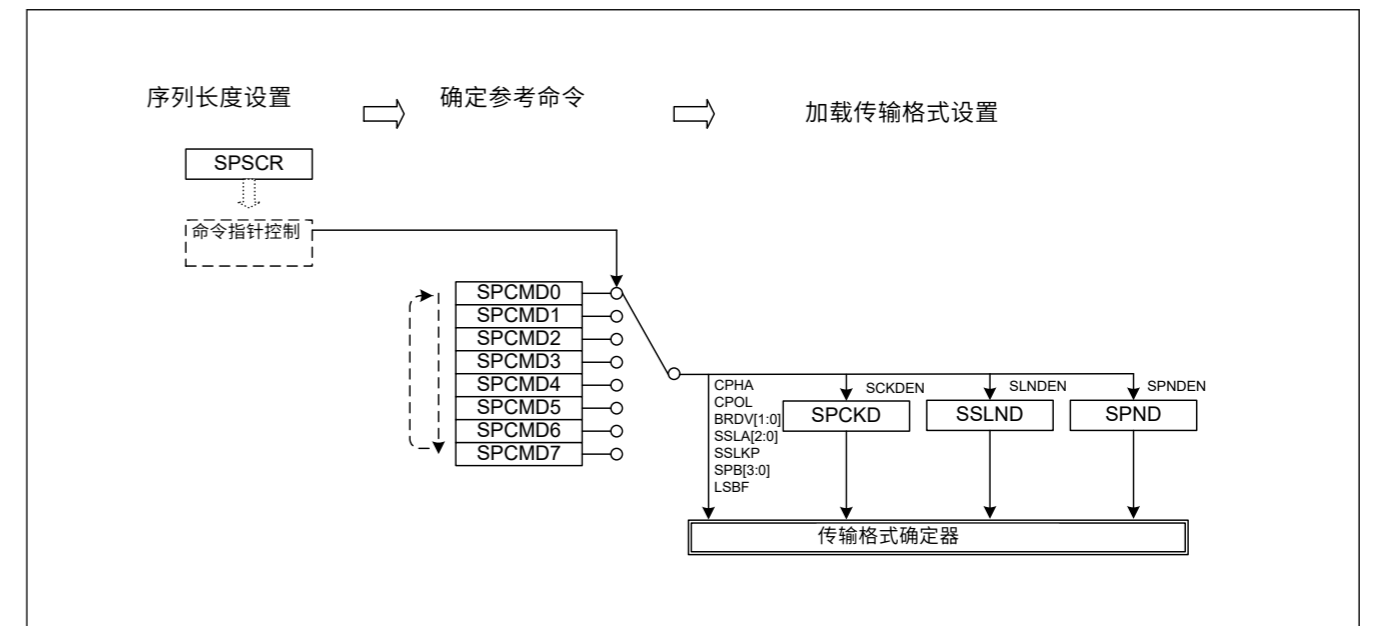


Figure 30.56 确定主机模式下串行传输形式的程序



In this section, a frame is the combination of the data (SPDR/SPDR\_HA) and the settings (SPCMDm).

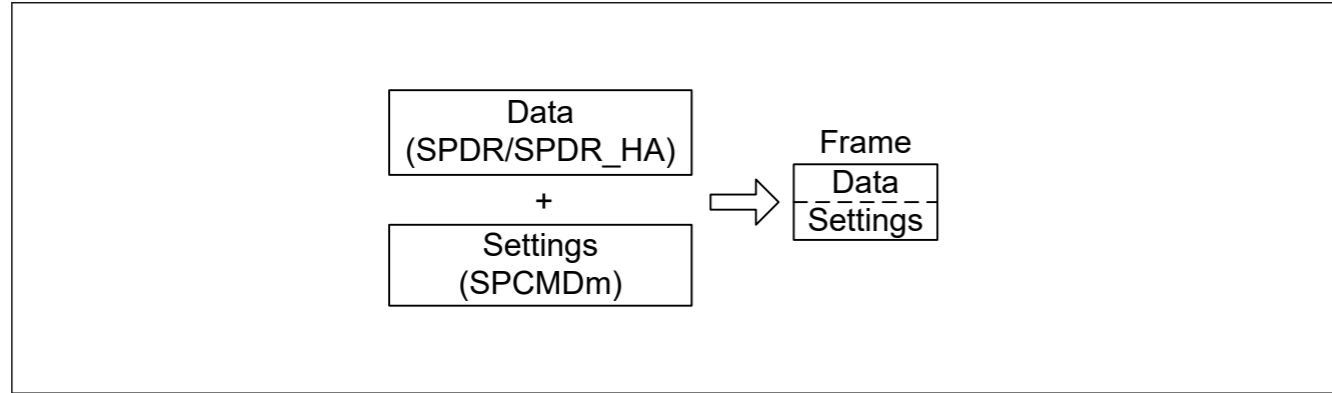


Figure 30.57 Conceptual diagram of frames

Figure 30.58 shows the relationship between the command and the transmit and receive buffers in the sequence of operations specified by the settings in Table 30.3.

在本节中，帧是数据(SPDR/SPDR\_HA)和设置(SPCMDm)的组合。

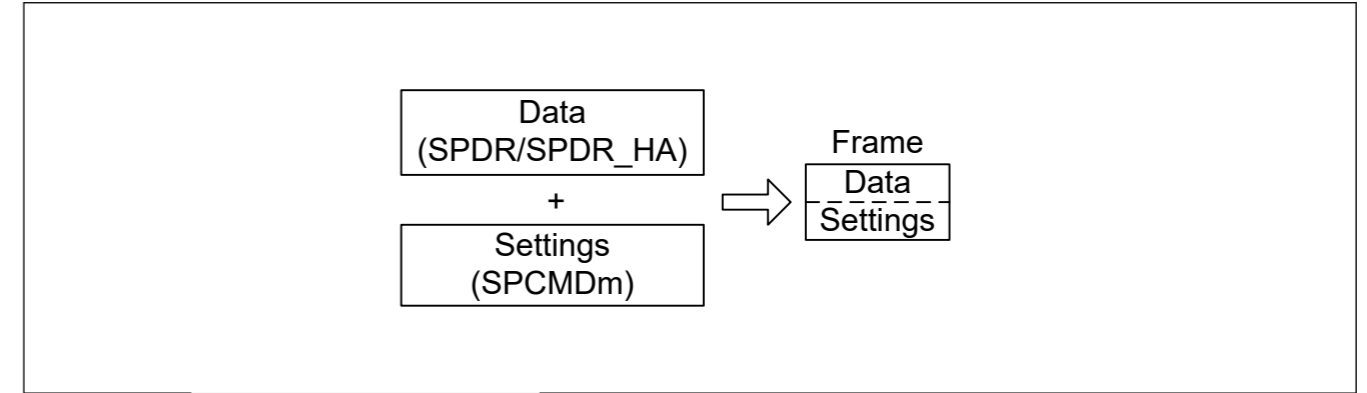


Figure 30.57 框架的概念图

图30.58显示了在表30.3中设置指定的操作顺序中命令与发送和接收缓冲区之间的关系。

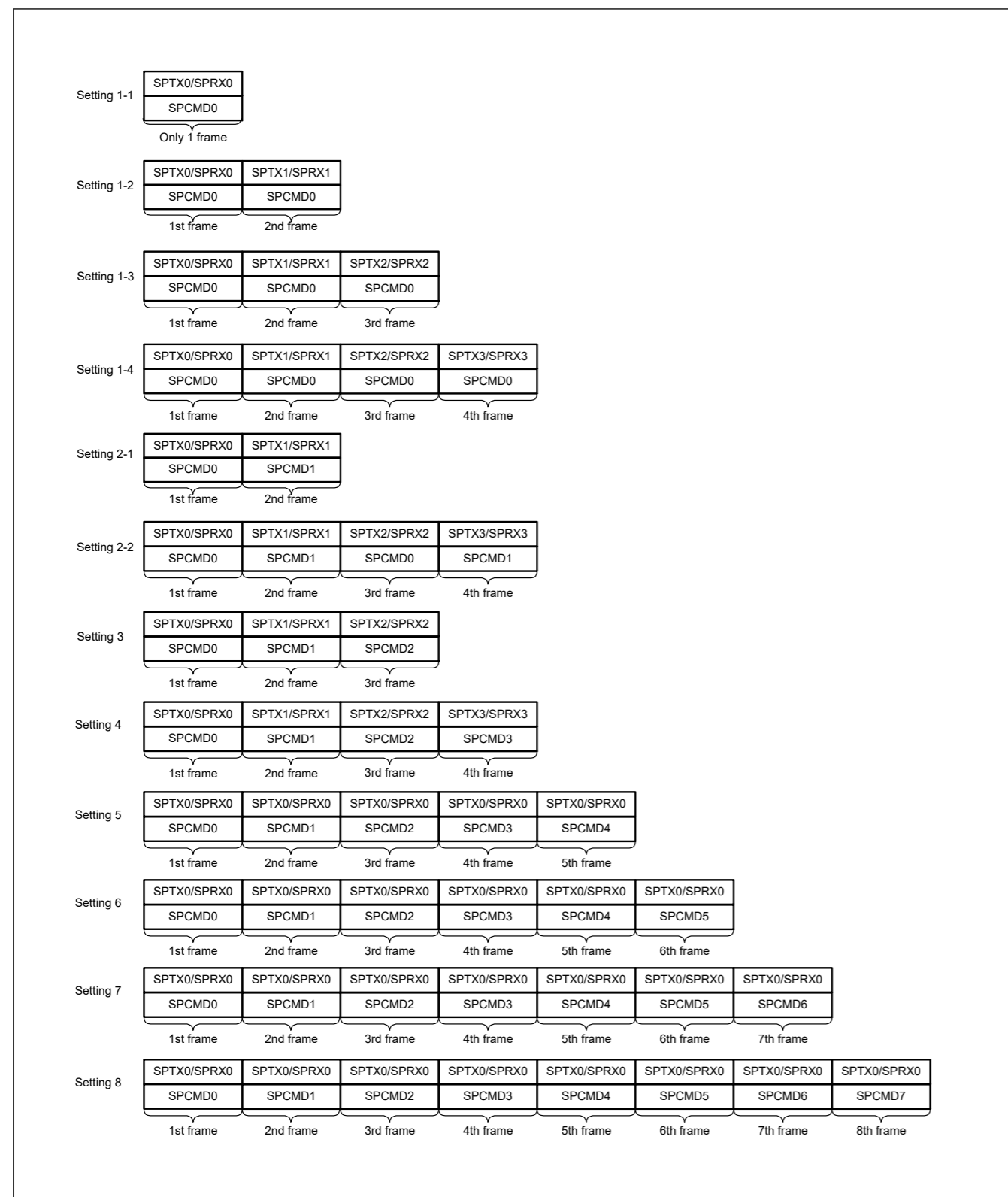


Figure 30.58 Correspondence between SPI Command Register and transmit and receive buffers in sequence operations

(4) Initialization flow

Figure 30.59 shows an example of initialization flow for clock synchronous operation when the SPI is used in master mode. For information on how to set up the ICU, DMAC or DTC, and I/O ports, see the descriptions given in the individual blocks.

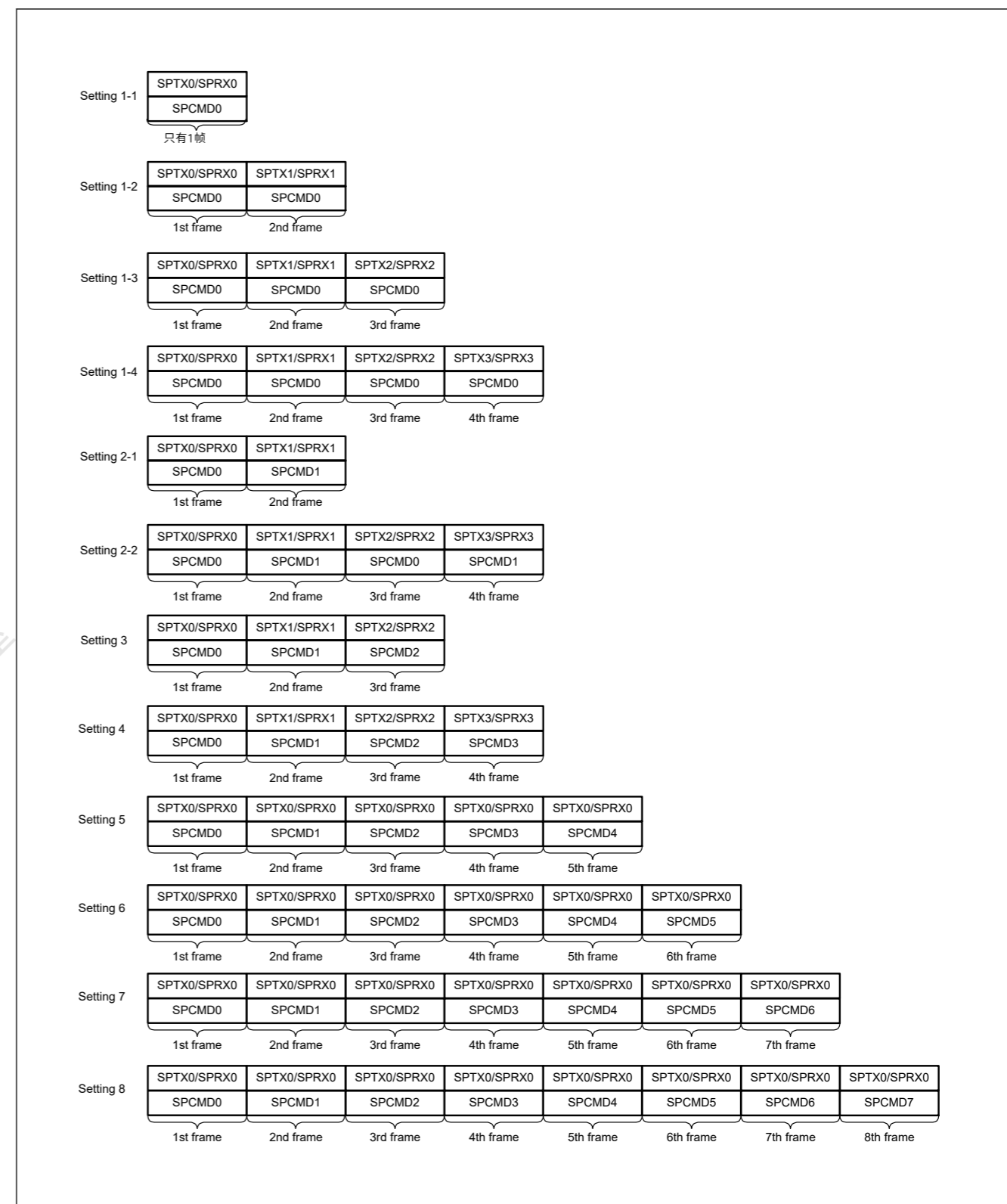


Figure 30.58 顺序操作中SPI命令寄存器与发送接收缓冲区的对应关系

(4) 初始化流程

图30.59显示了在主模式下使用SPI时钟同步操作的初始化流程示例。有关如何设置ICU、DMAC或DTC以及IO端口的信息，请参阅各个块中给出的说明。

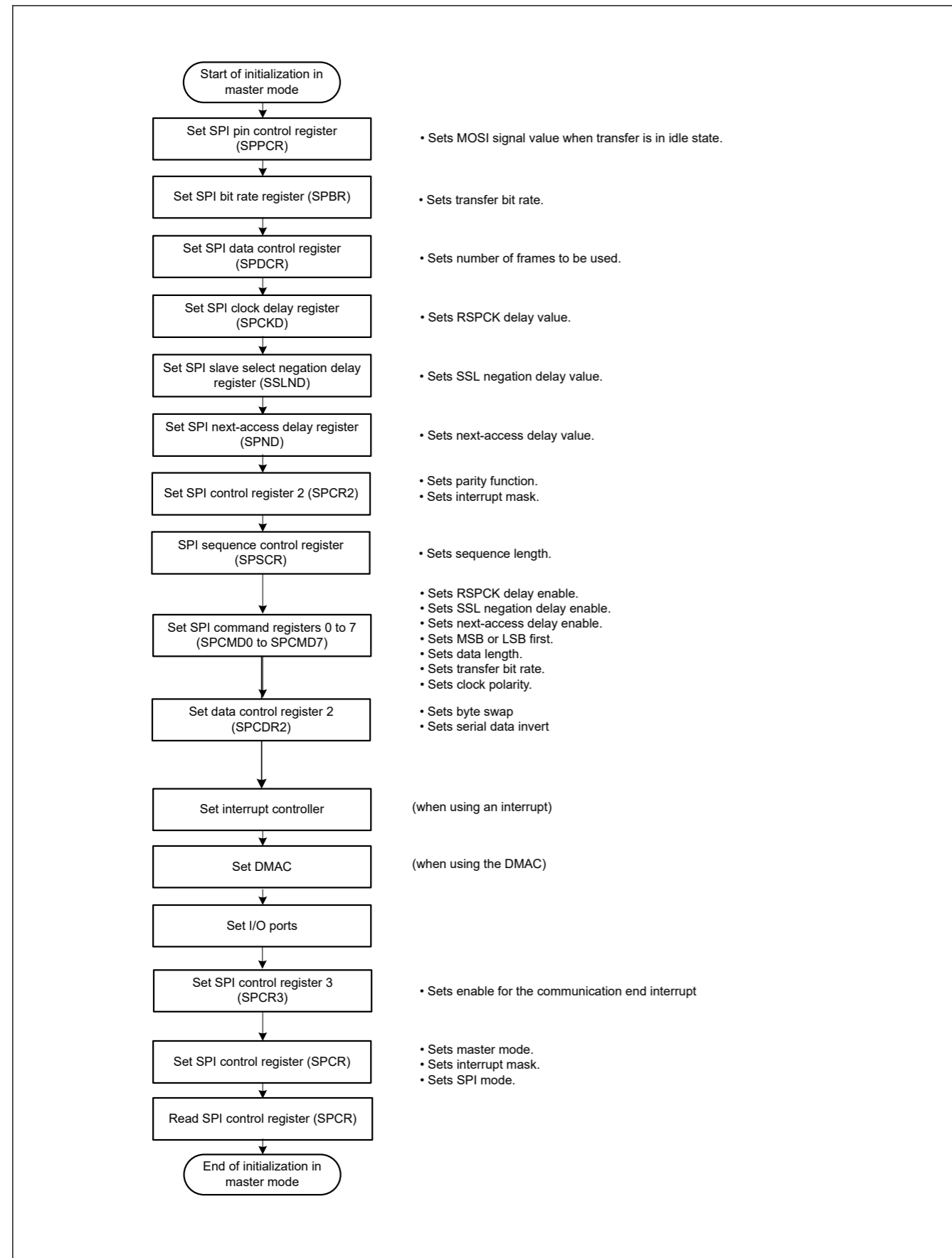


Figure 30.59 Example of initialization flow in master mode for clock synchronous operation

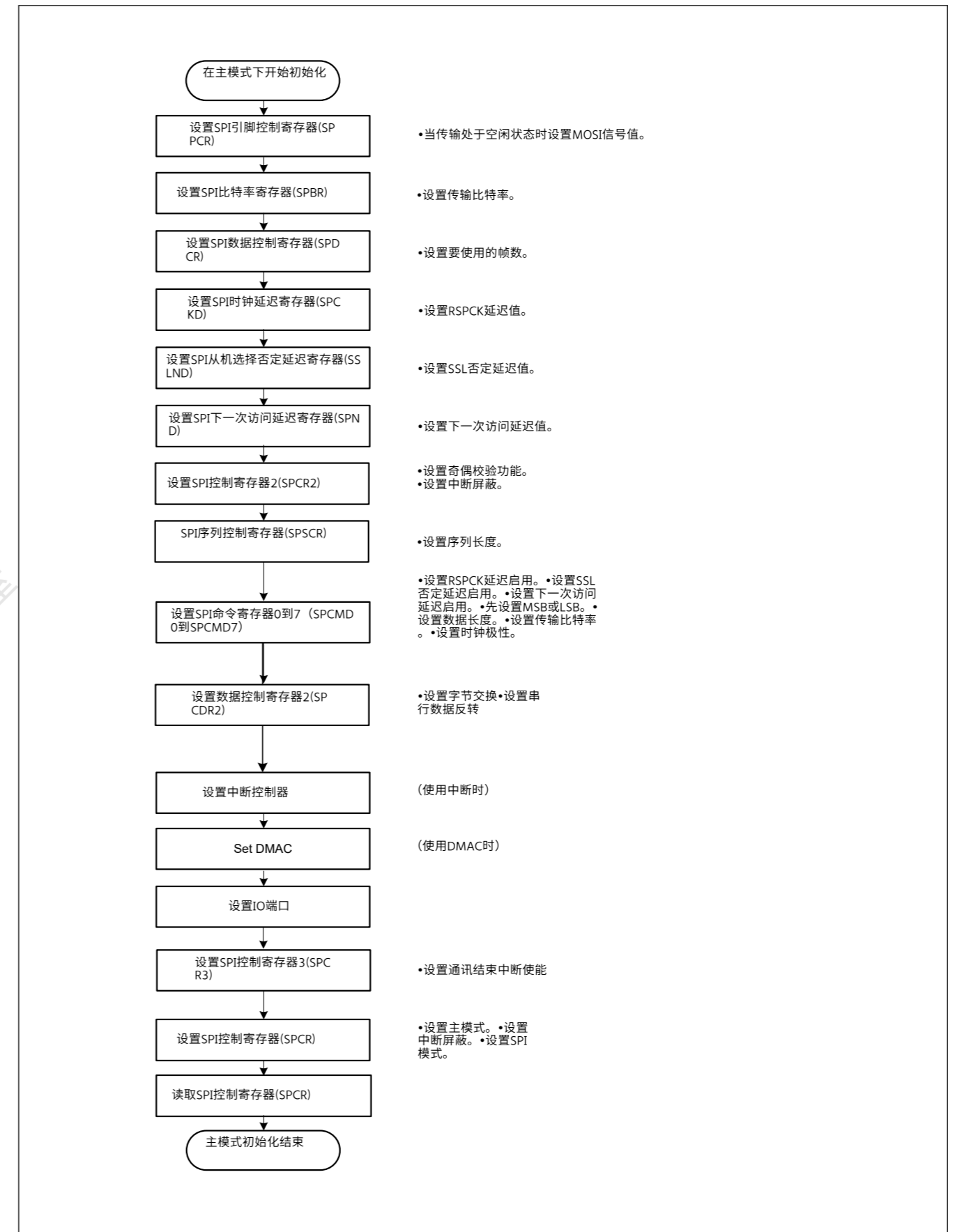


Figure 30.59 时钟同步操作的主模式初始化流程示例

### (5) Software processing flow

Software processing during clock synchronous master operation is the same as that for SPI master operation. For details, see (9) Software processing flow in [section 30.3.11.1. Master mode operation](#). Mode fault errors do not occur in clock synchronous operation.

### 30.3.12.2 Slave mode operation

#### (1) Starting serial transfer

When the SPCR.SPMS bit is 1, the first RSPCKn edge triggers the start of a serial transfer in the SPI, and the SPI drives the MISO output signal. The SSL0 input signal is not used in clock synchronous operation. For details on the SPI transfer format, see [section 30.3.5. Transfer Formats](#).

#### (2) Terminating serial transfer

The SPI terminates the serial transfer after detecting an RSPCKn edge corresponding to the final sampling timing. When free space is available in the receive buffer (the SPSR.SPRF flag is 0), on termination of serial transfer, the SPI copies received data from the shift register to the receive buffer of the SPDR/SPDR\_HA register. On termination of a serial transfer, the SPI changes the status of the shift register to empty regardless of the receive buffer.

The final sampling timing changes depending on the bit length of transfer data. In slave mode, the SPI data length depends on the SPCMD0.SPB[3:0] bits setting. For details on the SPI transfer format, see [section 30.3.5. Transfer Formats](#).

#### (3) Initialization flow

[Figure 30.60](#) shows an example of initialization flow for clock synchronous operation when the SPI is used in slave mode. For a description of how to set up the ICU, DTC, and I/O ports, see the descriptions given in the individual blocks.

### (5) 软件处理流程

时钟同步主机操作期间的软件处理与SPI主机操作相同。详见30.3.11.1 (9) 软件处理流程。主模式操作。时钟同步操作中不会发生模式故障错误。

### 30.3.12.2 从模式操作

#### (1) 开始串行传输

当SPCR.SPMS位为1时，第一个RSPCKn边沿触发SPI中串行传输的开始，并且SPI驱动MISO输出信号。SSL0输入信号不用于时钟同步操作。有关SPI传输格式的详细信息，请参见第30.3.5节。传输格式。

#### (2) 终止串行传输

SPI在检测到对应于最终采样时序的RSPCKn边沿后终止串行传输。当接收缓冲区中有可用空间（SPSR.SPRF标志为0）时，串行传输终止时，SPI将接收到的数据从移位寄存器复制到SPDRSPDR\_HA寄存器的接收缓冲区。在串行传输终止时，SPI将移位寄存器的状态更改为空，而与接收缓冲区无关。

最终的采样时序根据传输数据的位长而变化。在从机模式下，SPI数据长度取决于SPCMD0.SPB[3:0]位设置。有关SPI传输格式的详细信息，请参见第30.3.5节。传输格式。

#### (3) 初始化流程

图30.60显示了在从模式下使用SPI时时钟同步操作的初始化流程示例。有关如何设置ICU、DTC和IO端口的说明，请参见各个块中给出的说明。



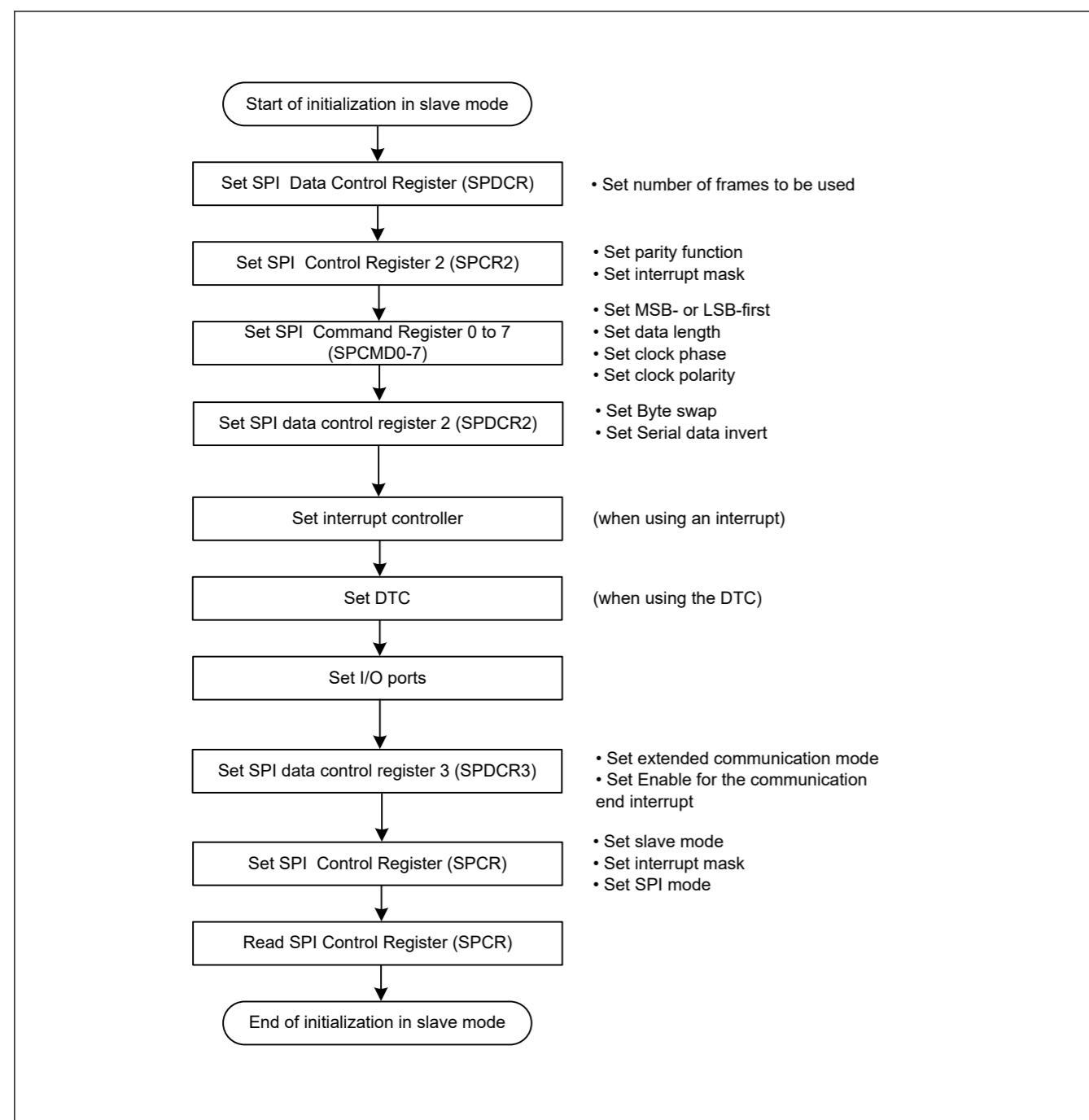


Figure 30.60 Example of initialization flow in slave mode for clock synchronous operation

#### (4) Software processing flow

Software processing during clock synchronous slave operation is the same as that for SPI slave operation. For details, see (6) [Software processing flow](#). Mode fault errors do not occur in clock synchronous mode.

#### 30.3.13 Loopback Mode

When 1 is written to the SPPCR.SPLP2 bit or SPPCR.SPLP bit, the SPI shuts off the path between the MISOn pin and the shift register if the SPCR.MSTR bit is 1, or between the MOSIn pin and the shift register if the SPCR.MSTR bit is 0, and connects the input and output paths of the shift register, establishing a loopback mode. The SPI does not shut off the path between the MOSIn pin and the shift register if the SPCR.MSTR bit is 1, or between the MISOn pin and the shift register if the SPCR.MSTR bit is 0. This is called loopback mode. When a serial transfer is executed in loopback mode, the transmit data for the SPI or the reversed transmit data becomes the received data for the SPI.

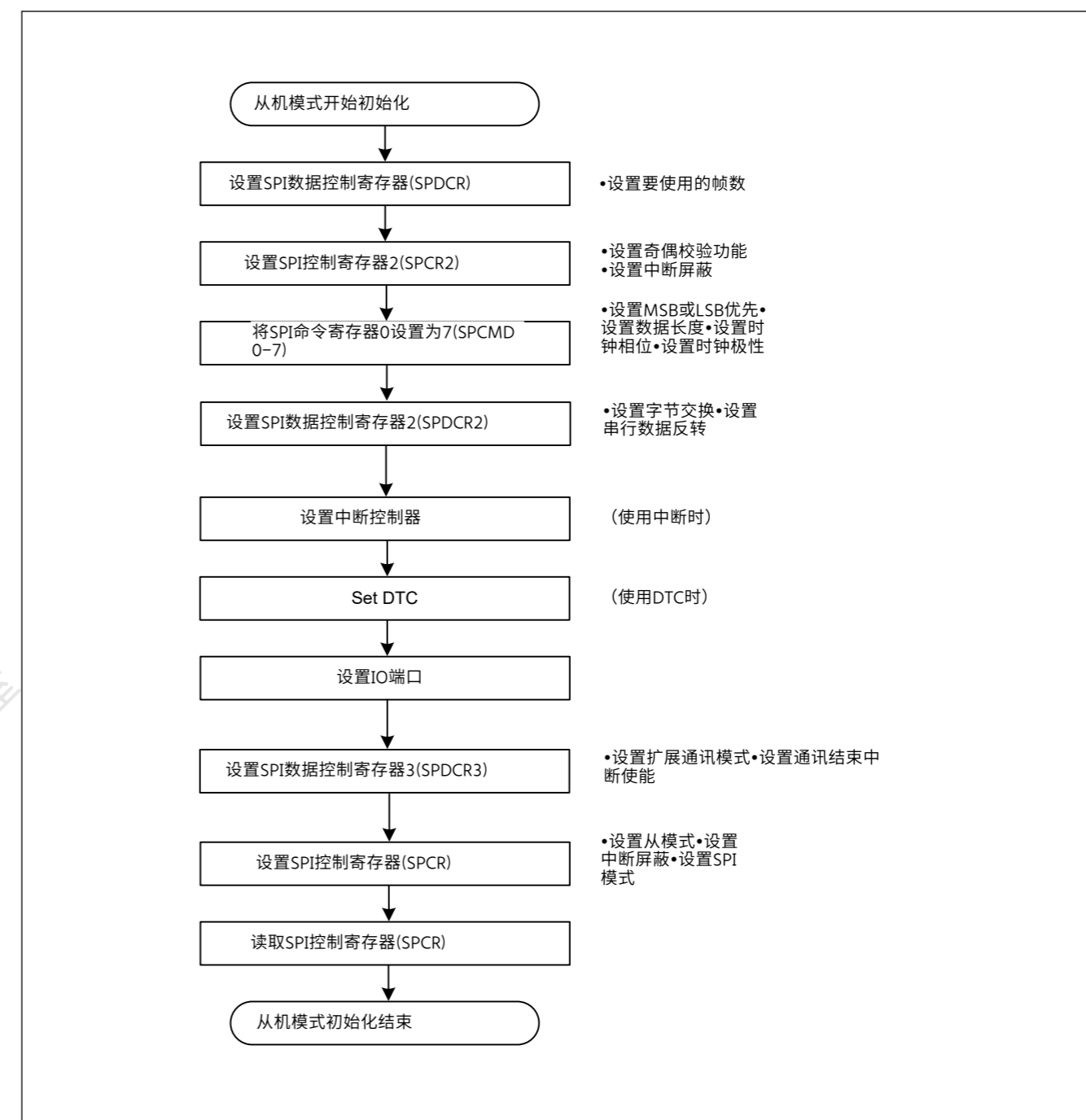


Figure 30.60 时钟同步操作的从模式初始化流程示例

#### (4) 软件处理流程

时钟同步从机操作期间的软件处理与SPI从机操作相同。详见 (6) [软件处理流程](#)。时钟同步模式下不会发生模式故障错误。

#### 30.3.13 Loopback Mode

当向SPPCR.SPLP2位或SPPCR.SPLP位写入1时，如果SPCR.MSTR位为1，则SPI关闭MISOn引脚和移位寄存器之间的路径，或者如果SPCR.MSTR位为0，连接移位寄存器的输入和输出路径，建立环回模式。如果SPCR.MSTR位为1，SPI不关闭MOSIn引脚和移位寄存器之间的路径，如果SPCR.MSTR位为0，则SPI不关闭MISOn引脚和移位寄存器之间的路径。这称为环回模式。当在环回模式下执行串行传输时，SPI的发送数据或反向发送数据将成为SPI的接收数据。

Table 30.13 lists the relationship between the SPLP2 and SPLP bits and the received data. Figure 30.61 shows the configuration of the shift register I/O paths when the SPI in master mode is set to loopback mode (SPPCR.SPLP2 = 0, SPPCR.SPLP = 1).

Table 30.13 SPLP2 and SPLP bit settings and received data

| SPPCR.SPLP2 bit | SPPCR.SPLP bit | Received data                             |
|-----------------|----------------|---|
| 0               | 0              | Input data from the MOSIn pin or MISO pin |
| 0               | 1              | Inverted transmit data                    |
| 1               | 0              | Transmit data                             |
| 1               | 1              | Transmit data                             |

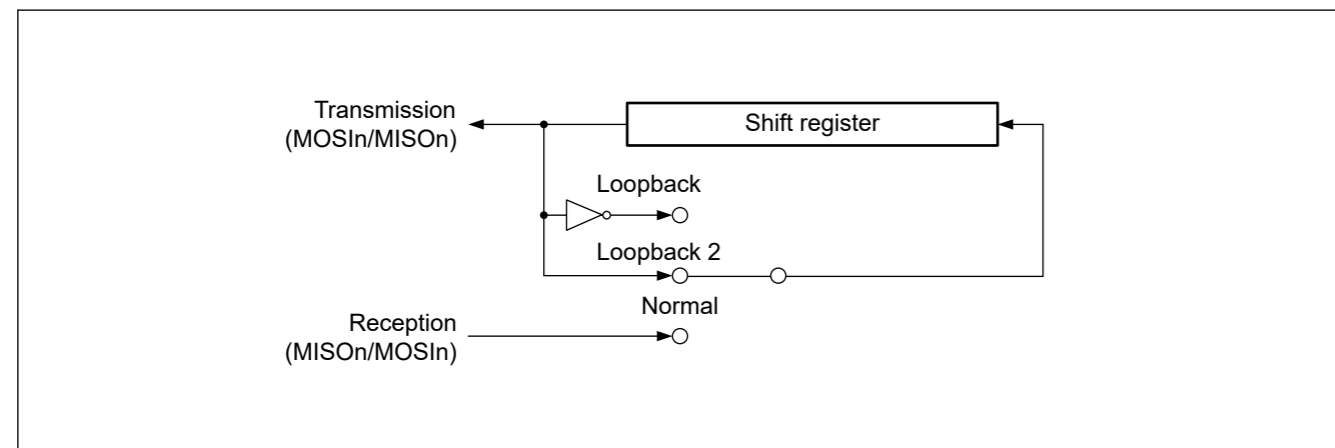


Figure 30.61 Configuration of shift register I/O paths in loopback mode for master mode

### 30.3.14 Self-Diagnosis of Parity Bit Function

The parity circuit consists of a parity bit adding unit used for transmit data and an error detecting unit used for received data. To detect defects in the parity bit adding unit and error detecting unit, the parity circuit performs self-diagnosis as shown in Figure 30.62.

表30.13列出了SPLP2和SPLP位与接收数据之间的关系。图30.61显示了当主模式下的SPI设置为环回模式 (SPPCR.SPLP2=0, SPPCR.SPLP=1) 时移位寄存器IO路径的配置。

Table 30.13 SPLP2和SPLP位设置和接收数据

| SPPCR.SPLP2 bit | SPPCR.SPLP bit | 接收数据                |
|-----------------|----------------|---------------------|
| 0               | 0              | 从MOSIn引脚或MISO引脚输入数据 |
| 0               | 1              | 反相传输数据              |
| 1               | 0              | 传输数据                |
| 1               | 1              | 传输数据                |

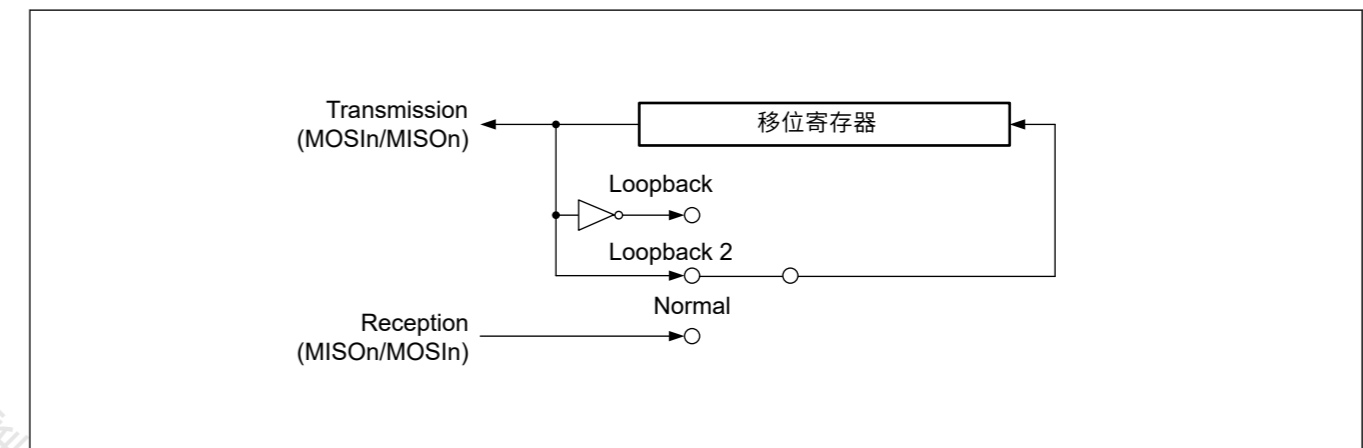


Figure 30.61 在主模式的环回模式下配置移位寄存器IO路径

### 30.3.14 奇偶校验位功能自诊断

奇偶校验电路由用于发送数据的奇偶校验位添加单元和用于接收数据的错误检测单元组成。为了检测奇偶校验位添加单元和错误检测单元中的缺陷，奇偶校验电路执行自诊断，如图所示 Figure 30.62.

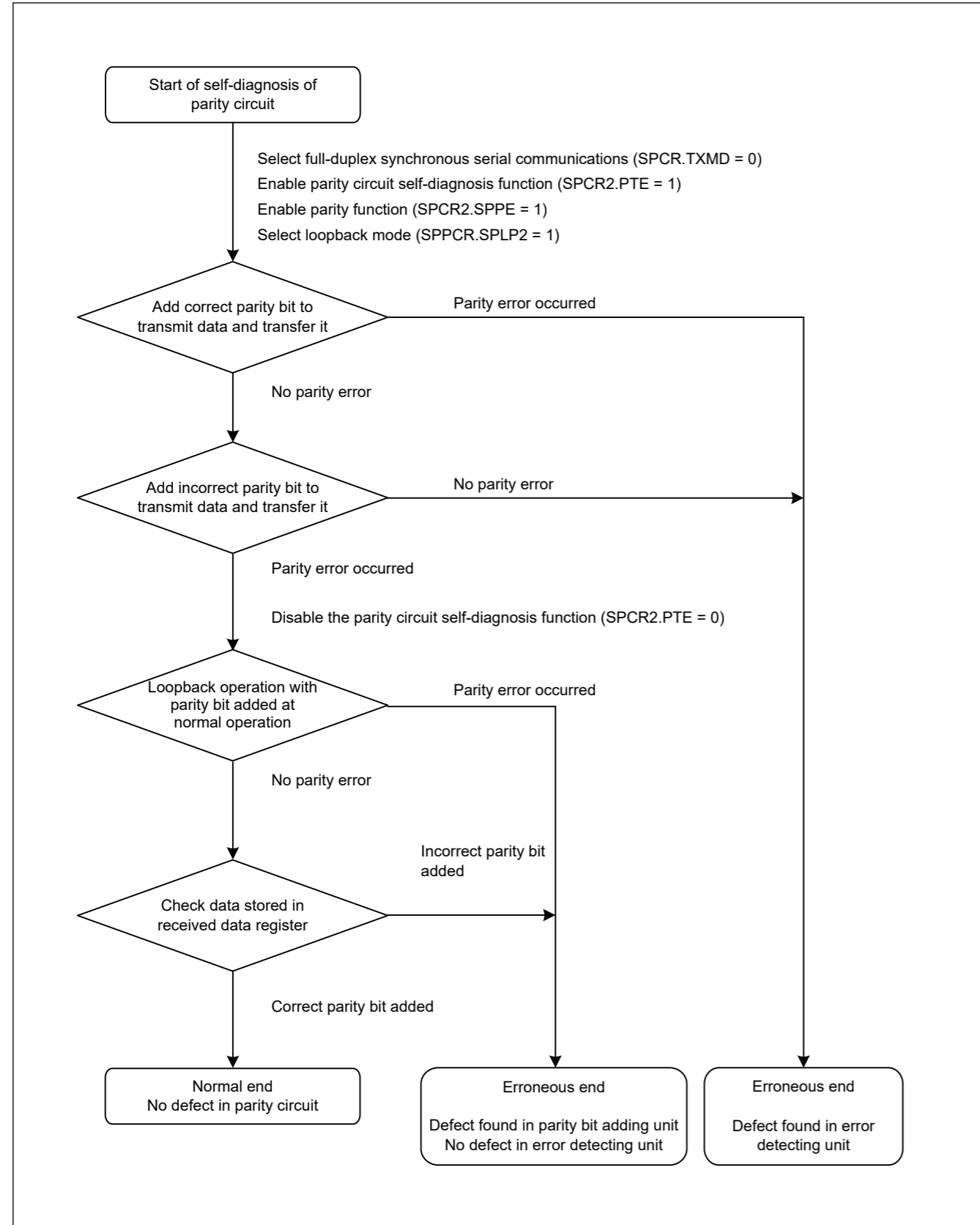


Figure 30.62 Self-diagnosis flow for parity circuit

### 30.3.15 Interrupt Sources

The SPI has the following interrupt sources:

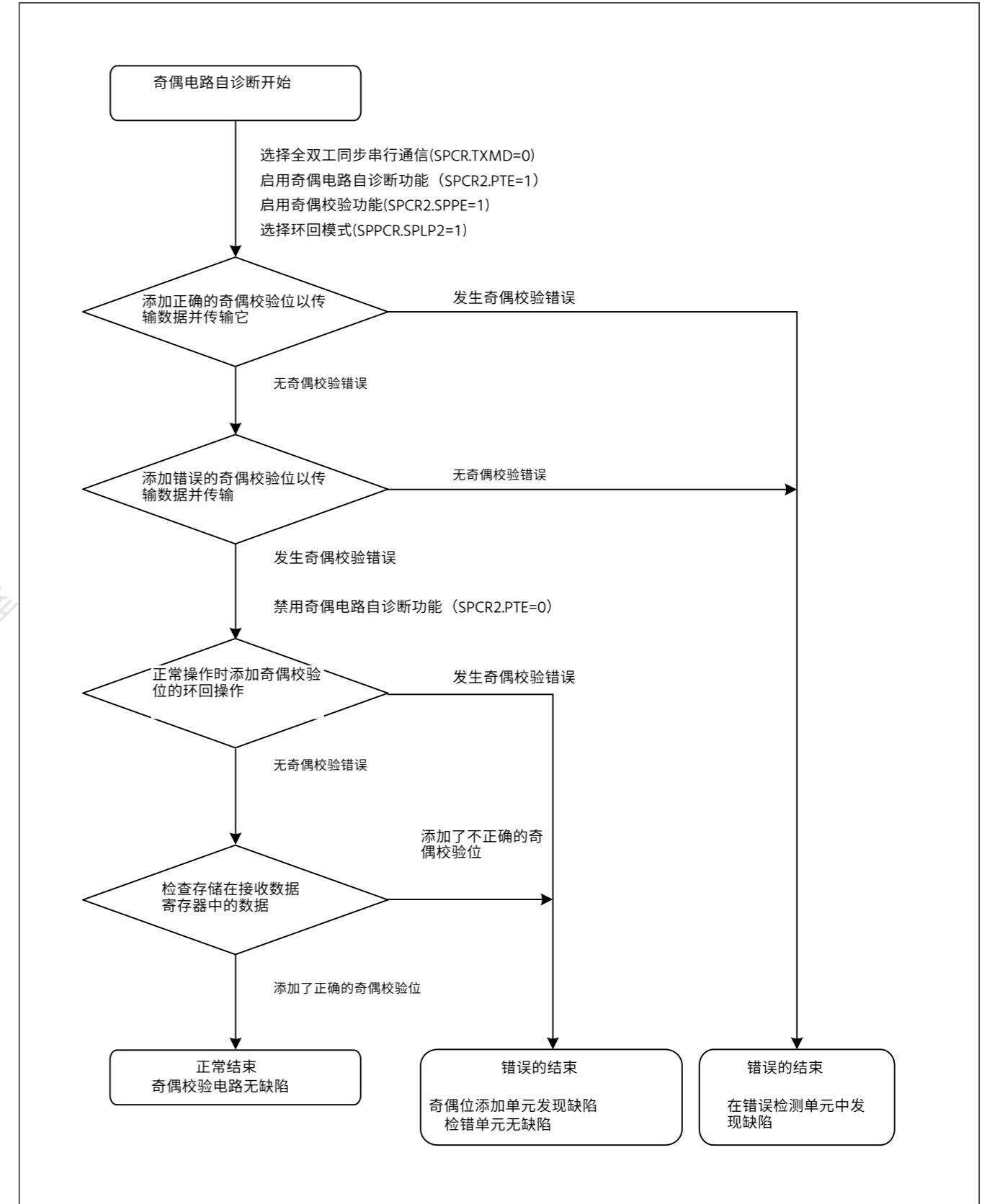


Figure 30.62 奇偶校验电路的自诊断流程

### 30.3.15 中断源

SPI有以下中断源:

- Receive buffer full
- Transmit buffer empty
- SPI error (mode-fault, underrun, overrun, or parity error)
- SPI idle
- Communication-end

The DMAC or DTC can be activated by the receive buffer full or transmit buffer empty interrupt to perform data transfer.

Because the vector address for the SPI<sub>i</sub>\_SPEI (SPI error interrupt) is allocated to interrupt requests on mode-fault, underrun, overrun, and parity errors, the actual interrupt source must be determined from the flags. Interrupt sources for the SPI are listed in Table 30.14. An interrupt is generated on satisfaction of one of the interrupt conditions in Table 30.14. Clear the receive buffer full and transmit buffer empty sources through a data transfer.

When using the DMAC or DTC to perform data transmission and reception, you must first set up the DMAC or DTC to be in a transfer-enabled status before setting the SPI. For information on setting up the DMAC or DTC, see section 16, DMA Controller (DMAC) and section 17, Data Transfer Controller (DTC).

If the conditions for generating a transmit buffer empty or receive buffer full interrupt occur while the ICU.IELSRn.IR flag is 1, the interrupt is not output as a request for the ICU but is retained internally (the capacity for retention is one request per source). A retained interrupt request is output when the ICU.IELSRn.IR flag becomes 0. A retained interrupt request is automatically discarded when it is output as an actual interrupt request. The interrupt enable bit (the SPCR.SPTIE or SPCR.SPRIE bit) for an internally retained interrupt request can also be set to 0.

Table 30.14 SPI interrupt sources

| Interrupt source   | Symbol                 | Interrupt condition  | DTC/DMAC activation |
|--|------------------------|--|---------------------|
| Receive buffer full  | SPI <sub>i</sub> _SPRI | The receive buffer becomes full (SPSR.SPRF flag is 1) while the SPCR.SPRIE bit is 1    | Possible            |
| Transmit buffer empty                                      | SPI <sub>i</sub> _SPTI | The transmit buffer becomes empty (SPSR.SPTEF flag is 1) while the SPCR.SPTIE bit is 1 | Possible            |
| SPI error (mode-fault, underrun, overrun, or parity error) | SPI <sub>i</sub> _SPEI | The SPSR.MODF, OVRF, UDRF or PERF flag sets to 1 while the SPCR.SPEIE bit is 1         | Impossible          |
| SPI idle   | SPI <sub>i</sub> _SPII | The SPSR.IDLNF flag sets to 0 while the SPCR2.SPIIE bit is 1                           | Impossible          |
| Communication-end  | SPI <sub>i</sub> _SPCI | CENDIE = 1 and CENDF = 1   | Impossible          |

### 30.4 Event Link Controller Event Output

The Event Link Controller (ELC) can produce the following event output signals:

- Receive buffer full event output
- Transmit buffer empty event output
- Mode-fault, underrun, overrun, or parity error event output
- SPI idle event output
- Transmission-completed event output

The event link output signal is output regardless of the interrupt enable bit setting.

#### 30.4.1 Receive Buffer Full Event Output

This event signal is output when received data is transferred from the shift register to the SPDR/SPDR\_HA on completion of serial transfer.

#### 30.4.2 Transmit Buffer Empty Event Output

This event signal is output when data for transmission is transferred from the transmit buffer to the shift register and when the value of the SPE bit changes from 0 to 1.

- 接收缓冲区已满
- 发送缓冲区空
- SPI错误（模式故障、欠载、溢出或奇偶校验错误）
- SPI空闲
- Communication-end

DMAC或DTC可由接收缓冲区满或发送缓冲区空中断激活以执行数据传输。

由于SPI<sub>i</sub>\_SPEI（SPI错误中断）的向量地址分配给模式错误、欠载、溢出和奇偶校验错误的中断请求，因此必须根据标志确定实际中断源。表30.14列出了SPI的中断源。满足表30.14中的中断条件之一时会产生中断。通过数据传输清除接收缓冲区满和发送缓冲区空源。

使用DMAC或DTC进行数据收发时，必须先将DMAC或DTC设置为传输使能状态，然后再设置SPI。有关设置DMA C或DTC的信息，请参阅第16节，DMA控制器(DMAC)和第17节，数据传输控制器(DTC)。

如果在ICU.IELSRn.IR标志为1时发生发送缓冲区空或接收缓冲区满中断的条件，则该中断不会作为对ICU的请求输出，而是在内部保留（保留容量为每个请求一个请求）资源。当ICU.IELSRn.IR标志变为0时，输出保留中断请求。当作为实际中断请求输出时，自动丢弃保留中断请求。内部保留中断请求的中断使能位（SPCR.SPTIE或SPCR.SPRIE位）也可以设置为0。

Table 30.14 SPI中断源

| 中断源                      | Symbol                 | 中断条件  | DTC/DMAC activation |
|--------------------------|------------------------|---|---------------------|
| 接收缓冲区已满                  | SPI <sub>i</sub> _SPRI | 当SPCR.SPRIE位为1时，接收缓冲区变满（SPSR.SPRF标志为1）        | Possible            |
| 发送缓冲区为空                  | SPI <sub>i</sub> _SPTI | 当SPCR.SPTIE位为1时，发送缓冲区变为空（SPSR.SPTEF标志为1）      | Possible            |
| SPI错误（模式错误、欠载、溢出或奇偶校验错误） | SPI <sub>i</sub> _SPEI | SPSR.MODF、OVRF、UDRF或PERF标志设置为1，而SPCR.SPEIE位为1 | Impossible          |
| SPI空闲                    | SPI <sub>i</sub> _SPII | SPSR.IDLNF标志设置为0，而SPCR2.SPIIE位为1              | Impossible          |
| Communication-end        | SPI <sub>i</sub> _SPCI | CENDIE = 1 and CENDF = 1                      | Impossible          |

### 30.4 事件链接控制器事件输出

事件链接控制器(ELC)可以产生以下事件输出信号：

- 接收缓冲区满事件输出
- 发送缓冲区空事件输出
- 模式故障、欠载、溢出或奇偶校验错误事件输出
- SPI空闲事件输出
- 传输完成事件输出

无论中断允许位设置如何，都会输出事件链接输出信号。

#### 30.4.1 接收缓冲区满事件输出

串行传输完成后，当接收到的数据从移位寄存器传输到SPDR/SPDR\_HA时，输出此事件信号。

#### 30.4.2 发送缓冲区空事件输出

当要发送的数据从发送缓冲器传送到移位寄存器时，以及SPE位的值从0变为1时，输出该事件信号。



### 30.4.3 Mode-Fault, Underrun, Overrun, or Parity Error Event Output

This event signal is output when mode-fault, underrun, overrun, or parity error is detected. See [section 30.5.4. Constraints on Mode-Fault, Underrun, Overrun, or Parity Error Event Output](#) if using this event signal.

#### (1) Mode-fault

[Table 30.15](#) lists the conditions for occurrence of a mode-fault event.

**Table 30.15 Conditions for mode-fault occurrence**

| SPI mode  | SPCR.MODFEN bit | SSLn0 pin  | Remarks  |
|---|-----------------|------------|--|
| SPI operation (SPMS = 0)<br>Slave (SPCR.MSTR = 0) | 1               | Not active | Event is output only when the SSLn0 pin is deactivated during transmission |

#### (2) Underrun

This event signal is output in response to an underrun when a serial transfer starts while the transmission data is not ready, and the value of the SPCR.MSTR bit is 0 and the SPCR.SPE bit is 1. Under these conditions, the MODF and UDRF flags are set to 1.

#### (3) Overrun

This event signal is output in response to an overrun when a serial transfer completes while the receive buffer contains unread data and the value of the SPCR.TXMD bit is 0. Under these conditions, the OVRF flag is set to 1.

#### (4) Parity error

This event signal is output in response to a parity error detected on completion of a serial transfer while the value of the TXMD bit in SPCR is 0 and the value of the SPPE bit in SPCR2 is 1.

### 30.4.4 SPI Idle Event Output

#### (1) In master mode

In master mode, an event is output when the condition for setting the IDLNF flag (SPI idle flag) to 0 is satisfied.

#### (2) In slave mode

In slave mode, an event is output when the SPCR.SPE bit is set to 0 (SPI is initialized).

### 30.4.5 Communication End Event Output

In master mode, an event is output when the IDLNF flag (RSPI idle flag) changes from 1 to 0. In slave mode, an event occurs with conditions shown in [Table 30.16](#) and [Table 30.17](#)

**Table 30.16 Communication End Event Generating Conditions (transmit-receive/transmit slave mode)**

|  | Transmit Buffer Status | Shift Register Status | Others   |
|--|------------------------|-----------------------|--|
| SPI operation (SPMS = 0)               | Empty                  | Empty                 | SSL0 input is negated  |
| Clock synchronous operation (SPMS = 1) | Empty                  | Empty                 | The last even edge of RSPCK of last data was detected (CPHA = 1) |

**Table 30.17 Communication End Event Generating Conditions (receive only slave mode)**

|  | Others   |
|--|--|
| SPI operation (SPMS = 0)               | SSL0 input is negated  |
| Clock synchronous operation (SPMS = 1) | The last even edge of RSPCK of last data was detected (CPHA = 1) |

Regardless of master mode or slave mode, no event is output when 0 is written to the SPCR.SPE bit during transmission or when the SPCR.SPE bit is cleared due to a mode fault error or an underrun error.

### 30.4.3 模式故障、欠载、溢出或奇偶校验错误事件输出

当检测到模式故障、欠载、溢出或奇偶校验错误时，输出此事件信号。请参阅第30.5.4节。如果使用此事件信号，则对模式故障、欠载、溢出或奇偶校验错误事件输出的约束。

#### (1) Mode-fault

表30.15列出了模式故障事件发生的条件。

**Table 30.15 模式故障发生的条件**

| SPI模式                            | SPCR.MODFEN bit | SSLn0 pin | Remarks                  |
|----------------------------------|-----------------|-----------|--------------------------|
| SPI操作(SPMS=0)从机(SP<br>CR.MSTR=0) | 1               | 不活跃       | 只有在传输过程中禁用SSLn0引脚时才会输出事件 |

#### (2) Underrun

当串行传输开始而传输数据尚未准备好，并且SPCR.MSTR位的值为0且SPCR.SPE位为1时，输出此事件信号以响应欠载。在这些条件下，MODF和UDRF标志设置为1。

#### (3) Overrun

当串行传输完成而接收缓冲区包含未读数据且SPCR.TXMD位的值为0时，输出此事件信号以响应溢出。在这些情况下，OVRF标志设置为1。

#### (4) 奇偶校验错误

该事件信号是响应在串行传输完成时检测到的奇偶校验错误而输出的，而SPCR中的TXMD位为0，SPCR2中的SPPE位的值为1。

### 30.4.4 SPI空闲事件输出

#### (1) 在主模式

在主机模式下，当将IDLNF标志（SPI空闲标志）设置为0的条件成立时输出事件。

#### (2) 在从模式

在从机模式下，当SPCR.SPE位设置为0（SPI初始化）时，会输出一个事件。

### 30.4.5 通讯结束事件输出

在主机模式下，当IDLNF标志（RSPI空闲标志）从1变为0时输出事件。在从机模式下，事件发生的条件如表30.16和表30.17所示

**Table 30.16 通信结束事件发生条件（发送-接收发送从模式）**

|                | 发送缓冲区状态 | 移位寄存器状态 | Others                          |
|----------------|---------|---------|---------------------------------|
| SPI操作(SPMS=0)  | Empty   | Empty   | SSL0输入被否定                       |
| 时钟同步操作(SPMS=1) | Empty   | Empty   | 检测到最后一个数据的RSPCK的最后一个偶边沿(CPHA=1) |

**Table 30.17 通信结束事件发生条件（仅接收从模式）**

|                | Others                          |
|----------------|---------------------------------|
| SPI操作(SPMS=0)  | SSL0输入被否定                       |
| 时钟同步操作(SPMS=1) | 检测到最后一个数据的RSPCK的最后一个偶边沿(CPHA=1) |

无论主模式还是从模式，在传输过程中向SPCR.SPE位写入0或由于模式故障错误或欠载错误而清除SPCR.SPE位时，不输出任何事件。

A communication end event is output at the following timing. The communication end event output timing in master operation is omitted because it is output at the same timing as an idle event.

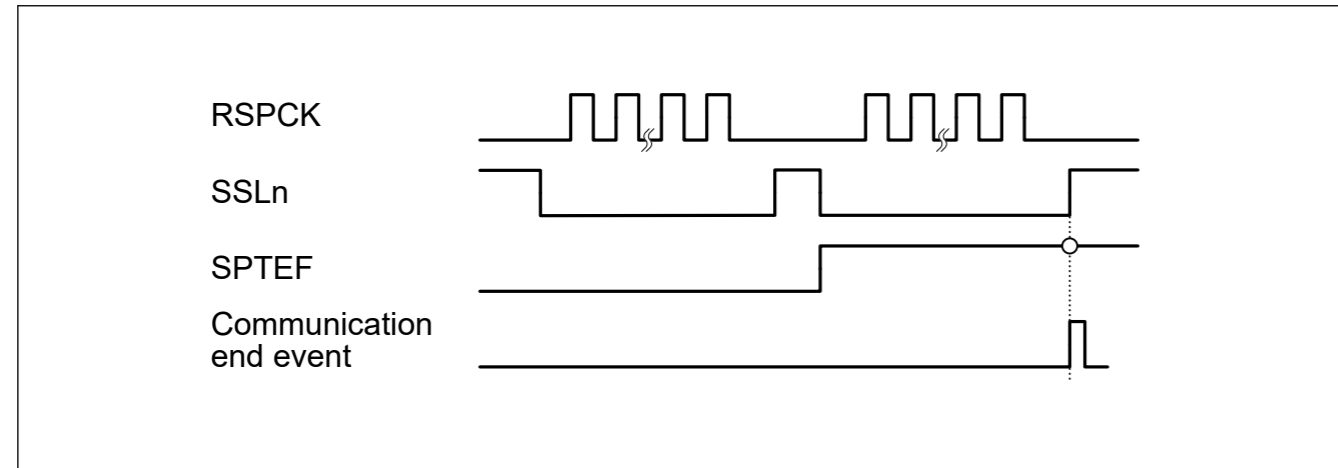


Figure 30.63 Communication End Event Output Timing (Transmit slave mode, SPI Operation)

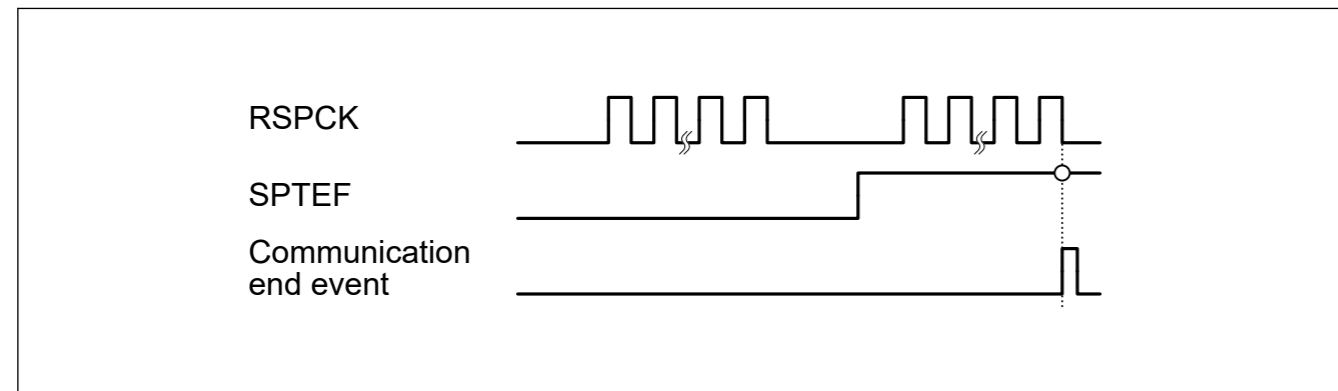


Figure 30.64 Communication End Event Output Timing (Transmit slave mode, Clock Synchronous Operation)

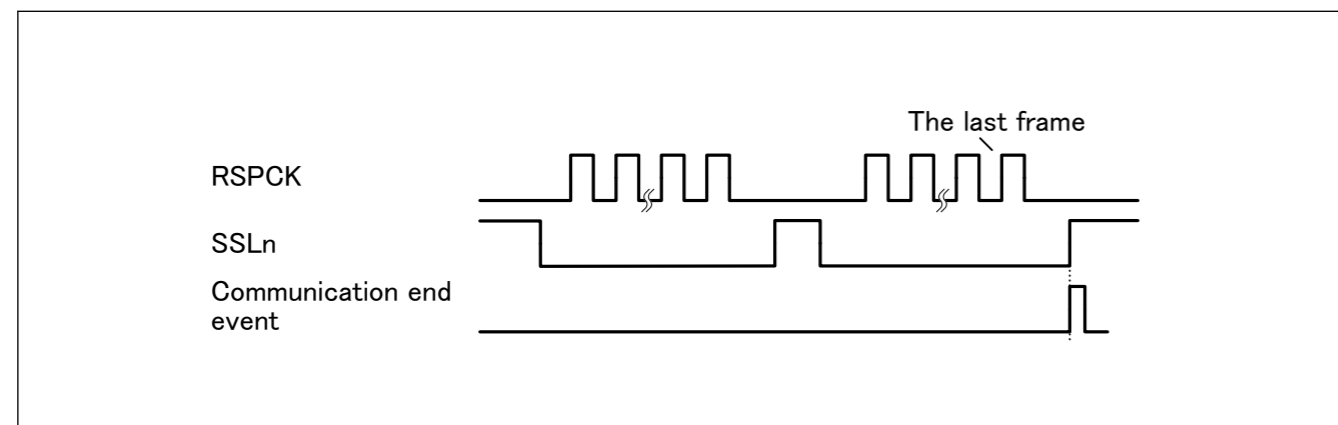


Figure 30.65 Communication End Event Output Timing (Receive only slave mode, SPI Operation)

在以下定时输出通信结束事件。主操作中的通信结束事件输出时序被省略，因为它与空闲事件在相同的时序输出。

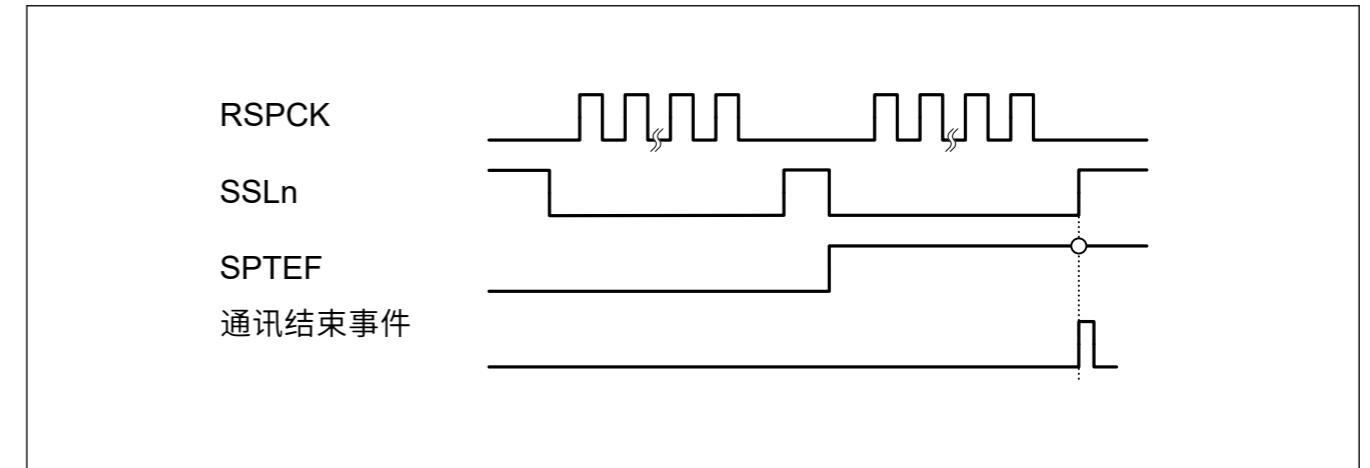


Figure 30.63 通信结束事件输出时序 (发送从机模式, SPI操作)

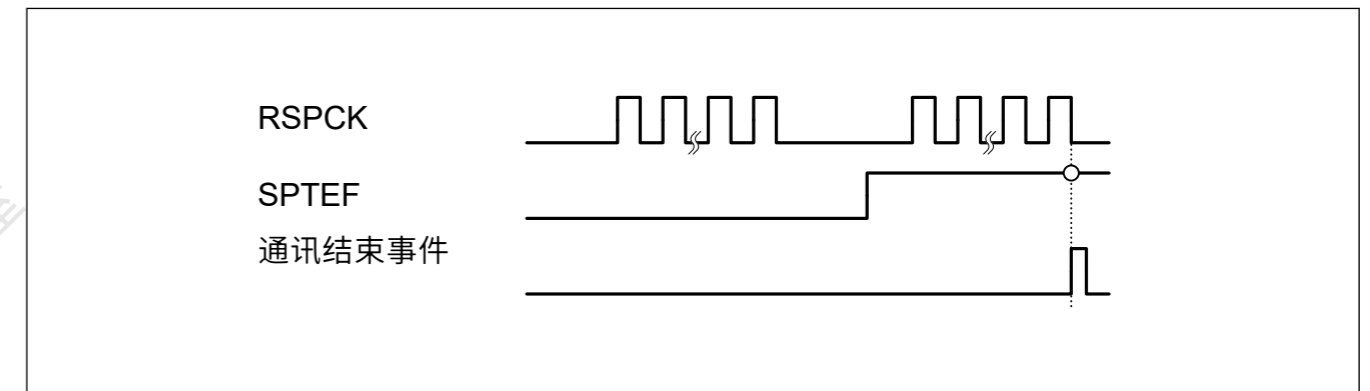


Figure 30.64 通信结束事件输出时序 (发送从机模式, 时钟同步 Operation)

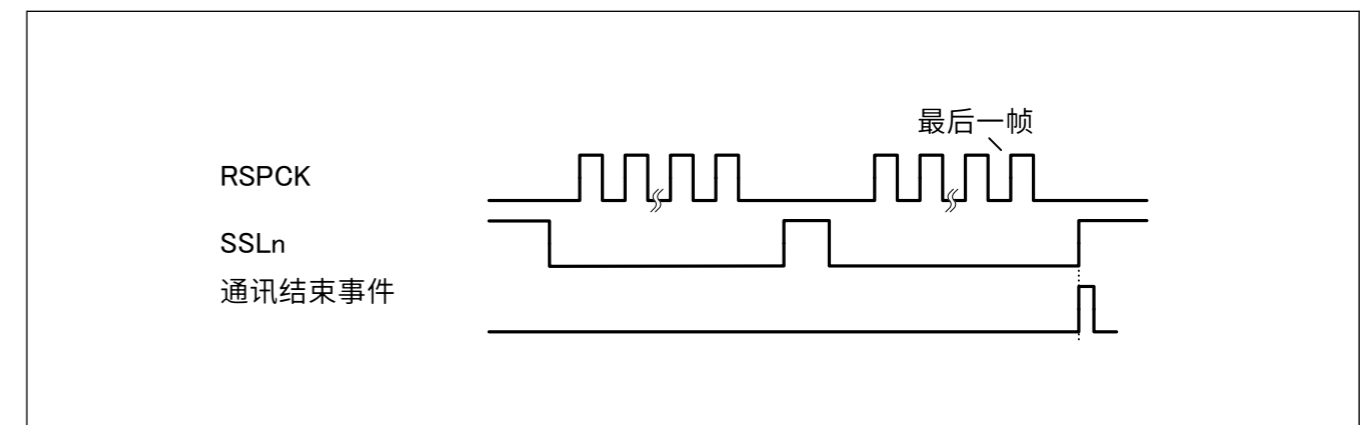


Figure 30.65 通信结束事件输出时序 (仅接收从机模式, SPI操作)

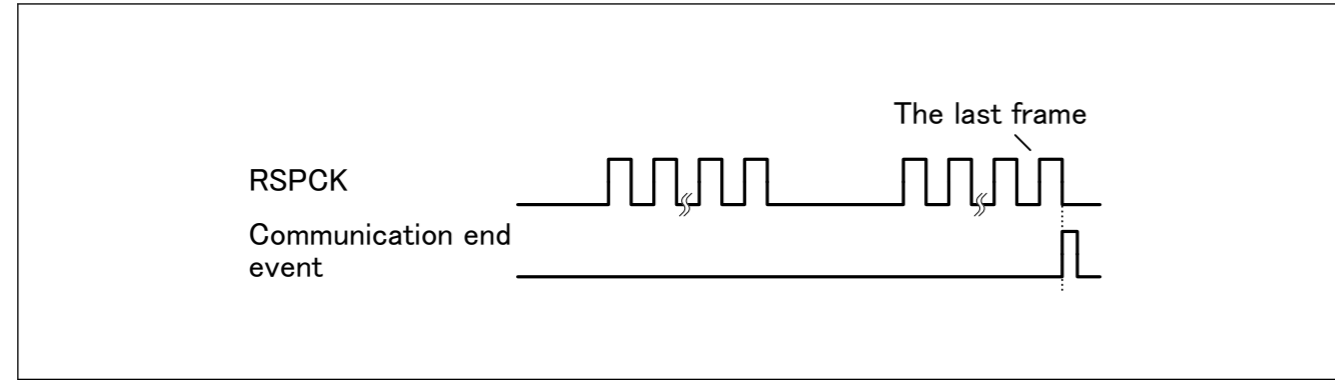


Figure 30.66 Communication End Event Output Timing (Receive only slave mode, Clock Synchronous Operation)

## 30.5 Usage Notes

### 30.5.1 Settings for the Module-Stop State

The Module Stop Control Register B (MSTPCRB) can enable or disable the SPI operation. The SPI is initially stopped after reset. Releasing the module-stop state enables access to the registers. For details on the Module Stop Control Register B, see [section 10, Low Power Modes](#).

### 30.5.2 Constraint on Low-Power Functions

When using the module-stop function and entering a low-power mode other than Sleep mode, set the SPCR.SPE bit to 0 before completing communication.

### 30.5.3 Constraints on Starting Transfer

If the ICU.IELSRn.IR flag is 1 when transfer starts, the interrupt request is internally retained, which can lead to unanticipated behavior of the ICU.IELSRn.IR flag.

To prevent this, use the following procedure to clear interrupt requests before enabling operations (by setting the SPCR.SPE bit to 1):

1. Confirm that transfer stopped (the SPCR.SPE bit is 0).
2. Set the associated interrupt enable bit (SPCR.SPTIE bit or SPCR.SPRIE bit) to 0.
3. Read the associated interrupt enable bit (SPCR.SPTIE bit or SPCR.SPRIE bit) and confirm that its value is 0.
4. Set the ICU.IELSRn.IR flag to 0.

### 30.5.4 Constraints on Mode-Fault, Underrun, Overrun, or Parity Error Event Output

Using the mode-fault, underrun, overrun, or parity error event is prohibited if the SPI is in multi-master mode (when the SPCR.SPMS bit is 0, the SPCR.MSTR bit is 1, and the SPCR.MODFEN bit is 1).

### 30.5.5 Constraints on the SPSR.SPRF and SPSR.SPTEF Flags

If the polling flags, SPRF and SPTEF, are used, using the interrupts is prohibited, and you must set the SPCR.SPRIE and SPCR.SPTIE bits to 0. Either the interrupts or the flags can be used, but not both.

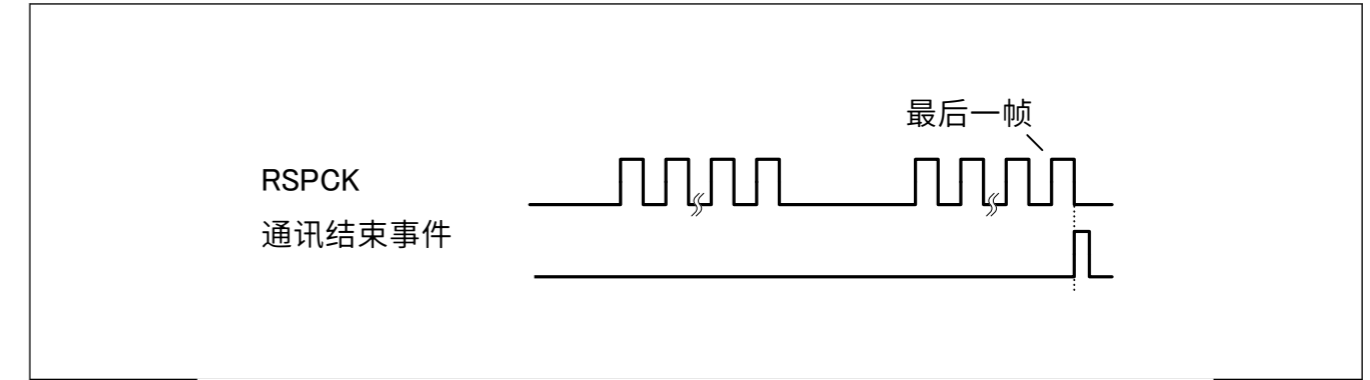


Figure 30.66 通信结束事件输出时序 (仅接收从机模式, 时钟同步 Operation)

## 30.5 使用说明

### 30.5.1 模块停止状态的设置

模块停止控制寄存器B(MSTPCRB)可以启用或禁用SPI操作。SPI在复位后最初停止。释放模块停止状态可以访问寄存器。有关模块停止控制寄存器B的详细信息, 请参见第10节, 低功耗模式。

### 30.5.2 对低功耗功能的约束

当使用模块停止功能并进入除睡眠模式以外的低功耗模式时, 在完成通信之前将SPCR.SPE位设置为0。

### 30.5.3 开始传输的限制

如果ICU.IELSRn.IR标志在传输开始时为1, 则内部保留中断请求, 这可能导致ICU.IELSRn.IR标志的意外行为。

为防止这种情况发生, 请使用以下程序在使能操作之前清除中断请求 (通过将SPCR.SPE位设置为1) :

1. 确认传输停止 (SPCR.SPE位为0)。
2. 将相关的中断使能位 (SPCR.SPTIE位或SPCR.SPRIE位) 设置为0。
3. 读取相关的中断使能位 (SPCR.SPTIE位或SPCR.SPRIE位) 并确认其值为0。
4. 将ICU.IELSRn.IR标志设置为0。

### 30.5.4 模式故障、欠载、溢出或奇偶校验错误事件输出的约束

如果SPI处于多主模式 (当 SPCR.SPMS位为0, SPCR.MSTR位为1, SPCR.MODFEN位为1)。

### 30.5.5 SPSR.SPRF和SPSR.SPTEF标志的约束

如果使用轮询标志SPRF和SPTEF, 则禁止使用中断, 您必须设置SPCR.SPRIE和SPCR.SPTIE位为0。可以使用中断或标志, 但不能同时使用。

## 31. Quad Serial Peripheral Interface (QSPI)

### 31.1 Overview

The QSPI is a memory controller for connecting a serial ROM (nonvolatile memory such as a serial flash memory, serial EEPROM, or serial FeRAM) that has an SPI-compatible interface.

Table 31.1 lists the QSPI specifications, Figure 31.1 shows a block diagram, and Table 31.2 lists the I/O pins.

**Table 31.1 QSPI specifications**

| Parameter                      | Specifications   |
|--------------------------------|--|
| Number of channels             | 1 channel  |
| SPI protocols                  | <ul style="list-style-type: none"> <li>Single SPI protocol, extended SPI protocol to achieve full-duplex communications<br/>Note: Standard or fast reading can only be used in single SPI operation.<br/>Four-wire communications with the serial flash memory by using the QSSL, QSPCLK, QIO0, and QIO1 pins (QIO0, QSSL, and QSPCLK for output, and QIO1 for input)</li> <li>Dual SPI protocol to achieve half-duplex communications<br/>Four-wire communications with the serial flash memory by using the QSSL, QSPCLK, QIO0, and QIO1 pins (QSSL and QSPCLK for output, and QIO0 and QIO1 for input and output)</li> <li>Quad SPI protocol to achieve half-duplex communications<br/>Six-wire communications with the serial flash memory by using the QSSL, QSPCLK, and QIO0 to QIO3 pins (QSSL and QSPCLK for output, and QIO0 to QIO3 for input and output)</li> </ul> |
| SPI mode                       | <ul style="list-style-type: none"> <li>SPI mode 0: The QSPCLK signal is driven low when the SPI bus is not active.</li> <li>SPI mode 3: The QSPCLK signal is driven high when the SPI bus is not active.</li> </ul>  |
| SPI timing adjustment function | <p>The following settings are possible to suit various types of serial flash memory device:</p> <ul style="list-style-type: none"> <li>SPI bus reference cycle (SFMSKC.SFMDV[4:0])</li> <li>Duty cycle correction (SFMSKC.SFMDTY)</li> <li>Adjustment of the number of dummy cycles (SFMSDC.SFMDN[3:0])</li> <li>Minimum width at high level for the QSSL signal (SFMSSC.SFMSW[3:0])</li> <li>QSSL signal setup time (SFMSSC.SFMSLD)</li> <li>QSSL signal hold time (SFMSSC.SFMSHD)</li> <li>Serial data output enable hold time (SFMSMD.SFMOEX)</li> </ul>  |
| ROM access mode                | <ul style="list-style-type: none"> <li>Support for Standard Read, Fast Read, Fast Read Dual Output, Fast Read Dual I/O, Fast Read Quad Output, and Fast Read Quad I/O instructions</li> <li>Substitutable instruction code</li> <li>Prefetch function (data are sequentially stored in a buffer after one request without waiting for further requests to read the serial flash memory)</li> <li>Polling processing</li> <li>SPI bus cycle extension function</li> <li>XIP mode (allowing skipping of the reception of an instruction code to read the serial flash memory)</li> </ul> <p>Note: ROM access mode is only possible with reading .</p>  |
| Direct communication mode      | Flexible support for a wide variety of serial flash memory instructions and functions through software control, including erase, ID read, and power-down control   |
| Interrupt source               | Error interrupts   |
| Module-stop function           | Module-stop state can be set to reduce power consumption.  |
| TrustZone Filter               | Security attribution is always non-secure  |

## 31. 四路串行外设接口(QSPI)

### 31.1 Overview

QSPI是一种存储器控制器，用于连接串行ROM（非易失性存储器，例如串行闪存、串行具有SPI兼容接口的EEPROM或串行FeRAM）。

表31.1列出了QSPI规范，图31.1显示了框图，表31.2列出了IO引脚。

**Table 31.1 QSPI specifications**

| Parameter            | Specifications   |
|----------------------|--|
| 通道数                  | 1 channel  |
| SPI协议                | <ul style="list-style-type: none"> <li>单SPI协议，扩展SPI协议实现全双工通信<br/>Note: 标准或快速读取只能在单个SPI操作中使用。<br/>使用QSSL、QSPCLK、QIO0和串行闪存进行四线通信<br/>QIO1引脚（QIO0、QSSL和QSPCLK用于输出，QIO1用于输入）</li> <li>双SPI协议实现半双工通信<br/>使用QSSL、QSPCLK、QIO0和串行闪存进行四线通信<br/>QIO1引脚（QSSL和QSPCLK用于输出，QIO0和QIO1用于输入和输出）</li> <li>QuadSPI协议实现半双工通信<br/>通过使用QSSL、QSPCLK和QIO0与串行闪存进行六线通信<br/>QIO3引脚（QSSL和QSPCLK用于输出，QIO0到QIO3用于输入和输出）</li> </ul> |
| SPI模式                | <ul style="list-style-type: none"> <li>SPI模式0: 当SPI总线处于非活动状态时，QSPCLK信号被驱动为低电平。</li> <li>SPI模式3: 当SPI总线不活动时，QSPCLK信号被驱动为高电平。</li> </ul>   |
| SPI时序调整功能            | <p>可以进行以下设置以适应各种类型的串行闪存设备：</p> <ul style="list-style-type: none"> <li>SPI总线参考周期(SFMSKC.SFMDV[4:0])</li> <li>占空比校正(SFMSKC.SFMDTY)</li> <li>调整虚拟周期数(SFMSDC.SFMDN[3:0])</li> <li>QSSL信号的高电平最小宽度(SFMSSC.SFMSW[3:0])</li> <li>QSSL信号建立时间(SFMSSC.SFMSLD)</li> <li>QSSL信号保持时间(SFMSSC.SFMSHD)</li> <li>串行数据输出使能保持时间(SFMSMD.SFMOEX)</li> </ul>  |
| ROM访问模式              | <ul style="list-style-type: none"> <li>支持标准读取、快速读取、快速读取双输出、快速读取双IO、快速读取四路输出和快速读取四路IO指令</li> <li>可替换指令代码</li> <li>预取功能（数据在一个请求后顺序存储在缓冲区中，无需等待进一步的请求来读取串行闪存）</li> <li>轮询处理</li> <li>SPI总线周期扩展功能</li> <li>XIP模式（允许跳过接收指令码来读取串行闪存）注意：</li> </ul> <p>ROM访问模式仅适用于读取。</p>   |
| 直接通讯方式               | 通过软件控制灵活支持各种串行闪存指令和功能，包括擦除、ID读取和断电控制   |
| 中断源                  | 错误中断   |
| Module-stop function | 可设置模块停止状态以降低功耗。  |
| TrustZone Filter     | 安全归因始终是不安全的  |



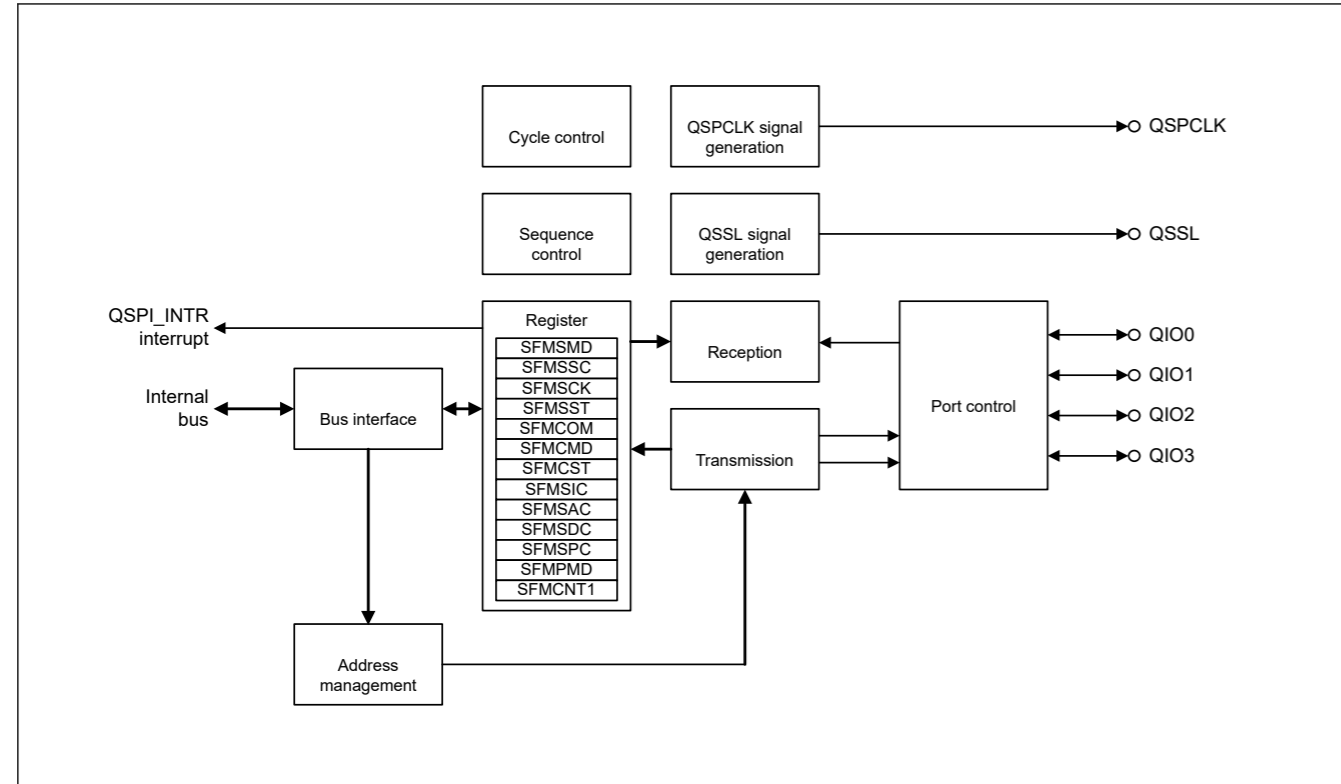


Figure 31.1 QSPI block diagram

Table 31.2 QSPI I/O pins

| Function | Pin name     | I/O    | Description            |
|----------|--------------|--------|------------------------|
| QSPI     | QSPCLK       | Output | QSPI clock output pin. |
|          | QSSL         | Output | QSPI slave output pin. |
|          | QIO0 to QIO3 | I/O    | Data0 to Data3         |

## 31.2 Register Descriptions

### 31.2.1 SFMSMD : Transfer Mode Control Register

Base address: QSPI = 0x6400\_0000

Offset address: 0x000

|                    |            |    |    |    |            |            |            |            |            |            |            |    |    |    |            |    |
|--------------------|------------|----|----|----|------------|------------|------------|------------|------------|------------|------------|----|----|----|------------|----|
| Bit position:      | 31         | 30 | 29 | 28 | 27         | 26         | 25         | 24         | 23         | 22         | 21         | 20 | 19 | 18 | 17         | 16 |
| Bit field:         | —          | —  | —  | —  | —          | —          | —          | —          | —          | —          | —          | —  | —  | —  | —          | —  |
| Value after reset: | 0          | 0  | 0  | 0  | 0          | 0          | 0          | 0          | 0          | 0          | 0          | 0  | 0  | 0  | 0          | 0  |
| Bit position:      | 15         | 14 | 13 | 12 | 11         | 10         | 9          | 8          | 7          | 6          | 5          | 4  | 3  | 2  | 1          | 0  |
| Bit field:         | SFMC<br>CE | —  | —  | —  | SFMO<br>SW | SFMO<br>HW | SFMO<br>EX | SFMM<br>D3 | SFMP<br>AE | SFMP<br>FE | SFMSE[1:0] | —  | —  | —  | SFMRM[2:0] | —  |
| Value after reset: | 0          | 0  | 0  | 0  | 0          | 0          | 0          | 0          | 0          | 0          | 0          | 0  | 0  | 0  | 0          | 0  |

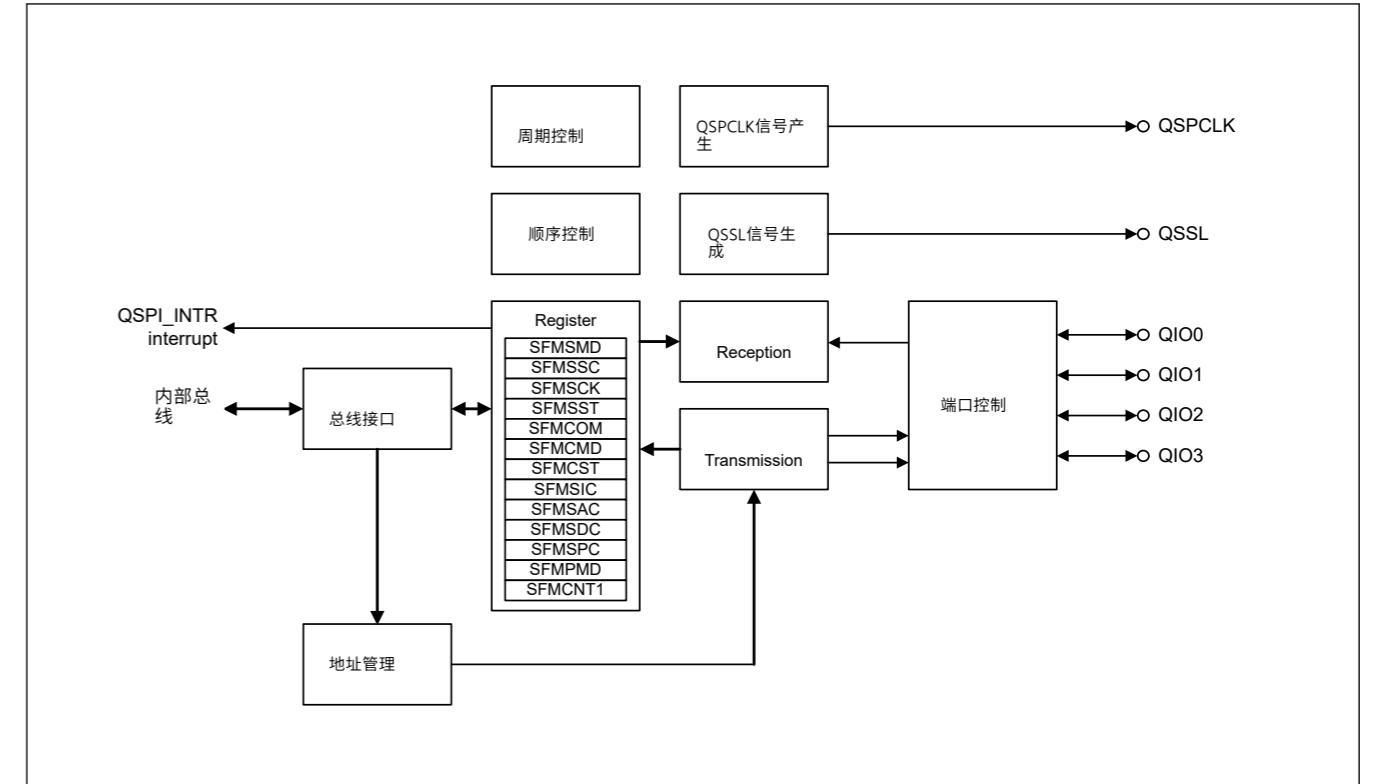


Figure 31.1 QSPI框图

Table 31.2 QSPI I/O pins

| Function | 引脚名称         | I/O    | Description    |
|----------|--------------|--------|----------------|
| QSPI     | QSPCLK       | Output | QSPI时钟输出引脚。    |
|          | QSSL         | Output | QSPI从机输出引脚。    |
|          | QIO0 to QIO3 | I/O    | Data0 to Data3 |

## 31.2 注册说明

### 31.2.1 SFMSMD:传输模式控制寄存器

Base address: QSPI = 0x6400\_0000

Offset address: 0x000

|               |            |    |    |    |            |            |            |            |            |            |            |    |    |    |            |    |
|---------------|------------|----|----|----|------------|------------|------------|------------|------------|------------|------------|----|----|----|------------|----|
| Bit position: | 31         | 30 | 29 | 28 | 27         | 26         | 25         | 24         | 23         | 22         | 21         | 20 | 19 | 18 | 17         | 16 |
| Bit field:    | —          | —  | —  | —  | —          | —          | —          | —          | —          | —          | —          | —  | —  | —  | —          | —  |
| 重置后的值:        | 0          | 0  | 0  | 0  | 0          | 0          | 0          | 0          | 0          | 0          | 0          | 0  | 0  | 0  | 0          | 0  |
| Bit position: | 15         | 14 | 13 | 12 | 11         | 10         | 9          | 8          | 7          | 6          | 5          | 4  | 3  | 2  | 1          | 0  |
| Bit field:    | SFMC<br>CE | —  | —  | —  | SFMO<br>SW | SFMO<br>HW | SFMO<br>EX | SFMM<br>D3 | SFMP<br>AE | SFMP<br>FE | SFMSE[1:0] | —  | —  | —  | SFMRM[2:0] | —  |
| 重置后的值:        | 0          | 0  | 0  | 0  | 0          | 0          | 0          | 0          | 0          | 0          | 0          | 0  | 0  | 0  | 0          | 0  |

| Bit   | Symbol     | Function  | R/W |
|-------|------------|---|-----|
| 2:0   | SFMRM[2:0] | Serial interface read mode select<br>0 0 0: Standard Read<br>0 0 1: Fast Read<br>0 1 0: Fast Read Dual Output<br>0 1 1: Fast Read Dual I/O<br>1 0 0: Fast Read Quad Output<br>1 0 1: Fast Read Quad I/O<br>Others: Setting prohibited | R/W |
| 3     | —          | This bit is read as 0. The write value should be 0.   | R/W |
| 5:4   | SFMSE[1:0] | QSSL extension function select after SPI bus access<br>0 0: Do not extend QSSL<br>0 1: Extend QSSL by 33 QSPCLK<br>1 0: Extend QSSL by 129 QSPCLK<br>1 1: Extend QSSL infinitely  | R/W |
| 6     | SFMPE      | Prefetch function select<br>0: Disable function<br>1: Enable function   | R/W |
| 7     | SFMPE      | Function select for stopping prefetch at locations other than on byte boundaries*1<br>0: Disable function<br>1: Enable function   | R/W |
| 8     | SFMMD3     | SPI mode select.<br>0: SPI mode 0<br>1: SPI mode 3  | R/W |
| 9     | SFMOEX     | Extension select for the I/O buffer output enable signal for the serial interface<br>0: Do not extend<br>1: Extend by 1 QSPCLK  | R/W |
| 10    | SFMOHW     | Hold time adjustment for serial transmission<br>0: Do not extend high-level width of QSPCLK during transmission<br>1: Extend high-level width of QSPCLK by 1 PCLKA during transmission  | R/W |
| 11    | SFMOSW     | Setup time adjustment for serial transmission<br>0: Do not extend low-level width of QSPCLK during transmission<br>1: Extend low-level width of QSPCLK by 1 PCLKA during transmission   | R/W |
| 14:12 | —          | These bits are read as 0. The write value should be 0.  | R/W |
| 15    | SFMCCE     | Read instruction code select<br>0: Uses automatically generated SPI instruction code*2<br>1: Use instruction code in the SFMSIC register  | R/W |
| 31:16 | —          | These bits are read as 0. The write value should be 0.  | R/W |

Note 1. The QSPI outputs additional one clock without accompanying data reception. For details, see [section 31.5.9. Serial Data Receiving Latency](#).

Note 2. When QSPI accesses serial flash memory, the instruction code is based on the SFMSAC register and SFMSMD register settings. See [section 31.6.1. SPI Instructions That Are Automatically Generated](#).

### 31.2.2 SFMSSC : Chip Selection Control Register

Base address: QSPI = 0x6400\_0000

Offset address: 0x004

|                    |    |    |    |    |    |    |    |    |    |    |         |         |            |    |    |    |
|--------------------|----|----|----|----|----|----|----|----|----|----|---------|---------|------------|----|----|----|
| Bit position:      | 31 | 30 | 29 | 28 | 27 | 26 | 25 | 24 | 23 | 22 | 21      | 20      | 19         | 18 | 17 | 16 |
| Bit field:         | —  | —  | —  | —  | —  | —  | —  | —  | —  | —  | —       | —       | —          | —  | —  | —  |
| Value after reset: | 0  | 0  | 0  | 0  | 0  | 0  | 0  | 0  | 0  | 0  | 0       | 0       | 0          | 0  | 0  | 0  |
| Bit position:      | 15 | 14 | 13 | 12 | 11 | 10 | 9  | 8  | 7  | 6  | 5       | 4       | 3          | 2  | 1  | 0  |
| Bit field:         | —  | —  | —  | —  | —  | —  | —  | —  | —  | —  | SFMS LD | SFMS HD | SFMSW[3:0] |    |    |    |
| Value after reset: | 0  | 0  | 0  | 0  | 0  | 0  | 0  | 0  | 0  | 0  | 1       | 1       | 0          | 1  | 1  | 1  |

| Bit   | Symbol     | Function  | R/W |
|-------|------------|---|-----|
| 2:0   | SFMRM[2:0] | 串行接口读取模式选择<br>000: 标准读取001: 快速读取<br>010: 快速读取双路输出011:<br>快速读取双路IO100: 快速读取<br>四路输出101: 快速读取四路IO<br><br>其他: 禁止设置 | R/W |
| 3     | —          | 该位读取为0。写入值应为0。  | R/W |
| 5:4   | SFMSE[1:0] | SPI总线访问后QSSL扩展功能选择<br>00: 不扩展QSSL01: 将QSSL扩展3<br>3个QSPCLK10: 将QSSL扩展129个Q<br>SPCLK11: 无限扩展QSSL                  | R/W |
| 6     | SFMPE      | 预取功能选择<br>0: 禁用功能1: 启<br>用功能  | R/W |
| 7     | SFMPE      | 用于在字节边界以外的位置停止预取的功能选择*1<br>0: 禁用功能1: 启<br>用功能   | R/W |
| 8     | SFMMD3     | SPI模式选择。<br>0: SPI模式0<br>1: SPI模式3  | R/W |
| 9     | SFMOEX     | 串行接口的IO缓冲器输出使能信号的扩展选择<br>0: 不扩展1: 扩展1个QS<br>PCLK  | R/W |
| 10    | SFMOHW     | 串行传输的保持时间调整<br>0: 在传输过程中不扩展QSPCLK的高电平宽度1: 在传输过程中将QSPCL<br>K的高电平宽度扩展1PCLKA                                       | R/W |
| 11    | SFMOSW     | 串行传输的建立时间调整<br>0: 在传输过程中不扩展QSPCLK的低电平宽度1: 在传输过程中将QSPC<br>LK的低电平宽度扩展1PCLKA                                       | R/W |
| 14:12 | —          | 这些位被读取为0。写入值应为0。  | R/W |
| 15    | SFMCCE     | 读取指令代码选择<br>0: 使用自动生成的SPI指令代码*2<br>1: 使用SFMSIC寄存器中的指令码  | R/W |
| 31:16 | —          | 这些位被读取为0。写入值应为0。  | R/W |

注1.QSPI输出额外的1个时钟而不伴随数据接收。有关详细信息，请参阅第31.5.9节。串行数据接收  
Latency。

注2.QSPI访问串行闪存时，指令代码基于SFMSAC寄存器和SFMSMD寄存器设置。  
请参阅第31.6.1节。自动生成的SPI指令。

### 31.2.2 SFMSSC:芯片选择控制寄存器

Base address: QSPI = 0x6400\_0000

Offset address: 0x004

|               |    |    |    |    |    |    |    |    |    |    |         |         |            |    |    |    |
|---------------|----|----|----|----|----|----|----|----|----|----|---------|---------|------------|----|----|----|
| Bit position: | 31 | 30 | 29 | 28 | 27 | 26 | 25 | 24 | 23 | 22 | 21      | 20      | 19         | 18 | 17 | 16 |
| Bit field:    | —  | —  | —  | —  | —  | —  | —  | —  | —  | —  | —       | —       | —          | —  | —  | —  |
| 重置后的值:        | 0  | 0  | 0  | 0  | 0  | 0  | 0  | 0  | 0  | 0  | 0       | 0       | 0          | 0  | 0  | 0  |
| Bit position: | 15 | 14 | 13 | 12 | 11 | 10 | 9  | 8  | 7  | 6  | 5       | 4       | 3          | 2  | 1  | 0  |
| Bit field:    | —  | —  | —  | —  | —  | —  | —  | —  | —  | —  | SFMS LD | SFMS HD | SFMSW[3:0] |    |    |    |
| 重置后的值:        | 0  | 0  | 0  | 0  | 0  | 0  | 0  | 0  | 0  | 0  | 1       | 1       | 0          | 1  | 1  | 1  |

| Bit  | Symbol     | Function   | R/W |
|------|------------|--|-----|
| 3:0  | SFMSW[3:0] | Minimum high-level width select for QSSL signal<br>0x0: 1 QSPCLK<br>0x1: 2 QSPCLK<br>0x2: 3 QSPCLK<br>0x3: 4 QSPCLK<br>0x4: 5 QSPCLK<br>0x5: 6 QSPCLK<br>0x6: 7 QSPCLK<br>0x7: 8 QSPCLK<br>0x8: 9 QSPCLK<br>0x9: 10 QSPCLK<br>0xA: 11 QSPCLK<br>0xB: 12 QSPCLK<br>0xC: 13 QSPCLK<br>0xD: 14 QSPCLK<br>0xE: 15 QSPCLK<br>0xF: 16 QSPCLK | R/W |
| 4    | SFMSHD     | QSSL Signal Hold Time<br>0: QSSL outputs high after 0.5 QSPCLK cycles from the last rising edge of QSPCLK.<br>1: QSSL outputs high after 1.5 QSPCLK cycles from the last rising edge of QSPCLK.  | R/W |
| 5    | SFMSLD     | QSSL Signal Setup Time<br>0: QSSL outputs low before 0.5 QSPCLK cycles from the first rising edge of QSPCLK.<br>1: QSSL outputs low before 1.5 QSPCLK cycles from the first rising edge of QSPCLK.   | R/W |
| 31:6 | —          | These bits are read as 0. The write value should be 0.   | R/W |

31.2.3 SFMSKC : Clock Control Register

Base address: QSPI = 0x6400\_0000

Offset address: 0x008

|                    |    |    |    |    |    |    |    |    |    |    |            |            |    |    |    |    |
|--------------------|----|----|----|----|----|----|----|----|----|----|------------|------------|----|----|----|----|
| Bit position:      | 31 | 30 | 29 | 28 | 27 | 26 | 25 | 24 | 23 | 22 | 21         | 20         | 19 | 18 | 17 | 16 |
| Bit field:         | —  | —  | —  | —  | —  | —  | —  | —  | —  | —  | —          | —          | —  | —  | —  | —  |
| Value after reset: | 0  | 0  | 0  | 0  | 0  | 0  | 0  | 0  | 0  | 0  | 0          | 0          | 0  | 0  | 0  | 0  |
| Bit position:      | 15 | 14 | 13 | 12 | 11 | 10 | 9  | 8  | 7  | 6  | 5          | 4          | 3  | 2  | 1  | 0  |
| Bit field:         | —  | —  | —  | —  | —  | —  | —  | —  | —  | —  | SFMD<br>TY | SFMDV[4:0] |    |    |    |    |
| Value after reset: | 0  | 0  | 0  | 0  | 0  | 0  | 0  | 0  | 0  | 0  | 0          | 0          | 1  | 0  | 0  | 0  |

| Bit  | Symbol     | Function  | R/W |
|------|------------|---|-----|
| 3:0  | SFMSW[3:0] | QSSL信号的最小高电平宽度选择<br>0x0: 1 QSPCLK<br>0x1: 2 QSPCLK<br>0x2: 3 QSPCLK<br>0x3: 4 QSPCLK<br>0x4: 5 QSPCLK<br>0x5: 6 QSPCLK<br>0x6: 7 QSPCLK<br>0x7: 8 QSPCLK<br>0x8: 9 QSPCLK<br>0x9: 10 QSPCLK<br>0xA: 11 QSPCLK<br>0xB: 12 QSPCLK<br>0xC: 13 QSPCLK<br>0xD: 14 QSPCLK<br>0xE: 15 QSPCLK<br>0xF: 16 QSPCLK | R/W |
| 4    | SFMSHD     | QSSL信号保持时间<br>0: 从QSPCLK的最后一个上升沿起0.5个QSPCLK周期后QSSL输出高电平。1: 从QSPCLK的最后一个上升沿开始1.5个QSPCLK周期后QSSL输出高电平。   | R/W |
| 5    | SFMSLD     | QSSL信号建立时间<br>0: QSSL在QSPCLK的第一个上升沿起0.5个QSPCLK周期之前输出低电平。<br>1: QSSL在QSPCLK的第一个上升沿起1.5个QSPCLK周期之前输出低电平。  | R/W |
| 31:6 | —          | 这些位被读取为0。写入值应为0。  | R/W |

31.2.3 SFMSKC:时钟控制寄存器

Base address: QSPI = 0x6400\_0000

Offset address: 0x008

|               |    |    |    |    |    |    |    |    |    |    |            |            |    |    |    |    |
|---------------|----|----|----|----|----|----|----|----|----|----|------------|------------|----|----|----|----|
| Bit position: | 31 | 30 | 29 | 28 | 27 | 26 | 25 | 24 | 23 | 22 | 21         | 20         | 19 | 18 | 17 | 16 |
| Bit field:    | —  | —  | —  | —  | —  | —  | —  | —  | —  | —  | —          | —          | —  | —  | —  | —  |
| 重置后的值:        | 0  | 0  | 0  | 0  | 0  | 0  | 0  | 0  | 0  | 0  | 0          | 0          | 0  | 0  | 0  | 0  |
| Bit position: | 15 | 14 | 13 | 12 | 11 | 10 | 9  | 8  | 7  | 6  | 5          | 4          | 3  | 2  | 1  | 0  |
| Bit field:    | —  | —  | —  | —  | —  | —  | —  | —  | —  | —  | SFMD<br>TY | SFMDV[4:0] |    |    |    |    |
| 重置后的值:        | 0  | 0  | 0  | 0  | 0  | 0  | 0  | 0  | 0  | 0  | 0          | 0          | 0  | 1  | 0  | 0  |

| Bit  | Symbol   | Function  | R/W |
|------|--|---|-----|
| 4:0  | SFMDV[4:0]   | Serial interface reference cycle select. (Pay attention to irregularities.)<br>0x00: 2 PCLKA<br>0x01: 3 PCLKA (divided by an odd number)* <sup>1</sup> <a href="#">section 31.2.3. SFMSKC : Clock Control Register</a><br>0x02: 4 PCLKA<br>0x03: 5 PCLKA (divided by an odd number)* <sup>1</sup> <a href="#">section 31.2.3. SFMSKC : Clock Control Register</a><br>0x04: 6 PCLKA<br>0x05: 7 PCLKA (divided by an odd number)* <sup>1</sup> <a href="#">section 31.2.3. SFMSKC : Clock Control Register</a><br>0x06: 8 PCLKA<br>0x07: 9 PCLKA (divided by an odd number)* <sup>1</sup> <a href="#">section 31.2.3. SFMSKC : Clock Control Register</a><br>0x08: 10 PCLKA<br>0x09: 11 PCLKA (divided by an odd number)* <sup>1</sup> <a href="#">section 31.2.3. SFMSKC : Clock Control Register</a><br>0x0A: 12 PCLKA<br>0x0B: 13 PCLKA (divided by an odd number)* <sup>1</sup> <a href="#">section 31.2.3. SFMSKC : Clock Control Register</a><br>0x0C: 14 PCLKA<br>0x0D: 15 PCLKA (divided by an odd number)* <sup>1</sup> <a href="#">section 31.2.3. SFMSKC : Clock Control Register</a><br>0x0E: 16 PCLKA<br>0x0F: 17 PCLKA (divided by an odd number)* <sup>1</sup> <a href="#">section 31.2.3. SFMSKC : Clock Control Register</a><br>0x10: 18 PCLKA<br>0x11: 20 PCLKA<br>0x12: 22 PCLKA<br>0x13: 24 PCLKA<br>0x14: 26 PCLKA<br>0x15: 28 PCLKA<br>0x16: 30 PCLKA<br>0x17: 32 PCLKA<br>0x18: 34 PCLKA<br>0x19: 36 PCLKA<br>0x1A: 38 PCLKA<br>0x1B: 40 PCLKA<br>0x1C: 42 PCLKA<br>0x1D: 44 PCLKA<br>0x1E: 46 PCLKA<br>0x1F: 48 PCLKA | R/W |
| 5    | SFMDTY <a href="#">section 31.2.3. SFMSKC : Clock Control Register</a> | Duty ratio correction function select for the QSPCLK signal when divided by an odd number<br>0: Make no correction<br>1: Make correction  | R/W |
| 31:6 | —  | These bits are read as 0. The write value should be 0.  | R/W |

Note 1. Set the SFMDTY bit to 1 when PCLKA is to be divided by an odd number.

| Bit  | Symbol   | Function   | R/W |
|------|--|--|-----|
| 4:0  | SFMDV[4:0]   | 串行接口参考周期选择。(注意违规行为。)<br>0x00: 2PCLKA0x01: 3PCLKA (除以奇数) *131.2.3节。SFMSKC:时钟控制寄存器<br>0x02: 4PCLKA0x03: 5PCLKA (除以奇数) *131.2.3节。SFMSKC:时钟控制寄存器<br>0x04: 6PCLKA0x05: 7PCLKA (除以奇数) *131.2.3节。SFMSKC:时钟控制寄存器<br>0x06: 8PCLKA0x07: 9PCLKA (除以奇数) *131.2.3节。SFMSKC:时钟控制寄存器<br>0x08: 10PCLKA0x09: 11PCLKA (除以奇数) *131.2.3节。SFMSKC:时钟控制寄存器<br>0x0A: 12PCLKA0x0B: 13PCLKA (除以奇数) *131.2.3节。SFMSKC:时钟控制寄存器<br>0x0C: 14PCLKA0x0D: 15PCLKA (除以奇数) *131.2.3节。SFMSKC:时钟控制寄存器<br>0x0E: 16PCLKA0x0F: 17PCLKA (除以奇数) *131.2.3节。SFMSKC:时钟控制寄存器<br>0x10: 18 PCLKA<br>0x11: 20 PCLKA<br>0x12: 22 PCLKA<br>0x13: 24 PCLKA<br>0x14: 26 PCLKA<br>0x15: 28 PCLKA<br>0x16: 30 PCLKA<br>0x17: 32 PCLKA<br>0x18: 34 PCLKA<br>0x19: 36 PCLKA<br>0x1A: 38 PCLKA<br>0x1B: 40 PCLKA<br>0x1C: 42 PCLKA<br>0x1D: 44 PCLKA<br>0x1E: 46 PCLKA<br>0x1F: 48 PCLKA | R/W |
| 5    | SFMDTY <a href="#">第31.2.3节。SFMSKC:时钟控制 Register</a> | QSPCLK信号除以奇数时的占空比校正功能选择<br>0: 不修正1: 修正   | R/W |
| 31:6 | —  | 这些位被读取为0。写入值应为0。   | R/W |

注1.当PCLKA除以奇数时，将SFMDTY位设置为1。



## 31.2.4 SFMSST : Status Register

Base address: QSPI = 0x6400\_0000

Offset address: 0x00C

|                    |    |    |    |    |    |    |    |    |       |       |    |            |    |    |    |    |
|--------------------|----|----|----|----|----|----|----|----|-------|-------|----|------------|----|----|----|----|
| Bit position:      | 31 | 30 | 29 | 28 | 27 | 26 | 25 | 24 | 23    | 22    | 21 | 20         | 19 | 18 | 17 | 16 |
| Bit field:         | —  | —  | —  | —  | —  | —  | —  | —  | —     | —     | —  | —          | —  | —  | —  | —  |
| Value after reset: | 0  | 0  | 0  | 0  | 0  | 0  | 0  | 0  | 0     | 0     | 0  | 0          | 0  | 0  | 0  | 0  |
| Bit position:      | 15 | 14 | 13 | 12 | 11 | 10 | 9  | 8  | 7     | 6     | 5  | 4          | 3  | 2  | 1  | 0  |
| Bit field:         | —  | —  | —  | —  | —  | —  | —  | —  | PFOFF | PFFUL | —  | PFCNT[4:0] |    |    |    |    |
| Value after reset: | 0  | 0  | 0  | 0  | 0  | 0  | 0  | 0  | 1     | 0     | 0  | 0          | 0  | 0  | 0  | 0  |

| Bit  | Symbol     | Function   | R/W |
|------|------------|--|-----|
| 4:0  | PFCNT[4:0] | Number of bytes of prefetched data<br>0x00: 0 byte<br>0x01: 1 byte<br>0x02: 2 bytes<br>0x03: 3 bytes<br>0x04: 4 bytes<br>0x05: 5 bytes<br>0x06: 6 bytes<br>0x07: 7 bytes<br>0x08: 8 bytes<br>0x09: 9 bytes<br>0x0A: 10 bytes<br>0x0B: 11 bytes<br>0x0C: 12 bytes<br>0x0D: 13 bytes<br>0x0E: 14 bytes<br>0x0F: 15 bytes<br>0x10: 16 bytes<br>0x11: 17 bytes<br>0x12: 18 bytes<br>Others: Reserved | R   |
| 5    | —          | This bit is read as 0.   | R   |
| 6    | PFFUL      | Prefetch buffer state<br>0: Prefetch buffer has free space<br>1: Prefetch buffer is full   | R   |
| 7    | PFOFF      | Prefetch function operating state<br>0: Prefetch function operating<br>1: Prefetch function not enabled or not operating   | R   |
| 31:8 | —          | These bits are read as 0.  | R   |

## 31.2.4 SFMSST:状态寄存器

Base address: QSPI = 0x6400\_0000

Offset address: 0x00C

|               |    |    |    |    |    |    |    |    |       |       |    |            |    |    |    |    |
|---------------|----|----|----|----|----|----|----|----|-------|-------|----|------------|----|----|----|----|
| Bit position: | 31 | 30 | 29 | 28 | 27 | 26 | 25 | 24 | 23    | 22    | 21 | 20         | 19 | 18 | 17 | 16 |
| Bit field:    | —  | —  | —  | —  | —  | —  | —  | —  | —     | —     | —  | —          | —  | —  | —  | —  |
| 重置后的值:        | 0  | 0  | 0  | 0  | 0  | 0  | 0  | 0  | 0     | 0     | 0  | 0          | 0  | 0  | 0  | 0  |
| Bit position: | 15 | 14 | 13 | 12 | 11 | 10 | 9  | 8  | 7     | 6     | 5  | 4          | 3  | 2  | 1  | 0  |
| Bit field:    | —  | —  | —  | —  | —  | —  | —  | —  | PFOFF | PFFUL | —  | PFCNT[4:0] |    |    |    |    |
| 重置后的值:        | 0  | 0  | 0  | 0  | 0  | 0  | 0  | 0  | 1     | 0     | 0  | 0          | 0  | 0  | 0  | 0  |

| Bit  | Symbol     | Function   | R/W |
|------|------------|--|-----|
| 4:0  | PFCNT[4:0] | 预取数据的字节数<br>0x00: 0字节<br>0x01: 1字节<br>0x02: 2字节<br>0x03: 3字节<br>0x04: 4字节<br>0x05: 5字节<br>0x06: 6字节<br>0x07: 7字节<br>0x08: 8字节<br>0x09: 9字节<br>0x0A: 10字节<br>0x0B: 11字节<br>0x0C: 12字节<br>0x0D: 13字节<br>0x0E: 14字节<br>0x0F: 15字节<br>0x10: 16字节<br>0x11: 17字节<br>0x12: 18字节<br>Others: Reserved | R   |
| 5    | —          | 该位读为0。   | R   |
| 6    | PFFUL      | 预取缓冲区状态<br>0: 预取缓冲区有空闲空间<br>1: 预取缓冲区已满   | R   |
| 7    | PFOFF      | 预取功能运行状态<br>0: 预取功能运行<br>1: 预取功能未使能或未运行  | R   |
| 31:8 | —          | 这些位读为0。  | R   |

### 31.2.5 SFMCOM : Communication Port Register

Base address: QSPI = 0x6400\_0000  
Offset address: 0x010

|                    |    |    |    |    |    |    |    |    |           |    |    |    |    |    |    |    |
|--------------------|----|----|----|----|----|----|----|----|-----------|----|----|----|----|----|----|----|
| Bit position:      | 31 | 30 | 29 | 28 | 27 | 26 | 25 | 24 | 23        | 22 | 21 | 20 | 19 | 18 | 17 | 16 |
| Bit field:         | —  | —  | —  | —  | —  | —  | —  | —  | —         | —  | —  | —  | —  | —  | —  | —  |
| Value after reset: | 0  | 0  | 0  | 0  | 0  | 0  | 0  | 0  | 0         | 0  | 0  | 0  | 0  | 0  | 0  | 0  |
| Bit position:      | 15 | 14 | 13 | 12 | 11 | 10 | 9  | 8  | 7         | 6  | 5  | 4  | 3  | 2  | 1  | 0  |
| Bit field:         | —  | —  | —  | —  | —  | —  | —  | —  | SFMD[7:0] |    |    |    |    |    |    |    |
| Value after reset: | 0  | 0  | 0  | 0  | 0  | 0  | 0  | 0  | x         | x  | x  | x  | x  | x  | x  | x  |

| Bit  | Symbol    | Function   | R/W |
|------|-----------|--|-----|
| 7:0  | SFMD[7:0] | Port for direct communication with the SPI bus<br>Input and output from this port are converted to an SPI bus cycle in direct communications mode (DCOM = 1). Access to this port is ignored in ROM access mode. | R/W |
| 31:8 | —         | These bits are read as 0. The write value should be 0.   | R/W |

### 31.2.6 SFMCMD : Communication Mode Control Register

Base address: QSPI = 0x6400\_0000  
Offset address: 0x014

|                    |    |    |    |    |    |    |    |    |    |    |    |    |    |    |    |      |
|--------------------|----|----|----|----|----|----|----|----|----|----|----|----|----|----|----|------|
| Bit position:      | 31 | 30 | 29 | 28 | 27 | 26 | 25 | 24 | 23 | 22 | 21 | 20 | 19 | 18 | 17 | 16   |
| Bit field:         | —  | —  | —  | —  | —  | —  | —  | —  | —  | —  | —  | —  | —  | —  | —  | —    |
| Value after reset: | 0  | 0  | 0  | 0  | 0  | 0  | 0  | 0  | 0  | 0  | 0  | 0  | 0  | 0  | 0  | 0    |
| Bit position:      | 15 | 14 | 13 | 12 | 11 | 10 | 9  | 8  | 7  | 6  | 5  | 4  | 3  | 2  | 1  | 0    |
| Bit field:         | —  | —  | —  | —  | —  | —  | —  | —  | —  | —  | —  | —  | —  | —  | —  | DCOM |
| Value after reset: | 0  | 0  | 0  | 0  | 0  | 0  | 0  | 0  | 0  | 0  | 0  | 0  | 0  | 0  | 0  | 0    |

| Bit  | Symbol | Function   | R/W |
|------|--------|--|-----|
| 0    | DCOM   | Mode select for communication with the SPI bus<br>0: ROM access mode<br>1: Direct communication mode*1 | R/W |
| 31:1 | —      | These bits are read as 0. The write value should be 0.   | R/W |

Note 1. SFMCMD.DCOM = 1 must be written when the transaction ends. For details, see [section 31.10. Direct Communication Mode](#).

### 31.2.5 SFMCOM:通讯端口寄存器

Base address: QSPI = 0x6400\_0000  
Offset address: 0x010

|               |    |    |    |    |    |    |    |    |           |    |    |    |    |    |    |    |
|---------------|----|----|----|----|----|----|----|----|-----------|----|----|----|----|----|----|----|
| Bit position: | 31 | 30 | 29 | 28 | 27 | 26 | 25 | 24 | 23        | 22 | 21 | 20 | 19 | 18 | 17 | 16 |
| Bit field:    | —  | —  | —  | —  | —  | —  | —  | —  | —         | —  | —  | —  | —  | —  | —  | —  |
| 重置后的值:        | 0  | 0  | 0  | 0  | 0  | 0  | 0  | 0  | 0         | 0  | 0  | 0  | 0  | 0  | 0  | 0  |
| Bit position: | 15 | 14 | 13 | 12 | 11 | 10 | 9  | 8  | 7         | 6  | 5  | 4  | 3  | 2  | 1  | 0  |
| Bit field:    | —  | —  | —  | —  | —  | —  | —  | —  | SFMD[7:0] |    |    |    |    |    |    |    |
| 重置后的值:        | 0  | 0  | 0  | 0  | 0  | 0  | 0  | 0  | x         | x  | x  | x  | x  | x  | x  | x  |

| Bit  | Symbol    | Function   | R/W |
|------|-----------|--|-----|
| 7:0  | SFMD[7:0] | 与SPI总线直接通信的端口<br>此端口的输入和输出在直接通信模式(DCOM=1)下转换为SPI总线周期。在ROM访问模式下，对该端口的访问被忽略。 | R/W |
| 31:8 | —         | 这些位被读取为0。写入值应为0。   | R/W |

### 31.2.6 SFMCMD:通信模式控制寄存器

Base address: QSPI = 0x6400\_0000  
Offset address: 0x014

|               |    |    |    |    |    |    |    |    |    |    |    |    |    |    |    |      |
|---------------|----|----|----|----|----|----|----|----|----|----|----|----|----|----|----|------|
| Bit position: | 31 | 30 | 29 | 28 | 27 | 26 | 25 | 24 | 23 | 22 | 21 | 20 | 19 | 18 | 17 | 16   |
| Bit field:    | —  | —  | —  | —  | —  | —  | —  | —  | —  | —  | —  | —  | —  | —  | —  | —    |
| 重置后的值:        | 0  | 0  | 0  | 0  | 0  | 0  | 0  | 0  | 0  | 0  | 0  | 0  | 0  | 0  | 0  | 0    |
| Bit position: | 15 | 14 | 13 | 12 | 11 | 10 | 9  | 8  | 7  | 6  | 5  | 4  | 3  | 2  | 1  | 0    |
| Bit field:    | —  | —  | —  | —  | —  | —  | —  | —  | —  | —  | —  | —  | —  | —  | —  | DCOM |
| 重置后的值:        | 0  | 0  | 0  | 0  | 0  | 0  | 0  | 0  | 0  | 0  | 0  | 0  | 0  | 0  | 0  | 0    |

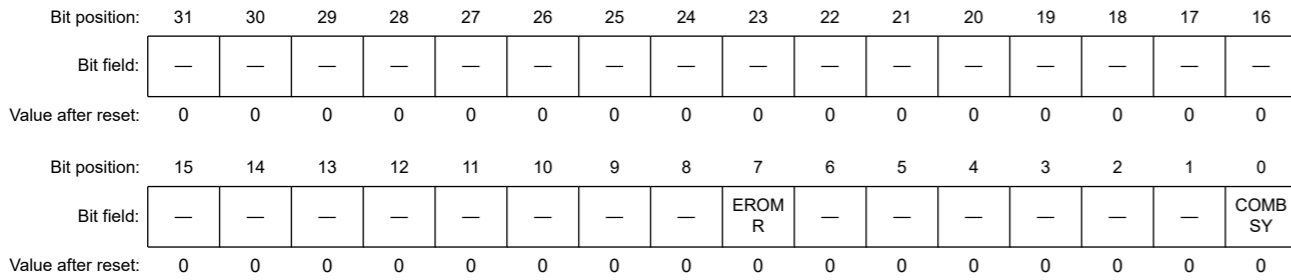
| Bit  | Symbol | Function                               | R/W |
|------|--------|--|-----|
| 0    | DCOM   | 与SPI总线通信的模式选择<br>0: ROM访问模式1: 直接通信模式*1 | R/W |
| 31:1 | —      | 这些位被读取为0。写入值应为0。                       | R/W |

注1.SFMCMD.DCOM=1必须在事务结束时写入。有关详细信息，请参阅第31.10节。直接通信模式。

### 31.2.7 SFMCST : Communication Status Register

Base address: QSPI = 0x6400\_0000

Offset address: 0x018



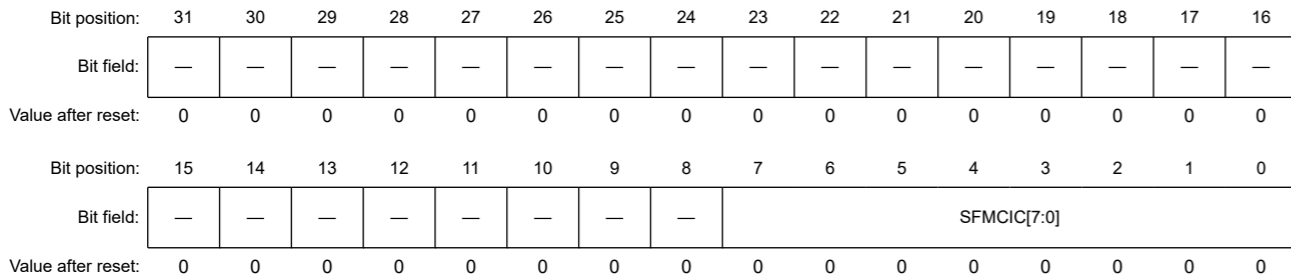
| Bit  | Symbol | Function  | R/W                 |
|------|--------|---|---------------------|
| 0    | COMBSY | SPI bus cycle completion state in direct communication<br>0: No serial transfer being processed<br>1: Serial transfer being processed | R                   |
| 6:1  | —      | These bits are read as 0. The write value should be 0.  | R/W                 |
| 7    | EROMR  | ROM access detection status in direct communication mode<br>0: ROM access not detected<br>1: ROM access detected                      | R/(W) <sup>*1</sup> |
| 31:8 | —      | These bits are read as 0. The write value should be 0.  | R/W                 |

Note 1. Only 0 can be written to this bit.

### 31.2.8 SFMSIC : Instruction Code Register

Base address: QSPI = 0x6400\_0000

Offset address: 0x020

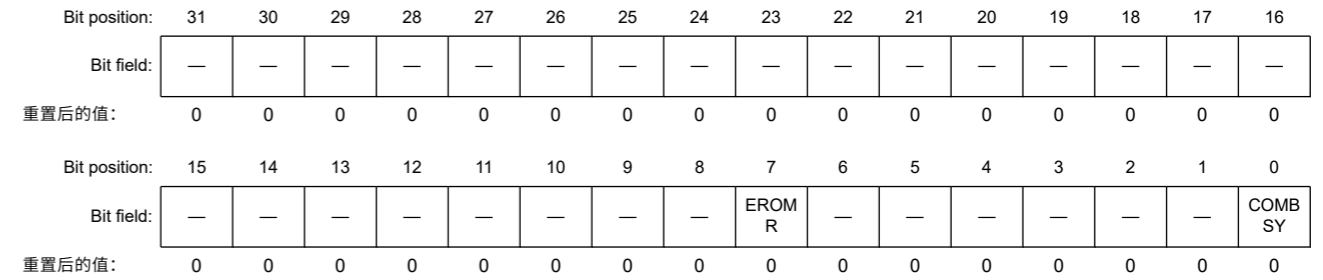


| Bit  | Symbol      | Function   | R/W |
|------|-------------|--|-----|
| 7:0  | SFMCIC[7:0] | Serial flash instruction code to substitute            | R/W |
| 31:8 | —           | These bits are read as 0. The write value should be 0. | R/W |

### 31.2.7 SFMCST:通讯状态寄存器

Base address: QSPI = 0x6400\_0000

Offset address: 0x018



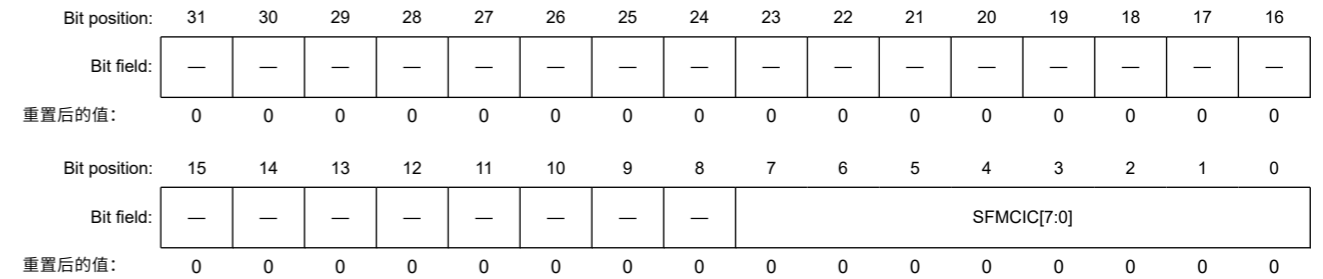
| Bit  | Symbol | Function                                     | R/W                 |
|------|--------|--|---------------------|
| 0    | COMBSY | 直接通信中的SPI总线周期完成状态<br>0: 未处理串行传输1: 正在处理串行传输   | R                   |
| 6:1  | —      | 这些位被读取为0。写入值应为0。                             | R/W                 |
| 7    | EROMR  | 直接通信模式下的ROM访问检测状态<br>0: 未检测到ROM访问1: 检测到ROM访问 | R/(W) <sup>*1</sup> |
| 31:8 | —      | 这些位被读取为0。写入值应为0。                             | R/W                 |

注1.该位只能写入0。

### 31.2.8 SMSIC:指令代码寄存器

Base address: QSPI = 0x6400\_0000

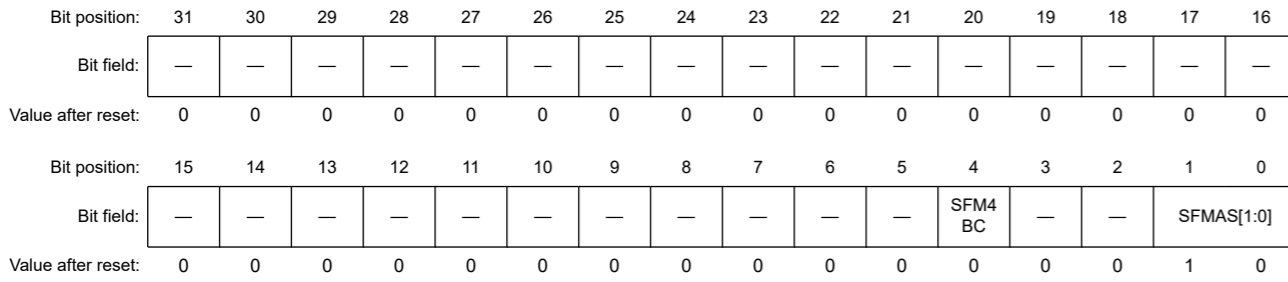
Offset address: 0x020



| Bit  | Symbol      | Function         | R/W |
|------|-------------|------------------|-----|
| 7:0  | SFMCIC[7:0] | 替代的串行闪存指令代码      | R/W |
| 31:8 | —           | 这些位被读取为0。写入值应为0。 | R/W |

31.2.9 SFMSAC : Address Mode Control Register

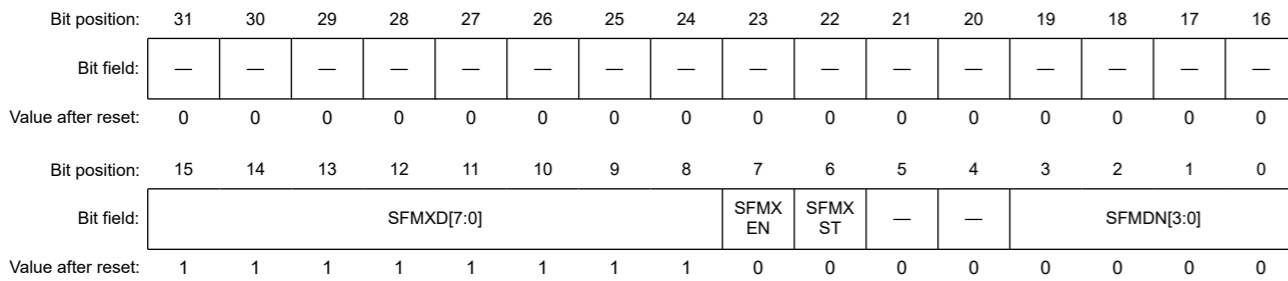
Base address: QSPI = 0x6400\_0000  
Offset address: 0x024



| Bit  | Symbol     | Function  | R/W |
|------|------------|---|-----|
| 1:0  | SFMAS[1:0] | Number of address bytes select for the serial interface<br>0 0: 1 byte<br>0 1: 2 bytes<br>1 0: 3 bytes<br>1 1: 4 bytes  | R/W |
| 3:2  | —          | These bits are read as 0. The write value should be 0.  | R/W |
| 4    | SFM4BC     | Selection of instruction code automatically generated when the serial interface address width is 4 bytes<br>0: Do not use 4-byte address read instruction code<br>1: Use 4-byte address read instruction code | R/W |
| 31:5 | —          | These bits are read as 0. The write value should be 0.  | R/W |

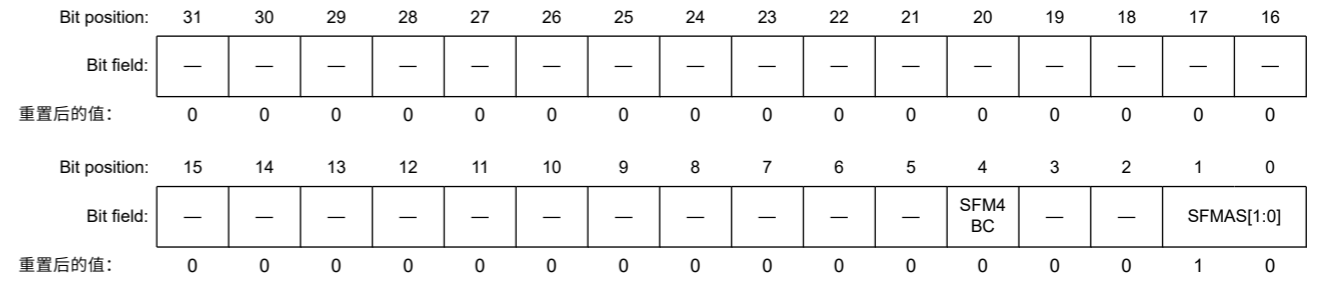
31.2.10 SFMSDC : Dummy Cycle Control Register

Base address: QSPI = 0x6400\_0000  
Offset address: 0x028



31.2.9 SFMSAC:地址模式控制寄存器

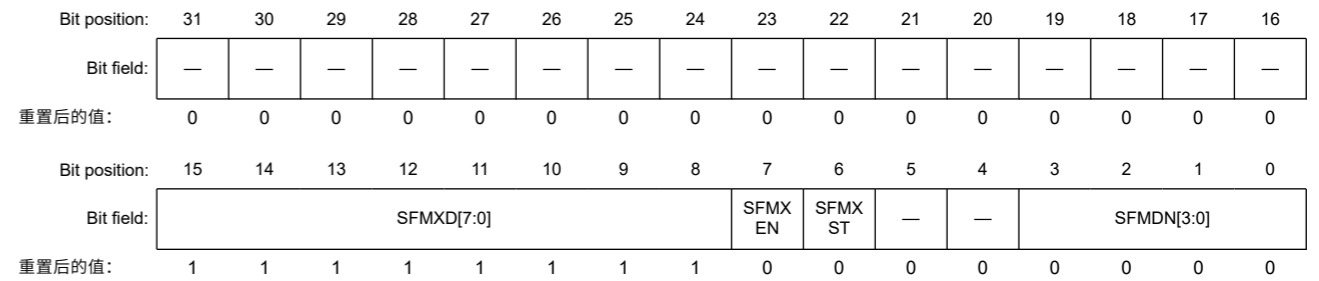
Base address: QSPI = 0x6400\_0000  
Offset address: 0x024



| Bit  | Symbol     | Function   | R/W |
|------|------------|--|-----|
| 1:0  | SFMAS[1:0] | 为串行接口选择的地址字节数<br>00: 1个字节0<br>01: 2个字节10<br>10: 3个字节11<br>11: 4个字节 | R/W |
| 3:2  | —          | 这些位被读取为0。写入值应为0。   | R/W |
| 4    | SFM4BC     | 串行接口地址宽度为4字节时自动生成的指令代码选择<br>0: 不使用4字节地址读取指令码<br>1: 使用4字节地址读取指令码    | R/W |
| 31:5 | —          | 这些位被读取为0。写入值应为0。   | R/W |

31.2.10 SFMSDC:虚拟周期控制寄存器

Base address: QSPI = 0x6400\_0000  
Offset address: 0x028





| Bit   | Symbol     | Function  | R/W |
|-------|------------|---|-----|
| 3:0   | SFMDN[3:0] | Number of dummy cycles select for Fast Read instructions<br>0x0: Default dummy cycles for each instruction:<br>- Fast Read Quad I/O: 6 QSPCLK<br>- Fast Read Quad Output: 8 QSPCLK<br>- Fast Read Dual I/O: 4 QSPCLK<br>- Fast Read Dual Output: 8 QSPCLK<br>- Fast Read: 8 QSPCLK<br>0x1: 3 QSPCLK*1<br>0x2: 4 QSPCLK<br>0x3: 5 QSPCLK<br>0x4: 6 QSPCLK<br>0x5: 7 QSPCLK<br>0x6: 8 QSPCLK<br>0x7: 9 QSPCLK<br>0x8: 10 QSPCLK<br>0x9: 11 QSPCLK<br>0xA: 12 QSPCLK<br>0xB: 13 QSPCLK<br>0xC: 14 QSPCLK<br>0xD: 15 QSPCLK<br>0xE: 16 QSPCLK<br>0xF: 17 QSPCLK | R/W |
| 5:4   | —          | These bits are read as 0. The write value should be 0.  | R/W |
| 6     | SFMXST     | XIP mode status<br>0: Normal (non-XIP) mode<br>1: XIP mode  | R   |
| 7     | SFMXEN     | XIP mode permission<br>0: Prohibit XIP mode<br>1: Permit XIP mode   | R/W |
| 15:8  | SFMXD[7:0] | Mode data for serial flash (Controls XIP mode.)*2   | R/W |
| 31:16 | —          | These bits are read as 0. The write value should be 0.  | R/W |

Note 1. To avoid a conflict with the input/output switch of the serial flash memory pin connected to QIO0 pin, select more than four cycles of QSPCLK as the number of dummy cycles for the fast read instruction when the output enable signal is extended by setting the SFMOEX bit in the SFMSMD register to 1.

Note 2. As the mode data for serial flash memory, specify the XIP mode setting data set in actual serial flash memory.

### 31.2.11 SFMSPC : SPI Protocol Control Register

Base address: QSPI = 0x6400\_0000

Offset address: 0x030

|                    |    |    |    |    |    |    |    |    |    |    |    |         |    |    |            |    |
|--------------------|----|----|----|----|----|----|----|----|----|----|----|---------|----|----|------------|----|
| Bit position:      | 31 | 30 | 29 | 28 | 27 | 26 | 25 | 24 | 23 | 22 | 21 | 20      | 19 | 18 | 17         | 16 |
| Bit field:         | —  | —  | —  | —  | —  | —  | —  | —  | —  | —  | —  | —       | —  | —  | —          | —  |
| Value after reset: | 0  | 0  | 0  | 0  | 0  | 0  | 0  | 0  | 0  | 0  | 0  | 0       | 0  | 0  | 0          | 0  |
| Bit position:      | 15 | 14 | 13 | 12 | 11 | 10 | 9  | 8  | 7  | 6  | 5  | 4       | 3  | 2  | 1          | 0  |
| Bit field:         | —  | —  | —  | —  | —  | —  | —  | —  | —  | —  | —  | SFMS DE | —  | —  | SFMSP[1:0] | —  |
| Value after reset: | 0  | 0  | 0  | 0  | 0  | 0  | 0  | 0  | 0  | 0  | 0  | 1       | 0  | 0  | 0          | 0  |

| Bit | Symbol     | Function  | R/W |
|-----|------------|---|-----|
| 1:0 | SFMSP[1:0] | SPI protocol select*1<br>0 0: Single SPI Protocol, Extended SPI protocol<br>0 1: Dual SPI protocol<br>1 0: Quad SPI protocol<br>1 1: Setting prohibited | R/W |

| Bit   | Symbol     | Function  | R/W |
|-------|------------|---|-----|
| 3:0   | SFMDN[3:0] | 为快速读取指令选择的虚拟周期数<br>0x0: 每条指令的默认虚拟周期: 快速读取四路I/O: 6QSPCLK快速读取四路输出: 8QSPCLK快速读取双路I/O: 4QSPCLK快速读取双路输出: 8QSPCLK快速读取: 8QSPCLK<br>0x1: 3 QSPCLK*1<br>0x2: 4 QSPCLK<br>0x3: 5 QSPCLK<br>0x4: 6 QSPCLK<br>0x5: 7 QSPCLK<br>0x6: 8 QSPCLK<br>0x7: 9 QSPCLK<br>0x8: 10 QSPCLK<br>0x9: 11 QSPCLK<br>0xA: 12 QSPCLK<br>0xB: 13 QSPCLK<br>0xC: 14 QSPCLK<br>0xD: 15 QSPCLK<br>0xE: 16 QSPCLK<br>0xF: 17 QSPCLK | R/W |
| 5:4   | —          | 这些位被读取为0。写入值应为0。  | R/W |
| 6     | SFMXST     | XIP模式状态<br>0: 正常 (非XIP) 模式1: XIP模式  | R   |
| 7     | SFMXEN     | XIP模式权限<br>0: 禁止XIP模式1: 允许XIP模式   | R/W |
| 15:8  | SFMXD[7:0] | 串行闪存的模式数据 (控制XIP模式。)*2  | R/W |
| 31:16 | —          | 这些位被读取为0。写入值应为0。  | R/W |

注1.为免与连接到QIO0引脚的串行闪存引脚的输入输出开关冲突, 请选择4个以上的周期QSPCLK作为快速读取指令的虚拟周期数, 当输出使能信号通过设置SFMSMD寄存器中的SFMOEX位为1。

注2.作为串行闪存的模式数据, 指定实际串行闪存中设置的XIP模式设置数据。

### 31.2.11 SFMSPC:SPI协议控制寄存器

Base address: QSPI = 0x6400\_0000

Offset address: 0x030

|               |    |    |    |    |    |    |    |    |    |    |    |         |    |    |            |    |
|---------------|----|----|----|----|----|----|----|----|----|----|----|---------|----|----|------------|----|
| Bit position: | 31 | 30 | 29 | 28 | 27 | 26 | 25 | 24 | 23 | 22 | 21 | 20      | 19 | 18 | 17         | 16 |
| Bit field:    | —  | —  | —  | —  | —  | —  | —  | —  | —  | —  | —  | —       | —  | —  | —          | —  |
| 重置后的值:        | 0  | 0  | 0  | 0  | 0  | 0  | 0  | 0  | 0  | 0  | 0  | 0       | 0  | 0  | 0          | 0  |
| Bit position: | 15 | 14 | 13 | 12 | 11 | 10 | 9  | 8  | 7  | 6  | 5  | 4       | 3  | 2  | 1          | 0  |
| Bit field:    | —  | —  | —  | —  | —  | —  | —  | —  | —  | —  | —  | SFMS DE | —  | —  | SFMSP[1:0] | —  |
| 重置后的值:        | 0  | 0  | 0  | 0  | 0  | 0  | 0  | 0  | 0  | 0  | 0  | 1       | 0  | 0  | 0          | 0  |

| Bit | Symbol     | Function  | R/W |
|-----|------------|---|-----|
| 1:0 | SFMSP[1:0] | SPI协议选择*1<br>00: 单SPI协议, 扩展SPI协议01: 双SPI协议10: 四线SPI协议11: 禁止设置 | R/W |

| Bit  | Symbol | Function   | R/W |
|------|--------|--|-----|
| 3:2  | —      | These bits are read as 0. The write value should be 0.   | R/W |
| 4    | SFMSDE | QSPCLK extended selection bit when switching I/O of QIOn pin<br>0: No QSPCLK extension<br>1: QSPCLK expansion when switching I/O direction of QIOn pin | R/W |
| 31:5 | —      | These bits are read as 0. The write value should be 0.   | R/W |

Note 1. The states of the QIO2 and QIO3 pins change depending on the settings of the SFMSMD.SFMRM[2:0] and SFMSPI[1:0] bits. For details, see [section 31.9. QIO2 and QIO3 Pin States](#).

### 31.2.12 SFMPMD : Port Control Register

Base address: QSPI = 0x6400\_0000

Offset address: 0x034

|                    |    |    |    |    |    |    |    |    |    |    |    |    |    |            |    |    |
|--------------------|----|----|----|----|----|----|----|----|----|----|----|----|----|------------|----|----|
| Bit position:      | 31 | 30 | 29 | 28 | 27 | 26 | 25 | 24 | 23 | 22 | 21 | 20 | 19 | 18         | 17 | 16 |
| Bit field:         | —  | —  | —  | —  | —  | —  | —  | —  | —  | —  | —  | —  | —  | —          | —  | —  |
| Value after reset: | 0  | 0  | 0  | 0  | 0  | 0  | 0  | 0  | 0  | 0  | 0  | 0  | 0  | 0          | 0  | 0  |
| Bit position:      | 15 | 14 | 13 | 12 | 11 | 10 | 9  | 8  | 7  | 6  | 5  | 4  | 3  | 2          | 1  | 0  |
| Bit field:         | —  | —  | —  | —  | —  | —  | —  | —  | —  | —  | —  | —  | —  | SFMW<br>PL | —  | —  |
| Value after reset: | 0  | 0  | 0  | 0  | 0  | 0  | 0  | 0  | 0  | 0  | 0  | 0  | 0  | 0          | 0  | 0  |

| Bit  | Symbol | Function  | R/W |
|------|--------|---|-----|
| 1:0  | —      | These bits are read as 0. The write value should be 0.      | R/W |
| 2    | SFMWPL | WP pin level specification<br>0: Low level<br>1: High level | R/W |
| 31:3 | —      | These bits are read as 0. The write value should be 0.      | R/W |

### 31.2.13 SFMCNT1 : External QSPI Address Register

Base address: QSPI = 0x6400\_0000

Offset address: 0x804

|                    |               |    |    |    |    |    |    |    |    |    |    |    |    |    |    |    |
|--------------------|---------------|----|----|----|----|----|----|----|----|----|----|----|----|----|----|----|
| Bit position:      | 31            | 30 | 29 | 28 | 27 | 26 | 25 | 24 | 23 | 22 | 21 | 20 | 19 | 18 | 17 | 16 |
| Bit field:         | QSPI_EXT[5:0] |    |    |    |    |    |    | —  | —  | —  | —  | —  | —  | —  | —  | —  |
| Value after reset: | 0             | 0  | 0  | 0  | 0  | 0  | 0  | 0  | 0  | 0  | 0  | 0  | 0  | 0  | 0  | 0  |
| Bit position:      | 15            | 14 | 13 | 12 | 11 | 10 | 9  | 8  | 7  | 6  | 5  | 4  | 3  | 2  | 1  | 0  |
| Bit field:         | —             | —  | —  | —  | —  | —  | —  | —  | —  | —  | —  | —  | —  | —  | —  | —  |
| Value after reset: | 0             | 0  | 0  | 0  | 0  | 0  | 0  | 0  | 0  | 0  | 0  | 0  | 0  | 0  | 0  | 0  |

| Bit  | Symbol | Function   | R/W |
|------|--------|--|-----|
| 25:0 | —      | These bits are read as 0. The write value should be 0. | R/W |

| Bit  | Symbol | Function   | R/W |
|------|--------|--|-----|
| 3:2  | —      | 这些位被读取为0。写入值应为0。   | R/W |
| 4    | SFMSDE | QSPCLK扩展选择在切换QIOn引脚的IO时<br>0: 无QSPCLK扩展 1: 切换QIOn引脚IO方向时QSPCLK扩展 | R/W |
| 31:5 | —      | 这些位被读取为0。写入值应为0。   | R/W |

注1.QIO2和QIO3引脚的状态根据SFMSMD.SFMRM[2:0]和SFMSPI[1:0]位的设置而变化。有关详细信息，请参阅第31.9节。QIO2和QIO3引脚状态。

### 31.2.12 SFMPMD:端口控制寄存器

Base address: QSPI = 0x6400\_0000

Offset address: 0x034

|               |    |    |    |    |    |    |    |    |    |    |    |    |    |            |    |    |
|---------------|----|----|----|----|----|----|----|----|----|----|----|----|----|------------|----|----|
| Bit position: | 31 | 30 | 29 | 28 | 27 | 26 | 25 | 24 | 23 | 22 | 21 | 20 | 19 | 18         | 17 | 16 |
| Bit field:    | —  | —  | —  | —  | —  | —  | —  | —  | —  | —  | —  | —  | —  | —          | —  | —  |
| 重置后的值:        | 0  | 0  | 0  | 0  | 0  | 0  | 0  | 0  | 0  | 0  | 0  | 0  | 0  | 0          | 0  | 0  |
| Bit position: | 15 | 14 | 13 | 12 | 11 | 10 | 9  | 8  | 7  | 6  | 5  | 4  | 3  | 2          | 1  | 0  |
| Bit field:    | —  | —  | —  | —  | —  | —  | —  | —  | —  | —  | —  | —  | —  | SFMW<br>PL | —  | —  |
| 重置后的值:        | 0  | 0  | 0  | 0  | 0  | 0  | 0  | 0  | 0  | 0  | 0  | 0  | 0  | 0          | 0  | 0  |

| Bit  | Symbol | Function                     | R/W |
|------|--------|------------------------------|-----|
| 1:0  | —      | 这些位被读取为0。写入值应为0。             | R/W |
| 2    | SFMWPL | WP引脚电平规范<br>0: 低电平<br>1: 高电平 | R/W |
| 31:3 | —      | 这些位被读取为0。写入值应为0。             | R/W |

### 31.2.13 SFMCNT1: 外部QSPI地址寄存器

Base address: QSPI = 0x6400\_0000

Offset address: 0x804

|               |               |    |    |    |    |    |    |    |    |    |    |    |    |    |    |    |
|---------------|---------------|----|----|----|----|----|----|----|----|----|----|----|----|----|----|----|
| Bit position: | 31            | 30 | 29 | 28 | 27 | 26 | 25 | 24 | 23 | 22 | 21 | 20 | 19 | 18 | 17 | 16 |
| Bit field:    | QSPI_EXT[5:0] |    |    |    |    |    |    | —  | —  | —  | —  | —  | —  | —  | —  | —  |
| 重置后的值:        | 0             | 0  | 0  | 0  | 0  | 0  | 0  | 0  | 0  | 0  | 0  | 0  | 0  | 0  | 0  | 0  |
| Bit position: | 15            | 14 | 13 | 12 | 11 | 10 | 9  | 8  | 7  | 6  | 5  | 4  | 3  | 2  | 1  | 0  |
| Bit field:    | —             | —  | —  | —  | —  | —  | —  | —  | —  | —  | —  | —  | —  | —  | —  | —  |
| 重置后的值:        | 0             | 0  | 0  | 0  | 0  | 0  | 0  | 0  | 0  | 0  | 0  | 0  | 0  | 0  | 0  | 0  |

| Bit  | Symbol | Function         | R/W |
|------|--------|------------------|-----|
| 25:0 | —      | 这些位被读取为0。写入值应为0。 | R/W |

| Bit   | Symbol        | Function  | R/W |
|-------|---------------|---|-----|
| 31:26 | QSPI_EXT[5:0] | Bank switching address<br>When accessing from 0x60000000 to 0x63FFFFFF, the address bus is set from QSPI_EXT[5:0] to the upper 6 bits of the internal bus address for the address bus.<br>0x00: QSPI bank 00<br>0x01: QSPI bank 01<br>0x02: QSPI bank 02<br>⋮<br>0x3C: QSPI bank 60<br>0x3D: QSPI bank 61<br>0x3E: QSPI bank 62<br>0x3F: Setting prohibited | R/W |

### 31.3 Memory Map

#### 31.3.1 External Bus Space

The locations of a serial flash memory and control register on the address space are determined by the address range of the area set in the configuration.

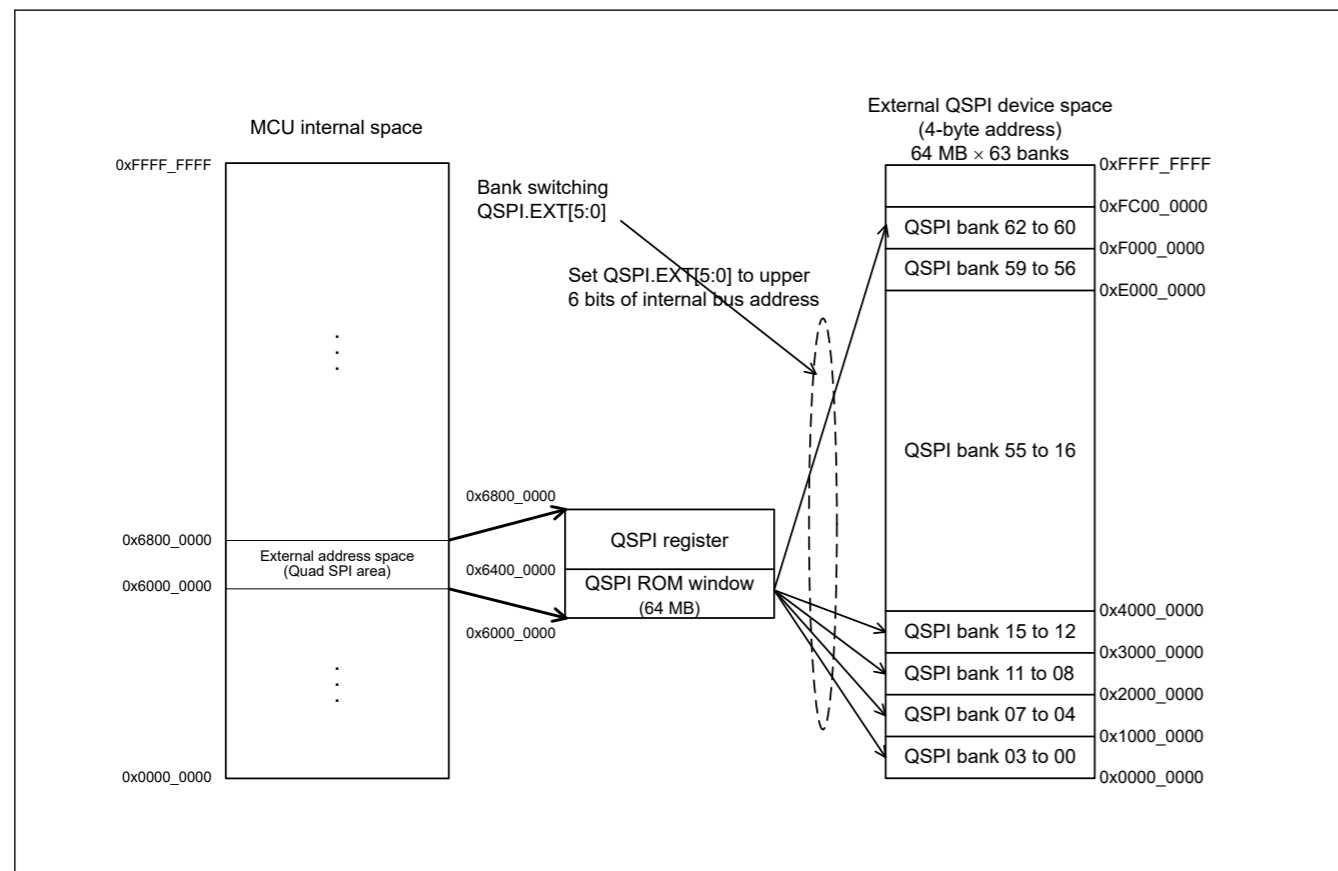


Figure 31.2 Default area setting and memory map

#### 31.3.2 Address Width of the SPI Space and SPI Bus

The SPI space has a 32-bit address width for referencing the serial flash memory. When the SPI space is accessed for a read, an SPI bus cycle starts automatically, and data read from the serial flash is returned.

The address width of the SPI space is fixed at 32 bits. However, the address width of the SPI bus is selectable to 8, 16, 24, or 32 bits in the SFMAS[1:0] bits in the Address Mode Control Register (SFMSAC) register. If 8, 16, or 24 bits is selected as the address width of the SPI bus, only the lower part of the address used to access the SPI space is posted to the serial flash memory through the SPI bus. As a result, the mirror image of the serial flash corresponding to the address width of the SPI bus repeatedly appears in the SPI space.

| Bit   | Symbol        | Function   | R/W |
|-------|---------------|--|-----|
| 31:26 | QSPI_EXT[5:0] | 银行转换地址<br>从0x60000000到0x63FFFFFF访问时，地址总线设置为QSPI_EXT[5:0]到地址总线的内部总线地址的高6位。<br>0x00: QSPI bank 00<br>0x01: QSPI bank 01<br>0x02: QSPI bank 02<br>⋮<br>0x3C: QSPIbank600x3D<br>: QSPIbank610x3E: QS<br>PIbank620x3F: 禁止设<br>置 | R/W |

### 31.3 内存映射

#### 31.3.1 外部总线空间

串行闪存和控制寄存器在地址空间上的位置由配置中设置的区域的地址范围决定。

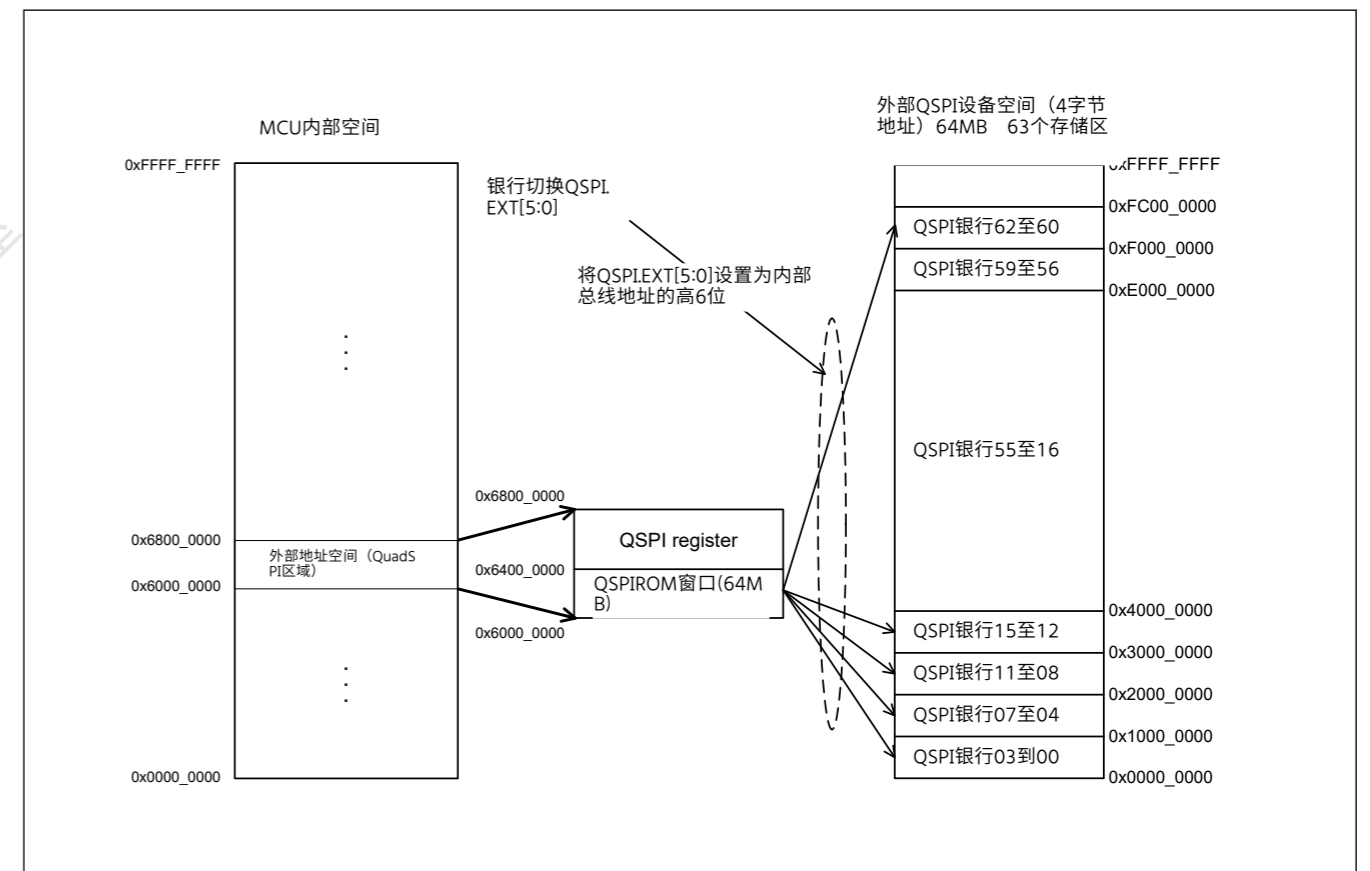


Figure 31.2 默认区域设置和内存映射

#### 31.3.2 SPI空间和SPI总线的地址宽度

SPI空间具有32位地址宽度，用于引用串行闪存。当访问SPI空间进行读取时，会自动启动一个SPI总线周期，并返回从串行闪存读取的数据。

SPI空间的地址宽度固定为32位。但是，SPI总线的地址宽度可选择为地址模式控制寄存器(SFMSAC)寄存器中的SFMAS[1:0]位中的8、16、24或32位。如果选择8位、16位或24位作为SPI总线的地址宽度，则只有用于访问SPI空间的地址的低部分通过SPI总线发布到串行闪存中。结果，对应于SPI总线地址宽度的串行闪存的镜像在SPI空间中反复出现。

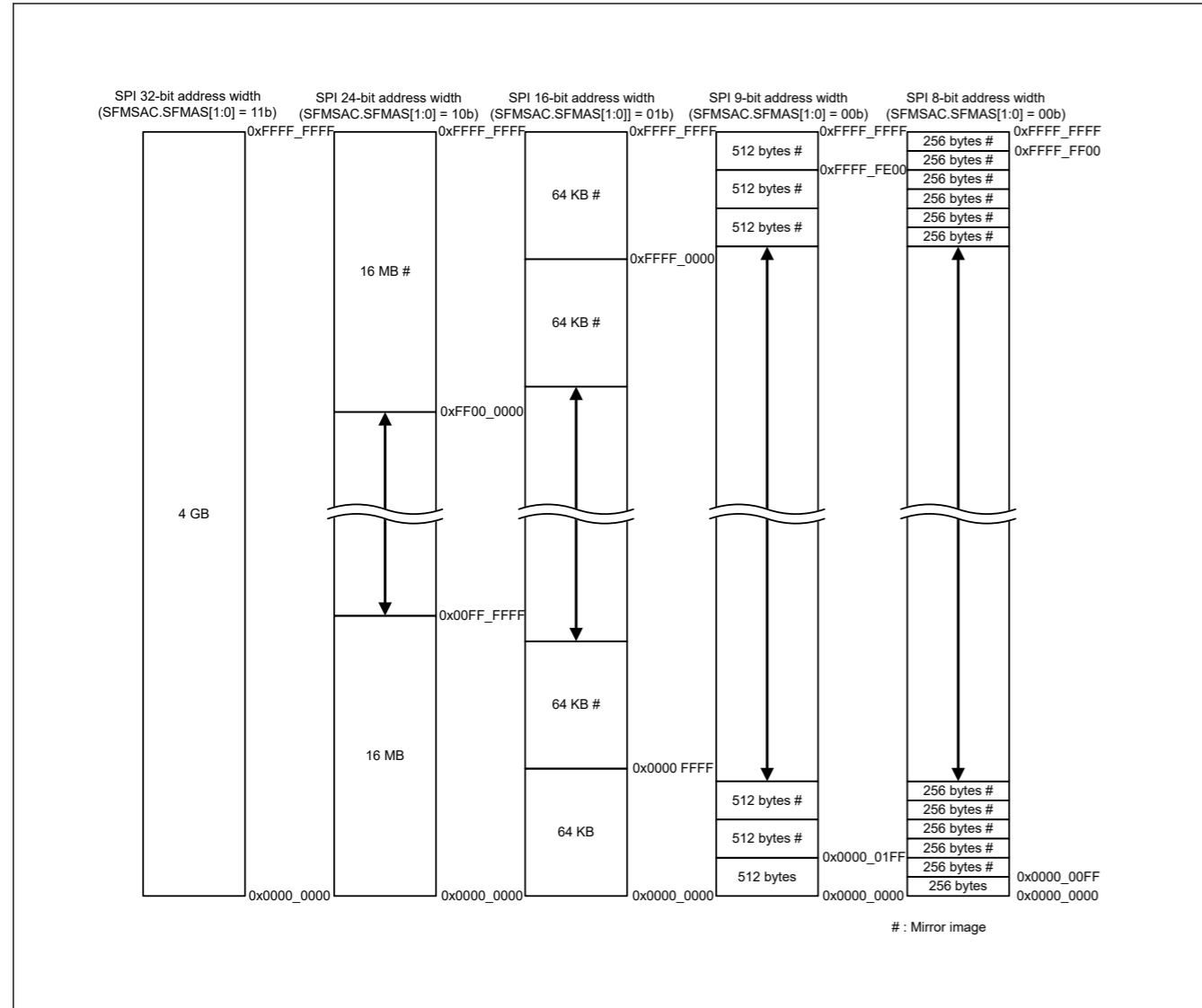


Figure 31.3 Memory map of SPI space

Note: The SPI bus address width is selectable to 8, 16, 24, or 32 bits in the SFMAS[1:0] bits in the SFMSAC register (cases 1 to 3 and 5 in the figure correspond to the respective address widths). When an 8-bit address width is selected, the address information of the ninth bit can be embedded in the Read instruction code. The memory map in case 4 in the figure is for the 9-bit address width. For details on the Read instruction, see [section 31.6.2. Standard Read Instruction](#).

### 31.4 SPI Bus

#### 31.4.1 SPI Protocol

Single SPI, extended SPI, dual SPI, and quad SPI are supported in addition to the SPI protocol used for serial flash memory connection.

The initial state of the SPI protocol is Single SPI, extended SPI and can be changed with the SFMSPI[1:0] bits in the SPI Protocol Control Register (SFMSPC) register.

The address and data pins used in the Single SPI, extended SPI protocol change depending on the setting of the serial interface read mode select bits SFMRM[2:0] in Transfer Mode Control Register (SFMSMD). [Table 31.3](#) and [Table 31.4](#) list the pins used for instruction code, addresses, and data in each of the SPI protocols.

Note: In read operation, the QSPI outputs additional one clock without accompanying data reception per one SPI bus cycle. For details, see [section 31.5.9. Serial Data Receiving Latency](#).

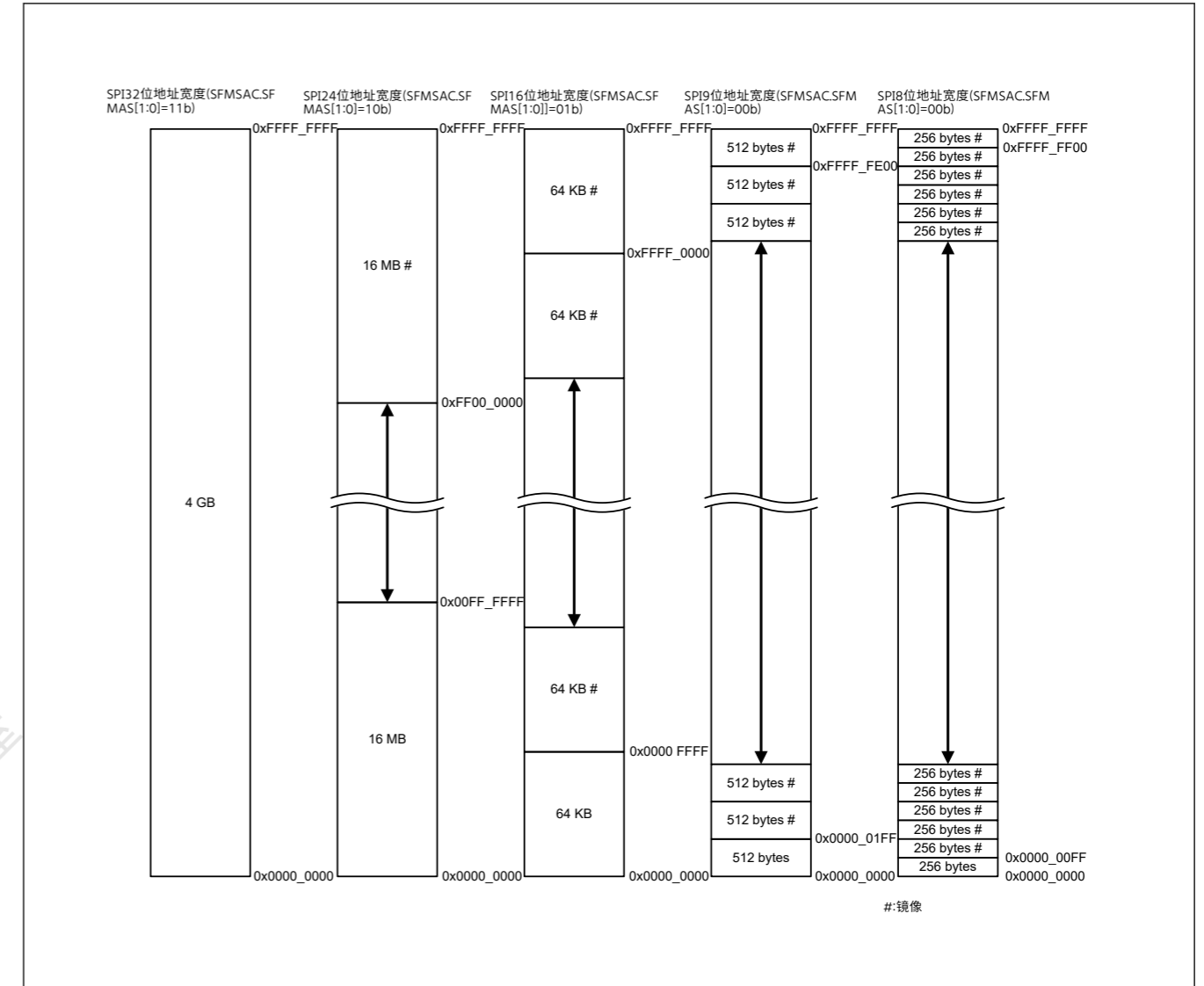


Figure 31.3 SPI空间的内存映射

Note: SPI总线地址宽度在SFMSAC寄存器的SFMAS[1:0]位中可选择为8、16、24或32位（图中的情况1到3和5对应于各自的地址宽度）。When an 8-bit address width is selected the address information of the ninth bit can be embedded in the Read instruction code.图中案例4中的内存映射是针对9位地址宽度的。有关读取指令的详细信息，请参阅第31.6.2节。标准阅读说明。

### 31.4 SPI总线

#### 31.4.1 SPI协议

除了用于串行闪存连接的SPI协议外，还支持单SPI、扩展SPI、双SPI和四SPI。

SPI协议的初始状态是Single SPI，扩展SPI，可以通过SPI中的SFMSPI[1:0]位改变协议控制寄存器(SFMSPC)寄存器。

单SPI、扩展SPI协议中使用的地址和数据引脚根据传输模式控制寄存器(SFMSMD)中串行接口读取模式选择位SFMRM[2:0]的设置而变化。表31.3和表31.4列出了每个SPI协议中用于指令代码、地址和数据的引脚。

Note: 在读操作中，QSPI会在每个SPI总线周期输出额外的一个时钟，而不会伴随数据接收。有关详细信息，请参阅第31.5.9节。串行数据接收延迟。



Table 31.3 List of SPI Protocols (1)

| SPI Protocol (SFMSPC.SFMSP[1:0])                    | Single SPI Protocol, Extended SPI Protocol |                          |                          |                          |                                      |                                      |
|---|--|--------------------------|--------------------------|--------------------------|--------------------------------------|--------------------------------------|
| Serial interface read mode select (SFMSMD.SFM[2:0]) | Standard read                              | Fast read                | Fast read dual output    | Fast read dual I/O       | Fast read quad output                | Fast read quad I/O                   |
| All pins used                                       | QSPCLK, QSSL, QIO0, QIO1                   | QSPCLK, QSSL, QIO0, QIO1 | QSPCLK, QSSL, QIO0, QIO1 | QSPCLK, QSSL, QIO0, QIO1 | QSPCLK, QSSL, QIO0, QIO1, QIO2, QIO3 | QSPCLK, QSSL, QIO0, QIO1, QIO2, QIO3 |
| Pins used for instruction code                      | QIO0                                       | QIO0                     | QIO0                     | QIO0                     | QIO0                                 | QIO0                                 |
| Pins used for addresses                             | QIO0                                       | QIO0                     | QIO0                     | QIO0, QIO1               | QIO0                                 | QIO0, QIO1, QIO2, QIO3               |
| Pins used for data                                  | QIO0/QIO1                                  | QIO0/QIO1                | QIO0, QIO1               | QIO0, QIO1               | QIO0, QIO1, QIO2, QIO3               | QIO0, QIO1, QIO2, QIO3               |

Note: Single SPI protocol operation is for standard read and fast read. Extended SPI protocol operation is fast read dual output, fast read dual I/O, fast read quad output, and fast read quad I/O.

Table 31.4 List of SPI Protocols (2)

| SPI Protocol (SFMSPC.SFMSP[1:0])                    | Dual-SPI Protocol        |                          | Quad-SPI Protocol                    |                                      |
|---|--------------------------|--------------------------|--------------------------------------|--------------------------------------|
| Serial interface read mode select (SFMSMD.SFM[2:0]) | Fast read dual output    | Fast read dual I/O       | Fast read quad output                | Fast read quad I/O                   |
| All pins used                                       | QSPCLK, QSSL, QIO0, QIO1 | QSPCLK, QSSL, QIO0, QIO1 | QSPCLK, QSSL, QIO0, QIO1, QIO2, QIO3 | QSPCLK, QSSL, QIO0, QIO1, QIO2, QIO3 |
| Pins used for instruction code                      | QIO0, QIO1               | QIO0, QIO1               | QIO0, QIO1, QIO2, QIO3               | QIO0, QIO1, QIO2, QIO3               |
| Pins used for addresses                             | QIO0, QIO1               | QIO0, QIO1               | QIO0, QIO1, QIO2, QIO3               | QIO0, QIO1, QIO2, QIO3               |
| Pins used for data                                  | QIO0, QIO1               | QIO0, QIO1               | QIO0, QIO1, QIO2, QIO3               | QIO0, QIO1, QIO2, QIO3               |

In single SPI protocol and extended SPI protocol, the instruction code is always output from the QIO0 pin. Address and data input/output operations are performed according to the settings in SFMSMD.SFM[2:0].

Table 31.3 SPI协议列表(1)

| SPI协议(SFMSPC.SFMSP[1:0])    | 单SPI协议, 扩展SPI协议          |                          |                          |                          |                                      |                                      |
|-----------------------------|--------------------------|--------------------------|--------------------------|--------------------------|--------------------------------------|--------------------------------------|
| 串行接口读取模式选择(SFMSMD.SFM[2:0]) | 标准阅读                     | 快速阅读                     | 快速读取双输出                  | 快速读取双IO                  | 快速读取四路输出                             | 快速读取四路IO                             |
| 使用的所有引脚                     | QSPCLK, QSSL, QIO0, QIO1 | QSPCLK, QSSL, QIO0, QIO1 | QSPCLK, QSSL, QIO0, QIO1 | QSPCLK, QSSL, QIO0, QIO1 | QSPCLK, QSSL, QIO0, QIO1, QIO2, QIO3 | QSPCLK, QSSL, QIO0, QIO1, QIO2, QIO3 |
| 用于指令代码的引脚                   | QIO0                     | QIO0                     | QIO0                     | QIO0                     | QIO0                                 | QIO0                                 |
| 用于地址的引脚                     | QIO0                     | QIO0                     | QIO0                     | QIO0, QIO1               | QIO0                                 | QIO0, QIO1, QIO2, QIO3               |
| 用于数据的引脚                     | QIO0/QIO1                | QIO0/QIO1                | QIO0, QIO1               | QIO0, QIO1               | QIO0, QIO1, QIO2, QIO3               | QIO0, QIO1, QIO2, QIO3               |

Note: 单SPI协议操作作用于标准读取和快速读取。扩展的SPI协议操作是快速读取双输出、快速读取双IO、快速读取四输出和快速读取四IO。

Table 31.4 SPI协议列表(2)

| SPI协议(SFMSPC.SFMSP[1:0])    | Dual-SPI Protocol        |                          | Quad-SPI Protocol                    |                                      |
|-----------------------------|--------------------------|--------------------------|--------------------------------------|--------------------------------------|
| 串行接口读取模式选择(SFMSMD.SFM[2:0]) | 快速读取双输出                  | 快速读取双IO                  | 快速读取四路输出                             | 快速读取四路I/O                            |
| 使用的所有引脚                     | QSPCLK, QSSL, QIO0, QIO1 | QSPCLK, QSSL, QIO0, QIO1 | QSPCLK, QSSL, QIO0, QIO1, QIO2, QIO3 | QSPCLK, QSSL, QIO0, QIO1, QIO2, QIO3 |
| 用于指令代码的引脚                   | QIO0, QIO1               | QIO0, QIO1               | QIO0, QIO1, QIO2, QIO3               | QIO0, QIO1, QIO2, QIO3               |
| 用于地址的引脚                     | QIO0, QIO1               | QIO0, QIO1               | QIO0, QIO1, QIO2, QIO3               | QIO0, QIO1, QIO2, QIO3               |
| 用于数据的引脚                     | QIO0, QIO1               | QIO0, QIO1               | QIO0, QIO1, QIO2, QIO3               | QIO0, QIO1, QIO2, QIO3               |

在单SPI协议和扩展SPI协议中, 指令代码总是从QIO0引脚输出。地址和数据输入输出操作根据SFMSMD.SFM[2:0]中的设置执行。

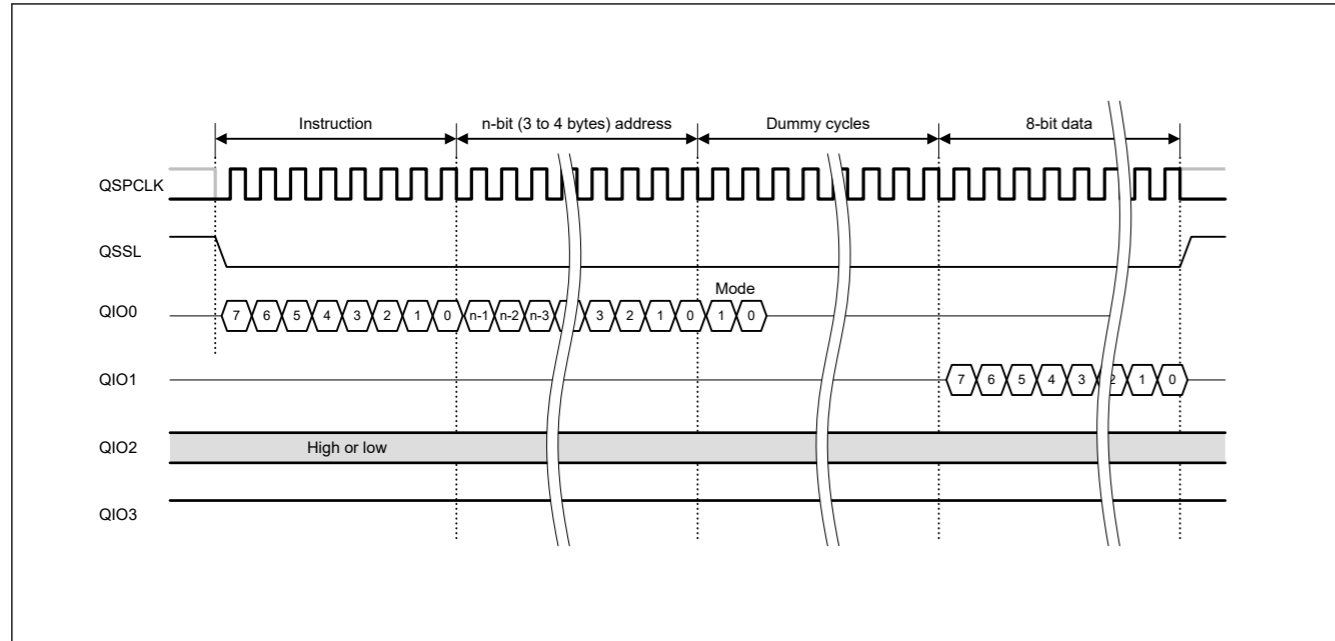


Figure 31.4 Single SPI Protocol example for Fast Read

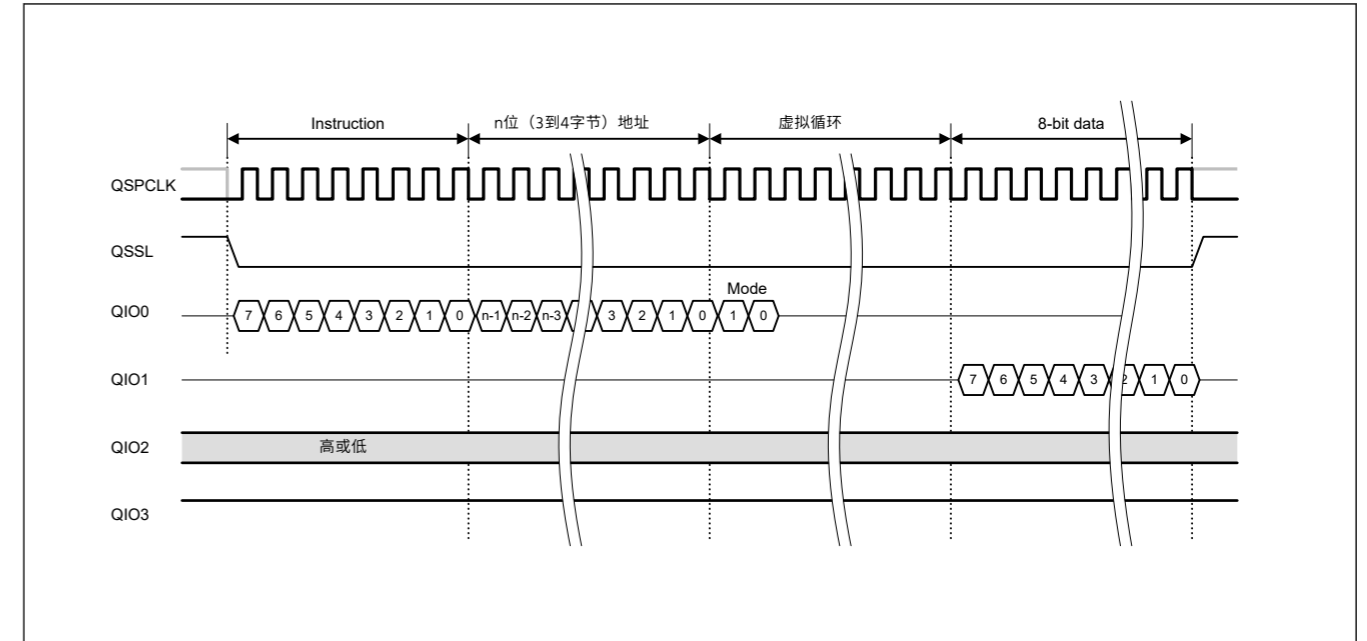


Figure 31.4 用于快速读取的单SPI协议示例

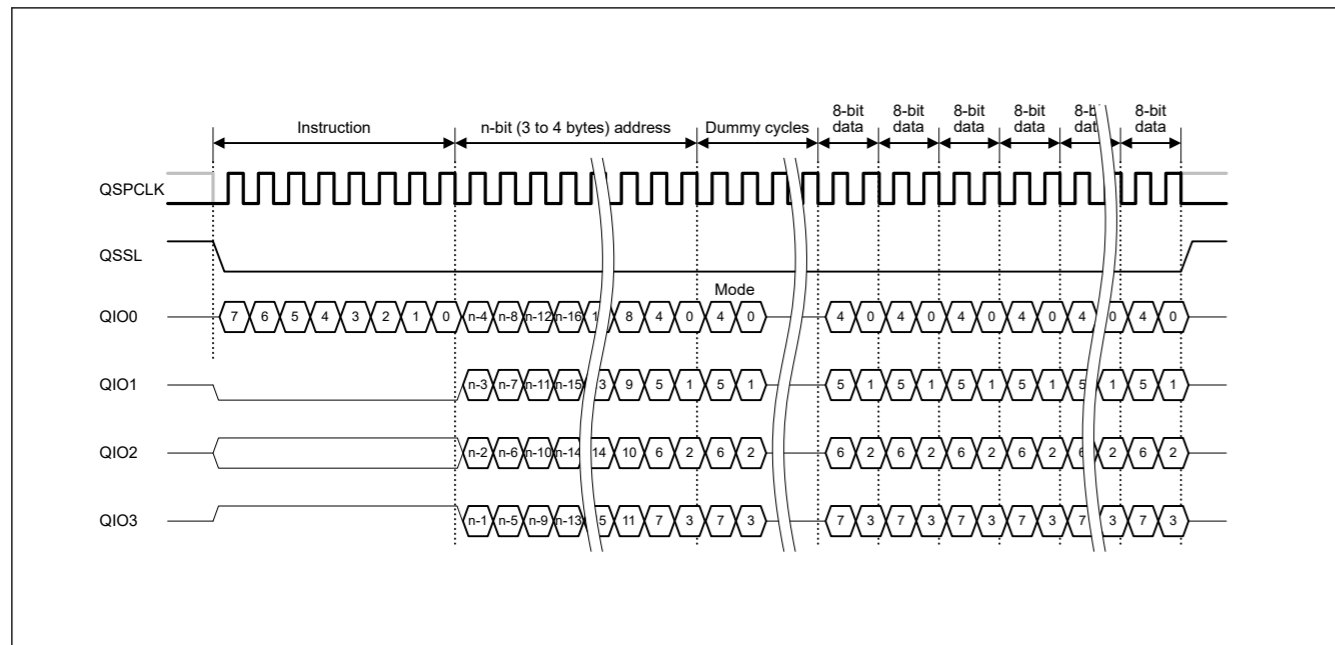


Figure 31.5 Extended SPI Protocol example for Fast Read Quad I/O

The Dual SPI protocol performs I/O operation of all signals such as instruction codes, addresses, and data using two pins, QIO0 and QIO1.

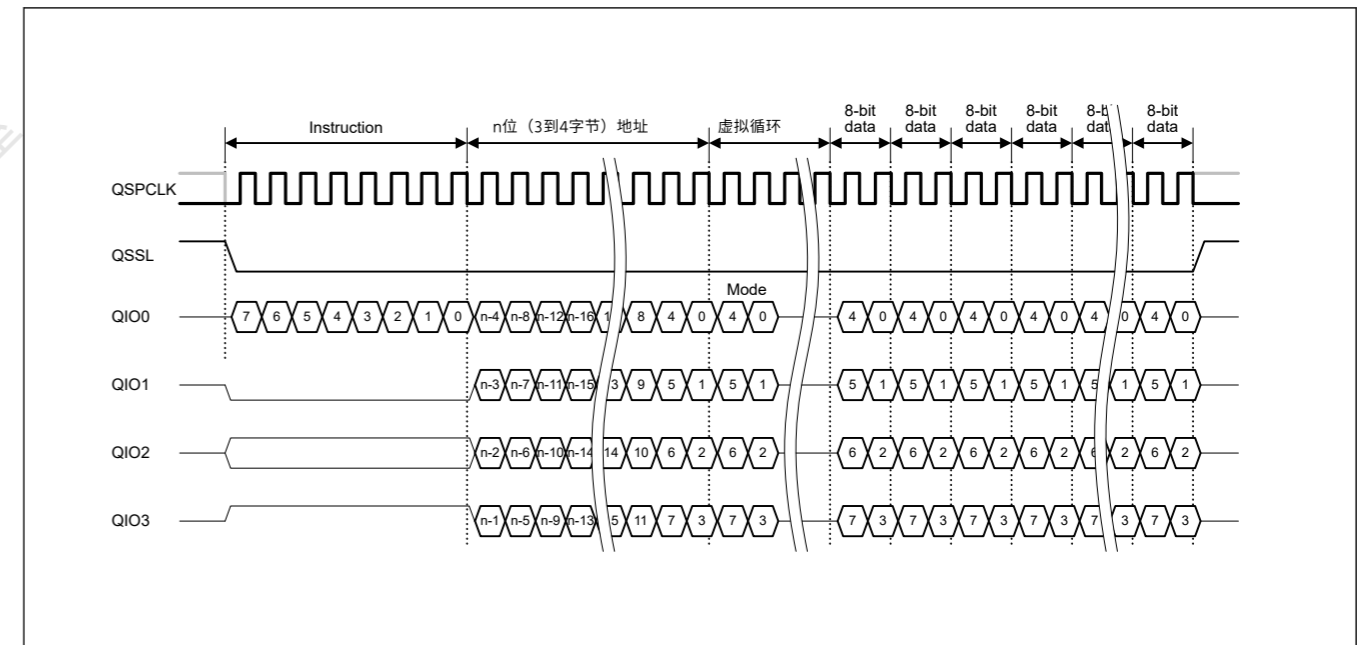


Figure 31.5 快速读取四路IO的扩展SPI协议示例

DualSPI协议使用两个引脚执行指令代码、地址和数据等所有信号的IO操作，QIO0 and QIO1.

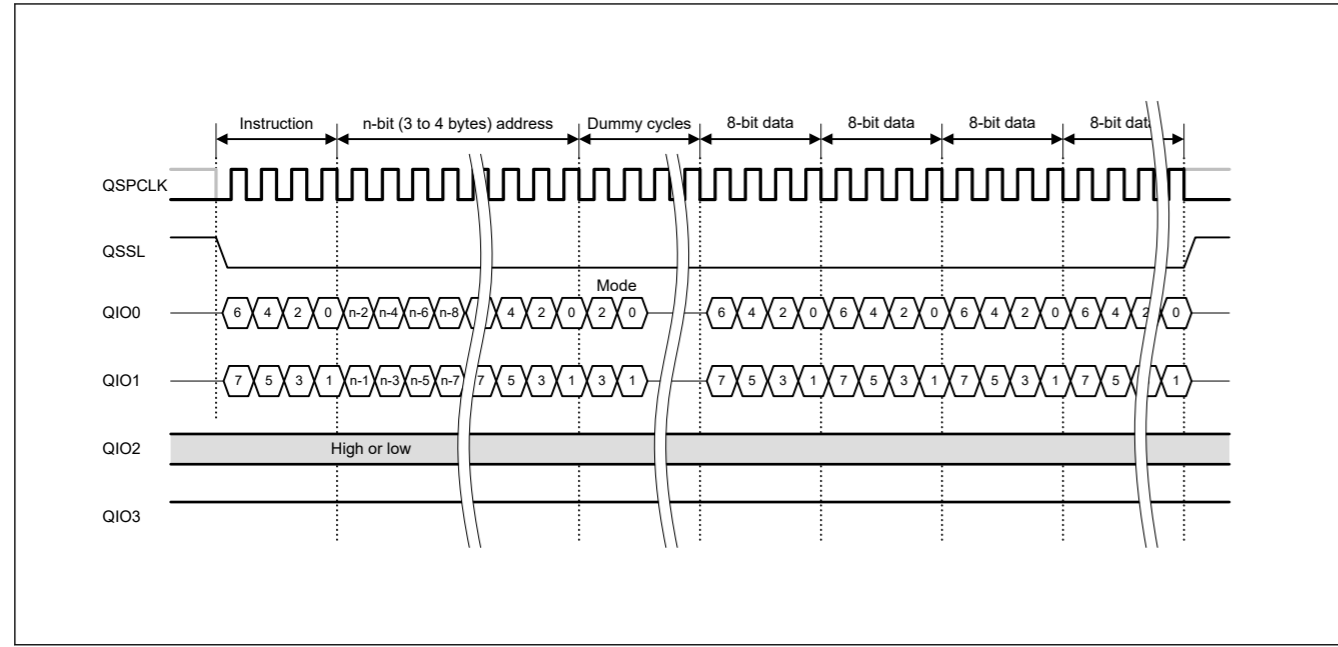


Figure 31.6 Dual SPI protocol example for Fast Read Quad I/O

The Quad SPI protocol performs I/O operation of all signals such as instruction codes, addresses, and data using four pins, QIO0, QIO1, QIO2, and QIO3.

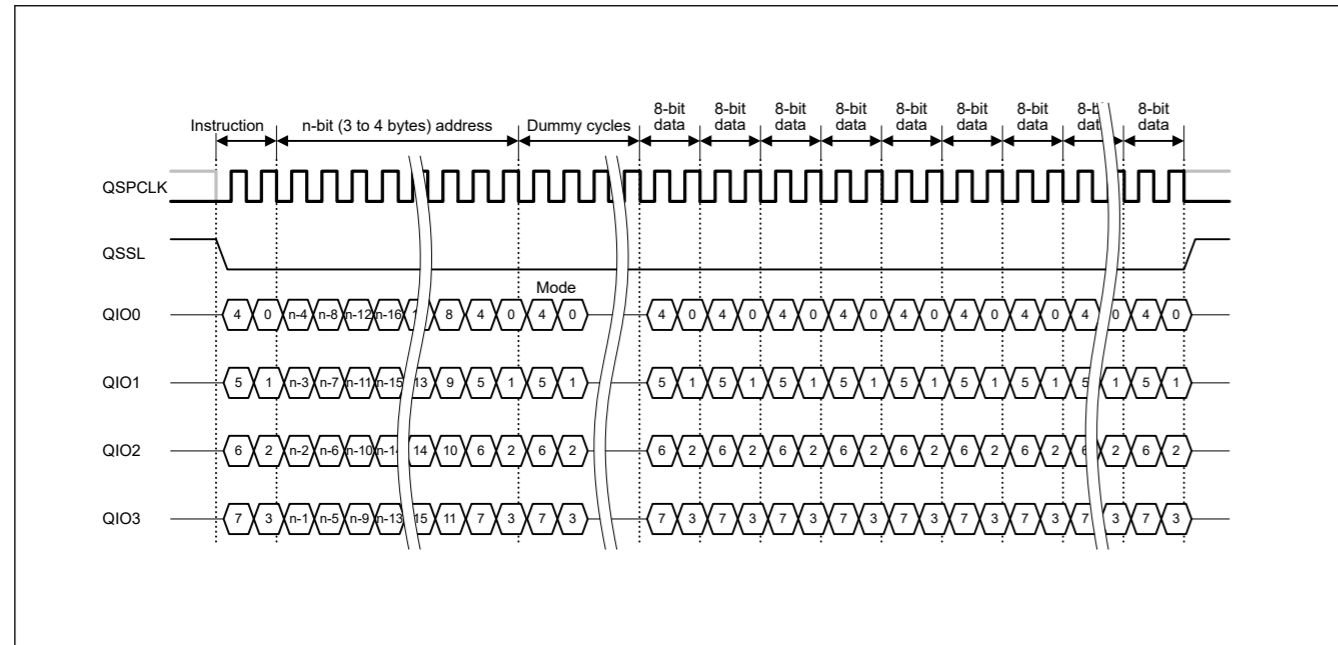


Figure 31.7 Quad SPI protocol example for Fast Read Quad I/O

### 31.4.2 SPI Mode

Either SPI mode 0 or SPI mode 3 can be selected as the SPI mode by the SFMSMD.SFMMMD3 bit. This can be switched by changing the register setting during operation. The difference between SPI modes 0 and 3 is the state of the QSPCLK signal when it is inactive. The standby level of the QSPCLK signal in SPI mode 0 is low, and high in SPI mode 3.

Serial data is output from the QSPI on a falling edge of the serial clock and is read into the serial flash memory on a rising edge of the serial clock. Serial data is output from the serial flash memory on a falling edge of the serial clock and is read into the QSPI on the next falling edge of the serial clock.

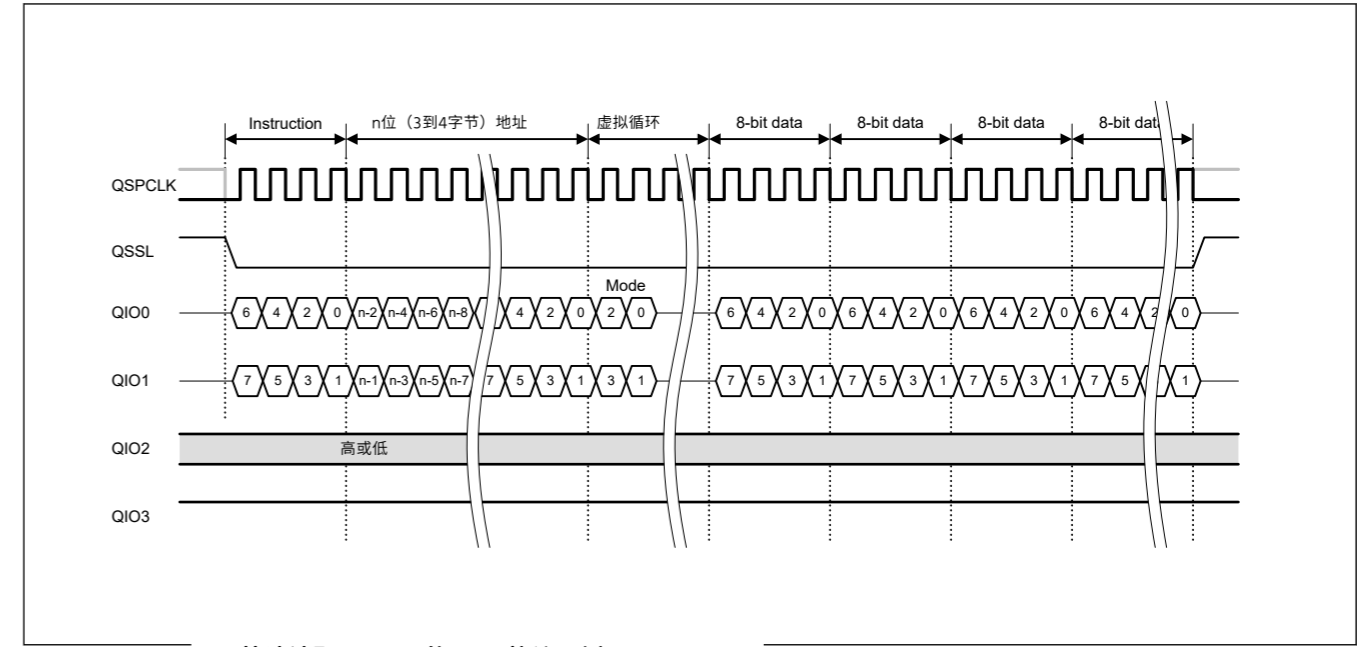


Figure 31.6 用于快速读取QuadIO的双SPI协议示例

QuadSPI协议使用四个引脚执行指令代码、地址和数据等所有信号的IO操作，QIO0, QIO1, QIO2, and QIO3。

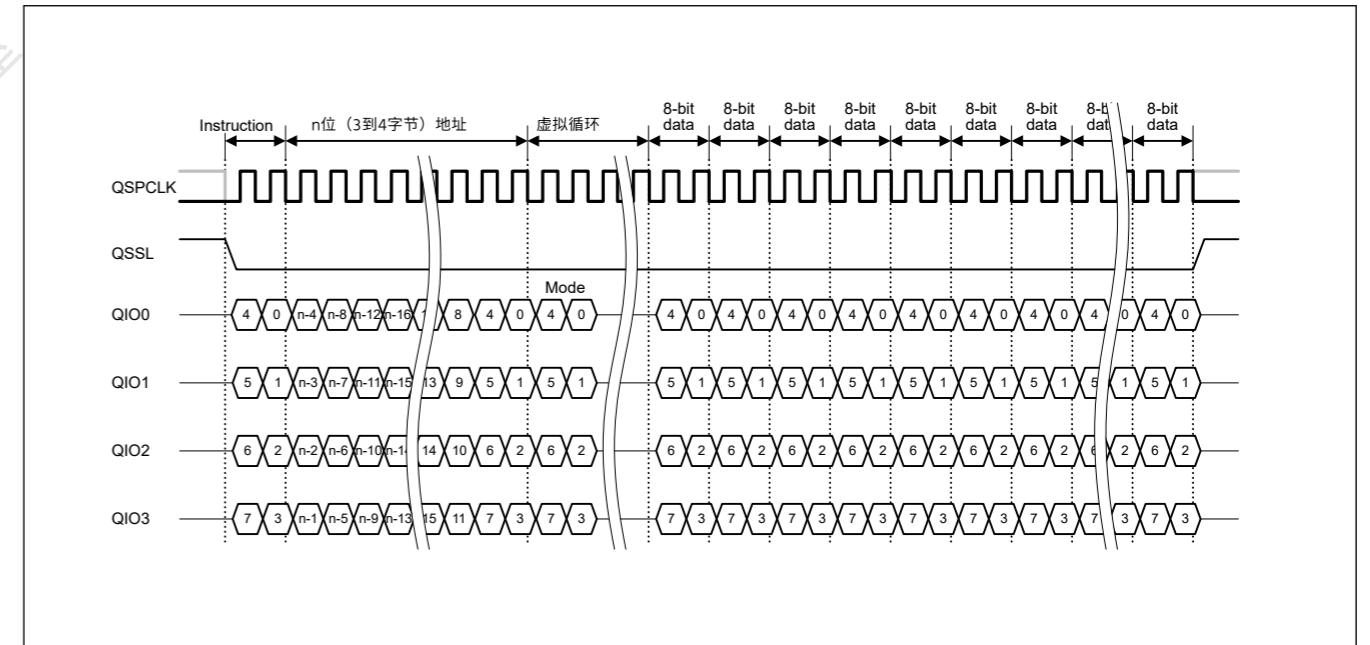


Figure 31.7 用于快速读取QuadIO的QuadSPI协议示例

### 31.4.2 SPI模式

可以通过SFMSMD.SFMMMD3位选择SPI模式0或SPI模式3作为SPI模式。这可以通过在操作期间更改寄存器设置来切换。SPI模式0和3之间的区别在于QSPCLK信号处于非活动状态时的状态。QSPCLK信号在SPI模式0中的待机电平为低，在SPI模式3中为高。

串行数据在串行时钟的下降沿从QSPI输出，并在串行时钟的上升沿读入串行闪存。串行数据在串行时钟的下降沿从串行闪存输出，并在串行时钟的下一个下降沿读入QSPI。

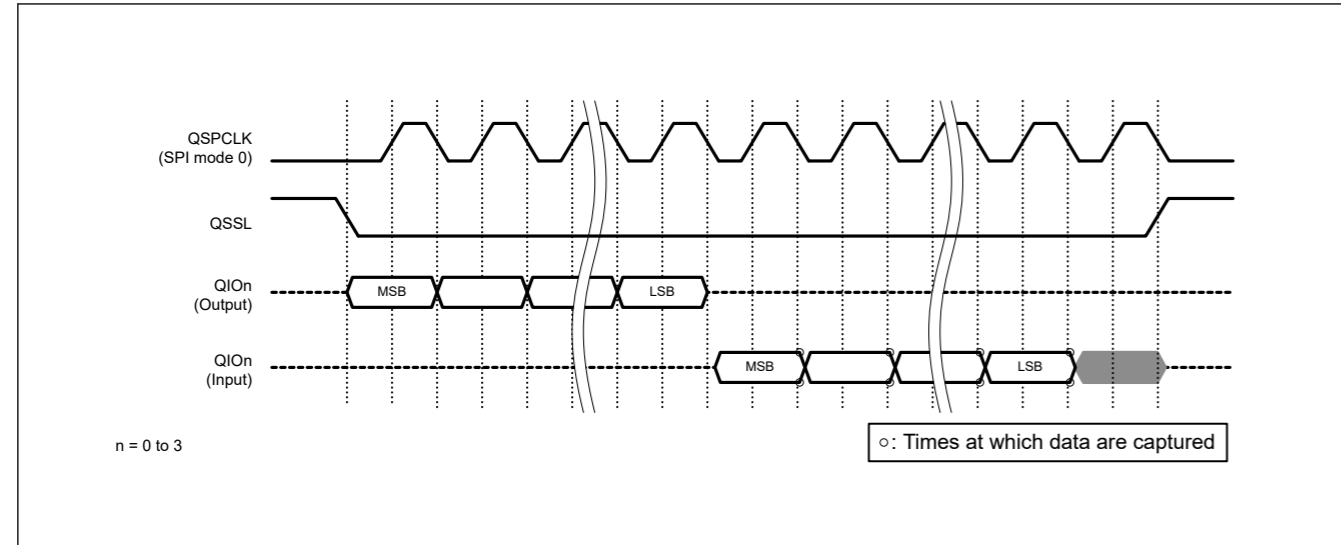


Figure 31.8 Basic serial interface timing (SPI mode 0)

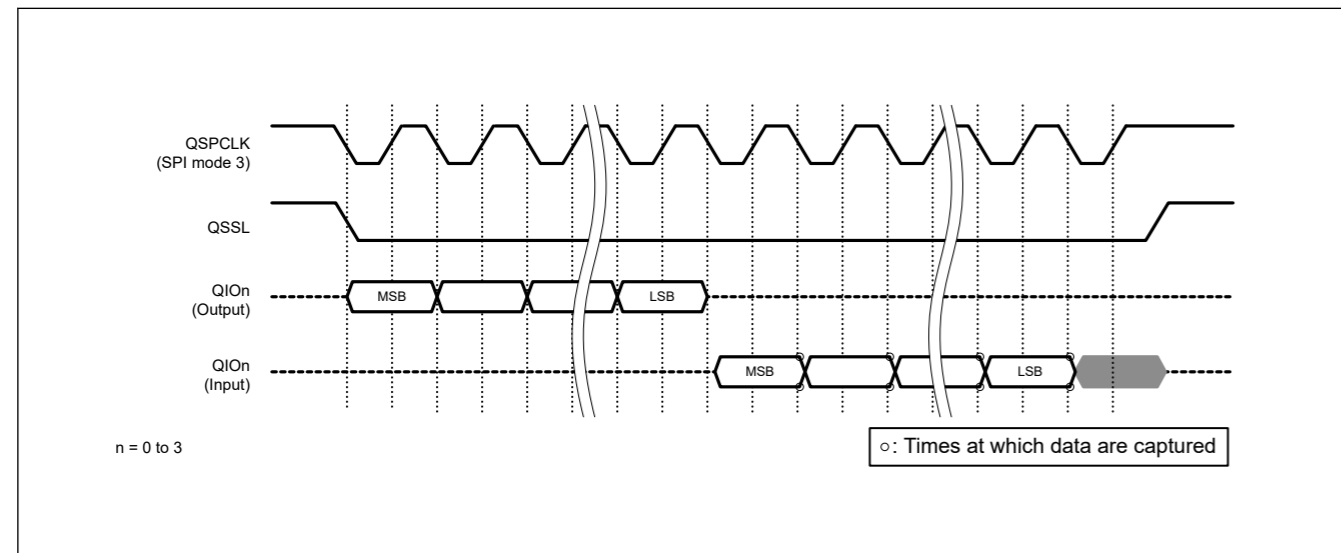


Figure 31.9 Basic serial interface timing (SPI mode 3)

### 31.5 SPI Bus Timing Adjustment

The timing of the SPI bus signal can be adjusted in the registers. The configured timing is applied to all SPI bus accesses, for both ROM access and direct communication.

#### 31.5.1 SPI Bus Reference Cycles

The SPI bus operates on reference cycles obtained by multiplying PCLKA by an integer. The reference cycles are selectable within the range of PCLKA multiplied by 2 to 48 in the SFMDV[4:0] bits in the Transfer Mode Control Register (SFMSKC) register.

Table 31.5 Relationship among SFMDV[4:0] bits, cycle multiplier, and serial clock frequencies (1 of 2)

| SFMDV[4:0] | Cycle multiplier | PCLKA = 100 [MHz] |
|------------|------------------|-------------------|
| 11111b     | 48               | 2.08              |
| 11110b     | 46               | 2.17              |
| 11101b     | 44               | 2.27              |
| 11100b     | 42               | 2.38              |
| 11011b     | 40               | 2.50              |

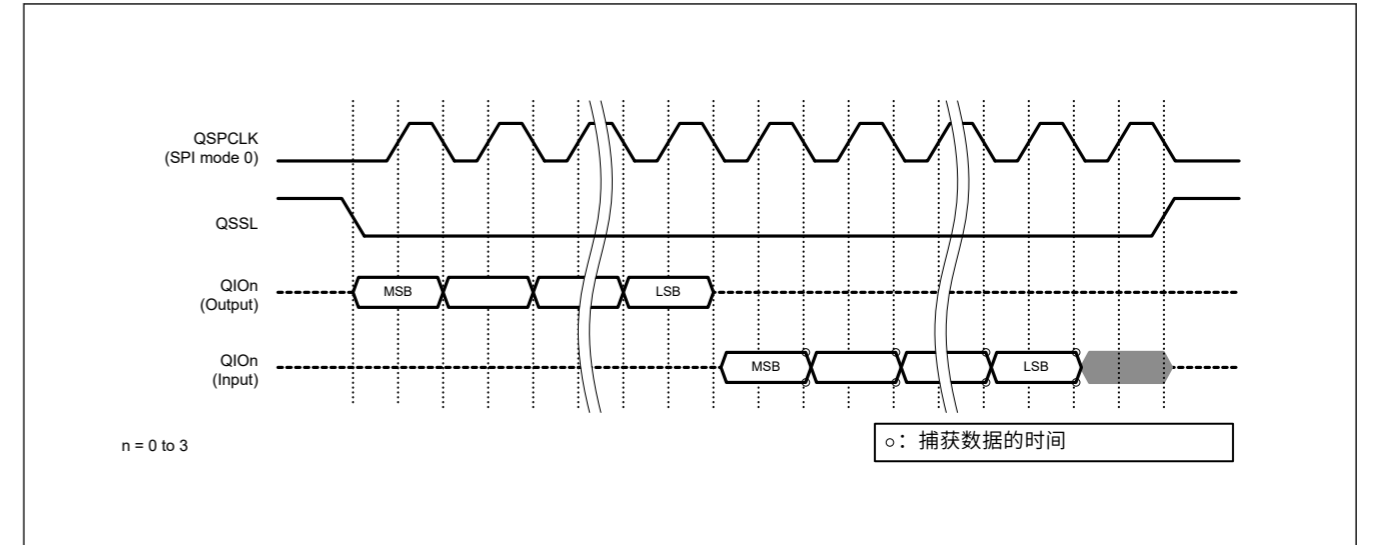


Figure 31.8 基本串行接口时序 (SPI模式0)

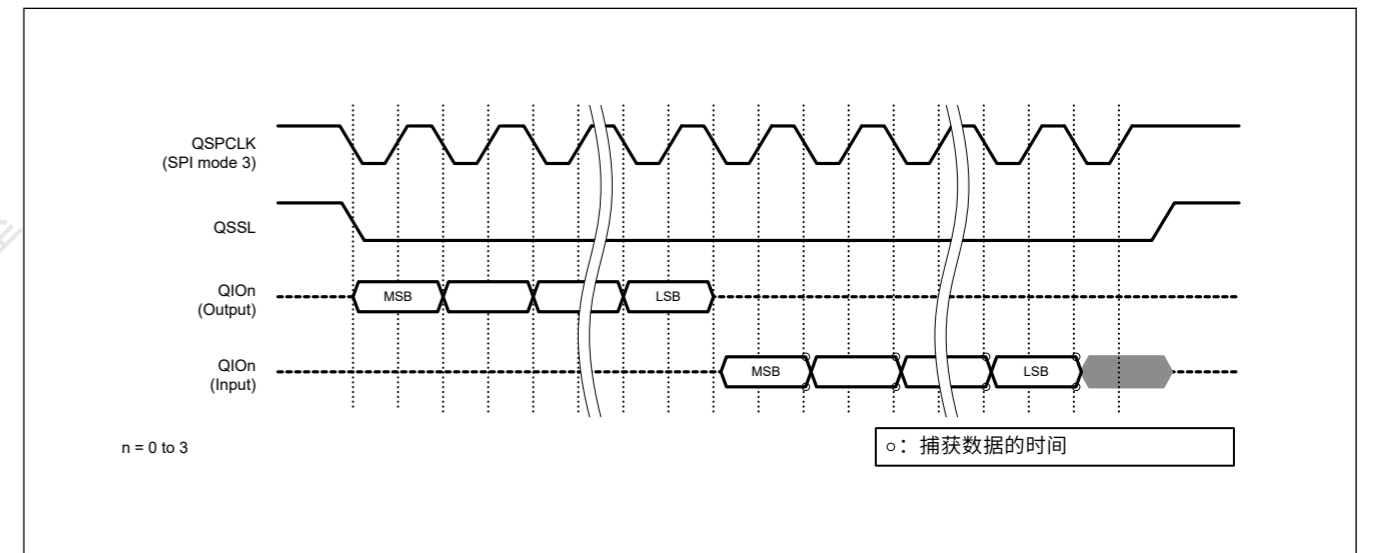


Figure 31.9 基本串行接口时序 (SPI模式3)

### 31.5 SPI总线时序调整

SPI总线信号的时序可以在寄存器中调整。配置的时序适用于所有SPI总线访问，包括ROM访问和直接通信。

#### 31.5.1 SPI总线参考周期

SPI总线在通过将PCLKA乘以一个整数获得的参考周期上运行。参考周期可在传输模式控制寄存器(SFMSKC)寄存器的SFMDV[4:0]位中的PCLKA乘以2到48的范围内选择。

Table 31.5 SFMDV[4:0]位、周期乘数和串行时钟频率之间的关系 (1of2)

| SFMDV[4:0] | 循环乘数 | PCLKA = 100 [MHz] |
|------------|------|-------------------|
| 11111b     | 48   | 2.08              |
| 11110b     | 46   | 2.17              |
| 11101b     | 44   | 2.27              |
| 11100b     | 42   | 2.38              |
| 11011b     | 40   | 2.50              |



Table 31.5 Relationship among SFMDV[4:0] bits, cycle multiplier, and serial clock frequencies (2 of 2)

| SFMDV[4:0] | Cycle multiplier | PCLKA = 100 [MHz] |
|------------|------------------|-------------------|
| 11010b     | 38               | 2.63              |
| 11001b     | 36               | 2.78              |
| 11000b     | 34               | 2.94              |
| 10111b     | 32               | 3.13              |
| 10110b     | 30               | 3.33              |
| 10101b     | 28               | 3.57              |
| 10100b     | 26               | 3.85              |
| 10011b     | 24               | 4.17              |
| 10010b     | 22               | 4.55              |
| 10001b     | 20               | 5.00              |
| 10000b     | 18               | 5.56              |
| 01111b     | 17               | 5.88              |
| 01110b     | 16               | 6.25              |
| 01101b     | 15               | 6.67              |
| 01100b     | 14               | 7.14              |
| 01011b     | 13               | 7.69              |
| 01010b     | 12               | 8.33              |
| 01001b     | 11               | 9.09              |
| 01000b     | 10               | 10.00             |
| 00111b     | 9                | 11.11             |
| 00110b     | 8                | 12.50             |
| 00101b     | 7                | 14.29             |
| 00100b     | 6                | 16.67             |
| 00011b     | 5                | 20.00             |
| 00010b     | 4                | 25.00             |
| 00001b     | 3                | 33.33             |
| 00000b     | 2                | 50.00             |

### 31.5.2 QSPCLK Signal Duty Ratio

When the reference clock is configured as PCLKA divided by an odd number without duty ratio correction, the duty ratio of the QSPCLK signal will not be 50%. When the reference clock is PCLKA divided by an odd number, be sure to enable the duty ratio correction function (SFMSKC.SFMDTY = 1).

When the reference clock is PCLKA divided by an even number, the SFMDTY setting in the SFMSKC register is ignored.

Table 31.5 SFMDV[4:0]位、周期乘数和串行时钟频率之间的关系(2of2)

| SFMDV[4:0] | 循环乘数 | PCLKA = 100 [MHz] |
|------------|------|-------------------|
| 11010b     | 38   | 2.63              |
| 11001b     | 36   | 2.78              |
| 11000b     | 34   | 2.94              |
| 10111b     | 32   | 3.13              |
| 10110b     | 30   | 3.33              |
| 10101b     | 28   | 3.57              |
| 10100b     | 26   | 3.85              |
| 10011b     | 24   | 4.17              |
| 10010b     | 22   | 4.55              |
| 10001b     | 20   | 5.00              |
| 10000b     | 18   | 5.56              |
| 01111b     | 17   | 5.88              |
| 01110b     | 16   | 6.25              |
| 01101b     | 15   | 6.67              |
| 01100b     | 14   | 7.14              |
| 01011b     | 13   | 7.69              |
| 01010b     | 12   | 8.33              |
| 01001b     | 11   | 9.09              |
| 01000b     | 10   | 10.00             |
| 00111b     | 9    | 11.11             |
| 00110b     | 8    | 12.50             |
| 00101b     | 7    | 14.29             |
| 00100b     | 6    | 16.67             |
| 00011b     | 5    | 20.00             |
| 00010b     | 4    | 25.00             |
| 00001b     | 3    | 33.33             |
| 00000b     | 2    | 50.00             |

### 31.5.2 QSPCLK信号占空比

当参考时钟配置为PCLKA除以奇数而不进行占空比校正时，QSPCLK信号的占空比不会为50%。当参考时钟为PCLKA除以奇数时，请务必启用占空比校正功能（SFMSKC.SFMDTY=1）。

当参考时钟为PCLKA除以偶数时，SFMSKC寄存器中的SFMDTY设置被忽略。

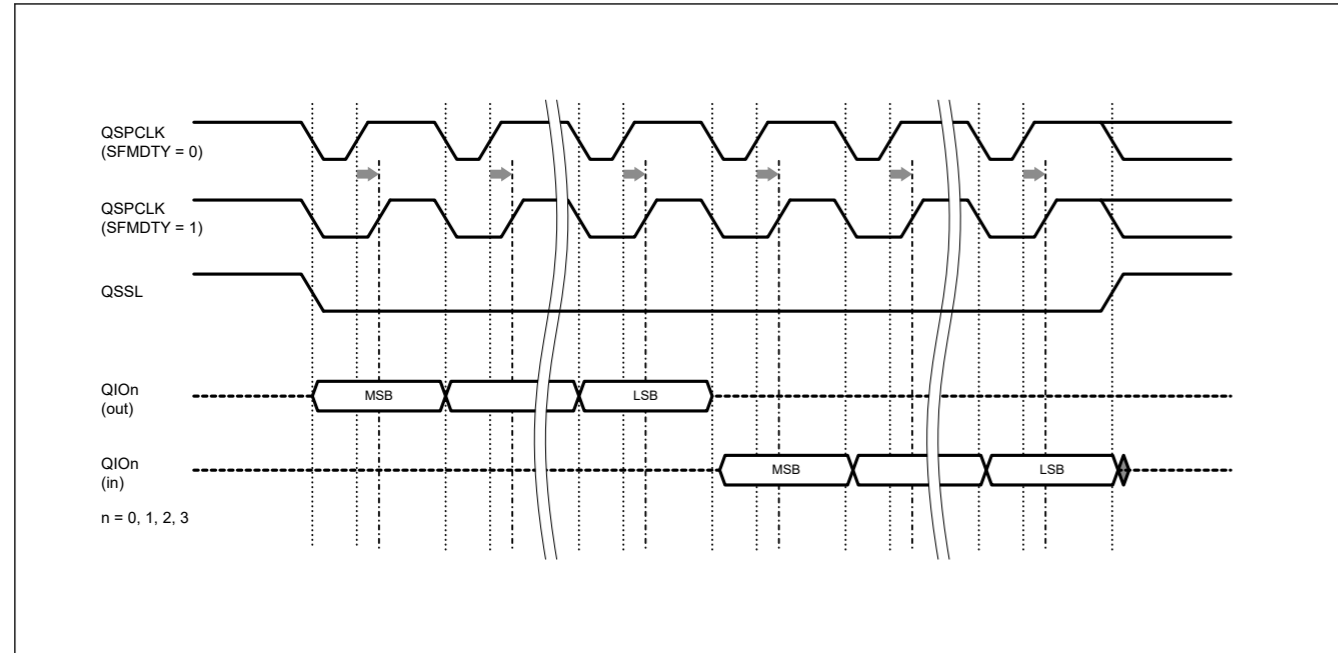


Figure 31.10 Example correction of the QSPCLK signal duty ratio using the SFMDTY bit, when PCLKA is multiplied by 3

### 31.5.3 Minimum High-Level Width for the QSSL Signal

Between adjacent SPI bus cycles, the QSSL signal must be held high (inactive) for a sufficient time to satisfy the deselect time required by the serial flash memory. The minimum high-level width of the QSSL output signal is selectable as the reference cycle multiplied by an integer from 1 to 16 in the SFMSW[3:0] bits in the Instruction Code Register (SFMSSC) register.

### 31.5.4 QSSL Signal Setup Time

The QSSL signal setup time that the serial flash memory requires after the QSSL signal is driven active low until the first rising edge of the QSPCLK signal can be configured. The setup time can be selected as 0.5 or 1.5 cycles of QSPCLK in the SFMSLD bit of the SFMSSC register.

Set a value that meets the most constrained timing condition for your application.

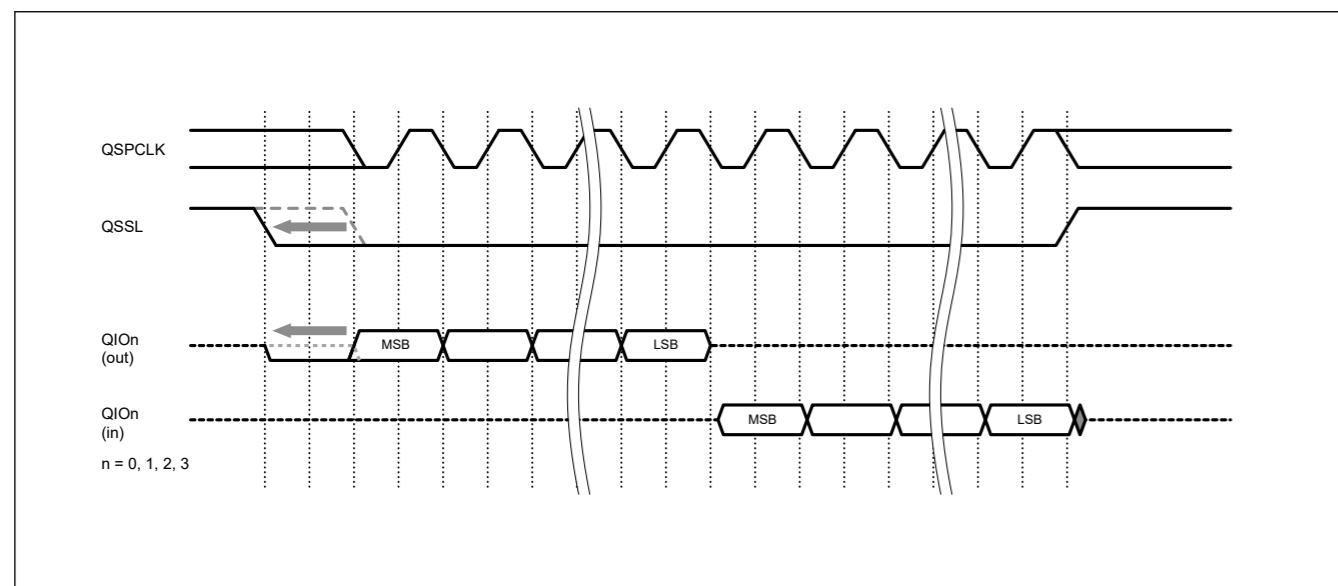


Figure 31.11 Setup time adjustment for the QSSL signal using the SFMSLD bit

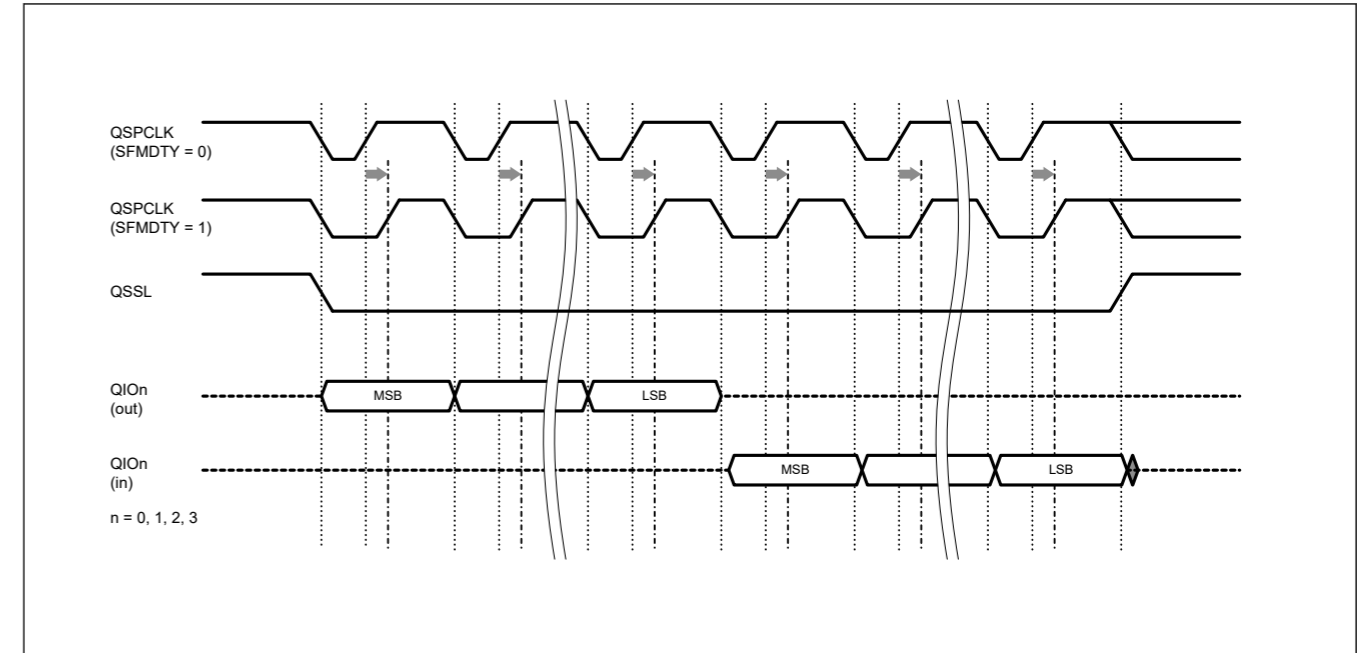


Figure 31.10 当PCLKA乘以3时，使用SFMDTY位校正QSPCLK信号占空比的示例

### 31.5.3 QSSL信号的最小高电平宽度

在相邻的SPI总线周期之间，QSSL信号必须保持高电平（无效）足够长的时间，以满足串行闪存所需的取消选择时间。QSSL输出信号的最小高电平宽度可选择为参考周期乘以指令代码寄存器(SFMSSC)寄存器中SFMSW[3:0]位中的1到16的整数。

### 31.5.4 QSSL信号建立时间

从QSSL信号被驱动为低电平有效到QSPCLK信号的第一个上升沿可以配置，串行闪存所需的QSSL信号建立时间。设置时间可以在SFMSLD位中选择为0.5或1.5个QSPCLK周期。

为您的应用设置一个满足最受约束的时序条件的值。

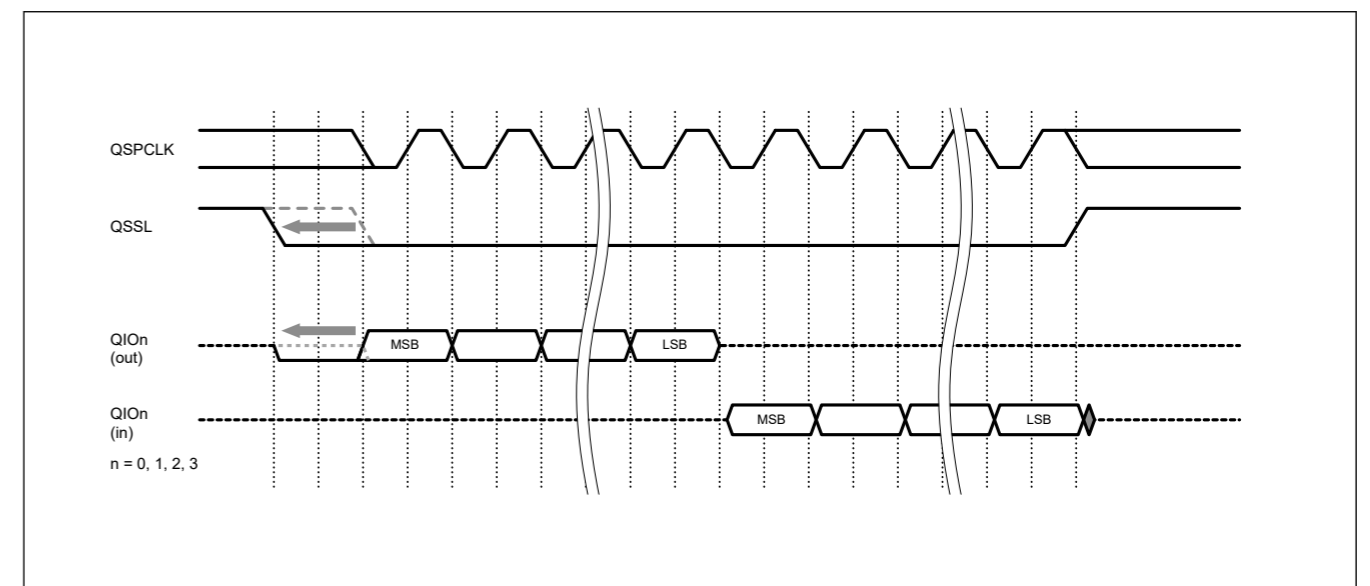


Figure 31.11 使用SFMSLD位调整QSSL信号的建立时间

### 31.5.5 QSSL Signal Hold Time

The QSSL signal hold time that the serial flash memory requires until the QSSL signal is driven high after the last rising edge of the QSPCLK signal can be configured. The hold time can be selected as 0.5 or 1.5 cycles of QSPCLK in the SFMSHD bit of the SFMSSC register.

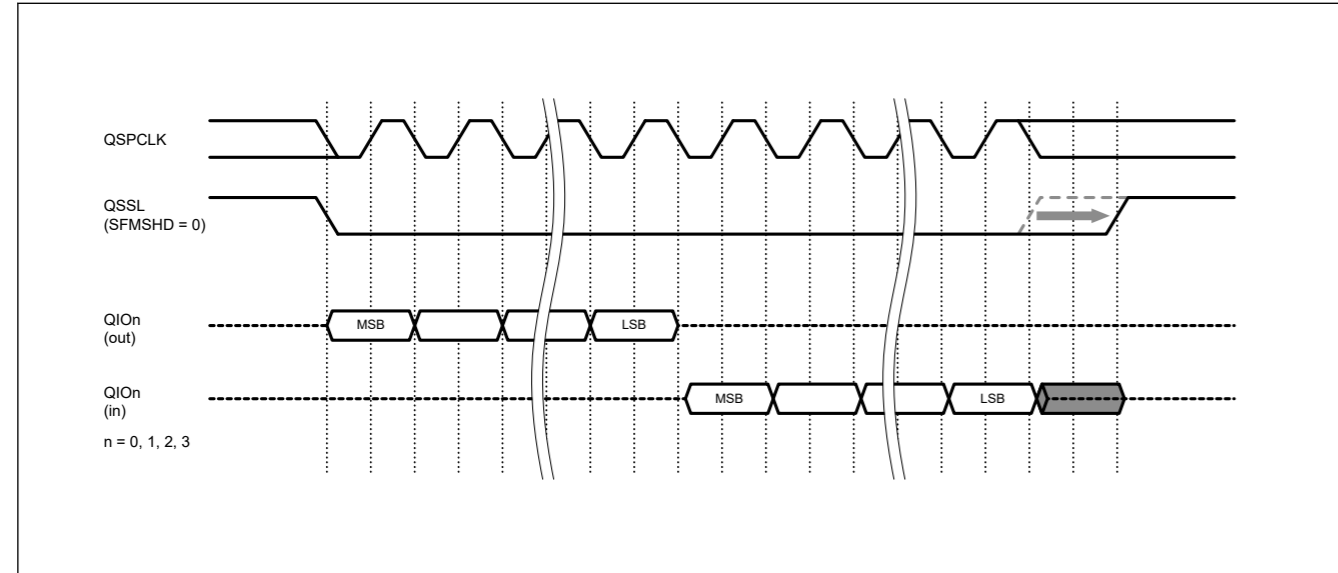


Figure 31.12 Hold time adjustment for the QSSL signal using the SFMSSD bit

### 31.5.6 Hold Time of the Serial Data Output Enable

The buffer output enable of the QIO0, QIO1, QIO2, or QIO3 pin can be extended by 1 QSPCLK using the SFMOEX bit in the SFMSMD register.

For a standard read instruction, it is extended immediately after an address code. For other read instructions, it is extended after two cycles of mode data (XIP mode control) of the serial flash memory in dummy cycles.

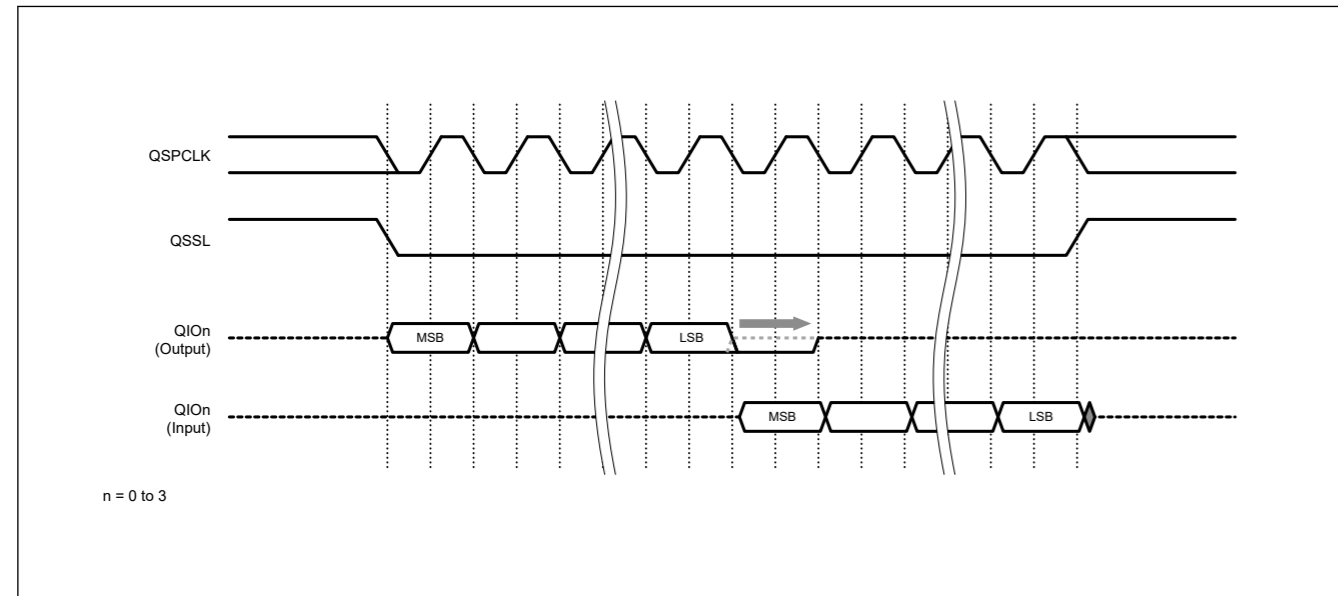


Figure 31.13 Hold time adjustment for output enable using the SFMOEX bit (Standard Read)

### 31.5.5 QSSL信号保持时间

可以配置在QSPCLK信号的最后一个上升沿之后，直到QSSL信号被驱动为高电平之前，串行闪存所需的QSSL信号保持时间。保持时间可以在SFMSSC寄存器的SFMSSD位中选择为0.5或1.5个QSPCLK周期。

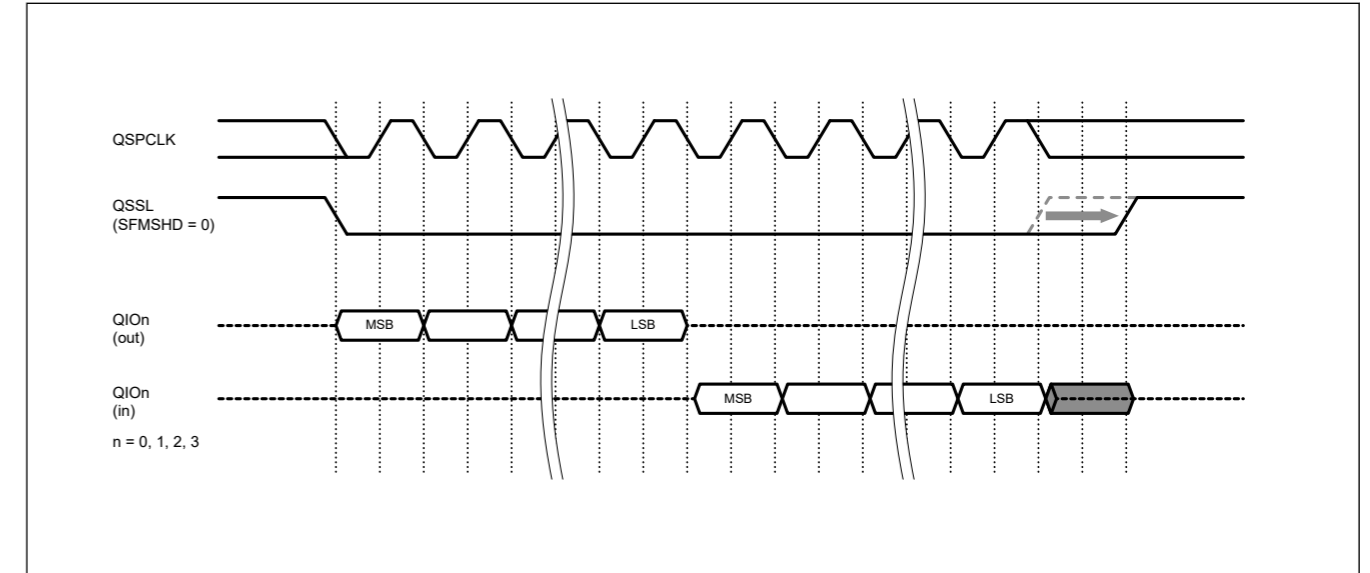


Figure 31.12 使用SFMSSD位调整QSSL信号的保持时间

### 31.5.6 串行数据输出使能的保持时间

可以使用SFMSMD寄存器中的SFMOEX位将QIO0、QIO1、QIO2或QIO3引脚的缓冲器输出使能扩展1个QSPCLK。

对于标准读指令，它在地址码之后立即扩展。对于其他读指令，它在串行闪存的两个模式数据（XIP模式控制）周期后以虚拟周期进行扩展。

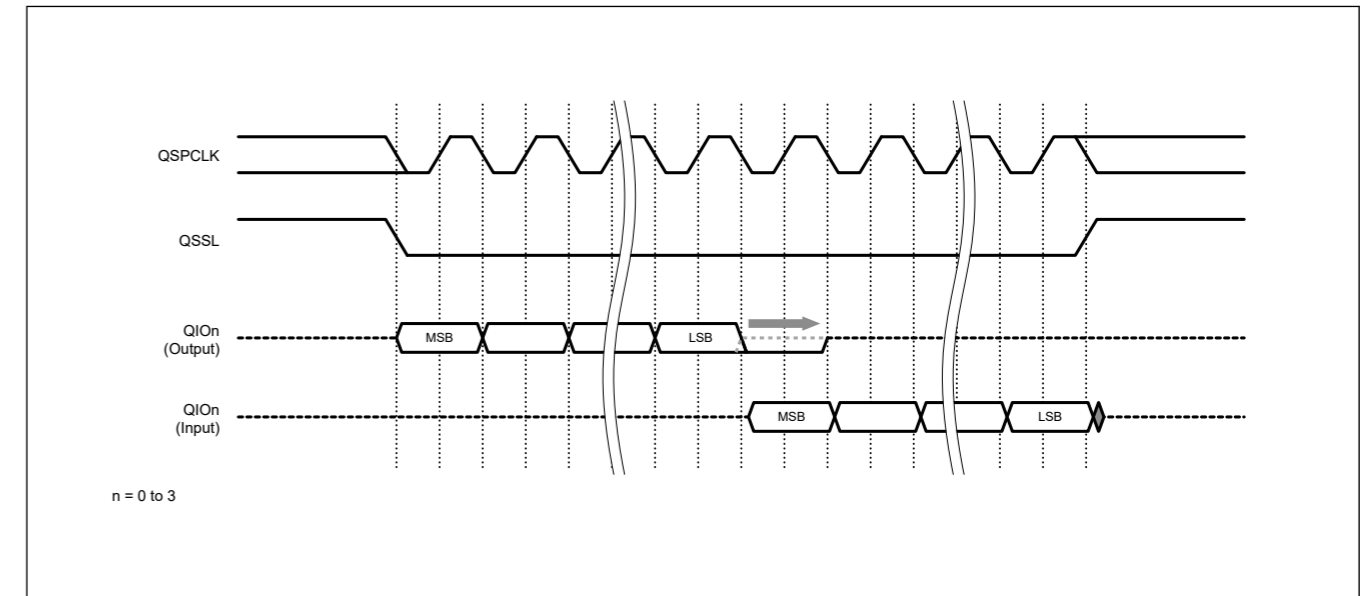


Figure 31.13 使用SFMOEX位（标准读取）调整输出使能的保持时间

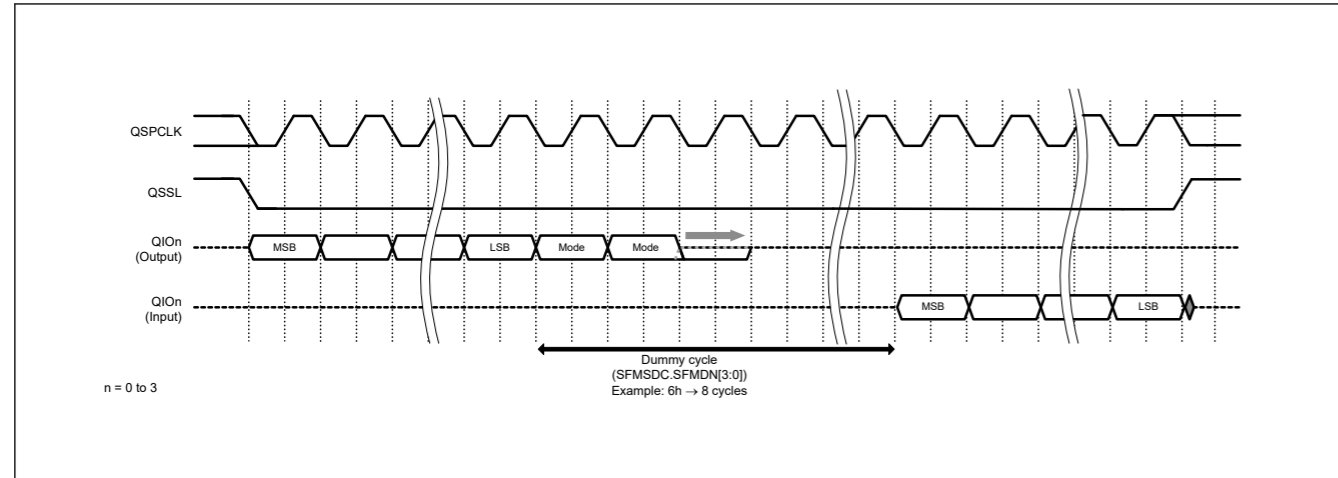


Figure 31.14 Hold Time Adjustment of Output Enabling Using the SFMOEX Bit (Fast Read)

### 31.5.7 Setup Time for Serial Data Output

When a command or address is transmitted to the serial flash memory, the setup time begins on serial data output and ends when the QSPCLK signal rises. If this setup time is insufficient, it can be extended by 1 PCLKA using the SFMOSW bit in the SFMSMD register. When SFMOSW is 1, the low-level width of QSPCLK during serial data transmission is extended by 1 PCLKA while data is being output from the QSPI. This function has no effect on serial data reception.

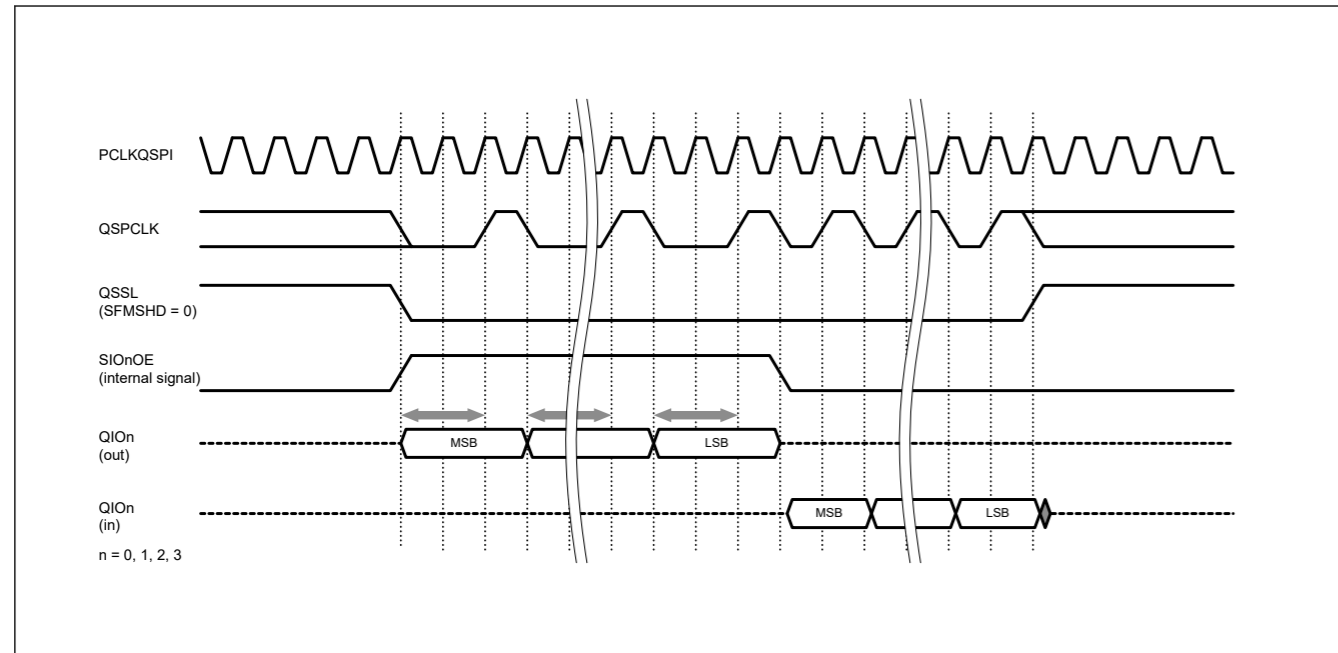


Figure 31.15 Setup time adjustment for serial data output using the SFMOSW bit

### 31.5.8 Hold Time for Serial Data Output

When a command or address is transmitted to the serial flash memory, the hold time begins on the rising edge of QSPCLK and ends when the serial data makes another transmission. If this hold time is insufficient, it can be extended by 1 PCLKA using the SFMOHW bit in the SFMSMD register. When SFMOSW is 1, the high-level width of QSPCLK during serial data transmission is extended by 1 PCLKA while data is being output from the QSPI. This function has no effect on serial data reception.

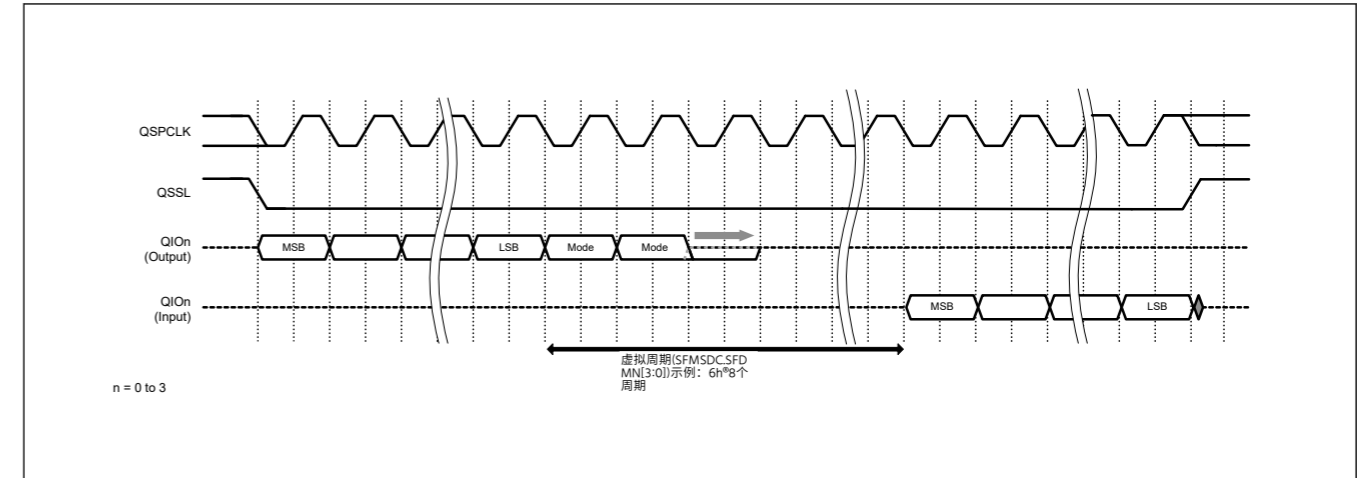


Figure 31.14 使用SFMOEX位（快速读取）调整输出使能的保持时间

### 31.5.7 串行数据输出的建立时间

当命令或地址传输到串行闪存时，设置时间从串行数据输出开始，到QSPCLK信号上升时结束。如果此建立时间不足，可以使用SFMSMD寄存器中的SFMOSW位将其延长1个PCLKA。当SFMOSW为1时，在从QSPI输出数据时，串行数据传输期间QSPCLK的低电平宽度扩展1PCLKA。该功能对串行数据接收没有影响。

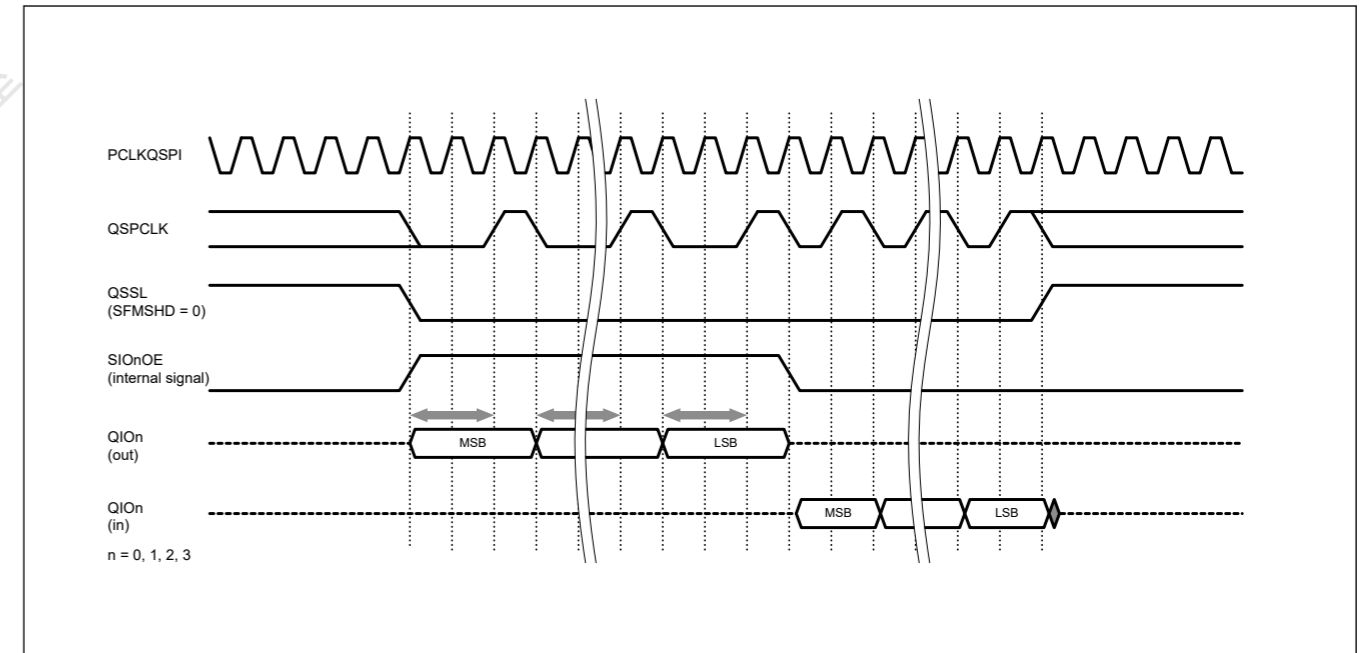


Figure 31.15 使用SFMOSW位调整串行数据输出的建立时间

### 31.5.8 串行数据输出的保持时间

当命令或地址传输到串行闪存时，保持时间从QSPCLK的上升沿开始，并在串行数据进行另一次传输时结束。如果该保持时间不足，可以使用SFMSMD寄存器中的SFMOHW位将其延长1个PCLKA。当SFMOSW为1时，在从QSPI输出数据时，串行数据传输期间QSPCLK的高电平宽度扩展1PCLKA。该功能对串行数据接收没有影响。



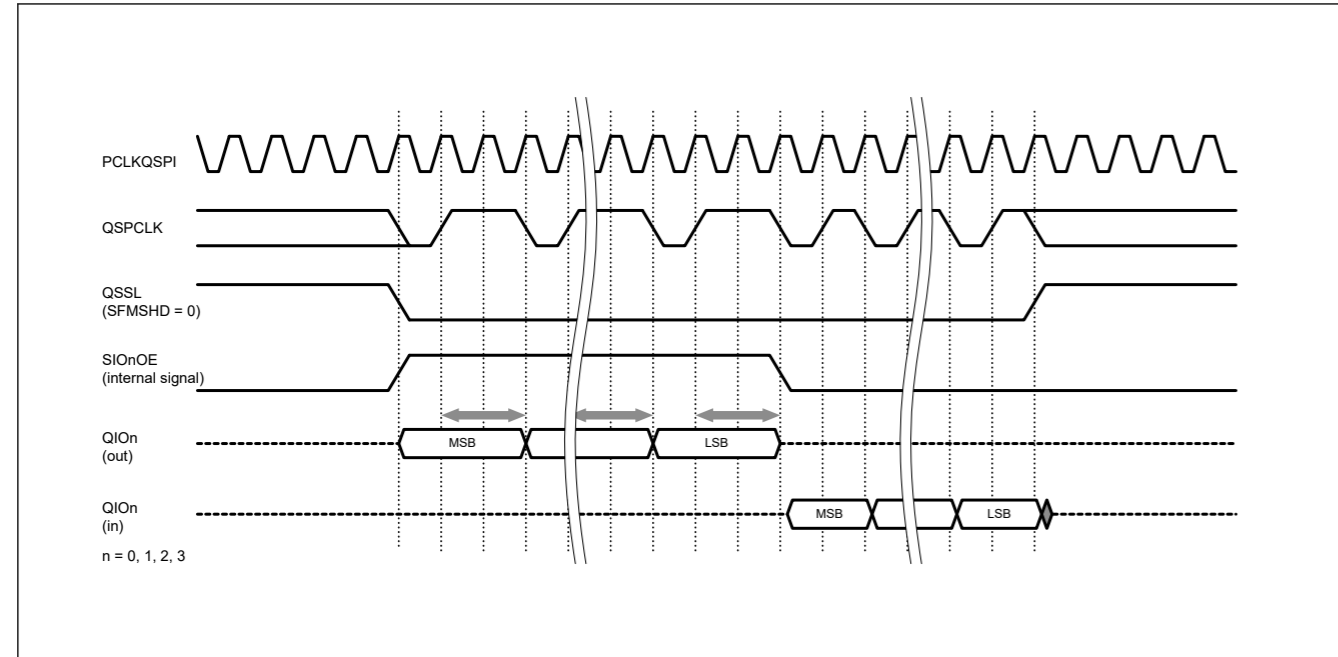


Figure 31.16 Hold time adjustment for serial data output using the SFMOHW bit

### 31.5.9 Serial Data Receiving Latency

The serial flash outputs data in synchronization with the falling edge of the QSPCLK signal. The QSPI receives that data in synchronization with the falling edge of the subsequent QSPCLK signal. The delay from when the serial flash starts outputting data until the QSPI receives that data is called the receiving latency. The QSPI adds a latency adjustment cycle immediately before the first data reception cycle in the SPI bus cycle. From the serial flash side, this is seen as an increase in the number of data reception cycles. This added latency adjustment cycle is not generated in the SPI bus cycle without accompanying data reception.

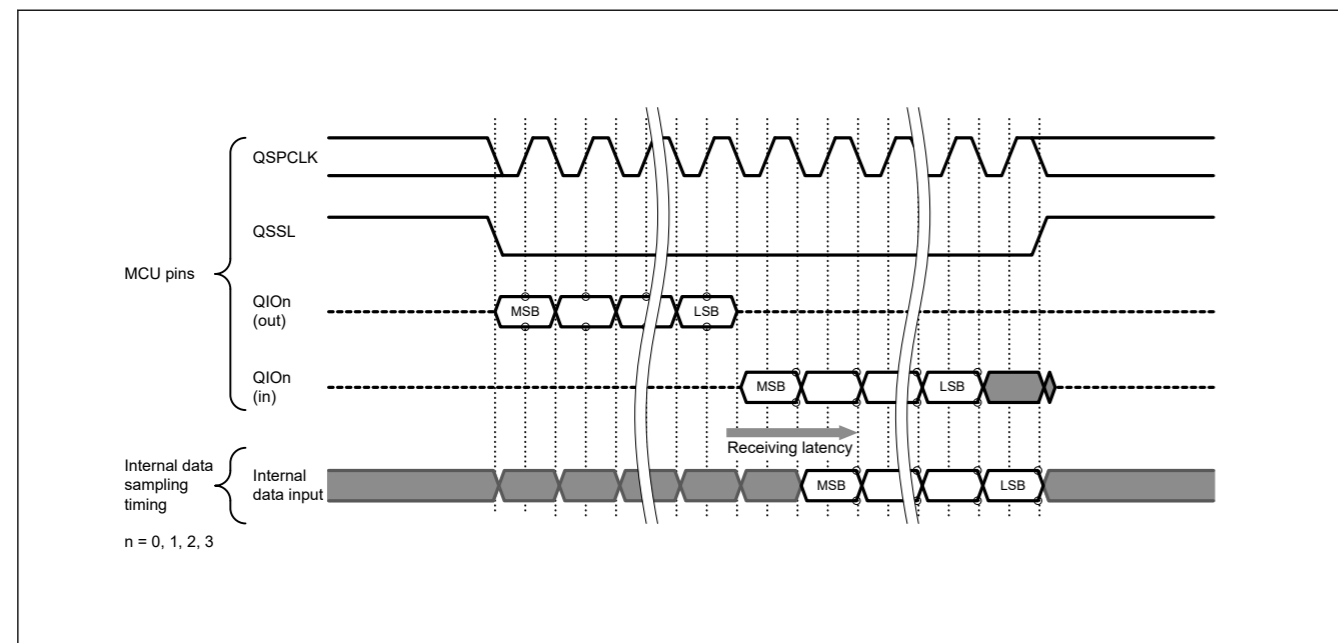


Figure 31.17 Receiving latency

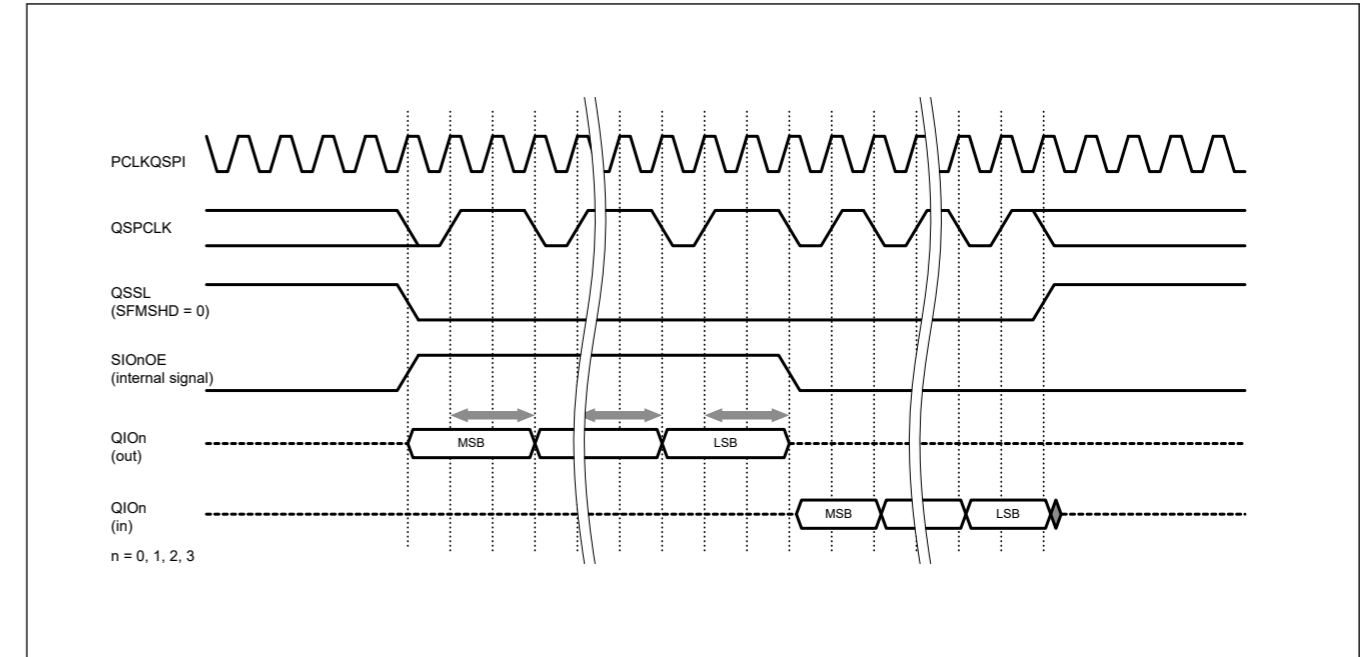


Figure 31.16 使用SFMOHW位调整串行数据输出的保持时间

### 31.5.9 串行数据接收延迟

串行闪存与QSPCLK信号的下降沿同步输出数据。QSPI与随后的QSPCLK信号的下降沿同步接收该数据。从串行闪存开始输出数据到QSPI接收到该数据的延迟称为接收延迟。QSPI在SPI总线周期的第一个数据接收周期之前添加一个延迟调整周期。从串行闪存方面来看，这被视为数据接收周期数的增加。如果没有伴随的数据接收，则不会在SPI总线周期中生成这个增加的延迟调整周期。

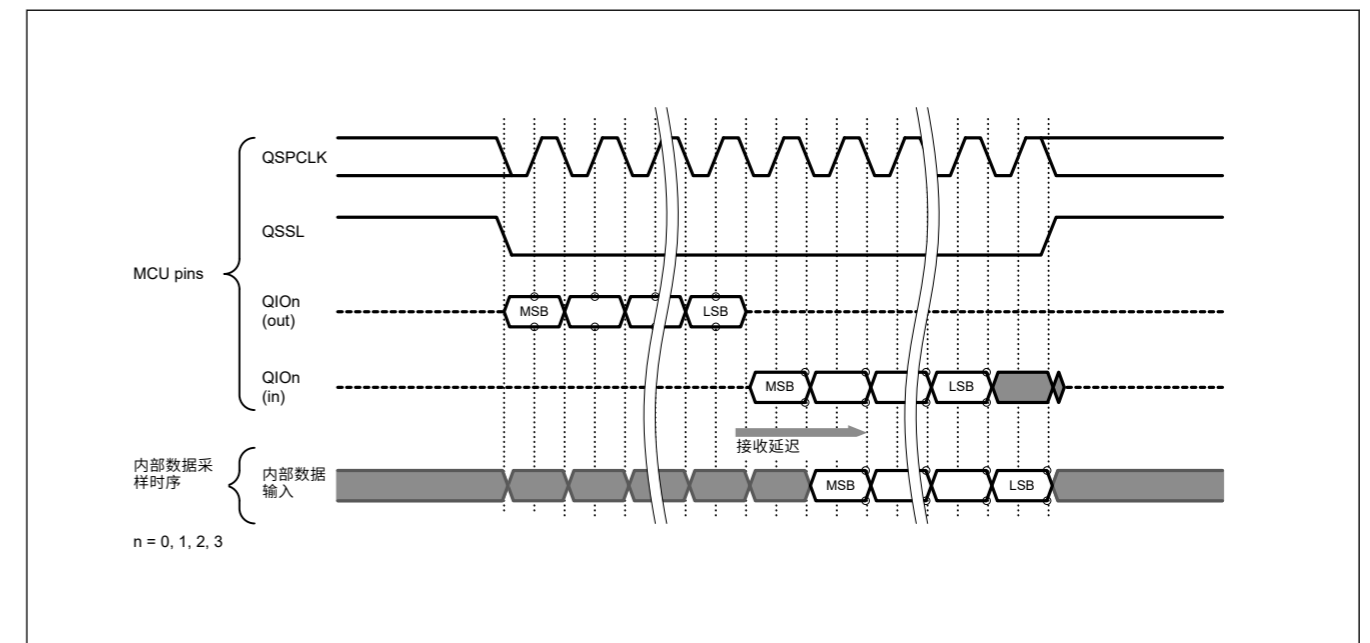


Figure 31.17 接收延迟

## 31.6 SPI Instruction Set Used for Serial Flash Memory Access

## 31.6.1 SPI Instructions That Are Automatically Generated

When the serial flash memory is accessed, an SPI bus cycle using the instructions described in Table 31.6 to Table 31.10 is automatically generated based on the settings in the SFMSAC register and in the SFMSMD register.

Table 31.6 SPI instructions automatically generated when SFMAS[1:0] = 00b

| SPI instruction | Instruction code   | Address bytes | Dummy cycles | Data bytes | Remarks                   |
|-----------------|--------------------|---------------|--------------|------------|---------------------------|
| Standard Read   | 0x03 <sup>*1</sup> | 1             | —            | 1 to ∞     | SFMRM[2:0] = 000b, A8 = 0 |
|                 | 0x0B <sup>*1</sup> | 1             | —            | 1 to ∞     | SFMRM[2:0] = 000b, A8 = 1 |

Note 1. If the SFMSMD.SFMCCE bit is set to 1, the SFMCIC[7:0] bits in the Instruction Code Register (SFMSIC) setting is used as an instruction code.

Table 31.7 SPI instructions automatically generated when SFMAS[1:0] = 01b

| SPI instruction | Instruction code   | Address bytes | Dummy cycles | Data bytes | Remarks           |
|-----------------|--------------------|---------------|--------------|------------|-------------------|
| Standard Read   | 0x03 <sup>*1</sup> | 2             | —            | 1 to ∞     | SFMRM[2:0] = 000b |

Note 1. If the SFMSMD.SFMCCE bit is set to 1, the SFMSIC.SFMCIC[7:0] setting is used as an instruction code.

Table 31.8 SPI instructions automatically generated when SFMAS[1:0] = 10b

| SPI instruction       | Instruction code   | Address bytes | Dummy cycles    | Data bytes | Remarks                       |
|-----------------------|--------------------|---------------|-----------------|------------|-------------------------------|
| Standard Read         | 0x03 <sup>*1</sup> | 3             | —               | 1 to ∞     | SFMRM[2:0] = 000b             |
| Fast Read             | 0x0B <sup>*1</sup> | 3             | 8 <sup>*2</sup> | 1 to ∞     | Selectable: SFMRM[2:0] = 001b |
| Fast Read Dual Output | 0x3B <sup>*1</sup> | 3             | 8 <sup>*2</sup> | 1 to ∞     | Selectable: SFMRM[2:0] = 010b |
| Fast Read Dual I/O    | 0xBB <sup>*1</sup> | 3             | 4 <sup>*2</sup> | 1 to ∞     | Selectable: SFMRM[2:0] = 011b |
| Fast Read Quad Output | 0x6B <sup>*1</sup> | 3             | 8 <sup>*2</sup> | 1 to ∞     | Selectable: SFMRM[2:0] = 100b |
| Fast Read Quad I/O    | 0xEB <sup>*1</sup> | 3             | 6 <sup>*2</sup> | 1 to ∞     | Selectable: SFMRM[2:0] = 101b |

Note 1. If the SFMSMD.SFMCCE bit is set to 1, the SFMSIC.SFMCIC[7:0] setting is used as an instruction code.

Note 2. The number of dummy cycles is configurable by using SFMDN[3:0] bits in the Dummy Cycle Control Register (SFMSDC).

Table 31.9 SPI instructions automatically generated when SFMAS[1:0] = 11b and SFM4BC = 0

| SPI instruction       | Instruction code   | Address bytes | Dummy cycles    | Data bytes | Remarks                       |
|-----------------------|--------------------|---------------|-----------------|------------|-------------------------------|
| Standard Read         | 0x03 <sup>*1</sup> | 4             | —               | 1 to ∞     | SFMRM[2:0] = 000b             |
| Fast Read             | 0x0B <sup>*1</sup> | 4             | 8 <sup>*2</sup> | 1 to ∞     | Selectable: SFMRM[2:0] = 001b |
| Fast Read Dual Output | 0x3B <sup>*1</sup> | 4             | 8 <sup>*2</sup> | 1 to ∞     | Selectable: SFMRM[2:0] = 010b |
| Fast Read Dual I/O    | 0xBB <sup>*1</sup> | 4             | 4 <sup>*2</sup> | 1 to ∞     | Selectable: SFMRM[2:0] = 011b |
| Fast Read Quad Output | 0x6B <sup>*1</sup> | 4             | 8 <sup>*2</sup> | 1 to ∞     | Selectable: SFMRM[2:0] = 100b |
| Fast Read Quad I/O    | 0xEB <sup>*1</sup> | 4             | 6 <sup>*2</sup> | 1 to ∞     | Selectable: SFMRM[2:0] = 101b |

Note 1. If the SFMSMD.SFMCCE bit is set to 1, the SFMSIC.SFMCIC[7:0] setting is used as an instruction code.

Note 2. The number of dummy cycles is configurable by using the SFMSDC.SFMDN[3:0] bits.

Table 31.10 SPI instructions automatically generated when SFMAS[1:0] = 11b and SFM4BC = 1 (1 of 2)

| SPI instruction | Instruction code   | Address bytes | Dummy cycles | Data bytes | Remarks           |
|-----------------|--------------------|---------------|--------------|------------|-------------------|
| Standard Read   | 0x13 <sup>*1</sup> | 4             | —            | 1 to ∞     | SFMRM[2:0] = 000b |

## 31.6 用于串行闪存访问的SPI指令集

## 31.6.1 自动生成的SPI指令

访问串行闪存时，会根据SFMSAC寄存器和SFMSMD寄存器中的设置自动生成使用表31.6至表31.10中描述的指令的SPI总线周期。

Table 31.6 SFMAS[1:0]=00b时自动生成SPI指令

| SPI指令 | 指令码                | 地址字节 | 虚拟循环 | 数据字节   | Remarks                   |
|-------|--------------------|------|------|--------|---------------------------|
| 标准阅读  | 0x03 <sup>*1</sup> | 1    | —    | 1 to ∞ | SFMRM[2:0] = 000b, A8 = 0 |
|       | 0x0B <sup>*1</sup> | 1    | —    | 1 to ∞ | SFMRM[2:0] = 000b, A8 = 1 |

注1.如果SFMSMD.SFMCCE位设置为1，则指令代码寄存器(SFMSIC)设置中的SFMCIC[7:0]位用作指令代码。

Table 31.7 SFMAS[1:0]=01b时自动生成SPI指令

| SPI指令 | 指令码                | 地址字节 | 虚拟循环 | 数据字节   | Remarks           |
|-------|--------------------|------|------|--------|-------------------|
| 标准阅读  | 0x03 <sup>*1</sup> | 2    | —    | 1 to ∞ | SFMRM[2:0] = 000b |

注1.如果SFMSMD.SFMCCE位设置为1，则SFMSIC.SFMCIC[7:0]设置用作指令代码。

Table 31.8 SFMAS[1:0]=10b时自动生成SPI指令

| SPI指令    | 指令码                | 地址字节 | 虚拟循环            | 数据字节   | Remarks                       |
|----------|--------------------|------|-----------------|--------|-------------------------------|
| 标准阅读     | 0x03 <sup>*1</sup> | 3    | —               | 1 to ∞ | SFMRM[2:0] = 000b             |
| 快速阅读     | 0x0B <sup>*1</sup> | 3    | 8 <sup>*2</sup> | 1 to ∞ | Selectable: SFMRM[2:0] = 001b |
| 快速读取双输出  | 0x3B <sup>*1</sup> | 3    | 8 <sup>*2</sup> | 1 to ∞ | Selectable: SFMRM[2:0] = 010b |
| 快速读取双IO  | 0xBB <sup>*1</sup> | 3    | 4 <sup>*2</sup> | 1 to ∞ | Selectable: SFMRM[2:0] = 011b |
| 快速读取四路输出 | 0x6B <sup>*1</sup> | 3    | 8 <sup>*2</sup> | 1 to ∞ | Selectable: SFMRM[2:0] = 100b |
| 快速读取四路IO | 0xEB <sup>*1</sup> | 3    | 6 <sup>*2</sup> | 1 to ∞ | Selectable: SFMRM[2:0] = 101b |

注1.如果SFMSMD.SFMCCE位设置为1，则SFMSIC.SFMCIC[7:0]设置用作指令代码。

注2.虚拟周期数可通过使用虚拟周期控制寄存器(SFMSDC)中的SFMDN[3:0]位进行配置。

Table 31.9 当SFMAS[1:0]=11b和SFM4BC=0时自动生成SPI指令

| SPI指令    | 指令码                | 地址字节 | 虚拟循环            | 数据字节   | Remarks                       |
|----------|--------------------|------|-----------------|--------|-------------------------------|
| 标准阅读     | 0x03 <sup>*1</sup> | 4    | —               | 1 to ∞ | SFMRM[2:0] = 000b             |
| 快速阅读     | 0x0B <sup>*1</sup> | 4    | 8 <sup>*2</sup> | 1 to ∞ | Selectable: SFMRM[2:0] = 001b |
| 快速读取双输出  | 0x3B <sup>*1</sup> | 4    | 8 <sup>*2</sup> | 1 to ∞ | Selectable: SFMRM[2:0] = 010b |
| 快速读取双IO  | 0xBB <sup>*1</sup> | 4    | 4 <sup>*2</sup> | 1 to ∞ | Selectable: SFMRM[2:0] = 011b |
| 快速读取四路输出 | 0x6B <sup>*1</sup> | 4    | 8 <sup>*2</sup> | 1 to ∞ | Selectable: SFMRM[2:0] = 100b |
| 快速读取四路IO | 0xEB <sup>*1</sup> | 4    | 6 <sup>*2</sup> | 1 to ∞ | Selectable: SFMRM[2:0] = 101b |

注1.如果SFMSMD.SFMCCE位设置为1，则SFMSIC.SFMCIC[7:0]设置用作指令代码。

注2.虚拟周期数可通过使用SFMSDC.SFMDN[3:0]位进行配置。

Table 31.10 当SFMAS[1:0]=11b和SFM4BC=1时自动生成SPI指令 (1 of 2)

| SPI指令 | 指令码                | 地址字节 | 虚拟循环 | 数据字节   | Remarks           |
|-------|--------------------|------|------|--------|-------------------|
| 标准阅读  | 0x13 <sup>*1</sup> | 4    | —    | 1 to ∞ | SFMRM[2:0] = 000b |

Table 31.10 SPI instructions automatically generated when SFMAS[1:0] = 11b and SFM4BC = 1 (2 of 2)

| SPI instruction       | Instruction code   | Address bytes | Dummy cycles    | Data bytes | Remarks                       |
|-----------------------|--------------------|---------------|-----------------|------------|-------------------------------|
| Fast Read             | 0x0C <sup>*1</sup> | 4             | 8 <sup>*2</sup> | 1 to ∞     | Selectable: SFMRM[2:0] = 001b |
| Fast Read Dual Output | 0x3C <sup>*1</sup> | 4             | 8 <sup>*2</sup> | 1 to ∞     | Selectable: SFMRM[2:0] = 010b |
| Fast Read Dual I/O    | 0xBC <sup>*1</sup> | 4             | 4 <sup>*2</sup> | 1 to ∞     | Selectable: SFMRM[2:0] = 011b |
| Fast Read Quad Output | 0x6C <sup>*1</sup> | 4             | 8 <sup>*2</sup> | 1 to ∞     | Selectable: SFMRM[2:0] = 100b |
| Fast Read Quad I/O    | 0xEC <sup>*1</sup> | 4             | 6 <sup>*2</sup> | 1 to ∞     | Selectable: SFMRM[2:0] = 101b |

Note 1. If the SFMSMD.SFMCCE bit is set to 1, the SFMSIC.SFMCIC[7:0] setting is used as an instruction code.  
 Note 2. The number of dummy cycles is configurable by using the SFMSDC.SFMDN[3:0] bits..

### 31.6.2 Standard Read Instruction

The standard Read instruction is a common read instruction supported by most serial flash memory. When an SPI bus cycle starts, the QSSL signal (serial flash memory select) is asserted, and the instruction code (0x03 or 0x13)<sup>\*1</sup> is output. Next, an address with a width of 1 to 4 bytes, specified in the SFMAS[1:0] bits in the SFMSAC register, is transmitted. Data is then received.

This standard Read instruction is selected in the initial QSPI settings.

Note 1. Many 4-KB serial flash memory devices have an address field not larger than 1 byte (A7-A0) to minimize the overhead and to receive A8 information from bit 3 of the Read instruction code. To support these devices, the QSPI only outputs A8 (address bit 8) to bit [3] of the standard Read instruction code when an address width of 1 byte is specified (SFMAS[1:0] = 00). This means that 0x0B might be output instead of 0x03 as the standard Read instruction code. This code duplicates the Fast Read instruction code. However, for most of the 2-KB or smaller serial flash memory, with an address width of 1 byte, bit 3 of a command is designed to be excluded from decoding as a don't-care bit, so such a Read instruction code is recognized correctly as the standard Read instruction code. In rare cases, some serial flash memory allow bit 3 to be decoded. When such a serial flash memory is connected, configure your application to avoid access resulting in A8 = 1.

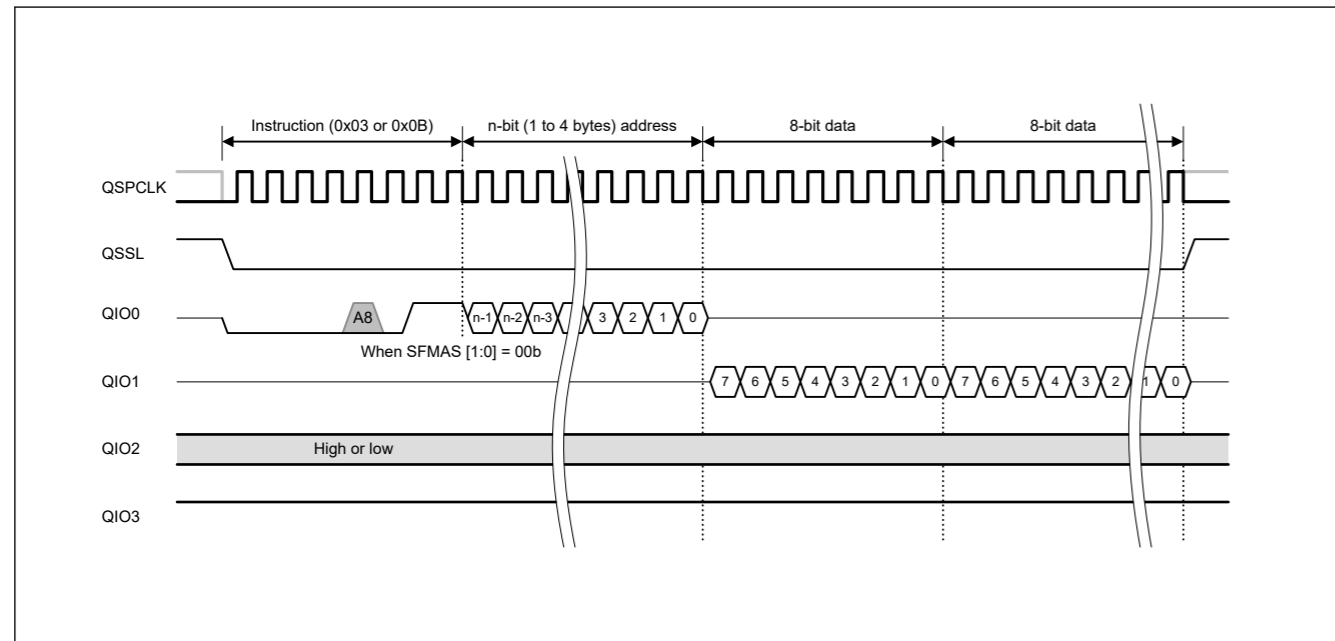


Figure 31.18 Standard Read bus cycle

### 31.6.3 Fast Read Instruction

The Fast Read instruction is a read instruction that supports a higher communication clock speed than the standard Read instruction. When an SPI bus cycle starts, the QSSL signal is asserted, and the instruction code (0x0B or 0x0C) is output.

Table 31.10 当SFMAS[1:0]=11b和SFM4BC=1(2of2)时自动生成SPI指令

| SPI指令    | 指令码                | 地址字节 | 虚拟循环            | 数据字节   | Remarks                       |
|----------|--------------------|------|-----------------|--------|-------------------------------|
| 快速阅读     | 0x0C <sup>*1</sup> | 4    | 8 <sup>*2</sup> | 1 to ∞ | Selectable: SFMRM[2:0] = 001b |
| 快速读取双输出  | 0x3C <sup>*1</sup> | 4    | 8 <sup>*2</sup> | 1 to ∞ | Selectable: SFMRM[2:0] = 010b |
| 快速读取双IO  | 0xBC <sup>*1</sup> | 4    | 4 <sup>*2</sup> | 1 to ∞ | Selectable: SFMRM[2:0] = 011b |
| 快速读取四路输出 | 0x6C <sup>*1</sup> | 4    | 8 <sup>*2</sup> | 1 to ∞ | Selectable: SFMRM[2:0] = 100b |
| 快速读取四路IO | 0xEC <sup>*1</sup> | 4    | 6 <sup>*2</sup> | 1 to ∞ | Selectable: SFMRM[2:0] = 101b |

注1.如果SFMSMD.SFMCCE位设置为1, 则SFMSIC.SFMCIC[7:0]设置用作指令代码。  
 注2.虚拟周期数可通过使用SFMSDC.SFMDN[3:0]位进行配置。

### 31.6.2 标准阅读说明

标准读指令是大多数串行闪存支持的常见读指令。当SPI总线周期开始时, QSSL信号(串行闪存选择)被置位, 并输出指令代码(0x03或0x13)<sup>\*1</sup>。接下来, 发送宽度为1到4字节的地址, 在SFMSAC寄存器的SFMAS[1:0]位中指定。然后接收数据。

在初始QSPI设置中选择此标准读取指令。

注1.许多4KB串行闪存器件的地址字段不大于1字节(A7-A0), 以尽量减少开销并从读取指令代码的第3位接收A8信息。为了支持这些器件, 当指定地址宽度为1字节(SFMAS[1:0]=00)时, QSPI仅将A8(地址位8)输出到标准读取指令代码的位[3]。这意味着可能会输出0x0B而不是0x03作为标准读取指令代码。此代码复制了快速读取指令代码。然而, 对于大多数2-KB或更小的串行闪存, 地址宽度为1字节, 命令的第3位被设计为作为无关位从解码中排除, 因此这样的读取指令代码被正确识别为标准读取指令代码。在极少数情况下, 某些串行闪存允许对第3位进行解码。连接此类串行闪存时, 配置您的应用程序以避免访问导致A8=1。

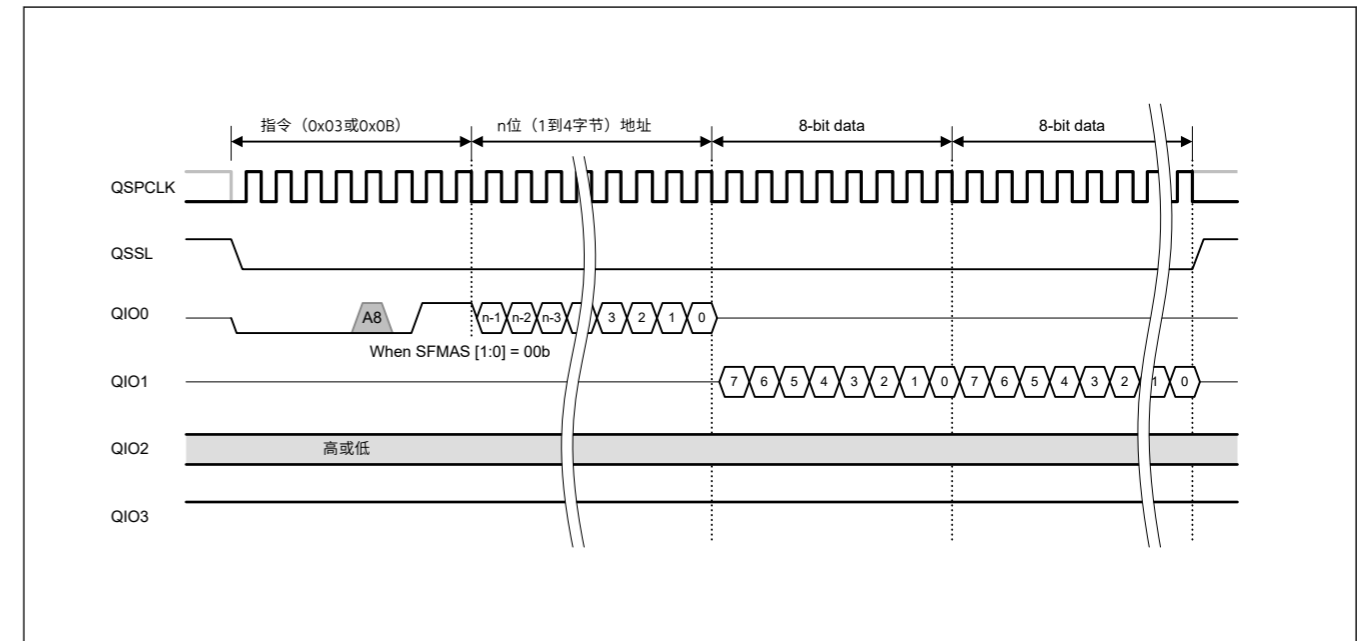


Figure 31.18 标准读总线周期

### 31.6.3 快速阅读说明

快速读取指令是一种读取指令, 它支持比标准读取指令更高的通信时钟速度。当一个SPI总线周期开始时, QSSL信号被置位, 并输出指令代码(0x0B或0x0C)。

Next, an address with a width of 1 to 4 bytes specified by the SFMSAC.SFMAS [1: 0] bits is transmitted, a dummy cycle specified by the SFMSDC register is generated, then the data is received.

The first two dummy cycles are used to select the XIP mode. When the XIP mode is selected, the same instruction used this time is applied to the next SPI bus cycle, and the instruction code is not output the next SPI bus cycle. For details on the XIP mode, see [section 31.8. XIP Control](#).

Switching to the Fast Read instruction is controlled in the SFMSMD register.

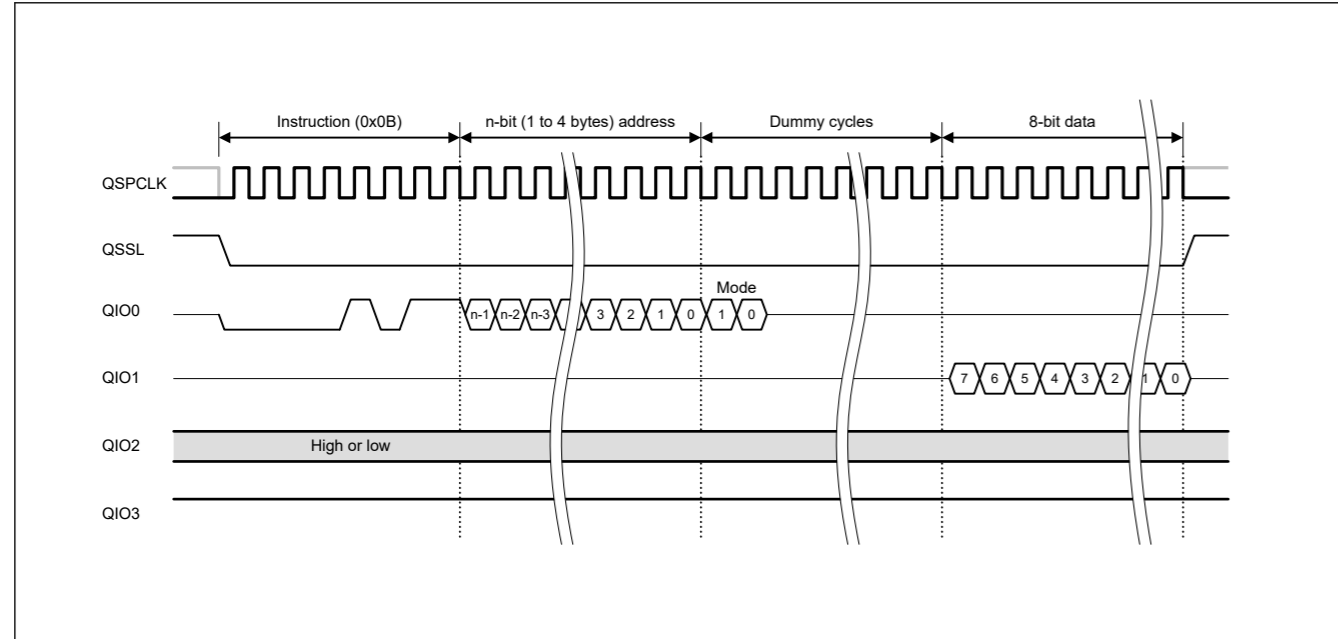


Figure 31.19 Fast Read bus cycle

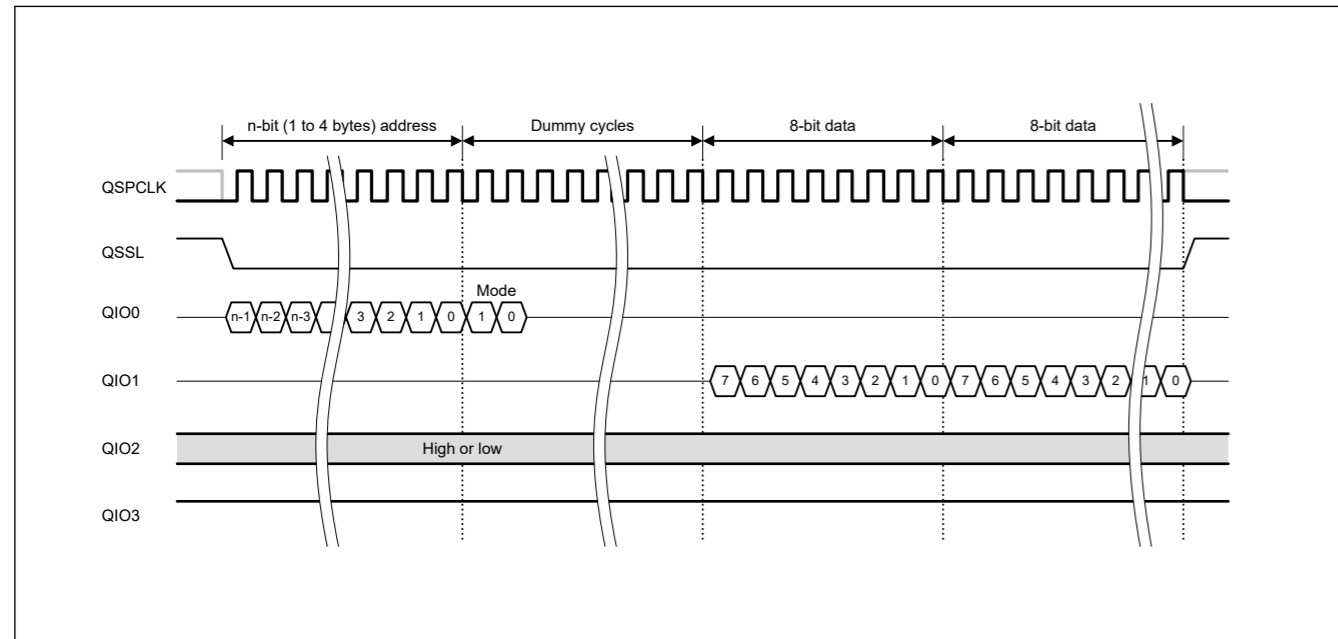


Figure 31.20 Fast Read bus cycle in XIP mode

Note: To use the Fast Read instruction, a serial flash memory that supports Fast Read transfers is required.

### 31.6.4 Fast Read Dual Output Instruction

The Fast Read Dual Output instruction is a read instruction that uses two signal lines to receive data. When the SPI bus cycle starts, the QSSL signal is asserted. The instruction code (0x3B or 0x3C) and an address with a width of 1 to 4 bytes,

接下来，发送由SFMSAC.SFMAS[1:0]位指定的1到4字节宽度的地址，生成由SFMSDC寄存器指定的虚拟周期，然后接收数据。

前两个虚拟周期用于选择XIP模式。选择XIP模式时，此时间使用的相同指令将应用于下一个SPI总线周期，并且指令代码未输出下一个SPI总线周期。有关XIP模式的详细信息，请参阅第31.8节。XIP控制。

切换到快速读取指令在SFMSMD寄存器中进行控制。

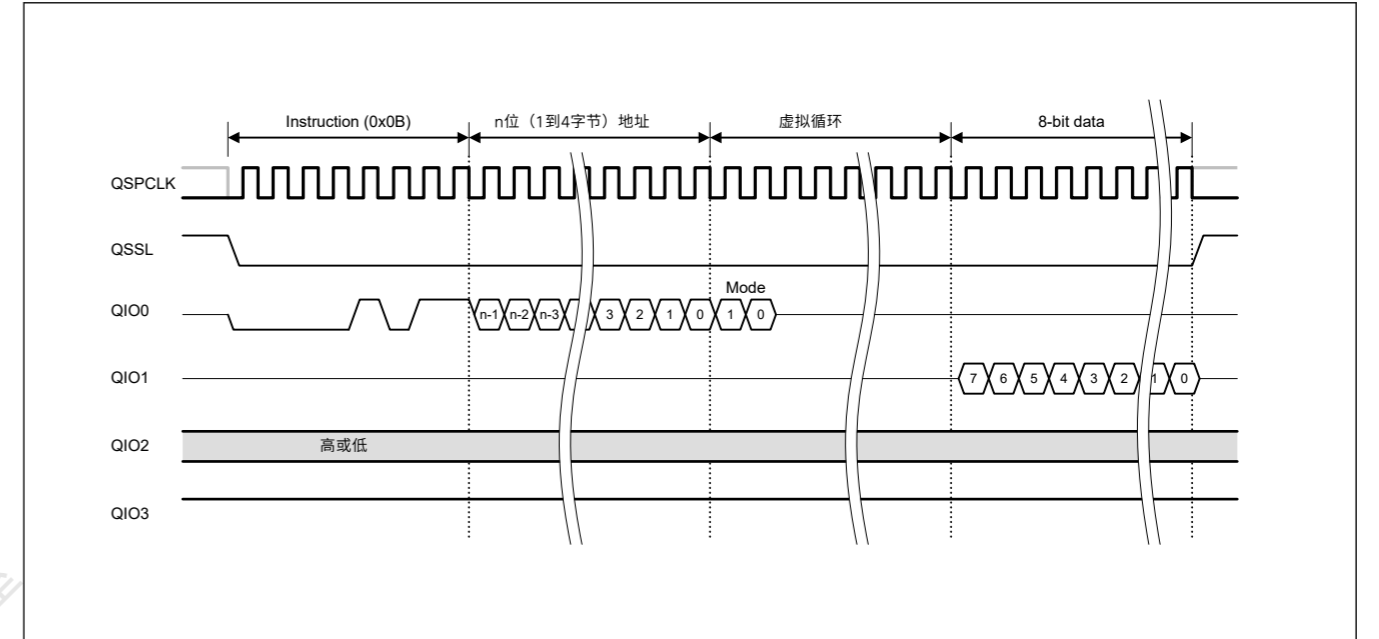


Figure 31.19 快速读取总线周期

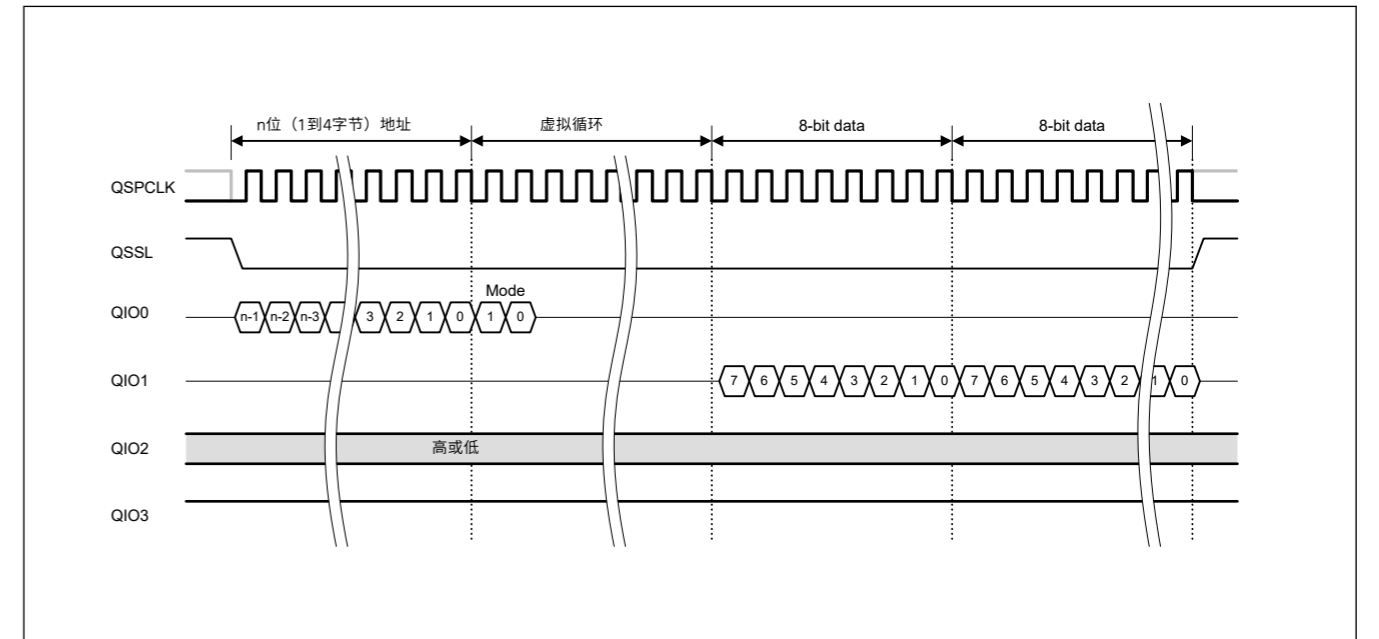


Figure 31.20 XIP模式下的快速读取总线周期

Note: 要使用快速读取指令，需要支持快速读取传输的串行闪存。

### 31.6.4 快速读取双输出指令

快速读取双输出指令是使用两条信号线接收数据的读取指令。当SPI总线周期开始时，QSSL信号被置位。指令代码 (0x3B或0x3C) 和一个宽度为1到4个字节的地址，



specified by the SFMSAC.SFMAS [1: 0] bits are transmitted from the QIO0 pin in the extended SPI protocol, and transmitted from the QIO0 and QIO1 pins in the Dual-SPI protocol. Next, a certain number of dummy cycles, specified in the SFMSDC register, is generated. Data is then received through the QIO0 and QIO1 pins. Even bit data is received from the QIO0 pin and odd bit data is received from the QIO1 pin.

The first two dummy cycles are used to select the XIP mode. When the XIP mode is selected, the same instruction used this time is applied to the next SPI bus cycle, and the instruction code is not output the next SPI bus cycle. For details on the XIP mode, see [section 31.8. XIP Control](#).

Switching to Fast Read Dual Output is controlled in the SFMSMD register.

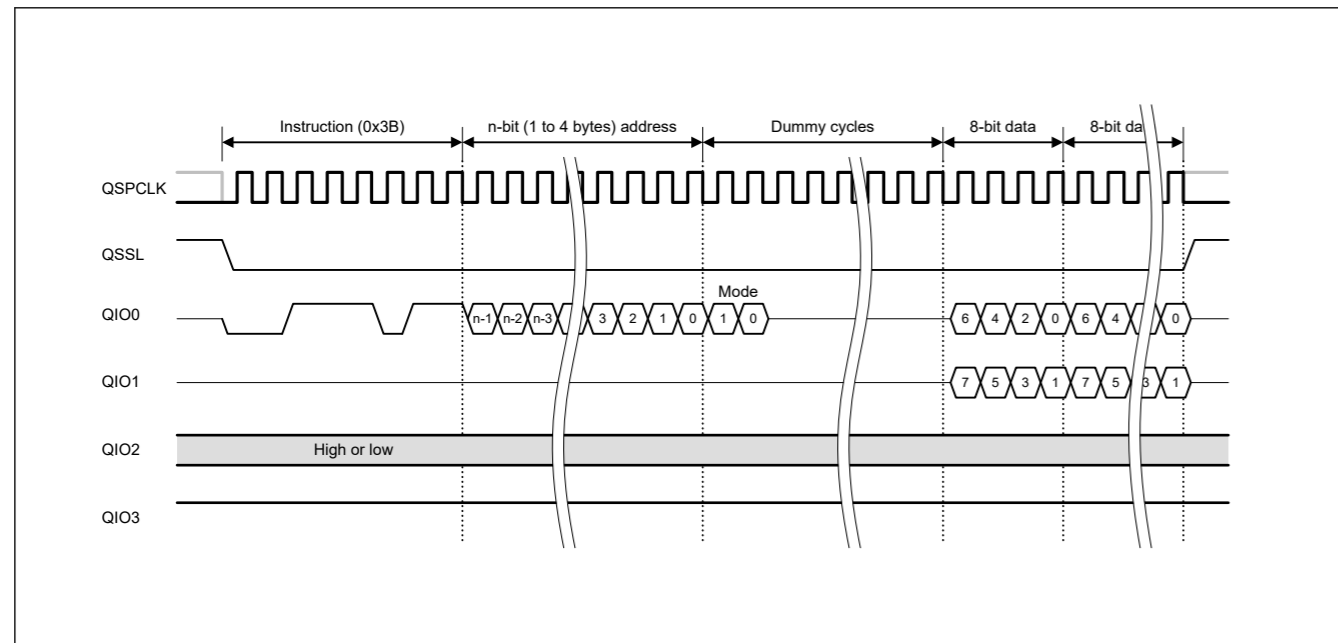


Figure 31.21 Fast Read Dual Output bus cycle (with extended SPI protocol)

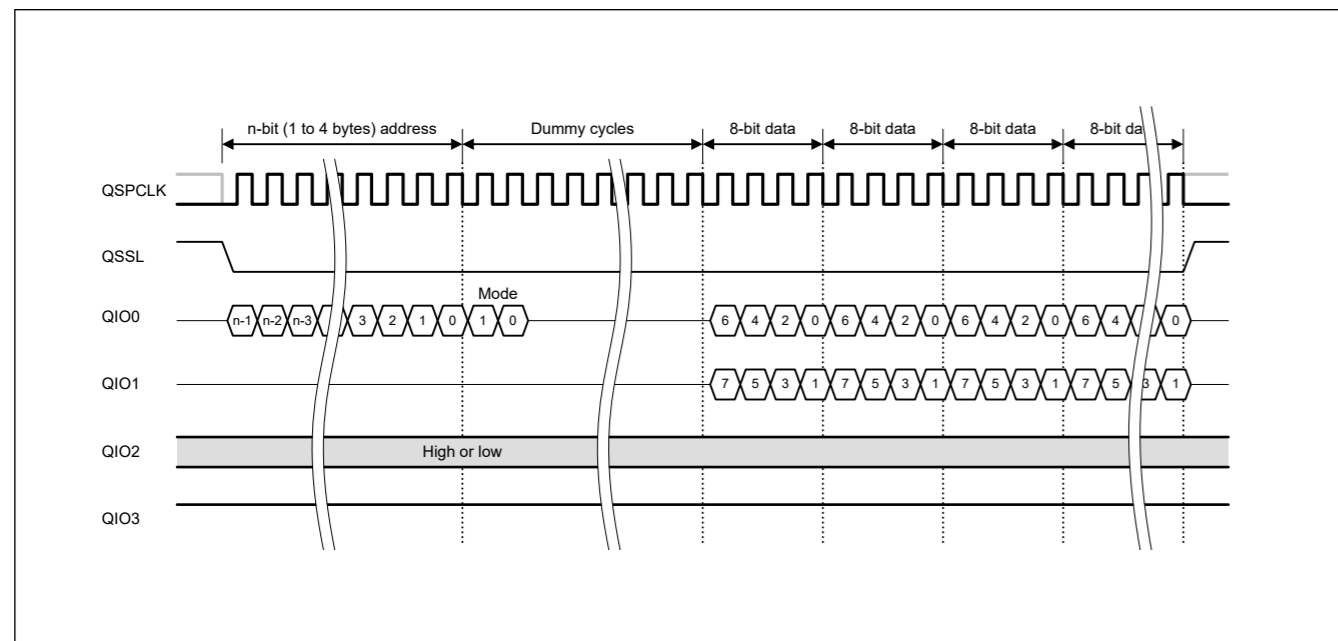


Figure 31.22 Fast Read Dual Output bus cycle in XIP mode (with extended SPI protocol)

Note: To use the Fast Read Dual Output instruction, a serial flash memory that supports Fast Read Dual Output transfers is required.

由SFMSAC.SFMAS[1:0]位指定在扩展SPI协议中从QIO0引脚传输，在Dual-SPI协议中从QIO0和QIO1引脚传输。接下来，生成在SFMSDC寄存器中指定的一定数量的虚拟周期。然后通过QIO0和QIO1引脚接收数据。从QIO0引脚接收偶数位数据，从QIO1引脚接收奇数位数据。

前两个虚拟周期用于选择XIP模式。选择XIP模式时，此时间使用的相同指令将应用于下一个SPI总线周期，并且指令代码未输出下一个SPI总线周期。有关XIP模式的详细信息，请参阅第31.8节。XIP控制。

切换到快速读取双路输出由SFMSMD寄存器控制。

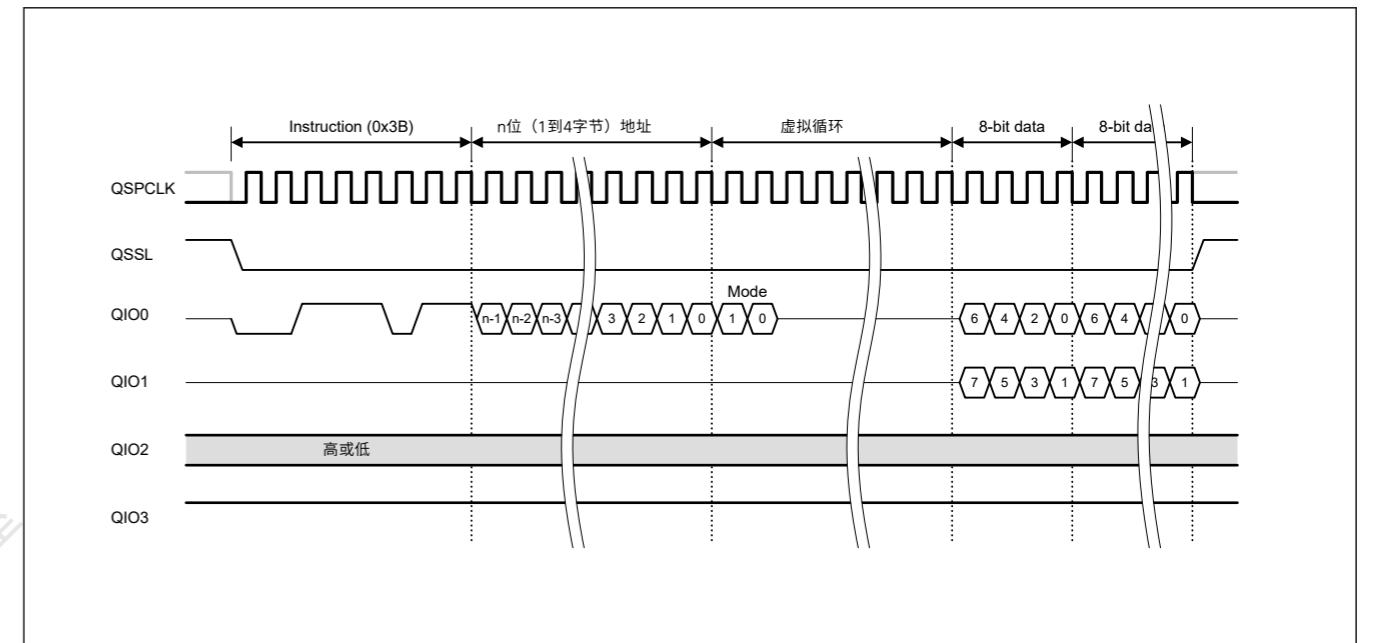


Figure 31.21 快速读取双输出总线周期（带有扩展SPI协议）

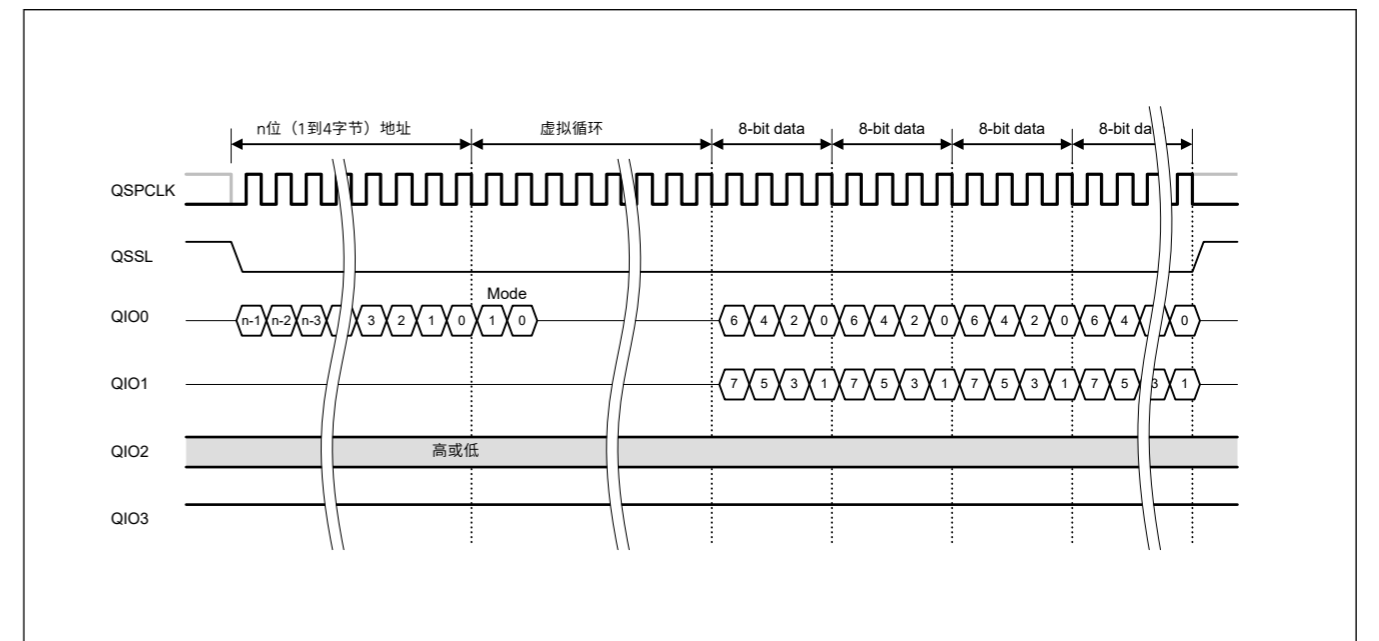


Figure 31.22 XIP模式下的快速读取双输出总线周期（使用扩展SPI协议）

Note: 要使用快速读取双输出指令，需要支持快速读取双输出传输的串行闪存。

31.6.5 Fast Read Dual I/O Instruction

The Fast Read Dual I/O instruction is a read instruction that uses two signal lines to transmit an address and receive data. When the SPI bus cycle starts, the QSSL signal is asserted, and the instruction code (0xBB / 0xBC) is transmitted from QIO0 pin in the extended SPI protocol and from QIO0, and QIO1 pins in the Dual SPI protocol. Next, an address with a width of 1 to 4 bytes, specified in the SFMAS[1:0] bits in the SFMSAC register, is transmitted through the QIO0 and QIO1 pins, and a certain number of dummy cycles, specified in the SFMSDC register, is generated. Data is then received through the QIO0 and QIO1 pins. Address and dummy cycle transmission and data reception are performed through the QIO0 pin for even bits and through the QIO1 pin for odd bits.

The first two dummy cycles are used to select the XIP mode. When the XIP mode is selected, the same instruction used this time is applied to the next SPI bus cycle, and the instruction code is not output the next SPI bus cycle. For details on the XIP mode, see section 31.8. XIP Control.

Switching to Fast Read Dual I/O is controlled in the SFMSMD register.

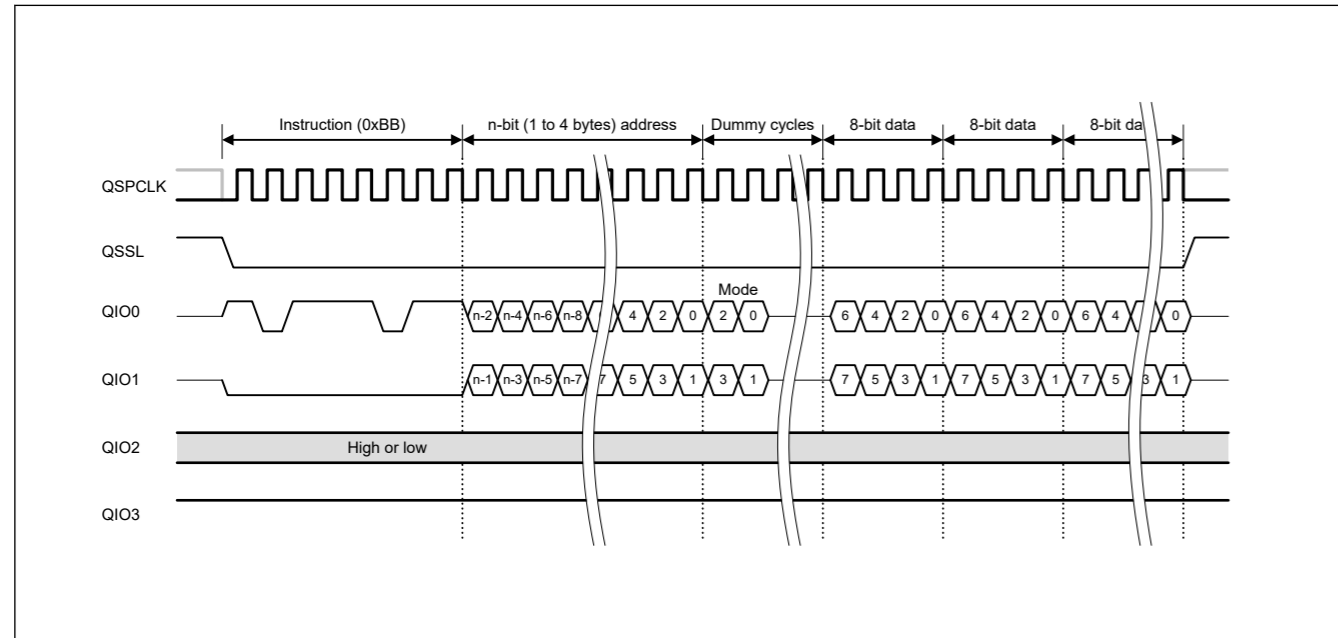


Figure 31.23 Fast Read Dual I/O bus cycle (with extended SPI protocol)

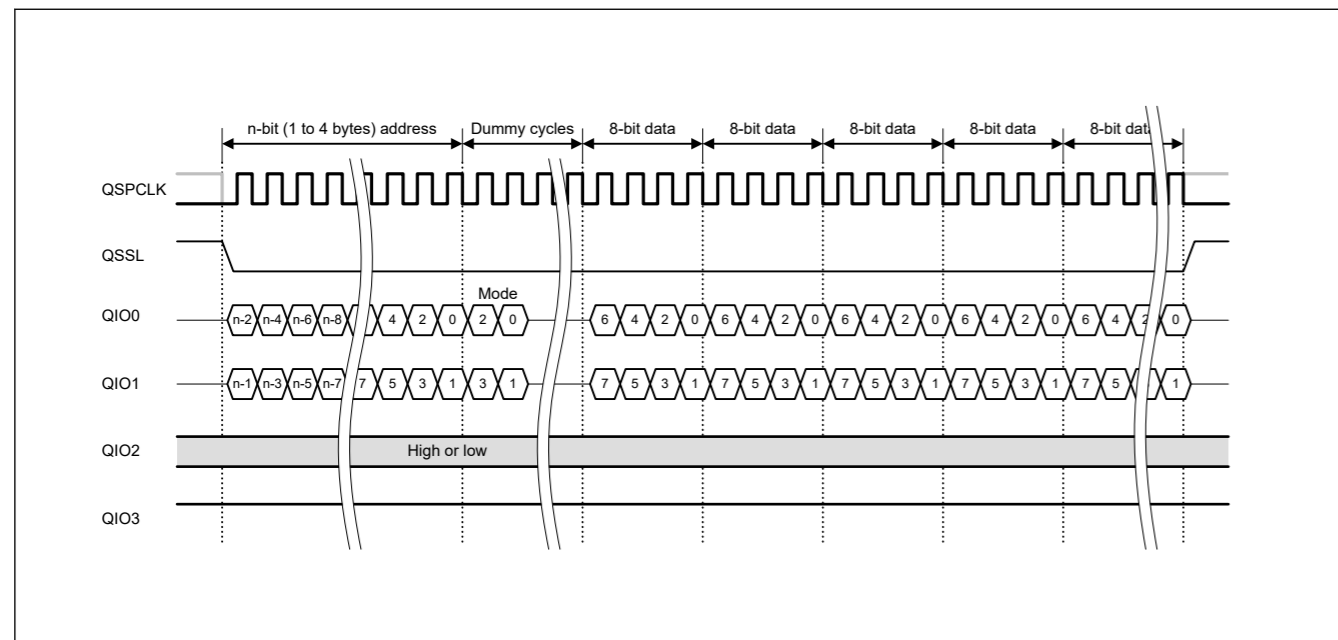


Figure 31.24 Fast Read Dual I/O bus cycle in XIP mode

31.6.5 快速读取双IO指令

FastReadDualIO指令是使用两条信号线传输地址和接收数据的读取指令。当SPI总线周期开始时，QSSL信号被置位，指令代码 (0xBB/0xBC) 从扩展SPI协议中的QIO0引脚和双SPI协议中的QIO0和QIO1引脚传输。接下来，在SFMSAC寄存器的SFMAS[1:0]位中指定的1到4字节宽度的地址通过QIO0和QIO1引脚以及在SFMSDC寄存器中指定的一定数量的空周期发送生成。然后通过QIO0和QIO1引脚接收数据。地址和虚拟周期的发送和数据接收通过QIO0引脚（偶数位）和QIO1引脚（奇数位）执行。

前两个虚拟周期用于选择XIP模式。选择XIP模式时，此时间使用的相同指令将应用于下一个SPI总线周期，并且指令代码未输出下一个SPI总线周期。有关XIP模式的详细信息，请参阅第31.8节。XIP控制。

切换到快速读取双IO由SFMSMD寄存器控制。

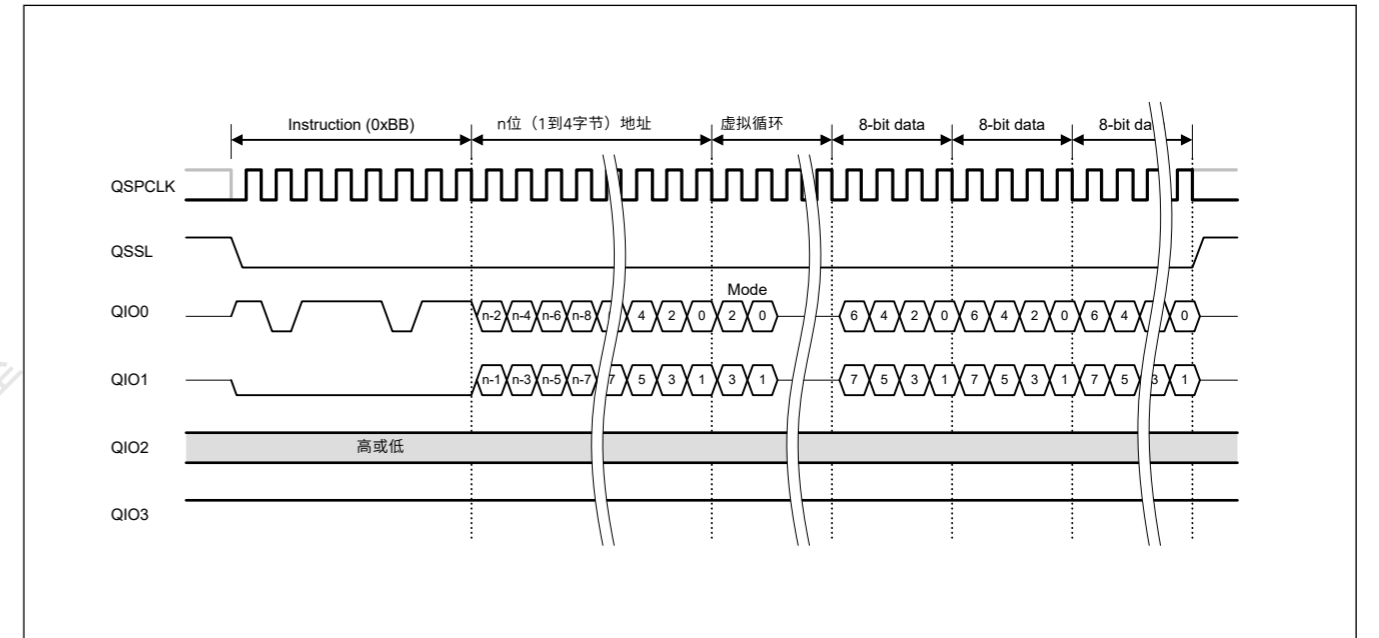


Figure 31.23 快速读取双IO总线周期（带有扩展SPI协议）

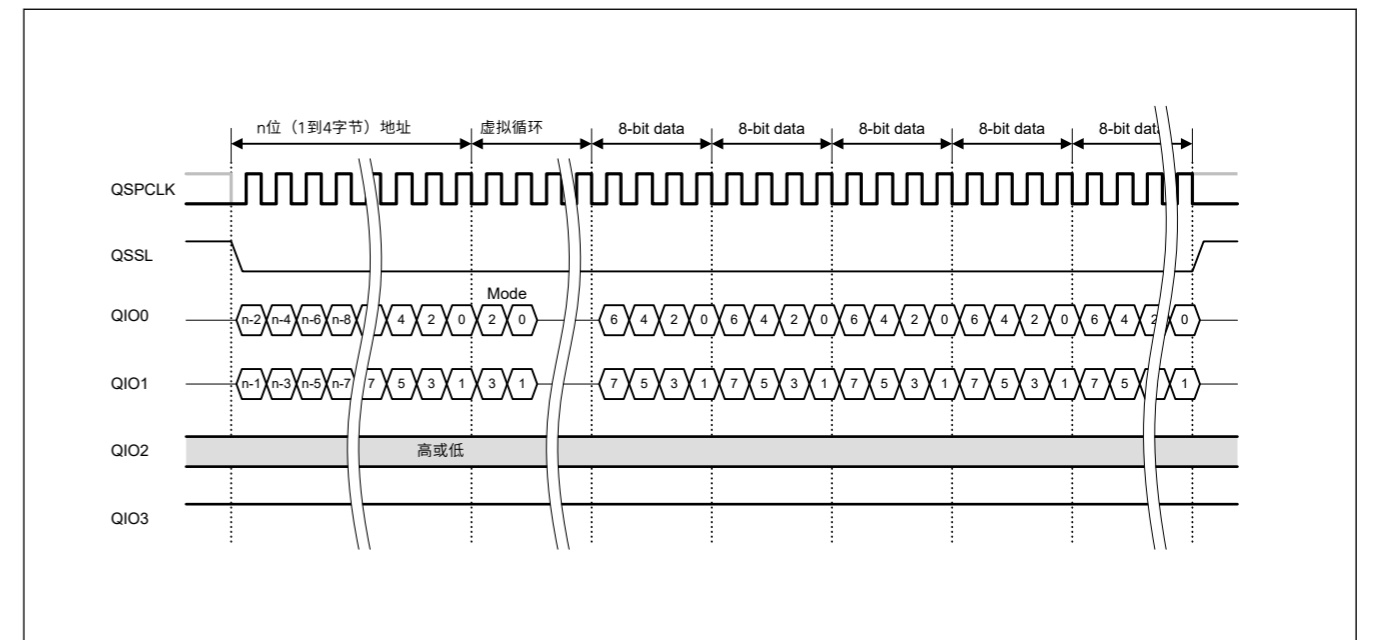


Figure 31.24 XIP模式下的快速读取双IO总线周期

Note: To use the Fast Read Dual I/O instruction, a serial flash memory that supports Fast Read Dual I/O transfers is required.

### 31.6.6 Fast Read Quad Output Instruction

The Fast Read Quad Output instruction is a read instruction that uses four signal lines to receive data. When the SPI bus cycle starts, the QSSL signal is asserted. The instruction code (0x6B or 0x6C) and an address with a width of 1 to 4 bytes, specified in the SFMAS[1:0] bits in the SFMSAC register, are output from the QIO0 pin. Next, a certain number of dummy cycles, specified in the SFMDN[3:0] bits in the SFMSMD register, are generated. Data is then received through the QIO0, QIO1, QIO2, and QIO3 pins.

The first two dummy cycles are used to select the XIP mode. When the XIP mode is selected, the same instruction used this time is applied to the next SPI bus cycle, and the instruction code is not output the next SPI bus cycle. For details on the XIP mode, see [section 31.8. XIP Control](#).

Switching to Fast Read Quad Output is controlled in the SFMSMD register.

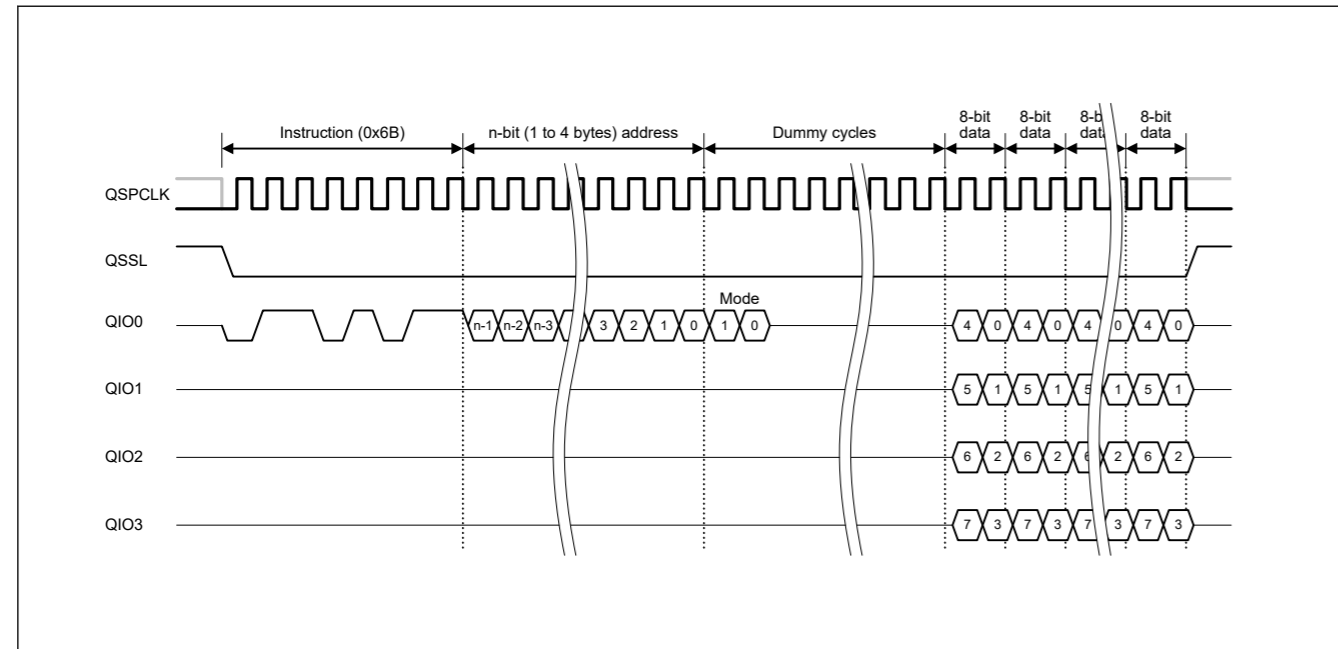


Figure 31.25 Fast Read Quad Output bus cycle (with extended SPI protocol)

Note: 要使用快速读取双IO指令，需要支持快速读取双IO传输的串行闪存。

### 31.6.6 快速读取四路输出指令

快速读取四路输出指令是使用四根信号线接收数据的读取指令。当SPI总线周期开始时，QSSL信号被置位。在SFMSAC寄存器的SFMAS[1:0]位中指定的指令代码（0x6B或0x6C）和宽度为1到4字节的地址从QIO0引脚输出。接下来，生成一定数量的空周期，在SFMSMD寄存器的SFMDN[3:0]位中指定。然后通过QIO0、QIO1、QIO2和QIO3引脚接收数据。

前两个虚拟周期用于选择XIP模式。选择XIP模式时，此时间使用的相同指令将应用于下一个SPI总线周期，并且指令代码未输出下一个SPI总线周期。有关XIP模式的详细信息，请参阅第31.8节。XIP控制。

切换到快速读取四路输出由SFMSMD寄存器控制。

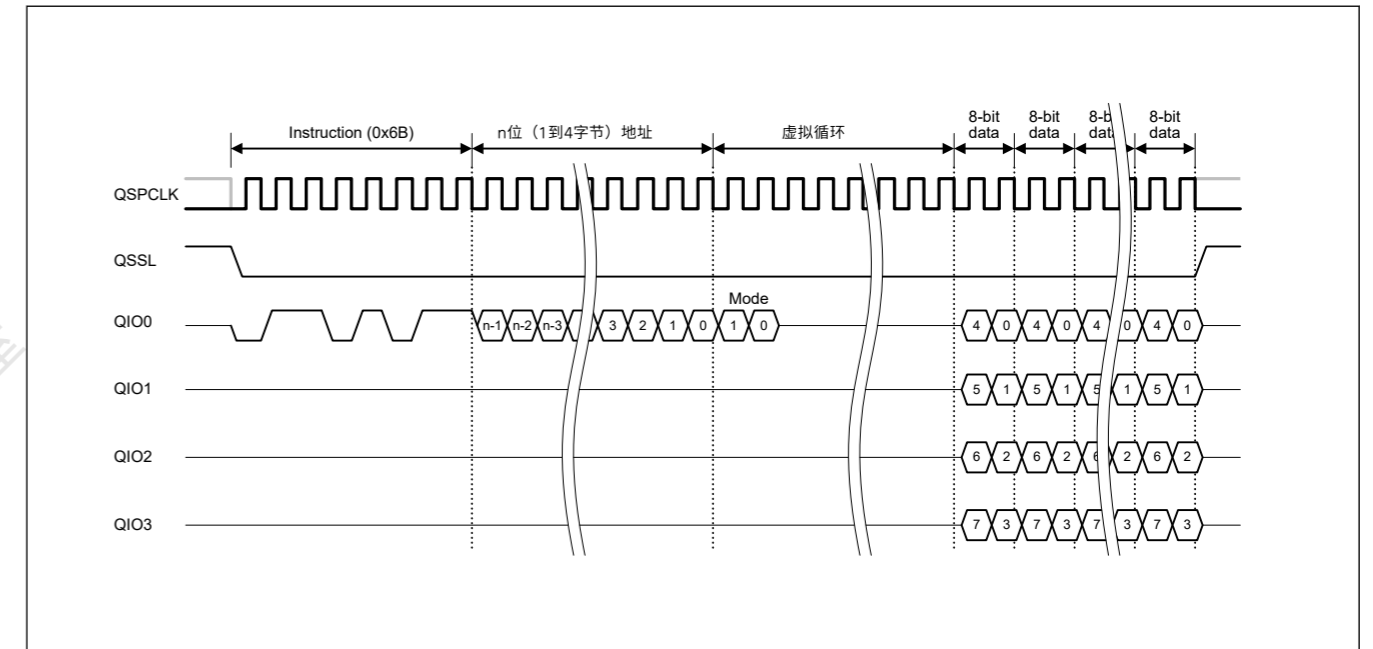


Figure 31.25 快速读取四路输出总线周期（使用扩展SPI协议）

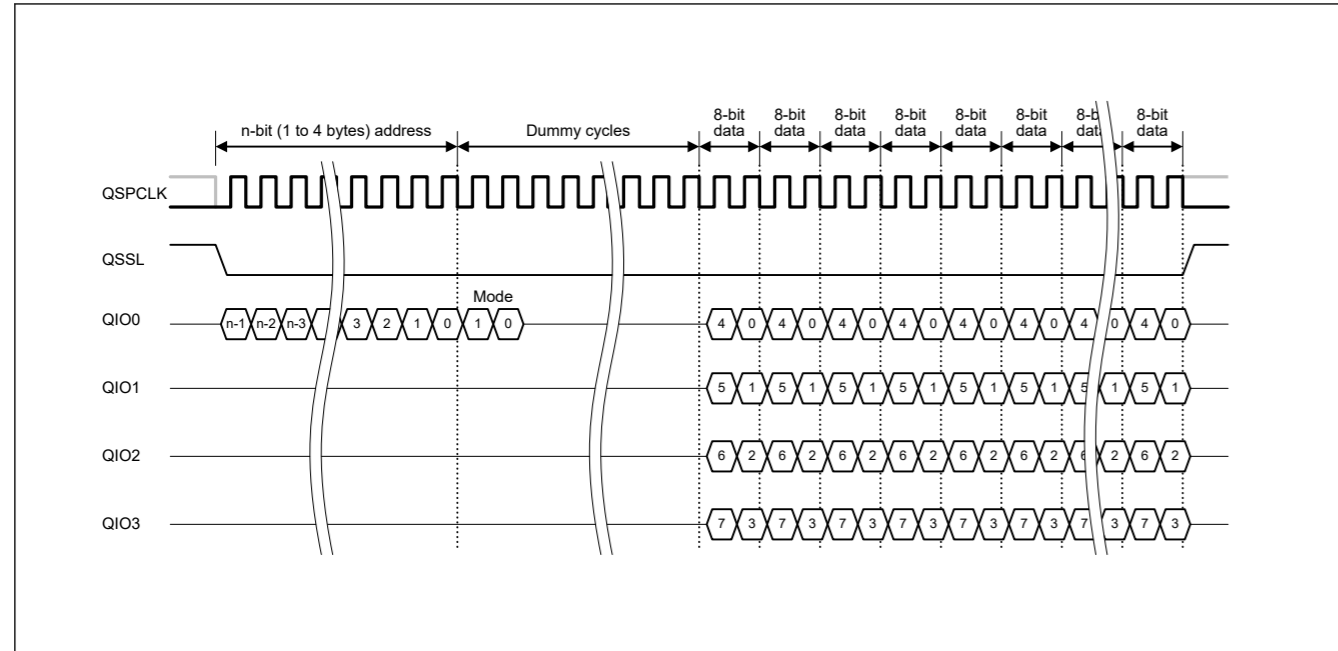


Figure 31.26 Fast Read Quad Output bus cycle in XIP mode (with extended SPI protocol)

Note: To use Fast Read Quad Output, a serial flash memory that supports Fast Read Quad Output transfer is required.

### 31.6.7 Fast Read Quad I/O Instruction

The Fast Read Quad I/O instruction is a read instruction that uses four signal lines to transmit an address and receive data. When the SPI bus cycle starts, the QSSL signal is asserted, and the instruction code (0xEB / 0xEC) is transmitted from QIO0 pin in the extended SPI protocol and from QIO0, QIO1, QIO2, and QIO3 pins in the Quad-SPI protocol. Next, an address with a width of 1 to 4 bytes, specified in the SFMAS[1:0] bits in the SFMSAC register, is transmitted through the QIO0, QIO1, QIO2, and QIO3 pins, and a certain number of dummy cycles, specified in the SFMDN[3:0] bits in the SFMSMD register, is generated. Data is then received through the QIO0, QIO1, QIO2, and QIO3 pins.

The first two dummy cycles are used to select the XIP mode. When the XIP mode is selected, the same instruction used this time is applied to the next SPI bus cycle, and the instruction code is not output the next SPI bus cycle. For details on the XIP mode, see [section 31.8. XIP Control](#).

Switching to Fast Read Quad I/O is controlled in the SFMSMD register.

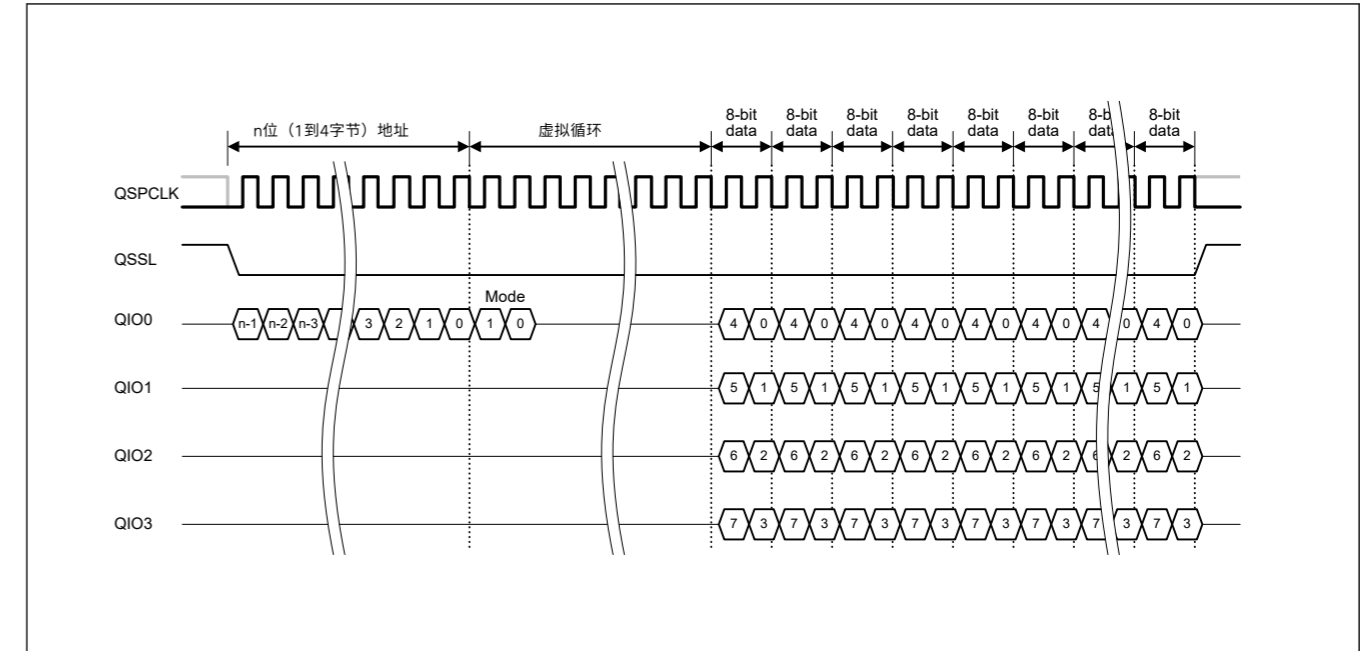


Figure 31.26 XIP模式下的快速读取四路输出总线周期 (使用扩展SPI协议)

Note: 要使用快速读取四路输出，需要支持快速读取四路输出传输的串行闪存。

### 31.6.7 快速读取QuadIO指令

FastReadQuadIO指令是使用四根信号线传输地址和接收数据的读取指令。当SPI总线周期开始时，QSSL信号被置位，指令代码（0xEB/0xEC）从扩展SPI协议的QIO0引脚和Quad-SPI协议的QIO0、QIO1、QIO2和QIO3引脚传输。接下来，在SFMSAC寄存器的SFMAS[1:0]位中指定的1到4字节宽度的地址通过QIO0、QIO1、QIO2和QIO3引脚和一定数量的空周期传输，在SFMDN[3:0]位中指定

SFMSMD寄存器，生成。然后通过QIO0、QIO1、QIO2和QIO3引脚接收数据。

前两个虚拟周期用于选择XIP模式。选择XIP模式时，此时间使用的相同指令将应用于下一个SPI总线周期，并且指令代码未输出下一个SPI总线周期。有关XIP模式的详细信息，请参阅第31.8节。XIP控制。

切换到快速读取四线IO由SFMSMD寄存器控制。



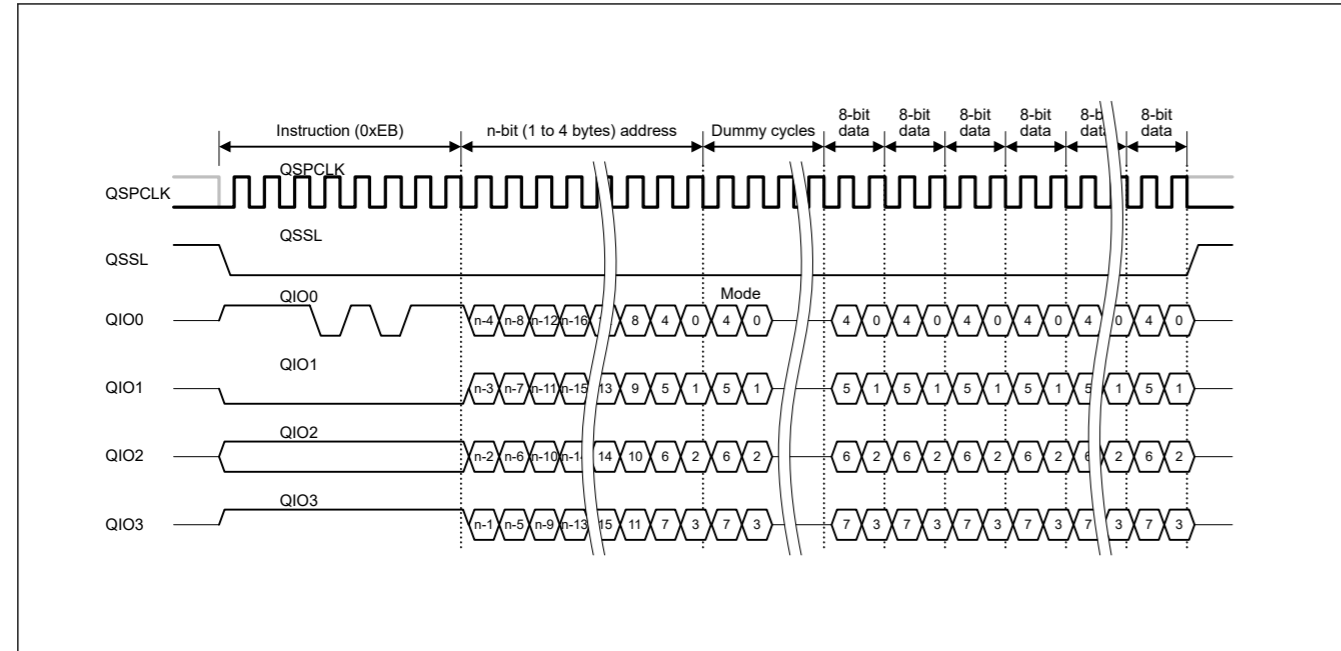


Figure 31.27 Fast Read Quad I/O bus cycle

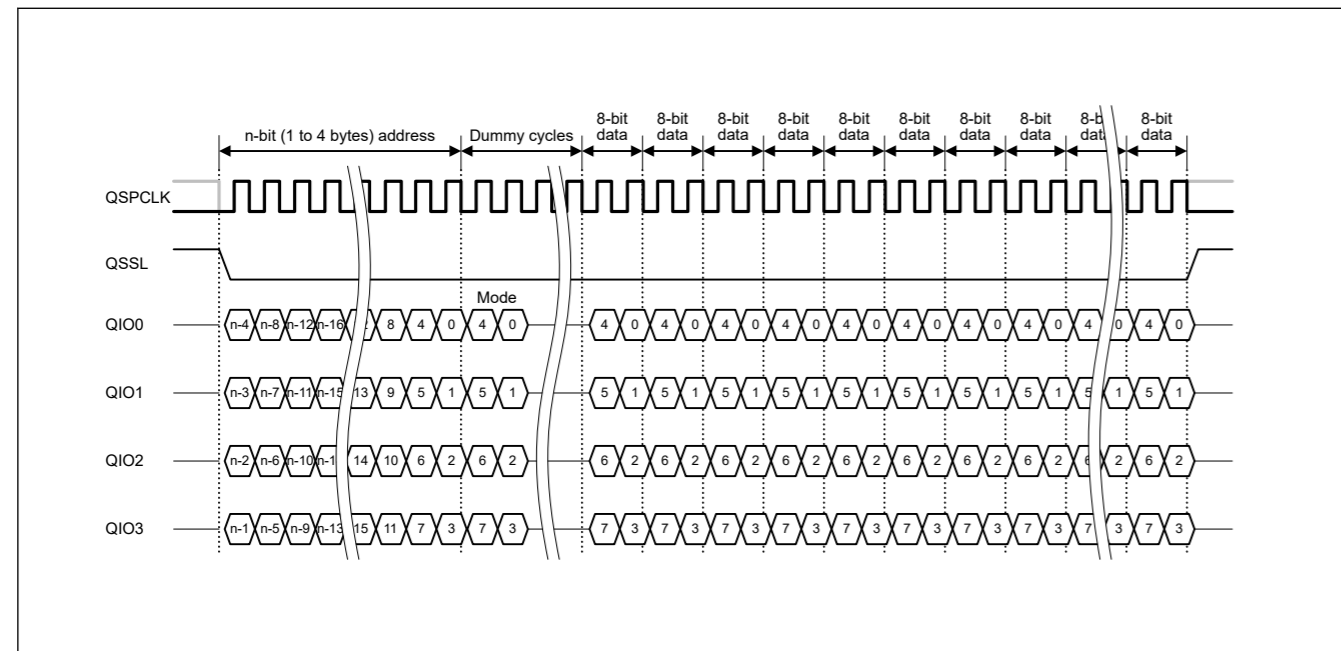


Figure 31.28 Fast Read Quad I/O bus cycle in XIP mode

Note: To use the Fast Read Quad I/O instruction, a serial flash memory that supports Fast Read Quad I/O transfers is required.

### 31.6.8 Enter 4-Byte Mode Instruction

The Enter 4-Byte Mode instruction sets the serial flash address width to 4 bytes. When the SPI bus cycle starts, the serial flash select signal is asserted, and the instruction code (0xB7) is output.

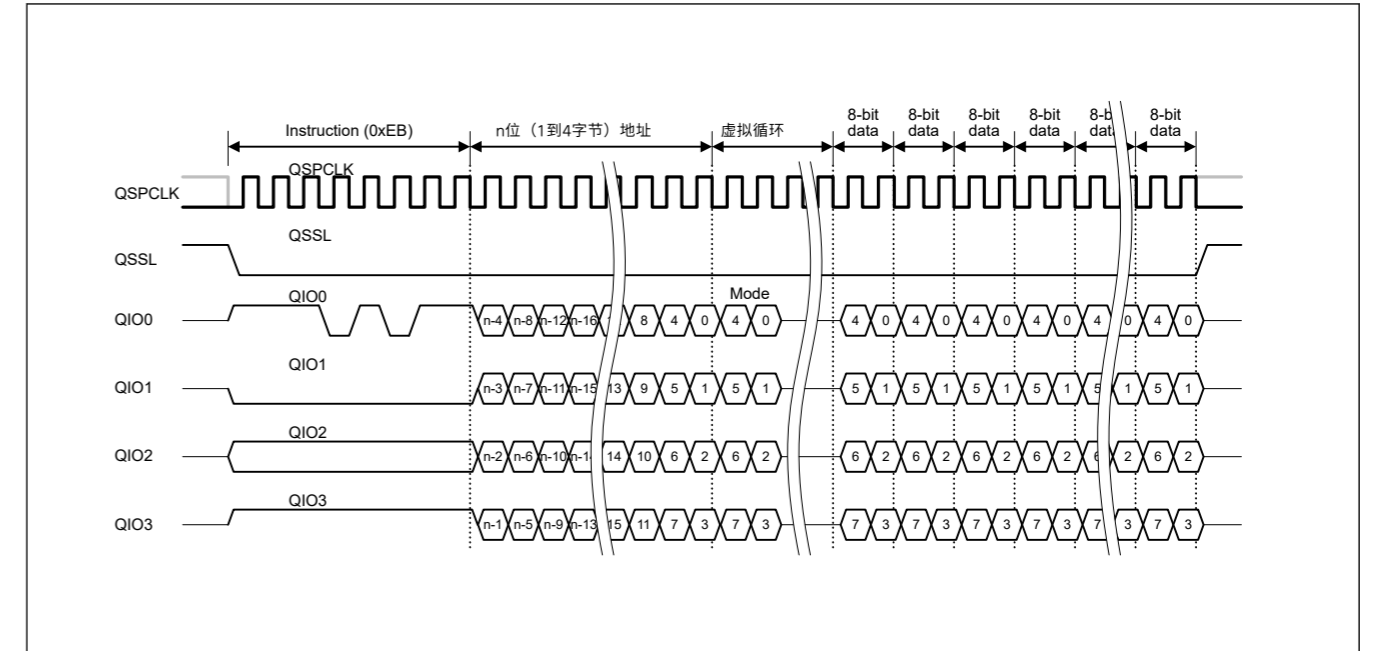


Figure 31.27 快速读取四IO总线周期

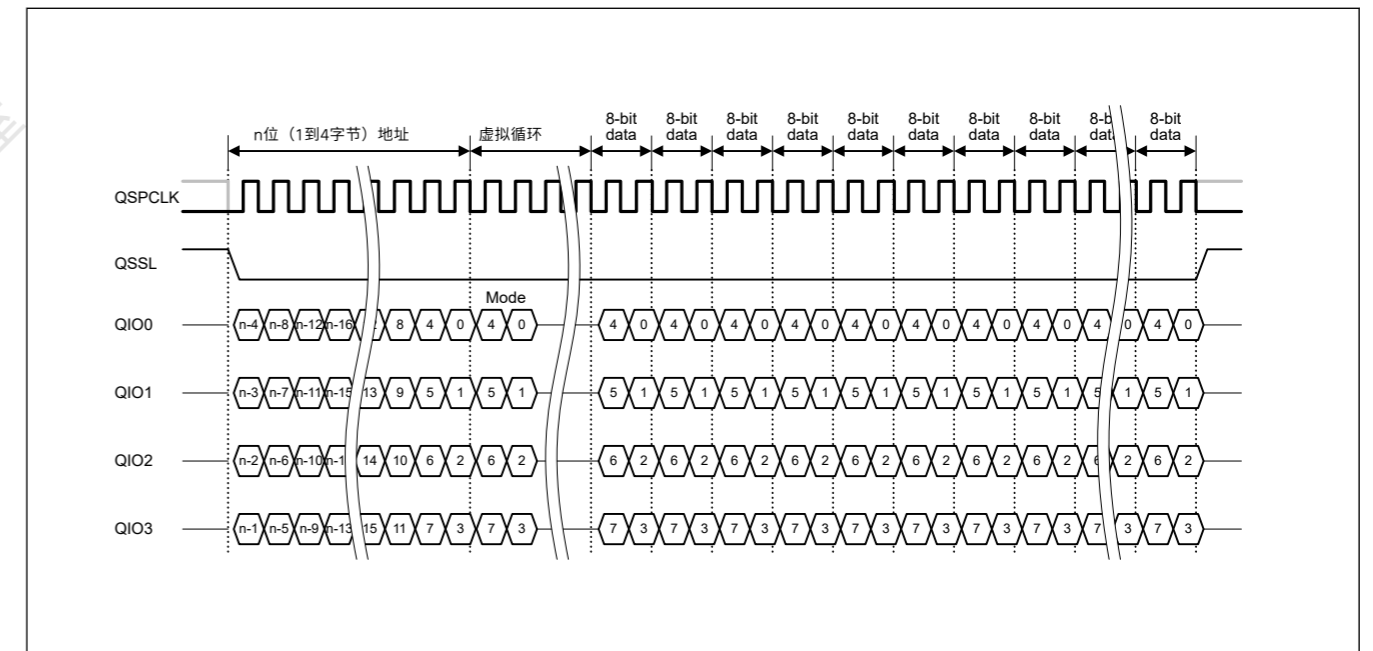


Figure 31.28 XIP模式下的快速读取QuadIO总线周期

Note: 要使用FastReadQuadIO指令，需要支持FastReadQuadIO传输的串行闪存。

### 31.6.8 进入4字节模式指令

进入4字节模式指令将串行闪存地址宽度设置为4字节。当SPI总线周期开始时，串行闪存选择信号被置位，并输出指令代码（0xB7）。

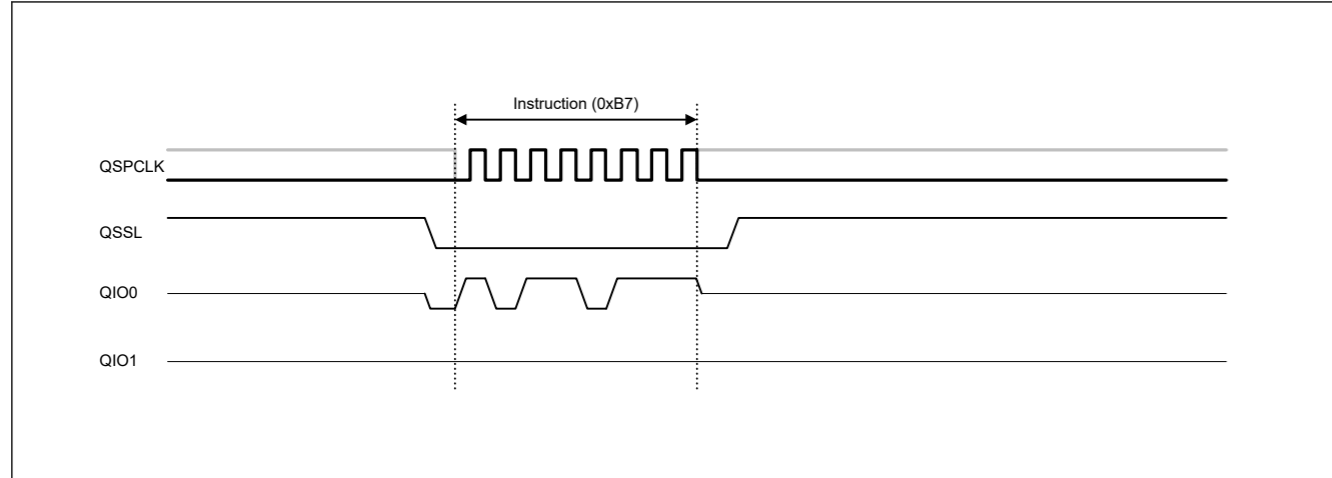


Figure 31.29 Enter 4-Byte Mode bus cycle

Note: The Enter 4-Byte Mode instruction is issued regardless of whether the serial flash is in 3- or 4-byte mode.

### 31.6.9 Exit 4-Byte Mode Instruction

The Exit 4-Byte Mode instruction sets the serial flash address width to 3 bytes. When the SPI bus cycle starts, the serial flash select signal is asserted, and the instruction code (0xE9) is output.

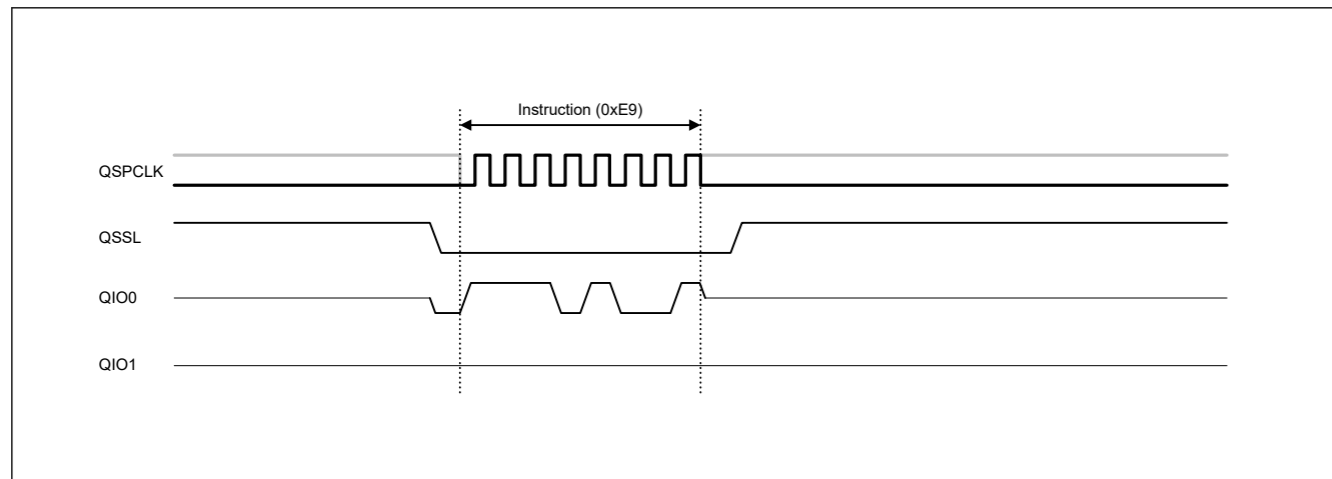


Figure 31.30 Exit 4-Byte Mode bus cycle

Note: The Exit 4-Byte Mode instruction is issued regardless of whether the serial flash is in 3- or 4-byte mode.

### 31.6.10 Write Enable Instruction

The Write Enable instruction enables changing of the serial flash address width. When the SPI bus cycle starts, the serial flash select signal is asserted, and the instruction code (0x06) is output.

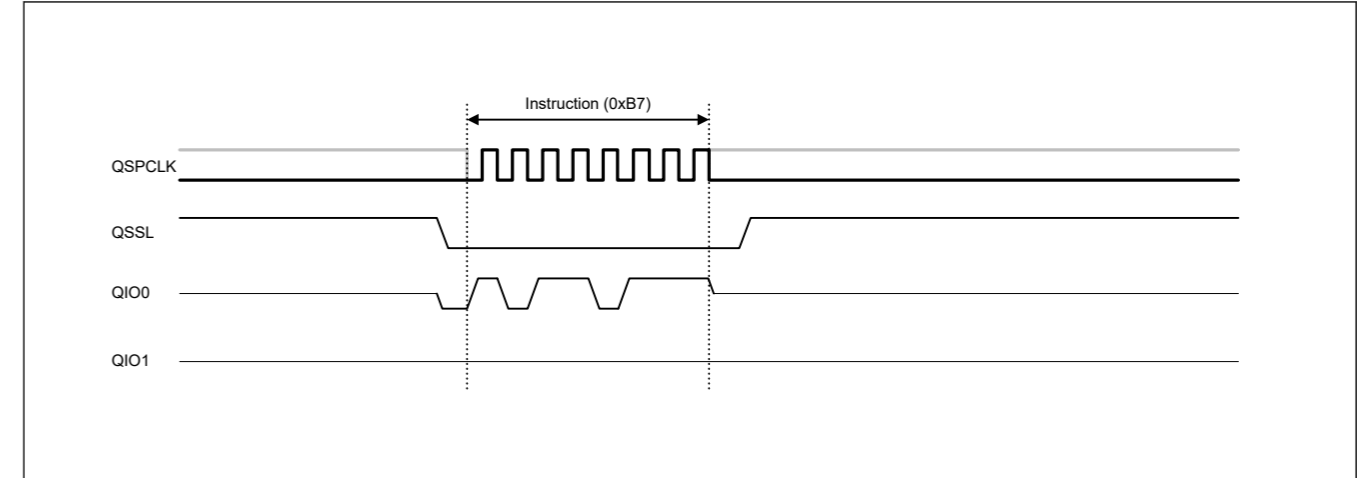


Figure 31.29 进入4字节模式总线周期

Note: 无论串行闪存处于3字节模式还是4字节模式，都会发出进入4字节模式指令。

### 31.6.9 退出4字节模式指令

退出4字节模式指令将串行闪存地址宽度设置为3字节。当SPI总线周期开始时，串行闪存选择信号被置位，并输出指令代码（0xE9）。

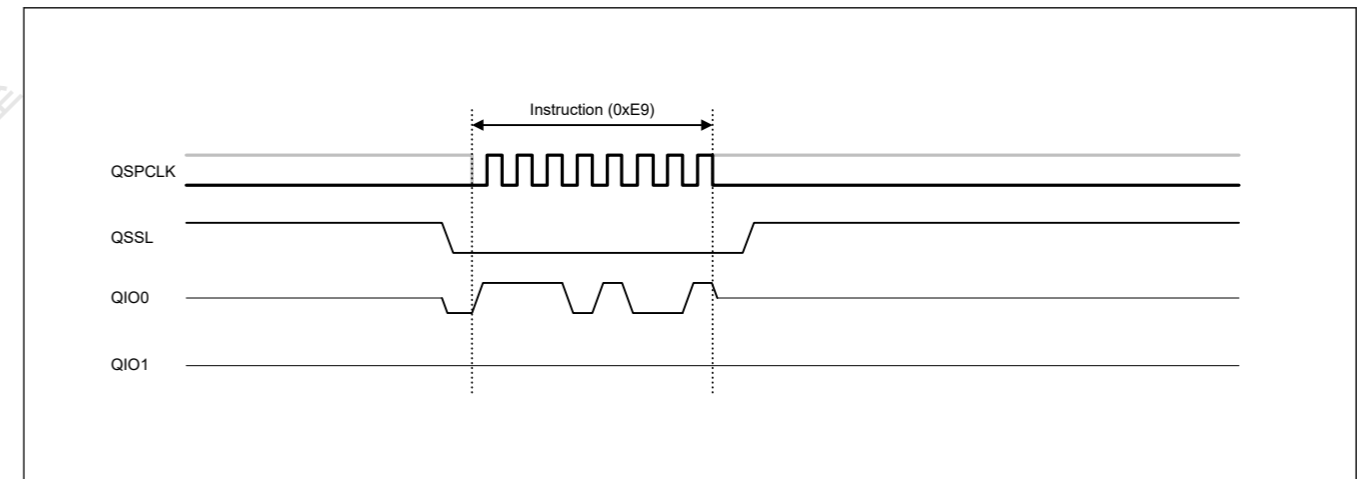


Figure 31.30 退出4字节模式总线周期

Note: 无论串行闪存处于3字节模式还是4字节模式，都会发出退出4字节模式指令。

### 31.6.10 写使能指令

写使能指令可以改变串行闪存地址宽度。当SPI总线周期开始时，串行闪存选择信号被置位，并输出指令代码（0x06）。

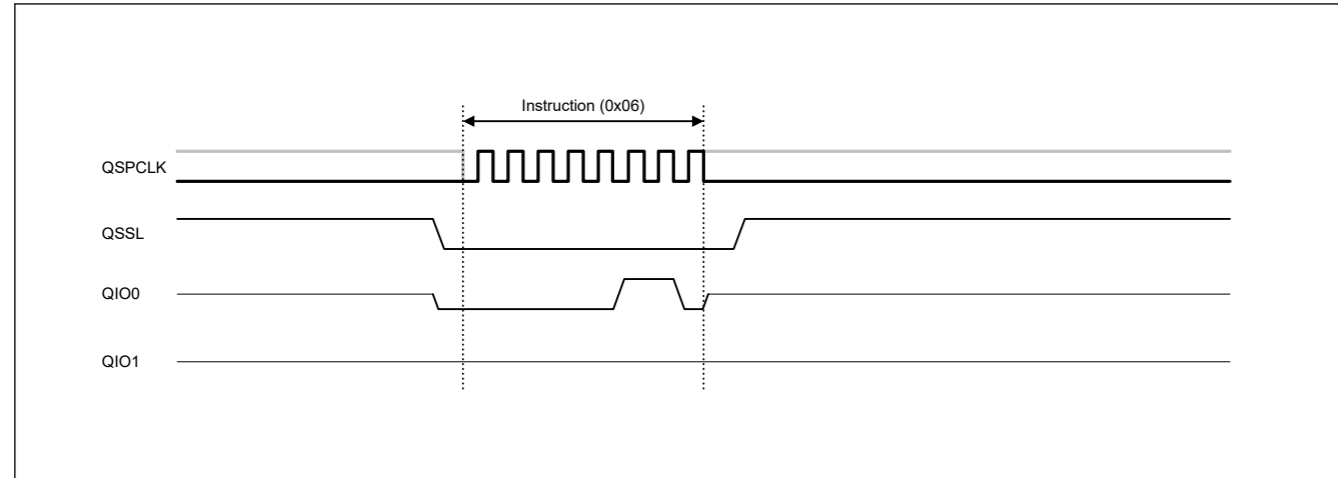


Figure 31.31 Write Enable bus cycle

### 31.7 SPI Bus Cycle Arrangement

#### 31.7.1 Serial Flash Memory Read Based on Individual Conversion

ROM read bus cycles are individually converted to SPI bus cycles on a one-to-one basis. When a ROM read bus cycle is detected, the QSSL signal is asserted, and an SPI bus cycle starts. When the data receiving is finished from the serial flash memory, the QSSL signal is negated and the SPI bus cycle is complete.

When the next ROM read bus cycle is detected, the QSSL signal set by the SFMSSC.SFMSW[3: 0] bits is asserted again, then the next SPI bus cycle starts.

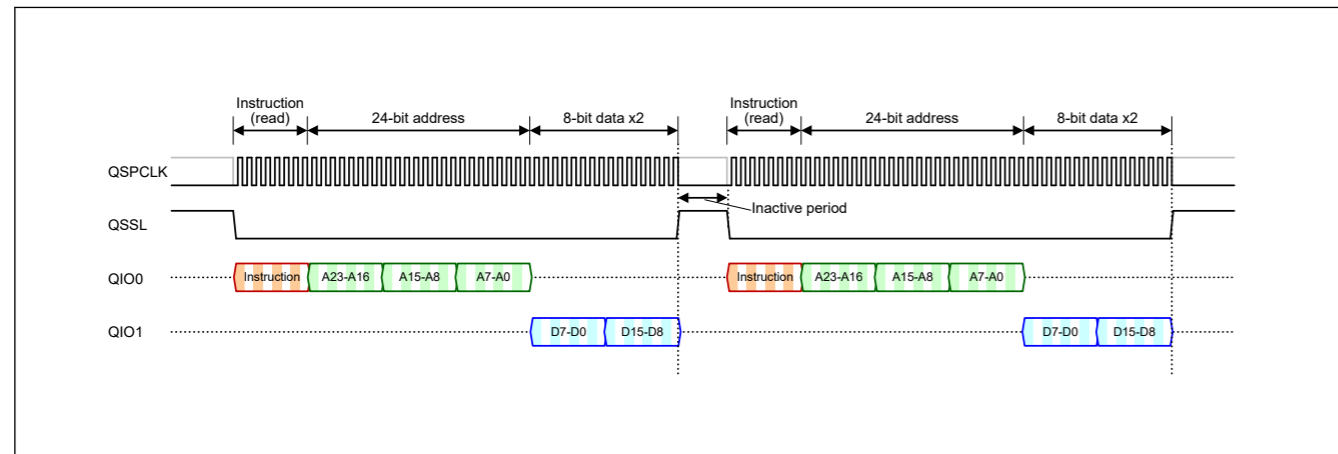


Figure 31.32 Successive data read operations based on individual conversion

#### 31.7.2 Serial Flash Memory Read Using the Prefetch Function

In operations such as CPU instruction execution and block data transfer, data is often read in ascending order from contiguous addresses. Serial flash memory provides the ability to repeat data reception without reissuing an instruction code and address. To work with this function, the QSPI has a prefetch function for continuous data reception. However, if the CPU issues a flash read request for discontinuous flash addresses, SPI bus cycles are separated from each other, disabling the prefetch function.

To enable the prefetch function of the QSPI, set the SFMPFE bit in the SFMSMD register to 1. When the prefetch function is enabled, data is received continuously and stored in the prefetch buffer of the QSPI, without waiting for another flash read request. When the CPU issues a flash read request, an address check is made. If an address match is confirmed, the data in the buffer is passed to the CPU. If an address mismatch is detected, the data in the buffer is discarded and a new SPI bus cycle is issued.

The buffer for prefetching is 18 bytes long. When this buffer is full, the SPI bus cycle is ended. When the buffer data is read to create free space, a new SPI bus cycle is automatically started to resume prefetching.

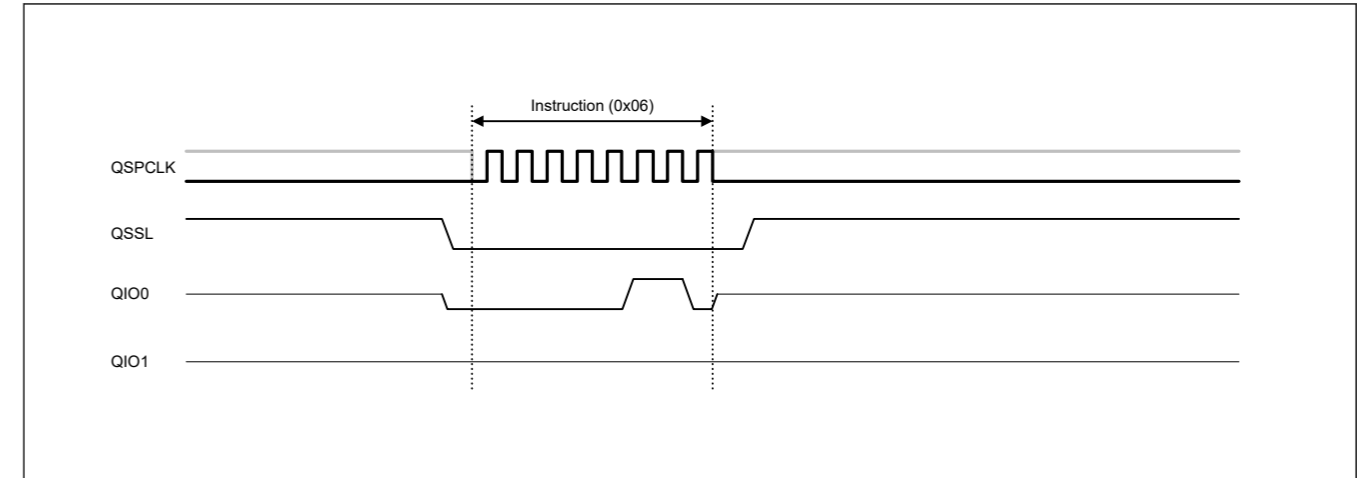


Figure 31.31 写使能总线周期

### 31.7 SPI总线周期安排

#### 31.7.1 基于单独转换的串行闪存读取

ROM读取总线周期以一对一的方式单独转换为SPI总线周期。当检测到ROM读取总线周期时，QSSL信号被置位，并且SPI总线周期开始。当从串行闪存完成数据接收时，QSSL信号被取反，SPI总线周期完成。

当检测到下一个ROM读取总线周期时，由SFMSSC.SFMSW[3:0]位设置的QSSL信号再次置位，然后下一个SPI总线周期开始。

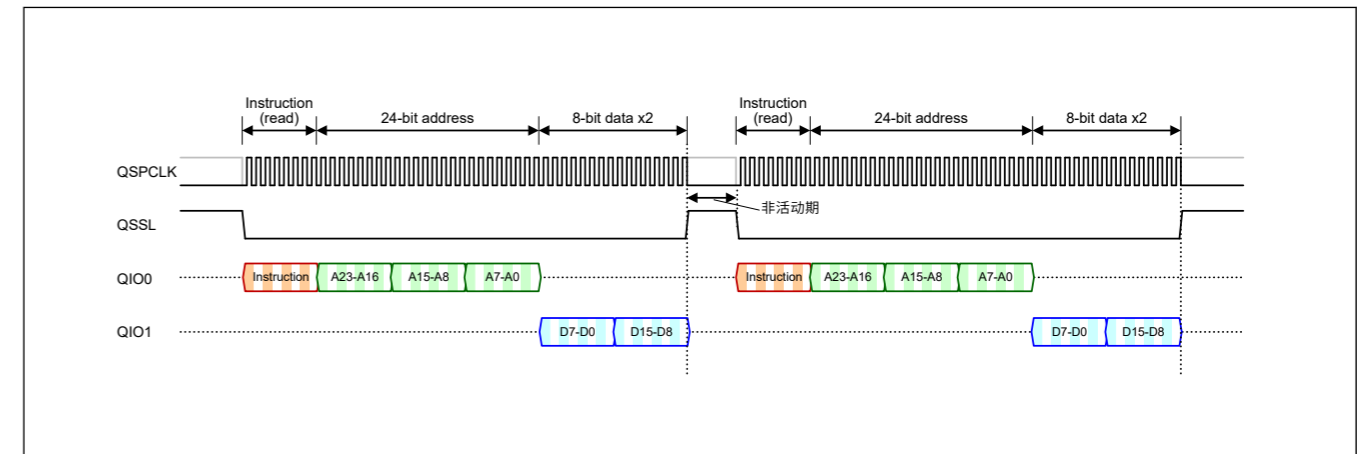


Figure 31.32 基于单独转换的连续数据读取操作

#### 31.7.2 使用预取功能读取串行闪存

在CPU指令执行和块数据传输等操作中，数据通常是从连续地址按升序读取的。串行闪存提供了重复数据接收的能力，而无需重新发出指令代码和地址。为了使用此功能，QSPI具有用于连续数据接收的预取功能。但是，如果CPU对不连续的闪存地址发出闪存读取请求，则SPI总线周期会相互分离，从而禁用预取功能。

要启用QSPI的预取功能，请将SFMSMD寄存器中的SFMPFE位设置为1。当使能预取功能时，会连续接收数据并存储在QSPI的预取缓冲区中，而无需等待另一个闪存读取请求。当CPU发出闪存读取请求时，会进行地址检查。如果确认地址匹配，则将缓冲区中的数据传递给CPU。如果检测到地址不匹配，则丢弃缓冲区中的数据并发送新的SPI总线周期。

用于预取的缓冲区为18字节长。当此缓冲区满时，SPI总线周期结束。当缓冲区数据被读取以创建空闲空间时，会自动启动一个新的SPI总线周期以恢复预取。

The prefetch function allows for efficient transfer operations when data is read in ascending order from contiguous addresses, as in instruction fetch and block data transfer.

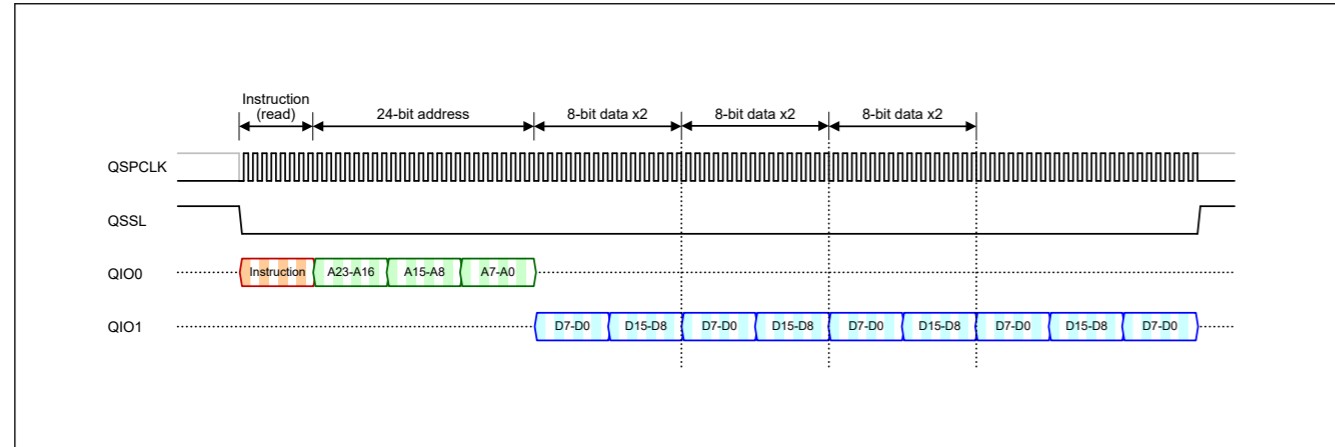


Figure 31.33 Successive data read operations using the prefetch function

### 31.7.3 Halt of Prefetching

If a serial flash memory read request for discontinuous addresses is issued when continuous data is being received by the prefetch function, the transfer of continuous data being made is halted and a new SPI bus cycle is started. Usually, such a halt of serial transfer occurs on data reception byte boundaries. However, if the SFMPAE bit in the SFMSMD register is set to 1, the halt can occur on locations other than byte boundaries.

### 31.7.4 Direct Specification of Prefetch Destination

When the prefetch function is enabled (SFMSMD.SFMPFE = 1), when writing to the QSPI window area occurs, after the writing is completed, prefetching starts from the write start address. Writes to serial flash memory cannot be performed.

Combining this function with described in section 31.7.5. Prefetch State Polling, can reduce the load on the internal bus when data is read from a low-speed serial flash memory.

Note: Writing to the QSPI window area with a data size of 2 bytes or more causes a hardfault.

### 31.7.5 Prefetch State Polling

A read by CPU from a low-speed serial flash memory causes the CPU system bus to be occupied until completion of the SPI reception bus cycle. The prefetch state polling function is provided to reduce this load.

The PFOFF bit in the Status Register (SFMSST) register indicates the state of the prefetch function, and the PFCNT[4:0] bits in the SFMSST register indicate the number of data bytes already prefetched. Place the polling program in the SRAM of this device.

```
//
// copy 1K byte (32bit x 256 word) data from serial flash to internal SRAM
//
unsigned long *sptr; // pointer for the serial flash
unsigned long *dptr; // pointer for the destination
int i;

SFMSMD |= 0x0040; // set SFMPFE bit to enable prefetch
*( (volatile unsigned char *) sptr ) = 0; // make the TAG valid to start prefetch

for ( i = 0 ; i < 256 ; i++ ){
while ( ( SFMSST & 0x00FF ) < 0x04 ){}; // waiting for 4-byte data to be received
*(dptr++) = *(sptr++);
}
```

Note: When executing a polling program, place the program outside of the serial flash memory. If the polling program is executed when the program is placed on the serial flash memory, the prefetch target frequently switches to an instruction code. This eliminates the effect of polling, and an infinite loop can result because the prefetch buffer is not filled.

当从连续地址以升序读取数据时，预取功能允许有效的传输操作，如在指令取指和块数据传输中。

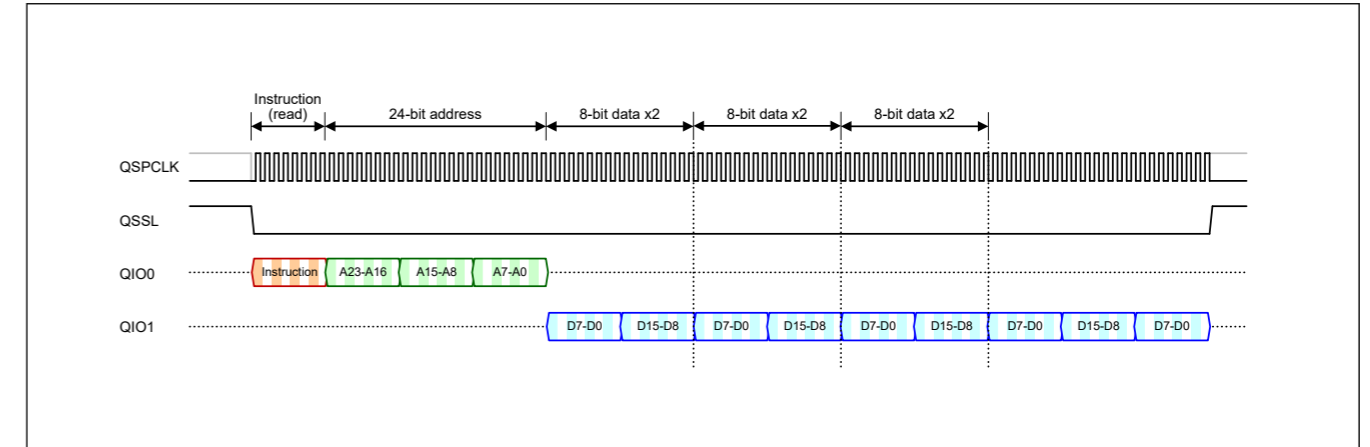


Figure 31.33 使用预取功能的连续数据读取操作

### 31.7.3 停止预取

如果在预取功能正在接收连续数据时发出对不连续地址的串行闪存读取请求，则正在进行的连续数据的传输将停止并开始新的SPI总线周期。通常，这种串行传输的停止发生在数据接收字节边界上。但是，如果SFMSMD寄存器中的SFMPAE位设置为1，则停止可能发生在字节边界以外的位置。

### 31.7.4 直接指定预取目的地

当预取功能使能时 (SFMSMD.SFMPFE=1)，当写入QSPI窗口区域时，写入完成后，从写入起始地址开始预取。无法执行对串行闪存的写入。

将此功能与第31.7.5节中的描述相结合。PrefetchStatePolling，可以减少从低速串行闪存读取数据时内部总线的负载。

Note: 写入数据大小为2字节或更大的QSPI窗口区域会导致硬故障。

### 31.7.5 预取状态轮询

CPU从低速串行闪存中读取会导致CPU系统总线被占用，直到完成SPI接收总线周期。提供了预取状态轮询功能来减少这种负载。

状态寄存器(SFMSST)寄存器中的PFOFF位指示预取功能的状态，SFMSST寄存器中的PFCNT[4:0]位指示已经预取的数据字节数。将轮询程序放在本设备的SRAM中。

```
将1K字节（32位x256字）数据从 串行闪存复制到内部SRAM无符号长*sptr；串行闪存指针un
signedlong*dptr;目标inti的指针；

SFMSMD=0x0040; 设置SFMPFE位以启用预取*((volatileunsignedchar*)sptr)=0;使TAG有效以开始预
取

for(i=0;i<256;i++){而((SFMSST&0x00FF)<0x04){ ;等待接收4字节数据*(dptr++)=*(sptr++);
```

Note: 执行轮询程序时，请将程序置于串行闪存之外。如果轮询程序在程序放在串行闪存上时执行，则预取目标频繁切换到指令代码。这消除了轮询的影响，并且由于未填充预取缓冲区可能导致无限循环。



### 31.7.6 SPI Bus Cycle Extension Function

If the SFMSE[1:0] bits in the SFMSMD register are set to a value other than 00b, the QSPI waits for the next flash read. At this time, the QSPCLK signal stops, the QSSL signal is kept active low even after data is obtained from the serial flash memory, and the SPI bus cycle is suspended.

If the address of the next flash read is contiguous in ascending order, the toggling of the QSPCLK signal is restarted to continue reception of subsequent data. If the address of the next flash read is not contiguous in ascending order, the QSSL signal is driven high once to end the SPI bus cycle being suspended. A new SPI bus cycle is then started.

When data is read intermittently from ascending order contiguous addresses, this function enables an efficient transfer operation to be performed by reducing the overhead for instruction code and address transmission.

The SPI bus cycle extension time is selectable in the SFMSE[1:0] bits in the SFMSMD register. When the specified extension time elapses, the QSSL signal returns to the high level to automatically end the SPI bus cycle being suspended. If the SFMSE[1:0] bits are set to 11b, QSSL is extended infinitely. This increases the power consumption of the serial flash memory.

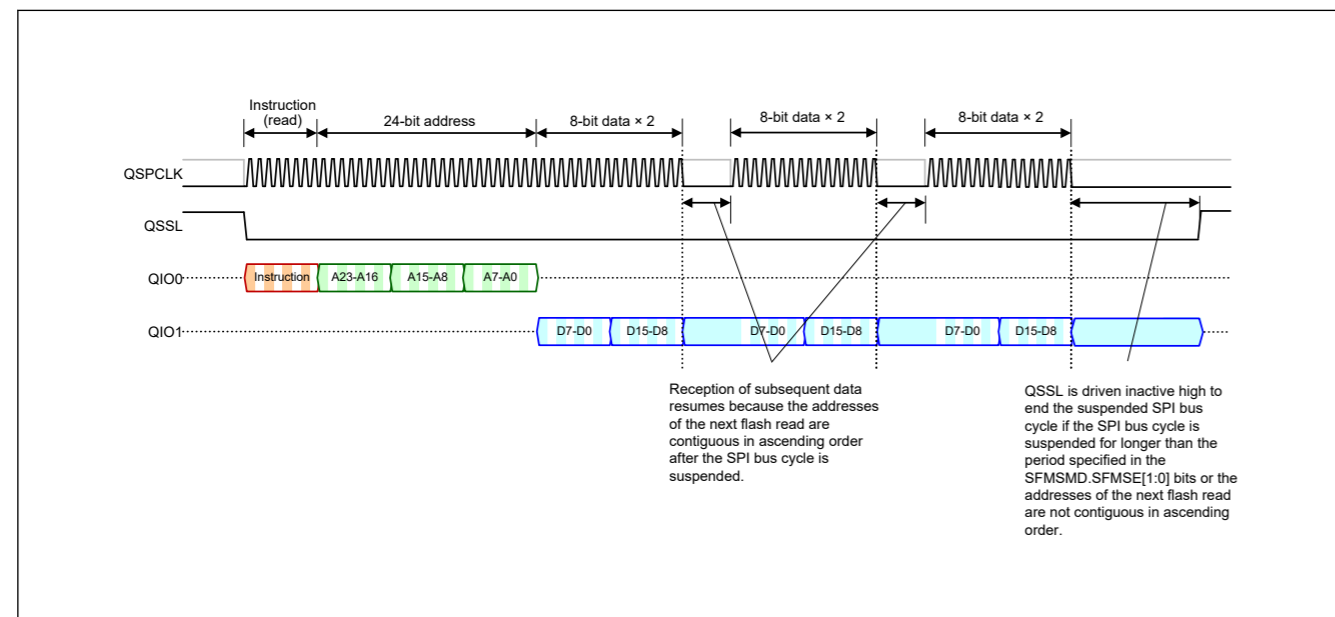


Figure 31.34 Successive data read operations using the SPI bus cycle extension

### 31.8 XIP Control

Some serial flash memory devices allow latencies to be reduced by skipping instruction code reception for flash reads. This instruction code skip function is selected in mode data received during the dummy cycle period of the previous serial bus cycle.

In the dummy cycle of the Fast Read instructions, the QSPI controls the XIP mode of the serial flash memory by using the serial data signal to send the mode data set in the SFMXD[7:0] bits in the SFMSDC register during the first 2 cycles, as shown in Figure 31.35.

The mode data to enable the XIP mode differs for each serial flash memory. Accordingly, set the appropriate mode data in the SFMXD[7:0] bits.

### 31.7.6 SPI总线周期扩展功能

如果SFMSMD寄存器中的SFMSE[1:0]位设置为00b以外的值,则QSPI等待下一次闪存读取。此时,QSPCLK信号停止,即使从串行闪存中获取数据后,QSSL信号也保持低电平有效,并且暂停SPI总线周期。

如果下一次闪存读取的地址按升序连续,则重新启动QSPCLK信号的翻转以继续接收后续数据。如果下一次flash读取的地址升序不连续,则QSSL信号被驱动一次高电平以结束暂停的SPI总线周期。然后开始一个新的SPI总线周期。

当从升序连续地址间歇性地读取数据时,该功能通过减少指令代码和地址传输的开销来实现高效的传输操作。

SPI总线周期延长时间可在SFMSMD寄存器的SFMSE[1:0]位中选择。当指定的延长时间过去后,QSSL信号返回高电平,自动结束暂停的SPI总线周期。如果SFMSE[1:0]位设置为11b,QSSL将无限扩展。这增加了串行闪存的功耗。

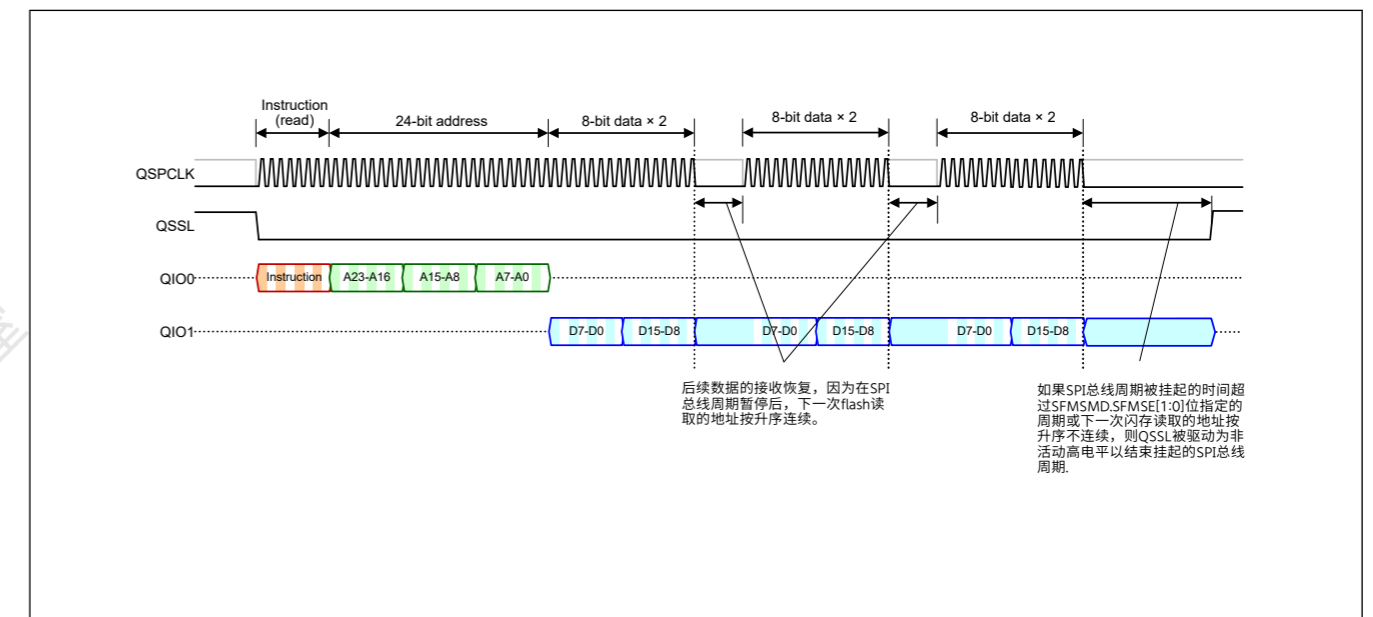


Figure 31.34 使用SPI总线周期扩展的连续数据读取操作

### 31.8 XIP Control

一些串行闪存设备允许通过跳过用于闪存读取的指令代码接收来减少延迟。在前一个串行总线周期的虚拟周期期间接收到的模式数据中选择此指令代码跳过功能。

在快速读取指令的空周期中,QSPI在前2循环,如图31.35所示。

启用XIP模式的模式数据因串行闪存而异。因此,在SFMXD[7:0]位中设置适当的模式数据。

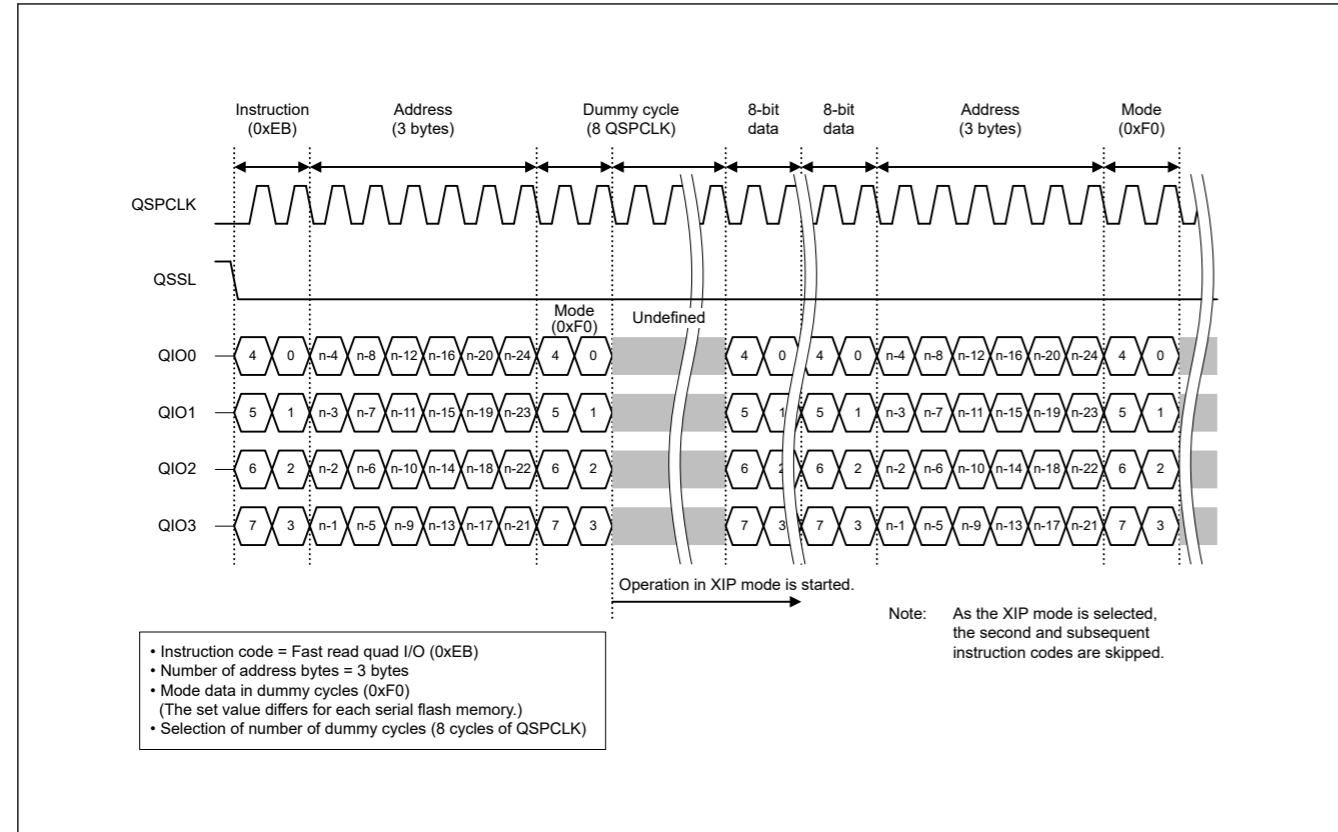


Figure 31.35 XIP mode control data

### 31.8.1 Setting XIP Mode

To start XIP mode in serial flash memory, perform the following register settings:

- Set a mode data value in the SFMXD[7:0] bits in the SFMSDC register.\*1
- Set the SFMXEN bit in the SFMSDC register to 1.

In the dummy cycle of the first fast read cycle after these registers are set, the mode data value set in the register is transferred. From that point, XIP mode is enabled in the serial flash memory. To confirm the current XIP mode status, read the SFMXST flag in the SFMSDC register.

Note 1. In the SFMXD[7:0] bits in the SFMSDC register, set the mode data that follows the specifications for the actual serial flash memory.

The following figure shows an example of the XIP mode setting procedure.

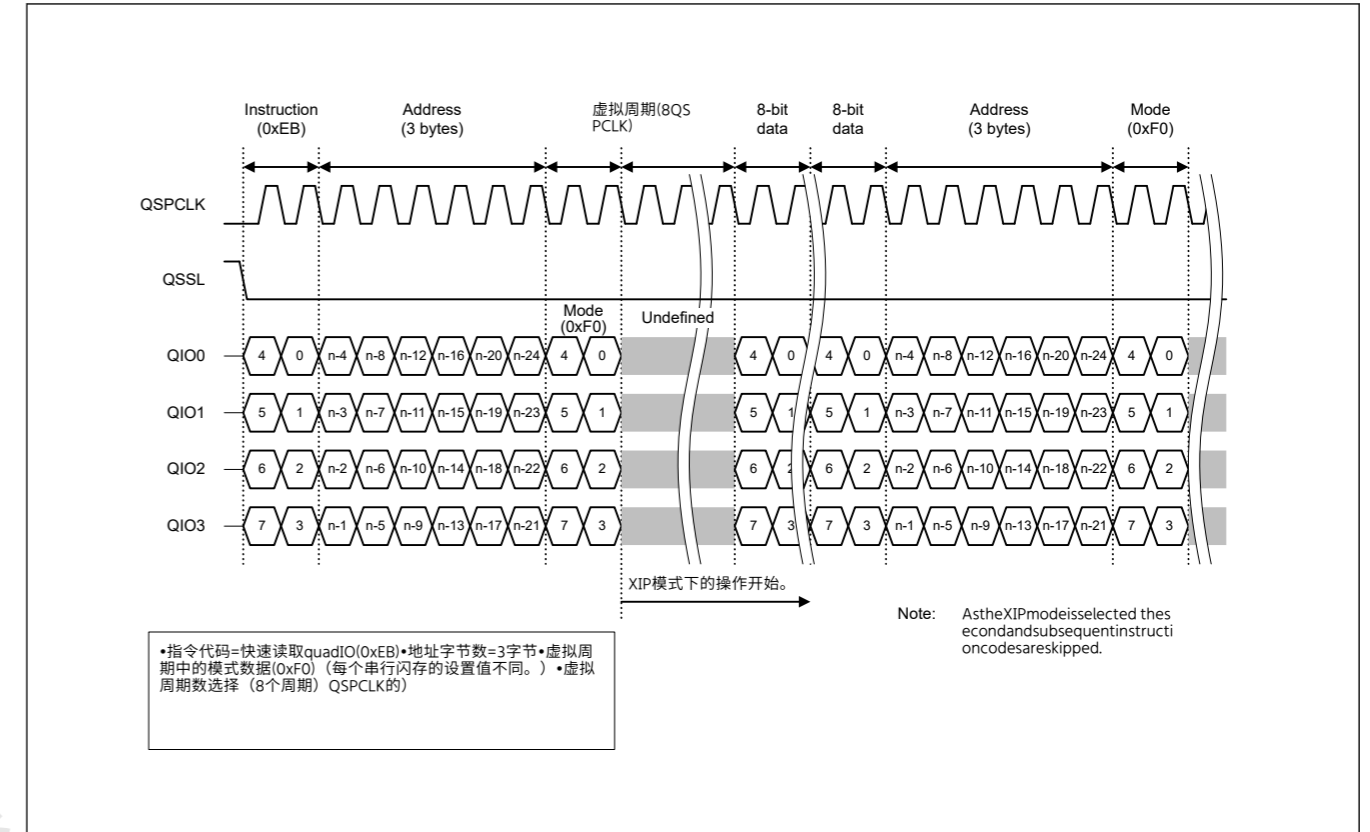


Figure 31.35 XIP模式控制数据

### 31.8.1 设置XIP模式

要在串行闪存中启动XIP模式，请执行以下寄存器设置：

- 在SFMSDC寄存器的SFMXD[7:0]位中设置模式数据值。\*1
- 将SFMSDC寄存器中的SFMXEN位设置为1。

在设置这些寄存器后的第一个快速读取周期的空周期中，传输寄存器中设置的模式数据值。从那时起，串行闪存中的XIP模式被启用。要确认当前XIP模式状态，请读取SFMSDC寄存器中的SFMXST标志。

注1.在SFMSDC寄存器的SFMXD[7:0]位中，设置符合实际串行闪存规范的模式数据。

下图显示了XIP模式设置过程的示例。

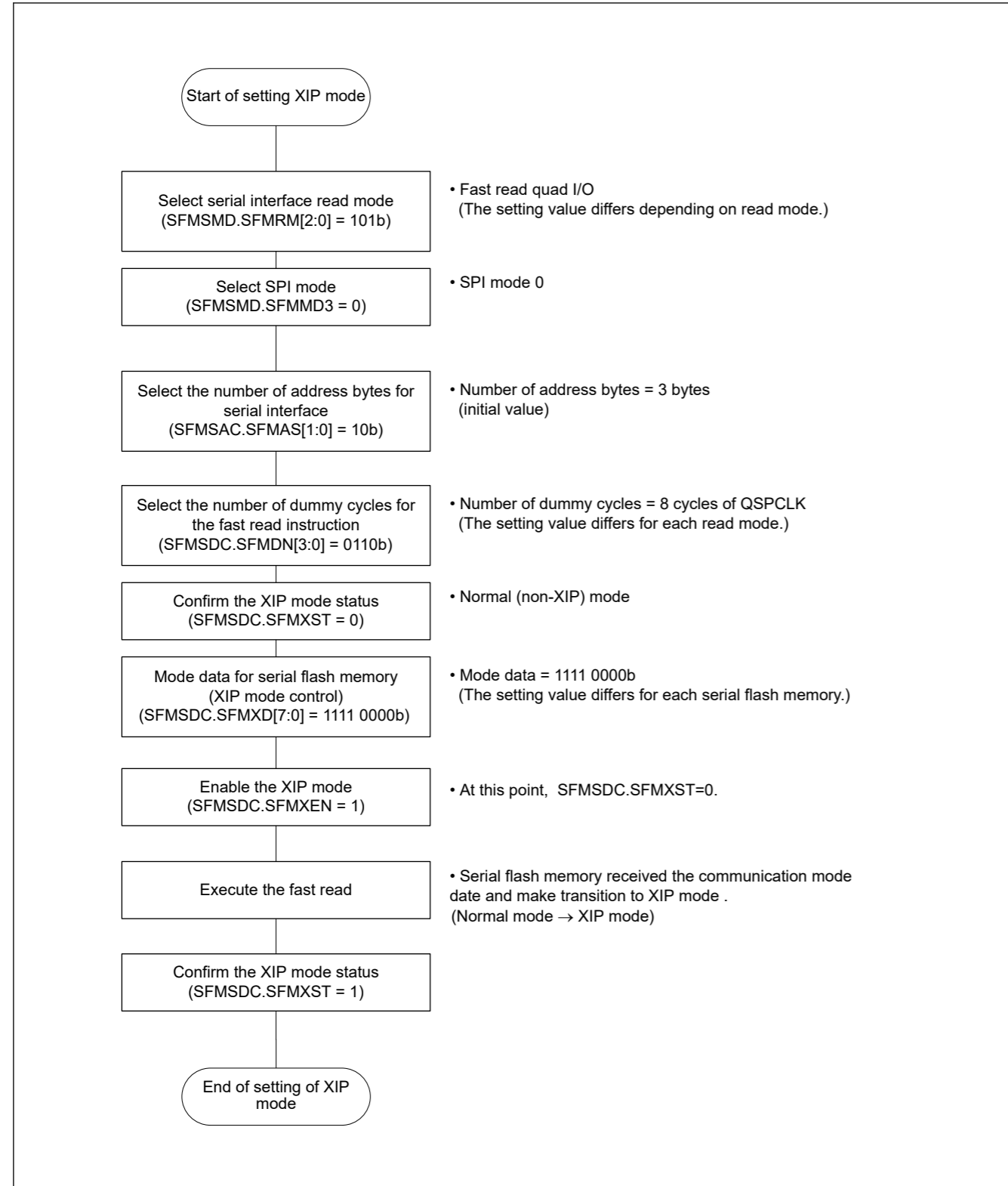


Figure 31.36 Flowchart of XIP Mode

### 31.8.2 Releasing the XIP Mode

To release XIP mode in serial flash memory, perform the following register setting:

- Set the mode data value to disable XIP mode in SFMSDC.SFMXD [7: 0] bits\*1
- Set the SFMXEN bit in the SFMSDC register to 0.

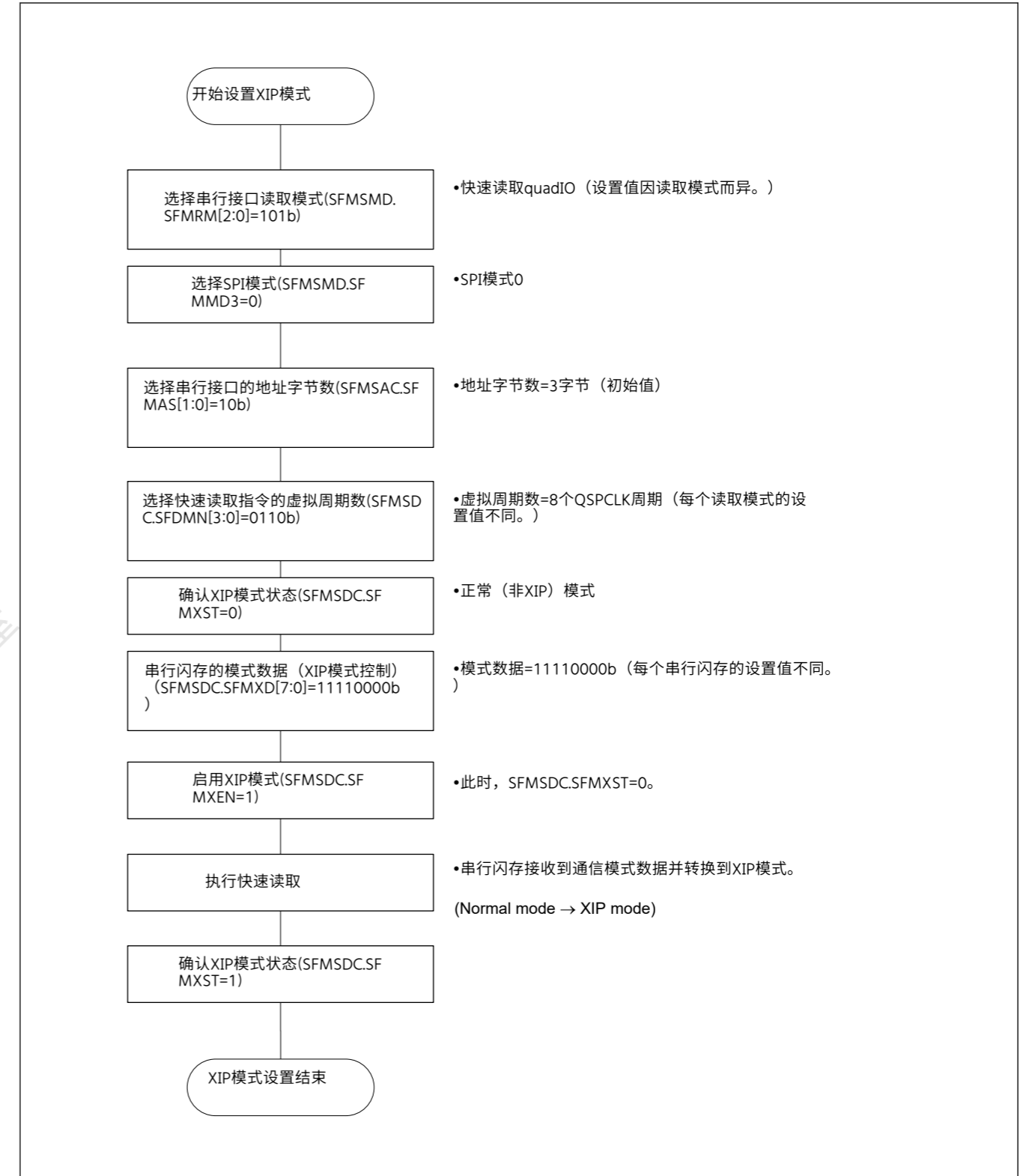


Figure 31.36 XIP模式流程图

### 31.8.2 释放XIP模式

要在串行闪存中释放XIP模式, 请执行以下寄存器设置:

- 在SFMSDC.SFMXD[7:0]位中设置模式数据值以禁用XIP模式\*1
- 将SFMSDC寄存器中的SFMXEN位设置为0。

In the dummy cycle of the first fast read cycle after this register is set, The mode data value that disables the XIP mode set in the register is transferred. From that point, XIP mode is disabled in the serial flash memory. To confirm the current XIP mode status, read the SFMXST flag in the SFMSDC register.

Note 1. Set the mode data in the SFMSDC.SFMXD [7: 0] bits according to the specifications of the serial flash memory.

Figure 31.37 shows an example of the procedure for releasing XIP mode.

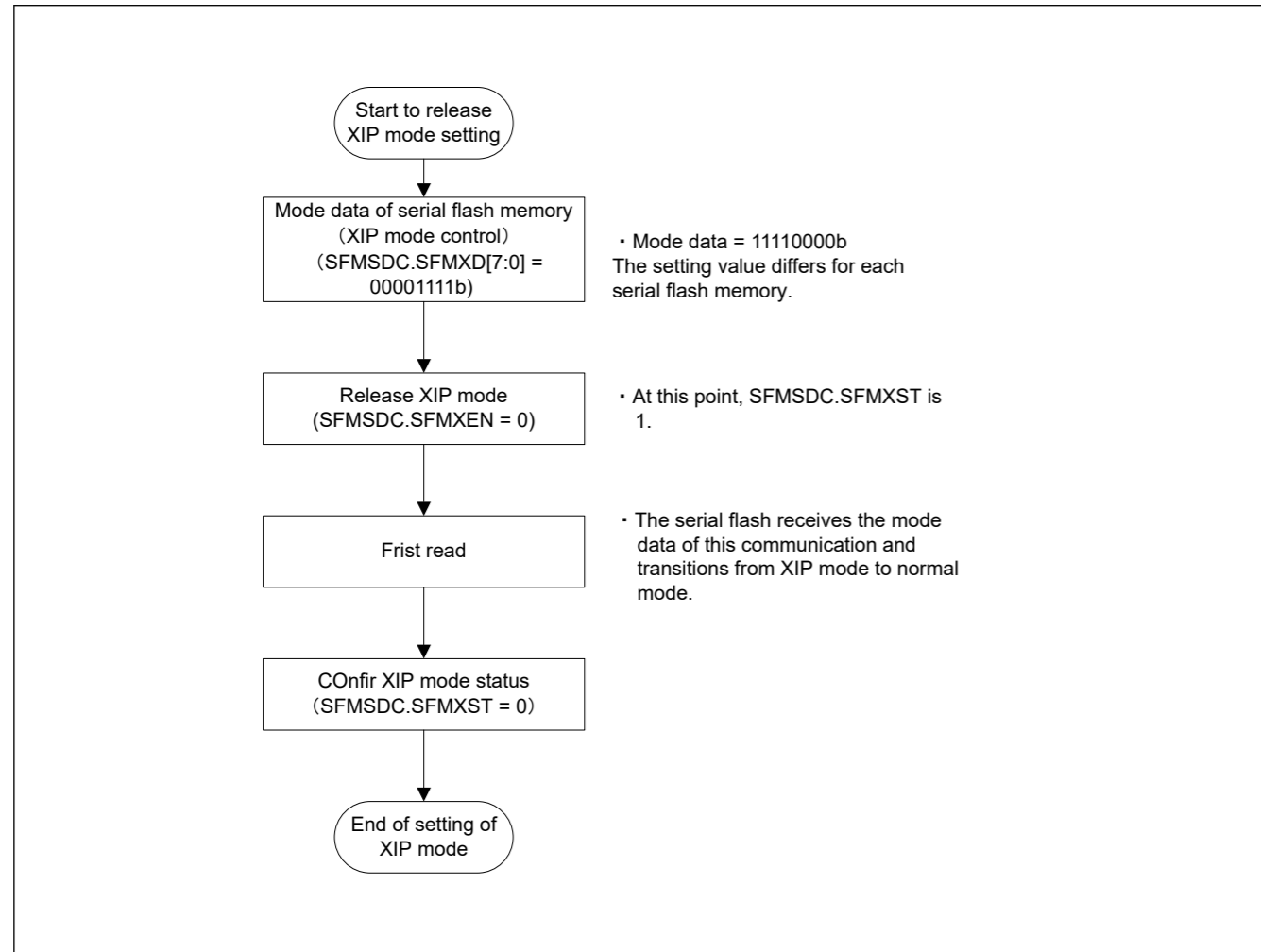


Figure 31.37 Releasing XIP mode (flowchart)

### 31.9 QIO2 and QIO3 Pin States

The QIO2 and QIO3 pin states depend on the serial interface read mode specified in the SFMRM[2:0] bits in the SFMSMD register.

Table 31.11 QIO2 and QIO3 pin states (1 of 2)

| SFMSMD.SFMRM[2:0] bits | QIO2 pin state*1  | QIO3 pin state*2  | Remarks               |
|------------------------|---|---|-----------------------|
| 111                    | Setting prohibited  |   |                       |
| 110                    |   |   |                       |
| 101                    | Input or output as serial data signal (The pin is in the Hi-Z state when it is inactive.) | Input or output as serial data signal (The pin is in the Hi-Z state when it is inactive.) | Fast Read Quad I/O    |
| 100                    |   |   | Fast Read Quad Output |

在设置该寄存器后的第一个快速读取周期的空周期中，传输寄存器中设置的禁用XIP模式的模式数据值。从那时起，串行闪存中的XIP模式被禁用。要确认当前XIP模式状态，请读取SFMSDC寄存器中的SFMXST标志。

注1.根据串行闪存的规格设置SFMSDC.SFMXD[7:0]位中的模式数据。

图31.37显示了释放XIP模式的过程示例。

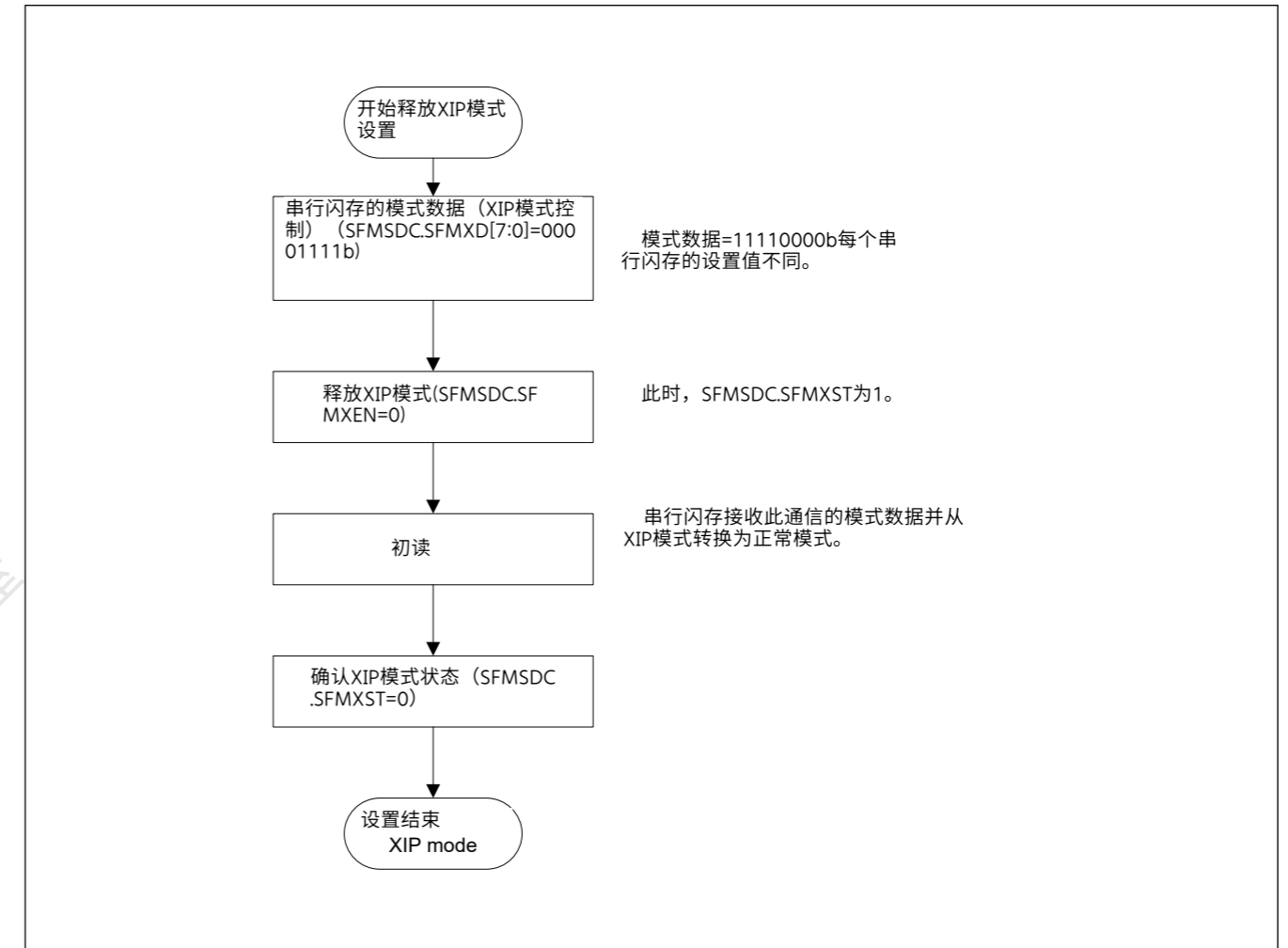


Figure 31.37 释放XIP模式 (流程图)

### 31.9 QIO2和QIO3引脚状态

QIO2和QIO3引脚状态取决于SFMSMD寄存器的SFMRM[2:0]位中指定的串行接口读取模式。

Table 31.11 QIO2和QIO3引脚状态 (1of2)

| SFMSMD.SFMRM[2:0] bits | QIO2引脚状态*1                           | QIO3引脚状态*2                           | Remarks  |
|------------------------|--------------------------------------|--------------------------------------|----------|
| 111                    | 禁止设定                                 |                                      |          |
| 110                    |                                      |                                      |          |
| 101                    | 作为串行数据信号的输入或输出 (引脚处于非活动状态时处于Hi-Z状态。) | 作为串行数据信号的输入或输出 (引脚处于非活动状态时处于Hi-Z状态。) | 快速读取四路IO |
| 100                    |                                      |                                      | 快速读取四路输出 |



Table 31.11 QIO2 and QIO3 pin states (2 of 2)

| SFMSMD.SFMRM[2:0] bits | QIO2 pin state*1  | QIO3 pin state*2  | Remarks                       |
|------------------------|---|-------------------|-------------------------------|
| 011                    | Output SFMWPL bit variable of the Port Control Register (SFMPMD) (initial value is low level) | Output high level | Fast Read Dual I/O            |
| 010                    |   |                   | Fast Read Dual Output         |
| 001                    |   |                   | Fast Read                     |
| 000                    |   |                   | Standard Read (Initial State) |

Note 1. The serial flash memory can also use the QIO2 pin for the write protect (WP) function. The WP function prohibits writes to the status registers. (The function is available in mode other than Quad-SPI mode.)

Note 2. The serial flash memory can also use the QIO3 pin for the HOLD or RESET function. The hold function places the I/O pin in an inactive state without deselecting the chip. (The function is available in mode other than Quad-SPI mode.) The reset function resets the serial flash memory. (The function is available when the QSSL pin function is disabled or in a mode in which the QIO3 pin is not used.)

## 31.10 Direct Communication Mode

### 31.10.1 About Direct Communication

The QSPI can read the serial flash memory contents by automatically converting from reading the QSPI window area to SPI bus cycles. However, serial flash memory have many different functions in addition to memory data read, including ID information read, erase, programming, and status information read. There is no standardized instruction set for using these functions, and more functions are being added rapidly by different vendors to different devices. Therefore, to support these functions, the software can create any required SPI bus cycle by communicating directly with serial flash memory.

### 31.10.2 Using Direct Communication Mode

To communicate directly with serial flash memory, transition to direct communication mode by setting the DCOM bit in the Communication Mode Control Register (SFMCMDCMD) register to 1. While direct communications mode is selected, the read operation to the serial flash memory by the QSPI window is invalid.

Note: If the QSPI is set to the XIP mode, you must terminate the XIP mode before starting direct communication mode.

### 31.10.3 Generating the SPI Bus Cycle during Direct Communication

The SPI bus cycle in direct communications starts on the first access to the SFMCOM register, and after a series of input / output operations are executed via the SFMCOM register, the bus cycle ends when 1 is written to the SFMCMDCMD register. At that point, a write to the SFMCOM port is converted to a one-byte transmission to the SPI bus, and a read from the SFMCOM register is converted to a one-byte reception from the SPI bus.

During the period from the first access to the SFMCOM register to the last write operation to the SFMCMDCMD register, the QSSL signal is held active to notify the serial flash memory that a series of SPI bus cycles is in progress.

Note: In direct communication mode, all writes to registers other than SFMCMDCMD and SFMCOM (including SFMSMD, SFMSSC, SFMSKC, SFMSST, SFMCST, SFMSIC, SFMSAC, SFMSDC, SFMSPC, and SFMPMD) are disabled.

Figure 31.38 to Figure 31.40 show direct communication program examples, and Figure 31.41 shows ID read direct communication timing examples.

Table 31.11 QIO2和QIO3引脚状态 (2个中的2个)

| SFMSMD.SFMRM[2:0] bits | QIO2引脚状态*1                                | QIO3引脚状态*2 | Remarks     |
|------------------------|---|------------|-------------|
| 011                    | 输出端口控制寄存器 (SFMPMD) 的 SFMWPL 位变量 (初始值为低电平) | 输出高电平      | 快速读取双IO     |
| 010                    |   |            | 快速读取双输出     |
| 001                    |   |            | 快速阅读        |
| 000                    |   |            | 标准读取 (初始状态) |

注1. 串行闪存也可以将QIO2引脚用于写保护(WP)功能。WP功能禁止写入状态寄存器。(该功能在Quad-SPI模式以外的模式下可用。)

注2. 串行闪存也可以将QIO3引脚用于HOLD或RESET功能。保持功能将IO引脚置于非活动状态, 而无需取消选择芯片。(该功能在除Quad-SPI mode.) 复位功能复位串行闪存。(当QSSL引脚功能被禁用或处于未使用QIO3引脚的模式时, 该功能可用。)

## 31.10 直接通讯方式

### 31.10.1 关于直接沟通

QSPI可以通过从读取QSPI窗口区域自动转换为SPI总线周期来读取串行闪存内容。然而, 串行闪存除了读取存储器数据外, 还有许多不同的功能, 包括ID信息读取、擦除、编程和状态信息读取。使用这些功能没有标准化的指令集, 更多的功能正在由不同的供应商迅速添加到不同的设备中。因此, 为了支持这些功能, 软件可以通过直接与串行闪存通信来创建任何所需的SPI总线周期。

### 31.10.2 使用直接通信模式

要直接与串行闪存通信, 通过设置DCOM位转换到直接通信模式 CommunicationModeControlRegister(SFMCMDCMD)register to 1. While direct communications mode is selected, the read operation to the serial flash memory by the QSPI window is invalid.

Note: 如果QSPI设置为XIP模式, 则必须在启动直接通信模式之前终止XIP模式。

### 31.10.3 在直接通信期间生成SPI总线周期

直接通信中的SPI总线周期从第一次访问SFMCOM寄存器开始, 通过SFMCOM寄存器执行一系列输入输出操作后, 总线周期在SFMCMDCMD寄存器写入1时结束。此时, 对SFMCOM端口的写入转换为向SPI总线发送一个字节, 从SFMCOM寄存器读取转换为从SPI总线接收一个字节。

在从第一次访问SFMCOM寄存器到最后一次写入SFMCMDCMD寄存器期间, QSSL信号保持有效, 以通知串行闪存一系列SPI总线周期正在进行中。

Note: 在直接通信模式下, 所有写入除SFMCMDCMD和SFMCOM以外的寄存器 (包括SFMSMD、SFMSSC、SFMSKC、SFMSST、SFMCST、SFMSIC、SFMSAC、SFMSDC、SFMSPC和SFMPMD) 被禁用。

图31.38至图31.40为直接通信程序示例, 图31.41为ID读取直接通信时序示例。

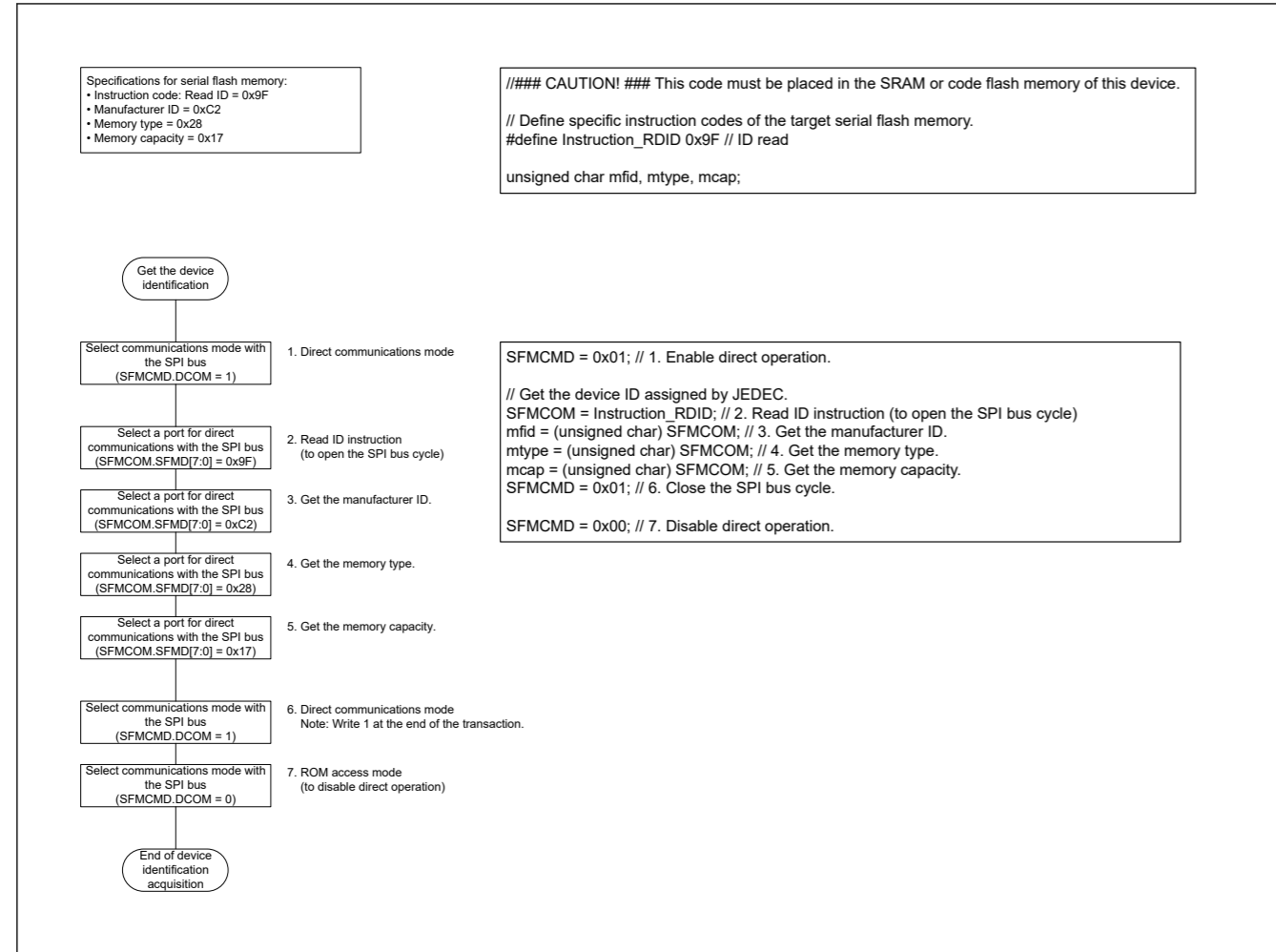


Figure 31.38 Flowchart of Device ID Acquisition

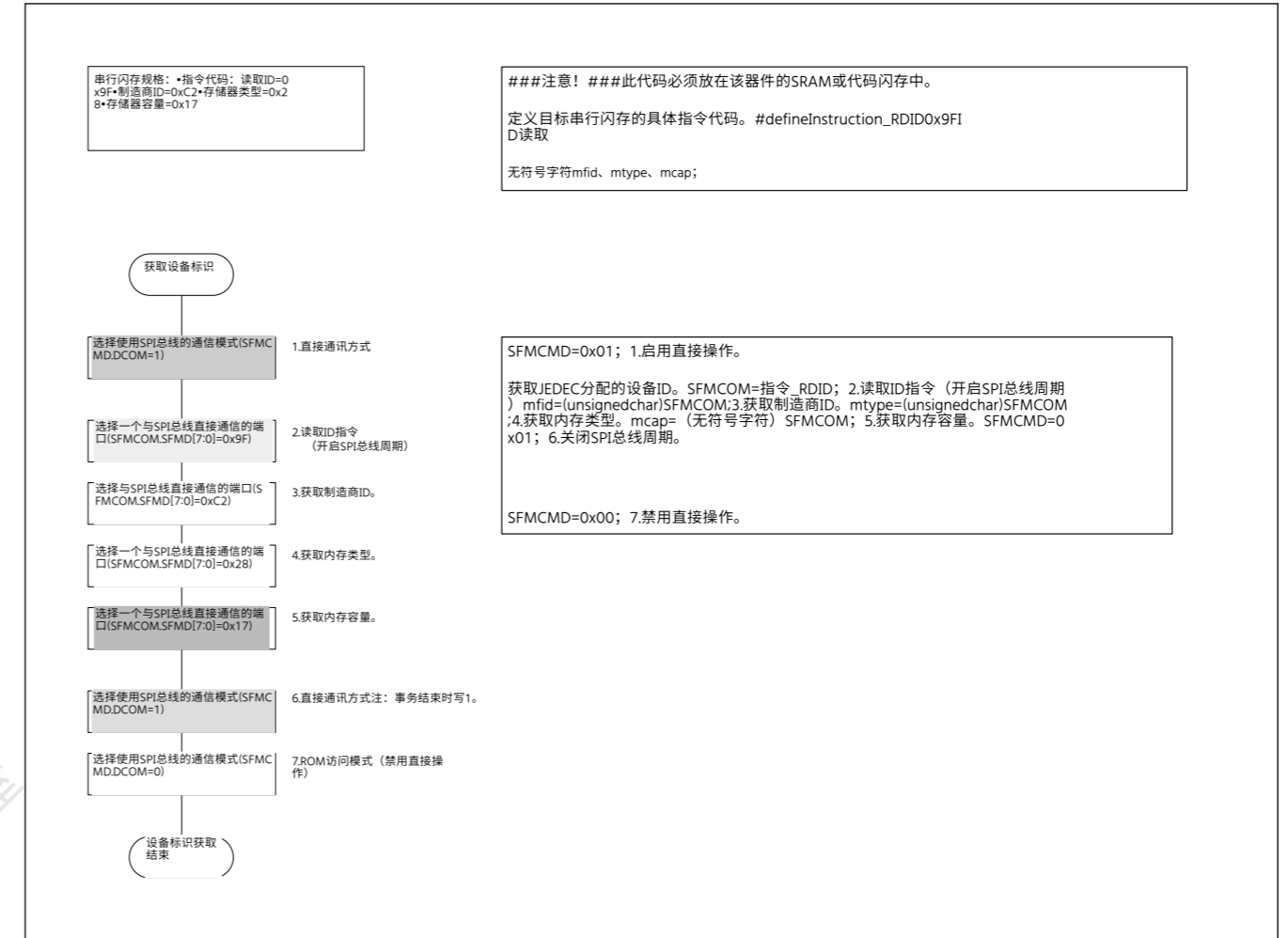


Figure 31.38 设备ID获取流程图

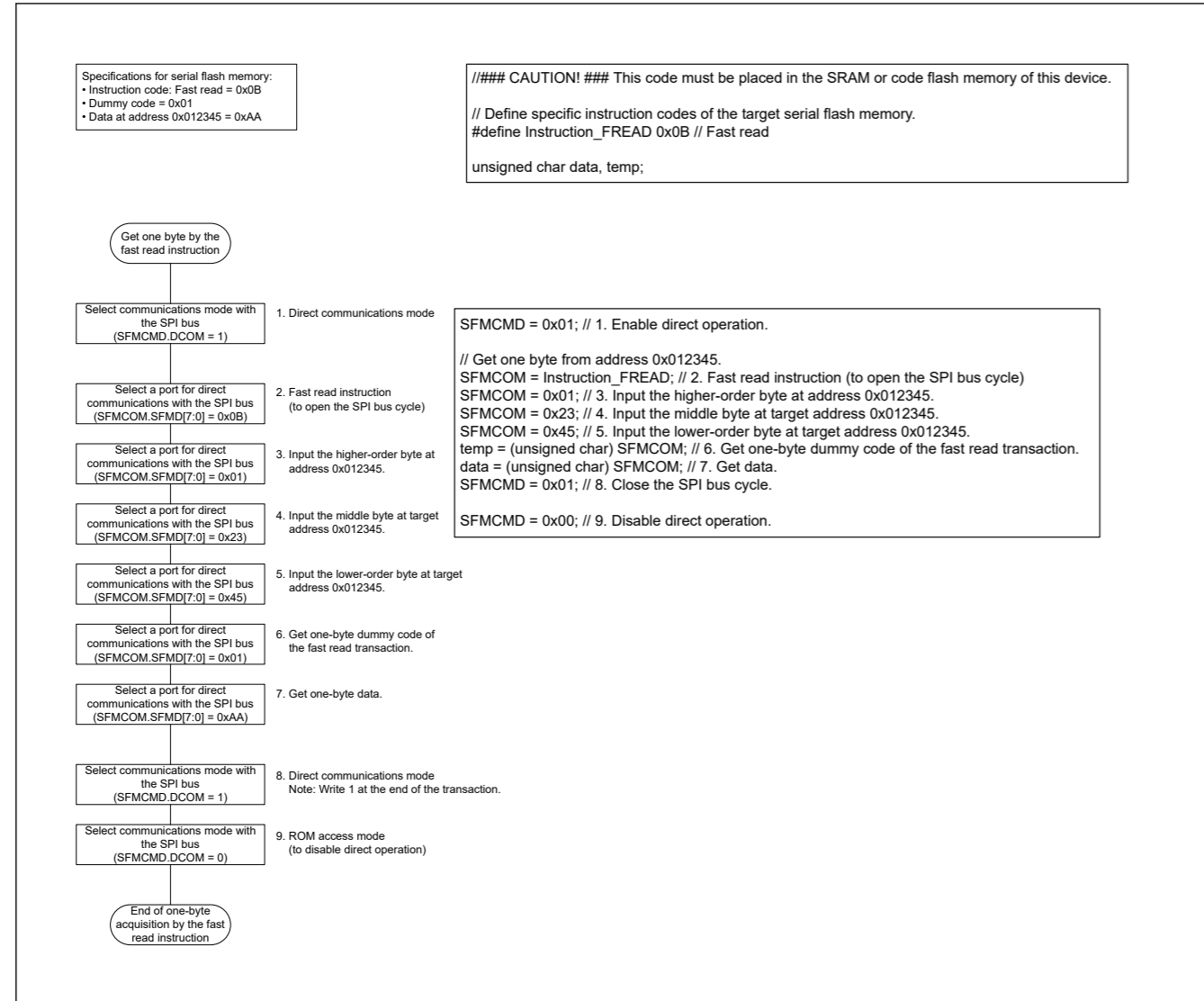


Figure 31.39 Flowchart of One-byte Acquisition by the Fast Read Instruction

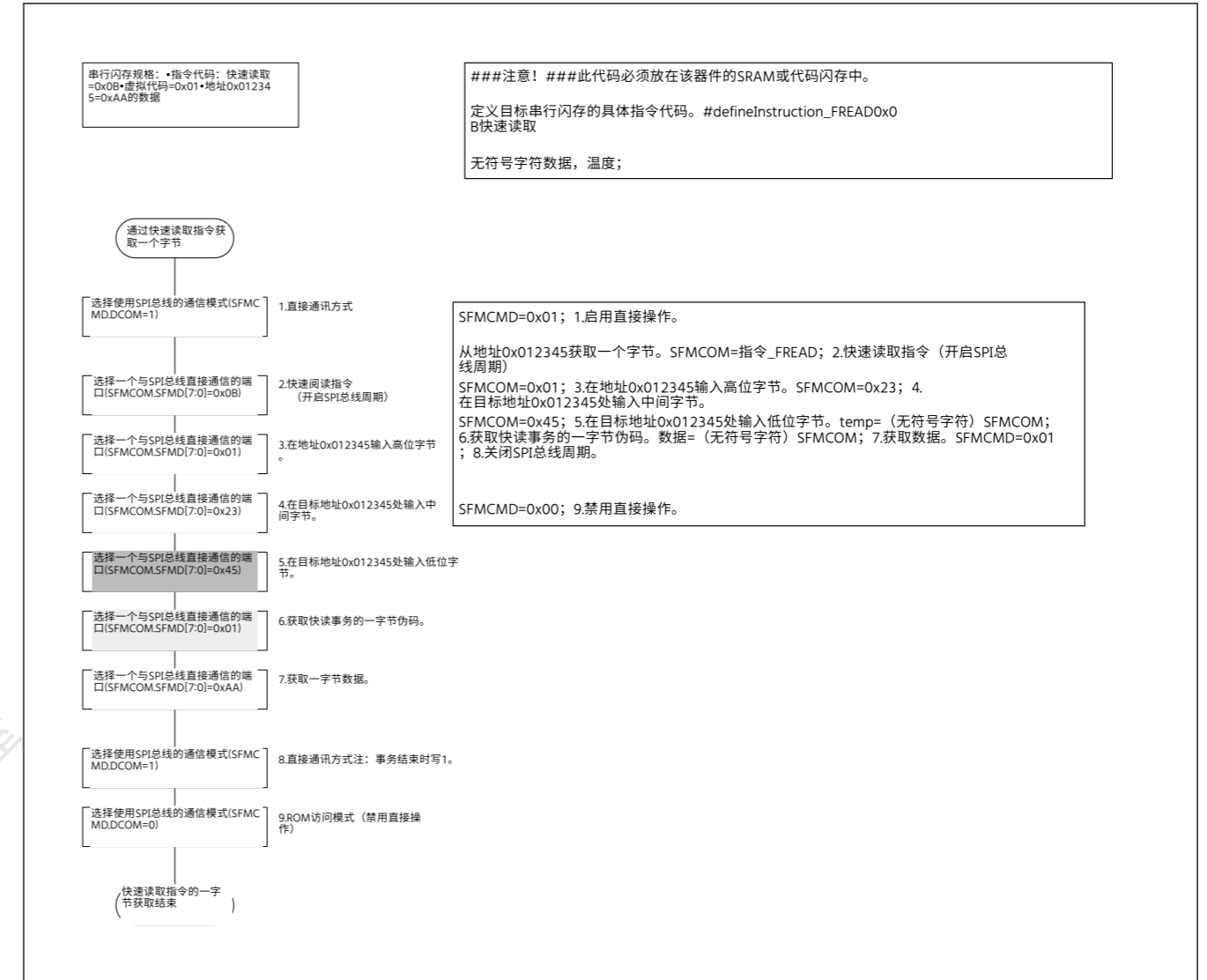


Figure 31.39 快速读取指令获取一字节的流程图

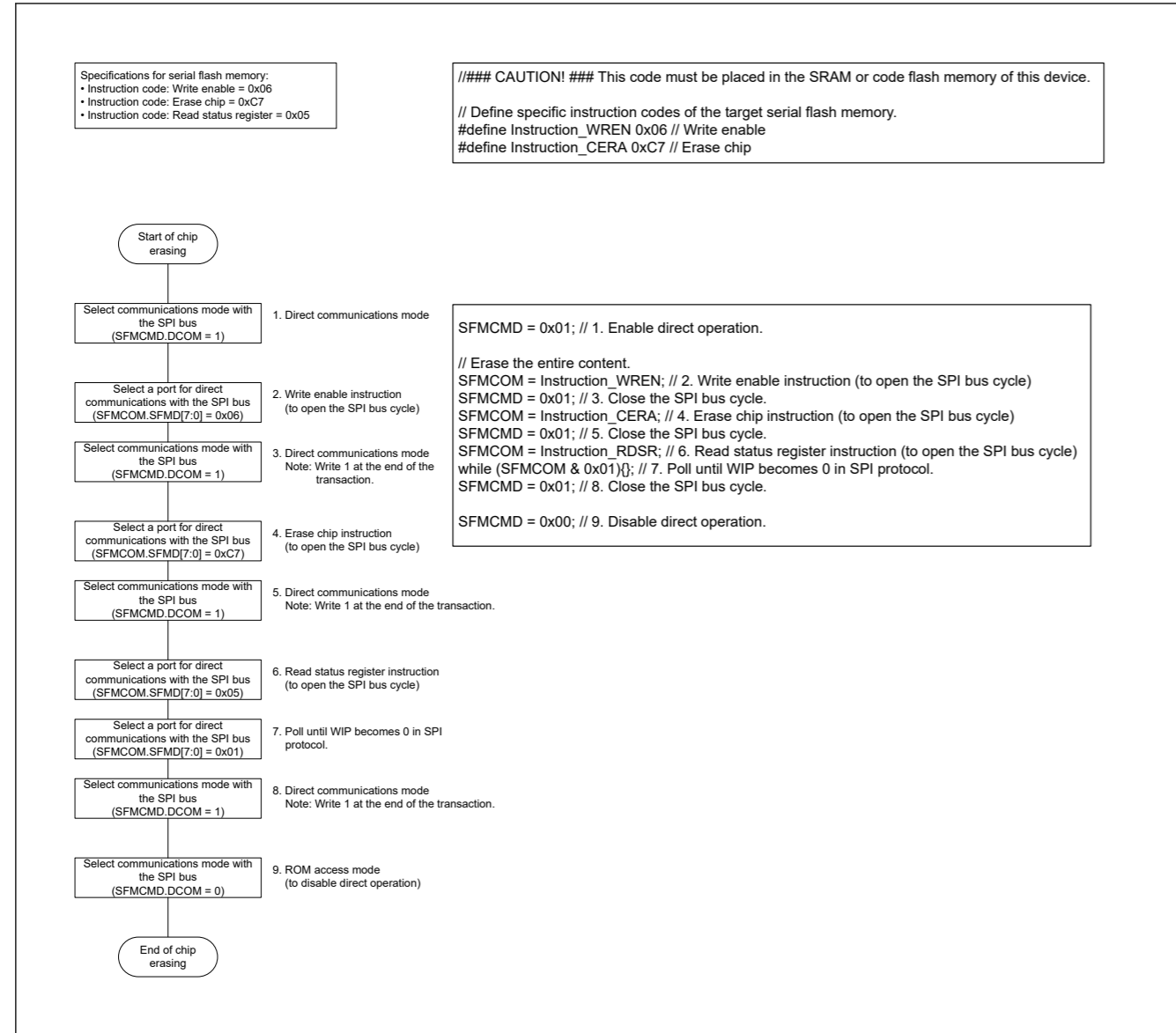


Figure 31.40 Flowchart of Chip Erasing

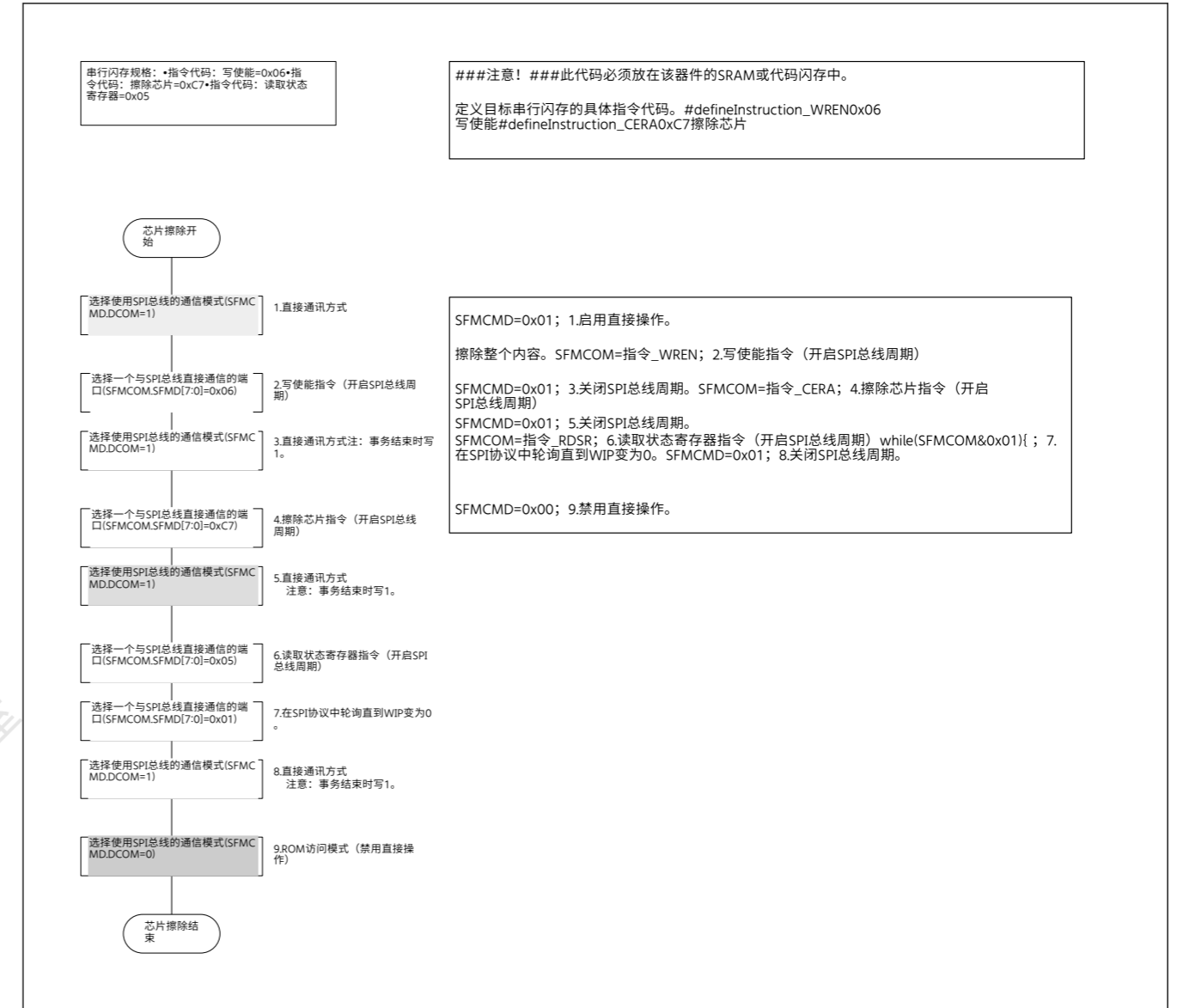


Figure 31.40 芯片擦除流程图



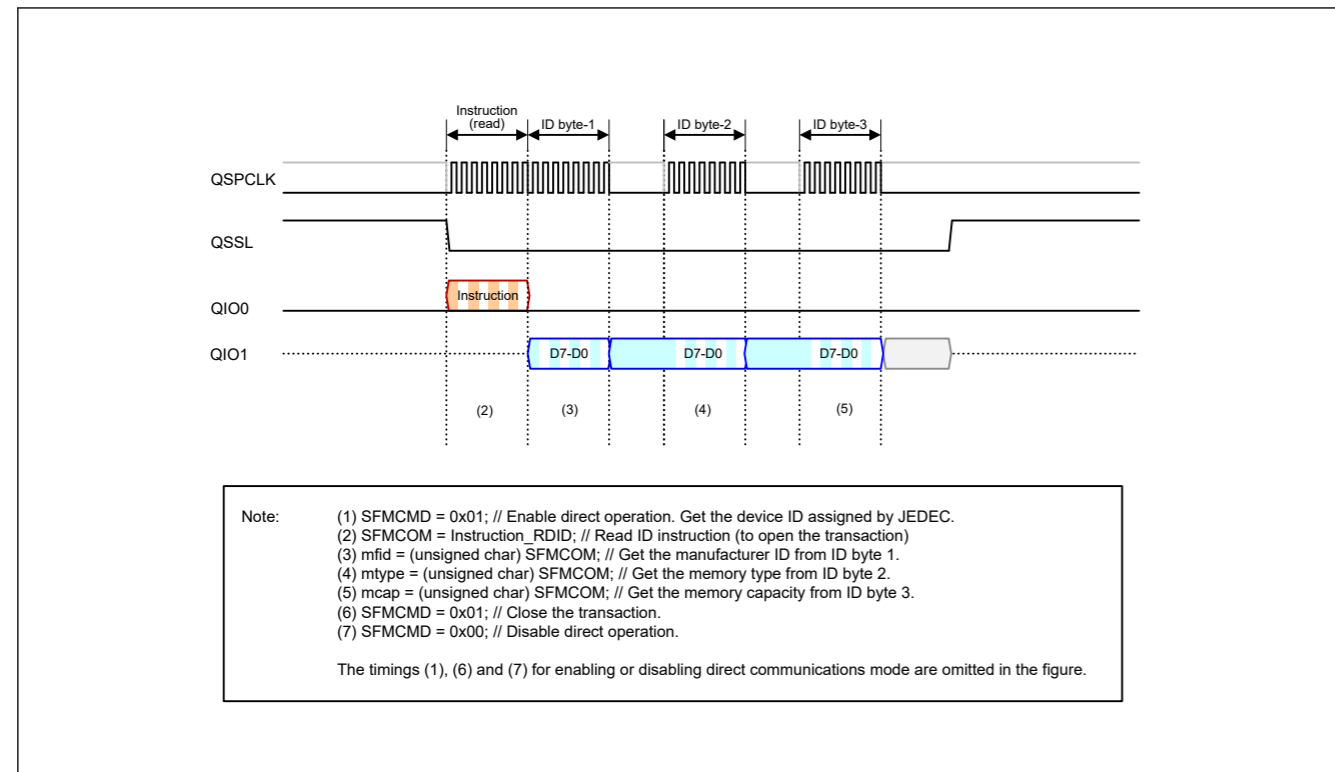


Figure 31.41 Example of direct communication timing for ID read

Note: When the Single SPI Protocol, Extended SPI Protocol is used in direct communication mode, the standard Read or Fast Read instruction must be used to reference the contents of the serial flash memory. The QSPI does not support Fast Read Dual Output, Fast Read Dual I/O, Fast Read Quad Output, or Fast Read Quad I/O transfers in this configuration. When these Fast Read operations are required, use ROM access memory.

### 31.11 Interrupts

When ROM read access is detected in direct communication mode, the SPMCST.EROMR flag is set to 1 and QSPI generates an interrupt request. Interrupt requests are retained until the EROMR flag is cleared by a 0 write. For details, see [section 13, Interrupt Controller Unit \(ICU\)](#).

### 31.12 Usage Note

#### 31.12.1 Settings for the Module-Stop Function

QSPI operation can be disabled or enabled using Module Stop Control Register B (MSTPCRB). The QSPI is initially stopped after reset. Releasing the module-stop state enables access to the registers. For details, see [section 10, Low Power Modes](#).

#### 31.12.2 Procedure for Changing Settings in Multiple Control Registers

The settings of the QSPI control registers can be modified dynamically during system operation. However, when the settings of multiple control registers are changed sequentially, an SPI bus cycle might occur before all of the registers are updated. The register setting sequence must be designed so that the SPI bus timing specifications are satisfied at all stages of register setting modification.

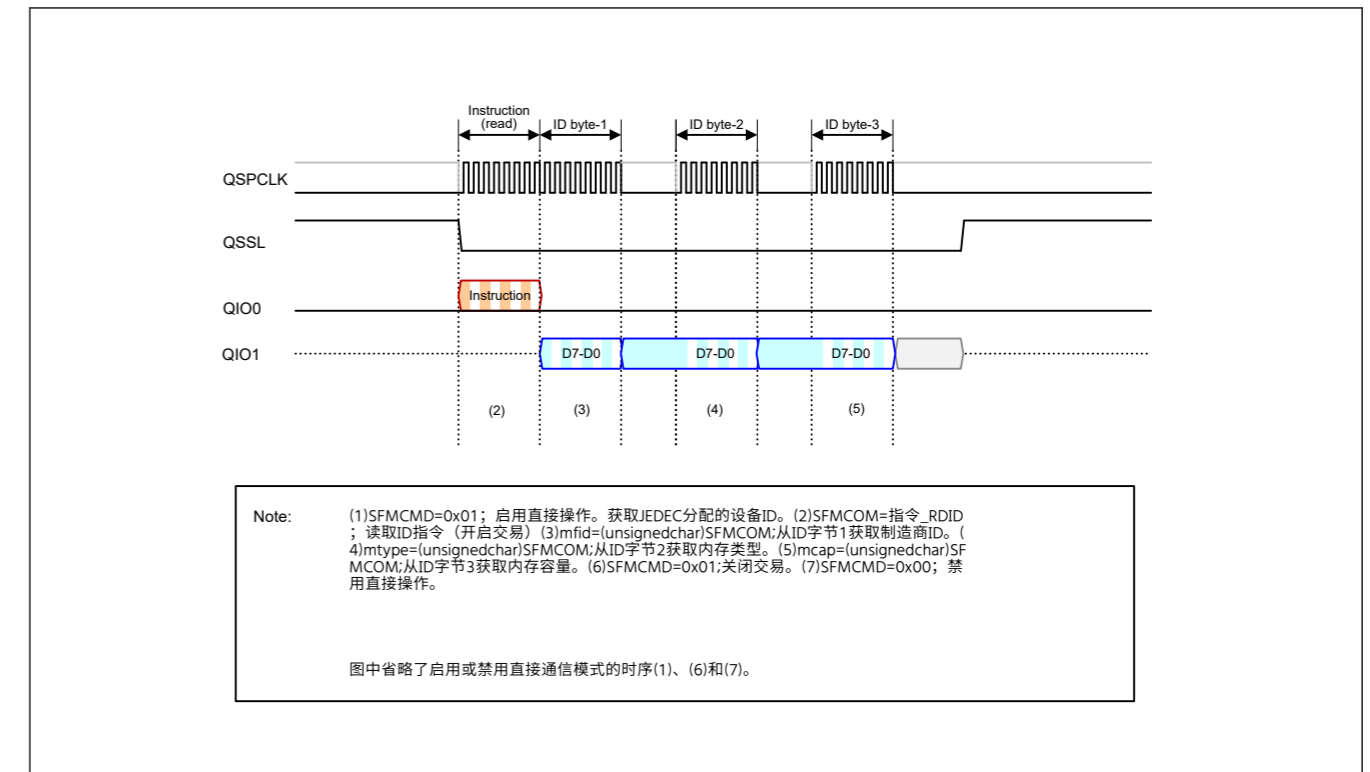


Figure 31.41 ID读取的直接通信时序示例

Note: 当单SPI协议、扩展SPI协议用于直接通信模式时，标准的Read或必须使用快速读取指令来引用串行闪存的内容。QSPI不支持此配置中的快速读取双输出、快速读取双IO、快速读取四输出或快速读取四IO传输。当需要这些快速读取操作时，请使用ROM存取存储器。

### 31.11 Interrupts

当在直接通信模式下检测到ROM读访问时，SPMCST.EROMR标志设置为1，并且QSPI产生中断请求。中断请求被保留，直到EROMR标志被0写入清除。有关详细信息，请参阅第13节，中断控制器单元(ICU)。

### 31.12 使用说明

#### 31.12.1 模块停止功能的设置

可以使用模块停止控制寄存器B(MSTPCRB)禁用或启用QSPI操作。QSPI在复位后最初停止。释放模块停止状态可以访问寄存器。有关详细信息，请参阅第10节，低功耗模式。

#### 31.12.2 更改多个控制寄存器中的设置的步骤

QSPI控制寄存器的设置可以在系统运行期间动态修改。但是，当多个控制寄存器的设置依次更改时，可能会在所有寄存器更新之前发生一个SPI总线周期。必须设计寄存器设置序列，以便在寄存器设置修改的所有阶段都满足SPI总线时序规范。

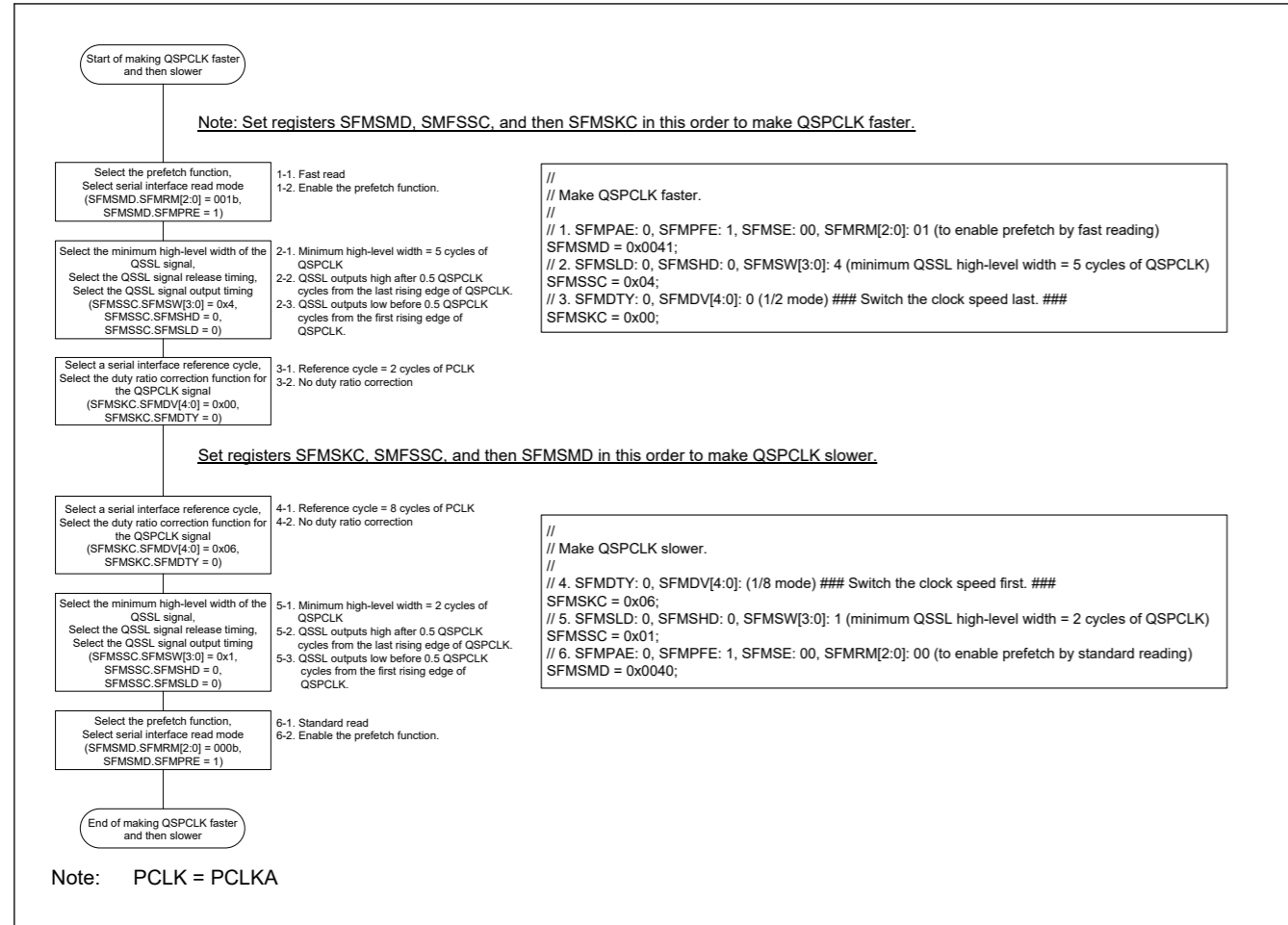


Figure 31.42 Flowchart of Making QSPCLK Faster and Slower



Figure 31.42 使QSPCLK更快和更慢的流程图

## 32. Serial Sound Interface Enhanced (SSIE)

### 32.1 Overview

The Serial Sound Interface Enhanced (SSIE) can transmit and receive audio data to and from various devices that support any of audio data formats, such as I<sup>2</sup>S, monaural, and TDM.

### 32.2 Features

Table 32.1 Features of SSIE

| Item   | Description   |  |
|--|---|--|
| Number of channels   | One channel, SSIE0  |  |
| Communication mode   | <ul style="list-style-type: none"> <li>Master/slave</li> <li>Transmission/reception (SSIE0 full duplex communication or half-duplex communication)</li> </ul>   |  |
| Communication format   | <ul style="list-style-type: none"> <li>I<sup>2</sup>S format</li> <li>Monaural format</li> <li>TDM format</li> </ul>  |  |
| Serial data  | <ul style="list-style-type: none"> <li>MSB first</li> <li>Data can be left-justified or right-justified.</li> <li>Data delay (1 clock cycle) or no delay selectable for the period from SSILRCK/SSIFS to SSITXD0/SSIRXD0/SSIDATA0</li> <li>System word length: 8, 16, 24, 32, 48, 64, 128, or 256 bits</li> <li>Data word length: 8, 16, 18, 20, 22, 24, or 32 bits</li> <li>Padding polarity: Low or high</li> </ul> |  |
| Bit clock (SSIBCK)   | In master mode  | <ul style="list-style-type: none"> <li>Two clock sources available (AUDIO_CLK/GPT output (GTIOC2A))</li> <li>Clock source division ratio: 1/1, 1/2, 1/4, 1/6, 1/8, 1/12, 1/16, 1/24, 1/32, 1/48, 1/64, 1/96, and 1/128.</li> <li>Supply/stop is selectable while communication is halted.</li> </ul> |
|  | In master/slave mode  | <ul style="list-style-type: none"> <li>Polarity (rising edge or falling edge) selectable</li> </ul>  |
| LR clock/frame synchronization (SSILRCK/SSIFS)                       | In master mode  | <ul style="list-style-type: none"> <li>Polarity (low level or high level) selectable</li> <li>Supply/stop is selectable while communication is halted.</li> </ul>  |
| Transmit data (SSITXD0/SSIDATA0) and receive data (SSIRXD0/SSIDATA0) | Transmission  | <ul style="list-style-type: none"> <li>Muting method (transmission of transmit FIFO data or transmission of data fixed to 0) selectable</li> </ul>   |
| FIFO   | Capacity  | <ul style="list-style-type: none"> <li>Transmit FIFO/receive FIFO: 4 bytes × 32 stages</li> </ul>  |
|  | Data alignment  | <ul style="list-style-type: none"> <li>Data alignment method (left-justification or right-justification) selectable for the data transfer between FIFO and shift register</li> </ul>   |
| Interrupt  | Interrupt output  | <ul style="list-style-type: none"> <li>Communication error/idle mode</li> <li>Receive data full</li> <li>Transmit data empty</li> </ul>  |
| Low power consumption function                                       |   |  |
| Module stop function   | <ul style="list-style-type: none"> <li>Module stop state can be set to reduce power consumption.</li> </ul>   |  |
| TrustZone Filter   | <ul style="list-style-type: none"> <li>Security attribution can be set.</li> </ul>  |  |

The following table lists and defines the terms used for the communication formats SSIE can use:

Table 32.2 Definition of terms (1 of 2)

| Term          | Definition   |
|---------------|--|
| Start trigger | First edge of the signal on the SSILRCK/SSIFS pin when the signal is set to the value specified in LRCKP to enable communication |

## 32. 串行声音接口增强(SSIE)

### 32.1 Overview

增强型串行声音接口(SSIE)可以向各种支持任何音频数据格式(例如I<sup>2</sup>S、单声道和TDM)的设备发送和接收音频数据。

### 32.2 Features

Table 32.1 SSIE的特点

| Item   | Description  |   |
|--|--|---|
| 通道数  | 一个通道, SSIE0  |   |
| 通讯方式   | <ul style="list-style-type: none"> <li>Master/slave</li> <li>发送接收 (SSIE0全双工通信或半双工通信)</li> </ul>  |   |
| 通讯格式   | <ul style="list-style-type: none"> <li>I<sup>2</sup>S format</li> <li>Monaural format</li> <li>TDM format</li> </ul>   |   |
| 串行数据   | <ul style="list-style-type: none"> <li>MSB first</li> <li>数据可以左对齐或右对齐。</li> <li>从SSILRCKSSIFS到SSITXD0SSIRXD0SSIDATA0期间可选择数据延迟(1个时钟周期)或无延迟</li> <li>系统字长: 8、16、24、32、48、64、128或256位</li> <li>数据字长: 8、16、18、20、22、24或32位</li> <li>填充极性: 低或高</li> </ul> |   |
| 位时钟(S SIBCK)                                   | 在主模式   | <ul style="list-style-type: none"> <li>提供两个时钟源(AUDIO_CLKGPT输出(GTIOC2A))</li> <li>时钟源分频比: 11、12、14、16、18、112、116、124、132、148、164、196和1128。</li> <li>通信停止时可选择停止供电。</li> </ul> |
|  | 在主从模式  | <ul style="list-style-type: none"> <li>极性(上升沿或下降沿)可选</li> </ul>   |
| LR clock/frame synchronization (SSILRCK/SSIFS) | 在主模式   | <ul style="list-style-type: none"> <li>极性(低电平或高电平)可选</li> <li>通信停止时可选择停止供电。</li> </ul>  |
| 发送数据(SSITXD0/SSIDATA0)和接收数据(SSIRXD0/SSIDATA0)  | Transmission   | <ul style="list-style-type: none"> <li>可选择静音方式(传送FIFO数据或传送固定为0的数据)</li> </ul>   |
| FIFO   | Capacity   | <ul style="list-style-type: none"> <li>发送FIFO接收FIFO: 4字节×32级</li> </ul>   |
|  | 数据对齐   | <ul style="list-style-type: none"> <li>FIFO和移位寄存器之间的数据传输可选择数据对齐方式(左对齐或右对齐)</li> </ul>   |
| Interrupt                                      | 中断输出   | <ul style="list-style-type: none"> <li>通信错误空闲模式</li> <li>接收数据已满</li> <li>传输数据为空</li> </ul>  |
| 低功耗功能  |  |   |
| 模块停止功能   | <ul style="list-style-type: none"> <li>可设置模块停止状态以降低功耗。</li> </ul>  |   |
| TrustZone Filter                               | <ul style="list-style-type: none"> <li>可以设置安全属性。</li> </ul>  |   |

下表列出并定义了用于SSIE可以使用的通信格式的术语:

Table 32.2 术语定义(1of2)

| Term  | Definition                                       |
|-------|--|
| 启动触发器 | 当信号设置为LRCKP中指定的值以启用通信时, SSILRCKSSIFS引脚上的信号的第一个边沿 |

Table 32.2 Definition of terms (2 of 2)

| Term                                   | Definition   |
|--|--|
| Frame boundary                         | Point where SSIE starts transferring the first data of a frame or the point where SSIE ends transferring the last data of the frame  |
| Frame word number                      | Number of sound channels per frame   |
| System word length                     | Number of bits per channel   |
| Data word length                       | Number of significant bits per channel   |
| Control bits for communication formats | <ul style="list-style-type: none"> <li>SSICR register: FRM, DWL, SWL, LRCKP, SPDP, SDTA, PDTA, and DEL bits</li> <li>SSIFCR register: BSW bit</li> <li>SSIOFR register: OMOD bit</li> <li>SSISCR register: TDES[4:0] and RDFS[4:0] bits</li> </ul> |

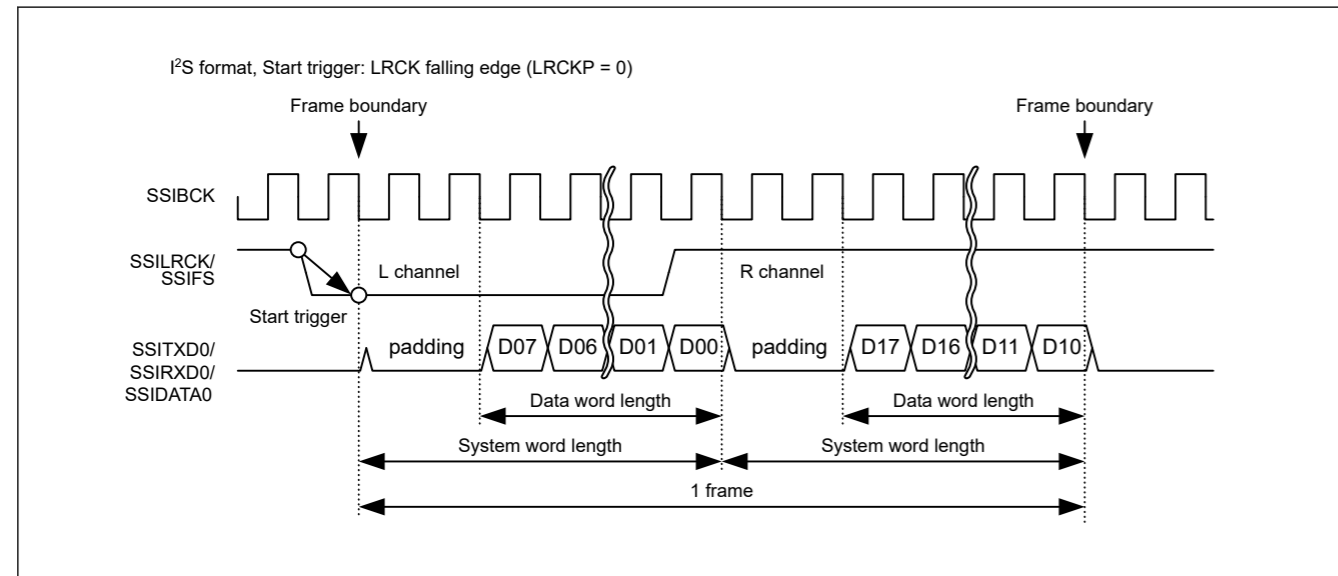


Figure 32.1 Definition of communication format

### 32.3 Block Diagram

Figure 32.2 shows a block diagram of SSIE.

Table 32.2 术语定义(2of2)

| Term     | Definition  |
|----------|---|
| 框架边界     | SSIE开始传输帧的第一个数据的点或SSIE结束传输帧的最后一个数据的点  |
| 帧字数      | 每帧声道数   |
| 系统字长     | 每个通道的位数   |
| 数据字长     | 每个通道的有效位数   |
| 通信格式的控制位 | <ul style="list-style-type: none"> <li>SSICR寄存器: FRM、DWL、SWL、LRCKP、SPDP、SDTA、PDTA和DEL位</li> <li>SSIFCR寄存器: BSW bit</li> <li>SSIOFR寄存器: OMOD bit</li> <li>SSISCR寄存器: TDES[4:0]和RDFS[4:0]位</li> </ul> |

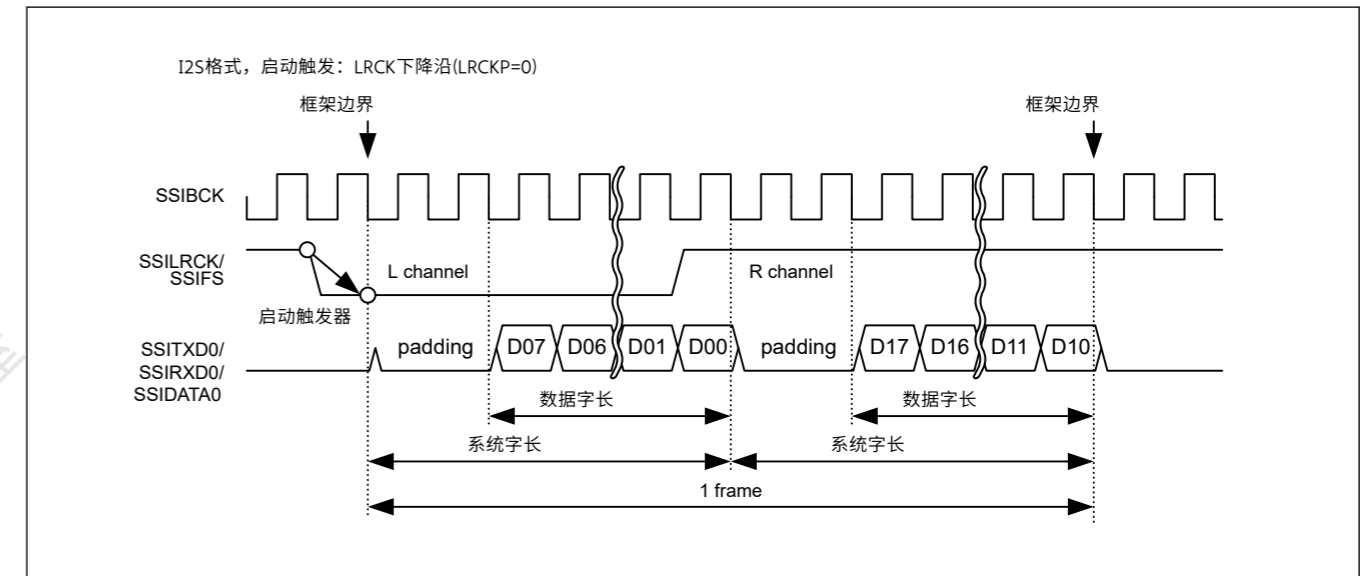


Figure 32.1 通讯格式的定义

### 32.3 框图

图32.2显示了SSIE的框图。



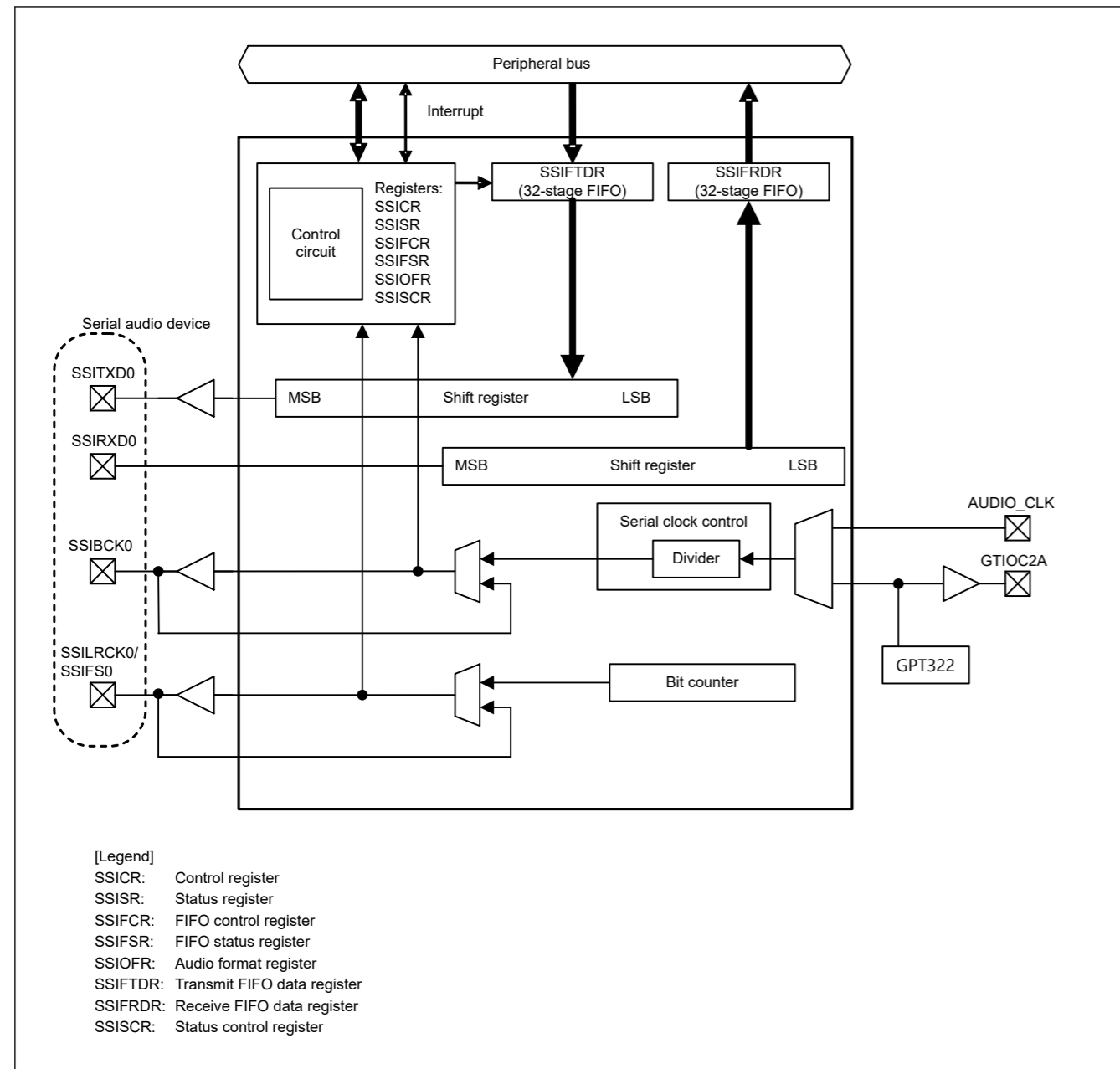


Figure 32.2 SSIE block diagram for full-duplex communication

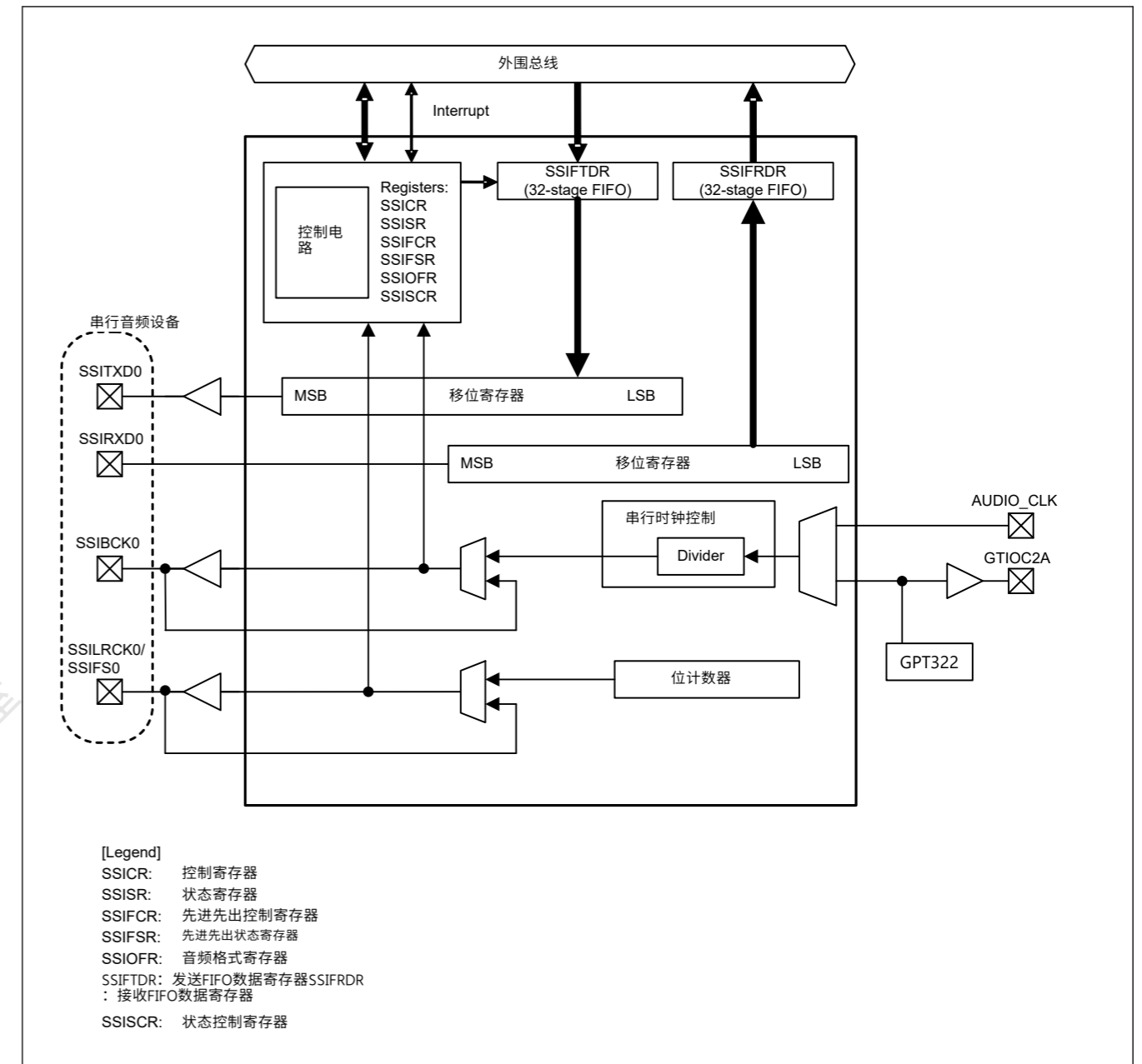


Figure 32.2 全双工通信的SSIE框图

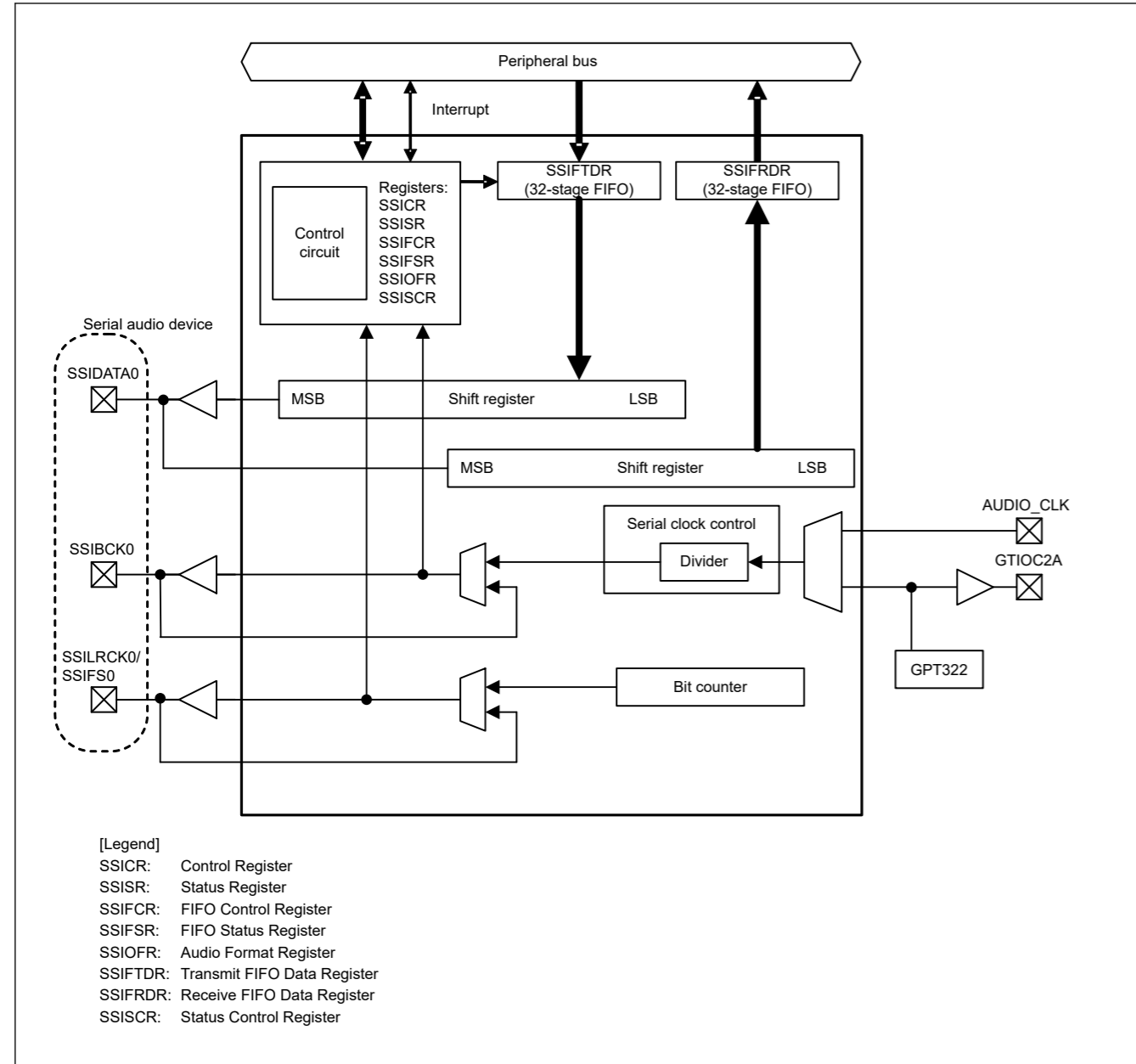


Figure 32.3 SSIE block diagram for half-duplex communication

Figure 32.4 shows the clock configuration of SSIE.

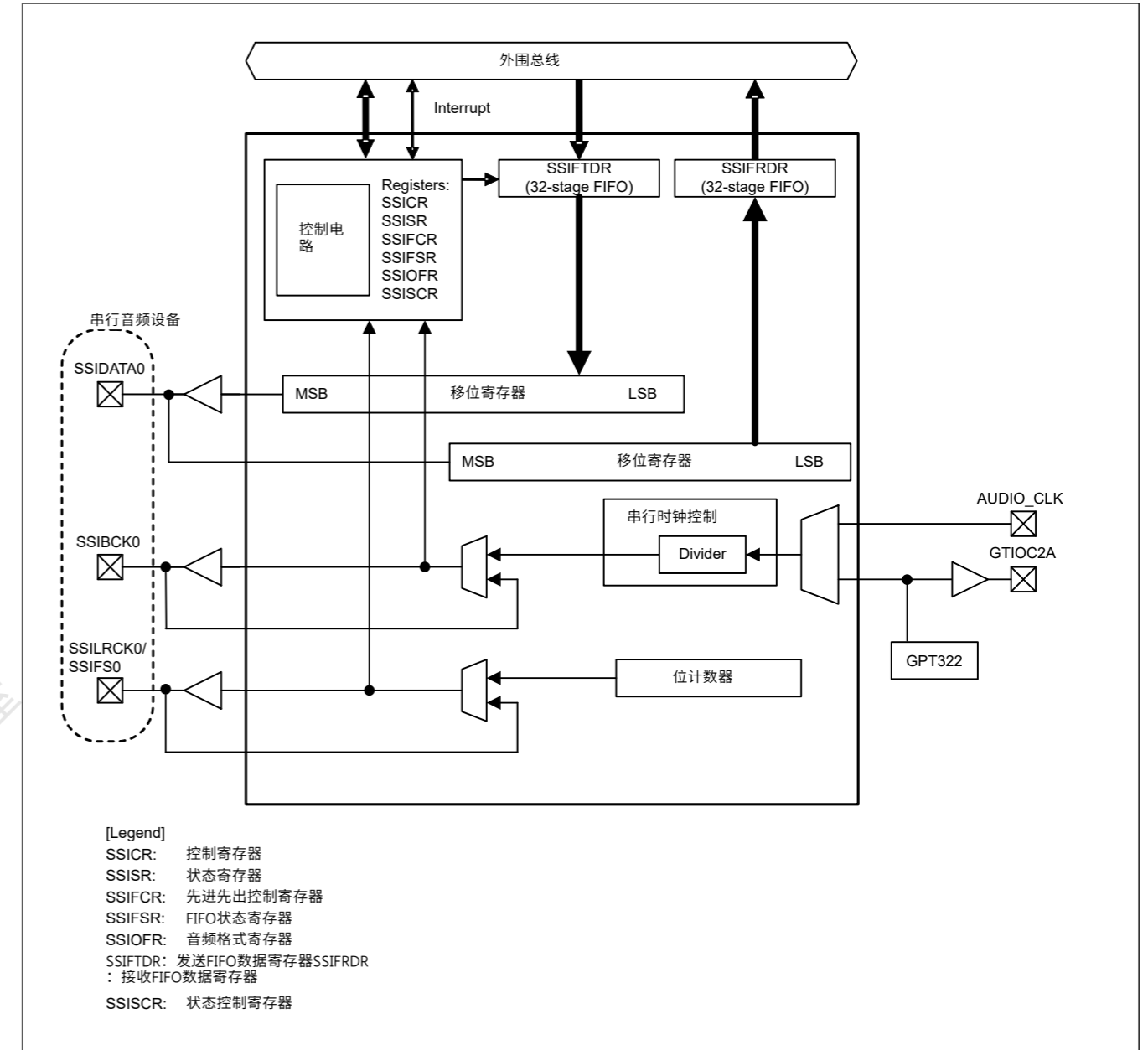


Figure 32.3 半双工通信的SSIE框图

图32.4显示了SSIE的时钟配置。

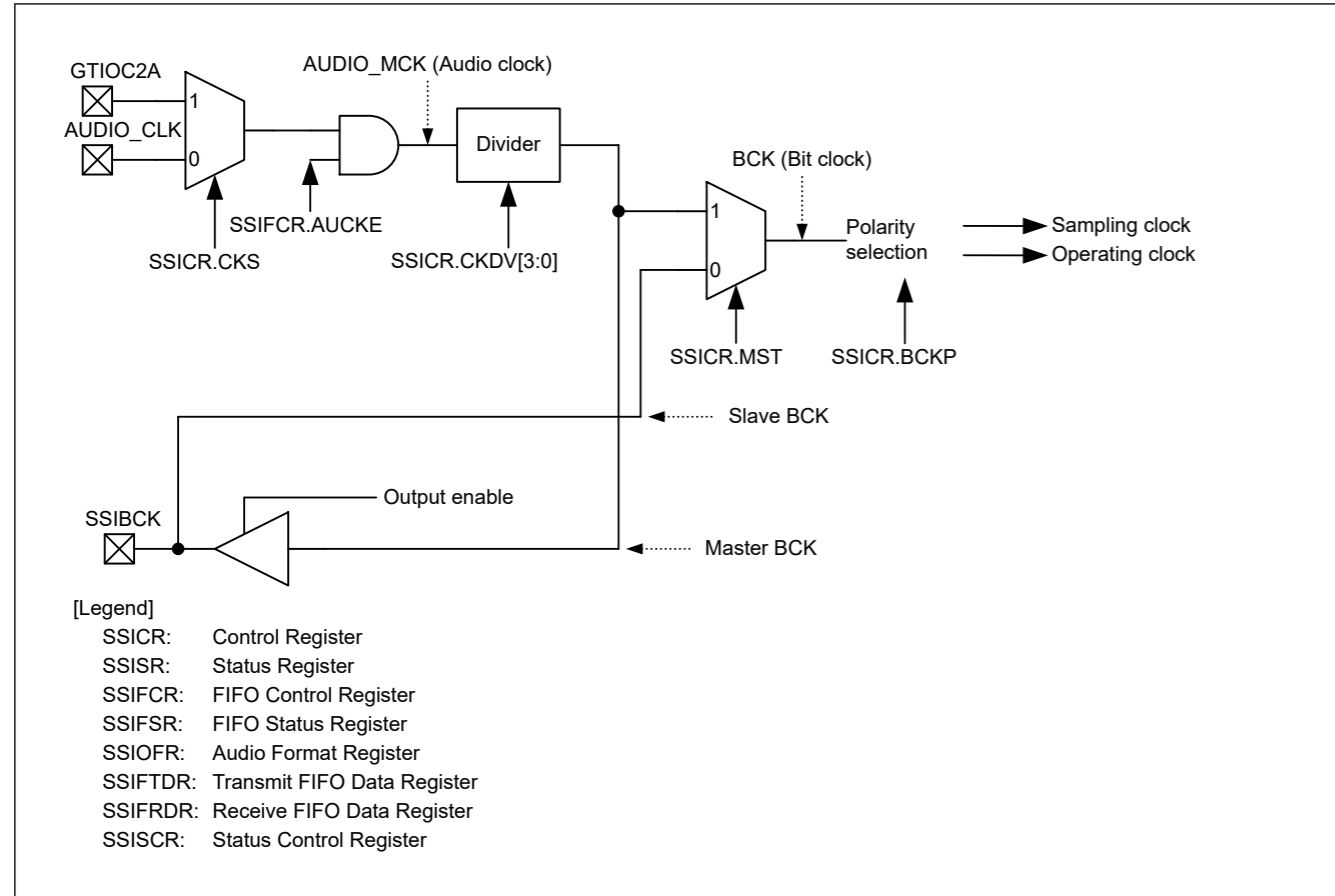


Figure 32.4 SSIE clock configuration

### 32.4 Register Descriptions

#### 32.4.1 SSICR : Control Register

Base address: SSIE0 = 0x4009\_D000

Offset address: 0x00

|                    |    |     |       |                   |       |       |      |     |           |          |          |     |     |    |    |    |
|--------------------|----|-----|-------|-------------------|-------|-------|------|-----|-----------|----------|----------|-----|-----|----|----|----|
| Bit position:      | 31 | 30  | 29    | 28                | 27    | 26    | 25   | 24  | 23        | 22       | 21       | 20  | 19  | 18 | 17 | 16 |
| Bit field:         | —  | CKS | TUIEN | TOIEN             | RUIEN | ROIEN | IEN  | —   | FRM[1:0]  | DWL[2:0] | SWL[2:0] |     |     |    |    |    |
| Value after reset: | 0  | 0   | 0     | 0                 | 0     | 0     | 0    | 0   | 0         | 0        | 0        | 0   | 0   | 0  | 0  | 0  |
| Bit position:      | 15 | 14  | 13    | 12                | 11    | 10    | 9    | 8   | 7         | 6        | 5        | 4   | 3   | 2  | 1  | 0  |
| Bit field:         | —  | MST | BCKP  | LRCK <sub>P</sub> | SPDP  | SDTA  | PDTA | DEL | CKDV[3:0] | MUEN     | —        | TEN | REN |    |    |    |
| Value after reset: | 0  | 0   | 0     | 0                 | 0     | 0     | 0    | 0   | 0         | 0        | 0        | 0   | 0   | 0  | 0  | 0  |

| Bit | Symbol | Function   | R/W |
|-----|--------|--|-----|
| 0   | REN    | Reception Enable*2<br>0: Disables reception<br>1: Enables reception (starts reception)             | R/W |
| 1   | TEN    | Transmission Enable*2<br>0: Disables transmission<br>1: Enables transmission (starts transmission) | R/W |
| 2   | —      | This bit is read as 0. The write value should be 0.  | R/W |

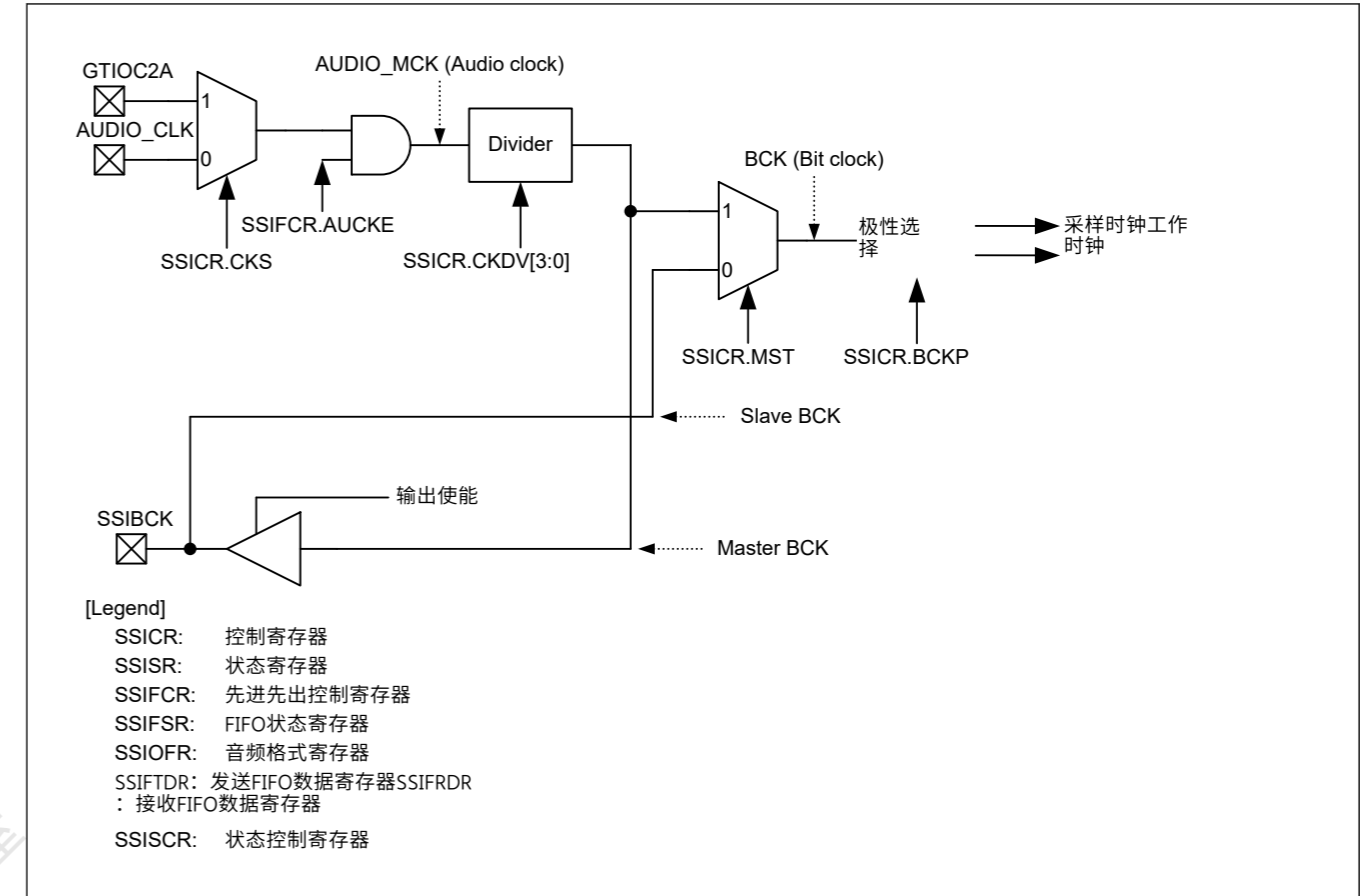


Figure 32.4 SSIE时钟配置

### 32.4 注册说明

#### 32.4.1 SSICR:控制寄存器

Base address: SSIE0 = 0x4009\_D000

Offset address: 0x00

|               |    |     |       |                   |       |       |      |     |           |          |          |     |     |    |    |    |
|---------------|----|-----|-------|-------------------|-------|-------|------|-----|-----------|----------|----------|-----|-----|----|----|----|
| Bit position: | 31 | 30  | 29    | 28                | 27    | 26    | 25   | 24  | 23        | 22       | 21       | 20  | 19  | 18 | 17 | 16 |
| Bit field:    | —  | CKS | TUIEN | TOIEN             | RUIEN | ROIEN | IEN  | —   | FRM[1:0]  | DWL[2:0] | SWL[2:0] |     |     |    |    |    |
| 重置后的值:        | 0  | 0   | 0     | 0                 | 0     | 0     | 0    | 0   | 0         | 0        | 0        | 0   | 0   | 0  | 0  | 0  |
| Bit position: | 15 | 14  | 13    | 12                | 11    | 10    | 9    | 8   | 7         | 6        | 5        | 4   | 3   | 2  | 1  | 0  |
| Bit field:    | —  | MST | BCKP  | LRCK <sub>P</sub> | SPDP  | SDTA  | PDTA | DEL | CKDV[3:0] | MUEN     | —        | TEN | REN |    |    |    |
| 重置后的值:        | 0  | 0   | 0     | 0                 | 0     | 0     | 0    | 0   | 0         | 0        | 0        | 0   | 0   | 0  | 0  | 0  |

| Bit | Symbol | Function                        | R/W |
|-----|--------|---------------------------------|-----|
| 0   | REN    | 接收启用*2<br>0: 禁止接收1: 允许接收 (开始接收) | R/W |
| 1   | TEN    | 传输启用*2<br>0: 禁止发送1: 允许发送 (开始发送) | R/W |
| 2   | —      | 该位读取为0。写入值应为0。                  | R/W |

| Bit | Symbol    | Function  | R/W |
|-----|-----------|---|-----|
| 3   | MUEN      | Mute Enable<br>0: Disables muting on the next frame boundary<br>1: Enables muting on the next frame boundary  | R/W |
| 7:4 | CKDV[3:0] | Selects Bit Clock Division Ratio*1<br>0x0: AUDIO_MCK<br>0x1: AUDIO_MCK/2<br>0x2: AUDIO_MCK/4<br>0x3: AUDIO_MCK/8<br>0x4: AUDIO_MCK/16<br>0x5: AUDIO_MCK/32<br>0x6: AUDIO_MCK/64<br>0x7: AUDIO_MCK/128<br>0x8: AUDIO_MCK/6<br>0x9: AUDIO_MCK/12<br>0xA: AUDIO_MCK/24<br>0xB: AUDIO_MCK/48<br>0xC: AUDIO_MCK/96<br>Others: Setting prohibited           | R/W |
| 8   | DEL       | Selects Serial Data Delay*1<br>In the monaural format, this bit controls the waveform of SSILRCK/SSIFS.<br>For details, see <a href="#">section 32.5.2. Monaural Format</a> .<br>0: Delay of 1 cycle of SSIBCK between SSILRCK/SSIFS and SSITXD0/SSIRXD0/SSIDATA0<br>1: No delay between SSILRCK/SSIFS and SSITXD0/SSIRXD0/SSIDATA0                   | R/W |
| 9   | PDTA      | Selects Placement Data Alignment*1<br>0: Left-justifies placement data (SSIFTDR, SSIFRDR)<br>1: Right-justifies placement data (SSIFTDR, SSIFRDR)   | R/W |
| 10  | SDTA      | Selects Serial Data Alignment*1<br>0: Transmits and receives serial data first and then padding bits<br>1: Transmit and receives padding bits first and then serial data  | R/W |
| 11  | SPDP      | Selects Serial Padding Polarity*1<br>0: Padding data is at a low level<br>1: Padding data is at a high level  | R/W |
| 12  | LRCKP     | Selects the Initial Value and Polarity of LR Clock/Frame Synchronization Signal*1<br>0: The initial value is at a high level.<br>The start trigger for a frame is synchronized with a falling edge of SSILRCK/SSIFS.<br>1: The initial value is at a low level.<br>The start trigger for a frame is synchronized with a rising edge of SSILRCK/SSIFS. | R/W |
| 13  | BCKP      | Selects Bit Clock Polarity*1<br>0: SSILRCK/SSIFS and SSITXD0/SSIRXD0/SSIDATA0 change at a falling edge (SSILRCK/SSIFS and SSIRXD0/SSIDATA0 are sampled at a rising edge of SSIBCK).<br>1: SSILRCK/SSIFS and SSITXD0/SSIRXD0/SSIDATA0 change at a rising edge (SSILRCK/SSIFS and SSIRXD0/SSIDATA0 are sampled at a falling edge of SSIBCK).            | R/W |
| 14  | MST       | Master Enable*1<br>0: Slave-mode communication<br>1: Master-mode communication  | R/W |
| 15  | —         | This bit is read as 0. The write value should be 0.   | R/W |

| Bit | Symbol    | Function  | R/W |
|-----|-----------|---|-----|
| 3   | MUEN      | 静音启用<br>0: 在下一帧边界禁用静音1: 在下一帧边界启用静音  | R/W |
| 7:4 | CKDV[3:0] | 选择位时钟分频比*1<br>0x0: AUDIO_MCK<br>0x1: AUDIO_MCK/2<br>0x2: AUDIO_MCK/4<br>0x3: AUDIO_MCK/8<br>0x4: AUDIO_MCK/16<br>0x5: AUDIO_MCK/32<br>0x6: AUDIO_MCK/64<br>0x7: AUDIO_MCK/128<br>0x8: AUDIO_MCK/6<br>0x9: AUDIO_MCK/12<br>0xA: AUDIO_MCK/24<br>0xB: AUDIO_MCK/48<br>0xC: AUDIO_MCK/96<br>其他: 禁止设置 | R/W |
| 8   | DEL       | 选择串行数据延迟*1<br>在单声道格式中, 该位控制SSILRCKSSIFS的波形。<br>有关详细信息, 请参阅第32.5.2节。单声道格式。<br>0: 在SSILRCKSSIFS和SSITXD0SSIRXD0SSIDATA0之间延迟1个SSIBCK周期<br>1: SSILRCKSSIFS和SSITXD0SSIRXD0SSIDATA0之间无延迟   | R/W |
| 9   | PDTA      | 选择放置数据对齐*1<br>0: 左对齐放置数据 (SSIFTDR、SSIFRDR) 1: 右对齐放置数据 (SSIFTDR、SSIFRDR)   | R/W |
| 10  | SDTA      | 选择串行数据对齐*1<br>0: 先发送和接收串行数据, 然后是填充位1: 先发送和接收填充位, 然后是串行数据  | R/W |
| 11  | SPDP      | 选择串行填充极性*1<br>0: 填充数据为低电平1: 填充数据为高电平  | R/W |
| 12  | LRCKP     | 选择LR时钟帧同步信号的初始值和极性*1<br>0: 初始值为高电平。<br>帧的开始触发与SSILRCK的下降沿同步SSIFS。<br>1: 初始值为低电平。<br>帧的开始触发与SSILRCK的上升沿同步SSIFS。  | R/W |
| 13  | BCKP      | 选择位时钟极性*1<br>0: SSILRCKSSIFS和SSITXD0SSIRXD0SSIDATA0在下降沿变化 (SSILRCKSSIFS和SSIRXD0SSIDATA0在SSIBCK的上升沿采样)。<br>1: SSILRCKSSIFS和SSITXD0SSIRXD0SSIDATA0在上升沿变化 (SSILRCKSSIFS和SSIRXD0SSIDATA0在SSIBCK的下降沿采样)。   | R/W |
| 14  | MST       | 主使能*1<br>0: Slave-mode communication<br>1: Master-mode communication  | R/W |
| 15  | —         | 该位读取为0。写入值应为0。  | R/W |



| Bit                                     | Symbol                 | Function  | R/W                                     |  |  |  |          |                        |                |           |     |   |   |                    |     |                    |                    |   |     |  |  |   |     |  |  |   |     |
|---|------------------------|---|---|--|--|--|----------|------------------------|----------------|-----------|-----|---|---|--------------------|-----|--------------------|--------------------|---|-----|--|--|---|-----|--|--|---|-----|
| 18:16                                   | SWL[2:0]               | Selects System Word Length*1<br>0 0 0: 8 bits<br>0 0 1: 16 bits<br>0 1 0: 24 bits<br>0 1 1: 32 bits<br>1 0 0: 48 bits<br>1 0 1: 64 bits<br>1 1 0: 128 bits<br>1 1 1: 256 bits   | R/W                                     |  |  |  |          |                        |                |           |     |   |   |                    |     |                    |                    |   |     |  |  |   |     |  |  |   |     |
| 21:19                                   | DWL[2:0]               | Selects Data Word Length*1<br>0 0 0: 8 bits<br>0 0 1: 16 bits<br>0 1 0: 18 bits<br>0 1 1: 20 bits<br>1 0 0: 22 bits<br>1 0 1: 24 bits<br>1 1 0: 32 bits<br>1 1 1: Setting prohibited  | R/W                                     |  |  |  |          |                        |                |           |     |   |   |                    |     |                    |                    |   |     |  |  |   |     |  |  |   |     |
| 23:22                                   | FRM[1:0]               | Selects Frame Word Number*1<br><table border="1"> <thead> <tr> <th colspan="4">Communication format (SSIOFR.OMOD[1:0])</th> </tr> <tr> <th>FRM[1:0]</th> <th>I<sup>2</sup>S (00b)</th> <th>Monaural (10b)</th> <th>TDM (01b)</th> </tr> </thead> <tbody> <tr> <td>00b</td> <td>2</td> <td>1</td> <td>Setting prohibited</td> </tr> <tr> <td>01b</td> <td>Setting prohibited</td> <td>Setting prohibited</td> <td>4</td> </tr> <tr> <td>10b</td> <td></td> <td></td> <td>5</td> </tr> <tr> <td>11b</td> <td></td> <td></td> <td>6</td> </tr> </tbody> </table> | Communication format (SSIOFR.OMOD[1:0]) |  |  |  | FRM[1:0] | I <sup>2</sup> S (00b) | Monaural (10b) | TDM (01b) | 00b | 2 | 1 | Setting prohibited | 01b | Setting prohibited | Setting prohibited | 4 | 10b |  |  | 5 | 11b |  |  | 6 | R/W |
| Communication format (SSIOFR.OMOD[1:0]) |                        |   |   |  |  |  |          |                        |                |           |     |   |   |                    |     |                    |                    |   |     |  |  |   |     |  |  |   |     |
| FRM[1:0]                                | I <sup>2</sup> S (00b) | Monaural (10b)  | TDM (01b)                               |  |  |  |          |                        |                |           |     |   |   |                    |     |                    |                    |   |     |  |  |   |     |  |  |   |     |
| 00b                                     | 2                      | 1   | Setting prohibited                      |  |  |  |          |                        |                |           |     |   |   |                    |     |                    |                    |   |     |  |  |   |     |  |  |   |     |
| 01b                                     | Setting prohibited     | Setting prohibited  | 4                                       |  |  |  |          |                        |                |           |     |   |   |                    |     |                    |                    |   |     |  |  |   |     |  |  |   |     |
| 10b                                     |                        |   | 5                                       |  |  |  |          |                        |                |           |     |   |   |                    |     |                    |                    |   |     |  |  |   |     |  |  |   |     |
| 11b                                     |                        |   | 6                                       |  |  |  |          |                        |                |           |     |   |   |                    |     |                    |                    |   |     |  |  |   |     |  |  |   |     |
| 24                                      | —                      | This bit is read as 0. The write value should be 0.   | R/W                                     |  |  |  |          |                        |                |           |     |   |   |                    |     |                    |                    |   |     |  |  |   |     |  |  |   |     |
| 25                                      | IIEN                   | Idle Mode Interrupt Output Enable<br>0: Disables idle mode interrupt output<br>1: Enables idle mode interrupt output  | R/W                                     |  |  |  |          |                        |                |           |     |   |   |                    |     |                    |                    |   |     |  |  |   |     |  |  |   |     |
| 26                                      | ROIEN                  | Receive Overflow Interrupt Output Enable<br>0: Disables receive overflow interrupt output<br>1: Enables receive overflow interrupt output   | R/W                                     |  |  |  |          |                        |                |           |     |   |   |                    |     |                    |                    |   |     |  |  |   |     |  |  |   |     |
| 27                                      | RUIEN                  | Receive Underflow Interrupt Output Enable<br>0: Disables receive underflow interrupt output<br>1: Enables receive underflow interrupt output  | R/W                                     |  |  |  |          |                        |                |           |     |   |   |                    |     |                    |                    |   |     |  |  |   |     |  |  |   |     |
| 28                                      | TOIEN                  | Transmit Overflow Interrupt Output Enable<br>0: Disables transmit overflow interrupt output<br>1: Enables transmit overflow interrupt output  | R/W                                     |  |  |  |          |                        |                |           |     |   |   |                    |     |                    |                    |   |     |  |  |   |     |  |  |   |     |
| 29                                      | TUIEN                  | Transmit Underflow Interrupt Output Enable<br>0: Disables transmit underflow interrupt output<br>1: Enables transmit underflow interrupt output   | R/W                                     |  |  |  |          |                        |                |           |     |   |   |                    |     |                    |                    |   |     |  |  |   |     |  |  |   |     |
| 30                                      | CKS                    | Selects an Audio Clock for Master-mode Communication*1<br>0: Selects the AUDIO_CLK input<br>1: Selects the GTIOC2A (GPT output)   | R/W                                     |  |  |  |          |                        |                |           |     |   |   |                    |     |                    |                    |   |     |  |  |   |     |  |  |   |     |
| 31                                      | —                      | This bit is read as 0. The write value should be 0.   | R/W                                     |  |  |  |          |                        |                |           |     |   |   |                    |     |                    |                    |   |     |  |  |   |     |  |  |   |     |

Note 1. Writing to these bits while SSIE is in a communication state (SSISR.IIRQ = 0) is prohibited. If the value of these bits is changed by rewriting, subsequent operation is unpredictable.

Note 2. If the TEN bit or REN bit is rewritten, make sure that the SSISR.IIRQ bit is in the desired status. If the value of the TEN or REN bit is changed by rewriting, subsequent operation is unpredictable. For example, when transmission or reception is enabled, check that SSISR.IIRQ is 0; when transmission or reception is disabled, check that SSISR.IIRQ is 1.

With this register, select an audio clock, control interrupt requests, select data formats, and set an operation mode.

| Bit                     | Symbol                 | Function  | R/W                     |  |  |  |          |                        |                |           |     |   |   |      |     |      |      |   |     |  |  |   |     |  |  |   |     |
|-------------------------|------------------------|---|-------------------------|--|--|--|----------|------------------------|----------------|-----------|-----|---|---|------|-----|------|------|---|-----|--|--|---|-----|--|--|---|-----|
| 18:16                   | SWL[2:0]               | 选择系统字长*1<br>0 0 0: 8 bits<br>0 0 1: 16 bits<br>0 1 0: 24 bits<br>0 1 1: 32 bits<br>1 0 0: 48 bits<br>1 0 1: 64 bits<br>1 1 0: 128 bits<br>1 1 1: 256 bits   | R/W                     |  |  |  |          |                        |                |           |     |   |   |      |     |      |      |   |     |  |  |   |     |  |  |   |     |
| 21:19                   | DWL[2:0]               | 选择数据字长*1<br>000: 8位<br>001: 16位<br>010: 18位<br>011: 20位<br>100: 22位<br>101: 24位<br>110: 32位<br>111: 禁止设置  | R/W                     |  |  |  |          |                        |                |           |     |   |   |      |     |      |      |   |     |  |  |   |     |  |  |   |     |
| 23:22                   | FRM[1:0]               | 选择帧字号*1<br><table border="1"> <thead> <tr> <th colspan="4">通讯格式 (SSIOFR.OMOD[1:0])</th> </tr> <tr> <th>FRM[1:0]</th> <th>I<sup>2</sup>S (00b)</th> <th>Monaural (10b)</th> <th>TDM (01b)</th> </tr> </thead> <tbody> <tr> <td>00b</td> <td>2</td> <td>1</td> <td>禁止设定</td> </tr> <tr> <td>01b</td> <td>禁止设定</td> <td>禁止设定</td> <td>4</td> </tr> <tr> <td>10b</td> <td></td> <td></td> <td>5</td> </tr> <tr> <td>11b</td> <td></td> <td></td> <td>6</td> </tr> </tbody> </table> | 通讯格式 (SSIOFR.OMOD[1:0]) |  |  |  | FRM[1:0] | I <sup>2</sup> S (00b) | Monaural (10b) | TDM (01b) | 00b | 2 | 1 | 禁止设定 | 01b | 禁止设定 | 禁止设定 | 4 | 10b |  |  | 5 | 11b |  |  | 6 | R/W |
| 通讯格式 (SSIOFR.OMOD[1:0]) |                        |   |                         |  |  |  |          |                        |                |           |     |   |   |      |     |      |      |   |     |  |  |   |     |  |  |   |     |
| FRM[1:0]                | I <sup>2</sup> S (00b) | Monaural (10b)  | TDM (01b)               |  |  |  |          |                        |                |           |     |   |   |      |     |      |      |   |     |  |  |   |     |  |  |   |     |
| 00b                     | 2                      | 1   | 禁止设定                    |  |  |  |          |                        |                |           |     |   |   |      |     |      |      |   |     |  |  |   |     |  |  |   |     |
| 01b                     | 禁止设定                   | 禁止设定  | 4                       |  |  |  |          |                        |                |           |     |   |   |      |     |      |      |   |     |  |  |   |     |  |  |   |     |
| 10b                     |                        |   | 5                       |  |  |  |          |                        |                |           |     |   |   |      |     |      |      |   |     |  |  |   |     |  |  |   |     |
| 11b                     |                        |   | 6                       |  |  |  |          |                        |                |           |     |   |   |      |     |      |      |   |     |  |  |   |     |  |  |   |     |
| 24                      | —                      | 该位读取为0。写入值应为0。  | R/W                     |  |  |  |          |                        |                |           |     |   |   |      |     |      |      |   |     |  |  |   |     |  |  |   |     |
| 25                      | IIEN                   | 空闲模式中中断输出使能<br>0: 禁用空闲模式中中断输出<br>1: 启用空闲模式中中断输出   | R/W                     |  |  |  |          |                        |                |           |     |   |   |      |     |      |      |   |     |  |  |   |     |  |  |   |     |
| 26                      | ROIEN                  | 接收溢出中断输出使能<br>0: 禁止接收溢出中断输出<br>1: 使能接收溢出中断输出  | R/W                     |  |  |  |          |                        |                |           |     |   |   |      |     |      |      |   |     |  |  |   |     |  |  |   |     |
| 27                      | RUIEN                  | 接收下溢中断输出使能<br>0: 禁止接收下溢中断输出<br>1: 使能接收下溢中断输出  | R/W                     |  |  |  |          |                        |                |           |     |   |   |      |     |      |      |   |     |  |  |   |     |  |  |   |     |
| 28                      | TOIEN                  | 发送溢出中断输出使能<br>0: 禁止发送溢出中断输出<br>1: 使能发送溢出中断输出  | R/W                     |  |  |  |          |                        |                |           |     |   |   |      |     |      |      |   |     |  |  |   |     |  |  |   |     |
| 29                      | TUIEN                  | 发送下溢中断输出使能<br>0: 禁止发送下溢中断输出<br>1: 使能发送下溢中断输出  | R/W                     |  |  |  |          |                        |                |           |     |   |   |      |     |      |      |   |     |  |  |   |     |  |  |   |     |
| 30                      | CKS                    | 选择主模式通信的音频时钟*1<br>0: 选择AUDIO_CLK输入<br>1: 选择GTIOC2A (GPT输出)  | R/W                     |  |  |  |          |                        |                |           |     |   |   |      |     |      |      |   |     |  |  |   |     |  |  |   |     |
| 31                      | —                      | 该位读取为0。写入值应为0。  | R/W                     |  |  |  |          |                        |                |           |     |   |   |      |     |      |      |   |     |  |  |   |     |  |  |   |     |

注1.禁止在SSIE处于通信状态(SSISR.IIRQ=0)时写入这些位。如果这些位的值通过重写而改变,后续的操作是不可预知的。

注2.如果TEN位或REN位被重写,请确保SSISR.IIRQ位处于所需状态。如果TEN或REN位的值因重写而改变,后续操作将无法预测。例如,启用发送或接收时,检查SSISR.IIRQ是否为0;当发送或接收被禁用时,检查SSISR.IIRQ是否为1。

使用该寄存器,选择音频时钟、控制中断请求、选择数据格式和设置操作模式。

**TEN and REN bits (Transmission and Reception Enable)**

The TEN and REN bits enable/disable transmission and reception. When 1 is written to one of these bits, the corresponding communication operation starts in synchronization with a start trigger by the SSILRCK/SSIFS signal. For details, see [section 32.8.2. Transmission](#) to [section 32.8.4. Transmission and Reception](#). When 0 is written to this bit, the current communication operation stops at the next frame boundary. To use SSIE for both transmission and reception, always write 1 to these bits together. When stopping the communication using SSIE, always disable both transmission and reception (write 0 to the TEN and REN bits).

If you want to stop SSIE before a frame boundary is reached, perform a software reset procedure.

**MUEN bit (Mute Enable)**

The MUEN bit sets/clears the mute function for the data output from the SSITXD0/SSIDATA0 pin. When this bit is set to 1 in the middle of a frame, the SSITXD0/SSIDATA0 output changes to 0 at the next frame boundary. When this bit is set to 0 in the middle of a frame, the SSITXD0/SSIDATA0 output changes to the data of transmit FIFO data register at the next frame boundary. Note that this bit controls data only. Status flags and interrupt signals are normally generated.

Changing the value of this bit must be performed only after setting the communication format to be used.

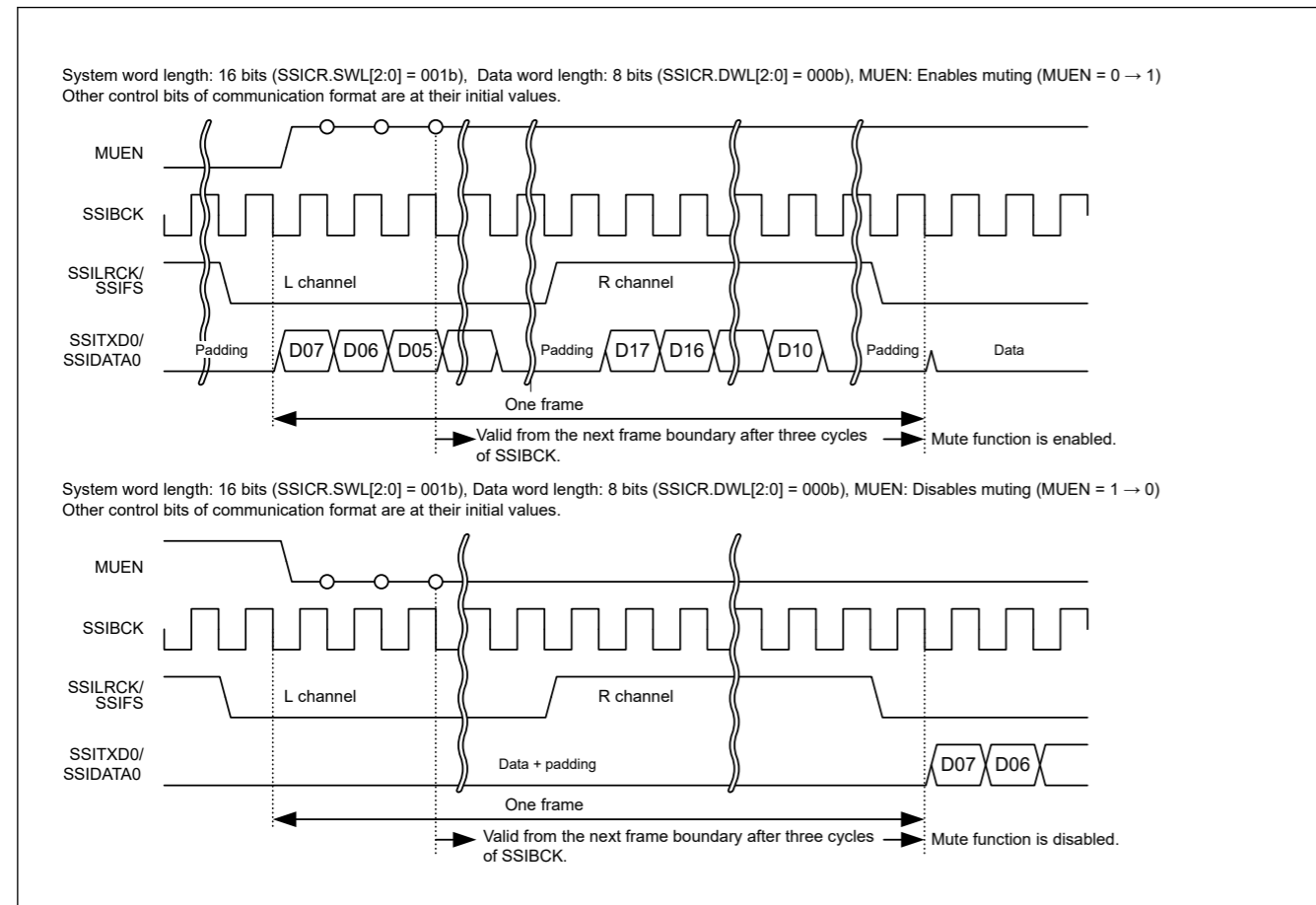


Figure 32.5 Transmit data with the mute function set

**CKDV[3:0] bits (Selects Bit Clock Division Ratio)**

The CKDV[3:0] bits set the division ratio of the bit clock based on AUDIO\_MCK in master-mode communication (MST=1). In slave-mode communication (MST=0), setting of these bits are invalid.

Writing to this bit must be performed when the supply of AUDIO\_MCK is stopped. For details about the timing, see the detailed description of the AUCKE bit in [section 32.4.3. SSIFCR : FIFO Control Register](#).

**TEN和REN位 (发送和接收使能)**

TEN和REN位使能禁用发送和接收。当这些位之一写入1时，相应的通信操作与SSILRCK/SSIFS信号的开始触发同步开始。有关详细信息，请参阅第32.8.2节。传输到第32.8.4节。传输和接收。当向该位写入0时，当前通信操作在下一帧边界处停止。要同时使用SSIE进行发送和接收，请始终将1一起写入这些位。使用SSIE停止通信时，始终禁用发送和接收（将0写入TEN和REN位）。

如果要在达到帧边界之前停止SSIE，请执行软件复位程序。

**MUEN bit (Mute Enable)**

MUEN位设置清除SSITXD0/SSIDATA0引脚数据输出的静音功能。当该位在帧中间设置为1时，SSITXD0/SSIDATA0输出在下一帧边界变为0。当该位在帧中间设置为0时，SSITXD0/SSIDATA0输出在下一帧边界变为发送FIFO数据寄存器的数据。请注意，该位仅控制数据。通常会产生状态标志和中断信号。

只有在设置要使用的通信格式后才能更改该位的值。

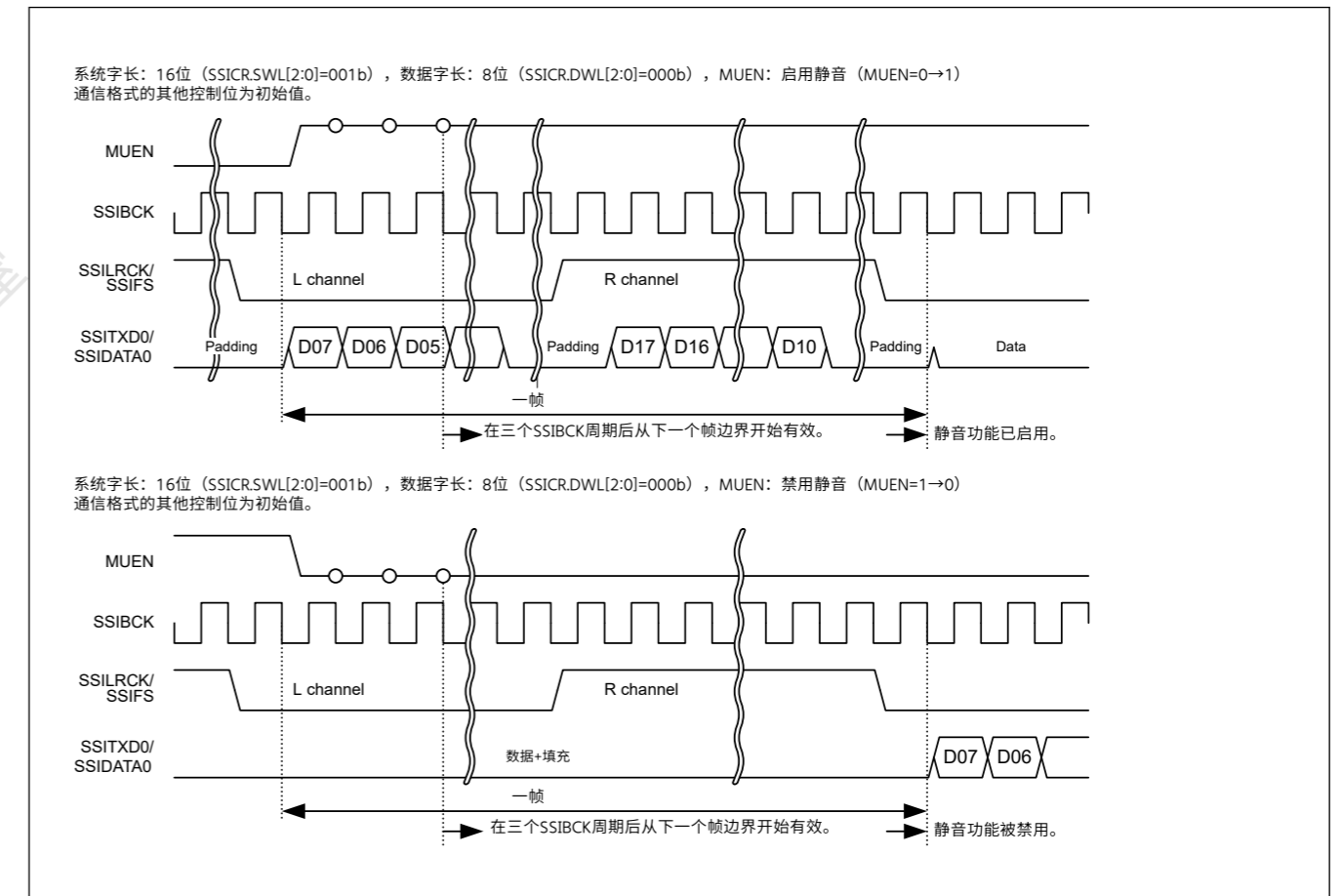


Figure 32.5 设置静音功能传输数据

**CKDV[3:0]位 (选择位时钟分频比)**

CKDV[3:0]位在主模式通信(MST=1)中根据AUDIO\_MCK设置位时钟的分频比。在从机模式通信(MST=0)中，这些位的设置无效。

当停止提供AUDIO\_MCK时，必须执行写入该位。有关时序的详细信息，请参见第32.4.3节中对AUCKE位的详细说明。SSIFCR: FIFO控制寄存器。

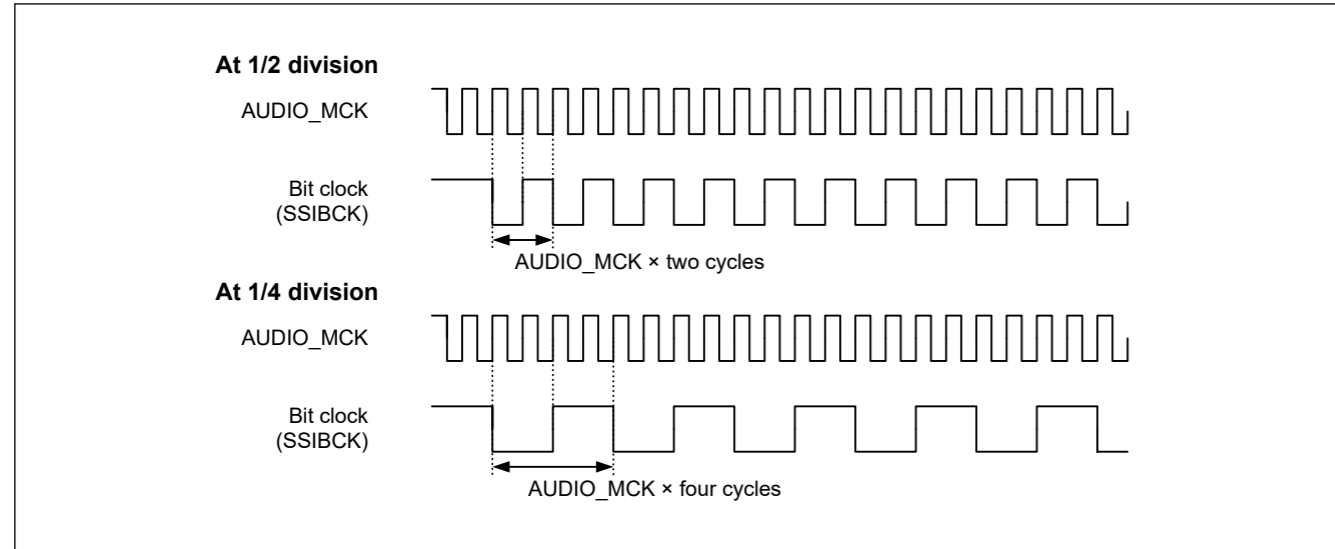


Figure 32.6 Sampling frequencies in master-mode communication

**DEL bit (Selects Serial Data Delay)**

The DEL bit sets whether or not there will be a delay between SSILRCK/SSIFS and SSITXD0/SSIRXD0/SSIDATA0.

For the I<sup>2</sup>S or TDM format, set the DEL bit to 0. When the monaural format is used, setting of this bit changes the high period width of SSILRCK/SSIFS. For details, see section 32.5.2. **Monaural Format**. When using a compatible communication format, specify a setting of this bit that enables communication.

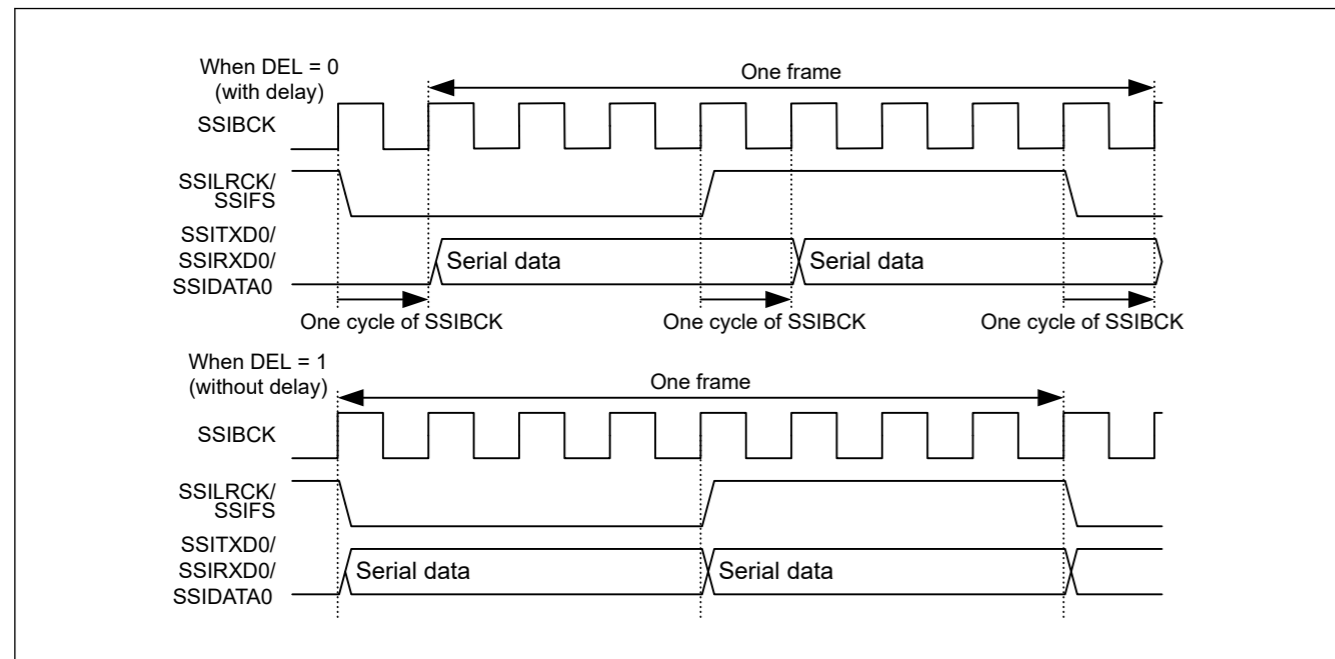


Figure 32.7 Setting of delay in serial data

**PDTA bit (Selects Placement Data Alignment)**

The PDTA bit sets how to align placement data. With the setting of data word length as 32 bits (SSICR.DWL[2:0] = 110b), this bit is invalid.

At transmission, see Figure 32.8.

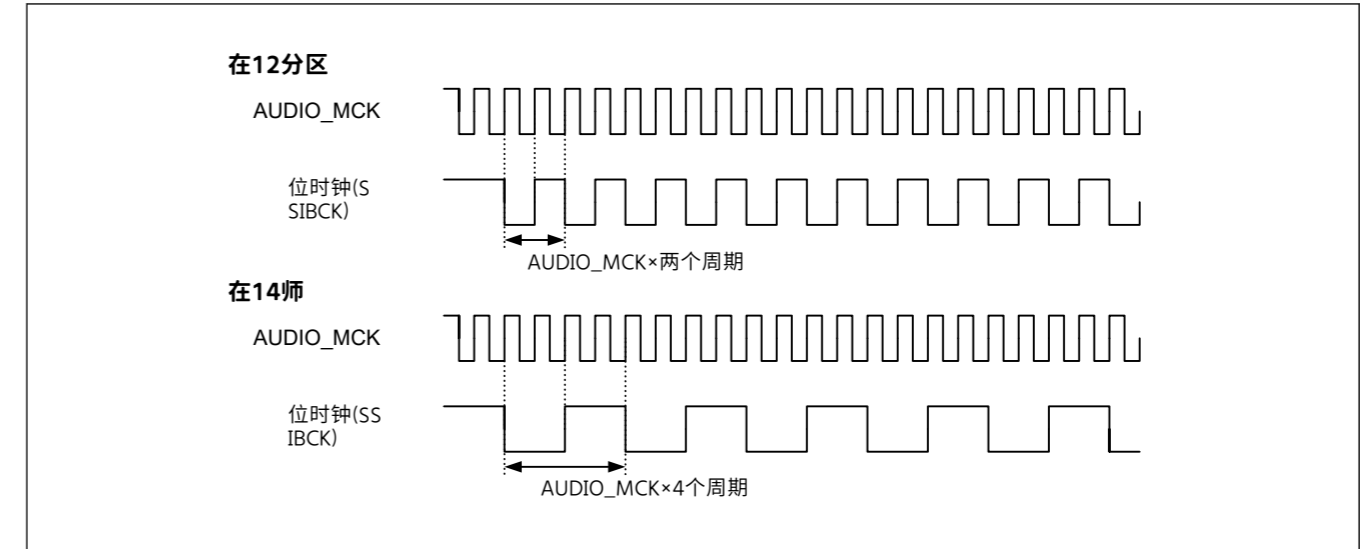


Figure 32.6 主模式通信中的采样频率

**DEL位 (选择串行数据延迟)**

DEL位设置SSILRCKSSIFS和SSITXD0SSIRXD0SSIDATA0之间是否会有延迟。

对于I<sup>2</sup>S或TDM格式，将DEL位设置为0。当使用单声道格式时，该位的设置会改变SSILRCKSSIFS的高周期宽度。有关详细信息，请参阅第32.5.2节。单声道格式。使用兼容的通信格式时，指定该位的设置以启用通信。

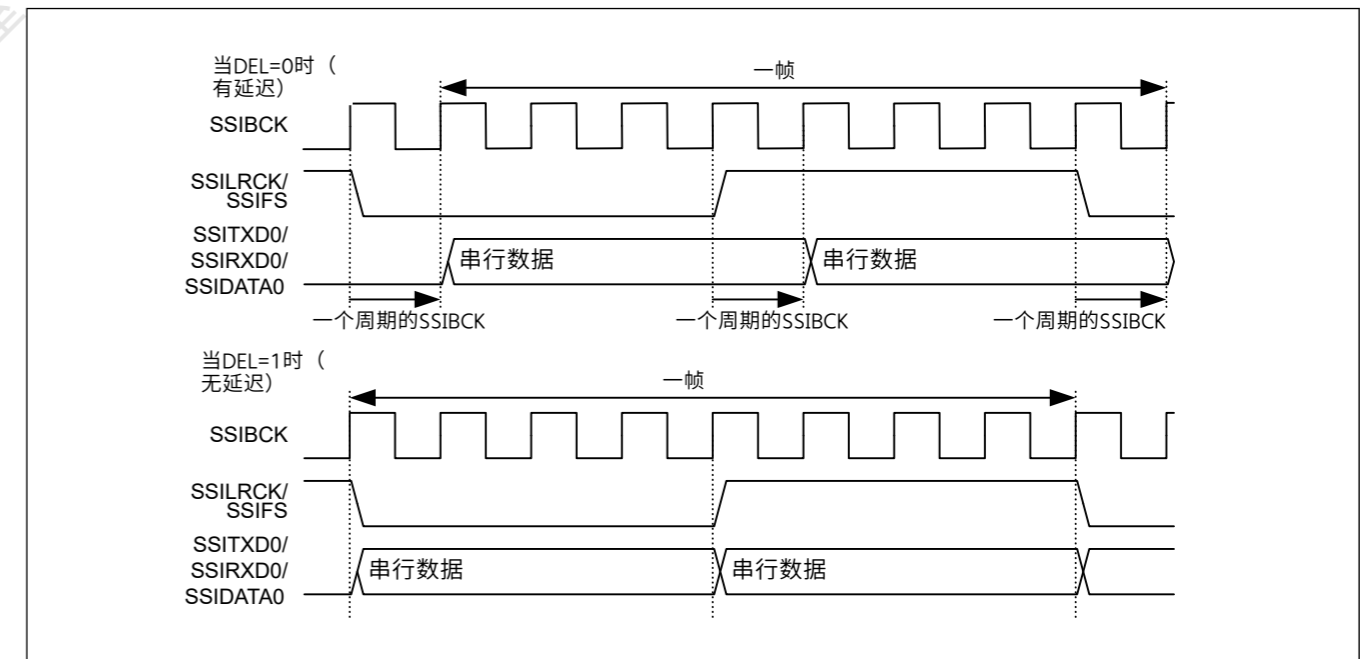


Figure 32.7 串行数据延迟设置

**PDTA位 (选择布局数据对齐)**

PDTA位设置如何对齐布局数据。数据字长设置为32位 (SSICR.DWL[2:0]=110b) 时，该位无效。

传输时，见图32.8。

|  |         | First transmission data | Second transmission data | Third transmission data  | Fourth transmission data    |         |
|--|---------|-------------------------|--------------------------|--------------------------|-----------------------------|---------|
| DWL[2:0]   | SSIFTDR |                         |                          |                          | Transmission shift register |         |
|  |         | PDTA = 0 (left-justify) |                          | PDTA = 1 (right-justify) |                             |         |
| 000 (8 bits)   |         | 7 0                     | Invalid                  | Setting prohibited       | 7 0                         | Invalid |
|  |         | 7 0                     | Invalid                  |                          | 7 0                         | Invalid |
|  |         | 7 0                     | Invalid                  |                          | 7 0                         | Invalid |
|  |         | 7 0                     | Invalid                  |                          | 7 0                         | Invalid |
| 001 (16 bits)  |         | 15 0                    | Invalid                  | Setting prohibited       | 15 0                        | Invalid |
|  |         | 15 0                    | Invalid                  |                          | 15 0                        | Invalid |
|  |         | 15 0                    | Invalid                  |                          | 15 0                        | Invalid |
|  |         | 15 0                    | Invalid                  |                          | 15 0                        | Invalid |
| 010 to 100<br>18bit : X = 17<br>20bit : X = 19<br>22bit : X = 21<br>24bit : X = 23 |         | X 0                     | Invalid                  | Invalid X 0              | X 0                         | Invalid |
|  |         | X 0                     | Invalid                  | Invalid X 0              | X 0                         | Invalid |
|  |         | X 0                     | Invalid                  | Invalid X 0              | X 0                         | Invalid |
|  |         | X 0                     | Invalid                  | Invalid X 0              | X 0                         | Invalid |
| 110 (32 bits)  |         | 31 0                    | 0                        | 31 0                     | 0                           | 0       |
|  |         | 31 0                    | 0                        | 31 0                     | 0                           | 0       |
|  |         | 31 0                    | 0                        | 31 0                     | 0                           | 0       |
|  |         | 31 0                    | 0                        | 31 0                     | 0                           | 0       |
| 111<br>(Setting prohibited)  |         |                         |                          |                          |                             |         |

Figure 32.8 Alignment of placement data at transmission

At reception, see Figure 32.9.

|  |         | 第一次传输数据                 | 二次传输数据  | 第三次传输数据                  | 第四次传输数据 |         |
|--|---------|-------------------------|---------|--------------------------|---------|---------|
| DWL[2:0]   | SSIFTDR |                         |         |                          | 传输移位寄存器 |         |
|  |         | PDTA = 0 (left-justify) |         | PDTA = 1 (right-justify) |         |         |
| 000 (8 bits)   |         | 7 0                     | Invalid | 禁止设定                     | 7 0     | Invalid |
|  |         | 7 0                     | Invalid |                          | 7 0     | Invalid |
|  |         | 7 0                     | Invalid |                          | 7 0     | Invalid |
|  |         | 7 0                     | Invalid |                          | 7 0     | Invalid |
| 001 (16 bits)  |         | 15 0                    | Invalid | 禁止设定                     | 15 0    | Invalid |
|  |         | 15 0                    | Invalid |                          | 15 0    | Invalid |
|  |         | 15 0                    | Invalid |                          | 15 0    | Invalid |
|  |         | 15 0                    | Invalid |                          | 15 0    | Invalid |
| 010 to 100<br>18bit : X = 17<br>20bit : X = 19<br>22bit : X = 21<br>24bit : X = 23 |         | X 0                     | Invalid | Invalid X 0              | X 0     | Invalid |
|  |         | X 0                     | Invalid | Invalid X 0              | X 0     | Invalid |
|  |         | X 0                     | Invalid | Invalid X 0              | X 0     | Invalid |
|  |         | X 0                     | Invalid | Invalid X 0              | X 0     | Invalid |
| 110 (32 bits)  |         | 31 0                    | 0       | 31 0                     | 0       | 0       |
|  |         | 31 0                    | 0       | 31 0                     | 0       | 0       |
|  |         | 31 0                    | 0       | 31 0                     | 0       | 0       |
|  |         | 31 0                    | 0       | 31 0                     | 0       | 0       |
| 111<br>(Setting prohibited)  |         |                         |         |                          |         |         |

Figure 32.8 在传输时对齐放置数据

在接待处，见图32.9。



| First transmission data  |                        | Second transmission data |                         | Third transmission data |                          | Fourth transmission data |  |
|--|------------------------|--------------------------|-------------------------|-------------------------|--------------------------|--------------------------|--|
| DWL[2:0]   | Receive shift register |                          | SSIFRDR                 |                         |                          |                          |  |
|  |                        |                          | PDTA = 0 (left-justify) |                         | PDTA = 1 (right-justify) |                          |  |
| 000 (8 bits)   | Invalid                | 7 0                      | 7 0                     | Invalid                 | Setting prohibited       |                          |  |
|  | Invalid                | 7 0                      | 7 0                     | Invalid                 |                          |                          |  |
|  | Invalid                | 7 0                      | 7 0                     | Invalid                 |                          |                          |  |
|  | Invalid                | 7 0                      | 7 0                     | Invalid                 |                          |                          |  |
| 001 (16 bits)  | Invalid                | 15 0                     | 15 0                    | Invalid                 | Setting prohibited       |                          |  |
|  | Invalid                | 15 0                     | 15 0                    | Invalid                 |                          |                          |  |
|  | Invalid                | 15 0                     | 15 0                    | Invalid                 |                          |                          |  |
|  | Invalid                | 15 0                     | 15 0                    | Invalid                 |                          |                          |  |
| 010 to 100<br>18bit : X = 17<br>20bit : X = 19<br>22bit : X = 21<br>24bit : X = 23 | Invalid                | X 0                      | X 0                     | Invalid                 | Invalid X 0              |                          |  |
|  | Invalid                | X 0                      | X 0                     | Invalid                 |                          |                          |  |
|  | Invalid                | X 0                      | X 0                     | Invalid                 |                          |                          |  |
|  | Invalid                | X 0                      | X 0                     | Invalid                 |                          |                          |  |
| 110 (32 bits)  | 31                     | 0                        | 31                      | 0                       | 31 0                     |                          |  |
|  | 31                     | 0                        | 31                      | 0                       |                          |                          |  |
|  | 31                     | 0                        | 31                      | 0                       |                          |                          |  |
|  | 31                     | 0                        | 31                      | 0                       |                          |                          |  |
| 111<br>(Setting prohibited)  |                        |                          |                         |                         |                          |                          |  |

Figure 32.9 Alignment of placement data at reception

**SDTA bit (Selects Serial Data Delay)**

The SDTA bit sets how to align serial data and padding bits. For communication without padding bits, this bit is invalid.

| 第一次传输数据  |         | 二次传输数据 |                         | 第三次传输数据 |                          | 第四次传输数据 |  |
|--|---------|--------|-------------------------|---------|--------------------------|---------|--|
| DWL[2:0]   | 接收移位寄存器 |        | SSIFRDR                 |         |                          |         |  |
|  |         |        | PDTA = 0 (left-justify) |         | PDTA = 1 (right-justify) |         |  |
| 000 (8 bits)   | Invalid | 7 0    | 7 0                     | Invalid | 禁止设定                     |         |  |
|  | Invalid | 7 0    | 7 0                     | Invalid |                          |         |  |
|  | Invalid | 7 0    | 7 0                     | Invalid |                          |         |  |
|  | Invalid | 7 0    | 7 0                     | Invalid |                          |         |  |
| 001 (16 bits)  | Invalid | 15 0   | 15 0                    | Invalid | 禁止设定                     |         |  |
|  | Invalid | 15 0   | 15 0                    | Invalid |                          |         |  |
|  | Invalid | 15 0   | 15 0                    | Invalid |                          |         |  |
|  | Invalid | 15 0   | 15 0                    | Invalid |                          |         |  |
| 010 to 100<br>18bit : X = 17<br>20bit : X = 19<br>22bit : X = 21<br>24bit : X = 23 | Invalid | X 0    | X 0                     | Invalid | Invalid X 0              |         |  |
|  | Invalid | X 0    | X 0                     | Invalid |                          |         |  |
|  | Invalid | X 0    | X 0                     | Invalid |                          |         |  |
|  | Invalid | X 0    | X 0                     | Invalid |                          |         |  |
| 110 (32 bits)  | 31      | 0      | 31                      | 0       | 31 0                     |         |  |
|  | 31      | 0      | 31                      | 0       |                          |         |  |
|  | 31      | 0      | 31                      | 0       |                          |         |  |
|  | 31      | 0      | 31                      | 0       |                          |         |  |
| 111<br>(Setting prohibited)  |         |        |                         |         |                          |         |  |

Figure 32.9 在接收时对齐放置数据

**SDTA位 (选择串行数据延迟)**

SDTA位设置如何对齐串行数据和填充位。对于没有填充位的通信，该位无效。

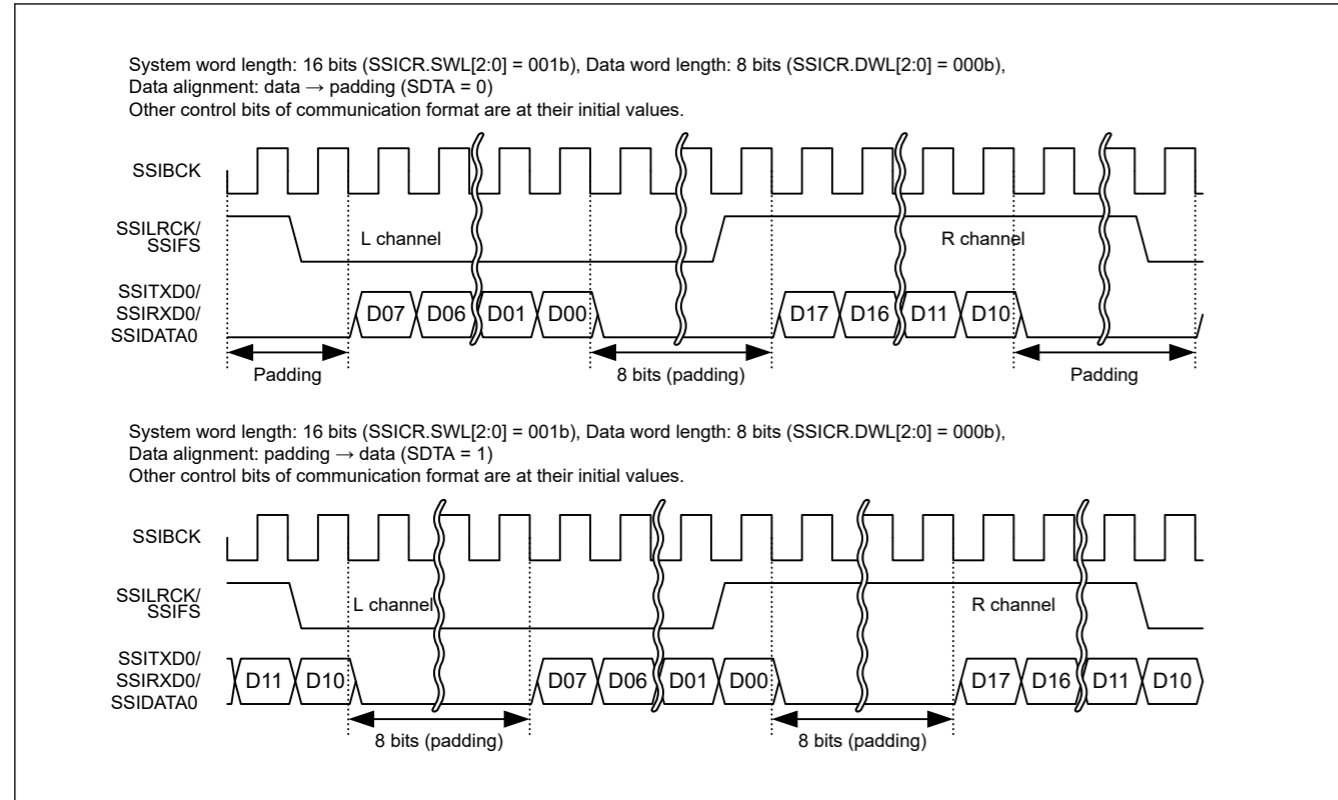


Figure 32.10 Alignment setting of serial data with padding bits

**SPDP bit (Selects Serial Padding Polarity)**

The SPDP bit sets polarity of padding bits.

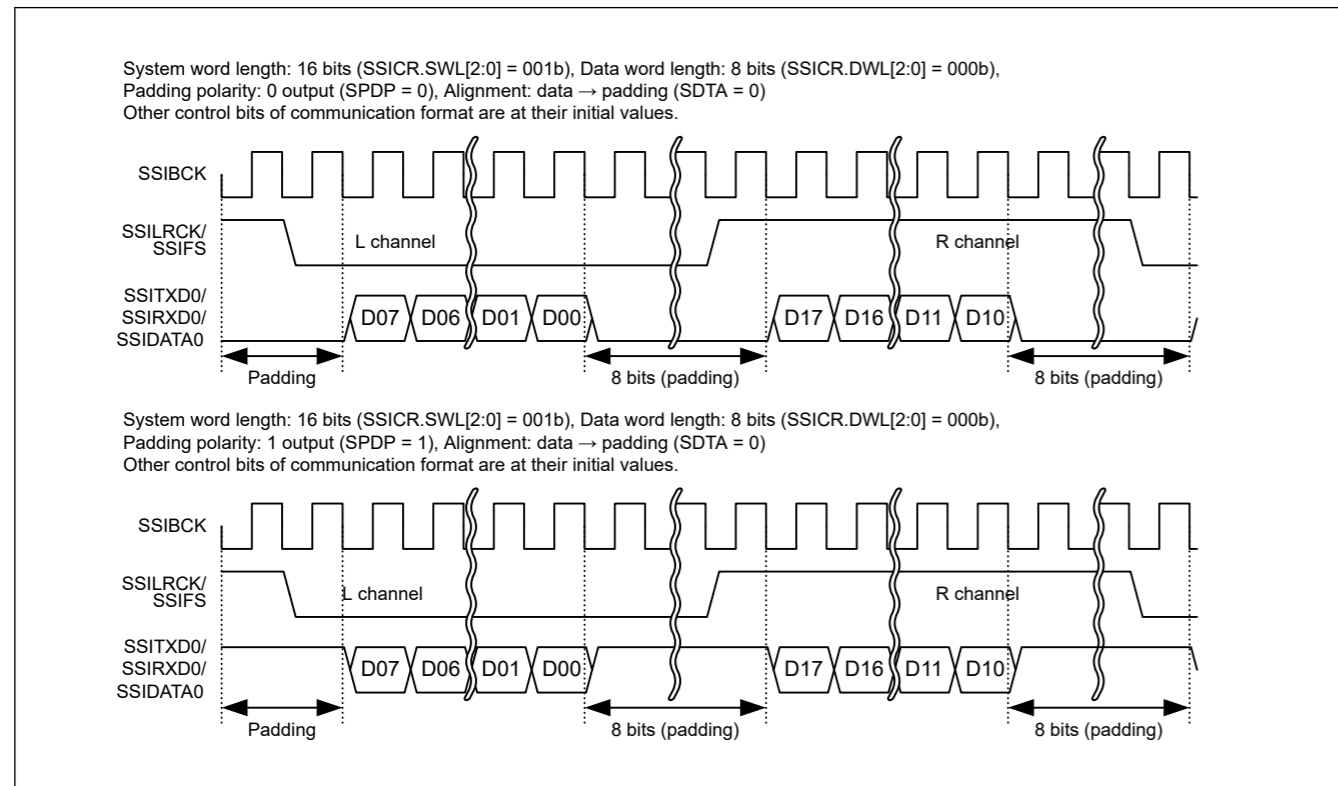


Figure 32.11 Padding bit polarity

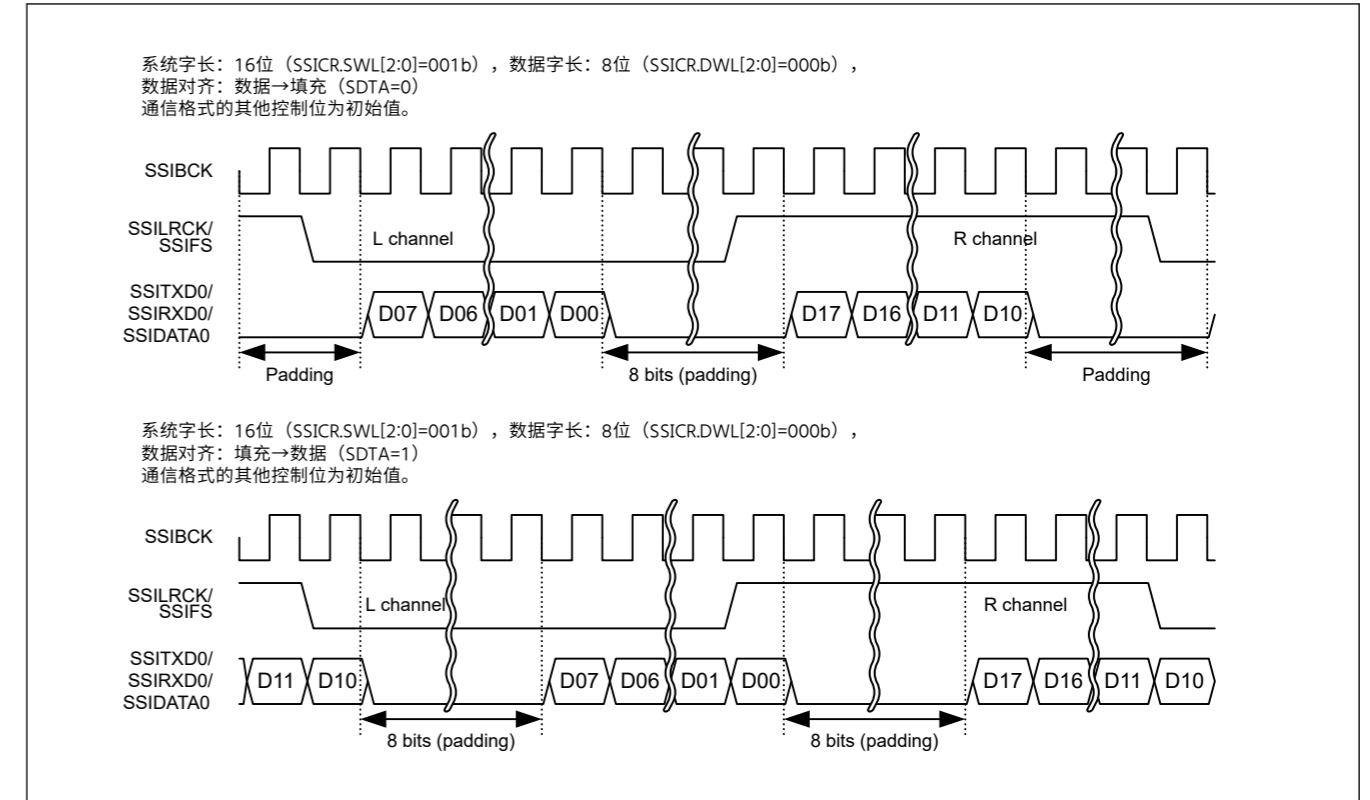


Figure 32.10 串行数据的对齐设置与填充位

**SPDP位 (选择串行填充极性)**

SPDP位设置填充位的极性。

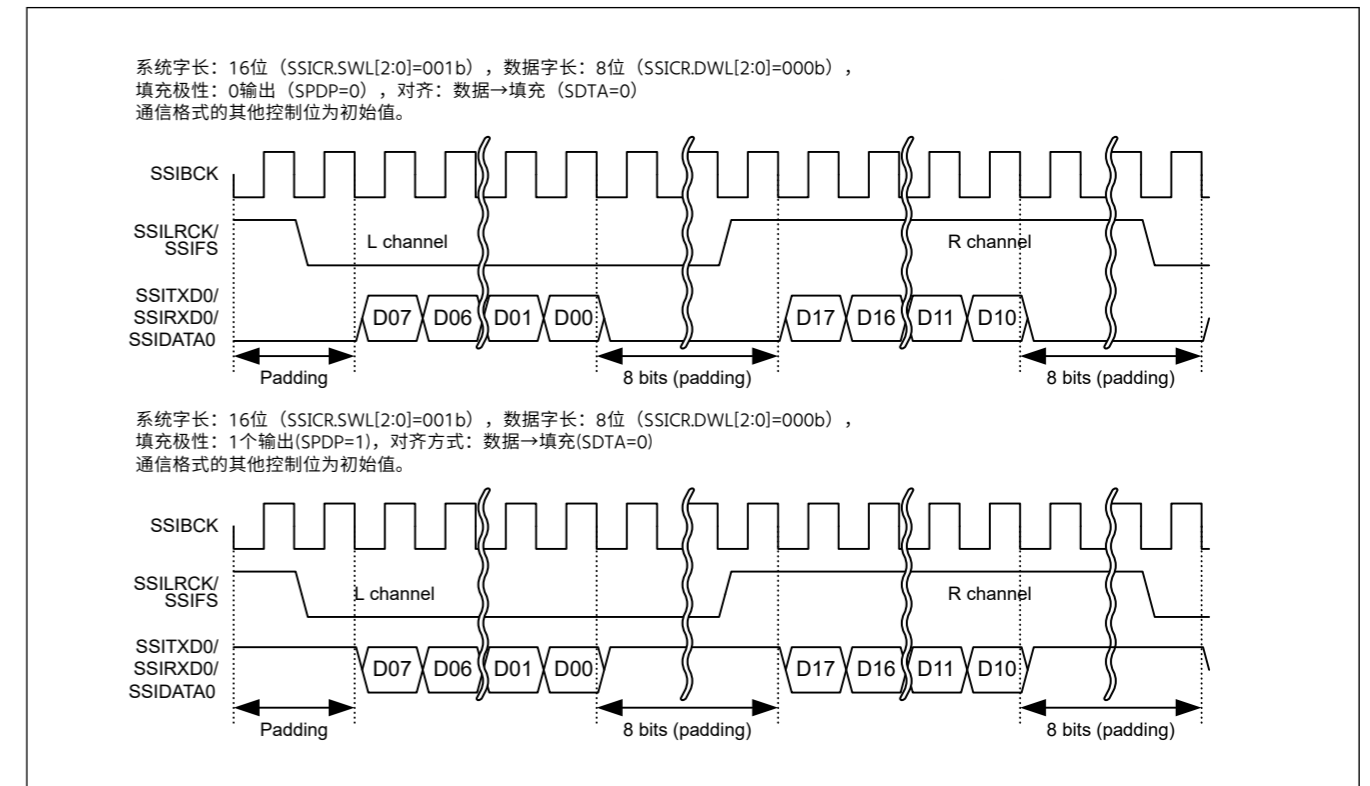


Figure 32.11 填充位极性

**LRCKP bit (Selects the Initial Value and Polarity of LR Clock/Frame Synchronization Signal)**

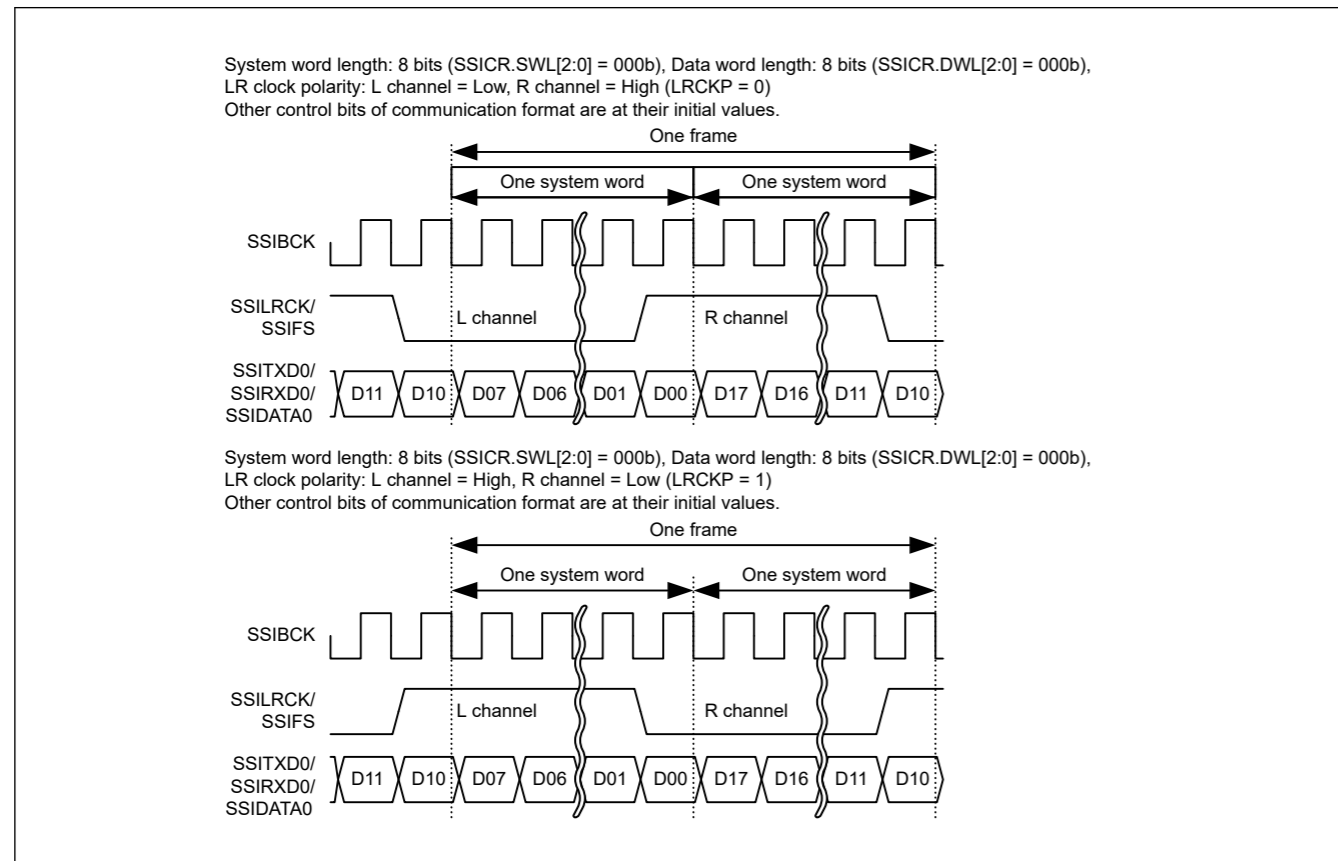
The LRCKP bit sets the initial value and polarity of SSILRCK/SSIFS. Set this bit according to the communication format to be used in SSIE. See Table 32.3 Initial output value and polarity of SSILRCK/SSIFS pin. For the slave-mode communication (MST = 0), only the start trigger is used.

Writing to these bits must be performed when the LR clock supply to the SSILRCK/SSIFS pin is stopped. For details about the output of LR clock, see the detailed description of the LRCONT bit in section 32.4.7. SSIOFR : Audio Format Register.

**Table 32.3 Initial output value and polarity of SSILRCK/SSIFS pin**

| Communication Format | Expected Initial State | Setting Value of LRCKP |
|----------------------|------------------------|------------------------|
| I <sup>2</sup> S     | High                   | 0                      |
| Monaural             | Low                    | 1                      |
| TDM                  | Low                    | 1                      |

Note: When the format to be used is compatible with the I<sup>2</sup>S, monaural, or TDM format, specify settings to enable communication with the respective formats.



**Figure 32.12 LR clock/frame synchronization polarity setting**

**BCKP bit (Selects Bit Clock Polarity)**

The BCKP bit sets the bit clock polarity.

Writing to this bit must be performed when the supply of AUDIO\_MCK is stopped. For details about the timing, see the detailed description of the AUCKE bit in section 32.4.3. SSIFCR : FIFO Control Register.

**Table 32.4 Bit clock polarity (1 of 2)**

| Communication | Master/Slave | Timing                       | BCKP = 0           | BCKP = 1            |
|---------------|--------------|------------------------------|--------------------|---------------------|
| Reception     | Slave        | At SSILRCK/SSIFS sampling    | SSIBCK rising edge | SSIBCK falling edge |
|               | Master/slave | At SSIRXD0/SSIDATA0 sampling | SSIBCK rising edge | SSIBCK falling edge |

**LRCKP位 (选择LR时钟帧同步信号的初始值和极性)**

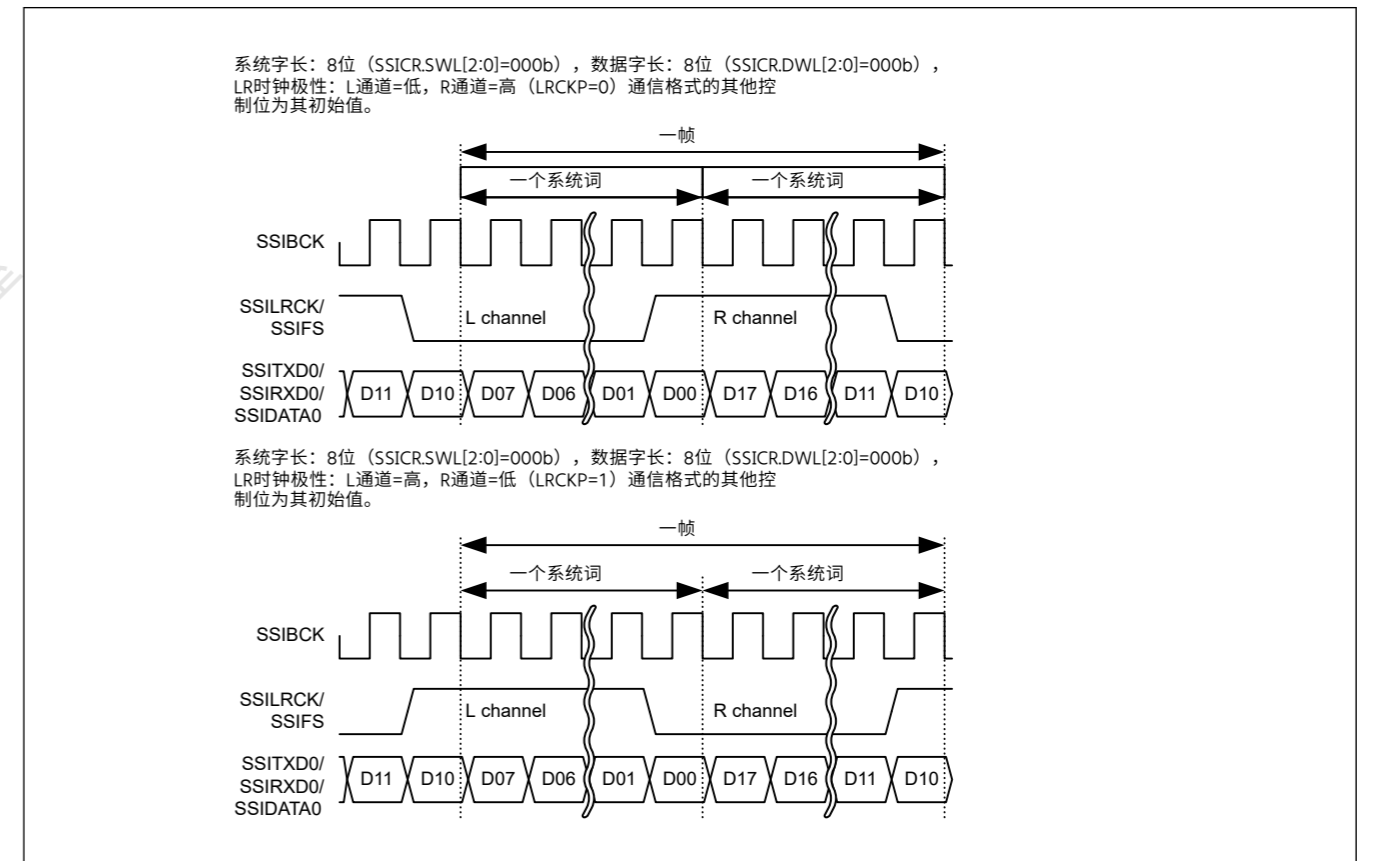
LRCKP位设置SSILRCKSSIFS的初始值和极性。根据要在SSIE中使用的通信格式设置该位。请参见表32.3SSILRCKSSIFS引脚的初始输出值和极性。对于从模式通信(MST=0)，仅使用启动触发器。

当向SSILRCKSSIFS引脚提供LR时钟停止时，必须执行写入这些位。LR时钟的输出详见32.4.7节LRCONT位的详细说明。SSIOFR：音频格式寄存器。

**Table 32.3 SSILRCKSSIFS管脚的初始输出值和极性**

| 通讯格式             | 预期的初始状态 | LRCKP设定值 |
|------------------|---------|----------|
| I <sup>2</sup> S | High    | 0        |
| Monaural         | Low     | 1        |
| TDM              | Low     | 1        |

Note: 当要使用的格式与I2S、单声道或TDM格式兼容时，指定设置以启用与相应格式的通信。



**Figure 32.12 LR时钟帧同步极性设置**

**BCKP位 (选择位时钟极性)**

BCKP位设置位时钟极性。

当停止提供AUDIO\_MCK时，必须执行写入该位。有关时序的详细信息，请参见第32.4.3节中对AUCKE位的详细说明。SSIFCR：FIFO控制寄存器。

**Table 32.4 位时钟极性 (1of2)**

| Communication | Master/Slave | Timing             | BCKP = 0  | BCKP = 1  |
|---------------|--------------|--------------------|-----------|-----------|
| Reception     | Slave        | 在SSILRCKSSIFS采样    | SSIBCK上升沿 | SSIBCK下降沿 |
|               | Master/slave | 在SSIRXD0SSIDATA0采样 | SSIBCK上升沿 | SSIBCK下降沿 |

Table 32.4 Bit clock polarity (2 of 2)

| Communication | Master/Slave | Timing                               | BCKP = 0            | BCKP = 1           |
|---------------|--------------|--------------------------------------|---------------------|--------------------|
| Transmission  | Master       | At change of SSILRCK/SSIFS output    | SSIBCK falling edge | SSIBCK rising edge |
|               | Master/slave | At change of SSITXD0/SSIDATA0 output | SSIBCK falling edge | SSIBCK rising edge |

**MST bit (Master Enable)**

The MST bit sets master-/slave-mode communication.

Writing to this bit must be performed when the supply of AUDIO\_MCK is stopped. For details about the timing, see the detailed description of the AUCKE bit in [section 32.4.3. SSIFCR : FIFO Control Register](#).

**SWL[2:0] bits (Selects System Word Length)**

The SWL[2:0] bits set the number of bits in one system word. Padding bits are sent and received in relation with one data word set with DWL[2:0]. See [Table 32.11](#) for details.

Writing to these bits must be performed when the LR clock supply to the SSILRCK/SSIFS pin is stopped. For details about the output of LR clock, see the detailed description of the LRCONT bit in [section 32.4.7. SSIOFR : Audio Format Register](#).

**DWL[2:0] bits (Selects Data Word Length)**

The DWL[2:0] bits set the number of bits in one data word. The data word length (number of bits per data word) must not exceed the system word length (number of bits per system word). For details, see [Table 32.11](#).

**FRM[1:0] bits (Selects Frame Word Number)**

The FRM[1:0] bits set the frame word number in individual communication formats.

Writing to these bits must be performed when the LR clock supply to the SSILRCK/SSIFS pin is stopped. For details about the output of LR clock, see the detailed description of the LRCONT bit in [section 32.4.7. SSIOFR : Audio Format Register](#).

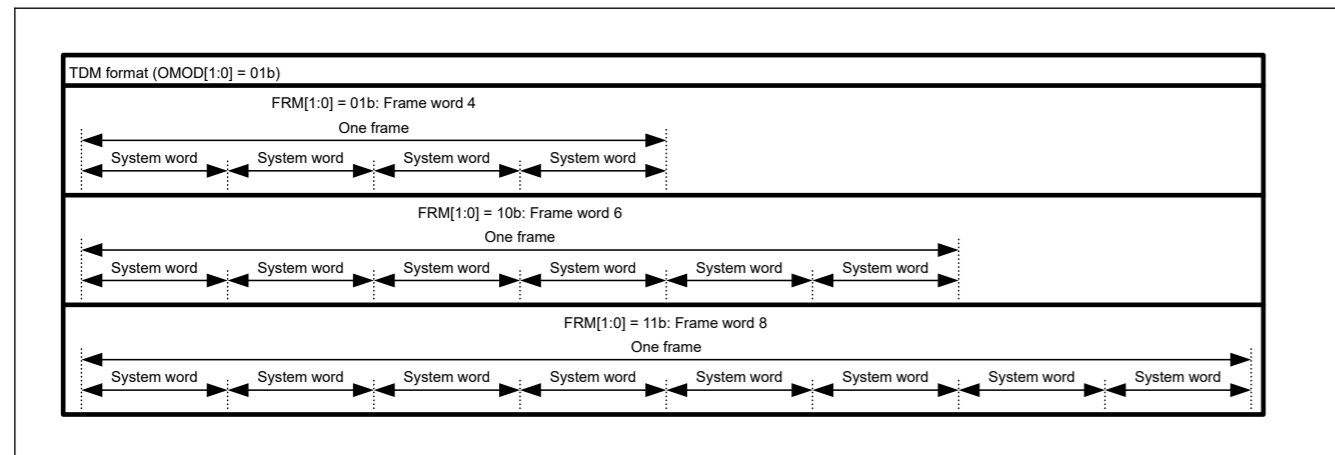


Figure 32.13 Frame word number

**IEN bit (Idle Mode Interrupt Output Enable)**

The IEN bit enables/disables output of idle mode interrupts. By enabling this bit (set it to 1), an interrupt is output at a rising edge of SSISR.IIRQ = 1. An interrupt is also output when this bit is changed from 0 to 1 while SSISR.IIRQ = 1.

**ROIEN bit (Receive Overflow Interrupt Output Enable)**

The ROIEN bit enables/disables output of receive overflow interrupts. By enabling this bit (set it to 1), an interrupt is output at a rising edge of SSISR.ROIQR = 1. An interrupt is also output when this bit is changed from 0 to 1 while SSISR.ROIQR = 1.

**RUIEN bit (Receive Underflow Interrupt Output Enable)**

The RUIEN bit enables/disables output of receive underflow interrupts. By enabling this bit (set it to 1), an interrupt is output at a rising edge of SSISR.RUIRQ = 1. An interrupt is also output when this bit is changed from 0 to 1 while SSISR.RUIRQ = 1.

Table 32.4 位时钟极性 (2之2)

| Communication | Master/Slave | Timing                | BCKP = 0  | BCKP = 1  |
|---------------|--------------|-----------------------|-----------|-----------|
| Transmission  | Master       | 在改变SSILRCKSSIFS输出时    | SSIBCK下降沿 | SSIBCK上升沿 |
|               | Master/slave | 在SSITXD0SSIDATA0输出变化时 | SSIBCK下降沿 | SSIBCK上升沿 |

**MST bit (Master Enable)**

MST位设置主从模式通信。

当停止提供AUDIO\_MCK时，必须执行写入该位。有关时序的详细信息，请参见第32.4.3节中对AUCKE位的详细说明。SSIFCR：FIFO控制寄存器。

**SWL[2:0]位 (选择系统字长)**

SWL[2:0]位设置一个系统字中的位数。填充位的发送和接收与使用DWL[2:0]设置的一个数据字相关。详见表32.11。

当向SSILRCKSSIFS引脚提供LR时钟停止时，必须执行写入这些位。LR时钟的输出详见32.4.7节LRCONT位的详细说明。SSIOFR：音频格式寄存器。

**DWL[2:0]位 (选择数据字长)**

DWL[2:0]位设置一个数据字中的位数。数据字长（每个数据字的位数）不得超过系统字长（每个系统字的位数）。详见表32.11。

**FRM[1:0]位 (选择帧字号)**

FRM[1:0]位设置各个通信格式中的帧字号。

当向SSILRCKSSIFS引脚提供LR时钟停止时，必须执行写入这些位。LR时钟的输出详见32.4.7节LRCONT位的详细说明。SSIOFR：音频格式寄存器。

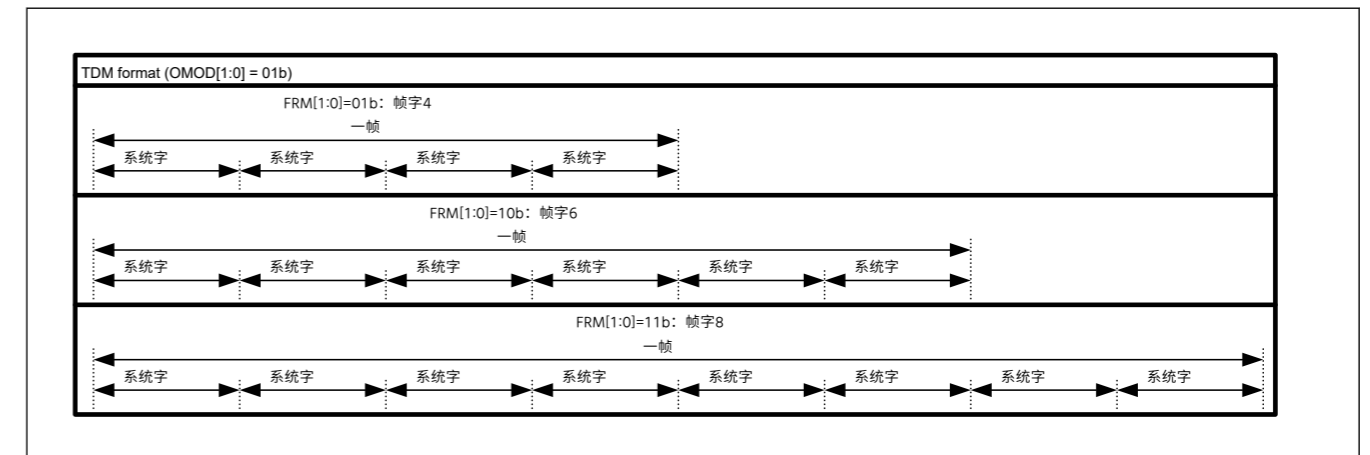


Figure 32.13 帧字数

**IEN位 (空闲模式中断输出使能)**

IEN位启用禁用空闲模式中断的输出。通过启用该位（将其设置为1），在SSISR.IIRQ=1的上升沿输出中断。当SSISR.IIRQ=1时该位从0变为1时也会输出中断。

**ROIEN位 (接收溢出中断输出使能)**

ROIEN位使能禁止接收溢出中断的输出。通过启用该位（将其设置为1），在SSISR.ROIQR=1的上升沿输出中断。当SSISR.ROIQR=1时该位从0变为1时也会输出中断。

**RUIEN位 (接收下溢中断输出使能)**

RUIEN位启用禁用接收下溢中断的输出。通过启用该位（将其设置为1），在SSISR.RUIRQ=1的上升沿输出中断。当SSISR.RUIRQ=1时该位从0变为1时也会输出中断。



**TOIEN bit (Transmit Overflow Interrupt Output Enable)**

The TOIEN bit enables/disables output of transmit overflow interrupts. By enabling this bit (set it to 1), an interrupt is output at a rising edge of SSISR.TOIRQ = 1. An interrupt is also output when this bit is changed from 0 to 1 while SSISR.TOIRQ = 1.

**TUIEN bit (Transmit Underflow Interrupt Output Enable)**

The TUIEN bit enables/disables output of transmit underflow interrupts. By enabling this bit (set it to 1), an interrupt is output at a rising edge of SSISR.TUIRQ = 1. An interrupt is also output when this bit is changed from 0 to 1 while SSISR.TUIRQ = 1.

**CKS bit (Selects an Audio Clock for Master-mode Communication)**

The CKS bit sets the audio clock in master-mode communication (MST = 1). In slave-mode communication (MST = 0), setting of this bit is invalid.

Writing to this bit must be performed when the supply of AUDIO\_MCK is stopped. For details about the timing, see the detailed description of the AUCKE bit in [section 32.4.3. SSIFCR : FIFO Control Register](#).

**32.4.2 SSISR : Status Register**

Base address: SSIE0 = 0x4009\_D000

Offset address: 0x04

|                    |    |    |       |       |       |       |      |    |    |    |    |    |    |    |    |    |
|--------------------|----|----|-------|-------|-------|-------|------|----|----|----|----|----|----|----|----|----|
| Bit position:      | 31 | 30 | 29    | 28    | 27    | 26    | 25   | 24 | 23 | 22 | 21 | 20 | 19 | 18 | 17 | 16 |
| Bit field:         | —  | —  | TUIRQ | TOIRQ | RUIRQ | ROIRQ | IIRQ | —  | —  | —  | —  | —  | —  | —  | —  | —  |
| Value after reset: | 0  | 0  | 0     | 0     | 0     | 0     | 1    | 0  | 0  | 0  | 0  | 0  | 0  | 0  | 0  | 0  |
| Bit position:      | 15 | 14 | 13    | 12    | 11    | 10    | 9    | 8  | 7  | 6  | 5  | 4  | 3  | 2  | 1  | 0  |
| Bit field:         | —  | —  | —     | —     | —     | —     | —    | —  | —  | —  | —  | —  | —  | —  | —  | —  |
| Value after reset: | 0  | 0  | 0     | 0     | 0     | 0     | 0    | 0  | 0  | 0  | 0  | 0  | 0  | 0  | 0  | 0  |

| Bit   | Symbol | Function  | R/W |
|-------|--------|---|-----|
| 24:0  | —      | These bits are read as 0. The write value should be 0.  | R/W |
| 25    | IIRQ   | Idle Mode Status Flag<br>0: In the communication state<br>1: In the idle state  | R   |
| 26    | ROIRQ  | Receive Overflow Error Status Flag<br>0: No receive overflow error is generated.<br>1: A receive overflow error is generated.       | R/W |
| 27    | RUIRQ  | Receive Underflow Error Status Flag<br>0: No receive underflow error is generated.<br>1: A receive underflow error is generated.    | R/W |
| 28    | TOIRQ  | Transmit Overflow Error Status Flag<br>0: No transmit overflow error is generated.<br>1: A transmit overflow error is generated.    | R/W |
| 29    | TUIRQ  | Transmit Underflow Error Status flag<br>0: No transmit underflow error is generated.<br>1: A transmit underflow error is generated. | R/W |
| 31:30 | —      | These bits are read as 0. The write value should be 0.  | R/W |

This register is configured with status flags that indicate SSIE operational state.

**IIRQ flag (Idle Mode Status Flag)**

The IIRQ flag is a status flag that indicates the idle state. It indicates whether SSIE is in the idle state or communication state.

For details, see [Figure 32.14](#) and [Figure 32.15](#).

**TOIEN位 (发送溢出中断输出使能)**

TOIEN位使能禁用发送溢出中断的输出。通过启用该位 (将其设置为1)，在SSISR.TOIRQ=1的上升沿输出中断。当SSISR.TOIRQ=1时该位从0变为1时也会输出中断。

**TUIEN位 (发送下溢中断输出使能)**

TUIEN位使能禁用发送下溢中断的输出。通过启用该位 (将其设置为1)，在SSISR.TUIRQ=1的上升沿输出中断。当SSISR.TUIRQ=1时该位从0变为1时也会输出中断。

**CKS位 (选择主模式通信的音频时钟)**

CKS位设置主模式通信中的音频时钟(MST=1)。在从机模式通信(MST=0)中，该位的设置无效。

当停止提供AUDIO\_MCK时，必须执行写入该位。有关时序的详细信息，请参见第32.4.3节中对AUCKE位的详细说明。SSIFCR：FIFO控制寄存器。

**32.4.2 SSISR：状态寄存器**

Base address: SSIE0 = 0x4009\_D000

Offset address: 0x04

|               |    |    |       |       |       |       |      |    |    |    |    |    |    |    |    |    |
|---------------|----|----|-------|-------|-------|-------|------|----|----|----|----|----|----|----|----|----|
| Bit position: | 31 | 30 | 29    | 28    | 27    | 26    | 25   | 24 | 23 | 22 | 21 | 20 | 19 | 18 | 17 | 16 |
| Bit field:    | —  | —  | TUIRQ | TOIRQ | RUIRQ | ROIRQ | IIRQ | —  | —  | —  | —  | —  | —  | —  | —  | —  |
| 重置后的值:        | 0  | 0  | 0     | 0     | 0     | 0     | 1    | 0  | 0  | 0  | 0  | 0  | 0  | 0  | 0  | 0  |
| Bit position: | 15 | 14 | 13    | 12    | 11    | 10    | 9    | 8  | 7  | 6  | 5  | 4  | 3  | 2  | 1  | 0  |
| Bit field:    | —  | —  | —     | —     | —     | —     | —    | —  | —  | —  | —  | —  | —  | —  | —  | —  |
| 重置后的值:        | 0  | 0  | 0     | 0     | 0     | 0     | 0    | 0  | 0  | 0  | 0  | 0  | 0  | 0  | 0  | 0  |

| Bit   | Symbol | Function                                | R/W |
|-------|--------|---|-----|
| 24:0  | —      | 这些位被读取为0。写入值应为0。                        | R/W |
| 25    | IIRQ   | 空闲模式状态标志<br>0: 处于通信状态1: 处于空闲状态          | R   |
| 26    | ROIRQ  | 接收溢出错误状态标志<br>0: 不产生接收溢出错误。1: 产生接收溢出错误。 | R/W |
| 27    | RUIRQ  | 接收下溢错误状态标志<br>0: 不产生接收下溢错误。1: 产生接收下溢错误。 | R/W |
| 28    | TOIRQ  | 发送溢出错误状态标志<br>0: 不产生发送溢出错误。1: 产生发送溢出错误。 | R/W |
| 29    | TUIRQ  | 发送下溢错误状态标志<br>0: 不产生发送下溢错误。1: 产生发送下溢错误。 | R/W |
| 31:30 | —      | 这些位被读取为0。写入值应为0。                        | R/W |

该寄存器配置有指示SSIE操作状态的状态标志。

**IIRQ标志 (空闲模式状态标志)**

IIRQ标志是指示空闲状态的状态标志。它指示SSIE是处于空闲状态还是通信状态。

详见图32.14和图32.15。

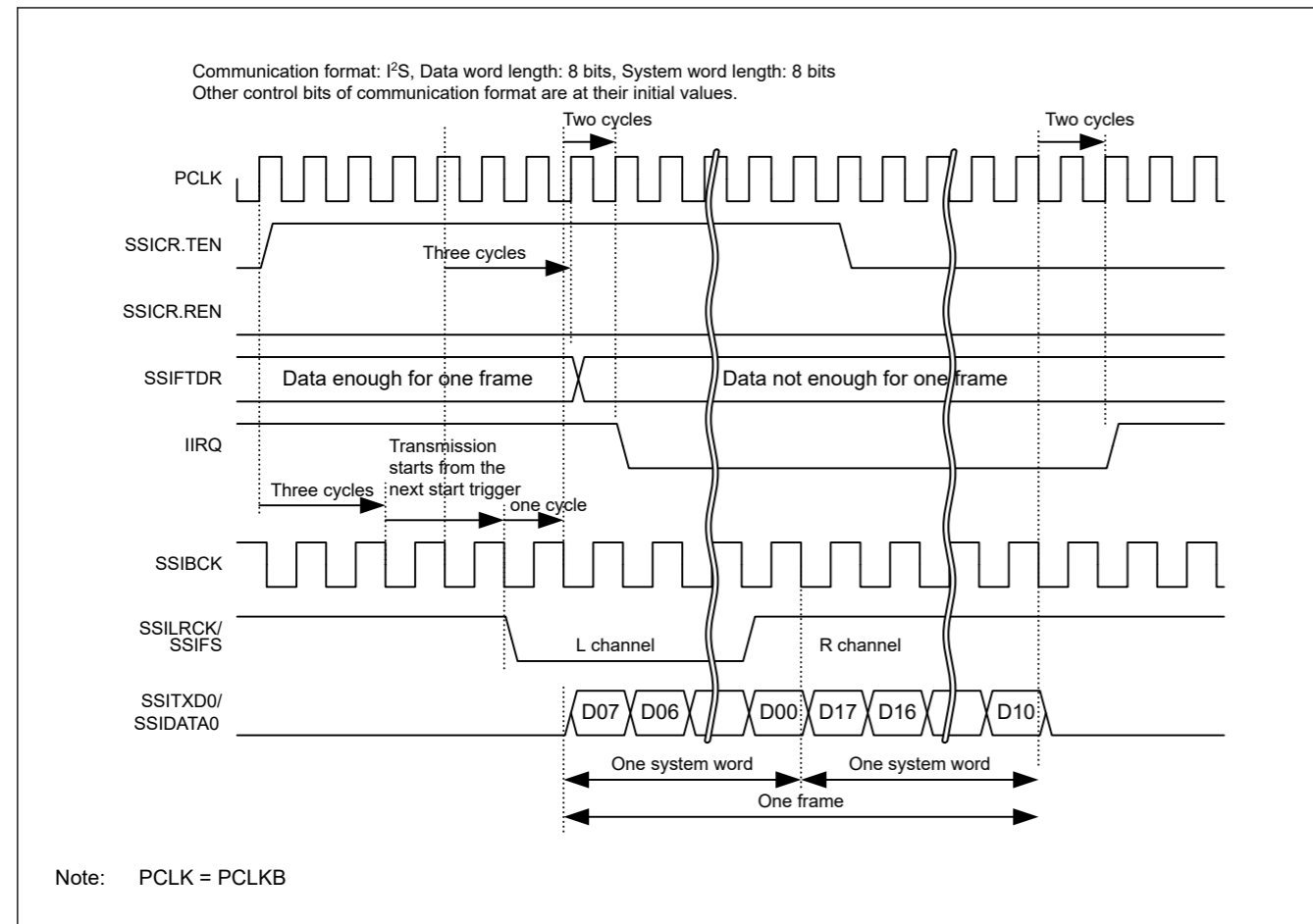


Figure 32.14 IIRQ setting timing (transmission)

- Transmitter (dedicated to transmission)

[Clearing condition]

While transmission was enabled (SSICR.TEN = 1 and SSICR.REN = 0), the transmit data for a transmission frame was written to the SSIFTDR register, and a start trigger was generated by the SSILRCK/SSIFS signal.

[Clearing timing]

1 SSIBCK cycle + 2 PCLKB cycles after generation of the start trigger that is the clearing condition.

[Setting condition]

While transmission and reception were disabled (SSICR.TEN = 0 and SSICR.REN = 0), transmission of one frame was complete.

[Setting timing]

2 PCLKB cycles after the end of transmission (at a frame boundary) that is the setting condition.

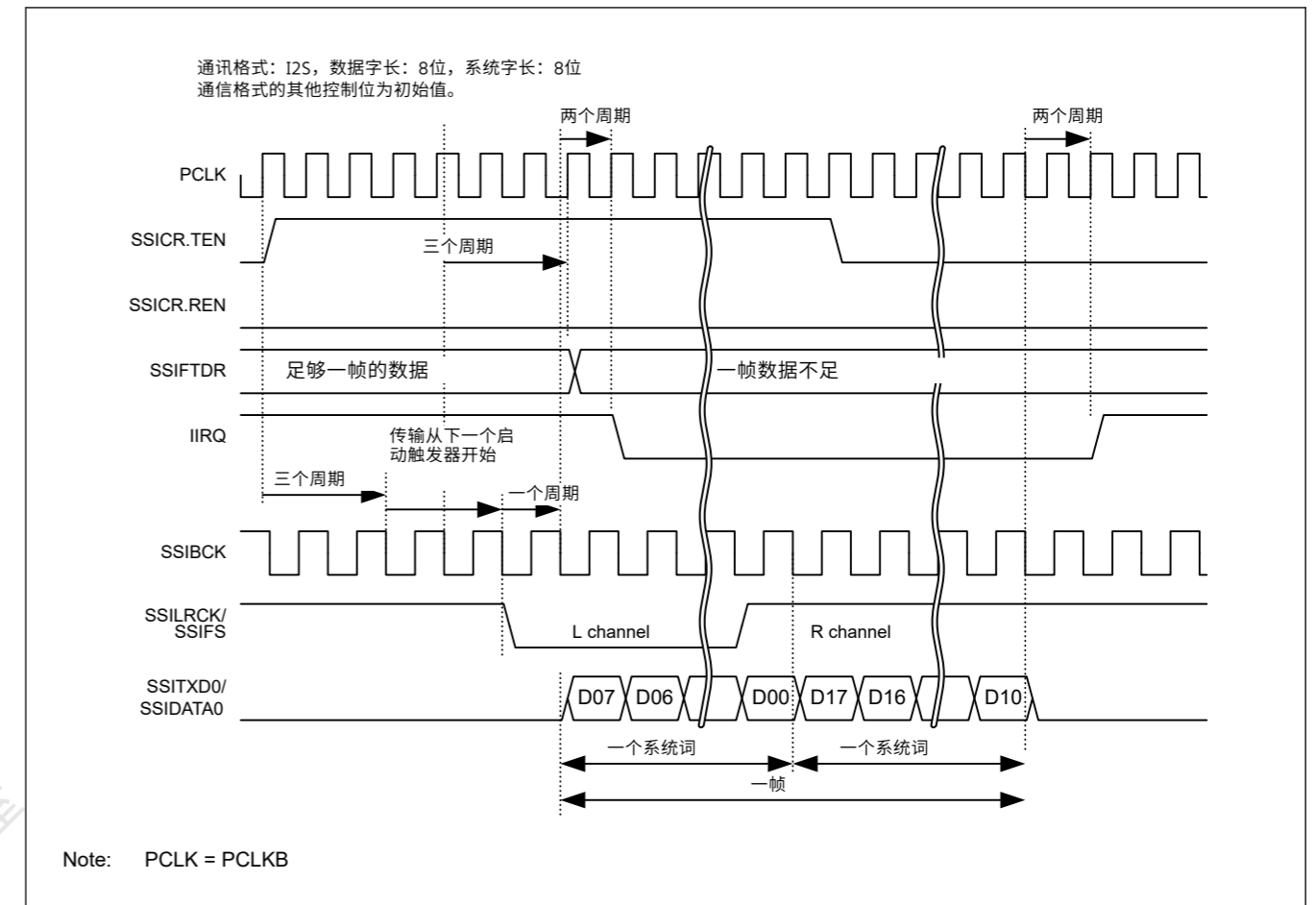


Figure 32.14 IIRQ设置时序 (传输)

- 发射器 (传输专用)

[Clearing condition]

启用传输时 (SSICR.TEN=1和SSICR.REN=0), 传输帧的传输数据被写入SSIFTDR寄存器, 并由SSILRCK/SSIFS信号生成启动触发。

[Clearing timing]

1个SSIBCK周期+2个PCLKB周期在产生作为清除条件的启动触发之后。

[Setting condition]

当发送和接收被禁用时 (SSICR.TEN=0和SSICR.REN=0), 一帧的发送完成。

[Setting timing]

在作为设置条件的传输结束后 (在帧边界处) 的2个PCLKB周期。

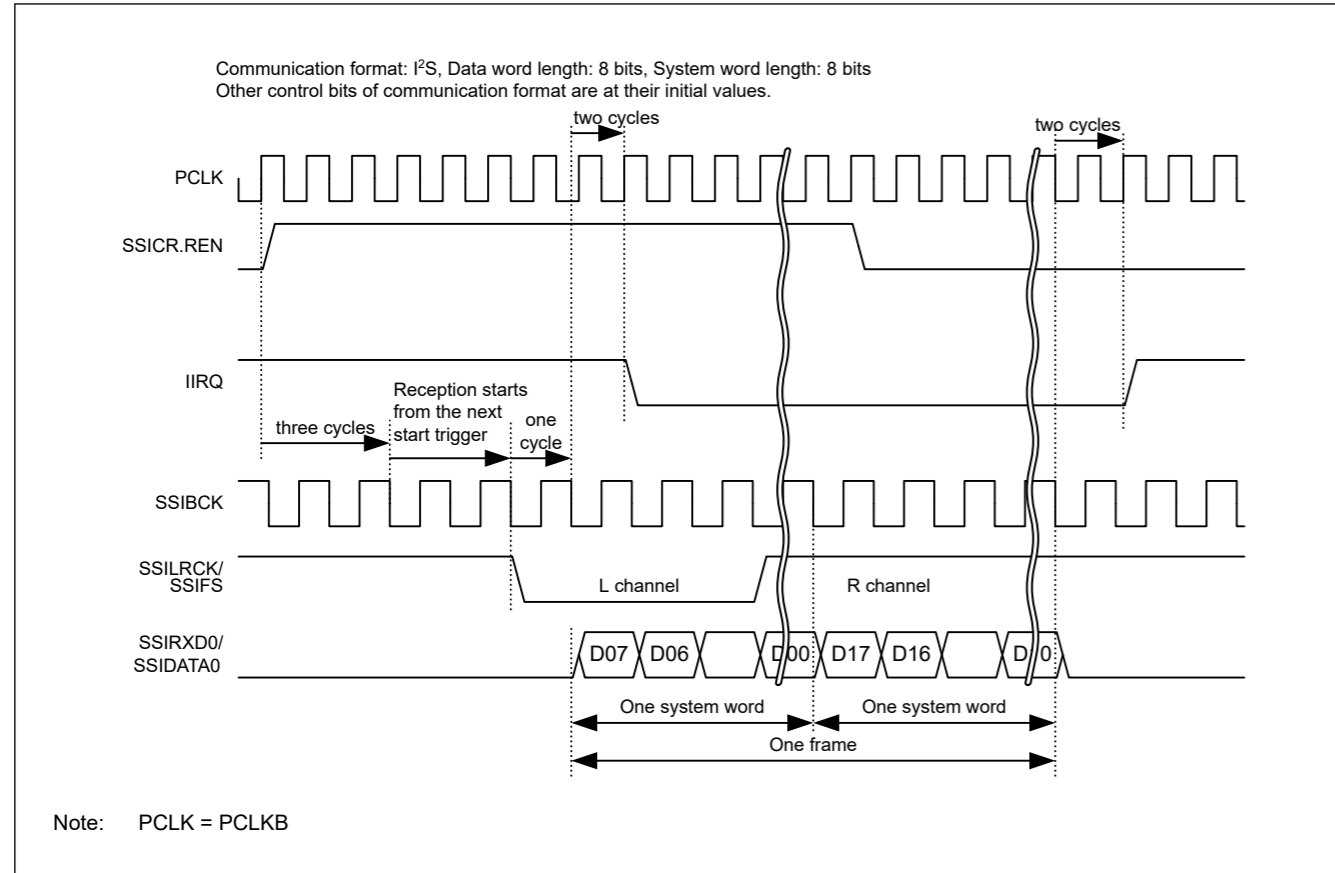


Figure 32.15 IIRQ setting timing (reception)

- Receiver (dedicated to reception)

[Clearing condition]

While reception was enabled (SSICR.TEN = 0 and SSICR.REN = 01, a start trigger was generated by the SSILRCK/SSIFS signal.

[Clearing timing]

1 SSIBCK cycle + 2 PCLKB cycles after generation of the start trigger that is the clearing condition.

[Setting condition]

While transmission and reception were disabled (SSICR.TEN = 0 and SSICR.REN = 0), reception of one frame was complete.

[Setting timing]

2 PCLKB cycles after the end of reception (at a frame boundary) that is the setting condition.

- Transceiver (transmission and reception)

[Clearing condition]

While transmission and reception were enabled (SSICR.TEN = 1 and SSICR.REN = 1), the transmit data for a transmission frame was written to the SSIFTDR register, and a start trigger was generated by the SSILRCK/SSIFS signal.

[Clearing timing]

1 SSIBCK cycle + 2 PCLKB cycles after generation of the start trigger that is the clearing condition.

[Setting condition]

While transmission and reception were disabled (SSICR.TEN = 0 and SSICR.REN = 0), transmission of one frame was complete.

[Setting timing]

2 PCLKB cycles after the end of transmission (at a frame boundary) that is the setting condition.

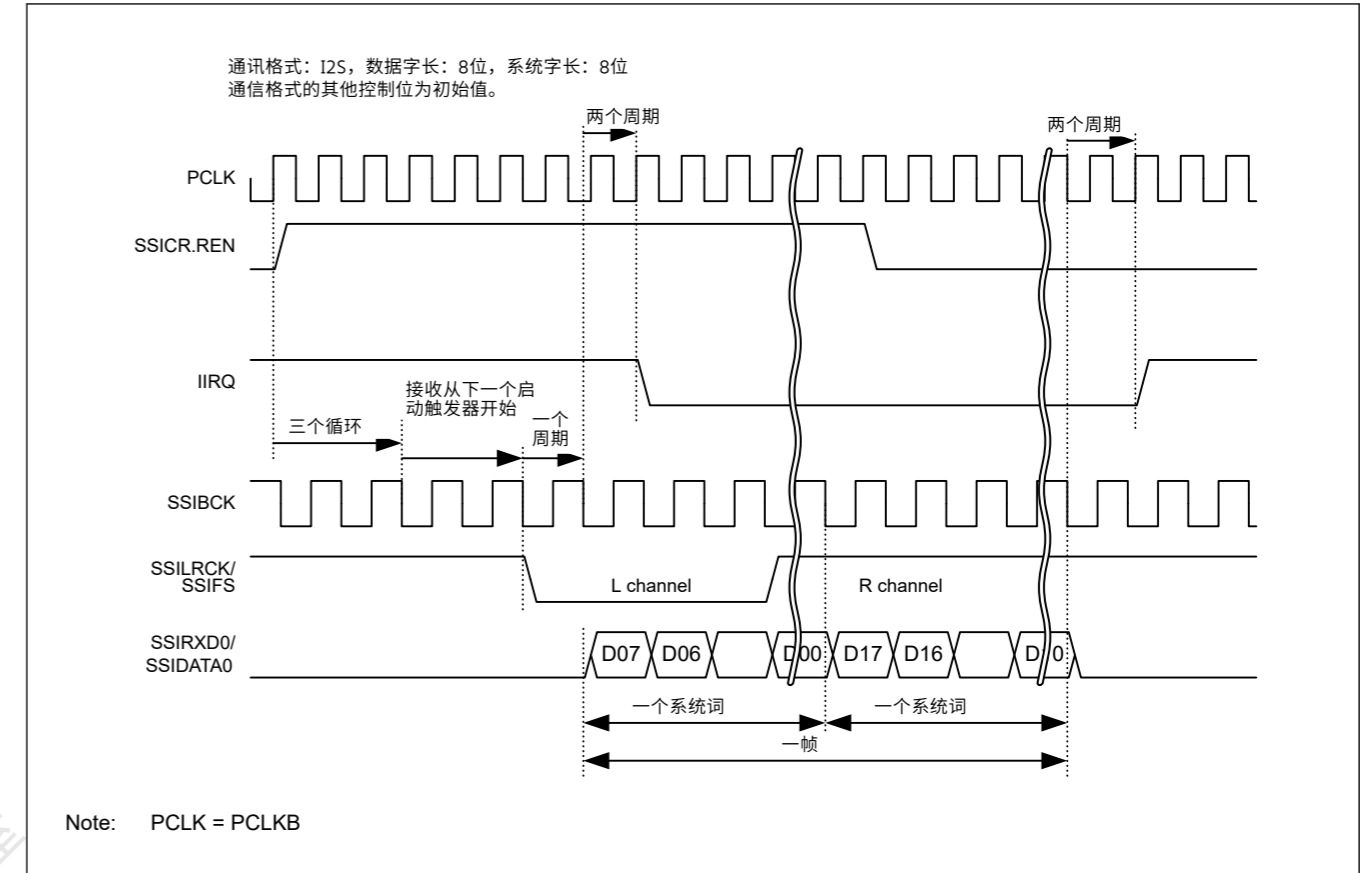


Figure 32.15 IIRQ设置时序 (接收)

- 接收器 (接收专用)

[Clearing condition]

在启用接收时 (SSICR.TEN=0和SSICR.REN=01, 由SSILRCKSSIFS信号生成启动触发信号。

[Clearing timing]

1个SSIBCK周期+2个PCLKB周期在产生作为清除条件的启动触发之后。

[Setting condition]

当发送和接收被禁用时 (SSICR.TEN=0和SSICR.REN=0), 一帧的接收完成。

[Setting timing]

在作为设置条件的接收结束 (在帧边界) 之后的2个PCLKB周期。

- 收发器 (发送和接收)

[Clearing condition]

在使能发送和接收时 (SSICR.TEN=1和SSICR.REN=1), 发送帧的发送数据被写入SSIFTDR寄存器, 并由SSILRCKSSIFS信号生成开始触发。

[Clearing timing]

1个SSIBCK周期+2个PCLKB周期在产生作为清除条件的启动触发之后。

[Setting condition]

当发送和接收被禁用时 (SSICR.TEN=0和SSICR.REN=0), 一帧的发送完成。

[Setting timing]

在作为设置条件的传输结束后 (在帧边界处) 的2个PCLKB周期。

**ROIRQ flag (Receive Overflow Error Status Flag)**

The ROIRQ flag is a status flag that indicates a receive overflow error. This flag is set by automatic determination but it must be cleared by register access. This flag indicates that received data is supplied at a higher rate than requested. Data is not transferred from the receive shift register to SSIFRDR where a receive overflow error is generated. For the procedure to recover from the overflow error, see [section 32.8.6. Error Handling](#). This flag is not cleared by a receive FIFO data register reset (SSIFCR.RFRST).

[Priority order for setting and clearing]

Setting is prioritized.\*1

[Clearing condition]

When either of the following operations is done:

1. Writing 0 to this bit after reading 1 from this bit\*2
2. Enabling communication (changing SSICR.REN from 0 to 1).

[Clearing timing]

Clearing timing corresponding to the above clearing condition:

1. When 0 is written to this bit after reading 1 from this bit (same as the timing in [Figure 32.19](#))
2. 1 PCLKB cycle after writing 1 to SSICR.REN.\*3

[Setting condition]

At completion of receiving new data while SSIFRDR is full.

[Setting timing]

3 cycles of PCLKB after reception is completed.

Note 1. This bit is cleared by a software reset (SSIFCR.SSIRST = 1). The software reset has priority over all the clearing conditions described above.

Note 2. After reading 1 from this bit, this bit is cleared when one of the following three conditions is met:

- A software reset (SSIFCR.SSIRST = 1) is done.
- After 1 has been read, writing of 0 is complete.
- 1 PCLKB cycle passes after 1 has been written to SSICR.REN.

Note 3. After communication is enabled (by changing the value of SSICR.REN bit from 0 to 1), the reception error flags (RUIRQ and ROIRQ in the SSISR register) are cleared. If, however, the SSISR register is read continuously, the cleared status of the reception error flags might be unable to be read.

**ROIRQ标志 (接收溢出错误状态标志)**

ROIRQ标志是指接收溢出错误的状态标志。该标志由自动确定设置，但必须通过寄存器访问清除。该标志表示接收到的数据以高于请求的速率提供。数据不会从接收移位寄存器传送到产生接收溢出错误的SSIFRDR。有关从溢出错误中恢复的过程，请参阅第32.8.6节。错误处理。该标志不会被接收FIFO数据寄存器复位(SSIFCR.RFRST)清除。

[设置和清除的优先顺序]

设置优先。\*1

[Clearing condition]

完成以下任一操作时：

- 1.从该位读取1后向该位写入0\*2
- 2.启用通信（将SSICR.REN从0更改为1）。

[Clearing timing]

与上述清零条件对应的清零时机：

- 1.当从该位读取1后向该位写入0时（与图32.19中的时序相同）
- 2.向SSICR.REN写入1后的1个PCLKB周期。\*3

[设置条件]在SSIFRDR已满时完成接收新数据时。

[设置时序]接收完成后的3个PCLKB周期。

注1.该位通过软件复位(SSIFCR.SSIRST=1)清零。软件复位优先于上述所有清除条件。

注2.从该位读取1后，当满足以下三个条件之一时，该位被清除：●软件复位(SSIFCR.SSIRST=1)完成。●读1后，写0完成。●在向SSICR.REN写入1之后经过1个PCLKB周期。

注3.使能通信后（通过将SSICR.REN位的值从0更改为1），接收错误标志（SSISR寄存器中的RUIRQ和ROIRQ）被清除。但是，如果连续读取SSISR寄存器，则可能无法读取接收错误标志的清除状态。



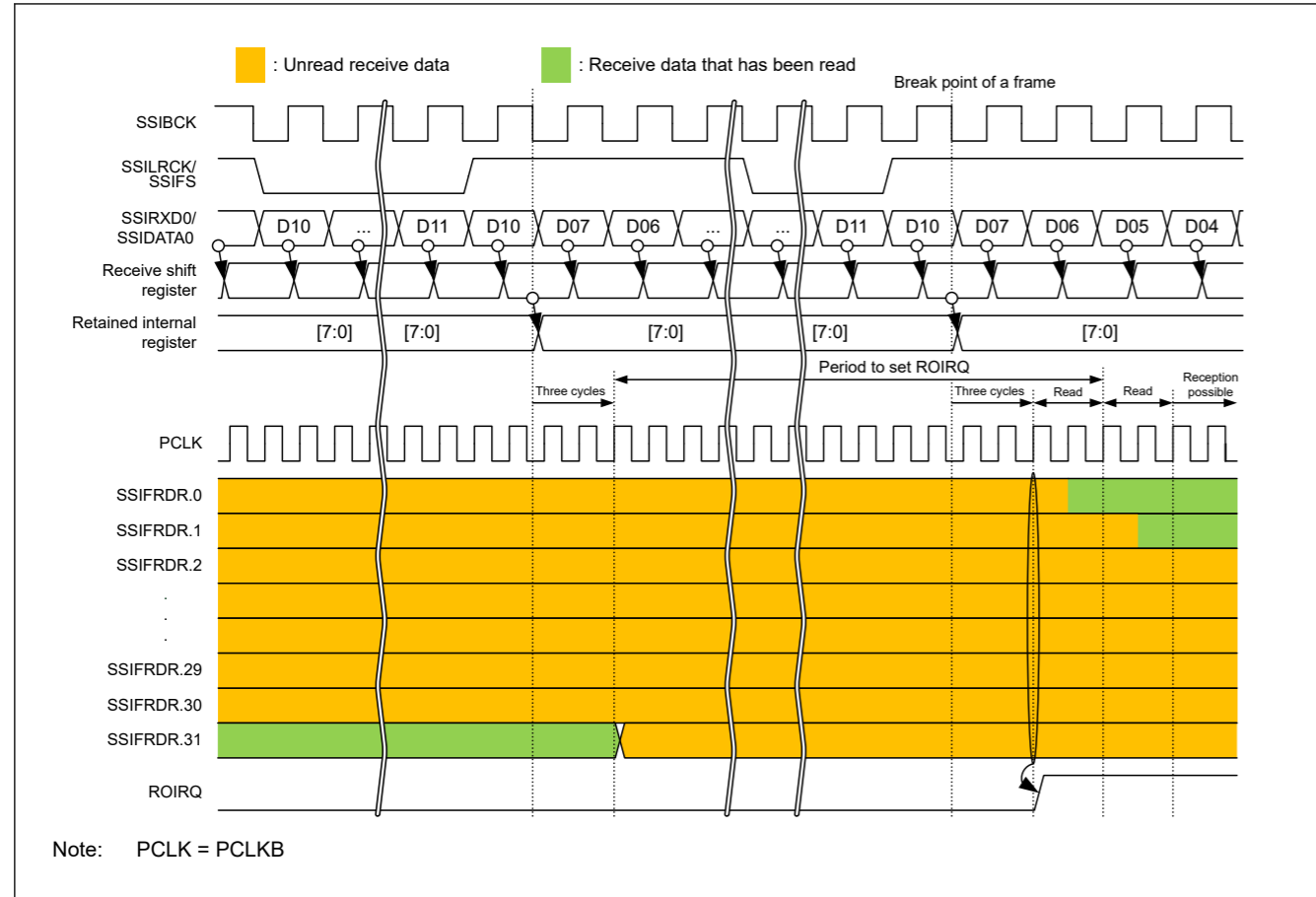


Figure 32.16 ROIRQ setting timing

**RUIRQ flag (Receive Underflow Error Status Flag)**

The RUIRQ flag is a status flag that indicates a receive underflow error. This flag is set by automatic determination but it must be cleared by register access. This flag indicates that SSIFRDR is read while it is empty. Data read from SSIFRDR where a receive underflow error is generated is invalid. See section 32.8.6. Error Handling for the error recovery procedure. This flag is not cleared by a receive FIFO data register reset (SSIFCR.RFRST). Note, however, that this flag is not set even if the SSIFRDR register is read while the receive FIFO data register is reset (by setting SSIFCR.RFRST to 1).

[Priority order for setting and clearing]

Setting is prioritized.\*1

[Clearing condition]

When either of the following operations is done:

1. Writing 0 to this bit after reading 1 from this bit\*2
2. Enabling communication (changing SSICR.REN from 0 to 1).

[Clearing timing]

Clearing timing corresponding to the above clearing condition

1. When 0 is written to this bit after reading 1 from this bit (same as the timing in Figure 32.19)
2. 1 PCLKB cycle after writing 1 to SSICR.REN.\*3

[Setting condition]

Reading from SSIFRDR while it is empty.

[Setting timing]

At completion of reading from SSIFRDR. See Figure 32.17.

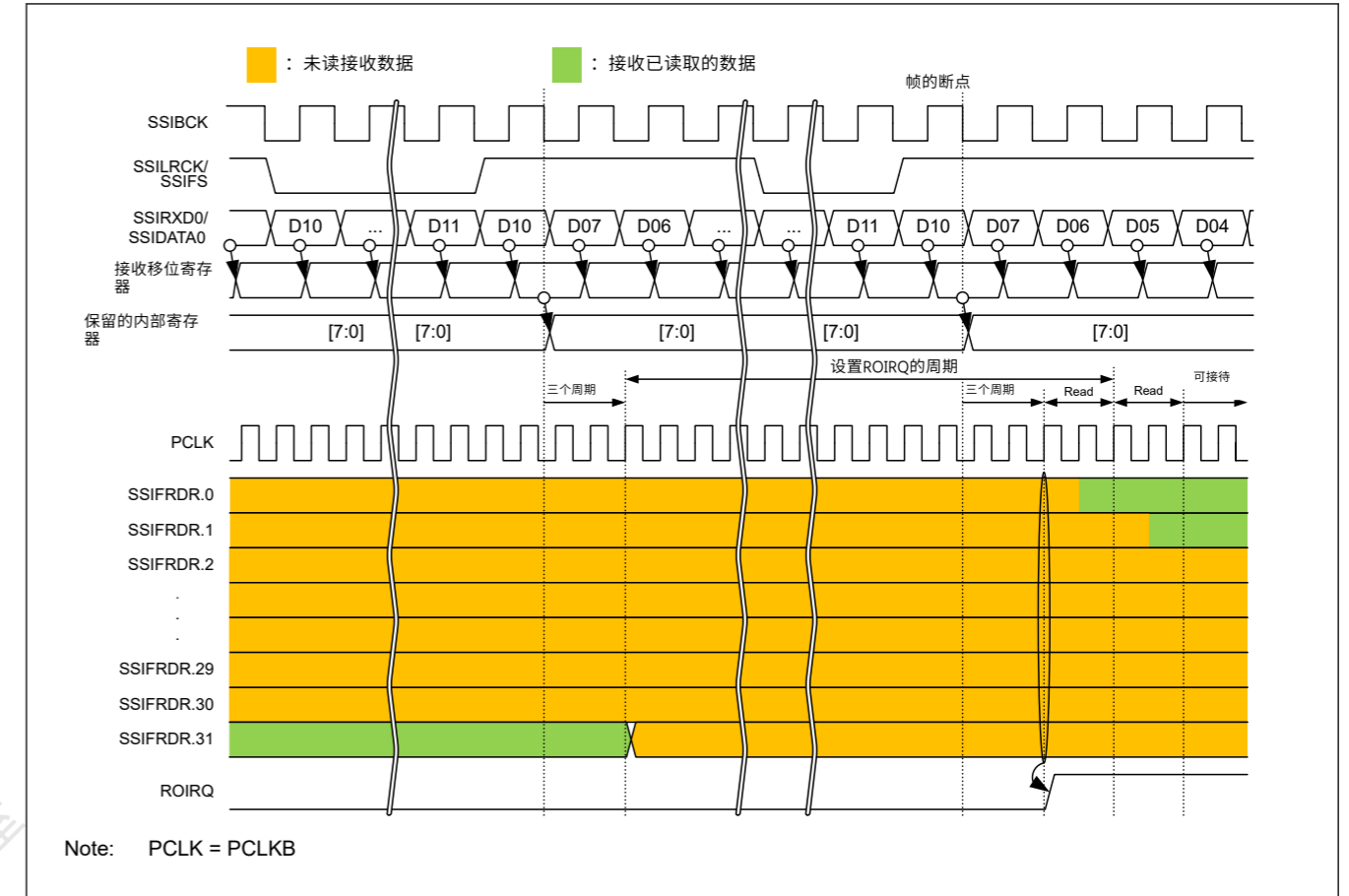


Figure 32.16 ROIRQ设置时序

**RUIRQ标志 (接收下溢错误状态标志)**

RUIRQ标志是指示接收下溢错误的状态标志。该标志由自动确定设置，但必须通过寄存器访问清除。此标志指示SSIFRDR在为空时被读取。从产生接收下溢错误的SSIFRDR读取的数据无效。请参阅第32.8.6节。错误恢复过程的错误处理。该标志不会被接收FIFO数据寄存器复位(SSIFCR.RFRST)清除。但是请注意，即使在接收FIFO数据寄存器复位（通过将SSIFCR.RFRST设置为1）时读取SSIFRDR寄存器，该标志也不会设置。

[设置和清除的优先顺序]

设置优先。\*1

[Clearing condition]

完成以下任一操作时：

- 1.从该位读取1后向该位写入0\*2
- 2.启用通信（将SSICR.REN从0更改为1）。

【清零时机】与上述清零条件对应的清零时机

- 1.当从该位读取1后向该位写入0时（与图32.19中的时序相同）
- 2.向SSICR.REN写入1后的1个PCLKB周期。\*3

[Setting condition]

在SSIFRDR为空时读取。

[Setting timing]

从SSIFRDR读取完成时。请参见图32.17。

- Note 1. This bit is cleared by a software reset (SSIFCR.SSIRST = 1). The software reset has priority over all the clearing conditions described above.
- Note 2. After reading 1 from this bit, this bit is cleared when one of the following three conditions is met:
- A software reset (SSIFCR.SSIRST = 1) is done.
  - After 1 has been read, writing of 0 is complete.
  - 1 PCLKB cycle passes after 1 has been written to SSICR.REN.
- Note 3. After communication is enabled (by changing the value of SSICR.REN bit from 0 to 1), the reception error flags (RUIRQ and ROIRQ in the SSISR register) are cleared. If, however, the SSISR register is read continuously, the cleared status of the reception error flags might be unable to be read.

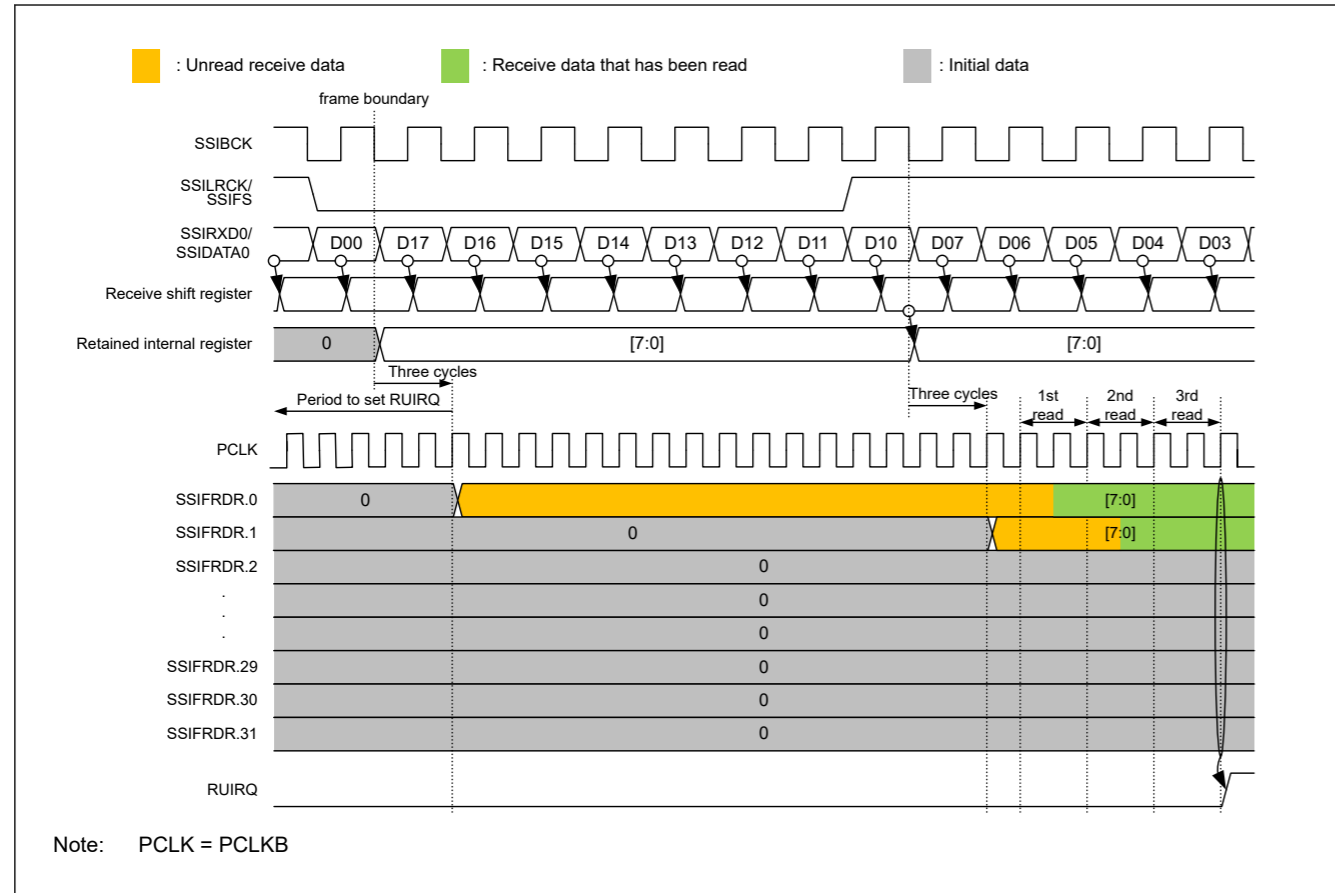


Figure 32.17 RUIRQ setting timing

**TOIRQ flag (Transmit Overflow Error Status Flag)**

The TOIRQ flag is a status flag that indicates a transmit overflow error. This flag is set by automatic determination but it must be cleared by register access. This flag indicates that an attempt has been made to write data to the SSIFTDR register when the register is full of data. The data writing that causes a transmit overflow is ignored. For the procedure to recover from the overflow error, see [section 32.8.6. Error Handling](#). This flag is not cleared by a transmit FIFO data register reset (SSIFCR.TFRST).

[Priority order for setting and clearing]

Setting is prioritized.\*1

[Clearing condition]

When either of the following operations is done:

1. Writing 0 to this bit after reading 1 from this bit\*2
2. Enabling communication (changing SSICR.TEN from 0 to 1).

[Clearing timing]

Clearing timing corresponding to the above clearing condition

注1.该位通过软件复位(SSIFCR.SSIRST=1)清零。软件复位优先于上述所有清除条件。

- 注2.从该位读取1后，当满足以下三个条件之一时，该位被清除：●
- 完成软件复位(SSIFCR.SSIRST=1)。
  - 读取1后，写入0完成。
  - 在将1写入SSICR.REN后经过1个PCLKB周期。

注3.使能通信后（通过将SSICR.REN位的值从0更改为1），接收错误标志（SSISR寄存器中的RUIRQ和ROIRQ）被清除。但是，如果连续读取SSISR寄存器，则可能无法读取接收错误标志的清除状态。

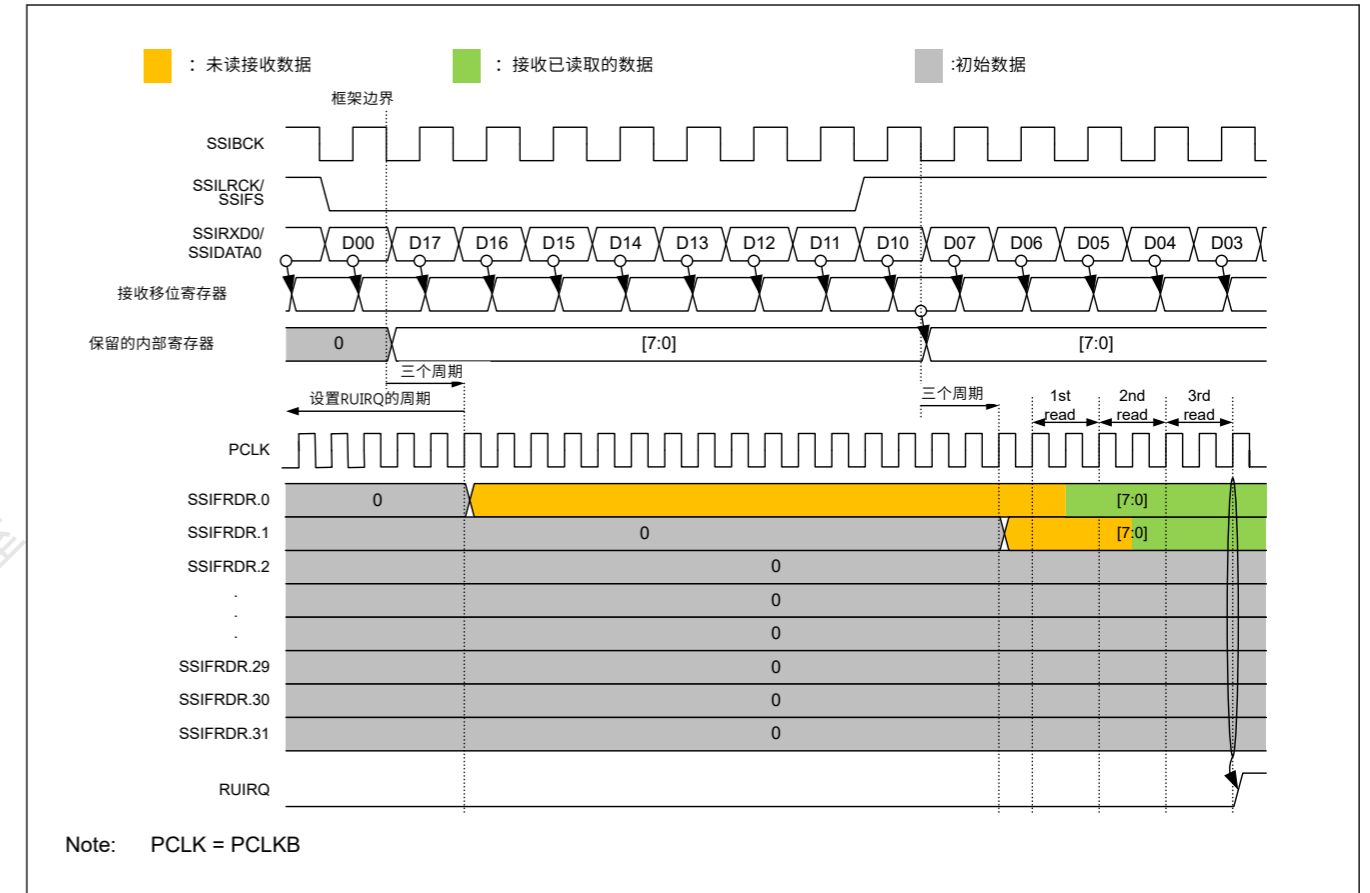


Figure 32.17 RUIRQ设置时序

**TOIRQ标志（发送溢出错误状态标志）**

TOIRQ标志是指示发送溢出错误的状态标志。该标志由自动确定设置，但必须通过寄存器访问清除。该标志表明当寄存器已满时尝试将数据写入SSIFTDR寄存器。导致发送溢出的数据写入将被忽略。有关从溢出错误中恢复的过程，请参阅第32.8.6节。错误处理。该标志不会被发送FIFO数据寄存器复位(SSIFCR.TFRST)清除。

[设置和清除的优先顺序]

设置优先。\*1

[Clearing condition]

完成以下任一操作时：

- 1.从该位读取1后向该位写入0\*2
- 2.启用通信（将SSICR.TEN从0更改为1）。

[Clearing timing]

与上述清零条件对应的清零时机

1. When 0 is written to this bit after reading 1 from this bit (same as the timing in [Figure 32.19](#))
2. 1 PCLKB cycle after writing 1 to SSICR.TEN.\*3

[Setting condition]

An attempt was made to write data to the SSIFTDR register when the register is full of data.

[Setting timing]

At completion of writing to SSIFTDR. For details, see [Figure 32.18](#).

Note 1. This bit is cleared by a software reset (SSIFCR.SSIRST = 1). The software reset has priority over all the clearing conditions described above.

Note 2. After reading 1 from this bit, this bit is cleared when one of the following three conditions is met:

- A software reset (SSIFCR.SSIRST = 1) is done.
- After 1 has been read, writing of 0 is complete.
- 1 PCLKB cycle passes after 1 has been written to SSICR.TEN.

Note 3. After communication is enabled (by changing the value of SSICR.TEN bit from 0 to 1), the transmission error flags (TOIRQ and TUIRQ in the SSISR register) are cleared. If, however, the SSISR register is read continuously, the cleared status of the transmission error flags might be unable to be read.

- 1.当从该位读取1后向该位写入0时（与图32.19中的时序相同）
- 2.向SSICR.TEN写入1后的1个PCLKB周期。\*3

[Setting condition]

当寄存器已满时，尝试将数据写入SSIFTDR寄存器。

[Setting timing]

完成对SSIFTDR的写入。详见图32.18。

注1.该位通过软件复位(SSIFCR.SSIRST=1)清零。软件复位优先于上述所有清除条件。

注2.从该位读取1后，当满足以下三个条件之一时，该位被清除：●软件复位(SSIFCR.SSIRST=1)完成。●读1后，写0完成。●在向SSICR.TEN写入1后经过1个PCLKB周期。

注3.使能通信后（通过将SSICR.TEN位的值从0更改为1），传输错误标志（SSISR寄存器中的TOIRQ和TUIRQ）被清除。但是，如果连续读取SSISR寄存器，则可能无法读取传输错误标志的清除状态。

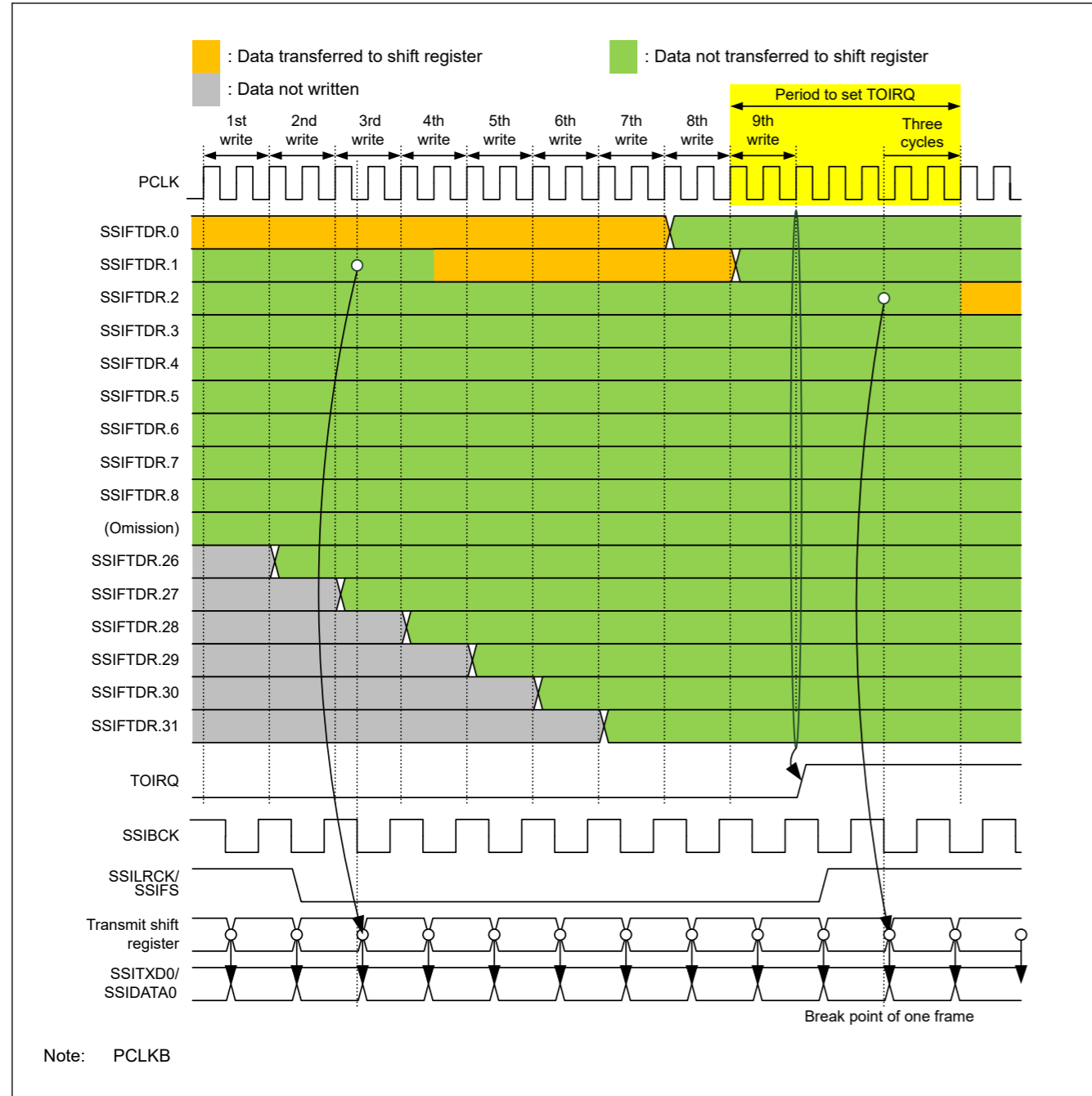


Figure 32.18 TOIRQ setting timing

**TUIRQ flag (Transmit Underflow Error Status flag)**

The TUIRQ flag is a status flag that indicates a transmit underflow error. This flag is set by automatic determination but it must be cleared by register access. This flag indicates that writing the serial data required for a frame to SSIFTDR did not catch up with transmission of the frame. Even if this flag is cleared after it has been set, the SSITXD0/SSIDATA0 output remains to be 0. To output the data written to the transmit FIFO data register (SSIFTDR) to the SSITXD0/SSIDATA0 pin, follow the communication stop procedure in Figure 32.56 and error-handling procedure in Figure 32.57. For the procedure to recover from an error, see section 32.8.6. Error Handling. This flag is not cleared by a reset of transmit FIFO data register (by the SSIFCR.TFRST signal).

[Priority order for setting and clearing]

Setting is prioritized.\*1

[Clearing condition]

When either of the following operations is done:

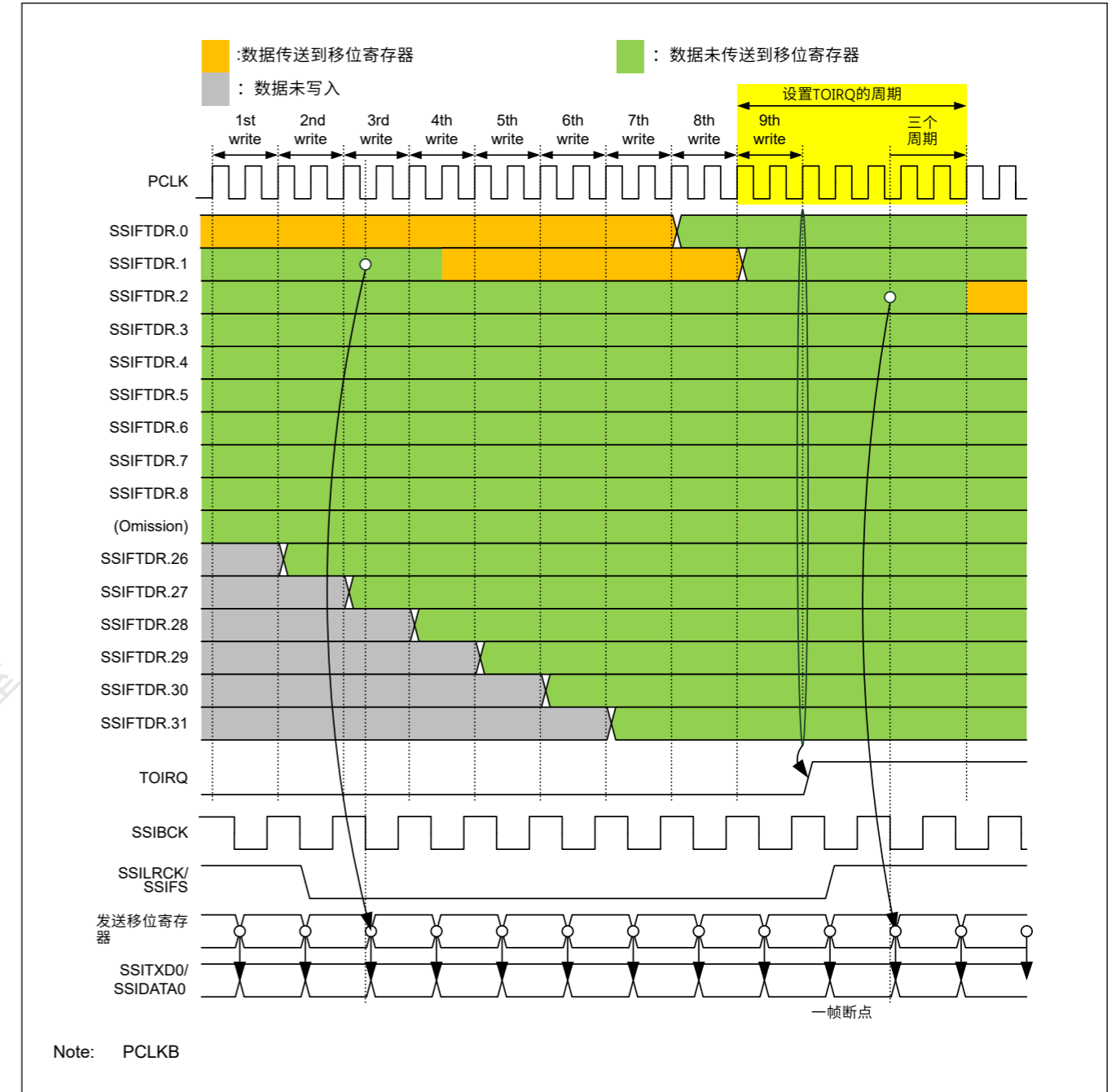


Figure 32.18 TOIRQ设置时序

**TUIRQ标志 (发送下溢错误状态标志)**

TUIRQ标志是指示发送下溢错误的状态标志。该标志由自动确定设置，但必须通过寄存器访问清除。该标志表示将帧所需的串行数据写入SSIFTDR没有赶上帧的传输。即使该标志在设置后被清除，SSITXD0SSIDATA0输出仍保持为0。要将写入发送FIFO数据寄存器(SSIFTDR)的数据输出到SSITXD0SSIDATA0引脚，请遵循图32.56中的通信停止程序并图32.57中的错误处理过程。有关从错误中恢复的过程，请参阅第32.8.6节。错误处理。该标志不会通过发送FIFO数据寄存器的复位（通过SSIFCR.TFRST信号）清除。

[设置和清除的优先顺序]

设置优先。\*1

[Clearing condition]

完成以下任一操作时：



1. Writing 0 to this bit after reading 1 from this bit\*2
2. Enabling communication (changing SSICR.TEN from 0 to 1).

## [Clearing timing]

Clearing timing corresponding to the above clearing condition

1. When 0 is written to this bit after reading 1 from this bit
2. 1 PCLKB cycle after writing 1 to SSICR.TEN.\*3

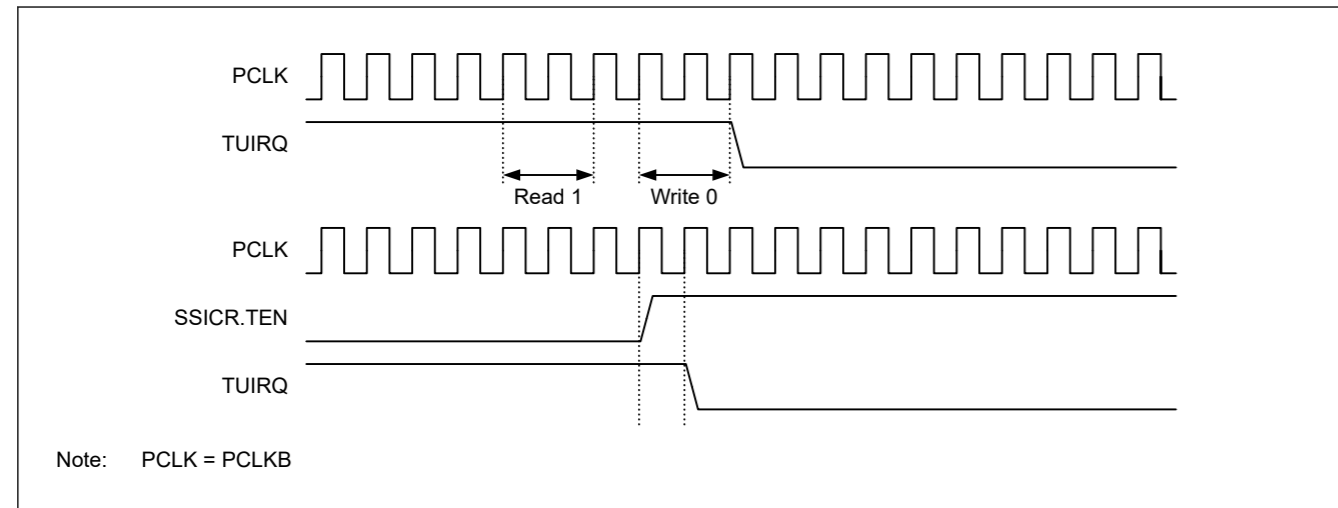


Figure 32.19 TUIRQ clearing timing

- Note 1. This bit is cleared by a software reset (SSIFCR.SSIRST = 1). The software reset has priority over all the clearing conditions described above.
- Note 2. After reading 1 from this bit, this bit is cleared when one of the following three conditions is met:
- A software reset (SSIFCR.SSIRST = 1) is done.
  - After 1 has been read, writing of 0 is complete.
  - 1 PCLKB cycle passes after 1 has been written to SSICR.TEN.
- Note 3. After communication is enabled (by changing the value of SSICR.TEN bit from 0 to 1), the transmission error flags (TOIRQ and TUIRQ in the SSISR register) are cleared. If, however, the SSISR register is read continuously, the cleared status of the transmission error flags might be unable to be read.

## [Setting condition]

When communication continues over a frame boundary, the transmit data required for the next frame has not been written to SSIFTDR. For details, see [Figure 32.20](#) and [Figure 32.21](#).

## [Setting timing]

3 PCLKB cycles after the frame boundary. For details, see [Figure 32.20](#).

- 1.从该位读取1后向该位写入0\*2
- 2.启用通信（将SSICR.TEN从0更改为1）。

## [Clearing timing]

与上述清零条件对应的清零时机

- 1.从该位读取1后向该位写入0
- 2.向SSICR.TEN写入1后的1个PCLKB周期。\*3

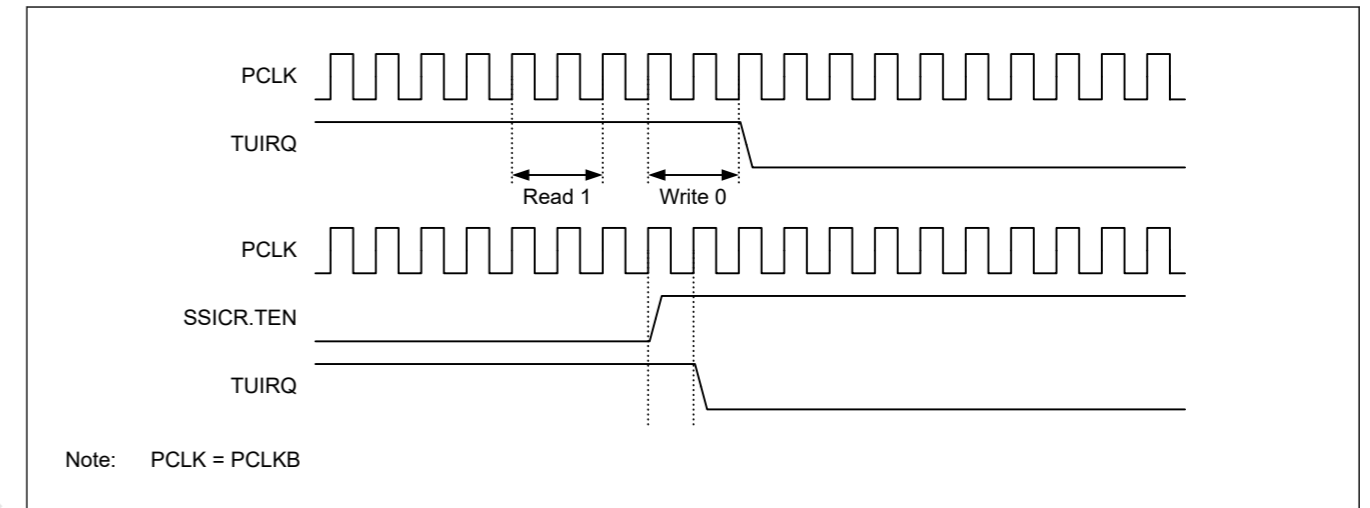


Figure 32.19 TUIRQ清零时机

注1.该位通过软件复位(SSIFCR.SSIRST=1)清零。软件复位优先于上述所有清除条件。

- 注2.从该位读取1后，当满足以下三个条件之一时，该位被清除：●
- 完成软件复位(SSIFCR.SSIRST=1)。
  - 读取1后，写入0完成。
  - 在将1写入SSICR.TEN之后经过1个PCLKB周期。

注3.使能通信后（通过将SSICR.TEN位的值从0更改为1），传输错误标志（SSISR寄存器中的TOIRQ和TUIRQ）被清除。但是，如果连续读取SSISR寄存器，则可能无法读取传输错误标志的清除状态。

## [Setting condition]

当通信继续通过帧边界时，下一帧所需的传输数据尚未写入 SSIFTDR。详见图32.20和图32.21。

## [Setting timing]

帧边界后3个PCLKB周期。详见图32.20。

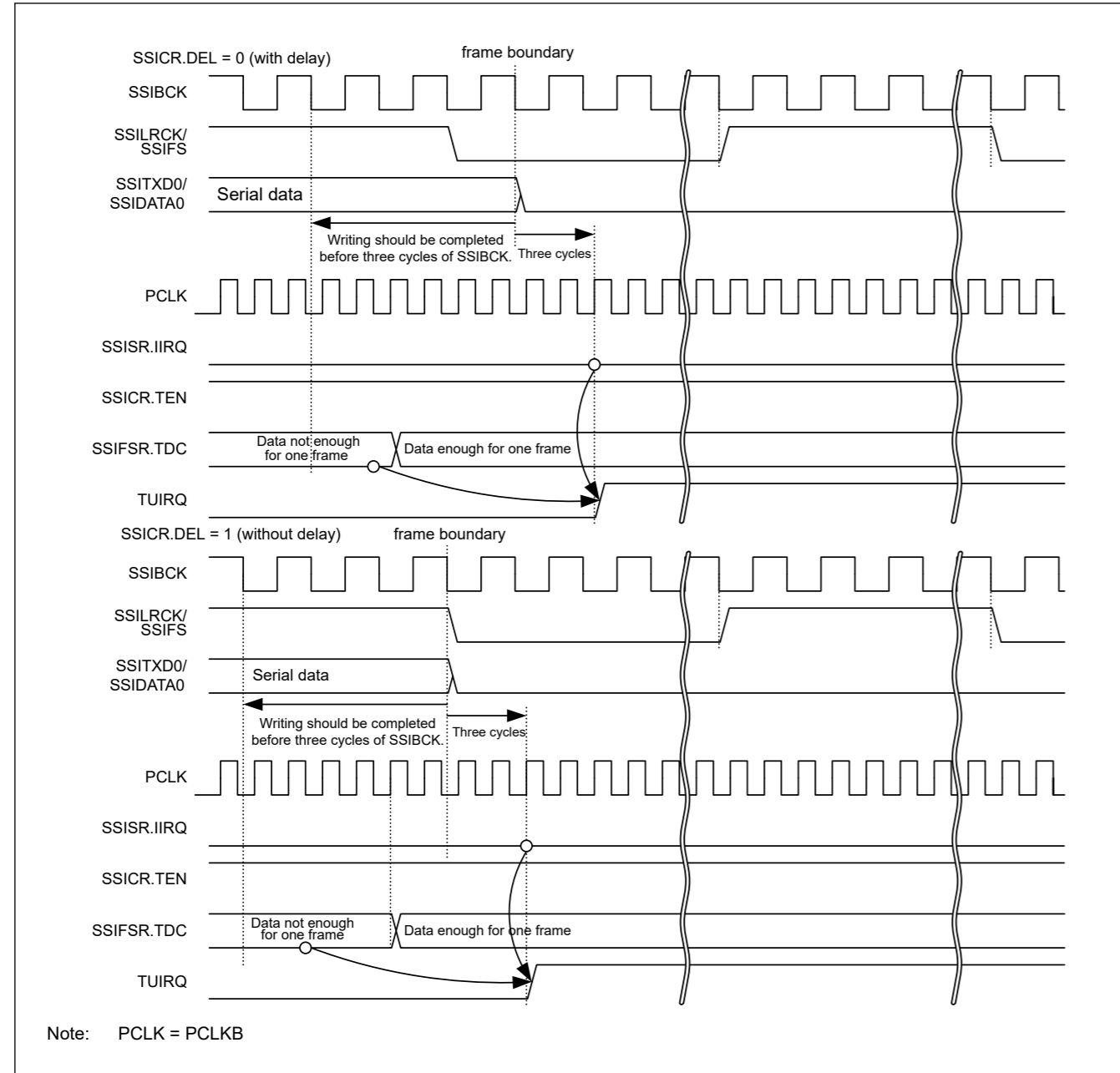


Figure 32.20 TUIRQ setting timing (when communication continues)

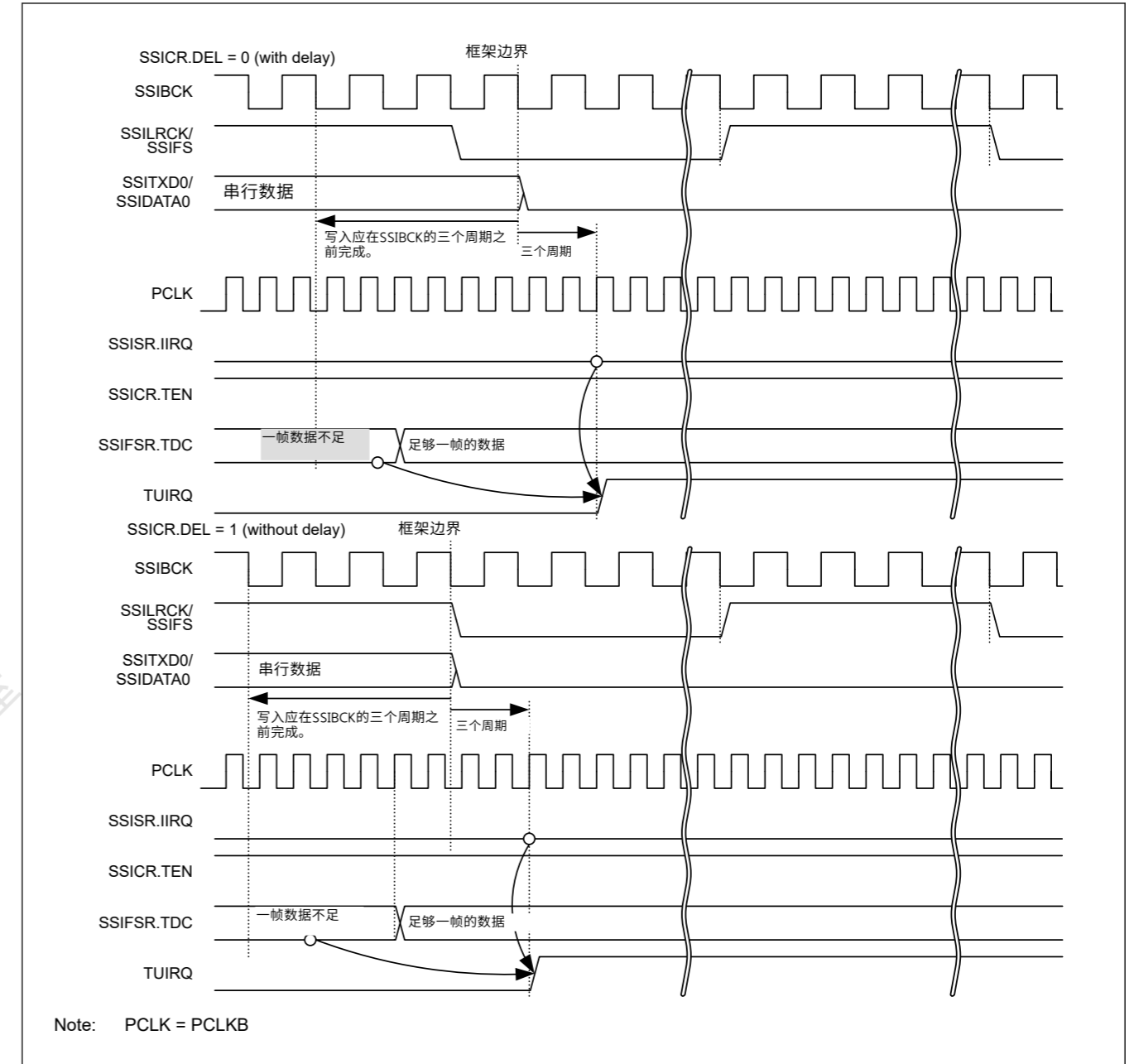


Figure 32.20 TUIRQ设置时间 (通信继续时)

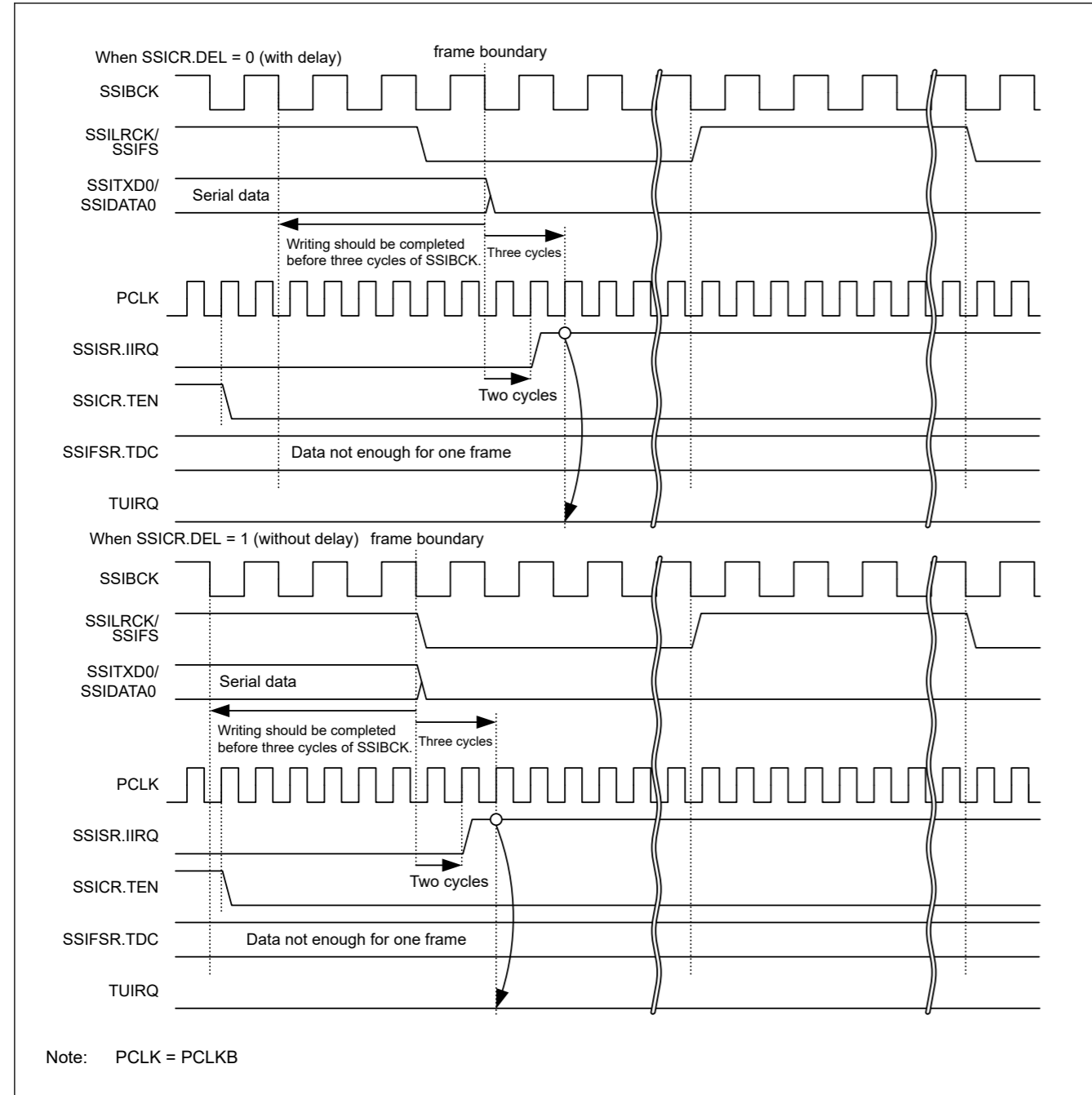


Figure 32.21 TUIRQ setting timing (when communication stops)

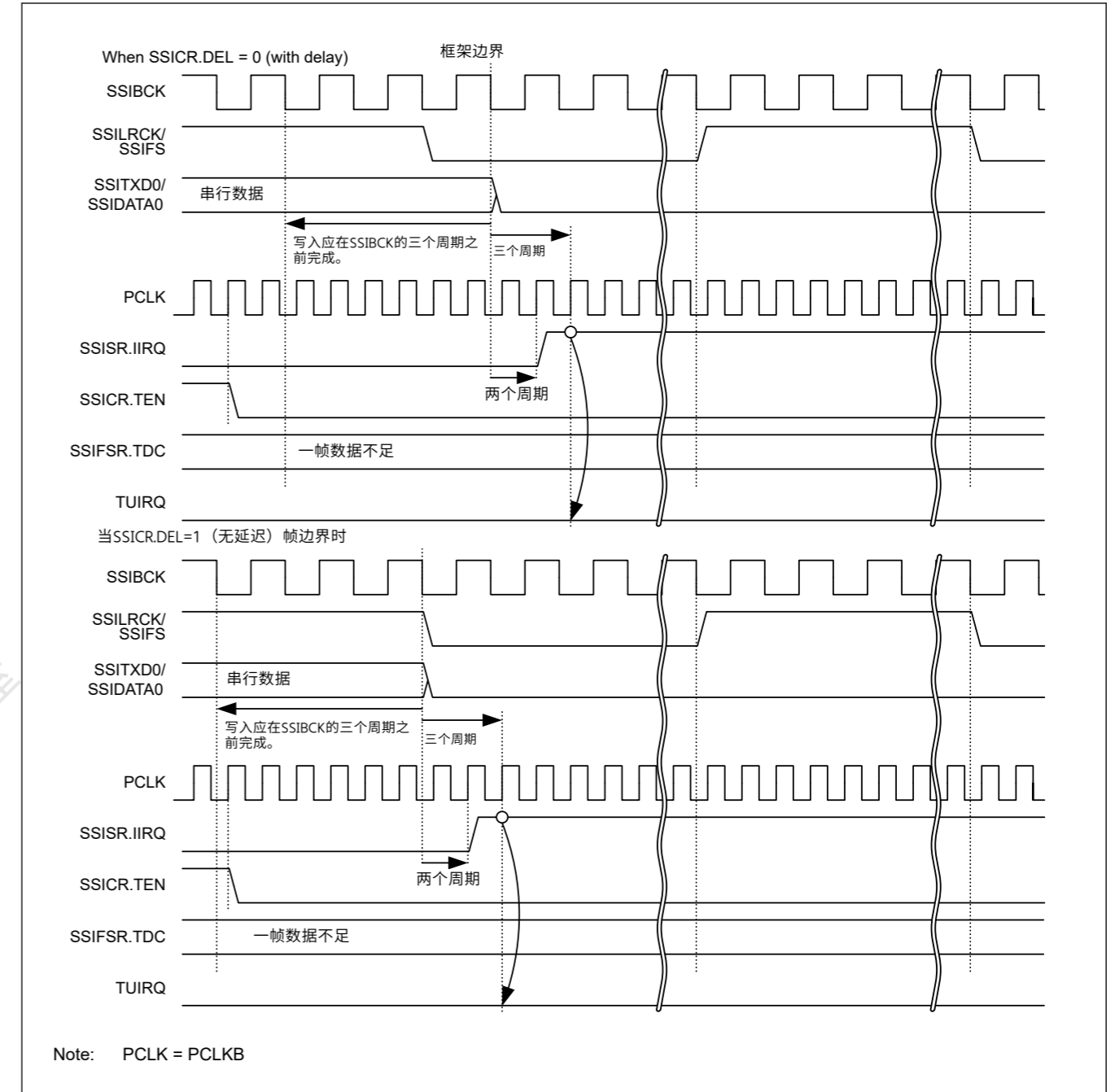


Figure 32.21 TUIRQ设置时间 (通信停止时)

## 32.4.3 SSIFCR : FIFO Control Register

Base address: SSIE0 = 0x4009\_D000

Offset address: 0x10

|                    |       |    |    |    |     |    |    |    |    |    |    |    |     |     |       |        |
|--------------------|-------|----|----|----|-----|----|----|----|----|----|----|----|-----|-----|-------|--------|
| Bit position:      | 31    | 30 | 29 | 28 | 27  | 26 | 25 | 24 | 23 | 22 | 21 | 20 | 19  | 18  | 17    | 16     |
| Bit field:         | AUCKE | —  | —  | —  | —   | —  | —  | —  | —  | —  | —  | —  | —   | —   | —     | SSIRST |
| Value after reset: | 0     | 0  | 0  | 0  | 0   | 0  | 0  | 0  | 0  | 0  | 0  | 0  | 0   | 0   | 0     | 0      |
| Bit position:      | 15    | 14 | 13 | 12 | 11  | 10 | 9  | 8  | 7  | 6  | 5  | 4  | 3   | 2   | 1     | 0      |
| Bit field:         | —     | —  | —  | —  | BSW | —  | —  | —  | —  | —  | —  | —  | TIE | RIE | TFRST | RFRST  |
| Value after reset: | 0     | 0  | 0  | 0  | 0   | 0  | 0  | 0  | 0  | 0  | 0  | 0  | 0   | 0   | 0     | 0      |

| Bit   | Symbol | Function  | R/W |
|-------|--------|---|-----|
| 0     | RFRST  | Receive FIFO Data Register Reset <sup>*1</sup><br>0: Clears a receive data FIFO reset condition<br>1: Sets a receive data FIFO reset condition    | R/W |
| 1     | TFRST  | Transmit FIFO Data Register Reset <sup>*1</sup><br>0: Clears a transmit data FIFO reset condition<br>1: Sets a transmit data FIFO reset condition | R/W |
| 2     | RIE    | Receive Data Full Interrupt Output Enable<br>0: Disables receive data full interrupts<br>1: Enables receive data full interrupts                  | R/W |
| 3     | TIE    | Transmit Data Empty Interrupt Output Enable<br>0: Disables transmit data empty interrupts<br>1: Enables transmit data empty interrupts            | R/W |
| 10:4  | —      | These bits are read as 0. The write value should be 0.  | R/W |
| 11    | BSW    | Byte Swap Enable <sup>*1</sup><br>0: Disables byte swap<br>1: Enables byte swap   | R/W |
| 15:12 | —      | These bits are read as 0. The write value should be 0.  | R/W |
| 16    | SSIRST | Software Reset<br>0: Clears a software reset condition<br>1: Sets a software reset condition  | R/W |
| 30:17 | —      | These bits are read as 0. The write value should be 0.  | R/W |
| 31    | AUCKE  | AUDIO_MCK Enable in Mastermode Communication <sup>*1</sup><br>0: Disables supply of AUDIO_MCK<br>1: Enables supply of AUDIO_MCK                   | R/W |

Note 1. Writing to these bits while SSIE is in a communication state (SSISR.IIRQ = 0) is prohibited. If the value of these bits is changed by rewriting, subsequent operation is unpredictable.

This register sets a software reset, byte swap, and enable/disable of interrupt requests.

**RFRST bit (Receive FIFO Data Register Reset)**

The RFRST bit sets a software reset of the receive FIFO data register (SSIFRDR). Writing 1 to this bit initializes the internal state related to SSIFRDR. The register bits subject to the software reset triggered by this bit are indicated by shading in Table 32.5. Because this bit is not automatically cleared after it has been set, write 0 to this bit to release the register bits from the software reset. After writing 0 to this bit, be sure to check that this bit is 0 before starting the next procedural step.

This bit is subject to the software reset by the SSIRST bit. Because the software reset by the SSIRST bit has priority over the reset by this bit, setting this bit is ignored when the SSIRST bit is set.

## 32.4.3 SSIFCR:FIFO控制寄存器

Base address: SSIE0 = 0x4009\_D000

Offset address: 0x10

|               |       |    |    |    |     |    |    |    |    |    |    |    |    |     |     |        |       |
|---------------|-------|----|----|----|-----|----|----|----|----|----|----|----|----|-----|-----|--------|-------|
| Bit position: | 31    | 30 | 29 | 28 | 27  | 26 | 25 | 24 | 23 | 22 | 21 | 20 | 19 | 18  | 17  | 16     |       |
| Bit field:    | AUCKE | —  | —  | —  | —   | —  | —  | —  | —  | —  | —  | —  | —  | —   | —   | SSIRST |       |
| 重置后的值:        | 0     | 0  | 0  | 0  | 0   | 0  | 0  | 0  | 0  | 0  | 0  | 0  | 0  | 0   | 0   | 0      |       |
| Bit position: | 15    | 14 | 13 | 12 | 11  | 10 | 9  | 8  | 7  | 6  | 5  | 4  | 3  | 2   | 1   | 0      |       |
| Bit field:    | —     | —  | —  | —  | BSW | —  | —  | —  | —  | —  | —  | —  | —  | TIE | RIE | TFRST  | RFRST |
| 重置后的值:        | 0     | 0  | 0  | 0  | 0   | 0  | 0  | 0  | 0  | 0  | 0  | 0  | 0  | 0   | 0   | 0      | 0     |

| Bit   | Symbol | Function   | R/W |
|-------|--------|--|-----|
| 0     | RFRST  | 接收FIFO数据寄存器复位*1<br>0: 清除接收数据FIFO复位条件1: 设置接收数据FIFO复位条件    | R/W |
| 1     | TFRST  | 发送FIFO数据寄存器复位*1<br>0: 清除发送数据FIFO复位条件1: 设置发送数据FIFO复位条件    | R/W |
| 2     | RIE    | 接收数据满中断输出使能<br>0: 禁止接收数据满中断1: 使能接收数据满中断                  | R/W |
| 3     | TIE    | 发送数据空中断输出使能<br>0: 禁用传输数据空中断1: 启用传输数据空中断                  | R/W |
| 10:4  | —      | 这些位被读取为0。写入值应为0。   | R/W |
| 11    | BSW    | 字节交换启用*1<br>0: 禁用字节交换1: 启用字节交换                           | R/W |
| 15:12 | —      | 这些位被读取为0。写入值应为0。   | R/W |
| 16    | SSIRST | 软件复位<br>0: 清除软件复位条件1: 设置软件复位条件                           | R/W |
| 30:17 | —      | 这些位被读取为0。写入值应为0。   | R/W |
| 31    | AUCKE  | AUDIO_MCK在主模式通信中启用*1<br>0: 禁用AUDIO_MCK供应1: 启用AUDIO_MCK供应 | R/W |

注1.禁止在SSIE处于通信状态(SSISR.IIRQ=0)时写入这些位。如果这些位的值通过重写而改变,后续的操作是不可预知的。

该寄存器设置软件复位、字节交换和中断请求的启用禁用。

**RFRST位 (接收FIFO数据寄存器复位)**

RFRST位设置接收FIFO数据寄存器(SSIFRDR)的软件复位。向该位写入1初始化与SSIFRDR相关的内部状态。受该位触发的软件复位的寄存器位在表32.5中用阴影表示。由于该位在被设置后不会自动清零,因此向该位写入0以从软件复位中释放寄存器位。向该位写入0后,请务必在开始下一个程序步骤之前检查该位是否为0。

该位受SSIRST位软件复位的影响。由于SSIRST位的软件复位优先于该位的复位,所以当SSIRST位置位时,该位的设置将被忽略。



Table 32.5 Bits subject to software reset by the RFRST bit

| Symbol  | Address (BASE+) | +0 |             |     |          |           |        |        |           | +1      |           |          |           |       |          |     |         |
|---------|-----------------|----|-------------|-----|----------|-----------|--------|--------|-----------|---------|-----------|----------|-----------|-------|----------|-----|---------|
|         |                 | 31 | 30          | 29  | 28       | 27        | 26     | 25     | 24        | 23      | 22        | 21       | 20        | 19    | 18       | 17  | 16      |
|         |                 | 15 | 14          | 13  | 12       | 11        | 10     | 9      | 8         | 7       | 6         | 5        | 4         | 3     | 2        | 1   | 0       |
| SSICR   | 0x00            | +0 | —           | CKS | TUI EN   | TOI EN    | RUI EN | ROI EN | IIEN      | —       | FRM[1:0]  | DWL[2:0] |           |       | SWL[2:0] |     |         |
|         |                 | +2 | —           | MST | BCK P    | LRC KP    | SPD P  | SDT A  | PDT A     | DEL     | CKDV[3:0] |          |           | MU EN | —        | TEN | REN     |
| SSISR   | 0x04            | +0 | —           | —   | TUI RQ   | TOI RQ    | RUI RQ | ROI RQ | IIRQ      | —       | —         | —        | —         | —     | —        | —   | —       |
|         |                 | +2 | —           | —   | —        | —         | —      | —      | —         | —       | —         | —        | —         | —     | —        | —   | —       |
| SSIFCR  | 0x10            | +0 | AUC KE      | —   | —        | —         | —      | —      | —         | —       | —         | —        | —         | —     | —        | —   | SSI RST |
|         |                 | +2 | —           | —   | —        | —         | BS W   | —      | —         | —       | —         | —        | —         | —     | TIE      | RIE | TFR ST  |
| SSIFSR  | 0x14            | +0 | —           | —   | TDC[5:0] |           |        |        |           | —       | —         | —        | —         | —     | —        | —   | TDE     |
|         |                 | +2 | —           | —   | RDC[5:0] |           |        |        |           | —       | —         | —        | —         | —     | —        | —   | RDF     |
| SSIFTDR | 0x18            | +0 | FTDR[31:16] |     |          |           |        |        |           |         |           |          |           |       |          |     |         |
|         |                 | +2 | FTDR[15:0]  |     |          |           |        |        |           |         |           |          |           |       |          |     |         |
| SSIFRDR | 0x1C            | +0 | FRDR[31:16] |     |          |           |        |        |           |         |           |          |           |       |          |     |         |
|         |                 | +2 | FRDR[15:0]  |     |          |           |        |        |           |         |           |          |           |       |          |     |         |
| SSIOFR  | 0x20            | +0 | —           | —   | —        | —         | —      | —      | —         | —       | —         | —        | —         | —     | —        | —   | —       |
|         |                 | +2 | —           | —   | —        | —         | —      | —      | BCK AST P | LRC ONT | —         | —        | —         | —     | —        | —   | —       |
| SSISCR  | 0x24            | +0 | —           | —   | —        | —         | —      | —      | —         | —       | —         | —        | —         | —     | —        | —   | —       |
|         |                 | +2 | —           | —   | —        | TDES[4:0] |        |        |           | —       | —         | —        | RDFS[4:0] |       |          |     |         |

**TFRST bit (Transmit FIFO Data Register Reset)**

The TFRST bit sets a software reset of the transmit FIFO data register (SSIFTDR). Writing 1 to this bit initializes the internal state related to SSIFTDR. The register bits subject to the software reset triggered by this bit are indicated by shading in Table 32.6. Because this bit is not automatically cleared after it has been set, write 0 to this bit to release the register bits from the software reset. After writing 0 to this bit, be sure to check that this bit is 0 before starting the next procedural step.

This bit is subject to the software reset by the SSIRST bit. Because the software reset by the SSIRST bit has priority over the reset by this bit, setting this bit is ignored when the SSIRST bit is set.

Table 32.6 Bits subject to software reset by the TFRST bit (1 of 2)

| Symbol | Address (BASE+) | +0 |    |     |        |        |        |        |       | +1  |           |          |    |       |          |     |     |
|--------|-----------------|----|----|-----|--------|--------|--------|--------|-------|-----|-----------|----------|----|-------|----------|-----|-----|
|        |                 | 31 | 30 | 29  | 28     | 27     | 26     | 25     | 24    | 23  | 22        | 21       | 20 | 19    | 18       | 17  | 16  |
|        |                 | 15 | 14 | 13  | 12     | 11     | 10     | 9      | 8     | 7   | 6         | 5        | 4  | 3     | 2        | 1   | 0   |
| SSICR  | 0x00            | +0 | —  | CKS | TUI EN | TOI EN | RUI EN | ROI EN | IIEN  | —   | FRM[1:0]  | DWL[2:0] |    |       | SWL[2:0] |     |     |
|        |                 | +2 | —  | MST | BCK P  | LRC KP | SPD P  | SDT A  | PDT A | DEL | CKDV[3:0] |          |    | MU EN | —        | TEN | REN |
| SSISR  | 0x04            | +0 | —  | —   | TUI RQ | TOI RQ | RUI RQ | ROI RQ | IIRQ  | —   | —         | —        | —  | —     | —        | —   | —   |
|        |                 | +2 | —  | —   | —      | —      | —      | —      | —     | —   | —         | —        | —  | —     | —        | —   | —   |

Table 32.5 受RFRST位软件复位的位

| Symbol  | Address (BASE+) | +0 |             |     |          |           |        |         |           | +1      |           |          |           |    |          |     |         |
|---------|-----------------|----|-------------|-----|----------|-----------|--------|---------|-----------|---------|-----------|----------|-----------|----|----------|-----|---------|
|         |                 | 31 | 30          | 29  | 28       | 27        | 26     | 25      | 24        | 23      | 22        | 21       | 20        | 19 | 18       | 17  | 16      |
|         |                 | 15 | 14          | 13  | 12       | 11        | 10     | 9       | 8         | 7       | 6         | 5        | 4         | 3  | 2        | 1   | 0       |
| SSICR   | 0x00            | +0 | —           | CKS | 途恩       | 托伊恩       | 瑞恩     | 投资回报率CN | IIEN      | —       | FRM[1:0]  | DWL[2:0] |           |    | SWL[2:0] |     |         |
|         |                 | +2 | —           | MST | BCK P    | LRC KP    | SPD P  | SDT A   | PDT A     | DEL     | CKDV[3:0] |          |           | 穆恩 | —        | TEN | REN     |
| SSISR   | 0x04            | +0 | —           | —   | TUI RQ   | TOI RQ    | RUI RQ | ROI RQ  | IIRQ      | —       | —         | —        | —         | —  | —        | —   | —       |
|         |                 | +2 | —           | —   | —        | —         | —      | —       | —         | —       | —         | —        | —         | —  | —        | —   | —       |
| SSIFCR  | 0x10            | +0 | AUC KE      | —   | —        | —         | —      | —       | —         | —       | —         | —        | —         | —  | —        | —   | SSI RST |
|         |                 | +2 | —           | —   | —        | —         | BS W   | —       | —         | —       | —         | —        | —         | —  | TIE      | RIE | TFR ST  |
| SSIFSR  | 0x14            | +0 | —           | —   | TDC[5:0] |           |        |         |           | —       | —         | —        | —         | —  | —        | —   | TDE     |
|         |                 | +2 | —           | —   | RDC[5:0] |           |        |         |           | —       | —         | —        | —         | —  | —        | —   | RDF     |
| SSIFTDR | 0x18            | +0 | FTDR[31:16] |     |          |           |        |         |           |         |           |          |           |    |          |     |         |
|         |                 | +2 | FTDR[15:0]  |     |          |           |        |         |           |         |           |          |           |    |          |     |         |
| SSIFRDR | 0x1C            | +0 | FRDR[31:16] |     |          |           |        |         |           |         |           |          |           |    |          |     |         |
|         |                 | +2 | FRDR[15:0]  |     |          |           |        |         |           |         |           |          |           |    |          |     |         |
| SSIOFR  | 0x20            | +0 | —           | —   | —        | —         | —      | —       | —         | —       | —         | —        | —         | —  | —        | —   | —       |
|         |                 | +2 | —           | —   | —        | —         | —      | —       | BCK AST P | LRC ONT | —         | —        | —         | —  | —        | —   | —       |
| SSISCR  | 0x24            | +0 | —           | —   | —        | —         | —      | —       | —         | —       | —         | —        | —         | —  | —        | —   | —       |
|         |                 | +2 | —           | —   | —        | TDES[4:0] |        |         |           | —       | —         | —        | RDFS[4:0] |    |          |     |         |

**TFRST位 (发送FIFO数据寄存器复位)**

TFRST位设置发送FIFO数据寄存器(SSIFTDR)的软件复位。向该位写入1初始化与SSIFTDR相关的内部状态。受该位触发的软件复位的寄存器位在表32.6中用阴影表示。由于该位在被设置后不会自动清零，因此向该位写入0以从软件复位中释放寄存器位。向该位写入0后，请务必在开始下一个程序步骤之前检查该位是否为0。

该位受SSIRST位软件复位的影响。由于SSIRST位的软件复位优先于该位的复位，所以当SSIRST位置位时，该位的设置将被忽略。

Table 32.6 受TFRST位软件复位的位 (2个中的1个)

| Symbol | Address (BASE+) | +0 |    |     |        |        |        |         |       | +1  |           |          |    |    |          |     |     |
|--------|-----------------|----|----|-----|--------|--------|--------|---------|-------|-----|-----------|----------|----|----|----------|-----|-----|
|        |                 | 31 | 30 | 29  | 28     | 27     | 26     | 25      | 24    | 23  | 22        | 21       | 20 | 19 | 18       | 17  | 16  |
|        |                 | 15 | 14 | 13  | 12     | 11     | 10     | 9       | 8     | 7   | 6         | 5        | 4  | 3  | 2        | 1   | 0   |
| SSICR  | 0x00            | +0 | —  | CKS | 途恩     | 托伊恩    | 瑞恩     | 投资回报率CN | IIEN  | —   | FRM[1:0]  | DWL[2:0] |    |    | SWL[2:0] |     |     |
|        |                 | +2 | —  | MST | BCK P  | LRC KP | SPD P  | SDT A   | PDT A | DEL | CKDV[3:0] |          |    | 穆恩 | —        | TEN | REN |
| SSISR  | 0x04            | +0 | —  | —   | TUI RQ | TOI RQ | RUI RQ | ROI RQ  | IIRQ  | —   | —         | —        | —  | —  | —        | —   | —   |
|        |                 | +2 | —  | —   | —      | —      | —      | —       | —     | —   | —         | —        | —  | —  | —        | —   | —   |

Table 32.6 Bits subject to software reset by the TFRST bit (2 of 2)

| Symbol  | Address (BASE+) | +0         |             |          |           |      |    |           |         | +1 |    |           |     |     |        |        |           |
|---------|-----------------|------------|-------------|----------|-----------|------|----|-----------|---------|----|----|-----------|-----|-----|--------|--------|-----------|
|         |                 | 31         | 30          | 29       | 28        | 27   | 26 | 25        | 24      | 23 | 22 | 21        | 20  | 19  | 18     | 17     | 16        |
|         |                 | 15         | 14          | 13       | 12        | 11   | 10 | 9         | 8       | 7  | 6  | 5         | 4   | 3   | 2      | 1      | 0         |
| SSIFCR  | 0x10            | +0         | AUC KE      | —        | —         | —    | —  | —         | —       | —  | —  | —         | —   | —   | —      | —      | SSI RST   |
|         | +2              | —          | —           | —        | —         | BS W | —  | —         | —       | —  | —  | —         | TIE | RIE | TFR ST | RFR ST |           |
| SSIFSR  | 0x14            | +0         | —           | —        | TDC[5:0]  |      |    |           | —       | —  | —  | —         | —   | —   | —      | —      | TDE       |
|         | +2              | —          | —           | RDC[5:0] |           |      |    | —         | —       | —  | —  | —         | —   | —   | —      | —      | RDF       |
| SSIFTDR | 0x18            | +0         | FTDR[31:16] |          |           |      |    |           |         |    |    |           |     |     |        |        |           |
|         | +2              | FTDR[15:0] |             |          |           |      |    |           |         |    |    |           |     |     |        |        |           |
| SSIFRDR | 0x1C            | +0         | FRDR[31:16] |          |           |      |    |           |         |    |    |           |     |     |        |        |           |
|         | +2              | FRDR[15:0] |             |          |           |      |    |           |         |    |    |           |     |     |        |        |           |
| SSIOFR  | 0x20            | +0         | —           | —        | —         | —    | —  | —         | —       | —  | —  | —         | —   | —   | —      | —      | —         |
|         | +2              | —          | —           | —        | —         | —    | —  | BCK AST P | LRC ONT | —  | —  | —         | —   | —   | —      | —      | OMOD[1:0] |
| SSISCR  | 0x24            | +0         | —           | —        | —         | —    | —  | —         | —       | —  | —  | —         | —   | —   | —      | —      | —         |
|         | +2              | —          | —           | —        | TDES[4:0] |      |    |           | —       | —  | —  | RDFS[4:0] |     |     |        |        |           |

**RIE bit (Receive Data Full Interrupt Output Enable)**

The RIE bit enables/disables output of receive data full interrupts. Use a receive data full interrupt as an interrupt to trigger data reading from the receive FIFO data register. Write 1 to this bit after specifying the setting condition for receive data full interrupt (by using the SSISCR.RDFS bit). Figure 32.22 shows the timing of generating the receive data full interrupt.

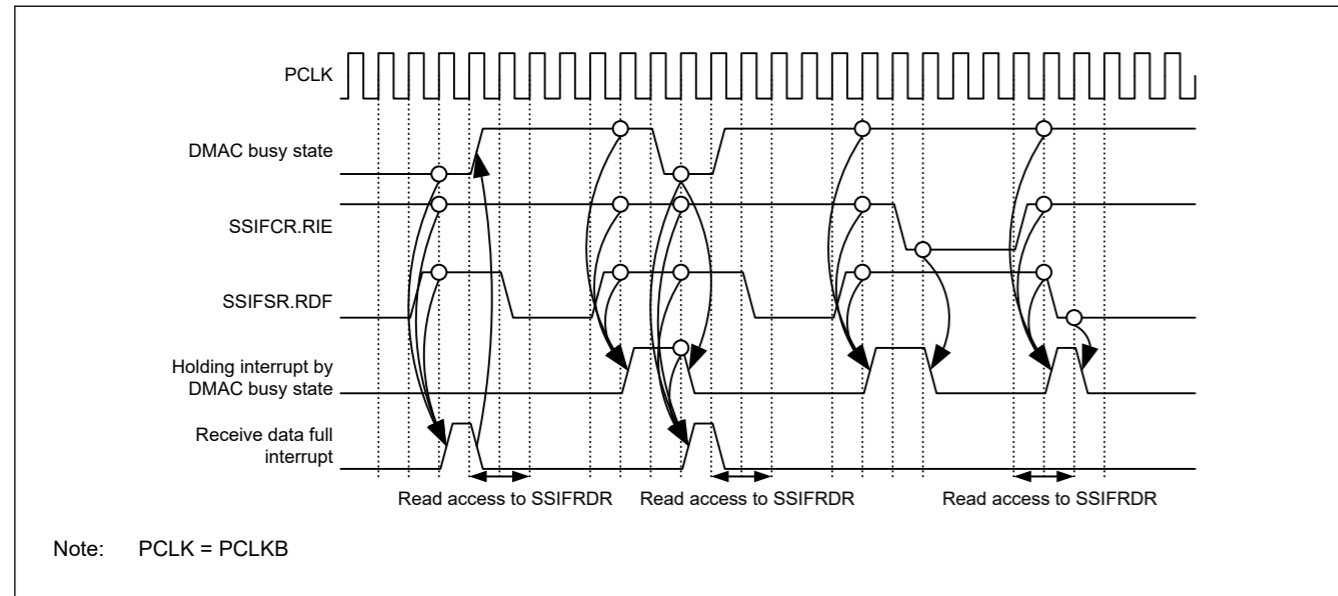


Figure 32.22 Timing of receive data full interrupt

**TIE bit (Transmit Data Empty Interrupt Output Enable)**

The TIE bit enables/disables output of transmit data empty interrupts. Use a transmit data empty interrupt as an interrupt to trigger data writing to the transmit FIFO data register. Write 1 to this bit after specifying the setting condition for transmit data empty interrupt (by using the SSISCR.TDES bit). Figure 32.23 shows the timing of generating the transmit data empty interrupt.

Table 32.6 受TFRST位软件复位的位 (2个中的2个)

| Symbol  | Address (BASE+) | +0         |             |          |           |      |    |           |         | +1 |    |           |     |     |        |        |           |
|---------|-----------------|------------|-------------|----------|-----------|------|----|-----------|---------|----|----|-----------|-----|-----|--------|--------|-----------|
|         |                 | 31         | 30          | 29       | 28        | 27   | 26 | 25        | 24      | 23 | 22 | 21        | 20  | 19  | 18     | 17     | 16        |
|         |                 | 15         | 14          | 13       | 12        | 11   | 10 | 9         | 8       | 7  | 6  | 5         | 4   | 3   | 2      | 1      | 0         |
| SSIFCR  | 0x10            | +0         | AUC KE      | —        | —         | —    | —  | —         | —       | —  | —  | —         | —   | —   | —      | —      | SSI RST   |
|         | +2              | —          | —           | —        | —         | BS W | —  | —         | —       | —  | —  | —         | TIE | RIE | TFR ST | RFR ST |           |
| SSIFSR  | 0x14            | +0         | —           | —        | TDC[5:0]  |      |    |           | —       | —  | —  | —         | —   | —   | —      | —      | TDE       |
|         | +2              | —          | —           | RDC[5:0] |           |      |    | —         | —       | —  | —  | —         | —   | —   | —      | —      | RDF       |
| SSIFTDR | 0x18            | +0         | FTDR[31:16] |          |           |      |    |           |         |    |    |           |     |     |        |        |           |
|         | +2              | FTDR[15:0] |             |          |           |      |    |           |         |    |    |           |     |     |        |        |           |
| SSIFRDR | 0x1C            | +0         | FRDR[31:16] |          |           |      |    |           |         |    |    |           |     |     |        |        |           |
|         | +2              | FRDR[15:0] |             |          |           |      |    |           |         |    |    |           |     |     |        |        |           |
| SSIOFR  | 0x20            | +0         | —           | —        | —         | —    | —  | —         | —       | —  | —  | —         | —   | —   | —      | —      | —         |
|         | +2              | —          | —           | —        | —         | —    | —  | BCK AST P | LRC ONT | —  | —  | —         | —   | —   | —      | —      | OMOD[1:0] |
| SSISCR  | 0x24            | +0         | —           | —        | —         | —    | —  | —         | —       | —  | —  | —         | —   | —   | —      | —      | —         |
|         | +2              | —          | —           | —        | TDES[4:0] |      |    |           | —       | —  | —  | RDFS[4:0] |     |     |        |        |           |

**RIE位 (接收数据满中断输出使能)**

RIE位启用禁用接收数据完整中断的输出。使用接收数据满中断作为中断来触发从接收FIFO数据寄存器读取数据。指定接收数据满中断的设置条件后（通过使用SSISCR.RDFS位）向该位写入1。图32.22显示了产生接收数据满中断的时序。

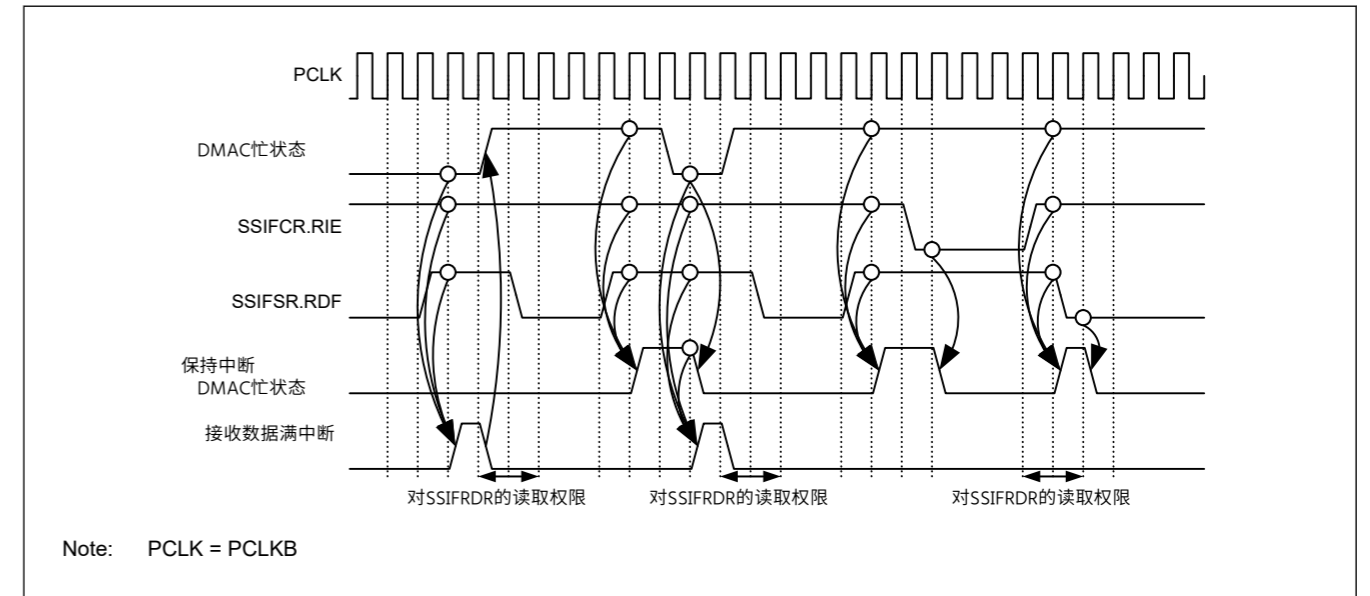


Figure 32.22 接收数据满中断的时序

**TIE位 (发送数据空中断输出使能)**

TIE位使能禁用发送数据空中断的输出。使用发送数据空中断作为中断来触发数据写入发送FIFO数据寄存器。在指定发送数据空中断的设置条件后（通过使用SSISCR.TDES位）向该位写入1。图32.23显示了产生发送数据空中断的时序。

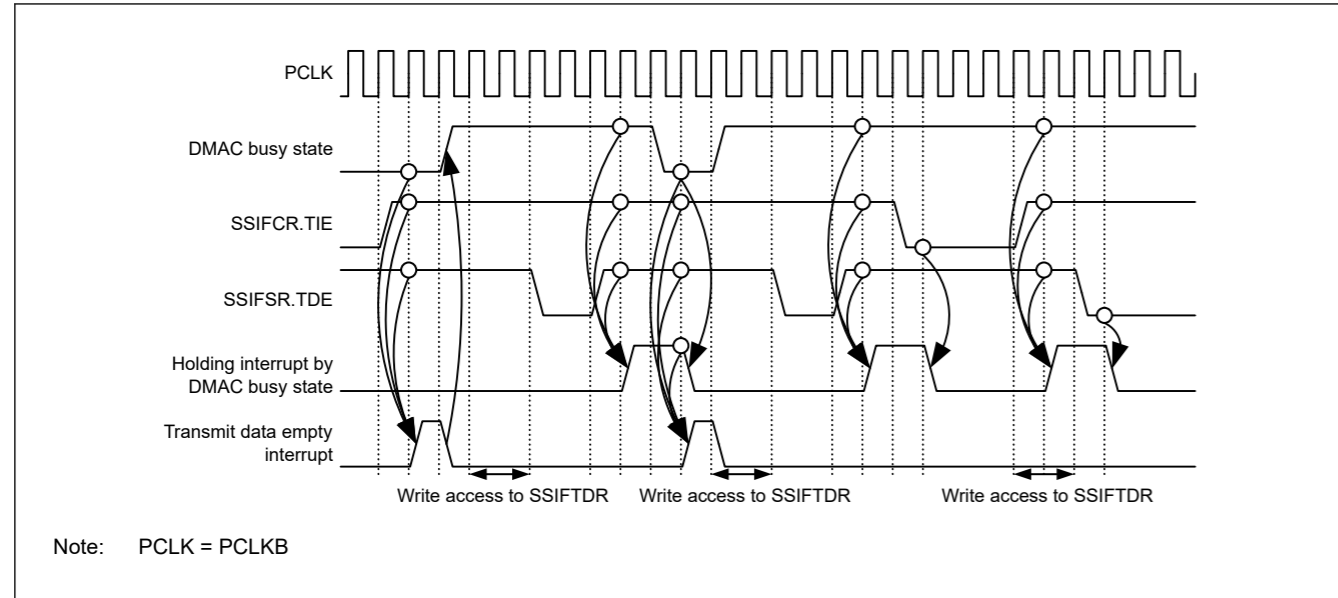


Figure 32.23 Timing of transmit data empty interrupt

**BSW bit (Byte Swap Enable)**

The BSW bit enables/disables byte swap of register access for the transmit FIFO data register (SSIFTDR) and the receive FIFO data register (SSIFRDR). This bit is valid only with 16-bit access or 32-bit access to SSIFTDR and SSIFRDR. For details, see Figure 32.24.

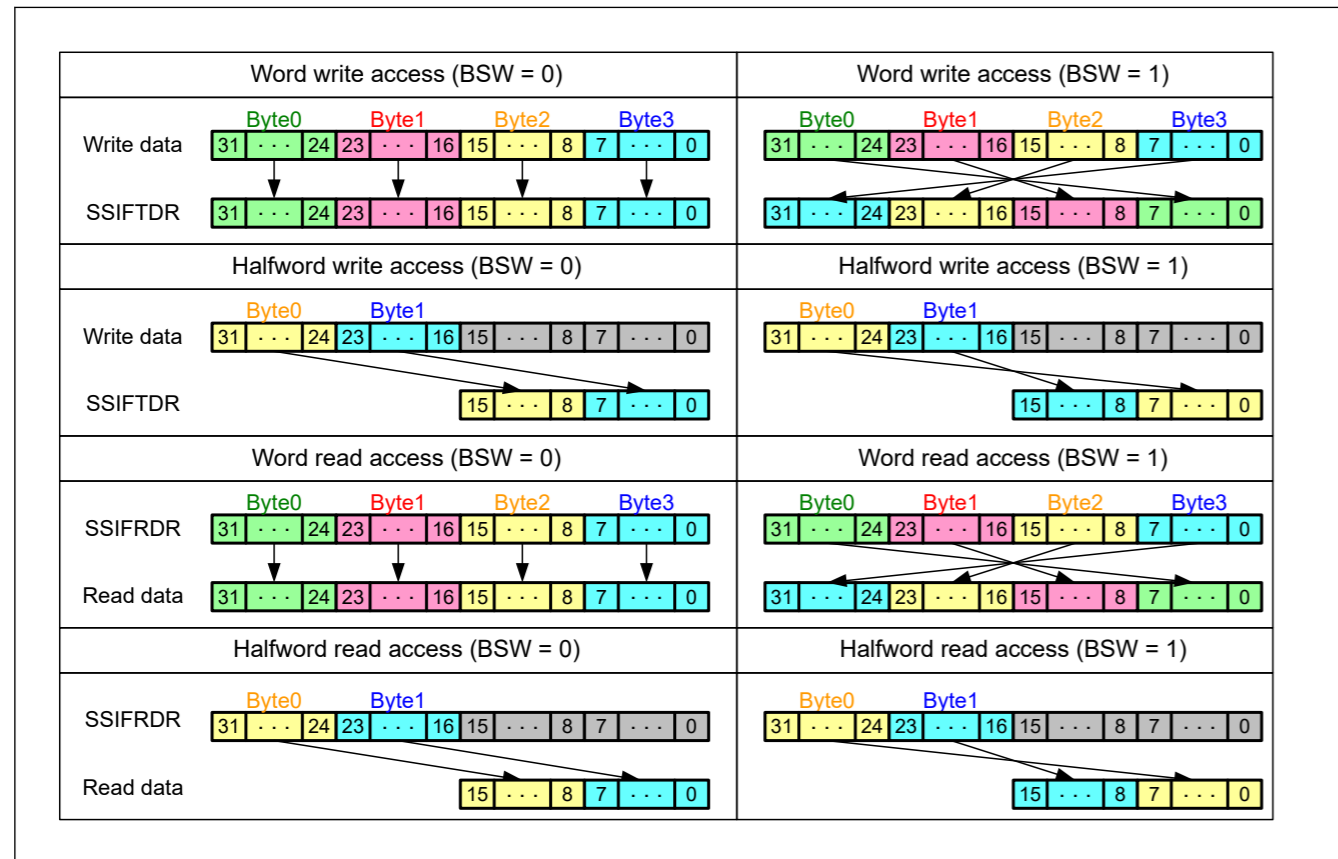


Figure 32.24 Operation example of byte swap

**SSIRST bit (Software Reset)**

The SSIRST bit sets a software reset of SSIE. Writing 1 to this bit initializes the internal state of SSIE. The register bits subject to the software reset triggered by this bit are indicated by shading in Table 32.7. Because this bit is not automatically

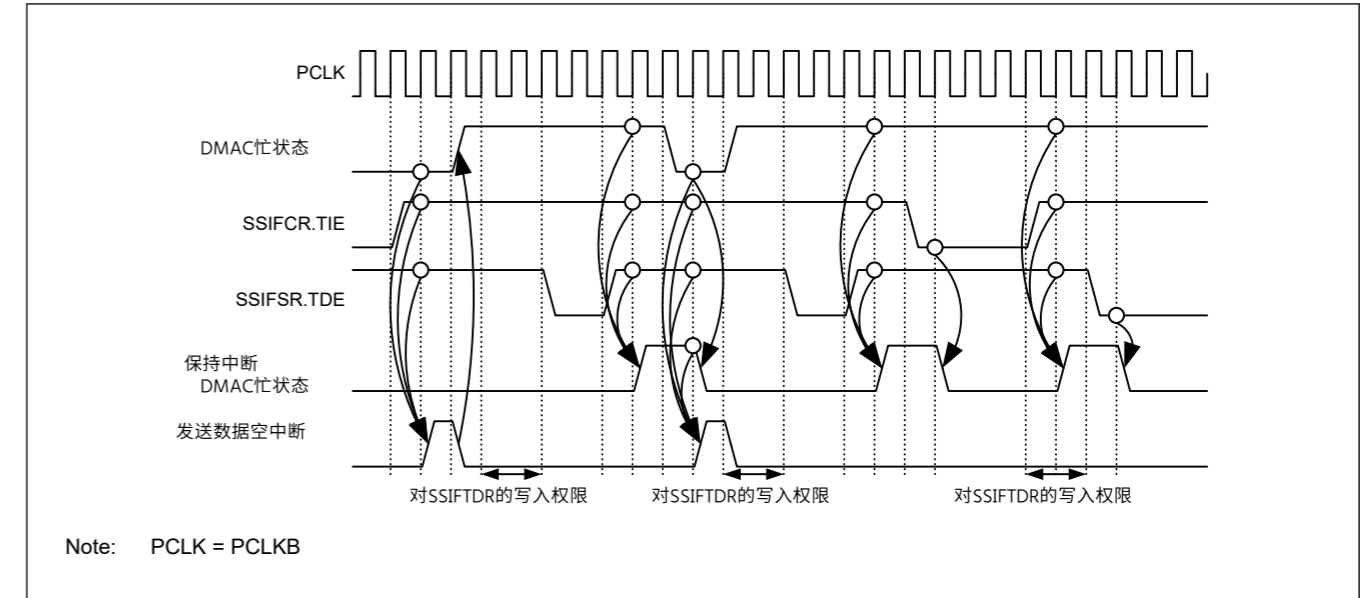


Figure 32.23 发送数据空中断的时序

**BSW位 (字节交换使能)**

BSW位启用禁用发送FIFO数据寄存器(SSIFTDR)和接收FIFO数据寄存器(SSIFRDR)的寄存器访问字节交换。该位仅对SSIFTDR和SSIFRDR的16位访问或32位访问有效。详见图32.24。

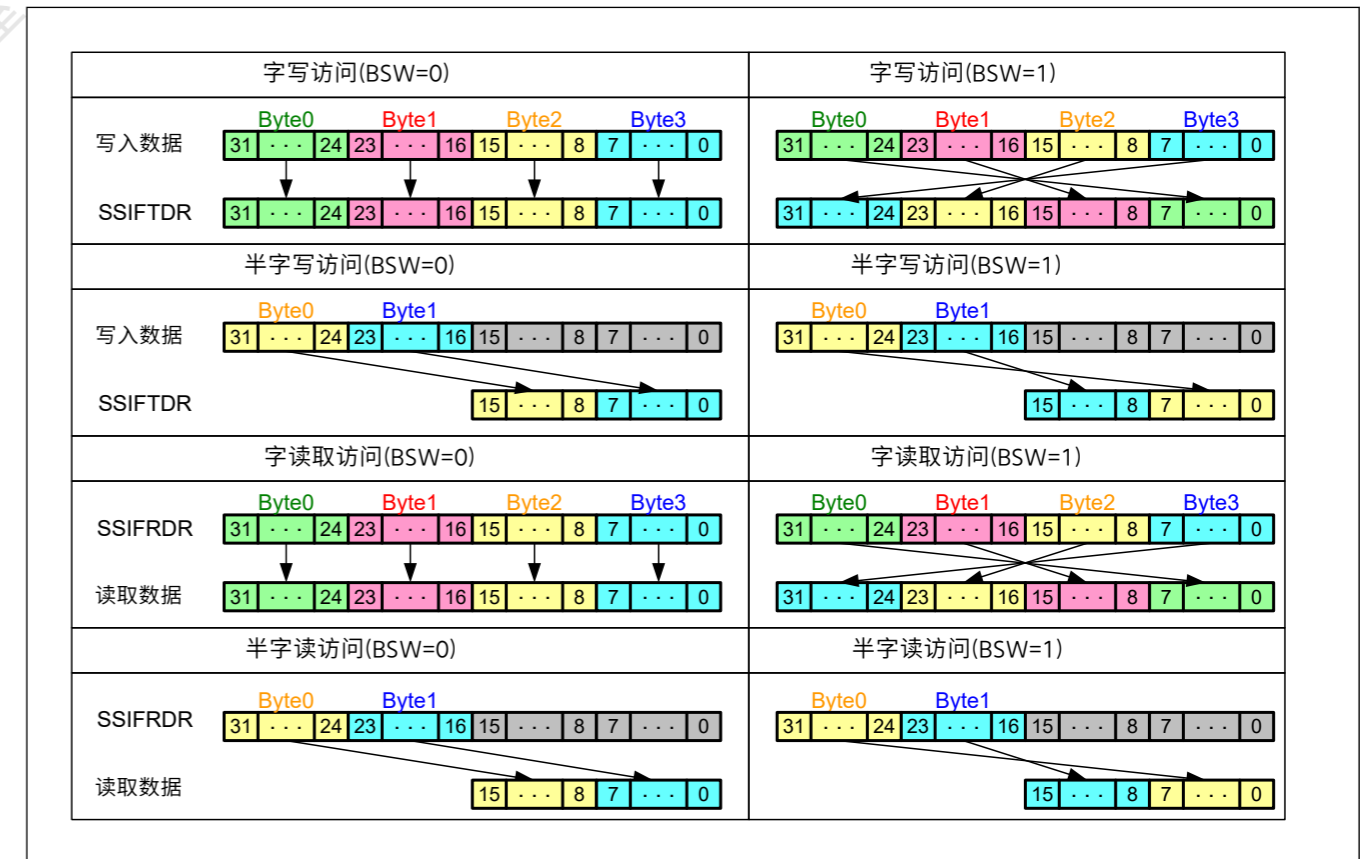


Figure 32.24 字节交换操作示例

**SSIRST bit (Software Reset)**

SSIRST位设置SSIE的软件复位。向该位写入1初始化SSIE的内部状态。受该位触发的软件复位的寄存器位在表32.7中用阴影表示。因为这个位不是自动的

cleared after it has been set, write 0 to this bit to release the register bits from the software reset. After writing 0 to this bit, be sure to check that this bit is 0 before starting the next procedural step.

To stop communication of SSIE immediately, after turning off the peripheral functions, write 1 to this bit. Initialization by a software reset is performed without any relation with the bit clock.

**Table 32.7 Bits subject to software reset by the SSIRST bit**

| Symbol  | Address (BASE+) |    | +0          |     |          |           |        |        |           |         | +1        |          |           |       |          |        |         |           |
|---------|-----------------|----|-------------|-----|----------|-----------|--------|--------|-----------|---------|-----------|----------|-----------|-------|----------|--------|---------|-----------|
|         |                 |    | 31          | 30  | 29       | 28        | 27     | 26     | 25        | 24      | 23        | 22       | 21        | 20    | 19       | 18     | 17      | 16        |
|         |                 |    | 15          | 14  | 13       | 12        | 11     | 10     | 9         | 8       | 7         | 6        | 5         | 4     | 3        | 2      | 1       | 0         |
| SSICR   | 0x00            | +0 | —           | CKS | TUI EN   | TOI EN    | RUI EN | ROI EN | I IEN     | —       | FRM[1:0]  | DWL[2:0] |           |       | SWL[2:0] |        |         |           |
|         |                 | +2 | —           | MST | BCK P    | LRC KP    | SPD P  | SDT A  | PDT A     | DEL     | CKDV[3:0] |          |           | MU EN | —        | TEN    | REN     |           |
| SSISR   | 0x04            | +0 | —           | —   | TUI RQ   | TOI RQ    | RUI RQ | ROI RQ | IIRQ      | —       | —         | —        | —         | —     | —        | —      | —       |           |
|         |                 | +2 | —           | —   | —        | —         | —      | —      | —         | —       | —         | —        | —         | —     | —        | —      | —       |           |
| SSIFCR  | 0x10            | +0 | AUC KE      | —   | —        | —         | —      | —      | —         | —       | —         | —        | —         | —     | —        | —      | SSI RST |           |
|         |                 | +2 | —           | —   | —        | —         | BS W   | —      | —         | —       | —         | —        | TIE       | RIE   | TFR ST   | RFR ST | —       |           |
| SSIFSR  | 0x14            | +0 | —           | —   | TDC[5:0] |           |        |        |           | —       | —         | —        | —         | —     | —        | —      | TDE     |           |
|         |                 | +2 | —           | —   | RDC[5:0] |           |        |        |           | —       | —         | —        | —         | —     | —        | —      | RDF     |           |
| SSIFTDR | 0x18            | +0 | FTDR[31:16] |     |          |           |        |        |           |         |           |          |           |       |          |        |         |           |
|         |                 | +2 | FTDR[15:0]  |     |          |           |        |        |           |         |           |          |           |       |          |        |         |           |
| SSIFRDR | 0x1C            | +0 | FRDR[31:16] |     |          |           |        |        |           |         |           |          |           |       |          |        |         |           |
|         |                 | +2 | FRDR[15:0]  |     |          |           |        |        |           |         |           |          |           |       |          |        |         |           |
| SSIOFR  | 0x20            | +0 | —           | —   | —        | —         | —      | —      | —         | —       | —         | —        | —         | —     | —        | —      | —       |           |
|         |                 | +2 | —           | —   | —        | —         | —      | —      | BCK AST P | LRC ONT | —         | —        | —         | —     | —        | —      | —       | OMOD[1:0] |
| SSISCR  | 0x24            | +0 | —           | —   | —        | —         | —      | —      | —         | —       | —         | —        | —         | —     | —        | —      | —       |           |
|         |                 | +2 | —           | —   | —        | TDES[4:0] |        |        |           | —       | —         | —        | RDFS[4:0] |       |          |        |         |           |

**AUCKE bit (AUDIO\_MCK Enable in Mastermode Communication)**

The AUCKE bit enables/disables supply to AUDIO\_MCK while in master-mode communication (MST = 1).

Changing the value of this bit must be performed only after specifying the settings related to AUDIO\_MCK (by using the CKS, MST, BCKP, and CKDV bits in the SSICR register).

置位后清零，向该位写入0以从软件复位中释放寄存器位。向该位写入0后，请务必在开始下一个程序步骤之前检查该位是否为0。

要立即停止SSIE通信，请在关闭外围功能后，向该位写入1。通过软件复位进行的初始化与位时钟没有任何关系。

**Table 32.7 受SSIRST位软件复位的位**

| Symbol  | Address (BASE+) |    | +0          |     |          |           |        |        |           |         | +1        |          |           |     |          |        |         |           |
|---------|-----------------|----|-------------|-----|----------|-----------|--------|--------|-----------|---------|-----------|----------|-----------|-----|----------|--------|---------|-----------|
|         |                 |    | 31          | 30  | 29       | 28        | 27     | 26     | 25        | 24      | 23        | 22       | 21        | 20  | 19       | 18     | 17      | 16        |
|         |                 |    | 15          | 14  | 13       | 12        | 11     | 10     | 9         | 8       | 7         | 6        | 5         | 4   | 3        | 2      | 1       | 0         |
| SSICR   | 0x00            | +0 | —           | CKS | 途恩       | 托伊恩       | 瑞恩     | 投回报率CN | I IEN     | —       | FRM[1:0]  | DWL[2:0] |           |     | SWL[2:0] |        |         |           |
|         |                 | +2 | —           | MST | BCK P    | LRC KP    | SPD P  | SDT A  | PDT A     | DEL     | CKDV[3:0] |          |           | 穆恩  | —        | TEN    | REN     |           |
| SSISR   | 0x04            | +0 | —           | —   | TUI RQ   | TOI RQ    | RUI RQ | ROI RQ | IIRQ      | —       | —         | —        | —         | —   | —        | —      | —       |           |
|         |                 | +2 | —           | —   | —        | —         | —      | —      | —         | —       | —         | —        | —         | —   | —        | —      | —       |           |
| SSIFCR  | 0x10            | +0 | AUC KE      | —   | —        | —         | —      | —      | —         | —       | —         | —        | —         | —   | —        | —      | SSI RST |           |
|         |                 | +2 | —           | —   | —        | —         | BS W   | —      | —         | —       | —         | —        | TIE       | RIE | TFR ST   | RFR ST | —       |           |
| SSIFSR  | 0x14            | +0 | —           | —   | TDC[5:0] |           |        |        |           | —       | —         | —        | —         | —   | —        | —      | TDE     |           |
|         |                 | +2 | —           | —   | RDC[5:0] |           |        |        |           | —       | —         | —        | —         | —   | —        | —      | RDF     |           |
| SSIFTDR | 0x18            | +0 | FTDR[31:16] |     |          |           |        |        |           |         |           |          |           |     |          |        |         |           |
|         |                 | +2 | FTDR[15:0]  |     |          |           |        |        |           |         |           |          |           |     |          |        |         |           |
| SSIFRDR | 0x1C            | +0 | FRDR[31:16] |     |          |           |        |        |           |         |           |          |           |     |          |        |         |           |
|         |                 | +2 | FRDR[15:0]  |     |          |           |        |        |           |         |           |          |           |     |          |        |         |           |
| SSIOFR  | 0x20            | +0 | —           | —   | —        | —         | —      | —      | —         | —       | —         | —        | —         | —   | —        | —      | —       |           |
|         |                 | +2 | —           | —   | —        | —         | —      | —      | BCK AST P | LRC ONT | —         | —        | —         | —   | —        | —      | —       | OMOD[1:0] |
| SSISCR  | 0x24            | +0 | —           | —   | —        | —         | —      | —      | —         | —       | —         | —        | —         | —   | —        | —      | —       |           |
|         |                 | +2 | —           | —   | —        | TDES[4:0] |        |        |           | —       | —         | —        | RDFS[4:0] |     |          |        |         |           |

**AUCKE位 (在主模式通信中启用AUDIO\_MCK)**

在主模式通信(MST=1)时，AUCKE位启用禁用对AUDIO\_MCK的供电。

只有在指定与AUDIO\_MCK相关的设置后才能更改该位的值 (通过使用SSICR寄存器中的CKS、MST、BCKP和CKDV位)。



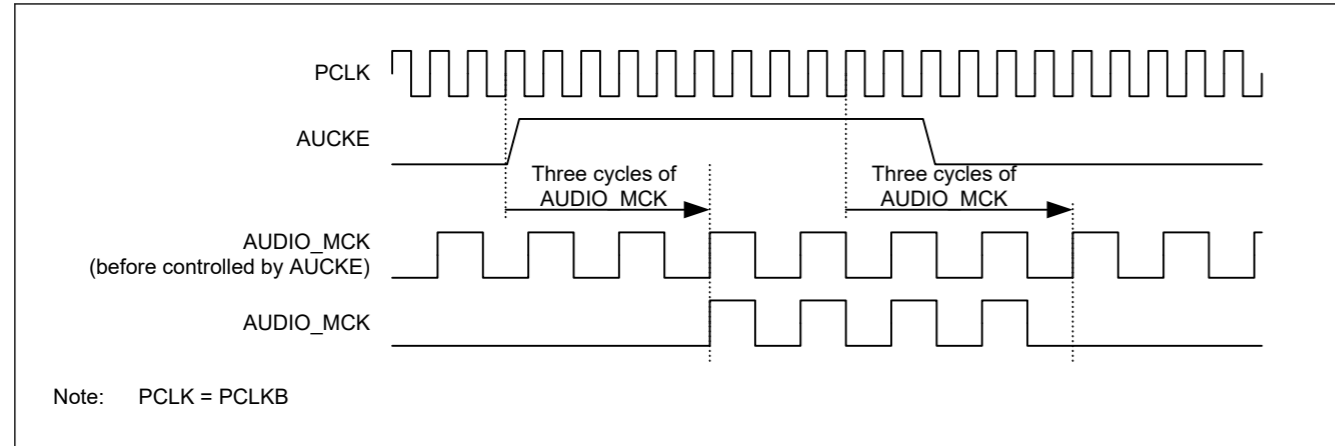


Figure 32.25 Stop/resume of AUDIO\_MCK

Note: In slave-mode communication (SSICR.MST = 0), SSIE needs supply of SSIBCK. To stop BCK on the master side, make sure that SSIE is in the idle state (SSISR.IIRQ = 1). If BCK is stopped before SSIE becomes idle, take the procedure to start communication in Figure 32.52 or wait for an idle state by taking the procedure to resume communication in Figure 32.58.

In master-mode communication (SSICR.MST = 1), SSIE operates with the audio clock (AUDIO\_MCK). To stop SSIE completely, make sure that SSIE is in the idle state (SSISR.IIRQ = 1) and then write 0 to SSIFCR.ADCKE. If 0 is written to SSIFCR.ADCKE before SSIE becomes idle, take the procedure to start communication in Figure 32.52.

Figure 32.26 and Figure 32.27 show the timings of signal operation in the period from setting this bit to 1 to the output to the SSIBCK pin.

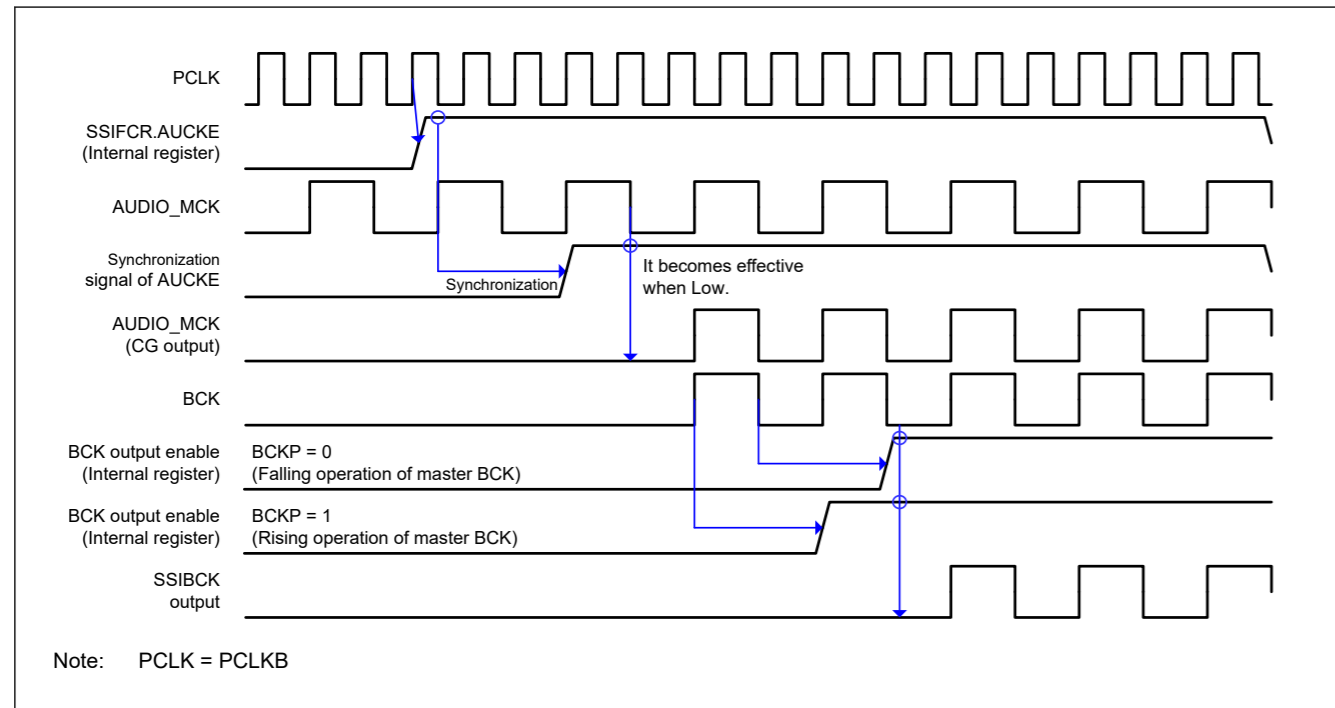


Figure 32.26 Timing diagram for the operation from system reset to start of master-mode communication

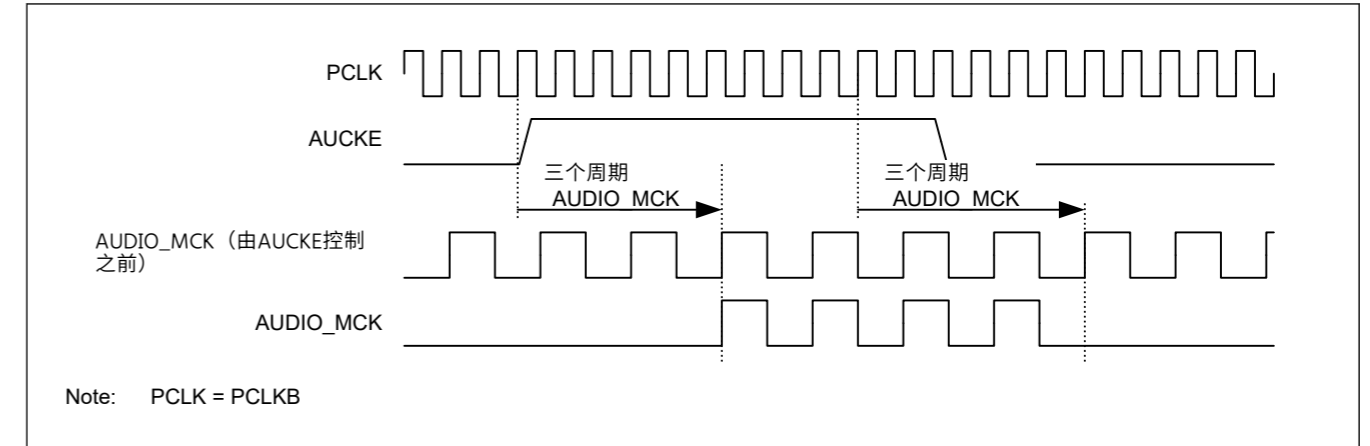


Figure 32.25 Stop/resume of AUDIO\_MCK

Note: 在从模式通信(SSICR.MST=0)中, SSIE需要提供SSIBCK。要在主设备端停止BCK, 请确保SSIE处于空闲状态(SSISR.IIRQ=1)。如果BCK在SSIE空闲之前停止, 则按照图32.52中的程序开始通信, 或按照图32.58中的程序恢复通信等待空闲状态。

在主模式通信(SSICR.MST=1)中, SSIE使用音频时钟(AUDIO\_MCK)运行。要完全停止SSIE, 请确保SSIE处于空闲状态(SSISR.IIRQ=1), 然后将0写入SSIFCR.ADCKE。如果在SSIE空闲之前将0写入SSIFCR.ADCKE, 则按照图32.52中的过程开始通信。

图32.26和图32.27显示了从将该位设置为1到输出到SSIBCK引脚期间的信号操作时序。

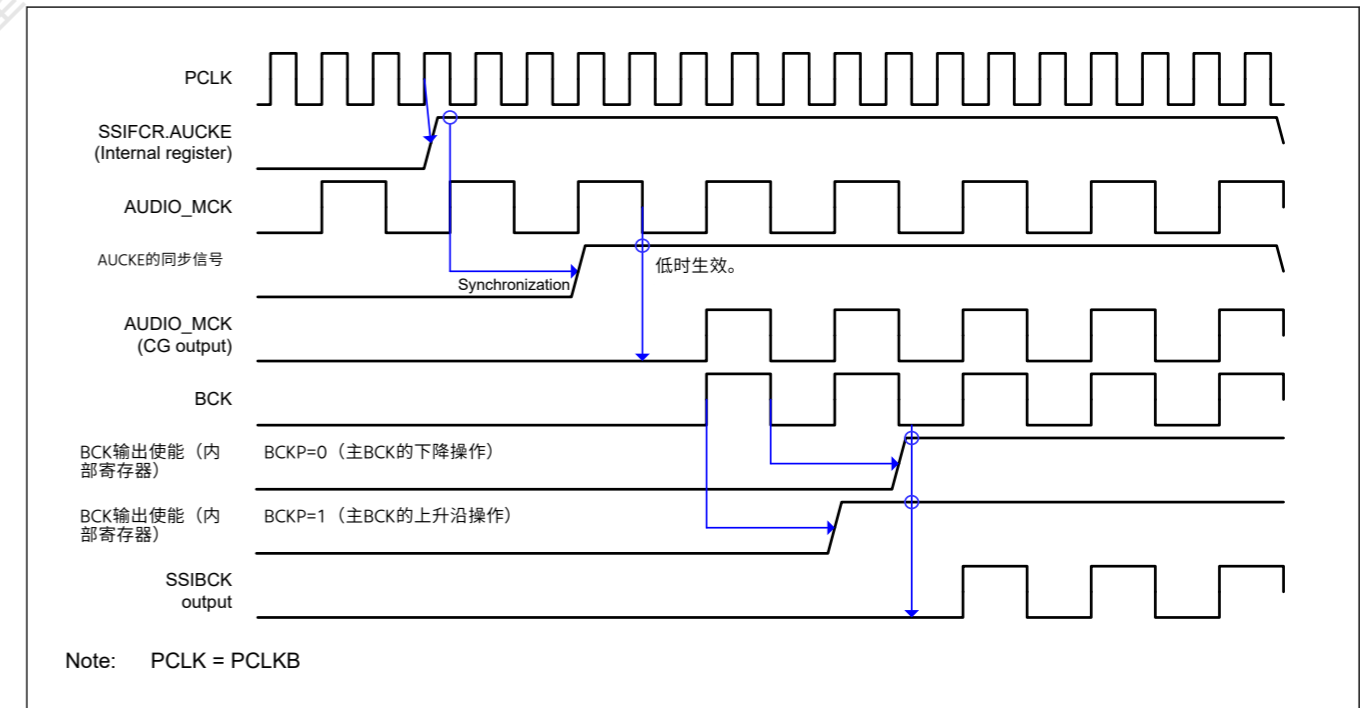


Figure 32.26 从系统复位到主模式通信开始的时序图

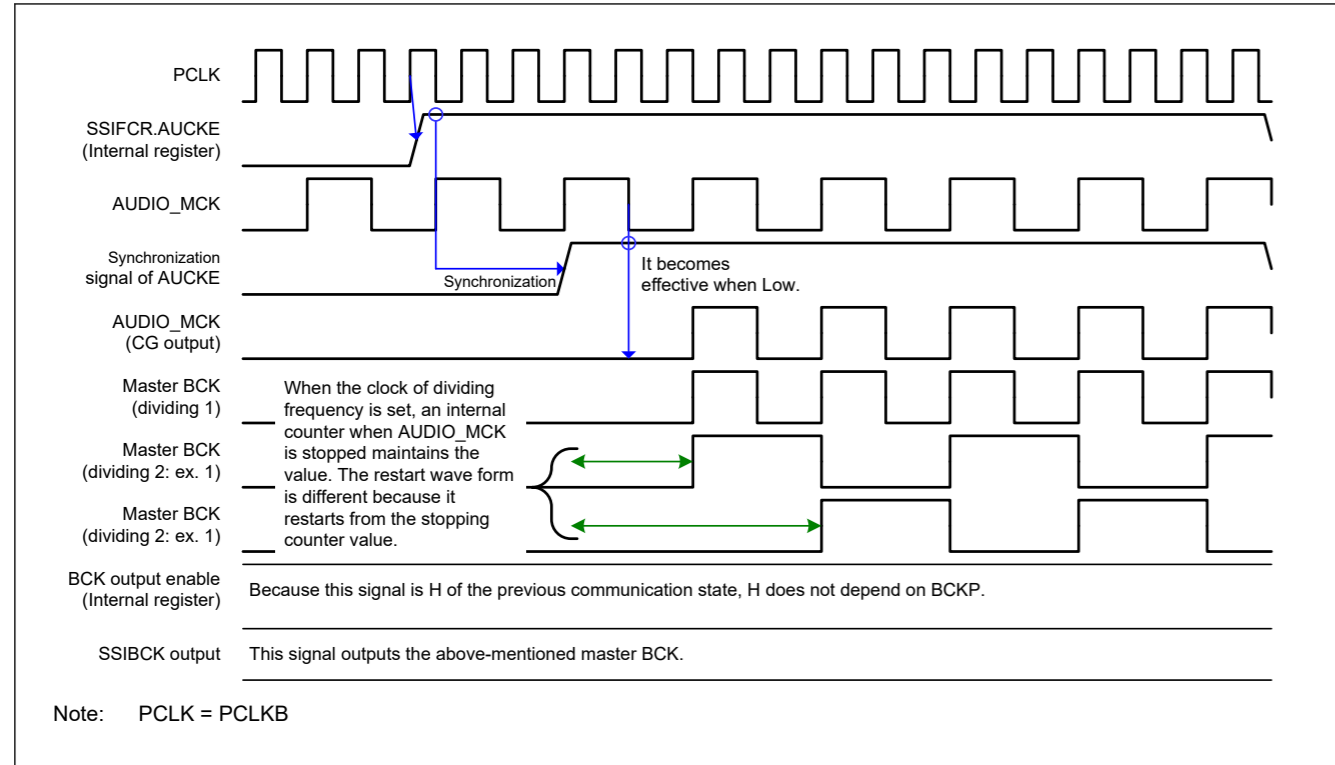


Figure 32.27 Timing diagram for the operation from stop of communication to start of master-mode communication

Note: If the supply of AUDIO\_MCK stops, the value of the SSIBCK pin is held. Therefore, the SSIBCK signal might stop in the H (high level) state.

32.4.4 SSIFSR : FIFO Status Register

Base address: SSIE0 = 0x4009\_D000

Offset address: 0x14

|                    |    |    |          |    |    |    |    |    |    |    |    |    |    |    |    |    |   |   |     |
|--------------------|----|----|----------|----|----|----|----|----|----|----|----|----|----|----|----|----|---|---|-----|
| Bit position:      | 31 | 30 | 29       | 28 | 27 | 26 | 25 | 24 | 23 | 22 | 21 | 20 | 19 | 18 | 17 | 16 |   |   |     |
| Bit field:         | —  | —  | TDC[5:0] |    |    |    |    |    |    |    |    |    | —  | —  | —  | —  | — | — | TDE |
| Value after reset: | 0  | 0  | 0        | 0  | 0  | 0  | 0  | 0  | 0  | 0  | 0  | 0  | 0  | 0  | 0  | 0  | 1 |   |     |
| Bit position:      | 15 | 14 | 13       | 12 | 11 | 10 | 9  | 8  | 7  | 6  | 5  | 4  | 3  | 2  | 1  | 0  |   |   |     |
| Bit field:         | —  | —  | RDC[5:0] |    |    |    |    |    |    |    |    |    | —  | —  | —  | —  | — | — | RDF |
| Value after reset: | 0  | 0  | 0        | 0  | 0  | 0  | 0  | 0  | 0  | 0  | 0  | 0  | 0  | 0  | 0  | 0  |   |   |     |

| Bit   | Symbol   | Function  | R/W |
|-------|----------|---|-----|
| 0     | RDF      | Receive Data Full Flag<br>0: The size of received data in SSIFRDR is not more than the value of SSISCR.RDFS.<br>1: The size of received data in SSIFRDR is not less than the value of SSISCR.RDFS plus one. | R/W |
| 7:1   | —        | These bits are read as 0. The write value should be 0.  | R/W |
| 13:8  | RDC[5:0] | Number of Receive FIFO Data Indication Flag<br>Number of receive FIFO data indication flag  | R   |
| 15:14 | —        | These bits are read as 0. The write value should be 0.  | R/W |

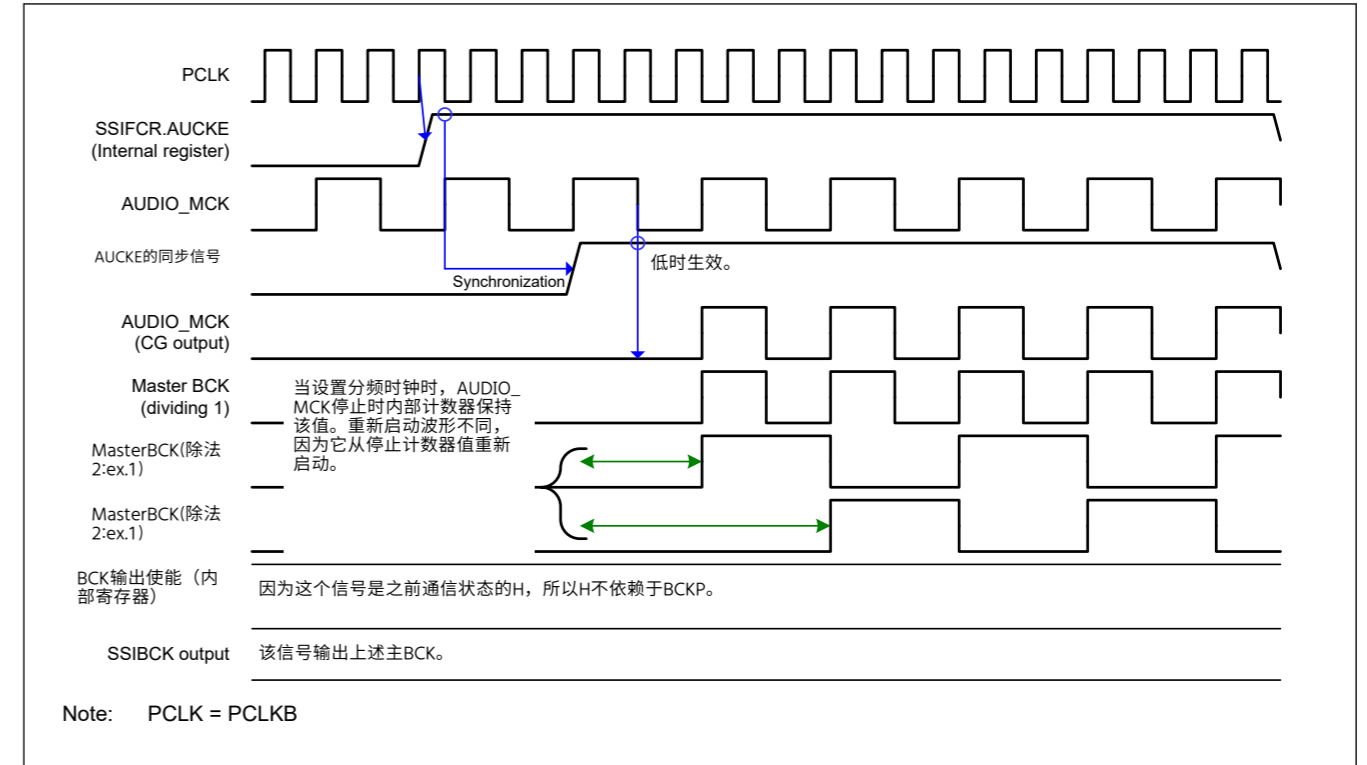


Figure 32.27 从停止通信到开始主模式通信的操作时序图

Note: 如果停止提供AUDIO\_MCK, 则保持SSIBCK引脚的值。因此, SSIBCK信号可能会停止在H (高电平) 状态。

32.4.4 SSIFSR:FIFO状态寄存器

Base address: SSIE0 = 0x4009\_D000

Offset address: 0x14

|               |    |    |          |    |    |    |    |    |    |    |    |    |    |    |    |    |   |   |     |
|---------------|----|----|----------|----|----|----|----|----|----|----|----|----|----|----|----|----|---|---|-----|
| Bit position: | 31 | 30 | 29       | 28 | 27 | 26 | 25 | 24 | 23 | 22 | 21 | 20 | 19 | 18 | 17 | 16 |   |   |     |
| Bit field:    | —  | —  | TDC[5:0] |    |    |    |    |    |    |    |    |    | —  | —  | —  | —  | — | — | TDE |
| 重置后的值:        | 0  | 0  | 0        | 0  | 0  | 0  | 0  | 0  | 0  | 0  | 0  | 0  | 0  | 0  | 0  | 0  | 1 |   |     |
| Bit position: | 15 | 14 | 13       | 12 | 11 | 10 | 9  | 8  | 7  | 6  | 5  | 4  | 3  | 2  | 1  | 0  |   |   |     |
| Bit field:    | —  | —  | RDC[5:0] |    |    |    |    |    |    |    |    |    | —  | —  | —  | —  | — | — | RDF |
| 重置后的值:        | 0  | 0  | 0        | 0  | 0  | 0  | 0  | 0  | 0  | 0  | 0  | 0  | 0  | 0  | 0  | 0  |   |   |     |

| Bit   | Symbol   | Function  | R/W |
|-------|----------|---|-----|
| 0     | RDF      | 接收数据满标志<br>0: SSIFRDR中接收数据的大小不大于SSISCR.RDFS的值。<br>1: SSIFRDR中接收数据的大小不小于SSISCR.RDFS的值加一。 | R/W |
| 7:1   | —        | 这些位被读取为0。写入值应为0。  | R/W |
| 13:8  | RDC[5:0] | 接收FIFO数据指示标志数<br>接收FIFO数据数指示标志  | R   |
| 15:14 | —        | 这些位被读取为0。写入值应为0。  | R/W |

| Bit   | Symbol   | Function  | R/W |
|-------|----------|---|-----|
| 16    | TDE      | Transmit Data Empty Flag<br>0: The free space of SSIFTDR is not more than the value of SSISCR.TDES.<br>1: The free space of SSIFTDR is not less than the value of SSISCR.TDES plus one. | R/W |
| 23:17 | —        | These bits are read as 0. The write value should be 0.  | R/W |
| 29:24 | TDC[5:0] | Number of Transmit FIFO Data Indication Flag<br>Number of transmit FIFO data indication flag  | R   |
| 31:30 | —        | These bits are read as 0. The write value should be 0.  | R/W |

This register is configured with status flags that indicate the status of the transmit FIFO data register and the receive FIFO data register.

#### RDF flag (Receive Data Full Flag)

The RDF flag indicates that the receive FIFO data register (SSIFRDR) has unread received data not less than the amount set with the SSISCR.RDFS bit plus one. This flag is set by automatic determination but it must be cleared by register access.

[Priority order for setting and clearing]

Clearing is prioritized.

[Clearing condition]

Either of the following two:<sup>\*1</sup>

1. Writing 0 to this bit after reading 1 from this bit (CPU operation)<sup>\*2</sup>
2. Last access (DTC/DMAC operation) to read data from SSIFRDR by an interrupt routine using the DTC and DMAC.

[Clearing timing]

Clearing timing corresponding to the above clearing condition

1. When 0 is written to this bit after reading 1 from this bit (same as the timing in Figure 32.19)
2. After the PCLKB cycle in which the last access instruction is issued to read data from SSIFRDR by an interrupt routine using the DTC and DMAC.

[Setting condition]

SSIFTDR has free space not less than the amount set with the SSIFCR.TTRG bit plus one.

[Setting timing]

At completion of transfer from the shift register that results in SSIFRDR having data not less than the amount set with the SSISCR.RDFS bit plus one.

Note 1. These bits are cleared by a software reset (SSIFCR.SSIRST = 1) and receive FIFO data register reset (SSIFCR.RFRST = 1). Reset conditions available for these bits are the software reset and receive FIFO data register reset as well as the clearing conditions described above.

Note 2. After reading 1 from this bit, this bit is cleared when one of the following four conditions is met:

- A software reset is done (SSIFCR.SSIRST = 1).
- A receive FIFO data register reset is done (SSIFCR.RFRST = 1).
- After 1 has been read, writing of 0 is complete.
- Last access is performed to read data from SSIFRDR by an interrupt routine using the DTC and DMAC.

| Bit   | Symbol   | Function  | R/W |
|-------|----------|---|-----|
| 16    | TDE      | 传输数据空标志<br>0: SSIFTDR的可用空间不大于SSISCR.TDES的值。1: SSIFTDR的可用空间不小于SSISCR.TDES的值加一。 | R/W |
| 23:17 | —        | 这些位被读取为0。写入值应为0。  | R/W |
| 29:24 | TDC[5:0] | 发送FIFO数据指示标志数<br>发送FIFO数据数指示标志  | R   |
| 31:30 | —        | 这些位被读取为0。写入值应为0。  | R/W |

该寄存器配置有状态标志，指示发送FIFO数据寄存器和接收FIFO数据寄存器的状态。

#### RDF标志（接收数据满标志）

RDF标志表示接收FIFO数据寄存器(SSIFRDR)的未读接收数据不少于SSISCR.RDFS位设置的数量加一。该标志由自动确定设置，但必须通过寄存器访问清除。

[设置和清除的优先顺序]

清算优先。

[Clearing condition]

以下两种之一：<sup>\*1</sup>

- 1.从该位读取1后向该位写入0（CPU操作）<sup>\*2</sup>
- 2.最后一次访问（DTC/DMAC操作）通过使用DTC和DMAC的中断例程从SSIFRDR读取数据。

[Clearing timing]

与上述清零条件对应的清零时机

- 1.当从该位读取1后向该位写入0时（与图32.19中的时序相同）
- 2.在发出最后一个访问指令以通过使用DTC和DMAC的中断例程从SSIFRDR读取数据的PCLKB周期之后。

[Setting condition]

SSIFTDR的可用空间不小于SSIFCR.TTRG位设置的数量加一。

[Setting timing]

在完成从移位寄存器的传输时，导致SSIFRDR的数据不小于用SSISCR.RDFS位加一。

注1.这些位通过软件复位(SSIFCR.SSIRST=1)和接收FIFO数据寄存器复位清零(SSIFCR.RFRST=1)。这些位可用的复位条件是软件复位和接收FIFO数据寄存器复位以及上述清除条件。

注2.从该位读取1后，当满足以下四个条件之一时，该位被清除：●软件复位完成(SSIFCR.SSIRST=1)。●完成接收FIFO数据寄存器复位(SSIFCR.RFRST=1)。●读1后，写0完成。●使用DTC和DMAC的中断例程执行最后一次访问以从SSIFRDR读取数据。

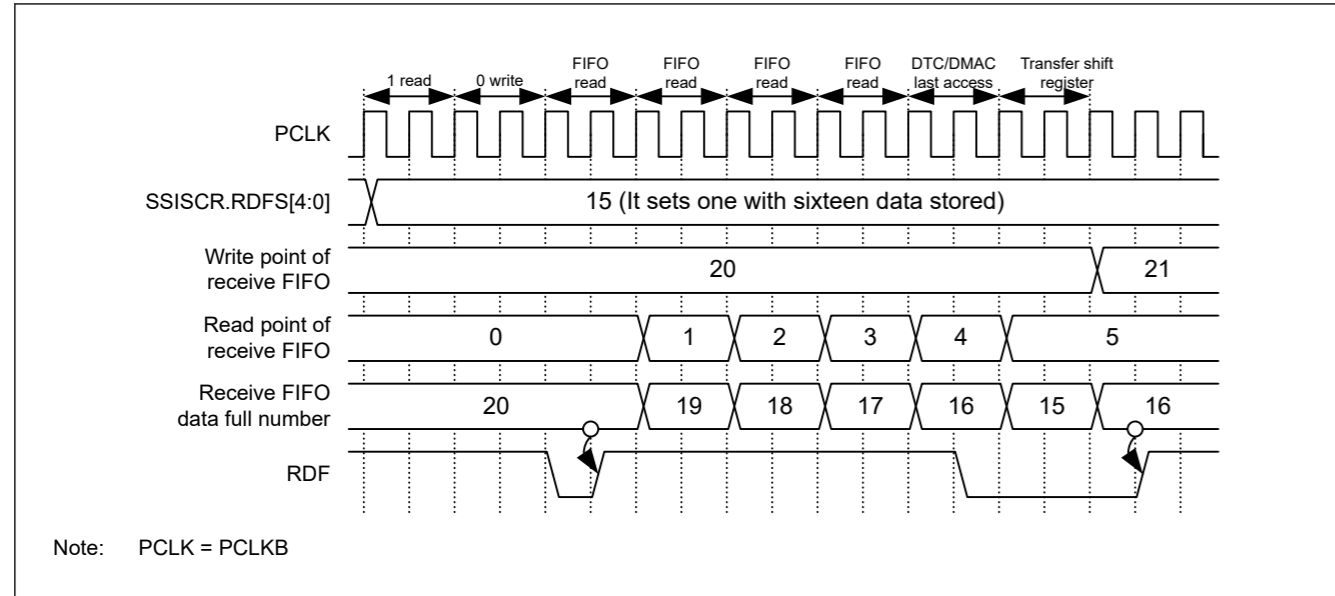


Figure 32.28 Timing diagram for setting and clearing RDF

**RDC[5:0] flags (Number of Receive FIFO Data Indication Flag)**

The RDC[5:0] flags indicate the number of valid data that are stored in the receive FIFO data register (SSIFRDR). With this flag as 0x00, there is no received data. With 0x20, the register is filled with received data and there is no free space.

**TDE flag (Transmit Data Empty Flag)**

The TDE flag indicates that the transmit FIFO data register (SSIFTDR) has free space not less than the amount set with the SSIFCR.TTRG bit plus one. This flag is set by automatic determination but it must be cleared by register access.

[Priority order for setting and clearing]

Clearing is prioritized.\*1

[Clearing condition]

Either of the following two:

1. Writing 0 to this bit after reading 1 from this bit (CPU operation)\*2
2. Last access (DTC/DMAC operation) to write data to SSIFTDR by an interrupt routine using the DTC and DMAC.

[Clearing timing]

Clearing timing corresponding to the above clearing condition

1. When 0 is written to this bit after reading 1 from this bit (same as the timing in Figure 32.19)
2. Last access (DTC/DMAC operation) to write data to SSIFTDR by an interrupt routine using the DTC and DMAC.

[Setting condition]

SSIFTDR has free space not less than the amount set with the SSIFCR.TTRG bit plus one.

[Setting timing]

While operating on PCLKB, SSIFTDR is found to have free space not less than “size set in the SSISCR.TDES bits + 1.”

Note 1. This bit is cleared by a software reset (SSIFCR.SSIRST = 1) and transmit FIFO data register reset (SSIFCR.TFRST = 1). The software reset and transmit FIFO data register reset have priority over all the clearing conditions described above.

Note 2. After reading 1 from this bit, this bit is cleared when one of the following four conditions is met:

- A software reset is done (SSIFCR.SSIRST = 1).
- A transmit FIFO data register reset is done (SSIFCR.TFRST = 1).
- After 1 has been read, writing of 0 is complete.
- Last access is performed to write data to SSIFTDR by an interrupt routine using the DTC and DMAC.

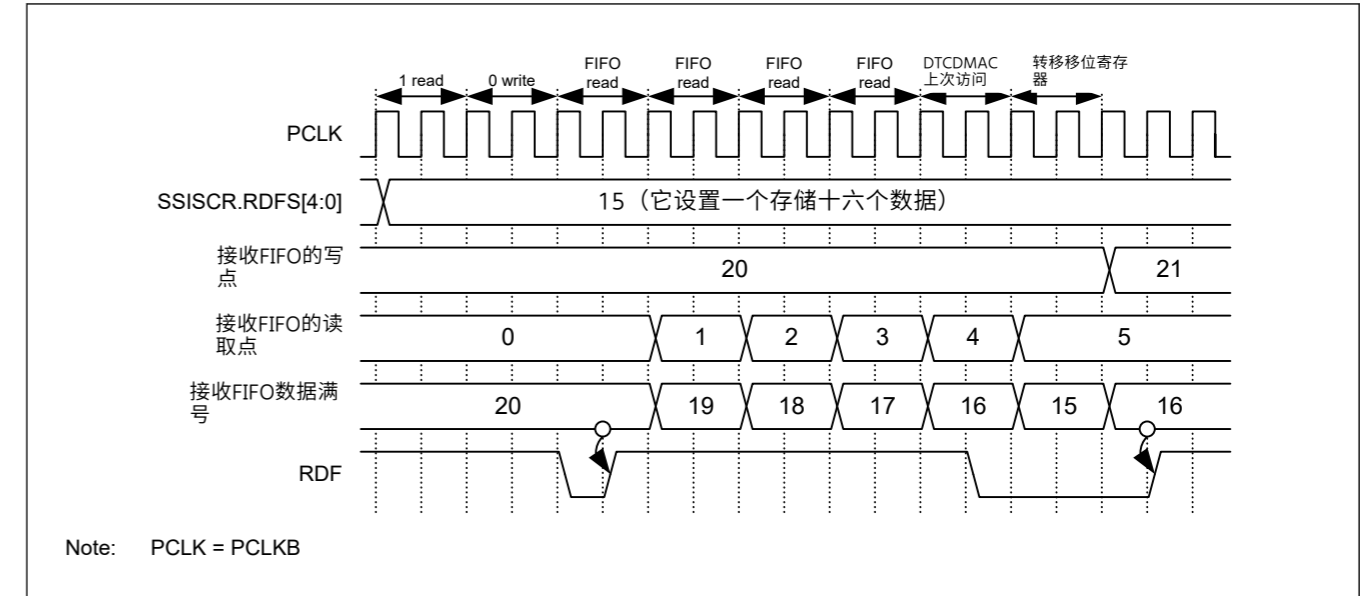


Figure 32.28 设置和清除RDF的时序图

**RDC[5:0] flags (接收FIFO数据指示标志数)**

RDC[5:0]标志指示存储在接收FIFO数据寄存器(SSIFRDR)中的有效数据数量。此标志为0x00时，没有接收到数据。使用0x20，寄存器被接收到的数据填充，没有可用空间。

**TDE标志 (传输数据空标志)**

TDE标志表示发送FIFO数据寄存器(SSIFTDR)的可用空间不小于用SSIFCR.TTRG位加一。该标志由自动确定设置，但必须通过寄存器访问清除。

[设置和清除的优先顺序]

清算优先。\*1

[Clearing condition]

以下两种之一：

- 1.从该位读取1后向该位写入0 (CPU操作) \*2
- 2.最后访问 (DTCDMAC操作) 通过使用DTC和DMAC的中断例程将数据写入SSIFTDR。

[Clearing timing]

与上述清零条件对应的清零时机

- 1.当从该位读取1后向该位写入0时 (与图32.19中的时序相同)
- 2.最后访问 (DTCDMAC操作) 通过使用DTC和DMAC的中断例程将数据写入SSIFTDR。

[Setting condition]

SSIFTDR的可用空间不小于SSIFCR.TTRG位设置的数量加一。

[Setting timing]

在PCLKB上运行时，发现SSIFTDR的可用空间不小于“SSISCR.TDES位中设置的大小+1”。

注1.该位通过软件复位(SSIFCR.SSIRST=1)和发送FIFO数据寄存器复位(SSIFCR.TFRST=1)清零。软件复位和发送FIFO数据寄存器复位优先于上述所有清除条件。

注2.从该位读取1后，当满足以下四个条件之一时，该位被清除：●软件复位完成(SSIFCR.SSIRST=1)。●发送FIFO数据寄存器复位完成(SSIFCR.TFRST=1)。●读1后，写0完成。●使用DTC和DMAC的中断例程执行最后访问以将数据写入SSIFTDR。



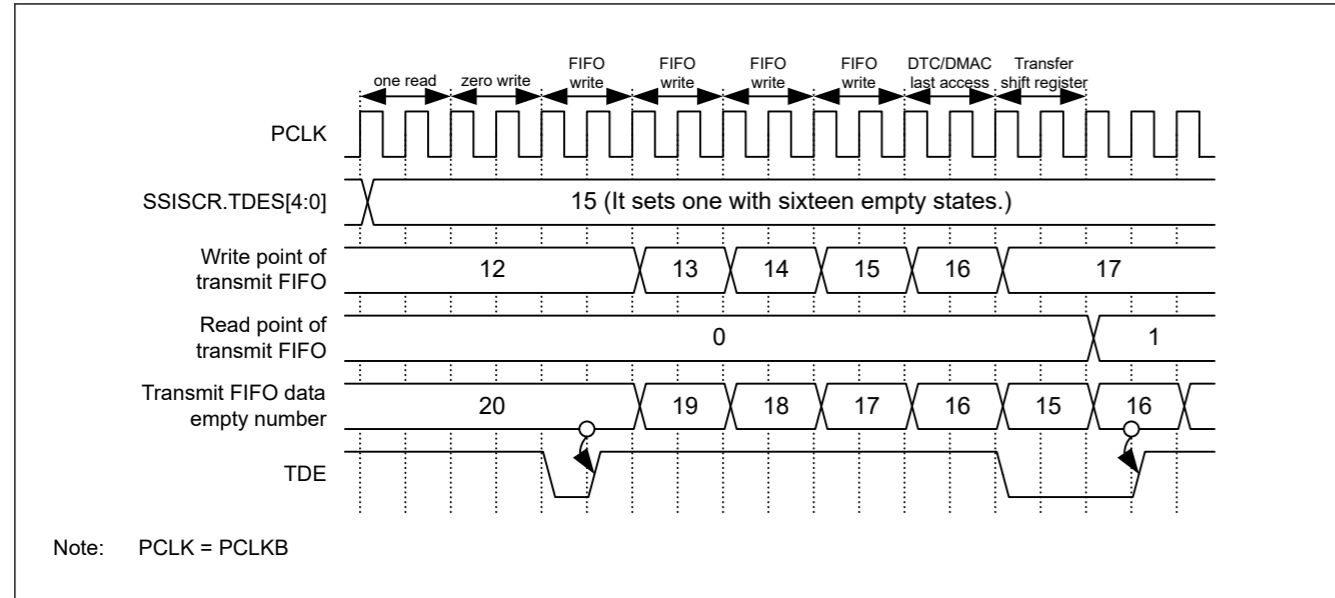


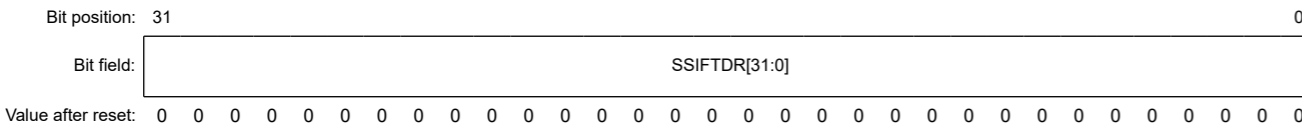
Figure 32.29 Timing diagram for setting and clearing TDE

**TDC[5:0] flags (Number of Transmit FIFO Data Indication Flag)**

The TDC[5:0] flags indicate the number of valid data that are stored in the transmit FIFO data register (SSIFTDR). With this flag as 0x00, there is no data to be transmitted. With 0x20, there is no space to write data.

**32.4.5 SSIFTDR : Transmit FIFO Data Register**

Base address: SSIE0 = 0x4009\_D000  
Offset address: 0x18



| Bit  | Symbol        | Function           | R/W |
|------|---------------|--------------------|-----|
| 31:0 | SSIFTDR[31:0] | Transmit FIFO Data | W   |

This register stores data to be serially transmitted. 0 is returned when this register is read.

When you use this register for transmission, specify data writing to this register as the DTC/DMAC operation that is triggered by a transmit data empty interrupt. Determine the access size to this register according to the data word length to be communicated in Table 32.8.

Table 32.8 Register access restriction to FIFOs (1 of 2)

| Access Size    |                  | Byte | Halfword | Word |
|----------------|------------------|------|----------|------|
| SSICR.DWL[2:0] | Data Word Length |      |          |      |
| 000b           | 8                | ✓    | —        | —    |
| 001b           | 16               | —    | ✓        | —    |
| 010b           | 18               | —    | —        | ✓    |
| 011b           | 20               | —    | —        | ✓    |
| 100b           | 22               | —    | —        | ✓    |
| 101b           | 24               | —    | —        | ✓    |
| 110b           | 32               | —    | —        | ✓    |

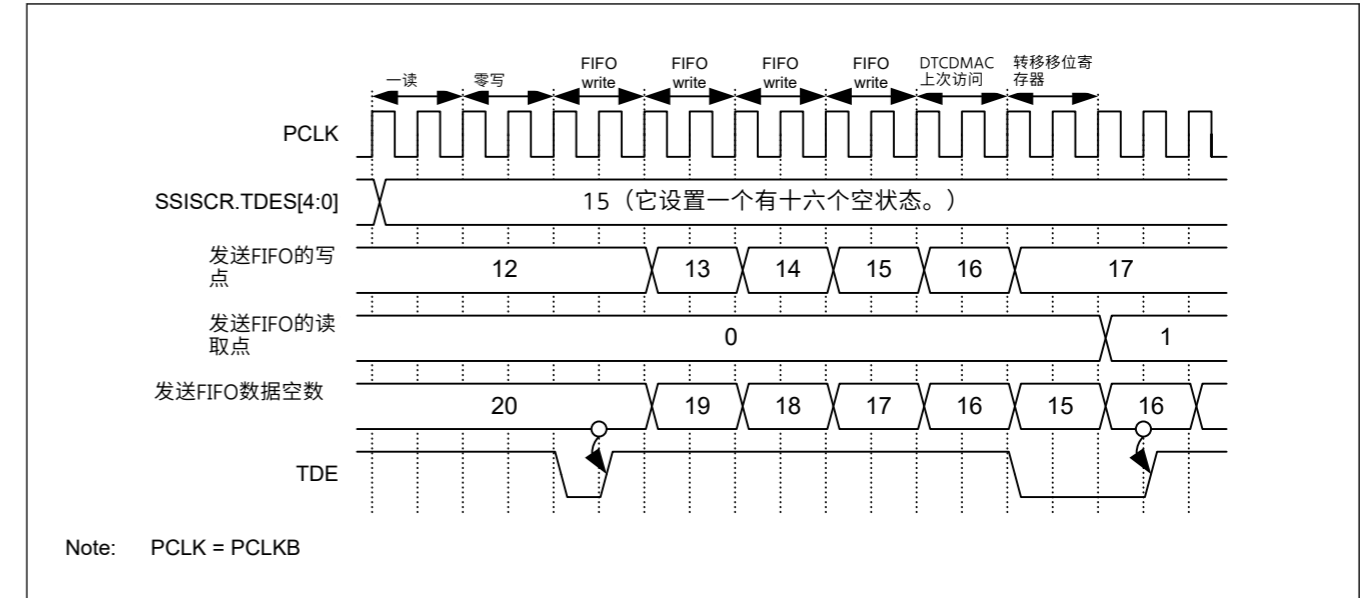


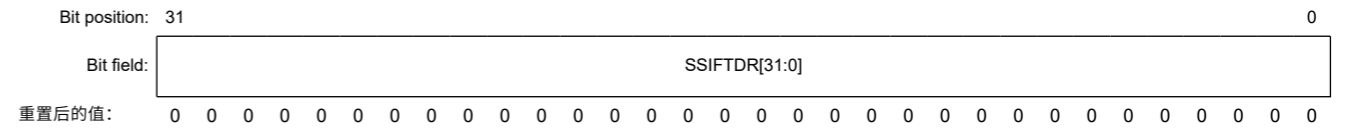
Figure 32.29 设置和清除TDE的时序图

**TDC[5:0]flags (发送FIFO数据指示标志数)**

TDC[5:0]标志指示存储在发送FIFO数据寄存器(SSIFTDR)中的有效数据数量。此标志为0x00时，没有要传输的数据。使用0x20，没有空间可以写入数据。

**32.4.5 SSIFTDR: 发送FIFO数据寄存器**

Base address: SSIE0 = 0x4009\_D000  
Offset address: 0x18



| Bit  | Symbol        | Function | R/W |
|------|---------------|----------|-----|
| 31:0 | SSIFTDR[31:0] | 发送FIFO数据 | W   |

该寄存器存储要串行传输的数据。读取该寄存器时返回0。

当您使用该寄存器进行传输时，将数据写入该寄存器指定为由传输数据空中断触发的DTC/DMAC操作。根据表32.8中要通信的数据字长确定对该寄存器的访问大小。

Table 32.8 对FIFO的寄存器访问限制 (1of2)

| 访问大小           |      | Byte | Halfword | Word |
|----------------|------|------|----------|------|
| SSICR.DWL[2:0] | 数据字长 |      |          |      |
| 000b           | 8    | ✓    | —        | —    |
| 001b           | 16   | —    | ✓        | —    |
| 010b           | 18   | —    | —        | ✓    |
| 011b           | 20   | —    | —        | ✓    |
| 100b           | 22   | —    | —        | ✓    |
| 101b           | 24   | —    | —        | ✓    |
| 110b           | 32   | —    | —        | ✓    |

Table 32.8 Register access restriction to FIFOs (2 of 2)

| Access Size    |                    | Byte | Halfword | Word |
|----------------|--------------------|------|----------|------|
| SSICR.DWL[2:0] | Data Word Length   |      |          |      |
| 111b           | Setting prohibited | —    | —        | —    |

Figure 32.30 shows register access to the transmit FIFO data register.

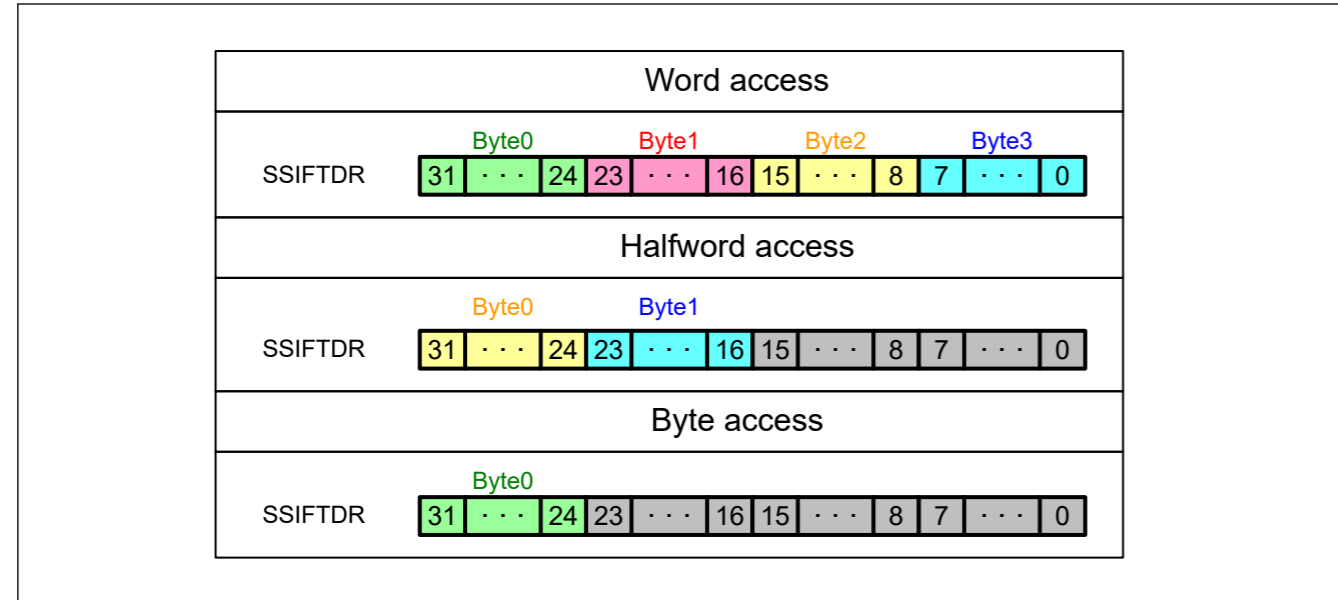


Figure 32.30 Example of register access to the transmit FIFO data register

Figure 32.31 shows the configurations and operation examples of the transmit FIFO data register and transmit shift register. The configurations are for storing data to FIFO and not related with communication.

Table 32.8 对FIFO的寄存器访问限制 (2个中的2个)

| 访问大小           |      | Byte | Halfword | Word |
|----------------|------|------|----------|------|
| SSICR.DWL[2:0] | 数据字长 |      |          |      |
| 111b           | 禁止设定 | —    | —        | —    |

图32.30显示了对发送FIFO数据寄存器的寄存器访问。

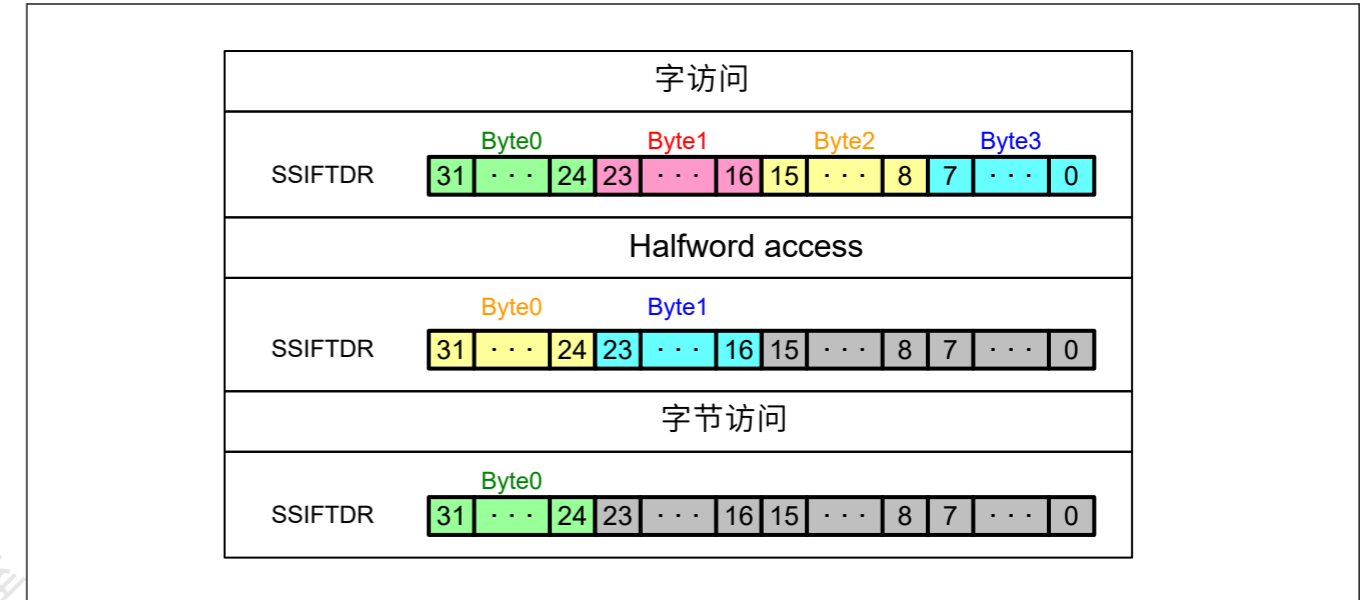


Figure 32.30 对发送FIFO数据寄存器的寄存器访问示例

图32.31显示了发送FIFO数据寄存器和发送移位寄存器的配置和操作示例。该配置用于将数据存储到FIFO，与通信无关。

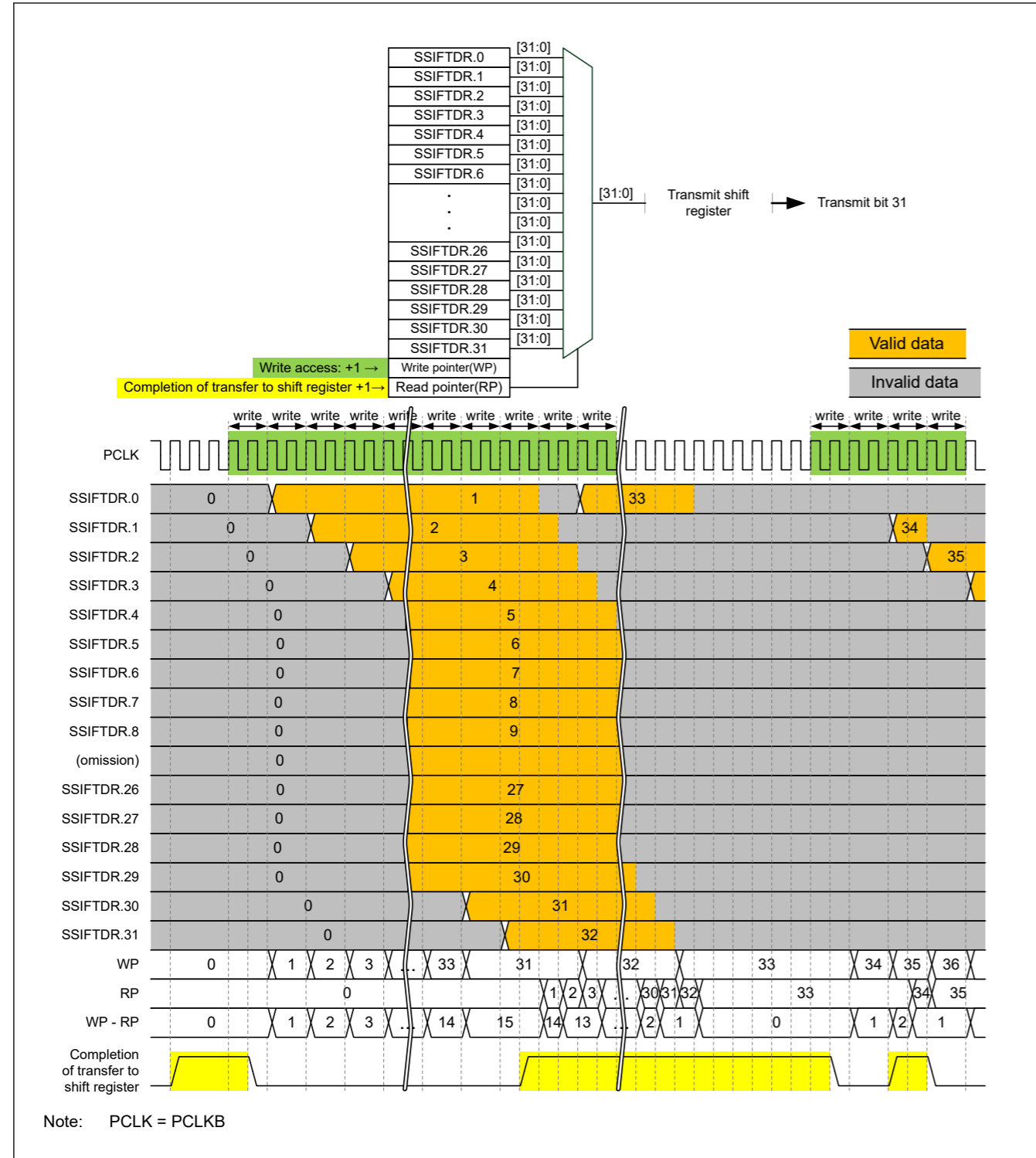


Figure 32.31 Configuration of the transmit FIFO data register and transmit shift register, and FIFO operation example

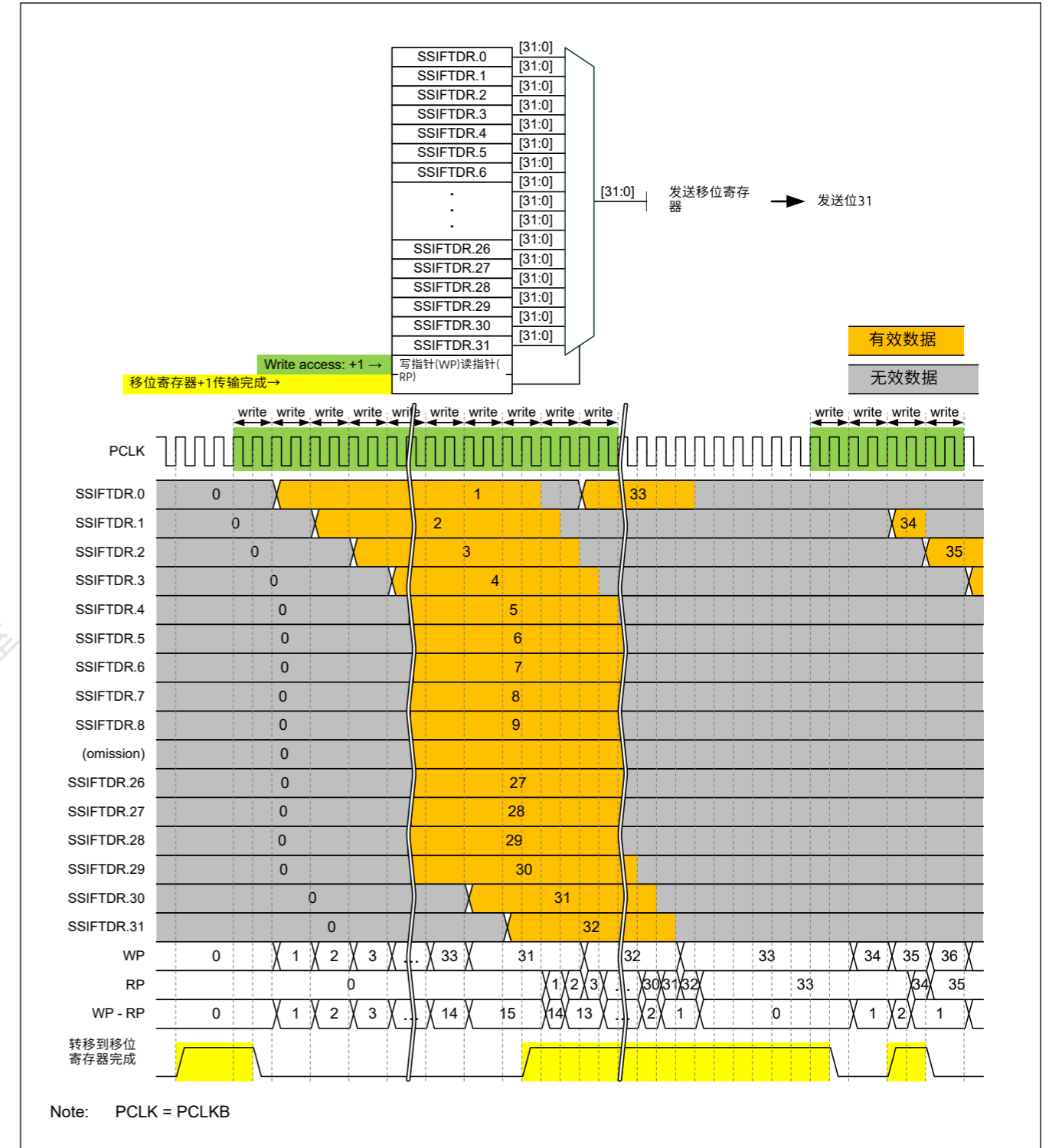


Figure 32.31 发送FIFO数据寄存器和发送移位寄存器的配置，以及FIFO操作示例

## 32.4.6 SSIFRDR : Receive FIFO Data Register

Base address: SSIE0 = 0x4009\_D000

Offset address: 0x1C

Bit position: 31 0

Bit field: SSIFRDR[31:0]

Value after reset: 0

| Bit  | Symbol        | Function          | R/W |
|------|---------------|-------------------|-----|
| 31:0 | SSIFRDR[31:0] | Receive FIFO Data | R   |

When you use this register for reception, specify data reading from this register as the DTC/DMAC operation that is triggered by a transmit data empty interrupt. Determine the access size to this register according to the data word length to be communicated in [Table 32.8](#).

Register access to the receive FIFO data register is same as for the transmit FIFO data register.

[Figure 32.31](#) shows the configurations and operation examples of the receive FIFO data register and receive shift register.

## 32.4.6 SSIFRDR:接收FIFO数据寄存器

Base address: SSIE0 = 0x4009\_D000

Offset address: 0x1C

Bit position: 31 0

Bit field: SSIFRDR[31:0]

重置后的值: 0

| Bit  | Symbol        | Function | R/W |
|------|---------------|----------|-----|
| 31:0 | SSIFRDR[31:0] | 接收FIFO数据 | R   |

当您使用该寄存器进行接收时，将从该寄存器读取的数据指定为由发送数据空中断触发的DTC/DMAC操作。根据表32.8中要通信的数据字长确定对该寄存器的访问大小。

对接收FIFO数据寄存器的寄存器访问与对发送FIFO数据寄存器的访问相同。

图32.31显示了接收FIFO数据寄存器和接收移位寄存器的配置和操作示例。



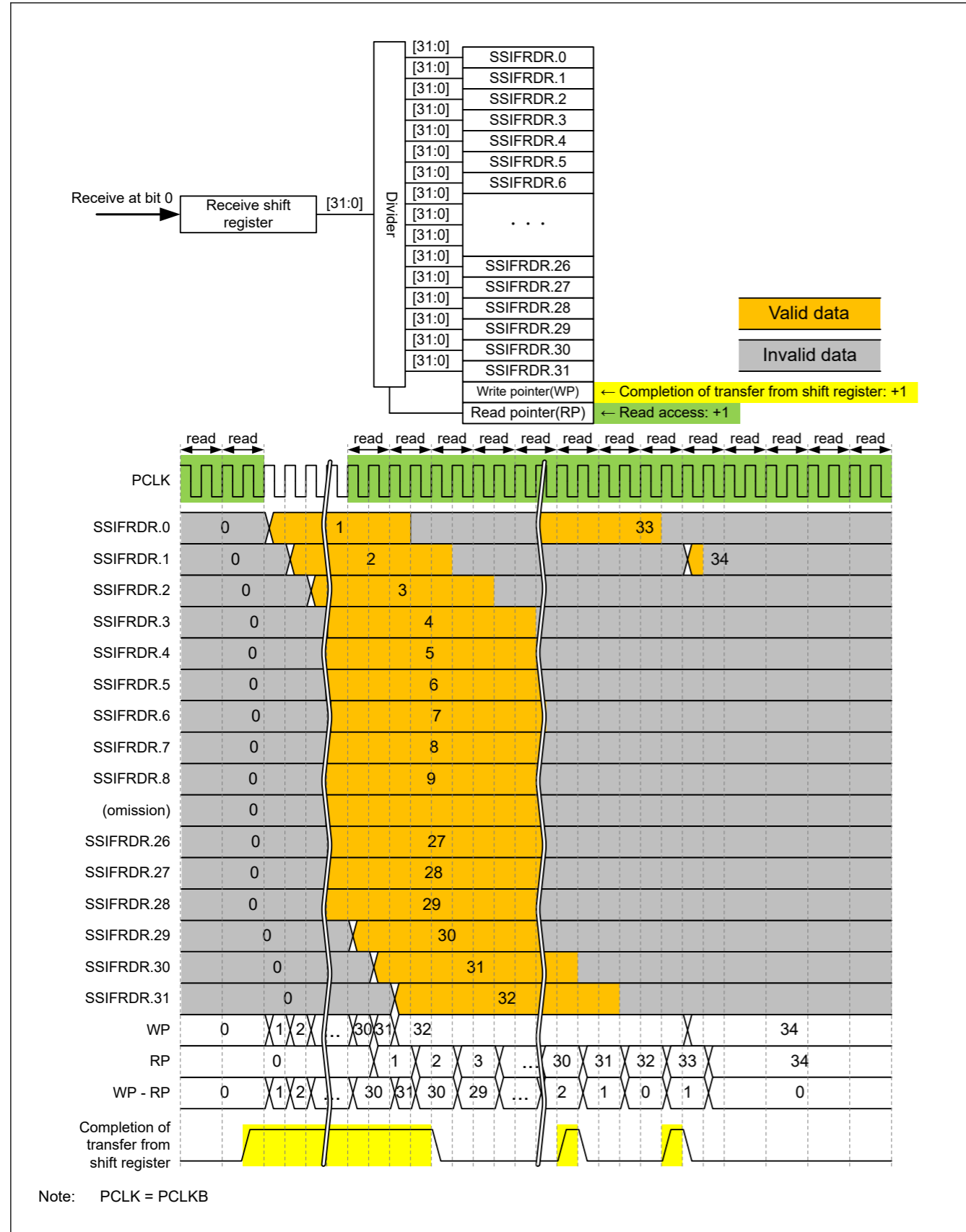


Figure 32.32 Configuration of the transmit FIFO data register and transmit shift register, and FIFO operation example

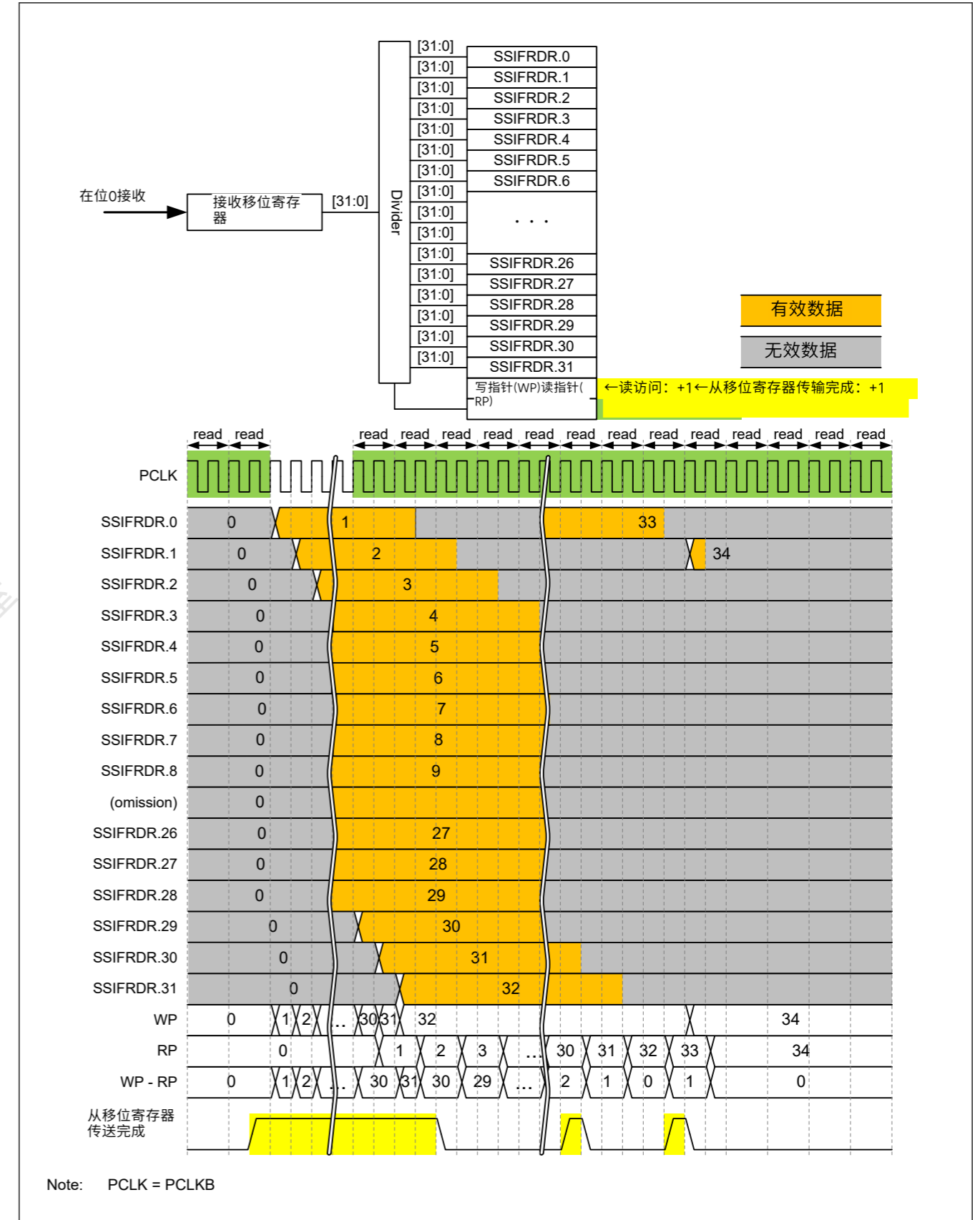


Figure 32.32 发送FIFO数据寄存器和发送移位寄存器的配置，以及FIFO操作示例

## 32.4.7 SSIOFR : Audio Format Register

Base address: SSIE0 = 0x4009\_D000

Offset address: 0x20

|                    |    |    |    |    |    |    |             |            |    |    |    |    |    |    |    |           |
|--------------------|----|----|----|----|----|----|-------------|------------|----|----|----|----|----|----|----|-----------|
| Bit position:      | 31 | 30 | 29 | 28 | 27 | 26 | 25          | 24         | 23 | 22 | 21 | 20 | 19 | 18 | 17 | 16        |
| Bit field:         | —  | —  | —  | —  | —  | —  | —           | —          | —  | —  | —  | —  | —  | —  | —  | —         |
| Value after reset: | 0  | 0  | 0  | 0  | 0  | 0  | 0           | 0          | 0  | 0  | 0  | 0  | 0  | 0  | 0  | 0         |
| Bit position:      | 15 | 14 | 13 | 12 | 11 | 10 | 9           | 8          | 7  | 6  | 5  | 4  | 3  | 2  | 1  | 0         |
| Bit field:         | —  | —  | —  | —  | —  | —  | BCKA<br>STP | LRCO<br>NT | —  | —  | —  | —  | —  | —  | —  | OMOD[1:0] |
| Value after reset: | 0  | 0  | 0  | 0  | 0  | 0  | 0           | 0          | 0  | 0  | 0  | 0  | 0  | 0  | 0  | 0         |

| Bit   | Symbol    | Function   | R/W |
|-------|-----------|--|-----|
| 1:0   | OMOD[1:0] | Audio Format Select <sup>*3 *4</sup><br>0 0: I <sup>2</sup> S format<br>0 1: TDM format<br>1 0: Monaural format<br>1 1: Setting prohibited   | R/W |
| 7:2   | —         | These bits are read as 0. The write value should be 0.   | R/W |
| 8     | LRCONT    | Whether to Enable LRCK/FS Continuation <sup>*1 *2</sup><br>0: Disables LRCK/FS continuation<br>1: Enables LRCK/FS continuation   | R/W |
| 9     | BCKASTP   | Whether to Enable Stopping BCK Output When SSIE is in Idle Status <sup>*1 *2</sup><br>0: Always outputs BCK to the SSIBCK pin<br>1: Automatically controls output of BCK to the SSIBCK pin | R/W |
| 31:10 | —         | These bits are read as 0. The write value should be 0.   | R/W |

Note 1. This bit is valid only in master-mode communication (SSICR.MST = 1). The setting is invalid in slave-mode communication (SSICR.MST = 0).

Note 2. The BCKASTP and LRCONT bits must not be set to 1 together.

Note 3. While SSIE is communicating (SSISR.IIRQ = 0), writing to these bits is prohibited. If the value of these bits is changed by writing, subsequent operation is unpredictable.

Note 4. If the communication format of other-party device is compatible with a communication format of SSIE, specify and use the communication format that enables communication with the other-party device.

This register is used to set an audio format (which involves the settings of communication format, LR clock/frame synchronization continuation mode, and BCK output stop).

**OMOD[1:0] bits (Audio Format Select)**

The OMOD[1:0] bits set an audio format. Writing to these bits must be performed when the LR clock supply to the SSILRCK/SSIFS pin is stopped. For details about the output of LR clock, see the detailed description of the LRCONT bit in [section 32.4.7. SSIOFR : Audio Format Register](#).

**LRCONT bit (Whether to Enable LRCK/FS Continuation)**

The LRCONT bit enables or disables the output from SSILRCK/SSIFS pin when the communication mode is master-mode communication (SSICR.MST = 1) and SSIE is in the idle state (SSISR.IIRQ = 1).

Even in the idle state, a signal can output from the SSILRCK/SSIFS pin when this bit is set to 1 (to enable LR clock/frame synchronization continuation) in master mode (SSICR.MST = 1).

## 32.4.7 SSIOFR:音频格式寄存器

Base address: SSIE0 = 0x4009\_D000

Offset address: 0x20

|               |    |    |    |    |    |    |             |            |    |    |    |    |    |    |    |           |
|---------------|----|----|----|----|----|----|-------------|------------|----|----|----|----|----|----|----|-----------|
| Bit position: | 31 | 30 | 29 | 28 | 27 | 26 | 25          | 24         | 23 | 22 | 21 | 20 | 19 | 18 | 17 | 16        |
| Bit field:    | —  | —  | —  | —  | —  | —  | —           | —          | —  | —  | —  | —  | —  | —  | —  | —         |
| 重置后的值:        | 0  | 0  | 0  | 0  | 0  | 0  | 0           | 0          | 0  | 0  | 0  | 0  | 0  | 0  | 0  | 0         |
| Bit position: | 15 | 14 | 13 | 12 | 11 | 10 | 9           | 8          | 7  | 6  | 5  | 4  | 3  | 2  | 1  | 0         |
| Bit field:    | —  | —  | —  | —  | —  | —  | BCKA<br>STP | LRCO<br>NT | —  | —  | —  | —  | —  | —  | —  | OMOD[1:0] |
| 重置后的值:        | 0  | 0  | 0  | 0  | 0  | 0  | 0           | 0          | 0  | 0  | 0  | 0  | 0  | 0  | 0  | 0         |

| Bit   | Symbol    | Function   | R/W |
|-------|-----------|--|-----|
| 1:0   | OMOD[1:0] | 音频格式选择 <sup>*3*4</sup><br>00: I2S格式01: TDM<br>格式10: 单声道格式1<br>1: 禁止设置              | R/W |
| 7:2   | —         | 这些位被读取为0。写入值应为0。   | R/W |
| 8     | LRCONT    | 是否开启LRCKFSContinuation <sup>*1*2</sup><br>0: 禁用LRCKFS延续1: 启用LRCKFS<br>S延续          | R/W |
| 9     | BCKASTP   | SSIE空闲时是否使能停止BCK输出 <sup>*1*2</sup><br>0: 始终向SSIBCK引脚输出BCK1: 自动控制向SSIBCK引脚<br>输出BCK | R/W |
| 31:10 | —         | 这些位被读取为0。写入值应为0。   | R/W |

注1.该位仅在主模式通信(SSICR.MST=1)中有效。该设置在从模式通信中无效(SSICR.MST=0)。

注2.BCKASTP和LRCONT位不能一起设置为1。

注3.当SSIE正在通信时(SSISR.IIRQ=0)，禁止写入这些位。如果这些位的值通过写来改变，后续的操作是不可预知的。

注4.如果对方设备的通信格式与SSIE的通信格式兼容，请指定并使用能够与对方设备进行通信的通信格式。

该寄存器用于设置音频格式（涉及通信格式、LR时钟帧同步持续模式、BCK输出停止的设置）。

**OMOD[1:0]位（音频格式选择）**

OMOD[1:0]位设置音频格式。当LR时钟提供给SSILRCK/SSIFS引脚停止。LR时钟的输出详见32.4.7节LRCONT位的详细说明。SSIOFR：音频格式寄存器。

**LRCONT位（是否使能LRCKFSContinuation）**

当通信模式为主机模式通信(SSICR.MST=1)且SSIE处于空闲状态(SSISR.IIRQ=1)时，LRCONT位启用或禁用SSILRCK/SSIFS引脚的输出。

即使在空闲状态下，当该位在主模式(SSICR.MST=1)下设置为1（以启用LR时钟帧同步继续）时，也可以从SSILRCK/SSIFS引脚输出信号。

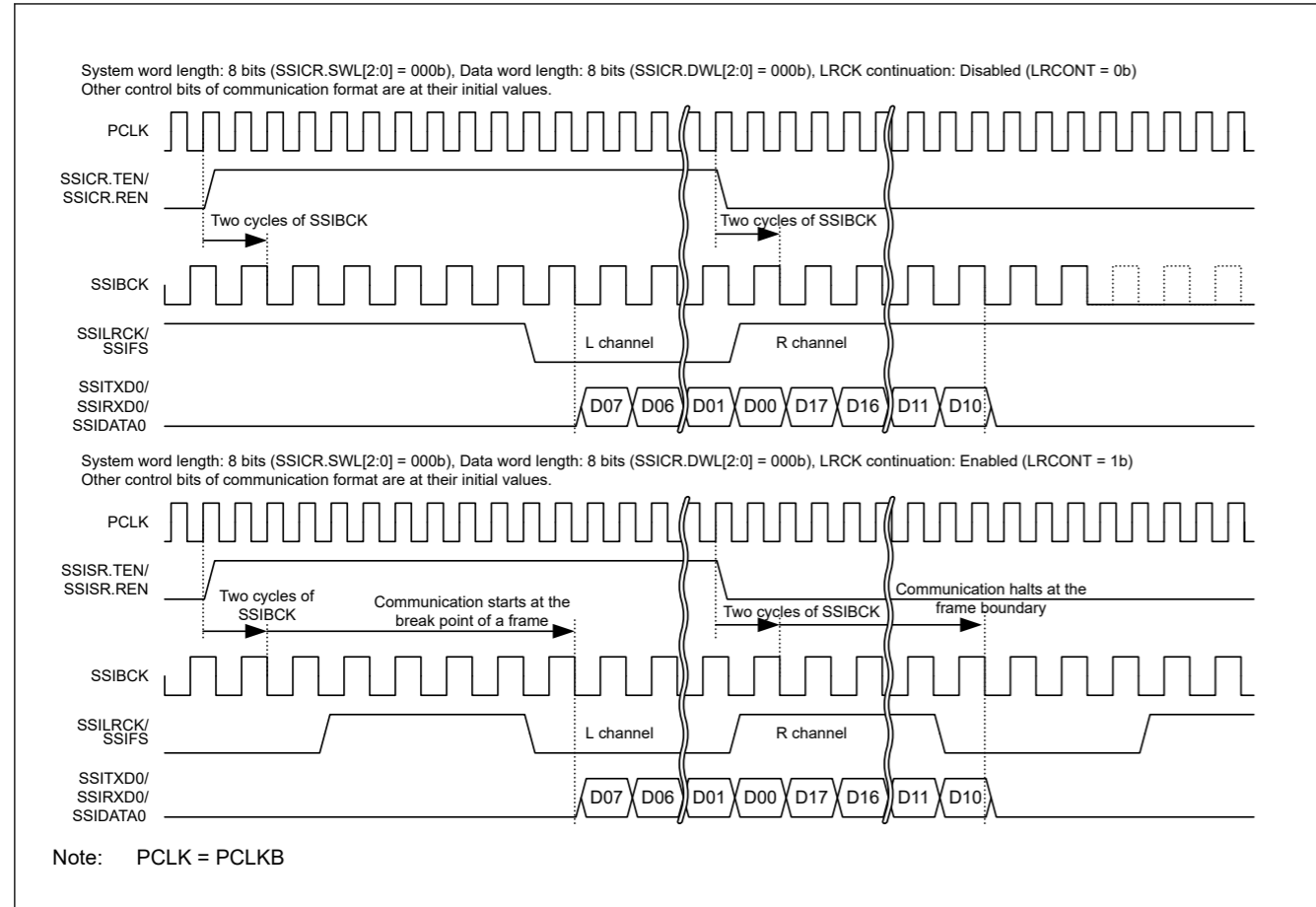


Figure 32.33 Example of LR clock/frame synchronization continuation operation

**BCKASTP bit (Whether to Enable Stopping BCK Output When SSIE is in Idle Status)**

The BCKASTP bit turns on or off the function to output BCK to the SSIBCK pin according to the communication shown in Figure 32.34 and Figure 32.35 in master-mode communication (SSICR.MST = 1).

Changing the value of this bit must be performed only after setting the communication format to be used.

This bit must be used in the following way:

Write 0 to the BCKASTP bit, and then start communication. During the communication, write 1 to the BCKASTP bit. By this operation, the bit clock output to the SSIBCK pin stops automatically when the communication stops. To resume the communication, set SSIE to the idle state (SSICR.IIRQ = 1), enable the supply of AUDIO\_MCK (SSIFCR.AUCKE = 1), and then write 0 to the BCKASTP bit.

When the communication mode is master-mode communication (SSICR.MST = 1) and SSIE is in the idle state (SSICR.IIRQ = 1):

Table 32.9 BCKASTP bit status and SSIBCK pin output

| BCKASTP Bit | SSIBCK Pin Output Status |
|-------------|--------------------------|
| 0           | Output                   |
| 1           | Stopped                  |

Note: The BCKASTP bit cannot be used when the other-party device (which is a slave) requires the clock output from the SSIBCK pin before and during communication. In such a case, use the BCKASTP bit to stop the clock only after communication. For the timing of enabling the clock stop function, see Figure 32.34.

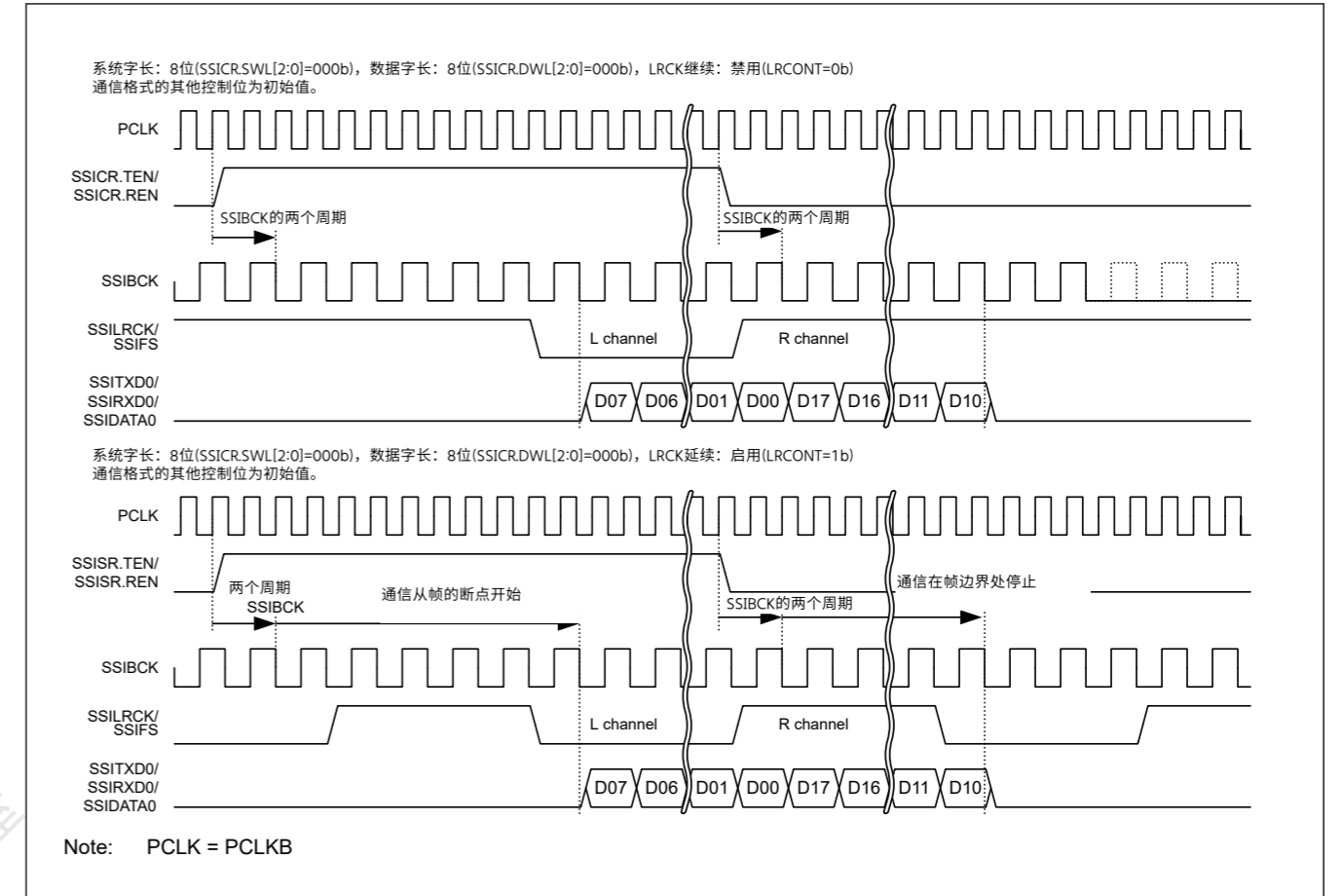


Figure 32.33 LR时钟帧同步继续操作示例

**BCKASTP位 (SSIE空闲时是否使能停止BCK输出)**

BCKASTP位根据中所示的通信打开或关闭将BCK输出到SSIBCK引脚的功能图32.34和图32.35在主模式通信(SSICR.MST=1)。

只有在设置要使用的通信格式后才能更改该位的值。

该位必须按以下方式使用:

将0写入BCKASTP位, 然后开始通信。在通信期间, 将1写入BCKASTP位。通过该操作, 当通信停止时, 向SSIBCK引脚输出的位时钟自动停止。要恢复通信, 请将SSIE设置为空闲状态(SSICR.IIRQ=1), 启用AUDIO\_MCK电源(SSIFCR.AUCKE=1), 然后将0写入BCKASTP位。

当通信模式为主模式通信 (SSICR.MST=1) 且SSIE处于空闲状态 (SSICR.IIRQ=1) 时:

Table 32.9 BCKASTP位状态和SSIBCK引脚输出

| BCKASTP Bit | SSIBCK引脚输出状态 |
|-------------|--------------|
| 0           | Output       |
| 1           | Stopped      |

Note: 当对方设备 (作为从设备) 在通信之前和通信期间需要从SSIBCK引脚输出时钟时, 不能使用BCKASTP位。在这种情况下, 仅在通信后使用BCKASTP位停止时钟。时钟停止功能的开启时序见图32.34。

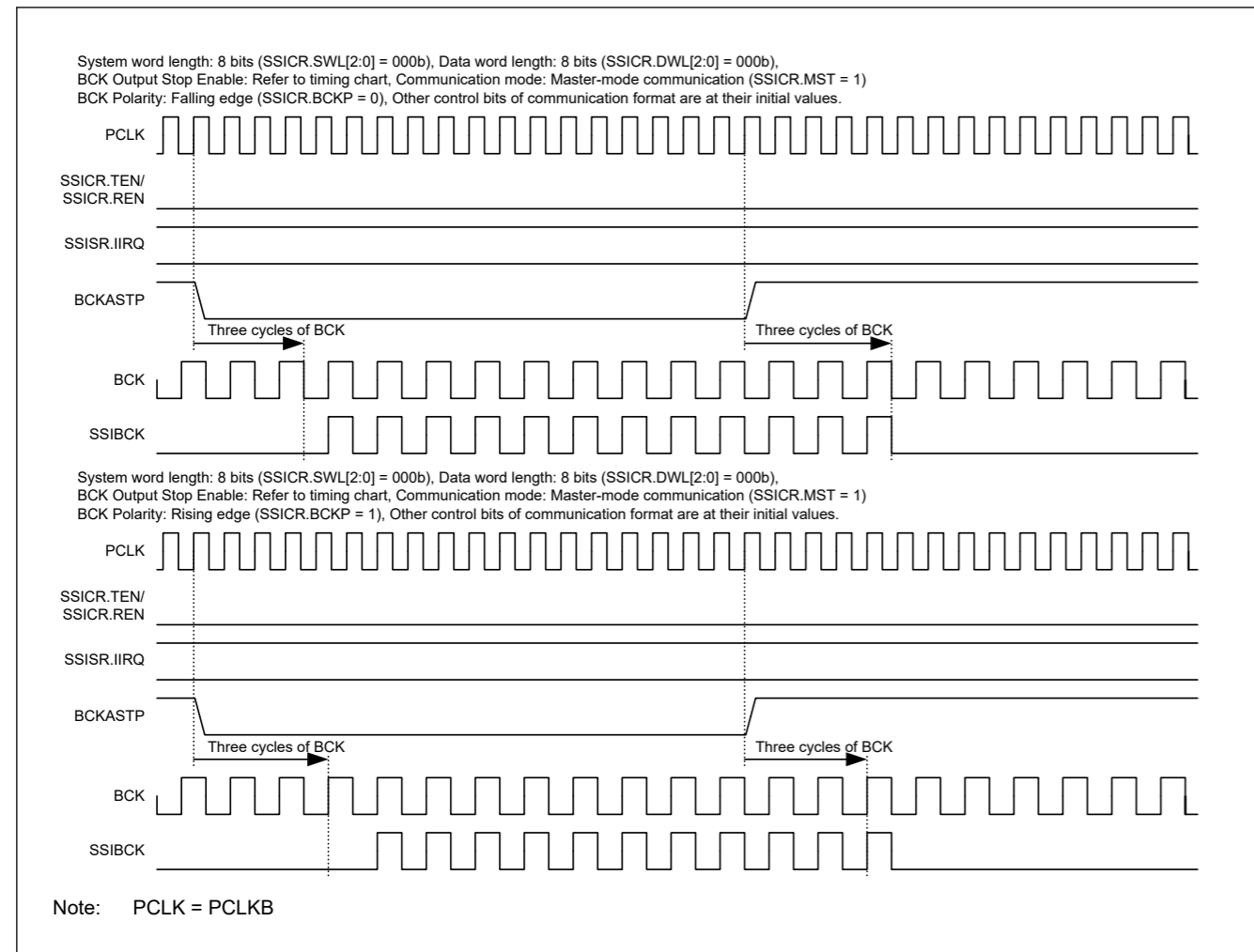


Figure 32.34 Example operation of the BCKASTP bit (idle state)

When the communication mode is master-mode communication (SSICR.MST = 1) and the BCK output stop function is enabled (BCKASTP = 1):

Details of the BCK output to the SSIBCK pin are as follows:

Output start timing: BCK is output in appropriate timing so that a valid edge is generated when the LR clock/frame synchronization signal shifts to a valid value.

Output stop timing: 1 to 1.5 clock cycles after a frame boundary.

For details about the timings, see the timing diagram in Figure 32.35.

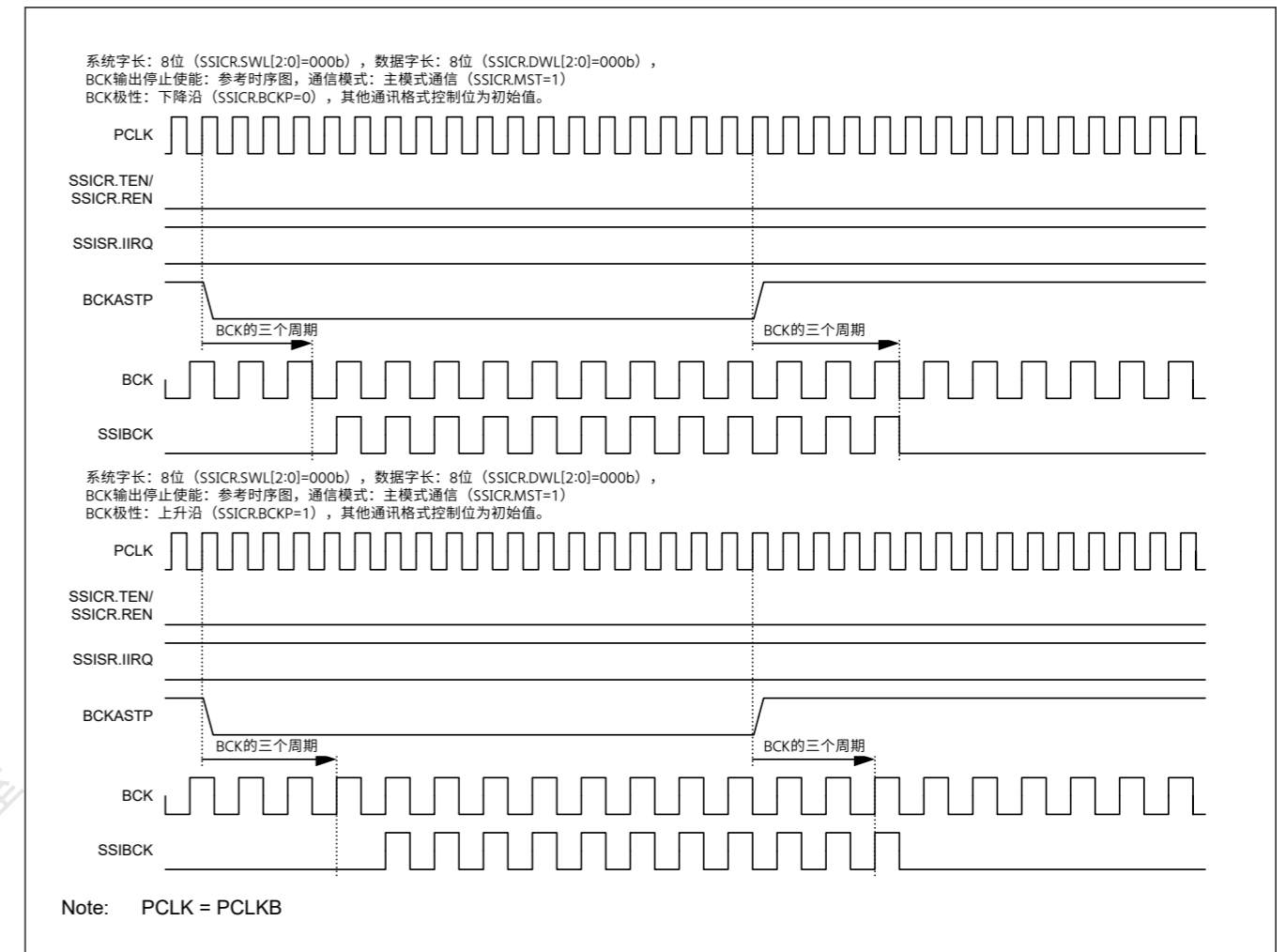


Figure 32.34 BCKASTP位的示例操作 (空闲状态)

当通信模式为主机模式通信(SSICR.MST=1)且BCK输出停止功能启用(BCKASTP=1)时:

BCK输出到SSIBCK引脚的详细信息如下:

输出开始时序: 在适当的时序输出BCK, 以便在LR时钟帧同步信号移位到有效值时产生有效边沿。

输出停止时序: 帧边界后1到1.5个时钟周期。

有关时序的详细信息, 请参见图32.35中的时序图。



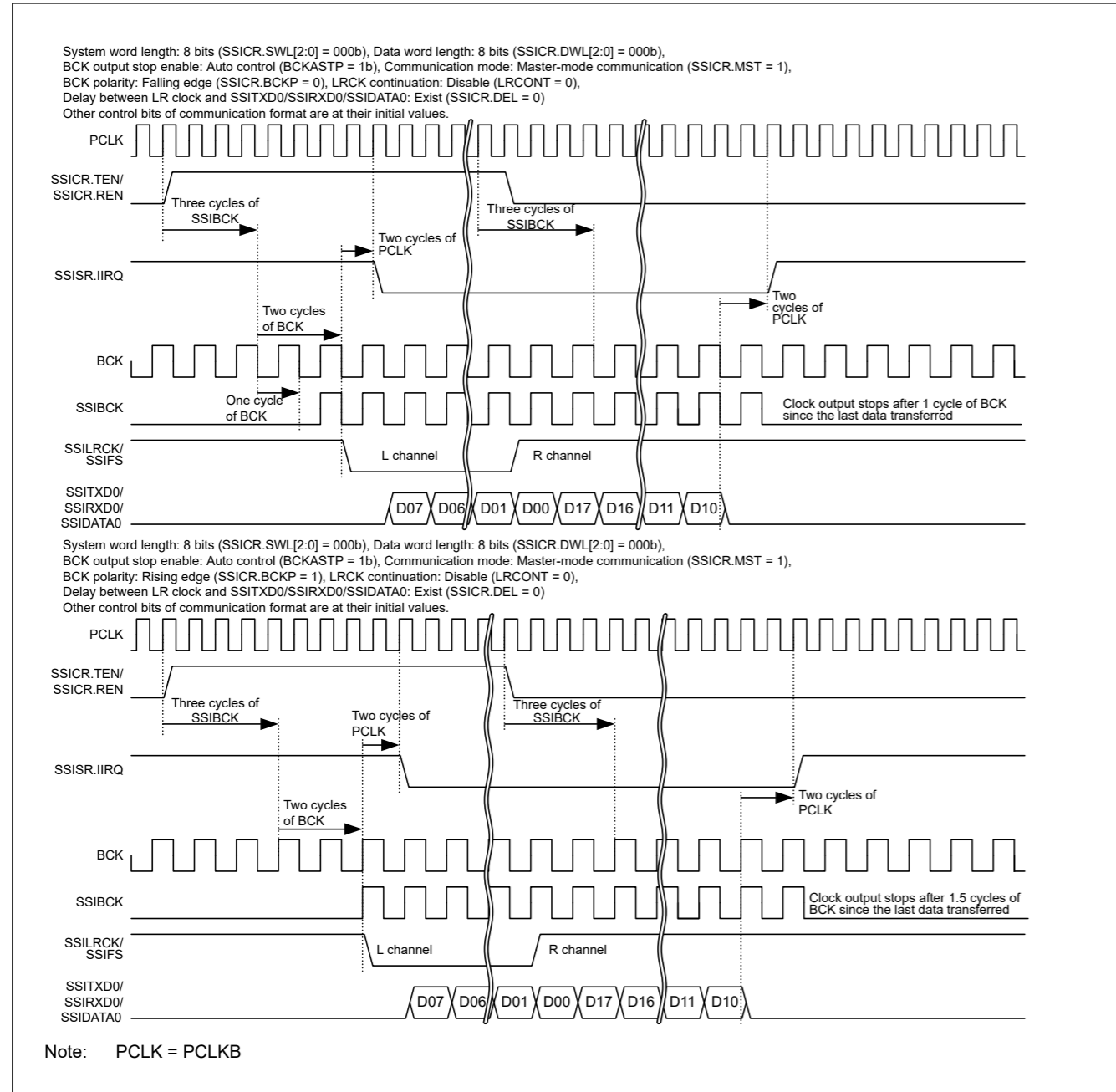


Figure 32.35 Example operation of the BCKASTP bit (communication operation with BCKASTP = 1)

32.4.8 SSISCR : Status Control Register

Base address: SSIE0 = 0x4009\_D000  
 Offset address: 0x24

|                    |    |    |    |           |    |    |    |    |    |    |           |    |    |    |    |    |   |
|--------------------|----|----|----|-----------|----|----|----|----|----|----|-----------|----|----|----|----|----|---|
| Bit position:      | 31 | 30 | 29 | 28        | 27 | 26 | 25 | 24 | 23 | 22 | 21        | 20 | 19 | 18 | 17 | 16 |   |
| Bit field:         | —  | —  | —  | —         | —  | —  | —  | —  | —  | —  | —         | —  | —  | —  | —  | —  |   |
| Value after reset: | 0  | 0  | 0  | 0         | 0  | 0  | 0  | 0  | 0  | 0  | 0         | 0  | 0  | 0  | 0  | 0  |   |
| Bit position:      | 15 | 14 | 13 | 12        | 11 | 10 | 9  | 8  | 7  | 6  | 5         | 4  | 3  | 2  | 1  | 0  |   |
| Bit field:         | —  | —  | —  | TDES[4:0] |    |    |    | —  | —  | —  | RDFS[4:0] |    |    |    | —  | —  | — |
| Value after reset: | 0  | 0  | 0  | 0         | 0  | 0  | 0  | 0  | 0  | 0  | 0         | 0  | 0  | 0  | 0  | 0  |   |

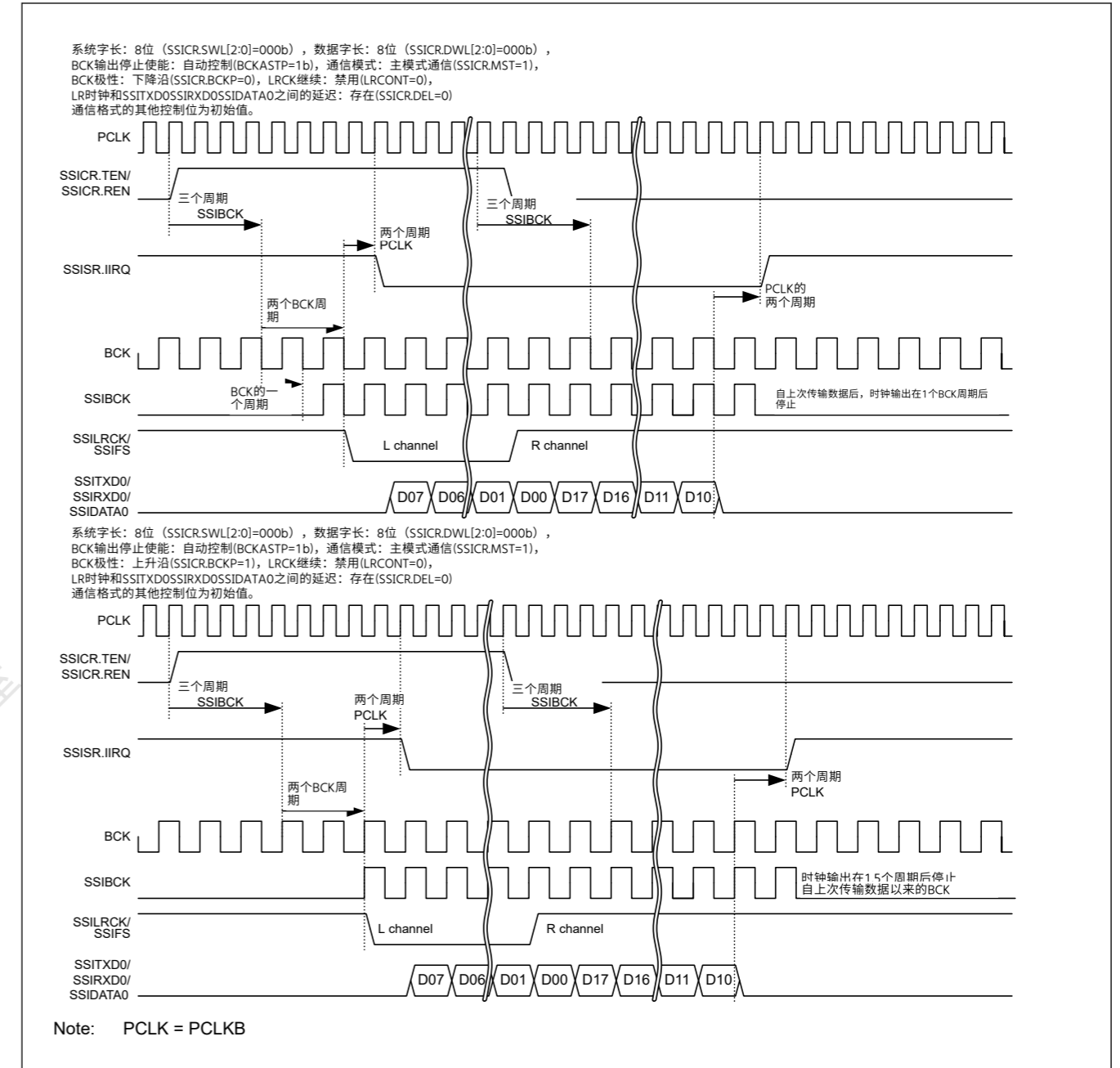


Figure 32.35 BCKASTP位的示例操作 (BCKASTP=1的通信操作)

32.4.8 SSISSCR:状态控制寄存器

Base address: SSIE0 = 0x4009\_D000  
 Offset address: 0x24

|               |    |    |    |           |    |    |    |    |    |    |           |    |    |    |    |    |   |
|---------------|----|----|----|-----------|----|----|----|----|----|----|-----------|----|----|----|----|----|---|
| Bit position: | 31 | 30 | 29 | 28        | 27 | 26 | 25 | 24 | 23 | 22 | 21        | 20 | 19 | 18 | 17 | 16 |   |
| Bit field:    | —  | —  | —  | —         | —  | —  | —  | —  | —  | —  | —         | —  | —  | —  | —  | —  |   |
| 重置后的值:        | 0  | 0  | 0  | 0         | 0  | 0  | 0  | 0  | 0  | 0  | 0         | 0  | 0  | 0  | 0  | 0  |   |
| Bit position: | 15 | 14 | 13 | 12        | 11 | 10 | 9  | 8  | 7  | 6  | 5         | 4  | 3  | 2  | 1  | 0  |   |
| Bit field:    | —  | —  | —  | TDES[4:0] |    |    |    | —  | —  | —  | RDFS[4:0] |    |    |    | —  | —  | — |
| 重置后的值:        | 0  | 0  | 0  | 0         | 0  | 0  | 0  | 0  | 0  | 0  | 0         | 0  | 0  | 0  | 0  | 0  |   |

| Bit   | Symbol    | Function   | R/W |
|-------|-----------|--|-----|
| 4:0   | RDFS[4:0] | RDF Setting Condition Select*1<br>0x00: SSIFRDR has one stage or more data size.<br>0x01: SSIFRDR has two stages or more data size.<br>⋮<br>0x1E: SSIFRDR has thirty-one stages or more data size.<br>0x1F: SSIFRDR has thirty-two stages or more data size.     | R/W |
| 7:5   | —         | These bits are read as 0. The write value should be 0.   | R/W |
| 12:8  | TDES[4:0] | TDE Setting Condition Select*1<br>0x00: SSIFTDR has one stage or more free space.<br>0x01: SSIFTDR has two stages or more free space.<br>⋮<br>0x1E: SSIFTDR has thirty-one stages or more free space.<br>0x1F: SSIFTDR has thirty-two stages or more free space. | R/W |
| 31:13 | —         | These bits are read as 0. The write value should be 0.   | R/W |

Note 1. Writing to these bits while SSIE is in a communication state (SSISR.IIRQ = 0) is prohibited. If written, the operation performed immediately after writing is not guaranteed.

**RDFS[4:0] bits (RDF Setting Condition Select)**

The RDFS[4:0] bits set the setting condition of the receive data full flag (RDF).

**TDES[4:0] bits (TDE Setting Condition Select)**

The TDES[4:0] bits set the setting condition of the transmit data empty flag (TDE).

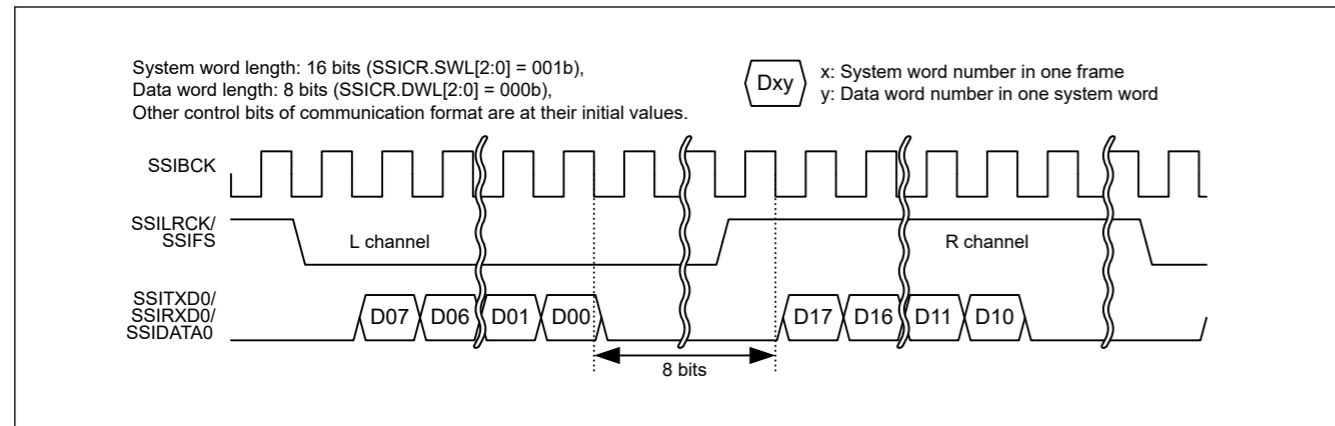
**32.5 Communication Formats**

SSIE supports three communication formats. Table 32.10 shows supported communication formats.

**Table 32.10 Supported communication formats**

| Communication Format    | SSIOFR.OMOD[1:0] |
|-------------------------|------------------|
| I <sup>2</sup> S format | 00               |
| TDM format              | 01               |
| Monaural format         | 10               |

The following describes the serial data structure shared by communication formats. A serial data structure is defined by the system word length (set in SSICR.SWL[2:0]) and the data word length (set in SSICR.DWL[2:0]). If the data word length is shorter than the system word length, padding bits are transferred in the serial data. For details, see Figure 32.36.



**Figure 32.36 Example of padding bit transfer (I<sup>2</sup>S format: system word length > data word length)**

Table 32.11 lists the number of padding bits to be transferred with each combination of system word length (SSICR.SWL[2:0]) and data word length (SSICR.DWL[2:0]). “-” indicates that the setting is prohibited.

| Bit   | Symbol    | Function   | R/W |
|-------|-----------|--|-----|
| 4:0   | RDFS[4:0] | RDF设置条件选择*1<br>0x00: SSIFRDR具有一级或更多数据大小。0x01: SSIFRDR具有两级或更多数据大小。<br>⋮<br>0x1E: SSIFRDR具有31级或更多数据大小。0x1F: SSIFRDR具有32级或更多数据大小。 | R/W |
| 7:5   | —         | 这些位被读取为0。写入值应为0。   | R/W |
| 12:8  | TDES[4:0] | TDE设定条件选择*1<br>0x00: SSIFTDR有一级或更多可用空间。0x01: SSIFTDR有两级或更多可用空间。<br>⋮<br>0x1E: SSIFTDR有31个或更多的可用空间。0x1F: SSIFTDR有32级或更多可用空间。    | R/W |
| 31:13 | —         | 这些位被读取为0。写入值应为0。   | R/W |

注1.禁止在SSIE处于通信状态(SSISR.IIRQ=0)时写入这些位。如果写入，则不保证写入后立即执行的操作。

**RDFS[4:0]位 (RDF设置条件选择)**

RDFS[4:0]位设置接收数据满标志(RDF)的设置条件。

**TDES[4:0]位 (TDE设置条件选择)**

TDES[4:0]位设置发送数据空标志(TDE)的设置条件。

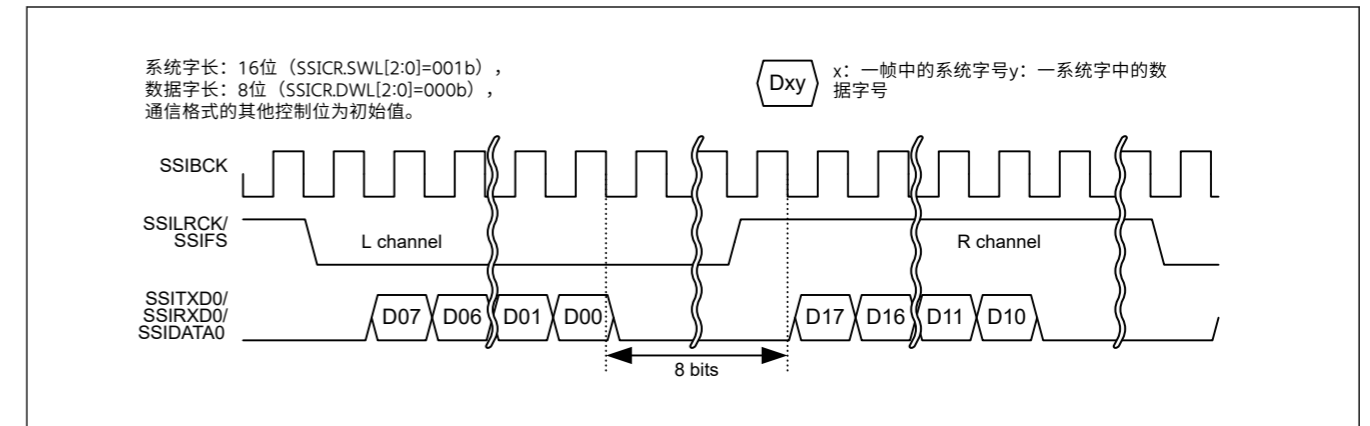
**32.5 通讯格式**

SSIE支持三种通信格式。表32.10显示了支持的通信格式。

**Table 32.10 支持的通讯格式**

| 通讯格式                    | SSIOFR.OMOD[1:0] |
|-------------------------|------------------|
| I <sup>2</sup> S format | 00               |
| TDM format              | 01               |
| Monaural format         | 10               |

下面介绍通信格式共享的串行数据结构。串行数据结构由系统字长（在SSICR.SWL[2:0]中设置）和数据字长（在SSICR.DWL[2:0]中设置）定义。如果数据字长短于系统字长，则在串行数据中传输填充位。详见图32.36。



**Figure 32.36 填充位传输示例 (I<sup>2</sup>S格式: 系统字长>数据字长)**

表32.11列出了使用系统字长(SSICR.SWL[2:0])和数据字长(SSICR.DWL[2:0])的每种组合传输的填充位数。“-”表示禁止设置。

Table 32.11 Number of padding bits

|                | SSICR.DWL[2:0]     | 000b | 001b | 010b | 011b | 100b | 101b | 110b | 111b               |
|----------------|--------------------|------|------|------|------|------|------|------|--------------------|
| SSICR.SWL[2:0] | System Word Length | 8    | 16   | 18   | 20   | 22   | 24   | 32   | Setting prohibited |
| 000b           | 8                  | 0    | —    | —    | —    | —    | —    | —    | —                  |
| 001b           | 16                 | 8    | 0    | —    | —    | —    | —    | —    | —                  |
| 010b           | 24                 | 16   | 8    | 6    | 4    | 2    | 0    | —    | —                  |
| 011b           | 32                 | 24   | 16   | 14   | 12   | 10   | 8    | 0    | —                  |
| 100b           | 48                 | 40   | 32   | 30   | 28   | 26   | 24   | 16   | —                  |
| 101b           | 64                 | 56   | 48   | 46   | 44   | 42   | 40   | 32   | —                  |
| 110b           | 128                | 120  | 112  | 110  | 108  | 106  | 104  | 96   | —                  |
| 111b           | 256                | 248  | 240  | 238  | 236  | 234  | 232  | 224  | —                  |

### 32.5.1 I<sup>2</sup>S Format

The I<sup>2</sup>S format is a communication format used for connection with I<sup>2</sup>S-compatible serial devices. With this format setting (SSIOFR.OMOD[1:0] = 00b), one frame is configured with two system words, one for the channel L and the other for channel R. The SSILRCK/SSIFS signals are at a low level for the channel L and at a high level for the channel R. Set the polarity of the signals with the SSICR.LRCKP bit. Figure 32.37 shows the I<sup>2</sup>S format without padding. See Figure 32.36 for the format with padding.

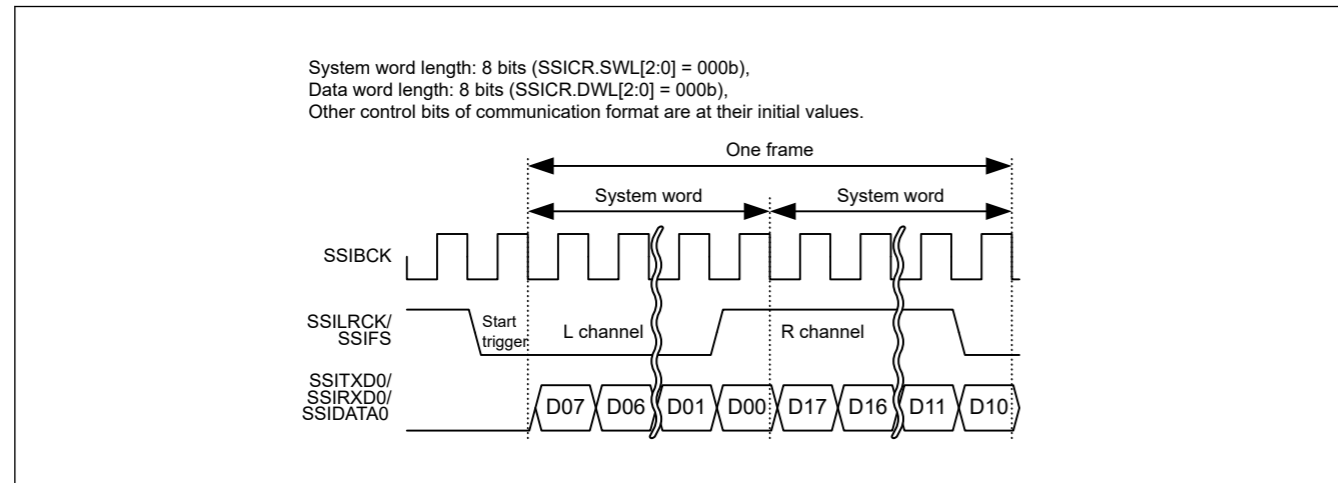


Figure 32.37 I<sup>2</sup>S format (without padding: system word length = data word length)

For the state of external pins when SSIE is in the idle state, see section 32.7.1. Idle State.

Note: SSIE has the SSILRCK/SSIFS pin, which indicates the synchronization of communication. When SSIE is in slave mode (SSICR.MST = 0), the communication format SSIE uses must match that of the other-party device to communicate. SSIE uses the signal input by the SSILRCK/SSIFS pin only as a trigger to start communication.

### 32.5.2 Monaural Format

The monaural format is a communication format used for connection with monaural-compatible serial devices. When the monaural format is specified (SSIOFR.OMOD[1:0] = 10b) for use, one frame consists of one system word. Also, a rising edge of the SSILRCK/SSIFS signal indicates a communication start trigger. Figure 32.38 and Figure 32.39 respectively show the monaural formats without and with padding.

Table 32.11 填充位数

|                | SSICR.DWL[2:0] | 000b | 001b | 010b | 011b | 100b | 101b | 110b | 111b |
|----------------|----------------|------|------|------|------|------|------|------|------|
| SSICR.SWL[2:0] | 系统字 Length     | 8    | 16   | 18   | 20   | 22   | 24   | 32   | 禁止设定 |
| 000b           | 8              | 0    | —    | —    | —    | —    | —    | —    | —    |
| 001b           | 16             | 8    | 0    | —    | —    | —    | —    | —    | —    |
| 010b           | 24             | 16   | 8    | 6    | 4    | 2    | 0    | —    | —    |
| 011b           | 32             | 24   | 16   | 14   | 12   | 10   | 8    | 0    | —    |
| 100b           | 48             | 40   | 32   | 30   | 28   | 26   | 24   | 16   | —    |
| 101b           | 64             | 56   | 48   | 46   | 44   | 42   | 40   | 32   | —    |
| 110b           | 128            | 120  | 112  | 110  | 108  | 106  | 104  | 96   | —    |
| 111b           | 256            | 248  | 240  | 238  | 236  | 234  | 232  | 224  | —    |

### 32.5.1 I<sup>2</sup>S Format

I<sup>2</sup>S格式是用于连接I<sup>2</sup>S兼容串行设备的通信格式。使用此格式设置(SSIOFR.OMOD[1:0]=00b)，一帧配置有两个系统字，一个用于通道L，另一个用于通道R。SSILRCKSSIFS信号对于通道处于低电平L和通道R为高电平。使用SSICR.LRCKP位设置信号的极性。图32.37显示了没有填充的I<sup>2</sup>S格式。带填充的格式见图32.36。

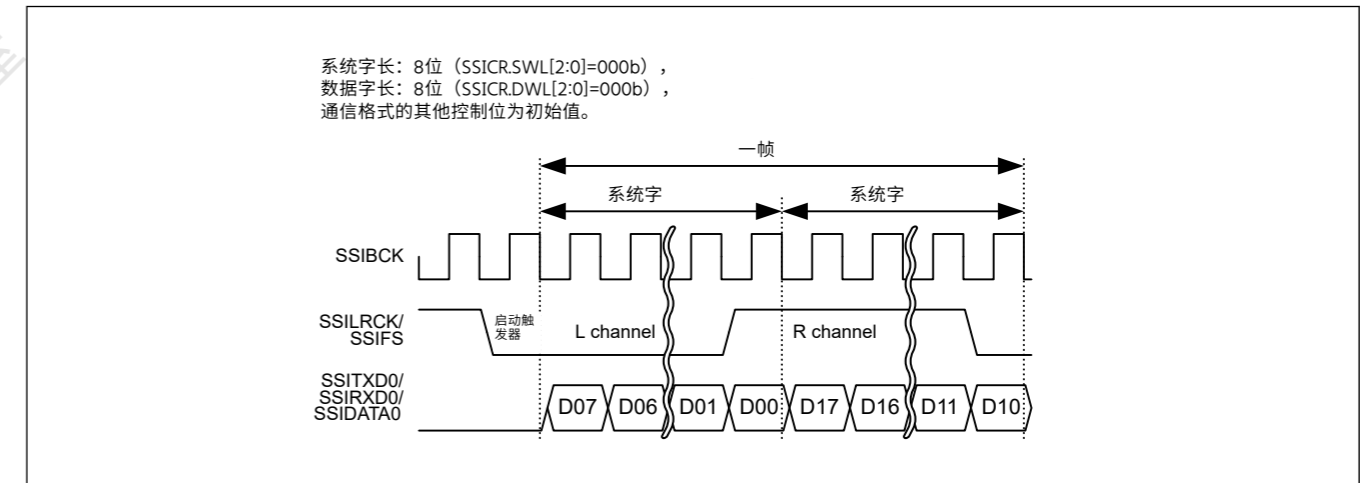


Figure 32.37 I<sup>2</sup>S格式 (无填充: 系统字长=数据字长)

SSIE处于空闲状态时外部管脚的状态见32.7.1节。空闲状态。

Note: SSIE有SSILRCKSSIFS引脚，表示通信同步。当SSIE处于从机模式 (SSICR.MST=0) 时，SSIE使用的通信格式必须与对方设备的通信格式相匹配。SSIE仅使用SSILRCKSSIFS引脚输入的信号作为启动通信的触发器。

### 32.5.2 Monaural Format

单声道格式是用于连接单声道兼容串行设备的通信格式。当指定使用单声道格式(SSIOFR.OMOD[1:0]=10b)时，一帧由一个系统字组成。此外，SSILRCKSSIFS信号的上升沿表示通信开始触发。图32.38和图32.39分别显示了没有和有填充的单声道格式。

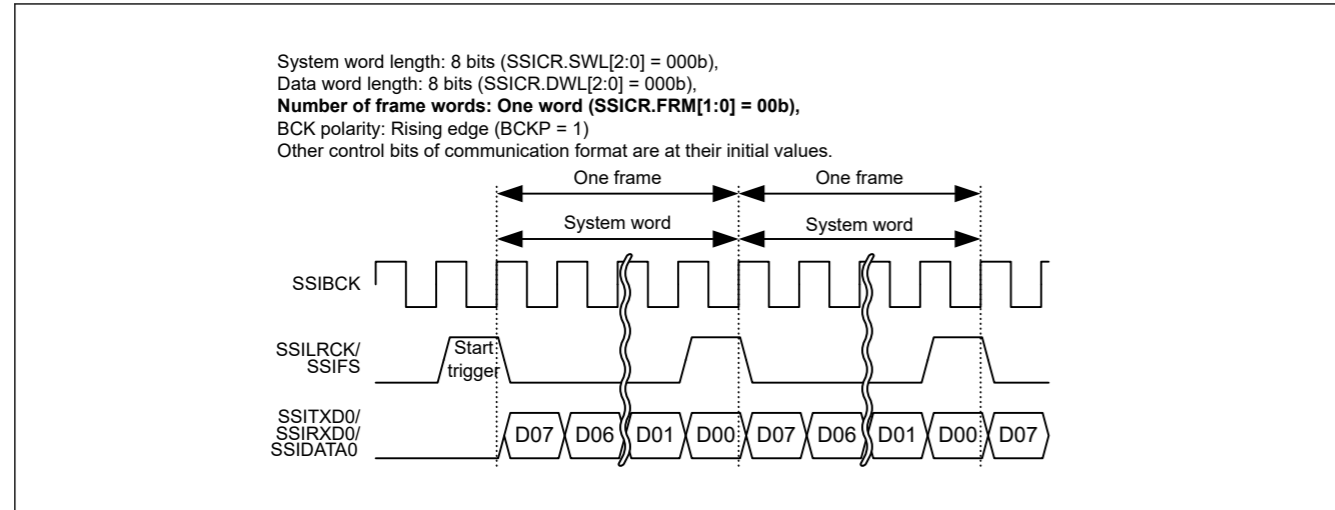


Figure 32.38 Short frame in monaural format (without padding: system word length = data word length)

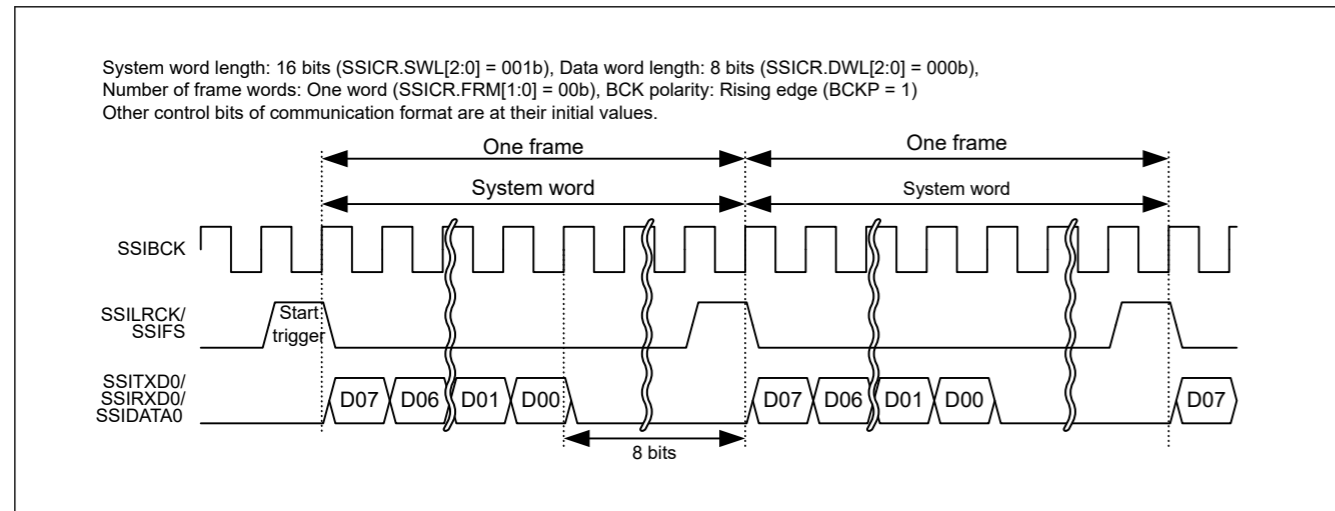


Figure 32.39 Short frame in monaural format (with padding: system word length > data word length)

The monaural formats supported by SSIE consist of short frames and long frames. See [section 32.5.2.1. Short frame](#) and [section 32.5.2.2. Long frame](#) for the difference between these two frames.

For the state of external pins state when SSIE is in the idle state, see [section 32.7.1. Idle State](#).

Note: SSIE has the SSILRCK/SSIFS pin, which indicates the synchronization of communication. When SSIE is in slave mode (SSICR.MST = 0), the communication format SSIE uses must match that of the other-party device to communicate. SSIE uses the signal input by the SSILRCK/SSIFS pin only as a trigger to start communication.

### 32.5.2.1 Short frame

When a short frame is used (SSICR.DEL = 0), the SSILRCK/SSIFS signal indicating the start of serial data is set to high level only for 1 cycle of SSIBCK. Data transfer starts at the falling edge of the signal.

### 32.5.2.2 Long frame

When a long frame is used (SSICR.DEL = 1), the SSILRCK/SSIFS signal indicating the start of serial data is set to high level only for 2 cycles of SSIBCK. See [Figure 32.40](#). Data transfer starts at the rising edge of the signal.

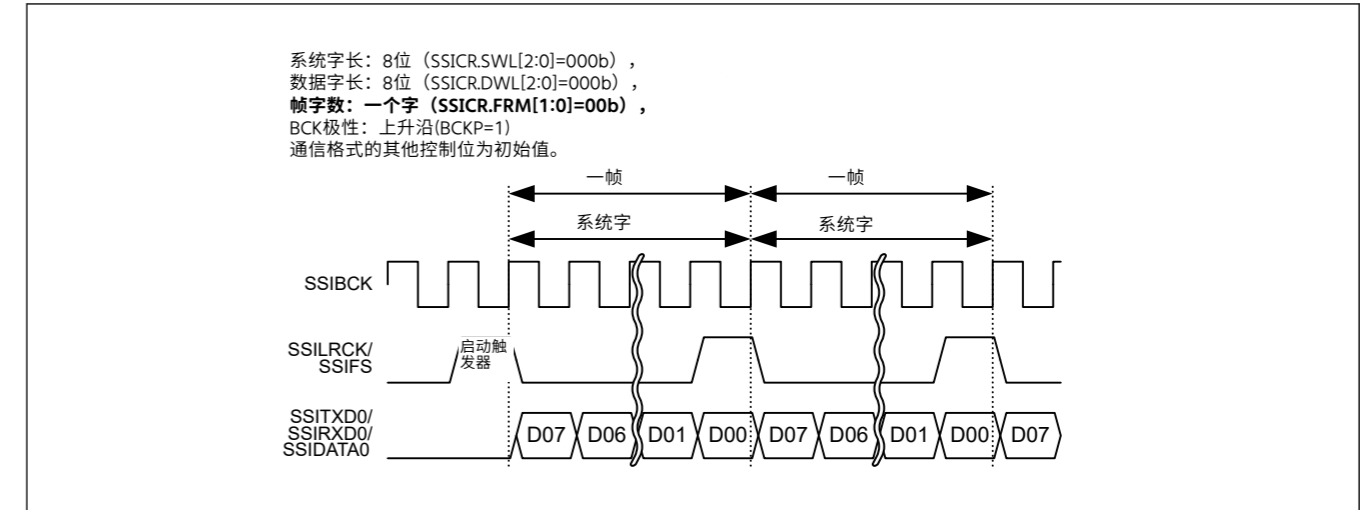


Figure 32.38 单声道格式的短帧 (无填充: 系统字长=数据字长)

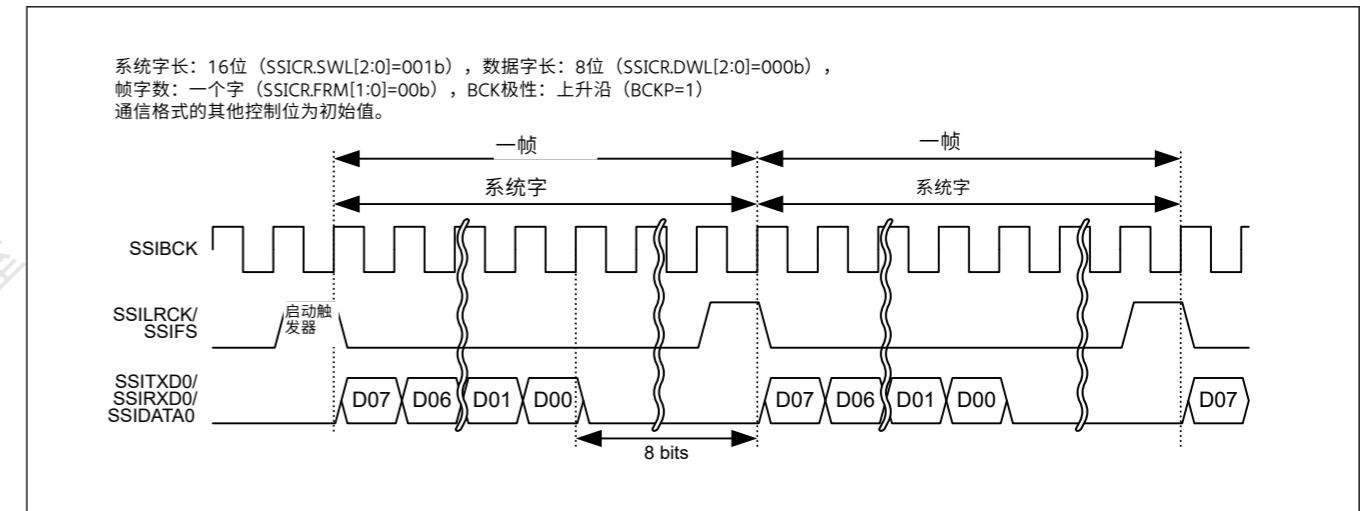


Figure 32.39 单声道格式的短帧 (带填充: 系统字长>数据字长)

SSIE支持的单声道格式包括短帧和长帧。请参见第32.5.2.1节。短框架和第32.5.2.2节。长帧为这两个帧的区别。

SSIE处于空闲状态时外部引脚状态的状态见32.7.1节。空闲状态。

Note: SSIE有SSILRCKSSIFS引脚, 表示通信同步。当SSIE处于从机模式 (SSICR.MST=0) 时, SSIE使用的通信格式必须与对方设备的通信格式相匹配。SSIE仅使用SSILRCKSSIFS引脚输入的信号作为启动通信的触发器。

### 32.5.2.1 短框

当使用短帧时 (SSICR.DEL=0), 指示串行数据开始的SSILRCKSSIFS信号仅在SSIBCK的1个周期内设置为高电平。数据传输从信号的下降沿开始。

### 32.5.2.2 长框

当使用长帧时 (SSICR.DEL=1), 指示串行数据开始的SSILRCKSSIFS信号仅在SSIBCK的2个周期内设置为高电平。请参见图32.40。数据传输从信号的上升沿开始。



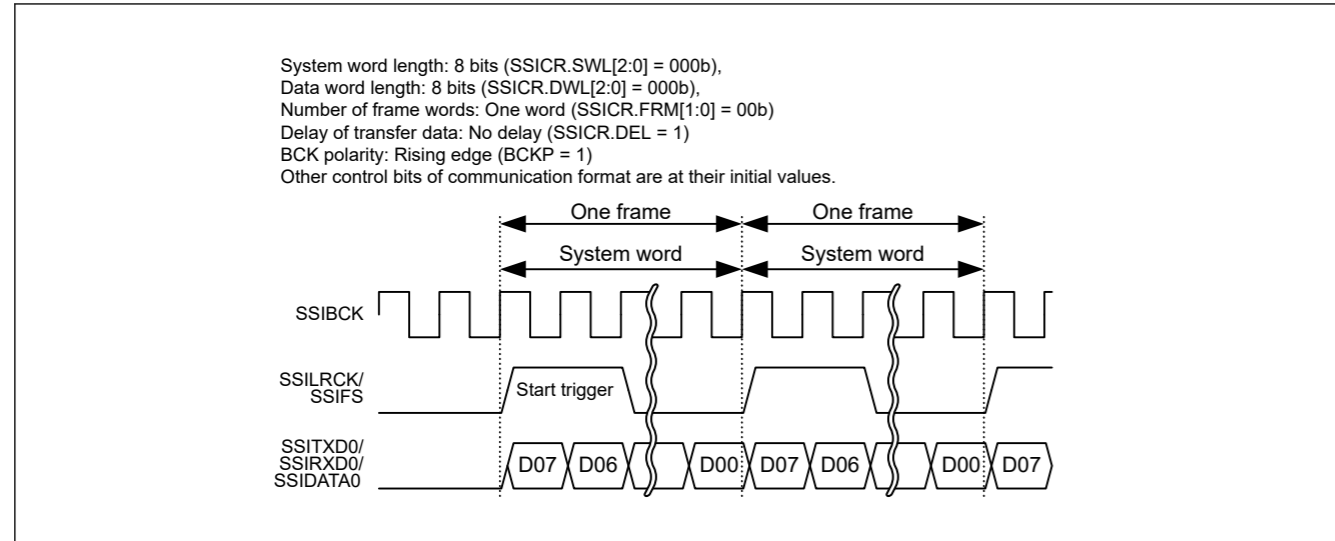


Figure 32.40 Long frame in mono format (without padding)

32.5.3 TDM Format

The TDM format is a communication format used for connection with TDM-compatible multi-channel devices. With this format setting (SSIOFR.OMOD[1:0] = 01b), one frame is configured with four to eight system words set with the SSICR.FRM[1:0] bits. With this format, the SSILRCK/SSIFS signal is at a high level for the first one system word and at a low level for the rest. The pulse generated on the SSILRCK/SSIFS signal is defined as the SYNC pulse and its rising edge means a start of one frame. Figure 32.41 and Figure 32.42 respectively show the TDM formats without and with padding.

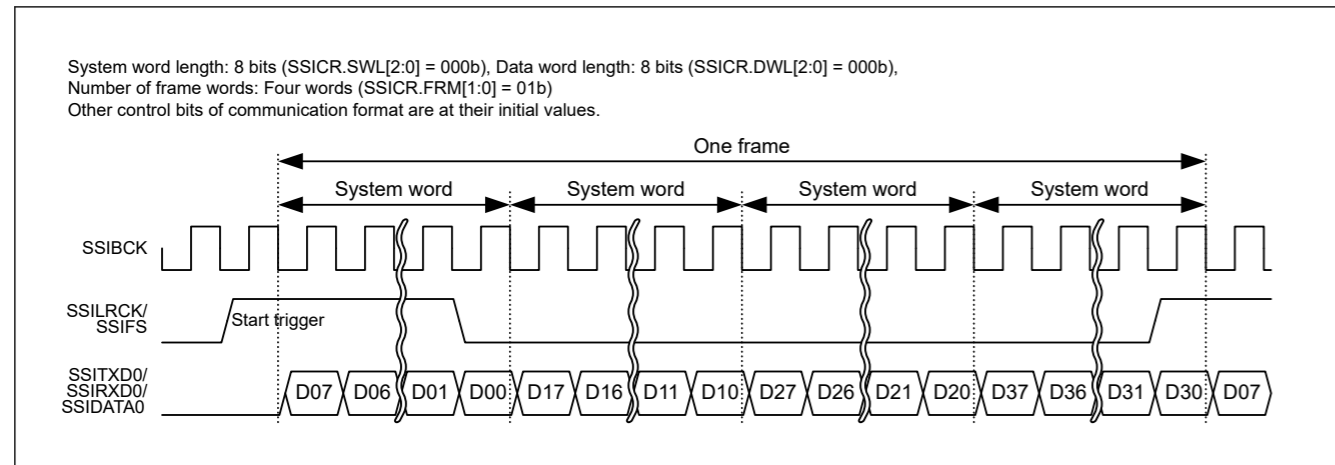


Figure 32.41 TDM format (without padding: system word length = data word length)

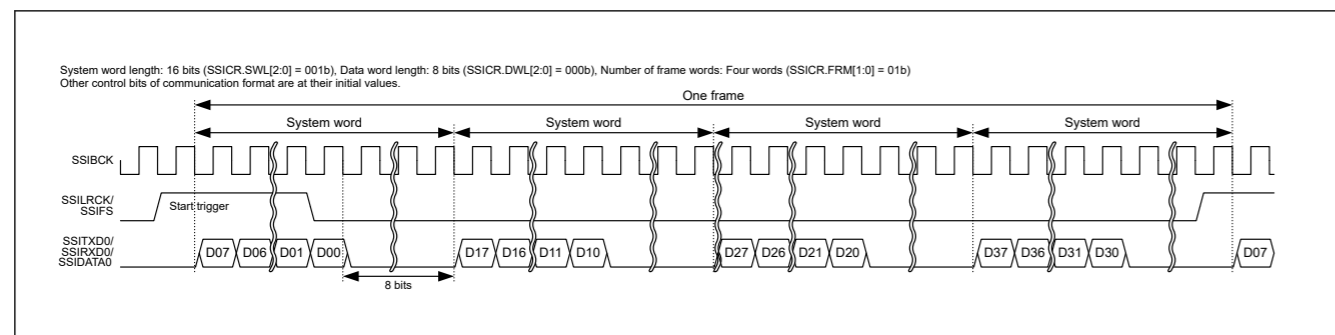


Figure 32.42 TDM format (with padding: system word length > data word length)

For the state of external pins when SSIE is in the idle state, see section 32.7.1. Idle State.

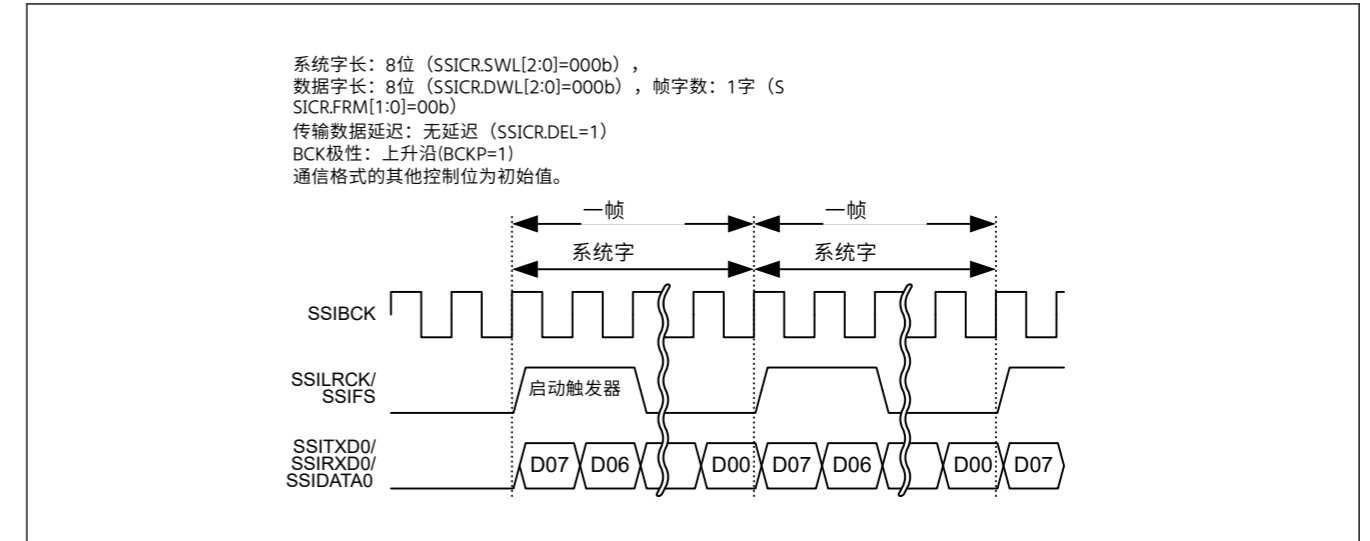


Figure 32.40 单声道格式的长帧 (无填充)

32.5.3 TDM Format

TDM格式是一种用于与兼容TDM的多通道设备连接的通信格式。使用此格式设置(SSIOFR.OMOD[1:0]=01b)，一帧配置有四到八个通过SSICR.FRM[1:0]位设置的系统字。使用这种格式，SSILRCKSSIFS信号对于第一个系统字处于高电平，而对于其余系统字处于低电平。SSILRCKSSIFS信号上产生的脉冲被定义为SYNC脉冲，其上升沿表示一帧的开始。图32.41和图32.42分别显示了没有和有填充的TDM格式。

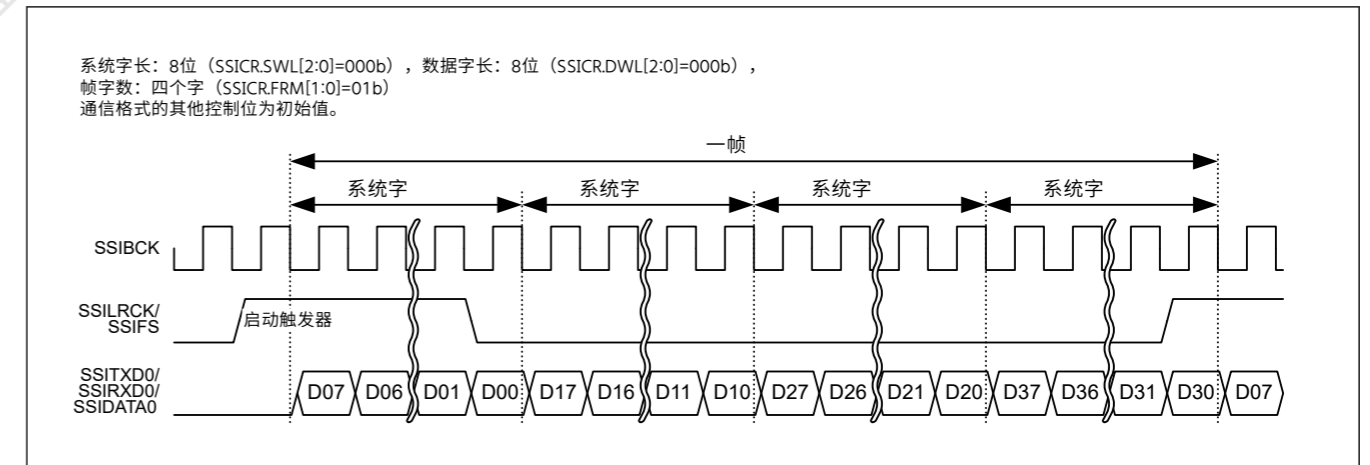


Figure 32.41 TDM格式 (无填充: 系统字长=数据字长)

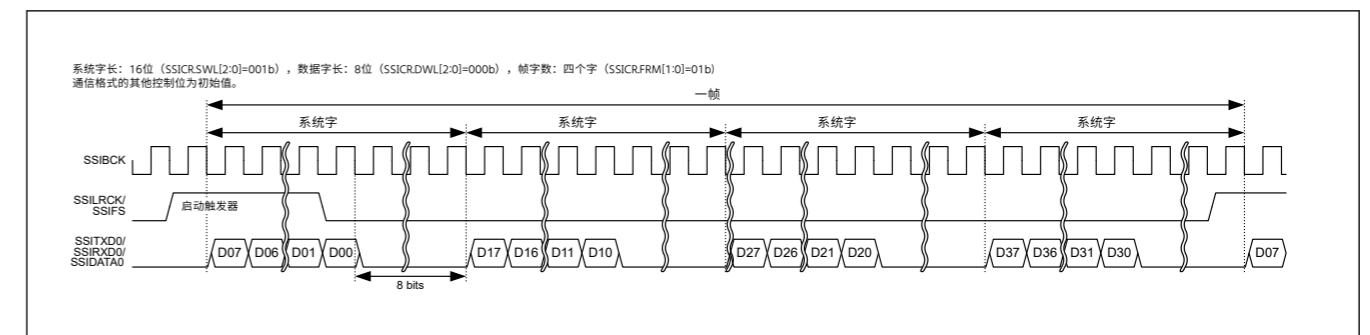


Figure 32.42 TDM格式 (带填充: 系统字长>数据字长)

SSIE处于空闲状态时外部管脚的状态见32.7.1节。空闲状态。

Note: SSIE has the SSILRCK/SSIFS pin, which indicates the synchronization of communication. When SSIE is in slave mode (SSICR.MST = 0), the communication format SSIE uses must match that of the other-party device to communicate. SSIE uses the signal input by the SSILRCK/SSIFS pin only as a trigger to start communication.

### 32.6 Communication Modes

SSIE supports the following communication modes. Table 32.13 lists the control bits that are not available with each communication mode. See section 32.6.1. Slave-mode Communication to section 32.6.5. Transmission and Reception for details of these communication modes.

Table 32.12 Communication modes

| Communication Mode                     | SSICR.MST Bit | SSICR.REN Bit | SSICR.TEN Bit |
|--|---------------|---------------|---------------|
| Slave-mode transmission                | 0             | 0             | 1             |
| Slave-mode reception                   | 0             | 1             | 0             |
| Slave-mode transmission and reception  | 0             | 1             | 1             |
| Master-mode transmission               | 1             | 0             | 1             |
| Master-mode reception                  | 1             | 1             | 0             |
| Master-mode transmission and reception | 1             | 1             | 1             |

Table 32.13 Control bits that cannot be used in each communication mode

| Control Bit    | Slave-mode Reception | Slave-mode Transmission | Slave-mode Transmission and Reception | Master-mode Reception | Master-mode Transmission | Master-mode Transmission and Reception |
|----------------|----------------------|-------------------------|---------------------------------------|-----------------------|--------------------------|--|
| SSICR.CKS      | Invalid              | Invalid                 | Invalid                               | Available             | Available                | Available                              |
| SSICR.CKDV     | Invalid              | Invalid                 | Invalid                               | Available             | Available                | Available                              |
| SSICR.MUEN     | Invalid              | Available               | Available                             | Invalid               | Available                | Available                              |
| SSICR.TEN      | Invalid              | Available               | Available                             | Invalid               | Available                | Available                              |
| SSICR.REN      | Available            | Invalid                 | Available                             | Available             | Invalid                  | Available                              |
| SSIFCR.AUCKEN  | Invalid              | Invalid                 | Invalid                               | Available             | Available                | Available                              |
| SSIFCR.TIE     | Invalid              | Available               | Available                             | Invalid               | Available                | Available                              |
| SSIFCR.RIE     | Available            | Invalid                 | Available                             | Available             | Invalid                  | Available                              |
| SSIFCR.TFRST   | Invalid              | Available               | Available                             | Invalid               | Available                | Available                              |
| SSIFCR.RFRST   | Available            | Invalid                 | Available                             | Available             | Invalid                  | Available                              |
| SSIOFR.BCKASTP | Invalid              | Invalid                 | Invalid                               | Available             | Available                | Available                              |
| SSIOFR.LRCONT  | Invalid              | Invalid                 | Invalid                               | Available             | Available                | Available                              |
| SSIOFR.OMOD    | Available            | Available               | Available                             | Available             | Available                | Available                              |
| SSISCR.TDES    | Invalid              | Available               | Available                             | Invalid               | Available                | Available                              |
| SSISCR.RDFS    | Available            | Invalid                 | Available                             | Available             | Invalid                  | Available                              |

“Invalid” means it has no effect on operation. Writing is possible.

#### 32.6.1 Slave-mode Communication

SSIE operates in slave mode with SSICR.MST = 0. The SSIBCK and SSILRCK/SSIFS signals to be used for serial-data communication must be supplied from an external device. If these signals do not match the communication format set for SSIE, operation is not guaranteed.

#### 32.6.2 Master-mode Communication

SSIE operates in master mode with SSICR.MST = 1. The SSIBCK and SSILRCK/SSIFS signals to be used for serialdata communication must be internally generated from the audio clock. These signals use the format according to the setting of

Note: SSIE有SSILRCKSSIFS引脚，表示通信同步。当SSIE处于从机模式（SSICR.MST=0）时，SSIE使用的通信格式必须与对方设备的通信格式相匹配。SSIE仅使用SSILRCKSSIFS引脚输入的信号作为启动通信的触发器。

### 32.6 通讯方式

SSIE支持以下通信模式。表32.13列出了每种通信模式不可用的控制位。请参阅第32.6.1节。从模式通信到第32.6.5节。有关这些通信模式的详细信息，请参见发送和接收。

Table 32.12 通讯方式

| 通讯方式                     | SSICR.MST Bit | SSICR.REN Bit | SSICR.TEN Bit |
|--------------------------|---------------|---------------|---------------|
| Slave-mode transmission  | 0             | 0             | 1             |
| Slave-mode reception     | 0             | 1             | 0             |
| 从模式发送和接收                 | 0             | 1             | 1             |
| Master-mode transmission | 1             | 0             | 1             |
| Master-mode reception    | 1             | 1             | 0             |
| 主模式传输和接收                 | 1             | 1             | 1             |

Table 32.13 不能在每种通信模式下使用的控制位

| 控制位            | Slave-mode Reception | Slave-mode Transmission | Slave-mode 传输和接收 | Master-mode Reception | Master-mode Transmission | 主模式传输和接收  |
|----------------|----------------------|-------------------------|------------------|-----------------------|--------------------------|-----------|
| SSICR.CKS      | Invalid              | Invalid                 | Invalid          | Available             | Available                | Available |
| SSICR.CKDV     | Invalid              | Invalid                 | Invalid          | Available             | Available                | Available |
| SSICR.MUEN     | Invalid              | Available               | Available        | Invalid               | Available                | Available |
| SSICR.TEN      | Invalid              | Available               | Available        | Invalid               | Available                | Available |
| SSICR.REN      | Available            | Invalid                 | Available        | Available             | Invalid                  | Available |
| SSIFCR.AUCKEN  | Invalid              | Invalid                 | Invalid          | Available             | Available                | Available |
| SSIFCR.TIE     | Invalid              | Available               | Available        | Invalid               | Available                | Available |
| SSIFCR.RIE     | Available            | Invalid                 | Available        | Available             | Invalid                  | Available |
| SSIFCR.TFRST   | Invalid              | Available               | Available        | Invalid               | Available                | Available |
| SSIFCR.RFRST   | Available            | Invalid                 | Available        | Available             | Invalid                  | Available |
| SSIOFR.BCKASTP | Invalid              | Invalid                 | Invalid          | Available             | Available                | Available |
| SSIOFR.LRCONT  | Invalid              | Invalid                 | Invalid          | Available             | Available                | Available |
| SSIOFR.OMOD    | Available            | Available               | Available        | Available             | Available                | Available |
| SSISCR.TDES    | Invalid              | Available               | Available        | Invalid               | Available                | Available |
| SSISCR.RDFS    | Available            | Invalid                 | Available        | Available             | Invalid                  | Available |

“无效”是指对操作没有影响。写作是可能的。

#### 32.6.1 Slave-mode Communication

SSIE在SSICR.MST=0的从机模式下运行。用于串行数据通信的SSIBCK和SSILRCKSSIFS信号必须由外部设备提供。如果这些信号与为SSIE设置的通信格式不匹配，则无法保证操作。

#### 32.6.2 Master-mode Communication

SSIE在SSICR.MST=1的主模式下运行。用于串行数据通信的SSIBCK和SSILRCKSSIFS信号必须由音频时钟在内部生成。这些信号使用根据设置的格式

SSIE. If the communication format the slave device uses does not match the communication format set for SSIE, the operation is unpredictable.

### 32.6.3 Transmission

SSIE transmits serial data to the other-party device when the SSICR.TEN bit is 1 and the SSICR.REN bit is 0. If the communication format the other-party device uses does not match the communication format set for SSIE, the operation is unpredictable.

### 32.6.4 Reception

SSIE receives serial data from the other-party device when the SSICR.TEN bit is 0 and the SSICR.REN bit is 1. If the communication format the other-party device uses does not match the communication format set for SSIE, the operation is unpredictable.

### 32.6.5 Transmission and Reception

SSIE transmits and receives serial data to and from the other-party device when the SSICR.TEN bit is 1 and the SSICR.REN bit is 1. If the communication format the other-party device uses does not match the communication format set for SSIE, the operation is unpredictable.

## 32.7 Operation

SSIE has the following two main operation states [Figure 32.43](#) shows SSIE state transition.

- Idle state (SSISR.IIRQ = 1)
- Communication state (SSISR.IIRQ = 0).

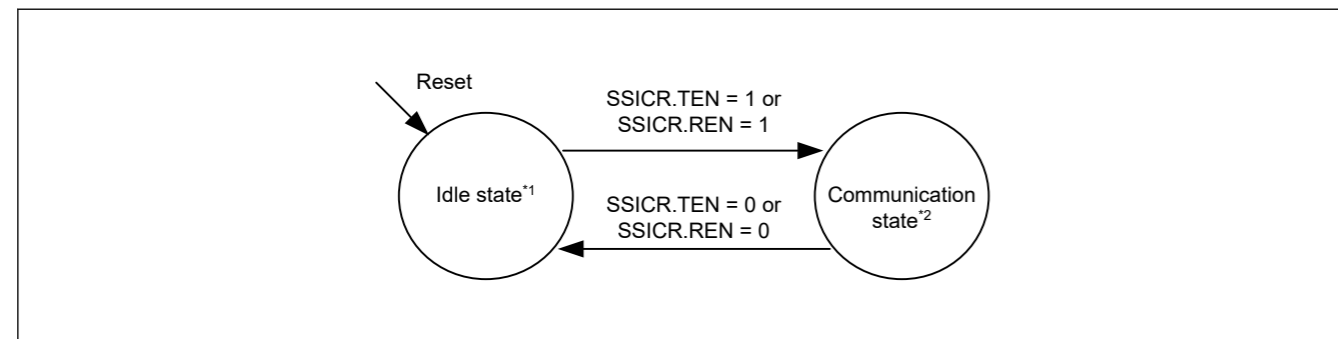


Figure 32.43 SSIE state transition

Note: See [section 32.8.1. Start Communication](#) for details of the idle state.  
See [section 32.8.2. Transmission](#) for details of the communication state.

### 32.7.1 Idle State

In this state, communication of SSIE is halted. If, however, the SSICR.MST bit is 1, output of the BCK and LR clock/frame synchronization signals to external pins can be controlled according to the settings of SSIOFR.BCKASTP and SSIOFR.LRCONT bits. This function is common to all formats. For details, see [Table 32.14](#).

Table 32.14 Output from external pins in the idle state (1 of 2)

| SSICR.MST | SSIOFR.BCKASTP | SSIOFR.LRCONT | Output from Pins |               |                  |
|-----------|----------------|---------------|------------------|---------------|------------------|
|           |                |               | SSIBCK           | SSILRCK/SSIFS | SSITXD0/SSIDATA0 |
| 0         | —              | —             | Stop             | Stop          | Stop             |
| 1         | 0              | 0             | Supply           | Stop          | Stop             |
| 1         | 0              | 1             | Supply           | Supply        | Stop             |
| 1         | 1              | 0             | Stop             | Stop          | Stop             |

SSIE。如果从设备使用的通信格式与为SSIE设置的通信格式不匹配，则操作是不可预测的。

### 32.6.3 Transmission

当SSICR.TEN位为1且SSICR.REN位为0时，SSIE向对方设备发送串口数据。如果对方设备使用的通信格式与为SSIE设置的通信格式不匹配，则操作为不可预料的。

### 32.6.4 Reception

当SSICR.TEN位为0且SSICR.REN位为1时，SSIE从对方设备接收串行数据。如果对方设备使用的通信格式与为SSIE设置的通信格式不匹配，则操作为不可预料的。

### 32.6.5 传输和接收

当SSICR.TEN位为1且SSICR.REN位为1。如果对方设备使用的通信格式与为SSIE设置的通信格式不匹配，则操作不可预知。

## 32.7 Operation

SSIE有以下两个主要操作状态图32.43显示了SSIE状态转换。

- 空闲状态 (SSISR.IIRQ=1)
- 通信状态 (SSISR.IIRQ=0)。

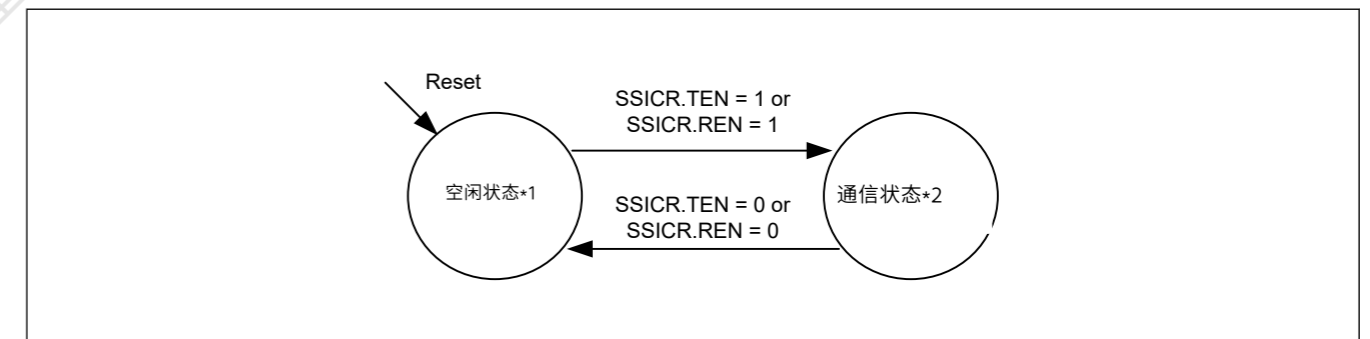


Figure 32.43 SSIE状态转换

Note: 请参阅第32.8.1节。开始通信以了解空闲状态的详细信息。  
请参阅第32.8.2节。传输以获取通信状态的详细信息。

### 32.7.1 空闲状态

在这种状态下，SSIE的通信停止。但是，如果SSICR.MST位为1，则可以根据SSIOFR.BCKASTP和SSIOFR.LRCONT位的设置来控制向外部引脚输出BCK和LR时钟帧同步信号。此功能适用于所有格式。详见表32.14。

Table 32.14 空闲状态下外部引脚的输出 (2个中的1个)

| SSICR.MST | SSIOFR.BCKASTP | SSIOFR.LRCONT | 引脚输出   |               |                  |
|-----------|----------------|---------------|--------|---------------|------------------|
|           |                |               | SSIBCK | SSILRCK/SSIFS | SSITXD0/SSIDATA0 |
| 0         | —              | —             | Stop   | Stop          | Stop             |
| 1         | 0              | 0             | Supply | Stop          | Stop             |
| 1         | 0              | 1             | Supply | Supply        | Stop             |
| 1         | 1              | 0             | Stop   | Stop          | Stop             |

Table 32.14 Output from external pins in the idle state (2 of 2)

| SSICR.MST | SSIOFR.BCKASTP | SSIOFR.LRCONT | Output from Pins |               |                  |
|-----------|----------------|---------------|------------------|---------------|------------------|
|           |                |               | SSIBCK           | SSILRCK/SSIFS | SSITXD0/SSIDATA0 |
| 1         | 1              | 1             | Stop             | Supply        | Stop             |

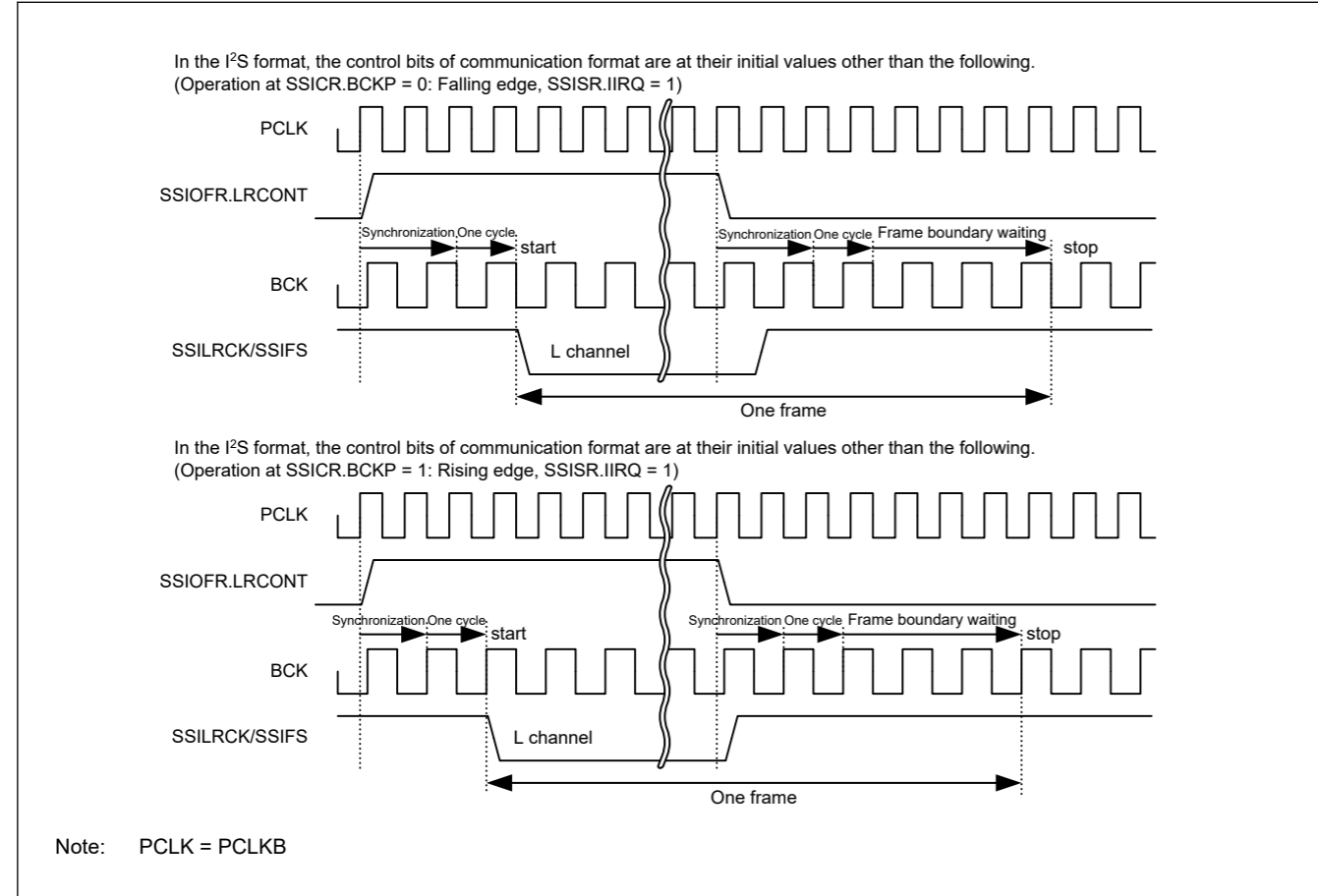


Figure 32.44 Example of disabling LR clock/frame synchronization continuation by SSIOFR.LRCONT

Note: To stop the output to the SSILRCK/SSIFS pin with SSIOFR.LRCONT when SSIE is in the idle state in mastermode communication (SSICR.MST = 1), note the following: The output stops when the value of the SSIOFR.LRCONT bit is changed from 1 to 0. Make sure that the other-party device is not affected.

Table 32.14 空闲状态下外部引脚的输出 (2个中的2个)

| SSICR.MST | SSIOFR.BCKASTP | SSIOFR.LRCONT | 引脚输出   |               |                  |
|-----------|----------------|---------------|--------|---------------|------------------|
|           |                |               | SSIBCK | SSILRCK/SSIFS | SSITXD0/SSIDATA0 |
| 1         | 1              | 1             | Stop   | Supply        | Stop             |

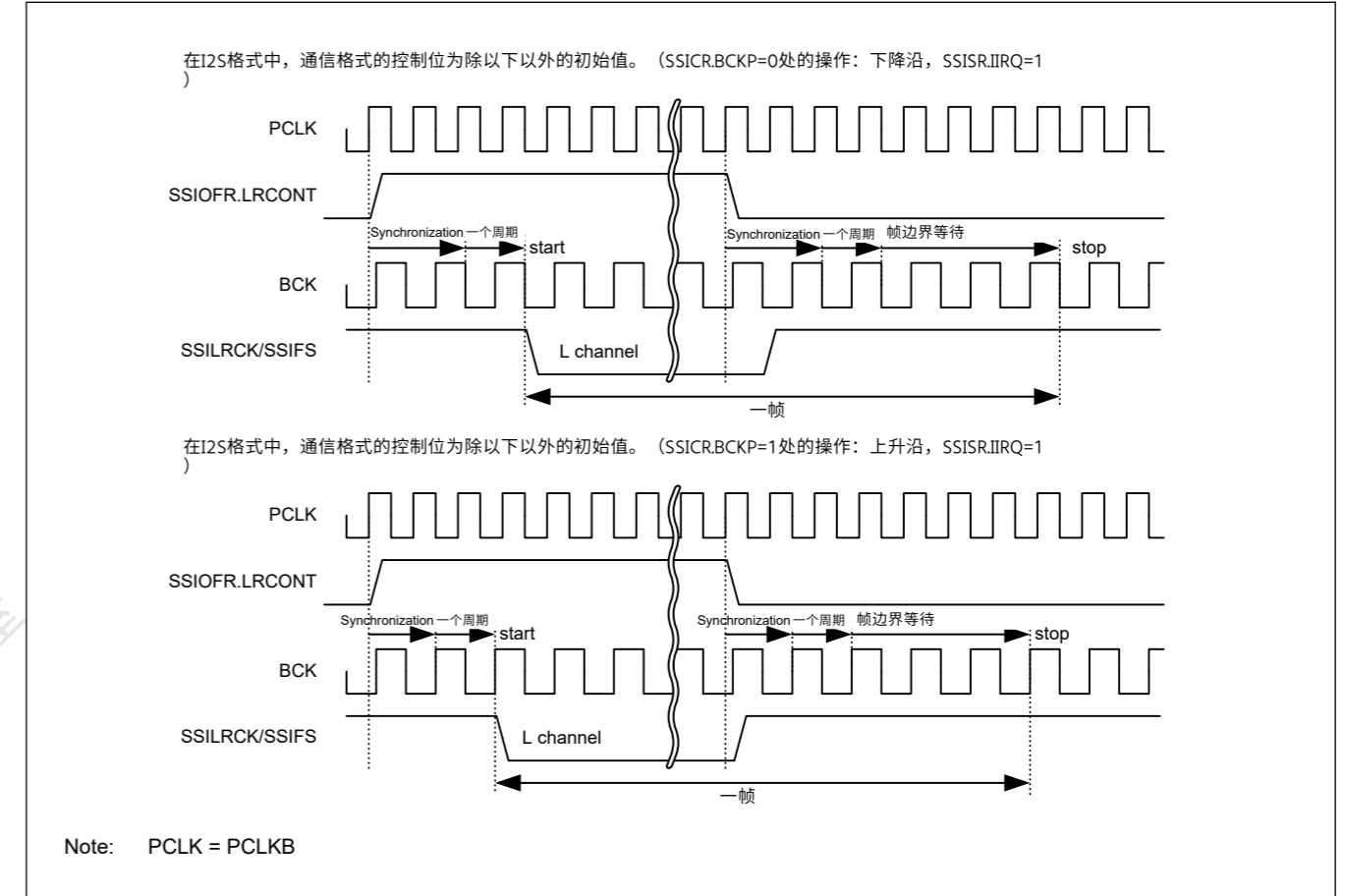


Figure 32.44 通过SSIOFR.LRCONT禁用LR时钟帧同步继续的示例

Note: 要在主模式通信 (SSICR.MST=1) 中SSIE处于空闲状态时通过SSIOFR.LRCONT停止向SSILRCKSSIFS引脚的输出，请注意以下几点：当SSIOFR.LRCONT位的值从1比0。确保对方设备不受影响。



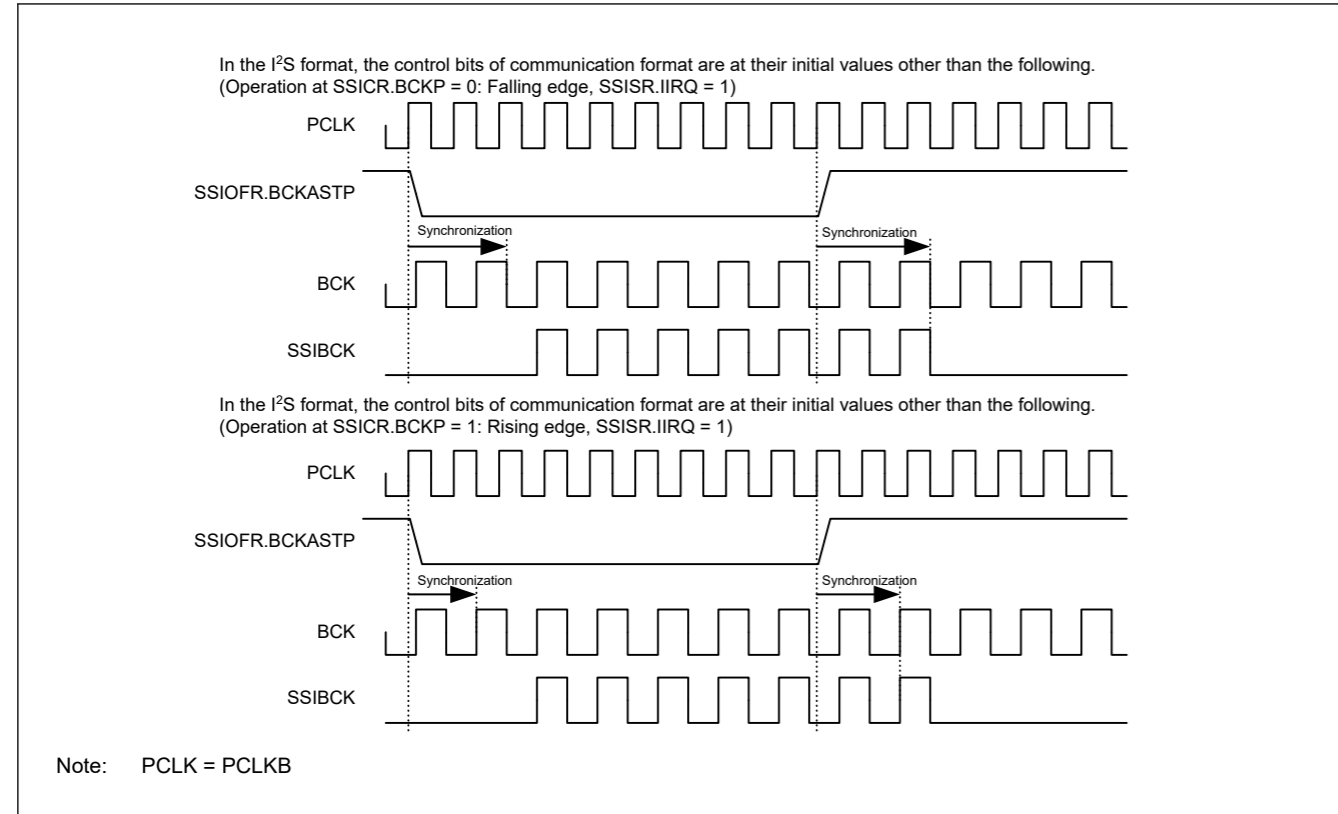


Figure 32.45 Example of stopping SSIBCK with SSIOFR.BCKASTP

Note: To stop the output to the SSIBCK pin with SSIOFR.BCKASTP in master-mode communication (SSICR.MST = 1) and while SSIE is in the idle state, note the following: The output stops when the value of the SSIOFR.BCKASTP bit is changed from 0 to 1. So, make sure that the other-party device is not affected.

### 32.7.2 Communication States

In this state, SSIE is during communication. Figure 32.46 shows transitions of communication states and Table 32.15 lists the conditions for transition. If the transition condition is not satisfied, the state does not transit.

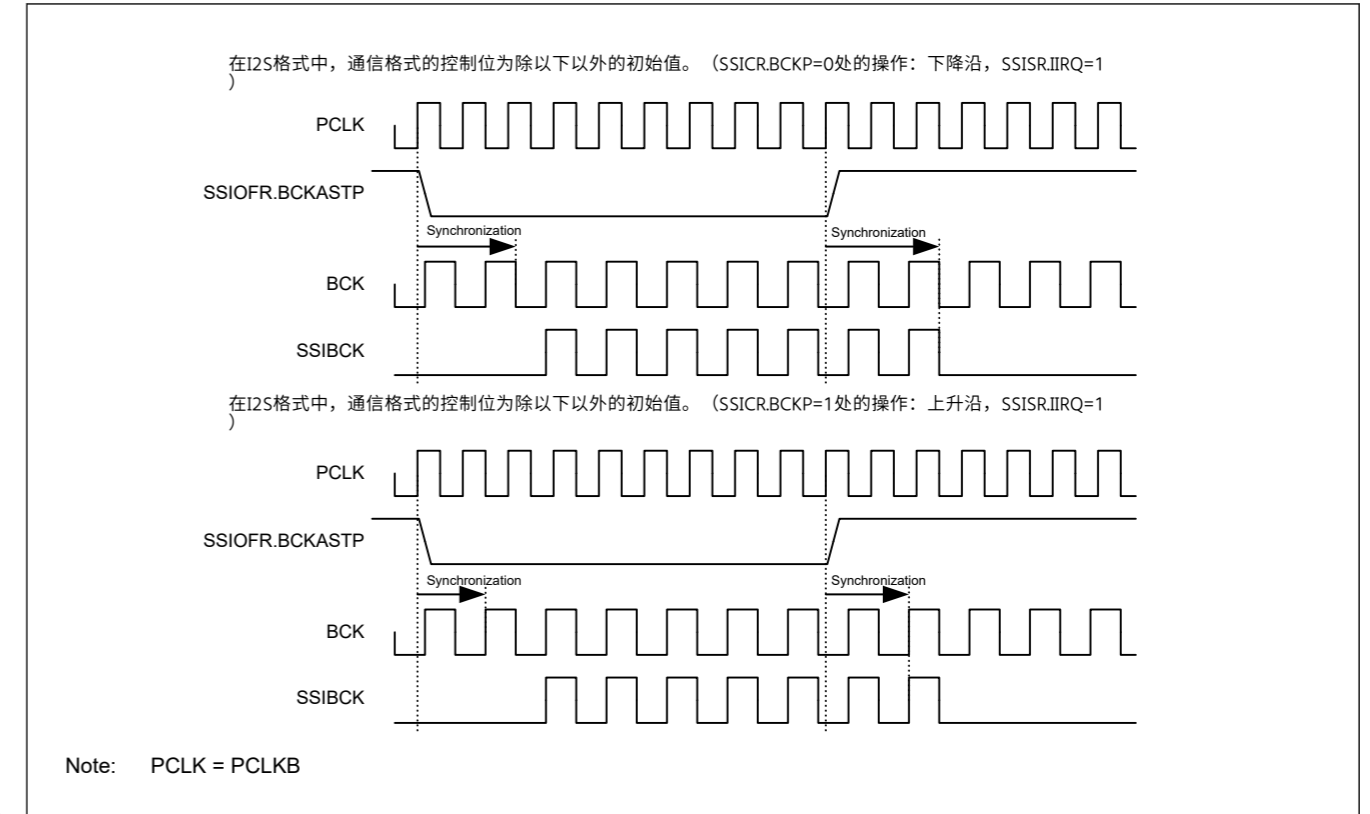


Figure 32.45 使用SSIOFR.BCKASTP停止SSIBCK的示例

Note: 要在主模式通信(SSICR.MST=1)和SSIE处于空闲状态时使用SSIOFR.BCKASTP停止向SSIBCK引脚的输出, 请注意以下几点: 当SSIOFR.BCKASTP位的值为从0变为1。因此, 请确保对方设备不受影响。

### 32.7.2 通讯状态

在此状态下, SSIE处于通信过程中。图32.46显示了通信状态的转换, 表32.15列出了转换的条件。如果不满足转移条件, 则状态不转移。

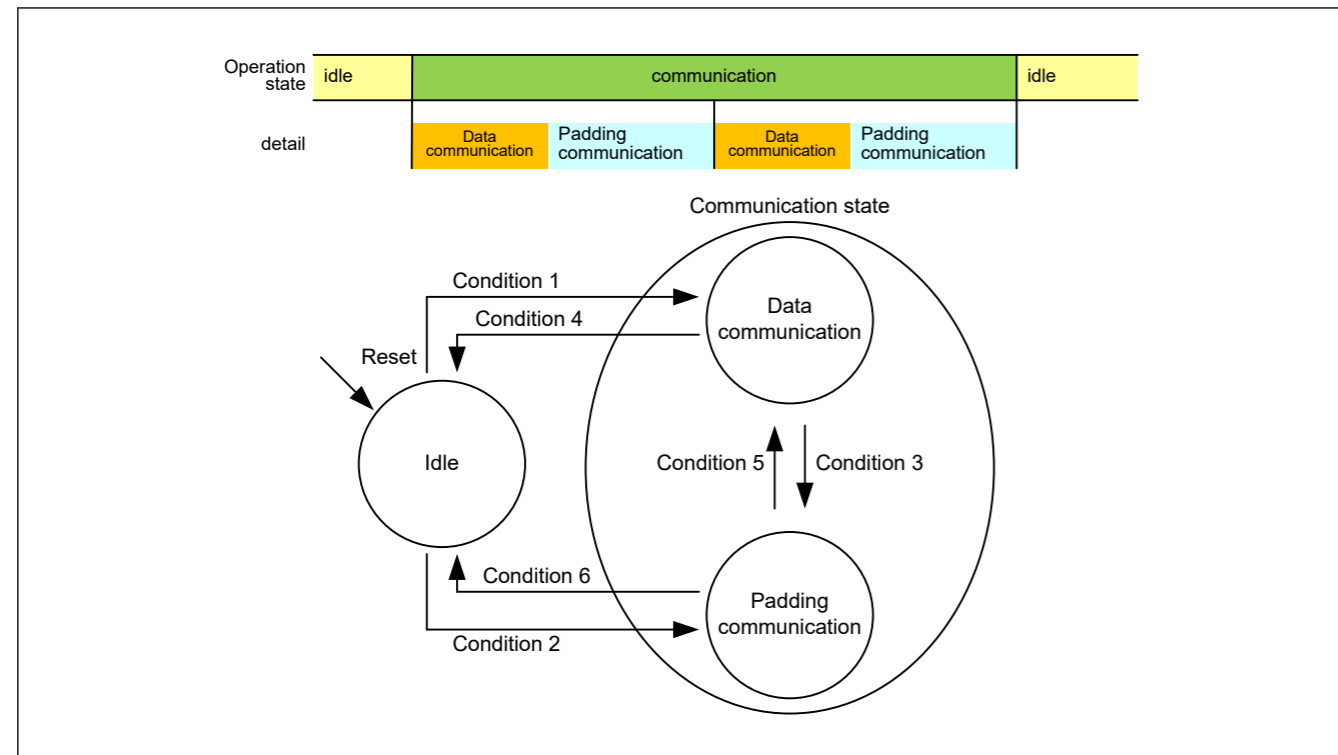


Figure 32.46 Communication state transition

Table 32.15 Condition for communication state transition

| Condition Number | Condition for Transition  |
|------------------|---|
| 1                | Writing SSICR.TEN = 1 or SSICR.REN = 1 while SSICR.SDTA = 0 or in the setting without padding bits.   |
| 2                | Writing SSICR.TEN = 1 or SSICR.REN = 1 while SSICR.SDTA = 1 and in the setting with padding bits.   |
| 3                | The following three conditions are all met: <ul style="list-style-type: none"> <li>SSICR.TEN = 1 or SSICR.REN = 1</li> <li>In the setting with padding bits</li> <li>The last bit of the data words has been transferred.</li> </ul>                |
| 4                | Both the following two conditions are met: <ul style="list-style-type: none"> <li>SSICR.SDTA = 1 or without padding bits</li> <li>While SSICR.TEN = 0 and SSICR.REN = 0, the last bit of the data words in a frame has been transferred.</li> </ul> |
| 5                | Transfer of the last padding bit is completed while SSICR.TEN = 1 or SSICR.REN = 1  |
| 6                | Both the following two conditions are met: <ul style="list-style-type: none"> <li>SSICR.SDTA = 0 and with padding bits</li> <li>While SSICR.TEN = 0 and SSICR.REN = 0, the last padding bit has been transferred.</li> </ul>                        |

See Table 32.11 for the setting with/without padding bits.

### 32.7.2.1 Data communication state

In this state, SSIE is during communication. Data of the data word length set with the SSICR.DWL[2:0] bits is transmitted, received, or transmitted and received.

- State Transition in the Setting without Padding Bits

During communication (SSISR.IIRQ = 0), SSIE is during data communication for all the time. By disabling transmission and reception (SSICR.TEN = 0, SSICR.REN = 0), SSIE transits to the idle state. For details, see Figure 32.47 and Figure 32.48.

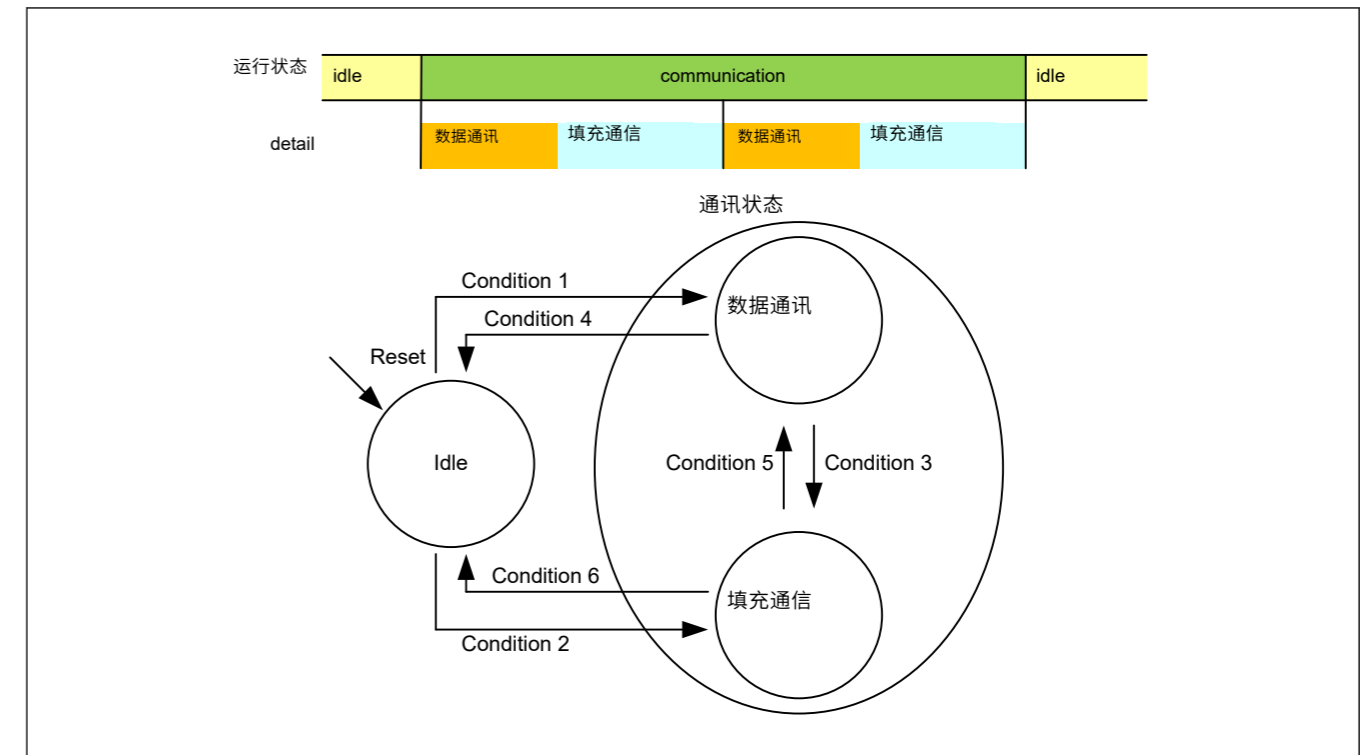


Figure 32.46 通信状态转换

Table 32.15 通信状态转移的条件

| 条件编号 | 过渡条件   |
|------|--|
| 1    | 在SSICR.SDTA=0或在没有填充位的设置中写入SSICR.TEN=1或SSICR.REN=1。   |
| 2    | 写入SSICR.TEN=1或SSICR.REN=1而SSICR.SDTA=1并在设置中使用填充位。  |
| 3    | 满足以下三个条件： <ul style="list-style-type: none"> <li>在带有填充位的设置中</li> <li>数据字的最后一位已传输。</li> </ul>                                       |
| 4    | 同时满足以下两个条件： <ul style="list-style-type: none"> <li>SSICR.SDTA=1或无填充位</li> <li>当SSICR.TEN=0和SSICR.REN=0时，帧中数据字的最后一位已被传输。</li> </ul> |
| 5    | 当SSICR.TEN=1或SSICR.REN=1时，最后一个填充位的传输完成   |
| 6    | 同时满足以下两个条件： <ul style="list-style-type: none"> <li>SSICR.SDTA=0并带有填充位</li> <li>当SSICR.TEN=0和SSICR.REN=0时，最后一个填充位已被传输。</li> </ul>   |

有关不带填充位的设置，请参见表32.11。

### 32.7.2.1 数据通讯状态

在此状态下，SSIE处于通信过程中。使用SSICR.DWL[2:0]位设置的数据字长的数据被发送、接收或发送和接收。

- 无填充位设置中的状态转换

在通信期间（SSISR.IIRQ=0），SSIE一直处于数据通信期间。通过禁用发送和接收（SSICR.TEN=0，SSICR.REN=0），SSIE转换到空闲状态。详见图32.47和图32.48。

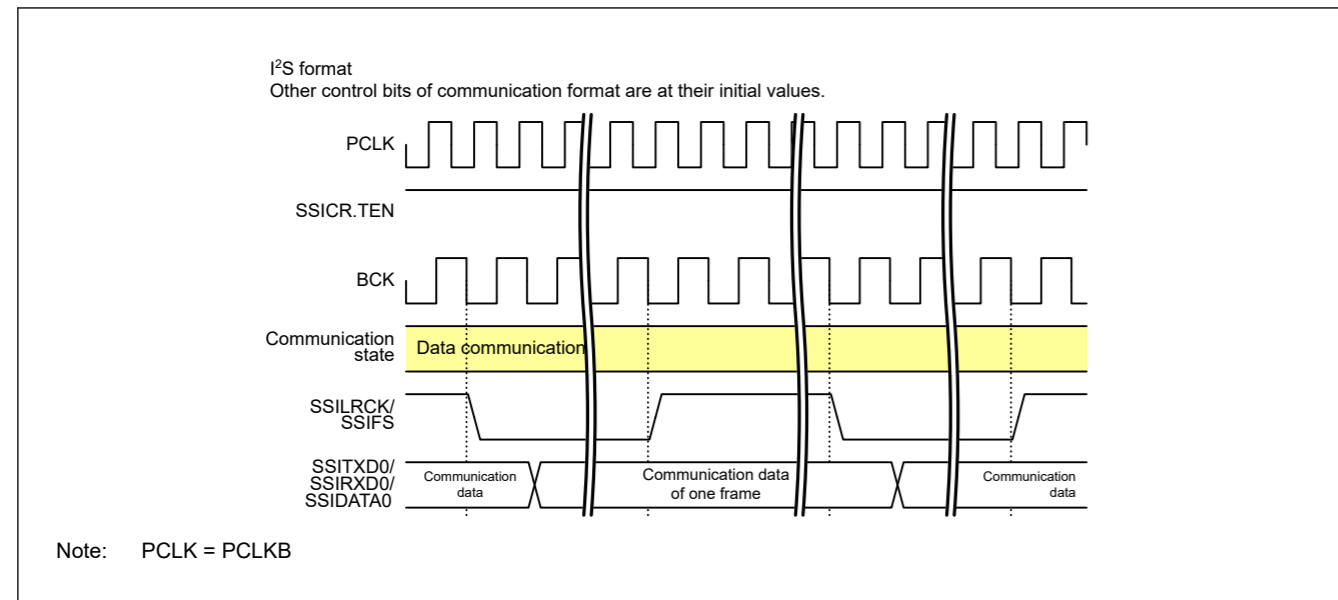


Figure 32.47 Continuation of the data communication

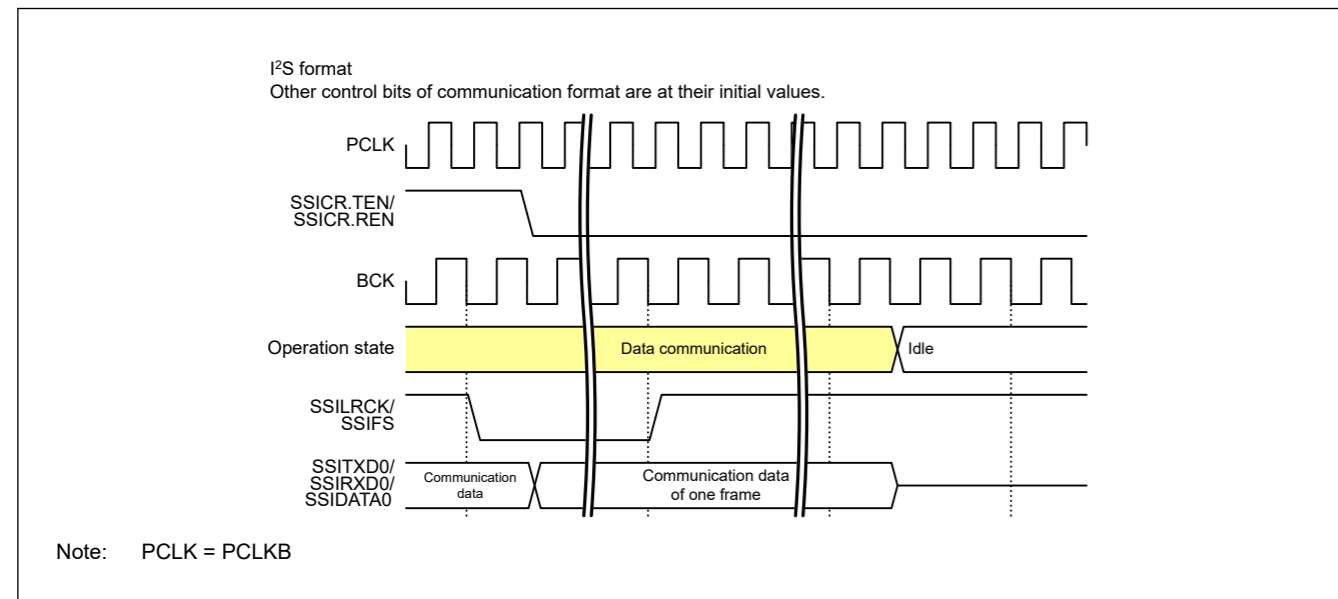


Figure 32.48 Halt from the data communication (without padding bits)

- State Transition in the Setting with Padding Bits

When SSIE ends transfer of the last bit of a data word during communication (SSISR.IIRQ = 0), SSIE transitions from the data communication state to the padding communication state in Figure 32.49. Except in the status with SSICR.SDTA = 1 and transmission and reception disabled (SSICR.TEN = 0 and SSICR.REN = 0), SSIE transitions from the data communication state to the idle state when it stops communication in Figure 32.51.

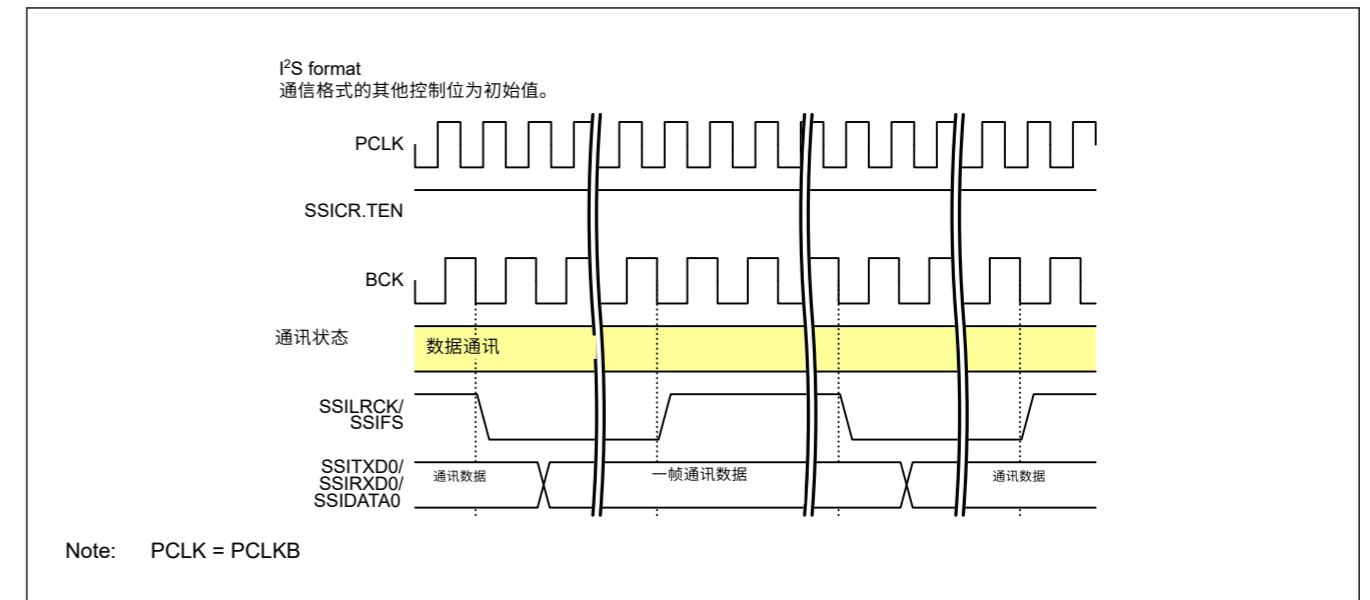


Figure 32.47 继续数据通信

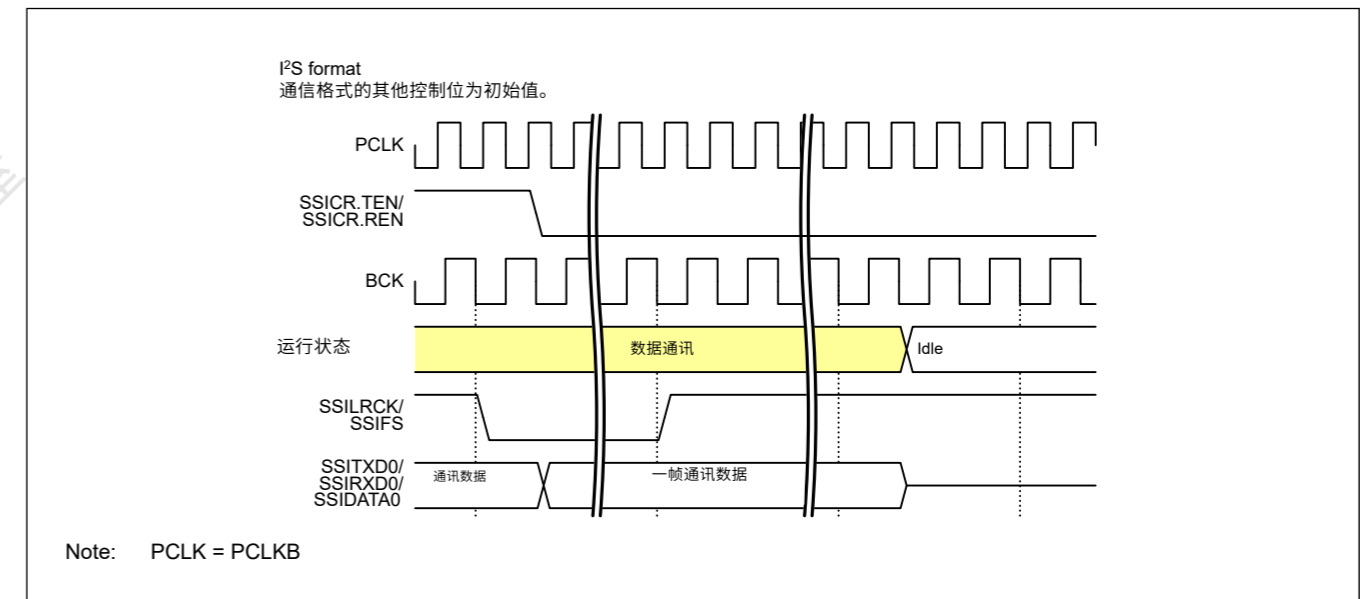


Figure 32.48 停止数据通信（无填充位）

- 具有填充位的设置中的状态转换

当SSIE在通信期间结束数据字的最后一位传输时（SSISR.IIRQ=0），SSIE从数据通信状态转换到图32.49中的填充通信状态。除了在SSICR.SDTA=1和发送和接收禁用的状态下（SSICR.TEN=0和SSICR.REN=0），SSIE在图32.51中停止通信时从数据通信状态转换到空闲状态。

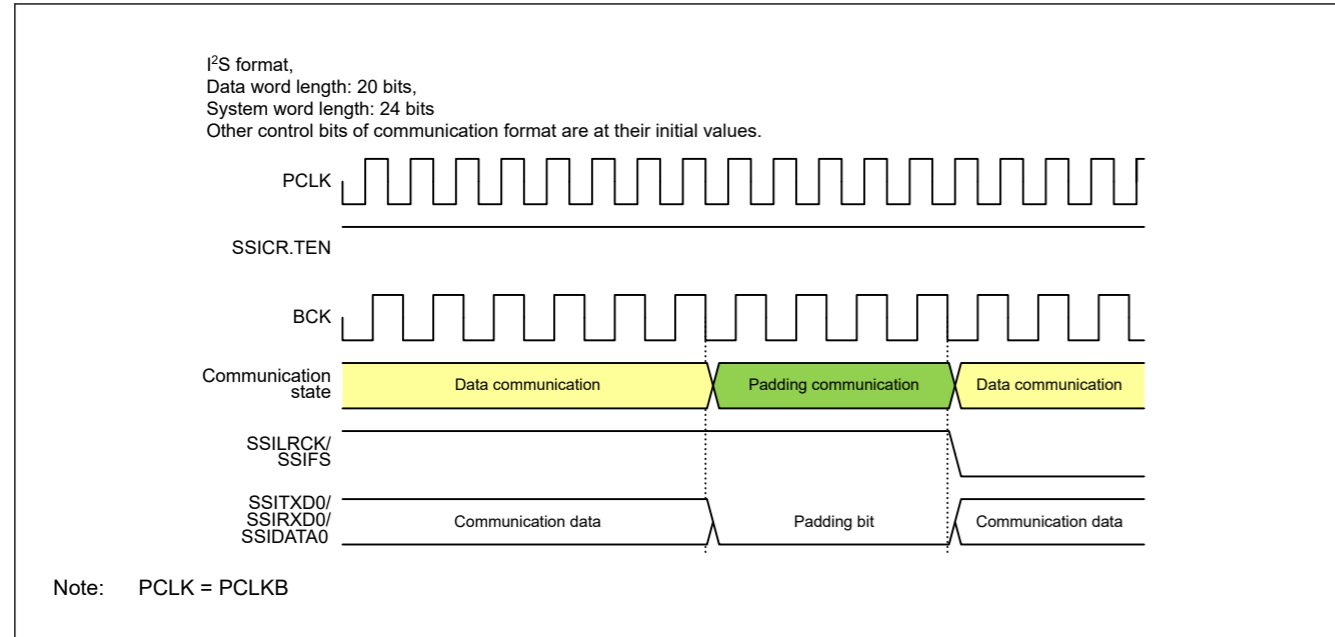


Figure 32.49 Transition from data communication to padding communication

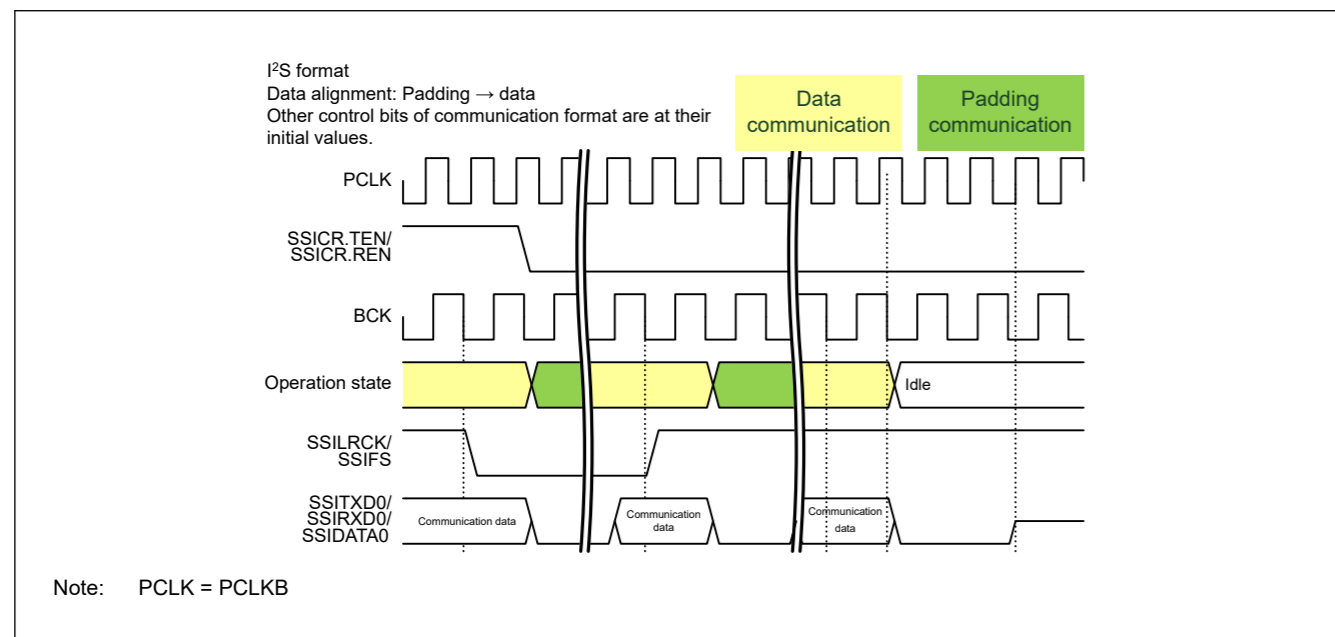


Figure 32.50 Halt from data communication (with padding bits)

### 32.7.2.2 Padding communication

In this state, SSIE is during communication. The padding bits set with the SSICR.SWL[2:0] bits and SSICR.DWL[2:0] bits are transmitted, received, or transmitted and received.

- State Transition in the Setting with Padding Bits

When SSIE ends transfer of the last padding bit during communication (SSISR.IIRQ = 0), SSIE transitions to the data communication state in Figure 32.49. If SSIE is in the status with SSICR.SDTA = 0 and transmission and reception disabled (SSICR.TEN = 0 and SSICR.REN = 0), SSIE transitions from the padding communication state to the idle state when it stops communication in Figure 32.51.

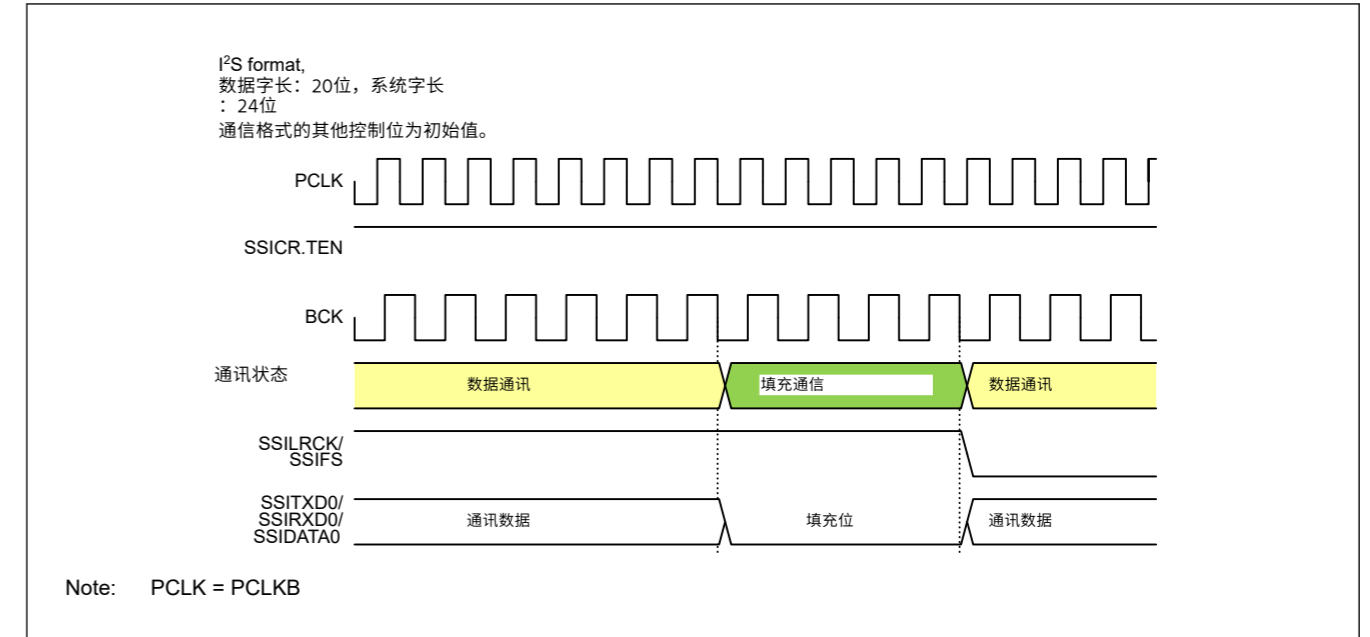


Figure 32.49 从数据通经过渡到填充通信

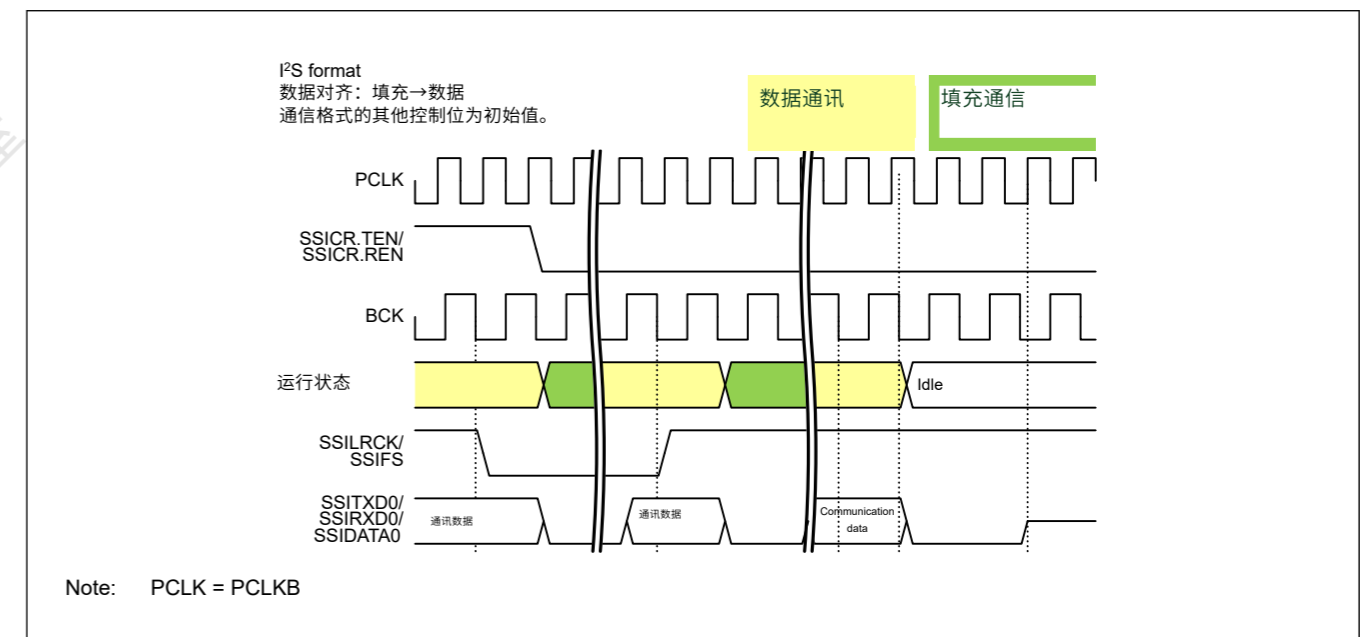


Figure 32.50 停止数据通信 (使用填充位)

### 32.7.2.2 填充通信

在此状态下, SSIE处于通信过程中。使用SSICR.SWL[2:0]位和SSICR.DWL[2:0]位设置的填充位被发送、接收或发送和接收。

- 具有填充位的设置中的状态转换

当SSIE在通信期间结束最后一个填充位的传输 (SSISR.IIRQ=0) 时, SSIE转换到图32.49中的数据通信状态。如果SSIE处于SSICR.SDTA=0且发送和接收禁用的状态 (SSICR.TEN=0和SSICR.REN=0), 则SSIE在图32.51中停止通信时从填充通信状态转换为空闲状态。



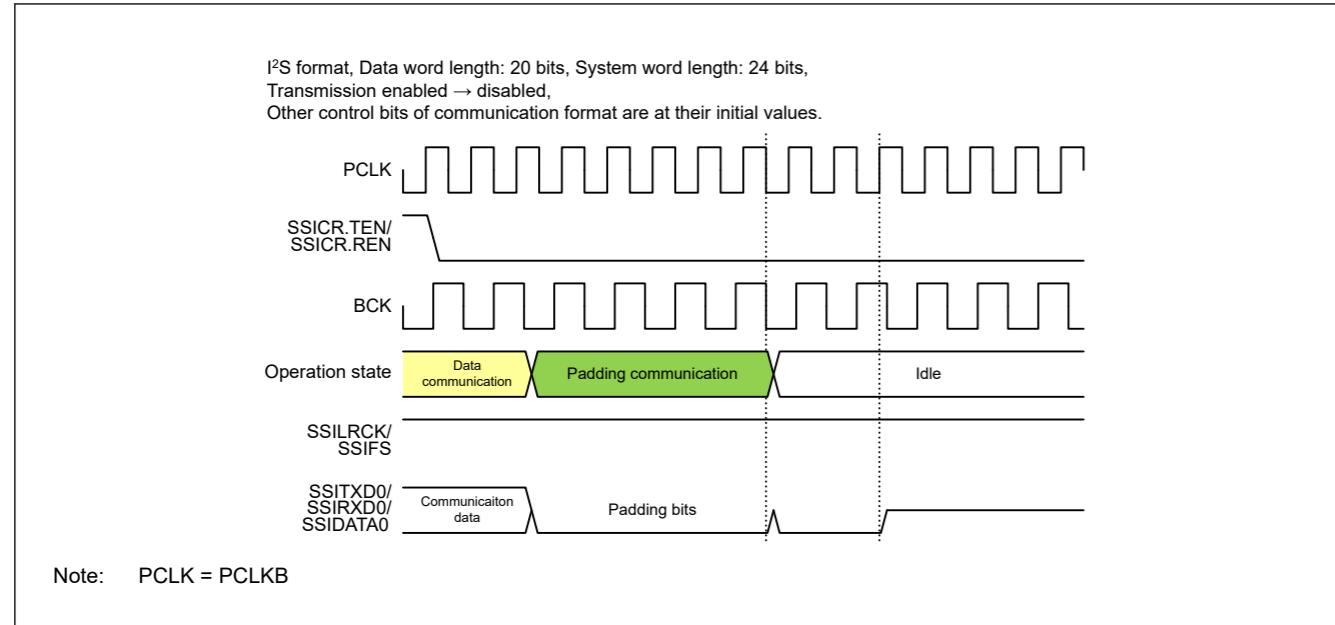


Figure 32.51 Halt from the padding communication

### 32.8 Communication Operation

Figure 32.52 shows the communication flow of SSIE.

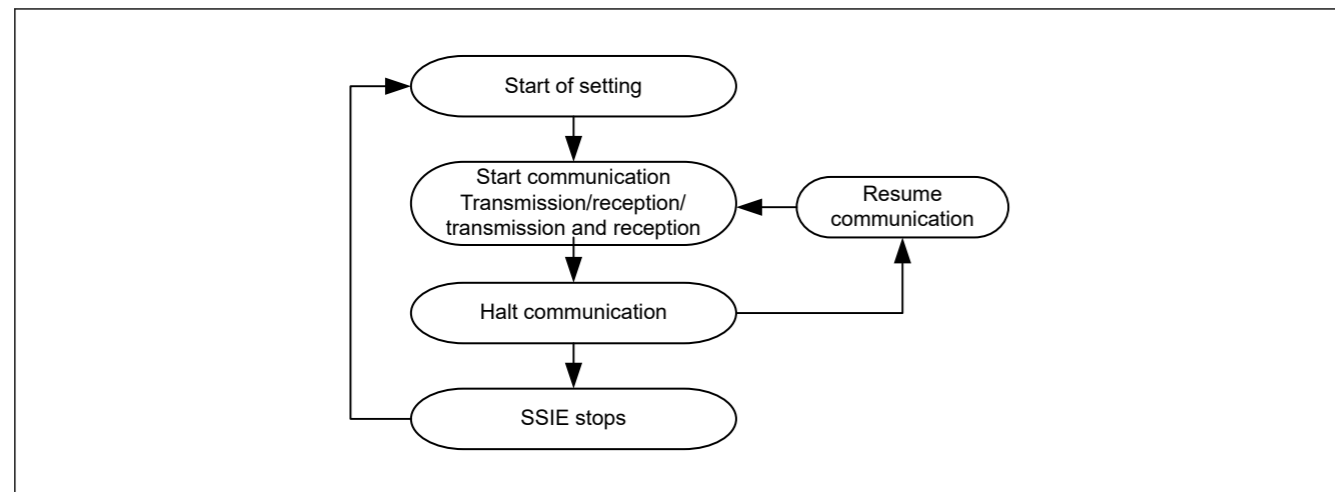


Figure 32.52 SSIE communication operation

The procedure of each operation is described from [section 32.8.1. Start Communication](#) to [section 32.8.7. Resume Communication](#).

#### 32.8.1 Start Communication

This section describes how to start communication of SSIE. [Figure 32.53](#) shows the procedure to start communication. Be sure to follow the procedure. See [section 32.8.2. Transmission](#) for transmission operation and [section 32.8.3. Reception](#) for reception operation.

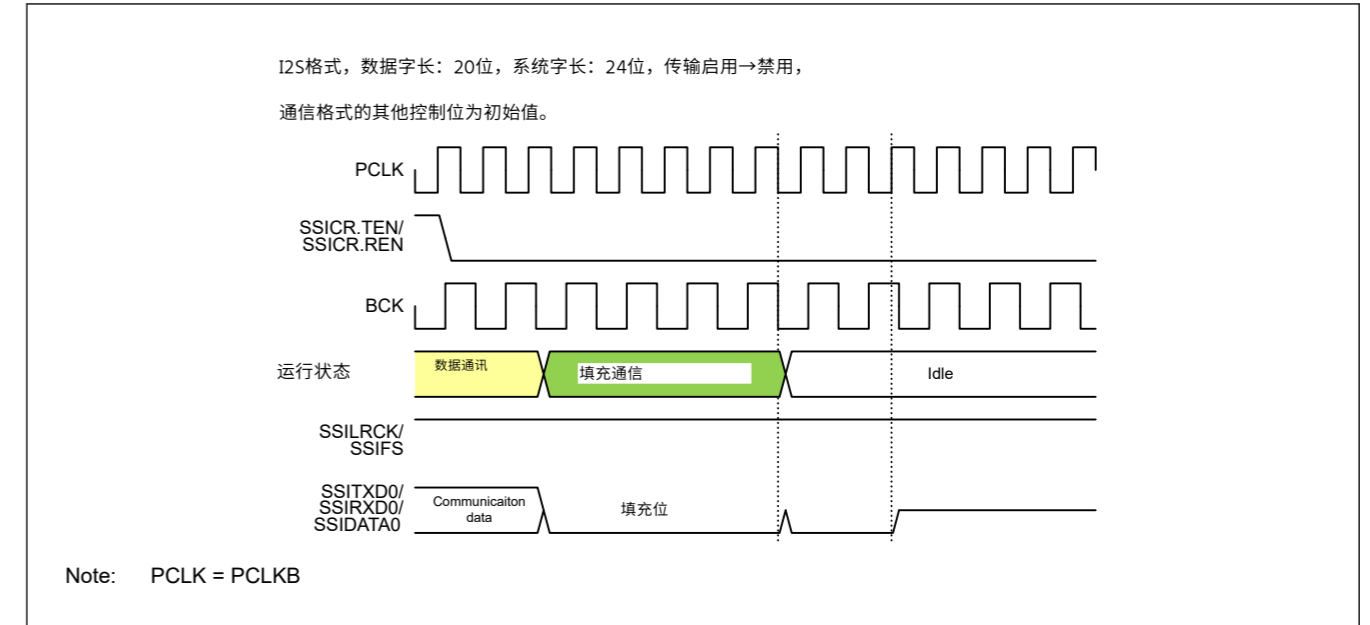


Figure 32.51 从填充通信中停止

### 32.8 通讯操作

图32.52显示了SSIE的通信流程。

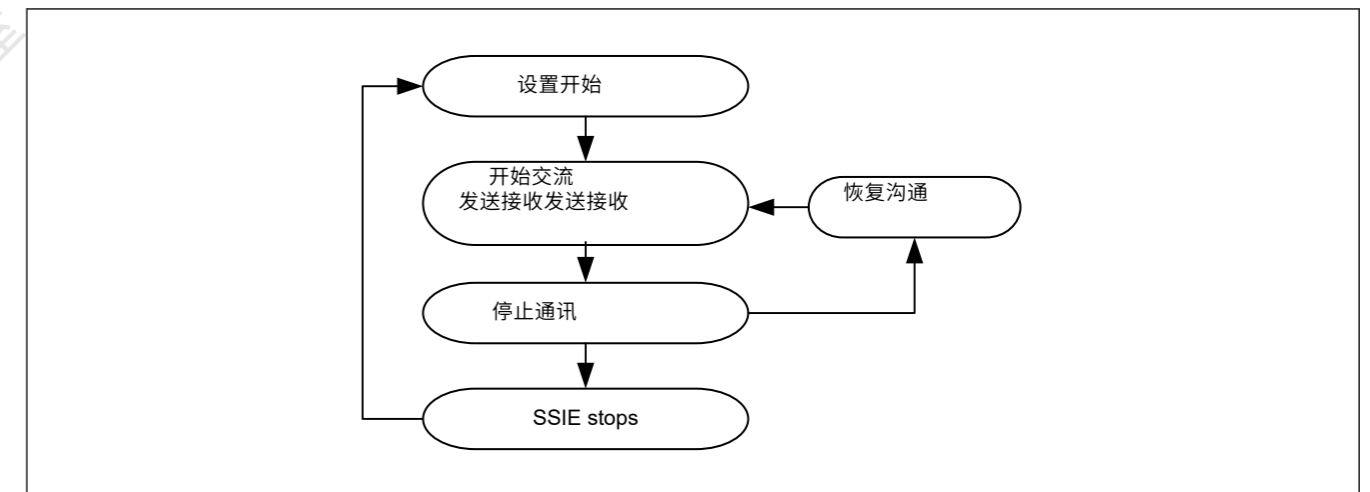


Figure 32.52 SSIE通信操作

每个操作的过程在第32.8.1节中描述。开始与第32.8.7节的通信。恢复Communication.

#### 32.8.1 开始沟通

本节介绍如何启动SSIE通信。图32.53显示了开始通信的过程。请务必遵守程序。请参阅第32.8.2节。传输操作和第32.8.3节的传输。接收操作的接收。

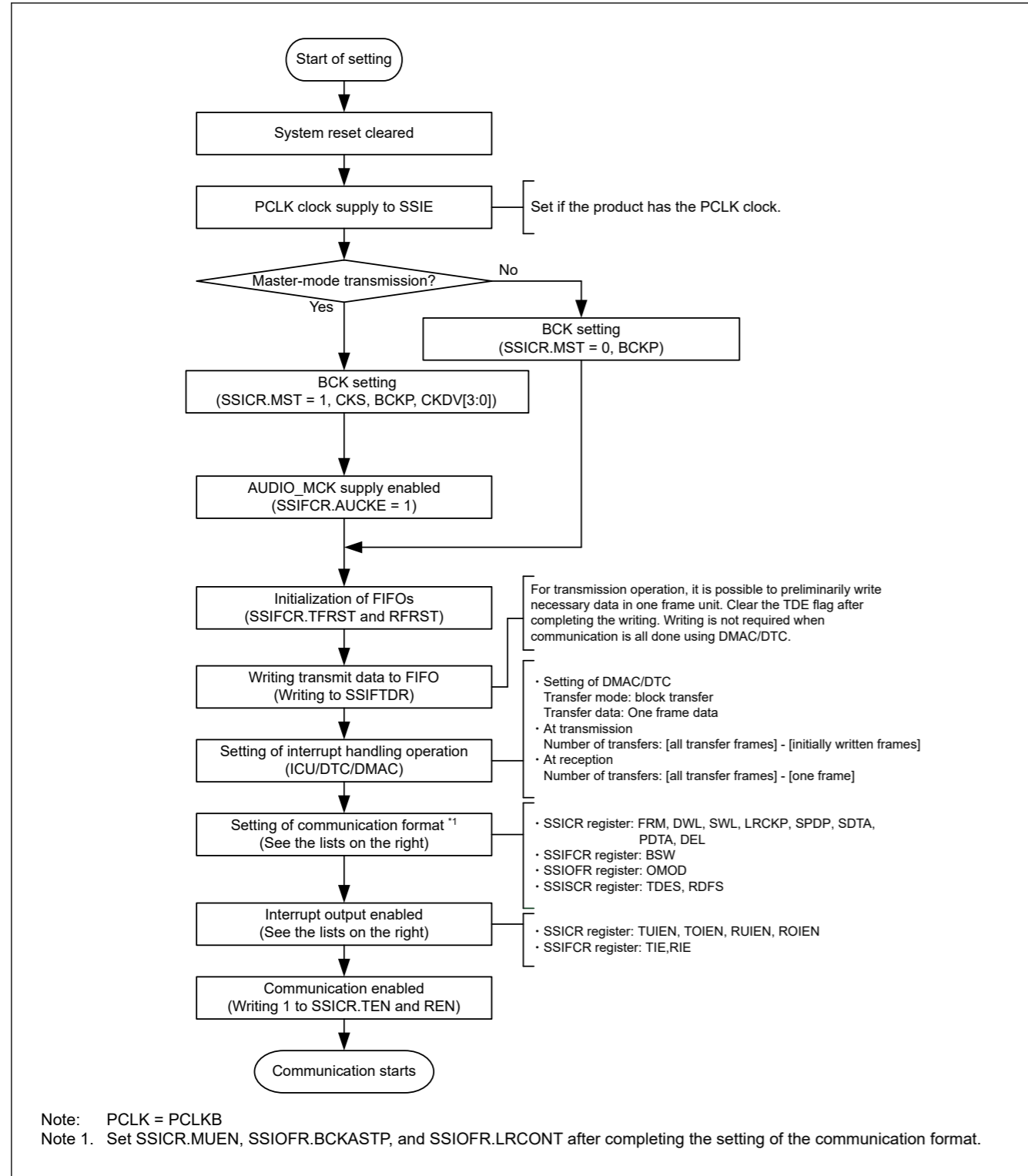


Figure 32.53 Procedure to start communication (CPU operation procedure)

SSIE can perform continuous communication based on interrupts by the DTC/DMAC. For transmission, write 1 to SSIFCR.TIE, SSICR.TUIEN, and SSICR.TOIE. For reception, write 1 to SSIFCR.RIE, SSICR.RUIEN, and SSICR.ROIEN.

### 32.8.2 Transmission

The transmission procedure in Figure 32.54 must be followed throughout a transmission operation.

After transmission is enabled (SSICR.TEN = 1 and SSICR.REN = 0), SSIE starts transmission when a start trigger is generated by SSILRCK/SSIFS with the serial data for at least a frame contained in the transmit FIFO data register

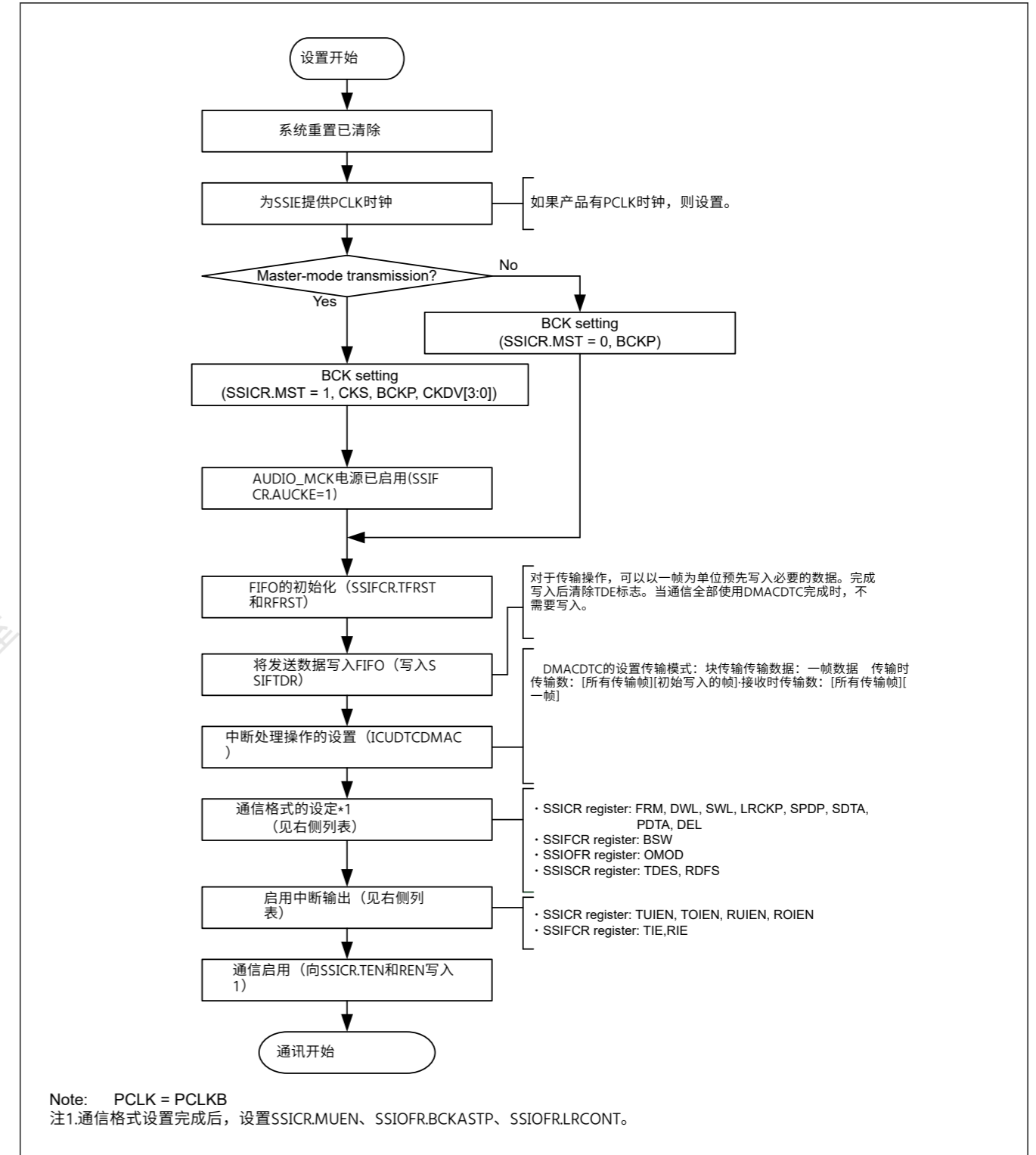


Figure 32.53 开始通信的步骤 (CPU操作步骤)

SSIE可以根据DTCDMAC的中断执行连续通信。对于传输, 写入1到SSIFCR.TIE、SSICR.TUIEN和SSICR.TOIE。对于接收, 将1写入SSIFCR.RIE、SSICR.RUIEN和SSICR.ROIEN。

### 32.8.2 Transmission

在整个传输操作中必须遵循图32.54中的传输过程。

使能传输后 (SSICR.TEN=1和SSICR.REN=0), 当SSILRCK/SSIFS使用发送FIFO数据寄存器中包含的至少一帧的串行数据生成启动触发时, SSIE开始传输

(SSIFTDR). SSIE outputs a transmit data empty interrupt to the DTC/DMAC according to the TDE setting condition (SSISCR.TDES) and the status of transmit data empty interrupt enable (SSIFCR.TIE) bit specified in the communication start procedure. This interrupt requests writing to the transmit FIFO data register (SSIFTDR). In the communication start procedure, specify writing to the transmit FIFO data register (SSIFTDR) as the DTC/DMAC operation in response to the transmit data empty interrupt. With this setting, SSIE can continuously transmit data not through the CPU. The transmit data empty interrupt is generated when the free space size of transmit FIFO data register reaches the value set in SSISCR.TDES. The number of times of writing must be specified in accordance with the free space size of the transmit FIFO data register indicated by the transmit data empty interrupt. If an error occurs, perform the error-handling procedure as instructed in the communication stop procedure.

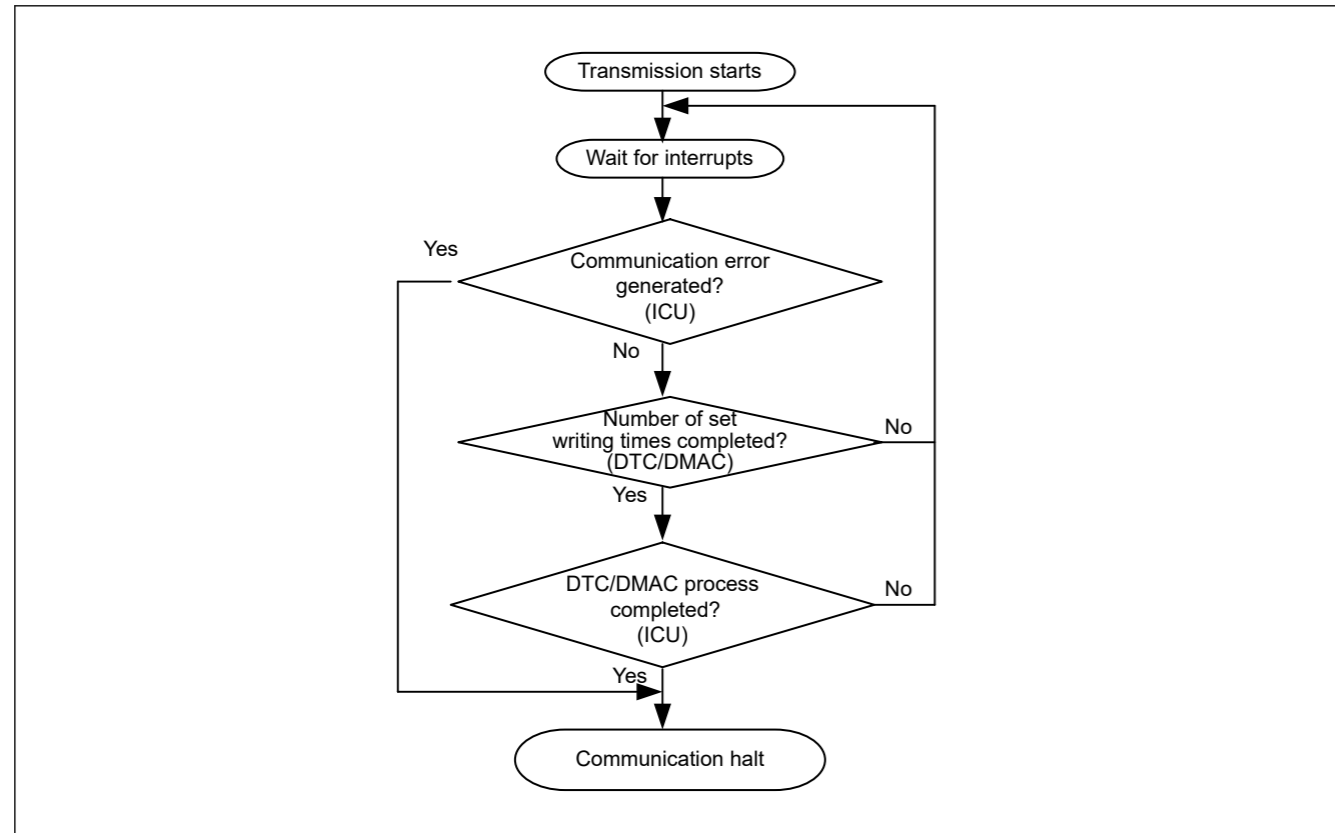


Figure 32.54 Transmission procedure

Note: The communication flow defined in SSIE uses the DTC/DMAC. If you do not use the DTC/DMAC, perform polling of the value 1 of SSIFSR.TDE to write data to SSIFTDR. The number of times of writing data to SSIFTDR by detecting the value 1 of SSIFSR.TDE must be in accordance with the free space size of the transmit FIFO data register specified by SSISCR.TDES. After as much transmit data as the free space size is written to SSIFTDR, the SSIFSR.TDE flag must be cleared. Continuous transmission is enabled by repeating data writing. If the SSIFSR.TDE flag is not cleared, the flag is not cleared automatically.

### 32.8.3 Reception

The reception procedure in Figure 32.55 must be followed throughout a reception operation.

After reception is enabled (SSICR.TEN = 0 and SSICR.REN = 1), SSIE starts reception when a start trigger is generated by SSILRCK/SSIFS. SSIE outputs a receive data full interrupt to the DTC/DMAC according to the RDF setting condition (SSISCR.RDFS) and the status of receive data full interrupt enable (SSIFCR.RIE) bit specified in the communication start procedure. This interrupt requests data reading from the receive FIFO data register (SSIFRDR). In the communication start procedure, specify reading from the receive FIFO data register (SSIFRDR) as the DTC/DMAC operation in response to the receive data full interrupt. With this setting, SSIE can continuously read data not through the CPU. The receive data full interrupt is generated when data as much as the capacity of receive FIFO data register has been stored. The number of times of reading must be specified in accordance with the data size of the receive FIFO data register indicated by the receive data full interrupt. If an error occurs, perform the error-handling procedure as instructed in the communication stop procedure.

(SSIFTDR)。SSIE根据通信启动过程中指定的TDE设置条件(SSISCR.TDES)和发送数据空中断使能(SSIFCR.TIE)位的状态，向DTCDMAC输出一个发送数据空中断。该中断请求写入发送FIFO数据寄存器(SSIFTDR)。在通信开始过程中，将写入发送FIFO数据寄存器(SSIFTDR)指定为DTCDMAC操作以响应发送数据空中断。使用此设置，SSIE可以不通过CPU连续传输数据。当发送FIFO数据寄存器的可用空间大小达到SSISCR.TDES中设置的值时，将产生发送数据空中断。写入次数必须根据发送数据空中断指示的发送FIFO数据寄存器的空闲空间大小来指定。如果发生错误，请按照通信停止程序中的说明执行错误处理程序。

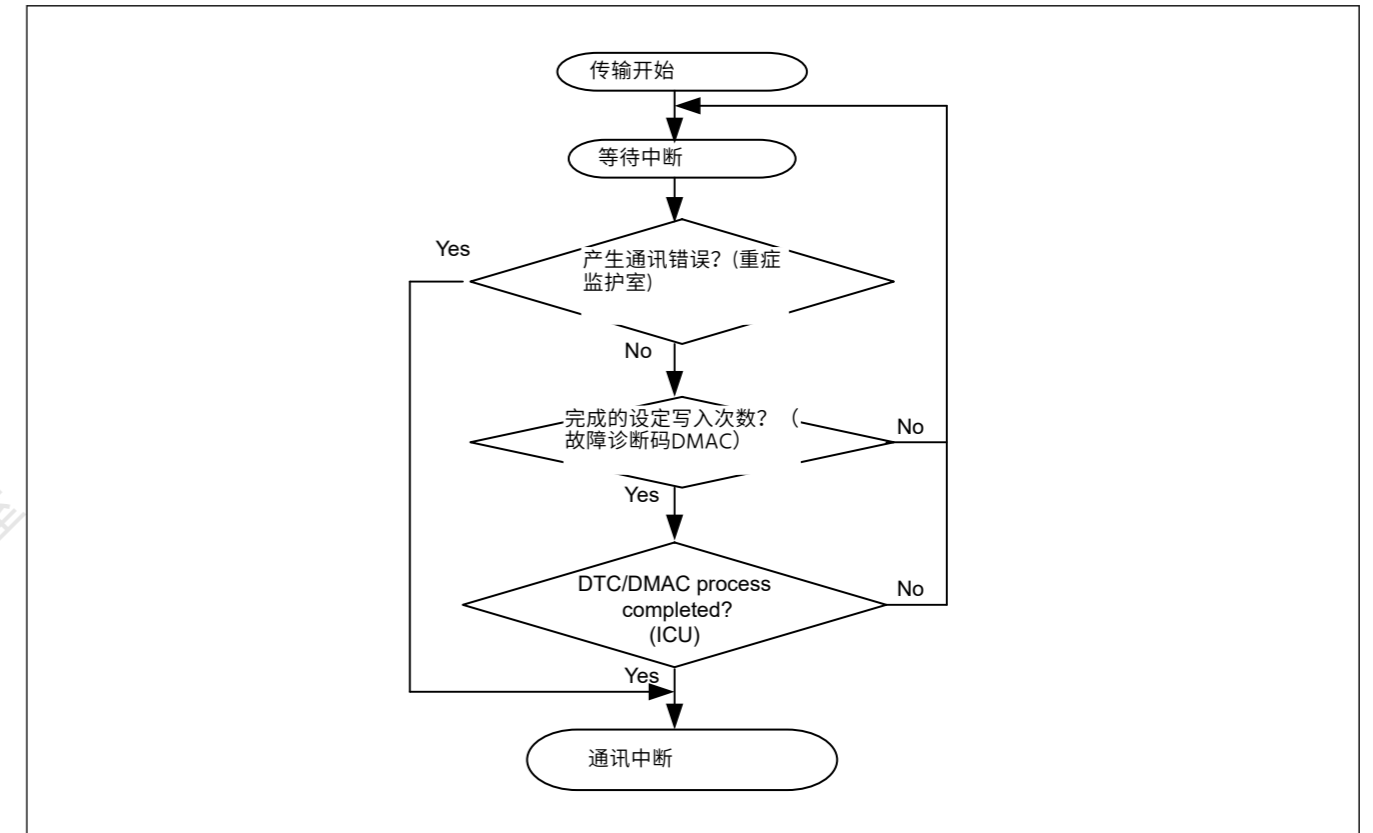


Figure 32.54 传输程序

Note: SSIE中定义的通信流使用DTCDMAC。如果不使用DTCDMAC，则轮询SSIFSR.TDE的值1以将数据写入SSIFTDR。通过检测SSIFSR.TDE的值为1向SSIFTDR写入数据的次数必须与SSIFSR.TDES指定的发送FIFO数据寄存器的空闲空间大小一致。在将与可用空间大小一样多的传输数据写入SSIFTDR后，必须清除SSIFSR.TDE标志。通过重复数据写入启用连续传输。如果

SSIFSR.TDE标志不清除，该标志不会自动清除。

### 32.8.3 Reception

在整个接收操作中必须遵循图32.55中的接收程序。

使能接收后 (SSICR.TEN=0和SSICR.REN=1)，SSIE会在以下条件产生开始触发时开始接收 SSILRCK/SSIFS。SSIE根据RDF设置条件(SSISCR.RDFS)和通信开始过程中指定的接收数据满中断使能(SSIFCR.RIE)位的状态向DTCDMAC输出一个接收数据满中断。该中断请求从接收FIFO数据寄存器(SSIFRDR)读取数据。在通信启动过程中，指定从接收FIFO数据寄存器(SSIFRDR)读取作为DTCDMAC操作以响应接收数据满中断。通过此设置，SSIE可以不通过CPU连续读取数据。当数据达到接收FIFO数据寄存器的容量时，产生接收数据满中断。读取次数必须根据接收数据满中断指示的接收FIFO数据寄存器的数据大小来指定。如果发生错误，请按照通信停止程序中的说明执行错误处理程序。

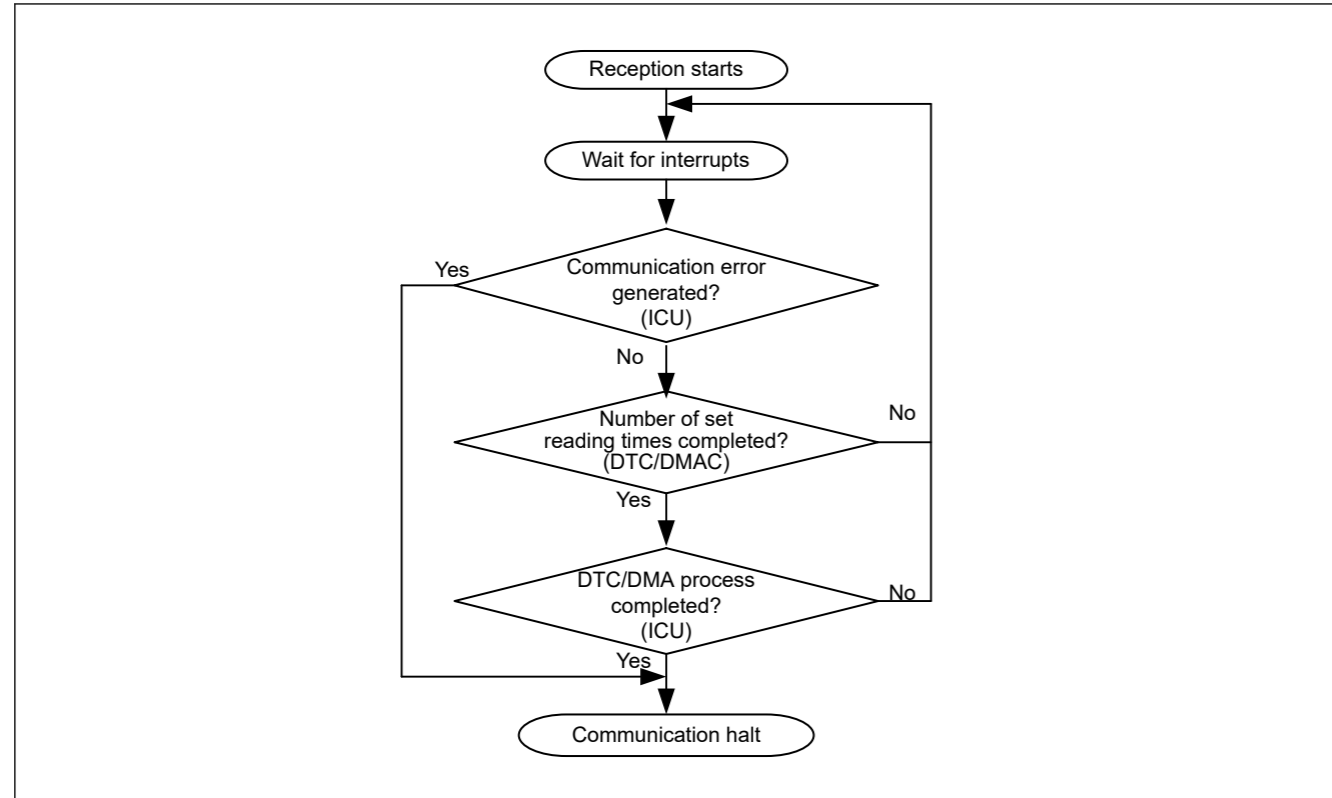


Figure 32.55 Reception procedure

Note: The communication flow defined in SSIE uses the DTC/DMAC. If you do not use the DTC/DMAC, perform polling of the value 1 of SSIFSR.RDF to read data from SSIFRDR. The number of times of reading data from SSIFRDR by detecting the value 1 of SSIFSR.RDF must be in accordance with the receive data storage capacity of the receive FIFO data register specified by SSISCR.RDFS. After received data is read from SSIFRDR, the SSIFSR.RDF flag must be cleared. Continuous reception is enabled by repeating data reading. If the SSIFSR.RDF flag is not cleared, the flag is not cleared automatically.

### 32.8.4 Transmission and Reception

After transmission and reception are enabled (SSICR.TEN = 1 and SSICR.REN = 1), SSIE starts transmission and reception when a start trigger is generated by SSILRCK/SSIFS with the serial data for at least a frame contained in the transmit FIFO data register (SSIFTDR). SSIE can continuously transmit and receive data by performing the procedures described in [section 32.8.2. Transmission](#) and [section 32.8.3. Reception](#), respectively. For how to stop transmission and reception, see [section 32.8.5. Halt Communication](#).

### 32.8.5 Halt Communication

This section describes how to halt communication of SSIE. [Figure 32.56](#) shows the procedure to halt communication. Be sure to follow the procedure.

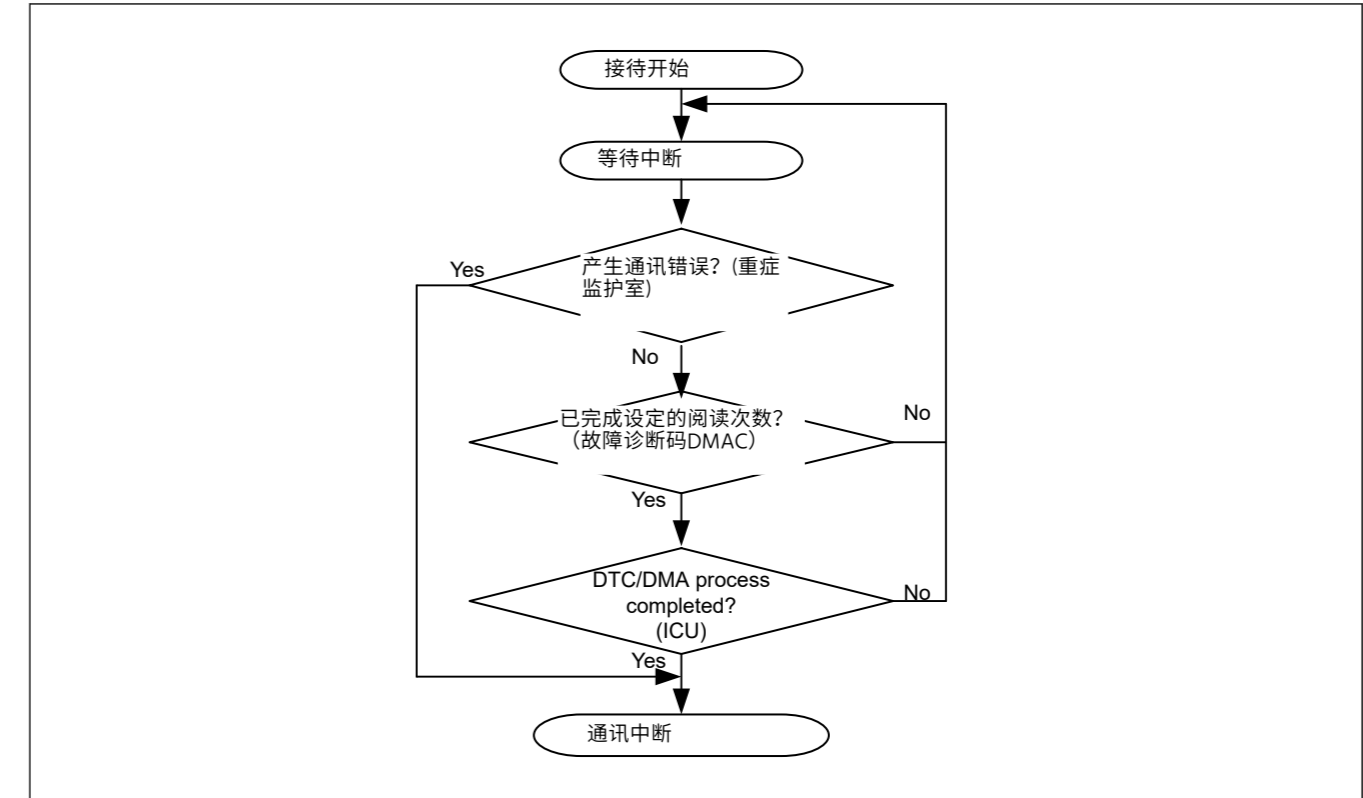


Figure 32.55 接待程序

Note: SSIE中定义的通信流使用DTC/DMAC。如果不使用DTC/DMAC，则轮询SSIFSR.RDF的值1以从SSIFRDR读取数据。检测SSIFSR.RDF的值为1从SSIFRDR读取数据的次数必须与SSISCR.RDFS指定的接收FIFO数据寄存器的接收数据存储容量一致。从SSIFRDR读取接收到的数据后，必须清除SSIFSR.RDF标志。通过重复数据读取启用连续接收。如果SSIFSR.RDF标志未清除，则该标志不会自动清除。

### 32.8.4 传输和接收

启用发送和接收后 (SSICR.TEN=1和SSICR.REN=1)，当SSILRCK/SSIFS使用发送FIFO数据寄存器中包含的至少一帧的串行数据产生开始触发时，SSIE开始发送和接收(SSIFTDR)。SSIE可以通过执行第32.8.2节中描述的过程来连续发送和接收数据。传输和接收，分别。关于如何停止发送和接收，请参见第32.8.5节。停止通讯。

### 32.8.5 停止通讯

本节介绍如何停止SSIE的通信。图32.56显示了停止通信的过程。请务必遵守程序。



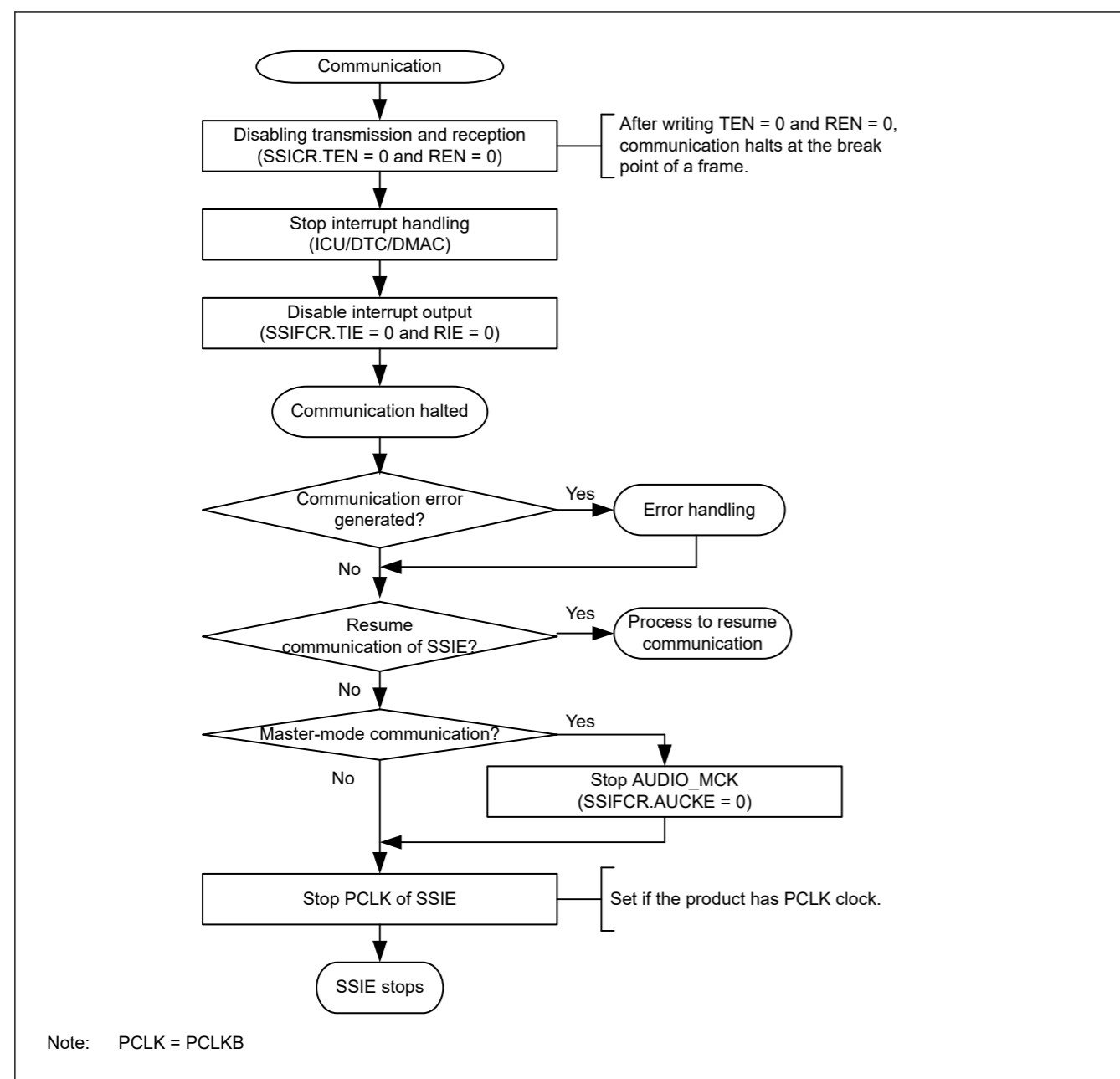


Figure 32.56 Procedure to halt communication (CPU operation procedure)

To halt the communication of SSIE, supply of the following clocks are required until the SSISR.IIRQ bit indicates an idle state.

- Input clock from the SSIBCK pin when SSICR.MST = 0
  - AUDIO\_MCK when SSICR.MST = 1
- To resume communication of SSIE in the previous setting, see [section 32.8.7. Resume Communication](#).

Note: When communication of SSIE is halted according to the procedure to halt communication in [Figure 32.56](#), resume communication according to the procedure to resume communication in [Figure 32.58](#).

### 32.8.6 Error Handling

SSIE has the following four errors.

- Transmit underflow error
- Transmit overflow error
- Receive underflow error

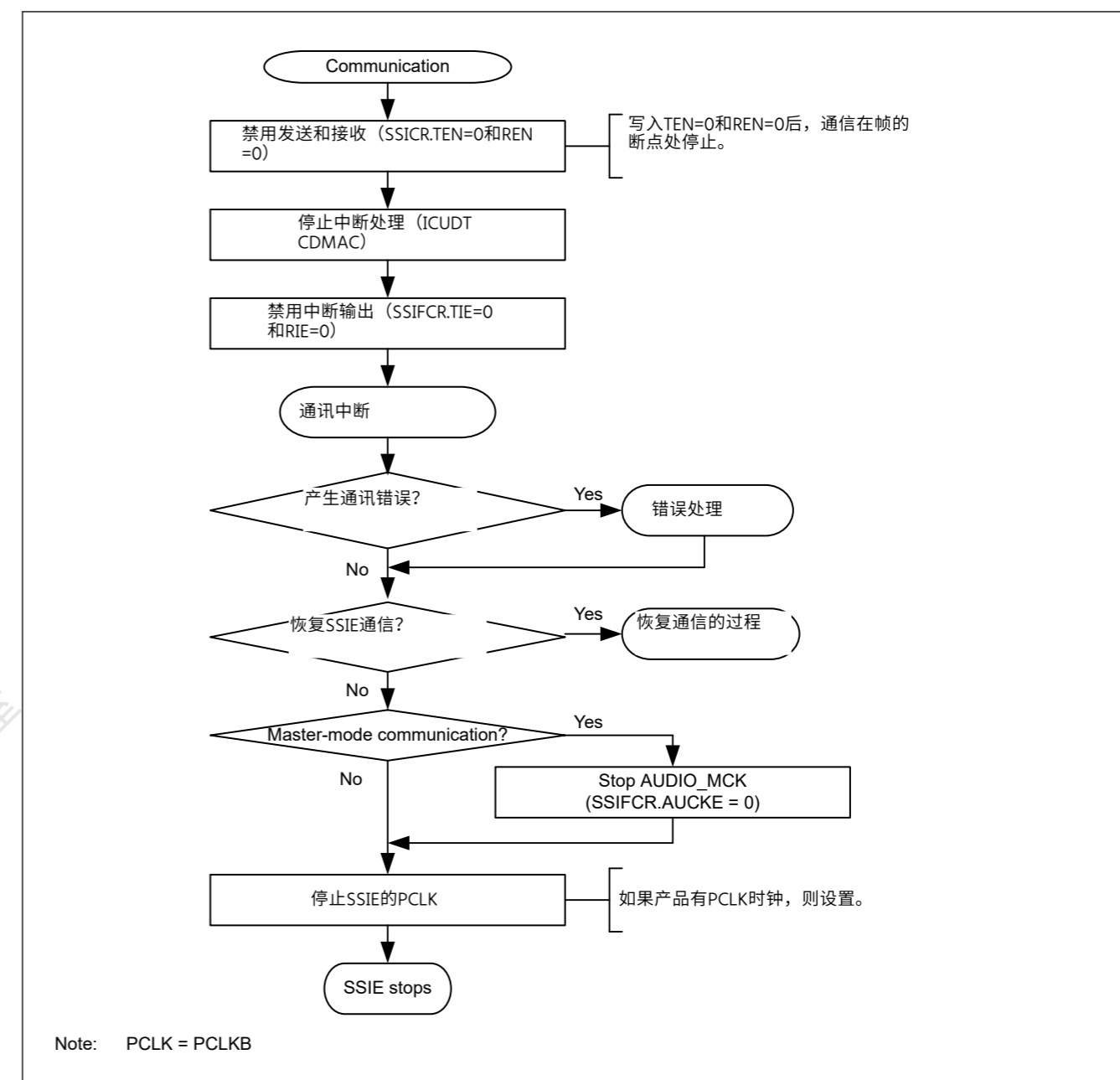


Figure 32.56 停止通信的步骤 (CPU操作步骤)

要停止SSIE的通信，需要提供以下时钟，直到SSISR.IIRQ位指示空闲状态。

- 当SSICR.MST=0时，来自SSIBCK引脚的输入时钟
  - AUDIO\_MCK when SSICR.MST = 1
- 要恢复之前设置的SSIE通信，请参阅第32.8.7节。恢复通信。

Note: 当SSIE的通信按照图32.56中的停止通信程序停止时，按照图32.58中的恢复通信程序恢复通信。

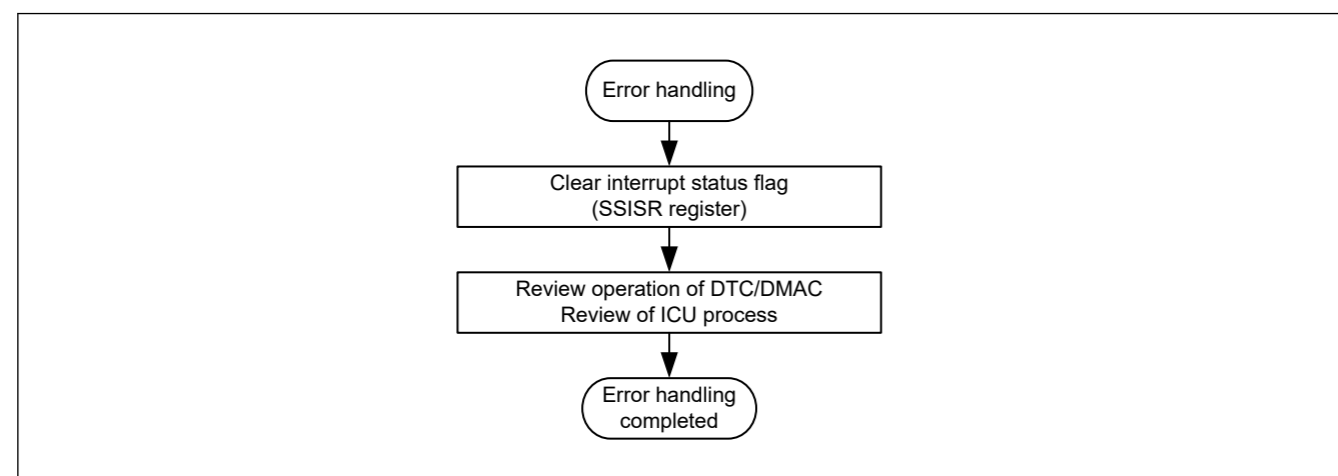
### 32.8.6 错误处理

SSIE有以下四个错误。

- 发送下溢错误
- 发送溢出错误
- 接收下溢错误

- Receive overflow error.

When an underflow error or overflow error is generated, SSIE need to be restarted. Follow the procedure to halt communication in [Figure 32.56](#) and error-handling procedure in [Figure 32.57](#).



**Figure 32.57 Error-handling procedure**

Four error operations are described as follows. When the interrupt output enable bit of the SSICR register is enabled and error flags are set, an error interrupt is generated. See [section 32.4.2. SSISR : Status Register](#) for the setting conditions of error flags.

#### (1) Transmit Underflow Error

If a transmit underflow error occurs, review the number of times of writing data to the transmit FIFO data register (SSIFTDR) in response to a transmit data empty interrupt. After a transmit underflow error occurs, SSIE outputs 0s as data. To normally output the serial data written to the transmit FIFO data register (SSIFTDR) to the SSITXD0/SSIDATA0 pin, follow the procedure to halt communication in [Figure 32.56](#) and error-handling procedure in [Figure 32.57](#). After this error occurs, serial data is consumed as usual. If you resume communication, write the serial data from the beginning.

#### (2) Transmit Overflow Error

If a transmit overflow error occurs, review the number of times of writing data to the transmit FIFO data register (SSIFTDR) in response to transmit data empty interrupts. The serial data written to the transmit FIFO data register (SSIFTDR) that caused the transmit overflow error becomes invalid. This error can occur regardless of whether a transmission operation is being done. To recover from the error, follow the procedure to halt communication in [Figure 32.56](#) and error-handling procedure in [Figure 32.57](#). When you resume communication, deal with the invalid serial data appropriately.

#### (3) Receive Underflow Error

If a receive underflow error occurs, review the number of times of reading data from the receive FIFO data register (SSIFRDR) in response to receive data full interrupts. The values read from the receive FIFO data register (SSIFRDR) that caused the receive underflow error are undefined. This error can occur regardless of whether a reception operation is being done. To recover from the error, follow the procedure to halt communication in [Figure 32.56](#) and error-handling procedure in [Figure 32.57](#).

#### (4) Receive Overflow Error

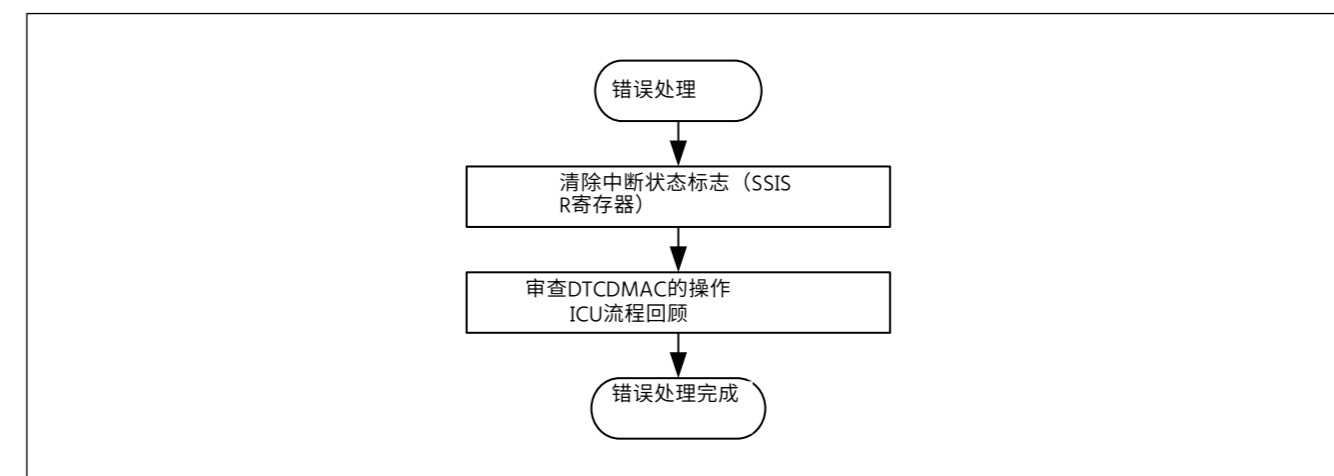
If a receive overflow error occurs, review the number of times of reading data from the receive FIFO data register (SSIFRDR) in response to receive data full interrupts. The receive data that caused the receive overflow error cannot be stored in the receive FIFO data register (SSIFRDR). To recover from the error, follow the procedure to halt communication in [Figure 32.56](#) and error-handling procedure in [Figure 32.57](#).

### 32.8.7 Resume Communication

When you resume the communication using SSIE, follow the communication resume procedure in [Figure 32.58](#). The communication resume procedure is designed on the assumption that you resume the communication stopped by the

- 接收溢出错误。

当产生下溢错误或上溢错误时，需要重启SSIE。按照图32.56中的程序停止通信和图32.57中的错误处理程序。



**Figure 32.57 Error-handling procedure**

四种错误操作描述如下。当SSICR寄存器的中断输出使能位使能且错误标志置位时，将产生错误中断。请参见第32.4.2节。SSISR：错误标志设置条件的状态寄存器。

#### (1) 发送下溢错误

如果发生发送下溢错误，请查看响应发送数据空中断而将数据写入发送FIFO数据寄存器(SSIFTDR)的次数。发生发送下溢错误后，SSIE输出0作为数据。要将写入发送FIFO数据寄存器(SSIFTDR)的串行数据正常输出到SSITXD0/SSIDATA0引脚，请按照图32.56中的程序停止通信和图32.57中的错误处理程序。发生此错误后，串行数据将照常使用。如果您恢复通信，请从头开始写入串行数据。

#### (2) 传输溢出错误

如果发生发送溢出错误，请查看响应发送数据空中断而将数据写入发送FIFO数据寄存器(SSIFTDR)的次数。写入导致发送溢出错误的发送FIFO数据寄存器(SSIFTDR)的串行数据变为无效。无论是否正在执行传输操作，都可能发生此错误。要从错误中恢复，请按照图32.56中的程序停止通信和图32.57中的错误处理程序。当您恢复通信时，请适当处理无效的串行数据。

#### (3) 接收下溢错误

如果发生接收下溢错误，请检查从接收FIFO数据寄存器(SSIFRDR)读取数据以响应接收数据满中断的次数。导致接收下溢错误的接收FIFO数据寄存器(SSIFRDR)读取的值未定义。无论是否正在执行接收操作，都可能发生此错误。要从错误中恢复，请按照图32.56中的程序停止通信和图32.57中的错误处理程序。

#### (4) 接收溢出错误

如果发生接收溢出错误，请检查从接收FIFO数据寄存器(SSIFRDR)读取数据以响应接收数据满中断的次数。导致接收溢出错误的接收数据不能存储在接收FIFO数据寄存器(SSIFRDR)中。要从错误中恢复，请按照图32.56中的程序停止通信和图32.57中的错误处理程序。

### 32.8.7 恢复沟通

当您使用SSIE恢复通信时，请遵循图32.58中的通信恢复过程。通信恢复过程的设计假设您恢复了由

communication stop procedure without changing any settings. If you want to change clock and slave/master settings, use and follow the communication start procedure in Figure 32.53. For details about the transmission operation and reception operation after starting communication, see section 32.8.2. Transmission and section 32.8.3. Reception, respectively.

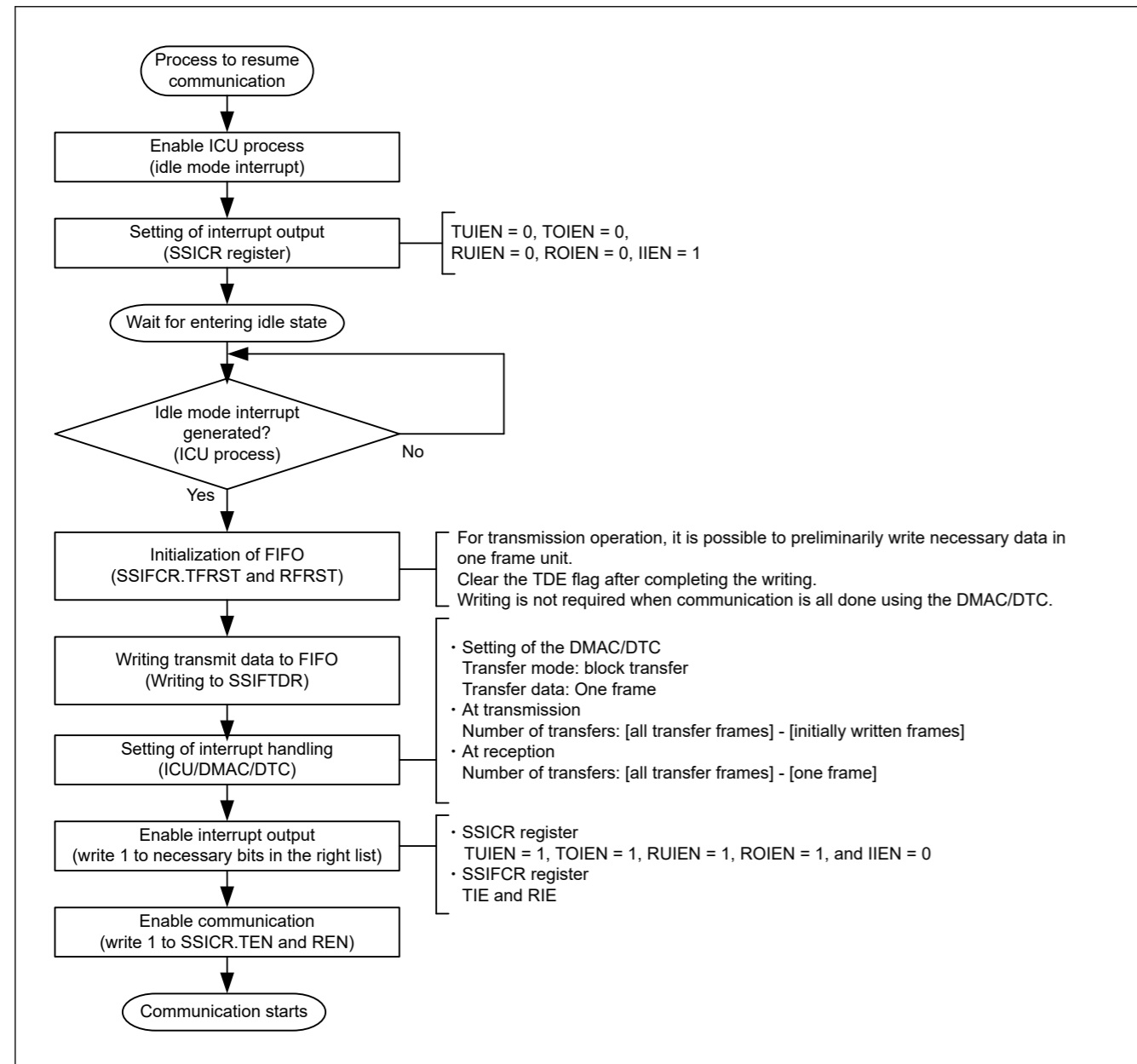


Figure 32.58 Procedure to resume communication (CPU operation procedure)

### 32.9 Interrupts

Table 32.16 lists the interrupt sources. Set enable/disable of interrupt output of each source with the TUIEN, TOIEN, RUIEN, ROIEN, and IIEN bits in the SSICR register and the TIE and RIE bits in the SSIFCR register.

通信停止程序，无需更改任何设置。如果要更改时钟和从主机设置，请使用并遵循图32.53中的通信启动程序。关于开始通信后的发送动作和接收动作的详细内容，请参阅32.8.2节。传输和32.8.3节。接待处，分别。

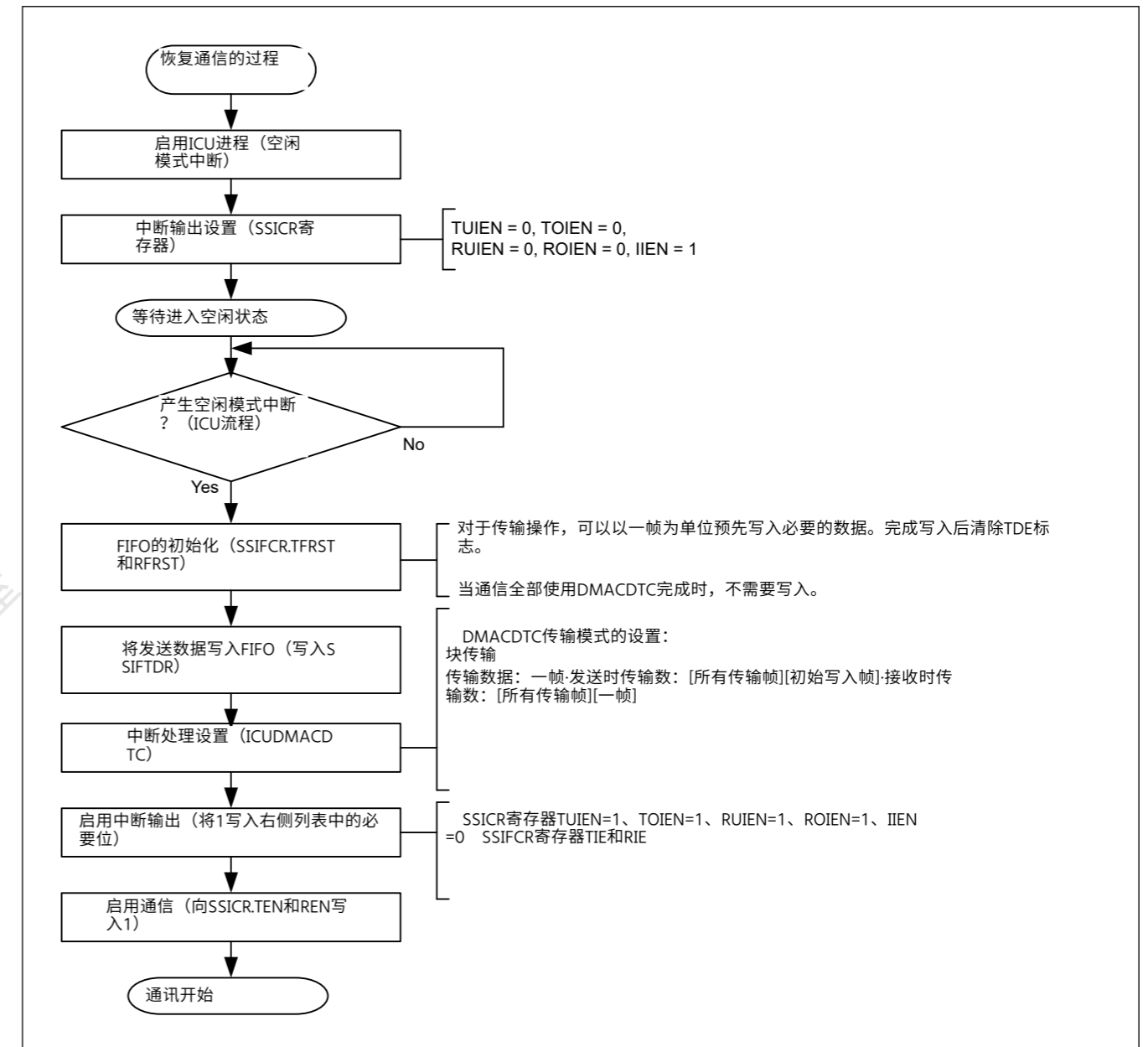


Figure 32.58 恢复通信的步骤 (CPU操作步骤)

### 32.9 Interrupts

表32.16列出了中断源。使用TUIEN、TOIEN、SSICR寄存器中的RUIEN、ROIEN和IIEN位以及SSIFCR寄存器中的TIE和RIE位。

Table 32.16 SSIE interrupt sources

| Channel | Interrupt source | Description  | Interrupt flag   | DMAC/DTC activation |
|---------|------------------|--|--|---------------------|
| SSIE0   | SSIE0_SSIF       | <ul style="list-style-type: none"> <li>Transmit underflow interrupt</li> <li>Transmit overflow interrupt</li> <li>Receive underflow interrupt</li> <li>Receive overflow interrupt</li> <li>Idle interrupt</li> </ul> | SSISR.TUIRQ<br>SSISR.TOIRQ<br>SSISR.RUIRQ<br>SSISR.ROIRQ<br>SSISR.IIRQ | Not possible        |
|         | SSIE0_SSIRXI     | Receive data full interrupt  | SSIFSR.RDF   | Possible            |
|         | SSIE0_SSITXI     | Transmit data empty interrupt  | SSIFSR.TDE   | Possible            |

### 32.9.1 SSIE0\_SSIF Interrupt

This interrupt source combines five interrupts. Enable output of necessary interrupts before using SSIE. The five interrupts are operated by using the flags assigned to individual interrupts and interrupt output enable bits. To clear an interrupt, set the interrupt enable to 0 or clear the interrupt flag to 0.

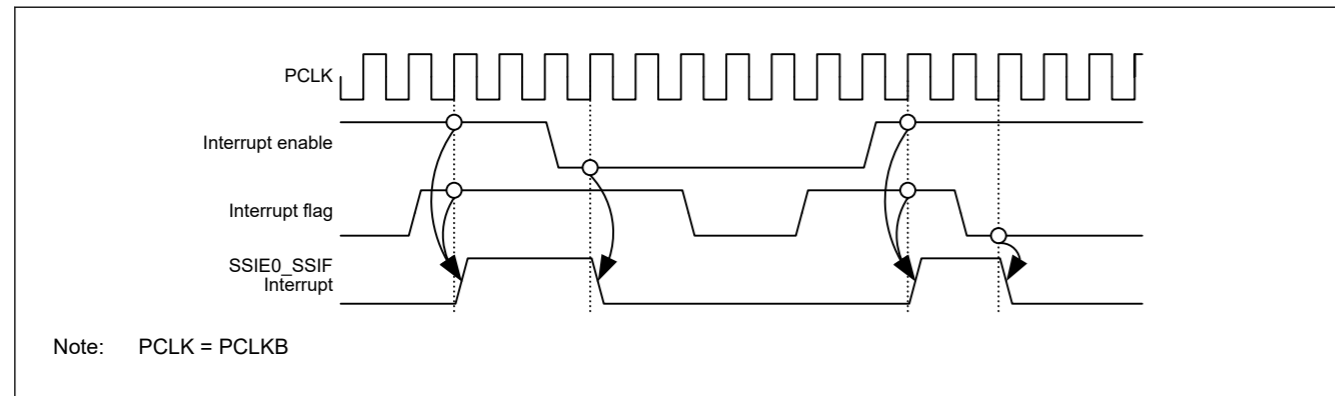


Figure 32.59 Timing Diagram of the common interrupt source, SSIE0\_SSIF

- Transmit underflow interrupt

As the transmit underflow interrupt, SSISR.TUIRQ is output while SSICR.TUIEN = 1. When you use SSIE for transmission, enable the output of this interrupt (SSICR.TUIRQ = 1). If this interrupt occurs, follow instructions in the procedure to halt communication in Figure 32.56 and error-handling procedure in Figure 32.57.

- Transmit overflow interrupt

As the transmit overflow interrupt, SSISR.TOIRQ is output while SSICR.TOIRQ = 1. When you use SSIE for transmission, enable the output of this interrupt (SSICR.TOIRQ = 1). If this interrupt occurs, follow instructions in the procedure to halt communication in Figure 32.56 and error-handling procedure in Figure 32.57.

- Receive underflow interrupt

As the receive underflow interrupt, SSISR.RUIRQ is output while SSICR.RUIRQ = 1. When you use SSIE for reception, enable the output of this interrupt (SSICR.RUIRQ = 1). If this interrupt occurs, follow instructions in the procedure to halt communication in Figure 32.56 and error-handling procedure in Figure 32.57.

- Receive overflow interrupt

As the receive overflow interrupt, SSISR.ROIRQ is output while SSICR.ROIRQ = 1. When you use SSIE for reception, enable the output of this interrupt (SSICR.ROIRQ = 1). If this interrupt occurs, follow instructions in the procedure to halt communication in Figure 32.56 and error-handling procedure in Figure 32.57.

- Idle mode interrupt

As the idle mode interrupt, SSISR.IIRQ is output while SSICR.IIEN = 1. This interrupt is used to make sure that communication has stopped fully.

Table 32.16 SSIE中断源

| Channel | 中断源          | Description  | 中断标志   | DMAC/DTC activation |
|---------|--------------|--|--|---------------------|
| SSIE0   | SSIE0_SSIF   | <ul style="list-style-type: none"> <li>发送下溢中断</li> <li>发送溢出中断</li> <li>接收下溢中断</li> <li>接收溢出中断</li> <li>空闲中断</li> </ul> | SSISR.TUIRQ<br>SSISR.TOIRQ<br>SSISR.RUIRQ<br>SSISR.ROIRQ<br>SSISR.IIRQ | 不可能                 |
|         | SSIE0_SSIRXI | 接收数据满中断  | SSIFSR.RDF   | Possible            |
|         | SSIE0_SSITXI | 发送数据空中断  | SSIFSR.TDE   | Possible            |

### 32.9.1 SSIE0\_SSIF Interrupt

该中断源结合了五个中断。在使用SSIE之前启用必要中断的输出。通过使用分配给各个中断的标志和中断输出使能位来操作五个中断。要清除中断，请将中断使能设置为0或将中断标志清除为0。

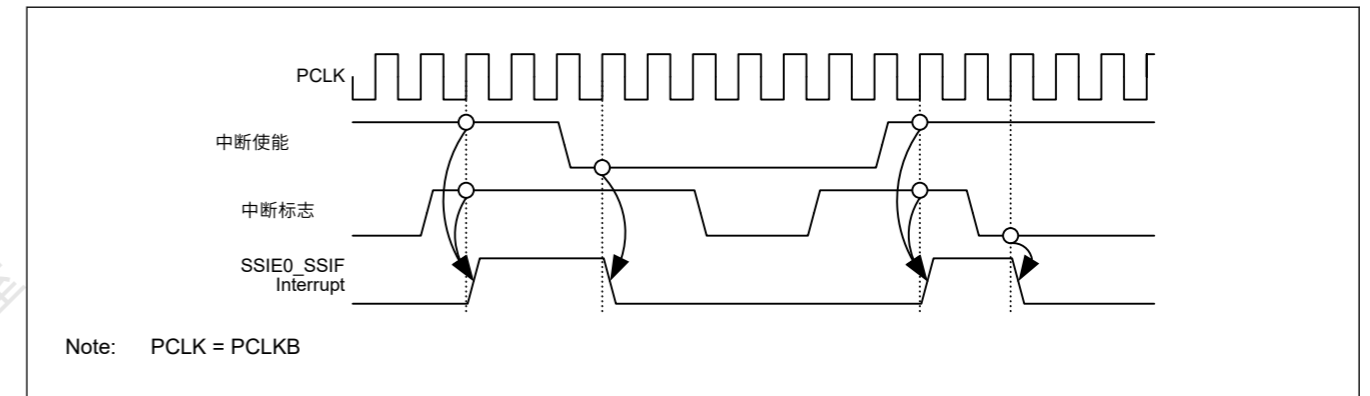


Figure 32.59 公共中断源的时序图, SSIE0\_SSIF

- 发送下溢中断

作为发送下溢中断，在SSICR.TUIEN=1时输出SSISR.TUIRQ。当使用SSIE进行发送时，使能该中断的输出（SSICR.TUIRQ=1）。如果发生此中断，请按照图32.56中的停止通信用过程和图32.57中的错误处理过程中的说明进行操作。

- 发送溢出中断

作为发送溢出中断，在SSICR.TOIRQ=1时输出SSISR.TOIRQ。当使用SSIE进行发送时，使能该中断的输出（SSICR.TOIRQ=1）。如果发生此中断，请按照图32.56中的停止通信用过程和图32.57中的错误处理过程中的说明进行操作。

- 接收下溢中断

作为接收下溢中断，在SSICR.RUIRQ=1时输出SSISR.RUIRQ。当使用SSIE进行接收时，使能该中断的输出（SSICR.RUIRQ=1）。如果发生此中断，请按照图32.56中的停止通信用过程和图32.57中的错误处理过程中的说明进行操作。

- 接收溢出中断

作为接收溢出中断，在SSICR.ROIRQ=1时输出SSISR.ROIRQ。当使用SSIE进行接收时，使能该中断的输出（SSICR.ROIRQ=1）。如果发生此中断，请按照图32.56中的停止通信用过程和图32.57中的错误处理过程中的说明进行操作。

- 空闲模式中断

作为空闲模式中断，在SSICR.IIEN=1时输出SSISR.IIRQ。此中断用于确保通信已完全停止。



### 32.9.2 SSIE0\_SSITXI Interrupt

The transmit data empty interrupt is a pulse interrupt that is output when the following condition is met:

- SSIFCR.TIE = 1 and SSIFSR.TDE = 1  
SSIE operation: When the value of SSIFSR.TDE changes from 0 to 1 while the value of SSIFCR.TIE is 1  
CPU instruction: When the value of SSIFCR.TIE changes from 0 to 1 while the value of SSIFSR.TDE is 1

This interrupt is subject to the interrupt suppression function. If an interrupt condition for this interrupt occurs when the DTC/DMAC is busy (when the DTC/DMAC cannot accept interrupts), the interrupt suppression function holds the output of this interrupt. The held interrupt will be output after the DTC/DMAC is enabled to accept interrupts. For details, see [Figure 32.60](#).

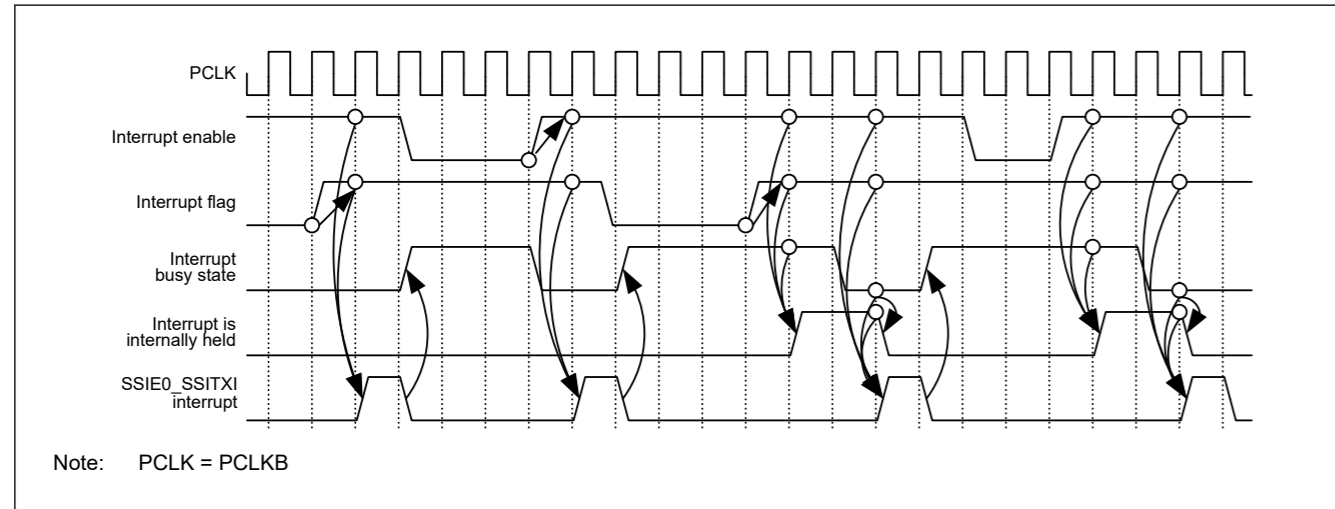


Figure 32.60 SSIE0\_SSITXI interrupt timing diagram

### 32.9.3 SSIE0\_SSIRXI Interrupt

The receive data full interrupt is a pulse interrupt that is output when the following condition is met:

- SSIFCR.RIE = 1 and SSIFSR.RDF = 1.  
SSIE operation: When the value of SSIFSR.RDF changes from 0 to 1 while the value of SSIFCR.RIE is 1  
CPU instruction: When the value of SSIFCR.RIE changes from 0 to 1 while the value of SSIFSR.RDE is 1

This interrupt is subject to the interrupt suppression function. If an interrupt condition for this interrupt occurs when the DTC/DMAC is busy (when the DTC/DMAC cannot accept interrupts), the interrupt suppression function holds the output of this interrupt. The held interrupt will be output after the DTC/DMAC is enabled to accept interrupts. The behavior of this interrupt is the same as the behavior shown in [Figure 32.60](#).

## 32.10 Software Resets

SSIE has three software reset bits to reset its states.

- SSIE software reset (SSIFCR.SSIRST)
- Transmit FIFO data register reset (SSIFCR.TFRST)
- Receive FIFO data register reset (SSIFCR.RFRST).

This section describes the procedures for the three types of software resets.

### 32.10.1 Software Reset Procedure

#### (1) SSIE Software Reset

For the SSIE software reset bit (SSIFCR.SSIRST), follow the procedure shown in [Figure 32.61](#). After a reset, the same setting is applied when it is resumed. To change the settings of clocks and slave/master mode, follow the procedure to start

### 32.9.2 SSIE0\_SSITXI Interrupt

发送数据空中断是一个脉冲中断，当满足以下条件时输出：

- SSIFCR.TIE = 1 and SSIFSR.TDE = 1  
SSIE操作：当SSIFSR.TDE的值从0变为1且SSIFCR.TIE的值为1时CPU指令：当SSIFCR.TIE的值从0变为1且SSIFSR.TDE的值为1时

该中断受中断抑制功能影响。如果在DTC/DMAC忙时（当DTC/DMAC不能接受中断时）发生此中断的中断条件，则中断抑制功能保持此中断的输出。在DTC/DMAC使能接受中断后，将输出保持的中断。详见图32.60。

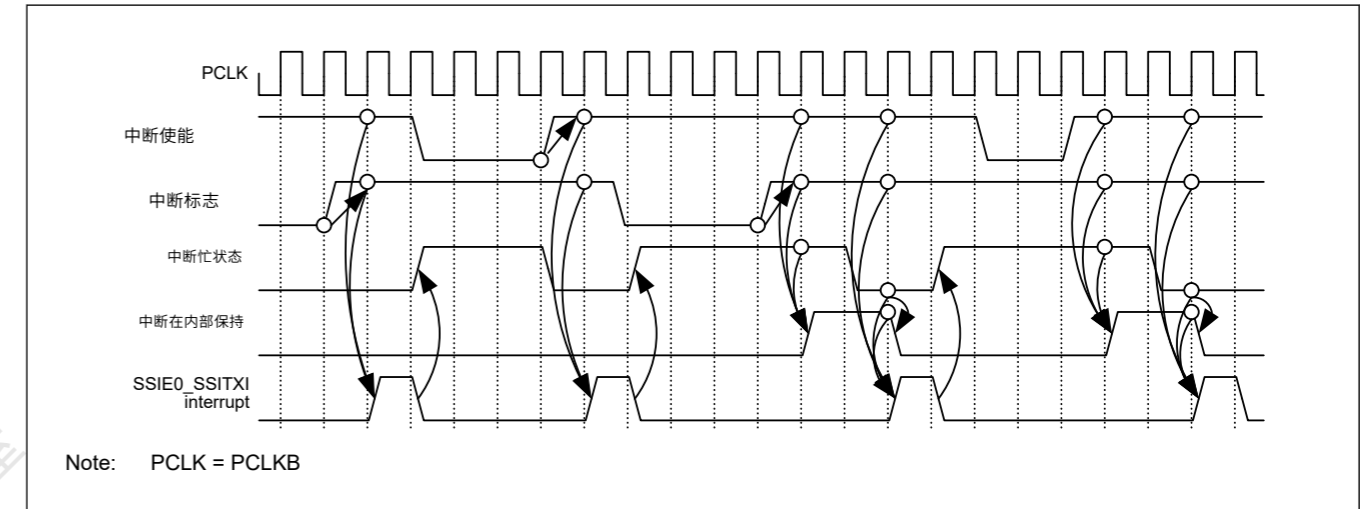


Figure 32.60 SSIE0\_SSITXI中断时序图

### 32.9.3 SSIE0\_SSIRXI Interrupt

接收数据满中断是一个脉冲中断，当满足以下条件时输出：

- SSIFCR.RIE = 1 and SSIFSR.RDF = 1.  
SSIE操作：当SSIFSR.RDF的值从0变为1且SSIFCR.RIE的值为1时CPU指令：当SSIFCR.RIE的值从0变为1且SSIFSR.RDE的值为1时

该中断受中断抑制功能影响。如果此中断的中断条件发生时，DTC/DMAC忙（当DTC/DMAC不能接受中断时），中断抑制功能保持该中断的输出。在DTC/DMAC使能接受中断后，将输出保持的中断。该中断的行为与图32.60中所示的行为相同。

## 32.10 软件复位

SSIE具有三个软件复位位来复位其状态。

- SSIE软件复位(SSIFCR.SSIRST)
- 发送FIFO数据寄存器复位(SSIFCR.TFRST)
- 接收FIFO数据寄存器复位(SSIFCR.RFRST)。

本节介绍三种软件复位的过程。

### 32.10.1 软件复位程序

#### (1) SSIE软件复位

对于SSIE软件复位位(SSIFCR.SSIRST)，请按照图32.61中所示的过程。重置后，恢复时应用相同的设置。要更改时钟和从主模式的设置，请按照以下步骤开始

communication in Figure 32.53. See section 32.8.2. Transmission and section 32.8.3. Reception respectively for transmission and reception after communication is resumed.

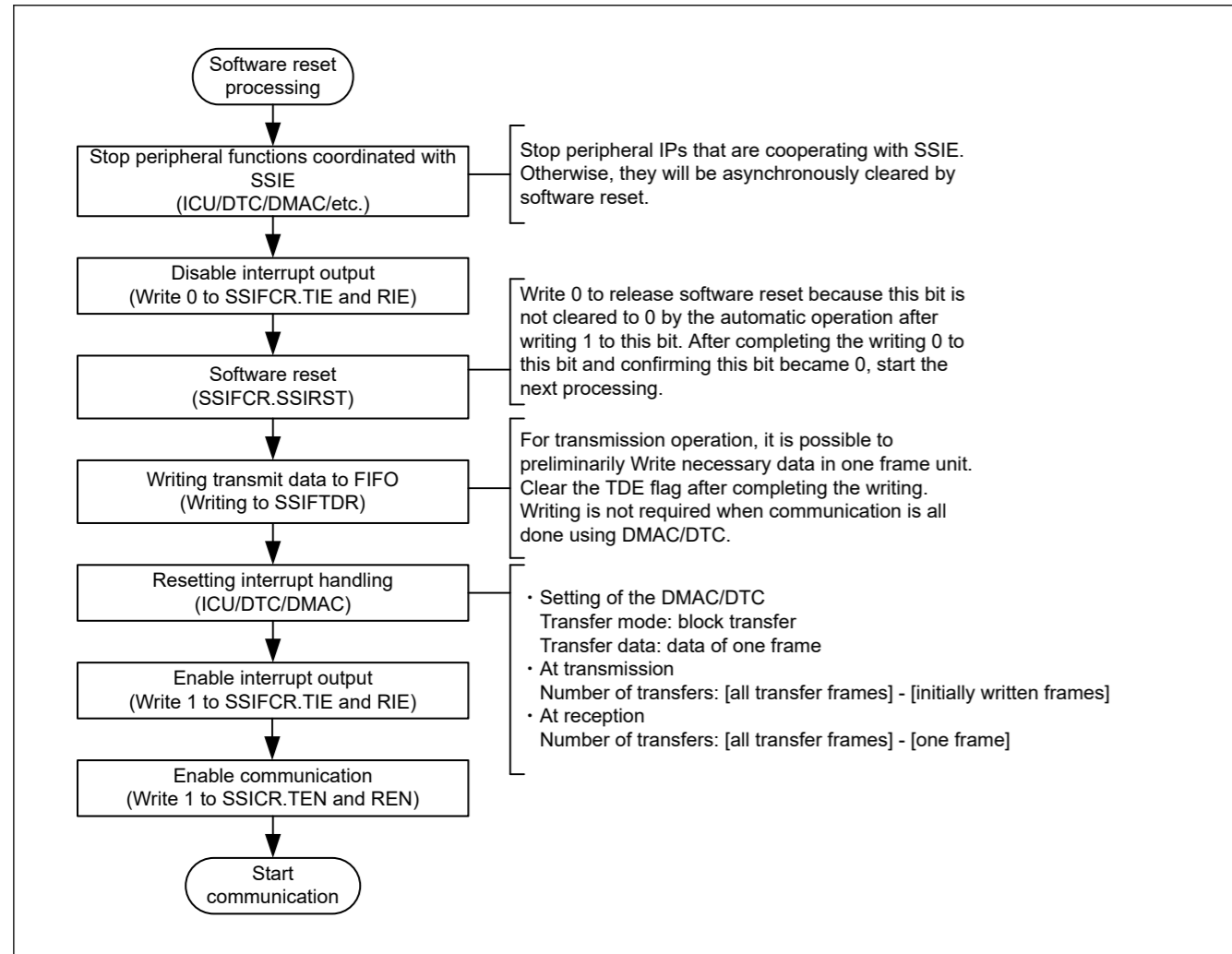


Figure 32.61 Software reset procedure (CPU operation procedure)

(2) Transmit FIFO data register reset

To perform a transmit FIFO data register reset, follow instructions in the procedure to start communication in Figure 32.53 and procedure to resume communication in Figure 32.58.

(3) Receive FIFO data register reset

To perform a receive FIFO data register reset, follow instructions in the procedure to start communication in Figure 32.53 and procedure to resume communication in Figure 32.58.

32.11 Notes

32.11.1 Notes for Slave-mode Communication

32.11.1.1 ADCKE control

In slave-mode communication (SSICR.MST = 0), SSIE needs supply of SSIBCK. To stop BCK on the master side, make sure that SSIE is in the idle state (SSISR.IIRQ = 1). If BCK is stopped before SSIE becomes idle, take the procedure to start communication in Figure 32.53 or wait for an idle state by taking the procedure to resume communication in Figure 32.58.

图32.53中的通信。请参阅第32.8.2节。传输和第32.8.3节。接收分别用于通信恢复后的发送和接收。

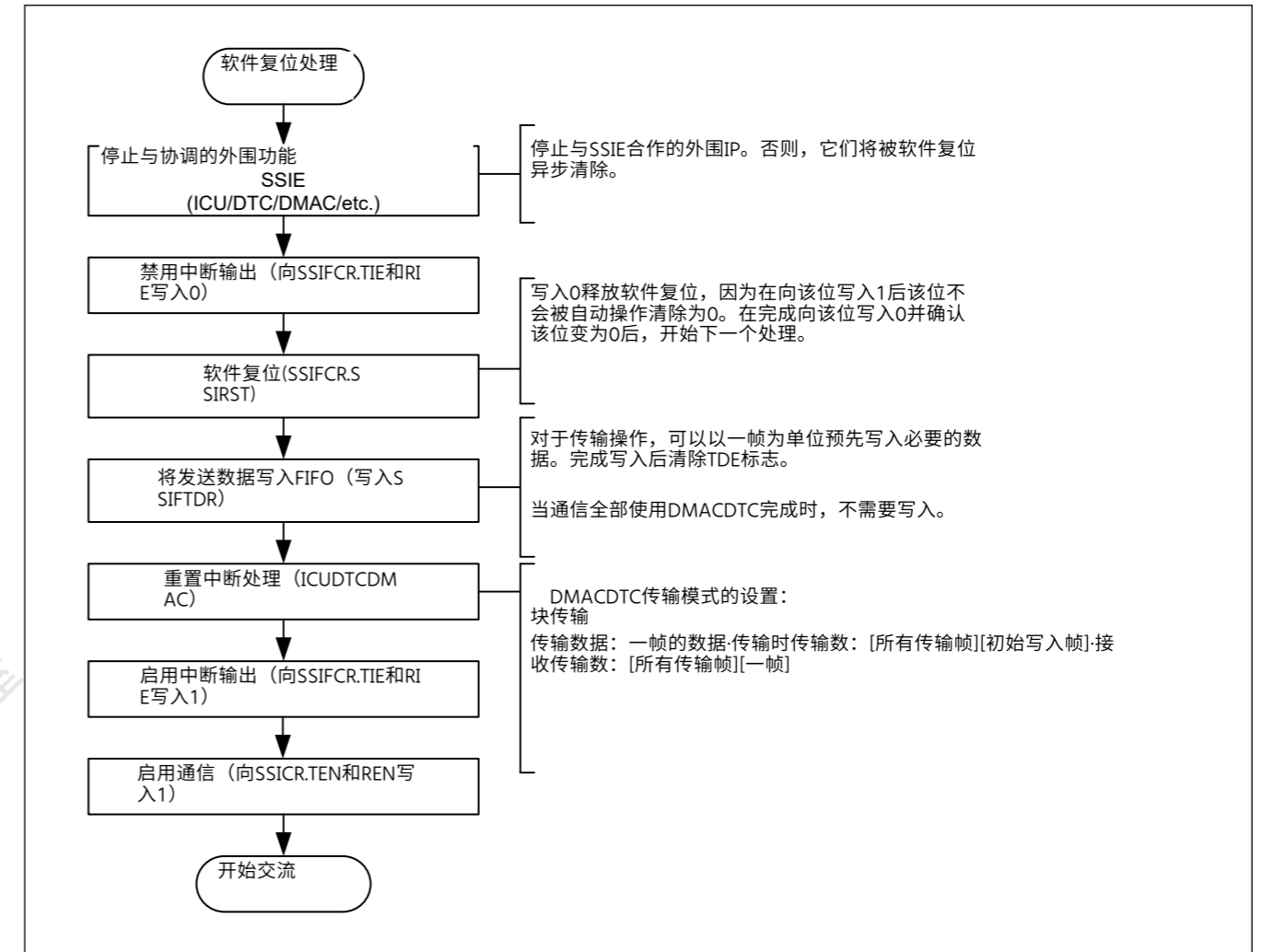


Figure 32.61 软件复位程序 (CPU操作程序)

(2) 发送FIFO数据寄存器复位

要执行发送FIFO数据寄存器复位，请按照图32.53中的开始通信过程和图32.58中恢复通信的过程中的说明进行操作。

(3) 接收FIFO数据寄存器复位

要执行接收FIFO数据寄存器复位，请按照图32.53中的开始通信过程和图32.58中恢复通信的过程中的说明进行操作。

32.11 Notes

32.11.1 从模式通信注意事项

32.11.1.1 ADCKE control

在从模式通信(SSICR.MST=0)中，SSIE需要提供SSIBCK。要在主设备端停止BCK，请确保SSIE处于空闲状态(SSISR.IIRQ=1)。如果BCK在SSIE空闲之前停止，则按照图32.53中的程序开始通信，或者按照图32.58中的程序恢复通信等待空闲状态。

### 32.11.1.2 SSILRCK/SSIFS pin

SSIE has the SSILRCK/SSIFS pin, which indicates the synchronization of communication. When SSIE is in slave mode (SSICR.MST = 0), the communication format SSIE uses must match that of the other-party device to communicate. SSIE uses the signal input by the SSILRCK/SSIFS pin only as a trigger to start communication.

## 32.11.2 Notes for Master-mode Communication

### 32.11.2.1 ADCKE control

In master-mode communication (SSICR.MST = 1), SSIE operates with the audio clock (AUDIO\_MCK). To stop SSIE completely, make sure that SSIE is in the idle state (SSISR.IIRQ = 1) and then write 0 to SSIFCR.ADCKE.

### 32.11.2.2 LRCONT control

To stop the output to the SSILRCK/SSIFS pin with SSIOFR.LRCONT when SSIE is in the idle state in master-mode communication (SSICR.MST = 1), note the following: The output stops when the value of the SSIOFR.LRCONT bit is changed from 1 to 0. Make sure that the other-party device is not affected. For details, see [Figure 32.44](#).

### 32.11.2.3 BCKASTP control

To stop the output to the SSIBCK pin with SSIOFR.BCKASTP in master-mode communication (SSICR.MST = 1) and while SSIE is in the idle state, note the following: The output stops when the value of the SSIOFR.BCKASTP bit is changed from 0 to 1. So, make sure that the other-party device is not affected. For details, see [Figure 32.45](#).

The BCKASTP bit cannot be used when the other-party device (which is a slave) requires the clock output from the SSIBCK pin before and during communication.

## 32.11.3 Notes for Communication Flow

### 32.11.3.1 When an error interrupt is generated

SSIE has the following four errors.

- Transmit underflow error
- Transmit overflow error
- Receive underflow error
- Receive overflow error

When an underflow error or overflow error is generated, SSIE need to be restarted. Follow the procedure to halt communication in [Figure 32.56](#) and error-handling procedure in [Figure 32.57](#).

#### (1) Transmit Underflow Error

If a transmit underflow error occurs, review the number of times of writing data to the transmit FIFO data register (SSIFTDR) in response to a transmit data empty interrupt. After a transmit underflow error occurs, SSIE outputs 0s as data. To normally output the serial data written to the transmit FIFO data register (SSIFTDR) to the SSITXD0/SSIDATA0 pin, follow the procedure to halt communication in [Figure 32.56](#) and error-handling procedure in [Figure 32.57](#). After this error occurs, serial data is consumed as usual. If you resume communication, write the serial data from the beginning.

#### (2) Transmit Overflow Error

If a transmit overflow error occurs, review the number of times of writing data to the Transmit FIFO Data Register (SSIFTDR) in response to transmit data empty interrupts. The serial data written to the Transmit FIFO Data Register (SSIFTDR) that caused the transmit overflow error becomes invalid. This error can occur regardless of whether a transmission operation is being done. To recover from the error, follow the procedure to halt communication in [Figure 32.56](#) and error-handling procedure in [Figure 32.57](#). When you resume communication, deal with the invalid serial data appropriately.

### 32.11.1.2 SSILRCK/SSIFS pin

SSIE有SSILRCKSSIFS引脚，表示通信同步。当SSIE处于从机模式（SSICR.MST=0）时，SSIE使用的通信格式必须与对方设备的通信格式相匹配。SSIE仅使用SSILRCKSSIFS引脚输入的信号作为启动通信的触发器。

## 32.11.2 主模式通信注意事项

### 32.11.2.1 ADCKE control

在主模式通信(SSICR.MST=1)中，SSIE使用音频时钟(AUDIO\_MCK)运行。要完全停止SSIE，请确保SSIE处于空闲状态(SSISR.IIRQ=1)，然后将0写入SSIFCR.ADCKE。

### 32.11.2.2 LRCONT control

当SSIE在主模式通信中处于空闲状态时（SSICR.MST=1），要使用SSIOFR.LRCONT停止向SSILRCKSSIFS引脚的输出，请注意以下几点：当SSIOFR.LRCONT位的值为从1变为0。确保对方设备不受影响。详见图32.44。

### 32.11.2.3 BCKASTP control

要在主模式通信(SSICR.MST=1)和SSIE处于空闲状态时使用SSIOFR.BCKASTP停止向SSIBCK引脚的输出，请注意以下几点：当SSIOFR.BCKASTP位的值为从0变为1。因此，请确保对方设备不受影响。详见图32.45。

当对方设备（从设备）需要时钟输出时，不能使用BCKASTP位  
SSIBCK引脚在通信之前和期间。

## 32.11.3 通信流程注意事项

### 32.11.3.1 产生错误中断时

SSIE有以下四个错误。

- 发送下溢错误
- 发送溢出错误
- 接收下溢错误
- 接收溢出错误

当产生下溢错误或上溢错误时，需要重启SSIE。按照图32.56中的程序停止通信和图32.57中的错误处理程序。

#### (1) 发送下溢错误

如果发生发送下溢错误，请查看响应发送数据空中断而将数据写入发送FIFO数据寄存器(SSIFTDR)的次数。发生发送下溢错误后，SSIE输出0作为数据。要将写入发送FIFO数据寄存器(SSIFTDR)的串行数据正常输出到SSITXD0/SSIDATA0引脚，请按照图32.56中的程序停止通信和图32.57中的错误处理程序。发生此错误后，串行数据将照常使用。如果您恢复通信，请从头开始写入串行数据。

#### (2) 传输溢出错误

如果发生发送溢出错误，请检查向发送FIFO数据寄存器(SSIFTDR)写入数据以响应发送数据空中断的次数。导致发送溢出错误的写入发送FIFO数据寄存器(SSIFTDR)的串行数据变为无效。无论是否正在执行传输操作，都可能发生此错误。要从错误中恢复，请按照图32.56中的程序停止通信和图32.57中的错误处理程序。当您恢复通信时，请适当处理无效的串行数据。



### (3) Receive Underflow Error

If a receive underflow error occurs, review the number of times of reading data from the receive FIFO data register (SSIFRDR) in response to receive data full interrupts. The values read from the receive FIFO data register (SSIFRDR) that caused the receive underflow error are undefined. This error can occur regardless of whether a reception operation is being done. To recover from the error, follow the procedure to halt communication in [Figure 32.56](#) and error-handling procedure in [Figure 32.57](#).

### (4) Receive Overflow Error

If a receive overflow error occurs, review the number of times of reading data from the receive FIFO data register (SSIFRDR) in response to receive data full interrupts. The receive data that caused the receive overflow error cannot be stored in the receive FIFO data register (SSIFRDR). To recover from the error, follow the procedure to halt communication in [Figure 32.56](#) and error-handling procedure in [Figure 32.57](#).

#### 32.11.3.2 Transmit data empty interrupt

The communication flow defined in SSIE uses the DTC/DMAC. If you do not use the DTC/DMAC, perform polling of the value 1 of SSIFSR.TDE to write data to SSIFTDR. The number of times of writing data to SSIFTDR by detecting the value 1 of SSIFSR.TDE must be in accordance with the free space size of the transmit FIFO data register specified by SSISCR.TDES. After as much transmit data as the free space size is written to SSIFTDR, the SSIFSR.TDE flag must be cleared. Continuous transmission is enabled by repeating data writing. If the SSIFSR.TDE flag is not cleared, the flag is not cleared automatically.

#### 32.11.3.3 Receive data full interrupt

The communication flow defined in SSIE uses the DTC/DMAC. If you do not use the DTC/DMAC, perform polling of the value 1 of SSIFSR.RDF to read data from SSIFRDR. The number of times of reading data from SSIFRDR by detecting the value 1 of SSIFSR.RDF must be in accordance with the receive data storage capacity of the receive FIFO data register specified by SSISCR.RDFS. After received data is read from SSIFRDR, the SSIFSR.RDF flag must be cleared. Continuous reception is enabled by repeating data reading. If the SSIFSR.RDF flag is not cleared, the flag is not cleared automatically.

#### 32.11.3.4 Switching transfer modes

1. For state transition from transmission, reception, and transmission and reception, disable transmission and reception (SSICR.TEN = 0, SSICR.REN = 0).
2. Confirm it is in the idle state (SSISR.IIRQ = 1).
3. In the idle state, set the SSICR.TEN bit and the SSICR.REN bit again and resume transfer.

#### 32.11.3.5 Resume communication after halting SSIE

When communication of SSIE is halted according to the procedure to halt communication in [Figure 32.56](#), resume communication according to the procedure to resume communication in [Figure 32.58](#).

### 32.11.4 Write Access Restriction

#### 32.11.4.1 SSICR register

If the TEN bit or REN bit is rewritten, make sure that the SSISR.IIRQ bit is in the desired status. If the value of the TEN or REN bit is changed by rewriting, subsequent operation is unpredictable. For example, when transmission or reception is enabled, check that SSISR.IIRQ is 0; when transmission or reception is disabled, check that SSISR.IIRQ is 1.

##### (1) TEN Bit and REN Bit

These bits enable/disable transmission and reception. When 1 is written to one of these bits, the corresponding communication operation starts in synchronization with a start trigger by the SSILRCK/SSIFS signal. For details, see [section 32.8.2. Transmission](#), [section 32.8.3. Reception](#), and [section 32.8.4. Transmission and Reception](#). When 0 is written to this bit, the current communication operation stops at the next frame boundary. To use SSIE for both transmission and reception, always write 1 to these bits together. When stopping the communication using SSIE, always disable both transmission and reception (write 0 to the TEN and REN bits).

### (3) 接收下溢错误

如果发生接收下溢错误，请检查从接收FIFO数据寄存器(SSIFRDR)读取数据以响应接收数据满中断的次数。导致接收下溢错误的接收FIFO数据寄存器(SSIFRDR)读取的值未定义。无论是否正在执行接收操作，都可能发生此错误。要从错误中恢复，请按照图32.56中的程序停止通信和图32.57中的错误处理程序。

### (4) 接收溢出错误

如果发生接收溢出错误，请检查从接收FIFO数据寄存器(SSIFRDR)读取数据以响应接收数据满中断的次数。导致接收溢出错误的接收数据不能存储在接收FIFO数据寄存器(SSIFRDR)中。要从错误中恢复，请按照图32.56中的程序停止通信和图32.57中的错误处理程序。

#### 32.11.3.2 发送数据空中断

SSIE中定义的通信流使用DTC/DMAC。如果不使用DTC/DMAC，则轮询SSIFSR.TDE的值1以将数据写入SSIFTDR。通过检测SSIFSR.TDE的值为1向SSIFTDR写入数据的次数必须与SSIFSR.TDES指定的发送FIFO数据寄存器的可用空间大小一致。在将与可用空间大小一样多的传输数据写入SSIFTDR后，必须清除SSIFSR.TDE标志。通过重复数据写入启用连续传输。如果未清除SSIFSR.TDE标志，则不会自动清除该标志。

#### 32.11.3.3 接收数据满中断

SSIE中定义的通信流使用DTC/DMAC。如果不使用DTC/DMAC，则轮询SSIFSR.RDF的值1以从SSIFRDR读取数据。通过检测SSIFSR.RDF的值为1从SSIFRDR读取数据的次数必须与SSISCR.RDFS指定的接收FIFO数据寄存器的接收数据存储容量一致。从SSIFRDR读取接收到的数据后，必须清除SSIFSR.RDF标志。通过重复数据读取启用连续接收。如果未清除SSIFSR.RDF标志，则不会自动清除该标志。

#### 32.11.3.4 切换传输模式

- 1.对于从发送、接收和发送和接收的状态转换，禁用发送和接收 (SSICR.TEN=0, SSICR.REN=0)。
- 2.确认它处于空闲状态 (SSISR.IIRQ=1)。
- 3.在空闲状态下，再次设置SSICR.TEN位和SSICR.REN位并恢复传输。

#### 32.11.3.5 停止SSIE后恢复通信

当SSIE的通信按照图32.56中的停止通信程序停止时，按照图32.58中的恢复通信程序恢复通信。

### 32.11.4 写访问限制

#### 32.11.4.1 SSICR register

如果TEN位或REN位被重写，请确保SSISR.IIRQ位处于所需状态。如果TEN的值或REN位通过改写改变，后续操作不可预知。例如，启用发送或接收时，检查SSISR.IIRQ是否为0；当发送或接收被禁用时，检查SSISR.IIRQ是否为1。

##### (1) 十位和仁位

这些位启用禁用发送和接收。当这些位之一写入1时，相应的通信操作与SSILRCK/SSIFS信号的开始触发同步开始。有关详细信息，请参阅第32.8.2节。传输，第32.8.3节。接待处和第32.8.4节。传输和接收。当向该位写入0时，当前通信操作在下一帧边界处停止。要同时使用SSIE进行发送和接收，请始终将1一起写入这些位。使用SSIE停止通信时，始终禁用发送和接收（将0写入TEN和REN位）。



32.11.4.2 SSISR register

(1) Clearing TUIRQ and TOIRQ

After communication is enabled (by changing the value of SSICR.TEN bit from 0 to 1), the transmission error flags (TOIRQ and TUIRQ in the SSISR register) are cleared. If, however, the SSISR register is read continuously, the cleared status of the transmission error flags might be unable to be read.

(2) Clearing RUIRQ and ROIRQ

After communication is enabled (by changing the value of SSICR.REN bit from 0 to 1), the reception error flags (RUIRQ and ROIRQ in the SSISR register) are cleared. If, however, the SSISR register is read continuously, the cleared status of the reception error flags might be unable to be read.

32.11.4.3 Communication state

Writing to the bits with orange-shaded area in Table 32.17 is prohibited. If written, the operation performed immediately after writing is not guaranteed.

Table 32.17 Bits protected from writing during communication

| Symbol  | Address (BASE+) |    | +0          |     |          |           |        |        |           |         | +1        |          |           |       |          |     |         |           |
|---------|-----------------|----|-------------|-----|----------|-----------|--------|--------|-----------|---------|-----------|----------|-----------|-------|----------|-----|---------|-----------|
|         |                 |    | 31          | 30  | 29       | 28        | 27     | 26     | 25        | 24      | 23        | 22       | 21        | 20    | 19       | 18  | 17      | 16        |
|         |                 |    | 15          | 14  | 13       | 12        | 11     | 10     | 9         | 8       | 7         | 6        | 5         | 4     | 3        | 2   | 1       | 0         |
| SSICR   | 0x00            | +0 | —           | CKS | TUI EN   | TOI EN    | RUI EN | ROI EN | IIEN      | —       | FRM[1:0]  | DWL[2:0] |           |       | SWL[2:0] |     |         |           |
|         |                 | +2 | —           | MST | BCK P    | LRC KP    | SPD P  | SDT A  | PDT A     | DEL     | CKDV[3:0] |          |           | MU EN | —        | TEN | REN     |           |
| SSISR   | 0x04            | +0 | —           | —   | TUI RQ   | TOI RQ    | RUI RQ | ROI RQ | IIRQ      | —       | —         | —        | —         | —     | —        | —   | —       |           |
|         |                 | +2 | —           | —   | —        | —         | —      | —      | —         | —       | —         | —        | —         | —     | —        | —   | —       |           |
| SSIFCR  | 0x10            | +0 | AUC KE      | —   | —        | —         | —      | —      | —         | —       | —         | —        | —         | —     | —        | —   | SSI RST |           |
|         |                 | +2 | —           | —   | —        | —         | BS W   | —      | —         | —       | —         | —        | —         | —     | TIE      | RIE | TFR ST  | RFR ST    |
| SSIFSR  | 0x14            | +0 | —           | —   | TDC[5:0] |           |        |        |           | —       | —         | —        | —         | —     | —        | —   | TDE     |           |
|         |                 | +2 | —           | —   | RDC[5:0] |           |        |        |           | —       | —         | —        | —         | —     | —        | —   | RDF     |           |
| SSIFTDR | 0x18            | +0 | FTDR[31:16] |     |          |           |        |        |           |         |           |          |           |       |          |     |         |           |
|         |                 | +2 | FTDR[15:0]  |     |          |           |        |        |           |         |           |          |           |       |          |     |         |           |
| SSIFRDR | 0x1C            | +0 | FRDR[31:16] |     |          |           |        |        |           |         |           |          |           |       |          |     |         |           |
|         |                 | +2 | FRDR[15:0]  |     |          |           |        |        |           |         |           |          |           |       |          |     |         |           |
| SSIOFR  | 0x20            | +0 | —           | —   | —        | —         | —      | —      | —         | —       | —         | —        | —         | —     | —        | —   | —       |           |
|         |                 | +2 | —           | —   | —        | —         | —      | —      | BCK AST P | LRC ONT | —         | —        | —         | —     | —        | —   | —       | OMOD[1:0] |
| SSISCR  | 0x24            | +0 | —           | —   | —        | —         | —      | —      | —         | —       | —         | —        | —         | —     | —        | —   | —       |           |
|         |                 | +2 | —           | —   | —        | TDES[4:0] |        |        |           | —       | —         | —        | RDFS[4:0] |       |          |     |         |           |

32.11.4.2 SSISR register

(1) 清除TUIRQ和TOIRQ

启用通信后（通过将SSICR.TEN位的值从0更改为1），传输错误标志（SSISR寄存器中的TOIRQ和TUIRQ）被清除。但是，如果连续读取SSISR寄存器，则可能无法读取传输错误标志的清除状态。

(2) 清除RUIRQ和ROIRQ

启用通信后（通过将SSICR.REN位的值从0更改为1），接收错误标志（SSISR寄存器中的RUIRQ和ROIRQ）被清除。但是，如果连续读取SSISR寄存器，则可能无法读取接收错误标志的清除状态。

32.11.4.3 通讯状态

禁止写入表32.17中橙色阴影区域的位。如果写入，则不保证写入后立即执行的操作。

Table 32.17 通信期间防止写入的位

| Symbol  | Address (BASE+) |    | +0          |     |          |           |        |        |           |         | +1        |          |           |    |          |     |         |           |
|---------|-----------------|----|-------------|-----|----------|-----------|--------|--------|-----------|---------|-----------|----------|-----------|----|----------|-----|---------|-----------|
|         |                 |    | 31          | 30  | 29       | 28        | 27     | 26     | 25        | 24      | 23        | 22       | 21        | 20 | 19       | 18  | 17      | 16        |
|         |                 |    | 15          | 14  | 13       | 12        | 11     | 10     | 9         | 8       | 7         | 6        | 5         | 4  | 3        | 2   | 1       | 0         |
| SSICR   | 0x00            | +0 | —           | CKS | 途恩       | 托伊恩       | 瑞恩     | 投源回率CN | IIEN      | —       | FRM[1:0]  | DWL[2:0] |           |    | SWL[2:0] |     |         |           |
|         |                 | +2 | —           | MST | BCK P    | LRC KP    | SPD P  | SDT A  | PDT A     | DEL     | CKDV[3:0] |          |           | 穆恩 | —        | TEN | REN     |           |
| SSISR   | 0x04            | +0 | —           | —   | TUI RQ   | TOI RQ    | RUI RQ | ROI RQ | IIRQ      | —       | —         | —        | —         | —  | —        | —   | —       |           |
|         |                 | +2 | —           | —   | —        | —         | —      | —      | —         | —       | —         | —        | —         | —  | —        | —   | —       |           |
| SSIFCR  | 0x10            | +0 | AUC KE      | —   | —        | —         | —      | —      | —         | —       | —         | —        | —         | —  | —        | —   | SSI RST |           |
|         |                 | +2 | —           | —   | —        | —         | BS W   | —      | —         | —       | —         | —        | —         | —  | TIE      | RIE | TFR ST  | RFR ST    |
| SSIFSR  | 0x14            | +0 | —           | —   | TDC[5:0] |           |        |        |           | —       | —         | —        | —         | —  | —        | —   | TDE     |           |
|         |                 | +2 | —           | —   | RDC[5:0] |           |        |        |           | —       | —         | —        | —         | —  | —        | —   | RDF     |           |
| SSIFTDR | 0x18            | +0 | FTDR[31:16] |     |          |           |        |        |           |         |           |          |           |    |          |     |         |           |
|         |                 | +2 | FTDR[15:0]  |     |          |           |        |        |           |         |           |          |           |    |          |     |         |           |
| SSIFRDR | 0x1C            | +0 | FRDR[31:16] |     |          |           |        |        |           |         |           |          |           |    |          |     |         |           |
|         |                 | +2 | FRDR[15:0]  |     |          |           |        |        |           |         |           |          |           |    |          |     |         |           |
| SSIOFR  | 0x20            | +0 | —           | —   | —        | —         | —      | —      | —         | —       | —         | —        | —         | —  | —        | —   | —       |           |
|         |                 | +2 | —           | —   | —        | —         | —      | —      | BCK AST P | LRC ONT | —         | —        | —         | —  | —        | —   | —       | OMOD[1:0] |
| SSISCR  | 0x24            | +0 | —           | —   | —        | —         | —      | —      | —         | —       | —         | —        | —         | —  | —        | —   | —       |           |
|         |                 | +2 | —           | —   | —        | TDES[4:0] |        |        |           | —       | —         | —        | RDFS[4:0] |    |          |     |         |           |

### 33. SD/MMC Host Interface (SDHI)

#### 33.1 Overview

The Secure Digital Host Interface (SDHI) and MultiMediaCard (MMC) Interface provide the functionality required to connect a variety of external memory cards with the MCU. The SDHI supports both 1- and 4-bit buses for connecting different memory cards that support SD, SDHC, and SDXC formats. When developing host devices that are compliant with the SD Specifications, you must comply with the SD Host/Ancillary Product License Agreement (SD HALA).

The MMC interface supports 1-bit, 4-bit, and 8-bit MMC buses that provide eMMC 4.51 (JEDEC Standard JESD 84- B451) device access. This interface also provides backward compatibility and supports for high-speed SDR transfer modes.

Table 33.1 lists the SD/MMC Host Interface specifications and Figure 33.1 shows a block diagram.

Table 33.1 SD/MMC Host Interface specifications

| Interface         | Parameter                       | Specifications  |
|-------------------|---------------------------------|---|
| SD                | SD bus interface                | <ul style="list-style-type: none"> <li>Compatible with SD memory card and SDIO card</li> <li>Transfer bus mode selectable from 4-bit wide bus mode or 1-bit default bus mode</li> <li>Compatible with SD, SDHC, and SDXC formats</li> </ul> |
| SD and MMC shared | SDHI clock frequency            | The SDHI clock is generated by dividing PCLKB by 2 <sup>n</sup> (n = 0 to 9)  |
|                   | Error check functions           | CRC7 (command/response), CRC16 (transfer data)  |
|                   | Interrupt sources               | Card access interrupt (SDHI_MMC0_ACCS), SDIO access interrupt (SDHI_MMC0_SDI0), Card detection interrupt (SDHI_MMC0_CARD)   |
|                   | DMA transfer sources            | DMAC and DTC triggerable by the SBFAl interrupt<br>SD buffer is read and write accessible using the DMAC  |
|                   | Other functions                 | <ul style="list-style-type: none"> <li>Card detect function</li> <li>Write protect support</li> </ul>   |
| MMC               | MMC bus interface               | Transfer bus mode selectable from 1-bit, 4-bit, or 8-bit  |
|                   | Transfer modes                  | Backward compatible mode or high-speed SDR mode selectable  |
|                   | Other functions                 | e.MMC device access supported   |
| TrustZone Filter  | Security attribution can be set |   |

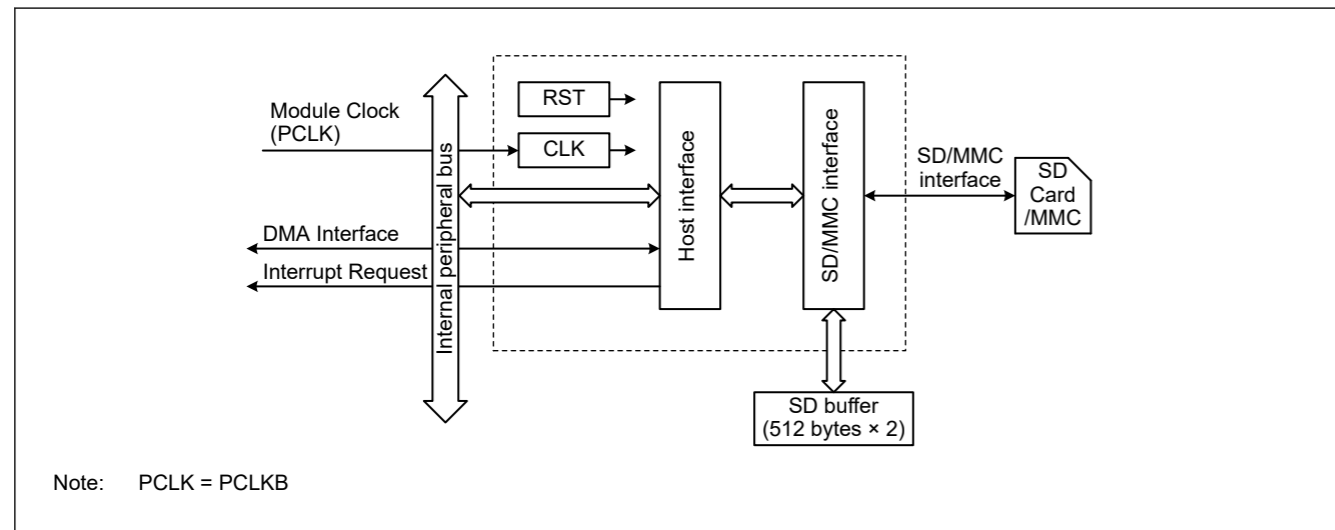


Figure 33.1 SD/MMC Host Interface block diagram

Table 33.2 SDHI I/O pins (n = 0) (1 of 2)

| Channel | Pin name | I/O    | Description |
|---------|----------|--------|-------------|
| Ch n    | SDnCLK   | Output | SDHI clock  |

### 33. SDMMC主机接口(SDHI)

#### 33.1 Overview

安全数字主机接口(SDHI)和多媒体卡(MMC)接口提供了将各种外部存储卡与MCU连接所需的功能。SDHI支持1位和4位总线，用于连接支持SD、SDHC和SDXC格式的不同存储卡。在开发符合SD规范的主机设备时，您必须遵守SD主机辅助产品许可协议(SDHALA)。

MMC接口支持提供eMMC4.51 (JEDEC标准JESD84B451) 器件访问的1位、4位和8位MMC总线。该接口还提供向后兼容性并支持高速SDR传输模式。

表33.1列出了SDMMC主机接口规范，图33.1显示了框图。

Table 33.1 SDMMC主机接口规格

| Interface        | Parameter | Specifications   |
|------------------|-----------|--|
| SD               | SD总线接口    | <ul style="list-style-type: none"> <li>兼容SD存储卡和SDIO卡</li> <li>传输总线模式可选择4位宽总线模式或1位默认总线模式</li> <li>兼容SD、SDHC和SDXC格式</li> </ul> |
| SD和MMC共享         | SDHI时钟频率  | SDHI时钟由PCLKB除以2 <sup>n</sup> (n=0到9)生成   |
|                  | 错误检查功能    | CRC7 (command/response), CRC16 (transfer data)   |
|                  | 中断源       | 卡访问中断 (SDHI_MMC0_ACCS)、SDIO访问中断 (SDHI_MMC0_SDI0)、卡检测中断 (SDHI_MMC0_CARD)  |
|                  | DMA传输源    | SBFAI中断可触发DMAC和DTC<br>SD缓冲区可使用DMAC进行读写访问   |
|                  | 其他功能      | <ul style="list-style-type: none"> <li>卡片检测功能</li> <li>写保护支持</li> </ul>  |
| MMC              | MMC总线接口   | 传输总线模式可选择1位、4位或8位  |
|                  | 传输模式      | 向后兼容模式或高速SDR模式可选   |
|                  | 其他功能      | 支持e.MMC设备访问  |
| TrustZone Filter | 可设置安全属性   |  |

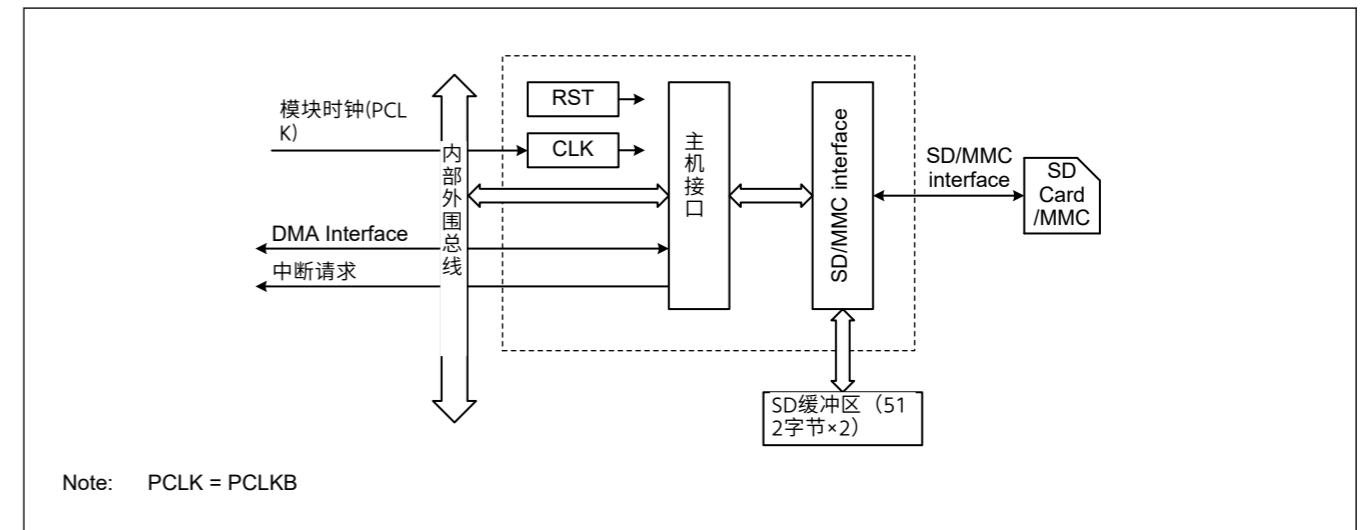


Figure 33.1 SDMMC主机接口框图

Table 33.2 SDHI I/O引脚(n=0)(1of2)

| Channel | 引脚名称   | I/O    | Description |
|---------|--------|--------|-------------|
| Ch n    | SDnCLK | Output | SDHI clock  |

Table 33.2 SDHI I/O pins (n = 0) (2 of 2)

| Channel | Pin name | I/O   | Description                    |
|---------|----------|-------|--------------------------------|
|         | SDnCMD   | I/O   | Command output, response input |
|         | SDnDAT0  | I/O   | Data 0 (DAT0)                  |
|         | SDnDAT1  | I/O   | Data 1 (DAT1), SDIO interrupt  |
|         | SDnDAT2  | I/O   | Data 2 (DAT2), SDIO Read wait  |
|         | SDnDAT3  | I/O   | Data 3 (DAT3), SD Card detect  |
|         | SDnDAT4  | I/O   | MMC Data 4 (DAT4)              |
|         | SDnDAT5  | I/O   | MMC Data 5 (DAT5)              |
|         | SDnDAT6  | I/O   | MMC Data 6 (DAT6)              |
|         | SDnDAT7  | I/O   | MMC Data 7 (DAT7)              |
|         | SDnCD    | Input | SD card detection              |
|         | SDnWP    | Input | SD card write protection       |

### 33.2 Register Descriptions

#### 33.2.1 SD\_CMD : Command Type Register

Base address: SDHI<sub>n</sub> 0 = 0x4009\_2000 + 0x0400 × n

Offset address: 0x000

|                    |              |        |        |        |            |           |    |    |    |    |    |    |    |    |    |             |
|--------------------|--------------|--------|--------|--------|------------|-----------|----|----|----|----|----|----|----|----|----|-------------|
| Bit position:      | 31           | 30     | 29     | 28     | 27         | 26        | 25 | 24 | 23 | 22 | 21 | 20 | 19 | 18 | 17 | 16          |
| Bit field:         | —            | —      | —      | —      | —          | —         | —  | —  | —  | —  | —  | —  | —  | —  | —  | —           |
| Value after reset: | 0            | 0      | 0      | 0      | 0          | 0         | 0  | 0  | 0  | 0  | 0  | 0  | 0  | 0  | 0  | 0           |
| Bit position:      | 15           | 14     | 13     | 12     | 11         | 10        | 9  | 8  | 7  | 6  | 5  | 4  | 3  | 2  | 1  | 0           |
| Bit field:         | CMD12AT[1:0] | TRST P | CMDR W | CMDT P | RSPTP[2:0] | ACMD[1:0] |    |    |    |    |    |    |    |    |    | CMDIDX[5:0] |
| Value after reset: | 0            | 0      | 0      | 0      | 0          | 0         | 0  | 0  | 0  | 0  | 0  | 0  | 0  | 0  | 0  | 0           |

| Bit  | Symbol      | Function   | R/W |
|------|-------------|--|-----|
| 5:0  | CMDIDX[5:0] | Command Index Field Value Select<br>These bits configure the command index field value. The examples shown include the bit values for the ACMD[1:0] bits.<br>0x06: CMD6<br>0x12: CMD18<br>0x4D: ACMD13   | R/W |
| 7:6  | ACMD[1:0]   | Command Type Select<br>0 0: CMD<br>0 1: ACMD<br>Others: Setting prohibited   | R/W |
| 10:8 | RSPTP[2:0]  | Response Type Select*1<br>0 0 0: Normal mode<br>Depending on the command, the response type and transfer method are selected in the ACMD[1:0] and CMDIDX[5:0] bits. At this time, the values for bits 15 to 11 in this register are invalid.<br>0 1 1: Extended mode and no response<br>1 0 0: Extended mode and R1, R5, R6, or R7 response<br>1 0 1: Extended mode and R1b response<br>1 1 0: Extended mode and R2 response<br>1 1 1: Extended mode and R3 or R4 response<br>Others: Setting prohibited | R/W |

Table 33.2 SDHIIO引脚(n=0)(2of2)

| Channel | 引脚名称    | I/O   | Description         |
|---------|---------|-------|---------------------|
|         | SDnCMD  | I/O   | 命令输出, 响应输入          |
|         | SDnDAT0 | I/O   | Data 0 (DAT0)       |
|         | SDnDAT1 | I/O   | 数据1(DAT1), SDIO中断   |
|         | SDnDAT2 | I/O   | 数据2(DAT2), SDIO读取等待 |
|         | SDnDAT3 | I/O   | 数据3(DAT3), SD卡检测    |
|         | SDnDAT4 | I/O   | MMC Data 4 (DAT4)   |
|         | SDnDAT5 | I/O   | MMC Data 5 (DAT5)   |
|         | SDnDAT6 | I/O   | MMC Data 6 (DAT6)   |
|         | SDnDAT7 | I/O   | MMC Data 7 (DAT7)   |
|         | SDnCD   | Input | SD卡检测               |
|         | SDnWP   | Input | SD卡写保护              |

### 33.2 注册说明

#### 33.2.1 SD\_CMD:命令类型寄存器

Base address: SDHI<sub>n</sub> 0 = 0x4009\_2000 + 0x0400 × n

Offset address: 0x000

|               |              |        |        |        |            |           |    |    |    |    |    |    |    |    |    |             |
|---------------|--------------|--------|--------|--------|------------|-----------|----|----|----|----|----|----|----|----|----|-------------|
| Bit position: | 31           | 30     | 29     | 28     | 27         | 26        | 25 | 24 | 23 | 22 | 21 | 20 | 19 | 18 | 17 | 16          |
| Bit field:    | —            | —      | —      | —      | —          | —         | —  | —  | —  | —  | —  | —  | —  | —  | —  | —           |
| 重置后的值:        | 0            | 0      | 0      | 0      | 0          | 0         | 0  | 0  | 0  | 0  | 0  | 0  | 0  | 0  | 0  | 0           |
| Bit position: | 15           | 14     | 13     | 12     | 11         | 10        | 9  | 8  | 7  | 6  | 5  | 4  | 3  | 2  | 1  | 0           |
| Bit field:    | CMD12AT[1:0] | TRST P | CMDR W | CMDT P | RSPTP[2:0] | ACMD[1:0] |    |    |    |    |    |    |    |    |    | CMDIDX[5:0] |
| 重置后的值:        | 0            | 0      | 0      | 0      | 0          | 0         | 0  | 0  | 0  | 0  | 0  | 0  | 0  | 0  | 0  | 0           |

| Bit  | Symbol      | Function   | R/W |
|------|-------------|--|-----|
| 5:0  | CMDIDX[5:0] | 命令索引字段值选择<br>这些位配置命令索引字段值。所示示例包括ACMD[1:0]位的位值。<br>0x06: CMD6<br>0x12: CMD18<br>0x4D: ACMD13  | R/W |
| 7:6  | ACMD[1:0]   | 命令类型选择<br>0 0: CMD<br>0 1: ACMD<br>其他: 禁止设置  | R/W |
| 10:8 | RSPTP[2:0]  | 响应类型选择*1<br>000: 正常模式<br>根据命令, 在ACMD[1:0]和CMDIDX[5:0]位中选择响应类型和传输方法。此时, 该寄存器中第15位到第11位的值无效。<br>011: 扩展模式和无响应100: 扩展模式和R1、R5、R6或R7响应101: 扩展模式和R1b响应110: 扩展模式和R2响应111: 扩展模式和R3或R4响应<br>其他: 禁止设置 | R/W |

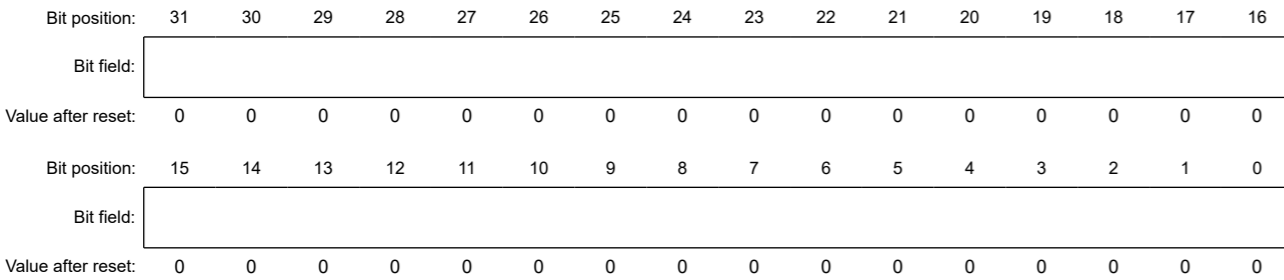
| Bit   | Symbol       | Function  | R/W |
|-------|--------------|---|-----|
| 11    | CMDTP        | Data Transfer Select*2<br>0: Do not include data transfer (bc, bcr, or ac) in command<br>1: Include data transfer (adtc) in command   | R/W |
| 12    | CMDRW        | Data Transfer Direction Select*3<br>0: Write (SD/MMC Host Interface → SD card/MMC)<br>1: Read (SD/MMC Host Interface ← SD card/MMC)   | R/W |
| 13    | TRSTP        | Block Transfer Select*3<br>0: Single block transfer<br>1: Multiple blocks transfer  | R/W |
| 15:14 | CMD12AT[1:0] | CMD12 Automatic Issue Select*4<br>0 0: Automatically issue CMD12 during multiblock transfer<br>0 1: Do not automatically issue CMD12 during multiblock transfer<br>Others: Setting prohibited | R/W |
| 31:16 | —            | These bits are read as 0. The write value should be 0.  | R/W |

Note 1. Some commands cannot be used in normal mode.  
 Note 2. The CMDTP bit is only valid when the RSPTP[2:0] bits are 011b, 100b, 101b, 110b, or 111b.  
 Note 3. Bits CMDRW and TRSTP are only valid when the RSPTP[2:0] bits are 011b, 100b, 101b, 110b, or 111b, and the CMDTP bit is 1.  
 Note 4. The CMD12AT[1:0] bits are only valid when the RSPTP[2:0] bits are 011b, 100b, 101b, 110b, or 111b, and the TRSTP bit is 1.

The command type and response type are set in the SD\_CMD register. The command type and transfer mode must be set when the RSPTP[2:0] bits are 011b, 100b, 101b, 110b, or 111b. The sequence starts when a value is written to this register. See Table 33.8 and Table 33.9 for setting examples. Do not write to the SD\_CMD register when the SD\_INFO2.CBSY flag is 1.

### 33.2.2 SD\_ARG : SD Command Argument Register

Base address: SDHI<sub>n</sub> 0 = 0x4009\_2000 + 0x0400 × n  
 Offset address: 0x008



| Bit  | Symbol | Function  | R/W |
|------|--------|---|-----|
| 31:0 | —      | These bits specify command format[39:8] (argument). | R/W |

The SD\_ARG register is used for setting the argument field value. Set the SD\_ARG register before setting the SD\_CMD register. The argument field value of the automatically issued CMD12 is 0x0000\_0000 regardless of the SD\_ARG register value.

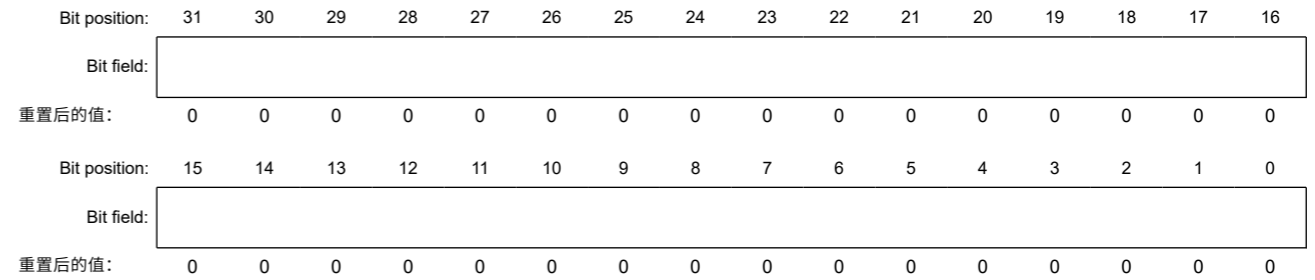
| Bit   | Symbol       | Function  | R/W |
|-------|--------------|---|-----|
| 11    | CMDTP        | 数据传输选择*2<br>0: 在命令中不包括数据传输 (bc、bcr或ac) 1: 在命令中包括数据传输 (adtc)               | R/W |
| 12    | CMDRW        | 数据传输方向选择*3<br>0: 写入 (SDMMC主机接口→SD卡MMC) 1: 读取 (SDMMC主机接口←SD卡MMC)           | R/W |
| 13    | TRSTP        | 块传输选择*3<br>0: 单块传输 1: 多块传输  | R/W |
| 15:14 | CMD12AT[1:0] | CMD12自动发行选择*4<br>00: 在多块传输过程中自动发出CMD12 01: 在多块传输过程中不自动发出CMD12<br>其他: 禁止设置 | R/W |
| 31:16 | —            | 这些位被读取为0。写入值应为0。  | R/W |

注1.某些命令不能在正常模式下使用。  
 注2.CMDTP位仅在RSPTP[2:0]位为011b、100b、101b、110b或111b时有效。  
 注3.CMDRW和TRSTP位仅在RSPTP[2:0]位为011b、100b、101b、110b或111b且CMDTP位为1时有效。  
 注4.CMD12AT[1:0]位仅在RSPTP[2:0]位为011b、100b、101b、110b或111b且TRSTP位为1时有效。

命令类型和响应类型在SD\_CMD寄存器中设置。当RSPTP[2:0]位为011b、100b、101b、110b或111b时，必须设置命令类型和传输模式。当一个值被写入该寄存器时，序列开始。设置示例见表33.8和表33.9。当SD\_INFO2.CBSY标志为1时，不要写入SD\_CMD寄存器。

### 33.2.2 SD\_ARG:SD命令参数寄存器

Base address: SDHI<sub>n</sub> 0 = 0x4009\_2000 + 0x0400 × n  
 Offset address: 0x008



| Bit  | Symbol | Function              | R/W |
|------|--------|-----------------------|-----|
| 31:0 | —      | 这些位指定命令格式[39:8] (参数)。 | R/W |

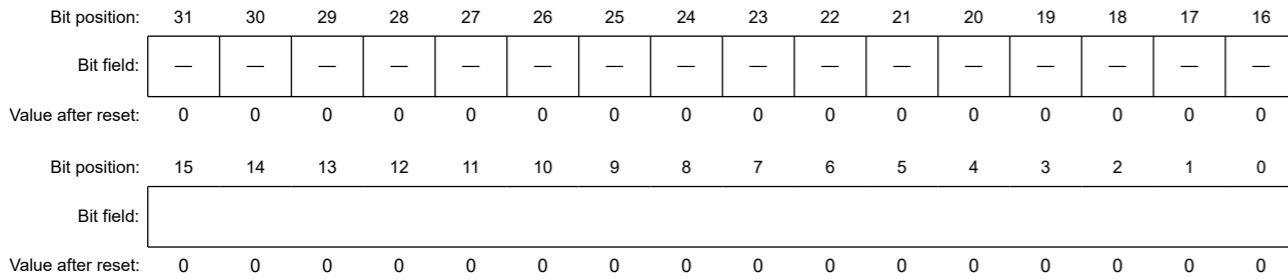
SD\_ARG寄存器用于设置参数字段值。在设置SD\_CMD寄存器之前设置SD\_ARG寄存器。无论SD\_ARG寄存器的值如何，自动发出的CMD12的参数字段值为0x0000\_0000。



### 33.2.3 SD\_ARG1 : SD Command Argument Register 1

Base address: SDHI<sub>n</sub> 0 = 0x4009\_2000 + 0x0400 × n

Offset address: 0x00C



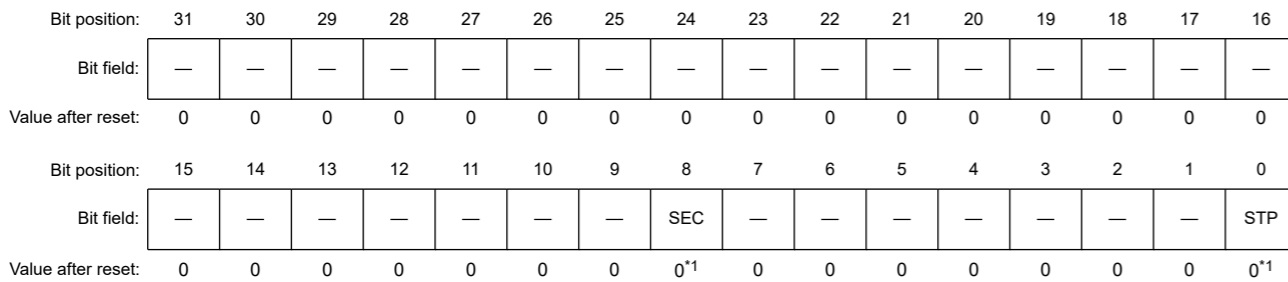
| Bit   | Symbol | Function   | R/W |
|-------|--------|--|-----|
| 15:0  | —      | These bits specify command format[39:24] (argument).   | R/W |
| 31:16 | —      | These bits are read as 0. The write value should be 0. | R/W |

The SD\_ARG1 register is used for setting the argument field value. Set the SD\_ARG1 register before setting the SD\_CMD register. The argument field value of the automatically issued CMD12 is 0x0000\_0000 regardless of the SD\_ARG1 register value.

### 33.2.4 SD\_STOP : Data Stop Register

Base address: SDHI<sub>n</sub> 0 = 0x4009\_2000 + 0x0400 × n

Offset address: 0x010



| Bit  | Symbol | Function  | R/W |
|------|--------|---|-----|
| 0    | STP    | Transfer Stop<br>Data transfer stops when this bit is set to 1.   | R/W |
| 7:1  | —      | These bits are read as 0. The write value should be 0.  | R/W |
| 8    | SEC    | Block Count Register Value Select <sup>2</sup><br>0: Disable SD_SECCNT register value<br>1: Enable SD_SECCNT register value | R/W |
| 31:9 | —      | These bits are read as 0. The write value should be 0.  | R/W |

Note 1. The value is initialized by a reset and also on reset triggered by the SOFT\_RST.SDRST flag.

Note 2. Do not rewrite this bit when the SD\_INFO2.CBSY flag is 1.

The SD\_STOP register stops data transfer. During a multiblock transfer sequence, the SD\_SECCNT register value (number of blocks to be transferred) can be set to valid or invalid by setting the SD\_STOP register.

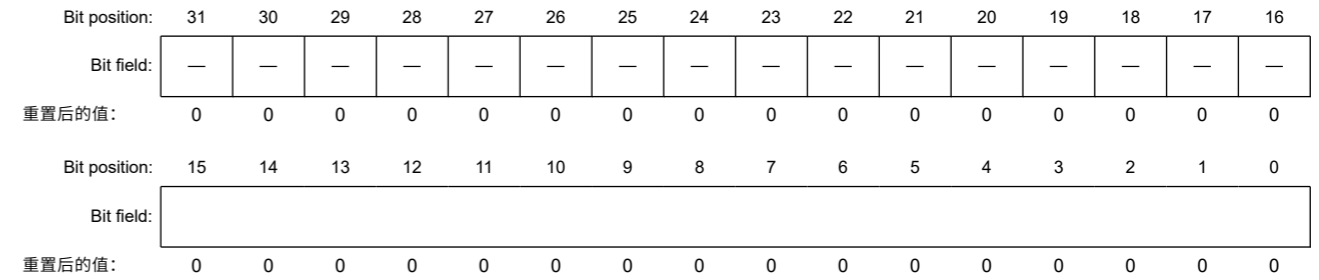
#### STP bit (Transfer Stop)

When the STP bit is set to 1 during multiple block transfer, CMD12 is issued to halt the transfer through the SDHI. However, if a command sequence is halted because of a communications error or timeout, CMD12 is not issued. Although

### 33.2.3 SD\_ARG1:SD命令参数寄存器1

Base address: SDHI<sub>n</sub> 0 = 0x4009\_2000 + 0x0400 × n

Offset address: 0x00C



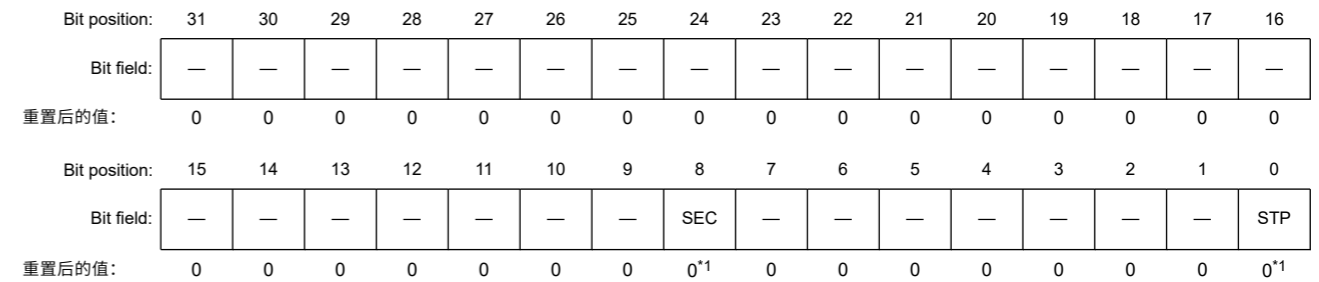
| Bit   | Symbol | Function               | R/W |
|-------|--------|------------------------|-----|
| 15:0  | —      | 这些位指定命令格式[39:24] (参数)。 | R/W |
| 31:16 | —      | 这些位被读取为0。写入值应为0。       | R/W |

SD\_ARG1寄存器用于设置参数字段值。在设置SD\_CMD寄存器之前设置SD\_ARG1寄存器。无论SD\_ARG1寄存器的值如何，自动发出的CMD12的参数字段值为0x0000\_0000。

### 33.2.4 SD\_STOP:数据停止寄存器

Base address: SDHI<sub>n</sub> 0 = 0x4009\_2000 + 0x0400 × n

Offset address: 0x010



| Bit  | Symbol | Function   | R/W |
|------|--------|--|-----|
| 0    | STP    | 中转站<br>当该位设置为1时，数据传输停止。  | R/W |
| 7:1  | —      | 这些位被读取为0。写入值应为0。   | R/W |
| 8    | SEC    | 块计数寄存器值选择 <sup>2</sup><br>0: 禁用SD_SECCNT寄存器值<br>1: 启用SD_SECCNT寄存器值 | R/W |
| 31:9 | —      | 这些位被读取为0。写入值应为0。   | R/W |

注1.该值由复位初始化，并且在由SOFT\_RST.SDRST标志触发的复位时初始化。

注2.当SD\_INFO2.CBSY标志为1时，请勿重写该位。

SD\_STOP寄存器停止数据传输。在多块传输序列期间，可以通过设置SD\_STOP寄存器将SD\_SECCNT寄存器值（要传输的块数）设置为有效或无效。

#### STP bit (Transfer Stop)

在多块传输期间STP位设置为1时，发出CMD12以停止通过SDHI的传输。但是，如果命令序列由于通信错误或超时而停止，则不会发出CMD12。虽然

continued buffer access is possible even after STP is set to 1, the buffer access error bit (ILR or ILW) in SD\_INFO2 is set accordingly.

When STP is set to 1 during transfer for single block write, the access end flag sets when SD\_BUF becomes empty, and CMD12 is not issued. If SD\_BUF does contain data, the access end flag sets on completion of reception of the busy state without CMD12 being issued.

When STP is set to 1 during transfer for single block read, the access end flag sets immediately after the STP bit is set, and CMD12 is not issued.

When STP is set to 1 during reception of the busy state after an R1b response, the access end flag sets on completion of reception of the busy state without CMD12 being issued.

When STP is set to 1 after a command sequence is completed, CMD12 is not issued and the access end flag does not set.

Set STP to 1 after the response end flag sets.

Set STP to 0 after the access end flag sets.

#### SEC bit (Block Count Register Value Select)

When SD\_CMD is set in the following section to start the command sequence while the SEC bit is set to 1, CMD12 is automatically issued to stop multiblock transfer with the number of blocks set in SD\_SECCNT.

CMD18 or CMD25 in normal mode (SD\_CMD[10:8] = 000b)

SD\_CMD[15:13] = 001b in extended mode (CMD12 is automatically issued, multiple block transfer)

When the command sequence is halted because of a communications error or timeout, CMD12 is not automatically issued.

#### 33.2.5 SD\_SECCNT : Block Count Register

Base address: SDHI<sub>n</sub> 0 = 0x4009\_2000 + 0x0400 × n

Offset address: 0x014

|                    |               |    |    |    |    |    |    |    |    |    |    |    |    |    |    |    |
|--------------------|---------------|----|----|----|----|----|----|----|----|----|----|----|----|----|----|----|
| Bit position:      | 31            | 30 | 29 | 28 | 27 | 26 | 25 | 24 | 23 | 22 | 21 | 20 | 19 | 18 | 17 | 16 |
| Bit field:         | [Empty field] |    |    |    |    |    |    |    |    |    |    |    |    |    |    |    |
| Value after reset: | 0             | 0  | 0  | 0  | 0  | 0  | 0  | 0  | 0  | 0  | 0  | 0  | 0  | 0  | 0  | 0  |
| Bit position:      | 15            | 14 | 13 | 12 | 11 | 10 | 9  | 8  | 7  | 6  | 5  | 4  | 3  | 2  | 1  | 0  |
| Bit field:         | [Empty field] |    |    |    |    |    |    |    |    |    |    |    |    |    |    |    |
| Value after reset: | 0             | 0  | 0  | 0  | 0  | 0  | 0  | 0  | 0  | 0  | 0  | 0  | 0  | 0  | 0  | 0  |

When performing a multiblock transfer, SD\_SECCNT is a read/write register used to set the number of blocks to be transferred. For example, when the register value is 0x0000\_0001, 1 block is transferred. When the register value is 0x0000\_FFFF, 65,535 blocks are transferred and when the register value is 0xFFFF\_FFFF, 4,294,967,295 blocks are transferred. Do not set this register to 0x0000\_0000. Do not rewrite the SD\_SECCNT register when the SD\_INFO2.CBSY flag is 1.

即使在STP设置为1后，仍可以继续访问缓冲区，相应地设置SD\_INFO2中的缓冲区访问错误位（ILR或ILW）。

在单块写入的传输过程中将STP设置为1时，当SD\_BUF为空时设置访问结束标志，并且不发出CMD12。如果SD\_BUF确实包含数据，则在发出CMD12的忙状态接收完成时设置访问结束标志。

当STP在单块读取传输期间设置为1时，在设置STP位后立即设置访问结束标志，并且未发出CMD12。

当在R1b响应后的忙状态接收期间将STP设置为1时，在发出CMD12的忙状态接收完成时设置访问结束标志。

当命令序列完成后STP设置为1时，不发出CMD12并且不设置访问结束标志。

设置响应结束标志后将STP设置为1。

设置访问结束标志后将STP设置为0。

#### SEC位（块计数寄存器值选择）

当在以下部分中设置SD\_CMD以启动命令序列而SEC位设置为1时，将自动发出CMD12以停止多块传输，其中块数在SD\_SECCNT中设置。

正常模式下的CMD18或CMD25(SD\_CMD[10:8]=000b)

SD\_CMD[15:13]=001b扩展模式（CMD12自动发出，多块传输）

当命令序列由于通信错误或超时而停止时，不会自动发出CMD12。

#### 33.2.5 SD\_SECCNT: 块计数寄存器

Base address: SDHI<sub>n</sub> 0 = 0x4009\_2000 + 0x0400 × n

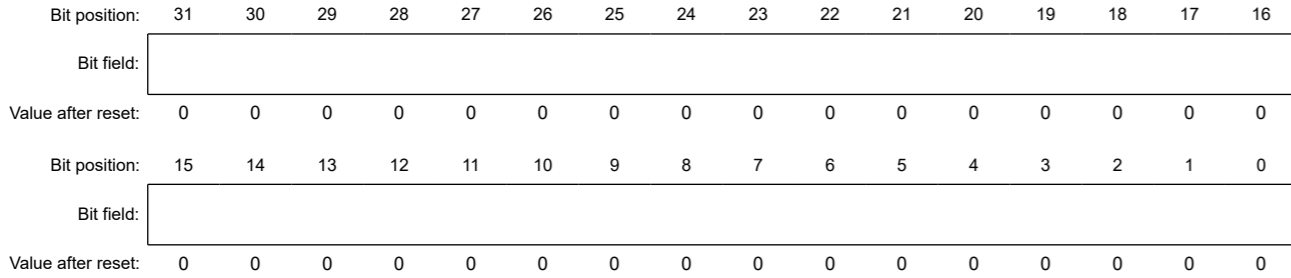
Offset address: 0x014

|               |               |    |    |    |    |    |    |    |    |    |    |    |    |    |    |    |
|---------------|---------------|----|----|----|----|----|----|----|----|----|----|----|----|----|----|----|
| Bit position: | 31            | 30 | 29 | 28 | 27 | 26 | 25 | 24 | 23 | 22 | 21 | 20 | 19 | 18 | 17 | 16 |
| Bit field:    | [Empty field] |    |    |    |    |    |    |    |    |    |    |    |    |    |    |    |
| 重置后的值:        | 0             | 0  | 0  | 0  | 0  | 0  | 0  | 0  | 0  | 0  | 0  | 0  | 0  | 0  | 0  | 0  |
| Bit position: | 15            | 14 | 13 | 12 | 11 | 10 | 9  | 8  | 7  | 6  | 5  | 4  | 3  | 2  | 1  | 0  |
| Bit field:    | [Empty field] |    |    |    |    |    |    |    |    |    |    |    |    |    |    |    |
| 重置后的值:        | 0             | 0  | 0  | 0  | 0  | 0  | 0  | 0  | 0  | 0  | 0  | 0  | 0  | 0  | 0  | 0  |

执行多块传输时，SD\_SECCNT是一个读写寄存器，用于设置要传输的块数。例如，当寄存器值为0x0000\_0001时，传输1个块。当寄存器值为0x0000\_FFFF时，传送65 535个块，当寄存器值为0xFFFF\_FFFF时，传送4 294 967 295个块。不要将此寄存器设置为0x0000\_0000。当SD\_INFO2.CBSY标志为1时，不要重写SD\_SECCNT寄存器。

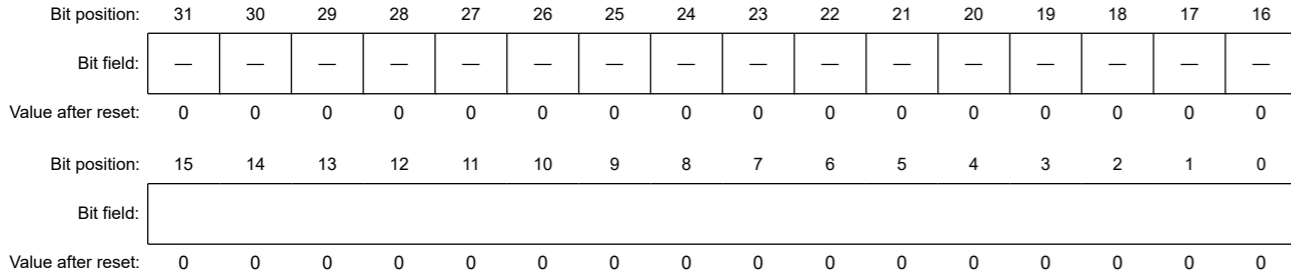
33.2.6 SD\_RSPi : SD Card Response Register i (i = 10, 32, 54)

Base address: SDHI<sub>n</sub> 0 = 0x4009\_2000 + 0x0400 × n  
 Offset address: 0x018; i = 10  
 0x020; i = 32  
 0x028; i = 54



33.2.7 SD\_RSPj : SD Card Response Register j (j = 1, 3, 5)

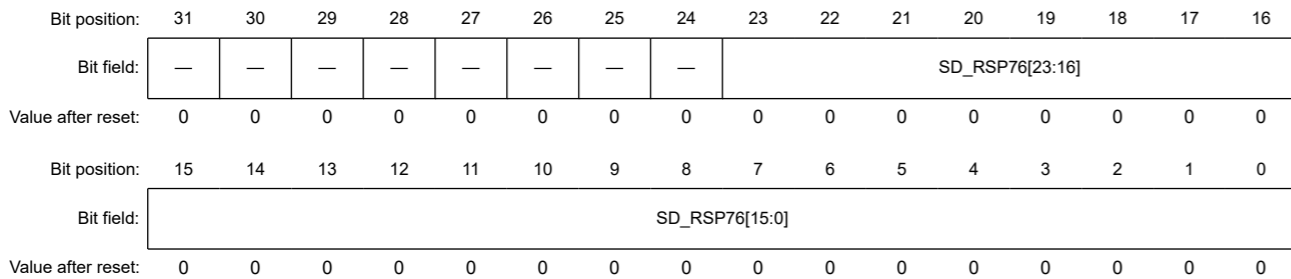
Base address: SDHI<sub>n</sub> 0 = 0x4009\_2000 + 0x0400 × n  
 Offset address: 0x01C + (0x4 × (j - 1))



| Bit   | Symbol | Function  | R/W |
|-------|--------|---|-----|
| 15:0  | —      | These bits store the response from the SD card/MMC. | R   |
| 31:16 | —      | These bits are read as 0.                           | R   |

33.2.8 SD\_RSP76 : SD Card Response Register 76

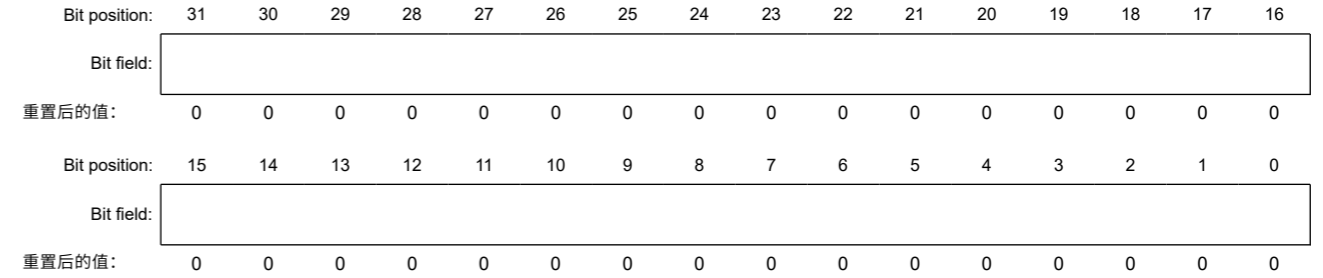
Base address: SDHI<sub>n</sub> 0 = 0x4009\_2000 + 0x0400 × n  
 Offset address: 0x030



| Bit   | Symbol         | Function  | R/W |
|-------|----------------|---|-----|
| 23:0  | SD_RSP76[23:0] | These bits store the response from the SD card/MMC. | R   |
| 31:24 | —              | These bits are read as 0.                           | R   |

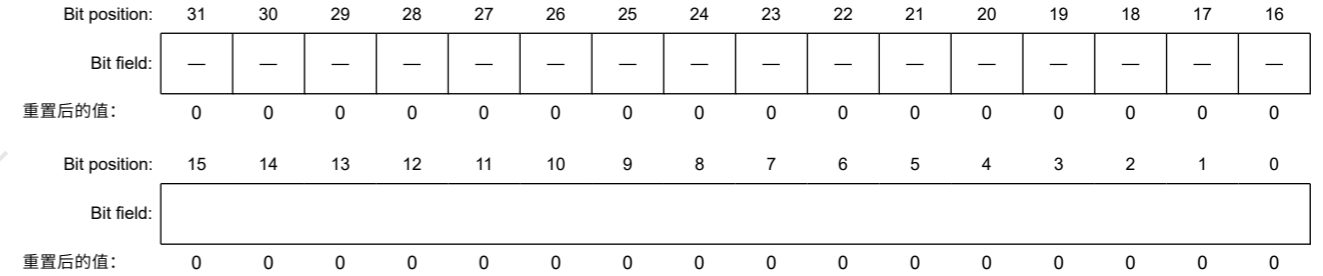
33.2.6 SD\_RSPi:SD卡响应寄存器i(i=10 32 54)

Base address: SDHI<sub>n</sub> 0 = 0x4009\_2000 + 0x0400 × n  
 Offset address: 0x018; i = 10  
 0x020; i = 32  
 0x028; i = 54



33.2.7 SD\_RSPj:SD卡响应寄存器j(j=1 3 5)

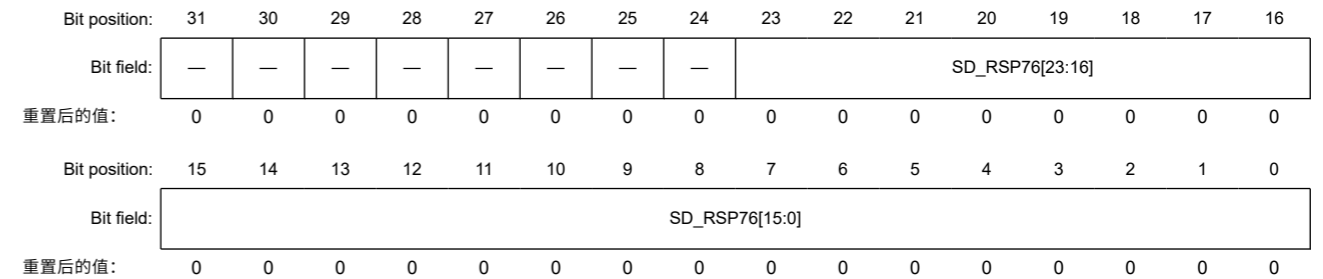
Base address: SDHI<sub>n</sub> 0 = 0x4009\_2000 + 0x0400 × n  
 Offset address: 0x01C + (0x4 × (j - 1))



| Bit   | Symbol | Function          | R/W |
|-------|--------|-------------------|-----|
| 15:0  | —      | 这些位存储来自SD卡MMC的响应。 | R   |
| 31:16 | —      | 这些位读为0。           | R   |

33.2.8 SD\_RSP76:SD卡响应寄存器76

Base address: SDHI<sub>n</sub> 0 = 0x4009\_2000 + 0x0400 × n  
 Offset address: 0x030

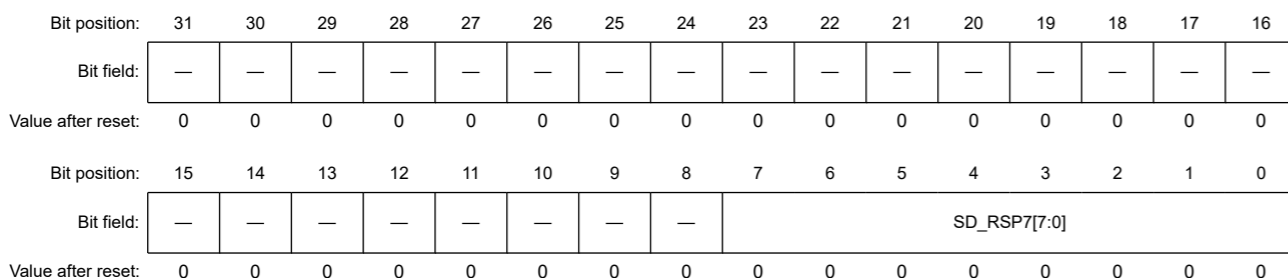


| Bit   | Symbol         | Function          | R/W |
|-------|----------------|-------------------|-----|
| 23:0  | SD_RSP76[23:0] | 这些位存储来自SD卡MMC的响应。 | R   |
| 31:24 | —              | 这些位读为0。           | R   |

### 33.2.9 SD\_RSP7 : SD Card Response Register 7

Base address: SDHI<sub>n</sub> 0 = 0x4009\_2000 + 0x0400 × n

Offset address: 0x034



| Bit  | Symbol       | Function  | R/W |
|------|--------------|---|-----|
| 7:0  | SD_RSP7[7:0] | These bits store the response from the SD card/MMC. | R   |
| 31:8 | —            | These bits are read as 0.                           | R   |

SD\_RSP10, SD\_RSP32, SD\_RSP54, SD\_RSP1, SD\_RSP3, SD\_RSP5, SD\_RSP76, and SD\_RSP7 are read-only registers that store the response from the SD card/MMC. Depending on the type of response from the SD card/MMC, the SD/MMC Host Interface divides and stores the response among the four registers.

Table 33.3 lists the correspondence between the response type and its storage destination.

Table 33.3 Correspondence between response type and storage destination

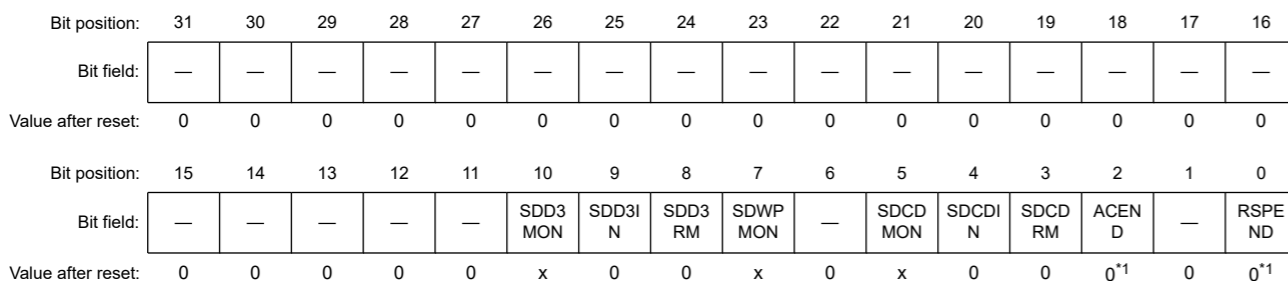
| Response type | SD_RSP10 register | SD_RSP32 register | SD_RSP54 register   | SD_RSP1 register | SD_RSP3 register | SD_RSP5 register | SD_RSP76 register | SD_RSP7 register |
|---------------|-------------------|-------------------|---------------------|------------------|------------------|------------------|-------------------|------------------|
| R1            | [39:8]            | —                 | [39:8] <sup>1</sup> | —                | —                | —                | —                 | —                |
| R1b           | [39:8]            | —                 | [39:8] <sup>1</sup> | —                | —                | —                | —                 | —                |
| R2            | [39:8]            | [71:40]           | [103:72]            | —                | —                | —                | [127:104]         | —                |
| R3            | [39:8]            | —                 | —                   | —                | —                | —                | —                 | —                |
| R4            | [39:8]            | —                 | —                   | —                | —                | —                | —                 | —                |
| R5            | [39:8]            | —                 | —                   | —                | —                | —                | —                 | —                |
| R6            | [39:8]            | —                 | —                   | —                | —                | —                | —                 | —                |
| R7            | [39:8]            | —                 | —                   | —                | —                | —                | —                 | —                |

Note 1. The responses for CMD18 and CMD25 are stored in registers SD\_RSP10 and SD\_RSP54. Therefore, even if the SD\_RSP10 register is overwritten with the response for the automatically issued CMD12, the response for CMD18 or CMD25 can be confirmed by reading the SD\_RSP54 register.

### 33.2.10 SD\_INFO1 : SD Card Interrupt Flag Register 1

Base address: SDHI<sub>n</sub> 0 = 0x4009\_2000 + 0x0400 × n

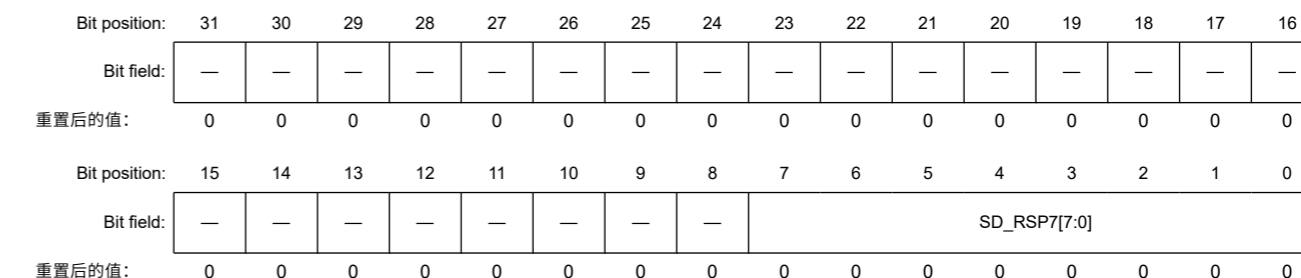
Offset address: 0x038



### 33.2.9 SD\_RSP7:SD卡响应寄存器7

Base address: SDHI<sub>n</sub> 0 = 0x4009\_2000 + 0x0400 × n

Offset address: 0x034



| Bit  | Symbol       | Function          | R/W |
|------|--------------|-------------------|-----|
| 7:0  | SD_RSP7[7:0] | 这些位存储来自SD卡MMC的响应。 | R   |
| 31:8 | —            | 这些位读为0。           | R   |

SD\_RSP10、SD\_RSP32、SD\_RSP54、SD\_RSP1、SD\_RSP3、SD\_RSP5、SD\_RSP76和SD\_RSP7是只读寄存器，用于存储来自SD卡MMC的响应。根据SD卡MMC的响应类型，SDMMC主机接口在四个寄存器之间划分和存储响应。

表33.3列出了响应类型与其存储目的地的对应关系。

Table 33.3 响应类型与存储目的地的对应关系

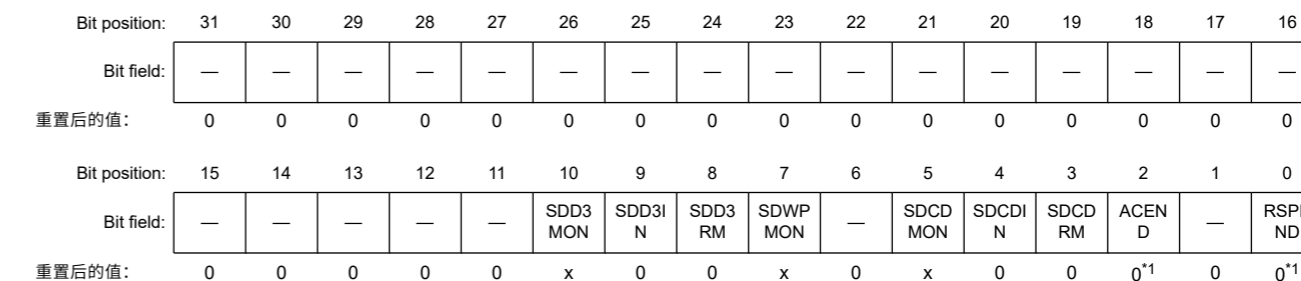
| 响应类型 | SD_RSP10 register | SD_RSP32 register | SD_RSP54 register   | SD_RSP1 register | SD_RSP3 register | SD_RSP5 register | SD_RSP76 register | SD_RSP7 register |
|------|-------------------|-------------------|---------------------|------------------|------------------|------------------|-------------------|------------------|
| R1   | [39:8]            | —                 | [39:8] <sup>1</sup> | —                | —                | —                | —                 | —                |
| R1b  | [39:8]            | —                 | [39:8] <sup>1</sup> | —                | —                | —                | —                 | —                |
| R2   | [39:8]            | [71:40]           | [103:72]            | —                | —                | —                | [127:104]         | —                |
| R3   | [39:8]            | —                 | —                   | —                | —                | —                | —                 | —                |
| R4   | [39:8]            | —                 | —                   | —                | —                | —                | —                 | —                |
| R5   | [39:8]            | —                 | —                   | —                | —                | —                | —                 | —                |
| R6   | [39:8]            | —                 | —                   | —                | —                | —                | —                 | —                |
| R7   | [39:8]            | —                 | —                   | —                | —                | —                | —                 | —                |

注1.CMD18和CMD25的响应存储在寄存器SD\_RSP10和SD\_RSP54中。因此，即使SD\_RSP10寄存器被自动发出的CMD12的响应覆盖，CMD18或CMD25的响应可以通过读取SD\_RSP54寄存器来确认。

### 33.2.10 SD\_INFO1:SD卡中断标志寄存器1

Base address: SDHI<sub>n</sub> 0 = 0x4009\_2000 + 0x0400 × n

Offset address: 0x038





| Bit   | Symbol  | Function   | R/W                |
|-------|---------|--|--------------------|
| 0     | RSPEND  | Response End Detection Flag<br>0: Response end not detected<br>1: Response end detected  | R/(W) <sup>2</sup> |
| 1     | —       | This bit is read as 0. The write value should be 0.  | R/W                |
| 2     | ACEND   | Access End Detection Flag<br>0: Access end not detected<br>1: Access end detected  | R/(W) <sup>2</sup> |
| 3     | SDCDRM  | SDnCD Removal Flag<br>0: SD card/MMC removal not detected by the SDnCD pin<br>1: SD card/MMC removal detected by the SDnCD pin             | R/(W) <sup>2</sup> |
| 4     | SDCDIN  | SDnCD Insertion Flag<br>0: SD card/MMC insertion not detected by the SDnCD pin<br>1: SD card/MMC insertion detected by the SDnCD pin       | R/(W) <sup>2</sup> |
| 5     | SDCDMON | SDnCD Pin Monitor Flag<br>0: SDnCD pin level is high <sup>3</sup><br>1: SDnCD pin level is low <sup>3</sup>                                | R                  |
| 6     | —       | This bit is read as 0. The write value should be 0.  | R/W                |
| 7     | SDWPMON | SDnWP Pin Monitor Flag<br>0: SDnWP pin level is high<br>1: SDnWP pin level is low  | R                  |
| 8     | SDD3RM  | SDnDAT3 Removal Flag<br>0: SD card/MMC removal not detected by the SDnDAT3 pin<br>1: SD card/MMC removal detected by the SDnDAT3 pin       | R/(W) <sup>2</sup> |
| 9     | SDD3IN  | SDnDAT3 Insertion Flag<br>0: SD card/MMC insertion not detected by the SDnDAT3 pin<br>1: SD card/MMC insertion detected by the SDnDAT3 pin | R/(W) <sup>2</sup> |
| 10    | SDD3MON | SDnDAT3 Pin Monitor Flag<br>0: SDnDAT3 pin level is low<br>1: SDnDAT3 pin level is high  | R                  |
| 31:11 | —       | These bits are read as 0. The write value should be 0.   | R/W                |

Note 1. The value is initialized by a reset and also on reset triggered by the SOFT\_RST.SDRST flag.

Note 2. The flag does not change even if set to 1. Writing 0 changes the flag value to 0.

Note 3. The flag changes when the pin level continues for the period set in the SD\_OPTION.CTOP[3:0] bits or longer.

The SD\_INFO1 register indicates the detection of a response end or access end for a command sequence. The SD\_INFO1 register also indicates the detection SD card/MMC insertion/removal and the write protection status.

During a multiblock transfer sequence, if CMD12 or CMD52 (SDIO abort) is issued, the ACEND flag sets to 1, but the RSPEND flag remains set to 0.

If the command sequence is stopped because of a communication error or timeout, the ACEND flag or RSPEND flag sets to 1.

After a reset is canceled, the SDD3MON bit, SDD3IN flag, and SDD3RM flag values are changed in accordance with the status of the SDnDAT3 (n = 0) pin, and their values are changed when data is being transferred in wide bus mode. These 3 bits are used only for SD card. Set flags to be cleared to 0. Set flags that are not being cleared to 1.

#### RSPEND flag (Response End Detection Flag)

The RSPEND flag indicates that a response end was detected.

[Setting conditions]

- When reception of the response is completed
- When transmission of a command without response is completed
- When reception of the busy state after R1b response is completed
- When reception of the response to CMD52 that was issued by setting the C52PUB bit to 1 is completed for transfer of multiple block read

| Bit   | Symbol  | Function   | R/W                |
|-------|---------|--|--------------------|
| 0     | RSPEND  | 响应结束检测标志<br>0: 未检测到响应结束1: 检测到响应结束                              | R/(W) <sup>2</sup> |
| 1     | —       | 该位读取为0。写入值应为0。   | R/W                |
| 2     | ACEND   | 访问结束检测标志<br>0: 未检测到访问结束1: 检测到访问结束                              | R/(W) <sup>2</sup> |
| 3     | SDCDRM  | SDnCD删除标志<br>0: SDnCD引脚未检测到SD卡MMC移除1: SDnCD引脚检测到SD卡MMC移除       | R/(W) <sup>2</sup> |
| 4     | SDCDIN  | SDnCD插入标志<br>0: SDnCD引脚未检测到SD卡MMC插入1: SDnCD引脚检测到SD卡MMC插入       | R/(W) <sup>2</sup> |
| 5     | SDCDMON | SDnCD引脚监控标志<br>0: SDnCD引脚电平为高*3<br>1: SDnCD引脚电平低*3             | R                  |
| 6     | —       | 该位读取为0。写入值应为0。   | R/W                |
| 7     | SDWPMON | SDnWP引脚监控标志<br>0: SDnWP引脚高电平1: SDnWP引脚低电平                      | R                  |
| 8     | SDD3RM  | SDnDAT3删除标志<br>0: SDnDAT3引脚未检测到SD卡MMC移除1: SDnDAT3引脚检测到SD卡MMC移除 | R/(W) <sup>2</sup> |
| 9     | SDD3IN  | SDnDAT3插入标志<br>0: SDnDAT3引脚未检测到SD卡MMC插入1: SDnDAT3引脚检测到SD卡MMC插入 | R/(W) <sup>2</sup> |
| 10    | SDD3MON | SDnDAT3引脚监控标志<br>0: SDnDAT3引脚低电平1: SDnDAT3引脚高电平                | R                  |
| 31:11 | —       | 这些位被读取为0。写入值应为0。   | R/W                |

注1.该值由复位初始化，并且在由SOFT\_RST.SDRST标志触发的复位时初始化。

注2.即使设置为1，标志也不会改变。写入0会将标志值更改为0。

注3.当引脚电平持续SD\_OPTION.CTOP[3:0]位中设置的周期或更长时间时，标志会发生变化。

SD\_INFO1寄存器指示对命令序列的响应结束或访问结束的检测。SD\_INFO1寄存器还指示检测SD卡MMC插入移除和写保护状态。

在多块传输序列期间，如果发出CMD12或CMD52（SDIO中止），则ACEND标志设置为1，但RSPEND标志保持设置为0。

如果命令序列由于通信错误或超时而停止，则ACEND标志或RSPEND标志设置为1。

复位取消后，SDD3MON位、SDD3IN标志和SDD3RM标志的值根据SDnDAT3(n=0)引脚的状态而改变，并且在宽总线模式下传输数据时它们的值也会改变。这3位仅用于SD卡。将要清除的标志设置为0。将未清除的标志设置为1。

#### RSPEND标志（响应结束检测标志）

RSPEND标志表示检测到响应结束。

[Setting conditions]

- 响应接收完成时
- 没有响应的命令传输完成时
- R1b响应后忙状态的接收完成时
- 多块读取传送的C52PUB位为1的CMD52响应接收完成时

- When reception of the response to CMD52 that was issued by setting the C52PUB bit to 1 is completed for transfer of multiple block write
- This bit is set when a command sequence is halted because of a communications error or timeout.

[Clearing conditions]

- When 0 is written to RSPEND
- When a command without data is issued.

Note: When a command is issued in absence of data transfer, the RSPEND flag becomes 1 after the command sequence ends.

#### ACEND flag (Access End Detection Flag)

The ACEND flag indicates that an access end was detected.

[Setting conditions]

- When read access to the buffer is completed for transfer of single block read
- When read access to the buffer for the last block of data is completed for transfer of multiple block read
- When read access to the buffer and reception of the response to CMD12 are completed for transfer of multiple block read with automatic issuing of CMD12
- When reception of the busy state after reception of the CRC status is completed for transfer of single block write
- When reception of the busy state after reception of the CRC status of the last block of data is completed for transfer of multiple block write
- When reception of the response busy state for CMD12 is completed for transfer of multiple block write with automatic issuing of CMD12
- When reception of the response to CMD12 that was issued by setting the STP bit to 1 is completed for transfer of multiple block read
- When reception of the response busy state for CMD12 that was issued by setting the STP bit to 1 is completed for transfer of multiple block write
- When reception of the response to CMD52 that was issued by setting the IOABT bit to 1 is completed for transfer of multiple block read
- When reception of the response to CMD52 that was issued by setting the IOABT bit to 1 is completed for transfer of multiple block write
- This bit is set when a command sequence is halted because of a communications error or timeout.

[Clearing conditions]

- When 0 is written to ACEND
- When the access end bit is set to 1.

Note: The ACEND flag becomes 1 after the command sequence ends.

#### SDCDRM flag (SDnCD Removal Flag)

The SDCDRM flag indicates that SDnCD was removed.

[Setting condition]

- After a change in SDnCD from 0 to 1, Mcycle elapsed with SDnCD held at 1.

[Clearing conditions]

- When 0 is written to SDCDRM.

Note: Mcycle is set in bits [3:0] in SD\_OPTION.

#### SDCDIN flag (SDnCD Insertion Flag)

The SD CDIN flag indicates that SDnCD was inserted.

- 多块写入传送的C52PUB位为1的CMD52响应接收完成时

- 当命令序列由于通信错误或超时而停止时，该位被设置。

[Clearing conditions]

- RSPEND写入0时
- 发出无数据指令时。

Note: 当在没有数据传输的情况下发出命令时，RSPEND标志在命令序列结束后变为1。

#### ACEND标志（访问结束检测标志）

ACEND标志表示检测到访问结束。

[Setting conditions]

- 当完成对缓冲区的读取访问以传输单块读取时
- 当完成对最后一个数据块的缓冲区的读取访问以传输多块读取时
- 当对缓冲区的读取访问和对CMD12的响应的接收完成时，通过自动发出CMD12传输多块读取
- 接收CRC状态后的busy状态接收完成时，用于单块写入传输
- 当接收到最后一个数据块的CRC状态后的忙碌状态接收完成时，用于多块写入的传输
- 当CMD12的响应忙状态接收完成时，用于传输多块写入并自动发出CMD12
- 在多块读取的传送中，通过将STP位设置为1发出的对CMD12的响应的接收完成时
- 多块写入的传送，通过将STP位设置为1发出的CMD12的响应忙状态接收完成时
- 多块读取传送时，通过将IOABT位设置为1发出的对CMD52的响应的接收完成时
- 多块写入传送的IOABT位为1的CMD52响应接收完成时
- 当命令序列由于通信错误或超时而停止时，该位被设置。

[Clearing conditions]

- ACEND写入0时
- 当访问结束位设置为1时。

Note: 命令序列结束后ACEND标志变为1。

#### SDCDRM标志（SDnCD移除标志）

SDCDRM标志表明SDnCD已被删除。

[Setting condition]

- 在SDnCD从0变为1后，Mcycle过去了，而SDnCD保持在1。

[Clearing conditions]

- 当0写入SDCDRM时。

Note: Mcycle在SD\_OPTION的位[3:0]中设置。

#### SDCDIN标志（SDnCD插入标志）

SDCDIN标志表明SDnCD已插入。

[Setting condition]

- After a change in SDnCD from 1 to 0, Mcycle elapsed with SDnCD held at 0.

[Clearing conditions]

- When 0 is written to SDCDIN.

Note: Mcycle is set in bits [3:0] in SD\_OPTION.

**SDD3RM flag (SDnDAT3 Removal Flag)**

The SDD3RM flag indicates that SDnDAT3 was removed.

[Setting condition]

- After a change in SDnDAT3 from 1 to 0, two cycles of PCLKB elapsed with SDnDAT3 held at 0.

[Clearing condition]

- When 0 is written to SDD3RM.

**SDD3IN flag (SDnDAT3 Insertion Flag)**

The SDD3IN flag indicates that SDnDAT3 was inserted.

[Setting condition]

- After a change in SDnDAT3 from 0 to 1, two cycles of PCLKB elapsed with SDnDAT3 held at 1.

[Clearing condition]

- When 0 is written to SDD3IN.

33.2.11 SD\_INFO2 : SD Card Interrupt Flag Register 2

Base address: SDHI<sub>n</sub> 0 = 0x4009\_2000 + 0x0400 × n

Offset address: 0x03C

|                    |                 |                 |                 |    |    |    |                 |                 |          |                 |                 |                 |                 |                 |                 |                 |
|--------------------|-----------------|-----------------|-----------------|----|----|----|-----------------|-----------------|----------|-----------------|-----------------|-----------------|-----------------|-----------------|-----------------|-----------------|
| Bit position:      | 31              | 30              | 29              | 28 | 27 | 26 | 25              | 24              | 23       | 22              | 21              | 20              | 19              | 18              | 17              | 16              |
| Bit field:         | —               | —               | —               | —  | —  | —  | —               | —               | —        | —               | —               | —               | —               | —               | —               | —               |
| Value after reset: | 0               | 0               | 0               | 0  | 0  | 0  | 0               | 0               | 0        | 0               | 0               | 0               | 0               | 0               | 0               | 0               |
| Bit position:      | 15              | 14              | 13              | 12 | 11 | 10 | 9               | 8               | 7        | 6               | 5               | 4               | 3               | 2               | 1               | 0               |
| Bit field:         | ILA             | CBSY            | SD_C LK_CT RLEN | —  | —  | —  | BWE             | BRE             | SDD0 MON | RSPT O          | ILR             | ILW             | DTO             | ENDE            | CRCE            | CMDE            |
| Value after reset: | 0 <sup>*1</sup> | 0 <sup>*1</sup> | 1 <sup>*1</sup> | 0  | x  | 0  | 0 <sup>*1</sup> | 0 <sup>*1</sup> | x        | 0 <sup>*1</sup> | 0 <sup>*1</sup> | 0 <sup>*1</sup> | 0 <sup>*1</sup> | 0 <sup>*1</sup> | 0 <sup>*1</sup> | 0 <sup>*1</sup> |

| Bit | Symbol | Function   | R/W               |
|-----|--------|--|-------------------|
| 0   | CMDE   | Command Error Detection Flag<br>0: Command error not detected<br>1: Command error detected | R/W <sup>*2</sup> |
| 1   | CRCE   | CRC Error Detection Flag<br>0: CRC error not detected<br>1: CRC error detected             | R/W <sup>*2</sup> |
| 2   | ENDE   | End Bit Error Detection Flag<br>0: End bit error not detected<br>1: End bit error detected | R/W <sup>*2</sup> |
| 3   | DTO    | Data Timeout Detection Flag<br>0: Data timeout not detected<br>1: Data timeout detected    | R/W <sup>*2</sup> |

[Setting condition]

- SDnCD从1变为0后, Mcycle在SDnCD保持在0的情况下经过。

[Clearing conditions]

- 当0写入SDCDIN时。

Note: Mcycle在SD\_OPTION的位[3:0]中设置。

**SDD3RM标志 (SDnDAT3移除标志)**

SDD3RM标志表示SDnDAT3已被删除。

[Setting condition]

- SDnDAT3从1变为0后, 经过两个PCLKB周期, SDnDAT3保持为0。

[Clearing condition]

- 当0写入SDD3RM时。

**SDD3IN标志 (SDnDAT3插入标志)**

SDD3IN标志表示SDnDAT3已插入。

[Setting condition]

- SDnDAT3从0变为1后, 经过两个PCLKB周期, SDnDAT3保持在1。

[Clearing condition]

- 当0写入SDD3IN时。

33.2.11 SD\_INFO2:SD卡中断标志寄存器2

Base address: SDHI<sub>n</sub> 0 = 0x4009\_2000 + 0x0400 × n

Offset address: 0x03C

|               |                 |                 |                 |    |    |    |                 |                 |          |                 |                 |                 |                 |                 |                 |                 |
|---------------|-----------------|-----------------|-----------------|----|----|----|-----------------|-----------------|----------|-----------------|-----------------|-----------------|-----------------|-----------------|-----------------|-----------------|
| Bit position: | 31              | 30              | 29              | 28 | 27 | 26 | 25              | 24              | 23       | 22              | 21              | 20              | 19              | 18              | 17              | 16              |
| Bit field:    | —               | —               | —               | —  | —  | —  | —               | —               | —        | —               | —               | —               | —               | —               | —               | —               |
| 重置后的值:        | 0               | 0               | 0               | 0  | 0  | 0  | 0               | 0               | 0        | 0               | 0               | 0               | 0               | 0               | 0               | 0               |
| Bit position: | 15              | 14              | 13              | 12 | 11 | 10 | 9               | 8               | 7        | 6               | 5               | 4               | 3               | 2               | 1               | 0               |
| Bit field:    | ILA             | CBSY            | SD_C LK_CT RLEN | —  | —  | —  | BWE             | BRE             | SDD0 MON | RSPT O          | ILR             | ILW             | DTO             | ENDE            | CRCE            | CMDE            |
| 重置后的值:        | 0 <sup>*1</sup> | 0 <sup>*1</sup> | 1 <sup>*1</sup> | 0  | x  | 0  | 0 <sup>*1</sup> | 0 <sup>*1</sup> | x        | 0 <sup>*1</sup> | 0 <sup>*1</sup> | 0 <sup>*1</sup> | 0 <sup>*1</sup> | 0 <sup>*1</sup> | 0 <sup>*1</sup> | 0 <sup>*1</sup> |

| Bit | Symbol | Function                             | R/W               |
|-----|--------|--------------------------------------|-------------------|
| 0   | CMDE   | 命令错误检测标志<br>0: 未检测到命令错误1: 检测到命令错误    | R/W <sup>*2</sup> |
| 1   | CRCE   | CRC错误检测标志<br>0: 未检测到CRC错误1: 检测到CRC错误 | R/W <sup>*2</sup> |
| 2   | ENDE   | 结束位错误检测标志<br>0: 未检测到结束位错误1: 检测到结束位错误 | R/W <sup>*2</sup> |
| 3   | DTO    | 数据超时检测标志<br>0: 未检测到数据超时1: 检测到数据超时    | R/W <sup>*2</sup> |

| Bit   | Symbol         | Function   | R/W              |
|-------|----------------|--|------------------|
| 4     | ILW            | SD_BUF0 Illegal Write Access Detection Flag<br>0: Illegal write access to the SD_BUF0 register not detected<br>1: Illegal write access to the SD_BUF0 register detected  | R/W <sup>2</sup> |
| 5     | ILR            | SD_BUF0 Illegal Read Access Detection Flag<br>0: Illegal read access to the SD_BUF0 register not detected<br>1: Illegal read access to the SD_BUF0 register detected   | R/W <sup>2</sup> |
| 6     | RSPTO          | Response Timeout Detection Flag<br>0: Response timeout not detected<br>1: Response timeout detected  | R/W <sup>2</sup> |
| 7     | SDD0MON        | SDHI_D0 Pin Status Flag<br>0: SDnDAT0 pin is low<br>1: SDnDAT0 pin is high   | R                |
| 8     | BRE            | SD_BUF0 Read Enable Flag<br>0: Disable read access to the SD_BUF0 register<br>1: Enable read access to the SD_BUF0 register  | R/W <sup>2</sup> |
| 9     | BWE            | SD_BUF0 Write Enable Flag<br>0: Disable write access to the SD_BUF0 register<br>1: Enable write access to the SD_BUF0 register   | R/W <sup>2</sup> |
| 10    | —              | This bit is read as 0. The write value should be 0.  | R/W              |
| 11    | —              | The read value is undefined. The write value should be 1.  | R/W              |
| 12    | —              | This bit is read as 0. The write value should be 0.  | R/W              |
| 13    | SD_CLK_CTRLLEN | SD_CLK_CTRL Write Enable Flag<br>0: SD/MMC bus (CMD and DAT lines) is busy, so write access to the SD_CLK_CTRL.CLKEN and CLKSEL[7:0] bits is disabled<br>1: SD/MMC bus (CMD and DAT lines) is not busy, so write access to the SD_CLK_CTRL.CLKEN and CLKSEL[7:0] bits is enabled | R                |
| 14    | CBSY           | Command Sequence Status Flag<br>0: Command sequence complete<br>1: Command sequence in progress (busy)   | R                |
| 15    | ILA            | Illegal Access Error Detection Flag<br>0: Illegal access error not detected<br>1: Illegal access error detected  | R/W <sup>2</sup> |
| 31:16 | —              | These bits are read as 0. The write value should be 0.   | R/W              |

Note 1. The value is initialized by a reset and also on reset triggered by the SOFT\_RST.SDRST flag.

Note 2. The flag does not change even if set to 1. Writing 0 changes the flag value to 0.

The SD\_INFO2 register indicates the status of the SD buffer and the status of the SD card/MMC. Set flags to be cleared to 0. Set flags that are not being cleared to 1.

#### CMDE flag (Command Error Detection Flag)

The CMDE flag indicates that a command error was detected. The command sequence stops when a command error occurs. When the SDIO\_MODE.C52PUB bit is set to 1 and CMD52 is automatically issued, if a communication error or response timeout occurs, the command sequence is not completed. Perform the error processing shown in section 33.3.12.

[IO\\_RW\\_EXTENDED Command \(SD: CMD53/Multiple Block Read\)](#) or [section 33.3.13. IO\\_RW\\_EXTENDED Command \(SD: CMD53/Multiple Block Write\)](#), and complete the command sequence.

[Setting conditions]

- The command index of the transmitted command differs from the command index of the received response.
- The command index of a command issued within a command sequence differs from the command index of the received response.

[Clearing condition]

- When 0 is written to CMDE.

| Bit   | Symbol         | Function  | R/W              |
|-------|----------------|---|------------------|
| 4     | ILW            | SD_BUF0非法写访问检测标志<br>0: 未检测到对SD_BUF0寄存器的非法写访问1: 检测到对SD_BUF0寄存器的非法写访问   | R/W <sup>2</sup> |
| 5     | ILR            | SD_BUF0非法读访问检测标志<br>0: 未检测到对SD_BUF0寄存器的非法读访问1: 检测到对SD_BUF0寄存器的非法读访问   | R/W <sup>2</sup> |
| 6     | RSPTO          | 响应超时检测标志<br>0: 未检测到响应超时1: 检测到响应超时   | R/W <sup>2</sup> |
| 7     | SDD0MON        | SDHI_D0引脚状态标志<br>0: SDnDAT0引脚为低电平<br>1: SDnDAT0引脚为高电平   | R                |
| 8     | BRE            | SD_BUF0读使能标志<br>0: 禁用对SD_BUF0寄存器的读访问1: 启用对SD_BUF0寄存器的读访问  | R/W <sup>2</sup> |
| 9     | BWE            | SD_BUF0写使能标志<br>0: 禁用对SD_BUF0寄存器的写访问1: 启用对SD_BUF0寄存器的写访问  | R/W <sup>2</sup> |
| 10    | —              | 该位读取为0。写入值应为0。  | R/W              |
| 11    | —              | 读取值未定义。写入值应为1。  | R/W              |
| 12    | —              | 该位读取为0。写入值应为0。  | R/W              |
| 13    | SD_CLK_CTRLLEN | SD_CLK_CTRL写使能标志<br>0: SDMMC总线 (CMD和DAT线) 忙, 因此禁止对SD_CLK_CTRL.CLKEN和CLKSEL[7:0]位的写访问<br>1: SDMMC总线 (CMD和DAT线) 不忙, 因此使能对SD_CLK_CTRL.CLKEN和CLKSEL[7:0]位的写访问 | R                |
| 14    | CBSY           | 命令序列状态标志<br>0: 命令序列完成1: 命令序列正在进行中(忙碌)   | R                |
| 15    | ILA            | 非法访问错误检测标志<br>0: 未检测到非法访问错误1: 检测到非法访问错误   | R/W <sup>2</sup> |
| 31:16 | —              | 这些位被读取为0。写入值应为0。  | R/W              |

注1.该值由复位初始化,并且在由SOFT\_RST.SDRST标志触发的复位时初始化。

注2.即使设置为1,标志也不会改变。写入0会将标志值更改为0。

SD\_INFO2寄存器指示SD缓冲区的状态和SD卡MMC的状态。将要清除的标志设置为0。将未清除的标志设置为1。

#### CMDE标志 (命令错误检测标志)

CMDE标志指示检测到命令错误。发生命令错误时命令序列停止。

当SDIO\_MODE.C52PUB位设置为1并自动发出CMD52时,如果发生通信错误或响应超时,则命令序列未完成。执行33.3.12节中所示的错误处理。IO\_RW\_EXTENDED命令 (SD: CMD53多块读取) 或第33.3.13节。IO\_RW\_EXTENDED命令 (SD: CMD53多块写入),完成命令序列。

[Setting conditions]

- 发送命令的命令索引与接收响应的命令索引不同。
- 命令序列中发出的命令的命令索引与接收到的响应的命令索引不同。

[Clearing condition]

- 当0写入CMDE时。



**CRCE flag (CRC Error Detection Flag)**

The CRCE flag indicates that a CRC error was detected. The command sequence stops when a CRC error occurs. When the SDIO\_MODE.C52PUB bit is set to 1 and CMD52 is automatically issued, if a communication error or response timeout occurs, the command sequence is not completed. Perform the error processing shown in [section 33.3.12](#).

[IO\\_RW\\_EXTENDED Command \(SD: CMD53/Multiple Block Read\)](#) or [section 33.3.13. IO\\_RW\\_EXTENDED Command \(SD: CMD53/Multiple Block Write\)](#), and complete the command sequence.

[Setting conditions]

- When an error occurs in the CRC status.
- When a CRC error occurs in the read data.
- When a CRC error occurs in the response.
- A CRC error in the response to a command issued within a command sequence.

[Clearing condition]

- When 0 is written to CRCE.

**ENDE flag (End Bit Error Detection Flag)**

The ENDE flag indicates that an end bit error was detected. The command sequence is stopped when an end bit error occurs. When the SDIO\_MODE.C52PUB bit is set to 1 and CMD52 is automatically issued, if a communication error or response timeout occurs, the command sequence is not completed. Perform the error processing shown in [section 33.3.12](#).

[IO\\_RW\\_EXTENDED Command \(SD: CMD53/Multiple Block Read\)](#) or [section 33.3.13. IO\\_RW\\_EXTENDED Command \(SD: CMD53/Multiple Block Write\)](#), and complete the command sequence.

[Setting conditions]

- When an error occurs in the response length (and the end bit is not detected).
- When an error occurs in the read data length (and the end bit is not detected among the valid bits).
- When an error occurs in the CRC status length (and the end bit is not detected).
- An error in the length of a response to a command issued within a command sequence, for example when the end bit is not detected.

[Clearing condition]

- When 0 is written to ENDE.

**DTO flag (Data Timeout Detection Flag)**

The DTO flag indicates that a data timeout was detected. The command sequence stops when a data timeout occurs.

[Setting conditions]

- After R1b response, the busy state (SDnDAT0 = 0) continues for longer than Ncycle.
- After CRC status, the busy state (SDnDAT0 = 0) continues for longer than Ncycle.
- After write data, the CRC status is not received though Ncycle has elapsed.
- After read command, read data is not received though a time longer than Ncycle has elapsed.
- After CMD12 is issued within a command sequence, the busy state (SDnDAT0 = 0) for longer than Ncycle continues.
- After the reception of read data, read data for the next block are not received though a time longer than Ncycle has elapsed.
- After release of the read wait state, read data for the next block are not received though a time longer than Ncycle has elapsed.

Note: Ncycle is set in bits [7:4] in SD\_OPTION.

[Clearing condition]

- When 0 is written to DTO.

**CRCE标志 (CRC错误检测标志)**

CRCE标志表示检测到CRC错误。当发生CRC错误时，命令序列停止。当。。。的时候SDIO\_MODE.C52PUB位设置为1并自动发出CMD52，如果发生通信错误或响应超时，则命令序列未完成。执行3.3.12节所示的错误处理。IO\_RW\_EXTENDED命令 (SD: CMD53多块读取) 或第33.3.13节。IO\_RW\_EXTENDED命令 (SD: CMD53MultipleBlockWrite)，完成命令序列。

[Setting conditions]

- CRC状态发生错误时。
- 读取数据发生CRC错误时。
- 当响应中出现CRC错误时。
- 对命令序列中发出的命令的响应中出现CRC错误。

[Clearing condition]

- CRCE写入0时。

**ENDE标志 (结束位错误检测标志)**

ENDE标志表示检测到结束位错误。当发生结束位错误时，命令序列停止。当SDIO\_MODE.C52PUB位设置为1并自动发出CMD52时，如果发生通信错误或响应超时，则命令序列未完成。执行33.3.12节所示的错误处理。IO\_RW\_EXTENDED命令 (SD: CMD53多块读取) 或第33.3.13节。IO\_RW\_EXTENDED命令 (SD: CMD53MultipleBlockWrite)，完成命令序列。

[Setting conditions]

- 响应长度发生错误 (未检测到结束位) 时。
- 读取数据长度出错时 (有效位中未检测到结束位)。
- CRC状态长度出错 (未检测到结束位) 时。
- 对命令序列中发出的命令的响应长度错误，例如未检测到结束位时。

[Clearing condition]

- 0写入ENDE时。

**DTO标志 (数据超时检测标志)**

DTO标志表示检测到数据超时。当发生数据超时时，命令序列停止。

[Setting conditions]

- R1b响应后，忙碌状态 (SDnDAT0=0) 持续时间超过Ncycle。
- CRC状态后，忙碌状态 (SDnDAT0=0) 持续时间超过Ncycle。
- 写入数据后，虽然Ncycle已过，但仍未收到CRC状态。
- 读取命令后，经过Ncycle后仍未收到读取数据。
- 在命令序列内发出CMD12后，忙碌状态 (SDnDAT0=0) 持续时间超过Ncycle。
- 读取数据接收后，虽然经过了Ncycle以上的时间，但没有接收到下一个块的读取数据。
- 读取等待状态解除后，虽然经过了Ncycle以上的时间，但没有接收到下一个块的读取数据。

Note: Ncycle在SD\_OPTION的位[7:4]中设置。

[Clearing condition]

- 当0写入DTO时。

**ILW flag (SD\_BUF0 Illegal Write Access Detection Flag)**

The ILW flag indicates that an SD\_BUF0 illegal write access was detected.

[Setting conditions]

- When data is written to SD\_BUF0 while it is not in the data read/write command state.
- When data is written to SD\_BUF0 while SD\_BUF is full.
- When data is written to SD\_BUF0 while an error occurs in the CRC status or CRC status length.
- When data is written to SD\_BUF0 while a busy state after the CRC status continues for longer than Ncycle.

Note: Ncycle is set in bits [7:4] in SD\_OPTION.

[Clearing condition]

- When 0 is written to ILW.

**ILR flag (SD\_BUF0 Illegal Read Access Detection Flag)**

The ILR flag indicates that an SD\_BUF0 illegal read access was detected.

[Setting conditions]

- When SD\_BUF is empty while SD\_BUF0 is read.
- When data with a CRC error or END error is read from SD\_BUF0.

[Clearing condition]

- When 0 is written to ILR.

**RSPTO flag (Response Timeout Detection Flag)**

The RSPTO flag indicates that a response timeout was detected. The command sequence is stopped when a response timeout occurs. When the SDIOMD.C52PUB bit is set to 1 and CMD52 is automatically issued, if a communication error or response timeout occurs, the command sequence is not completed. Perform the error processing shown in [section 33.3.12. IO\\_RW\\_EXTENDED Command \(SD: CMD53/Multiple Block Read\)](#) or [section 33.3.13. IO\\_RW\\_EXTENDED Command \(SD: CMD53/Multiple Block Write\)](#), and complete the command sequence.

[Setting condition]

- When a response is not received though a time longer than 640 cycles of SD/MMC clock has elapsed (including a response to a command issued within a command sequence).

[Clearing condition]

- When 0 is written to RSPTO.

**SDD0MON flag (SDHI\_D0 Pin Status Flag)**

The SDD0MON flag indicates the status of the SDHI\_D0 pin. If the data timeout (DTO) is set but the response timeout (RSPTO) is not set after the Erase command is issued, the end of the Erase sequence (SDD0MON = 1) is confirmed by polling DAT0.

If a communication error or timeout occurs during a write sequence, the DAT0 bit might retain the value 0.

While the SD/MMC clock is stopped, the DAT0 bit retains the value before the clock is stopped.

**BRE flag (SD\_BUF0 Read Enable Flag)**

The BRE flag indicates that SD\_BUF0 is enabled for reading.

[Setting conditions]

- When data set in SD\_SIZE is stored in SD\_BUF0 at single block transfer.
- When data set in SD\_SIZE is stored in either bank 1 or bank 2 of SD\_BUF0 at multiple block transfer.

[Clearing conditions]

- When 0 is written to BRE

**ILW标志 (SD\_BUF0非法写访问检测标志)**

ILW标志表示检测到SD\_BUF0非法写访问。

[Setting conditions]

- 数据写入SD\_BUF0时，SD\_BUF0不处于数据读写命令状态。
- 当SD\_BUF已满而数据写入SD\_BUF0时。
- 当数据写入SD\_BUF0且CRC状态或CRC状态长度发生错误时。
- 当数据写入SD\_BUF0时，CRC状态后的忙碌状态持续时间超过Ncycle。

Note: Ncycle在SD\_OPTION的位[7:4]中设置。

[Clearing condition]

- 当0写入ILW时。

**ILR标志 (SD\_BUF0非法读访问检测标志)**

ILR标志表示检测到SD\_BUF0非法读取访问。

[Setting conditions]

- 读取SD\_BUF0时SD\_BUF为空。
- 从SD\_BUF0读取CRC错误或END错误的的数据时。

[Clearing condition]

- 当0写入ILR时。

**RSPTO标志 (响应超时检测标志)**

RSPTO标志表示检测到响应超时。当发生响应超时时，命令序列停止。当SDIOMD.C52PUB位设置为1并自动发出CMD52时，如果发生通信错误或响应超时，则命令序列未完成。执行33.3.12节所示的错误处理。IO\_RW\_EXTENDED命令 (SD: CMD53多块读取) 或第33.3.13节。IO\_RW\_EXTENDED命令 (SD: CMD53MultipleBlockWrite)，完成命令序列。

[Setting condition]

- 超过640个SDMMC时钟周期后仍未收到响应时 (包括对命令序列内发出的命令的响应)。

[Clearing condition]

- 当0写入RSPTO时。

**SDD0MON标志 (SDHI\_D0引脚状态标志)**

SDD0MON标志指示SDHI\_D0引脚的状态。如果在发出擦除命令后设置了数据超时(DTO)但未设置响应超时(RSPTO)，则通过轮询DAT0确认擦除序列的结束(SDD0MON=1)。

如果在写入序列期间发生通信错误或超时，则DAT0位可能会保留值0。

SDMMC时钟停止时，DAT0位保持时钟停止前的值。

**BRE标志 (SD\_BUF0读取启用标志)**

BRE标志指示SD\_BUF0已启用读取。

[Setting conditions]

- 当SD\_SIZE中设置的数据在单块传输时存储在SD\_BUF0中。
- 当SD\_SIZE中设置的数据在多块传输中存储在SD\_BUF0的bank1或bank2中时。

[Clearing conditions]

- BRE写入0时

- Reading of a block of data from SD\_BUF0 by DMA transfer

When data is read from SD\_BUF0 by the CPU, clear BRE then read the amount of data specified in SD\_SIZE.

Even if a CRC error or an END error occurs while block data is read, data is stored in SD\_BUF0 and BRE is set.

**BWE flag (SD\_BUF0 Write Enable Flag)**

The BWE flag indicates that SD\_BUF0 is enabled for writing.

[Setting conditions]

- When SD\_BUF0 is empty at single block transfer.
- When either bank 1 or bank 2 of SD\_BUF0 is empty at multiple block transfer.

[Clearing conditions]

- When 0 is written to BWE.
- Writing of a block of data to SD\_BUF0 by DMA transfer.

When data is written to SD\_BUF0 by the CPU, clear BWE and then write the amount of data specified in SD\_SIZE.

**SD\_CLK\_CTRLLEN flag (SD\_CLK\_CTRL Write Enable Flag)**

When a command sequence is started by writing to SD\_CMD, the CBSY bit is set to 1 and, at the same time, the SD\_CLK\_CTRLLEN bit is set to 0. The SD\_CLK\_CTRLLEN bit is set to 1 after 8 cycles of SDCLK have elapsed after the CBSY bit clears to 0 on completion of the command sequence.

**ILA flag (Illegal Access Error Detection Flag)**

The ILA flag indicates that an illegal access error was detected.

[Setting conditions]

- Writing of data to SD\_CMD within a command sequence (CBSY = 1).
- When SD\_CMD[11] = 1 (command with data transfer) and SD\_CMD[7:0] = 0000 1100b (CMD12) are set in SD\_CMD.

[Clearing condition]

- When 0 is written to ILA.

**33.2.12 SD\_INFO1\_MASK : SD INFO1 Interrupt Mask Register**

Base address: SDHI<sub>n</sub> 0 = 0x4009\_2000 + 0x0400 × n

Offset address: 0x040

|                    |    |    |    |    |    |    |             |             |    |    |    |             |             |            |    |             |
|--------------------|----|----|----|----|----|----|-------------|-------------|----|----|----|-------------|-------------|------------|----|-------------|
| Bit position:      | 31 | 30 | 29 | 28 | 27 | 26 | 25          | 24          | 23 | 22 | 21 | 20          | 19          | 18         | 17 | 16          |
| Bit field:         | —  | —  | —  | —  | —  | —  | —           | —           | —  | —  | —  | —           | —           | —          | —  | —           |
| Value after reset: | 0  | 0  | 0  | 0  | 0  | 0  | 0           | 0           | 0  | 0  | 0  | 0           | 0           | 0          | 0  | 0           |
| Bit position:      | 15 | 14 | 13 | 12 | 11 | 10 | 9           | 8           | 7  | 6  | 5  | 4           | 3           | 2          | 1  | 0           |
| Bit field:         | —  | —  | —  | —  | —  | —  | SDD3I<br>NM | SDD3<br>RMM | —  | —  | —  | SDCDI<br>NM | SDCD<br>RMM | ACEN<br>DM | —  | RSPE<br>NDM |
| Value after reset: | 0  | 0  | 0  | 0  | 0  | 0  | 1           | 1           | 0  | 0  | 0  | 1           | 1           | 1          | 0  | 1           |

| Bit | Symbol  | Function   | R/W |
|-----|---------|--|-----|
| 0   | RSPENDM | Response End Interrupt Request Mask<br>0: Do not mask response end interrupt request<br>1: Mask response end interrupt request | R/W |
| 1   | —       | This bit is read as 0. The write value should be 0.  | R/W |

- 通过DMA传输从SD\_BUF0读取数据块

当CPU从SD\_BUF0读取数据时,清除BRE,然后读取SD\_SIZE中指定的数据量。

即使在读取块数据时发生CRC错误或END错误,数据也会存储在SD\_BUF0中并设置BRE。

**BWE标志 (SD\_BUF0写使能标志)**

BWE标志指示SD\_BUF0已启用写入。

[Setting conditions]

- 单块传输时SD\_BUF0为空时。
- 多块传输时SD\_BUF0的bank1或bank2为空时。

[Clearing conditions]

- 当0写入BWE时。
- 通过DMA传输将数据块写入SD\_BUF0。

当CPU将数据写入SD\_BUF0时,清除BWE,然后写入SD\_SIZE中指定的数据量。

**SD\_CLK\_CTRLLEN标志 (SD\_CLK\_CTRL写使能标志)**

当通过写入SD\_CMD启动命令序列时,CBSY位设置为1,同时,SD\_CLK\_CTRLLEN位设置为0。SD\_CLK\_CTRLLEN位在SDCLK 的8个周期后设置为1。CBSY位在命令序列完成时清零。

**ILA标志 (非法访问错误检测标志)**

ILA标志表示检测到非法访问错误。

[Setting conditions]

- 在命令序列中将数据写入SD\_CMD(CBSY=1)。
- 当SD\_CMD[11]=1 (有数据传输的命令)且SD\_CMD[7:0]=00001100b(CMD12)在SD\_CMD中设置。

[Clearing condition]

- 当0写入ILA时。

**33.2.12 SD\_INFO1\_MASK:SDINFO1中断屏蔽寄存器**

Base address: SDHI<sub>n</sub> 0 = 0x4009\_2000 + 0x0400 × n

Offset address: 0x040

|               |    |    |    |    |    |    |             |             |    |    |    |             |             |            |    |             |
|---------------|----|----|----|----|----|----|-------------|-------------|----|----|----|-------------|-------------|------------|----|-------------|
| Bit position: | 31 | 30 | 29 | 28 | 27 | 26 | 25          | 24          | 23 | 22 | 21 | 20          | 19          | 18         | 17 | 16          |
| Bit field:    | —  | —  | —  | —  | —  | —  | —           | —           | —  | —  | —  | —           | —           | —          | —  | —           |
| 重置后的值:        | 0  | 0  | 0  | 0  | 0  | 0  | 0           | 0           | 0  | 0  | 0  | 0           | 0           | 0          | 0  | 0           |
| Bit position: | 15 | 14 | 13 | 12 | 11 | 10 | 9           | 8           | 7  | 6  | 5  | 4           | 3           | 2          | 1  | 0           |
| Bit field:    | —  | —  | —  | —  | —  | —  | SDD3I<br>NM | SDD3<br>RMM | —  | —  | —  | SDCDI<br>NM | SDCD<br>RMM | ACEN<br>DM | —  | RSPE<br>NDM |
| 重置后的值:        | 0  | 0  | 0  | 0  | 0  | 0  | 1           | 1           | 0  | 0  | 0  | 1           | 1           | 1          | 0  | 1           |

| Bit | Symbol  | Function                                  | R/W |
|-----|---------|---|-----|
| 0   | RSPENDM | 响应结束中断请求掩码<br>0: 不屏蔽响应结束中断请求1: 屏蔽响应结束中断请求 | R/W |
| 1   | —       | 该位读取为0。写入值应为0。                            | R/W |



| Bit   | Symbol  | Function  | R/W |
|-------|---------|---|-----|
| 2     | ACENDM  | Access End Interrupt Request Mask<br>0: Do not mask access end interrupt request<br>1: Mask access end interrupt request  | R/W |
| 3     | SDCDRMM | SDnCD Removal Interrupt Request Mask<br>0: Do not mask SD card/MMC removal interrupt request by the SDnCD pin<br>1: Mask SD card/MMC removal interrupt request by the SDnCD pin             | R/W |
| 4     | SDCDINM | SDnCD Insertion Interrupt Request Mask<br>0: Do not mask SD card/MMC insertion interrupt request by the SDnCD pin<br>1: Mask SD card/MMC insertion interrupt request by the SDnCD pin       | R/W |
| 7:5   | —       | These bits are read as 0. The write value should be 0.  | R/W |
| 8     | SDD3RMM | SDnDAT3 Removal Interrupt Request Mask<br>0: Do not mask SD card/MMC removal interrupt request by the SDnDAT3 pin<br>1: Mask SD card/MMC removal interrupt request by the SDnDAT3 pin       | R/W |
| 9     | SDD3INM | SDnDAT3 Insertion Interrupt Request Mask<br>0: Do not mask SD card/MMC insertion interrupt request by the SDnDAT3 pin<br>1: Mask SD card/MMC insertion interrupt request by the SDnDAT3 pin | R/W |
| 31:10 | —       | These bits are read as 0. The write value should be 0.  | R/W |

The SD\_INFO1\_MASK register enables or disables interrupt requests from the status flags in the SD\_INFO1 register. See Table 33.5, for details on the relationship between the status flags and the requested interrupt source.

### 33.2.13 SD\_INFO2\_MASK : SD INFO2 Interrupt Mask Register

Base address: SDHIn 0 = 0x4009\_2000 + 0x0400 × n

Offset address: 0x044

| Bit position:      | 31   | 30 | 29 | 28 | 27 | 26 | 25   | 24   | 23 | 22     | 21   | 20   | 19   | 18    | 17    | 16    |
|--------------------|------|----|----|----|----|----|------|------|----|--------|------|------|------|-------|-------|-------|
| Bit field:         | —    | —  | —  | —  | —  | —  | —    | —    | —  | —      | —    | —    | —    | —     | —     | —     |
| Value after reset: | 0    | 0  | 0  | 0  | 0  | 0  | 0    | 0    | 0  | 0      | 0    | 0    | 0    | 0     | 0     | 0     |
| Bit position:      | 15   | 14 | 13 | 12 | 11 | 10 | 9    | 8    | 7  | 6      | 5    | 4    | 3    | 2     | 1     | 0     |
| Bit field:         | ILAM | —  | —  | —  | —  | —  | BWEM | BREM | —  | RSPTOM | ILRM | ILWM | DTOM | ENDEM | CRCEM | CMDEM |
| Value after reset: | 1    | 0  | 0  | 0  | 1  | 0  | 1    | 1    | 0  | 1      | 1    | 1    | 1    | 1     | 1     | 1     |

| Bit | Symbol | Function   | R/W |
|-----|--------|--|-----|
| 0   | CMDEM  | Command Error Interrupt Request Mask<br>0: Do not mask command error interrupt request<br>1: Mask command error interrupt request  | R/W |
| 1   | CRCEM  | CRC Error Interrupt Request Mask<br>0: Do not mask CRC error interrupt request<br>1: Mask CRC error interrupt request  | R/W |
| 2   | ENDEM  | End Bit Error Interrupt Request Mask<br>0: Do not mask end bit detection error interrupt request<br>1: Mask end bit detection error interrupt request  | R/W |
| 3   | DTOM   | Data Timeout Interrupt Request Mask<br>0: Do not mask data timeout interrupt request<br>1: Mask data timeout interrupt request   | R/W |
| 4   | ILWM   | SD_BUF0 Register Illegal Write Interrupt Request Mask<br>0: Do not mask illegal write detection interrupt request for the SD_BUF0 register<br>1: Mask illegal write detection interrupt request for the SD_BUF0 register | R/W |
| 5   | ILRM   | SD_BUF0 Register Illegal Read Interrupt Request Mask<br>0: Do not mask illegal read detection interrupt request for the SD_BUF0 register<br>1: Mask illegal read detection interrupt request for the SD_BUF0 register    | R/W |

| Bit   | Symbol  | Function   | R/W |
|-------|---------|--|-----|
| 2     | ACENDM  | 访问结束中断请求掩码<br>0: 不屏蔽访问结束中断请求1: 屏蔽访问结束中断请求                                    | R/W |
| 3     | SDCDRMM | SDnCD移除中断请求掩码<br>0: 不通过SDnCD引脚屏蔽SD卡MMC移除中断请求1: 通过SDnCD引脚屏蔽SD卡MMC移除中断请求       | R/W |
| 4     | SDCDINM | SDnCD插入中断请求掩码<br>0: 不通过SDnCD引脚屏蔽SD卡MMC插入中断请求1: 通过SDnCD引脚屏蔽SD卡MMC插入中断请求       | R/W |
| 7:5   | —       | 这些位被读取为0。写入值应为0。   | R/W |
| 8     | SDD3RMM | SDnDAT3移除中断请求掩码<br>0: 不通过SDnDAT3引脚屏蔽SD卡MMC移除中断请求1: 通过SDnDAT3引脚屏蔽SD卡MMC移除中断请求 | R/W |
| 9     | SDD3INM | SDnDAT3插入中断请求掩码<br>0: 不通过SDnDAT3引脚屏蔽SD卡MMC插入中断请求1: 通过SDnDAT3引脚屏蔽SD卡MMC插入中断请求 | R/W |
| 31:10 | —       | 这些位被读取为0。写入值应为0。   | R/W |

SD\_INFO1\_MASK寄存器启用或禁用来自SD\_INFO1寄存器中状态标志的中断请求。看表33.5, 详细了解状态标志和请求的中断源之间的关系。

### 33.2.13 SD\_INFO2\_MASK:SDINFO2中断屏蔽寄存器

Base address: SDHIn 0 = 0x4009\_2000 + 0x0400 × n

Offset address: 0x044

| Bit position: | 31   | 30 | 29 | 28 | 27 | 26 | 25   | 24   | 23 | 22     | 21   | 20   | 19   | 18    | 17    | 16    |
|---------------|------|----|----|----|----|----|------|------|----|--------|------|------|------|-------|-------|-------|
| Bit field:    | —    | —  | —  | —  | —  | —  | —    | —    | —  | —      | —    | —    | —    | —     | —     | —     |
| 重置后的值:        | 0    | 0  | 0  | 0  | 0  | 0  | 0    | 0    | 0  | 0      | 0    | 0    | 0    | 0     | 0     | 0     |
| Bit position: | 15   | 14 | 13 | 12 | 11 | 10 | 9    | 8    | 7  | 6      | 5    | 4    | 3    | 2     | 1     | 0     |
| Bit field:    | ILAM | —  | —  | —  | —  | —  | BWEM | BREM | —  | RSPTOM | ILRM | ILWM | DTOM | ENDEM | CRCEM | CMDEM |
| 重置后的值:        | 1    | 0  | 0  | 0  | 1  | 0  | 1    | 1    | 0  | 1      | 1    | 1    | 1    | 1     | 1     | 1     |

| Bit | Symbol | Function   | R/W |
|-----|--------|--|-----|
| 0   | CMDEM  | 命令错误中断请求掩码<br>0: 不屏蔽命令错误中断请求1: 屏蔽命令错误中断请求                                  | R/W |
| 1   | CRCEM  | CRC错误中断请求掩码<br>0: 不屏蔽CRC错误中断请求1: 屏蔽CRC错误中断请求                               | R/W |
| 2   | ENDEM  | 结束位错误中断请求掩码<br>0: 不屏蔽结束位检测错误中断请求1: 屏蔽结束位检测错误中断请求                           | R/W |
| 3   | DTOM   | 数据超时中断请求掩码<br>0: 不屏蔽数据超时中断请求1: 屏蔽数据超时中断请求                                  | R/W |
| 4   | ILWM   | SD_BUF0寄存器非法写中断请求掩码<br>0: 不屏蔽SD_BUF0寄存器的非法写检测中断请求1: 屏蔽SD_BUF0寄存器的非法写检测中断请求 | R/W |
| 5   | ILRM   | SD_BUF0寄存器非法读中断请求掩码<br>0: 不屏蔽SD_BUF0寄存器的非法读检测中断请求1: 屏蔽SD_BUF0寄存器的非法读检测中断请求 | R/W |



| Bit   | Symbol             | Function  | R/W |
|-------|--------------------|---|-----|
| 6     | RSPTOM             | Response Timeout Interrupt Request Mask<br>0: Do not mask response timeout interrupt request<br>1: Mask response timeout interrupt request                              | R/W |
| 7     | —                  | This bit is read as 0. The write value should be 0.   | R/W |
| 8     | BREM <sup>*1</sup> | BRE Interrupt Request Mask<br>0: Do not mask read enable interrupt request for the SD buffer<br>1: Mask read enable interrupt request for the SD buffer                 | R/W |
| 9     | BWEM <sup>*1</sup> | BWE Interrupt Request Mask<br>0: Do not mask write enable interrupt request for the SD_BUF0 register<br>1: Mask write enable interrupt request for the SD_BUF0 register | R/W |
| 10    | —                  | This bit is read as 0. The write value should be 0.   | R/W |
| 11    | —                  | This bit is read as 1. The write value should be 1.   | R/W |
| 14:12 | —                  | These bits are read as 0. The write value should be 0.  | R/W |
| 15    | ILAM               | Illegal Access Error Interrupt Request Mask<br>0: Do not mask illegal access error interrupt request<br>1: Mask illegal access error interrupt request                  | R/W |
| 31:16 | —                  | These bits are read as 0. The write value should be 0.  | R/W |

Note 1. When the SD\_INFO2\_MASK.BWEM bit is 0 or the SD\_INFO2\_MASK.BREM bit is 0, set the SD\_DMAEN.DMAEN bit to 0. When the SD\_DMAEN.DMAEN bit is 1, set the SD\_INFO2\_MASK.BWEM bit to 1 and the SD\_INFO2\_MASK.BREM bit to 1.

The SD\_INFO2\_MASK register enables or disables interrupt requests from the status flags in the SD\_INFO2 register. See Table 33.5 for details on the relationship between the status flags and the requested interrupt source.

### 33.2.14 SD\_CLK\_CTRL : SD Clock Control Register

Base address: SDHI<sub>n</sub> 0 = 0x4009\_2000 + 0x0400 × n

Offset address: 0x048

|                    |    |    |    |    |    |    |                   |                 |             |    |    |    |    |    |    |    |   |   |   |
|--------------------|----|----|----|----|----|----|-------------------|-----------------|-------------|----|----|----|----|----|----|----|---|---|---|
| Bit position:      | 31 | 30 | 29 | 28 | 27 | 26 | 25                | 24              | 23          | 22 | 21 | 20 | 19 | 18 | 17 | 16 |   |   |   |
| Bit field:         | —  | —  | —  | —  | —  | —  | —                 | —               | —           | —  | —  | —  | —  | —  | —  | —  |   |   |   |
| Value after reset: | 0  | 0  | 0  | 0  | 0  | 0  | 0                 | 0               | 0           | 0  | 0  | 0  | 0  | 0  | 0  | 0  |   |   |   |
| Bit position:      | 15 | 14 | 13 | 12 | 11 | 10 | 9                 | 8               | 7           | 6  | 5  | 4  | 3  | 2  | 1  | 0  |   |   |   |
| Bit field:         | —  | —  | —  | —  | —  | —  | CLKC<br>TRLE<br>N | CLKE<br>N       | CLKSEL[7:0] |    |    |    |    |    |    |    | — | — | — |
| Value after reset: | 0  | 0  | 0  | 0  | 0  | 0  | 0                 | 0 <sup>*1</sup> | 0           | 0  | 1  | 0  | 0  | 0  | 0  | 0  |   |   |   |

| Bit | Symbol      | Function   | R/W |
|-----|-------------|--|-----|
| 7:0 | CLKSEL[7:0] | SDHI Clock Frequency Select <sup>*2</sup><br>0xFF: PCLKB<br>0x00: PCLKB/2<br>0x01: PCLKB/4<br>0x02: PCLKB/8<br>0x04: PCLKB/16<br>0x08: PCLKB/32<br>0x10: PCLKB/64<br>0x20: PCLKB/128<br>0x40: PCLKB/256<br>0x80: PCLKB/512<br>Others: Setting prohibited | R/W |
| 8   | CLKEN       | SD/MMC Clock Output Control <sup>*2</sup><br>0: Disable SD/MMC clock output (fix SDnCLK signal low)<br>1: Enable SD/MMC clock output   | R/W |

| Bit   | Symbol             | Function   | R/W |
|-------|--------------------|--|-----|
| 6     | RSPTOM             | 响应超时中断请求掩码<br>0: 不屏蔽响应超时中断请求<br>1: 屏蔽响应超时中断请求                    | R/W |
| 7     | —                  | 该位读取为0。写入值应为0。   | R/W |
| 8     | BREM <sup>*1</sup> | BRE中断请求掩码<br>0: 不屏蔽SD缓冲区的读使能中断请求<br>1: 屏蔽SD缓冲区的读使能中断请求           | R/W |
| 9     | BWEM <sup>*1</sup> | BWE中断请求掩码<br>0: 不屏蔽SD_BUF0寄存器的写使能中断请求<br>1: 屏蔽SD_BUF0寄存器的写使能中断请求 | R/W |
| 10    | —                  | 该位读取为0。写入值应为0。   | R/W |
| 11    | —                  | 该位读取为1。写入值应为1。   | R/W |
| 14:12 | —                  | 这些位被读取为0。写入值应为0。   | R/W |
| 15    | ILAM               | 非法访问错误中断请求掩码<br>0: 不屏蔽非法访问错误中断请求<br>1: 屏蔽非法访问错误中断请求              | R/W |
| 31:16 | —                  | 这些位被读取为0。写入值应为0。   | R/W |

注1.当SD\_INFO2\_MASK.BWEM位为0或SD\_INFO2\_MASK.BREM位为0时，将SD\_DMAEN.DMAEN位设置为0。当SD\_DMAEN.DMAEN位为1时，将SD\_INFO2\_MASK.BWEM位设置为1和SD\_INFO2\_MASK.BREM位为1。

SD\_INFO2\_MASK寄存器启用或禁用来自SD\_INFO2寄存器中状态标志的中断请求。看表33.5详细说明了状态标志和请求的中断源之间的关系。

### 33.2.14 SD\_CLK\_CTRL:SD时钟控制寄存器

Base address: SDHI<sub>n</sub> 0 = 0x4009\_2000 + 0x0400 × n

Offset address: 0x048

|               |    |    |    |    |    |    |                   |                 |             |    |    |    |    |    |    |    |   |   |   |
|---------------|----|----|----|----|----|----|-------------------|-----------------|-------------|----|----|----|----|----|----|----|---|---|---|
| Bit position: | 31 | 30 | 29 | 28 | 27 | 26 | 25                | 24              | 23          | 22 | 21 | 20 | 19 | 18 | 17 | 16 |   |   |   |
| Bit field:    | —  | —  | —  | —  | —  | —  | —                 | —               | —           | —  | —  | —  | —  | —  | —  | —  |   |   |   |
| 重置后的值:        | 0  | 0  | 0  | 0  | 0  | 0  | 0                 | 0               | 0           | 0  | 0  | 0  | 0  | 0  | 0  | 0  |   |   |   |
| Bit position: | 15 | 14 | 13 | 12 | 11 | 10 | 9                 | 8               | 7           | 6  | 5  | 4  | 3  | 2  | 1  | 0  |   |   |   |
| Bit field:    | —  | —  | —  | —  | —  | —  | CLKC<br>TRLE<br>N | CLKE<br>N       | CLKSEL[7:0] |    |    |    |    |    |    |    | — | — | — |
| 重置后的值:        | 0  | 0  | 0  | 0  | 0  | 0  | 0                 | 0 <sup>*1</sup> | 0           | 0  | 1  | 0  | 0  | 0  | 0  | 0  |   |   |   |

| Bit | Symbol      | Function  | R/W |
|-----|-------------|---|-----|
| 7:0 | CLKSEL[7:0] | SDHI时钟频率选择 <sup>*2</sup><br>0xFF: PCLKB<br>0x00: PCLKB/2<br>0x01: PCLKB/4<br>0x02: PCLKB/8<br>0x04: PCLKB/16<br>0x08: PCLKB/32<br>0x10: PCLKB/64<br>0x20: PCLKB/128<br>0x40: PCLKB/256<br>0x80: PCLKB/512<br>其他: 禁止设置 | R/W |
| 8   | CLKEN       | SDMMC时钟输出控制 <sup>*2</sup><br>0: 禁用SDMMC时钟输出 (固定SDnCLK信号为低电平)<br>1: 启用SDMMC时钟输出  | R/W |

| Bit   | Symbol     | Function  | R/W |
|-------|------------|---|-----|
| 9     | CLKCTRLLEN | SD/MMC Clock Output Automatic Control Select<br>0: Disable automatic control of SD/MMC clock output<br>1: Enable automatic control of SD/MMC clock output | R/W |
| 31:10 | —          | These bits are read as 0. The write value should be 0.  | R/W |

Note 1. The value is initialized by a reset and also on reset triggered by the SOFT\_RST.SDRST flag.  
 Note 2. Bits CLKSEL[7:0] and CLKEN cannot be write accessed when the SD\_INFO2.SD\_CLK\_CTRLLEN flag is 0.

The SDCLKCTRL register controls the SD/MMC clock frequency settings and output. Set the CLKEN bit to 1 before writing to the SD\_CMD register to start a command sequence. Do not write to the SDCLKCTRL register when the SD\_INFO2.SD\_CLK\_CTRLLEN flag is 0.

**CLKCTRLLEN bit (SD/MMC Clock Output Automatic Control Select)**

The CLKCTRLLEN bit enables or disables the automatic control function for SD/MMC clock output, which causes the SD/MMC clock to output only within a command sequence.

The timing with which SD/MMC clock output starts and stops is as follows:

- SD/MMC clock output starts after writing to SD\_CMD
- SD/MMC clock output stops when 8 cycles of SD/MMC clock have elapsed after the end of the command sequence.

In addition, SD/MMC clock is fixed to 0 while SCLKEN of SD\_CLK\_CTRL is 0, regardless of the value of this bit.

**33.2.15 SD\_SIZE : Transfer Data Length Register**

Base address: SDHI<sub>n</sub> 0 = 0x4009\_2000 + 0x0400 × n

Offset address: 0x04C

|                    |    |    |    |    |    |    |          |    |    |    |    |    |    |    |    |    |   |
|--------------------|----|----|----|----|----|----|----------|----|----|----|----|----|----|----|----|----|---|
| Bit position:      | 31 | 30 | 29 | 28 | 27 | 26 | 25       | 24 | 23 | 22 | 21 | 20 | 19 | 18 | 17 | 16 |   |
| Bit field:         | —  | —  | —  | —  | —  | —  | —        | —  | —  | —  | —  | —  | —  | —  | —  | —  |   |
| Value after reset: | 0  | 0  | 0  | 0  | 0  | 0  | 0        | 0  | 0  | 0  | 0  | 0  | 0  | 0  | 0  | 0  |   |
| Bit position:      | 15 | 14 | 13 | 12 | 11 | 10 | 9        | 8  | 7  | 6  | 5  | 4  | 3  | 2  | 1  | 0  |   |
| Bit field:         | —  | —  | —  | —  | —  | —  | LEN[9:0] |    |    |    |    |    |    |    |    | —  | — |
| Value after reset: | 0  | 0  | 0  | 0  | 0  | 0  | 1        | 0  | 0  | 0  | 0  | 0  | 0  | 0  | 0  | 0  |   |

| Bit   | Symbol   | Function   | R/W |
|-------|----------|--|-----|
| 9:0   | LEN[9:0] | Transfer Data Size Setting<br>These bits specify the transfer data size.*1 | R/W |
| 31:10 | —        | These bits are read as 0. The write value should be 0.                     | R/W |

Note 1. Do not rewrite these bits when the SD\_INFO2.CBSY flag is 1.

The SD\_SIZE register sets the transfer data size.

**LEN[9:0] bits (Transfer Data Size Setting)**

When using single block transfer, the transfer data size can be set in the LEN[9:0] bits from 1 byte to 512 bytes. When CMD12 is automatically issued during a multiblock transfer sequence (CMD18 and CMD25), the transfer data size can only be set to 512 bytes. When CMD12 is not automatically issued during a multiblock transfer sequence, the transfer data size can be set to 32, 64, 128, 256, or 512 bytes. However, a 32-, 64-, 128-, or 256-byte multiblock read transfer can only be performed during an SDIO multiblock transfer (CMD53). Do not set these bits to 0 when using a command that includes data transfer.

| Bit   | Symbol     | Function  | R/W |
|-------|------------|---|-----|
| 9     | CLKCTRLLEN | SDMMC时钟输出自动控制选择<br>0: 禁止SDMMC时钟输出自动控制1: 使能SDMMC时钟输出自动控制 | R/W |
| 31:10 | —          | 这些位被读取为0。写入值应为0。  | R/W |

注1.该值由复位初始化，并且在由SOFT\_RST.SDRST标志触发的复位时初始化。  
 注2.当SD\_INFO2.SD\_CLK\_CTRLLEN标志为0时，不能写访问位CLKSEL[7:0]和CLKEN。

SDCLK\_CTRL寄存器控制SDMMC时钟频率设置和输出。在写入SD\_CMD寄存器以启动命令序列之前，将CLKEN位设置为1。当SD\_INFO2.SD\_CLK\_CTRLLEN标志为0时，不要写入SDCLK\_CTRL寄存器。

**CLKCTRLLEN位 (SDMMC时钟输出自动控制选择)**

CLKCTRLLEN位启用或禁用SDMMC时钟输出的自动控制功能，这会导致SDMMC时钟仅在命令序列内输出。

SDMMC时钟输出开始和停止的时序如下：

- 写入SD\_CMD后开始SDMMC时钟输出
- 在命令序列结束后经过8个SDMMC时钟周期时，SDMMC时钟输出停止。

此外，SDMMC时钟固定为0，而SD\_CLK\_CTRL的SCLKEN为0，与该位的值无关。

**33.2.15 SD\_SIZE：传输数据长度寄存器**

Base address: SDHI<sub>n</sub> 0 = 0x4009\_2000 + 0x0400 × n

Offset address: 0x04C

|               |    |    |    |    |    |    |          |    |    |    |    |    |    |    |    |    |   |
|---------------|----|----|----|----|----|----|----------|----|----|----|----|----|----|----|----|----|---|
| Bit position: | 31 | 30 | 29 | 28 | 27 | 26 | 25       | 24 | 23 | 22 | 21 | 20 | 19 | 18 | 17 | 16 |   |
| Bit field:    | —  | —  | —  | —  | —  | —  | —        | —  | —  | —  | —  | —  | —  | —  | —  | —  |   |
| 重置后的值:        | 0  | 0  | 0  | 0  | 0  | 0  | 0        | 0  | 0  | 0  | 0  | 0  | 0  | 0  | 0  | 0  |   |
| Bit position: | 15 | 14 | 13 | 12 | 11 | 10 | 9        | 8  | 7  | 6  | 5  | 4  | 3  | 2  | 1  | 0  |   |
| Bit field:    | —  | —  | —  | —  | —  | —  | LEN[9:0] |    |    |    |    |    |    |    |    | —  | — |
| 重置后的值:        | 0  | 0  | 0  | 0  | 0  | 0  | 1        | 0  | 0  | 0  | 0  | 0  | 0  | 0  | 0  | 0  |   |

| Bit   | Symbol   | Function                   | R/W |
|-------|----------|----------------------------|-----|
| 9:0   | LEN[9:0] | 传输数据大小设置<br>这些位指定传输数据大小。*1 | R/W |
| 31:10 | —        | 这些位被读取为0。写入值应为0。           | R/W |

注1.当SD\_INFO2.CBSY标志为1时，不要重写这些位。

SD\_SIZE寄存器设置传输数据大小。

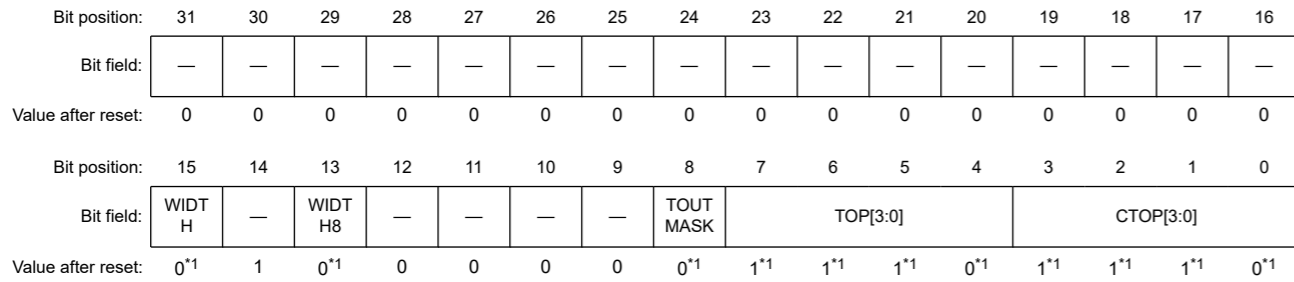
**LEN[9:0]位 (传输数据大小设置)**

使用单块传输时，传输数据大小可以在LEN[9:0]位中设置，从1字节到512字节。什么时候CMD12在多块传输序列 (CMD18和CMD25) 期间自动发出，传输数据大小只能设置为512字节。在多块传输序列期间未自动发出CMD12时，传输数据大小可设置为32、64、128、256或512字节。但是，只能在SDIO多块传输(CMD53)期间执行32、64、128或256字节的多块读取传输。使用包含数据传输的命令时，请勿将这些位设置为0。

33.2.16 SD\_OPTION : SD Card Access Control Option Register

Base address: SDHI<sub>n</sub> 0 = 0x4009\_2000 + 0x0400 × n

Offset address: 0x050

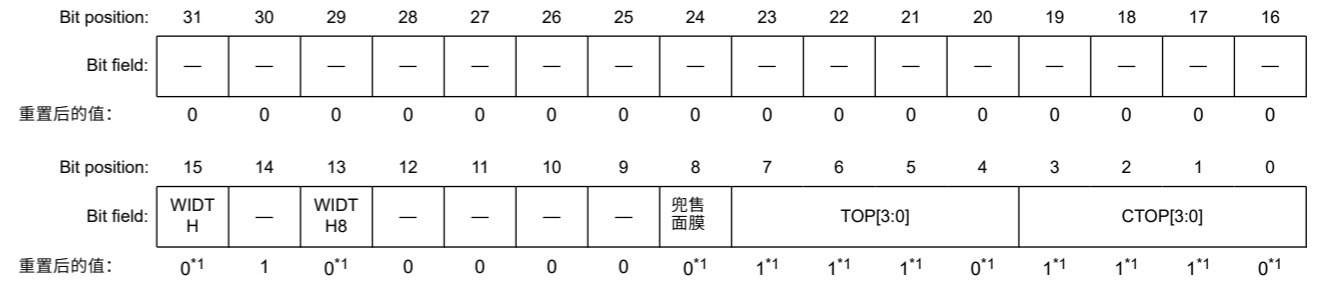


| Bit  | Symbol    | Function  | R/W |
|------|-----------|---|-----|
| 3:0  | CTOP[3:0] | Card Detection Time Counter*2<br>0x0: PCLKB × 2 <sup>10</sup><br>0x1: PCLKB × 2 <sup>11</sup><br>0x2: PCLKB × 2 <sup>12</sup><br>0x3: PCLKB × 2 <sup>13</sup><br>0x4: PCLKB × 2 <sup>14</sup><br>0x5: PCLKB × 2 <sup>15</sup><br>0x6: PCLKB × 2 <sup>16</sup><br>0x7: PCLKB × 2 <sup>17</sup><br>0x8: PCLKB × 2 <sup>18</sup><br>0x9: PCLKB × 2 <sup>19</sup><br>0xA: PCLKB × 2 <sup>20</sup><br>0xB: PCLKB × 2 <sup>21</sup><br>0xC: PCLKB × 2 <sup>22</sup><br>0xD: PCLKB × 2 <sup>23</sup><br>0xE: PCLKB × 2 <sup>24</sup><br>0xF: Setting prohibited  | R/W |
| 7:4  | TOP[3:0]  | Timeout Counter*2<br>0x0: SDHI clock × 2 <sup>13</sup><br>0x1: SDHI clock × 2 <sup>14</sup><br>0x2: SDHI clock × 2 <sup>15</sup><br>0x3: SDHI clock × 2 <sup>16</sup><br>0x4: SDHI clock × 2 <sup>17</sup><br>0x5: SDHI clock × 2 <sup>18</sup><br>0x6: SDHI clock × 2 <sup>19</sup><br>0x7: SDHI clock × 2 <sup>20</sup><br>0x8: SDHI clock × 2 <sup>21</sup><br>0x9: SDHI clock × 2 <sup>22</sup><br>0xA: SDHI clock × 2 <sup>23</sup><br>0xB: SDHI clock × 2 <sup>24</sup><br>0xC: SDHI clock × 2 <sup>25</sup><br>0xD: SDHI clock × 2 <sup>26</sup><br>0xE: SDHI clock × 2 <sup>27</sup><br>0xF: Setting prohibited | R/W |
| 8    | TOUTMASK  | Timeout Mask<br>0: Activate timeout<br>1: Inactivate timeout (do not set RSPTO and DTO bits of SD_INFO2 or CRCBSYTO, CRCTO, RDTO, BSYTO1, BSYTO0, RSPTO1 and RSPTO0 bits of SD_ERR_STS2)<br>When timeout occurs because of an inactivated timeout, execute a software reset to terminate the command sequence.  | R/W |
| 12:9 | —         | These bits are read as 0. The write value should be 0.  | R/W |

33.2.16 SD\_OPTION:SD卡访问控制选项寄存器

Base address: SDHI<sub>n</sub> 0 = 0x4009\_2000 + 0x0400 × n

Offset address: 0x050



| Bit  | Symbol    | Function  | R/W |
|------|-----------|---|-----|
| 3:0  | CTOP[3:0] | 卡片检测时间计数器*2<br>0x0: PCLKB × 2 <sup>10</sup><br>0x1: PCLKB × 2 <sup>11</sup><br>0x2: PCLKB × 2 <sup>12</sup><br>0x3: PCLKB × 2 <sup>13</sup><br>0x4: PCLKB × 2 <sup>14</sup><br>0x5: PCLKB × 2 <sup>15</sup><br>0x6: PCLKB × 2 <sup>16</sup><br>0x7: PCLKB × 2 <sup>17</sup><br>0x8: PCLKB × 2 <sup>18</sup><br>0x9: PCLKB × 2 <sup>19</sup><br>0xA: PCLKB × 2 <sup>20</sup><br>0xB: PCLKB × 2 <sup>21</sup><br>0xC: PCLKB × 2 <sup>22</sup><br>0xD: PCLKB × 2 <sup>23</sup><br>0xE: PCLKB × 2 <sup>24</sup><br>0xF: 禁止设置  | R/W |
| 7:4  | TOP[3:0]  | 超时计数器*2<br>0x0: SDHI clock × 2 <sup>13</sup><br>0x1: SDHI clock × 2 <sup>14</sup><br>0x2: SDHI clock × 2 <sup>15</sup><br>0x3: SDHI clock × 2 <sup>16</sup><br>0x4: SDHI clock × 2 <sup>17</sup><br>0x5: SDHI clock × 2 <sup>18</sup><br>0x6: SDHI clock × 2 <sup>19</sup><br>0x7: SDHI clock × 2 <sup>20</sup><br>0x8: SDHI clock × 2 <sup>21</sup><br>0x9: SDHI clock × 2 <sup>22</sup><br>0xA: SDHI clock × 2 <sup>23</sup><br>0xB: SDHI clock × 2 <sup>24</sup><br>0xC: SDHI clock × 2 <sup>25</sup><br>0xD: SDHI clock × 2 <sup>26</sup><br>0xE: SDHI clock × 2 <sup>27</sup><br>0xF: 禁止设置 | R/W |
| 8    | TOUTMASK  | 超时掩码<br>0: 激活超时1: 不激活超时 (不要设置SD_INFO2的RSPTO和DTO位或CRCBSYTO、CRCTO、RDTO、BSYTO1、BSYTO0、RSPTO1和RSPTO0位<br><br>SD_ERR_STS2)<br>当由于未激活超时而发生超时时, 执行软件复位以终止命令序列。   | R/W |
| 12:9 | —         | 这些位被读取为0。写入值应为0。  | R/W |

| Bit   | Symbol | Function   | R/W   |        |           |   |   |             |   |   |             |   |   |             |   |   |             |     |
|-------|--------|--|-------|--------|-----------|---|---|-------------|---|---|-------------|---|---|-------------|---|---|-------------|-----|
| 13    | WIDTH8 | Bus Width <sup>2</sup><br>See bit 15 WIDTH bit.  | R/W   |        |           |   |   |             |   |   |             |   |   |             |   |   |             |     |
| 14    | —      | This bit is read as 1. The write value should be 1.  | R/W   |        |           |   |   |             |   |   |             |   |   |             |   |   |             |     |
| 15    | WIDTH  | Bus Width <sup>2</sup><br><table border="1" style="width: 100%; border-collapse: collapse;"> <thead> <tr> <th>WIDTH</th> <th>WIDTH8</th> <th>Bus Width</th> </tr> </thead> <tbody> <tr> <td>0</td> <td>1</td> <td>8-bit width</td> </tr> <tr> <td>0</td> <td>0</td> <td>4-bit width</td> </tr> <tr> <td>1</td> <td>0</td> <td>1-bit width</td> </tr> <tr> <td>1</td> <td>1</td> <td>1-bit width</td> </tr> </tbody> </table> For 1-byte write transfers, set 4-bit or 1-bit width. Do not set 8-bit width. | WIDTH | WIDTH8 | Bus Width | 0 | 1 | 8-bit width | 0 | 0 | 4-bit width | 1 | 0 | 1-bit width | 1 | 1 | 1-bit width | R/W |
| WIDTH | WIDTH8 | Bus Width  |       |        |           |   |   |             |   |   |             |   |   |             |   |   |             |     |
| 0     | 1      | 8-bit width  |       |        |           |   |   |             |   |   |             |   |   |             |   |   |             |     |
| 0     | 0      | 4-bit width  |       |        |           |   |   |             |   |   |             |   |   |             |   |   |             |     |
| 1     | 0      | 1-bit width  |       |        |           |   |   |             |   |   |             |   |   |             |   |   |             |     |
| 1     | 1      | 1-bit width  |       |        |           |   |   |             |   |   |             |   |   |             |   |   |             |     |
| 31:16 | —      | These bits are read as 0. The write value should be 0.   | R/W   |        |           |   |   |             |   |   |             |   |   |             |   |   |             |     |

Note 1. The value is initialized by a reset and also on reset triggered by the SOFT\_RST.SDRST flag.  
 Note 2. Do not rewrite these bits when the SD\_INFO2.CBSY flag is 1.

The SD bus width and timeout counter are set in the SD\_OPTION register.

### 33.2.17 SD\_ERR\_STS1 : SD Error Status Register 1

Base address: SDHIn 0 = 0x4009\_2000 + 0x0400 × n  
 Offset address: 0x058

|                    |    |                |                |                |                |                |                |                |          |         |                |                |                |                |                |                |
|--------------------|----|----------------|----------------|----------------|----------------|----------------|----------------|----------------|----------|---------|----------------|----------------|----------------|----------------|----------------|----------------|
| Bit position:      | 31 | 30             | 29             | 28             | 27             | 26             | 25             | 24             | 23       | 22      | 21             | 20             | 19             | 18             | 17             | 16             |
| Bit field:         | —  | —              | —              | —              | —              | —              | —              | —              | —        | —       | —              | —              | —              | —              | —              | —              |
| Value after reset: | x  | x              | x              | x              | x              | x              | x              | x              | x        | x       | x              | x              | x              | x              | x              | x              |
| Bit position:      | 15 | 14             | 13             | 12             | 11             | 10             | 9              | 8              | 7        | 6       | 5              | 4              | 3              | 2              | 1              | 0              |
| Bit field:         | —  | CRCTK[2:0]     | CRCT KE        | RDCR CE        | RSPC RCE1      | RSPC RCE0      | —              | —              | CRCL ENE | RDLE NE | RSPL ENE1      | RSPL ENE0      | CMDE 1         | CMDE 0         | —              | —              |
| Value after reset: | 0  | 0 <sup>1</sup> | 1 <sup>1</sup> | 0 <sup>1</sup> | 0 <sup>1</sup> | 0 <sup>1</sup> | 0 <sup>1</sup> | 0 <sup>1</sup> | 0        | 0       | 0 <sup>1</sup> | 0 <sup>1</sup> | 0 <sup>1</sup> | 0 <sup>1</sup> | 0 <sup>1</sup> | 0 <sup>1</sup> |

| Bit | Symbol  | Function  | R/W |
|-----|---------|---|-----|
| 0   | CMDE0   | Command Error Flag 0<br>0: No error exists in command index field value of a command <sup>2</sup> response<br>1: Error exists in command index field value of a command <sup>2</sup> response   | R   |
| 1   | CMDE1   | Command Error Flag 1<br>0: No error exists in command index field value of a command <sup>3</sup> response<br>1: Error exists in command index field value of a command <sup>3</sup> response (with SD_CMD.CMDIDX[5:0] setting, an error that occurs with CMD12 issue is indicated in the CMDE0 flag) | R   |
| 2   | RSPLNE0 | Response Length Error Flag 0<br>0: No error exists in command <sup>2</sup> response length<br>1: Error exists in command <sup>2</sup> response length   | R   |
| 3   | RSPLNE1 | Response Length Error Flag 1<br>0: No error exists in command <sup>3</sup> response length<br>1: Error exists in command <sup>3</sup> response length (with SD_CMD.CMDIDX[5:0] setting, an error that occurs with CMD12 issue is indicated in the RSPLNE0 flag)                                       | R   |
| 4   | RDLENE  | Read Data Length Error Flag<br>0: No read data length error occurred<br>1: Read data length error occurred  | R   |
| 5   | CRCLNE  | CRC Status Token Length Error Flag<br>0: No CRC status token length error occurred<br>1: CRC status token length error occurred   | R   |

| Bit   | Symbol | Function   | R/W   |        |      |   |   |             |   |   |             |   |   |             |   |   |             |     |
|-------|--------|--|-------|--------|------|---|---|-------------|---|---|-------------|---|---|-------------|---|---|-------------|-----|
| 13    | WIDTH8 | 总线宽度*2<br>请参见位15WIDTH位。  | R/W   |        |      |   |   |             |   |   |             |   |   |             |   |   |             |     |
| 14    | —      | 该位读取为1。写入值应为1。   | R/W   |        |      |   |   |             |   |   |             |   |   |             |   |   |             |     |
| 15    | WIDTH  | 总线宽度*2<br><table border="1" style="width: 100%; border-collapse: collapse;"> <thead> <tr> <th>WIDTH</th> <th>WIDTH8</th> <th>总线宽度</th> </tr> </thead> <tbody> <tr> <td>0</td> <td>1</td> <td>8-bit width</td> </tr> <tr> <td>0</td> <td>0</td> <td>4-bit width</td> </tr> <tr> <td>1</td> <td>0</td> <td>1-bit width</td> </tr> <tr> <td>1</td> <td>1</td> <td>1-bit width</td> </tr> </tbody> </table> 对于1字节写传输，设置4位或1位宽度。不要设置8位宽度。 | WIDTH | WIDTH8 | 总线宽度 | 0 | 1 | 8-bit width | 0 | 0 | 4-bit width | 1 | 0 | 1-bit width | 1 | 1 | 1-bit width | R/W |
| WIDTH | WIDTH8 | 总线宽度   |       |        |      |   |   |             |   |   |             |   |   |             |   |   |             |     |
| 0     | 1      | 8-bit width  |       |        |      |   |   |             |   |   |             |   |   |             |   |   |             |     |
| 0     | 0      | 4-bit width  |       |        |      |   |   |             |   |   |             |   |   |             |   |   |             |     |
| 1     | 0      | 1-bit width  |       |        |      |   |   |             |   |   |             |   |   |             |   |   |             |     |
| 1     | 1      | 1-bit width  |       |        |      |   |   |             |   |   |             |   |   |             |   |   |             |     |
| 31:16 | —      | 这些位被读取为0。写入值应为0。   | R/W   |        |      |   |   |             |   |   |             |   |   |             |   |   |             |     |

注1.该值由复位初始化，并且在由SOFT\_RST.SDRST标志触发的复位时初始化。  
 注2.当SD\_INFO2.CBSY标志为1时，不要重写这些位。

SD总线宽度和超时计数器在SD\_OPTION寄存器中设置。

### 33.2.17 SD\_ERR\_STS1：SD错误状态寄存器1

Base address: SDHIn 0 = 0x4009\_2000 + 0x0400 × n  
 Offset address: 0x058

|               |    |                |                |                |                |                |                |                |          |         |                |                |                |                |                |                |
|---------------|----|----------------|----------------|----------------|----------------|----------------|----------------|----------------|----------|---------|----------------|----------------|----------------|----------------|----------------|----------------|
| Bit position: | 31 | 30             | 29             | 28             | 27             | 26             | 25             | 24             | 23       | 22      | 21             | 20             | 19             | 18             | 17             | 16             |
| Bit field:    | —  | —              | —              | —              | —              | —              | —              | —              | —        | —       | —              | —              | —              | —              | —              | —              |
| 重置后的值:        | x  | x              | x              | x              | x              | x              | x              | x              | x        | x       | x              | x              | x              | x              | x              | x              |
| Bit position: | 15 | 14             | 13             | 12             | 11             | 10             | 9              | 8              | 7        | 6       | 5              | 4              | 3              | 2              | 1              | 0              |
| Bit field:    | —  | CRCTK[2:0]     | CRCT KE        | RDCR CE        | RSPC RCE1      | RSPC RCE0      | —              | —              | CRCL ENE | RDLE NE | RSPL ENE1      | RSPL ENE0      | CMDE 1         | CMDE 0         | —              | —              |
| 重置后的值:        | 0  | 0 <sup>1</sup> | 1 <sup>1</sup> | 0 <sup>1</sup> | 0 <sup>1</sup> | 0 <sup>1</sup> | 0 <sup>1</sup> | 0 <sup>1</sup> | 0        | 0       | 0 <sup>1</sup> | 0 <sup>1</sup> | 0 <sup>1</sup> | 0 <sup>1</sup> | 0 <sup>1</sup> | 0 <sup>1</sup> |

| Bit | Symbol  | Function  | R/W |
|-----|---------|---|-----|
| 0   | CMDE0   | 命令错误标志0<br>0: 命令*2响应的命令索引字段值不存在错误1: 命令*2响应的命令索引字段值存在错误  | R   |
| 1   | CMDE1   | 命令错误标志1<br>0: 命令*3响应的命令索引字段值中不存在错误1: 命令*3响应的命令索引字段值中存在错误 (带有 SD_CMD.CMDIDX[5:0]设置, CMD12问题发生的错误在CMDE0标志中指示) | R   |
| 2   | RSPLNE0 | 响应长度错误标志0<br>0: 指令*2响应长度无错误1: 指令*2响应长度有错误   | R   |
| 3   | RSPLNE1 | 响应长度错误标志1<br>0: 命令*3响应长度中不存在错误1: 命令*3响应长度中存在错误 (使用SD_CMD.CMDIDX[5:0]设置, 在RSPLNE0标志中指示CMD12问题发生的错误)          | R   |
| 4   | RDLENE  | 读取数据长度错误标志<br>0: 未发生读取数据长度错误1: 发生读取数据长度错误   | R   |
| 5   | CRCLNE  | CRC状态令牌长度错误标志<br>0: 未发生CRC状态令牌长度错误1: 发生CRC状态令牌长度错误  | R   |



| Bit   | Symbol     | Function  | R/W |
|-------|------------|---|-----|
| 7:6   | —          | These bits are read as 0.   | R   |
| 8     | RSPCRCE0   | Response CRC Error Flag 0<br>0: No CRC error detected in command <sup>*2</sup> response<br>1: CRC error detected in command <sup>*2</sup> response  | R   |
| 9     | RSPCRCE1   | Response CRC Error Flag 1<br>0: No CRC error detected in command <sup>*3</sup> response (with SD_CMD.CMDIDX[5:0] setting, an error that occurs with CMD12 issue is indicated in the RSPCRCE0 flag)<br>1: CRC error detected in command <sup>*3</sup> response | R   |
| 10    | RDCRCE     | Read Data CRC Error Flag<br>0: No CRC error detected in read data<br>1: CRC error detected in read data   | R   |
| 11    | CRCTKE     | CRC Status Token Error Flag<br>0: No error detected in CRC status token<br>1: Error detected in CRC status token  | R   |
| 14:12 | CRCTK[2:0] | CRC Status Token<br>These bits store the CRC status token value (normal value is 010b).   | R   |
| 15    | —          | This bit is read as 0.  | R   |
| 31:16 | —          | These bits are read as 0.   | R   |

Note 1. The value is initialized by a reset and also on reset triggered by the SOFT\_RST.SDRST flag.  
 Note 2. CMD other than CMD12 when automatic issuing is enabled for multiple block transfer by the setting in SD\_CMD, CMD12 when the STP bit in SD\_STOP is set to 1, or CMD52 when the C52PUB or IOABT bit in SDIO\_MODE is set to 1.  
 Note 3. CMD12 when automatic issuing is enabled for multiple block transfer by the setting in SD\_CMD, CMD12 when the STP bit in SD\_STOP is set to 1, or CMD52 when the C52PUB or IOABT bit in SDIO\_MODE is set to 1.

The SD\_ERR\_STS1 register indicates the CRC status token, CRC error, end bit error, and command error.

### 33.2.18 SD\_ERR\_STS2 : SD Error Status Register 2

Base address: SDHI<sub>n</sub> 0 = 0x4009\_2000 + 0x0400 × n  
 Offset address: 0x05C

|                    |    |    |    |    |    |    |    |    |    |                 |                 |                 |                 |                 |                 |                 |
|--------------------|----|----|----|----|----|----|----|----|----|-----------------|-----------------|-----------------|-----------------|-----------------|-----------------|-----------------|
| Bit position:      | 31 | 30 | 29 | 28 | 27 | 26 | 25 | 24 | 23 | 22              | 21              | 20              | 19              | 18              | 17              | 16              |
| Bit field:         | —  | —  | —  | —  | —  | —  | —  | —  | —  | —               | —               | —               | —               | —               | —               | —               |
| Value after reset: | 0  | 0  | 0  | 0  | 0  | 0  | 0  | 0  | 0  | 0               | 0               | 0               | 0               | 0               | 0               | 0               |
| Bit position:      | 15 | 14 | 13 | 12 | 11 | 10 | 9  | 8  | 7  | 6               | 5               | 4               | 3               | 2               | 1               | 0               |
| Bit field:         | —  | —  | —  | —  | —  | —  | —  | —  | —  | CRCB SYTO       | CRCT O          | RDTO            | BSYT O1         | BSYT O0         | RSPT O1         | RSPT O0         |
| Value after reset: | 0  | 0  | 0  | 0  | 0  | 0  | 0  | 0  | 0  | 0 <sup>*1</sup> | 0 <sup>*1</sup> | 0 <sup>*1</sup> | 0 <sup>*1</sup> | 0 <sup>*1</sup> | 0 <sup>*1</sup> | 0 <sup>*1</sup> |

| Bit | Symbol | Function  | R/W |
|-----|--------|---|-----|
| 0   | RSPTO0 | Response Timeout Flag 0<br>0: After command <sup>*2</sup> was issued, response was received in less than 640 cycles of the SD/MMC clock<br>1: After command <sup>*2</sup> was issued, response was not received in 640 or more cycles of the SD/MMC clock   | R   |
| 1   | RSPTO1 | Response Timeout Flag 1<br>0: After command <sup>*3</sup> was issued, response was received in less than 640 cycles of the SD/MMC clock<br>1: After command <sup>*3</sup> was issued, response was not received after 640 or more cycles of the SD/MMC clock (with SD_CMD.CMDIDX[5:0] setting, an error that occurs with CMD12 issue is indicated in the RSPTO0 flag) | R   |

| Bit   | Symbol     | Function   | R/W |
|-------|------------|--|-----|
| 7:6   | —          | 这些位读为0。  | R   |
| 8     | RSPCRCE0   | 响应CRC错误标志0<br>0: 在命令*2响应中未检测到CRC错误1: 在命令*2响应中检测到CRC错误  | R   |
| 9     | RSPCRCE1   | 响应CRC错误标志1<br>0: 在命令*3响应中未检测到CRC错误 (使用SD_CMD.CMDIDX[5:0]设置, 在RSPCRCE0标志中指示CMD12问题发生的错误)<br>1: 在命令*3响应中检测到CRC错误 | R   |
| 10    | RDCRCE     | 读取数据CRC错误标志<br>0: 读取数据中未检测到CRC错误1: 读取数据中检测到CRC错误   | R   |
| 11    | CRCTKE     | CRC状态令牌错误标志<br>0: 在CRC状态令牌中未检测到错误1: 在CRC状态令牌中检测到错误   | R   |
| 14:12 | CRCTK[2:0] | CRC状态令牌<br>这些位存储CRC状态令牌值 (正常值为010b)。   | R   |
| 15    | —          | 该位读为0。   | R   |
| 31:16 | —          | 这些位读为0。  | R   |

注1.该值由复位初始化, 并且在由SOFT\_RST.SDRST标志触发的复位时初始化。  
 注2.通过SD\_CMD中的设置, CMD12之外的CMD SD\_STOP中的STP位设置为1, 或者当SDIO\_MODE中的C52PUB或IOABT位设置为1时为CMD52。  
 注3.通过SD\_CMD中的设置为多块传输启用自动发布时的CMD12, 当STP位中的CMD12 SD\_STOP设置为1, 或当SDIO\_MODE中的C52PUB或IOABT位设置为1时为CMD52。

SD\_ERR\_STS1寄存器指示CRC状态令牌、CRC错误、结束位错误和命令错误。

### 33.2.18 SD\_ERR\_STS2 : SD错误状态寄存器2

Base address: SDHI<sub>n</sub> 0 = 0x4009\_2000 + 0x0400 × n  
 Offset address: 0x05C

|               |    |    |    |    |    |    |    |    |    |    |                 |                 |                 |                 |                 |                 |                 |
|---------------|----|----|----|----|----|----|----|----|----|----|-----------------|-----------------|-----------------|-----------------|-----------------|-----------------|-----------------|
| Bit position: | 31 | 30 | 29 | 28 | 27 | 26 | 25 | 24 | 23 | 22 | 21              | 20              | 19              | 18              | 17              | 16              |                 |
| Bit field:    | —  | —  | —  | —  | —  | —  | —  | —  | —  | —  | —               | —               | —               | —               | —               | —               |                 |
| 重置后的值:        | 0  | 0  | 0  | 0  | 0  | 0  | 0  | 0  | 0  | 0  | 0               | 0               | 0               | 0               | 0               | 0               |                 |
| Bit position: | 15 | 14 | 13 | 12 | 11 | 10 | 9  | 8  | 7  | 6  | 5               | 4               | 3               | 2               | 1               | 0               |                 |
| Bit field:    | —  | —  | —  | —  | —  | —  | —  | —  | —  | —  | CRCB SYTO       | CRCT O          | RDTO            | BSYT O1         | BSYT O0         | RSPT O1         | RSPT O0         |
| 重置后的值:        | 0  | 0  | 0  | 0  | 0  | 0  | 0  | 0  | 0  | 0  | 0 <sup>*1</sup> | 0 <sup>*1</sup> | 0 <sup>*1</sup> | 0 <sup>*1</sup> | 0 <sup>*1</sup> | 0 <sup>*1</sup> | 0 <sup>*1</sup> |

| Bit | Symbol | Function   | R/W |
|-----|--------|--|-----|
| 0   | RSPTO0 | 响应超时标志0<br>0: 发出命令*2后, 在不到640个SDMMC时钟周期内收到响应<br>1: 发出命令*2后, 在SDMMC时钟的640或更多周期内未收到响应  | R   |
| 1   | RSPTO1 | 响应超时标志1<br>0: 发出命令*3后, 在不到640个SDMMC时钟周期内收到响应<br>1: 发出命令*3后, 在SDMMC时钟的640或更多周期后未收到响应 (使用SD_CMD.CMDIDX[5:0]设置, 在RSPTO0标志中指示CMD12问题发生的错误) | R   |

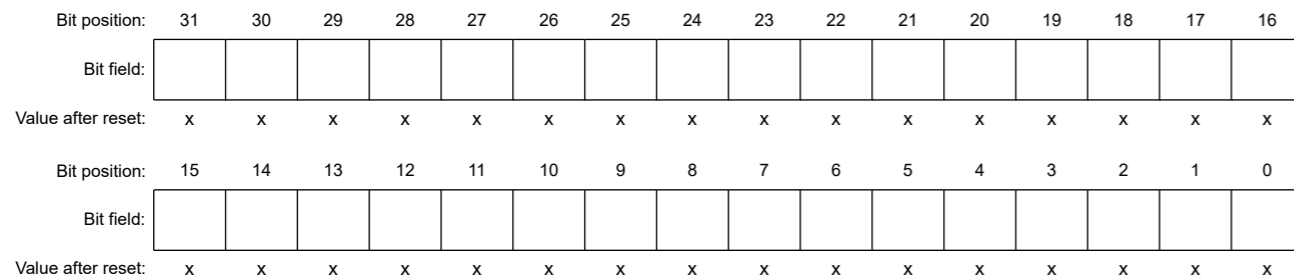
| Bit  | Symbol   | Function  | R/W |
|------|----------|---|-----|
| 2    | BSYTO0   | Busy Timeout Flag 0<br>0: After R1b response was received, SD/MMC was released from the busy state during the specified period <sup>4</sup><br>1: After R1b response was received, SD/MMC was in the busy state after the specified period <sup>4</sup> elapsed   | R   |
| 3    | BSYTO1   | Busy Timeout Flag 1<br>0: After CMD12 was automatically issued, SD/MMC was released from the busy state during the specified period <sup>4</sup><br>1: After CMD12 was automatically issued, SD/MMC was in the busy state after the specified period <sup>4</sup> elapsed (with SD_CMD.CMDIDX[5:0] setting, an error that occurs with CMD12 issue is indicated in the BSYTO0 flag)  | R   |
| 4    | RDTO     | Read Data Timeout Flag<br>When a read command is issued, this flag sets to 1 when read data is not received after the specified period <sup>4</sup> elapses.<br>When read data is received, this flag sets to 1 when the next block of read data is not received after the specified period <sup>4</sup> elapses.<br>When the SD/MMC exits the read wait state, this flag sets to 1 when the next block of read data is not received after the specified period <sup>4</sup> elapses. | R   |
| 5    | CRCTO    | CRC Status Token Timeout Flag<br>0: After CRC data was written to the SD card/MMC, a CRC status token was received during the specified period <sup>4</sup><br>1: After CRC data was written to the SD card/MMC, a CRC status token was not received after the specified period <sup>4</sup> elapsed  | R   |
| 6    | CRCBSYTO | CRC Status Token Busy Timeout Flag<br>0: After a CRC status token was received, the SD/MMC was released from the busy state during the specified period <sup>4</sup><br>1: After a CRC status token was received, the SD/MMC was in the busy state after the specified period <sup>4</sup> elapsed  | R   |
| 31:7 | —        | These bits are read as 0.   | R   |

- Note 1. The value is initialized by a reset and also on reset triggered by the SOFT\_RST.SDRST flag.
- Note 2. CMD other than CMD12 when automatic issuing is enabled for multiple block transfer by the setting in SD\_CMD, CMD12 when the STP bit in SD\_STOP is set to 1, or CMD52 when the C52PUB or IOABT bit in SDIO\_MODE is set to 1.
- Note 3. CMD12 when automatic issuing is enabled for multiple block transfer by the setting in SD\_CMD, CMD12 when the STP bit in SD\_STOP is set to 1, or CMD52 when the C52PUB or IOABT bit in SDIO\_MODE is set to 1.
- Note 4. Set the SD\_OPTION.TOP[3:0] bits to select the number of n cycles.

The SD\_ERR\_STS2 register indicates the timeout status.

### 33.2.19 SD\_BUF0 : SD Buffer Register

Base address: SDHI n 0 = 0x4009\_2000 + 0x0400 × n  
Offset address: 0x060



When writing to the SD card, the write data is written to this register. When reading from the SD card, the read data is read from this register. This register is internally connected to two 512-byte buffers.

If both buffers are not empty when executing multiple block read, the SD card/MMC clock is stopped to suspend receiving data. When one of the buffers is empty, the SD card/MMC clock is supplied to resume receiving data.

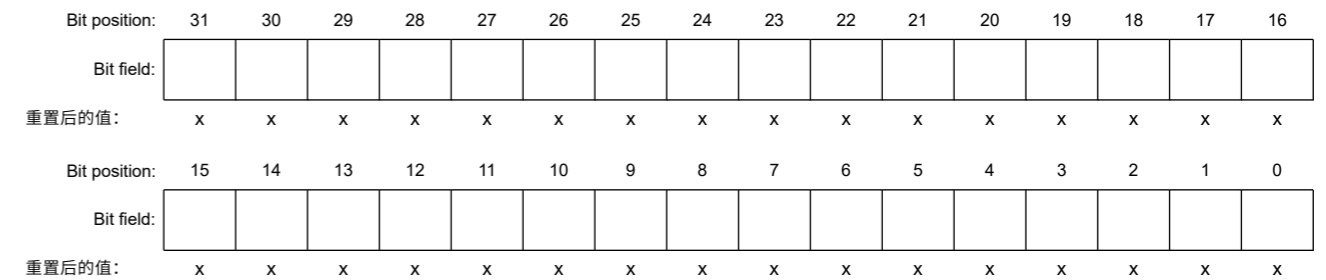
| Bit  | Symbol   | Function  | R/W |
|------|----------|---|-----|
| 2    | BSYTO0   | 忙超时标志0<br>0: 收到R1b响应后, SDMMC在指定时间段内从忙状态中释放*4<br>1: 收到R1b响应后, 经过指定时间*4后SDMMC处于忙碌状态   | R   |
| 3    | BSYTO1   | 忙超时标志1<br>0: CMD12自动下发后, SDMMC在指定时间段内从忙状态释放*4<br>1: 自动发出CMD12后, 经过指定时间*4后SDMMC处于忙碌状态 (使用SD_CMD.CMDIDX[5:0]设置, 在BSYTO0标志中指示CMD12发出的错误)                 | R   |
| 4    | RDTO     | 读取数据超时标志<br>发出读取命令时, 如果经过指定时间*4后仍未接收到读取数据, 则此标志设置为1。当接收到读取数据时, 如果经过指定的时间*4后没有接收到下一个读取数据块, 则此标志设置为1。当SDMMC退出读取等待状态时, 如果经过指定时间*4后未接收到下一个读取数据块, 此标志设置为1。 | R   |
| 5    | CRCTO    | CRC状态令牌超时标志<br>0: CRC数据写入SD卡MMC后, 在指定时间段内收到CRC状态令牌*4<br>1: 将CRC数据写入SD卡MMC后, 经过指定时间*4后未收到CRC状态令牌   | R   |
| 6    | CRCBSYTO | CRC状态令牌忙超时标志<br>0: 收到CRC状态令牌后, SDMMC在指定时间段内从忙碌状态中释放*4<br>1: 收到CRC状态令牌后, 经过指定时间*4后SDMMC处于忙碌状态  | R   |
| 31:7 | —        | 这些位读为0。   | R   |

- 注1.该值由复位初始化, 并且在由SOFT\_RST.SDRST标志触发的复位时初始化。
- 注2.通过SD\_CMD中的设置, CMD12之外的CMD SD\_STOP中的STP位设置为1, 或者当SDIO\_MODE中的C52PUB或IOABT位设置为1时为CMD52。
- 注3.通过SD\_CMD中的设置为多块传输启用自动发布时的CMD12, 当STP位中的CMD12 SD\_STOP设置为1, 或当SDIO\_MODE中的C52PUB或IOABT位设置为1时为CMD52。
- 注4.设置SD\_OPTION.TOP[3:0]位以选择n个周期数。

SD\_ERR\_STS2寄存器指示超时状态。

### 33.2.19 SD\_BUF0:SD缓冲寄存器

Base address: SDHI n 0 = 0x4009\_2000 + 0x0400 × n  
Offset address: 0x060



写入SD卡时, 写入数据写入该寄存器。从SD卡读取时, 从该寄存器读取读取的数据。该寄存器在内部连接到两个512字节的缓冲区。

如果执行多块读取时两个缓冲区都不为空, 则停止SD卡MMC时钟以暂停接收数据。当其中一个缓冲区为空时, 提供SD卡MMC时钟以恢复接收数据。

## 33.2.20 SDIO\_MODE : SDIO Mode Control Register

Base address: SDHI<sub>n</sub> 0 = 0x4009\_2000 + 0x0400 × n

Offset address: 0x068

|                    |    |    |    |    |    |    |            |       |    |    |    |    |    |           |    |       |
|--------------------|----|----|----|----|----|----|------------|-------|----|----|----|----|----|-----------|----|-------|
| Bit position:      | 31 | 30 | 29 | 28 | 27 | 26 | 25         | 24    | 23 | 22 | 21 | 20 | 19 | 18        | 17 | 16    |
| Bit field:         | —  | —  | —  | —  | —  | —  | —          | —     | —  | —  | —  | —  | —  | —         | —  | —     |
| Value after reset: | 0  | 0  | 0  | 0  | 0  | 0  | 0          | 0     | 0  | 0  | 0  | 0  | 0  | 0         | 0  | 0     |
| Bit position:      | 15 | 14 | 13 | 12 | 11 | 10 | 9          | 8     | 7  | 6  | 5  | 4  | 3  | 2         | 1  | 0     |
| Bit field:         | —  | —  | —  | —  | —  | —  | C52P<br>UB | IOABT | —  | —  | —  | —  | —  | RWRE<br>Q | —  | INTEN |
| Value after reset: | 0  | 0  | 0  | 0  | 0  | 0  | 0          | 0     | 0  | 0  | 0  | 0  | 0  | 0         | 0  | 0     |

| Bit   | Symbol | Function   | R/W |
|-------|--------|--|-----|
| 0     | INTEN  | SDIO Interrupt Acceptance Enable*1<br>0: Disable SDIO interrupt acceptance<br>1: Enable SDIO interrupt acceptance  | R/W |
| 1     | —      | This bit is read as 0. The write value should be 0.  | R/W |
| 2     | RWREQ  | Read Wait Request<br>0: Allow SD/MMC to exit read wait state<br>1: Request for SD/MMC to enter read wait state   | R/W |
| 7:3   | —      | These bits are read as 0. The write value should be 0.   | R/W |
| 8     | IOABT  | SDIO Abort<br>If this bit is set to 1 during multiblock transfer triggered by CMD53, CMD52 is immediately issued, and the command sequence is aborted.                                   | R/W |
| 9     | C52PUB | SDIO None Abort<br>If this bit is set to 1 during multiblock transfer triggered by CMD53, CMD52 is issued after the transfer process is complete, and the command sequence is completed. | R/W |
| 31:10 | —      | These bits are read as 0. The write value should be 0.   | R/W |

Note 1. Do not rewrite this bit when the SD\_INFO2.CBSY flag is 1.

The SDIO\_MODE register controls reception of the SDIO interrupt, CMD52 issuance during multiblock transfer, and read wait request. Do not set bits C52PUB and IOABT to 1 at the same time.

**RWREQ bit (Read Wait Request)**

When RWREQ is set to 1 in the CMD53 (multiple block) read sequence, the block transfer enters the read wait state between blocks.

[Read wait state releasing]

- The read wait state is released, when RWREQ is cleared to 0 in the read wait state.
- When IOABT is set to 1 in the read wait state, RWREQ is automatically cleared to 0 after CMD52 is issued, and then the read wait state is released.
- When C52PUB and RWREQ are set to 1 simultaneously in the CMD53 (multiple block) read sequence, the read wait state is not automatically released. Therefore, after the CMD52 response is received, clear RWREQ. You must set RWREQ and C52PUB simultaneously.

When RWREQ is set to 1 while the last block in the CMD53 (multiple block) read sequence is transferred, the read wait state is not entered and RWREQ is automatically cleared to 0 by setting access end. Set RWREQ to 1 after the response end flag sets.

**IOABT bit (SDIO Abort)**

When the IOABT bit is set to 1 in a CMD53 (multiple block) sequence, the CMD53 sequence is halted and CMD52 is issued. However, if a command sequence is halted because of a communication error or timeout, CMD52 is not issued.

## 33.2.20 SDIO\_MODE:SDIO模式控制寄存器

Base address: SDHI<sub>n</sub> 0 = 0x4009\_2000 + 0x0400 × n

Offset address: 0x068

|               |    |    |    |    |    |    |            |       |    |    |    |    |    |           |    |       |
|---------------|----|----|----|----|----|----|------------|-------|----|----|----|----|----|-----------|----|-------|
| Bit position: | 31 | 30 | 29 | 28 | 27 | 26 | 25         | 24    | 23 | 22 | 21 | 20 | 19 | 18        | 17 | 16    |
| Bit field:    | —  | —  | —  | —  | —  | —  | —          | —     | —  | —  | —  | —  | —  | —         | —  | —     |
| 重置后的值:        | 0  | 0  | 0  | 0  | 0  | 0  | 0          | 0     | 0  | 0  | 0  | 0  | 0  | 0         | 0  | 0     |
| Bit position: | 15 | 14 | 13 | 12 | 11 | 10 | 9          | 8     | 7  | 6  | 5  | 4  | 3  | 2         | 1  | 0     |
| Bit field:    | —  | —  | —  | —  | —  | —  | C52P<br>UB | IOABT | —  | —  | —  | —  | —  | RWRE<br>Q | —  | INTEN |
| 重置后的值:        | 0  | 0  | 0  | 0  | 0  | 0  | 0          | 0     | 0  | 0  | 0  | 0  | 0  | 0         | 0  | 0     |

| Bit   | Symbol | Function  | R/W |
|-------|--------|---|-----|
| 0     | INTEN  | SDIO中断接受使能*1<br>0: 禁止SDIO中断接受1: 使能SDIO中<br>断接受                    | R/W |
| 1     | —      | 该位读取为0。写入值应为0。  | R/W |
| 2     | RWREQ  | 读取等待请求<br>0: 允许SDMMC退出读取等待状态1: 请求SDM<br>MC进入读取等待状态                | R/W |
| 7:3   | —      | 这些位被读取为0。写入值应为0。  | R/W |
| 8     | IOABT  | SDIO Abort<br>如果在CMD53触发的多块传输期间该位设置为1, 则立即发出CMD52, 并中止命令序列。       | R/W |
| 9     | C52PUB | SDIO无中止<br>如果在CMD53触发的多块传输期间该位设置为1, 则在传输过程完成后发出CMD52, 命令<br>序列完成。 | R/W |
| 31:10 | —      | 这些位被读取为0。写入值应为0。  | R/W |

注1.当SD\_INFO2.CBSY标志为1时, 请勿重写该位。

SDIO\_MODE寄存器控制SDIO中断的接收、多块传输期间CMD52的发布和读取等待请求。不要同时将位C52PUB和IOABT设置为1。

**RWREQ位 (读取等待请求)**

当CMD53 (多块) 读取序列中RWREQ设置为1时, 块传输进入块之间的读取等待状态。

[读取等待状态释放]

- 在读取等待状态下, 当RWREQ被清0时, 读等待状态被释放。
- 读等待状态下IOABT置1时, 发出CMD52后RWREQ自动清0, 然后解除读等待状态。
- 当C52PUB和RWREQ在CMD53 (多块) 读序列中同时置1时, 读等待状态不会自动解除。因此, 在收到CMD52响应后, 清除RWREQ。您必须同时设置RWREQ和C52PUB。

当RWREQ设置为1时CMD53 (多块) 读取序列中的最后一个块被传输时, 不会进入读取等待状态, 并且通过设置访问结束将RWREQ自动清除为0。设置响应结束标志后将RWREQ设置为1。

**IOABT bit (SDIO Abort)**

当CMD53 (多块) 序列中的IOABT位设置为1时, CMD53序列停止并发出CMD52。但是, 如果命令序列由于通信错误或超时而停止, 则不会发出CMD52。



Although continued buffer access is possible even after IOABT is set to 1, the buffer access error bit (ILR or ILW) in SD\_INFO2 is set accordingly. Set SD\_ARG before setting IOABT to 1.

When IOABT is set to 1 during transfer for a single block write, the access end flag sets when SD\_BUF0 becomes empty, and CMD52 is not issued. If SD\_BUF0 contains data, the access end flag sets on completion of reception of the busy state without CMD52 being issued.

When IOABT is set to 1 during transfer for single block read, the access end flag sets immediately after IOABT is set, and CMD52 is not issued.

When IOABT is set to 1 during reception of the busy state after an R1b response, the access end flag sets on completion of reception of the busy state without CMD52 being issued.

When IOABT is set to 1 after a command sequence is completed, CMD52 is not issued and the access end flag does not set.

Set IOABT to 1 after the response end flag sets.

Set IOABT to 0 after the access end flag sets.

### C52PUB bit (SDIO None Abort)

When the C52PUB bit is set to 1 in the CMD53 (multiple block) write sequence, CMD52 is automatically issued between blocks if SD\_BUF0 becomes empty. C52PUB is automatically cleared to 0 after reception of the response to CMD52 is completed. Additionally, if C52PUB is set to 1 while the last block is being transferred, CMD52 is not issued. In this case, C52PUB is automatically cleared to 0 after the access end flag sets to 1.

When C52PUB and RWREQ are set to 1 in the CMD53 (multiple block) read sequence, the block transfer enters the read wait state between blocks and CMD52 is automatically issued. C52PUB is automatically cleared to 0 after reception of the response to CMD52 is completed. Additionally, if C52PUB is set to 1 while the last block is being transferred, CMD52 is not issued. In this case, C52PUB is automatically cleared to 0 after the access end flag sets to 1.

If C52PUB is set to 1 in the CMD53 (multiple block) read sequence, you must set RWREQ to 1 in addition to C52PUB.

Set SD\_ARG before setting C52PUB to 1.

Set C52PUB to 1 after the response end flag sets.

### 33.2.21 SDIO\_INFO1 : SDIO Interrupt Flag Register

Base address: SDHI<sub>n</sub> 0 = 0x4009\_2000 + 0x0400 × n

Offset address: 0x06C

|                    |                 |                 |    |    |    |    |    |    |    |    |    |    |    |    |    |                 |
|--------------------|-----------------|-----------------|----|----|----|----|----|----|----|----|----|----|----|----|----|-----------------|
| Bit position:      | 31              | 30              | 29 | 28 | 27 | 26 | 25 | 24 | 23 | 22 | 21 | 20 | 19 | 18 | 17 | 16              |
| Bit field:         | —               | —               | —  | —  | —  | —  | —  | —  | —  | —  | —  | —  | —  | —  | —  | —               |
| Value after reset: | 0               | 0               | 0  | 0  | 0  | 0  | 0  | 0  | 0  | 0  | 0  | 0  | 0  | 0  | 0  | 0               |
| Bit position:      | 15              | 14              | 13 | 12 | 11 | 10 | 9  | 8  | 7  | 6  | 5  | 4  | 3  | 2  | 1  | 0               |
| Bit field:         | EXWT            | EXPUB52         | —  | —  | —  | —  | —  | —  | —  | —  | —  | —  | —  | —  | —  | IOIRQ           |
| Value after reset: | 0 <sup>*1</sup> | 0 <sup>*1</sup> | 0  | 0  | 0  | 0  | 0  | 0  | 0  | 0  | 0  | 0  | 0  | x  | x  | 0 <sup>*1</sup> |

| Bit   | Symbol  | Function  | R/W                 |
|-------|---------|---|---------------------|
| 0     | IOIRQ   | SDIO Interrupt Status Flag<br>0: No SDIO interrupt detected<br>1: SDIO interrupt detected | R/(W) <sup>*2</sup> |
| 2:1   | —       | The read values are undefined. The write value should be 1.                               | R/W                 |
| 13:3  | —       | These bits are read as 0. The write value should be 0.                                    | R/W                 |
| 14    | EXPUB52 | EXPUB52 Status Flag<br>Indicates the status of the EXPUB52.                               | R/(W) <sup>*2</sup> |
| 15    | EXWT    | EXWT Status Flag<br>Indicates the status of the EXWT.                                     | R/(W) <sup>*2</sup> |
| 31:16 | —       | These bits are read as 0. The write value should be 0.                                    | R/W                 |

尽管即使在IOABT设置为1后仍可以继续访问缓冲区，但缓冲区访问错误位 (ILR或ILW) 在 SD\_INFO2相应设置。在将IOABT设置为1之前设置SD\_ARG。

当IOABT在单块写入传输期间设置为1时，SD\_BUF0变为空时设置访问结束标志，并且不发出CMD52。如果SD\_BUF0包含数据，则在未发出CMD52的忙状态接收完成时设置访问结束标志。

当IOABT在单块读取传输期间设置为1时，在设置IOABT后立即设置访问结束标志，并且未发出CMD52。

如果在R1b响应后接收忙碌状态期间将IOABT设置为1，则在未发出CMD52的情况下完成忙碌状态接收时设置访问结束标志。

当命令序列完成后IOABT设置为1时，不发出CMD52并且不设置访问结束标志。

设置响应结束标志后将IOABT设置为1。

设置访问结束标志后将IOABT设置为0。

### C52PUB位 (SDIO无中止)

在CMD53 (多块) 写入序列中将C52PUB位设置为1时，如果SD\_BUF0为空，则在块之间自动发出CMD52。C52PUB在接收到对CMD52的响应完成后自动清零。此外，如果在传输最后一个块时将C52PUB设置为1，则不会发出CMD52。在这种情况下，访问结束标志设置为1后，C52PUB自动清零。

当CMD53 (多块) 读序列中C52PUB和RWREQ置1时，块传输进入块间读等待状态，自动发出CMD52。C52PUB在接收到对CMD52的响应完成后自动清零。此外，如果在传输最后一个块时将C52PUB设置为1，则不会发出CMD52。在这种情况下，访问结束标志设置为1后，C52PUB自动清零。

如果在CMD53 (多块) 读取序列中将C52PUB设置为1，则除了C52PUB之外，还必须将RWREQ设置为1。

在将C52PUB设置为1之前设置SD\_ARG。

在响应结束标志设置后将C52PUB设置为1。

### 33.2.21 SDIO\_INFO1:SDIO中断标志 寄存器

Base address: SDHI<sub>n</sub> 0 = 0x4009\_2000 + 0x0400 × n

Offset address: 0x06C

|               |                 |                 |    |    |    |    |    |    |    |    |    |    |    |    |    |       |                 |
|---------------|-----------------|-----------------|----|----|----|----|----|----|----|----|----|----|----|----|----|-------|-----------------|
| Bit position: | 31              | 30              | 29 | 28 | 27 | 26 | 25 | 24 | 23 | 22 | 21 | 20 | 19 | 18 | 17 | 16    |                 |
| Bit field:    | —               | —               | —  | —  | —  | —  | —  | —  | —  | —  | —  | —  | —  | —  | —  | —     |                 |
| 重置后的值:        | 0               | 0               | 0  | 0  | 0  | 0  | 0  | 0  | 0  | 0  | 0  | 0  | 0  | 0  | 0  | 0     |                 |
| Bit position: | 15              | 14              | 13 | 12 | 11 | 10 | 9  | 8  | 7  | 6  | 5  | 4  | 3  | 2  | 1  | 0     |                 |
| Bit field:    | EXWT            | EXPUB52         | —  | —  | —  | —  | —  | —  | —  | —  | —  | —  | —  | —  | —  | IOIRQ |                 |
| 重置后的值:        | 0 <sup>*1</sup> | 0 <sup>*1</sup> | 0  | 0  | 0  | 0  | 0  | 0  | 0  | 0  | 0  | 0  | 0  | 0  | x  | x     | 0 <sup>*1</sup> |

| Bit   | Symbol  | Function                                | R/W                 |
|-------|---------|---|---------------------|
| 0     | IOIRQ   | SDIO中断状态标志<br>0: 未检测到SDIO中断1: 检测到SDIO中断 | R/(W) <sup>*2</sup> |
| 2:1   | —       | 读取的值未定义。写入值应为1。                         | R/W                 |
| 13:3  | —       | 这些位被读取为0。写入值应为0。                        | R/W                 |
| 14    | EXPUB52 | EXPUB52状态标志<br>指示EXPUB52的状态。            | R/(W) <sup>*2</sup> |
| 15    | EXWT    | EXWT状态标志<br>指示EXWT的状态。                  | R/(W) <sup>*2</sup> |
| 31:16 | —       | 这些位被读取为0。写入值应为0。                        | R/W                 |



Note 1. The value is initialized by a reset and also on reset triggered by the SOFT\_RST.SDRST flag.  
 Note 2. Only 0 can be written to clear the bit.

The SDIO\_INFO1 register indicates the status of the SDIO card access. Set flags to be cleared to 0. Set flags that are not being cleared to 1.

**IOIRQ flag (SDIO Interrupt Status Flag)**

The IOIRQ flag indicates that an SDIO interrupt occurred.

[Setting condition]

- When SDIO interrupt from an SDIO card is received while INTEN in SDIO\_MODE is set to 1.

[Clearing condition]

- When 0 is written to IOIRQ.\*1

Note 1. Before clearing this bit, access the SDIO card to negate the SDIO interrupt signal from the SDIO card. If the interrupt signal is not negated, this bit can be set again.

**EXPUB52 flag (EXPUB52 Status Flag)**

The EXPUB52 flag indicates the EXPUB52 status.

[Setting conditions]

- While the last block in the CMD53 (multiple block) sequence is transferred, C52PUB in SDIO\_MODE is set to 1.
- While C52PUB is set to 1 in the CMD53 (multiple block) write sequence, the last block is transferred.

[Clearing condition]

- When 0 is written to EXPUB52.

**EXWT flag (EXWT Status Flag)**

The EXWT flag indicates the EXWT status.

[Setting condition]

- While the last block in the CMD53 (multiple block) read sequence is transferred, RWREQ in SDIO\_MODE is set to 1.

[Clearing condition]

- When 0 is written to EXWT.

**33.2.22 SDIO\_INFO1\_MASK : SDIO INFO1 Interrupt Mask Register**

Base address: SDHI<sub>n</sub> 0 = 0x4009\_2000 + 0x0400 × n

Offset address: 0x070

|                    |           |              |    |    |    |    |    |    |    |    |    |    |    |    |    |            |
|--------------------|-----------|--------------|----|----|----|----|----|----|----|----|----|----|----|----|----|------------|
| Bit position:      | 31        | 30           | 29 | 28 | 27 | 26 | 25 | 24 | 23 | 22 | 21 | 20 | 19 | 18 | 17 | 16         |
| Bit field:         | —         | —            | —  | —  | —  | —  | —  | —  | —  | —  | —  | —  | —  | —  | —  | —          |
| Value after reset: | 0         | 0            | 0  | 0  | 0  | 0  | 0  | 0  | 0  | 0  | 0  | 0  | 0  | 0  | 0  | 0          |
| Bit position:      | 15        | 14           | 13 | 12 | 11 | 10 | 9  | 8  | 7  | 6  | 5  | 4  | 3  | 2  | 1  | 0          |
| Bit field:         | EXWT<br>M | EXPU<br>B52M | —  | —  | —  | —  | —  | —  | —  | —  | —  | —  | —  | —  | —  | IOIRQ<br>M |
| Value after reset: | 1         | 1            | 0  | 0  | 0  | 0  | 0  | 0  | 0  | 0  | 0  | 0  | 0  | 0  | 1  | 1          |

| Bit | Symbol | Function  | R/W |
|-----|--------|---|-----|
| 0   | IOIRQM | IOIRQ Interrupt Mask Control<br>0: Do not mask IOIRQ interrupts<br>1: Mask IOIRQ interrupts | R/W |
| 2:1 | —      | These bits are read as 1. The write value should be 1.                                      | R/W |

注1.该值由复位初始化，并且在由SOFT\_RST.SDRST标志触发的复位时初始化。  
 注2.只能写入0来清除该位。

SDIO\_INFO1寄存器指示SDIO卡访问的状态。将要清除的标志设置为0。将未清除的标志设置为1。

**IOIRQ标志 (SDIO中断状态标志)**

IOIRQ标志表示发生了SDIO中断。

[Setting condition]

- 当SDIO\_MODE中的INTEN设置为1时，接收到来自SDIO卡的SDIO中断。

[Clearing condition]

- 0写入IOIRQ时。\*1

注1.在清除该位之前，访问SDIO卡以否定来自SDIO卡的SDIO中断信号。如果中断信号没有被否定，这个位可以被重新设置。

**EXPUB52标志 (EXPUB52状态标志)**

EXPUB52标志指示EXPUB52状态。

[Setting conditions]

- 当CMD53 (多块) 序列中的最后一个块被传输时，SDIO\_MODE中的C52PUB设置为1。
- 在CMD53 (多块) 写入序列中，当C52PUB设置为1时，传输最后一个块。

[Clearing condition]

- 当0写入EXPUB52时。

**EXWT标志 (EXWT状态标志)**

EXWT标志指示EXWT状态。

[Setting condition]

- 当CMD53 (多块) 读取序列中的最后一个块被传输时，SDIO\_MODE中的RWREQ设置为1。

[Clearing condition]

- 当0写入EXWT时。

**33.2.22 SDIO\_INFO1\_MASK:SDIOINFO1中断屏蔽寄存器**

Base address: SDHI<sub>n</sub> 0 = 0x4009\_2000 + 0x0400 × n

Offset address: 0x070

|               |           |              |    |    |    |    |    |    |    |    |    |    |    |    |    |            |
|---------------|-----------|--------------|----|----|----|----|----|----|----|----|----|----|----|----|----|------------|
| Bit position: | 31        | 30           | 29 | 28 | 27 | 26 | 25 | 24 | 23 | 22 | 21 | 20 | 19 | 18 | 17 | 16         |
| Bit field:    | —         | —            | —  | —  | —  | —  | —  | —  | —  | —  | —  | —  | —  | —  | —  | —          |
| 重置后的值:        | 0         | 0            | 0  | 0  | 0  | 0  | 0  | 0  | 0  | 0  | 0  | 0  | 0  | 0  | 0  | 0          |
| Bit position: | 15        | 14           | 13 | 12 | 11 | 10 | 9  | 8  | 7  | 6  | 5  | 4  | 3  | 2  | 1  | 0          |
| Bit field:    | EXWT<br>M | EXPU<br>B52M | —  | —  | —  | —  | —  | —  | —  | —  | —  | —  | —  | —  | —  | IOIRQ<br>M |
| 重置后的值:        | 1         | 1            | 0  | 0  | 0  | 0  | 0  | 0  | 0  | 0  | 0  | 0  | 0  | 0  | 1  | 1          |

| Bit | Symbol | Function                                 | R/W |
|-----|--------|--|-----|
| 0   | IOIRQM | IOIRQ中断屏蔽控制<br>0: 不屏蔽IOIRQ中断1: 屏蔽IOIRQ中断 | R/W |
| 2:1 | —      | 这些位被读取为1。写入值应为1。                         | R/W |

| Bit   | Symbol   | Function  | R/W |
|-------|----------|---|-----|
| 13:3  | —        | These bits are read as 0. The write value should be 0.  | R/W |
| 14    | EXPUB52M | EXPUB52 Interrupt Request Mask Control<br>0: Do not mask EXPUB52 interrupt requests<br>1: Mask EXPUB52 interrupt requests | R/W |
| 15    | EXWTM    | EXWT Interrupt Request Mask Control<br>0: Do not mask EXWT interrupt requests<br>1: Mask EXWT interrupt requests          | R/W |
| 31:16 | —        | These bits are read as 0. The write value should be 0.  | R/W |

The SDIO\_INFO1\_MASK register enables or disables interrupt requests from the status flags in the SDIO\_INFO1 register. See Table 33.5 for details on the relationship between the status flags and the requested interrupt source.

### 33.2.23 SD\_DMAEN : DMA Mode Enable Register

Base address: SDHI<sub>n</sub> 0 = 0x4009\_2000 + 0x0400 × n

Offset address: 0x1B0

|                    |    |    |    |    |    |    |    |    |    |    |    |    |    |    |       |    |
|--------------------|----|----|----|----|----|----|----|----|----|----|----|----|----|----|-------|----|
| Bit position:      | 31 | 30 | 29 | 28 | 27 | 26 | 25 | 24 | 23 | 22 | 21 | 20 | 19 | 18 | 17    | 16 |
| Bit field:         | —  | —  | —  | —  | —  | —  | —  | —  | —  | —  | —  | —  | —  | —  | —     | —  |
| Value after reset: | 0  | 0  | 0  | 0  | 0  | 0  | 0  | 0  | 0  | 0  | 0  | 0  | 0  | 0  | 0     | 0  |
| Bit position:      | 15 | 14 | 13 | 12 | 11 | 10 | 9  | 8  | 7  | 6  | 5  | 4  | 3  | 2  | 1     | 0  |
| Bit field:         | —  | —  | —  | —  | —  | —  | —  | —  | —  | —  | —  | —  | —  | —  | DMAEN | —  |
| Value after reset: | 0  | 0  | 0  | 1  | 0  | 0  | 0  | 0  | 0  | 0  | 0  | 0  | 1  | 0  | 0     | 0  |

| Bit   | Symbol | Function  | R/W |
|-------|--------|---|-----|
| 0     | —      | This bit is read as 0. The write value should be 0.   | R/W |
| 1     | DMAEN  | DMA Transfer Enable <sup>*1 *2</sup><br>0: Disable use of DMA transfer to access SD_BUF0 register<br>1: Enable use of DMA transfer to access SD_BUF0 register | R/W |
| 3:2   | —      | These bits are read as 0. The write value should be 0.  | R/W |
| 4     | —      | This bit is read as 1. The write value should be 1.   | R/W |
| 11:5  | —      | These bits are read as 0. The write value should be 0.  | R/W |
| 12    | —      | This bit is read as 1. The write value should be 1.   | R/W |
| 31:13 | —      | These bits are read as 0. The write value should be 0.  | R/W |

Note 1. Do not rewrite this bit when the SD\_INFO2.CBSY bit is 1.

Note 2. When the SD\_INFO2\_MASK.BWEM bit is 0 or the SD\_INFO2\_MASK.BREM bit is 0, set the SD\_DMAEN.DMAEN bit to 0. When the SD\_DMAEN.DMAEN bit is 1, set the SD\_INFO2\_MASK.BWEM bit to 1 and the SD\_INFO2\_MASK.BREM bit to 1.

The SD\_DMAEN register enables or disables DMA transfers.

#### DMAEN bit (DMA Transfer Enable)

When using DMA transfer to access the SD buffer, set the DMAEN bit to 1 before setting the SD\_CMD register.

| Bit   | Symbol   | Function   | R/W |
|-------|----------|--|-----|
| 13:3  | —        | 这些位被读取为0。写入值应为0。                                     | R/W |
| 14    | EXPUB52M | EXPUB52中断请求屏蔽控制<br>0: 不屏蔽EXPUB52中断请求1: 屏蔽EXPUB52中断请求 | R/W |
| 15    | EXWTM    | EXWT中断请求屏蔽控制<br>0: 不屏蔽EXWT中断请求1: 屏蔽EXWT中断请求          | R/W |
| 31:16 | —        | 这些位被读取为0。写入值应为0。                                     | R/W |

SDIO\_INFO1\_MASK寄存器启用或禁用来自SDIO\_INFO1寄存器中状态标志的中断请求。有关状态标志和请求中断源之间关系的详细信息，请参见表33.5。

### 33.2.23 SD\_DMAEN:DMA模式使能寄存器

Base address: SDHI<sub>n</sub> 0 = 0x4009\_2000 + 0x0400 × n

Offset address: 0x1B0

|               |    |    |    |    |    |    |    |    |    |    |    |    |    |    |       |    |
|---------------|----|----|----|----|----|----|----|----|----|----|----|----|----|----|-------|----|
| Bit position: | 31 | 30 | 29 | 28 | 27 | 26 | 25 | 24 | 23 | 22 | 21 | 20 | 19 | 18 | 17    | 16 |
| Bit field:    | —  | —  | —  | —  | —  | —  | —  | —  | —  | —  | —  | —  | —  | —  | —     | —  |
| 重置后的值:        | 0  | 0  | 0  | 0  | 0  | 0  | 0  | 0  | 0  | 0  | 0  | 0  | 0  | 0  | 0     | 0  |
| Bit position: | 15 | 14 | 13 | 12 | 11 | 10 | 9  | 8  | 7  | 6  | 5  | 4  | 3  | 2  | 1     | 0  |
| Bit field:    | —  | —  | —  | —  | —  | —  | —  | —  | —  | —  | —  | —  | —  | —  | DMAEN | —  |
| 重置后的值:        | 0  | 0  | 0  | 1  | 0  | 0  | 0  | 0  | 0  | 0  | 0  | 0  | 1  | 0  | 0     | 0  |

| Bit   | Symbol | Function  | R/W |
|-------|--------|---|-----|
| 0     | —      | 该位读取为0。写入值应为0。  | R/W |
| 1     | DMAEN  | DMA传输启用*1*2<br>0: 禁止使用DMA传输访问SD_BUF0寄存器1: 启用使用DMA传输访问SD_BUF0寄存器 | R/W |
| 3:2   | —      | 这些位被读取为0。写入值应为0。  | R/W |
| 4     | —      | 该位读取为1。写入值应为1。  | R/W |
| 11:5  | —      | 这些位被读取为0。写入值应为0。  | R/W |
| 12    | —      | 该位读取为1。写入值应为1。  | R/W |
| 31:13 | —      | 这些位被读取为0。写入值应为0。  | R/W |

注1.当SD\_INFO2.CBSY位为1时，请勿重写该位。

注2.当SD\_INFO2\_MASK.BWEM位为0或SD\_INFO2\_MASK.BREM位为0时，将SD\_DMAEN.DMAEN位设置为0。当SD\_DMAEN.DMAEN位为1时，将SD\_INFO2\_MASK.BWEM位设置为1和SD\_INFO2\_MASK.BREM位为1。

SD\_DMAEN寄存器启用或禁用DMA传输。

#### DMAEN位 (DMA传输使能)

使用DMA传输访问SD缓冲区时，在设置SD\_CMD寄存器之前将DMAEN位设置为1。

33.2.24 SOFT\_RST : Software Reset Register

Base address: SDHI<sub>n</sub> 0 = 0x4009\_2000 + 0x0400 × n  
 Offset address: 0x1C0

|                    |    |    |    |    |    |    |    |    |    |    |    |    |    |    |    |       |
|--------------------|----|----|----|----|----|----|----|----|----|----|----|----|----|----|----|-------|
| Bit position:      | 31 | 30 | 29 | 28 | 27 | 26 | 25 | 24 | 23 | 22 | 21 | 20 | 19 | 18 | 17 | 16    |
| Bit field:         | —  | —  | —  | —  | —  | —  | —  | —  | —  | —  | —  | —  | —  | —  | —  | —     |
| Value after reset: | 0  | 0  | 0  | 0  | 0  | 0  | 0  | 0  | 0  | 0  | 0  | 0  | 0  | 0  | 0  | 0     |
| Bit position:      | 15 | 14 | 13 | 12 | 11 | 10 | 9  | 8  | 7  | 6  | 5  | 4  | 3  | 2  | 1  | 0     |
| Bit field:         | —  | —  | —  | —  | —  | —  | —  | —  | —  | —  | —  | —  | —  | —  | —  | SDRST |
| Value after reset: | 0  | 0  | 0  | 0  | 0  | 0  | 0  | 0  | 0  | 0  | 0  | 0  | 0  | 0  | 1  | 1     |

| Bit  | Symbol | Function   | R/W |
|------|--------|--|-----|
| 0    | SDRST  | Software Reset Control<br>0: Reset SD/MMC Host Interface software<br>1: Cancel reset of SD/MMC Host Interface software | R/W |
| 2:1  | —      | These bits are read as 1. The write value should be 1.   | R/W |
| 31:3 | —      | These bits are read as 0. The write value should be 0.   | R/W |

Table 33.4 lists the bits and flags initialized by SD/MMC Host Interface software reset.

Table 33.4 Bits and flags initialized by SD/MMC Host Interface software reset

| Register    | Bit/flag  |
|-------------|---|
| SD_STOP     | SEC, STP  |
| SD_INFO1    | RSPEND, ACEND   |
| SD_INFO2    | CMDE, CRCE, ENDE, DTO, ILW, ILR, RSPTO, BRE, BWE, SD_CLK_CTRLLEN, CBSY, ILA                     |
| SD_CLK_CTRL | CLKEN   |
| SD_OPTION   | CTOP[3:0], TOP[3:0], TOUTMASK, WIDTH8, WIDTH  |
| SD_ERR_STS1 | CMDE0, CMDE1, RSPLNE0, RSPLNE1, RDLENE, CRCLENE, RSPCRCE0, RSPCRCE1, RDCRCE, CRCTKE, CRCTK[2:0] |
| SD_ERR_STS2 | RSPTO0, RSPTO1, BSYTO0, BSYTO1, RDTO, CRCTO, CRCBSYTO   |
| SDIO_INFO1  | IOIRQ, EXPUB52, EXWT  |
| SDIF_MODE   | NOCHKCR   |

33.2.25 SDIF\_MODE : SD Interface Mode Setting Register

Base address: SDHI<sub>n</sub> 0 = 0x4009\_2000 + 0x0400 × n  
 Offset address: 0x1CC

|                    |    |    |    |    |    |    |    |                |    |    |    |    |    |    |    |    |
|--------------------|----|----|----|----|----|----|----|----------------|----|----|----|----|----|----|----|----|
| Bit position:      | 31 | 30 | 29 | 28 | 27 | 26 | 25 | 24             | 23 | 22 | 21 | 20 | 19 | 18 | 17 | 16 |
| Bit field:         | —  | —  | —  | —  | —  | —  | —  | —              | —  | —  | —  | —  | —  | —  | —  | —  |
| Value after reset: | 0  | 0  | 0  | 0  | 0  | 0  | 0  | 0              | 0  | 0  | 0  | 0  | 0  | 0  | 0  | 0  |
| Bit position:      | 15 | 14 | 13 | 12 | 11 | 10 | 9  | 8              | 7  | 6  | 5  | 4  | 3  | 2  | 1  | 0  |
| Bit field:         | —  | —  | —  | —  | —  | —  | —  | NOCHKCR        | —  | —  | —  | —  | —  | —  | —  | —  |
| Value after reset: | 0  | 0  | 0  | 0  | 0  | 0  | 0  | 0 <sup>1</sup> | 0  | 0  | 0  | 0  | 0  | 0  | 0  | 0  |

33.2.24 SOFT\_RST : 软件复位寄存器

Base address: SDHI<sub>n</sub> 0 = 0x4009\_2000 + 0x0400 × n  
 Offset address: 0x1C0

|               |    |    |    |    |    |    |    |    |    |    |    |    |    |    |    |       |
|---------------|----|----|----|----|----|----|----|----|----|----|----|----|----|----|----|-------|
| Bit position: | 31 | 30 | 29 | 28 | 27 | 26 | 25 | 24 | 23 | 22 | 21 | 20 | 19 | 18 | 17 | 16    |
| Bit field:    | —  | —  | —  | —  | —  | —  | —  | —  | —  | —  | —  | —  | —  | —  | —  | —     |
| 重置后的值:        | 0  | 0  | 0  | 0  | 0  | 0  | 0  | 0  | 0  | 0  | 0  | 0  | 0  | 0  | 0  | 0     |
| Bit position: | 15 | 14 | 13 | 12 | 11 | 10 | 9  | 8  | 7  | 6  | 5  | 4  | 3  | 2  | 1  | 0     |
| Bit field:    | —  | —  | —  | —  | —  | —  | —  | —  | —  | —  | —  | —  | —  | —  | —  | SDRST |
| 重置后的值:        | 0  | 0  | 0  | 0  | 0  | 0  | 0  | 0  | 0  | 0  | 0  | 0  | 0  | 0  | 1  | 1     |

| Bit  | Symbol | Function                                     | R/W |
|------|--------|--|-----|
| 0    | SDRST  | 软件复位控制<br>0: 复位SDMMC主机接口软件1: 取消复位SDMMC主机接口软件 | R/W |
| 2:1  | —      | 这些位被读取为1。写入值应为1。                             | R/W |
| 31:3 | —      | 这些位被读取为0。写入值应为0。                             | R/W |

表33.4列出了SDMMC主机接口软件复位初始化的位和标志。

Table 33.4 由SDMMC主机接口软件复位初始化的位和标志

| Register    | Bit/flag  |
|-------------|---|
| SD_STOP     | SEC, STP  |
| SD_INFO1    | RSPEND, ACEND   |
| SD_INFO2    | CMDE, CRCE, ENDE, DTO, ILW, ILR, RSPTO, BRE, BWE, SD_CLK_CTRLLEN, CBSY, ILA                     |
| SD_CLK_CTRL | CLKEN   |
| SD_OPTION   | CTOP[3:0], TOP[3:0], TOUTMASK, WIDTH8, WIDTH  |
| SD_ERR_STS1 | CMDE0, CMDE1, RSPLNE0, RSPLNE1, RDLENE, CRCLENE, RSPCRCE0, RSPCRCE1, RDCRCE, CRCTKE, CRCTK[2:0] |
| SD_ERR_STS2 | RSPTO0, RSPTO1, BSYTO0, BSYTO1, RDTO, CRCTO, CRCBSYTO   |
| SDIO_INFO1  | IOIRQ, EXPUB52, EXWT  |
| SDIF_MODE   | NOCHKCR   |

33.2.25 SDIF\_MODE:SD接口模式设置寄存器

Base address: SDHI<sub>n</sub> 0 = 0x4009\_2000 + 0x0400 × n  
 Offset address: 0x1CC

|               |    |    |    |    |    |    |    |                |    |    |    |    |    |    |    |    |
|---------------|----|----|----|----|----|----|----|----------------|----|----|----|----|----|----|----|----|
| Bit position: | 31 | 30 | 29 | 28 | 27 | 26 | 25 | 24             | 23 | 22 | 21 | 20 | 19 | 18 | 17 | 16 |
| Bit field:    | —  | —  | —  | —  | —  | —  | —  | —              | —  | —  | —  | —  | —  | —  | —  | —  |
| 重置后的值:        | 0  | 0  | 0  | 0  | 0  | 0  | 0  | 0              | 0  | 0  | 0  | 0  | 0  | 0  | 0  | 0  |
| Bit position: | 15 | 14 | 13 | 12 | 11 | 10 | 9  | 8              | 7  | 6  | 5  | 4  | 3  | 2  | 1  | 0  |
| Bit field:    | —  | —  | —  | —  | —  | —  | —  | NOCHKCR        | —  | —  | —  | —  | —  | —  | —  | —  |
| 重置后的值:        | 0  | 0  | 0  | 0  | 0  | 0  | 0  | 0 <sup>1</sup> | 0  | 0  | 0  | 0  | 0  | 0  | 0  | 0  |

| Bit  | Symbol  | Function   | R/W |
|------|---------|--|-----|
| 7:0  | —       | These bits are read as 0. The write value should be 0.   | R/W |
| 8    | NOCHKCR | CRC Check Mask<br>CRC check mask bit for MMC test commands. Set when CRC16 or CRC status value check is not executed.<br>0: Enable CRC check<br>1: Disable CRC Check (ignore CRC16 valued when reading and ignore CRC status value when writing) | R/W |
| 31:9 | —       | These bits are read as 0. The write value should be 0.   | R/W |

Note 1. The value is initialized by a reset and also on reset triggered by the SOFT\_RST.SDRST flag.

#### NOCHKCR bit (CRC Check Mask)

The NOCHKCR bit is used for MMC test commands. This bit is set when CRC16 or CRC status value check is not executed.

### 33.2.26 EXT\_SWAP : Swap Control Register

Base address: SDHI<sub>n</sub> 0 = 0x4009\_2000 + 0x0400 × n

Offset address: 0x1E0

| Bit position:      | 31 | 30 | 29 | 28 | 27 | 26 | 25 | 24 | 23        | 22        | 21 | 20 | 19 | 18 | 17 | 16 |
|--------------------|----|----|----|----|----|----|----|----|-----------|-----------|----|----|----|----|----|----|
| Bit field:         | —  | —  | —  | —  | —  | —  | —  | —  | —         | —         | —  | —  | —  | —  | —  | —  |
| Value after reset: | 0  | 0  | 0  | 0  | 0  | 0  | 0  | 0  | 0         | 0         | 0  | 0  | 0  | 0  | 0  | 0  |
| Bit position:      | 15 | 14 | 13 | 12 | 11 | 10 | 9  | 8  | 7         | 6         | 5  | 4  | 3  | 2  | 1  | 0  |
| Bit field:         | —  | —  | —  | —  | —  | —  | —  | —  | BRSW<br>P | BWS<br>WP | —  | —  | —  | —  | —  | —  |
| Value after reset: | 0  | 0  | 0  | 0  | 0  | 0  | 0  | 0  | 0         | 0         | 0  | 0  | 0  | 0  | 0  | 0  |

| Bit  | Symbol | Function  | R/W |
|------|--------|---|-----|
| 5:0  | —      | These bits are read as 0. The write value should be 0.  | R/W |
| 6    | BWSWP  | SD_BUF0 Swap Write*1<br>0: Normal write operation<br>1: Swap the byte endian order before writing to SD_BUF0 register | R/W |
| 7    | BRSWP  | SD_BUF0 Swap Read*1<br>0: Normal read operation<br>1: Swap the byte endian order before reading SD_BUF0 register      | R/W |
| 31:8 | —      | These bits are read as 0. The write value should be 0.  | R/W |

Note 1. Do not rewrite this bit when the SD\_INFO2.CBSY flag is 1.

The EXT\_SWAP register selects whether or not the byte endian order is swapped when accessing the SD\_BUF0 register. See [section 33.3.1. SD/MMC Interface](#) for details on the differences in accessing the SD\_BUF0 register based on the EXT\_SWAP register value.

### 33.3 Operation

#### 33.3.1 SD/MMC Interface

When data is read from the SD card/MMC, the process is as follows:

1. The SD/MMC Host Interface receives data from the SD card/MMC through the SDnDAT signal (see [Figure 33.2](#) and [Figure 33.3](#)).
2. The received data is stored in SD\_BUF of the MMC Host Interface (see [Figure 33.4](#)).
3. The data stored in SD\_BUF is read from SD\_BUF0 (see [Figure 33.5](#)).

| Bit  | Symbol  | Function  | R/W |
|------|---------|---|-----|
| 7:0  | —       | 这些位被读取为0。写入值应为0。  | R/W |
| 8    | NOCHKCR | CRC校验掩码<br>MMC测试命令的CRC校验掩码位。不执行CRC16或CRC状态值检查时置位。<br>0: 启用CRC校验 1: 禁用CRC校验 (读取时忽略CRC16值, 写入时忽略CRC状态值) | R/W |
| 31:9 | —       | 这些位被读取为0。写入值应为0。  | R/W |

注1.该值由复位初始化,并且在由SOFT\_RST.SDRST标志触发的复位时初始化。

#### NOCHKCR位 (CRC校验掩码)

NOCHKCR位用于MMC测试命令。当不执行CRC16或CRC状态值检查时,该位置位。

### 33.2.26 EXT\_SWAP:交换控制寄存器

Base address: SDHI<sub>n</sub> 0 = 0x4009\_2000 + 0x0400 × n

Offset address: 0x1E0

| Bit position: | 31 | 30 | 29 | 28 | 27 | 26 | 25 | 24 | 23        | 22        | 21 | 20 | 19 | 18 | 17 | 16 |
|---------------|----|----|----|----|----|----|----|----|-----------|-----------|----|----|----|----|----|----|
| Bit field:    | —  | —  | —  | —  | —  | —  | —  | —  | —         | —         | —  | —  | —  | —  | —  | —  |
| 重置后的值:        | 0  | 0  | 0  | 0  | 0  | 0  | 0  | 0  | 0         | 0         | 0  | 0  | 0  | 0  | 0  | 0  |
| Bit position: | 15 | 14 | 13 | 12 | 11 | 10 | 9  | 8  | 7         | 6         | 5  | 4  | 3  | 2  | 1  | 0  |
| Bit field:    | —  | —  | —  | —  | —  | —  | —  | —  | BRSW<br>P | BWS<br>WP | —  | —  | —  | —  | —  | —  |
| 重置后的值:        | 0  | 0  | 0  | 0  | 0  | 0  | 0  | 0  | 0         | 0         | 0  | 0  | 0  | 0  | 0  | 0  |

| Bit  | Symbol | Function  | R/W |
|------|--------|---|-----|
| 5:0  | —      | 这些位被读取为0。写入值应为0。                                    | R/W |
| 6    | BWSWP  | SD_BUF0交换写入*1<br>0: 正常写操作 1: 在写入SD_BUF0寄存器之前交换字节顺序  | R/W |
| 7    | BRSWP  | SD_BUF0交换读取*1<br>0: 正常读取操作 1: 在读取SD_BUF0寄存器之前交换字节顺序 | R/W |
| 31:8 | —      | 这些位被读取为0。写入值应为0。                                    | R/W |

注1.当SD\_INFO2.CBSY标志为1时,请勿重写该位。

EXT\_SWAP寄存器选择在访问SD\_BUF0寄存器时是否交换字节顺序。请参阅第33.3.1节。SDMMC接口了解访问SD\_BUF0寄存器的差异的详细信息,基于EXT\_SWAP寄存器值。

### 33.3 Operation

#### 33.3.1 SD/MMC Interface

从SD卡MMC读取数据时,流程如下:

- 1.SDMMC主机接口通过SDnDAT信号从SD卡MMC接收数据(参见图33.2和[Figure 33.3](#))。
- 2.接收到的数据存储在MMC主机接口的SD\_BUF中(见图33.4)。
- 3.SD\_BUF中存储的数据从SD\_BUF0中读取(见图33.5)。



When data is written to the SD card/MMC, the specified procedure is reversed.

When accessing SD\_BUF0, pay attention to the transfer order in SDnDAT and the store order in SD\_BUF. If required, you can change the byte endian of the data read from or written to SD\_BUF0 using the SDSWAP register. See Figure 33.6.

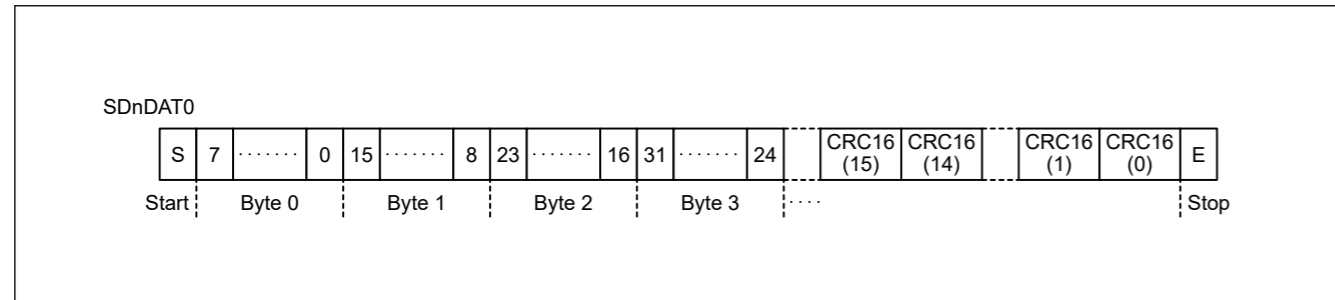


Figure 33.2 SDnDAT in 1-bit width mode

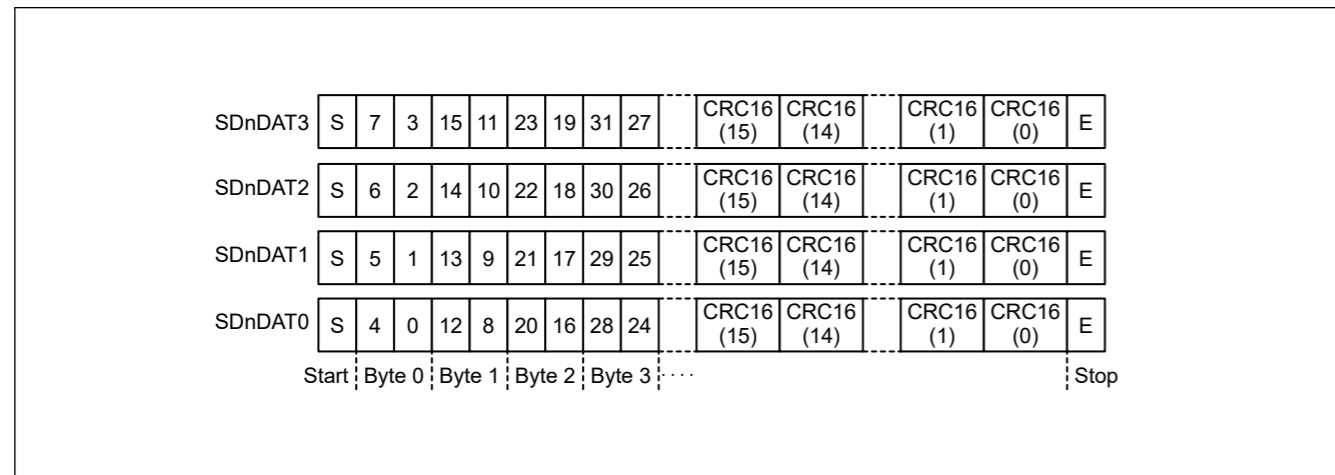


Figure 33.3 SDnDAT in 4-bit width mode

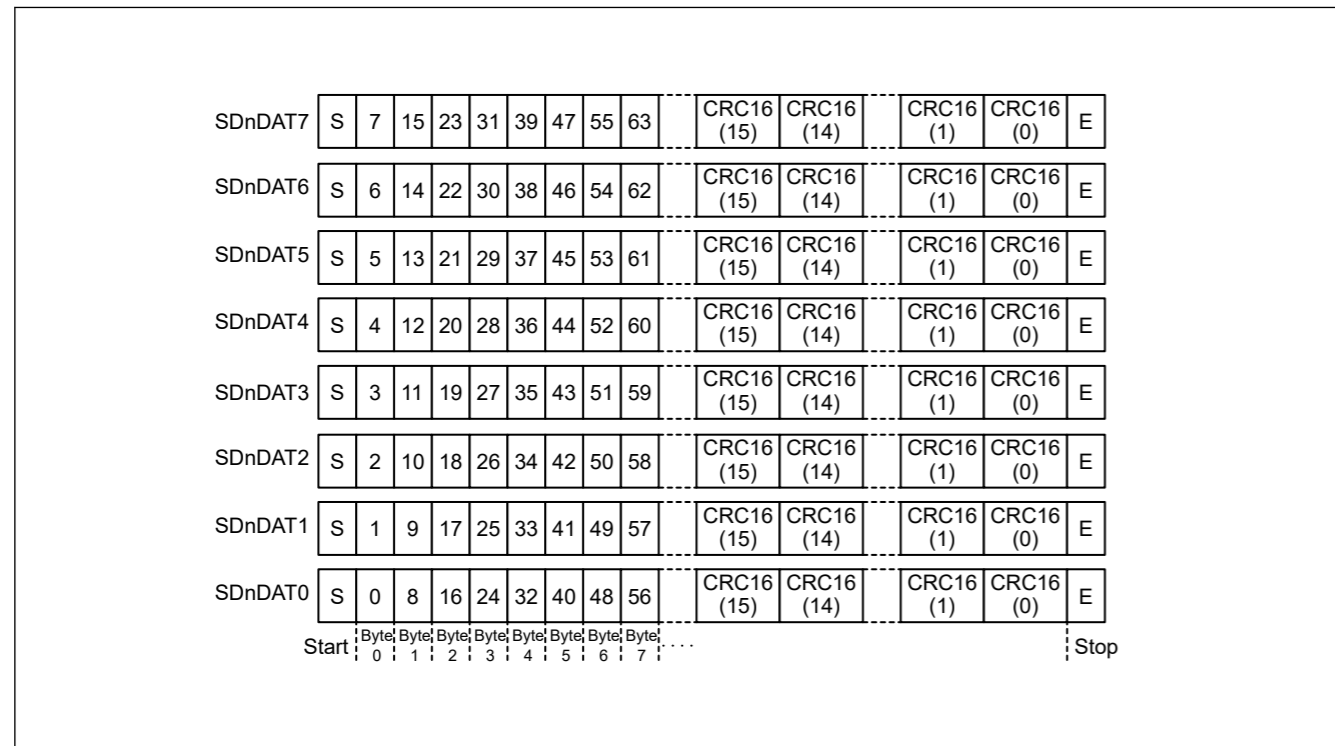


Figure 33.4 SDnDAT in 8-bit width mode

当数据写入SD卡MMC时，指定的过程相反。

访问SD\_BUF0时，注意SDnDAT中的传输顺序和SD\_BUF中的存储顺序。如果需要，您可以使用SDSWAP寄存器更改从SD\_BUF0读取或写入数据的字节字节序。请参见图33.6。

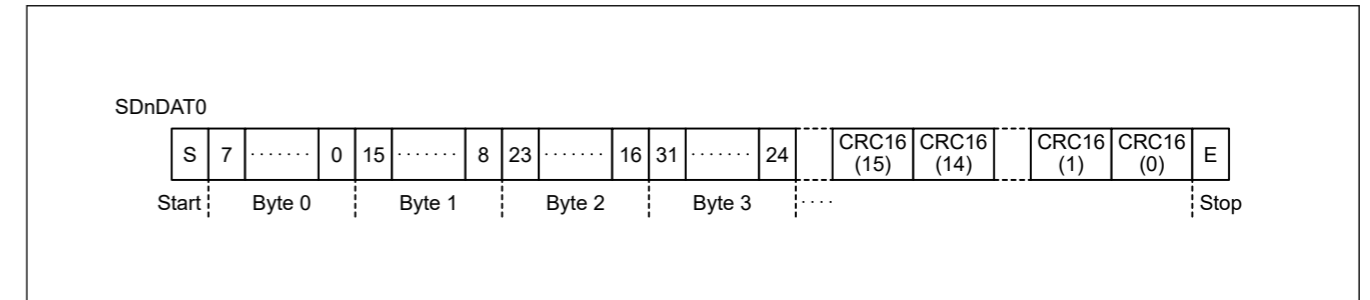


Figure 33.2 SDnDAT在1位宽模式下

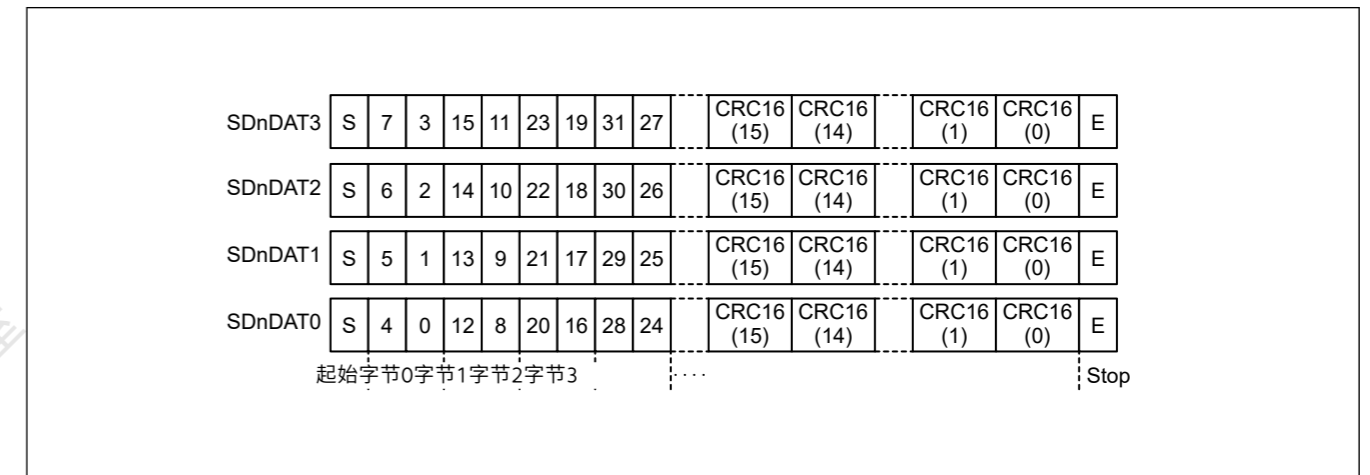


Figure 33.3 SDnDAT在4位宽模式下

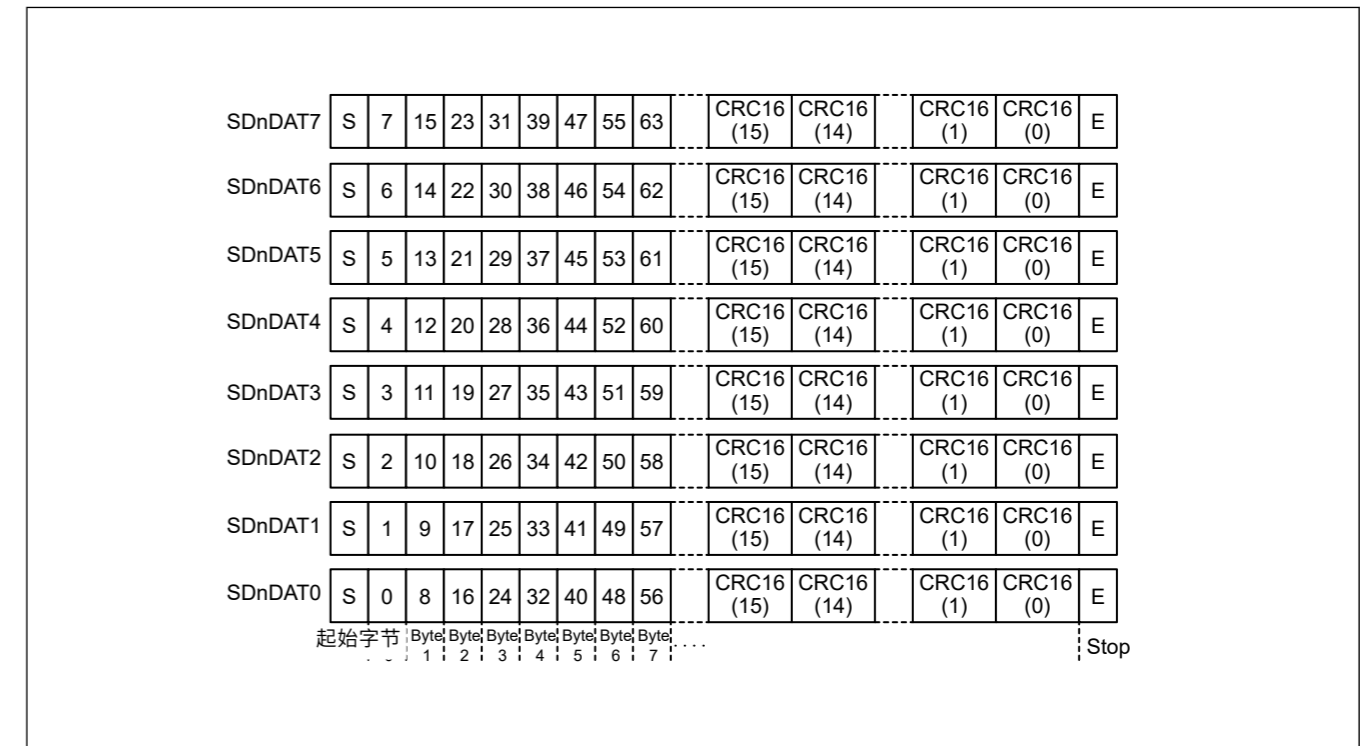


Figure 33.4 SDnDAT在8位宽度模式下

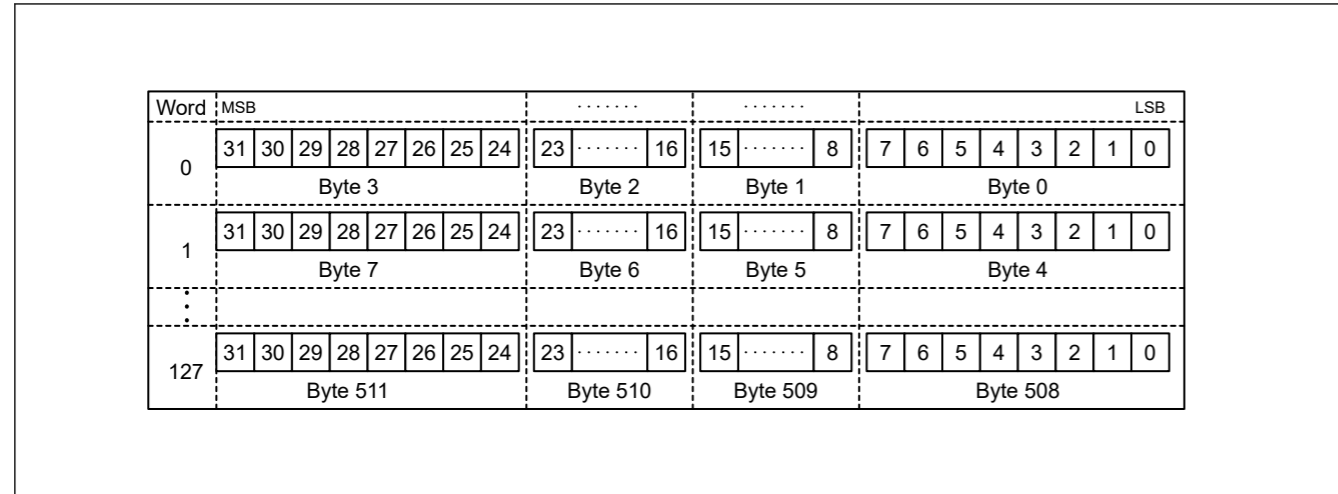


Figure 33.5 SD\_BUF store data

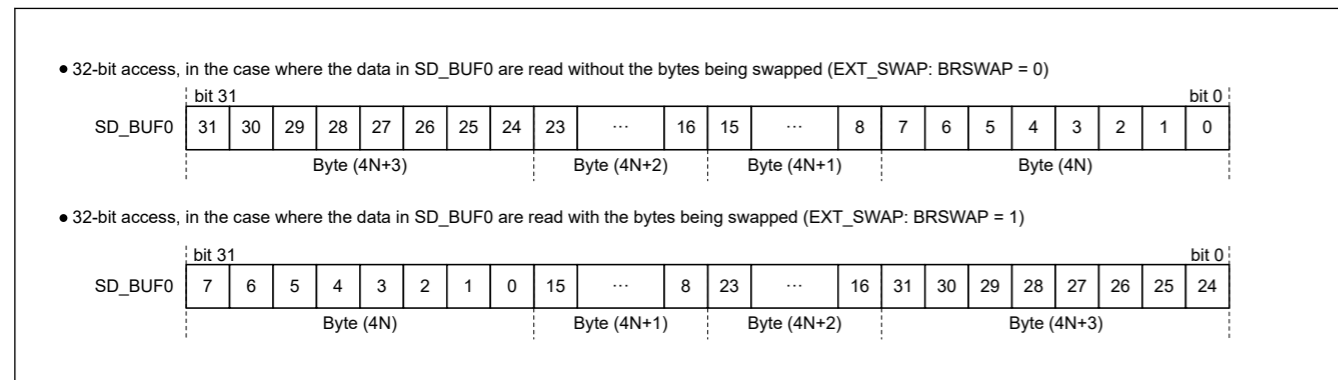


Figure 33.6 Read from SD\_BUF0

### 33.3.2 Card Detect/Write Protect

#### 33.3.2.1 Card detect

The SD/MMC Host Interface has two types of card detect functions.

##### (1) Card detect with SDnCD (n = 0)

Figure 33.7 shows the timing for card detect using SDnCD. SDnCD is connected to the card socket and pulled up on the host device. The resistance of the pull-up resistor is determined by the specification of the SD/MMC host device.

##### (2) Card insertion

SDnCD is pulled down when a card is inserted. At this point, if SDnCD is pulled down for the Mcycle period (set in SD\_OPTION), SDCDIN in SD\_INFO1 is set to 1. It is cleared by writing 0.

##### (3) Card removal

SDnCD is pulled up when a card is removed. At this point, if SDnCD is pulled up for the Mcycle period (set in SD\_OPTION), SDCDRM in SD\_INFO1 is set to 1. It is cleared by writing 0.

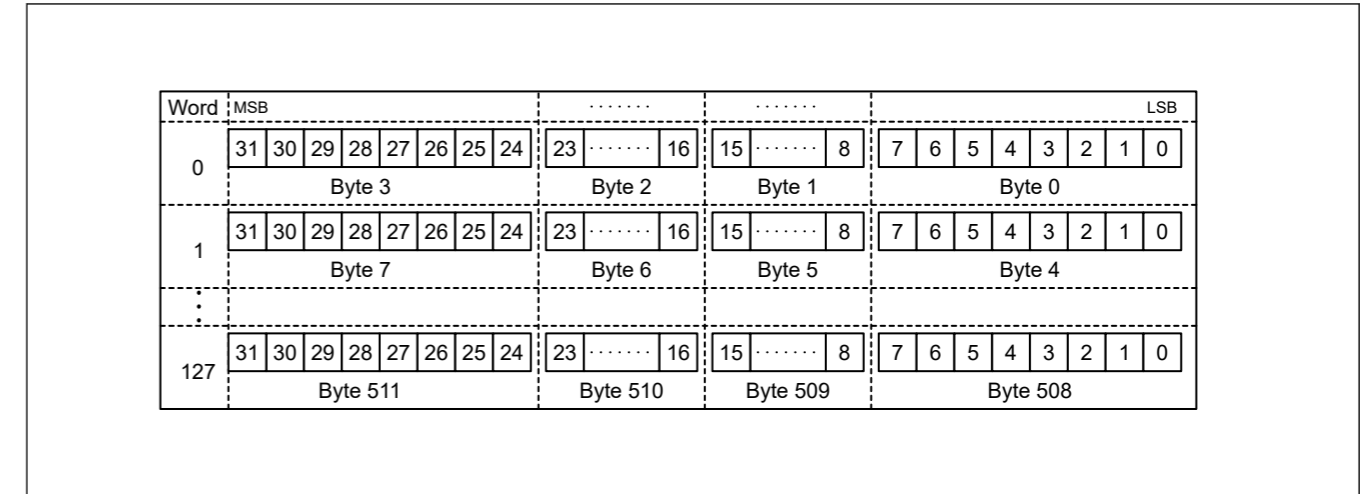


Figure 33.5 SD\_BUF存储数据

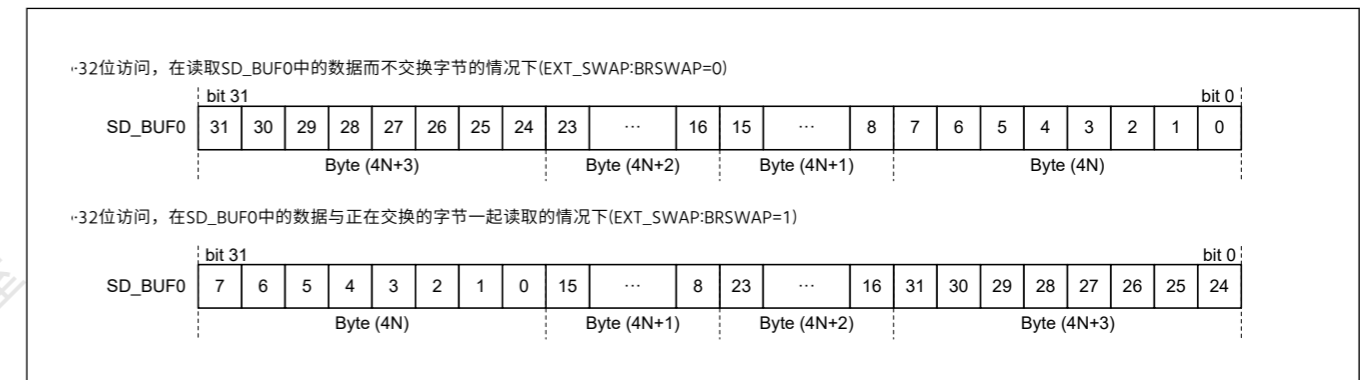


Figure 33.6 从SD\_BUF0读取

### 33.3.2 卡检测写保护

#### 33.3.2.1 卡检测

SDMMC主机接口有两种类型的卡检测功能。

##### (1) SDnCD卡检测(n=0)

图33.7显示了使用SDnCD进行卡检测的时序。SDnCD连接到卡插槽并在主机设备上拉高。上拉电阻的阻值由SDMMC主机设备的规格决定。

##### (2) 插卡

SDnCD在插入卡时被拉下。此时，如果SDnCD被下拉Mcycle周期（设置在SD\_OPTION），SD\_INFO1中的SDCDIN设置为1。写入0清除。

##### (3) 取卡

取出卡时，SDnCD被拉起。此时，如果SDnCD被拉高了Mcycle周期（设置在SD\_OPTION），SD\_INFO1中的SDCDRM设置为1，写入0清零。

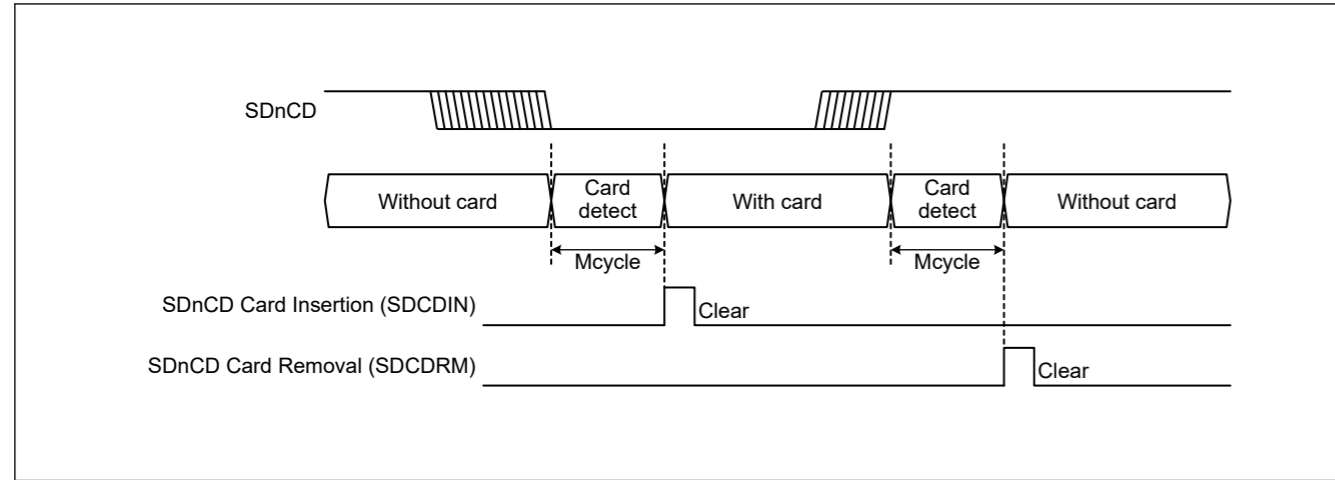


Figure 33.7 Example of card detect with SDnCD

(4) SD card detect with SDnDAT3 (n = 0)

Figure 33.8 shows the timing when the SD card is detected with SDnDAT3. In addition, SDnDAT3 is pulled down by the host device, and the resistance value for pulling down is determined by the specification of the SD host device.

(5) Card insertion

When an SD card is inserted, SDnDAT3 is pulled up and SDD3IN in SD\_INFO1 is set to 1. It is cleared by writing 0.

(6) Card removal

When an SD card is removed, SDnDAT3 is pulled down and SDD3RM in SD\_INFO1 is set to 1. It is cleared by writing 0.

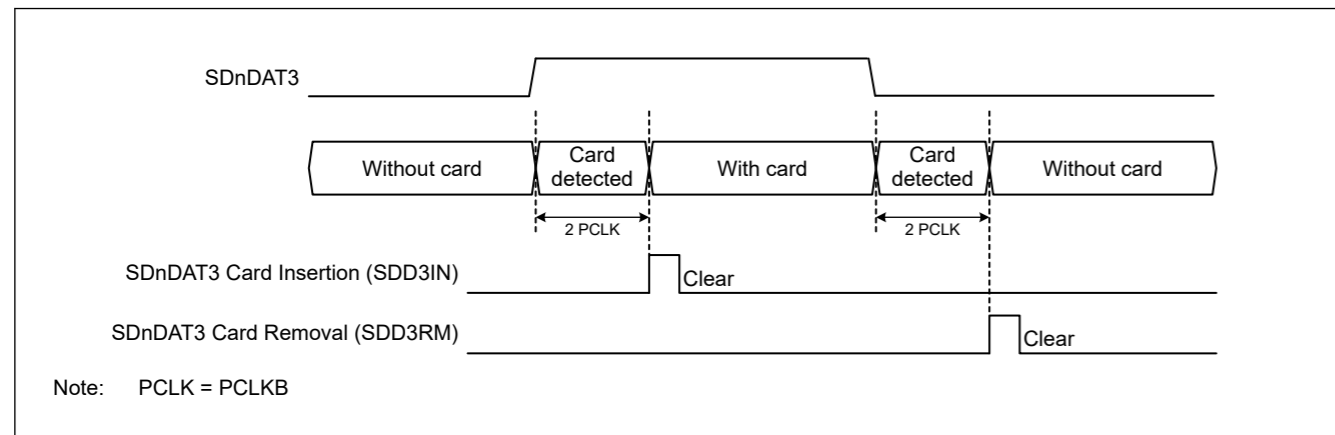


Figure 33.8 SD card detect with SDnDAT3

33.3.2.2 Write protect

The SD/MMC Host Interface has two types of write protect functions.

(1) Write protect with SDnWP (n = 0)

SDnWP is connected to the card socket and pulled up or pulled down by the card insertion. The selection of pulling up or pulling down and the resistance value is determined by the specification of the SD host device. When the SDnWP state is reflected to SDWPMON in SD\_INFO1, the write protect state is set after the SD card is inserted.

(2) Write protect with command

The internal write protection of the card and the lock/unlock operation of the card are realized by the command.

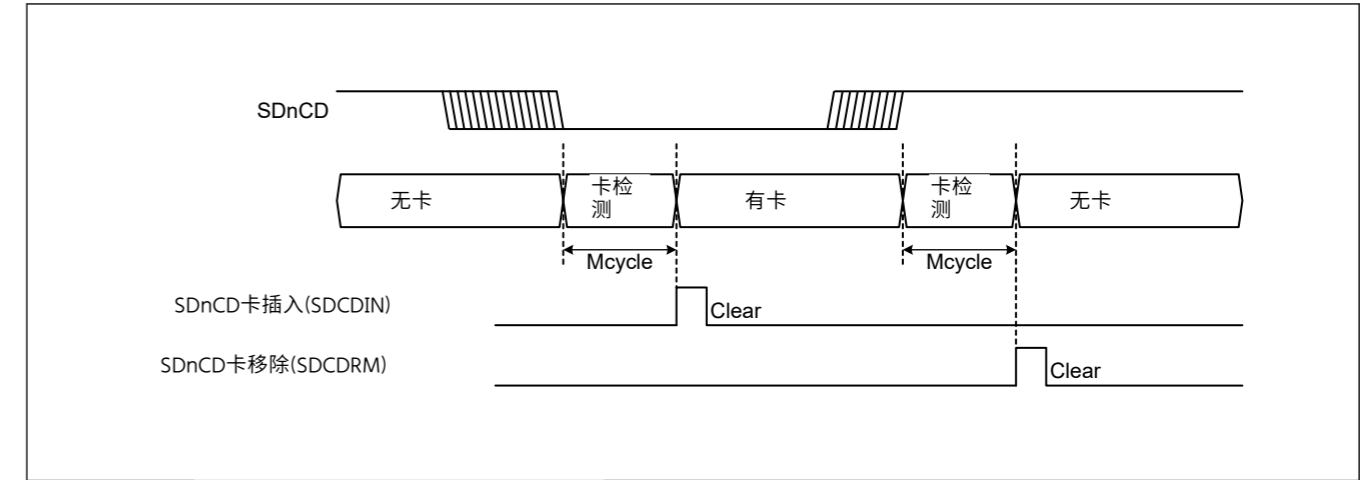


Figure 33.7 SDnCD卡检测示例

(4) 使用SDnDAT3(n=0)检测SD卡

图33.8显示了使用SDnDAT3检测到SD卡的时序。此外，SDnDAT3由主机设备下拉，下拉电阻值由SD主机设备的规格决定。

(5) 插卡

插入SD卡时，SDnDAT3上拉，SD\_INFO1中的SDD3IN置1，写0清零。

(6) 取卡

取出SD卡时，SDnDAT3被拉低，SD\_INFO1中的SDD3RM置1。写0清零。

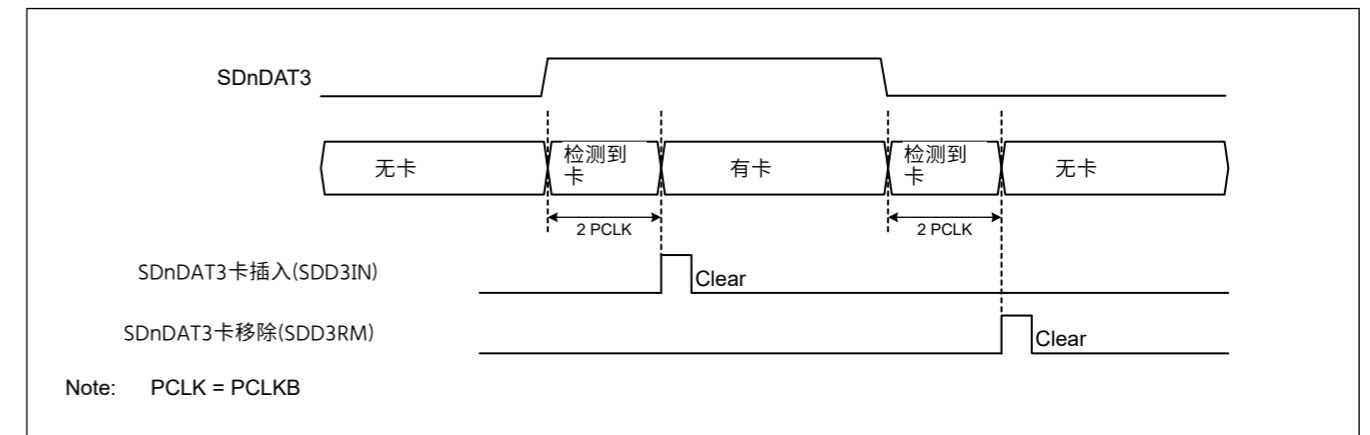


Figure 33.8 使用SDnDAT3检测SD卡

33.3.2.2 写保护

SDMMC主机接口有两种类型的写保护功能。

(1) 使用SDnWP进行写保护(n=0)

SDnWP与卡座相连，通过插卡进行上拉或下拉。上拉或下拉的选择和阻值由SD主机设备的规格决定。当SDnWP状态反映到SD\_INFO1中的SDWPMON时，插入SD卡后设置写保护状态。

(2) 用命令写保护

卡的内部写保护和卡的开锁操作都是通过命令实现的。

## 33.3.3 Interrupt Request and DMA Transfer Request

## 33.3.3.1 Interrupts

Table 33.5 lists the SDHI interrupt sources. The SDHI requests an interrupt when:

- The status flags in registers SD\_INFO1, SD\_INFO2, and SDIO\_INFO1 set to 1.
- The associated bits in the SD\_INFO1\_MASK, SD\_INFO2\_MASK, and SDIO\_INFO1\_MASK registers are 0.

When clearing the status flags in registers SD\_INFO1, SD\_INFO2, and SDIO\_INFO1, write 0 to the status flags to be cleared and write 1 to the status flags that are not being cleared.

Table 33.5 Interrupt sources

| Interrupt sources             | Status flag register |                               | Interrupt mask register |            | Interrupt name<br>Ch n (n = 0) |         |                 |          |                |
|-------------------------------|----------------------|-------------------------------|-------------------------|------------|--------------------------------|---------|-----------------|----------|----------------|
|                               | Register symbol      | Bit symbol                    | Register symbol         | Bit symbol |                                |         |                 |          |                |
| Card Access Interrupt (CACI)  | SD_INFO1             | ACEND                         | SD_INFO1_MASK           | ACENDM     | SDHI_MMCn_ACCS                 |         |                 |          |                |
|                               |                      | RSPEND                        |                         | RSPENDM    |                                |         |                 |          |                |
|                               | SD_INFO2             | ILA                           | SD_INFO2_MASK           | ILAM       |                                |         |                 |          |                |
|                               |                      | BWE                           |                         | BWEM       |                                |         |                 |          |                |
|                               |                      | BRE                           |                         | BREM       |                                |         |                 |          |                |
|                               |                      | RSPTO                         |                         | RSPTOM     |                                |         |                 |          |                |
|                               |                      | ILR                           |                         | ILRM       |                                |         |                 |          |                |
|                               |                      | ILW                           |                         | ILWM       |                                |         |                 |          |                |
|                               |                      | DTO                           |                         | DTOM       |                                |         |                 |          |                |
|                               |                      | ENDE                          |                         | ENDEM      |                                |         |                 |          |                |
|                               |                      | CRCE                          |                         | CRCEM      |                                |         |                 |          |                |
|                               |                      | CMDE                          |                         | CMDEM      |                                |         |                 |          |                |
|                               |                      | SDIO Access Interrupt (SDACI) |                         | SDIO_INFO1 |                                | EXWT    | SDIO_INFO1_MASK | EXWTM    | SDHI_MMCn_SDIO |
|                               |                      |                               |                         |            |                                | EXPUB52 |                 | EXPUB52M |                |
| IOIRQ                         | IOIRQM               |                               |                         |            |                                |         |                 |          |                |
| Card Detect Interrupt (CDETI) | SD_INFO1             | SDD3IN                        | SD_INFO1_MASK           | SDD3INM    | SDHI_MMCn_CARD                 |         |                 |          |                |
|                               |                      | SDD3RM                        |                         | SDD3RMM    |                                |         |                 |          |                |
|                               |                      | SDCDIN                        |                         | SDCDINM    |                                |         |                 |          |                |
|                               |                      | SDCDRM                        |                         | SDCDRMM    |                                |         |                 |          |                |

## 33.3.3.2 DMA transfer requests (SDHI\_MMCn\_ODMSDBREQ, n = 0)

The SD/MMC Host Interface has two types of DMA transfer requests.

## (1) SD\_BUF write DMA transfer request

- When the BWE bit in SD\_INFO2 is set to 1 while the DMAEN bit in SD\_DMAEN is set to 1, the SD\_BUF write DMA transfer request is asserted.
- The SD\_BUF write DMA transfer request is negated when the last data in one block (based on the transfer data size set in SD\_SIZE) is transferred. The SD\_BUF write DMA transfer request is also negated by clearing the SDRST bit in SOFT\_RST to 0 or setting the STP bit in SD\_STOP to 1. However, if a communications error or timeout occurs at the DMA transfer, the SD\_BUF write DMA transfer request is not negated.
- The BWE bit in SD\_INFO2 is cleared after transfer of the last data in one block following a request for writing to SD\_BUF by DMA transfer.
- The number of DMA transfers must be  $n \times$  one block. (n = integer, one block = the transfer data size set in SD\_SIZE)
- When the IOABT bit in SDIO\_MODE is set to 1, the SD\_BUF write DMA transfer request is negated.

## 33.3.3 中断请求和DMA传输请求

## 33.3.3.1 Interrupts

表33.5列出了SDHI中断源。SDHI在以下情况下请求中断：

- 寄存器SD\_INFO1、SD\_INFO2和SDIO\_INFO1中的状态标志设置为1。
- SD\_INFO1\_MASK、SD\_INFO2\_MASK和SDIO\_INFO1\_MASK寄存器中的相关位为0。

清除寄存器SD\_INFO1、SD\_INFO2和SDIO\_INFO1中的状态标志时，将要清除的状态标志写入0，将未清除的状态标志写入1。

Table 33.5 中断源

| 中断源          | 状态标志寄存器  |                 | 中断屏蔽寄存器       |            | 中断名称<br>Ch n (n = 0) |         |                 |          |                |
|--------------|----------|-----------------|---------------|------------|----------------------|---------|-----------------|----------|----------------|
|              | 注册符号     | 位符号             | 注册符号          | 位符号        |                      |         |                 |          |                |
| 卡访问中断(CACI)  | SD_INFO1 | ACEND           | SD_INFO1_MASK | ACENDM     | SDHI_MMCn_ACCS       |         |                 |          |                |
|              |          | RSPEND          |               | RSPENDM    |                      |         |                 |          |                |
|              | SD_INFO2 | ILA             | SD_INFO2_MASK | ILAM       |                      |         |                 |          |                |
|              |          | BWE             |               | BWEM       |                      |         |                 |          |                |
|              |          | BRE             |               | BREM       |                      |         |                 |          |                |
|              |          | RSPTO           |               | RSPTOM     |                      |         |                 |          |                |
|              |          | ILR             |               | ILRM       |                      |         |                 |          |                |
|              |          | ILW             |               | ILWM       |                      |         |                 |          |                |
|              |          | DTO             |               | DTOM       |                      |         |                 |          |                |
|              |          | ENDE            |               | ENDEM      |                      |         |                 |          |                |
|              |          | CRCE            |               | CRCEM      |                      |         |                 |          |                |
|              |          | CMDE            |               | CMDEM      |                      |         |                 |          |                |
|              |          | SDIO访问中断(SDACI) |               | SDIO_INFO1 |                      | EXWT    | SDIO_INFO1_MASK | EXWTM    | SDHI_MMCn_SDIO |
|              |          |                 |               |            |                      | EXPUB52 |                 | EXPUB52M |                |
| IOIRQ        | IOIRQM   |                 |               |            |                      |         |                 |          |                |
| 卡检测中断(CDETI) | SD_INFO1 | SDD3IN          | SD_INFO1_MASK | SDD3INM    | SDHI_MMCn_CARD       |         |                 |          |                |
|              |          | SDD3RM          |               | SDD3RMM    |                      |         |                 |          |                |
|              |          | SDCDIN          |               | SDCDINM    |                      |         |                 |          |                |
|              |          | SDCDRM          |               | SDCDRMM    |                      |         |                 |          |                |

## 33.3.3.2 DMA传输请求(SDHI\_MMCn\_ODMSDBREQ n=0)

SDMMC主机接口有两种类型的DMA传输请求。

## (1) SD\_BUF写DMA传输请求

- 当SD\_INFO2中的BWE位设置为1而SD\_DMAEN中的DMAEN位设置为1时，SD\_BUF写DMA传输请求被置位。
- 当一个块中的最后一个数据（基于SD\_SIZE中设置的传输数据大小）被传输时，SD\_BUF写DMA传输请求被否定。SD\_BUF写DMA传输请求也可以通过将SOFT\_RST中的SDRST位清0或将SD\_STOP中的STP位设置为1来取消。但是，如果通信错误或超时发生在DMA传输，SD\_BUF写DMA传输请求不被否定。
- SD\_INFO2中的BWE位在通过DMA传输向SD\_BUF写入请求后传输一个块中的最后一个数据后被清除。
- DMA传输的数量必须是 $n \times$ 1个块。（n=整数，1块=SD\_SIZE中设置的传输数据大小）
- 当SDIO\_MODE中的IOABT位设置为1时，SD\_BUF写DMA传输请求被否定。



- The DMA transfer request is also negated by clearing the DMAEN bit to 0. However, the DMA transfer request is asserted again when the DMAEN bit is set to 1 before writing to SD\_CMD.
- Because the BWE bit in SD\_INFO2 is not cleared in response to setting the STP/IOABT bit, or to a communications error or timeout, clear the bit to 0 before issuing the next command. The next request to write to SD\_BUF by DMA transfer is not issued while the BWE bit is set.

(2) SD\_BUF read DMA transfer request

- When the BRE bit in SD\_INFO2 is set to 1 while the DMAEN bit in the SD\_DMAEN register is set to 1, the SD\_BUF read DMA transfer request is asserted.
- The SD\_BUF read DMA transfer request is negated when the last data in one block (based on the transfer data size set in SD\_SIZE) is transferred. The SD\_BUF read DMA transfer request is also negated by clearing the SDRST bit in SOFT\_RST to 0 or setting the STP bit in SD\_STOP to 1. However, if a communications error or timeout occurs at the DMA transfer, the SD\_BUF read DMA transfer request is not negated.
- The BRE bit in SD\_INFO2 is cleared after transfer of the last data in one block following a request to write to SD\_BUF by DMA transfer.
- The number of DMA transfers must be n × one block. (n = integer, one block = the transfer data size set in SD\_SIZE)
- When the IOABT bit in SDIO\_MODE is set to 1, the SD\_BUF read DMA transfer request is negated.
- The DMA transfer request is also negated by clearing the DMAEN bit to 0. However, the DMA transfer request is asserted again when the DMAEN bit is set to 1 before writing to SD\_CMD.
- Because the BRE bit in SD\_INFO2 is not cleared in response to setting the STP/IOABT bit or in response to a communications error or timeout, clear the bit to 0 before issuing the next command. The next request to write to SD\_BUF by DMA transfer is not issued while the BRE bit is set.

33.3.4 Communication Errors and Timeouts

When a communication error or timeout error occurs, depending on the type of error, the associated status flag in the SD\_INFO2 register sets to 1. Also, depending on the source of the error, the associated flag in the SD\_ERR\_STS1 or SD\_ERR\_STS2 register sets to 1.

The status flags in registers SD\_ERR\_STS1 and SD\_ERR\_STS2 clear to 0 by writing to the SD\_CMD register, or by setting the SOFT\_RST.SDRST bit to 0.

Table 33.6 Communication errors

| Communication error | Interrupt flag register |            | Error status register |            | This occurs when...  |
|---------------------|-------------------------|------------|-----------------------|------------|--|
|                     | Register symbol         | Bit symbol | Register symbol       | Bit symbol |  |
| End bit error       | SD_INFO2                | ENDE       | SD_ERR_STS1           | CRCLENE    | The CRC status token length is in error  |
|                     |                         |            |                       | RDLENE     | The read data length is in error   |
|                     |                         |            |                       | RSPLNE1    | The response length is in error*1  |
|                     |                         |            |                       | RSPLNE0    | The response length is in error*2  |
| CRC error           | SD_INFO2                | CRCE       | SD_ERR_STS1           | CRCTKE     | The CRC status token is in error   |
|                     |                         |            |                       | RDCRCE     | There is a CRC error in the read data  |
|                     |                         |            |                       | RSPCRCE1   | There is a CRC error in the response*1   |
|                     |                         |            |                       | RSPCRCE0   | There is a CRC error in the response*2   |
| Command error       | SD_INFO2                | CMDE       | SD_ERR_STS1           | CMDE1      | The command index field value for the transmitted command and received response do not match*1 |
|                     |                         |            |                       | CMDE0      | The command index field value for the transmitted command and received response do not match*2 |

Note 1. CMD12 when automatic issuing is enabled for multiple block transfer by the setting in SD\_CMD, CMD12 when the STP bit in SD\_STOP is set to 1, or CMD52 when the C52PUB or IOABT bit in SDIO\_MODE is set to 1.

Note 2. CMD other than CMD12 when automatic issuing is enabled for multiple block transfer by the setting in SD\_CMD, CMD12 when the STP bit in SD\_STOP is set to 1, or CMD52 when the C52PUB or IOABT bit in SDIO\_MODE is set to 1.

- DMA传输请求也可以通过将DMAEN位清除为0来取消。但是，当DMAEN位在写入SD\_CMD之前设置为1时，DMA传输请求会再次被断言。
- 由于SD\_INFO2中的BWE位不会因设置STPIOABT位、通信错误或超时而清除，所以在发出下一个命令之前将该位清除为0。当BWE位置位时，不会发出通过DMA传输写入SD\_BUF的下一个请求。

(2) SD\_BUF读取DMA传输请求

- 当SD\_INFO2中的BRE位设置为1且SD\_DMAEN寄存器中的DMAEN位设置为1时，SD\_BUF读取DMA传输请求被断言。
- 当一个块中的最后一个数据（基于SD\_SIZE中设置的传输数据大小）被传输时，SD\_BUF读DMA传输请求被否定。SD\_BUF读取DMA传输请求也可以通过将SOFT\_RST中的SDRST位清0或将SD\_STOP中的STP位设置为1来取消。但是，如果通信错误或超时发生在DMA传输，SD\_BUF读DMA传输请求不被否定。
- SD\_INFO2中的BRE位在通过DMA传输请求写入SD\_BUF后传输一个块中的最后一个数据后清除。
- DMA传输的数量必须是n×1个块。（n=整数，1块=SD\_SIZE中设置的传输数据大小）
- 当SDIO\_MODE中的IOABT位设置为1时，SD\_BUF读DMA传输请求被否定。
- DMA传输请求也可以通过将DMAEN位清除为0来取消。但是，当DMAEN位在写入SD\_CMD之前设置为1时，DMA传输请求会再次被断言。
- 因为SD\_INFO2中的BRE位没有被清除以响应设置STPIOABT位或响应通信错误或超时，在发出下一个命令之前将该位清零。当BRE位置位时，不会发出下一个通过DMA传输写入SD\_BUF的请求。

33.3.4 通信错误和超时

当发生通信错误或超时错误时，根据错误类型，SD\_INFO2寄存器中的相关状态标志设置为1。此外，根据错误源，SD\_ERR\_STS1或SD\_ERR\_STS2寄存器设置为1。

通过写入SD\_CMD寄存器或将SOFT\_RST.SDRST位设置为0，寄存器SD\_ERR\_STS1和SD\_ERR\_STS2中的状态标志清零。

Table 33.6 通讯错误

| 通信故障      | 中断标志寄存器  |      | 错误状态寄存器     |          | 这发生在……                 |
|-----------|----------|------|-------------|----------|------------------------|
|           | 注册符号     | 位符号  | 注册符号        | 位符号      |                        |
| 结束位错误     | SD_INFO2 | ENDE | SD_ERR_STS1 | CRCLENE  | CRC状态令牌长度错误            |
|           |          |      |             | RDLENE   | 读取数据长度错误               |
|           |          |      |             | RSPLNE1  | 响应长度错误*1               |
|           |          |      |             | RSPLNE0  | 响应长度错误*2               |
| CRC error | SD_INFO2 | CRCE | SD_ERR_STS1 | CRCTKE   | CRC状态令牌错误              |
|           |          |      |             | RDCRCE   | 读取数据有CRC错误             |
|           |          |      |             | RSPCRCE1 | 响应中有CRC错误*1            |
|           |          |      |             | RSPCRCE0 | 响应中有CRC错误*2            |
| 命令错误      | SD_INFO2 | CMDE | SD_ERR_STS1 | CMDE1    | 发送命令和接收响应的命令索引字段值不匹配*1 |
|           |          |      |             | CMDE0    | 发送命令和接收响应的命令索引字段值不匹配*2 |

注1.通过SD\_CMD中的设置为多块传输启用自动发布时的CMD12，当STP位中的CMD12 SD\_STOP设置为1，或当SDIO\_MODE中的C52PUB或IOABT位设置为1时为CMD52。

注2.通过SD\_CMD中的设置，CMD12之外的CMD SD\_STOP中的STP位设置为1，或者当SDIO\_MODE中的C52PUB或IOABT位设置为1时为CMD52。

Table 33.7 Timeouts

| Timeout                                   | Interrupt flag register   |            | Error status register |   | This occurs when...  |
|---|---|------------|-----------------------|---|--|
|   | Register symbol   | Bit symbol | Register symbol       | Bit symbol  |  |
| Response timeout                          | SD_INFO2  | RSPTO      | SD_ERR_STS2           | RSPTO1  | A response is not received even after a minimum of 640 SDHI clock cycles elapse*1                                      |
|   |   |            |                       | RSPTO0  | A response is not received even after a minimum of 640 SDHI clock cycles elapse*2                                      |
| Data timeout (excluding response timeout) | SD_INFO2  | DTO        | SD_ERR_STS2           | CRCBSYTO  | After the CRC status token is received, the SDHI is busy for at least the period set*3                                 |
|   |   |            |                       | CRCTO   | After the write data is transmitted, the CRC status token is not received even after at least the period set*3 elapses |
|   |   |            |                       | RDTO  | After the read command is issued, the read data is not received even after at least the period set*3 elapses           |
|   |   |            |                       |   | After the read data is received, the next block read data is not received even after at least the period set*3 elapses |
|   |   |            |                       | After the SDHI exits the read wait state, the next block read data is not received even after at least the period set*3 elapses |  |
| BSYTO1                                    | After CMD12 is issued during the command sequence, the SDHI is busy for at least the period set*3   |            |                       |   |  |
| BSYTO0                                    | After the R1b response is received, the SDHI is busy for at least the period set*3 (a command other than CMD12 is issued during the command sequence) |            |                       |   |  |

Note 1. CMD12 when automatic issuing is enabled for multiple block transfer by the setting in SD\_CMD, CMD12 when the STP bit in SD\_STOP is set to 1, or CMD52 when the C52PUB or IOABT bit in SDIO\_MODE is set to 1.

Note 2. CMD other than CMD12 when automatic issuing is enabled for multiple block transfer by the setting in SD\_CMD, CMD12 when the STP bit in SD\_STOP bit is set to 1, or CMD52 when the C52PUB or IOABT bit in SDIO\_MODE is set to 1.

Note 3. The period is set in the SD\_OPTION.TOP[3:0] bits.

### 33.3.5 Command without Data Transfer (SD/MMC)

Figure 33.9 and Figure 33.10 show example flows.

Table 33.7 Timeouts

| Timeout       | 中断标志寄存器  |       | 错误状态寄存器     |  | 这发生在……                                 |
|---------------|--|-------|-------------|--|--|
|               | 注册符号   | 位符号   | 注册符号        | 位符号  |  |
| 响应超时          | SD_INFO2   | RSPTO | SD_ERR_STS2 | RSPTO1                                       | 即使经过至少640个SDHI时钟周期，也没有收到响应*1           |
|               |  |       |             | RSPTO0                                       | 即使经过至少640个SDHI时钟周期，也没有收到响应*2           |
| 数据超时（不包括响应超时） | SD_INFO2   | DTO   | SD_ERR_STS2 | CRCBSYTO                                     | 收到CRC状态令牌后，SDHI至少在设置的时间段内处于忙碌状态*3      |
|               |  |       |             | CRCTO  | 发送写入数据后，即使经过至少设置的时间段*3也不会接收到CRC状态令牌    |
|               |  |       |             | RDTO   | 发出读取命令后，即使经过至少设置的周期*3也不会接收到读取数据        |
|               |  |       |             |  | 在接收到读取数据后，即使经过至少设置的时间段*3也不会接收到下一个块读取数据 |
|               |  |       |             | 在SDHI退出读取等待状态后，即使经过至少设置的时间段*3，也不会接收到下一个块读取数据 |  |
| BSYTO1        | 在命令序列期间发出CMD12后，SDHI至少在设置的时间段内处于忙碌状态*3               |       |             |  |  |
| BSYTO0        | 收到R1b响应后，SDHI至少在设置的时间段*3内处于忙碌状态（在命令序列期间发出CMD12以外的命令） |       |             |  |  |

注1.通过SD\_CMD中的设置为多块传输启用自动发布时的CMD12，当STP位中的CMD12 SD\_STOP设置为1，或当SDIO\_MODE中的C52PUB或IOABT位设置为1时为CMD52。

注2.通过SD\_CMD中的设置，CMD12之外的CMD SD\_STOP位中的STP位设置为1，或者当SDIO\_MODE中的C52PUB或IOABT位设置为1时为CMD52。

注3.周期在SD\_OPTION.TOP[3:0]位中设置。

### 33.3.5 无数据传输的命令(SDMMC)

图33.9和图33.10显示了示例流程。

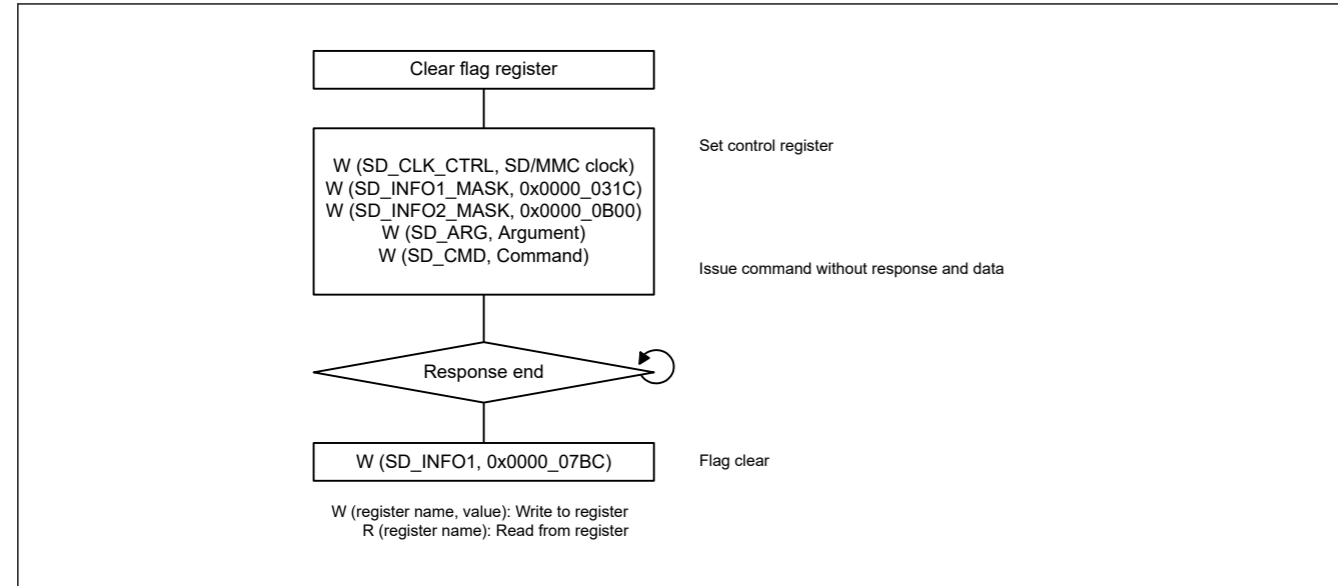


Figure 33.9 Example flow of command without response or data

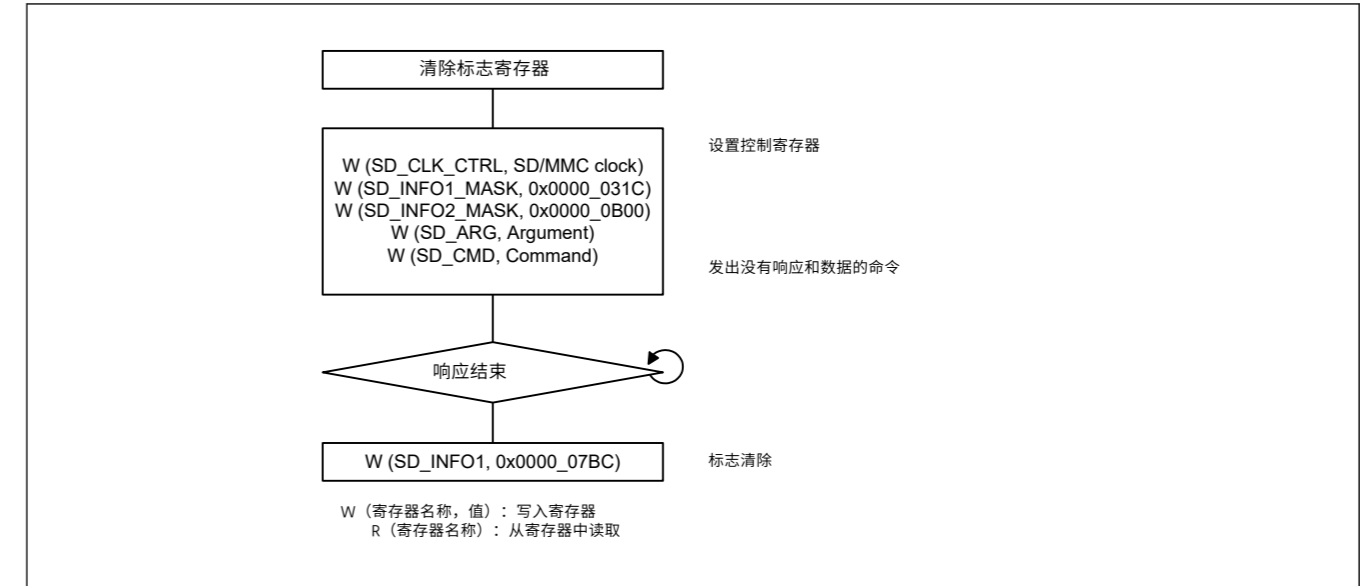


Figure 33.9 没有响应或数据的命令流示例

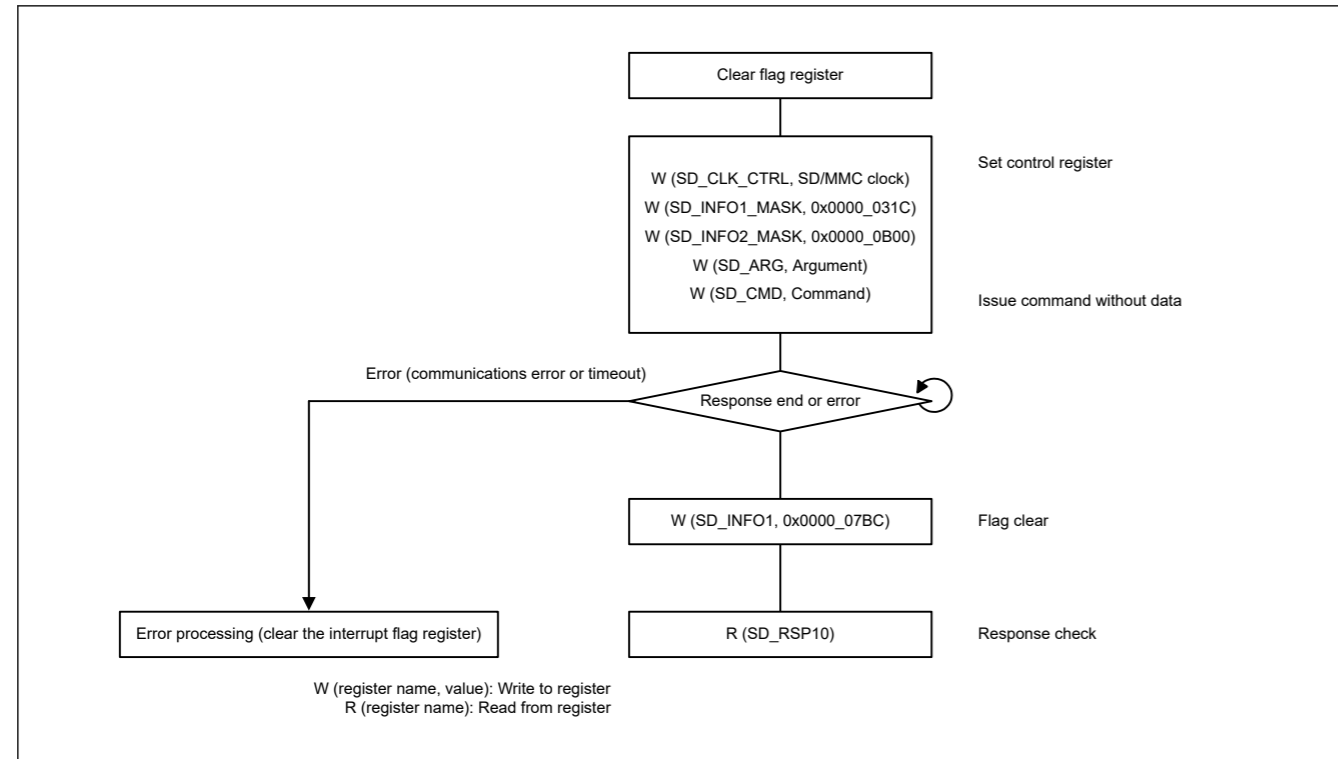


Figure 33.10 Example flow of command without data

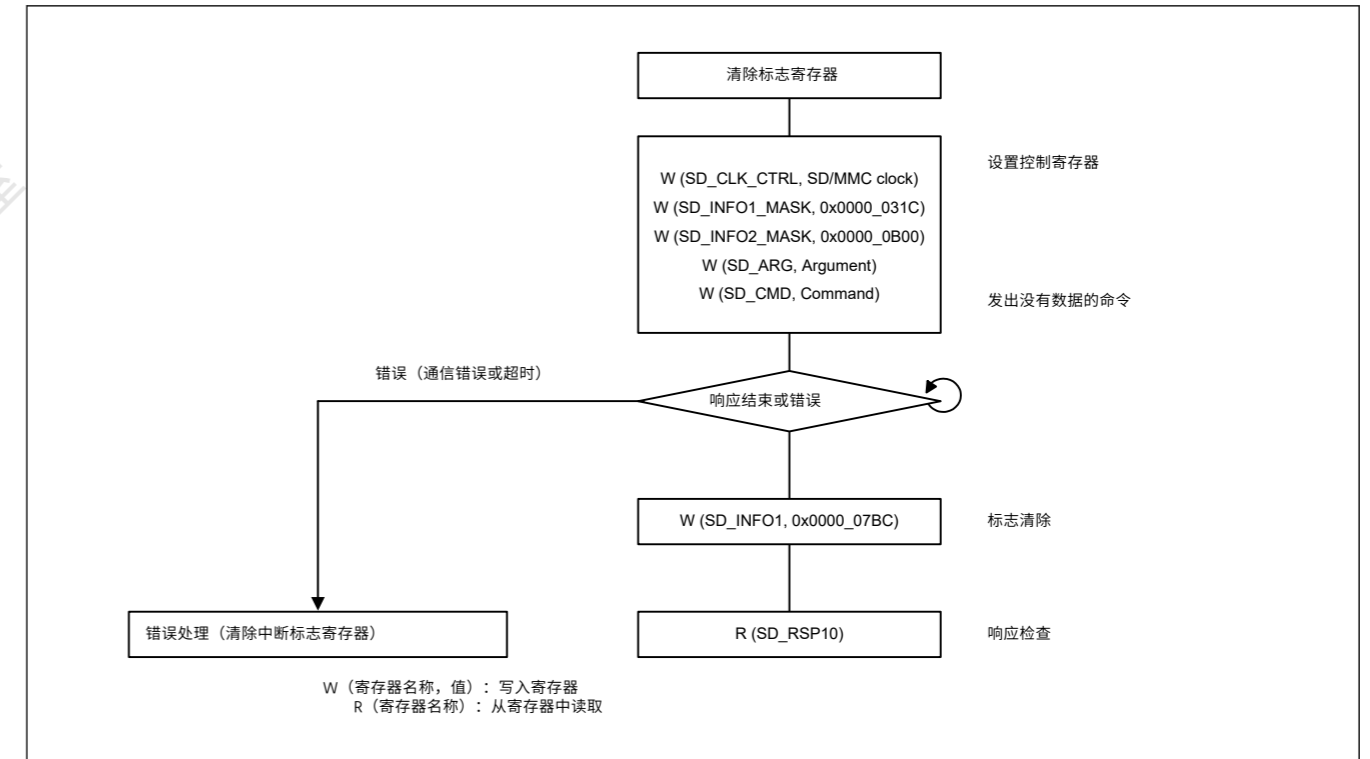


Figure 33.10 没有数据的命令流示例

33.3.5.1 Operation for command without data transfer

The following legend is used for description of register read/write.

W (register name, value): Write to register

R (register name): Read from register

The operation is described in the following section.

(1) Command without response and data

- a. Flag register clear  
First, clear the bits in the flag register. (SD\_INFO1 and SD\_INFO2)

33.3.5.1 无数据传输的命令操作

以下图例用于描述寄存器读写。

W (寄存器名称, 值): 写入寄存器

R (寄存器名称): 从寄存器中读取

该操作在下一节中描述。

(1) 没有响应和数据的命令

- a. 标志寄存器清除  
首先, 清除标志寄存器中的位。(SD\_INFO1和SD\_INFO2)

- b. Control register set  
Set the SD/MMC clock and interrupt masking. (SD\_CLK\_CTRL, SD\_INFO1\_MASK, and SD\_INFO2\_MASK)
- c. Command issue  
Set CMD argument in SD\_ARG and write to SD\_CMD.  
Accordingly, CMD is issued, and the operation is started.
- d. Flag clear  
When transmission of a command is completed, RSPEND (response end) in SD\_INFO1 is set to 1 to generate an interrupt. Clear RSPEND to 0.

## (2) Command without data

- a. Flag register clear  
First, clear the bits in the flag register. (SD\_INFO1 and SD\_INFO2)
- b. Control register set  
Set the SD/MMC clock and interrupt masking. (SD\_CLK\_CTRL, SD\_INFO1\_MASK, and SD\_INFO2\_MASK)
- c. Command issue  
Set CMD argument in SD\_ARG and write to the SD\_CMD.  
Accordingly, CMD is issued, and the operation is started.
- d. Flag clear  
When a response is received, RSPEND (response end) in SD\_INFO1 is set to 1 to generate an interrupt. Clear RSPEND to 0.
- e. Read a response from SD\_RSP10. Additionally, perform error processing (clear the interrupt flag register) if a communication error or timeout occurs.

### 33.3.6 Single Block Read (SD/MMC)

Figure 33.11 shows an example flow of a single block read operation.

- 湾。控制寄存器组  
设置SDMMC时钟和中断屏蔽。(SD\_CLK\_CTRL、SD\_INFO1\_MASK和SD\_INFO2\_MASK)
- c. 命令问题  
在SD\_ARG中设置CMD参数并写入SD\_CMD。因此，发出CMD，并开始操作。
- d. 标志清除  
当命令传输完成时，SD\_INFO1中的RSPEND（响应结束）设置为1以产生中断。将RSPEND清除为0。

## (2) 没有数据的命令

- a. 标志寄存器清除  
首先，清除标志寄存器中的位。(SD\_INFO1和SD\_INFO2)
- 湾。控制寄存器组  
设置SDMMC时钟和中断屏蔽。(SD\_CLK\_CTRL、SD\_INFO1\_MASK和SD\_INFO2\_MASK)
- c. 命令问题  
在SD\_ARG中设置CMD参数并写入SD\_CMD。  
因此，发出CMD，并开始操作。
- d. 标志清除  
当收到响应时，SD\_INFO1中的RSPEND（响应结束）置1以产生中断。将RSPEND清除为0。
- e. 从SD\_RSP10读取响应。此外，如果发生通信错误或超时，请执行错误处理（清除中断标志寄存器）。

### 33.3.6 单块读取(SDMMC)

图33.11显示了单个块读取操作的示例流程。



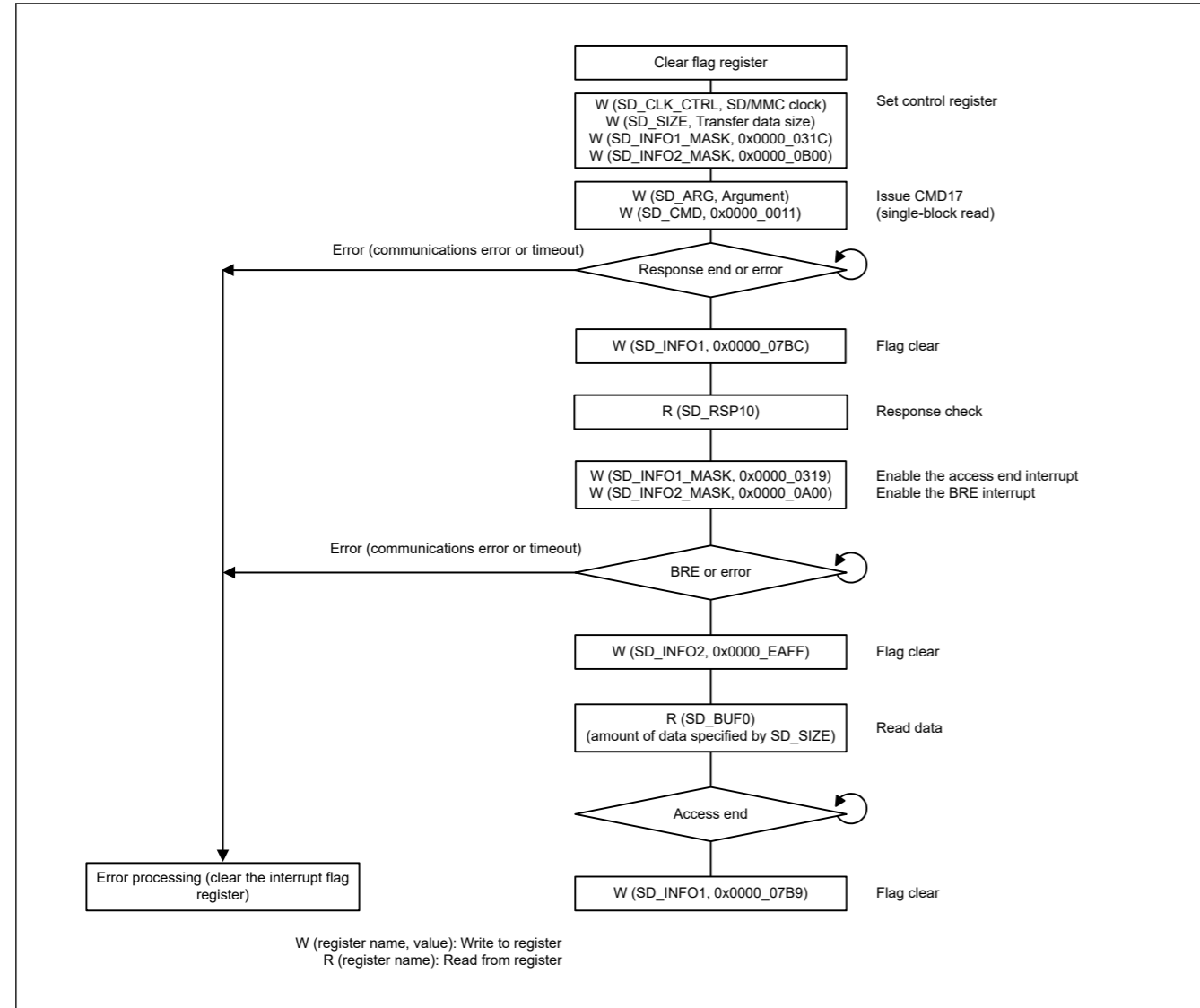


Figure 33.11 Example flow of single block read operation

### 33.3.6.1 Single block read operation

The operation of the single block read is described as follows:

- Flag register clear**  
First, clear the bits in the flag register (SD\_INFO1 and SD\_INFO2).
- Control register set**  
Set the SD/MMC clock, transfer data size, interrupt mask (SD\_CLK\_CTRL, SD\_SIZE, SD\_INFO1\_MASK, and SD\_INFO2\_MASK).
- Command issue (CMD17)**  
Set CMD17 argument in SD\_ARG and write 0x0000\_0011 to SD\_CMD. CMD17 is issued and the single block read operation is started.
- Response check**  
On receiving the response, RSPEND (response end) in SD\_INFO1 is set to 1 to generate an interrupt. Clear RSPEND to 0 and read the response from SD\_RSP10. If the result of response decoding is an error, the command sequence can be halted by setting the STP bit in SD\_STP or the IOABT bit in SDIO\_MODE to 1. In addition, this causes CMD12 and CMD52 to not be issued. If the ACEND bit (access end) in SD\_INFO1 is set, halting the command sequence also leads to the generation of an interrupt.
- Data receive from SD card/MMC and data read**

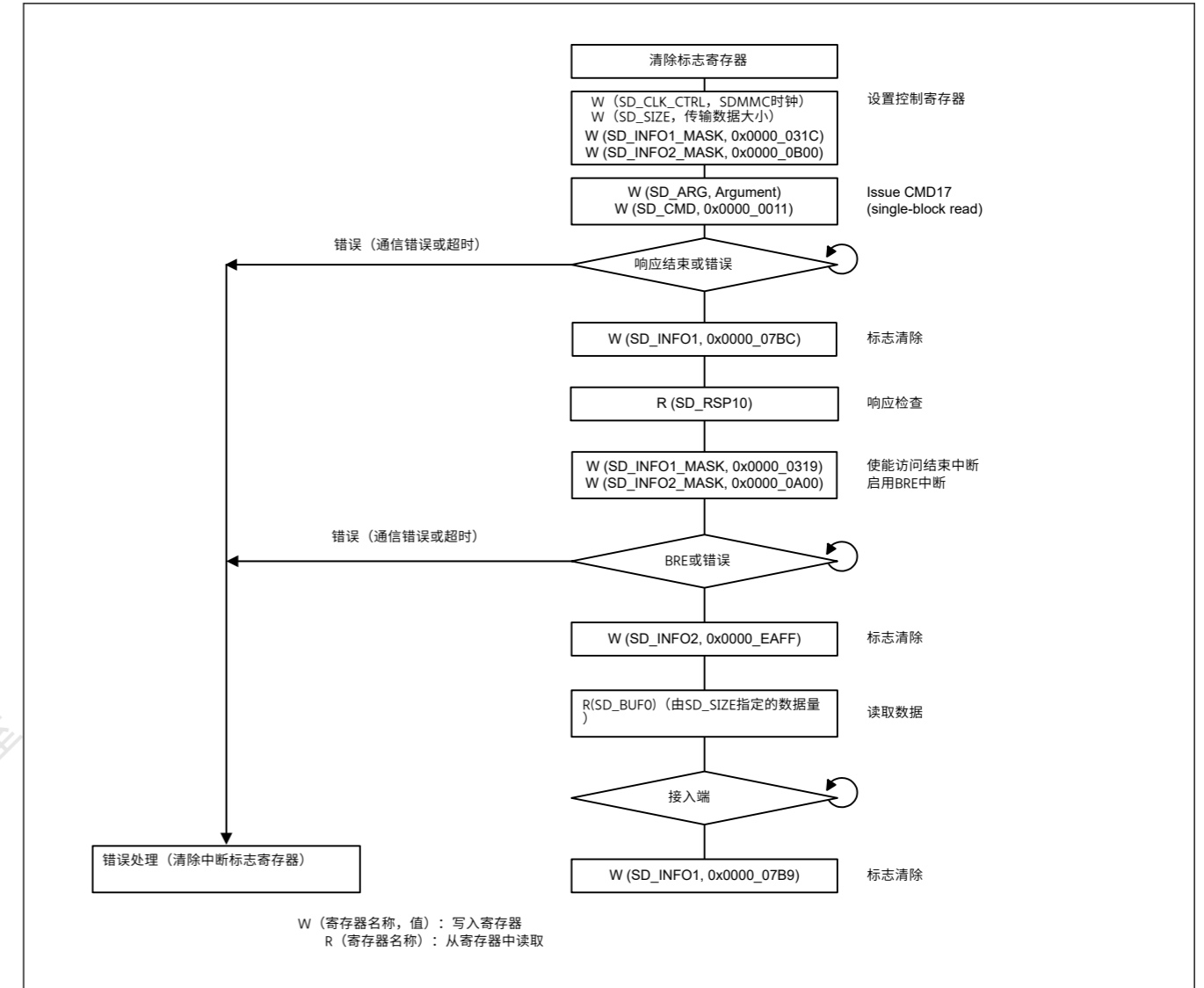


Figure 33.11 单块读操作示例流程

### 33.3.6.1 单块读操作

单块读取的操作描述如下:

- 标志寄存器清除**  
首先, 清除标志寄存器 (SD\_INFO1和SD\_INFO2) 中的位。
- 控制寄存器组**  
设置SDMMC时钟、传输数据大小、中断屏蔽 (SD\_CLK\_CTRL、SD\_SIZE、SD\_INFO1\_MASK和SD\_INFO2\_MASK)。
- 命令问题(CMD17)**  
在SD\_ARG中设置CMD17参数并将0x0000\_0011写入SD\_CMD。发出CMD17并开始单块读取操作。
- 响应检查**  
收到响应后, SD\_INFO1中的RSPEND (响应结束) 置1以产生中断。将RSPEND清零并从SD\_RSP10读取响应。如果响应解码的结果是错误的, 可以通过将SD\_STP中的STP位或SDIO\_MODE中的IOABT位设置为1来停止命令序列。此外, 这会导致CMD12和CMD52不发出。如果SD\_INFO1中的ACEND位 (访问结束) 被设置, 停止命令序列也会导致产生中断。
- 从SD卡MMC接收数据并读取数据**

Write 0x0000\_0319 to SD\_INFO1\_MASK to enable the access end interrupt. In addition, write 0x0000\_0A00 to SD\_INFO2\_MASK to enable the BRE interrupt. When the data received from the SD card/MMC is completed, the BRE bit in SD\_INFO2 is set to 1 to generate an interrupt. Clear the BRE bit to 0 and read the amount of data specified in SD\_SIZE from SD\_BUF0.

A communication error or timeout might be generated if data is being received while reading of SD\_BUF0 is in progress.

f. Operation complete

When the data read from SD\_BUF0 is completed, ACEND (access end) in SD\_INFO1 is set to 1 to generate an interrupt. Clear ACEND to 0 to end the single block read operation.

Additionally, perform error processing (clear the interrupt flag register) if a communication error or timeout occurs.

33.3.7 Single Block Write (SD/MMC)

Figure 33.12 shows an example flow of a single block write operation.

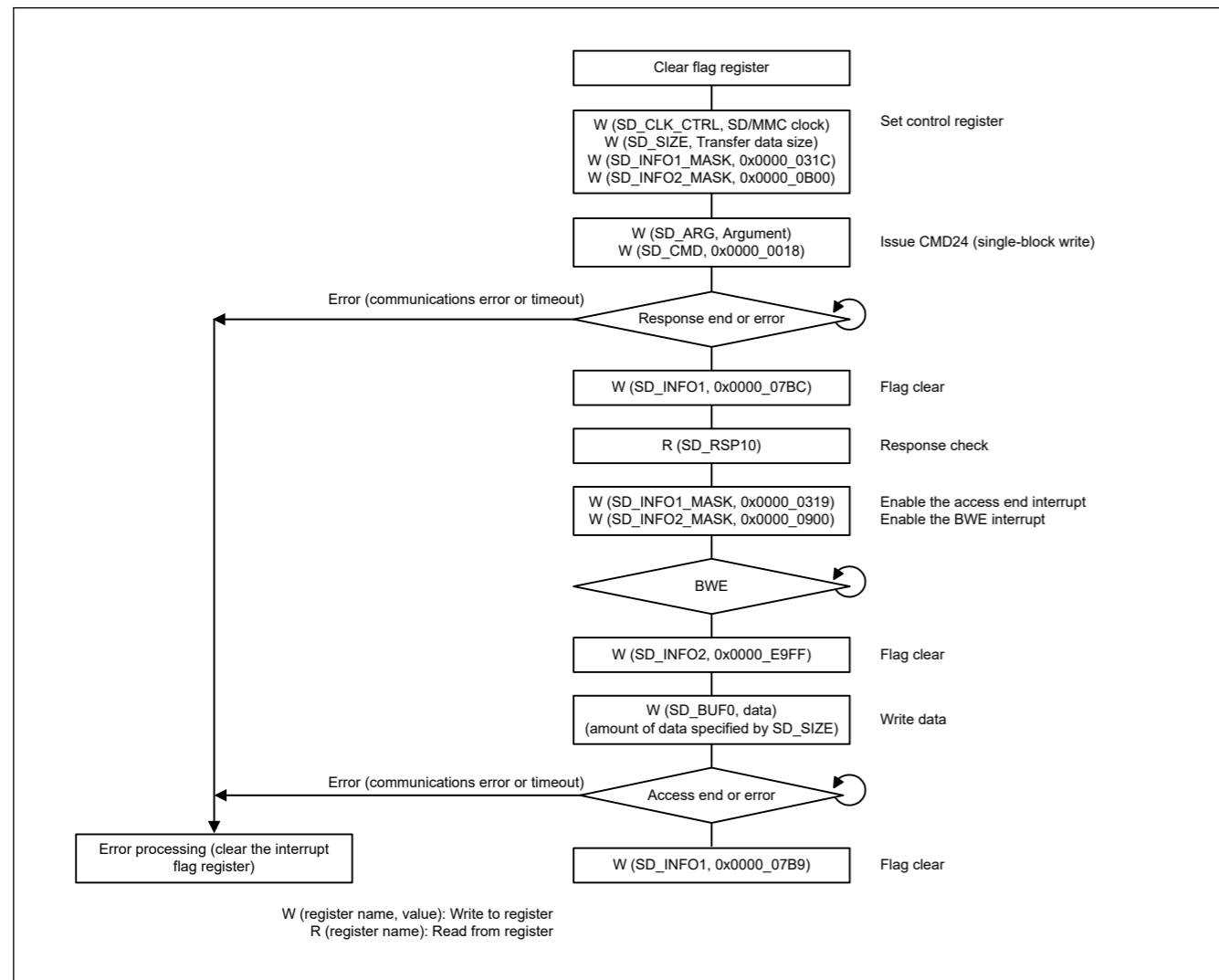


Figure 33.12 Example of single block write operation

33.3.7.1 Single block write operation

The operation of the single block write is described as follows:

- a. Flag register clear  
First, clear the bits in the flag register (SD\_INFO1 and SD\_INFO2).
- b. Control register set

将0x0000\_0319写入SD\_INFO1\_MASK以使能访问结束中断。此外，将0x0000\_0A00写入SD\_INFO2\_MASK启用BRE中断。当从SD卡MMC接收到数据完成时，SD\_INFO2中的BRE位设置为1以产生中断。将BRE位清0并从SD\_BUF0中读取SD\_SIZE中指定的数据量。

如果在读取SD\_BUF0时正在接收数据，则可能会产生通信错误或超时。

f. 操作完成

当从SD\_BUF0读取数据完成后，SD\_INFO1中的ACEND（访问结束）置1以产生中断。将ACEND清0结束单块读操作。此外，如果发生通信错误或超时，请执行错误处理（清除中断标志寄存器）。

33.3.7 单块写入(SDMMC)

图33.12显示了单个块写入操作的示例流程。

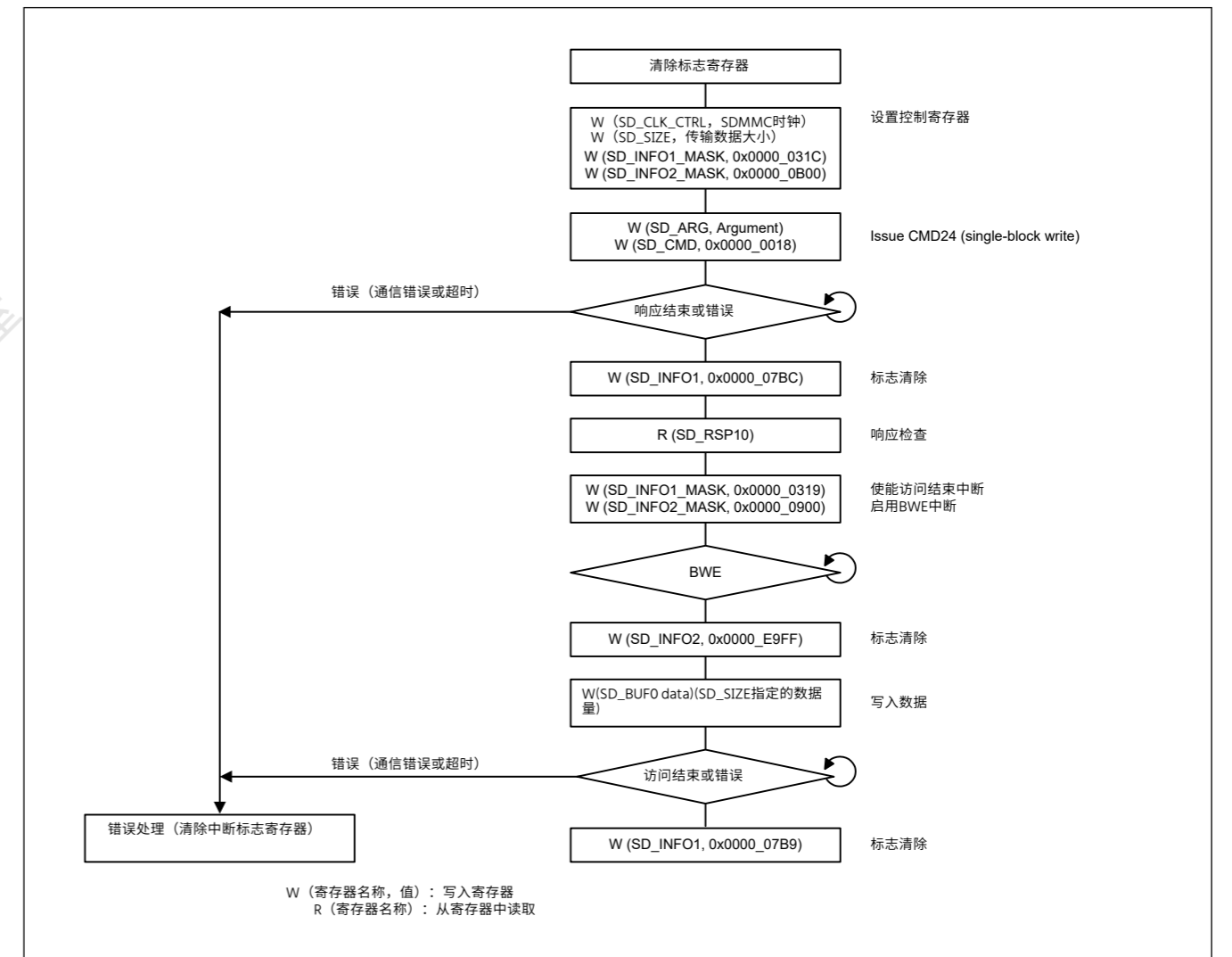


Figure 33.12 单块写操作示例

33.3.7.1 单块写操作

单块写操作描述如下：

- a. 标志寄存器清除  
首先，清除标志寄存器（SD\_INFO1和SD\_INFO2）中的位。

- Set the SD/MMC clock, transfer data size, interrupt mask (SD\_CLK\_CTRL, SD\_SIZE, SD\_INFO1\_MASK, and SD\_INFO2\_MASK).
- c. Command issue (CMD24)  
Set CMD24 argument in SD\_ARG and write 0x0000\_0018 to SD\_CMD. CMD24 is issued and the single block write operation is started.
- d. Response check  
On receiving the response, RSPEND (response end) in SD\_INFO1 is set to 1 to generate an interrupt. Clear RSPEND to 0 and read the response from SD\_RSP10. If the result of response decoding is an error, the command sequence can be halted by setting the STP bit in SD\_STP or the IOABT bit in SDIO\_MODE to 1. In addition, this causes CMD12 and CMD52 to not be issued. If the ACEND bit (access end) in SD\_INFO is set, halting the command sequence also leads to the generation of an interrupt.
- e. Data write and data transmit to SD card/MMC  
Write 0x0000\_0319 to SD\_INFO1\_MASK to enable the access end interrupt. In addition, write 0x0000\_0900 to SD\_INFO2\_MASK to enable the BWE interrupt. When SD\_BUF0 is ready for the data to be written, the BWE bit in SD\_INFO2 is set to 1 to generate an interrupt. Clear the BWE bit to 0 and write the amount of data specified in SD\_SIZE to SD\_BUF0. When the data write to SD\_BUF0 is completed, data is transmitted to the SD card. Then, the CRC status and busy state are received from the SD card/MMC.  
However, a communications error or timeout might be generated if data is being transmitted after writing to SD\_BUF0.
- f. Operation complete  
When the CRC status and busy state are received from the SD card/MMC, ACEND (access end) in SD\_INFO1 is set to 1 to generate an interrupt. Clear the ACEND bit to 0 to end the single block write operation.  
In addition, perform error processing (clear the interrupt flag register) if a communication error or timeout occurs.

### 33.3.8 Multiple Block Read (SD/MMC)

Figure 33.13 shows an example flow of a multiple block read operation.

- 设置SDMMC时钟、传输数据大小、中断屏蔽 (SD\_CLK\_CTRL、SD\_SIZE、SD\_INFO1\_MASK和SD\_INFO2\_MASK)。
- c. 命令问题(CMD24)  
在SD\_ARG中设置CMD24参数并将0x0000\_0018写入SD\_CMD。发出CMD24并开始单块写入操作。
- d. 响应检查  
收到响应后，SD\_INFO1中的RSPEND（响应结束）置1以产生中断。将RSPEND清零并从SD\_RSP10读取响应。如果响应解码的结果是错误的，可以通过将SD\_STP中的STP位或SDIO\_MODE中的IOABT位设置为1来停止命令序列。此外，这会导致CMD12和CMD52不发出。如果SD\_INFO中的ACEND位（访问结束）被设置，停止命令序列也会导致中断的产生。
- e. 数据写入和数据传输到SD卡MMC  
将0x0000\_0319写入SD\_INFO1\_MASK以启用访问结束中断。此外，将0x0000\_0900写入SD\_INFO2\_MASK以启用BWE中断。当SD\_BUF0准备好写入数据时，SD\_INFO2中的BWE位设置为1以产生中断。将BWE位清0并写入指定的数据量  
SD\_SIZE到SD\_BUF0。数据写入SD\_BUF0完成后，将数据传输到SD卡。然后，从SD卡MMC接收CRC状态和忙状态。  
但是，如果在写入SD\_BUF0后正在传输数据，则可能会产生通信错误或超时。
- f. 操作完成  
当从SD卡MMC接收到CRC状态和忙状态时，SD\_INFO1中的ACEND（访问端）置1以产生中断。将ACEND位清0以结束单块写操作。此外，如果发生通信错误或超时，请执行错误处理（清除中断标志寄存器）。

### 33.3.8 多块读取(SDMMC)

图33.13显示了多块读取操作的示例流程。

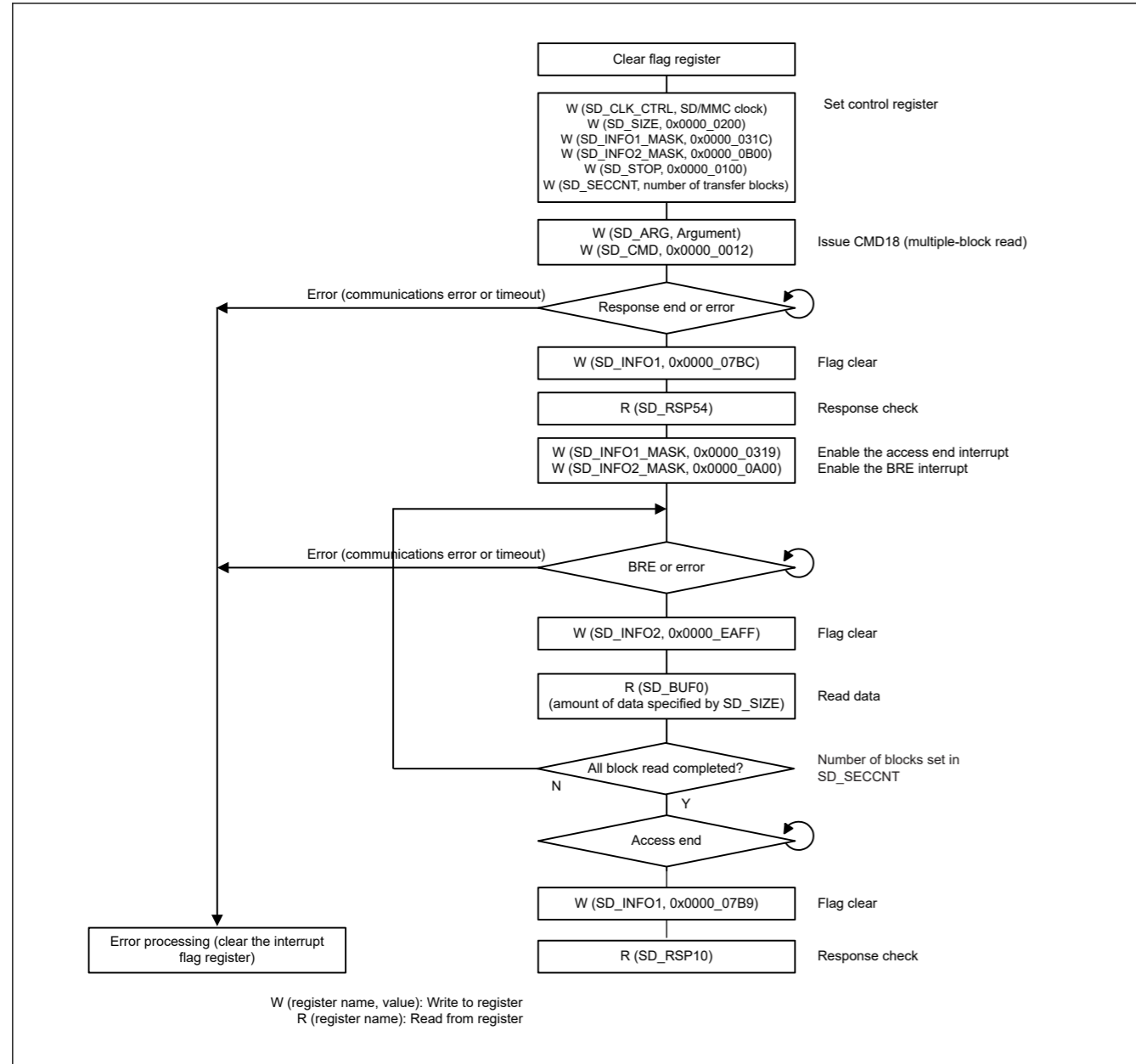


Figure 33.13 Example of multiple block read operation

### 33.3.8.1 Multiple block read operation

The operation of the multiple block read is described as follows:

- Flag register clear**  
First, clear the bits in the flag register (SD\_INFO1 and SD\_INFO2).
- Control register set**  
Set the SD/MMC clock, transfer data size, interrupt mask (SD\_CLK\_CTRL, SD\_SIZE, SD\_INFO1\_MASK, and SD\_INFO2\_MASK).  
Set SEC in SD\_STOP to 1, and set the number of transfer blocks in SD\_SECCNT.
- Command issue (CMD18)**  
Set CMD18 argument in SD\_ARG and write 0x0000\_0012 to SD\_CMD. CMD18 is issued and the multiple block read operation is started.
- Response check**  
On receiving the response, RSPEND (response end) in SD\_INFO1 is set to 1 to generate an interrupt. Clear RSPEND to 0 and read the response from SD\_RSP54. If the result of response decoding is an error, the command sequence can be

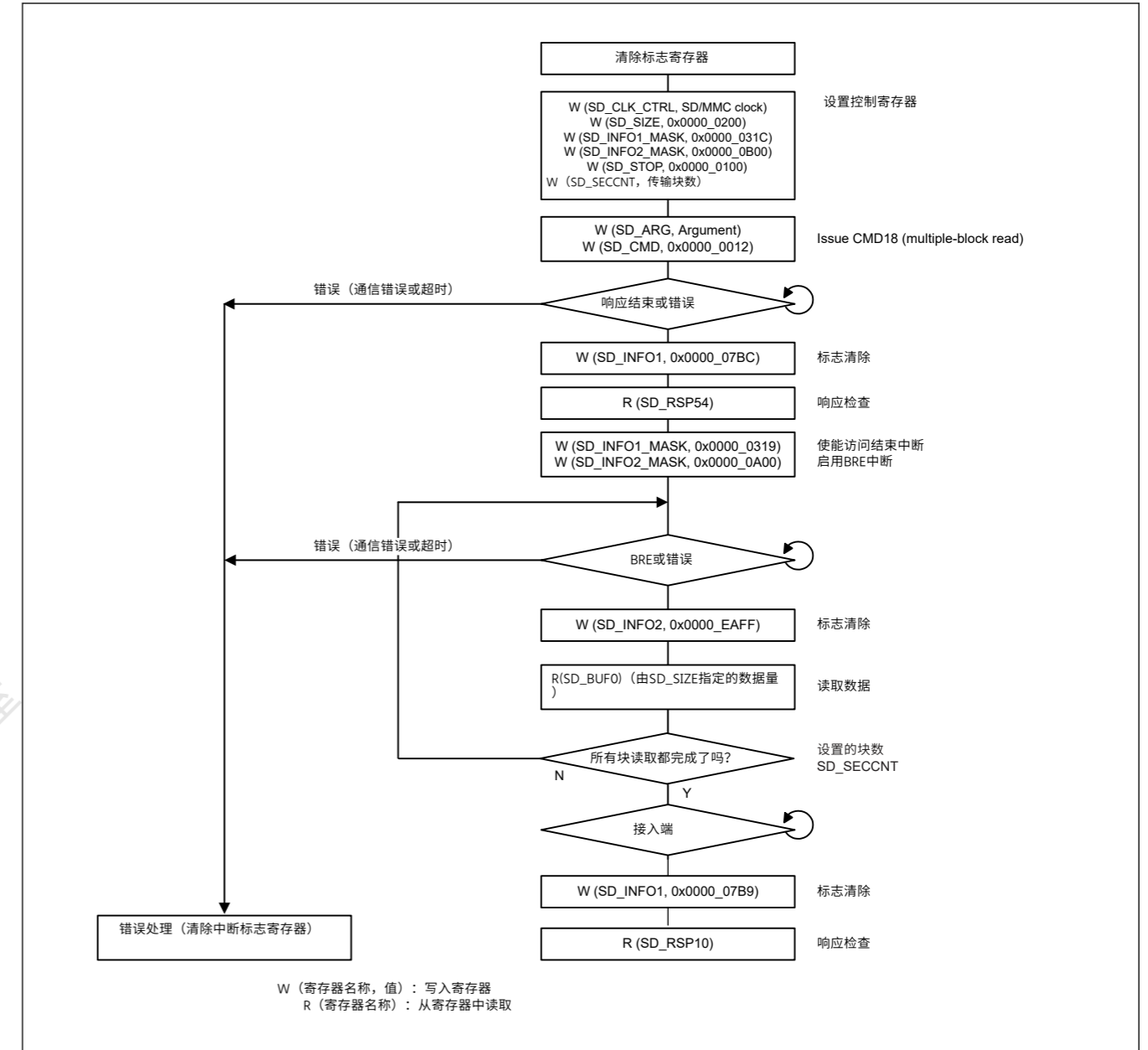


Figure 33.13 多块读取操作示例

### 33.3.8.1 多块读操作

多块读取的操作描述如下:

- 标志寄存器清除**  
首先, 清除标志寄存器 (SD\_INFO1和SD\_INFO2) 中的位。
- 控制寄存器组**  
设置SDMMC时钟、传输数据大小、中断屏蔽 (SD\_CLK\_CTRL、SD\_SIZE、SD\_INFO1\_MASK和SD\_INFO2\_MASK).  
将SD\_STOP中的SEC设置为1, 并在SD\_SECCNT中设置传输块数。
- 命令问题(CMD18)**  
在SD\_ARG中设置CMD18参数并将0x0000\_0012写入SD\_CMD。发出CMD18并开始多块读取操作。
- 响应检查**  
收到响应后, SD\_INFO1中的RSPEND (响应结束) 置1以产生中断。将RSPEND清零并从SD\_RSP54读取响应。如果响应解码的结果是错误的, 命令序列可以是



halted by setting the STP bit in SD\_STP to 1. Setting the STP bit to 1 also causes CMD12 to be issued and the response received. If the command sequence is halted because the access end interrupt is enabled, an interrupt is generated when the ACEND bit (access end) bit in SD\_INFO1 sets to 1 on completion of response reception. Clear the ACEND bit to 0 and read the response.

e. Data receive from SD card/MMC and data read

Write 0x0000\_0319 to SD\_INFO1\_MASK to enable the access end interrupt. In addition, write 0x0000\_0A00 to SD\_INFO2\_MASK to enable the BRE interrupt. When one-block data received from the SD card/MMC is completed, the BRE bit in SD\_INFO2 is set to 1 to generate an interrupt. Clear the BRE bit to 0 and read the amount of data specified in SD\_SIZE from SD\_BUF0. Doing this repeats transfer of the number of blocks set in SD\_SECCNT. However, a communication error or timeout might be generated if data is being received while reading of SD\_BUF0 is in progress. CMD12 is automatically issued to stop multiblock transfer with the number of blocks that is set to SD\_SECCNT and the response is received. At this point, CMD12 argument is automatically set to 0x0000\_0000.

f. Operation complete

When all-block data read and the CMD12 response received are completed, ACEND (access end) in SD\_INFO1 is set to 1 to generate an interrupt. Clear ACEND to 0 to read the response. This is the end of multiple block read operation. In addition, perform error processing (clear the interrupt flag register) if a communication error or timeout occurs.

### 33.3.9 Multiple Block Write (SD/MMC Using Internal Timer)

Figure 33.14 shows an example flow of a multiple block write using internal timer.

通过将SD\_STP中的STP位设置为1来停止。将STP位设置为1也会导致发出CMD12并接收响应。如果由于使能访问结束中断而暂停命令序列，则在完成响应接收时SD\_INFO1中的ACEND位（访问结束）位设置为1时产生中断。将ACEND位清0并读取响应。

e. 从SD卡MMC接收数据并读取数据

将0x0000\_0319写入SD\_INFO1\_MASK以使能访问结束中断。此外，将0x0000\_0A00写入SD\_INFO2\_MASK以启用BRE中断。当从SD卡MMC接收到单块数据完成时，SD\_INFO2中的BRE位被设置为1以产生中断。将BRE位清0并从SD\_BUF0中读取SD\_SIZE中指定的数据量。这样做会重复传输SD\_SECCNT中设置的块数。但是，如果在读取SD\_BUF0时正在接收数据，则可能会产生通信错误或超时。自动发出CMD12以停止多块传输，块数设置为SD\_SECCNT并接收响应。此时，CMD12参数自动设置为0x0000\_0000。

f. 操作完成

当全块数据读取和接收到的CMD12响应完成时，SD\_INFO1中的ACEND（访问结束）置1以产生中断。将ACEND清除为0以读取响应。这是多块读取操作的结束。此外，如果发生通信错误或超时，请执行错误处理（清除中断标志寄存器）。

### 33.3.9 多块写入（使用内部定时器的SDMMC）

图33.14显示了使用内部定时器进行多块写入的示例流程。

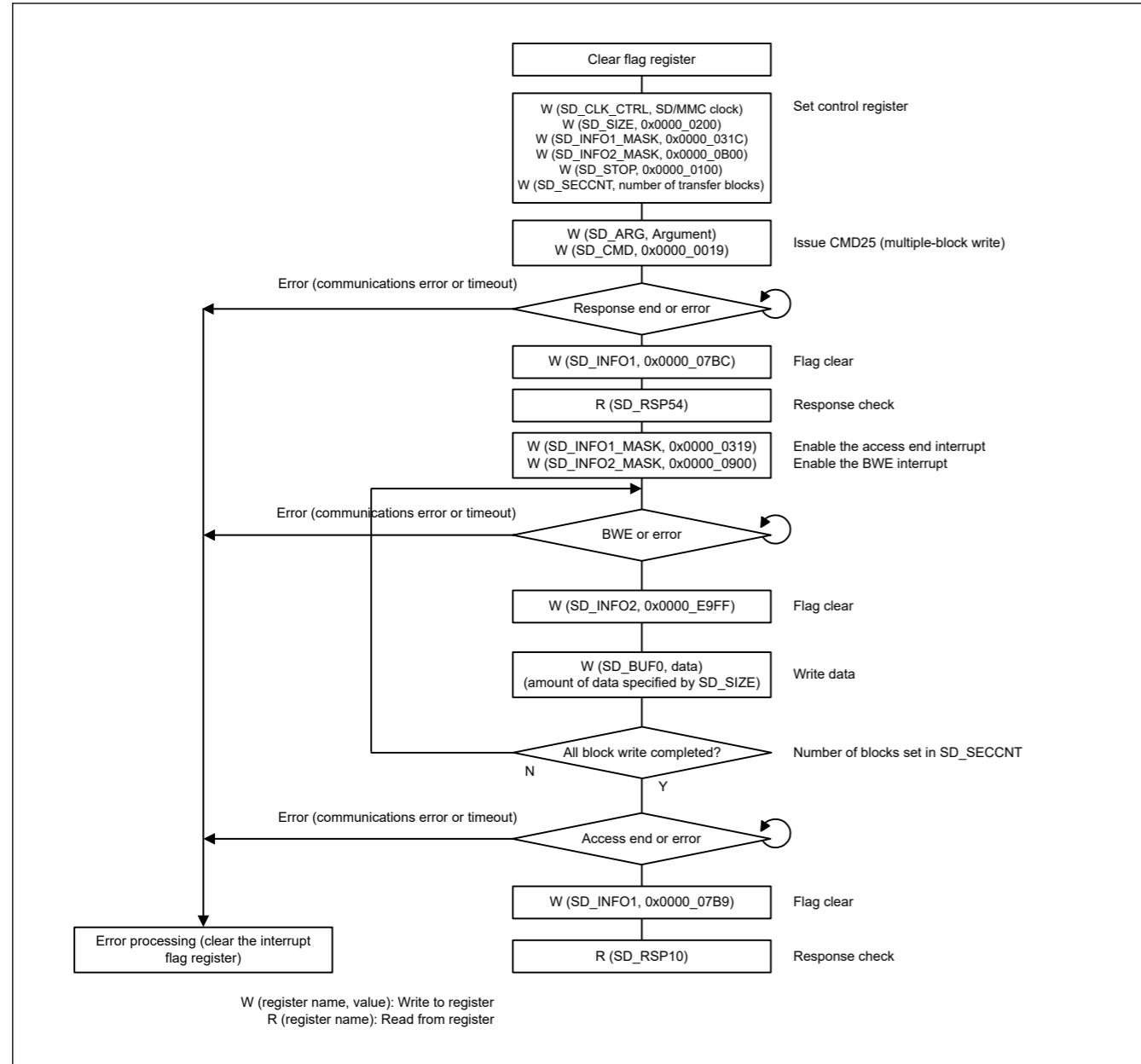


Figure 33.14 Example of multiple block write operation using internal timer

33.3.9.1 Multiple block write operation using internal timer

The operation of the multiple block write is described as follows:

- Flag register clear  
First, clear the bits in the flag register (SD\_INFO1 and SD\_INFO2).
- Control register set  
Set the SD/MMC clock, transfer data size, interrupt mask (SD\_CLK\_CTRL, SD\_SIZE, SD\_INFO1\_MASK, and SD\_INFO2\_MASK).  
Set the SEC bit in SD\_STOP to 1, and set the number of transfer blocks in SD\_SECCNT.
- Command issue (CMD25)  
Set CMD25 argument in SD\_ARG and write 0x0000\_0019 to SD\_CMD. CMD25 is issued and the multiple block write operation is started.
- Response check  
On receiving the response, the RSPEND bit (response end) in SD\_INFO1 is set to 1 to generate an interrupt.  
Clear the RSPEND bit to 0 and read the response from SD\_RSP54. If the result of response decoding is an error, the command sequence can be halted by setting the STP bit in SD\_STP to 1. Setting the STP bit to 1 also causes CMD12 to

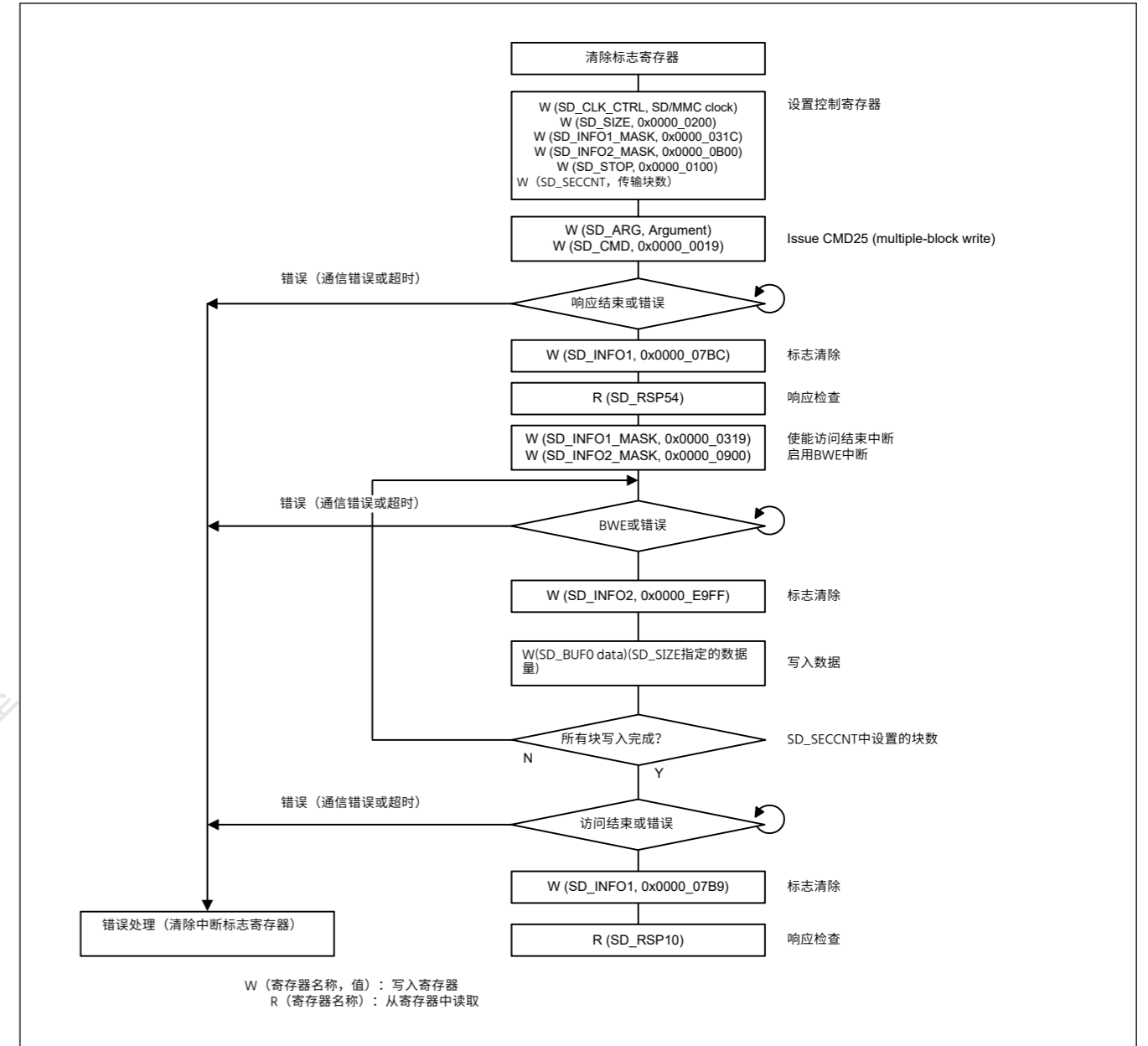


Figure 33.14 使用内部定时器的多块写入操作示例

33.3.9.1 使用内部定时器的多块写操作

多块写入的操作描述如下:

- 标志寄存器清除  
首先,清除标志寄存器(SD\_INFO1和SD\_INFO2)中的位。
- 湾. 控制寄存器组  
设置SDMMC时钟、传输数据大小、中断屏蔽(SD\_CLK\_CTRL、SD\_SIZE、SD\_INFO1\_MASK和SD\_INFO2\_MASK).  
将SD\_STOP中的SEC位设置为1,并在SD\_SECCNT中设置传输块数。
- c. 命令问题(CMD25)  
在SD\_ARG中设置CMD25参数并将0x0000\_0019写入SD\_CMD。发出CMD25并开始多块写入操作。
- d. 响应检查  
收到响应后,SD\_INFO1中的RSPEND位(响应结束)置1以产生中断。  
将RSPEND位清0并从SD\_RSP54读取响应。如果响应解码的结果是错误的,可以通过将SD\_STP中的STP位设置为1来暂停命令序列。将STP位设置为1也会导致CMD12

be issued and the response received. If the command sequence is halted because the access end interrupt is enabled, an interrupt is generated by when the ACEND bit (access end) bit in SD\_INFO1 sets to 1 on completion of response reception. Clear the ACEND bit to 0 and read the response.

e. Data write and data transmit to SD card/MMC

Write 0x0000\_0319 to SD\_INFO1\_MASK to enable the access end interrupt. In addition, write 0x0000\_0900 to SD\_INFO2\_MASK to enable the BWE interrupt. When SD\_BUF0 is ready for the data to be written, the BWE bit in the SD\_INFO2 register is set to 1 to generate an interrupt. Clear the BWE bit to 0 and write the amount of data specified in SD\_SIZE to SD\_BUF0. When the data write to SD\_BUF0 is completed, data is transmitted to the SD card/MMC. The CRC status and busy state are received from the SD card/MMC. This repeats transfer of the number of blocks set in SD\_SECCNT. However, a communication error or timeout might be generated if data is being received while writing to SD\_BUF0 is in progress. CMD12 is automatically issued to stop multiblock transfer with the number of blocks which is set to SD\_SECCNT and the response is received. At this point, CMD12 argument is automatically set to 0x0000\_0000.

f. Operation complete

When all-block data transmit and the CRC status receive are completed, the ACEND bit (access end) in SD\_INFO1 is set to 1 to generate an interrupt. Clear the ACEND bit to 0 to read the response. This is the end of multiple block write operation. Additionally, perform error processing (clear the interrupt flag register) if a communications error or timeout occurs.

### 33.3.10 Multiple Block Write (MMC using external timer)

Figure 33.15 shows an example flow of a multiple block write using an external timer.

发出并收到响应。如果由于使能访问结束中断而暂停命令序列，则在完成响应接收时SD\_INFO1中的ACEND位（访问结束）位设置为1时产生中断。将ACEND位清0并读取响应。

e. 数据写入和数据传输到SD卡MMC

将0x0000\_0319写入SD\_INFO1\_MASK以使能访问结束中断。此外，将0x0000\_0900写入SD\_INFO2\_MASK启用BWE中断。当SD\_BUF0准备好写入数据时，SD\_INFO2寄存器设置为1以产生中断。将BWE位清除为0，并将SD\_SIZE中指定的数据量写入SD\_BUF0。当数据写入SD\_BUF0完成后，数据被传输到SD卡MMC。这从SD卡MMC接收CRC状态和忙状态。这将重复传输设置的块数SD\_SECCNT。但是，如果在写入SD\_BUF0时正在接收数据，则可能会产生通信错误或超时。自动发出CMD12以停止多块传输，块数设置为SD\_SECCNT并接受响应。此时，CMD12参数自动设置为0x0000\_0000。

f. 操作完成

当全块数据发送和CRC状态接收完成时，SD\_INFO1中的ACEND位（访问结束）置1以产生中断。将ACEND位清0以读取响应。这是多块写操作的结束。此外，如果发生通信错误或超时，请执行错误处理（清除中断标志寄存器）。

### 33.3.10 多块写入（使用外部定时器的MMC）

图33.15显示了使用外部定时器进行多块写入的示例流程。

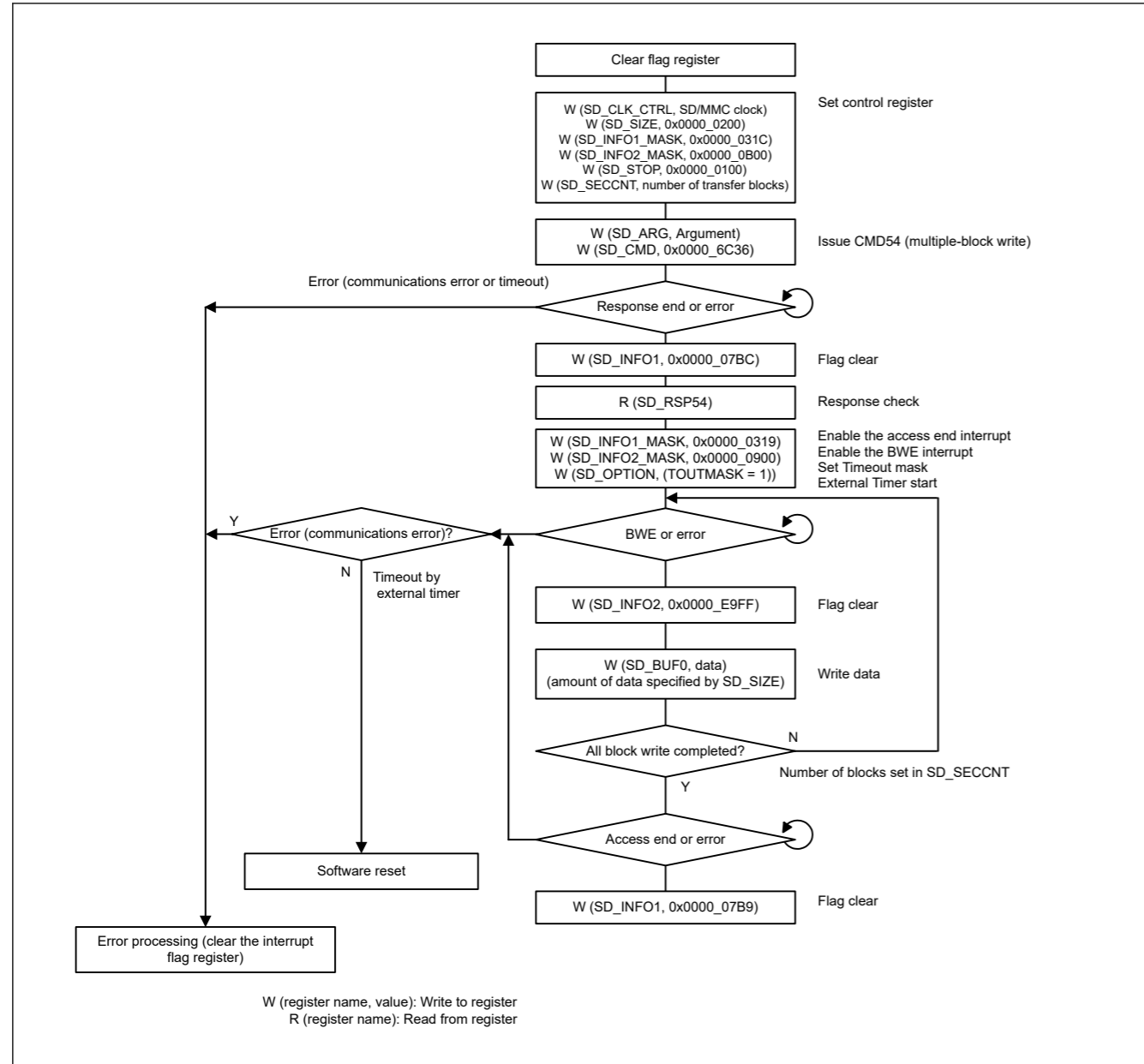


Figure 33.15 Example of multiple block write operation using external timer

### 33.3.10.1 Multiple block write operation using external timer

The operation of the multiple block write is described as follows:

- Flag register clear**  
First, clear the bits in the flag register (SD\_INFO1 and SD\_INFO2).
- Control register set**  
Set the MMC clock, transfer data size, interrupt mask (SD\_CLK\_CTRL, SD\_SIZE, SD\_INFO1\_MASK, and SD\_INFO2\_MASK).  
Set the SEC bit in SD\_STOP to 1, and set the number of transfer blocks in SD\_SECCNT.
- Command issue (CMD54)**  
Set CMD54 Argument in SD\_ARG and write 0x0000\_6C36 to SD\_CMD. CMD54 is issued and the multiple block write operation is started.
- Response check**  
On receiving the response, the RSPEND bit (response end) in SD\_INFO1 is set to 1 to generate an interrupt. Clear the RSPEND bit to 0 and read the response from SD\_RSP54. If the result of response decoding is an error, the command sequence can be halted by setting the STP bit in SD\_STP to 1. Setting the STP bit to 1 also causes CMD12 to be issued

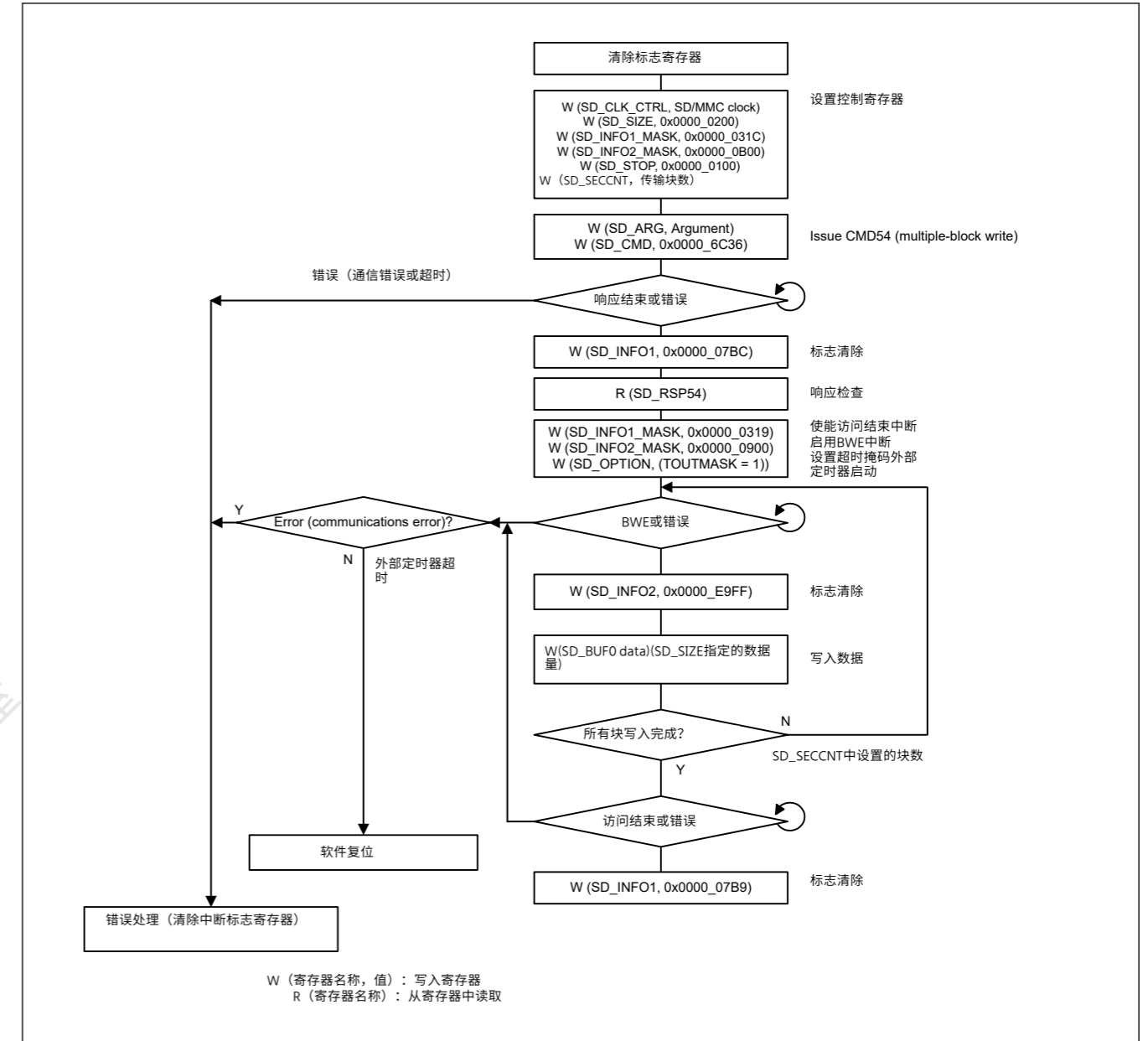


Figure 33.15 使用外部定时器的多块写入操作示例

### 33.3.10.1 使用外部定时器的多块写操作

多块写入的操作描述如下：

- 标志寄存器清除**  
首先，清除标志寄存器（SD\_INFO1和SD\_INFO2）中的位。
- 控制寄存器组**  
设置MMC时钟、传输数据大小、中断屏蔽（SD\_CLK\_CTRL、SD\_SIZE、SD\_INFO1\_MASK和SD\_INFO2\_MASK）。  
将SD\_STOP中的SEC位设置为1，并在SD\_SECCNT中设置传输块数。
- 命令问题(CMD54)**在SD\_ARG中设置CMD54参数并将0x0000\_6C36写入SD\_CMD。发出CMD54并开始多块写入操作。
- 响应检查**  
收到响应后，SD\_INFO1中的RSPEND位（响应结束）置1以产生中断。将RSPEND位清0并从SD\_RSP54读取响应。如果响应解码的结果是错误的，可以通过将SD\_STP中的STP位设置为1来暂停命令序列。将STP位设置为1也会导致发出CMD12



and the response received. If the command sequence is halted because the access end interrupt is enabled, an interrupt is generated by when the ACEND bit (access end) bit in SD\_INFO1 sets to 1 on completion of response reception. Clear the ACEND bit to 0 and read the response.

e. Data write and data transmit to MMC

Write 0x0000\_0319 to SD\_INFO1\_MASK to enable the access end interrupt, write 0x0000\_0900 to SD\_INFO2\_MASK to enable the BWE interrupt and set 1 to TOUTMASK of SD\_OPTION to inactivate timeout. In addition, start external timer. When SD\_BUF0 is ready for the data to be written, the BWE bit in the SD\_INFO2 register is set to 1 to generate an interrupt. Clear the BWE bit to 0 and write the amount of data specified in SD\_SIZE to SD\_BUF0. When the data write to SD\_BUF0 is completed, data is transmitted to the MMC. The CRC status and busy state are received from the MMC. Doing this repeats transfer of the number of blocks set in SD\_SECCNT. However, a communication error or timeout might be generated if data is being received while writing to SD\_BUF0 is in progress.

f. Operation complete

When all-block data transmit and the CRC status receive are completed, the ACEND bit (access end) in SD\_INFO1 is set to 1 to generate an interrupt. Clear the ACEND bit to 0 to read the response. This is the end of multiple block write operation. Additionally, perform error processing (clear the interrupt flag register) if a communications error or timeout occurs when receiving response. Execute software reset if a timeout by external timer occurs when transmitting data.

33.3.11 IO\_RW\_DIRECT Command (SD: CMD52)

Figure 33.16 shows an example flow of an IO\_DIRECT command (CMD52) operation.

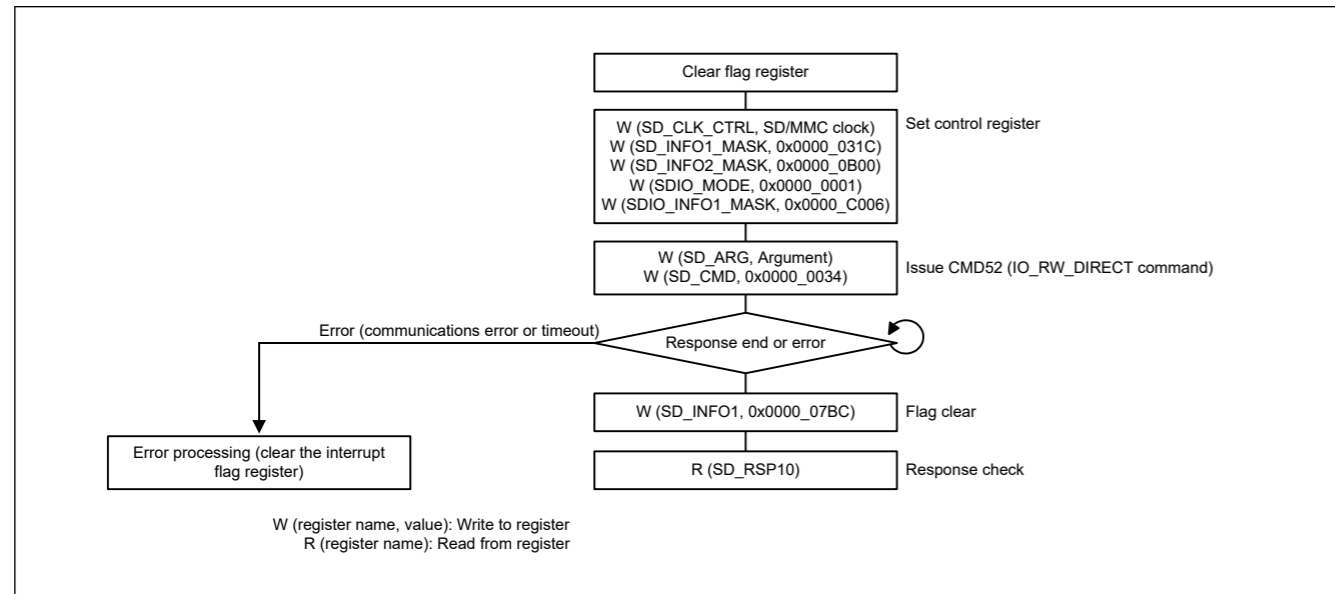


Figure 33.16 Example of IO\_RW\_DIRECT command (CMD52) operation

33.3.12 IO\_RW\_EXTENDED Command (SD: CMD53/Multiple Block Read)

Figure 33.17 shows an example flow for a CMD53 multiple block read operation.

以及收到的回复。如果由于使能访问结束中断而暂停命令序列，则在完成响应接收时SD\_INFO1中的ACEND位（访问结束）位设置为1时产生中断。将ACEND位清0并读取响应。

e. 数据写入和数据传输到MMC

向SD\_INFO1\_MASK写入0x0000\_0319使能访问结束中断，向SD\_INFO1\_MASK写入0x0000\_0900 SD\_INFO2\_MASK启用BWE中断并将SD\_OPTION的TOUTMASK设置为1以禁用超时。另外，启动外部定时器。当SD\_BUF0准备好写入数据时，SD\_INFO2寄存器中的BWE位设置为1以产生中断。将BWE位清除为0，并将SD\_SIZE中指定的数据量写入SD\_BUF0。当数据写入SD\_BUF0完成后，数据被传输到MMC。从MMC接收CRC状态和忙碌状态。这样做会重复传输SD\_SECCNT中设置的块数。但是，如果在写入SD\_BUF0时正在接收数据，则可能会产生通信错误或超时。

f. 操作完成

当全块数据发送和CRC状态接收完成时，SD\_INFO1中的ACEND位（访问结束）置1以产生中断。将ACEND位清0以读取响应。这是多块写操作的结束。此外，如果在接收响应时发生通信错误或超时，请执行错误处理（清除中断标志寄存器）。如果在传输数据时发生外部定时器超时，则执行软件复位。

33.3.11 IO\_RW\_DIRECT Command (SD: CMD52)

图33.16显示了IO\_DIRECT命令(CMD52)操作的示例流程。

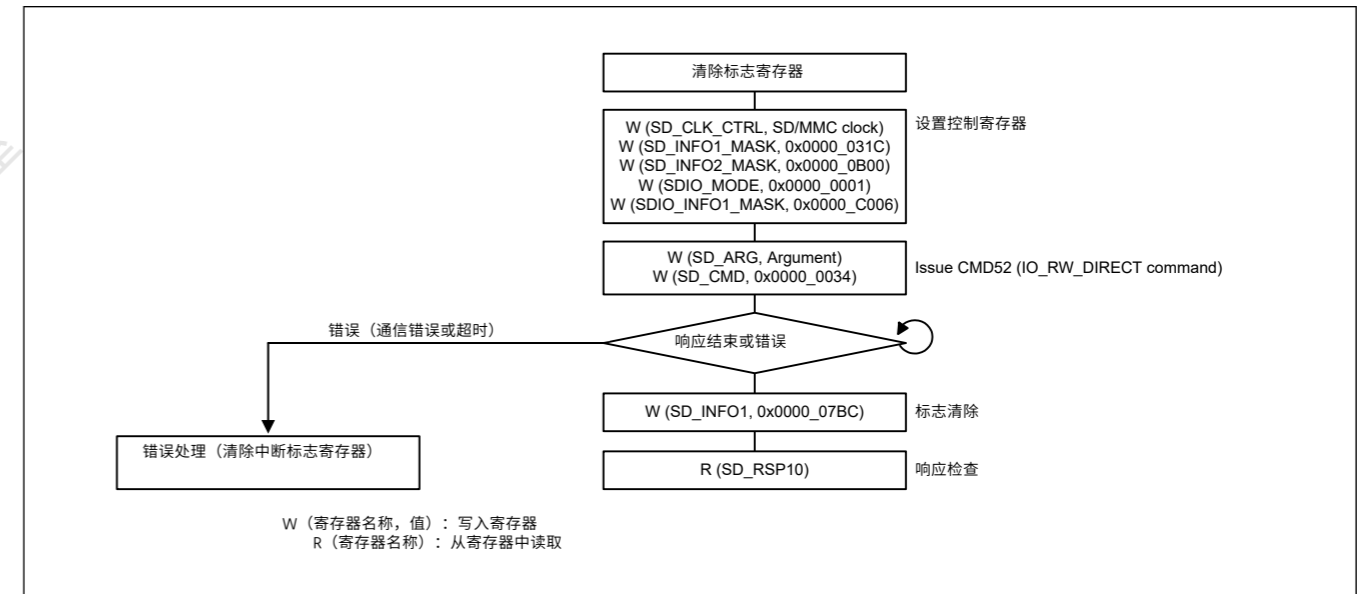


Figure 33.16 IO\_RW\_DIRECT命令(CMD52)操作示例

33.3.12 IO\_RW\_EXTENDED命令 (SD: CMD53多块读取)

图33.17显示了CMD53多块读取操作的示例流程。

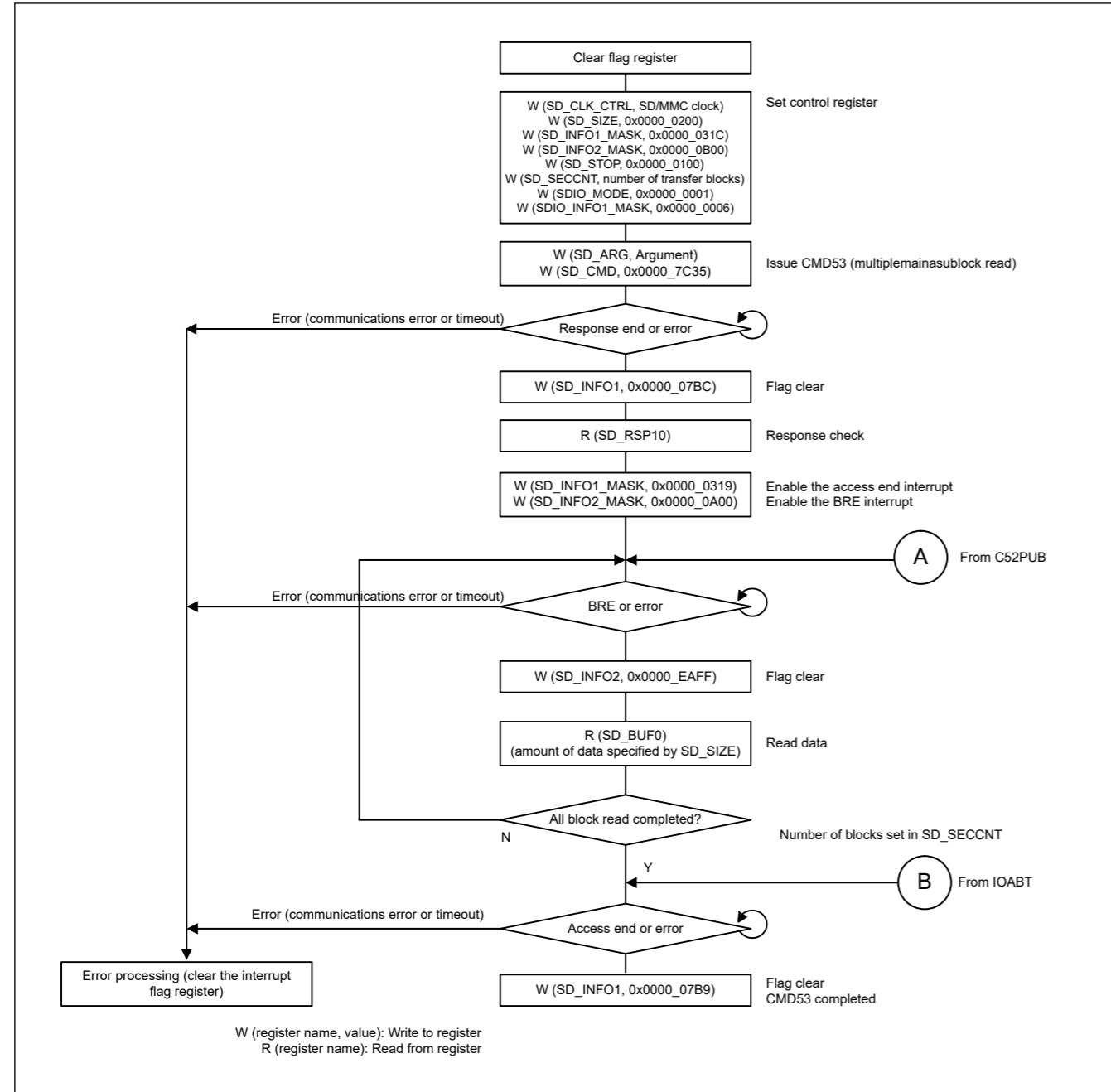


Figure 33.17 Example of IO\_RW\_EXTENDED command (CMD53) for multiple block read operation

Figure 33.18 shows an example flow when CMD52 (SDIO abort) is issued during a CMD53 multiple block read.

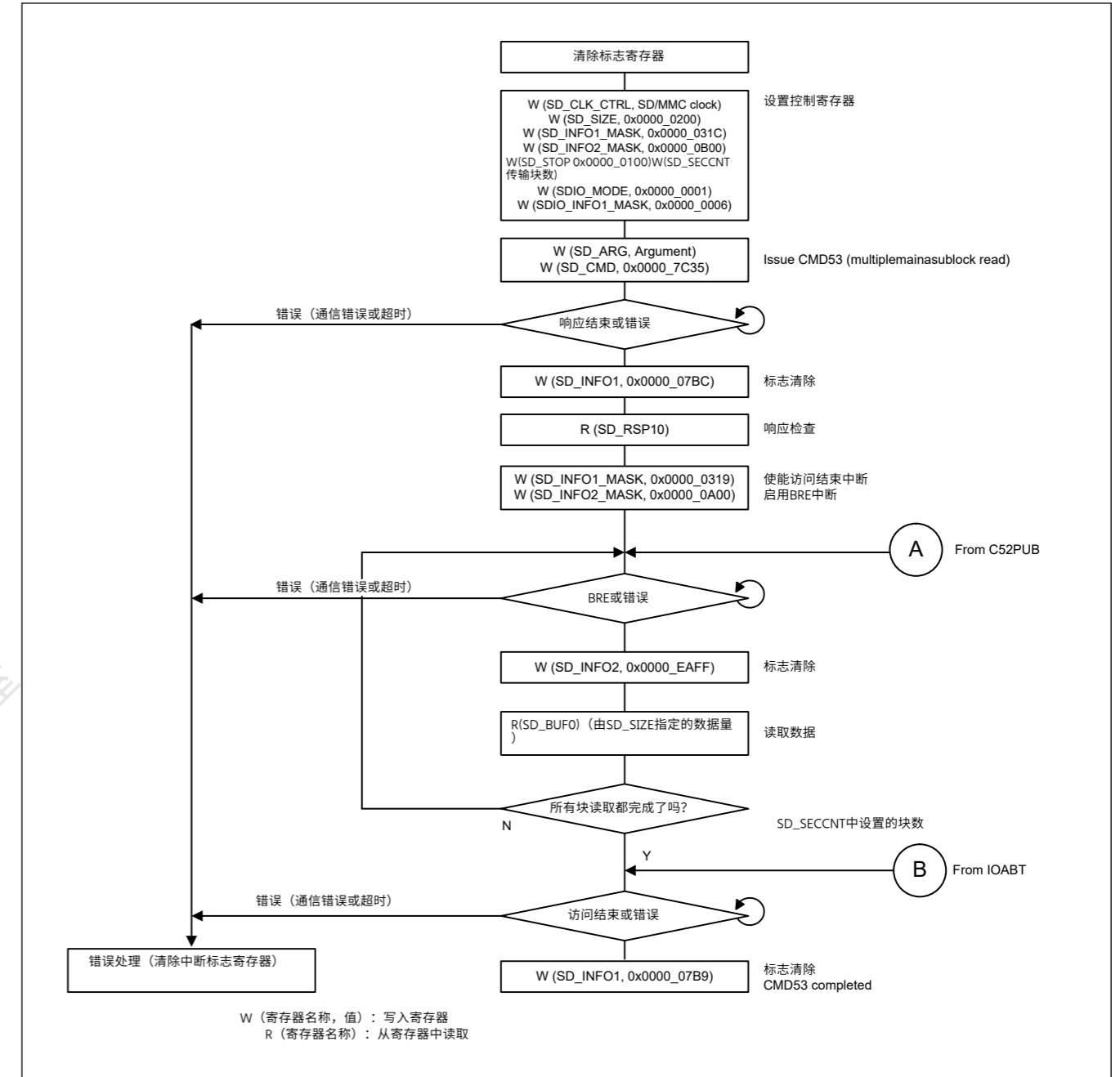


Figure 33.17 用于多块读取操作的IO\_RW\_EXTENDED命令(CMD53)示例

图33.18显示了在CMD53多块读取期间发出CMD52（SDIO中止）的示例流程。

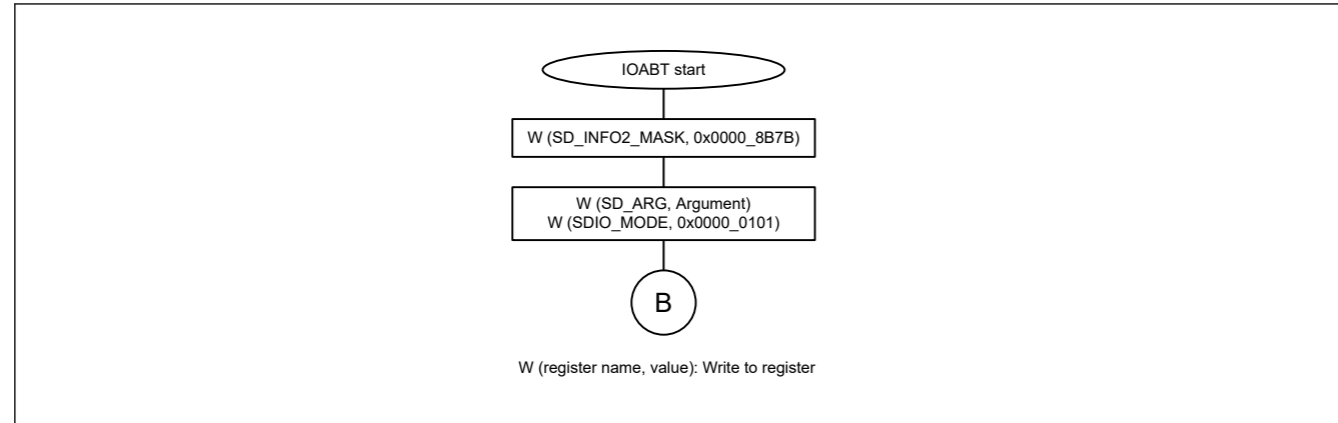


Figure 33.18 Flow when CMD52 (SDIO abort) is issued during a CMD53 multiple block read

Figure 33.19 shows an example flow when CMD52 (SDIO none abort) is issued at a CMD53 multiple block read while the SDHI is in the read wait state.

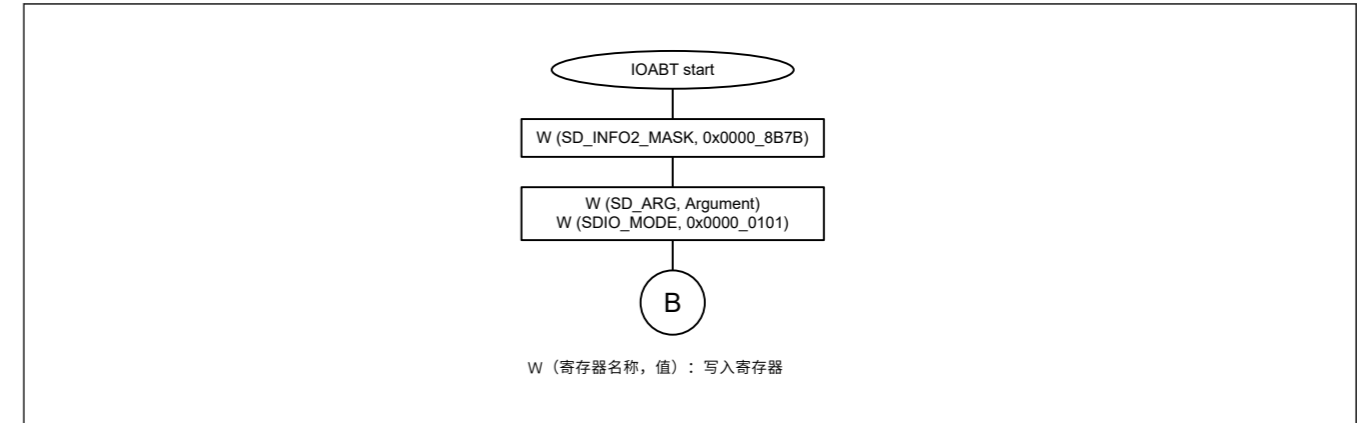


Figure 33.18 在CMD53多块读取期间发出CMD52 (SDIO中止) 时的流程

图33.19显示了在CMD53多块读取时发出CMD52 (SDIO无中止) 的示例流程, 而SDHI处于读取等待状态。

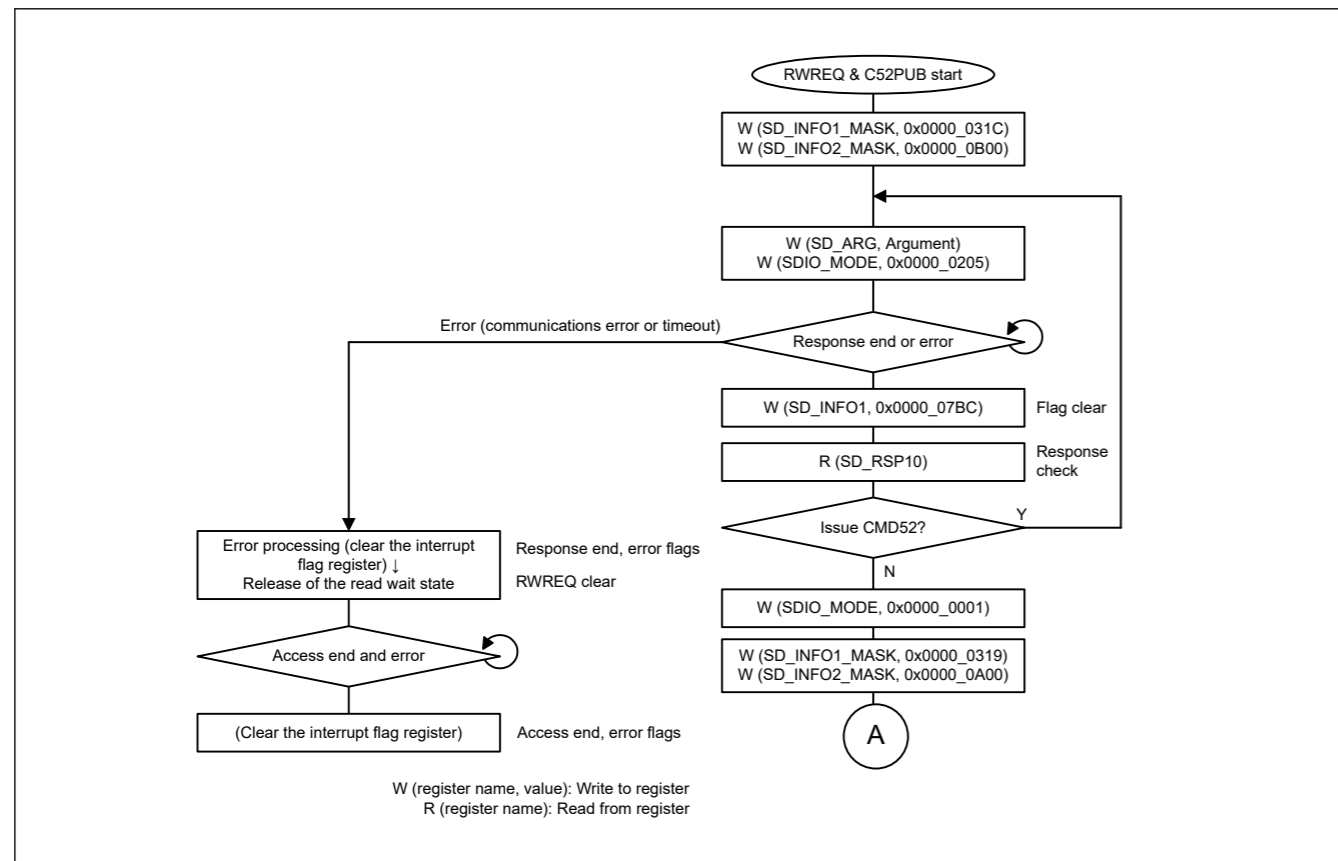


Figure 33.19 Flow when CMD52 (SDIO no abort) is issued during a CMD53 multiple block read while the SD Host Interface is in read wait state

33.3.13 IO\_RW\_EXTENDED Command (SD: CMD53/Multiple Block Write)

Figure 33.20 shows an example flow for a CMD53 multiple block write.

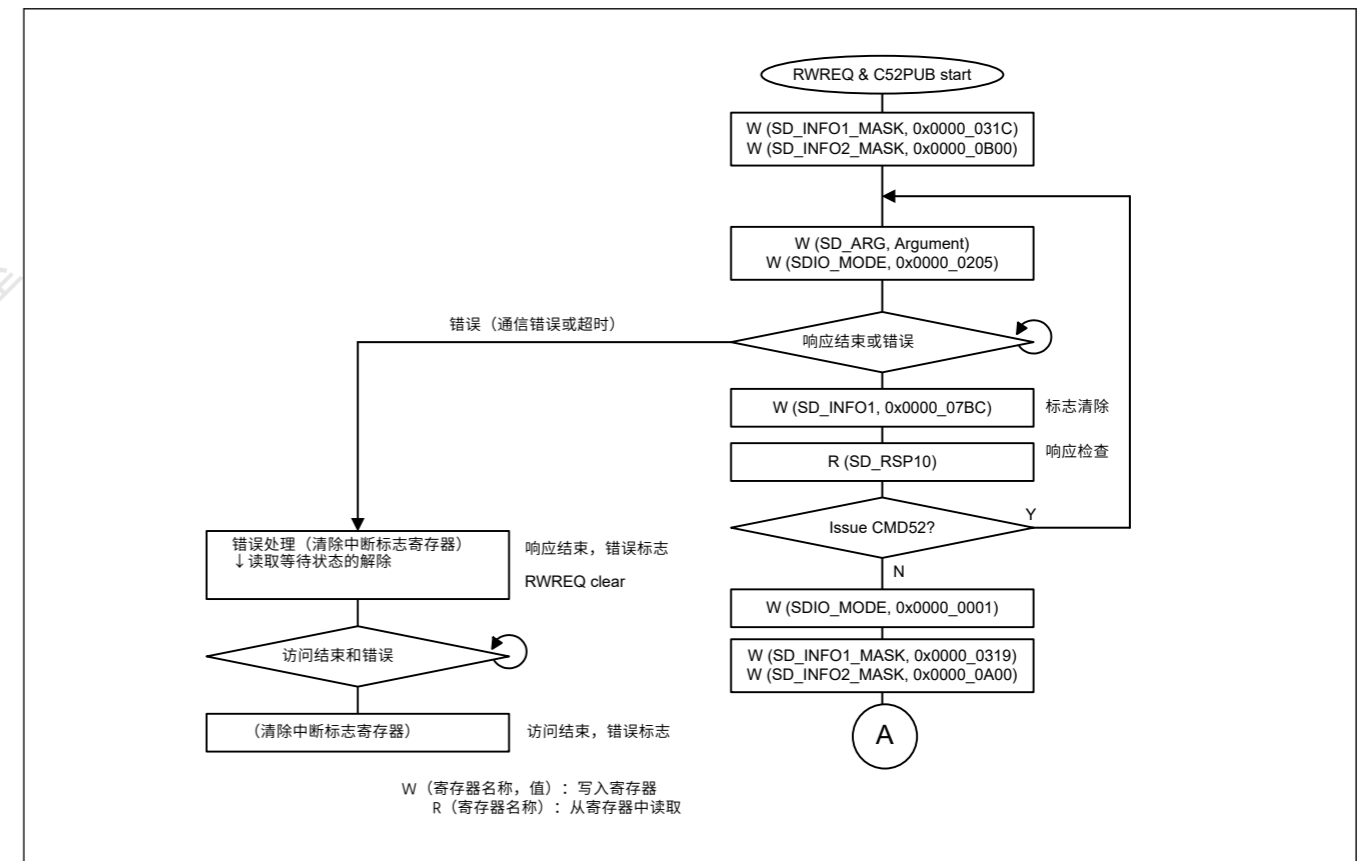


Figure 33.19 在CMD53多块读取期间发出CMD52 (SDIO无中止) 时的流程, 而SD主机接口处于读取等待状态

33.3.13 IO\_RW\_EXTENDED命令 (SD: CMD53多块写入)

图33.20显示了CMD53多块写入的示例流程。

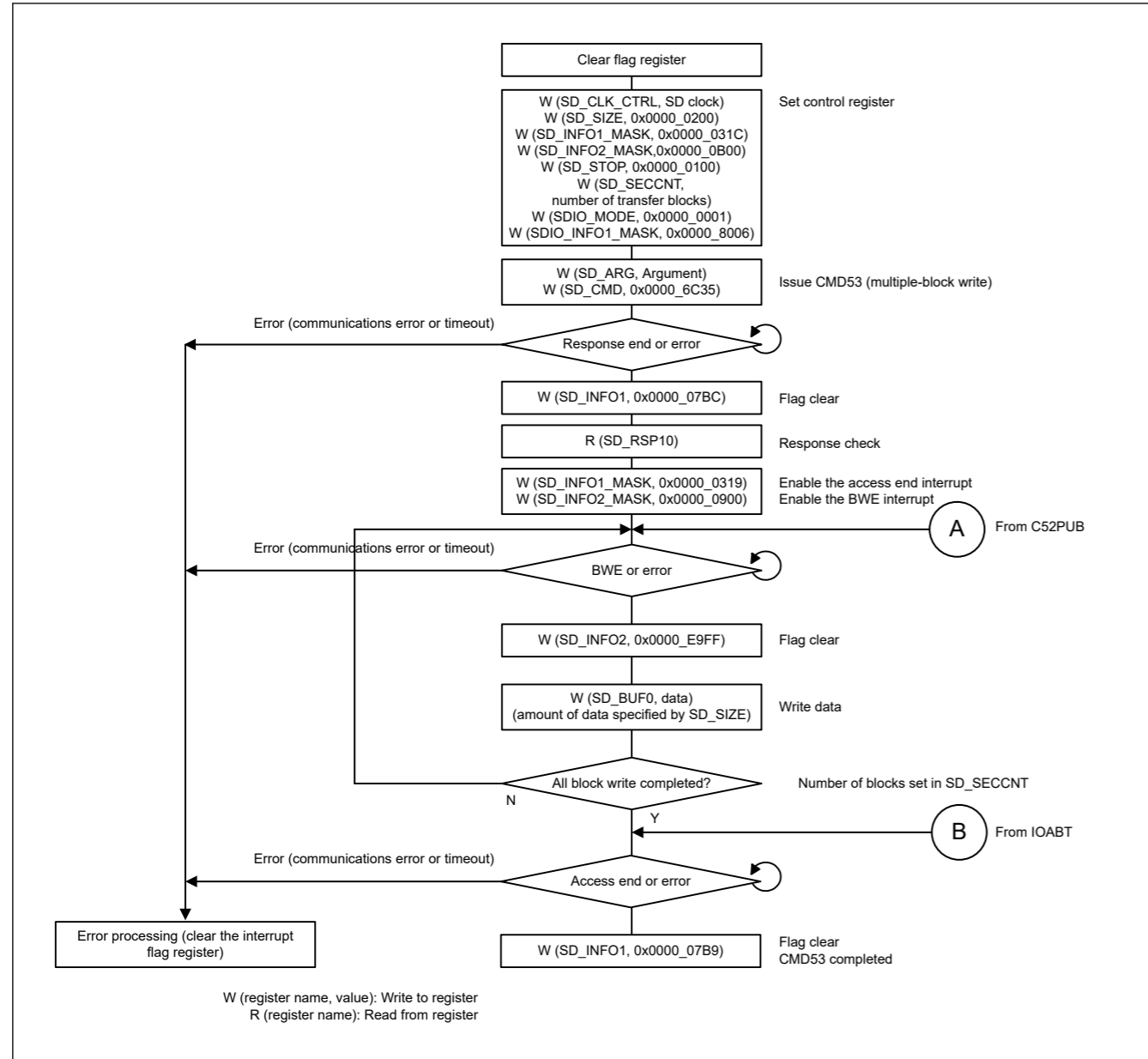


Figure 33.20 Example of IO\_RW\_EXTENDED command during a CMD53 multiple block write operation

Figure 33.21 shows an example flow when CMD52 (SDIO abort) is issued at CMD53 multiple block write.

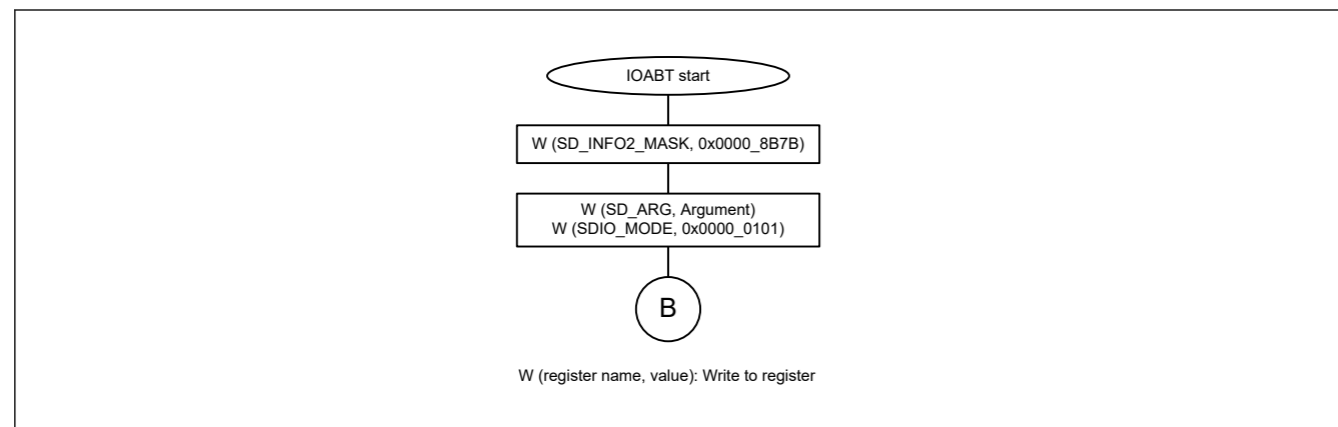


Figure 33.21 Flow when CMD52 (SDIO Abort) is issued during a CMD53 multiple block write

Figure 33.22 shows an example flow when CMD52 (SDIO none abort) is issued at CMD53 multiple block write.

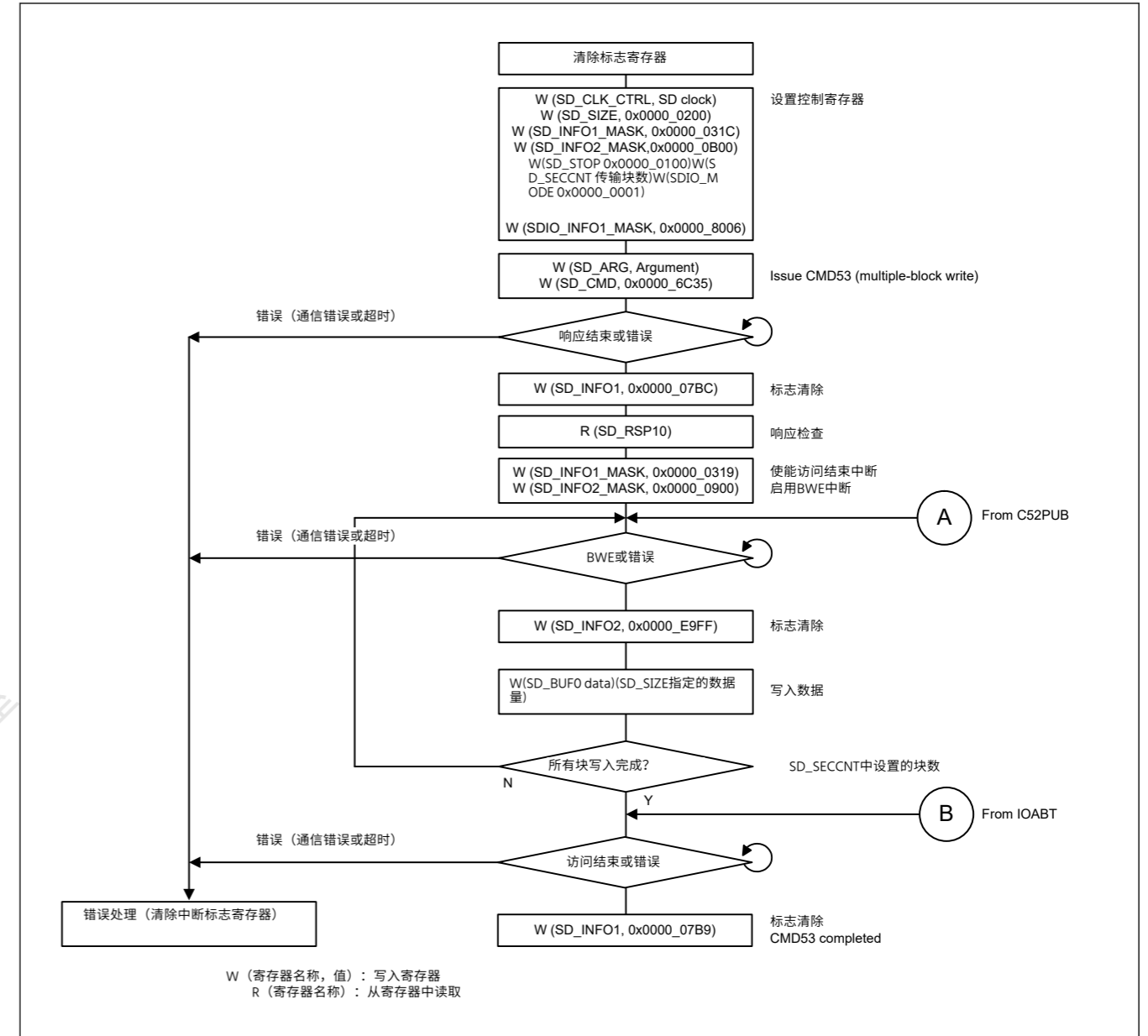


Figure 33.20 CMD53多块写入操作期间的IO\_RW\_EXTENDED命令示例

图33.21显示了在CMD53多块写入时发出CMD52 (SDIO中止) 的示例流程。

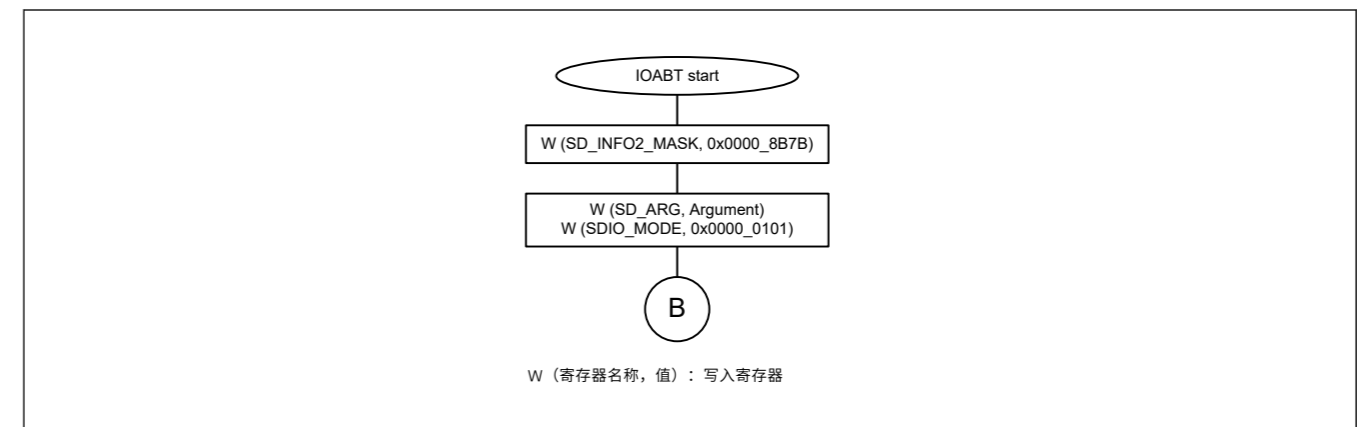


Figure 33.21 在CMD53多块写入期间发出CMD52 (SDIO中止) 时的流程

图33.22显示了在CMD53多块写入时发出CMD52 (SDIO无中止) 的示例流程。



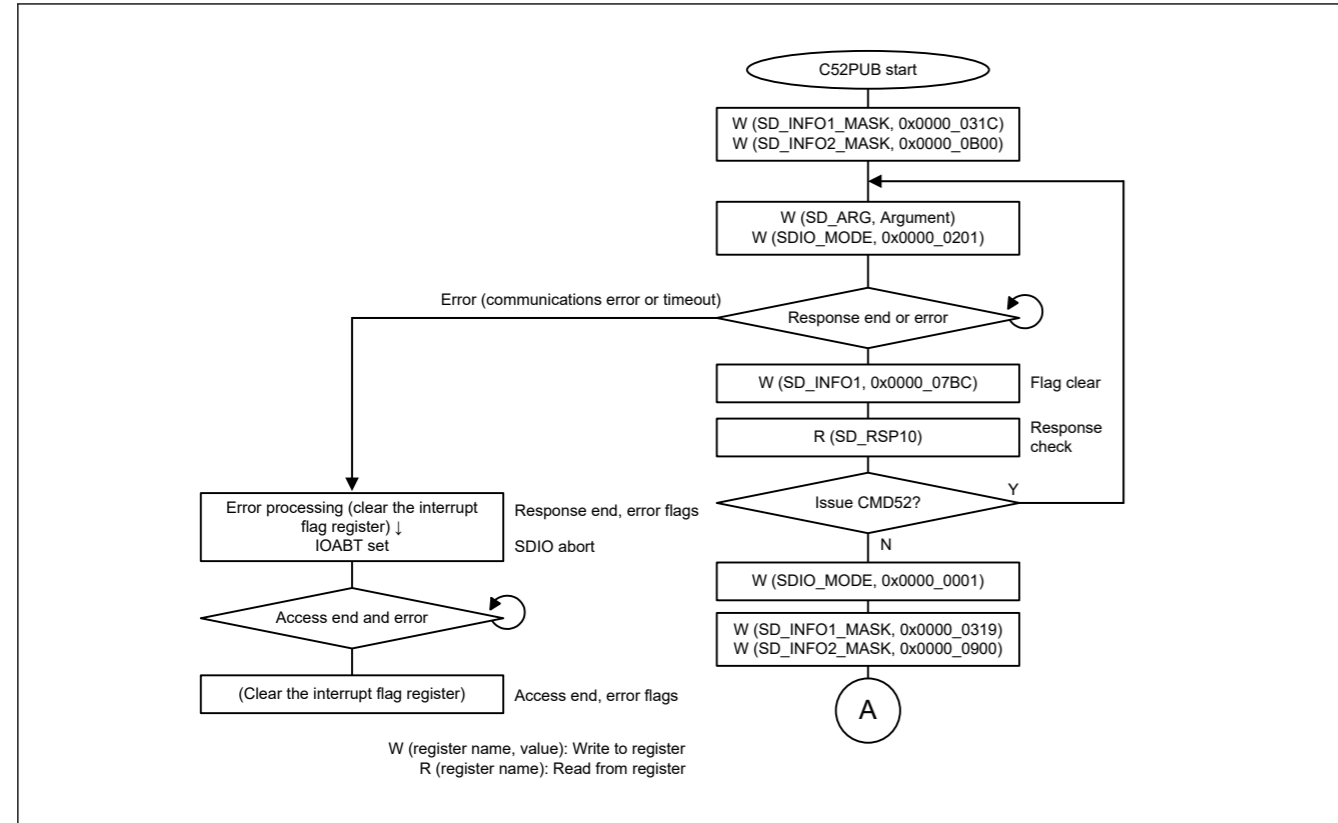


Figure 33.22 Flow when CMD52 (SDIO no abort) is issued during a CMD53 multiple block write

33.3.14 DMA Transfer (SD/MMC)

33.3.14.1 SD\_BUF DMA transfer

Figure 33.23 shows an example flow for SD\_BUF DMA read when CMD18 multiple block read is issued.

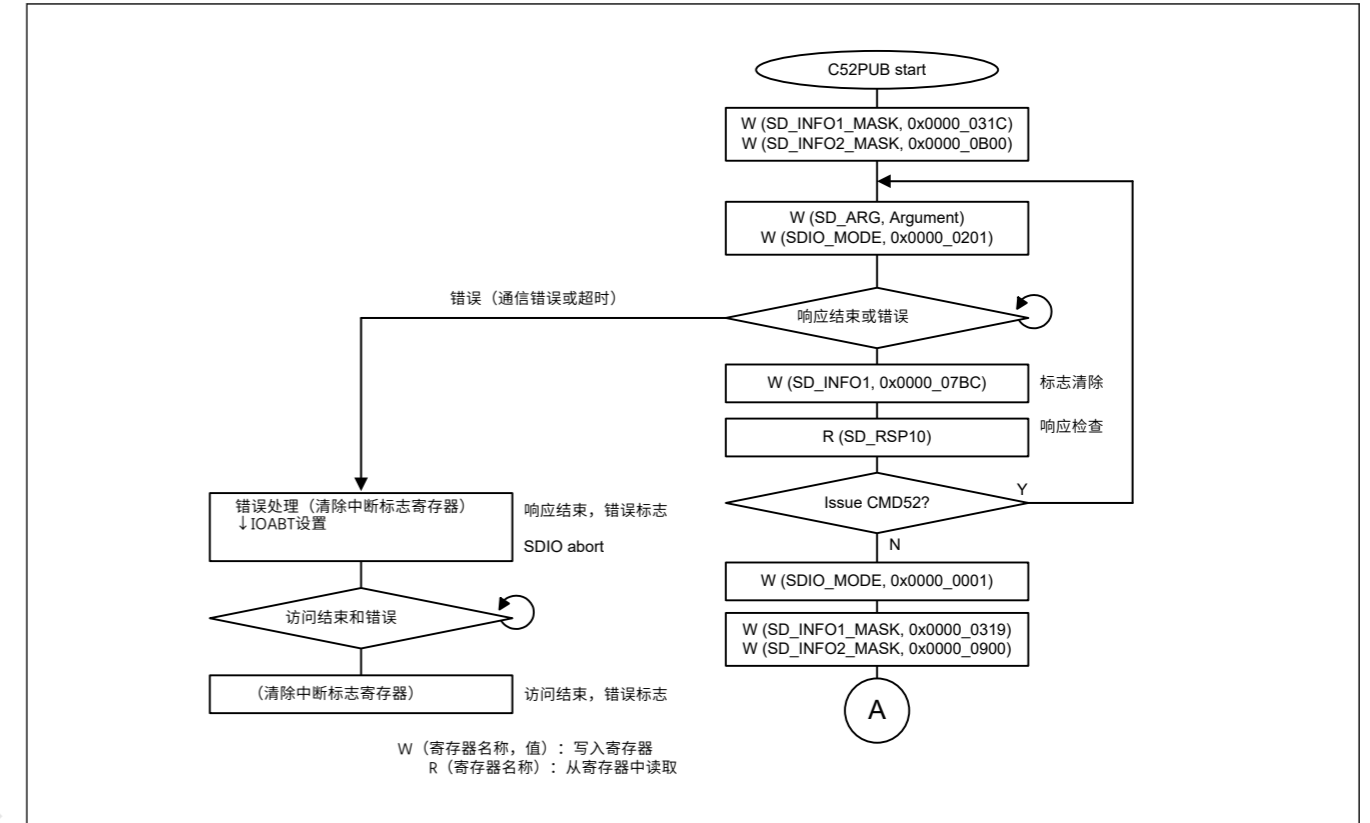


Figure 33.22 在CMD53多块写入期间发出CMD52 (SDIO无中止) 时的流程

33.3.14 DMA Transfer (SD/MMC)

33.3.14.1 SD\_BUF DMA transfer

图33.23显示了发出CMD18多块读取时SD\_BUFDMA读取的示例流程。

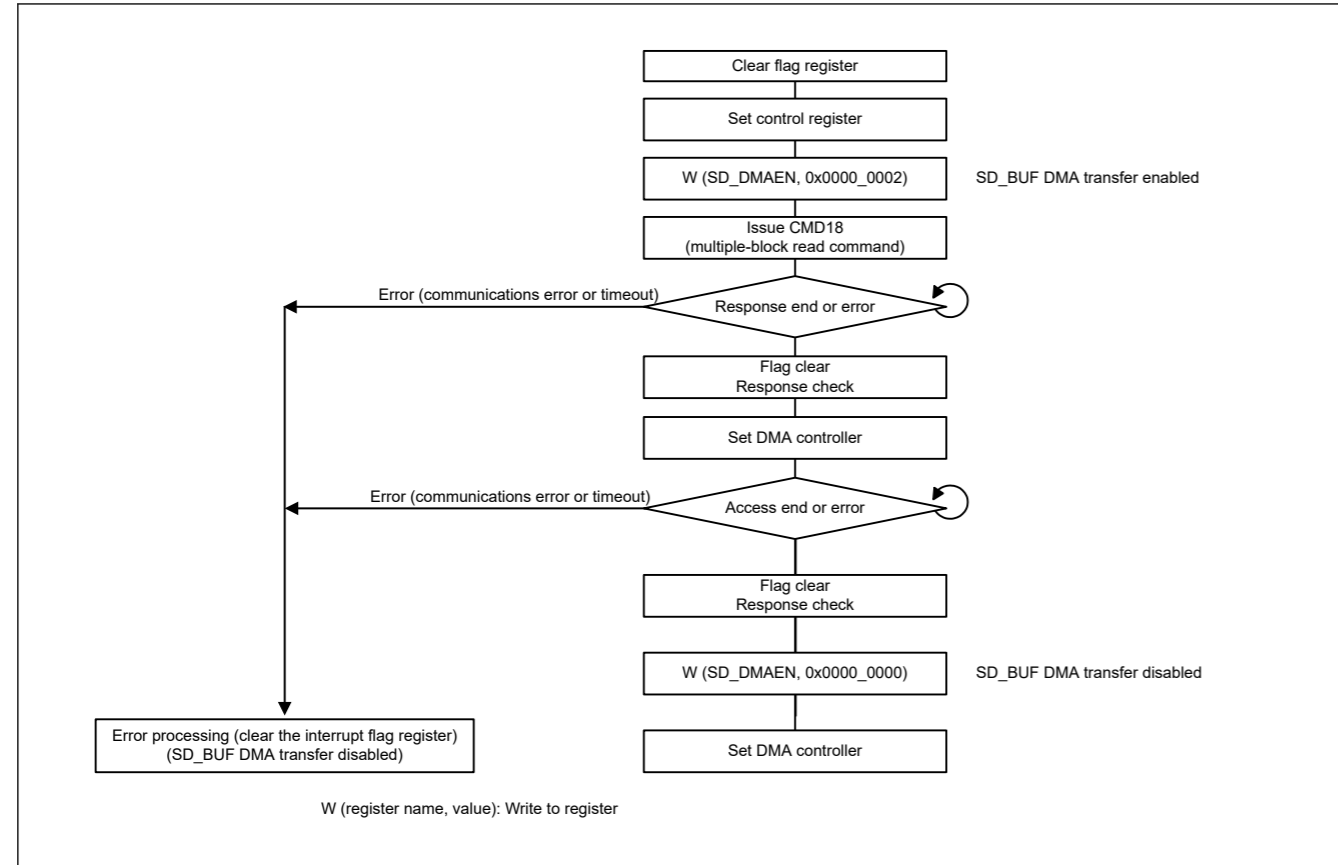


Figure 33.23 Example of SD\_BUF\_DMA read operation

Figure 33.24 shows an example flow for SD\_BUF DMA write when CMD25 multiple block write is issued.

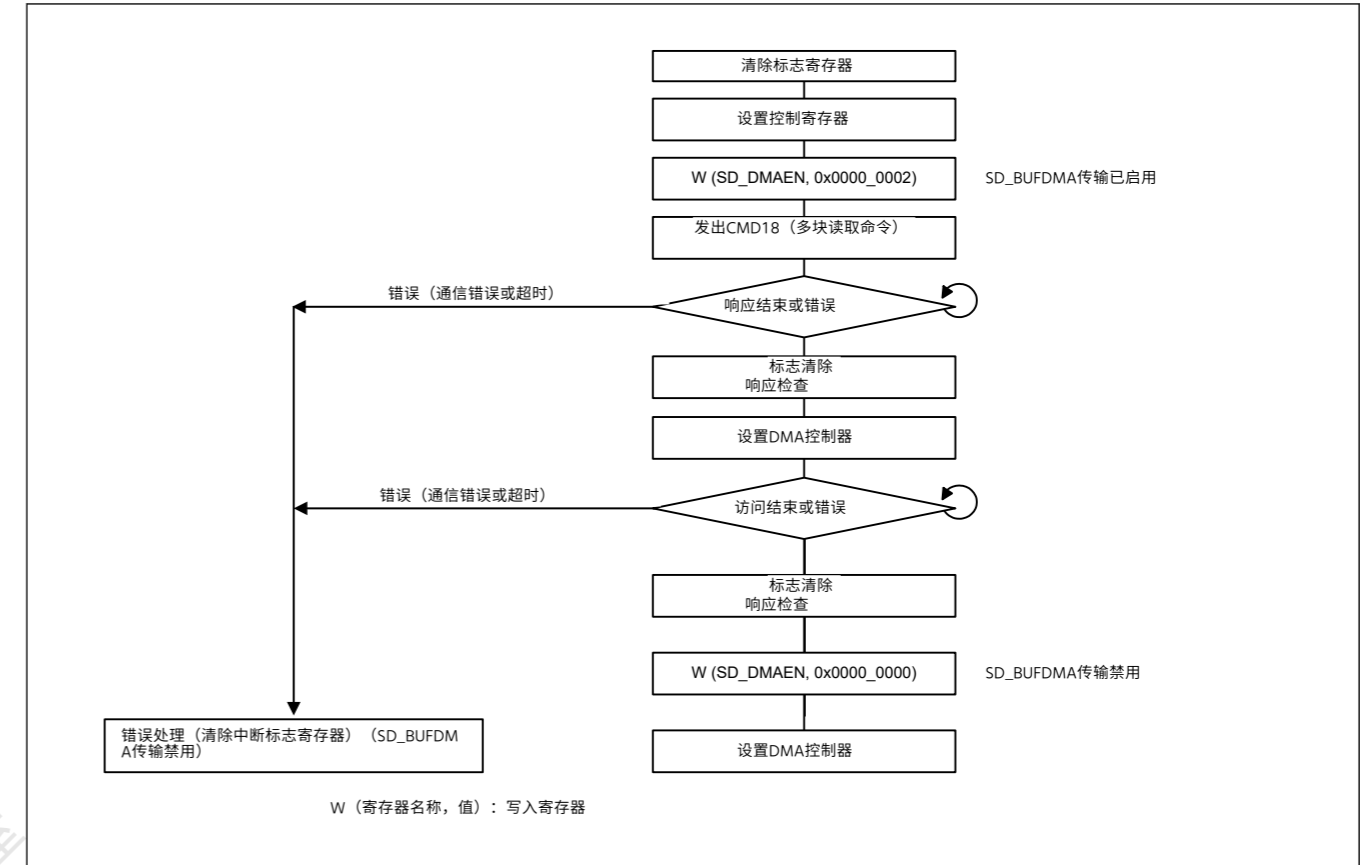


Figure 33.23 SD\_BUF\_DMA读取操作示例

图33.24显示了发出CMD25多块写入时SD\_BUFDMA写入的示例流程。

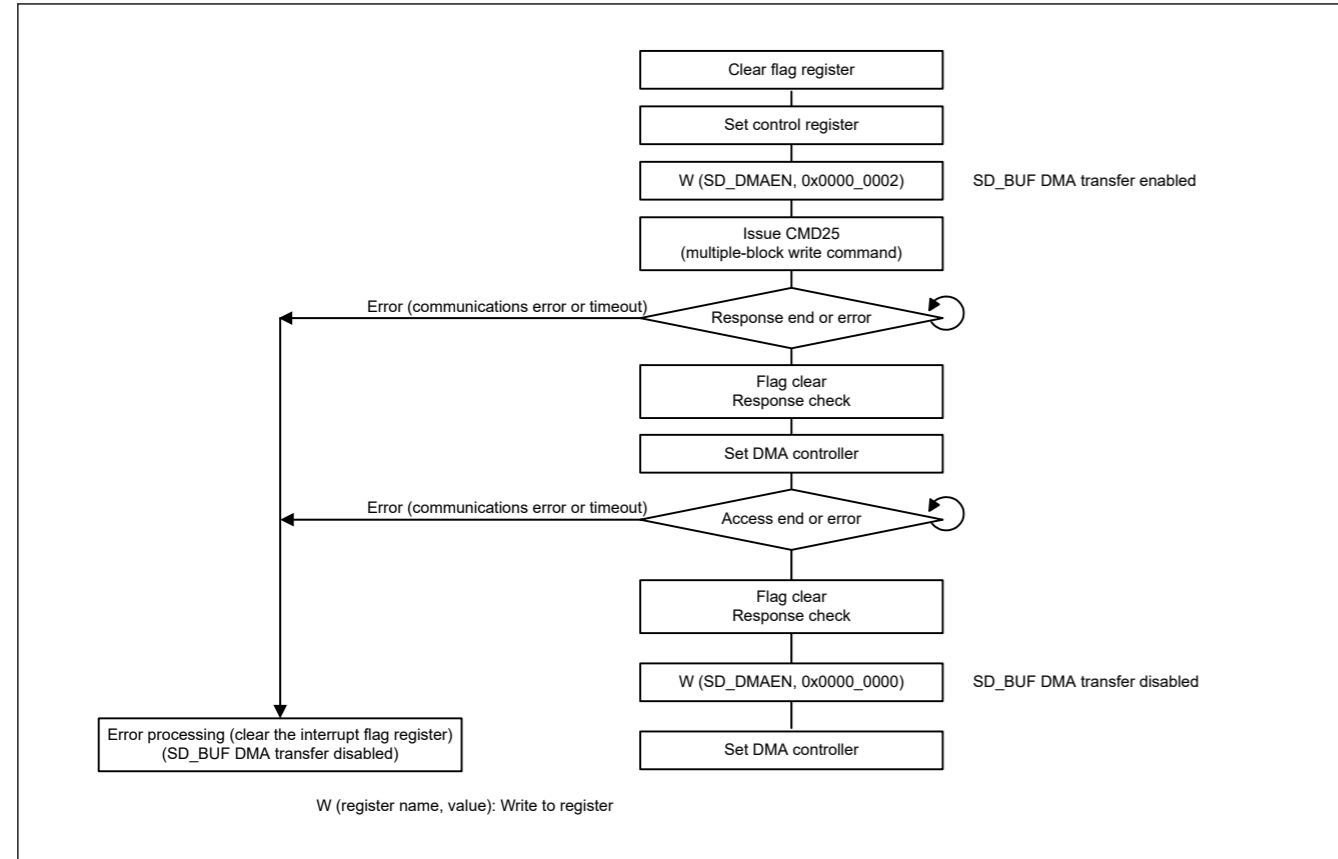


Figure 33.24 Example of SD\_BUF\_DMA write operation

33.3.15 Example of SD\_CMD Register Setting

Table 33.8 and Table 33.9 list the SD\_CMD register setting.

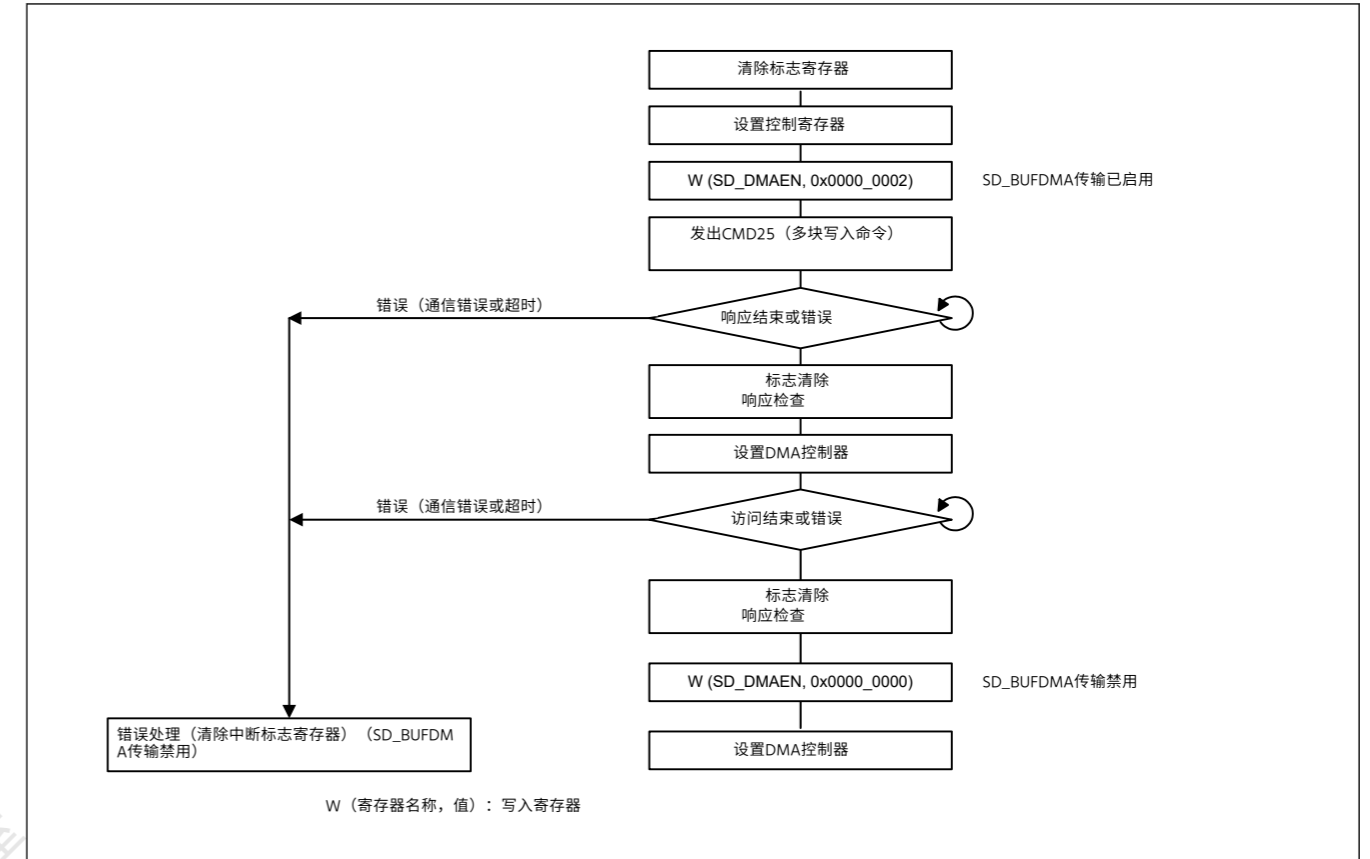


Figure 33.24 SD\_BUF\_DMA写操作示例

33.3.15 SD\_CMD寄存器设置示例

表33.8和表33.9列出了SD\_CMD寄存器设置。

Table 33.8 Example SD\_CMD register settings for SD (1 of 2)

| Type        | Command     | Example SD_CMD register setting   | Remark  |
|-------------|-------------|---|---|
| CMD         | CMD0        | 0x0000_0000   | —   |
|             | CMD2        | 0x0000_0002   | —   |
|             | CMD3        | 0x0000_0003   | —   |
|             | CMD4        | 0x0000_0004   | —   |
|             | CMD5        | 0x0000_0705 or 0x0000_0005  | —   |
|             | CMD6        | 0x0000_1C06 or 0x0000_0006  | —   |
|             | CMD7        | 0x0000_0007   | When the card is placed in the deselected state, the response timeout flag sets because there is no response. |
|             | CMD8        | 0x0000_0408 or 0x0000_0008  | —   |
|             | CMD9        | 0x0000_0009   | —   |
|             | CMD10       | 0x0000_000A   | —   |
|             | CMD11       | 0x0000_040B or 0x0000_000B  | —   |
|             | CMD12       | 0x0000_000C   | —   |
|             | CMD13       | 0x0000_000D   | —   |
|             | CMD15       | 0x0000_000F   | —   |
|             | CMD16       | 0x0000_0010   | —   |
|             | CMD17       | 0x0000_0011   | —   |
|             | CMD18       | 0x0000_0012   | With automatic CMD12  |
|             | CMD20       | 0x0000_0514 or 0x0000_0014  | —   |
|             | CMD24       | 0x0000_0018   | —   |
|             | CMD25       | 0x0000_0019   | With automatic CMD12  |
|             | CMD27       | 0x0000_001B   | —   |
|             | CMD28       | 0x0000_001C   | —   |
|             | CMD29       | 0x0000_001D   | —   |
|             | CMD30       | 0x0000_001E   | —   |
|             | CMD32       | 0x0000_0020   | —   |
|             | CMD33       | 0x0000_0021   | —   |
|             | CMD38       | 0x0000_0026   | —   |
|             | CMD42       | 0x0000_002A   | —   |
|             | CMD52       | 0x0000_0434 or 0x0000_0034  | —   |
|             | CMD53       | 0x0000_1C35   | Single read   |
|             |             | 0x0000_0C35   | Single write  |
|             |             | 0x0000_7C35   | Multiple read   |
|             |             | 0x0000_6C35   | Multiple write  |
| 0x0000_0035 |             | The value on the left can be set for both single and multiple operations. However, the CF39 bit in SD_ARG must be set as follows.<br>Read: 0 Write: 1 |   |
| CMD55       | 0x0000_0037 | —   |   |
| CMD56       | 0x0000_0038 | —   |   |

Table 33.8 SD的示例SD\_CMD寄存器设置 (1of2)

| Type        | Command     | 示例SD_CMD寄存器设置                                  | Remark                        |
|-------------|-------------|--|-------------------------------|
| CMD         | CMD0        | 0x0000_0000                                    | —                             |
|             | CMD2        | 0x0000_0002                                    | —                             |
|             | CMD3        | 0x0000_0003                                    | —                             |
|             | CMD4        | 0x0000_0004                                    | —                             |
|             | CMD5        | 0x0000_0705 or 0x0000_0005                     | —                             |
|             | CMD6        | 0x0000_1C06 or 0x0000_0006                     | —                             |
|             | CMD7        | 0x0000_0007                                    | 当卡被置于取消选择状态时，响应超时标志设置，因为没有响应。 |
|             | CMD8        | 0x0000_0408 or 0x0000_0008                     | —                             |
|             | CMD9        | 0x0000_0009                                    | —                             |
|             | CMD10       | 0x0000_000A                                    | —                             |
|             | CMD11       | 0x0000_040B or 0x0000_000B                     | —                             |
|             | CMD12       | 0x0000_000C                                    | —                             |
|             | CMD13       | 0x0000_000D                                    | —                             |
|             | CMD15       | 0x0000_000F                                    | —                             |
|             | CMD16       | 0x0000_0010                                    | —                             |
|             | CMD17       | 0x0000_0011                                    | —                             |
|             | CMD18       | 0x0000_0012                                    | 带自动CMD12                      |
|             | CMD20       | 0x0000_0514 or 0x0000_0014                     | —                             |
|             | CMD24       | 0x0000_0018                                    | —                             |
|             | CMD25       | 0x0000_0019                                    | 带自动CMD12                      |
|             | CMD27       | 0x0000_001B                                    | —                             |
|             | CMD28       | 0x0000_001C                                    | —                             |
|             | CMD29       | 0x0000_001D                                    | —                             |
|             | CMD30       | 0x0000_001E                                    | —                             |
|             | CMD32       | 0x0000_0020                                    | —                             |
|             | CMD33       | 0x0000_0021                                    | —                             |
|             | CMD38       | 0x0000_0026                                    | —                             |
|             | CMD42       | 0x0000_002A                                    | —                             |
|             | CMD52       | 0x0000_0434 or 0x0000_0034                     | —                             |
|             | CMD53       | 0x0000_1C35                                    | 单读                            |
|             |             | 0x0000_0C35                                    | 单写                            |
|             |             | 0x0000_7C35                                    | 多读                            |
|             |             | 0x0000_6C35                                    | 多次写入                          |
| 0x0000_0035 |             | 左侧的值可以设置为单个和多个操作。但是，SD_ARG中的CF39位必须如下设置。读：0写：1 |                               |
| CMD55       | 0x0000_0037 | —  |                               |
| CMD56       | 0x0000_0038 | —  |                               |



Table 33.8 Example SD\_CMD register settings for SD (2 of 2)

| Type | Command | Example SD_CMD register setting | Remark |
|------|---------|---------------------------------|--------|
| ACMD | ACMD6   | 0x0000_0046                     | —      |
|      | ACMD13  | 0x0000_004D                     | —      |
|      | ACMD22  | 0x0000_0056                     | —      |
|      | ACMD23  | 0x0000_0057                     | —      |
|      | ACMD41  | 0x0000_0069                     | —      |
|      | ACMD42  | 0x0000_006A                     | —      |
|      | ACMD51  | 0x0000_0073                     | —      |

Table 33.8 SD的示例SD\_CMD寄存器设置 (2个中的2个)

| Type | Command | 示例SD_CMD寄存器设置 | Remark |
|------|---------|---------------|--------|
| ACMD | ACMD6   | 0x0000_0046   | —      |
|      | ACMD13  | 0x0000_004D   | —      |
|      | ACMD22  | 0x0000_0056   | —      |
|      | ACMD23  | 0x0000_0057   | —      |
|      | ACMD41  | 0x0000_0069   | —      |
|      | ACMD42  | 0x0000_006A   | —      |
|      | ACMD51  | 0x0000_0073   | —      |

RA生态工作室

Table 33.9 Example SD\_CMD register settings for MMC

| Type  | Command     | Example SD_CMD register setting | Remark  |                         |
|-------|-------------|---------------------------------|---|-------------------------|
| CMD   | CMD0        | 0x0000_0000                     | —   |                         |
|       | CMD1        | 0x0000_0701                     | —   |                         |
|       | CMD2        | 0x0000_0002                     | —   |                         |
|       | CMD3        | 0x0000_0003                     | —   |                         |
|       | CMD4        | 0x0000_0004                     | —   |                         |
|       | CMD5        | 0x0000_0505                     | —   |                         |
|       | CMD6        | 0x0000_0506                     | 0x0000_0406   | (with response busy)    |
|       |             |                                 | 0x0000_0406   | (without response busy) |
|       | CMD7        | 0x0000_0007                     | When the card is placed in the deselected state, the response timeout flag sets because there is no response. |                         |
|       | CMD8        | 0x0000_1C08                     | —   |                         |
|       | CMD9        | 0x0000_0009                     | —   |                         |
|       | CMD10       | 0x0000_000A                     | —   |                         |
|       | CMD12       | 0x0000_000C                     | —   |                         |
|       | CMD13       | 0x0000_000D                     | —   |                         |
|       | CMD14       | 0x0000_1C0E                     | Required setting: SD_IFMODE = 0x0000_0100 (CRC check is invalid)  |                         |
|       | CMD15       | 0x0000_000F                     | —   |                         |
|       | CMD16       | 0x0000_0010                     | —   |                         |
|       | CMD17       | 0x0000_0011                     | —   |                         |
|       | CMD18       | 0x0000_7C12                     | Pre-defined   |                         |
|       | CMD19       | 0x0000_0C13                     | Required setting: SD_IFMODE = 0x0000_0100 (CRC check is invalid)  |                         |
|       | CMD21       | 0x0000_1C15                     | DDR mode is inhibited   |                         |
|       | CMD23       | 0x0000_0017                     | —   |                         |
|       | CMD24       | 0x0000_0018                     | —   |                         |
|       | CMD25       | 0x0000_6C19                     | Pre-defined   |                         |
|       | CMD26       | 0x0000_0C1A                     | —   |                         |
|       | CMD27       | 0x0000_001B                     | —   |                         |
|       | CMD28       | 0x0000_001C                     | —   |                         |
|       | CMD29       | 0x0000_001D                     | —   |                         |
|       | CMD30       | 0x0000_001E                     | —   |                         |
|       | CMD31       | 0x0000_1C1F                     | —   |                         |
|       | CMD35       | 0x0000_0423                     | —   |                         |
|       | CMD36       | 0x0000_0424                     | —   |                         |
| CMD38 | 0x0000_0026 | —                               |   |                         |
| CMD39 | 0x0000_0427 | —                               |   |                         |
| CMD40 | 0x0000_0428 | —                               |   |                         |
| CMD42 | 0x0000_002A | —                               |   |                         |
| CMD49 | 0x0000_0C31 | —                               |   |                         |
| CMD53 | 0x0000_7C35 | —                               |   |                         |
| CMD54 | 0x0000_6C36 | —                               |   |                         |
| CMD55 | 0x0000_0037 | —                               |   |                         |
| CMD56 | 0x0000_0038 | —                               |   |                         |

Table 33.9 MMC的示例SD\_CMD寄存器设置

| Type  | Command     | 示例SD_CMD寄存器设置 | Remark                                |                         |
|-------|-------------|---------------|---------------------------------------|-------------------------|
| CMD   | CMD0        | 0x0000_0000   | —                                     |                         |
|       | CMD1        | 0x0000_0701   | —                                     |                         |
|       | CMD2        | 0x0000_0002   | —                                     |                         |
|       | CMD3        | 0x0000_0003   | —                                     |                         |
|       | CMD4        | 0x0000_0004   | —                                     |                         |
|       | CMD5        | 0x0000_0505   | —                                     |                         |
|       | CMD6        | 0x0000_0506   | 0x0000_0406                           | (with response busy)    |
|       |             |               | 0x0000_0406                           | (without response busy) |
|       | CMD7        | 0x0000_0007   | 当卡被置于取消选择状态时，响应超时标志设置，因为没有响应。         |                         |
|       | CMD8        | 0x0000_1C08   | —                                     |                         |
|       | CMD9        | 0x0000_0009   | —                                     |                         |
|       | CMD10       | 0x0000_000A   | —                                     |                         |
|       | CMD12       | 0x0000_000C   | —                                     |                         |
|       | CMD13       | 0x0000_000D   | —                                     |                         |
|       | CMD14       | 0x0000_1C0E   | 所需设置: SD_IFMODE=0x0000_0100 (CRC校验无效) |                         |
|       | CMD15       | 0x0000_000F   | —                                     |                         |
|       | CMD16       | 0x0000_0010   | —                                     |                         |
|       | CMD17       | 0x0000_0011   | —                                     |                         |
|       | CMD18       | 0x0000_7C12   | Pre-defined                           |                         |
|       | CMD19       | 0x0000_0C13   | 所需设置: SD_IFMODE=0x0000_0100 (CRC校验无效) |                         |
|       | CMD21       | 0x0000_1C15   | DDR模式被禁止                              |                         |
|       | CMD23       | 0x0000_0017   | —                                     |                         |
|       | CMD24       | 0x0000_0018   | —                                     |                         |
|       | CMD25       | 0x0000_6C19   | Pre-defined                           |                         |
|       | CMD26       | 0x0000_0C1A   | —                                     |                         |
|       | CMD27       | 0x0000_001B   | —                                     |                         |
|       | CMD28       | 0x0000_001C   | —                                     |                         |
|       | CMD29       | 0x0000_001D   | —                                     |                         |
|       | CMD30       | 0x0000_001E   | —                                     |                         |
|       | CMD31       | 0x0000_1C1F   | —                                     |                         |
|       | CMD35       | 0x0000_0423   | —                                     |                         |
|       | CMD36       | 0x0000_0424   | —                                     |                         |
| CMD38 | 0x0000_0026 | —             |                                       |                         |
| CMD39 | 0x0000_0427 | —             |                                       |                         |
| CMD40 | 0x0000_0428 | —             |                                       |                         |
| CMD42 | 0x0000_002A | —             |                                       |                         |
| CMD49 | 0x0000_0C31 | —             |                                       |                         |
| CMD53 | 0x0000_7C35 | —             |                                       |                         |
| CMD54 | 0x0000_6C36 | —             |                                       |                         |
| CMD55 | 0x0000_0037 | —             |                                       |                         |
| CMD56 | 0x0000_0038 | —             |                                       |                         |

### 33.4 Usage Notes

#### 33.4.1 SD\_BUF Illegal Write Access (SD/MMC)

When writing data to SD\_BUF0 after the single block write or multi block write command is issued, the data of the size specified in SD\_SIZE must be written.

If the data exceeds the size specified in SD\_SIZE is written, the ERR4 bit in SD\_INFO2 is set to 1. In addition, the data written to SD\_BUF0 might not be transmitted and the SD\_CLK\_CTRLLEN bit in SD\_INFO2 is held at the value of 0. If this occurs, clearing the SDRST bit in SOFT\_RST to 0 and then restoring its value to 1 clears the SD\_CLK\_CTRLLEN bit to 1.

However, this does not apply to the single byte or three bytes when the SD\_SIZE setting is odd, or to the fraction of bytes when the SD\_SIZE setting is even (the 2 bytes that are not in a 4-byte unit), because the portion of dummy data writing is regarded as excess data and ignored.

#### 33.4.2 Block Number Constraint for Multiple Block Read (SD)

When performing a multiple block read of one or two blocks, depending on the timing with which the SD card response register is read, the response value might not be read properly. To prevent this, do one of the following:

1. When receiving one or two blocks of data, use single block reading.
2. Read the response to CMD18 from SD\_RSP54.

##### 33.4.2.1 Mechanism of incorrect reading

Figure 33.25 shows the processing flows of the SDHI (hardware) operation and software operation when a multiple block read is performed on two blocks. As shown in the incorrect operation in Figure 33.25, when an interrupt is generated on reception of the CMD18 response and the timing with which the SD card response register (SD\_RSP10) is read by the interrupt is delayed, the data during the CMD12 response reception or the CMD12 response might be read. This problem does not occur for multiple block reads of three or more blocks, because CMD12 is not issued until the block of data is read. The problem also does not occur for multiple block writes, because the CMD25 response is read before the block of data is sent.

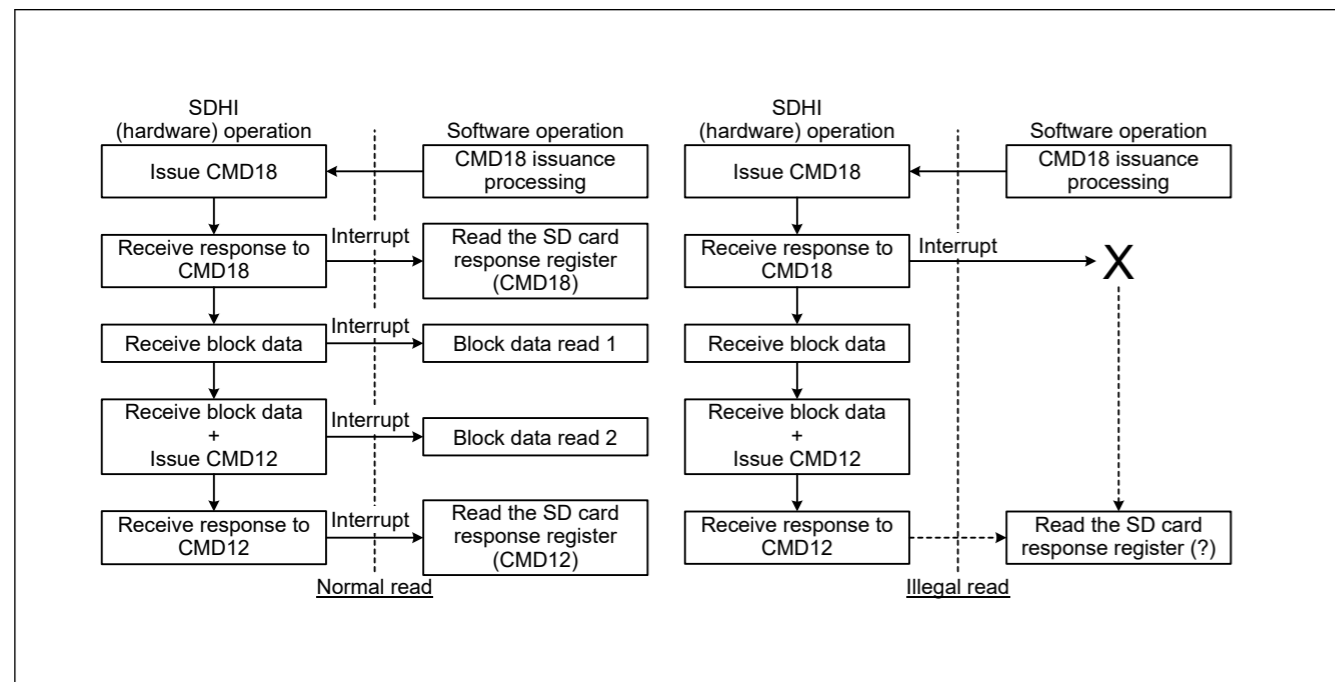


Figure 33.25 Multiple block read operation flow chart (two blocks)

#### 33.4.3 Automatic Control of SD/MMC Clock Output (SD/MMC)

In the SD Card/MMC standard, 74 cycles of SD/MMC clock must be output before initialization of the card. For this reason, use automatic control of SD/MMC clock output after 74 cycles of SD/MMC clock are output. In addition, if

### 33.4 使用说明

#### 33.4.1 SD\_BUF非法写访问(SDMMC)

在发出单块写入或多块写入命令后向SD\_BUF0写入数据时，必须写入SD\_SIZE中指定大小的数据。

如果写入的数据超过SD\_SIZE中指定的大小，则SD\_INFO2中的ERR4位设置为1。此外，写入SD\_BUF0的数据可能不会被传输，并且SD\_INFO2中的SD\_CLK\_CTRLLEN位将保持为0。如果这发生时，将SOFT\_RST中的SDRST位清除为0，然后将其值恢复为1，将SD\_CLK\_CTRLLEN位清除为1。

但是，这不适用于SD\_SIZE设置为奇数时的单个字节或三个字节，或适用于SD\_SIZE设置为偶数时的字节部分（不在4字节单元中的2个字节），因为该部分虚拟数据写入的次数被视为多余数据并被忽略。

#### 33.4.2 多块读取(SD)的块号约束

执行1个或2个块的多块读取时，根据读取SD卡响应寄存器的时序，可能无法正确读取响应值。为防止这种情况，请执行以下操作之一：

- 1、接收一两块数据时，使用单块读取。
- 2.从SD\_RSP54读取对CMD18的响应。

##### 33.4.2.1 误读机制

图33.25显示了对两个块执行多块读取时的SDHI（硬件）操作和软件操作的处理流程。如图33.25中的错误操作所示，当接收到CMD18响应时产生中断并且中断读取SD卡响应寄存器(SD\_RSP10)的时序延迟时，CMD12响应接收期间的数据或可能会读取CMD12响应。对于三个或更多块的多块读取不会出现此问题，因为在读取数据块之前不会发出CMD12。多次块写入也不会出现该问题，因为在发送数据块之前读取了CMD25响应。

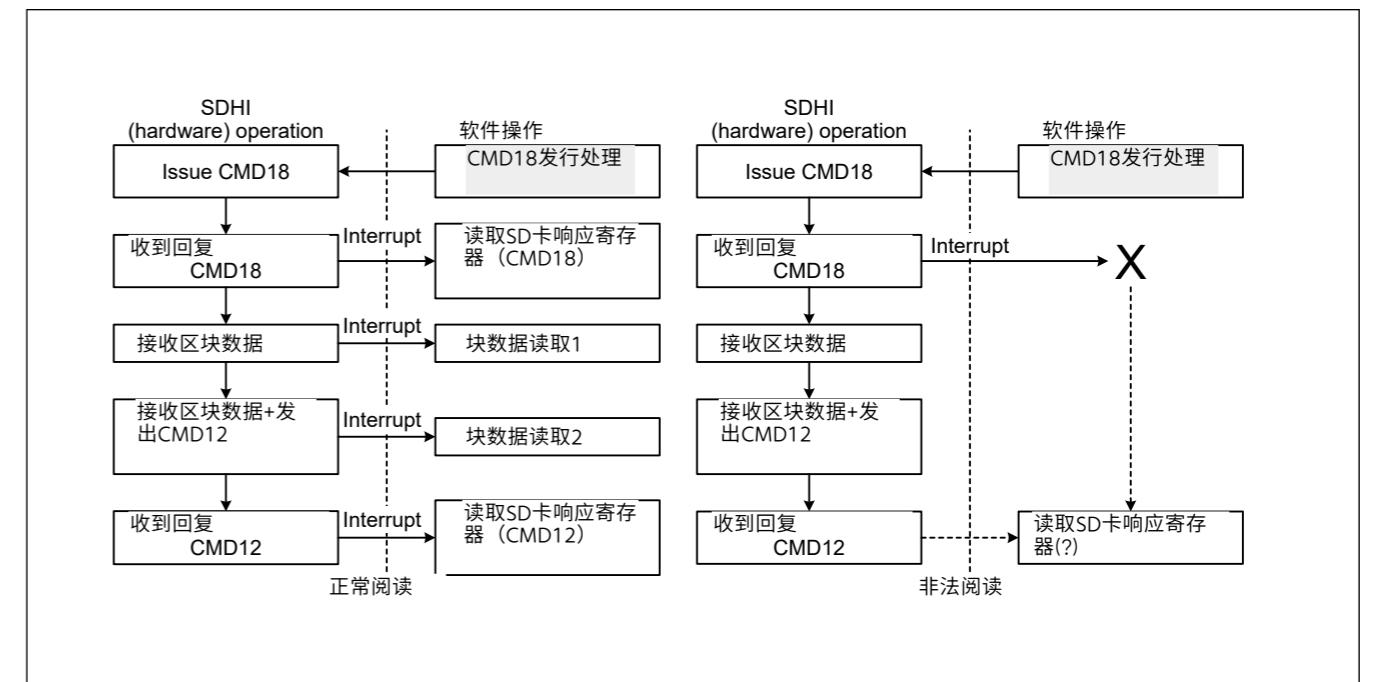


Figure 33.25 多块读取操作流程图 (两个块)

#### 33.4.3 SDMMC时钟输出(SDMMC)的自动控制

在SD卡MMC标准中，必须在卡初始化之前输出74个周期的SDMMC时钟。为此，在输出SDMMC时钟的74个周期后使用SDMMC时钟输出的自动控制。此外，如果

automatic control of SD/MMC clock output was in use, SD/MMC clock output is stopped on completion of the sequence for a communications error or timeout. When state transitions within the SD card/MMC are necessary after completion of the sequence, release automatic control of SD/MMC clock output and restart supply of the SD/MMC clock to the SD card/MMC.

#### 33.4.4 Control of the C52PUB Setting for Multiple Block Write (SD)

If the C52PUB bit in SDIO\_MODE is set to 1 during a sequence of multiple block write because of CMD53, CMD52 is not issued until SD\_BUF becomes empty. For this reason, set the C52PUB bit after suspending writing to SD\_BUF by using one of the following procedures, as appropriate:

##### (a) When DMA transfer is not in use

1. Before setting the C52PUB bit, suspend writing to SD\_BUF by making the setting in SD\_INFO2 to disable BWE interrupts.
2. Set the C52PUB bit in SDIO\_MODE to 1 (so that CMD52 is issued when SD\_BUF becomes empty).
3. After the RSPEND interrupt processing in SD\_INFO1 because the issuing of CMD52 is completed, restart writing to SD\_BUF by making the setting in SD\_INFO2 to enable BWE interrupts.

##### (b) When DMA transfer is in use

1. Every time DMA transfer of the value set in SD\_SIZE × n blocks (where n = 1, 2,...) proceeds, suspend writing to SD\_BUF by DMA transfer before the C52PUB bit is set.
2. Set the C52PUB bit in SDIO\_MODE to 1 (so that CMD52 is issued when SD\_BUF becomes empty).
3. After the RSPEND interrupt processing in SD\_INFO1 because the issuing of CMD52 is completed, restart writing to SD\_BUF by DMA transfer.

#### 33.4.5 Notes on SD\_CLK\_CTRL Register Settings (SD/MMC)

When the SD\_CLK\_CTRLLEN bit in SD\_INFO2 is 0, SD\_CLK\_CTRL cannot be written to. Before writing to SD\_CLK\_CTRL, you must check that the SD\_CLK\_CTRLLEN bit in SD\_INFO2 is 1.

#### 33.4.6 Specification Limitations

1. The Suspend/Resume operation of the SDIO is not supported.
2. The SPI bus is not supported. (SD/MMC)
3. The shared bus and 8-bit SD bus of the embedded SDIO are not supported.
4. Stream transfer of MMC is not supported.
5. High Priority Interrupt (HPI) of MMC is not supported.
6. Boot Operation/Alternative Boot Operation of MMC is not supported.
7. Open-ended multiple block transfer of MMC is not supported.

#### 33.4.7 STP Bit Setting during Multiple Block Read (SD/MMC)

During execution of multiple block read with automatic CMD12 execution by setting the SEC bit in SD\_STOP to 1, even if the STP bit in SD\_STOP is set to 1 to forcibly stop the execution, the command sequence might not stop depending on the timing of setting the STP bit.

To avoid this, when setting the STP bit in SD\_STOP to 1 during multiple block transfer, clear the SEC bit in SD\_STOP to 0 at the same time. (Even when the SD\_CLK\_CTRLLEN bit in SD\_INFO2 is 0, change the SEC bit from 1 to 0.)

When the command sequence does not stop because the SEC bit was not cleared to 0, the command sequence can be stopped by clearing the SDRST bit in SOFT\_RST to 0.

When forcibly terminating the CMD53 multiple block transfer through the IOABT bit in SDIO\_MODE, you must leave the SEC bit in SD\_STOP as 1.

SDMMC时钟输出的自动控制正在使用中，SDMMC时钟输出在完成通信错误或超时的序列时停止。当序列完成后需要SD卡MMC内的状态转换时，解除SDMMC时钟输出的自动控制并重新开始向SD卡MMC提供SDMMC时钟。

#### 33.4.4 控制多块写入(SD)的C52PUB设置

如果SDIO\_MODE中的C52PUB位由于CMD53而在多个块写入序列期间设置为1，则在SD\_BUF变空之前不会发出CMD52。因此，在暂停写入SD\_BUF后，根据需要以下过程之一设置C52PUB位：

##### (a)不使用DMA传输时

- 1.在设置C52PUB位之前，通过在SD\_INFO2中进行设置以禁用BWE中断来暂停写入SD\_BUF。
- 2.将SDIO\_MODE中的C52PUB位设置为1（以便当SD\_BUF为空时发出CMD52）。
- 3.在SD\_INFO1中的RSPEND中断处理后，因为CMD52的发布完成，通过在SD\_INFO2中进行设置来重新开始写入SD\_BUF以启用BWE中断。

##### (b)使用DMA传输时

- 1.每次对SD\_SIZE×n块中设置的值（其中n=1 2...）进行DMA传输时，在C52PUB位置位之前暂停通过DMA传输对SD\_BUF的写入。
- 2.将SDIO\_MODE中的C52PUB位设置为1（以便当SD\_BUF为空时发出CMD52）。
- 3.SD\_INFO1中的RSPEND中断处理后，因为CMD52的下发完成，通过DMA传输重新开始写入SD\_BUF。

#### 33.4.5 SD\_CLK\_CTRL寄存器设置注意事项(SDMMC)

当SD\_INFO2中的SD\_CLK\_CTRLLEN位为0时，无法写入SD\_CLK\_CTRL。在写信之前SD\_CLK\_CTRL，必须检查SD\_INFO2中的SD\_CLK\_CTRLLEN位是否为1。

#### 33.4.6 规格限制

- 1、不支持SDIO的SuspendResume操作。
- 2.不支持SPI总线。(标清MMC)
- 3、不支持嵌入式SDIO的共享总线和8位SD总线。
- 4.不支持MMC的流传输。
- 5.不支持MMC的高优先级中断(HPI)。
- 6.BootOperationAlternativeBootOperation不支持MMC。
- 7.不支持MMC的开放式多块传输。

#### 33.4.7 多块读取(SDMMC)期间的STP位设置

在通过将SD\_STOP中的SEC位设置为1并通过自动CMD12执行执行多块读取时，即使将SD\_STOP中的STP位设置为1以强制停止执行，命令序列也可能不会停止，具体取决于设置STP位。

为避免这种情况，在多块传输期间将SD\_STOP中的STP位设置为1时，同时将SD\_STOP中的SEC位清除为0。（即使SD\_INFO2中的SD\_CLK\_CTRLLEN位为0，也将SEC位从1更改为0。）

当由于SEC位未清0而导致命令序列未停止时，可通过将SOFT\_RST中的SDRST位清0来停止命令序列。

当通过SDIO\_MODE中的IOABT位强制终止CMD53多块传输时，必须离开SD\_STOP中的SEC位为1。



### 33.4.8 Register Setting Notes

1. All registers in [section 33.2. Register Descriptions](#) are accessed in 32-bit access-only.
2. When setting registers, set them after the I/O Port Register setting.

### 33.4.8 注册设置注意事项

- 1.第33.2节中的所有寄存器。寄存器描述只能以32位访问方式访问。
- 2.设置寄存器时，请在IOPortRegister设置后进行设置。

RA生态工作室

## 34. Cyclic Redundancy Check (CRC) Calculator

### 34.1 Overview

The Cyclic Redundancy Check (CRC) calculator generates CRC codes to detect errors in the data. The bit order of CRC calculation results can be switched for LSB-first or MSB-first communication. Additionally, various CRC-generation polynomials are available.

Table 34.1 lists the CRC calculator specifications and Figure 34.1 shows a block diagram.

Table 34.1 CRC calculator specifications

| Parameter                  | Specifications for 8-bit data   | Specifications for 32-bit data  |
|----------------------------|---|---|
| Data size                  | 8-bit   | 32-bit  |
| Data for CRC calculation*1 | CRC code generated for data in 8n-bit units (where n is a natural number)   | CRC code generated for data in 32n-bit units (where n is a natural number)  |
| CRC processor unit         | Operation executed on 8 bits in parallel  | Operation executed on 32 bits in parallel   |
| CRC generating polynomial  | One of three generating polynomials that is selectable:<br>[8-bit CRC]<br><ul style="list-style-type: none"> <li><math>X^8 + X^2 + X + 1</math> (CRC-8)</li> </ul> [16-bit CRC]<br><ul style="list-style-type: none"> <li><math>X^{16} + X^{15} + X^2 + 1</math> (CRC-16)</li> <li><math>X^{16} + X^{12} + X^5 + 1</math> (CRC-CCITT).</li> </ul> | One of two generating polynomials that is selectable:<br>[32-bit CRC]<br><ul style="list-style-type: none"> <li><math>X^{32} + X^{26} + X^{23} + X^{22} + X^{16} + X^{12} + X^{11} + X^{10} + X^8 + X^7 + X^5 + X^4 + X^2 + X + 1</math> (CRC-32)</li> <li><math>X^{32} + X^{28} + X^{27} + X^{26} + X^{25} + X^{23} + X^{22} + X^{20} + X^{19} + X^{18} + X^{14} + X^{13} + X^{11} + X^{10} + X^9 + X^8 + X^6 + 1</math> (CRC-32C).</li> </ul> |
| CRC calculation switching  | The bit order of CRC calculation results can be switched for LSB-first or MSB-first communication   |   |
| Module-stop function       | Module-stop state can be set to reduce power consumption  |   |
| TrustZone Filter           | Security attribution can be set   |   |

Note 1. This function cannot divide data used in CRC calculations. Write data in 8-bit or 32-bit units.

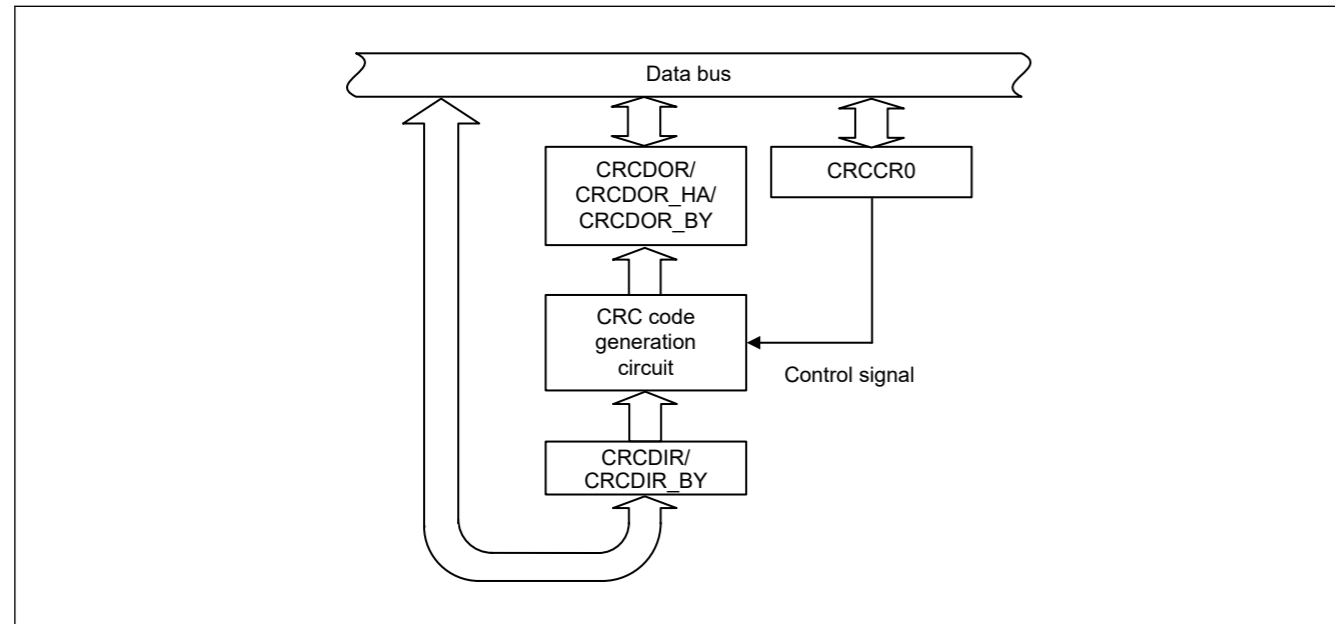


Figure 34.1 CRC calculator block diagram

### 34.2 Register Descriptions

## 34. 循环冗余校验(CRC)计算器

### 34.1 Overview

循环冗余校验(CRC)计算器生成CRC代码以检测数据中的错误。CRC计算结果的位顺序可以切换为LSB-first或MSB-first通信。此外，还可以使用各种CRC生成多项式。

表34.1列出了CRC计算器规格，图34.1显示了框图。

Table 34.1 CRC计算器规格

| Parameter            | 8位数据规格  | 32位数据规格   |
|----------------------|---|---|
| 数据大小                 | 8-bit   | 32-bit  |
| CRC计算数据*1            | 为8n位单元中的数据生成的CRC码 (其中n是自然数)   | 为32n位单元中的数据生成的CRC码 (其中n是自然数)  |
| CRC处理器单元             | 在8位上并行执行的操作   | 在32位上并行执行的操作  |
| CRC生成多项式             | 可选择的三个生成多项式之一: [8位CRC]<br><ul style="list-style-type: none"> <li><math>X^8 + X^2 + X + 1</math> (CRC-8)</li> </ul> [16-bit CRC]<br><ul style="list-style-type: none"> <li><math>X^{16} + X^{15} + X^2 + 1</math> (CRC-16)</li> <li><math>X^{16} + X^{12} + X^5 + 1</math> (CRC-CCITT).</li> </ul> | 可选择的两个生成多项式之一: [32位CRC]<br><ul style="list-style-type: none"> <li><math>X^{32} + X^{26} + X^{23} + X^{22} + X^{16} + X^{12} + X^{11} + X^{10} + X^8 + X^7 + X^5 + X^4 + X^2 + X + 1</math> (CRC-32)</li> <li><math>X^{32} + X^{28} + X^{27} + X^{26} + X^{25} + X^{23} + X^{22} + X^{20} + X^{19} + X^{18} + X^{14} + X^{13} + X^{11} + X^{10} + X^9 + X^8 + X^6 + 1</math> (CRC-32C).</li> </ul> |
| CRC计算切换              | CRC计算结果的位顺序可以切换为LSB-first或MSB-first通信   |   |
| Module-stop function | 可设置模块停止状态以降低功耗  |   |
| TrustZone Filter     | 可设置安全属性   |   |

注1.此功能不能除以CRC计算中使用的数据。以8位或32位为单位写入数据。

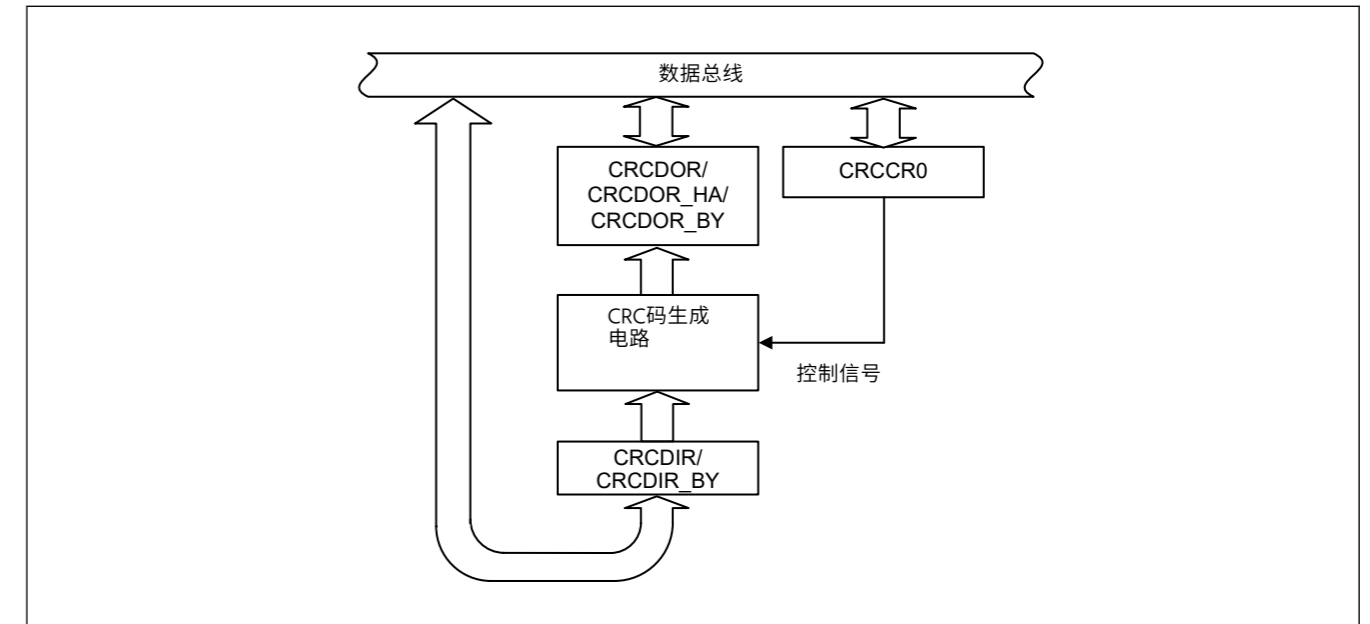


Figure 34.1 CRC计算器框图

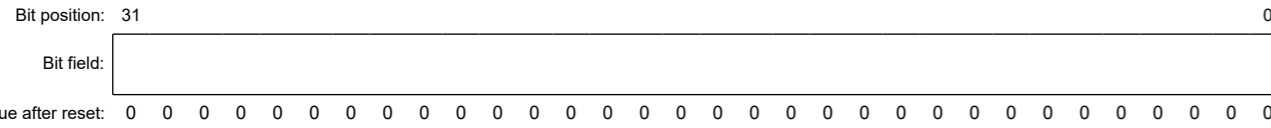
### 34.2 注册说明



34.2.3 CRCDOR/CRCDOR\_HA/CRCDOR\_BY : CRC Data Output Register

Base address: CRC = 0x4010\_8000

Offset address: 0x08



| Bit  | Symbol | Function  | R/W |
|------|--------|---|-----|
| 31:0 | n/a    | CRC output data<br>The CRCDOR register is a 32-bit read/write register for CRC-32 or CRC-32C calculation. The CRCDOR_HA (CRCDOR[31:16]) register is a 16-bit read/write register for CRC-16 or CRC-CCITT calculation. The CRCDOR_BY (CRCDOR[31:24]) register is an 8-bit read/write register for CRC-8 calculation. Because its initial value is 0x00000000, rewrite the CRCDOR/CRCDOR_HA/CRCDOR_BY register to perform the calculations using a value other than the initial value. Data written to the CRCDIR/CRCDIR_BY register is CRC calculated and the result is stored in the CRCDOR/CRCDOR_HA/CRCDOR_BY register. If the CRC code is calculated following the transferred data and the result is 0x00000000, there is no CRC error. | R/W |

34.3 Operation

34.3.1 Basic Operation

The CRC calculator generates CRC codes for use in LSB-first or MSB-first transfer.

The following examples show CRC code generation for input data (0xF0) using the 16-bit CRC-CCITT generating polynomial ( $X^{16} + X^{12} + X^5 + 1$ ). In these examples, the value of the CRC Data Output Register (CRCDOR\_HA) is cleared before CRC calculation.

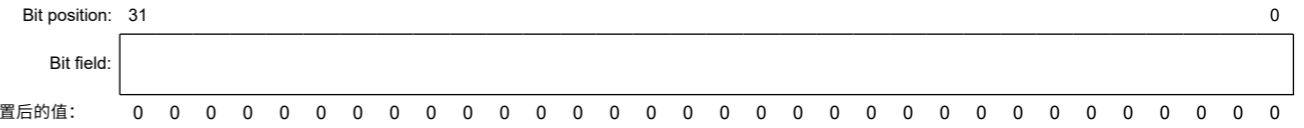
When an 8-bit CRC (with the polynomial  $X^8 + X^2 + X + 1$ ) is in use, the valid bits of the CRC code are obtained in CRCDOR\_BY. When a 32-bit CRC is in use, the valid bits of the CRC code are obtained in CRCDOR.

Figure 34.2 and Figure 34.3 show the LSB-first and MSB-first data transmission examples respectively. Figure 34.4 and Figure 34.5 show the LSB-first and MSB-first data reception examples.

34.2.3 CRCDOR/CRCDOR\_HA/CRCDOR\_BY: CRC数据输出寄存器

Base address: CRC = 0x4010\_8000

Offset address: 0x08



| Bit  | Symbol | Function  | R/W |
|------|--------|---|-----|
| 31:0 | n/a    | CRC输出数据<br>CRCDOR寄存器是一个32位读写寄存器，用于CRC-32或CRC-32C计算。CRCDOR_HA(CRCDOR[31:16])寄存器是用于CRC-16或CRC-CCITT计算。<br>CRCDOR_BY(CRCDOR[31:24])寄存器是一个用于CRC-8计算的8位读写寄存器。由于其初始值为0x00000000，因此重写CRCDOR/CRCDOR_HA/CRCDOR_BY寄存器以使用初始值以外的值执行计算。写入CRCDIR/CRCDIR_BY寄存器的数据经过CRC计算，结果存储在CRCDOR/CRCDOR_HA/CRCDOR_BY寄存器中。如果在传输数据之后计算CRC码，结果为0x00000000，则没有CRC错误。 | R/W |

34.3 Operation

34.3.1 基本操作

CRC计算器生成用于LSB优先或MSB优先传输的CRC代码。

以下示例显示了使用16位CRC-CCITT生成多项式( $X^{16} + X^{12} + X^5 + 1$ )为输入数据(0xF0)生成CRC码。在这些示例中，CRC数据输出寄存器(CRCDOR\_HA)的值在CRC计算之前被清除。

当使用8位CRC (多项式 $X^8 + X^2 + X + 1$ )时，CRC码的有效位在CRCDOR\_BY。使用32位CRC时，在CRCDOR中获取CRC码的有效位。

图34.2和图34.3分别显示了LSB-first和MSB-first数据传输示例。图34.4和图34.5显示了LSB优先和MSB优先的数据接收示例。



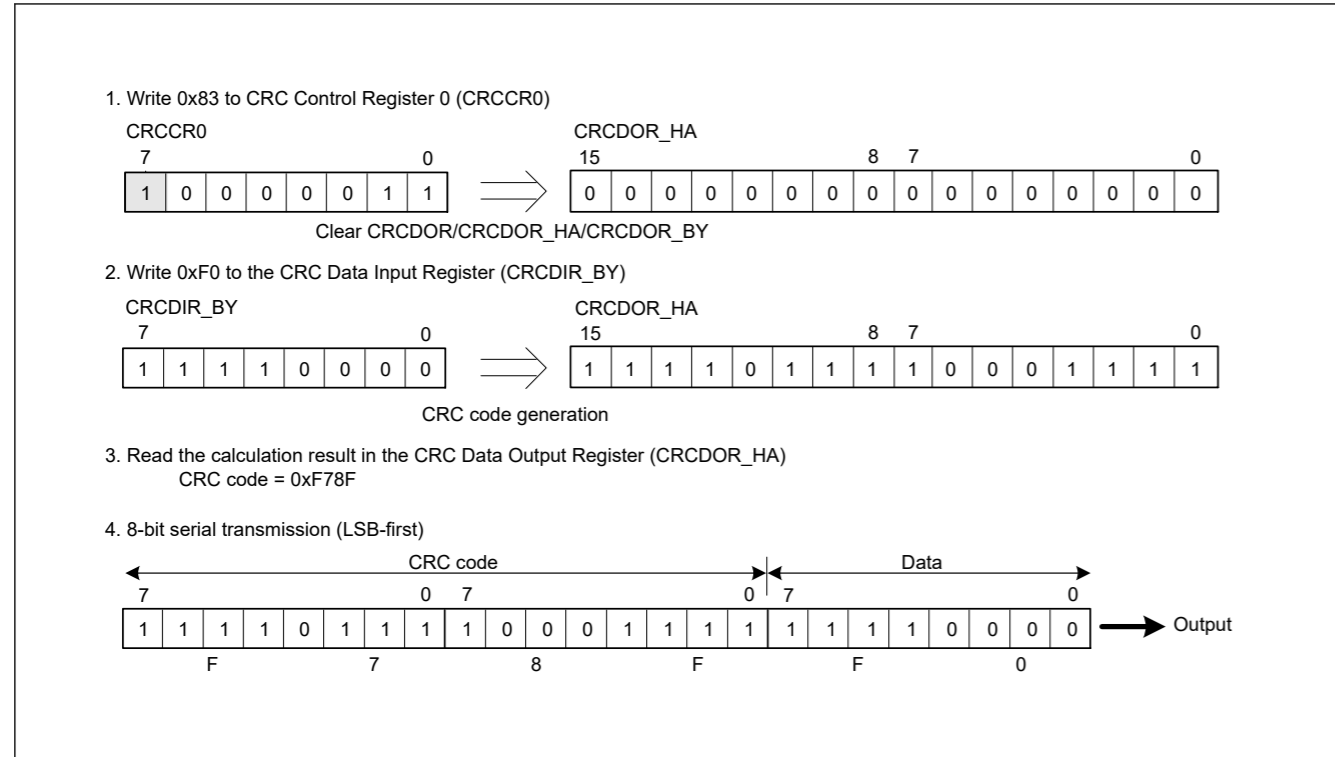


Figure 34.2 LSB-first data transmission

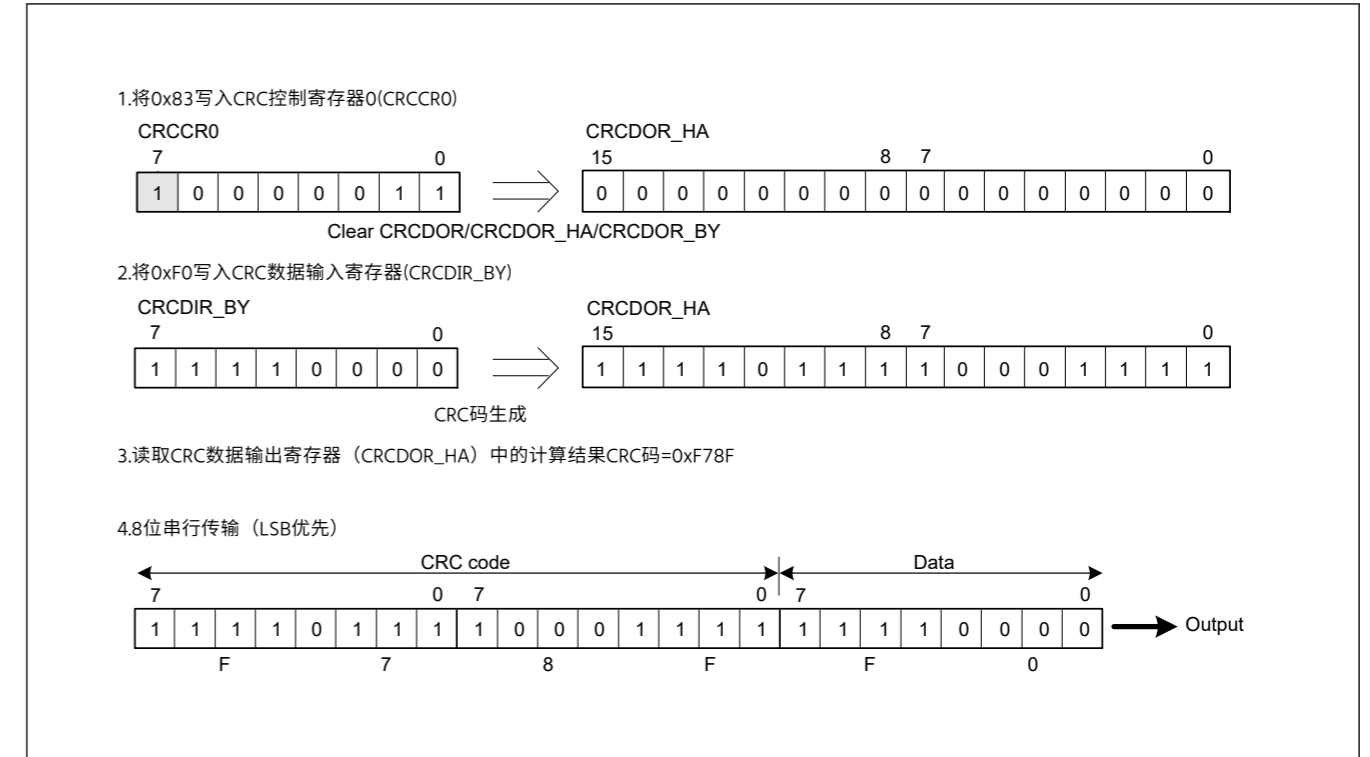


Figure 34.2 LSB-first数据传输

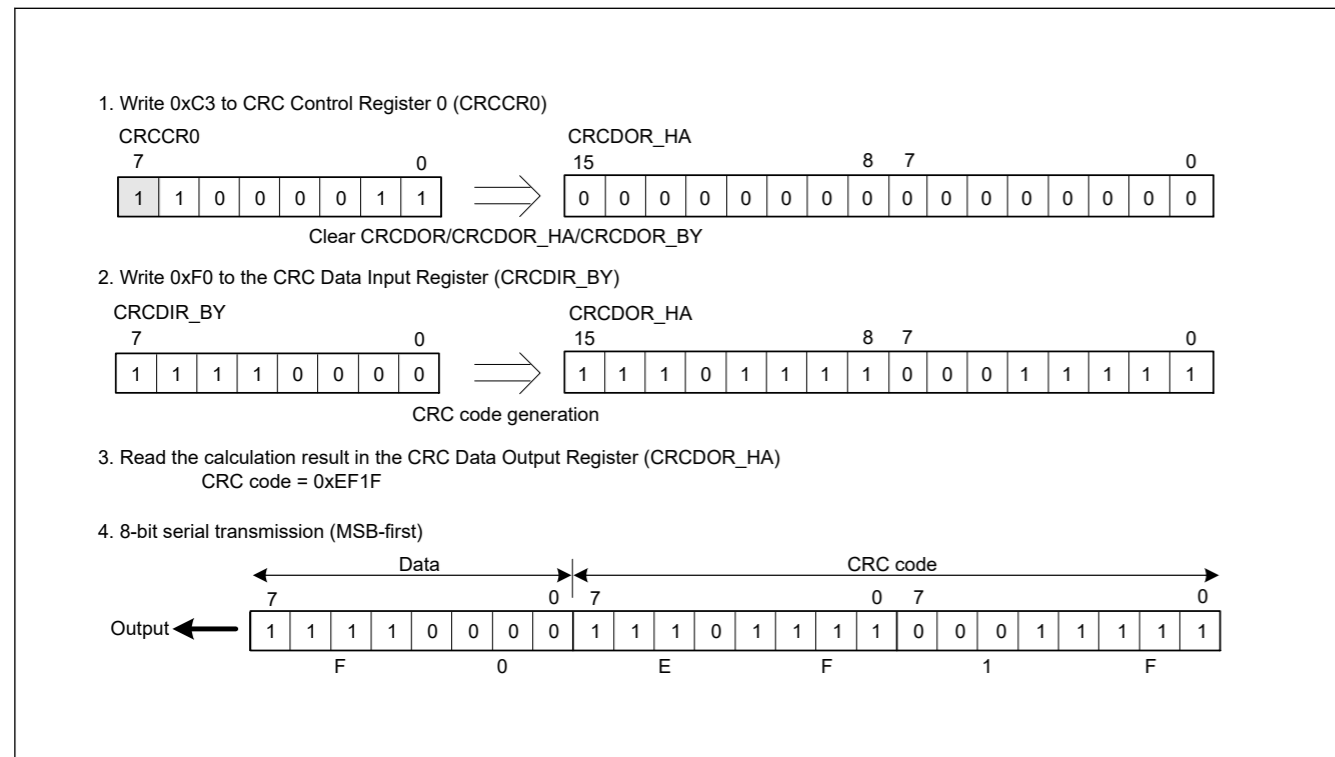


Figure 34.3 MSB-first data transmission

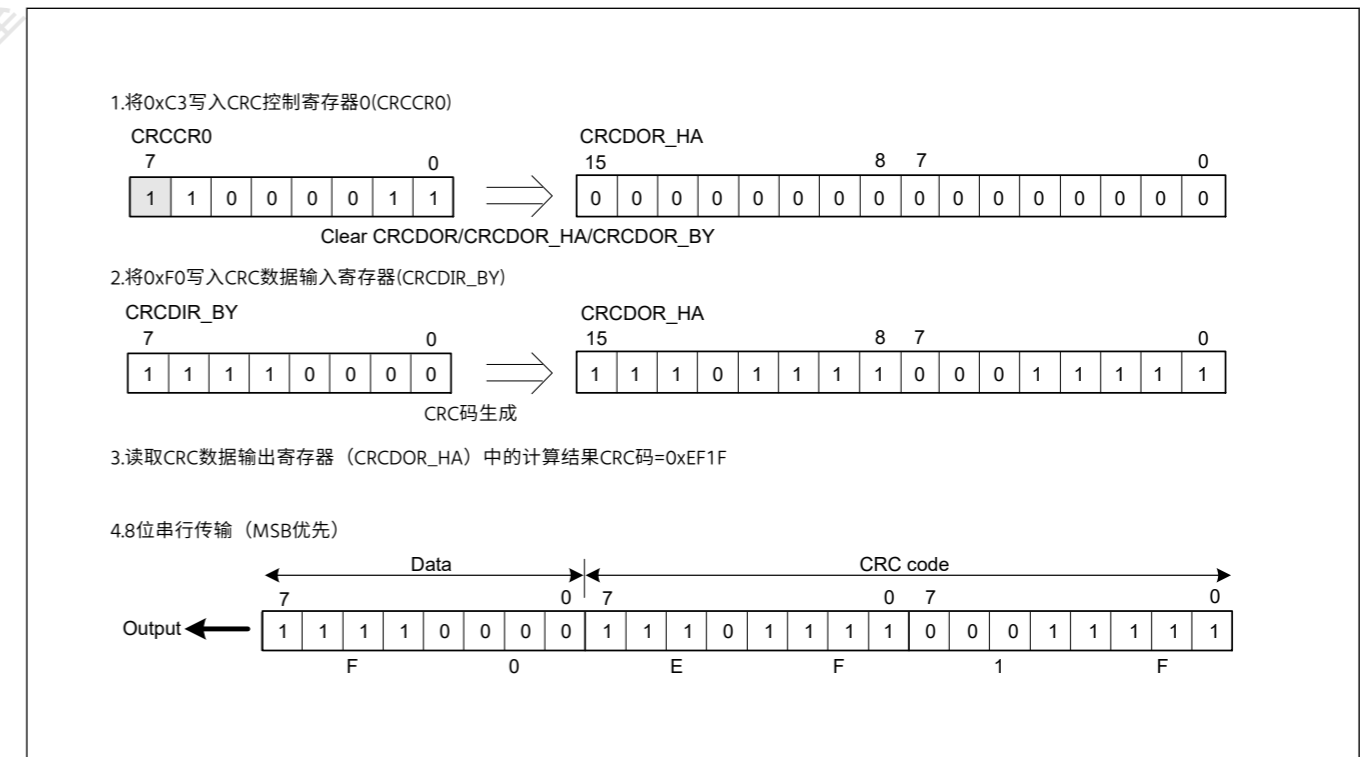


Figure 34.3 MSB优先数据传输

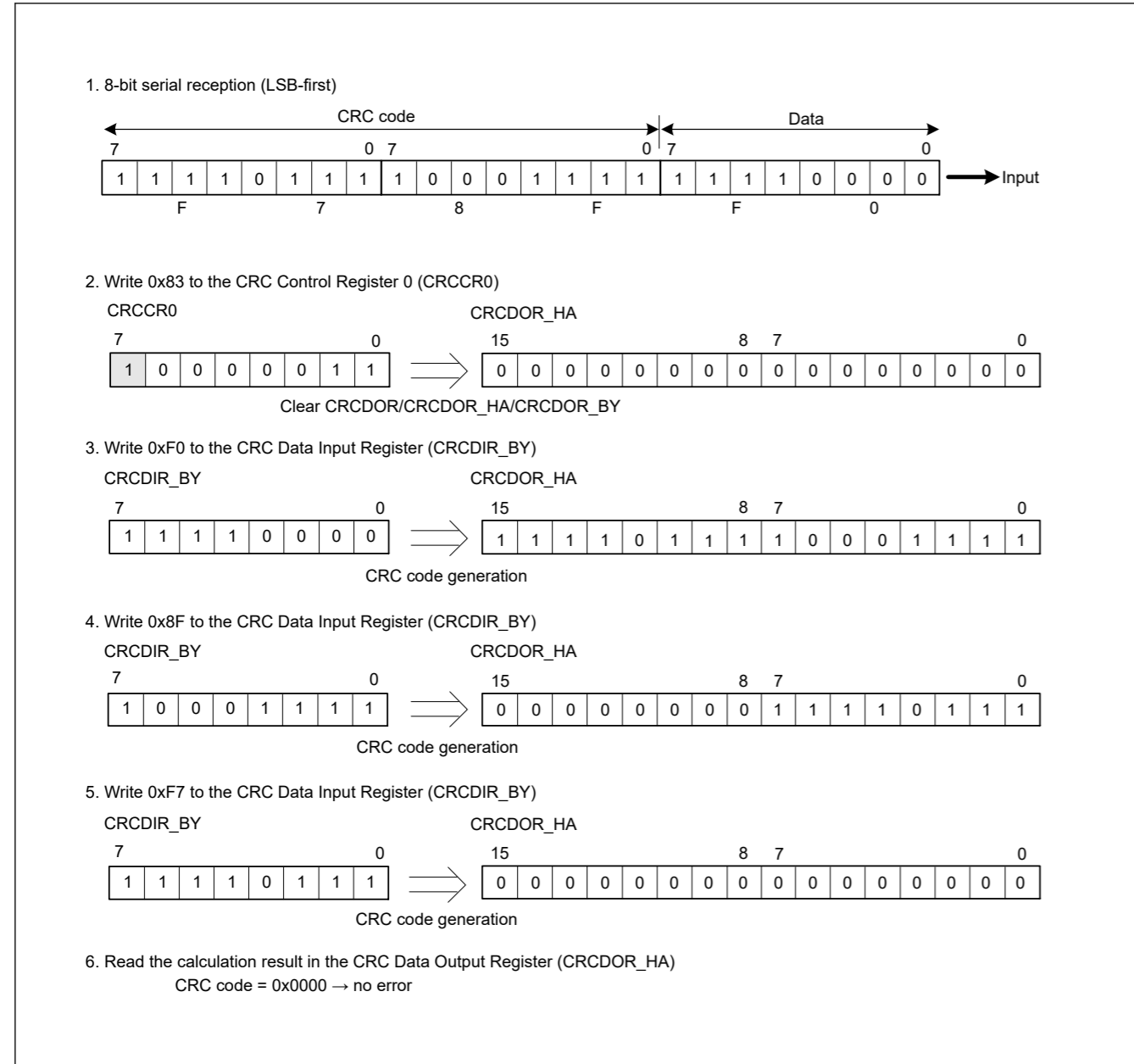


Figure 34.4 LSB-first data reception

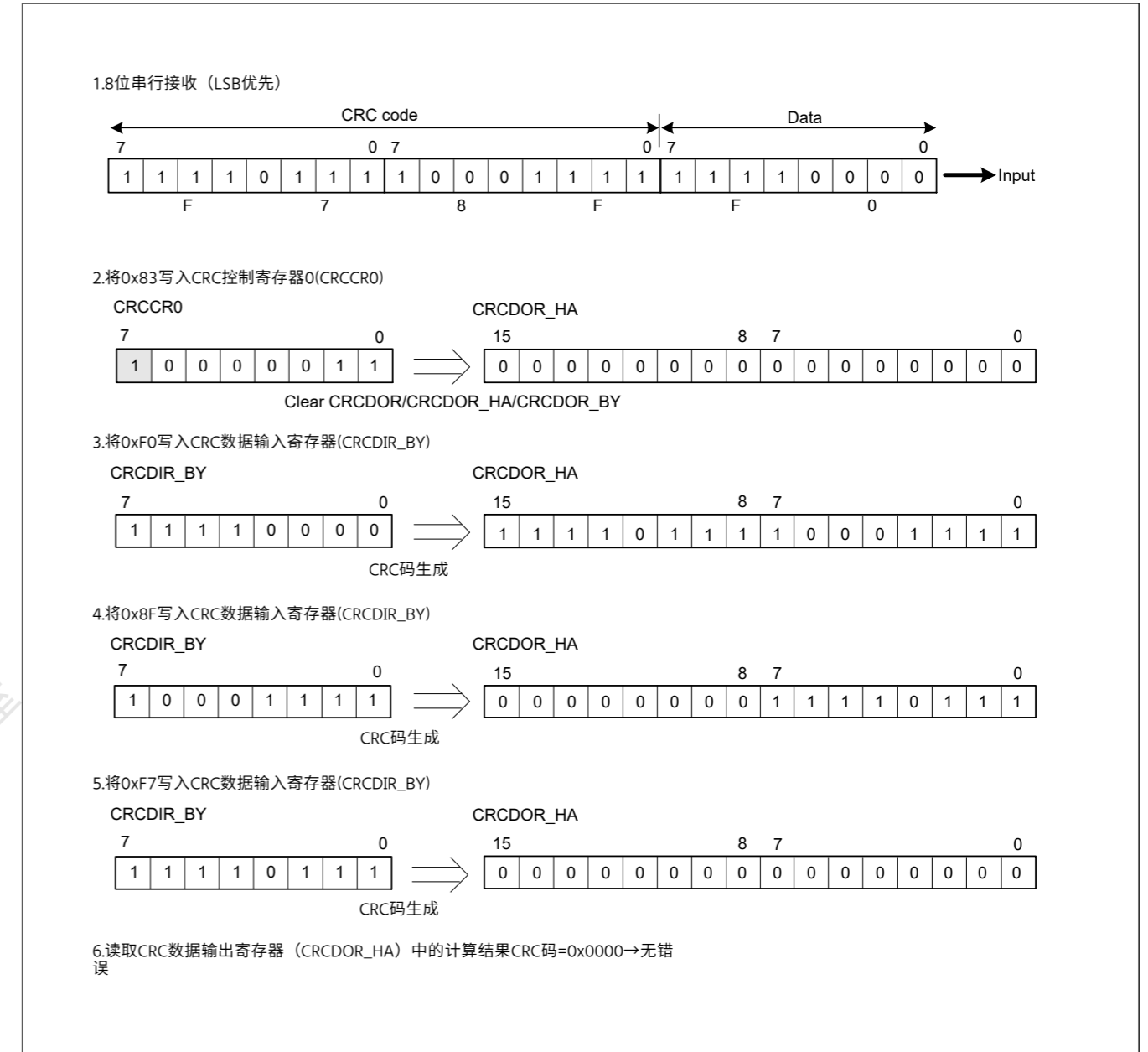


Figure 34.4 LSB-first数据接收

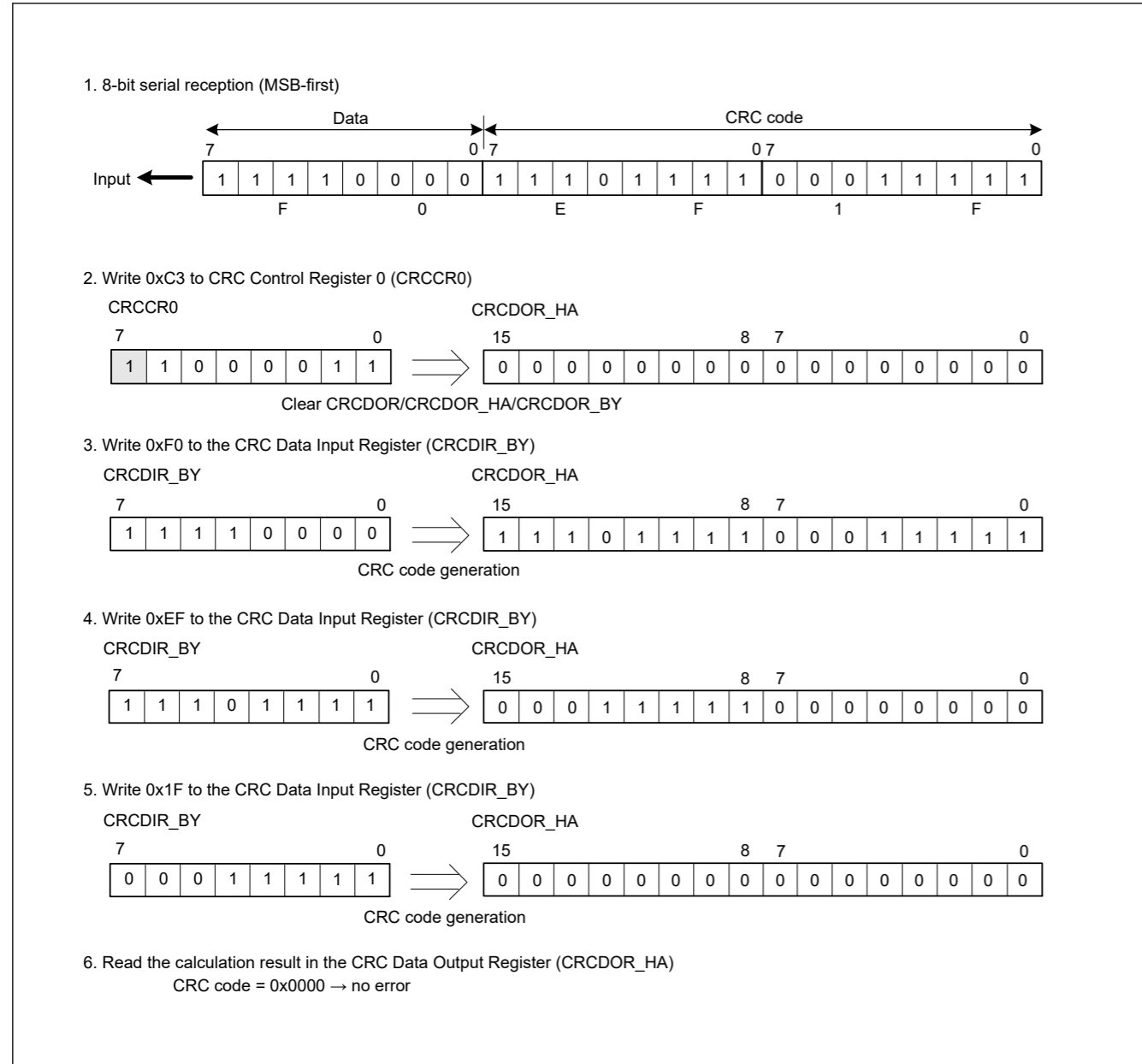


Figure 34.5 MSB-first data reception

34.4 Usage Notes

34.4.1 Settings for the Module-Stop State

The Module Stop Control Register C (MSTPCRC) can enable or disable CRC calculator operation. The CRC calculator is initially stopped after a reset. Releasing the module-stop state enables access to the registers. For details, see [section 10, Low Power Modes](#).

34.4.2 Note on Transmission

The transmission sequence for the CRC code differs based on whether the transmission is LSB-first or MSB-first. [Figure 34.6](#) shows an LSB-first and MSB-first data transmission.

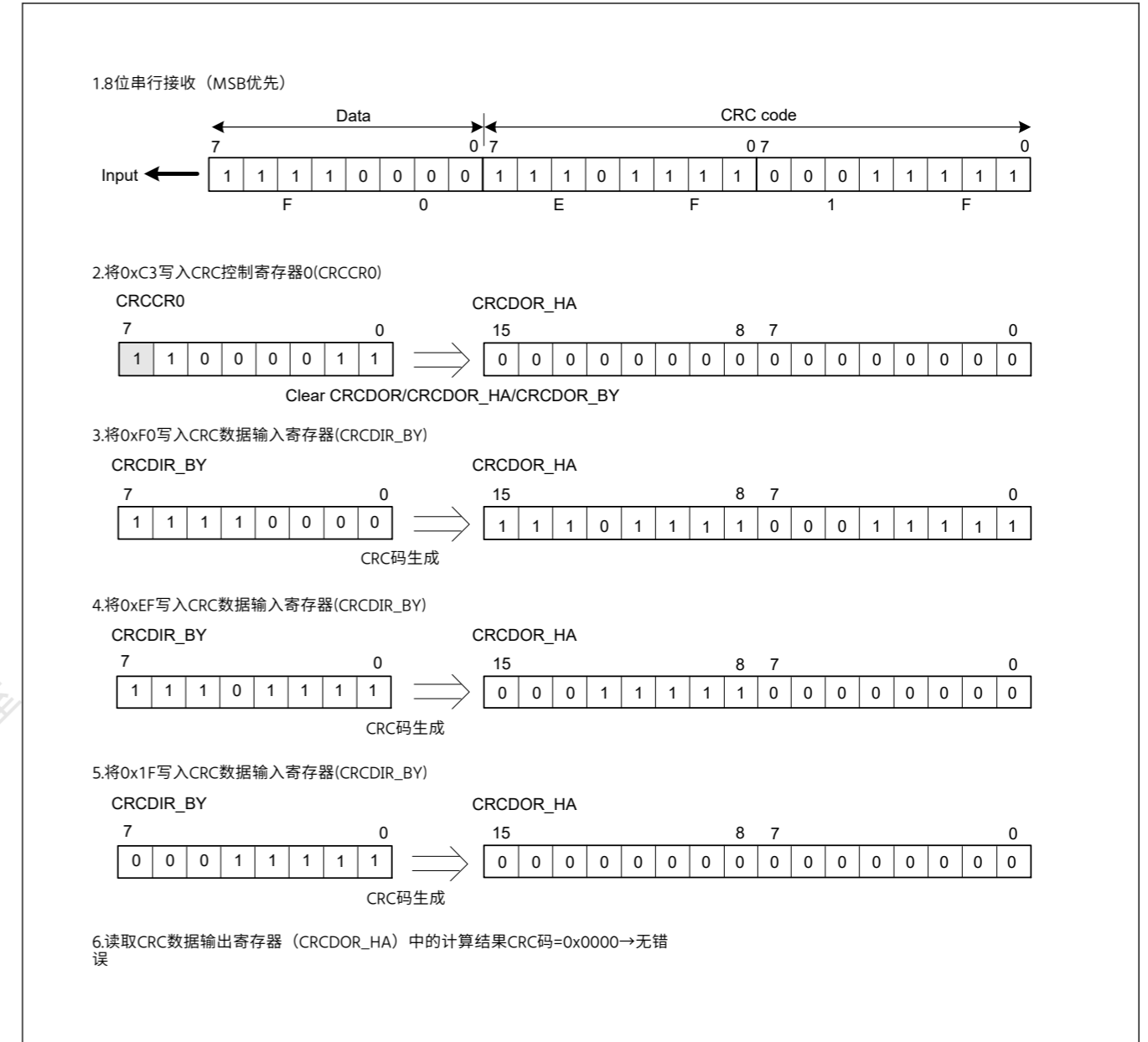


Figure 34.5 MSB优先数据接收

34.4 使用说明

34.4.1 模块停止状态的设置

模块停止控制寄存器C(MSTPCRC)可以启用或禁用CRC计算器操作。CRC计算器在复位后最初停止。释放模块停止状态可以访问寄存器。有关详细信息，请参阅第10节，低功耗模式。

34.4.2 传输注意事项

CRC码的传输顺序根据传输是LSB在先还是MSB在先而有所不同。图34.6显示了LSB优先和MSB优先的数据传输。

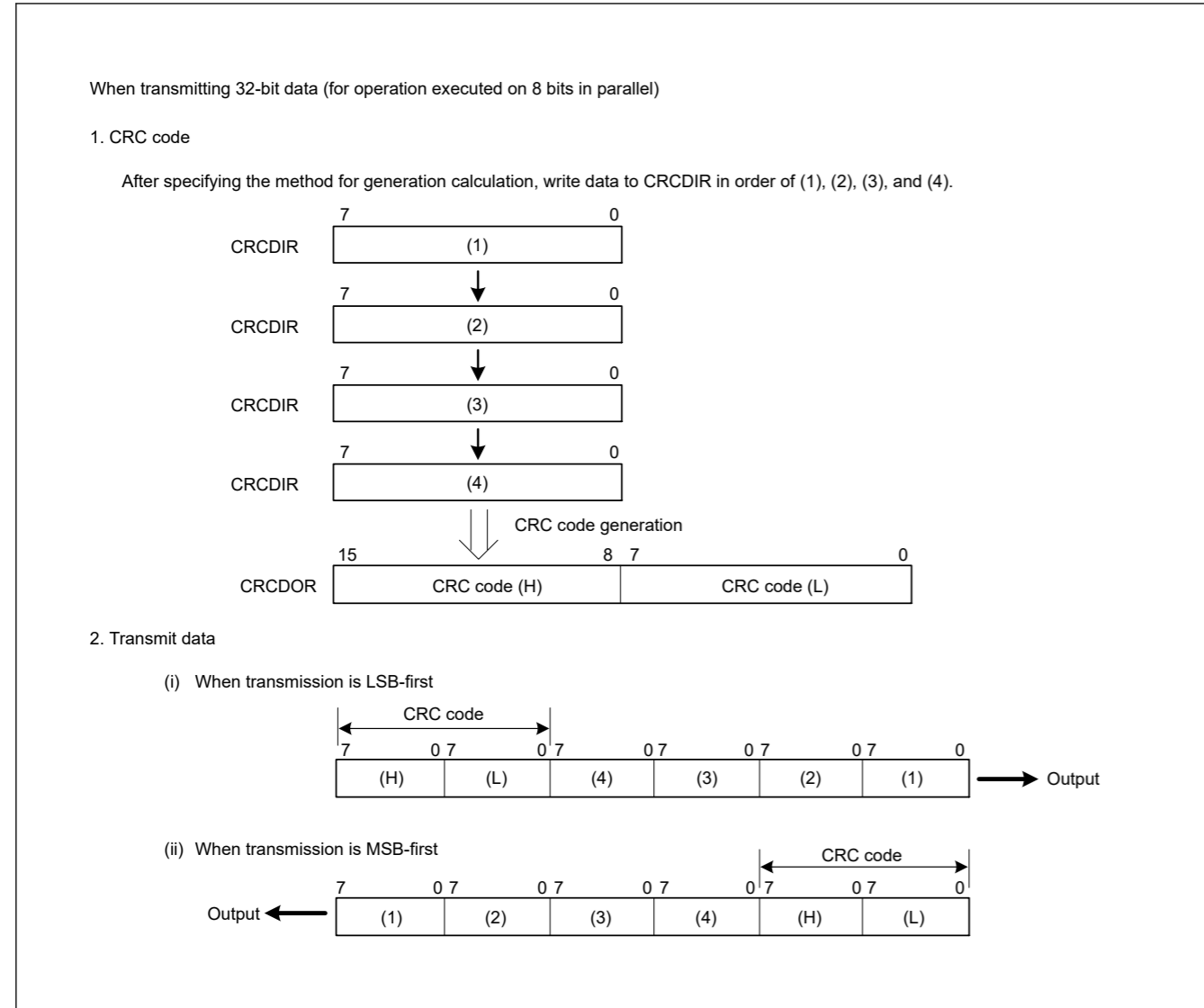


Figure 34.6 LSB-first and MSB-first data transmission

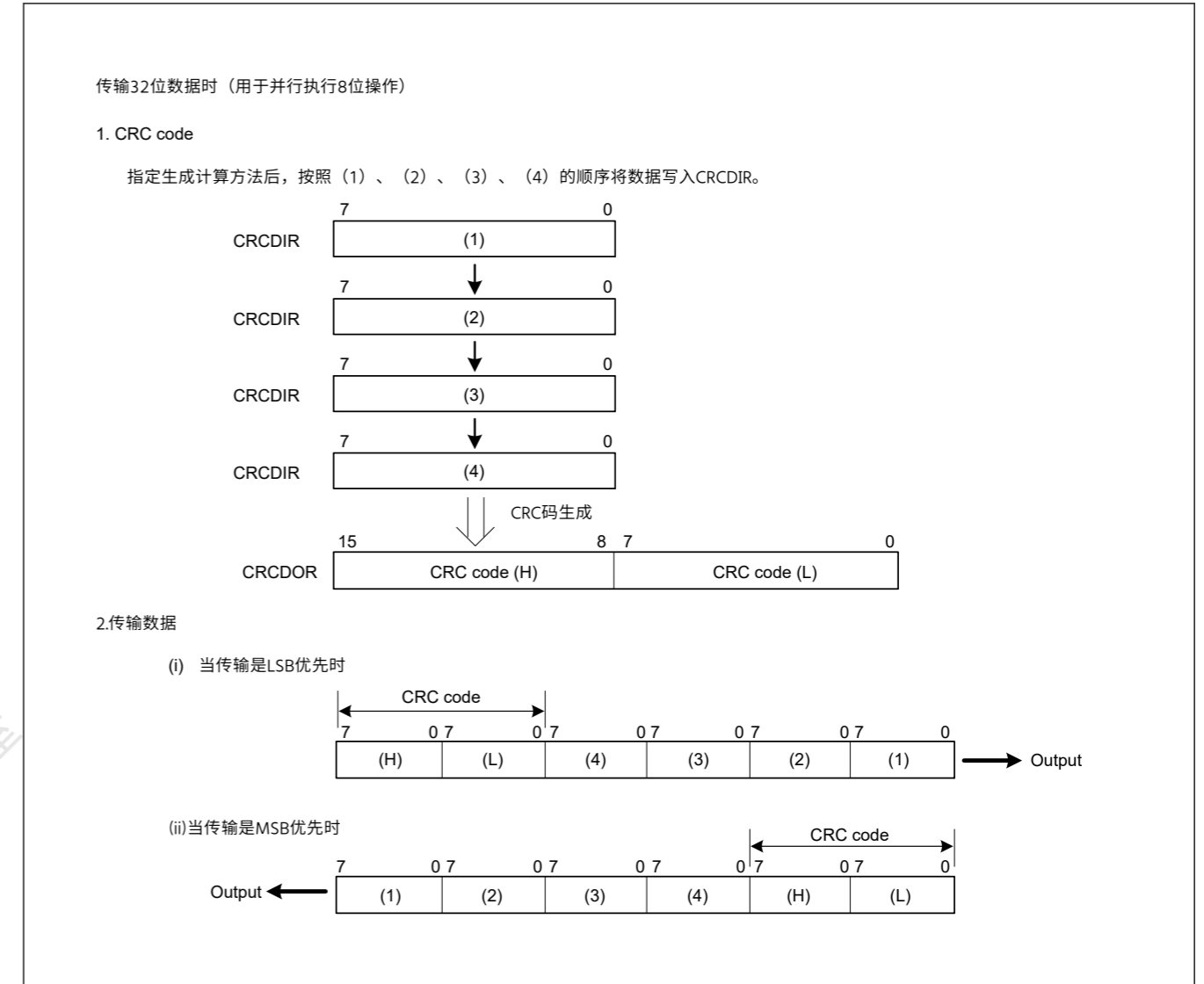


Figure 34.6 LSB-first和MSB-first数据传输



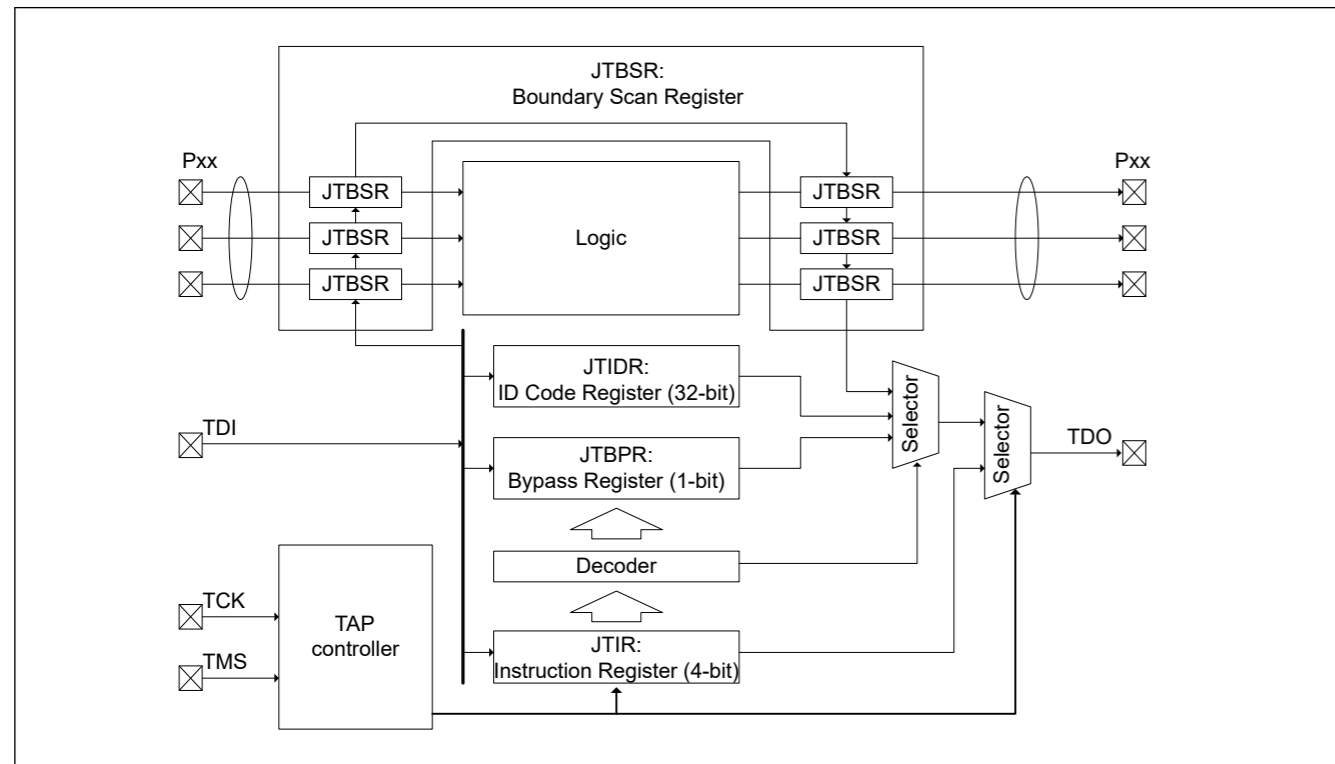
## 35. Boundary Scan

### 35.1 Overview

The boundary scan function provides a serial I/O interface based on the JTAG (Joint Test Action Group), IEEE Std.1149.1, and IEEE Standard Test Access Port and Boundary Scan Architecture. [Table 35.1](#) lists the boundary scan specifications, [Figure 35.1](#) shows a block diagram, and [Table 35.2](#) lists the I/O pins.

**Table 35.1** Boundary scan specifications

| Parameter           | Specifications   |
|---------------------|--|
| Execution condition | Boundary scan must be executed when the RES pin is driven low.   |
| Test modes          | <ul style="list-style-type: none"> <li>• BYPASS mode</li> <li>• EXTEST mode</li> <li>• SAMPLE/PRELOAD mode</li> <li>• CLAMP mode</li> <li>• HIGHZ mode</li> <li>• IDCODE mode</li> </ul> |



**Figure 35.1** Boundary scan function block diagram

**Table 35.2** Boundary scan I/O pins

| Pin name | I/O    | Description  |
|----------|--------|--|
| TCK      | Input  | Test clock input pin<br>Clock signal for boundary scan. The input clock duty cycle is 50% when the boundary scan function is used. |
| TMS      | Input  | Test mode select pin   |
| TDI      | Input  | Test data input pin  |
| TDO      | Output | Test data output pin   |

Note: This device does not support the TRST pin for the JTAG interface.

### 35.2 Register Descriptions

[Table 35.3](#) lists the boundary scan registers.

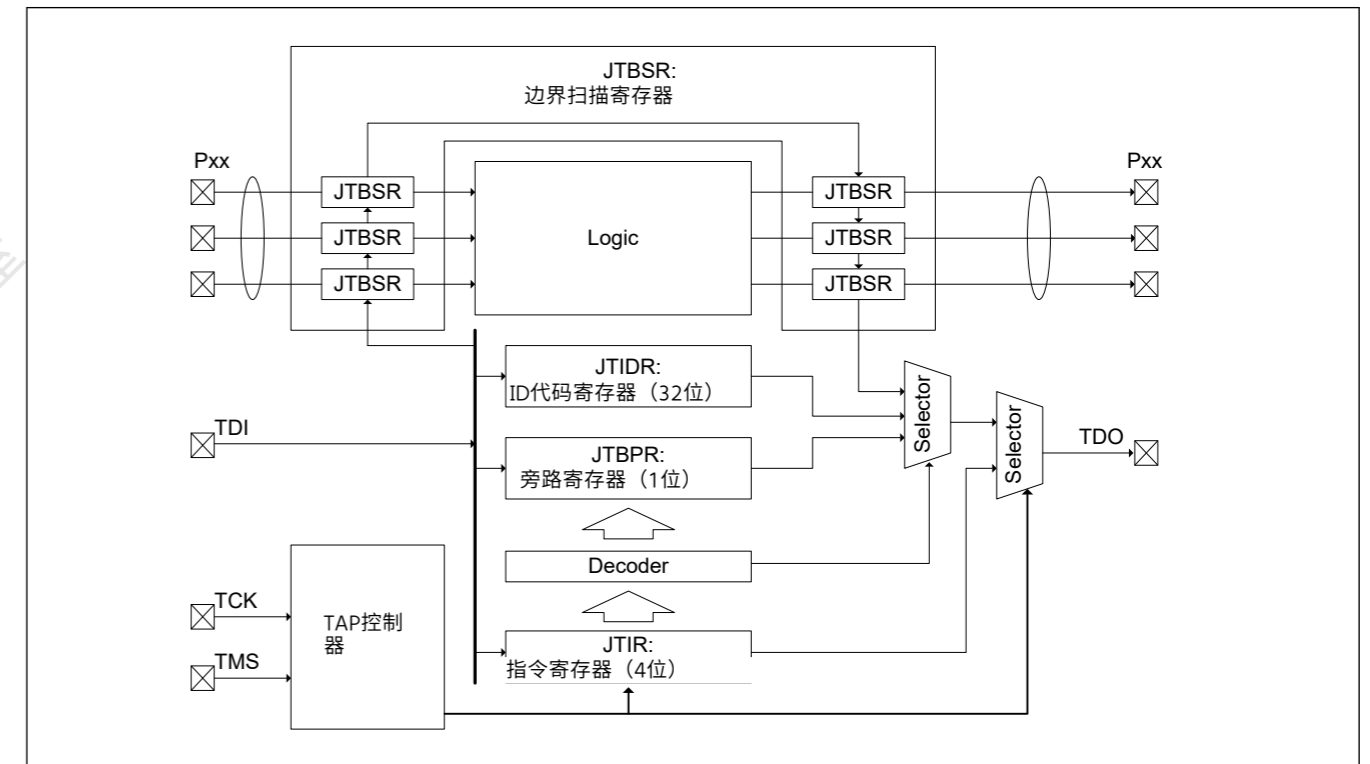
## 35. 边界扫描

### 35.1 Overview

边界扫描功能提供基于JTAG（联合测试行动组）、IEEE Std.1149.1和IEEE标准测试访问端口和边界扫描架构的串行IO接口。表35.1列出了边界扫描规范，图35.1显示了框图，表35.2列出了IO引脚。

**Table 35.1** 边界扫描规格

| Parameter | Specifications  |
|-----------|---|
| 执行条件      | 当RES引脚驱动为低电平时，必须执行边界扫描。   |
| 测试模式      | <ul style="list-style-type: none"> <li>• 旁路模式</li> <li>• EXTEST mode</li> <li>• SAMPLE/PRELOAD mode</li> <li>• 钳位模式</li> <li>• HIGHZ mode</li> <li>• IDCODE mode</li> </ul> |



**Figure 35.1** 边界扫描功能框图

**Table 35.2** 边界扫描IO引脚

| 引脚名称 | I/O    | Description                                  |
|------|--------|--|
| TCK  | Input  | 测试时钟输入引脚<br>边界扫描的时钟信号。使用边界扫描功能时，输入时钟占空比为50%。 |
| TMS  | Input  | 测试模式选择引脚                                     |
| TDI  | Input  | 测试数据输入引脚                                     |
| TDO  | Output | 测试数据输出引脚                                     |

Note: 该器件不支持JTAG接口的TRST引脚。

### 35.2 注册说明

表35.3列出了边界扫描寄存器。

Table 35.3 Boundary scan registers

| Register name          | Symbol | Value after reset |
|------------------------|--------|-------------------|
| Instruction Register   | JTIR   | 0xE               |
| ID Code Register       | JTIDR  | 0x0840_A447       |
| Bypass Register        | JTBPR  | Undefined         |
| Boundary Scan Register | JTBSR  | Undefined         |

Usage notes for the boundary scan registers:

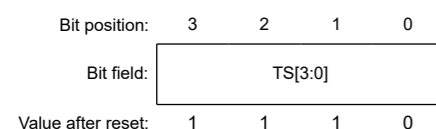
- Instructions can be input to the Instruction Register (JTIR) through the TDI pin by serial transfer.
- The Bypass Register (JTBPR), which is a 1-bit register, is connected between the TDI and TDO pins in BYPASS mode.
- The Boundary Scan Register (JTBSR), which is configured according to the BSDL description, is connected between the TDI and TDO pins when test data is being shifted in.

Table 35.4 shows the availability of serial transfer for the registers.

Table 35.4 Serial transfer for registers

| Register name                  | Serial input | Serial output |
|--------------------------------|--------------|---------------|
| Instruction Register (JTIR)    | Available    | Available     |
| ID Code Register (JTIDR)       | Available    | Available     |
| Bypass Register (JTBPR)        | Available    | Available     |
| Boundary Scan Register (JTBSR) | Available    | Available     |

### 35.2.1 JTIR : Instruction Register



| Bit     | Symbol                | Function   | R/W     |             |     |        |     |                |     |                       |     |       |     |       |     |        |        |          |  |
|---------|-----------------------|--|---------|-------------|-----|--------|-----|----------------|-----|-----------------------|-----|-------|-----|-------|-----|--------|--------|----------|--|
| 3:0     | TS[3:0]               | Test Bit Set<br>The command configuration for these bits   | —       |             |     |        |     |                |     |                       |     |       |     |       |     |        |        |          |  |
|         |                       | <table border="1"> <thead> <tr> <th>TS[3:0]</th> <th>Instruction</th> </tr> </thead> <tbody> <tr> <td>0x0</td> <td>EXTEST</td> </tr> <tr> <td>0x1</td> <td>SAMPLE/PRELOAD</td> </tr> <tr> <td>0x3</td> <td>IDCODE (Renesas code)</td> </tr> <tr> <td>0x5</td> <td>CLAMP</td> </tr> <tr> <td>0x6</td> <td>HIGHZ</td> </tr> <tr> <td>0xF</td> <td>BYPASS</td> </tr> <tr> <td>Others</td> <td>Reserved</td> </tr> </tbody> </table> | TS[3:0] | Instruction | 0x0 | EXTEST | 0x1 | SAMPLE/PRELOAD | 0x3 | IDCODE (Renesas code) | 0x5 | CLAMP | 0x6 | HIGHZ | 0xF | BYPASS | Others | Reserved |  |
| TS[3:0] | Instruction           |  |         |             |     |        |     |                |     |                       |     |       |     |       |     |        |        |          |  |
| 0x0     | EXTEST                |  |         |             |     |        |     |                |     |                       |     |       |     |       |     |        |        |          |  |
| 0x1     | SAMPLE/PRELOAD        |  |         |             |     |        |     |                |     |                       |     |       |     |       |     |        |        |          |  |
| 0x3     | IDCODE (Renesas code) |  |         |             |     |        |     |                |     |                       |     |       |     |       |     |        |        |          |  |
| 0x5     | CLAMP                 |  |         |             |     |        |     |                |     |                       |     |       |     |       |     |        |        |          |  |
| 0x6     | HIGHZ                 |  |         |             |     |        |     |                |     |                       |     |       |     |       |     |        |        |          |  |
| 0xF     | BYPASS                |  |         |             |     |        |     |                |     |                       |     |       |     |       |     |        |        |          |  |
| Others  | Reserved              |  |         |             |     |        |     |                |     |                       |     |       |     |       |     |        |        |          |  |

JTAG instructions can be transferred to the JTIR register by serial input from the TDI pin. The JTIR register is initialized when a power-on reset occurs, or when the TAP controller is in the Test-Logic-Reset state.

### 35.2.2 JTIDR : ID Code Register

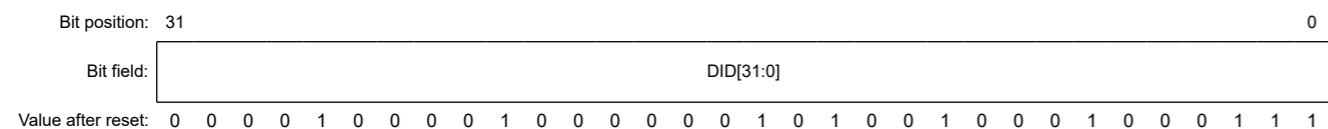


Table 35.3 边界扫描寄存器

| 注册名称    | Symbol | 重置后的值       |
|---------|--------|-------------|
| 指令寄存器   | JTIR   | 0xE         |
| ID代码寄存器 | JTIDR  | 0x0840_A447 |
| 绕过寄存器   | JTBPR  | Undefined   |
| 边界扫描寄存器 | JTBSR  | Undefined   |

边界扫描寄存器的使用说明:

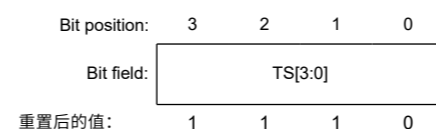
- 指令可以通过串行传输的方式通过TDI引脚输入指令寄存器 (JTIR)。
- BypassRegister(JTBPR)是一个1位寄存器, 在BYPASS模式下连接在TDI和TDO引脚之间。
- 根据BSDL描述配置的边界扫描寄存器(JTBSR)在测试数据移入时连接在TDI和TDO引脚之间。

表35.4显示了寄存器串行传输的可用性。

Table 35.4 寄存器的串行传输

| 注册名称           | 串行输入      | 串行输出      |
|----------------|-----------|-----------|
| 指令寄存器(JTIR)    | Available | Available |
| ID代码寄存器(JTIDR) | Available | Available |
| 旁路寄存器(JTBPR)   | Available | Available |
| 边界扫描寄存器(JTBSR) | Available | Available |

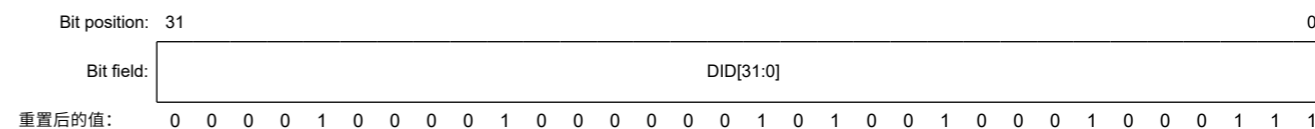
### 35.2.1 JTIR:指令寄存器



| Bit     | Symbol                | Function   | R/W     |             |     |        |     |                |     |                       |     |       |     |       |     |        |        |          |  |
|---------|-----------------------|--|---------|-------------|-----|--------|-----|----------------|-----|-----------------------|-----|-------|-----|-------|-----|--------|--------|----------|--|
| 3:0     | TS[3:0]               | 测试位组<br>这些位的命令配置   | —       |             |     |        |     |                |     |                       |     |       |     |       |     |        |        |          |  |
|         |                       | <table border="1"> <thead> <tr> <th>TS[3:0]</th> <th>Instruction</th> </tr> </thead> <tbody> <tr> <td>0x0</td> <td>EXTEST</td> </tr> <tr> <td>0x1</td> <td>SAMPLE/PRELOAD</td> </tr> <tr> <td>0x3</td> <td>IDCODE (Renesas code)</td> </tr> <tr> <td>0x5</td> <td>CLAMP</td> </tr> <tr> <td>0x6</td> <td>HIGHZ</td> </tr> <tr> <td>0xF</td> <td>BYPASS</td> </tr> <tr> <td>Others</td> <td>Reserved</td> </tr> </tbody> </table> | TS[3:0] | Instruction | 0x0 | EXTEST | 0x1 | SAMPLE/PRELOAD | 0x3 | IDCODE (Renesas code) | 0x5 | CLAMP | 0x6 | HIGHZ | 0xF | BYPASS | Others | Reserved |  |
| TS[3:0] | Instruction           |  |         |             |     |        |     |                |     |                       |     |       |     |       |     |        |        |          |  |
| 0x0     | EXTEST                |  |         |             |     |        |     |                |     |                       |     |       |     |       |     |        |        |          |  |
| 0x1     | SAMPLE/PRELOAD        |  |         |             |     |        |     |                |     |                       |     |       |     |       |     |        |        |          |  |
| 0x3     | IDCODE (Renesas code) |  |         |             |     |        |     |                |     |                       |     |       |     |       |     |        |        |          |  |
| 0x5     | CLAMP                 |  |         |             |     |        |     |                |     |                       |     |       |     |       |     |        |        |          |  |
| 0x6     | HIGHZ                 |  |         |             |     |        |     |                |     |                       |     |       |     |       |     |        |        |          |  |
| 0xF     | BYPASS                |  |         |             |     |        |     |                |     |                       |     |       |     |       |     |        |        |          |  |
| Others  | Reserved              |  |         |             |     |        |     |                |     |                       |     |       |     |       |     |        |        |          |  |

JTAG指令可以通过TDI引脚的串行输入传输到JTIR寄存器。当发生上电复位或TAP控制器处于Test-Logic-Reset状态时, JTIR寄存器被初始化。

### 35.2.2 JTIDR:ID代码寄存器



| Bit  | Symbol    | Function  | R/W |
|------|-----------|---|-----|
| 31:0 | DID[31:0] | Device ID<br>These bits store the fixed value that indicates the device IDCODE (0x0840_A447). | —   |

The JTIDR register data is output from the TDO pin when the IDCODE instruction is executed. After a reset release, the DID[31:0] of JTIDR changes into the Arm® debug code. See the *Arm® CoreSight™ SoC-400 Technical Reference Manual* (ARM DDI 0480F).

### 35.2.3 JTBPR : Bypass Register

The JTBPR register is a 1-bit register and is connected between the TDI and TDO pins when the JTIR register is set to BYPASS mode. The JTBPR register cannot be read from or written to by the CPU.

### 35.2.4 JTBSR : Boundary Scan Register

The JTBSR register is a shift register for controlling the external input and output pins of this device, and is distributed across the pads. To apply the JTBSR register in boundary-scan testing, issue the EXTEST, SAMPLE/PRELOAD, CLAMP, and HIGHZ instructions. The BSDL file describes the associations between the JTBSR register bits and the pins of this device. The value after reset is undefined.

## 35.3 Operation

During a reset, the JTAG ports, TCK, TMS, TDI, and TDO, are assigned as default pin functions. The TCK, TMS, and TDI pins are pulled up by the pull-up resistors. Boundary scan testing can be executed after the setup time elapses when POR is negated and RES is driven low.

### 35.3.1 TAP Controller

Figure 35.2 shows the state transition diagram of the TAP controller. All transitions are controlled by the TMS signal.

| Bit  | Symbol    | Function                                  | R/W |
|------|-----------|---|-----|
| 31:0 | DID[31:0] | 设备ID<br>这些位存储指示设备IDCODE(0x0840_A447)的固定值。 | —   |

执行IDCODE指令时，从TDO引脚输出JTIDR寄存器数据。复位释放后，JTIDR的DID[31:0]更改为Arm®调试代码。请参阅Arm®CoreSight SoC-400技术参考手册(ARMDDI0480F)。

### 35.2.3 JTBPR:旁路寄存器

JTBPR寄存器是一个1位寄存器，当JTIR寄存器设置为旁路模式。CPU无法读取或写入JTBPR寄存器。

### 35.2.4 JTBSR:边界扫描寄存器

JTBSR寄存器是一个移位寄存器，用于控制该器件的外部输入和输出引脚，分布在各个焊盘上。要在边界扫描测试中应用JTBSR寄存器，请发出EXTEST、SAMPLE/PRELOAD、CLAMP和HIGHZ指令。BSDL文件描述了JTBSR寄存器位和该器件引脚之间的关联。复位后的值未定义。

## 35.3 Operation

在复位期间，JTAG端口、TCK、TMS、TDI和TDO被分配为默认引脚功能。TCK、TMS和TDI引脚由上拉电阻上拉。当POR被否定并且RES被驱动为低电平时，可以在设置时间过去后执行边界扫描测试。

### 35.3.1 水龙头控制器

图35.2显示了TAP控制器的状态转换图。所有转换都由TMS信号控制。

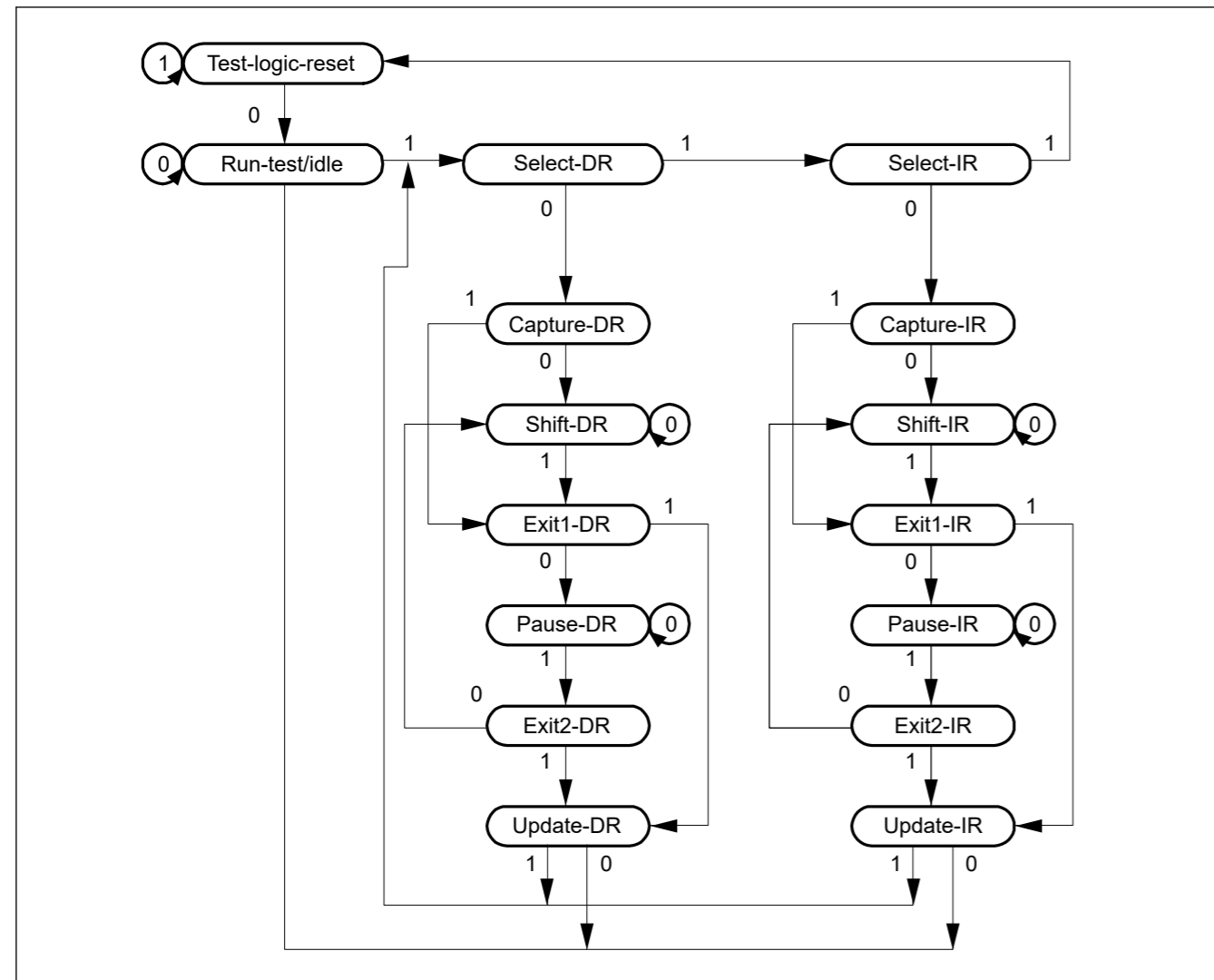


Figure 35.2 State transition diagram of TAP controller

### 35.3.2 Commands

#### (1) BYPASS

The BYPASS instruction drives the Bypass Register (JTBPR). This instruction shortens the shift path, facilitating the transfer of serial data to other LSIs on a printed circuit board at higher speeds. While this instruction is being executed, the test circuit has no effect on the system circuits.

The JTBPR register is connected between the TDI and TDO pins. Bypass operation is initiated from the Shift-DR operation. The TDO is low in the first clock cycle in the Shift-DR state. In the subsequent clock cycles, values input to the TDI pin are output from the TDO pin.

#### (2) EXTEST

The EXTEST instruction is used to test external circuits when this device is installed on the printed circuit board. If this instruction is executed, output pins are used to output test data (specified in the SAMPLE/PRELOAD instruction) from the Boundary Scan Register (JTBSR) to the other devices, and input pins are used to input the test result.

#### (3) SAMPLE/PRELOAD

The SAMPLE/PRELOAD instruction is used to input data from the internal circuits of this device to the JTBSR register, output data from the scan path, and reload the data to the scan path. While this instruction is executed, input signals are directly input to this device and output signals are also directly output to the external circuits. This device system circuit is not affected by this instruction.

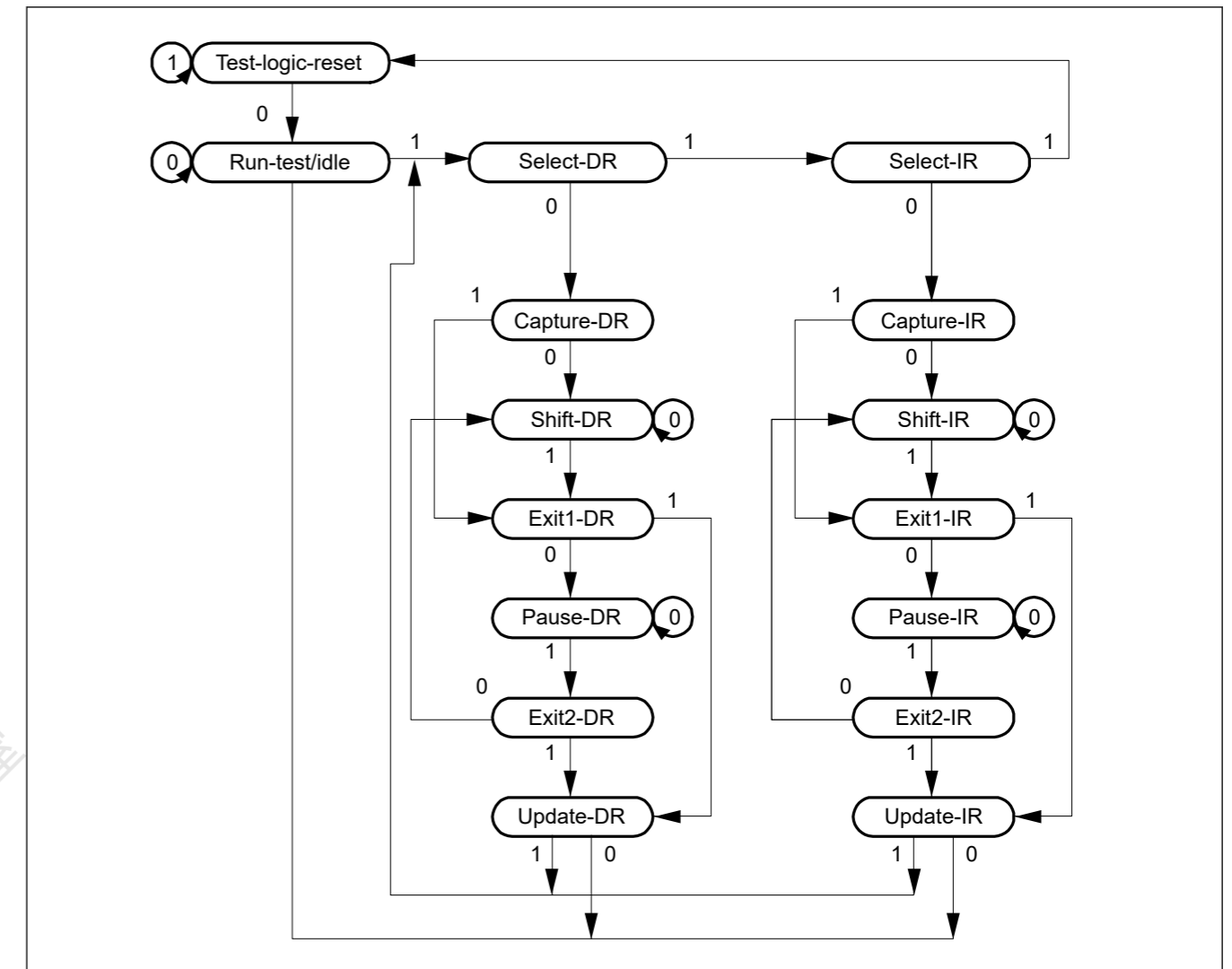


Figure 35.2 TAP控制器的状态转移图

### 35.3.2 Commands

#### (1) BYPASS

BYPASS指令驱动旁路寄存器(JTBPR)。该指令缩短了移位路径，便于将串行数据以更高的速度传输到印刷电路板上的其他LSI。在执行该指令时，测试电路对系统电路没有影响。

JTBPR寄存器连接在TDI和TDO引脚之间。旁路操作从Shift-DR操作开始。TDO在Shift-DR状态的第一个时钟周期内为低电平。在随后的时钟周期中，输入到TDI引脚的值从TDO引脚输出。

#### (2) EXTEST

当本设备安装在印刷电路板上时，EXTEST指令用于测试外部电路。如果执行该指令，输出引脚用于将测试数据（在SAMPLE/PRELOAD指令中指定）从边界扫描寄存器(JTBSR)输出到其他设备，输入引脚用于输入测试结果。

#### (3) SAMPLE/PRELOAD

SAMPLE/PRELOAD指令用于将数据从本器件内部电路输入到JTBSR寄存器，从扫描路径输出数据，并将数据重新加载到扫描路径。执行该指令时，输入信号直接输入到本设备，输出信号也直接输出到外部电路。本设备系统电路不受本指令影响。



In SAMPLE operation, the JTBSR register latches a snapshot of the data transferred from the input pins to the internal circuit or data transferred from the internal circuit to the output pins. The latched data is read from the scan path. The JTBSR register latches the data snapshot on the rising edge of the TCK pin in the Capture-DR state. The data snapshot is only transferred from the internal circuit to the output pins during a reset.

In PRELOAD operation, the initial value is written from the scan path to the parallel output latch of the JTBSR register prior to the EXTEST instruction execution. If EXTEST is executed without executing this PRELOAD operation, undefined values are output from the beginning to the end (transfer to the output latch) of the EXTEST sequence. (In the EXTEST instruction, output parallel latches are always output to the output pins.)

#### (4) IDCODE

When the IDCODE instruction is selected, the ID Code Register (JTIDR) value is output to the TDO pin in the Shift-DR state of the TAP controller. In this case, the JTIDR register value is output LSB-first. During this instruction execution, the test circuit does not affect the system circuit.

#### (5) CLAMP

When the CLAMP instruction is selected, output pins output the JTBSR register value that was specified in the SAMPLE/PRELOAD instruction in advance. While the CLAMP instruction is selected, the status of the JTBSR register is maintained regardless of the TAP controller state.

The JTBPR register is connected between the TDI and TDO pins, leading to the same operation as when the BYPASS instruction is selected.

#### (6) HIGHZ

When the HIGHZ instruction is selected, all output pins enter high-impedance state. While the HIGHZ instruction is selected, the JTBSR register is maintained regardless of the state of the TAP controller.

The JTBPR register is connected between the TDI and TDO pins, leading to the same operation as when the BYPASS instruction is selected.

### 35.4 Usage Notes

The boundary scan function is subject to the following constraints:

- The boundary scan must be executed when the RES pin is driven low
- Serial data input/output is in LSB order, as shown in [Figure 35.3](#)

在SAMPLE操作中，JTBSR寄存器锁存从输入引脚传输到内部电路的数据或从内部电路传输到输出引脚的数据的快照。从扫描路径读取锁存的数据。在Capture-DR状态下，JTBSR寄存器在TCK引脚的上升沿锁存数据快照。数据快照仅在复位期间从内部电路传输到输出引脚。

在PRELOAD操作中，在执行EXTEST指令之前，将初始值从扫描路径写入JTBSR寄存器的并行输出锁存器。如果不执行此PRELOAD操作的情况下执行EXTEST，则从EXTEST序列的开头到结尾（传输到输出锁存器）输出未定义的值。（在EXTEST指令中，输出并行锁存器始终输出到输出引脚。）

#### (4) IDCODE

When the IDCODE instruction is selected, the ID Code Register (JTIDR) value is output to the TDO pin in the Shift-DR state of the TAP controller. In this case, the JTIDR register value is output LSB-first. During this instruction execution, the test circuit does not affect the system circuit.

#### (5) CLAMP

选择夹具指令时，输出引脚输出样品中指定的JTBSR寄存器值  
预先PRELOAD指令。选择CLAMP指令时，无论TAP控制器状态如何，都将保持JTBSR寄存器的状态。

JTBPR寄存器连接在TDI和TDO引脚之间，导致与选择BYPASS指令时相同的操作。

#### (6) HIGHZ

选择Highz指令时，所有输出引脚都输入高阻抗状态。选择HIGHZ指令时，无论TAP控制器的状态如何，都会保持JTBSR寄存器。

JTBPR寄存器连接在TDI和TDO引脚之间，导致与选择BYPASS指令时相同的操作。

### 35.4 使用说明

边界扫描函数受以下约束：

- RES引脚拉低时必须执行边界扫描
- 串行数据输入输出按LSB顺序，如图35.3所示

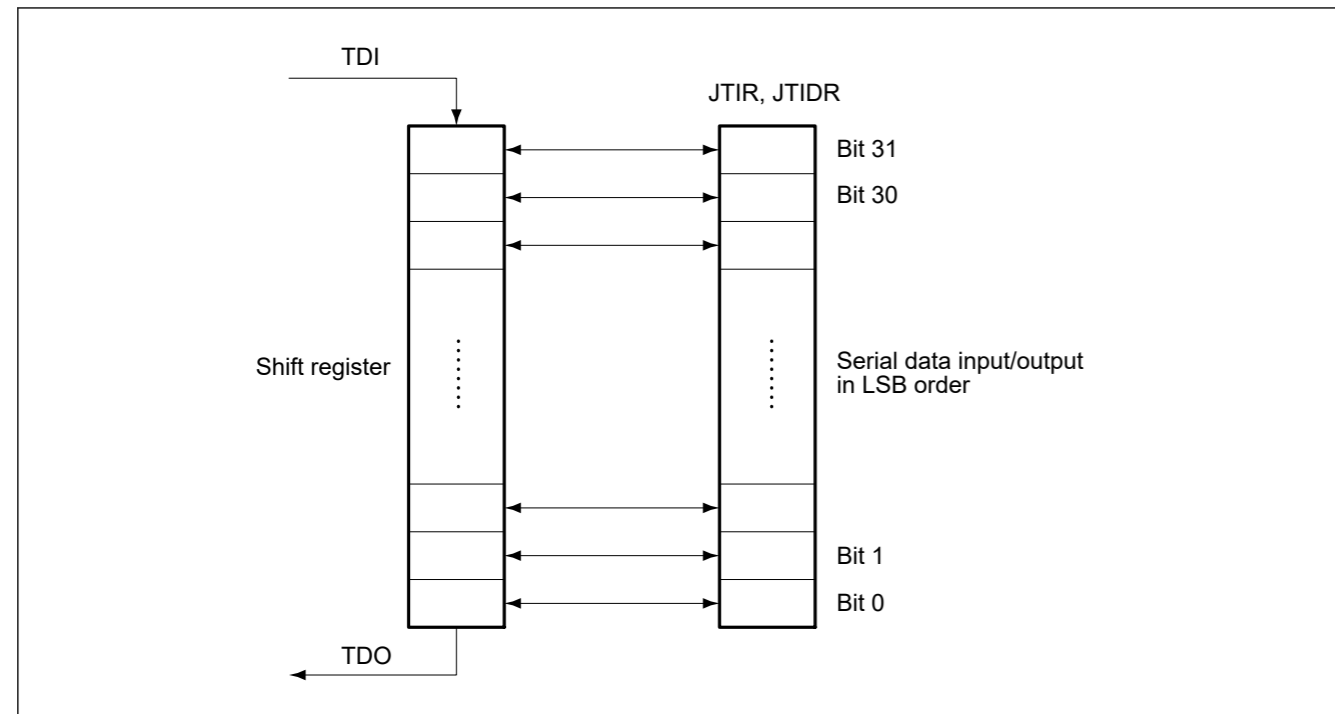


Figure 35.3 Serial data input/output

The following pins cannot be boundary-scanned:

- Power supply pins (VCC, VCL, VCL0, VSS, VBATT, AVCC0, AVSS0, VCC\_USB, and VSS\_USB)
- Analog reference pins (VREFH0, VREFL0, VREFH, VREFL)
- Clock pins (EXTAL, XTAL, XCIN, and XCOU)
- Reset pin (RES)
- USB-dedicated pins (USB\_DP, USB\_DM)
- The boundary-scan pins (TCK, TMS, TDI, and TDO).

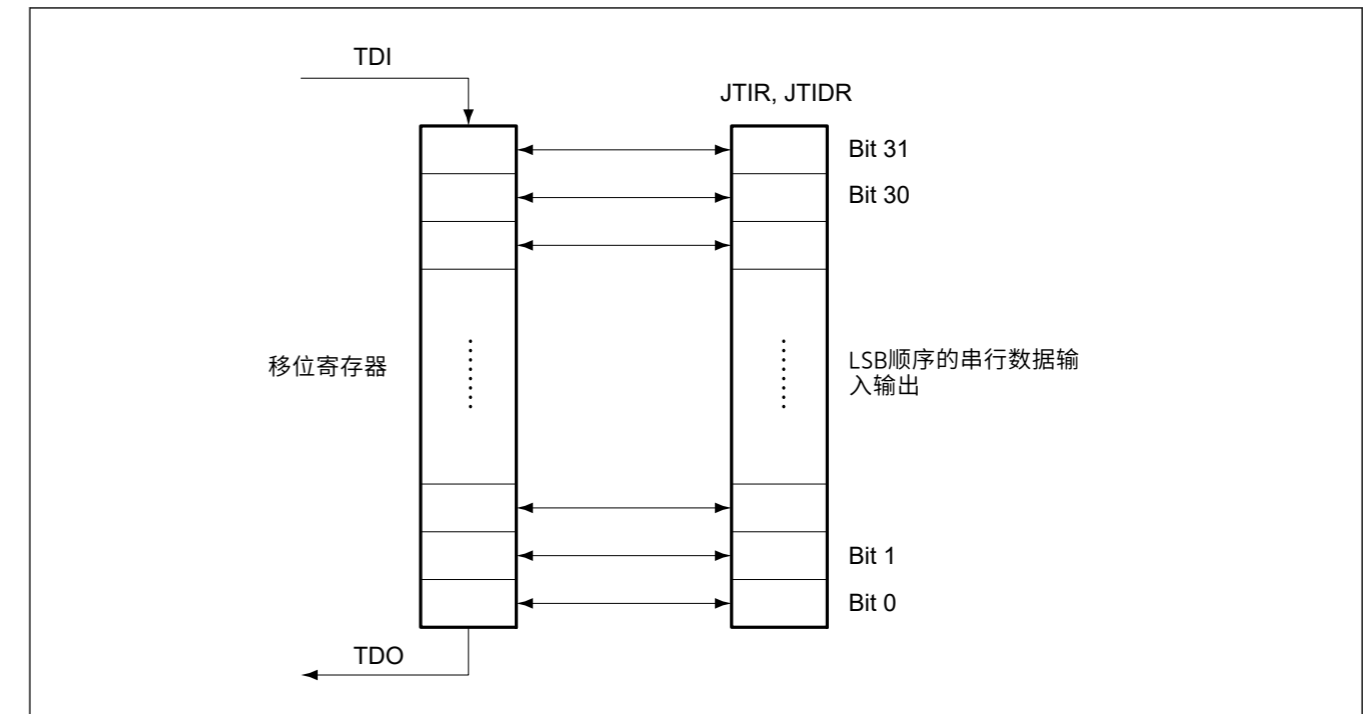


Figure 35.3 串行数据输入输出

以下引脚不能进行边界扫描：

- 电源引脚 (VCC、VCL、VCL0、VSS、VBATT、AVCC0、AVSS0、VCC\_USB和VSS\_USB)
- 模拟参考引脚 (VREFH0、VREFL0、VREFH、VREFL)
- 时钟引脚 (EXTAL、XTAL、XCIN和XCOU)
- 复位引脚 (RES)
- USB-dedicated pins (USB\_DP, USB\_DM)
- 边界扫描引脚 (TCK、TMS、TDI和TDO)。

## 36. Secure Cryptographic Engine (SCE9)

### 36.1 Overview

The Secure Cryptographic Engine (SCE9) consists of the access management circuit, encryption engine, and random number generation circuit. In combination with the SCE9 library, the SCE9 can prevent eavesdropping (to maintain confidentiality), falsification of information (to ensure integrity), and impersonation (to verify authenticity).

Because key information required for encryption and decryption is stored only in the SCE9 and all accesses from the outside can be blocked, SCE9 enables building a more robust security system.

Table 36.1 lists the SCE9 specifications. Figure 36.1 shows the SCE9 block diagram.

**Table 36.1 SCE9 specifications (1 of 2)**

| Parameter                             | Specifications   |
|---------------------------------------|--|
| Access control                        | Access management circuit <ul style="list-style-type: none"> <li>In case of irregular access to the SCE9 due to a tampered program or CPU runaway, this circuit blocks all subsequent accesses and stops data output from the SCE9</li> </ul>  |
| Encryption engine                     | <p>AES: Compliant with NIST FIPS PUB 197</p> <ul style="list-style-type: none"> <li>Key length: 128, 192, or 256 bits</li> <li>Data block size: 128 bits</li> <li>Encryption usage modes</li> </ul> <p>ECB, CBC, CTR: Compliant with NIST SP 800-38A</p> <p>CMAC: Compliant with NIST SP 800-38B</p> <p>CCM: Compliant with NIST SP 800-38C</p> <p>GCM: Compliant with NIST SP 800-38D</p> <p>XTS: Compliant with NIST SP 800-38E</p> <p>GCTR</p> <ul style="list-style-type: none"> <li>Throughput for 128-bit data</li> <li>11 PCLKA cycles for 128-bit key</li> <li>13 PCLKA cycles for 192-bit key</li> <li>15 PCLKA cycles for 256-bit key*1</li> </ul> <p>AES-GCM</p> <ul style="list-style-type: none"> <li>AES-GCM is realized by combining AES-GCTR and GHASH.</li> </ul> <p>Key management</p> <ul style="list-style-type: none"> <li>Wrapped keys are only valid within the SCE9</li> </ul> |
| Random number generation              | 128-bit true random number generation circuit  |
| Signature generation and verification | <p>RSA</p> <ul style="list-style-type: none"> <li>Support for 1024-bit, 2048-bit, 3072-bit, and 4096-bit key sizes</li> <li>Signature generation, signature verification, public-key encryption, private-key decryption</li> </ul> <p>DSA</p> <ul style="list-style-type: none"> <li>Support for DSA key sizes:           <ul style="list-style-type: none"> <li>(1024-bit, 160-bit)</li> <li>(2048-bit, 224-bit)</li> <li>(2048-bit, 256-bit)</li> </ul> </li> <li>Signature generation, signature verification</li> </ul> <p>ECC</p> <ul style="list-style-type: none"> <li>Support for curve           <ul style="list-style-type: none"> <li>NIST P-192, P-224, P-256, and P-384</li> <li>Brainpool P256r1, P384r1, and P512r1</li> </ul> </li> <li>Signature generation, signature verification</li> </ul>  |
| Message digest computation            | <p>HASH</p> <ul style="list-style-type: none"> <li>SHA224 and SHA256</li> </ul>  |
| Hardware Unique Key                   | <ul style="list-style-type: none"> <li>A read-only, 256-bit Hardware Unique Key (HUK) is exclusively accessible by the SCE access management circuit through a dedicated bus.</li> <li>Key derivation functions (KDFs) combine the Hardware Unique Key with the key generation information. The derived keys implement the key wrapping for user key secure storage.</li> <li>The HUK uniqueness prevents the illicit cloning and copying of keys to another MCU of the MCU group.</li> <li>The HUK itself is stored in wrapped (encrypted, non-plain) format in an isolated memory area. Therefore it is protected from illicit access and copy.</li> </ul>   |

## 36. 安全加密引擎(SCE9)

### 36.1 Overview

安全密码引擎 (SCE9) 由访问管理电路、加密引擎和随机数生成电路组成。结合SCE9库, SCE9可以防止窃听 (以保持机密性)、伪造信息 (以确保完整性) 和假冒 (以验证真实性)。

由于加密和解密所需的关键信息只存储在SCE9中, 并且可以阻止来自外部的所有访问, 因此SCE9可以构建更强大的安全系统。

表36.1列出了SCE9规范。图36.1显示了SCE9框图。

**Table 36.1 SCE9规范 (2个中的1个)**

| Parameter | Specifications  |
|-----------|---|
| 访问控制      | 访问管理电路●<br>如果由于程序被篡改或CPU失控而导致对SCE9的非正常访问, 该电路将阻止所有后续访问并停止从SCE9输出数据  |
| 加密引擎      | <p>AES: 符合NISTFIPSPUB197●</p> <ul style="list-style-type: none"> <li>密钥长度: 128、192或256位</li> <li>数据块大小: 128位</li> <li>加密使用模式</li> </ul> <p>ECB、CBC、CTR: 符合NISTSP800-38A</p> <p>CMAC: 符合NISTSP800-38BCCM: 符合NISTSP800-38CGCM: 符合NISTSP800-38DXTS: 符合NISTSP800-38E</p> <p>GCTR</p> <ul style="list-style-type: none"> <li>128位数据的吞吐量128位密钥的1个PCLKA周期192位密钥的13个PCLKA周期256位密钥的15个PCLKA周期*1</li> </ul> <p>AES-GCM</p> <ul style="list-style-type: none"> <li>AES-GCM是通过结合AES-GCTR和GHASH实现的。</li> </ul> <p>密钥管理●</p> <ul style="list-style-type: none"> <li>封装的密钥仅在SCE9内有效</li> </ul> |
| 随机数生成     | 128位真随机数产生电路  |
| 签名生成和验证   | <p>RSA</p> <ul style="list-style-type: none"> <li>支持1024位、2048位、3072位和4096位密钥大小</li> <li>●签名生成、签名验证、公钥加密、私钥解密DSA●</li> </ul> <p>支持DSA密钥大小:</p> <ul style="list-style-type: none"> <li>(1024-bit, 160-bit)</li> <li>(2048-bit, 224-bit)</li> <li>(2048-bit, 256-bit)</li> </ul> <ul style="list-style-type: none"> <li>签名生成、签名验证</li> </ul> <p>ECC</p> <ul style="list-style-type: none"> <li>支持曲线           <ul style="list-style-type: none"> <li>NIST P-192, P-224, P-256, and P-384</li> <li>Brainpool P256r1, P384r1, and P512r1</li> </ul> </li> <li>签名生成、签名验证</li> </ul>  |
| 消息摘要计算    | <p>HASH</p> <ul style="list-style-type: none"> <li>SHA224 and SHA256</li> </ul>   |
| 硬件唯一密钥    | <ul style="list-style-type: none"> <li>只读的256位硬件唯一密钥(HUK)可由SCE访问管理电路通过专用总线独占访问。</li> <li>密钥派生函数(KDF)将硬件唯一密钥与密钥生成信息相结合。派生密钥实现了用户密钥安全存储的密钥包装。</li> <li>HUK唯一性可防止将密钥非法克隆和复制到MCU组的另一个MCU。</li> <li>HUK本身以封装(加密, 非纯)格式存储在隔离的内存区域中。因此, 它受到保护, 免受非法访问和复制。</li> </ul>   |

Table 36.1 SCE9 specifications (2 of 2)

| Parameter             | Specifications   |
|-----------------------|--|
| Unique ID             | <ul style="list-style-type: none"> <li>A read-only, 128-bit ID unique to an MCU (Unique ID) is accessible from the access management circuit.</li> <li>Key derivation functions (KDFs) combine the Unique ID with the key generation information. Such derived keys are used to unwrap the HUK within the SCE boundary.</li> </ul> |
| Low power consumption | Setting of the module-stop state is possible   |

Note 1. This does not include the overhead of calling SCE9 library functions.

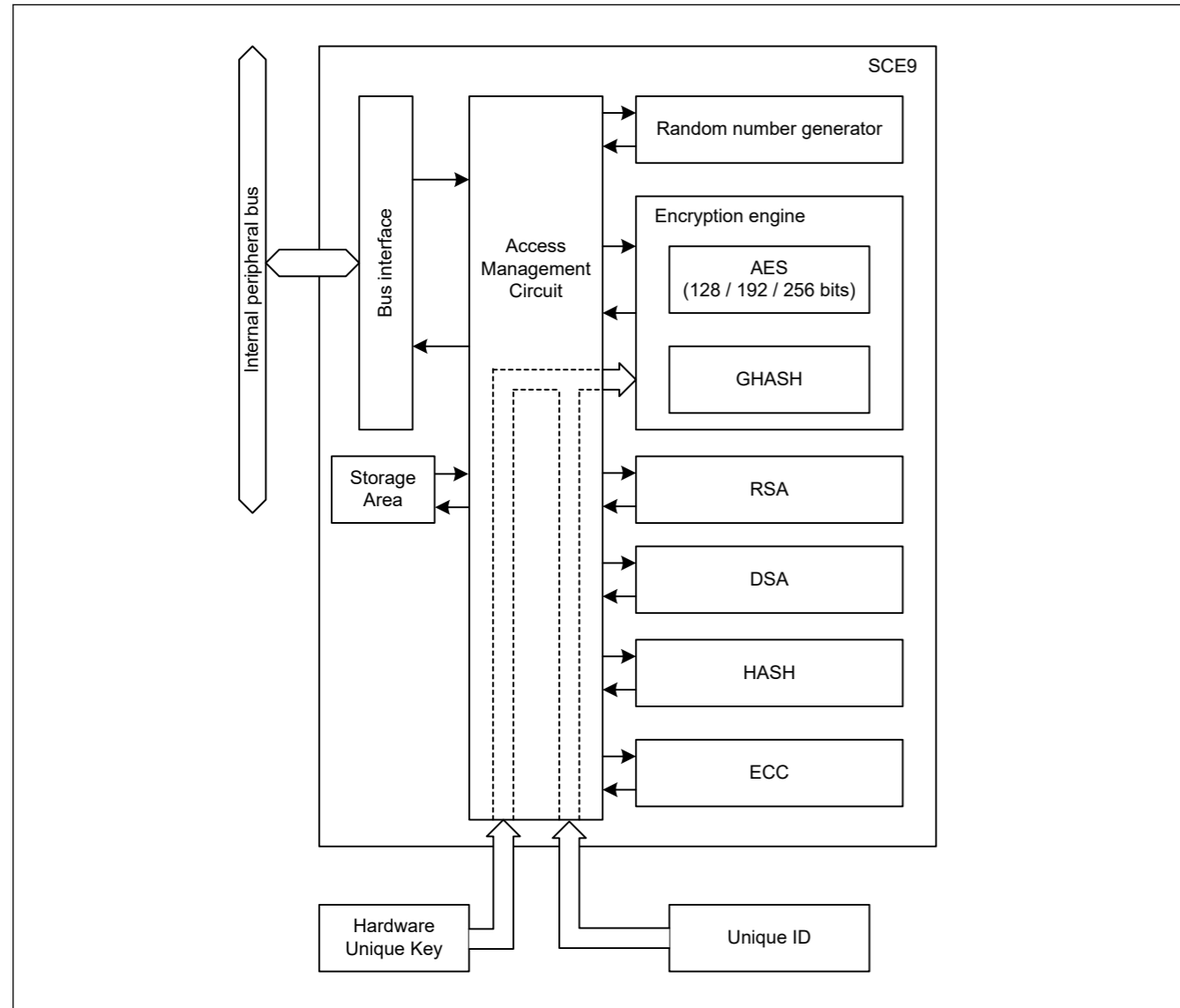


Figure 36.1 SCE9 block diagram

## 36.2 Operation

### 36.2.1 Encryption Engine

Figure 36.2 shows conceptual diagram of the encryption engine installed in the SCE9.

The encryption engine uses the key generation information, and converts the plaintext data to ciphertext or ciphertext data to plaintext through the hardware.

The encryption/decryption process can be completed without exposing the key data and the process's intermediate data to the outside of the SCE9.

Table 36.1 SCE9规范 (2个中的2个)

| Parameter | Specifications  |
|-----------|---|
| 唯一身份      | <ul style="list-style-type: none"> <li>MCU唯一的只读128位ID (唯一ID) 可从访问管理电路访问。</li> <li>密钥派生函数(KDF)将唯一ID与密钥生成信息相结合。此类派生密钥用于在SCE边界内解开HUK。</li> </ul> |
| 低功耗       | 可以设置模块停止状态  |

注1.这不包括调用SCE9库函数的开销。

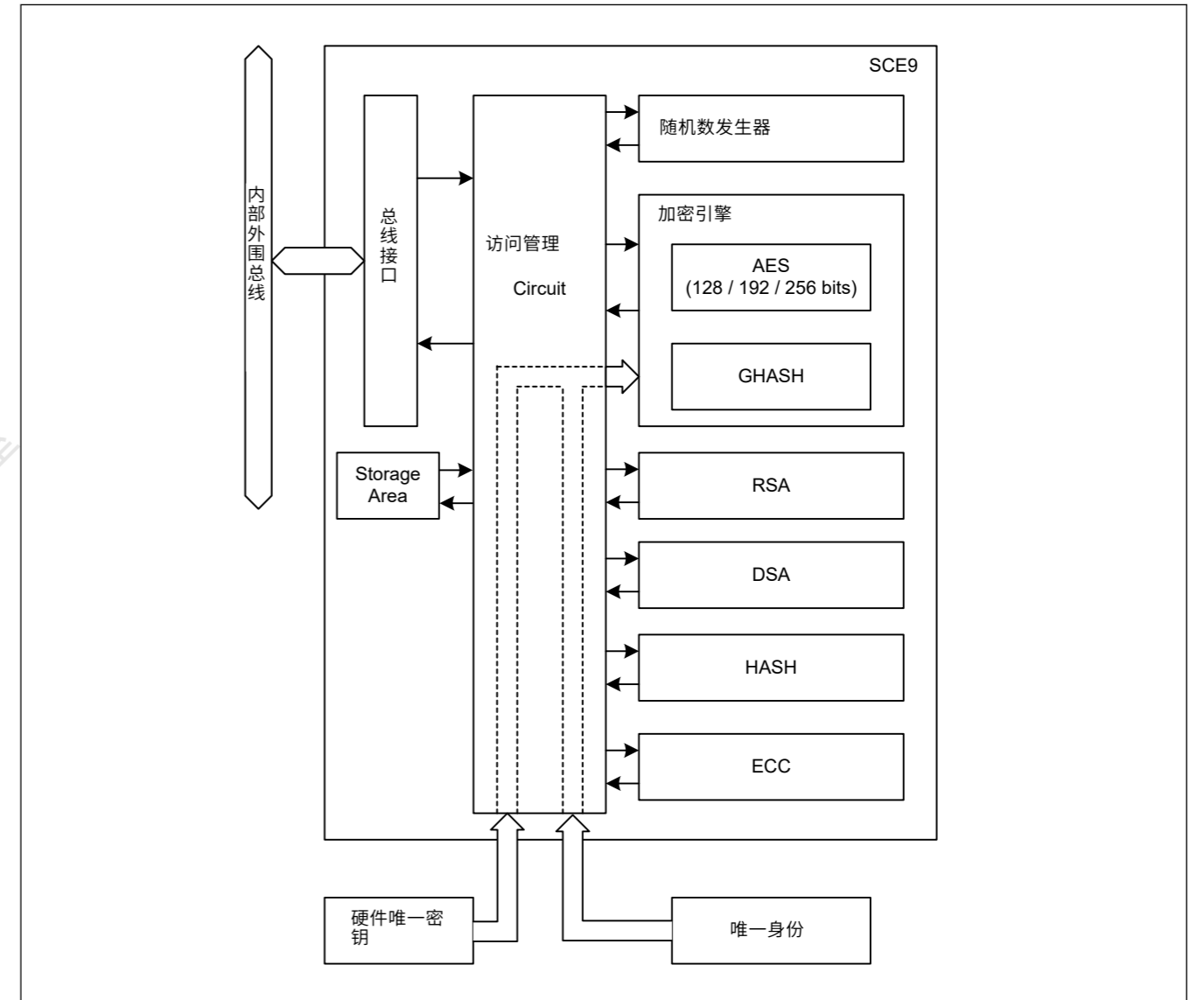


Figure 36.1 SCE9框图

## 36.2 Operation

### 36.2.1 加密引擎

图36.2显示了安装在SCE9中的加密引擎的概念图。

加密引擎使用密钥生成信息，通过硬件将明文数据转换为密文或将密文数据转换为明文。

加密解密过程可以在不将密钥数据和过程中间数据暴露在SCE9外部的情况下完成。



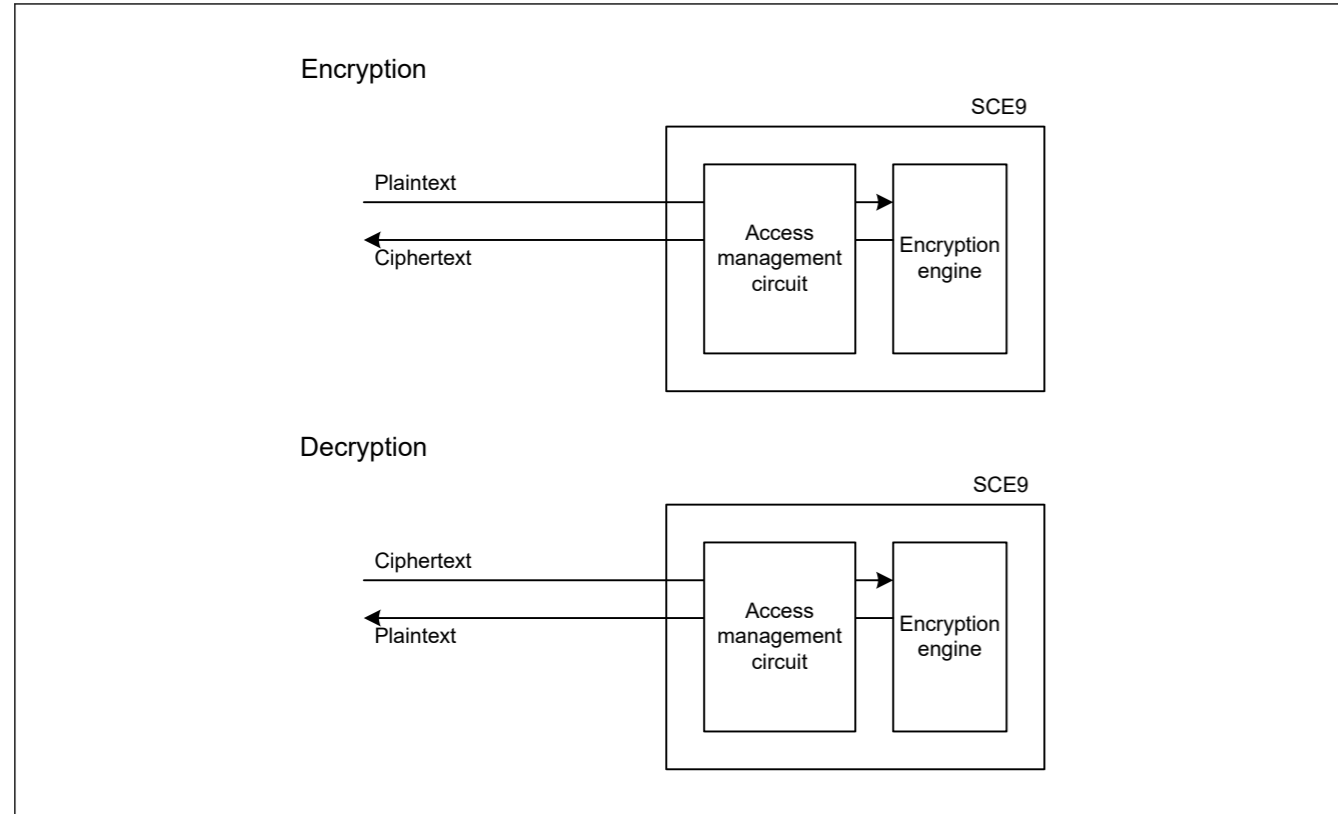


Figure 36.2 Conceptual diagram of the encryption engine

### 36.2.2 Encryption and Decryption

Follow the procedure below to encrypt and decrypt the data:

1. Enter the key generation information to the SCE9 and restore the key data.
2. Enter the target data to the SCE9. Plaintext data is converted to ciphertext and ciphertext data to plaintext.
3. Read the converted data.

The encryption engine has input and output buffers, and can perform encryption/decryption in parallel with data input/output. Figure 36.3 shows the encryption engine timing.

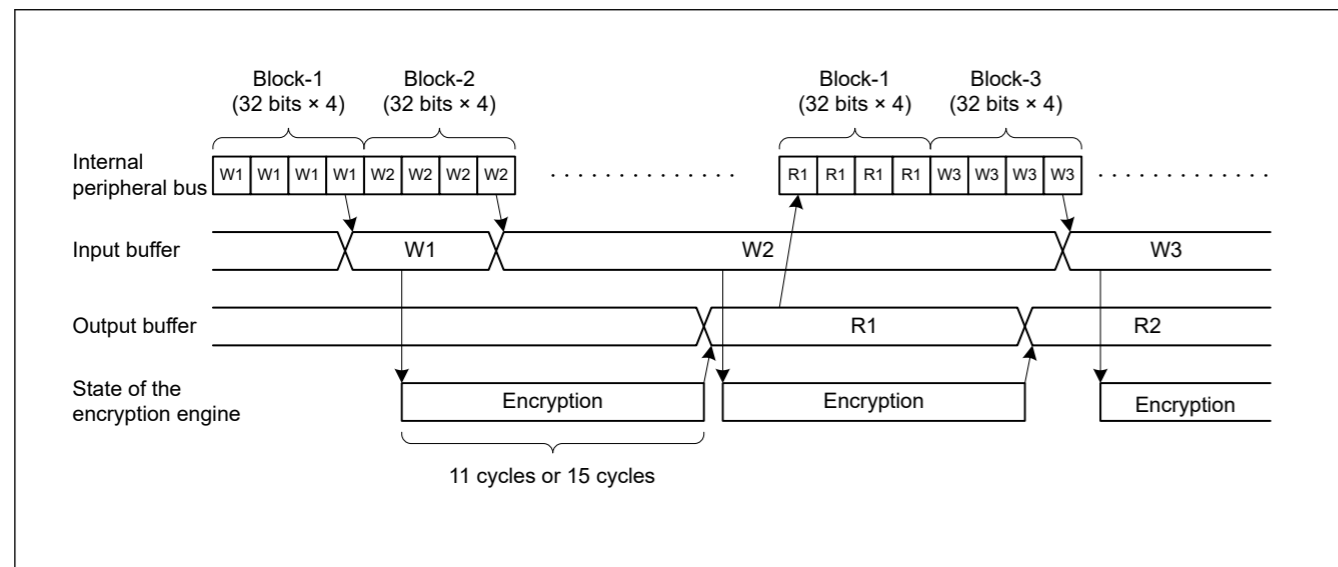


Figure 36.3 Encryption and decryption timing (AES)

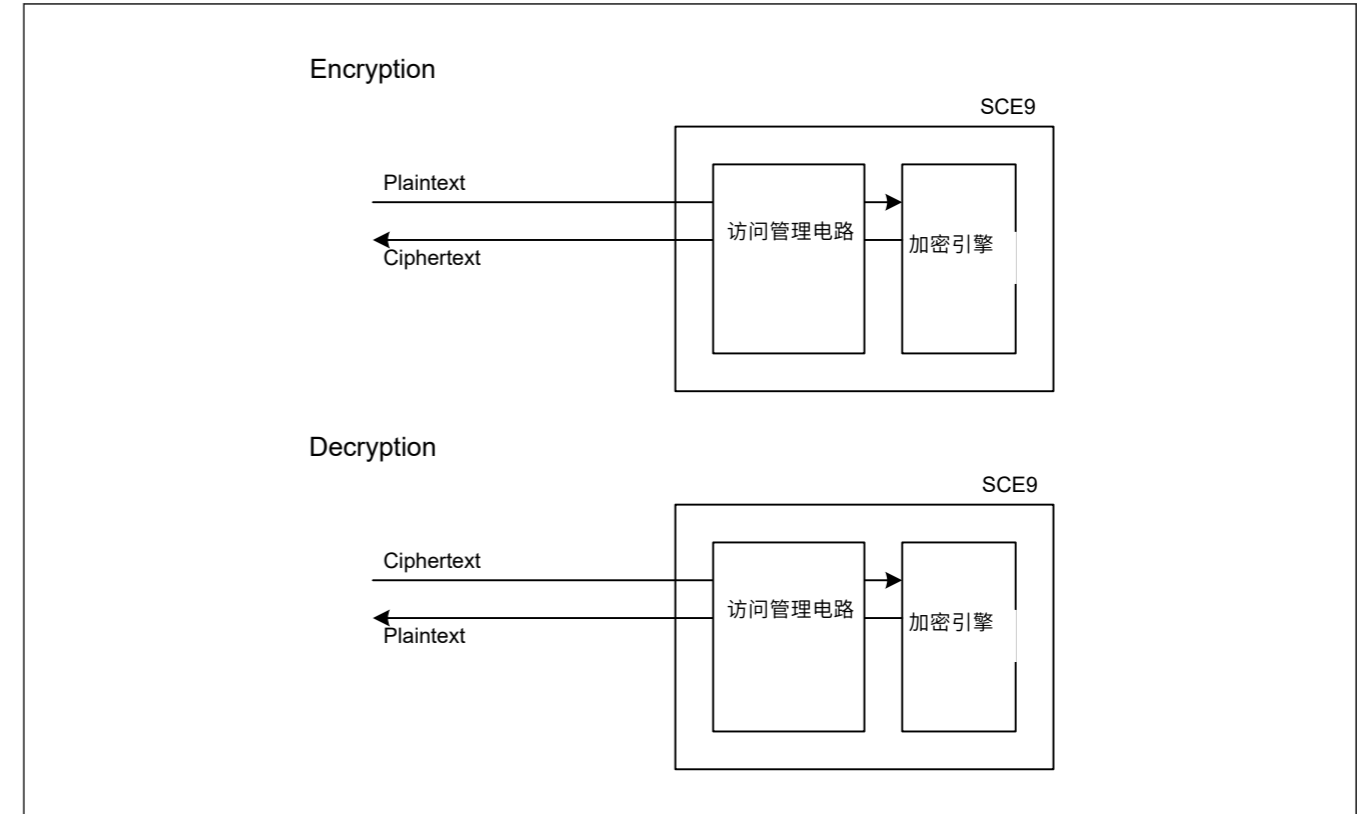


Figure 36.2 加密引擎的概念图

### 36.2.2 加密和解密

请按照以下步骤对数据进行加密和解密：

- 1.将密钥生成信息输入SCE9，恢复密钥数据。
- 2.将目标数据输入到SCE9。明文数据转换为密文，密文数据转换为明文。
- 3.读取转换后的数据。

加密引擎具有输入和输出缓冲区，可以与数据输入输出并行进行加密解密。图36.3显示了加密引擎的时序。

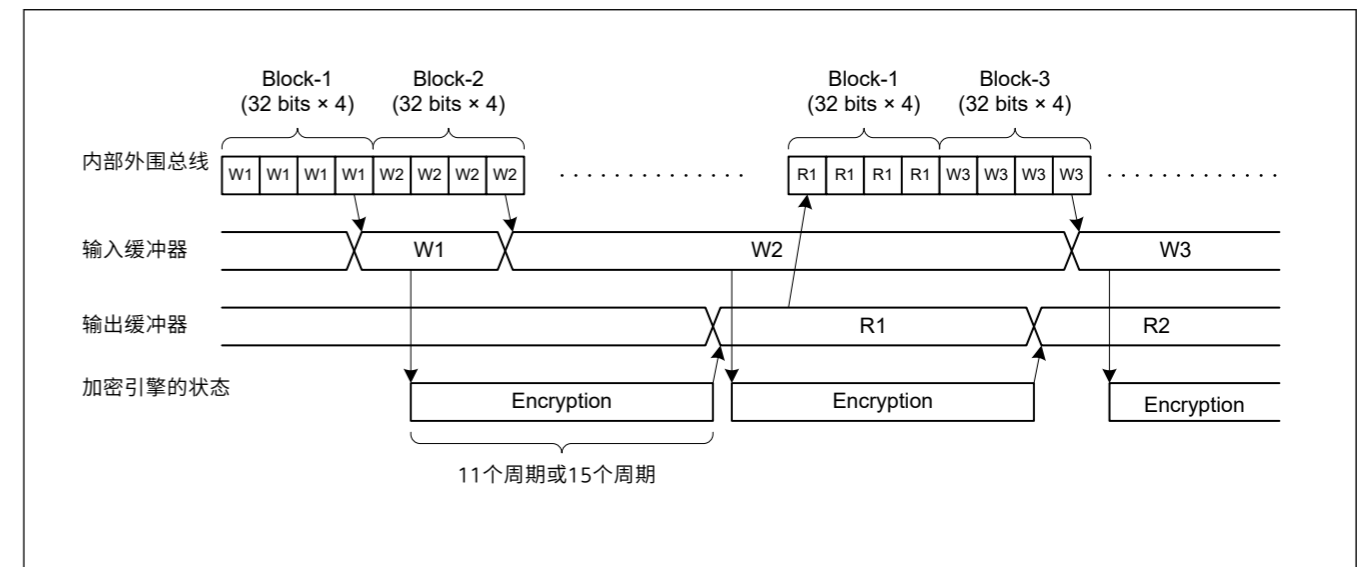


Figure 36.3 加密和解密时序 (AES)

### 36.3 Usage Notes

#### 36.3.1 Software Standby Mode

When the software standby mode is entered while the encryption engine is in process, proper processing cannot be resumed after the software standby mode is exited. The software standby mode should therefore be entered while the encryption engine is not running.

#### 36.3.2 Module-Stop Function Setting

SCE9 operation can be disabled or enabled using Module Stop Control Register C (MSTPCRC). The SCE9 module is initially stopped after reset. Releasing the module-stop state enables access to the registers.

### 36.3 使用说明

#### 36.3.1 软件待机模式

当加密引擎正在运行时进入软件待机模式时，退出软件待机模式后无法恢复正常处理。因此，应在加密引擎未运行时进入软件待机模式。

#### 36.3.2 模块停止功能设置

可以使用模块停止控制寄存器C(MSTPCRC)禁用或启用SCE9操作。SCE9模块在复位后最初停止。释放模块停止状态可以访问寄存器。

## 37. 12-Bit A/D Converter (ADC12)

### 37.1 Overview

The MCU includes 12-bit successive approximation A/D converter (ADC12) units. In unit 0, up to 12 analog input channels are selectable. In unit 1, up to 10 analog input channels, temperature sensor output, internal reference voltage can be selected for conversion in respective units.

The A/D conversion accuracy is selectable from 12-bit, 10-bit, 8-bit conversion, making it possible to optimize the trade-off between speed and resolution in generating a digital value.

The ADC12 supports the following operating modes:

- Single scan mode to convert analog inputs of selected channels in ascending order of channel number
- Continuous scan mode to convert analog inputs of selected channels continuously in ascending order of channel number
- Group scan mode to divide analog inputs of channels into two groups (group A and B) and convert the analog inputs of selected channels for each group in ascending order of channel number.

In group scan mode, select two groups (group A and B). You can individually select the scan start conditions for each group (group A, B) and start scanning of each group at different times. In addition, when group A priority control operation is set, the ADC12 accepts group A scan start during group B A/D conversion, suspending group B conversion. This allows you to assign higher priority to A/D conversion start for group A.

In double trigger mode, the analog input of a selected channel is converted in single scan mode or group scan mode (group A), and data converted by the first and second A/D conversion start triggers are stored in different registers, providing duplexing of A/D converted data.

Self-diagnosis is performed once at the beginning of each scan, and one of the three reference voltage values generated in ADC12 is A/D converted.

The temperature sensor output and the internal reference voltage are selectable at the same time as the analog input of the channel. First A/D conversion is performed for the analog input of the channel, next the temperature sensor output, and then the internal reference voltage.

The ADC12 also provides a compare function (window A and window B). The compare function specifies the upper reference value for window A and lower reference value for window B, and outputs an interrupt when the A/D converted value of the selected channel meets the comparison conditions.

The A/D data storage buffer is a ring buffer consisting of 16 buffers to sequentially store A/D converted data.

Table 37.1 lists the ADC12 specifications and Table 37.2 list the functions. Figure 37.1 shows a block diagram of ADC12 and Table 37.3 lists the I/O pins.

Table 37.1 ADC12 specifications (1 of 3)

| Parameter            | Specifications  |
|----------------------|---|
| Number of units      | two units   |
| Input channels       | Up to 22 channels (AN000 to AN009, AN012, AN013, AN100 to AN102, AN116 to AN122) Extended   |
| Analog function      | Temperature sensor output, internal reference voltage   |
| Conversion method    | Successive approximation method   |
| Resolution           | 12-bit, 10-bit, 8-bit   |
| Conversion time      | 0.4 μs/channel (when 12-bit A/D conversion clock PCLKC (ADCLK) is operating at 50 MHz)  |
| A/D conversion clock | Peripheral module clock PCLKA and A/D conversion clock PCLKC (ADCLK) can be set with the following division ratios: PCLKA to PCLKC (ADCLK) frequency ratio = 1:1, 2:1, 4:1, 8:1, 1:2, 1:4 |

## 37. 12-Bit A/D Converter (ADC12)

### 37.1 Overview

MCU包括12位逐次逼近模数转换器(ADC12)单元。在单元0中,最多可选择12个模拟输入通道。在单元1中,可以选择最多10个模拟输入通道、温度传感器输出、内部参考电压进行相应单元的转换。

AD转换精度可从12位、10位、8位转换中选择,从而可以在生成数字值时优化速度和分辨率之间的权衡。

ADC12支持以下工作模式:

- 单次扫描模式,以通道号升序转换所选通道的模拟输入
- 连续扫描模式,以通道号升序连续转换所选通道的模拟输入
- 组扫描模式,将通道的模拟输入分为两组(A组和B组),并按通道编号升序对每组所选通道的模拟输入进行转换。

在组扫描模式下,选择两个组(A组和B组)。您可以单独选择每个组(A、B组)的扫描开始条件,并在不同时间开始每个组的扫描。此外,当设置A组优先控制操作时,ADC12在B组AD转换期间接受A组扫描启动,暂停B组转换。这允许您为A组的AD转换启动分配更高的优先级。

在双触发模式下,选定通道的模拟输入转换为单扫描模式或组扫描模式(组A),由第一个和第二个AD转换启动触发器转换的数据存储在不同的寄存器中,提供AD转换数据的双工。

自诊断在每次扫描开始时执行一次,并在生成的三个参考电压值之一ADC12经过AD转换。

温度传感器输出和内部参考电压可与通道的模拟输入同时选择。首先对通道的模拟输入进行AD转换,然后是温度传感器输出,然后是内部参考电压。

ADC12还提供比较功能(窗口A和窗口B)。比较函数指定窗口A的上参考值和窗口B的下参考值,当所选通道的AD转换值满足比较条件时输出中断。

AD数据存储缓冲区是由16个缓冲区组成的环形缓冲区,用于顺序存储AD转换后的数据。

表37.1列出了ADC12规格,表37.2列出了功能。图37.1显示了ADC12的框图,表37.3列出了IO引脚。

Table 37.1 ADC12规格(1of3)

| Parameter  | Specifications   |
|------------|--|
| 单位数量       | 两个单元   |
| 输入通道       | 多达22个通道(AN000至AN009、AN012、AN013、AN100至AN102、AN116至AN122)扩展                             |
| 模拟功能       | 温度传感器输出,内部参考电压   |
| 转换方法       | 逐次逼近法  |
| Resolution | 12-bit, 10-bit, 8-bit  |
| 转换时间       | 0.4μs通道(当12位AD转换时钟PCLKC(ADCLK)工作在50MHz时)   |
| AD转换时钟     | 外设模块时钟PCLKA和AD转换时钟PCLKC(ADCLK)可以设置为以下分频比:PCLKA与PCLKC(ADCLK)频率比=1:1 2:1 4:1 8:1 1:2 1:4 |

Table 37.1 ADC12 specifications (2 of 3)

| Parameter                           | Specifications  |
|-------------------------------------|---|
| Data registers*1                    | <ul style="list-style-type: none"> <li>22 registers for analog input</li> <li>One register for A/D-converted data duplication in double trigger mode</li> <li>Two registers for A/D-converted data duplication during extended operation in double trigger mode</li> <li>One register for temperature sensor output</li> <li>One register for internal reference voltage</li> <li>One register for self-diagnosis</li> <li>A/D conversion results are stored in A/D data registers</li> <li>12-bit, 10-bit, 8-bit accuracy for A/D conversion results</li> <li>A/D-converted value addition mode, in which the sum of all A/D-converted results is stored in the A/D data registers as a value with the conversion accuracy bit count + extended bits</li> <li>Double-trigger mode (selectable in single scan and group scan modes): <ul style="list-style-type: none"> <li>The first unit of A/D-converted analog input data on one selected channel is stored in the data register for the channel, and the second unit is stored in the duplication register.</li> </ul> </li> <li>Extended operation in double trigger mode (available for specific triggers): <ul style="list-style-type: none"> <li>A/D-converted analog input data on one selected channel is stored in the duplication register provided for the associated trigger.</li> </ul> </li> </ul>   |
| Operating modes*2                   | <ul style="list-style-type: none"> <li>Single scan mode: <ul style="list-style-type: none"> <li>A/D conversion is performed only once on the analog inputs of arbitrarily selected channels, on the temperature sensor output, on the internal reference voltage.</li> </ul> </li> <li>Continuous scan mode: <ul style="list-style-type: none"> <li>A/D conversion is performed repeatedly on the analog inputs of the selected channels, on the temperature sensor output, and on the internal reference voltage.</li> </ul> </li> <li>Group scan mode: <ul style="list-style-type: none"> <li>Analog inputs of selected channels, the temperature sensor output, and the internal reference voltage are divided into groups A and B. Then A/D conversion of the analog inputs selected on a group basis is performed once.</li> <li>The scan start conditions can be independently selected for group A, B, allowing A/D conversion of group A, B to be started independently.</li> </ul> </li> <li>Group scan mode (when group priority operation is selected): <ul style="list-style-type: none"> <li>If a priority group trigger is input during scanning of a lower-priority group, the scanning of the lower-priority group is stopped and then scanning of the priority group is started. The order of priority is group A &gt; group B.</li> <li>It is possible to select whether to restart scanning (rescan) of the lower-priority group upon completion of the priority group scan. It is also possible to specify rescanning to be started from the first channel of the selected channels or from the channel for which A/D conversion has not been completed.</li> </ul> </li> </ul> |
| Conditions for A/D conversion start | <ul style="list-style-type: none"> <li>Software trigger</li> <li>Synchronous triggers from the Event Link Controller (ELC)</li> <li>Asynchronous triggering by the external trigger pins, ADTRG0 (unit 0) and ADTRG1 (unit 1)</li> </ul>  |
| Functions                           | <ul style="list-style-type: none"> <li>Variable sampling state count</li> <li>Self-diagnosis of A/D converter</li> <li>Selectable A/D-converted value addition mode or average mode</li> <li>Analog input disconnection detection function (discharge and precharge functions)</li> <li>Double-trigger mode (duplication of A/D conversion data)</li> <li>Automatic clear function for A/D data registers</li> <li>Digital comparison of values in the comparison register and data register, and comparison between values in the data registers</li> <li>Interleave function</li> <li>Ring buffer</li> </ul>  |

Table 37.1 ADC12规格 (2个, 共3个)

| Parameter     | Specifications   |
|---------------|--|
| 数据寄存器*1       | <ul style="list-style-type: none"> <li>22个模拟输入寄存器</li> <li>一个寄存器用于双触发模式下的AD转换数据复制</li> <li>双触发模式下扩展操作期间用于AD转换数据复制的两个寄存器</li> <li>1个温度传感器输出寄存器</li> <li>1个内部参考电压寄存器</li> <li>一个自我诊断寄存器</li> <li>AD转换结果存储在AD数据寄存器中</li> <li>AD转换结果的12位、10位、8位精度</li> <li>一种D转换值相加模式，其中所有AD转换结果的总和作为转换精度位数+扩展位的值存储在AD数据寄存器中</li> <li>双触发模式（可在单次扫描和组扫描模式下选择）： <ul style="list-style-type: none"> <li>一个选定通道上的AD转换模拟输入数据的第一个单元存储在该通道的数据寄存器中，第二个单元存储在复制寄存器中。</li> </ul> </li> <li>双触发模式下的扩展操作（可用于特定触发）： <ul style="list-style-type: none"> <li>一个选定通道上的D转换模拟输入数据存储在为相关触发提供的复制寄存器中。</li> </ul> </li> </ul>  |
| 操作模式*2        | <ul style="list-style-type: none"> <li>单次扫描模式： <ul style="list-style-type: none"> <li>D转换仅在任意选择通道的模拟输入、温度传感器输出和内部参考电压上执行一次。</li> </ul> </li> <li>连续扫描模式： <ul style="list-style-type: none"> <li>在选定通道的模拟输入、温度传感器输出和内部参考电压上重复执行D转换。</li> </ul> </li> <li>组扫描模式： <ul style="list-style-type: none"> <li>所选通道的模拟输入、温度传感器输出和内部参考电压分为A组和B组。然后对按组选择的模拟输入进行一次AD转换。</li> <li>A、B组可以独立选择扫描开始条件，可以独立启动A、B组的A/D转换。</li> </ul> </li> <li>组扫描模式（选择组优先操作时）： <ul style="list-style-type: none"> <li>如果在较低优先级组的扫描期间输入了优先级组触发，则较低优先级组的扫描停止，然后开始优先级组的扫描。优先顺序为A组&gt;B组。</li> <li>可以选择在完成优先级组扫描后是否重新开始低优先级组的扫描（重新扫描）。也可以指定从所选通道的第一个通道或未完成AD转换的通道开始重新扫描。</li> </ul> </li> </ul> |
| AD转换开始的条<br>件 | <ul style="list-style-type: none"> <li>软件触发</li> <li>来自事件链接控制器(ELC)的同步触发器</li> <li>由外部触发引脚ADTRG0（单元0）和ADTRG1（单元1）异步触发</li> </ul>   |
| Functions     | <ul style="list-style-type: none"> <li>可变采样状态计数</li> <li>AD转换器的自诊断</li> <li>可选择AD转换值加法模式或平均模式</li> <li>模拟输入断线检测功能（放电和预充电功能）</li> <li>双触发模式（AD转换数据的复制）</li> <li>AD数据寄存器的自动清除功能</li> <li>比较寄存器和数据寄存器中值的数字比较，以及数据寄存器中的值之间的比较</li> <li>Interleave function</li> <li>环形缓冲区</li> </ul>   |



Table 37.1 ADC12 specifications (3 of 3)

| Parameter            | Specifications   |
|----------------------|--|
| Interrupt sources    | <ul style="list-style-type: none"> <li>In single scan mode (double trigger deselected), an A/D scan end interrupt request (ADC12i_ADI (i = 0, 1)) and ELC event signal (ADC12i_ADI (i = 0, 1)) can be generated on completion of single scan. <ul style="list-style-type: none"> <li>A compare interrupt request (ADC12i_CMPAI (i = 0, 1)/ADC12i_CMPBI (i = 0, 1)) can be generated in response to a match with a digital comparison condition.</li> <li>A window compare ELC event signal (ADC12i_WCMPPM (i = 0, 1)) can be generated in response to a match with a digital comparison condition.</li> <li>A window compare ELC event signal (ADC12i_WCMPUM (i = 0, 1)) can be generated in response to a mismatch with a digital comparison condition.</li> </ul> </li> <li>In single scan mode (double trigger selected), an A/D scan end interrupt request (ADC12i_ADI (i = 0, 1)) and ELC event signal (ADC12i_ADI (i = 0, 1)) is generated on completion of two scans.</li> <li>In continuous scan mode, an A/D scan end interrupt request (ADC12i_ADI (i = 0, 1)) and ELC event signal (ADC12i_ADI (i = 0, 1)) is generated on completion of all the selected channel scans.</li> <li>In group scan mode (double trigger deselected), an A/D scan end interrupt request (ADC12i_ADI (i = 0, 1)) and ELC event signal (ADC12i_ADI (i = 0, 1)) is generated on completion of group A scan, and an A/D scan end interrupt request for group B (ADC12i_GBADI (i = 0, 1)) can be generated on completion of group B scan.</li> <li>In group scan mode (double trigger selected), an A/D scan end interrupt request (ADC12i_ADI (i = 0, 1)) and ELC event signal (ADC12i_ADI (i = 0, 1)) is generated on completion of two group A scans, and an A/D scan end interrupt request for group B (ADC12i_GBADI (i = 0, 1)) can be generated on completion of group B scan.</li> <li>ADC12i_ADI (i = 0, 1), ADC12i_GBADI (i = 0, 1), ADC12i_WCMPPM (i = 0, 1), and ADC12i_WCMPUM (i = 0, 1) can activate the Data Transfer Controller (DTC).</li> </ul> |
| ELC interface        | <ul style="list-style-type: none"> <li>An event is generated upon completion of group A scan in group-scan mode.</li> <li>An event is generated upon completion of group B scan in group-scan mode.</li> <li>An event is generated when all scans complete.</li> <li>Scan can be started by a trigger from the ELC.</li> <li>An event is generated according to conditions of the compare function window in single-scan mode.</li> </ul>  |
| Reference voltage    | <ul style="list-style-type: none"> <li>Unit 0: VREFH0 is the high potential reference voltage. VREFL0 is the low potential reference voltage.</li> <li>Unit 1: VREFH1 is the high potential reference voltage. VREFL1 is the low potential reference voltage.</li> </ul>   |
| Module-stop function | Module-stop state can be set to reduce power consumption.*3  |
| TrustZone Filter     | Security attribution can be set for each units   |

Note 1. Changing the A/D conversion accuracy also changes the A/D conversion time. For details, see [section 37.3.7. Analog Input Sampling and Scan Conversion Time](#).

Note 2. When selecting the temperature sensor output, the internal reference voltage, do not use continuous scan mode or group scan mode.

Note 3. For details, see [section 10, Low Power Modes](#).

Table 37.2 ADC12 functions (1 of 2)

| Parameter                           | function  |                   |  |
|-------------------------------------|---|-------------------|--|
| Analog input channel                | AN000 to AN009, AN012, AN013(unit 0), AN100 to AN102, AN116 to AN122(unit 1)<br>Internal reference voltage<br>Temperature sensor output |                   |  |
| Conditions for A/D conversion start | Software  | Software trigger  | Enabled  |
|                                     | Asynchronous trigger (external trigger)   | Trigger input pin | ADTRGn (n = 0, 1)  |
|                                     | Synchronous trigger (trigger from ELC)  | ELC trigger       | ELC_AD00 (unit 0) and ELC_AD10 (unit 1), ELC_AD01 (unit 0) and ELC_AD11 (unit 1) |
| Interrupt                           | ADC12i_ADI (i = 0, 1)<br>ADC12i_GBADI (i = 0, 1)<br>ADC12i_CMPAI (i = 0, 1)<br>ADC12i_CMPBI (i = 0, 1)                                  |                   |  |
| Output to ELC                       | ADC12i_ADI (i = 0, 1)<br>ADC12i_WCMPPM (i = 0, 1)<br>ADC12i_WCMPUM (i = 0, 1)   |                   |  |

Table 37.1 ADC12规格 (3个中的3个)

| Parameter            | Specifications  |
|----------------------|---|
| 中断源                  | <ul style="list-style-type: none"> <li>在单次扫描模式下（取消选择双触发），在完成单次扫描时会产生AD扫描结束中断请求（ADC12i_ADI(i=0 1)）和ELC事件信号（ADC12i_ADI(i=0 1)）。 <ul style="list-style-type: none"> <li>比较中断请求(ADC12i_CMPAI(i=0 1)/ADC12i_CMPBI(i=0 1))可以响应与数字比较条件的匹配而产生。</li> <li>响应与数字比较条件的匹配，可以生成窗口比较ELC事件信号(ADC12i_WCMPPM(i=0 1))。</li> <li>响应与数字比较条件的不匹配，可以生成窗口比较ELC事件信号(ADC12i_WCMPUM(i=0 1))。</li> </ul> </li> <li>在单次扫描模式下（选择双触发），在完成两次扫描时会产生一个AD扫描结束中断请求(ADC12i_ADI(i=0 1))和ELC事件信号(ADC12i_ADI(i=0 1))。</li> <li>在连续扫描模式下，在完成所有选定通道扫描后，将生成AD扫描结束中断请求(ADC12i_ADI(i=0 1))和ELC事件信号(ADC12i_ADI(i=0 1))。</li> <li>在组扫描模式下（取消选择双触发），在完成A组扫描时产生AD扫描结束中断请求（ADC12i_ADI(i=0 1)）和ELC事件信号（ADC12i_ADI(i=0 1)），并且在完成B组扫描时，可以生成B组(ADC12i_GBADI(i=0 1))的AD扫描结束中断请求。</li> <li>在组扫描模式下（选择双触发），AD扫描结束中断请求（ADC12i_ADI(i=0 1)）和ELC事件信号（ADC12i_ADI(i=0 1)）在两个A组扫描完成时产生，完成B组扫描后，可以生成B组的AD扫描结束中断请求(ADC12i_GBADI(i=0 1))。</li> <li>ADC12i_ADI(i=0 1)、ADC12i_GBADI(i=0 1)、ADC12i_WCMPPM(i=0 1)和ADC12i_WCMPUM(i=0 1)可以激活数据传输控制器(DTC)。</li> </ul> |
| ELC interface        | <ul style="list-style-type: none"> <li>在组扫描模式下完成A组扫描时会生成一个事件。</li> <li>在组扫描模式下完成B组扫描时会生成一个事件。</li> <li>当所有扫描完成时会生成一个事件。</li> <li>扫描可以通过来自ELC的触发器启动。</li> <li>在单扫描模式下，根据比较功能窗口的条件生成事件。</li> </ul>  |
| 参考电压                 | <ul style="list-style-type: none"> <li>Unit 0: VREFH0是高电位参考电压。VREFL0是低电位参考电压。</li> <li>Unit 1: VREFH1是高电位参考电压。VREFL1是低电位参考电压。</li> </ul>  |
| Module-stop function | 可设置模块停止状态以降低功耗。*3   |
| TrustZone Filter     | 可以为每个单元设置安全属性   |

注1.更改AD转换精度也会更改AD转换时间。有关详细信息，请参阅第37.3.7节。模拟输入采样和扫描转换时间。

注2.选择温度传感器输出、内部参考电压时，不要使用连续扫描模式或组扫描模式。

注3.有关详细信息，请参阅第10节，低功耗模式。

Table 37.2 ADC12功能(1of2)

| Parameter | function   |             |  |
|-----------|--|-------------|--|
| 模拟输入通道    | AN000 to AN009, AN012, AN013(unit 0), AN100 to AN102, AN116 to AN122(unit 1)<br>内部参考电压温度传感器输出          |             |  |
| AD转换开始的条件 | Software   | 软件触发        | Enabled  |
|           | 异步触发（外部触发）   | 触发输入引脚      | ADTRGn (n = 0, 1)  |
|           | 同步触发（来自ELC的触发）   | ELC trigger | ELC_AD00 (unit 0) and ELC_AD10 (unit 1), ELC_AD01 (unit 0) and ELC_AD11 (unit 1) |
| Interrupt | ADC12i_ADI (i = 0, 1)<br>ADC12i_GBADI (i = 0, 1)<br>ADC12i_CMPAI (i = 0, 1)<br>ADC12i_CMPBI (i = 0, 1) |             |  |
| 输出到ELC    | ADC12i_ADI (i = 0, 1)<br>ADC12i_WCMPPM (i = 0, 1)<br>ADC12i_WCMPUM (i = 0, 1)                          |             |  |

Table 37.2 ADC12 functions (2 of 2)

| Parameter                          | function   |
|------------------------------------|--|
| Module-stop function settings*1 *2 | MSTPCRD.MSTPD16 bit (unit 0) ,<br>MSTPCRD.MSTPD15 bit (unit 1) |

Note 1. For details, see [section 10, Low Power Modes](#).

Note 2. Wait 1  $\mu$ s or longer to start A/D conversion after release from the module-stop state.

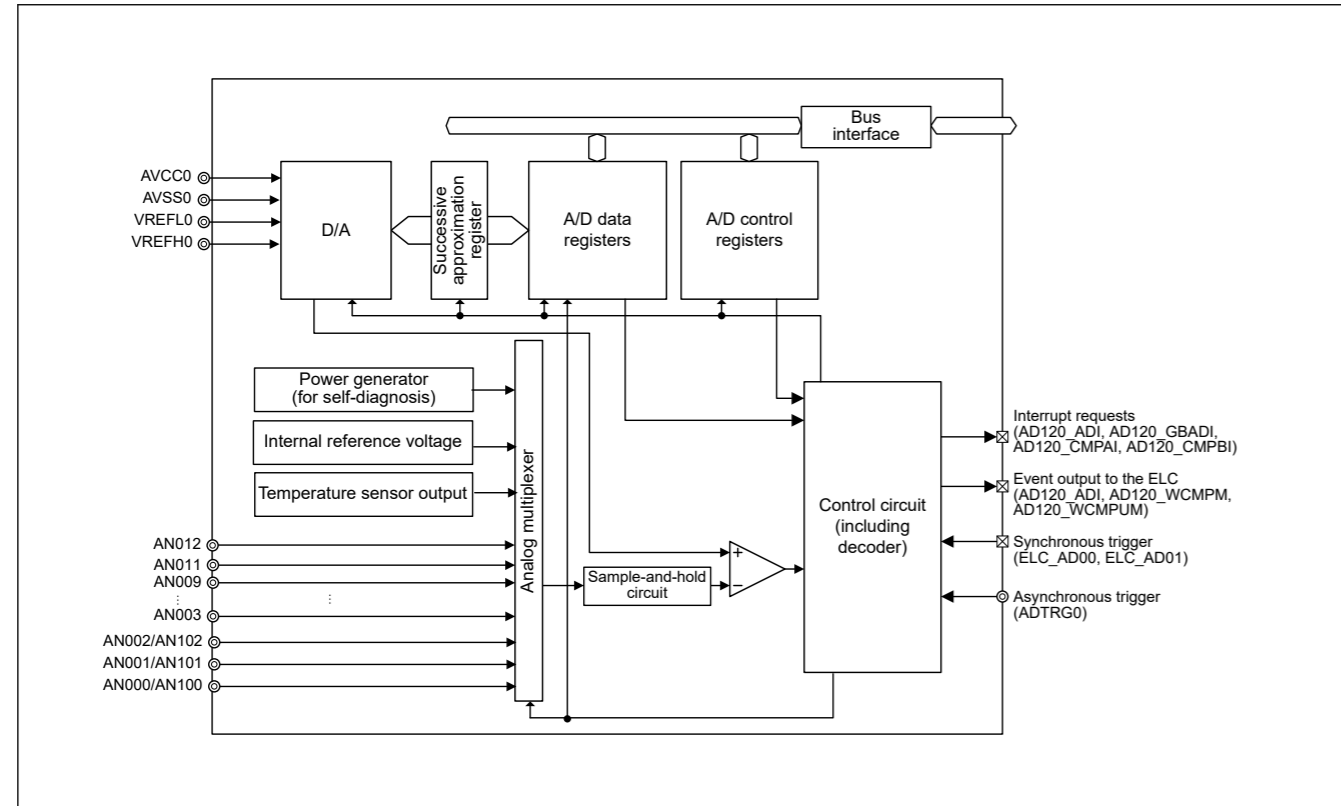


Figure 37.1 ADC12 block diagram (unit 0)

Table 37.2 ADC12功能 (2个中的2个)

| Parameter    | function   |
|--------------|--|
| 模块停止功能设置*1*2 | MSTPCRD.MSTPD16 bit (unit 0) ,<br>MSTPCRD.MSTPD15 bit (unit 1) |

注1.有关详细信息, 请参阅第10节, 低功耗模式。

注2.从模块停止状态释放后, 等待1  $\mu$ s或更长时间开始AD转换。

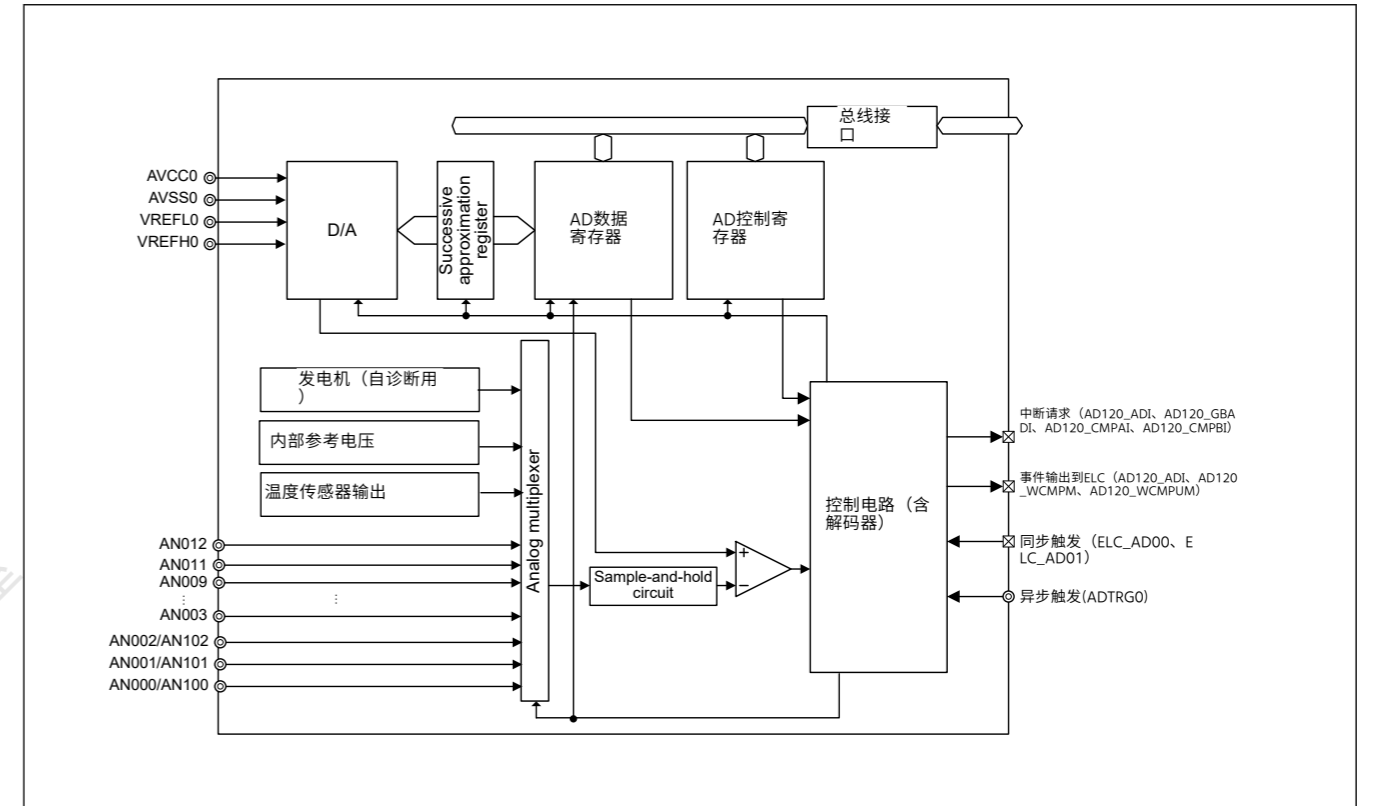


Figure 37.1 ADC12框图 (单元0)

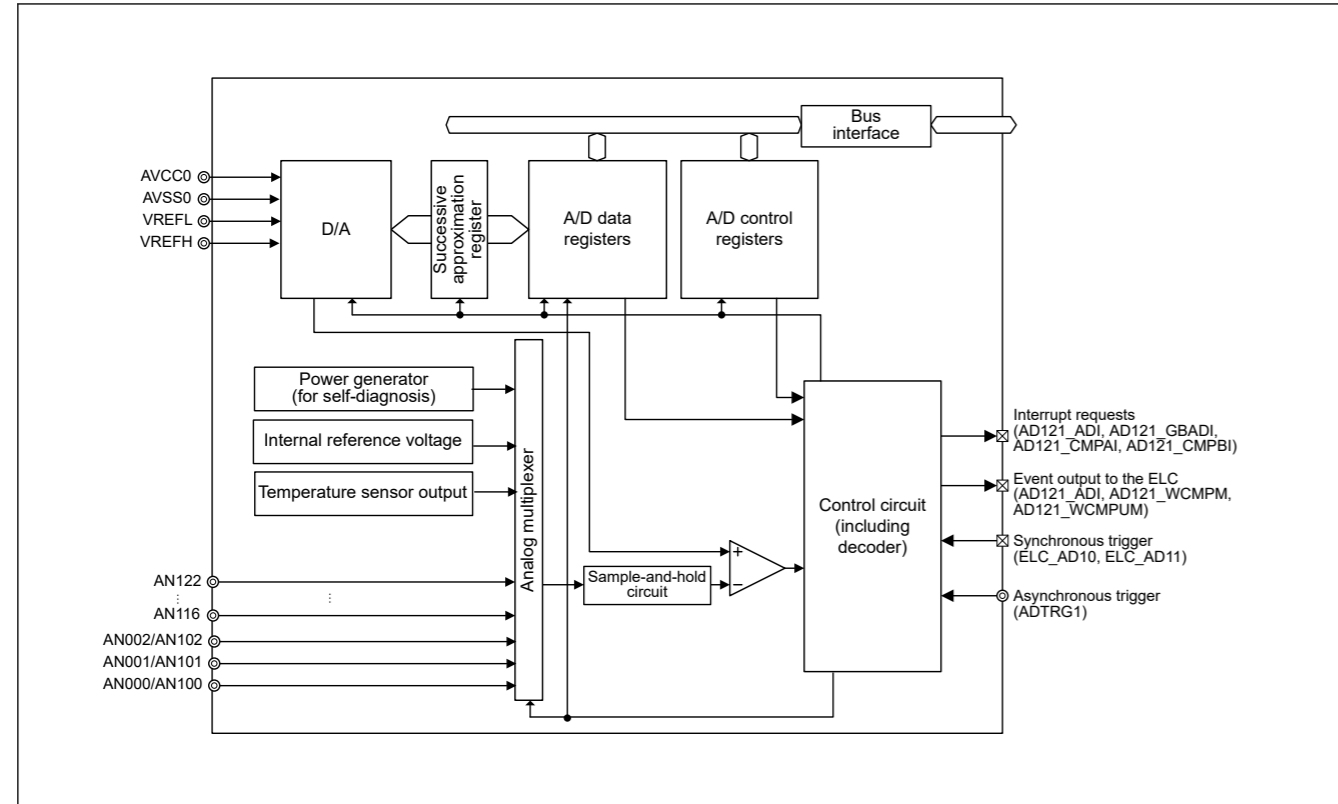


Figure 37.2 ADC12 block diagram (unit 1)

Table 37.3 lists the ADC12 I/O pins.

Table 37.3 ADC12 I/O pins (unit 0)

| Pin name                     | I/O   | Function  |
|------------------------------|-------|---|
| AVCC0                        | Input | Analog block power supply pin (Connect to VCC when ADC12/DAC12 is not used.)        |
| AVSS0                        | Input | Analog block power supply ground pin (Connect to VSS when ADC12/DAC12 is not used.) |
| VREFH0                       | Input | Reference high-potential power supply pin   |
| VREFL0                       | Input | Reference low-potential power supply ground pin                                     |
| AN000 to AN009, AN012, AN013 | Input | Analog input pins 0 to 9, 12, 13  |
| ADTRG0                       | Input | External trigger input pin for starting A/D conversion                              |

Table 37.4 ADC12 I/O pins (unit 1)

| Pin name                       | I/O   | Function   |
|--------------------------------|-------|--|
| AVCC0                          | Input | Analog block power supply pin                          |
| AVSS0                          | Input | Analog block power supply ground pin                   |
| VREFH                          | Input | Reference power supply pin                             |
| VREFL                          | Input | Reference power supply ground pin                      |
| AN100 to AN102, AN116 to AN122 | Input | Analog input pins 0 to 2, 16 to 22                     |
| ADTRG1                         | Input | External trigger input pin for starting A/D conversion |

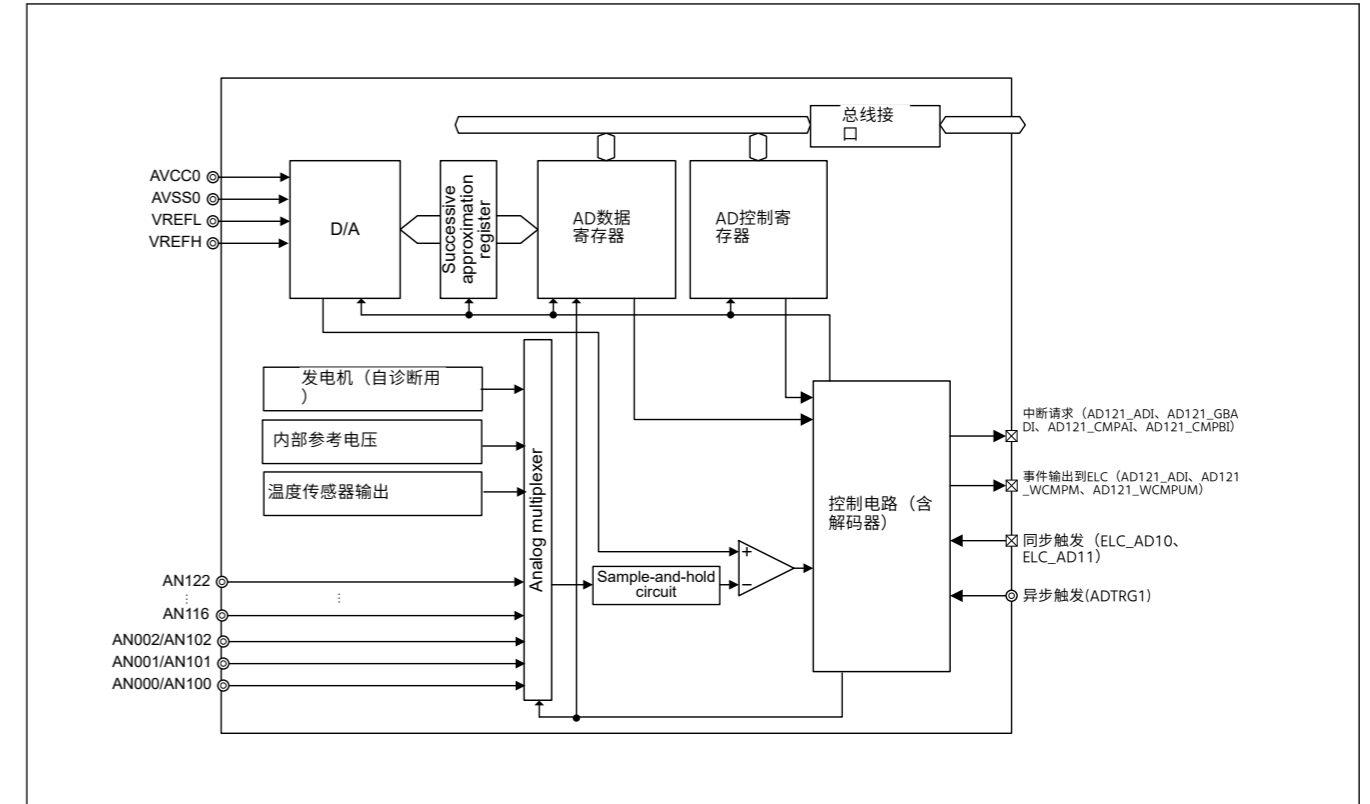


Figure 37.2 ADC12框图 (单元1)

表37.3列出了ADC12 I/O引脚。

Table 37.3 ADC12 I/O pins (unit 0)

| 引脚名称                         | I/O   | Function                            |
|------------------------------|-------|-------------------------------------|
| AVCC0                        | Input | 模拟模块电源引脚 (不使用ADC12/DAC12时连接到VCC。)   |
| AVSS0                        | Input | 模拟模块电源接地引脚 (不使用ADC12/DAC12时连接到VSS。) |
| VREFH0                       | Input | 参考高电位电源引脚                           |
| VREFL0                       | Input | 参考低电位电源接地引脚                         |
| AN000 to AN009, AN012, AN013 | Input | 模拟输入引脚0至9、12、13                     |
| ADTRG0                       | Input | 用于启动AD转换的外部触发输入引脚                   |

Table 37.4 ADC12 I/O pins (unit 1)

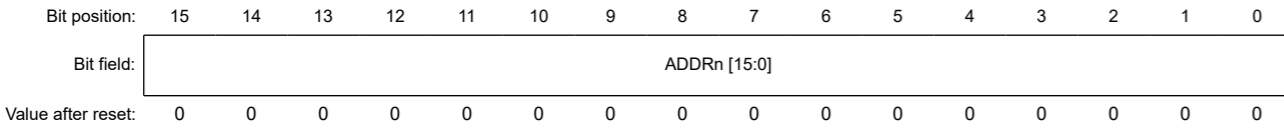
| 引脚名称                           | I/O   | Function          |
|--------------------------------|-------|-------------------|
| AVCC0                          | Input | 模拟模块电源引脚          |
| AVSS0                          | Input | 模拟模块电源接地引脚        |
| VREFH                          | Input | 参考电源引脚            |
| VREFL                          | Input | 参考电源接地引脚          |
| AN100 to AN102, AN116 to AN122 | Input | 模拟输入引脚0至2、16至22   |
| ADTRG1                         | Input | 用于启动AD转换的外部触发输入引脚 |

### 37.2 Register Descriptions

#### 37.2.1 ADDRn : A/D Data Registers n

Base address:  $ADC12m = 0x4017\_0000 + 0x0200 \times m$  ( $m = 0, 1$ )

Offset address:  $0x020 + 0x2 \times n$  ( $n = 0$  to 9, 12, 13,  $m = 0$ )  
 $0x020 + 0x2 \times n$  ( $n = 0$  to 2, 16 to 22,  $m = 1$ )



| Bit  | Symbol       | Function   | R/W |
|------|--------------|--|-----|
| 15:0 | ADDRn [15:0] | Converted Value 15 to 0<br>Functions vary depending on the selected mode and accuracy. See <a href="#">Table 37.5</a> and <a href="#">Table 37.6</a> . | R   |

ADDRn registers are 16-bit read-only registers to store A/D conversion results.

The following conditions determine the formats for data in the A/D data registers:

- Setting of the A/D Data Register Format Select bit (ADCER.ADRFMT) (flush-left or flush-right)
- The setting in the A/D Conversion Accuracy Select bits (ADCER.ADRPC[1:0]) (12-bit, 10-bit, 8-bit is selectable.)
- Setting of the Addition/Average Count Select bits (ADADC.ADC[2:0]) (1, 2, 3, 4, or 16 times)
- Setting of the Average Mode Enable bit (ADADC.AVEE) (addition or average).

This section describes the data formats for these conditions in different modes.

##### (1) When A/D-converted value addition/average mode is not selected

[Table 37.5](#) shows the example of bit assignment for 12-bit accuracy.

**Table 37.5 Example of bit assignment for 12-bit accuracy**

| Accuracy                                  | b15  | b14 | b13 | b12 | b11  | b10 | b9 | b8 | b7 | b6 | b5 | b4 | b3                        | b2 | b1 | b0 |
|---|--|-----|-----|-----|--|-----|----|----|----|----|----|----|---------------------------|----|----|----|
| Right-justified data with 12-bit accuracy | These bits are read as 0.                              |     |     |     | Converted Value 11 to 0:<br>12-bit A/D-converted value |     |    |    |    |    |    |    |                           |    |    |    |
| Left-justified data with 12-bit accuracy  | Converted Value 11 to 0:<br>12-bit A/D-converted value |     |     |     |  |     |    |    |    |    |    |    | These bits are read as 0. |    |    |    |

##### (2) When A/D-converted value average mode is selected

A/D-converted value average mode can be selected when 2 or 4 times is specified in the A/D-converted value addition mode. When A/D converted value average mode is selected, These registers indicate the mean of A/D-converted values on a specific channel. The value is stored in the A/D data register based on the setting of the A/D Data Register Format Select bit in the same way as for normal A/D conversion.

##### (3) When A/D-converted value addition mode is selected

For 12-bit, 10-bit, 8-bit accuracy, 1, 2, 3, or 4 times can be selected in the A/D-converted value addition mode. A/D conversion results are stored in the A/D data register as a 2-bit-extended value of the specified conversion accuracy.

For 12-bit accuracy, 16 times can also be selected in the A/D-converted value addition mode. In A/D-converted value addition mode, these registers indicate the value that is obtained by adding A/D-converted values on a specific channel. A/D conversion results are stored in the A/D data register as a 4-bit-extended value of the specified conversion accuracy.

When A/D-converted value addition mode is selected, the value is stored in the A/D data register based on the settings of the A/D Data Register Format Select bits.

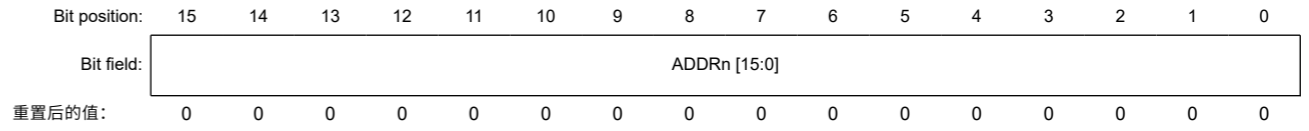
[Table 37.6](#) shows example of the bit assignment for 12-bit accuracy.

### 37.2 注册说明

#### 37.2.1 ADDRn:AD数据寄存器n

Base address:  $ADC12m = 0x4017\_0000 + 0x0200 \times m$  ( $m = 0, 1$ )

Offset address:  $0x020 + 0x2 \times n$  ( $n = 0$  to 9, 12, 13,  $m = 0$ )  
 $0x020 + 0x2 \times n$  ( $n = 0$  to 2, 16 to 22,  $m = 1$ )



| Bit  | Symbol       | Function                                 | R/W |
|------|--------------|--|-----|
| 15:0 | ADDRn [15:0] | 将值15转换为0<br>功能因所选模式和精度而异。请参见表37.5和表37.6。 | R   |

ADDRn寄存器是16位只读寄存器，用于存储AD转换结果。

以下条件决定了AD数据寄存器中的数据格式：

- AD数据寄存器格式选择位(ADCER.ADRFMT)的设置（左对齐或右对齐）
- AD转换精度选择位(ADCER.ADRPC[1:0])中的设置（可选择12位、10位、8位。）
- 加法平均计数选择位(ADADC.ADC[2:0])的设置（1、2、3、4或16次）
- 设置平均模式启用位(ADADC.AVEE)（加法或平均）。

本节介绍不同模式下这些条件的数据格式。

##### (1) 未选择AD转换值加法平均模式时

表37.5显示了12位精度的位分配示例。

**Table 37.5 12位精度的位分配示例**

| Accuracy      | b15               | b14 | b13 | b12 | b11               | b10 | b9 | b8 | b7 | b6 | b5 | b4 | b3      | b2 | b1 | b0 |
|---------------|-------------------|-----|-----|-----|-------------------|-----|----|----|----|----|----|----|---------|----|----|----|
| 具有12位精度的右对齐数据 | 这些位读为0。           |     |     |     | 转换值11到0: 12位AD转换值 |     |    |    |    |    |    |    |         |    |    |    |
| 具有12位精度的左对齐数据 | 转换值11到0: 12位AD转换值 |     |     |     |                   |     |    |    |    |    |    |    | 这些位读为0。 |    |    |    |

##### (2) 选择AD转换值平均模式时

当在AD转换值相加模式中指定2或4次时，可以选择D转换值平均模式。WhenADconvertedvalueaveragemodeisselected TheseregistersindicatethemeanofAD-convertedvaluesonaspecificchannel.该值根据AD数据寄存器格式选择位的设置以与正常AD转换相同的方式存储在AD数据寄存器中。

##### (3) 选择AD转换值相加模式时

对于12位、10位、8位精度，可以在AD转换值相加模式中选择1、2、3或4次。AD转换结果作为指定转换精度的2位扩展值存储在AD数据寄存器中。

对于12位精度，在AD转换值相加模式中也可以选择16倍。在AD转换值相加模式中，这些寄存器指示通过在特定通道上添加AD转换值获得的值。AD转换结果作为指定转换精度的4位扩展值存储在AD数据寄存器中。

WhenAD-convertedvalueadditionmodeisselected thevalueisstoredintheADdataregisterbasedonthesettingsof theADDataRegisterFormatSelectbits.

表37.6显示了12位精度的位分配示例。

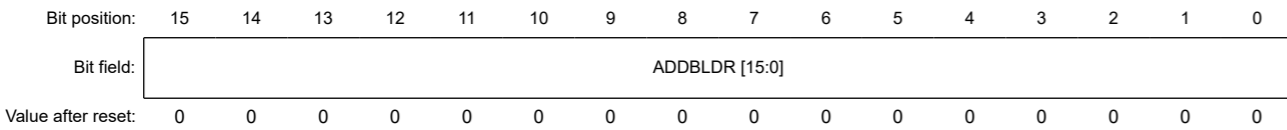


**Table 37.6 Example of bit assignment for 12-bit accuracy when A/D-converted value addition mode is selected**

| Accuracy                                  |  | b15   | b14 | b13   | b12 | b11 | b10 | b9 | b8 | b7 | b6 | b5 | b4 | b3 | b2 | b1                        | b0 |
|---|--|---|-----|---|-----|-----|-----|----|----|----|----|----|----|----|----|---------------------------|----|
| Right-justified data with 12-bit accuracy | When 16 conversion times is specified            | Added Value 15 to 0: 16-bit sum of A/D conversion results |     |   |     |     |     |    |    |    |    |    |    |    |    |                           |    |
|   | When 1, 2, 3, or 4 conversion times is specified | These bits are read as 0.                                 |     | Added Value 13 to 0: 14-bit sum of A/D conversion results |     |     |     |    |    |    |    |    |    |    |    |                           |    |
| Left-justified data with 12-bit accuracy  | When 1, 2, 3, or 4 conversion times is specified | Added Value 15 to 0: 16-bit sum of A/D conversion results |     |   |     |     |     |    |    |    |    |    |    |    |    |                           |    |
|   | When 16 conversion times is specified            | Added Value 13 to 0: 14-bit sum of A/D conversion results |     |   |     |     |     |    |    |    |    |    |    |    |    | These bits are read as 0. |    |

**37.2.2 ADDBLDR : A/D Data Duplexing Register**

Base address:  $ADC12m = 0x4017\_0000 + 0x0200 \times m$  ( $m = 0, 1$ )  
 Offset address: 0x018



| Bit  | Symbol         | Function   | R/W |
|------|----------------|--|-----|
| 15:0 | ADDBLDR [15:0] | Converted Value 15 to 0<br>Functions vary depending on the selected mode and accuracy. See <a href="#">Table 37.7</a> and <a href="#">Table 37.8</a> . | R   |

ADDBLDR register is a 16-bit read-only register to store A/D conversion results in response to a second trigger in double-trigger mode.

The following conditions determine the formats for data in the A/D data registers:

- Setting of the A/D Data Register Format Select bit (ADCER.ADRFMT) (flush-left or flush-right)
- The setting in the A/D Conversion Accuracy Select bits (ADCER.ADPRC[1:0]) (12-bit, 10-bit, 8-bit is selectable.)
- Setting of the Addition/Average Count Select bits (ADADC.ADC[2:0]) (1, 2, 3, 4, or 16 times)
- Setting of the Average Mode Enable bit (ADADC.AVEE) (addition or average).

This section describes the data formats for these conditions in different modes.

**(1) When A/D-converted value addition/average mode is not selected**

[Table 37.7](#) shows the example of bit assignment for 12-bit accuracy.

**Table 37.7 Example of bit assignment for 12-bit accuracy**

| Accuracy                                  |   | b15   | b14 | b13 | b12 | b11 | b10 | b9 | b8 | b7 | b6 | b5 | b4 | b3 | b2 | b1 | b0 |
|---|---|---|-----|-----|-----|-----|-----|----|----|----|----|----|----|----|----|----|----|
| Right-justified data with 12-bit accuracy | These bits are read as 0.                           | Converted Value 11 to 0: 12-bit A/D-converted value |     |     |     |     |     |    |    |    |    |    |    |    |    |    |    |
| Left-justified data with 12-bit accuracy  | Converted Value 11 to 0: 12-bit A/D-converted value | These bits are read as 0.                           |     |     |     |     |     |    |    |    |    |    |    |    |    |    |    |

**(2) When A/D-converted value average mode is selected**

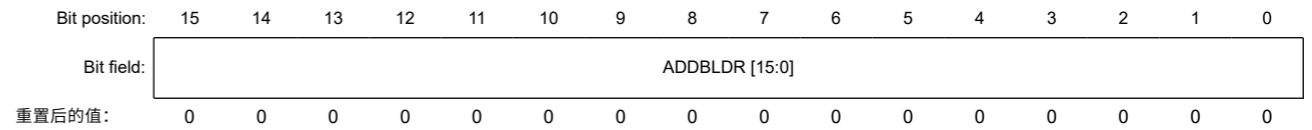
A/D-converted value average mode can be selected when 2 or 4 times is specified in the A/D-converted value addition mode. When A/D converted value average mode is selected, This register indicates the mean of A/D-converted values on a

**Table 37.6 选择AD转换值相加模式时12位精度的位分配示例**

| Accuracy      |                | b15                  | b14 | b13                  | b12 | b11 | b10 | b9 | b8 | b7 | b6 | b5 | b4 | b3 | b2 | b1      | b0 |
|---------------|----------------|----------------------|-----|----------------------|-----|-----|-----|----|----|----|----|----|----|----|----|---------|----|
| 具有12位精度的右对齐数据 | 指定16个转换时间时     | 附加值15到0: AD转换结果的16位和 |     |                      |     |     |     |    |    |    |    |    |    |    |    |         |    |
|               | 指定1、2、3或4转换时间时 | 这些位读为0。              |     | 附加值13到0: AD转换结果的14位和 |     |     |     |    |    |    |    |    |    |    |    |         |    |
| 具有12位精度的左对齐数据 | 指定1、2、3或4转换时间时 | 附加值15到0: AD转换结果的16位和 |     |                      |     |     |     |    |    |    |    |    |    |    |    |         |    |
|               | 指定16个转换时间时     | 附加值13到0: AD转换结果的14位和 |     |                      |     |     |     |    |    |    |    |    |    |    |    | 这些位读为0。 |    |

**37.2.2 ADDBLDR:AD数据双工寄存器**

Base address:  $ADC12m = 0x4017\_0000 + 0x0200 \times m$  ( $m = 0, 1$ )  
 Offset address: 0x018



| Bit  | Symbol         | Function                                 | R/W |
|------|----------------|--|-----|
| 15:0 | ADDBLDR [15:0] | 将值15转换为0<br>功能因所选模式和精度而异。请参见表37.7和表37.8。 | R   |

ADDBLDR寄存器是一个16位只读寄存器，用于存储AD转换结果，以响应双触发模式下的第二次触发。

以下条件决定了AD数据寄存器中的数据格式：

- AD数据寄存器格式选择位(ADCER.ADRFMT)的设置（左对齐或右对齐）
- AD转换精度选择位(ADCER.ADPRC[1:0])中的设置（可选择12位、10位、8位。）
- 加法平均计数选择位(ADADC.ADC[2:0])的设置（1、2、3、4或16次）
- 设置平均模式启用位(ADADC.AVEE)（加法或平均）。

本节介绍不同模式下这些条件的数据格式。

**(1) 未选择AD转换值加法平均模式时**

表37.7显示了12位精度的位分配示例。

**Table 37.7 12位精度的位分配示例**

| Accuracy      |                   | b15               | b14 | b13 | b12 | b11 | b10 | b9 | b8 | b7 | b6 | b5 | b4 | b3 | b2 | b1 | b0 |
|---------------|-------------------|-------------------|-----|-----|-----|-----|-----|----|----|----|----|----|----|----|----|----|----|
| 具有12位精度的右对齐数据 | 这些位读为0。           | 转换值11到0: 12位AD转换值 |     |     |     |     |     |    |    |    |    |    |    |    |    |    |    |
| 具有12位精度的左对齐数据 | 转换值11到0: 12位AD转换值 | 这些位读为0。           |     |     |     |     |     |    |    |    |    |    |    |    |    |    |    |

**(2) 选择AD转换值平均模式时**

当在AD转换值相加模式中指定2或4次时，可以选择D转换值平均模式。WhenADconvertedvalueaveragemodeiselected ThisregisterindicatesthemeanofAD-convertedvaluesona

specific channel. The value is stored in the A/D data register based on the setting of the A/D Data Register Format Select bit in the same way as for normal A/D conversion.

(3) When A/D-converted value addition mode is selected

For 12-bit, 10-bit, 8-bit accuracy, 1, 2, 3, or 4 times can be selected in the A/D-converted value addition mode. A/D conversion results are stored in the A/D data register as a 2-bit-extended value of the specified conversion accuracy.

For 12-bit accuracy, 16 times can also be selected in the A/D-converted value addition mode. In A/D-converted value addition mode, this register indicates the value that is obtained by adding A/D-converted values on a specific channel. A/D conversion results are stored in the A/D data register as a 4-bit-extended value of the specified conversion accuracy.

When A/D-converted value addition mode is selected, the value is stored in the A/D data register based on the settings of the A/D Data Register Format Select bits.

Table 37.8 shows example of the bit assignment for 12-bit accuracy.

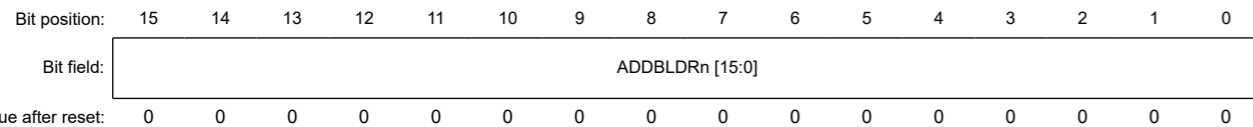
Table 37.8 Example of bit assignment for 12-bit accuracy when A/D-converted value addition mode is selected

| Accuracy                                  |  | b15  | b14 | b13  | b12 | b11 | b10 | b9 | b8 | b7 | b6 | b5 | b4 | b3 | b2 | b1                        | b0 |
|---|--|--|-----|--|-----|-----|-----|----|----|----|----|----|----|----|----|---------------------------|----|
| Right-justified data with 12-bit accuracy | When 16 conversion times is specified            | Added Value 15 to 0:<br>16-bit sum of A/D conversion results |     |  |     |     |     |    |    |    |    |    |    |    |    |                           |    |
|   | When 1, 2, 3, or 4 conversion times is specified | These bits are read as 0.                                    |     | Added Value 13 to 0:<br>14-bit sum of A/D conversion results |     |     |     |    |    |    |    |    |    |    |    |                           |    |
| Left-justified data with 12-bit accuracy  | When 1, 2, 3, or 4 conversion times is specified | Added Value 15 to 0:<br>16-bit sum of A/D conversion results |     |  |     |     |     |    |    |    |    |    |    |    |    |                           |    |
|   | When 16 conversion times is specified            | Added Value 13 to 0:<br>14-bit sum of A/D conversion results |     |  |     |     |     |    |    |    |    |    |    |    |    | These bits are read as 0. |    |

37.2.3 ADDBLDRn : A/D Data Duplexing Register n (n = A, B)

Base address: ADC12m = 0x4017\_0000 + 0x0200 × m (m = 0, 1)

Offset address: 0x084 (n = A)  
0x086 (n = B)



| Bit  | Symbol          | Function   | R/W |
|------|-----------------|--|-----|
| 15:0 | ADDBLDRn [15:0] | Converted Value 15 to 0<br>Functions vary depending on the selected mode and accuracy. See Table 37.9 and Table 37.10. | R   |

ADDBLDRn registers are 16-bit read-only registers to store A/D conversion results in response to respective triggers during extended operation in double-trigger mode.

The following conditions determine the formats for data in the A/D data registers:

- Setting of the A/D Data Register Format Select bit (ADCER.ADRFMT) (flush-left or flush-right)
- The setting in the A/D Conversion Accuracy Select bits (ADCER.ADPRC[1:0]) (12-bit, 10-bit, 8-bit is selectable.)
- Setting of the Addition/Average Count Select bits (ADADC.ADC[2:0]) (1, 2, 3, 4, or 16 times)
- Setting of the Average Mode Enable bit (ADADC.AVEE) (addition or average).

This section describes the data formats for these conditions in different modes.

具体渠道。该值根据AD数据寄存器格式选择位的设置以与正常AD转换相同的方式存储在AD数据寄存器中。

(3) 选择AD转换值相加模式时

对于12位、10位、8位精度，可以在AD转换值相加模式中选择1、2、3或4次。AD转换结果作为指定转换精度的2位扩展值存储在AD数据寄存器中。

对于12位精度，在AD转换值相加模式中也可以选择16倍。在AD转换值相加模式下，该寄存器指示通过在特定通道上相加AD转换值获得的值。AD转换结果作为指定转换精度的4位扩展值存储在AD数据寄存器中。

WhenAD-convertedvalueadditionmodeisselected thevalueisstoredintheADdataregisterbasedonthesettings of theADDataRegisterFormatSelectbits.

表37.8显示了12位精度的位分配示例。

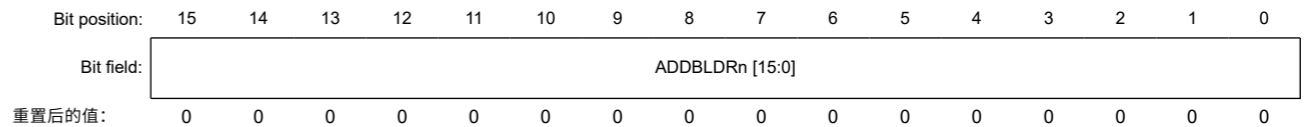
Table 37.8 选择AD转换值相加模式时12位精度的位分配示例

| Accuracy      |                | b15                  | b14 | b13                  | b12 | b11 | b10 | b9 | b8 | b7 | b6 | b5 | b4 | b3 | b2 | b1      | b0 |
|---------------|----------------|----------------------|-----|----------------------|-----|-----|-----|----|----|----|----|----|----|----|----|---------|----|
| 具有12位精度的右对齐数据 | 指定16个转换时间时     | 附加值15到0: AD转换结果的16位和 |     |                      |     |     |     |    |    |    |    |    |    |    |    |         |    |
|               | 指定1、2、3或4转换时间时 | 这些位读为0。              |     | 附加值13到0: AD转换结果的14位和 |     |     |     |    |    |    |    |    |    |    |    |         |    |
| 具有12位精度的左对齐数据 | 指定1、2、3或4转换时间时 | 附加值15到0: AD转换结果的16位和 |     |                      |     |     |     |    |    |    |    |    |    |    |    |         |    |
|               | 指定16个转换时间时     | 附加值13到0: AD转换结果的14位和 |     |                      |     |     |     |    |    |    |    |    |    |    |    | 这些位读为0。 |    |

37.2.3 ADDBLDRn:AD数据双工寄存器n(n=A B)

Base address: ADC12m = 0x4017\_0000 + 0x0200 × m (m = 0, 1)

Offset address: 0x084 (n = A)  
0x086 (n = B)



| Bit  | Symbol          | Function                                  | R/W |
|------|-----------------|---|-----|
| 15:0 | ADDBLDRn [15:0] | 将值15转换为0<br>功能因所选模式和精度而异。请参见表37.9和表37.10。 | R   |

ADDBLDRn寄存器是16位只读寄存器，用于在双触发模式的扩展操作期间存储AD转换结果以响应相应的触发。

以下条件决定了AD数据寄存器中的数据格式：

- AD数据寄存器格式选择位(ADCER.ADRFMT)的设置（左对齐或右对齐）
- AD转换精度选择位(ADCER.ADPRC[1:0])中的设置（可选择12位、10位、8位。）
- 加法平均计数选择位(ADADC.ADC[2:0])的设置（1、2、3、4或16次）
- 设置平均模式启用位(ADADC.AVEE)（加法或平均）。

本节介绍不同模式下这些条件的数据格式。

(1) When A/D-converted value addition/average mode is not selected

Table 37.9 shows the example of bit assignment for 12-bit accuracy.

Table 37.9 Example of bit assignment for 12-bit accuracy

| Accuracy                                  | b15   | b14 | b13 | b12 | b11   | b10 | b9 | b8 | b7 | b6 | b5                        | b4 | b3 | b2 | b1 | b0 |
|---|---|-----|-----|-----|---|-----|----|----|----|----|---------------------------|----|----|----|----|----|
| Right-justified data with 12-bit accuracy | These bits are read as 0.                           |     |     |     | Converted Value 11 to 0: 12-bit A/D-converted value |     |    |    |    |    |                           |    |    |    |    |    |
| Left-justified data with 12-bit accuracy  | Converted Value 11 to 0: 12-bit A/D-converted value |     |     |     |   |     |    |    |    |    | These bits are read as 0. |    |    |    |    |    |

(2) When A/D-converted value average mode is selected

A/D-converted value average mode can be selected when 2 or 4 times is specified in the A/D-converted value addition mode. When A/D converted value average mode is selected, These registers indicate the mean of A/D-converted values on a specific channel. The value is stored in the A/D data register based on the setting of the A/D Data Register Format Select bit in the same way as for normal A/D conversion.

(3) When A/D-converted value addition mode is selected

For 12-bit, 10-bit, 8-bit accuracy, 1, 2, 3, or 4 times can be selected in the A/D-converted value addition mode. A/D conversion results are stored in the A/D data register as a 2-bit-extended value of the specified conversion accuracy.

For 12-bit accuracy, 16 times can also be selected in the A/D-converted value addition mode. In A/D-converted value addition mode, these registers indicate the value that is obtained by adding A/D-converted values on a specific channel. A/D conversion results are stored in the A/D data register as a 4-bit-extended value of the specified conversion accuracy.

When A/D-converted value addition mode is selected, the value is stored in the A/D data register based on the settings of the A/D Data Register Format Select bits.

Table 37.10 shows example of the bit assignment for 12-bit accuracy.

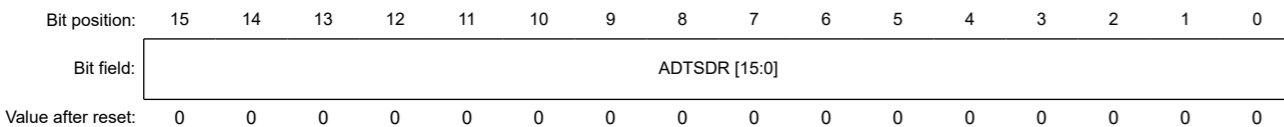
Table 37.10 Example of bit assignment for 12-bit accuracy when A/D-converted value addition mode is selected

| Accuracy                                  | b15  | b14 | b13   | b12 | b11   | b10 | b9 | b8 | b7 | b6 | b5 | b4 | b3 | b2 | b1 | b0                        |
|---|--|-----|---|-----|---|-----|----|----|----|----|----|----|----|----|----|---------------------------|
| Right-justified data with 12-bit accuracy | When 16 conversion times is specified            |     | Added Value 15 to 0: 16-bit sum of A/D conversion results |     |   |     |    |    |    |    |    |    |    |    |    |                           |
|   | When 1, 2, 3, or 4 conversion times is specified |     | These bits are read as 0.                                 |     | Added Value 13 to 0: 14-bit sum of A/D conversion results |     |    |    |    |    |    |    |    |    |    |                           |
| Left-justified data with 12-bit accuracy  | When 1, 2, 3, or 4 conversion times is specified |     | Added Value 15 to 0: 16-bit sum of A/D conversion results |     |   |     |    |    |    |    |    |    |    |    |    |                           |
|   | When 16 conversion times is specified            |     | Added Value 13 to 0: 14-bit sum of A/D conversion results |     |   |     |    |    |    |    |    |    |    |    |    | These bits are read as 0. |

37.2.4 ADTSDR : A/D Temperature Sensor Data Register

Base address: ADC12m = 0x4017\_0000 + 0x0200 × m (m = 0, 1)

Offset address: 0x01A



(1) 未选择AD转换值加法平均模式时

表37.9显示了12位精度的位分配示例。

Table 37.9 12位精度的位分配示例

| Accuracy      | b15               | b14 | b13 | b12 | b11               | b10 | b9 | b8 | b7 | b6 | b5      | b4 | b3 | b2 | b1 | b0 |
|---------------|-------------------|-----|-----|-----|-------------------|-----|----|----|----|----|---------|----|----|----|----|----|
| 具有12位精度的右对齐数据 | 这些位读为0。           |     |     |     | 转换值11到0: 12位AD转换值 |     |    |    |    |    |         |    |    |    |    |    |
| 具有12位精度的左对齐数据 | 转换值11到0: 12位AD转换值 |     |     |     |                   |     |    |    |    |    | 这些位读为0。 |    |    |    |    |    |

(2) 选择AD转换值平均模式时

当在AD转换值相加模式中指定2或4次时，可以选择D转换值平均模式。WhenADconvertedvalueaveragemodeisselected TheseregistersindicatethemeanofAD-convertedvaluesonaspecificchannel.该值根据AD数据寄存器格式选择位的设置以与正常AD转换相同的方式存储在AD数据寄存器中。

(3) 选择AD转换值相加模式时

对于12位、10位、8位精度，可以在AD转换值相加模式中选择1、2、3或4次。AD转换结果作为指定转换精度的2位扩展值存储在AD数据寄存器中。

对于12位精度，在AD转换值相加模式中也可以选择16倍。在AD转换值相加模式中，这些寄存器指示通过在特定通道上添加AD转换值获得的值。AD转换结果作为指定转换精度的4位扩展值存储在AD数据寄存器中。

WhenAD-convertedvalueadditionmodeisselected thevalueisstoredintheADdataregisterbasedonthesettingsof theADDataRegisterFormatSelectbits.

表37.10显示了12位精度的位分配示例。

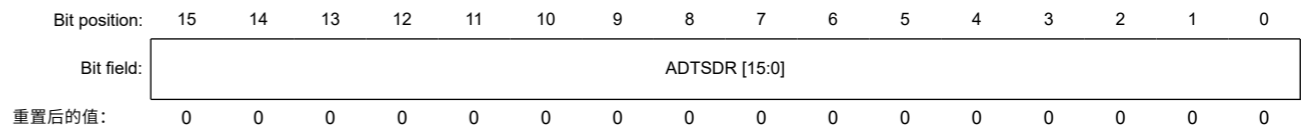
Table 37.10 选择AD转换值相加模式时12位精度的位分配示例

| Accuracy      | b15            | b14 | b13                  | b12 | b11                  | b10 | b9 | b8 | b7 | b6 | b5 | b4 | b3 | b2 | b1 | b0      |
|---------------|----------------|-----|----------------------|-----|----------------------|-----|----|----|----|----|----|----|----|----|----|---------|
| 具有12位精度的右对齐数据 | 指定16个转换时间时     |     | 附加值15到0: AD转换结果的16位和 |     |                      |     |    |    |    |    |    |    |    |    |    |         |
|               | 指定1、2、3或4转换时间时 |     | 这些位读为0。              |     | 附加值13到0: AD转换结果的14位和 |     |    |    |    |    |    |    |    |    |    |         |
| 具有12位精度的左对齐数据 | 指定1、2、3或4转换时间时 |     | 附加值15到0: AD转换结果的16位和 |     |                      |     |    |    |    |    |    |    |    |    |    |         |
|               | 指定16个转换时间时     |     | 附加值13到0: AD转换结果的14位和 |     |                      |     |    |    |    |    |    |    |    |    |    | 这些位读为0。 |

37.2.4 ATSDR:AD温度传感器数据寄存器

Base address: ADC12m = 0x4017\_0000 + 0x0200 × m (m = 0, 1)

Offset address: 0x01A





| Bit  | Symbol        | Function  | R/W |
|------|---------------|---|-----|
| 15:0 | ADTSDR [15:0] | Converted Value 15 to 0<br>Functions vary depending on the selected mode and accuracy. See Table 37.11 and Table 37.12. | R   |

ADTSDR register is a 16-bit read-only register to store A/D conversion result of the temperature sensor output.

The following conditions determine the formats for data in the A/D data registers:

- Setting of the A/D Data Register Format Select bit (ADCER.ADRFMT) (flush-left or flush-right)
- The setting in the A/D Conversion Accuracy Select bits (ADCER.ADPRC[1:0]) (12-bit, 10-bit, 8-bit is selectable.)
- Setting of the Addition/Average Count Select bits (ADADC.ADC[2:0]) (1, 2, 3, 4, or 16 times)
- Setting of the Average Mode Enable bit (ADADC.AVEE) (addition or average).

This section describes the data formats for these conditions in different modes.

(1) When A/D-converted value addition/average mode is not selected

Table 37.11 shows the example of bit assignment for 12-bit accuracy.

Table 37.11 Example of bit assignment for 12-bit accuracy

| Accuracy                                  | b15   | b14 | b13 | b12 | b11   | b10 | b9 | b8 | b7 | b6 | b5 | b4 | b3                        | b2 | b1 | b0 |
|---|---|-----|-----|-----|---|-----|----|----|----|----|----|----|---------------------------|----|----|----|
| Right-justified data with 12-bit accuracy | These bits are read as 0.                           |     |     |     | Converted Value 11 to 0: 12-bit A/D-converted value |     |    |    |    |    |    |    |                           |    |    |    |
| Left-justified data with 12-bit accuracy  | Converted Value 11 to 0: 12-bit A/D-converted value |     |     |     |   |     |    |    |    |    |    |    | These bits are read as 0. |    |    |    |

(2) When A/D-converted value average mode is selected

A/D-converted value average mode can be selected when 2 or 4 times is specified in the A/D-converted value addition mode. When A/D converted value average mode is selected, This register indicates the mean of A/D-converted values on a specific channel. The value is stored in the A/D data register based on the setting of the A/D Data Register Format Select bit in the same way as for normal A/D conversion.

(3) When A/D-converted value addition mode is selected

For 12-bit, 10-bit, 8-bit accuracy, 1, 2, 3, or 4 times can be selected in the A/D-converted value addition mode. A/D conversion results are stored in the A/D data register as a 2-bit-extended value of the specified conversion accuracy.

For 12-bit accuracy, 16 times can also be selected in the A/D-converted value addition mode. In A/D-converted value addition mode, this register indicates the value that is obtained by adding A/D-converted values on a specific channel. A/D conversion results are stored in the A/D data register as a 4-bit-extended value of the specified conversion accuracy.

When A/D-converted value addition mode is selected, the value is stored in the A/D data register based on the settings of the A/D Data Register Format Select bits.

Table 37.12 shows example of the bit assignment for 12-bit accuracy.

Table 37.12 Example of bit assignment for 12-bit accuracy when A/D-converted value addition mode is selected (1 of 2)

| Accuracy                                  | b15  | b14 | b13   | b12 | b11   | b10 | b9 | b8 | b7 | b6 | b5 | b4 | b3 | b2 | b1 | b0 |
|---|--|-----|---|-----|---|-----|----|----|----|----|----|----|----|----|----|----|
| Right-justified data with 12-bit accuracy | When 16 conversion times is specified            |     | Added Value 15 to 0: 16-bit sum of A/D conversion results |     |   |     |    |    |    |    |    |    |    |    |    |    |
|   | When 1, 2, 3, or 4 conversion times is specified |     | These bits are read as 0.                                 |     | Added Value 13 to 0: 14-bit sum of A/D conversion results |     |    |    |    |    |    |    |    |    |    |    |

| Bit  | Symbol        | Function                                   | R/W |
|------|---------------|--|-----|
| 15:0 | ADTSDR [15:0] | 将值15转换为0<br>功能因所选模式和精度而异。请参见表37.11和表37.12。 | R   |

ADTSDR寄存器是一个16位只读寄存器，用于存储温度传感器输出的AD转换结果。

以下条件决定了AD数据寄存器中的数据格式：

- AD数据寄存器格式选择位(ADCER.ADRFMT)的设置（左对齐或右对齐）
- AD转换精度选择位(ADCER.ADPRC[1:0])中的设置（可选择12位、10位、8位。）
- 加法平均计数选择位(ADADC.ADC[2:0])的设置（1、2、3、4或16次）
- 设置平均模式启用位(ADADC.AVEE)（加法或平均）。

本节介绍不同模式下这些条件的数据格式。

(1) 未选择AD转换值加法平均模式时

表37.11显示了12位精度的位分配示例。

Table 37.11 12位精度的位分配示例

| Accuracy      | b15               | b14 | b13 | b12 | b11               | b10 | b9 | b8 | b7 | b6 | b5 | b4 | b3      | b2 | b1 | b0 |
|---------------|-------------------|-----|-----|-----|-------------------|-----|----|----|----|----|----|----|---------|----|----|----|
| 具有12位精度的右对齐数据 | 这些位读为0。           |     |     |     | 转换值11到0: 12位AD转换值 |     |    |    |    |    |    |    |         |    |    |    |
| 具有12位精度的左对齐数据 | 转换值11到0: 12位AD转换值 |     |     |     |                   |     |    |    |    |    |    |    | 这些位读为0。 |    |    |    |

(2) 选择AD转换值平均模式时

当在AD转换值相加模式中指定2或4次时，可以选择D转换值平均模式。WhenADconvertedvalueaveragemodeisselected ThisregisterindicatesthemeanofAD-convertedvaluesonaspecificchannel.该值根据AD数据寄存器格式选择位的设置以与正常AD转换相同的方式存储在AD数据寄存器中。

(3) 选择AD转换值相加模式时

对于12位、10位、8位精度，可以在AD转换值相加模式中选择1、2、3或4次。AD转换结果作为指定转换精度的2位扩展值存储在AD数据寄存器中。

对于12位精度，在AD转换值相加模式中也可以选择16倍。在AD转换值相加模式下，该寄存器指示通过在特定通道上相加AD转换值获得的值。AD转换结果作为指定转换精度的4位扩展值存储在AD数据寄存器中。

WhenAD-convertedvalueadditionmodeisselected thevalueisstoredintheADdataregisterbasedonthesettings of theADDataRegisterFormatSelectbits.

表37.12显示了12位精度的位分配示例。

Table 37.12 选择AD转换值相加模式时12位精度的位分配示例 (1 of 2)

| Accuracy      | b15            | b14 | b13                  | b12 | b11                  | b10 | b9 | b8 | b7 | b6 | b5 | b4 | b3 | b2 | b1 | b0 |
|---------------|----------------|-----|----------------------|-----|----------------------|-----|----|----|----|----|----|----|----|----|----|----|
| 具有12位精度的右对齐数据 | 指定16个转换时间时     |     | 附加值15到0: AD转换结果的16位和 |     |                      |     |    |    |    |    |    |    |    |    |    |    |
|               | 指定1、2、3或4转换时间时 |     | 这些位读为0。              |     | 附加值13到0: AD转换结果的14位和 |     |    |    |    |    |    |    |    |    |    |    |

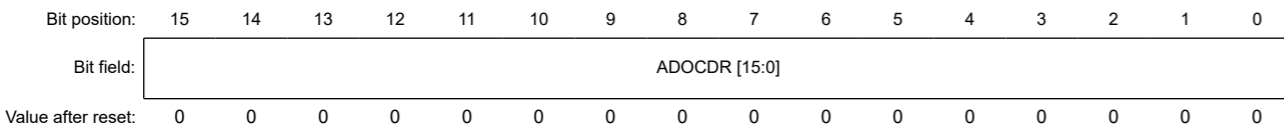


**Table 37.12 Example of bit assignment for 12-bit accuracy when A/D-converted value addition mode is selected (2 of 2)**

| Accuracy                                 | b15  | b14 | b13 | b12 | b11 | b10 | b9 | b8 | b7 | b6 | b5 | b4 | b3 | b2 | b1 | b0   |
|--|--|-----|-----|-----|-----|-----|----|----|----|----|----|----|----|----|----|--|
| Left-justified data with 12-bit accuracy | When 1, 2, 3, or 4 conversion times is specified |     |     |     |     |     |    |    |    |    |    |    |    |    |    | Added Value 15 to 0:<br>16-bit sum of A/D conversion results |
|  | When 16 conversion times is specified            |     |     |     |     |     |    |    |    |    |    |    |    |    |    | Added Value 13 to 0:<br>14-bit sum of A/D conversion results |

### 37.2.5 ADOCDR : A/D Internal Reference Voltage Data Register

Base address: ADC12m = 0x4017\_0000 + 0x0200 × m (m = 0, 1)  
Offset address: 0x01C



| Bit  | Symbol        | Function   | R/W |
|------|---------------|--|-----|
| 15:0 | ADOCDR [15:0] | Converted Value 15 to 0<br>Functions vary depending on the selected mode and accuracy. See <a href="#">Table 37.13</a> and <a href="#">Table 37.14</a> . | R   |

ADOCDR register is a 16-bit read-only register to store A/D conversion result of the internal reference voltage.

The following conditions determine the formats for data in the A/D data registers:

- Setting of the A/D Data Register Format Select bit (ADCER.ADRFMT) (flush-left or flush-right)
- The setting in the A/D Conversion Accuracy Select bits (ADCER.ADPRC[1:0]) (12-bit, 10-bit, 8-bit is selectable.)
- Setting of the Addition/Average Count Select bits (ADADC.ADC[2:0]) (1, 2, 3, 4, or 16 times)
- Setting of the Average Mode Enable bit (ADADC.AVEE) (addition or average).

This section describes the data formats for these conditions in different modes.

#### (1) When A/D-converted value addition/average mode is not selected

[Table 37.13](#) shows the example of bit assignment for 12-bit accuracy.

**Table 37.13 Example of bit assignment for 12-bit accuracy**

| Accuracy                                  | b15  | b14 | b13 | b12 | b11 | b10  | b9 | b8 | b7 | b6 | b5 | b4 | b3                        | b2 | b1 | b0 |
|---|--|-----|-----|-----|-----|--|----|----|----|----|----|----|---------------------------|----|----|----|
| Right-justified data with 12-bit accuracy | These bits are read as 0.                              |     |     |     |     | Converted Value 11 to 0:<br>12-bit A/D-converted value |    |    |    |    |    |    |                           |    |    |    |
| Left-justified data with 12-bit accuracy  | Converted Value 11 to 0:<br>12-bit A/D-converted value |     |     |     |     |  |    |    |    |    |    |    | These bits are read as 0. |    |    |    |

#### (2) When A/D-converted value average mode is selected

A/D-converted value average mode can be selected when 2 or 4 times is specified in the A/D-converted value addition mode. When A/D converted value average mode is selected, This register indicates the mean of A/D-converted values on a specific channel. The value is stored in the A/D data register based on the setting of the A/D Data Register Format Select bit in the same way as for normal A/D conversion.

#### (3) When A/D-converted value addition mode is selected

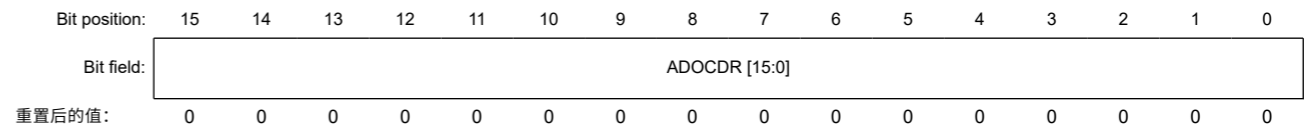
For 12-bit, 10-bit, 8-bit accuracy, 1, 2, 3, or 4 times can be selected in the A/D-converted value addition mode. A/D conversion results are stored in the A/D data register as a 2-bit-extended value of the specified conversion accuracy.

**Table 37.12 选择AD转换值相加模式时12位精度的位分配示例 (2之2)**

| Accuracy      | b15            | b14 | b13 | b12 | b11 | b10 | b9 | b8 | b7 | b6 | b5 | b4 | b3 | b2 | b1 | b0                   |
|---------------|----------------|-----|-----|-----|-----|-----|----|----|----|----|----|----|----|----|----|----------------------|
| 具有12位精度的左对齐数据 | 指定1、2、3或4转换时间时 |     |     |     |     |     |    |    |    |    |    |    |    |    |    | 附加值15到0: AD转换结果的16位和 |
|               | 指定16个转换时间时     |     |     |     |     |     |    |    |    |    |    |    |    |    |    | 附加值13到0: AD转换结果的14位和 |

### 37.2.5 ADOCDR:AD内部参考电压数据寄存器

Base address: ADC12m = 0x4017\_0000 + 0x0200 × m (m = 0, 1)  
Offset address: 0x01C



| Bit  | Symbol        | Function                                   | R/W |
|------|---------------|--|-----|
| 15:0 | ADOCDR [15:0] | 将值15转换为0<br>功能因所选模式和精度而异。请参见表37.13和表37.14。 | R   |

AOCDR寄存器是一个16位只读寄存器，用于存储内部参考电压的AD转换结果。

以下条件决定了AD数据寄存器中的数据格式：

- AD数据寄存器格式选择位(ADCER.ADRFMT)的设置（左对齐或右对齐）
- AD转换精度选择位(ADCER.ADPRC[1:0])中的设置（可选择12位、10位、8位。）
- 加法平均计数选择位(ADADC.ADC[2:0])的设置（1、2、3、4或16次）
- 设置平均模式启用位(ADADC.AVEE)（加法或平均）。

本节介绍不同模式下这些条件的数据格式。

#### (1) 未选择AD转换值加法平均模式时

表37.13显示了12位精度的位分配示例。

**Table 37.13 12位精度的位分配示例**

| Accuracy      | b15               | b14 | b13 | b12 | b11 | b10               | b9 | b8 | b7 | b6 | b5 | b4 | b3      | b2 | b1 | b0 |
|---------------|-------------------|-----|-----|-----|-----|-------------------|----|----|----|----|----|----|---------|----|----|----|
| 具有12位精度的右对齐数据 | 这些位读为0。           |     |     |     |     | 转换值11到0: 12位AD转换值 |    |    |    |    |    |    |         |    |    |    |
| 具有12位精度的左对齐数据 | 转换值11到0: 12位AD转换值 |     |     |     |     |                   |    |    |    |    |    |    | 这些位读为0。 |    |    |    |

#### (2) 选择AD转换值平均模式时

当在AD转换值相加模式中指定2或4次时，可以选择D转换值平均模式。WhenADconvertedvalueaveragemodeisselected ThisregisterindicatesthemeanofAD-convertedvaluesonaspecificchannel.该值根据AD数据寄存器格式选择位的设置以与正常AD转换相同的方式存储在AD数据寄存器中。

#### (3) 选择AD转换值相加模式时

对于12位、10位、8位精度，可以在AD转换值相加模式中选择1、2、3或4次。AD转换结果作为指定转换精度的2位扩展值存储在AD数据寄存器中。

For 12-bit accuracy, 16 times can also be selected in the A/D-converted value addition mode. In A/D-converted value addition mode, this register indicates the value that is obtained by adding A/D-converted values on a specific channel. A/D conversion results are stored in the A/D data register as a 4-bit-extended value of the specified conversion accuracy.

When A/D-converted value addition mode is selected, the value is stored in the A/D data register based on the settings of the A/D Data Register Format Select bits.

Table 37.14 shows example of the bit assignment for 12-bit accuracy.

Table 37.14 Example of bit assignment for 12-bit accuracy when A/D-converted value addition mode is selected

| Accuracy                                  |  | b15  | b14 | b13  | b12 | b11 | b10 | b9 | b8 | b7 | b6 | b5 | b4 | b3 | b2 | b1                        | b0 |
|---|--|--|-----|--|-----|-----|-----|----|----|----|----|----|----|----|----|---------------------------|----|
| Right-justified data with 12-bit accuracy | When 16 conversion times is specified            | Added Value 15 to 0:<br>16-bit sum of A/D conversion results |     |  |     |     |     |    |    |    |    |    |    |    |    |                           |    |
|   | When 1, 2, 3, or 4 conversion times is specified | These bits are read as 0.                                    |     | Added Value 13 to 0:<br>14-bit sum of A/D conversion results |     |     |     |    |    |    |    |    |    |    |    |                           |    |
| Left-justified data with 12-bit accuracy  | When 1, 2, 3, or 4 conversion times is specified | Added Value 15 to 0:<br>16-bit sum of A/D conversion results |     |  |     |     |     |    |    |    |    |    |    |    |    |                           |    |
|   | When 16 conversion times is specified            | Added Value 13 to 0:<br>14-bit sum of A/D conversion results |     |  |     |     |     |    |    |    |    |    |    |    |    | These bits are read as 0. |    |

### 37.2.6 ADRD : A/D Self-Diagnosis Data Register

Base address: ADC12m = 0x4017\_0000 + 0x0200 × m (m = 0, 1)

Offset address: 0x01E



| Bit   | Symbol      | Function   | R/W |
|-------|-------------|--|-----|
| 11:0  | AD[11:0]    | Converted Value 11 to 0<br>12-bit A/D-converted value  | R   |
| 13:12 | —           | These bits are read as 0.  | R   |
| 15:14 | DIAGST[1:0] | Self-Diagnosis Status<br>0 0: Self-diagnosis not executed after power-on.<br>0 1: Self-diagnosis was executed using the 0 V voltage.<br>1 0: Self-diagnosis was executed using the reference power supply*1 voltage × 1/2.<br>1 1: Self-diagnosis was executed using the reference power supply*1 voltage.<br>For details on self-diagnosis, see section 37.2.15. ADCER : A/D Control Extended Register. | R   |

Note: The example of the bit assignment for the right-justified data with 12-bit accuracy is indicated.

Note 1. The reference voltage refers to VREFH0 for unit 0 and to VREFH for unit 1.

ADRD is a 16-bit read-only register that holds the A/D conversion results based on the self-diagnosis of the ADC12. In addition to the AD[11:0] bits indicating the A/D-converted value, it includes the Self-Diagnosis Status bit (DIAGST[1:0]).

The settings of the A/D data register format and the A/D conversion accuracy determines the formats for data in this register.

The A/D-converted value addition and average modes cannot be applied to the A/D self-diagnosis function. For details on self-diagnosis, see section 37.2.15. ADCER : A/D Control Extended Register.

This section describes the data formats for each condition. The register diagram and the register bit table shown in this section indicate example of the bit assignment for the left and right-justified data with 12-bit accuracy.

对于12位精度，在AD转换值相加模式中也可以选择16倍。在AD转换值相加模式下，该寄存器指示通过在特定通道上相加AD转换值获得的值。AD转换结果作为指定转换精度的4位扩展值存储在AD数据寄存器中。

When AD-converted value addition mode is selected the value is stored in the AD data register based on the settings of the AD Data Register Format Select bits.

表37.14显示了12位精度的位分配示例。

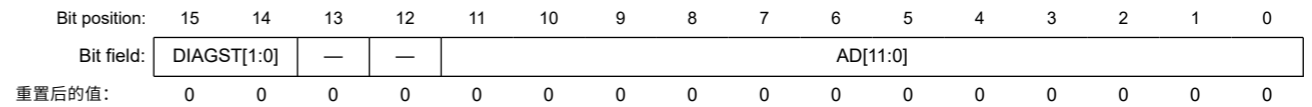
Table 37.14 选择AD转换值相加模式时12位精度的位分配示例

| Accuracy      |                | b15                  | b14 | b13                  | b12 | b11 | b10 | b9 | b8 | b7 | b6 | b5 | b4 | b3 | b2 | b1      | b0 |
|---------------|----------------|----------------------|-----|----------------------|-----|-----|-----|----|----|----|----|----|----|----|----|---------|----|
| 具有12位精度的右对齐数据 | 指定16个转换时间时     | 附加值15到0: AD转换结果的16位和 |     |                      |     |     |     |    |    |    |    |    |    |    |    |         |    |
|               | 指定1、2、3或4转换时间时 | 这些位读为0。              |     | 附加值13到0: AD转换结果的14位和 |     |     |     |    |    |    |    |    |    |    |    |         |    |
| 具有12位精度的左对齐数据 | 指定1、2、3或4转换时间时 | 附加值15到0: AD转换结果的16位和 |     |                      |     |     |     |    |    |    |    |    |    |    |    |         |    |
|               | 指定16个转换时间时     | 附加值13到0: AD转换结果的14位和 |     |                      |     |     |     |    |    |    |    |    |    |    |    | 这些位读为0。 |    |

### 37.2.6 ADRD:AD自诊断数据寄存器

Base address: ADC12m = 0x4017\_0000 + 0x0200 × m (m = 0, 1)

Offset address: 0x01E



| Bit   | Symbol      | Function  | R/W |
|-------|-------------|---|-----|
| 11:0  | AD[11:0]    | 将值11转换为0<br>12-bit A/D-converted value  | R   |
| 13:12 | —           | 这些位读为0。   | R   |
| 15:14 | DIAGST[1:0] | Self-Diagnosis Status<br>00: 上电后不进行自诊断。01:使用0V电压执行自诊断。10: 使用基准电源+1电压×1/2执行自诊断。11: 使用基准电源+1电压执行自诊断。<br>有关自诊断的详细信息，请参阅第37.2.15节。ADCER: AD控制扩展寄存器。 | R   |

Note: 显示了具有12位精度的右对齐数据的位分配示例。

注1.参考电压是指单元0的VREFH0和单元1的VREFH。

ADRD是一个16位只读寄存器，保存基于ADC12自诊断的AD转换结果。除了指示AD转换值的AD[11:0]位外，它还包括自诊断状态位(DIAGST[1:0])。

AD数据寄存器格式和AD转换精度的设置决定了该寄存器中数据的格式。

AD转换值加法和平均模式不能应用于AD自诊断功能。有关自诊断的详细信息，请参阅第37.2.15节。ADCER: A/D控制扩展寄存器。

本节介绍每个条件的数据格式。本节所示的寄存器图和寄存器位表表示以12位精度进行左右对齐数据的位分配示例。

**Table 37.15 Bit assignment for each right-justified accuracy**

| Accuracy                                  | b15         | b14 | b13 | b12 | b11      | b10 | b9 | b8 | b7 | b6 | b5 | b4 | b3 | b2 | b1 | b0 |
|---|-------------|-----|-----|-----|----------|-----|----|----|----|----|----|----|----|----|----|----|
| Right-justified data with 12-bit accuracy | DIAGST[1:0] |     | —   |     | AD[11:0] |     |    |    |    |    |    |    |    |    |    |    |

**Table 37.16 Bit assignment for each left-justified accuracy**

| Accuracy                                 | b15      | b14 | b13 | b12 | b11 | b10 | b9 | b8 | b7 | b6 | b5 | b4 | b3 | b2 | b1          | b0 |
|--|----------|-----|-----|-----|-----|-----|----|----|----|----|----|----|----|----|-------------|----|
| Left-justified data with 12-bit accuracy | AD[11:0] |     |     |     |     |     |    |    |    |    |    |    | —  |    | DIAGST[1:0] |    |

### 37.2.7 ADCSR : A/D Control Register

Base address: ADC12m = 0x4017\_0000 + 0x0200 × m (m = 0, 1)

Offset address: 0x000

| Bit position:      | 15   | 14        | 13 | 12 | 11 | 10 | 9 | 8    | 7     | 6    | 5      | 4 | 3 | 2           | 1 | 0 |
|--------------------|------|-----------|----|----|----|----|---|------|-------|------|--------|---|---|-------------|---|---|
| Bit field:         | ADST | ADCS[1:0] |    | —  |    | —  |   | TRGE | EXTRG | DBLE | GBADIE | — |   | DBLANS[4:0] |   |   |
| Value after reset: | 0    | 0         | 0  | 0  | 0  | 0  | 0 | 0    | 0     | 0    | 0      | 0 | 0 | 0           | 0 | 0 |

| Bit   | Symbol      | Function  | R/W |
|-------|-------------|---|-----|
| 4:0   | DBLANS[4:0] | Double Trigger Channel Select<br>These bits select one analog input channel for double trigger operation. The setting is only valid in double-trigger mode.   | R/W |
| 5     | —           | This bit is read as 0. The write value should be 0.   | R/W |
| 6     | GBADIE      | Group B Scan End Interrupt and ELC Event Enable<br>Group B scan only works in group scan mode.<br>0: Disable ADC12i_GBADI (i = 0, 1) interrupt generation on group B scan completion.<br>1: Enable ADC12i_GBADI (i = 0, 1) interrupt generation on group B scan completion. | R/W |
| 7     | DBLE        | Double Trigger Mode Select<br>0: Deselect double-trigger mode.<br>1: Select double-trigger mode.  | R/W |
| 8     | EXTRG       | Trigger Select*1<br>0: Start A/D conversion by the synchronous trigger (ELC).<br>1: Start A/D conversion by the asynchronous trigger (ADTRG0).  | R/W |
| 9     | TRGE        | Trigger Start Enable<br>0: Disable A/D conversion to be started by the synchronous or asynchronous trigger<br>1: Enable A/D conversion to be started by the synchronous or asynchronous trigger   | R/W |
| 10    | —           | These bits are read as 0. The write value should be 0.  | R/W |
| 11    | —           | These bits are read as 0. The write value should be 0.  | R/W |
| 12    | —           | These bits are read as 0. The write value should be 0.  | R/W |
| 14:13 | ADCS[1:0]   | Scan Mode Select<br>00: Single scan mode<br>01: Group scan mode<br>10: Continuous scan mode<br>11: Setting prohibited   | R/W |
| 15    | ADST        | A/D Conversion Start<br>0: Stop A/D conversion process.<br>1: Start A/D conversion process.   | R/W |

Note 1. To start A/D conversion using an external pin (asynchronous trigger):  
After a high-level signal is input to the external pin (ADTRG0), write 1 to both the TRGE and EXTRG bits in the ADCSR register and drive the ADTRG0 pin low. With these settings, the scan conversion process starts on detection of the falling edge of ADTRG0. The pulse width of the low-level input must be at least PCLKA 1.5 clock cycles.

**Table 37.15 每个右对齐精度的位分配**

| Accuracy      | b15         | b14 | b13 | b12 | b11      | b10 | b9 | b8 | b7 | b6 | b5 | b4 | b3 | b2 | b1 | b0 |
|---------------|-------------|-----|-----|-----|----------|-----|----|----|----|----|----|----|----|----|----|----|
| 具有12位精度的右对齐数据 | DIAGST[1:0] |     | —   |     | AD[11:0] |     |    |    |    |    |    |    |    |    |    |    |

**Table 37.16 每个左对齐精度的位分配**

| Accuracy      | b15      | b14 | b13 | b12 | b11 | b10 | b9 | b8 | b7 | b6 | b5 | b4 | b3 | b2 | b1          | b0 |
|---------------|----------|-----|-----|-----|-----|-----|----|----|----|----|----|----|----|----|-------------|----|
| 具有12位精度的左对齐数据 | AD[11:0] |     |     |     |     |     |    |    |    |    |    |    | —  |    | DIAGST[1:0] |    |

### 37.2.7 ADCSR:AD控制寄存器

Base address: ADC12m = 0x4017\_0000 + 0x0200 × m (m = 0, 1)

Offset address: 0x000

| Bit position: | 15   | 14        | 13 | 12 | 11 | 10 | 9 | 8    | 7     | 6    | 5      | 4 | 3 | 2           | 1 | 0 |
|---------------|------|-----------|----|----|----|----|---|------|-------|------|--------|---|---|-------------|---|---|
| Bit field:    | ADST | ADCS[1:0] |    | —  |    | —  |   | TRGE | EXTRG | DBLE | GBADIE | — |   | DBLANS[4:0] |   |   |
| 重置后的值:        | 0    | 0         | 0  | 0  | 0  | 0  | 0 | 0    | 0     | 0    | 0      | 0 | 0 | 0           | 0 | 0 |

| Bit   | Symbol      | Function   | R/W |
|-------|-------------|--|-----|
| 4:0   | DBLANS[4:0] | 双触发通道选择<br>这些位选择一个模拟输入通道进行双触发操作。该设置仅在双触发模式下有效。   | R/W |
| 5     | —           | 该位读取为0。写入值应为0。   | R/W |
| 6     | GBADIE      | B组扫描结束中断和ELC事件启用<br>B组扫描仅适用于组扫描模式。<br>0: 在B组扫描完成时禁用ADC12i_GBADI(i=0 1)中断生成。<br>1: 在B组扫描完成时启用ADC12i_GBADI(i=0 1)中断生成。 | R/W |
| 7     | DBLE        | 双触发模式选择<br>0: 取消选择双触发模式。1: 选择双触发模式。  | R/W |
| 8     | EXTRG       | 触发选择*1<br>0: 通过同步触发 (ELC) 启动AD转换。1: 通过异步触发 (ADTRG0) 启动AD转换。  | R/W |
| 9     | TRGE        | 触发启动启用<br>0: 禁止由同步或异步触发器启动的AD转换<br>1: 使能由同步或异步触发器启动的AD转换   | R/W |
| 10    | —           | 这些位被读取为0。写入值应为0。   | R/W |
| 11    | —           | 这些位被读取为0。写入值应为0。   | R/W |
| 12    | —           | 这些位被读取为0。写入值应为0。   | R/W |
| 14:13 | ADCS[1:0]   | 扫描模式选择<br>00: 单次扫描模式<br>01: 组扫描模式<br>10: 连续扫描模式<br>11: 禁止设置  | R/W |
| 15    | ADST        | AD转换开始<br>0: 停止AD转换过程。1: 开始AD转换过程。   | R/W |

注1.使用外部引脚（异步触发）启动AD转换：  
向外部引脚(ADTRG0)输入高电平信号后，向ADCSR寄存器的TRGE和EXTRG位写入1并将ADTRG0引脚驱动为低电平。通过这些设置，扫描转换过程在检测到ADTRG0的下降沿时开始。低电平输入的脉冲宽度必须至少为PCLKA1.5个时钟周期。



The ADCSR register sets double-trigger mode and A/D conversion start trigger, enables or disables scan end interrupt, selects the scan mode, and starts or stops A/D conversion.

#### DBLANS[4:0] bits (Double Trigger Channel Select)

The DBLANS[4:0] bits select one channel for A/D conversion data duplication in double trigger mode. This can be selected by setting the binary value of the channel number to be duplicated. The A/D conversion results of the analog input of the channel selected in the DBLANS[4:0] bits are stored in A/D Data Register y when conversion is started by the first trigger, and in the A/D Data Duplexing Register when conversion is started by the second trigger.

In double trigger mode, the channels selected in the ADANSA0 and ADANSA1 registers are invalid, and the channel selected in the DBLANS[4:0] bits is A/D converted instead.

When double trigger mode is used in group scan mode, double trigger control is only applied to group A and not to group B. Therefore, multiple channel analog input can be selected for group B even in double trigger mode.

Only set the DBLANS[4:0] bits when the ADST bit is 0. Do not set the DBLANS[4:0] bits at the same time that you write 1 to the ADST bit.

To enter A/D-converted value addition/average mode when in double trigger mode, select the channel using the DBLANS[4:0] bits in the ADANSA0 and ADANSA1 registers.

A/D-converted data from the self-diagnosis function, temperature sensor output, and internal reference voltage cannot be used in double trigger mode.

#### GBADIE bit (Group B Scan End Interrupt and ELC Event Enable)

The GBADIE bit enables or disables group B scan end interrupt (ADC12i\_GBADI (i = 0, 1)) in group scan mode.

#### DBLE bit (Double Trigger Mode Select)

The DBLE bit selects or deselects double-trigger mode. Double-trigger mode can only be operated by the synchronous trigger (ELC) selected in the ADSTRGR.TRSA[5:0] bits.

Double-trigger operation is as follows:

1. The ADC12i\_ADI (i = 0, 1) interrupt is not output on completion of the first conversion but on completion of the second conversion.
2. The A/D conversion results from the duplication channel (selected in DBLANS[4:0]) started by the first trigger are stored in A/D Data Register y and those started by the second trigger are stored in the A/D Data Duplexing Register.

When the DBLE bit is set (double trigger mode is selected), the channels specified in the ADANSA0 and ADANSA1 registers are invalid. Double trigger mode is deselected by setting DBLE to 0. Setting DBLE to 1 again enables the same double-trigger operation described in 1. and 2. for first time scanning with the first trigger.

Do not select double trigger mode in continuous scan mode. Software triggering cannot be used in double trigger mode. Always set the ADST bit to 0 before setting the DBLE bit. Do not set the DBLE bit at that same time as writing 1 to the ADST bit.

#### EXTRG bit (Trigger Select)

The EXTRG bit selects the synchronous or asynchronous trigger as the trigger for starting A/D conversion.

In group-scan mode, the setting of this bit takes effect on the trigger selected for group A. For groups B, A/D conversion is started by the selected synchronous trigger regardless of this bit setting.

#### TRGE bit (Trigger Start Enable)

The TRGE bit enables or disables A/D conversion by the synchronous and asynchronous triggers. In group scan mode, set this bit to 1.

#### ADCS[1:0] bits (Scan Mode Select)

The ADCS[1:0] bits select the scan mode.

In single scan mode, A/D conversion is performed for the analog inputs of the channels selected in the ADANSA0 and ADANSA1 registers, in ascending order of channel number. When 1 cycle of A/D conversion completes for all the selected channels, the scan conversion stops.

ADCSR寄存器设置双触发模式和AD转换启动触发，使能或禁止扫描结束中断，选择扫描模式，启动或停止A/D转换。

#### DBLANS[4:0]位（双触发通道选择）

DBLANS[4:0]位选择一个通道用于双触发模式下的AD转换数据复制。这可以通过设置要复制的通道号的二进制值来选择。在DBLANS[4:0]位中选择的通道的模拟输入的AD转换结果在第一次触发开始转换时存储在AD数据寄存器y中，当转换开始时存储在AD数据双工寄存器中。第二个触发器。

双触发模式下，ADANSA0和ADANSA1寄存器选择的通道无效，DBLANS[4:0]位选择的通道改为AD转换。

在组扫描模式下使用双触发模式时，双触发控制仅适用于A组，不适用于B组。因此，即使在双触发模式下，也可以为B组选择多通道模拟输入。

仅当ADST位为0时设置DBLANS[4:0]位。不要在将1写入ADST位的同时设置DBLANS[4:0]位。

要在双触发模式下进入AD转换值加法平均模式，请使用ADANSA0和ADANSA1寄存器中的DBLANS[4:0]位。

自诊断功能、温度传感器输出和内部参考电压的D转换数据不能用于双触发模式。

#### GBADIE位（B组扫描结束中断和ELC事件使能）

GBADIE位在组扫描模式下启用或禁用组B扫描结束中断(ADC12i\_GBADI(i=0 1))。

#### DBLE位（双触发模式选择）

DBLE位选择或取消选择双触发模式。双触发模式只能由在ADSTRGR.TRSA[5:0]位中选择的同步触发(ELC)操作。

双触发操作如下：

1.ADC12i\_ADI(i=0 1)中断不是在第一次转换完成时输出，而是在第二次转换完成时输出。

2.由第一次触发启动的复制通道（在DBLANS[4:0]中选择）的AD转换结果存储在AD数据寄存器y中，由第二次触发启动的数据存储在AD数据双工寄存器中。

当设置DBLE位（选择双触发模式）时，在ADANSA0和ADANSA1寄存器中指定的通道无效。通过将DBLE设置为0来取消选择双触发模式。再次将DBLE设置为1可以启用与1和2.中描述的相同的双触发操作，以使用第一个触发进行首次扫描。

在连续扫描模式下不要选择双触发模式。双触发模式下不能使用软件触发。在设置DBLE位之前，始终将ADST位设置为0。不要在将DBLE位设置为1的同时ADST bit.

#### EXTRG bit (Trigger Select)

EXTRG位选择同步或异步触发作为启动AD转换的触发。

在组扫描模式下，该位的设置对A组选择的触发生效。对于B组，无论该位设置如何，都由选择的同步触发启动A/D转换。

#### TRGE位（触发启动使能）

TRGE位通过同步和异步触发启用或禁用AD转换。在组扫描模式下，将此位设置为1。

#### ADCS[1:0]位（扫描模式选择）

ADCS[1:0]位选择扫描模式。

在单次扫描模式下，对ADANSA0中选择的通道的模拟输入执行AD转换，并且ADANSA1寄存器，按通道号升序排列。当所有选定通道的1个AD转换周期完成时，扫描转换停止。



In continuous scan mode, when the ADCSR.ADST bit is 1, A/D conversion is performed for the analog inputs of the channels selected with the ADANSA0 and ADANSA1 registers, in ascending order of channel number. When 1 cycle of A/D conversion completes for all the selected channels, A/D conversion repeats from the first channel. If the ADCSR.ADST bit is set to 0 during continuous scan, A/D conversion stops even if scanning is in progress.

In group scan mode:

- Group A scanning is started by the synchronous trigger (ELC) selected in the TRSA[5:0] bits in the ADSTRGR register. A/D conversion is performed on group A analog inputs of the channels selected in the ADANSA0 and ADANSA1 registers, in ascending order of channel number. When 1 cycle of A/D conversion completes for all the selected channels, A/D conversion stops.
- Group B scanning is started by the synchronous trigger (ELC) selected in the ADSTRGR.TRSB[5:0] bits. A/D conversion is performed on group B analog inputs of the channels selected in the ADANSB0 and ADANSB1 registers, in ascending order of channel number. When 1 cycle of A/D conversion completes for all the selected channels, A/D conversion stops.

If the conversion processes in group A and B occur at the same time, those conversions cannot be controlled separately. In this case, set group A Priority Control Setting bit (ADGSPCR.PGS) in the A/D Group Scan Priority Control Register (ADGSPCR) to 1 to assign a priority to group A conversion.

In group scan mode, select different channels and triggers for group A and group B.

Only set the ADCS[1:0] bits when the ADST bit is 0. Do not set the ADCS[1:0] bits at the same time that you write 1 to the ADST bit.

Table 37.17 Selectable targets for A/D conversion depending on scan and double-trigger mode settings

| Scan mode setting | Double-trigger mode setting | Targets for A/D conversion |                        |                        |                           |                            |
|-------------------|-----------------------------|----------------------------|------------------------|------------------------|---------------------------|----------------------------|
|                   |                             | Self-diagnosis             | Analog input (group A) | Analog input (group B) | Temperature sensor output | Internal reference voltage |
| Single scan       | DBLE = 0                    | ✓                          | ✓                      | —                      | ✓                         | ✓                          |
|                   | DBLE = 1                    | —                          | ✓ (1 ch only)          | —                      | —                         | —                          |
| Continuous scan   | DBLE = 0                    | ✓                          | ✓                      | —                      | ✓                         | ✓                          |
|                   | DBLE = 1                    | —                          | —                      | —                      | —                         | —                          |
| Group scan        | DBLE = 0                    | ✓                          | ✓                      | ✓                      | ✓                         | ✓                          |
|                   | DBLE = 1                    | —                          | ✓ (1 ch only)          | ✓                      | ✓                         | ✓                          |

Note: ✓: Selectable, —: Not selectable

#### ADST bit (A/D Conversion Start)

The ADST bit starts or stops the A/D conversion process. Before the ADST bit is set to 1, set the A/D conversion clock, the conversion mode, and the conversion target analog input.

[Setting conditions]

- 1 is written.
- The synchronous trigger (ELC) selected in the ADSTRGR.TRSA[5:0] bits is detected when ADCSR.EXTRG is 0 and ADCSR.TRGE is 1.
- The synchronous trigger (ELC) selected in the ADSTRGR.TRSB[5:0] bits is detected when ADCSR.TRGE is set to 1 in group scan mode.
- The asynchronous trigger is detected when the ADCSR.TRGE and ADCSR.EXTRG bits are set to 1 and the ADSTRGR.TRSA[5:0] bits are set to 0x00.
- When group priority operation mode is enabled (ADCSR.ADCS[1:0] bits = 01b and ADGSPCR.PGS bit = 1), the ADGSPCR.GBRP bit is set to 1, and each time A/D conversion on the group with the lowest priority is started.

[Clearing conditions]

- 0 is written.

在连续扫描模式下，当ADCSR.ADST位为1时，ADANSA0和ADANSA1寄存器选择的通道的模拟输入按通道编号的升序执行AD转换。当所有选定通道的1个AD转换周期完成时，AD转换从第一个通道开始重复。如果

ADCSR.ADST位在连续扫描期间设置为0，即使在扫描过程中AD转换也会停止。

在组扫描模式下：

- A组扫描由在ADSTRGR寄存器的TRSA[5:0]位中选择的同步触发(ELC)启动。AD转换在ADANSA0和ADANSA1寄存器中选择的通道的A组模拟输入上执行，按通道编号的升序排列。当所有选定通道完成1个AD转换周期时，AD转换停止。
- B组扫描由在ADSTRGR.TRSB[5:0]位中选择的同步触发(ELC)启动。广告转换是在ADANSB0和ADANSB1寄存器中选择的通道的B组模拟输入上执行的，按通道编号的升序排列。当所有选定通道完成1个AD转换周期时，AD转换停止。

如果A组和B组中的转换过程同时发生，则不能单独控制这些转换。在这种情况下，将AD组扫描优先级控制寄存器(ADGSPCR)中的A组优先级控制设置位(ADGSPCR.PGS)设置为1，以将优先级分配给A组转换。

在组扫描模式下，为A组和B组选择不同的通道和触发。

仅当ADST位为0时才设置ADCS[1:0]位。不要在向寄存器写入1的同时设置ADCS[1:0]位ADST bit。

Table 37.17 AD转换的可选目标取决于扫描和双触发模式设置

| 扫描模式设置 | 双触发模式设置  | AD转换的目标        |               |           |         |        |
|--------|----------|----------------|---------------|-----------|---------|--------|
|        |          | Self-diagnosis | 模拟输入 (A组)     | 模拟输入 (B组) | 温度传感器输出 | 内部参考电压 |
| 单次扫描   | DBLE = 0 | ✓              | ✓             | —         | ✓       | ✓      |
|        | DBLE = 1 | —              | ✓ (1 ch only) | —         | —       | —      |
| 连续扫描   | DBLE = 0 | ✓              | ✓             | —         | ✓       | ✓      |
|        | DBLE = 1 | —              | —             | —         | —       | —      |
| 组扫描    | DBLE = 0 | ✓              | ✓             | ✓         | ✓       | ✓      |
|        | DBLE = 1 | —              | ✓ (1 ch only) | ✓         | ✓       | ✓      |

Note: :可选择 —:不可选择

#### ADST位 (AD转换开始)

ADST位启动或停止AD转换过程。在ADST位设置为1之前，设置AD转换时钟、转换模式和转换目标模拟输入。

[Setting conditions]

- 写入1。
- 当ADCSR.EXTRG为0且ADCSR.TRGE为1时，检测在ADSTRGR.TRSA[5:0]位中选择的同步触发(ELC)。
- 在组扫描模式下，当ADCSR.TRGE设置为1时，检测到在ADSTRGR.TRSB[5:0]位中选择的同步触发(ELC)。
- 当ADCSR.TRGE和ADCSR.EXTRG位设置为1且ADSTRGR.TRSA[5:0]位设置为0x00时，检测到异步触发。
- 当启用组优先操作模式时 (ADCSR.ADCS[1:0]位=01b和ADGSPCR.PGS位=1)，ADGSPCR.GBRP位设置为1，并且每次对最低组进行AD转换优先启动。

[Clearing conditions]

- 写入0。

- The A/D conversion of all the selected channels, the temperature sensor output, the internal reference voltage completes in single scan mode.
- Group A scan completes in group scan mode.
- Group B scan completes in group scan mode.
- When group priority operation mode is enabled (ADCSR.ADCS[1:0] bits = 01b and ADGSPCR.PGS bit = 1), the ADGSPCR.GBRSCN bit is set to 1, and A/D conversion on the group with the lowest priority started by trigger completes.

Note: When group priority operation mode is enabled (ADCSR.ADCS[1:0] bits = 01b and ADGSPCR.PGS bit = 1), do not set the ADST bit to 1.

Note: When group priority operation mode is enabled (ADCSR.ADCS[1:0] bits = 01b and ADGSPCR.PGS bit = 1), do not set the ADST bit to 0. When forcing A/D conversion to terminate, follow the procedure for clearing the ADST bit.

### 37.2.8 ADANSA0 : A/D Channel Select Register A0

Base address: ADC12m = 0x4017\_0000 + 0x0200 × m (m = 0, 1)

Offset address: 0x004

|                    |         |         |         |         |         |         |         |         |         |         |         |         |         |         |         |         |
|--------------------|---------|---------|---------|---------|---------|---------|---------|---------|---------|---------|---------|---------|---------|---------|---------|---------|
| Bit position:      | 15      | 14      | 13      | 12      | 11      | 10      | 9       | 8       | 7       | 6       | 5       | 4       | 3       | 2       | 1       | 0       |
| Bit field:         | ANSA 15 | ANSA 14 | ANSA 13 | ANSA 12 | ANSA 11 | ANSA 10 | ANSA 09 | ANSA 08 | ANSA 07 | ANSA 06 | ANSA 05 | ANSA 04 | ANSA 03 | ANSA 02 | ANSA 01 | ANSA 00 |
| Value after reset: | 0       | 0       | 0       | 0       | 0       | 0       | 0       | 0       | 0       | 0       | 0       | 0       | 0       | 0       | 0       | 0       |

| Bit  | Symbol | Function   | R/W |
|------|--------|--|-----|
| 15:0 | ANSAn  | A/D Conversion Channels Select<br>Bit 15 (ANSA15) is associated with ANm15 and bit 0 (ANSA00) is associated with ANm00.<br>0: Do not select associated input channel.<br>1: Select associated input channel. | R/W |

Note: n = 00 to 09, 12, 13(unit 0), 00 to 02(unit 1)

Note: Bits associated with non-existent pins are reserved. This bit is read as 0. The write value should be 0.

ADANSA0 register selects analog input channels for A/D conversion. In group scan mode, this register selects group A channels.

Only set the ADANSA0 register when the ADCSR.ADST bit is 0.

#### ANSAn bits (A/D Conversion Channels Select)

The ADANSA0 register selects any combination of analog input channels for A/D conversion. The channels and the number of channels can be arbitrarily set.

In double trigger mode, the channels selected in the ADANSA0 register are invalid, and the channel selected in the ADCSR.DBLANS[4:0] bits is selected in group A instead.

When group scan mode is selected, do not select the channels specified in A/D Channel Select Register B0 (ADANSB0) and A/D Channel Select Register B1 (ADANSB1).

### 37.2.9 ADANSA1 : A/D Channel Select Register A1

Base address: ADC12m = 0x4017\_0000 + 0x0200 × m (m = 0, 1)

Offset address: 0x006

|                    |         |         |         |         |         |         |         |         |         |         |         |         |         |         |         |         |
|--------------------|---------|---------|---------|---------|---------|---------|---------|---------|---------|---------|---------|---------|---------|---------|---------|---------|
| Bit position:      | 15      | 14      | 13      | 12      | 11      | 10      | 9       | 8       | 7       | 6       | 5       | 4       | 3       | 2       | 1       | 0       |
| Bit field:         | ANSA 31 | ANSA 30 | ANSA 29 | ANSA 28 | ANSA 27 | ANSA 26 | ANSA 25 | ANSA 24 | ANSA 23 | ANSA 22 | ANSA 21 | ANSA 20 | ANSA 19 | ANSA 18 | ANSA 17 | ANSA 16 |
| Value after reset: | 0       | 0       | 0       | 0       | 0       | 0       | 0       | 0       | 0       | 0       | 0       | 0       | 0       | 0       | 0       | 0       |

- 所有选定通道的AD转换、温度传感器输出、内部参考电压均在单次扫描模式下完成。

- A组扫描在组扫描模式下完成。

- B组扫描在组扫描模式下完成。

- 当组优先操作模式使能时（ADCSR.ADCS[1:0]位=01b和ADGSPCR.PGS位=1），ADGSPCR.GBRSCN位设置为1，最低优先级组的AD转换开始按触发器完成。

Note: 当启用组优先操作模式时（ADCSR.ADCS[1:0]位=01b和ADGSPCR.PGS位=1），请勿将ADST位设置为1。

Note: 当启用组优先操作模式时（ADCSR.ADCS[1:0]位=01b和ADGSPCR.PGS位=1），请勿将ADST位设置为0。当强制终止AD转换时，请按照清除程序ADST位。

### 37.2.8 ADANSA0:AD通道选择寄存器A0

Base address: ADC12m = 0x4017\_0000 + 0x0200 × m (m = 0, 1)

Offset address: 0x004

|               |         |         |         |         |         |         |         |         |         |         |         |         |         |         |         |         |
|---------------|---------|---------|---------|---------|---------|---------|---------|---------|---------|---------|---------|---------|---------|---------|---------|---------|
| Bit position: | 15      | 14      | 13      | 12      | 11      | 10      | 9       | 8       | 7       | 6       | 5       | 4       | 3       | 2       | 1       | 0       |
| Bit field:    | ANSA 15 | ANSA 14 | ANSA 13 | ANSA 12 | ANSA 11 | ANSA 10 | ANSA 09 | ANSA 08 | ANSA 07 | ANSA 06 | ANSA 05 | ANSA 04 | ANSA 03 | ANSA 02 | ANSA 01 | ANSA 00 |
| 重置后的值:        | 0       | 0       | 0       | 0       | 0       | 0       | 0       | 0       | 0       | 0       | 0       | 0       | 0       | 0       | 0       | 0       |

| Bit  | Symbol | Function   | R/W |
|------|--------|--|-----|
| 15:0 | ANSAn  | AD转换通道选择<br>位15(ANSA15)与ANm15相关联，位0(ANSA00)与ANm00相关联。<br>0: 不选择关联的输入通道。1: 选择关联的输入通道。 | R/W |

Note: n = 00 to 09, 12, 13(unit 0), 00 to 02(unit 1)

Note: 与不存在的引脚相关的位被保留。该位读取为0。写入值应为0。

ADANSA0寄存器选择用于AD转换的模拟输入通道。在组扫描模式下，该寄存器选择A组通道。

仅当ADCSR.ADST位为0时设置ADANSA0寄存器。

#### ANSAn位 (AD转换通道选择)

ADANSA0寄存器为AD转换选择任意模拟输入通道组合。通道和通道数可以任意设置。

双触发模式下，ADANSA0寄存器中选择的通道无效，在ADANSA0寄存器中选择的通道无效。改为在A组中选择ADCSR.DBLANS[4:0]位。

选择组扫描模式时，不要选择AD通道选择寄存器B0(ADANSB0)和AD通道选择寄存器B1(ADANSB1)中指定的通道。

### 37.2.9 ADANSA1:AD通道选择寄存器A1

Base address: ADC12m = 0x4017\_0000 + 0x0200 × m (m = 0, 1)

Offset address: 0x006

|               |         |         |         |         |         |         |         |         |         |         |         |         |         |         |         |         |
|---------------|---------|---------|---------|---------|---------|---------|---------|---------|---------|---------|---------|---------|---------|---------|---------|---------|
| Bit position: | 15      | 14      | 13      | 12      | 11      | 10      | 9       | 8       | 7       | 6       | 5       | 4       | 3       | 2       | 1       | 0       |
| Bit field:    | ANSA 31 | ANSA 30 | ANSA 29 | ANSA 28 | ANSA 27 | ANSA 26 | ANSA 25 | ANSA 24 | ANSA 23 | ANSA 22 | ANSA 21 | ANSA 20 | ANSA 19 | ANSA 18 | ANSA 17 | ANSA 16 |
| 重置后的值:        | 0       | 0       | 0       | 0       | 0       | 0       | 0       | 0       | 0       | 0       | 0       | 0       | 0       | 0       | 0       | 0       |

| Bit  | Symbol | Function   | R/W |
|------|--------|--|-----|
| 15:0 | ANSAn  | A/D Conversion Channels Select<br>Bit 15 (ANSA31) is associated with ANm31 and bit 0 (ANSA16) is associated with ANm16.<br>0: Do not select associated input channel.<br>1: Select associated input channel. | R/W |

Note: n = 16 to 22(unit 1)

Note: Bits associated with non-existent pins are reserved. This bit is read as 0. The write value should be 0.

ADANSA1 register selects analog input channels for A/D conversion. In group scan mode, this register selects group A channels.

Only set the ADANSA1 register when the ADCSR.ADST bit is 0.

#### ANSAn bits (A/D Conversion Channels Select)

The ADANSA1 register selects any combination of analog input channels for A/D conversion. The channels and the number of channels can be arbitrarily set.

In double trigger mode, the channels selected in the ADANSA1 register are invalid, and the channel selected in the ADCSR.DBLANS[4:0] bits is selected in group A instead.

When group scan mode is selected, do not select the channels specified in A/D Channel Select Register B0 (ADANSB0) and A/D Channel Select Register B1 (ADANSB1).

#### 37.2.10 ADANSB0 : A/D Channel Select Register B0

Base address:  $ADC12m = 0x4017\_0000 + 0x0200 \times m$  (m = 0, 1)

Offset address: 0x014

| Bit position:      | 15         | 14         | 13         | 12         | 11         | 10         | 9          | 8          | 7          | 6          | 5          | 4          | 3          | 2          | 1          | 0          |
|--------------------|------------|------------|------------|------------|------------|------------|------------|------------|------------|------------|------------|------------|------------|------------|------------|------------|
| Bit field:         | ANSB<br>15 | ANSB<br>14 | ANSB<br>13 | ANSB<br>12 | ANSB<br>11 | ANSB<br>10 | ANSB<br>09 | ANSB<br>08 | ANSB<br>07 | ANSB<br>06 | ANSB<br>05 | ANSB<br>04 | ANSB<br>03 | ANSB<br>02 | ANSB<br>01 | ANSB<br>00 |
| Value after reset: | 0          | 0          | 0          | 0          | 0          | 0          | 0          | 0          | 0          | 0          | 0          | 0          | 0          | 0          | 0          | 0          |

| Bit  | Symbol | Function   | R/W |
|------|--------|--|-----|
| 15:0 | ANSBn  | A/D Conversion Channels Select<br>Bit 15 (ANSB15) is associated with ANm15 and bit 0 (ANSB00) is associated with ANm00.<br>0: Do not select associated input channel.<br>1: Select associated input channel. | R/W |

Note: n = 00 to 09, 12, 13(unit 0), 00 to 02(unit 1)

Note: Bits associated with non-existent pins are reserved. This bit is read as 0. The write value should be 0.

ADANSB0 selects analog input channels for A/D conversion in group B when group scan mode is selected. The ADANSB0 register is not used in any scan mode other than group scan mode.

Only set the ADANSB0 register when the ADCSR.ADST bit is 0.

#### ANSBn bits (A/D Conversion Channels Select)

The ADANSB0 register selects any combination of analog input channels in group B for A/D conversion when group scan mode is selected. The ADANSB0 register is used for group scan mode only and not for any other modes.

Do not select channels specified in group A as selected in the ADANSA0 and ADANSA1 registers or the ADCSR.DBLANS[4:0] bits in double trigger mode.

| Bit  | Symbol | Function  | R/W |
|------|--------|---|-----|
| 15:0 | ANSAn  | AD转换通道选择<br>位15(ANSA31)与ANm31相关联, 位0(ANSA16)与ANm16相关联。<br>0: 不选择关联的输入通道。1: 选择关联的输入通道。 | R/W |

Note: n = 16 to 22(unit 1)

Note: 与不存在的引脚相关的位被保留。该位读取为0。写入值应为0。

ADANSA1寄存器选择用于AD转换的模拟输入通道。在组扫描模式下, 该寄存器选择A组通道。

仅当ADCSR.ADST位为0时设置ADANSA1寄存器。

#### ANSAn位 (AD转换通道选择)

ADANSA1寄存器为AD转换选择任意模拟输入通道组合。通道和通道数可以任意设置。

双触发模式下, ADANSA1寄存器中选择的通道无效, 在ADANSA1寄存器中选择的通道无效。改为在A组中选择ADCSR.DBLANS[4:0]位。

选择组扫描模式时, 不要选择AD通道选择寄存器B0(ADANSB0)和AD通道选择寄存器B1(ADANSB1)中指定的通道。

#### 37.2.10 ADANSB0:AD通道选择寄存器B0

Base address:  $ADC12m = 0x4017\_0000 + 0x0200 \times m$  (m = 0, 1)

Offset address: 0x014

| Bit position: | 15         | 14         | 13         | 12         | 11         | 10         | 9          | 8          | 7          | 6          | 5          | 4          | 3          | 2          | 1          | 0          |
|---------------|------------|------------|------------|------------|------------|------------|------------|------------|------------|------------|------------|------------|------------|------------|------------|------------|
| Bit field:    | ANSB<br>15 | ANSB<br>14 | ANSB<br>13 | ANSB<br>12 | ANSB<br>11 | ANSB<br>10 | ANSB<br>09 | ANSB<br>08 | ANSB<br>07 | ANSB<br>06 | ANSB<br>05 | ANSB<br>04 | ANSB<br>03 | ANSB<br>02 | ANSB<br>01 | ANSB<br>00 |
| 重置后的值:        | 0          | 0          | 0          | 0          | 0          | 0          | 0          | 0          | 0          | 0          | 0          | 0          | 0          | 0          | 0          | 0          |

| Bit  | Symbol | Function  | R/W |
|------|--------|---|-----|
| 15:0 | ANSBn  | AD转换通道选择<br>位15(ANSB15)与ANm15相关联, 位0(ANSB00)与ANm00相关联。<br>0: 不选择关联的输入通道。1: 选择关联的输入通道。 | R/W |

Note: n = 00 to 09, 12, 13(unit 0), 00 to 02(unit 1)

Note: 与不存在的引脚相关的位被保留。该位读取为0。写入值应为0。

ADANSB0在选择组扫描模式时选择B组中AD转换的模拟输入通道。ADANSB0寄存器不用于除组扫描模式以外的任何扫描模式。

仅当ADCSR.ADST位为0时才设置ADANSB0寄存器。

#### ANSBn位 (AD转换通道选择)

TheADANSB0registerselectsanycombinationofanaloginputchannelsingroupBforADconversionwhengroupscanmodeisselected.ADANSB0寄存器仅用于组扫描模式, 不用于任何其他模式。

不要选择在ADANSA0和ADANSA1寄存器中选择的A组中指定的通道, 或者双触发模式下的ADCSR.DBLANS[4:0]位。



## 37.2.11 ADANSB1 : A/D Channel Select Register B1

Base address: ADC12m = 0x4017\_0000 + 0x0200 × m (m = 0, 1)

Offset address: 0x016

|                    |            |            |            |            |            |            |            |            |            |            |            |            |            |            |            |            |
|--------------------|------------|------------|------------|------------|------------|------------|------------|------------|------------|------------|------------|------------|------------|------------|------------|------------|
| Bit position:      | 15         | 14         | 13         | 12         | 11         | 10         | 9          | 8          | 7          | 6          | 5          | 4          | 3          | 2          | 1          | 0          |
| Bit field:         | ANSB<br>31 | ANSB<br>30 | ANSB<br>29 | ANSB<br>28 | ANSB<br>27 | ANSB<br>26 | ANSB<br>25 | ANSB<br>24 | ANSB<br>23 | ANSB<br>22 | ANSB<br>21 | ANSB<br>20 | ANSB<br>19 | ANSB<br>18 | ANSB<br>17 | ANSB<br>16 |
| Value after reset: | 0          | 0          | 0          | 0          | 0          | 0          | 0          | 0          | 0          | 0          | 0          | 0          | 0          | 0          | 0          | 0          |

| Bit  | Symbol | Function   | R/W |
|------|--------|--|-----|
| 15:0 | ANSBn  | A/D Conversion Channels Select<br>Bit 15 (ANSB31) is associated with ANm31 and bit 0 (ANSB16) is associated with ANm16.<br>0: Do not select associated input channel.<br>1: Select associated input channel. | R/W |

Note: n = 16 to 22(unit 1)

Note: Bits associated with non-existent pins are reserved. This bit is read as 0. The write value should be 0.

ADANSB1 selects analog input channels for A/D conversion in group B when group scan mode is selected. The ADANSB1 register is not used in any scan mode other than group scan mode.

Only set the ADANSB1 register when the ADCSR.ADST bit is 0.

**ANSBn bits (A/D Conversion Channels Select)**

The ADANSB1 register selects any combination of analog input channels in group B for A/D conversion when group scan mode is selected. The ADANSB1 register is used for group scan mode only and not for any other modes.

Do not select channels specified in group A as selected in the ADANSA0 and ADANSA1 registers or the ADCSR.DBLANS[4:0] bits in double trigger mode.

## 37.2.12 ADADS0 : A/D-Converted Value Addition/Average Channel Select Register 0

Base address: ADC12m = 0x4017\_0000 + 0x0200 × m (m = 0, 1)

Offset address: 0x008

|                    |       |       |       |       |       |       |       |       |       |       |       |       |       |       |       |       |
|--------------------|-------|-------|-------|-------|-------|-------|-------|-------|-------|-------|-------|-------|-------|-------|-------|-------|
| Bit position:      | 15    | 14    | 13    | 12    | 11    | 10    | 9     | 8     | 7     | 6     | 5     | 4     | 3     | 2     | 1     | 0     |
| Bit field:         | ADS15 | ADS14 | ADS13 | ADS12 | ADS11 | ADS10 | ADS09 | ADS08 | ADS07 | ADS06 | ADS05 | ADS04 | ADS03 | ADS02 | ADS01 | ADS00 |
| Value after reset: | 0     | 0     | 0     | 0     | 0     | 0     | 0     | 0     | 0     | 0     | 0     | 0     | 0     | 0     | 0     | 0     |

| Bit  | Symbol | Function  | R/W |
|------|--------|---|-----|
| 15:0 | ADSn   | A/D-Converted Value Addition/Average Channel Select<br>Bit 15 (ADS15) is associated with ANm15 and bit 0 (ADS00) is associated with ANm00.<br>0: Do not select associated input channel.<br>1: Select associated input channel. | R/W |

Note: n = 00 to 09, 12, 13(unit 0), 00 to 02(unit 1)

Note: Bits associated with non-existent pins are reserved. This bit is read as 0. The write value should be 0.

**ADSn bits (A/D-Converted Value Addition/Average Channel Select)**

The ADSn bits determine which A/D-converted channels are subject to A/D-converted value addition/averaging. When an ADSn bit associated with a channel selected for A/D conversion is set to 1, A/D conversion of the analog input of the respective channel is performed successively 1, 2, 3, 4, or 16 times, as specified in the ADC[2:0] bits in the ADADC register.

When the ADADC.AVEE bit is 0, the value obtained by addition is stored in the A/D data register. When the ADADC.AVEE bit is 1, the mean value of the results obtained by addition is stored in the A/D data register.

The ADSn bits apply only to channels that are selected for A/D conversion in:

- The ANSAn bits in the ADANSA0 register or the DBLANS[4:0] bits in the ADCSR register

## 37.2.11 ADANSB1:AD通道选择寄存器B1

Base address: ADC12m = 0x4017\_0000 + 0x0200 × m (m = 0, 1)

Offset address: 0x016

|               |            |            |            |            |            |            |            |            |            |            |            |            |            |            |            |            |
|---------------|------------|------------|------------|------------|------------|------------|------------|------------|------------|------------|------------|------------|------------|------------|------------|------------|
| Bit position: | 15         | 14         | 13         | 12         | 11         | 10         | 9          | 8          | 7          | 6          | 5          | 4          | 3          | 2          | 1          | 0          |
| Bit field:    | ANSB<br>31 | ANSB<br>30 | ANSB<br>29 | ANSB<br>28 | ANSB<br>27 | ANSB<br>26 | ANSB<br>25 | ANSB<br>24 | ANSB<br>23 | ANSB<br>22 | ANSB<br>21 | ANSB<br>20 | ANSB<br>19 | ANSB<br>18 | ANSB<br>17 | ANSB<br>16 |
| 重置后的值:        | 0          | 0          | 0          | 0          | 0          | 0          | 0          | 0          | 0          | 0          | 0          | 0          | 0          | 0          | 0          | 0          |

| Bit  | Symbol | Function  | R/W |
|------|--------|---|-----|
| 15:0 | ANSBn  | AD转换通道选择<br>位15(ANSB31)与ANm31相关联, 位0(ANSB16)与ANm16相关联。<br>0: 不选择关联的输入通道。1: 选择关联的输入通道。 | R/W |

Note: n = 16 to 22(unit 1)

Note: 与不存在的引脚相关的位被保留。该位读取为0。写入值应为0。

ADANSB1在选择组扫描模式时选择B组中AD转换的模拟输入通道。ADANSB1寄存器不用于除组扫描模式以外的任何扫描模式。

仅当ADCSR.ADST位为0时设置ADANSB1寄存器。

**ANSBn位 (AD转换通道选择)**

The ADANSB1 register selects any combination of analog input channels in group B for AD conversion when group scan mode is selected. ADANSB1 寄存器仅用于组扫描模式, 不用于任何其他模式。

不要选择在ADANSA0和ADANSA1寄存器中选择的A组中指定的通道, 或者双触发模式下的ADCSR.DBLANS[4:0]位。

## 37.2.12 ADADS0:D转换值加法平均通道选择寄存器0

Base address: ADC12m = 0x4017\_0000 + 0x0200 × m (m = 0, 1)

Offset address: 0x008

|               |       |       |       |       |       |       |       |       |       |       |       |       |       |       |       |       |
|---------------|-------|-------|-------|-------|-------|-------|-------|-------|-------|-------|-------|-------|-------|-------|-------|-------|
| Bit position: | 15    | 14    | 13    | 12    | 11    | 10    | 9     | 8     | 7     | 6     | 5     | 4     | 3     | 2     | 1     | 0     |
| Bit field:    | ADS15 | ADS14 | ADS13 | ADS12 | ADS11 | ADS10 | ADS09 | ADS08 | ADS07 | ADS06 | ADS05 | ADS04 | ADS03 | ADS02 | ADS01 | ADS00 |
| 重置后的值:        | 0     | 0     | 0     | 0     | 0     | 0     | 0     | 0     | 0     | 0     | 0     | 0     | 0     | 0     | 0     | 0     |

| Bit  | Symbol | Function  | R/W |
|------|--------|---|-----|
| 15:0 | ADSn   | 一个D转换的增值平均通道选择<br>位15(ADS15)与ANm15相关联, 位0(ADS00)与ANm00相关联。<br>0: 不选择关联的输入通道。1: 选择关联的输入通道。 | R/W |

Note: n = 00 to 09, 12, 13(unit 0), 00 to 02(unit 1)

Note: 与不存在的引脚相关的位被保留。该位读取为0。写入值应为0。

**ADSn位 (AD转换值加法平均通道选择)**

ADSn位确定哪些AD转换通道要进行AD转换值加法平均。当一个与选择用于AD转换的通道相关的ADSn位设置为1, 相应通道的模拟输入的AD转换按ADC[2:0]中的规定连续执行1、2、3、4或16次ADADC寄存器中的位。

当ADADC.AVEE位为0时, 相加得到的值存储在AD数据寄存器中。当ADADC.AVEE位为1时, 加法所得结果的平均值存储在AD数据寄存器中。

ADSn位仅适用于为AD转换选择的通道:

- ADANSA0寄存器中的ANSAn位或ADCSR寄存器中的DBLANS[4:0]位



- The ANSBn bits in the ADANSB0 register

For channels on which the A/D conversion is performed and for which addition/average mode is not selected, a normal 1-time conversion is executed and the conversion result is stored in the A/D data register.

Only set ADADS0 register bits when the ADCSR.ADST bit is 0.

Figure 37.3 shows a scanning operation sequence in which the ADADS0 register bits (channel c and g) are set to 1. In this figure:

- Addition mode is selected (ADADC.AVEE = 0)
- The number of conversions is set to 4 (ADADC.ADC[1:0] = 11b)
- The analog input channels (a to h) are selected by ADANSA0 register in continuous scan mode (ADCSR.ADCS[1:0] = 10b).

The conversion process begins with analog input A (channel a). The analog input C (channel c) conversion is performed successively 4 times and the added value is returned to A/D Data Register c (ADDRc). Next, the analog input D (channel d) conversion process is started. The analog input G (channel g) is performed successively 4 times and the added value is returned to A/D Data Register g (ADDRg). After conversion of analog input H (channel h), the conversion operation repeats in the same sequence starting with analog input A (channel a).

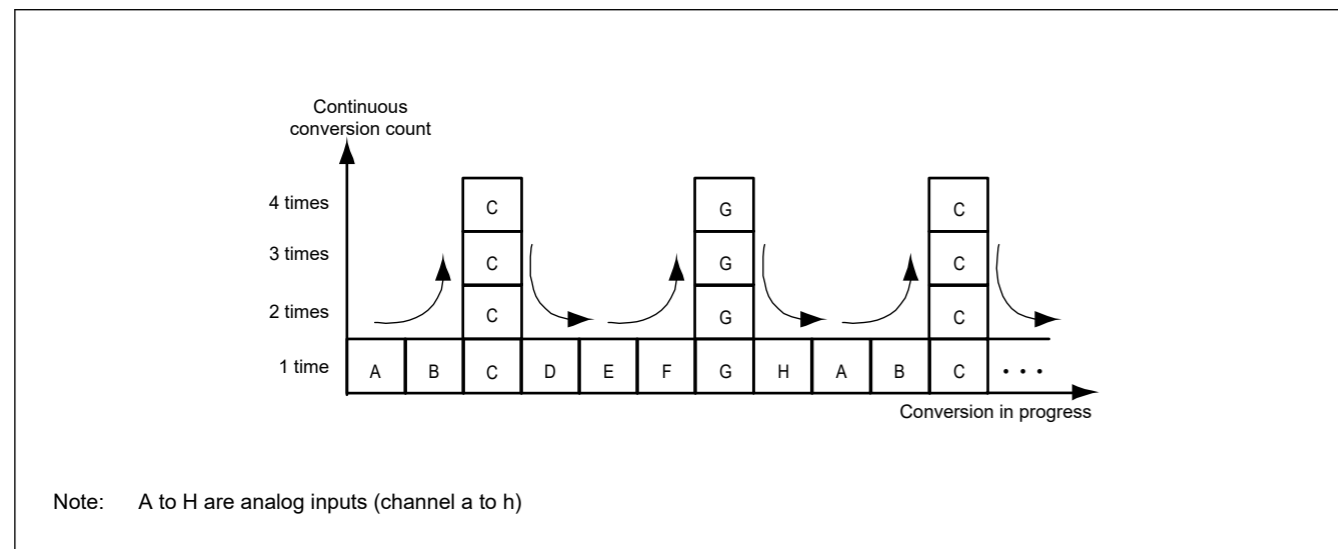


Figure 37.3 Scan conversion sequence with ADADC.ADC[2:0] = 011b, set 1 for analog inputs C and G by ADADS0/1

### 37.2.13 ADADS1 : A/D-Converted Value Addition/Average Channel Select Register 1

Base address: ADC12m = 0x4017\_0000 + 0x0200 × m (m = 0, 1)

Offset address: 0x00A

|                    |       |       |       |       |       |       |       |       |       |       |       |       |       |       |       |       |
|--------------------|-------|-------|-------|-------|-------|-------|-------|-------|-------|-------|-------|-------|-------|-------|-------|-------|
| Bit position:      | 15    | 14    | 13    | 12    | 11    | 10    | 9     | 8     | 7     | 6     | 5     | 4     | 3     | 2     | 1     | 0     |
| Bit field:         | ADS31 | ADS30 | ADS29 | ADS28 | ADS27 | ADS26 | ADS25 | ADS24 | ADS23 | ADS22 | ADS21 | ADS20 | ADS19 | ADS18 | ADS17 | ADS16 |
| Value after reset: | 0     | 0     | 0     | 0     | 0     | 0     | 0     | 0     | 0     | 0     | 0     | 0     | 0     | 0     | 0     | 0     |

| Bit  | Symbol           | Function  | R/W |
|------|------------------|---|-----|
| 15:0 | ADS <sub>n</sub> | A/D-Converted Value Addition/Average Channel Select<br>Bit 15 (ADS31) is associated with ANm31 and bit 0 (ADS16) is associated with ANm16.<br>0: Do not select associated input channel.<br>1: Select associated input channel. | R/W |

Note: n = 16 to 22(unit 1)

Note: Bits associated with non-existent pins are reserved. This bit is read as 0. The write value should be 0.

- ADANSB0寄存器中的ANSBn位

对于执行AD转换且未选择加法平均模式的通道，将执行正常的1次转换，并将转换结果存储在AD数据寄存器中。

仅当ADCSR.ADST位为0时设置ADADS0寄存器位。

图37.3显示了扫描操作序列，其中ADADS0寄存器位（通道c和g）设置为1。在该图中：

- 选择加法模式 (ADADC.AVEE=0)
- 转换次数设置为4(ADADC.ADC[1:0]=11b)
- 模拟输入通道 (a到h) 在连续扫描模式下由ADANSA0寄存器选择 (ADCSR.ADCS[1:0]=10b)。

转换过程从模拟输入A（通道a）开始。模拟输入C（通道c）转换连续执行4次，相加后的值返回到AD数据寄存器c（ADDRc）。接下来，开始模拟输入D（通道d）转换过程。模拟输入G（通道g）连续执行4次，相加后的值返回到AD数据寄存器g（ADDRg）。模拟输入H（通道h）转换后，转换操作从模拟输入A（通道a）开始以相同的顺序重复。

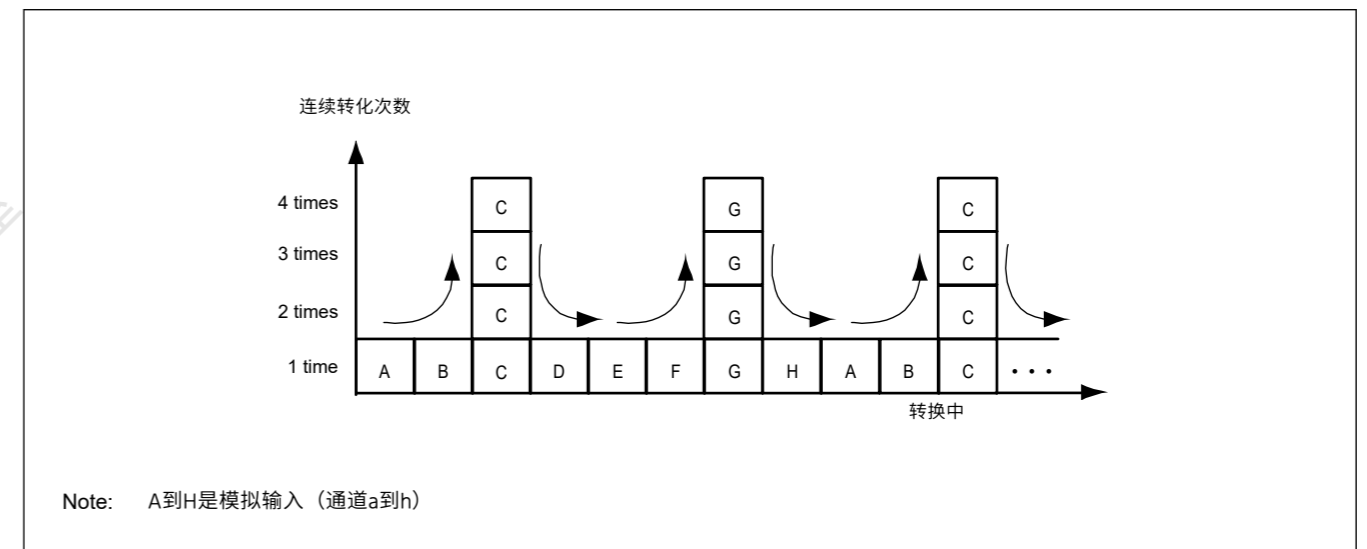


Figure 37.3 使用ADADC.ADC[2:0]=011b扫描转换序列，将模拟输入C和G设置为1 ADADS0/1

### 37.2.13 ADADS1：一个D转换值加法平均通道选择寄存器1

Base address: ADC12m = 0x4017\_0000 + 0x0200 × m (m = 0, 1)

Offset address: 0x00A

|               |       |       |       |       |       |       |       |       |       |       |       |       |       |       |       |       |
|---------------|-------|-------|-------|-------|-------|-------|-------|-------|-------|-------|-------|-------|-------|-------|-------|-------|
| Bit position: | 15    | 14    | 13    | 12    | 11    | 10    | 9     | 8     | 7     | 6     | 5     | 4     | 3     | 2     | 1     | 0     |
| Bit field:    | ADS31 | ADS30 | ADS29 | ADS28 | ADS27 | ADS26 | ADS25 | ADS24 | ADS23 | ADS22 | ADS21 | ADS20 | ADS19 | ADS18 | ADS17 | ADS16 |
| 重置后的值:        | 0     | 0     | 0     | 0     | 0     | 0     | 0     | 0     | 0     | 0     | 0     | 0     | 0     | 0     | 0     | 0     |

| Bit  | Symbol           | Function   | R/W |
|------|------------------|--|-----|
| 15:0 | ADS <sub>n</sub> | 一个D转换的增值平均通道选择<br>位15(ADS31)与ANm31相关联，位0(ADS16)与ANm16相关联。<br>0：不选择关联的输入通道。1：选择关联的输入通道。 | R/W |

Note: n = 16 to 22(unit 1)

Note: 与不存在的引脚相关的位被保留。该位读取为0。写入值应为0。

**ADSn bits (A/D-Converted Value Addition/Average Channel Select)**

The ADSn bits determine which A/D-converted channels are subject to A/D-converted value addition/averaging. When an ADSn bit associated with a channel selected for A/D conversion is set to 1, A/D conversion of the analog input of the respective channel is performed successively 1, 2, 3, 4, or 16 times, as specified in the ADC[2:0] bits in the ADADC register.

When the ADADC.AVEE bit is 0, the value obtained by addition is stored in the A/D data register. When the ADADC.AVEE bit is 1, the mean value of the results obtained by addition is stored in the A/D data register.

The ADSn bits apply only to channels that are selected for A/D conversion in:

- The ANSAn bits in the ADANSA1 register or the DBLANS[4:0] bits in the ADCSR register
- The ANSBn bits in the ADANSB1 register.

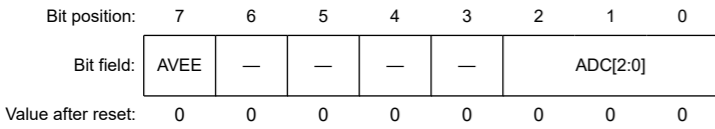
For channels on which the A/D conversion is performed and for which addition/average mode is not selected, a normal 1-time conversion is executed and the conversion result is stored in the A/D data register.

Only set ADADS1 register when the ADCSR.ADST bit is 0.

**37.2.14 ADADC : A/D-Converted Value Addition/Average Count Select Register**

Base address: ADC12m = 0x4017\_0000 + 0x0200 × m (m = 0, 1)

Offset address: 0x00C



| Bit | Symbol   | Function  | R/W |
|-----|----------|---|-----|
| 2:0 | ADC[2:0] | Addition/Average Count Select<br>0 0 0: 1-time conversion (no addition, same as normal conversion)<br>0 0 1: 2-time conversion (one addition)<br>0 1 0: 3-time conversion (two additions)Setting prohibited<br>0 1 1: 4-time conversion (three additions)<br>1 0 1: 16-time conversion (15 additions)<br>Others: Setting prohibited | R/W |
| 6:3 | —        | These bits are read as 0. The write value should be 0.  | R/W |
| 7   | AVEE     | Average Mode Select<br>0: Enable addition mode<br>1: Enable average mode  | R/W |

ADADC sets the addition or average mode and addition count for A/D conversion. Table 37.18 lists the settable combinations of ADADC register.

**Table 37.18 Settable combinations of ADADC register**

| Average mode select (AVEE) | Conversion time |         |         |         |          |
|----------------------------|-----------------|---------|---------|---------|----------|
|                            | 1-time          | 2-times | 3-times | 4-times | 16-times |
| 1'b0                       | ✓               | ✓       | ✓       | ✓       | ✓        |
|                            | ✓               | ✓       | ✓       | ✓       | ✓        |
|                            | ✓               | ✓       | ✓       | ✓       | ✓        |
| 1'b1                       | ✓               | ✓       | —       | ✓       | —        |

Note: ✓: Selectable, —: Not selectable

**ADSn位 (AD转换值加法平均通道选择)**

ADSn位确定哪些AD转换通道要进行AD转换值加法平均。当一个与选择用于AD转换的通道相关的ADSn位设置为1，相应通道的模拟输入的AD转换按ADC[2:0]中的规定连续执行1、2、3、4或16次ADADC寄存器中的位。

当ADADC.AVEE位为0时，相加得到的值存储在AD数据寄存器中。当ADADC.AVEE位为1时，加法所得结果的平均值存储在AD数据寄存器中。

ADSn位仅适用于为AD转换选择的通道：

- ADANSA1寄存器中的ANSAn位或ADCSR寄存器中的DBLANS[4:0]位
- ADANSB1寄存器中的ANSBn位。

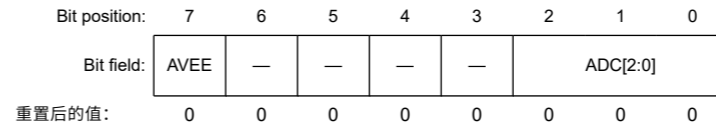
对于执行AD转换且未选择加法平均模式的通道，将执行正常的1次转换，并将转换结果存储在AD数据寄存器中。

仅当ADCSR.ADST位为0时设置ADADS1寄存器。

**37.2.14 ADADC:D转换值加法平均计数选择寄存器**

Base address: ADC12m = 0x4017\_0000 + 0x0200 × m (m = 0, 1)

Offset address: 0x00C



| Bit | Symbol   | Function  | R/W |
|-----|----------|---|-----|
| 2:0 | ADC[2:0] | 加法平均计数选择<br>000: 1次转换 (不加, 同普通转换) 001: 2次转换 (1次加法) 010: 3次转换 (2次加法) 禁止设置011: 4次转换 (3次加法) 101: 16次转换 (15次加法)<br>Others: 禁止设定 | R/W |
| 6:3 | —        | 这些位被读取为0。写入值应为0。  | R/W |
| 7   | AVEE     | 平均模式选择<br>0: 启用加法模式1: 启用平均模式  | R/W |

ADADC设置AD转换的加法或平均模式和加法计数。表37.18列出了ADADC寄存器的可设置组合。

**Table 37.18 ADADC寄存器的可设置组合**

| 平均模式选择 (AVEE) | 转换时间   |         |         |         |          |
|---------------|--------|---------|---------|---------|----------|
|               | 1-time | 2-times | 3-times | 4-times | 16-times |
| 1'b0          | ✓      | ✓       | ✓       | ✓       | ✓        |
|               | ✓      | ✓       | ✓       | ✓       | ✓        |
|               | ✓      | ✓       | ✓       | ✓       | ✓        |
| 1'b1          | ✓      | ✓       | —       | ✓       | —        |

Note: ✓: 可选择 —: 不可选择

**ADC[2:0] bits (Addition/Average Count Select)**

The ADC[2:0] bits set the addition count in all channels for which A/D conversion and addition/average mode are selected, including the channel selected in double trigger mode with the ADCSR.DBLANS[4:0] bits. The count also applies to A/D conversion of the temperature sensor output and internal reference voltage.

When self-diagnosis is executed (ADCER.DIAGM = 1), do not set the ADC[2:0] bits to any value other than 000b.

**AVEE bit (Average Mode Select)**

The AVEE bit selects addition or average mode in all channels for which A/D conversion and addition/average mode are selected, including the channels selected in double-trigger mode in the ADCSR.DBLANS[4:0] bits, temperature sensor output, internal reference voltage.

**37.2.15 ADCER : A/D Control Extended Register**

Base address: ADC12m = 0x4017\_0000 + 0x0200 × m (m = 0, 1)

Offset address: 0x00E

|                    |        |    |    |    |       |        |              |   |   |     |   |   |            |   |   |   |
|--------------------|--------|----|----|----|-------|--------|--------------|---|---|-----|---|---|------------|---|---|---|
| Bit position:      | 15     | 14 | 13 | 12 | 11    | 10     | 9            | 8 | 7 | 6   | 5 | 4 | 3          | 2 | 1 | 0 |
| Bit field:         | ADRFMT | —  | —  | —  | DIAGM | DIAGLD | DIAGVAL[1:0] | — | — | ACE | — | — | ADPRC[1:0] | — | — | — |
| Value after reset: | 0      | 0  | 0  | 0  | 0     | 0      | 0            | 0 | 0 | 0   | 0 | 0 | 0          | 0 | 0 | 0 |

| Bit   | Symbol       | Function   | R/W |
|-------|--------------|--|-----|
| 0     | —            | These bits are read as 0. The write value should be 0.   | R/W |
| 2:1   | ADPRC[1:0]   | A/D Conversion Accuracy Specify<br>0 0: 12-bit accuracy<br>0 1: 10-bit accuracy<br>1 0: 8-bit accuracy<br>1 1: Setting prohibited  | R/W |
| 4:3   | —            | These bits are read as 0. The write value should be 0.   | R/W |
| 5     | ACE          | A/D Data Register Automatic Clearing Enable<br>0: Disable automatic clearing<br>1: Enable automatic clearing   | R/W |
| 7:6   | —            | These bits are read as 0. The write value should be 0.   | R/W |
| 9:8   | DIAGVAL[1:0] | Self-Diagnosis Conversion Voltage Select<br>0 0: Setting prohibited when self-diagnosis is enabled<br>0 1: 0 volts<br>1 0: Reference power supply*1 voltage × 1/2<br>1 1: Reference power supply*1 voltage | R/W |
| 10    | DIAGLD       | Self-Diagnosis Mode Select<br>0: Select rotation mode for self-diagnosis voltage<br>1: Select mixed mode for self-diagnosis voltage  | R/W |
| 11    | DIAGM        | Self-Diagnosis Enable<br>0: Disable ADC12 self-diagnosis<br>1: Enable ADC12 self-diagnosis   | R/W |
| 14:12 | —            | These bits are read as 0. The write value should be 0.   | R/W |
| 15    | ADRFMT       | A/D Data Register Format Select<br>0: Select right-justified for the A/D data register format<br>1: Select left-justified for the A/D data register format   | R/W |

Note 1. The reference voltage refers to VREFH0 for unit 0 and to VREFH for unit 1.

**ADPRC[1:0] bit (A/D Conversion Accuracy Specify)**

The ADPRC[1:0] bits set the A/D conversion accuracy. Changing the A/D conversion accuracy also changes the bit width of valid data stored in the result register and the A/D conversion time. For details, see [section 37.3.7. Analog Input Sampling and Scan Conversion Time](#) section 45.3.6, Analog Input Sampling and Scan Conversion Time. Only set the ADPRC[1:0] bits while the ADCSR.ADST bit is 0.

**ADC[2:0]位 (加法平均计数选择)**

ADC[2:0]位设置选择了AD转换和加法平均模式的所有通道的加法计数，包括使用ADCSR.DBLANS[4:0]位在双触发模式选择的通道。该计数也适用于温度传感器输出和内部参考电压的AD转换。执行自诊断时(ADCER.DIAGM=1)，请勿将ADC[2:0]位设置为000b以外的任何值。

**AVEE位 (平均模式选择)**

AVEE位在选择了AD转换和加法平均模式的所有通道中选择加法或平均模式，包括在ADCSR.DBLANS[4:0]位中选择的双触发模式的通道、温度传感器输出、内部参考电压。

**37.2.15 ADCER:AD控制扩展寄存器**

Base address: ADC12m = 0x4017\_0000 + 0x0200 × m (m = 0, 1)

Offset address: 0x00E

|               |        |    |    |    |       |        |              |   |   |     |   |   |            |   |   |   |
|---------------|--------|----|----|----|-------|--------|--------------|---|---|-----|---|---|------------|---|---|---|
| Bit position: | 15     | 14 | 13 | 12 | 11    | 10     | 9            | 8 | 7 | 6   | 5 | 4 | 3          | 2 | 1 | 0 |
| Bit field:    | ADRFMT | —  | —  | —  | DIAGM | DIAGLD | DIAGVAL[1:0] | — | — | ACE | — | — | ADPRC[1:0] | — | — | — |
| 重置后的值:        | 0      | 0  | 0  | 0  | 0     | 0      | 0            | 0 | 0 | 0   | 0 | 0 | 0          | 0 | 0 | 0 |

| Bit   | Symbol       | Function   | R/W |
|-------|--------------|--|-----|
| 0     | —            | 这些位被读取为0。写入值应为0。   | R/W |
| 2:1   | ADPRC[1:0]   | AD转换精度指定<br>00: 12位精度01: 10位精度10: 8位精度11: 禁止设置                 | R/W |
| 4:3   | —            | 这些位被读取为0。写入值应为0。   | R/W |
| 5     | ACE          | AD数据寄存器自动清零使能<br>0: 关闭自动清零1: 开启自动清零                            | R/W |
| 7:6   | —            | 这些位被读取为0。写入值应为0。   | R/W |
| 9:8   | DIAGVAL[1:0] | 自诊断转换电压选择<br>00: 自诊断有效时禁止设置01: 0伏特10: 参考电源*1电压×1/211: 参考电源*1电压 | R/W |
| 10    | DIAGLD       | 自诊断模式选择<br>0: 自诊断电压选择旋转模式1: 自诊断电压选择混合模式                        | R/W |
| 11    | DIAGM        | Self-Diagnosis Enable<br>0: 禁用ADC12自诊断1: 启用ADC12自诊断            | R/W |
| 14:12 | —            | 这些位被读取为0。写入值应为0。   | R/W |
| 15    | ADRFMT       | AD数据寄存器格式选择<br>0: AD数据寄存器格式选择右对齐1: AD数据寄存器格式选择左对齐              | R/W |

注1.参考电压是指单元0的VREFH0和单元1的VREFH。

**ADPRC[1:0]位 (AD转换精度指定)**

ADPRC[1:0]位设置AD转换精度。更改AD转换精度也会更改存储在结果寄存器中的有效数据的位宽和AD转换时间。有关详细信息，请参阅第37.3.7节。模拟输入采样和扫描转换时间第45.3.6节，模拟输入采样和扫描转换时间。只设置

ADPRC[1:0]位，而ADCSR.ADST位为0。



**ACE bit (A/D Data Register Automatic Clearing Enable)**

The ACE bit enables or disables automatic clearing (all 0) of the ADDRy, ADRD, ADDBLDR, ADDBLDRA, ADDBLDRB, ADTSDR, or ADOCADR register after any of these registers is read by the CPU or DTC. Automatic clearing of the A/D data registers enables detection of failures that are not updated in the A/D data registers. For details, see [section 37.3.8. Usage Example of A/D Data Register Automatic Clearing Function.](#)

**DIAGVAL[1:0] bits (Self-Diagnosis Conversion Voltage Select)**

The DIAGVAL[1:0] bits select the voltage value used in self-diagnosis fixed voltage mode. For details, see the DIAGLD bit description.

Do not execute self-diagnosis by setting the DIAGLD bit to 1 when the DIAGVAL[1:0] bits are set to 00b.

**DIAGLD bit (Self-Diagnosis Mode Select)**

The DIAGLD bit selects whether the three voltage values are rotated or the fixed voltage is used in self-diagnosis.

Setting the DIAGLD bit to 0 selects conversion of the voltages in rotation mode, where 0 V, the reference power supply voltage  $\times 1/2$ , and the reference power supply voltage are converted, in that order. After reset and when self-diagnosis voltage rotation mode is selected, self-diagnosis is executed from 0 V. The self-diagnosis voltage value does not return to 0 V when scan conversion completes. When scan conversion is restarted, rotation starts at the voltage value following the previous value.

Setting the DIAGLD bit to 1 selects fixed voltage, in which the fixed voltage specified in the ADCER.DIAGVAL[1:0] bits is converted. If fixed mode is switched to rotation mode, rotation starts at the fixed voltage value.

Only set the DIAGLD bit when the ADCSR.ADST bit is 0.

**DIAGM bit (Self-Diagnosis Enable)**

The DIAGM bit enables or disables self-diagnosis.

Self-diagnosis is used to detect a failure of the ADC12. In self-diagnosis mode, one of the three voltage values (0 V, the reference power supply voltage  $\times 1/2$ , or the reference power supply voltage) is converted. When conversion completes, information on the converted voltage and the conversion result is stored into the A/D Self-Diagnosis Data Register (ADRD). The ADRD register can be read to determine whether the conversion result falls within the normal or abnormal range.

Self-diagnosis is executed once at the beginning of each scan, and one of the three voltages is converted. In double trigger mode (ADCSR.DBLE = 1), self-diagnosis (DIAGM = 0) is deselected. When self-diagnosis is selected in group scan mode, self-diagnosis is executed separately for group A and group B.

Only set the DIAGM bit when the ADCSR.ADST bit is 0.

**ADRFMT bit (A/D Data Register Format Select)**

The ADRFMT bit specifies flush-right or flush-left for data to be stored in the ADDRy, ADDBLDR, ADDBLDRA, ADDBLDRB, ADTSDR, ADOCADR, ADCMPDR0/1, ADWINLLB, ADWINULB, or ADRD register.

Only set the ADRFMT bit when the ADCSR.ADST bit is 0.

**37.2.16 ADSTRGR : A/D Conversion Start Trigger Select Register**

Base address: ADC12m = 0x4017\_0000 + 0x0200  $\times$  m (m = 0, 1)

Offset address: 0x010

|                    |    |    |           |    |    |    |   |   |   |           |   |   |   |   |   |   |
|--------------------|----|----|-----------|----|----|----|---|---|---|-----------|---|---|---|---|---|---|
| Bit position:      | 15 | 14 | 13        | 12 | 11 | 10 | 9 | 8 | 7 | 6         | 5 | 4 | 3 | 2 | 1 | 0 |
| Bit field:         | —  | —  | TRSA[5:0] |    |    |    |   | — | — | TRSB[5:0] |   |   |   |   |   |   |
| Value after reset: | 0  | 0  | 0         | 0  | 0  | 0  | 0 | 0 | 0 | 0         | 0 | 0 | 0 | 0 | 0 | 0 |

| Bit | Symbol    | Function   | R/W |
|-----|-----------|--|-----|
| 5:0 | TRSB[5:0] | A/D Conversion Start Trigger Select for Group B<br>Select the A/D conversion start trigger for group B in group scan mode. | R/W |
| 7:6 | —         | These bits are read as 0. The write value should be 0.   | R/W |

**ACE位 (AD数据寄存器自动清除使能)**

ACE位启用或禁用ADDRy、ADRD、ADDBLDR、ADDBLDRA、ADDBLDRB、ADTSDR或ADOCADR寄存器。自动清除AD数据寄存器可以检测未在AD数据寄存器中更新的故障。有关详细信息，请参阅第37.3.8节。AD数据寄存器自动清除功能的使用示例。

**DIAGVAL[1:0]位 (自诊断转换电压选择)**

DIAGVAL[1:0]位选择用于自诊断固定电压模式的电压值。有关详细信息，请参见DIAGLD位说明。

当DIAGVAL[1:0]位设置为00b时，不要通过将DIAGLD位设置为1来执行自诊断。

**DIAGLD位 (自诊断模式选择)**

DIAGLD位选择是旋转三个电压值还是使用固定电压进行自诊断。

将DIAGLD位设置为0选择在旋转模式下转换电压，其中0V、参考电源电压 $\times 1/2$ 和参考电源电压按此顺序转换。复位后，选择自诊断电压旋转模式时，从0V开始执行自诊断。扫描转换完成时，自诊断电压值不会返回到0V。重新开始扫描转换时，从前一个值之后的电压值开始旋转。

将DIAGLD位设置为1选择固定电压，其中转换ADCER.DIAGVAL[1:0]位中指定的固定电压。如果将固定模式切换到旋转模式，则从固定电压值开始旋转。

仅当ADCSR.ADST位为0时设置DIAGLD位。

**DIAGM bit (Self-Diagnosis Enable)**

DIAGM位启用或禁用自诊断。

自诊断用于检测ADC12的故障。在自诊断模式下，转换三个电压值之一（0V、参考电源电压 $\times 1/2$ 或参考电源电压）。转换完成后，转换电压和转换结果的信息将存储到AD自诊断数据寄存器(ADRD)中。可以读取ADRD寄存器来确定转换结果是否在正常或异常范围内。

自诊断在每次扫描开始时执行一次，并转换三个电压之一。在双触发模式(ADCSR.DBLE=1)中，自诊断(DIAGM=0)被取消选择。在组扫描模式下选择自诊断时，对A组和B组分别执行自诊断。

仅当ADCSR.ADST位为0时设置DIAGM位。

**ADRFMT位 (AD数据寄存器格式选择)**

ADRFMT位指定要存储在ADDRy、ADDBLDR、ADDBLDRA、ADDBLDRB、ADTSDR、ADOCADR、ADCMPDR0/1、ADWINLLB、ADWINULB或ADRD寄存器。

仅当ADCSR.ADST位为0时才设置ADRFMT位。

**37.2.16 ADSTRGR:AD转换开始触发选择寄存器**

Base address: ADC12m = 0x4017\_0000 + 0x0200  $\times$  m (m = 0, 1)

Offset address: 0x010

|               |    |    |           |    |    |    |   |   |   |           |   |   |   |   |   |   |
|---------------|----|----|-----------|----|----|----|---|---|---|-----------|---|---|---|---|---|---|
| Bit position: | 15 | 14 | 13        | 12 | 11 | 10 | 9 | 8 | 7 | 6         | 5 | 4 | 3 | 2 | 1 | 0 |
| Bit field:    | —  | —  | TRSA[5:0] |    |    |    |   | — | — | TRSB[5:0] |   |   |   |   |   |   |
| 重置后的值:        | 0  | 0  | 0         | 0  | 0  | 0  | 0 | 0 | 0 | 0         | 0 | 0 | 0 | 0 | 0 | 0 |

| Bit | Symbol    | Function                               | R/W |
|-----|-----------|--|-----|
| 5:0 | TRSB[5:0] | B组的AD转换开始触发选择<br>在组扫描模式下选择B组的AD转换启动触发。 | R/W |
| 7:6 | —         | 这些位被读取为0。写入值应为0。                       | R/W |



| Bit   | Symbol    | Function   | R/W |
|-------|-----------|--|-----|
| 13:8  | TRSA[5:0] | A/D Conversion Start Trigger Select<br>Select the A/D conversion start trigger in single scan mode and continuous scan mode. In group scan mode, the A/D conversion start trigger for group A is selected. | R/W |
| 15:14 | —         | These bits are read as 0. The write value should be 0.   | R/W |

#### TRSB[5:0] bits (A/D Conversion Start Trigger Select for Group B)

The TRSB[5:0] bits select the trigger to start scanning of the analog input selected in group B. The TRSB[5:0] bits must only be set in group scan mode and are not used in any other scan mode. For the scan conversion start trigger for group B, setting a software trigger or an asynchronous trigger is prohibited. In group scan mode, set the TRSB[5:0] bits to a value other than 0x00 and set the ADCSR.TRGE bit to 1.

When group A is given priority in group scan mode, setting the ADGSPCR.GBRP bit to 1 allows group B to continuously operate in single scan mode. When setting the ADGSPCR.GBRP bit to 1, set the TRSB[5:0] bits to 0x3F. The issuance period for a conversion trigger must be more than or equal to the actual scan conversion time ( $t_{SCAN}$ ). If the issuance period is less than  $t_{SCAN}$ , A/D conversion by the trigger might have no effect.

When the GPT module is selected as an A/D conversion start trigger, a delay for synchronization processing occurs. For details, see [section 37.3.7. Analog Input Sampling and Scan Conversion Time](#).

Table 37.19 lists the A/D conversion startup sources selected in the TRSB[5:0] bits.

**Table 37.19 Selection of A/D conversion start sources in the TRSB[5:0] bits**

| Source   | Remarks | TRSB[5] | TRSB[4] | TRSB[3] | TRSB[2] | TRSB[1] | TRSB[0] |
|--|---------|---------|---------|---------|---------|---------|---------|
| Trigger source deselected state  | —       | 1       | 1       | 1       | 1       | 1       | 1       |
| ELC_AD00 (unit 0) and ELC_AD10 (unit 1)  | ELC     | 0       | 0       | 1       | 0       | 0       | 1       |
| ELC_AD01 (unit 0) and ELC_AD11 (unit 1)  | ELC     | 0       | 0       | 1       | 0       | 1       | 0       |
| ELC_AD00 (unit 0) and ELC_AD10 (unit 1), ELC_AD01 (unit 0) and ELC_AD11 (unit 1) | ELC     | 0       | 0       | 1       | 0       | 1       | 1       |

#### TRSA[5:0] bits (A/D Conversion Start Trigger Select)

The TRSA[5:0] bits select the trigger to start A/D conversion in single scan mode and continuous scan mode, or the trigger to start scanning of group A analog inputs in group scan mode. When scanning is executed in group scan mode or double trigger mode, software trigger or asynchronous trigger is prohibited.

- When using a synchronous trigger (ELC), set the TRGE bit in the ADCSR register to 1 and set the EXTRG bit in the ADCSR register to 0.
- When using the asynchronous trigger (ADTRG0), set the TRGE bit in the ADCSR register to 1 and set the EXTRG bit in the ADCSR register to 1.
- Software trigger (ADCSR.ADST) is enabled regardless of the settings of the ADCSR.TRGE bit, the ADCSR.EXTRG bit, or the TRSA[5:0] bits.

The issuance period for a conversion trigger must be more than or equal to the actual scan conversion time ( $t_{SCAN}$ ). If the issuance period is less than  $t_{SCAN}$ , A/D conversion by a trigger might have no effect.

Table 37.20 lists the A/D conversion start sources selected in the TRSA[5:0] bits.

| Bit   | Symbol    | Function   | R/W |
|-------|-----------|--|-----|
| 13:8  | TRSA[5:0] | AD转换开始触发选择<br>在单次扫描模式和连续扫描模式中选择AD转换启动触发。在组扫描模式下，选择A组的AD转换启动触发。 | R/W |
| 15:14 | —         | 这些位被读取为0。写入值应为0。   | R/W |

#### TRSB[5:0]位 (B组的AD转换开始触发选择)

TRSB[5:0]位选择触发以开始扫描组B中选择的模拟输入。TRSB[5:0]位只能在组扫描模式下设置，不得用于任何其他扫描模式。对于B组的扫描转换开始触发，禁止设置软件触发或异步触发。在组扫描模式下，将TRSB[5:0]位设置为0x00以外的值，并将ADCSR.TRGE位设置为1。

当A组在组扫描模式下具有优先权时，将ADGSPCR.GBRP位设置为1允许B组在单次扫描模式下连续工作。将ADGSPCR.GBRP位设置为1时，将TRSB[5:0]位设置为0x3F。转换触发的发布周期必须大于或等于实际扫描转换时间( $t_{SCAN}$ )。如果发行周期小于 $t_{SCAN}$ ，触发器的AD转换可能无效。

When the GPT module is selected as an A/D conversion start trigger, a delay for synchronization processing occurs. For details, please refer to [section 37.3.7](#). Analog input sampling and scan conversion time.

表37.19列出了在TRSB[5:0]位中选择的AD转换启动源。

**Table 37.19 在TRSB[5:0]位中选择AD转换起始源**

| Source   | Remarks | TRSB[5] | TRSB[4] | TRSB[3] | TRSB[2] | TRSB[1] | TRSB[0] |
|--|---------|---------|---------|---------|---------|---------|---------|
| 触发源取消选择状态  | —       | 1       | 1       | 1       | 1       | 1       | 1       |
| ELC_AD00 (unit 0) and ELC_AD10 (unit 1)  | ELC     | 0       | 0       | 1       | 0       | 0       | 1       |
| ELC_AD01 (unit 0) and ELC_AD11 (unit 1)  | ELC     | 0       | 0       | 1       | 0       | 1       | 0       |
| ELC_AD00 (unit 0) and ELC_AD10 (unit 1), ELC_AD01 (unit 0) and ELC_AD11 (unit 1) | ELC     | 0       | 0       | 1       | 0       | 1       | 1       |

#### TRSA[5:0]位 (AD转换开始触发选择)

TRSA[5:0]位选择触发以在单次扫描模式和连续扫描模式下启动AD转换，或在组扫描模式下选择启动A组模拟输入扫描的触发。在组扫描模式或双触发模式下执行扫描时，禁止软件触发或异步触发。

- 使用同步触发(ELC)时，将ADCSR寄存器中的TRGE位设置为1，并将ADCSR寄存器中的EXTRG位设置为0。
- 使用异步触发(ADTRG0)时，将ADCSR寄存器的TRGE位设置为1，并将ADCSR寄存器的EXTRG位设置为1。
- 无论ADCSR.TRGE位、ADCSR.EXTRG位或TRSA[5:0]位的设置如何，都启用软件触发(ADCSR.ADST)。

转换触发的发布周期必须大于或等于实际扫描转换时间( $t_{SCAN}$ )。如果发行周期小于 $t_{SCAN}$ ，触发的AD转换可能无效。

表37.20列出了在TRSA[5:0]位中选择的AD转换起始源。

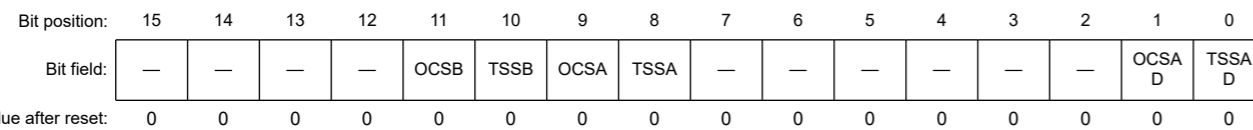
Table 37.20 Selection of A/D activation sources in the TRSA[5:0] bits

| Source   | Remarks                   | TRSA[5] | TRSA[4] | TRSA[3] | TRSA[2] | TRSA[1] | TRSA[0] |
|--|---------------------------|---------|---------|---------|---------|---------|---------|
| Trigger source deselected state  | —                         | 1       | 1       | 1       | 1       | 1       | 1       |
| ADTRGn (n = 0, 1)  | Input pin for the trigger | 0       | 0       | 0       | 0       | 0       | 0       |
| ELC_AD00 (unit 0) and ELC_AD10 (unit 1)  | ELC                       | 0       | 0       | 1       | 0       | 0       | 1       |
| ELC_AD01 (unit 0) and ELC_AD11 (unit 1)  | ELC                       | 0       | 0       | 1       | 0       | 1       | 0       |
| ELC_AD00 (unit 0) and ELC_AD10 (unit 1), ELC_AD01 (unit 0) and ELC_AD11 (unit 1) | ELC                       | 0       | 0       | 1       | 0       | 1       | 1       |

37.2.17 ADEXICR : A/D Conversion Extended Input Control Registers

Base address: ADC12m = 0x4017\_0000 + 0x0200 × m (m = 0, 1)

Offset address: 0x012



| Bit   | Symbol | Function   | R/W |
|-------|--------|--|-----|
| 0     | TSSAD  | Temperature Sensor Output A/D-Converted Value Addition/Average Mode Select<br>0: Do not select addition/average mode for temperature sensor output.<br>1: Select addition/average mode for temperature sensor output.    | R/W |
| 1     | OCSAD  | Internal Reference Voltage A/D-Converted Value Addition/Average Mode Select<br>0: Do not select addition/average mode for internal reference voltage.<br>1: Select addition/average mode for internal reference voltage. | R/W |
| 7:2   | —      | These bits are read as 0. The write value should be 0.   | R/W |
| 8     | TSSA   | Temperature Sensor Output A/D Conversion Select<br>0: Disable A/D conversion of temperature sensor output<br>1: Enable A/D conversion of temperature sensor output   | R/W |
| 9     | OCSA   | Internal Reference Voltage A/D Conversion Select<br>0: Disable A/D conversion of internal reference voltage<br>1: Enable A/D conversion of internal reference voltage  | R/W |
| 10    | TSSB   | Temperature Sensor Output A/D Conversion Select for Group B<br>0: Disable A/D conversion of temperature sensor output<br>1: Enable A/D conversion of temperature sensor output   | R/W |
| 11    | OCSB   | Internal Reference Voltage A/D Conversion Select for Group B<br>0: Disable A/D conversion of internal reference voltage<br>1: Enable A/D conversion of internal reference voltage  | R/W |
| 15:12 | —      | These bits are read as 0. The write value should be 0.   | R/W |

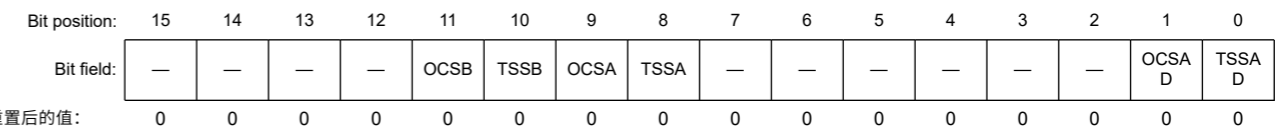
Table 37.20 在TRSA[5:0]位中选择AD激活源

| Source   | Remarks  | TRSA[5] | TRSA[4] | TRSA[3] | TRSA[2] | TRSA[1] | TRSA[0] |
|--|----------|---------|---------|---------|---------|---------|---------|
| 触发源取消选择状态  | —        | 1       | 1       | 1       | 1       | 1       | 1       |
| ADTRGn (n = 0, 1)  | 触发器的输入引脚 | 0       | 0       | 0       | 0       | 0       | 0       |
| ELC_AD00 (unit 0) and ELC_AD10 (unit 1)  | ELC      | 0       | 0       | 1       | 0       | 0       | 1       |
| ELC_AD01 (unit 0) and ELC_AD11 (unit 1)  | ELC      | 0       | 0       | 1       | 0       | 1       | 0       |
| ELC_AD00 (unit 0) and ELC_AD10 (unit 1), ELC_AD01 (unit 0) and ELC_AD11 (unit 1) | ELC      | 0       | 0       | 1       | 0       | 1       | 1       |

37.2.17 ADEXICR:AD转换扩展输入控制寄存器

Base address: ADC12m = 0x4017\_0000 + 0x0200 × m (m = 0, 1)

Offset address: 0x012



| Bit   | Symbol | Function  | R/W |
|-------|--------|---|-----|
| 0     | TSSAD  | 温度传感器输出AD转换值加法平均模式选择<br>0: 温度传感器输出不选择加法平均模式。1: 温度传感器输出选择加法平均模式。 | R/W |
| 1     | OCSAD  | 内部参考电压AD转换值加法平均模式选择<br>0: 内部参考电压不选择加法平均模式。1: 选择内部参考电压的加法平均模式。   | R/W |
| 7:2   | —      | 这些位被读取为0。写入值应为0。  | R/W |
| 8     | TSSA   | 温度传感器输出AD转换选择<br>0: 禁止温度传感器输出AD转换1: 使能温度传感器输出AD转换               | R/W |
| 9     | OCSA   | 内部参考电压AD转换选择<br>0: 禁止内部参考电压AD转换1: 使能内部参考电压AD转换                  | R/W |
| 10    | TSSB   | B组温度传感器输出AD转换选择<br>0: 禁止温度传感器输出AD转换1: 使能温度传感器输出AD转换             | R/W |
| 11    | OCSB   | B组的内部参考电压AD转换选择<br>0: 禁止内部参考电压AD转换1: 使能内部参考电压AD转换               | R/W |
| 15:12 | —      | 这些位被读取为0。写入值应为0。  | R/W |

**TSSAD bit (Temperature Sensor Output A/D-Converted Value Addition/Average Mode Select)**

When the TSSAD bit is set to 1, A/D conversion of the temperature sensor output is selected and performed successively the number of times specified in the ADC[2:0] bits in ADADC. The maximum addition count differs depending on the conversion accuracy (see section 37.2.6. [ADRD : A/D Self-Diagnosis Data Register](#)). When the ADADC.AVEE bit is 0, the value obtained by addition (integration) is returned to the A/D Temperature sensor Data Register (ADTSDR). When the ADADC.AVEE bit is 1, the mean value is returned to ADTSDR.

Only set the TSSAD bit while the ADCSR.ADST bit is 0.

**OCSAD bit (Internal Reference Voltage A/D-Converted Value Addition/Average Mode Select)**

When the OCSAD bit is set to 1, A/D conversion of the internal reference voltage is selected and performed successively the number of times specified in the ADC[2:0] bits in ADADC. The maximum addition count differs depending on the conversion accuracy (see section 37.2.6. [ADRD : A/D Self-Diagnosis Data Register](#)). When the ADADC.AVEE bit is 0, the value obtained by addition (integration) is returned to the A/D Internal Reference Voltage Data Register (ADOCADR). When the ADADC.AVEE bit is 1, the mean value is returned to ADOCADR.

Only set the OCSAD bit while the ADCSR.ADST bit is 0.

**TSSA bit (Temperature Sensor Output A/D Conversion Select)**

The TSSA bit selects A/D conversion of the temperature sensor output for group A in single scan mode, continuous scan mode, or group scan mode. When A/D conversion of the temperature sensor output is selected and performed, set the ADCSR.DBLE bit to 0.

Only set the TSSA bit while the ADCSR.ADST bit is 0.

**OCSA bit (Internal Reference Voltage A/D Conversion Select)**

The OCSA bit selects A/D conversion of the internal reference voltage for group A in single scan mode, continuous scan mode, or group scan mode. When A/D conversion of the internal reference voltage is selected and performed, set the ADCSR.DBLE bit to 0.

Only set the OCSA bit while the ADCSR.ADST bit is 0. In addition, wait for 400 ns or more after the OCSA bit is set to 1 before starting A/D conversion.

**TSSB bit (Temperature Sensor Output A/D Conversion Select for Group B)**

The TSSB bit selects A/D conversion of the temperature sensor output for group B in group scan mode. Only set the TSSB bit while the ADCSR.ADST bit is 0. Do not set the TSSB bit to 1 while the TSSA bit is 1.

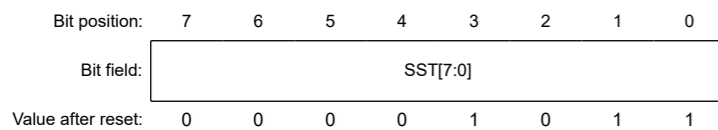
**OCSB bit (Internal Reference Voltage A/D Conversion Select for Group B)**

The OCSB bit selects A/D conversion of the internal reference voltage for group B in group scan mode. Only set the OCSB bit while the ADCSR.ADST bit is 0. Do not set the OCSB bit to 1 while the OCSA bit is 1. Moreover, start the A/D conversion after waiting for 400 ns or more after the OCSB bit is set to 1.

**37.2.18 ADSSTRn/ADSSTRL/ADSSTRT/ADSSTRO : A/D Sampling State Register**

Base address:  $ADC12m = 0x4017\_0000 + 0x0200 \times m$  ( $m = 0, 1$ )

Offset address:  $0x0E0 + 0x1 \times n$  ( $n = 0$  to 9, 12, 13,  $m = 0$ )  
 $0x0E0 + 0x1 \times n$  ( $n = 0$  to 2,  $m = 1$ )  
 0x0DD (ADSSTRL)  
 0x0DE (ADSSTRT)  
 0x0DF (ADSSTRO)



| Bit | Symbol   | Function   | R/W |
|-----|----------|--|-----|
| 7:0 | SST[7:0] | Sampling Time Setting<br>These bits set the sampling time in the range from 5 to 255 states. | R/W |

**TSSAD位 (温度传感器输出AD转换值加法平均模式选择)**

当TSSAD位设置为1时, 选择温度传感器输出的AD转换并连续执行ADADC中ADC[2:0]位指定的次数。最大加法计数因转换精度而异 (参见第37.2.6节。ADRD: AD自诊断数据寄存器)。当ADADC.AVEE位为0时, 通过加法 (积分) 获得的值返回到AD温度传感器数据寄存器(ADTSDR)。当ADADC.AVEE位为1时, 平均值返回给ADTSDR。

仅在ADCSR.ADST位为0时设置TSSAD位。

**OCSAD位 (内部参考电压AD转换值加法平均模式选择)**

当OCSAD位设置为1时, 选择内部参考电压的AD转换, 并按ADADC的ADC[2:0]位指定的次数连续执行。最大加法计数因转换精度而异 (参见第37.2.6节。ADRD: AD自诊断数据寄存器)。当ADADC.AVEE位为0时, 通过加法 (积分) 获得的值返回到AD内部参考电压数据寄存器 (ADOCADR)。当ADADC.AVEE位为1时, 平均值返回给ADOCADR。

仅在ADCSR.ADST位为0时设置OCSAD位。

**TSSA位 (温度传感器输出AD转换选择)**

TSSA位在单次扫描模式、连续扫描模式或组扫描模式下选择A组温度传感器输出的AD转换。WhenADconversionofthetemperatureoutputisselectedandperformedsettheADCSR.DBLEbitto0.

仅在ADCSR.ADST位为0时设置TSSA位。

**OCSA位 (内部参考电压AD转换选择)**

OCSA位在单次扫描模式、连续扫描模式或组扫描模式下选择A组内部参考电压的AD转换。WhenADconversionoftheinternalreferencevoltageisselectedandperformedsettheADCSR.DBLEbitto0.

仅在ADCSR.ADST位为0时设置OCSA位。此外, 在OCSA位设置为1后等待400ns或更长时间, 然后再开始AD转换。

**TSSB位 (B组的温度传感器输出AD转换选择)**

TSSB位选择组扫描模式下B组温度传感器输出的AD转换。仅在ADCSR.ADST位为0时设置TSSB位。不要在TSSA位为1时将TSSB位设置为1。

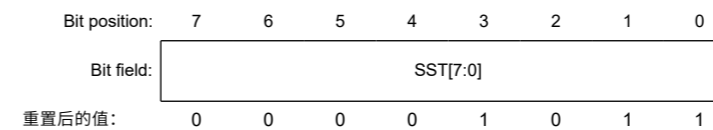
**OCSB位 (B组的内部参考电压AD转换选择)**

OCSB位选择组扫描模式下B组内部参考电压的AD转换。仅在ADCSR.ADST位为0时设置OCSB位。不要在OCSA位为1时将OCSB位设置为1。此外, 在OCSB位设置为1后等待400ns或更长时间后开始AD转换。

**37.2.18 ADSSTRnADSSTRLADSSTRTADSSTRO:AD采样状态寄存器**

Base address:  $ADC12m = 0x4017\_0000 + 0x0200 \times m$  ( $m = 0, 1$ )

Offset address:  $0x0E0 + 0x1 \times n$  ( $n = 0$  to 9, 12, 13,  $m = 0$ )  
 $0x0E0 + 0x1 \times n$  ( $n = 0$  to 2,  $m = 1$ )  
 0x0DD (ADSSTRL)  
 0x0DE (ADSSTRT)  
 0x0DF (ADSSTRO)



| Bit | Symbol   | Function                         | R/W |
|-----|----------|----------------------------------|-----|
| 7:0 | SST[7:0] | 采样时间设置<br>这些位在5到255个状态范围内设置采样时间。 | R/W |



The ADSSTRn register sets the sampling time for analog input.

The sampling time can be adjusted if the impedance of the analog input signal source is too high to secure sufficient sampling time, or if the ADCLK clock is slow. The set value indicates the time for one ADCLK cycle, and the required sampling time is specified by the voltage conditions. about detail, see [section 47.5. ADC12 Characteristics](#)

The lower limit of the sampling time setting depends on the frequency ratio:

- If the frequency ratio of PCLKA to PCLKC (ADCLK) = 1:1, 2:1, 4:1, or 8:1 the sampling time must be set to a value of more than 5 states
- If the frequency ratio of PCLKA to PCLKC (ADCLK) = 1:2 or 1:4, the sampling time must be set to a value of more than 6 states.

[Table 37.21](#) shows the relationship between the A/D Sampling State Register and the associated channels. For details, see [section 37.3.7. Analog Input Sampling and Scan Conversion Time](#).

Only set the SST[7:0] bits when the ADCSR.ADST bit is 0.

**Table 37.21 Relationship between A/D sampling state register and associated channels**

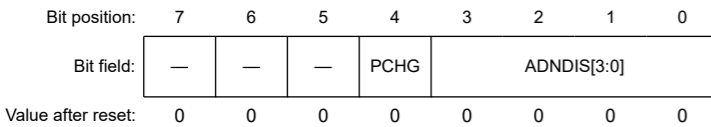
| Bit name   | Associated channels                          |
|--|--|
| ADSSTRn.SST[7:0] bits (n = 0 to 9, 12, 13(unit 0), 0 to 2(unit 1)) <sup>*1</sup> | AN000 to AN009, AN012, AN013, AN100 to AN102 |
| ADSSTRL.SST[7:0] bits  | AN116 to AN122                               |
| ADSSTRT.SST[7:0] bits  | Temperature sensor output                    |
| ADSSTRO.SST[7:0] bits  | Internal reference voltage                   |

Note 1. When the self-diagnosis function is selected, the sampling time set in the ADSSTRO.SST[7:0] bits is applied.

### 37.2.19 ADDISCR : A/D Disconnection Detection Control Register

Base address: ADC12m = 0x4017\_0000 + 0x0200 × m (m = 0, 1)

Offset address: 0x07A



| Bit | Symbol      | Function   | R/W |
|-----|-------------|--|-----|
| 3:0 | ADNDIS[3:0] | Disconnection Detection Assist Setting<br>0x00: The disconnection detection assist function is disabled<br>0x01: Setting prohibited<br>Others: The number of states for the discharge or precharge period. | R/W |
| 4   | PCHG        | Precharge/discharge select<br>0: Discharge<br>1: Precharge   | R/W |
| 7:5 | —           | These bits are read as 0. The write value should be 0.   | R/W |

The ADDISCR register selects either precharge or discharge, and the period of precharge or discharge for the A/D disconnection detection assist function. Only set the ADDISCR register when the ADCSR.ADST bit is 0. When the temperature sensor output or internal reference voltage is converted, the A/D converter executes discharge automatically.

Disable the disconnection detection assist function if any of the following functions are used:

- The temperature sensor
- The internal reference voltage
- A/D self-diagnosis

ADSSTRn寄存器设置模拟输入的采样时间。

如果模拟输入信号源的阻抗太高而无法保证足够的采样时间，或者如果ADCLK时钟很慢，则可以调整采样时间。设定值表示一个ADCLK周期的时间，所需的采样时间由电压条件指定。有关详细信息，请参阅第47.5节。ADC12特性

采样时间设置的下限取决于频率比：

- 如果PCLKA与PCLKC(ADCLK)的频率比=1:1、2:1、4:1或8:1，则必须将采样时间设置为超过5个状态的值
- 如果PCLKA与PCLKC(ADCLK)的频率比=1:2或1:4，则必须将采样时间设置为6个以上状态的值。

表37.21显示了AD采样状态寄存器和相关通道之间的关系。有关详细信息，请参阅第37.3.7节。模拟输入采样和扫描转换时间。

仅当ADCSR.ADST位为0时设置SST[7:0]位。

**Table 37.21 AD采样状态寄存器与相关通道的关系**

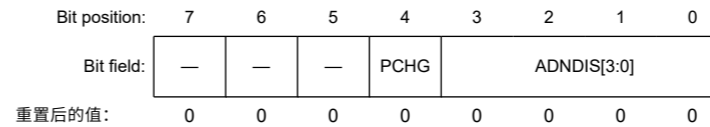
| 位名称  | 关联频道   |
|--|--|
| ADSSTRn.SST[7:0]位 (n=0到9、12、13 (单元0)、0到2 (单元1)) *1 | AN000 to AN009, AN012, AN013, AN100 to AN102 |
| ADSSTRL.SST[7:0] bits                              | AN116 to AN122                               |
| ADSSTRT.SST[7:0] bits                              | 温度传感器输出                                      |
| ADSSTRO.SST[7:0] bits                              | 内部参考电压                                       |

注1.选择自诊断功能时，应用ADSSTRO.SST[7:0]位中设置的采样时间。

### 37.2.19 ADDISCR:AD断线检测控制寄存器

Base address: ADC12m = 0x4017\_0000 + 0x0200 × m (m = 0, 1)

Offset address: 0x07A



| Bit | Symbol      | Function   | R/W |
|-----|-------------|--|-----|
| 3:0 | ADNDIS[3:0] | 断线检测辅助设置<br>0x00: 断线检测辅助功能禁用0x01: 设置禁止<br>其他: 放电或预充电期的状态数。 | R/W |
| 4   | PCHG        | Precharge/discharge select<br>0: Discharge<br>1: Precharge | R/W |
| 7:5 | —           | 这些位被读取为0。写入值应为0。   | R/W |

ADDISCR寄存器选择预充电或放电，以及AD断线检测辅助功能的预充电或放电周期。仅当ADCSR.ADST位为0时才设置ADDISCR寄存器。当温度传感器输出或内部参考电压转换时，AD转换器自动执行放电。

如果使用以下任何功能，请禁用断线检测辅助功能：

- 温度传感器
- 内部参考电压
- A/D self-diagnosis



**ADNDIS[3:0] bits (Disconnection Detection Assist Setting)**

The ADNDIS[3:0] bits specify the period of precharge or discharge. When ADNDIS[3:0] = 0000b, the disconnection detection assist function is disabled. Setting the ADNDIS[3:0] bits to 0001b is prohibited. Except when ADNDIS[3:0] = 0000b or 0001b, the specified value indicates the number of states for the period of precharge or discharge. When the ADNDIS[3:0] bits are set to any values other than 0000b or 0001b, the disconnection detection assistance function is enabled.

**PCHG bit (Precharge/discharge select)**

The PCHG bit selects either precharge or discharge.

**37.2.20 ADGSPCR : A/D Group Scan Priority Control Register**

Base address: ADC12m = 0x4017\_0000 + 0x0200 × m (m = 0, 1)

Offset address: 0x080

|                    |      |       |    |    |    |    |   |   |   |   |   |   |   |   |        |     |
|--------------------|------|-------|----|----|----|----|---|---|---|---|---|---|---|---|--------|-----|
| Bit position:      | 15   | 14    | 13 | 12 | 11 | 10 | 9 | 8 | 7 | 6 | 5 | 4 | 3 | 2 | 1      | 0   |
| Bit field:         | GBRP | LGRRS | —  | —  | —  | —  | — | — | — | — | — | — | — | — | GBRSCN | PGS |
| Value after reset: | 0    | 0     | 0  | 0  | 0  | 0  | 0 | 0 | 0 | 0 | 0 | 0 | 0 | 0 | 0      | 0   |

| Bit  | Symbol | Function   | R/W |
|------|--------|--|-----|
| 0    | PGS    | Group Priority Operation Setting*1<br>0: Operate without group priority control.<br>1: Operate with group priority control.  | R/W |
| 1    | GBRSCN | Lower-Priority Group Restart Setting<br>(enabled only when PGS = 1 and reserved when PGS = 0.)<br>0: Disable rescanning of the group that was stopped in group priority operation<br>1: Enable rescanning of the group that was stopped in group priority operation. | R/W |
| 13:2 | —      | These bits are read as 0. The write value should be 0.   | R/W |
| 14   | LGRRS  | Restart Channel Select<br>Enabled only when PGS = 1 and GBRSCN = 1.<br>0: Start rescanning from the first channel for scanning<br>1: Start rescanning from the channel for which A/D conversion is not completed.  | R/W |
| 15   | GBRP   | Single Scan Continuous Start*2<br>(enabled only when PGS = 1 and reserved when PGS = 0.)<br>0: Single scan is not continuously activated.<br>1: Single scan for the group with the lower-priority is continuously activated.   | R/W |

Note 1. The ADCSR.ADCS[1:0] bits must be set to 01b (group scan mode) before setting PGS to 1. Operation is not guaranteed if these bits are set to any other value.

Note 2. When the GBRP bit is set to 1, single scan is performed continuously for the group with the lower-priority regardless of the setting in the GBRSCN bit.

**PGS bit (Group Priority Operation Setting)**

Set the PGS bit to 1 to enable group priority operation.

The ADCSR.ADCS[1:0] bits must be set to 01b (group scan mode) before setting the PGS bit to 1. Operation is not guaranteed if the bits are set to any other value.

When the PGS bit is set to 0, a clear operation must be performed by software as described in [section 37.6.3. Constraints on Stopping A/D Conversion](#). When the PGS bit is set to 1, use the settings described in [section 37.3.4.3. Group Priority Operation](#).

**GBRSCN bit (Lower-Priority Group Restart Setting)**

The GBRSCN bit controls the restarting of scan operation in group priority operation.

When the GBRSCN bit is set to 1, if the scan operation of a lower-priority group is stopped by a trigger input of a priority group, the lower-priority group scanning is restarted on completion of the priority group scanning. If a trigger of a lower-priority group is input during scanning of the priority group, the lower-priority group scanning is started on completion of the priority group scanning.

**ADNDIS[3:0]位 (断线检测辅助设置)**

ADNDIS[3:0]位指定预充电或放电周期。当ADNDIS[3:0]=0000b时，断线检测辅助功能被禁用。禁止将ADNDIS[3:0]位设置为0001b。除了ADNDIS[3:0]=0000b或0001b时，指定值表示预充电或放电期间的状态数。当ADNDIS[3:0]位设置为0000b或0001b以外的任何值时，将启用断线检测辅助功能。

**PCHG bit (Precharge/discharge select)**

PCHG位选择预充电或放电。

**37.2.20 ADGSPCR:AD组扫描优先级控制寄存器**

Base address: ADC12m = 0x4017\_0000 + 0x0200 × m (m = 0, 1)

Offset address: 0x080

|               |      |       |    |    |    |    |   |   |   |   |   |   |   |   |        |     |
|---------------|------|-------|----|----|----|----|---|---|---|---|---|---|---|---|--------|-----|
| Bit position: | 15   | 14    | 13 | 12 | 11 | 10 | 9 | 8 | 7 | 6 | 5 | 4 | 3 | 2 | 1      | 0   |
| Bit field:    | GBRP | LGRRS | —  | —  | —  | —  | — | — | — | — | — | — | — | — | GBRSCN | PGS |
| 重置后的值:        | 0    | 0     | 0  | 0  | 0  | 0  | 0 | 0 | 0 | 0 | 0 | 0 | 0 | 0 | 0      | 0   |

| Bit  | Symbol | Function  | R/W |
|------|--------|---|-----|
| 0    | PGS    | 组优先操作设置*1<br>0: 无组优先控制运行。1: 以组优先控制运行。   | R/W |
| 1    | GBRSCN | 低优先级组重启设置 (仅在PGS=1时启用, 在PGS=0时保留。)<br>0: 禁止重新扫描在组优先操作中停止的组1: 允许重新扫描在组优先操作中停止的组。 | R/W |
| 13:2 | —      | 这些位被读取为0。写入值应为0。  | R/W |
| 14   | LGRRS  | 重启频道选择<br>仅当PGS=1且GBRSCN=1时启用。<br>0: 从第一个扫描通道开始重新扫描1: 从未完成AD转换的通道开始重新扫描。        | R/W |
| 15   | GBRP   | 单次扫描连续启动*2<br>(仅在PGS=1时启用, 在PGS=0时保留。)<br>0: 单次扫描不连续激活。1: 连续激活低优先级组的单次扫描。       | R/W |

注1.ADCSR.ADCS[1:0]位必须在PGS设置为1之前设置为01b (组扫描模式)。如果这些位设置为任何其他值, 则无法保证操作。

注2.当GBRP位设置为1时, 无论GBRSCN位的设置如何, 都会对优先级较低的组连续执行单次扫描。

**PGS位 (组优先操作设置)**

将PGS位设置为1以启用组优先操作。

在将PGS位设置为1之前, 必须将ADCSR.ADCS[1:0]位设置为01b (组扫描模式)。如果这些位设置为任何其他值, 则无法保证操作。

当PGS位设置为0时, 必须通过软件执行清零操作, 如第37.6.3节所述。约束停止AD转换。当PGS位设置为1时, 使用第37.3.4.3节中描述的设置。团体优先操作。

**GBRSCN位 (低优先级组重启设置)**

GBRSCN位控制组优先操作中扫描操作的重新启动。

当GBRSCN位被设置为1时, 如果低优先级组的扫描操作被优先级组的触发输入停止, 则低优先级组扫描在优先级组扫描完成时重新开始。如果在优先级组扫描期间输入了较低优先级组的触发, 则在完成优先级组扫描时开始较低优先级组扫描。

When the GBRSCN bit is set to 0, triggers input during scanning are ignored. Set the GBRSCN bit while the ADCSR.ADST bit is 0.

**LGRRS bit (Restart Channel Select)**

This bit sets the channel from which rescanning is to be started in group priority operation. The setting of the LGRRS bit is valid when the PGS and GBRSCN bits are 1.

If the LGRRS bit is 0, scanning of a lower-priority group that was stopped in group priority operation is restarted from the first channel after scanning of the priority group completes.

If the LGRRS bit is 1, scanning of a lower-priority group that was stopped in group priority operation is restarted (upon completion of scanning of the priority group) from the channel for which A/D conversion is not complete. If A/D conversion of the addition setting channel was not completed the specified number of times when scanning stopped, A/D conversion of the addition setting channel is performed again the specified number of times when scanning restarts.

Set the LGRRS bit while the ADCSR.ADST bit is 0.

**GBRP bit (Single Scan Continuous Start)**

The GBRP bit is set when a single scan operation is to be performed continuously on the group with the lower-priority.

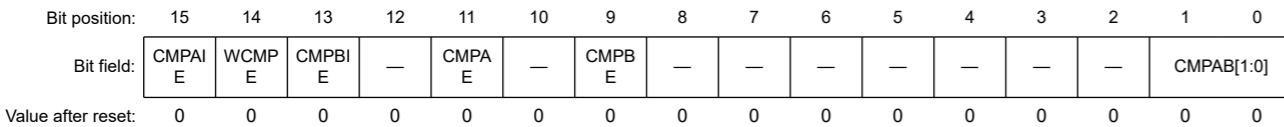
Setting the GBRP bit to 1 starts a single scan of the group with the lower-priority. On completion of the scan, another single scan of the group with the lower-priority is started automatically. If scanning has been stopped during group priority operation, single scan of the group with the lower-priority is automatically restarted on completion of the A/D conversion of the priority group.

Before setting the GBRP bit to 1, disable input of a trigger for the lower-priority group. If the GBRP bit is set to 1, rescanning is performed only on the group with the lower-priority even if the GBRSCN bit is set to 0.

**37.2.21 ADCMPCR : A/D Compare Function Control Register**

Base address: ADC12m = 0x4017\_0000 + 0x0200 × m (m = 0, 1)

Offset address: 0x090



| Bit | Symbol     | Function  | R/W |
|-----|------------|---|-----|
| 1:0 | CMPAB[1:0] | Window A/B Composite Conditions Setting<br>These bits are valid when both window A and window B are enabled (CMPAE = 1 and CMPBE = 1).<br>00: Output ADC12i_WCMPM (i = 0, 1) when window A OR window B comparison conditions are met. Otherwise, output ADC12i_WCMPUM (i = 0, 1).<br>01: Output ADC12i_WCMPM (i = 0, 1) when window A EXOR window B comparison conditions are met. Otherwise, output ADC12i_WCMPUM (i = 0, 1).<br>10: Output ADC12i_WCMPM (i = 0, 1) when window A AND window B comparison conditions are met. Otherwise, output ADC12i_WCMPUM (i = 0, 1).<br>11: Setting prohibited. | R/W |
| 8:2 | —          | These bits are read as 0. The write value should be 0.  | R/W |
| 9   | CMPBE      | Compare Window B Operation Enable<br>0: Disable compare window B operation.<br>Disable ADC12i_WCMPM (i = 0, 1) and ADC12i_WCMPUM (i = 0, 1) outputs.<br>1: Enable compare window B operation.   | R/W |
| 10  | —          | This bit is read as 0. The write value should be 0.   | R/W |
| 11  | CMPAE      | Compare Window A Operation Enable<br>0: Disable compare window A operation.<br>Disable ADC12i_WCMPM (i = 0, 1) and ADC12i_WCMPUM (i = 0, 1) outputs.<br>1: Enable compare window A operation.   | R/W |
| 12  | —          | This bit is read as 0. The write value should be 0.   | R/W |

当GBRSCN位设置为0时，扫描期间的触发输入将被忽略。设置GBRSCN位，而 ADCSR.ADST位为0。

**LGRRS位 (重启通道选择)**

该位设置在组优先操作中要从哪个通道开始重新扫描。当PGS和GBRSCN位为1时，LGRRS位的设置有效。

如果LGRRS位为0，则在优先级组扫描完成后，从第一个通道开始重新开始对在组优先级操作中停止的低优先级组的扫描。

如果LGRRS位为1，则从AD转换未完成的通道重新开始（在完成优先级组的扫描时）组优先操作中停止的低优先级组的扫描。如果在扫描停止时加法设置通道的AD转换未完成指定次数，则在扫描重新开始时再次执行加法设置通道的AD转换指定次数。

当ADCSR.ADST位为0时设置LGRRS位。

**GBRP位 (单次扫描连续启动)**

当要对优先级较低的组连续执行单次扫描操作时，设置GBRP位。

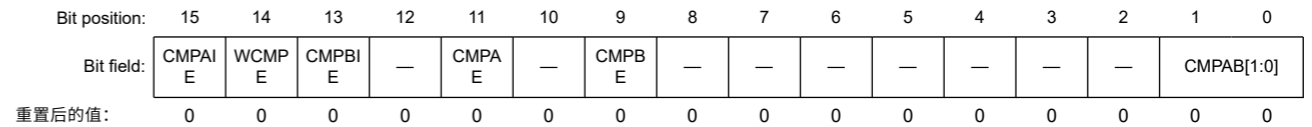
将GBRP位设置为1开始对具有较低优先级的组进行单次扫描。扫描完成后，将自动开始对具有较低优先级的组进行另一次单次扫描。如果在组优先操作期间扫描已停止，则在优先组的AD转换完成时，将自动重新开始优先级较低的组的单次扫描。

在将GBRP位设置为1之前，禁用低优先级组的触发器输入。如果GBRP位设置为1，即使GBRSCN位设置为0，也仅对具有较低优先级的组执行重新扫描。

**37.2.21 ADCMPCR:AD比较功能控制寄存器**

Base address: ADC12m = 0x4017\_0000 + 0x0200 × m (m = 0, 1)

Offset address: 0x090



| Bit | Symbol     | Function  | R/W |
|-----|------------|---|-----|
| 1:0 | CMPAB[1:0] | 窗口AB复合条件设置<br>这些位在窗口A和窗口B都启用时有效 (CMPAE=1和CMPBE = 1).<br>00: 当窗口AOR窗口B比较条件满足时，输出ADC12i_WCMPM(i=0 1)。否则，输出ADC12i_WCMPUM(i=0 1)。<br>01: 当窗口AEXOR窗口B比较条件满足时，输出ADC12i_WCMPM(i=0 1)。否则，输出ADC12i_WCMPUM(i=0 1)。<br>10: 当窗口A和窗口B比较条件满足时，输出ADC12i_WCMPM(i=0 1)。否则，输出ADC12i_WCMPUM(i=0 1)。<br>11: 禁止设置。 | R/W |
| 8:2 | —          | 这些位被读取为0。写入值应为0。  | R/W |
| 9   | CMPBE      | 比较窗口B操作启用<br>0: 禁止比较窗口B操作。<br>禁用ADC12i_WCMPM(i=0 1)和ADC12i_WCMPUM(i=0 1)输出。<br>1: 启用比较窗口B操作。  | R/W |
| 10  | —          | 该位读取为0。写入值应为0。  | R/W |
| 11  | CMPAE      | 比较窗口A操作启用<br>0: 禁止比较窗口A操作。<br>禁用ADC12i_WCMPM(i=0 1)和ADC12i_WCMPUM(i=0 1)输出。<br>1: 启用比较窗口A操作。  | R/W |
| 12  | —          | 该位读取为0。写入值应为0。  | R/W |

| Bit | Symbol | Function  | R/W |
|-----|--------|---|-----|
| 13  | CMPBIE | Compare B Interrupt Enable<br>0: Disable ADC12i_CMPBI (i = 0, 1) interrupt when comparison conditions (window B) are met.<br>1: Enable ADC12i_CMPBI (i = 0, 1) interrupt when comparison conditions (window B) are met.   | R/W |
| 14  | WCMPE  | Window Function Setting<br>0: Disable window function<br>Window A and window B operate as a comparator to compare the single value on the lower side with the A/D conversion result.<br>1: Enable window function<br>Window A and window B operate as a comparator to compare the two values on the upper and lower sides with the A/D conversion result. | R/W |
| 15  | CMPAIE | Compare A Interrupt Enable<br>0: Disable ADC12i_CMPAI (i = 0, 1) interrupt when comparison conditions (window A) are met.<br>1: Enable ADC12i_CMPAI (i = 0, 1) interrupt when comparison conditions (window A) are met.   | R/W |

**CMPAB[1:0] bits (Window A/B Composite Conditions Setting)**

The CMPAB[1:0] bits are valid when both window A and window B are enabled (CMPAE = 1 and CMPBE = 1) in single scan mode. These bits specify the compare function match/mismatch event output conditions and monitoring conditions of ADWINMON.MONCOMB. Only set the CMPAB[1:0] bits while the ADCSR.ADST bit is 0.

**CMPBE bit (Compare Window B Operation Enable)**

The CMPBE bit enables or disables the compare window B operation. Set the CMPBE bit while the ADCSR.ADST bit is 0.

Set this bit to 0 before setting the following registers:

- A/D Channel Select Registers A0, A1, B0, B1 (ADANSA0, ADANSA1, ADANSB0, ADANSB1)
- OCSB, TSSB, OCSA, or TSSA bits in the A/D Conversion Extended Input Control Register (ADEXICR)
- CMPCHB[5:0] bits in the Window B Channel Select Register (ADCMPBNSR)

**CMPAE bit (Compare Window A Operation Enable)**

The CMPAE bit enables or disables the compare window A operation. Set the CMPAE bit while the ADCSR.ADST bit is 0.

Set this bit to 0 before setting the following registers:

- A/D Channel Select Registers A0, A1, B0, B1 (ADANSA0, ADANSA1, ADANSB0, ADANSB1)
- OCSB, TSSB, OCSA, or TSSA bits in the A/D Conversion Extended Input Control Register (ADEXICR)
- Window A Channel Select Registers 0 and 1 (ADCMPANSR0 and ADCMPANSR1)
- Window A Extended Input Select Register (ADCMPANSER)

**CMPBIE bit (Compare B Interrupt Enable)**

The CMPBIE bit enables or disables the ADC12i\_CMPBI (i = 0, 1) interrupt output when the comparison conditions (window B) are met.

**WCMPE bit (Window Function Setting)**

The WCMPE bit enables or disables the window function. Set the WCMPE bit while the ADCSR.ADST bit is 0.

**CMPAIE bit (Compare A Interrupt Enable)**

The CMPAIE bit enables or disables the ADC12i\_CMPAI (i = 0, 1) interrupt output when the comparison conditions (window A) are met.

| Bit | Symbol | Function  | R/W |
|-----|--------|---|-----|
| 13  | CMPBIE | 比较B中断使能<br>0: 当满足比较条件 (窗口B) 时, 禁用ADC12i_CMPBI(i=0 1)中断。<br>1: 当满足比较条件 (窗口B) 时, 使能ADC12i_CMPBI(i=0 1)中断。   | R/W |
| 14  | WCMPE  | 窗口功能设置<br>0: 关闭窗口功能<br>窗口A和窗口B用作比较器, 将下侧的单个值与AD转换结果进行比较。<br>1: 启用窗口功能<br>窗口A和窗口B用作比较器, 将上下两个值与AD转换结果进行比较。 | R/W |
| 15  | CMPAIE | 比较中断使能<br>0: 当满足比较条件 (窗口A) 时, 禁止ADC12i_CMPAI(i=0 1)中断。<br>1: 当满足比较条件 (窗口A) 时, 使能ADC12i_CMPAI(i=0 1)中断。    | R/W |

**CMPAB[1:0]位 (窗口AB复合条件设置)**

当窗口A和窗口B在单次扫描模式下启用 (CMPAE=1和CMPBE=1) 时, CMPAB[1:0]位有效。这些位指定比较函数匹配不匹配事件的输出条件和ADWINMON.MONCOMB的监视条件。仅在ADCSR.ADST位为0时设置CMPAB[1:0]位。

**CMPBE位 (比较窗口B操作使能)**

CMPBE位启用或禁用比较窗口B操作。当ADCSR.ADST位为0时设置CMPBE位。

在设置以下寄存器之前将此位设置为0:

- AD通道选择寄存器A0、A1、B0、B1 (ADANSA0、ADANSA1、ADANSB0、ADANSB1)
- AD转换扩展输入控制寄存器(ADEXICR)中的OCSB、TSSB、OCSA或TSSA位
- 窗口B通道选择寄存器(ADCMPBNSR)中的CMPCHB[5:0]位

**CMPAE位 (比较窗口A操作使能)**

CMPAE位启用或禁用比较窗口A操作。当ADCSR.ADST位为0时设置CMPAE位。

在设置以下寄存器之前将此位设置为0:

- AD通道选择寄存器A0、A1、B0、B1 (ADANSA0、ADANSA1、ADANSB0、ADANSB1)
- AD转换扩展输入控制寄存器(ADEXICR)中的OCSB、TSSB、OCSA或TSSA位
- 窗口A通道选择寄存器0和1 (ADCMPANSR0和ADCMPANSR1)
- 窗口A扩展输入选择寄存器(ADCMPANSER)

**CMPBIE位 (比较B中断允许)**

当满足比较条件 (窗口B) 时, CMPBIE位启用或禁用ADC12i\_CMPBI(i=0 1)中断输出。

**WCMPE位 (窗口功能设置)**

WCMPE位启用或禁用窗口功能。当ADCSR.ADST位为0时设置WCMPE位。

**CMPAIE位 (比较中断允许)**

当满足比较条件 (窗口A) 时, CMPAIE位启用或禁用ADC12i\_CMPAI(i=0 1)中断输出。



## 37.2.22 ADCMPANSR0 : A/D Compare Function Window A Channel Select Register 0

Base address: ADC12m = 0x4017\_0000 + 0x0200 × m (m = 0, 1)

Offset address: 0x094

|                    |               |               |               |               |               |               |               |               |               |               |               |               |               |               |               |               |
|--------------------|---------------|---------------|---------------|---------------|---------------|---------------|---------------|---------------|---------------|---------------|---------------|---------------|---------------|---------------|---------------|---------------|
| Bit position:      | 15            | 14            | 13            | 12            | 11            | 10            | 9             | 8             | 7             | 6             | 5             | 4             | 3             | 2             | 1             | 0             |
| Bit field:         | CMPCH<br>HA15 | CMPCH<br>HA14 | CMPCH<br>HA13 | CMPCH<br>HA12 | CMPCH<br>HA11 | CMPCH<br>HA10 | CMPCH<br>HA09 | CMPCH<br>HA08 | CMPCH<br>HA07 | CMPCH<br>HA06 | CMPCH<br>HA05 | CMPCH<br>HA04 | CMPCH<br>HA03 | CMPCH<br>HA02 | CMPCH<br>HA01 | CMPCH<br>HA00 |
| Value after reset: | 0             | 0             | 0             | 0             | 0             | 0             | 0             | 0             | 0             | 0             | 0             | 0             | 0             | 0             | 0             | 0             |

| Bit  | Symbol  | Function  | R/W |
|------|---------|---|-----|
| 15:0 | CMPCHAN | Compare Window A Channel Select<br>Bit 15 (CMPCHA15) is associated with ANm15 and bit 0 (CMPCHA00) is associated with ANm00.<br>0: Disable compare function for associated input channel<br>1: Enable compare function for associated input channel | R/W |

Note: n = 00 to 09, 12, 13(unit 0), 00 to 02(unit 1)

Note: Bits associated with non-existent pins are reserved. This bit is read as 0. The write value should be 0.

**CMPCHAN bits (Compare Window A Channel Select)**

The compare function is enabled by writing 1 to the CMPCHAN bit with the same number as the A/D conversion channel selected in the ADANSA0.ANSAn bits and the ADANSB0.ANSBn bits.

Set the CMPCHAN bits while the ADCSR.ADST bit is 0.

## 37.2.23 ADCMPANSR1 : A/D Compare Function Window A Channel Select Register 1

Base address: ADC12m = 0x4017\_0000 + 0x0200 × m (m = 0, 1)

Offset address: 0x096

|                    |               |               |               |               |               |               |               |               |               |               |               |               |               |               |               |               |
|--------------------|---------------|---------------|---------------|---------------|---------------|---------------|---------------|---------------|---------------|---------------|---------------|---------------|---------------|---------------|---------------|---------------|
| Bit position:      | 15            | 14            | 13            | 12            | 11            | 10            | 9             | 8             | 7             | 6             | 5             | 4             | 3             | 2             | 1             | 0             |
| Bit field:         | CMPCH<br>HA31 | CMPCH<br>HA30 | CMPCH<br>HA29 | CMPCH<br>HA28 | CMPCH<br>HA27 | CMPCH<br>HA26 | CMPCH<br>HA25 | CMPCH<br>HA24 | CMPCH<br>HA23 | CMPCH<br>HA22 | CMPCH<br>HA21 | CMPCH<br>HA20 | CMPCH<br>HA19 | CMPCH<br>HA18 | CMPCH<br>HA17 | CMPCH<br>HA16 |
| Value after reset: | 0             | 0             | 0             | 0             | 0             | 0             | 0             | 0             | 0             | 0             | 0             | 0             | 0             | 0             | 0             | 0             |

| Bit  | Symbol  | Function  | R/W |
|------|---------|---|-----|
| 15:0 | CMPCHAN | Compare Window A Channel Select<br>Bit 15 (CMPCHA31) is associated with ANm31 and bit 0 (CMPCHA16) is associated with ANm16.<br>0: Disable compare function for associated input channel<br>1: Enable compare function for associated input channel | R/W |

Note: n = 16 to 22(unit 1)

Note: Bits associated with non-existent pins are reserved. This bit is read as 0. The write value should be 0.

**CMPCHAN bits (Compare Window A Channel Select)**

The compare function is enabled by writing 1 to the CMPCHAN bit with the same number as the A/D conversion channel selected in the ADANSA1.ANSAn bits and the ADANSB1.ANSBn bits.

Set the CMPCHAN bits while the ADCSR.ADST bit is 0.

## 37.2.22 ADCMPANSR0:AD比较功能窗口A通道选择寄存器0

Base address: ADC12m = 0x4017\_0000 + 0x0200 × m (m = 0, 1)

Offset address: 0x094

|               |               |               |               |               |               |               |               |               |               |               |               |               |               |               |               |               |
|---------------|---------------|---------------|---------------|---------------|---------------|---------------|---------------|---------------|---------------|---------------|---------------|---------------|---------------|---------------|---------------|---------------|
| Bit position: | 15            | 14            | 13            | 12            | 11            | 10            | 9             | 8             | 7             | 6             | 5             | 4             | 3             | 2             | 1             | 0             |
| Bit field:    | CMPCH<br>HA15 | CMPCH<br>HA14 | CMPCH<br>HA13 | CMPCH<br>HA12 | CMPCH<br>HA11 | CMPCH<br>HA10 | CMPCH<br>HA09 | CMPCH<br>HA08 | CMPCH<br>HA07 | CMPCH<br>HA06 | CMPCH<br>HA05 | CMPCH<br>HA04 | CMPCH<br>HA03 | CMPCH<br>HA02 | CMPCH<br>HA01 | CMPCH<br>HA00 |
| 重置后的值:        | 0             | 0             | 0             | 0             | 0             | 0             | 0             | 0             | 0             | 0             | 0             | 0             | 0             | 0             | 0             | 0             |

| Bit  | Symbol  | Function   | R/W |
|------|---------|--|-----|
| 15:0 | CMPCHAN | 比较窗口A通道选择<br>位15(CMPCHA15)与ANm15相关联, 位0(CMPCHA00)与ANm00。<br>0: 禁用关联输入通道的比较功能1: 启用关联输入通道的比较功能 | R/W |

Note: n = 00 to 09, 12, 13(unit 0), 00 to 02(unit 1)

Note: 与不存在的引脚相关的位被保留。该位读取为0。写入值应为0。

**CMPCHAN位 (比较窗口A通道选择)**

通过将1写入CMPCHAN位来启用比较功能, 该位与在ADANSA0.ANSAn位和ADANSB0.ANSBn位中选择的AD转换通道的编号相同。

当ADCSR.ADST位为0时, 设置CMPCHAN位。

## 37.2.23 ADCMPANSR1:AD比较功能窗口A通道选择寄存器1

Base address: ADC12m = 0x4017\_0000 + 0x0200 × m (m = 0, 1)

Offset address: 0x096

|               |               |               |               |               |               |               |               |               |               |               |               |               |               |               |               |               |
|---------------|---------------|---------------|---------------|---------------|---------------|---------------|---------------|---------------|---------------|---------------|---------------|---------------|---------------|---------------|---------------|---------------|
| Bit position: | 15            | 14            | 13            | 12            | 11            | 10            | 9             | 8             | 7             | 6             | 5             | 4             | 3             | 2             | 1             | 0             |
| Bit field:    | CMPCH<br>HA31 | CMPCH<br>HA30 | CMPCH<br>HA29 | CMPCH<br>HA28 | CMPCH<br>HA27 | CMPCH<br>HA26 | CMPCH<br>HA25 | CMPCH<br>HA24 | CMPCH<br>HA23 | CMPCH<br>HA22 | CMPCH<br>HA21 | CMPCH<br>HA20 | CMPCH<br>HA19 | CMPCH<br>HA18 | CMPCH<br>HA17 | CMPCH<br>HA16 |
| 重置后的值:        | 0             | 0             | 0             | 0             | 0             | 0             | 0             | 0             | 0             | 0             | 0             | 0             | 0             | 0             | 0             | 0             |

| Bit  | Symbol  | Function   | R/W |
|------|---------|--|-----|
| 15:0 | CMPCHAN | 比较窗口A通道选择<br>位15(CMPCHA31)与ANm31相关联, 位0(CMPCHA16)与ANm16。<br>0: 禁用关联输入通道的比较功能1: 启用关联输入通道的比较功能 | R/W |

Note: n = 16 to 22(unit 1)

Note: 与不存在的引脚相关的位被保留。该位读取为0。写入值应为0。

**CMPCHAN位 (比较窗口A通道选择)**

通过将1写入CMPCHAN位来启用比较功能, 该位与在ADANSA1.ANSAn位和ADANSB1.ANSBn位中选择的AD转换通道的编号相同。

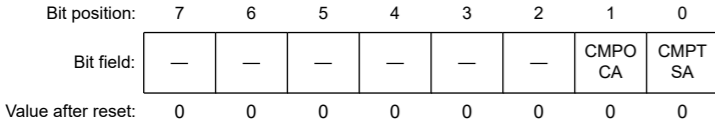
当ADCSR.ADST位为0时, 设置CMPCHAN位。



### 37.2.24 ADCMPANSER : A/D Compare Function Window A Extended Input Select Register

Base address: ADC12m = 0x4017\_0000 + 0x0200 × m (m = 0, 1)

Offset address: 0x092



| Bit | Symbol | Function  | R/W |
|-----|--------|---|-----|
| 0   | CMPTSA | Temperature Sensor Output Compare Select<br>0: Exclude the temperature sensor output from the compare Window A target range.<br>1: Include the temperature sensor output in the compare Window A target range.    | R/W |
| 1   | CMPOCA | Internal Reference Voltage Compare Select<br>0: Exclude the internal reference voltage from the compare Window A target range.<br>1: Include the internal reference voltage in the compare Window A target range. | R/W |
| 7:2 | —      | These bits are read as 0. The write value should be 0.  | R/W |

#### CMPTSA bit (Temperature Sensor Output Compare Select)

The compare Window A function is enabled by setting the CMPTSA bit to 1 while the ADEXICR.TSSA bit or the ADEXICR.TSSB bit is 1. Set the CMPTSA bit while the ADCSR.ADST bit is 0.

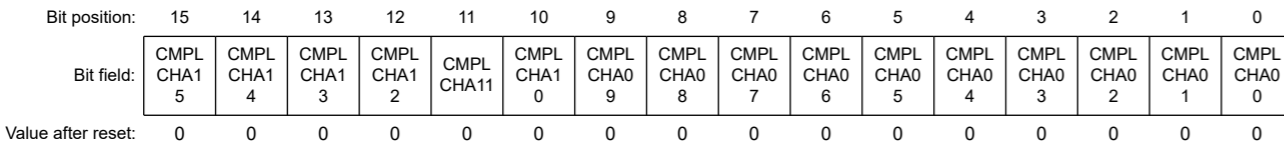
#### CMPOCA bit (Internal Reference Voltage Compare Select)

The compare window A function is enabled by setting the CMPOCA bit to 1 when the ADEXICR.OCSA and ADEXICR.OCSB bit is 1. Set the CMPOCA bit when the ADCSR.ADST bit is 0.

### 37.2.25 ADCMPLR0 : A/D Compare Function Window A Comparison Condition Setting Register 0

Base address: ADC12m = 0x4017\_0000 + 0x0200 × m (m = 0, 1)

Offset address: 0x098



| Bit  | Symbol   | Function  | R/W |
|------|----------|---|-----|
| 15:0 | CMPLCHAN | Compare Window A Comparison Condition Select<br>These bits set comparison conditions for channels to which Window A comparison conditions are applied.<br>Bit 15 (CMPLCHA15) is associated with ANm15 and bit 0 (CMPLCHA00) is associated with ANm00.<br>Comparison conditions are shown in Figure 37.4.<br>0: When window function is disabled (ADCMPCR.WCMPE = 0):<br>ADCMPDR0 value > A/D-converted value<br>When window function is enabled (ADCMPCR.WCMPE = 1):<br>A/D-converted value < ADCMPDR0 value,<br>or ADCMPDR1 value < A/D-converted value<br>1: When window function is disabled (ADCMPCR.WCMPE = 0):<br>ADCMPDR0 value < A/D-converted value<br>When window function is enabled (ADCMPCR.WCMPE = 1):<br>ADCMPDR0 value < A/D-converted value < ADCMPDR1 value | R/W |

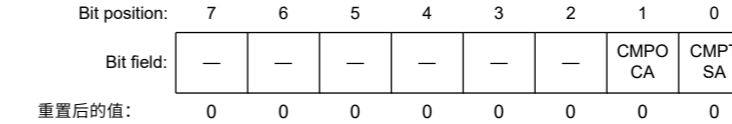
Note: n = 00 to 09, 12, 13(unit 0), 00 to 02(unit 1)

Note: Bits associated with non-existent pins are reserved. This bit is read as 0. The write value should be 0.

### 37.2.24 ADCMPANSER:AD比较功能窗口A扩展输入选择 Register

Base address: ADC12m = 0x4017\_0000 + 0x0200 × m (m = 0, 1)

Offset address: 0x092



| Bit | Symbol | Function   | R/W |
|-----|--------|--|-----|
| 0   | CMPTSA | 温度传感器输出比较选择<br>0: 将温度传感器输出排除在比较窗口A目标范围之外。1: 将温度传感器输出包括在比较窗口A目标范围内。 | R/W |
| 1   | CMPOCA | 内部参考电压比较选择<br>0: 将内部参考电压排除在比较窗口A目标范围之外。1: 在比较窗口A目标范围内包含内部参考电压。     | R/W |
| 7:2 | —      | 这些位被读取为0。写入值应为0。   | R/W |

#### CMPTSA位 (温度传感器输出比较选择)

比较窗口A功能通过将CMPTSA位设置为1而ADEXICR.TSSA位或ADXICR.TSSB位为1。在ADCSR.ADST位为0时设置CMPTSA位。

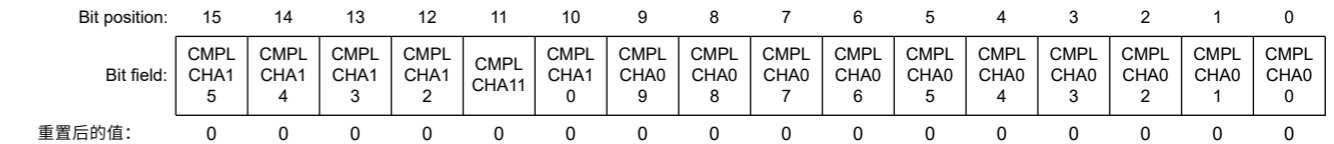
#### CMPOCA位 (内部参考电压比较选择)

当ADEXICR.OCSA和ADXICR.OCSB位为1。当ADCSR.ADST位为0时，设置CMPOCA位。

### 37.2.25 ADCMPLR0:AD比较功能窗口A比较条件设置 Register 0

Base address: ADC12m = 0x4017\_0000 + 0x0200 × m (m = 0, 1)

Offset address: 0x098



| Bit  | Symbol   | Function  | R/W |
|------|----------|---|-----|
| 15:0 | CMPLCHAN | 比较窗口A比较条件选择<br>这些位设置应用窗口A比较条件的通道的比较条件。位15(CMPLCHA15)与ANm15相关联，位0(CMPLCHA00)与ANm00。<br>比较条件如图37.4所示。<br>0: 禁用窗口功能时 (ADCMPCR.WCMPE=0) : ADCMPDR0值>D转换值当启用窗口功能时 (ADCMPCR.WCMPE=1) :<br>D转换值<ADCMPDR0值, 或ADCMPDR1值<AD转换值<br>1: 当窗口功能禁用时 (ADCMPCR.WCMPE=0) : ADCMPDR0值<AD转换值<br>启用窗口功能时(ADCMPCR.WCMPE=1):<br>ADCMPDR0 value < A/D-converted value < ADCMPDR1 value | R/W |

Note: n = 00 to 09, 12, 13(unit 0), 00 to 02(unit 1)

Note: 与不存在的引脚相关的位被保留。该位读取为0。写入值应为0。

**CMPLCHAn bits (Compare Window A Comparison Condition Select)**

The CMPLCHAn bits specify the comparison conditions for channels to which Window A comparison conditions are applied. These bits can be set for each analog input to be compared. When the comparison result of each analog input meets the set condition, the ADCMPSTR0.CMPSTCHAn flag sets to 1 and a compare interrupt (ADC12i\_CMPAI (i = 0, 1)) is generated.

|  |         |
|--|---------|
| Comparison conditions when the window function is disabled |         |
| CMPLCHAn = 0   |         |
| ADCMPDR0 value ≤ A/D converted value                       | Not met |
| ADCMPDR0 value > A/D converted value                       | Met     |
| CMPLCHAn = 1   |         |
| ADCMPDR0 value < A/D converted value                       | Met     |
| ADCMPDR0 value ≥ A/D converted value                       | Not met |
| Comparison conditions when the window function is enabled  |         |
| CMPLCHAn = 0   |         |
| ADCMPDR1 value < A/D converted value                       | Met     |
| ADCMPDR0 value ≤ A/D converted value ≤ ADCMPDR1 value      | Not met |
| A/D converted value < ADCMPDR0 value                       | Met     |
| CMPLCHAn = 1   |         |
| ADCMPDR1 value ≤ A/D converted value                       | Not met |
| ADCMPDR0 value < A/D converted value < ADCMPDR1 value      | Met     |
| A/D converted value ≤ ADCMPDR0 value                       | Not met |

Figure 37.4 Explanation of comparison conditions for compare function Window A

**37.2.26 ADCMPLR1 : A/D Compare Function Window A Comparison Condition Setting Register 1**

Base address: ADC12m = 0x4017\_0000 + 0x0200 × m (m = 0, 1)

Offset address: 0x09A

|                    |                   |                   |                   |                   |                   |                   |                   |                   |                   |                   |                   |                   |                   |                   |                   |                   |
|--------------------|-------------------|-------------------|-------------------|-------------------|-------------------|-------------------|-------------------|-------------------|-------------------|-------------------|-------------------|-------------------|-------------------|-------------------|-------------------|-------------------|
| Bit position:      | 15                | 14                | 13                | 12                | 11                | 10                | 9                 | 8                 | 7                 | 6                 | 5                 | 4                 | 3                 | 2                 | 1                 | 0                 |
| Bit field:         | CMPL<br>CHA3<br>1 | CMPL<br>CHA3<br>0 | CMPL<br>CHA2<br>9 | CMPL<br>CHA2<br>8 | CMPL<br>CHA2<br>7 | CMPL<br>CHA2<br>6 | CMPL<br>CHA2<br>5 | CMPL<br>CHA2<br>4 | CMPL<br>CHA2<br>3 | CMPL<br>CHA2<br>2 | CMPL<br>CHA2<br>1 | CMPL<br>CHA2<br>0 | CMPL<br>CHA1<br>9 | CMPL<br>CHA1<br>8 | CMPL<br>CHA1<br>7 | CMPL<br>CHA1<br>6 |
| Value after reset: | 0                 | 0                 | 0                 | 0                 | 0                 | 0                 | 0                 | 0                 | 0                 | 0                 | 0                 | 0                 | 0                 | 0                 | 0                 | 0                 |

**CMPLCHAn位 (比较窗口A比较条件选择)**

CMPLCHAn位指定应用窗口A比较条件的通道的比较条件。可以为要比较的每个模拟输入设置这些位。当每个模拟输入的比较结果满足设置条件时，ADCMPSTR0.CMPSTCHAn标志设置为1，并产生比较中断(ADC12i\_CMPAI(i=0 1))。

|                               |     |
|-------------------------------|-----|
| 禁用窗口功能时的比较条件                  |     |
| CMPLCHAn = 0                  |     |
| ADCMPDR0值 ≤ AD转换值             | 没见过 |
| ADCMPDR0值 > AD转换值             | Met |
| CMPLCHAn = 1                  |     |
| ADCMPDR0值 < AD转换值             | Met |
| ADCMPDR0值 ≥ AD转换值             | 没见过 |
| 启用窗口功能时的比较条件                  |     |
| CMPLCHAn = 0                  |     |
| ADCMPDR1值 < AD转换值             | Met |
| ADCMPDR0值 ≤ AD转换值 ≤ ADCMPDR1值 | 没见过 |
| AD转换值 < ADCMPDR0值             | Met |
| CMPLCHAn = 1                  |     |
| ADCMPDR1值 ≤ AD转换值             | 没见过 |
| ADCMPDR0值 < AD转换值 < ADCMPDR1值 | Met |
| AD转换值 ≤ ADCMPDR0值             | 没见过 |

Figure 37.4 比较功能窗口A的比较条件说明

**37.2.26 ADCMPLR1:AD比较功能窗口A比较条件设置 Register 1**

Base address: ADC12m = 0x4017\_0000 + 0x0200 × m (m = 0, 1)

Offset address: 0x09A

|               |                   |                   |                   |                   |                   |                   |                   |                   |                   |                   |                   |                   |                   |                   |                   |                   |
|---------------|-------------------|-------------------|-------------------|-------------------|-------------------|-------------------|-------------------|-------------------|-------------------|-------------------|-------------------|-------------------|-------------------|-------------------|-------------------|-------------------|
| Bit position: | 15                | 14                | 13                | 12                | 11                | 10                | 9                 | 8                 | 7                 | 6                 | 5                 | 4                 | 3                 | 2                 | 1                 | 0                 |
| Bit field:    | CMPL<br>CHA3<br>1 | CMPL<br>CHA3<br>0 | CMPL<br>CHA2<br>9 | CMPL<br>CHA2<br>8 | CMPL<br>CHA2<br>7 | CMPL<br>CHA2<br>6 | CMPL<br>CHA2<br>5 | CMPL<br>CHA2<br>4 | CMPL<br>CHA2<br>3 | CMPL<br>CHA2<br>2 | CMPL<br>CHA2<br>1 | CMPL<br>CHA2<br>0 | CMPL<br>CHA1<br>9 | CMPL<br>CHA1<br>8 | CMPL<br>CHA1<br>7 | CMPL<br>CHA1<br>6 |
| 重置后的值:        | 0                 | 0                 | 0                 | 0                 | 0                 | 0                 | 0                 | 0                 | 0                 | 0                 | 0                 | 0                 | 0                 | 0                 | 0                 | 0                 |

| Bit  | Symbol   | Function  | R/W |
|------|----------|---|-----|
| 15:0 | CMPLCHAN | <p>Compare Window A Comparison Condition Select<br/>These bits set comparison conditions for channels to which Window A comparison conditions are applied.</p> <p>Bit 15 (CMPLCHA31) is associated with ANm31 and bit 0 (CMPLCHA16) is associated with ANm16.<br/>Comparison conditions are shown in <a href="#">Figure 37.4</a>.</p> <p>0: When window function is disabled (ADCMPCR.WCMPE = 0):<br/>ADCMPDR0 value &gt; A/D-converted value<br/>When window function is enabled (ADCMPCR.WCMPE = 1):<br/>A/D-converted value &lt; ADCMPDR0 value,<br/>or ADCMPDR1 value &lt; A/D-converted value</p> <p>1: When window function is disabled (ADCMPCR.WCMPE = 0):<br/>ADCMPDR0 value &lt; A/D-converted value<br/>When window function is enabled (ADCMPCR.WCMPE = 1):<br/>ADCMPDR0 value &lt; A/D-converted value &lt; ADCMPDR1 value</p> | R/W |

Note: n = 16 to 22(unit 1)

Note: Bits associated with non-existent pins are reserved. This bit is read as 0. The write value should be 0.

**CMPLCHAN bits (Compare Window A Comparison Condition Select)**

The CMPLCHAN bits specify the comparison conditions for analog channels to which window A comparison conditions are applied. These bits can be set for each analog input to be compared. When the comparison result of each analog input meets the set condition, the ADCMPSR1.CMPSTCHAN bit is set to 1 and a compare interrupt (ADC12i\_CMPAI (i = 0, 1)) is generated.

**37.2.27 ADCMPLER : A/D Compare Function Window A Extended Input Comparison Condition Setting Register**

Base address: ADC12m = 0x4017\_0000 + 0x0200 × m (m = 0, 1)

Offset address: 0x093

|                    |   |   |   |   |   |   |             |             |
|--------------------|---|---|---|---|---|---|-------------|-------------|
| Bit position:      | 7 | 6 | 5 | 4 | 3 | 2 | 1           | 0           |
| Bit field:         | — | — | — | — | — | — | CMPL<br>OCA | CMPL<br>TSA |
| Value after reset: | 0 | 0 | 0 | 0 | 0 | 0 | 0           | 0           |

| Bit | Symbol  | Function   | R/W |
|-----|---------|--|-----|
| 0   | CMPLTSA | <p>Compare Window A Temperature Sensor Output Comparison Condition Select<br/>Comparison conditions are shown in <a href="#">Figure 37.4</a>.</p> <p>0: When window function is disabled (ADCMPCR.WCMPE = 0):<br/>ADCMPDR0 value &gt; A/D-converted value<br/>Compare Window A Temperature Sensor Output Comparison Condition Select<br/>When window function is enabled (ADCMPCR.WCMPE = 1):<br/>Compare Window A Temperature Sensor Output Comparison Condition A/D-converted value &lt; ADCMPDR0 value,<br/>or A/D-converted value &gt; ADCMPDR1 value</p> <p>1: When window function is disabled (ADCMPCR.WCMPE = 0):<br/>ADCMPDR0 value &lt; A/D-converted value<br/>When window function is enabled (ADCMPCR.WCMPE = 1):<br/>ADCMPDR0 value &lt; A/D-converted value &lt; ADCMPDR1 value</p> | R/W |
| 1   | CMPLOCA | <p>Compare Window A Internal Reference Voltage Comparison Condition Select<br/>Comparison conditions are shown in <a href="#">Figure 37.4</a>.</p> <p>0: When window function is disabled (ADCMPCR.WCMPE = 0):<br/>ADCMPDR0 value &gt; A/D-converted value<br/>When window function is enabled (ADCMPCR.WCMPE = 1):<br/>A/D-converted value &lt; ADCMPDR0 value,<br/>or A/D-converted value &gt; ADCMPDR1 value</p> <p>1: When window function is disabled (ADCMPCR.WCMPE = 0):<br/>ADCMPDR0 value &lt; A/D-converted value<br/>When window function is enabled (ADCMPCR.WCMPE = 1):<br/>ADCMPDR0 value &lt; A/D-converted value &lt; ADCMPDR1 value</p>   | R/W |

| Bit  | Symbol   | Function  | R/W |
|------|----------|---|-----|
| 15:0 | CMPLCHAN | <p>比较窗口A比较条件选择<br/>这些位设置应用窗口A比较条件的通道的比较条件。</p> <p>位15(CMPLCHA31)与ANm31相关联，位0(CMPLCHA16)与ANm16。<br/>比较条件如图37.4所示。</p> <p>0: 禁用窗口功能时 (ADCMPCR.WCMPE=0) : ADCMPDR0值&gt;D<br/>转换值当启用窗口功能时 (ADCMPCR.WCMPE=1) :<br/><br/>D转换值&lt;ADCMPDR0值, 或ADCMPDR1值&lt;<br/>AD转换值</p> <p>1: 当窗口功能禁用时 (ADCMPCR.WCMPE=0) : ADCMPDR0值<br/>&lt;AD转换值<br/>启用窗口功能时(ADCMPCR.WCMPE=1):<br/>ADCMPDR0 value &lt; A/D-converted value &lt; ADCMPDR1 value</p> | R/W |

Note: n = 16 to 22(unit 1)

Note: 与不存在的引脚相关的位被保留。该位读取为0。写入值应为0。

**CMPLCHAN位 (比较窗口A比较条件选择)**

CMPLCHAN位指定应用窗口A比较条件的模拟通道的比较条件。可以为要比较的每个模拟输入设置这些位。当每个模拟输入的比较结果满足设置条件时，ADCMPSR1.CMPSTCHAN位设置为1，并产生比较中断(ADC12i\_CMPAI(i=0, 1))。

**37.2.27 ADCMPLER:AD比较功能窗口A扩展输入比较条件设置寄存器**

Base address: ADC12m = 0x4017\_0000 + 0x0200 × m (m = 0, 1)

Offset address: 0x093

|               |   |   |   |   |   |   |             |             |
|---------------|---|---|---|---|---|---|-------------|-------------|
| Bit position: | 7 | 6 | 5 | 4 | 3 | 2 | 1           | 0           |
| Bit field:    | — | — | — | — | — | — | CMPL<br>OCA | CMPL<br>TSA |
| 重置后的值:        | 0 | 0 | 0 | 0 | 0 | 0 | 0           | 0           |

| Bit | Symbol  | Function   | R/W |
|-----|---------|--|-----|
| 0   | CMPLTSA | <p>比较窗口A温度传感器输出比较条件选择<br/>比较条件如图37.4所示。</p> <p>0: 当窗口功能被禁用时 (ADCMPCR.WCMPE=0) :<br/>ADCMPDR0值&gt;AD转换值比较窗口A温度<br/>传感器输出比较条件选择<br/>启用窗口功能时(ADCMPCR.WCMPE=1):<br/>比较窗口A温度传感器输出比较条件AD转换值&lt;ADCMPDR0值, 或AD转换值&gt;<br/>ADCMPDR1值</p> <p>1: 禁用窗口功能时 (ADCMPCR.WCMPE=0) : ADCMPDR0值&lt;A<br/>D转换值<br/>启用窗口功能时(ADCMPCR.WCMPE=1):<br/>ADCMPDR0 value &lt; A/D-converted value &lt; ADCMPDR1 value</p> | R/W |
| 1   | CMPLOCA | <p>比较窗口A内部参考电压比较条件选择<br/>比较条件如图37.4所示。</p> <p>0: 当窗口功能禁用时 (ADCMPCR.WCMPE=0) : ADCMPDR0值&gt;<br/>D转换值当窗口功能启用时 (ADCMPCR.WCMPE=1) :<br/><br/>D转换值&lt;ADCMPDR0值, 或D转换值&gt;ADCM<br/>PDR1值</p> <p>1: 当窗口功能禁用时 (ADCMPCR.WCMPE=0) : ADCMPDR0值<br/>&lt;AD转换值<br/>启用窗口功能时(ADCMPCR.WCMPE=1):<br/>ADCMPDR0 value &lt; A/D-converted value &lt; ADCMPDR1 value</p>  | R/W |

| Bit | Symbol | Function   | R/W |
|-----|--------|--|-----|
| 7:2 | —      | These bits are read as 0. The write value should be 0. | R/W |

**CMPLTSA bit (Compare Window A Temperature Sensor Output Comparison Condition Select)**

The CMPLTSA bit specifies comparison conditions when the temperature sensor output is the target for the Window A comparison condition. When the temperature sensor output comparison result meets the set condition, the ADCMPSEr.CMPSTTSA flag sets to 1 and a compare interrupt (ADC12i\_CMPAI (i = 0, 1)) is generated.

**CMPLOCA bit (Compare Window A Internal Reference Voltage Comparison Condition Select)**

The CMPLOCA bit specifies comparison conditions when the internal reference voltage is the target for the Window A comparison condition. When the internal reference voltage comparison result meets the set condition, the ADCMPSEr.CMPSTOCA flag sets to 1 and a compare interrupt (ADC12i\_CMPAI (i = 0, 1)) is generated.

**37.2.28 ADCMPDRn : A/D Compare Function Window A Lower-Side/Upper-Side Level Setting Register (n = 0, 1)**

Base address:  $ADC12m = 0x4017\_0000 + 0x0200 \times m$  (m = 0, 1)

Offset address:  $0x09C + (0x2 \times n)$

| Bit position:      | 15          | 14 | 13 | 12 | 11 | 10 | 9 | 8 | 7 | 6 | 5 | 4 | 3 | 2 | 1 | 0 |
|--------------------|-------------|----|----|----|----|----|---|---|---|---|---|---|---|---|---|---|
| Bit field:         | [Empty box] |    |    |    |    |    |   |   |   |   |   |   |   |   |   |   |
| Value after reset: | 0           | 0  | 0  | 0  | 0  | 0  | 0 | 0 | 0 | 0 | 0 | 0 | 0 | 0 | 0 | 0 |

The ADCMPDRy (y = 0, 1) register specifies the reference data when the compare window A function is used. ADCMPDR0 sets the lower reference for window A, and ADCMPDR1 sets the upper reference for window A.

ADCMPDRy are read/write registers.

ADCMPDRy are writable even during A/D conversion. The reference data can be dynamically changed by rewriting register values during A/D conversion\*1.

Set these registers so that the upper reference is not less than the lower reference ( $ADCMPDR1 \geq ADCMPDR0$  and ). ADCMPDR1 and are not used when the window function is disabled.

Note 1. The lower and the upper references are changed when each register is written. For example, when the upper reference value is changed and the lower reference value is being changed, the MCU compares the upper reference (after rewrite), and the lower reference (before rewrite) with the A/D conversion result. See Figure 37.5. If the comparison during the rewriting of these two references is erroneous, then rewrite these reference values when both ADCSR.ADST and the target Compare Window Operation Enable bit (ADCMPSEr.CMPAE or ADCMPSEr.CMPBE) are 0.

| Bit | Symbol | Function         | R/W |
|-----|--------|------------------|-----|
| 7:2 | —      | 这些位被读取为0。写入值应为0。 | R/W |

**CMPLTSA位 (比较窗口A温度传感器输出比较条件选择)**

当温度传感器输出是窗口A比较条件的目标时，CMPLTSA位指定比较条件。当温度传感器输出比较结果满足设置条件时，ADCMPSEr.CMPSTTSA标志设置为1并产生比较中断(ADC12i\_CMPAI(i=0 1))。

**CMPLOCA位 (比较窗口A内部参考电压比较条件选择)**

当内部参考电压是窗口A比较条件的目标时，CMPLOCA位指定比较条件。当内部参考电压比较结果满足设置条件时，ADCMPSEr.CMPSTOCA标志设置为1并产生比较中断(ADC12i\_CMPAI(i=0 1))。

**37.2.28 ADCMPDRn:AD比较功能窗口ALower-SideUpper-SideLevel设置寄存器(n=0 1)**

Base address:  $ADC12m = 0x4017\_0000 + 0x0200 \times m$  (m = 0, 1)

Offset address:  $0x09C + (0x2 \times n)$

| Bit position: | 15          | 14 | 13 | 12 | 11 | 10 | 9 | 8 | 7 | 6 | 5 | 4 | 3 | 2 | 1 | 0 |
|---------------|-------------|----|----|----|----|----|---|---|---|---|---|---|---|---|---|---|
| Bit field:    | [Empty box] |    |    |    |    |    |   |   |   |   |   |   |   |   |   |   |
| 重置后的值:        | 0           | 0  | 0  | 0  | 0  | 0  | 0 | 0 | 0 | 0 | 0 | 0 | 0 | 0 | 0 | 0 |

ADCMPDRy(y=0 1)寄存器指定使用比较窗口A功能时的参考数据。ADCMPDR0设置窗口A的下参考值，而ADCMPDR1设置窗口A的上参考值。

ADCMPDRy是读写寄存器。

ADCMPDRy即使在AD转换期间也是可写的。在AD转换\*1期间，可以通过重写寄存器值来动态更改参考数据。

设置这些寄存器，使参考上限不小于参考下限 ( $ADCMPDR1 \geq ADCMPDR0$ 和)。ADCMPDR1并且在窗口功能被禁用时不使用。

注1.写入每个寄存器时，低位和低位参考值会发生变化。例如，当上参考值改变和下参考值改变时，MCU将上参考(重写后)和下参考(重写前)与AD转换结果进行比较。请参见图37.5。如果在重写这两个参考时比较错误，则在ADCSR.ADST和目标比较窗口操作使能位(ADCMPSEr.CMPAE或ADCMPSEr.CMPBE)都为0时重写这些参考值。



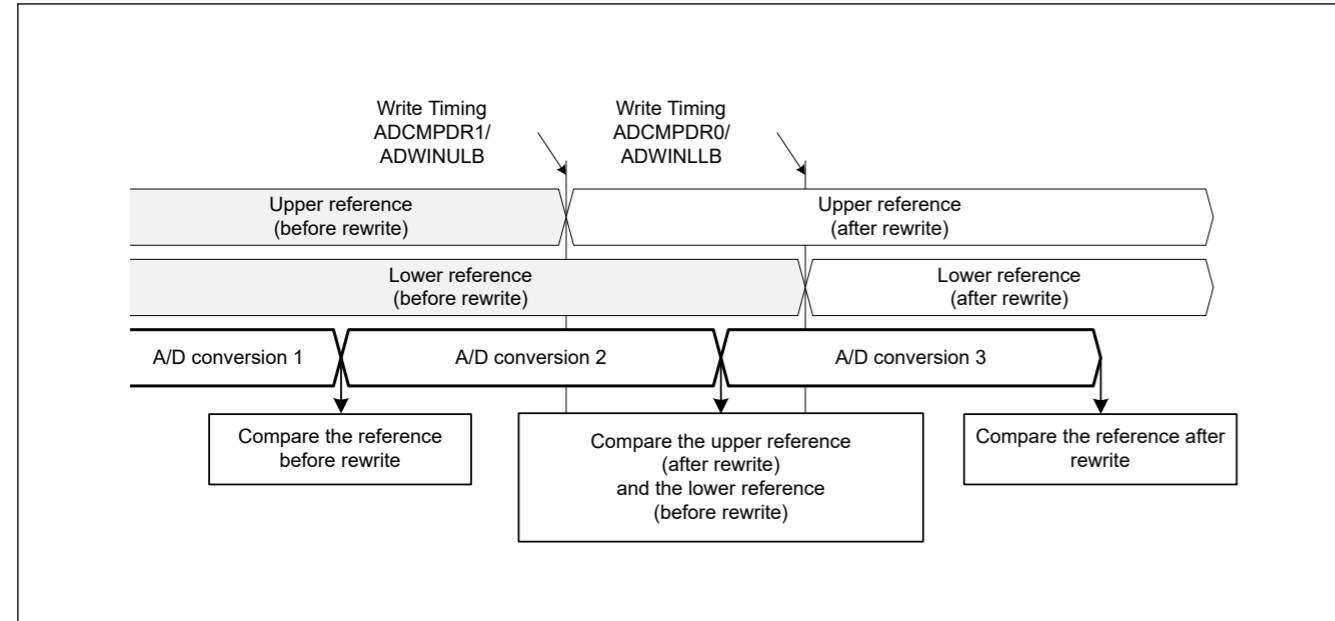


Figure 37.5 Comparison between upper and lower references before and after a rewrite

The ADCMPDRy registers use different formats depending on the following conditions:

- The value of A/D Data Register Format Select bit (flush-right or flush-left)
- The value of the A/D Conversion Accuracy Select bit (12-bit, 10-bit, 8-bit)
- The value of A/D-Converted Value Addition/Average Channel Select bits (A/D-converted value addition mode selected or not selected).

The data formats for each condition are shown as follows:

1. When A/D-converted value addition mode is not selected
  - Flush-right data with 12-bit accuracy — Lower 12 bits ([11:0]) are valid
  - Flush-right data with 10-bit accuracy — Lower 10 bits ([9:0]) are valid
  - Flush-right data with 8-bit accuracy — Lower 8 bits ([7:0]) are valid
  - Flush-left data with 12-bit accuracy — Upper 12 bits ([15:4]) are valid
  - Flush-left data with 10-bit accuracy — Upper 10 bits ([15:6]) are valid
  - Flush-left data with 8-bit accuracy — Upper 8 bits ([15:8]) are valid
2. When A/D-converted value addition mode is selected
  - Flush-right data with 12-bit accuracy — Lower 14 bits ([13:0]) are valid
  - Flush-right data with 10-bit accuracy — Lower 12 bits ([11:0]) are valid
  - Flush-right data with 8-bit accuracy — Lower 10 bits ([9:0]) are valid
  - Flush-left data with 12-bit accuracy — Upper 14 bits ([15:2]) are valid
  - Flush-left data with 10-bit accuracy — Upper 12 bits ([15:4]) are valid
  - Flush-left data with 8-bit accuracy — Upper 10 bits ([15:6]) are valid

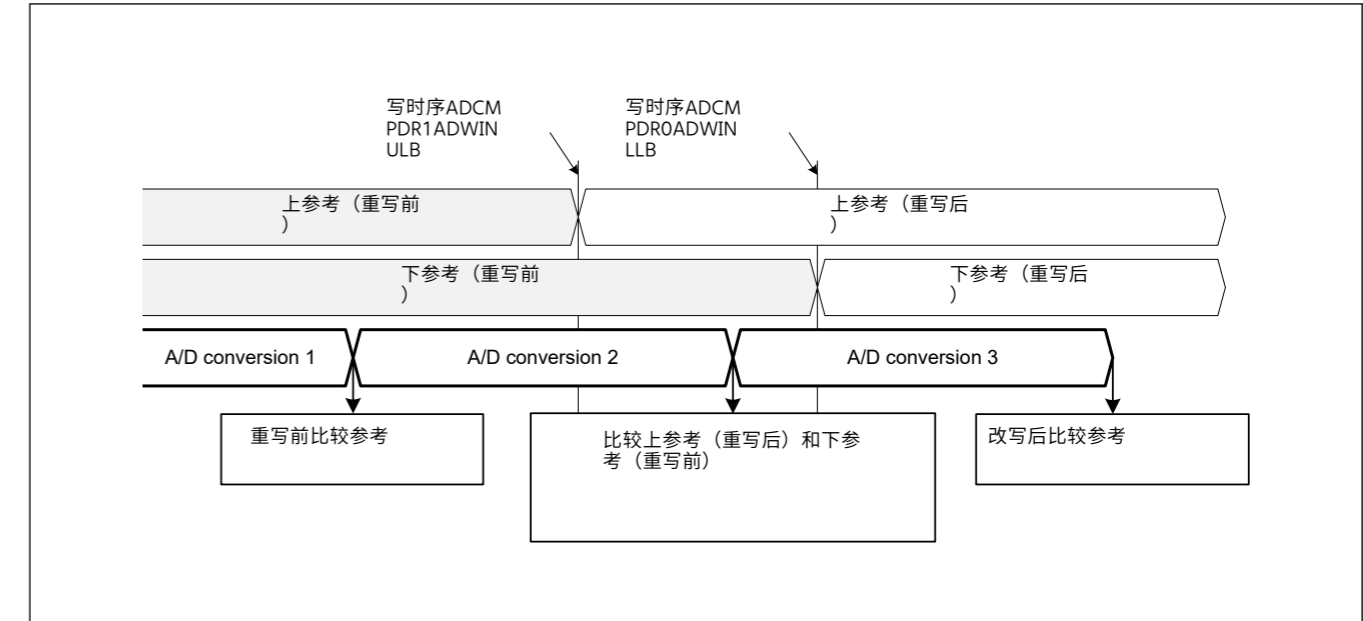


Figure 37.5 重写前后上下引用的比较

ADCMPDRy寄存器根据以下条件使用不同的格式:

- AD数据寄存器格式选择位的值 (flush-right或flush-left)
- AD转换精度选择位 (12位、10位、8位) 的值
- AD-Converted Value Addition/Average Channel Select位的值 (选择或不选择AD-converted value添加模式)。

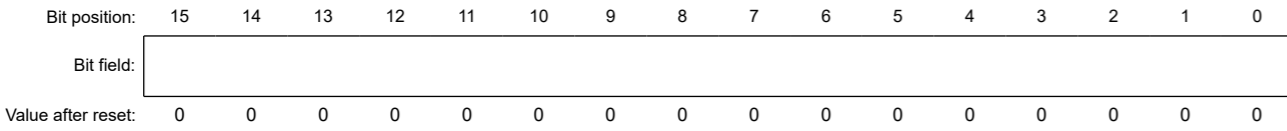
每个条件的数据格式如下所示:

1. 未选择AD转换值加法模式时
  - 12位精度的右刷新数据—低12位([11:0])有效
  - 10位精度的右刷新数据—低10位([9:0])有效
  - 8位精度的右刷新数据—低8位([7:0])有效
  - 12位精度的左刷新数据—高12位([15:4])有效
  - 10位精度的左刷新数据—高10位([15:6])有效
  - 8位精度的左刷新数据—高8位([15:8])有效
2. 选择AD转换值加法模式时
  - 12位精度的右刷新数据—低14位([13:0])有效
  - 10位精度的右刷新数据—低12位([11:0])有效
  - 8位精度的右刷新数据—低10位([9:0])有效
  - 12位精度的左刷新数据—高14位([15:2])有效
  - 10位精度的左刷新数据—高12位([15:4])有效
  - 8位精度的左刷新数据—高10位([15:6])有效

37.2.29 ADWINnLB : A/D Compare Function Window B Lower-Side/Upper-Side Level Setting Register (n = L, U)

Base address:  $ADC12m = 0x4017\_0000 + 0x0200 \times m$  (m = 0, 1)

Offset address: 0x0A8 (n = L)  
0x0AA (n = U)



The ADWINULB and ADWINLLB registers specify the reference data when the compare window B function is used. ADWINLLB sets the lower reference for window B, and ADWINULB sets the upper reference for window B.

ADWINnLB are read/write registers.

ADWINnLB are writable even during A/D conversion. The reference data can be dynamically changed by rewriting register values during A/D conversion\*1.

Set these registers so that the upper reference is not less than the lower reference ( and  $ADWINULB \geq ADWINLLB$  ), and ADWINULB are not used when the window function is disabled.

Note 1. The lower and the upper references are changed when each register is written. For example, when the upper reference value is changed and the lower reference value is being changed, the MCU compares the upper reference (after rewrite), and the lower reference (before rewrite) with the A/D conversion result. See Figure 37.6. If the comparison during the rewriting of these two references is erroneous, then rewrite these reference values when both ADCSR.ADST and the target Compare Window Operation Enable bit (ADCMPCR.CMPAE or ADCMPCR.CMPBE) are 0.

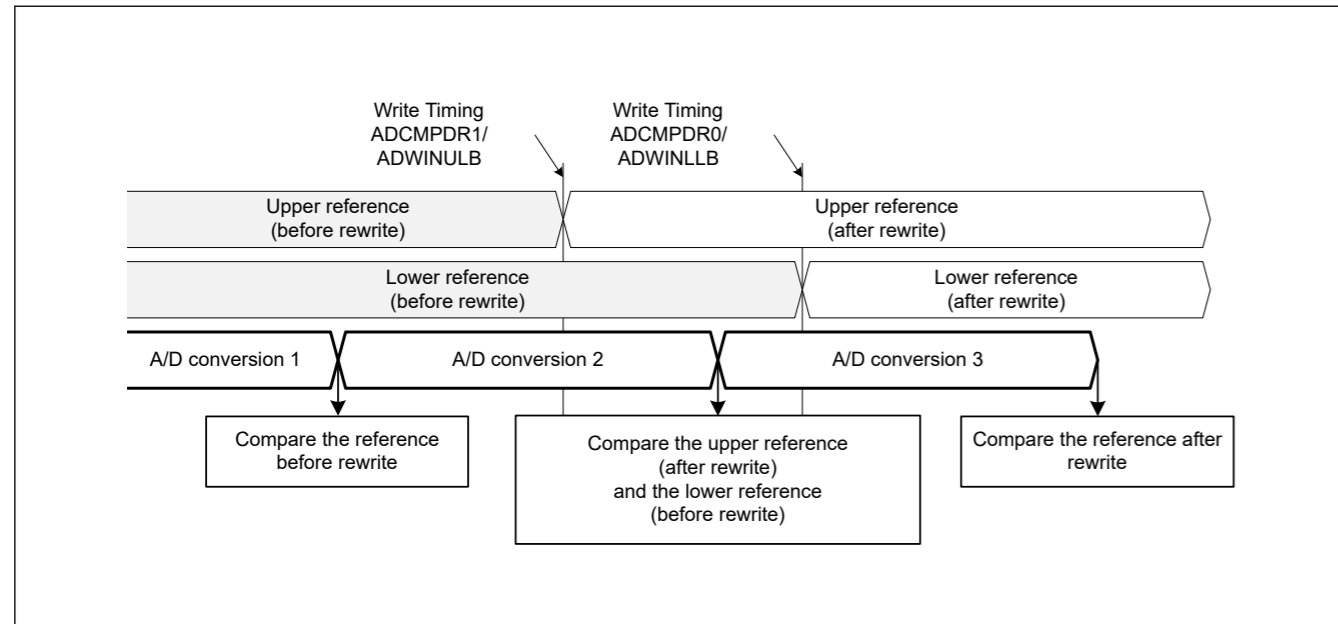


Figure 37.6 Comparison between upper and lower references before and after a rewrite

The ADWINnLB registers use different formats depending on the following conditions:

- The value of A/D Data Register Format Select bit (flush-right or flush-left)
- The value of the A/D Conversion Accuracy Select bit (12-bit, 10-bit, 8-bit)
- The value of A/D-Converted Value Addition/Average Channel Select bits (A/D-converted value addition mode selected or not selected).

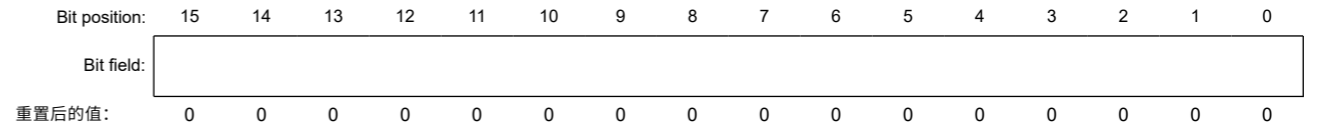
The data formats for each condition are shown as follows:

1. When A/D-converted value addition mode is not selected

37.2.29 ADWINnLB:AD比较函数窗口B Lower-Side/Upper-Side Level 设置寄存器(n=L U)

Base address:  $ADC12m = 0x4017\_0000 + 0x0200 \times m$  (m = 0, 1)

Offset address: 0x0A8 (n = L)  
0x0AA (n = U)



ADWINULB和ADWINLLB寄存器指定使用比较窗口B功能时的参考数据。ADWINLLB设置窗口B的下参考，ADWINULB设置窗口B的上参考。

ADWINnLB是读写寄存器。

ADWINnLB即使在AD转换期间也是可写的。在AD转换\*1期间，可以通过重写寄存器值来动态更改参考数据。

设置这些寄存器，使上限参考值不小于下限参考值（并且 $ADWINULB \geq ADWINLLB$ ）。和禁用窗口功能时不使用ADWINULB。

注1.写入每个寄存器时，低位和高位参考值会发生变化。例如，当上参考值改变和下参考值改变时，MCU将上参考（重写后）和下参考（重写前）与AD转换结果进行比较。请参见图37.6。如果在重写这两个参考时比较错误，则在ADCSR.ADST和目标比较窗口操作使能位（ADCMPCR.CMPAE或ADCMPCR.CMPBE）都为0时重写这些参考值。

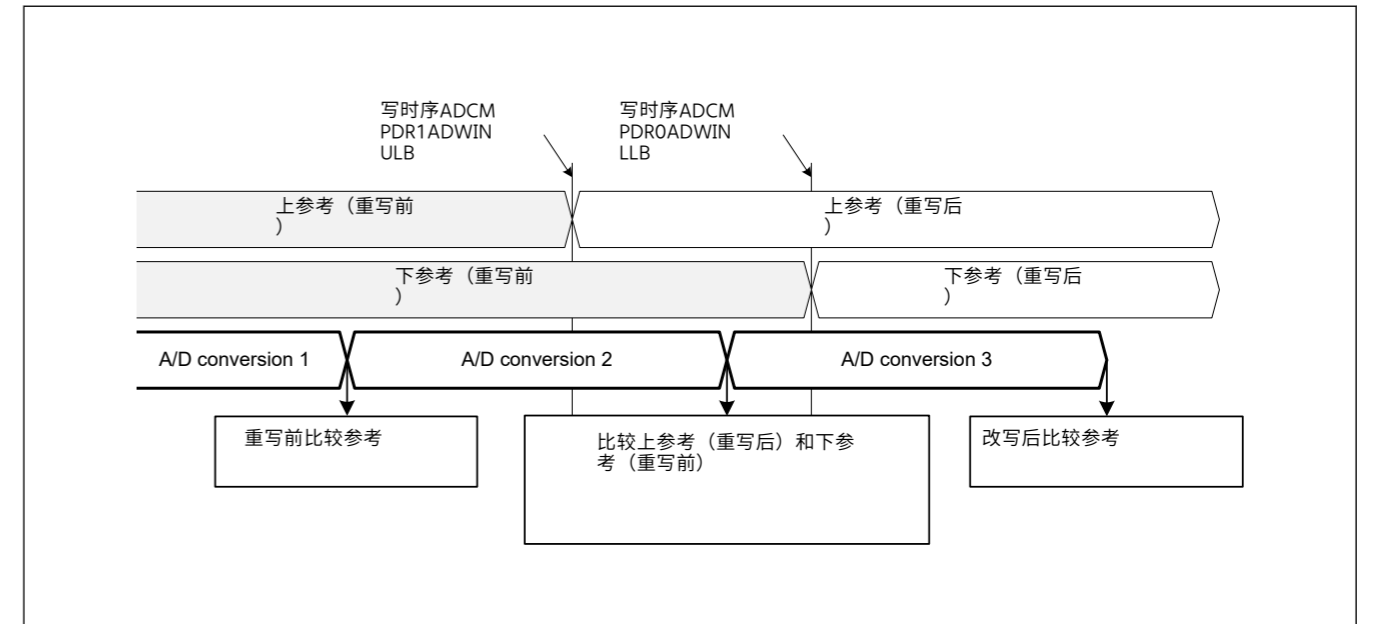


Figure 37.6 重写前后上下引用的比较

ADWINnLB寄存器根据以下条件使用不同的格式:

- AD数据寄存器格式选择位的值 (flush-right or flush-left)
- AD转换精度选择位 (12位、10位、8位) 的值
- AD-Converted Value Addition/Average Channel Select 位的值 (选择或不选择AD-converted value 添加模式)。

每个条件的数据格式如下所示:

1. 未选择AD转换值加法模式时

- Flush-right data with 12-bit accuracy — Lower 12 bits ([11:0]) are valid
- Flush-right data with 10-bit accuracy — Lower 10 bits ([9:0]) are valid
- Flush-right data with 8-bit accuracy — Lower 8 bits ([7:0]) are valid
- Flush-left data with 12-bit accuracy — Upper 12 bits ([15:4]) are valid
- Flush-left data with 10-bit accuracy — Upper 10 bits ([15:6]) are valid
- Flush-left data with 8-bit accuracy — Upper 8 bits ([15:8]) are valid

2. When A/D-converted value addition mode is selected

- Flush-right data with 12-bit accuracy — Lower 14 bits ([13:0]) are valid
- Flush-right data with 10-bit accuracy — Lower 12 bits ([11:0]) are valid
- Flush-right data with 8-bit accuracy — Lower 10 bits ([9:0]) are valid
- Flush-left data with 12-bit accuracy — Upper 14 bits ([15:2]) are valid
- Flush-left data with 10-bit accuracy — Upper 12 bits ([15:4]) are valid
- Flush-left data with 8-bit accuracy — Upper 10 bits ([15:6]) are valid

37.2.30 ADCMPSTR0 : A/D Compare Function Window A Channel Status Register 0

Base address: ADC12m = 0x4017\_0000 + 0x0200 × m (m = 0, 1)

Offset address: 0x0A0

|                    |            |            |            |            |            |            |            |            |            |            |            |            |            |            |            |            |
|--------------------|------------|------------|------------|------------|------------|------------|------------|------------|------------|------------|------------|------------|------------|------------|------------|------------|
| Bit position:      | 15         | 14         | 13         | 12         | 11         | 10         | 9          | 8          | 7          | 6          | 5          | 4          | 3          | 2          | 1          | 0          |
| Bit field:         | CMPSTCHA15 | CMPSTCHA14 | CMPSTCHA13 | CMPSTCHA12 | CMPSTCHA11 | CMPSTCHA10 | CMPSTCHA09 | CMPSTCHA08 | CMPSTCHA07 | CMPSTCHA06 | CMPSTCHA05 | CMPSTCHA04 | CMPSTCHA03 | CMPSTCHA02 | CMPSTCHA01 | CMPSTCHA00 |
| Value after reset: | 0          | 0          | 0          | 0          | 0          | 0          | 0          | 0          | 0          | 0          | 0          | 0          | 0          | 0          | 0          | 0          |

| Bit  | Symbol    | Function  | R/W |
|------|-----------|---|-----|
| 15:0 | CMPSTCHAN | Compare Window A Flag<br>When Window A operation is enabled (ADCMPSTR.CMPAE = 1b), these bits indicate the comparison result of channels to which Window A comparison conditions are applied. Bit 15 (CMPSTCHA15) is associated with ANm15 and bit 0 (CMPSTCHA00) is associated with ANm00.<br>0: Comparison conditions are not met.<br>1: Comparison conditions are met. | R/W |

Note: n = 00 to 09, 12, 13(unit 0), 00 to 02(unit 1)  
 Note: Bits associated with non-existent pins are reserved. This bit is read as 0. The write value should be 0.

**CMPSTCHAN flags (Compare Window A Flag)**

The CMPSTCHAN flags indicate the comparison results for channels to which Window A comparison conditions are applied. When a comparison condition set in ADCMPSTR0.CMPLCHAN is met at the end of A/D conversion, the associated CMPSTCHAN flag sets to 1. When the ADCMPSTR.CMPAIE bit is 1, a compare interrupt request (ADC12i\_CMPAI (i = 0, 1)) is generated when this flag sets to 1.

Writing 1 to the CMPSTCHAN flags is invalid.

[Setting condition]

- The condition set in ADCMPSTR0.CMPLCHAN is met when ADCMPSTR.CMPAE = 1.

[Clearing condition]

- Writing 0 after reading 1.

- 12位精度的右冲洗数据—低12位([11:0])有效
- 10位精度的右刷新数据—低10位([9:0])有效
- 8位精度的右冲洗数据—低8位([7:0])有效
- 12位精度的左刷新数据—高12位([15:4])有效
- 10位精度的左刷新数据—高10位([15:6])有效
- 8位精度的左刷新数据—高8位([15:8])有效

2.选择AD转换值加法模式时

- 12位精度的右刷新数据—低14位([13:0])有效
- 10位精度的右刷新数据—低12位([11:0])有效
- 8位精度的右冲洗数据—低10位([9:0])有效
- 12位精度的左刷新数据—高14位([15:2])有效
- 10位精度的左刷新数据—高12位([15:4])有效
- 8位精度的左刷新数据—高10位([15:6])有效

37.2.30 ADCMPSTR0:AD比较功能窗口A通道状态寄存器0

Base address: ADC12m = 0x4017\_0000 + 0x0200 × m (m = 0, 1)

Offset address: 0x0A0

|               |            |            |            |            |            |            |            |            |            |            |            |            |            |            |            |            |
|---------------|------------|------------|------------|------------|------------|------------|------------|------------|------------|------------|------------|------------|------------|------------|------------|------------|
| Bit position: | 15         | 14         | 13         | 12         | 11         | 10         | 9          | 8          | 7          | 6          | 5          | 4          | 3          | 2          | 1          | 0          |
| Bit field:    | CMPSTCHA15 | CMPSTCHA14 | CMPSTCHA13 | CMPSTCHA12 | CMPSTCHA11 | CMPSTCHA10 | CMPSTCHA09 | CMPSTCHA08 | CMPSTCHA07 | CMPSTCHA06 | CMPSTCHA05 | CMPSTCHA04 | CMPSTCHA03 | CMPSTCHA02 | CMPSTCHA01 | CMPSTCHA00 |
| 重置后的值:        | 0          | 0          | 0          | 0          | 0          | 0          | 0          | 0          | 0          | 0          | 0          | 0          | 0          | 0          | 0          | 0          |

| Bit  | Symbol    | Function   | R/W |
|------|-----------|--|-----|
| 15:0 | CMPSTCHAN | 比较窗口A标志<br>当窗口A操作使能时 (ADCMPSTR.CMPAE=1b)，这些位指示应用窗口A比较条件的通道的比较结果。位15(CMPSTCHA15)与ANm15相关联，位0(CMPSTCHA00)与ANm00相关联。<br>0: 不满足比较条件。1: 满足比较条件。 | R/W |

Note: n = 00 to 09, 12, 13(unit 0), 00 to 02(unit 1)  
 Note: 与不存在的引脚相关的位被保留。该位读取为0。写入值应为0。

**CMPSTCHAN标志 (比较窗口A标志)**

CMPSTCHAN标志指示应用窗口A比较条件的通道的比较结果。当ADCMPSTR0.CMPLCHAN中设置的比较条件在AD转换结束时满足，相关的CMPSTCHAN标志设置为1。当ADCMPSTR.CMPAIE位为1时，比较中断请求(ADC12i\_CMPAI(i=0,1))为当此标志设置为1时生成。

将1写入CMPSTCHAN标志是无效的。

[Setting condition]

- ADCMPSTR0.CMPLCHAN中设置的条件在ADCMPSTR.CMPAE=1时满足。

[Clearing condition]

- 读1后写0。

37.2.31 ADCMPSTR1 : A/D Compare Function Window A Channel Status Register1

Base address: ADC12m = 0x4017\_0000 + 0x0200 × m (m = 0, 1)  
 Offset address: 0x0A2

|                    |            |            |            |            |            |            |            |            |            |            |            |            |            |            |            |            |
|--------------------|------------|------------|------------|------------|------------|------------|------------|------------|------------|------------|------------|------------|------------|------------|------------|------------|
| Bit position:      | 15         | 14         | 13         | 12         | 11         | 10         | 9          | 8          | 7          | 6          | 5          | 4          | 3          | 2          | 1          | 0          |
| Bit field:         | CMPSTCHA31 | CMPSTCHA30 | CMPSTCHA29 | CMPSTCHA28 | CMPSTCHA27 | CMPSTCHA26 | CMPSTCHA25 | CMPSTCHA24 | CMPSTCHA23 | CMPSTCHA22 | CMPSTCHA21 | CMPSTCHA20 | CMPSTCHA19 | CMPSTCHA18 | CMPSTCHA17 | CMPSTCHA16 |
| Value after reset: | 0          | 0          | 0          | 0          | 0          | 0          | 0          | 0          | 0          | 0          | 0          | 0          | 0          | 0          | 0          | 0          |

| Bit  | Symbol    | Function  | R/W |
|------|-----------|---|-----|
| 15:0 | CMPSTCHAN | Compare Window A Flag<br>When Window A operation is enabled (ADCMPSTR1.CMPSTCHAE = 1), these bits indicate the comparison result of channels to which Window A comparison conditions are applied. Bit 15 (CMPSTCHA31) is associated with ANm31 and bit 0 (CMPSTCHA16) is associated with ANm16.<br>0: Comparison conditions are not met.<br>1: Comparison conditions are met. | R/W |

Note: n = 16 to 22(unit 1)  
 Note: Bits associated with non-existent pins are reserved. This bit is read as 0. The write value should be 0.

**CMPSTCHAN flags (Compare Window A Flag)**

The CMPSTCHAN flags indicate the comparison results for channels to which Window A comparison conditions are applied. When the comparison condition set in ADCMPSTR1.CMPSTCHAN is met at the end of A/D conversion, the associated CMPSTCHAN flag sets to 1. When the ADCMPSTR1.CMPSTCHAE bit is 1, a compare interrupt request (ADC12i\_CMPSTR1(i = 0, 1)) is generated when this flag sets to 1.

Writing 1 to the CMPSTCHAN flags is invalid.

[Setting condition]

- The condition set in ADCMPSTR1.CMPSTCHAN is met when ADCMPSTR1.CMPSTCHAE = 1.

[Clearing condition]

- Writing 0 after reading 1.

37.2.32 ADCMPSTR2 : A/D Compare Function Window A Extended Input Channel Status Register

Base address: ADC12m = 0x4017\_0000 + 0x0200 × m (m = 0, 1)  
 Offset address: 0x0A4

|                    |   |   |   |   |   |   |           |           |
|--------------------|---|---|---|---|---|---|-----------|-----------|
| Bit position:      | 7 | 6 | 5 | 4 | 3 | 2 | 1         | 0         |
| Bit field:         | — | — | — | — | — | — | CMPSTTOCA | CMPSTTTSA |
| Value after reset: | 0 | 0 | 0 | 0 | 0 | 0 | 0         | 0         |

| Bit | Symbol    | Function  | R/W |
|-----|-----------|---|-----|
| 0   | CMPSTTTSA | Compare Window A Temperature Sensor Output Compare Flag<br>When Window A operation is enabled (ADCMPSTR2.CMPSTSTR2E = 1), this bit indicates the temperature sensor output comparison result.<br>0: Comparison conditions are not met.<br>1: Comparison conditions are met.   | R/W |
| 1   | CMPSTTOCA | Compare Window A Internal Reference Voltage Compare Flag<br>When Window A operation is enabled (ADCMPSTR2.CMPSTSTR2E = 1), this bit indicates the internal reference voltage comparison result.<br>0: Comparison conditions are not met.<br>1: Comparison conditions are met. | R/W |

37.2.31 ADCMPSTR1:AD比较功能窗口A通道状态寄存器1

Base address: ADC12m = 0x4017\_0000 + 0x0200 × m (m = 0, 1)  
 Offset address: 0x0A2

|               |            |            |            |            |            |            |            |            |            |            |            |            |            |            |            |            |
|---------------|------------|------------|------------|------------|------------|------------|------------|------------|------------|------------|------------|------------|------------|------------|------------|------------|
| Bit position: | 15         | 14         | 13         | 12         | 11         | 10         | 9          | 8          | 7          | 6          | 5          | 4          | 3          | 2          | 1          | 0          |
| Bit field:    | CMPSTCHA31 | CMPSTCHA30 | CMPSTCHA29 | CMPSTCHA28 | CMPSTCHA27 | CMPSTCHA26 | CMPSTCHA25 | CMPSTCHA24 | CMPSTCHA23 | CMPSTCHA22 | CMPSTCHA21 | CMPSTCHA20 | CMPSTCHA19 | CMPSTCHA18 | CMPSTCHA17 | CMPSTCHA16 |
| 重置后的值:        | 0          | 0          | 0          | 0          | 0          | 0          | 0          | 0          | 0          | 0          | 0          | 0          | 0          | 0          | 0          | 0          |

| Bit  | Symbol    | Function  | R/W |
|------|-----------|---|-----|
| 15:0 | CMPSTCHAN | 比较窗口A标志<br>当窗口A操作使能 (ADCMPSTR1.CMPSTCHAE=1) 时, 这些位指示应用窗口A比较条件的通道的比较结果。位15(CMPSTCHA31)与ANm31相关联, 位0(CMPSTCHA16)与ANm16相关联。<br>0: 不满足比较条件。1: 满足比较条件。 | R/W |

Note: n = 16 to 22(unit 1)  
 Note: 与不存在的引脚相关的位被保留。该位读取为0。写入值应为0。

**CMPSTCHAN标志 (比较窗口A标志)**

CMPSTCHAN标志指示应用窗口A比较条件的通道的比较结果。当ADCMPSTR1.CMPSTCHAN中设置的比较条件在AD转换结束时满足, 相关的CMPSTCHAN标志设置为1。当ADCMPSTR1.CMPSTCHAE位为1时, 比较中断请求(ADC12i\_CMPSTR1(i=0 1))当此标志设置为1时生成。

将1写入CMPSTCHAN标志是无效的。

[Setting condition]

- ADCMPSTR1.CMPSTCHAN中设置的条件在ADCMPSTR1.CMPSTCHAE=1时满足。

[Clearing condition]

- 读1后写0。

37.2.32 ADCMPSTR2:AD比较功能窗口A扩展输入通道状态寄存器

Base address: ADC12m = 0x4017\_0000 + 0x0200 × m (m = 0, 1)  
 Offset address: 0x0A4

|               |   |   |   |   |   |   |           |           |
|---------------|---|---|---|---|---|---|-----------|-----------|
| Bit position: | 7 | 6 | 5 | 4 | 3 | 2 | 1         | 0         |
| Bit field:    | — | — | — | — | — | — | CMPSTTOCA | CMPSTTTSA |
| 重置后的值:        | 0 | 0 | 0 | 0 | 0 | 0 | 0         | 0         |

| Bit | Symbol    | Function   | R/W |
|-----|-----------|--|-----|
| 0   | CMPSTTTSA | 比较窗口A温度传感器输出比较标志<br>当窗口A操作使能 (ADCMPSTR2.CMPSTSTR2E=1) 时, 该位指示温度传感器输出比较结果。<br>0: 不满足比较条件。1: 满足比较条件。 | R/W |
| 1   | CMPSTTOCA | 比较窗口A内部参考电压比较标志<br>当窗口A操作使能时 (ADCMPSTR2.CMPSTSTR2E=1), 该位指示内部参考电压比较结果。<br>0: 不满足比较条件。1: 满足比较条件。    | R/W |



| Bit | Symbol | Function   | R/W |
|-----|--------|--|-----|
| 7:2 | —      | These bits are read as 0. The write value should be 0. | R/W |

The ADCMPSEER register stores compare results of compare function window A.

#### CMPSTTSA flag (Compare Window A Temperature Sensor Output Compare Flag)

The CMPSTTSA flag indicates the temperature sensor output comparison result. When the comparison condition set in ADCMPLEER.CMPLTSA is met at the end of A/D conversion, this flag sets to 1. When the ADCMPCEER.CMPAIE bit is 1, a compare interrupt request (ADC12i\_CMPAI (i = 0, 1)) is generated when this flag sets to 1.

Writing 1 to the CMPSTTSA flag is invalid.

[Setting condition]

- The condition set in ADCMPLEER.CMPLTSA is met when ADCMPCEER.CMPAIE = 1.

[Clearing condition]

- Writing 0 after reading 1.

#### CMPSTOCA flag (Compare Window A Internal Reference Voltage Compare Flag)

The CMPSTOCA flag indicates the internal reference voltage comparison result. When the comparison condition set in ADCMPLEER.CMPLOCA is met at the end of A/D conversion, this flag sets to 1. When the ADCMPCEER.CMPAIE bit is 1, a compare interrupt request (ADC12i\_CMPAI (i = 0, 1)) is generated when this flag sets to 1.

Writing 1 to the CMPSTOCA flag is invalid.

[Setting condition]

- The condition set in ADCMPLEER.CMPLOCA is met when ADCMPCEER.CMPAIE = 1.

[Clearing condition]

- Writing 0 after reading 1.

### 37.2.33 ADCMPBNSR : A/D Compare Function Window B Channel Select Register

Base address: ADC12m = 0x4017\_0000 + 0x0200 × m (m = 0, 1)

Offset address: 0x0A6

| Bit position:      | 7        | 6 | 5           | 4 | 3 | 2 | 1 | 0 |
|--------------------|----------|---|-------------|---|---|---|---|---|
| Bit field:         | CMP<br>B | — | CMPCHB[5:0] |   |   |   |   |   |
| Value after reset: | 0        | 0 | 0           | 0 | 0 | 0 | 0 | 0 |

| Bit | Symbol | Function         | R/W |
|-----|--------|------------------|-----|
| 7:2 | —      | 这些位被读取为0。写入值应为0。 | R/W |

ADCMPSEER寄存器存储比较功能窗口A的比较结果。

#### CMPSTTSA标志 (比较窗口A温度传感器输出比较标志)

CMPSTTSA标志指示温度传感器输出比较结果。当比较条件设置在ADCMPLEER.CMPLTSA在AD转换结束时满足，该标志设置为1。当ADCMPCEER.CMPAIE位为1时，当该标志设置为1时产生比较中断请求(ADC12i\_CMPAI(i=0 1))。

将1写入CMPSTTSA标志无效。

[Setting condition]

- 当ADCMPCEER.CMPAIE=1时，满足ADCMPLEER.CMPLTSA中设置的条件。

[Clearing condition]

- 读1后写0。

#### CMPSTOCA标志 (比较窗口A内部参考电压比较标志)

CMPSTOCA标志指示内部参考电压比较结果。当比较条件设置在ADCMPLEER.CMPLOCA在AD转换结束时满足，该标志设置为1。当ADCMPCEER.CMPAIE位为1时，当该标志设置为1时产生比较中断请求(ADC12i\_CMPAI(i=0 1))。

将1写入CMPSTOCA标志无效。

[Setting condition]

- 当ADCMPCEER.CMPAIE=1时，满足ADCMPLEER.CMPLOCA中设置的条件。

[Clearing condition]

- 读1后写0。

### 37.2.33 ADCMPBNSR:AD比较功能窗口B通道选择寄存器

Base address: ADC12m = 0x4017\_0000 + 0x0200 × m (m = 0, 1)

Offset address: 0x0A6

| Bit position: | 7        | 6 | 5           | 4 | 3 | 2 | 1 | 0 |
|---------------|----------|---|-------------|---|---|---|---|---|
| Bit field:    | CMP<br>B | — | CMPCHB[5:0] |   |   |   |   |   |
| 重置后的值:        | 0        | 0 | 0           | 0 | 0 | 0 | 0 | 0 |

| Bit         | Symbol                     | Function   | R/W         |        |        |      |       |       |      |       |       |      |       |       |      |       |               |   |   |   |      |       |               |      |       |               |      |       |               |      |               |       |      |               |       |   |   |   |      |               |       |      |                    |  |      |                            |  |      |               |  |        |                    |  |  |
|-------------|----------------------------|--|-------------|--------|--------|------|-------|-------|------|-------|-------|------|-------|-------|------|-------|---------------|---|---|---|------|-------|---------------|------|-------|---------------|------|-------|---------------|------|---------------|-------|------|---------------|-------|---|---|---|------|---------------|-------|------|--------------------|--|------|----------------------------|--|------|---------------|--|--------|--------------------|--|--|
| 5:0         | CMPCHB[5:0]                | Compare Window B Channel Select<br>These bits select channels to be compared with the compare Window B conditions.   | R/W         |        |        |      |       |       |      |       |       |      |       |       |      |       |               |   |   |   |      |       |               |      |       |               |      |       |               |      |               |       |      |               |       |   |   |   |      |               |       |      |                    |  |      |                            |  |      |               |  |        |                    |  |  |
|             |                            | <table border="1"> <thead> <tr> <th>CMPCHB[5:0]</th> <th>Unit 0</th> <th>Unit 1</th> </tr> </thead> <tbody> <tr><td>0x00</td><td>AN000</td><td>AN100</td></tr> <tr><td>0x01</td><td>AN001</td><td>AN101</td></tr> <tr><td>0x02</td><td>AN002</td><td>AN102</td></tr> <tr><td>0x03</td><td>AN003</td><td>Do not select</td></tr> <tr><td>:</td><td>:</td><td>:</td></tr> <tr><td>0x09</td><td>AN009</td><td>Do not select</td></tr> <tr><td>0x0C</td><td>AN012</td><td>Do not select</td></tr> <tr><td>0x0D</td><td>AN013</td><td>Do not select</td></tr> <tr><td>0x10</td><td>Do not select</td><td>AN116</td></tr> <tr><td>0x11</td><td>Do not select</td><td>AN117</td></tr> <tr><td>:</td><td>:</td><td>:</td></tr> <tr><td>0x16</td><td>Do not select</td><td>AN122</td></tr> <tr><td>0x20</td><td>Temperature sensor</td><td></td></tr> <tr><td>0x21</td><td>Internal reference voltage</td><td></td></tr> <tr><td>0x3F</td><td>Do not select</td><td></td></tr> <tr><td>Others</td><td>Setting prohibited</td><td></td></tr> </tbody> </table> | CMPCHB[5:0] | Unit 0 | Unit 1 | 0x00 | AN000 | AN100 | 0x01 | AN001 | AN101 | 0x02 | AN002 | AN102 | 0x03 | AN003 | Do not select | : | : | : | 0x09 | AN009 | Do not select | 0x0C | AN012 | Do not select | 0x0D | AN013 | Do not select | 0x10 | Do not select | AN116 | 0x11 | Do not select | AN117 | : | : | : | 0x16 | Do not select | AN122 | 0x20 | Temperature sensor |  | 0x21 | Internal reference voltage |  | 0x3F | Do not select |  | Others | Setting prohibited |  |  |
| CMPCHB[5:0] | Unit 0                     | Unit 1   |             |        |        |      |       |       |      |       |       |      |       |       |      |       |               |   |   |   |      |       |               |      |       |               |      |       |               |      |               |       |      |               |       |   |   |   |      |               |       |      |                    |  |      |                            |  |      |               |  |        |                    |  |  |
| 0x00        | AN000                      | AN100  |             |        |        |      |       |       |      |       |       |      |       |       |      |       |               |   |   |   |      |       |               |      |       |               |      |       |               |      |               |       |      |               |       |   |   |   |      |               |       |      |                    |  |      |                            |  |      |               |  |        |                    |  |  |
| 0x01        | AN001                      | AN101  |             |        |        |      |       |       |      |       |       |      |       |       |      |       |               |   |   |   |      |       |               |      |       |               |      |       |               |      |               |       |      |               |       |   |   |   |      |               |       |      |                    |  |      |                            |  |      |               |  |        |                    |  |  |
| 0x02        | AN002                      | AN102  |             |        |        |      |       |       |      |       |       |      |       |       |      |       |               |   |   |   |      |       |               |      |       |               |      |       |               |      |               |       |      |               |       |   |   |   |      |               |       |      |                    |  |      |                            |  |      |               |  |        |                    |  |  |
| 0x03        | AN003                      | Do not select  |             |        |        |      |       |       |      |       |       |      |       |       |      |       |               |   |   |   |      |       |               |      |       |               |      |       |               |      |               |       |      |               |       |   |   |   |      |               |       |      |                    |  |      |                            |  |      |               |  |        |                    |  |  |
| :           | :                          | :  |             |        |        |      |       |       |      |       |       |      |       |       |      |       |               |   |   |   |      |       |               |      |       |               |      |       |               |      |               |       |      |               |       |   |   |   |      |               |       |      |                    |  |      |                            |  |      |               |  |        |                    |  |  |
| 0x09        | AN009                      | Do not select  |             |        |        |      |       |       |      |       |       |      |       |       |      |       |               |   |   |   |      |       |               |      |       |               |      |       |               |      |               |       |      |               |       |   |   |   |      |               |       |      |                    |  |      |                            |  |      |               |  |        |                    |  |  |
| 0x0C        | AN012                      | Do not select  |             |        |        |      |       |       |      |       |       |      |       |       |      |       |               |   |   |   |      |       |               |      |       |               |      |       |               |      |               |       |      |               |       |   |   |   |      |               |       |      |                    |  |      |                            |  |      |               |  |        |                    |  |  |
| 0x0D        | AN013                      | Do not select  |             |        |        |      |       |       |      |       |       |      |       |       |      |       |               |   |   |   |      |       |               |      |       |               |      |       |               |      |               |       |      |               |       |   |   |   |      |               |       |      |                    |  |      |                            |  |      |               |  |        |                    |  |  |
| 0x10        | Do not select              | AN116  |             |        |        |      |       |       |      |       |       |      |       |       |      |       |               |   |   |   |      |       |               |      |       |               |      |       |               |      |               |       |      |               |       |   |   |   |      |               |       |      |                    |  |      |                            |  |      |               |  |        |                    |  |  |
| 0x11        | Do not select              | AN117  |             |        |        |      |       |       |      |       |       |      |       |       |      |       |               |   |   |   |      |       |               |      |       |               |      |       |               |      |               |       |      |               |       |   |   |   |      |               |       |      |                    |  |      |                            |  |      |               |  |        |                    |  |  |
| :           | :                          | :  |             |        |        |      |       |       |      |       |       |      |       |       |      |       |               |   |   |   |      |       |               |      |       |               |      |       |               |      |               |       |      |               |       |   |   |   |      |               |       |      |                    |  |      |                            |  |      |               |  |        |                    |  |  |
| 0x16        | Do not select              | AN122  |             |        |        |      |       |       |      |       |       |      |       |       |      |       |               |   |   |   |      |       |               |      |       |               |      |       |               |      |               |       |      |               |       |   |   |   |      |               |       |      |                    |  |      |                            |  |      |               |  |        |                    |  |  |
| 0x20        | Temperature sensor         |  |             |        |        |      |       |       |      |       |       |      |       |       |      |       |               |   |   |   |      |       |               |      |       |               |      |       |               |      |               |       |      |               |       |   |   |   |      |               |       |      |                    |  |      |                            |  |      |               |  |        |                    |  |  |
| 0x21        | Internal reference voltage |  |             |        |        |      |       |       |      |       |       |      |       |       |      |       |               |   |   |   |      |       |               |      |       |               |      |       |               |      |               |       |      |               |       |   |   |   |      |               |       |      |                    |  |      |                            |  |      |               |  |        |                    |  |  |
| 0x3F        | Do not select              |  |             |        |        |      |       |       |      |       |       |      |       |       |      |       |               |   |   |   |      |       |               |      |       |               |      |       |               |      |               |       |      |               |       |   |   |   |      |               |       |      |                    |  |      |                            |  |      |               |  |        |                    |  |  |
| Others      | Setting prohibited         |  |             |        |        |      |       |       |      |       |       |      |       |       |      |       |               |   |   |   |      |       |               |      |       |               |      |       |               |      |               |       |      |               |       |   |   |   |      |               |       |      |                    |  |      |                            |  |      |               |  |        |                    |  |  |
| 6           | —                          | This bit is read as 0. The write value should be 0.  | R/W         |        |        |      |       |       |      |       |       |      |       |       |      |       |               |   |   |   |      |       |               |      |       |               |      |       |               |      |               |       |      |               |       |   |   |   |      |               |       |      |                    |  |      |                            |  |      |               |  |        |                    |  |  |
| 7           | CMPLB                      | Compare Window B Comparison Condition Setting<br>This bit sets comparison conditions for channels for Window B. The comparison conditions are shown in Figure 37.7.<br><br>0: When window function is disabled (ADCMPCR.WCMPE = 0):<br>ADWINLLB value > A/D-converted value<br>When window function is enabled (ADCMPCR.WCMPE = 1):<br>A/D-converted value < ADWINLLB value, or ADWINULB value < A/D-converted value<br><br>1: When window function is disabled (ADCMPCR.WCMPE = 0):<br>ADWINLLB value < A/D-converted value<br>When window function is enabled (ADCMPCR.WCMPE = 1):<br>ADWINLLB value < A/D-converted value < ADWINULB value  | R/W         |        |        |      |       |       |      |       |       |      |       |       |      |       |               |   |   |   |      |       |               |      |       |               |      |       |               |      |               |       |      |               |       |   |   |   |      |               |       |      |                    |  |      |                            |  |      |               |  |        |                    |  |  |

#### CMPCHB[5:0] bits (Compare Window B Channel Select)

The CMPCHB[5:0] bits specify the channels to be compared with the compare Window B conditions from AN000 to AN009, AN012, AN013, AN100 to AN102, AN116 to AN122, the temperature sensor, the internal reference voltage. The compare Window B function is enabled by specifying the hexadecimal number of the A/D conversion channel selected in the ADANSA0, ADANSA1, ADANSB0, ADANSB1 registers.

Set the CMPCHB[5:0] bits while the ADCSR.ADST bit is 0.

#### CMPLB bit (Compare Window B Comparison Condition Setting)

The CMPLB bit specifies the comparison conditions for channels for Window B. When the comparison result of an analog input meets the set condition, the associated ADCMPBSR.CMPSTB flag sets to 1 and a compare interrupt request (ADC12i\_CMPBI (i = 0, 1)) is generated.

| Bit         | Symbol             | Function   | R/W         |        |        |      |       |       |      |       |       |      |       |       |      |       |      |   |   |   |      |       |      |      |       |      |      |       |      |      |      |       |      |      |       |   |   |   |      |      |       |      |                    |  |      |        |  |      |      |  |        |      |  |  |
|-------------|--------------------|--|-------------|--------|--------|------|-------|-------|------|-------|-------|------|-------|-------|------|-------|------|---|---|---|------|-------|------|------|-------|------|------|-------|------|------|------|-------|------|------|-------|---|---|---|------|------|-------|------|--------------------|--|------|--------|--|------|------|--|--------|------|--|--|
| 5:0         | CMPCHB[5:0]        | 比较窗口B通道选择<br>这些位选择要与比较窗口B条件进行比较的通道。  | R/W         |        |        |      |       |       |      |       |       |      |       |       |      |       |      |   |   |   |      |       |      |      |       |      |      |       |      |      |      |       |      |      |       |   |   |   |      |      |       |      |                    |  |      |        |  |      |      |  |        |      |  |  |
|             |                    | <table border="1"> <thead> <tr> <th>CMPCHB[5:0]</th> <th>Unit 0</th> <th>Unit 1</th> </tr> </thead> <tbody> <tr><td>0x00</td><td>AN000</td><td>AN100</td></tr> <tr><td>0x01</td><td>AN001</td><td>AN101</td></tr> <tr><td>0x02</td><td>AN002</td><td>AN102</td></tr> <tr><td>0x03</td><td>AN003</td><td>不要选择</td></tr> <tr><td>:</td><td>:</td><td>:</td></tr> <tr><td>0x09</td><td>AN009</td><td>不要选择</td></tr> <tr><td>0x0C</td><td>AN012</td><td>不要选择</td></tr> <tr><td>0x0D</td><td>AN013</td><td>不要选择</td></tr> <tr><td>0x10</td><td>不要选择</td><td>AN116</td></tr> <tr><td>0x11</td><td>不要选择</td><td>AN117</td></tr> <tr><td>:</td><td>:</td><td>:</td></tr> <tr><td>0x16</td><td>不要选择</td><td>AN122</td></tr> <tr><td>0x20</td><td>Temperature sensor</td><td></td></tr> <tr><td>0x21</td><td>内部参考电压</td><td></td></tr> <tr><td>0x3F</td><td>不要选择</td><td></td></tr> <tr><td>Others</td><td>禁止设定</td><td></td></tr> </tbody> </table> | CMPCHB[5:0] | Unit 0 | Unit 1 | 0x00 | AN000 | AN100 | 0x01 | AN001 | AN101 | 0x02 | AN002 | AN102 | 0x03 | AN003 | 不要选择 | : | : | : | 0x09 | AN009 | 不要选择 | 0x0C | AN012 | 不要选择 | 0x0D | AN013 | 不要选择 | 0x10 | 不要选择 | AN116 | 0x11 | 不要选择 | AN117 | : | : | : | 0x16 | 不要选择 | AN122 | 0x20 | Temperature sensor |  | 0x21 | 内部参考电压 |  | 0x3F | 不要选择 |  | Others | 禁止设定 |  |  |
| CMPCHB[5:0] | Unit 0             | Unit 1   |             |        |        |      |       |       |      |       |       |      |       |       |      |       |      |   |   |   |      |       |      |      |       |      |      |       |      |      |      |       |      |      |       |   |   |   |      |      |       |      |                    |  |      |        |  |      |      |  |        |      |  |  |
| 0x00        | AN000              | AN100  |             |        |        |      |       |       |      |       |       |      |       |       |      |       |      |   |   |   |      |       |      |      |       |      |      |       |      |      |      |       |      |      |       |   |   |   |      |      |       |      |                    |  |      |        |  |      |      |  |        |      |  |  |
| 0x01        | AN001              | AN101  |             |        |        |      |       |       |      |       |       |      |       |       |      |       |      |   |   |   |      |       |      |      |       |      |      |       |      |      |      |       |      |      |       |   |   |   |      |      |       |      |                    |  |      |        |  |      |      |  |        |      |  |  |
| 0x02        | AN002              | AN102  |             |        |        |      |       |       |      |       |       |      |       |       |      |       |      |   |   |   |      |       |      |      |       |      |      |       |      |      |      |       |      |      |       |   |   |   |      |      |       |      |                    |  |      |        |  |      |      |  |        |      |  |  |
| 0x03        | AN003              | 不要选择   |             |        |        |      |       |       |      |       |       |      |       |       |      |       |      |   |   |   |      |       |      |      |       |      |      |       |      |      |      |       |      |      |       |   |   |   |      |      |       |      |                    |  |      |        |  |      |      |  |        |      |  |  |
| :           | :                  | :  |             |        |        |      |       |       |      |       |       |      |       |       |      |       |      |   |   |   |      |       |      |      |       |      |      |       |      |      |      |       |      |      |       |   |   |   |      |      |       |      |                    |  |      |        |  |      |      |  |        |      |  |  |
| 0x09        | AN009              | 不要选择   |             |        |        |      |       |       |      |       |       |      |       |       |      |       |      |   |   |   |      |       |      |      |       |      |      |       |      |      |      |       |      |      |       |   |   |   |      |      |       |      |                    |  |      |        |  |      |      |  |        |      |  |  |
| 0x0C        | AN012              | 不要选择   |             |        |        |      |       |       |      |       |       |      |       |       |      |       |      |   |   |   |      |       |      |      |       |      |      |       |      |      |      |       |      |      |       |   |   |   |      |      |       |      |                    |  |      |        |  |      |      |  |        |      |  |  |
| 0x0D        | AN013              | 不要选择   |             |        |        |      |       |       |      |       |       |      |       |       |      |       |      |   |   |   |      |       |      |      |       |      |      |       |      |      |      |       |      |      |       |   |   |   |      |      |       |      |                    |  |      |        |  |      |      |  |        |      |  |  |
| 0x10        | 不要选择               | AN116  |             |        |        |      |       |       |      |       |       |      |       |       |      |       |      |   |   |   |      |       |      |      |       |      |      |       |      |      |      |       |      |      |       |   |   |   |      |      |       |      |                    |  |      |        |  |      |      |  |        |      |  |  |
| 0x11        | 不要选择               | AN117  |             |        |        |      |       |       |      |       |       |      |       |       |      |       |      |   |   |   |      |       |      |      |       |      |      |       |      |      |      |       |      |      |       |   |   |   |      |      |       |      |                    |  |      |        |  |      |      |  |        |      |  |  |
| :           | :                  | :  |             |        |        |      |       |       |      |       |       |      |       |       |      |       |      |   |   |   |      |       |      |      |       |      |      |       |      |      |      |       |      |      |       |   |   |   |      |      |       |      |                    |  |      |        |  |      |      |  |        |      |  |  |
| 0x16        | 不要选择               | AN122  |             |        |        |      |       |       |      |       |       |      |       |       |      |       |      |   |   |   |      |       |      |      |       |      |      |       |      |      |      |       |      |      |       |   |   |   |      |      |       |      |                    |  |      |        |  |      |      |  |        |      |  |  |
| 0x20        | Temperature sensor |  |             |        |        |      |       |       |      |       |       |      |       |       |      |       |      |   |   |   |      |       |      |      |       |      |      |       |      |      |      |       |      |      |       |   |   |   |      |      |       |      |                    |  |      |        |  |      |      |  |        |      |  |  |
| 0x21        | 内部参考电压             |  |             |        |        |      |       |       |      |       |       |      |       |       |      |       |      |   |   |   |      |       |      |      |       |      |      |       |      |      |      |       |      |      |       |   |   |   |      |      |       |      |                    |  |      |        |  |      |      |  |        |      |  |  |
| 0x3F        | 不要选择               |  |             |        |        |      |       |       |      |       |       |      |       |       |      |       |      |   |   |   |      |       |      |      |       |      |      |       |      |      |      |       |      |      |       |   |   |   |      |      |       |      |                    |  |      |        |  |      |      |  |        |      |  |  |
| Others      | 禁止设定               |  |             |        |        |      |       |       |      |       |       |      |       |       |      |       |      |   |   |   |      |       |      |      |       |      |      |       |      |      |      |       |      |      |       |   |   |   |      |      |       |      |                    |  |      |        |  |      |      |  |        |      |  |  |
| 6           | —                  | 该位读取为0。写入值应为0。   | R/W         |        |        |      |       |       |      |       |       |      |       |       |      |       |      |   |   |   |      |       |      |      |       |      |      |       |      |      |      |       |      |      |       |   |   |   |      |      |       |      |                    |  |      |        |  |      |      |  |        |      |  |  |
| 7           | CMPLB              | 比较窗口B比较条件设置<br>该位设置窗口B的通道比较条件。比较条件如图37.7所示。<br><br>0: 禁用窗口功能时 (ADCMPCR.WCMPE=0) : ADWINLLB值>D转换值<br>启用窗口功能时(ADCMPCR.WCMPE=1):<br>D转换值<ADWINLLB值, 或ADWINULB值<AD转换值<br><br>1: 禁用窗口功能时 (ADCMPCR.WCMPE=0) : ADWINLLB值<A<br>D转换值<br>启用窗口功能时(ADCMPCR.WCMPE=1): ADWINLLB值<AD转<br>换值<ADWINULB值   | R/W         |        |        |      |       |       |      |       |       |      |       |       |      |       |      |   |   |   |      |       |      |      |       |      |      |       |      |      |      |       |      |      |       |   |   |   |      |      |       |      |                    |  |      |        |  |      |      |  |        |      |  |  |

#### CMPCHB[5:0]位 (比较窗口B通道选择)

CMPCHB[5:0]位指定要与比较窗口B条件 (从AN000到 AN009、AN012、AN013、AN100到AN102、AN116到AN122、温度传感器、内部参考电压。通过指定在ADANSA0、ADANSA1、ADANSB0、ADANSB1寄存器中选择的AD转换通道的十六进制数来启用比较窗口B功能。

当ADCSR.ADST位为0时，设置CMPCHB[5:0]位。

#### CMPLB位 (比较窗口B比较条件设置)

CMPLB位指定窗口B的通道比较条件。当模拟输入的比较结果满足设置条件时，相关的ADCMPBSR.CMPSTB标志设置为1，并发出比较中断请求(ADC12i\_CMPBI(i=0, 1))生成。

|   |         |                                      |         |
|---|---------|--------------------------------------|---------|
| Compare conditions when the window function is disabled |         |                                      |         |
| C MPLB = 0  |         | C MPLB = 1                           |         |
| ADWINLLB value ≤ A/D converted value                    | Not met | ADWINLLB value < A/D converted value | Met     |
| ADWINLLB value > A/D converted value                    | Met     | ADWINLLB value ≥ A/D converted value | Not met |
| Compare conditions when the window function is enabled  |         |                                      |         |
| C MPLB = 0  |         | C MPLB = 1                           |         |
| A/D converted value > ADWINULB value                    | Met     |                                      |         |
| ADWINLLB value ≤ A/D converted value ≤ ADWINULB value   | Not met |                                      |         |
| A/D converted value < ADWINLLB value                    | Met     |                                      |         |
| A/D converted value ≥ ADWINULB value                    | Not met |                                      |         |
| ADWINLLB value < A/D converted value < ADWINULB value   | Met     |                                      |         |
| A/D converted value ≤ ADWINLLB value                    | Not met |                                      |         |

Figure 37.7 Explanation of compare conditions for compare function Window B

37.2.34 ADCMPBSR : A/D Compare Function Window B Status Register

Base address: ADC12m = 0x4017\_0000 + 0x0200 × m (m = 0, 1)

Offset address: 0x0AC

|                    |   |   |   |   |   |   |   |         |
|--------------------|---|---|---|---|---|---|---|---------|
| Bit position:      | 7 | 6 | 5 | 4 | 3 | 2 | 1 | 0       |
| Bit field:         | — | — | — | — | — | — | — | CMPS TB |
| Value after reset: | 0 | 0 | 0 | 0 | 0 | 0 | 0 | 0       |

| Bit | Symbol | Function  | R/W |
|-----|--------|---|-----|
| 0   | CMPSTB | Compare Window B Flag<br>When Window B operation is enabled (ADCMPCR.CMPBE = 1), this bit indicates the comparison result of channels to which Window B comparison conditions are applied, temperature sensor output, internal reference voltage.<br>0: Comparison conditions are not met.<br>1: Comparison conditions are met. | R/W |
| 7:1 | —      | These bits are read as 0. The write value should be 0.  | R/W |

CMPSTB flag (Compare Window B Flag)

The CMPSTB flag indicates the comparison result of channels to which Window B comparison conditions are applied, the temperature sensor output, internal reference voltage. When the comparison condition set in ADCMPBSR.CMPLB is met

|                               |     |                   |     |
|-------------------------------|-----|-------------------|-----|
| 比较禁用窗口功能时的条件                  |     |                   |     |
| C MPLB = 0                    |     | C MPLB = 1        |     |
| ADWINLLB值 ≤ AD转换值             | 没见过 | ADWINLLB值 < AD转换值 | Met |
| ADWINLLB值 > AD转换值             | Met | ADWINLLB值 ≥ AD转换值 | 没见过 |
| 启用窗口功能时比较条件                   |     |                   |     |
| C MPLB = 0                    |     | C MPLB = 1        |     |
| AD转换值 > ADWINULB值             | Met |                   |     |
| ADWINLLB值 ≤ AD转换值 ≤ ADWINULB值 | 没见过 |                   |     |
| AD转换值 < ADWINLLB值             | Met |                   |     |
| AD换算值 ≥ ADWINULB值             | 没见过 |                   |     |
| ADWINLLB值 < AD转换值 < ADWINULB值 | Met |                   |     |
| AD换算值 ≤ ADWINLLB值             | 没见过 |                   |     |

Figure 37.7 比较功能窗口B的比较条件说明

37.2.34 ADCMPBSR:AD比较功能窗口B状态寄存器

Base address: ADC12m = 0x4017\_0000 + 0x0200 × m (m = 0, 1)

Offset address: 0x0AC

|               |   |   |   |   |   |   |   |         |
|---------------|---|---|---|---|---|---|---|---------|
| Bit position: | 7 | 6 | 5 | 4 | 3 | 2 | 1 | 0       |
| Bit field:    | — | — | — | — | — | — | — | CMPS TB |
| 重置后的值:        | 0 | 0 | 0 | 0 | 0 | 0 | 0 | 0       |

| Bit | Symbol | Function  | R/W |
|-----|--------|---|-----|
| 0   | CMPSTB | 比较窗口B标志<br>当窗口B操作使能时 (ADCMPCR.CMPBE=1)，该位指示应用窗口B比较条件的通道的比较结果、温度传感器输出、内部参考电压。<br>0: 不满足比较条件。1: 满足比较条件。 | R/W |
| 7:1 | —      | 这些位被读取为0。写入值应为0。  | R/W |

CMPSTB标志 (比较窗口B标志)

CMPSTB标志指示应用窗口B比较条件的通道的比较结果、温度传感器输出、内部参考电压。当ADCMPBSR.CMPLB中设置的比较条件满足时

at the end of A/D conversion, this flag sets to 1. When the ADCMPCR.CMPBIE bit is 1, a compare interrupt request (ADC12i\_CMPBI (i = 0, 1)) is generated when this flag sets to 1.

Writing 1 to the CMPSTB flag is invalid.

[Setting condition]

- The condition set in ADCMPBNSR.CMPLB is met when ADCMPCR.CMPBE = 1.

[Clearing condition]

- Writing 0 after reading 1.

### 37.2.35 ADWINMON : A/D Compare Function Window A/B Status Monitor Register

Base address: ADC12m = 0x4017\_0000 + 0x0200 × m (m = 0, 1)

Offset address: 0x08C

|                    |   |   |             |             |   |   |   |             |
|--------------------|---|---|-------------|-------------|---|---|---|-------------|
| Bit position:      | 7 | 6 | 5           | 4           | 3 | 2 | 1 | 0           |
| Bit field:         | — | — | MONC<br>MPB | MONC<br>MPA | — | — | — | MONC<br>OMB |
| Value after reset: | 0 | 0 | 0           | 0           | 0 | 0 | 0 | 0           |

| Bit | Symbol  | Function   | R/W |
|-----|---------|--|-----|
| 0   | MONCOMB | Combination Result Monitor<br>This bit indicates the combination result. This bit is valid when both Window A and Window B operations are enabled.<br>0: Window A/B composite conditions are not met.<br>1: Window A/B composite conditions are met. | R   |
| 3:1 | —       | These bits are read as 0.  | R   |
| 4   | MONCMPA | Comparison Result Monitor A<br>0: Window A comparison conditions are not met.<br>1: Window A comparison conditions are met.  | R   |
| 5   | MONCMPB | Comparison Result Monitor B<br>0: Window B comparison conditions are not met.<br>1: Window B comparison conditions are met.  | R   |
| 7:6 | —       | These bits are read as 0.  | R   |

#### MONCOMB bit (Combination Result Monitor)

The read-only MONCOMB bit indicates the combined result of comparison condition results A and B based on the combination condition set in the ADCMPCR.CMPAB[1:0] bits.

[Setting condition]

- The combined result meets the combination condition set in the ADCMPCR.CMPAB[1:0] bits when ADCMPCR.CMPAE = 1 and ADCMPCR.CMPBE = 1.

[Clearing conditions]

- The combined result does not meet the combination condition set in the ADCMPCR.CMPAB[1:0] bits.
- ADCMPCR.CMPAE = 0 or ADCMPCR.CMPBE = 0.

#### MONCMPA bit (Comparison Result Monitor A)

The read-only MONCMPA bit is read as 1 when the A/D-converted value of the Window A target channel meets the condition set in ADCMPLR0/ADCMPLR1 and ADCMPLER. Otherwise, it is read as 0.

[Setting condition]

- The A/D-converted value meets the condition set in the ADCMPLR0/ADCMPLR1 and ADCMPLER registers when ADCMPCR.CMPAE = 1.

[Clearing conditions]

在AD转换结束时，该标志设置为1。当ADCMPCR.CMPBIE位为1时，当该标志设置为1时产生比较中断请求(ADC12i\_CMPBI(i=0 1))。

将1写入CMPSTB标志无效。

[Setting condition]

- 当ADCMPCR.CMPBE=1时，满足ADCMPBNSR.CMPLB中设置的条件。

[Clearing condition]

- 读1后写0。

### 37.2.35 ADWINMON:AD比较功能窗口AB状态监视器寄存器

Base address: ADC12m = 0x4017\_0000 + 0x0200 × m (m = 0, 1)

Offset address: 0x08C

|               |   |   |             |             |   |   |   |             |
|---------------|---|---|-------------|-------------|---|---|---|-------------|
| Bit position: | 7 | 6 | 5           | 4           | 3 | 2 | 1 | 0           |
| Bit field:    | — | — | MONC<br>MPB | MONC<br>MPA | — | — | — | MONC<br>OMB |
| 重置后的值:        | 0 | 0 | 0           | 0           | 0 | 0 | 0 | 0           |

| Bit | Symbol  | Function   | R/W |
|-----|---------|--|-----|
| 0   | MONCOMB | 组合结果监视器<br>该位指示组合结果。该位在WindowA和Window都有效B操作已启用。<br>0: 不满足窗口AB合成条件。1: 满足窗口AB复合条件。 | R   |
| 3:1 | —       | 这些位读为0。  | R   |
| 4   | MONCMPA | 比较结果监视器A<br>0: 不满足窗口A比较条件。1: 满足窗口A比较条件。  | R   |
| 5   | MONCMPB | 比较结果监视器B<br>0: 不满足窗口B比较条件。1: 满足窗口B比较条件。  | R   |
| 7:6 | —       | 这些位读为0。  | R   |

#### MONCOMB位 (组合结果监视器)

只读MONCOMB位指示比较条件结果A和B基于ADCMPCR.CMPAB[1:0]位中设置的组合条件的组合结果。

[Setting condition]

- 当ADCMPCR.CMPAE=1且ADCMPCR.CMPBE=1时，合并结果满足ADCMPCR.CMPAB[1:0]位中设置的合并条件。

[Clearing conditions]

- 合并结果不满足ADCMPCR.CMPAB[1:0]位设置的合并条件。
- ADCMPCR.CMPAE = 0 or ADCMPCR.CMPBE = 0.

#### MONCMPA位 (比较结果监视器A)

当窗口A目标通道的AD转换值满足ADCMPLR0ADCMPLR1和ADCMPLER中设置的条件时，只读MONCMPA位被读取为1。否则，读为0。

[Setting condition]

- 当ADCMPCR.CMPAE=1时，AD转换后的值满足ADCMPLR0ADCMPLR1和ADCMPLER寄存器中设置的条件。

[Clearing conditions]



- The A/D-converted value does not meet the condition set in the ADCMPLR0/ADCMPLR1 and ADCMPLE registers when ADCMPCR.CMPAE = 1.
- ADCMPCR.CMPAE = 0 (automatically cleared when the ADCMPCR.CMPAE value changes from 1 to 0).

#### MONCMPB bit (Comparison Result Monitor B)

The read-only MONCMPB bit is read as 1 when the A/D-converted value of the Window B target channel meets the condition set in the ADCMPBNSR.CMPLB bit. Otherwise, it is read as 0.

[Setting condition]

- The A/D-converted value meets the condition set in ADCMPBNSR.CMPLB when ADCMPCR.CMPBE = 1.

[Clearing conditions]

- The A/D-converted value does not meet the condition set in ADCMPBNSR.CMPLB when ADCMPCR.CMPBE = 1.
- ADCMPCR.CMPBE = 0 (automatically cleared when the ADCMPCR.CMPBE value changes from 1 to 0).

#### 37.2.36 ADBUFEN : A/D Data Buffer Enable Register

Base address: ADC12m = 0x4017\_0000 + 0x0200 × m (m = 0, 1)

Offset address: 0x0D0

|                    |   |   |   |   |   |   |   |       |
|--------------------|---|---|---|---|---|---|---|-------|
| Bit position:      | 7 | 6 | 5 | 4 | 3 | 2 | 1 | 0     |
| Bit field:         | — | — | — | — | — | — | — | BUFEN |
| Value after reset: | 0 | 0 | 0 | 0 | 0 | 0 | 0 | 0     |

| Bit | Symbol | Function   | R/W |
|-----|--------|--|-----|
| 0   | BUFEN  | Data Buffer Enable<br>0: The data buffer is not used.<br>1: The data buffer is used. | R/W |
| 7:1 | —      | These bits are read as 0. The write value should be 0.                               | R/W |

The ADBUFEN register sets whether to enable the data buffer.

#### BUFEN bit (Data Buffer Enable)

This bit enables the use of the data buffer.

When BUFEN = 1b, A/D conversion result (addition result) other than self-diagnosis result is stored in ADBUFn.

Disable the data storage operation (BUFEN = 0b) before reading ADBUFPTR.

Do not use the data buffer for data duplexing, or group scan.

#### 37.2.37 ADBUFPTR : A/D Data Buffer Pointer Register

Base address: ADC12m = 0x4017\_0000 + 0x0200 × m (m = 0, 1)

Offset address: 0x0D2

|                    |   |   |   |         |             |   |   |   |
|--------------------|---|---|---|---------|-------------|---|---|---|
| Bit position:      | 7 | 6 | 5 | 4       | 3           | 2 | 1 | 0 |
| Bit field:         | — | — | — | PTRO VF | BUFPTR[3:0] |   |   |   |
| Value after reset: | 0 | 0 | 0 | 0       | 0           | 0 | 0 | 0 |

| Bit | Symbol      | Function  | R/W |
|-----|-------------|---|-----|
| 3:0 | BUFPTR[3:0] | Data Buffer Pointer<br>These bits indicate the number of data buffer to which the next A/D converted data is transferred. | R/W |

- ADCMPCR.CMPAE=1时，AD转换后的值不满足ADCMPLR0ADCMPLR1和ADCMPLE寄存器中设置的条件。
- ADCMPCR.CMPAE=0（ADCMPCR.CMPAE值从1变为0时自动清零）。

#### MONCMPB位（比较结果监视器B）

当窗口B目标通道的AD转换值满足ADCMPBNSR.CMPLB位中设置的条件时，只读MONCMPB位被读取为1。否则，读为0。

[Setting condition]

- 当ADCMPCR.CMPBE=1时，AD转换后的值满足ADCMPBNSR.CMPLB中设置的条件。

[Clearing conditions]

- ADCMPCR.CMPBE=1时，AD转换后的值不满足ADCMPBNSR.CMPLB中设置的条件。
- ADCMPCR.CMPBE=0（ADCMPCR.CMPBE值从1变为0时自动清零）。

#### 37.2.36 ADBUFEN:AD数据缓冲器使能寄存器

Base address: ADC12m = 0x4017\_0000 + 0x0200 × m (m = 0, 1)

Offset address: 0x0D0

|               |   |   |   |   |   |   |   |       |
|---------------|---|---|---|---|---|---|---|-------|
| Bit position: | 7 | 6 | 5 | 4 | 3 | 2 | 1 | 0     |
| Bit field:    | — | — | — | — | — | — | — | BUFEN |
| 重置后的值:        | 0 | 0 | 0 | 0 | 0 | 0 | 0 | 0     |

| Bit | Symbol | Function                           | R/W |
|-----|--------|------------------------------------|-----|
| 0   | BUFEN  | 数据缓冲区启用<br>0: 不使用数据缓冲区。1: 使用数据缓冲区。 | R/W |
| 7:1 | —      | 这些位被读取为0。写入值应为0。                   | R/W |

ADBUFEN寄存器设置是否启用数据缓冲区。

#### BUFEN位（数据缓冲器使能）

该位使能数据缓冲区的使用。

BUFEN=1b时，ADBUFn中存储自诊断结果以外的AD转换结果（加法结果）。

在读取ADBUFPTR之前禁用数据存储操作(BUFEN=0b)。

不要将数据缓冲区用于数据双工或组扫描。

#### 37.2.37 ADBUFPTR:AD数据缓冲区指针寄存器

Base address: ADC12m = 0x4017\_0000 + 0x0200 × m (m = 0, 1)

Offset address: 0x0D2

|               |   |   |   |         |             |   |   |   |
|---------------|---|---|---|---------|-------------|---|---|---|
| Bit position: | 7 | 6 | 5 | 4       | 3           | 2 | 1 | 0 |
| Bit field:    | — | — | — | PTRO VF | BUFPTR[3:0] |   |   |   |
| 重置后的值:        | 0 | 0 | 0 | 0       | 0           | 0 | 0 | 0 |

| Bit | Symbol      | Function                               | R/W |
|-----|-------------|--|-----|
| 3:0 | BUFPTR[3:0] | 数据缓冲区指针<br>这些位指示下一个AD转换数据传输到的数据缓冲区的编号。 | R/W |

| Bit | Symbol | Function  | R/W |
|-----|--------|---|-----|
| 4   | PTROVF | Pointer Overflow Flag<br>0: The data buffer pointer has not overflowed.<br>1: The data buffer pointer has overflowed. | R/W |
| 7:5 | —      | These bits are read as 0. The write value should be 0.  | R/W |

ADBUFPtr is a register that indicates the data buffer pointer and overflow status.

#### BUFPtr[3:0] bit (Data Buffer Pointer)

These bits indicate the number of data buffer to which the next A/D converted data is transferred.

When data has been transferred to data buffer 15, the pointer value becomes 0000b and the PTROVF bit is set to 1.

When the next data has been transferred, the data in data buffer 0 is overwritten.

Writing 00h to this register clears the value of these bits. Writing a value other than 00h is disabled.

#### PTROVF bit (Pointer Overflow Flag)

This bit indicates whether the data buffer pointer has overflowed. This bit is set to 1 when the pointer value becomes 0000b (overflow).

Writing 00h to this register clears this bit value. Writing a value other than 00h is disabled.

### 37.2.38 ADBUFn : A/D Data Buffer Registers n (n = 0 to 15)

Base address:  $ADC12m = 0x4017\_0000 + 0x0200 \times m$  (m = 0, 1)

Offset address:  $0x0B0 + 0x2 \times n$  (n = 0 to 15)

| Bit position:      | 15     | 14 | 13 | 12 | 11 | 10 | 9 | 8 | 7 | 6 | 5 | 4 | 3 | 2 | 1 | 0 |
|--------------------|--------|----|----|----|----|----|---|---|---|---|---|---|---|---|---|---|
| Bit field:         | ADBUFn |    |    |    |    |    |   |   |   |   |   |   |   |   |   |   |
| Value after reset: | 0      | 0  | 0  | 0  | 0  | 0  | 0 | 0 | 0 | 0 | 0 | 0 | 0 | 0 | 0 | 0 |

| Bit  | Symbol | Function   | R/W |
|------|--------|--|-----|
| 15:0 | ADBUFn | Converted Value 15 to 0<br>Functions vary depending on the selected mode and accuracy. See <a href="#">Table 37.22</a> and <a href="#">Table 37.23</a> . | R   |

ADBUFn registers are 16-bit read-only registers that sequentially store all A/D conversion results. The automatic clear function is not applied to these registers.

ADBUFn settings are the same as the A/D data register format settings. about details see section 1.2.1 ADDRn : A/D Data Registers n.

The following conditions determine the formats for data in the ADBUFn registers:

- Setting of the Register Format Select bit (ADCER.ADRFMT) (flush-left or flush-right)
- Setting of the Addition/Average Count Select bits (ADADC.ADC[2:0]) (1, 2, 3, 4, or 16 times)
- Setting of the Average Mode Enable bit (ADADC.AVEE) (addition or average).

This section describes the data formats for these conditions in different modes.

#### (1) When A/D-converted value addition/average mode is not selected

[Table 37.22](#) shows the bit assignment for each accuracy.

**Table 37.22 Bit assignment for each accuracy (1 of 2)**

| Accuracy                                  | b15                       | b14 | b13 | b12 | b11  | b10 | b9 | b8 | b7 | b6 | b5 | b4 | b3 | b2 | b1 | b0 |
|---|---------------------------|-----|-----|-----|--|-----|----|----|----|----|----|----|----|----|----|----|
| Right-justified data with 12-bit accuracy | These bits are read as 0. |     |     |     | Converted Value 11 to 0:<br>12-bit A/D-converted value |     |    |    |    |    |    |    |    |    |    |    |

| Bit | Symbol | Function                               | R/W |
|-----|--------|--|-----|
| 4   | PTROVF | 指针溢出标志<br>0: 数据缓冲区指针没有溢出。1: 数据缓冲区指针溢出。 | R/W |
| 7:5 | —      | 这些位被读取为0。写入值应为0。                       | R/W |

ADBUFPtr是指示数据缓冲区指针和溢出状态的寄存器。

#### BUFPtr[3:0]位 (数据缓冲区指针)

这些位指示下一个AD转换数据传输到的数据缓冲区的编号。

当数据已传输到数据缓冲区15时，指针值变为0000b并且PTROVF位设置为1。

当下一个数据传输完毕后，数据缓冲区0中的数据将被覆盖。

向该寄存器写入00h会清除这些位的值。禁止写入00h以外的值。

#### PTROVF位 (指针溢出标志)

该位指示数据缓冲区指针是否溢出。当指针值变为0000b (溢出) 时，该位设置为1。

向该寄存器写入00h会清除该位值。禁止写入00h以外的值。

### 37.2.38 ADBUFn:AD数据缓冲寄存器n(n=0到15)

Base address:  $ADC12m = 0x4017\_0000 + 0x0200 \times m$  (m = 0, 1)

Offset address:  $0x0B0 + 0x2 \times n$  (n = 0 to 15)

| Bit position: | 15     | 14 | 13 | 12 | 11 | 10 | 9 | 8 | 7 | 6 | 5 | 4 | 3 | 2 | 1 | 0 |
|---------------|--------|----|----|----|----|----|---|---|---|---|---|---|---|---|---|---|
| Bit field:    | ADBUFn |    |    |    |    |    |   |   |   |   |   |   |   |   |   |   |
| 重置后的值:        | 0      | 0  | 0  | 0  | 0  | 0  | 0 | 0 | 0 | 0 | 0 | 0 | 0 | 0 | 0 | 0 |

| Bit  | Symbol | Function                                   | R/W |
|------|--------|--|-----|
| 15:0 | ADBUFn | 将值15转换为0<br>功能因所选模式和精度而异。请参见表37.22和表37.23。 | R   |

ADBUFn寄存器是16位只读寄存器，顺序存储所有AD转换结果。自动清除功能不适用于这些寄存器。

ADBUFn设置与AD数据寄存器格式设置相同。有关详细信息，请参阅第1.2.1节ADDRn:ADData Registers n。

以下条件决定了ADBUFn寄存器中数据的格式：

- 寄存器格式选择位(ADCER.ADRFMT)的设置 (左对齐或右对齐)
- 加法平均计数选择位(ADADC.ADC[2:0])的设置 (1、2、3、4或16次)
- 设置平均模式启用位(ADADC.AVEE) (加法或平均)。

本节介绍不同模式下这些条件的数据格式。

#### (1) 未选择AD转换值加法平均模式时

表37.22显示了每个精度的位分配。

**Table 37.22 每个精度的位分配 (1of2)**

| Accuracy      | b15     | b14 | b13 | b12 | b11               | b10 | b9 | b8 | b7 | b6 | b5 | b4 | b3 | b2 | b1 | b0 |
|---------------|---------|-----|-----|-----|-------------------|-----|----|----|----|----|----|----|----|----|----|----|
| 具有12位精度的右对齐数据 | 这些位读为0。 |     |     |     | 转换值11到0: 12位AD转换值 |     |    |    |    |    |    |    |    |    |    |    |

Table 37.22 Bit assignment for each accuracy (2 of 2)

| Accuracy                                 | b15  | b14 | b13 | b12 | b11 | b10 | b9 | b8 | b7 | b6 | b5 | b4 | b3                        | b2 | b1 | b0 |
|--|--|-----|-----|-----|-----|-----|----|----|----|----|----|----|---------------------------|----|----|----|
| Left-justified data with 12-bit accuracy | Converted Value 11 to 0:<br>12-bit A/D-converted value |     |     |     |     |     |    |    |    |    |    |    | These bits are read as 0. |    |    |    |

## (2) When A/D-converted value average mode is selected

A/D-converted value average mode can be selected when 2 or 4 times is specified in the A/D-converted value addition mode. When A/D converted value average mode is selected, This register indicates These registers indicate the mean of A/D-converted values on a specific channel. The value is stored in the A/D data register based on the setting of the A/D Data Register Format Select bit in the same way as for normal A/D conversion.

## (3) When A/D-converted value addition mode is selected

For 12-bit, 10-bit, 8-bit accuracy, 1, 2, 3, or 4 times can be selected in the A/D-converted value addition mode. A/D conversion results are stored in the A/D data register as a 2-bit-extended value of the specified conversion accuracy.

For 12-bit accuracy, 16 times can also be selected in the A/D-converted value addition mode. In A/D-converted value addition mode, this register indicates these registers indicate the value that is obtained by adding A/D-converted values on a specific channel. A/D conversion results are stored in the A/D data register as a 4-bit-extended value of the specified conversion accuracy.

When A/D-converted value addition mode is selected, the value is stored in the A/D data register based on the settings of the A/D Data Register Format Select bits.

Table 37.23 shows the bit assignment for each accuracy.

Table 37.23 Bit assignment for each accuracy when A/D-converted value addition mode is selected

| Accuracy                                  | b15  | b14  | b13 | b12  | b11 | b10 | b9 | b8 | b7 | b6 | b5 | b4 | b3 | b2 | b1                        | b0 |
|---|--|--|-----|--|-----|-----|----|----|----|----|----|----|----|----|---------------------------|----|
| Right-justified data with 12-bit accuracy | When 16 conversion times is specified            | Added Value 15 to 0:<br>16-bit sum of A/D conversion results |     |  |     |     |    |    |    |    |    |    |    |    |                           |    |
|   | When 1, 2, 3, or 4 conversion times is specified | These bits are read as 0.                                    |     | Added Value 13 to 0:<br>14-bit sum of A/D conversion results |     |     |    |    |    |    |    |    |    |    |                           |    |
| Left-justified data with 12-bit accuracy  | When 1, 2, 3, or 4 conversion times is specified | Added Value 15 to 0:<br>16-bit sum of A/D conversion results |     |  |     |     |    |    |    |    |    |    |    |    |                           |    |
|   | When 16 conversion times is specified            | Added Value 13 to 0:<br>14-bit sum of A/D conversion results |     |  |     |     |    |    |    |    |    |    |    |    | These bits are read as 0. |    |

## 37.3 Operation

## 37.3.1 Scanning Operation

In scanning, A/D conversion is performed sequentially on the analog inputs of the specified channels.

Scan conversion is performed in any of the three operating modes:

- Single scan mode
- Continuous scan mode
- Group scan mode

In single scan mode, one or more specified channels are scanned once. In continuous scan mode, one or more specified channels are scanned repeatedly until software sets the ADCSR.ADST bit to 0. In group scan mode, the selected channels in group A, B are scanned once after scan starts in response to the respective synchronous trigger.

In single scan mode and continuous scan mode, A/D conversion is performed for the ANn channels selected in the ADANSA0 and ADANSA1 registers, starting from the channel with the smallest number n. In group scan mode, A/D conversion is performed for the ANn channels in group A selected in the ADANSA0 and ADANSA1 registers, and for the

Table 37.22 每种精度的位分配 (2个中的2个)

| Accuracy      | b15               | b14 | b13 | b12 | b11 | b10 | b9 | b8 | b7 | b6 | b5 | b4 | b3      | b2 | b1 | b0 |
|---------------|-------------------|-----|-----|-----|-----|-----|----|----|----|----|----|----|---------|----|----|----|
| 具有12位精度的左对齐数据 | 转换值11到0: 12位AD转换值 |     |     |     |     |     |    |    |    |    |    |    | 这些位读为0。 |    |    |    |

## (2) 选择AD转换值平均模式时

当在AD转换值相加模式中指定2或4次时, 可以选择D转换值平均模式。WhenADconvertedvalueaveragemodeisselected Thisregisterindicates These registers indicate the mean of AD-converted values on a specific channel. 该值根据AD的设置存储在AD数据寄存器中

数据寄存器格式选择位的方式与正常AD转换相同。

## (3) 选择AD转换值相加模式时

对于12位、10位、8位精度, 可以在AD转换值相加模式中选择1、2、3或4次。AD转换结果作为指定转换精度的2位扩展值存储在AD数据寄存器中。

对于12位精度, 在AD转换值相加模式中也可以选择16倍。在AD转换值相加模式下, 该寄存器表示这些寄存器表示通过在特定通道上添加AD转换值获得的值。AD转换结果作为指定转换精度的4位扩展值存储在AD数据寄存器中。

WhenAD-convertedvalueadditionmodeisselected thevalueisstoredintheADdataregisterbasedonthesettings of theADDataRegisterFormatSelectbits.

表37.23显示了每个精度的位分配。

Table 37.23 选择AD转换值相加模式时的每个精度的位分配

| Accuracy      | b15            | b14                  | b13 | b12                  | b11 | b10 | b9 | b8 | b7 | b6 | b5 | b4 | b3 | b2 | b1      | b0 |
|---------------|----------------|----------------------|-----|----------------------|-----|-----|----|----|----|----|----|----|----|----|---------|----|
| 具有12位精度的右对齐数据 | 指定16个转换时间时     | 附加值15到0: AD转换结果的16位和 |     |                      |     |     |    |    |    |    |    |    |    |    |         |    |
|               | 指定1、2、3或4转换时间时 | 这些位读为0。              |     | 附加值13到0: AD转换结果的14位和 |     |     |    |    |    |    |    |    |    |    |         |    |
| 具有12位精度的左对齐数据 | 指定1、2、3或4转换时间时 | 附加值15到0: AD转换结果的16位和 |     |                      |     |     |    |    |    |    |    |    |    |    |         |    |
|               | 指定16个转换时间时     | 附加值13到0: AD转换结果的14位和 |     |                      |     |     |    |    |    |    |    |    |    |    | 这些位读为0。 |    |

## 37.3 Operation

## 37.3.1 扫描操作

扫描时, 对指定通道的模拟输入依次进行AD转换。

扫描转换在以下三种操作模式中的任何一种中执行:

- 单次扫描模式
- 连续扫描模式
- 组扫描模式

在单次扫描模式下, 一个或多个指定通道被扫描一次。在连续扫描模式下, 重复扫描一个或多个指定通道, 直到软件将ADCSR.ADST位设置为0。在组扫描模式下, 在扫描开始后对A、B组中选定的通道进行一次扫描, 以响应相应的同步触发。

在单次扫描模式和连续扫描模式下, 对选择的ANn通道进行AD转换 ADANSA0和ADANSA1寄存器, 从编号n最小的通道开始。在组扫描模式下, 对在ADANSA0和ADANSA1寄存器中选择的A组中的ANn通道执行AD转换, 并为



ANn channels in group B selected in the ADANSB0 and ADANSB1 registers, starting from the channel with the smallest number n.

When self-diagnosis is selected, it is executed once at the beginning of each scan and one of the three reference voltages is converted.

The temperature sensor output and internal reference voltage can be selected at the same time as the analog input of the channels, and A/D conversion is performed on the analog input of channels, temperature sensor output, and internal reference voltage, in that order.

Double trigger mode can be used with single scan mode or group scan mode. With double trigger mode enabled (ADCSR.DBLE = 1), A/D conversion data of a channel selected in the ADCSR.DBLANS[4:0] bits is duplicated only if the conversion is started by the synchronous trigger (ELC) selected in the ADSTRGR.TRSA[5:0] bits. In group scan mode, only group A can use double trigger mode.

In the extended operation of double trigger mode, the A/D conversion operation is generated from the synchronous trigger combination selected in the ADSTRGR.TRSA[5:0] bits. In addition to normal double trigger mode operation, A/D conversion data with odd number trigger (ELC\_AD00 (unit 0) and ELC\_AD10 (unit 1)) is stored in A/D Data Duplexing Register A (ADDBLDRA), and A/D conversion data with even number trigger (ELC\_AD01 (unit 0) and ELC\_AD11 (unit 1)) is stored in A/D Data Duplexing Register B (ADDBLDRB). In the extended operation of double trigger mode, when one of the trigger combinations occurs at the same time, the data duplexing register settings for the specified triggers do not work, and A/D conversion data is stored in A/D Data Duplexing Register B (ADDBLDRB).

The ADC12 ignores a synchronous trigger that occurs during the A/D conversion started by another synchronous trigger.

### 37.3.2 Single Scan Mode

#### 37.3.2.1 Basic Operation

In basic operation of single scan mode, A/D conversion is performed once on the analog input of the specified channels as follows:

1. When the ADCSR.ADST bit is set to 1 (A/D conversion start) by a software trigger, a synchronous trigger input (ELC), or an asynchronous trigger input, A/D conversion is performed for the ANn channels selected in the ADANSA0 and ADANSA1 registers, starting from the channel with the smallest number n.
2. Each time A/D conversion of a single channel completes, the A/D conversion result is stored in the associated A/D data register (ADDRy).
3. When A/D conversion of all the selected channels completes, an ADC12i\_ADI (i = 0, 1) interrupt request is generated.
4. The ADST bit remains 1 (A/D conversion start) during A/D conversion, and is automatically set to 0 when A/D conversion of all the selected channels completes. The ADC12 then enters a wait state.

在ADANSB0和ADANSB1寄存器中选择的B组中的ANn通道，从具有最小编号n的通道开始。

选择自诊断时，在每次扫描开始时执行一次，并转换三个参考电压之一。

温度传感器输出和内部参考电压可以与通道的模拟输入同时选择，通道的模拟输入、温度传感器输出和内部参考电压依次进行AD转换。

双触发模式可与单扫描模式或组扫描模式一起使用。启用双触发模式(ADCSR.DBLE=1)时，仅当转换由ADSTRGR中选择的同步触发(ELC)启动时，ADCSR.DBLANS[4:0]位中选择的通道的AD转换数据才会被复制。TRSA[5:0]位。在组扫描模式下，只有A组可以使用双触发模式。

在双触发模式的扩展操作中，ADSTRGR.TRSA[5:0]位中选择的同步触发组合产生AD转换操作。除了正常的双触发模式操作外，奇数触发的AD转换数据(ELC\_AD00(单元0)和ELC\_AD10(单元1))存储在AD数据双工寄存器A(ADDBLDRA)中，偶数触发的AD转换数据(ELC\_AD01(单元0)和ELC\_AD11(单元1))存储在AD数据双工寄存器B(ADDBLDRB)中。在双触发模式的扩展操作中，当其中一种触发组合同时发生时，指定触发的数据双工寄存器设置不起作用，AD转换数据存储在AD数据双工寄存器B(ADDBLDRB)中。

ADC12忽略由另一个同步触发的AD转换期间发生的同步触发。

### 37.3.2 单次扫描模式

#### 37.3.2.1 基本操作

在单扫描模式的基本操作中，对指定通道的模拟输入进行一次AD转换，如下所示：

- 1.当通过软件触发、同步触发输入(ELC)或异步触发输入将ADCSR.ADST位设置为1(AD转换开始)时，对在ADANSA0和ADANSA1中选择的ANn通道执行AD转换寄存器，从具有最小编号n的通道开始。
- 2.每次完成单个通道的AD转换，AD转换结果存储在相关的AD数据寄存器(ADDRy)中。
- 3.当所有选定通道的AD转换完成时，会产生一个ADC12i\_ADI(i=0,1)中断请求。
- 4.ADST位在AD转换期间保持1(AD转换开始)，当所有选定通道的AD转换完成时自动设置为0。ADC12然后进入等待状态。



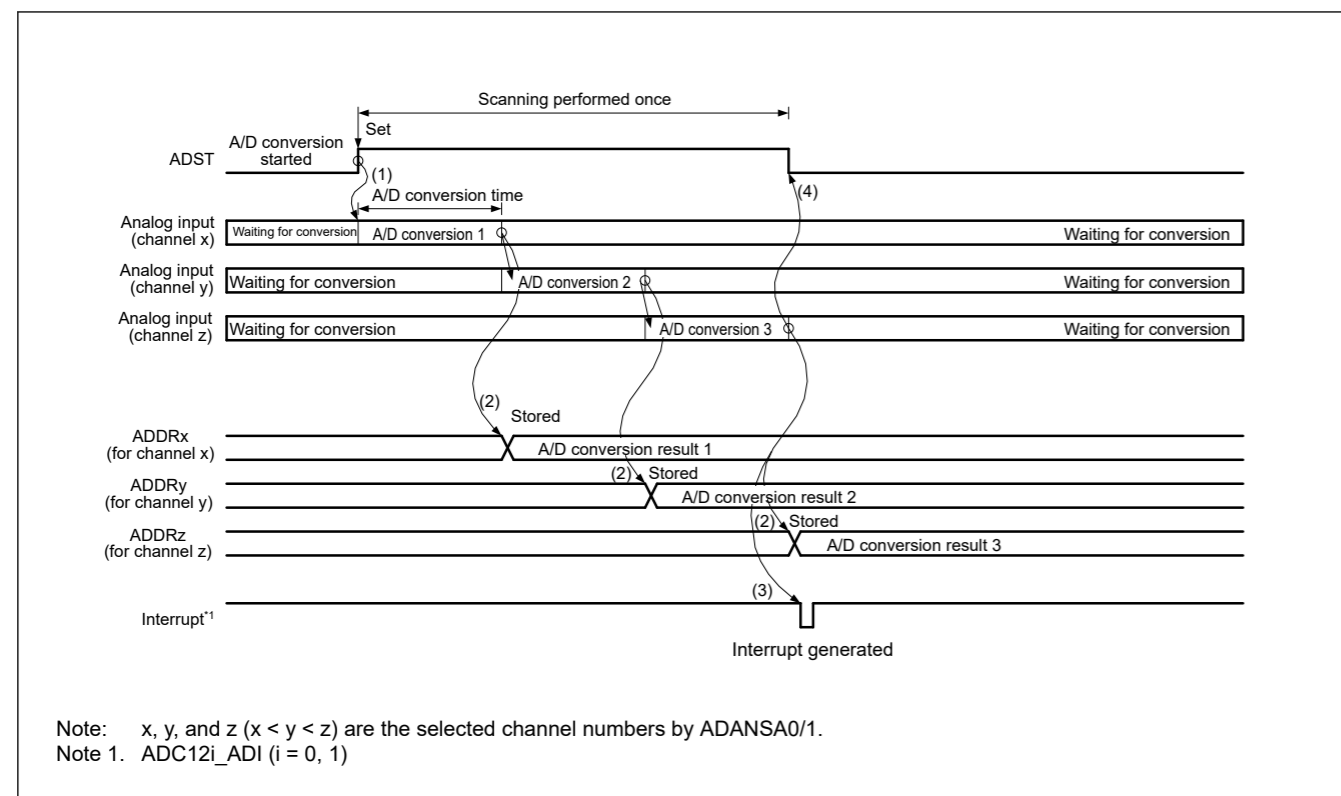


Figure 37.8 Example basic operation in single scan mode when the analog inputs (channel x to z) are selected

### 37.3.2.2 Channel Selection and Self-Diagnosis

When channels and self-diagnosis are selected, A/D conversion is first performed for the reference voltage VREFH0, VREFH ( $x0 \times 1/2$ , or  $x1$ ), then A/D conversion is performed once on the analog input of the selected channels as follows:

1. A/D conversion for self-diagnosis is first started when the ADCSR.ADST bit is set to 1 (A/D conversion start) by a software trigger, a synchronous trigger input (ELC), or an asynchronous trigger input.
2. When A/D conversion for self-diagnosis completes, the A/D conversion result is stored in the A/D Self-Diagnosis Data Register (ADDRD). A/D conversion is then performed for the ANn channels selected in the ADANSA0 and ADANSA1 registers, starting from the channel with the smallest number n.
3. Each time A/D conversion of a single channel completes, the A/D conversion result is stored in the associated A/D data register (ADDRy).
4. When A/D conversion of all the selected channels completes, an ADC12i\_ADI ( $i = 0, 1$ ) interrupt request is generated.
5. The ADCSR.ADST bit remains 1 (A/D conversion start) during A/D conversion and is automatically set to 0 when A/D conversion of all the selected channels completes. The ADC12 then enters a wait state.

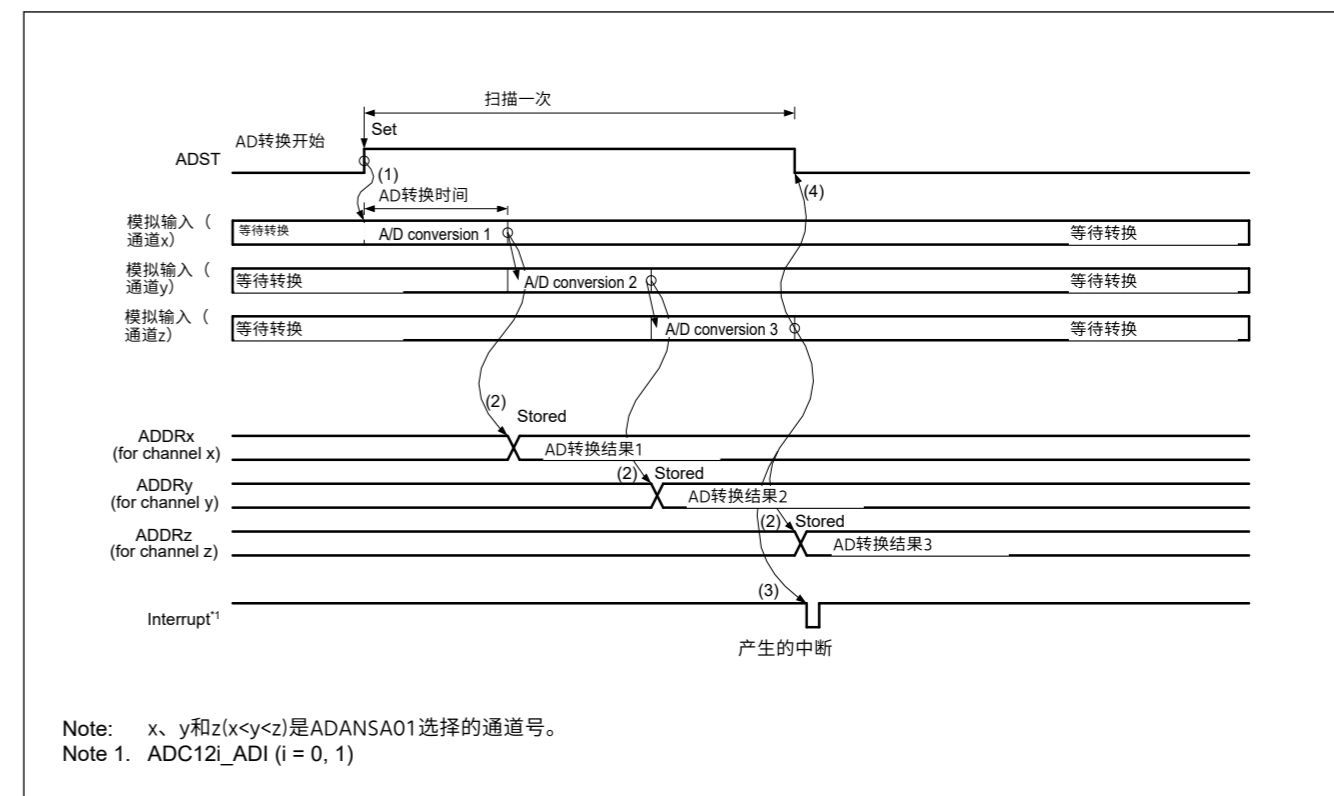


Figure 37.8 选择模拟输入（通道x至z）时单次扫描模式下的基本操作示例

### 37.3.2.2 频道选择和自诊断

选择通道和自诊断时，首先对参考电压VREFH0进行AD转换，VREFH ( $x0 \times 1/2$ 或 $x1$ )，然后在所选通道的模拟输入上执行一次AD转换，如下所示：

- 1.通过软件触发、同步触发输入(ELC)或异步触发输入将ADCSR.ADST位设置为1（AD转换开始）时，首先启动用于自诊断的D转换。
- 2.当用于自诊断的AD转换完成时，AD转换结果存储在AD自诊断数据寄存器(ADDRD)中。然后对在ADANSA0和ADANSA1寄存器中选择的ANn通道执行D转换，从编号最小的通道开始。
- 3.每次完成单个通道的AD转换，AD转换结果存储在相关的AD数据寄存器（ADDRy）中。
- 4.当所有选定通道的AD转换完成时，会产生一个ADC12i\_ADI( $i=0, 1$ )中断请求。
- 5.ADCSR.ADST位在AD转换期间保持1（AD转换开始），并在所有选定通道的AD转换完成时自动设置为0。ADC12然后进入等待状态。

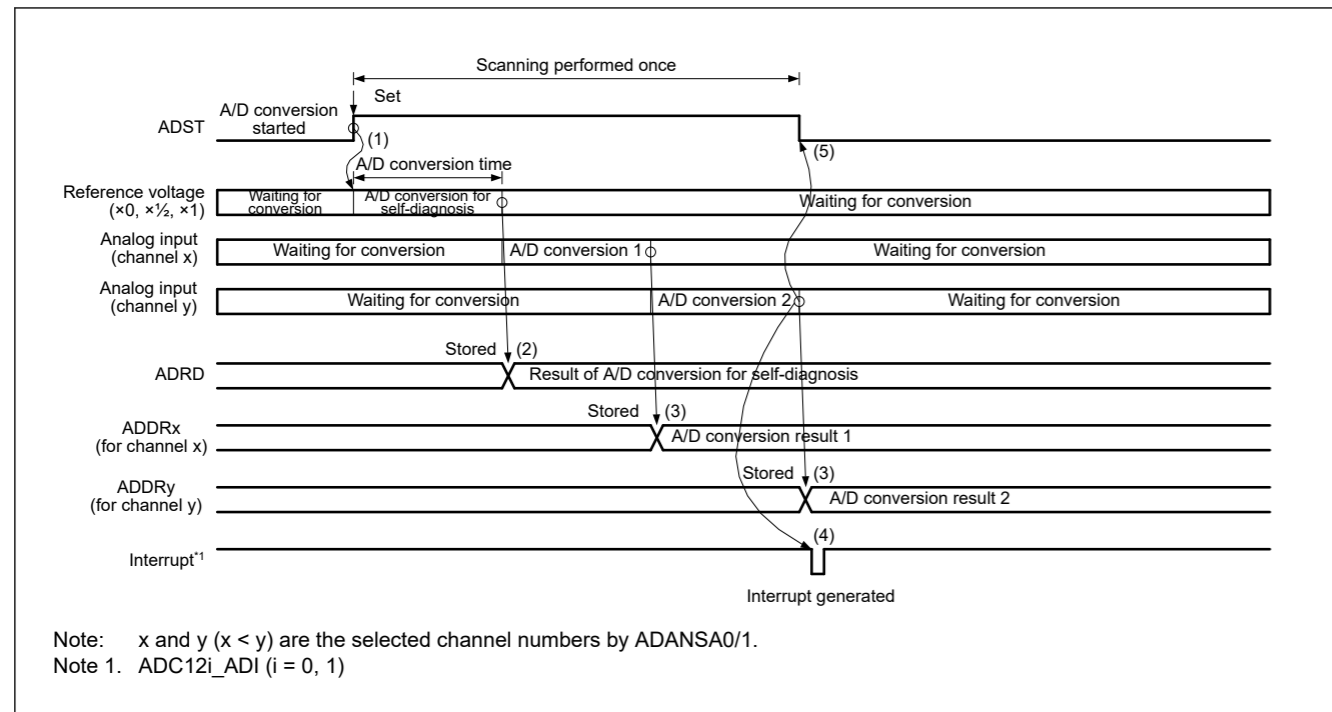


Figure 37.9 Example basic operation in single scan mode when the analog inputs (channel x and y) are selected with self-diagnosis

### 37.3.2.3 A/D conversion of temperature sensor output or internal reference voltage

When the channels and temperature sensor output or internal reference voltage are selected at the same time, A/D conversion is performed first on the analog input of the selected channels, and once on the temperature sensor output or internal reference voltage. When both temperature sensor output and internal reference voltage are selected, A/D conversion of the temperature sensor output and internal reference voltage is performed, in that order. With the channels deselected, selecting only the temperature sensor output or internal reference voltage is also possible.

The operation is as follows:

1. When a software trigger, synchronous trigger (ELC), or asynchronous trigger sets the ADCSR.ADST bit to 1 (A/D conversion start), A/D conversion is performed for the ANn channels selected in the ADANSA0 and ADANSA1 registers, starting from the channel with the smallest number n.
2. On completion of A/D conversion on the channels, the result is stored in the associated A/D Data Register y (ADDRy), and then A/D conversion of the temperature sensor output starts.
3. On completion of A/D conversion of the temperature sensor output, the result is stored in the associated A/D Temperature Sensor Data Register (ADTSDR), and then A/D conversion of the internal reference voltage starts.
4. On completion of A/D conversion of the internal reference voltage, the result is stored in the associated A/D Internal Reference Voltage Data Register (ADOCDR), and an ADC12i\_ADI (i = 0, 1) interrupt request is generated (no register setting).
5. The ADCSR.ADST bit remains 1 (A/D conversion start) during A/D conversion, and is automatically cleared to 0 on completion of A/D conversion. Then, the ADC12 enters a wait state.

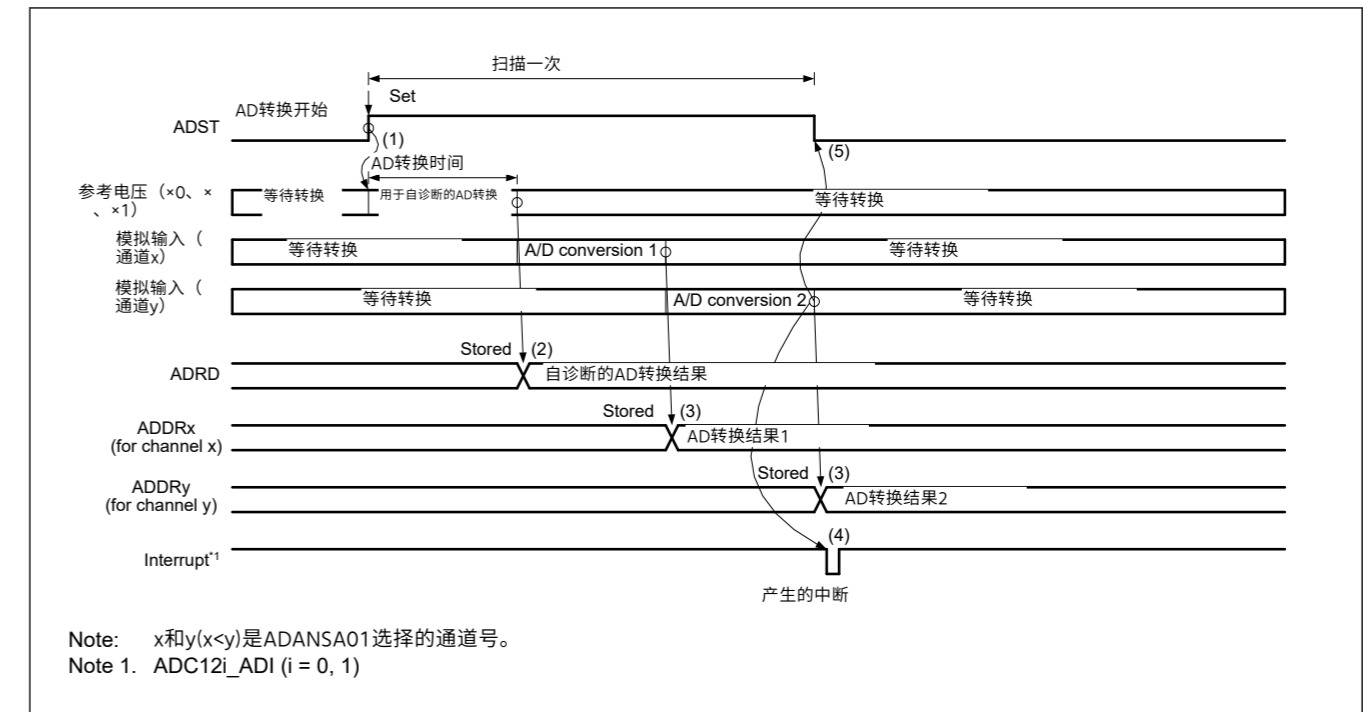


Figure 37.9 使用自诊断选择模拟输入（通道x和y）时单次扫描模式下的基本操作示例

### 37.3.2.3 温度传感器输出或内部参考电压的AD转换

当同时选择通道和温度传感器输出或内部参考电压时，首先对所选通道的模拟输入进行AD转换，再对温度传感器输出或内部参考电压进行一次AD转换。当同时选择温度传感器输出和内部参考电压时，按顺序执行温度传感器输出和内部参考电压的AD转换。取消选择通道后，也可以仅选择温度传感器输出或内部参考电压。

操作如下：

- 1.当软件触发、同步触发(ELC)或异步触发将ADCSR.ADST位设置为1（AD转换开始）时，对ADANSA0和ADANSA1寄存器中选择的ANn通道执行AD转换，从通道开始用最小的数n。
- 2.在通道上完成AD转换后，结果存储在相关的AD数据寄存器y(ADDRy)中，然后温度传感器输出的AD转换开始。
- 3.温度传感器输出的AD转换完成后，结果存储在相关的AD中温度传感器数据寄存器(ADTSDR)，然后内部参考电压的AD转换开始。
- 4.内部参考电压的AD转换完成后，结果存储在相关的ADInternal参考电压数据寄存器(AOCDR)，并产生一个ADC12i\_ADI(i=0 1)中断请求（无寄存器设置）。
- 5.ADCSR.ADST位在AD转换期间保持1（AD转换开始），并在AD转换完成时自动清零。然后，ADC12进入等待状态。

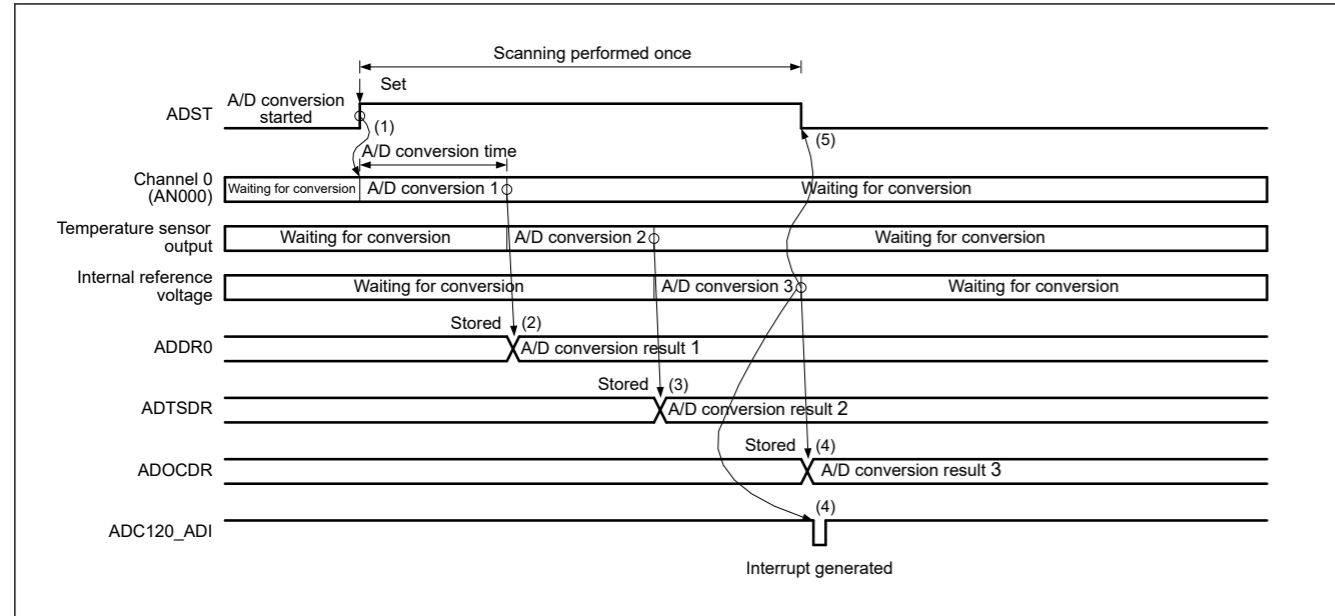


Figure 37.10 Example basic operation in single scan mode when AN000 and temperature sensor output or internal reference voltage are selected

#### 37.3.2.4 A/D conversion in double-trigger mode

When double trigger mode is selected in single scan mode, two rounds of single scan operation started by a synchronous trigger (ELC) are performed in sequence.

Deselect self-diagnosis and set the temperature sensor output A/D conversion select bit (ADEXICR.TSSA and ADEXICR.TSSB) and the internal reference voltage A/D conversion select bit (ADEXICR.OCSA and ADEXICR.OCSB) to 0.

Duplication of A/D conversion data is enabled by setting the channel numbers to be duplicated in the ADCSR.DBLANS[4:0] bits and setting the ADCSR.DBLE bit to 1. When the ADCSR.DBLE bit is set to 1, channel selection using the ADANSA0 and ADANSA1 registers is invalid.

In double trigger mode, select a synchronous trigger (ELC) with the ADSTRGR.TRSA[5:0] bits. Additionally, set the ADCSR.EXTRG bit to 0 and the ADCSR.TRGE bit to 1. Do not use a software trigger.

The operation is as follows:

1. When the ADCSR.ADST bit is set to 1 (A/D conversion start) by a synchronous trigger input (ELC), A/D conversion starts on the single channel selected in the ADCSR.DBLANS[4:0] bits.
2. Each time A/D conversion of a single channel completes, the A/D conversion result is stored in the associated A/D Data Register y (ADDRy).
3. The ADCSR.ADST bit is automatically set to 0 and the ADC12 enters a wait state. An ADC12i\_ADI (i = 0, 1) interrupt request is not generated.
4. When the ADCSR.ADST bit is set to 1 (A/D conversion start) by the second trigger input, A/D conversion starts on the single channel selected in the ADCSR.DBLANS[4:0] bits.
5. When A/D conversion completes, the result is stored in the A/D Data Duplexing Register (ADDBLDR), which is exclusively used in double-trigger mode.
6. An ADC12i\_ADI (i = 0, 1) interrupt request is generated if the setting of the ADCSR.ADIE bit
7. The ADCSR.ADST bit remains 1 (A/D conversion start) during A/D conversion, and is automatically set to 0 when A/D conversion completes. Then the ADC12 enters a wait state.

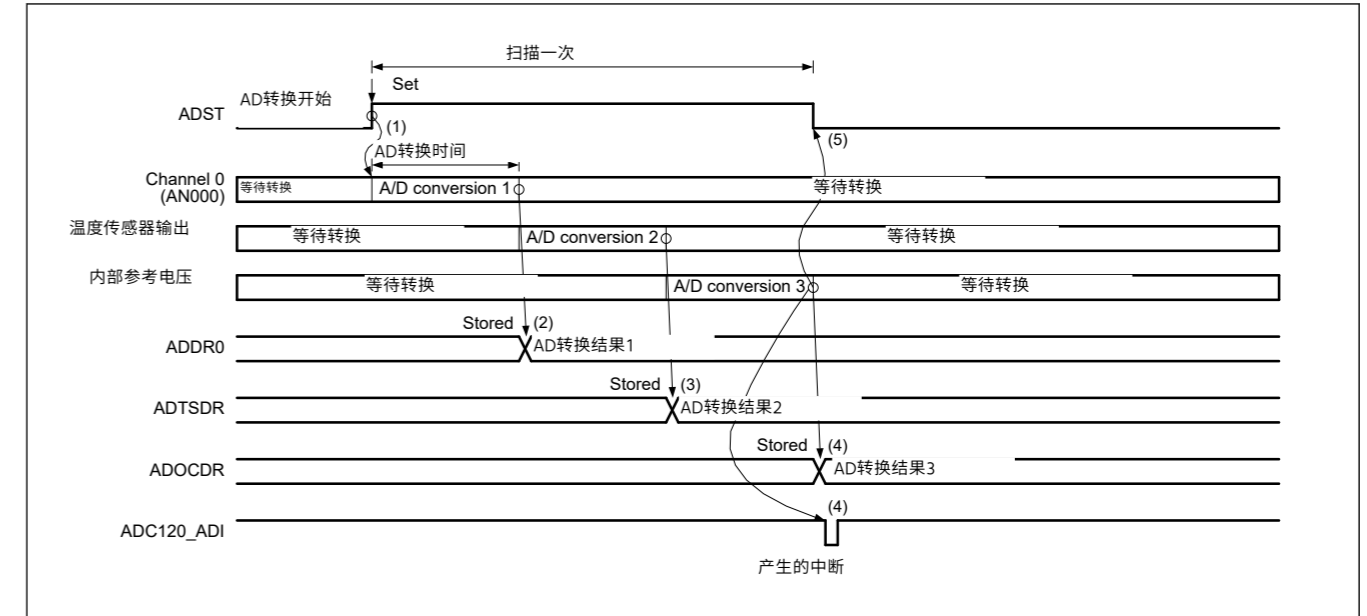


Figure 37.10 选择AN000和温度传感器输出或内部参考电压时单次扫描模式下的基本操作示例

#### 37.3.2.4 双触发模式下的AD转换

在单扫描模式下选择双触发模式时，由同步触发(ELC)启动的两轮单扫描操作将依次执行。

取消选择自诊断并设置温度传感器输出AD转换选择位(ADEXICR.TSSA和ADEXICR.TSSB)和内部参考电压AD转换选择位(ADEXICR.OCSA和ADEXICR.OCSB)为0。

AD转换数据的复制通过在ADCSR.DBLANS[4:0]位并将ADCSR.DBLE位设置为1。当ADCSR.DBLE位设置为1时，使用ADANSA0和ADANSA1寄存器的通道选择无效。

在双触发模式下，使用ADSTRGR.TRSA[5:0]位选择同步触发(ELC)。此外，设置ADCSR.EXTRG位为0，ADCSR.TRGE位为1。不要使用软件触发。

操作如下：

- 1.当同步触发输入(ELC)将ADCSR.ADST位设置为1（AD转换开始）时，ADCSR.DBLANS[4:0]位中选择的单通道开始AD转换。
- 2.每次完成单个通道的AD转换，AD转换结果存储在相关的AD数据寄存器y(ADDRy)中。
- 3.ADCSR.ADST位自动设置为0，ADC12进入等待状态。不会产生ADC12i\_ADI(i=0 1)中断请求。
- 4.当第二个触发输入将ADCSR.ADST位设置为1（AD转换开始）时，AD转换在ADCSR.DBLANS[4:0]位中选择的单通道上开始。
- 5.当AD转换完成时，结果存储在AD数据双工寄存器(ADDBLDR)中，该寄存器专用于双触发模式。
- 6.如果设置ADCSR.ADIE位，则会产生ADC12i\_ADI(i=0 1)中断请求
- 7.ADCSR.ADST位在AD转换期间保持1（AD转换开始），并在AD转换完成时自动设置为0。然后ADC12进入等待状态。

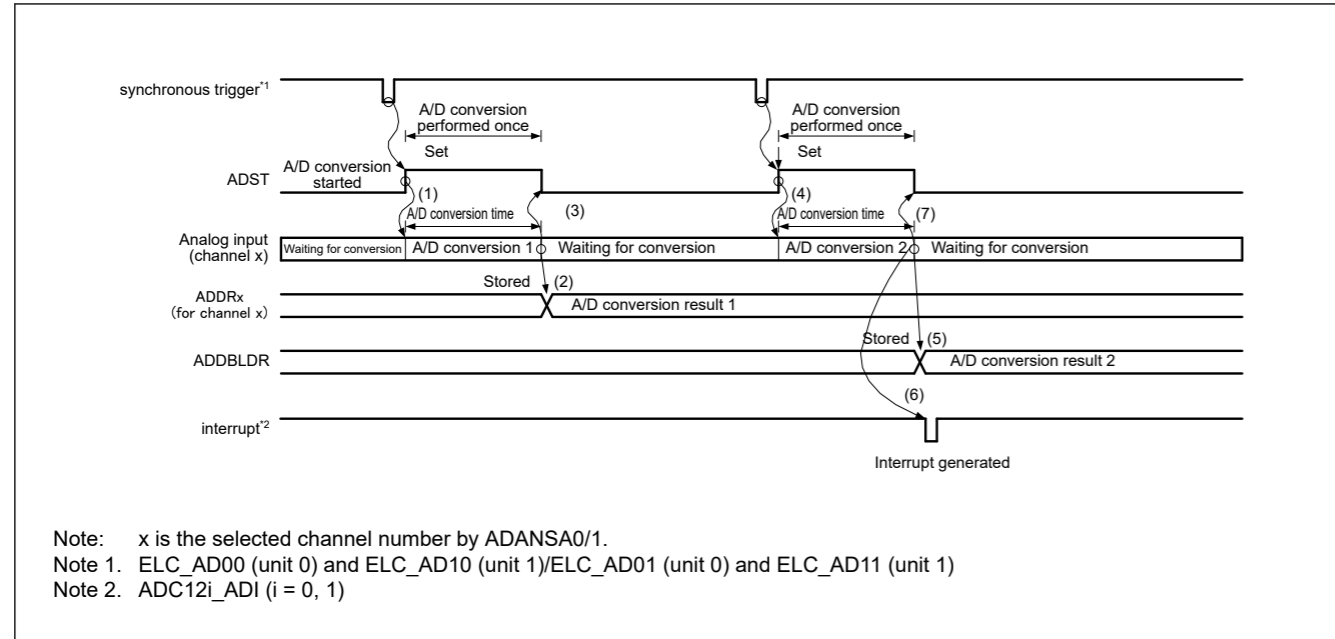


Figure 37.11 Example operation in single scan mode when double-trigger mode is selected and the analog input (channel x) is duplicated

### 37.3.2.5 Extended operations when double-trigger mode is selected

When double trigger mode is selected in single scan mode, and a synchronous trigger (ELC\_AD00 (unit 0) and ELC\_AD10 (unit 1)/ELC\_AD01 (unit 0) and ELC\_AD11 (unit 1)) is selected as the trigger for the start of A/D conversion, two rounds of single scan operation are performed.

Deselect self-diagnosis and set the temperature sensor output A/D conversion select bit (ADEXICR.TSSA and ADEXICR.TSSB), and the internal reference voltage A/D conversion select bit (ADEXICR.OCSA and ADEXICR.OCSB) to 0.

Duplication of A/D conversion data is enabled by setting the channel number to be duplicated to the ADCSR.DBLANS[4:0] bits and setting the ADCSR.DBLE bit to 1. When the ADCSR.DBLE bit is set to 1, channel selection using the ADANSA0 and ADANSA1 registers is invalid.

In extended double trigger mode, select a synchronous trigger combination ELC\_AD00 (unit 0) and ELC\_AD10 (unit 1)/ELC\_AD01 (unit 0) and ELC\_AD11 (unit 1) by setting the ADSTRGR.TRSA[5:0] bits to 0x0B, set the ADCSR.EXTRG bit to 0, and set the ADCSR.TRGE bit to 1. Do not use a software trigger.

The operation is as follows:

1. When the ADCSR.ADST bit is set to 1 (A/D conversion start) by a synchronous trigger input (ELC\_AD00 (unit 0) and ELC\_AD10 (unit 1)/ELC\_AD01 (unit 0) and ELC\_AD11 (unit 1)), A/D conversion starts on the single channel selected in the ADCSR.DBLANS[4:0] bits.
2. When A/D conversion completes, the A/D conversion result is stored in the associated A/D Data Register (ADDRy) and in A/D Data Duplexing Register A (ADDBLDR A) or A/D Data Duplexing Register B (ADDBLDR B) when the ELC\_ADi0 or ELC\_ADi1 trigger is input respectively (i = 1).
3. The ADCSR.ADST bit is automatically set to 0 and the ADC12 enters a wait state. An ADC12i\_ADI (i = 0, 1) interrupt request is not generated.
4. When the ADCSR.ADST bit is set to 1 (A/D conversion start) by the second trigger (ELC\_AD00 (unit 0) and ELC\_AD10 (unit 1)/ELC\_AD01 (unit 0) and ELC\_AD11 (unit 1)), A/D conversion starts on the single channel selected in the ADCSR.DBLANS[4:0] bits.
5. When A/D conversion completes, the A/D conversion result is stored in the A/D Data Duplexing Register (ADDBLDR) and in A/D Data Duplexing Register A (ADDBLDR A) or A/D Data Duplexing Register B (ADDBLDR B) when the ELC\_ADi0 or ELC\_ADi1 trigger is input respectively (i = 1).
6. An ADC12i\_ADI (i = 0, 1) interrupt request is generated.

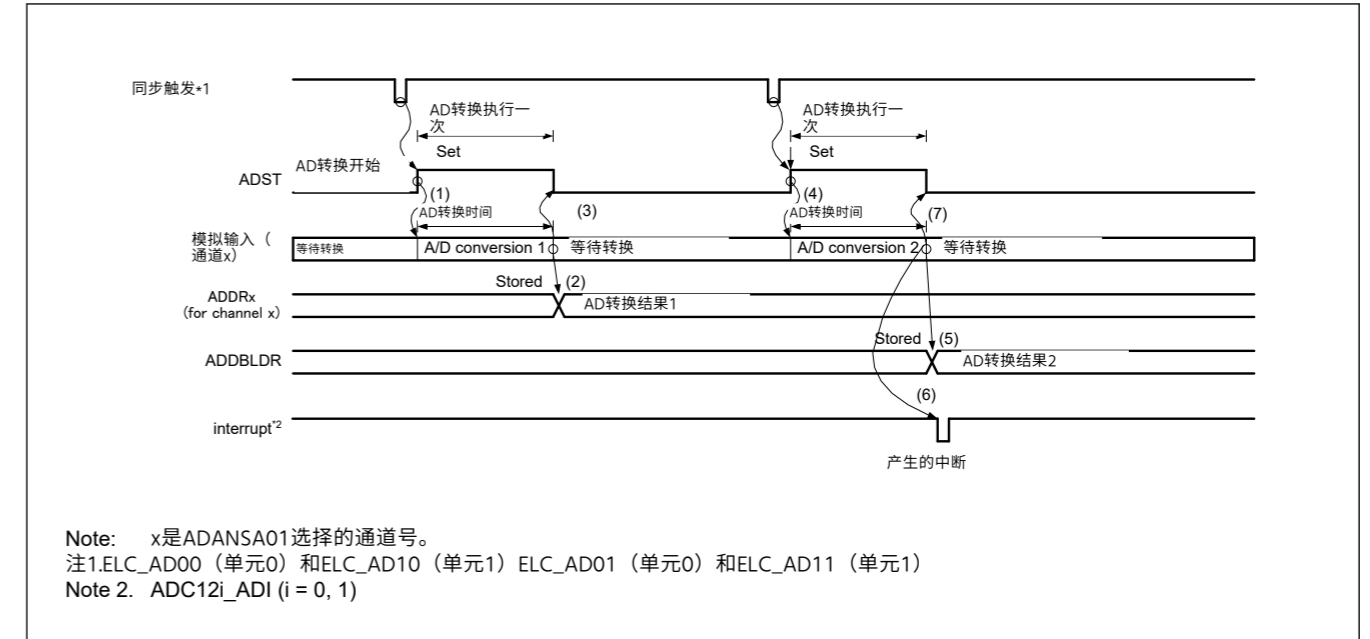


Figure 37.11 选择双触发模式并复制模拟输入 (通道x) 时的单扫描模式操作示例

### 37.3.2.5 选择双触发模式时的扩展操作

在单扫描模式下选择双触发模式时，选择同步触发 (ELC\_AD00 (单元0) 和ELC\_AD10 (单元1) ELC\_AD01 (单元0) 和ELC\_AD11 (单元1)) 作为AD转换开始的触发，执行两轮单扫描操作。

取消选择自诊断并设置温度传感器输出AD转换选择位(ADEXICR.TSSA和ADEXICR.TSSB)，内部参考电压AD转换选择位 (ADEXICR.OCSA和ADEXICR.OCSB) 为0。

通过将要复制的通道号设置为ADCSR.DBLANS[4:0]位并将ADCSR.DBLE位设置为1，启用AD转换数据的复制。当ADCSR.DBLE位设置为1时，通道选择使用ADANSA0和ADANSA1寄存器无效。

在扩展双触发模式下，通过将ADSTRGR.TRSA[5:0]位设置为0x0B，选择同步触发组合ELC\_AD00 (单元0) 和ELC\_AD10 (单元1) ELC\_AD01 (单元0) 和ELC\_AD11 (单元1)，设置ADCSR.EXTRG位为0，ADCSR.TRGE位为1。不要使用软件触发。

操作如下：

- 1.当同步触发输入 (ELC\_AD00 (单元0) 和ELC\_AD10 (单元1) ELC\_AD01 (单元0) 和ELC\_AD11 (单元1)) 将ADCSR.ADST位设置为1 (AD转换开始) 时，AD转换开始在ADCSR.DBLANS[4:0]位中选择的单个通道上。
- 2.当AD转换完成时，当ELC\_ADi0或ELC\_ADi1触发输入时，AD转换结果分别存储在相关的AD数据寄存器(ADDRy)和AD数据双工寄存器A(ADDBLDR A)或AD数据双工寄存器B(ADDBLDR B)中(i=1)。
- 3.ADCSR.ADST位自动设置为0，ADC12进入等待状态。不会产生ADC12i\_ADI(i=0 1)中断请求。
- 4.当ADCSR.ADST位被第二次触发(ELC\_AD00(unit0)和ELC\_AD10 (单元1) ELC\_AD01 (单元0) 和ELC\_AD11 (单元1))，AD转换在ADCSR.DBLANS[4:0]位中选择的单个通道上开始。
- 5.当AD转换完成时，当ELC\_ADi0或ELC\_ADi1触发输入时，AD转换结果分别存储在AD数据双工寄存器(ADDBLDR)和AD数据双工寄存器A(ADDBLDR A)或AD数据双工寄存器B(ADDBLDR B)中(i=1)。
- 6.产生一个ADC12i\_ADI(i=0 1)中断请求。



7. The ADCSR.ADST bit remains 1 (A/D conversion start) during A/D conversion and is automatically set to 0 when A/D conversion completes. The ADC12 then enters a wait state.

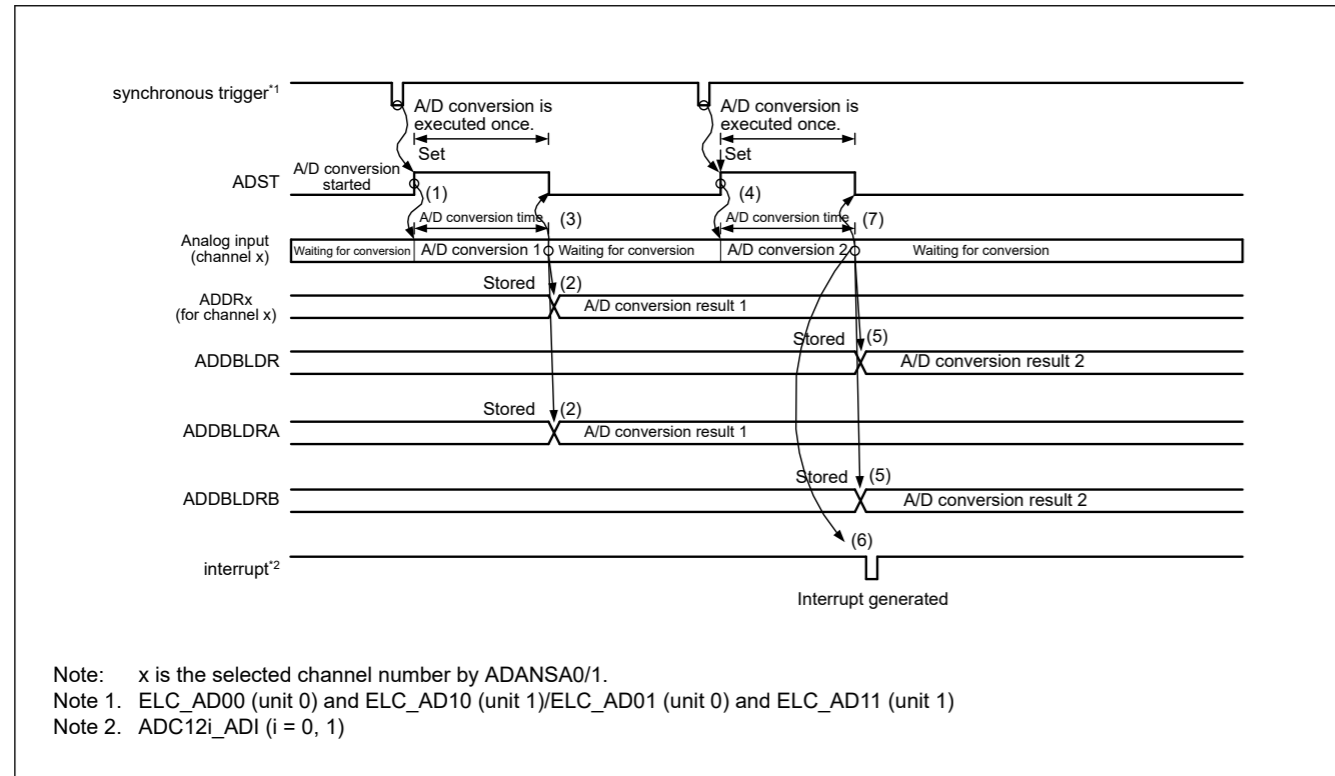


Figure 37.12 Example extended operation in double trigger mode with duplication selected for the analog input (channel x) and ELC\_AD00 (unit 0) and ELC\_AD10 (unit 1)/ELC\_AD01 (unit 0) and ELC\_AD11 (unit 1)

### 37.3.3 Continuous Scan Mode

#### 37.3.3.1 Basic Operation

In continuous scan mode, A/D conversion is performed repeatedly on the analog input of the specified channels.

The operation is as follows:

- When the ADCSR.ADST bit is set to 1 (A/D conversion start) by a software trigger, a synchronous trigger input (ELC), or an asynchronous trigger input, A/D conversion is performed for ANn channels selected in the ADANSA0 and ADANSA1 registers, starting from the channel with the smallest number n.
- Each time A/D conversion of a single channel completes, the A/D conversion result is stored in the associated A/D Data Register (ADDRy).
- When A/D conversion of all the selected channels completes, an ADC12i\_ADI (i = 0, 1) interrupt request is generated. The ADC12 sequentially starts A/D conversion for the ANn channels selected in the ADANSA0 and ADANSA1 registers, starting from the channel with the smallest number n.
- The ADCSR.ADST bit is not automatically cleared, and steps 2. and 3. are repeated as long as ADCSR.ADST remains 1 (A/D conversion start). When the ADCSR.ADST bit is set to 0 (A/D conversion stop), A/D conversion stops and the ADC12 enters a wait state.
- When the ADCSR.ADST bit is later set to 1 (A/D conversion start), A/D conversion starts again for the ANn channels selected in the ADANSA0 and ADANSA1 registers, starting from the channel with the smallest number n.

7. ADCSR.ADST位在AD转换期间保持1（AD转换开始），并在AD转换完成时自动设置为0。ADC12然后进入等待状态。

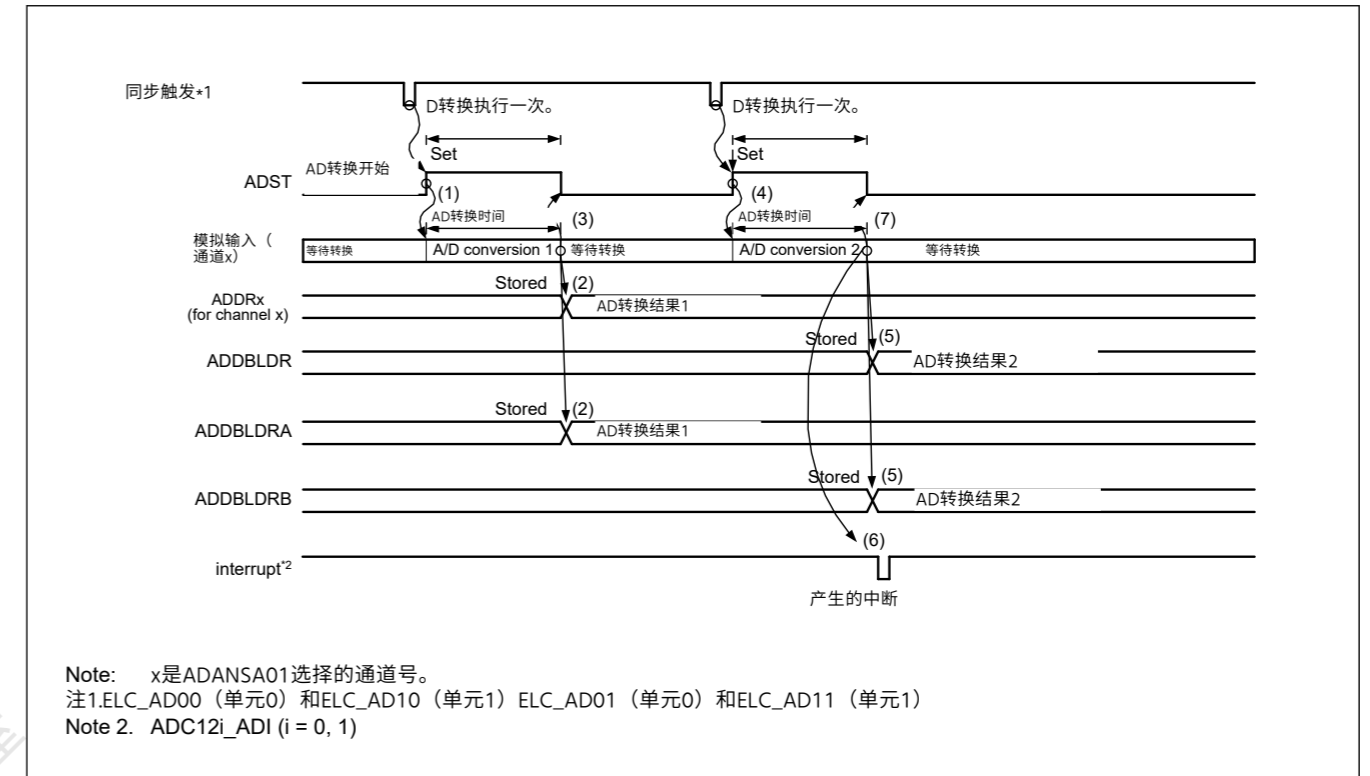


Figure 37.12 双触发模式下的扩展操作示例，为模拟输入（通道x）和ELC\_AD00（单元0）和ELC\_AD10（单元1）选择了重复ELC\_AD01（单元0）和ELC\_AD11（单元1）

### 37.3.3 连续扫描模式

#### 37.3.3.1 基本操作

在连续扫描模式下，对指定通道的模拟输入重复进行AD转换。

操作如下：

- 当软件触发、同步触发输入(ELC)或异步触发输入将ADCSR.ADST位设置为1（AD转换开始）时，对在ADANSA0和ADANSA1寄存器中选择的ANn通道执行AD转换，从编号n最小的通道开始。
- 每次完成单个通道的AD转换，AD转换结果存储在相关的AD数据寄存器(ADDRy)中。
- 当所有选定通道的AD转换完成时，会产生一个ADC12i\_ADI(i=0,1)中断请求。ADC12从编号n最小的通道开始依次启动ADANSA0和ADANSA1寄存器中选择的ANn通道的A/D转换。
- ADCSR.ADST位不会自动清零，只要ADCSR.ADST保持1（AD转换开始），就会重复步骤2和3。当ADCSR.ADST位设置为0（AD转换停止）时，AD转换停止并且ADC12进入等待状态。
- 当ADCSR.ADST位稍后设置为1（AD转换开始）时，AD转换再次开始在ADANSA0和ADANSA1寄存器中选择的ANn通道，从具有最小编号n的通道开始。

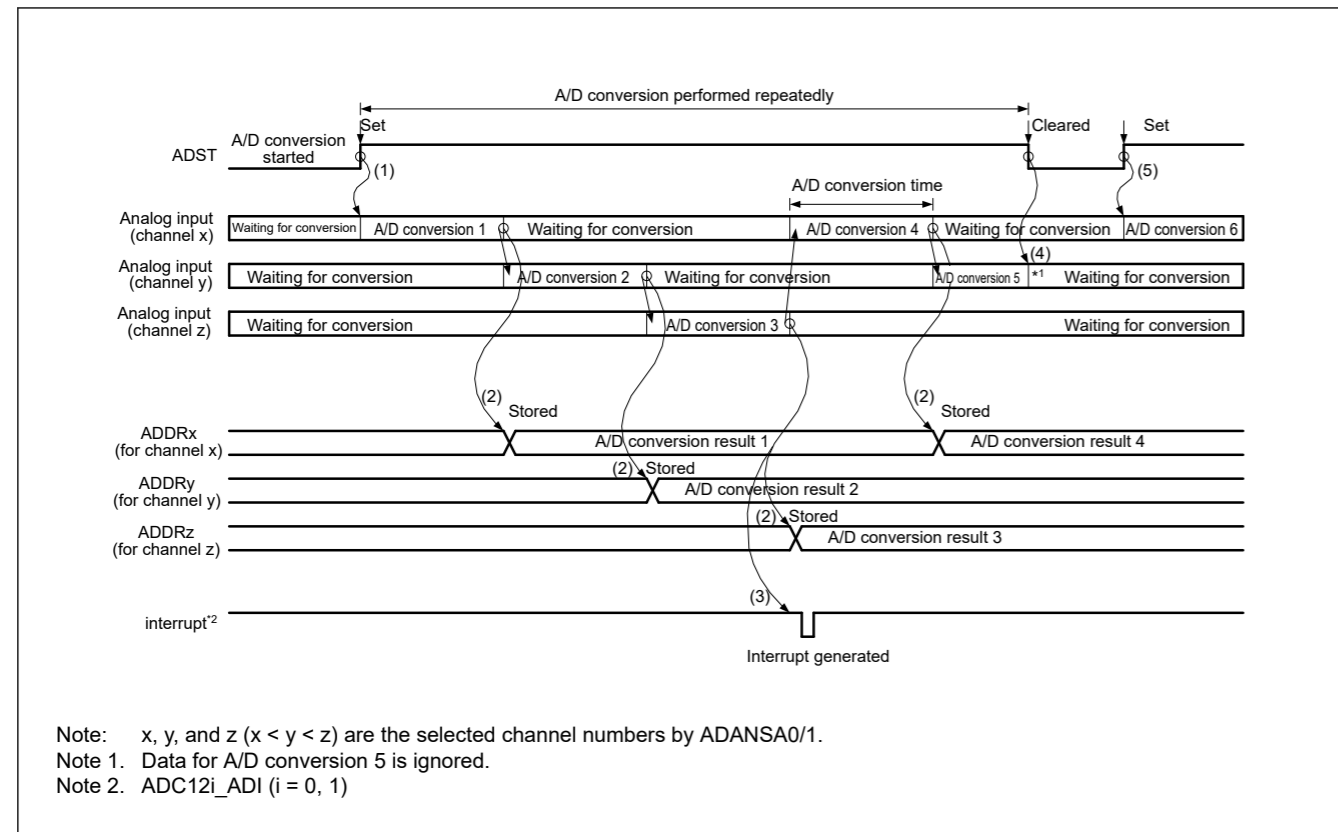


Figure 37.13 Example basic operation in continuous scan mode when the analog inputs (channel x to z) are selected

### 37.3.3.2 Channel Selection and Self-Diagnosis

When channels and self-diagnosis are selected at the same time, A/D conversion is first performed for the reference voltage VREFH0, VREFH ( $\times 0$ ,  $\times 1/2$ , or  $\times 1$ ) supplied to the ADC12, and A/D conversion is performed on the analog input of the selected channels. This sequence is repeated as described in the section that follows.

The operation is as follows:

1. A/D conversion for self-diagnosis is first started when the ADCSR.ADST bit is set to 1 (A/D conversion start) by a software trigger, a synchronous trigger input (ELC), or an asynchronous trigger input.
2. When A/D conversion for self-diagnosis completes, the A/D conversion result is stored in the A/D Self-Diagnosis Data Register (ADRD). A/D conversion is then performed for the ANn channels selected in the ADANSA0 and ADANSA1 registers, starting from the channel with the smallest number n.
3. Each time A/D conversion of a single channel completes, the A/D conversion result is stored in the corresponding A/D Data Register (ADDRy).
4. When A/D conversion of all the selected channels completes, an ADC12i\_ADI ( $i = 0, 1$ ) interrupt request is generated. At the same time, the ADC12 starts A/D conversion for self-diagnosis and then on the ANn channels selected in the ADANSA0 and ADANSA1 registers, starting from the channel with the smallest number n.
5. The ADCSR.ADST bit is not automatically cleared, and steps 2. to 4. are repeated as long as the ADCSR.ADST bit remains 1. When the ADST bit is set to 0 (A/D conversion stop), A/D conversion stops and the ADC12 enters a wait state.
6. When the ADST bit is later set to 1 (A/D conversion start), the A/D conversion for self-diagnosis is started again.

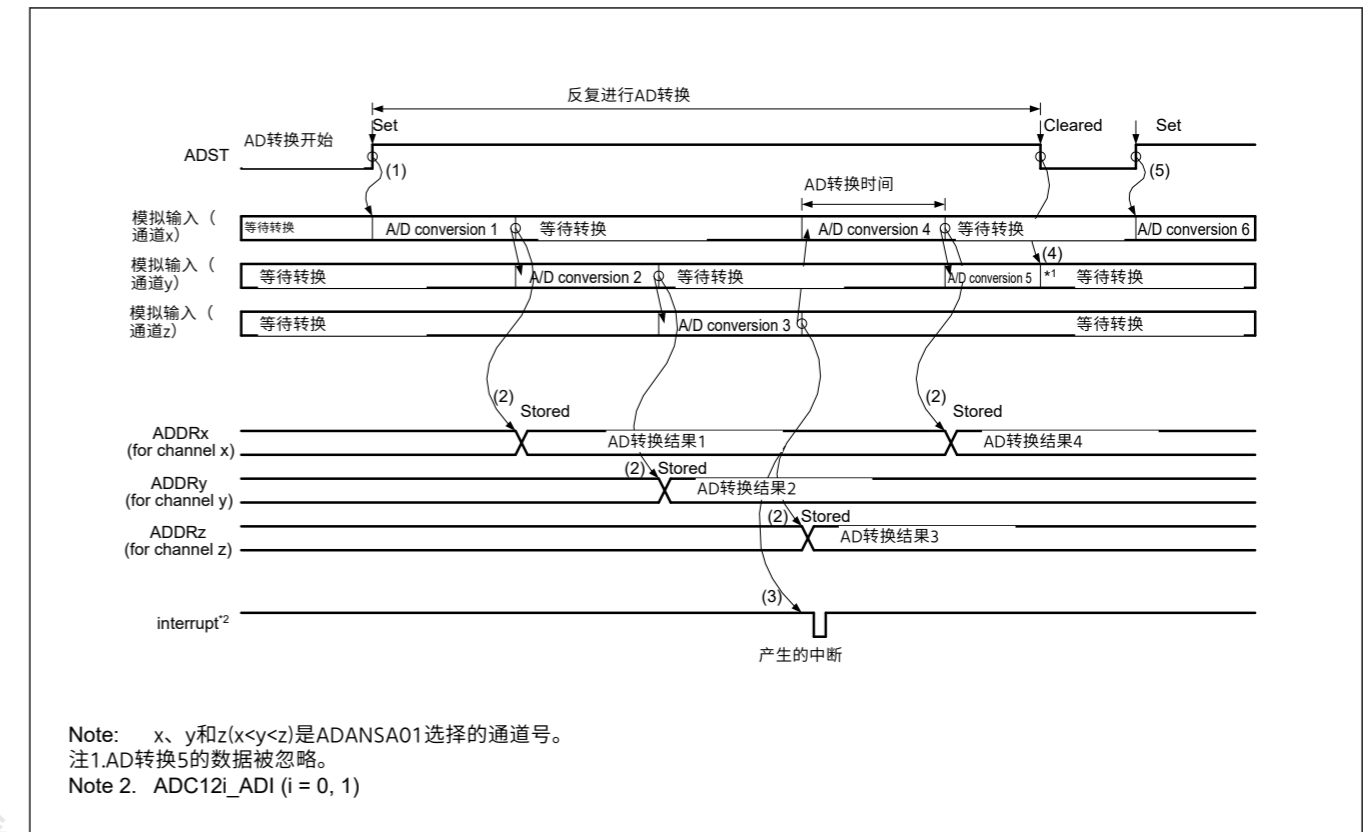


Figure 37.13 选择模拟输入（通道x至z）时连续扫描模式下的基本操作示例

### 37.3.3.2 频道选择和自诊断

同时选择通道和自诊断时，首先对参考电压进行A/D转换

提供给ADC12的VREFH0、VREFH ( $\times 0$ 、 $\times 1/2$ 或 $\times 1$ )，并对所选通道的模拟输入执行A/D转换。如以下部分所述重复此序列。

操作如下：

- 1.通过软件触发、同步触发输入(ELC)或异步触发输入将ADCSR.ADST位设置为1（AD转换开始）时，首先启动用于自诊断的D转换。
- 2.当用于自诊断的AD转换完成时，AD转换结果存储在AD自诊断数据寄存器(ADRD)中。然后对在ADANSA0和ADANSA1寄存器中选择的ANn通道执行D转换，从编号最小的通道开始。
- 3、每完成一次单通道的AD转换，AD转换结果存入对应的AD数据寄存器（ADDRy）。
- 4.当所有选定通道的AD转换完成时，会产生一个ADC12i\_ADI( $i=0, 1$ )中断请求。同时，ADC12启动AD转换进行自诊断，然后在选择的ANn通道上进行自诊断。  
ADANSA0和ADANSA1寄存器，从编号n最小的通道开始。
- 5.ADCSR.ADST位不会自动清零，只要ADCSR.ADST位保持为1，就会重复步骤2.到4.。当ADST位设置为0（AD转换停止）时，AD转换停止并且ADC12进入等待状态。
- 6.当ADST位稍后设置为1（AD转换开始）时，用于自诊断的AD转换再次开始。

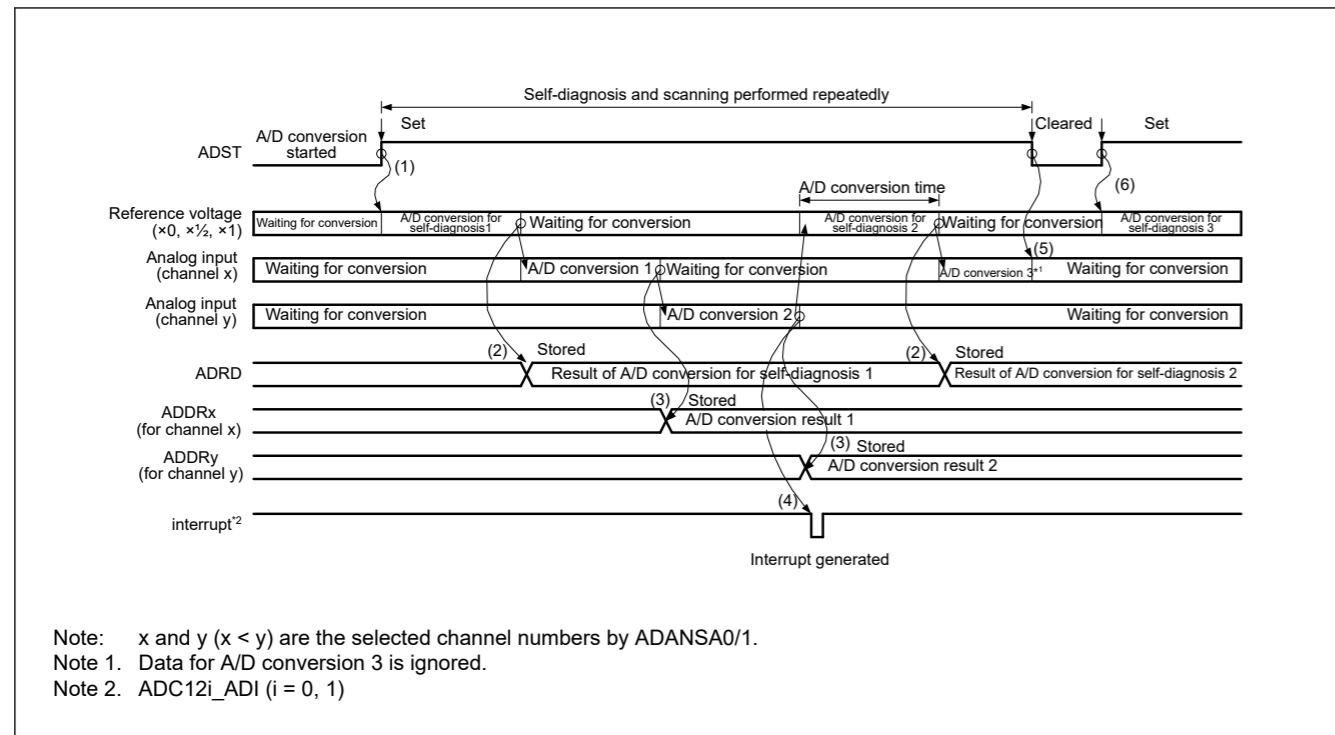


Figure 37.14 Example basic operation in continuous scan mode when the analog inputs (channel x and y) selected with self-diagnosis

### 37.3.3.3 A/D conversion of temperature sensor output or internal reference voltage

When the channels and temperature sensor output or internal reference voltage are selected at the same time, A/D conversion is first performed on the analog input of the selected channels, and then the A/D conversion of the temperature sensor output or internal reference voltage is repeated. When both the temperature sensor output and internal reference voltage are selected, A/D conversion of the temperature sensor output and internal reference voltage is performed, in that order.

With the channels deselected, selecting only the temperature sensor output or internal reference voltage is also possible.

The operation is as follows:

1. When a software trigger, synchronous trigger (ELC), or asynchronous trigger sets the ADCSR.ADST bit to 1 (A/D conversion start), A/D conversion is performed for the ANn channels selected in the ADANSA0 and ADANSA1 registers, starting from the channel with the smallest number n.
2. On completion of A/D conversion on the channels, the result is stored in the associated A/D Data Register y (ADDRy), and then A/D conversion of temperature sensor output starts.
3. On completion of A/D conversion of the temperature sensor output, the result is stored in the associated A/D Temperature Sensor Data Register (ADTSDR), and then A/D conversion of the internal reference voltage starts.
4. On completion of A/D conversion of the internal reference voltage, the result is stored in the associated A/D Internal Reference Voltage Data Register (ADOCDR), and an ADC12i\_ADI (i = 0, 1) interrupt request is generated. In addition, the ADC12 continuously starts A/D conversion for the ANn channels selected in the ADANSA0 and ADANSA1 registers, starting from the channel with the lowest number n.
5. The ADCSR.ADST bit is not cleared automatically, and steps 2 to 4 are repeated as long as this bit remains set to 1. When the ADCSR.ADST bit is set to 0 (A/D conversion stop), A/D conversion stops and the ADC12 enters a wait state.
6. When the ADCSR.ADST bit is then set to 1 (A/D conversion start), A/D conversion starts again for the ANn channels selected in the ADANSA0 and ADANSA1 registers, starting from the channel with the lowest number n.

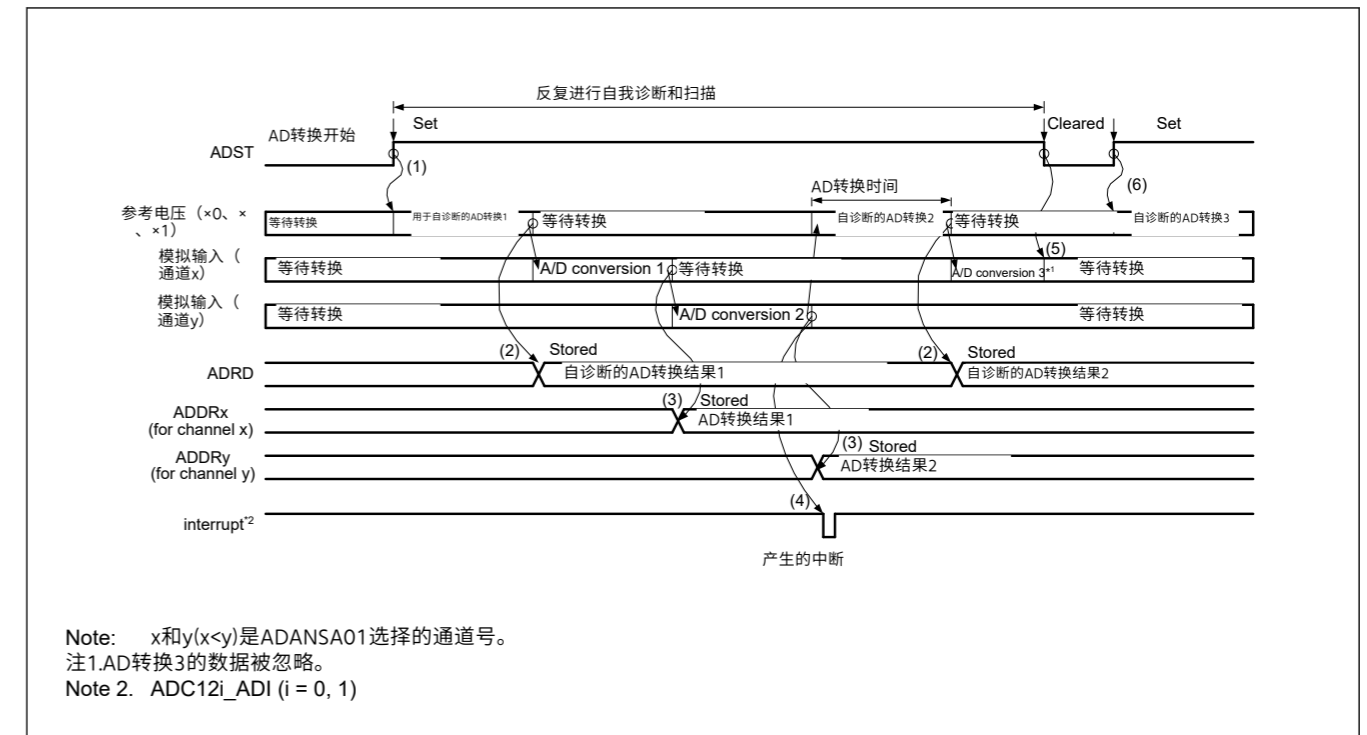


Figure 37.14 使用自诊断选择模拟输入（通道x和y）时连续扫描模式下的基本操作示例

### 37.3.3.3 温度传感器输出或内部参考电压的AD转换

当同时选择通道和温度传感器输出或内部参考电压时，首先对所选通道的模拟输入进行AD转换，然后重复温度传感器输出或内部参考电压的AD转换。当同时选择温度传感器输出和内部参考电压时，按顺序执行温度传感器输出和内部参考电压的AD转换。

取消选择通道后，也可以仅选择温度传感器输出或内部参考电压。

操作如下：

- 1.当软件触发、同步触发(ELC)或异步触发将ADCSR.ADST位设置为1（AD转换开始）时，对ADANSA0和ADANSA1寄存器中选择的ANn通道执行AD转换，从通道开始用最小的数n。
- 2.通道上的AD转换完成后，结果存储在相关的AD数据寄存器y(ADDRy)中，然后温度传感器输出的AD转换开始。
- 3.温度传感器输出的AD转换完成后，结果存储在相关的AD中温度传感器数据寄存器(ADTSDR)，然后内部参考电压的AD转换开始。
- 4.内部参考电压的AD转换完成后，结果存储在相关的ADInternal参考电压数据寄存器(AOCDR)和ADC12i\_ADI(i=0 1)中断请求产生。此外，ADC12连续启动ADANSA0和ADANSA1寄存器中选择的ANn通道的AD转换，从编号最小的通道n开始。
- 5.ADCSR.ADST位不会自动清零，只要该位保持设置为1，就会重复步骤2到4。当ADCSR.ADST位设置为0（AD转换停止）时，AD转换停止并且ADC12进入等待状态。
- 6.当ADCSR.ADST位被设置为1（AD转换开始）时，AD转换再次开始在ADANSA0和ADANSA1寄存器中选择的ANn通道，从编号最小的通道n开始。



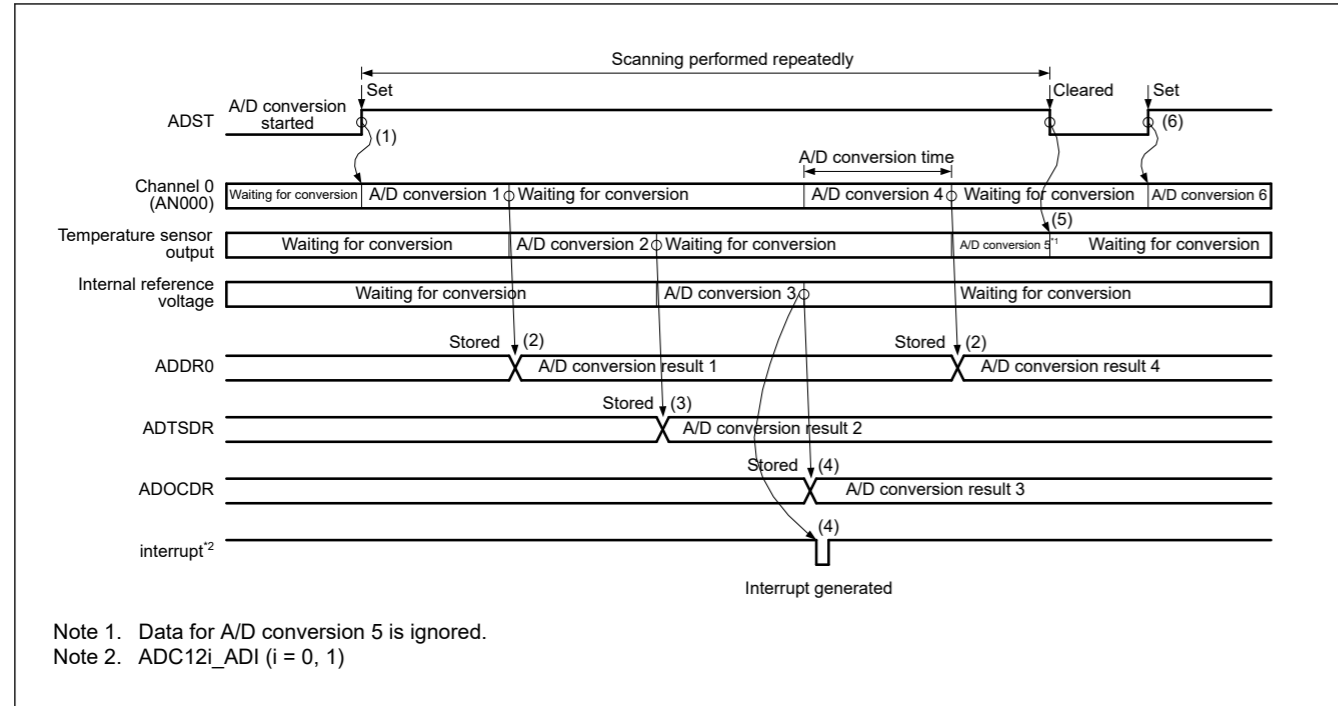


Figure 37.15 Example basic operation in continuous scan mode when AN000 and temperature sensor output or internal reference voltage are selected

### 37.3.4 Group Scan Mode

#### 37.3.4.1 Basic operation

In group scan mode, A/D conversion is performed once on the analog input of all the specified channels in group A and B after scanning is started by a synchronous trigger (ELC). The scan operation of each group is similar to the scan operation in single scan mode.

The synchronous triggers can be selected in the ADSTRGR.TRSA[5:0] bits for group A and in the ADSTRGR.TRSB[5:0] bits for group B. Use different triggers for group A and B to prevent simultaneous A/D conversion of the two groups. Do not use a software trigger.

The group A channels to be A/D-converted are selected using the ADANSA0 and ADANSA1 registers and the ADEXICR.TSSA and OCSA bits. The group B channels to be A/D-converted are selected using the ADANSB0 and ADANSB1 registers and the ADEXICR.TSSB and OCSB bits. Group A and B cannot use the same channels.

When self-diagnosis is selected in group scan mode, self-diagnosis is separately executed for Group A and B.

The following sequence describes operation in group scan mode using a synchronous trigger from the ELC. In this example, the ELC\_AD00 (unit 0) and ELC\_AD10 (unit 1) trigger from the ELC is used to start conversion of group A and the ELC\_AD01 (unit 0) and ELC\_AD11 (unit 1) trigger from the ELC is used to start conversion of group B. In addition, ELC\_AD00 (unit 0) and ELC\_AD10 (unit 1) and ELC\_AD01 (unit 0) and ELC\_AD11 (unit 1) are selected for the GPT event in the associated ELC.ELSRn registers.

The operation is as follows:

1. Scanning of group A is started by ELC\_AD00 (unit 0) and ELC\_AD10 (unit 1).
2. When group A scanning completes, an ADC12i\_ADI (i = 0, 1) interrupt is generated (no register setting).
3. Scanning of group B is started by ELC\_AD01 (unit 0) and ELC\_AD11 (unit 1).
4. When group B scanning completes, an ADC12i\_GBADI (i = 0, 1) interrupt is generated if the ADCSR.GBADIE bit is 1 (ADC12i\_GBADI (i = 0, 1) interrupt when scanning completion is enabled).

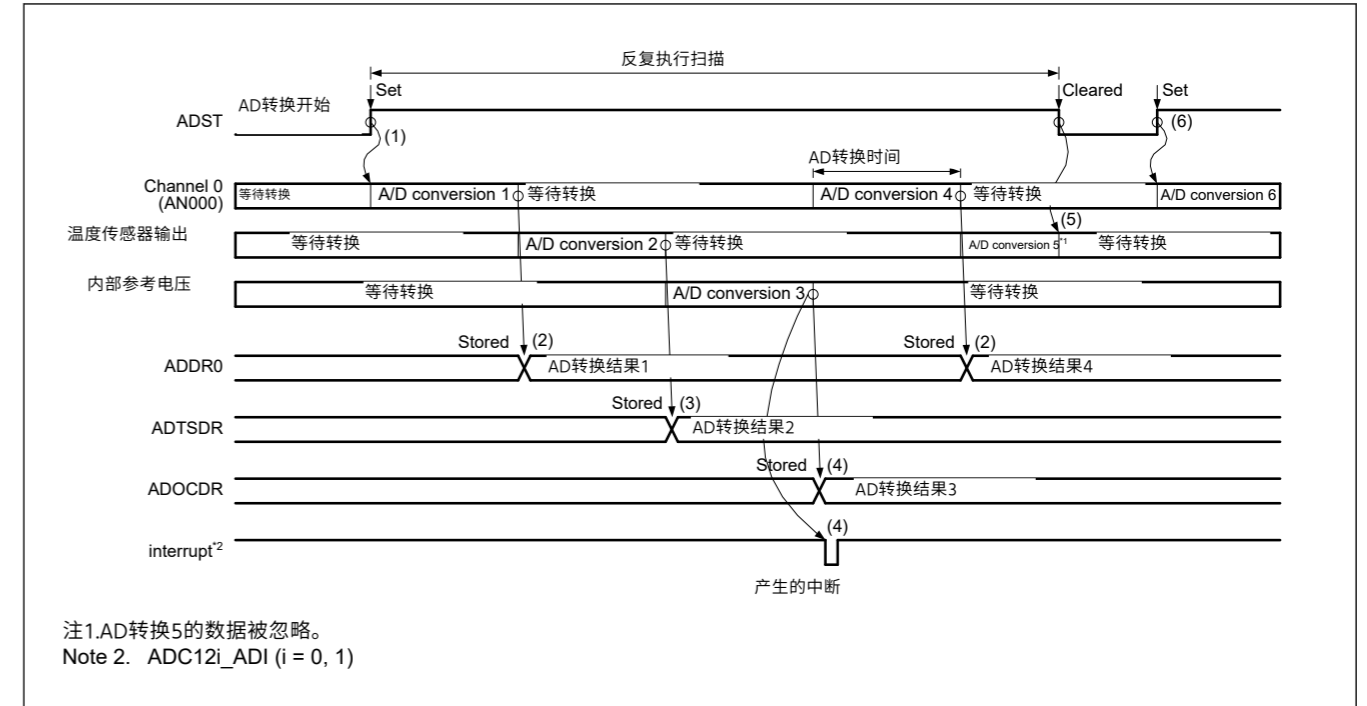


Figure 37.15 选择AN000和温度传感器输出或内部参考电压时连续扫描模式下的基本操作示例

### 37.3.4 组扫描模式

#### 37.3.4.1 基本操作

在组扫描模式下，通过同步触发（ELC）开始扫描后，对A组和B组中所有指定通道的模拟输入进行一次AD转换。每组的扫描操作类似于单次扫描模式下的扫描操作。

可以在A组的ADSTRGR.TRSA[5:0]位和B组的ADSTRGR.TRSB[5:0]位中选择同步触发。对A组和B组使用不同的触发以防止同时进行AD转换两组。不要使用软件触发。

使用ADANSA0和ADANSA1寄存器选择要进行AD转换的A组通道ADXICR.TSSA和OCSA位。要进行AD转换的B组通道使用ADANSB0和ADANSB1寄存器以及ADXICR.TSSB和OCSB位。A组和B组不能使用相同的通道。

在组扫描模式下选择自诊断时，对A组和B组分别执行自诊断。

以下序列描述了使用来自ELC的同步触发在组扫描模式下的操作。在此示例中，来自ELC的ELC\_AD00（单元0）和ELC\_AD10（单元1）触发器用于启动A组的转换，来自ELC的ELC\_AD01（单元0）和ELC\_AD11（单元1）触发器用于启动转换B组。此外，

ELC\_AD00（单元0）和ELC\_AD10（单元1）和ELC\_AD01（单元0）和ELC\_AD11（单元1）被选择用于相关ELC.ELSRn寄存器中的GPT事件。

操作如下：

- 1.A组扫描由ELC\_AD00（单元0）和ELC\_AD10（单元1）启动。
- 2.A组扫描完成后，会产生ADC12i\_ADI(i=0 1)中断（无寄存器设置）。
- 3.B组扫描由ELC\_AD01（单元0）和ELC\_AD11（单元1）启动。
- 4.B组扫描完成时，如果ADCSR.GBADIE位为1，则产生ADC12i\_GBADI(i=0 1)中断（使能扫描完成时的ADC12i\_GBADI(i=0 1)中断）。



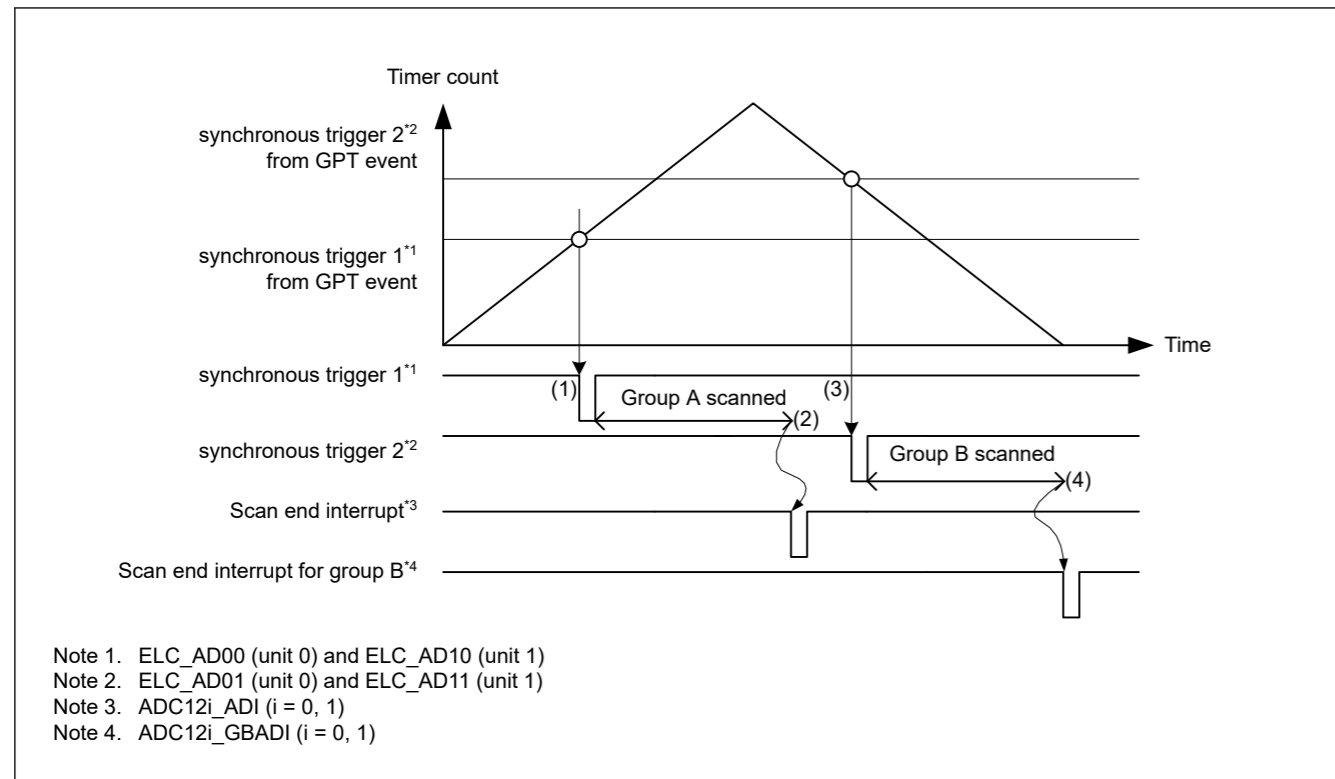


Figure 37.16 Example basic operation in group scan mode when synchronous triggers from the ELC are used

#### 37.3.4.2 A/D conversion in double-trigger mode

When double trigger mode is selected in group scan mode, two rounds of single scan operation started by a synchronous trigger (ELC) are performed as a sequence for group A. For group B, single scan operation started by a synchronous trigger (ELC) is performed once.

In group scan mode, the synchronous trigger can be selected in the ADSTRGR.TRSA[5:0] bits for group A and in the ADSTRGR.TRSB[5:0] bits for group B. Use different triggers for group A, B to prevent simultaneous A/D conversion of the two groups. Do not use a software trigger or an asynchronous trigger.

When an ELC\_AD00 (unit 0) and ELC\_AD10 (unit 1)/ELC\_AD01 (unit 0) and ELC\_AD11 (unit 1) is selected as group A synchronous triggers by setting the ADSTRGR.TRSA[5:0] bits to 0x0B, operation proceeds in extended double trigger mode.

The group A channel to be A/D-converted is selected using the DBLANS[4:0] bits in the ADCSR register, while the group B channels to be A/D-converted are selected using the ADANSB0 and ADANSB1 registers. Group A, B cannot use the same channels.

When double-trigger mode is selected in group scan mode, set the A/D conversion select bits for both the temperature sensor output (ADEXICR.TSSA) and the internal reference voltage (ADEXICR.OCSA) to 0 (deselected).

Self-diagnosis cannot be selected when double trigger mode is selected in group scan mode.

Duplication of A/D conversion data is enabled by setting the channel numbers to be duplicated in the ADCSR.DBLANS[4:0] bits and setting the ADCSR.DBLE bit to 1.

The following sequence describes operation in group scan mode with double trigger mode selected and using a synchronous trigger from the ELC. In this example, the ELC\_AD00 (unit 0) and ELC\_AD10 (unit 1) trigger is used to start conversion of group A and the ELC\_AD01 (unit 0) and ELC\_AD11 (unit 1) trigger is used to start conversion of group B. In addition, ELC\_AD00 (unit 0) and ELC\_AD10 (unit 1) and ELC\_AD01 (unit 0) and ELC\_AD11 (unit 1) are selected for the GPT event in the associated ELC.ELSRn registers.

The operation is as follows:

1. Scanning of group B is started by the ELC\_AD00 (unit 0) and ELC\_AD10 (unit 1) trigger from the ELC.

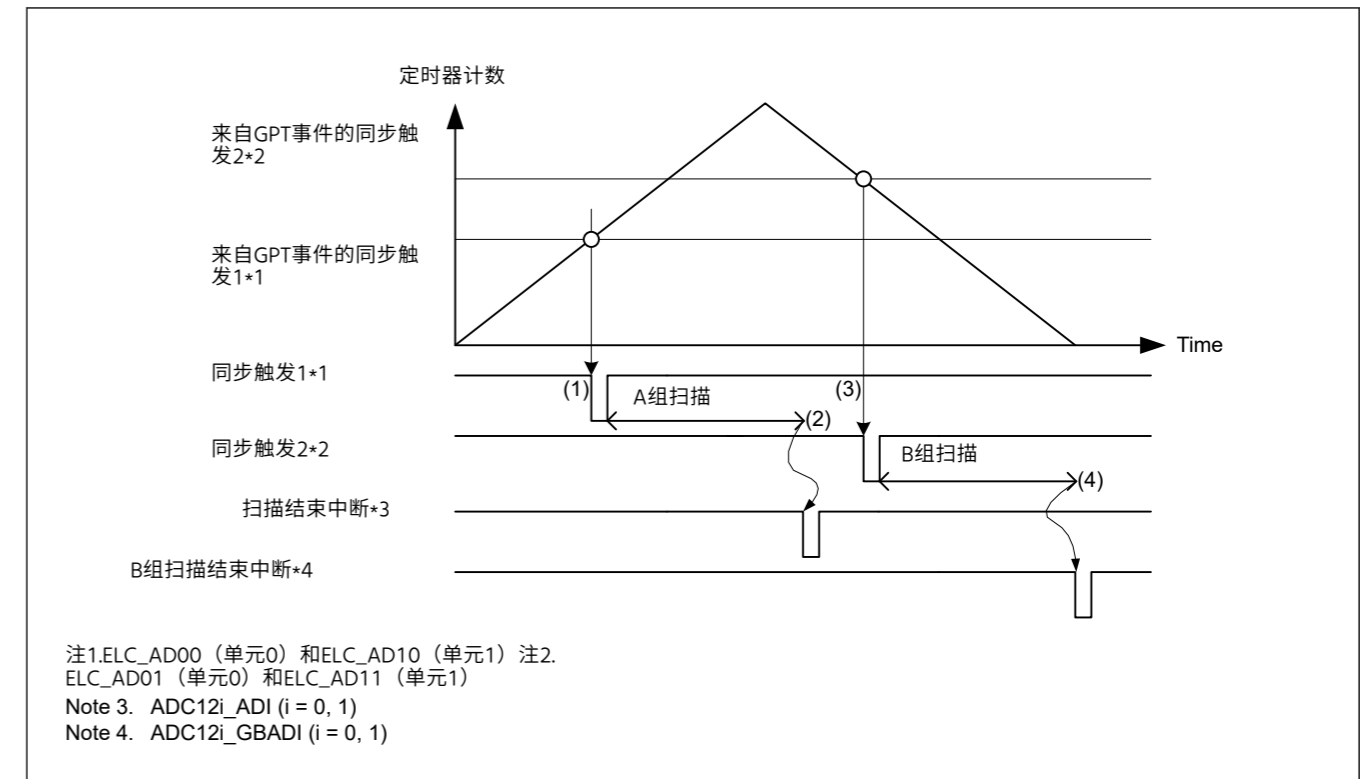


Figure 37.16 使用来自ELC的同步触发时组扫描模式下的基本操作示例

#### 37.3.4.2 双触发模式下的AD转换

在组扫描模式中选择双触发模式时，由同步触发(ELC)启动的两轮单扫描操作作为A组的顺序执行。对于B组，由同步触发(ELC)启动的单扫描操作是执行一次。

在组扫描模式下，可以在ADSTRGR.TRSA[5:0]位中为A组选择同步触发，并在组B的ADSTRGR.TRSB[5:0]位。对组A、B使用不同的触发，以防止两组同时进行AD转换。不要使用软件触发或异步触发。

当通过将ADSTRGR.TRSA[5:0]位设置为0x0B来选择ELC\_AD00 (单元0) 和 ELC\_AD10 (单元1) ELC\_AD01 (单元0) 和 ELC\_AD11 (单元1) 作为A组同步触发时，操作以扩展方式进行双触发模式。

使用ADCSR寄存器中的DBLANS[4:0]位选择要进行AD转换的A组通道，而组使用ADANSB0和ADANSB1寄存器选择要进行AD转换的B通道。A、B组不能使用相同的通道。

在组扫描模式中选择双触发模式时，将温度传感器输出(ADEXICR.TSSA)和内部参考电压(ADEXICR.OCSA)的A/D转换选择位设置为0 (取消选择)。

在组扫描模式中选择双触发模式时，不能选择自诊断。

AD转换数据的复制通过在ADCSR.DBLANS[4:0]位并将ADCSR.DBLE位设置为1。

以下序列描述了组扫描模式下的操作，其中选择了双触发模式并使用来自ELC的同步触发。在此示例中，ELC\_AD00 (单元0) 和 ELC\_AD10 (单元1) 触发器用于启动A组转换，ELC\_AD01 (单元0) 和 ELC\_AD11 (单元1) 触发器用于启动B组转换。此外，ELC\_AD00 (单元0) 和 ELC\_AD10 (单元1) 和 ELC\_AD01 (单元0) 和 ELC\_AD11 (单元1) 在关联的ELC.ELSRn寄存器中为GPT事件选择。

操作如下：

1. B组的扫描由ELC的ELC\_AD00 (单元0) 和 ELC\_AD10 (单元1) 触发开始。

- When group B scanning completes, an ADC12i\_GBADI ( $i = 0, 1$ ) interrupt is generated if the GBADIE bit in ADCSR is 1 (ADC12i\_GBADI ( $i = 0, 1$ ) interrupt when scanning completion is enabled).
- The first scan of group A is started by the first ELC\_AD01 (unit 0) and ELC\_AD11 (unit 1) trigger.
- When the first scan of group A completes, the conversion result is stored in the associated A/D Data Register y (ADDRy); an ADC12i\_ADI ( $i = 0, 1$ ) interrupt request is not generated.
- The second scan of group A is started by the second ELC\_AD01 (unit 0) and ELC\_AD11 (unit 1) trigger.
- When the second scan of group A completes, the conversion result is stored in ADDBLDR. An ADC12i\_ADI ( $i = 0, 1$ ) interrupt is generated.

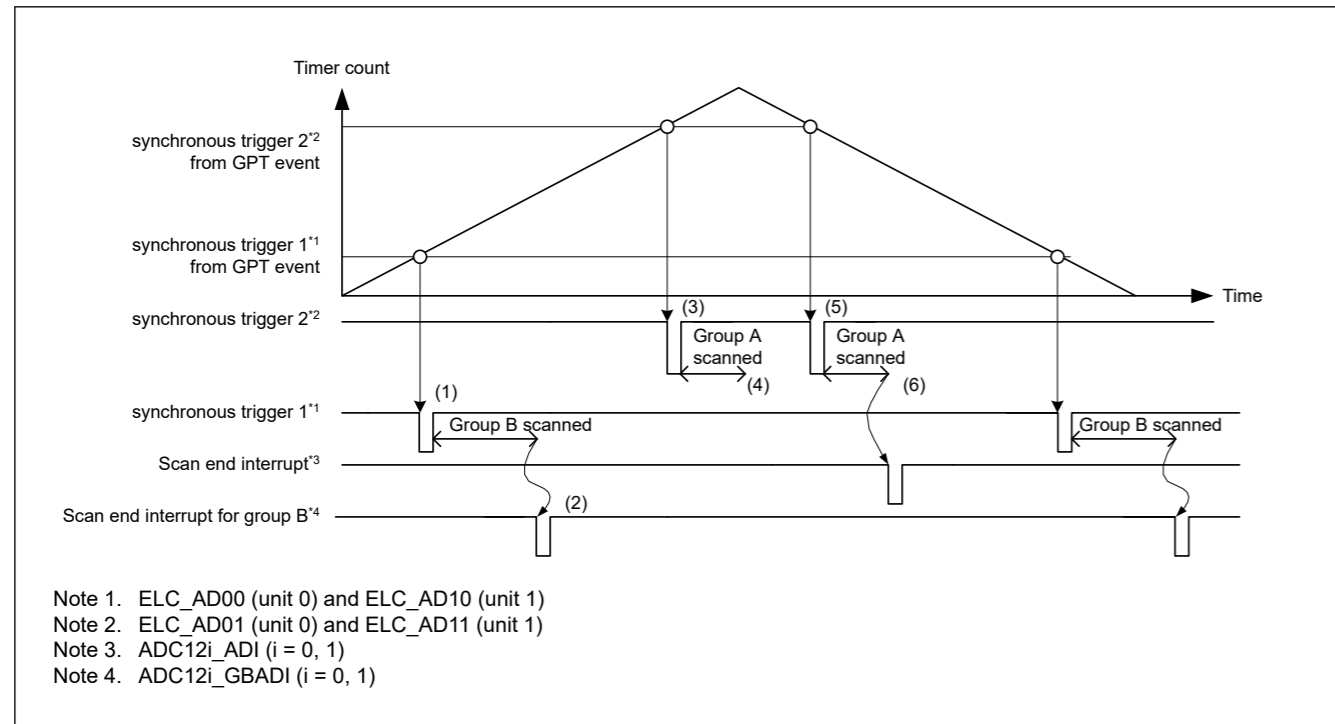


Figure 37.17 Example basic operation in group scan mode with double-trigger mode when synchronous triggers from the ELC are used

### 37.3.4.3 Group Priority Operation

Group priority operation is performed by setting the ADGSPCR.PGS bit to 1 in group-scan mode. The priority of groups is group A > group B.

When setting the PGS bit in the ADGSPCR register to 1, follow the procedure described in Figure 37.18. If the procedure is not followed, A/D conversion operation and stored data are not guaranteed.

As the basic operation in group-scan mode, a trigger input generated during A/D conversion of group A, B is ignored, and the A/D conversion operation of each group is similar to the operation in single-scan mode.

In group priority operation, if a trigger for a priority group is input during scanning of a lower-priority group, A/D conversion for the lower-priority group is stopped and A/D conversion for the priority group is performed.

If the setting of the ADGSPCR.GBRSCN bit is 0, the lower-priority group enters a wait state when A/D conversion for the priority group completes. A trigger input of the lower-priority group generated during A/D conversion is ignored.

If the setting of the ADGSPCR.GBRSCN bit is 1, A/D conversion for the lower-priority group automatically restarts upon completion of A/D conversion for the priority group. A trigger input of the lower-priority group generated during A/D conversion on the priority group takes effect, and A/D conversion for the lower-priority group is automatically performed upon completion of A/D conversion on the priority group.

If the ADGSPCR.GBRSCN bit is 1 and the ADGSPCR.LGRRS bit is 0, A/D conversion for the lower-priority group is restarted from the first channel. If the setting of the ADGSPCR.LGRRS bit is 1, A/D conversion for the lower-priority group is restarted from the channel for which the conversion stopped. However, if the self-diagnosis function is used, the A/D conversion is restarted from the channel for which the conversion stopped after self-diagnosis completed.

- B组扫描完成时，如果ADCSR中的GBADIE位为1，则产生ADC12i\_GBADI( $i=0, 1$ )中断（使能扫描完成时ADC12i\_GBADI( $i=0, 1$ )中断）。
- A组的第一次扫描由第一个ELC\_AD01（单元0）和ELC\_AD11（单元1）触发器启动。
- A组第一次扫描完成后，转换结果存入相关的AD数据寄存器y（ADDRy）；不会产生ADC12i\_ADI( $i=0, 1$ )中断请求。
- A组的第二次扫描由第二个ELC\_AD01（单元0）和ELC\_AD11（单元1）触发开始。
- A组第二次扫描完成后，转换结果存入ADDBLDR。产生一个ADC12i\_ADI( $i=0, 1$ )中断。

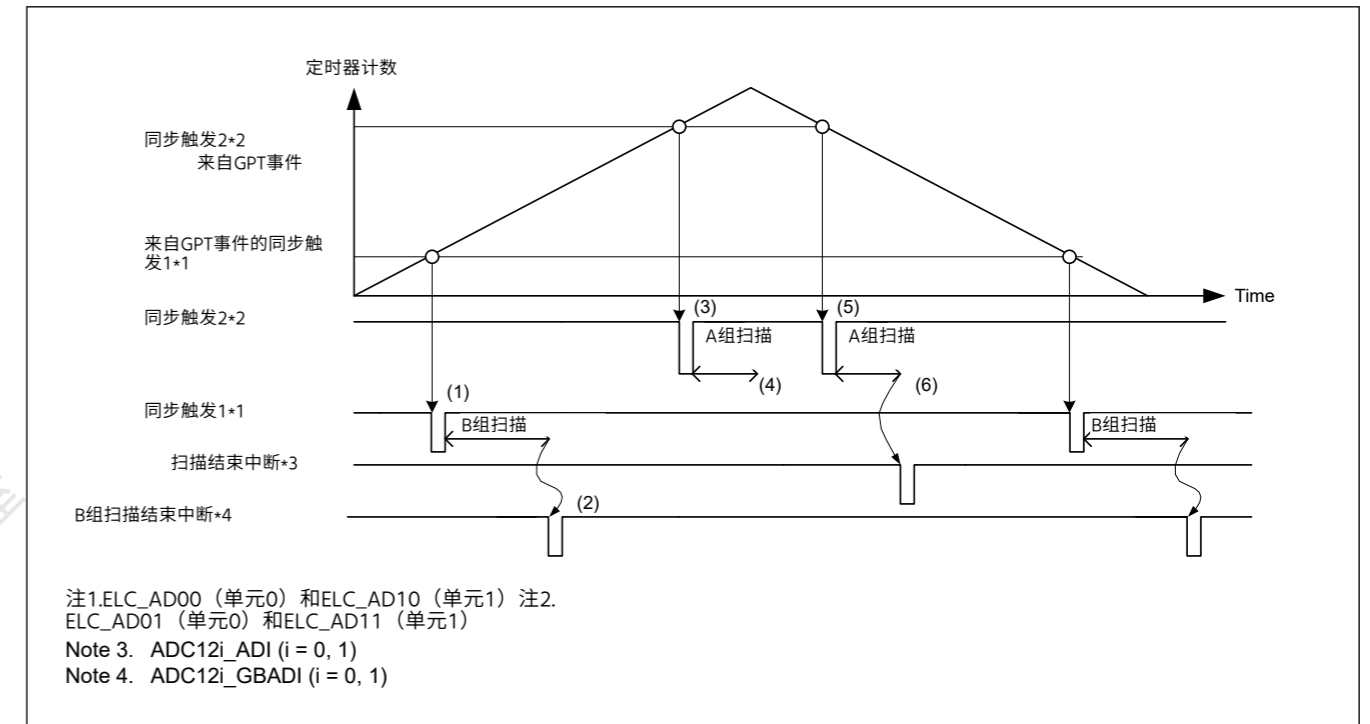


Figure 37.17 当使用来自ELC的同步触发时，具有双触发模式的组扫描模式下的基本操作示例

### 37.3.4.3 集团优先运营

在组扫描模式下，通过将ADGSPCR.PGS位设置为1来执行组优先级操作。组的优先级为A组>B组。

将ADGSPCR寄存器中的PGS位设置为1时，请遵循图37.18中描述的过程。如果不遵循该程序，则无法保证AD转换操作和存储数据。

作为组扫描模式下的基本操作，A、B组A/D转换过程中产生的触发输入被忽略，各组的A/D转换操作与单扫描模式下的操作类似。

在组优先操作中，如果在低优先级组的扫描期间输入了优先级组的触发，则停止低优先级组的AD转换并执行优先级组的AD转换。

如果ADGSPCR.GBRSCN位设置为0，则当优先级组的AD转换完成时，低优先级组进入等待状态。AD转换期间产生的低优先级组的触发输入被忽略。

如果ADGSPCR.GBRSCN位设置为1，则在优先级组的AD转换完成后，低优先级组的AD转换自动重新开始。对优先级组进行AD转换时产生的低优先级组的触发输入生效，在优先级组的AD转换完成后，自动进行低优先级组的AD转换。

如果ADGSPCR.GBRSCN位为1，ADGSPCR.LGRRS位为0，则从第一个通道重新开始低优先级组的AD转换。如果ADGSPCR.LGRRS位设置为1，则低优先级组的AD转换从转换停止的通道重新开始。但是，如果使用自诊断功能，则从自诊断完成后停止转换的通道重新开始AD转换。

Table 37.24 summarizes operations in response to the input of a trigger during A/D conversion with the settings of the ADGSPCR.GBRSCN bit.

If the setting of the ADGSPCR.GBRP bit is 1, A/D conversion operation for the lowest-priority group is to continuously perform single scans.

For the trigger settings in group-scan mode, select a synchronous trigger for group A by using the ADSTRGR.TRSA[5:0] bits, a synchronous trigger for group B by using the ADSTRGR.TRSB[5:0] bits. Each trigger must be different from each other. Set the ADSTRGR.TRSB[5:0] bits to 0x3F when setting the ADGSPCR.GBRP bit to 1.

The channels to be scanned must be selected in the registers shown in section 37.3.4. Group Scan Mode.

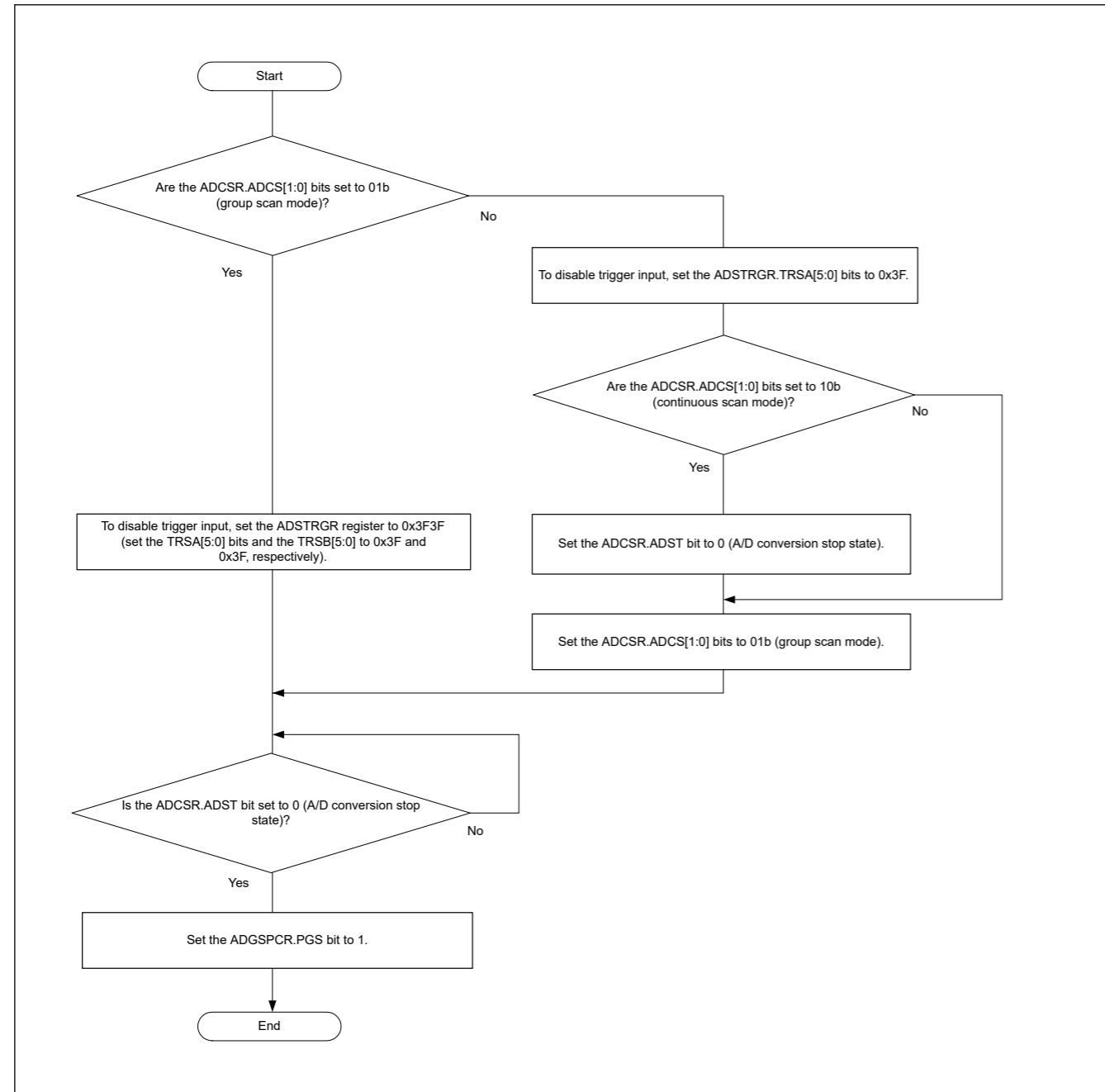


Figure 37.18 Flowchart for ADGSPCR.PGS bit setting

表37.24总结了在AD转换期间响应触发输入的操作，其中设置为ADGSPCR.GBRSCN bit。

如果ADGSPCR.GBRP位设置为1，则最低优先级组的AD转换操作是连续执行单次扫描。

对于组扫描模式下的触发设置，使用ADSTRGR.TRSA[5:0]位选择A组同步触发，使用ADSTRGR.TRSB[5:0]位选择B组同步触发。每个触发器必须彼此不同。将ADGSPCR.GBRP位设置为1时，将ADSTRGR.TRSB[5:0]位设置为0x3F。

要扫描的通道必须在第37.3.4节所示的寄存器中选择。组扫描模式。

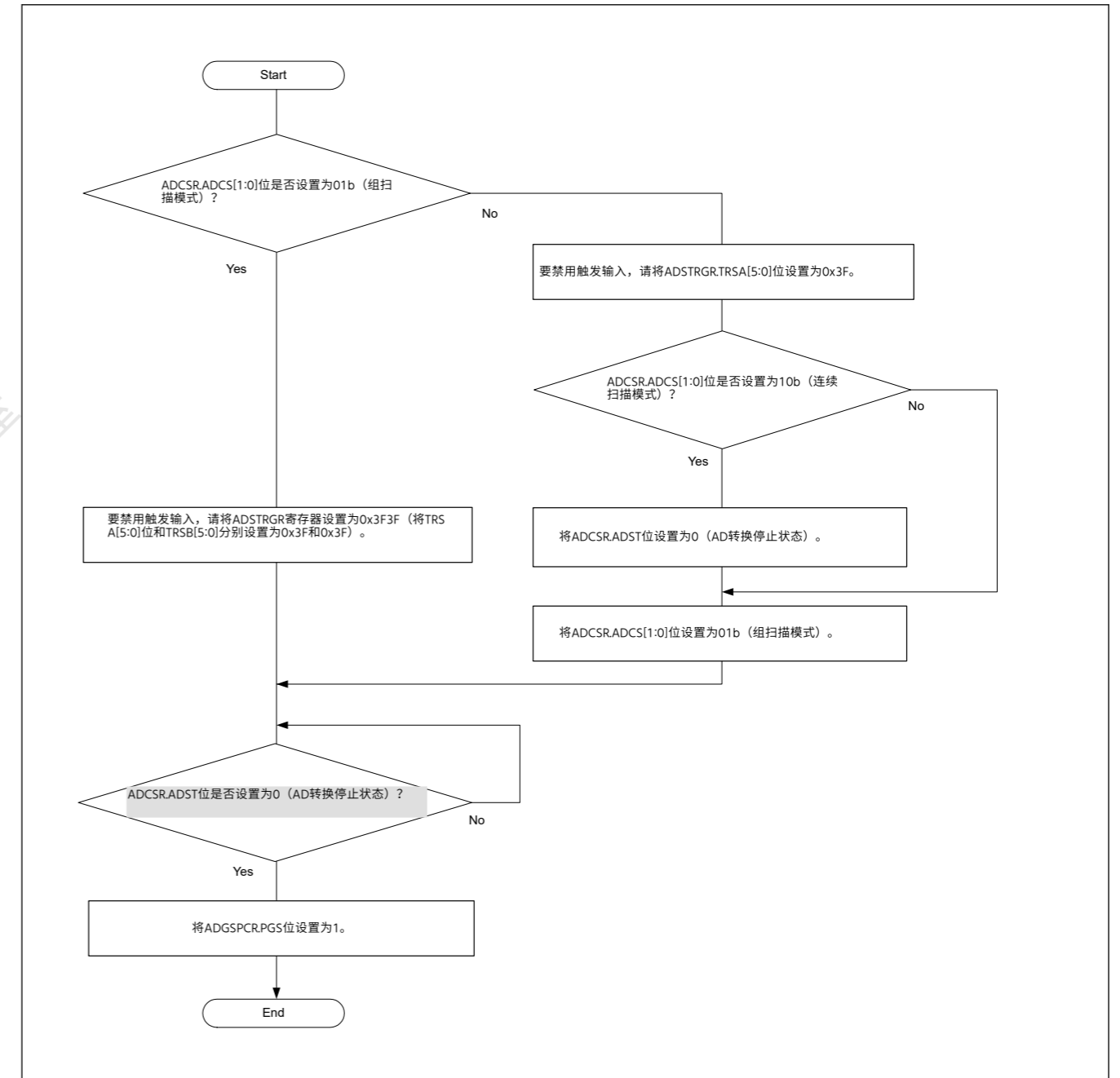


Figure 37.18 ADGSPCR.PGS位设置流程图



Table 37.24 Control of A/D conversion operations according to ADGSPCR.GBRSCN bit setting

| A/D conversion operation                       | Trigger input                | ADGSPCR.GBRSCN = 0  | ADGSPCR.GBRSCN = 1   |
|--|------------------------------|---|--|
| When A/D conversion for group A is in progress | Input of trigger for group A | Trigger input is ineffective.   | Trigger input is ineffective.  |
|  | Input of trigger for group B | Trigger input is ineffective.   | A/D conversion for group B is performed after A/D conversion for group A completes.  |
| When A/D conversion for group B is in progress | Input of trigger for group A | A/D conversion for group B is discontinued and A/D conversion for group A starts. | <ul style="list-style-type: none"> <li>A/D conversion for group B is discontinued and A/D conversion for group A starts.</li> <li>A/D conversion for group B starts after A/D conversion for group A completes.</li> </ul> |
|  | Input of trigger for group B | Trigger input is ineffective.   | Trigger input is ineffective.  |

To use group priority operation mode, select the operation mode to be implemented and set the registers according to the following table.

Table 37.25 Group priority operation setting and operation mode for two groups (ADGSPCR.PGS = 1)

| ADGSPCR |       |      | Operation category  |
|---------|-------|------|---|
| GBRSCN  | LGRRS | GBRP |   |
| 0       | x     | 0    | Group priority operation for two groups (groups A and B) <ul style="list-style-type: none"> <li>When a trigger of group A is input, A/D conversion for group B is terminated (and will not be restarted).</li> </ul>  |
| 1       | 0     | 0    | Group priority operation for two groups (groups A and B) <ul style="list-style-type: none"> <li>After A/D conversion for group B stopped, when A/D conversion for group A completes, A/D conversion for the group B channels selected in the ADANSB0 and ADANSB1 registers restarts according to the conversion order of smaller channel number.</li> </ul>   |
| 1       | 1     | 0    | Group priority operation for two groups (groups A and B) <ul style="list-style-type: none"> <li>After A/D conversion for group B stopped, when A/D conversion for group A completes, A/D conversion for the group B channels selected in the ADANSB0/1 register restarts according to the conversion order of smaller channel number, beginning from the channel for which A/D conversion stopped.*1</li> </ul>   |
| x       | 0     | 1    | Group priority operation for two groups (groups A and B) <ul style="list-style-type: none"> <li>Single scanning for group B is continuously performed without a start trigger input. After A/D conversion for group B stopped, when A/D conversion for group A completes, single scanning for the channels selected in the ADANSB0/1 register restarts according to the conversion order of smaller channel number.</li> </ul>  |
| 1       | 1     | 1    | Group priority operation for two groups (groups A and B) <ul style="list-style-type: none"> <li>Single scanning for group B is continuously performed without a start trigger input. After A/D conversion for group B stopped, when A/D conversion for group A completes, single scanning for the channels selected in the ADANSB0/1 register restarts according to the conversion order of smaller channel number, beginning from the channel for which A/D conversion stopped.*1</li> </ul> |

Note: x: Don't care.

Note 1. When the self-diagnosis function is enabled (ADCER.DIAGM = 1), A/D conversion for the channel that has been stopped is started after self-diagnosis is performed.

(1) Group priority operation for two groups (when ADGSPCR.PGS = 1)

Operation examples 1-1 to 1-5 show group priority operations in group-scan mode (when ADGSPCR.GBRSCN = 1, ADGSPCR.GBRP = 0, and ADGSPCR.LGRRS = 0) when channel 0 is selected for group A and channels 1 to 3 are selected for group B.

Operation example 1-1: "Group A trigger input during group B scan" when rescanning is enabled

- When input of a trigger for group B sets the ADCSR.ADST bit to 1 (starting A/D conversion), A/D conversion for the analog input channels selected in the ADANSB0 and ADANSB1 registers starts according to the conversion order from the channel with the smallest number n.
- On completion of A/D conversion for each channel in group B, the result is stored in the corresponding A/D Data Register y (ADDRy).

Table 37.24 根据ADGSPCR.GBRSCN位设置控制AD转换操作

| AD转换操作       | 触发输入    | ADGSPCR.GBRSCN = 0   | ADGSPCR.GBRSCN = 1  |
|--------------|---------|----------------------|---|
| 正在进行A组的AD转换时 | A组触发器输入 | 触发输入无效。              | 触发输入无效。   |
|              | B组触发器输入 | 触发输入无效。              | 在A组的AD转换完成后，执行B组的AD转换。  |
| 正在进行B组的AD转换时 | A组触发器输入 | B组的AD转换停止，A组的AD转换开始。 | <ul style="list-style-type: none"> <li>B组的AD转换停止，A组的AD转换开始。</li> <li>B组的AD转换在A组的AD转换完成后开始。</li> </ul> |
|              | B组触发器输入 | 触发输入无效。              | 触发输入无效。   |

要使用组优先操作模式，请根据下表选择要执行的操作模式并设置寄存器。

Table 37.25 两组的组优先操作设置和操作模式 (ADGSPCR.PGS=1)

| ADGSPCR |       |      | 操作类别  |
|---------|-------|------|---|
| GBRSCN  | LGRRS | GBRP |   |
| 0       | x     | 0    | 两组 (A组和B组) 的组优先操作●<br>当输入A组的触发时，B组的AD转换将终止 (并且不会重新启动)。  |
| 1       | 0     | 0    | 两组 (A组和B组) 的组优先操作●<br>B组AD转换停止后，当A组AD转换完成时，ADANSB0和ADANSB1寄存器中选择的B组通道的AD转换按照通道号较小的转换顺序重新开始。                                 |
| 1       | 1     | 0    | 两组 (A组和B组) 的组优先操作●<br>B组AD转换停止后，当A组AD转换完成时，ADANSB0寄存器中选择的B组通道的AD转换按照通道号较小的转换顺序重新开始，从AD转换停止的通道开始。*1                          |
| x       | 0     | 1    | 两组 (A组和B组) 的组优先操作●<br>B组的单次扫描在没有启动触发输入的情况下连续执行。B组AD转换停止后，当A组AD转换完成时，按照通道号较小的转换顺序重新开始对ADANSB01寄存器中选择的通道进行单次扫描。               |
| 1       | 1     | 1    | 两组 (A组和B组) 的组优先操作●<br>B组的单次扫描在没有启动触发输入的情况下连续执行。B组AD转换停止后，当A组AD转换完成时，对ADANSB01寄存器中选择的通道的单次扫描按照通道号较小的转换顺序重新开始，从AD转换停止的通道开始。*1 |

Note: x: Don't care.

注1.自诊断功能有效时 (ADCER.DIAGM=1)，自诊断完成后，已停止通道的AD转换开始。

(1) 两个组的组优先操作 (当ADGSPCR.PGS=1时)

操作示例1-1到1-5显示了当为组A和通道1选择通道0时，组扫描模式下的组优先操作 (当ADGSPCR.GBRSCN=1、ADGSPCR.GBRP=0和ADGSPCR.LGRRS=0时) 为B组选择3至3个。

操作示例1-1: 启用重新扫描时的“B组扫描期间A组触发输入”

- 当B组的触发输入将ADCSR.ADST位设置为1 (开始AD转换) 时，ADANSB0和ADANSB1寄存器中选择的模拟输入通道的AD转换按照转换顺序从最小通道开始号码n。
- B组中每个通道的AD转换完成后，将结果存储在相应的AD数据寄存器y(ADDRy)中。



- When a trigger for group A is input during A/D conversion for group B, A/D conversion for group B stops while the ADCSR.ADST bit remains 1. Then A/D conversion for the group A analog input channels selected in the ADANSA0 and ADANSA1 registers starts according to the conversion order from the channel with the smallest number n. If A/D conversion stops before it is completed, the conversion result is not stored in the A/D Data Register y (ADDRy).
- On completion of A/D conversion on the channels, the result is stored in the corresponding A/D Data Register y (ADDRy).
- If the setting of the ADCSR.ADIE bit is 1 (enabling interrupt generation upon completion of scanning), a scan end interrupt request is generated.
- If the setting of the ADGSPCR.GBRSCN bit is 1 (enabling rescanning of the group that was stopped in group priority operation), A/D conversion for the group B analog input channels selected in the ADANSB0 and ADANSB1 registers restarts according to the conversion order from the channel with the smallest number n while the ADCSR.ADST remains 1.
- On completion of A/D conversion on the channels, the result is stored in the corresponding A/D Data Register y (ADDRy).
- If the setting of the ADCSR.GBADIE bit is 1 (enabling interrupt generation on completion of group B scan), a group B scan end interrupt request is generated.
- When A/D conversion for all the channels completes, the ADCSR.ADST bit is automatically cleared and the A/D converter enters a wait state.

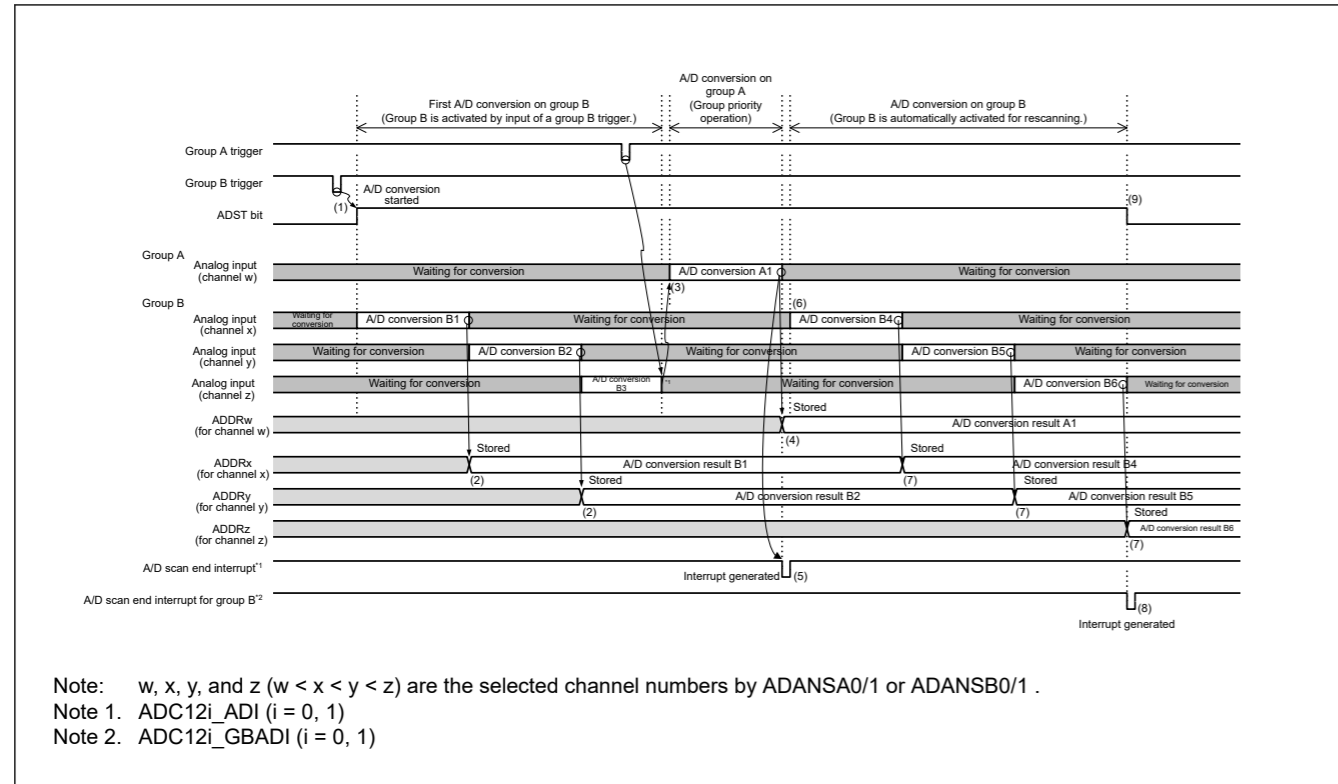


Figure 37.19 Example of group priority operation 1-1: Group A trigger input during group B scanning when rescanning is enabled (when ADGSPCR.GBRSCN = 1, ADGSPCR.GBRP = 0, and ADGSPCR.LGRRS = 0)

Operation example 1-2: “Group A trigger input during rescanning of group B” when rescanning is enabled

Figure 37.20 shows the operation when a group A trigger is input during rescanning operation for group B.

Even during rescanning operation, when a trigger for group A is input, A/D conversion on group B stops and A/D conversion for group A starts. A/D conversion for group B starts after A/D conversion for group A completes.

Operations for setting the ADCSR.ADST bit, storing the A/D conversion result in the corresponding A/D Data Register y (ADDRy), and generating interrupt requests are the same as those in operation example 1-1.

- 在B组的AD转换期间输入A组的触发信号时，B组的AD转换停止，而ADCSR.ADST位保持为1。然后在ADANSA0和ADANSA1寄存器中选择的A组模拟输入通道的AD转换开始根据编号n最小的通道的转换顺序。如果AD转换在完成之前停止，则转换结果不会存储在AD数据寄存器y(ADDRy)中。
- 在通道上完成AD转换后，结果将存储在相应的AD数据寄存器y(ADDRy)中。
- 如果ADCSR.ADIE位设置为1（扫描完成时允许产生中断），则产生扫描结束中断请求。
- 如果ADGSPCR.GBRSCN位设置为1（允许重新扫描在组优先操作中停止的组），则ADANSB0和ADANSB1寄存器中选择的B组模拟输入通道的AD转换根据转换顺序重新启动当ADCSR.ADST保持为1时，来自编号为n的最小通道。
- 在通道上完成AD转换后，结果将存储在相应的AD数据寄存器y(ADDRy)中。
- 如果ADCSR.GBADIE位设置为1（使能在B组扫描完成时产生中断），则产生B组扫描结束中断请求。
- 当所有通道的AD转换完成时，ADCSR.ADST位自动清零，AD转换器进入等待状态。

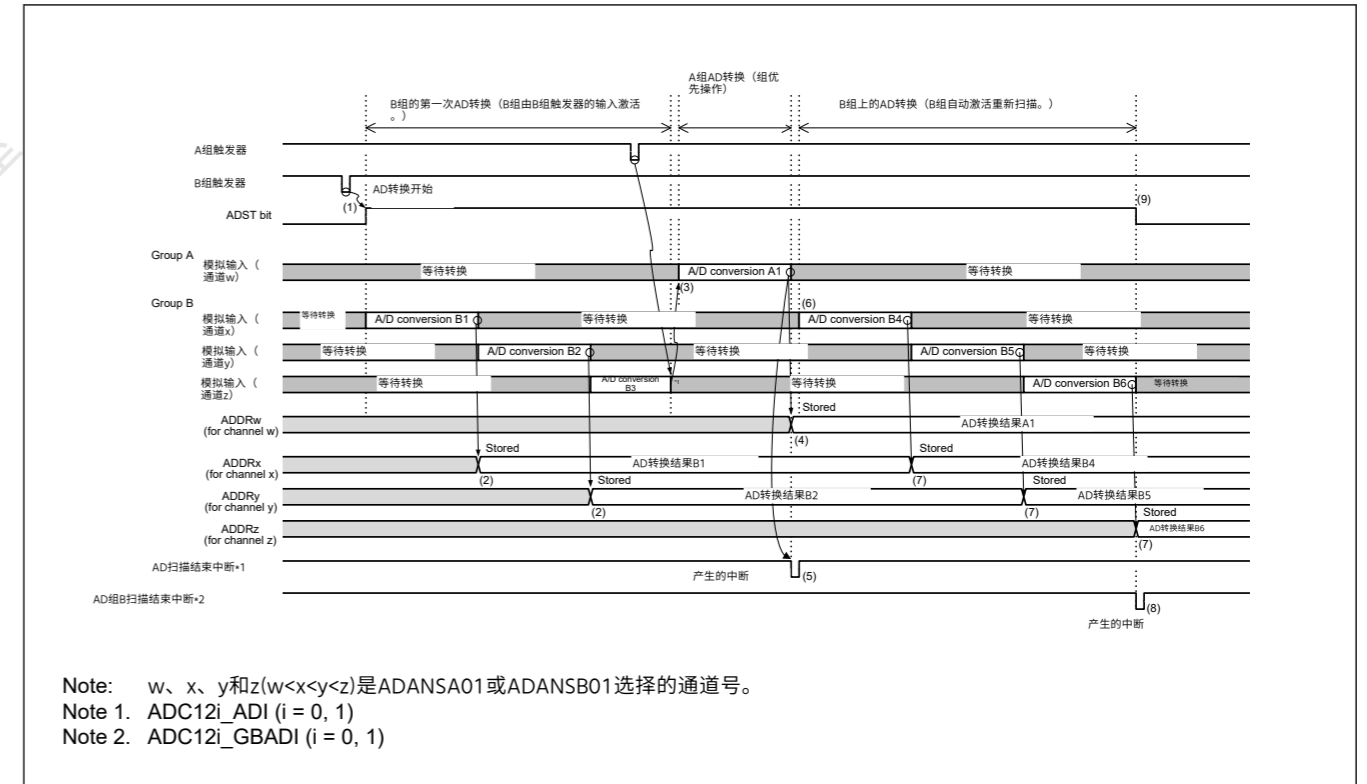


Figure 37.19 组优先操作1-1示例：启用重新扫描时，在B组扫描期间A组触发输入（当ADGSPCR.GBRSCN=1、ADGSPCR.GBRP=0和ADGSPCR.LGRRS=0时）

操作示例1-2：启用重新扫描时的“B组重新扫描期间A组触发输入”

图37.20显示了在B组重新扫描操作期间输入A组触发时的操作。

即使在重新扫描操作期间，当输入A组触发时，B组的AD转换停止，A组的AD转换开始。B组的AD转换在A组的AD转换完成后开始。

设置ADCSR.ADST位、将AD转换结果存储到相应的AD数据寄存器y(ADDRy)以及产生中断请求的操作与操作示例1-1中的操作相同。

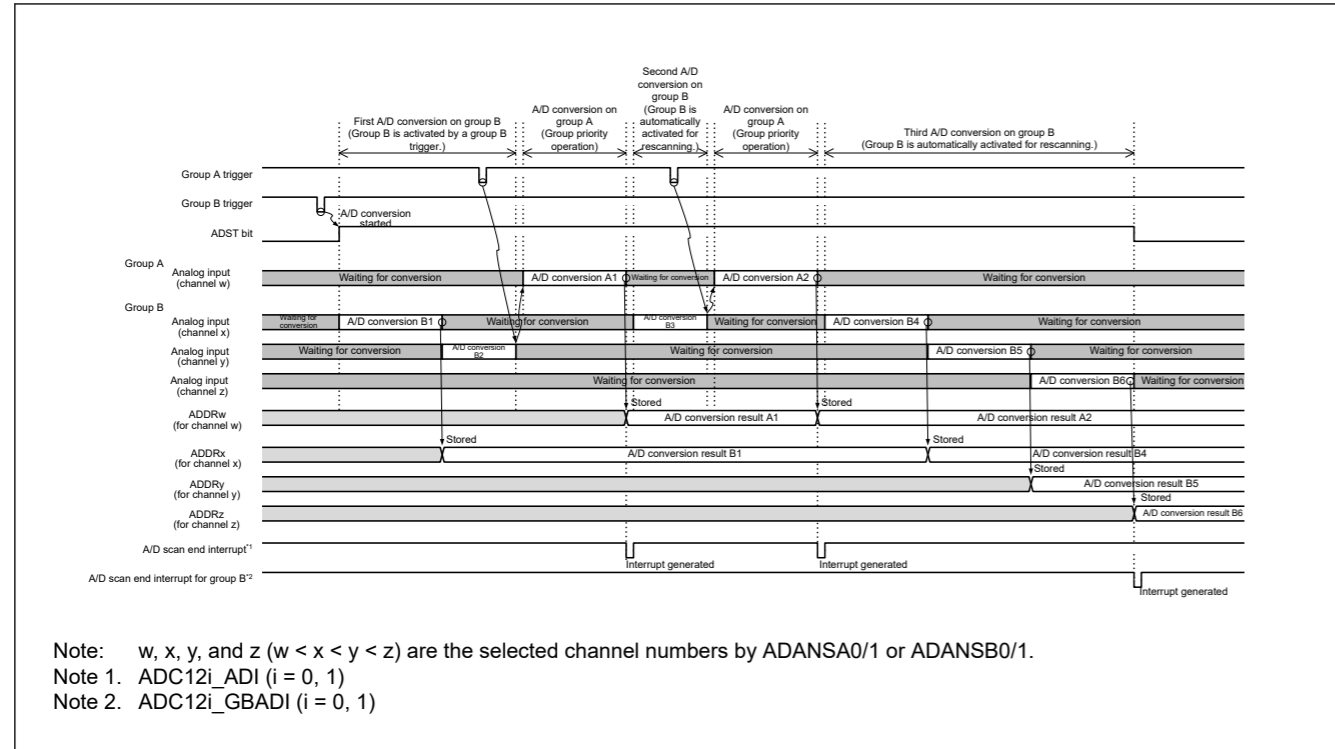


Figure 37.20 Example of group priority operation 1-2: Group A trigger input during rescanning of group B when rescanning is enabled (when ADGSPCR.GBRSCN = 1, ADGSPCR.GBRP = 0, and ADGSPCR.LGRRS = 0)

Operation example 1-3: “Group B trigger input during group A scan” when rescanning is enabled

The following describes the operation when the setting of the ADGSPCR.GBRSCN bit is 1 (enabling rescanning of the group that was stopped in group priority operation) and a trigger for group B is input during scanning operation for group A.

If the setting of the ADGSPCR.GBRSCN bit is 0, any trigger for group B that is input during scanning operation for group A is invalid.

- When input of a trigger for group A sets the ADCSR.ADST bit to 1 (starting A/D conversion), A/D conversion for the group A analog input channels selected in the ADANSA0 and ADANSA1 registers starts according to the conversion order from the channel with the smallest number n.
- When a trigger for group B is input during A/D conversion for group A, group B is ready for A/D conversion.
- On completion of A/D conversion for each channel in group A, the result is stored in the corresponding A/D Data Register y (ADDRy).
- If the setting of the ADCSR.ADIE bit is 1 (enabling interrupt generation upon completion of scanning), a scan end interrupt request is generated.
- When A/D conversion for group A completes, while the ADCSR.ADST bit remains 1, A/D conversion for the group B analog input channels selected in the ADANSB0 and ADANSB1 registers starts according to the conversion order from the channel with the smallest number n.  
(As with the case of operation example 1-1, if a trigger for group A is input during A/D conversion for group B, A/D conversion for group A starts. Then A/D conversion for group B starts upon completion of A/D conversion for group A.)
- On completion of A/D conversion of a single channel, the result is stored in the corresponding A/D Data Register y (ADDRy).
- Upon completion of A/D conversion for group B, a group B scan end interrupt request is generated if the setting of the ADCSR.GBADIE bit is 1 (enabling interrupt generation on completion of group B scan).
- When A/D conversion for all the channels completes, the ADCSR.ADST bit is automatically cleared and the A/D converter enters a wait state.

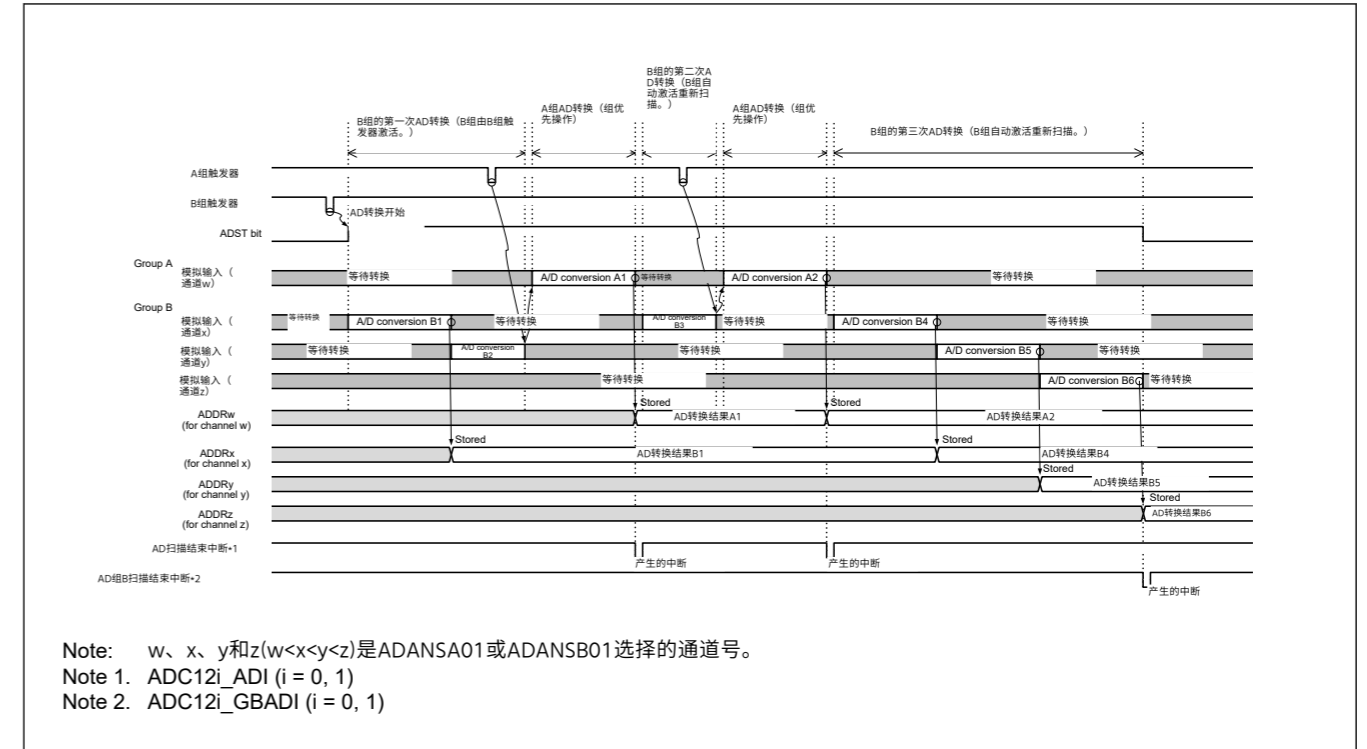


Figure 37.20 组优先操作1-2示例：启用重新扫描时（当ADGSPCR.GBRSCN=1、ADGSPCR.GBRP=0和ADGSPCR.LGRRS=0时）在B组重新扫描期间A组触发输入

操作示例1-3：启用重新扫描时的“A组扫描期间B组触发输入”

下面介绍当ADGSPCR.GBRSCN位设置为1（允许重新扫描在组优先操作中停止的组）并且在A组扫描操作期间输入B组触发器时的操作。

如果ADGSPCR.GBRSCN位设置为0，则在组扫描操作期间输入的任何组B触发A无效。

- 当A组的触发输入将ADCSR.ADST位设置为1（开始AD转换）时，ADANSA0和ADANSA1寄存器中选择的A组模拟输入通道的AD转换根据通道的转换顺序开始最小的数n。
- 在A组AD转换期间输入B组触发器时，B组准备好进行AD转换。
- A组中每个通道的AD转换完成后，将结果存储在相应的AD数据寄存器y(ADDRy)中。
- 如果ADCSR.ADIE位设置为1（扫描完成时允许产生中断），则产生扫描结束中断请求。
- 当A组的AD转换完成，而ADCSR.ADST位保持为1时，ADANSB0和ADANSB1寄存器中选择的B组模拟输入通道的AD转换按照编号n最小通道的转换顺序开始。（与操作示例1-1的情况一样，如果在B组的AD转换期间输入了A组的触发信号，则A组的AD转换开始。然后，在A组的AD转换完成后，开始B组的AD转换。）
- 单通道AD转换完成后，结果存入对应的AD数据寄存器y(ADDRy)。
- B组的AD转换完成后，如果ADCSR.GBADIE位设置为1，则产生B组扫描结束中断请求（在B组扫描完成时允许产生中断）。
- 当所有通道的AD转换完成时，ADCSR.ADST位自动清零，AD转换器进入等待状态。

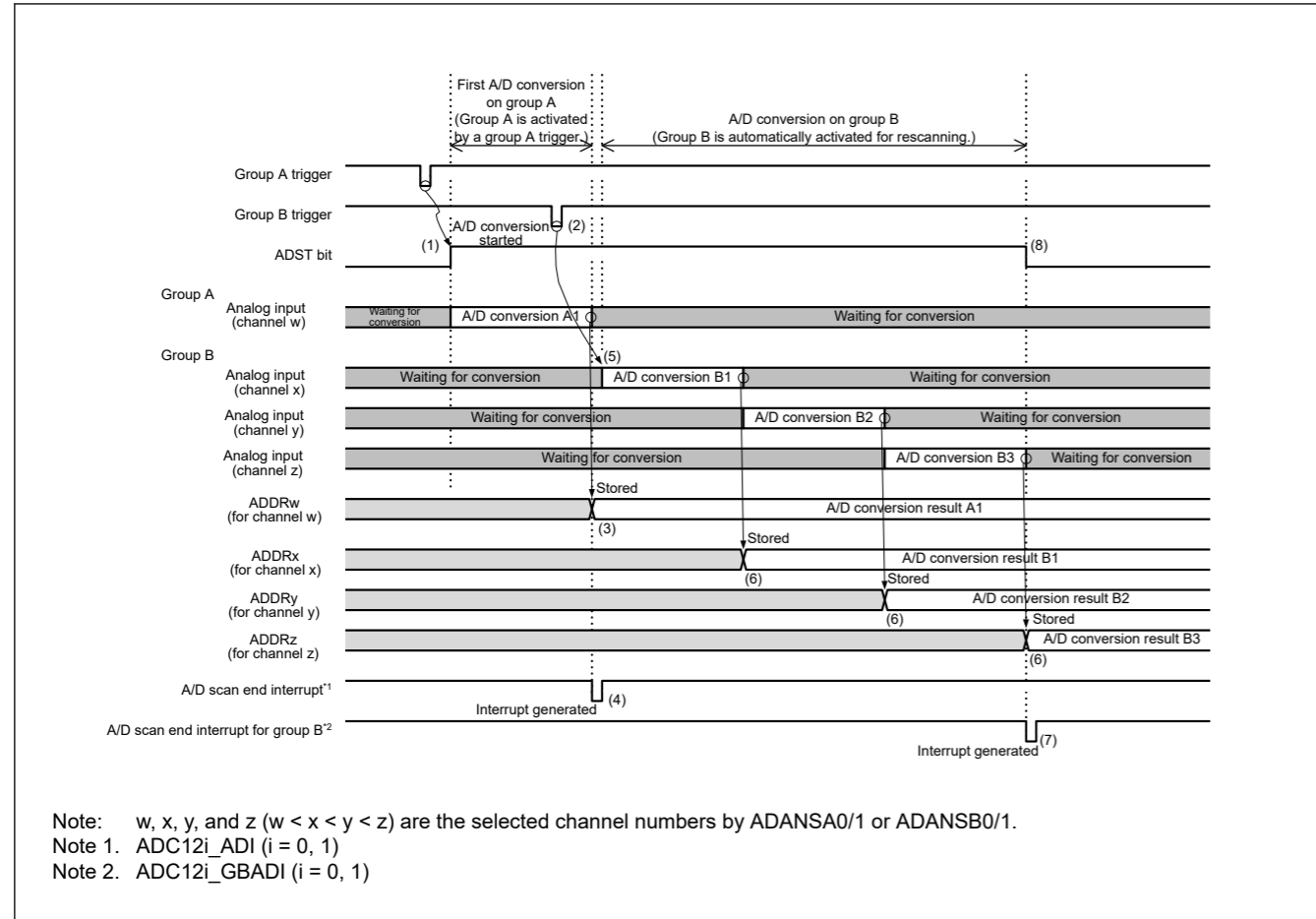


Figure 37.21 Example of group priority operation 1-3: Group B trigger input during group A scan when rescanning is enabled (when ADGSPCR.GBRSCN = 1, ADGSPCR.GBRP = 0, and ADGSPCR.LGRRS = 0)

Operation example 1-4 shows the group priority operation in group-scan mode (when ADGSPCR.GBRSCN = 0, ADGSPCR.GBRP = 0, and ADGSPCR.LGRRS = 0) when channel 0 is selected for group A and channels 1 to 3 are selected for group B.

**Operation example 1-4: “Group A trigger input during group B scan” when rescanning is disabled**

- When input of a trigger for group B sets the ADCSR.ADST bit to 1 (starting A/D conversion), A/D conversion for the analog input channels selected in the ADANSB0 and ADANSB1 registers starts according to the conversion order from the channel with the smallest number n.
- On completion of A/D conversion for each channel in group B, the result is stored in the corresponding A/D Data Register y (ADDRy).
- When a trigger for group A is input during A/D conversion for group B, A/D conversion for group B stops while the ADCSR.ADST bit remains 1, and then A/D conversion for the group A analog input channels selected in the ADANSA0 and ADANSA1 registers starts according to the conversion order from the channel with the smallest number n. If A/D conversion stops before it is completed, the conversion result is not stored in the A/D Data Register y (ADDRy).
- On completion of A/D conversion of a single channel, the result is stored in the corresponding A/D Data Register y (ADDRy).
- On completion of A/D conversion for group A, a scan end interrupt request is generated if the setting of the ADCSR.ADIE bit is 1 (enabling interrupt generation upon completion of scanning).
- When A/D conversion for group A completes, the ADCSR.ADST bit is automatically cleared and the A/D converter enters a wait state. A/D conversion for group B is not performed until a trigger for group B is input the next time.

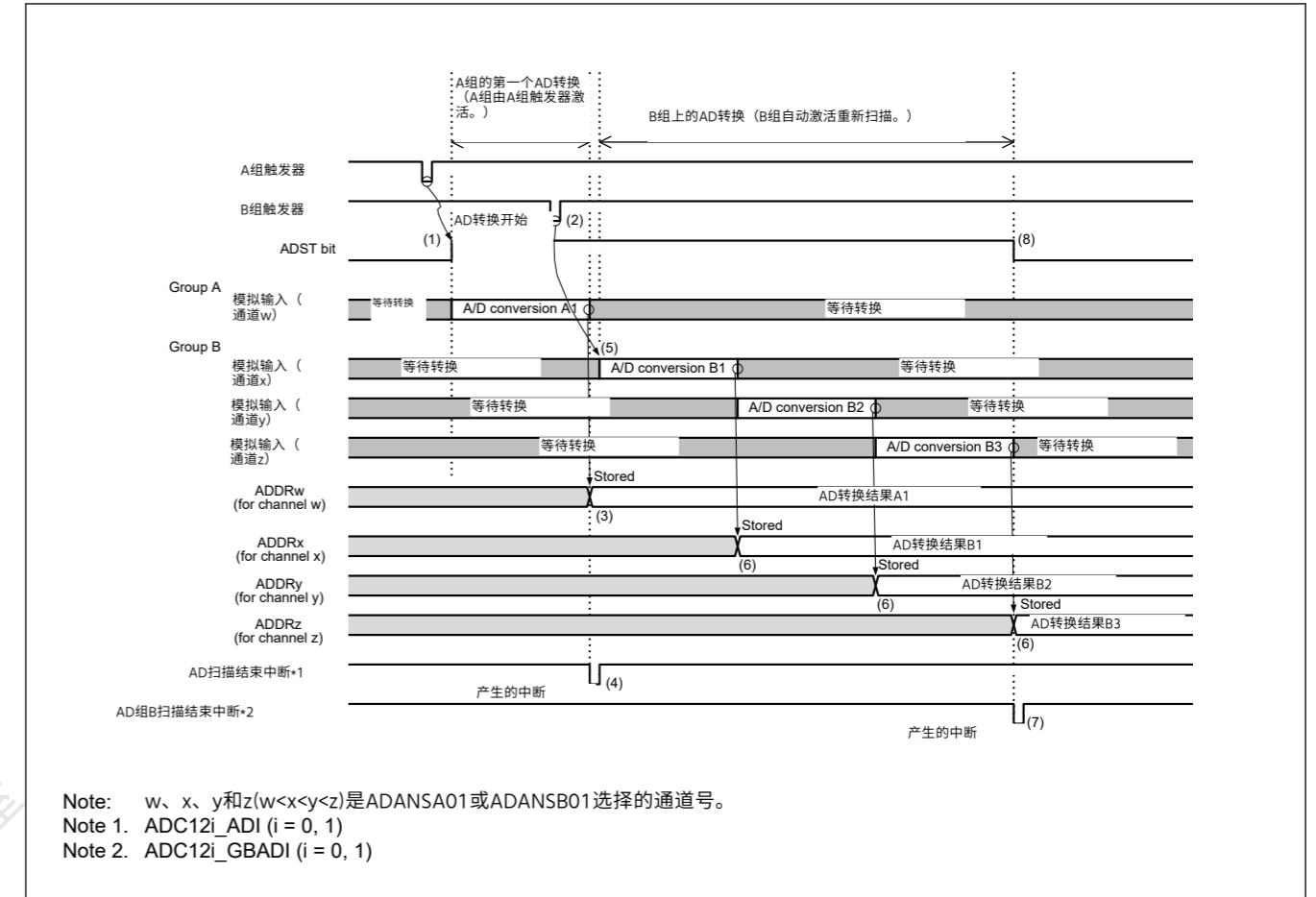


Figure 37.21 组优先操作1-3示例：启用重新扫描时A组扫描期间的B组触发输入（当ADGSPCR.GBRSCN=1、ADGSPCR.GBRP=0和ADGSPCR.LGRRS=0时）

操作示例1-4显示了组扫描模式下的组优先级操作（当ADGSPCR.GBRSCN=0时，ADGSPCR.GBRP=0和ADGSPCR.LGRRS=0）当为A组选择通道0并且为B组选择通道1至3时。

**操作示例1-4：禁用重新扫描时的“B组扫描期间A组触发输入”**

- 当B组的触发输入将ADCSR.ADST位设置为1（开始AD转换）时，ADANSB0和ADANSB1寄存器中选择的模拟输入通道的AD转换按照转换顺序从最小通道开始号码n。
- B组中每个通道的AD转换完成后，将结果存储在相应的AD数据寄存器y(ADDRy)中。
- 在B组AD转换期间输入A组触发时，在ADCSR.ADST位保持1时停止B组AD转换，然后在ADANSA0和ADANSA1寄存器按照转换顺序从编号n最小的通道开始。如果AD转换在完成之前停止，则转换结果不会存储在AD数据寄存器y(ADDRy)中。
- 单通道AD转换完成后，结果存入对应的AD数据寄存器y(ADDRy)。
- 完成A组的AD转换后，如果ADCSR.ADIE位设置为1，则产生扫描结束中断请求（扫描完成时允许产生中断）。
- 当A组的AD转换完成时，ADCSR.ADST位自动清零，AD转换器进入等待状态。直到下次输入B组的触发后，才会执行B组的AD转换。



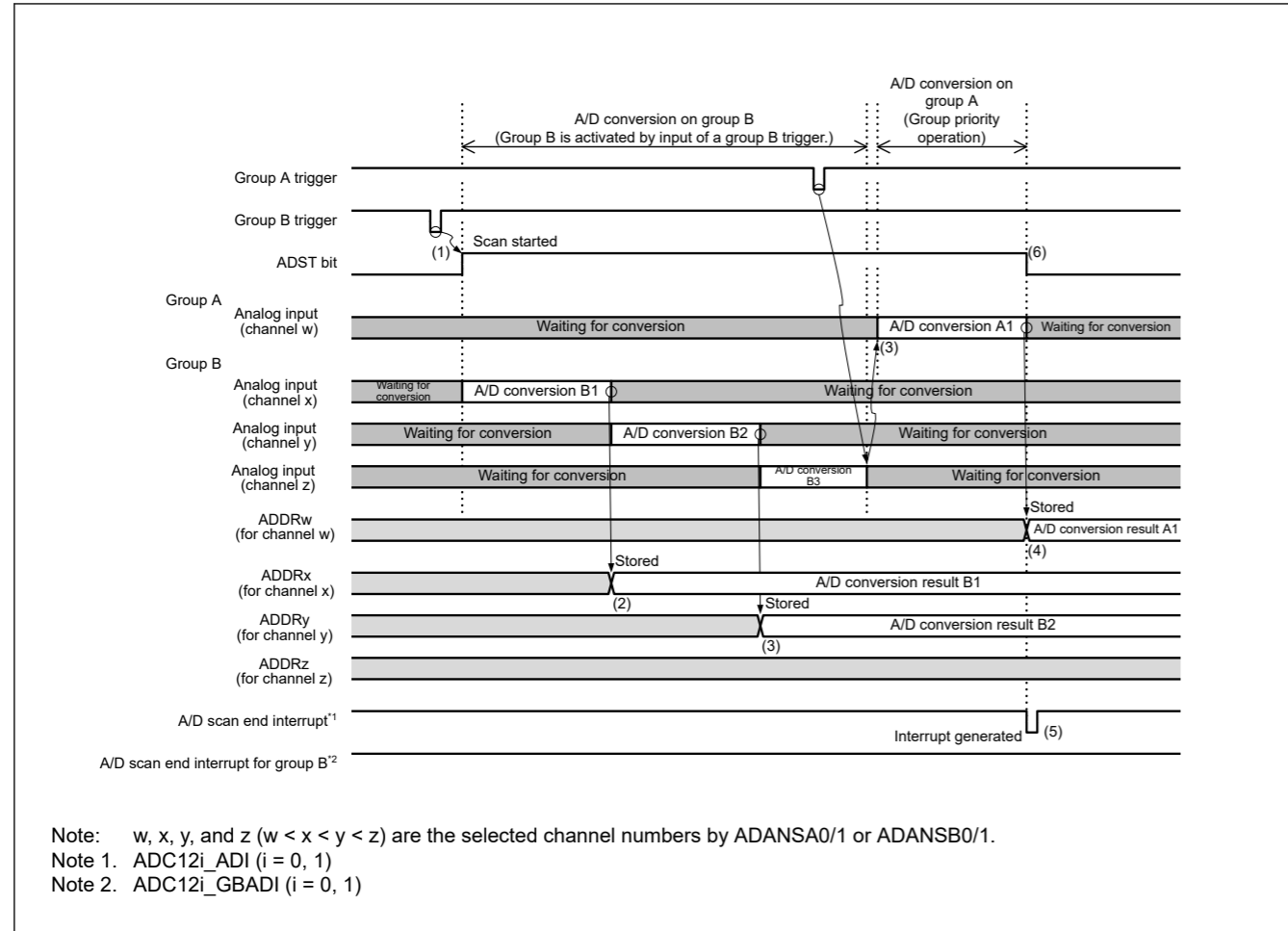


Figure 37.22 Group priority operation example 1-4: “Group A trigger is input during group B scan” when rescanning is disabled (when ADGSPCR.GBRSCN = 0, ADGSPCR.GBRP = 0, and ADGSPCR.LGRRS = 0)

Operation example 1-5 shows the group priority operation in group-scan mode (when ADGSPCR.GBRP = 1, and ADGSPCR.LGRRS = 0) when channel 0 is selected for group A and channels 1 and 2 are selected for group B.

**Operation example 1-5: Continuously activating single-scan operation for group B**

- When ADGSPCR.GBRP = 1 is set, the ADCSR.ADST bit is set to 1 (starting A/D conversion) and A/D conversion for the analog input channels selected in the ADANSB0 and ADANSB1 registers starts according to the conversion order from the channel with the smallest number n.
- On completion of A/D conversion for each channel in group B, the result is stored in the corresponding A/D Data Register y (ADDRy).
- When a trigger for group A is input during A/D conversion for group B, A/D conversion for group B stops while the ADCSR.ADST bit remains 1, and then A/D conversion for group A analog input channels selected in the ADANSA0 and ADANSA1 registers starts according to the conversion order z from the channel with the smallest number n. If A/D conversion stops before it is completed, the conversion result is not stored in the A/D Data Register y (ADDRy).
- On completion of A/D conversion of a single channel, the result is stored in the corresponding A/D Data Register y (ADDRy).
- On completion of A/D conversion for group A, a scan end interrupt request is generated if the setting of the ADCSR.ADIE bit is 1 (enabling interrupt generation upon completion of scanning).
- If ADGSPCR.GBRP = 1 is set (performing single scan continuously), A/D conversion for the group B analog input channels selected in the ADANSB0 and ADANSB1 registers restarts according to the conversion order from the channel with the smallest number n while the ADCSR.ADST remains 1 (starting A/D conversion).
- On completion of A/D conversion of a single channel, the result is stored in the corresponding A/D Data Register y (ADDRy).

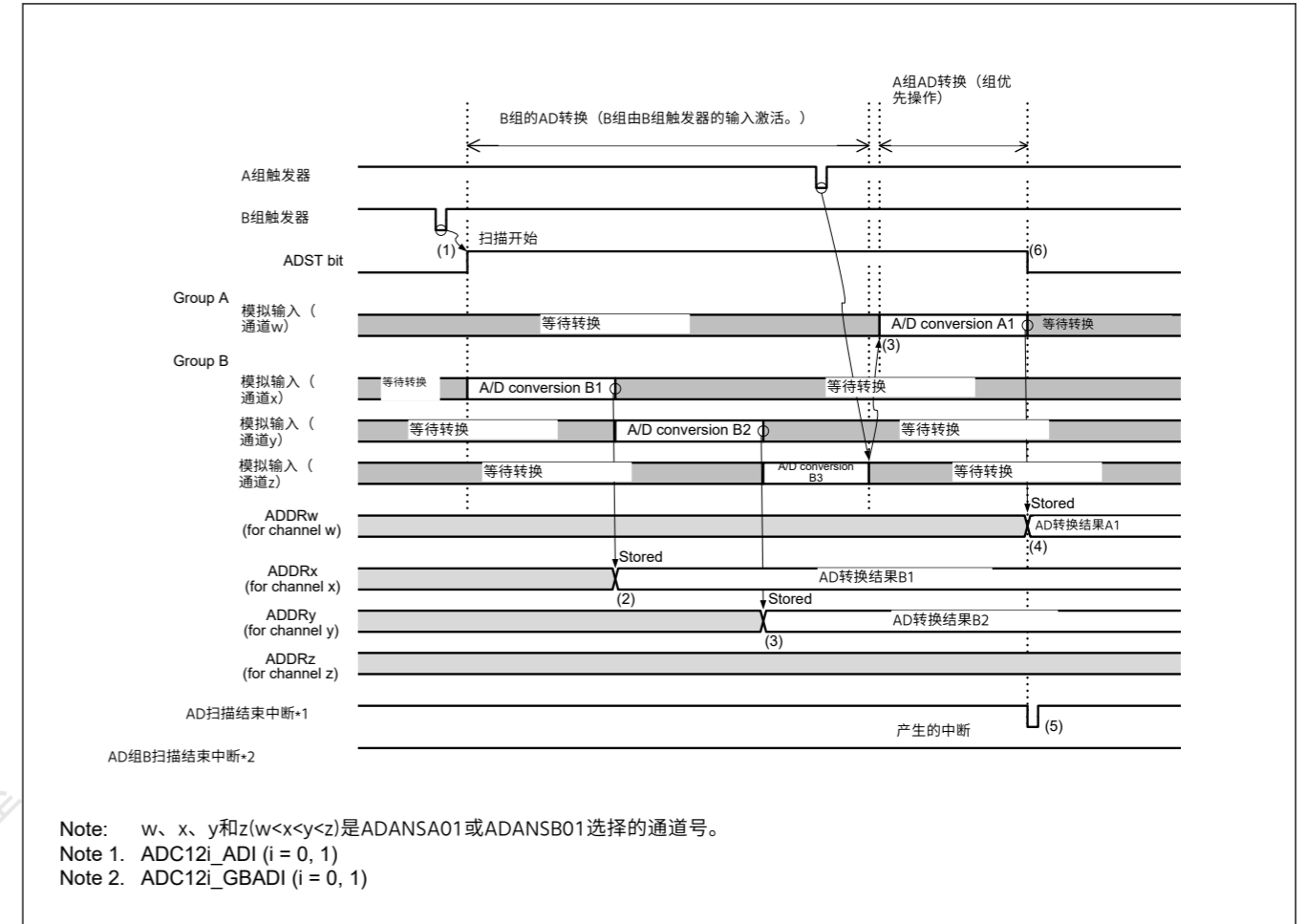


Figure 37.22 组优先操作示例1-4: “在B组扫描期间输入A组触发”当禁用重新扫描时 (当ADGSPCR.GBRSCN=0、ADGSPCR.GBRP=0和ADGSPCR.LGRRS=0时)

操作示例1-5显示了组扫描模式下的组优先级操作 (当ADGSPCR.GBRP=1, 并且ADGSPCR.LGRRS=0) 当为A组选择通道0并且为B组选择通道1和2时。

**操作示例1-5: B组连续激活单扫描操作**

- 当设置ADGSPCR.GBRP=1时, ADCSR.ADST位设置为1 (开始AD转换), 并且ADANSB0和ADANSB1寄存器中选择的模拟输入通道的AD转换根据通道的转换顺序开始最小的数n。
- B组中每个通道的AD转换完成后, 将结果存储在相应的AD数据寄存器y(ADDRy)中。
- 在B组的AD转换期间输入A组的触发信号时, B组的AD转换停止, 而ADCSR.ADST位保持为1, 然后在ADANSA0和ADANSA1寄存器中选择的A组模拟输入通道的AD转换开始根据编号为n的通道的转换顺序z。如果AD转换在完成之前停止, 则转换结果不会存储在AD数据寄存器y(ADDRy)中。
- 单通道AD转换完成后, 结果存入对应的AD数据寄存器y(ADDRy)。
- 完成A组的AD转换后, 如果ADCSR.ADIE位设置为1, 则产生扫描结束中断请求 (扫描完成时允许产生中断)。
- 如果设置ADGSPCR.GBRP=1 (连续执行单次扫描), B组模拟输入的AD转换在ADANSB0和ADANSB1寄存器中选择的通道根据转换顺序从具有最小编号n的通道重新启动, 而ADCSR.ADST保持为1 (开始AD转换)。
- 单通道AD转换完成后, 结果存入对应的AD数据寄存器y(ADDRy)。



- If the setting of the ADCSR.GBADIE bit is 1 (enabling interrupt generation on completion of group B scan), a group B scan end interrupt request is generated.
- If ADGSPCR.GBRP = 1 is set (performing single scan continuously), A/D conversion for the group B analog input channels selected in the ADANSB0 and ADANSB1 registers restarts according to the conversion order from the channel with the smallest number n while the ADCSR.ADST remains 1 (starting A/D conversion).

Steps 6 to 9 are repeated as long as the ADGSPCR.GBRP bit remains 1. Do not clear the ADCSR.ADST bit as long as the ADGSPCR.GBRP bit is 1. To forcibly stop A/D conversion while ADGSPCR.GBRP = 1, follow the procedure shown in Figure 37.38.

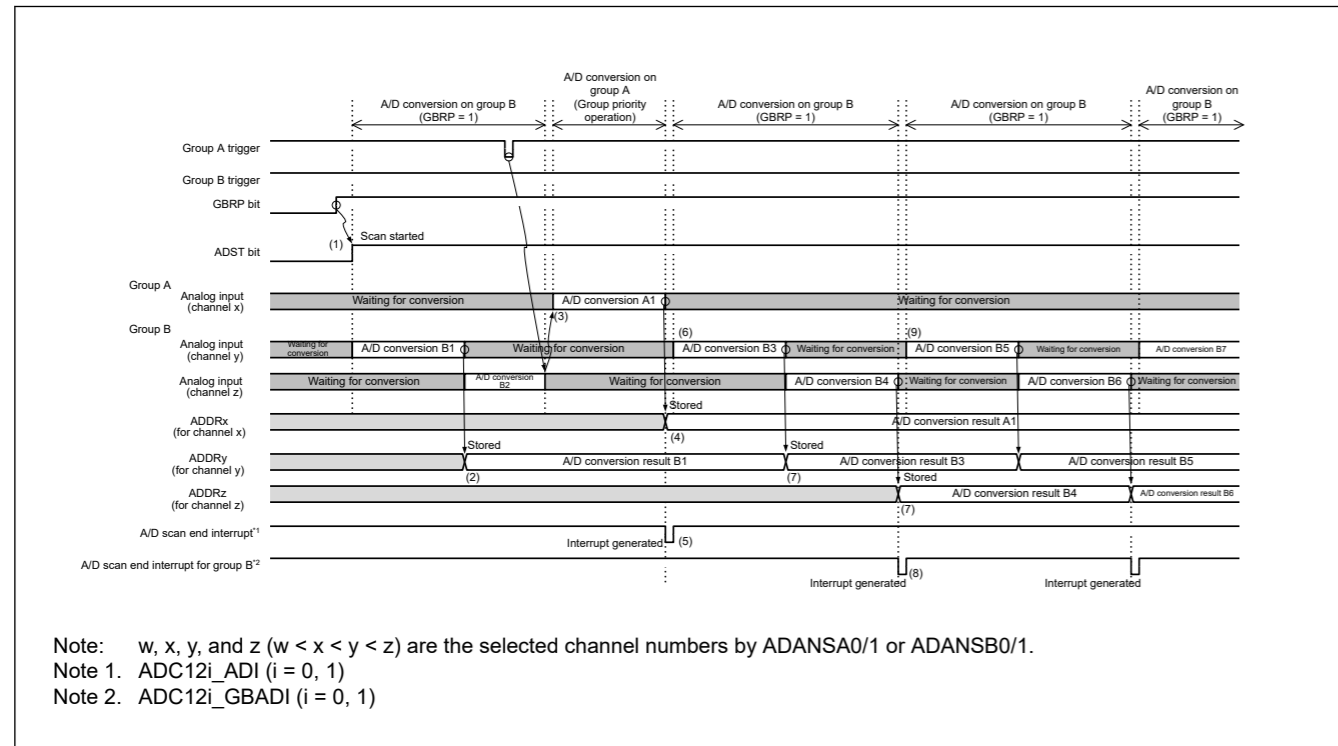


Figure 37.23 Group priority operation example 1-5: Continuously activating single scan for group B (when ADGSPCR.GBRP = 1, ADGSPCR.LGRRS = 0)

Note: To continuously activate single-scan operation for group B, disable group B trigger input.

### 37.3.5 Interleaved operation

Interleaved operation is that two ADC units convert same one pin alternately in order to obtain the data faster. This function can be used with the channel AN000/AN100, AN001/AN101 or AN002/AN102 and can be used in single scan mode and continuous scan mode. Regarding trigger, synchronous trigger and external trigger are suitable to use. It is recommended to use synchronous trigger with AGT or GPT events in order to ensure AD conversion timing.

#### 37.3.5.1 Trigger input timing

Trigger input timing for each ADC units should be controlled not to overlap each sampling period as shown in Figure 37.24 and Table 37.26. For timing parameter ( $t_{SPL}$ ,  $t_{SAM}$  and  $t_{SCAN}$ ), refer to Table 37.27.

- 如果ADCSR.GBADIE位设置为1（使能在B组扫描完成时产生中断），则产生B组扫描结束中断请求。
- 如果设置ADGSPCR.GBRP=1（连续执行单次扫描），B组模拟输入的AD转换在ADANSB0和ADANSB1寄存器中选择的通道根据转换顺序从具有最小编号n的通道重新启动，而ADCSR.ADST保持为1（开始AD转换）。

只要ADGSPCR.GBRP位保持为1，就重复步骤6到9。不要清除ADCSR.ADST位，只要ADGSPCR.GBRP位为1。要在ADGSPCR.GBRP=1时强制停止AD转换，请按照以下步骤进行操作 Figure 37.38.

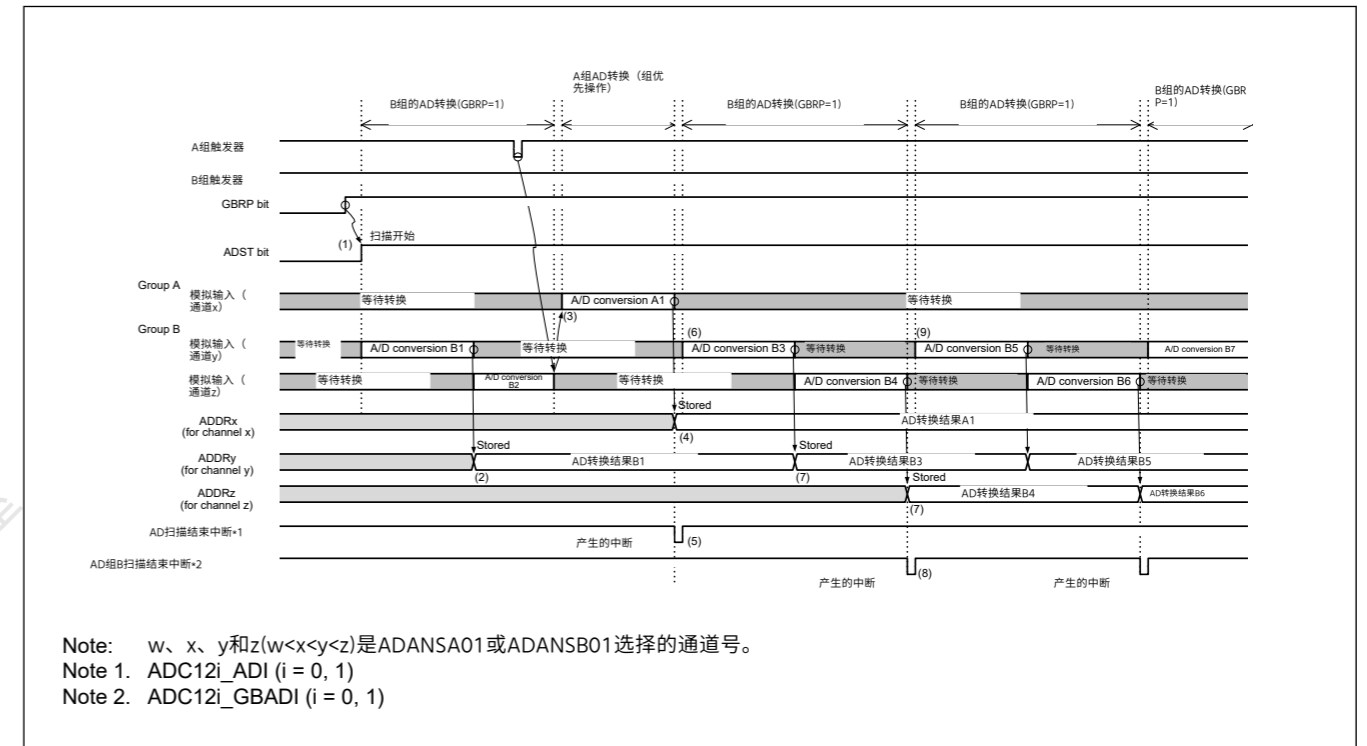


Figure 37.23 组优先操作示例1-5: B组连续激活单次扫描 (当 ADGSPCR.GBRP = 1, ADGSPCR.LGRRS = 0)

Note: 要连续激活B组的单次扫描操作，请禁用B组触发输入。

### 37.3.5 Interleaved operation

交错操作是两个ADC单元交替转换相同的一个引脚以更快地获取数据。此功能可与通道AN000AN100、AN001AN101或AN002AN102一起使用，可用于单次扫描模式和连续扫描模式。关于触发，适合使用同步触发和外触发。建议使用与AGT或GPT事件同步触发，以确保AD转换时序。

#### 37.3.5.1 触发输入时序

每个ADC单元的触发输入时序应控制为不与每个采样周期重叠，如图37.24和表37.26所示。关于时序参数 ( $t_{SPL}$ 、 $t_{SAM}$ 和 $t_{SCAN}$ )，请参见表37.27。

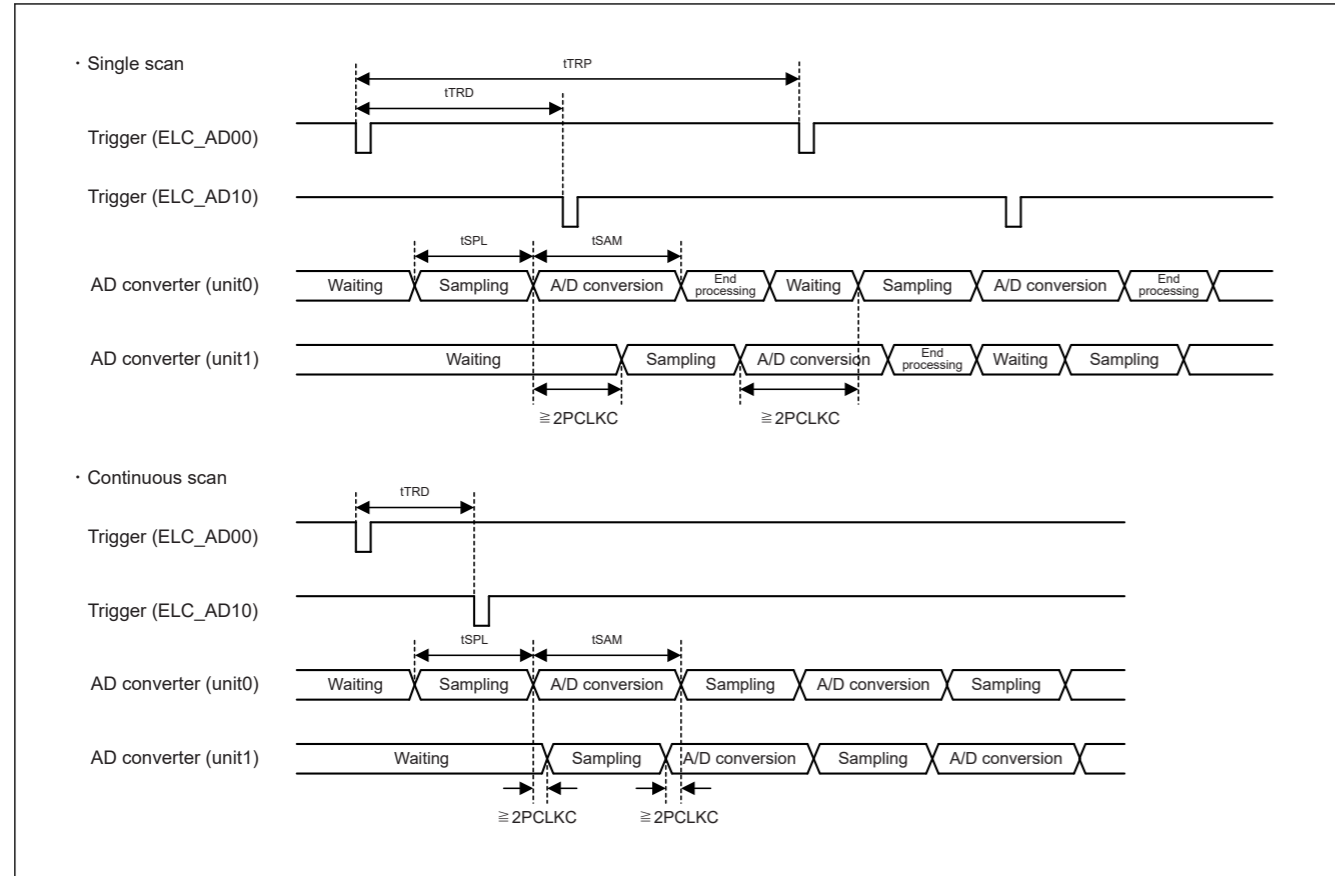


Figure 37.24 Trigger input timing in interleaved operation

Table 37.26 Setting for trigger input timing in interleaved operation

| Parameter                     | Symbol          | Min                | Max                          |
|-------------------------------|-----------------|--------------------|------------------------------|
| Trigger issuance delay period | Single scan     | $t_{SPL} + 2PCLKC$ | $t_{TRP} - t_{SPL} - 2PCLKC$ |
|                               | Continuous scan | $t_{TRD}$          | $t_{SAM} - 2PCLKC$           |
| Trigger issuance period       | $t_{TRP}$       | $t_{SCAN}$         | —                            |

### 37.3.5.2 Continuous scan mode

In this operation, assuming two ADC units are set to the same sampling period and conversion period.

The operation is as follows:

- When the ADCSR.ADST bit of ADC0 is set to 1 by a synchronous trigger input (ELC) or asynchronous trigger input, A/D conversion is performed for the selected channel.
- After certain period is elapsed after ADC0 starts (refer to [section 37.3.5.1. Trigger input timing](#)), when ADCSR.ADST bit of ADC1 is set to 1 by a synchronous trigger input (ELC) or asynchronous trigger input for the channel which is same analog input pin with ADC0.
- A/D conversion of ADC0 completes prior to completion of ADC1. Then ADC120\_ADI interrupt request is generated. ADC0 sequentially starts A/D conversion. A/D conversion is continued as long as ADCSR.ADST remains 1.
- A/D conversion of ADC1 completes after completion of ADC0. Then ADC121\_ADI interrupt request is generated. A/D conversion of ADC1 is continued as well as ADC0.

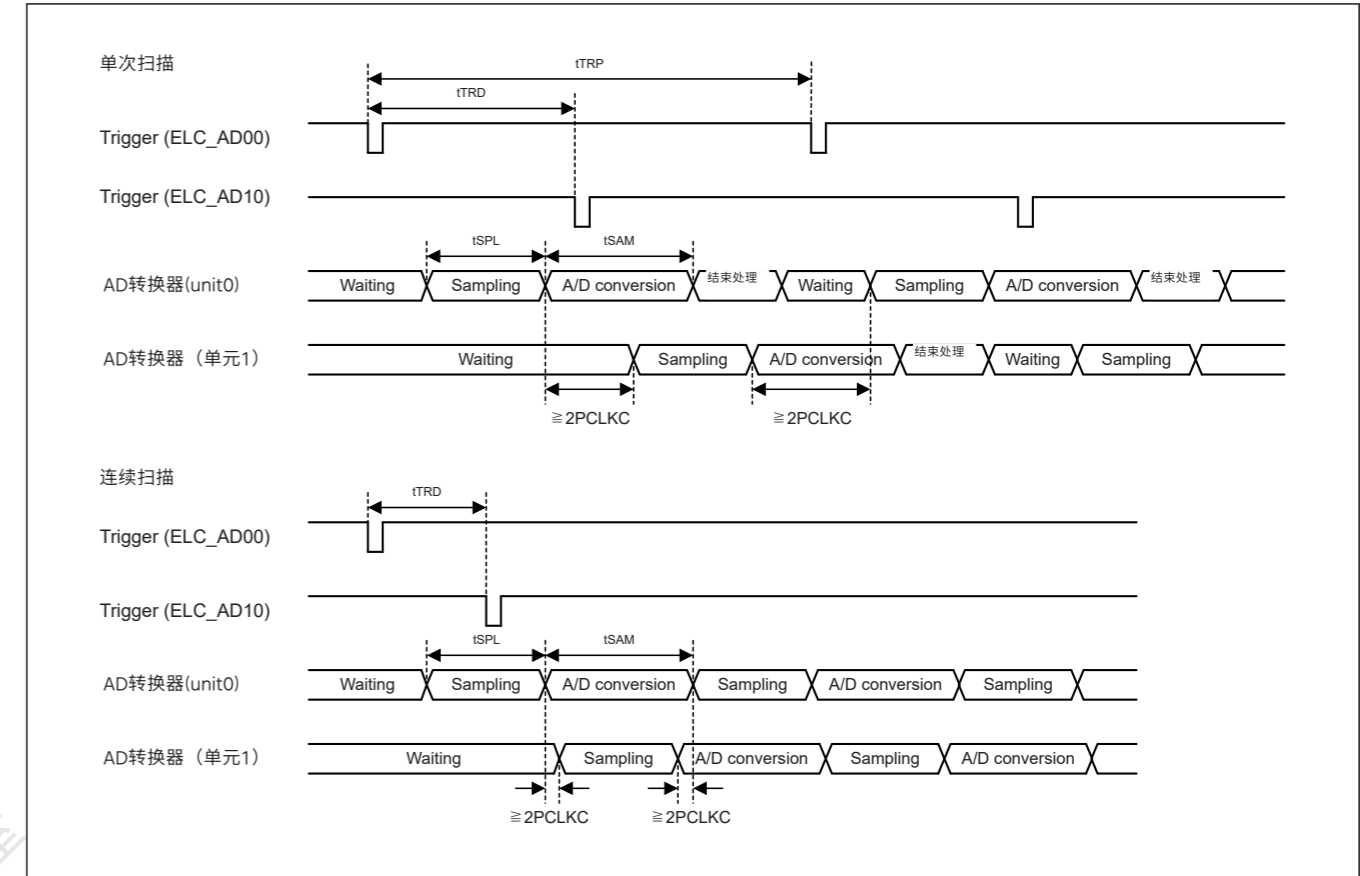


Figure 37.24 交错操作中的触发输入时序

Table 37.26 交错操作中触发输入时序的设置

| Parameter | Symbol    | Min                | Max                          |
|-----------|-----------|--------------------|------------------------------|
| 触发行延迟期    | 单次扫描      | $t_{SPL} + 2PCLKC$ | $t_{TRP} - t_{SPL} - 2PCLKC$ |
|           | 连续扫描      | $t_{TRD}$          | $t_{SAM} - 2PCLKC$           |
| 触发行期      | $t_{TRP}$ | $t_{SCAN}$         | —                            |

### 37.3.5.2 连续扫描模式

在此操作中，假设两个ADC单元设置为相同的采样周期和转换周期。

操作如下：

- 当同步触发输入(ELC)或异步触发输入将ADC0的ADCSR.ADST位设置为1时，对所选通道执行AD转换。
- ADC0启动后经过一定时间后（参见第37.3.5.1节。触发输入时序），当ADC1的ADCSR.ADST位通过同步触发输入(ELC)或异步触发输入设置为1的通道时，是与ADC0相同的模拟输入引脚。
- ADC0的AD转换在ADC1完成之前完成。然后产生ADC120\_ADI中断请求。ADC0依次启动AD转换。只要ADCSR.ADST保持1，D转换就会继续。
- ADC0完成后，ADC1的AD转换完成。然后产生ADC121\_ADI中断请求。ADC1的D转换与ADC0一样继续进行。

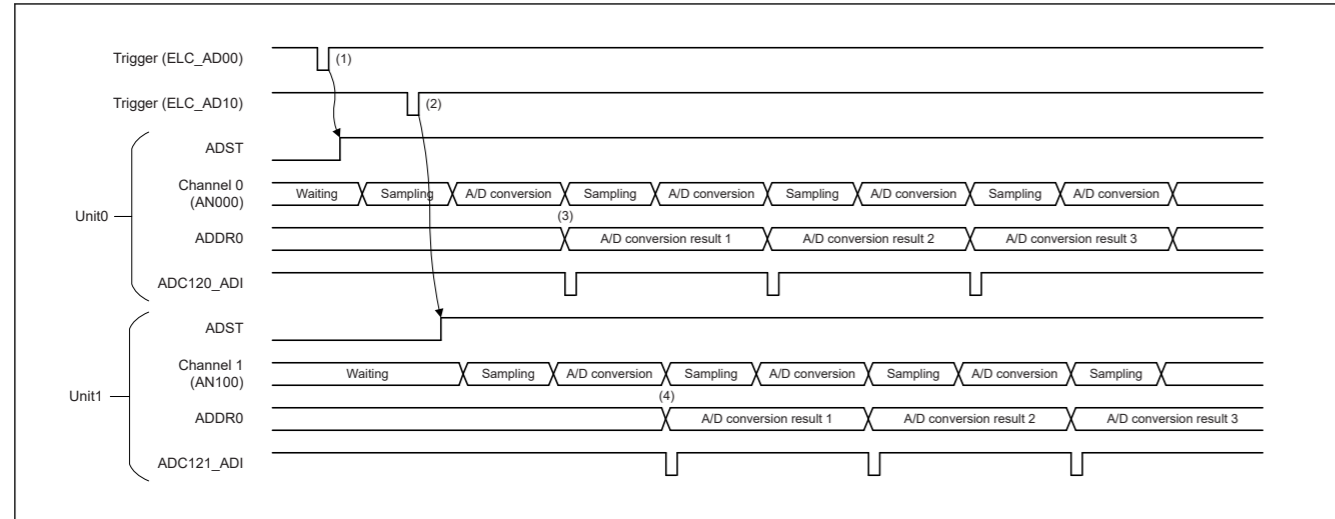


Figure 37.25 Example operation in continuous scan mode when AN000 and AN100 are selected in interleaved operation

### 37.3.5.3 Single scan mode

In this operation, assuming two ADC units are set to the same sampling period and conversion period.

The operation is as follows:

1. When the ADCSR.ADST bit of ADC0 is set to 1 by a synchronous trigger input (ELC) or asynchronous trigger input, A/D conversion is performed for the selected channel.
2. After certain period is elapsed after ADC0 starts (refer to [section 37.3.5.1. Trigger input timing](#)), when ADCSR.ADST bit of ADC1 is set to 1 by a synchronous trigger input (ELC) or asynchronous trigger input for the channel which is same analog input pin with ADC0.
3. A/D conversion of ADC0 completes prior to completion of ADC1. Then ADC120\_ADI interrupt request is generated.
4. When A/D conversion of ADC0 completes, ADCSR.ADST bit is automatically cleared to 0. Then ADC120 enters a wait state.
5. Restart A/D conversion of ADC0. Let the sampling starts during conversion period of ADC1.
6. A/D conversion of ADC1 completes after the restart of ADC0. Then ADC121\_ADI interrupt request is generated.
7. When A/D conversion of ADC1 completes, ADCSR.ADST bit is automatically cleared to 0. Then ADC121 enters a wait state.
8. Restart A/D conversion of ADC1. Let the sampling starts during conversion period of ADC0.

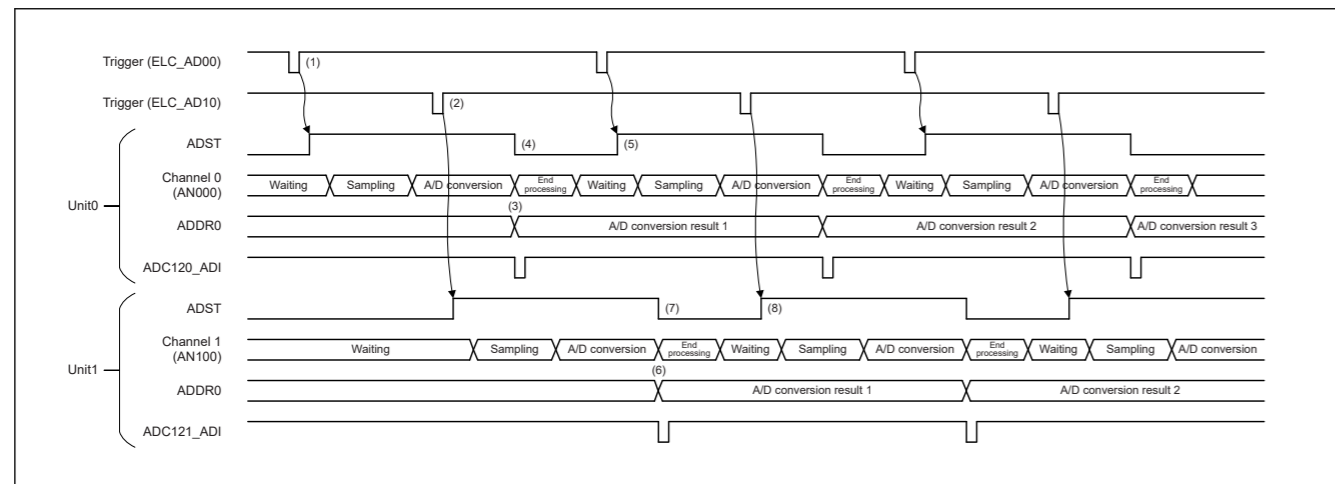


Figure 37.26 Example operation in single scan mode when AN000 and AN100 are selected in interleaved operation

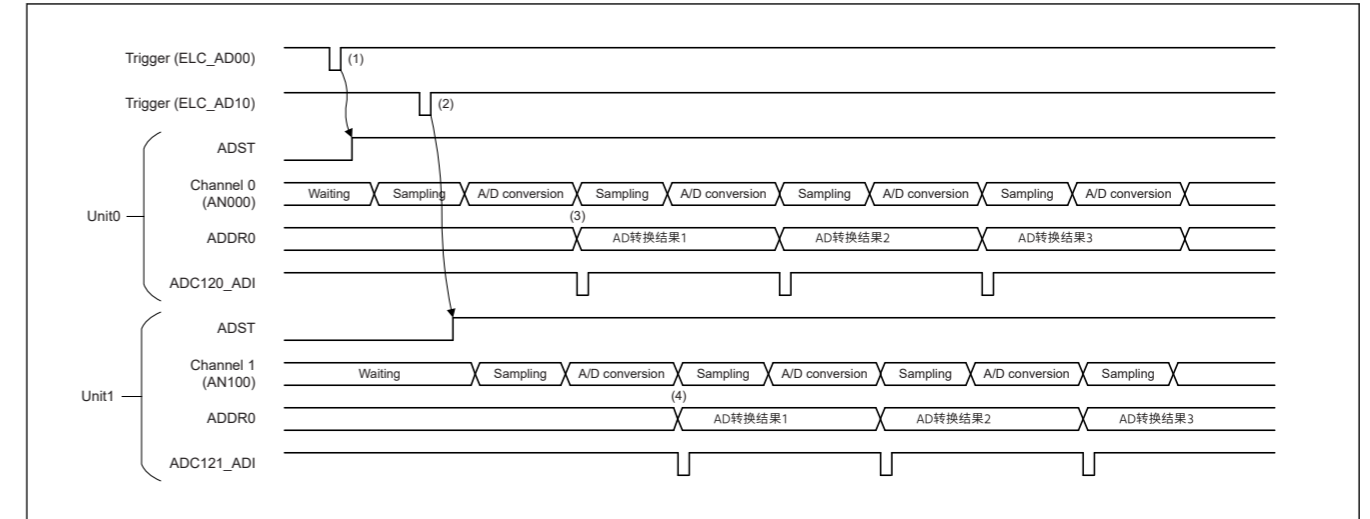


Figure 37.25 在交错操作中选择AN000和AN100时连续扫描模式下的示例操作

### 37.3.5.3 单次扫描模式

在此操作中，假设两个ADC单元设置为相同的采样周期和转换周期。

操作如下：

- 1.当同步触发输入(ELC)或异步触发输入将ADC0的ADCSR.ADST位设置为1时，对所选通道执行AD转换。
- 2.ADC0启动后经过一定时间后（参见第37.3.5.1节。触发输入时序），当ADC1的ADCSR.ADST位通过同步触发输入(ELC)或异步触发输入设置为1的通道时，是与ADC0相同的模拟输入引脚。
- 3.ADC0的AD转换在ADC1完成之前完成。然后产生ADC120\_ADI中断请求。
- 4.ADC0的AD转换完成后，ADCSR.ADST位自动清0。ADC120进入等待状态。
- 5.重启ADC0的AD转换。让采样在ADC1的转换期间开始。
- 6.ADC0重启后ADC1的AD转换完成。然后产生ADC121\_ADI中断请求。
- 7.ADC1AD转换完成后，ADCSR.ADST位自动清0。ADC121进入等待状态。
- 8.重新启动ADC1的AD转换。让采样在ADC0的转换期间开始。

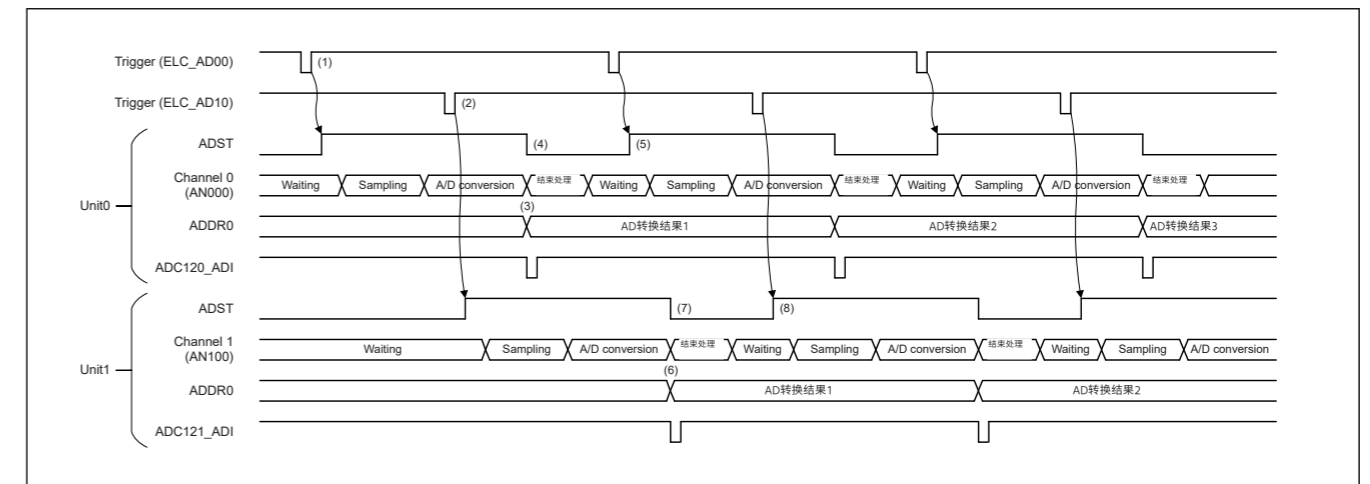


Figure 37.26 在交错操作中选择AN000和AN100时单扫描模式下的示例操作

### 37.3.5.4 Single scan mode with extended double-trigger mode

In this operation, assuming two ADC units are set to the same sampling period and conversion period.

For details of operation in extended double-trigger mode, please refer to [section 37.3.2.5. Extended operations when double-trigger mode is selected.](#)

This operation can decimate period of interrupt generation and the conversion data can be read in consecutive address with ADDBLDRA and ADDBLDRB register.

The operation is as follows:

1. When the ADCSR.ADST bit of ADC0 is set to 1 by a synchronous trigger input (ELC\_AD00), A/D conversion starts on the single channel selected in the ADCSR.DBLANS[4:0] bits.
2. After certain period is elapsed after ADC0 starts (refer to [section 37.3.5.1. Trigger input timing](#)), when ADCSR.ADST bit of ADC1 is set to 1 by a synchronous trigger input (ELC\_AD10) for the channel which is same analog input pin with ADC0.
3. A/D conversion of ADC0 completes prior to completion of ADC1. The A/D conversion result is stored in the ADC0's associated A/D Data Register y (ADDRy) and in A/D Data Duplexing Register A (ADDBLDRA).
4. The ADCSR.ADST bit is automatically cleared to 0 and the ADC120 enters a wait state. An ADC120\_ADI interrupt request is not generated.
5. Restart A/D conversion of ADC0 by a synchronous trigger input (ELC\_AD01). Let the sampling starts during conversion period of ADC1.
6. A/D conversion of ADC1 completes. The A/D conversion result is stored in the ADC1's associated A/D Data Register y (ADDRy) and in A/D Data Duplexing Register A (ADDBLDRA).
7. The ADCSR.ADST bit is automatically cleared to 0 and the ADC121 enters a wait state. An ADC121\_ADI interrupt request is not generated.
8. Restart A/D conversion of ADC1 by a synchronous trigger input (ELC\_AD11). Let the sampling starts during conversion period of ADC0.
9. A/D conversion of ADC0 completes. The A/D conversion result is stored in the ADC0's A/D Data Duplexing Register (ADDBLDR) and in A/D Data Duplexing Register B (ADDBLDRB).
10. The ADCSR.ADST bit is automatically cleared to 0 and the ADC120 enters a wait state. An ADC120\_ADI interrupt request is generated.
11. Restart A/D conversion of ADC0 by a synchronous trigger input (ELC\_AD00). Let the sampling starts during conversion period of ADC1.
12. A/D conversion of ADC1 completes. The A/D conversion result is stored in the ADC1's A/D Data Duplexing Register (ADDBLDR) and in A/D Data Duplexing Register B (ADDBLDRB).
13. The ADCSR.ADST bit is automatically cleared to 0 and the ADC121 enters a wait state. An ADC121\_ADI interrupt request is generated.
14. Restart A/D conversion of ADC1 by a synchronous trigger input (ELC\_AD10). Let the sampling starts during conversion period of ADC0.

### 37.3.5.4 具有扩展双触发模式的单扫描模式

在此操作中，假设两个ADC单元设置为相同的采样周期和转换周期。

扩展双触发模式下的操作细节请参考37.3.2.5节。选择双触发模式时的扩展操作。

此操作可以抽取中断产生的周期，并且可以在连续地址中读取转换数据 ADDBLDRA和ADDBLDRB寄存器。

操作如下：

- 1.当同步触发输入(ELC\_AD00)将ADC0的ADCSR.ADST位设置为1时，ADCSR.DBLANS[4:0]位中选择的单通道开始AD转换。
- 2.ADC0启动后经过一定时间后（请参阅第37.3.5.1节。触发输入时序），当ADC1的ADCSR.ADST位被同步触发输入(ELC\_AD10)设置为1时，对于相同的模拟输入通道引脚与ADC0。
- 3.ADC0的AD转换在ADC1完成之前完成。AD转换结果存储在ADC0相关的AD数据寄存器y(ADDRy)和AD数据双工寄存器A(ADDBLDRA)中。
- 4.ADCSR.ADST位自动清零，ADC120进入等待状态。不会产生ADC120\_ADI中断请求。
- 5.通过同步触发输入(ELC\_AD01)重新启动ADC0的AD转换。让采样在ADC1的转换期间开始。
- 6.ADC1的AD转换完成。AD转换结果存储在ADC1相关的AD数据寄存器y(ADDRy)和AD数据双工寄存器A(ADDBLDRA)中。
- 7.ADCSR.ADST位自动清零，ADC121进入等待状态。不会产生ADC121\_ADI中断请求。
- 8.通过同步触发输入(ELC\_AD11)重新启动ADC1的AD转换。让采样在ADC0的转换期间开始。
- 9.ADC0的AD转换完成。AD转换结果存储在ADC0的AD数据双工寄存器(ADDBLDR)和AD数据双工寄存器B(ADDBLDRB)中。
- 10.ADCSR.ADST位自动清零，ADC120进入等待状态。产生一个ADC120\_ADI中断请求。
- 11.通过同步触发输入(ELC\_AD00)重新启动ADC0的AD转换。让采样在ADC1的转换期间开始。
- 12.ADC1的AD转换完成。AD转换结果存储在ADC1的AD数据双工寄存器(ADDBLDR)和AD数据双工寄存器B(ADDBLDRB)中。
- 13.ADCSR.ADST位自动清零，ADC121进入等待状态。产生一个ADC121\_ADI中断请求。
- 14.通过同步触发输入(ELC\_AD10)重新启动ADC1的AD转换。让采样在ADC0的转换期间开始。



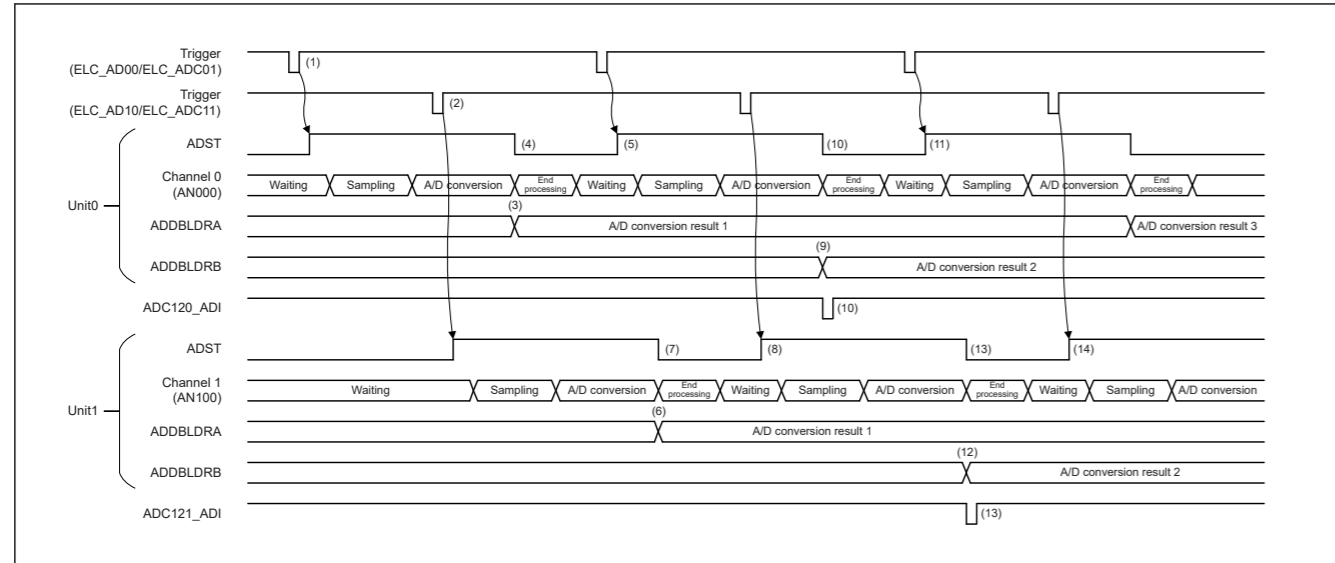


Figure 37.27 Example operation in single scan mode with extended double-trigger mode when AN000 and AN100 are selected in interleaved operation

### 37.3.6 Compare Function for Windows A and B

#### 37.3.6.1 Compare function windows A and B

The compare function compares a reference value with the A/D conversion result. The reference value can be set for Window A and Window B independently. When the compare function is in use, the self-diagnosis function and double trigger mode cannot be used. The main differences between Window A and Window B are their different interrupt output signals and the constraint on Window B of only one selectable channel.

This section provides an example operation that combines continuous scan mode and the compare function.

The operation is as follows:

- When the ADCSR.ADST bit is set to 1 (A/D conversion start) by software, a synchronous trigger (ELC) or an asynchronous trigger, A/D conversion starts in the order of the selected channels, temperature sensor, and internal reference voltage.
- On completion of A/D conversion, the A/D conversion result is stored in the associated A/D Data Register y (ADDRy, ADTSDR, or ADOCDR). When ADCMPCR.CMPAE = 1, if bits in the ADCMPANSRy register or the ADCMPANSER register are set for Window A, the A/D conversion result is compared with the set ADCMPDR0/1 register value. When ADCMPCR.CMPBE = 1, if bits in the ADCMPBNSR register are set for Window B, the A/D conversion result is compared with the ADWINULB/ADWINLLB register setting.
- As a result of the comparison, when Window A meets the condition set in ADCMPLR0/1 or ADCMPLER, the Compare Window A Flag (ADCMPSR0.CMPSTCHAn, ADCMPSR1.CMPSTCHAn, ADCMPSESR.CMPSTTSA, or ADCMPSESR.CMPSTOCA) sets 1. At this time, if the ADCMPCR.CMPAIE bit is 1, an ADC12i\_CMPAI (i = 0, 1) interrupt request is generated. In the same way, when Window B meets the condition set in ADCMPBNSR.CMPLB, the Compare Window B Flag (ADCMPBSR.CMPSTB) sets to 1. At this time, if the ADCMPCR.CMPBIE bit is 1, an ADC12i\_CMPBI (i = 0, 1) interrupt request is generated.
- On completion of all selected A/D conversions and comparisons, scan restarts.
- After the ADC12i\_CMPAI (i = 0, 1) and ADC12i\_CMPBI (i = 0, 1) interrupts are accepted, the ADCSR.ADST bit is set to 0 (A/D conversion stop) and processing is performed for channels for which the compare flag is set to 1.
- When all compare flags of Window A are cleared, the ADC12i\_CMPAI (i = 0, 1) interrupt request is canceled. In the same way, when all compare flags of Window B are cleared, the ADC12i\_CMPBI (i = 0, 1) interrupt request is reset. To perform comparison again, restart the A/D conversion.

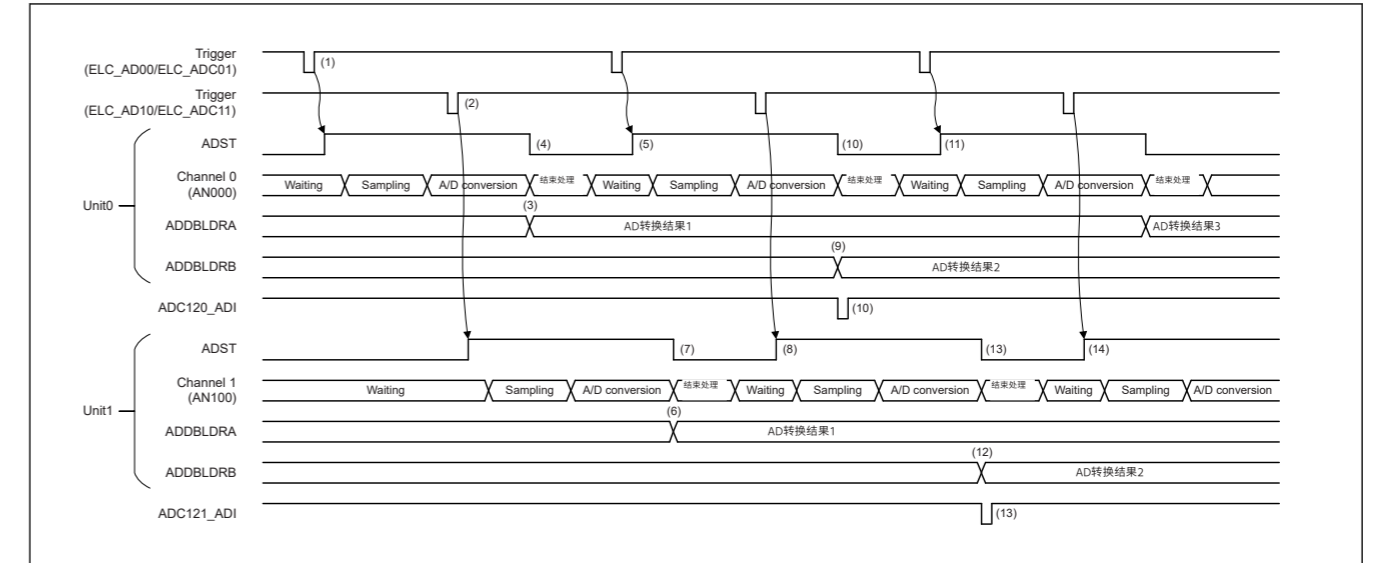


Figure 37.27 当AN000和扩展双触发模式时，单扫描模式下的示例操作 AN100在交错操作中选择

### 37.3.6 比较WindowsA和B的函数

#### 37.3.6.1 比较功能窗口A和B

比较功能将参考值与AD转换结果进行比较。参考值可设置为窗口A和窗口B独立。使用比较功能时，不能使用自诊断功能和双触发模式。WindowA和WindowB的主要区别在于它们的中断输出信号不同以及WindowB只能选择一个通道的限制。

本节提供结合连续扫描模式和比较功能的示例操作。

操作如下：

- 当ADCSR.ADST位通过软件设置为1（AD转换开始）时，同步触发(ELC)或异步触发，AD转换按所选通道、温度传感器和内部参考电压的顺序开始。
- AD转换完成后，AD转换结果存储在相关的AD数据寄存器y（ADDRy、ADTSDR或ADOCDR）中。当ADCMPCR.CMPAE=1时，如果ADCMPANSRy寄存器或ADCMPANSER寄存器中的位为窗口A设置，则AD转换结果将与设置的ADCMPDR0/1寄存器值进行比较。当ADCMPCR.CMPBE=1时，如果ADCMPBNSR寄存器中的位为窗口B设置，则将AD转换结果与ADWINULBADWINLLB寄存器设置进行比较。
- 作为比较的结果，当窗口A满足在ADCMPLR0/1或ADCMPLER中设置的条件时，比较窗口A标志（ADCMPSR0.CMPSTCHAn、ADCMPSR1.CMPSTCHAn、ADCMPSESR.CMPSTTSA或ADCMPSESR.CMPSTOCA）设置为1。此时，如果ADCMPCR.CMPAIE位为1，则产生ADC12i\_CMPAI(i=0,1)中断请求。同样，当窗口B满足ADCMPBNSR.CMPLB中设置的条件时，比较窗口B标志（ADCMPBSR.CMPSTB）设置为1。此时，如果ADCMPCR.CMPBIE位为1，则ADC12i\_CMPBI(i=0,1)中断请求产生。
- 完成所有选定的AD转换和比较后，重新开始扫描。
- 接受ADC12i\_CMPAI(i=0,1)和ADC12i\_CMPBI(i=0,1)中断后，ADCSR.ADST位设置为0（A/D转换停止）并对比较标志的通道执行处理设置为1。
- 当窗口A的所有比较标志被清除时，ADC12i\_CMPAI(i=0,1)中断请求被取消。在里面同样，当窗口B的所有比较标志都被清除时，ADC12i\_CMPBI(i=0,1)中断请求被复位。要再次进行比较，请重新开始AD转换。

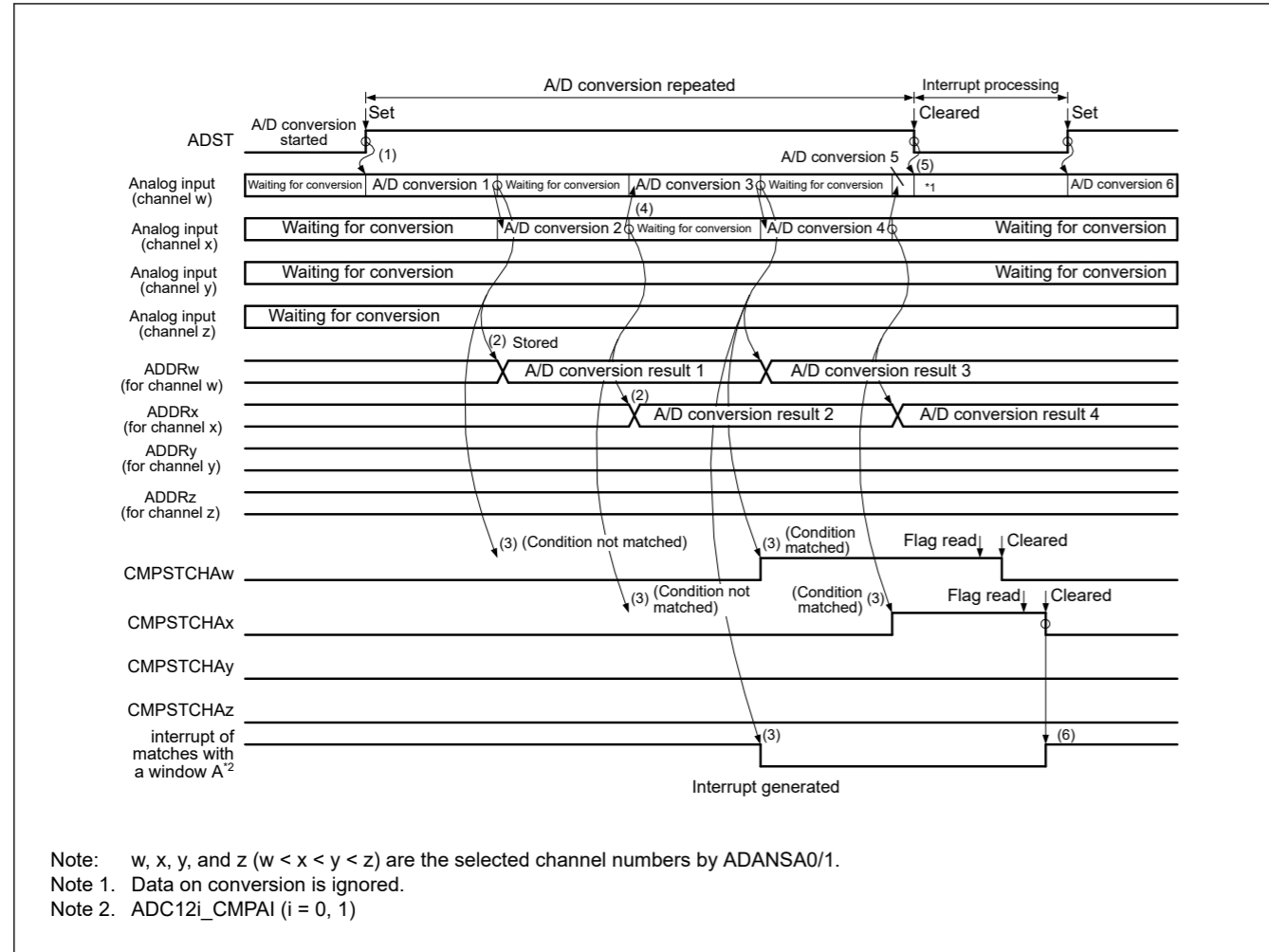


Figure 37.28 Example of compare function operation, when the analog inputs (channel w to z) are compared

### 37.3.6.2 Event output of compare function

The event output of the compare function specifies the upper-side reference voltage value and the lower-side reference voltage value for window A and window B, respectively. The output compares the A/D converted value of the selected channel with the upper and lower side reference voltage value and outputs events (ADC12i\_WCMPPM (i = 0, 1)/ADC12i\_WCMPUM (i = 0, 1)) based on event conditions (A or B, A and B, A xor B) and comparison result of window A and window B.

If more than one channel is selected for window A, and even when one channel in window A meets the comparison condition, the comparison result of window A is met. When using this function, perform A/D conversion in single scan mode.

Any channels from analog input, internal reference voltage, and temperature sensor output are selectable for window A.

One channel from analog input, internal reference voltage, and temperature sensor output is selectable for window B.

The following sequence is an example of how to set up and use the event output of the compare function:

1. Confirm that the value in the ADCSR.ADCS bits is 00b (single scan mode).
2. Select the channel for window A in the ADCMPANSR0/1 and ADCMPANSER registers. Set the window comparison conditions in the ADCMPLR0/1 and ADCMPLER registers. Set the upper-side and lower-side reference values in the ADCMPDR0/1 registers.
3. Select the channel and comparison conditions for Window B in the ADCMPBNSR register, and set the upper and lower reference values in the ADWINULB and ADWINLLB registers.
4. Set the composite conditions for window A/B, window A/B operation enable, and interrupt output enable in the ADCMPCR register.

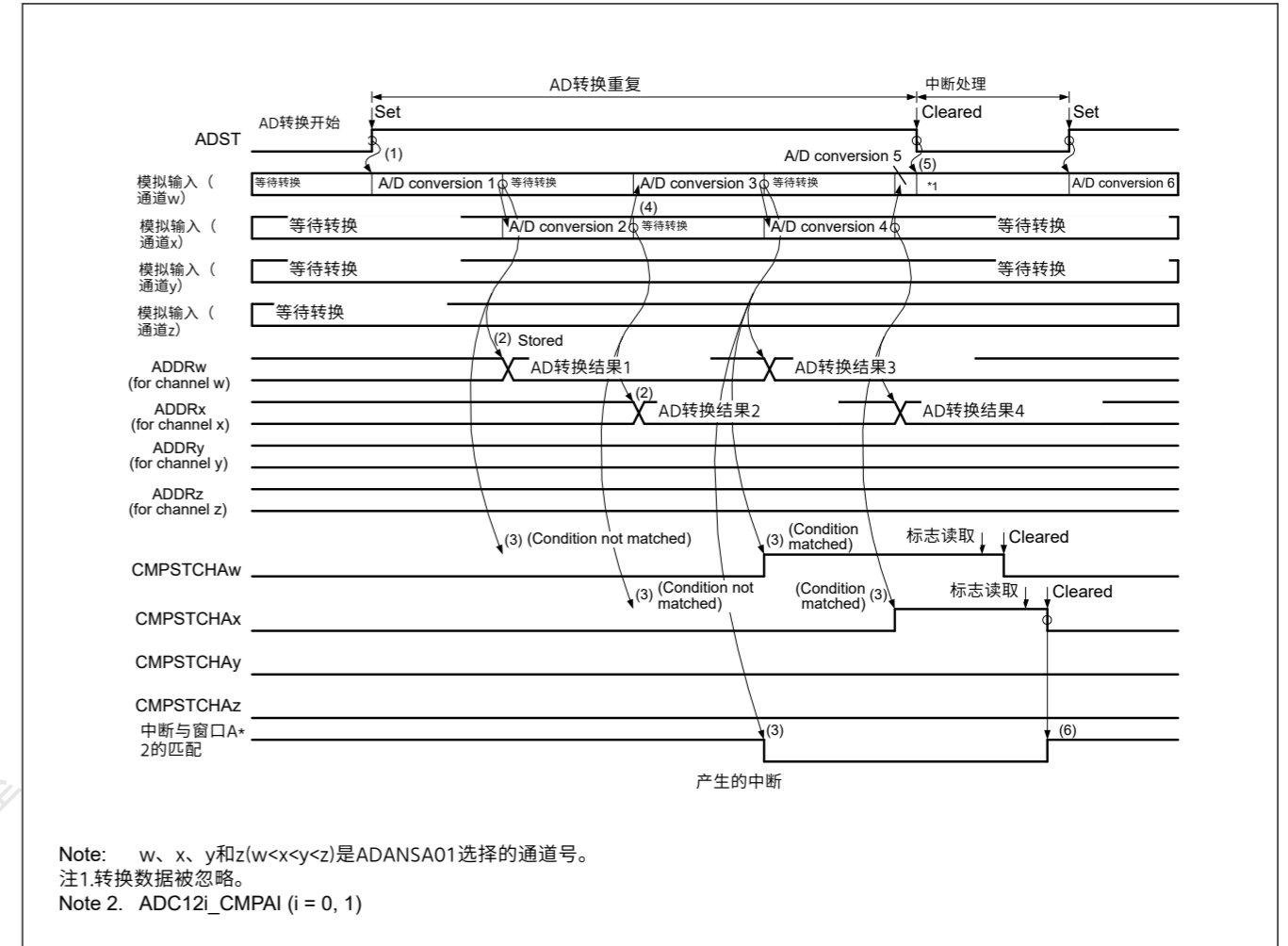


Figure 37.28 比较功能操作示例，比较模拟输入（通道w到z）时

### 37.3.6.2 比较函数的事件输出

比较函数的事件输出分别指定窗口A和窗口B的上侧参考电压值和下侧参考电压值。输出将所选通道的AD转换值与上下侧参考电压值进行比较，并根据事件条件（A或B、AandB AxorB)和窗口A和窗口B的比较结果。

如果窗口A选择了多个通道，即使窗口A中的一个通道满足比较条件，也满足窗口A的比较结果。使用此功能时，请在单次扫描模式下进行AD转换。

来自模拟输入、内部参考电压和温度传感器输出的任何通道都可选择用于窗口A。

窗口B可选择模拟输入、内部参考电压和温度传感器输出的一个通道。

以下序列是如何设置和使用比较函数的事件输出的示例：

- 1.确认ADCSR.ADCS位中的值为00b（单次扫描模式）。
- 2.在ADCMPANSR01和ADCMPANSER寄存器中选择窗口A的通道。在ADCMPLR01和ADCMPLER寄存器中设置窗口比较条件。在ADCMPDR01寄存器中设置上侧和下侧参考值。
- 3.在ADCMPBNSR寄存器中选择窗口B的通道和比较条件，并在ADWINULB和ADWINLLB寄存器中设置上下参考值。
- 4.在ADCMPCR寄存器中设置窗口AB、窗口AB操作使能和中断输出使能的复合条件。

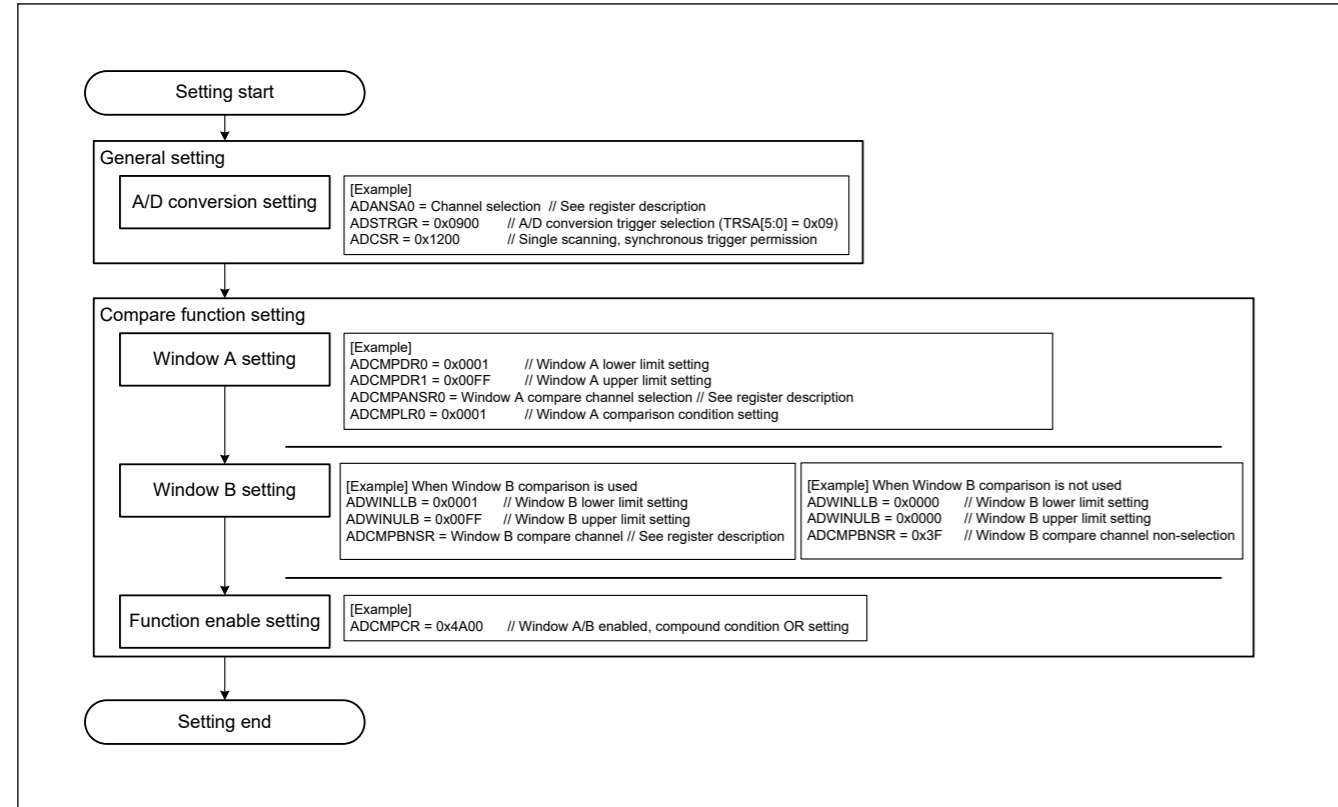


Figure 37.29 Setting example when using the event output of the compare function

For event output usage when using only window A for the compare function, note the following:

- Enable both Window A and Window B (ADCMPCR.CMPAE = 1, ADCMPCR.CMPBE = 1)
- Set the compound condition of Window A and Window B to “OR condition” (ADCMPCR.CMPAB[1:0] = 00b)
- Set the compared channel of Window B to “No selection” (ADCMBNSR.CMPCHB[5:0] = 0x3F)
- Set the compare condition of Window B to “0 < results < 0 always means mismatch”. (ADCMPCR.WCMPE = 1, ADWINLLB[15:0] = ADWINULB[15:0] = 0x0000, and ADCMPBNSR.CMPLB = 1)

Figure 37.30 shows the event output operation example of compare function.

A scan end event (ADC12i\_ADI (i = 0, 1)) is output with the same timing as single scan completion. A match or mismatch event (ADC12i\_WCMPPM (i = 0, 1)/ADC12i\_WCMPUM (i = 0, 1)) is output with 1 PCLKA cycle delay depending on the ADCMPCR.CMPAB[1:0] settings.

Note: The match and mismatch events are exclusive, so both events are never output simultaneously.

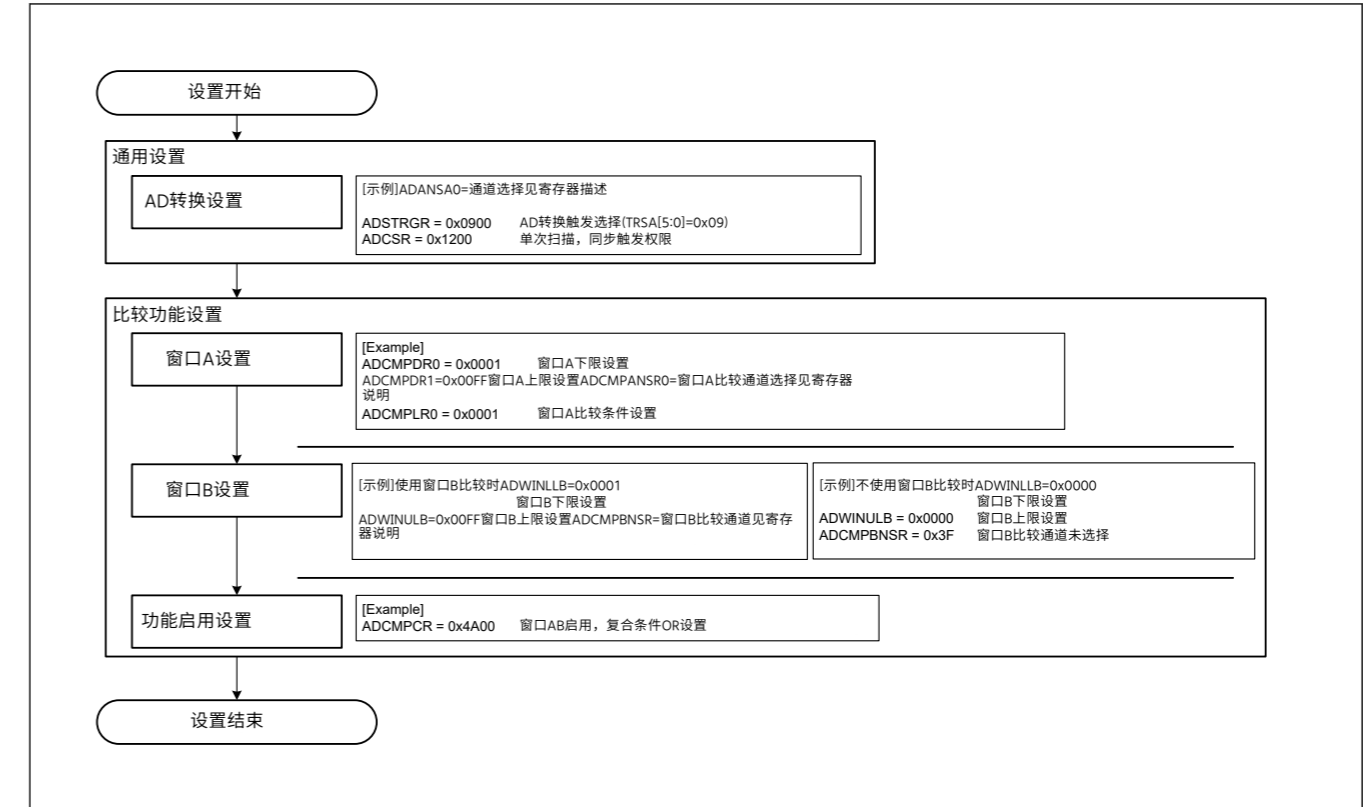


Figure 37.29 使用比较功能的事件输出时的设置示例

对于仅将窗口A用于比较功能时的事件输出用法, 请注意以下几点:

- 启用窗口A和窗口B (ADCMPCR.CMPAE=1 ADCMPCR.CMPBE=1)
- 将窗口A和窗口B的复合条件设置为“或条件” (ADCMPCR.CMPAB[1:0]=00b)
- 将窗口B的比较通道设置为“无选择” (ADCMBNSR.CMPCHB[5:0]=0x3F)
- 将窗口B的比较条件设置为“0<结果<0总是不匹配”。 (ADCMPCR.WCMPE=1, ADWINLLB[15:0]=ADWINULB[15:0]=0x0000, ADCMPBNSR.CMPLB=1)

图37.30显示了比较功能的事件输出操作示例。

以与单次扫描完成相同的时序输出扫描结束事件(ADC12i\_ADI(i=0, 1))。匹配或不匹配事件(ADC12i\_WCMPPM(i=0, 1)/ADC12i\_WCMPUM(i=0, 1))以1个PCLKA周期延迟输出, 具体取决于ADCMPCR.CMPAB[1:0]设置。

Note: match和mismatch事件是互斥的, 因此这两个事件永远不会同时输出。

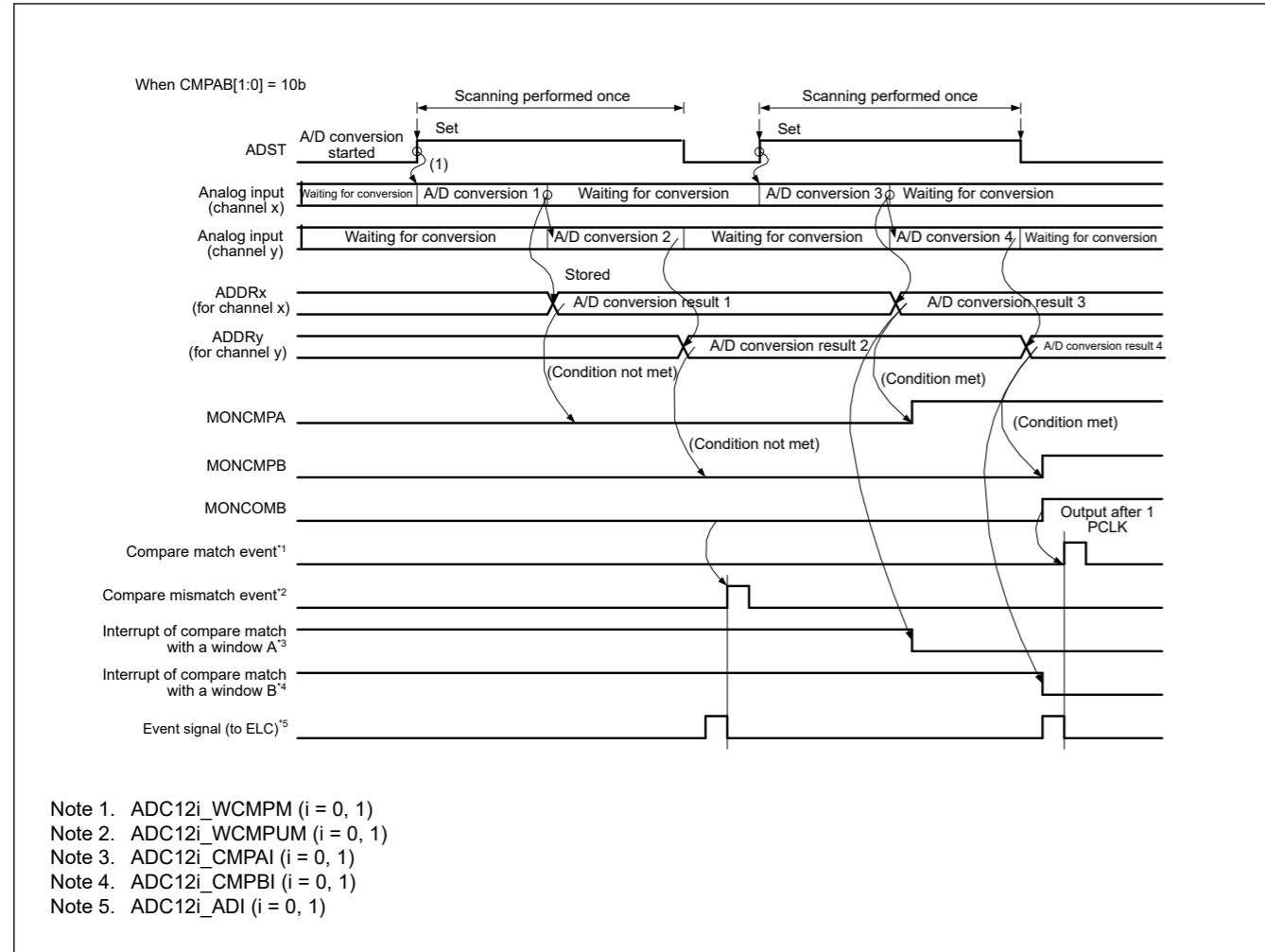


Figure 37.30 Example operation of the compare function event output, when the analog inputs (channel x and y) are compared

Note: Event output of compare function outputs match/mismatch from the comparison results of Window A and Window B, based on the ADCMPCR.CMPAB[1:0] settings.

Note: The comparison result of Window A is the logical addition of the comparison results of the comparison target channels of Window A. The comparison results of Window A and Window B are updated by each A/D conversion, and are kept even when single scan ends. Set ADCMPCR.CMPAE and ADCMPCR.CMPBE to 0 to clear the comparison results to 0.

### 37.3.6.3 Restrictions on the compare function

The following constraints apply for the compare function:

- The compare function cannot be used together with the self-diagnosis function or double-trigger mode. (The compare function is not available for ADRD, ADDBLDR, ADDBLDRA, and ADDBLDRB.)
- Specify single scan mode when using match/mismatch event outputs.
- When the temperature sensor output, internal reference voltage is selected for Window A, Window B operations are disabled.
- When the temperature sensor output, internal reference voltage is selected for Window B, Window A operations are disabled.
- Setting the same channel for Window A and Window B is prohibited.
- Set the reference voltage values so that the high-potential reference voltage value is equal to or larger than the low potential reference voltage value.

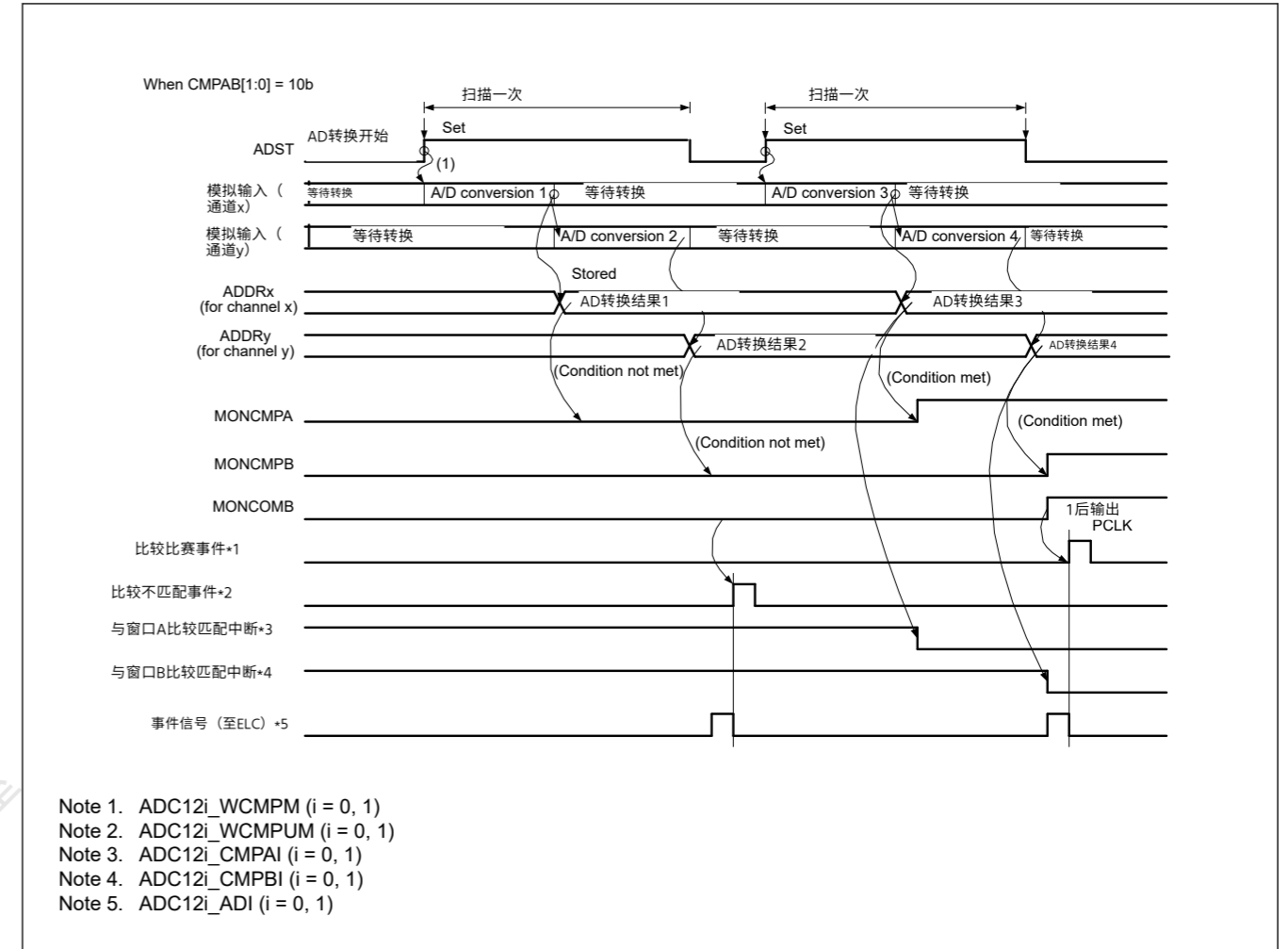


Figure 37.30 比较模拟输入（通道x和y）时比较功能事件输出的示例操作

Note: 根据ADCMPCR.CMPAB[1:0]设置，比较函数输出的事件输出与窗口A和窗口B的比较结果匹配不匹配。

Note: 窗口A的比较结果是窗口A的比较目标通道的比较结果的逻辑相加。窗口A和窗口B的比较结果在每次AD转换时更新，即使在单次扫描结束时也会保持。将ADCMPCR.CMPAE和ADCMPCR.CMPBE设置为0，将比较结果清除为0。

### 37.3.6.3 比较功能的限制

以下约束适用于比较功能：

- 比较功能不能与自诊断功能或双触发模式一起使用。（比较功能不适用于ADRD、ADDBLDR、ADDBLDRA和ADDBLDRB。）
- 使用匹配不匹配事件输出时指定单次扫描模式。
- 当温度传感器输出时，WindowA选择内部参考电压，WindowB操作被禁用。
- 当温度传感器输出时，WindowB选择内部参考电压，WindowA操作被禁用。
- 禁止窗口A和窗口B设置相同的通道。
- 设置参考电压值，使高电位参考电压值等于或大于低电位参考电压值。



### 37.3.7 Analog Input Sampling and Scan Conversion Time

Scan conversion can be activated either by a software trigger, a synchronous trigger (ELC), or an asynchronous trigger (ADTRGn (n = 0, 1)). After the start-of-scanning-delay time ( $t_D$ ) has elapsed, processing for disconnection detection assistance, and processing of conversion for self-diagnosis all proceed, followed by processing for A/D conversion.

Figure 37.31 shows the scan conversion timing, in which scan conversion is activated by a software trigger or a synchronous trigger (ELC). Figure 37.32 shows the scan conversion timing, in which scan conversion is activated by an asynchronous trigger (ADTRGn (n = 0, 1)). The scan conversion time ( $t_{SCAN}$ ) includes the start-of-scanning-delay time ( $t_D$ ), disconnection detection assistance processing time ( $t_{DIS}$ )<sup>\*1</sup>, self-diagnosis A/D conversion processing time ( $t_{DIAG}$  and  $t_{DSD}$ )<sup>\*2</sup>, A/D conversion processing time ( $t_{CONV}$ ), and end-of-scanning-delay time ( $t_{ED}$ ).

The A/D conversion processing time ( $t_{CONV}$ ) consists of input sampling time ( $t_{SPL}$ ) and time for conversion by successive approximation ( $t_{SAM}$ ). The sampling time ( $t_{SPL}$ ) is used to charge sample-and-hold circuits in the A/D converter. If there is not sufficient sampling time due to the high impedance of an analog input signal source, or if the A/D conversion clock (ADCLK) is slow, sampling time can be adjusted using the ADSSTRn register.

The time for conversion by successive approximation ( $t_{SAM}$ ) is the following

- 13 ADCLK states with 12-bit accuracy selected.
- 11 ADCLK states with 10-bit accuracy selected.
- 9 ADCLK states with 8-bit accuracy selected.

Table 37.27 shows the time for conversion by successive approximation ( $t_{SAM}$ ).

The scan conversion time ( $t_{SCAN}$ ) in single scan mode for which the number of selected channels is n can be determined as follows:

$$t_{SCAN} = t_D + (t_{DIS} \times n) + t_{DIAG} + t_{ED} + (t_{CONV} \times n)^{*3}$$

The scan conversion time for the first cycle in continuous scan mode is  $t_{SCAN}$  for single scan minus  $t_{ED}$ . The scan conversion time for the second and subsequent cycles in continuous scan mode is fixed in the following:

$$(t_{DIS} \times n) + t_{DIAG} + t_{DSD} + (t_{CONV} \times n)^{*3}$$

Note 1. When disconnection detection assistance is not selected,  $t_{DIS} = 0$ .

Only when the temperature sensor or internal reference voltage is A/D-converted, the auto-discharge period of 15 ADCLK states is inserted.

Note 2. When the self-diagnosis function is not used,  $t_{DIAG} = 0$ ,  $t_{DSD} = 0$ .

Note 3. When input sampling times ( $t_{SPL}$ ) of all selected channels are the same, this element equals  $t_{CONV} \times n$ . If each channel has a different sampling time, this element equals that of  $t_{SPL}$  and  $t_{SAM}$  set to each selected channel.

Table 37.27 shows the times for conversion during scanning.

### 37.3.7 模拟输入采样和扫描转换时间

扫描转换可以通过软件触发、同步触发(ELC)或异步触发(ADTRGn(n=0 1))来激活。在经过扫描开始延迟时间( $t_D$ )之后,断线检测辅助处理和自诊断转换处理全部进行,接着进行AD转换处理。

图37.31显示了扫描转换时序,其中扫描转换由软件触发或同步触发(ELC)激活。图37.32显示了扫描转换时序,其中扫描转换由异步触发(ADTRGn(n=0 1))激活。扫描转换时间( $t_{SCAN}$ )包括扫描开始延迟时间( $t_D$ )、断线检测辅助处理时间( $t_{DIS}$ )<sup>\*1</sup>、自诊断AD转换处理时间( $t_{DIAG}$ 和 $t_{DSD}$ )<sup>\*2</sup>如图2所示,AD转换处理时间( $t_{CONV}$ )和扫描结束延迟时间( $t_{ED}$ )。

AD转换处理时间( $t_{CONV}$ )由输入采样时间( $t_{SPL}$ )和逐次逼近转换时间( $t_{SAM}$ )组成。采样时间( $t_{SPL}$ )用于为AD转换器中的采样保持电路充电。如果由于模拟输入信号源的高阻抗而没有足够的采样时间,或者如果AD转换时钟(ADCLK)很慢,则可以使用ADSSTRn寄存器调整采样时间。

逐次逼近转换时间( $t_{SAM}$ )如下

- 13个ADCLK状态,选择12位精度。
- 11个ADCLK状态,选择精度为10位。
- 选择8位精度的9个ADCLK状态。

表37.27显示了逐次逼近转换的时间( $t_{SAM}$ )。

选择通道数为n的单次扫描模式下的扫描转换时间( $t_{SCAN}$ )可以确定如下:

$$t_{SCAN} = t_D + t_{DIS} \times n + t_{DIAG} + t_{ED} + t_{CONV} \times n \times 3$$

连续扫描模式下第一个周期的扫描转换时间是单次扫描的 $t_{SCAN}$ 减去 $t_{ED}$ 。连续扫描模式下第二个和后续周期的扫描转换时间固定如下:  $t_{DIS} \times n + t_{DIAG} + t_{DSD} + t_{CONV} \times n \times 3$

注1.未选择断线检测辅助时,  $t_{DIS} = 0$ 。

仅当温度传感器或内部参考电压为AD转换时,自动放电周期为15 ADCLK状态被插入。

注2.不使用自诊断功能时,  $t_{DIAG} = 0$ ,  $t_{DSD} = 0$ 。

注3.当所有选定通道的输入采样时间( $t_{SPL}$ )相同时,该元素等于 $t_{CONV} \times n$ 。如果每个通道具有不同的采样时间,则该元素等于为每个选定通道设置的 $t_{SPL}$ 和 $t_{SAM}$ 。

表37.27显示了扫描期间的转换时间。

Table 37.27 Conversion times during scanning (in numbers of cycles of ADCLK and PCLKA)

| Item   | Symbol   | Type/Conditions   |   |                   | Unit   |        |   |
|--|--|---|---|-------------------|--|--------|---|
|  |  | Synchronous trigger*4   | Asynchronous trigger                                | Software trigger  |  |        |   |
| Scan start processing time*1 *2  | A/D conversion on group A under group A priority control.                          | Group B is to be stopped (Group A is activated after group B is stopped by of an A/D conversion source from group A). | 3 PCLKA + 6 ADCLK<br>5 PCLKA + 3 ADCLK*5            | —                 | —  | Cycles |   |
|  |  | Group B is not to be stopped (activation by an A/D conversion source from group A).                                   | 2 PCLKA + 4 ADCLK                                   | —                 | —  |        |   |
|  | A/D conversion when self-diagnosis is enabled.                                     | A/D conversion for self-diagnosis is to be started.   | 2 PCLKA + 6 ADCLK                                   | 4 PCLKA + 6 ADCLK | 6 ADCLK  |        |   |
|  | All other  | 2 PCLKA + 4 ADCLK   | 2 PCLKA + 4 ADCLK                                   | 4 ADCLK           |  |        |   |
| Disconnection detection assistance processing time   |  | tDIS  | Setting in ADNDIS[3:0] (initial value = 0h) × ADCLK |                   |  |        |   |
| Self-diagnosis conversion processing time*1  | Sampling time  |   | tDIAG   | tSPL              | Setting in ADSSTR00 (initial value = 0Bh) × ADCLK*3  | —      | — |
|  | Time for conversion by successive approximation                                    | 12-bit conversion accuracy  | tSAM  | 15 ADCLK          | —  | —      |   |
|  |  | 10-bit conversion accuracy  |   | 13 ADCLK          | —  | —      |   |
|  |  | 8-bit conversion accuracy   |   | 11 ADCLK          | —  | —      |   |
|  | Wait time between self-diagnosis conversion end and analog channel sampling start. |   | tBED  | 2 ADCLK           |  |        |   |
| Wait time between last channel conversion end and self-diagnosis sampling start in continuous scan mode. |  | tDSD  | 2 ADCLK   |                   |  |        |   |
| A/D conversion processing time*1   | Sampling time  |   | tCONV   | tSPL              | Setting in ADSSTRn (n = 0 to 9, 12, 13(unit 0), 0 to 2(unit 1), L, T, O) (initial value = 0Bh) × ADCLK + 0.5 ADCLK | —      | — |
|  | Time for conversion by successive approximation                                    | 12-bit conversion accuracy  | tSAM  | 13 ADCLK          | —  | —      |   |
|  |  | 10-bit conversion accuracy  |   | 11 ADCLK          | —  | —      |   |
|  |  | 8-bit conversion accuracy   |   | 9 ADCLK           | —  | —      |   |
| Scan end processing time*1   |  | tED   | 1 PCLKA + 3 ADCLK<br>2 PCLKA + 3 ADCLK*5            |                   |  |        |   |

Note 1. See Figure 37.31 and Figure 37.32 for an illustration of times tD, tSPLSH, tDIAG, tCONV, and tED.  
 Note 2. This is the maximum time required from software writing or trigger input to A/D conversion start.  
 Note 3. The sampling time setting must satisfy the electrical characteristics.  
 Note 4. This does not include the time consumed in the path from timer output to trigger input.  
 Note 5. If ADCLK is faster than PCLKA (PCLKA to ADCLK frequency ratio = 1:2 or 1:4), the scan end processing time changes.

Table 37.27 扫描期间的转换时间（以ADCLK和PCLKA的周期数计）

| Item                              | Symbol                   | Type/Conditions          |  |                   | Unit   |        |   |
|-----------------------------------|--------------------------|--------------------------|--|-------------------|--|--------|---|
|                                   |                          | 同步触发*4                   | 异步触发                                     | 软件触发              |  |        |   |
| 扫描开始处理时间*1 *2                     | A组优先控制下A组AD转换。           | B组停止（A组的AD转换源停止B组后激活A组）。 | 3 PCLKA + 6 ADCLK<br>5 PCLKA + 3 ADCLK*5 | —                 | —  | Cycles |   |
|                                   |                          | B组不停止（由A组的AD转换源激活）。      | 2 PCLKA + 4 ADCLK                        | —                 | —  |        |   |
|                                   | 启用自诊断时的AD转换。             | 将启动用于自诊断的D转换。            | 2 PCLKA + 6 ADCLK                        | 4 PCLKA + 6 ADCLK | 6 ADCLK  |        |   |
|                                   | 所有其他                     | 2 PCLKA + 4 ADCLK        | 2 PCLKA + 4 ADCLK                        | 4 ADCLK           |  |        |   |
| 断线检测辅助处理时间                        |                          | tDIS                     | ADNDIS[3:0]中的设置（初始值=0h）×ADCLK            |                   |  |        |   |
| 自诊断转换处理时间*1                       | 采样时间                     |                          | tDIAG                                    | tSPL              | ADSSTR00中的设置（初始值=0Bh）×ADCLK*3  | —      | — |
|                                   | 逐次逼近转换时间                 | 12位转换精度                  | tSAM                                     | 15 ADCLK          | —  | —      |   |
|                                   |                          | 10位转换精度                  |  | 13 ADCLK          | —  | —      |   |
|                                   |                          | 8位转换精度                   |  | 11 ADCLK          | —  | —      |   |
|                                   | 自诊断转换结束到模拟通道采样开始之间的等待时间。 |                          | tBED                                     | 2 ADCLK           |  |        |   |
| 连续扫描模式下最后一次通道转换结束和自诊断采样开始之间的等待时间。 |                          | tDSD                     | 2 ADCLK                                  |                   |  |        |   |
| AD转换处理时间*1                        | 采样时间                     |                          | tCONV                                    | tSPL              | 在ADSSTRn中设置（n=0到9、12、13（单元0）、0到2（单元1）、L、T、O）（初始值 = 0Bh）× ADCLK + 0.5 ADCLK | —      | — |
|                                   | 逐次逼近转换时间                 | 12位转换精度                  | tSAM                                     | 13 ADCLK          | —  | —      |   |
|                                   |                          | 10位转换精度                  |  | 11 ADCLK          | —  | —      |   |
|                                   |                          | 8位转换精度                   |  | 9 ADCLK           | —  | —      |   |
| 扫描结束处理时间*1                        |                          | tED                      | 1 PCLKA + 3 ADCLK<br>2 PCLKA + 3 ADCLK*5 |                   |  |        |   |

注1.有关时间tD、tSPLSH、tDIAG、tCONV和tED的说明，请参见图37.31和图37.32。注2.这是从软件写入或触发输入到AD转换开始所需的最长时间。  
 注3.采样时间设置必须满足电气特性。  
 注4.这包括从定时器输出到触发输入的路径中消耗的时间。  
 注5.如果ADCLK比PCLKA快（PCLKA与ADCLK频率比=1:2或1:4），则扫描结束处理时间会发生变化。

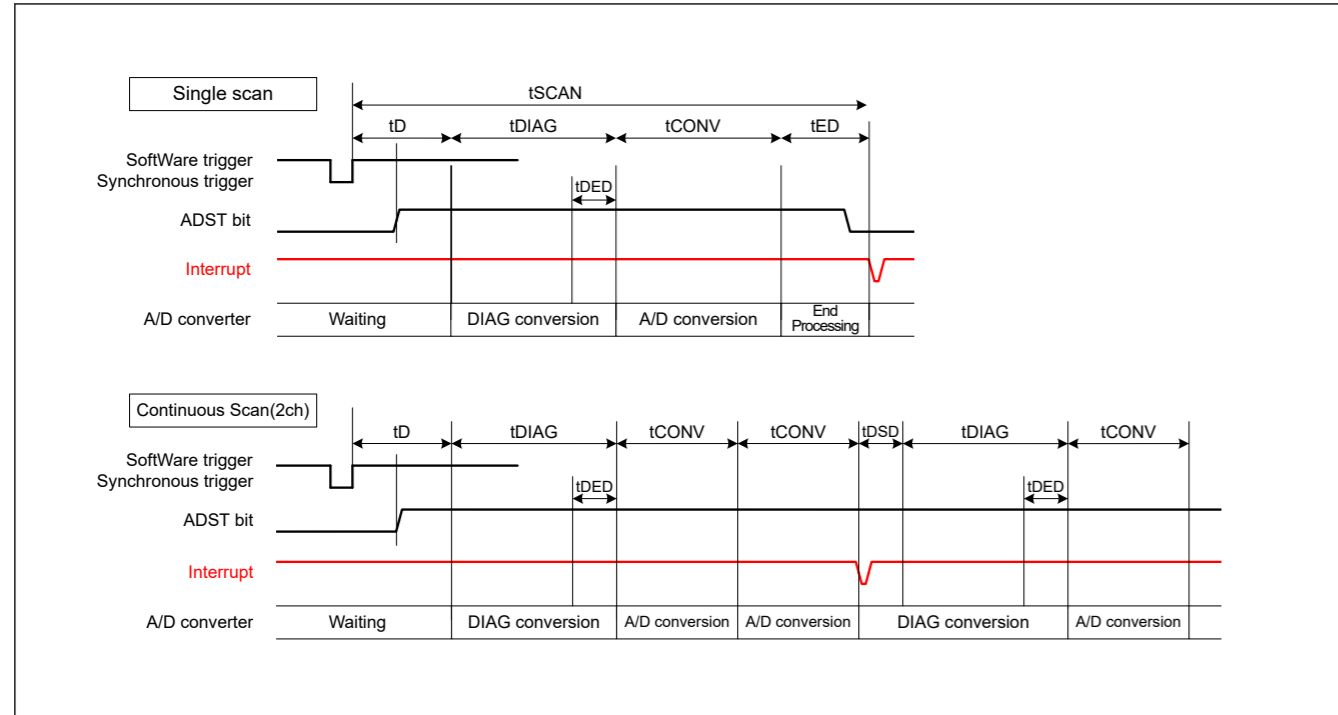


Figure 37.31 Scan conversion timing when activated by software or a synchronous trigger input (ELC)

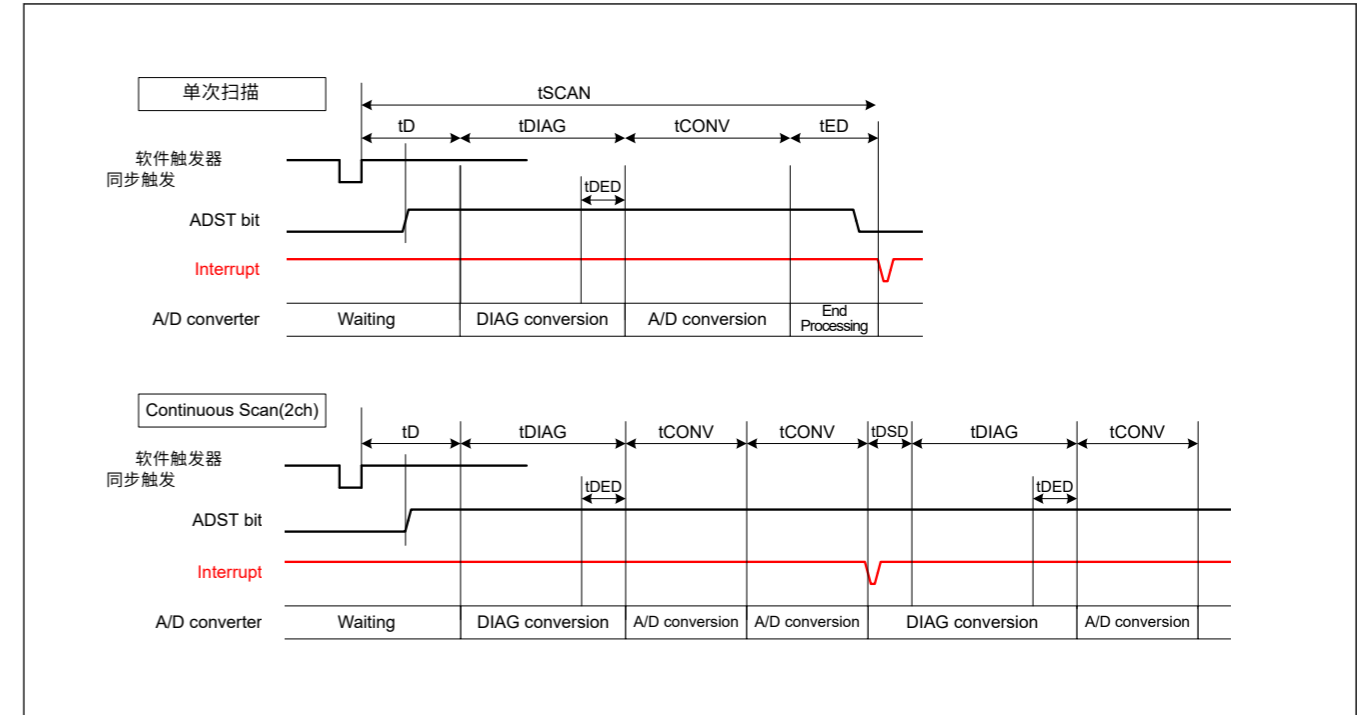


Figure 37.31 由软件或同步触发输入(ELC)激活时的扫描转换时序

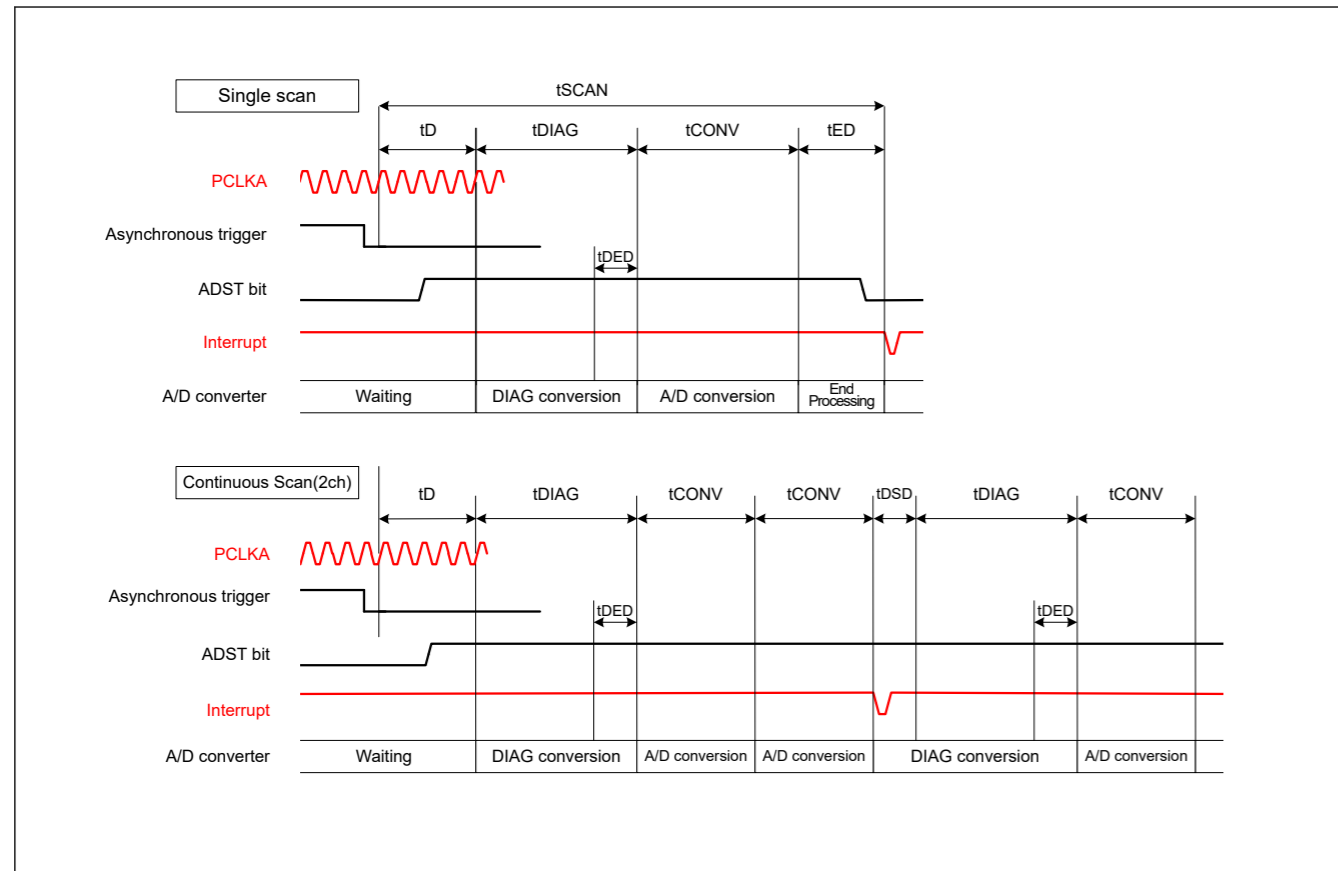


Figure 37.32 Scan conversion timing when activated by an asynchronous trigger input (ADTRG0)

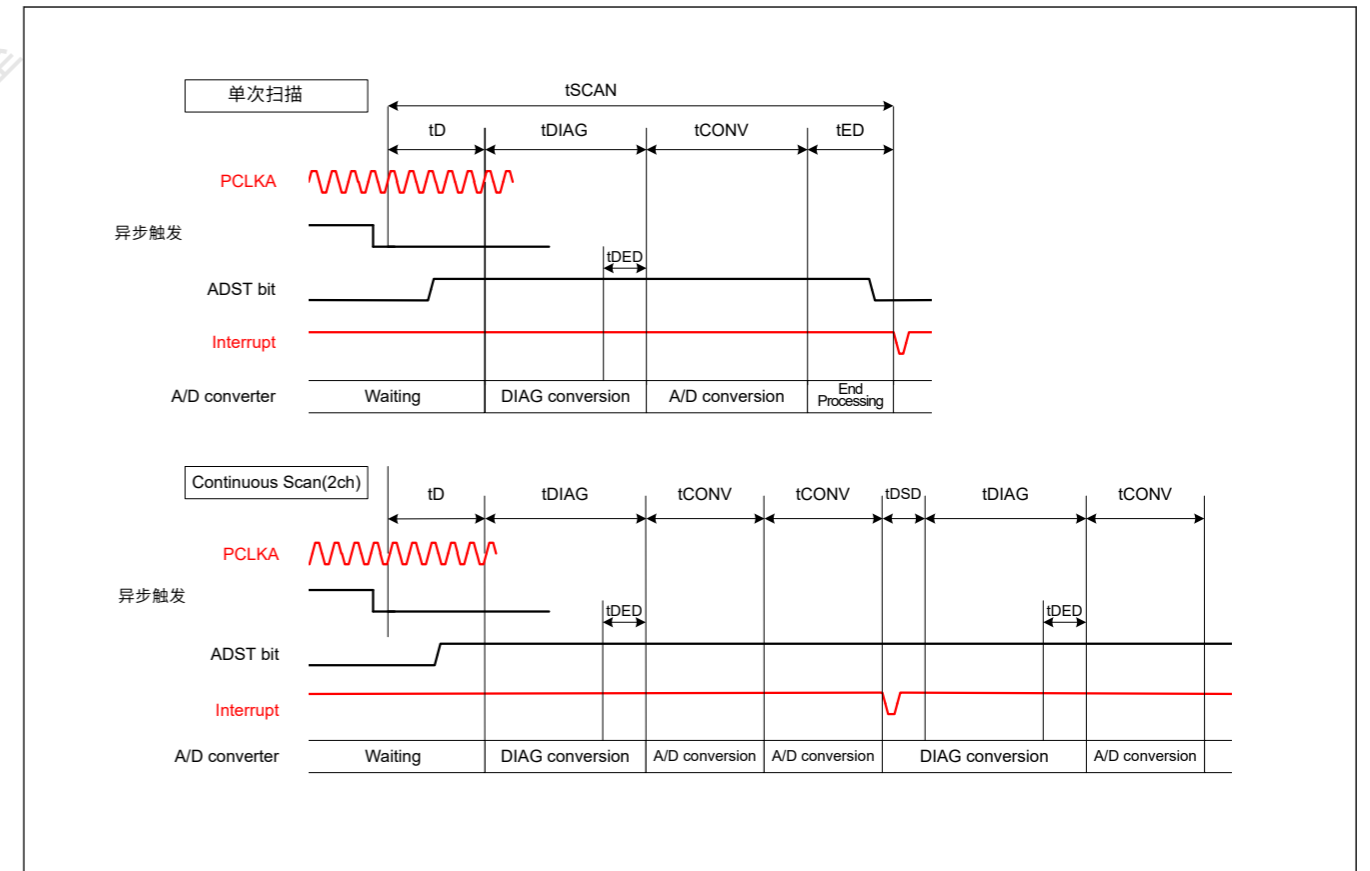


Figure 37.32 由异步触发输入(ADTRG0)激活时的扫描转换时序

### 37.3.8 Usage Example of A/D Data Register Automatic Clearing Function

Setting the ADCER.ACE bit to 1 automatically clears the A/D data registers (ADDRy, ADDR, ADDBLDR, ADDBLDRA, ADDBLDRB, ADTSDR, ADOCDR) to 0x0000 when the A/D data registers are read by the CPU or DTC or DMAC.

### 37.3.8 AD数据寄存器自动清除功能的使用示例

将ADCER.ACE位设置为1会自动清除AD数据寄存器 (ADDRy、ADDR、ADDBLDR、ADDBLDRA、ADDBLDRB、ADTSDR、ADOCDR)为0x0000。当CPU或DTC或DMAC读取AD数据寄存器时, ADDBLDRB、ADTSDR、ADOCDR)为0x0000。

This function enables detection of update failures of the A/D data registers (ADDRy, ADRD, ADDBLDR, ADDBLDRA, ADDBLDRB, ADTSDR, ADOCDR). This section describes examples in which the function to automatically clear the ADDRy register is enabled and disabled.

- If the ADCER.ACE bit is 0 (automatic clearing is disabled) and for some reason, if the A/D conversion result (0x0222) is not written to the ADDRy register, the ADDRy value retains the old data (0x0111). In addition, if this ADDRy value is read into a general-purpose register using an A/D scan end interrupt, the old data (0x0111) can be saved in the general-purpose register. When checking whether there is an update failure, it is necessary to frequently save the old data in SRAM or in a general-purpose register.
- If the ADCER.ACE bit is 1 (automatic clearing is enabled), when ADDRy = 0x0111 is read by the CPU or DTC or DMAC, ADDRy is automatically set to 0x0000. Next, if the A/D conversion result of 0x0222 cannot be transferred to ADDRy for some reason, the cleared data (0x0000) remains as the ADDRy value. If this ADDRy value is read into a general-purpose register using an A/D scan end interrupt, 0x0000 is saved in the general-purpose register. Occurrence of an ADDRy update failure can be determined by checking that the read data value is 0x0000.

### 37.3.9 A/D-Converted Value Addition/Average Mode

A/D-converted value addition/average mode can be used when A/D conversion of the analog input of the selected channels, the temperature sensor output, the internal reference voltage is selected.

In A/D-converted value addition mode, the same channel is A/D-converted 1, 2, 3, 4, or 16 consecutive times, and the sum of the converted values is stored in the data register. The conversion count of the addition function can be set to 16 only when 12-bit accuracy is selected. In A/D-converted value average mode, the same channel is A/D-converted 1, 2, or 4 consecutive times, and the mean of the converted values is stored in the data register. The use of the average of these results can improve the accuracy of A/D conversion, depending on the types of noise components that are present. This function, however, cannot always guarantee an improvement in A/D conversion accuracy.

The A/D-converted value addition/average function can be used when A/D conversion of the analog inputs of the selected channels or A/D conversion of the temperature sensor output or A/D conversion of the internal reference voltage is selected. The A/D-converted value addition/average function can also be used for channels for which the double-trigger function is selected.

The addition function for self-diagnosis is not provided.

### 37.3.10 Disconnection Detection Assist Function

The ADC12 incorporates a function to fix the charge for sampling capacitance to the specified state (VREFH0 or VREFL0 for unit 0, VREFH or VREFL for unit 1) before the start of A/D conversion. This function enables disconnection detection in wiring of analog inputs.

Figure 37.33 shows the A/D conversion operation when the disconnection detection assist function is used. Figure 37.34 shows an example of disconnection detection when precharge is selected. Figure 37.35 shows an example of disconnection detection when discharge is selected.

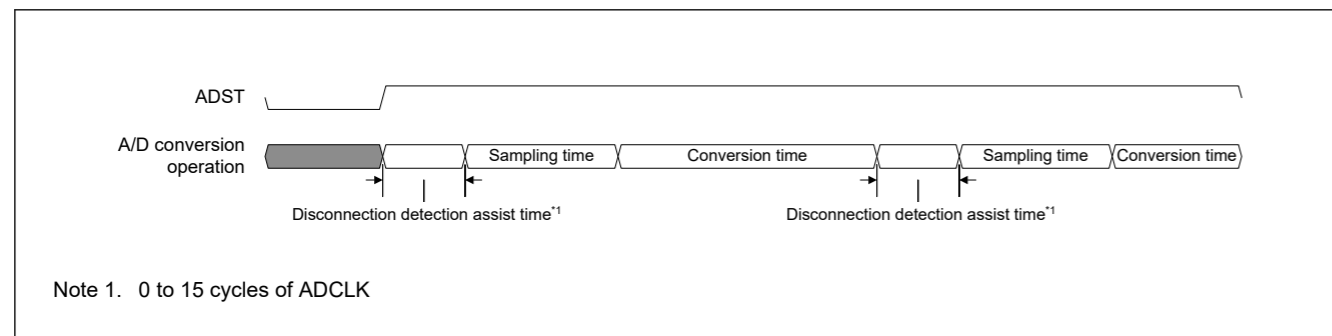


Figure 37.33 Operation of A/D conversion when disconnection detection assist function is used

此功能可以检测AD数据寄存器 (ADDRy、ADRD、ADDBLDR、ADDBLDRA、ADDBLDRB、ADTSDR、ADOCDR)。本节介绍自动清除功能的示例 ADDRy寄存器被启用和禁用。

- 如果ADCER.ACE位为0（禁止自动清零）并且由于某种原因，如果AD转换结果（0x0222）没有写入ADDRy寄存器，则ADDRy值保留旧数据（0x0111）。此外，如果使用AD扫描结束中断将该ADDRy值读入通用寄存器，则可以将旧数据（0x0111）保存在通用寄存器中。在检查是否有更新失败时，需要经常将旧数据保存在SRAM或通用寄存器中。
- 如果ADCER.ACE位为1（使能自动清除），当ADDRy=0x0111时由CPU或DTC或DMAC ADDRy自动设置为0x0000。接下来，如果0x0222的AD转换结果由于某种原因无法传送到ADDRy，则清除的数据（0x0000）仍保留为ADDRy值。如果使用AD扫描结束中断将该ADDRy值读入通用寄存器，则将0x0000保存在通用寄存器中。ADDRy更新失败的发生可以通过检查读取的数据值为0x0000来确定。

### 37.3.9 一种D转换的增值平均模式

AD-converted value addition/average mode can be used when A/D conversion of the analog input of the selected channels, the temperature sensor output, the internal reference voltage is selected.

在AD转换值加法模式下，同一通道连续1、2、3、4或16次AD转换，转换值的总和存储在数据寄存器中。只有选择12位精度时，才能将加法功能的转换计数设置为16。在AD转换值平均模式下，同一通道连续1、2或4次AD转换，转换值的平均值存储在数据寄存器中。根据存在的噪声成分的类型，使用这些结果的平均值可以提高AD转换的精度。但是，该功能不能始终保证AD转换精度的提高。

选择通道的模拟输入的AD转换或温度传感器输出的AD转换或内部参考电压的AD转换时，可以使用AD转换值加法平均功能。AD转换值加法平均功能也可用于选择了双触发功能的通道。

不提供自我诊断的附加功能。

### 37.3.10 断线检测辅助功能

ADC12具有在开始AD转换之前将采样电容的电荷固定到指定状态（单元0为VREFH0或VREFL0，单元1为VREFH或VREFL）的功能。此功能可在模拟输入接线中进行断线检测。

图37.33显示了使用断线检测辅助功能时的AD转换操作。图37.34显示了选择预充电时的断线检测示例。图37.35显示了选择放电时的断线检测示例。

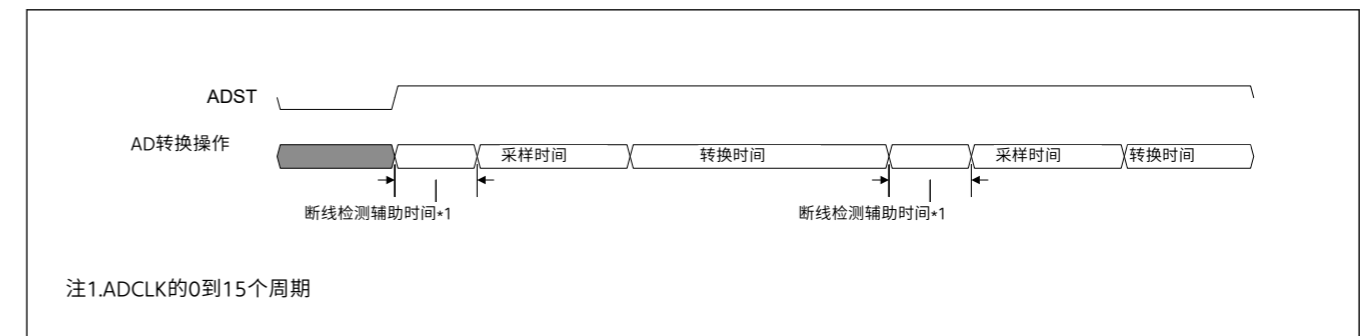


Figure 37.33 使用断线检测辅助功能时的AD转换动作



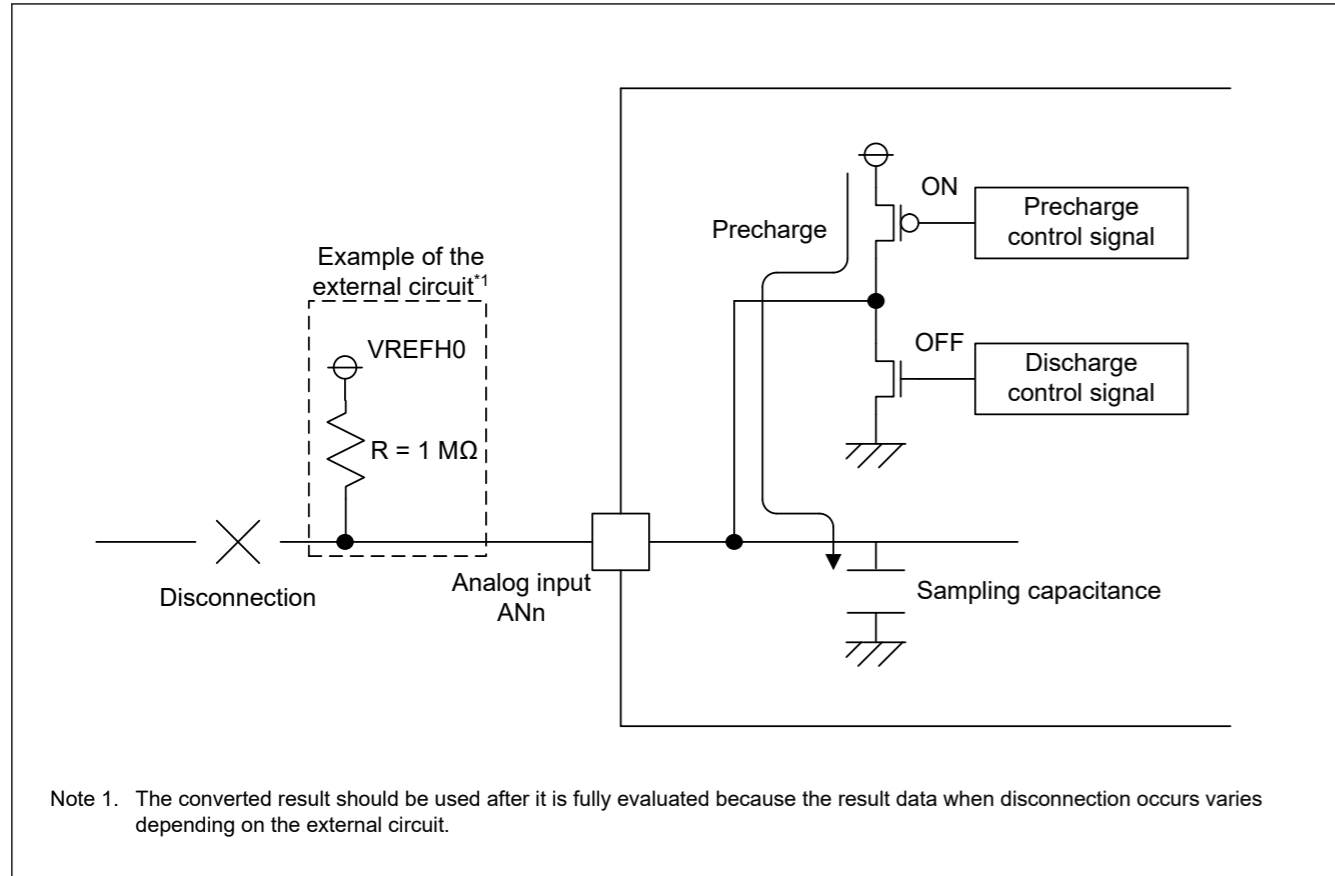


Figure 37.34 Example of disconnection detection when precharge is selected

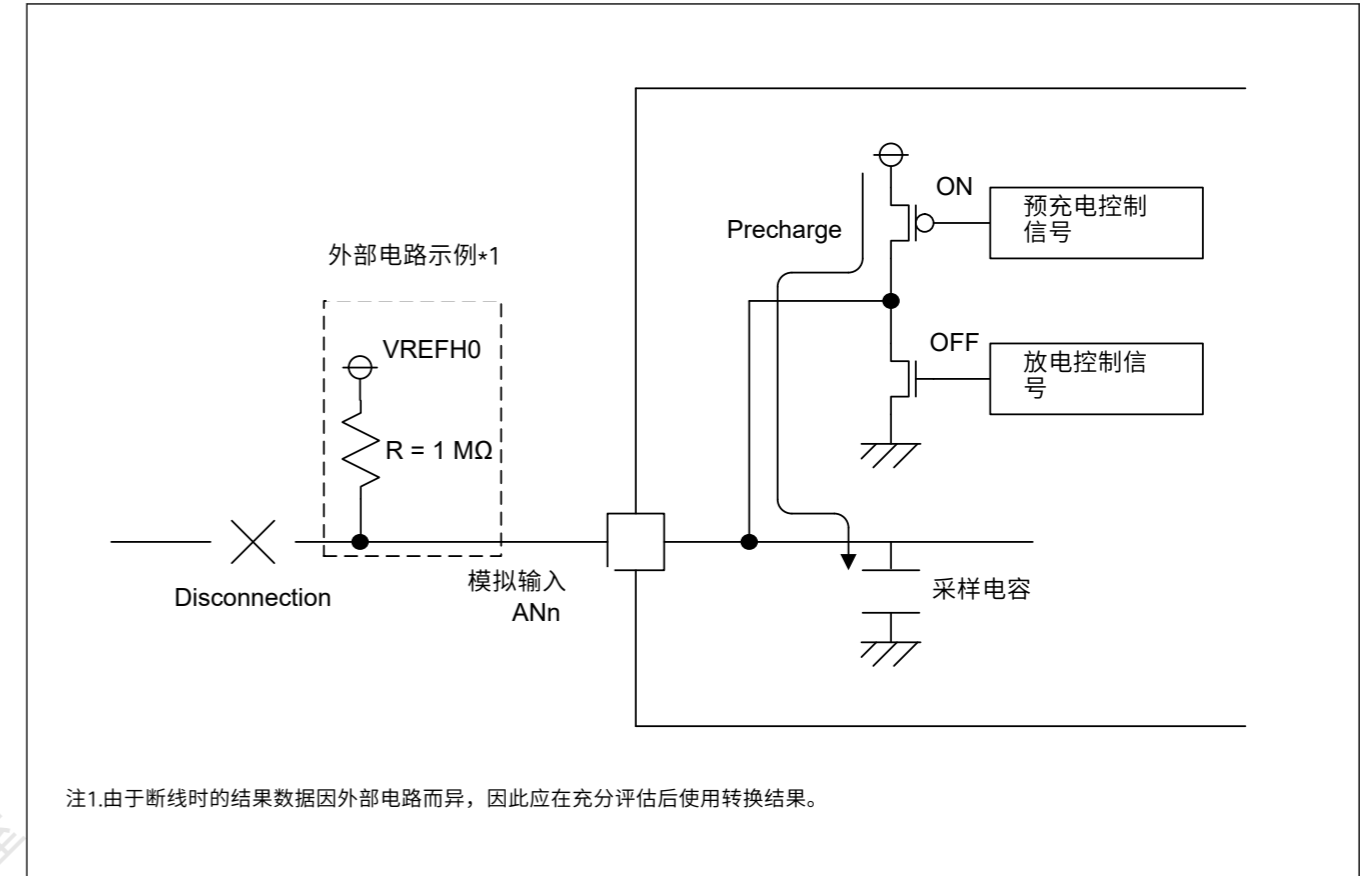
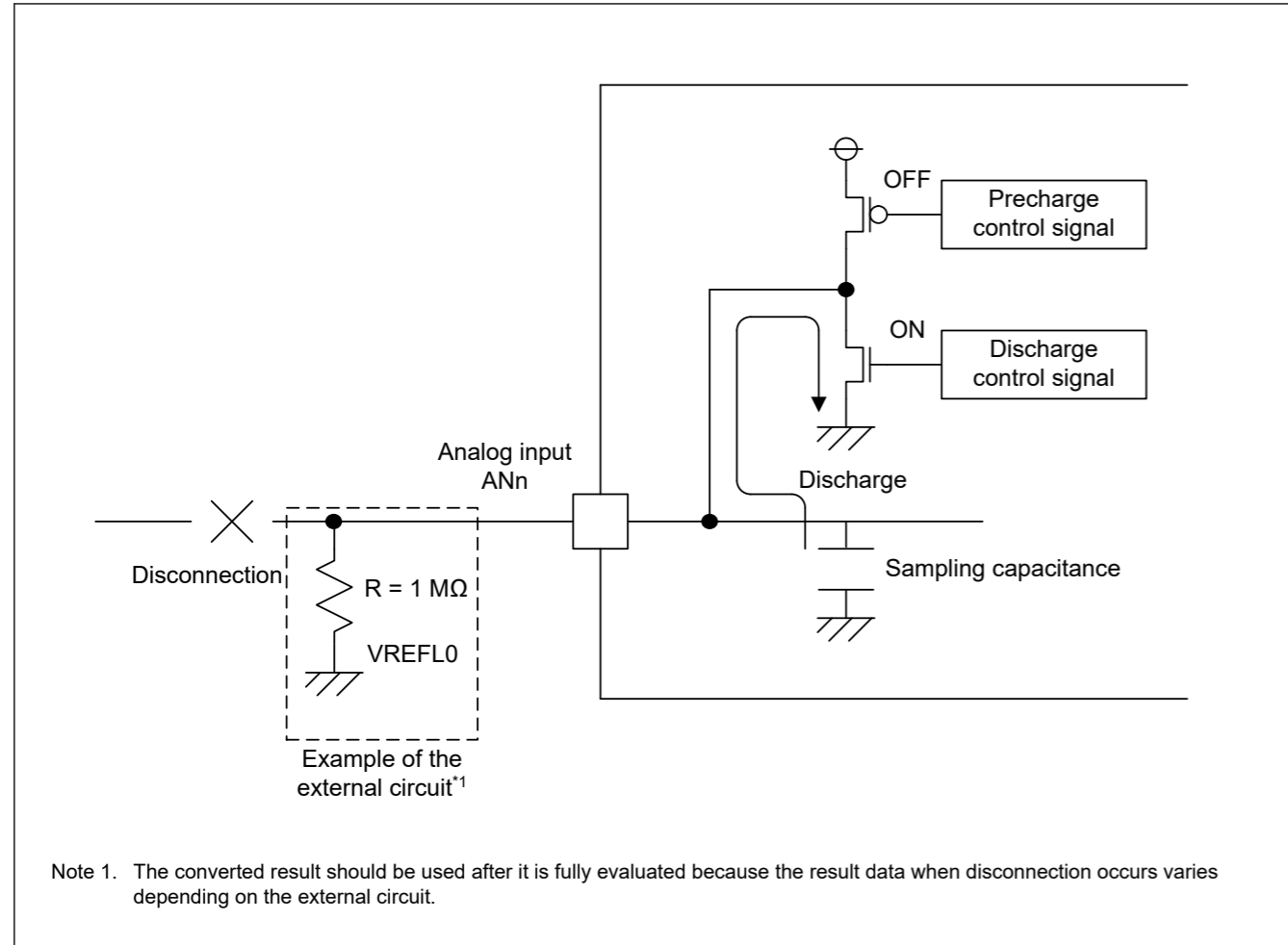


Figure 37.34 选择预充电时的断线检测示例



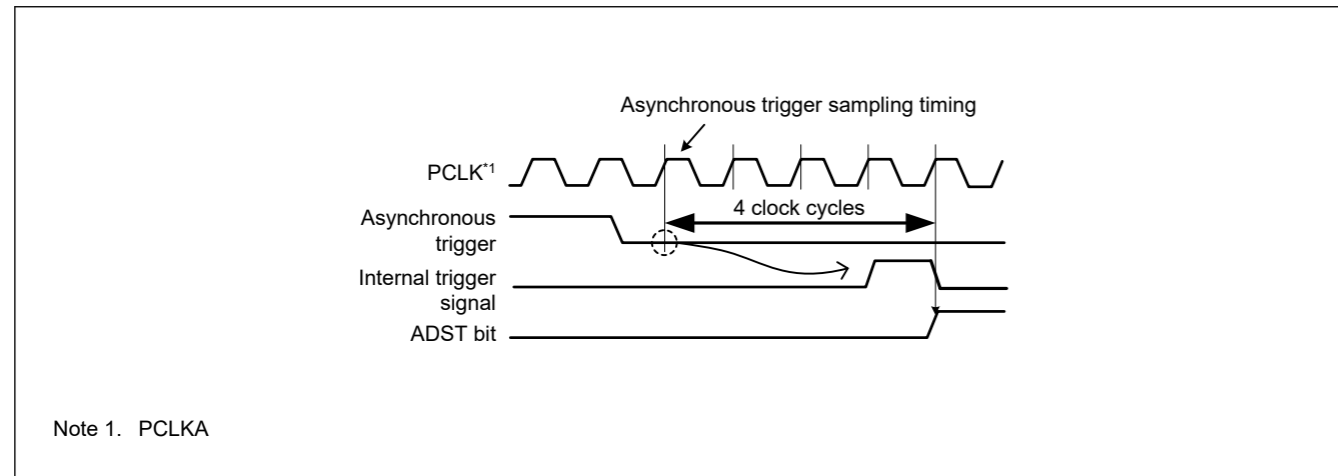
Note 1. The converted result should be used after it is fully evaluated because the result data when disconnection occurs varies depending on the external circuit.

Figure 37.35 Example of disconnection detection when discharge is selected

### 37.3.11 Starting A/D Conversion with an Asynchronous Trigger

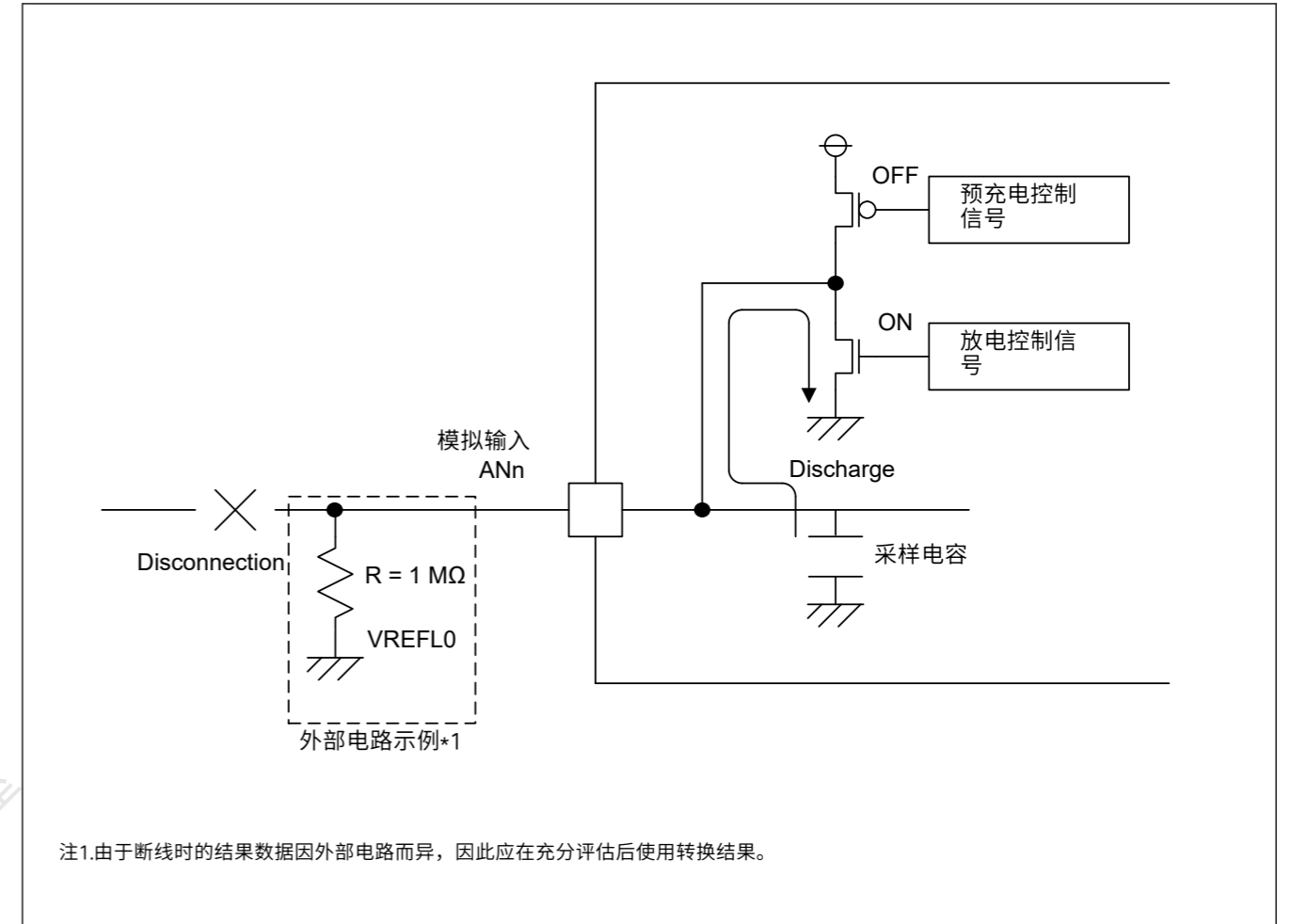
A/D conversion can be started by the input of an asynchronous trigger. To start A/D conversion by an asynchronous trigger, set the pin function in the PmnPFS register, set the A/D Conversion Start Trigger Select bits (ADSTRGR.TRSA[5:0]) to 0x00, then input a high-level signal to the asynchronous trigger (ADTRGn (n = 0, 1) pin). Finally, set both the ADCSR.TRGE and ADCSR.EXTRG bits to 1. Figure 37.36 shows timing of the asynchronous trigger input.

An asynchronous trigger cannot be selected in the A/D conversion start trigger for group B used in group scan mode. For details on setting the pin function, see section 19, I/O Ports.



Note 1. PCLKA

Figure 37.36 Asynchronous trigger input timing



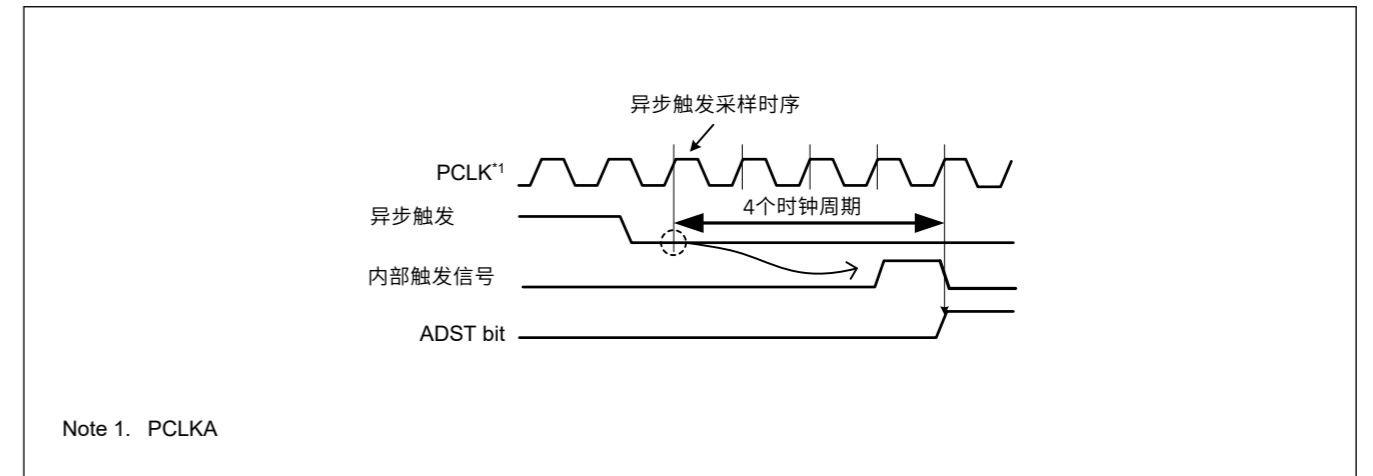
注1.由于断线时的结果数据因外部电路而异，因此应在充分评估后使用转换结果。

Figure 37.35 选择放电时的断线检测示例

### 37.3.11 使用异步触发启动AD转换

可以通过输入异步触发器来启动D转换。要通过异步触发启动AD转换，请在PmnPFS寄存器中设置引脚功能，将AD转换启动触发选择位(ADSTRGR.TRSA[5:0])设置为0x00，然后向异步触发输入高电平信号(ADTRGn(n=0,1)引脚)。最后，将ADCSR.TRGE和ADCSR.EXTRG位都设置为1。图37.36显示了异步触发输入的时序。

在组扫描模式中使用的B组的AD转换开始触发中不能选择异步触发。有关设置引脚功能的详细信息，请参见第19节，IO端口。



Note 1. PCLKA

Figure 37.36 异步触发输入时序

### 37.3.12 Starting A/D Conversion with a Synchronous Trigger from a Peripheral Module

A/D conversion can be started by a synchronous trigger (ELC). To do this, set the ADCSR.TRGE bit to 1 and the ADCSR.EXTRG bit to 0, and select the relevant sources in the ADSTRGR.TRSA[5:0] and ADSTRGR.TRSB[5:0] bits.

### 37.3.13 Using Data Buffers

This IP is provided with a ring buffer function consisting of 16 A/D data buffers. This function sequentially stores A/D conversion results other than self-diagnosis result (including addition/average results) in data buffers (ADBUF<sub>n</sub>, n = 0 to 15).

Each conversion result is stored at the timing when the A/D conversion result is stored in the data register, and most recent 16 conversion result data are retained.

The figure-below shows the schematic of data buffers, pointer, and overflow flag operations. When the BUFEN bit is set to 1, the A/D conversion result is transferred at each end of A/D conversion. The pointer indicates the number of data buffer to which the next transferred data is to be written. When data is written to up to buffer 15, the pointer is reset to 0000b and the overflow flag is set to 1. Subsequently transferred data overwrites the previously written data.

The overflow flag is reset to the initial value by writing 00h to the ADBUFPTR register.

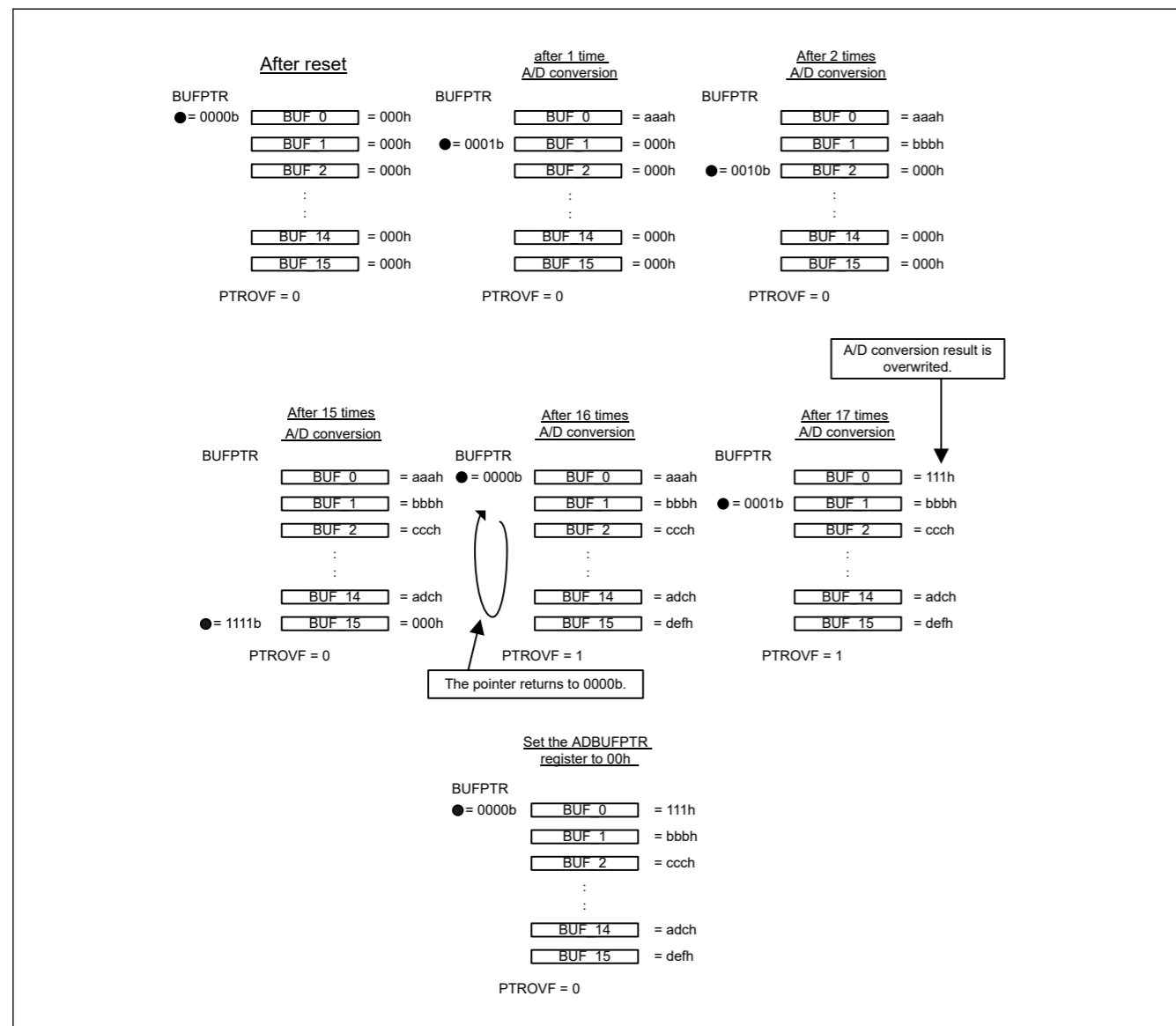


Figure 37.37 Data Buffers, Pointer, and Overflow Flag Operations

### 37.3.12 使用来自外设模块的同步触发启动AD转换

D转换可以通过同步触发器(ELC)启动。为此，将ADCSR.TRGE位设置为1，并将ADCSR.EXTRG位为0，并在ADSTRGR.TRSA[5:0]和ADSTRGR.TRSB[5:0]位中选择相关源。

### 37.3.13 使用数据缓冲区

该IP具有由16个AD数据缓冲区组成的环形缓冲区功能。该功能将除自诊断结果以外的AD转换结果（包括加法平均结果）依次存储在数据缓冲区（ADBUF<sub>n</sub>, n=0至15）中。

每个转换结果在AD转换结果存储在数据寄存器中时存储，并保留最近的16个转换结果数据。

下图显示了数据缓冲区、指针和溢出标志操作的示意图。当BUFEN位设置为1时，AD转换结果在AD转换的每一端传送。指针指示要写入下一个传输数据的数据缓冲区的编号。当数据写入缓冲区15时，指针复位为0000b，溢出标志设置为1。随后传输的数据将覆盖先前写入的数据。

通过将00h写入ADBUFPTR寄存器，溢出标志复位为初始值。

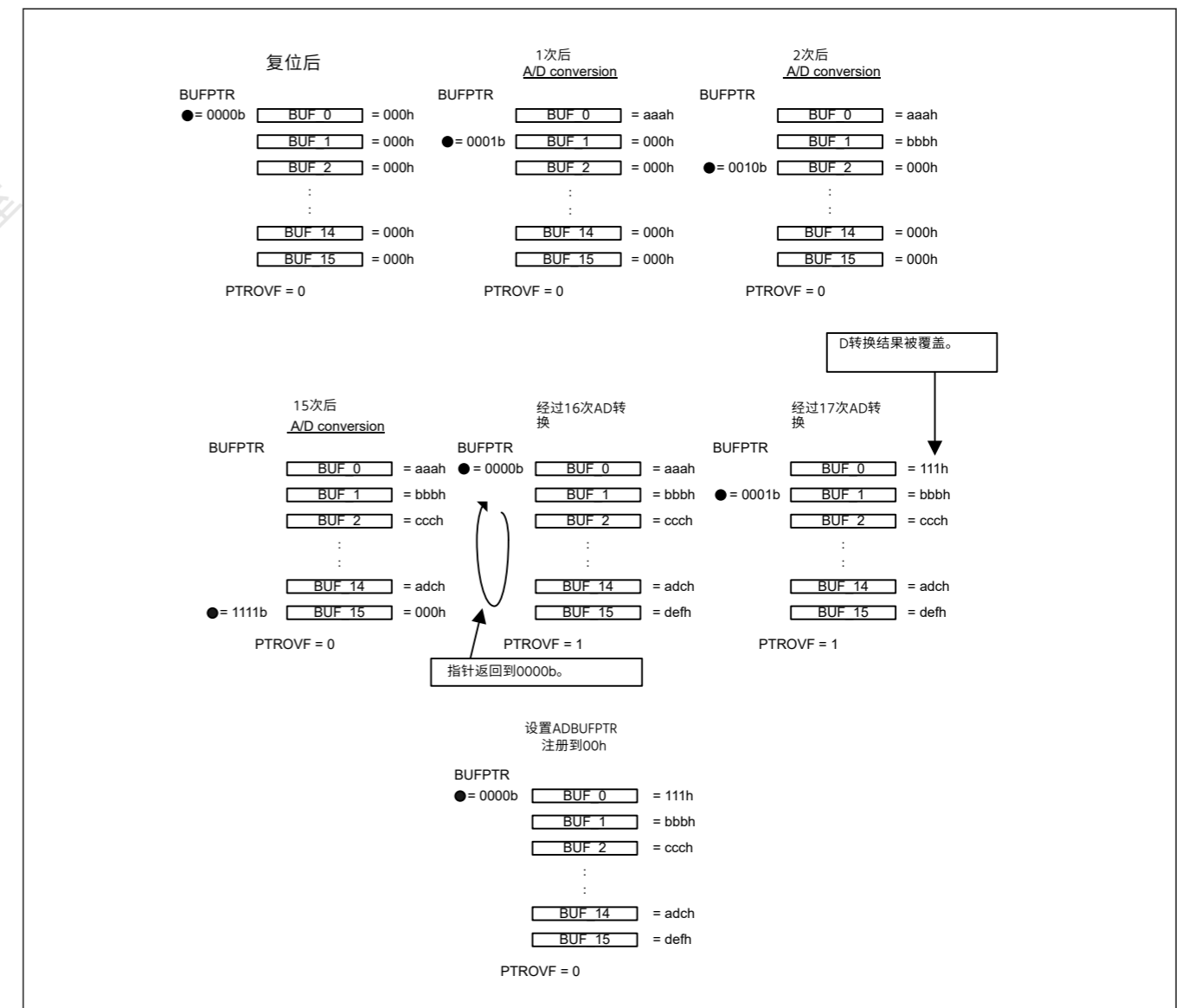


Figure 37.37 数据缓冲区、指针和溢出标志操作

37.4 Interrupt Sources and DTC, DMAC Transfer Requests

37.4.1 Interrupt Requests

The ADC12 can send scan end interrupt requests ADC12i\_ADI (i = 0, 1) and ADC12i\_GBADI (i = 0, 1) to the CPU. The ADC12 also generates the ADC12i\_CMPAI (i = 0, 1)/ADC12i\_CMPBI (i = 0, 1) interrupt for the CPU in response to matches with a condition for comparison.

An ADC12i\_ADI (i = 0, 1) interrupt is always generated. An ADC12i\_GBADI (i = 0, 1) interrupt can be generated by setting the ADCSR.GBADIE bit to 1. Similarly, ADC12i\_CMPAI (i = 0, 1) and ADC12i\_CMPBI (i = 0, 1) interrupts can be generated by setting the ADCMPCR.CMPAIE and ADCMPCR.CMPBIE bit to 1.

In addition, the DTC or DMAC can be started when an ADC12i\_ADI (i = 0, 1) or an ADC12i\_GBADI (i = 0, 1) interrupt is generated. Using an ADC12i\_ADI (i = 0, 1) or ADC12i\_GBADI (i = 0, 1) interrupt to activate the DTC or DMAC to read the converted data enables continuous conversion without a burden on software.

Table 37.28 describes the interrupt sources and ELC events available for the ADC12.

Table 37.28 The interrupt source and ELC event of ADC12 (1 of 2)

| Operation            |                     |                             | Interrupt request or ELC event | Interrupt request | DTC or DMAC activation | ELC event request   | Function   |
|----------------------|---------------------|-----------------------------|--------------------------------|-------------------|------------------------|---|--|
| Scan mode            | Double trigger mode | Compare function Window A/B |                                |                   |                        |   |  |
| Single scan mode     | Deselected          | Deselected                  | ADC12i_ADI (i = 0, 1)          | ✓                 | ✓                      | ✓   | ADC12i_ADI (i = 0, 1) generated at the end of single scan                                  |
|                      |                     | Selected                    | ADC12i_ADI (i = 0, 1)          | ✓                 | ✓                      | ✓   | ADC12i_ADI (i = 0, 1) generated at the end of single scan                                  |
|                      |                     |                             | ADC12i_CMPAI (i = 0, 1)        | ✓                 | —                      | —   | ADC12i_CMPAI (i = 0, 1) generated on a match comparison condition of Window A              |
|                      |                     |                             | ADC12i_CMPBI (i = 0, 1)        | ✓                 | —                      | —   | ADC12i_CMPBI (i = 0, 1) generated on a match comparison condition of Window B              |
|                      |                     |                             | ADC12i_WCMPPM (i = 0, 1)       | —                 | ✓                      | ✓   | ADC12i_WCMPPM (i = 0, 1) generated on a match condition of the Window A/B compare function |
|                      |                     | ADC12i_WCMPUM (i = 0, 1)    | —                              | ✓                 | ✓                      | ADC12i_WCMPUM (i = 0, 1) generated on a mismatch condition of the Window A/B compare function |  |
| Continuous scan mode | Deselected          | Deselected                  | ADC12i_ADI (i = 0, 1)          | ✓                 | ✓                      | ✓   | ADC12i_ADI (i = 0, 1) generated at the end of scan of all selected channels                |
|                      |                     | Selected                    | ADC12i_CMPAI (i = 0, 1)        | ✓                 | —                      | —   | ADC12i_CMPAI (i = 0, 1) generated on a match comparison condition of Window A              |
|                      |                     |                             | ADC12i_CMPBI (i = 0, 1)        | ✓                 | —                      | —   | ADC12i_CMPBI (i = 0, 1) generated on a match comparison condition of Window B              |

37.4 中断源和DTC、DMAC传输请求

37.4.1 中断请求

ADC12可以向CPU发送扫描结束中断请求ADC12i\_ADI(i=0 1)和ADC12i\_GBADI(i=0 1)。这ADC12还为CPU生成ADC12i\_CMPAI(i=0 1)ADC12i\_CMPBI(i=0 1)中断，以响应与比较条件的匹配。

始终会产生ADC12i\_ADI(i=0 1)中断。ADC12i\_GBADI(i=0 1)中断可以通过将ADCSR.GBADIE位设置为1来产生。类似地，ADC12i\_CMPAI(i=0 1)和ADC12i\_CMPBI(i=0 1)中断可以通过设置ADCMPCR来产生.CMPAIE和ADCMPCR.CMPBIE位为1。

此外，当ADC12i\_ADI(i=0 1)或ADC12i\_GBADI(i=0 1)中断产生时，可以启动DTC或DMAC。使用ADC12i\_ADI(i=0 1)或ADC12i\_GBADI(i=0 1)中断来激活DTC或DMAC以读取转换后的数据可实现连续转换，而无需软件负担。

表37.28描述了ADC12可用的中断源和ELC事件。

Table 37.28 ADC12的中断源和ELC事件 (1of2)

| Operation |            |                          | 中断请求或ELC事件               | 中断请求 | DTC或DMAC激活 | ELC事件请求                                | Function                              |
|-----------|------------|--------------------------|--------------------------|------|------------|--|---------------------------------------|
| 扫描模式      | 双触发模式      | 比较函数窗口AB                 |                          |      |            |  |                                       |
| 单次扫描模式    | Deselected | Deselected               | ADC12i_ADI (i = 0, 1)    | ✓    | ✓          | ✓                                      | ADC12i_ADI(i=0 1)在单次扫描结束时生成           |
|           |            | Selected                 | ADC12i_ADI (i = 0, 1)    | ✓    | ✓          | ✓                                      | ADC12i_ADI(i=0 1)在单次扫描结束时生成           |
|           |            |                          | ADC12i_CMPAI (i = 0, 1)  | ✓    | —          | —                                      | 在窗口A的匹配比较条件下生成的ADC12i_CMPAI(i=0 1)    |
|           |            |                          | ADC12i_CMPBI (i = 0, 1)  | ✓    | —          | —                                      | 在窗口B的匹配比较条件下生成的ADC12i_CMPBI(i=0 1)    |
|           |            |                          | ADC12i_WCMPPM (i = 0, 1) | —    | ✓          | ✓                                      | ADC12i_WCMPPM(i=0 1)在窗口AB比较功能的匹配条件下生成 |
|           |            | ADC12i_WCMPUM (i = 0, 1) | —                        | ✓    | ✓          | ADC12i_WCMPUM(i=0 1)在窗口AB比较功能的不匹配条件下生成 |                                       |
| 连续扫描模式    | Deselected | Deselected               | ADC12i_ADI (i = 0, 1)    | ✓    | ✓          | ✓                                      | ADC12i_ADI(i=0 1)在所有选定通道的扫描结束时生成      |
|           |            | Selected                 | ADC12i_CMPAI (i = 0, 1)  | ✓    | —          | —                                      | 在窗口A的匹配比较条件下生成的ADC12i_CMPAI(i=0 1)    |
|           |            |                          | ADC12i_CMPBI (i = 0, 1)  | ✓    | —          | —                                      | 在窗口B的匹配比较条件下生成的ADC12i_CMPBI(i=0 1)    |



Table 37.28 The interrupt source and ELC event of ADC12 (2 of 2)

| Operation       |                     |                             | Interrupt request or ELC event | Interrupt request | DTC or DMAC activation | ELC event request   | Function   |
|-----------------|---------------------|-----------------------------|--------------------------------|-------------------|------------------------|---|--|
| Scan mode       | Double trigger mode | Compare function Window A/B |                                |                   |                        |   |  |
| Group scan mode | Deselected          | Deselected                  | ADC12i_ADI (i = 0, 1)          | ✓                 | ✓                      | ✓   | ADC12i_ADI (i = 0, 1) generated at the end of group A scan                             |
|                 |                     |                             | ADC12i_GBADI (i = 0, 1)        | ✓                 | ✓                      | —   | ADC12i_GBADI (i = 0, 1) dedicated to group B generated at the end of group B scan      |
|                 |                     | Selected                    | ADC12i_ADI (i = 0, 1)          | ✓                 | ✓                      | ✓   | ADC12i_ADI (i = 0, 1) generated at the end of group A scan                             |
|                 |                     |                             | ADC12i_GBADI (i = 0, 1)        | ✓                 | ✓                      | —   | ADC12i_GBADI (i = 0, 1) dedicated to group B generated at the end of group B scan      |
|                 |                     |                             | ADC12i_CMPAI (i = 0, 1)        | ✓                 | —                      | —   | ADC12i_CMPAI (i = 0, 1) generated on a match comparison condition of Window A          |
|                 |                     |                             | ADC12i_CMPBI (i = 0, 1)        | ✓                 | —                      | —   | ADC12i_CMPBI (i = 0, 1) generated on a match comparison condition of Window B          |
|                 | Selected            | Deselected                  | ADC12i_ADI (i = 0, 1)          | ✓                 | ✓                      | ✓   | ADC12i_ADI (i = 0, 1) generated at the end of group A scans in the even-numbered times |
|                 |                     | ADC12i_GBADI (i = 0, 1)     | ✓                              | ✓                 | —                      | ADC12i_GBADI (i = 0, 1) dedicated to group B generated at the end of group B scan |  |

Note: ✓ available  
—: unavailable

For details on DTC settings, see [section 17, Data Transfer Controller \(DTC\)](#).

## 37.5 Event Link Function

### 37.5.1 Event Output to the ELC

The ELC uses the ADC12i\_ADI (i = 0, 1) interrupt request signal as an event signal ADC12i\_ADI (i = 0, 1), enabling link operation for the preset module. The ADC12i\_GBADI (i = 0, 1) interrupt and ADC12i\_CMPAI (i = 0, 1)/ADC12i\_CMPBI (i = 0, 1) interrupts cannot be used as an event signal. For details, see [Table 37.28](#).

An event signal can be output regardless of the settings of the corresponding interrupt request enable bits. For the scan end event (ADC12i\_ADI (i = 0, 1)), a high-level pulse for one PCLKA cycle is output at the same output timing as the interrupt output (ADC12i\_ADI (i = 0, 1)) shown in [Table 37.28](#), irrespective of the setting of ADCSR.ADIE. For a compare match (ADC12i\_WCMPI (i = 0, 1)) and mismatch event (ADC12i\_WCMPUM (i = 0, 1)) to the ELC, a high-level pulse for one PCLKA cycle is output at the timing delayed by one cycle (PCLKA) from the interrupt output (ADC12i\_ADI (i = 0, 1)) shown in [Table 37.28](#).

To use compare match (ADC12i\_WCMPI (i = 0, 1)) or mismatch event (ADC12i\_WCMPUM (i = 0, 1)) to the ELC, specify single-scan mode.

### 37.5.2 ADC12 Operation through an Event from the ELC

The ADC12 can start A/D conversion by the preset event specified in the ELSRn settings for the ELC as follows:

- Select the ELC\_AD00 (unit 0) signal in the ELC.ELSR8 register

Table 37.28 ADC12的中断源和ELC事件(2of2)

| Operation |            |                         | 中断请求或ELC事件              | 中断请求 | DTC或DMAC激活 | ELC事件请求                             | Function                            |
|-----------|------------|-------------------------|-------------------------|------|------------|-------------------------------------|-------------------------------------|
| 扫描模式      | 双触发模式      | 比较函数窗口AB                |                         |      |            |                                     |                                     |
| 组扫描模式     | Deselected | Deselected              | ADC12i_ADI (i = 0, 1)   | ✓    | ✓          | ✓                                   | ADC12i_ADI(i=0 1)在A组扫描结束时生成         |
|           |            |                         | ADC12i_GBADI (i = 0, 1) | ✓    | ✓          | —                                   | ADC12i_GBADI(i=0 1)专用于在B组扫描结束时生成的B组 |
|           |            | Selected                | ADC12i_ADI (i = 0, 1)   | ✓    | ✓          | ✓                                   | ADC12i_ADI(i=0 1)在A组扫描结束时生成         |
|           |            |                         | ADC12i_GBADI (i = 0, 1) | ✓    | ✓          | —                                   | ADC12i_GBADI(i=0 1)专用于在B组扫描结束时生成的B组 |
|           |            |                         | ADC12i_CMPAI (i = 0, 1) | ✓    | —          | —                                   | 在窗口A的匹配比较条件下生成的ADC12i_CMPAI(i=0 1)  |
|           |            |                         | ADC12i_CMPBI (i = 0, 1) | ✓    | —          | —                                   | 在窗口B的匹配比较条件下生成的ADC12i_CMPBI(i=0 1)  |
|           | Selected   | Deselected              | ADC12i_ADI (i = 0, 1)   | ✓    | ✓          | ✓                                   | ADC12i_ADI(i=0 1)在偶数次扫描A组结束时生成      |
|           |            | ADC12i_GBADI (i = 0, 1) | ✓                       | ✓    | —          | ADC12i_GBADI(i=0 1)专用于在B组扫描结束时生成的B组 |                                     |

Note: 可用—: 不可用

有关DTC设置的详细信息，请参阅第17节，数据传输控制器(DTC)。

## 37.5 事件链接功能

### 37.5.1 事件输出到ELC

ELC使用ADC12i\_ADI(i=0 1)中断请求信号作为事件信号ADC12i\_ADI(i=0 1)，启用预设模块的链接操作。ADC12i\_GBADI(i=0 1)中断和ADC12i\_CMPAI(i=0 1)/ADC12i\_CMPBI(i=0 1)中断不能用作事件信号。详见表37.28。

无论相应中断请求使能位的设置如何，都可以输出事件信号。对于扫描结束事件(ADC12i\_ADI(i=0 1))，在与表37.28所示的中断输出(ADC12i\_ADI(i=0 1))相同的输出时序输出一个PCLKA周期的高电平脉冲，与ADCSR.ADIE的设置无关。对于到ELC的比较匹配(ADC12i\_WCMPI(i=0 1))和失配事件(ADC12i\_WCMPUM(i=0 1))，在延迟一个周期的时序上输出一个PCLKA周期的高电平脉冲(PCLKA)来自表37.28所示的中断输出(ADC12i\_ADI(i=0 1))。

要将比较匹配(ADC12i\_WCMPI(i=0 1))或不匹配事件(ADC12i\_WCMPUM(i=0 1))用于ELC，请指定单扫描模式。

### 37.5.2 ADC12通过来自ELC的事件进行操作

ADC12可以通过ELC的ELSRn设置中指定的预设事件启动AD转换，如下所示：

- 选择ELC.ELSR8寄存器中的ELC\_AD00 (单元0) 信号

- Select the ELC\_AD01 (unit 0) signal in the ELC.ELSR9 register
- Select the ELC\_AD10 (unit 1) signal in the ELC.ELSR10 register
- Select the ELC\_AD11 (unit 1) signal in the ELC.ELSR11 register.

If an ELC event occurs during A/D conversion, the event is disabled.

## 37.6 Usage Notes

### 37.6.1 Constraints on Setting the Registers

Set each register while the ADCSR.ADST bit is 0.

### 37.6.2 Constraints on Reading the Data Registers

The following registers must be read in halfword units:

- A/D Data Registers
- A/D Data Duplexing Register
- A/D Data Duplexing Register A
- A/D Data Duplexing Register B
- A/D Temperature Sensor Data Register
- A/D Internal Reference Voltage Register
- A/D Self-Diagnosis Data Register
- A/D Data Buffer Registers n (N = 0 to 15)

If a register is read twice in byte units, that is, the upper byte and lower byte are read separately, the A/D-converted value read initially might disagree with the A/D-converted value read subsequently. To prevent this, never read the data registers in byte units.

### 37.6.3 Constraints on Stopping A/D Conversion

#### (1) A/D Conversion Stop Procedure

To stop A/D conversion when an asynchronous trigger or a synchronous trigger is selected as the condition for starting A/D conversion, follow the procedure shown in [Figure 37.38](#).

- 选择ELC.ELSR9寄存器中的ELC\_AD01（单元0）信号
- 选择ELC.ELSR10寄存器中的ELC\_AD10（单元1）信号
- 选择ELC.ELSR11寄存器中的ELC\_AD11（单元1）信号。

如果在AD转换期间发生ELC事件，则该事件被禁用。

## 37.6 使用说明

### 37.6.1 设置寄存器的限制

当ADCSR.ADST位为0时设置每个寄存器。

### 37.6.2 读取数据寄存器的限制

以下寄存器必须以半字为单位读取：

- AD数据寄存器
- AD数据双工寄存器
- AD数据双工寄存器A
- AD数据双工寄存器B
- AD温度传感器数据寄存器
- AD内部参考电压寄存器
- AD自诊断数据寄存器
- AD数据缓冲寄存器n(N=0to15)

如果以字节为单位读取寄存器两次，即分别读取高字节和低字节，则最初读取的AD转换值可能与随后读取的AD转换值不一致。为防止这种情况，切勿以字节为单位读取数据寄存器。

### 37.6.3 停止AD转换的约束

#### (1) AD转换停止程序

To stop A/D conversion when an asynchronous trigger or a synchronous trigger is selected as the condition for starting A/D conversion, follow the procedure shown in [Figure 37.38](#).

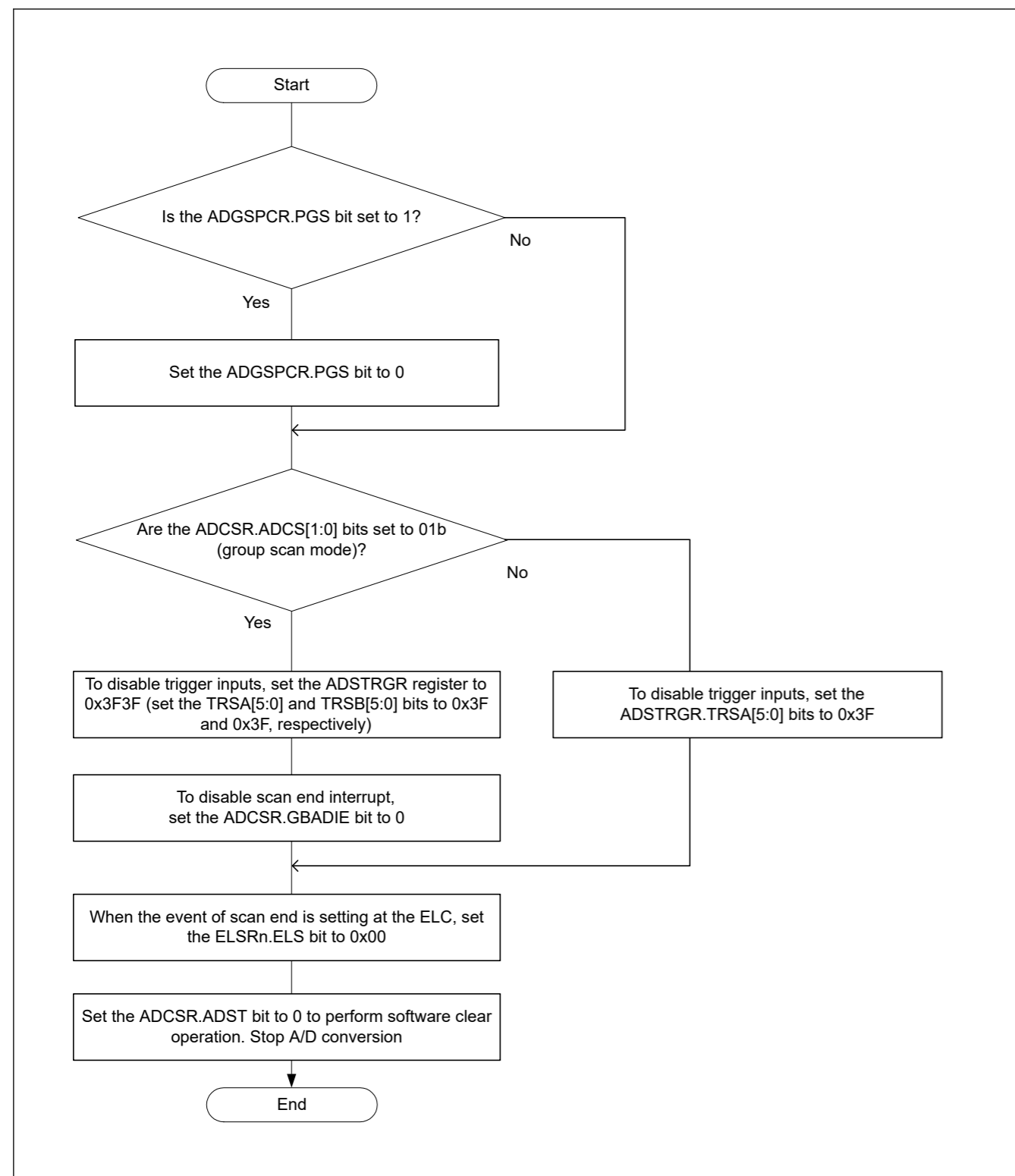


Figure 37.38 Procedures for clearing the ADCSR.ADST bit by software

To specify the following settings after performing the clear operation by software, provide a wait period for at least two ADCLK cycles.

- Enabling scan end interrupts
- Enabling scan end events for the event link controller
- Starting A/D conversion by software
- Enabling trigger input

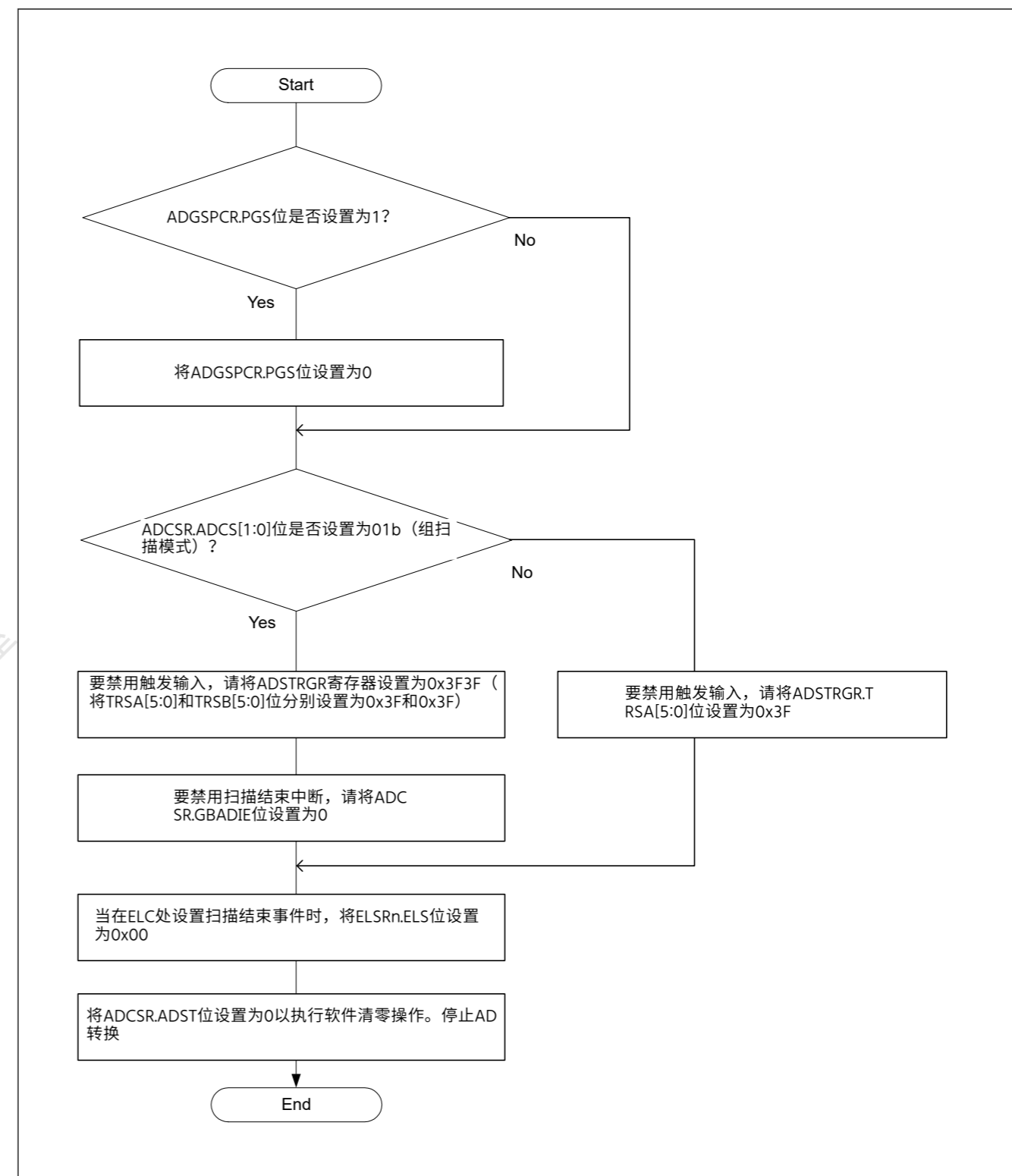


Figure 37.38 通过软件清除ADCSR.ADST位的程序

要在通过软件执行清除操作后指定以下设置, 请提供至少两个等待时间ADCLK cycles.

- 启用扫描结束中断
- 为事件链接控制器启用扫描结束事件
- 通过软件启动AD转换
- 启用触发输入

## (2) Notes on Modes and Status Bits

If necessary, individually initialize or set again the voltage status for self-diagnosis, the judgment of the even number or odd number specified for double-trigger mode, and the monitor flags of the compare function.

- To set again the voltage status for self-diagnosis, set the ADCER.DIAGLD bit to 1 and then set a desired value in the ADCER.DIAGVAL[1:0] bits.
- If the setting of the ADCSR.DBLE bit is changed from 0 to 1, the double-trigger mode operation starts from the first scanning.
- To initialize the monitor flags of the compare function (MONCMPA, MONCMPB, and MONCOMB), set the ADCMPCR.CMPAE and ADCMPCR.CMPBE bits to 0.

### 37.6.4 A/D Conversion Restart and Termination Timing

A maximum of 6 ADCLK cycles is required for the idle analog unit of the ADC12 to restart on setting the ADCSR.ADST bit to 1. A maximum of 2 ADCLK cycles is required for the operating analog unit of the ADC12 to terminate on setting the ADCSR.ADST bit to 0.

### 37.6.5 Constraints on Scan End Interrupt Handling

When scanning the same analog input twice using any trigger, the first A/D-converted data is overwritten with the second A/D-converted data. This occurs when the CPU does not complete the reading of the A/D-converted data by the time the A/D conversion of the first analog input for the second scan ends after the first scan end interrupt is generated.

### 37.6.6 Settings for the Module-Stop Function

The Module Stop Control Register can enable or disable ADC12 operation. The ADC12 is initially stopped after a reset. The registers become accessible on release from the module-stop state. After release from the module-stop state, wait for at least 1 μs before starting A/D conversion. For details, see [section 10, Low Power Modes](#).

### 37.6.7 Notes on Entering the Low-Power States

Before entering the module-stop state or Software Standby mode, be sure to stop A/D conversion. Set the ADCSR.ADST bit in ADCSR to 0 and secure a period of time until the analog unit of the ADC12 stops. Follow the procedure shown in [Figure 37.38](#) to clear the ADCSR.ADST bit with software. Then, wait for 2 clock cycles of ADCLK before entering the module-stop state or Software Standby mode.

### 37.6.8 Error in Absolute Accuracy When Disconnection Detection Assistance Is in Use

Using disconnection detection assistance leads to an error in absolute accuracy of the ADC12. This error arises because an erroneous voltage is input to the analog input pins due to the resistive voltage division between the pull-up or pull-down resistor (Rp) and the resistance of the signal source (Rs). This error in absolute accuracy is calculated from the following formula:

$$\text{Maximum error in absolute accuracy (LSB)} = (2^{\text{Resolution}} - 1) \times R_s / (R_s + R_p)$$

Only use disconnection detection assistance after thorough evaluation.

### 37.6.9 Constraints on Operating Modes and Status Bits

Initialize or set again individually, if necessary, the voltage values in self-diagnosis, the value of the first scan or second scan in double trigger mode, the data buffer pointer, and status monitor in the compare function.

- Select the voltage values in self-diagnosis (ADCER.DIAGVAL[1:0]) after setting ADCER.DIAGLD to 1.
- Double-trigger mode operates as the first scan after setting ADCSR.DBLE from 0 to 1.
- The status monitor bits (MONCMPA, MONCMPB, MONCOMB) in the compare function are initialized after setting ADCMPCR.CMPAE and ADCMPCR.CMPBE to 0.

## (2) 模式和状态位注意事项

如有必要，单独初始化或重新设置电压状态以进行自诊断、双触发模式指定的偶数或奇数判断以及比较功能的监视标志。

- 要再次设置自诊断的电压状态，请将ADCER.DIAGLD位设置为1，然后在ADCER.DIAGVAL[1:0]位中设置所需的值。
- 如果ADCSR.DBLE位的设置从0变为1，则双触发模式操作从第一次扫描开始。
- 要初始化比较函数的监控标志（MONCMPA、MONCMPB和MONCOMB），请将ADCMPCR.CMPAE和ADCMPCR.CMPBE位设置为0。

### 37.6.4 AD转换重启和终止时序

ADC12的空闲模拟单元最多需要6个ADCLK周期才能在将ADCSR.ADST位设置为1时重新启动。ADC12的操作模拟单元需要最多2个ADCLK周期才能在设置ADCSR时终止ADST位为0。

### 37.6.5 扫描结束中断处理的约束

当使用任何触发器扫描相同的模拟输入两次时，第一个AD转换数据将被第二个AD转换数据覆盖。当CPU在

在产生第一次扫描结束中断后，第二次扫描的第一个模拟输入的D转换结束。

### 37.6.6 模块停止功能的设置

模块停止控制寄存器可以启用或禁用ADC12操作。ADC12在复位后最初停止。寄存器在从模块停止状态释放时变得可访问。从模块停止状态释放后，至少等待1 μs再开始AD转换。有关详细信息，请参阅第10节，低功耗模式。

### 37.6.7 进入低功耗状态的注意事项

在进入模块停止状态或软件待机模式之前，请务必停止AD转换。将ADCSR中的ADCSR.ADST位设置为0，并确保一段时间，直到ADC12的模拟单元停止。按照图37.38所示的过程用软件清零ADCSR.ADST位。然后，在进入模块停止状态或软件待机模式之前等待ADCLK的2个时钟周期。

### 37.6.8 使用断线检测辅助时的绝对精度误差

使用断开检测辅助会导致ADC12的绝对精度出现误差。由于上拉或下拉电阻(Rp)与信号源电阻(Rs)之间的电阻分压，导致错误电压输入到模拟输入引脚，因此会出现此错误。该绝对精度误差由以下公式计算得出：

$$\text{绝对精度的最大误差(LSB)} = 2^{\text{分辨率}} \times R_s R_p / (R_s + R_p)$$

仅在全面评估后使用断线检测辅助。

### 37.6.9 操作模式和状态位的限制

必要时单独初始化或重新设置自诊断中的电压值、双触发模式下的第一次扫描或第二次扫描的值、数据缓冲区指针和比较功能中的状态监视器。

- 设置ADCER.DIAGLD为1后，选择自诊断中的电压值（ADCER.DIAGVAL[1:0]）。
- 双触发模式在将ADCSR.DBLE从0设置为1后作为第一次扫描运行。
- 比较功能中的状态监控位（MONCMPA、MONCMPB、MONCOMB）在设置ADCMPCR.CMPAE和ADCMPCR.CMPBE为0后被初始化。



### 37.6.10 Notes on Board Design

The board should be designed so that digital circuits and analog circuits are separated from each other as far as possible. In addition, digital circuit signal lines and analog circuit signal lines should not intersect or be placed near each other. If these rules are not followed, noise can occur on analog signals and A/D conversion accuracy is affected. The analog input pins, reference power supply pin (VREFH0, VREFH), reference ground pin (VREFL0, VREFL), and analog power supply (AVCC0) should be separated from digital circuits using the analog ground (AVSS0). The analog ground (AVSS0) should be connected to a stable digital ground (VSS) on the board (single-point ground plane connection).

### 37.6.11 Constraints on Noise Prevention

To prevent the analog input pins from being destroyed by abnormal voltage such as excessive surge, insert a capacitor between AVCC0 and AVSS0 and between VREFH0 and VREFL0 and between VREFH and VREFL. Additionally, connect a protection circuit to protect the analog input pins as shown in Figure 37.39.

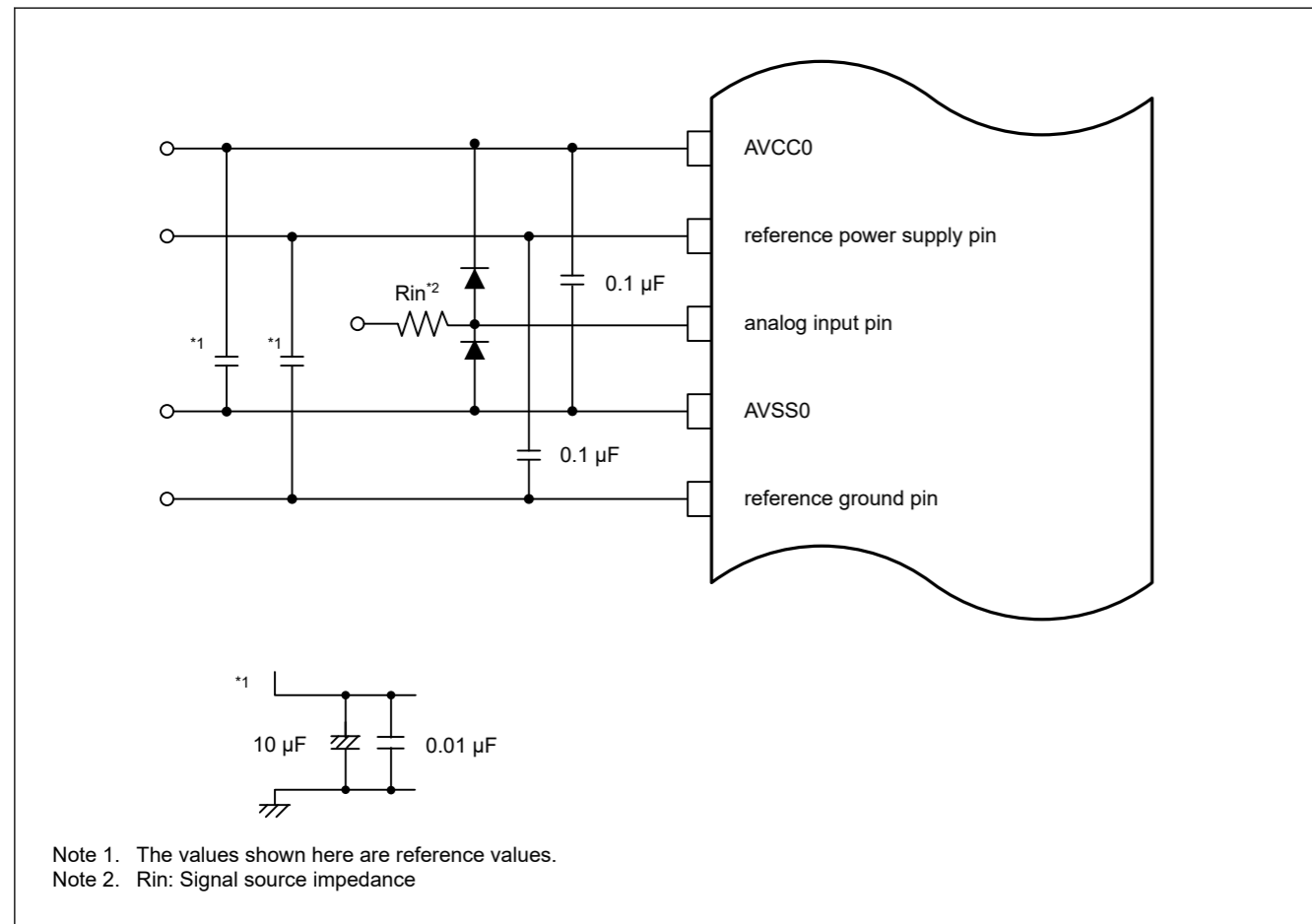


Figure 37.39 Example protection circuit for analog inputs

### 37.6.12 Port Settings When Using the ADC12 Input

When using the high-precision channels, do not use PORT0 as general I/O. Renesas recommends that you do not use the digital output that is also used as the AD analog input if normal-precision channel is used. If the digital output that is also used as the AD analog input is used for output signals, perform A/D conversion several times, eliminate the maximum and minimum values, and obtain the average of the other results.

### 37.6.13 Notes on Canceling Software Standby Mode

After software standby mode is canceled, wait at least 1 μs after the stabilization time for the oscillator elapses and before starting A/D conversion. For details, see section 10, Low Power Modes

### 37.6.10 电路板设计注意事项

电路板的设计应使数字电路和模拟电路尽可能分开。此外，数字电路信号线和模拟电路信号线不应交叉或靠近。如果不遵守这些规则，模拟信号上可能会出现噪声，影响AD转换精度。模拟输入引脚、参考电源引脚(VREFH0、VREFH)、参考接地引脚(VREFL0、VREFL)和模拟电源(AVCC0)应与使用模拟接地(AVSS0)的数字电路分开。模拟接地(AVSS0)应连接到板上的稳定数字接地(VSS) (单点接地层连接)。

### 37.6.11 防止噪音的限制

为防止模拟输入引脚被过大浪涌等异常电压损坏，请在AVCC0和AVSS0之间、VREFH0和VREFL0之间以及VREFH和VREFL之间插入一个电容器。此外，连接保护电路以保护模拟输入引脚，如图37.39所示。

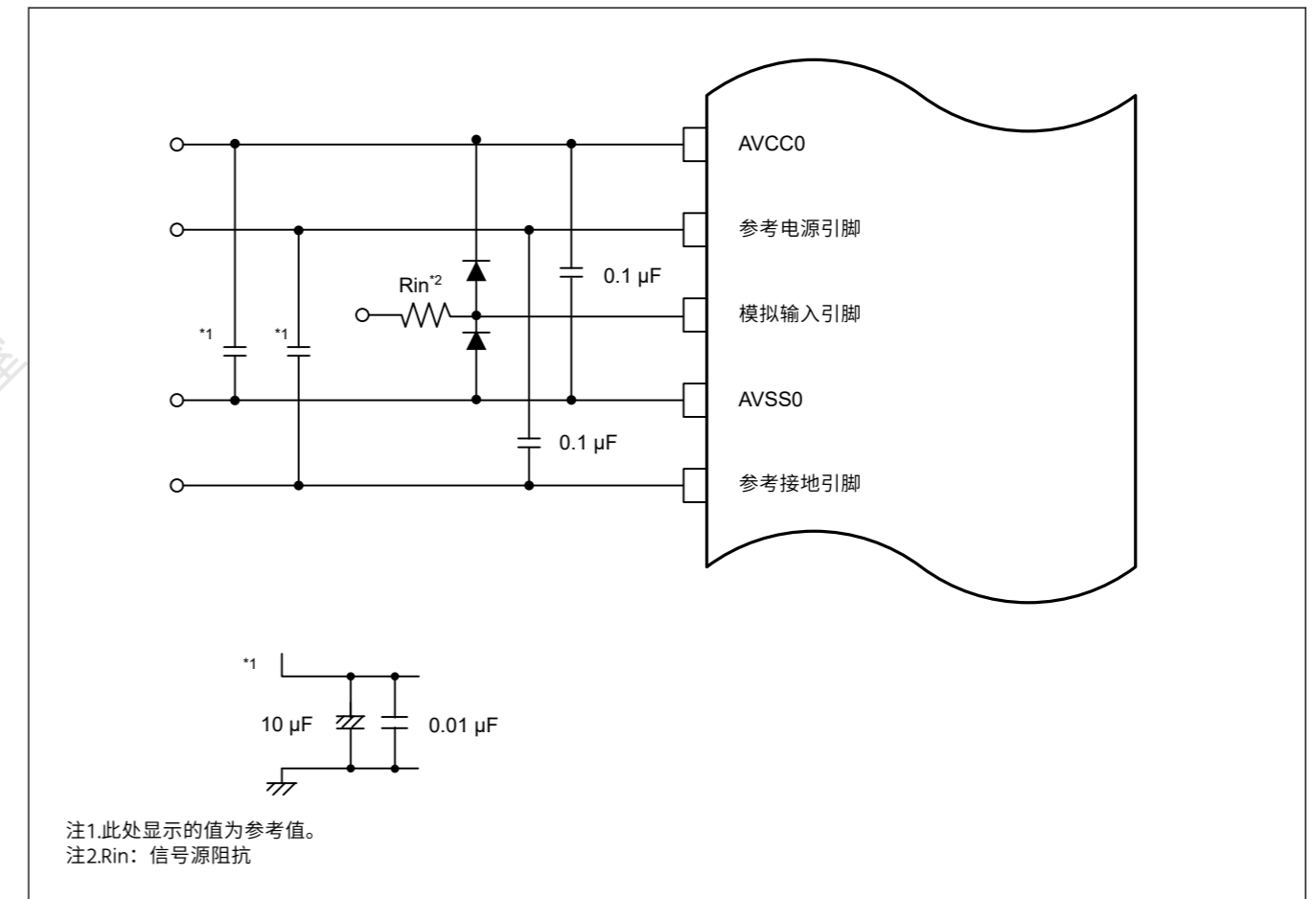


Figure 37.39 模拟输入保护电路示例

### 37.6.12 使用ADC12输入时的端口设置

使用高精度通道时，请勿将PORT0用作通用IO。如果使用普通精度通道，瑞萨建议您不要使用同时用作AD模拟输入的数字输出。如果同时用作AD模拟输入的数字输出用于输出信号，则进行数次A/D转换，消除最大值和最小值，取其他结果的平均值。

### 37.6.13 关于取消软件待机模式的注意事项

取消软件待机模式后，在振荡器的稳定时间过去后至少等待1 μs，然后再开始AD转换。有关详细信息，请参阅第10节，低功耗模式

## 37.6.14 Calculation for sampling time

The sampling time can be easily estimated by the following figure and formula. This is the time to reach the voltage within 1/4 LSB.

$$t_{SPL} = (R_{EXT} + R_{AD}) \times (C_{EXT} + C_{AD}) \times \ln(C_{AD} / (C_{EXT} + C_{AD}) \times 2^{N+2})$$

$R_{EXT}$  shows external signal source impedance

$C_{EXT}$  shows external capacitance (pin capacitance<sup>\*1</sup> + PCB parasitic capacitance)

$N = 12, 10$  or  $8$  (conversion resolution)

$C_{AD} = 5$  pF (internal capacitance)

$R_{AD} = 1.0$  k $\Omega$  (internal resistance, case of high-speed channels)

$R_{AD} = 2.0$  k $\Omega$  (internal resistance, case of normal-speed channels)

Note 1. Typical value of analog input pin is 5 pF

For example, if  $R_{EXT}$  is 1 k $\Omega$ ,  $C_{EXT}$  is 10 pF and  $N$  is 12 bits,  $t_{SPL}$  of high-speed channel is 258 ns.

This formula simplifies the general use case. This formula is not guaranteed and should be used only for estimation.

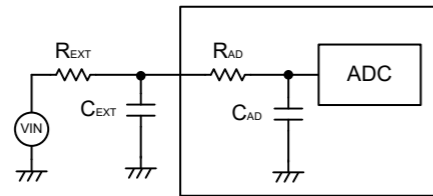


Figure 37.40 Sample and hold circuit simplified diagram

## 37.6.14 采样时间计算

采样时间可以通过下图和公式轻松估算。这是在14LSB内达到电压的时间。

$$t_{SPL} = (R_{EXT} + R_{AD}) \times (C_{EXT} + C_{AD}) \times \ln(C_{AD} / (C_{EXT} + C_{AD}) \times 2^{N+2})$$

$R_{EXT}$ 显示外部信号源阻抗

$C_{EXT}$ 表示外部电容（引脚电容+PCB寄生电容）

$N = 12, 10$  or  $8$  (conversion resolution)

$C_{AD} = 5$  pF (internal capacitance)

$R_{AD} = 1.0$  k $\Omega$  (内部电阻, 高速通道的情况)

$R_{AD} = 2.0$  k $\Omega$  (内部电阻, 正常速度通道的情况)

注1. 模拟输入引脚的典型值为5pF

例如, 如果 $R_{EXT}$ 为1k $\Omega$ ,  $C_{EXT}$ 为10pF,  $N$ 为12位, 则高速通道的 $t_{SPL}$ 为258ns。

此公式简化了一般用例。这个公式不能保证, 只能用于估计。

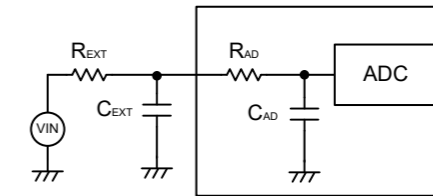


Figure 37.40 采样保持电路简化图

## 38. 12-Bit D/A Converter (DAC12)

### 38.1 Overview

The MCU provides a 12-bit D/A Converter (DAC12) with an output amplifier. Table 38.1 lists the DAC12 specifications, Figure 38.1 shows a block diagram, and Table 38.2 lists the I/O pins.

Table 38.1 DAC12 specifications

| Parameter                                     | Specifications   |
|---|--|
| Resolution                                    | 12 bits  |
| Output channels                               | 2 channels   |
| Interference reduction between analog modules | Methods provided to minimize interference between D/A and A/D conversion: <ul style="list-style-type: none"> <li>D/A converted data update timing is controlled by the synchronous D/A conversion enable input signal from the ADC12 (unit 1)</li> <li>Degradation of A/D conversion accuracy caused by interference is reduced by controlling the DAC12 inrush current generation timing with the enable signal.</li> </ul> |
| Module-stop function                          | Module-stop state can be set to reduce power consumption   |
| Event link function (input)                   | The DA0 and DA1 conversion can be started on input of an event signal  |
| D/A output amplifier control function         | Controls whether the output amplifier (for both amplifier-through and amplifier-bias controls) is used   |
| TrsutZone Filter                              | Security attribution can be set  |

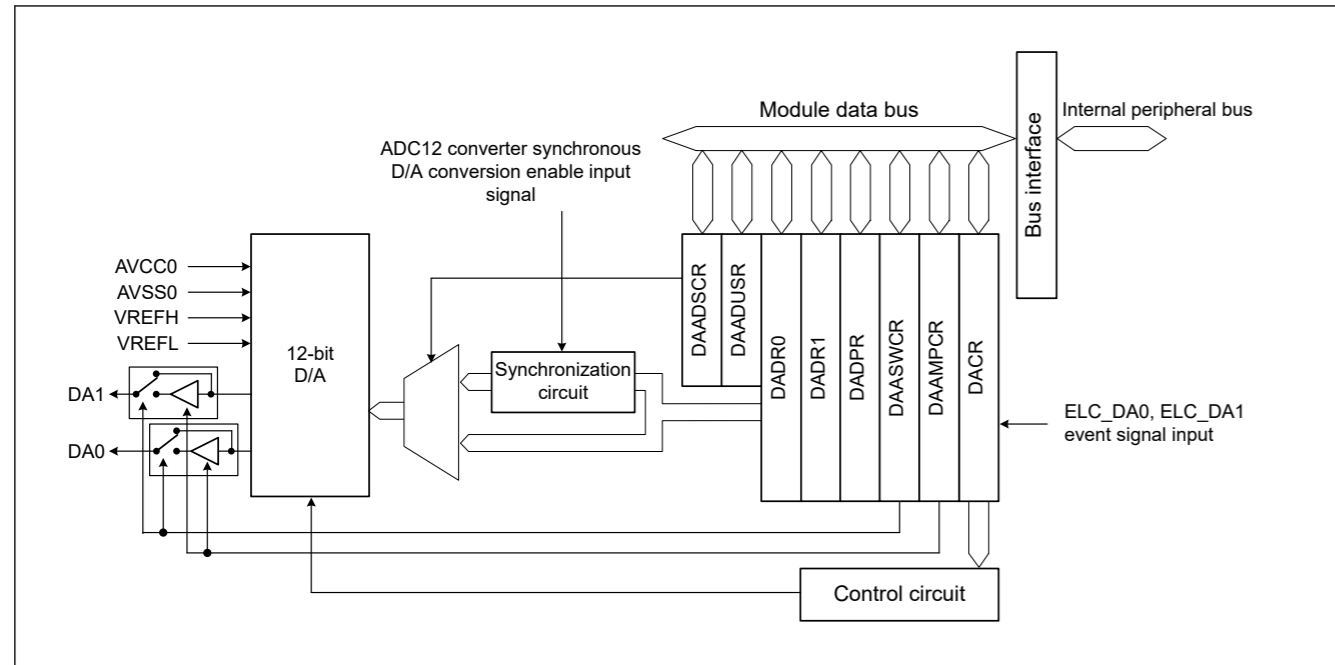


Figure 38.1 DAC12 block diagram

Table 38.2 lists the pin configuration of the DAC12.

Table 38.2 DAC12 I/O pins (1 of 2)

| Pin name | I/O   | Function   |
|----------|-------|--|
| AVCC0    | Input | <ul style="list-style-type: none"> <li>Analog power and analog reference top voltage supply pin for ADC12 and DAC12.</li> <li>Connect to VCC when these modules are not used.</li> </ul> |
| AVSS0    | Input | <ul style="list-style-type: none"> <li>Analog ground and analog reference ground supply pin for ADC12 and DAC12.</li> <li>Connect to VSS when these modules are not used.</li> </ul>     |
| VREFH    | Input | Analog reference top voltage supply pin for the ADC12 (unit 1) and the DAC12   |
| VREFL    | Input | Analog reference ground pin for the ADC12 (unit 1) and the DAC12   |

## 38. 12-Bit D/A Converter (DAC12)

### 38.1 Overview

MCU提供带输出放大器的12位DA转换器(DAC12)。表38.1列出了DAC12规格，图38.1显示了框图，表38.2列出了IO引脚。

Table 38.1 DAC12 specifications

| Parameter            | Specifications   |
|----------------------|--|
| Resolution           | 12 bits  |
| 输出通道                 | 2 channels   |
| 减少模拟模块之间的干扰          | 为尽量减少DA和AD转换之间的干扰提供的方法: <ul style="list-style-type: none"> <li>DA转换数据更新时序由来自ADC12 (单元1) 的同步DA转换使能输入信号控制</li> <li>通过使能信号控制DAC12浪涌电流的产生时序,可以减少由干扰引起的AD转换精度下降。</li> </ul> |
| Module-stop function | 可设置模块停止状态以降低功耗   |
| 事件链接功能 (输入)          | DA0和DA1转换可以在输入事件信号时启动  |
| DA输出放大器控制功能          | 控制是否使用输出放大器 (用于放大器直通和放大器偏置控制)  |
| TrsutZone Filter     | 可设置安全属性  |

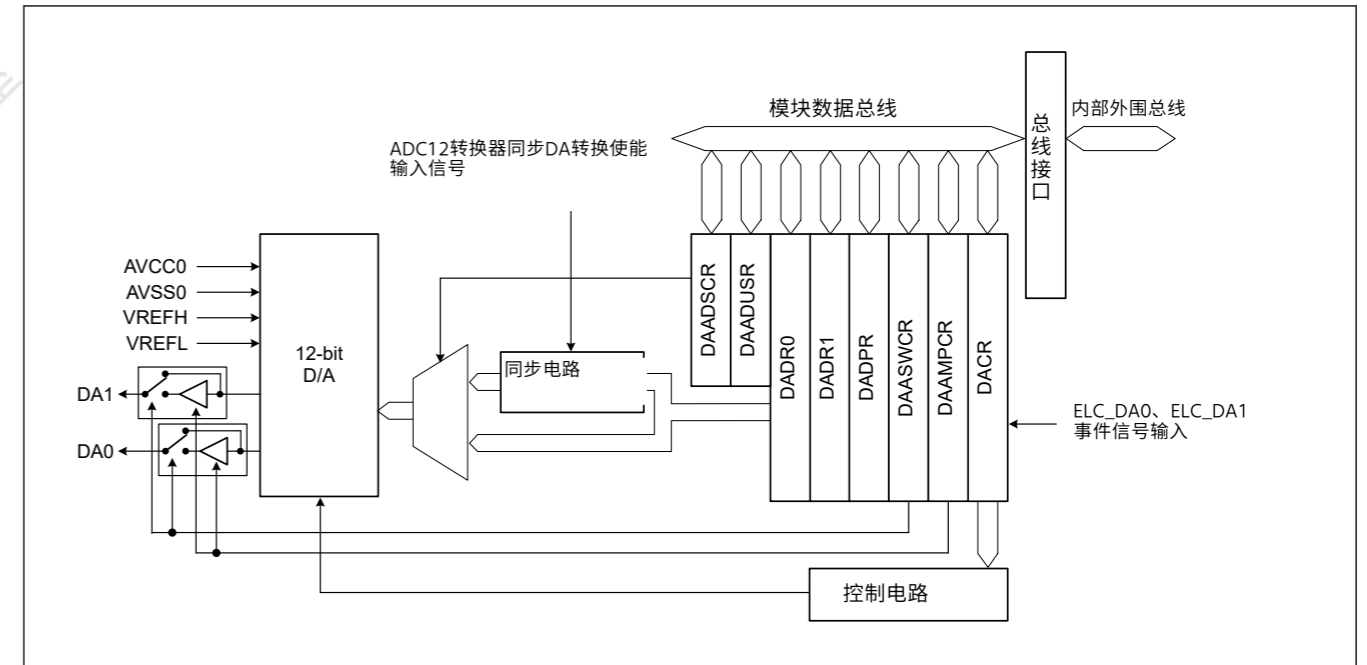


Figure 38.1 DAC12框图

表38.2列出了DAC12的引脚配置。

Table 38.2 DAC12IO引脚 (2个中的1个)

| 引脚名称  | I/O   | Function  |
|-------|-------|---|
| AVCC0 | Input | <ul style="list-style-type: none"> <li>ADC12和DAC12的模拟电源和模拟参考最高电压电源引脚。</li> <li>不使用这些模块时连接到VCC。</li> </ul> |
| AVSS0 | Input | <ul style="list-style-type: none"> <li>ADC12和DAC12的模拟地和模拟参考地电源引脚。</li> <li>不使用这些模块时连接到VSS。</li> </ul>     |
| VREFH | Input | ADC12 (单元1) 和DAC12的模拟参考最高电压电源引脚   |
| VREFL | Input | ADC12 (单元1) 和DAC12的模拟参考接地引脚   |

**Table 38.2 DAC12 I/O pins (2 of 2)**

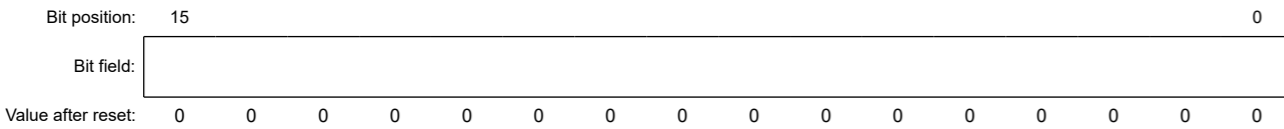
| Pin name | I/O    | Function   |
|----------|--------|--|
| DA0      | Output | Channel 0 output pin for the analog signals processed by the DAC12 |
| DA1      | Output | Channel 1 output pin for the analog signals processed by the DAC12 |

### 38.2 Register Descriptions

#### 38.2.1 DADRn : D/A Data Register n (n = 0, 1)

Base address: DAC12 = 0x4017\_1000

Offset address: 0x00 + 0x02 × n



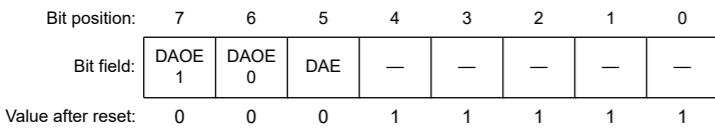
DADRn register is 16-bit read/write registers that store data for D/A conversion. When an analog output is enabled, the values in DADRn are converted and output to the analog output pins.

12-bit data can be formatted as left- or right-justified in the DADPR.DPSEL bit setting. In right-justified format (DADPR.DPSEL = 0), the lower 12 bits, [11:0], are valid. In left-justified format (DADPR.DPSEL = 1), the upper 12 bits, [15:4], are valid.

#### 38.2.2 DACR : D/A Control Register

Base address: DAC12 = 0x4017\_1000

Offset address: 0x04



| Bit | Symbol            | Function   | R/W |
|-----|-------------------|--|-----|
| 4:0 | —                 | These bits are read as 1. The write value should be 1.   | R/W |
| 5   | DAE <sup>*1</sup> | D/A Enable<br>0: Control D/A conversion of channels 0 and 1 individually<br>1: Control D/A conversion of channels 0 and 1 collectively | R/W |
| 6   | DAOE0             | D/A Output Enable 0<br>0: Disable analog output of channel 0 (DA0)<br>1: Enable D/A conversion of channel 0 (DA0)                      | R/W |
| 7   | DAOE1             | D/A Output Enable 1<br>0: Disable analog output of channel 1 (DA1)<br>1: Enable D/A conversion of channel 1 (DA1)                      | R/W |

Note 1. This bit controls D/A conversion in combination with the DAOEi bit (i = 0, 1), which controls the output of the conversion results. For details, see Table 38.3.

**Table 38.2 DAC12 I/O引脚 (2个中的2个)**

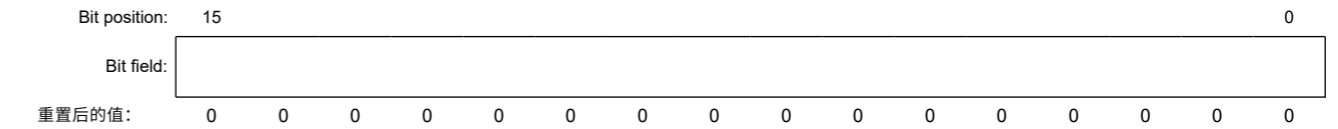
| 引脚名称 | I/O    | Function             |
|------|--------|----------------------|
| DA0  | Output | DAC12处理的模拟信号的通道0输出引脚 |
| DA1  | Output | DAC12处理的模拟信号的通道1输出引脚 |

### 38.2 注册说明

#### 38.2.1 DADRn:DA数据寄存器n(n=0 1)

Base address: DAC12 = 0x4017\_1000

Offset address: 0x00 + 0x02 × n



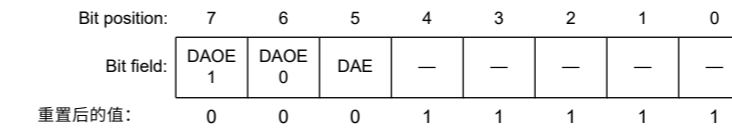
DADRn寄存器是16位读写寄存器，用于存储用于DA转换的数据。当模拟输出使能时，DADRn中的值被转换并输出到模拟输出引脚。

在DADPR.DPSEL位设置中，12位数据可以被格式化为左对齐或右对齐。在右对齐格式(DADPR.DPSEL=0)中，低12位[11:0]有效。在左对齐格式(DADPR.DPSEL=1)中，高12位[15:4]有效。

#### 38.2.2 DACR:DA控制寄存器

Base address: DAC12 = 0x4017\_1000

Offset address: 0x04



| Bit | Symbol            | Function  | R/W |
|-----|-------------------|---|-----|
| 4:0 | —                 | 这些位被读取为1。写入值应为1。  | R/W |
| 5   | DAE <sup>*1</sup> | D/A Enable<br>0: 分别控制通道0和通道1的DA转换<br>1: 控制通道0和通道1的DA转换  | R/W |
| 6   | DAOE0             | DA输出使能0<br>0: 禁用通道0 (DA0) 的模拟输出<br>1: 启用通道0 (DA0) 的DA转换 | R/W |
| 7   | DAOE1             | DA输出使能1<br>0: 禁用通道1 (DA1) 的模拟输出<br>1: 启用通道1 (DA1) 的DA转换 | R/W |

注1.该位与DAOEi位(i=0 1)一起控制DA转换，DAOEi位控制转换结果的输出。详见表38.3。



Table 38.3 D/A conversion controls

| DAE | DAOE1 | DAOE0 | Description  |
|-----|-------|-------|--|
| 0   | 0     | 0     | Disable D/A conversion and analog output pins (DA0, DA1)*1   |
|     |       | 1     | <ul style="list-style-type: none"> <li>Enable D/A conversion of channel 0 and disable D/A conversion of channel 1</li> <li>Enable analog output of channel 0 (DA0) and disable analog output of channel 1 (DA1)*1</li> </ul> |
|     | 1     | 0     | <ul style="list-style-type: none"> <li>Disable D/A conversion of channel 0 and enable D/A conversion of channel 1</li> <li>Disable analog output of channel 0 (DA0)*1 and enable analog output of channel 1 (DA1)</li> </ul> |
|     |       | 1     | <ul style="list-style-type: none"> <li>Enable D/A conversion of channels 0 and 1</li> <li>Enable analog output of channels 0 and 1 (DA0, DA1)</li> </ul>   |
| 1   | x     | x     | <ul style="list-style-type: none"> <li>Enable D/A conversion of channels 0 and 1</li> <li>Collective enable analog output of channels 0 and 1 (DA0, DA1)</li> </ul>  |

Note: x: Don't care

Note 1. When analog output is disabled, the analog output signal is placed in the Hi-Z state.

Only set this register while the ADC12 is halted when the DAADSCR.DAADST bit is 1 (interference reduction between D/A and A/D conversion is enabled). Only set DACR while the ADCSR.ADST bit is 0 and after selecting the software trigger, for the ADC12 trigger to securely stop the ADC12. This MCU only supports ADC12 (unit 1).

#### DAE bit (D/A Enable)

The DAE bit controls D/A conversion, amplifier operation, and analog output in combination with the DAOEi bit (i = 0, 1) and the DAMMPCR.DAAMPi bit (i = 0, 1). See Table 38.4.

When interference reduction between D/A and A/D conversions is enabled (DAADSCR.DAADST = 1), set the ADCSR.ADST bit of the ADC12 (unit 1) to 0. Then, select the software trigger for the ADC12 (unit 1) trigger to securely stop the ADC12 (unit 1).

#### DAOEi bit (D/A Output Enable i)

The DAOEi bit (i = 0, 1) controls D/A conversion, amplifier operation, and analog output in combination with the DAE bit and DAMMPCR.DAAMPi bit (i = 0, 1). See Table 38.4.

When both the DAOEi bit (i = 0, 1) and DAE bit are 0, D/A conversion of channel i (i = 0, 1) is not processed, and no conversion result is output.

When interference reduction between D/A and A/D conversions is enabled (DAADSCR.DAADST = 1), set the DAOEi bit while the ADCSR.ADST bit of the ADC12 (unit 1) is set to 0. Then, select the software trigger for the ADC12 (unit 1) trigger to securely stop the ADC12 (unit 1).

The event link function can be used to set the DAOEi bit to 1. The DAOE0 bit is set to 1 when the event specified in the ELSR12 register of the ELC (ELC\_DA0 event) occurs, and output of the D/A conversion results starts. The DAOE1 bit is set to 1 when the event specified in the ELSR13 register of the ELC (ELC\_DA1 event) occurs, and output of the D/A conversion results starts.

Table 38.4 D/A conversion and analog output control

| DACR |       | DAAMPCR |   | Channel i operation | Amplifier operation of channel i | Analog output of channel i |
|------|-------|---------|---|---------------------|----------------------------------|----------------------------|
| DAE  | DAOEi | DAAMPi  |   |                     |                                  |                            |
| 0    | 0     | 0       | 0 | Stop                | Stop                             | Hi-Z                       |
|      |       | 1       | 1 | Stop                | Stop                             | Hi-Z                       |
|      | 1     | 0       | 0 | Run                 | Stop                             | Amplifier-through          |
|      |       | 1       | 1 | Run                 | Run                              | Amplifier output           |
| 1    | 0     | 0       | 0 | Run                 | Stop                             | Amplifier-through          |
|      |       | 1       | 1 | Run                 | Run                              | Amplifier output           |
|      | 1     | 0       | 0 | Run                 | Stop                             | Amplifier-through          |
|      |       | 1       | 1 | Run                 | Run                              | Amplifier output           |

Table 38.3 DA转换控制

| DAE | DAOE1 | DAOE0 | Description   |
|-----|-------|-------|---|
| 0   | 0     | 0     | 禁用DA转换和模拟输出引脚(DA0 DA1)*1  |
|     |       | 1     | <ul style="list-style-type: none"> <li>启用通道0的DA转换和禁用通道1的DA转换</li> <li>启用通道0(DA0)的模拟输出和禁用通道1(DA1)的模拟输出*1</li> </ul>  |
|     | 1     | 0     | <ul style="list-style-type: none"> <li>禁用通道0的DA转换, 启用通道1的DA转换</li> <li>禁用通道0(DA0)*1的模拟输出并启用通道1(DA1)的模拟输出</li> </ul> |
|     |       | 1     | <ul style="list-style-type: none"> <li>启用通道0和1的DA转换</li> <li>启用通道0和1 (DA0、DA1) 的模拟输出</li> </ul>                     |
| 1   | x     | x     | <ul style="list-style-type: none"> <li>启用通道0和1的DA转换</li> <li>通道0和1 (DA0、DA1) 的集体启用模拟输出</li> </ul>                   |

Note: x: Don't care

注1.当模拟输出禁用时, 模拟输出信号置于Hi-Z状态。

仅当DAADSCR.DAADST位为1时ADC12停止时才设置此寄存器(之间的干扰减少DA和AD转换已启用)。只有在ADCSR.ADST位为0且选择软件触发后设置DACR, ADC12触发才能安全停止ADC12。此MCU仅支持ADC12(单元1)。

#### DAE位 (DA启用)

DAE位与DAOEi位(i=0 1)和DAMMPCR.DAAMPi位(i=0 1)一起控制DA转换、放大器操作和模拟输出。见表38.4。

当启用DA和AD转换之间的干扰减少(DAADSCR.DAADST=1)时, 设置ADC12(单元1)的ADCSR.ADST位为0。然后, 选择ADC12(单元1)触发的软件触发以安全停止ADC12(单元1)。

#### DAOEi位 (DA输出使能i)

DAOEi位(i=0 1)与DAE位和DAMMPCR.DAAMPi位(i=0 1)一起控制DA转换、放大器操作和模拟输出。见表38.4。

当DAOEi位(i=0 1)和DAE位均为0时, 通道i(i=0 1)的DA转换不进行处理, 也不输出转换结果。

当启用DA和AD转换之间的干扰降低时(DAADSCR.DAADST=1), 设置DAOEi位, 同时将ADC12(单元1)的ADCSR.ADST位设置为0。然后, 选择ADC12的软件触发(单元1)触发以安全地停止ADC12(单元1)。

事件链接功能可用于将DAOEi位设置为1。当在发生ELC(ELC\_DA0事件)的ELSR12寄存器, 开始输出DA转换结果。当发生ELC的ELSR13寄存器中指定的事件(ELC\_DA1事件)时, DAOE1位设置为1, 并开始输出DA转换结果。

Table 38.4 DA转换和模拟输出控制

| DACR |       | DAAMPCR |   | 通道i操作 | 通道i的放大器操作 | 通道i的模拟输出          |
|------|-------|---------|---|-------|-----------|-------------------|
| DAE  | DAOEi | DAAMPi  |   |       |           |                   |
| 0    | 0     | 0       | 0 | Stop  | Stop      | Hi-Z              |
|      |       | 1       | 1 | Stop  | Stop      | Hi-Z              |
|      | 1     | 0       | 0 | Run   | Stop      | Amplifier-through |
|      |       | 1       | 1 | Run   | Run       | 放大器输出             |
| 1    | 0     | 0       | 0 | Run   | Stop      | Amplifier-through |
|      |       | 1       | 1 | Run   | Run       | 放大器输出             |
|      | 1     | 0       | 0 | Run   | Stop      | Amplifier-through |
|      |       | 1       | 1 | Run   | Run       | 放大器输出             |

Note: i = 0, 1

## 38.2.3 DADPR : DADRn Format Select Register

Base address: DAC12 = 0x4017\_1000

Offset address: 0x05

|                    |       |   |   |   |   |   |   |   |
|--------------------|-------|---|---|---|---|---|---|---|
| Bit position:      | 7     | 6 | 5 | 4 | 3 | 2 | 1 | 0 |
| Bit field:         | DPSEL | — | — | — | — | — | — | — |
| Value after reset: | 0     | 0 | 0 | 0 | 0 | 0 | 0 | 0 |

| Bit | Symbol | Function   | R/W |
|-----|--------|--|-----|
| 6:0 | —      | These bits are read as 0. The write value should be 0.                       | R/W |
| 7   | DPSEL  | DADRn Format Select<br>0: Right-justified format<br>1: Left-justified format | R/W |

## 38.2.4 DAADSCR : D/A A/D Synchronous Start Control Register

Base address: DAC12 = 0x4017\_1000

Offset address: 0x06

|                    |        |   |   |   |   |   |   |   |
|--------------------|--------|---|---|---|---|---|---|---|
| Bit position:      | 7      | 6 | 5 | 4 | 3 | 2 | 1 | 0 |
| Bit field:         | DAADST | — | — | — | — | — | — | — |
| Value after reset: | 0      | 0 | 0 | 0 | 0 | 0 | 0 | 0 |

| Bit | Symbol | Function   | R/W |
|-----|--------|--|-----|
| 6:0 | —      | These bits are read as 0. The write value should be 0.   | R/W |
| 7   | DAADST | D/A A/D Synchronous Conversion<br>0: Do not synchronize DAC12 with ADC12 (unit 1) operation (disable interference reduction between D/A and A/D conversion).<br>1: Synchronize DAC12 with ADC12 (unit 1) operation (enable interference reduction between D/A and A/D conversion). | R/W |

To minimize interference between D/A and A/D conversion, the DAADSCR register enables synchronization of the start timing of D/A conversion with the ADC12 synchronous D/A conversion enable input signal.

Only set this register while the ADC12 (unit 1) is halted, that is, while the ADCSR.ADST bit is 0 after selecting the software trigger as the ADC12 (unit 1) trigger.

Select unit 1 as the target ADC12 unit before setting the DAADST bit to 1. Set DAADUSR[1] bit to 1 to select unit 1. This MCU only supports ADC12 unit 1.

**DAADST bit (D/A A/D Synchronous Conversion)**

Setting the DAADST bit to 0 allows the DADRn register value to be converted into analog data at any time. Setting the DAADST bit to 1 allows synchronization of D/A conversion with the synchronous D/A conversion enable input signal from the ADC12 (unit 1). With this bit set, D/A conversion does not start until the ADC12 (unit 1) completes A/D conversion, even when the DADRn register is changed.

Set this bit while the ADCSR.ADST bit is set to 0. Then, select the software trigger for the ADC12 (unit 1) trigger to securely stop the ADC12 (unit 1). Set the DAADUSR.AMADSEL1 bit to 1 before setting the DAADST bit to 1.

The event link function cannot be used when the DAADST bit is set to 1. Stop the event link function by setting the ELSR12 and ELSR13 registers of the ELC. The setting of the DAADST bit is shared by channels 0 and 1 of the DAC12.

Note: i = 0, 1

## 38.2.3 DADPR:DADRn格式选择寄存器

Base address: DAC12 = 0x4017\_1000

Offset address: 0x05

|               |       |   |   |   |   |   |   |   |
|---------------|-------|---|---|---|---|---|---|---|
| Bit position: | 7     | 6 | 5 | 4 | 3 | 2 | 1 | 0 |
| Bit field:    | DPSEL | — | — | — | — | — | — | — |
| 重置后的值:        | 0     | 0 | 0 | 0 | 0 | 0 | 0 | 0 |

| Bit | Symbol | Function   | R/W |
|-----|--------|--|-----|
| 6:0 | —      | 这些位被读取为0。写入值应为0。   | R/W |
| 7   | DPSEL  | DADRn格式选择<br>0: Right-justified format<br>1: Left-justified format | R/W |

## 38.2.4 DAADSCR:DAAD同步启动控制寄存器

Base address: DAC12 = 0x4017\_1000

Offset address: 0x06

|               |        |   |   |   |   |   |   |   |
|---------------|--------|---|---|---|---|---|---|---|
| Bit position: | 7      | 6 | 5 | 4 | 3 | 2 | 1 | 0 |
| Bit field:    | DAADST | — | — | — | — | — | — | — |
| 重置后的值:        | 0      | 0 | 0 | 0 | 0 | 0 | 0 | 0 |

| Bit | Symbol | Function   | R/W |
|-----|--------|--|-----|
| 6:0 | —      | 这些位被读取为0。写入值应为0。   | R/W |
| 7   | DAADST | DAAD同步转换<br>0: 不将DAC12与ADC12（单元1）操作同步（禁用DA和AD转换之间的干扰降低）。<br>1: DAC12与ADC12（单元1）操作同步（启用DA和AD转换之间的干扰降低）。 | R/W |

为了尽量减少DA和AD转换之间的干扰，DAADSCR寄存器使DA转换的开始时序与ADC12同步DA转换使能输入信号同步。

仅在ADC12（单元1）停止时设置该寄存器，即选择软件触发作为ADC12（单元1）触发后ADCSR.ADST位为0。

在将DAADST位设置为1之前选择单元1作为目标ADC12单元。将DAADUSR[1]位设置为1以选择单元1。这MCU仅支持ADC12单元1。

**DAADST位 (DAAD同步转换)**

将DAADST位设置为0可以随时将DADRn寄存器值转换为模拟数据。设置DAADST位为1允许DA转换与来自ADC12（单元1）的同步DA转换使能输入信号同步。设置该位后，在ADC12（单元1）完成AD转换之前，即使DADRn寄存器发生更改，DA转换也不会开始。

在ADCSR.ADST位设置为0时设置该位。然后，选择ADC12（单元1）触发器的软件触发器以安全地停止ADC12（单元1）。在将DAADST位设置为1之前，将DAADUSR.AMADSEL1位设置为1。

当DAADST位设置为1时，不能使用事件链接功能。通过设置ELC的ELSR12和ELSR13寄存器。DAADST位的设置由DAC12的通道0和1共享。

## 38.2.5 DAAMPCR : D/A Output Amplifier Control Register

Base address: DAC12 = 0x4017\_1000

Offset address: 0x08

|                    |        |        |   |   |   |   |   |   |
|--------------------|--------|--------|---|---|---|---|---|---|
| Bit position:      | 7      | 6      | 5 | 4 | 3 | 2 | 1 | 0 |
| Bit field:         | DAAMP1 | DAAMP0 | — | — | — | — | — | — |
| Value after reset: | 0      | 0      | 0 | 0 | 0 | 0 | 0 | 0 |

| Bit | Symbol | Function   | R/W |
|-----|--------|--|-----|
| 5:0 | —      | These bits are read as 0. The write value should be 0.   | R/W |
| 6   | DAAMP0 | Amplifier Control 0<br>0: Do not use channel 0 output amplifier<br>1: Use channel 0 output amplifier | R/W |
| 7   | DAAMP1 | Amplifier Control 1<br>0: Do not use channel 1 output amplifier<br>1: Use channel 1 output amplifier | R/W |

The DAAMPCR register selects D/A output with or without using the amplifier.

**DAAMP0 bit (Amplifier Control 0)**

When the DAAMP0 bit is 0, analog values are output for D/A output of channel 0 without using the amplifier. When the DAAMP0 bit is 1, analog values are output for D/A output of channel 0 through the amplifier.

When both the DACR.DAE and DACR.DAOE0 bits are 0, the amplifier is not used regardless of the setting of the DAAMP0 bit. See [Table 38.4](#) for details.

**DAAMP1 bit (Amplifier Control 1)**

When the DAAMP1 bit is 0, analog values are output for D/A output of channel 1 without using the amplifier. When the DAAMP1 bit is 1, analog values are output for D/A output of channel 1 through the amplifier.

When both the DACR.DAE and DACR.DAOE1 bits are 0, the amplifier is not used regardless of the setting of the DAAMP1 bit. See [Table 38.4](#) for details.

## 38.2.6 DAASWCR : D/A Amplifier Stabilization Wait Control Register

Base address: DAC12 = 0x4017\_1000

Offset address: 0x1C

|                    |        |        |   |   |   |   |   |   |
|--------------------|--------|--------|---|---|---|---|---|---|
| Bit position:      | 7      | 6      | 5 | 4 | 3 | 2 | 1 | 0 |
| Bit field:         | DAASW1 | DAASW0 | — | — | — | — | — | — |
| Value after reset: | 0      | 0      | 0 | 0 | 0 | 0 | 0 | 0 |

| Bit | Symbol | Function  | R/W |
|-----|--------|---|-----|
| 5   | —      | These bits are read as 0. The write value should be 0.  | R/W |
| 6   | DAASW0 | D/A Amplifier Stabilization Wait 0<br>0: Amplifier stabilization wait off (output) for channel 0<br>1: Amplifier stabilization wait on (high-Z) for channel 0 | R/W |
| 7   | DAASW1 | D/A Amplifier Stabilization Wait 1<br>0: Amplifier stabilization wait off (output) for channel 1<br>1: Amplifier stabilization wait on (high-Z) for channel 1 | R/W |

The DAASWCR register controls D/A output with the output amplifier. This register is used in the initialization procedure to wait for stabilization of the D/A output amplifier. Each bit in DAASWCR should be set to 1 when both the DACR.DAE bit and the DACR.DAOE<sub>i</sub> (i = 0, 1) bit are 0. See [section 38.6.5. Initialization Procedure with the Output Amplifier](#).

## 38.2.5 DAAMPCR:DA输出放大器控制寄存器

Base address: DAC12 = 0x4017\_1000

Offset address: 0x08

|               |        |        |   |   |   |   |   |   |
|---------------|--------|--------|---|---|---|---|---|---|
| Bit position: | 7      | 6      | 5 | 4 | 3 | 2 | 1 | 0 |
| Bit field:    | DAAMP1 | DAAMP0 | — | — | — | — | — | — |
| 重置后的值:        | 0      | 0      | 0 | 0 | 0 | 0 | 0 | 0 |

| Bit | Symbol | Function                              | R/W |
|-----|--------|---------------------------------------|-----|
| 5:0 | —      | 这些位被读取为0。写入值应为0。                      | R/W |
| 6   | DAAMP0 | 放大器控制0<br>0: 不使用通道0输出放大器1: 使用通道0输出放大器 | R/W |
| 7   | DAAMP1 | 放大器控制1<br>0: 不使用通道1输出放大器1: 使用通道1输出放大器 | R/W |

DAAMPCR寄存器选择使用或不使用放大器的DA输出。

**DAAMP0位 (放大器控制0)**

当DAAMP0位为0时，模拟值输出通道0的DA输出，而不使用放大器。当。。的时候DAAMP0位为1，模拟值通过放大器输出通道0的DA输出。

当DACR.DAE和DACR.DAOE0位都为0时，无论设置如何都不会使用放大器DAAMP0位。详见表38.4。

**DAAMP1位 (放大器控制1)**

当DAAMP1位为0时，模拟值输出通道1的DA输出，而不使用放大器。当。。的时候DAAMP1位为1，模拟值通过放大器输出到通道1的DA输出。

当DACR.DAE和DACR.DAOE1位都为0时，无论设置如何都不会使用放大器DAAMP1位。详见表38.4。

## 38.2.6 DAASWCR:DA放大器稳定等待控制寄存器

Base address: DAC12 = 0x4017\_1000

Offset address: 0x1C

|               |        |        |   |   |   |   |   |   |
|---------------|--------|--------|---|---|---|---|---|---|
| Bit position: | 7      | 6      | 5 | 4 | 3 | 2 | 1 | 0 |
| Bit field:    | DAASW1 | DAASW0 | — | — | — | — | — | — |
| 重置后的值:        | 0      | 0      | 0 | 0 | 0 | 0 | 0 | 0 |

| Bit | Symbol | Function   | R/W |
|-----|--------|--|-----|
| 5   | —      | 这些位被读取为0。写入值应为0。   | R/W |
| 6   | DAASW0 | DA放大器稳定等待0<br>0: 通道0的放大器稳定等待关闭 (输出) 1: 通道0的放大器稳定等待打开 (高阻态) | R/W |
| 7   | DAASW1 | DA放大器稳定等待1<br>0: 通道1的放大器稳定等待关闭 (输出) 1: 通道1的放大器稳定等待打开 (高阻态) | R/W |

DAASWCR寄存器通过输出放大器控制DA输出。该寄存器在初始化过程中用于等待DA输出放大器的稳定。当DACR.DAE位和DACR.DAOE<sub>i</sub>(i=0 1)位均为0时，DAASWCR中的每个位都应设置为1。请参见第38.6.5节。输出放大器的初始化程序。



**DAASW0 bit (D/A Amplifier Stabilization Wait 0)**

Set the DAASW0 bit to 1 in the initialization procedure to wait for the stabilization of the D/A channel 0 output amplifier. When DAASW0 is set to 1, D/A conversion operates, but the conversion result of D/A is not output from channel 0. When the DAASW0 bit is 0, the stabilization wait time stops, and the D/A conversion result of channel 0 is output through the output amplifier.

**DAASW1 bit (D/A Amplifier Stabilization Wait 1)**

Set the DAASW1 bit to 1 in the initialization procedure to wait for the stabilization of the D/A channel 1 output amplifier. When DAASW1 is set to 1, D/A conversion operates, but the conversion result of D/A is not output from channel 1. When the DAASW1 bit is 0, the stabilization wait time stops, and the D/A conversion result of channel 1 is output through the output amplifier.

**38.2.7 DAADUSR : D/A A/D Synchronous Unit Select Register**

Base address: DAC12 = 0x4017\_1000

Offset address: 0x10C0

|                    |   |   |   |   |   |   |          |   |
|--------------------|---|---|---|---|---|---|----------|---|
| Bit position:      | 7 | 6 | 5 | 4 | 3 | 2 | 1        | 0 |
| Bit field:         | — | — | — | — | — | — | AMADSEL1 | — |
| Value after reset: | 0 | 0 | 0 | 0 | 0 | 0 | 0        | 0 |

| Bit | Symbol   | Function   | R/W |
|-----|----------|--|-----|
| 0   | —        | This bit is read as 0. The write value should be 0.              | R/W |
| 1   | AMADSEL1 | A/D Unit 1 Select<br>0: Do not select unit 1<br>1: Select unit 1 | R/W |
| 7:2 | —        | These bits are read as 0. The write value should be 0.           | R/W |

The DAADUSR register selects the target ADC12 unit for D/A and A/D synchronous conversions. Set the AMADSEL1 bit to 1 to select unit 1 as the target synchronous unit for the MCU. When setting the DAADSCR.DAADST bit to 1 for synchronous conversions, select the target unit in this register in advance.

Only set the DAADUSR register while the ADCSR.ADST bit of the ADC12 is set to 0 and the DAADSCR.DAADST bit is set to 0.

**38.3 Operation**

The DAC12 includes D/A conversion circuits for two channels, each of which can operate independently. When the DAOEn bit (n = 0, 1) in DACR is set to 1, DAC12 is enabled and the conversion result is output.

This following example shows D/A conversion on channel 0. Figure 38.2 shows the timing of this operation.

To process D/A conversion on channel 0:

1. Set the data for D/A conversion in the DADR0 register and the data format in the DADPR.DPSEL bit.
2. Set the DACR.DAOE0 bit to 1 to start D/A conversion. The conversion result is output from the analog output pin DA0 after the conversion time  $t_{DCONV}$  elapses. The conversion result continues to be output until DADR0 is written to again or the DAOE0 bit is set to 0. The output value (reference) is expressed by the following formula:

$$\frac{\text{Setting in DADR0}}{4096} \times VREFH$$

3. To start conversion again, write another value to DADR0. The conversion result is output after the conversion time  $t_{DCONV}$  elapses.  
When the DAADSCR.DAADST bit is 1 (interference reduction between D/A and A/D conversion is enabled), a maximum of one A/D conversion time is required for D/A conversion to start. When ADCLK is faster than the peripheral clock, a longer time might be required.
4. To disable analog output, set the DAOE0 bit to 0.

**DAASW0位 (DA放大器稳定等待0)**

在初始化过程中将DAASW0位设置为1，以等待DA通道0输出放大器稳定。当DAASW0设置为1时，DA转换进行，但DA的转换结果不从通道0输出。当DAASW0位为0时，稳定等待时间停止，通过输出输出通道0的DA转换结果放大器。

**DAASW1位 (DA放大器稳定等待1)**

在初始化过程中将DAASW1位设置为1，以等待DA通道1输出放大器稳定。当DAASW1设置为1时，DA转换进行，但DA的转换结果不从通道1输出。当DAASW1位为0时，稳定等待时间停止，通道1的DA转换结果通过输出输出放大器。

**38.2.7 DAADUSR:DAAD同步单元选择寄存器**

Base address: DAC12 = 0x4017\_1000

Offset address: 0x10C0

|               |   |   |   |   |   |   |          |   |
|---------------|---|---|---|---|---|---|----------|---|
| Bit position: | 7 | 6 | 5 | 4 | 3 | 2 | 1        | 0 |
| Bit field:    | — | — | — | — | — | — | AMADSEL1 | — |
| 重置后的值:        | 0 | 0 | 0 | 0 | 0 | 0 | 0        | 0 |

| Bit | Symbol   | Function                         | R/W |
|-----|----------|----------------------------------|-----|
| 0   | —        | 该位读取为0。写入值应为0。                   | R/W |
| 1   | AMADSEL1 | AD单元1选择<br>0: 不选择单元1<br>1: 选择单元1 | R/W |
| 7:2 | —        | 这些位被读取为0。写入值应为0。                 | R/W |

DAADUSR寄存器为DA和AD同步转换选择目标ADC12单元。将AMADSEL1位设置为1以选择单元1作为MCU的目标同步单元。将DAADSCR.DAADST位设置为1以进行同步转换时，请预先在该寄存器中选择目标单位。

仅在ADC12的ADCSR.ADST位设置为0且DAADSCR.DAADST位设置为0时设置DAADUSR寄存器。

**38.3 Operation**

DAC12包含两个通道的DA转换电路，每个通道都可以独立工作。当。。。的时候DACR中的DAOEn位(n=0,1)设置为1，使能DAC12并输出转换结果。

以下示例显示了通道0上的DA转换。图38.2显示了此操作的时序。

在通道0上处理DA转换：

- 1.在DADR0寄存器中设置用于DA转换的数据，在DADPR.DPSEL位中设置数据格式。
- 2.将DACR.DAOE0位设置为1以启动DA转换。经过转换时间 $t_{DCONV}$ 后，转换结果从模拟输出引脚DA0输出。转换结果继续输出，直到再次写入DADR0或将DAOE0位设置为0。输出值（参考值）由以下公式表示：

$$\frac{\text{DADR04096中的设置}}{4096} \times VREFH$$

- 3.要再次开始转换，向DADR0写入另一个值。在经过转换时间 $t_{DCONV}$ 后输出转换结果。当DAADSCR.DAADST位为1时（启用DA和AD转换之间的干扰降低），最多需要一个AD转换时间才能启动DA转换。当ADCLK比外设时钟快时，可能需要更长的时间。

- 4.要禁用模拟输出，请将DAOE0位设置为0。



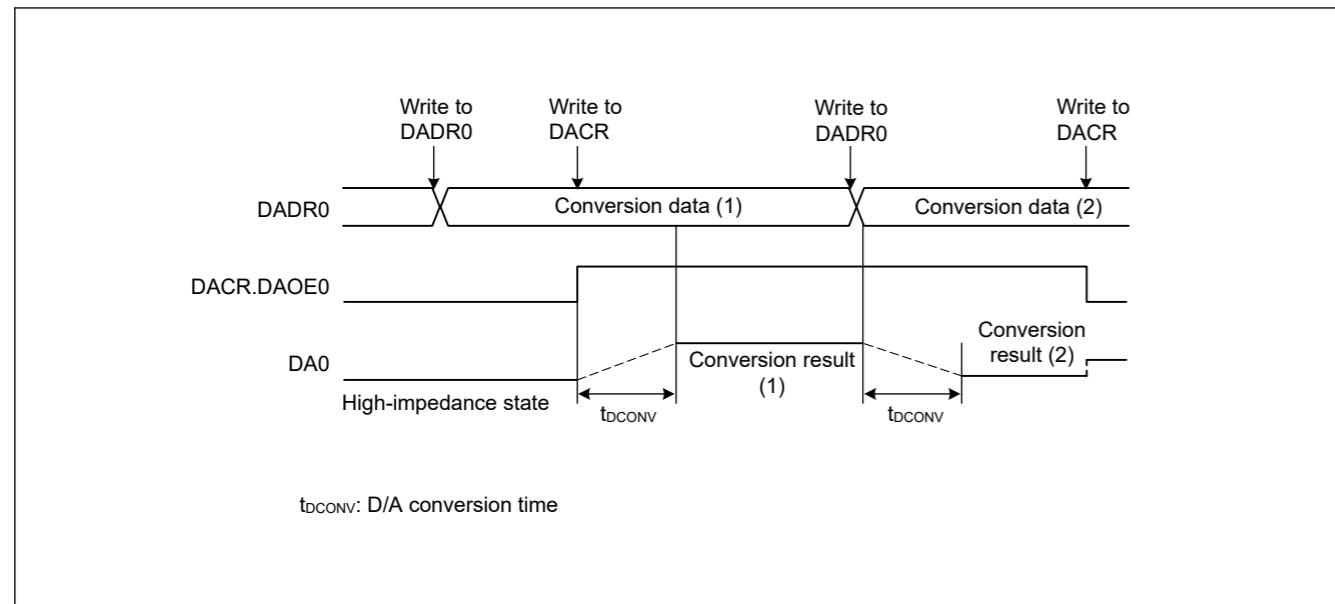


Figure 38.2 Example of DAC12 operation

### 38.3.1 Reducing Interference between D/A and A/D Conversion

When D/A conversion starts, the DAC12 generates inrush current. Because the DAC12 and ADC12 (unit 1) share the same analog power supply, the generated inrush current can interfere with ADC12 (unit 1) operation.

While the DAADSCR.DAADST bit is 1, D/A conversion does not start immediately on updating the DADRm register. Instead:

- If the DADRm register data is modified while the ADC12 is halted, D/A conversion starts in 1 PCLKA cycle.
- If the DADRm register data is modified while the ADC12 is performing a 12-bit A/D conversion, D/A conversion starts on A/D conversion completion. Therefore, it takes up to one A/D conversion time period for the DADRm register data update to be reflected as the D/A conversion circuit output. Until the D/A conversion completes, the DADRm register value does not correspond to the analog output value.

When the DAADSCR.DAADST bit is 1, it is not possible to check through software whether the DADRm register value was D/A-converted.

The following sequence provides an example of channel 0 D/A conversion, in which the DAC12 is synchronized with the ADC12 (unit 1). Figure 38.3 shows the timing of this operation.

To perform D/A conversion on channel 0 in synchronization with the ADC12 (unit 1):

1. Confirm that the ADC12 (unit 1) is halted and set the DAADUSR.AMA DSEL1 bit to 1.
2. Confirm that the ADC12 (unit 1) is halted and set the DAADSCR.DAADST bit to 1.
3. Confirm that the ADC12 (unit 1) is halted and set the DACR.DAOE0 bit to 1.
4. Set the DADR0 register. If ADCLK is faster than the peripheral clock, D/A conversion might be delayed for longer than one A/D conversion time.
  - If the ADC12 (unit 1) is halted (ADCSR.ADST = 0) when the DADR0 register is modified, D/A conversion starts in 1 PCLKA cycle.
  - If the 12-bit A/D conversion is in progress (ADCSR.ADST = 1) when the DADR0 register is modified, D/A conversion starts on A/D conversion completion. If the DADR0 register is modified twice during A/D conversion, the first update might not be converted.

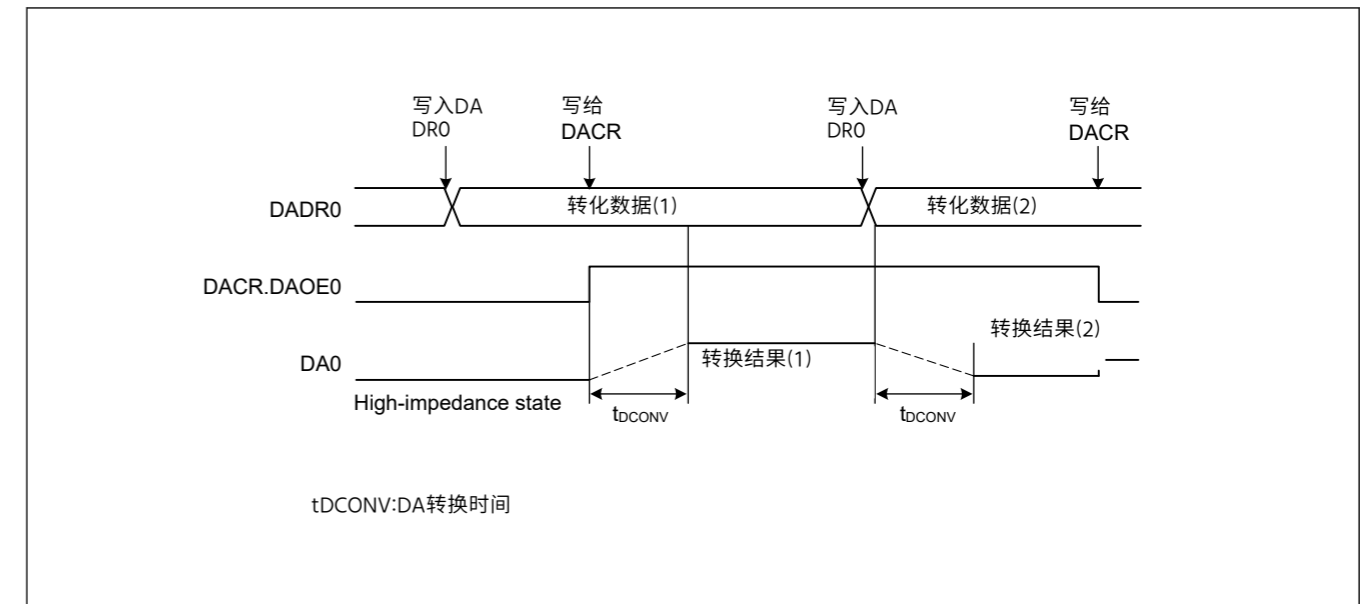


Figure 38.2 DAC12操作示例

### 38.3.1 减少DA和AD转换之间的干扰

当DA转换开始时，DAC12会产生浪涌电流。由于DAC12和ADC12（单元1）共享相同的模拟电源，所产生的浪涌电流会干扰ADC12（单元1）的运行。

当DAADSCR.DAADST位为1时，DA转换不会在更新DADRm寄存器时立即开始。Instead:

- 如果在ADC12停止时修改了DADRm寄存器数据，则DA转换在1个PCLKA周期内开始。
- 如果在ADC12执行12位AD转换时修改了DADRm寄存器数据，则DA转换在AD转换完成时开始。因此，DADRm寄存器数据更新最多需要一个AD转换时间周期才能反映为DA转换电路输出。在DA转换完成之前，DADRm寄存器的值与模拟输出值不对应。

当DAADSCR.DAADST位为1时，无法通过软件检查DADRm寄存器值是否经过DA转换。

以下序列提供了通道0DA转换的示例，其中DAC12与ADC12（单元1）。图38.3显示了该操作的时序。

与ADC12（单元1）同步在通道0上执行DA转换：

- 1.确认ADC12（单元1）已停止并将DAADUSR.AMA DSEL1位设置为1。
- 2.确认ADC12（单元1）已停止并将DAADSCR.DAADST位设置为1。
- 3.确认ADC12（单元1）已停止并将DACR.DAOE0位设置为1。
- 4.设置DADR0寄存器。如果ADCLK比外设时钟快，则DA转换可能会延迟超过一次AD转换时间。

- 如果在修改DADR0寄存器时ADC12（单元1）停止（ADCSR.ADST=0），则DA转换在1个PCLKA周期内开始。
- 如果在修改DADR0寄存器时正在进行12位AD转换（ADCSR.ADST=1），则DA转换在AD转换完成时开始。如果在AD转换期间DADR0寄存器被修改两次，第一次更新可能不会被转换。

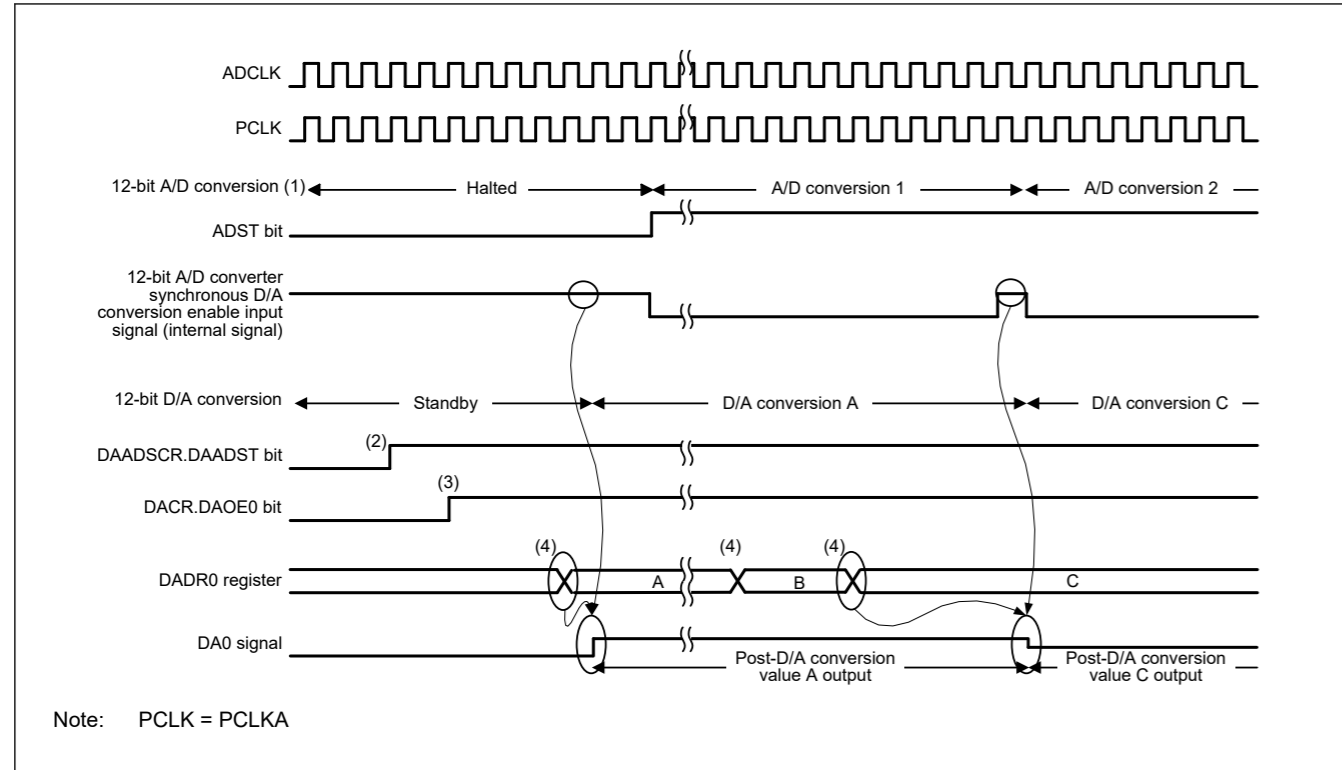


Figure 38.3 Example conversion when DAC12 is synchronized with ADC12 (unit 1)

When ADCLK is faster than PCLKA, the DAC12 might not be able to capture the synchronous D/A conversion enable input signal from the ADC12 (unit 1) during the 1 ADCLK cycle that is output between A/D conversion 1 and A/D conversion 2, as shown in Figure 38.4. In this case, post-D/A conversion value A is continuously output as the DA0 signal.

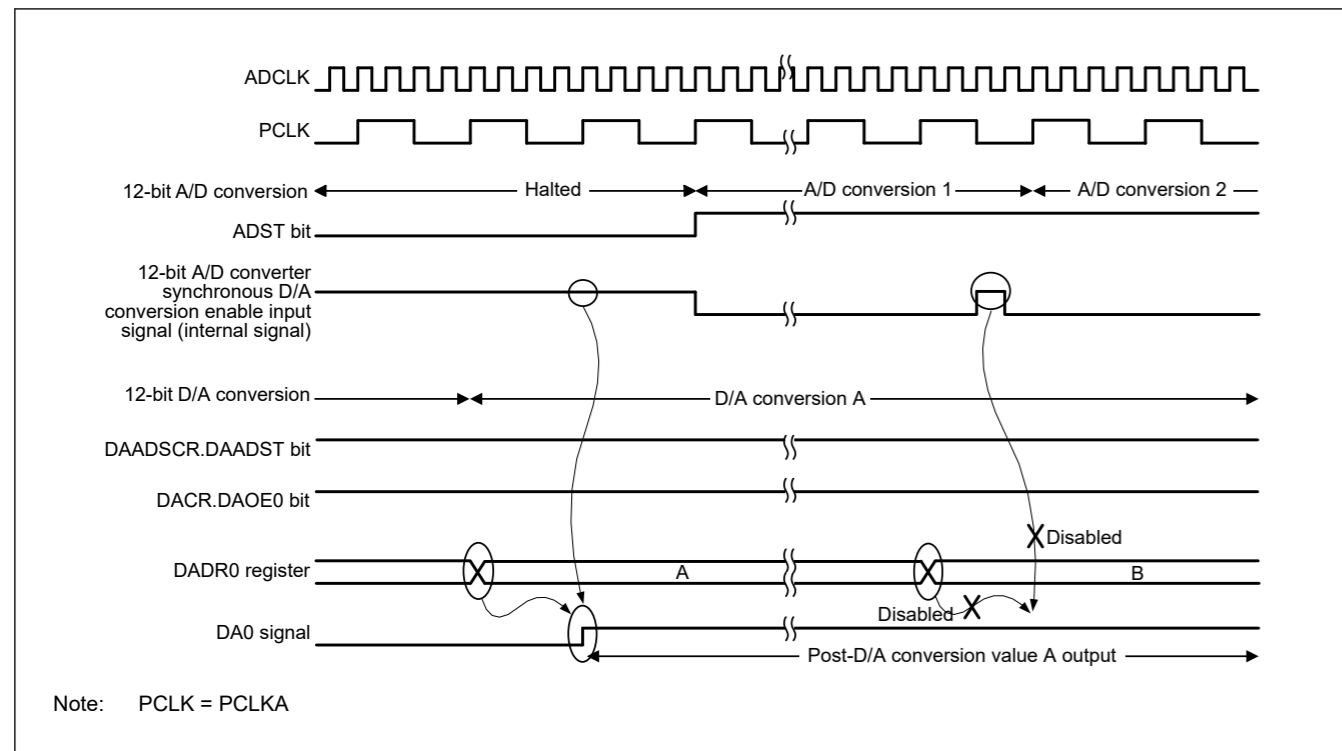


Figure 38.4 Example when the DAC12 cannot capture the synchronous D/A conversion enable input signal from the ADC12 (unit 1)

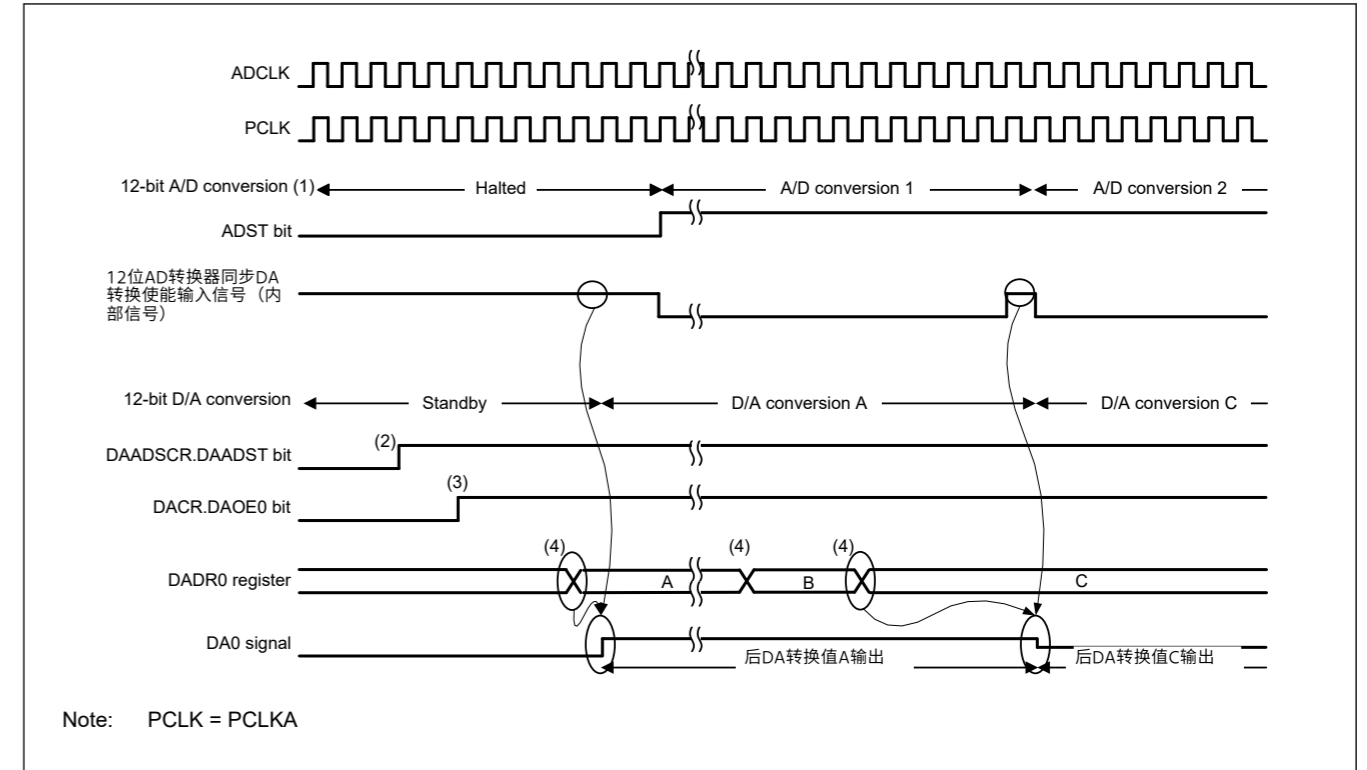


Figure 38.3 DAC12与ADC12同步时的转换示例 (单元1)

当ADCLK快于PCLKA时，DAC12可能无法在AD转换1和AD转换2之间输出的1个ADCLK周期内捕获来自ADC12 (单元1) 的同步DA转换使能输入信号，如图所示38.4。在这种情况下，后DA转换值A作为DA0信号连续输出。

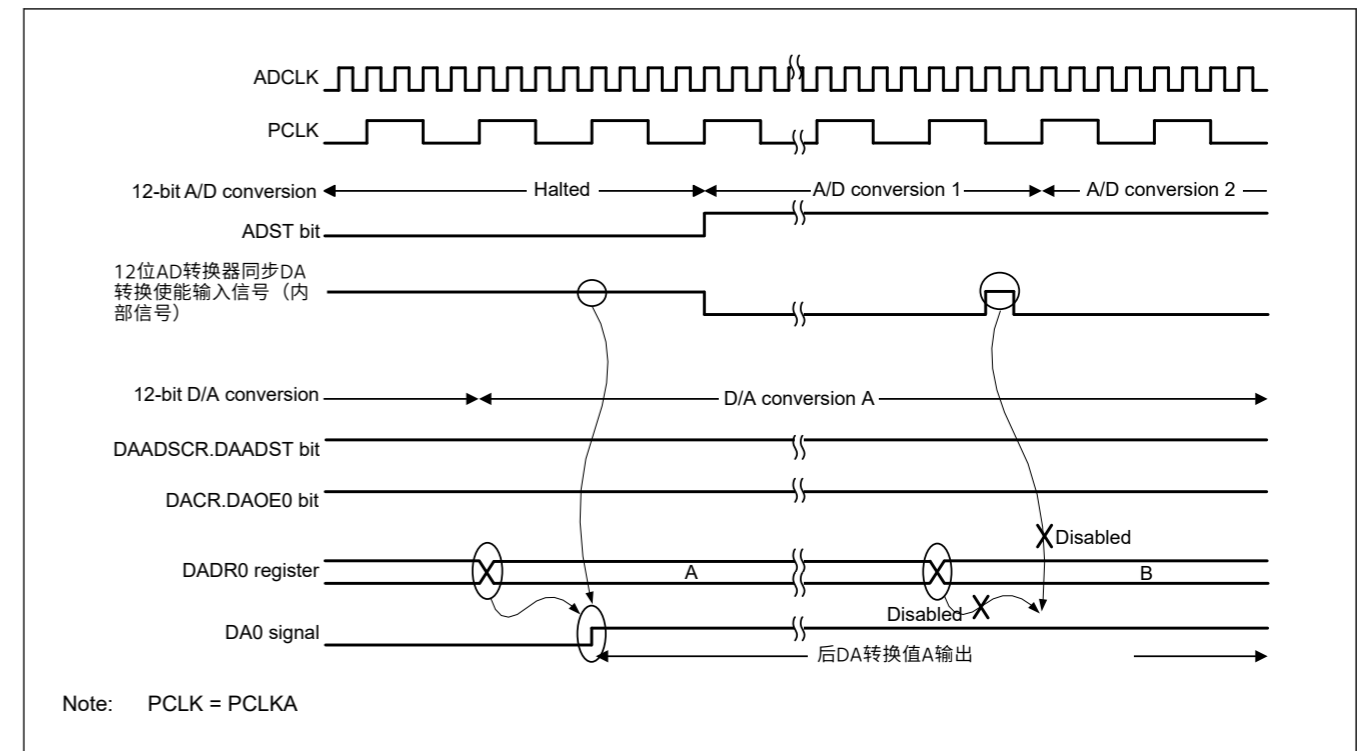


Figure 38.4 DAC12无法捕获来自ADC12 (单元1) 的同步DA转换使能输入信号时的示例

## 38.4 Event Link Operation Setting Procedure

This section describes the procedures used in event link operation.

### 38.4.1 DA0 Event Link Operation Setting Procedure

To set up DA0 event link operation:

1. Set the DADPR.DPSEL bit and the data for D/A conversion in the DADR0 register.
2. Set the ELC\_DA0 event signal to be linked to each peripheral module in the ELSR12 register.
3. Set the ELCR.ELCON bit to 1. This enables event link operation for all modules with the event link function selected.
4. Set the event output source module to activate the event link. After the event is output from the module, the DACR.DAOE0 bit becomes 1, and D/A conversion starts on channel 0.
5. Set the ELSR12 register to 0x0000 to stop event link operation of DAC12 channel 0. All event link operation is stopped when the ELCR.ELCON bit is set to 0.

### 38.4.2 DA1 Event Link Operation Setting Procedure

To set up DA1 event link operation:

1. Set the DADPR.DPSEL bit and set the data for D/A conversion in the DADR1 register.
2. Set the ELC\_DA1 event signal to be linked to each peripheral module in the ELSR13 register.
3. Set the ELCR.ELCON bit to 1. This enables the event link operation for all modules with the event link function selected.
4. Set the event output source module to activate the event link. After the event is output from the module, the DACR.DAOE1 bit becomes 1, and D/A conversion starts on channel 1.
5. Set the ELSR13 register to 0x0000 to stop event link operation on DAC12 channel 1. All event link operation is stopped when the ELCR.ELCON bit is set to 0.

## 38.5 Usage Notes on Event Link Operation

- When the event link function is used, do not use the amplifier output function.
- When the event link function is used, set the DACR.DAE bit to 0.
- When the event specified for the ELC\_DA0 event signal is generated while a write to the DACR.DAOE0 bit is performed, the write cycle is stopped, and the generated event takes precedence in setting the bit to 1.
- When the event specified for the ELC\_DA1 event signal is generated while a write to the DACR.DAOE1 bit is performed, the write cycle is stopped, and the generated event takes precedence in setting the bit to 1.
- Use of the event link function is prohibited when the DAADSCR.DAADST bit is set to 1 to reduce interference between D/A and A/D conversions.

## 38.6 Usage Notes

### 38.6.1 Settings for the Module-Stop Function

DAC12 operation can be disabled or enabled using the Module Stop Control Register. The DAC12 is initially stopped after reset. Releasing the module-stop state enables access to the registers. For details, see [section 10, Low Power Modes](#).

### 38.6.2 DAC12 Operation in the Module-Stop State

When the MCU enters the module-stop state with D/A conversion enabled, the D/A outputs are retained, and the analog power supply current is the same as during D/A conversion. If the analog power supply current must be reduced in the module-stop state, disable D/A conversion by setting the DACR.DAOE1, DAOE0, and DAE bits to 0.

## 38.4 事件链接操作设置步骤

本节介绍事件链接操作中使用的过程。

### 38.4.1 DA0事件链接操作设置步骤

设置DA0事件链接操作：

- 1.设置DADPR.DPSEL位和DADR0寄存器中用于DA转换的数据。
- 2.在ELSR12寄存器中设置ELC\_DA0事件信号链接到每个外围模块。
- 3.将ELCR.ELCON位设置为1。这将为所有选择了事件链接功能的模块启用事件链接操作。
- 4.设置事件输出源模块，激活事件链接。模块输出事件后，DACR.DAOE0位变为1，通道0开始DA转换。
- 5.将ELSR12寄存器设置为0x0000以停止DAC12通道0的事件链接操作。所有事件链接操作在ELCR.ELCON位设置为0时停止。

### 38.4.2 DA1事件链接操作设置步骤

设置DA1事件链接操作：

- 1.设置DADPR.DPSEL位并在DADR1寄存器中设置用于DA转换的数据。
- 2.在ELSR13寄存器中设置ELC\_DA1事件信号链接到每个外围模块。
- 3.将ELCR.ELCON位设置为1。这将为所有选择了事件链接功能的模块启用事件链接操作。
- 4.设置事件输出源模块，激活事件链接。模块输出事件后，DACR.DAOE1位变为1，通道1开始DA转换。
- 5.将ELSR13寄存器设置为0x0000以停止DAC12通道1上的事件链接操作。所有事件链接操作在ELCR.ELCON位设置为0时停止。

## 38.5 事件链接操作使用说明

- 使用事件链接功能时，请勿使用放大器输出功能。
- 使用事件链接功能时，将DACR.DAE位设置为0。
- 如果在执行对DACR.DAOE0位的写入时产生了为ELC\_DA0事件信号指定的事件，则写入周期停止，并且产生的事件优先将该位设置为1。
- 如果在执行对DACR.DAOE1位的写入时产生了为ELC\_DA1事件信号指定的事件，则写入周期停止，并且产生的事件优先将该位设置为1。
- DAADSCR.DAADST位设置为1时禁止使用事件链接功能，以减少DA和AD转换之间的干扰。

## 38.6 使用说明

### 38.6.1 模块停止功能的设置

可以使用模块停止控制寄存器禁用或启用DAC12操作。DAC12在复位后最初停止。释放模块停止状态可以访问寄存器。有关详细信息，请参阅第10节，低功耗模式。

### 38.6.2 DAC12在模块停止状态下的操作

当MCU进入模块停止状态并启用DA转换时，DA输出保持不变，模拟电源电流与DA转换时相同。如果在模块停止状态下必须降低模拟电源电流，则通过将DACR.DAOE1、DAOE0和DAE位设置为0来禁用DA转换。

### 38.6.3 DAC12 Operation in Software Standby Mode

When the MCU enters Software Standby mode with D/A conversion enabled, the D/A outputs are retained, and the analog power supply current is the same as during D/A conversion. If the analog power supply current must be reduced in Software Standby mode, disable D/A conversion by setting the DACR.DAOE1, DAOE0, and DAE bits to 0.

### 38.6.4 Constraint on Entering Deep Software Standby Mode

When the MCU enters Deep Software Standby mode with D/A conversion enabled, the outputs of the DAC12 are placed in a high impedance state.

### 38.6.5 Initialization Procedure with the Output Amplifier

Use the following initialization procedures with the output amplifier. The example shows the case for channel 0.

To initialize the DAC12 with the output amplifier:

1. Write 0x0000 to the DADR0 register.
2. Set the DAASWCR.DAASW0 bit to 1.
3. Set the DAAMPCR.DAAMP0 bit to 1.
4. Set the DACR.DAE bit or the DACR.DAOE0 bit to 1 to start operation of the amplifier.
5. Clear the DAASWCR.DAASW0 bit to 0 after waiting for the duration of D/A conversion time  $t_{DCONV}$ .
6. Write the value to be converted in the DADR0 register.

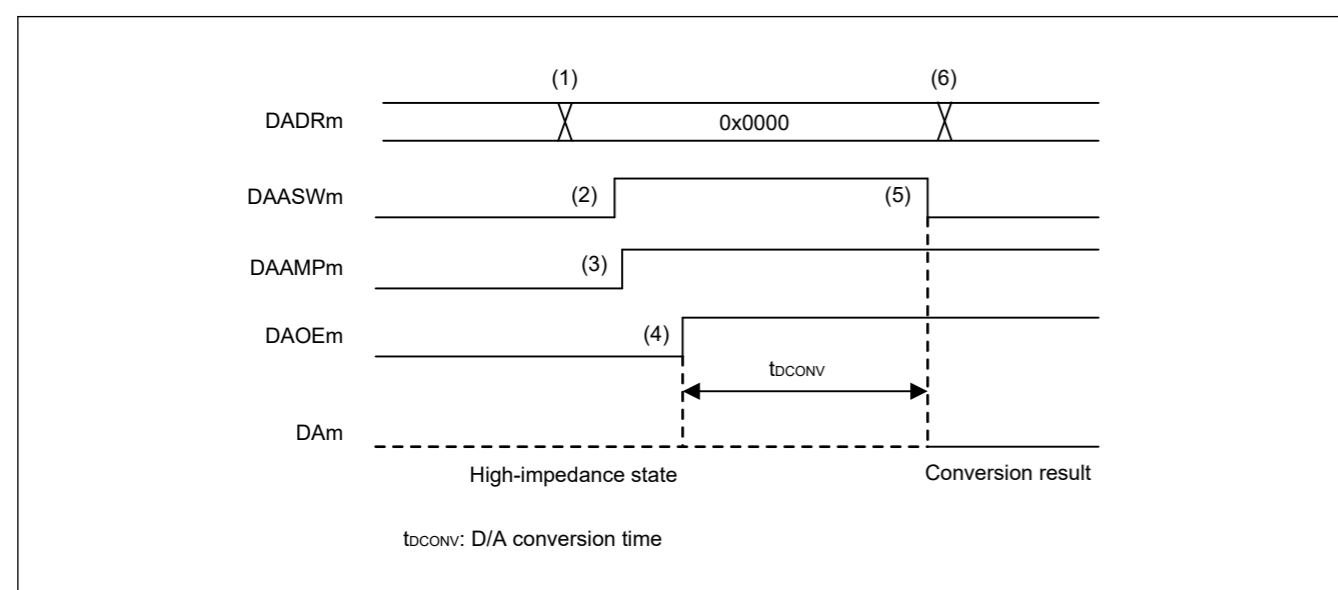


Figure 38.5 Example of the initial flow with the output amplifier in DAC12

While the amplifier is running, clearing the DACR.DAE and DACR.DAOE0 bits to 0 allows the amplifier to stop operation. To use the amplifier again, repeat steps 1 to 6.

### 38.6.6 Constraint on Usage When Interference Reduction between D/A and A/D Conversion Is Enabled

When the DAADSCR.DAADST bit is 1, enabling interference reduction between D/A and A/D conversion, do not place the ADC12 in the module-stop state. Doing so can halt D/A conversion in addition to A/D conversion.

### 38.6.3 DAC12在软件待机模式下的操作

当MCU进入软件待机模式并启用DA转换时，DA输出保持不变，模拟电源电流与DA转换期间相同。如果在软件待机模式下必须降低模拟电源电流，则通过将DACR.DAOE1、DAOE0和DAE位设置为0来禁用DA转换。

### 38.6.4 进入深度软件待机模式的限制

当MCU在启用DA转换的情况下进入深度软件待机模式时，DAC12的输出置于高阻抗状态。

### 38.6.5 输出放大器的初始化程序

对输出放大器使用以下初始化程序。该示例显示了通道0的情况。

使用输出放大器初始化DAC12：

- 1.将0x0000写入DADR0寄存器。
- 2.将DAASWCR.DAASW0位设置为1。
- 3.将DAAMPCR.DAAMP0位设置为1。
- 4.将DACR.DAE位或DACR.DAOE0位设置为1以启动放大器的操作。
- 5.等待DA转换时间 $t_{DCONV}$ 后，将DAASWCR.DAASW0位清零。
- 6.将要转换的值写入DADR0寄存器。

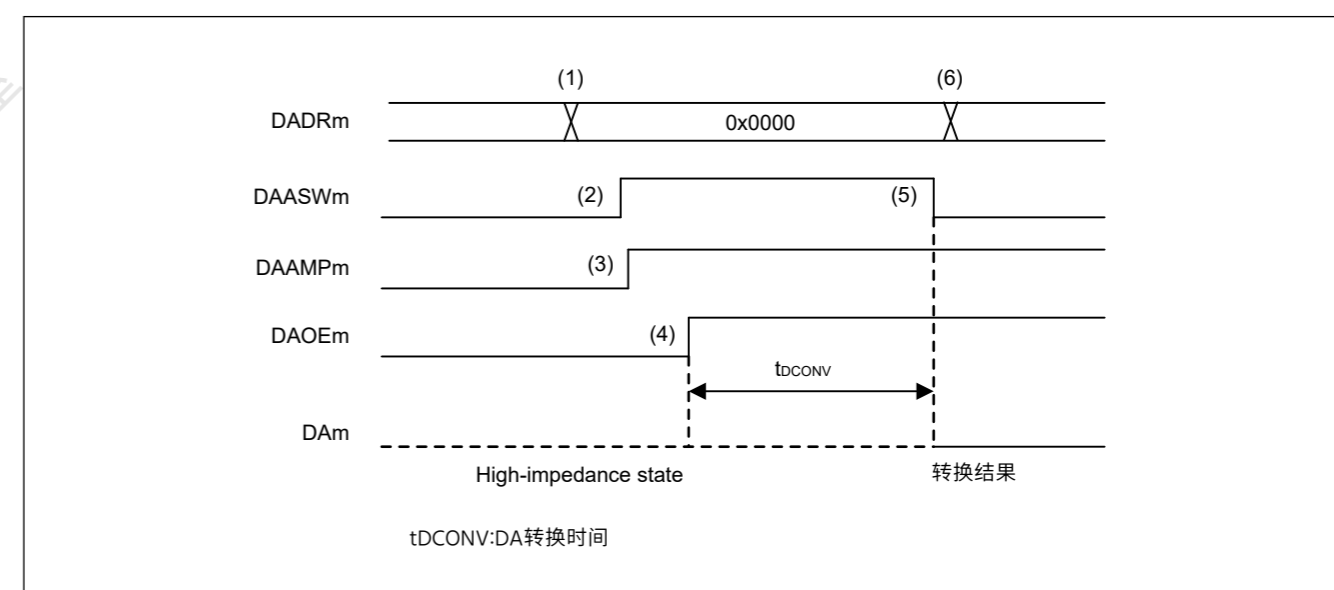


Figure 38.5 DAC12中输出放大器的初始流程示例

在放大器运行时，将DACR.DAE和DACR.DAOE0位清零可让放大器停止运行。要再次使用放大器，请重复步骤1至6。

### 38.6.6 DA和AD之间减少干扰时的使用限制 转换已启用

当DAADSCR.DAADST位为1时，启用DA和AD转换之间的干扰减少，不要放置ADC12处于模块停止状态。除了AD转换之外，这样做还可以停止DA转换。



## 39. Temperature Sensor (TSN)

### 39.1 Overview

The on-chip Temperature Sensor (TSN) determines and monitors the die temperature for reliable operation of the device. The sensor outputs a voltage directly proportional to the die temperature, and the relationship between the die temperature and the output voltage is fairly linear. The output voltage is provided to the ADC12 for conversion and can be further used by the end application.

Table 39.1 lists the TSN specifications, and Figure 39.1 shows a block diagram.

Table 39.1 TSN specifications

| Item                                | Description   |
|-------------------------------------|---|
| Temperature sensor voltage output   | Temperature sensor outputs a voltage to the 12-bit A/D converter                  |
| Module-stop function                | Module-stop state can be set to reduce power consumption                          |
| Temperature sensor calibration data | Reference data measured for each chip at factory shipment is stored in a register |
| TrustZone Filter                    | Security attribution can be set   |

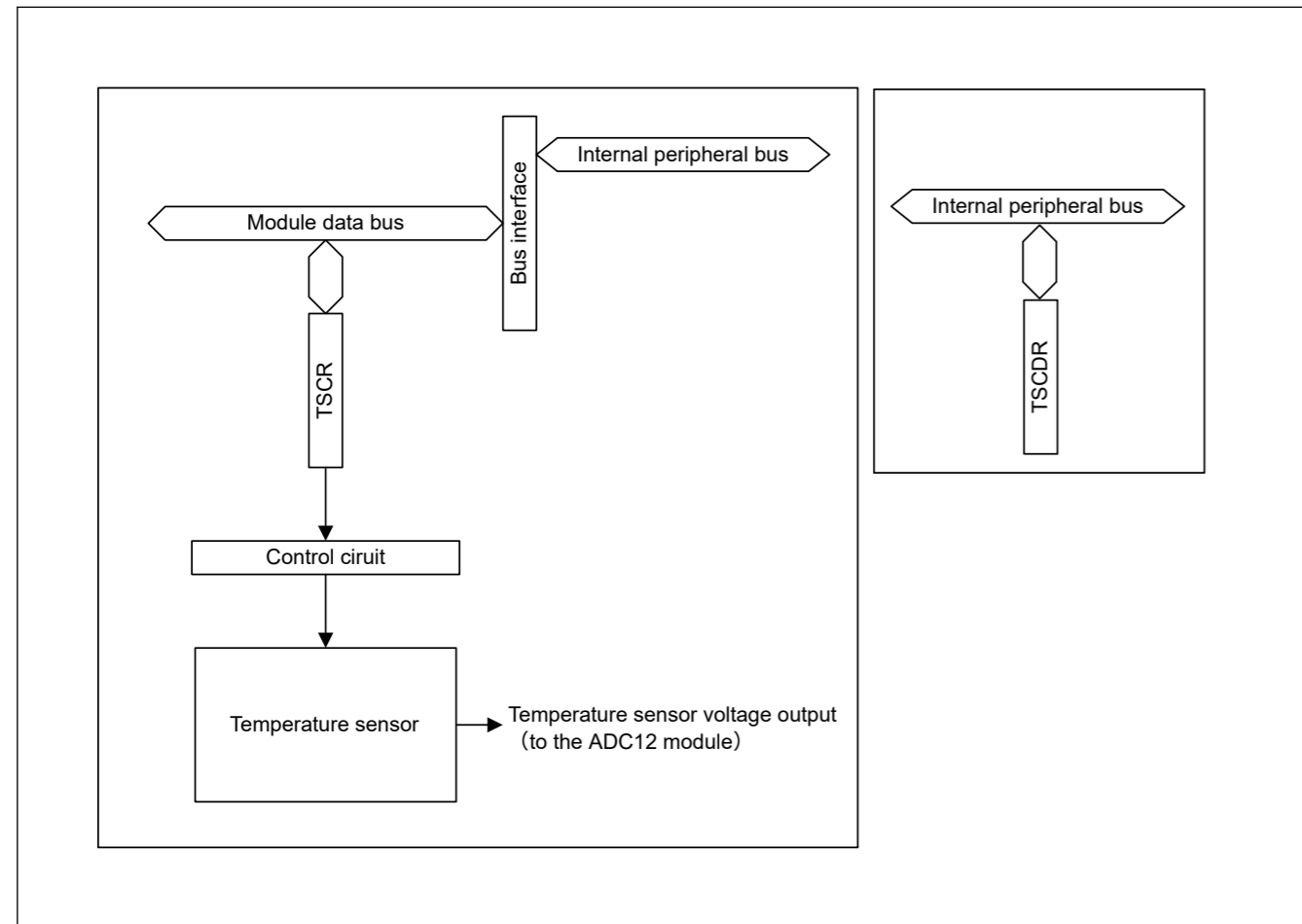


Figure 39.1 TSN block diagram

## 39. 温度传感器(TSN)

### 39.1 Overview

片上温度传感器(TSN)确定并监控芯片温度，以确保器件可靠运行。传感器输出与管芯温度成正比的电压，管芯温度与输出电压之间的关系相当线性。输出电压被提供给ADC12进行转换，并且可以被最终应用进一步使用。

表39.1列出了TSN规范，图39.1显示了框图。

Table 39.1 TSN specifications

| Item                 | Description            |
|----------------------|------------------------|
| 温度传感器电压输出            | 温度传感器向12位AD转换器输出电压     |
| Module-stop function | 可设置模块停止状态以降低功耗         |
| 温度传感器校准数据            | 出厂时为每个芯片测量的参考数据存储在寄存器中 |
| TrustZone Filter     | 可设置安全属性                |

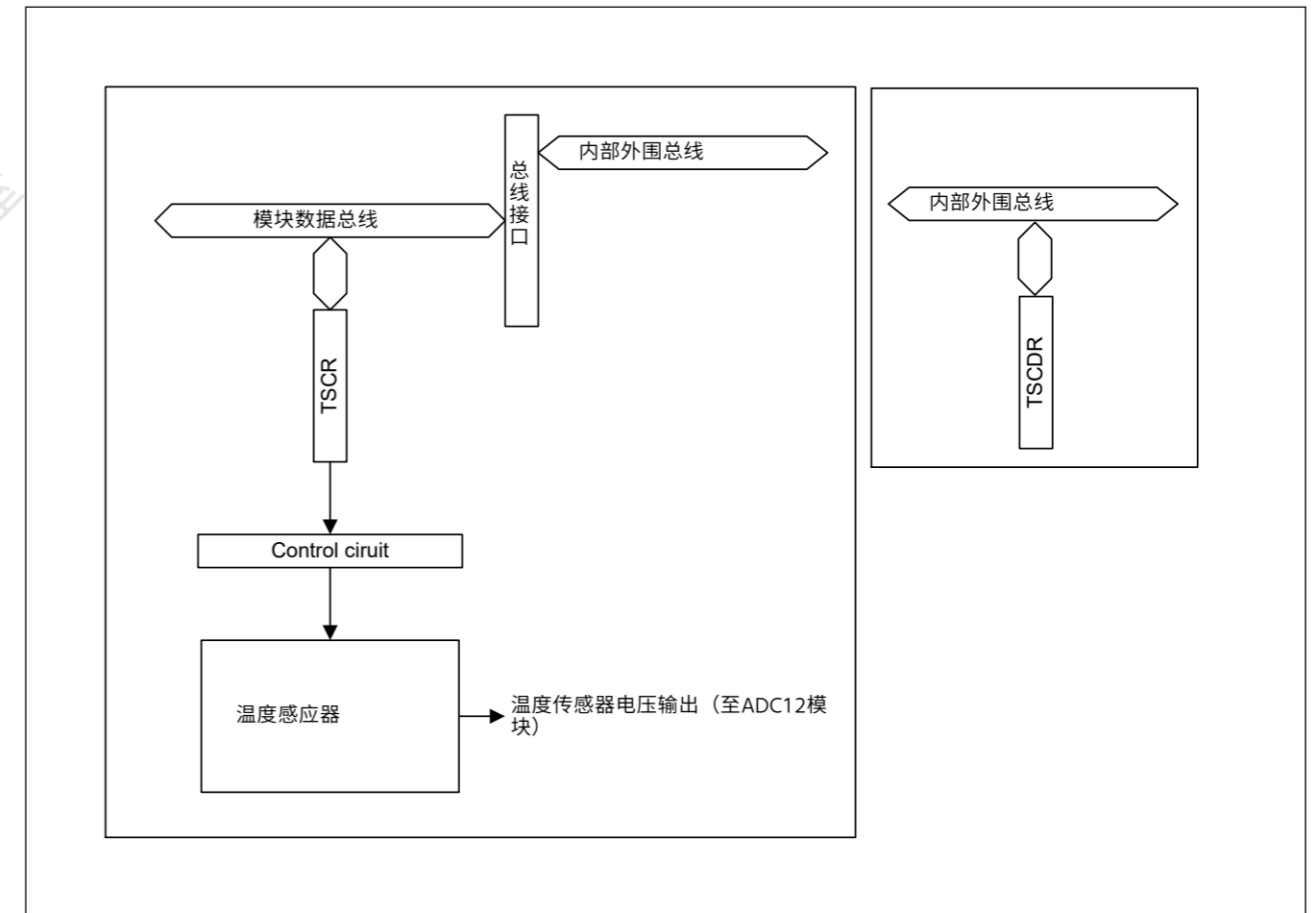
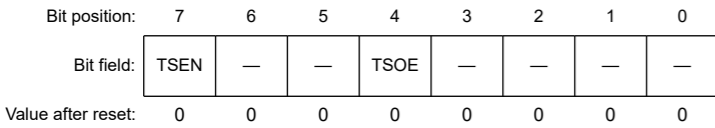


Figure 39.1 TSN框图

### 39.2 Register Descriptions

#### 39.2.1 TSCR : Temperature Sensor Control Register

Base address: TSN = 0x400F\_3000  
Offset address: 0x00



| Bit | Symbol | Function  | R/W |
|-----|--------|---|-----|
| 3:0 | —      | These bits are read as 0. The write value should be 0.  | R/W |
| 4   | TSOE   | Temperature Sensor Output Enable<br>0: Disable output from the temperature sensor to the ADC12<br>1: Enable output from the temperature sensor to the ADC12 | R/W |
| 6:5 | —      | These bits are read as 0. The write value should be 0.  | R/W |
| 7   | TSEN   | Temperature Sensor Enable<br>0: Stop the temperature sensor<br>1: Start the temperature sensor.   | R/W |

The TSCR is a register which controls the temperature sensor. The timing constraints shown in Figure 39.3 apply to the settings of the TSCR register.

##### TSOE bit (Temperature Sensor Output Enable)

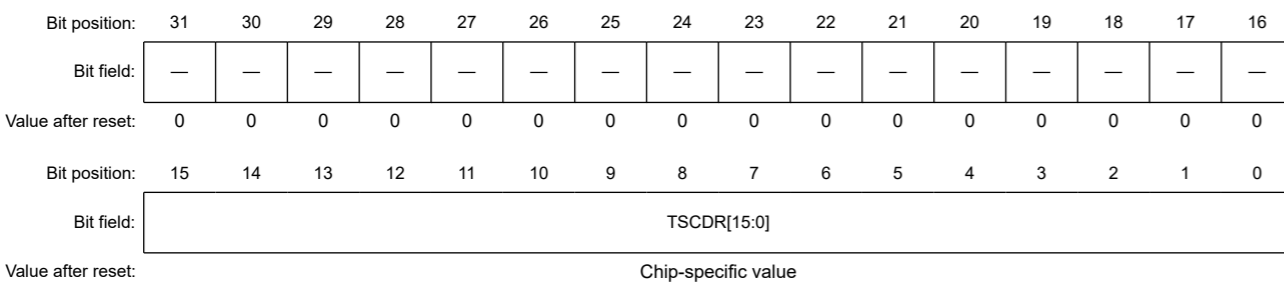
The TSOE bit enables or disables the temperature sensor output to ADC12.

##### TSEN bit (Temperature Sensor Enable)

The TSEN bit starts or stops the temperature sensor.

#### 39.2.2 TSCDR : Temperature Sensor Calibration Data Register

Base address: TSD = 0x407F\_B000  
Offset Address: 0x017C



| Bit   | Symbol      | Function   | R/W |
|-------|-------------|--|-----|
| 15:0  | TSCDR[15:0] | Temperature Sensor Calibration Data<br>Chip-specific value | R   |
| 31:16 | —           | These bits are read as 0.                                  | R   |

The TSCDR register stores temperature sensor calibration data measured for each chip at factory shipment.

Temperature sensor calibration data is the output voltage of the temperature sensor under the conditions  $T_j = 127^\circ\text{C}$  and  $AVCC0 = VREFH0 = 3.3\text{ V}$  converted to a digital value by the 12-bit A/D converter.

The TSCDR register is a read-only 32-bit register. Read from this register in 32-bit units.

### 39.2 注册说明

#### 39.2.1 TSCR: 温度传感器控制寄存器

Base address: TSN = 0x400F\_3000  
Offset address: 0x00



| Bit | Symbol | Function  | R/W |
|-----|--------|---|-----|
| 3:0 | —      | 这些位被读取为0。写入值应为0。  | R/W |
| 4   | TSOE   | 温度传感器输出使能<br>0: 禁用从温度传感器到ADC12的输出<br>1: 启用从温度传感器到ADC12的输出 | R/W |
| 6:5 | —      | 这些位被读取为0。写入值应为0。  | R/W |
| 7   | TSEN   | 温度传感器启用<br>0: 停止温度传感器<br>1: 启动温度传感器。                      | R/W |

TSCR是一个控制温度传感器的寄存器。图39.3所示的时序约束适用于TSCR寄存器的设置。

##### TSOE位 (温度传感器输出使能)

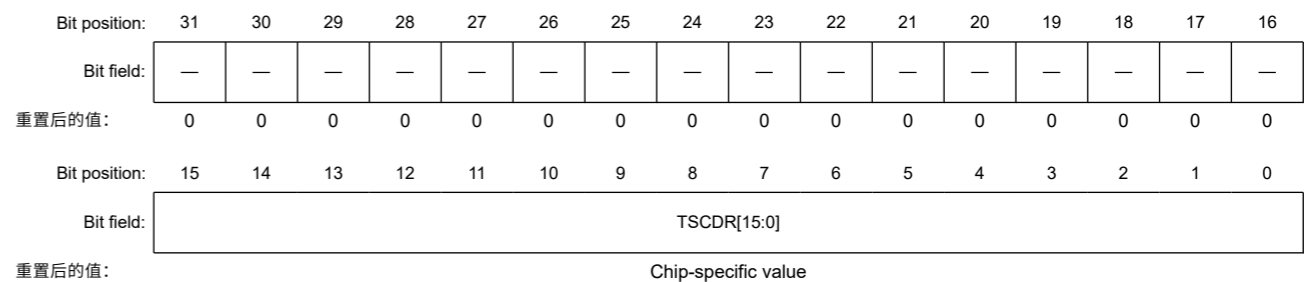
TSOE位启用或禁用温度传感器输出到ADC12。

##### TSEN位 (温度传感器使能)

TSEN位启动或停止温度传感器。

#### 39.2.2 TSCDR: 温度传感器校准数据寄存器

Base address: TSD = 0x407F\_B000  
Offset Address: 0x017C



| Bit   | Symbol      | Function                         | R/W |
|-------|-------------|----------------------------------|-----|
| 15:0  | TSCDR[15:0] | 温度传感器校准数据<br>Chip-specific value | R   |
| 31:16 | —           | 这些位读为0。                          | R   |

TSCDR寄存器存储在出厂时为每个芯片测量的温度传感器校准数据。

温度传感器校准数据是温度传感器在条件 $T_j = 127^\circ\text{C}$ 和 $AVCC0 = VREFH0 = 3.3\text{ V}$ 通过12位AD转换器转换为数字值。

TSCDR寄存器是一个只读的32位寄存器。以32位为单位从该寄存器中读取。

Temperature sensor calibration data is stored in the lower 12 bits of the TSCDR register.

### 39.3 Using the Temperature Sensor

The temperature sensor outputs a voltage that varies with the temperature. This voltage is converted to a digital value by the 12-bit A/D converter. To obtain the die temperature, convert this value into the temperature.

#### 39.3.1 Preparation for Using the Temperature Sensor

The ambient temperature (T) is proportional to the temperature sensor voltage output (Vs), so ambient temperature is calculated with the following formula:

$$T = (V_s - V_1) / \text{slope} + T_1$$

- T: Ambient temperature of MCU as calculation result (°C)
- Vs: Voltage output by the temperature sensor on temperature measurement (V)
- T1: Temperature experimentally measured at one point (°C)
- V1: Voltage output by the temperature sensor on measurement of T1 (V)
- T2: Temperature experimentally measured at a second point (°C)
- V2: Voltage output by the temperature sensor on measurement of T2 (V)
- Slope: Temperature gradient of the temperature sensor (V / °C), slope = (V2 - V1) / (T2 - T1)

Characteristics vary between sensors, so Renesas recommends measuring two different sample temperatures as follows:

1. Use the 12-bit A/D converter to measure the voltage V1 output by the temperature sensor at temperature T1.
2. Again use the 12-bit A/D converter to measure the voltage V2 output by the temperature sensor at a different temperature T2.
3. Obtain the temperature gradient (slope = (V2 - V1) / (T2 - T1)) from these results.
4. Subsequently, obtain temperatures by substituting the slope into the formula for the temperature characteristic (T = (Vs - V1) / slope + T1).

If you are using the temperature gradient given in [section 47, Electrical Characteristics](#), use the A/D converter to measure the voltage V1 output by the temperature sensor at temperature T1, then calculate the temperature characteristic using the following formula:

$$T = (V_s - V_1) / \text{slope} + T_1$$

Note: This method produces less accurate temperatures than measurement at two points.

In this MCU, the TSCDR register stores the temperature value (CAL127) of the temperature sensor measured under the condition Ta = Tj = 127°C and AVCC0 = VREFH0 = 3.3 V. If you use this value as the sample measurement result at the first point, you can omit the preparation before using the temperature sensor.

V1 is calculated from CAL127:

$$V_1 = 3.3 \times \text{CAL127} / 4096 \text{ [V]} \text{ (In case of 12 bit accuracy)}$$

Using this value, the measured temperature can be calculated according to the following formula:

$$T = (V_s - V_1) / \text{slope} + 127 \text{ [°C]}$$

- T: Ambient temperature of MCU as calculation result (°C)
- Vs: Voltage output by the temperature sensor when the temperature is measured (V)
- V1: Voltage output by the temperature sensor when Ta = Tj = 127°C and AVCC0 = VREFH0 = 3.3 V (V)
- Slope: Temperature gradient of the temperature sensor\*1 / 1000 (V/°C)

Note 1. See [section 47, Electrical Characteristics](#)

#### 39.3.2 Procedures for Using the Temperature Sensor

Figure 39.2 shows the procedure for using the TSN.

温度传感器校准数据存储在TSCDR寄存器的低12位中。

### 39.3 使用温度传感器

温度传感器输出随温度变化的电压。该电压由12位AD转换器转换为数字值。要获得芯片温度，请将该值转换为温度。

#### 39.3.1 使用温度传感器的准备工作

环境温度(T)与温度传感器电压输出(Vs)成正比，因此使用以下公式计算环境温度：

$$T = (V_s - V_1) / \text{slope} + T_1$$

- T: 作为计算结果的MCU的环境温度 (°C)
- Vs: 温度传感器测温时的电压输出 (V)
- T1: 在某一点实验测量的温度(°C)
- V1: 温度传感器在测量T1 (V) 时输出的电压
- T2: 在第二点实验测量的温度(°C)
- V2: 温度传感器在测量T2 (V) 时输出的电压
- 斜率: 温度传感器的温度梯度 (V/°C) , 斜率= (V2-V1) / (T2-T1)

传感器的特性各不相同，因此瑞萨电子建议测量两种不同的样品温度，如下所示：

1. 使用12位AD转换器测量温度T1时温度传感器输出的电压V1。
2. 再次使用12位AD转换器测量温度传感器在不同温度T2下输出的电压V2。
3. 从这些结果中获得温度梯度 (斜率=(V2-V1)/(T2-T1))。
4. 随后，通过将斜率代入温度特性公式(T=(Vs-V1)/斜率+T1)来获得温度。

如果您使用第47节“电气特性”中给出的温度梯度，请使用AD转换器测量温度传感器在温度T1下输出的电压V1，然后使用以下公式计算温度特性：

$$T = (V_s - V_1) / \text{slope} + T_1$$

Note: 这种方法产生的温度不如两点测量准确。

在此MCU中，TSCDR寄存器存储在Ta=Tj=127°C和AVCC0=VREFH0=3.3V条件下测量的温度传感器的温度值(CAL127)。如果您使用此值作为第一次的样本测量结果点，您可以省略使用温度传感器之前的准备工作。

V1由CAL127计算得出：

$$V_1 = 3.3 \times \text{CAL127} / 4096 \text{ [V]} \text{ (在12位精度的情况下)}$$

使用该值，可根据以下公式计算测得的温度：

$$T = (V_s - V_1) / \text{slope} + 127 \text{ [°C]}$$

- T: 作为计算结果的MCU的环境温度 (°C)
- Vs: 测温时温度传感器输出的电压 (V)
- V1: Ta=Tj=127°C且AVCC0=VREFH0=3.3V(V)时温度传感器输出的电压
- 斜率: 温度传感器的温度梯度\*11000(V/°C)

注1.见第47节，电气特性

#### 39.3.2 使用温度传感器的步骤

图39.2显示了使用TSN的过程。

For details, see [section 37, 12-Bit A/D Converter \(ADC12\)](#).

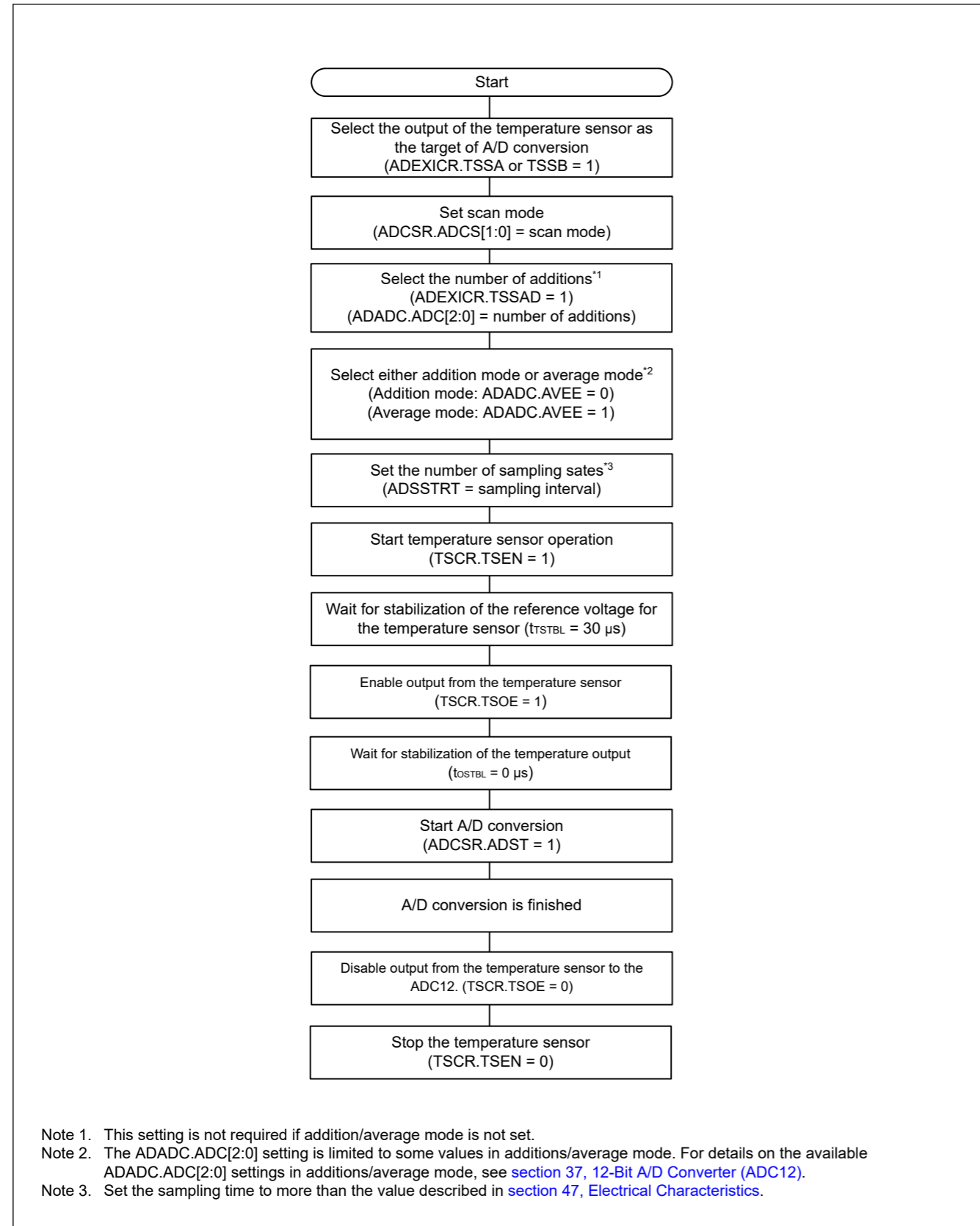


Figure 39.2 Procedure example for using the TSN

有关详细信息，请参阅第37节，12位AD转换器(ADC12)。

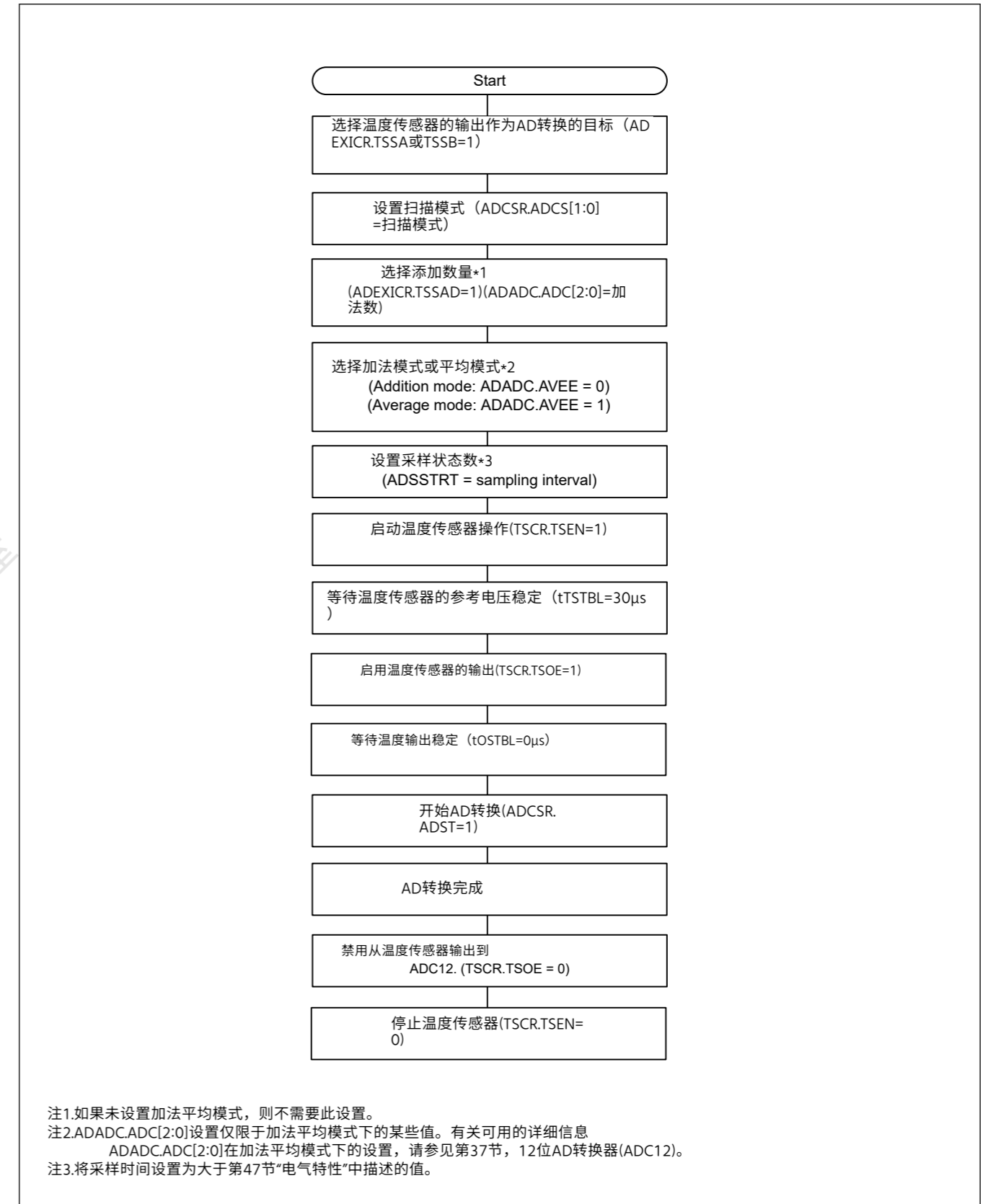


Figure 39.2 使用TSN的过程示例



Figure 39.3 shows the timing from the start of temperature sensor operation until the completion of A/D conversion when the ADC12 is in single scan mode (the conversion target is the temperature sensor output only). The times shown in the figure are described in Table 39.2

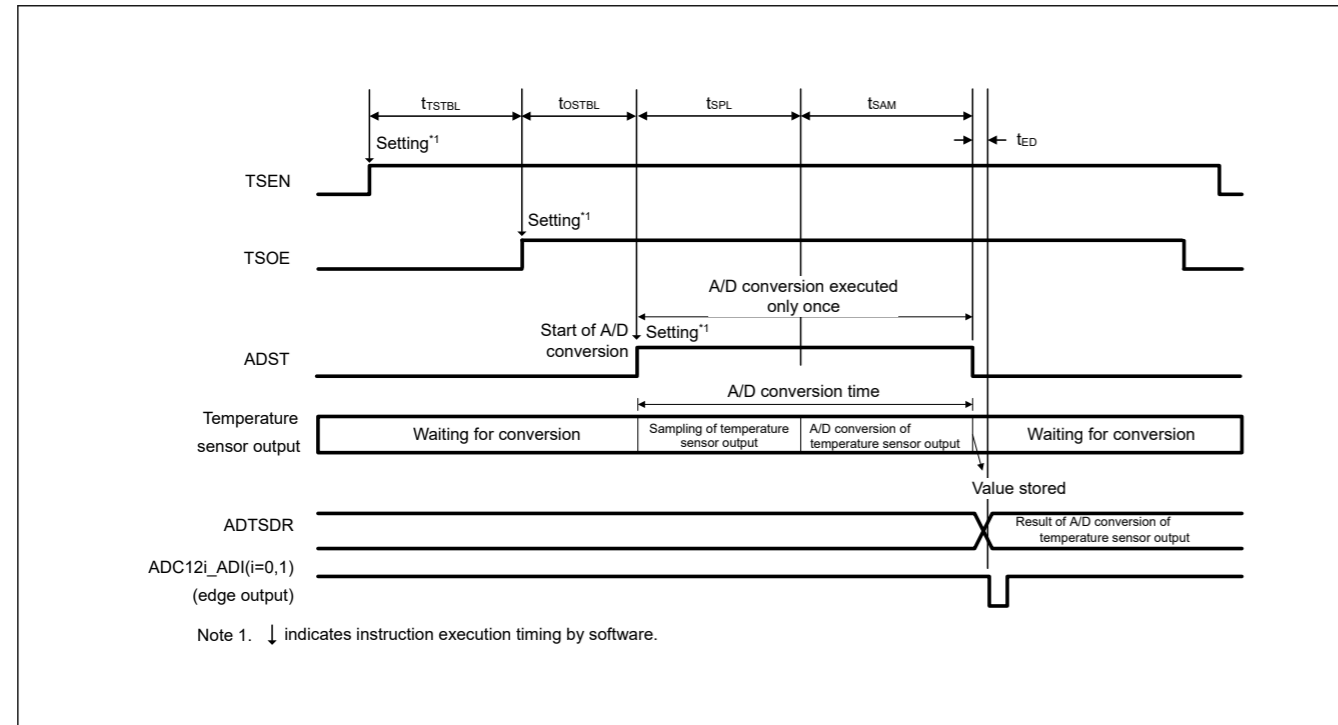


Figure 39.3 Timing from start of temperature sensor operation until completion of A/D conversion

Table 39.2 Time until completion of A/D conversion after start of temperature sensor operation

| Parameter  | Symbol      | Time   |
|--|-------------|--|
| Wait time for temperature sensor reference voltage stabilization | $t_{TSTBL}$ | 30 $\mu$ s (min)   |
| Wait time for temperature sensor output stabilization            | $t_{OSTBL}$ | 0 $\mu$ s (min)  |
| A/D converter input sampling time                                | $t_{sPL}$   | ADSSTRT setting $\times$ ADCLK cycles  |
| A/D conversion time  | $t_{sAM}$   | See the table in section 37.3.7. Analog Input Sampling and Scan Conversion Time. |
| Scan conversion end delay  | $t_{ED}$    |  |

### 39.4 Usage Notes

#### 39.4.1 Settings for the Module-Stop Function

TSN operation can be disabled or enabled using the associated bit in Module Stop Control Register D (MSTPCRD). The TSN is initially stopped after reset. Releasing the module-stop state enables access to the registers. For details, see section 10, Low Power Modes.

图39.3显示了当ADC12处于单次扫描模式（转换目标仅为温度传感器输出）时，从温度传感器操作开始到AD转换完成的时序。图中所示时间见表39.2

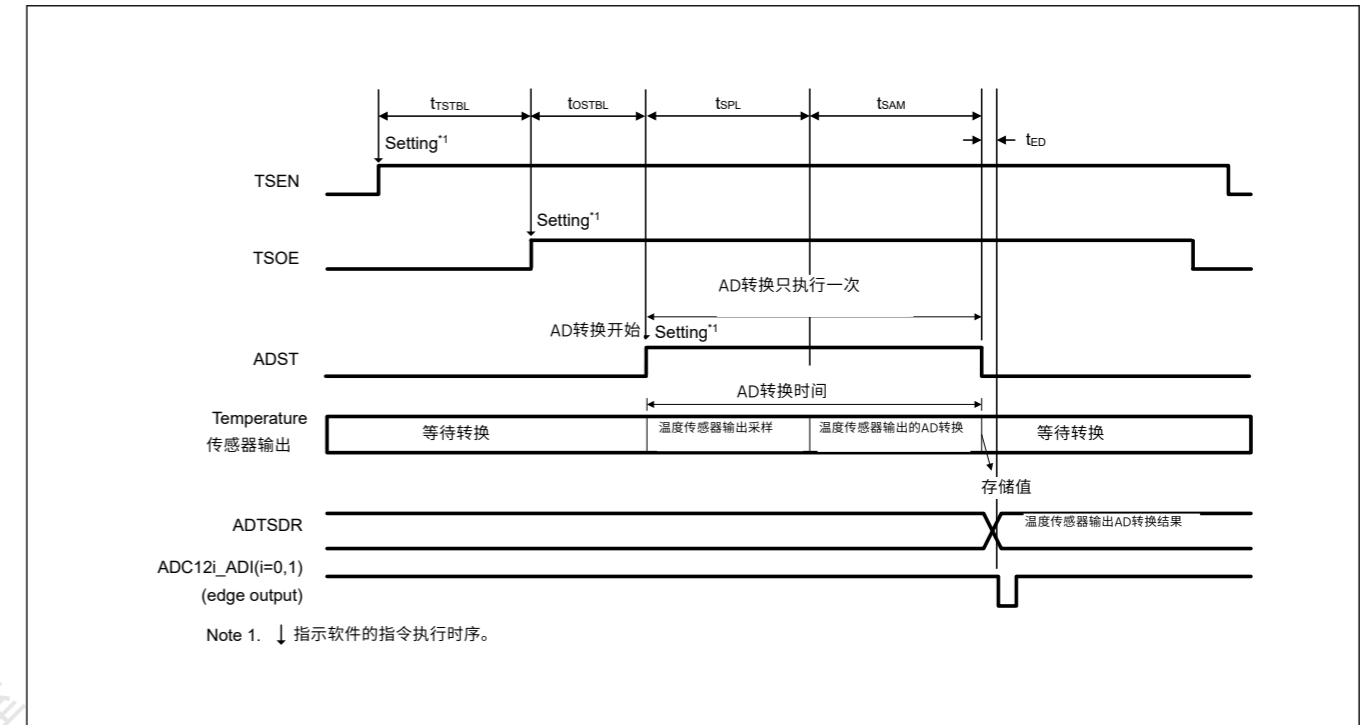


Figure 39.3 从温度传感器操作开始到AD转换完成的时间

Table 39.2 温度传感器动作开始后到AD转换完成的时间

| Parameter        | Symbol      | Time                           |
|------------------|-------------|--------------------------------|
| 温度传感器参考电压稳定的等待时间 | $t_{TSTBL}$ | 30 $\mu$ s (min)               |
| 温度传感器输出稳定的等待时间   | $t_{OSTBL}$ | 0 $\mu$ s (min)                |
| AD转换器输入采样时间      | $t_{sPL}$   | ADSTRT设置 $\times$ ADCLK周期      |
| AD转换时间           | $t_{sAM}$   | 请参见第37.3.7节中的表格。模拟输入采样和扫描转换时间。 |
| 扫描转换结束延迟         | $t_{ED}$    |                                |

### 39.4 使用说明

#### 39.4.1 模块停止功能的设置

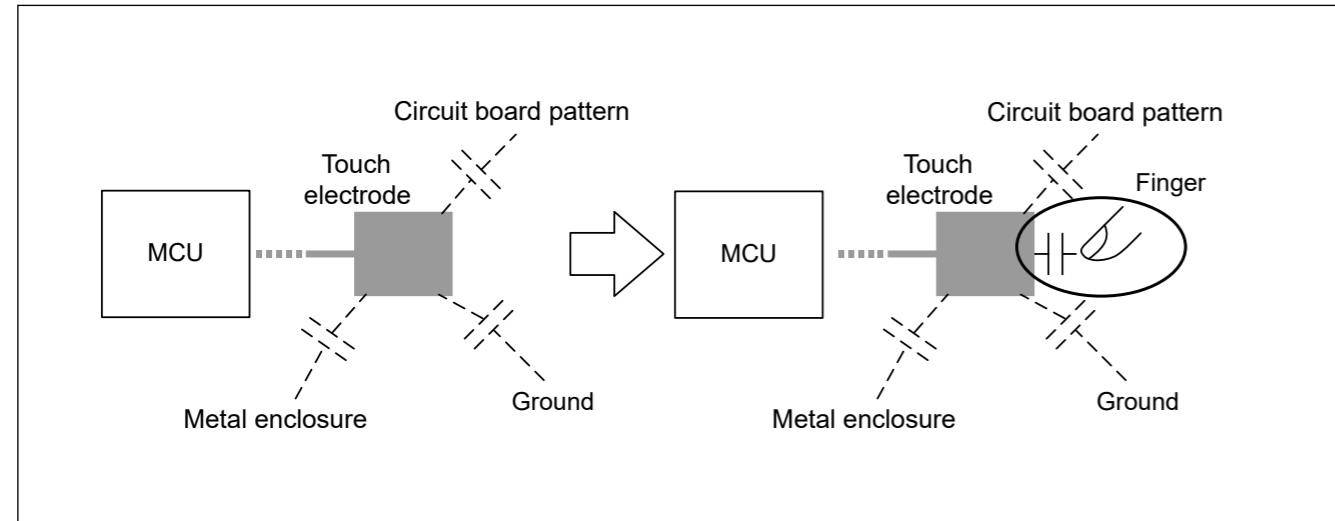
使用模块停止控制寄存器D(MSTPCRD)中的相关位可以禁用或启用TSN操作。TSN在复位后最初停止。释放模块停止状态可以访问寄存器。有关详细信息，请参阅第10节，低功耗模式。

## 40. Capacitive Touch Sensing Unit (CTSUS)

### 40.1 Overview

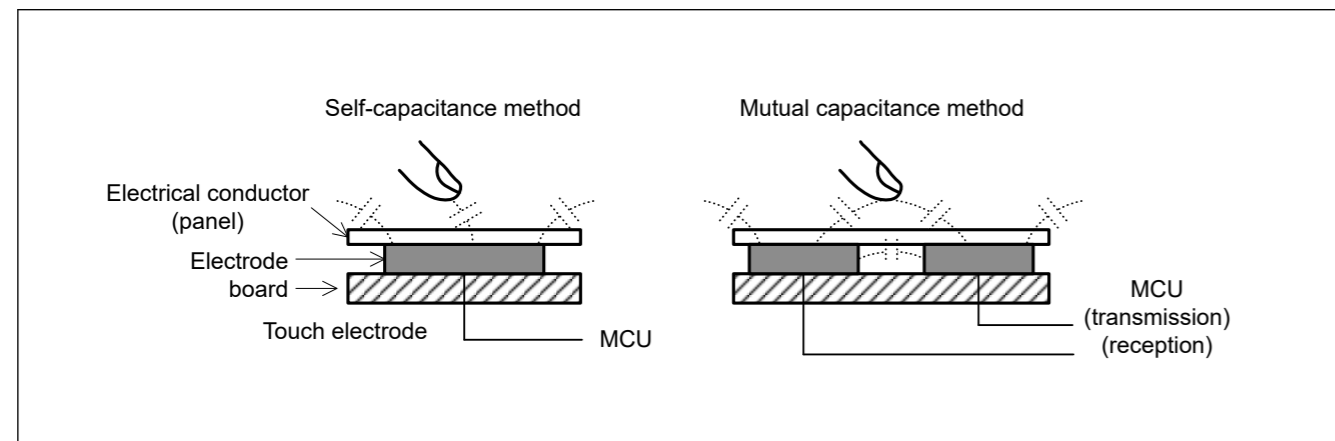
The Capacitive Touch Sensing Unit (CTSUS) measures the electrostatic capacitance of the touch sensor. Changes in the electrostatic capacitance are determined by software that enables the CTSUS to detect whether a finger is in contact with the touch sensor. The electrode surface of the touch sensor is usually enclosed with an electrical conductor so that a finger does not come into direct contact with the electrode.

As [Figure 40.1](#) shows, electrostatic capacitance (parasitic capacitance) exists between the electrode and the surrounding conductors. Because the human body is an electrical conductor, when a finger is placed close to the electrode, the value of electrostatic capacitance increases.



**Figure 40.1** Increased electrostatic capacitance because of the presence of a finger

Electrostatic capacitance is detected by the self-capacitance and mutual capacitance methods. In the self-capacitance method, the CTSUS detects electrostatic capacitance generated between a finger and a single electrode. In the mutual capacitance method, two electrodes are used one as a transmit electrode and the other as a receive electrode, and the CTSUS detects the change in the electrostatic capacitance generated between the two when a finger is placed close to them.



**Figure 40.2** Self-capacitance and mutual capacitance methods

Electrostatic capacitance is measured by counting a clock signal whose frequency changes according to the amount of charged or discharged current, for a specified period. For details on the measurement principles of the CTSUS, see [section 40.3.1. Principles of Measurement Operation](#).

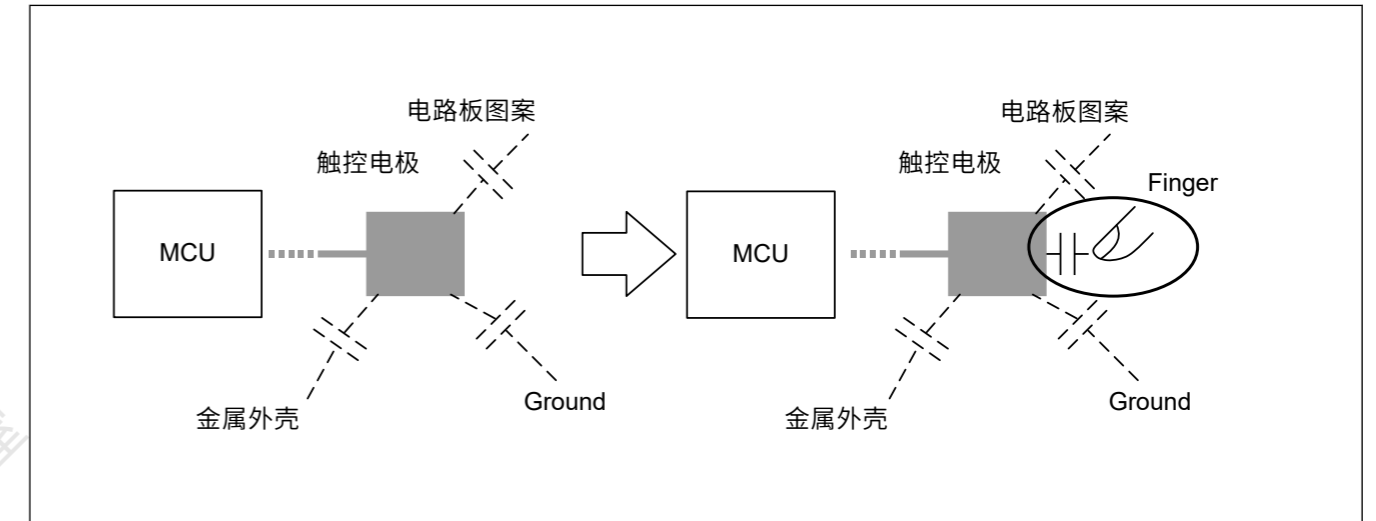
[Table 40.1](#) lists the CTSUS specifications and [Figure 40.3](#) shows a block diagram.

## 40. 电容式触控感应单元(CTSUS)

### 40.1 Overview

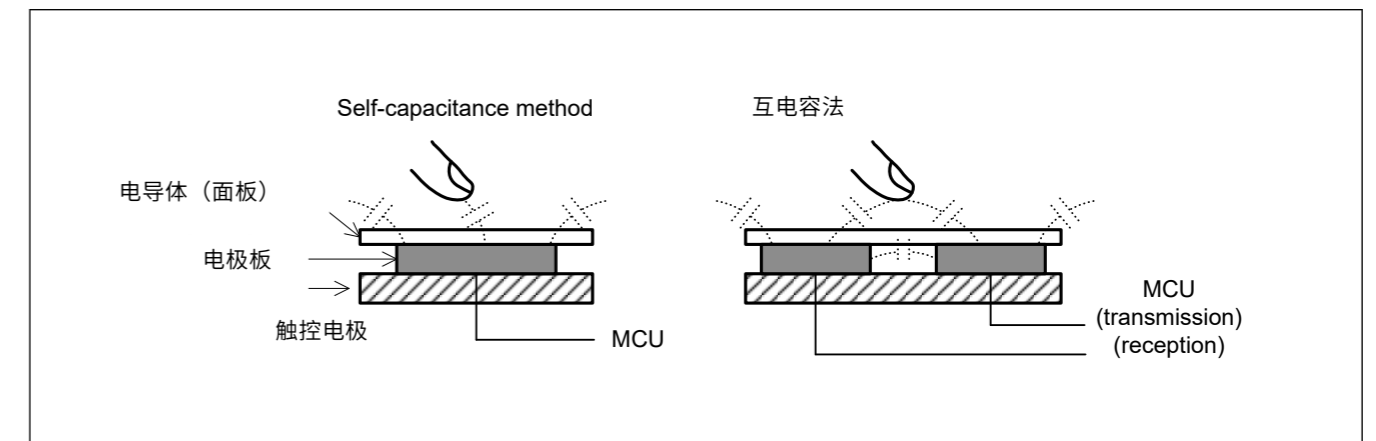
电容式触摸传感单元(CTSUS)测量触摸传感器的静电电容。静电电容的变化由软件确定，该软件使CTSUS能够检测手指是否与触摸传感器接触。触摸传感器的电极表面通常被电导体包围，因此手指不会直接接触电极。

如图40.1所示，静电电容（寄生电容）存在于电极和周围导体之间。因为人体是电导体，当手指靠近电极时，静电电容值会增加。



**Figure 40.1** 由于手指的存在而增加了静电电容

静电电容的检测方法有自电容法和互电容法。在自电容法中，CTSUS检测手指和单个电极之间产生的静电电容。在互电容法中，使用两个电极，一个作为发送电极，另一个作为接收电极，当手指靠近它们时，CTSUS会检测两者之间产生的静电电容的变化。



**Figure 40.2** 自电容和互电容方法

静电电容是通过时钟信号计数来测量的，该时钟信号的频率根据充电或放电电流的大小而变化，在指定的时间段内。CTSUS的测量原理详见40.3.1节。测量操作原理。

表40.1列出了CTSUS规格，图40.3显示了框图。

Table 40.1 CTSU specifications

| Parameter                    | Specifications   |  |
|------------------------------|--|--|
| Operating clock              | PCLKB, PCLKB/2, or PCLKB/4   |  |
| Pins                         | Electrostatic capacitance measurement  | 20 channels  |
|                              | TSCAP  | Low Pass Filter (LPF) connection pin   |
| Measurement modes            | Self-capacitance single scan mode  | Electrostatic capacitance is measured on one channel using the self-capacitance method.                      |
|                              | Self-capacitance multiscan mode  | Electrostatic capacitance is measured successively on multiple channels using the self-capacitance method.   |
|                              | Mutual capacitance full scan mode  | Electrostatic capacitance is measured successively on multiple channels using the mutual capacitance method. |
| Calibration mode             | Improvement of measured value accuracy by calibration of sensor ICO  |  |
| Noise prevention             | Synchronous noise prevention, high-pass noise prevention   |  |
| Measurement start conditions | <ul style="list-style-type: none"> <li>Software trigger</li> <li>External trigger (ELC_CTSU from the Event Link Controller (ELC))</li> </ul> |  |
| TrustZone Filter             | Security attribution can be set  |  |

As Figure 40.3 shows, the CTSU consists of the following components:

- Status control block
- Trigger control block
- Clock control block
- Channel control block
- Port control block
- Sensor drive pulse generator
- Measurement block
- Interrupt block
- I/O registers

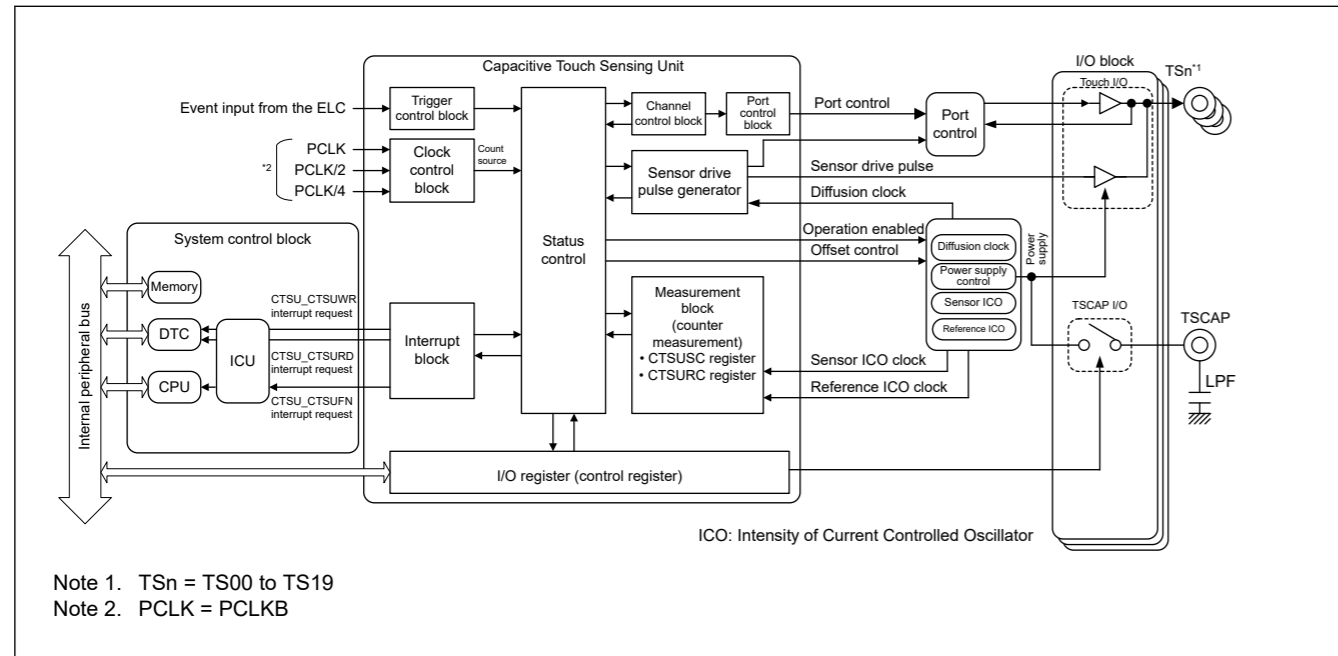


Figure 40.3 CTSU block diagram

Table 40.1 CTSU specifications

| Parameter        | Specifications  |                       |
|------------------|---|-----------------------|
| 工作时钟             | PCLKB, PCLKB/2, or PCLKB/4  |                       |
| Pins             | 静电电容测量  | 20 channels           |
|                  | TSCAP   | 低通滤波器(LPF)连接引脚        |
| 测量模式             | 自电容单次扫描模式   | 使用自电容法在一个通道上测量静电电容。   |
|                  | Self-capacitance multiscan mode   | 使用自电容法在多个通道上连续测量静电电容。 |
|                  | 互电容全扫描模式  | 使用互电容法在多个通道上连续测量静电电容。 |
| 校准模式             | 通过传感器校准提高测量值精度<br>ICO   |                       |
| 噪音预防             | 同步防噪、防高通防噪  |                       |
| 测量开始条件           | <ul style="list-style-type: none"> <li>软件触发</li> <li>外部触发器 (来自事件链接控制器(ELC)的ELC_CTSU)</li> </ul> |                       |
| TrustZone Filter | 可设置安全属性   |                       |

如图40.3所示，CTSUS由以下组件组成：

- 状态控制块
- 触发控制块
- 时钟控制块
- 通道控制块
- 端口控制块
- 传感器驱动脉冲发生器
- 测量块
- 中断块
- I/O registers

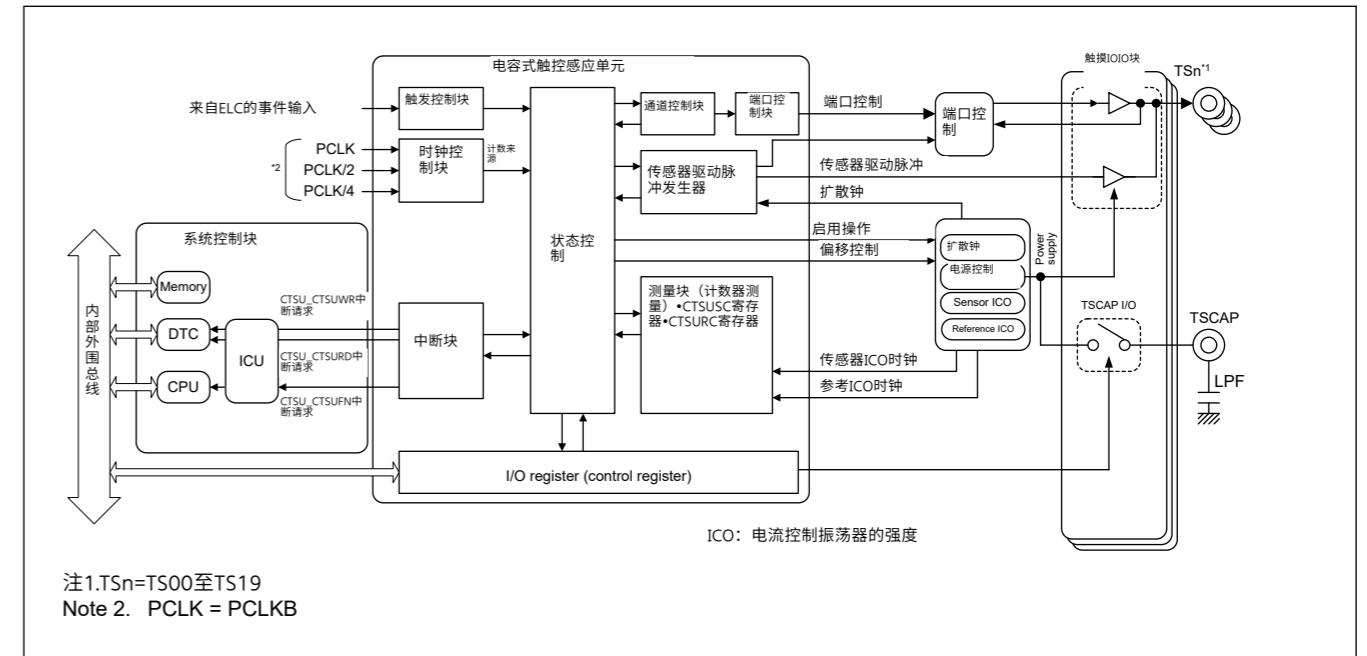


Figure 40.3 CTSU框图

Table 40.2 CTSU I/O pins

| Pin name     | I/O   | Function   |
|--------------|-------|--|
| TS00 to TS19 | Input | Electrostatic capacitive measurement pins (touch pins) |
| TSCAP        | —     | LPF connection pin                                     |

## 40.2 Register Descriptions

## 40.2.1 CTSUCR0 : CTSU Control Register 0

Base address: CTSU = 0x400D\_0000

Offset address: 0x00

| Bit position:      | 7          | 6 | 5 | 4       | 3       | 2       | 1       | 0        |
|--------------------|------------|---|---|---------|---------|---------|---------|----------|
| Bit field:         | CTSUTXVSEL | — | — | CTSUIOC | CTSUIOC | CTSUSNZ | CTSUCAP | CTSUSTRT |
| Value after reset: | 0          | 0 | 0 | 0       | 0       | 0       | 0       | 0        |

| Bit | Symbol     | Function  | R/W |
|-----|------------|---|-----|
| 0   | CTSUSTRT   | CTSU Measurement Operation Start<br>0: Stop measurement operation*1<br>1: Start measurement operation   | R/W |
| 1   | CTSUCAP    | CTSU Measurement Operation Start Trigger Select<br>0: Software trigger<br>1: External trigger   | R/W |
| 2   | CTSUSNZ    | CTSU Wait State Power-Saving Enable<br>0: Disable power-saving function during wait state<br>1: Enable power-saving function during wait state  | R/W |
| 3   | CTSUIOC    | CTSU Transmit Pin Control<br>0: The TS pins are driven low<br>1: The TS pins are driven high  | R/W |
| 4   | CTSUIINIT  | CTSU Control Block Initialization<br>Writing 1 to this bit initializes the CTSU control block and CTSUSC, CTSURC, CTSUMCH0, CTSUMCH1, and CTSUST registers. This bit is read as 0.                | W   |
| 6:5 | —          | These bits are read as 0. The write value should be 0.  | R/W |
| 7   | CTSUTXVSEL | CTSU Transmission Power Supply Select<br>0: TSCAP is selected as the power-supply voltage for the transmission pins.<br>1: VCL is selected as the power-supply voltage for the transmission pins. | R/W |

Note 1. When the CTSU is not used, fix the value of this bit to 0.

Only set the CTSUCAP, CTSUSNZ, CTSUTXVSEL2 and CTSUTXVSEL bits when the CTSUSTRT bit is 0. These bits can be set at the same time that measurement operation starts.

**CTSUSTRT bit (CTSU Measurement Operation Start)**

The CTSUSTRT bit specifies whether CTSU operation starts or stops. When the CTSUSTRT bit is 0, measurement starts when the software writes 1 to the CTSUSTRT bit (software trigger) and stops when the hardware clears the CTSUSTRT bit to 0. When the CTSUSTRT bit is 1, the CTSU waits for an external trigger by writing 1 to the CTSUSTRT bit, and measurement starts on the rising edge of the external trigger. When measurement is stopped, the CTSU waits for the next external trigger and operation continues.

Table 40.3 lists the CTSU states.

Table 40.3 CTSU status (1 of 2)

| CTSUSTRT bit | CTSUCAP bit | CTSU state |
|--------------|-------------|------------|
| 0            | 0           | Stopped    |

Table 40.2 CTSU I/O pins

| 引脚名称         | I/O   | Function       |
|--------------|-------|----------------|
| TS00 to TS19 | Input | 静电电容测量引脚（触摸引脚） |
| TSCAP        | —     | LPF连接引脚        |

## 40.2 注册说明

## 40.2.1 CTSUCR0:CTSU控制寄存器0

Base address: CTSU = 0x400D\_0000

Offset address: 0x00

| Bit position: | 7          | 6 | 5 | 4       | 3       | 2       | 1       | 0        |
|---------------|------------|---|---|---------|---------|---------|---------|----------|
| Bit field:    | CTSUTXVSEL | — | — | CTSUIOC | CTSUIOC | CTSUSNZ | CTSUCAP | CTSUSTRT |
| 重置后的值:        | 0          | 0 | 0 | 0       | 0       | 0       | 0       | 0        |

| Bit | Symbol     | Function  | R/W |
|-----|------------|---|-----|
| 0   | CTSUSTRT   | CTSU测量操作开始<br>0: 停止测量操作*1<br>1: 开始测量操作  | R/W |
| 1   | CTSUCAP    | CTSU测量操作开始触发选择<br>0: 软件触发1: 外部触发  | R/W |
| 2   | CTSUSNZ    | CTSU等待状态省电使能<br>0: 等待状态下关闭省电功能1: 等待状态下开启省电功能                                    | R/W |
| 3   | CTSUIOC    | CTSU发送引脚控制<br>0: TS引脚驱动为低电平1: TS引脚驱动为高电平  | R/W |
| 4   | CTSUIINIT  | CTSU控制块初始化<br>向该位写入1初始化CTSU控制模块和CTSUSC、CTSURC、CTSUMCO、CTSUMCH1和CTSUST寄存器。该位读为0。 | W   |
| 6:5 | —          | 这些位被读取为0。写入值应为0。  | R/W |
| 7   | CTSUTXVSEL | CTSU传输电源选择<br>0: 选择TSCAP作为发送引脚的电源电压。1: 选择VCL作为发送引脚的电源电压。                        | R/W |

注1.不使用CTSU时，将该位的值固定为0。

仅当CTSUSTRT位为0时设置CTSUCAP、CTSUSNZ、CTSUTXVSEL2和CTSUTXVSEL位。这些位可以在测量操作开始的同时设置。

**CTSUSTRT位 (CTSU测量操作开始)**

CTSUSTRT位指定CTSU操作是开始还是停止。当CTSUSTRT位为0时，软件将1写入CTSUSTRT位（软件触发）时开始测量，并在硬件将CTSUSTRT位清为0时停止测量。当CTSUSTRT位为1时，CTSU通过写入等待外部触发1到CTSUSTRT位，并在外部触发的上升沿开始测量。当测量停止时，CTSU等待下一个外部触发并继续操作。

表40.3列出了CTSU状态。

Table 40.3 CTSU状态(1of2)

| CTSUSTRT bit | CTSUCAP bit | CTSU state |
|--------------|-------------|------------|
| 0            | 0           | Stopped    |



Table 40.3 CTSU status (2 of 2)

| CTSUSTRT bit | CTSUCAP bit | CTSU state  |
|--------------|-------------|---|
| 0            | 1           | Stopped   |
| 1            | 0           | Measurement in progress                                       |
| 1            | 1           | Measurement in progress and waiting for an external trigger*1 |

Note 1. The state can be read from the CTSUST.CTSUSTC[2:0] flags as follows:  
 During measurement: CTSUST.CTSUSTC[2:0] flags ≠ 000b  
 While waiting for an external trigger: CTSUST.CTSUSTC[2:0] flags = 000b  
 When the CTSU is not used, fix the value of this bit to 0.

If the software sets the CTSUSTRT bit to 1 when the bit is already 1, the write is ignored and operation continues. To force operation to stop through the software when the CTSUSTRT bit is 1, set the CTSUSTRT bit to 0 and the CTSUINIT bit to 1 at the same time.

#### CTSUCAP bit (CTSU Measurement Operation Start Trigger Select)

The CTSUCAP bit specifies the measurement start condition. For details, see [CTSUSTRT bit \(CTSU Measurement Operation Start\)](#).

#### CTSUSNZ bit (CTSU Wait State Power-Saving Enable)

The CTSUSNZ bit enables or disables power-saving operation during a wait state. It can also suspend the CTSU power supply, which decreases power consumption during the wait state. In the suspended state, the CTSU power supply is turned off while the external TSCAP is still charged.

Table 40.4 shows the CTSU power supply state control.

Table 40.4 CTSU power supply state control

| CTSUCR1.CTSUPON bit | CTSUSNZ bit | CTSUCAP bit | CTSUSTRT bit | CTSU power supply state |
|---------------------|-------------|-------------|--------------|-------------------------|
| 0                   | 0           | 0           | 0            | Stopped                 |
| 1                   | 0           | —           | —            | Operating               |
| 1                   | 1           | 0           | 0            | Suspended               |

Note: Other settings are prohibited.

To start measurement from the suspended state, set the CTSUSNZ bit to 0, and then set the CTSUSTRT bit to 1. To suspend the module after measurement stops, set the CTSUSNZ bit to 1.

#### CTSUIOC bit (CTSU Transmit Pin Control)

The CTSUIOC bit selects the logic level of the TS pin when the CTSUERRS.CTSUTSOD bit is set to 1. This bit setting is ignored when the CTSUTSOD bit is 0.

#### CTSUINIT bit (CTSU Control Block Initialization)

Write 1 to the CTSUINIT bit to initialize the internal control registers. To force the current operation to stop, set the CTSUSTRT bit to 0 and the CTSUINIT bit to 1 at the same time. This stops the operation and initializes the internal control registers.

Do not write 1 to the CTSUINIT bit when the CTSUSTRT bit is 1.

#### CTSUTXVSEL bit (CTSU Transmission Power Supply Select)

The CTSUTXVSEL bit is used to switch the power supply for the transmit buffer in mutual capacitance full scan mode.

Set this bit to 0 for any other mode or when the VCC voltage is lower than 2.7 V. This bit switches the power supply for touch I/O, which is set for transmission by the CTSUCHTRCn registers. Table 40.5 lists the power supply for the TSm pin. When the VCC voltage fluctuates greatly due to switching of the output buffer, switching to the internal logic power supply can reduce the effect on the voltage fluctuation.

Table 40.3 CTSU状态 (2个中的2个)

| CTSUSTRT bit | CTSUCAP bit | CTSU state    |
|--------------|-------------|---------------|
| 0            | 1           | Stopped       |
| 1            | 0           | 测量中           |
| 1            | 1           | 测量中, 等待外部触发*1 |

注1.可以从CTSUST.CTSUSTC[2:0]标志读取状态, 如下所示:  
 测量期间: CTSUST.CTSUSTC[2:0]flags≠000b  
 等待外部触发时: CTSUST.CTSUSTC[2:0]flags=000b  
 不使用CTSU时, 将该位的值固定为0。

如果在CTSUSTRT位已经为1时软件将该位设置为1, 则忽略写入并继续操作。要在CTSUSTRT位为1时通过软件强制停止操作, 请将CTSUSTRT位设置为0, 同时将CTSUINIT位设置为1。

#### CTSUCAP位 (CTSU测量操作开始触发选择)

CTSUCAP位指定测量开始条件。有关详细信息, 请参阅CTSUSTRT位 (CTSU测量 Operation Start)。

#### CTSUSNZ位 (CTSU等待状态省电使能)

CTSUSNZ位在等待状态期间启用或禁用省电操作。它还可以暂停CTSU电源, 从而降低等待状态下的功耗。在挂起状态下, CTSU电源关闭, 而外部TSCAP仍在充电。

CTSU电源状态控制如表40.4所示。

Table 40.4 CTSU电源状态控制

| CTSUCR1.CTSUPON位 | CTSUSNZ位 | CTSUCAP位 | CTSUSTRT位 | CTSU电源状态  |
|------------------|----------|----------|-----------|-----------|
| 0                | 0        | 0        | 0         | Stopped   |
| 1                | 0        | —        | —         | Operating |
| 1                | 1        | 0        | 0         | Suspended |

Note: 禁止其他设置。

要从暂停状态开始测量, 请将CTSUSNZ位设置为0, 然后将CTSUSTRT位设置为1。要在测量停止后暂停模块, 请将CTSUSNZ位设置为1。

#### CTSUIOC位 (CTSU发送引脚控制)

CTSUERRS.CTSUTSOD位设置为1时, CTSUIOC位选择TS引脚的逻辑电平。当CTSUTSOD位为0时, 该位设置被忽略。

#### CTSUINIT位 (CTSU控制块初始化)

向CTSUINIT位写入1以初始化内部控制寄存器。要强制停止当前操作, 请将CTSUSTRT位为0, CTSUINIT位同时为1。这将停止操作并初始化内部控制寄存器。

当CTSUSTRT位为1时, 不要将1写入CTSUINIT位。

#### CTSUTXVSEL位 (CTSU发送电源选择)

CTSUTXVSEL位用于在互电容全扫描模式下切换发送缓冲器的电源。

对于任何其他模式或当VCC电压低于2.7V时, 将该位设置为0。该位切换触摸IO的电源, 由CTSUCHTRCn寄存器设置为发送。表40.5列出了TSm引脚的电源。当VCC电压因输出缓冲器的切换而大幅波动时, 切换到内部逻辑电源可以减少对电压波动的影响。

Table 40.5 Power supplied to the TSm pins

| Setting of CTSUCHTRCn Register | CTSUTXVSEL bit                  | Power supply of TSm pins    |
|--------------------------------|---------------------------------|-----------------------------|
| 0 (Reception)                  | *                               | VCC                         |
| 1 (Transmission)               | 0 (VCC)                         | Internal logic power supply |
|                                | 1 (Internal logic power supply) |                             |

## 40.2.2 CTSUCR1 : CTSU Control Register 1

Base address: CTSU = 0x400D\_0000

Offset address: 0x01

| Bit position:      | 7           | 6            | 5         | 4 | 3       | 2       | 1 | 0 |
|--------------------|-------------|--------------|-----------|---|---------|---------|---|---|
| Bit field:         | CTSUMD[1:0] | CTSUCLK[1:0] | CTSUTUNE1 | — | CTSUCSW | CTSUPON |   |   |
| Value after reset: | 0           | 0            | 0         | 0 | 0       | 0       | 0 | 0 |

| Bit | Symbol       | Function   | R/W |
|-----|--------------|--|-----|
| 0   | CTSUPON      | CTSUS Power Supply Enable<br>0: Power off the CTSUS<br>1: Power on the CTSUS   | R/W |
| 1   | CTSUCSW      | CTSUS LPF Capacitance Charging Control<br>This bit controls charging of the LPF capacitance connected to the TSCAP pin.<br>0: Turn off capacitance switch<br>1: Turn on capacitance switch | R/W |
| 2   | —            | This bit is read as 0. The write value should be 0.  | R/W |
| 3   | CTSUTUNE1    | CTSUS Power Supply Capacity Adjustment<br>0: Normal output<br>1: High-current output   | R/W |
| 5:4 | CTSUCLK[1:0] | CTSUS Operating Clock Select<br>00: PCLKB<br>01: PCLKB/2 (PCLKB divided by 2)<br>10: PCLKB/4 (PCLKB divided by 4)<br>11: Setting prohibited  | R/W |
| 7:6 | CTSUMD[1:0]  | CTSUS Measurement Mode Select<br>00: Self-capacitance single scan mode<br>01: Self-capacitance multiscan mode<br>10: Setting prohibited<br>11: Mutual capacitance full scan mode           | R/W |

Only set the CTSUCR1 register when the CTSUCR0.CTSUSTRT bit is 0.

**CTSUPON bit (CTSUS Power Supply Enable)**

The CTSUPON bit controls the power supply to the CTSUS. Set the CTSUPON and CTSUCSW bits to the same value.

**CTSUCSW bit (CTSUS LPF Capacitance Charging Control)**

The CTSUCSW bit controls charging of the LPF capacitor connected to the TSCAP pin by turning the capacitance switch on or off. After the capacitance switch is turned on, wait until the capacitance connected to the TSCAP pin is charged for the specified time before starting measurement by setting CTSUCR0.CTSUSTRT to 1. Before starting measurement, use an I/O port to output low to the TSCAP pin, and discharge the existing LPF capacitance. Set the CTSUPON and CTSUCSW bits to the same value.

**CTSUTUNE1 bit (CTSUS Power Supply Capacity Adjustment)**

The CTSUTUNE1 bit sets the capacity of the CTSUS power supply. Normally, set this bit to 0.

Table 40.5 为TSm引脚供电

| CTSUTCHRCn寄存器CTSUTXVSEL位的设置 | TSm管脚电源           |
|-----------------------------|-------------------|
| 0 (Reception)               | VCC               |
| 1 (Transmission)            | 0 (VCC)           |
|                             | 1 (内部逻辑电源) 内部逻辑电源 |

## 40.2.2 CTSUCR1: CTSUS控制寄存器1

Base address: CTSUS = 0x400D\_0000

Offset address: 0x01

| Bit position: | 7           | 6            | 5         | 4 | 3       | 2       | 1 | 0 |
|---------------|-------------|--------------|-----------|---|---------|---------|---|---|
| Bit field:    | CTSUMD[1:0] | CTSUCLK[1:0] | CTSUTUNE1 | — | CTSUCSW | CTSUPON |   |   |
| 重置后的值:        | 0           | 0            | 0         | 0 | 0       | 0       | 0 | 0 |

| Bit | Symbol       | Function   | R/W |
|-----|--------------|--|-----|
| 0   | CTSUPON      | CTSUS电源使能<br>0: 关闭CTSUS1: 打开CTSUS  | R/W |
| 1   | CTSUCSW      | CTSUS LPF电容充电控制<br>该位控制连接到TSCAP引脚的LPF电容的充电。<br>0: 关闭电容开关1: 打开电容开关            | R/W |
| 2   | —            | 该位读取为0。写入值应为0。   | R/W |
| 3   | CTSUTUNE1    | CTSUS电源容量调整<br>0: 正常输出1: 大电流输出   | R/W |
| 5:4 | CTSUCLK[1:0] | CTSUS工作时钟选择<br>00: PCLKB01: PCLKB2 (PCLKB2分频) 10: PCLKB4 (PCLKB4分频) 11: 禁止设置 | R/W |
| 7:6 | CTSUMD[1:0]  | CTSUS测量模式选择<br>00: 自电容单扫描模式01: 自电容多扫描模式10: 禁止设置11: 互电容全扫描模式                  | R/W |

仅当CTSUCR0.CTSUSTRT位为0时设置CTSUCR1寄存器。

**CTSUPON位 (CTSUS电源使能)**

CTSUPON位控制CTSUS的电源。将CTSUPON和CTSUCSW位设置为相同的值。

**CTSUCSW位 (CTSUS LPF电容充电控制)**

CTSUCSW位通过打开或关闭电容开关来控制连接到TSCAP引脚的LPF电容的充电。电容开关打开后, 通过设置CTSUCR0.CTSUSTRT为1, 等到连接到TSCAP引脚的电容充电指定时间后开始测量。开始测量之前, 使用IO端口输出低电平到TSCAP引脚, 并对现有的LPF电容进行放电。将CTSUPON和CTSUCSW位设置为相同的值。

**CTSUTUNE1位 (CTSUS电源容量调整)**

CTSUTUNE1位设置CTSUS电源的容量。通常, 将此位设置为0。

**CTSUCLK[1:0] bits (CTSU Operating Clock Select)**

The CTSUCLK[1:0] bits select the operating clock.

**CTSUMD[1:0] bits (CTSU Measurement Mode Select)**

The CTSUMD[1:0] bits set the measurement mode. For details, see [section 40.3.2. Measurement Modes](#).

**40.2.3 CTSUSDPRS : CTSU Synchronous Noise Reduction Setting Register**

Base address: CTSU = 0x400D\_0000

Offset address: 0x02

|                    |   |           |                 |                  |   |   |   |   |
|--------------------|---|-----------|-----------------|------------------|---|---|---|---|
| Bit position:      | 7 | 6         | 5               | 4                | 3 | 2 | 1 | 0 |
| Bit field:         | — | CTSU SOFF | CTSUPRMODE[1:0] | CTSUPRRATIO[3:0] |   |   |   |   |
| Value after reset: | 0 | 0         | 0               | 0                | 0 | 0 | 0 | 0 |

| Bit | Symbol           | Function  | R/W |
|-----|------------------|---|-----|
| 3:0 | CTSUPRRATIO[3:0] | CTSU Measurement Time and Pulse Count Adjustment<br>These bits set the measurement time and the measurement pulse count setting.<br>Recommended setting: 3 (0011b)                        | R/W |
| 5:4 | CTSUPRMODE[1:0]  | CTSU Base Period and Pulse Count Setting<br>These bits set the base pulse count.<br>0 0: 510 pulses<br>0 1: 126 pulses<br>1 0: 62 pulses (recommended setting)<br>1 1: Setting prohibited | R/W |
| 6   | CTSUSOFF         | CTSU High-Pass Noise Reduction Function Off Setting<br>This bit turns spectrum diffusion on or off to reduce high-pass noise.<br>0: Turn on<br>1: Turn off                                | R/W |
| 7   | —                | This bit is read as 0. The write value should be 0.   | R/W |

Only set the CTSUSDPRS register when the CTSUCR0.CTSUSTRT bit is 0.

**CTSUPRRATIO[3:0] bits (CTSU Measurement Time and Pulse Count Adjustment)**

The CTSUPRRATIO[3:0] bits are used to determine the measurement time and the measurement pulse count. These values are calculated using the following formulas, where the base pulse count is determined by the CTSUPRMODE[1:0] setting:

Measurement pulse count = base pulse count × (CTSUPRRATIO[3:0] bits + 1)

Measurement time = (base pulse count × (CTSUPRRATIO[3:0] bits + 1) + (base pulse count - 2) × 0.25) × base clock cycle

Note: For details on the base clock cycle, see [section 40.2.17. CTSUSO1 : CTSU Sensor Offset Register 1](#).

**CTSUPRMODE[1:0] bits (CTSU Base Period and Pulse Count Setting)**

The CTSUPRMODE[1:0] bits select the number of base pulses that occur during measurement.

**CTSUSOFF bit (CTSU High-Pass Noise Reduction Function Off Setting)**

The CTSUSOFF bit turns on or off the function for reducing high-pass noise. Set this bit to 1 to turn the function off.

**CTSUCLK[1:0]位 (CTSU工作时钟选择)**

CTSUCLK[1:0]位选择工作时钟。

**CTSUMD[1:0]位 (CTSU测量模式选择)**

CTSUMD[1:0]位设置测量模式。有关详细信息，请参阅第40.3.2节。测量模式。

**40.2.3 CTSUSDPRS:CTSU同步降噪设置寄存器**

Base address: CTSU = 0x400D\_0000

Offset address: 0x02

|               |   |           |                 |                  |   |   |   |   |
|---------------|---|-----------|-----------------|------------------|---|---|---|---|
| Bit position: | 7 | 6         | 5               | 4                | 3 | 2 | 1 | 0 |
| Bit field:    | — | CTSU SOFF | CTSUPRMODE[1:0] | CTSUPRRATIO[3:0] |   |   |   |   |
| 重置后的值:        | 0 | 0         | 0               | 0                | 0 | 0 | 0 | 0 |

| Bit | Symbol           | Function   | R/W |
|-----|------------------|--|-----|
| 3:0 | CTSUPRRATIO[3:0] | CTSU测量时间和脉冲计数调整<br>这些位设置测量时间和测量脉冲计数设置。<br>Recommended setting: 3 (0011b)         | R/W |
| 5:4 | CTSUPRMODE[1:0]  | CTSU基本周期和脉冲计数设置<br>这些位设置基本脉冲计数。<br>00: 510脉冲01: 126脉冲10: 62脉冲<br>(推荐设置) 11: 禁止设置 | R/W |
| 6   | CTSUSOFF         | CTSU高通降噪功能关闭设置<br>该位打开或关闭频谱扩散以减少高通噪声。<br>0: 开启1<br>: 关闭                          | R/W |
| 7   | —                | 该位读取为0。写入值应为0。   | R/W |

仅当CTSUCR0.CTSUSTRT位为0时设置CTSUSDPRS寄存器。

**CTSUPRRATIO[3:0]位 (CTSU测量时间和脉冲计数调整)**

CTSUPRRATIO[3:0]位用于确定测量时间和测量脉冲计数。这些值使用以下公式计算，其中基本脉冲计数由CTSUPRMODE[1:0]设置确定：

测量脉冲计数=基本脉冲计数×CTSUPRRATIO[3:0]位+1 )

测量时间=基本脉冲计数×CTSUPRRATIO[3:0]位+1+基本脉冲计数-2×0.25×基本时钟周期 )

Note: 有关基本时钟周期的详细信息，请参阅第40.2.17节。CTSUSO1: CTSU传感器偏移寄存器1。

**CTSUPRMODE[1:0]位 (CTSU基本周期和脉冲计数设置)**

CTSUPRMODE[1:0]位选择测量期间出现的基本脉冲数。

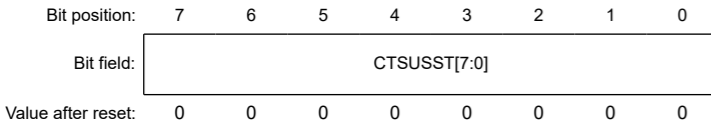
**CTSUSOFF位 (CTSU高通降噪功能关闭设置)**

CTSUSOFF位打开或关闭降低高通噪声的功能。将此位设置为1可关闭该功能。

## 40.2.4 CTSUSST : CTSU Sensor Stabilization Wait Control Register

Base address: CTSU = 0x400D\_0000

Offset address: 0x03



| Bit | Symbol       | Function   | R/W |
|-----|--------------|--|-----|
| 7:0 | CTSUSST[7:0] | CTSUSST Sensor Stabilization Wait Control<br>Fix the value of these bits to 00010000b. | R/W |

Only set the CTSUSST register when the CTSUCR0.CTSUSTRT bit is 0.

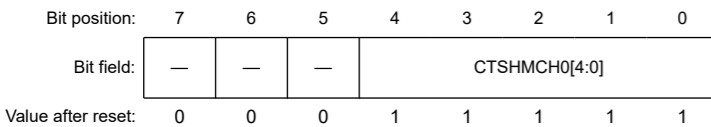
**CTSUSST[7:0] bits (CTSUSST Sensor Stabilization Wait Control)**

The CTSUSST[7:0] bits set the stabilization wait time for the TSCAP pin voltage. Always fix these bits to 00010000b. If these bits are not set, the TSCAP voltage will be unstable at the start of measurement, and the CTSU will be unable to obtain correct touch measurement results.

## 40.2.5 CTSUMCH0 : CTSU Measurement Channel Register 0

Base address: CTSU = 0x400D\_0000

Offset address: 0x04



| Bit | Symbol        | Function   | R/W              |
|-----|---------------|--|------------------|
| 4:0 | CTSHMCH0[4:0] | CTSUSST Measurement Channel 0<br>In self-capacitance single scan mode, these bits set the channel to be measured. Other than when specified, starting measurement operation by setting CTSUCR0.CTSUSTRT to 1 is prohibited after these bits are set. In other measurement modes, these bits indicate the channel that is currently being measured.<br><br>0x00: TS00<br>0x01: TS01<br>⋮<br>0x12: TS18<br>0x13: TS19<br>0x1F: Measurement is being stopped. (Except in self-capacitance single scan mode) | R/W <sup>1</sup> |
| 7:5 | —             | These bits are read as 0. The write value should be 0.   | R/W              |

Note 1. Writing to these bits is only enabled in self-capacitance single scan mode (CTSUCR1.CTSUMD[1:0] bits = 00b).

Only set the CTSUMCH0 register when the CTSUCR0.CTSUSTRT bit is 0.

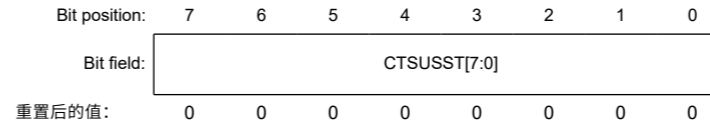
**CTSHMCH0[4:0] bits (CTSUSST Measurement Channel 0)**

In self-capacitance single scan mode, the CTSHMCH0[4:0] bits set the channel to be measured. In this mode, only specify enabled channels (TS00 to TS19). In other modes, these indicate the receive channel that is being measured, and writing to these bits has no effect.

## 40.2.4 CTSUSST:CTSUSST传感器稳定等待控制寄存器

Base address: CTSU = 0x400D\_0000

Offset address: 0x03



| Bit | Symbol       | Function                            | R/W |
|-----|--------------|-------------------------------------|-----|
| 7:0 | CTSUSST[7:0] | CTSUSST传感器稳定等待控制将这些位的值固定为00010000b。 | R/W |

仅当CTSUCR0.CTSUSTRT位为0时设置CTSUSST寄存器。

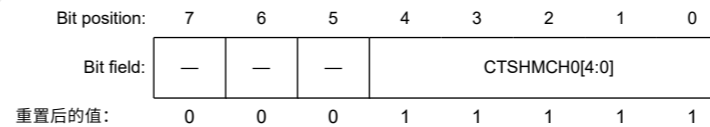
**CTSUSST[7:0]位 (CTSUSST传感器稳定等待控制)**

CTSUSST[7:0]位设置TSCAP引脚电压的稳定等待时间。始终将这些位固定为00010000b。如果未设置这些位，TSCAP电压将在测量开始时不稳定，CTSUSST将无法获得正确的触摸测量结果。

## 40.2.5 CTSUCH0:CTSUSST测量通道寄存器0

Base address: CTSU = 0x400D\_0000

Offset address: 0x04



| Bit | Symbol        | Function   | R/W              |
|-----|---------------|--|------------------|
| 4:0 | CTSHMCH0[4:0] | CTSUSST测量通道0<br>在自电容单次扫描模式下，这些位设置要测量的通道。除指定时，通过设置开始测量操作设置这些位后，禁止CTSUCR0.CTSUSTRT为1。在其他测量模式下，这些位指示当前正在测量的通道。<br><br>0x00: TS00<br>0x01: TS01<br>⋮<br>0x12: TS18<br>0x13: TS19<br>0x1F: 测量正在停止。(自电容单次扫描模式除外) | R/W <sup>1</sup> |
| 7:5 | —             | 这些位被读取为0。写入值应为0。   | R/W              |

注1.写入这些位仅在自电容单次扫描模式下启用 (CTSUCR1.CTSUMD[1:0]位=00b)。

仅当CTSUCR0.CTSUSTRT位为0时设置CTSUSST寄存器。

**CTSHMCH0[4:0]位 (CTSUSST测量通道0)**

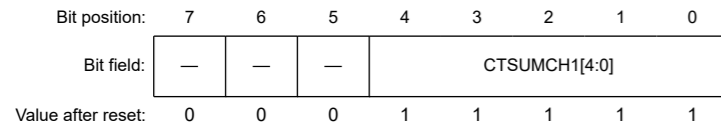
在自电容单次扫描模式下，CTSHMCH0[4:0]位设置要测量的通道。在此模式下，仅指定启用的通道 (TS00到TS19)。在其他模式下，这些表示正在测量的接收通道，写入这些位无效。



## 40.2.6 CTSUMCH1 : CTSU Measurement Channel Register 1

Base address: CTSU = 0x400D\_0000

Offset address: 0x05



| Bit | Symbol        | Function  | R/W |
|-----|---------------|---|-----|
| 4:0 | CTSUMCH1[4:0] | CTSUS Measurement Channel 1<br>0x00: TS00<br>0x01: TS01<br>⋮<br>0x12: TS18<br>0x13: TS19<br>0x1F: Measurement is being stopped. | R   |
| 7:5 | —             | These bits are read as 0.   | R   |

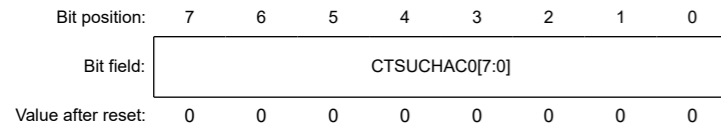
**CTSUSMCH1[4:0] bits (CTSUS Measurement Channel 1)**

In full scan mode, the CTSUSMCH1[4:0] bits indicate the transmit channel that is being measured. They are always 0x1F when measurement is stopped, or in self-capacitance single scan and multi-scan modes.

## 40.2.7 CTSUCHAC0 : CTSUS Channel Enable Control Register 0

Base address: CTSU = 0x400D\_0000

Offset address: 0x06



| Bit | Symbol         | Function   | R/W |
|-----|----------------|--|-----|
| 7:0 | CTSUCHAC0[7:0] | CTSUS Channel Enable Control 0<br>These bits select whether the associated TS pin is measured. bit0 is associated with TS00 and bit7 with TS07.<br>0: Do not measure<br>1: Measure | R/W |

Only set the CTSUCHAC0 register when the CTSUCR0.CTUSUSTR bit is 0.

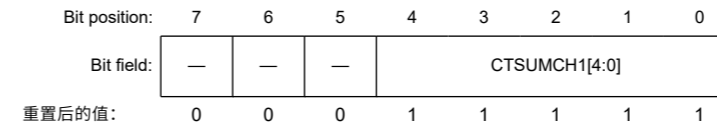
**CTSUCHAC0[7:0] bits (CTSUS Channel Enable Control 0)**

The CTSUCHAC0[7:0] bits select the receive and transmit pins whose electrostatic capacitance is to be measured.

## 40.2.6 CTSUCH1 : CTSUS测量通道寄存器1

Base address: CTSU = 0x400D\_0000

Offset address: 0x05



| Bit | Symbol         | Function   | R/W |
|-----|----------------|--|-----|
| 4:0 | CTSUSMCH1[4:0] | CTSUS测量通道1<br>0x00: TS00<br>0x01: TS01<br>⋮<br>0x12: TS18<br>0x13: TS19<br>0x1F: 测量正在停止。 | R   |
| 7:5 | —              | 这些位读为0。  | R   |

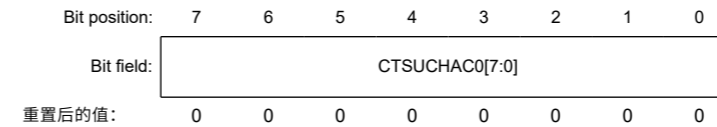
**CTSUSCH1[4:0]位 (CTSUS测量通道1)**

在全扫描模式下, CTSUSMCH1[4:0]位指示正在测量的发送通道。停止测量时, 或在自电容单次扫描和多次扫描模式下, 它们始终为0x1F。

## 40.2.7 CTSUCHAC0 : CTSUS通道使能控制寄存器0

Base address: CTSU = 0x400D\_0000

Offset address: 0x06



| Bit | Symbol         | Function  | R/W |
|-----|----------------|---|-----|
| 7:0 | CTSUCHAC0[7:0] | CTSUS通道使能控制0<br>这些位选择是否测量相关的TS引脚。bit0与TS00相关联, 而bit7与TS07相关联。<br>0: 不测量 1: 测量 | R/W |

仅当CTSUCR0.CTUSUSTR位为0时设置CTSUCHAC0寄存器。

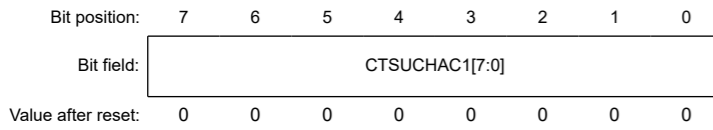
**CTSUCHAC0[7:0]位 (CTSUS通道使能控制0)**

CTSUCHAC0[7:0]位选择要测量其静电电容的接收和发送引脚。

## 40.2.8 CTSUCHAC1 : CTSU Channel Enable Control Register 1

Base address: CTSU = 0x400D\_0000

Offset address: 0x07



| Bit | Symbol         | Function   | R/W |
|-----|----------------|--|-----|
| 7:0 | CTSUCHAC1[7:0] | CTSUS Channel Enable Control 1<br>These bits select whether the associated TS pin is measured. bit0 is associated with TS08 and bit7 with TS15.<br>0: Do not measure<br>1: Measure | R/W |

Only set the CTSUCHAC1 register when the CTSUCR0.CTSUSTRT bit is 0.

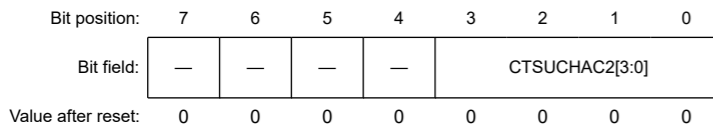
**CTSUCHAC1[7:0] bits (CTSUS Channel Enable Control 1)**

The CTSUCHAC1[7:0] bits select the receive and transmit pins whose electrostatic capacitance is to be measured.

## 40.2.9 CTSUCHAC2 : CTSUS Channel Enable Control Register 2

Base address: CTSU = 0x400D\_0000

Offset address: 0x08



| Bit | Symbol         | Function   | R/W |
|-----|----------------|--|-----|
| 3:0 | CTSUCHAC2[3:0] | CTSUS Channel Enable Control 2<br>These bits select whether the associated TS pin is measured. bit0 is associated with TS16 and bit3 with TS19.<br>0: Do not measure<br>1: Measure | R/W |
| 7:4 | —              | These bits are read as 0. The write value should be 0.   | R/W |

Only set the CTSUCHAC2 register when the CTSUCR0.CTSUSTRT bit = 0.

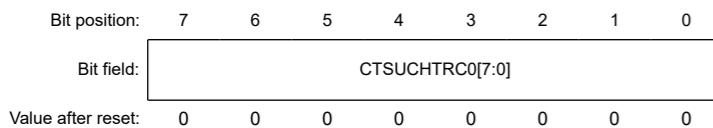
**CTSUCHAC2[3:0] bits (CTSUS Channel Enable Control 2)**

The CTSUCHAC2[3:0] bits select the receive and transmit pins whose electrostatic capacitance is to be measured.

## 40.2.10 CTSUCHTRC0 : CTSUS Channel Transmit/Receive Control Register 0

Base address: CTSU = 0x400D\_0000

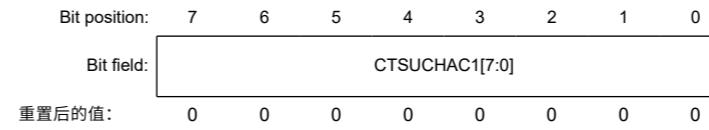
Offset address: 0x0B



## 40.2.8 CTSUCHAC1: CTSUS通道使能控制寄存器1

Base address: CTSU = 0x400D\_0000

Offset address: 0x07



| Bit | Symbol         | Function   | R/W |
|-----|----------------|--|-----|
| 7:0 | CTSUCHAC1[7:0] | CTSUS通道使能控制1<br>这些位选择是否测量相关的TS引脚。bit0与TS08相关联，而bit7与TS15相关联。<br>0: 不测量 1: 测量 | R/W |

仅当CTSUCR0.CTSUSTRT位为0时设置CTSUCHAC1寄存器。

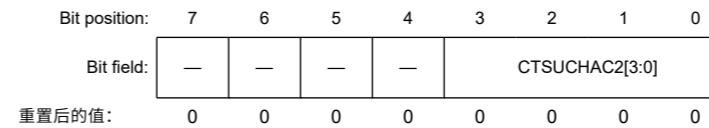
**CTSUCHAC1[7:0]位 (CTSUS通道使能控制1)**

CTSUCHAC1[7:0]位选择要测量其静电电容的接收和发送引脚。

## 40.2.9 CTSUCHAC2: CTSUS通道使能控制寄存器2

Base address: CTSU = 0x400D\_0000

Offset address: 0x08



| Bit | Symbol         | Function   | R/W |
|-----|----------------|--|-----|
| 3:0 | CTSUCHAC2[3:0] | CTSUS通道启用控制2<br>这些位选择是否测量相关的TS引脚。bit0与TS16相关联，而bit3与TS19相关联。<br>0: 不测量 1: 测量 | R/W |
| 7:4 | —              | 这些位被读取为0。写入值应为0。   | R/W |

仅当CTSUCR0.CTSUSTRT位=0时设置CTSUCHAC2寄存器。

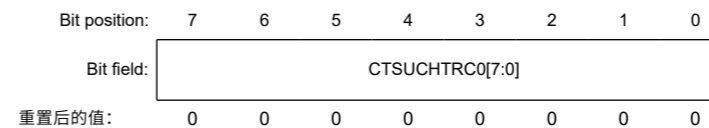
**CTSUCHAC2[3:0]位 (CTSUS通道使能控制2)**

CTSUCHAC2[3:0]位选择要测量其静电电容的接收和发送引脚。

## 40.2.10 CTSUCHTRC0: CTSUS通道发送接收控制寄存器0

Base address: CTSU = 0x400D\_0000

Offset address: 0x0B



| Bit | Symbol          | Function  | R/W |
|-----|-----------------|---|-----|
| 7:0 | CTSUCHTRC0[7:0] | CTSUS Channel Transmit/Receive Control 0<br>bit0 is associated with TS00 and bit7 with TS07.<br>0: Reception<br>1: Transmission | R/W |

Only set the CTSUCHTRC0 register when the CTSUCR0.CTSUSTRT bit is 0.

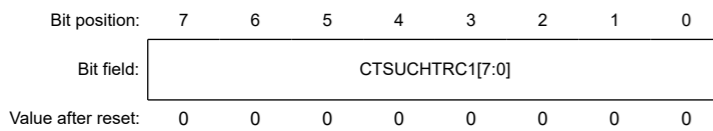
#### CTSUCHTRC0[7:0] bits (CTSUS Channel Transmit/Receive Control 0)

In full scan mode, the CTSUCHTRC0[7:0] bits allocate reception or transmission to the associated TS pins. The setting is ignored in self-capacitance single scan and multi-scan modes.

#### 40.2.11 CTSUCHTRC1 : CTSUS Channel Transmit/Receive Control Register 1

Base address: CTSUS = 0x400D\_0000

Offset address: 0x0C



| Bit | Symbol          | Function  | R/W |
|-----|-----------------|---|-----|
| 7:0 | CTSUCHTRC1[7:0] | CTSUS Channel Transmit/Receive Control 1<br>bit0 is associated with TS08 and bit7 with TS15.<br>0: Reception<br>1: Transmission | R/W |

Only set the CTSUCHTRC1 register when the CTSUCR0.CTSUSTRT bit is 0.

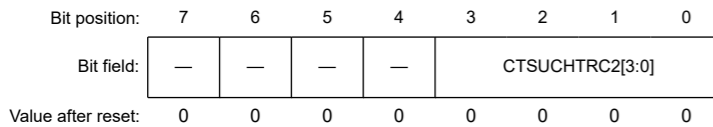
#### CTSUCHTRC1[7:0] bits (CTSUS Channel Transmit/Receive Control 1)

In full scan mode, the CTSUCHTRC1[7:0] bits allocate reception or transmission to the associated TS pins. The setting is ignored in self-capacitance single scan and multiscan modes.

#### 40.2.12 CTSUCHTRC2 : CTSUS Channel Transmit/Receive Control Register 2

Base address: CTSUS = 0x400D\_0000

Offset address: 0x0D



| Bit | Symbol          | Function  | R/W |
|-----|-----------------|---|-----|
| 3:0 | CTSUCHTRC2[3:0] | CTSUS Channel Transmit/Receive Control 2<br>bit0 is associated with TS16 and bit3 with TS19.<br>0: Reception<br>1: Transmission | R/W |
| 7:4 | —               | These bits are read as 0. The write value should be 0.  | R/W |

Only set the CTSUCHTRC2 register when the CTSUCR0.CTSUSTRT bit is 0.

#### CTSUCHTRC2[3:0] bits (CTSUS Channel Transmit/Receive Control 2)

In full scan mode, the CTSUCHTRC2[3:0] bits allocate reception or transmission to the associated TS pins. The setting is ignored in self-capacitance single scan and multiscan modes.

| Bit | Symbol          | Function  | R/W |
|-----|-----------------|---|-----|
| 7:0 | CTSUCHTRC0[7:0] | CTSUS通道发送接收控制0位0与TS00相关联，位7与TS07相关联。<br>0: 接收 1: 发送 | R/W |

仅在CTSUCR0.CTSUSTRT位为0时设置CTSUCHTRC0寄存器。

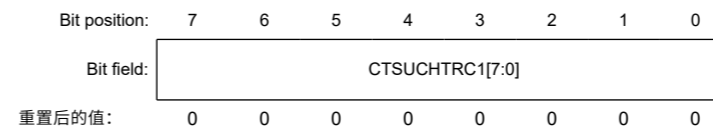
#### CTSUCHTRC0[7:0]位 (CTSUS通道发送接收控制0)

在全扫描模式下，CTSUCHTRC0[7:0]位将接收或发送分配给相关的TS引脚。在自电容单次扫描和多次扫描模式下，该设置被忽略。

#### 40.2.11 CTSUCHTRC1: CTSUS通道发送接收控制寄存器1

Base address: CTSUS = 0x400D\_0000

Offset address: 0x0C



| Bit | Symbol          | Function  | R/W |
|-----|-----------------|---|-----|
| 7:0 | CTSUCHTRC1[7:0] | CTSUS通道发送接收控制1位0与TS08相关联，位7与TS15相关联。<br>0: 接收 1: 发送 | R/W |

仅在CTSUCR0.CTSUSTRT位为0时设置CTSUCHTRC1寄存器。

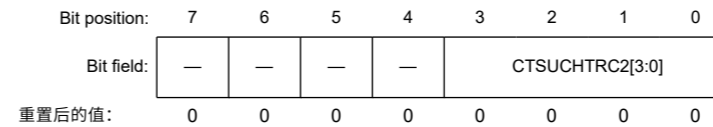
#### CTSUCHTRC1[7:0]位 (CTSUS通道发送接收控制1)

在全扫描模式下，CTSUCHTRC1[7:0]位将接收或发送分配给相关的TS引脚。在自电容单扫描和多扫描模式下，该设置被忽略。

#### 40.2.12 CTSUCHTRC2: CTSUS通道发送接收控制寄存器2

Base address: CTSUS = 0x400D\_0000

Offset address: 0x0D



| Bit | Symbol          | Function  | R/W |
|-----|-----------------|---|-----|
| 3:0 | CTSUCHTRC2[3:0] | CTSUS通道发送接收控制2位0与TS16相关联，位3与TS19相关联。<br>0: 接收 1: 发送 | R/W |
| 7:4 | —               | 这些位被读取为0。写入值应为0。                                    | R/W |

仅当CTSUCR0.CTSUSTRT位为0时设置CTSUCHTRC2寄存器。

#### CTSUCHTRC2[3:0]位 (CTSUS通道发送接收控制2)

在全扫描模式下，CTSUCHTRC2[3:0]位将接收或发送分配给相关的TS引脚。在自电容单扫描和多扫描模式下，该设置被忽略。

## 40.2.13 CTSUDCLKC : CTSU High-Pass Noise Reduction Control Register

Base address: CTSU = 0x400D\_0000

Offset address: 0x10

|                    |   |   |                |   |   |   |                |   |
|--------------------|---|---|----------------|---|---|---|----------------|---|
| Bit position:      | 7 | 6 | 5              | 4 | 3 | 2 | 1              | 0 |
| Bit field:         | — | — | CTSUSSCNT[1:0] | — | — | — | CTSUSSMOD[1:0] | — |
| Value after reset: | 0 | 0 | 0              | 0 | 0 | 0 | 0              | 0 |

| Bit | Symbol         | Function  | R/W |
|-----|----------------|---|-----|
| 1:0 | CTSUSSMOD[1:0] | CTSU Diffusion Clock Mode Select<br>Set these bits to 00b.  | R/W |
| 3:2 | —              | These bits are read as 0. The write value should be 0.      | R/W |
| 5:4 | CTSUSSCNT[1:0] | CTSU Diffusion Clock Mode Control<br>Set these bits to 11b. | R/W |
| 7:6 | —              | These bits are read as 0. The write value should be 0.      | R/W |

Only set the CTSUDCLKC register when the CTSUCR0.CTSUSTRT bit is 0.

**CTSUSSMOD[1:0] bits (CTSU Diffusion Clock Mode Select)**

The CTSUSSMOD[1:0] bits set the mode of the spectrum diffusion clock for high-pass noise reduction. When using the high-pass function, always fix these bits to 00b. If these bits are not set, the CTSU will be unable to effectively reduce high-pass noise.

**CTSUSSCNT[1:0] bits (CTSU Diffusion Clock Mode Control)**

The CTSUSSCNT[1:0] bits adjust the amount of spectrum diffusion applied to reduce high-pass noise. When using the high-pass noise reduction function, always fix these bits to 11b. If these bits are not set, touch measurement might be performed incorrectly.

## 40.2.14 CTSUST : CTSU Status Register

Base address: CTSU = 0x400D\_0000

Offset address: 0x11

|                    |         |           |           |           |   |   |              |   |
|--------------------|---------|-----------|-----------|-----------|---|---|--------------|---|
| Bit position:      | 7       | 6         | 5         | 4         | 3 | 2 | 1            | 0 |
| Bit field:         | CTSU PS | CTSU ROVF | CTSU SOVF | CTSU DTSR | — | — | CTSUSTC[2:0] | — |
| Value after reset: | 0       | 0         | 0         | 0         | 0 | 0 | 0            | 0 |

| Bit | Symbol       | Function   | R/W |
|-----|--------------|--|-----|
| 2:0 | CTSUSTC[2:0] | CTSU Measurement Status Counter<br>These counters indicate the current measurement status.<br>0 0 0: Status 0<br>0 0 1: Status 1<br>0 1 0: Status 2<br>0 1 1: Status 3<br>1 0 0: Status 4<br>1 0 1: Status 5 | R   |
| 3   | —            | This bit is read as 0. The write value should be 0.  | R/W |
| 4   | CTSUDTSR     | CTSU Data Transfer Status Flag<br>This flag indicates whether the measurement result stored in the sensor counter and the reference counter was read.<br>0: Read<br>1: Not read                              | R   |

## 40.2.13 CTSUDCLKC:CTSU高通降噪控制寄存器

Base address: CTSU = 0x400D\_0000

Offset address: 0x10

|               |   |   |                |   |   |   |                |   |
|---------------|---|---|----------------|---|---|---|----------------|---|
| Bit position: | 7 | 6 | 5              | 4 | 3 | 2 | 1              | 0 |
| Bit field:    | — | — | CTSUSSCNT[1:0] | — | — | — | CTSUSSMOD[1:0] | — |
| 重置后的值:        | 0 | 0 | 0              | 0 | 0 | 0 | 0              | 0 |

| Bit | Symbol         | Function                    | R/W |
|-----|----------------|-----------------------------|-----|
| 1:0 | CTSUSSMOD[1:0] | CTSU扩散时钟模式选择<br>将这些位设置为00b。 | R/W |
| 3:2 | —              | 这些位被读取为0。写入值应为0。            | R/W |
| 5:4 | CTSUSSCNT[1:0] | CTSU扩散时钟模式控制<br>将这些位设置为11b。 | R/W |
| 7:6 | —              | 这些位被读取为0。写入值应为0。            | R/W |

仅当CTSUCR0.CTSUSTRT位为0时设置CTSUDCLKC寄存器。

**CTSUSSMOD[1:0]位 (CTSU扩散时钟模式选择)**

CTSUSSMOD[1:0]位设置频谱扩散时钟的模式以降低高通噪声。使用高通功能时，请始终将这些位固定为00b。如果未设置这些位，CTSU将无法有效降低高通噪声。

**CTSUSSCNT[1:0]位 (CTSU扩散时钟模式控制)**

CTSUSSCNT[1:0]位调整应用的频谱扩散量以减少高通噪声。使用高通降噪功能时，请始终将这些位固定为11b。如果未设置这些位，则可能会错误地执行触摸测量。

## 40.2.14 CTSUST:CTSU状态寄存器

Base address: CTSU = 0x400D\_0000

Offset address: 0x11

|               |         |           |           |           |   |   |              |   |
|---------------|---------|-----------|-----------|-----------|---|---|--------------|---|
| Bit position: | 7       | 6         | 5         | 4         | 3 | 2 | 1            | 0 |
| Bit field:    | CTSU PS | CTSU ROVF | CTSU SOVF | CTSU DTSR | — | — | CTSUSTC[2:0] | — |
| 重置后的值:        | 0       | 0         | 0         | 0         | 0 | 0 | 0            | 0 |

| Bit | Symbol       | Function   | R/W |
|-----|--------------|--|-----|
| 2:0 | CTSUSTC[2:0] | CTSU测量状态计数器<br>这些计数器指示当前的测量状态。<br>0 0 0: Status 0<br>0 0 1: Status 1<br>0 1 0: Status 2<br>0 1 1: Status 3<br>1 0 0: Status 4<br>1 0 1: Status 5 | R   |
| 3   | —            | 该位读取为0。写入值应为0。   | R/W |
| 4   | CTSUDTSR     | CTSU数据传输状态标志<br>该标志指示存储在传感器计数器和参考计数器中的测量结果是否被读取。<br>0: 读取1:<br>未读取   | R   |



| Bit | Symbol   | Function   | R/W |
|-----|----------|--|-----|
| 5   | CTSUSOVF | CTSU Sensor Counter Overflow Flag<br>This flag indicates an overflow on the sensor counter.<br>0: No overflow occurred<br>1: Overflow occurred                           | R/W |
| 6   | CTSUROVF | CTSU Reference Counter Overflow Flag<br>This flag indicates an overflow on the reference counter.<br>0: No overflow occurred<br>1: Overflow occurred                     | R/W |
| 7   | CTSUPS   | CTSU Mutual Capacitance Status Flag<br>This flag indicates the measurement status in mutual capacitance full scan mode.<br>0: First measurement<br>1: Second measurement | R   |

When using the CTSUCR0.CTSUINIT bit to clear an overflow flag, make sure that the CTSUCR0.CTSUSTRT bit is 0.

#### CTSUSTC[2:0] flags (CTSU Measurement Status Counter)

The CTSUSTC[2:0] flags are a counter indicating the current measurement status. For details on each status, see [section 40.3.2.2. Status counter](#).

#### CTSUDTSR flag (CTSU Data Transfer Status Flag)

The CTSUDTSR flag indicates whether the measurement result stored in the sensor counter and the reference counter was read. The flag sets to 1 when measurement completes and 0 when the reference counter is read by software or the DTC. The flag can also be cleared using the CTSUCR0.CTSUINIT bit.

#### CTSUSOVF flag (CTSU Sensor Counter Overflow Flag)

The CTSUSOVF flag sets to 1 when the sensor counter, CTSUSC, overflows. On overflow, the counter value reads as 0xFFFF. Measurement processing continues for the specified period.

No interrupt occurs on an overflow. To determine the channel on which the overflow occurred, read the measurement result of each channel after measurement completes, signaled by a measurement end interrupt.

This flag is cleared when 0 is written after 1 is read by software. It can also be cleared using the CTSUCR0.CTSUINIT bit.

#### CTSUROVF flag (CTSU Reference Counter Overflow Flag)

The CTSUROVF flag sets to 1 when the reference counter, CTSURC, overflows. On overflow, the counter value reads as 0xFFFF. Measurement processing continues for the specified period.

No interrupt occurs on an overflow. To determine the channel on which the overflow occurred, read the measurement result of each channel after measurement completes, signaled by a measurement end interrupt.

This flag is cleared when 0 is written after 1 is read by software. It can also be cleared using the CTSUCR0.CTSUINIT bit.

#### CTSUPS flag (CTSU Mutual Capacitance Status Flag)

In mutual capacitance full scan mode, when CTSUCR1.CTSUMD[1:0] = 11b, the CTSUPS flag indicates whether the measurement is the first or second of two measurements for each channel. When measurement is stopped or in other measurement modes, this flag is always 0.

### 40.2.15 CTSUSSC : CTSU High-Pass Noise Reduction Spectrum Diffusion Control Register

Base address: CTSU = 0x400D\_0000

Offset address: 0x12

| Bit position:      | 15 | 14 | 13 | 12 | 11             | 10 | 9 | 8 | 7 | 6 | 5 | 4 | 3 | 2 | 1 | 0 |
|--------------------|----|----|----|----|----------------|----|---|---|---|---|---|---|---|---|---|---|
| Bit field:         | —  | —  | —  | —  | CTSUSSDIV[3:0] |    |   |   | — | — | — | — | — | — | — | — |
| Value after reset: | 0  | 0  | 0  | 0  | 0              | 0  | 0 | 0 | 0 | 0 | 0 | 0 | 0 | 0 | 0 | 0 |

| Bit | Symbol   | Function  | R/W |
|-----|----------|---|-----|
| 5   | CTSUSOVF | CTSU传感器计数器溢出标志<br>该标志表示传感器计数器溢出。<br>0: 未发生溢出1: 发生溢出     | R/W |
| 6   | CTSUROVF | CTSU参考计数器溢出标志<br>该标志表示参考计数器溢出。<br>0: 未发生溢出1: 发生溢出       | R/W |
| 7   | CTSUPS   | CTSU互电容状态标志<br>该标志指示互电容全扫描模式下的测量状态。<br>0: 第一次测量1: 第二次测量 | R   |

使用CTSUCR0.CTSUINIT位清除溢出标志时，请确保CTSUCR0.CTSUSTRT位为0。

#### CTSUSTC[2:0]标志 (CTSU测量状态计数器)

CTSUSTC[2:0]标志是指示当前测量状态的计数器。有关每个状态的详细信息，请参阅第40.3.2.2节。状态计数器。

#### CTSUDTSR标志 (CTSU数据传输状态标志)

CTSUDTSR标志指示存储在传感器计数器和参考计数器中的测量结果是否被读取。当测量完成时，该标志设置为1，当软件或DTC读取参考计数器时，该标志设置为0。也可以使用CTSUCR0.CTSUINIT位清除该标志。

#### CTSUSOVF标志 (CTSU传感器计数器溢出标志)

当传感器计数器CTSUSC溢出时，CTSUSOVF标志设置为1。溢出时，计数器值读取为0xFFFF。测量处理持续指定的时间。

溢出时不发生中断。要确定发生溢出的通道，请在测量完成后读取每个通道的测量结果，由测量结束中断发出信号。

当软件读取1后写入0时清除该标志。它也可以使用CTSUCR0.CTSUINIT位清零。

#### CTSUROVF标志 (CTSU参考计数器溢出标志)

当参考计数器CTSURC溢出时，CTSUROVF标志设置为1。溢出时，计数器值读取为0xFFFF。测量处理持续指定的时间。

溢出时不发生中断。要确定发生溢出的通道，请在测量完成后读取每个通道的测量结果，由测量结束中断发出信号。

当软件读取1后写入0时清除该标志。它也可以使用CTSUCR0.CTSUINIT位清零。

#### CTSUPS标志 (CTSU互电容状态标志)

在互电容全扫描模式下，当CTSUCR1.CTSUMD[1:0]=11b时，CTSUPS标志指示测量是每个通道的两次测量中的第一个还是第二个。当测量停止或处于其他测量模式时，该标志始终为0。

### 40.2.15 CTSUSSC:CTSU高通降噪频谱扩散控制 Register

Base address: CTSU = 0x400D\_0000

Offset address: 0x12

| Bit position: | 15 | 14 | 13 | 12 | 11             | 10 | 9 | 8 | 7 | 6 | 5 | 4 | 3 | 2 | 1 | 0 |
|---------------|----|----|----|----|----------------|----|---|---|---|---|---|---|---|---|---|---|
| Bit field:    | —  | —  | —  | —  | CTSUSSDIV[3:0] |    |   |   | — | — | — | — | — | — | — | — |
| 重置后的值:        | 0  | 0  | 0  | 0  | 0              | 0  | 0 | 0 | 0 | 0 | 0 | 0 | 0 | 0 | 0 | 0 |

| Bit   | Symbol         | Function   | R/W |
|-------|----------------|--|-----|
| 7:0   | —              | These bits are read as 0. The write value should be 0.   | R/W |
| 11:8  | CTSUSSDIV[3:0] | CTSU Spectrum Diffusion Frequency Division Setting<br>These bits specify the spectrum diffusion frequency division setting based on the base clock frequency division setting. | R/W |
| 15:12 | —              | These bits are read as 0. The write value should be 0.   | R/W |

**CTSUSSDIV[3:0] bits (CTSU Spectrum Diffusion Frequency Division Setting)**

The CTSUSSDIV[3:0] bits specify the spectrum diffusion frequency derived from the base clock frequency division setting. To calculate the correct setting for CTSUSSDIV[3:0], see the relationship between base clock frequencies and the settings in Table 40.6.

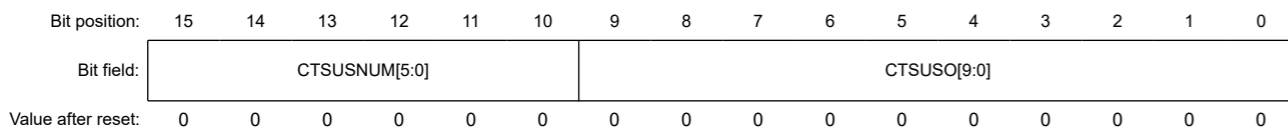
**Table 40.6 Relationship between base clock frequencies and CTSUSSDIV[3:0] bits settings**

| Base clock frequency fb (MHz) | CTSUSSDIV[3:0] bit setting |
|-------------------------------|----------------------------|
| 4.00 ≤ fb                     | 0000b                      |
| 2.00 ≤ fb < 4.00              | 0001b                      |
| 1.33 ≤ fb < 2.00              | 0010b                      |
| 1.00 ≤ fb < 1.33              | 0011b                      |
| 0.80 ≤ fb < 1.00              | 0100b                      |
| 0.67 ≤ fb < 0.80              | 0101b                      |
| 0.57 ≤ fb < 0.67              | 0110b                      |
| 0.50 ≤ fb < 0.57              | 0111b                      |
| 0.44 ≤ fb < 0.50              | 1000b                      |
| 0.40 ≤ fb < 0.44              | 1001b                      |
| 0.36 ≤ fb < 0.40              | 1010b                      |
| 0.33 ≤ fb < 0.36              | 1011b                      |
| 0.31 ≤ fb < 0.33              | 1100b                      |
| 0.29 ≤ fb < 0.31              | 1101b                      |
| 0.27 ≤ fb < 0.29              | 1110b                      |
| fb < 0.27                     | 1111b                      |

**40.2.16 CTSUSO0 : CTSU Sensor Offset Register 0**

Base address: CTSU = 0x400D\_0000

Offset address: 0x14



| Bit | Symbol      | Function  | R/W |
|-----|-------------|---|-----|
| 9:0 | CTSUSO[9:0] | CTSU Sensor Offset Adjustment<br>These bits adjust the electronic capacitance when the electrode is not being touched.<br>0x000: Current offset is 0.<br>0x001: Current offset is 1.<br>0x002: Current offset is 2.<br>⋮<br>0x3FE: Current offset is 1022.<br>0x3FF: Current offset is maximum. | R/W |

| Bit   | Symbol         | Function                                  | R/W |
|-------|----------------|---|-----|
| 7:0   | —              | 这些位被读取为0。写入值应为0。                          | R/W |
| 11:8  | CTSUSSDIV[3:0] | CTSU频谱扩散频分设置<br>这些位指定基于基本时钟频率设置的频谱扩散频分设置。 | R/W |
| 15:12 | —              | 这些位被读取为0。写入值应为0。                          | R/W |

**CTSUSSDIV[3:0]位 (CTSU频谱扩散频分设置)**

CTSUSSDIV[3:0]位指定从基本时钟频率设置得出的频谱扩散频率。要计算CTSUSSDIV[3:0]的正确设置，请参见表40.6中基本时钟频率和设置之间的关系。

**Table 40.6 基本时钟频率与CTSUSSDIV[3:0]位设置之间的关系**

| 基本时钟频率fb(MHz)    | CTSUSSDIV[3:0]位设置 |
|------------------|-------------------|
| 4.00 ≤ fb        | 0000b             |
| 2.00 ≤ fb < 4.00 | 0001b             |
| 1.33 ≤ fb < 2.00 | 0010b             |
| 1.00 ≤ fb < 1.33 | 0011b             |
| 0.80 ≤ fb < 1.00 | 0100b             |
| 0.67 ≤ fb < 0.80 | 0101b             |
| 0.57 ≤ fb < 0.67 | 0110b             |
| 0.50 ≤ fb < 0.57 | 0111b             |
| 0.44 ≤ fb < 0.50 | 1000b             |
| 0.40 ≤ fb < 0.44 | 1001b             |
| 0.36 ≤ fb < 0.40 | 1010b             |
| 0.33 ≤ fb < 0.36 | 1011b             |
| 0.31 ≤ fb < 0.33 | 1100b             |
| 0.29 ≤ fb < 0.31 | 1101b             |
| 0.27 ≤ fb < 0.29 | 1110b             |
| fb < 0.27        | 1111b             |

**40.2.16 CTSUSO0: CTSU传感器偏移寄存器0**

Base address: CTSU = 0x400D\_0000

Offset address: 0x14



| Bit | Symbol      | Function  | R/W |
|-----|-------------|---|-----|
| 9:0 | CTSUSO[9:0] | CTSU传感器偏移调整<br>这些位在电极未被触摸时调整电子电容。<br>0x000: 当前偏移为0。0x001: 当前偏移为1。0x002: 当前偏移为2。<br>⋮<br>0x3FE: 当前偏移量为1022。0x3FF: 当前偏移量最大。 | R/W |

| Bit   | Symbol        | Function  | R/W |
|-------|---------------|---|-----|
| 15:10 | CTSUSNUM[5:0] | CTSUS Measurement Count Setting<br>These bits set the number of measurements. | R/W |

**CTSUSO[9:0] bits (CTSUS Sensor Offset Adjustment)**

The CTSUSO[9:0] bits offset the sensor ICO input current generated from electrostatic capacitance during touch measurement when the electrode is not being touched. This prevents the CTSUS sensor counter from overflowing. Set the TS pin that is to be measured next after a CTSUS\_CTSUWR interrupt occurs.

**CTSUSNUM[5:0] bits (CTSUS Measurement Count Setting)**

The CTSUSNUM[5:0] bits specify how many times the measurement pulse count specified in the CTSUSDPRS.CTSUPRRATIO[3:0] and CTSUSDPRS.CTSUPRMODE[1:0] bits is repeated during the measurement time. The measurement pulse count is repeated (CTSUSNUM[5:0] bits + 1) times. Set the TS pin that is to be measured next after a CTSUS\_CTSUWR interrupt is generated.

**40.2.17 CTSUSO1 : CTSUS Sensor Offset Register 1**

Base address: CTSUS = 0x400D\_0000

Offset address: 0x16

| Bit position:      | 15 | 14 | 13             | 12 | 11            | 10 | 9 | 8 | 7              | 6 | 5 | 4 | 3 | 2 | 1 | 0 |
|--------------------|----|----|----------------|----|---------------|----|---|---|----------------|---|---|---|---|---|---|---|
| Bit field:         | —  |    | CTSUSICOG[1:0] |    | CTSUSDPA[4:0] |    |   |   | CTSURICOA[7:0] |   |   |   |   |   |   |   |
| Value after reset: | 0  | 0  | 0              | 0  | 0             | 0  | 0 | 0 | 0              | 0 | 0 | 0 | 0 | 0 | 0 | 0 |

| Bit | Symbol         | Function   | R/W |
|-----|----------------|--|-----|
| 7:0 | CTSURICOA[7:0] | CTSUS Reference ICO Current Adjustment<br>These bits adjust the input current of the reference ICO.<br>0x00: Current offset is 0<br>0x01: Current offset is 1<br>0x02: Current offset is 2<br>⋮<br>0xFE: Current offset is 254<br>0xFF: Current offset is maximum. | R/W |

| Bit   | Symbol        | Function                  | R/W |
|-------|---------------|---------------------------|-----|
| 15:10 | CTSUSNUM[5:0] | CTSUS测量计数设置<br>这些位设置测量次数。 | R/W |

**CTSUSO[9:0]位 (CTSUS传感器偏移调整)**

CTSUSO[9:0]位在电极未被触摸时在触摸测量期间抵消由静电电容产生的传感器ICO输入电流。这可以防止CTSUS传感器计数器溢出。在发生CTSUS\_CTSUWR中断后设置接下来要测量的TS引脚。

**CTSUSNUM[5:0]位 (CTSUS测量计数设置)**

CTSUSNUM[5:0]位指定测量脉冲计数的次数。CTSUSDPRS.CTSUPRRATIO[3:0]和CTSUSDPRS.CTSUPRMODE[1:0]位在测量期间重复。测量脉冲计数重复(CTSUSNUM[5:0]位+1)次。在产生CTSUS\_CTSUWR中断后设置接下来要测量的TS引脚。

**40.2.17 CTSUSO1: CTSUS传感器偏移寄存器1**

Base address: CTSUS = 0x400D\_0000

Offset address: 0x16

| Bit position: | 15 | 14 | 13             | 12 | 11            | 10 | 9 | 8 | 7              | 6 | 5 | 4 | 3 | 2 | 1 | 0 |
|---------------|----|----|----------------|----|---------------|----|---|---|----------------|---|---|---|---|---|---|---|
| Bit field:    | —  |    | CTSUSICOG[1:0] |    | CTSUSDPA[4:0] |    |   |   | CTSURICOA[7:0] |   |   |   |   |   |   |   |
| 重置后的值:        | 0  | 0  | 0              | 0  | 0             | 0  | 0 | 0 | 0              | 0 | 0 | 0 | 0 | 0 | 0 | 0 |

| Bit | Symbol         | Function   | R/W |
|-----|----------------|--|-----|
| 7:0 | CTSURICOA[7:0] | CTSUS参考ICO电流调整<br>这些位调整参考ICO的输入电流。<br>0x00: 当前偏移为0x0<br>1: 当前偏移为10x02:<br>当前偏移为2<br>⋮<br>0xFE: 当前偏移量为254x0FF: 当前偏移量最大。 | R/W |

| Bit   | Symbol        | Function  | R/W |
|-------|---------------|---|-----|
| 12:8  | CTSUSDPA[4:0] | CTSU Base Clock Setting<br>These bits are used to generate the base clock.<br>0x00: Operating clock divided by 2 <sup>1</sup><br>0x01: Operating clock divided by 4<br>0x02: Operating clock divided by 6<br>0x03: Operating clock divided by 8<br>0x04: Operating clock divided by 10<br>0x05: Operating clock divided by 12<br>0x06: Operating clock divided by 14<br>0x07: Operating clock divided by 16<br>0x08: Operating clock divided by 18<br>0x09: Operating clock divided by 20<br>0x0A: Operating clock divided by 22<br>0x0B: Operating clock divided by 24<br>0x0C: Operating clock divided by 26<br>0x0D: Operating clock divided by 28<br>0x0E: Operating clock divided by 30<br>0x0F: Operating clock divided by 32<br>0x10: Operating clock divided by 34<br>0x11: Operating clock divided by 36<br>0x12: Operating clock divided by 38<br>0x13: Operating clock divided by 40<br>0x14: Operating clock divided by 42<br>0x15: Operating clock divided by 44<br>0x16: Operating clock divided by 46<br>0x17: Operating clock divided by 48<br>0x18: Operating clock divided by 50<br>0x19: Operating clock divided by 52<br>0x1A: Operating clock divided by 54<br>0x1B: Operating clock divided by 56<br>0x1C: Operating clock divided by 58<br>0x1D: Operating clock divided by 60<br>0x1E: Operating clock divided by 62<br>0x1F: Operating clock divided by 64 | R/W |
| 14:13 | CTSUICOG[1:0] | CTSU ICO Gain Adjustment<br>These bits adjust the output frequency gain of the sensor ICO and the reference ICO.<br>0 0: 100% gain<br>0 1: 66% gain<br>1 0: 50% gain<br>1 1: 40% gain   | R/W |
| 15    | —             | This bit is read as 0. The write value should be 0.   | R/W |

Note 1. Do not set the CTSUSDPA[4:0] bits set to 00000b while the high-pass noise reduction function is turned off (CTSUSDPRS.CTUSOFF bit = 1) in mutual capacitance full scan mode (CTSUCR1.CTUMD[1:0] bits = 11b).

After a CTSU\_CTSUWR interrupt occurs, write first to the CTSUSSC register, next to the CTSUSO0 register, and then to the CTSUSO1 register. The write to the CTSUSO1 register causes a transition to Status 3. (See Table 40.7 and Table 40.8.) Set all of the bits in a single operation when writing to the CTSUSO1 register.

#### CTSURICOA[7:0] bits (CTSUS Reference ICO Current Adjustment)

The CTSURICOA[7:0] bits adjust the oscillation frequency using the input current of the reference ICO.

#### CTSUSDPA[4:0] bits (CTSUS Base Clock Setting)

The CTSUSDPA[4:0] bits select the base clock used as the source for the sensor drive pulse by dividing the operating clock. For details on the setting procedure, see section 40.3.2.1. Initial settings flow.

#### CTSUICOG[1:0] bits (CTSUS ICO Gain Adjustment)

The CTSUICOG[1:0] bits adjust the output frequency gain of the sensor ICO and the reference ICO. Normally, set these bits to 00b for the maximum gain. If changes in the capacitance between when the electrode is touched and when it is not touched greatly exceed the dynamic range of the sensor ICO, adjust the gain appropriately with this setting.

| Bit   | Symbol        | Function   | R/W |
|-------|---------------|--|-----|
| 12:8  | CTSUSDPA[4:0] | CTSU基本时钟设置<br>这些位用于生成基本时钟。<br>0x00: 工作时钟除以2+1<br>0x01: 工作时钟4分频0x02: 工作时钟6分频0x03: 工作时钟8分频0x04: 工作时钟10分频0x05: 工作时钟12分频0x06: 工作时钟14分频0x07: 工作时钟16分频0x08: 工作时钟除以180x09: 工作时钟除以200x0A: 工作时钟除以220x0B: 工作时钟除以240x0C: 工作时钟除以260x0D: 工作时钟除以280x0E: 工作时钟除以300x0F: 工作时钟32分频0x10: 工作时钟34分频0x11: 工作时钟36分频0x12: 工作时钟38分频0x13: 工作时钟40分频0x14: 工作时钟42分频0x15: 工作时钟44分频0x16: 工作时钟46分频0x17: 工作时钟48分频0x18: 工作时钟50分频0x19: 工作时钟52分频0x1A: 工作时钟54分频0x1B: 工作时钟56分频0x1C: 工作时钟分频by580x1D: 工作时钟除以600x1E: 工作时钟除以620x1F: 工作时钟除以64 | R/W |
| 14:13 | CTSUICOG[1:0] | CTSUICO增益调整<br>这些位调整传感器ICO和参考ICO的输出频率增益。<br>0 0: 100% gain<br>0 1: 66% gain<br>1 0: 50% gain<br>1 1: 40% gain  | R/W |
| 15    | —             | 该位读取为0。写入值应为0。   | R/W |

注1.关闭高通降噪功能时，请勿将CTSUSDPA[4:0]位设置为00000b (CTSUSDPRS.CTUSOFF位=1) 在互电容全扫描模式下 (CTSUCR1.CTUMD[1:0]位=11b)。

发生CTSUSO1寄存器中断后，先写入CTSUSSC寄存器，然后写入CTSUSO0寄存器，然后写入CTSUSO1寄存器。写入CTSUSO1寄存器会导致转换到状态3。（参见表40.7和表40.8。）在写入CTSUSO1寄存器时，在一次操作中设置所有位。

#### CTSURICOA[7:0]位 (CTSUS参考ICO电流调整)

CTSURICOA[7:0]位使用参考ICO的输入电流调整振荡频率。

#### CTSUSDPA[4:0]位 (CTSUS基本时钟设置)

CTSUSDPA[4:0]位通过对工作时钟进行分频来选择用作传感器驱动脉冲源的基本时钟。有关设置过程的详细信息，请参阅第40.3.2.1节。初始设置流程。

#### CTSUICOG[1:0]位 (CTSUSICO增益调整)

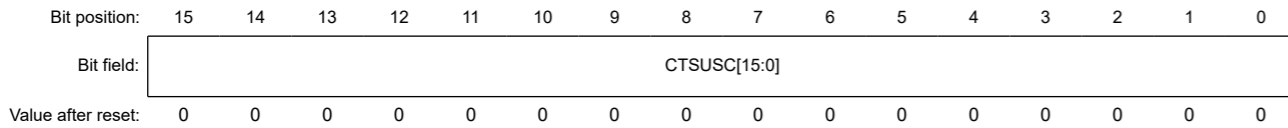
CTSUICOG[1:0]位调整传感器ICO和参考ICO的输出频率增益。通常，将这些位设置为00b以获得最大增益。如果触摸电极和未触摸电极之间的电容变化大大超过传感器ICO的动态范围，请使用此设置适当调整增益。



## 40.2.18 CTSUSC : CTSU Sensor Counter

Base address: CTSU = 0x400D\_0000

Offset address: 0x18



| Bit  | Symbol       | Function   | R/W |
|------|--------------|--|-----|
| 15:0 | CTSUSC[15:0] | CTSUSC Sensor Counter<br>These bits indicate the measurement result of the sensor ICO. They read 0xFFFF when an overflow occurs. | R   |

After a CTSU\_CTSURD interrupt occurs, read first from the CTSUSC counter and then from the CTSURC counter.

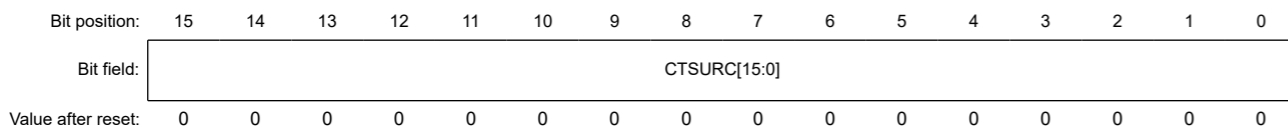
**CTSUSC[15:0] bits (CTSUSC Sensor Counter)**

The CTSUSC[15:0] bits are configured as an increment counter for the sensor ICO clock. Read these bits after a CTSU\_CTSURD interrupt occurs. After the CTSURC counter is read, these bits are cleared immediately before the CTSU measurement status counter value changes to Status 4 (the CTSUST.CTSUSTC[2:0] flags changes to 100b) in the next measurement. They can also be cleared using the CTSUCR0.CTSUINIT bit.

## 40.2.19 CTSURC : CTSU Reference Counter

Base address: CTSU = 0x400D\_0000

Offset address: 0x1A



| Bit  | Symbol       | Function  | R/W |
|------|--------------|---|-----|
| 15:0 | CTSURC[15:0] | CTSURC Reference Counter<br>These bits indicate the measurement result of the reference ICO. They read FFFFh when an overflow occurs. | R   |

After a CTSU\_CTSURD interrupt occurs, read first from the CTSUSC counter and then from the CTSURC counter.

Status 3 continues until the CTSURC counter is read, even if the stabilization time specified for Status 3 elapses.

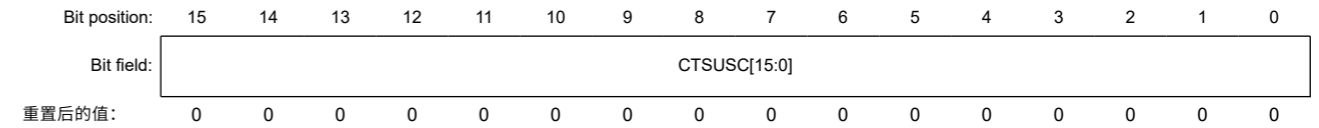
**CTSURC[15:0] bits (CTSURC Reference Counter)**

The CTSURC[15:0] bits are configured as an increment counter for the reference ICO clock. The reference ICO optimizes touch measurement performed by the sensor ICO. There is some deviation depending on the internal sensor ICO and the reference ICO in the CTSU, but both ICOs have almost the same characteristics, including the dynamic range and the current-to-frequency characteristics. The range of current amount that can be set in the reference ICO current adjustment bits is about the same as the dynamic range of both ICOs, and the current amount input to the sensor ICO must be within this dynamic range. To ensure this, use the reference ICO to check the differences between the ICOs and measure the current-to-oscillation frequency characteristics. Because the reference ICO oscillation frequency can be obtained from the reference ICO counter, the ICO oscillation frequency (counter value/measurement time) for the input current amount can be measured by setting the value in the reference ICO current adjustment bits and measuring the reference ICO counter. The reference ICO counter value measured using the maximum value in the reference ICO current adjustment bits is the maximum value of the ICO dynamic range. The current to the sensor ICO must be offset in the offset adjustment bits so that the sensor ICO counter value does not exceed this value.

## 40.2.18 CTSUSC:CTSUSC传感器计数器

Base address: CTSU = 0x400D\_0000

Offset address: 0x18



| Bit  | Symbol       | Function  | R/W |
|------|--------------|---|-----|
| 15:0 | CTSUSC[15:0] | CTSUSC传感器计数器<br>这些位表示传感器ICO的测量结果。当发生溢出时，它们读取0xFFFF。 | R   |

发生CTSUSC\_CTSURD中断后，先从CTSUSC计数器读取，然后再从CTSURC计数器读取。

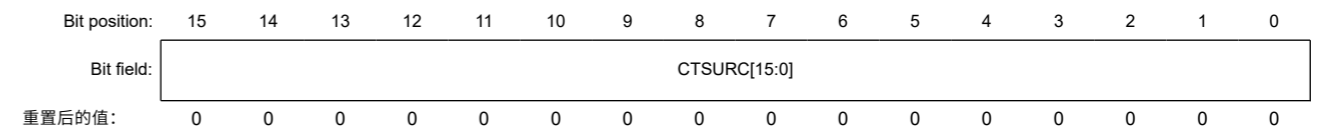
**CTSUSC[15:0]位 (CTSUSC传感器计数器)**

CTSUSC[15:0]位配置为传感器ICO时钟的增量计数器。后读取这些位 CTSU\_CTSURD中断发生。读取CTSURC计数器后，在下次测量中CTSUSC测量状态计数器值变为状态4 (CTSUST.CTSUSTC[2:0]标志变为100b) 之前，立即清除这些位。它们也可以使用CTSUCR0.CTSUINIT位清零。

## 40.2.19 CTSURC:CTSUSC参考计数器

Base address: CTSU = 0x400D\_0000

Offset address: 0x1A



| Bit  | Symbol       | Function  | R/W |
|------|--------------|---|-----|
| 15:0 | CTSURC[15:0] | CTSUSC参考计数器<br>这些位表示参考ICO的测量结果。它们在发生溢出时读取FFFFh。 | R   |

发生CTSUSC\_CTSURD中断后，先从CTSUSC计数器读取，然后再从CTSURC计数器读取。

状态3一直持续到读取CTSURC计数器为止，即使为状态3指定的稳定时间已过。

**CTSURC[15:0]位 (CTSUSC参考计数器)**

CTSURC[15:0]位配置为参考ICO时钟的增量计数器。参考ICO优化了传感器ICO执行的触摸测量。CTSUSC中的内部传感器ICO和参考ICO存在一些偏差，但两种ICO具有几乎相同的特性，包括动态范围和电流频率特性。参考ICO电流调整位可设置的电流范围与两个ICO的动态范围大致相同，输入到传感器ICO的电流必须在此动态范围内。为确保这一点，请使用参考ICO检查ICO之间的差异并测量电流-振荡频率特性。因为可以从参考ICO计数器获得参考ICO振荡频率，所以可以通过设置参考ICO电流调整位中的值并测量参考ICO计数器来测量输入电流的ICO振荡频率 (计数器值/测量时间)。使用参考ICO电流调整位中的最大值测量的参考ICO计数器值是ICO动态范围的最大值。传感器ICO的电流必须在偏移调整位中进行偏移，以使传感器ICO计数器值不超过此值。

Read the CTSURC[15:0] bits after a CTSU\_CTSURD interrupt occurs. After these bits are read, they are cleared immediately before the CTSU measurement status counter value changes to Status 4 (the CTSUST.CTSUSTC[2:0] flags changes to 100b) in the next measurement. They can also be cleared using the CTSUCR0.CTSUINIT bit.

#### 40.2.20 CTSUERRS : CTSU Error Status Register

Base address: CTSU = 0x400D\_0000

Offset address: 0x1C

|                    |               |    |    |    |    |    |   |   |               |   |   |   |              |               |               |   |
|--------------------|---------------|----|----|----|----|----|---|---|---------------|---|---|---|--------------|---------------|---------------|---|
| Bit position:      | 15            | 14 | 13 | 12 | 11 | 10 | 9 | 8 | 7             | 6 | 5 | 4 | 3            | 2             | 1             | 0 |
| Bit field:         | CTSUI<br>COMP | —  | —  | —  | —  | —  | — | — | CTSUS<br>TSOC | — | — | — | CTSUS<br>DRV | CTSUS<br>TSOD | CTSUSPMD[1:0] |   |
| Value after reset: | x             | 0  | 0  | 0  | 0  | 0  | 0 | 0 | 0             | 0 | 0 | 0 | 0            | 0             | 0             | 0 |

| Bit  | Symbol        | Function   | R/W |
|------|---------------|--|-----|
| 1:0  | CTSUSPMD[1:0] | Calibration Mode<br>0 0: Capacitance measurement mode<br>1 0: Calibration mode<br>Others: Setting prohibited | R/W |
| 2    | CTSUTSOD      | TS Pin Fixed Output<br>0: Capacitance measurement mode<br>1: TS pins are forced to be high or low            | R/W |
| 3    | CTSUDRV       | Calibration Setting 1<br>0: Capacitance measurement mode<br>1: Calibration setting 1                         | R/W |
| 6:4  | —             | These bits are read as 0. The write value should be 0.   | R/W |
| 7    | CTSUTSOC      | Calibration Setting 2<br>0: Capacitance measurement mode<br>1: Calibration setting 2                         | R/W |
| 14:8 | —             | These bits are read as 0. The write value should be 0.   | R/W |
| 15   | CTSUICOMP     | TSCAP Voltage Error Monitor<br>0: Normal TSCAP voltage<br>1: Abnormal TSCAP voltage                          | R   |

##### CTSUSPMD[1:0] bits (Calibration Mode)

The CTSUSPMD[1:0] bits are used to calibrate the CTSU. When measuring the capacitance, set these bits to 00b.

##### CTSUTSOD bit (TS Pin Fixed Output)

The CTSUTSOD bit is used to calibrate the CTSU. When setting this bit to 1, the TS pins are forced to the logic level specified by the CTSUCR0.CTSUIOC bit. When measuring the capacitance, set this bit to 0.

##### CTSUDRV bit (Calibration Setting 1)

The CTSUDRV bit is used to calibrate the CTSU. When measuring the capacitance, set this bit to 0.

##### CTSUTSOC bit (Calibration Setting 2)

The CTSUTSOC bit is used to calibrate the CTSU. When measuring capacitance, set this bit to 0.

##### CTSUICOMP bit (TSCAP Voltage Error Monitor)

If the offset current amount set in the CTSUSO1 register exceeds the sensor ICO input current during touch measurement, the TSCAP voltage becomes abnormal and touch measurement cannot be performed correctly. The CTSUICOMP bit monitors the TSCAP voltage and it sets to 1 if the voltage becomes abnormal.

If the TSCAP voltage becomes abnormal, the sensor ICO counter value becomes undefined, but touch measurement completes normally, so it is difficult to detect an abnormality by reading the sensor ICO counter value. If the CTSU reference ICO current adjustment bits (CTSURICOA[7:0]) in the CTSUSO1 register are set to any value other than 0, always check this bit when touch measurement completes.

在CTSUS\_CTSURD中断发生后读取CTSURC[15:0]位。读取这些位后，在CTSUS测量状态计数器值在下次测量中立即变为状态4（CTSUST.CTSUSTC[2:0]标志变为100b）之前将它们清零。它们也可以使用CTSUCR0.CTSUINIT位清零。

#### 40.2.20 CTSUERRS:CTSUS错误状态寄存器

Base address: CTSU = 0x400D\_0000

Offset address: 0x1C

|               |               |    |    |    |    |    |   |   |               |   |   |   |              |               |               |   |
|---------------|---------------|----|----|----|----|----|---|---|---------------|---|---|---|--------------|---------------|---------------|---|
| Bit position: | 15            | 14 | 13 | 12 | 11 | 10 | 9 | 8 | 7             | 6 | 5 | 4 | 3            | 2             | 1             | 0 |
| Bit field:    | CTSUI<br>COMP | —  | —  | —  | —  | —  | — | — | CTSUS<br>TSOC | — | — | — | CTSUS<br>DRV | CTSUS<br>TSOD | CTSUSPMD[1:0] |   |
| 重置后的值:        | x             | 0  | 0  | 0  | 0  | 0  | 0 | 0 | 0             | 0 | 0 | 0 | 0            | 0             | 0             | 0 |

| Bit  | Symbol        | Function   | R/W |
|------|---------------|--|-----|
| 1:0  | CTSUSPMD[1:0] | 校准模式<br>00: 电容测量模式10: 校准模式<br>Others: Setting prohibited | R/W |
| 2    | CTSUTSOD      | TS引脚固定输出<br>0: 电容测量模式1: TS引脚强制为高电平或低电平                   | R/W |
| 3    | CTSUDRV       | 校准设置1<br>0: 电容测量模式1: 校准设置1                               | R/W |
| 6:4  | —             | 这些位被读取为0。写入值应为0。   | R/W |
| 7    | CTSUTSOC      | 校准设置2<br>0: 电容测量模式1: 校准设置2                               | R/W |
| 14:8 | —             | 这些位被读取为0。写入值应为0。   | R/W |
| 15   | CTSUICOMP     | TSCAP电压错误监视器<br>0: 正常TSCAP电压1: 异常TSCAP电压                 | R   |

##### CTSUSPMD[1:0] bits (Calibration Mode)

CTSUSPMD[1:0]位用于校准CTSUS。测量电容时，将这些位设置为00b。

##### CTSUTSOD位 (TS引脚固定输出)

CTSUTSOD位用于校准CTSUS。将该位设置为1时，TS引脚被强制为CTSUCR0.CTSUIOC位指定的逻辑电平。测量电容时，将此位设置为0。

##### CTSUDRV位 (校准设置1)

CTSUDRV位用于校准CTSUS。测量电容时，将此位设置为0。

##### CTSUTSOC位 (校准设置2)

CTSUTSOC位用于校准CTSUS。测量电容时，将此位设置为0。

##### CTSUICOMP位 (TSCAP电压错误监视器)

如果CTSUSO1寄存器中设置的偏移电流量在触摸测量期间超过传感器ICO输入电流，则TSCAP电压会异常，无法正确执行触摸测量。CTSUICOMP位监控TSCAP电压，如果电压异常，它设置为1。

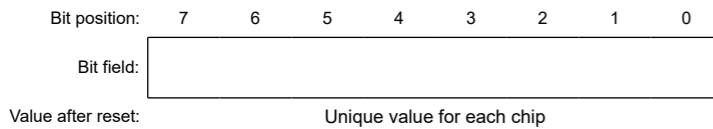
如果TSCAP电压异常，传感器ICO计数器值变得不确定，但触摸测量正常完成，因此很难通过读取传感器ICO计数器值来检测异常。如果CTSUSO1寄存器中的CTSUS参考ICO电流调整位(CTSURICOA[7:0])设置为0以外的任何值，则在触摸测量完成时始终检查该位。

This bit is cleared by writing 0 to the CTSUCR1.CTSUPON bit and turning off the power supply.

#### 40.2.21 CTSUTRMR : CTSU Reference Current Calibration Register

Base address: CTSU = 0x400D\_0000

Offset address: 0x20



The CTSUTRMR register stores a reference current value calibrated under the specified condition for each chip at factory shipment. When rewriting this register, set the CTSUERRS.CTSUSPMD[1:0] bits to 10b (calibration mode). When resetting the MCU, the values returns to the factory setting value. Do not rewrite this register when the CTSUSPMD[1:0] bits are 00b (capacitance measurement mode).

### 40.3 Operation

#### 40.3.1 Principles of Measurement Operation

Figure 40.4 shows the measurement circuit.

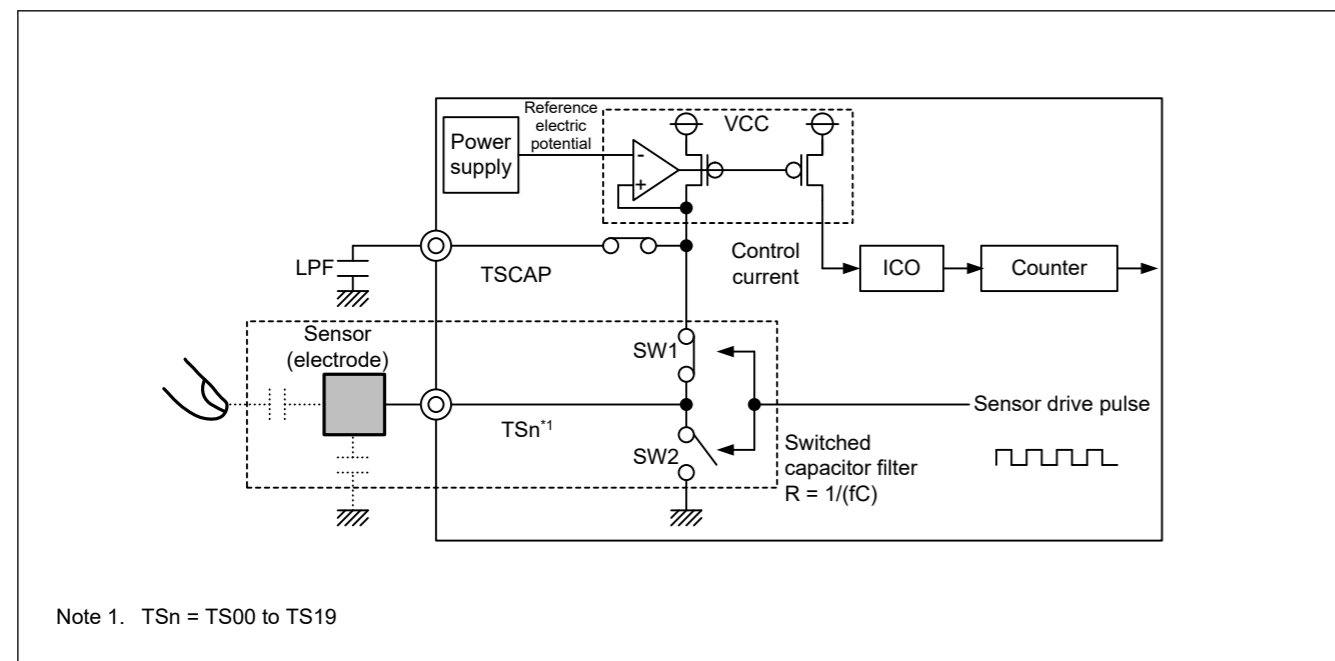


Figure 40.4 Measurement circuit

Figure 40.5 to Figure 40.7 explain the electrostatic capacitance measurement operation principles of the CTSU current frequency conversion. The operation is as follows:

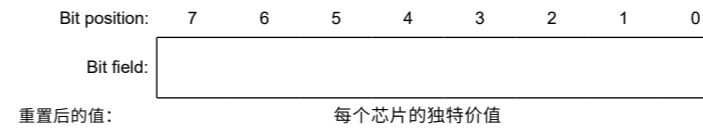
1. The electrostatic capacitance of the electrode is charged by turning SW1 on and SW2 off (Figure 40.5).
2. The charged capacitance is discharged by turning SW1 off and SW2 on (Figure 40.6).
3. Current flows to the switched capacitor filter by switching between charging and discharging. At this point, if a finger is in close proximity, the capacitance and the flowing current change. A clock is generated by supplying the control current, which is proportional to the amount of current flowing through the switched capacitor filter, from the circuit that generates the TSCAP power supply to the ICO. The counter measures the clock frequency that changes depending on whether a finger is in close proximity. The software uses the value read from the counter to determine contact with a finger (Figure 40.7).

通过向CTSUCR1.CTSUPON位写入0并关闭电源来清除该位。

#### 40.2.21 CTSUTRMR:CTSUS参考电流校准寄存器

Base address: CTSU = 0x400D\_0000

Offset address: 0x20



CTSUTRMR电阻存储在出厂时为每个芯片在指定条件下校准的参考电流值。重写此寄存器时，将CTSUERRS.CTSUSPMD[1:0]位设置为10b（校准模式）。复位MCU时，数值恢复为出厂设置值。当CTSUSPMD[1:0]位为00b（电容测量模式）时，请勿重写此寄存器。

### 40.3 Operation

#### 40.3.1 测量操作原理

图40.4显示了测量电路。

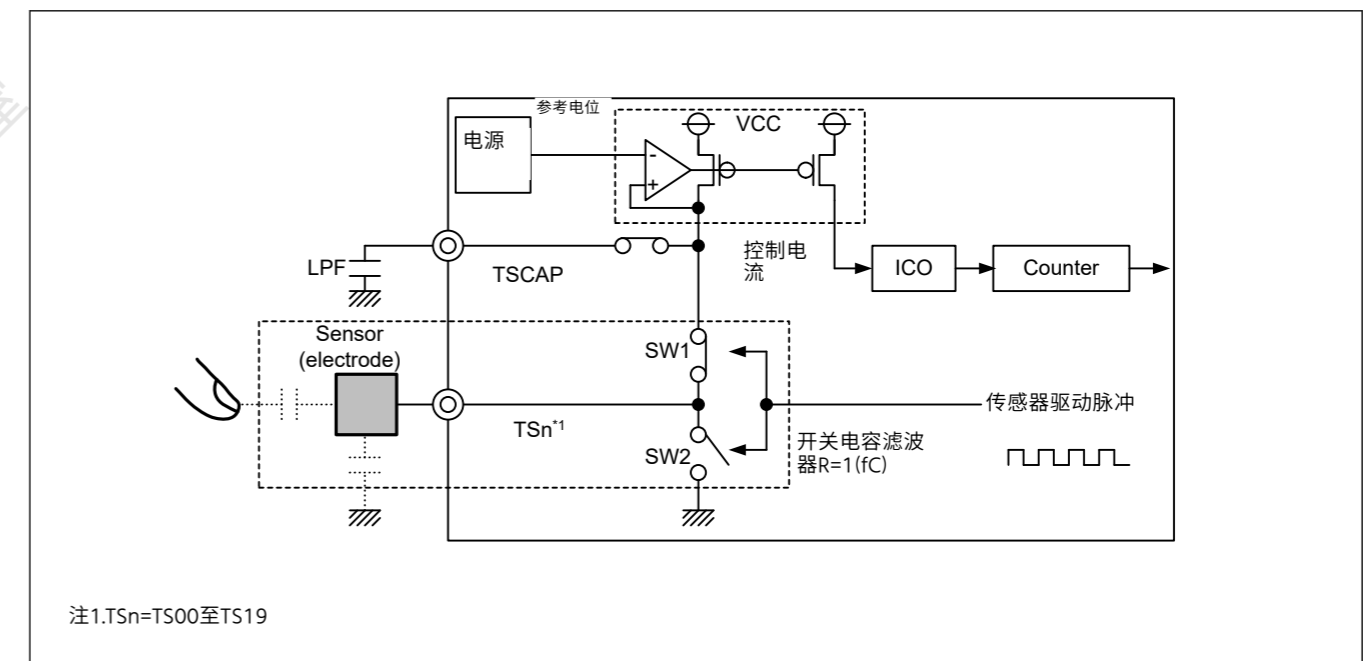


Figure 40.4 测量电路

图40.5至图40.7说明了CTSUS电流变频的静电电容测量操作原理。操作如下：

- 1.通过打开SW1和关闭SW2对电极的静电电容进行充电（图40.5）。
- 2.通过关闭SW1和打开SW2对充电的电容进行放电（图40.6）。
- 3.电流通过在充电和放电之间切换而流向开关电容滤波器。此时，如果手指靠近，则电容和流动电流会发生变化。通过从产生TSCAP电源的电路向ICO提供与流过开关电容滤波器的电流量成比例的控制电流来产生时钟。计数器测量时钟频率，该频率根据手指是否靠近而变化。软件使用从计数器读取的值来确定与手指的接触（图40.7）。

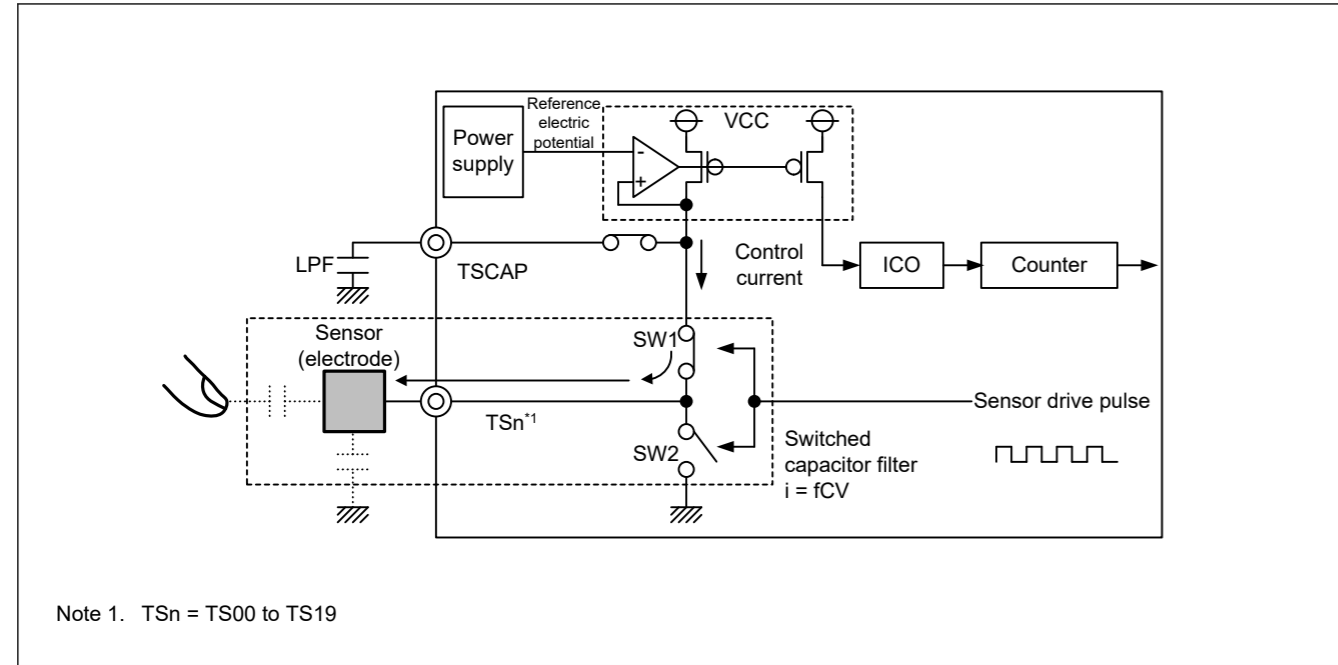


Figure 40.5 Charging operation

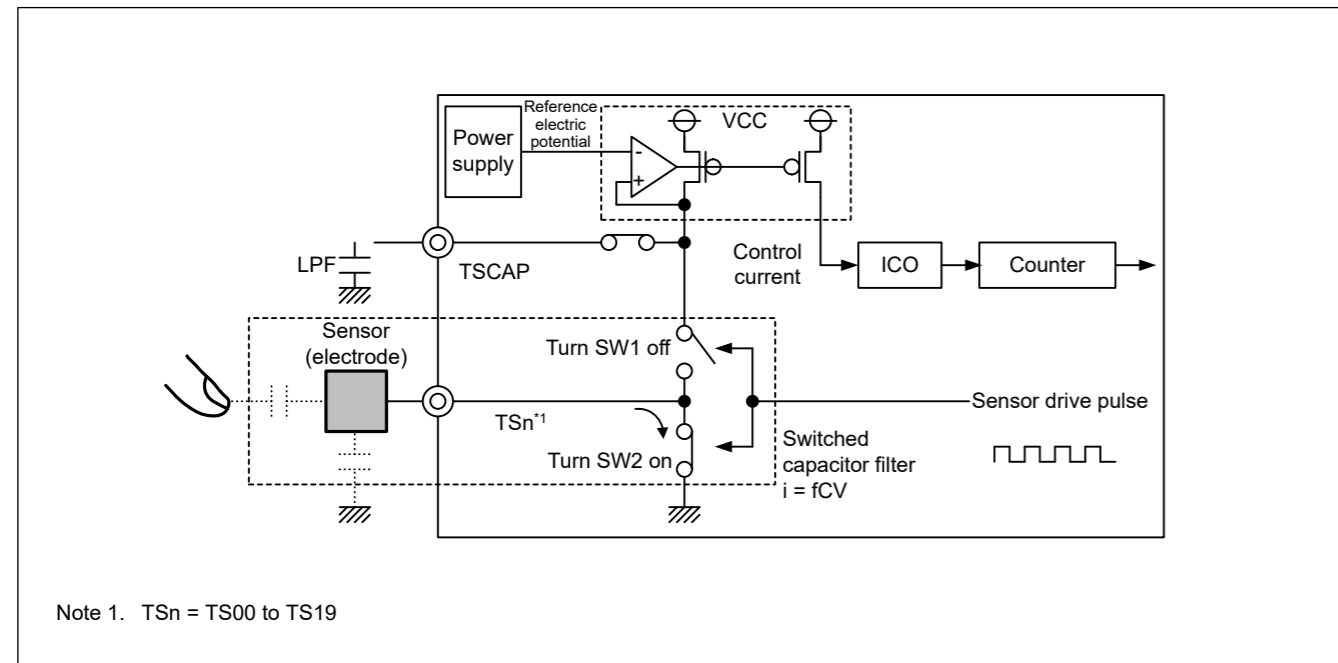


Figure 40.6 Discharging operation

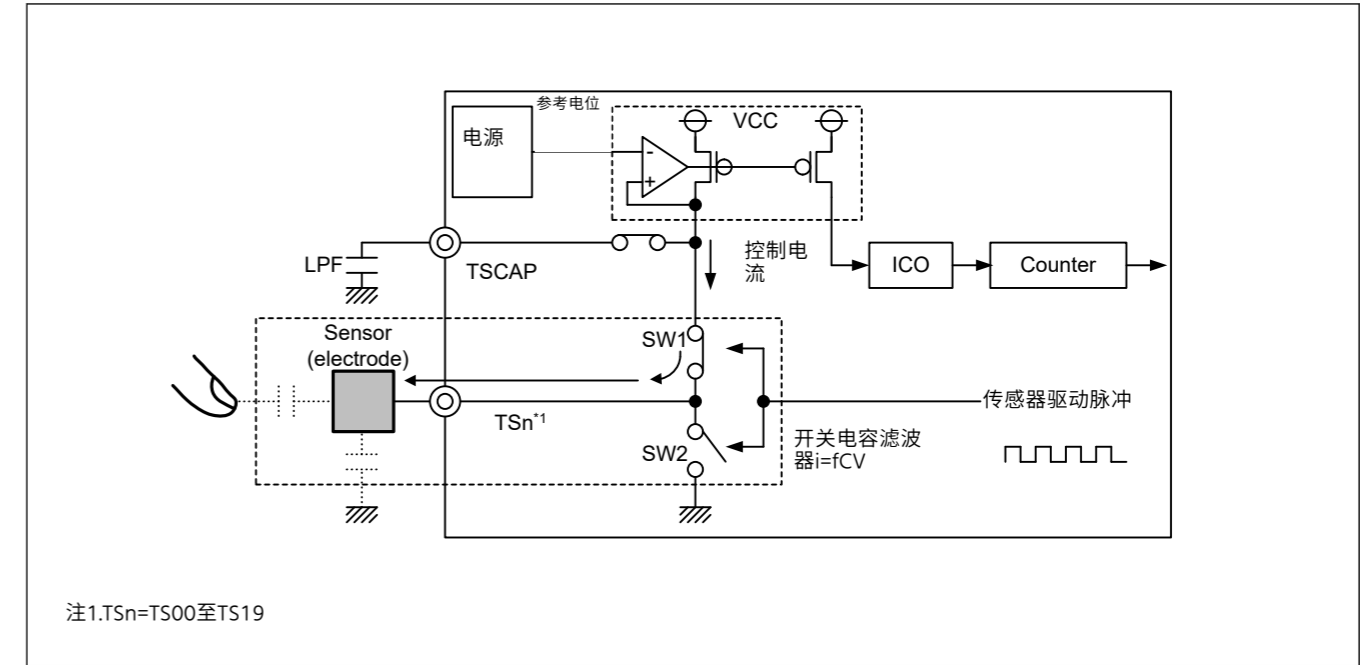


Figure 40.5 充电操作

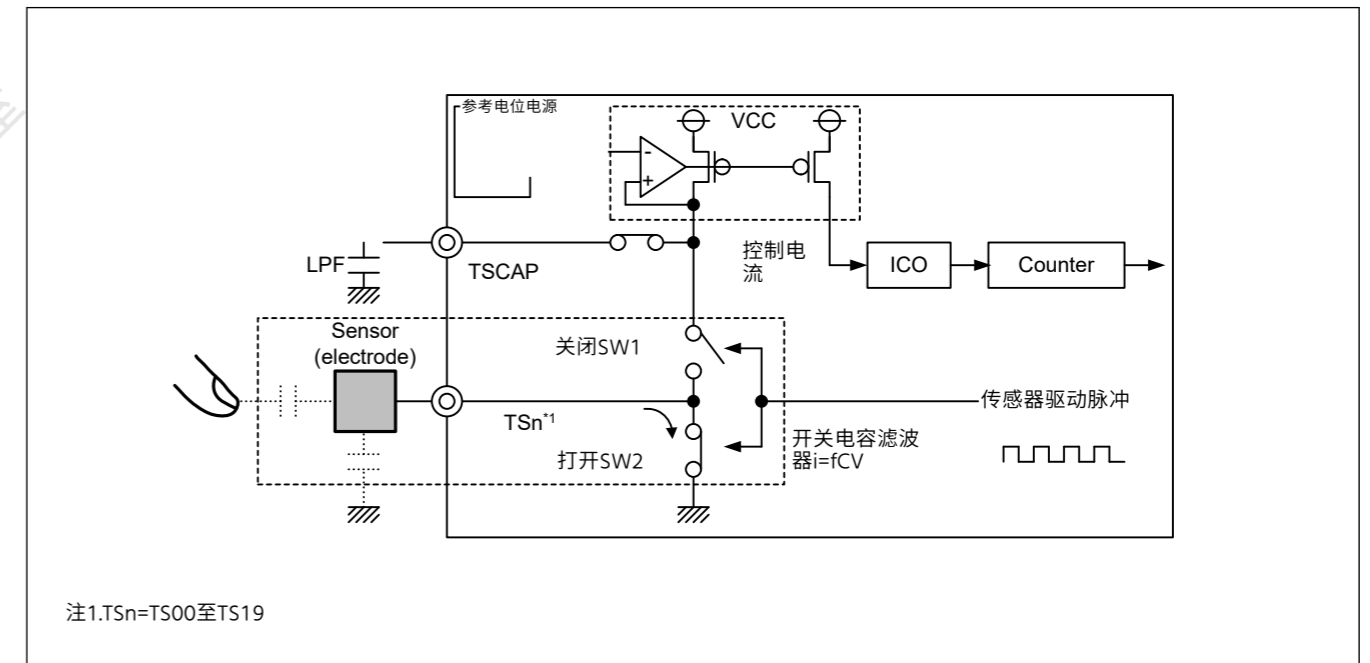


Figure 40.6 卸料作业



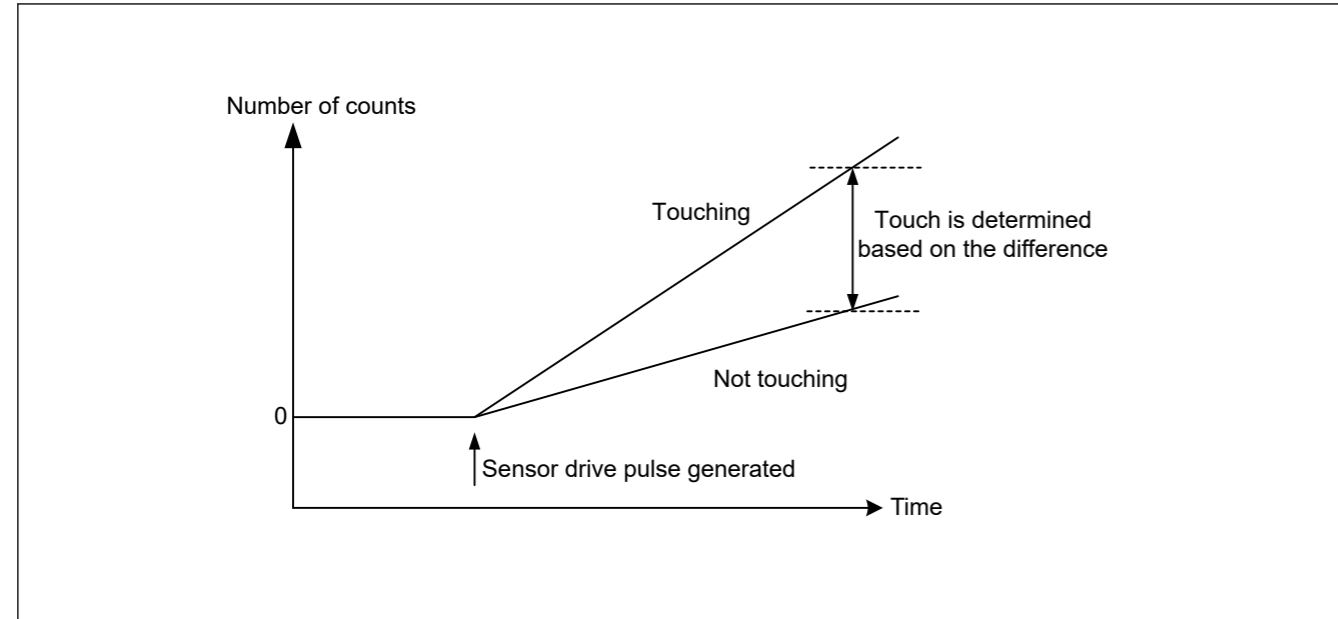
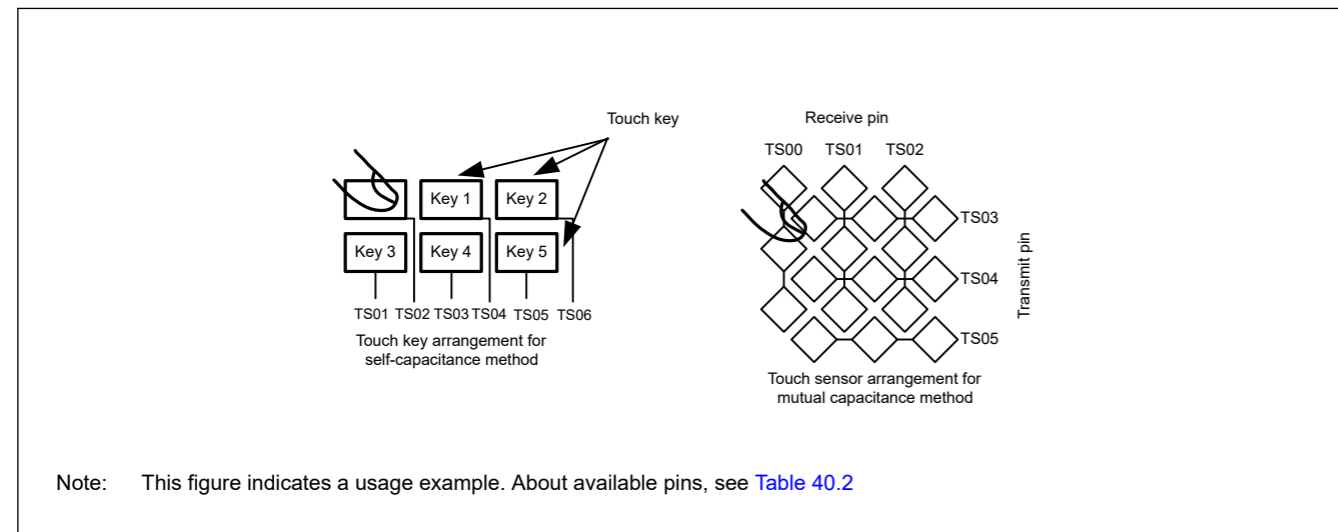


Figure 40.7 Change in measured value when finger is touching and not touching

### 40.3.2 Measurement Modes

The CTSU supports self-capacitance and mutual capacitance methods. Figure 40.8 illustrates these methods.



Note: This figure indicates a usage example. About available pins, see Table 40.2

Figure 40.8 Overview of self-capacitance method and mutual capacitance method

In the self-capacitance method, a single touch pin is allocated to a single touch key to measure individual electrostatic capacitance when a finger is in close proximity. In this method, capacitance can be measured in both single scan and multiscan modes.

In the mutual capacitance method, the capacitance between two opposing electrodes (transmit and receive pins) is measured.

#### 40.3.2.1 Initial settings flow

Figure 40.9 shows the flow for the CTSU initial settings.

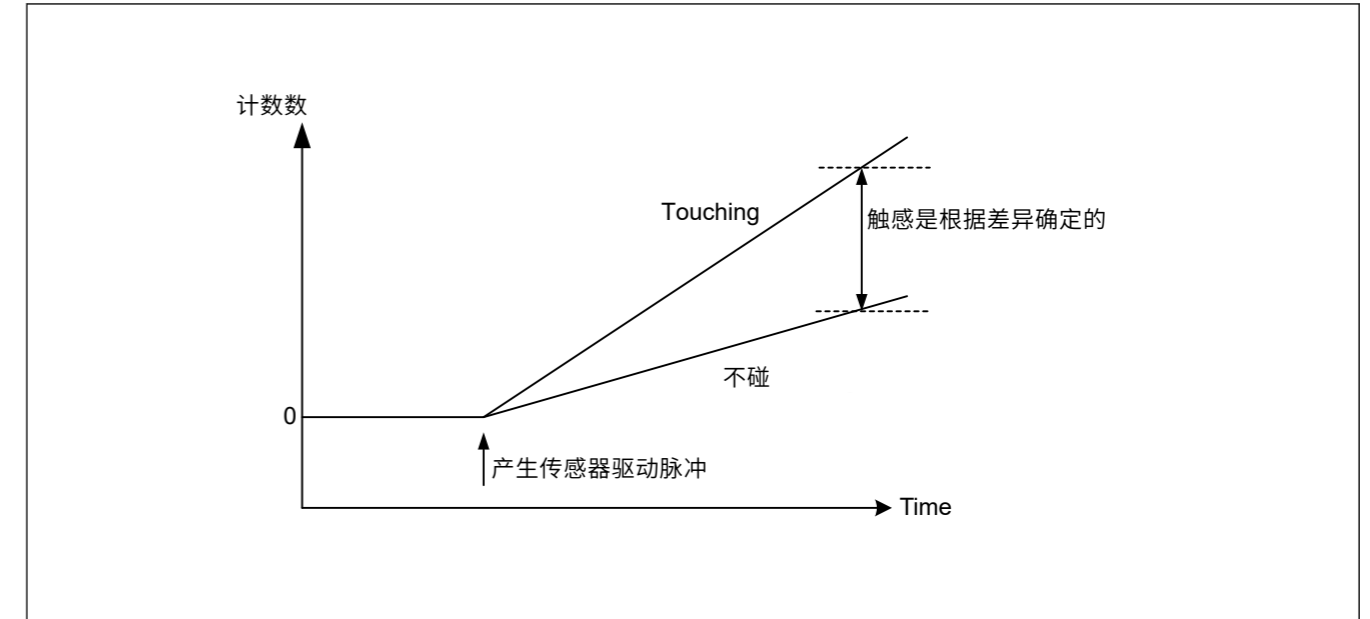
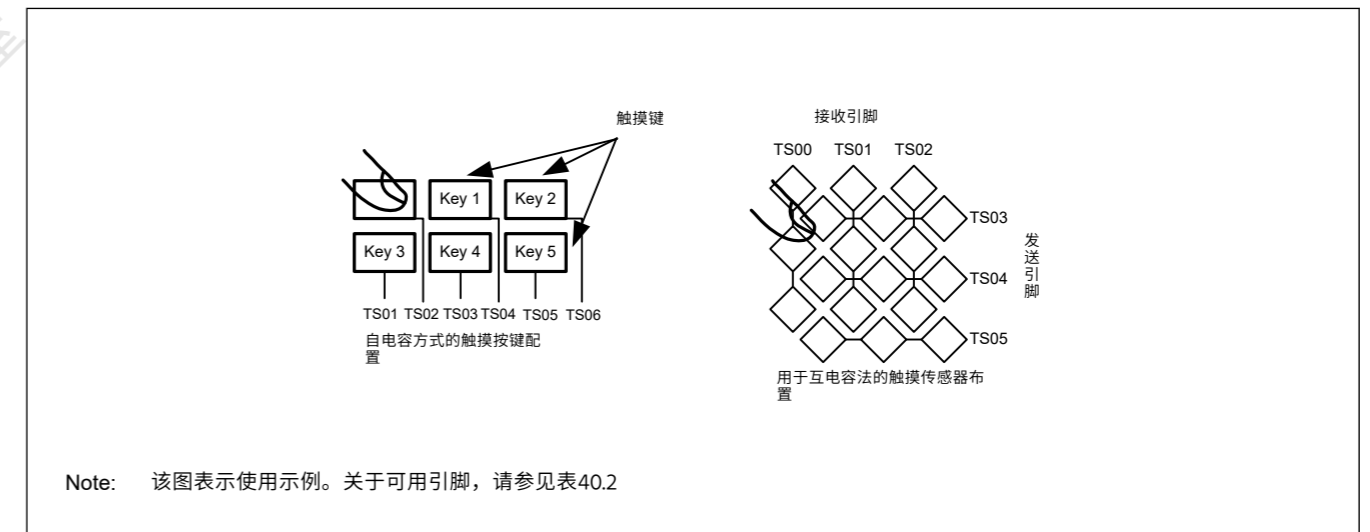


Figure 40.7 手指接触和不接触时测量值的变化

### 40.3.2 测量模式

CTSUS支持自电容和互电容方法。图40.8说明了这些方法。



Note: 该图表示使用示例。关于可用引脚，请参见表40.2

Figure 40.8 自电容法和互电容法概述

在自电容法中，将单个触摸引脚分配给单个触摸键，以在手指靠近时测量单个静电电容。在这种方法中，可以在单扫描和多扫描模式下测量电容。

在互电容法中，测量两个相对电极（发送和接收引脚）之间的电容。

#### 40.3.2.1 初始设置流程

图40.9显示了CTSUS初始设置的流程。

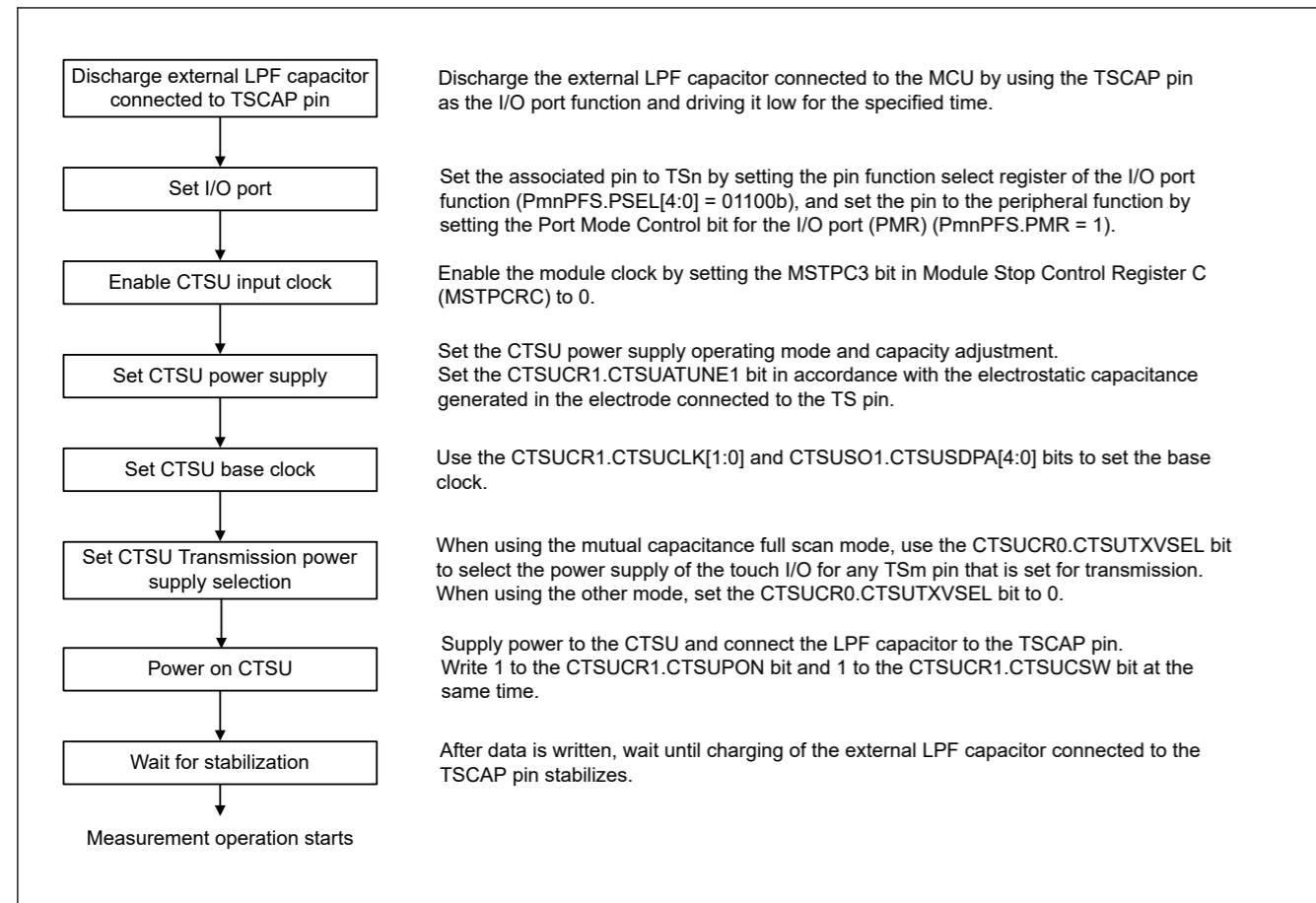


Figure 40.9 CTSU initial settings flow

Figure 40.10 shows the flow for stopping CTSU operation and invoking the standby state.

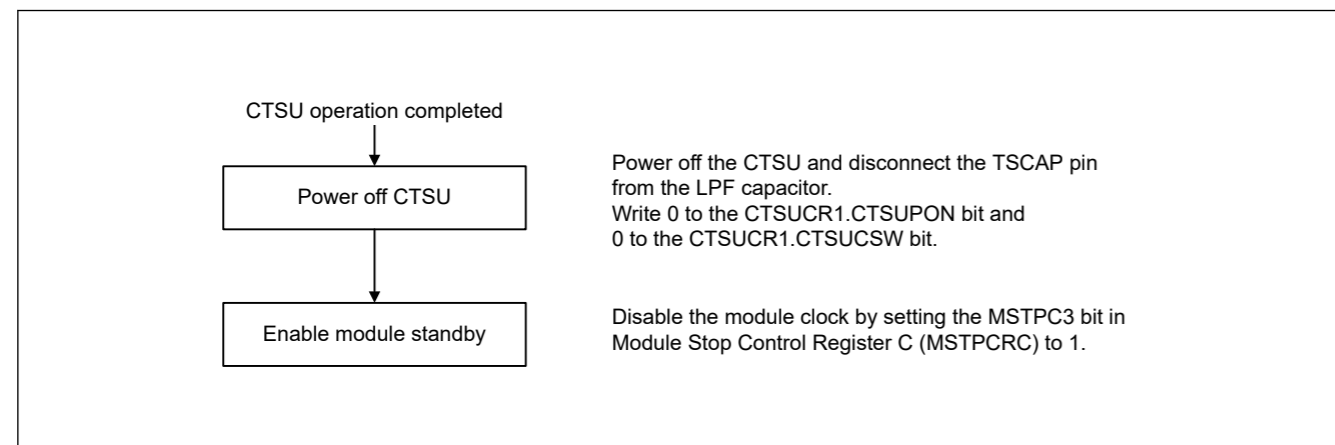


Figure 40.10 CTSU stopping flow

When restarting operation after it stops, follow the initial settings flow shown in Figure 40.9.

#### 40.3.2.2 Status counter

The measurement status counter of the CTSU Status Register (CTSUST) indicates the current measurement status. The measurement status is shared by all three modes. Figure 40.11 shows the status operation transitions.

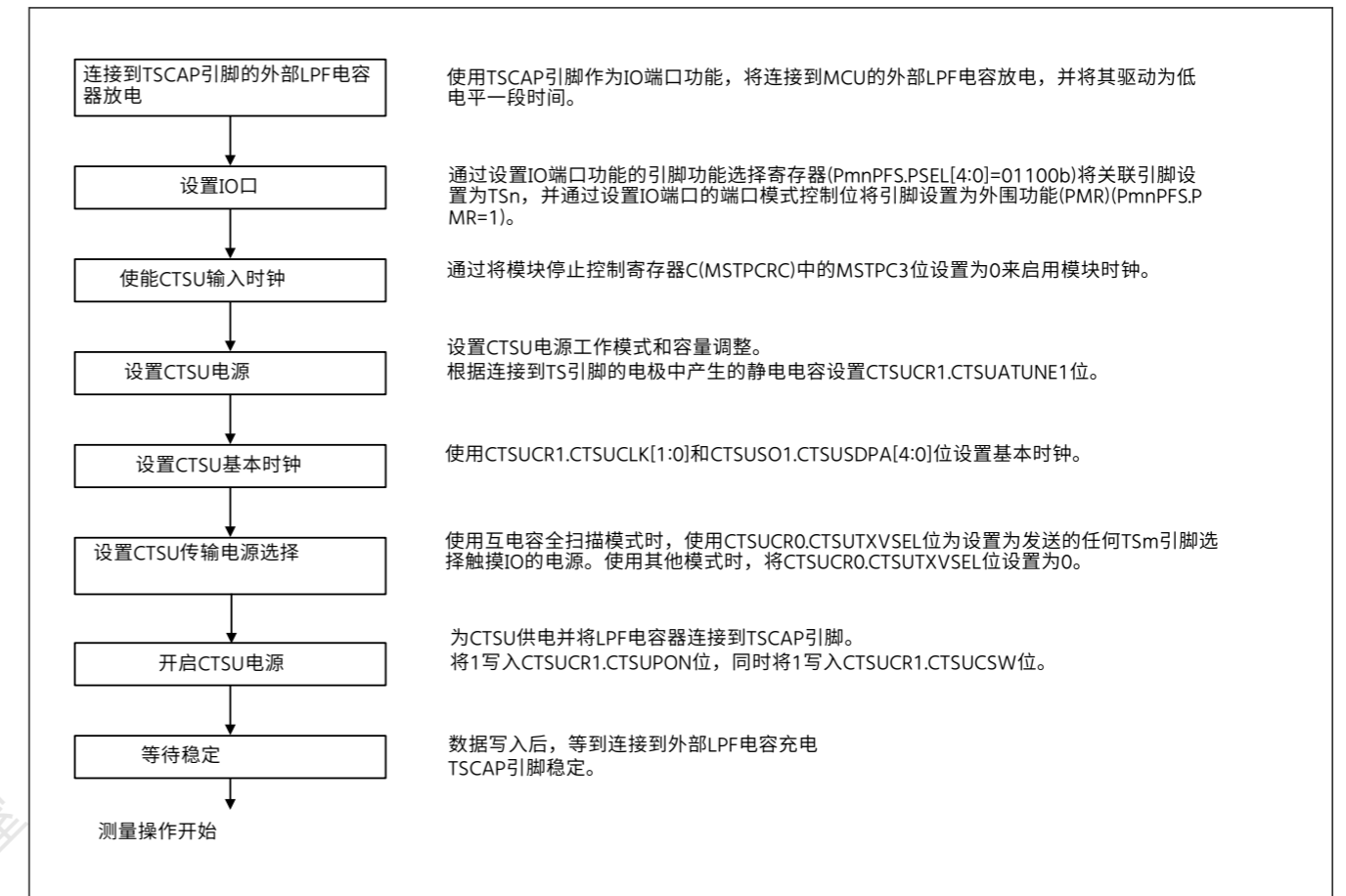


Figure 40.9 CTSU初始设置流程

图40.10显示了停止CTSUS操作并调用待机状态的流程。

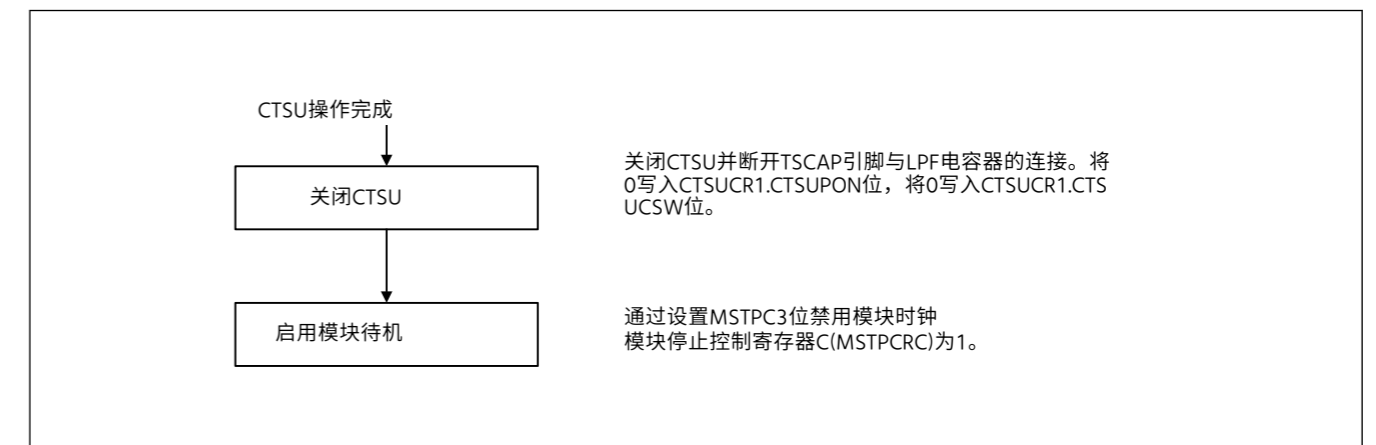


Figure 40.10 CTSUS停止流程

停止后重新运行时，请按照图40.9所示的初始设置流程进行操作。

#### 40.3.2.2 状态计数器

CTSUS状态寄存器(CTSUST)的测量状态计数器指示当前测量状态。测量状态由所有三种模式共享。图40.11显示了状态操作转换。

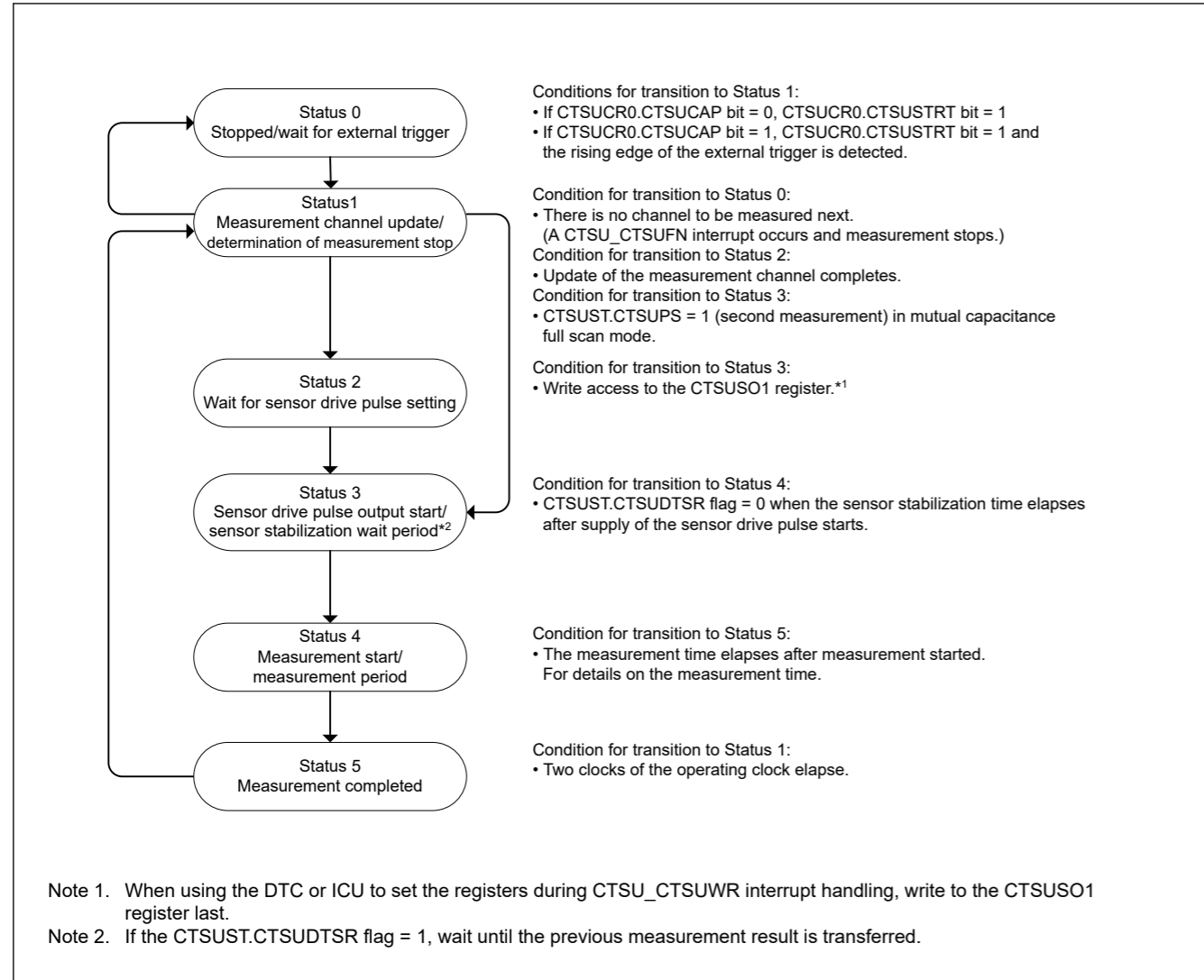


Figure 40.11 Status operation transitions

The status counter transitions to Status 0 when all of the specified measurement channels are measured.

The CTSUCR0.CTSUSTRT bit is set to 0 by hardware when a software trigger is used. When an external trigger is used, the value of 1 is retained, and the CTSU waits for the next trigger.

When operation is forced to stop during measurement or the trigger wait state, by a simultaneous 0 write to the CTSUCR0.CTSUSTRT bit and a 1 write to the CTSUCR0.CTSUINIT bit, the status transitions to Status 0 and measurement stops.

If the channel to be measured is not set in the CTSUCHAC0 to CTSUCHAC2 or CTSUCHTRC0 to CTSUCHTRC2 registers, a CTSU\_CTSUFN interrupt occurs immediately after a transition to Status 1, and then the status transitions to Status 0.

In the following situations, there is no channel to be measured:

- No measurement target channel is specified in the CTSUCHAC0 to CTSUCHAC2 registers.
- In self-capacitance single scan mode, the channel specified in the CTSUMCH0 register is not a measurement target in the CTSUCHAC0 to CTSUCHAC2 registers.
- In full scan modes, there is no transmit channel or receive channel to be measured based on the combined settings of the CTSUCHAC0 to CTSUCHAC2 and CTSUCHTRC0 to CTSUCHTRC2 registers.

If there is no channel to be measured based on these settings, a CTSU\_CTSUFN interrupt occurs immediately after a transition to Status 1, and the counter transitions to Status 0.

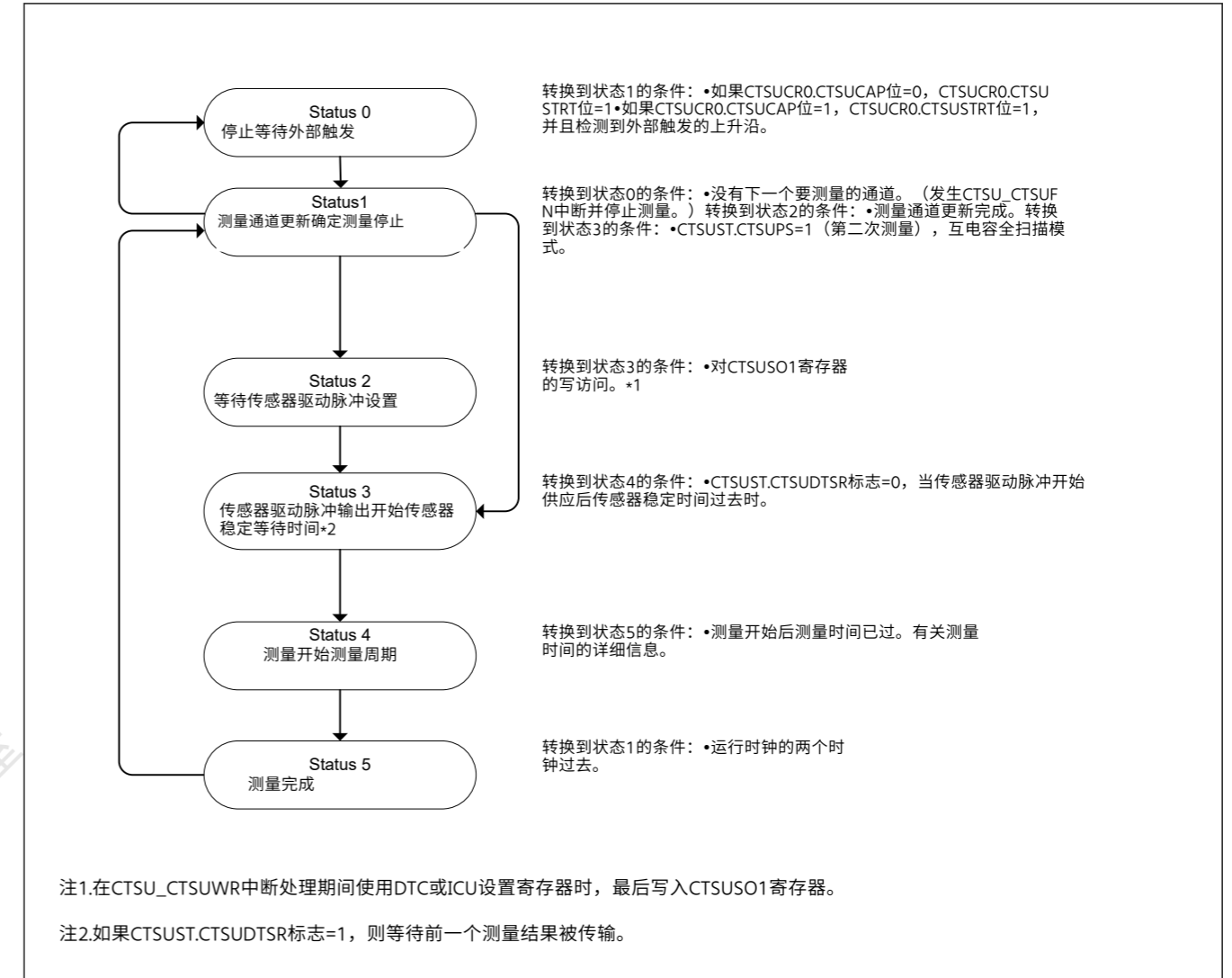


Figure 40.11 状态操作转换

当测量所有指定的测量通道时, 状态计数器转换为状态0。

当使用软件触发时, CTSUCR0.CTSUSTRT位由硬件设置为0。使用外部触发时, 保留值1, CTSU等待下一次触发。

在测量或触发等待状态期间强制停止操作时, 通过同时向CTSUCR0.CTSUSTRT位写入0和向CTSUCR0.CTSUINIT位写入1, 状态转换为状态0并停止测量。

如果要测量的通道未在CTSUCHAC0到CTSUCHAC2或CTSUCHTRC0到CTSUCHTRC2寄存器中设置, 则在转换到状态1后立即发生CTSU\_CTSUFN中断, 然后状态转换到状态0。

在以下情况下, 没有要测量的通道:

- CTSUCHAC0至CTSUCHAC2寄存器中未指定测量目标通道。
- 在自电容单次扫描模式下, CTSUCHAC0寄存器中指定的通道不是CTSUCHAC0至CTSUCHAC2寄存器中的测量目标。
- 在全扫描模式下, 根据CTSUCHAC0到CTSUCHAC2和CTSUCHTRC0到CTSUCHTRC2寄存器的组合设置, 没有要测量的发送通道或接收通道。

如果根据这些设置没有要测量的通道, 则在转换到状态1后立即发生CTSU\_CTSUFN中断, 并且计数器转换到状态0。

40.3.2.3 Self-capacitance single scan mode operation

In self-capacitance single scan mode, electrostatic capacitance on one channel is measured. Figure 40.12 shows the software flow and an operation example, and Figure 40.13 shows the timing.

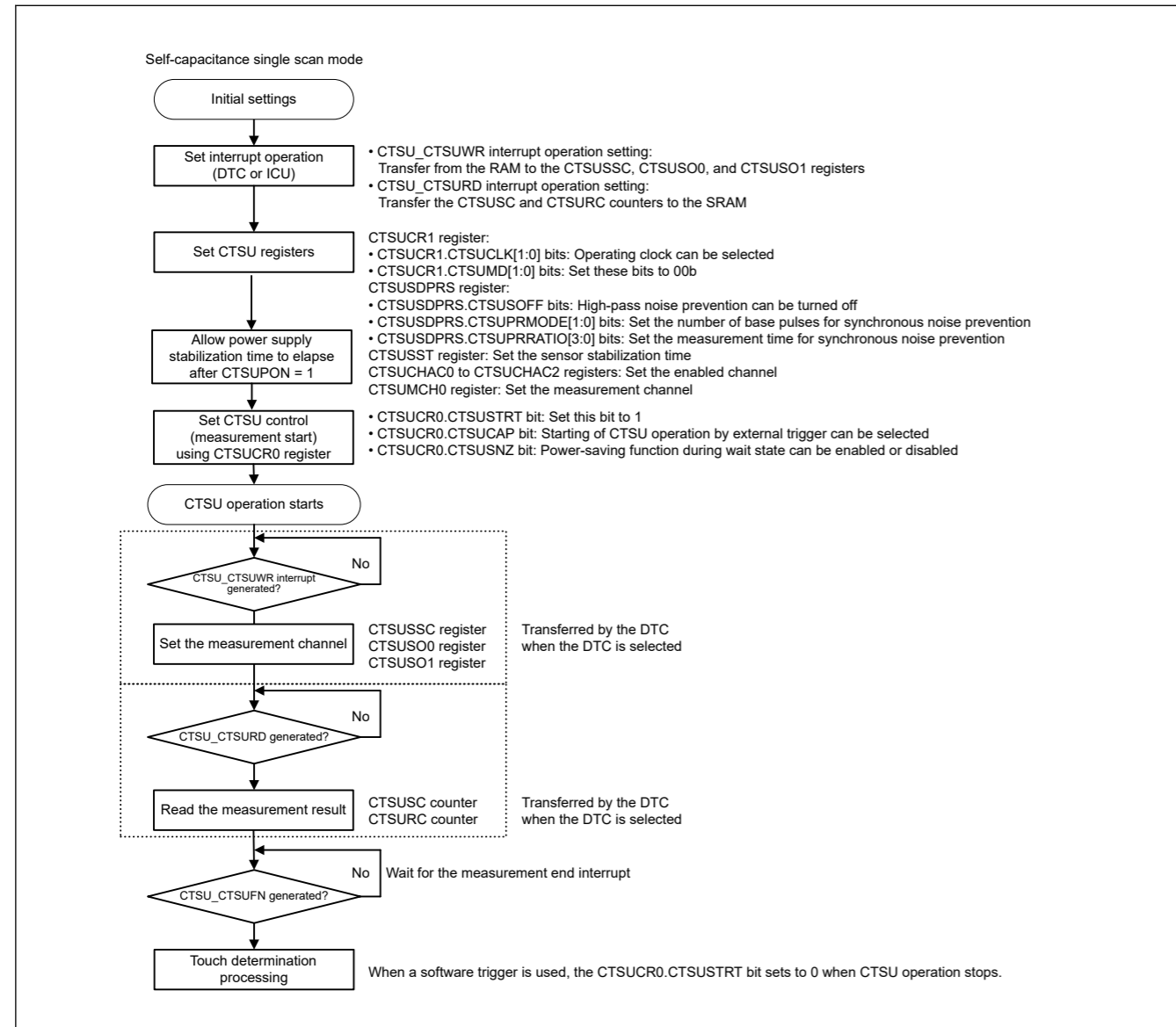


Figure 40.12 Software flow and example operation for self-capacitance single scan mode

40.3.2.3 自电容单次扫描模式操作

在自电容单次扫描模式下，测量一个通道上的静电电容。图40.12显示了软件流程和操作示例，图40.13显示了时序。

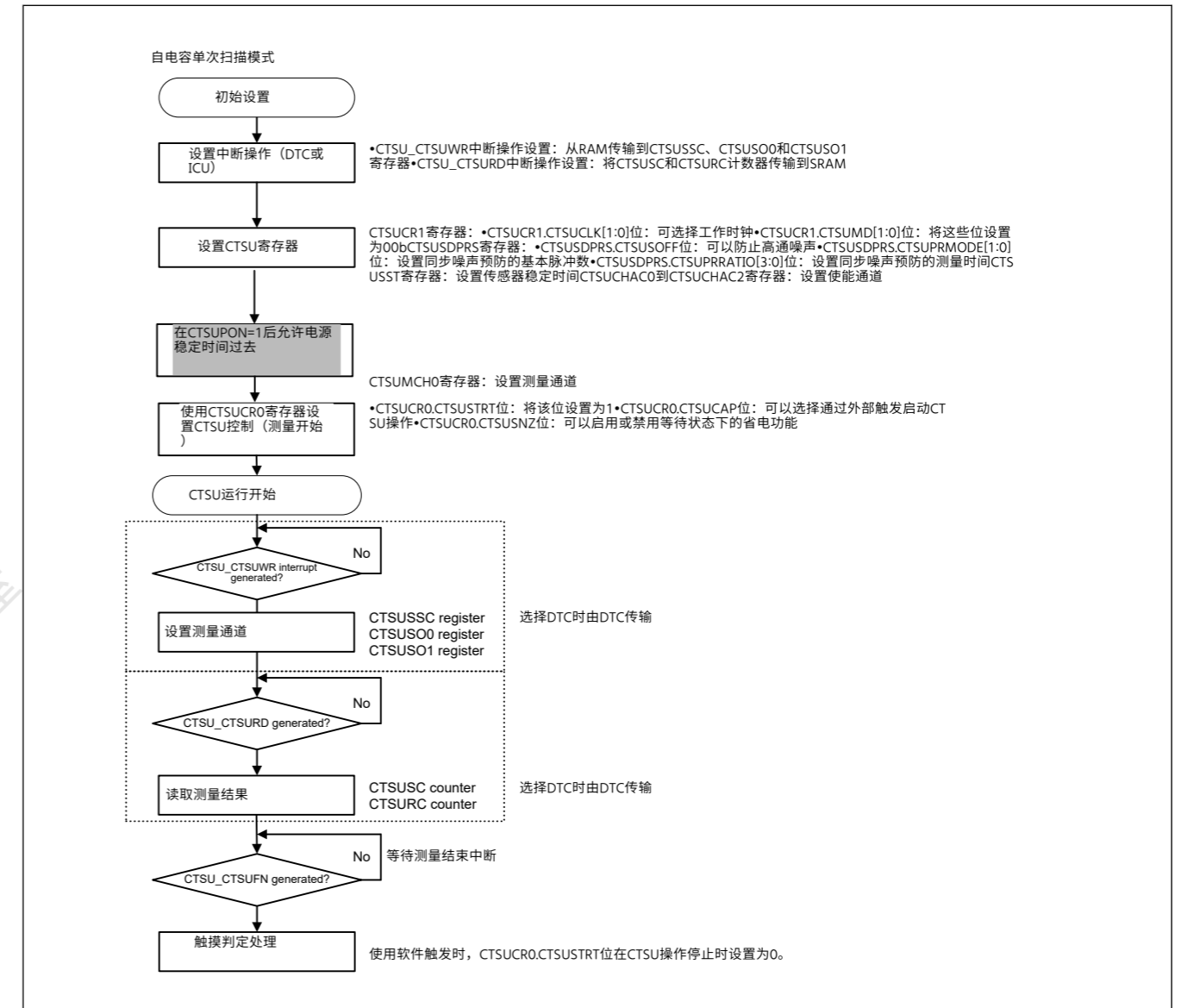


Figure 40.12 自电容单次扫描模式的软件流程和示例操作



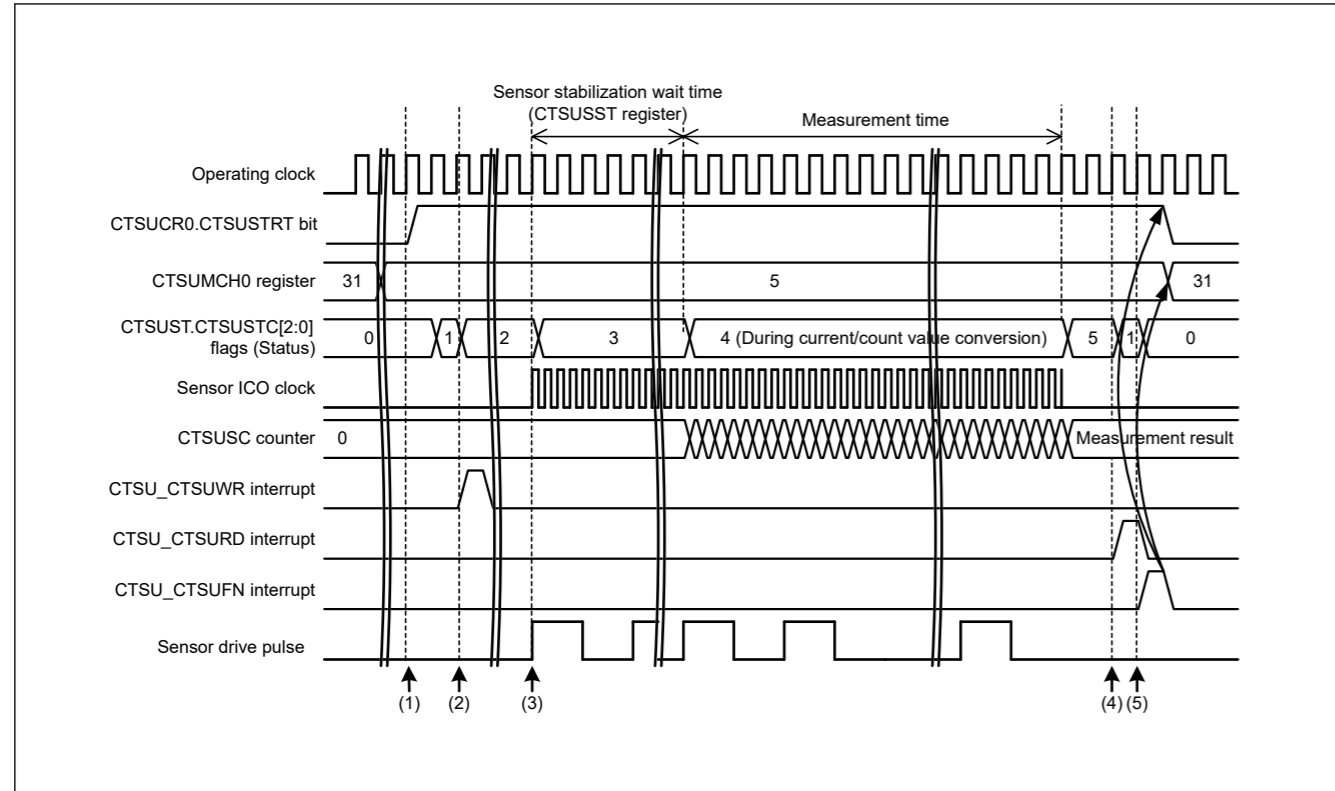


Figure 40.13 Timing of self-capacitance single scan mode when the measurement start condition is a software trigger

The following describes the operation shown in Figure 40.13.

1. After initial settings are made, operation is started by writing 1 to the CTSUCR0.CTSUSTRTRT bit.
2. After the channel to be measured is determined in accordance with the preset conditions, a request for setting the channel (CTSU\_CTSUWR) is output.
3. On completion of writing the measurement channel settings (CTSUSSC, CTSUSO0, and CTSUSO1 registers), the sensor drive pulse is output and the sensor ICO clock and reference ICO clock operate.
4. After the sensor stabilization wait time and the measurement time elapse, and measurement stops, a measurement result read request (CTSU\_CTSURD) is output.
5. A measurement end interrupt (CTSU\_CTSUFN) is output and measurement stops (transition to Status 0).

Table 40.7 lists the touch pin states in self-capacitance single scan mode.

Table 40.7 Touch pin states in self-capacitance single scan mode

| Status | Touch pin        |                      |
|--------|------------------|----------------------|
|        | Measured channel | Non-measured channel |
| 0      | Low              | Low                  |
| 1      | Low              | Low                  |
| 2      | Low              | Low                  |
| 3      | Pulse            | Low                  |
| 4      | Pulse            | Low                  |
| 5      | Low              | Low                  |

#### 40.3.2.4 Self-capacitance multi-scan mode operation

In self-capacitance multi-scan mode, electrostatic capacitance on all channels that are specified as measurement targets in the CTSUCHAC0 to CTSUCHAC2 registers is measured sequentially in ascending order. Figure 40.14 shows the software flow and an operation example, and Figure 40.15 shows the timing.

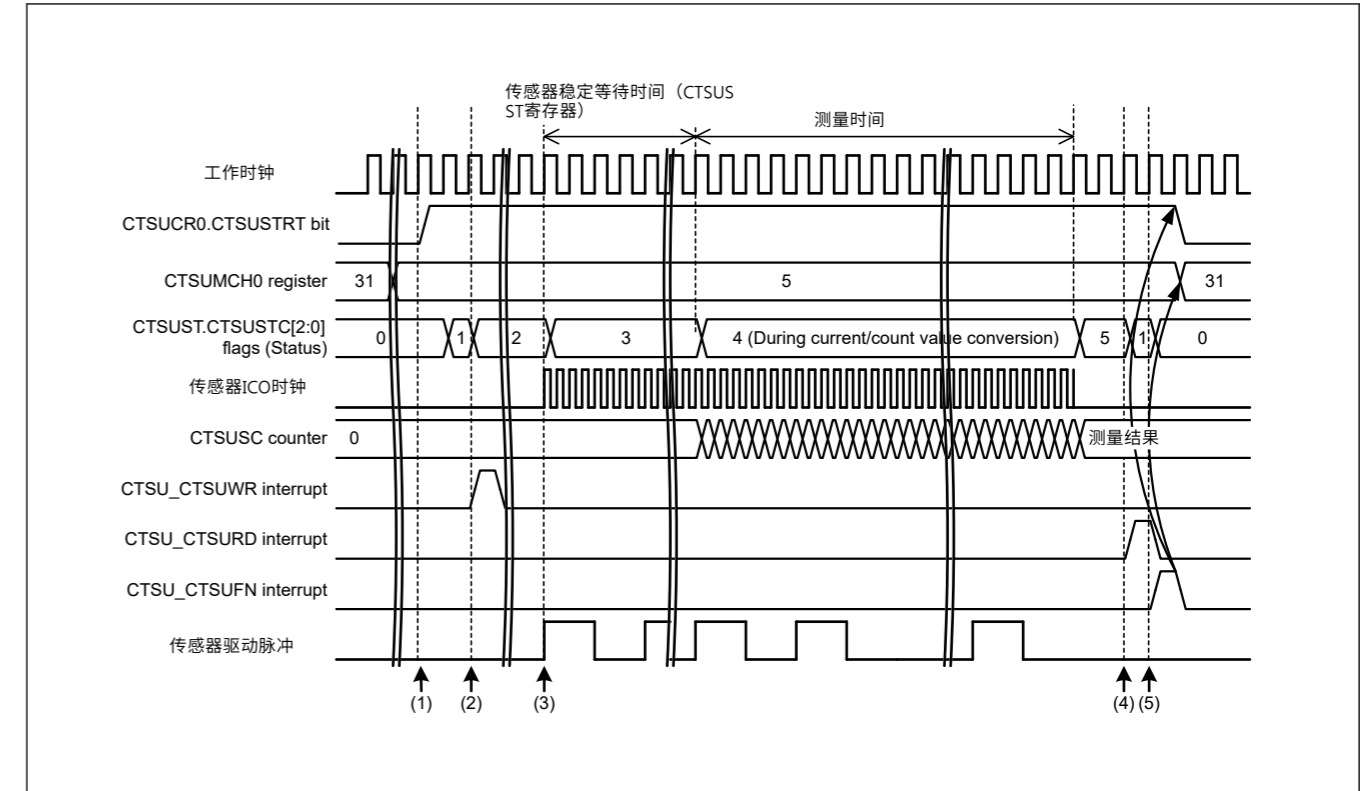


Figure 40.13 测量开始条件为软件触发时的自电容单次扫描模式时序

下面介绍图40.13所示的操作。

- 1.进行初始设置后，通过向CTSUCR0.CTSUSTRTRT位写入1开始操作。
- 2、根据预设条件确定待测通道后，输出通道设置请求（CTSU\_CTSUWR）。
- 3.写入测量通道设置（CTSUSSC、CTSUSO0和CTSUSO1寄存器）完成后，输出传感器驱动脉冲，传感器ICO时钟和参考ICO时钟运行。
- 4.经过传感器稳定等待时间和测量时间后，测量停止，输出测量结果读取请求（CTSU\_CTSURD）。
- 5.输出测量结束中断(CTSU\_CTSUFN)并停止测量（转换到状态0）。

表40.7列出了自电容单次扫描模式下的触摸引脚状态。

Table 40.7 自电容单次扫描模式下的触摸引脚状态

| Status | 触摸针   |                      |
|--------|-------|----------------------|
|        | 测量通道  | Non-measured channel |
| 0      | Low   | Low                  |
| 1      | Low   | Low                  |
| 2      | Low   | Low                  |
| 3      | Pulse | Low                  |
| 4      | Pulse | Low                  |
| 5      | Low   | Low                  |

#### 40.3.2.4 自电容多扫描模式操作

在自电容多重扫描模式下，CTSUCHAC0至CTSUCHAC2寄存器中指定为测量目标的所有通道上的静电电容按升序顺序测量。图40.14显示了软件流程和操作示例，图40.15显示了时序。

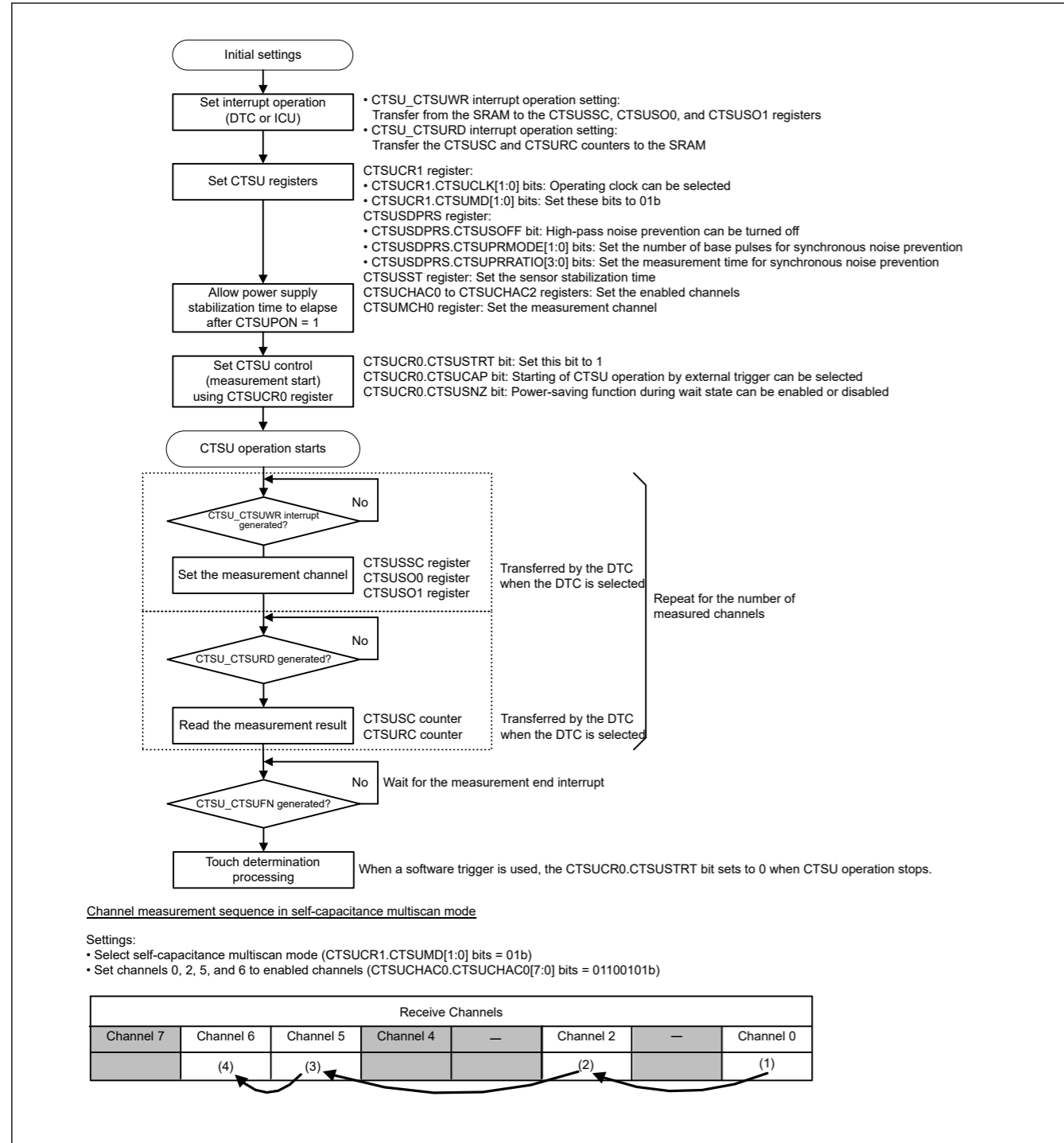


Figure 40.14 Software flow and example operation for self-capacitance multi-scan mode

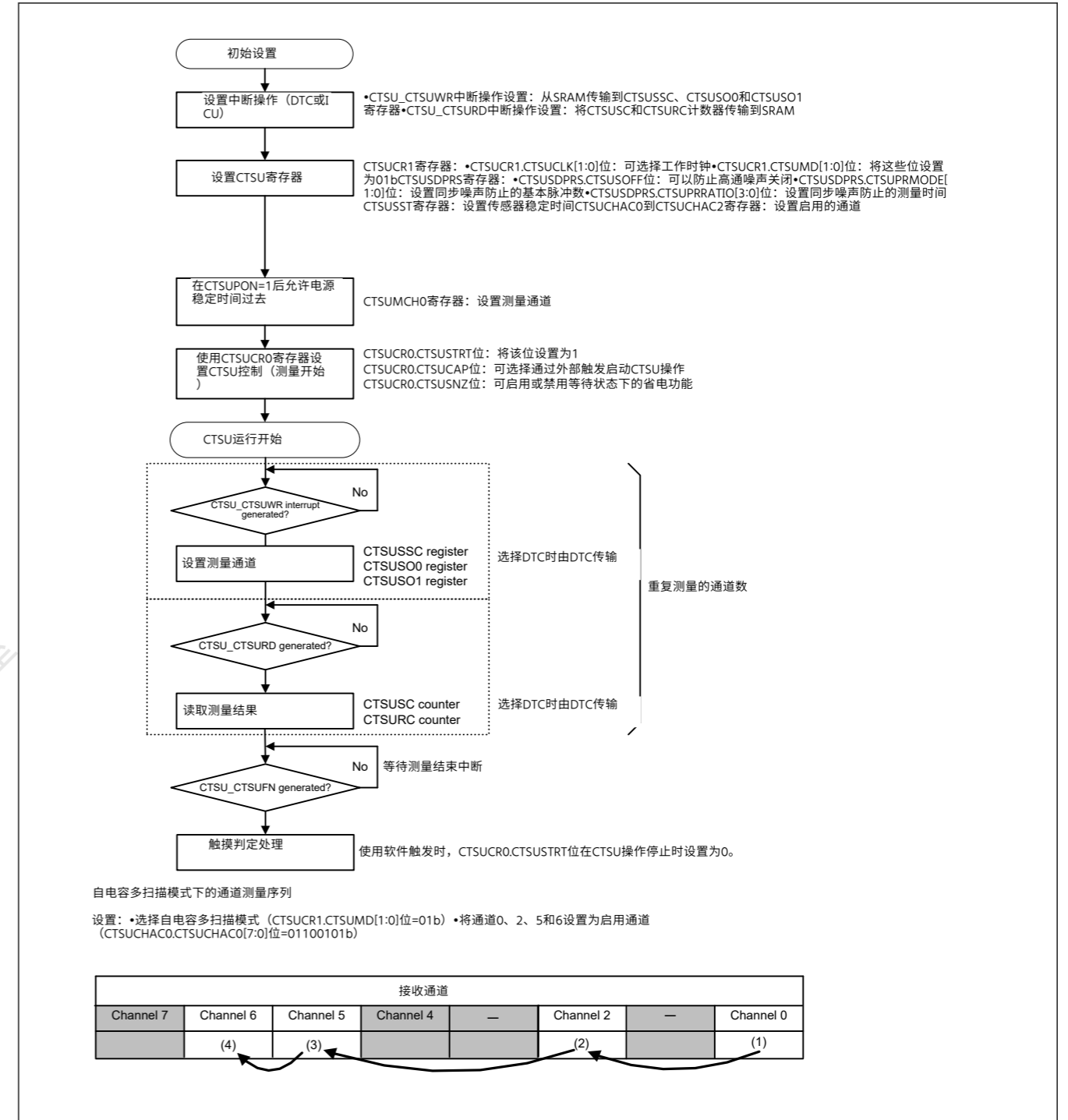


Figure 40.14 自电容多扫描模式的软件流程和示例操作

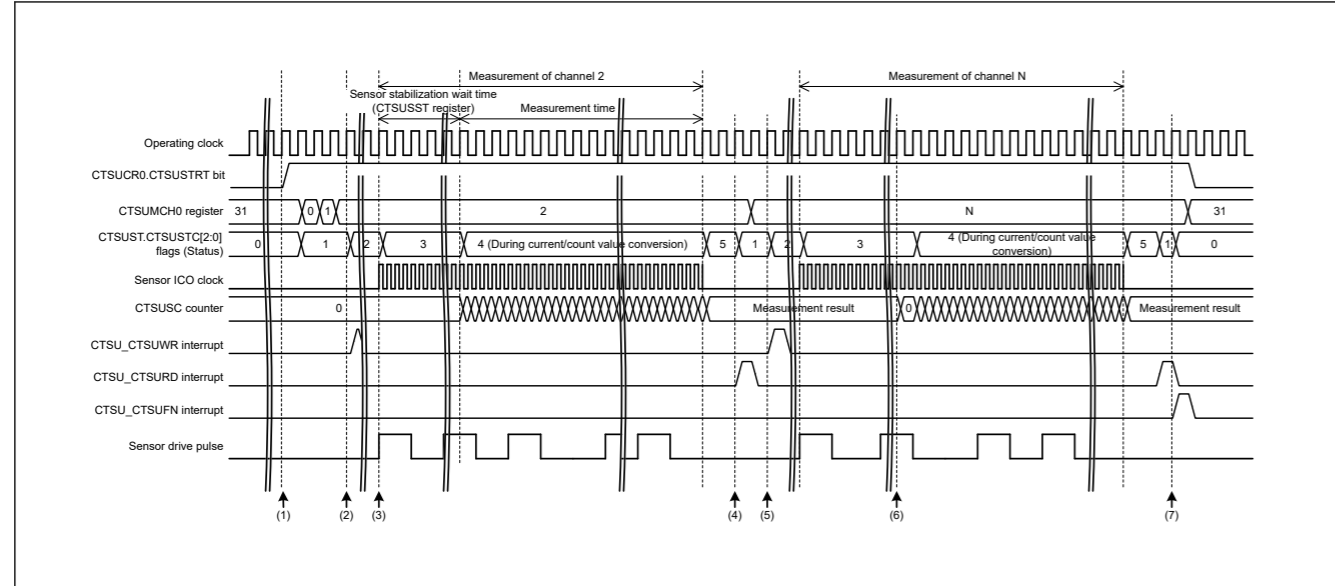


Figure 40.15 Timing of self-capacitance multi-scan mode when the measurement start condition is a software trigger

The following describes the operation shown in Figure 40.15:

1. After initial settings are made, operation is started by writing 1 to the CTSUCR0.CTSUSTRT bit.
2. After the channel to be measured is determined in accordance with the preset conditions, a request for setting the channel (CTSU\_CTSUWR) is output.
3. On completion of writing the measurement channel settings (CTSUSSC, CTSUSO0, and CTSUSO1 registers), the sensor drive pulse is output and the sensor ICO clock and the reference ICO clock operate.
4. After the sensor stabilization wait time and the measurement time elapse, and measurement stops, a measurement result read request (CTSU\_CTSURD) is output.
5. After the channel to be measured next is determined, a measurement channel setting request (CTSU\_CTSUWR) is output.
6. After the stabilization wait time elapses and when the previous measurement is read, the result is cleared and measurement starts.
7. On completion of all measurement channels, a measurement end interrupt (CTSU\_CTSUFN) is output and measurement is stopped (transition to Status 0).

Table 40.8 lists the touch pin states in self-capacitance multi-scan mode.

Table 40.8 Touch pin states in self-capacitance multi-scan mode

| Status | Touch pin        |                      |
|--------|------------------|----------------------|
|        | Measured channel | Non-measured channel |
| 0      | Low              | Low                  |
| 1      | Low              | Low                  |
| 2      | Low              | Low                  |
| 3      | Pulse            | Low                  |
| 4      | Pulse            | Low                  |
| 5      | Low              | Low                  |

### 40.3.2.5 Mutual capacitance full scan mode operation

In mutual capacitance full scan mode, measurement is performed during the high-level period of the sensor drive pulse on the receive channel by applying the edge to the target transmit channel to be measured. A single measurement target is measured twice, on the rising and falling edges. The difference between the data of these two measurements determines whether or not the electrode was touched, which results in a higher touch sensitivity.

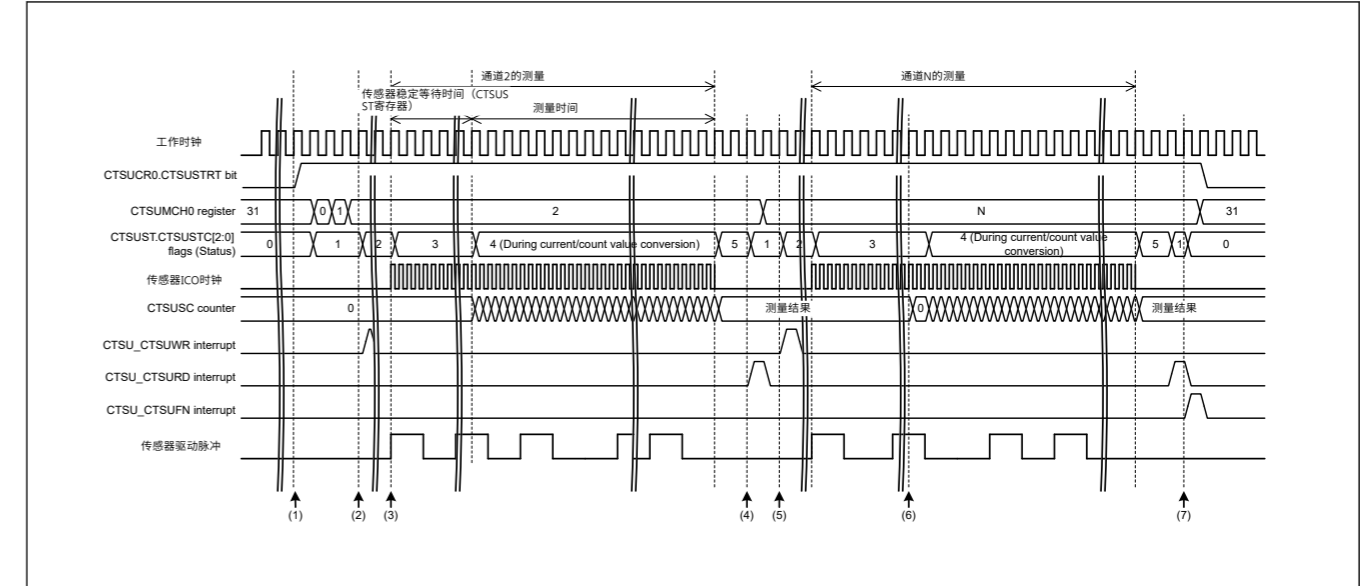


Figure 40.15 测量开始条件为软件触发时的自电容多次扫描模式时序

下面描述图40.15所示的操作：

- 1.进行初始设置后，通过向CTSUCR0.CTSUSTRT位写入1开始操作。
- 2.根据预设条件确定待测通道后，输出通道设置请求（CTSU\_CTSUWR）。
- 3.写入测量通道设置（CTSUSSC、CTSUSO0和CTSUSO1寄存器）完成后，输出传感器驱动脉冲，传感器ICO时钟和参考ICO时钟运行。
- 4.经过传感器稳定等待时间和测量时间后，测量停止，输出测量结果读取请求（CTSU\_CTSURD）。
- 5.确定下一个要测量的通道后，输出测量通道设置请求（CTSU\_CTSUWR）。
- 6.经过稳定等待时间后，当读取前一次测量时，结果被清除并开始测量。
- 7.所有测量通道完成后，输出测量结束中断(CTSU\_CTSUFN)并停止测量（转换到状态0）。

表40.8列出了自电容多扫描模式下的触摸引脚状态。

Table 40.8 自电容多扫描模式下的触摸引脚状态

| Status | 触摸针   |                      |
|--------|-------|----------------------|
|        | 测量通道  | Non-measured channel |
| 0      | Low   | Low                  |
| 1      | Low   | Low                  |
| 2      | Low   | Low                  |
| 3      | Pulse | Low                  |
| 4      | Pulse | Low                  |
| 5      | Low   | Low                  |

### 40.3.2.5 互电容全扫描模式操作

在互电容全扫描模式下，在接收通道上的传感器驱动脉冲的高电平期间通过将边沿施加到要测量的目标发送通道来执行测量。在上升沿和下降沿对单个测量目标进行两次测量。这两次测量的数据之间的差异决定了电极是否被触摸，从而导致更高的触摸灵敏度。

Electrostatic capacitance is measured sequentially on channels set to transmission or reception in the CTSUCHTRC0 to CTSUCHTRC2 registers, and specified as measurement targets in the CTSUCHAC0 to CTSUCHAC2 registers. The capacitance is measured by combining these signals. Figure 40.16 shows the software flow and an operation example, and Figure 40.17 shows the timing.

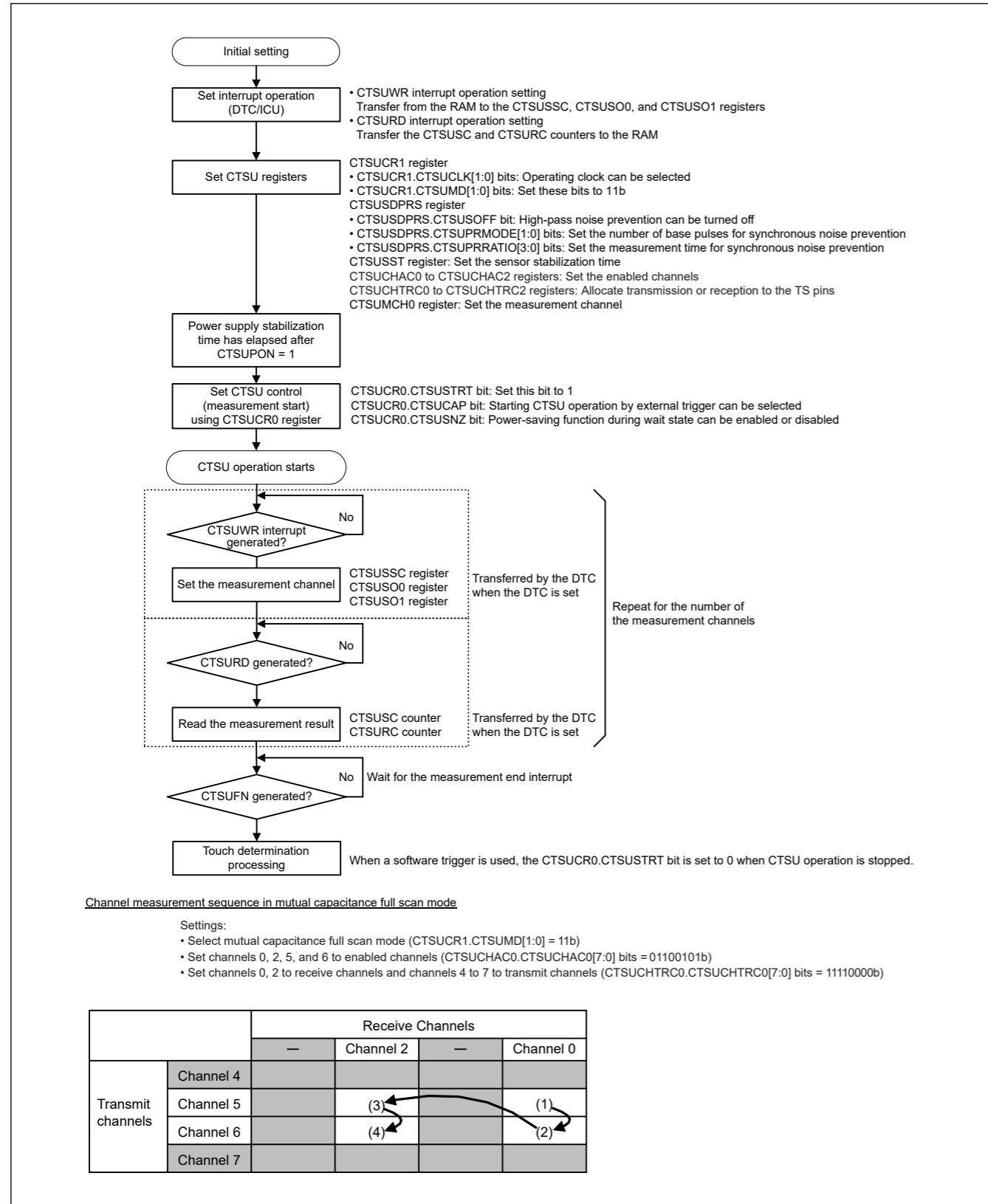


Figure 40.16 Software flow and example operation for mutual capacitance full scan mode

在CTSUCHTRC0中设置为发送或接收的通道上依次测量静电电容 CTSUCHAC2寄存器,并在CTSUCHAC0至CTSUCHAC2寄存器中指定为测量目标。通过组合这些信号来测量电容。图40.16显示了软件流程和操作示例,图40.17显示了时序。

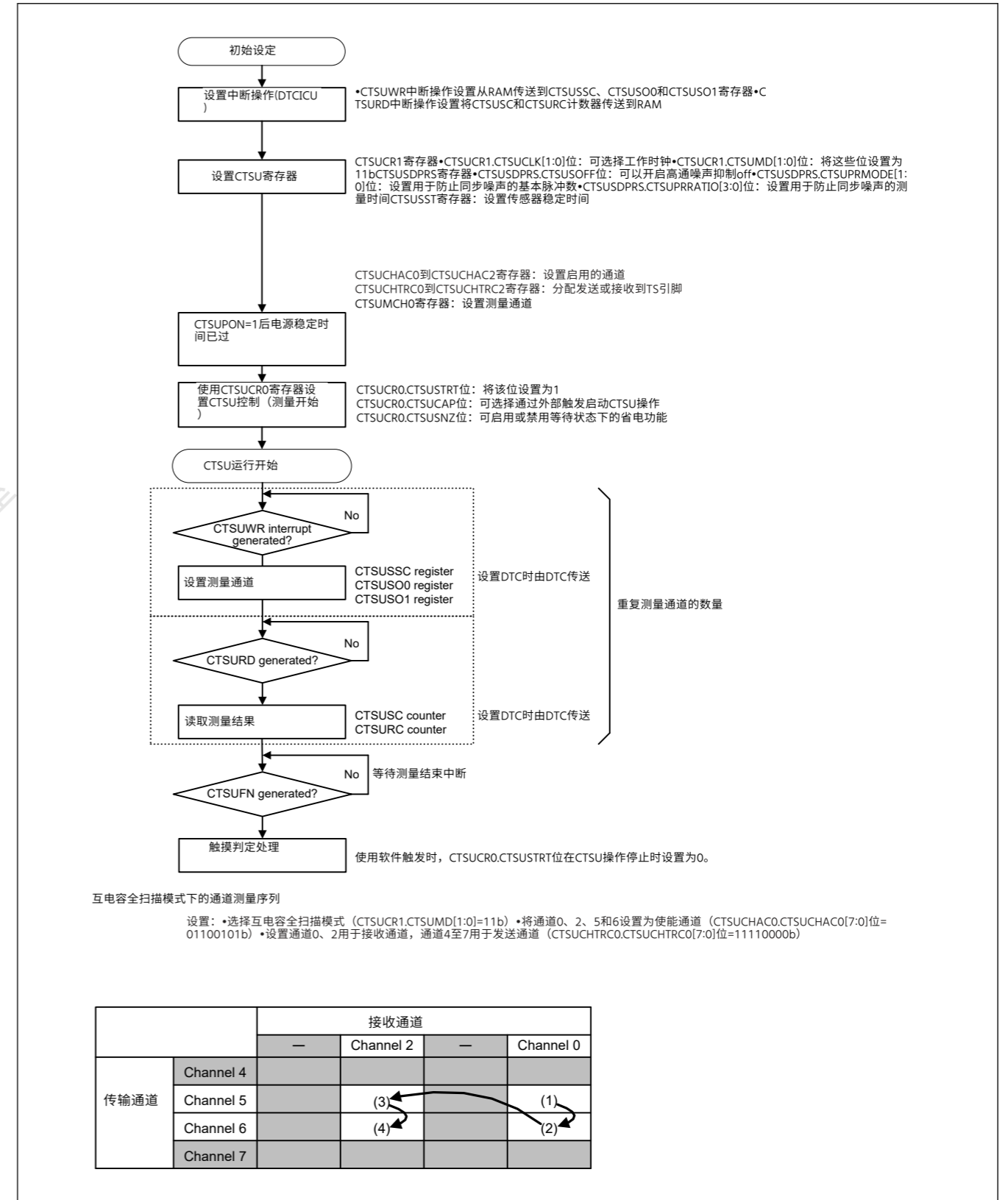


Figure 40.16 互电容全扫描模式的软件流程和示例操作



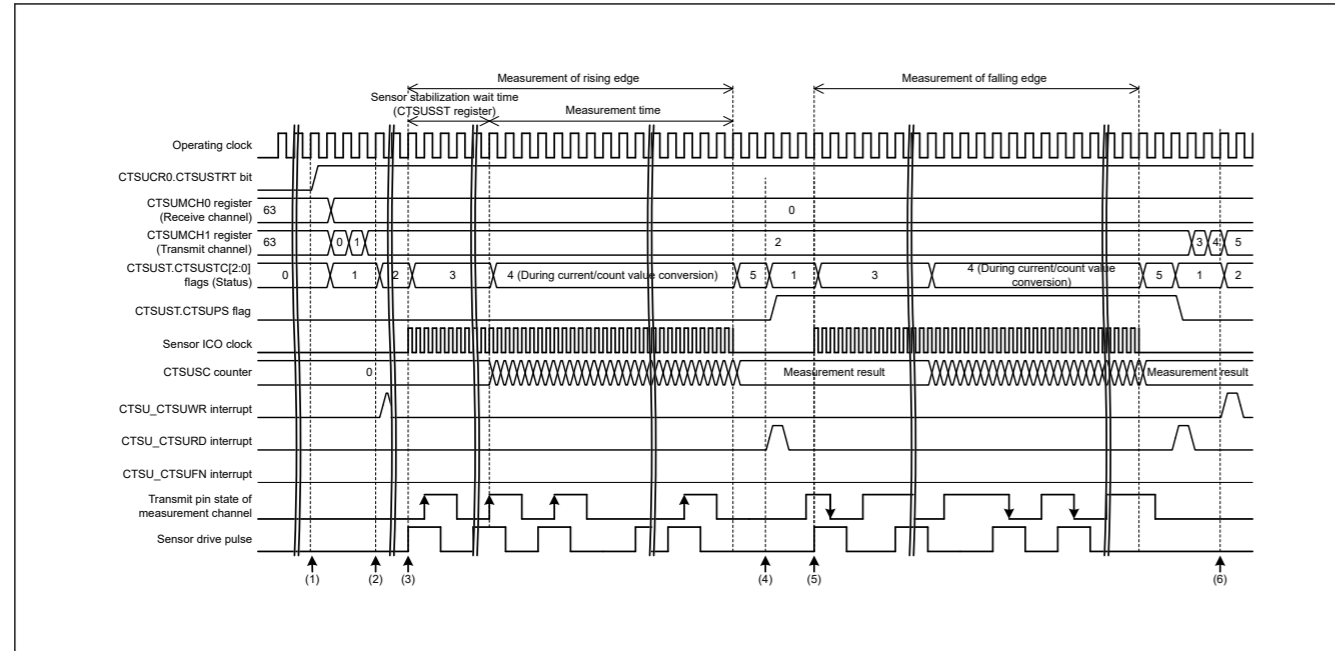


Figure 40.17 Timing of mutual capacitance full scan mode when the measurement start condition is a software trigger

The following describes the operation shown in Figure 40.17

1. After initial settings are made, operation is started by writing 1 to the CTSUCR0.CTSUSTRT bit.
2. After the channel to be measured is determined in accordance with the preset conditions, a request for setting the channel (CTSU\_CTSUWR) is output.
3. On completion of writing the measurement channel settings (CTSUSSC, CTSUSO0, and CTSUSO1 registers), the sensor drive pulse is output and the sensor ICO clock and the reference ICO clock operate. At the same time, a pulse detected on the rising edge is output to the transmit pin on the measurement channel during the high-level period of the sensor drive pulse.
4. After the sensor stabilization wait time and the measurement time elapsed and measurement stops, a measurement result read request (CTSU\_CTSURD) is output.
5. The same channel is measured by outputting a pulse detected on the falling edge during the high-level period of the sensor drive pulse.
6. After the same channel is measured twice, the channel to be measured next is determined and measured in the same way.
7. On completion of all measurement channels, a measurement end interrupt (CTSU\_CTSUFN) is output and measurement stops (transition to Status 0).

The mutual capacitance measurement status flag (CTSUST.CTSUPS bit) changes when Status 5 transitions to Status 1. Table 40.9 lists the touch pin states in mutual capacitance full scan mode.

Table 40.9 Touch pin states in mutual capacitance full scan mode (1 of 2)

| Status | Touch pins for receive channels |                      | Touch pins for transmit channels |                      | Remarks   |
|--------|---------------------------------|----------------------|----------------------------------|----------------------|---|
|        | Measured channel                | Non-measured channel | Measured channel                 | Non-measured channel |   |
| 0      | Low                             | Low                  | Low                              | Low                  | —   |
| 1      | Low                             | Low                  | Low/high                         | Low                  | —   |
| 2      | Low                             | Low                  | Low                              | Low                  | —   |
| 3      | Pulse                           | Low                  | Pulse                            | Low                  | The phase pulse is the same as that of the receive channel on the first measurement and opposite on the second measurement. |
| 4      | Pulse                           | Low                  | Pulse                            | Low                  | —   |

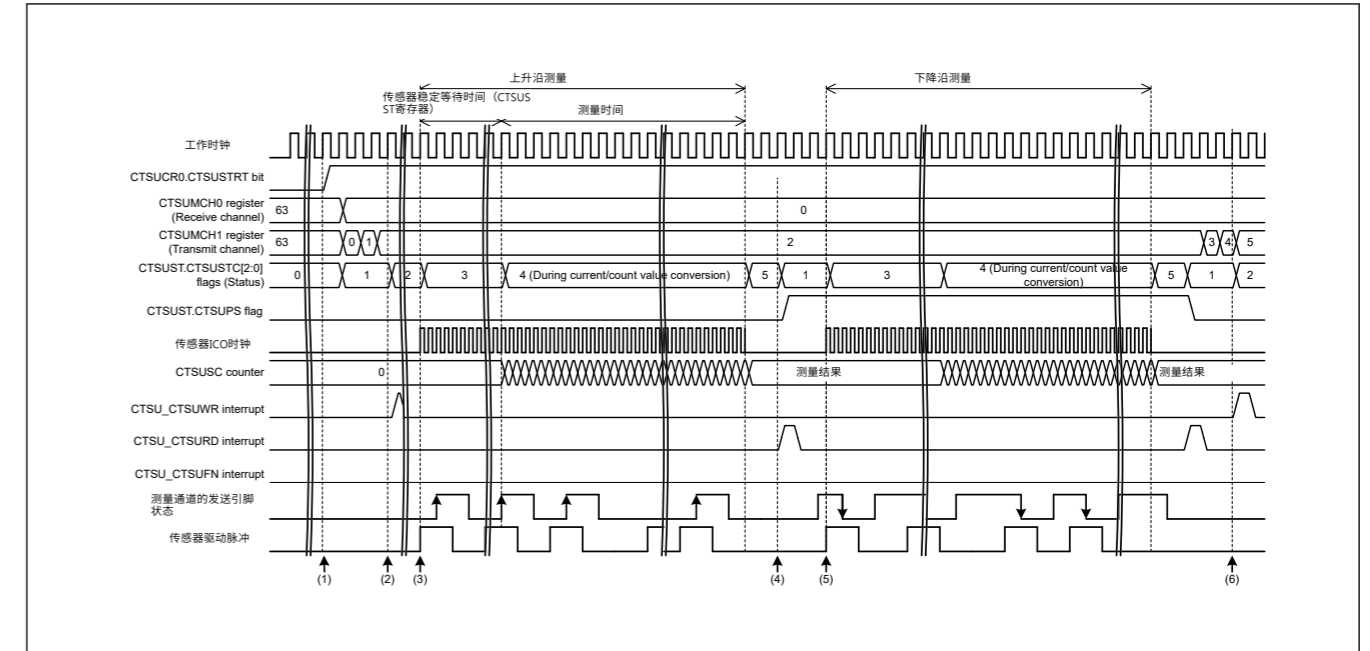


Figure 40.17 测量开始条件为软件触发时互电容全扫描模式的时序

下面介绍图40.17所示的操作

1. 进行初始设置后，通过向CTSUCR0.CTSUSTRT位写入1开始操作。
2. 根据预设条件确定待测通道后，输出通道设置请求（CTSU\_CTSUWR）。
3. 写入测量通道设置（CTSUSSC、CTSUSO0和CTSUSO1寄存器）完成后，输出传感器驱动脉冲，传感器ICO时钟和参考ICO时钟运行。同时，在传感器驱动脉冲的高电平期间，将在上升沿检测到的脉冲输出到测量通道的发送引脚。
4. 在传感器稳定等待时间和测量时间过去并停止测量后，输出测量结果读取请求（CTSU\_CTSURD）。
5. 通过在传感器驱动脉冲的高电平期间输出下降沿检测到的脉冲来测量同一通道。
6. 同一个通道测量两次后，确定下一个要测量的通道，用同样的方法测量。
7. 所有测量通道完成后，输出测量结束中断(CTSU\_CTSUFN)并停止测量（转换到状态0）。

互电容测量状态标志（CTSUST.CTSUPS位）在状态5转换为状态1时发生变化。表40.9列出了互电容全扫描模式下的触摸引脚状态。

Table 40.9 互电容全扫描模式下的触摸引脚状态（1of2）

| Status | 接收通道的触摸引脚 |                      | 用于传输通道的触摸引脚 |                      | Remarks                              |
|--------|-----------|----------------------|-------------|----------------------|--------------------------------------|
|        | 测量通道      | Non-measured channel | 测量通道        | Non-measured channel |                                      |
| 0      | Low       | Low                  | Low         | Low                  | —                                    |
| 1      | Low       | Low                  | Low/high    | Low                  | —                                    |
| 2      | Low       | Low                  | Low         | Low                  | —                                    |
| 3      | Pulse     | Low                  | Pulse       | Low                  | 相位脉冲在第一次测量时与接收通道的相位脉冲相同，而在第二次测量时则相反。 |
| 4      | Pulse     | Low                  | Pulse       | Low                  | —                                    |

Table 40.9 Touch pin states in mutual capacitance full scan mode (2 of 2)

| Status | Touch pins for receive channels |                      | Touch pins for transmit channels |                      | Remarks |
|--------|---------------------------------|----------------------|----------------------------------|----------------------|---------|
|        | Measured channel                | Non-measured channel | Measured channel                 | Non-measured channel |         |
| 5      | Low                             | Low                  | Low                              | Low                  | —       |

## 40.3.3 Parameters Common to Multiple Modes

## 40.3.3.1 Sensor stabilization wait time and measurement time

Figure 40.18 shows the timing of the sensor stabilization wait and measurement.

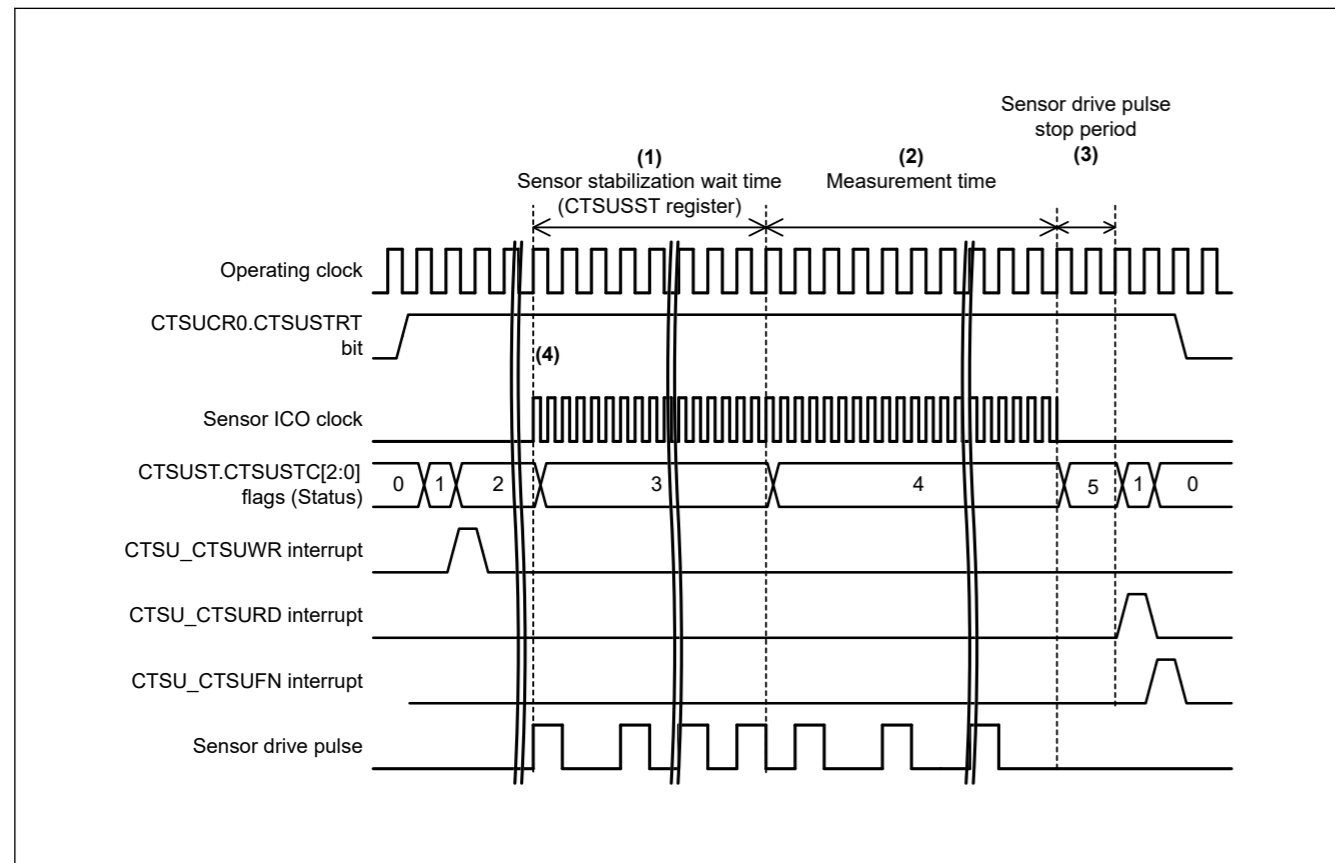


Figure 40.18 Sensor stabilization wait and measurement timing

The following describes the operation shown in Figure 40.18:

- In response to the CTSU\_CTSUWR interrupt request, output of the sensor drive pulse is started by a write access to the CTSUSO1 register. The CTSU waits for the stabilization time set in the CTSUSST register.
- When the sensor stabilization time elapses and the CTSUST.CTSUDTSR flag clears to 0, measurement starts on transition to Status 4. The measurement time is determined by the base clock cycle setting and the CTSUSDPRS.CTSUPRMODE[1:0], CTSUPRRATIO[3:0], and CTSUSO0.CTSUSNUM[5:0] bits. When the measurement time elapses, measurement of the channel stops.
- After the measurement time elapses, the status transitions to Status 1 after two operating clock cycles, and a CTSU\_CTSURD interrupt occurs. Read the data from the CTSUSC and CTSURC counters. At this time, the sensor drive pulse is output at the low level. When measurement of all specified channels is completed, the CTSUCR0.CTSUSTRT bit clears to 0.
- The sensor ICO clock oscillates while the CTSUST.CTSUSTC[2:0] flags = 011b (Status 3) or 100b (Status 4).

Table 40.9 互电容全扫描模式下的触摸引脚状态 (2个中的2个)

| Status | 接收通道的触摸引脚 |                      | 用于传输通道的触摸引脚 |                      | Remarks |
|--------|-----------|----------------------|-------------|----------------------|---------|
|        | 测量通道      | Non-measured channel | 测量通道        | Non-measured channel |         |
| 5      | Low       | Low                  | Low         | Low                  | —       |

## 40.3.3 多种模式共有的参数

## 40.3.3.1 传感器稳定等待时间和测量时间

图40.18显示了传感器稳定等待和测量的时序。

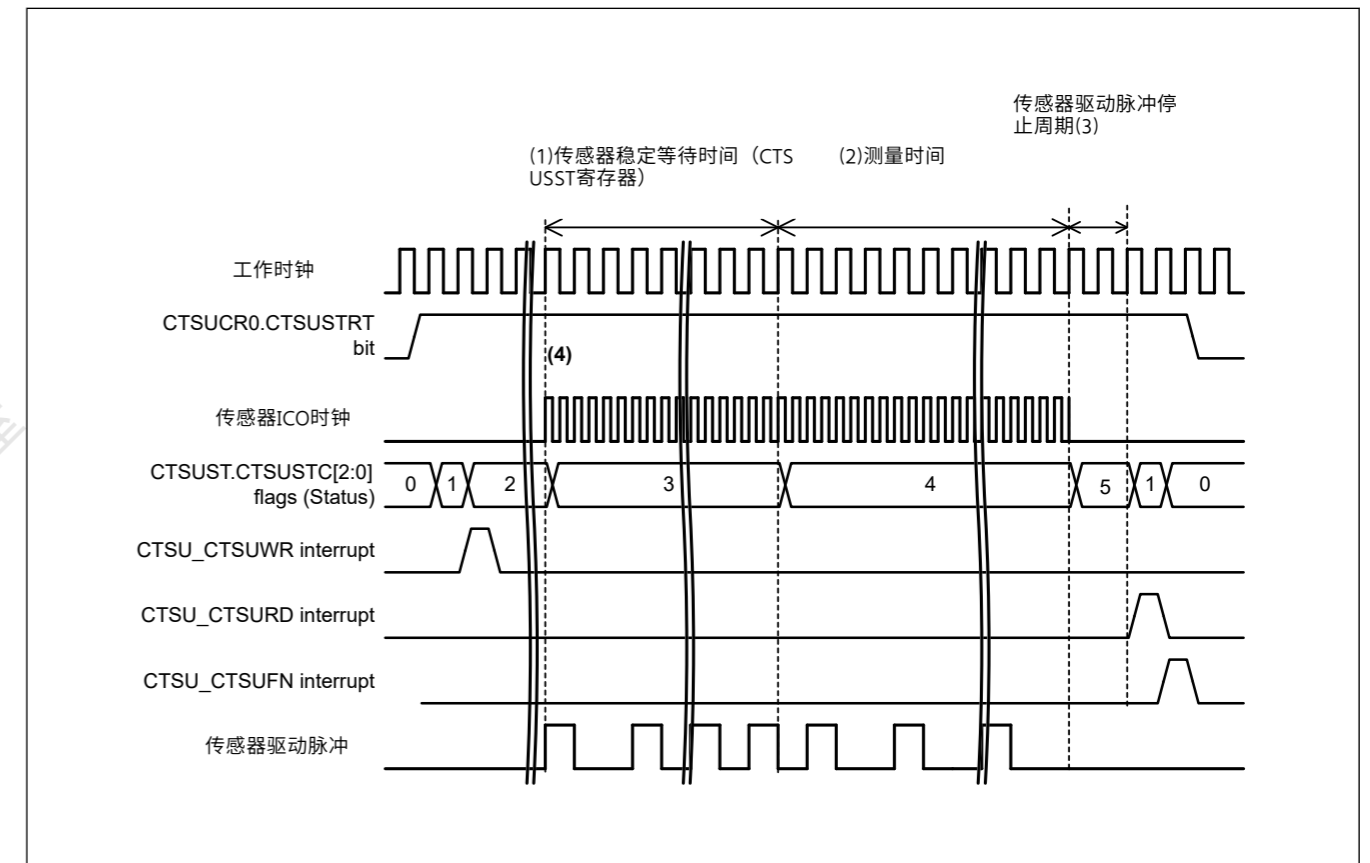


Figure 40.18 传感器稳定等待和测量定时

下面介绍图40.18所示的操作：

- 响应CTSU\_CTSUWR中断请求，通过对CTSUSO1寄存器的写访问开始输出传感器驱动脉冲。CTSUSST寄存器中设置的稳定时间。
- 当传感器稳定时间过去且CTSUST.CTSUDTSR标志清除为0时，测量开始转换到状态4。测量时间由基本时钟周期设置和CTSUSDPRS.CTSUPRMODE[1:0]、CTSUPRRATIO[3:0]和CTSUSO0.CTSUSNUM[5:0]位。当测量时间过去时，通道的测量将停止。
- 测量时间过去后，状态会在两个工作时钟周期后转换为状态1，并且 CTSU\_CTSURD中断发生。从CTSUSC和CTSURC计数器读取数据。此时，传感器驱动脉冲输出为低电平。完成所有指定通道的测量后，CTSUCR0.CTSUSTRT位清零。
- 传感器ICO时钟在CTSUST.CTSUSTC[2:0]标志=011b（状态3）或100b（状态4）时振荡。

## 40.3.3.2 Interrupts

The CTSU supports the following interrupts:

- Write request interrupt for setting registers for each channel (CTSUSUWR)
- Measurement data transfer request interrupt (CTSUSURD)
- Measurement end interrupt (CTSUSUFN)

## (1) Write request interrupt for setting registers for each channel (CTSUSUWR)

Store the settings for each measurement channel in the SRAM, and set up the DTC or ICU transfer associated with the CTSUSUWR interrupt in advance. The CTSUSUWR interrupt is output when Status 1 transitions to Status 2. Write the settings for the selected channel from the SRAM to the CTSUSSC, CTSUSO0, and CTSUSO1 registers (Figure 40.19). Because write access to the CTSUSO1 register controls the transition to the next status, you must set this register last.

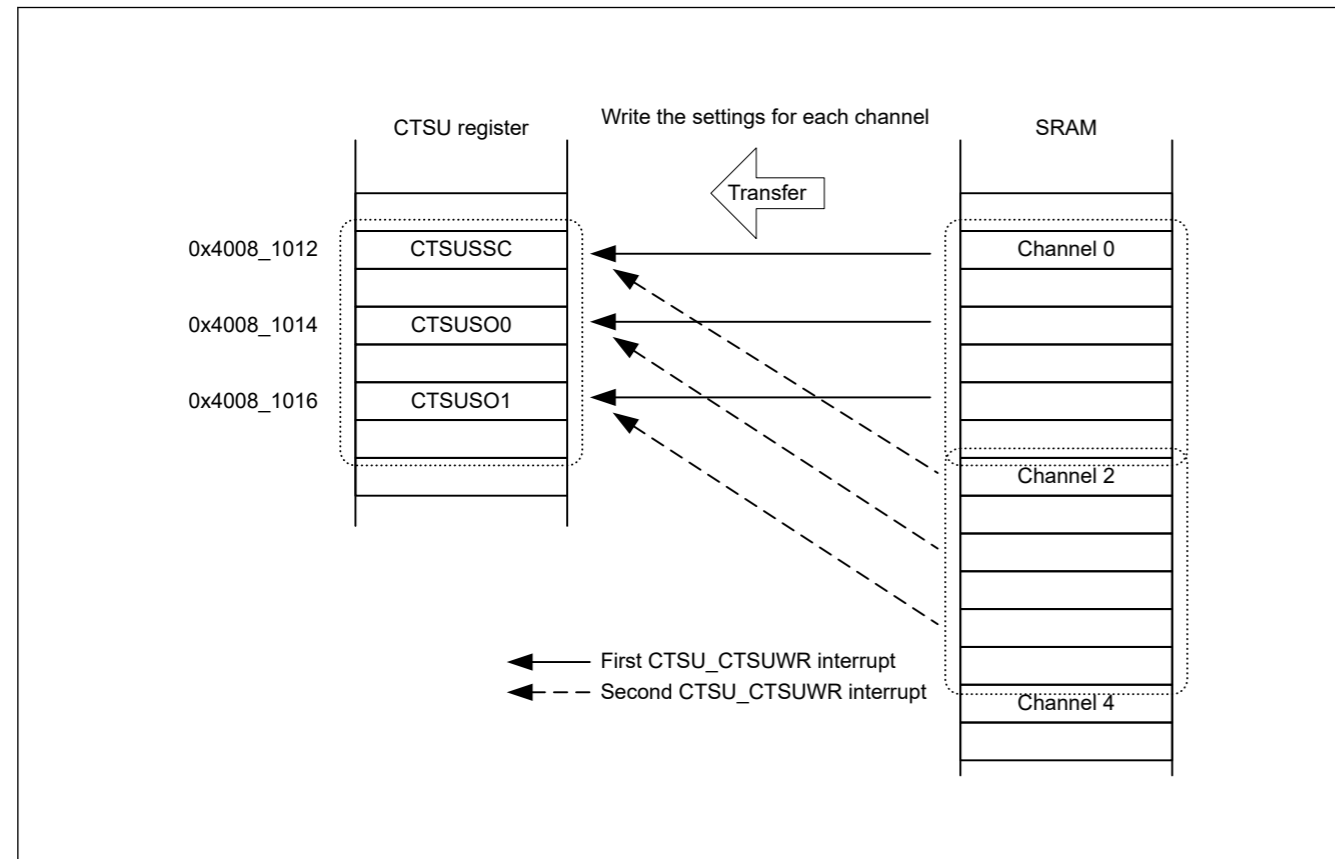


Figure 40.19 Example of DTC transfer operation using the CTSUSUWR interrupt

The registers to be set (CTSUSSC, CTSUSO0, and CTSUSO1) are allocated at sequential addresses. On CTSUSUWR interrupt generation, set up the operation as follows:

- Transfer destination address: CTSUSSC register address
- Handling at the transfer destination address: Transfer 2-byte data three times with a single interrupt. The address of the start byte is fixed.
- Transfer source address: CTSUSSC register data storage address for the lowest number channel in the settings stored in the SRAM
- Handling at the transfer source address: Transfer 2-byte data three times with a single interrupt. The address of the first byte is continued from the previous interrupt handling.
- Number of transfers per interrupt: Specify the number of measurements.

## 40.3.3.2 Interrupts

CTSUS支持以下中断:

- 各通道设置寄存器的写请求中断(CTSUSUWR)
- 测量数据传输请求中断 (CTSUSURD)
- 测量结束中断 (CTSUSUFN)

## (1) 为每个通道设置寄存器的写请求中断(CTSUSUWR)

将每个测量通道的设置存储在SRAM中，并提前设置与CTSUSUWR中断相关的DTC或ICU传输。当状态1切换到状态2时输出CTSUSUWR中断。

将所选通道的设置从SRAM写入CTSUSSC、CTSUSO0和CTSUSO1寄存器（图40.19）。因为对CTSUSO1寄存器的写访问控制到下一个状态的转换，所以您必须最后设置该寄存器。

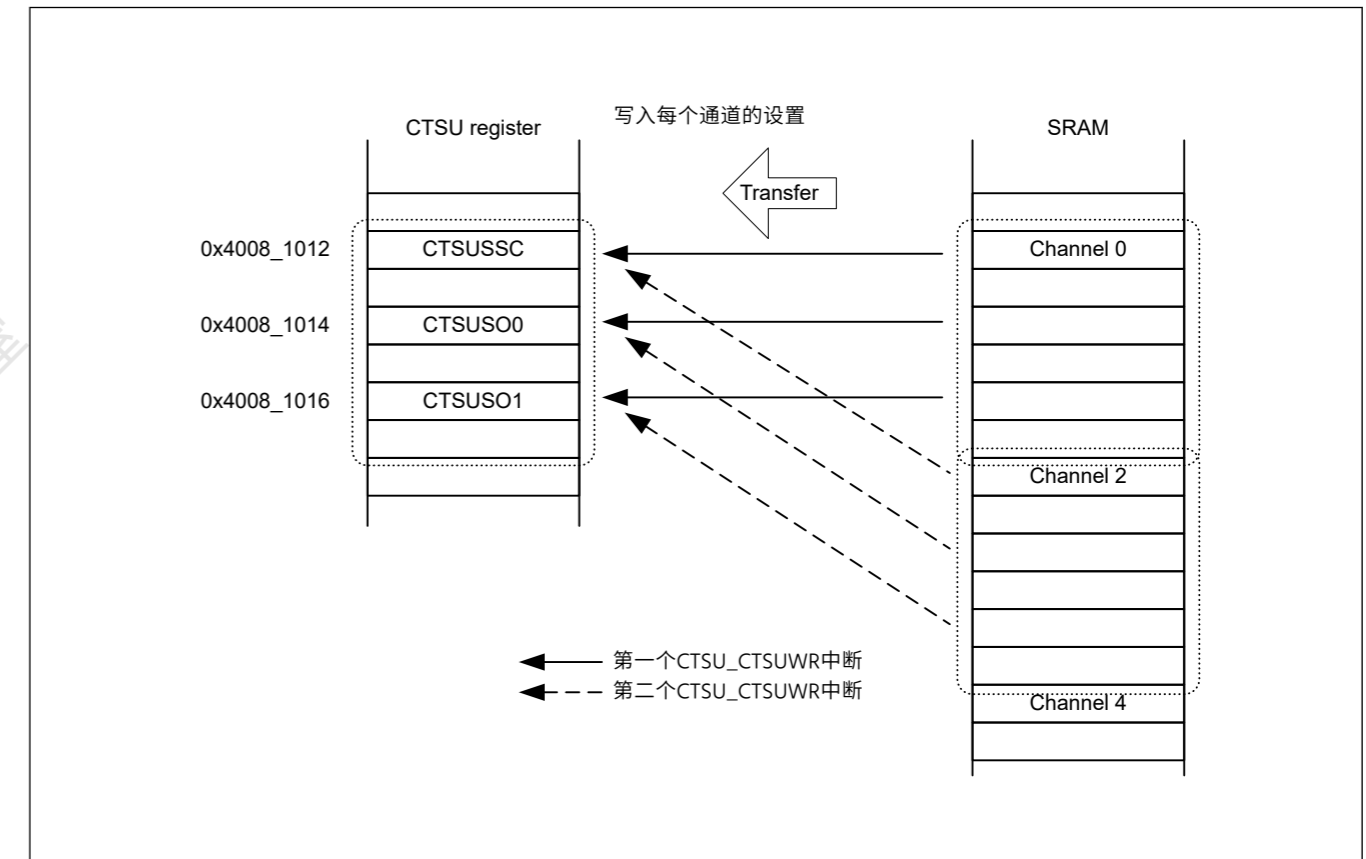


Figure 40.19 使用CTSUSUWR中断的DTC传输操作示例

要设置的寄存器（CTSUSSC、CTSUSO0和CTSUSO1）分配在顺序地址。在产生CTSUSUWR中断时，按如下方式设置操作：

- 传输目标地址：CTSUSSC寄存器地址
- 在传送目标地址处处理：一次中断传送3次2字节数据。起始字节的地址是固定的。
- 传输源地址：CTSUSSC寄存器数据存储地址，用于存储在SRAM中的设置中的最低编号通道
- 在传输源地址处处理：一次中断传输3次2字节数据。第一个字节的地址从先前的中断处理继续。
- 每个中断的传输次数：指定测量次数。

## (2) Measurement data transfer request interrupt (CTSUS\_CTSURD)

Set up the DTC or ICU transfer associated with the CTSUS\_CTSURD interrupt in advance. The CTSUS\_CTSURD interrupt is output when Status 5 transitions to Status 1. Read the measurement result from the CTSUSC and CTSURC counters (Figure 40.20).

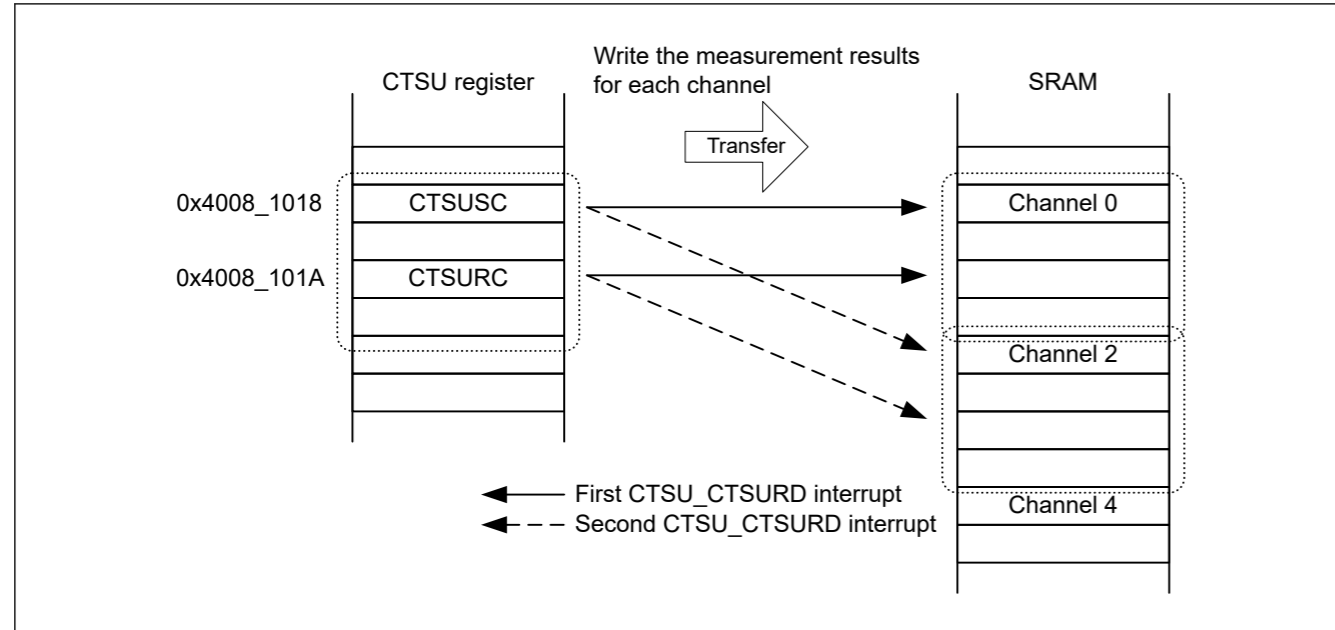


Figure 40.20 Example of DTC transfer operation using the CTSUS\_CTSURD interrupt

The measurement result registers (CTSUSC and CTSURC counters) used as transfer sources are allocated at sequential addresses. On CTSUS\_CTSURD interrupt generation, set up the operation as follows:

- Transfer source address: CTSUSC counter address
- Handling at the transfer source address: Transfer 2-byte data twice with a single interrupt. The start address is fixed.
- Transfer destination address: CTSUSC counter data storage address for the lowest number channel in the settings stored in the SRAM
- Handling at the transfer destination address: Transfer 2-byte data twice with a single interrupt. The start address is continued from the previous interrupt handling.
- Number of transfers per interrupt: Specify the number of measurements.

## (3) Measurement end interrupt (CTSUS\_CTSUFN)

When all channels are measured, an interrupt occurs when Status 1 transitions to Status 0. In the software, check the overflow flags (CTSUST.CTSUSOVF and CTSUROVF) and read the measurement results to determine whether or not the electrode was touched. Interrupt requests are accepted or disabled in the interrupt control block.

## 40.4 Usage Notes

## 40.4.1 Measurement Result Data (CTSUSC and CTSURC Counters)

Read access during measurement is prohibited. If the measurement result data is accessed, an incorrect value might be read because of asynchronous operation.

## 40.4.2 Constraint on Software Trigger

When 10b (PCLKB/4) is selected in the CTSUCR1.CTSUCLK[1:0] bits, to restart measurement by writing 1 to the CTSUR0.CTSUSTRT bit after measurement is complete, wait for at least 3 cycles to elapse after an interrupt occurs, and then write to the CTSUCR0.CTSUSTRT bit.

## (2) 测量数据传输请求中断(CTSUS\_CTSURD)

提前设置与CTSUS\_CTSURD中断相关的DTC或ICU传输。当状态5转换为状态1时输出CTSUS\_CTSURD中断。从CTSUSC和CTSURC计数器读取测量结果(图40.20)。

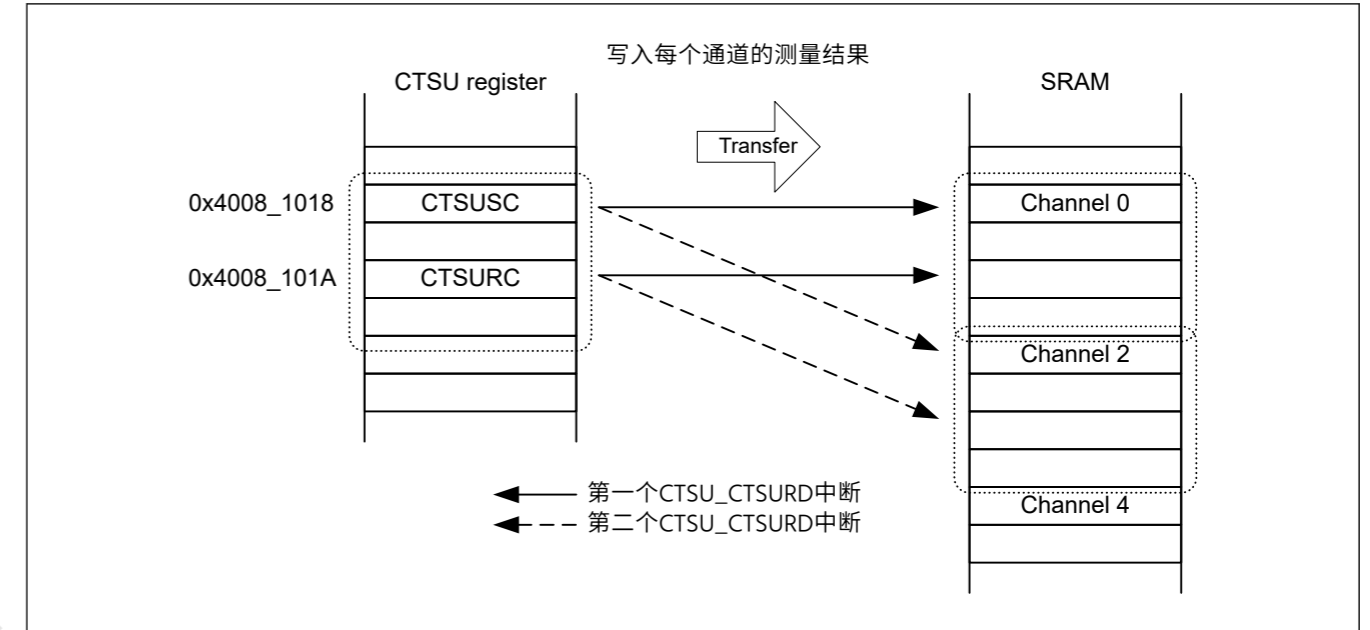


Figure 40.20 使用CTSUS\_CTSURD中断的DTC传输操作示例

用作传输源的测量结果寄存器（CTSUSC和CTSURC计数器）按顺序分配。在CTSUS\_CTSURD中断生成时，按如下方式设置操作：

- 传输源地址：CTSUSC计数器地址
- 在传输源地址处处理：一次中断传输2字节数据两次。起始地址是固定的。
- 传输目标地址：SRAM中存储的设置中编号最小的通道的CTSUSC计数器数据存储地址
- 传送目标地址处的处理：一次中断传送2字节数据两次。起始地址从先前的中断处理继续。
- 每个中断的传输次数：指定测量次数。

## (3) 测量结束中断(CTSUS\_CTSUFN)

测量所有通道时，状态1转换为状态0时发生中断。在软件中，检查溢出标志（CTSUST.CTSUSOVF和CTSUROVF）并读取测量结果以确定电极是否被触摸。在中断控制块中接受或禁用中断请求。

## 40.4 使用说明

## 40.4.1 测量结果数据（CTSUSC和CTSURC计数器）

禁止在测量期间进行读取访问。如果访问测量结果数据，可能会因为异步操作而读取到不正确的值。

## 40.4.2 软件触发约束

当在CTSUCR1.CTSUCLK[1:0]位中选择10b(PCLKB/4)时，通过将1写入测量完成后CTSUR0.CTSUSTRT位，在发生中断后至少等待3个周期，然后写入CTSUCR0.CTSUSTRT位。



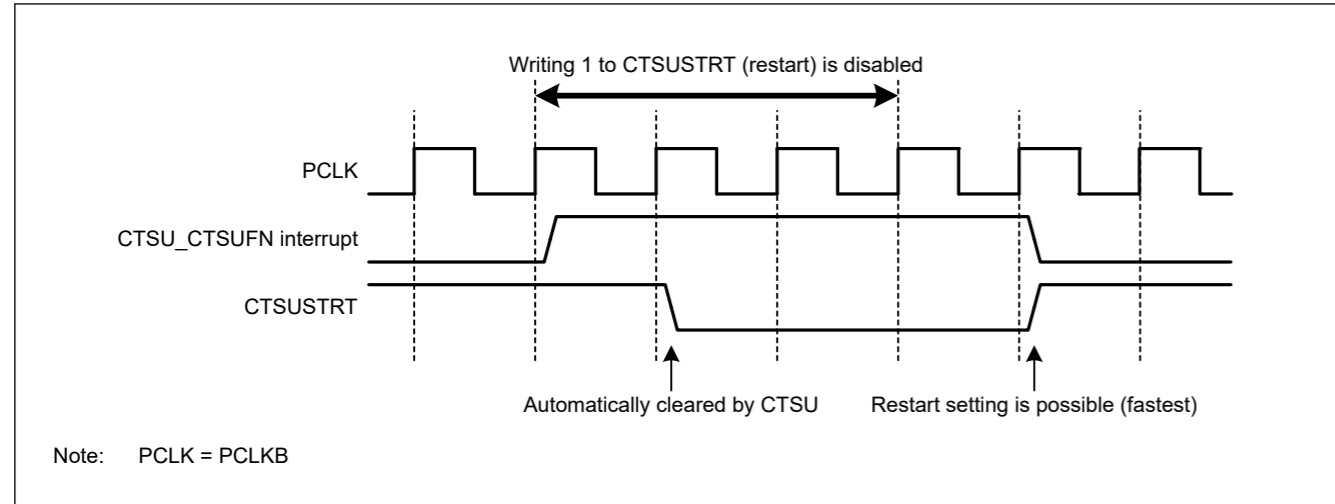


Figure 40.21 Notes on restarting measurement

#### 40.4.3 Constraints on External Triggers

- If an external trigger is input during the measurement time, measurement does not start. The next external event is enabled after 1 cycle of the operating clock when a CTSU\_CTSUFN interrupt occurs.
- To stop external trigger mode, write 0 to the CTSUCR0.CTSUSTRT bit and 0 to the CTSUCR0.CTSUINIT bit at the same time (forced stop).

#### 40.4.4 Constraints on Forced Stops

To force the current operation to stop, write 0 to the CTSUCR0.CTSUSTRT bit and 1 to the CTSUCR0.CTSUINIT bit at the same time. After this setting, the operation is stopped and the internal control registers are initialized.

When the CTSUCR0.CTSUINIT bit is used for initialization, the following registers are initialized in addition to the initialization of the internal measurement state.

- CTSUMCH0 register
- CTSUMCH1 register
- CTSUST register
- CTSUSC counter
- CTSURC counter

If operation is forced to stop, an interrupt request might be generated depending on the internal state. After a forced stop, also perform the processing for stopping and disabling the DTC or ICU. If a DTC transfer is stopped in an installed system for some reason, also perform the processing for forcing stop to and initializing the CTSU.

#### 40.4.5 TSCAP Pin

The TSCAP pin requires an external decoupling capacitor to stabilize CTSU internal voltage. The traces between the TSCAP pin and the capacitor, and the capacitor and ground should be as short and wide as physically possible.

The capacitor connected to the TSCAP pin should be fully discharged using I/O port control to output a low level, before turning on the switch (CTSUCR1.CTSUCSW bit = 1) to establish a connection.

#### 40.4.6 Constraints on Measurement Operation (CTSUCR0.CTSUSTRT Bit = 1)

During measurement (CTSUCR0.CTSUSTRT bit = 1), do not use the settings for stopping the peripheral clock or changing the port settings related to the touch pins (TSn and TSCAP pins) and Transmission power supply selection (CTSUCR0.CTSUTXVSEL) in the higher layers of the system.

If control settings non-compliant with these constraints are made, operation is forced to stop (CTSUCR0.CTSUSTRT bit = 0 and CTSUCR0.CTSUINIT bit = 1), write 0 to the CTSUCR1.CTSUPON bit and 0 to the CTSUCR1.CTSUCSW bit at the same time, and set the CTSUCR0.CTSUSNZ bit to 0. Next, restart from the initial settings flow shown in Figure 40.9.

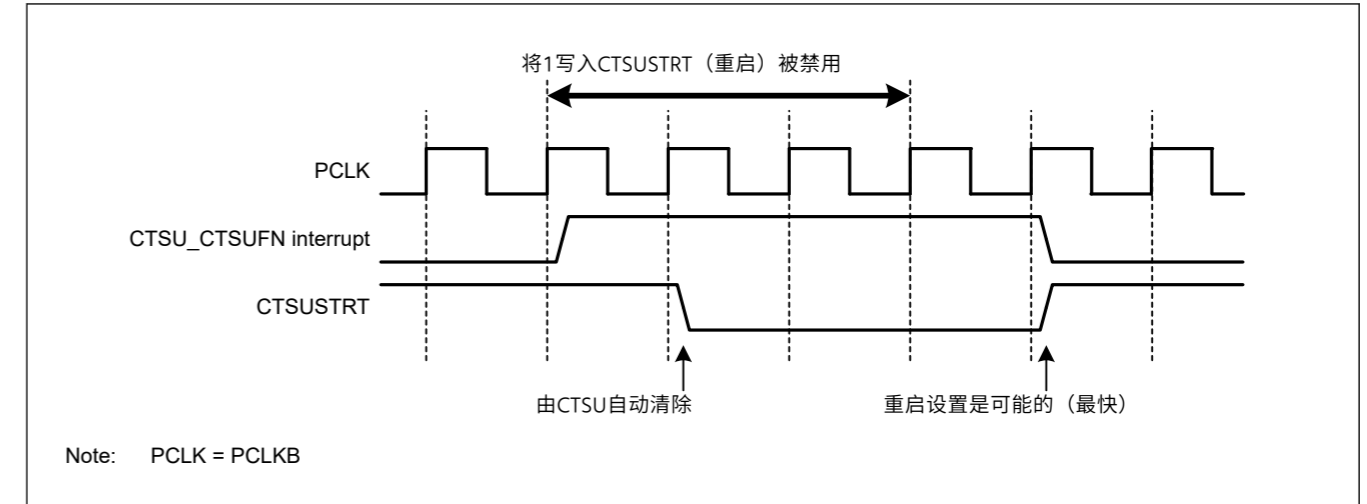


Figure 40.21 重新开始测量的注意事项

#### 40.4.3 外部触发器的约束

- 如果在测量期间输入了外部触发，则测量不会开始。当CTSUS\_CTSUFN中断发生时，下一个外部事件在工作时钟的1个周期后启用。
- 要停止外部触发模式，同时将0写入CTSUCR0.CTSUSTRT位和0写入CTSUCR0.CTSUINIT位（强制停止）。

#### 40.4.4 强制停止的约束

要强制停止当前操作，请同时向CTSUCR0.CTSUSTRT位写入0，向CTSUCR0.CTSUINIT位写入1。设置完成后，操作停止，内部控制寄存器初始化。

当CTSUCR0.CTSUINIT位用于初始化时，除了内部测量状态的初始化之外，还初始化以下寄存器。

- CTSUMCH0 register
- CTSUMCH1 register
- CTSUST register
- CTSUSC counter
- CTSURC counter

如果操作被强制停止，根据内部状态可能会产生中断请求。强制停止后，还要执行停止和禁用DTC或ICU的处理。如果由于某种原因在已安装的系统中停止了DTC传输，则还要执行强制停止和初始化CTSUS的处理。

#### 40.4.5 TSCAP Pin

TSCAP引脚需要一个外部去耦电容来稳定CTSUS内部电压。之间的痕迹TSCAP引脚和电容器，以及电容器和地线应尽可能短且宽。

在打开开关（CTSUCR1.CTSUCSW位=1）建立连接之前，应使用IO端口控制将连接到TSCAP引脚的电容器完全放电以输出低电平。

#### 40.4.6 测量操作的限制（CTSUCR0.CTSUSTRT位=1）

在测量期间（CTSUCR0.CTSUSTRT位=1），请勿使用与触摸引脚（TSn和TSCAP引脚）和发送电源选择（CTSUCR0.CTSUTXVSEL）相关的端口设置停止外围时钟或更改高位系统的层次。

如果进行了不符合这些约束的控制设置，则强制停止操作（CTSUCR0.CTSUSTRT位=0且CTSUCR0.CTSUINIT位=1），将0写入CTSUCR1.CTSUPON位并将0写入CTSUCR1.CTSUCSW位同时，将CTSUCR0.CTSUSNZ位设置为0。接下来，从图40.9所示的初始设置流程重新启动。

## 41. Data Operation Circuit (DOC)

### 41.1 Overview

The Data Operation Circuit (DOC) compares, adds, and subtracts 16-bit data. When a selected condition applies, 16-bit data is compared and an interrupt can be generated. Table 41.1 lists the DOC specifications and Figure 41.1 shows a block diagram.

Table 41.1 DOC specifications

| Parameter                                      | Specifications  |
|--|---|
| Data operation function                        | 16-bit data comparison, addition, and subtraction   |
| Module-stop function                           | The module-stop state can be set to reduce power consumption.   |
| Interrupts and event link function (DOC_DOPCI) | An interrupt occurs on the following conditions: <ul style="list-style-type: none"> <li>The compared values either match or mismatch</li> <li>The result of data addition is greater than 0xFFFF</li> <li>The result of data subtraction is less than 0x0000</li> </ul> |
| TrustZone Filter                               | Security attribution can be set   |

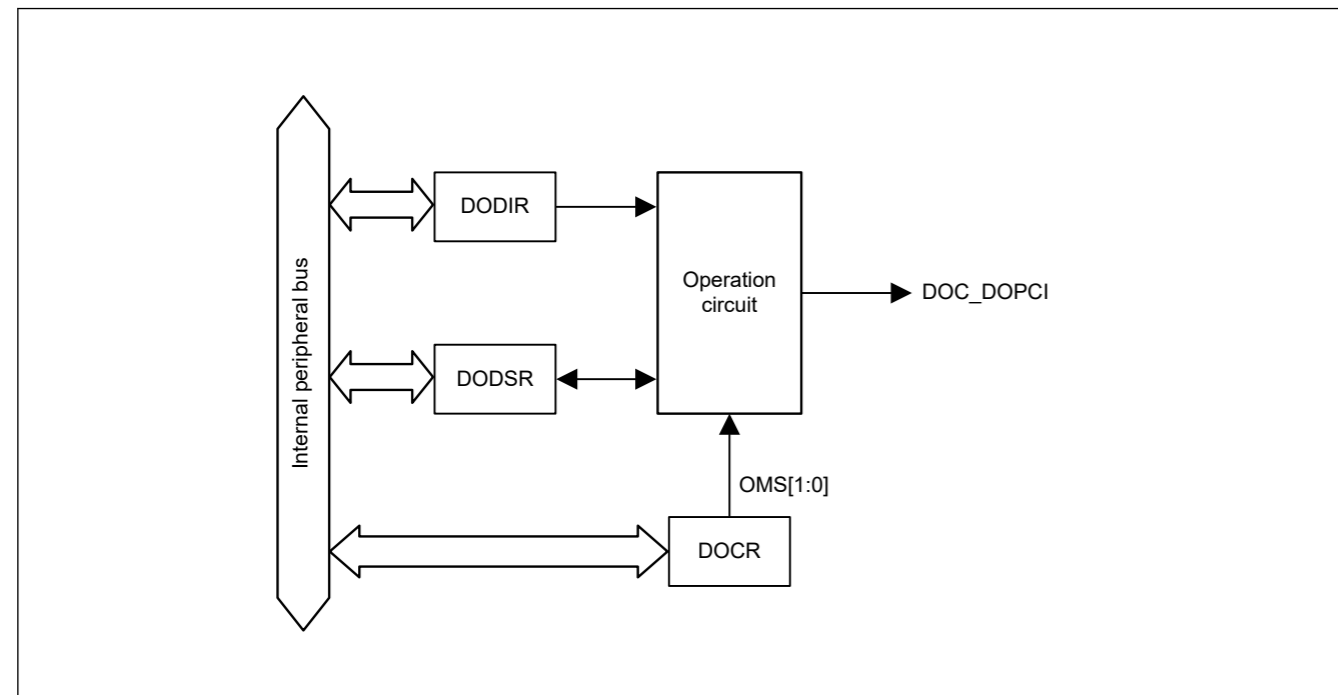


Figure 41.1 DOC block diagram

### 41.2 DOC Register Descriptions

#### 41.2.1 DOCR : DOC Control Register

Base address: DOC = 0x4010\_9000

Offset address: 0x00

|                    |   |             |           |   |   |           |          |   |
|--------------------|---|-------------|-----------|---|---|-----------|----------|---|
| Bit position:      | 7 | 6           | 5         | 4 | 3 | 2         | 1        | 0 |
| Bit field:         | — | DOPC<br>FCL | DOPC<br>F | — | — | DCSE<br>L | OMS[1:0] |   |
| Value after reset: | 0 | 0           | 0         | 0 | 0 | 0         | 0        | 0 |

## 41. 数据运算电路(DOC)

### 41.1 Overview

数据运算电路(DOC)对16位数据进行比较、加法和减法。当适用选定条件时, 比较16位数据并可以生成中断。表4.1.1列出了DOC规范, 图4.1.1显示了框图。

Table 41.1 文档规范

| Parameter             | Specifications   |
|-----------------------|--|
| 数据运算功能                | 16位数据比较、加法和减法  |
| Module-stop function  | 可设置模块停止状态以降低功耗。  |
| 中断和事件链接功能 (DOC_DOPCI) | 在以下情况下会发生中断: ●<br>比较的值匹配或不匹配<br>● 数据相加结果大于0xFFFF<br>● 数据减法结果小于0x0000 |
| TrustZone Filter      | 可设置安全属性  |

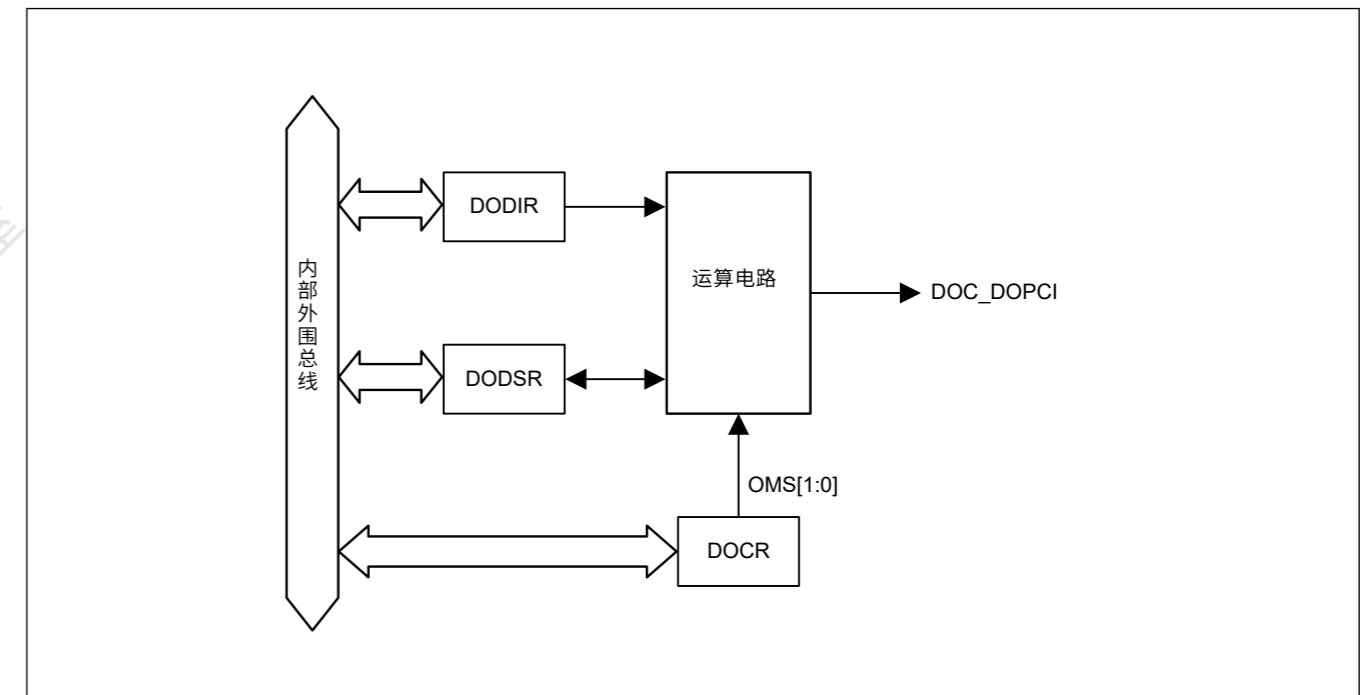


Figure 41.1 文档框图

### 41.2 DOC寄存器说明

#### 41.2.1 DOCR:DOC控制寄存器

Base address: DOC = 0x4010\_9000

Offset address: 0x00

|               |   |             |           |   |   |           |          |   |
|---------------|---|-------------|-----------|---|---|-----------|----------|---|
| Bit position: | 7 | 6           | 5         | 4 | 3 | 2         | 1        | 0 |
| Bit field:    | — | DOPC<br>FCL | DOPC<br>F | — | — | DCSE<br>L | OMS[1:0] |   |
| 重置后的值:        | 0 | 0           | 0         | 0 | 0 | 0         | 0        | 0 |

| Bit | Symbol   | Function   | R/W |
|-----|----------|--|-----|
| 1:0 | OMS[1:0] | Operating Mode Select<br>0 0: Data comparison mode<br>0 1: Data addition mode<br>1 0: Data subtraction mode<br>1 1: Setting prohibited | R/W |
| 2   | DCSEL*1  | Detection Condition Select<br>0: Set DOPCF flag when data mismatch is detected<br>1: Set DOPCF flag when data match is detected        | R/W |
| 4:3 | —        | These bits are read as 0. The write value should be 0.   | R/W |
| 5   | DOPCF    | DOC Flag<br>Indicates the result of an operation.  | R   |
| 6   | DOPCFCL  | DOPCF Clear<br>0: Retain DOPCF flag state<br>1: Clear DOPCF flag   | R/W |
| 7   | —        | These bits are read as 0. The write value should be 0.   | R/W |

Note 1. Only valid when data comparison mode is selected.

#### OMS[1:0] bits (Operating Mode Select)

The OMS[1:0] bits select the operating mode of the DOC.

#### DCSEL bit (Detection Condition Select)

The DCSEL bit selects the detection condition in data comparison mode. This bit is only valid when data comparison mode is selected.

#### DOPCF flag (DOC Flag)

The DOPCF flag indicates the result of an operation.

[Setting conditions]

- The result of data comparison matches the condition selected in the DCSEL bit
- A data addition result is greater than 0xFFFF
- A data subtraction result is less than 0x0000

[Clearing condition]

- Writing 1 to the DOPCFCL bit

#### DOPCFCL bit (DOPCF Clear)

Setting the DOPCFCL bit to 1 clears the DOPCF flag. This bit is read as 0.

### 41.2.2 DODIR : DOC Data Input Register

Base address: DOC = 0x4010\_9000

Offset address: 0x02

|                    |             |    |    |    |    |    |   |   |   |   |   |   |   |   |   |   |
|--------------------|-------------|----|----|----|----|----|---|---|---|---|---|---|---|---|---|---|
| Bit position:      | 15          | 14 | 13 | 12 | 11 | 10 | 9 | 8 | 7 | 6 | 5 | 4 | 3 | 2 | 1 | 0 |
| Bit field:         | [Empty box] |    |    |    |    |    |   |   |   |   |   |   |   |   |   |   |
| Value after reset: | 0           | 0  | 0  | 0  | 0  | 0  | 0 | 0 | 0 | 0 | 0 | 0 | 0 | 0 | 0 | 0 |

| Bit  | Symbol | Function                                      | R/W |
|------|--------|---|-----|
| 15:0 | n/a    | It stores 16-bit data used in the operations. | R/W |

| Bit | Symbol   | Function   | R/W |
|-----|----------|--|-----|
| 1:0 | OMS[1:0] | 操作模式选择<br>00: 数据比较模式<br>01: 数据加法模式<br>10: 数据减法模式<br>11: 禁止设置 | R/W |
| 2   | DCSEL*1  | 检测条件选择<br>0: 检测到数据不匹配时设置DOPCF标志<br>1: 检测到数据匹配时设置DOPCF标志      | R/W |
| 4:3 | —        | 这些位被读取为0。写入值应为0。   | R/W |
| 5   | DOPCF    | 文档标志<br>表示操作的结果。   | R   |
| 6   | DOPCFCL  | DOPCF Clear<br>0: 保持DOPCF标志状态<br>1: 清除DOPCF标志                | R/W |
| 7   | —        | 这些位被读取为0。写入值应为0。   | R/W |

注1. 仅在在选择数据比较模式时有效。

#### OMS[1:0]位 (操作模式选择)

OMS[1:0]位选择DOC的工作模式。

#### DCSEL位 (检测条件选择)

DCSEL位选择数据比较模式下的检测条件。该位仅在在选择数据比较模式时有效。

#### DOPCF flag (DOC Flag)

DOPCF标志指示操作的结果。

[Setting conditions]

- 数据比较的结果符合DCSEL位中选择的条件
- 数据相加结果大于0xFFFF
- 数据减法结果小于0x0000

[Clearing condition]

- DOPCFCL位写1

#### DOPCFCL bit (DOPCF Clear)

将DOPCFCL位设置为1会清除DOPCF标志。该位读为0。

### 41.2.2 DODIR:DOC数据输入寄存器

Base address: DOC = 0x4010\_9000

Offset address: 0x02

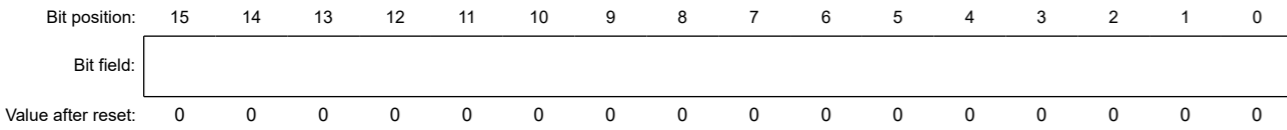
|               |             |    |    |    |    |    |   |   |   |   |   |   |   |   |   |   |
|---------------|-------------|----|----|----|----|----|---|---|---|---|---|---|---|---|---|---|
| Bit position: | 15          | 14 | 13 | 12 | 11 | 10 | 9 | 8 | 7 | 6 | 5 | 4 | 3 | 2 | 1 | 0 |
| Bit field:    | [Empty box] |    |    |    |    |    |   |   |   |   |   |   |   |   |   |   |
| 重置后的值:        | 0           | 0  | 0  | 0  | 0  | 0  | 0 | 0 | 0 | 0 | 0 | 0 | 0 | 0 | 0 | 0 |

| Bit  | Symbol | Function        | R/W |
|------|--------|-----------------|-----|
| 15:0 | n/a    | 它存储操作中使用的16位数据。 | R/W |

41.2.3 DODSR : DOC Data Setting Register

Base address: DOC = 0x4010\_9000

Offset address: 0x04



| Bit  | Symbol | Function   | R/W |
|------|--------|--|-----|
| 15:0 | n/a    | It stores 16-bit data used as a reference in data comparison mode. This register also stores the results of operations in data addition and subtraction modes. | R/W |

41.3 Operation

41.3.1 Data Comparison Mode

Figure 41.2 shows an example operation in data comparison mode operation by the DOC. The following sequence is an example operation when DCSEL is set to 0 (data mismatch is detected as a result of data comparison):

1. Write 00b to the DOCR.OMS[1:0] bits to select data comparison mode.
2. Set 16-bit reference data in DODSR.
3. Write the 16-bit data for comparison to DODIR.
4. Continue writing the 16-bit data until all data for comparison is written to DODIR.
5. If a value written to DODIR does not match that in DODSR, the DOCR.DOPCF flag is set to 1.

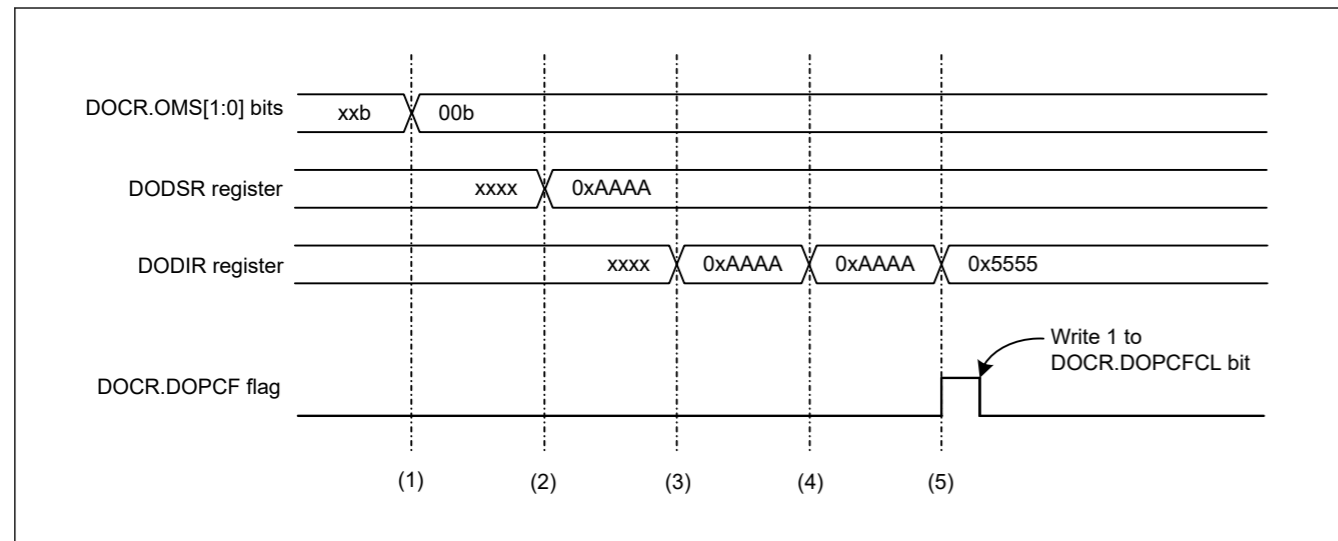


Figure 41.2 Example of operation in data comparison mode

41.3.2 Data Addition Mode

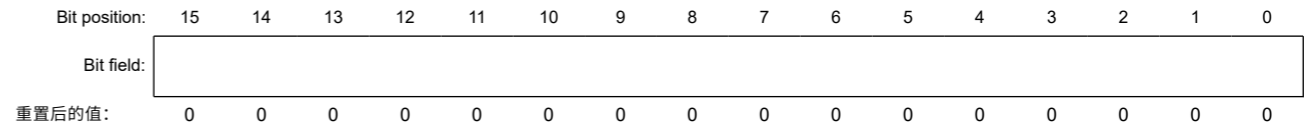
Figure 41.3 shows an example operation in data addition mode. The steps are as follows:

1. Write 01b to the DOCR.OMS[1:0] bits to select data addition mode.
2. Set 16-bit data as the initial value in the DODSR register.
3. Write the 16-bit data to be added to the DODIR register. The result of the operation is stored in the DODSR register.
4. Continue writing the 16-bit data until all data to be added is written to the DODIR.
5. If the result of an operation is greater than 0xFFFF, the DOCR.DOPCF flag is set to 1.

41.2.3 DODSR:DOC数据设置寄存器

Base address: DOC = 0x4010\_9000

Offset address: 0x04



| Bit  | Symbol | Function                                      | R/W |
|------|--------|---|-----|
| 15:0 | n/a    | 它存储在数据比较模式中用作参考的16位数据。该寄存器还存储数据加法和减法模式下的运算结果。 | R/W |

41.3 Operation

41.3.1 数据比较模式

图41.2显示了DOC在数据比较模式操作中的示例操作。以下序列是DCSEL设置为0时的示例操作（通过数据比较检测到数据不匹配）：

- 1.将00b写入DOCR.OMS[1:0]位以选择数据比较模式。
- 2.在DODSR中设置16位参考数据。
- 3.将16位数据写入DODIR进行比较。
- 4.继续写入16位数据，直到所有用于比较的数据都写入DODIR。
- 5.如果写入DODIR的值与DODSR中的值不匹配，则DOCR.DOPCF标志设置为1。

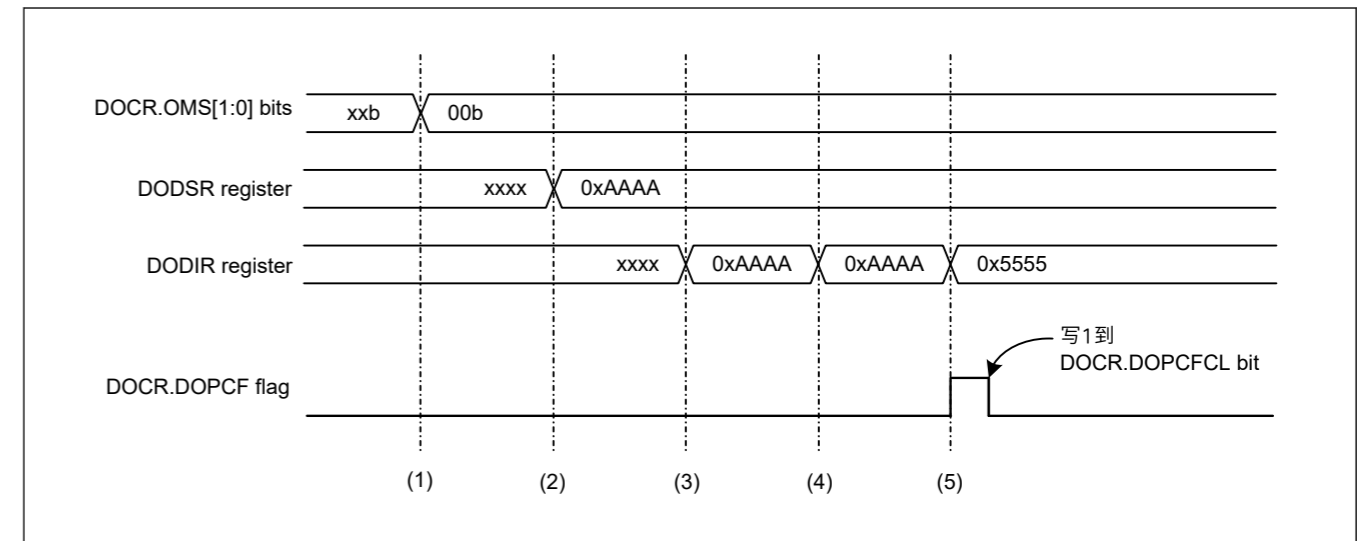


Figure 41.2 数据比较模式的操作示例

41.3.2 数据加法模式

图41.3显示了数据添加模式下的示例操作。步骤如下：

- 1.将01b写入DOCR.OMS[1:0]位以选择数据添加模式。
- 2.在DODSR寄存器中设置16位数据作为初始值。
- 3.将要添加的16位数据写入DODIR寄存器。运算结果存储在DODSR寄存器中。
- 4.继续写入16位数据，直到所有要添加的数据都写入DODIR。
- 5.如果运算结果大于0xFFFF，则DOCR.DOPCF标志设置为1。



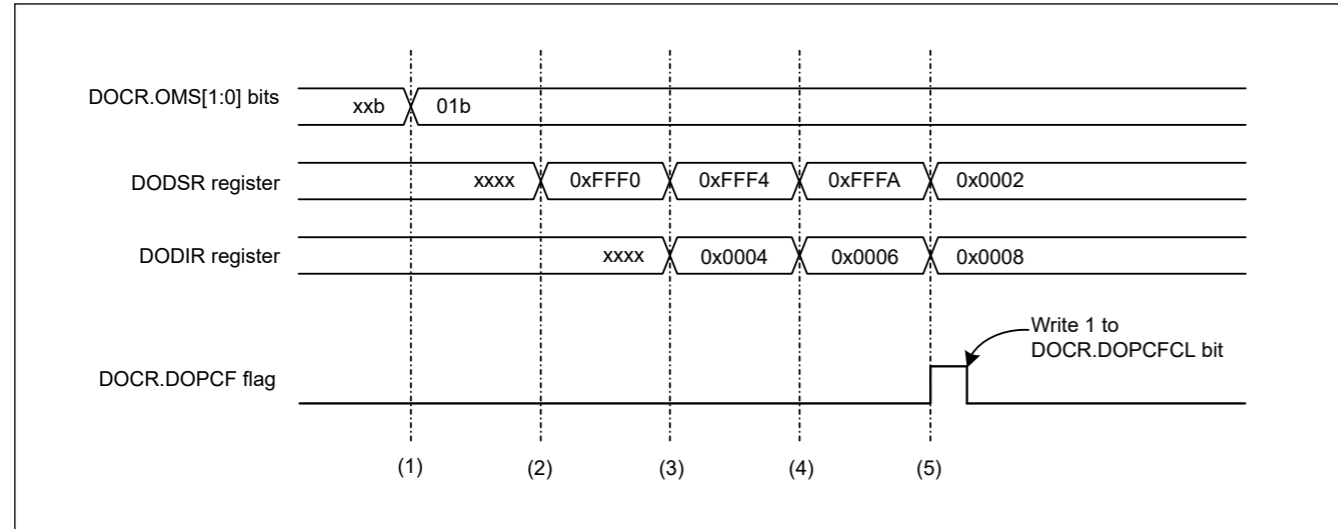


Figure 41.3 Example of operation in data addition mode

### 41.3.3 Data Subtraction Mode

Figure 41.4 shows an example operation in data subtraction mode. The steps are as follows:

1. Write 10b to the DOCR.OMS[1:0] bits to select data subtraction mode.
2. Set 16-bit data as the initial value in the DODSR register.
3. Write the 16-bit data to be subtracted to the DODIR register. The result of the operation is stored in DODSR.
4. Continue writing the 16-bit data to the DODIR register until all data to be subtracted is written.
5. If the result of an operation is less than 0x0000, the DOCR.DOPCF flag is set to 1.

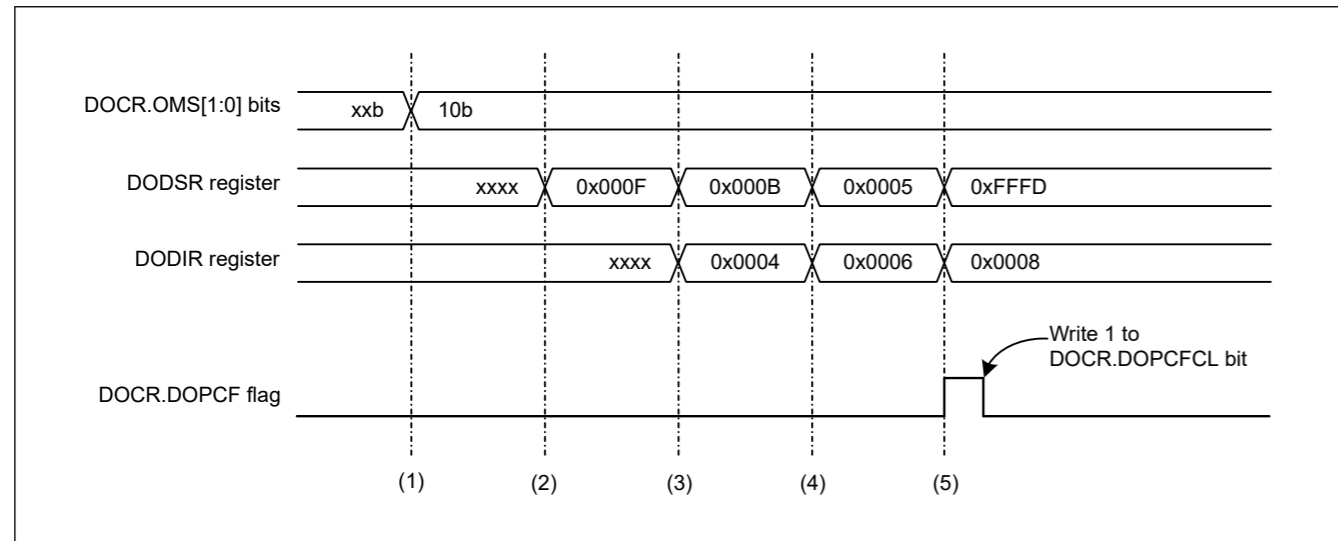


Figure 41.4 Example of operation in data subtraction mode

### 41.4 Interrupt Source

The DOC generates the DOC interrupt (DOC\_DOPCI) as an interrupt request. Table 41.2 describes the DOC interrupt request.

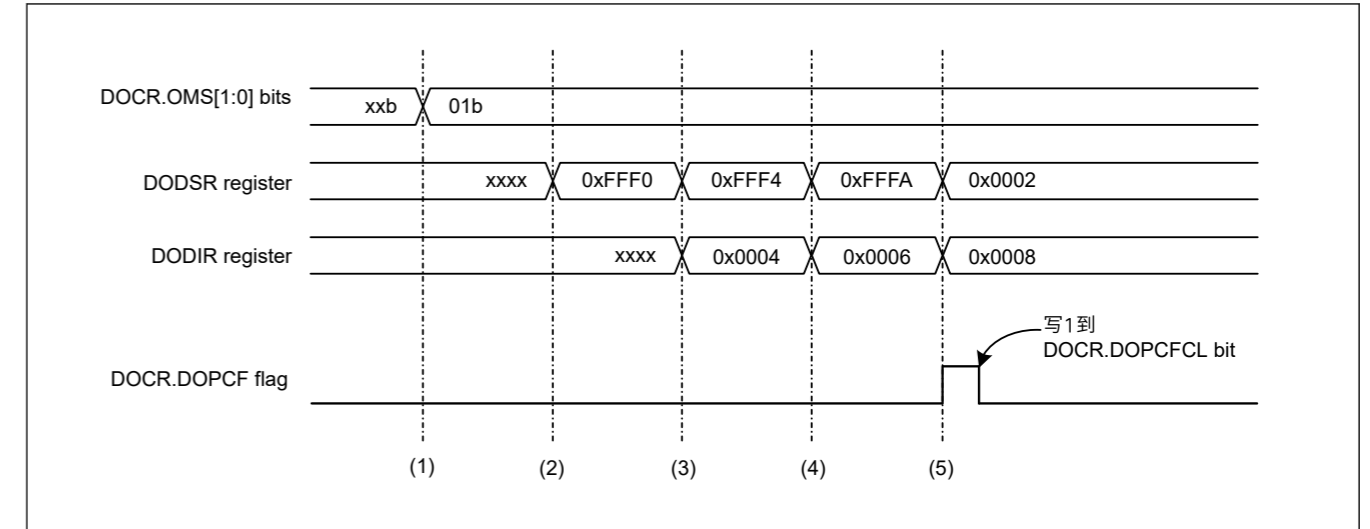


Figure 41.3 数据添加模式中的操作示例

### 41.3.3 数据减法模式

图41.4显示了数据减法模式下的示例操作。步骤如下：

- 1.将10b写入DOCR.OMS[1:0]位以选择数据减法模式。
- 2.在DODSR寄存器中设置16位数据作为初始值。
- 3.将要减去的16位数据写入DODIR寄存器。操作结果存储在DODSR中。
- 4.继续将16位数据写入DODIR寄存器，直到写入所有要减去的数据。
- 5.如果运算结果小于0x0000，则DOCR.DOPCF标志设置为1。

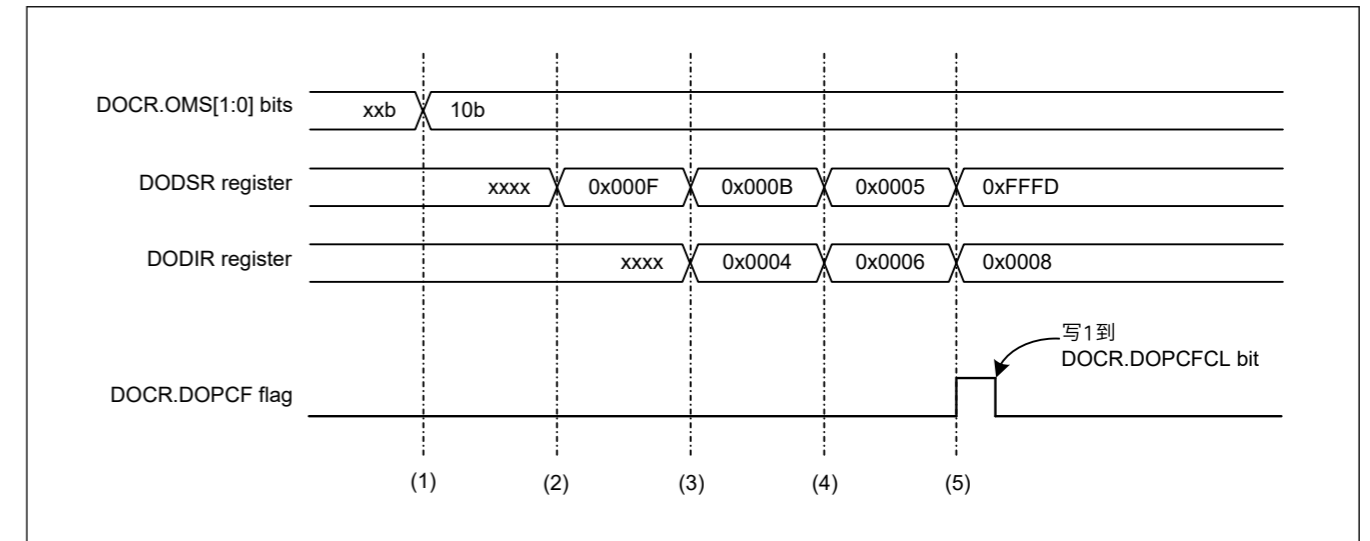


Figure 41.4 数据减法模式下的操作示例

### 41.4 中断源

DOC生成DOC中断(DOC\_DOPCI)作为中断请求。表41.2描述了DOC中断请求。

Table 41.2 Interrupt request from DOC

| Interrupt request | Status flag | Interrupt source  |
|-------------------|-------------|---|
| DOC interrupt     | DOPCF       | <ul style="list-style-type: none"> <li>The result of data comparison matches the condition selected in the DOCR.DCSEL bit.</li> <li>The result of data addition is greater than 0xFFFF.</li> <li>The result of data subtraction is less than 0x0000.</li> </ul> |

### 41.5 Output of an Event Signal to the Event Link Controller (ELC)

The DOC outputs an event signal for the ELC under the following conditions:

- The compared values either match or mismatch
- The data addition result is greater than 0xFFFF
- The data subtraction result is less than 0x0000

This signal can be used to initiate operations by other modules selected in advance and can also be used as an interrupt request. When an event signal is generated, the DOC Flag (DOCR.DOPCF) is set to 1.

### 41.6 Usage Notes

#### 41.6.1 Settings for the Module-Stop State

The module Stop Control Register C (MSTPCRC) can enable or disable DOC operation. The DOC is initially stopped after reset. Releasing the module-stop state enables access to the registers. For details, see [section 10, Low Power Modes](#).

Table 41.2 来自DOC的中断请求

| 中断请求 | 状态标志  | 中断源   |
|------|-------|---|
| 文档中断 | DOPCF | <ul style="list-style-type: none"> <li>数据比较的结果与DOCR.DCSEL位中选择的条件相匹配。</li> <li>数据相加的结果大于0xFFFF。</li> <li>数据减法的结果小于0x0000。</li> </ul> |

### 41.5 将事件信号输出到事件链接控制器(ELC)

DOC在以下条件下为ELC输出事件信号：

- 比较值匹配或不匹配
- 数据相加结果大于0xFFFF
- 数据减法结果小于0x0000

该信号可用于启动其他预先选择的模块的操作，也可用作中断请求。生成事件信号时，DOC标志(DOCR.DOPCF)设置为1。

### 41.6 使用说明

#### 41.6.1 模块停止状态的设置

模块停止控制寄存器C(MSTPCRC)可以启用或禁用DOC操作。DOC在复位后最初停止。释放模块停止状态可以访问寄存器。有关详细信息，请参阅第10节，低功耗模式。

## 42. SRAM

### 42.1 Overview

The MCU provides an on-chip, high-density SRAM module with either parity-bit checking or Error Correction Code (ECC). The first 64 KB area of the SRAM0 is the ECC. Parity check is performed on the other areas.

Table 42.1 lists the SRAM specifications.

**Table 42.1 SRAM specifications**

| Parameter               | Without ECC  | With ECC  |
|-------------------------|--|---|
| SRAM capacity           | SRAM0: 64 KB   | SRAM0: 64 KB  |
| SRAM address            | SRAM0: 0x2001_0000 to 0x2001_FFFF  | SRAM0: 0x2000_0000 to 0x2000_FFFF                                 |
| Access                  | Can access with no wait. One wait access is set at initial state. For details, see section 42.3.9. Access Cycle  |   |
| Data retention function | Not available in deep standby mode   |   |
| Module-stop function    | Module-stop state can be set to reduce power consumption   |   |
| Parity                  | Even parity with 8-bit data and 1-bit parity   | No parity   |
| Error checking          | even-parity (Data:8bit, parity:1bit)   | SEC-DED (Single-Error Correction and Double-Error Detection Code) |
| Security                | TrustZone Filter is integrated for memory access and SFR access. Access to the memory space is controlled by setting the memory Security Attribution (SA). And, access to I/O space (SFR) space is controlled by setting the register SA. See section 42.3.6. TrustZone Filter function. |   |

### 42.2 Register Descriptions

#### 42.2.1 SRAMSAR : SRAM Security Attribution Register

Base address: CPSCU = 0x4000\_8000

Offset address: 0x10

|                    |    |    |    |    |    |    |    |    |    |    |    |    |    |          |          |          |
|--------------------|----|----|----|----|----|----|----|----|----|----|----|----|----|----------|----------|----------|
| Bit position:      | 31 | 30 | 29 | 28 | 27 | 26 | 25 | 24 | 23 | 22 | 21 | 20 | 19 | 18       | 17       | 16       |
| Bit field:         | —  | —  | —  | —  | —  | —  | —  | —  | —  | —  | —  | —  | —  | —        | —        | —        |
| Value after reset: | 1  | 1  | 1  | 1  | 1  | 1  | 1  | 1  | 1  | 1  | 1  | 1  | 1  | 1        | 1        | 1        |
| Bit position:      | 15 | 14 | 13 | 12 | 11 | 10 | 9  | 8  | 7  | 6  | 5  | 4  | 3  | 2        | 1        | 0        |
| Bit field:         | —  | —  | —  | —  | —  | —  | —  | —  | —  | —  | —  | —  | —  | SRAM SA2 | SRAM SA1 | SRAM SA0 |
| Value after reset: | 1  | 1  | 1  | 1  | 1  | 1  | 1  | 1  | 1  | 1  | 1  | 1  | 1  | 1        | 1        | 1        |

| Bit  | Symbol  | Function   | R/W |
|------|---------|--|-----|
| 0    | SRAMSA0 | Security attributes of registers for SRAM Protection<br>0: Secure<br>1: Non-Secure   | R/W |
| 1    | SRAMSA1 | Security attributes of registers for SRAM Protection 2<br>0: Secure<br>1: Non-Secure | R/W |
| 2    | SRAMSA2 | Security attributes of registers for ECC Relation<br>0: Secure<br>1: Non-Secure      | R/W |
| 31:3 | —       | These bits are read as 1. The write value should be 1.                               | R/W |

Note: Only secure access can write to this register. Both secure access and Non-secure read access are allowed but Non-secure write access is not allowed and TrustZone access error is not generated.

Note: This register is write-protected by PRCR register.

## 42. SRAM

### 42.1 Overview

MCU提供片上高密度SRAM模块，具有奇偶校验位检查或纠错码(ECC)。SRAM0的第一个64KB区域是ECC。对其他区域执行奇偶校验。

表42.1列出了SRAM规格。

**Table 42.1 SRAM specifications**

| Parameter            | Without ECC  | With ECC                          |
|----------------------|--|-----------------------------------|
| SRAM capacity        | SRAM0: 64 KB   | SRAM0: 64 KB                      |
| SRAM address         | SRAM0: 0x2001_0000 to 0x2001_FFFF  | SRAM0: 0x2000_0000 to 0x2000_FFFF |
| Access               | 无需等待即可访问。在初始状态设置一个等待访问。详见42.3.9节。访问周期  |                                   |
| 数据保留功能               | 在深度待机模式下不可用  |                                   |
| Module-stop function | 可设置模块停止状态以降低功耗   |                                   |
| Parity               | 8位数据和1位奇偶校验的偶校验  | 无平价                               |
| 错误检查                 | even-parity (Data:8bit, parity:1bit)   | SEC-DED (单纠错和双纠错 Detection Code)  |
| Security             | TrustZone过滤器集成用于内存访问和SFR访问。通过设置内存安全属性 (SA) 来控制对内存空间的访问。并且，通过设置寄存器SA来控制对IO空间(SFR)空间的访问。请参阅第42.3.6节。TrustZone过滤功能。 |                                   |

### 42.2 注册说明

#### 42.2.1 SRAMSAR: SRAM安全属性寄存器

Base address: CPSCU = 0x4000\_8000

Offset address: 0x10

|               |    |    |    |    |    |    |    |    |    |    |    |    |    |          |          |          |
|---------------|----|----|----|----|----|----|----|----|----|----|----|----|----|----------|----------|----------|
| Bit position: | 31 | 30 | 29 | 28 | 27 | 26 | 25 | 24 | 23 | 22 | 21 | 20 | 19 | 18       | 17       | 16       |
| Bit field:    | —  | —  | —  | —  | —  | —  | —  | —  | —  | —  | —  | —  | —  | —        | —        | —        |
| 重置后的值:        | 1  | 1  | 1  | 1  | 1  | 1  | 1  | 1  | 1  | 1  | 1  | 1  | 1  | 1        | 1        | 1        |
| Bit position: | 15 | 14 | 13 | 12 | 11 | 10 | 9  | 8  | 7  | 6  | 5  | 4  | 3  | 2        | 1        | 0        |
| Bit field:    | —  | —  | —  | —  | —  | —  | —  | —  | —  | —  | —  | —  | —  | SRAM SA2 | SRAM SA1 | SRAM SA0 |
| 重置后的值:        | 1  | 1  | 1  | 1  | 1  | 1  | 1  | 1  | 1  | 1  | 1  | 1  | 1  | 1        | 1        | 1        |

| Bit  | Symbol  | Function                                       | R/W |
|------|---------|--|-----|
| 0    | SRAMSA0 | SRAM保护寄存器的安全属性<br>0: Secure<br>1: Non-Secure   | R/W |
| 1    | SRAMSA1 | SRAM保护2的寄存器的安全属性<br>0: Secure<br>1: Non-Secure | R/W |
| 2    | SRAMSA2 | ECC关系寄存器的安全属性<br>0: Secure<br>1: Non-Secure    | R/W |
| 31:3 | —       | 这些位被读取为1。写入值应为1。                               | R/W |

Note: 只有安全访问才能写入该寄存器。允许安全访问和非安全读取访问，但不允许非安全写入访问，并且不会生成TrustZone访问错误。

Note: 该寄存器由PRCR寄存器写保护。

**SRAMSA0 bit (Security attributes of registers for SRAM Protection)**

Security attributes of registers for SRAM Protection. The target registers are as follow.

- PARIOAD
- SRAMPRCR

**SRAMSA1 bit (Security attributes of registers for SRAM Protection 2)**

Security attributes of registers for SRAM Protection 2. The target registers are as follow.

- SRAMWTSC
- SRAMPRCR2

**SRAMSA2 bit (Security attributes of registers for ECC Relation)**

Security attributes of registers for ECC Relation. The target registers are as follow.

- ECCMODE
- ECC2STS
- ECC1STSEN
- ECC1STS
- ECCPRCR
- ECCPRCR2
- ECCETST
- ECCOAD

**42.2.2 PARIOAD : SRAM Parity Error Operation After Detection Register**

Base address: SRAM = 0x4000\_2000

Offset address: 0x00

|                    |   |   |   |   |   |   |   |     |
|--------------------|---|---|---|---|---|---|---|-----|
| Bit position:      | 7 | 6 | 5 | 4 | 3 | 2 | 1 | 0   |
| Bit field:         | — | — | — | — | — | — | — | OAD |
| Value after reset: | 0 | 0 | 0 | 0 | 0 | 0 | 0 | 0   |

| Bit | Symbol | Function   | R/W |
|-----|--------|--|-----|
| 0   | OAD    | Operation After Detection<br>0: Reset<br>1: Non-maskable interrupt | R/W |
| 7:1 | —      | These bits are read as 0. The write value should be 0.             | R/W |

Note: If the security attribution is configured as secure:

- Secure access and Non-secure read access are allowed
- Non-secure write access is ignored, and TrustZone access error is not generated.

If the security attribution is configured as Non-secure:

- Secure and Non-secure access are allowed.

The PARIOAD register controls the operation on detection of a parity error. The SRAM Protection Register (SRAMPRCR) protects this register against writes. Always set the SRAMPRCR bit in SRAMPRCR to enabled before writing to this bit. Do not write to the PARIOAD register while accessing the SRAM.

**OAD bit (Operation After Detection)**

The OAD bit specifies either a reset or non-maskable interrupt when a parity error is detected. The OAD bit is used for SRAM0 (without ECC)/Standby SRAM.

**SRAMSA0位 (SRAM保护寄存器的安全属性)**

SRAM保护寄存器的安全属性。目标寄存器如下。

- PARIOAD
- SRAMPRCR

**SRAMSA1位 (SRAM保护2寄存器的安全属性)**

SRAM保护寄存器的安全属性2。目标寄存器如下。

- SRAMWTSC
- SRAMPRCR2

**SRAMSA2位 (ECC关系寄存器的安全属性)**

ECC关系的寄存器的安全属性。目标寄存器如下。

- ECCMODE
- ECC2STS
- ECC1STSEN
- ECC1STS
- ECCPRCR
- ECCPRCR2
- ECCETST
- ECCOAD

**42.2.2 PARIOAD: 检测寄存器后的SRAM奇偶校验错误操作**

Base address: SRAM = 0x4000\_2000

Offset address: 0x00

|               |   |   |   |   |   |   |   |     |
|---------------|---|---|---|---|---|---|---|-----|
| Bit position: | 7 | 6 | 5 | 4 | 3 | 2 | 1 | 0   |
| Bit field:    | — | — | — | — | — | — | — | OAD |
| 重置后的值:        | 0 | 0 | 0 | 0 | 0 | 0 | 0 | 0   |

| Bit | Symbol | Function                 | R/W |
|-----|--------|--------------------------|-----|
| 0   | OAD    | 检测后的操作<br>0: 复位1: 不可屏蔽中断 | R/W |
| 7:1 | —      | 这些位被读取为0。写入值应为0。         | R/W |

Note: 如果安全属性配置为安全: ●

- 允许安全访问和非安全读取访问
- 忽略非安全写入访问, 不会生成TrustZone访问错误。

如果安全属性配置为非安全: ●

- 允许安全和非安全访问。

PARIOAD寄存器控制检测奇偶校验错误时的操作。SRAM保护寄存器(SRAMPRCR)保护该寄存器不被写入。在写入该位之前, 始终将SRAMPRCR中的SRAMPRCR位设置为启用。访问SRAM时不要写入PARIOAD寄存器。

**OAD位 (检测后操作)**

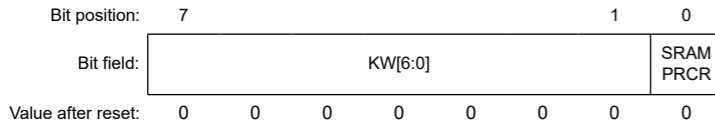
当检测到奇偶校验错误时, OAD位指定复位或不可屏蔽中断。OAD位用于SRAM0 (without ECC)/Standby SRAM。



## 42.2.3 SRAMPRCR : SRAM Protection Register

Base address: SRAM = 0x4000\_2000

Offset address: 0x04



| Bit | Symbol   | Function  | R/W |
|-----|----------|---|-----|
| 0   | SRAMPRCR | Register Write Control<br>0: Disable writes to protected registers<br>1: Enable writes to protected registers | R/W |
| 7:1 | KW[6:0]  | Write Key Code<br>These bits enable or disable writes to the SRAMPRCR bit                                     | W   |

Note: If the security attribution is configured as secure:

- Secure access and Non-secure read access are allowed
  - Non-secure write access is ignored, and TrustZone access error is not generated.
- If the security attribution is configured as Non-secure:
- Secure and Non-secure access are allowed.

**SRAMPRCR bit (Register Write Control)**

The SRAMPRCR bit controls the write mode of the PARIOD register. Setting the bit to 1 enables writes to the PARIOD register. When you write to this bit, always write 0x78 to KW[6:0] bits simultaneously.

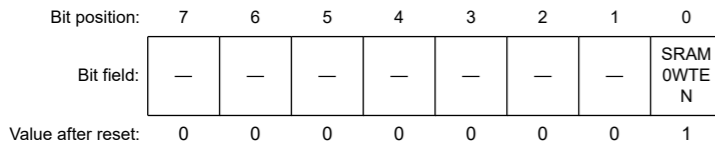
**KW[6:0] bits (Write Key Code)**

The KW[6:0] bits enable or disable writes to the SRAMPRCR bit. When you write to the SRAMPRCR bit, always write 0x78 to these bits simultaneously. When a value other than 0x78 is written to KW[6:0], the SRAMPRCR bit is not updated. The KW[6:0] bits are always read as 0x00.

## 42.2.4 SRAMWTSC : SRAM Wait State Control Register

Base address: SRAM = 0x4000\_2000

Offset address: 0x08



| Bit | Symbol    | Function   | R/W |
|-----|-----------|--|-----|
| 0   | SRAM0WTEN | SRAM0 wait enable<br>0: No wait<br>1: Add wait state in read access cycle to SRAM0 | R/W |
| 7:1 | —         | These bits are read as 0. The write value should be 0.                             | R/W |

Note: If the security attribution is configured as secure:

- Secure access and Non-secure read access are allowed
  - Non-secure write access is ignored, and TrustZone access error is not generated.
- If the security attribution is configured as Non-secure:
- Secure and Non-secure access are allowed.

This register can be rewritten only when the SRAMPRCR2 bit in the SRAMPRCR2 register is 1.

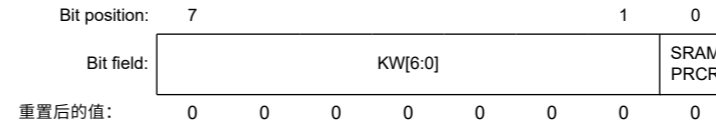
The protection register (SRAMPRCR2) protects this register against writing. Change the effective bit in the protection register (SRAMPRCR2) to write in this register.

Do not write to SRAMWTSC while access to SRAM is in progress.

## 42.2.3 SRAMPRCR:SRAM保护寄存器

Base address: SRAM = 0x4000\_2000

Offset address: 0x04



| Bit | Symbol   | Function                             | R/W |
|-----|----------|--------------------------------------|-----|
| 0   | SRAMPRCR | 寄存器写控制<br>0: 禁止写入受保护寄存器1: 允许写入受保护寄存器 | R/W |
| 7:1 | KW[6:0]  | 编写关键代码<br>这些位启用或禁用对SRAMPRCR位的写入      | W   |

Note: 如果安全属性配置为安全: ●

- 允许安全访问和非安全读取访问
  - 忽略非安全写入访问, 不会生成TrustZone访问错误。
- 如果安全属性配置为非安全: ●
- 允许安全和非安全访问。

**SRAMPRCR位 (寄存器写控制)**

SRAMPRCR位控制PARIOD寄存器的写模式。将该位设置为1可以写入PARIOD寄存器。写入该位时, 始终同时将0x78写入KW[6:0]位。

**KW[6:0]位 (写入密钥代码)**

KW[6:0]位启用或禁用对SRAMPRCR位的写入。当您写入SRAMPRCR位时, 请始终同时将0x78写入这些位。当向KW[6:0]写入0x78以外的值时, SRAMPRCR位不会更新。KW[6:0]位总是被读取为0x00。

## 42.2.4 SRAMWTSC:SRAM等待状态控制寄存器

Base address: SRAM = 0x4000\_2000

Offset address: 0x08



| Bit | Symbol    | Function                                 | R/W |
|-----|-----------|--|-----|
| 0   | SRAM0WTEN | SRAM0等待使能<br>0: 无等待1: 在SRAM0读访问周期中添加等待状态 | R/W |
| 7:1 | —         | 这些位被读取为0。写入值应为0。                         | R/W |

Note: 如果安全属性配置为安全: ●

- 允许安全访问和非安全读取访问
  - 忽略非安全写入访问, 不会生成TrustZone访问错误。
- 如果安全属性配置为非安全: ●
- 允许安全和非安全访问。

只有当SRAMPRCR2寄存器中的SRAMPRCR2位为1时, 才能重写该寄存器。

保护寄存器(SRAMPRCR2)保护该寄存器不被写入。更改保护寄存器(SRAMPRCR2)中的有效位以写入该寄存器。

在访问SRAM的过程中不要写入SRAMWTSC。

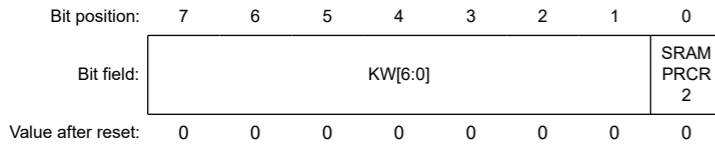
**SRAM0WTEN bit (SRAM0 wait enable)**

This bit sets the wait cycle to the operation region in SRAM0 (Both parity and ECC areas). When it is set 1 in the SRAM0WTEN bit, 1 wait cycle is inserted into the read cycle of operation region in SRAM0. And also 1 wait cycle is also inserted between the “write to read/write” sequential cycle in the same mat of SRAM0. When read access frequency is more than 100 MHz, it is necessary to set 1 wait cycle in SRAM0WTEN bit.

**42.2.5 SRAMPSCR2 : SRAM Protection Register 2**

Base address: SRAM = 0x4000\_2000

Offset address: 0x0C



| Bit | Symbol    | Function  | R/W |
|-----|-----------|---|-----|
| 0   | SRAMPSCR2 | Register Write Control<br>0: Disable writes to the protected registers<br>1: Enable writes to the protected registers | R/W |
| 7:1 | KW[6:0]   | Write Key Code<br>These bits enable or disable writes to the SRAMPSCR2 bit  | W   |

Note: If the security attribution is configured as secure:

- Secure access and Non-secure read access are allowed
  - Non-secure write access is ignored, and TrustZone access error is not generated.
- If the security attribution is configured as Non-secure:
- Secure and Non-secure access are allowed.

**SRAMPSCR2 bit (Register Write Control)**

The SRAMPSCR2 bit controls the write mode of the SRAMWTSC register. Setting the bit to 1 enables writes to the SRAMWTSC register. When you write to this bit, always write 0x78 to KW[6:0] at the same time.

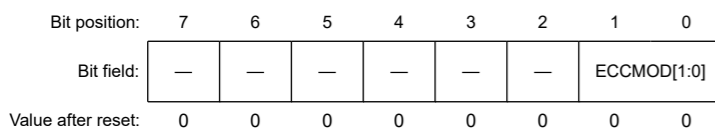
**KW[6:0] bits (Write Key Code)**

The KW[6:0] bits enable or disable writes to the SRAMPSCR2 bit. When you write to SRAMPSCR2 bit, always write 0x78 to these bits at the same time. When a value other than 0x78 is written to KW[6:0], the SRAMPSCR2 bit is not updated. The KW[6:0] bits are always read as 0x00.

**42.2.6 ECCMODE : ECC Operating Mode Control Register**

Base address: SRAM = 0x4000\_2000

Offset address: 0xC0



| Bit | Symbol      | Function   | R/W |
|-----|-------------|--|-----|
| 1:0 | ECCMOD[1:0] | ECC Operating Mode Select<br>0 0: Disable ECC function<br>0 1: Setting prohibited<br>1 0: Enable ECC function without error checking<br>1 1: Enable ECC function with error checking | R/W |
| 7:2 | —           | These bits are read as 0. The write value should be 0.   | R/W |

Note: If the security attribution is configured as secure:

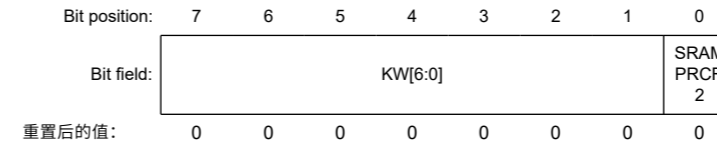
**SRAM0WTEN位 (SRAM0等待使能)**

该位将等待周期设置为SRAM0中的操作区域（奇偶校验和ECC区域）。当它设置为1时SRAM0WTEN位，1个等待周期插入到SRAM0中操作区的读周期。并且在SRAM0的同一块中的“写到读”顺序周期之间也插入了1个等待周期。当读访问频率大于100MHz时，需要在SRAM0WTEN位中设置1个等待周期。

**42.2.5 SRAMPSCR2: SRAM保护寄存器2**

Base address: SRAM = 0x4000\_2000

Offset address: 0x0C



| Bit | Symbol    | Function                             | R/W |
|-----|-----------|--------------------------------------|-----|
| 0   | SRAMPSCR2 | 寄存器写控制<br>0: 禁止写保护寄存器<br>1: 允许写保护寄存器 | R/W |
| 7:1 | KW[6:0]   | 编写关键代码<br>这些位启用或禁用对SRAMPSCR2位的写入     | W   |

Note: 如果安全属性配置为安全: ●

- 允许安全访问和非安全读取访问
  - 忽略非安全写入访问，不会生成TrustZone访问错误。
- 如果安全属性配置为非安全: ●
- 允许安全和非安全访问。

**SRAMPSCR2位 (寄存器写控制)**

SRAMPSCR2位控制SRAMWTSC寄存器的写模式。将该位设置为1可以写入SRAMWTSC寄存器。写入该位时，始终同时将0x78写入KW[6:0]。

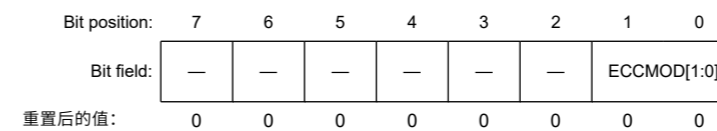
**KW[6:0]位 (写入密钥代码)**

KW[6:0]位启用或禁用对SRAMPSCR2位的写入。当您写入SRAMPSCR2位时，请始终同时向这些位写入0x78。当向KW[6:0]写入0x78以外的值时，SRAMPSCR2位不会更新。KW[6:0]位总是被读取为0x00。

**42.2.6 ECCMODE: ECC操作模式控制寄存器**

Base address: SRAM = 0x4000\_2000

Offset address: 0xC0



| Bit | Symbol      | Function   | R/W |
|-----|-------------|--|-----|
| 1:0 | ECCMOD[1:0] | ECC操作模式选择<br>00: 禁用ECC功能<br>01: 设置禁止<br>10: 启用ECC功能不进行错误检查<br>11: 启用ECC功能并进行错误检查 | R/W |
| 7:2 | —           | 这些位被读取为0。写入值应为0。   | R/W |

Note: 如果安全属性配置为安全:

- Secure access and Non-secure read access are allowed
  - Non-secure write access is ignored, and TrustZone access error is not generated.
- If the security attribution is configured as Non-secure:
- Secure and Non-secure access are allowed.

The ECCMODE register specifies the ECC operating mode. The ECC Protection Register (ECCPRCR) protects this register against writes. Before writing to this register, set the ECCPRCR bit in the ECCPRCR register to 1 (write protection disabled). Do not write to the ECCMODE register while accessing the SRAM.

#### ECCMOD[1:0] bits (ECC Operating Mode Select)

The ECCMOD[1:0] bits set the access mode to the ECC area in SRAM0.

#### 42.2.7 ECC2STS : ECC 2-Bit Error Status Register

Base address: SRAM = 0x4000\_2000

Offset address: 0xC1

|                    |   |   |   |   |   |   |   |         |
|--------------------|---|---|---|---|---|---|---|---------|
| Bit position:      | 7 | 6 | 5 | 4 | 3 | 2 | 1 | 0       |
| Bit field:         | — | — | — | — | — | — | — | ECC2ERR |
| Value after reset: | 0 | 0 | 0 | 0 | 0 | 0 | 0 | 0       |

| Bit | Symbol  | Function  | R/W              |
|-----|---------|---|------------------|
| 0   | ECC2ERR | ECC 2-Bit Error Status<br>0: No 2-bit ECC error occurred<br>1: 2-bit ECC error occurred | R/W <sup>1</sup> |
| 7:1 | —       | These bits are read as 0. The write value should be 0.                                  | R/W              |

Note: If the security attribution is configured as secure:

- Secure access and Non-secure read access are allowed
  - Non-secure write access is ignored, and TrustZone access error is not generated.
- If the security attribution is configured as Non-secure:
- Secure and Non-secure access are allowed.

Note 1. Only 0 can be written to clear the bit.

#### ECC2ERR bit (ECC 2-Bit Error Status)

The ECC2ERR bit indicates whether a 2-bit ECC error occurred in the ECC area of SRAM0. When a 2-bit error is detected while ECC operations are enabled and error checking is selected, the ECC2ERR bit is set to 1. The SRAM error signal is also asserted at this time. The 2-bit ECC error can be cleared by writing 0 to the ECC2ERR bit.

The SRAM error can be specified as a non-maskable interrupt or a reset in the ECCOAD register. Do not access the ECC area in SRAM0 while writing 0 to this register.

#### 42.2.8 ECC1STSEN : ECC 1-Bit Error Information Update Enable Register

Base address: SRAM = 0x4000\_2000

Offset address: 0xC2

|                    |   |   |   |   |   |   |   |         |
|--------------------|---|---|---|---|---|---|---|---------|
| Bit position:      | 7 | 6 | 5 | 4 | 3 | 2 | 1 | 0       |
| Bit field:         | — | — | — | — | — | — | — | E1STSEN |
| Value after reset: | 0 | 0 | 0 | 0 | 0 | 0 | 0 | 0       |

| Bit | Symbol  | Function   | R/W |
|-----|---------|--|-----|
| 0   | E1STSEN | ECC 1-Bit Error Information Update Enable<br>0: Disable updating of 1-bit ECC error information<br>1: Enable updating of 1-bit ECC error information | R/W |
| 7:1 | —       | These bits are read as 0. The write value should be 0.   | R/W |

Note: If the security attribution is configured as secure:

- 允许安全访问和非安全读取访问
  - 忽略非安全写入访问，不会生成TrustZone访问错误。
- 如果安全属性配置为非安全：●
- 允许安全和非安全访问。

ECCMODE寄存器指定ECC工作模式。ECC保护寄存器(ECCPRCR)保护该寄存器不被写入。在写入该寄存器之前，将ECCPRCR寄存器中的ECCPRCR位设置为1（禁用写保护）。访问SRAM时不要写入ECCMODE寄存器。

#### ECCMOD[1:0]位 (ECC操作模式选择)

ECCMOD[1:0]位将访问模式设置为SRAM0中的ECC区域。

#### 42.2.7 ECC2STS: ECC2位错误状态寄存器

Base address: SRAM = 0x4000\_2000

Offset address: 0xC1

|               |   |   |   |   |   |   |   |         |
|---------------|---|---|---|---|---|---|---|---------|
| Bit position: | 7 | 6 | 5 | 4 | 3 | 2 | 1 | 0       |
| Bit field:    | — | — | — | — | — | — | — | ECC2ERR |
| 重置后的值:        | 0 | 0 | 0 | 0 | 0 | 0 | 0 | 0       |

| Bit | Symbol  | Function                                   | R/W              |
|-----|---------|--|------------------|
| 0   | ECC2ERR | ECC2位错误状态<br>0: 未发生2位ECC错误<br>1: 发生2位ECC错误 | R/W <sup>1</sup> |
| 7:1 | —       | 这些位被读取为0。写入值应为0。                           | R/W              |

Note: 如果安全属性配置为安全：●

- 允许安全访问和非安全读取访问
  - 忽略非安全写入访问，不会生成TrustZone访问错误。
- 如果安全属性配置为非安全：●
- 允许安全和非安全访问。

注1.只能写入0来清除该位。

#### ECC2ERR位 (ECC2位错误状态)

ECC2ERR位指示SRAM0的ECC区域是否发生2位ECC错误。当启用ECC操作并选择错误检查时检测到2位错误时，ECC2ERR位设置为1。此时SRAM错误信号也被置位。将0写入ECC2ERR位可清除2位ECC错误。

SRAM错误可以指定为不可屏蔽中断或ECCOAD寄存器中的复位。向该寄存器写入0时不要访问SRAM0中的ECC区域。

#### 42.2.8 ECC1STSEN: ECC1位错误信息更新使能寄存器

Base address: SRAM = 0x4000\_2000

Offset address: 0xC2

|               |   |   |   |   |   |   |   |         |
|---------------|---|---|---|---|---|---|---|---------|
| Bit position: | 7 | 6 | 5 | 4 | 3 | 2 | 1 | 0       |
| Bit field:    | — | — | — | — | — | — | — | E1STSEN |
| 重置后的值:        | 0 | 0 | 0 | 0 | 0 | 0 | 0 | 0       |

| Bit | Symbol  | Function  | R/W |
|-----|---------|---|-----|
| 0   | E1STSEN | ECC1位错误信息更新启用<br>0: 禁止更新1位ECC错误信息<br>1: 允许更新1位ECC错误信息 | R/W |
| 7:1 | —       | 这些位被读取为0。写入值应为0。                                      | R/W |

Note: 如果安全属性配置为安全:

- Secure access and Non-secure read access are allowed
  - Non-secure write access is ignored, and TrustZone access error is not generated.
- If the security attribution is configured as Non-secure:
- Secure and Non-secure access are allowed.

The ECC1STSEN register enables or disables updating of the ECC 1-bit Error Status Register (ECC1STS) in response to a 1-bit error ECC error in the SRAM0 (ECC area).

The ECC Protection Register (ECCPRCR) protects this register against writes. Before writing to this bit, set the ECCPRCR bit in the ECCPRCR register to 1 (write protection disabled).

**E1STSEN bit (ECC 1-Bit Error Information Update Enable)**

The E1STSEN bit enables or disables updating of the SRAM (ECC area) 1-Bit Error Status Register (ECC1STS) in response to a 1-bit error in the ECC area of SRAM0. This register also functions as an interrupt or a reset mask.

**42.2.9 ECC1STS : ECC 1-Bit Error Status Register**

Base address: SRAM = 0x4000\_2000

Offset address: 0xC3



| Bit | Symbol  | Function  | R/W                |
|-----|---------|---|--------------------|
| 0   | ECC1ERR | ECC 1-Bit Error Status<br>0: No 1-bit ECC error occurred<br>1: 1-bit ECC error occurred | R/(W) <sup>1</sup> |
| 7:1 | —       | These bits are read as 0. The write value should be 0.                                  | R/W                |

Note: If the security attribution is configured as secure:

- Secure access and Non-secure read access are allowed
- Non-secure write access is ignored, and TrustZone access error is not generated.

If the security attribution is configured as Non-secure:

- Secure and Non-secure access are allowed.

Note 1. Only 0 can be written to clear the bit.

**ECC1ERR bit (ECC 1-Bit Error Status)**

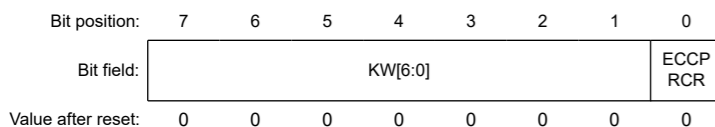
The ECC1ERR bit indicates whether a 1-bit ECC error occurred in the ECC area of SRAM0. When a 1-bit error is detected while ECC operations are enabled and error checking is selected, the ECC1ERR bit is set to 1. The SRAM error signal is also asserted at this time. The 1-bit ECC error can be cleared by writing 0 to the ECC1ERR bit.

The SRAM error can be specified as a non-maskable interrupt or a reset in the ECCOAD register. Do not access the ECC area in SRAM0 while writing 0 to this register.

**42.2.10 ECCPRCR : ECC Protection Register**

Base address: SRAM = 0x4000\_2000

Offset address: 0xC4



| Bit | Symbol  | Function  | R/W |
|-----|---------|---|-----|
| 0   | ECCPRCR | Register Write Control<br>0: Disable writes to the protected registers<br>1: Enable writes to the protected registers | R/W |

- 允许安全访问和非安全读取访问
  - 忽略非安全写入访问，不会生成TrustZone访问错误。
- 如果安全属性配置为非安全:
- 允许安全和非安全访问。

ECC1STSEN寄存器启用或禁用ECC1位错误状态寄存器(ECC1STS)的更新，以响应SRAM0 (ECC区域) 中的1位错误ECC错误。

ECC保护寄存器(ECCPRCR)保护该寄存器不被写入。在写入该位之前，将ECCPRCR寄存器中的ECCPRCR位设置为1 (禁用写保护)。

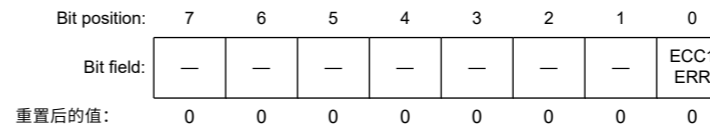
**E1STSEN位 (ECC1位错误信息更新使能)**

E1STSEN位启用或禁用SRAM (ECC区域) 1位错误状态寄存器(ECC1STS)的更新，以响应SRAM0的ECC区域中的1位错误。该寄存器还用作中断或复位掩码。

**42.2.9 ECC1STS:ECC1位错误状态寄存器**

Base address: SRAM = 0x4000\_2000

Offset address: 0xC3



| Bit | Symbol  | Function                                   | R/W                |
|-----|---------|--|--------------------|
| 0   | ECC1ERR | ECC1位错误状态<br>0: 未发生1位ECC错误<br>1: 发生1位ECC错误 | R/(W) <sup>1</sup> |
| 7:1 | —       | 这些位被读取为0。写入值应为0。                           | R/W                |

Note: 如果安全属性配置为安全:

- 允许安全访问和非安全读取访问
- 忽略非安全写入访问，不会生成TrustZone访问错误。

如果安全属性配置为非安全:

- 允许安全和非安全访问。

注1.只能写入0来清除该位。

**ECC1ERR位 (ECC1位错误状态)**

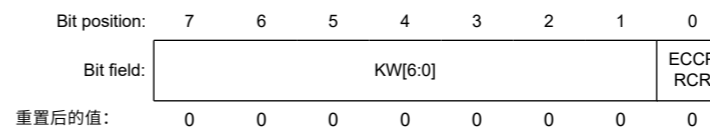
ECC1ERR位指示SRAM0的ECC区域是否发生1位ECC错误。如果在启用ECC操作并选择错误检查时检测到1位错误，则ECC1ERR位设置为1。此时SRAM错误信号也被置位。将0写入ECC1ERR位可清除1位ECC错误。

SRAM错误可以指定为不可屏蔽中断或ECCOAD寄存器中的复位。向该寄存器写入0时不要访问SRAM0中的ECC区域。

**42.2.10 ECPCRR:ECC保护寄存器**

Base address: SRAM = 0x4000\_2000

Offset address: 0xC4



| Bit | Symbol  | Function                                 | R/W |
|-----|---------|--|-----|
| 0   | ECCPRCR | 寄存器写控制<br>0: 禁止写入受保护寄存器<br>1: 允许写入受保护寄存器 | R/W |



| Bit | Symbol  | Function  | R/W |
|-----|---------|---|-----|
| 7:1 | KW[6:0] | Write Key Code<br>0x78: Enable write to the ECCPRCR bit<br>Others: Disable write to the ECCPRCR bit | W   |

Note: If the security attribution is configured as secure:

- Secure access and Non-secure read access are allowed
- Non-secure write access is ignored, and TrustZone access error is not generated.

If the security attribution is configured as Non-secure:

- Secure and Non-secure access are allowed.

#### ECCPRCR bit (Register Write Control)

The ECCPRCR bit controls the write of the ECCMODE, ECC1STSEN, and ECCOAD registers. When this bit is set to 1, writing to the ECCMODE, ECC1STSEN, and ECCOAD registers is enabled. When writing to this bit, write 0x78 to the KW[6:0] bits at the same time.

#### KW[6:0] bits (Write Key Code)

The KW[6:0] bits enable or disable writes to the ECCPRCR bit. When writing to ECCPRCR bit, write 0x78 to the KW[6:0] bits at the same time. When a value other than 0x78 is written to the KW[6:0] bits, the ECCPRCR bit is not updated. The KW[6:0] bits are always read as 0x00.

### 42.2.11 ECCPRCR2 : ECC Protection Register 2

Base address: SRAM = 0x4000\_2000

Offset address: 0xD0

| Bit position:      | 7        | 6 | 5 | 4 | 3 | 2 | 1 | 0        |
|--------------------|----------|---|---|---|---|---|---|----------|
| Bit field:         | KW2[6:0] |   |   |   |   |   |   | ECCPRCR2 |
| Value after reset: | 0        | 0 | 0 | 0 | 0 | 0 | 0 | 0        |

| Bit | Symbol   | Function  | R/W |
|-----|----------|---|-----|
| 0   | ECCPRCR2 | Register Write Control<br>0: Disable writes to the protected registers<br>1: Enable writes to the protected registers | R/W |
| 7:1 | KW2[6:0] | Write Key Code<br>0x78: Enable write to the ECCPRCR2 bit<br>Others: Disable write to the ECCPRCR2 bit                 | W   |

Note: If the security attribution is configured as secure:

- Secure access and Non-secure read access are allowed
- Non-secure write access is ignored, and TrustZone access error is not generated.

If the security attribution is configured as Non-secure:

- Secure and Non-secure access are allowed.

#### ECCPRCR2 bit (Register Write Control)

The ECCPRCR2 bit controls the write mode of the ECCETST register. When the ECCPRCR2 bit is set to 1, writes to the ECCETST register is enabled. When writing to this bit, write 0x78 to the KW2[6:0] bits at the same time.

#### KW2[6:0] bits (Write Key Code)

The KW2[6:0] bits enable or disable writes to the ECCPRCR2 bit. When writing to ECCPRCR2 bit, write 0x78 to the KW2[6:0] bits at the same time. When a value other than 0x78 is written to the KW2[6:0] bits, the ECCPRCR2 bit is not updated. The KW2[6:0] bits are always read as 0x00.

| Bit | Symbol  | Function                                       | R/W |
|-----|---------|--|-----|
| 7:1 | KW[6:0] | 编写关键代码<br>0x78: 允许写入ECPCRR位<br>其他: 禁止写入ECPCRR位 | W   |

Note: 如果安全属性配置为安全: ●

- 允许安全访问和非安全读取访问
- 忽略非安全写入访问, 不会生成TrustZone访问错误。

如果安全属性配置为非安全: ●

- 允许安全和非安全访问。

#### ECPCRR位 (寄存器写控制)

ECPCRR位控制ECCMODE、ECC1STSEN和ECCOAD寄存器的写入。当该位设置为1时, 允许写入ECCMODE、ECC1STSEN和ECCOAD寄存器。写入该位时, 同时将0x78写入KW[6:0]位。

#### KW[6:0]位 (写入密钥代码)

KW[6:0]位启用或禁用对ECPCRR位的写入。写入ECCPRCR位时, 同时向KW[6:0]位写入0x78。当向KW[6:0]位写入0x78以外的值时, 不会更新ECPCRR位。KW[6:0]位总是被读取为0x00。

### 42.2.11 ECPCRR2:ECC保护寄存器2

Base address: SRAM = 0x4000\_2000

Offset address: 0xD0

| Bit position: | 7        | 6 | 5 | 4 | 3 | 2 | 1 | 0        |
|---------------|----------|---|---|---|---|---|---|----------|
| Bit field:    | KW2[6:0] |   |   |   |   |   |   | ECCPRCR2 |
| 重置后的值:        | 0        | 0 | 0 | 0 | 0 | 0 | 0 | 0        |

| Bit | Symbol   | Function   | R/W |
|-----|----------|--|-----|
| 0   | ECCPRCR2 | 寄存器写控制<br>0: 禁止写入受保护寄存器1: 允许写入受保护寄存器             | R/W |
| 7:1 | KW2[6:0] | 编写关键代码<br>0x78: 允许写入ECPCRR2位<br>其他: 禁止写入ECPCRR2位 | W   |

Note: 如果安全属性配置为安全: ●

- 允许安全访问和非安全读取访问
- 忽略非安全写入访问, 不会生成TrustZone访问错误。

如果安全属性配置为非安全: ●

- 允许安全和非安全访问。

#### ECPCRR2位 (寄存器写控制)

ECPCRR2位控制ECCETST寄存器的写模式。当ECPCRR2位设置为1时, 写入ECCETST寄存器使能。写入该位时, 同时向KW2[6:0]位写入0x78。

#### KW2[6:0]位 (写入密钥代码)

KW2[6:0]位启用或禁用对ECPCRR2位的写入。当写入ECPCRR2位时, 将0x78写入KW2[6:0]位。当向KW2[6:0]位写入0x78以外的值时, 不会更新ECPCRR2位。KW2[6:0]位总是读为0x00。

## 42.2.12 ECCETST : ECC Test Control Register

Base address: SRAM = 0x4000\_2000

Offset address: 0xD4

|                    |   |   |   |   |   |   |   |        |
|--------------------|---|---|---|---|---|---|---|--------|
| Bit position:      | 7 | 6 | 5 | 4 | 3 | 2 | 1 | 0      |
| Bit field:         | — | — | — | — | — | — | — | TSTBYP |
| Value after reset: | 0 | 0 | 0 | 0 | 0 | 0 | 0 | 0      |

| Bit | Symbol | Function   | R/W |
|-----|--------|--|-----|
| 0   | TSTBYP | ECC Bypass Select<br>0: Disable ECC bypass<br>1: Enable ECC bypass | R/W |
| 7:1 | —      | These bits are read as 0. The write value should be 0.             | R/W |

Note: If the security attribution is configured as secure:

- Secure access and Non-secure read access are allowed
- Non-secure write access is ignored, and TrustZone access error is not generated.

If the security attribution is configured as Non-secure:

- Secure and Non-secure access are allowed.

The ECC Protection Register 2 (ECCPRCR2) protects this register against writes. Before writing to this bit, set the ECCPRCR2 bit in the ECCPRCR2 register to 1 (write protection disabled). Do not write to the ECCETST register while accessing the SRAM.

**TSTBYP bit (ECC Bypass Select)**

The TSTBYP bit enables direct access to the ECC code by bypassing the ECC function. When the ECC bypass function is used, the ECCMOD[1:0] bits in the ECCMODE register are set to 00b. The ECC must be accessed in 32 bits using the same address for 32-bit data. The ECC code is assigned to the lower 7 bits of the 32-bit data. When writing the ECC code, the upper 25 bits are ignored. When reading the ECC code, the upper 25 bits are undefined.

Note: For details of ECC test, see [section 42.3.4. ECC Decoder Testing](#).

## 42.2.13 ECCOAD : SRAM ECC Error Operation After Detection Register

Base address: SRAM = 0x4000\_2000

Offset address: 0xD8

|                    |   |   |   |   |   |   |   |     |
|--------------------|---|---|---|---|---|---|---|-----|
| Bit position:      | 7 | 6 | 5 | 4 | 3 | 2 | 1 | 0   |
| Bit field:         | — | — | — | — | — | — | — | OAD |
| Value after reset: | 0 | 0 | 0 | 0 | 0 | 0 | 0 | 0   |

| Bit | Symbol | Function   | R/W |
|-----|--------|--|-----|
| 0   | OAD    | Operation After Detection<br>0: Non-maskable interrupt<br>1: Reset | R/W |
| 7:1 | —      | These bits are read as 0. The write value should be 0.             | R/W |

Note: If the security attribution is configured as secure:

- Secure access and Non-secure read access are allowed
- Non-secure write access is ignored, and TrustZone access error is not generated.

If the security attribution is configured as Non-secure:

- Secure and Non-secure access are allowed.

The ECC Protection Register (ECCPRCR) protects this register against writes. Before writing to this bit, set the ECCPRCR bit in the ECCPRCR register to 1 (write protection disabled). Do not write to the ECCOAD register while accessing the SRAM.

## 42.2.12 ECCETST:ECC测试控制寄存器

Base address: SRAM = 0x4000\_2000

Offset address: 0xD4

|               |   |   |   |   |   |   |   |        |
|---------------|---|---|---|---|---|---|---|--------|
| Bit position: | 7 | 6 | 5 | 4 | 3 | 2 | 1 | 0      |
| Bit field:    | — | — | — | — | — | — | — | TSTBYP |
| 重置后的值:        | 0 | 0 | 0 | 0 | 0 | 0 | 0 | 0      |

| Bit | Symbol | Function                        | R/W |
|-----|--------|---------------------------------|-----|
| 0   | TSTBYP | ECC旁路选择<br>0: 禁用ECC旁路1: 启用ECC旁路 | R/W |
| 7:1 | —      | 这些位被读取为0。写入值应为0。                | R/W |

Note: 如果安全属性配置为安全: ●  
允许安全访问和非安全读取访问

- 忽略非安全写入访问, 不会生成TrustZone访问错误。

如果安全属性配置为非安全: ●  
允许安全和非安全访问。

ECC保护寄存器2(ECCPRCR2)保护该寄存器不被写入。在写入该位之前, 将ECCPRCR2寄存器中的ECCPRCR2位为1 (写保护禁用)。访问SRAM时不要写入ECCETST寄存器。

**TSTBYP位 (ECC旁路选择)**

TSTBYP位允许通过绕过ECC功能直接访问ECC代码。使用ECC旁路功能时, ECCMODE寄存器中的ECCMOD[1:0]位设置为00b。必须使用32位数据的相同地址以32位访问ECC。ECC代码分配给32位数据的低7位。写入ECC代码时, 忽略高25位。读取ECC码时, 高25位未定义。

Note: 有关ECC测试的详细信息, 请参见第42.3.4节。ECC解码器测试。

## 42.2.13 ECCOAD: 检测寄存器后的SRAMECC错误操作

Base address: SRAM = 0x4000\_2000

Offset address: 0xD8

|               |   |   |   |   |   |   |   |     |
|---------------|---|---|---|---|---|---|---|-----|
| Bit position: | 7 | 6 | 5 | 4 | 3 | 2 | 1 | 0   |
| Bit field:    | — | — | — | — | — | — | — | OAD |
| 重置后的值:        | 0 | 0 | 0 | 0 | 0 | 0 | 0 | 0   |

| Bit | Symbol | Function                 | R/W |
|-----|--------|--------------------------|-----|
| 0   | OAD    | 检测后的操作<br>0: 不可屏蔽中断1: 复位 | R/W |
| 7:1 | —      | 这些位被读取为0。写入值应为0。         | R/W |

Note: 如果安全属性配置为安全: ●  
允许安全访问和非安全读取访问

- 忽略非安全写入访问, 不会生成TrustZone访问错误。

如果安全属性配置为非安全: ●  
允许安全和非安全访问。

ECC保护寄存器(ECCPRCR)保护该寄存器不被写入。在写入该位之前, 将ECCPRCR寄存器中的ECCPRCR位设置为1 (禁用写保护)。访问SRAM时不要写入ECCOAD寄存器。

**OAD bit (Operation After Detection)**

The OAD bit selects whether to generate a reset or a non-maskable interrupt when an ECC error is detected. The OAD bit in the ECCOAD register is used for SRAM0 (ECC area).

**42.3 Operation****42.3.1 Module Stop Function**

Power consumption can be reduced by setting module stop control register A (MSTPCRA) to stop supply of the clock signal to SRAM.

SRAM0 is controlled by SRAM0 bit in MSTPCRA register and, in the case of 1, SRAM0 becomes the clock stop state.

The SRAM is thus placed in the module-stop state by stopping supply of the clock signals. The SRAM operates after a reset.

SRAM is not accessible if it is in the module-stop state. A transition to the module-stop state should not be made while access to SRAM is in progress.

Access to the SRAM in the module-stop state is prohibited. If access is attempted, correct operation is not guaranteed.

For details on the MSTPCRA register, see [section 10, Low Power Modes](#).

**42.3.2 Correction of ECC errors**

Enabling and disabling of ECC error correction can be selected through ECCMODE register setting. In the initial state, ECC error correction is disabled. The ECC check type is SEC-DED (Single-Error Correction and Double-Error Detection Code).

When ECC function is enabled, 7-bit check bits are appended to 32-bit data for writing. For reading, 39-bit (data: 32 bits, check bits: 7 bits) data is read out from the SRAM (ECC area).

When ECC function is enabled and error checking is selected by setting ECCMOD[1:0] in the ECCMODE register to 00b, error correction is done if a 1-bit error occurs and the ECC1ERR bit in the ECC1STS register is set to 1 if the E1STSEN bit in the ECC1STSEN register is 1. If a 2-bit error occurs, error detection is done and the ECC2ERR bit in the ECC2STS register is set to 1, though error correction is not performed.

When ECC function is enabled and the error checking is disable, error correction is done if a 1-bit error occurs but ECC1ERR bit in the ECC1STS register is not updated although E1STSEN bit in the ECC1STSEN register is 1. If a 2-bit error occurs, this error is detected but the ECC2ERR bit in the ECC2STS register is not updated, and error correction is not performed.

When ECC function is disable, neither error correction nor error detection is done although 1-bit or 2-bit error occur.

So ECC1ERR bit and ECC2ERR bit are not updated.

There is no way to confirm the location where the error was found. Therefore, when after the occurrence of an error, update all the data.

When updating all the data after the occurrence of an error, the only support of 32 bit data writing.

Since the SRAM data is undefined after power on and release from deep software standby mode, accessing the SRAM when ECC function is enabled and error checking is selected causes an ECC error to occur. Therefore, before using ECC function, initial writing with 32bit data size to the area to be used in the SRAM should be done.

When a read access is executed in a row after a write access, read access is executed with priority. Therefore, during initialization, please do not perform the read access in a row after the write access.

**42.3.3 ECC Error Interrupt Function**

When ECC function is enabled and error checking is applied to the SRAM(ECC area), an ECC error occurs when either the ECC2ERR bit in the ECC2STS register or the ECC1ERR bit in the ECC1STS register becomes 1 to indicate that ECC checking revealed a 2-bit error or a 1-bit error, respectively.

An ECC error is output with a pulse width of t<sub>CLK</sub>. When the ECC 1-bit error is to be masked, set the ECC1STSEN.E1STSEN bit to 0 to disable updating of the ECC1ERR bit. An ECC error will not be generated while ECC function is disabled or when ECC function is enabled but error checking is not selected.

**OAD位 (检测后操作)**

OAD位选择在检测到ECC错误时是否产生复位或不可屏蔽中断。ECCOAD寄存器中的OAD位用于SRAM0 (ECC区域)。

**42.3 Operation****42.3.1 模块停止功能**

通过设置模块停止控制寄存器A(MSTPCRA)停止向SRAM提供时钟信号,可以降低功耗。

SRAM0由MSTPCRA寄存器中的SRAM0位控制,在为1的情况下,SRAM0变为时钟停止状态。

因此,通过停止提供时钟信号,SRAM被置于模块停止状态。SRAM在复位后运行。

如果SRAM处于模块停止状态,则无法访问。在访问SRAM的过程中,不应转换到模块停止状态。

禁止在模块停止状态下访问SRAM。如果尝试访问,则无法保证正确操作。

有关MSTPCRA寄存器的详细信息,请参见第10节,低功耗模式。

**42.3.2 纠正ECC错误**

可以通过ECCMODE寄存器设置来选择ECC纠错的启用和禁用。在初始状态下,ECC纠错被禁用。ECC校验类型为SEC-DED(单纠错双错误检测码)。

当ECC功能使能时,7位校验位被附加到32位数据中进行写入。读取时,从SRAM(ECC区域)中读取39位(数据:32位,校验位:7位)数据。

当ECC功能使能并且通过将ECCMODE寄存器中的ECCMOD[1:0]设置为00b来选择错误检查时,如果发生1位错误,则进行纠错,并且如果ECC1STS寄存器中的ECC1ERR位设置为1,则ECC1STSEN寄存器中的E1STSEN位为1。如果发生2位错误,则进行错误检测并将ECC2STS寄存器中的ECC2ERR位设置为1,但不执行错误纠正。

当启用ECC功能且禁用错误检查时,如果发生1位错误,则进行错误纠正,但尽管ECC1STSEN寄存器中的E1STSEN位为1,但ECC1STS寄存器中的ECC1ERR位不更新。如果发生2位错误,则会检测到该错误,但不会更新ECC2STS寄存器中的ECC2ERR位,也不执行纠错。

当ECC功能被禁用时,即使发生1位或2位错误,也不会进行纠错或错误检测。

因此ECC1ERR位和ECC2ERR位不会更新。

无法确认发现错误的位置。因此,当发生错误后,更新所有数据。

发生错误后更新所有数据时,仅支持32位数据写入。

由于上电并从深度软件待机模式释放后SRAM数据未定义,因此在启用ECC功能并选择错误检查时访问SRAM会导致发生ECC错误。因此,在使用ECC功能之前,应先将32位数据大小的数据写入SRAM中要使用的区域。

在写访问之后连续执行读访问时,优先执行读访问。因此,在初始化过程中,请不要在写访问之后连续进行读访问。

**42.3.3 ECC错误中断功能**

当启用ECC功能并对SRAM(ECC区域)应用错误检查时,当任一ECC2STS寄存器中的ECC2ERR位或ECC1STS寄存器中的ECC1ERR位变为1,分别表示ECC检查发现2位错误或1位错误。

以t<sub>CLK</sub>的脉冲宽度输出ECC错误。当要屏蔽ECC1位错误时,将ECC1STSEN.E1STSEN位设置为0以禁用ECC1ERR位的更新。禁用ECC功能或启用ECC功能但未选择错误检查时,不会产生ECC错误。

ECC error can choose non maskable interrupt or reset by ECCOAD register. When set 1 in the OAD bit of the ECCOAD register, ECC error is output to the Reset function. When set 0 in the OAD bit of the ECCOAD register, ECC Error interrupt is output to the ICU as non-maskable interrupt.

#### 42.3.4 ECC Decoder Testing

Figure 42.1 shows the ECC decoder testing.

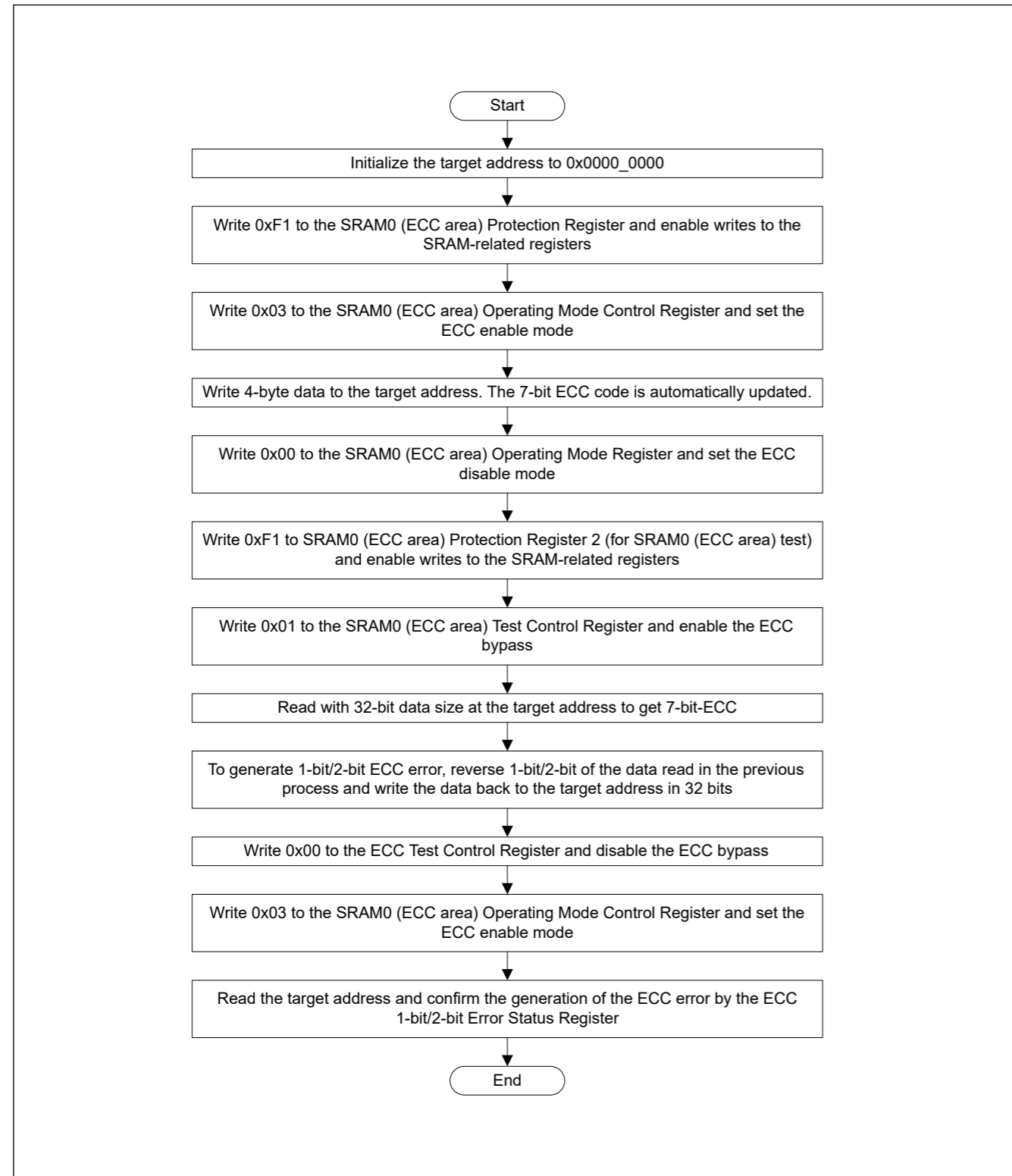


Figure 42.1 ECC decoder testing

ECC错误可以选择不可屏蔽中断或通过ECCOAD寄存器复位。当ECCOAD寄存器的OAD位设置为1时，ECC错误输出到复位功能。当ECCOAD寄存器的OAD位设置为0时，ECC错误中断作为不可屏蔽中断输出到ICU。

#### 42.3.4 ECC解码器测试

图42.1显示了ECC解码器测试。

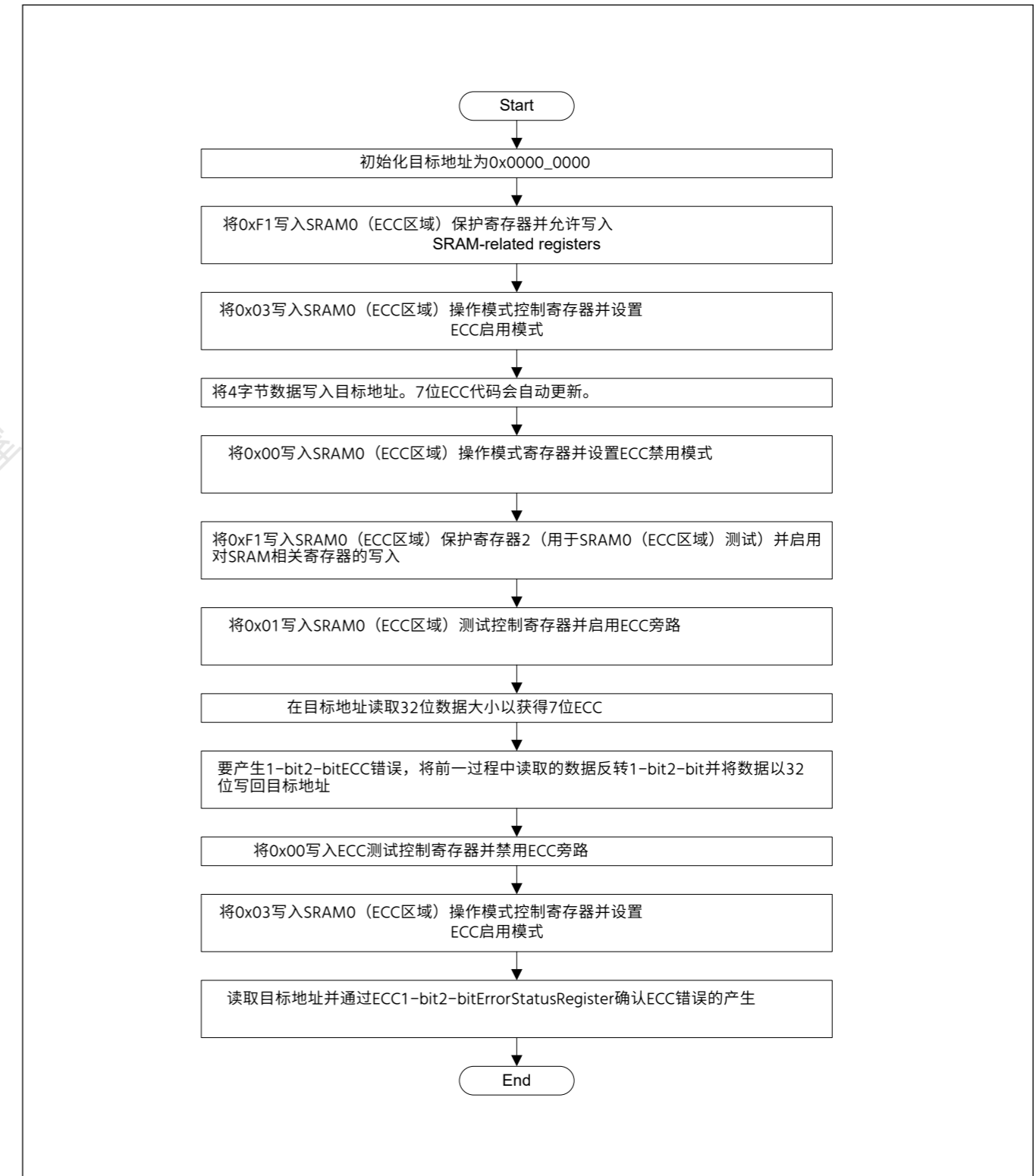


Figure 42.1 ECC解码器测试



42.3.5 Parity Calculation Function

The IEC60730 standard requires the checking of SRAM data. When data is written, a parity bit is added to every 8-bit data in the SRAM which has 32-bit data width, and when data is read, the parity is checked. When a parity error occurs, a parity-error notification is generated. This function can also be used to trigger a reset.

The parity-error notification can be specified as a non-maskable interrupt or a reset in the OAD bit of the PARIODAD register. When the OAD bit is set to 1, a parity error is output to the reset function. When the OAD bit is set to 0, a parity error is output to the ICU as a non-maskable interrupt.

Parity errors often occur because of noise. To confirm whether the cause of the parity error is noise or corruption, follow the parity check flows shown in Figure 42.2 and Figure 42.3.

When a read access is executed in a row after a write access, read access is executed with priority. Therefore, during initialization, do not perform the read access in a row after the write access.

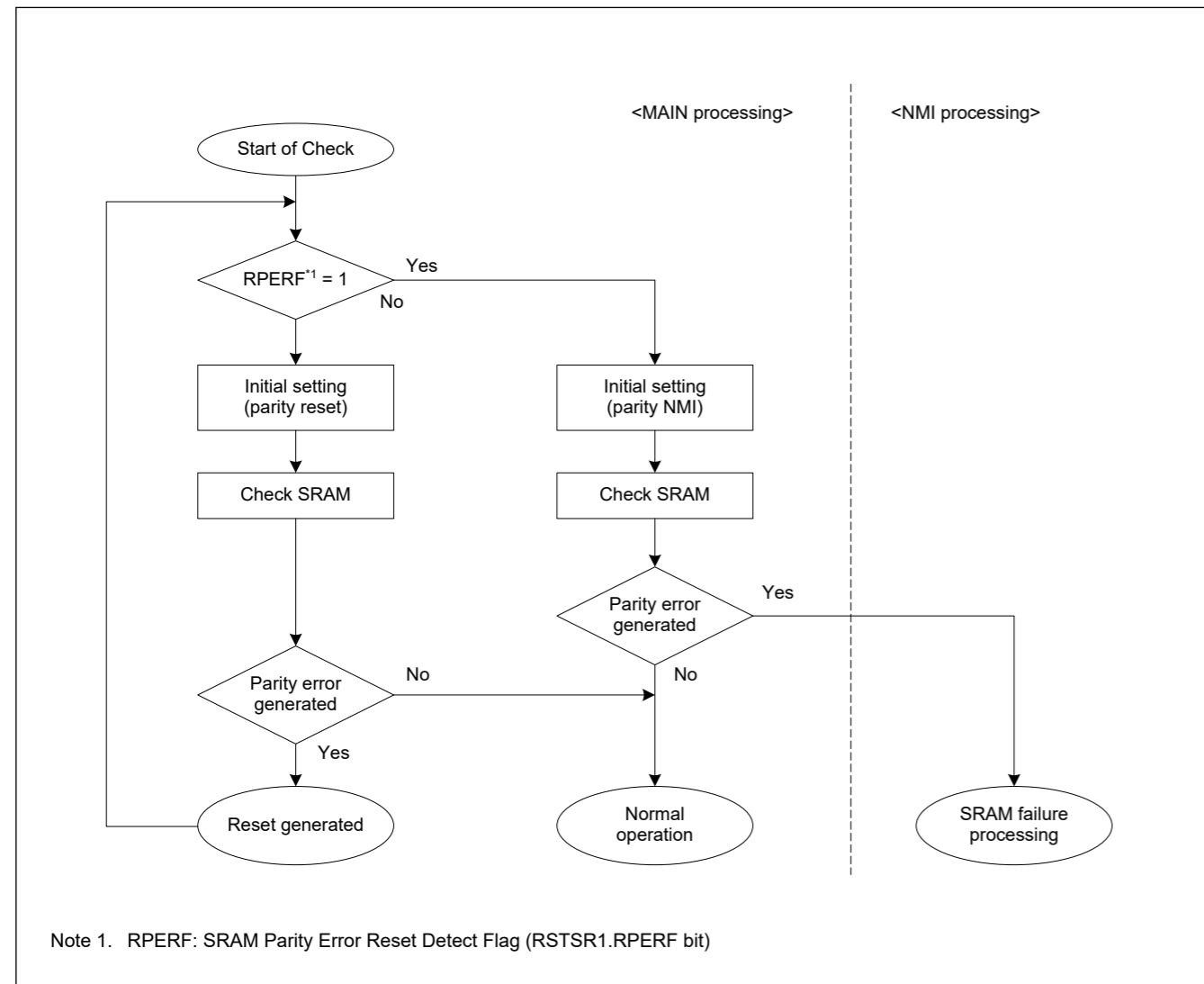


Figure 42.2 Flow of SRAM parity check when SRAM parity reset is enabled

42.3.5 奇偶校验计算功能

IEC60730标准要求检查SRAM数据。写入数据时，对32位数据宽度的SRAM中的每8位数据添加一个奇偶校验位，读取数据时检查奇偶校验位。发生奇偶校验错误时，会生成奇偶校验错误通知。此功能也可用于触发复位。

奇偶校验错误通知可以指定为不可屏蔽中断或PARIODAD寄存器的OAD位中的复位。当OAD位设置为1时，奇偶校验错误输出到复位功能。当OAD位设置为0时，奇偶校验错误作为不可屏蔽中断输出到ICU。

奇偶校验错误经常因噪声而发生。要确认奇偶校验错误的原因是噪声还是损坏，请遵循图42.2和图42.3所示的奇偶校验流程。

在写访问之后连续执行读访问时，优先执行读访问。因此，在初始化过程中，不要在写访问之后连续执行读访问。

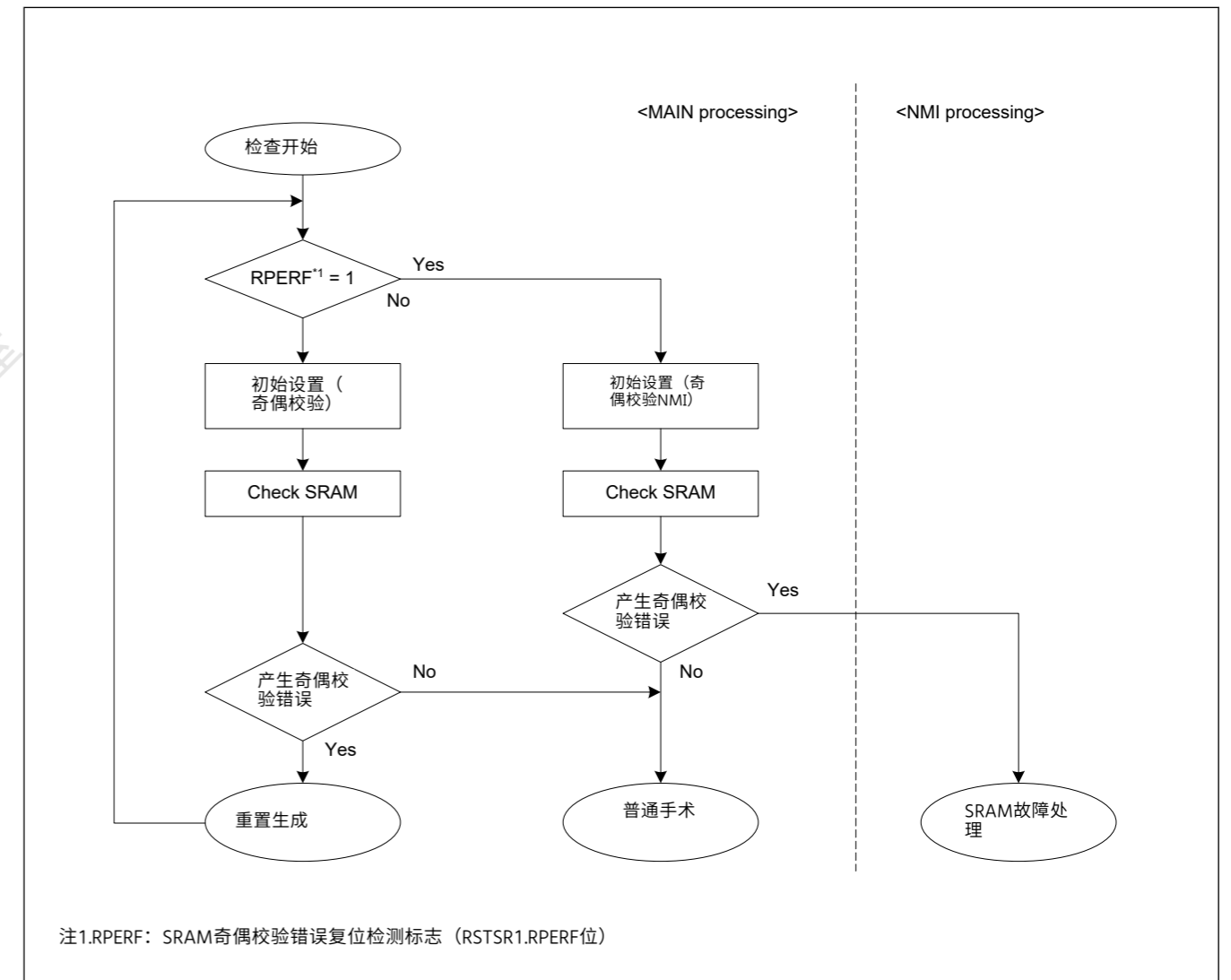


Figure 42.2 启用SRAM奇偶校验复位时的SRAM奇偶校验流程

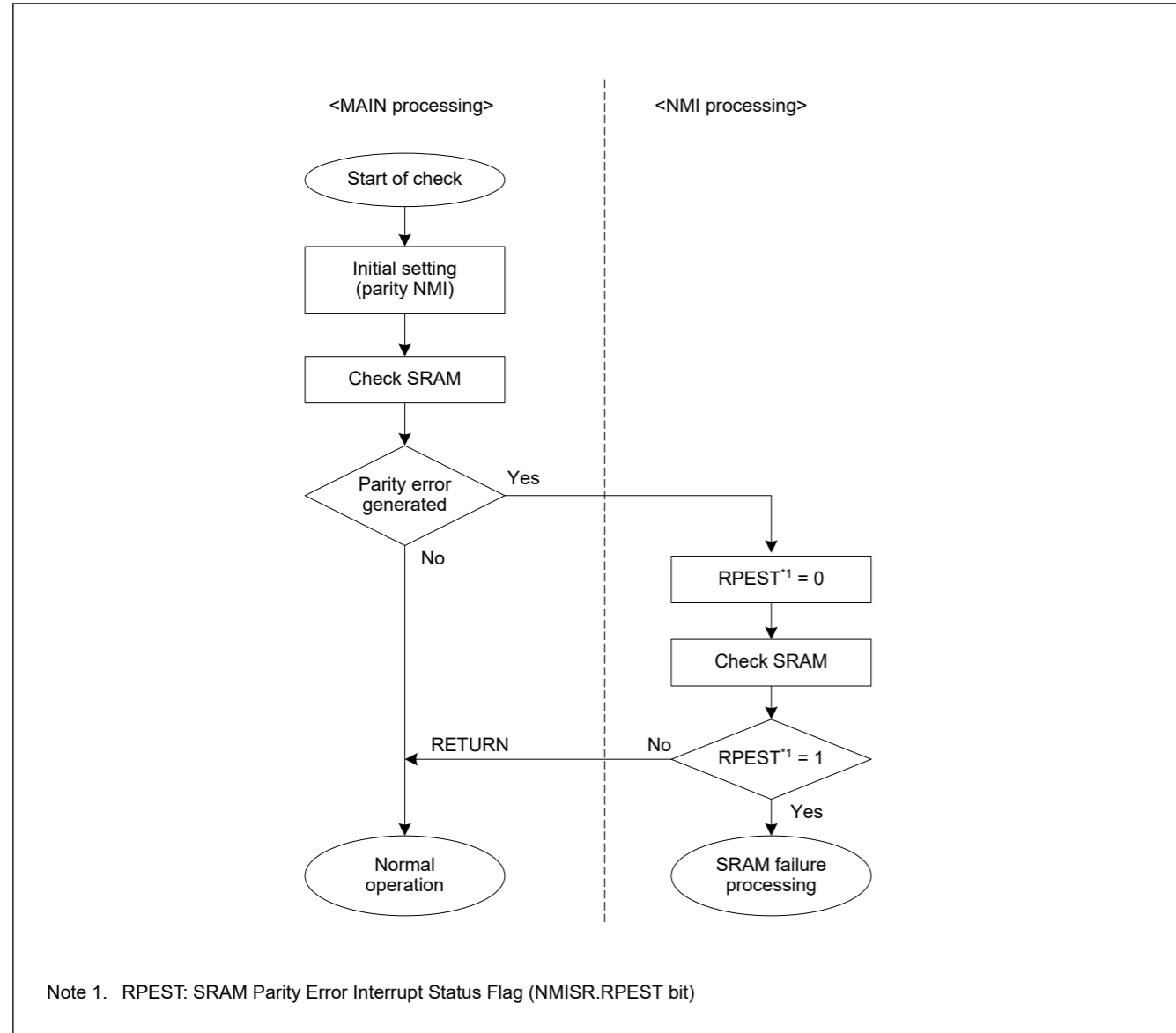


Figure 42.3 Flow of SRAM parity check when SRAM parity interrupt is enabled

### 42.3.6 TrustZone Filter function

There are two types of TrustZone Filter function for SRAM.

- TrustZone Filter for SRAM register protection
- TrustZone Filter for SRAM memory protection

#### 42.3.6.1 TrustZone Filter for SRAM register protection

SRAM registers can be protected with a Security Attribution (SA) from Non-secure access. When SA indicates that SRAM registers are secure status, non-secure access can not overwrite them because TrustZone Filter detects finds an error and protects the write access. SA for SRAM registers is just one to be used commonly among SRAM registers.

Table 42.2 Register protection (1 of 2)

| SA     | Access status | Write access                     | Read access |
|--------|---------------|----------------------------------|-------------|
| Secure | Secure        | Permit                           | Permit      |
|        | Non-secure    | TrustZone Filter error Protected | Permit      |

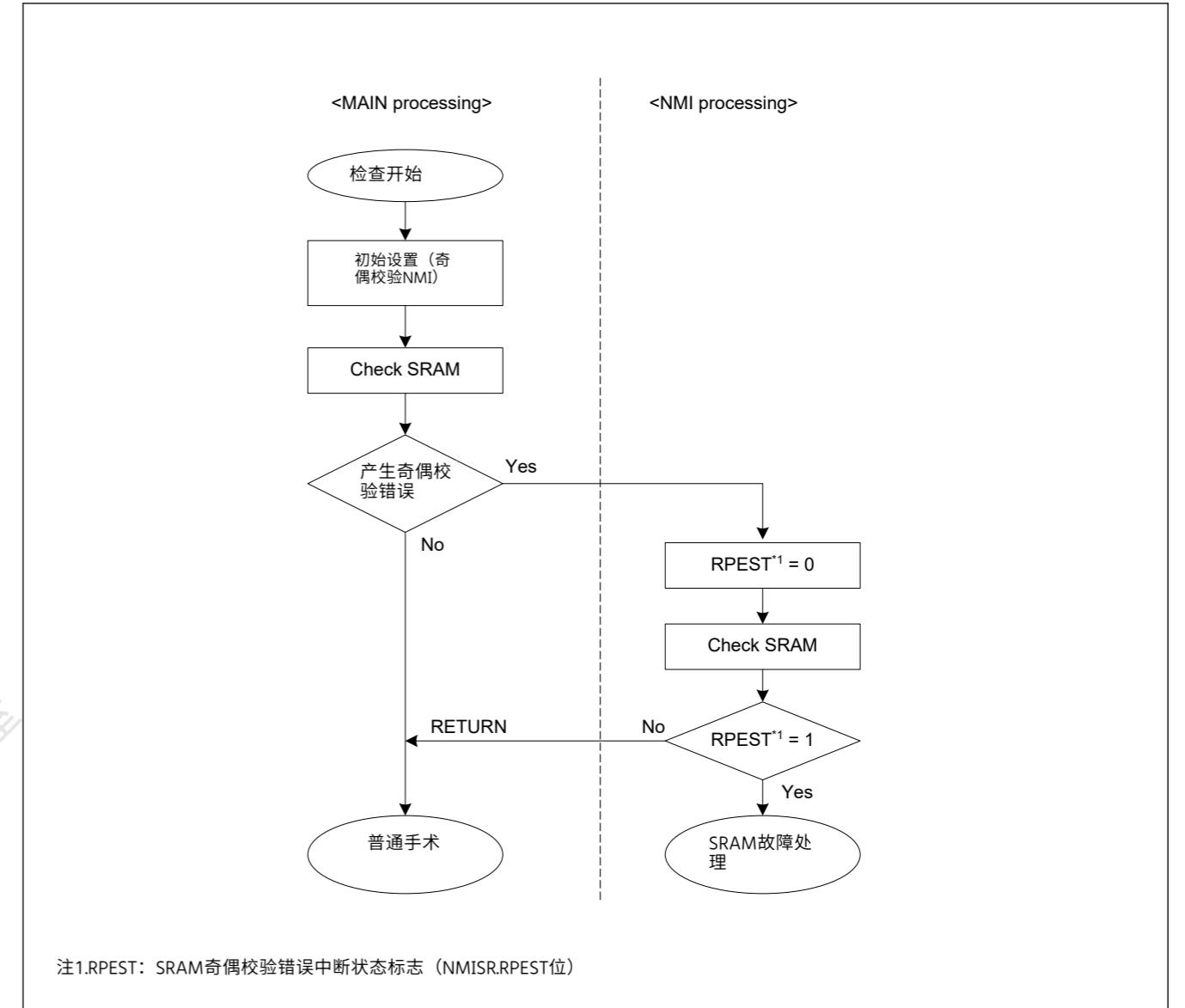


Figure 42.3 启用SRAM奇偶校验中断时的SRAM奇偶校验流程

### 42.3.6 TrustZone过滤器功能

SRAM有两种TrustZoneFilter功能。

- 用于SRAM寄存器保护的TrustZone过滤器
- 用于SRAM内存保护的TrustZone过滤器

#### 42.3.6.1 用于SRAM寄存器保护的TrustZone过滤器

可以使用安全属性(SA)保护SRAM寄存器免受非安全访问。当SA指示SRAM寄存器处于安全状态时，非安全访问无法覆盖它们，因为TrustZoneFilter检测到发现错误并保护写访问。SRAM寄存器的SA只是SRAM寄存器中常用的一种。

Table 42.2 寄存器保护(1of2)

| SA     | 访问状态       | 写访问               | 读取权限   |
|--------|------------|-------------------|--------|
| Secure | Secure     | Permit            | Permit |
|        | Non-secure | TrustZone过滤器错误受保护 | Permit |

Table 42.2 Register protection (2 of 2)

| SA         | Access status | Write access | Read access |
|------------|---------------|--------------|-------------|
| Non-secure | Secure        | Permit       | Permit      |
|            | Non-secure    | Permit       | Permit      |

When TrustZone Filter error for SRAM register access occurs, no error notification and no error response occurs.

### 42.3.6.2 TrustZone Filter for SRAM memory protection

SRAM memory, e.g. SRAM0 include ECC region and Parity can be divided into Secure/Non secure callable/Non secure status with Memory Security Attribution (MSA) and can be protected from Non-secure access. When MSA indicates that SRAM memory region are Secure or Non secure callable status, Non-secure access can't overwrite them.

Table 42.3 Memory protection

| SA                           | Access status | Write access  | Read access  |
|------------------------------|---------------|---|--|
| Secure / Non secure callable | Secure        | Permit  | Permit   |
|                              | Non-secure    | TrustZone Filter error <ul style="list-style-type: none"> <li>Protected</li> <li>Error response occurs</li> </ul> | TrustZone Filter error <ul style="list-style-type: none"> <li>Read data is 0</li> <li>Error response occurs</li> </ul> |
| Non-secure                   | Secure        | Permit  | Permit   |
|                              | Non-secure    | Permit  | Permit   |

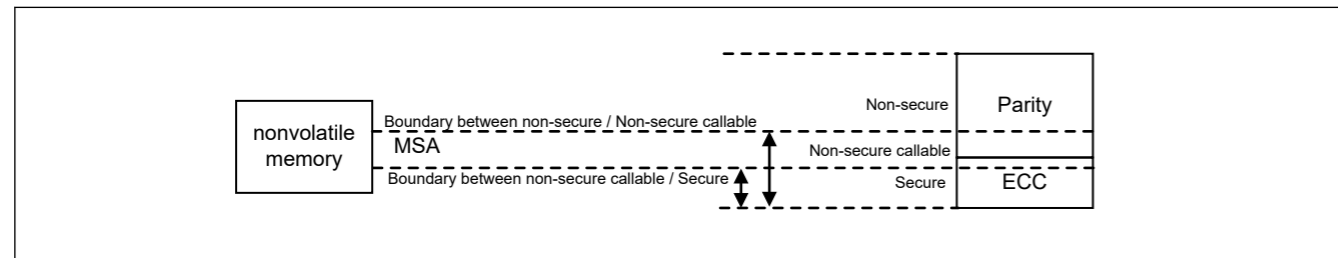


Figure 42.4 TrustZone Filter for SRAM memory

When TrustZone Filter error for SRAM memory access occurs, an error notification which become Reset request or NMI request occurs. See section 46.2. Arm TrustZone Security .

### 42.3.7 Interrupt Source

The SRAM interrupt source includes an ECC error, Parity error and TrustZone filter error. ECC error and Parity error can choose non-maskable interrupt or reset by OAD bit. When the debugger is connected, reset and non-maskable interrupt are maskable. Also, if these masks are set by the debugger, each status register is not set even if an ECC error occurs. For details on the debug mode, see section 2, CPU.

Table 42.4 SRAM Interrupt Source

| Name      | Interrupt Source                          | DTC Activation | DMAC Activation |
|-----------|---|----------------|-----------------|
| ECCERR    | ECC error (ECC operation region in SRAM0) | Not possible   | Not possible    |
| PARITYERR | Parity error                              | Not possible   | Not possible    |
| TZFLT     | TrustZone filter error                    | Not possible   | Not possible    |

### 42.3.8 Wait state

Depending on the operating frequency of ICLK, the WAIT setting for SRAM access has the following conditions.

[ICLK frequency] (SRAM0):

- 100 MHz ≥ ICLK = No-wait

Table 42.2 注册保护(2of2)

| SA         | 访问状态       | 写访问    | 读取权限   |
|------------|------------|--------|--------|
| Non-secure | Secure     | Permit | Permit |
|            | Non-secure | Permit | Permit |

当发生SRAM寄存器访问的TrustZoneFilter错误时，不会发生错误通知和错误响应。

### 42.3.6.2 用于SRAM内存保护的TrustZone过滤器

SRAM存储器，例如SRAM0包括ECC区域和Parity可分为SecureNonsecurecallableNonsecurestatuswithMemory SecurityAttribution(MSA)并可防止非安全访问。当MSA指示SRAM内存区域为安全或非安全可调用状态时，非安全访问无法覆盖它们。

Table 42.3 内存保护

| SA         | 访问状态       | 写访问   | 读取权限  |
|------------|------------|---|---|
| 安全非安全可调用   | Secure     | Permit  | Permit  |
|            | Non-secure | TrustZone过滤器错误 <ul style="list-style-type: none"> <li>发生错误响应</li> </ul> | TrustZone过滤器错误 <ul style="list-style-type: none"> <li>读取数据为0</li> <li>发生错误响应</li> </ul> |
| Non-secure | Secure     | Permit  | Permit  |
|            | Non-secure | Permit  | Permit  |

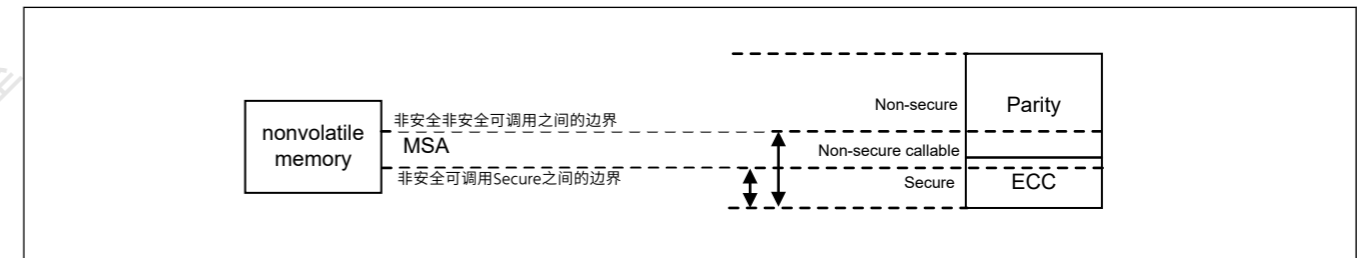


Figure 42.4 用于SRAM存储器的TrustZone过滤器

当发生SRAM内存访问的TrustZoneFilter错误时，会发生错误通知，成为Resetrequest或NMIrequest。见第46.2节。ArmTrustZone安全。

### 42.3.7 中断源

SRAM中断源包括ECC错误、奇偶校验错误和TrustZone过滤器错误。ECC错误和奇偶校验错误可以选择不可屏蔽中断或通过OAD位复位。当调试器连接时，复位和不可屏蔽中断都是可屏蔽的。此外，如果调试器设置了这些掩码，则即使发生ECC错误，也不会设置每个状态寄存器。有关调试模式的详细信息，请参见第2节CPU。

Table 42.4 SRAM中断源

| Name      | 中断源                    | DTC Activation | DMAC Activation |
|-----------|------------------------|----------------|-----------------|
| ECCERR    | ECC错误 (SRAM0中的ECC操作区域) | 不可能            | 不可能             |
| PARITYERR | 奇偶校验错误                 | 不可能            | 不可能             |
| TZFLT     | TrustZone过滤器错误         | 不可能            | 不可能             |

### 42.3.8 等待状态

根据ICLK的工作频率，SRAM访问的WAIT设置具有以下条件。

[ICLK frequency] (SRAM0):

- 100 MHz ≥ ICLK = No-wait

## 42.3.9 Access Cycle

- Number of cycles from the CPU
  - When the cache is hit, access is one cycle.
  - For cache off or non cacheable

Table 42.5 SRAM0 (ECC Area)

| Register Setting         |               | Read (cycles) |                       | Write (cycles) |                       |
|--------------------------|---------------|---------------|-----------------------|----------------|-----------------------|
|                          |               | Word access   | Half-word/Byte access | Word access    | Half-word/Byte access |
| ECC Off<br>ECCMOD[1] = 0 | SRAM0WTEN = 0 | 3             |                       | 2 <sup>1</sup> |                       |
|                          | SRAM0WTEN = 1 | 4             |                       | 2 <sup>1</sup> |                       |
| ECC On<br>ECCMOD[1] = 1  | SRAM0WTEN = 0 | 3             |                       | 2 <sup>1</sup> | 4                     |
|                          | SRAM0WTEN = 1 | 4             |                       | 2 <sup>1</sup> | 4                     |

Note 1. For efficiency of the access, when read access occurs to the same memory after write, memory write by the precedent write command delays it until for the next idle cycle or the next write access. When read continues, it is given priority to read.

Table 42.6 SRAM0 (Parity Area)

| Register Setting |  | Read (cycles) |                       | Write (cycles) |                       |
|------------------|--|---------------|-----------------------|----------------|-----------------------|
|                  |  | Word access   | Half-word/Byte access | Word access    | Half-word/Byte access |
| SRAM0WTEN = 0    |  | 3             |                       | 2 <sup>1</sup> |                       |
| SRAM0WTEN = 1    |  | 4             |                       | 2 <sup>1</sup> |                       |

Note 1. For efficiency of the access, when read access occurs to the same memory after write, memory write by the precedent write command delays it until for the next idle cycle or the next write access. When read continues, it is given priority to read.

- For cache on and cacheble (When the cache miss hit)

Table 42.7 SRAM0 (ECC Area)

| Register Setting         |               | Read (cycles) |                       | Write (cycles) |                       |
|--------------------------|---------------|---------------|-----------------------|----------------|-----------------------|
|                          |               | Word access   | Half-word/Byte access | Word access    | Half-word/Byte access |
| ECC Off<br>ECCMOD[1] = 0 | SRAM0WTEN = 0 | 3             |                       | 1 <sup>1</sup> |                       |
|                          | SRAM0WTEN = 1 | 4             |                       | 1 <sup>1</sup> |                       |
| ECC On<br>ECCMOD[1] = 1  | SRAM0WTEN = 0 | 3             |                       | 1 <sup>1</sup> |                       |
|                          | SRAM0WTEN = 1 | 4             |                       | 1 <sup>1</sup> |                       |

Note 1. For efficiency of the access, when read access occurs to the same memory after write, memory write by the precedent write command delays it until for the next idle cycle or the next write access. When read continues, it is given priority to read.

Table 42.8 SRAM0 (Parity Area)

| Register Setting |  | Read (cycles) |                       | Write (cycles) |                       |
|------------------|--|---------------|-----------------------|----------------|-----------------------|
|                  |  | Word access   | Half-word/Byte access | Word access    | Half-word/Byte access |
| SRAM0WTEN = 0    |  | 3             |                       | 1 <sup>1</sup> |                       |
| SRAM0WTEN = 1    |  | 4             |                       | 1 <sup>1</sup> |                       |

Note 1. For efficiency of the access, when read access occurs to the same memory after write, memory write by the precedent write command delays it until for the next idle cycle or the next write access. When read continues, it is given priority to read.

## 42.3.9 访问周期

- CPU的周期数
  - 当缓存命中时，访问为一个周期。
  - 对于缓存关闭或不可缓存

Table 42.5 SRAM0 (ECC Area)

| 寄存器设置                    |               | Read (cycles) |                       | Write (cycles) |                       |
|--------------------------|---------------|---------------|-----------------------|----------------|-----------------------|
|                          |               | 字访问           | Half-word/Byte access | 字访问            | Half-word/Byte access |
| ECC Off<br>ECCMOD[1] = 0 | SRAM0WTEN = 0 | 3             |                       | 2 <sup>1</sup> |                       |
|                          | SRAM0WTEN = 1 | 4             |                       | 2 <sup>1</sup> |                       |
| ECC On<br>ECCMOD[1] = 1  | SRAM0WTEN = 0 | 3             |                       | 2 <sup>1</sup> | 4                     |
|                          | SRAM0WTEN = 1 | 4             |                       | 2 <sup>1</sup> | 4                     |

注1.为提高访问效率，当写入后对同一内存进行读取访问时，先行写入命令的内存写入会将其延迟到下一个空闲周期或下一次写入访问。继续读取时，优先读取。

Table 42.6 SRAM0 (Parity Area)

| 寄存器设置         |  | Read (cycles) |                       | Write (cycles) |                       |
|---------------|--|---------------|-----------------------|----------------|-----------------------|
|               |  | 字访问           | Half-word/Byte access | 字访问            | Half-word/Byte access |
| SRAM0WTEN = 0 |  | 3             |                       | 2 <sup>1</sup> |                       |
| SRAM0WTEN = 1 |  | 4             |                       | 2 <sup>1</sup> |                       |

注1.为提高访问效率，当写入后对同一内存进行读取访问时，先行写入命令的内存写入会将其延迟到下一个空闲周期或下一次写入访问。继续读取时，优先读取。

- forcacheonandcacheble (当缓存未命中时)

Table 42.7 SRAM0 (ECC Area)

| 寄存器设置                    |               | Read (cycles) |                       | Write (cycles) |                       |
|--------------------------|---------------|---------------|-----------------------|----------------|-----------------------|
|                          |               | 字访问           | Half-word/Byte access | 字访问            | Half-word/Byte access |
| ECC Off<br>ECCMOD[1] = 0 | SRAM0WTEN = 0 | 3             |                       | 1 <sup>1</sup> |                       |
|                          | SRAM0WTEN = 1 | 4             |                       | 1 <sup>1</sup> |                       |
| ECC On<br>ECCMOD[1] = 1  | SRAM0WTEN = 0 | 3             |                       | 1 <sup>1</sup> |                       |
|                          | SRAM0WTEN = 1 | 4             |                       | 1 <sup>1</sup> |                       |

注1.为提高访问效率，当写入后对同一内存进行读取访问时，先行写入命令的内存写入会将其延迟到下一个空闲周期或下一次写入访问。继续读取时，优先读取。

Table 42.8 SRAM0 (Parity Area)

| 寄存器设置         |  | Read (cycles) |                       | Write (cycles) |                       |
|---------------|--|---------------|-----------------------|----------------|-----------------------|
|               |  | 字访问           | Half-word/Byte access | 字访问            | Half-word/Byte access |
| SRAM0WTEN = 0 |  | 3             |                       | 1 <sup>1</sup> |                       |
| SRAM0WTEN = 1 |  | 4             |                       | 1 <sup>1</sup> |                       |

注1.为提高访问效率，当写入后对同一内存进行读取访问时，先行写入命令的内存写入会将其延迟到下一个空闲周期或下一次写入访问。继续读取时，优先读取。



## 42.3.10 ECC encode specification

The following table shows ECC encoding specifications. Add the ECC cord (eout [6:0]) formed by the following calculating formula to higher 7 bits (din [38:32]) of write data and write in it at SRAM.

Table 42.9 ECC encode

| ECC code | calculation formula   |
|----------|---|
| eout[6]  | $(din[13] \wedge din[12] \wedge din[11] \wedge din[10] \wedge din[9] \wedge din[8] \wedge din[7] \wedge din[6] \wedge din[5] \wedge din[4] \wedge din[3] \wedge din[2] \wedge din[1] \wedge din[0])$            |
| eout[5]  | $(din[23] \wedge din[22] \wedge din[21] \wedge din[20] \wedge din[19] \wedge din[18] \wedge din[17] \wedge din[16] \wedge din[15] \wedge din[14] \wedge din[3] \wedge din[2] \wedge din[1] \wedge din[0])$      |
| eout[4]  | $(din[29] \wedge din[28] \wedge din[27] \wedge din[26] \wedge din[25] \wedge din[24] \wedge din[17] \wedge din[16] \wedge din[15] \wedge din[14] \wedge din[7] \wedge din[6] \wedge din[5] \wedge din[4])$      |
| eout[3]  | $(din[31] \wedge din[30] \wedge din[26] \wedge din[25] \wedge din[24] \wedge din[20] \wedge din[19] \wedge din[18] \wedge din[14] \wedge din[10] \wedge din[9] \wedge din[8] \wedge din[4] \wedge din[0])$      |
| eout[2]  | $(din[31] \wedge din[30] \wedge din[28] \wedge din[27] \wedge din[24] \wedge din[22] \wedge din[21] \wedge din[18] \wedge din[15] \wedge din[12] \wedge din[11] \wedge din[8] \wedge din[5] \wedge din[1])$     |
| eout[1]  | $\sim(din[30] \wedge din[29] \wedge din[27] \wedge din[25] \wedge din[23] \wedge din[21] \wedge din[19] \wedge din[16] \wedge din[13] \wedge din[11] \wedge din[9] \wedge din[6] \wedge din[2] \wedge din[0])$  |
| eout[0]  | $\sim(din[31] \wedge din[29] \wedge din[28] \wedge din[26] \wedge din[23] \wedge din[22] \wedge din[20] \wedge din[17] \wedge din[13] \wedge din[12] \wedge din[10] \wedge din[7] \wedge din[3] \wedge din[0])$ |

Note: eout[6:0] = ECC code, din[31:0] = write data

## 42.3.10 ECC编码规范

下表显示了ECC编码规范。将由以下计算公式形成的ECC线 (eout[6:0]) 添加到写入数据的高7位 (din[38:32]) 中，并写入SRAM中。

Table 42.9 ECC encode

| ECC code | 计算公式  |
|----------|---|
| eout[6]  | $(din[13] \wedge din[12] \wedge din[11] \wedge din[10] \wedge din[9] \wedge din[8] \wedge din[7] \wedge din[6] \wedge din[5] \wedge din[4] \wedge din[3] \wedge din[2] \wedge din[1] \wedge din[0])$            |
| eout[5]  | $(din[23] \wedge din[22] \wedge din[21] \wedge din[20] \wedge din[19] \wedge din[18] \wedge din[17] \wedge din[16] \wedge din[15] \wedge din[14] \wedge din[3] \wedge din[2] \wedge din[1] \wedge din[0])$      |
| eout[4]  | $(din[29] \wedge din[28] \wedge din[27] \wedge din[26] \wedge din[25] \wedge din[24] \wedge din[17] \wedge din[16] \wedge din[15] \wedge din[14] \wedge din[7] \wedge din[6] \wedge din[5] \wedge din[4])$      |
| eout[3]  | $(din[31] \wedge din[30] \wedge din[26] \wedge din[25] \wedge din[24] \wedge din[20] \wedge din[19] \wedge din[18] \wedge din[14] \wedge din[10] \wedge din[9] \wedge din[8] \wedge din[4] \wedge din[0])$      |
| eout[2]  | $(din[31] \wedge din[30] \wedge din[28] \wedge din[27] \wedge din[24] \wedge din[22] \wedge din[21] \wedge din[18] \wedge din[15] \wedge din[12] \wedge din[11] \wedge din[8] \wedge din[5] \wedge din[1])$     |
| eout[1]  | $\sim(din[30] \wedge din[29] \wedge din[27] \wedge din[25] \wedge din[23] \wedge din[21] \wedge din[19] \wedge din[16] \wedge din[13] \wedge din[11] \wedge din[9] \wedge din[6] \wedge din[2] \wedge din[0])$  |
| eout[0]  | $\sim(din[31] \wedge din[29] \wedge din[28] \wedge din[26] \wedge din[23] \wedge din[22] \wedge din[20] \wedge din[17] \wedge din[13] \wedge din[12] \wedge din[10] \wedge din[7] \wedge din[3] \wedge din[0])$ |

Note: eout[6:0]=ECC代码, din[31:0]=写入数据

## 43. Standby SRAM

### 43.1 Overview

An on-chip SRAM is provided to retain data in Deep Software Standby mode. Table 43.1 lists the Standby SRAM specifications.

**Table 43.1 Standby SRAM specifications**

| Item                    | Description  |
|-------------------------|--|
| SRAM capacity           | 1 KB   |
| SRAM address            | 0x2800_0000 to 0x2800_03FF   |
| Access                  | Standby SRAM clock is the same clock as the PCLKB. See section 43.3.5. Access Cycle for details.   |
| Data retention function | Data can be retained in deep standby mode. See section 43.3.1. Data Retention for details.   |
| parity                  | Even parity (data: 8 bits, parity: 1 bit)  |
| Module-stop function    | Module-stop state can be set to reduce power consumption. See section 43.3.2. Setting for the Module-stop Function for details.                      |
| Security                | Permits the read and write operations to Standby RAM following TrustZone Filter function. See section 43.3.4. TrustZone Filter function for details. |

### 43.2 Register Descriptions

#### 43.2.1 STBRAMSAR : Standby RAM memory Security Attribution Register

Base address: CPSCU = 0x4000\_8000

Offset address: 0x014

| Bit position:      | 31 | 30 | 29 | 28 | 27 | 26 | 25 | 24 | 23 | 22 | 21 | 20 | 19 | 18 | 17 | 16           |
|--------------------|----|----|----|----|----|----|----|----|----|----|----|----|----|----|----|--------------|
| Bit field:         | —  | —  | —  | —  | —  | —  | —  | —  | —  | —  | —  | —  | —  | —  | —  | —            |
| Value after reset: | 1  | 1  | 1  | 1  | 1  | 1  | 1  | 1  | 1  | 1  | 1  | 1  | 1  | 1  | 1  | 1            |
| Bit position:      | 15 | 14 | 13 | 12 | 11 | 10 | 9  | 8  | 7  | 6  | 5  | 4  | 3  | 2  | 1  | 0            |
| Bit field:         | —  | —  | —  | —  | —  | —  | —  | —  | —  | —  | —  | —  | —  | —  | —  | NSBSTBR[3:0] |
| Value after reset: | 1  | 1  | 1  | 1  | 1  | 1  | 1  | 1  | 1  | 1  | 1  | 1  | 1  | 0  | 0  | 0            |

| Bit  | Symbol       | Function  | R/W |
|------|--------------|---|-----|
| 3:0  | NSBSTBR[3:0] | Security attributes of each region for Standby RAM<br>0x0: Region7-0 are all Secure.<br>0x1: Region7 is Non-secure. Region6-0 are Secure<br>0x2: Region7-6 are Non-secure. Region5-0 are Secure.<br>0x3: Region7-5 are Non-secure. Region4-0 are Secure.<br>0x4: Region7-4 are Non-secure. Region 3-0 are Secure.<br>0x5: Region7-3 are Non-secure. Region 2-0 are Secure.<br>0x6: Region7-2 are Non-secure. Region 1-0 are Secure.<br>0x7: Region7-1 are Non-Secure. Region0 is Secure.<br>Others: Region7-0 are all Non-Secure. | R/W |
| 31:4 | —            | This bit is read as 1.  | R   |

Note: Only secure access can write to this register. Both secure access and Non-secure read access are allowed but Non-secure write access is not allowed and TrustZone access error is not generated.

Note: This register is write-protected by PRCR register.

## 43. Standby SRAM

### 43.1 Overview

提供片上SRAM以在深度软件待机模式下保留数据。表43.1列出了备用SRAM规格。

**Table 43.1 备用SRAM规格**

| Item                 | Description  |
|----------------------|--|
| SRAM capacity        | 1 KB   |
| SRAM address         | 0x2800_0000 to 0x2800_03FF   |
| Access               | 备用SRAM时钟与PCLKB时钟相同。请参阅第43.3.5节。访问周期了解详情。                           |
| 数据保留功能               | 数据可以在深度待机模式下保留。请参见第43.3.1节。有关详细信息的数据保留。                            |
| parity               | 偶校验 (数据: 8位, 奇偶校验: 1位)   |
| Module-stop function | 可设置模块停止状态以降低功耗。请参见第43.3.2节。设置为模块停止功能了解详情。                          |
| Security             | 允许在TrustZone过滤器功能之后对备用RAM进行读取和写入操作。请参见第43.3.4节。TrustZone过滤器功能了解详情。 |

### 43.2 注册说明

#### 43.2.1 STBRAMSAR:备用RAM内存安全属性寄存器

Base address: CPSCU = 0x4000\_8000

Offset address: 0x014

| Bit position: | 31 | 30 | 29 | 28 | 27 | 26 | 25 | 24 | 23 | 22 | 21 | 20 | 19 | 18 | 17 | 16           |
|---------------|----|----|----|----|----|----|----|----|----|----|----|----|----|----|----|--------------|
| Bit field:    | —  | —  | —  | —  | —  | —  | —  | —  | —  | —  | —  | —  | —  | —  | —  | —            |
| 重置后的值:        | 1  | 1  | 1  | 1  | 1  | 1  | 1  | 1  | 1  | 1  | 1  | 1  | 1  | 1  | 1  | 1            |
| Bit position: | 15 | 14 | 13 | 12 | 11 | 10 | 9  | 8  | 7  | 6  | 5  | 4  | 3  | 2  | 1  | 0            |
| Bit field:    | —  | —  | —  | —  | —  | —  | —  | —  | —  | —  | —  | —  | —  | —  | —  | NSBSTBR[3:0] |
| 重置后的值:        | 1  | 1  | 1  | 1  | 1  | 1  | 1  | 1  | 1  | 1  | 1  | 1  | 1  | 0  | 0  | 0            |

| Bit  | Symbol       | Function   | R/W |
|------|--------------|--|-----|
| 3:0  | NSBSTBR[3:0] | StandbyRAM各区域的安全属性<br>0x0: Region7-0都是安全的。0x1: Region7不安全。Region6-0是安全的。0x2: Region7-6是非安全的。Region5-0是安全的。0x3: Region7-5不安全。Region4-0是安全的。0x4: Region7-4不安全。区域3-0是安全的。0x5: Region7-3不安全。区域2-0是安全的。0x6: Region7-2不安全。区域1-0是安全的。0x7: Region7-1是非安全的。Region0是安全的。<br>其他: Region7-0都是非安全的。 | R/W |
| 31:4 | —            | 该位读为1。   | R   |

Note: 只有安全访问才能写入该寄存器。允许安全访问和非安全读取访问, 但不允许非安全写入访问, 并且不会生成TrustZone访问错误。

Note: 该寄存器由PRCR寄存器写保护。

**NSBSTBR[3:0] bit (Security attributes of each region for Standby RAM)**

Standby RAM is divided into 8 regions. Each region can be set as Secure or Non-secure state with NSBSTBR[3:0]

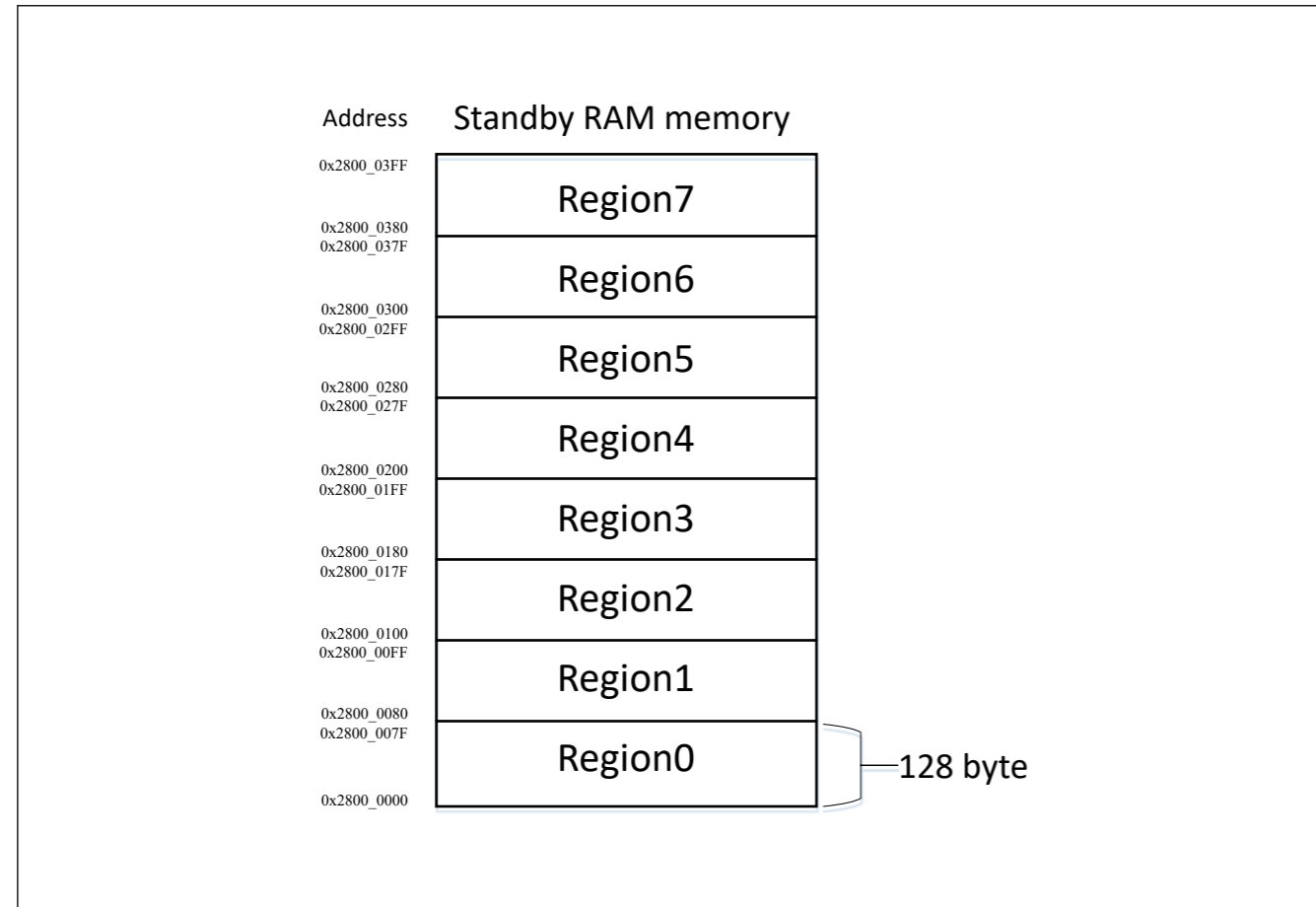


Figure 43.1 Standby RAM regions

### 43.3 Operation

#### 43.3.1 Data Retention

The power supply to the Standby SRAM in Deep Software Standby mode is enabled by the DPSBYCR.DEEPCUT[1:0] bits. If the DPSBYCR.DEEPCUT[1:0] bits are set to 00b, data in the Standby SRAM is retained in Deep Software Standby mode. See [section 10, Low Power Modes](#), for details on the DPSBYCR.DEEPCUT[1:0] bits.

#### 43.3.2 Setting for the Module-stop Function

Power consumption can be reduced by setting module stop control register A (MSTPCRA) to stop supply of the clock signal to SRAM.

If the Standby SRAM bit in MSTPCRA is set to 1, supply of the clock signal to the Standby SRAM is stopped.

The Standby SRAM is thus placed in the module-stop state by stopping supply of the clock signals. The Standby SRAM operates after a reset.

The Standby SRAM is not accessible if it is in the module-stop state. A transition to the module-stop state should not be made while access to the standby SRAM is in progress.

For details on the MSTPCRA register, see [section 10, Low Power Modes](#).

#### 43.3.3 Parity Calculation Function

The parity calculation Function for Standby SRAM is as same as SRAM without ECC.

**NSBSTBR[3:0]位 (StandbyRAM每个区域的安全属性)**

备用RAM分为8个区域。每个区域都可以通过NSBSTBR[3:0]设置为安全或非安全状态

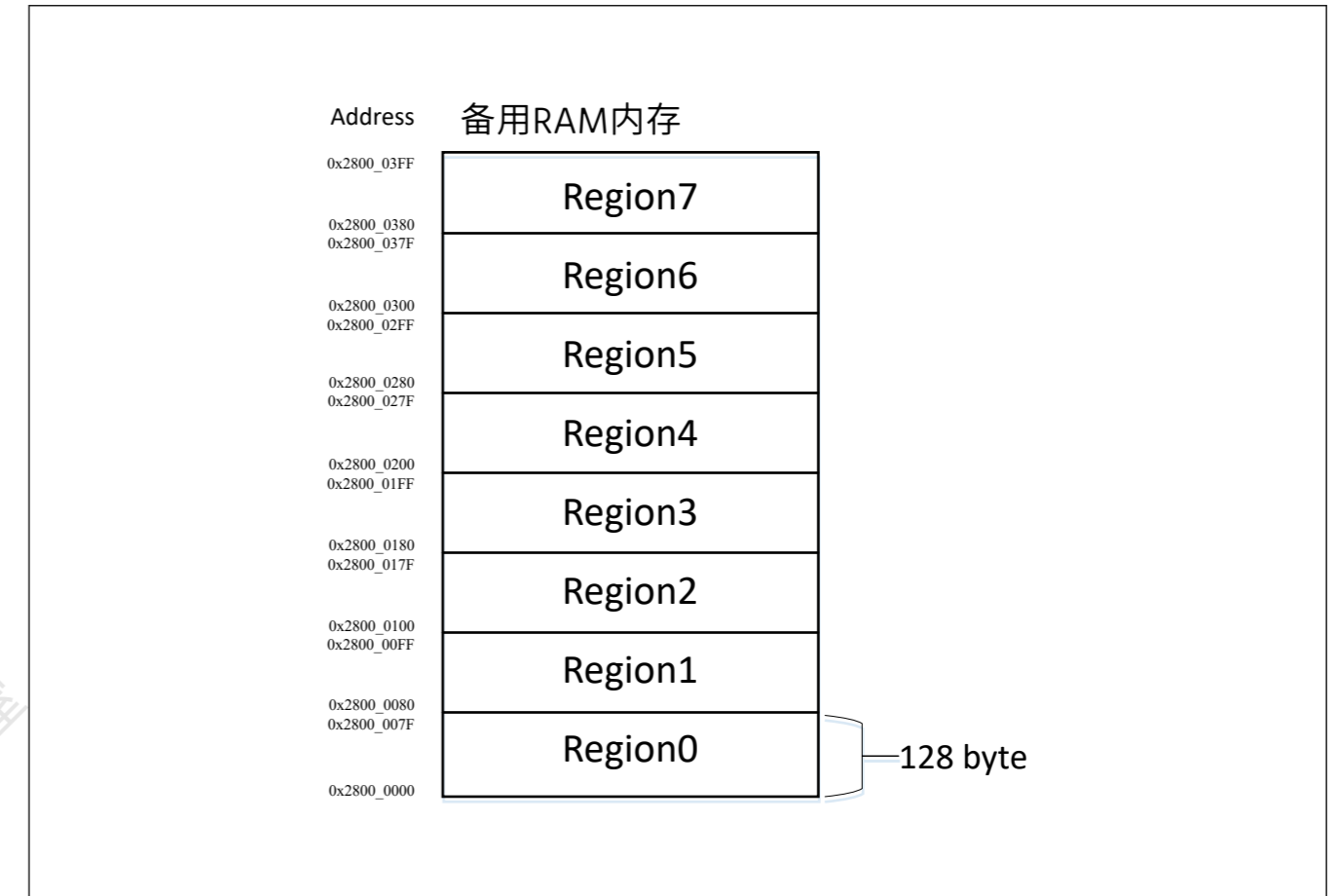


Figure 43.1 备用RAM区域

### 43.3 Operation

#### 43.3.1 数据保留

深度软件待机模式下的待机SRAM电源由DPSBYCR.DEEPCUT[1:0]位启用。如果DPSBYCR.DEEPCUT[1:0]位设置为00b，则待机SRAM中的数据将保留在深度软件待机模式中。有关DPSBYCR.DEEPCUT[1:0]位的详细信息，请参见第10节，低功耗模式。

#### 43.3.2 模块停止功能的设置

通过设置模块停止控制寄存器A(MSTPCRA)停止向SRAM提供时钟信号，可以降低功耗。

如果MSTPCRA中的StandbySRAM位设置为1，则停止向StandbySRAM提供时钟信号。

因此，通过停止提供时钟信号，备用SRAM进入模块停止状态。待机SRAM在复位后运行。

如果处于模块停止状态，则无法访问备用SRAM。在访问备用SRAM的过程中，不应转换到模块停止状态。

有关MSTPCRA寄存器的详细信息，请参见第10节，低功耗模式。

#### 43.3.3 奇偶校验计算功能

StandbySRAM的奇偶校验计算功能与无ECC的SRAM相同。

See section 42.3.5. Parity Calculation Function and section 42.3.7. Interrupt Source.

OAD bit in PARIOAD register is commonly used for SRAM0 (without ECC) / Standby SRAM.

### 43.3.4 TrustZone Filter function

There is only one type of TrustZone Filter function for Standby SRAM and that is, TrustZone Filter for SRAM memory protection

#### 43.3.4.1 TrustZone Filter for Standby SRAM Memory Protection

Standby SRAM memory can be divided into 8 regions, 128 bytes each with a Security Attribution (SA) to be protected from Non-secure access. When SA indicates that the region in Standby SRAM is secure status, non-secure access can not overwrite them because TrustZone Filter detects finds an error and protects the write access.

**Table 43.2 Security Attribution and Access status**

| SA         | Access status | Write access                       | Read access                             |
|------------|---------------|------------------------------------|---|
| Secure     | Secure        | Permit                             | Permit                                  |
|            | Non-secure    | TrustZone Filter error - Protected | TrustZone Filter error - Read data is 0 |
| Non-secure | Secure        | Permit                             | Permit                                  |
|            | Non-secure    | Permit                             | Permit                                  |

When TrustZone Filter error for Standby SRAM access occurs, no error notification and no error response occurs.

### 43.3.5 Access Cycle

Number of cycles from the CPU.

For Standby SRAM, cache always has non-cacheable access.

**Table 43.3 Standby SRAM (Parity Area 0x2800\_0000 to 0x2800\_03FF)**

|              | Read cycle   |                       | Write cycle                                      |                       |
|--------------|--|-----------------------|--|-----------------------|
|              | Word access  | Half-word/Byte access | Word access                                      | Half-word/Byte access |
| ICLK ≥ PCLKB | Min.: 2 ICLK + 2 PCLKB<br>Max.: (n + 1) ICLK + 2 PCLKB |                       | Min.: 1 ICLK + 1 PCLKB<br>Max.: n ICLK + 1 PCLKB |                       |

Note: When the frequency ratio of ICLK : PCLKB is n : 1

## 43.4 Usage Notes

### 43.4.1 Instruction Fetch from the Standby SRAM Area

When using Standby SRAM to operate a program, initialize the Standby SRAM area so that the CPU can correctly prefetch data. A parity error might occur if the CPU prefetches from an area that is not initialized. Initialize the additional 12-byte area from the end address of the program with the 4-byte boundary. Renesas recommends using the NOP instruction for data initialization.

请参见第42.3.5节。奇偶校验计算函数和第42.3.7节。中断源。

PARIOAD寄存器中的OAD位常用于SRAM0（无ECC）备用SRAM。

### 43.3.4 TrustZone过滤器功能

StandbySRAM只有一种TrustZoneFilter功能，即用于SRAM内存保护的TrustZoneFilter

#### 43.3.4.1 用于备用SRAM内存保护的TrustZone过滤器

备用SRAM存储器可分为8个区域，每个128字节具有安全属性(SA)非安全访问。当SA指示StandbySRAM中的区域为安全状态时，非安全访问无法覆盖它们，因为TrustZone Filter检测发现错误并保护写访问。

**Table 43.2 安全属性和访问状态**

| SA         | 访问状态       | 写访问               | 读取权限                 |
|------------|------------|-------------------|----------------------|
| Secure     | Secure     | Permit            | Permit               |
|            | Non-secure | TrustZone过滤器错误受保护 | TrustZone过滤器错误读取数据为0 |
| Non-secure | Secure     | Permit            | Permit               |
|            | Non-secure | Permit            | Permit               |

当StandbySRAM访问的TrustZoneFilter错误发生时，不会发生错误通知和错误响应。

### 43.3.5 访问周期

CPU的周期数。

对于备用SRAM，缓存始终具有不可缓存的访问权限。

**Table 43.3 备用SRAM（奇偶校验区0x2800\_0000至0x2800\_03FF）**

|              | 读周期  |                       | 写周期  |                       |
|--------------|--|-----------------------|--|-----------------------|
|              | 字访问  | Half-word/Byte access | 字访问  | Half-word/Byte access |
| ICLK ≥ PCLKB | Min.: 2 ICLK + 2 PCLKB<br>Max.: (n + 1) ICLK + 2 PCLKB |                       | Min.: 1 ICLK + 1 PCLKB<br>Max.: n ICLK + 1 PCLKB |                       |

Note: 当ICLK:PCLKB的频率比为n:1时

## 43.4 使用说明

### 43.4.1 从备用SRAM区域取指令

使用StandbySRAM操作程序时，初始化StandbySRAM区域，以便CPU可以正确预取数据。如果CPU从未初始化的区域预取，则可能发生奇偶校验错误。用4字节边界从程序的结束地址初始化额外的12字节区域。瑞萨推荐使用NOP指令进行数据初始化。



## 44. Flash Memory

This MCU incorporates code flash memory, data flash memory, and option-setting memory. The code flash memory stores instructions and operands, and the data flash memory stores data. For option-setting memory, see [section 6, Option-Setting Memory](#).

### 44.1 Overview

[Table 44.1](#) lists the specifications of the flash memory, and [Figure 44.1](#) is block diagrams of the flash memory related modules.

The I/O pins used in boot mode, see [Table 44.29](#).

The FCU (flash control unit) controls programming and erasure of the flash memory. The FACL (flash application command interface) controls the FCU according to the specified FACL commands.

Regarding the configuration of the code flash memory, see [Figure 44.2](#) to [section 44.2. Structure of Memory](#), and for the configuration of the data flash memory, see [Figure 44.3](#).

**Table 44.1 Specifications of flash memory (1 of 2)**

| Item                              | Code flash memory   | Data flash memory  |
|-----------------------------------|---|--|
| Memory capacity                   | User area: 1 Mbytes max   | Data area: 8 Kbytes  |
| Read cycle                        | See <a href="#">section 44.16.3. Access Cycle</a>   | See <a href="#">section 44.16.3. Access Cycle</a>  |
| Value after erasure               | 0xFF  | Undefined  |
| Programming/erasing method        | <ul style="list-style-type: none"> <li>Programming and erasing the code flash memory and data flash memory, and programming the option-setting memory are handled by the FACL commands specified in the FACL command issuing area (0x407E_0000) (self-programming).</li> <li>Programming/erasure through transfer by a serial-programmer via a serial interface (serial programming)</li> </ul>   |  |
| Protection                        | Protects against erroneous rewriting of the flash memory  |  |
| Block swap function               | The block swap structure makes a safe update for a part of non-secure application possible in case where programming is suspended.  | Not available  |
| Background operations (BGOs)      | <ul style="list-style-type: none"> <li>The data flash memory can be read while the code flash memory is being programmed or erased.</li> <li>The code flash memory can be read while the data flash memory is being programmed or erased.</li> </ul>  |  |
| Units of programming and erasure  | <ul style="list-style-type: none"> <li>Units of programming for the user area: 128 bytes</li> <li>Units of erasure for the user area: Block units</li> </ul>  | <ul style="list-style-type: none"> <li>Unit of programming for the data area: 4/8/16 bytes</li> <li>Unit of erasure for the data area: 64/128/256 bytes</li> </ul> |
| Other functions                   | Interrupts can be accepted during self-programming. In the initial settings of this MCU, an expansion area of the option-setting memory can be set.   |  |
| On-board programming (four types) | Programming/erasure in boot mode (for the SCI interface) <ul style="list-style-type: none"> <li>The asynchronous serial interface (SCI9) is used.</li> <li>The transfer rate is adjusted automatically.</li> </ul> Programming/erasure in boot mode (for the USB interface) <ul style="list-style-type: none"> <li>USBFS is used.</li> <li>Dedicated hardware is not required, so direct connection to a PC is possible.</li> </ul> Programming/erasure in On-chip debug mode <ul style="list-style-type: none"> <li>JTAG or SWD interface is used</li> </ul> Programming and erasure by self-programming <ul style="list-style-type: none"> <li>This allows code flash memory programming/erasure without resetting the system.</li> </ul> |  |
| Unique ID                         | A 16-byte ID code provided for each MCU   |  |

## 44. 闪存

该MCU包含代码闪存、数据闪存和选项设置存储器。代码闪存存储指令和操作数，数据闪存存储数据。有关选项设置内存，请参阅第6节，选项设置内存。

### 44.1 Overview

表44.1列出了闪存的规格，图44.1是闪存相关模块的框图。

引导模式下使用的IO引脚，请参见表44.29。

FCU（闪存控制单元）控制闪存的编程和擦除。FACL（闪存应用命令接口）根据指定的FACL命令控制FCU。

关于代码闪存的配置，请参见图44.2至44.2节。内存结构，以及数据闪存的配置，见图44.3。

**Table 44.1 闪存规格(1 of 2)**

| Item                              | 代码闪存   | 数据闪存   |
|-----------------------------------|--|--|
| 内存容量                              | 用户区：最大1MB  | Data area: 8 Kbytes  |
| 读周期                               | 请参见第44.16.3节。访问周期  | 请参见第44.16.3节。访问周期  |
| 擦除后的值                             | 0xFF   | Undefined  |
| Programming/erasing method        | <ul style="list-style-type: none"> <li>编程和擦除代码闪存和数据闪存以及编程选项设置存储器由FACL命令发出区域(0x407E_0000)中指定的FACL命令处理（自编程）。</li> <li>通过串行编程器通过串行接口传输的编程擦除（串行编程）</li> </ul>  |  |
| Protection                        | 防止闪存的错误重写  |  |
| 区块交换功能                            | 区块交换结构可以在编程暂停的情况下对部分非安全应用程序进行安全更新。   | 无法使用   |
| 后台操作(BGO)                         | <ul style="list-style-type: none"> <li>在对代码闪存进行编程或擦除时，可以读取数据闪存。</li> <li>在对数据闪存进行编程或擦除时，可以读取代码闪存。</li> </ul>   |  |
| 编程和擦除单元                           | <ul style="list-style-type: none"> <li>用户区编程单位：128字节</li> <li>用户区擦除单位：块单位</li> </ul>   | <ul style="list-style-type: none"> <li>数据区编程单位：4816字节</li> <li>数据区擦除单位：64128256字节</li> </ul> |
| 其他功能                              | 自编程期间可以接受中断。在此MCU的初始设置中，可以设置选项设置存储器的扩展区域。  |  |
| On-board programming (four types) | 引导模式下的编程擦除（用于SCI接口）● <ul style="list-style-type: none"> <li>使用异步串行接口(SCI9)。</li> <li>传输速率会自动调整。</li> </ul> 引导模式下的编程擦除（针对USB接口）● <ul style="list-style-type: none"> <li>使用USBFS。</li> <li>不需要专用硬件，因此可以直接连接到PC。</li> </ul> 片上调试模式下的编程擦除● <ul style="list-style-type: none"> <li>使用JTAG或SWD接口</li> </ul> 通过自编程进行编程和擦除● <ul style="list-style-type: none"> <li>这允许在不重置系统的情况下擦除代码闪存编程。</li> </ul> |  |
| 唯一身份                              | 为每个MCU提供一个16字节的ID代码  |  |

Table 44.1 Specifications of flash memory (2 of 2)

| Item               | Code flash memory  | Data flash memory   |
|--------------------|--|---|
| FACI command       | Program : 128 bytes<br>Block erase: 1 block (8 KB or 32 KB)<br>P/E suspend<br>P/E resume<br>Forced Stop<br>Status Clear<br>Configuration set (16 bytes)  | Program: 4/8/16 bytes<br>Block Erase: 1 block (64 bytes)<br>Multi Block Erase: 64/128/256 bytes<br>P/E suspend<br>P/E resume<br>Forced Stop<br>Blank Check: 4 bytes to data flash memory capacity<br>Status Clear |
| Security function  | Protects against illicit tampering with or reading out of data in flash memory<br>Startup area select setting protection <ul style="list-style-type: none"> <li>• BTFGL and FSUACR registers are protected by the FSPR bit.</li> </ul> Permanent block protect setting protection <ul style="list-style-type: none"> <li>• Code flash memory is permanently protected from programming/erasure operation by the permanent block protect function.</li> </ul> Flash memory protection for TrustZone <ul style="list-style-type: none"> <li>• Protection for flash memory area (P/E)</li> <li>• Protection for flash memory area (read)</li> <li>• Protection for register</li> <li>• Protection during FACI command operation.</li> <li>• Code flash P/E mode entry protection</li> </ul> |   |
| Safety function    | Software protection <ul style="list-style-type: none"> <li>• FACI command protection by FENTRYR register.</li> <li>• Flash memory is protected by FWEPROR register</li> <li>• The user area is protected by the block protect setting</li> </ul> Error protection <ul style="list-style-type: none"> <li>• Error is detected when unintended commands or prohibited settings occur. The FACI command is not accepted after an error detection.</li> </ul> Boot area protection <ul style="list-style-type: none"> <li>• The start-up area select function allows customer to safely update the boot firmware. The size of the start-up area is 8 KB.</li> </ul>  |   |
| Interrupt request  | <ul style="list-style-type: none"> <li>• FRDYI (flash sequencer ready (processing end)) : Enabled by FRDYIE bit.</li> <li>• FIFERR (flash sequencer error) : Enabled by CFAEIE/CMDLKIE/DFAEIE bits</li> </ul>  |   |
| Address conversion | <ul style="list-style-type: none"> <li>• Start-up area select function is supported</li> <li>• Block swap function is supported</li> </ul>   |   |

Note 1. Limitations apply to the combinations of the address ranges for programming/erasure process and reading process: see Table 44.31.

Figure 44.1 shows how modules related to flash memory can be configured. The flash sequencer is configured with the FCU and FACI. The FCU executes basic control for rewriting of the flash memory. The FACI receives FACI commands using peripheral bus, and controls FCU operations accordingly.

In response to a reset, the FACI transfers data from the flash memory to the option byte storage registers.

Table 44.1 闪存规格(2of2)

| Item   | 代码闪存  | 数据闪存   |
|--------|---|--|
| FACI命令 | 程序: 128字节<br>块擦除: 1个块 (8KB或32KB)<br>PE暂停PE恢复强制停止<br>状态清除<br><br>配置集 (16字节)  | Program: 4/8/16 bytes<br>Block Erase: 1 block (64 bytes)<br>多块擦除: 64/128/256字节<br>PE暂停PE恢复强制停止<br><br>空白检查: 4字节到数据闪存容量状态清除 |
| 安全功能   | 防止非法篡改或读取闪存中的数据<br>启动区选择设置保护●<br>BTFGL和FSUACR寄存器受FSPR位保护。<br>永久块保护设置保护●<br>永久块保护功能永久保护代码闪存免受编程擦除操作的影响。TrustZone的闪存保护●<br><br>闪存区保护(PE) <ul style="list-style-type: none"> <li>• 保护闪存区域 (读取)</li> <li>• 注册保护</li> <li>• FACI命令操作期间的保护。</li> <li>• CodeflashPE模式进入保护</li> </ul> |  |
| 安全功能   | 软件保护●<br>FACI命令由FENTRYR寄存器保护。 <ul style="list-style-type: none"> <li>• 闪存受FWEPROR寄存器保护</li> <li>• 用户区受块保护 设置保护</li> </ul> 错误保护●<br>发生意外命令或禁止设置时会检测到错误。错误检测后不接受FACI命令。引导区保护●<br><br>启动区域选择功能允许客户安全地更新启动固件。启动区的大小为8KB。  |  |
| 中断请求   | <ul style="list-style-type: none"> <li>• FRDYI (闪存序列器就绪 (处理结束)) : 由FRDYIE位启用。</li> <li>• FIFERR (flash sequencer error) : 由CFAEIE/CMDLKIE/DFAEIE位启用</li> </ul>  |  |
| 地址转换   | <ul style="list-style-type: none"> <li>• 支持启动区域选择功能</li> <li>• 支持区块交换功能</li> </ul>  |  |

注1.限制适用于编程擦除过程和读取过程的地址范围组合: 见表44.31。

图44.1显示了如何配置与闪存相关的模块。闪存定序器配置有FCU和FACI。FCU执行闪存重写的基本控制。FACI使用外围总线接收FACI命令, 并相应地控制FCU操作。

响应复位, FACI将数据从闪存传输到选项字节存储寄存器。

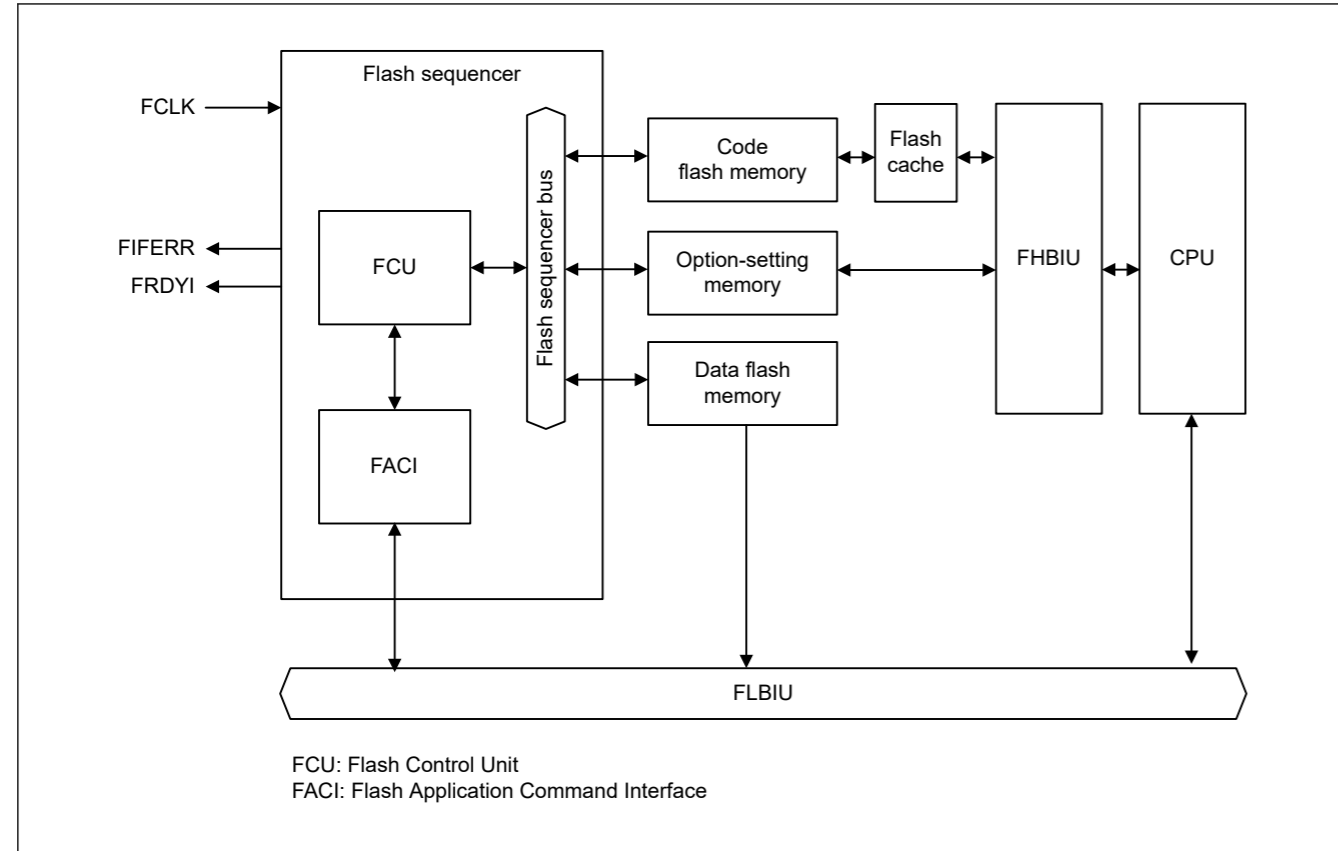


Figure 44.1 Block diagram of flash memory-related modules

#### 44.2 Structure of Memory

Figure 44.2 shows the memory map of code flash memory.

The user area of the code flash memory in this MCU is divided into 8- and 32-Kbyte blocks, which serve as the units of erasure.

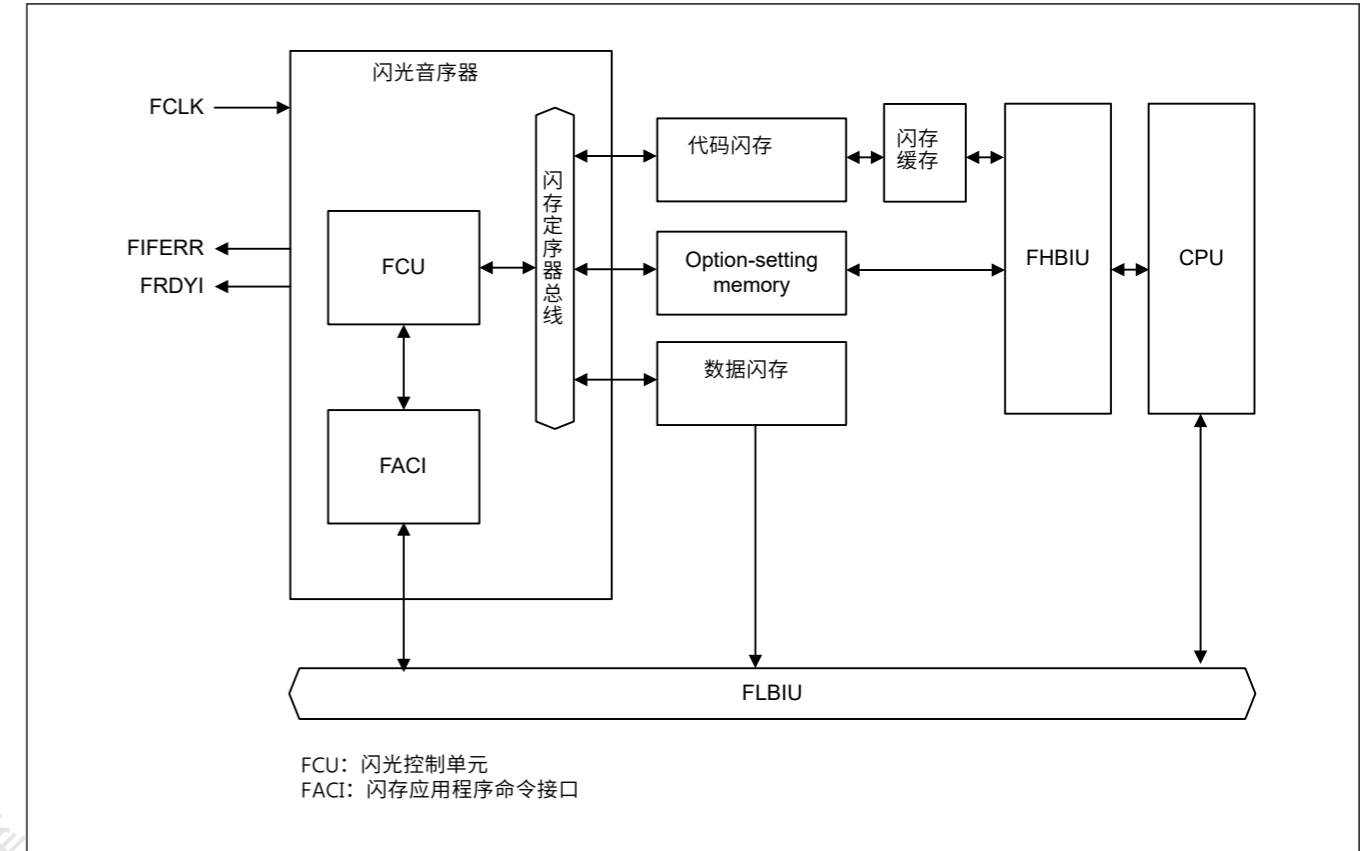


Figure 44.1 闪存相关模块框图

#### 44.2 内存结构

图44.2显示了代码闪存的内存映射。

本MCU中代码闪存的用户区分为8和32KB块，作为擦除单位。

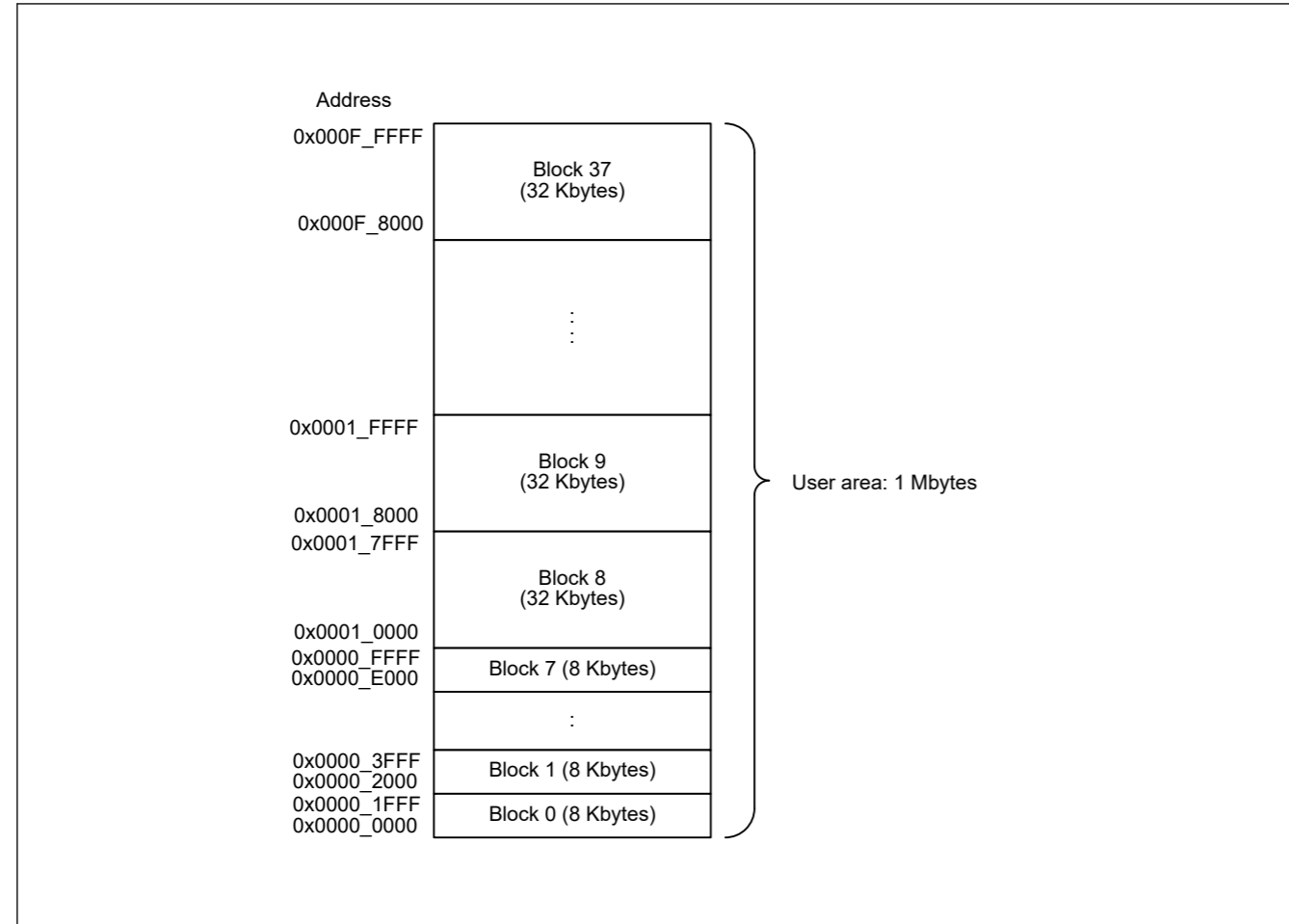


Figure 44.2 Map of the Code Flash Memory

Table 44.2 Read and programming/erasure address by product for the code flash memory

| Product            | Address                    | Number of blocks |
|--------------------|----------------------------|------------------|
| 1 Mbytes product   | 0x0000_0000 to 0x000F_FFFF | 0 to 37          |
| 768 Kbytes product | 0x0000_0000 to 0x000B_FFFF | 0 to 29          |
| 512 Kbytes product | 0x0000_0000 to 0x0007_FFFF | 0 to 21          |

The data area of the data flash memory in this MCU is divided into 64-byte blocks, with each being a unit for erasure. Figure 44.3 shows the mapping of the data flash memory.

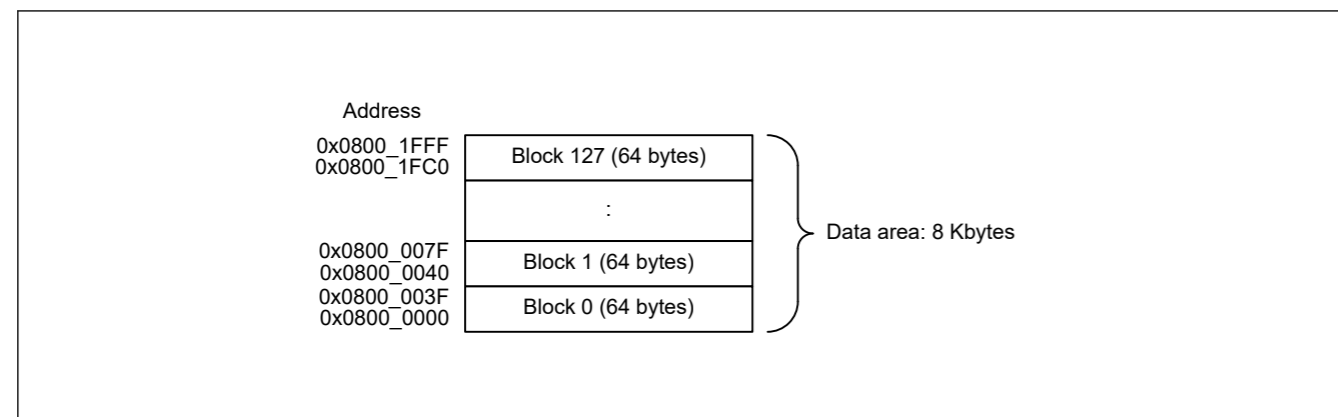


Figure 44.3 Map of the Data Flash Memory

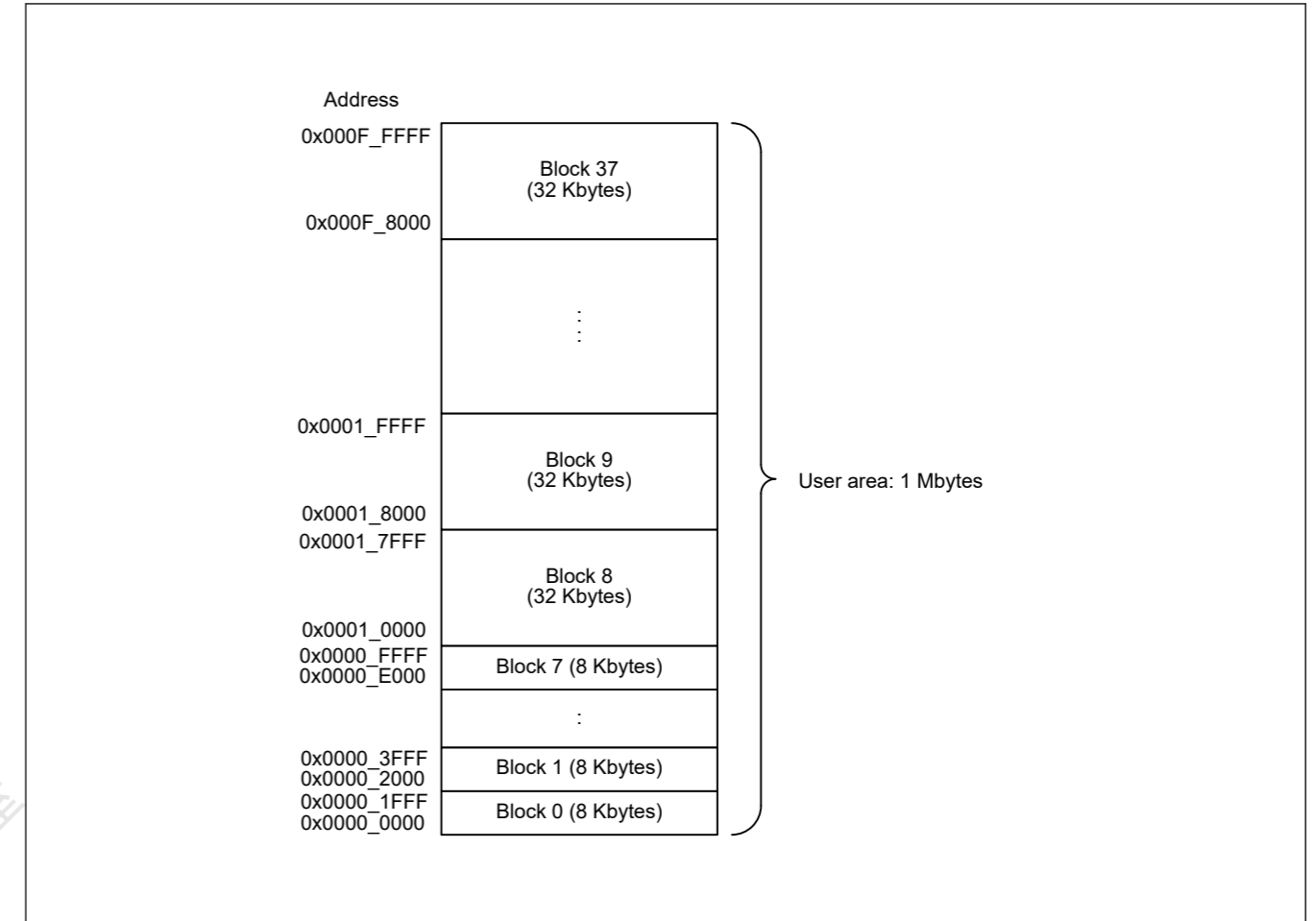


Figure 44.2 代码闪存映射

Table 44.2 按产品读取和编程代码闪存的擦除地址

| Product            | Address                    | 块数      |
|--------------------|----------------------------|---------|
| 1 Mbytes product   | 0x0000_0000 to 0x000F_FFFF | 0 to 37 |
| 768 Kbytes product | 0x0000_0000 to 0x000B_FFFF | 0 to 29 |
| 512 Kbytes product | 0x0000_0000 to 0x0007_FFFF | 0 to 21 |

本单片机中数据闪存的数据区被划分为64字节块，每个块为一个擦除单元。图44.3显示了数据闪存的映射。

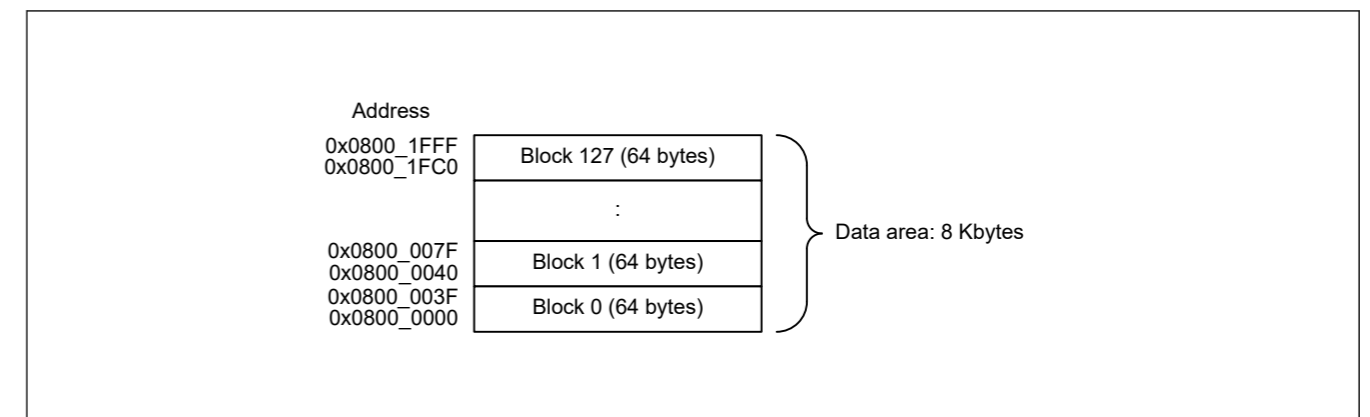


Figure 44.3 数据闪存映射



### 44.3 Address Space

Using the hardware interface with flash memory requires access to all registers of the hardware, which is for issuing FACL commands. Table 44.3 provides information about the hardware interface.

**Table 44.3 Information on the hardware interface area**

| Area  | Address                                  | Capacity                                 |
|---|--|--|
| Area containing various registers of the hardware | See section 44.4. Register Descriptions. | See section 44.4. Register Descriptions. |
| FACL command-issuing area                         | 0x407E_0000                              | 4 bytes                                  |

For the address information of the flash memory, see Figure 44.2.

### 44.4 Register Descriptions

#### 44.4.1 FCACHEE : Flash Cache Enable Register

Base address: FCACHE = 0x4001\_C100

Offset address: 0x000

| Bit position:      | 15 | 14 | 13 | 12 | 11 | 10 | 9 | 8 | 7 | 6 | 5 | 4 | 3 | 2 | 1 | 0        |
|--------------------|----|----|----|----|----|----|---|---|---|---|---|---|---|---|---|----------|
| Bit field:         | —  | —  | —  | —  | —  | —  | — | — | — | — | — | — | — | — | — | FCACHEEN |
| Value after reset: | 0  | 0  | 0  | 0  | 0  | 0  | 0 | 0 | 0 | 0 | 0 | 0 | 0 | 0 | 0 | 0        |

| Bit  | Symbol   | Function  | R/W |
|------|----------|---|-----|
| 0    | FCACHEEN | Flash Cache Enable<br>0: FCACHE is disabled<br>1: FCACHE is enabled | R/W |
| 15:1 | —        | These bits are read as 0. The write value should be 0.              | R/W |

This register is not controlled by any security attribute register.

#### FCACHEEN bit (Flash Cache Enable)

FCACHEE.FCACHEEN bit enable and disables the function of Flash Cache of FCACHE1, FCACHE2 and FLPF.

FCACHEE.FCACHEEN bit dose not influence for FCACHEIV.FCACHEIV.

When FCACHE is enabled, it works for accesses marked as cacheable.

It is prohibited to disable FCACHE after enabling.

#### 44.4.2 FCACHEIV : Flash Cache Invalidate Register

Base address: FCACHE = 0x4001\_C100

Offset address: 0x004

| Bit position:      | 15 | 14 | 13 | 12 | 11 | 10 | 9 | 8 | 7 | 6 | 5 | 4 | 3 | 2 | 1 | 0        |
|--------------------|----|----|----|----|----|----|---|---|---|---|---|---|---|---|---|----------|
| Bit field:         | —  | —  | —  | —  | —  | —  | — | — | — | — | — | — | — | — | — | FCACHEIV |
| Value after reset: | 0  | 0  | 0  | 0  | 0  | 0  | 0 | 0 | 0 | 0 | 0 | 0 | 0 | 0 | 0 | 0        |

### 44.3 地址空间

使用带有闪存的硬件接口需要访问硬件的所有寄存器，用于发出FACL命令。表44.3提供了有关硬件接口的信息。

**Table 44.3 硬件接口区信息**

| Area         | Address         | Capacity        |
|--------------|-----------------|-----------------|
| 包含各种硬件寄存器的区域 | 请参见第44.4节。注册说明。 | 请参见第44.4节。注册说明。 |
| FACL指挥区      | 0x407E_0000     | 4 bytes         |

Flash存储器的地址信息见图44.2。

### 44.4 注册说明

#### 44.4.1 FCACHEE:闪存缓存启用寄存器

Base address: FCACHE = 0x4001\_C100

Offset address: 0x000

| Bit position: | 15 | 14 | 13 | 12 | 11 | 10 | 9 | 8 | 7 | 6 | 5 | 4 | 3 | 2 | 1 | 0        |
|---------------|----|----|----|----|----|----|---|---|---|---|---|---|---|---|---|----------|
| Bit field:    | —  | —  | —  | —  | —  | —  | — | — | — | — | — | — | — | — | — | FCACHEEN |
| 重置后的值:        | 0  | 0  | 0  | 0  | 0  | 0  | 0 | 0 | 0 | 0 | 0 | 0 | 0 | 0 | 0 | 0        |

| Bit  | Symbol   | Function                         | R/W |
|------|----------|----------------------------------|-----|
| 0    | FCACHEEN | 闪存缓存启用<br>0: 禁用FCACHE1: 启用FCACHE | R/W |
| 15:1 | —        | 这些位被读取为0。写入值应为0。                 | R/W |

该寄存器不受任何安全属性寄存器的控制。

#### FCACHEEN位（闪存使能）

FCACHEE.FCACHEEN位启用和禁用FCACHE1、FCACHE2和FLPF的FlashCache功能。

FCACHEE.FCACHEEN位对FCACHEIV.FCACHEIV没有影响。

启用FCACHE后，它适用于标记为可缓存的访问。

禁止启用后禁用FCACHE。

#### 44.4.2 FCACHEIV:闪存缓存无效寄存器

Base address: FCACHE = 0x4001\_C100

Offset address: 0x004

| Bit position: | 15 | 14 | 13 | 12 | 11 | 10 | 9 | 8 | 7 | 6 | 5 | 4 | 3 | 2 | 1 | 0        |
|---------------|----|----|----|----|----|----|---|---|---|---|---|---|---|---|---|----------|
| Bit field:    | —  | —  | —  | —  | —  | —  | — | — | — | — | — | — | — | — | — | FCACHEIV |
| 重置后的值:        | 0  | 0  | 0  | 0  | 0  | 0  | 0 | 0 | 0 | 0 | 0 | 0 | 0 | 0 | 0 | 0        |

| Bit  | Symbol   | Function   | R/W |
|------|----------|--|-----|
| 0    | FCACHEIV | Flash Cache Invalidate<br>0: Read: Do not invalidate.<br>Write: The setting is ignored.<br>1: Invalidate<br>FCACHE is invalidated. | R/W |
| 15:1 | —        | These bits are read as 0. The write value should be 0.   | R/W |

This register is not controlled by any security attribute register.

**FCACHEIV bit (Flash Cache Invalidate)**

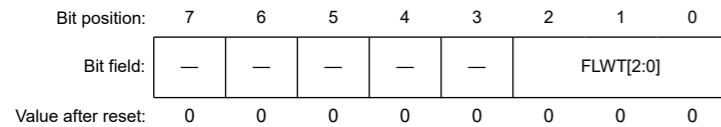
When 1 is written to FCACHEIV.FCACHEIV bit, the Flash cache data of FCACHE1, FCACHE2 and FLPF is invalidated.

Invalidate FCACHE with keeping FCACHE enabled after programming or erasing the code flash or the option setting memory.

**44.4.3 FLWT : Flash Wait Cycle Register**

Base address: FCACHE = 0x4001\_C100

Offset address: 0x01C



| Bit | Symbol    | Function   | R/W |
|-----|-----------|--|-----|
| 2:0 | FLWT[2:0] | Flash Wait Cycle<br>0 0 0: 0 wait (ICLK ≤ 50 MHz)<br>0 0 1: 1 wait (ICLK > 50 MHz)<br>0 1 0: 2 wait Not specified<br>0 1 1: 3 wait Not specified<br>Others: Setting prohibited | R/W |
| 7:3 | —         | These bits are read as 0. The write value should be 0.   | R/W |

Note: If the security attribution is configured as secure:  
 • Secure access and Non-secure read access are allowed  
 • Non-secure write access is ignored, and TrustZone access error is not generated.  
 If the security attribution is configured as Non-secure:  
 • Secure and Non-secure access are allowed.

**FLWT[2:0] bits (Flash Wait Cycle)**

The Flash Wait Cycle Register (FLWT) sets the access wait count for the flash memory.

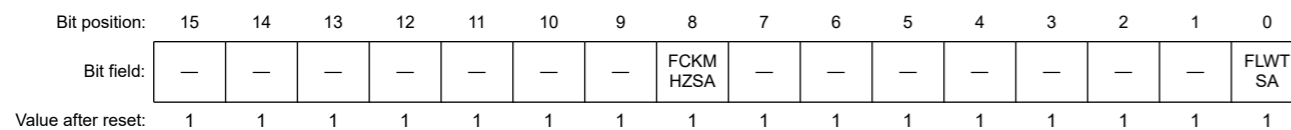
For faster clock frequencies, set FLWT.FLWT before changing the clock frequency. For slower clock frequencies, set FLWT.FLWT after changing the clock frequency.

For information on the frequency setting, see [section 8, Clock Generation Circuit](#).

**44.4.4 FSAR : Flash Security Attribution Register**

Base address: FCACHE = 0x4001\_C100

Offset address: 0x040



| Bit  | Symbol   | Function  | R/W |
|------|----------|---|-----|
| 0    | FCACHEIV | 闪存缓存失效<br>0: 读取: 不无效。<br>写入: 忽略该设置。<br>1: Invalidate<br>FCACHE无效。 | R/W |
| 15:1 | —        | 这些位被读取为0。写入值应为0。  | R/W |

该寄存器不受任何安全属性寄存器的控制。

**FCACHEIV位 (FlashCache无效)**

当FCACHEIV.FCACHEIV位写入1时, FCACHE1、FCACHE2和FLPF的Flash缓存数据无效。

在编程或擦除代码闪存或选项设置存储器后保持FCACHE使能, 使FCACHE无效。

**44.4.3 FLWT: 闪存等待周期寄存器**

Base address: FCACHE = 0x4001\_C100

Offset address: 0x01C



| Bit | Symbol    | Function   | R/W |
|-----|-----------|--|-----|
| 2:0 | FLWT[2:0] | 闪存等待周期<br>0 0 0: 0 wait (ICLK ≤ 50 MHz)<br>0 0 1: 1 wait (ICLK > 50 MHz)<br>010:2等待未指定<br>011:3等待未指定<br>其他: 禁止设置 | R/W |
| 7:3 | —         | 这些位被读取为0。写入值应为0。   | R/W |

Note: 如果安全属性配置为安全: ●  
 允许安全访问和非安全读取访问  
 • 忽略非安全写入访问, 不会生成TrustZone访问错误。  
 如果安全属性配置为非安全: ●  
 允许安全和非安全访问。

**FLWT[2:0]位 (闪存等待周期)**

闪存等待周期寄存器(FLWT)设置闪存的访问等待计数。

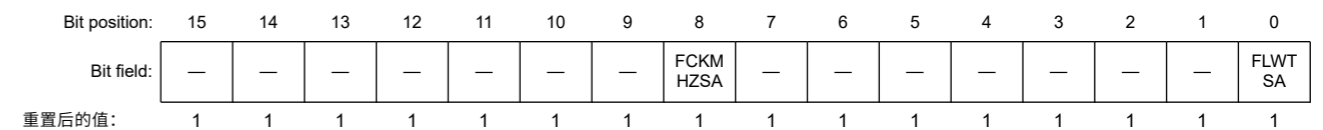
要获得更快的时钟频率, 请在更改时钟频率之前设置FLWT.FLWT。对于较慢的时钟频率, 设置改变时钟频率后的FLWT.FLWT。

有关频率设置的信息, 请参见第8节, 时钟生成电路。

**44.4.4 FSAR:Flash安全属性寄存器**

Base address: FCACHE = 0x4001\_C100

Offset address: 0x040



| Bit  | Symbol   | Function  | R/W |
|------|----------|---|-----|
| 0    | FLWTSA   | FLWT Security Attribution<br>Target register : FLWT<br>0: Secure<br>1: Non-Secure     | R/W |
| 7:1  | —        | These bits are read as 1. The write value should be 1.                                | R/W |
| 8    | FCKMHZSA | FCKMHZ Security Attribution<br>Target register : FCKMHZ<br>0: Secure<br>1: Non-Secure | R/W |
| 15:9 | —        | These bits are read as 1. The write value should be 1.                                | R/W |

Note: Only secure access can write to this register. Both secure access and Non-secure read access are allowed but Non-secure write access is not allowed and TrustZone access error is not generated.

Note: This register is write-protected by PRCR register.

Write access is invalid when PRCR.PRC4 bit is 0. See [section 12, Register Write Protection](#).

#### FLWTSA bit (FLWT Security Attribution)

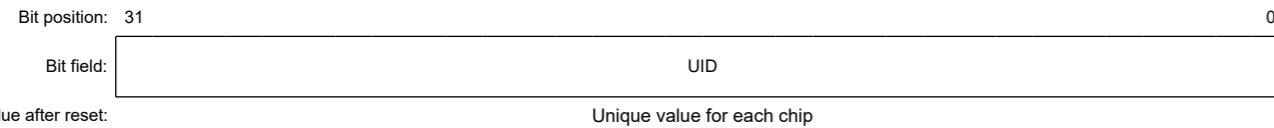
This bit sets the security attribute of FLWT.

#### FCKMHZSA bit (FCKMHZ Security Attribution)

This bit sets the security attribute of FCKMHZ.

#### 44.4.5 UIDRn : Unique ID Registers n (n = 0 to 3)

Address: 0x0100\_8190 + n × 4

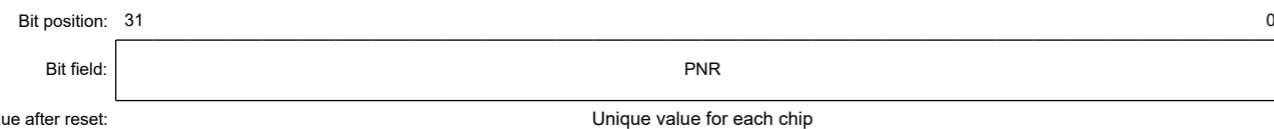


| Bit  | Symbol | Function  | R/W |
|------|--------|-----------|-----|
| 31:0 | UID    | Unique ID | R   |

The UIDRn is a read-only register that stores a 16-byte ID code (unique ID) for identifying the individual MCU. The UIDRn register should be read in 32-bit units. When reading by the signature request command of the serial programming interface, the data is read in order from the data with the large address. That is, the data in 0x0100\_819F is read first, and in 0x0100\_8190 is read last.

#### 44.4.6 PNRn : Part Numbering Register n (n = 0 to 3)

Address: 0x0100\_80F0 + n × 4



| Bit  | Symbol | Function    | R/W |
|------|--------|-------------|-----|
| 31:0 | PNR    | Part Number | R   |

The PNRn is a read-only register that stores a 16-byte part numbering. The PNRn register should be read in 32-bit units. Each byte corresponds to the ASCII code representation of the product part number as detailed in Table 1.13 Product list. The first character ("R", 0x52 in ASCII code) of the part number is stored in the byte with the smallest address

| Bit  | Symbol   | Function   | R/W |
|------|----------|--|-----|
| 0    | FLWTSA   | FLWT安全归因<br>目标寄存器: FLWT<br>0: Secure<br>1: Non-Secure      | R/W |
| 7:1  | —        | 这些位被读取为1。写入值应为1。   | R/W |
| 8    | FCKMHZSA | FCKMHZ安全归属地<br>目标寄存器: FCKMHZ<br>0: Secure<br>1: Non-Secure | R/W |
| 15:9 | —        | 这些位被读取为1。写入值应为1。   | R/W |

Note: 只有安全访问才能写入该寄存器。允许安全访问和非安全读取访问，但不允许非安全写入访问，并且不会生成TrustZone访问错误。

Note: 该寄存器由PRCR寄存器写保护。

当PRCR.PRC4位为0时，写访问无效。参见第12节，寄存器写保护。

#### FLWTSA位 (FLWT安全属性)

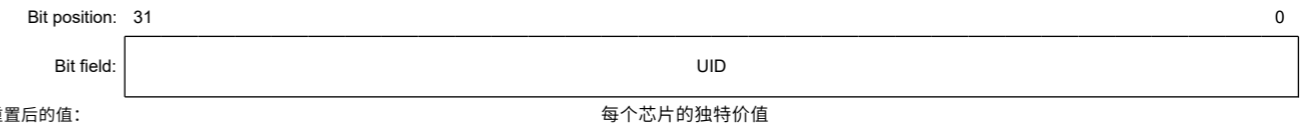
该位设置FLWT的安全属性。

#### FCKMHZSA位 (FCKMHZ安全属性)

该位设置FCKMHZ的安全属性。

#### 44.4.5 UIDRn: 唯一ID寄存器n (n=0到3)

Address: 0x0100\_8190 + n × 4

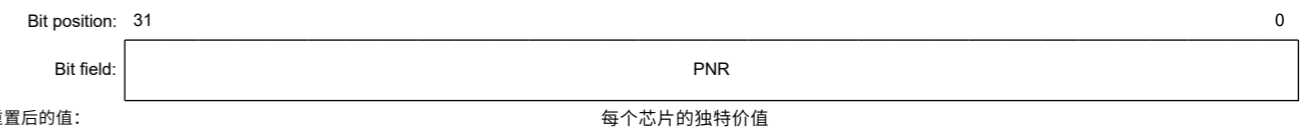


| Bit  | Symbol | Function | R/W |
|------|--------|----------|-----|
| 31:0 | UID    | 唯一身份     | R   |

UIDRn是一个只读寄存器，它存储一个16字节的ID代码（唯一ID），用于识别单个MCU。这UIDRn寄存器应以32位为单位读取。通过串口编程接口的签名请求命令读取时，从地址大的数据开始依次读取。即先读取0x0100\_819F中的数据，最后读取0x0100\_8190中的数据。

#### 44.4.6 PNRn: 零件编号寄存器n (n=0到3)

Address: 0x0100\_80F0 + n × 4

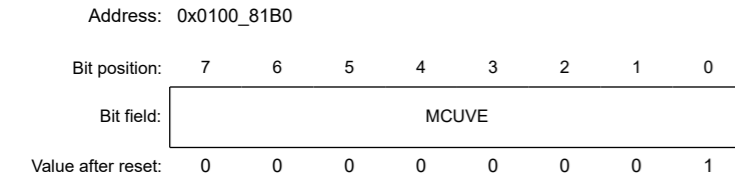


| Bit  | Symbol | Function | R/W |
|------|--------|----------|-----|
| 31:0 | PNR    | 零件号      | R   |

PNRn是一个只读寄存器，存储一个16字节的零件编号。PNRn寄存器应以32位为单位读取。每个字节对应于表1.13产品列表中详细的产品部件号的ASCII代码表示。零件编号的第一个字符（“R”，ASCII码中的0x52）存储在地址最小的字节中

(0x0100\_80F0). When reading by the signature request command of the serial programming interface, the data is read in order from the data with the small address. That is, the data in 0x0100\_80F0 is read first, and in 0x0100\_80FF is read last.

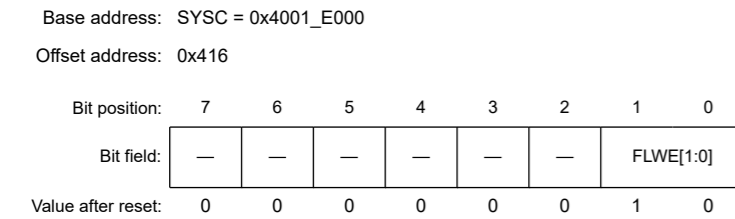
#### 44.4.7 MCOVER : MCU Version Register



| Bit | Symbol | Function    | R/W |
|-----|--------|-------------|-----|
| 7:0 | MCUVE  | MCU Version | R   |

The MCOVER is a read-only register that stores a MCU version. The MCOVER register should be read in 8-bit units.

#### 44.4.8 FWEPROR : Flash P/E Protect Register



| Bit | Symbol    | Function  | R/W |
|-----|-----------|---|-----|
| 1:0 | FLWE[1:0] | Flash Programming and Erasure<br>00: Prohibits Program, Block Erase, Multi Block Erase, Blank Check, and Configuration set command processing.<br>01: Permits Program, Block Erase, Multi Block Erase, Blank Check, and Configuration set command processing.<br>10: Prohibits Program, Block Erase, Multi Block Erase, Blank Check, and Configuration set command processing.<br>11: Prohibits Program, Block Erase, Multi Block Erase, Blank Check, and Configuration set command processing. | R/W |
| 7:2 | —         | These bits are read as 0. The write value should be 0.  | R/W |

It is possible that Program, Block Erase, Multi Block Erase, Blank Check, and Configuration set command processing are prohibited by software.

The FWEPROR register is initialized by a reset from the following:

- All reset source
- Transition to Deep Software Standby mode
- Transition to Software Standby mode.

##### FLWE[1:0] bits (Flash Programming and Erasure)

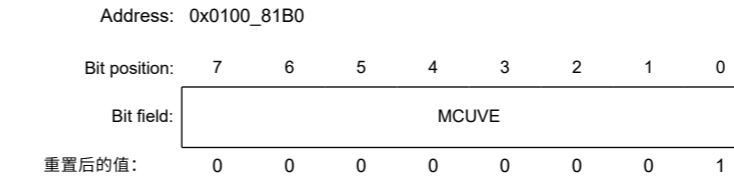
The FLWE[1:0] bits are used to set the flash P/E protection. The value after reset is 10b.

If these bits are set to other than 01b that does not allow programming and erasure of the flash memory, the following commands cannot be executed. Issuing any of the following commands leads to setting of the FLWEERR bit in the FSTATR register to 1.

Program / Block Erase / Multi Block Erase / Blank Check / Configuration set command

(0x0100\_80F0)。通过串行编程接口的签名请求命令读取时，从地址小的数据开始依次读取。即先读取0x0100\_80F0中的数据，最后读取0x0100\_80FF中的数据。

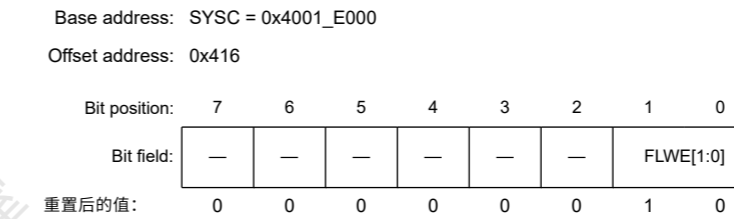
#### 44.4.7 MCOVER:MCU版本寄存器



| Bit | Symbol | Function    | R/W |
|-----|--------|-------------|-----|
| 7:0 | MCUVE  | MCU Version | R   |

MCOVER是一个只读寄存器，用于存储MCU版本。MCOVER寄存器应以8位为单位读取。

#### 44.4.8 FWEPROR:FlashPE保护寄存器



| Bit | Symbol    | Function   | R/W |
|-----|-----------|--|-----|
| 1:0 | FLWE[1:0] | 闪存编程和擦除<br>00: 禁止编程、块擦除、多块擦除、空白检查和配置设置命令处理。<br>01: 允许编程、块擦除、多块擦除、空白检查和配置设置命令处理。<br>10: 禁止编程、块擦除、多块擦除、空白检查和配置设置命令处理。<br>11: 禁止Program、BlockErase、MultiBlockErase、BlankCheck和Configurationset命令处理。 | R/W |
| 7:2 | —         | 这些位被读取为0。写入值应为0。   | R/W |

程序、块擦除、多块擦除、空白检查和配置设置命令处理可能被软件禁止。

FWEPROR寄存器通过以下复位进行初始化:

- 所有复位源
- 转换到深度软件待机模式
- 转换到软件待机模式。

##### FLWE[1:0]位 (闪存编程和擦除)

FLWE[1:0]位用于设置flashPE保护。复位后的值为10b。

如果这些位设置为不允许对闪存进行编程和擦除的01b以外，则无法执行以下命令。发出以下任何命令都会将FSTATR寄存器中的FLWEERR位设置为1。

ProgramBlockEraseMultiBlockEraseBlankCheckConfigurationset命令



## 44.4.9 FASTAT : Flash Access Status Register

Base address: FACL = 0x407F\_E000

Offset address: 0x10

|                    |      |   |   |       |      |   |   |   |
|--------------------|------|---|---|-------|------|---|---|---|
| Bit position:      | 7    | 6 | 5 | 4     | 3    | 2 | 1 | 0 |
| Bit field:         | CFAE | — | — | CMDLK | DFAE | — | — | — |
| Value after reset: | 0    | 0 | 0 | 0     | 0    | 0 | 0 | 0 |

| Bit | Symbol | Function  | R/W              |
|-----|--------|---|------------------|
| 2:0 | —      | These bits are read as 0. The write value should be 0.  | R/W              |
| 3   | DFAE   | Data Flash Memory Access Violation Flag<br>0: No data flash memory access violation has occurred<br>1: A data flash memory access violation has occurred. | R/W <sup>1</sup> |
| 4   | CMDLK  | Command Lock Flag<br>0: The flash sequencer is not in the command-locked state<br>1: The flash sequencer is in the command-locked state.                  | R                |
| 6:5 | —      | These bits are read as 0. The write value should be 0.  | R/W              |
| 7   | CFAE   | Code Flash Memory Access Violation Flag<br>0: No code flash memory access violation has occurred<br>1: A code flash memory access violation has occurred. | R/W <sup>1</sup> |

Note 1. Only 0 can be written to clear the flag after 1 is read.

The FASTAT register indicates whether a code flash or data flash memory access violation has occurred. If any of the CFAE, CMDLK, and DFAE bits is set to 1, the flash sequencer enters the command-locked state (see [section 44.11.2. Error Protection](#)). To release it from the command-locked state, issue a status clear command or Forced Stop command to the flash sequencer.

**DFAE bit (Data Flash Memory Access Violation Flag)**

The DFAE bit indicates whether a data flash memory access violation occurred. When this bit is set to 1, the ILGLERR bit in the FSTATR register is set to 1, placing the flash sequencer in the command-locked state.

[Setting conditions]

FACL commands issued in the data flash P/E mode are as follows:

- The setting of the FSADDR or FEADDR register is the reserved portion of the data area
- FACL commands of non-secure access are issued while the setting of the FSADDR or FEADDR register is the secure region address.

[Clearing conditions]

- When this bit is written as 0 after it is set to 1
- When the flash sequencer starts to process the Status Clear or Forced Stop command.

**CMDLK bit (Command Lock Flag)**

The CMDLK bit indicates that the flash sequencer is in the command-locked state.

[Setting conditions]

- The flash sequencer detects an error and enters the command-locked state.

[Clearing conditions]

- When the flash sequencer starts to process the Status Clear or Forced Stop command.

**CFAE bit (Code Flash Memory Access Violation Flag)**

The CFAE bit indicates whether a code flash memory access violation has occurred. When this bit is set to 1, the ILGLERR bit in the FSTATR register is set to 1, placing the flash sequencer in the command-locked state.

## 44.4.9 FASTAT: 闪存访问状态寄存器

Base address: FACL = 0x407F\_E000

Offset address: 0x10

|               |      |   |   |       |      |   |   |   |
|---------------|------|---|---|-------|------|---|---|---|
| Bit position: | 7    | 6 | 5 | 4     | 3    | 2 | 1 | 0 |
| Bit field:    | CFAE | — | — | CMDLK | DFAE | — | — | — |
| 重置后的值:        | 0    | 0 | 0 | 0     | 0    | 0 | 0 | 0 |

| Bit | Symbol | Function   | R/W              |
|-----|--------|--|------------------|
| 2:0 | —      | 这些位被读取为0。写入值应为0。                                       | R/W              |
| 3   | DFAE   | 数据闪存访问违规标志<br>0: 未发生数据闪存访问违规<br>1: 发生数据闪存访问违规。         | R/W <sup>1</sup> |
| 4   | CMDLK  | 命令锁定标志<br>0: flash定序器不处于命令锁定状态<br>1: flash定序器处于命令锁定状态。 | R                |
| 6:5 | —      | 这些位被读取为0。写入值应为0。                                       | R/W              |
| 7   | CFAE   | 代码闪存访问违规标志<br>0: 未发生代码闪存访问违规<br>1: 发生代码闪存访问违规。         | R/W <sup>1</sup> |

注1. 读取1后, 只能写入0以清除标志。

FASTAT寄存器指示是否发生了代码闪存或数据闪存访问违规。如果任何一个CFAE、CMDLK和DFAE位设置为1, 闪存定序器进入命令锁定状态(参见第44.11.2节。错误保护)。要将其从命令锁定状态释放, 请向闪存定序器发出状态清除命令或强制停止命令。

**DFAE位 (数据闪存访问违规标志)**

DFAE位指示是否发生数据闪存访问违规。当该位设置为1时, FSTATR寄存器中的ILGLERR位设置为1, 将闪存定序器置于命令锁定状态。

[Setting conditions]

数据闪存PE模式下发出的FACL命令如下:

- FSADDR或FEADDR寄存器的设置是数据区的保留部分
- FSADDR或FEADDR寄存器的设置是安全区域地址时发出非安全访问的FACL命令。

[Clearing conditions]

- 该位设置为1后写入0时
- 当flashsequencer开始处理StatusClear或ForcedStop命令时。

**CMDLK位 (命令锁定标志)**

CMDLK位指示闪存定序器处于命令锁定状态。

[Setting conditions]

- 闪存定序器检测到错误并进入命令锁定状态。

[Clearing conditions]

- 当flashsequencer开始处理StatusClear或ForcedStop命令时。

**CFAE位 (代码闪存访问违规标志)**

CFAE位指示是否发生代码闪存访问违规。当该位设置为1时, FSTATR寄存器中的ILGLERR位设置为1, 将闪存定序器置于命令锁定状态。

[Setting conditions]

FACI commands issued in the code flash P/E mode are as follows:

- The setting of the FSADDR register is the reserved portion of the user area
- The Configuration set command is issued while the setting of the FSADDR register is from 0x0000A100 to 0x0000A2F0 in self-programming mode
- FACI commands of non-secure access are issued while the setting of the FSADDR register is the secure region address.

[Clearing conditions]

- When this bit is written as 0 after it is set to 1
- When the flash sequencer starts to process the Status Clear or Forced Stop command.

#### 44.4.10 FAEINT : Flash Access Error Interrupt Enable Register

Base address: FACI = 0x407F\_E000

Offset address: 0x14

|                    |        |   |   |         |        |   |   |   |
|--------------------|--------|---|---|---------|--------|---|---|---|
| Bit position:      | 7      | 6 | 5 | 4       | 3      | 2 | 1 | 0 |
| Bit field:         | CFAEIE | — | — | CMDLKIE | DFAEIE | — | — | — |
| Value after reset: | 1      | 0 | 0 | 1       | 1      | 0 | 0 | 0 |

| Bit | Symbol  | Function  | R/W |
|-----|---------|---|-----|
| 2:0 | —       | These bits are read as 0. The write value should be 0.  | R/W |
| 3   | DFAEIE  | Data Flash Memory Access Violation Interrupt Enable<br>0: Generation of an FIFERR interrupt request is disabled when FASTAT.DFAE is set to 1<br>1: Generation of an FIFERR interrupt request is enabled when FASTAT.DFAE is set to 1. | R/W |
| 4   | CMDLKIE | Command Lock Interrupt Enable<br>0: Generation of an FIFERR interrupt request is disabled when FASTAT.CMDLK is set to 1<br>1: Generation of an FIFERR interrupt request is enabled when FASTAT.CMDLK is set to 1.                     | R/W |
| 6:5 | —       | These bits are read as 0. The write value should be 0.  | R/W |
| 7   | CFAEIE  | Code Flash Memory Access Violation Interrupt Enable<br>0: Generation of an FIFERR interrupt request is disabled when FASTAT.CFAE is set to 1<br>1: Generation of an FIFERR interrupt request is enabled when FASTAT.CFAE is set to 1. | R/W |

The FAEINT register enables or disables generation of a flash access error (FIFERR) interrupt request.

##### DFAEIE bit (Data Flash Memory Access Violation Interrupt Enable)

The DFAEIE bit enables or disables generation of an FIFERR interrupt request when a data flash memory access violation occurs, setting the DFAE bit in the FASTAT register to 1.

##### CMDLKIE bit (Command Lock Interrupt Enable)

The CMDLKIE bit enables or disables generation of an FIFERR interrupt request when the flash sequencer enters the command-locked state, setting the CMDLK bit in the FASTAT register to 1.

##### CFAEIE bit (Code Flash Memory Access Violation Interrupt Enable)

The CFAEIE bit enables or disables generation of an FIFERR interrupt request when a code flash memory access violation occur, setting the CFAE bit in the FASTAT register to 1.

[Setting conditions]

CodeflashPE模式下发出的FACI命令如下:

- FSADDR寄存器的设置是用户区的保留部分
- 自编程模式下FSADDR寄存器的设置从0x0000A100到0x0000A2F0时发出配置设置命令
- FSADDR寄存器的设置是安全区域地址时发出非安全访问的FACI命令。

[Clearing conditions]

- 该位设置为1后写入0时
- 当flashsequencer开始处理StatusClear或ForcedStop命令时。

#### 44.4.10 FAEINT: 闪存访问错误中断使能寄存器

Base address: FACI = 0x407F\_E000

Offset address: 0x14

|               |        |   |   |         |        |   |   |   |
|---------------|--------|---|---|---------|--------|---|---|---|
| Bit position: | 7      | 6 | 5 | 4       | 3      | 2 | 1 | 0 |
| Bit field:    | CFAEIE | — | — | CMDLKIE | DFAEIE | — | — | — |
| 重置后的值:        | 1      | 0 | 0 | 1       | 1      | 0 | 0 | 0 |

| Bit | Symbol  | Function   | R/W |
|-----|---------|--|-----|
| 2:0 | —       | 这些位被读取为0。写入值应为0。   | R/W |
| 3   | DFAEIE  | 数据闪存访问冲突中断使能<br>0: 当FASTAT.DFAE设置为1时, 禁止生成FIFERR中断请求<br>1: 当FASTAT.DFAE设置为1时, 使能FIFERR中断请求的生成。 | R/W |
| 4   | CMDLKIE | 命令锁定中断使能<br>0: 当FASTAT.CMDLK设置为1时, 禁止生成FIFERR中断请求<br>1: 当FASTAT.CMDLK设置为1时, 使能FIFERR中断请求的生成。   | R/W |
| 6:5 | —       | 这些位被读取为0。写入值应为0。   | R/W |
| 7   | CFAEIE  | 代码闪存访问冲突中断启用<br>0: 当FASTAT.CFAE设置为1时, 禁止生成FIFERR中断请求<br>1: 当FASTAT.CFAE设置为1时, 使能FIFERR中断请求的生成。 | R/W |

FAEINT寄存器启用或禁用闪存访问错误(FIFERR)中断请求的生成。

##### DFAEIE位 (数据闪存访问冲突中断允许)

当发生数据闪存访问违规时, DFAEIE位启用或禁用FIFERR中断请求的生成, 将FASTAT寄存器中的DFAE位设置为1。

##### CMDLKIE位 (命令锁定中断使能)

当闪存定序器进入命令锁定状态时, CMDLKIE位启用或禁用FIFERR中断请求的生成, 将FASTAT寄存器中的CMDLK位设置为1。

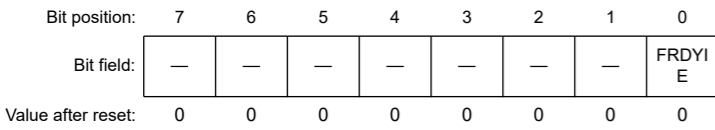
##### CFAEIE位 (代码闪存访问冲突中断允许)

当发生代码闪存访问违规时, CFAEIE位启用或禁用FIFERR中断请求的生成, 将FASTAT寄存器中的CFAE位设置为1。

44.4.11 FRDYIE : Flash Ready Interrupt Enable Register

Base address: FACL = 0x407F\_E000

Offset address: 0x18



| Bit | Symbol | Function   | R/W |
|-----|--------|--|-----|
| 0   | FRDYIE | Flash Ready Interrupt Enable<br>0: Generation of an FRDY interrupt request is disabled<br>1: Generation of an FRDY interrupt request is enabled. | R/W |
| 7:1 | —      | These bits are read as 0. The write value should be 0.   | R/W |

The FRDYIE register enables or disables generation of a flash ready (FRDY) interrupt.

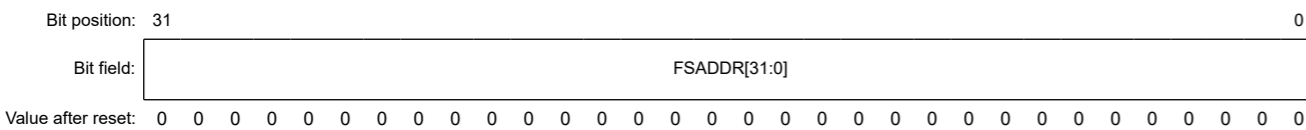
FRDYIE bit (Flash Ready Interrupt Enable)

The FRDYIE bit enables or disables generation of an FRDY interrupt request when the FRDY bit in the FSTATR register is changed from 0 to 1 on completion of processing by the flash sequencer of the Program, Block Erase, Multi Block Erase, Blank Check, and Configuration set command.

44.4.12 FSADDR : FACL Command Start Address Register

Base address: FACL = 0x407F\_E000

Offset address: 0x30



| Bit  | Symbol       | Function                                  | R/W              |
|------|--------------|---|------------------|
| 31:0 | FSADDR[31:0] | Start Address for FACL Command Processing | R/W <sup>1</sup> |

Note 1. These bits can be written when the FRDY bit in the FSTATR register is 1. Writing to these bits are ignored when the FRDY bit is 0. Note that b0 and b1 are read-only.

Table 44.4 FACL command address boundary

| Command                               | Address Boundary |
|---------------------------------------|------------------|
| Program (code flash memory)           | 128-byte         |
| Program (data flash memory)           | 4, 8, 16 -byte   |
| Block Erase (code flash memory)       | 8-KB or 32-KB    |
| Block Erase (data flash memory)       | 64-byte          |
| Multi Block Erase (data flash memory) | 64-byte          |
| Blank Check (data flash memory)       | 4-byte           |
| Configuration set                     | 16-byte          |

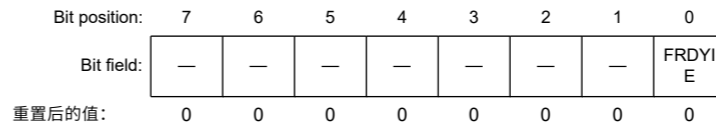
The FSADDR register specifies the address where the target area for command processing starts when the FACL command for Program, Block Erase, Multi Block Erase, Blank Check, or Configuration set is issued.

The FSADDR value is initialized when the SUINIT bit in the FSUINITR register is set to 1. It is also initialized by a reset.

44.4.11 FRDYIE:闪存就绪中断使能寄存器

Base address: FACL = 0x407F\_E000

Offset address: 0x18



| Bit | Symbol | Function  | R/W |
|-----|--------|---|-----|
| 0   | FRDYIE | 闪存就绪中断使能<br>0: 禁止产生FRDY中断请求<br>1: 允许产生FRDY中断请求。 | R/W |
| 7:1 | —      | 这些位被读取为0。写入值应为0。                                | R/W |

FRDYIE寄存器启用或禁用闪存就绪(FRDY)中断的生成。

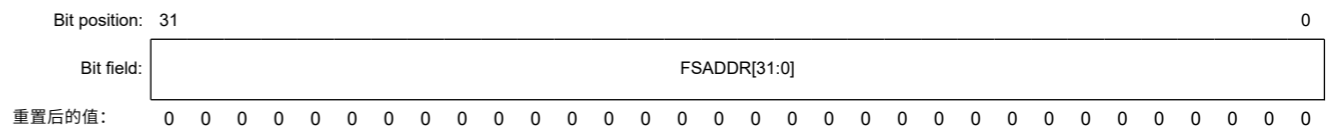
FRDYIE位 (闪存就绪中断使能)

当FSTATR寄存器中的FRDY位在程序、块擦除、多块擦除、空白检查和配置的闪存序列器的处理完成时从0变为1时，FRDYIE位启用或禁用FRDY中断请求的产生设置命令。

44.4.12 FSADDR:FACL命令起始地址寄存器

Base address: FACL = 0x407F\_E000

Offset address: 0x30



| Bit  | Symbol       | Function      | R/W              |
|------|--------------|---------------|------------------|
| 31:0 | FSADDR[31:0] | FACL命令处理的起始地址 | R/W <sup>1</sup> |

注1.当FSTATR寄存器中的FRDY位为1时可以写入这些位。当FRDY位为0时忽略写入这些位。请注意，b0和b1是只读的。

Table 44.4 FACL命令地址边界

| Command     | 地址边界           |
|-------------|----------------|
| 程序 (代码闪存)   | 128-byte       |
| 程序 (数据闪存)   | 4, 8, 16 -byte |
| 块擦除 (代码闪存)  | 8-KB or 32-KB  |
| 块擦除 (数据闪存)  | 64-byte        |
| 多块擦除 (数据闪存) | 64-byte        |
| 空白检查 (数据闪存) | 4-byte         |
| 配置集         | 16-byte        |

FSADDR寄存器指定在发出用于编程、块擦除、多块擦除、空白检查或配置集的FACL命令时命令处理的目标区域开始的地址。

FSADDR值在FSUINITR寄存器中的SUINIT位设置为1时被初始化。它也通过复位被初始化。

**FSADDR[31:0] bits (Start Address for FACI Command Processing)**

The FSADDR[31:0] bits specify the start address for FACI command processing. Bits [31:24] are ignored in FACI command processing for the code flash memory. Bits [31:17] are ignored in FACI command processing for the data flash memory. Bits associated with the address bits of lower order than the address boundary listed in Table 44.4 are also ignored.

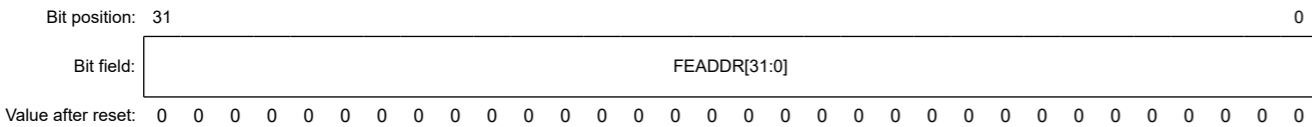
For information on the addresses of the code flash memory and the data flash memory, see section 44.2. Structure of Memory.

For information on the addresses of the configuration setting, see section 44.9.3.15. Configuration Set Command.

**44.4.13 FEADDR : FACI Command End Address Register**

Base address: FACL = 0x407F\_E000

Offset address: 0x34



| Bit  | Symbol       | Function                                | R/W              |
|------|--------------|---|------------------|
| 31:0 | FEADDR[31:0] | End Address for FACI Command Processing | R/W <sup>1</sup> |

Note 1. These bits can be written when the FRDY bit in the FSTATR register is 1. Writing to these bits are ignored when the FRDY bit is 0. Note that bit [0] and bit [1] are read-only.

The FEADDR register specifies the end address of the target area for Multi Block Erase and Blank Check command processing. When incremental mode is selected as the addressing mode for Blank Checking (when FBCCNT.BCDIR = 0), the address specified in the FSADDR register should be equal to or smaller than the address in the FEADDR register. Conversely, the address in the FSADDR register should be equal to or larger than the address in the FEADDR register when decremental mode is selected as the addressing mode for Blank Check (i.e. when FBCCNT.BCDIR = 1). If the BCDIR, FSADDR, and FEADDR bit settings are inconsistent with the specified rules, the flash sequencer enters the command-locked state (see section 44.11.2. Error Protection).

The FEADDR value is initialized when the SUINIT bit in the FSUINTR register is set to 1. It is also initialized by a reset.

**FEADDR[31:0] bits (End Address for FACI Command Processing)**

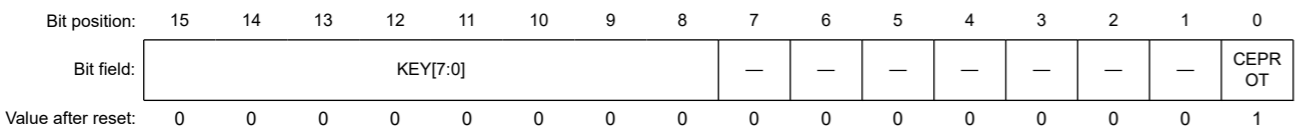
The FEADDR[31:0] bits specify the end address for Multi Block Erase and Blank Check command processing. In command processing, bits 31 to 17 and any bits that do not reach the address boundaries listed in the section 44.4.12. FSADDR : FACI Command Start Address Register are ignored.

For information on the addresses of the flash memory, see section 44.2. Structure of Memory.

**44.4.14 FMEPROT : Flash P/E Mode Entry Protection Register**

Base address: FACL = 0x407F\_E000

Offset address: 0x44



| Bit | Symbol | Function  | R/W                       |
|-----|--------|---|---------------------------|
| 0   | CEPROT | Code Flash P/E Mode Entry Protection<br>0: FENTRYC bit is not protected<br>1: FENTRYC bit is protected. | R/W <sup>1</sup> *2<br>*4 |
| 7:1 | —      | These bits are read as 0. The write value should be 0.  | R/W                       |

**FSADDR[31:0]位 (FACI命令处理的起始地址)**

FSADDR[31:0]位指定FACI命令处理的起始地址。在代码闪存的FACI命令处理中忽略位[31:24]。在数据闪存的FACI命令处理中忽略位[31:17]。与低于表44.4中列出的地址边界的地址位相关的位也被忽略。

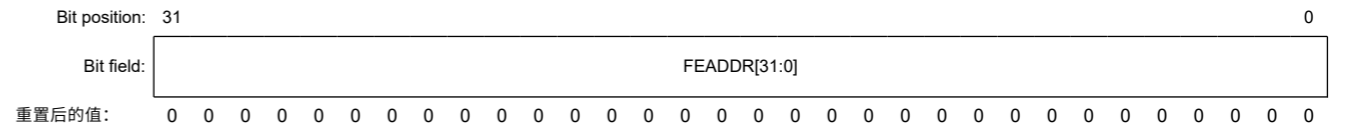
有关代码闪存和数据闪存地址的信息，请参见第44.2节。结构Memory。

有关配置设置地址的信息，请参阅第44.9.3.15节。配置集命令。

**44.4.13 FEADDR:FACI命令结束地址寄存器**

Base address: FACL = 0x407F\_E000

Offset address: 0x34



| Bit  | Symbol       | Function      | R/W              |
|------|--------------|---------------|------------------|
| 31:0 | FEADDR[31:0] | FACI命令处理的结束地址 | R/W <sup>1</sup> |

注1.当FSTATR寄存器中的FRDY位为1时可以写入这些位。当FRDY位为0时忽略写入这些位。请注意，位[0]和位[1]是只读的。

FEADDR寄存器指定多块擦除和空白检查命令处理的目标区域的结束地址。When incremental mode is selected as the addressing mode for Blank Checking (when FBCCNT.BCDIR = 0) the address specified in the FSADDR registers should be equal to or smaller than the address in the FEADDR register. Conversely the address in the FSADDR registers should be equal to or larger than the address in the FEADDR register when decremental mode is selected as the addressing mode for Blank Check (i.e. when FBCCNT.BCDIR = 1).如果BCDIR、FSADDR和FEADDR位设置与指定规则不一致，则闪存定序器进入命令锁定状态（请参阅第44.11.2.错误保护部分）。

FEADDR值在FSUINTR寄存器中的SUINIT位设置为1时被初始化。它也通过复位被初始化。

**FEADDR[31:0]位 (FACI命令处理的结束地址)**

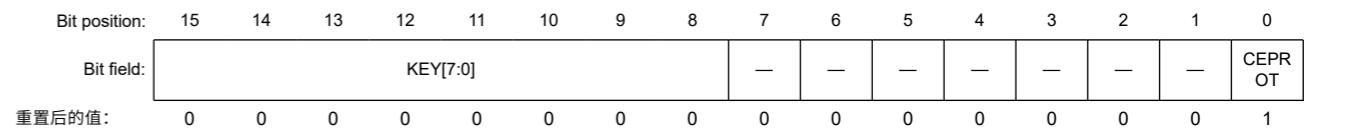
FEADDR[31:0]位指定多块擦除和空白检查命令处理的结束地址。在命令处理中，位31到17以及任何未到达44.4.12节中列出的地址边界的位。FSADDR：FACI命令起始地址寄存器被忽略。

有关闪存地址的信息，请参阅第44.2节。内存结构。

**44.4.14 FMEPROT:FlashPE模式进入保护寄存器**

Base address: FACL = 0x407F\_E000

Offset address: 0x44



| Bit | Symbol | Function  | R/W                       |
|-----|--------|---|---------------------------|
| 0   | CEPROT | CodeFlashPE模式进入保护<br>0: FENTRYC位不受保护1: FENTRYC位受保护。 | R/W <sup>1</sup> *2<br>*4 |
| 7:1 | —      | 这些位被读取为0。写入值应为0。                                    | R/W                       |



| Bit  | Symbol   | Function | R/W              |
|------|----------|----------|------------------|
| 15:8 | KEY[7:0] | Key Code | R/W <sup>3</sup> |

Note 1. Writing to this bit is only possible when the FRDY bit in the FSTATR register is 1. Writing to this bit while the FRDY bit = 0 is ignored.

Note 2. Writing to this bit is only possible when 16 bits are written and the value written to the KEY bits is D9h.

Note 3. Written values are not retained by these bits (always read as 0x00).

Note 4. Only secure access can write to this register. Both secure access and non-secure read access are allowed. Non-secure write access is denied, but TrustZone access error is not generated.

#### CEPROT bit (Code Flash P/E Mode Entry Protection)

The CEPROT bit specifies the protection setting of the FRNTRYC bit in the FENTRYR register.

[Setting condition]

- 1 being written to the CEPROT bit while writing to FMEPROT is enabled.

[Clearing condition]

- 0 being written to the CEPROT bit while writing to FMEPROT is enabled.

#### 44.4.15 FBPROT0 : Flash Block Protection Register

Base address: FACL = 0x407F\_E000

Offset address: 0x78

| Bit position:      | 15       | 14 | 13 | 12 | 11 | 10 | 9 | 8 | 7 | 6 | 5 | 4 | 3 | 2 | 1 | 0     |
|--------------------|----------|----|----|----|----|----|---|---|---|---|---|---|---|---|---|-------|
| Bit field:         | KEY[7:0] |    |    |    |    |    |   |   |   |   | — | — | — | — | — | BPCN0 |
| Value after reset: | 0        | 0  | 0  | 0  | 0  | 0  | 0 | 0 | 0 | 0 | 0 | 0 | 0 | 0 | 0 | 0     |

| Bit  | Symbol   | Function   | R/W                 |
|------|----------|--|---------------------|
| 0    | BPCN0    | Block Protection for Non-secure Cancel<br>0: Block protection is enabled<br>1: Block protection is disabled. | R/W <sup>1</sup> *2 |
| 7:1  | —        | These bits are read as 0. The write value should be 0.   | R/W                 |
| 15:8 | KEY[7:0] | Key Code   | R/W <sup>3</sup>    |

Note 1. This bit can be written when the FRDY bit in the FSTATR register is 1. Writing to this bit is ignored when the FRDY bit is 0.

Note 2. Writing to this bit is only possible when 16 bits are written and the value written to the KEY[7:0] bits is 0x78.

Note 3. Written values are not retained by these bits (always read as 0x00).

The FBPROT0 register is used to disable the block protect function for non-secure. When the block protect setting is locked by the permanent block setting, it cannot be disabled by this register.

The FBPROT0 value is initialized when the SUINIT bit in the FSUINITR is set to 1, because the FENTRYR value is initialized to 0x0000. It is also initialized by a reset.

#### BPCN0 bit (Block Protection for Non-secure Cancel)

The BPCN0 bit disables the block protect setting for non-secure function.

[Setting condition]

- When the write-enabling conditions are satisfied and the FENTRYR is not 0x0000, write 1 to this bit.

[Clearing conditions]

- 8 bits being written to FBPROT0 while the FRDY bit is 1.
- A value other than 0x78 specified in the KEY bits and 16 bits are written to FBPROT0 while the FRDY bit is 1.
- 0 being written to the BPCN0 bit while writing to FBPROT0 is enabled.
- The FENTRYR register value is 0x0000.

| Bit  | Symbol   | Function | R/W              |
|------|----------|----------|------------------|
| 15:8 | KEY[7:0] | 关键代码     | R/W <sup>3</sup> |

注1.仅当FSTATR寄存器中的FRDY位为1时才可以写入该位。当FRDY位=0时写入该位被忽略。

注2.仅当写入16位且写入KEY位的值为D9h时才能写入该位。

注3.这些位不保留写入的值（始终读取为0x00）。

注4.只有安全访问才能写入该寄存器。允许安全访问和非安全读取访问。非安全写入访问被拒绝，但生成了TrustZone访问错误。

#### CEPROT位（代码闪存PE模式进入保护）

CEPROT位指定FENTRYR寄存器中FRNTRYC位的保护设置。

[Setting condition]

- 写入FMEPROT时将1写入CEPROT位使能。

[Clearing condition]

- 使能写入FMEPROT时将0写入CEPROT位。

#### 44.4.15 FBPROT0：闪存块保护寄存器

Base address: FACL = 0x407F\_E000

Offset address: 0x78

| Bit position: | 15       | 14 | 13 | 12 | 11 | 10 | 9 | 8 | 7 | 6 | 5 | 4 | 3 | 2 | 1 | 0 |       |
|---------------|----------|----|----|----|----|----|---|---|---|---|---|---|---|---|---|---|-------|
| Bit field:    | KEY[7:0] |    |    |    |    |    |   |   |   |   | — | — | — | — | — | — | BPCN0 |
| 重置后的值:        | 0        | 0  | 0  | 0  | 0  | 0  | 0 | 0 | 0 | 0 | 0 | 0 | 0 | 0 | 0 | 0 |       |

| Bit  | Symbol   | Function                      | R/W                 |
|------|----------|-------------------------------|---------------------|
| 0    | BPCN0    | 非安全取消的块保护<br>0: 启用块保护1: 禁用块保护 | R/W <sup>1</sup> *2 |
| 7:1  | —        | 这些位被读取为0。写入值应为0。              | R/W                 |
| 15:8 | KEY[7:0] | 关键代码                          | R/W <sup>3</sup>    |

注1.当FSTATR寄存器中的FRDY位为1时可以写入该位。当FRDY位为0时忽略写入该位。

注2.仅当写入16位且写入KEY[7:0]位的值为0x78时，才能写入该位。

注3.这些位不保留写入的值（始终读取为0x00）。

FBPROT0寄存器用于禁用非安全的块保护功能。当块保护设置被永久块设置锁定时，该寄存器不能将其禁用。

FBPROT0值在FSUINITR中的SUINIT位设置为1时被初始化，因为FENTRYR值被初始化为0x0000。它由复位初始化。

#### BPCN0位（非安全取消的块保护）

BPCN0位禁用非安全功能的块保护设置。

[Setting condition]

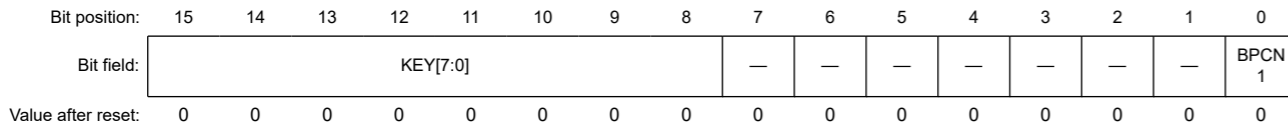
- 当写使能条件满足且FENTRYR不为0x0000时，向该位写1。

[Clearing conditions]

- FRDY位为1时，将8位写入FBPROT0。
- 当FRDY位为1时，将KEY位中指定的0x78和16位以外的值写入FBPROT0。
- 写入FBPROT0时将0写入BPCN0位使能。
- FENTRYR寄存器值为0x0000。

44.4.16 FBPROT1 : Flash Block Protection for Secure Register

Base address: FACL = 0x407F\_E000  
Offset address: 0x7C



| Bit  | Symbol   | Function   | R/W                 |
|------|----------|--|---------------------|
| 0    | BPCN1    | Block Protection for Secure Cancel<br>0: Block protection is enabled<br>1: Block protection is disabled. | R/W <sup>1</sup> *2 |
| 7:1  | —        | These bits are read as 0. The write value should be 0.   | R/W                 |
| 15:8 | KEY[7:0] | Key Code   | R/W <sup>3</sup>    |

Note 1. Writing to this bit is only possible when the FRDY bit in the FSTATR register is 1. Writing to this bit while FRDY bit = 0 is ignored.  
Note 2. Writing to this bit is only possible when 16 bits are written and the value written to the KEY[7:0] bits is 0xB1.  
Note 3. Written values are not retained by these bits (always read as 0x00).

The FBPROT1 register is used to disable the block protect function for secure developer. When the block protect setting is locked by the permanent block setting, it cannot be disabled by this register.

The FBPROT1 value is initialized when the SUINIT bit in the FSUINITR is set to 1, because the FENTRYR value is initialized to 0x0000. It is also initialized by a reset.

**BPCN1 bit (Block Protection for Secure Cancel)**

The BPCN1 bit disables the block protect setting for secure function.

[Setting condition]

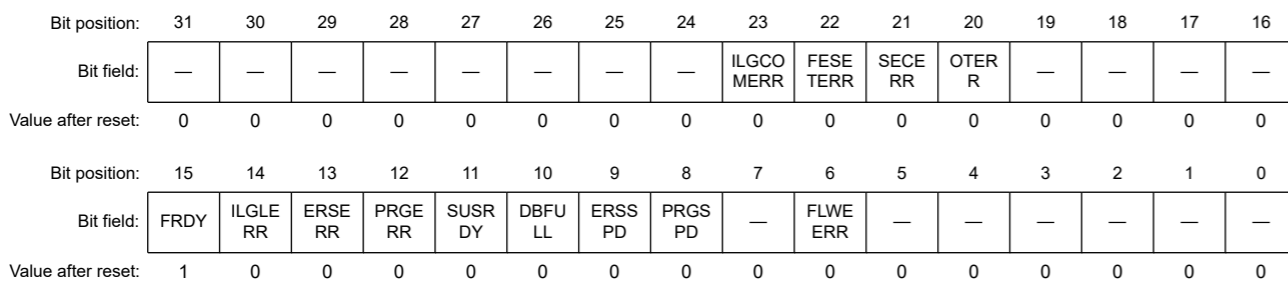
- When the write-enabling conditions are satisfied and the FENTRYR is not 0x0000, write 1 to BPCN1.

[Clearing conditions]

- 8 bits being written to FBPROT1 while the FRDY bit is 1.
- A value other than 0xB1 specified in the KEY bits and 16 bits are written to FBPROT1 while the FRDY bit is 1.
- 0 being written to the BPCN1 bit while writing to FBPROT1 is enabled.
- The FENTRYR register value is 0x0000.

44.4.17 FSTATR : Flash Status Register

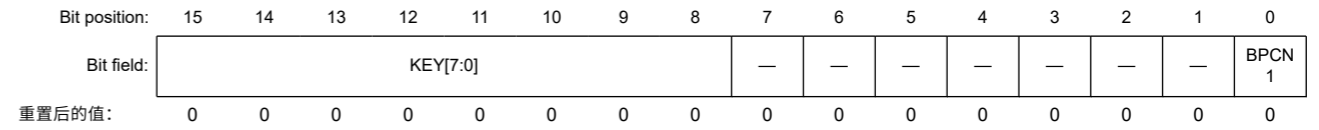
Base address: FACL = 0x407F\_E000  
Offset address: 0x80



| Bit | Symbol | Function   | R/W |
|-----|--------|--|-----|
| 5:0 | —      | These bits are read as 0. The write value should be 0. | R/W |

44.4.16 FBPROT1：安全寄存器的闪存块保护

Base address: FACL = 0x407F\_E000  
Offset address: 0x7C



| Bit  | Symbol   | Function                      | R/W                 |
|------|----------|-------------------------------|---------------------|
| 0    | BPCN1    | 安全取消的块保护<br>0: 启用块保护1: 禁用块保护。 | R/W <sup>1</sup> *2 |
| 7:1  | —        | 这些位被读取为0。写入值应为0。              | R/W                 |
| 15:8 | KEY[7:0] | 关键代码                          | R/W <sup>3</sup>    |

注1.仅当FSTATR寄存器中的FRDY位为1时才可以写入该位。当FRDY位=0时写入该位被忽略。  
注2.仅当写入16位且写入KEY[7:0]位的值为0xB1时，才能写入该位。  
注3.这些位不保留写入的值（始终读取为0x00）。

FBPROT1寄存器用于禁用安全开发人员的块保护功能。当块保护设置被永久块设置锁定时，该寄存器不能将其禁用。

FBPROT1值在FSUINITR中的SUINIT位设置为1时被初始化，因为FENTRYR值被初始化为0x0000。它也由复位初始化。

**BPCN1位（安全取消的块保护）**

BPCN1位禁用安全功能的块保护设置。

[Setting condition]

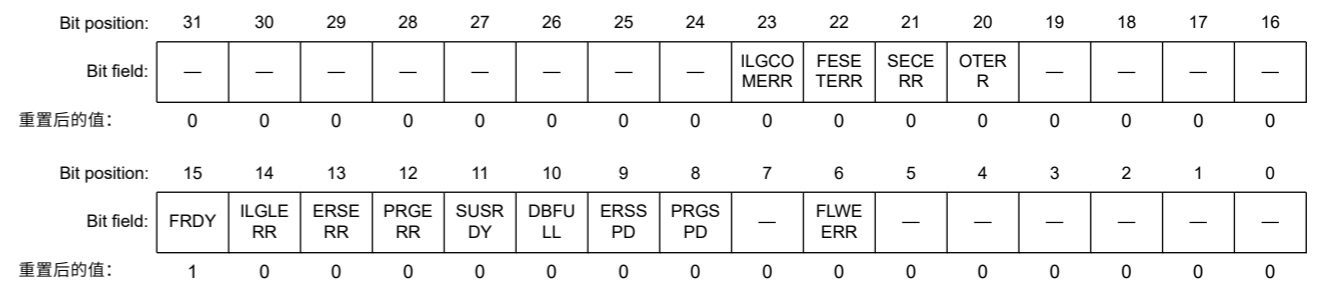
- 当写使能条件满足且FENTRYR不为0x0000时，向BPCN1写1。

[Clearing conditions]

- FRDY位为1时，将8位写入FBPROT1。
- 当FRDY位为1时，将KEY位中指定的0xB1和16位以外的值写入FBPROT1。
- 写入FBPROT1时将0写入BPCN1位使能。
- FENTRYR寄存器值为0x0000。

44.4.17 FSTATR：闪存状态寄存器

Base address: FACL = 0x407F\_E000  
Offset address: 0x80



| Bit | Symbol | Function         | R/W |
|-----|--------|------------------|-----|
| 5:0 | —      | 这些位被读取为0。写入值应为0。 | R/W |

| Bit   | Symbol    | Function  | R/W |
|-------|-----------|---|-----|
| 6     | FLWEERR   | Flash Write/Erase Protect Error Flag<br>0: An error has not occurred<br>1: An error has occurred.   | R   |
| 7     | —         | These bits are read as 0. The write value should be 0.  | R/W |
| 8     | PRGSPD    | Programming Suspend Status Flag<br>0: The flash sequencer is in a state other than those corresponding to the value 1<br>1: The flash sequencer is in the programming suspension processing state or programming suspended state. | R   |
| 9     | ERSSPD    | Erase Suspend Status Flag<br>0: The flash sequencer is in a state other than those corresponding to the value 1<br>1: The flash sequencer is in the erasure suspension processing state or the erasure suspended state.           | R   |
| 10    | DBFULL    | Data Buffer Full Flag<br>0: The data buffer is empty<br>1: The data buffer is full.   | R   |
| 11    | SUSRDY    | Suspend Ready Flag<br>0: The flash sequencer cannot receive P/E suspend commands<br>1: The flash sequencer can receive P/E suspend commands.  | R   |
| 12    | PRGERR    | Programming Error Flag<br>0: Programming has completed successfully<br>1: An error has occurred during programming.   | R   |
| 13    | ERSERR    | Erase Error Flag<br>0: Erasure has completed successfully<br>1: An error has occurred during erasure.   | R   |
| 14    | ILGLERR   | Illegal Command Error Flag<br>0: The flash sequencer has not detected an illegal FACL command or illegal flash memory access<br>1: The flash sequencer has detected an illegal FACL command or illegal flash memory access.       | R   |
| 15    | FRDY      | Flash Ready Flag<br>0: Program, Block Erase, Multi Block Erase, P/E suspend, P/E resume, Forced Stop, Blank Check, or Configuration set command processing is in progress<br>1: None of the above is in progress.                 | R   |
| 19:16 | —         | These bits are read as 0. The write value should be 0.  | R/W |
| 20    | OTERR     | Other Error<br>0: A status clear or forced stop command processing is complete<br>1: An error has occurred.   | R   |
| 21    | SECERR    | Security Error<br>0: A status clear or forced stop command processing is complete<br>1: An error has occurred.  | R/W |
| 22    | FESETERR  | FENTRY Setting Error<br>0: A status clear or forced stop command processing is complete<br>1: An error has occurred.  | R   |
| 23    | ILGCOMERR | Illegal Command Error<br>0: A status clear or forced stop command processing is complete<br>1: An error has occurred.   | R   |
| 31:24 | —         | These bits are read as 0. The write value should be 0.  | R/W |

The FSTATR register indicates the state of the flash sequencer.

#### FLWEERR flag (Flash Write/Erase Protect Error Flag)

The FLWEERR flag indicates a violation of the flash memory overwrite protection setting in the FWEPROR register. When this flag is 1, the flash sequencer is in the command-locked state.

[Setting condition]

- An error has occurred.

| Bit   | Symbol    | Function  | R/W |
|-------|-----------|---|-----|
| 6     | FLWEERR   | 闪存写擦除保护错误标志<br>0: 未发生错误1: 发生错误  | R   |
| 7     | —         | 这些位被读取为0。写入值应为0。  | R/W |
| 8     | PRGSPD    | 编程挂起状态标志<br>0: flashsequencer处于与值1对应的状态以外的状态1: flashsequencer处于编程暂停处理状态或编程暂停状态。 | R   |
| 9     | ERSSPD    | 擦除挂起状态标志<br>0: 闪存定序器处于与值1对应的状态以外的状态1: 闪存定序器处于擦除暂停处理状态或擦除暂停状态。                   | R   |
| 10    | DBFULL    | 数据缓冲区满标志<br>0: 数据缓冲区为空1: 数据缓冲区已满。   | R   |
| 11    | SUSRDY    | 挂起就绪标志<br>0: flash定序器不能接收PE挂起命令1: flash定序器可以接收PE挂起命令。                           | R   |
| 12    | PRGERR    | 编程错误标志<br>0: 烧录成功1: 烧录出错。   | R   |
| 13    | ERSERR    | 擦除错误标志<br>0: 擦除已成功完成1: 擦除过程中发生错误。   | R   |
| 14    | ILGLERR   | 非法命令错误标志<br>0: 闪存定序器未检测到非法FACL命令或非法闪存访问<br>1: 闪存定序器检测到非法FACL命令或非法闪存访问。          | R   |
| 15    | FRDY      | 闪存就绪标志<br>0: 正在处理编程、块擦除、多块擦除、PE暂停、PE恢复、强制停止、空白检查或配置设置命令处理<br>1: 以上均未进行。         | R   |
| 19:16 | —         | 这些位被读取为0。写入值应为0。  | R/W |
| 20    | OTERR     | 其他错误<br>0: 状态清除或强制停止命令处理完成1: 发生错误。  | R   |
| 21    | SECERR    | 安全错误<br>0: 状态清除或强制停止命令处理完成1: 发生错误。  | R/W |
| 22    | FESETERR  | FENTRY设置错误<br>0: 状态清除或强制停止命令处理完成1: 发生错误。  | R   |
| 23    | ILGCOMERR | 非法命令错误<br>0: 状态清除或强制停止命令处理完成1: 发生错误。  | R   |
| 31:24 | —         | 这些位被读取为0。写入值应为0。  | R/W |

FSTATR寄存器指示闪存定序器的状态。

#### FLWEERR标志 (闪存写擦除保护错误标志)

FLWEERR标志表示违反了FWEPROR寄存器中的闪存覆盖保护设置。当该标志为1时，闪存定序器处于命令锁定状态。

[Setting condition]

- 发生错误。

[Clearing condition]

- The flash sequencer starts processing the Forced Stop command.

**PRGSPD flag (Programming Suspend Status Flag)**

The PRGSPD flag indicates that the flash sequencer is in the programming suspension processing state or programming suspended state.

[Setting condition]

- The flash sequencer starts processing in response to the programming suspend command.

[Clearing conditions]

- Reception of the P/E resume command by the flash sequencer (after write access to the FACI command-issuing area is complete)
- The flash sequencer starts processing the Forced Stop command.

**ERSSPD flag (Erasure Suspend Status Flag)**

The ERSSPD flag indicates that the flash sequencer is in the erasure suspension processing state or erasure suspended state.

[Setting condition]

- The flash sequencer starts processing in response to an erasure suspend command.

[Clearing condition]

- Reception of the P/E resume command by the flash sequencer (after write access to the FACI command-issuing area is complete)
- The flash sequencer starts processing of the Forced Stop command.

**DBFULL flag (Data Buffer Full Flag)**

The DBFULL flag indicates the state of the data buffer when the program command is issued. The flash sequencer incorporates a buffer for write data (data buffer). When data for writing to the flash memory are written to the FACI command-issuing area while the data buffer is full, the flash sequencer inserts a wait cycle in the peripheral bus.

[Setting condition]

- The data buffer becomes full while program commands are issued.

[Clearing condition]

- The data buffer becomes empty.

**SUSRDY flag (Suspend Ready Flag)**

The SUSRDY flag indicates whether the flash sequencer can receive a P/E suspend command.

[Setting condition]

- After starting programming/erasure processing, the flash sequencer enters a state in which P/E suspend commands can be received.

[Clearing conditions]

- Reception of the P/E suspend command or Forced Stop command by the flash sequencer (after write access to the FACI command-issuing area is complete)
- During programming or erasure, the flash sequencer enters the command-locked state
- Programming or erasure has completed.

**PRGERR flag (Programming Error Flag)**

The PRGERR flag indicates the result of programming of the flash memory. When this flag is 1, the flash sequencer is in the command-locked state.

[Setting condition]

[Clearing condition]

- 闪存定序器开始处理强制停止命令。

**PRGSPD标志 (编程暂停状态标志)**

PRGSPD标志指示闪存定序器处于编程暂停处理状态或编程暂停状态。

[Setting condition]

- 闪存定序器响应编程暂停命令开始处理。

[Clearing conditions]

- 闪存定序器接收到P/Eresume命令 (在对FACI命令发出区域的写访问完成后)
- 闪存定序器开始处理强制停止命令。

**ERSSPD标志 (擦除挂起状态标志)**

ERSSPD标志指示闪存定序器处于擦除暂停处理状态或擦除暂停状态。

[Setting condition]

- 闪存定序器响应擦除挂起命令开始处理。

[Clearing condition]

- 闪存定序器接收到P/Eresume命令 (在对FACI命令发出区域的写访问完成后)
- 闪存定序器开始处理强制停止命令。

**DBFULL标志 (数据缓冲区满标志)**

DBFULL标志指示发出程序命令时数据缓冲区的状态。闪存定序器包含一个用于写入数据的缓冲区 (数据缓冲区)。当用于写入闪存的数据写入到FACI命令发布区, 而数据缓冲区已满时, 闪存定序器会在外围总线中插入一个等待周期。

[Setting condition]

- 发出程序命令时数据缓冲区已满。

[Clearing condition]

- 数据缓冲区变空。

**SUSRDY标志 (挂起就绪标志)**

SUSRDY标志指示闪存定序器是否可以接收PE挂起命令。

[Setting condition]

- 开始编程擦除处理后, flash定序器进入可以接收PE挂起命令的状态。

[Clearing conditions]

- 闪存定序器接收到PE暂停命令或强制停止命令 (在对FACI命令发布区域的写访问完成后)
- 在编程或擦除期间, 闪存定序器进入命令锁定状态
- 编程或擦除已完成。

**PRGERR标志 (编程错误标志)**

PRGERR标志指示闪存的编程结果。当该标志为1时, 闪存定序器处于命令锁定状态。

[Setting condition]



- An error has occurred during programming.

[Clearing condition]

- The flash sequencer starts processing of the Status Clear or Forced Stop command.

#### ERSERR flag (Erasure Error Flag)

The ERSERR flag indicates the result of erasure of the flash memory. When this flag is 1, the flash sequencer is in the command-locked state.

[Setting condition]

- An error has occurred during erasure.

[Clearing condition]

- The flash sequencer starts processing of the Status Clear or Forced Stop command.

#### ILGLERR flag (Illegal Command Error Flag)

The ILGLERR flag indicates that the flash sequencer has detected an illegal FACI command or flash memory access. If this flag is 1, the flash sequencer is in the command-locked state.

[Setting conditions]

- See [section 44.11.2. Error Protection](#).

[Clearing condition]

- The flash sequencer starts processing of the Status Clear or Forced Stop command.

#### FRDY flag (Flash Ready Flag)

The FRDY flag indicates the command processing state of the flash sequencer.

[Setting conditions]

- The flash sequencer completes command processing
- The flash sequencer receives a P/E suspend command and suspends programming of the flash memory
- The flash sequencer received the Forced Stop command and ended command processing.

[Clearing conditions]

- The flash sequencer received an FACI command
- For Program and Configuration setting, the first write access to the FACI command-issuing area
- For other commands, the last write access to the FACI command-issuing area.

#### OTERR flag (Other Error)

See [Table 44.23](#). When this flag is 1, the flash sequencer is in the command-lock state.

[Setting condition]

- An error has occurred.

[Clearing condition]

- The status clear or forced stop command processing is complete.

#### SECERR flag (Security Error)

See [Table 44.23](#). When this flag is 1, the flash sequencer is in the command-lock state.

[Setting condition]

- An error has occurred.

[Clearing condition]

- The status clear or forced stop command processing is complete.

- 编程过程中出现错误。

[Clearing condition]

- 闪存定序器开始处理状态清除或强制停止命令。

#### ERSERR标志 (擦除错误标志)

ERSERR标志指示闪存擦除的结果。当该标志为1时, 闪存定序器处于命令锁定状态。

[Setting condition]

- 擦除过程中发生错误。

[Clearing condition]

- 闪存定序器开始处理状态清除或强制停止命令。

#### ILGLERR标志 (非法命令错误标志)

ILGLERR标志表示闪存定序器检测到非法FACI命令或闪存访问。如果该标志为1, 则闪存定序器处于命令锁定状态。

[Setting conditions]

- 请参阅第44.11.2节。错误保护。

[Clearing condition]

- 闪存定序器开始处理状态清除或强制停止命令。

#### FRDY标志 (闪存就绪标志)

FRDY标志指示闪存定序器的命令处理状态。

[Setting conditions]

- flashsequencer完成命令处理
- 闪存定序器收到PE暂停命令并暂停闪存的编程
- 闪存定序器收到强制停止命令并结束命令处理。

[Clearing conditions]

- 闪存定序器收到FACI命令
- 对于ProgramandConfiguration设置, 对FACI命令发布区的第一次写访问
- 对于其他命令, 对FACI命令发布区的最后一次写访问。

#### OTERR flag (Other Error)

见表44.23。当该标志为1时, 闪存定序器处于命令锁定状态。

[Setting condition]

- 发生错误。

[Clearing condition]

- 状态清除或强制停止命令处理完成。

#### SECERR flag (Security Error)

见表44.23。当该标志为1时, 闪存定序器处于命令锁定状态。

[Setting condition]

- 发生错误。

[Clearing condition]

- 状态清除或强制停止命令处理完成。

**FESETERR flag (FENTRY Setting Error)**

See Table 44.23. When this flag is 1, the flash sequencer is in the command-lock state.

[Setting condition]

- An error has occurred.

[Clearing condition]

- The status clear or forced stop command processing is complete.

**ILGCOMERR flag (Illegal Command Error)**

See Table 44.23. When this flag is 1, the flash sequencer is in the command-lock state.

[Setting condition]

- An error has occurred.

[Clearing condition]

- The status clear or forced stop command processing is complete.

**44.4.18 FENTRYR : Flash P/E Mode Entry Register**

Base address: FACL = 0x407F\_E000

Offset address: 0x84

|                    |          |    |    |    |    |    |   |         |   |   |   |   |   |   |   |         |
|--------------------|----------|----|----|----|----|----|---|---------|---|---|---|---|---|---|---|---------|
| Bit position:      | 15       | 14 | 13 | 12 | 11 | 10 | 9 | 8       | 7 | 6 | 5 | 4 | 3 | 2 | 1 | 0       |
| Bit field:         | KEY[7:0] |    |    |    |    |    |   | FENTRYD | — | — | — | — | — | — | — | FENTRYC |
| Value after reset: | 0        | 0  | 0  | 0  | 0  | 0  | 0 | 0       | 0 | 0 | 0 | 0 | 0 | 0 | 0 | 0       |

| Bit  | Symbol   | Function  | R/W                |
|------|----------|---|--------------------|
| 0    | FENTRYC  | Code Flash P/E Mode Entry<br>0: Code flash is in read mode<br>1: Code flash is in P/E mode. | R/W <sup>1,2</sup> |
| 6:1  | —        | These bits are read as 0. The write value should be 0.                                      | R/W                |
| 7    | FENTRYD  | Data Flash P/E Mode Entry<br>0: Data flash is in read mode<br>1: Data flash is in P/E mode. | R/W <sup>1,2</sup> |
| 15:8 | KEY[7:0] | Key Code  | R/W <sup>3</sup>   |

Note 1. These bits can be written when the FRDY bit in the FSTATR register is 1. Writing to these bits are ignored when the FRDY bit is 0.  
Note 2. Writing to these bits is only possible when 16 bits are written and the value written to the KEY[7:0] bits is 0xAA.  
Note 3. Written values are not retained by these bits (always read 0x00).

FENTRYR is used to specify code flash P/E mode or data flash P/E mode. To specify the code flash P/E mode or data flash P/E mode so that the flash sequencer can receive FACL commands, set either the FENTRYD or FENTRYC bit to 1 to place the flash sequencer in P/E mode.

FENTRYR is initialized when the SUINIT bit in FSUINITR is set to 1. It is also initialized by a reset.

Note: Writing a value of 0XAA81 to this register causes the ILGLERR bit in the FSTATR register to be set to 1, resulting in the flash sequencer being placed in the command-locked state.

**FENTRYC bit (Code Flash P/E Mode Entry)**

The FENTRYC bit specifies P/E mode for the code flash memory.

[Setting condition]

- Write 1 to the FENTRYC bit while writing to FENTRYR is enabled and FENTRYR is 0x0000.

[Clearing conditions]

**FESETERR标志 (FENTRY设置错误)**

见表44.23。当该标志为1时，闪存定序器处于命令锁定状态。

[Setting condition]

- 发生错误。

[Clearing condition]

- 状态清除或强制停止命令处理完成。

**ILGCOMERR标志 (非法命令错误)**

见表44.23。当该标志为1时，闪存定序器处于命令锁定状态。

[Setting condition]

- 发生错误。

[Clearing condition]

- 状态清除或强制停止命令处理完成。

**44.4.18 FENTRYR:FlashPE模式进入寄存器**

Base address: FACL = 0x407F\_E000

Offset address: 0x84

|               |          |    |    |    |    |    |   |         |   |   |   |   |   |   |   |         |
|---------------|----------|----|----|----|----|----|---|---------|---|---|---|---|---|---|---|---------|
| Bit position: | 15       | 14 | 13 | 12 | 11 | 10 | 9 | 8       | 7 | 6 | 5 | 4 | 3 | 2 | 1 | 0       |
| Bit field:    | KEY[7:0] |    |    |    |    |    |   | FENTRYD | — | — | — | — | — | — | — | FENTRYC |
| 重置后的值:        | 0        | 0  | 0  | 0  | 0  | 0  | 0 | 0       | 0 | 0 | 0 | 0 | 0 | 0 | 0 | 0       |

| Bit  | Symbol   | Function   | R/W                |
|------|----------|--|--------------------|
| 0    | FENTRYC  | CodeFlashPE模式进入<br>0: Codeflash处于读取模式1<br>: Codeflash处于PE模式。 | R/W <sup>1,2</sup> |
| 6:1  | —        | 这些位被读取为0。写入值应为0。   | R/W                |
| 7    | FENTRYD  | 数据闪存PE模式进入<br>0: 数据闪存处于读取模式1<br>: 数据闪存处于PE模式。                | R/W <sup>1,2</sup> |
| 15:8 | KEY[7:0] | 关键代码   | R/W <sup>3</sup>   |

注1.当FSTATR寄存器中的FRDY位为1时可以写入这些位。当FRDY位为0时忽略写入这些位。  
注2.仅当写入16位且写入KEY[7:0]位的值为0xAA时，才能写入这些位。  
注3.这些位不保留写入的值（始终读取0x00）。

FENTRYR用于指定代码闪存PE模式或数据闪存PE模式。要指定代码闪存PE模式或数据闪存PE模式，以便闪存定序器可以接收FACL命令，请将FENTRYD或FENTRYC位设置为1以将闪存定序器置于PE模式。

当FSUINITR中的SUINIT位设置为1时，FENTRYR被初始化。它也被复位初始化。

Note: 将值0XAA81写入该寄存器会导致FSTATR寄存器中的ILGLERR位设置为1，从而导致闪存定序器置于命令锁定状态。

**FENTRYC位 (代码闪存PE模式进入)**

FENTRYC位指定代码闪存的PE模式。

[Setting condition]

- 写入1到FENTRYC位，同时写入FENTRYR使能并且FENTRYR为0x0000。

[Clearing conditions]

- Write 8 bits to FENTRYR while the FRDY bit is 1
- A value other than 0xAA is specified in the KEY[7:0] bits and 16 bits are written to FENTRYR while the FRDY bit is 1
- Write 0 to the FENTRYC bit while writing to FENTRYR is enabled
- Write to FENTRYR while writing is enabled and its value is other than 0x0000
- The protection of FMEPROT register is enabled.

**FENTRYD bit (Data Flash P/E Mode Entry)**

The FENTRYD bit specifies P/E mode for the data flash memory.

[Setting condition]

- Write 1 to the FENTRYD bit while writing to FENTRYR is enabled and FENTRYR is 0x0000.

[Clearing conditions]

- Write 8 bits to FENTRYR while the FRDY bit is 1
- Writing of 16 bits to FENTRYR with a value other than 0xAA specified for the KEY[7:0] bits while the FRDY bit is 1
- Write 0 to the FENTRYD bit while writing to FENTRYR is enabled
- Write to FENTRYR while writing is enabled and its value is other than 0x0000.

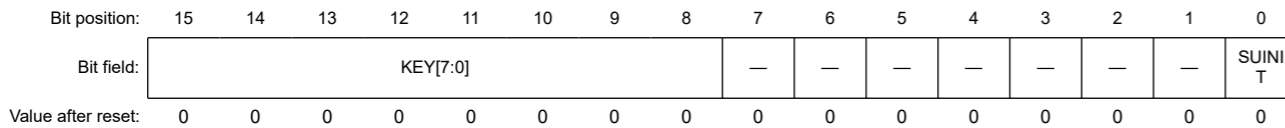
**KEY[7:0] bits (Key Code)**

The KEY[7:0] bits control writing permission to the FENTRYD or FENTRYC bits.

**44.4.19 FSUINTR : Flash Sequencer Setup Initialization Register**

Base address: FACL = 0x407F\_E000

Offset address: 0x8C



| Bit  | Symbol   | Function   | R/W                |
|------|----------|--|--------------------|
| 0    | SUINIT   | Set-Up Initialization<br>0: The FSADDR, FEADDR, FBPROT0, FBPROT1, FENTRYR, FBCCNT, and FCPSR flash sequencer setup registers keep their current values<br>1: The FSADDR, FEADDR, FBPROT0, FBPROT1, FENTRYR, FBCCNT, and FCPSR flash sequencer setup registers are initialized. | R/W <sup>1,2</sup> |
| 7:1  | —        | These bits are read as 0. The write value should be 0.   | R/W                |
| 15:8 | KEY[7:0] | Key Code   | R/W <sup>3</sup>   |

Note 1. This bit can be written when the FRDY bit in the FSTATR register is 1. Writing to this bit is ignored when the FRDY bit is 0.

Note 2. Writing to these bits is only possible when 16 bits are written and the value written to the KEY[7:0] bits is 0x2D.

Note 3. Written values are not retained by these bits (always read 0x00).

FSUINTR is used for initialization of the flash sequencer setup.

**SUINIT bit (Set-Up Initialization)**

The SUINIT bit initializes the following flash sequencer setup registers:

- FSADDR
- FEADDR
- FBPROT0
- FBPROT1
- FENTRYR

- FRDY位为1时向FENTRYR写入8位
- KEY[7:0]位中指定了0xAA以外的值，当FRDY位为1时，将16位写入FENTRYR
- 使能写入FENTRYR时向FENTRYC位写入0
- 启用写入时写入FENTRYR，其值不是0x0000
- FMEPROT寄存器保护使能。

**FENTRYD位 (数据闪存PE模式进入)**

FENTRYD位指定数据闪存的PE模式。

[Setting condition]

- 写入1到FENTRYD位，同时写入FENTRYR使能并且FENTRYR为0x0000。

[Clearing conditions]

- FRDY位为1时向FENTRYR写入8位
- 当FRDY位为1时，将16位写入FENTRYR，其中KEY[7:0]位指定的值不是0xAA
- 使能写入FENTRYR时向FENTRYD位写入0
- 写入启用时写入FENTRYR，其值不是0x0000。

**KEY[7:0] bits (Key Code)**

KEY[7:0]位控制对FENTRYD或FENTRYC位的写入权限。

**44.4.19 FSUINTR: 闪存定序器设置初始化寄存器**

Base address: FACL = 0x407F\_E000

Offset address: 0x8C



| Bit  | Symbol   | Function  | R/W                |
|------|----------|---|--------------------|
| 0    | SUINIT   | Set-Up Initialization<br>0: FSADDR、FEADDR、FBPROT0、FBPROT1、FENTRYR、FBCCNT和FCPSR闪存定序器设置寄存器保持其当前值<br>1: 初始化FSADDR、FEADDR、FBPROT0、FBPROT1、FENTRYR、FBCCNT和FCPSR闪存定序器设置寄存器。 | R/W <sup>1,2</sup> |
| 7:1  | —        | 这些位被读取为0。写入值应为0。  | R/W                |
| 15:8 | KEY[7:0] | 关键代码  | R/W <sup>3</sup>   |

注1.当FSTATR寄存器中的FRDY位为1时可以写入该位。当FRDY位为0时忽略写入该位。

注2.仅当写入16位且写入KEY[7:0]位的值为0x2D时才能写入这些位。

注3.这些位不保留写入的值（始终读取0x00）。

FSUINTR用于初始化闪存定序器设置。

**SUINIT bit (Set-Up Initialization)**

SUINIT位初始化以下闪存定序器设置寄存器：

- FSADDR
- FEADDR
- FBPROT0
- FBPROT1
- FENTRYR

- FBCCNT
- FCPSR.

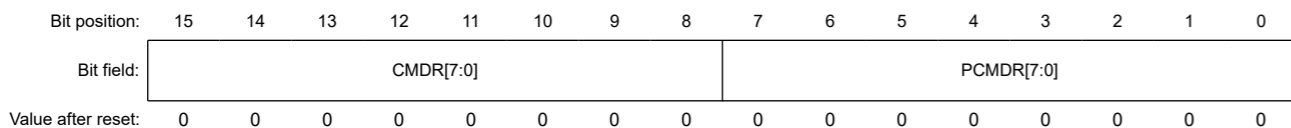
**KEY[7:0] bits (Key Code)**

The KEY[7:0] bits control writing permission to the SUNIT bit.

**44.4.20 FCMDR : FACL Command Register**

Base address: FACL = 0x407F\_E000

Offset address: 0xA0



| Bit  | Symbol     | Function  | R/W |
|------|------------|---|-----|
| 7:0  | PCMDR[7:0] | Pre-command Flag<br>The command just before the latest command is stored. | R   |
| 15:8 | CMDR[7:0]  | Command Flag<br>The latest command is stored.                             | R   |

FCMDR records the two most recent commands accepted by the flash sequencer.

**PCMDR[7:0] bits (Pre-command Flag)**

The PCMDR[7:0] bits indicate the command received immediately before the latest command received by the flash sequencer.

**CMDR[7:0] bits (Command Flag)**

The CMDR[7:0] bits indicate the latest command received by the flash sequencer.

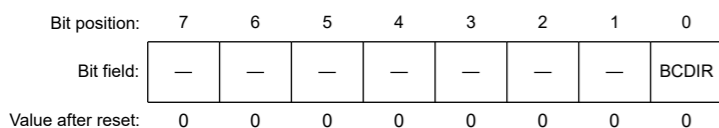
**Table 44.5 States of FCMDR after receiving commands**

| Command           | CMDR | PCMDR            |
|-------------------|------|------------------|
| Program           | 0xE8 | Previous command |
| Block erase       | 0xD0 | 0x20             |
| Multi block erase | 0xD0 | 0x21             |
| P/E suspend       | 0xB0 | Previous command |
| P/E resume        | 0xD0 | Previous command |
| Status Clear      | 0x50 | Previous command |
| Forced Stop       | 0xB3 | Previous command |
| Blank Check       | 0xD0 | 0x71             |
| Configuration set | 0x40 | Previous command |

**44.4.21 FBCCNT : Blank Check Control Register**

Base address: FACL = 0x407F\_E000

Offset address: 0xD0



- FBCCNT
- FCPSR.

**KEY[7:0] bits (Key Code)**

KEY[7:0]位控制对SUNIT位的写入权限。

**44.4.20 FCMDR:FACL命令寄存器**

Base address: FACL = 0x407F\_E000

Offset address: 0xA0



| Bit  | Symbol     | Function                         | R/W |
|------|------------|----------------------------------|-----|
| 7:0  | PCMDR[7:0] | Pre-command Flag<br>存储最新命令之前的命令。 | R   |
| 15:8 | CMDR[7:0]  | 命令标志<br>存储最新的命令。                 | R   |

FCMDR记录闪存定序器最近接受的两个命令。

**PCMDR[7:0] bits (Pre-command Flag)**

PCMDR[7:0]位指示在闪存定序器接收到的最新命令之前收到的命令。

**CMDR[7:0] bits (Command Flag)**

CMDR[7:0]位指示闪存定序器接收到的最新命令。

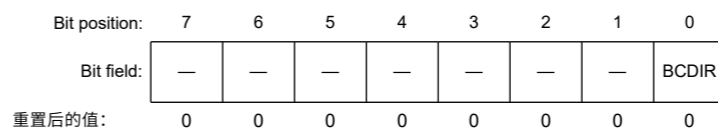
**Table 44.5 FCMDR收到指令后的状态**

| Command     | CMDR | PCMDR |
|-------------|------|-------|
| Program     | 0xE8 | 上一条命令 |
| 块擦除         | 0xD0 | 0x20  |
| 多块擦除        | 0xD0 | 0x21  |
| P/E suspend | 0xB0 | 上一条命令 |
| P/E resume  | 0xD0 | 上一条命令 |
| 状态清除        | 0x50 | 上一条命令 |
| 强制停止        | 0xB3 | 上一条命令 |
| 空白支票        | 0xD0 | 0x71  |
| 配置集         | 0x40 | 上一条命令 |

**44.4.21 FBCCNT:空白检查控制寄存器**

Base address: FACL = 0x407F\_E000

Offset address: 0xD0







BCST bit in the FBCSTAT register is 1 and while the FRDY bit in the FSTATR register is 1. When the BCST bit in the FBCSTAT register is 0, the PSADR[16:0] bits hold the address produced by the previous check.

44.4.24 FSUASMON : Flash Startup Area Select Monitor Register

Base address: FACL = 0x407F\_E000  
Offset address: 0xDC

|                    |       |    |    |    |    |    |    |    |    |    |    |    |    |    |    |    |
|--------------------|-------|----|----|----|----|----|----|----|----|----|----|----|----|----|----|----|
| Bit position:      | 31    | 30 | 29 | 28 | 27 | 26 | 25 | 24 | 23 | 22 | 21 | 20 | 19 | 18 | 17 | 16 |
| Bit field:         | BTFLG | —  | —  | —  | —  | —  | —  | —  | —  | —  | —  | —  | —  | —  | —  | —  |
| Value after reset: | 0/1   | 0  | 0  | 0  | 0  | 0  | 0  | 0  | 0  | 0  | 0  | 0  | 0  | 0  | 0  | 0  |
| Bit position:      | 15    | 14 | 13 | 12 | 11 | 10 | 9  | 8  | 7  | 6  | 5  | 4  | 3  | 2  | 1  | 0  |
| Bit field:         | FSPR  | —  | —  | —  | —  | —  | —  | —  | —  | —  | —  | —  | —  | —  | —  | —  |
| Value after reset: | 0/1   | 0  | 0  | 0  | 0  | 0  | 0  | 0  | 0  | 0  | 0  | 0  | 0  | 0  | 0  | 0  |

| Bit   | Symbol | Function   | R/W |
|-------|--------|--|-----|
| 14:0  | —      | These bits are read as 0. The write value should be 0.   | R   |
| 15    | FSPR   | Protection Programming Flag to set Boot Flag and Startup Area Control<br>0: Protected state<br>1: Non-protected state.                                   | R   |
| 30:16 | —      | These bits are read as 0. The write value should be 0.   | R   |
| 31    | BTFLG  | Flag of Startup Area Select for Boot Swap<br>0: The startup area is the alternate block (block 1)<br>1: The startup area is the default block (block 0). | R   |

**FSPR bit (Protection Programming Flag to set Boot Flag and Startup Area Control)**

The FSPR bit indicates the protection state against the configuration set command for the BTFLG bit, and FSUACR Register.

In response to a reset or configuration set command, the FACL transfers data from flash memory to this register.

**BTFLG bit (Flag of Startup Area Select for Boot Swap)**

The BTFLG bit indicates whether the address of the startup area is exchanged for the boot swap function or not.

In response to a reset or configuration set command, the FACL transfers data from flash memory to this register.

44.4.25 FCPSR : Flash Sequencer Processing Switching Register

Base address: FACL = 0x407F\_E000  
Offset address: 0xE0

|                    |    |    |    |    |    |    |   |   |   |   |   |   |   |   |   |         |
|--------------------|----|----|----|----|----|----|---|---|---|---|---|---|---|---|---|---------|
| Bit position:      | 15 | 14 | 13 | 12 | 11 | 10 | 9 | 8 | 7 | 6 | 5 | 4 | 3 | 2 | 1 | 0       |
| Bit field:         | —  | —  | —  | —  | —  | —  | — | — | — | — | — | — | — | — | — | ESUSPMD |
| Value after reset: | 0  | 0  | 0  | 0  | 0  | 0  | 0 | 0 | 0 | 0 | 0 | 0 | 0 | 0 | 0 | 0       |

| Bit  | Symbol  | Function   | R/W |
|------|---------|--|-----|
| 0    | ESUSPMD | Erase Suspend Mode<br>0: Suspension priority mode<br>1: Erasure priority mode. | R/W |
| 15:1 | —       | These bits are read as 0. The write value should be 0.                         | R/W |

FCPSR selects the erasure suspension mode. FCPSR is initialized when the SUINIT bit in FSUINTR is set to 1. It is also initialized by a reset.

FBCSTAT寄存器中的BCST位为1，而FSTATR寄存器中的FRDY位为1。当FBCSTAT寄存器为0，PSADR[16:0]位保存上一次检查产生的地址。

44.4.24 FSUASMON:闪存启动区选择监控寄存器

Base address: FACL = 0x407F\_E000  
Offset address: 0xDC

|               |       |    |    |    |    |    |    |    |    |    |    |    |    |    |    |    |
|---------------|-------|----|----|----|----|----|----|----|----|----|----|----|----|----|----|----|
| Bit position: | 31    | 30 | 29 | 28 | 27 | 26 | 25 | 24 | 23 | 22 | 21 | 20 | 19 | 18 | 17 | 16 |
| Bit field:    | BTFLG | —  | —  | —  | —  | —  | —  | —  | —  | —  | —  | —  | —  | —  | —  | —  |
| 重置后的值:        | 0/1   | 0  | 0  | 0  | 0  | 0  | 0  | 0  | 0  | 0  | 0  | 0  | 0  | 0  | 0  | 0  |
| Bit position: | 15    | 14 | 13 | 12 | 11 | 10 | 9  | 8  | 7  | 6  | 5  | 4  | 3  | 2  | 1  | 0  |
| Bit field:    | FSPR  | —  | —  | —  | —  | —  | —  | —  | —  | —  | —  | —  | —  | —  | —  | —  |
| 重置后的值:        | 0/1   | 0  | 0  | 0  | 0  | 0  | 0  | 0  | 0  | 0  | 0  | 0  | 0  | 0  | 0  | 0  |

| Bit   | Symbol | Function  | R/W |
|-------|--------|---|-----|
| 14:0  | —      | 这些位被读取为0。写入值应为0。  | R   |
| 15    | FSPR   | 保护编程标志设置引导标志和启动区控制<br>0: 保护状态1: 非保护状态。  | R   |
| 30:16 | —      | 这些位被读取为0。写入值应为0。  | R   |
| 31    | BTFLG  | 引导交换的启动区域选择标志<br>0: 启动区为alternateblock (block1) 1: 启动区为defaultblock (block0)。 | R   |

**FSPR位 (用于设置引导标志和启动区域控制的保护编程标志)**

FSPR位指示针对BTFLG位的配置设置命令的保护状态，而FSUACR Register。

响应复位或配置设置命令，FACL将数据从闪存传输到该寄存器。

**BTFLG位 (用于引导交换的启动区域选择标志)**

BTFLG位指示启动区域的地址是否被交换为引导交换功能。

响应复位或配置设置命令，FACL将数据从闪存传输到该寄存器。

44.4.25 FCPSR:闪存定序器处理切换寄存器

Base address: FACL = 0x407F\_E000  
Offset address: 0xE0

|               |    |    |    |    |    |    |   |   |   |   |   |   |   |   |   |         |
|---------------|----|----|----|----|----|----|---|---|---|---|---|---|---|---|---|---------|
| Bit position: | 15 | 14 | 13 | 12 | 11 | 10 | 9 | 8 | 7 | 6 | 5 | 4 | 3 | 2 | 1 | 0       |
| Bit field:    | —  | —  | —  | —  | —  | —  | — | — | — | — | — | — | — | — | — | ESUSPMD |
| 重置后的值:        | 0  | 0  | 0  | 0  | 0  | 0  | 0 | 0 | 0 | 0 | 0 | 0 | 0 | 0 | 0 | 0       |

| Bit  | Symbol  | Function                      | R/W |
|------|---------|-------------------------------|-----|
| 0    | ESUSPMD | 擦除挂起模式<br>0: 暂停优先模式1: 擦除优先模式。 | R/W |
| 15:1 | —       | 这些位被读取为0。写入值应为0。              | R/W |

FCPSR选择擦除暂停模式。当FSUINTR中的SUINIT位设置为1时，FCPSR被初始化。它也被复位初始化。

**ESUSPMD bit (Erasure Suspend Mode)**

The ESUSPMD bit selects the erasure suspension mode when a P/E suspend command is issued while the flash sequencer is executing erasure processing (see [section 44.9.3.10. P/E Suspend Command](#)). This bit should be set before issuing Block Erase or Multi Block Erase command.

**44.4.26 FPCKAR : Flash Sequencer Processing Clock Notification Register**

Base address: FACL = 0x407F\_E000

Offset address: 0xE4



| Bit  | Symbol    | Function  | R/W                |
|------|-----------|---|--------------------|
| 7:0  | PCKA[7:0] | Flash Sequencer Operating Clock Notification<br>These bits are used to set the operating frequency of the flash sequencer while processing FACL commands. | R/W <sup>1,2</sup> |
| 15:8 | KEY[7:0]  | Key Code  | R/W <sup>3</sup>   |

Note 1. This bit can be written when the FRDY bit in the FSTATR register is 1. Writing to this bit is ignored when the FRDY bit is 0.

Note 2. Writing to these bits is only possible when 16 bits are written and the value written to the KEY[7:0] bits is 0x1E.

Note 3. Written values are not retained by these bits (always read 0x00).

FPCKAR specifies the operating frequency of the flash sequencer while processing FACL commands. The highest operating frequency for the given product is set as the initial value.

**PCKA[7:0] bits (Flash Sequencer Operating Clock Notification)**

The PCKA[7:0] bits specify the operating frequency of the flash sequencer while processing FACL commands. Set the desired frequency for these bits before issuing an FACL command. Specifically, convert the frequency in MHz to a binary number and set it for these bits.

Example:

Frequency is 35.9 MHz (PCKA = 0x24)

Round up the first decimal place of 35.9 MHz to a whole number (= 36) and convert it into a binary number.

If the value set in these bits is smaller than the actual operating frequency of the flash sequencer, the flash memory programming/erasure characteristics cannot be guaranteed. If the value set in these bits is greater than the actual operating frequency of the flash sequencer, the flash memory programming/erasure characteristics can be guaranteed but the FACL command processing time such as the time programming/erasure takes will increase. The minimum FACL command processing time is obtained when the operating frequency of the flash sequencer is the same as the PCKA value.

**KEY[7:0] bits (Key Code)**

The KEY[7:0] bits control writing permission to the PCKA bit.

**44.4.27 FSUACR : Flash Startup Area Control Register**

Base address: FACL = 0x407F\_E000

Offset address: 0xE8

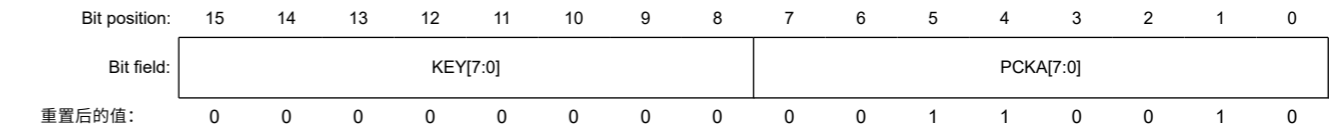
**ESUSPMD位 (擦除挂起模式)**

当闪存定序器正在执行擦除处理时发出PE暂停命令时，ESUSPMD位选择擦除暂停模式（请参阅第44.9.3.10节。PE暂停命令）。该位应在发出块擦除或多块擦除命令之前设置。

**44.4.26 FPCKAR:闪存定序器处理时钟通知寄存器**

Base address: FACL = 0x407F\_E000

Offset address: 0xE4



| Bit  | Symbol    | Function                                     | R/W                |
|------|-----------|--|--------------------|
| 7:0  | PCKA[7:0] | 闪存定序器工作时钟通知<br>这些位用于在处理时设置闪存定序器的工作频率 FACL命令。 | R/W <sup>1,2</sup> |
| 15:8 | KEY[7:0]  | 关键代码   | R/W <sup>3</sup>   |

注1.当FSTATR寄存器中的FRDY位为1时可以写入该位。当FRDY位为0时忽略写入该位。

注2.仅当写入16位且写入KEY[7:0]位的值为0x1E时，才能写入这些位。

注3.这些位不保留写入的值（始终读取0x00）。

FPCKAR在处理FACL命令时指定闪存定序器的工作频率。将给定产品的最高工作频率设置为初始值。

**PCKA[7:0]位 (闪存定序器工作时钟通知)**

PCKA[7:0]位指定闪存定序器在处理FACL命令时的工作频率。在发出FACL命令之前为这些位设置所需的频率。具体来说，将以MHz为单位的频率转换为二进制数并为这些位设置它。

Example:

频率为35.9MHz(PCKA=0x24)

将35.9MHz的第一个小数位四舍五入为整数(=36)并将其转换为二进制数。

如果这些位中设置的值小于闪存定序器的实际工作频率，则无法保证闪存编程擦除特性。如果这些位中设置的值大于闪存定序器的实际工作频率，则可以保证闪存编程擦除特性，但FACL命令处理时间（例如编程擦除所花费的时间）会增加。当闪存定序器的工作频率与PCKA值相同时，得到最小FACL命令处理时间。

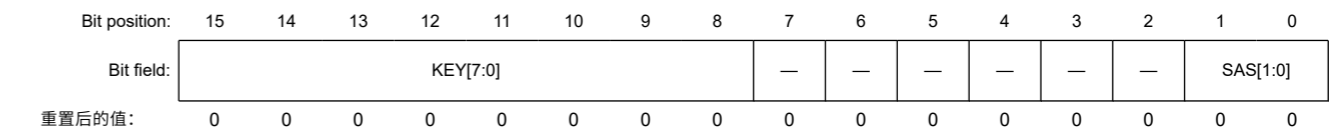
**KEY[7:0] bits (Key Code)**

KEY[7:0]位控制对PCKA位的写入权限。

**44.4.27 FSUACR: 闪存启动区控制寄存器**

Base address: FACL = 0x407F\_E000

Offset address: 0xE8



| Bit  | Symbol   | Function   | R/W                 |
|------|----------|--|---------------------|
| 1:0  | SAS[1:0] | Startup Area Select<br>0 0: Startup area is selected by BTFGL bit<br>0 1: Startup area is selected by BTFGL bit<br>1 0: Startup area is temporarily switched to the default area (block 0)<br>1 1: Startup area is temporarily switched to the alternate area (block 1). | R/W <sup>1</sup> *3 |
| 7:2  | —        | These bits are read as 0. The write value should be 0.   | R/W                 |
| 15:8 | KEY[7:0] | Key Code   | R/W <sup>2</sup>    |

Note 1. Following described the write condition of these bits (these conditions are required at the same time).

1. Access size to this register is 16 bits
2. The value of KEY[7:0] is 0x66
3. The FSPR bit is 1.

Note 2. Written values are not retained by these bits (always read 0x00).

Note 3. Only secure access can write to this register. Both secure access and non-secure read access are allowed. Non-secure write access is denied, but TrustZone access error is not generated.

FSUACR sets the startup area for the boot swap function.

#### SAS[1:0] bits (Startup Area Select)

The SAS[1:0] bits select the startup area. Three methods are available for changing the startup area.

#### KEY[7:0] bits (Key Code)

The KEY[7:0] bits control writing permission to the SAS [1:0] bits.

### 44.4.28 FCKMHZ : Data Flash Access Frequency Register

Base address: FLAD = 0x407F\_C000

Offset address: 0x40

|                    |             |   |   |   |   |   |   |   |
|--------------------|-------------|---|---|---|---|---|---|---|
| Bit position:      | 7           | 6 | 5 | 4 | 3 | 2 | 1 | 0 |
| Bit field:         | FCKMHZ[7:0] |   |   |   |   |   |   |   |
| Value after reset: | 0           | 0 | 1 | 1 | 1 | 1 | 0 | 0 |

| Bit | Symbol      | Function  | R/W |
|-----|-------------|---|-----|
| 7:0 | FCKMHZ[7:0] | Data Flash Access Frequency Register<br>These bits optimize the speed of reading the data flash memory. | R/W |

Note: If the security attribution is configured as secure:

- Secure access and Non-secure read access are allowed
  - Non-secure write access is ignored, and TrustZone access error is not generated.
- If the security attribution is configured as Non-secure:
- Secure and Non-secure access are allowed.

This register optimizes the speed of reading the data flash memory.

Set the frequency of the peripheral module clock (FCLK) of internal peripheral bus which is the clock for access to the data flash memory, in MHz units. For example, 35.9 MHz should be rounded up and set the frequency to 36. Number of cycles required for access to the data flash memory are inserted according to the frequency. When changing the frequency of the FCLK, follow the procedure below to modify the value of the data flash access frequency register (FCKMHZ) in either of the following ways according to whether operation is at a lower frequency before or after the change.

- When changing the speed from low to high: Modify FCKMHZ. After confirming the change by reading FCKMHZ, change the frequency.
- When changing the speed from high to low: Change the frequency. After the frequency is changed, modify FCKMHZ.

## 44.5 Flash Cache

### 44.5.1 Feature of flash cache

| Bit  | Symbol   | Function   | R/W                 |
|------|----------|--|---------------------|
| 1:0  | SAS[1:0] | 启动区域选择<br>00: 启动区域由BTFGL位选择01: 启动区域由BTFGL位选择10: 启动区域暂时切换到默认区域 (块0) 11: 启动区域暂时切换到备用区域 (块1)。 | R/W <sup>1</sup> *3 |
| 7:2  | —        | 这些位被读取为0。写入值应为0。   | R/W                 |
| 15:8 | KEY[7:0] | 关键代码   | R/W <sup>2</sup>    |

注1.下面描述了这些位的写入条件 (这些条件是同时需要的)。1.对该寄存器的访问大小为16位2.KEY[7:0]的值为0x663.FSPR位为1。

注2.这些位不保留写入的值 (始终读取0x00)。

注3.只有安全访问才能写入该寄存器。允许安全访问和非安全读取访问。非安全写入访问被拒绝,但生成了TrustZone访问错误。

FSUACR设置引导交换功能的启动区域。

#### SAS[1:0]位 (启动区域选择)

SAS[1:0]位选择启动区域。三种方法可用于更改启动区域。

#### KEY[7:0] bits (Key Code)

KEY[7:0]位控制对SAS[1:0]位的写入权限。

### 44.4.28 FCKMHZ:数据闪存访问频率寄存器

Base address: FLAD = 0x407F\_C000

Offset address: 0x40

|               |             |   |   |   |   |   |   |   |
|---------------|-------------|---|---|---|---|---|---|---|
| Bit position: | 7           | 6 | 5 | 4 | 3 | 2 | 1 | 0 |
| Bit field:    | FCKMHZ[7:0] |   |   |   |   |   |   |   |
| 重置后的值:        | 0           | 0 | 1 | 1 | 1 | 1 | 0 | 0 |

| Bit | Symbol      | Function                        | R/W |
|-----|-------------|---------------------------------|-----|
| 7:0 | FCKMHZ[7:0] | 数据闪存访问频率寄存器<br>这些位优化了数据闪存的读取速度。 | R/W |

Note: 如果安全属性配置为安全: ●

- 允许安全访问和非安全读取访问
  - 忽略非安全写入访问,不会生成TrustZone访问错误。
- 如果安全属性配置为非安全: ●
- 允许安全和非安全访问。

该寄存器优化了数据闪存的读取速度。

设置内部外围总线的外围模块时钟(FCLK)的频率,它是访问数据闪存的时钟,以MHz为单位。例如,35.9MHz应向上取整,并将频率设置为36。根据频率插入访问数据闪存所需的周期数。当改变FCLK的频率时,根据改变之前或之后是在较低频率下操作,按照以下步骤,通过以下任一方式修改数据闪存访问频率寄存器(FCKMHZ)的值。

- 转速由低变高时: 修改FCKMHZ。通过读取FCKMHZ确认更改后,更改频率。
- 速度由高变低时: 改变频率。频率改变后,修改FCKMHZ。

## 44.5 闪存缓存

### 44.5.1 闪存缓存的特点



The FCACHE (Flash Cache) speeds up read access from bus master to the flash memory. The FCACHE includes:

- FCACHE1, for CPU instruction fetches
- FCACHE2, for CPU operand access
- FLPF, for the prefetch access in CPU instruction fetches

**Table 44.6 Flash Cache 1 (FCACHE1) overview**

|                     |  |
|---------------------|--|
| Cache Target Region | 0x0000_0000 - 0x007F_FFFF  |
| Target Bus Master   | CPU instruction Fetch  |
| Capacity            | 256 Bytes  |
| Associativity       | 8WAY set associative<br>128 bits/entry (128 bit aligned data), 2 entries/way |
| Access Cycle        | Cache Hit : 0 wait<br>Cache Miss : wait number of Flash Wait Cycle Register  |

**Table 44.7 Flash Cache 2 (FCACHE2) overview**

|                     |   |
|---------------------|---|
| Cache Target Region | 0x0000_0000 - 0x007F_FFFF   |
| Target Bus Master   | CPU Operand Access  |
| Capacity            | 16 Bytes  |
| Associativity       | Full Associative<br>128 bits/entry (128 bit aligned data), 1 entry          |
| Access Cycle        | Cache Hit : 0 wait<br>Cache Miss : wait number of Flash Wait Cycle Register |

**Table 44.8 Prefetch Buffer (FLPF) overview**

|                     |   |
|---------------------|---|
| Cache Target Region | 0x0000_0000 - 0x007F_FFFF   |
| Capacity            | 32 Bytes  |
| Associativity       | Full Associative<br>128 bits/entry (128 bit aligned data), 2 entries        |
| Request Address     | Next address of previous CPU Instruction                                    |
| Access Cycle        | Cache Hit : 0 wait<br>Cache Miss : wait number of Flash Wait Cycle Register |

FCACHE(FlashCache)加快了从总线主机到闪存的读取访问。FCACHE包括:

- FCACHE1, 用于CPU取指
- FCACHE2, 用于CPU操作数访问
- FLPF, 用于CPU取指中的预取访问

**Table 44.6 闪存1(FCACHE1)概述**

|               |   |
|---------------|---|
| 缓存目标区域        | 0x0000_0000 - 0x007F_FFFF               |
| 目标总线主控        | CPU指令取指                                 |
| Capacity      | 256 Bytes                               |
| Associativity | 8WAY集合关联<br>128位入口 (128位对齐数据), 2入口方式    |
| 访问周期          | 缓存命中: 0等待<br>CacheMiss:Flash等待周期寄存器的等待数 |

**Table 44.7 闪存2(FCACHE2)概述**

|               |   |
|---------------|---|
| 缓存目标区域        | 0x0000_0000 - 0x007F_FFFF               |
| 目标总线主控        | CPU操作数访问                                |
| Capacity      | 16 Bytes                                |
| Associativity | 全联想<br>128位条目 (128位对齐数据), 1个条目          |
| 访问周期          | 缓存命中: 0等待<br>CacheMiss:Flash等待周期寄存器的等待数 |

**Table 44.8 预取缓冲区(FLPF)概述**

|               |   |
|---------------|---|
| 缓存目标区域        | 0x0000_0000 - 0x007F_FFFF               |
| Capacity      | 32 Bytes                                |
| Associativity | 全联想<br>128位条目 (128位对齐数据), 2个条目          |
| 请求地址          | 上一条CPU指令的下一个地址                          |
| 访问周期          | 缓存命中: 0等待<br>CacheMiss:Flash等待周期寄存器的等待数 |

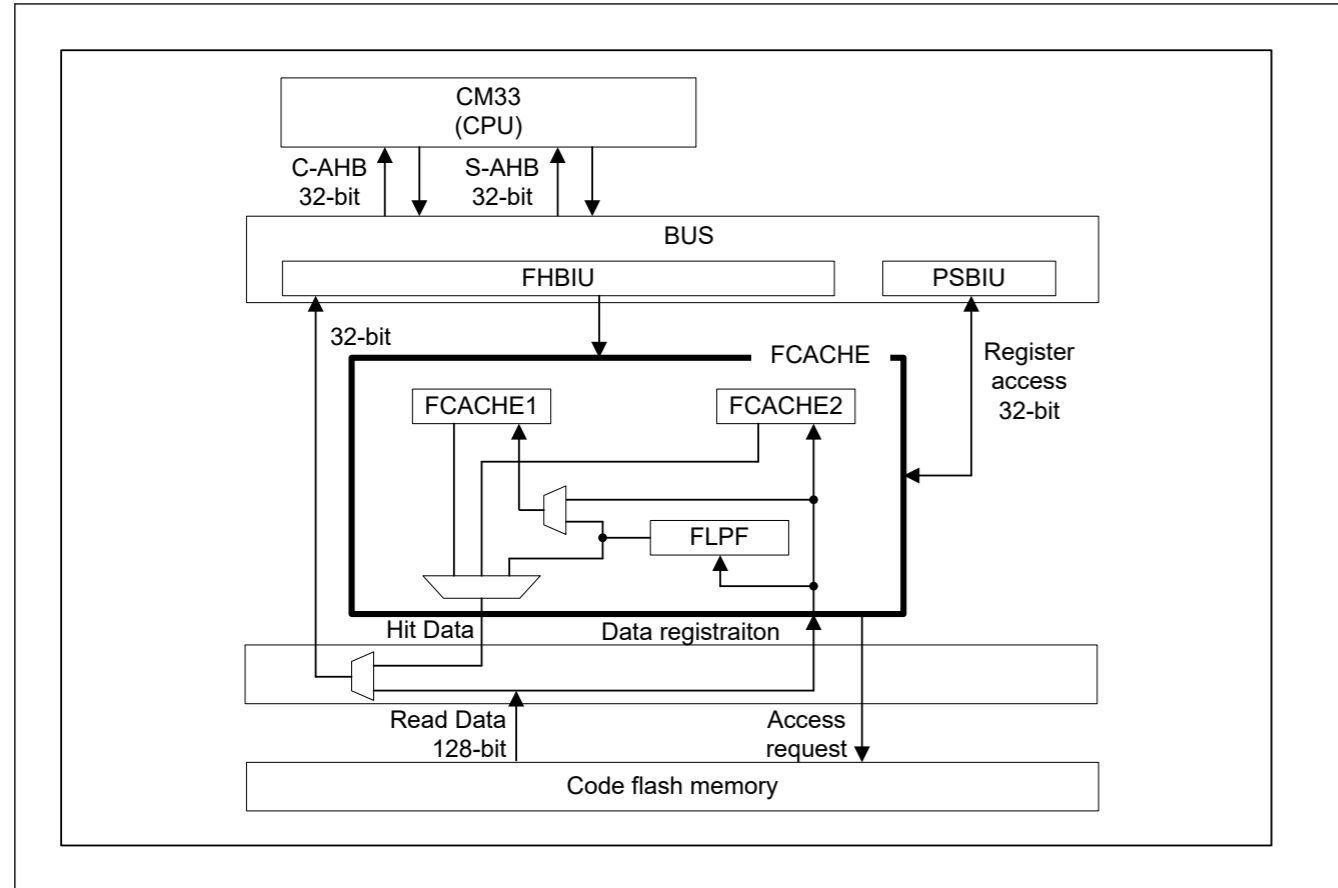


Figure 44.4 Block diagram of FCACHE

44.6 Operating Modes Associated with Flash Memory

Figure 44.5 is a diagram of the mode transitions associated with the flash memory. For the procedures for setting the modes, see section 6, Option-Setting Memory.

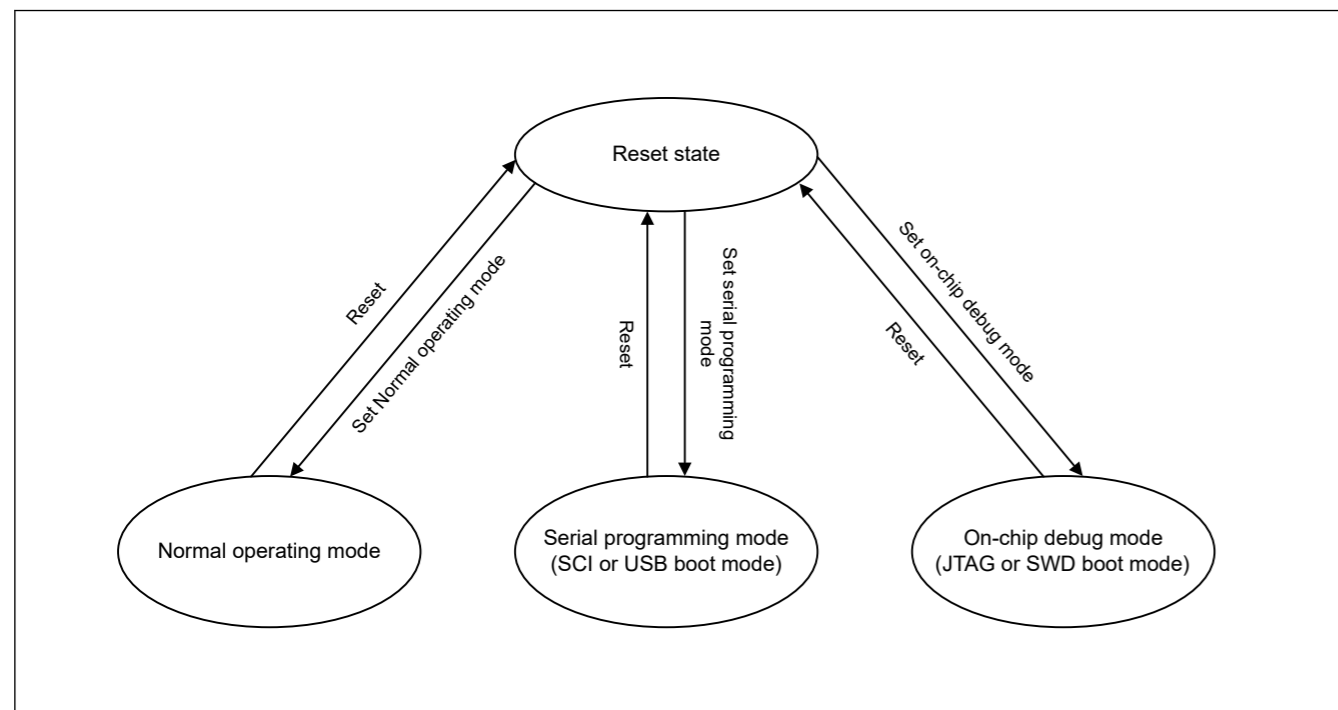


Figure 44.5 Mode Transitions Associated with Flash Memory

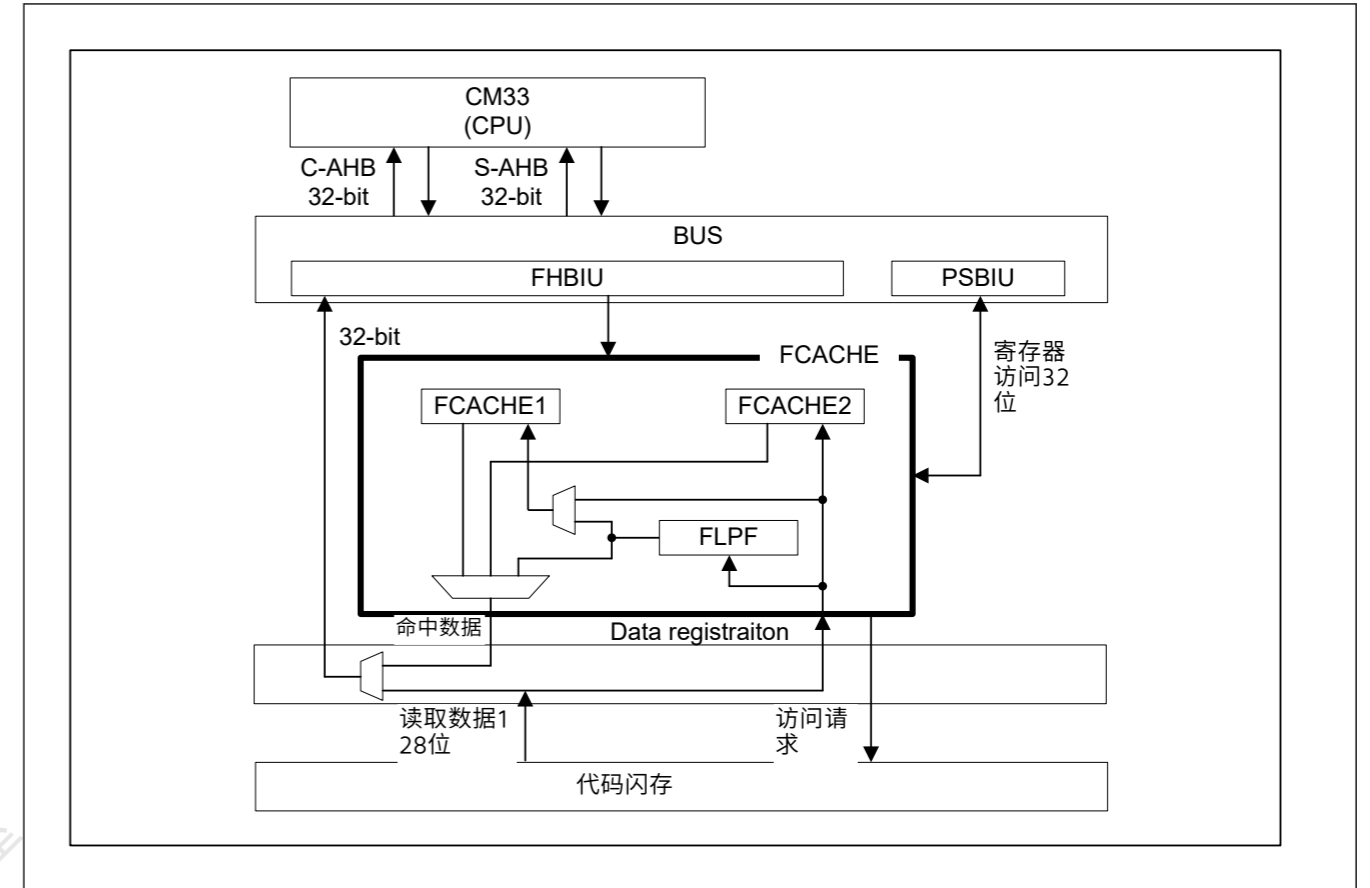


Figure 44.4 FCACHE的框图

44.6 与闪存相关的操作模式

图44.5是与闪存相关的模式转换图。有关设置模式的步骤，请参阅第6节，选项设置内存。

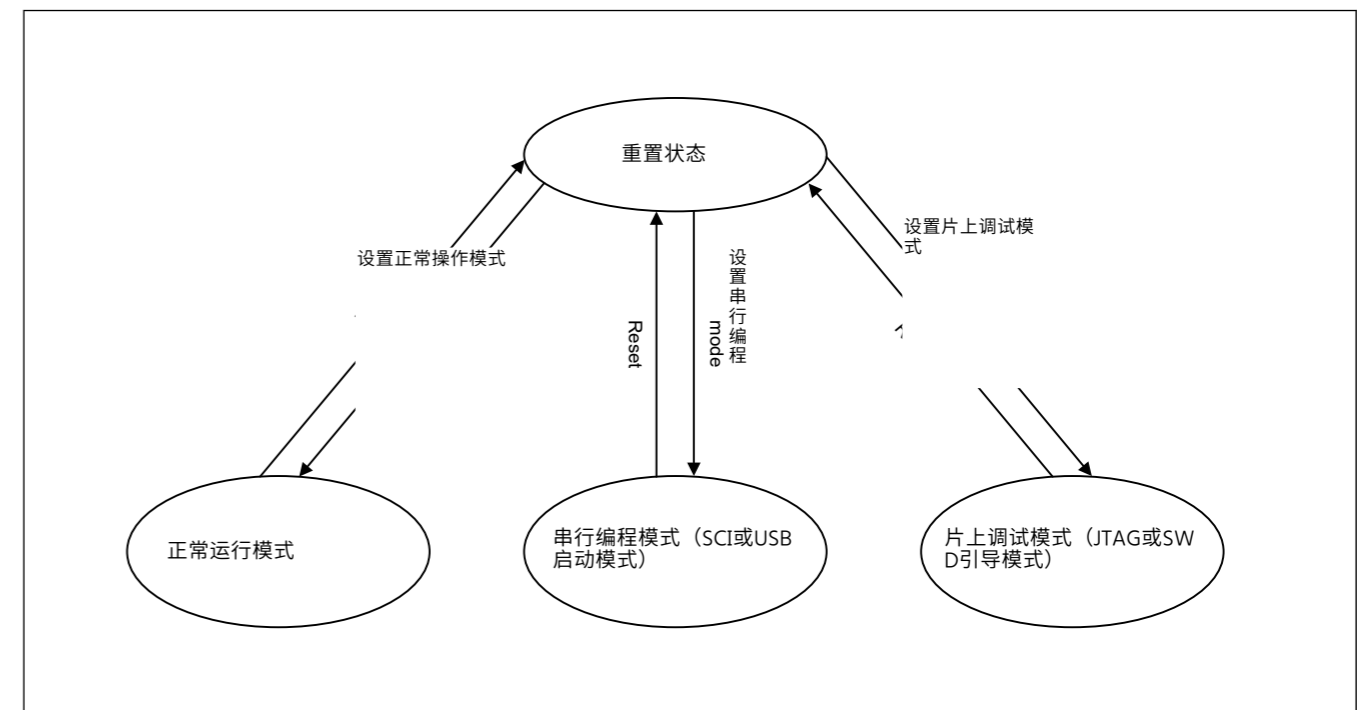


Figure 44.5 与闪存相关的模式转换

The flash memory area where programming and erasure are permitted and the boot program after a reset are different according to each mode. The differences between modes are listed in Table 44.9.

Table 44.9 Differences between Modes

| Parameter                       | Normal operating mode  | Serial programming mode (SCI or USB boot mode)   | On-chip debug mode (JTAG or SWD boot mode)   |
|---------------------------------|--|--|--|
| Programmable and erasable areas | <ul style="list-style-type: none"> <li>Code flash memory</li> <li>Data flash memory</li> <li>Option setting memory (programming only)</li> </ul> | <ul style="list-style-type: none"> <li>Code flash memory</li> <li>Data flash memory</li> <li>Option setting memory (programming only)</li> </ul> | <ul style="list-style-type: none"> <li>Code flash memory</li> <li>Data flash memory</li> <li>Option setting memory (programming only)</li> </ul> |
| Erasure in block units          | Possible   | Possible   | Possible   |
| Boot program at a reset         | User area program  | Embedded program for serial programming  | Depends on debug command   |

## 44.7 Overview of Functions

By using a dedicated flash-memory programmer to program the flash memory through a serial interface (serial programming) or JTAG/SWD interface (on-chip debug mode), the device can be rewritten regardless of whether this is before or after it is mounted on the target system.

Furthermore, security functions to prohibit rewriting or reading of the user program written to the flash memory are incorporated, and this can prevent falsification and illicit reading of the programs by third parties.

Programming by the user program (self-programming) is available to suit applications where the application on the target system may require updating after manufacturing or shipment. Protection features for the safe rewriting of the flash memory are also incorporated. Furthermore, interrupt processing during self-programming is supported, so programming can proceed at the same time as processing for external communications, etc., and this is the case in various situations. Table 44.10 lists the overview of the methods of programming and the corresponding operating modes.

Table 44.10 Programming methods

| Programming method      | Functional overview  | Operating mode          |
|-------------------------|--|-------------------------|
| Serial programming      | <p>A dedicated flash-memory programmer through the SCI or USBFS interface enables on-board programming of the flash memory after the device is mounted on the target system.</p> <p>A dedicated flash-memory programmer through the SCI or USBFS interface and a dedicated programming adapter board allow off-board programming of the flash memory, for example, programming of the device before it is mounted on the target system.</p>  | Serial programming mode |
| Self-programming        | <p>A user program written to memory in advance of serial programming execution can also program the flash memory. The background operation capability makes it possible to fetch instructions or otherwise read data from the code flash memory while the data flash memory is programmed. As a result, a program resident in the code flash memory is able to program the data flash memory.</p> <p>For background operations that are not possible, instructions in the code flash memory cannot be fetched and data cannot be accessed while the code flash memory is being programmed by self-programming. In such cases, a program for programming from the internal SRAM or external memory must be transferred in advance and executed.</p> | Normal operating mode   |
| JTAG or SWD programming | <p>A dedicated flash-memory programmer or an on-chip debugger through JTAG or SWD enables on-board programming of the flash memory after the device is mounted on the target system.</p> <p>A dedicated flash-memory programmer or an on-chip debugger through JTAG or SWD and a dedicated programming adapter board allow off-board programming of the flash memory, for example, programming of the device before it is mounted on the target system.</p>  | On-chip debug mode      |

Table 44.11 lists the functions of the flash memory. Serial programmer commands realize each function of serial programming, while reading of the flash memory by an FACI command or the user program realizes each function of self-programming.

允许编程和擦除的闪存区域和复位后的引导程序根据每种模式而不同。模式之间的差异在表44.9中列出。

Table 44.9 模式之间的差异

| Parameter | 正常运行模式   | 串行编程模式 (SCI或USB启动模式)   | 片上调试模式 (JTAG或SWD引导模式)  |
|-----------|--|--|--|
| 可编程和可擦除区域 | <ul style="list-style-type: none"> <li>代码闪存</li> <li>数据闪存</li> <li>选项设置内存 (仅编程)</li> </ul> | <ul style="list-style-type: none"> <li>代码闪存</li> <li>数据闪存</li> <li>Option-setting memory (programming only)</li> </ul> | <ul style="list-style-type: none"> <li>代码闪存</li> <li>数据闪存</li> <li>选项设置内存 (仅编程)</li> </ul> |
| 以块为单位擦除   | Possible   | Possible   | Possible   |
| 复位时的引导程序  | 用户区程序  | 用于串行编程的嵌入式程序   | 取决于调试命令  |

## 44.7 功能概述

通过使用专用闪存编程器通过串行接口 (串行编程) 或JTAG/SWD接口 (片上调试模式) 对闪存进行编程, 无论是在安装之前还是之后, 都可以重写设备目标系统。

此外, 内置了禁止重写或读取写入闪存的用户程序的安全功能, 这可以防止第三方篡改和非法读取程序。

用户程序编程 (自编程) 适用于目标系统上的应用程序在制造或发货后可能需要更新的应用程序。还集成了用于安全重写闪存的保护功能。此外, 支持自编程期间的中断处理, 因此可以与外部通信处理等同时进行编程, 这在各种情况下都是如此。表44.10列出了编程方法和相应操作模式的概述。

Table 44.10 编程方法

| 编程方法             | 功能概览   | 操作模式   |
|------------------|--|--------|
| 串行编程             | <p>通过SCI或USBFS接口的专用闪存编程器可在器件安装到目标系统后对闪存进行板载编程。</p> <p>通过SCI或USBFS接口的专用闪存编程器和专用编程适配器板允许对闪存进行板外编程, 例如, 在将设备安装到目标系统之前对其进行编程。</p>  | 串行编程模式 |
| Self-programming | <p>在串行编程执行之前写入存储器的用户程序也可以对闪存进行编程。后台操作能力使得在对数据闪存进行编程时, 可以从代码闪存中获取指令或以其他方式读取数据。结果, 驻留在代码闪存中的程序能够对数据闪存进行编程。对于无法进行的后台操作, 在自编程对代码闪存进行编程时, 无法获取代码闪存中的指令并且无法访问数据。在这种情况下, 必须预先传输并执行从内部SRAM或外部存储器进行编程的程序。</p> | 正常运行模式 |
| JTAG或SWD编程       | <p>专用闪存编程器或通过JTAG或SWD的片上调试器可在器件安装到目标系统后对闪存进行板载编程。专用闪存编程器或片上调试器通过</p> <p>JTAG或SWD和专用编程适配器板允许对闪存进行板外编程, 例如, 在将器件安装到目标系统之前对其进行编程。</p>   | 片上调试模式 |

表44.11列出了闪存的功能。串行编程器命令实现串行编程的各个功能, 而通过FACI命令或用户程序读取闪存实现自编程的各个功能。

Table 44.11 Basic Functions

| Function                              | Functional overview   | Availability       |   |
|---------------------------------------|---|--------------------|---|
|                                       |   | Serial programming | Self-programming  |
| Blank check                           | Checks a specified block to ensure that writing to it has not already proceeded. Results of reading from data flash memory to which nothing is written after erasure are not guaranteed, so use blank checking to confirm that writing to memory has not proceeded after erasure. | Not supported      | Supported (data flash programming only)                           |
| Block erasure                         | Erases the memory contents in the specified block   | Supported          | Supported   |
| Programming                           | Writes to the specified address   | Supported          | Supported   |
| CRC                                   | Calculates the CRC in the specified range of the flash memory and transfers it to the flash programmer  | Supported          | Non supported   |
| Read                                  | Reads data programmed in the flash memory   | Supported          | Not supported (read by user program is possible)                  |
| Start-up program protection functions | Configures the start-up program protection functions  | Supported          | Supported   |
| Option function selection             | Selects the option function, and modifies the initial setting of this MCU   | Supported          | Supported   |
| Block swap function                   | Setting block swap functions  | Supported          | Supported   |
| Block protection                      | Setting block protection  | Supported          | Supported   |
| Device lifecycle transition           | Transitions the device lifecycle  | Supported          | Not supported   |
| Memory security attribution           | Setting the memory security attribution   | Supported          | Not supported   |
| Key                                   | Injects key   | Supported          | Supported (except the key related to device lifecycle transition) |
| All erasure                           | Erase the flash memory to the state after shipment  | Supported          | Not supported   |

The flash memory supports various security functions.

Table 44.12 lists the security functions supported by the flash memory.

Table 44.12 Lists of Security Functions

| Function                               | Description  |
|--|--|
| Security flag for Start-up area select | Start-up area selection can be protected by setting of security flag (FSPR).   |
| Permanently block protection           | Programming or erasure of each block of code flash memory can be protected permanently.  |
| Protection for TrustZone               | Programming or erasure area, readable area, register access, and FACI command operation are protected by ARM TrustZone security. |
| Programming or erasure mode protection | Only secure developer can enter the programming or erasure mode for code flash.  |

## 44.8 Operating Modes of the Flash Sequencer

The flash sequencer has three operating modes as shown in Figure 44.6. Transitions between modes are initiated by changing the value of the FENTRYR register.

When the value of the FENTRYR register is 0x0000, the flash sequencer is in read mode. In this mode, it does not receive FACI commands. The code flash memory and data flash memory are both readable.

When the value of the FENTRYR register is 0x0001, the flash sequencer is in code flash P/E mode where the code flash memory can be programmed or erased by FACI commands. In this mode, the data flash memory is readable.

When the value of the FENTRYR register is 0x0080, the flash sequencer is in data flash P/E mode where the data flash memory can be programmed or erased by FACI commands. In this mode, the data flash memory is not readable. However, the code flash memory is readable.

Table 44.11 基本功能

| Function    | 功能概述  | Availability |                      |
|-------------|---|--------------|----------------------|
|             |   | 串行编程         | 自编程                  |
| 空白支票        | 检查指定的块以确保尚未对其进行写入。无法保证从擦除后没有写入任何内容的数据闪存中读取的结果，因此使用空白检查来确认擦除后没有继续写入内存。 | 不支持          | 支持（仅数据闪存编程）          |
| 块擦除         | 擦除指定块中的内存内容   | Supported    | Supported            |
| Programming | 写入指定地址  | Supported    | Supported            |
| CRC         | 计算flash存储器指定范围内的CRC，并传送给flash编程器                                      | Supported    | 不支持                  |
| Read        | 读取闪存中编程的数据  | Supported    | 不支持（可由用户程序读取）        |
| 启动程序保护功能    | 配置启动程序保护功能  | Supported    | Supported            |
| 选项功能选择      | 选择选项功能，修改本MCU的初始设置  | Supported    | Supported            |
| 区块交换功能      | 设置块交换功能   | Supported    | Supported            |
| 块保护         | 设置块保护   | Supported    | Supported            |
| 设备生命周期过渡    | 过渡设备生命周期  | Supported    | 不支持                  |
| 内存安全归属      | 设置内存安全属性  | Supported    | 不支持                  |
| Key         | 注入密钥  | Supported    | 支持（设备生命周期转换相关的key除外） |
| 全部擦除        | 擦除闪存到出货后的状态   | Supported    | 不支持                  |

闪存支持各种安全功能。

表44.12列出了闪存支持的安全功能。

Table 44.12 安全功能列表

| Function    | Description                                   |
|-------------|---|
| 启动区域选择的安全标志 | 启动区域选择可以通过设置安全标志(FSPR)来保护。                    |
| 永久阻止保护      | 可以永久保护每个代码闪存块的编程或擦除。                          |
| 保护TrustZone | 编程或擦除区域、可读区域、寄存器访问和FACI命令操作受ARMTrustZone安全保护。 |
| 编程或擦除模式保护   | 只有安全的开发人员才能进入代码闪存的编程或擦除模式。                    |

## 44.8 FlashSequencer的操作模式

闪存定序器具有三种操作模式，如图44.6所示。通过更改FENTRYR寄存器的值来启动模式之间的转换。

当FENTRYR寄存器的值为0x0000时，闪存定序器处于读取模式。在这种模式下，它不接收FACI命令。代码闪存和数据闪存都是可读的。

当FENTRYR寄存器的值为0x0001时，闪存定序器处于代码闪存PE模式，代码闪存可以通过FACI命令进行编程或擦除。在这种模式下，数据闪存是可读的。

当FENTRYR寄存器的值为0x0080时，闪存定序器处于数据闪存PE模式，可以通过FACI命令对数据闪存进行编程或擦除。在这种模式下，数据闪存是不可读的。但是，代码闪存是可读的。



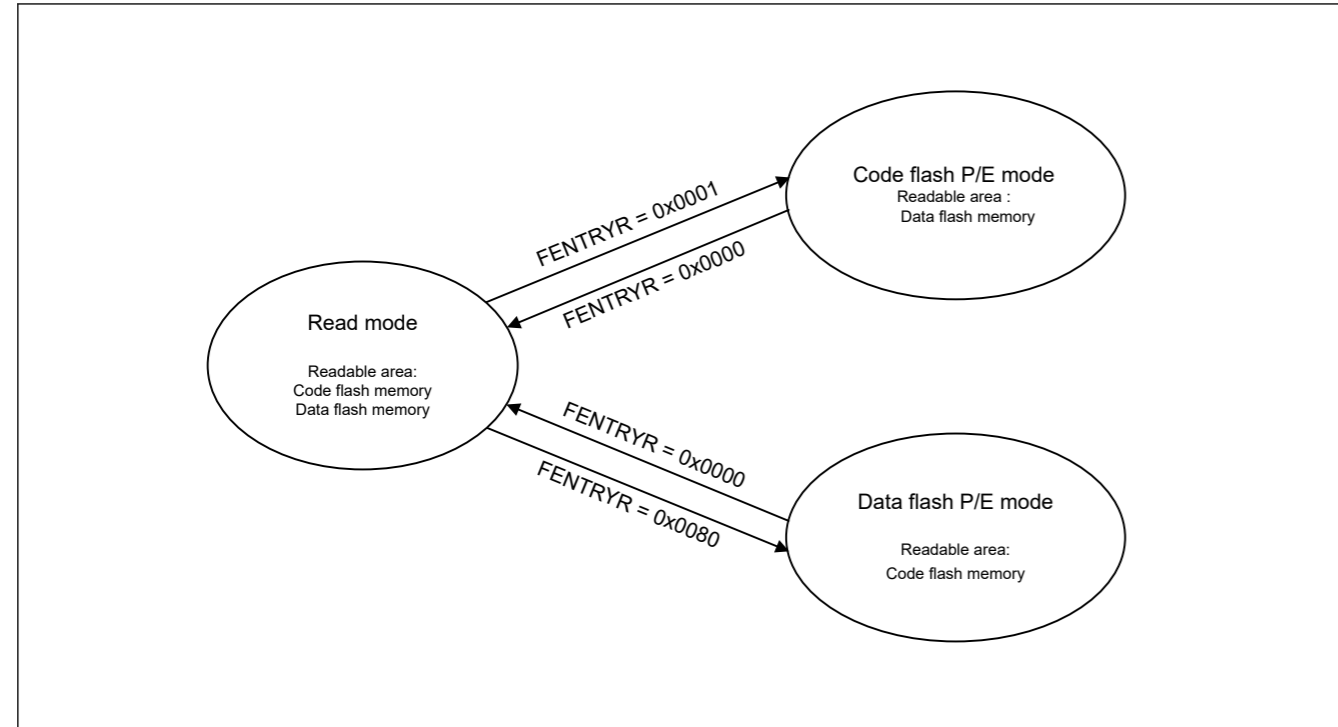


Figure 44.6 Modes of the flash sequencer

## 44.9 FACI Commands

### 44.9.1 List of FACI Commands

The FACI controls the FCU according to the specified FACI commands.

This section describes information about the FACI commands and Table 44.13 lists the FACI commands.

Table 44.13 FACI commands

| FACI command      | Function   |
|-------------------|--|
| Program           | Programs the user area and data area. Units of programming are 128 bytes for the user area and 4, 8, or 16 bytes for the data area.  |
| Block erase       | Erases user area and data area. The erase unit is 8 KB or 32 KB for user area, and 64 bytes for data flash.  |
| Multi block erase | Erases data area. The erase unit is 64, 128, 256 bytes for data flash.   |
| P/E suspend       | Suspends programming or erasure processing.  |
| P/E resume        | Resumes suspended programming or erasure processing.   |
| Status clear      | Initializes the ILGLERR, ERSERR, PRGERR, ILGCOMERR, FESETERR, SECERR, and OTERR bits in the FSTATR register and the CMDLK, CFAE, and DFAE bits in the FASTAT register, and the flash sequencer released from command-locked state. |
| Forced stop       | Forcibly stops processing of FACI commands and initializes the FSTATR and FASTAT registers.  |
| Blank check       | Checks if data areas are blank. Units of Blank Check: 4 bytes to data flash memory capacity (specified in 4-byte units).   |
| Configuration set | Sets the option-setting memory. Units of setting: 16 bytes.  |

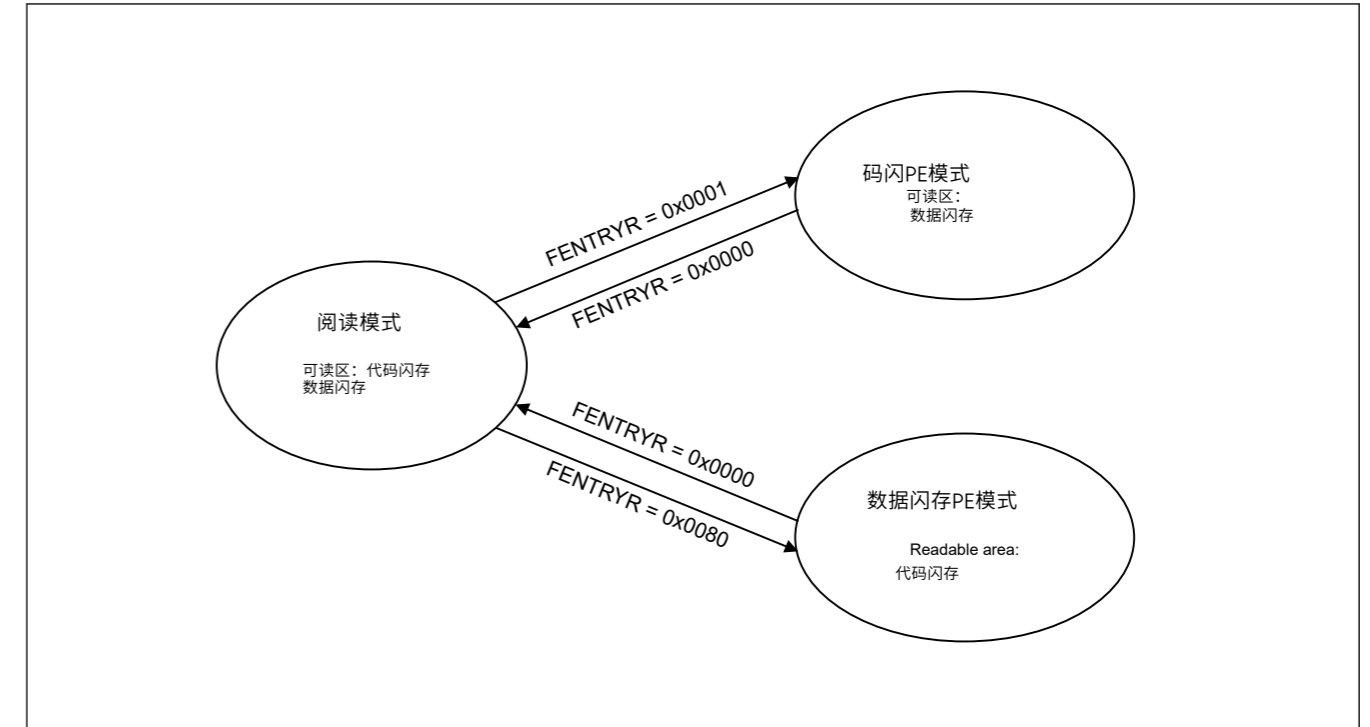


Figure 44.6 闪存音序器的模式

## 44.9 FACI命令

### 44.9.1 FACI命令列表

FACI根据指定的FACI命令控制FCU。

本节介绍有关FACI命令的信息，表44.13列出了FACI命令。

Table 44.13 FACI命令

| FACI命令      | Function   |
|-------------|--|
| Program     | 对用户区和数据区进行编程。用户区的编程单元为128字节，数据区为4、8或16字节。  |
| 块擦除         | 擦除用户区和数据区。用户区的擦除单元为8KB或32KB，数据闪存为64字节。   |
| 多块擦除        | 擦除数据区。数据闪存的擦除单元为64、128、256字节。  |
| P/E suspend | 暂停编程或擦除处理。   |
| P/E resume  | 恢复暂停的编程或擦除处理。  |
| 状态清除        | Initializes the ILGLERR, ERSERR, PRGERR, ILGCOMERR, FSTATR寄存器中的FESETERR、SECERR和OTERR位以及FASTAT寄存器中的CMDLK、CFAE和DFAE位，并且闪存定序器从命令锁定状态释放。 |
| 强制停止        | 强制停止处理FACI命令并初始化FSTATR和FASTAT寄存器。  |
| 空白支票        | 检查数据区域是否为空白。空白检查单位：4字节到数据闪存容量（以4字节为单位指定）。  |
| 配置集         | 设置选项设置内存。设置单位：16字节。  |

The FACI commands are issued by writing to the FACI command-issuing area (see Table 44.3). When write access as shown in Table 44.14 proceeds in the specified state, the flash sequencer executes the processing associated with the given command (see section 44.9.2. Relationship between the Flash Sequencer State and FACI Commands).

Table 44.14 FACI command formats

| FACI commands   | Number of write access | Write data to the FACI command-issuing area |                                     |                       |                |
|---|------------------------|---|-------------------------------------|-----------------------|----------------|
|   |                        | 1st access                                  | 2nd access                          | 3rd to (N+2)th access | (N+3)th access |
| Program (user area)<br>N = 64   | 67                     | 0xE8  | 0x40 (=N)                           | WD1 to WD64           | 0xD0           |
| Program (data area)<br>4-byte programming: N = 2<br>8-byte programming: N = 4<br>16-byte programming: N = 8 | N+3                    | 0xE8  | 0x02 (=N)<br>0x04 (=N)<br>0x08 (=N) | WD1 to WDN            | 0xD0           |
| Block Erase<br>(user area 8K/32K Bytes)   | 2                      | 0x20  | 0xD0                                | —                     | —              |
| Block Erase<br>(data area 64 bytes)   | 2                      | 0x20  | 0xD0                                | —                     | —              |
| Multi block erase<br>(data area 64/128/256 bytes)   | 2                      | 0x21  | 0xD0                                | —                     | —              |
| P/E suspend   | 1                      | 0xB0  | —                                   | —                     | —              |
| P/E resume  | 1                      | 0xD0  | —                                   | —                     | —              |
| Status Clear  | 1                      | 0x50  | —                                   | —                     | —              |
| Forced Stop   | 1                      | 0xB3  | —                                   | —                     | —              |
| Blank Check   | 2                      | 0x71  | 0xD0                                | —                     | —              |
| Configuration set<br>N = 8  | 11                     | 0x40  | 0x08 (=N)                           | WD1 to WD8            | 0xD0           |

Note: WDN (N = 1, 2, ...): Nth 16-bit data to be programmed.

The flash sequencer clears the FSTATR.FRDY bit to 0 at the start of a command processing other than the Status Clear command, and sets this bit to 1 on completion.

If the FRDYIE.FRDYIE bit setting is 1, a flash ready (FRDY) interrupt is generated when the FSTATR.FRDY bit is set to 1.

#### 44.9.2 Relationship between the Flash Sequencer State and FACI Commands

The FACI commands are accepted according to the mode/state of the flash sequencer. FACI commands should be issued after transitioning of the flash sequencer to the code flash P/E mode or data flash P/E mode and after checking the state of the flash sequencer.

Use the FSTATR and FASTAT registers to check the state of the flash sequencer. In addition, the occurrence of errors in general can be checked by reading the CMDLK bit in the FASTAT register. The value of the CMDLK bit is the logical OR of the following bits in the FSTATR register:

- ILGLERR
- ILGCOMERR
- FESETERR
- SECERR
- OTERR
- ERSERR
- PRGERR
- FLWEERR.

Table 44.15 lists the available FACI commands in each operating mode.

FACI命令通过写入FACI命令发布区域来发布（参见表44.3）。当表44.14所示的写访问在指定状态下进行时，闪存定序器执行与给定命令相关的处理（请参阅第44.9.2节。闪存定序器状态和FACI命令之间的关系）。

Table 44.14 FACI命令格式

| FACI命令  | 写访问次数 | 将数据写入FACI命令发布区 |                                     |               |                |
|---|-------|----------------|-------------------------------------|---------------|----------------|
|   |       | 1st access     | 2nd access                          | 第3次到第(N+2)次访问 | (N+3)th access |
| Program (user area)<br>N = 64   | 67    | 0xE8           | 0x40 (=N)                           | WD1 to WD64   | 0xD0           |
| Program (data area)<br>4-byte programming: N = 2<br>8-byte programming: N = 4<br>16-byte programming: N = 8 | N+3   | 0xE8           | 0x02 (=N)<br>0x04 (=N)<br>0x08 (=N) | WD1 to WDN    | 0xD0           |
| 块擦除（用户区8K/32K字节）  | 2     | 0x20           | 0xD0                                | —             | —              |
| 块擦除（数据区64字节）  | 2     | 0x20           | 0xD0                                | —             | —              |
| 多块擦除（数据区64/128/256字节）   | 2     | 0x21           | 0xD0                                | —             | —              |
| P/E suspend   | 1     | 0xB0           | —                                   | —             | —              |
| P/E resume  | 1     | 0xD0           | —                                   | —             | —              |
| 状态清除  | 1     | 0x50           | —                                   | —             | —              |
| 强制停止  | 1     | 0xB3           | —                                   | —             | —              |
| 空白支票  | 2     | 0x71           | 0xD0                                | —             | —              |
| 配置集<br>N = 8  | 11    | 0x40           | 0x08 (=N)                           | WD1 to WD8    | 0xD0           |

Note: WDN(N=1 2...): 要编程的第N个16位数据。

闪存定序器在除状态清除命令之外的命令处理开始时将FSTATR.FRDY位清除为0，并在完成时将此位设置为1。

如果FRDYIE.FRDYIE位设置为1，则当FSTATR.FRDY位设置为1时会产生闪存就绪(FRDY)中断。

#### 44.9.2 FlashSequencerState和FACI命令之间的关系

根据闪存定序器的模式状态接受FACI命令。FACI命令应在闪存定序器转换到代码闪存PE模式或数据闪存PE模式并检查闪存定序器的状态之后发出。

使用FSTATR和FASTAT寄存器检查闪存定序器的状态。此外，一般可以通过读取FASTAT寄存器中的CMDLK位来检查错误的发生。CMDLK位的值是FSTATR寄存器中以下位的逻辑或：

- ILGLERR
- ILGCOMERR
- FESETERR
- SECERR
- OTERR
- ERSERR
- PRGERR
- FLWEERR.

表44.15列出了每种操作模式下可用的FACI命令。

Table 44.15 Operating mode and available FACL commands

| Operating mode      | FENTRYR | Available FACL commands  |
|---------------------|---------|--|
| Read mode           | 0x0000  | None   |
| Code flash P/E mode | 0x0001  | Program<br>Block erase<br>P/E suspend<br>P/E resume<br>Status Clear<br>Forced Stop<br>Configuration set                |
| Data flash P/E mode | 0x0080  | Program<br>Block erase<br>Multi block erase<br>P/E suspend<br>P/E resume<br>Status Clear<br>Forced Stop<br>Blank Check |

Table 44.16 shows the state of the flash sequencer and acceptable FACL commands. An appropriate mode is assumed to have been set before the commands are executed.

Table 44.16 Acceptable FACL commands and state of the flash sequencer

|                                  | Program, block erase or multi block erase command processing | Configuration set command processing | Program, block erase or multi block erase command suspension processing | Blank check command processing | Programming suspended | Erase suspended | Programming while erasure is suspended | Command-locked state (FRDY = 1) | Command-locked state (FRDY = 0) | Processing of forced stop command | Other state    |
|----------------------------------|--|--------------------------------------|---|--------------------------------|-----------------------|-----------------|--|---------------------------------|---------------------------------|-----------------------------------|----------------|
| FRDY bit                         | 0  | 0                                    | 0   | 0                              | 1                     | 1               | 0                                      | 1                               | 0                               | 0                                 | 1              |
| SUSRDY bit                       | 1  | 0                                    | 0   | 0                              | 0                     | 0               | 0                                      | 0                               | 0                               | 0                                 | 0              |
| ERSSPD bit                       | 0  | 0                                    | 0/1   | 0/1                            | 0                     | 1               | 1                                      | 0/1                             | 0/1                             | 0                                 | 0              |
| PRGSPD bit                       | 0  | 0                                    | 0/1   | 0/1                            | 1                     | 0               | 0                                      | 0/1                             | 0/1                             | 0                                 | 0              |
| CMDLK bit                        | 0  | 0                                    | 0   | 0                              | 0                     | 0               | 0                                      | 1                               | 1                               | 0                                 | 0              |
| Program                          | X  | X <sup>4</sup>                       | X   | X                              | X                     | O <sup>3</sup>  | X                                      | X                               | X                               | X                                 | O              |
| Block erase or multi block erase | X  | X <sup>4</sup>                       | X   | X                              | X                     | X               | X                                      | X                               | X                               | X                                 | O              |
| P/E suspend                      | O  | X <sup>4</sup>                       | X   | X                              | X                     | X               | X                                      | —                               | X                               | X                                 | —              |
| P/E resume                       | X  | X <sup>4</sup>                       | X   | X                              | O                     | O               | X                                      | X                               | X                               | X                                 | X              |
| Status clear                     | X  | X <sup>4</sup>                       | X   | X                              | O                     | O               | X                                      | O                               | X                               | X                                 | O              |
| Forced stop                      | O  | O <sup>4</sup>                       | O   | O                              | O                     | O               | O                                      | O                               | O                               | O                                 | O              |
| Blank check                      | X  | X <sup>4</sup>                       | X   | X                              | O <sup>1</sup>        | O <sup>1</sup>  | X                                      | X                               | X                               | X                                 | O <sup>1</sup> |
| Configuration set                | X  | X <sup>4</sup>                       | X   | X                              | X                     | X               | X                                      | X                               | X                               | X                                 | O <sup>2</sup> |

Note: O: Acceptable

Table 44.15 操作模式和可用的FACL命令

| 操作模式     | FENTRYR | 可用的FACL命令                                      |
|----------|---------|--|
| 阅读模式     | 0x0000  | None   |
| 码闪PE模式   | 0x0001  | Program<br>块擦除PE暂停PE恢复状态清除强制停止<br><br>配置集      |
| 数据闪存PE模式 | 0x0080  | Program<br>块擦除多块擦除<br><br>PE暂停PE恢复状态清除强制停止空白检查 |

表44.16显示了闪存定序器的状态和可接受的FACL命令。假设在执行命令之前已经设置了适当的模式。

Table 44.16 可接受的FACL命令和闪存定序器的状态

|             | 编程、块擦除或多块擦除命令处理 | 配置集命令处理        | 编程、块擦除或多块擦除命令暂停处理 | 空白检查命令处理 | 编程暂停           | 擦除暂停           | 擦除暂停时编程 | Command-locked state (FRDY = 1) | Command-locked state (FRDY = 0) | 强制停止指令的处理 | 其他状态           |
|-------------|-----------------|----------------|-------------------|----------|----------------|----------------|---------|---------------------------------|---------------------------------|-----------|----------------|
| FRDY bit    | 0               | 0              | 0                 | 0        | 1              | 1              | 0       | 1                               | 0                               | 0         | 1              |
| SUSRDY bit  | 1               | 0              | 0                 | 0        | 0              | 0              | 0       | 0                               | 0                               | 0         | 0              |
| ERSSPD bit  | 0               | 0              | 0/1               | 0/1      | 0              | 1              | 1       | 0/1                             | 0/1                             | 0         | 0              |
| PRGSPD bit  | 0               | 0              | 0/1               | 0/1      | 1              | 0              | 0       | 0/1                             | 0/1                             | 0         | 0              |
| CMDLK bit   | 0               | 0              | 0                 | 0        | 0              | 0              | 0       | 1                               | 1                               | 0         | 0              |
| Program     | X               | X <sup>4</sup> | X                 | X        | X              | O <sup>3</sup> | X       | X                               | X                               | X         | O              |
| 块擦除或多块擦除    | X               | X <sup>4</sup> | X                 | X        | X              | X              | X       | X                               | X                               | X         | O              |
| P/E suspend | O               | X <sup>4</sup> | X                 | X        | X              | X              | X       | —                               | X                               | X         | —              |
| P/E resume  | X               | X <sup>4</sup> | X                 | X        | O              | O              | X       | X                               | X                               | X         | X              |
| 状态清除        | X               | X <sup>4</sup> | X                 | X        | O              | O              | X       | O                               | X                               | X         | O              |
| 强制停止        | O               | O <sup>4</sup> | O                 | O        | O              | O              | O       | O                               | O                               | O         | O              |
| 空白支票        | X               | X <sup>4</sup> | X                 | X        | O <sup>1</sup> | O <sup>1</sup> | X       | X                               | X                               | X         | O <sup>1</sup> |
| 配置集         | X               | X <sup>4</sup> | X                 | X        | X              | X              | X       | X                               | X                               | X         | O <sup>2</sup> |

Note: O: Acceptable

X: Not acceptable (places the sequencer in the command-locked state)  
 —: Ignored

- Note 1. Only acceptable in data flash P/E mode.
- Note 2. Only acceptable in code flash P/E mode
- Note 3. Acceptable when programming area is other than erase suspending block.
- Note 4. When configuration set is processing and when FSTATR.DBFULL bit is 1, do not issue this command.

### 44.9.3 Usage of FACI Commands

#### 44.9.3.1 Overview of Command Usage in Code Flash P/E Mode

Figure 44.7 show an overview of FACI command usage in code flash P/E mode. For the available commands in code flash P/E mode, see Table 44.15.

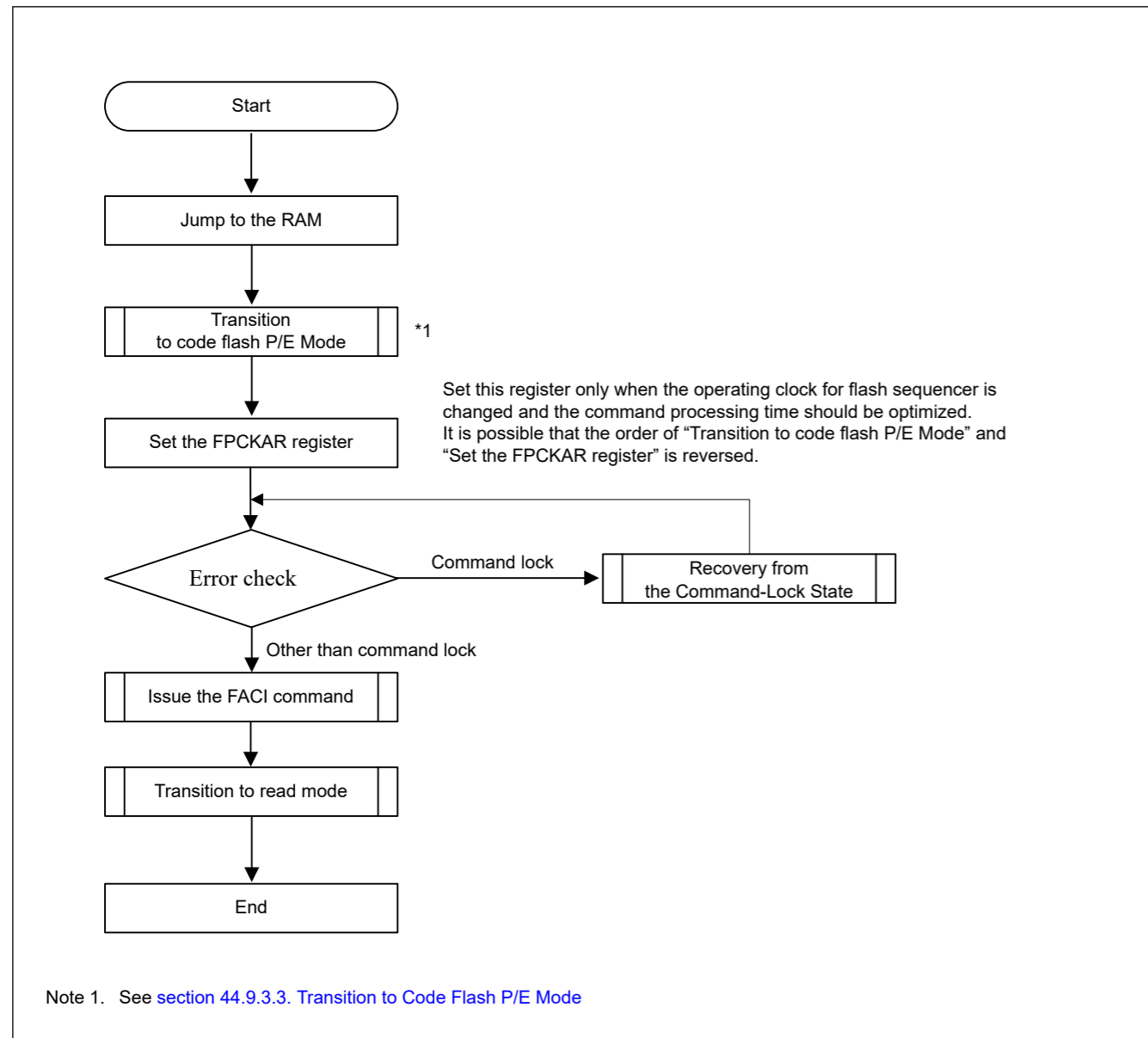


Figure 44.7 Overview of command usage in code flash P/E mode

#### 44.9.3.2 Overview of Command Usage in Data Flash P/E Mode

Figure 44.8 shows an overview of FACI command usage in data flash P/E and Table 44.15 lists the available commands in data flash P/E mode.

X: 不可接受 (将定序器置于命令锁定状态) —: 忽略

- 注1.仅在数据闪存PE模式下可接受。注2.仅在代码闪存PE模式下可接受
- 注3.当编程区域不是擦除暂停块时可接受。
- 注4.当配置集正在处理并且FSTATR.DBFULL位为1时, 不要发出此命令。

### 44.9.3 FACI命令的使用

#### 44.9.3.1 CodeFlashPE模式中的命令使用概述

图44.7显示了代码闪存PE模式下的FACI命令使用概览。对于代码闪存中的可用命令PE模式, 见表44.15。

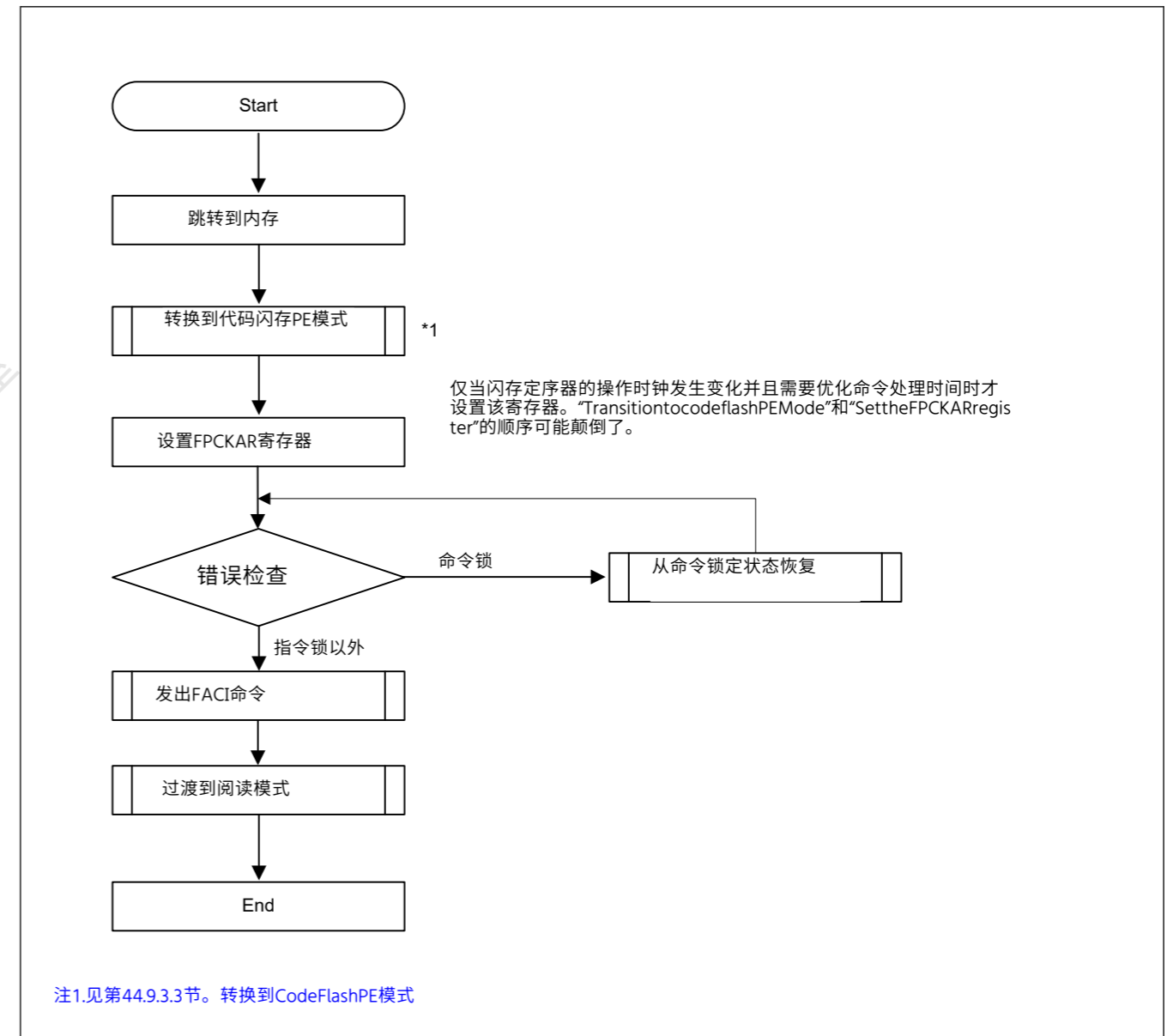


Figure 44.7 CodeflashPE模式下的命令使用概述

#### 44.9.3.2 DataFlashPE模式下的命令使用概述

图44.8显示了数据闪存PE中FACI命令使用的概述, 表44.15列出了数据闪存PE模式下的可用命令。



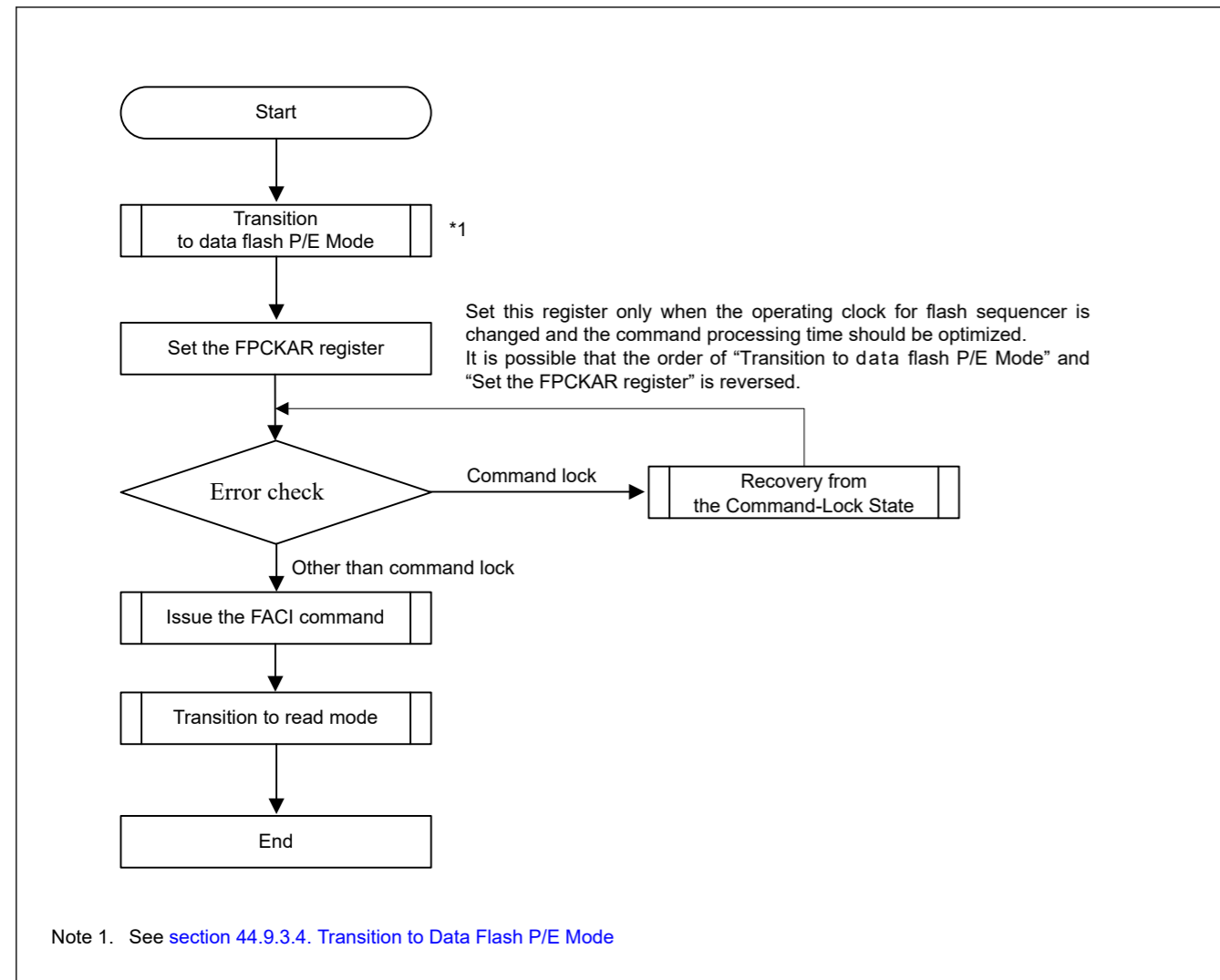


Figure 44.8 Overview of command usage in data flash P/E mode

### 44.9.3.3 Transition to Code Flash P/E Mode

To issue FACL commands for the code flash memory, a transition to code flash P/E mode is required by setting the FENTRYC bit in the FENTRYR register to 1.

Figure 44.9 shows the procedure to transition to code flash P/E mode.

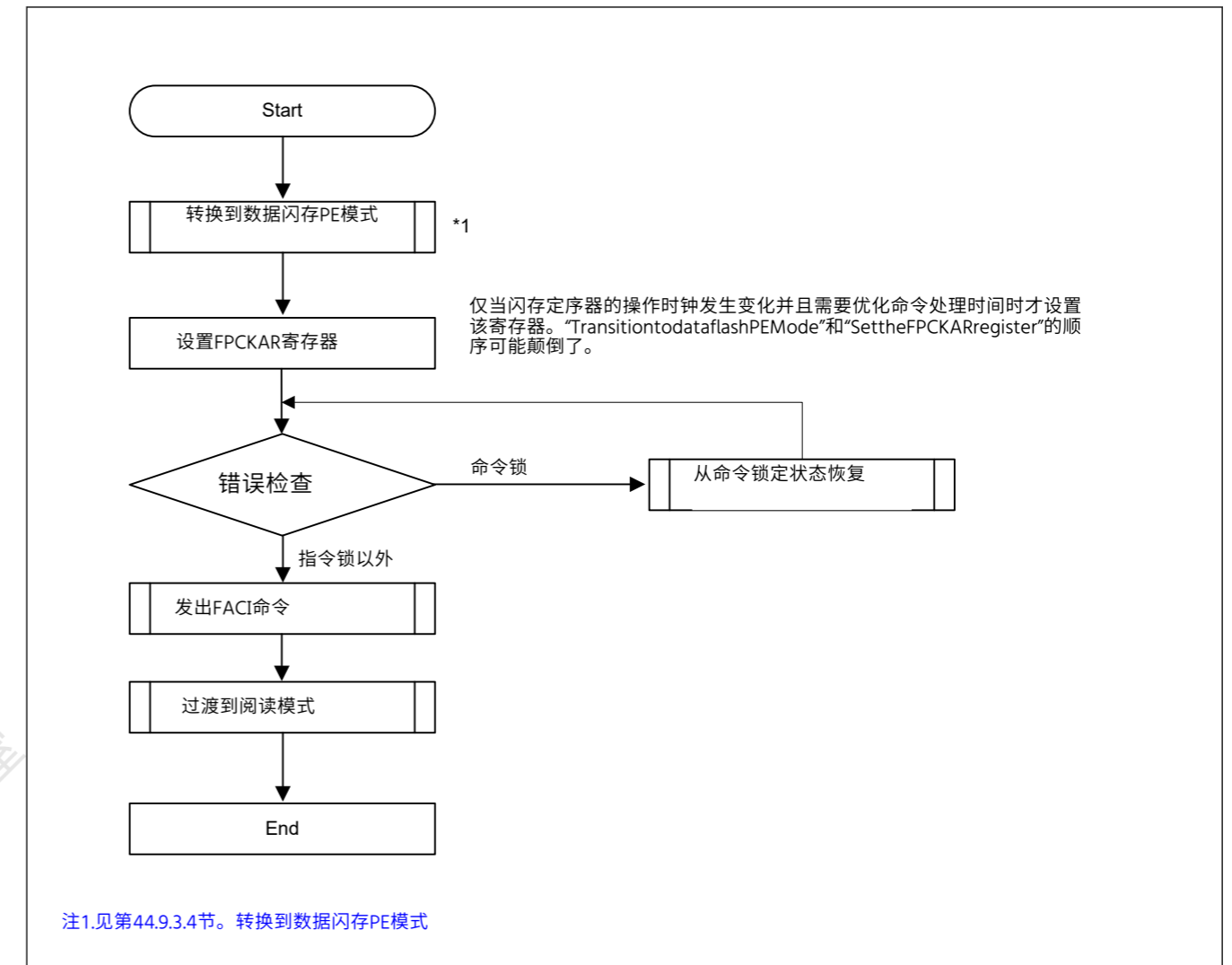


Figure 44.8 数据闪存PE模式下的命令使用概述

### 44.9.3.3 转换到CodeFlashPE模式

要为代码闪存发出FACL命令，需要通过设置FENTRYR寄存器中的FENTRYC位为1。

图44.9显示了转换到代码闪存PE模式的过程。

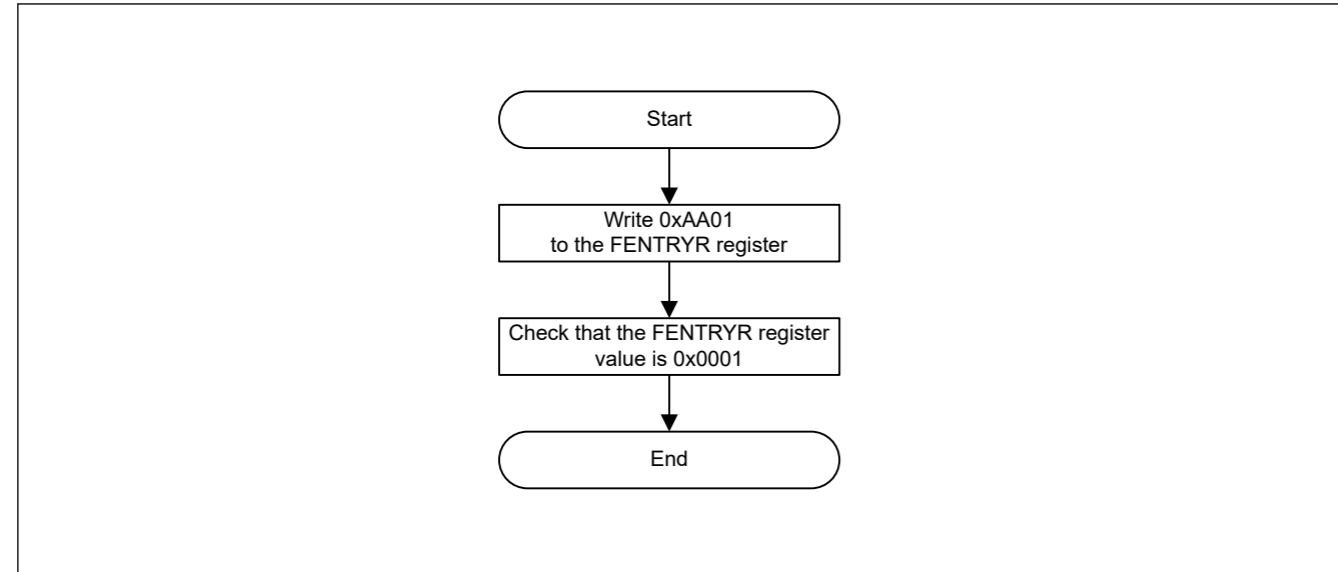


Figure 44.9 Procedure to transition to code flash P/E mode

#### 44.9.3.4 Transition to Data Flash P/E Mode

To issue FACL commands for the data flash memory, a transition to data flash P/E mode is required by setting the FENTRYD bit in the FENTRYR register to 1.

Figure 44.10 shows the procedure to transition to data flash P/E mode.

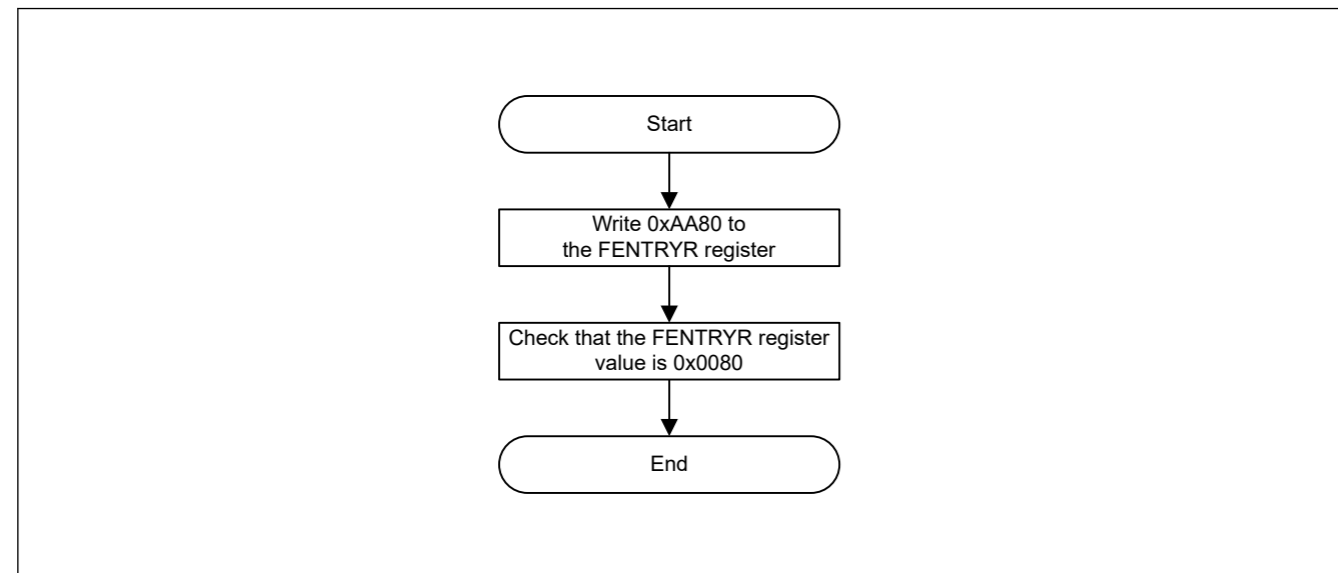


Figure 44.10 Procedure to transition to data flash P/E mode

#### 44.9.3.5 Transition to Read Mode

To read the flash memory, a transition to read mode is required by setting the FENTRYR register to 0x0000. The transition to read mode should be made after the flash sequencer completes the processing and while operation is not in the command-locked state.

Figure 44.11 shows the procedure to transition to read mode.

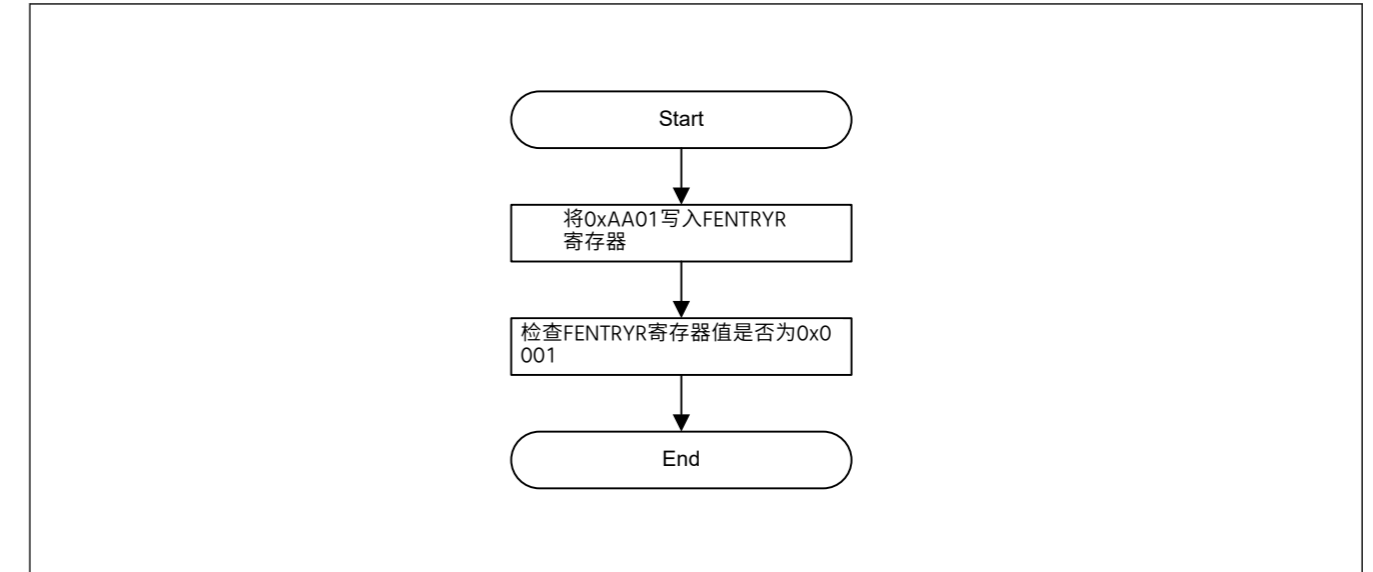


Figure 44.9 转换到代码闪存PE模式的程序

#### 44.9.3.4 转换到数据闪存PE模式

要为数据闪存发出FACL命令，需要通过设置FENTRYR寄存器中的FENTRYD位为1。

图44.10显示了转换到数据闪存PE模式的过程。

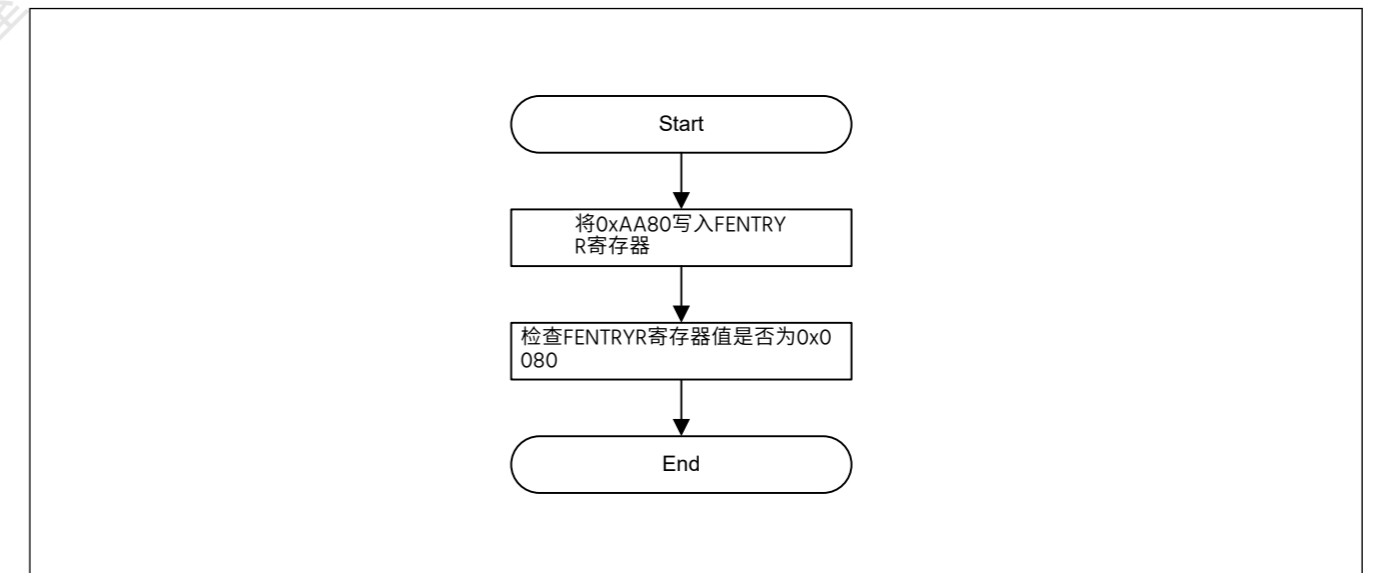


Figure 44.10 转换到数据闪存PE模式的步骤

#### 44.9.3.5 过渡到阅读模式

要读取闪存，需要通过将FENTRYR寄存器设置为0x0000转换到读取模式。闪存定序器完成处理后且操作未处于命令锁定状态时，应转换到读取模式。

图44.11显示了转换到读取模式的过程。

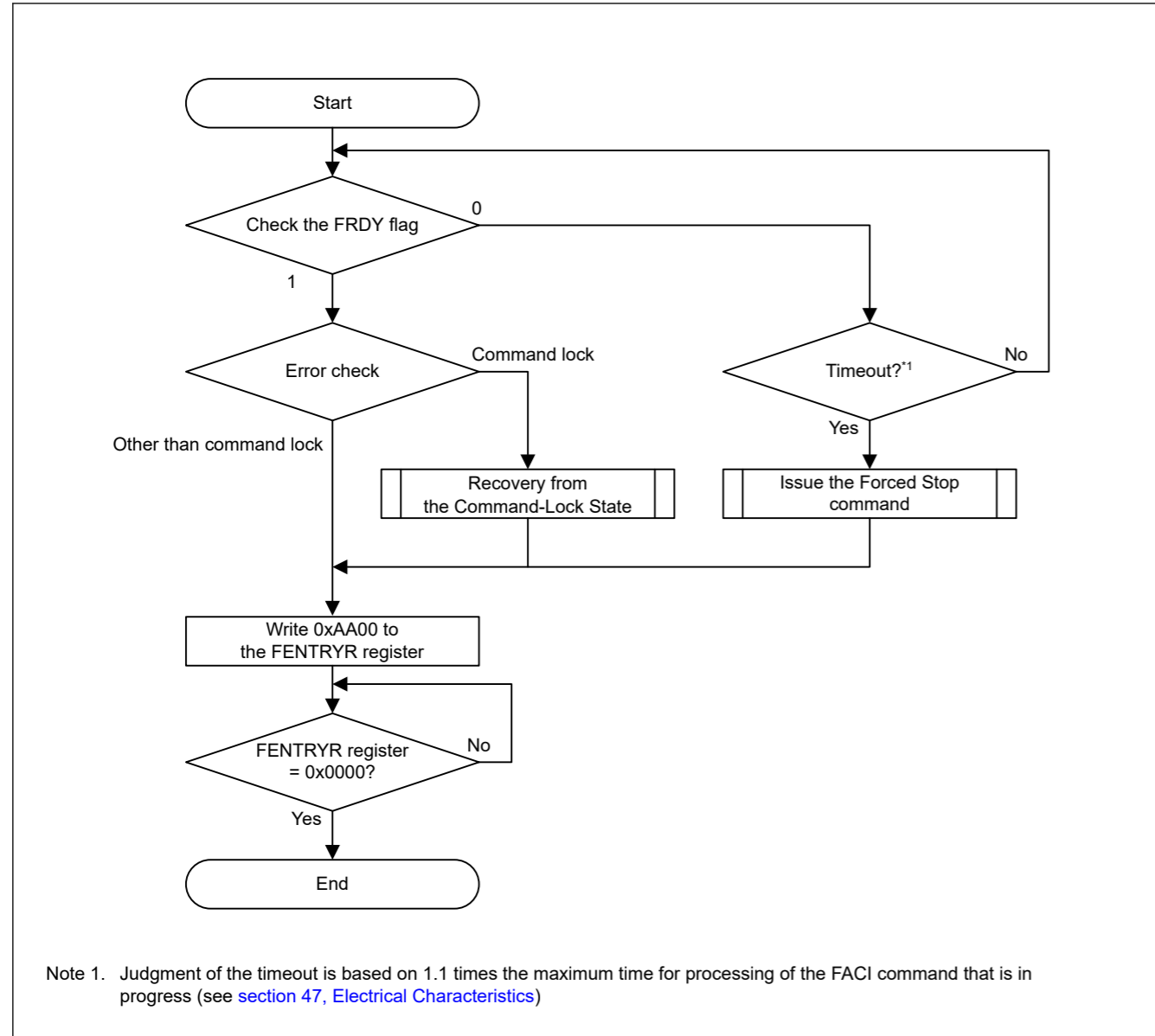


Figure 44.11 Procedure to transition to read mode

#### 44.9.3.6 Recovery from the Command-Locked State

When the flash sequencer enters the command-locked state, FACY commands cannot be accepted. To release the sequencer from the command-locked state, use the status clear command, forced stop command, or FASTAT register.

When the command-locked state is detected by checking for an error before issuing the P/E suspend command, the FRDY bit in the FSTATR register might be 0 even though command processing has not completed. If processing is not complete by the maximum programming/erasure time specified in the electrical characteristics, this is a timeout and the flash sequencer must be stopped with the forced stop command.

The FLWEERR bit in the FSTATR register does not change from 1 to 0 with the status clear command. When these bits are set to 1, use the forced stop command to release from the command-locked state. Bits other than FRDY and FLWEERR in FSTATR register that indicate the command-locked state can be changed from 1 to 0 with the status clear or forced stop command.

Figure 44.12 shows the recovery flow from the command-locked state.

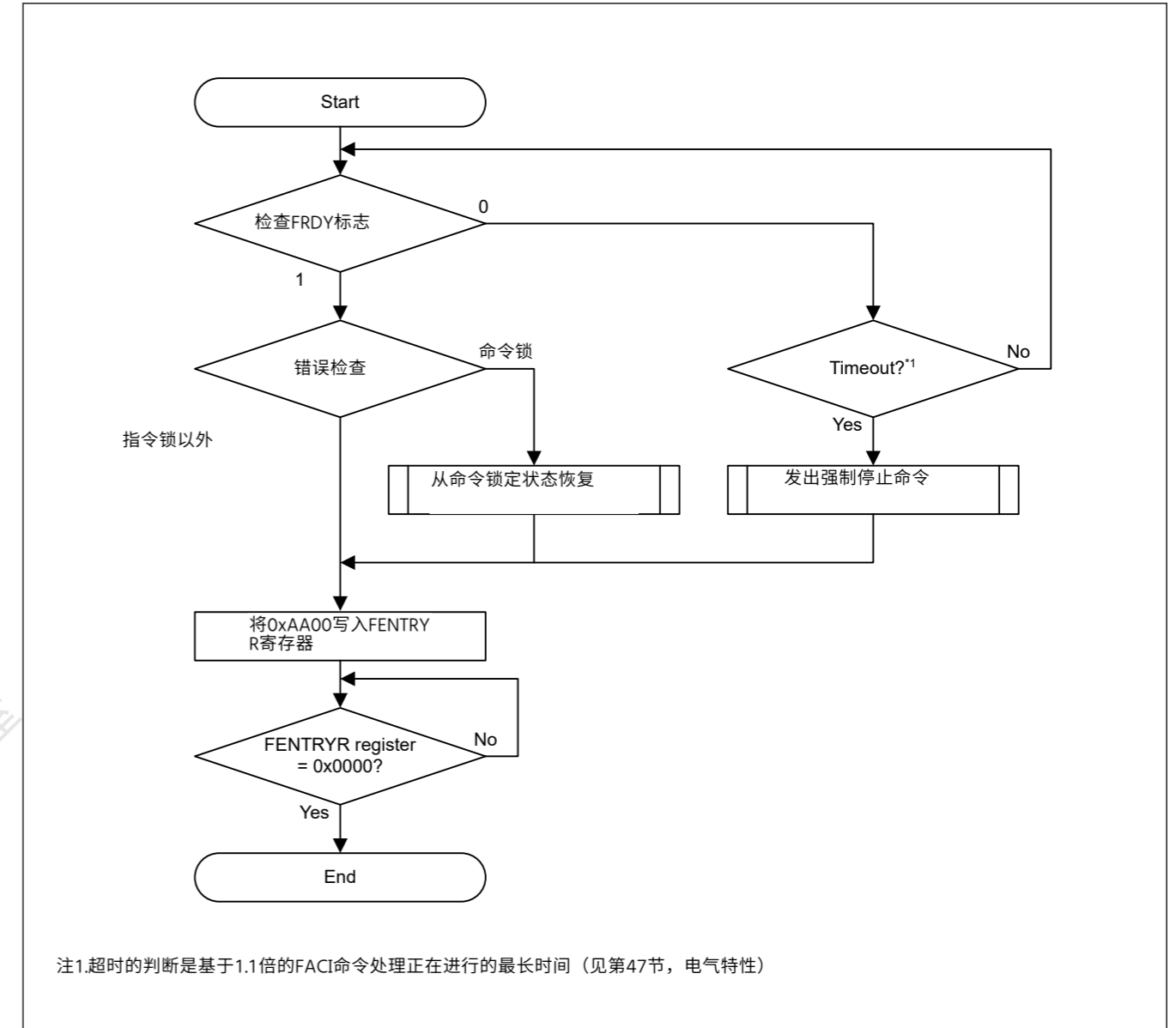


Figure 44.11 转换到阅读模式的过程

#### 44.9.3.6 从命令锁定状态恢复

当闪存定序器进入命令锁定状态时，无法接受FACY命令。要从命令锁定状态释放定序器，请使用状态清除命令、强制停止命令或FASTAT寄存器。

当通过在发出PE挂起命令之前检查错误来检测命令锁定状态时，即使命令处理尚未完成，FSTATR寄存器中的FRDY位也可能为0。如果在电气特性中指定的最大编程擦除时间未完成处理，则这是一个超时，并且必须使用强制停止命令停止闪存定序器。

FSTATR寄存器中的FLWEERR位不会随着状态清除命令从1变为0。当这些位设置为1时，使用强制停止命令从命令锁定状态中释放。FSTATR寄存器中除FRDY和FLWEERR以外的位指示命令锁定状态可以通过状态清除或强制停止命令从1更改为0。

图44.12显示了从命令锁定状态的恢复流程。

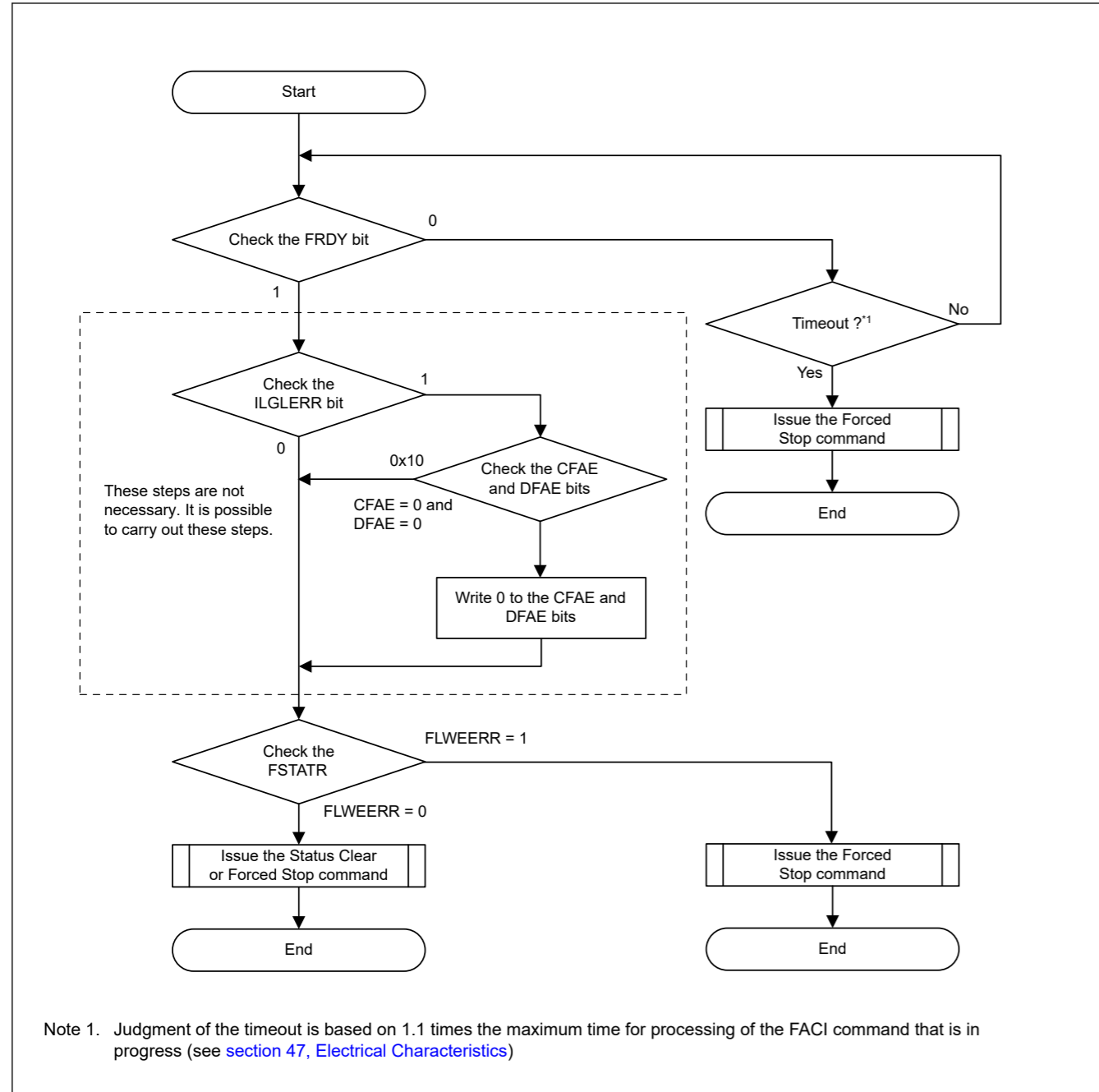


Figure 44.12 Recovery flow from the command-locked state

### 44.9.3.7 Program Command

The program command is used for writing to the user area and data area. Before issuing the FACL program command, set the first address of the target block in the FSADDR register. Writing 0xD0 at the final access of the FACL command-issuing area starts the program command processing. If the target area of program command processing contains area that are not for writing, write 0xFFFF to the corresponding area.

Issuing the program command while the FACL internal data buffer is full leads to a wait on the peripheral bus that might affect communications performance of other peripheral modules. To avoid a wait, set the DBFULL bit in the FSTATR register to 0 when issuing the FACL command. Writing to the data area does not lead to the data buffer becoming full.

Figure 44.13 shows the usage of the program command.

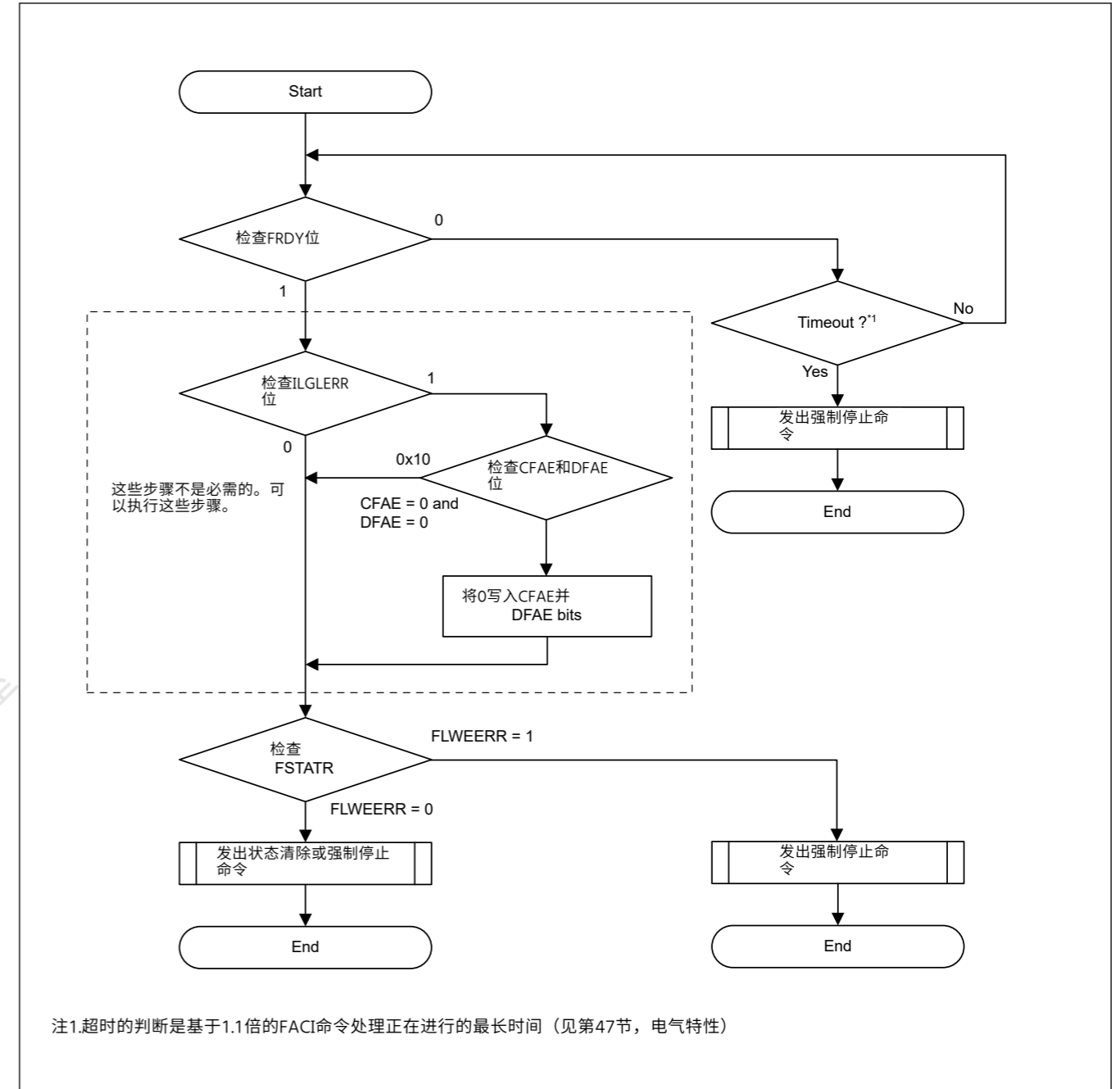


Figure 44.12 从命令锁定状态恢复流程

### 44.9.3.7 程序命令

程序命令用于写入用户区和数据区。在发出FACL程序命令之前，在FSADDR寄存器中设置目标块的首地址。在最终访问FACL命令发布区域时写入0xD0开始程序命令处理。如果程序命令处理的目标区域包含非写入区域，则将0xFFFF写入相应区域。

在FACL内部数据缓冲区已满时发出程序命令会导致外围总线等待，这可能会影响其他外围模块的通信性能。为避免等待，请在发出FACL命令时将FSTATR寄存器中的DBFULL位设置为0。写入数据区不会导致数据缓冲区变满。

图44.13显示了程序命令的用法。



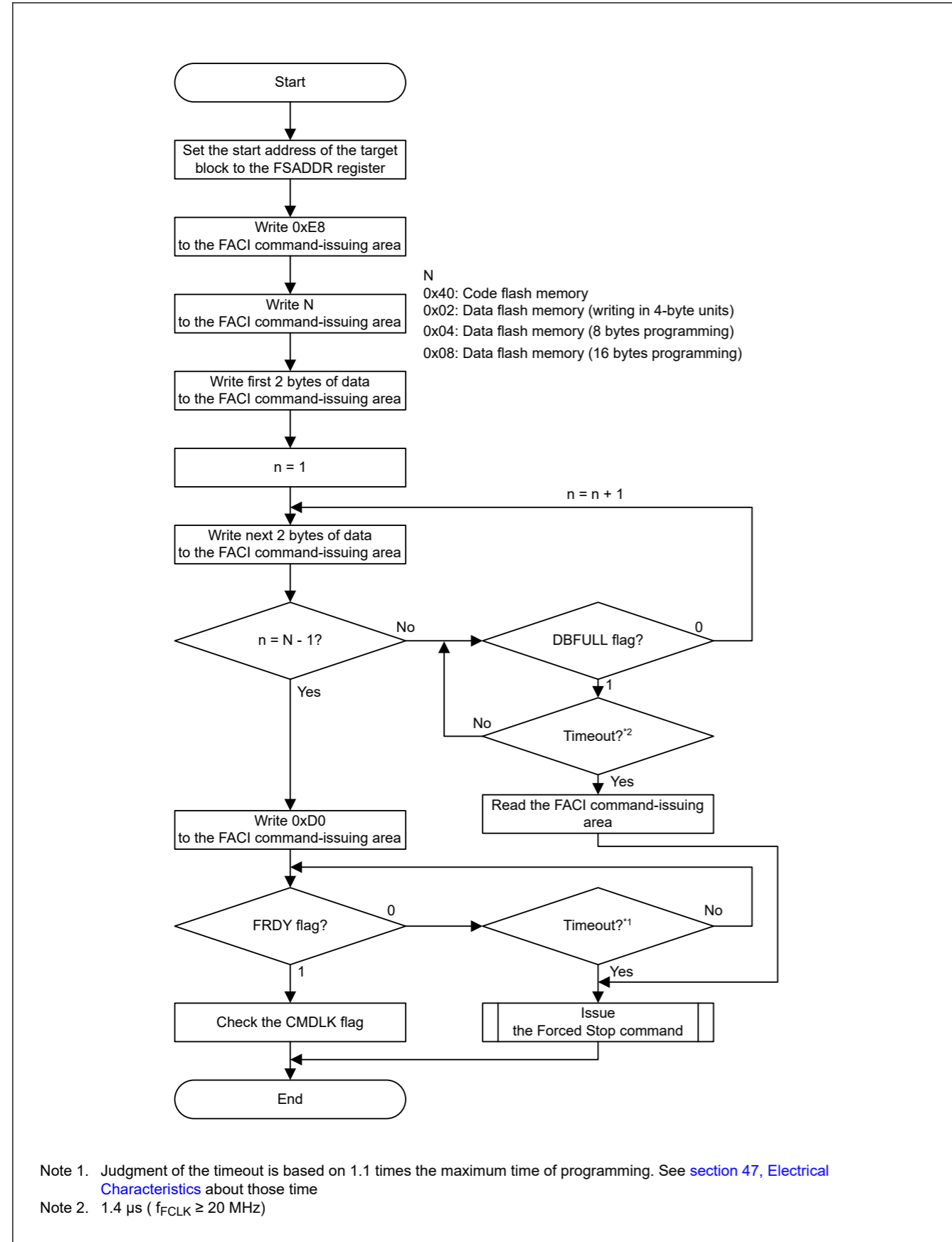


Figure 44.13 Usage flow of the program command

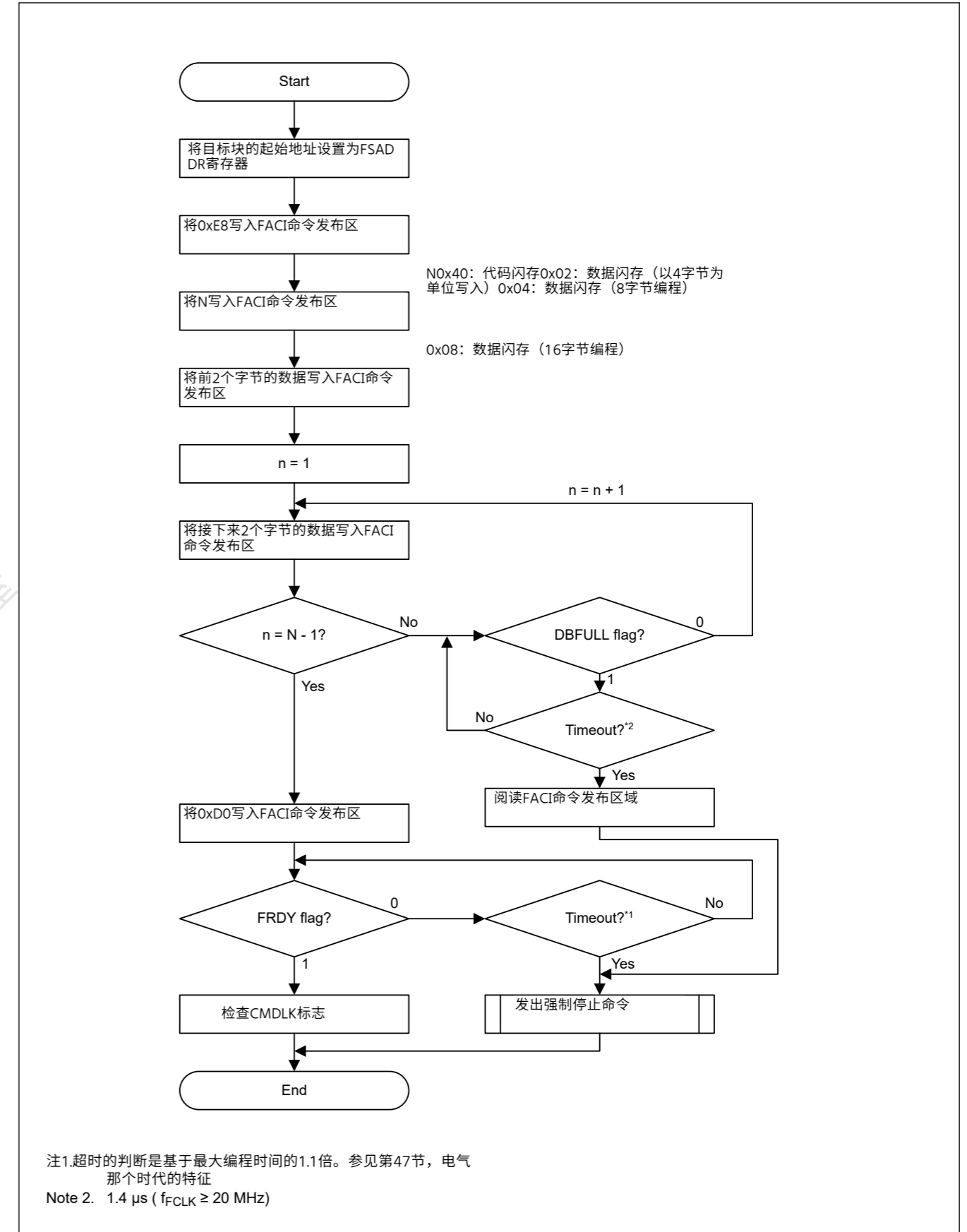


Figure 44.13 程序指令的使用流程

### 44.9.3.8 Block Erase Command

The block erase command is used for erasing user area or data area. The erase unit is one block. Before issuing a block erase command, set the first address of the target block to FSADRR register. Writing 0xD0 at the second write access of the FACI command triggers the FACI to start the block erase command processing. Completion of command processing can be confirmed with the FRDY bit of FSTATR register.

Set the FCPSR registers before issuing the block erase command. Additionally, FCPSR must be set when the erasure-suspended mode is to be switched.

Figure 44.14 shows the usage of the block erase command.

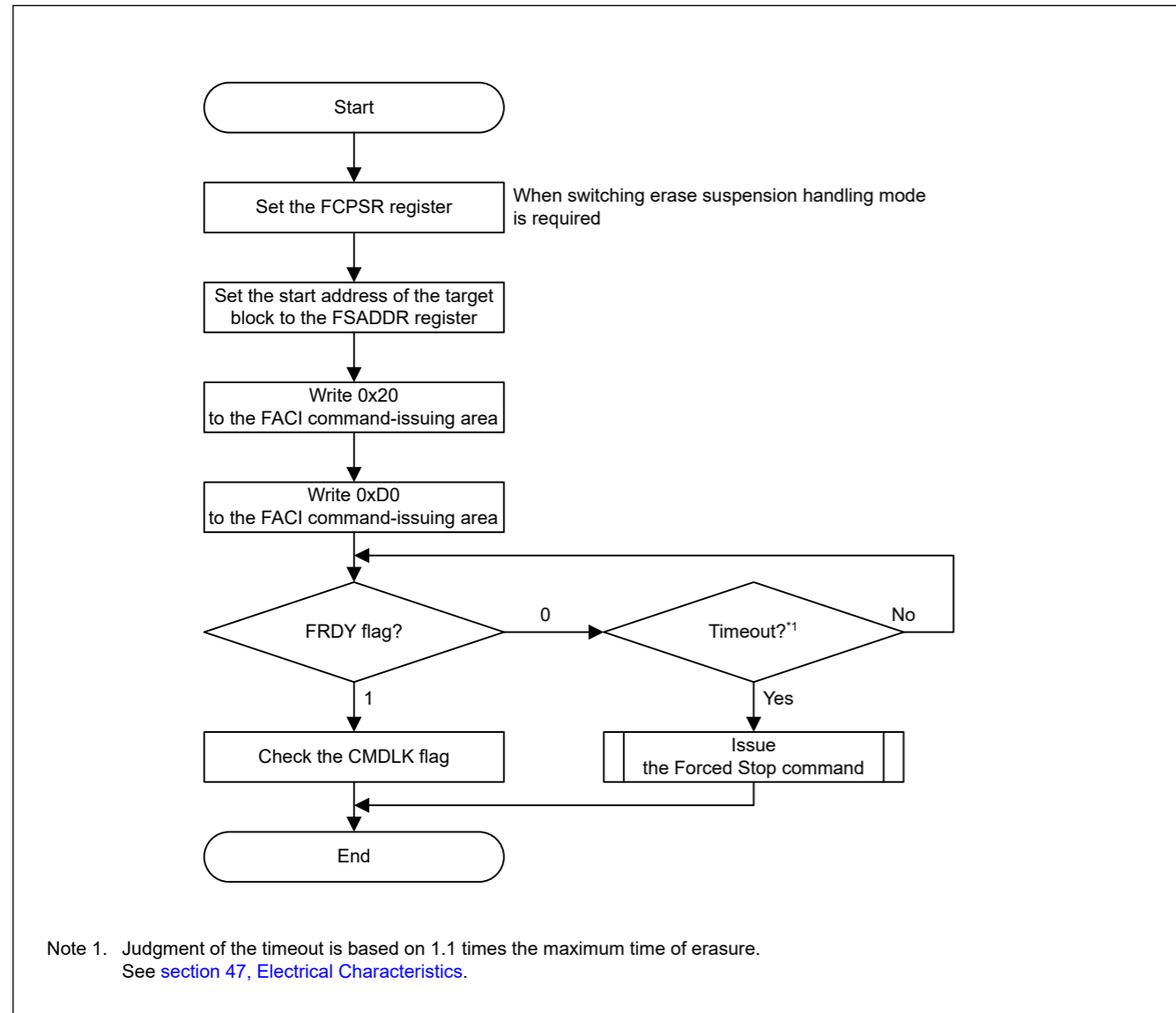


Figure 44.14 Usage flow of the block erase command

### 44.9.3.9 Multi Block Erase Command

The multi block erase command is used for erasing data area. The erase unit is 64, 128, or 256 bytes. Before issuing the multi block erase command, set the start address to FSADRR register and the end address to FEADDR register. Writing 0xD0 at the second write access of the FACI command triggers FACI to start the multi block erase command processing. Completion of command processing can be confirmed with the FRDY bit of FSTATR register.

Set the FCPSR registers before issuing the multi block erase command. Additionally, FCPSR must be set when the erasure-suspended mode is to be switched.

### 44.9.3.8 块擦除命令

块擦除命令用于擦除用户区或数据区。擦除单位是一个块。在发出块擦除命令之前，将目标块的首地址设置为FSA DRR寄存器。在FACI命令的第二次写访问时写入0xD0会触发FACI开始块擦除命令处理。命令处理的完成可以通过F STATR寄存器的FRDY位来确认。

在发出块擦除命令之前设置FCPSR寄存器。此外，当要切换擦除暂停模式时，必须设置FCPSR。

图44.14显示了块擦除命令的用法。

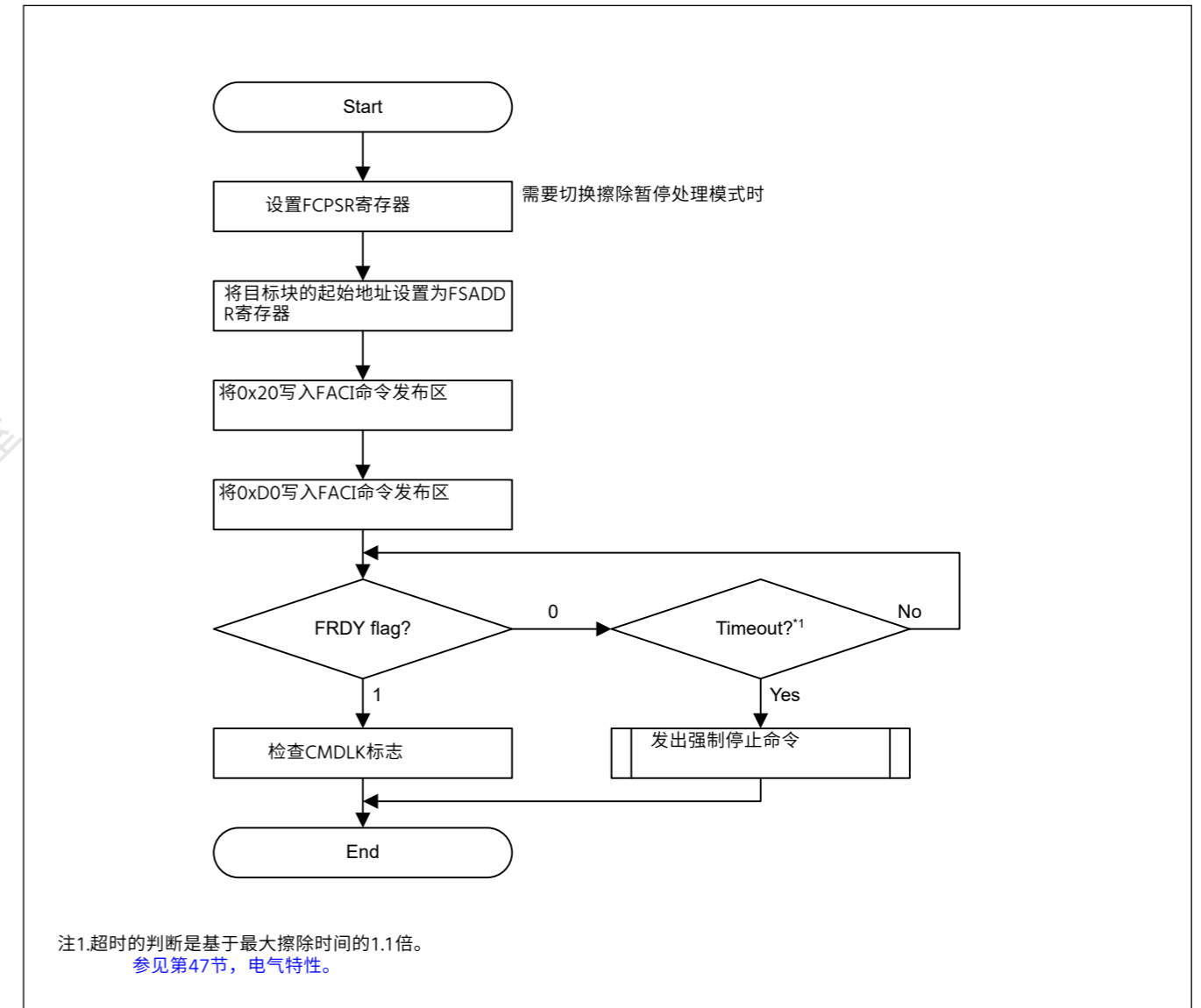


Figure 44.14 块擦除命令的使用流程

### 44.9.3.9 多块擦除命令

多块擦除命令用于擦除数据区域。擦除单元为64、128或256字节。在发出多块擦除命令之前，将起始地址设置为FSADRR寄存器，将结束地址设置为FEADDR寄存器。在FACI命令的第二次写访问时写入0xD0会触发FACI开始多块擦除命令处理。命令处理的完成可以通过FSTATR寄存器的FRDY位来确认。

在发出多块擦除命令之前设置FCPSR寄存器。此外，当要切换擦除暂停模式时，必须设置FCPSR。

The erase size is specified by both the FSADDR and FEADDR settings. Table 44.17 describes how to set the FSADDR and FEADDR.

Table 44.17 Settings for the erase size

| Erase size | FSADDR                               | FEADDR        |
|------------|--------------------------------------|---------------|
| 64 bytes   | FSA0 to FSA5 = 0 (64 byte-boundary)  | FSADDR + 0x3C |
| 128 bytes  | FSA0 to FSA6 = 0 (128 byte-boundary) | FSADDR + 0x7C |
| 256 bytes  | FSA0 to FSA7 = 0 (256 byte-boundary) | FSADDR + 0xFC |

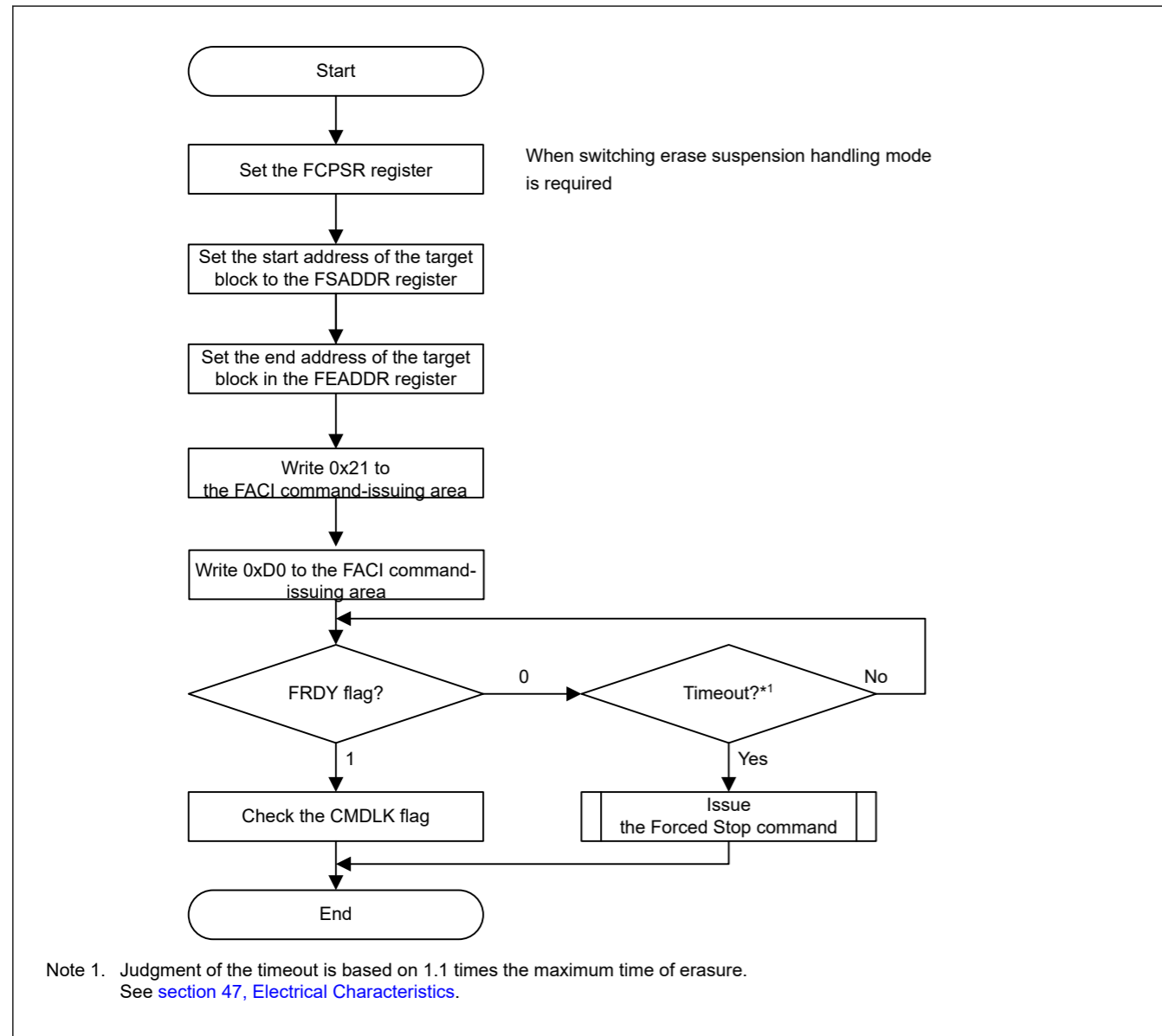


Figure 44.15 Usage flow of the multi block command

44.9.3.10 P/E Suspend Command

The P/E suspend command is used to suspend programming/erasure. Before issuing a P/E suspend command, check that the CMDLK bit in the FASTAT register is 0, and that the execution of programming/erasure is performed normally. To confirm that the P/E suspend command can be received, check that the SUSRDY bit in the FSTATR register is 1. After issuing a P/E suspend command, read the CMDLK bit to confirm that no error occurs.

If an error occurs during programming/erasure, the CMDLK bit is set to 1. When programming/erasure processing has finished from the time when the SUSRDY bit is 1 to when the P/E suspend command is received, no error occurs and the

擦除大小由FSADDR和FEADDR设置指定。表44.17描述了如何设置FSADDR和FEADDR。

Table 44.17 擦除大小的设置

| 擦除大小      | FSADDR                               | FEADDR        |
|-----------|--------------------------------------|---------------|
| 64 bytes  | FSA0 to FSA5 = 0 (64 byte-boundary)  | FSADDR + 0x3C |
| 128 bytes | FSA0 to FSA6 = 0 (128 byte-boundary) | FSADDR + 0x7C |
| 256 bytes | FSA0 to FSA7 = 0 (256 byte-boundary) | FSADDR + 0xFC |

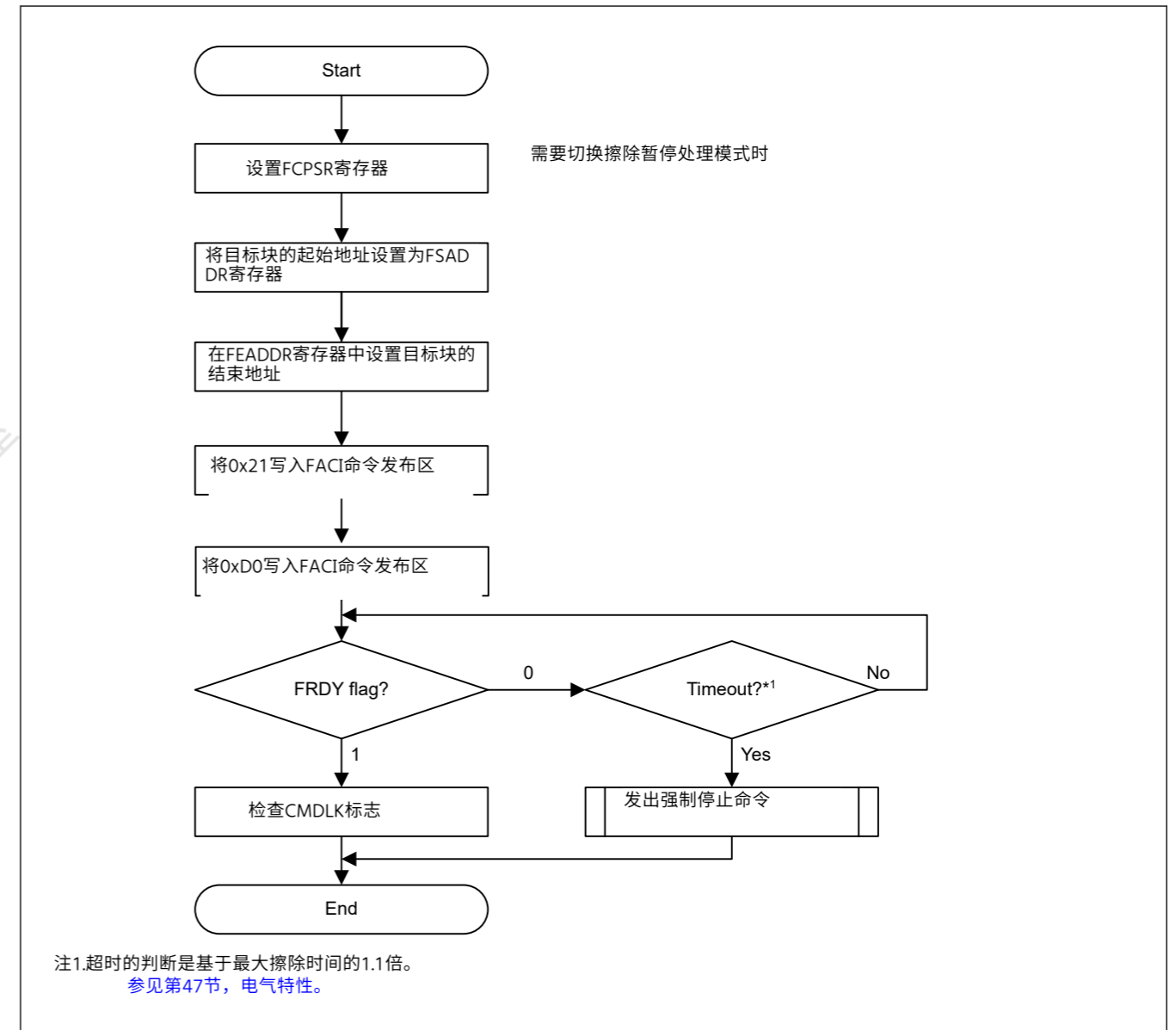


Figure 44.15 多块命令的使用流程

44.9.3.10 PE挂起命令

PE暂停命令用于暂停编程擦除。在发出PE挂起命令之前，请检查FASTAT寄存器中的CMDLK位是否为0，并且编程擦除的执行是否正常执行。要确认可以接收到PE挂起命令，请检查FSTATR寄存器中的SUSRDY位是否为1。发出PE挂起命令后，读取CMDLK位以确认没有错误发生。

如果在编程擦除过程中发生错误，则将CMDLK位设置为1。从SUSRDY位为1到接收到PE暂停命令时，当编程擦除处理完成时，不会发生错误，并且

suspended state is not entered (the FRDY bit in the FSTATR register is 1 and the ERSSPD and PRGSPD bits in FSTATR are 0).

When a P/E suspend command is received and the programming/erasure suspend processing finishes normally, the flash sequencer enters the suspended state, the FRDY bit is set to 1, and the ERSSPD or PRGSPD bit is 1. After issuing a P/E suspend command, check that the ERSSPD or PRGSPD bit is 1 and the suspended state is entered, then proceed with the subsequent flow. If a P/E resume command is issued in the subsequent flow even when the suspended state is not entered, an illegal command error occurs and the flash sequencer shifts to the command-locked state (see [section 44.11.2. Error Protection](#)).

If the erasure suspended state is entered, programming to blocks other than an erasure target block can be performed. Additionally, the programming and erasure suspended states can shift to read mode by clearing the FENTRYR register.

[Figure 44.16](#) shows the usage of the P/E suspend command.

未进入挂起状态（FSTATR寄存器中的FRDY位为1，FSTATR中的ERSSPD和PRGSPD位为0）。

当接收到PE挂起命令并且编程擦除挂起处理正常完成时，闪存定序器进入挂起状态，FRDY位设置为1，ERSPD或PRGSPD位为1。发出PE挂起命令后，检查是否ERSPD或PRGSPD位为1，进入挂起状态，然后进行后续流程。如果在后续流程中发出PEresume命令，即使未进入挂起状态，也会发生非法命令错误，并且闪存定序器会切换到命令锁定状态（参见第44.11.2节。错误保护）。

如果进入擦除暂停状态，则可以执行对擦除目标块以外的块的编程。此外，通过清除FENTRYR寄存器，编程和擦除暂停状态可以转换为读取模式。

图44.16显示了PE挂起命令的用法。



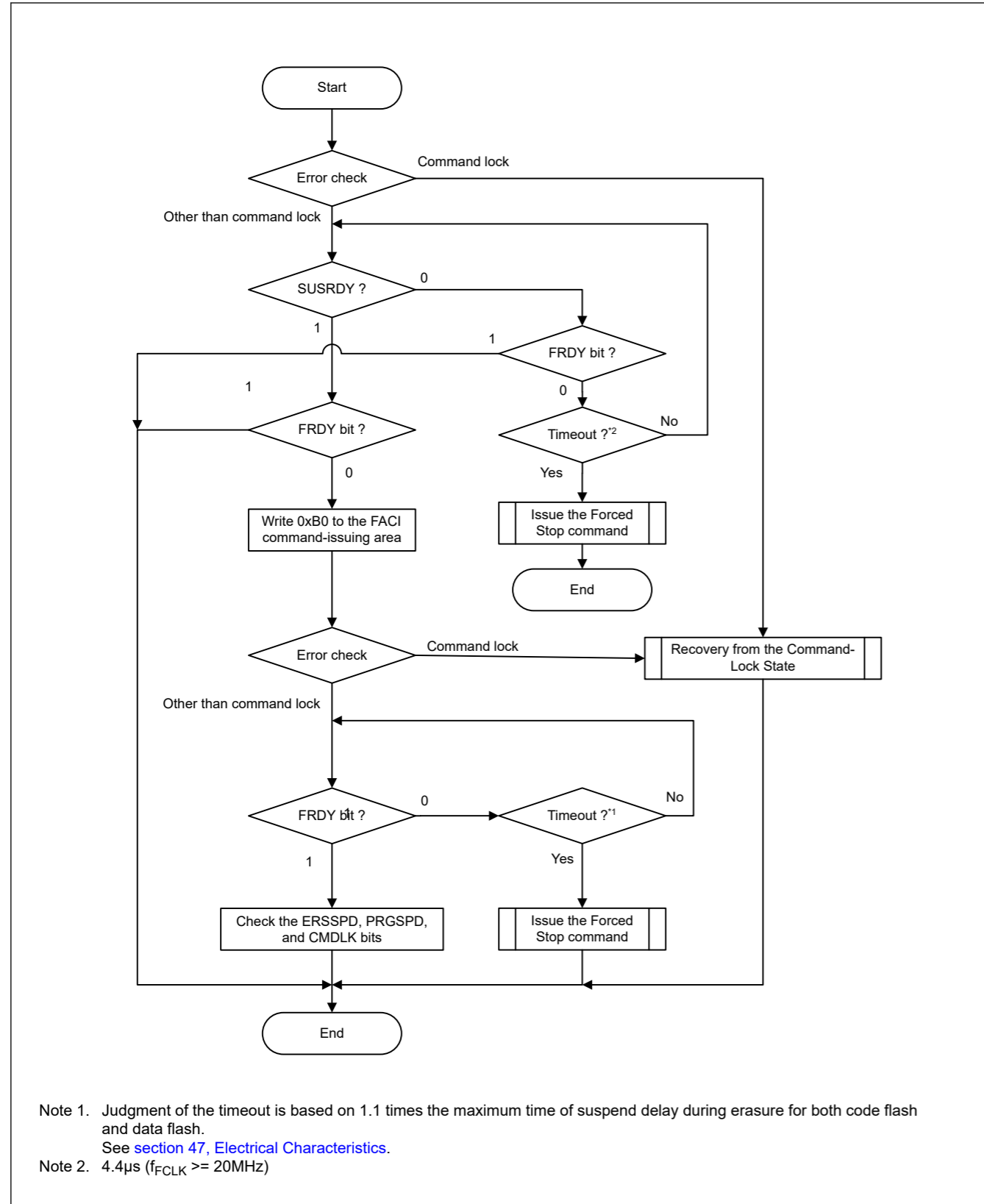


Figure 44.16 Usage flow of the P/E suspend command

(1) Suspension during Programming

When issuing a P/E suspend command during flash memory programming, the flash sequencer suspends programming processing. Figure 44.17 shows the suspend programming operation. When receiving programming-related command, the flash sequencer clears the FRDY bit in the FSTATR register to 0 to start programming. If the flash sequencer enters the state

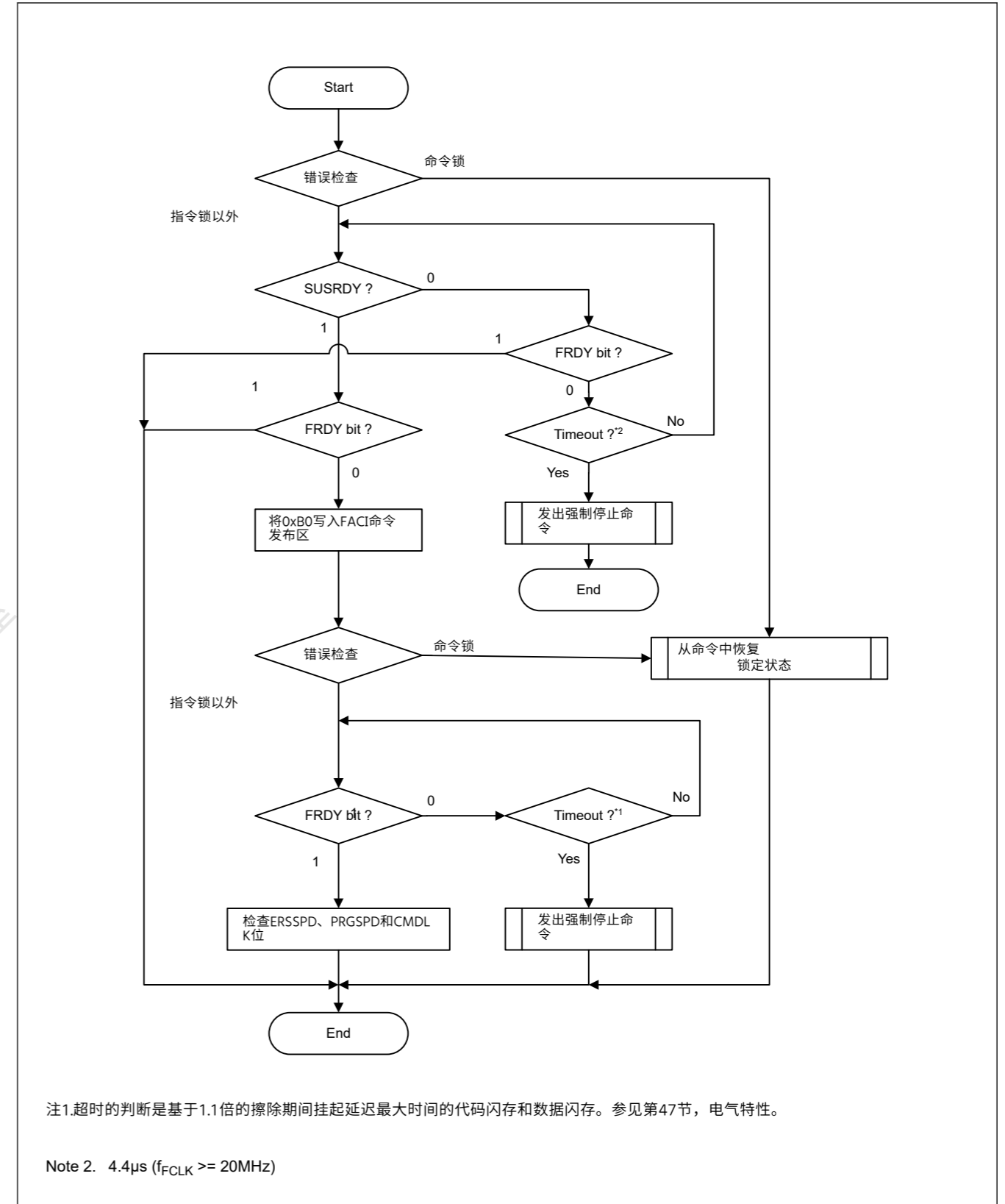


Figure 44.16 PE挂起命令的使用流程

(1) 编程期间暂停

在闪存编程期间发出PE暂停命令时，闪存定序器暂停编程处理。图44.17显示了挂起编程操作。当接收到编程相关命令时，flashsequencer将FSTATR寄存器中的FRDY位清0以开始编程。如果闪存定序器进入状态

in which the P/E suspend command can be received after programming starts, it sets the SUSRDY bit in the FSTATR register to 1.

When a P/E suspend command is issued, the flash sequencer receives the command and clears the SUSRDY bit to 0. If the flash sequencer receives a P/E suspend command while a programming pulse is applied, the flash sequencer continues with the pulse. After the specified pulse application time, the flash sequencer finishes pulse application, starts the programming suspend processing, and sets the PRGSPD bit in the FSTATR register to 1.

When a suspended processing finishes, the flash sequencer sets the FRDY bit to 1 to enter the programming suspended state. When receiving a P/E resume command in the programming suspended state, the flash sequencer clears the FRDY and PRGSPD bits to 0 and resumes programming.

Figure 44.17 shows the timing for suspension during programming.

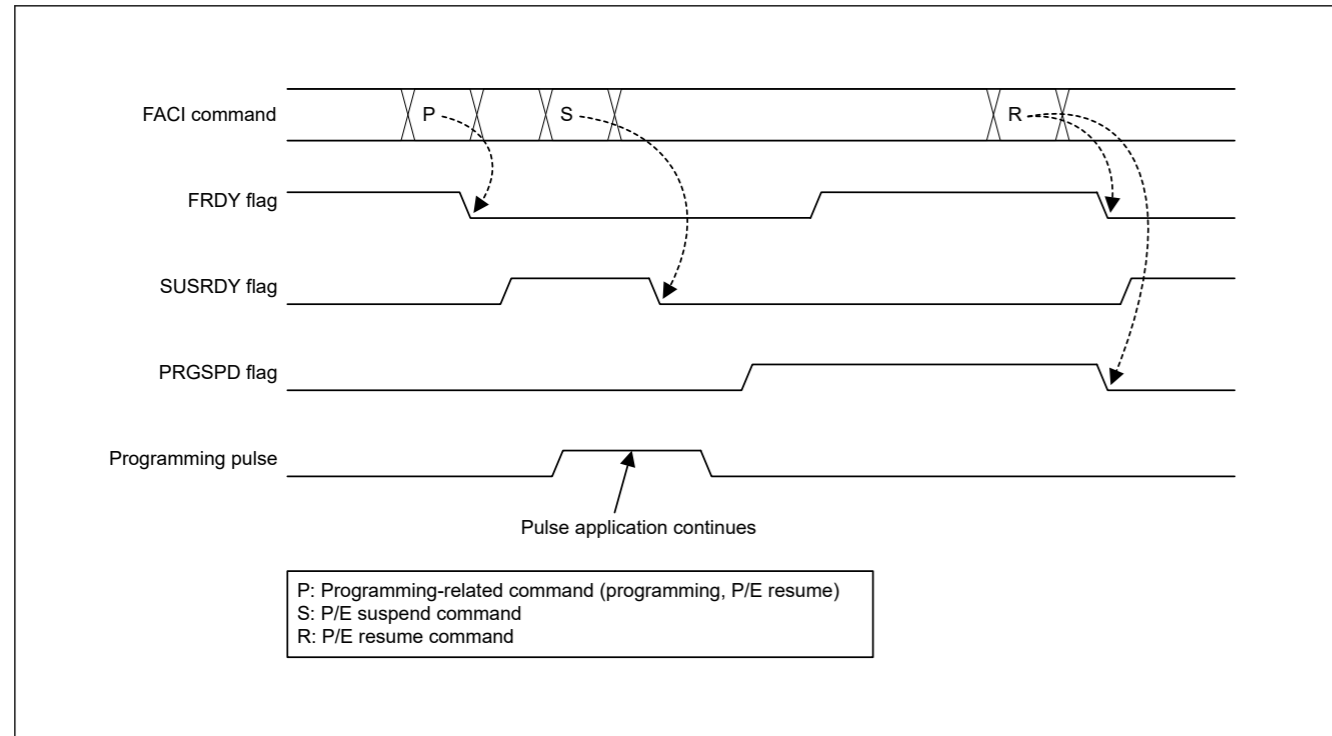


Figure 44.17 Suspension during programming

## (2) Suspension during Erasure (Suspension Priority Mode)

The flash sequencer has a suspension priority mode for the suspension of erasure. Figure 44.18 shows the suspend operation of erasure when the erasure suspend mode is set to the suspension priority mode (the ESUSPMD bit in the FCPSR register is 0).

When receiving an erasure-related command, the flash sequencer clears the FRDY bit in the FSTATR register to 0 to start erasure. If the flash sequencer enters the state in which the P/E suspend command can be received after erasure starts, it sets the SUSRDY bit in the FSTATR register to 1.

When a P/E suspend command is issued, the flash sequencer receives the command and clears the SUSRDY bit to 0.

When receiving a suspend command during erasure, the flash sequencer starts the suspend processing and sets the ERSSPD bit in the FSTATR register to 1 even when it is applying an erasure pulse. When the suspended processing finishes, the flash sequencer sets the FRDY bit to 1 to enter the erasure suspended state. When receiving a P/E resume command in the erasure suspended state, the flash sequencer clears the FRDY and ERSSPD bits to 0 and resumes erasure. Operations of the FRDY, SUSRDY, and ERSSPD bits at the suspension and resumption of erasure are the same, regardless of the erasure suspend mode.

The setting of the erasure suspend mode affects the control method of erasure pulses. In suspension priority mode, when receiving a P/E suspend command while erasure pulse A that has not been previously suspended is being applied, the flash sequencer suspends the application of erasure pulse A and enters the erasure suspended state. When receiving a P/E suspend command while reapplying erasure pulse A after erasure is resumed with a P/E resume command, the flash sequencer

在编程开始后接收PE挂起命令的情况下，它将FSTATR寄存器中的SUSRDY位设置为1。

当发出PE暂停命令时，闪存定序器接收该命令并将SUSRDY位清除为0。如果在施加编程脉冲时闪存定序器接收到PE暂停命令，则闪存定序器继续执行该脉冲。在指定的脉冲施加时间之后，闪存定序器完成脉冲施加，开始编程暂停处理，并将FSTATR寄存器中的PRGSPD位设置为1。

当暂停处理完成时，闪存定序器将FRDY位设置为1以进入编程暂停状态。当在编程暂停状态下接收到PEresume命令时，闪存定序器将FRDY和PRGSPD位清除为0并恢复编程。

图44.17显示了编程期间暂停的时序。

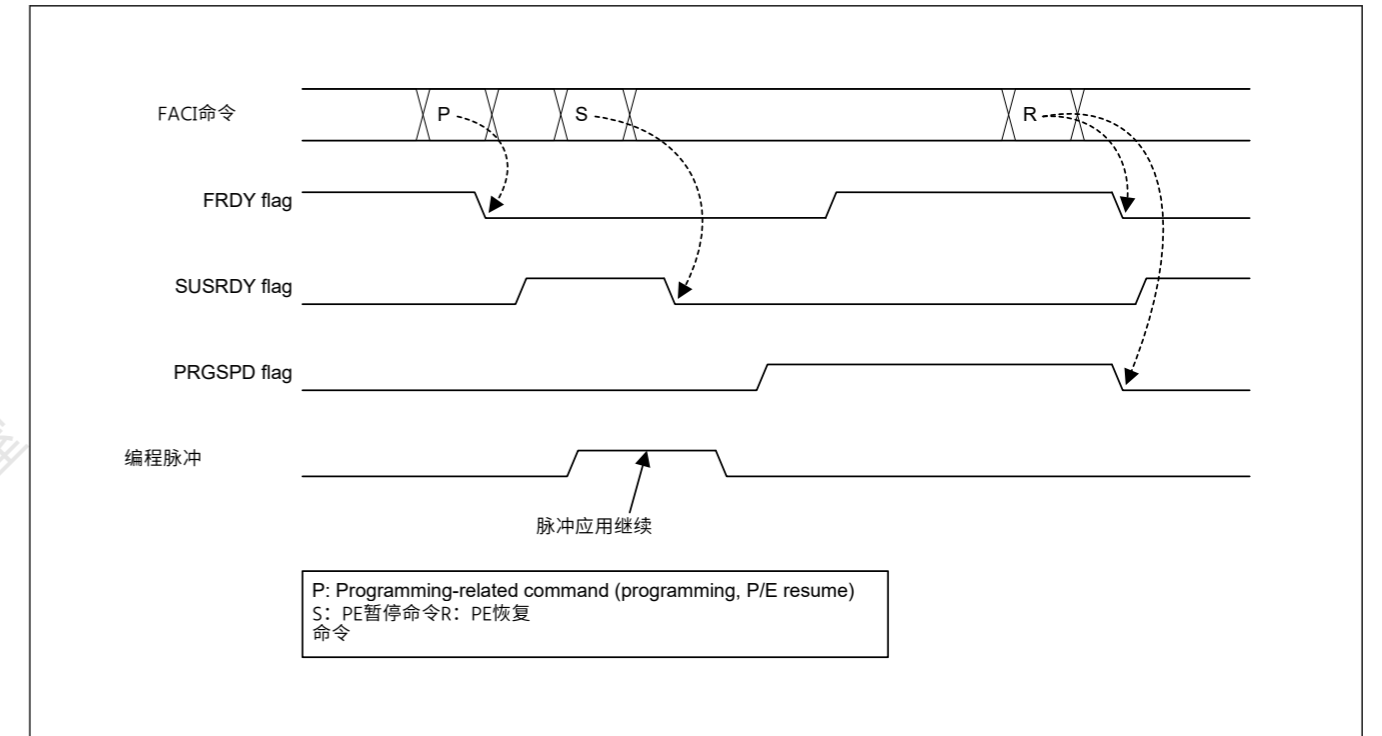


Figure 44.17 编程期间暂停

## (2) 擦除期间暂停（暂停优先模式）

闪存定序器具有用于暂停擦除的暂停优先模式。图44.18显示了擦除挂起模式设置为挂起优先模式时的擦除挂起操作（FCPSR寄存器中的ESUSPMD位为0）。

当接收到擦除相关命令时，闪存定序器将FSTATR寄存器中的FRDY位清零以开始擦除。如果闪存定序器在擦除开始后进入可以接收PE挂起命令的状态，它会将FSTATR寄存器中的SUSRDY位设置为1。

当发出PE挂起命令时，闪存定序器接收该命令并将SUSRDY位清除为0。

在擦除期间接收到挂起命令时，闪存定序器启动挂起处理并将FSTATR寄存器中的ERSSPD位设置为1，即使它正在施加擦除脉冲。当挂起处理完成时，闪存定序器将FRDY位设置为1以进入擦除挂起状态。当在擦除暂停状态下接收到PE恢复命令时，闪存定序器将FRDY和ERSSPD位清除为0并恢复擦除。无论擦除暂停模式如何，FRDY、SUSRDY和ERSSPD位在擦除暂停和恢复时的操作都是相同的。

擦除暂停模式的设置会影响擦除脉冲的控制方法。在挂起优先模式下，当在施加先前未被挂起的擦除脉冲A的同时接收到PE挂起命令时，闪存定序器挂起擦除脉冲A的施加并进入擦除挂起状态。在使用PE恢复命令恢复擦除后，在重新应用擦除脉冲A的同时接收到PE暂停命令时，闪存定序器

continues to apply erasure pulse A. After the specified pulse application time, the flash sequencer finishes erasure pulse application and enters the erasure suspended state.

When the flash sequencer receives a P/E resume command next and erasure pulse B is being applied, the flash sequencer receives a P/E suspend command again, and the application of erasure pulse B is then suspended. In suspension priority mode, delays due to suspension can be minimized because the application of an erasure pulse is suspended once per pulse, and priority is given to the suspend processing.

If the interval of suspension after resume is longer than  $t_{REST1}$  (Resume time: priority on suspension, resume after the 1st suspend for the same pulse), suspend delay will be always  $t_{SESD1}$  (Suspend delay: priority on suspension, the 1st suspend for the same pulse).

If the interval of suspension after resume is shorter than  $t_{REST1}$ , suspend delay becomes either  $t_{SESD1}$  or  $t_{SESD2}$  (Suspend delay: priority on suspension, the 2nd suspend for the same pulse).

(The value of  $t_{REST1}$  /  $t_{SESD1}$  /  $t_{SESD2}$ , see [section 47, Electrical Characteristics](#).)

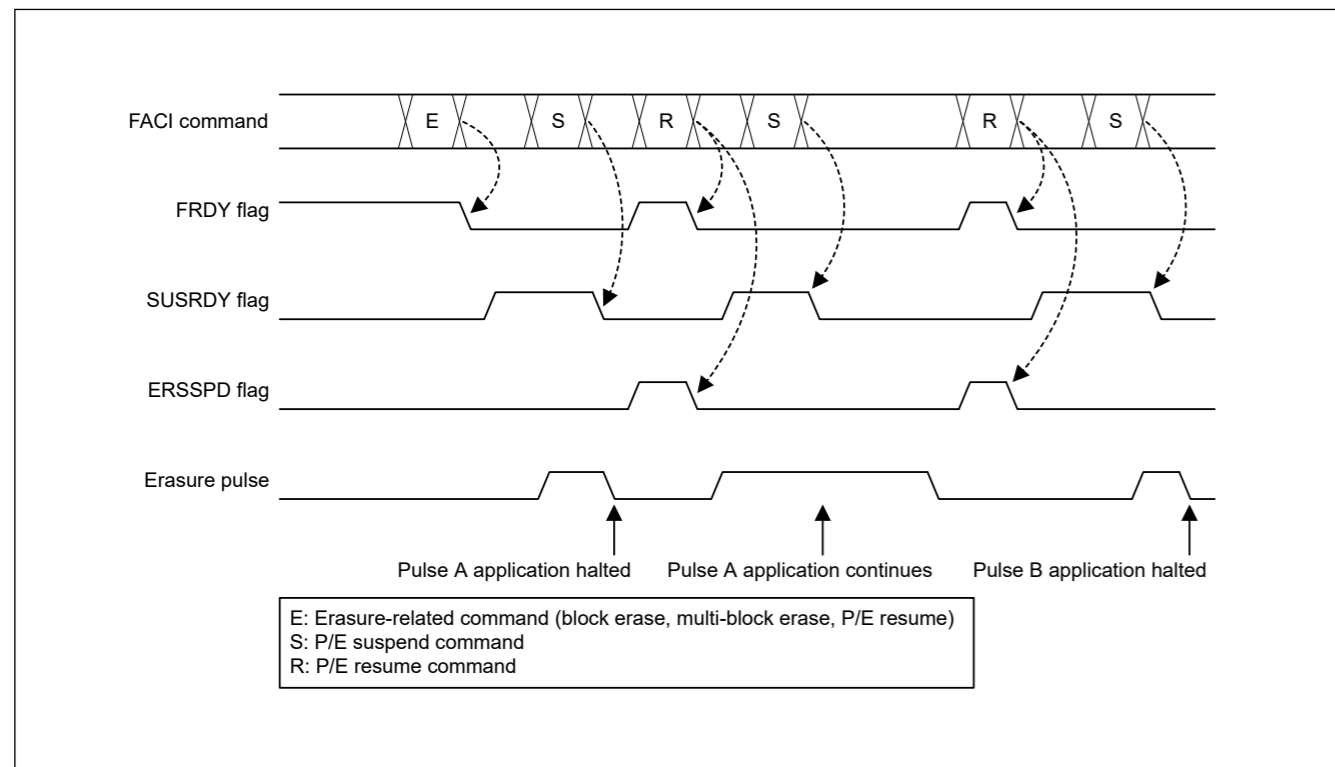


Figure 44.18 Suspension during erasure (suspension priority mode)

### (3) Suspension during Erasure (Erasure Priority Mode)

The flash sequencer has an erasure priority mode for the suspension of erasure. [Figure 44.19](#) shows the suspend operation of erasure when the erasure suspend mode is set to the erasure priority mode (the ESUSPMD bit in the FCPSR register is 1). The control method of erasure pulses in erasure priority mode is the same as that of programming pulses for the programming suspend processing.

If the flash sequencer receives a P/E suspend command while an erasure pulse is applied, the flash sequencer continues to apply the pulse. In this mode, the required time for the erasure processing can be reduced compared to the suspension priority mode because the re-application of erasure pulses does not occur when a P/E resume command is issued.

继续施加擦除脉冲A。在指定的脉冲施加时间之后，闪存定序器完成擦除脉冲施加并进入擦除暂停状态。

当闪存定序器接下来接收到PE恢复命令并且正在施加擦除脉冲B时，闪存定序器再次接收到PE暂停命令，然后暂停擦除脉冲B的施加。在挂起优先模式中，由于擦除脉冲的施加在每个脉冲中挂起一次，因此挂起引起的延迟可以被最小化，并且挂起处理具有优先权。

如果恢复后挂起的时间间隔大于 $t_{REST1}$ （恢复时间：挂起优先，相同脉冲第一次挂起后恢复），挂起延迟将始终为 $t_{SESD1}$ （挂起延迟：挂起优先，第一次挂起相同的脉冲）。

如果恢复后的暂停间隔小于 $t_{REST1}$ ，则暂停延迟变为 $t_{SESD1}$ 或 $t_{SESD2}$ （暂停延迟：暂停优先，相同脉冲的第2次暂停）。

( $t_{REST1}$  $t_{SESD1}$  $t_{SESD2}$ 的值，请参见第47节，电气特性。)

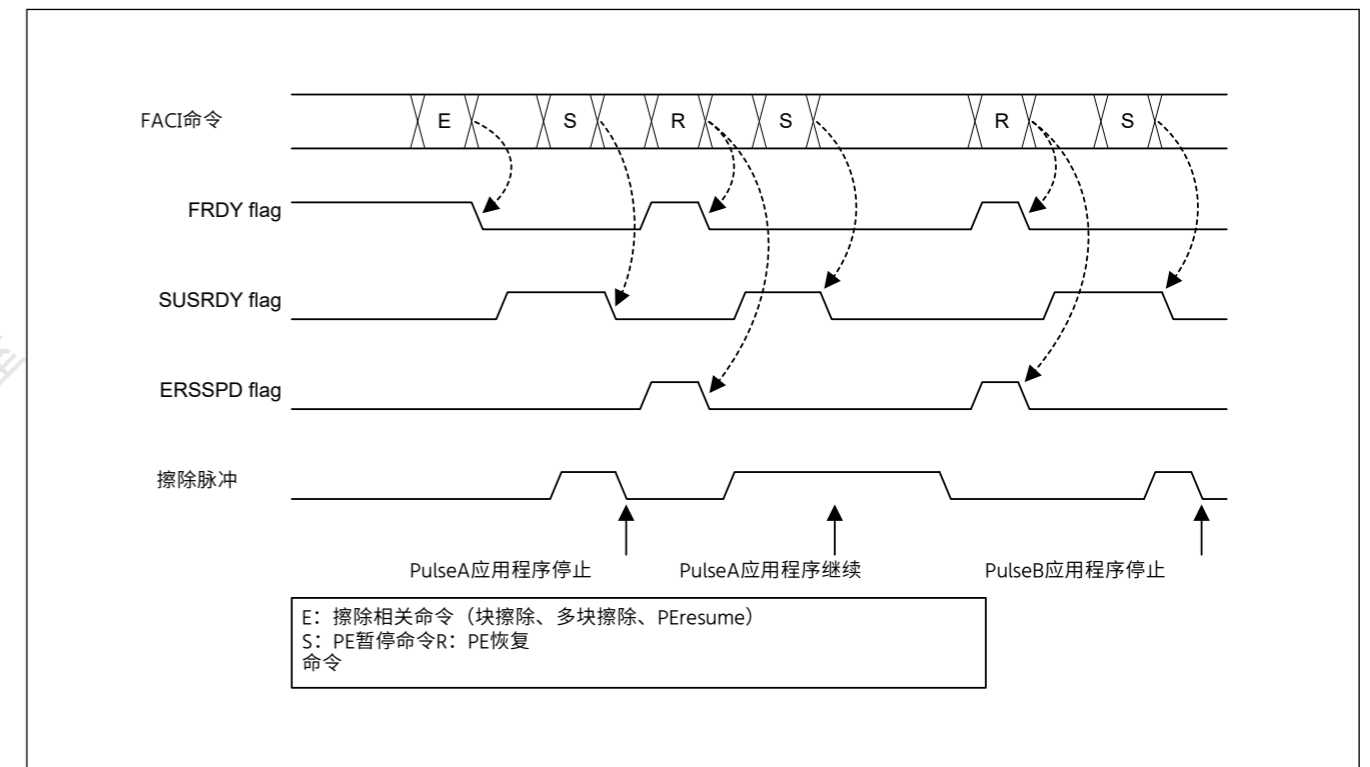


Figure 44.18 擦除期间暂停（暂停优先模式）

### (3) 擦除期间暂停（擦除优先模式）

闪存定序器具有用于暂停擦除的擦除优先模式。图44.19显示了擦除挂起模式设置为擦除优先模式时的擦除挂起操作（FCPSR寄存器中的ESUSPMD位为1）。擦除优先模式中擦除脉冲的控制方法与用于编程暂停处理的编程脉冲的控制方法相同。

如果在施加擦除脉冲时闪存定序器接收到PE暂停命令，则闪存定序器继续施加脉冲。在这种模式下，与暂停优先模式相比，擦除处理所需的时间可以减少，因为当发出PE恢复命令时不会发生擦除脉冲的重新施加。

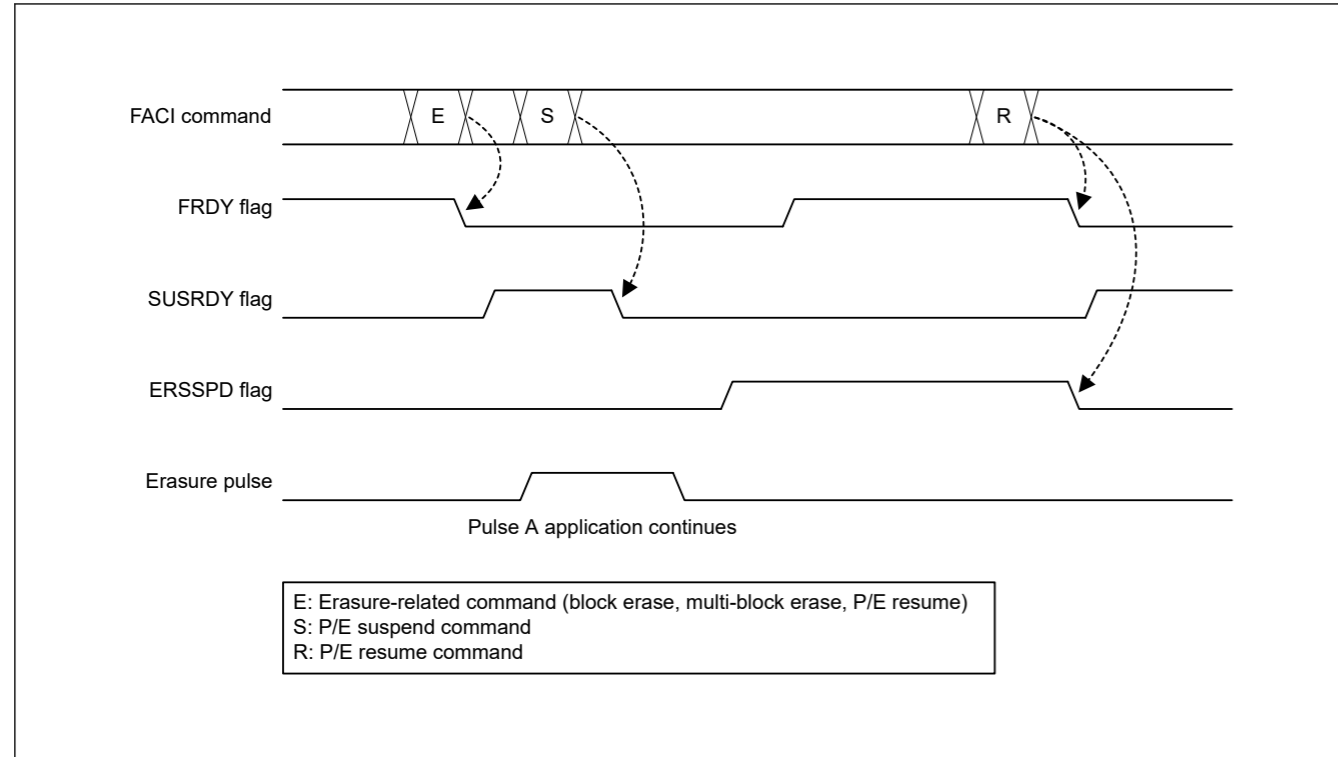
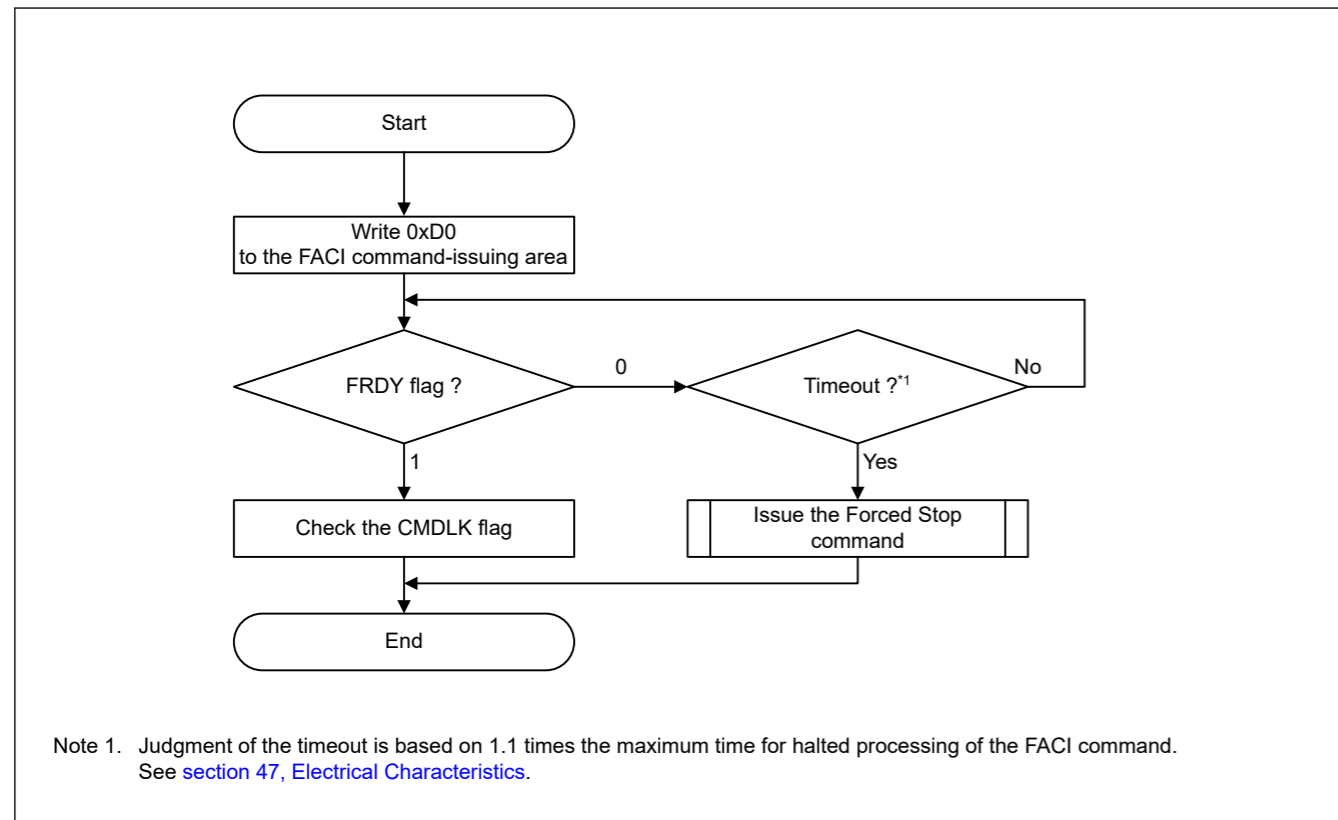


Figure 44.19 Suspension during erasure (erasure priority mode)

44.9.3.11 P/E Resume Command

The P/E resume command is used to resume suspended programming or erasure. If the FENTRYR setting has been modified during suspension, issue a P/E resume command only after resetting FENTRYR to the previous value that was held before the P/E suspend command. Figure 44.20 shows usage of the P/E resume command.



Note 1. Judgment of the timeout is based on 1.1 times the maximum time for halted processing of the FACL command. See section 47, Electrical Characteristics.

Figure 44.20 Usage flow of the P/E resume command

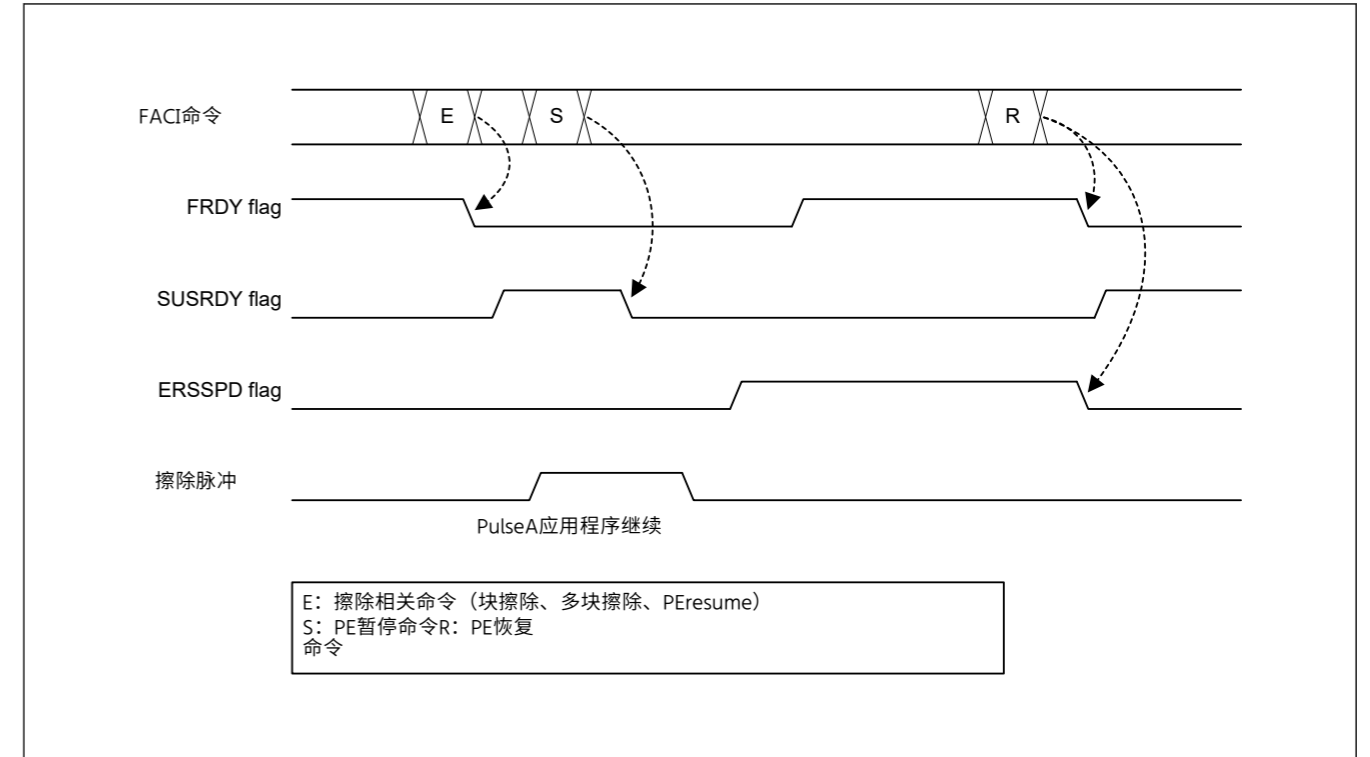
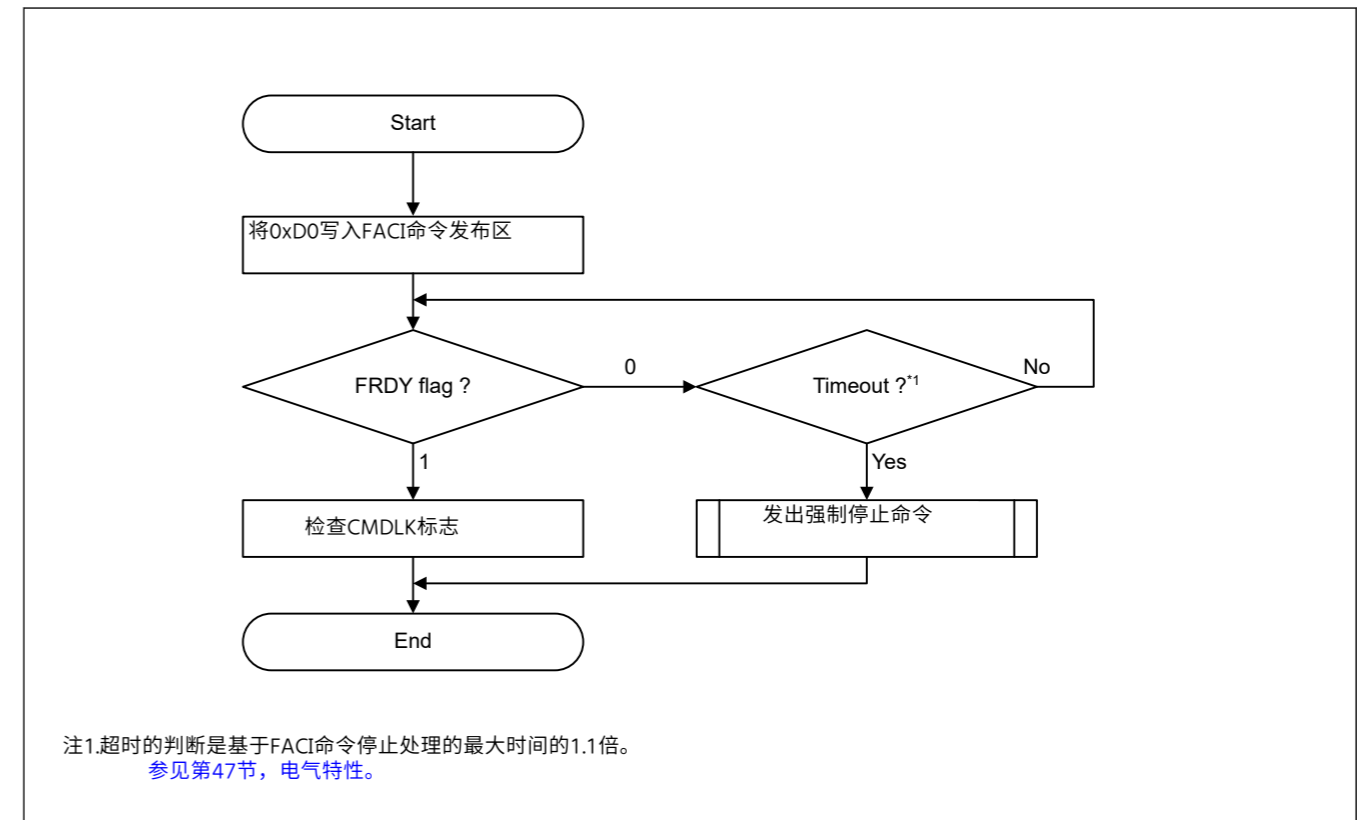


Figure 44.19 擦除期间暂停 (擦除优先模式)

44.9.3.11 PE恢复命令

PEresume命令用于恢复暂停的编程或擦除。如果在挂起期间修改了FENTRYR设置，则仅在将FENTRYR重置为发出PE挂起命令之前保持的先前值之后才发出PEresume命令。图44.20显示了PEresume命令的用法。



注1.超时的判断是基于FACL命令停止处理的最大时间的1.1倍。参见第47节，电气特性。

Figure 44.20 PEresume命令的使用流程



### 44.9.3.12 Status Clear Command

The status clear command is used to clear the command-locked state (see [section 44.9.3.6. Recovery from the Command-Locked State](#)).

You can use the status clear command to clear the following bits in the FSTATR register in the command-locked state:

- ILGLERR
- ILGCOMERR
- FESETERR
- SECERR
- OTERR
- ERSERR
- PRGERR

Figure 44.21 shows usage of the status clear command.

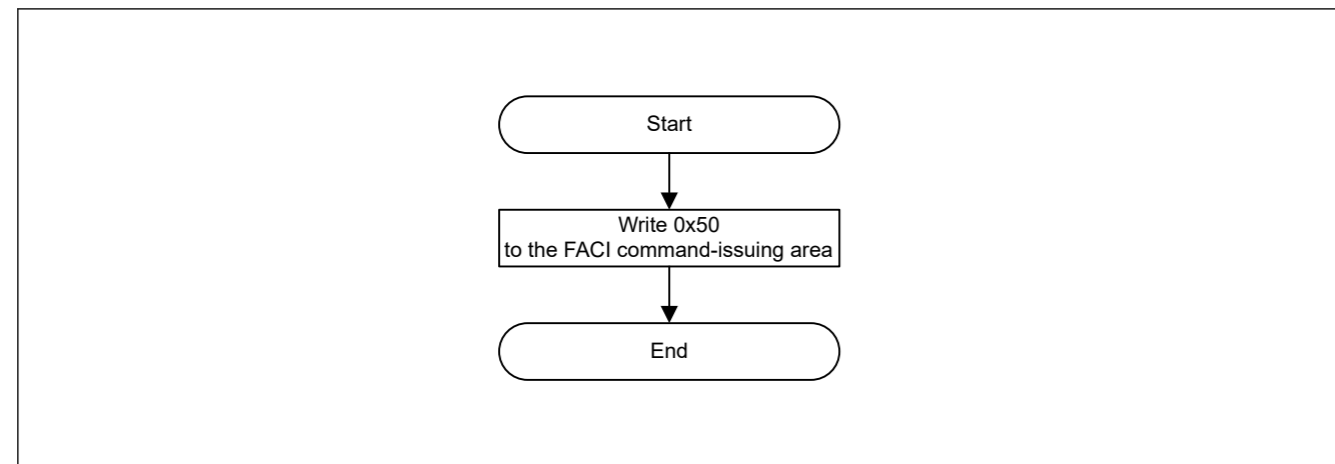


Figure 44.21 Usage flow of the status clear command

### 44.9.3.13 Forced Stop Command

The forced stop command is used to forcibly end command processing by the flash sequencer. Although this command halts command processing more quickly than the P/E suspension command, values from the programming or erasure that are in progress are not guaranteed. Additionally, resumption of processing is not possible. Processing of programming or erasure that is halted by the forced stop command is also defined as one programming round.

Executing the forced stop command also initializes part of the FACL, the whole FCU, the FSTATR and FASTAT registers. This command can be used in the procedure for recovery from the command-locked state and for processing in response to a timeout of the flash sequencer (see [section 44.9.3.6. Recovery from the Command-Locked State](#)).

Figure 44.22 shows usage of the forced stop command.

### 44.9.3.12 状态清除命令

statusclear命令用于清除命令锁定状态（参见第44.9.3.6节。从命令中恢复锁定状态）。

在命令锁定状态下，您可以使用statusclear命令清除FSTATR寄存器中的以下位：

- ILGLERR
- ILGCOMERR
- FESETERR
- SECERR
- OTERR
- ERSERR
- PRGERR

图44.21显示了statusclear命令的用法。

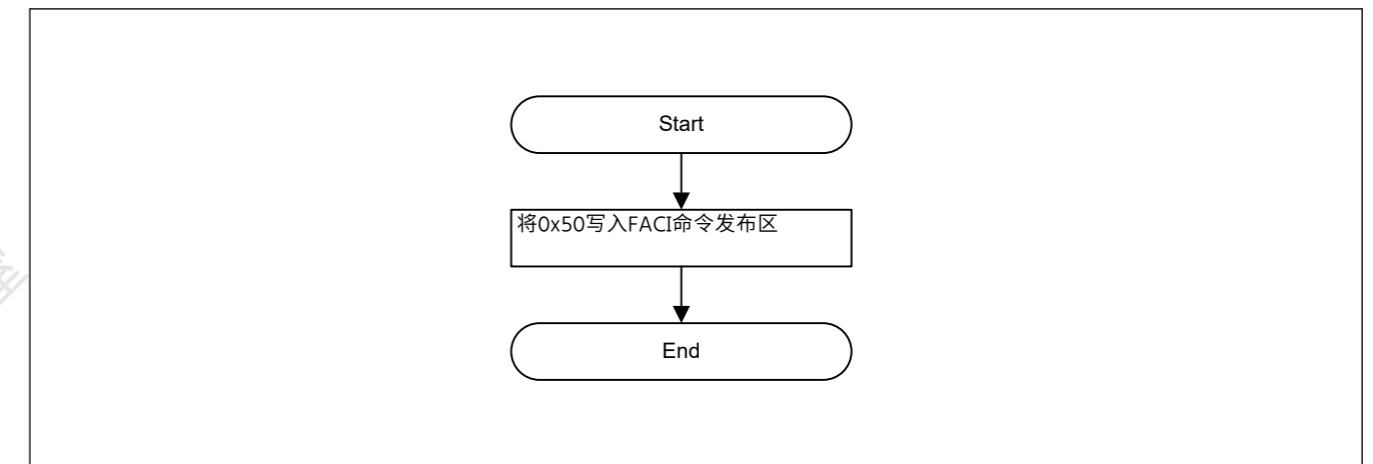


Figure 44.21 statusclear命令的使用流程

### 44.9.3.13 强制停止命令

强制停止命令用于强制结束闪存定序器的命令处理。尽管此命令比PE暂停命令更快地停止命令处理，但不能保证正在进行的编程或擦除的值。此外，无法恢复处理。由强制停止命令停止的编程或擦除的处理也被定义为一轮编程。

执行强制停止命令还会初始化部分FACL、整个FCU、FSTATR和FASTAT寄存器。此命令可用于从命令锁定状态恢复的过程以及用于响应闪存定序器超时的处理（请参阅第44.9.3.6节。从命令锁定状态恢复）。

图44.22显示了强制停止命令的用法。

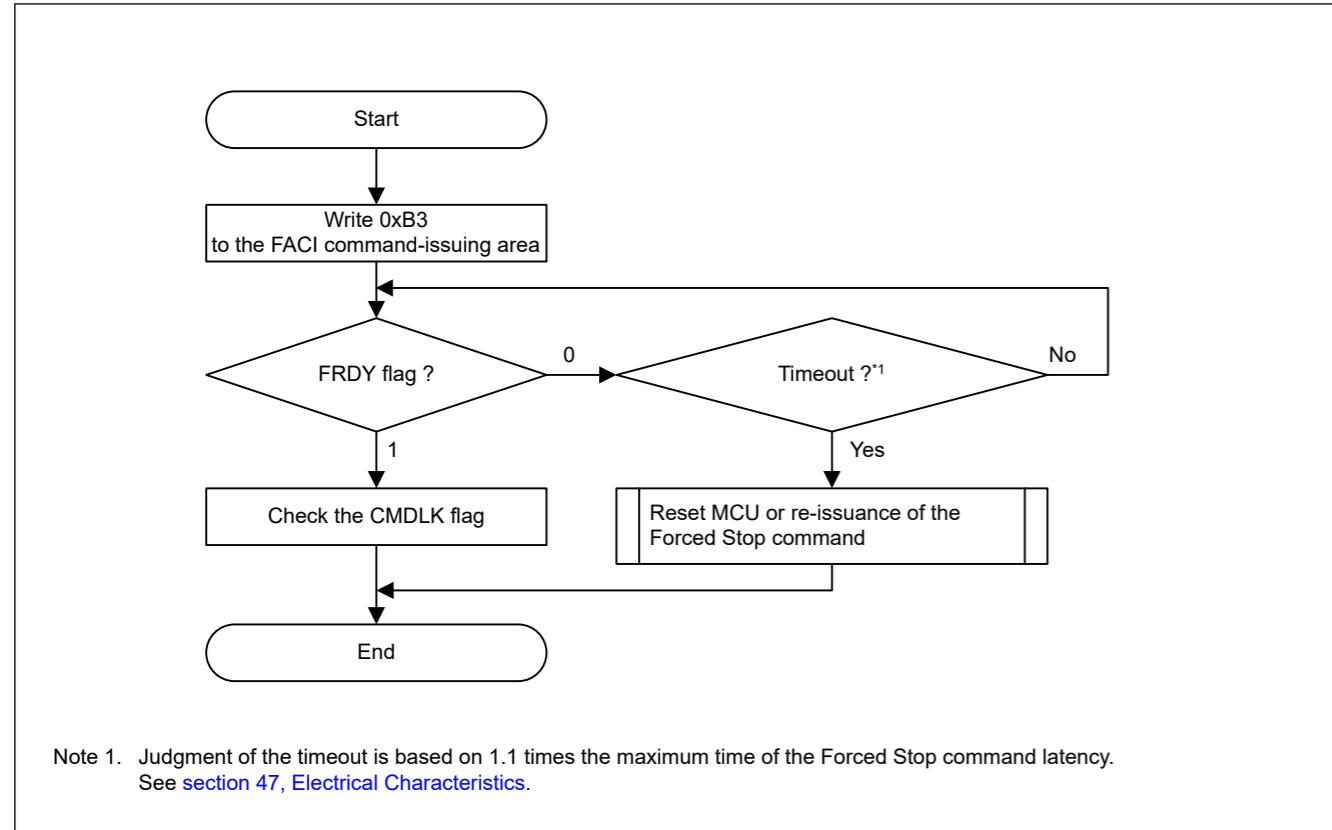


Figure 44.22 Usage flow of the forced stop command

## (1) Notes on Using the Forced Stop Command during Command Issue

When using the forced stop command at the timeout occurrence by DBFULL bit of the program command, writing in the FACI command-issuing area is sometimes processed as writing in data of the program command. See Table 44.3 in section 44.3. Address Space for information on the FACI command-issuing area to force a command lock. Then issue a forced stop command with return method from the command lock status (see Figure 44.13). Locking commands is possible in any case where the unit for reading the FACI command issuing area is 8, 16, or 32 bits.

## 44.9.3.14 Blank Check Command

The blank check command is used to confirm that an area is in the non-programmed state. Values read from the data flash memory that have been erased but not yet programmed again that is in the non-programmed state, are undefined.

Before issuing the Blank Check command, set addressing mode, start address, and end address of the target area for Blank Check to the FBCCNT, FSADDR, and FEADDR registers. When Blank Check addressing mode is set to decremental mode (i.e. FBCCNT.BCDIR = 1), address specified in FSADDR should be equal to or larger than address in FEADDR.

On the other hand, the address in FSADDR should be equal to or smaller than address in FEADDR when Blank Check addressing mode is set to incremental mode (i.e. FBCCNT.BCDIR = 0).

If the settings of the BCDIR bit, FSADDR, and FEADDR are inconsistent, the flash sequencer enters the command-locked state. The size of the target area for Blank Check is in the range from 4 bytes to the data flash memory capacity and is set in units of 4 bytes.

Write 0x71 and 0xD0 to the FACI command-issuing area to start Blank Check. Completion of processing can be confirmed by the FRDY bit of the FSTATR register. At the end of processing, the result of Blank Check is stored in the BCST bit in the FBCSTAT register. If non-programmed data exists within the target area for Blank Check, flash sequencer stops Blank Check command operation. In this case, address of non-programmed data is indicated to FPSADDR register.

Figure 44.23 shows usage of the blank check command.

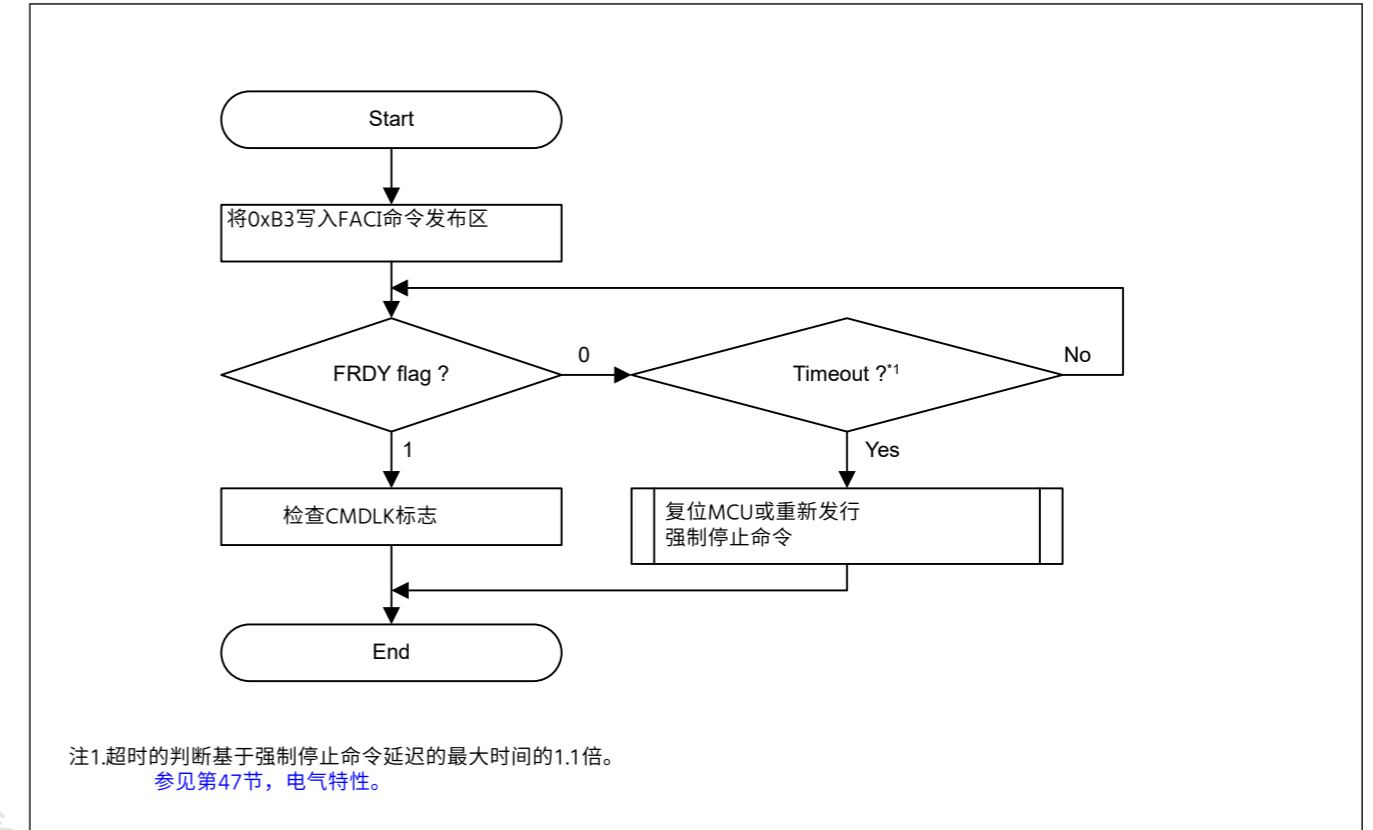


Figure 44.22 强制停止命令的使用流程

## (1) 命令发出期间使用强制停止命令的注意事项

通过程序命令的DBFULL位在超时发生时使用强制停止命令时，写入FACI命令发布区域有时被处理为写入程序命令的数据。请参见第44.3节中的表44.3。FACI命令发布区域信息的地址空间以强制命令锁定。然后从命令锁定状态发出带返回方法的强制停止命令（见图44.13）。在读取FACI命令发布区域的单位为8、16或32位的任何情况下，锁定命令都是可能的。

## 44.9.3.14 空白检查命令

空白检查命令用于确认某个区域处于非编程状态。从处于未编程状态的已擦除但尚未再次编程的数据闪存读取的值未定义。

在发出空白检查命令之前，设置空白目标区域的寻址方式、起始地址和结束地址检查FBCCNT、FSADDR和FEADDR寄存器。当空白检查寻址模式设置为递减模式（即FBCCNT.BCDIR=1）时，FSADDR中指定的地址应等于或大于FEADDR中的地址。

另一方面，当空白检查寻址模式设置为增量模式（即FBCCNT.BCDIR=0）时，FSADDR中的地址应等于或小于FEADDR中的地址。

如果BCDIR位、FSADDR和FEADDR的设置不一致，则flashsequencer进入command-locked状态。BlankCheck的目标区域大小在4字节到数据闪存容量的范围内，以4字节为单位设置。

将0x71和0xD0写入FACI命令发出区域以启动空白检查。可通过FSTATR寄存器的FRDY位确认处理完成。处理结束时，空白检查的结果存储在FBCSTAT寄存器的BCST位中。如果空白检查的目标区域内存在未编程的数据，闪存定序器将停止空白

检查命令操作。在这种情况下，非编程数据的地址被指示到FPSADDR寄存器。

图44.23显示了空白检查命令的用法。

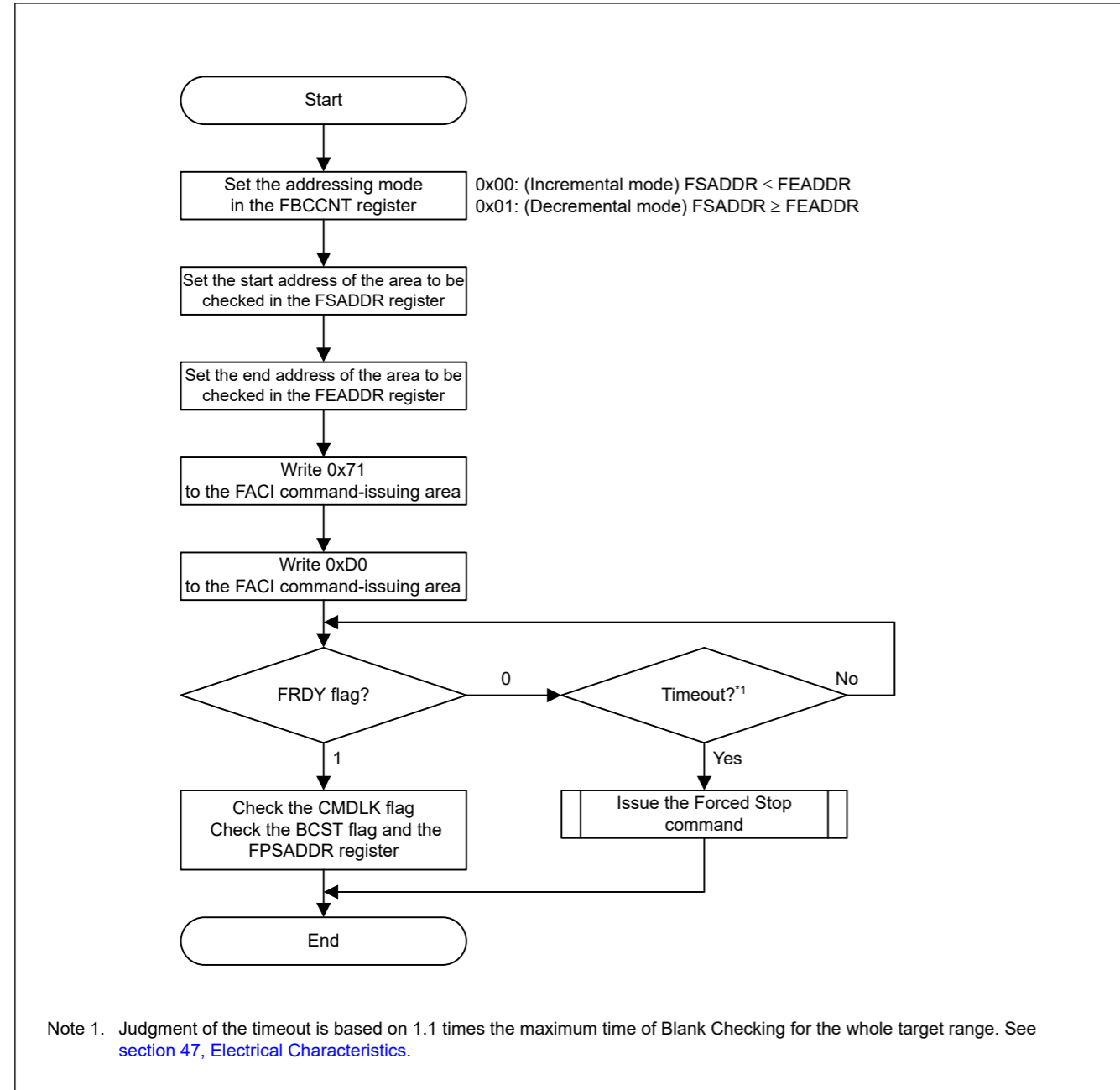


Figure 44.23 Usage flow of the blank check command

### 44.9.3.15 Configuration Set Command

The Configuration set command is used to set option-setting memory. Before issuing the Configuration set command, set the specified address (shown in Table 44.18) in the FSADDR register. Writing 0xD0 to the FACL command-issuing area in the final access for issuing the FACL command starts FACL processing of the Configuration set command.

Figure 44.24 shows usage of the configuration set command.

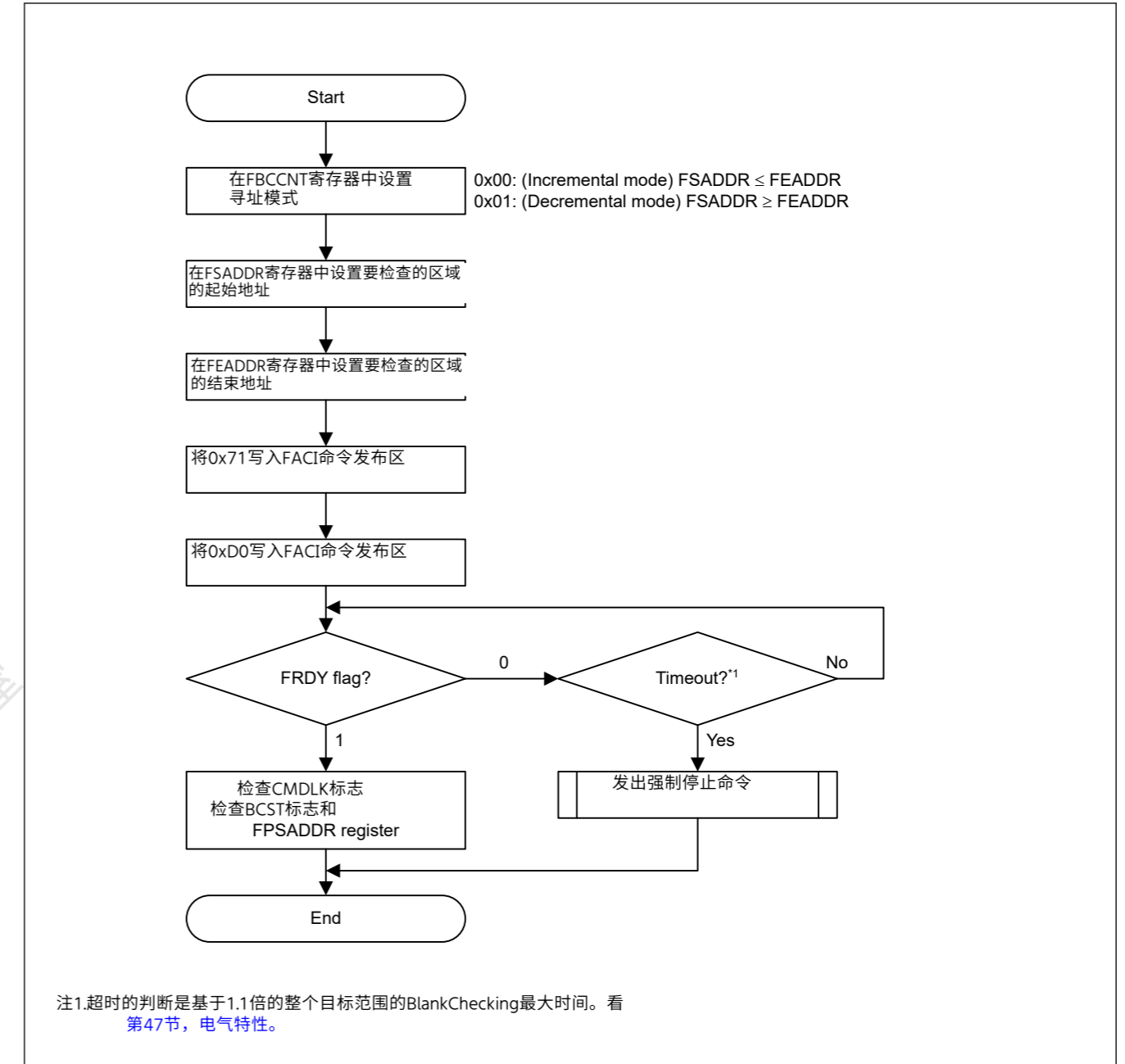


Figure 44.23 空白检查命令的使用流程

### 44.9.3.15 配置集命令

Configurationset命令用于设置选项设置内存。在发出配置设置命令之前，在FSADDR寄存器中设置指定的地址（如表44.18所示）。在发出FACL命令的最终访问中将0xD0写入FACL命令发出区域，开始配置设置命令的FACL处理。

图44.24显示了配置集命令的用法。

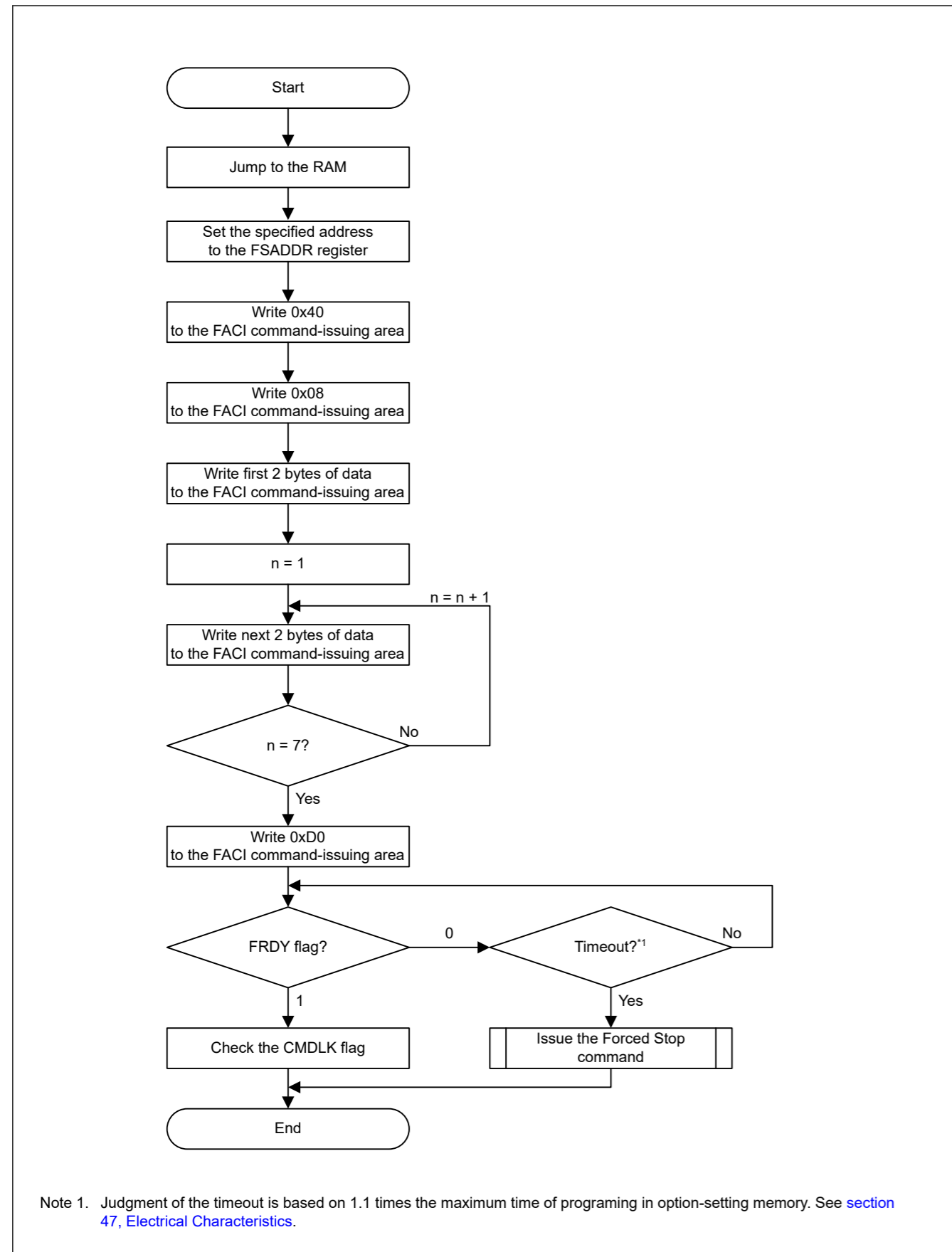


Figure 44.24 Usage flow of the configuration set command

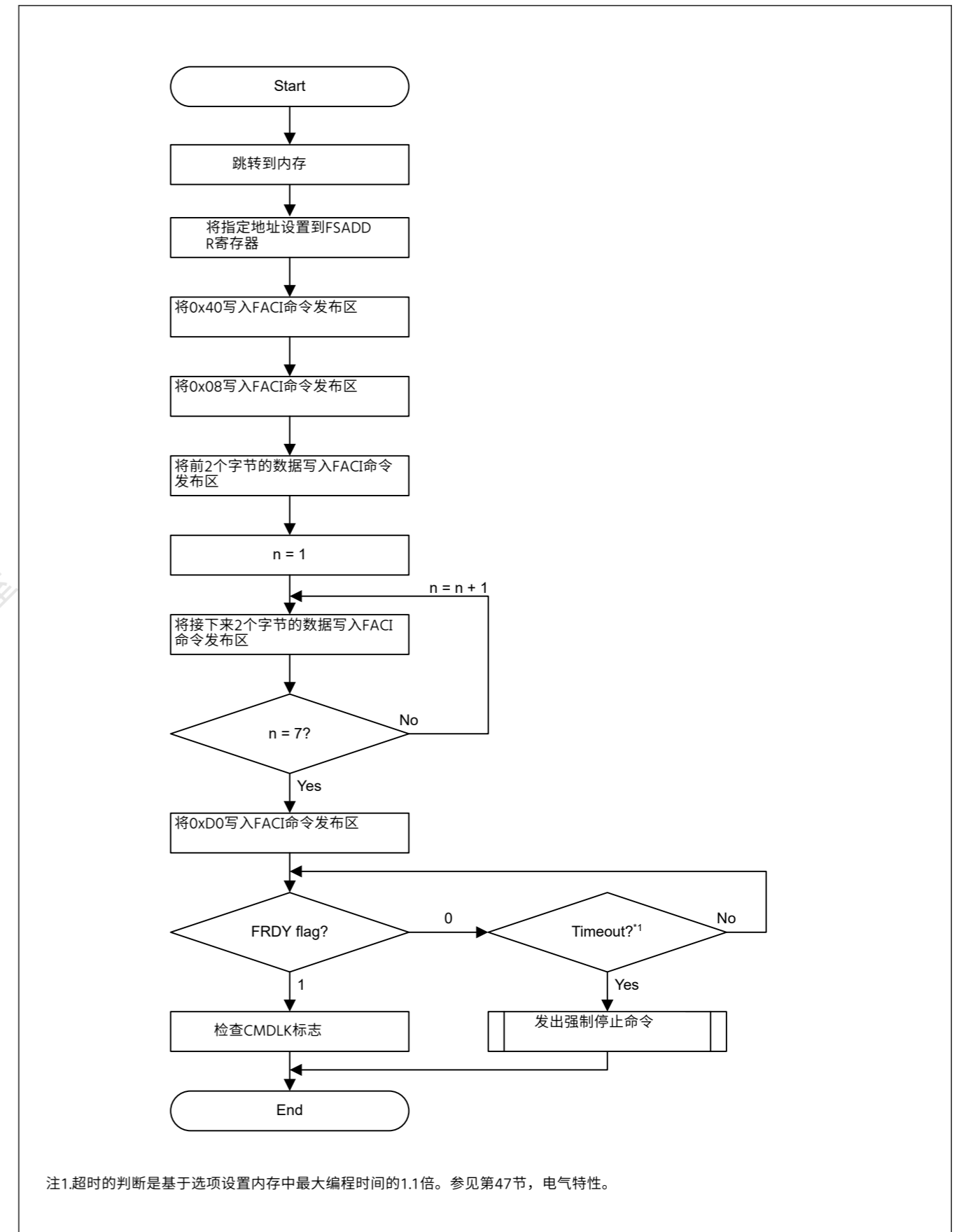


Figure 44.24 配置集命令使用流程



The correspondence between the possible target data for configuration setting and the address value set in the FSADDR register is shown in Table 44.18. For details, see section 44.4.12. FSADDR : FACI Command Start Address Register.

Table 44.18 Address Used by Configuration Set Command

| Address     | FSADDR Register Value | Setting Data   | Operation of additional writing              |  | Timing when the Setting is Enabled  |
|-------------|-----------------------|--|--|--|-------------------------------------|
|             |                       |  | SAS.FSPR bit is 1                            | SAS.FSPR bit is 0                            |                                     |
| 0x0100_A100 | 0x0100_A100           | Option Function Select Register 0 (OFS0)                   | Writable                                     | Writable                                     | At a reset                          |
| 0x0100_A134 | 0x0100_A134           | Start-up Area Setting Register (SAS)                       | Writable                                     | Not writable <sup>*1</sup>                   | When a reset or command is executed |
| 0x0100_A180 | 0x0100_A180           | Option Function Select Register 1 (OFS1)                   | Writable                                     | Writable                                     | At a reset                          |
| 0x0100_A190 | 0x0100_A190           | Bank Select Register (BANKSEL)                             | Writable                                     | Writable                                     | At a reset                          |
| 0x0100_A1C0 | 0x0100_A1C0           | Block Protect Setting Register (BPS)                       | Writable <sup>*2</sup>                       | Writable <sup>*2</sup>                       | When a reset or command is executed |
| 0x0100_A1E0 | 0x0100_A1E0           | Permanent Block Protect Setting Register (PBPS)            | Writable <sup>*3</sup><br>(from 1 to 0 only) | Writable <sup>*3</sup><br>(from 1 to 0 only) | When a reset or command is executed |
| 0x0100_A200 | 0x0100_A200           | Option Function Select Register 1 Secure (OFS1_SEC)        | Writable                                     | Writable                                     | At a reset                          |
| 0x0100_A210 | 0x0100_A210           | Bank Select Register Secure (BANKSEL_SEC)                  | Writable                                     | Writable                                     | At a reset                          |
| 0x0100_A240 | 0x0100_A240           | Block Protect Setting Register Secure (BPS_SEC)            | Writable <sup>*4</sup>                       | Writable <sup>*4</sup>                       | When a reset or command is executed |
| 0x0100_A260 | 0x0100_A260           | Permanent Block Protect Setting Register Secure (PBPS_SEC) | Writable <sup>*5</sup><br>(from 1 to 0 only) | Writable <sup>*5</sup><br>(from 1 to 0 only) | When a reset or command is executed |
| 0x0100_A280 | 0x0100_A280           | Option Function Select Register 1 Select (OFS1_SEL)        | Writable                                     | Writable                                     | At a reset                          |
| 0x0100_A290 | 0x0100_A290           | Bank Select Register Select (BANKSEL_SEL)                  | Writable                                     | Writable                                     | At a reset                          |
| 0x0100_A2C0 | 0x0100_A2C0           | Block Protect Setting Register Select (BPS_SEL)            | Writable                                     | Writable                                     | At a reset                          |

Note 1. The SAS.FSPR bit cannot be restored to 1 by using the Configuration set command once it is set to 0. Therefore, setting the start-up area select flags again becomes impossible. (when the Configuration set command is issued to the address of 0x0100A134, the command is locked.) Exercise extra caution when handling the SAS.FSPRbit.

Note 2. Once PBPS[n] bit is set to 0, the BPS[n] bit cannot be restored to 1 by using the Configuration set command.

Note 3. Once these bits are set to 0, the bits cannot be restored to 1 by using the Configuration set command. The PBPS[n] bit can not be set to 0 by using the Configuration set command when the BPS[n] bit is 1.

Note 4. Once PBPS\_SEC[n] bit is set to 0, the BPS\_SEC[n] bit cannot be restored to 1 by using the Configuration set command.

Note 5. Once these bits are set to 0, the bits cannot be restored to 1 by using the Configuration set command. The PBPS\_SEC[n] bit cannot be set to 0 by using the Configuration set command when the BPS\_SEC[n] bit is 1.

#### 44.10 Suspend Operation

Reading from the flash memory is not possible during programming or erasure if the conditions for background operation given in Table 44.31 are not satisfied. When a P/E suspend command is issued to suspend the programming or erasure of the flash memory, reading from the flash memory is enabled. Regarding P/E suspend commands, there are one suspend command mode for programming and two suspend command modes for erasure (suspension priority mode and erasure priority mode). To resume suspended programming or erasure, the P/E resume command is available. See details on the suspend operation, refer to Figure 44.16.

配置设置的可能目标数据与FSADDR寄存器中设置的地址值的对应关系如表44.18所示。有关详细信息，请参阅第44.4.12节。FSADDR：FACI命令起始地址寄存器。

Table 44.18 配置设置命令使用的地址

| Address     | FSADDR 寄存器值设置数据 |                              | 追加写入的操作                                      |  | 启用设置的时间  |
|-------------|-----------------|------------------------------|--|--|----------|
|             |                 |                              | SAS.FSPR位为1                                  | SAS.FSPR位为0                                  |          |
| 0x0100_A100 | 0x0100_A100     | 选项功能选择寄存器0(OFS0)             | Writable                                     | Writable                                     | 复位时      |
| 0x0100_A134 | 0x0100_A134     | 启动区设置寄存器(SAS)                | Writable                                     | Not writable <sup>*1</sup>                   | 执行复位或命令时 |
| 0x0100_A180 | 0x0100_A180     | 选项功能选择寄存器1(OFS1)             | Writable                                     | Writable                                     | 复位时      |
| 0x0100_A190 | 0x0100_A190     | 银行选择寄存器(BANKSEL)             | Writable                                     | Writable                                     | 复位时      |
| 0x0100_A1C0 | 0x0100_A1C0     | 块保护设置寄存器(BPS)                | Writable <sup>*2</sup>                       | Writable <sup>*2</sup>                       | 执行复位或命令时 |
| 0x0100_A1E0 | 0x0100_A1E0     | 永久块保护设置 Register (PBPS)      | Writable <sup>*3</sup><br>(from 1 to 0 only) | Writable <sup>*3</sup><br>(from 1 to 0 only) | 执行复位或命令时 |
| 0x0100_A200 | 0x0100_A200     | 选项功能选择寄存器1 Secure (OFS1_SEC) | Writable                                     | Writable                                     | 复位时      |
| 0x0100_A210 | 0x0100_A210     | 银行选择寄存器安全(BANKSEL_SEC)       | Writable                                     | Writable                                     | 复位时      |
| 0x0100_A240 | 0x0100_A240     | 块保护设置寄存器 Secure (BPS_SEC)    | Writable <sup>*4</sup>                       | Writable <sup>*4</sup>                       | 执行复位或命令时 |
| 0x0100_A260 | 0x0100_A260     | 永久块保护设置 注册安全(PBPS_SEC)       | Writable <sup>*5</sup><br>(from 1 to 0 only) | Writable <sup>*5</sup><br>(from 1 to 0 only) | 执行复位或命令时 |
| 0x0100_A280 | 0x0100_A280     | 选项功能选择寄存器1 Select (OFS1_SEL) | Writable                                     | Writable                                     | 复位时      |
| 0x0100_A290 | 0x0100_A290     | 银行选择寄存器选择 (BANKSEL_SEL)      | Writable                                     | Writable                                     | 复位时      |
| 0x0100_A2C0 | 0x0100_A2C0     | 块保护设置寄存器 Select (BPS_SEL)    | Writable                                     | Writable                                     | 复位时      |

注1.SAS.FSPR位一旦设置为0，就无法通过Configurationset命令恢复为1。因此，再次设置启动区域选择标志变得不可能。（当向0x0100A134地址发出Configurationset命令时，该命令被锁定。）处理SAS.FSPRbit时要格外小心。

注2.一旦PBPS[n]位设置为0，BPS[n]位不能通过使用配置设置命令恢复为1。

注3.一旦这些位设置为0，就不能使用配置设置命令将这些位恢复为1。当BPS[n]位为1时，不能使用配置设置命令将PBPS[n]位设置为0。

注4.一旦PBPS\_SEC[n]位设置为0，则BPS\_SEC[n]位无法通过使用配置设置命令恢复为1。

注5.一旦这些位设置为0，就不能使用配置设置命令将这些位恢复为1。当BPS\_SEC[n]位为1时，无法使用配置设置命令将PBPS\_SEC[n]位设置为0。

#### 44.10 暂停操作

如果不满足表44.31中给出的后台操作条件，则在编程或擦除期间无法从闪存读取。当发出PE暂停命令以暂停闪存的编程或擦除时，将启用从闪存读取。关于PE挂起命令，有一种用于编程的挂起命令模式和两种用于擦除的挂起命令模式（挂起优先模式和擦除优先模式）。要恢复暂停的编程或擦除，可以使用PEresume命令。详见挂起操作，参见图44.16。

## 44.11 Protection Function

### 44.11.1 Software Protection

Software protection disables programming and erasure of the code flash memory through the settings of control registers and block protect setting in the user area. If an attempt is made to issue an FACI command against software protection, the flash sequencer enters the command-locked state.

#### 44.11.1.1 Protection through FWEPROR

Unless the FWEPROR.FLWE[1:0] bits are set to 01b, programming cannot proceed in any mode.

#### 44.11.1.2 Protection by FENTRYR

When the FENTRYR register is set to 0x0000, the flash sequencer enters read mode. In read mode, FACI commands cannot be accepted. If an attempt is made to issue an FACI command in read mode, the flash sequencer enters the command-locked state.

#### 44.11.1.3 Protection by Block Protect Setting

Each block in user area has the block protect setting (BPS or BPS\_SEC). When the FBPROT0 or FBPROT1 register is 0x0000 and the block protect bit is 0, issuing the Program or Block Erase command to user area of the code flash causes the command-locked state. To program or erase the block whose block protect bit is 0, set the FBPROT0 or FBPROT1 register to 0x0001.

The block protect setting can be locked by the permanent block protect setting (PBPS or PBPS\_SEC). When the permanent block protect setting and the block protect setting are 0, issuing a Program or Block erase command to user area of the code flash causes the flash sequencer to enter the command-locked state regardless of the FBPROT0 and FBPROT1 register settings.

Valid block protect setting (BPS or BPS\_SEC) depends on the Block Protect Select bit (BPS\_SEL).

See [section 44.12.2. Permanent Block Protect Setting](#) for details of the block protect setting and permanent block protect setting. See [section 44.4.15. FBPROT0 : Flash Block Protection Register](#) and [section 44.4.16. FBPROT1 : Flash Block Protection for Secure Register](#) for more information.

For details of block protect setting (BPS or BPS\_SEC) and block protect select (BPS\_SEL), see [section 6, Option-Setting Memory](#).

The protected area by the block protect setting is always determined by the address of the FSADDR register setting regardless of the address swapping function setting (the startup area select, and the block swap). [Table 44.19](#) to [section 44.11.1.3. Protection by Block Protect Setting](#) show the relation of user area and the block protect setting in each function setting.

- BPS[0] to BPS[n] or BPS\_SEC[0] to BPS\_SEC[n] are assigned to the block of user area (for example, address is 0x00\_0000 to the last block address).
- BPS[0]/BPS\_SEC[0] and BPS[1]/BPS\_SEC[1] are assigned to the block of user area depending on the startup area select setting (SAS.BTFLG bit). (See [section 44.11.3. Start-Up Program Protection](#)).
- The second half of FLI user area is assigned to block protect setting depending on the block swap select setting (BANKSEL.BLCKSWP[2:0] bits). See [section 44.11.4. Block Swap Function](#).

[Table 44.19](#) shows the block protect setting when the startup area select is disabled (not swapping).

[Table 44.19](#) and later show example of the block protect setting when the address conversion function is used.

**Table 44.19 Example of Block Protect setting when SAS.BTFLG is 1 (1 of 2)**

| FSADDR[23:0]           | Block size | Block protect setting | User area block number | Notes |
|------------------------|------------|-----------------------|------------------------|-------|
| The last block address | 32 KB      | BPS[n] or BPS_SEC[n]  | Block n                | —     |
| ⋮                      | ⋮          | ⋮                     | ⋮                      | —     |
| 0x01_8000 to 0x01_FFFF | 32 KB      | BPS[9] or BPS_SEC[9]  | Block 9                | —     |

## 44.11 保护功能

### 44.11.1 软件保护

软件保护通过控制寄存器的设置和用户区的块保护设置禁用代码闪存的编程和擦除。如果尝试针对软件保护发出FACI命令，则闪存定序器进入命令锁定状态。

#### 44.11.1.1 通过FWEPROR进行保护

除非FWEPROR.FLWE[1:0]位设置为01b，否则无法在任何模式下进行编程。

#### 44.11.1.2 FENTRYR的保护

当FENTRYR寄存器设置为0x0000时，闪存定序器进入读取模式。在读取模式下，无法接受FACI命令。如果尝试在读取模式下发出FACI命令，则闪存定序器进入命令锁定状态。

#### 44.11.1.3 通过块保护设置进行保护

用户区的每个块都有块保护设置（BPS或BPS\_SEC）。当FBPROT0或FBPROT1寄存器为0x0000且块保护位为0时，向代码闪存的用户区发出Program或BlockErase命令会导致命令锁定状态。要编程或擦除块保护位为0的块，请将FBPROT0或FBPROT1寄存器设置为0x0001。

块保护设置可以通过永久块保护设置（PBPS或PBPS\_SEC）锁定。当永久块保护设置和块保护设置为0时，无论FBPROT0和FBPROT1寄存器设置如何，向代码闪存的用户区发出程序或块擦除命令都会使闪存定序器进入命令锁定状态。

有效的块保护设置（BPS或BPS\_SEC）取决于块保护选择位（BPS\_SEL）。

请参见[第44.12.2节。永久块保护设置有关块保护设置和永久块保护设置的详细信息。请参见第44.4.15节。FBPROT0：闪存块保护寄存器和第44.4.16节。FBPROT1：安全寄存器的闪存块保护了解更多信息。](#)

有关块保护设置（BPS或BPS\_SEC）和块保护选择（BPS\_SEL）的详细信息，请参阅[第6节，选项设置Memory](#)。

块保护设置的保护区始终由FSADDR寄存器设置的地址确定，与地址交换功能设置（启动区域选择和块交换）无关。[表44.19至第44.11.1.3节](#)。块保护设置的保护显示了用户区域和每个功能设置中的块保护设置的关系。

- BPS[0]到BPS[n]或BPS\_SEC[0]到BPS\_SEC[n]分配给用户区的块（例如，地址是0x00\_0000到最后一个块地址）。
- BPS[0]/BPS\_SEC[0]和BPS[1]/BPS\_SEC[1]根据启动区选择设置（SAS.BTFLG位）分配给用户区块。（参见[第4.11.3节。启动程序保护](#)）。
- FLI用户区的后半部分根据块交换选择设置（BANKSEL.BLCKSWP[2:0]位）分配给块保护设置。请参见[第44.11.4节。块交换功能](#)。

[表44.19](#)显示了禁用启动区域选择（不交换）时的块保护设置。

[表44.19](#)及以后显示了使用地址转换功能时的块保护设置示例。

**Table 44.19 SAS.BTFLG为1时的块保护设置示例（1 of 2）**

| FSADDR[23:0]           | 块大小   | 块保护设置                | 用户区块号   | Notes |
|------------------------|-------|----------------------|---------|-------|
| 最后一个区块地址               | 32 KB | BPS[n] or BPS_SEC[n] | Block n | —     |
| ⋮                      | ⋮     | ⋮                    | ⋮       | —     |
| 0x01_8000 to 0x01_FFFF | 32 KB | BPS[9] or BPS_SEC[9] | Block 9 | —     |

Table 44.19 Example of Block Protect setting when SAS.BTFLG is 1 (2 of 2)

| FSADDR[23:0]           | Block size | Block protect setting | User area block number | Notes  |
|------------------------|------------|-----------------------|------------------------|--|
| 0x01_0000 to 0x01_7FFF | 32 KB      | BPS[8] or BPS_SEC[8]  | Block 8                | —  |
| 0x00_E000 to 0x00_FFFF | 8 KB       | BPS[7] or BPS_SEC[7]  | Block 7                | —  |
| 0x00_C000 to 0x00_DFFF | 8 KB       | BPS[6] or BPS_SEC[6]  | Block 6                | —  |
| ⋮                      | ⋮          | ⋮                     | ⋮                      | —  |
| 0x00_2000 to 0x00_3FFF | 8 KB       | BPS[1] or BPS_SEC[1]  | Block 1                | Not swap block 0 and block 1 in this startup area select setting |
| 0x00_0000 to 0x00_1FFF | 8 KB       | BPS[0] or BPS_SEC[0]  | Block 0                | Not swap block 0 and block 1 in this startup area select setting |

Table 44.20 Example of Block Protect setting when SAS.BTFLG is 0

| FSADDR[23:0]           | Block size | Block protect setting | User area block number | Notes  |
|------------------------|------------|-----------------------|------------------------|--|
| The last block address | 32 KB      | BPS[n] or BPS_SEC[n]  | Block n                | —  |
| ⋮                      | ⋮          | ⋮                     | ⋮                      | —  |
| 0x01_8000 to 0x01_FFFF | 32 KB      | BPS[9] or BPS_SEC[9]  | Block 9                | —  |
| 0x01_0000 to 0x01_7FFF | 32 KB      | BPS[8] or BPS_SEC[8]  | Block 8                | —  |
| 0x00_E000 to 0x00_FFFF | 8 KB       | BPS[7] or BPS_SEC[7]  | Block 7                | —  |
| 0x00_C000 to 0x00_DFFF | 8 KB       | BPS[6] or BPS_SEC[6]  | Block 6                | —  |
| ⋮                      | ⋮          | ⋮                     | ⋮                      | —  |
| 0x00_2000 to 0x00_3FFF | 8 KB       | BPS[1] or BPS_SEC[1]  | Block 0                | Swap block 0 and block 1 in this startup area select setting |
| 0x00_0000 to 0x00_1FFF | 8 KB       | BPS[0] or BPS_SEC[0]  | Block 1                | Swap block 0 and block 1 in this startup area select setting |

Table 44.21 Example of Block Protect setting when BANKSEL.BLCKSWP is 1 (1 of 2)

| FSADDR[23:0]                                    | Block size | Block protect setting | User area block number | Notes  |
|---|------------|-----------------------|------------------------|--|
| The last block address                          | 32 KB      | BPS[n] or BPS_SEC[n]  | Block n                | —  |
| ⋮   | ⋮          | ⋮                     | ⋮                      | —  |
| The upper side address of the block swap target | 32 KB      | BPS[b] or BPS_SEC[b]  | Block b                | Not swap block a and block b in this block swap select setting |
| ⋮   | ⋮          | ⋮                     | ⋮                      | —  |
| The lower side address of the block swap target | 32 KB      | BPS[a] or BPS_SEC[a]  | Block a                | Not swap block a and block b in this block swap select setting |
| ⋮   | ⋮          | ⋮                     | ⋮                      | —  |
| 0x01_8000 to 0x01_FFFF                          | 32 KB      | BPS[9] or BPS_SEC[9]  | Block 9                | —  |
| 0x01_0000 to 0x01_7FFF                          | 32 KB      | BPS[8] or BPS_SEC[8]  | Block 8                | —  |
| 0x00_E000 to 0x00_FFFF                          | 8 KB       | BPS[7] or BPS_SEC[7]  | Block 7                | —  |
| 0x00_C000 to 0x00_DFFF                          | 8 KB       | BPS[6] or BPS_SEC[6]  | Block 6                | —  |
| ⋮   | ⋮          | ⋮                     | ⋮                      | —  |
| 0x002000 to 0x00_3FFF                           | 8 KB       | BPS[1] or BPS_SEC[1]  | Block 1                | —  |

Table 44.19 SAS.BTFLG为1时的块保护设置示例(2of2)

| FSADDR[23:0]           | 块大小   | 块保护设置                | 用户区块号   | Notes               |
|------------------------|-------|----------------------|---------|---------------------|
| 0x01_0000 to 0x01_7FFF | 32 KB | BPS[8] or BPS_SEC[8] | Block 8 | —                   |
| 0x00_E000 to 0x00_FFFF | 8 KB  | BPS[7] or BPS_SEC[7] | Block 7 | —                   |
| 0x00_C000 to 0x00_DFFF | 8 KB  | BPS[6] or BPS_SEC[6] | Block 6 | —                   |
| ⋮                      | ⋮     | ⋮                    | ⋮       | —                   |
| 0x00_2000 to 0x00_3FFF | 8 KB  | BPS[1] or BPS_SEC[1] | Block 1 | 不交换此启动区域中的块0和块1选择设置 |
| 0x00_0000 to 0x00_1FFF | 8 KB  | BPS[0] or BPS_SEC[0] | Block 0 | 不交换此启动区域中的块0和块1选择设置 |

Table 44.20 SAS.BTFLG为0时的块保护设置示例

| FSADDR[23:0]           | 块大小   | 块保护设置                | 用户区块号   | Notes              |
|------------------------|-------|----------------------|---------|--------------------|
| 最后一个区块地址               | 32 KB | BPS[n] or BPS_SEC[n] | Block n | —                  |
| ⋮                      | ⋮     | ⋮                    | ⋮       | —                  |
| 0x01_8000 to 0x01_FFFF | 32 KB | BPS[9] or BPS_SEC[9] | Block 9 | —                  |
| 0x01_0000 to 0x01_7FFF | 32 KB | BPS[8] or BPS_SEC[8] | Block 8 | —                  |
| 0x00_E000 to 0x00_FFFF | 8 KB  | BPS[7] or BPS_SEC[7] | Block 7 | —                  |
| 0x00_C000 to 0x00_DFFF | 8 KB  | BPS[6] or BPS_SEC[6] | Block 6 | —                  |
| ⋮                      | ⋮     | ⋮                    | ⋮       | —                  |
| 0x00_2000 to 0x00_3FFF | 8 KB  | BPS[1] or BPS_SEC[1] | Block 0 | 在此启动区域选择设置中交换块0和块1 |
| 0x00_0000 to 0x00_1FFF | 8 KB  | BPS[0] or BPS_SEC[0] | Block 1 | 在此启动区域选择设置中交换块0和块1 |

Table 44.21 BANKSEL.BLCKSWP为1时的块保护设置示例(1of2)

| FSADDR[23:0]           | 块大小   | 块保护设置                | 用户区块号   | Notes              |
|------------------------|-------|----------------------|---------|--------------------|
| 最后一个区块地址               | 32 KB | BPS[n] or BPS_SEC[n] | Block n | —                  |
| ⋮                      | ⋮     | ⋮                    | ⋮       | —                  |
| 块交换目标的高位地址             | 32 KB | BPS[b] or BPS_SEC[b] | Block b | 在此块交换选择设置中不交换块a和块b |
| ⋮                      | ⋮     | ⋮                    | ⋮       | —                  |
| 块交换目标的低端地址             | 32 KB | BPS[a] or BPS_SEC[a] | Block a | 在此块交换选择设置中不交换块a和块b |
| ⋮                      | ⋮     | ⋮                    | ⋮       | —                  |
| 0x01_8000 to 0x01_FFFF | 32 KB | BPS[9] or BPS_SEC[9] | Block 9 | —                  |
| 0x01_0000 to 0x01_7FFF | 32 KB | BPS[8] or BPS_SEC[8] | Block 8 | —                  |
| 0x00_E000 to 0x00_FFFF | 8 KB  | BPS[7] or BPS_SEC[7] | Block 7 | —                  |
| 0x00_C000 to 0x00_DFFF | 8 KB  | BPS[6] or BPS_SEC[6] | Block 6 | —                  |
| ⋮                      | ⋮     | ⋮                    | ⋮       | —                  |
| 0x002000 to 0x00_3FFF  | 8 KB  | BPS[1] or BPS_SEC[1] | Block 1 | —                  |



Table 44.21 Example of Block Protect setting when BANKSEL.BLCKSWP is 1 (2 of 2)

| FSADDR[23:0]           | Block size | Block protect setting | User area block number | Notes |
|------------------------|------------|-----------------------|------------------------|-------|
| 0x00_0000 to 0x00_1FFF | 8 KB       | BPS[0] or BPS_SEC[0]  | Block 0                | —     |

Table 44.22 Example of Block Protect setting when BANKSEL.BLCKSWP is 0

| FSADDR[23:0]  | Block size | Block protect setting | User area block number | Notes  |
|---|------------|-----------------------|------------------------|--|
| The last block address                              | 32 KB      | BPS[n] or BPS_SEC[n]  | Block n                | —  |
| ⋮   | ⋮          | ⋮                     | ⋮                      | —  |
| The updating side address of the block swap target  | 32 KB      | BPS[b] or BPS_SEC[b]  | Block a                | Swap block a and block b in this block swap select setting |
| ⋮   | ⋮          | ⋮                     | ⋮                      | —  |
| The operating side address of the block swap target | 32 KB      | BPS[a] or BPS_SEC[a]  | Block b                | Swap block a and block b in this block swap select setting |
| ⋮   | ⋮          | ⋮                     | ⋮                      | —  |
| 0x01_8000 to 0x01_FFFF                              | 32 KB      | BPS[9] or BPS_SEC[9]  | Block 9                | —  |
| 0x01_0000 to 0x01_7FFF                              | 32 KB      | BPS[8] or BPS_SEC[8]  | Block 8                | —  |
| 0x00_E000 to 0x00_FFFF                              | 8 KB       | BPS[7] or BPS_SEC[7]  | Block 7                | —  |
| 0x00_C000 to 0x00_DFFF                              | 8 KB       | BPS[6] or BPS_SEC[6]  | Block 6                | —  |
| ⋮   | ⋮          | ⋮                     | ⋮                      | —  |
| 0x00_2000 to 0x00_3FFF                              | 8 KB       | BPS[1] or BPS_SEC[1]  | Block 1                | —  |
| 0x00_0000 to 0x00_1FFF                              | 8 KB       | BPS[0] or BPS_SEC[0]  | Block 0                | —  |

#### 44.11.2 Error Protection

Error protection detects the issuing of illegal FACL commands, illegal access, and flash sequencer malfunction. FACL command acceptance is disabled (command-locked state) in response to the detection of these errors. The flash memory cannot be programmed or erased while the flash sequencer is in the command-locked state. For release from the command-locked state, issue the Status Clear or Forced Stop command. The Status Clear command can only be used while the FRDY bit in the FSTATR register is 1. The Forced Stop command can be used regardless of the value of the FRDY bit. While the CMDLKIE bit in the FAEINT register is 1, a flash access error (FIFERR) interrupt is generated if the flash sequencer enters the command-locked state (the CMDLK bit in the FASTAT register is set to 1).

If the flash sequencer enters the command-locked state in response to a command other than the P/E suspend command during programming or erasure processing, the flash sequencer continues the processing for programming or erasure. In this state, the P/E suspend command cannot be used to suspend the processing for programming or erasure. If a command is issued in the command-locked state, the IGLERR bit becomes 1 and the other bits retain the values set from previous error detection.

Table 44.23 shows the error protection types and status bit values after error detections.

Table 44.23 Error protection type (1 of 3)

| Error type            | Description  | ILGOMERR | FESERR | SECERR | OTERR | ILGLERR | ERSERR | PRGERR | FLWEERR | CFAE | DFAE |
|-----------------------|--|----------|--------|--------|-------|---------|--------|--------|---------|------|------|
| FENTRYR setting error | The value set in FENTRYR is not 0x0000, 0x0001, or 0x0080              | 0        | 1      | 0      | 0     | 1       | 0      | 0      | 0       | 0    | 0    |
|                       | The FENTRYR setting at suspension is different from that at resumption | 0        | 1      | 0      | 0     | 1       | 0      | 0      | 0       | 0    | 0    |

Table 44.21 BANKSEL.BLCKSWP为1时的块保护设置示例(2of2)

| FSADDR[23:0]           | 块大小  | 块保护设置                | 用户区块号   | Notes |
|------------------------|------|----------------------|---------|-------|
| 0x00_0000 to 0x00_1FFF | 8 KB | BPS[0] or BPS_SEC[0] | Block 0 | —     |

Table 44.22 BANKSEL.BLCKSWP为0时的块保护设置示例

| FSADDR[23:0]           | 块大小   | 块保护设置                | 用户区块号   | Notes             |
|------------------------|-------|----------------------|---------|-------------------|
| 最后一个区块地址               | 32 KB | BPS[n] or BPS_SEC[n] | Block n | —                 |
| ⋮                      | ⋮     | ⋮                    | ⋮       | —                 |
| 块交换目标的更新端地址            | 32 KB | BPS[b] or BPS_SEC[b] | Block a | 在此块交换选择设置中交换块a和块b |
| ⋮                      | ⋮     | ⋮                    | ⋮       | —                 |
| 块交换目标的操作端地址            | 32 KB | BPS[a] or BPS_SEC[a] | Block b | 在此块交换选择设置中交换块a和块b |
| ⋮                      | ⋮     | ⋮                    | ⋮       | —                 |
| 0x01_8000 to 0x01_FFFF | 32 KB | BPS[9] or BPS_SEC[9] | Block 9 | —                 |
| 0x01_0000 to 0x01_7FFF | 32 KB | BPS[8] or BPS_SEC[8] | Block 8 | —                 |
| 0x00_E000 to 0x00_FFFF | 8 KB  | BPS[7] or BPS_SEC[7] | Block 7 | —                 |
| 0x00_C000 to 0x00_DFFF | 8 KB  | BPS[6] or BPS_SEC[6] | Block 6 | —                 |
| ⋮                      | ⋮     | ⋮                    | ⋮       | —                 |
| 0x00_2000 to 0x00_3FFF | 8 KB  | BPS[1] or BPS_SEC[1] | Block 1 | —                 |
| 0x00_0000 to 0x00_1FFF | 8 KB  | BPS[0] or BPS_SEC[0] | Block 0 | —                 |

#### 44.11.2 错误保护

错误保护检测非法FACL命令的发出、非法访问和闪存定序器故障。FACL命令接受被禁用（命令锁定状态）以响应检测到这些错误。闪存定序器处于命令锁定状态时，无法对闪存进行编程或擦除。要从命令锁定状态释放，请发出状态清除或强制停止命令。状态清除命令只能在FSTATR寄存器中的FRDY位为1时使用。无论FRDY位的值如何，都可以使用强制停止命令。当FAEINT寄存器中的CMDLKIE位为1时，如果闪存定序器进入命令锁定状态（FASTAT寄存器中的CMDLK位设置为1），则会产生闪存访问错误(FIFERR)中断。

如果闪存定序器在编程或擦除处理期间响应于除了PE暂停命令之外的命令而进入命令锁定状态，则闪存定序器继续进行编程或擦除处理。在这种状态下，PE挂起命令不能用于挂起编程或擦除处理。如果在命令锁定状态下发出命令，则IGLERR位变为1，其他位保留先前错误检测设置的值。

表44.23显示了错误检测后的错误保护类型和状态位值。

Table 44.23 错误保护类型(1of3)

| 错误类型        | Description                        | ILGOMERR | FESERR | SECERR | OTERR | ILGLERR | ERSERR | PRGERR | FLWEERR | CFAE | DFAE |
|-------------|------------------------------------|----------|--------|--------|-------|---------|--------|--------|---------|------|------|
| FENTRYR设置错误 | FENTRYR中设置的值不是0x0000、0x0001或0x0080 | 0        | 1      | 0      | 0     | 1       | 0      | 0      | 0       | 0    | 0    |
|             | 暂停时的FENTRYR设置与恢复时的设置不同             | 0        | 1      | 0      | 0     | 1       | 0      | 0      | 0       | 0    | 0    |



Table 44.23 Error protection type (2 of 3)

| Error type  | Description   | ILGOMERR | FESETERR | SECERR | OTERR | ILGLERR | ERSERR | PRGERR | FLWEERR | CFAE | DFAE      |
|---|---|----------|----------|--------|-------|---------|--------|--------|---------|------|-----------|
| Illegal command error   | An undefined size is specified in the first cycle of the command. (not byte-write)  | 1        | 0        | 0      | 0     | 1       | 0      | 0      | 0       | 0    | 0         |
|   | An undefined code is written in the first access of the FACL command  | 1        | 0        | 0      | 0     | 1       | 0      | 0      | 0       | 0    | 0         |
|   | The value specified in the last access of the multiple-access FACL command is not 0xD0  | 1        | 0        | 0      | 0     | 1       | 0      | 0      | 0       | 0    | 0         |
|   | The value (N) specified in the second write access of the FACL command in the program or configuration set command is wrong                                     | 1        | 0        | 0      | 0     | 1       | 0      | 0      | 0       | 0    | 0         |
|   | Blank Check command is issued with inconsistent BCDIR, FSADDR, and FEADDR settings (see section 44.4.13. FEADDR : FACL Command End Address Register)            | 1        | 0        | 0      | 0     | 1       | 0      | 0      | 0       | 0    | 0/1<br>*1 |
|   | A multi block erase command is issued with inconsistent FSADDR and FEADDR settings.<br>• FSADDR > FEADDR<br>• FEADDR is set to reserved area.                   | 1        | 0        | 0      | 0     | 1       | 0      | 0      | 0       | 0    | 0/1<br>*1 |
|   | An FACL command not acceptable in each mode is issued (see Table 44.15)   | 1        | 0        | 0      | 0     | 1       | 0      | 0      | 0       | 0    | 0         |
|   | An FACL command is issued when command acceptance conditions are not satisfied (see Table 44.16)  | 0/1      | 0/1      | 0/1    | 0/1   | 1       | 0/1    | 0/1    | 0/1     | 0/1  | 0/1       |
|   | A program or block erase command is issued against the area protected by the block protect setting (see section 44.11.1.3. Protection by Block Protect Setting) | 1        | 0        | 0      | 0     | 1       | 0      | 0      | 0       | 0    | 0         |
| A program command is issued against the erase area in erase suspend | 1   | 0        | 0        | 0      | 1     | 0       | 0      | 0      | 0       | 0    |           |
| Erase error   | An error occurs during erasure  | 0        | 0        | 0      | 0     | 0       | 1      | 0      | 0       | 0    | 0         |
| Programming error   | An error occurs during programming  | 0        | 0        | 0      | 0     | 0       | 0      | 1      | 0       | 0    | 0         |
| Code flash memory access violation                                  | An FACL command is issued to the reserved portion of the user area in code flash P/E mode   | 0        | 0        | 0      | 0     | 1       | 0      | 0      | 0       | 1    | 0         |
|   | Configuration set command is issued to the reserved option-setting memory   | 0        | 0        | 0      | 0     | 1       | 0      | 0      | 0       | 1    | 0         |
|   | Configuration set command of non-secure access is issued to the secure region of TrustZone in the code flash  | 0        | 0        | 0      | 0     | 1       | 0      | 0      | 0       | 1    | 0         |
|   | Program or block erase command of non-secure access is issued to the secure region of user area.  | 0        | 0        | 0      | 0     | 1       | 0      | 0      | 0       | 1    | 0         |

Table 44.23 错误保护类型 (2个, 共3个)

| 错误类型               | Description  | ILGOMERR | FESETERR | SECERR | OTERR | ILGLERR | ERSERR | PRGERR | FLWEERR | CFAE | DFAE      |
|--------------------|--|----------|----------|--------|-------|---------|--------|--------|---------|------|-----------|
| 非法命令错误             | 在命令的第一个循环中指定了未定义的大小。(不是字节写入)   | 1        | 0        | 0      | 0     | 1       | 0      | 0      | 0       | 0    | 0         |
|                    | 在FACL命令的第一次访问中写入了未定义的代码  | 1        | 0        | 0      | 0     | 1       | 0      | 0      | 0       | 0    | 0         |
|                    | 多路访问FACL命令的最后一次访问指定的值不是0xD0  | 1        | 0        | 0      | 0     | 1       | 0      | 0      | 0       | 0    | 0         |
|                    | 程序或配置集命令中FACL命令的第二次写访问指定的值(N)错误  | 1        | 0        | 0      | 0     | 1       | 0      | 0      | 0       | 0    | 0         |
|                    | 使用不一致的BCDIR、FSADDR和FEADDR设置发出空白检查命令(请参阅第44.4.13节。<br>FEADDR:FACL命令结束地址 Register) | 1        | 0        | 0      | 0     | 1       | 0      | 0      | 0       | 0    | 0/1<br>*1 |
|                    | 使用不一致的FSADDR和FEADDR设置发出多块擦除命令。<br>• FEADDR设置为保留区域。                               | 1        | 0        | 0      | 0     | 1       | 0      | 0      | 0       | 0    | 0/1<br>*1 |
|                    | 发出在每种模式下都不可接受的FACL命令(参见表44.15)   | 1        | 0        | 0      | 0     | 1       | 0      | 0      | 0       | 0    | 0         |
|                    | 当命令接受条件不满足时发出FACL命令(见表44.16)   | 0/1      | 0/1      | 0/1    | 0/1   | 1       | 0/1    | 0/1    | 0/1     | 0/1  | 0/1       |
|                    | 针对受块保护设置保护的区域发出编程或块擦除命令(参见第44.11.1.3节。块保护设置保护)                                   | 1        | 0        | 0      | 0     | 1       | 0      | 0      | 0       | 0    | 0         |
| 在擦除挂起中针对擦除区域发出编程命令 | 1  | 0        | 0        | 0      | 1     | 0       | 0      | 0      | 0       | 0    |           |
| 擦除错误               | 擦除过程中发生错误  | 0        | 0        | 0      | 0     | 0       | 1      | 0      | 0       | 0    | 0         |
| 编程错误               | 编程过程中出现错误  | 0        | 0        | 0      | 0     | 0       | 0      | 1      | 0       | 0    | 0         |
| 代码闪存访问冲突           | 在代码闪存PE模式下,向用户区的保留部分发出FACL命令   | 0        | 0        | 0      | 0     | 1       | 0      | 0      | 0       | 1    | 0         |
|                    | 向保留的选项设置内存发出配置设置命令   | 0        | 0        | 0      | 0     | 1       | 0      | 0      | 0       | 1    | 0         |
|                    | 向代码闪存中的TrustZone的安全区域发出非安全访问的配置集命令   | 0        | 0        | 0      | 0     | 1       | 0      | 0      | 0       | 1    | 0         |
|                    | 对用户区的安全区域发出非安全访问的程序或块擦除命令。   | 0        | 0        | 0      | 0     | 1       | 0      | 0      | 0       | 1    | 0         |

Table 44.23 Error protection type (3 of 3)

| Error type                         | Description   | ILGOMERR | FESETERR | SECERR | OTERR | ILGLERR | ERSERR | PRGERR | FLWEERR | CFAE | DFAE |
|------------------------------------|---|----------|----------|--------|-------|---------|--------|--------|---------|------|------|
| Data flash memory access violation | A program or block erase command is issued to the reserved data area in data flash P/E mode   | 0        | 0        | 0      | 0     | 1       | 0      | 0      | 0       | 0    | 1    |
|                                    | A multi block erase command is issued to the reserved data area in data flash P/E mode. (FSADDR is set to reserved data area).                  | 1        | 0        | 0      | 0     | 1       | 0      | 0      | 0       | 0    | 1    |
|                                    | Blank Check command is issued to reserved data area in data flash P/E mode. (FSADDR is set to reserved data area ).                             | 1        | 0        | 0      | 0     | 1       | 0      | 0      | 0       | 0    | 1    |
|                                    | A program, block erase, multi block erase, or blank check command of non-secure access is issued to the secure region of data area.             | 0        | 0        | 0      | 0     | 1       | 0      | 0      | 0       | 0    | 1    |
| Security error                     | Configuration set command for the SAS.BTFLG bit setting is issued when the SAS.FSPR bit is 0 (see section 44.9.3.15. Configuration Set Command) | 0        | 0        | 1      | 0     | 1       | 0      | 0      | 0       | 0    | 0    |
| Others                             | An FACL command-issuing area is accessed in read mode   | 0        | 0        | 0      | 1     | 1       | 0      | 0      | 0       | 0    | 0    |
|                                    | An FACL command-issuing area is read in code flash P/E mode or data flash P/E mode  | 0        | 0        | 0      | 1     | 1       | 0      | 0      | 0       | 0    | 0    |
| Flash write erase protection error | A flash memory write protection error is detected by the FWEPROR register setting*2 during command processing by the flash sequencer            | 0        | 0        | 0      | 0     | 0       | 0/1    | 0/1    | 1       | 0    | 0    |

Note 1. DFAE value depends on the FSADDR setting.

Note 2. For details on the FWEPROR register, see section 44.4.8. FWEPROR : Flash P/E Protect Register.

### 44.11.3 Start-Up Program Protection

Protection of the startup program is for protection of the program to be started after a reset (the startup program). This function provides a way to safely update the startup program when rewriting is suspended during a reset.

The startup area is 8 Kbytes in size and is assigned to the user area in the code flash memory. This function uses the values of the SAS.BTFLG bit and the FSUACR.SAS[1:0] bits to change the area where the startup program is stored in block units (see Figure 44.25 to Figure 44.28).

In protection of the startup program, the state of the selection of the startup area can be fixed by the FSPR bit. However, the SAS.FSPR bit never be restored to 1 once the flag is set to 0. Exercise extra caution when handling the SAS.FSPR bit.

Table 44.23 错误保护类型 (3之3)

| 错误类型         | Description  | ILGOMERR | FESETERR | SECERR | OTERR | ILGLERR | ERSERR | PRGERR | FLWEERR | CFAE | DFAE |
|--------------|--|----------|----------|--------|-------|---------|--------|--------|---------|------|------|
| 数据闪存访问违规     | 在数据闪存PE模式下，向保留数据区域发出程序或块擦除命令                               | 0        | 0        | 0      | 0     | 1       | 0      | 0      | 0       | 0    | 1    |
|              | 在数据闪存PE模式下，向保留数据区域发出多块擦除命令。(FSADDR设置为保留数据区)。               | 1        | 0        | 0      | 0     | 1       | 0      | 0      | 0       | 0    | 1    |
|              | 在数据闪存PE模式下，向保留数据区域发出空白检查命令。(FSADDR设置为保留数据区)。               | 1        | 0        | 0      | 0     | 1       | 0      | 0      | 0       | 0    | 1    |
|              | 向数据区域的安全区域发出非安全访问的编程、块擦除、多块擦除或空白检查命令。                      | 0        | 0        | 0      | 0     | 1       | 0      | 0      | 0       | 0    | 1    |
| 安全错误         | 当SAS.FSPR位为0时，发出SAS.BTFLG位设置的配置设置命令(请参阅第44.9.3.15节。配置设置命令) | 0        | 0        | 1      | 0     | 1       | 0      | 0      | 0       | 0    | 0    |
| Others       | 以读取模式访问FACL命令发布区域  | 0        | 0        | 0      | 1     | 1       | 0      | 0      | 0       | 0    | 0    |
|              | 在代码闪存PE模式或数据闪存PE模式下读取FACL命令发布区域                            | 0        | 0        | 0      | 1     | 1       | 0      | 0      | 0       | 0    | 0    |
| Flash写擦除保护错误 | 在闪存定序器的命令处理期间，通过FWEPROR寄存器设置*2检测到闪存写保护错误                   | 0        | 0        | 0      | 0     | 0       | 0/1    | 0/1    | 1       | 0    | 0    |

注1.DFAE值取决于FSADDR设置。

注2.关于FWEPROR寄存器的详细信息，请参阅44.4.8节。FWEPROR：闪存PE保护寄存器。

### 44.11.3 启动程序保护

启动程序的保护是为了保护复位后要启动的程序(启动程序)。此功能提供了一种在复位期间暂停重写时安全更新启动程序的方法。

启动区大小为8KB，分配给代码闪存中的用户区。该函数使用SAS.BTFLG位和FSUACR.SAS[1:0]位的值来改变以块为单位存储启动程序的区域(见图44.25至图44.28)。

在启动程序的保护中，启动区域的选择状态可以通过FSPR位来固定。但是，那一旦标志设置为0，SAS.FSPR位永远不会恢复为1。处理SAS.FSPR位时要格外小心。

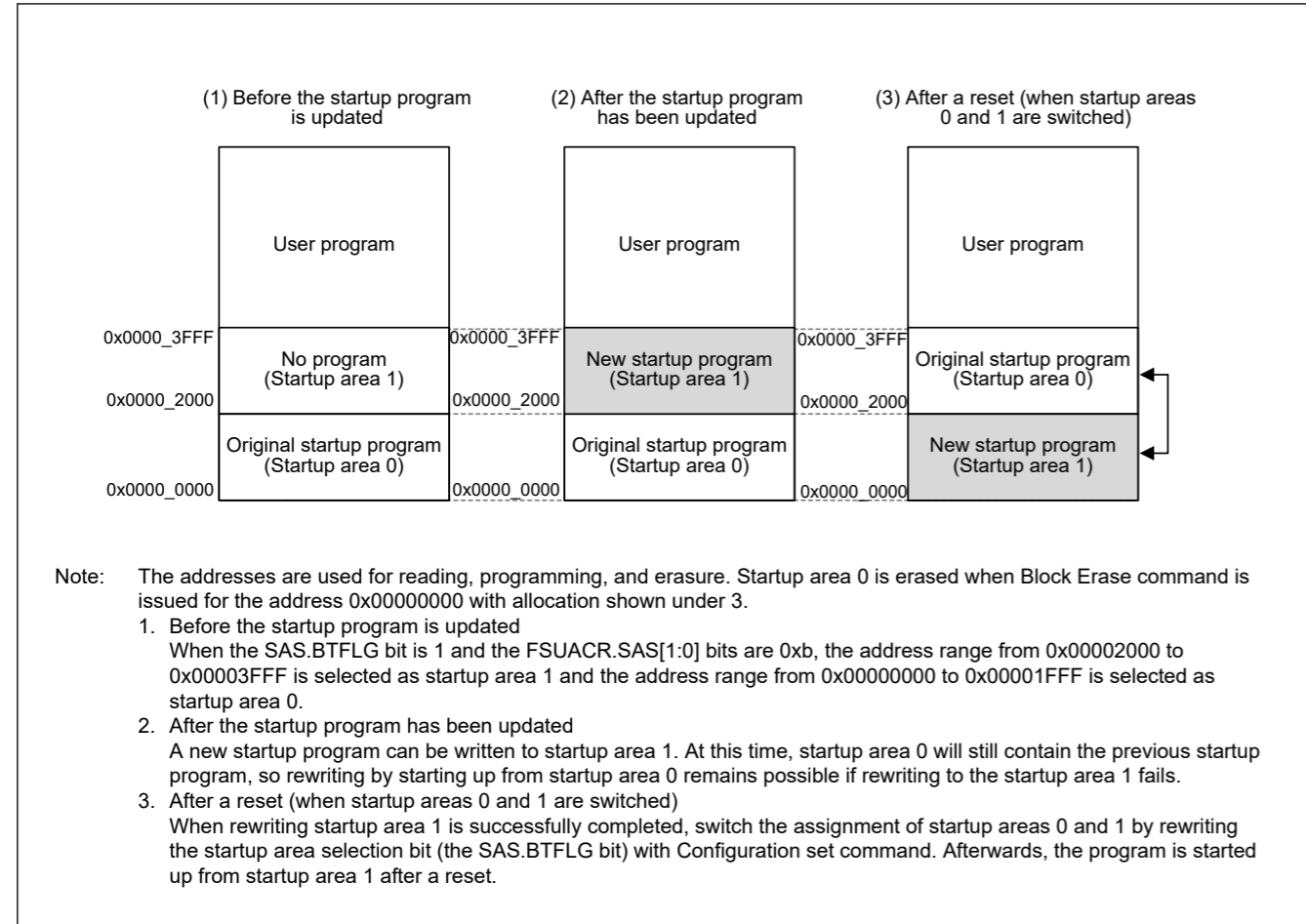


Figure 44.25 Concept of Protection of the Startup Program

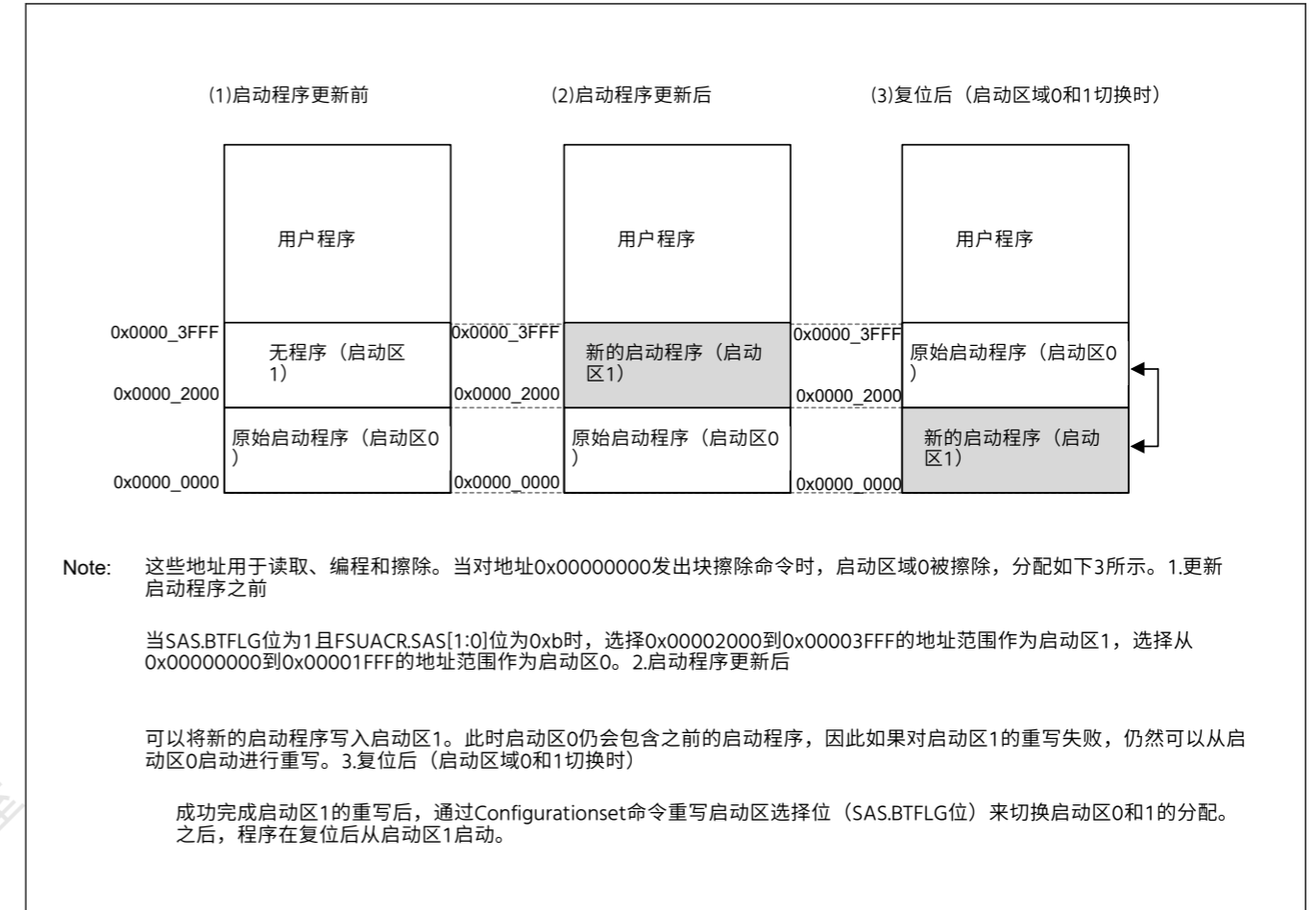


Figure 44.25 保护启动程序的概念

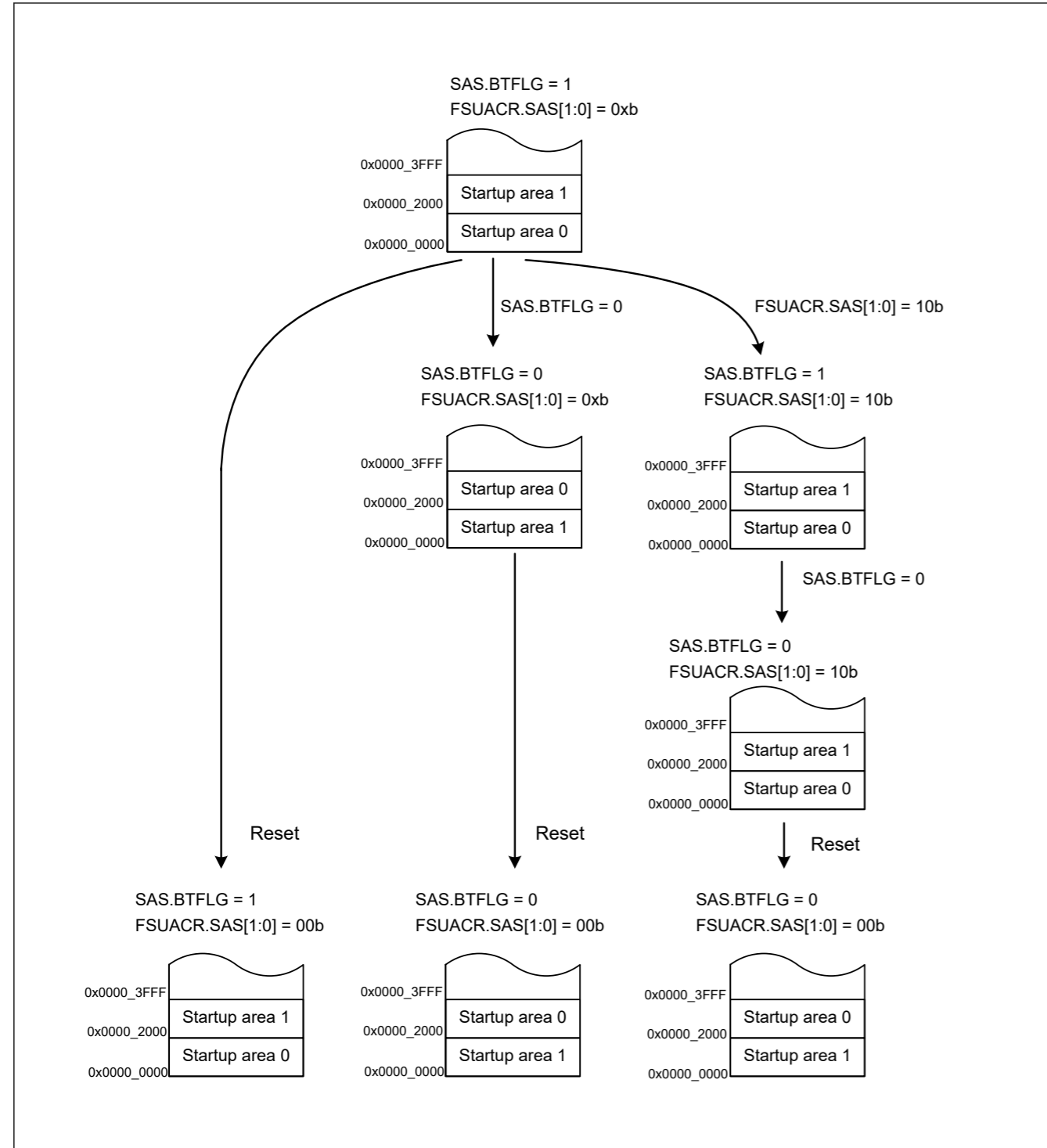


Figure 44.26 Example 1 of Transitions for Startup Program Protection Settings

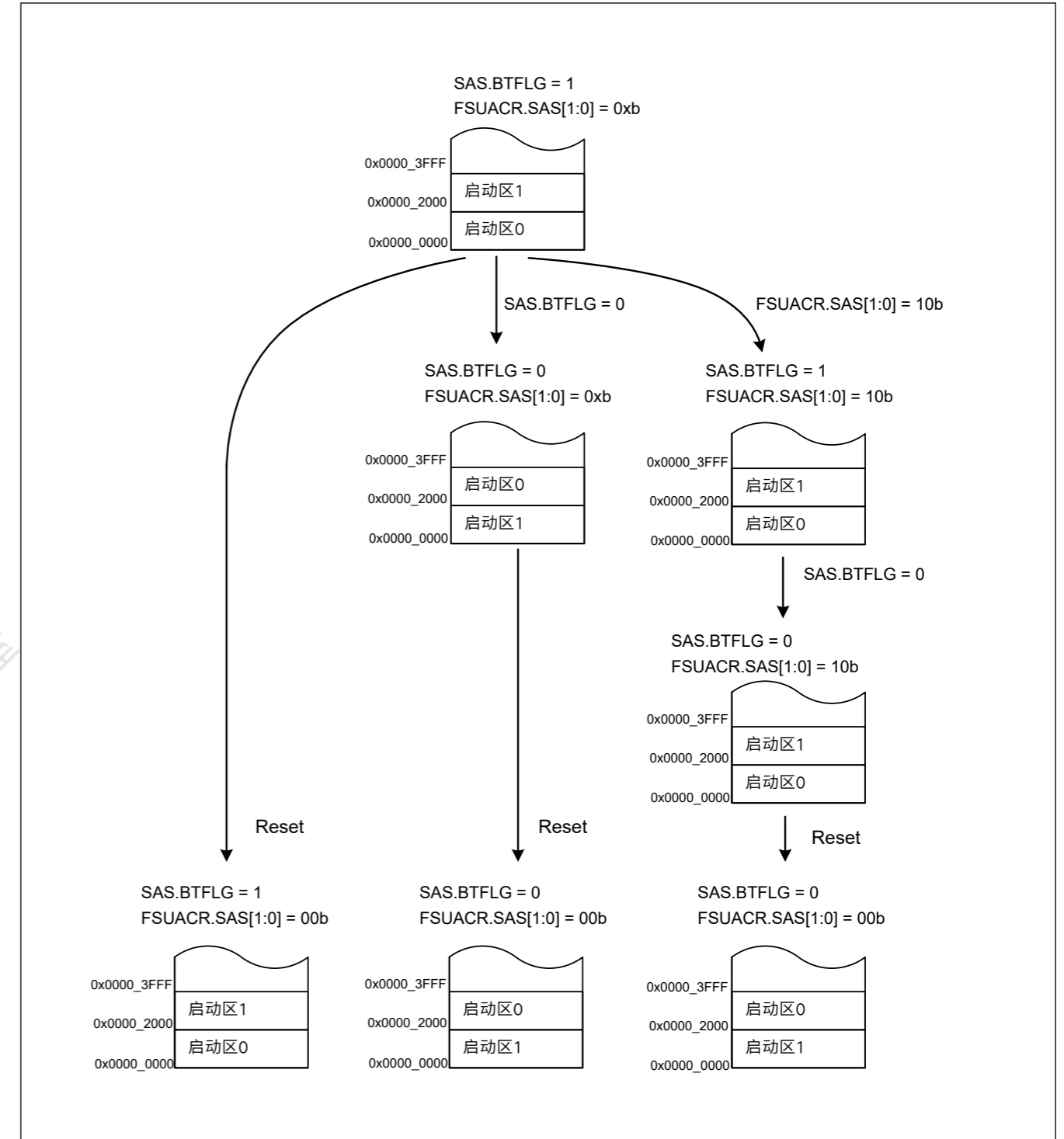


Figure 44.26 启动程序保护设置的转换示例1



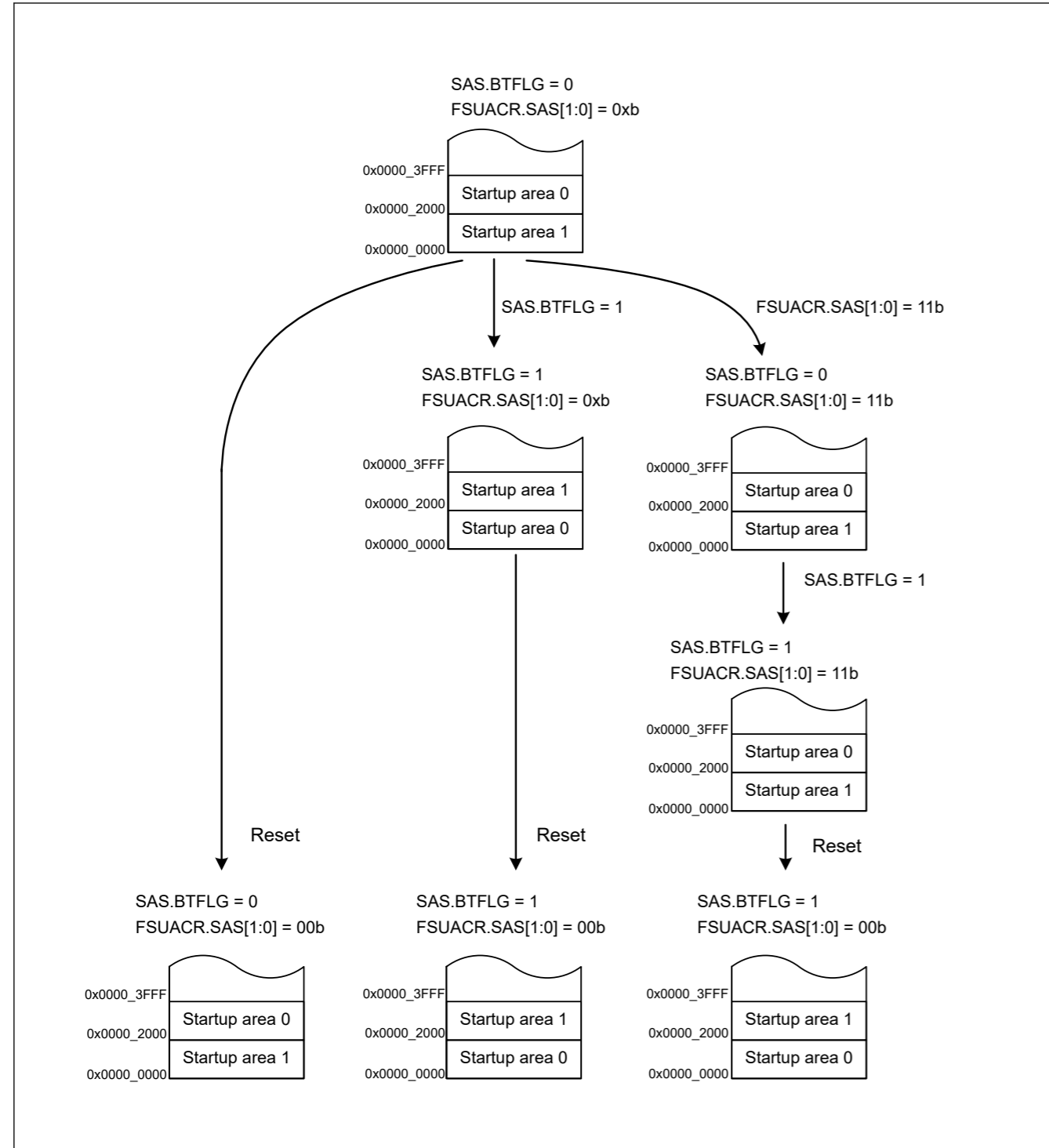


Figure 44.27 Example 2 of Transitions for Startup Program Protection Settings

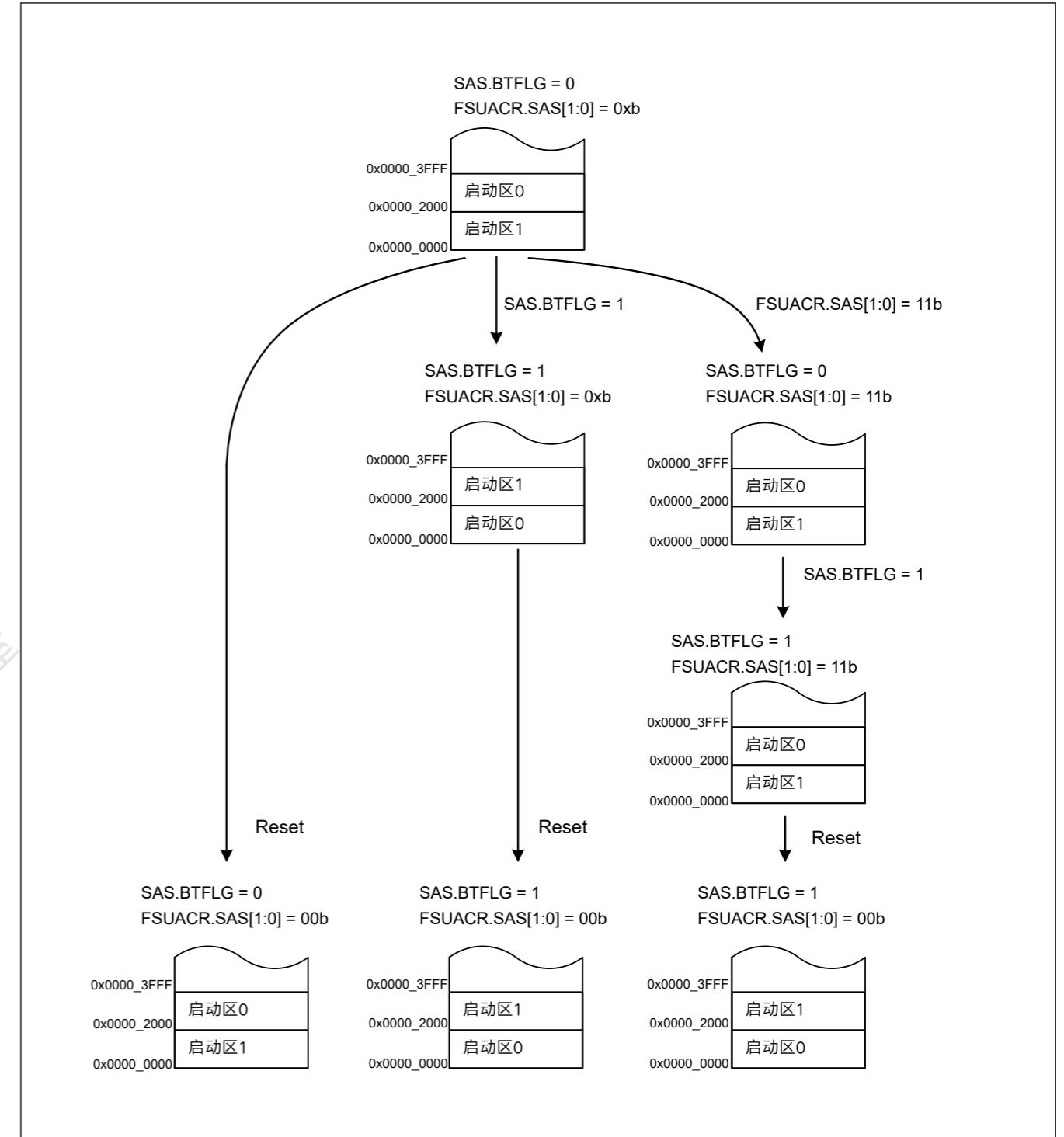


Figure 44.27 启动程序保护设置的转换示例2

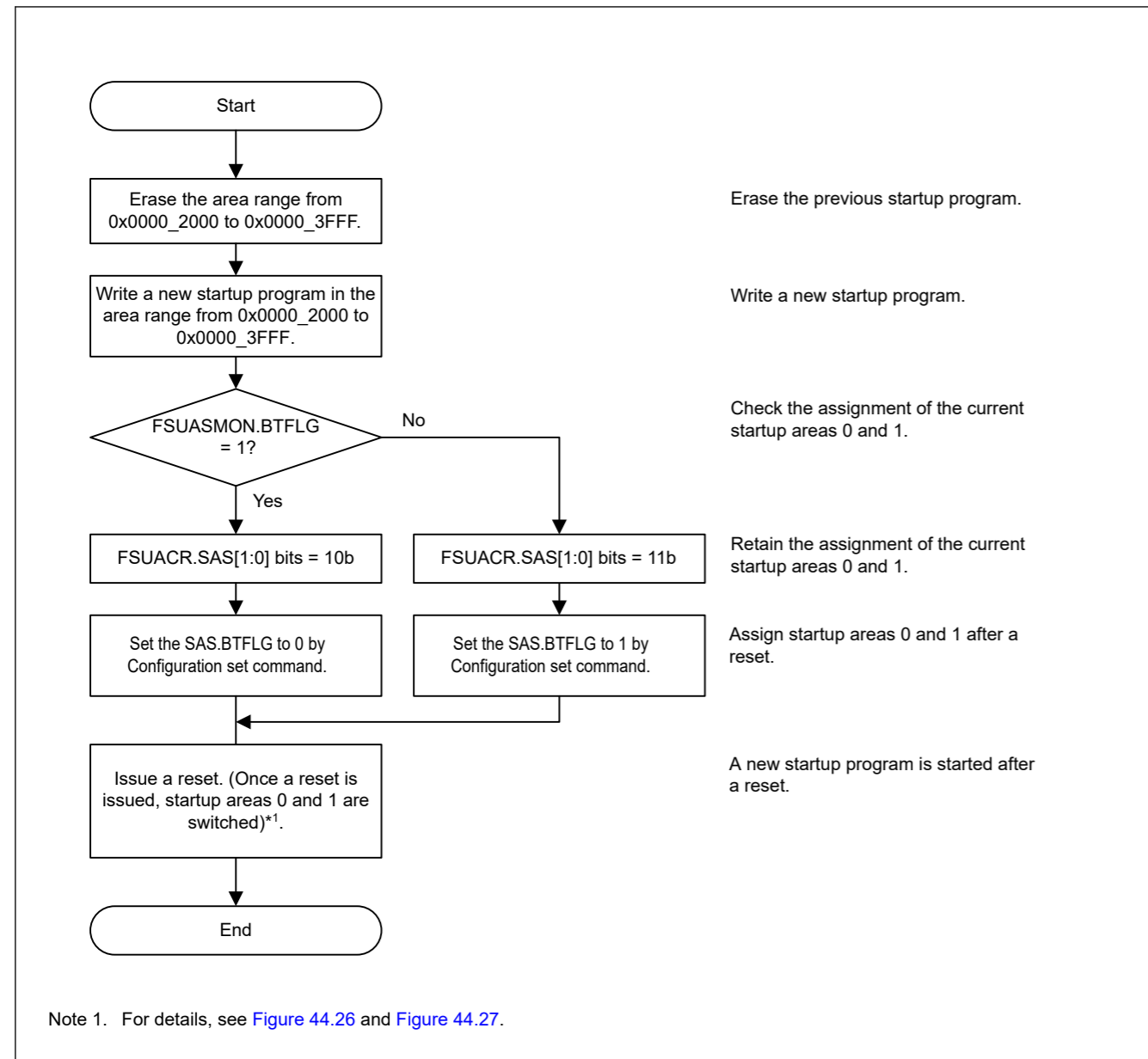


Figure 44.28 Concept of Protection of the Startup Program

#### 44.11.4 Block Swap Function

This protection uses the functions of block swap selection to update a program while a user program is running and to provide a safe method of updating in cases where programming is suspended during a reset.

##### 44.11.4.1 Selecting the Block Swap

Block swap selection provides a way to safely update the program when programming is suspended during a reset. [Figure 44.29](#) is a schematic view of block swap selection and [Figure 44.30](#) shows an example of the flow of block swap selection. A reset after setting the value of the BANKSEL.BLCKSWP bit in the option-setting memory changes the addresses of block A and B. When the address is switched, the Programming/erasure target for the FACL commands is also switched.

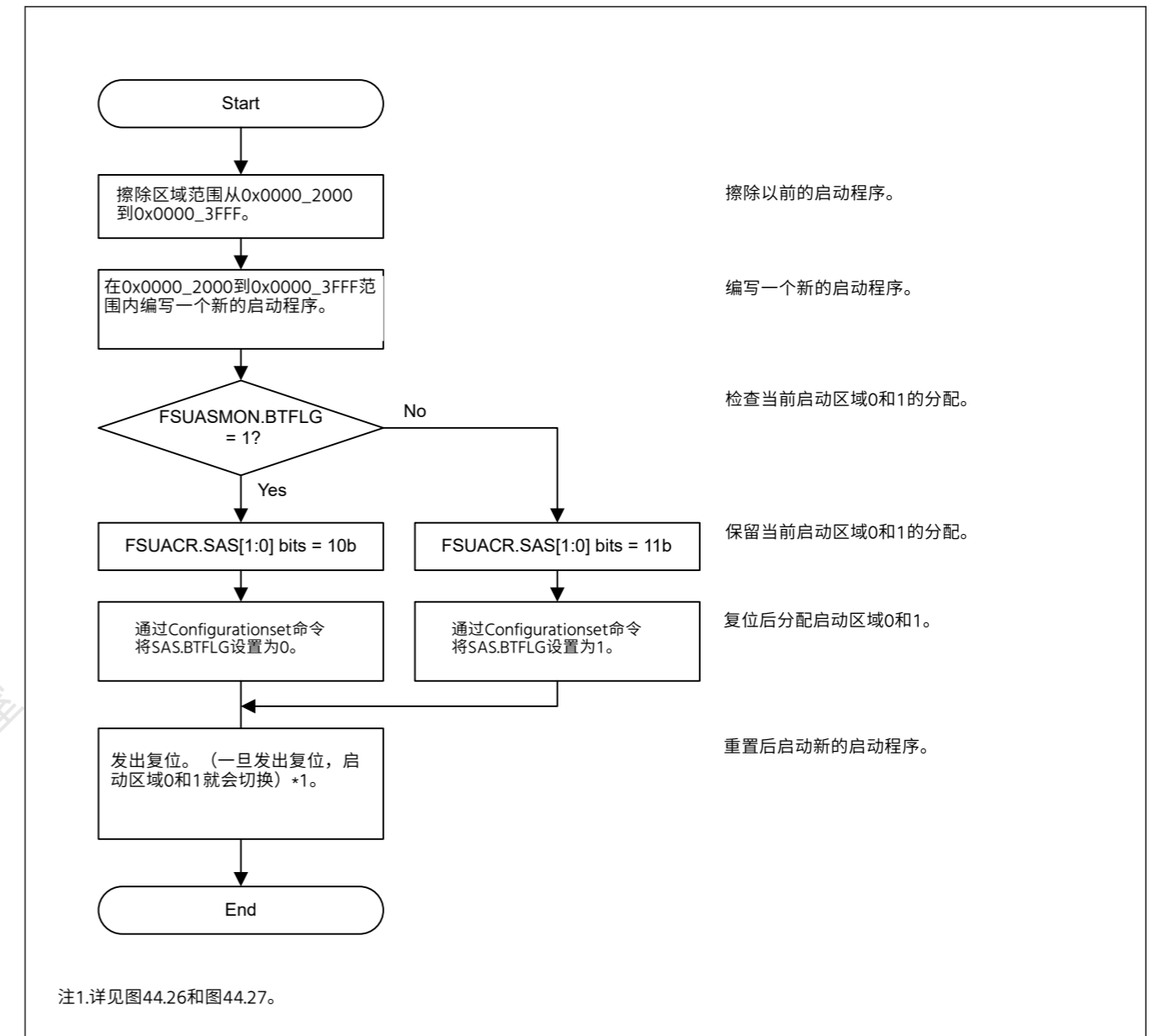


Figure 44.28 保护启动程序的概念

#### 44.11.4 区块交换功能

此保护使用块交换选择功能在用户程序运行时更新程序，并在复位期间暂停编程的情况下提供安全的更新方法。

##### 44.11.4.1 选择块交换

块交换选择提供了一种在复位期间编程暂停时安全更新程序的方法。图44.29是块交换选择的示意图，图44.30显示了块交换选择流程的示例。设置选项设置存储器中的BANKSEL.BLCKSWP位的值后的复位会改变块A和B的地址。当地址切换时，FACL命令的编程擦除目标也会切换。

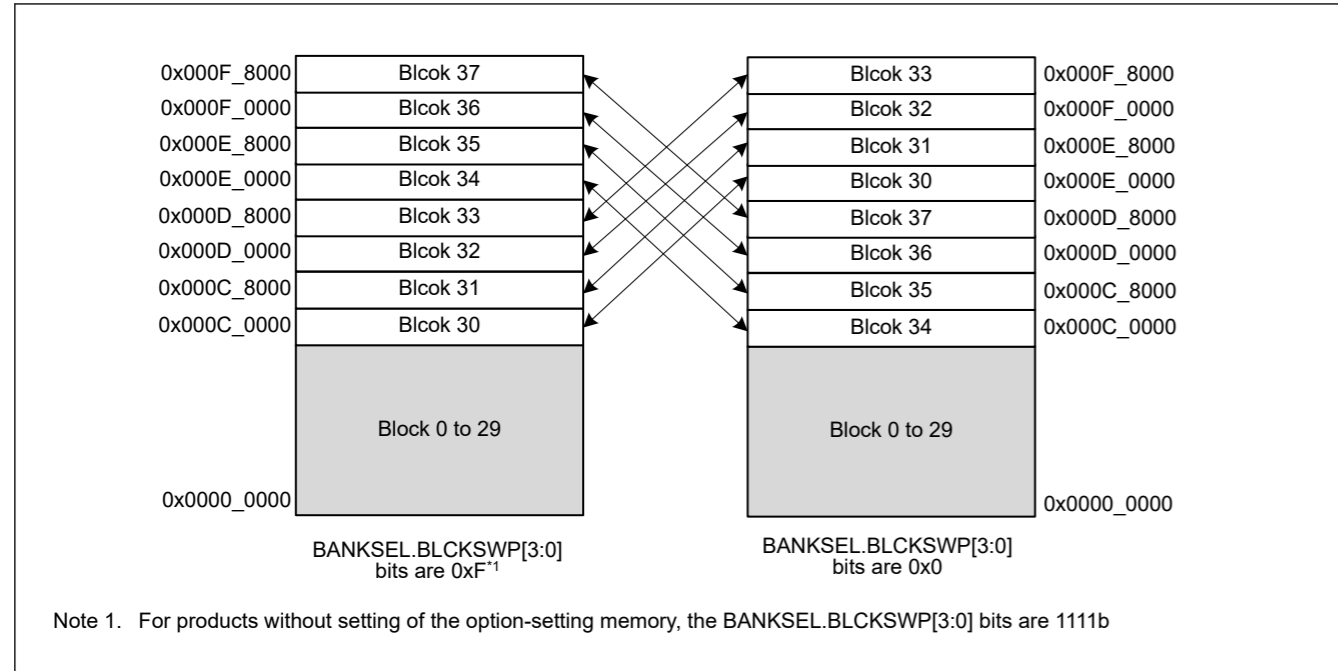


Figure 44.29 Example of Block Swap Selection (For Products with 1 Mbytes of Code Flash Memory)

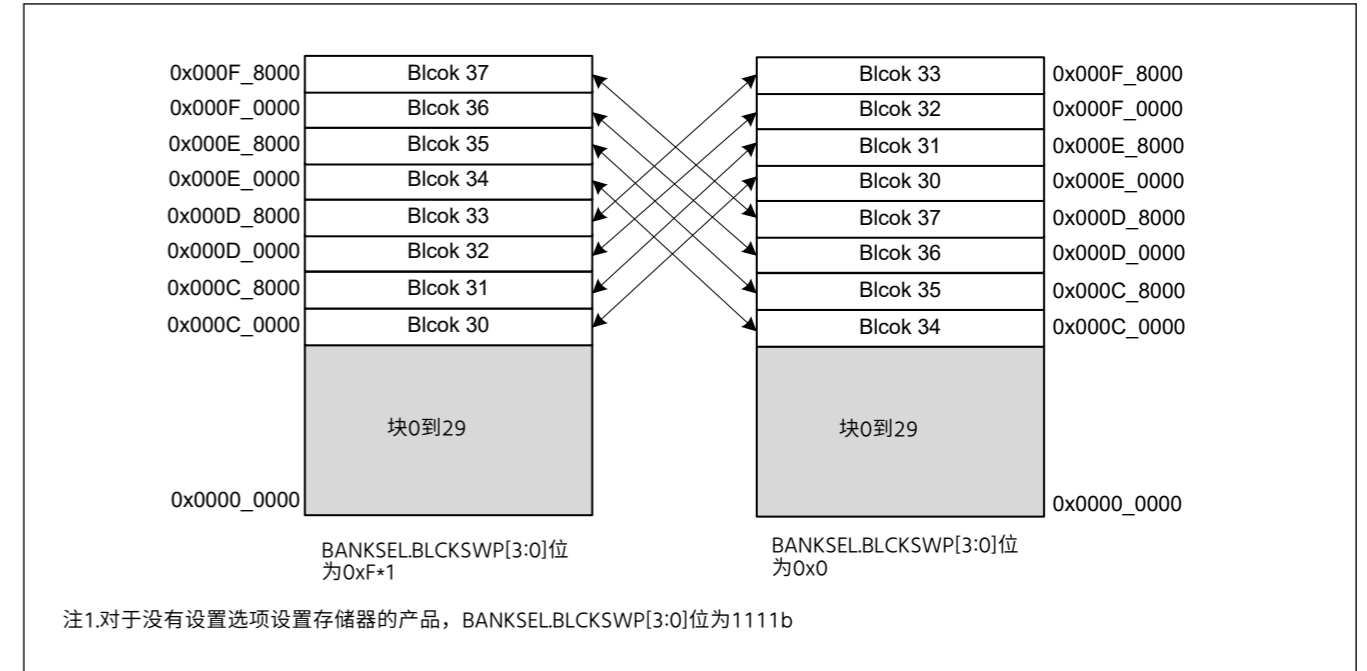


Figure 44.29 块交换选择示例 (适用于具有1MB代码闪存的产品)

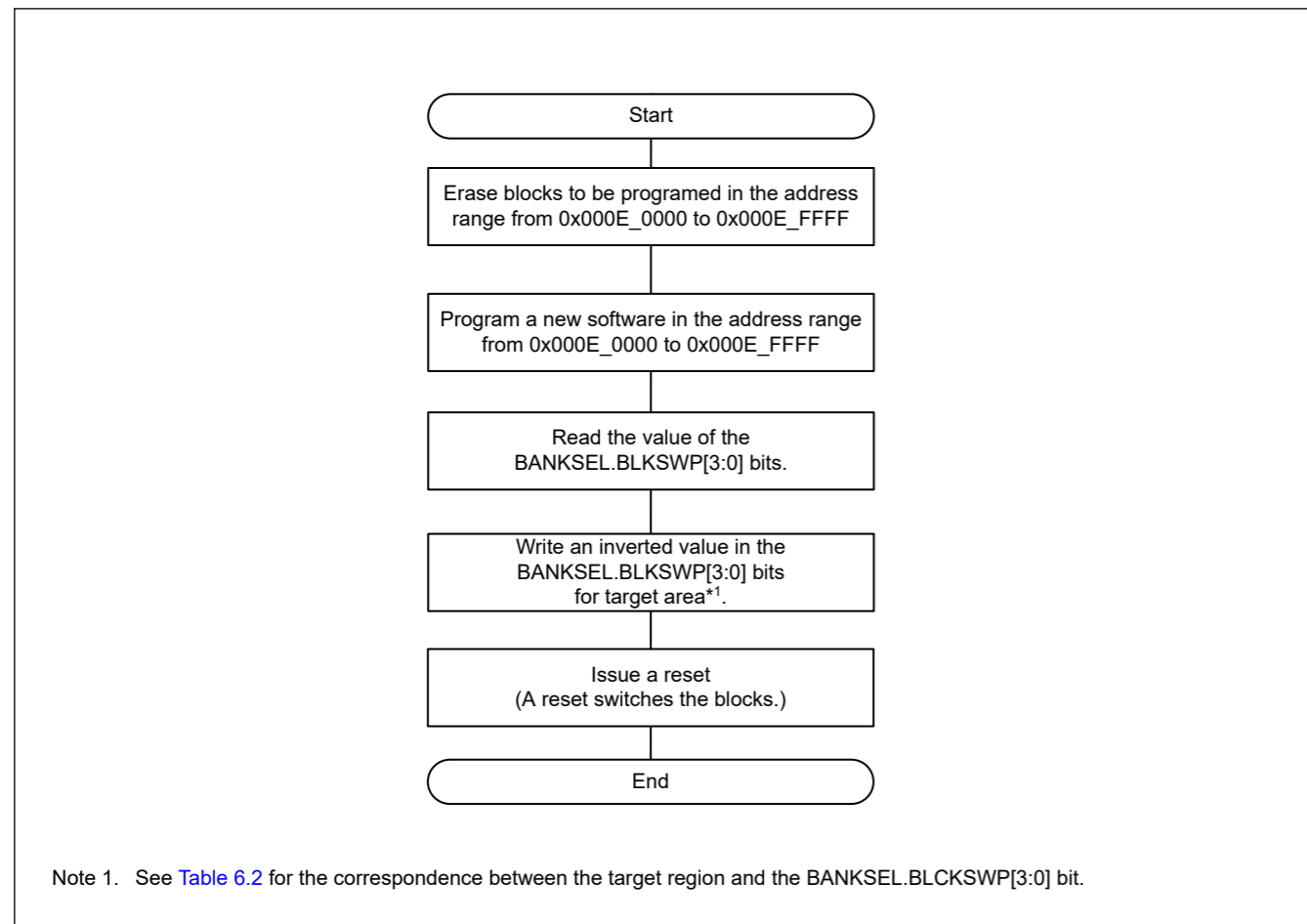


Figure 44.30 Example of Block Swap Selection Flow (For Products with 1 Mbytes of Code Flash Memory)

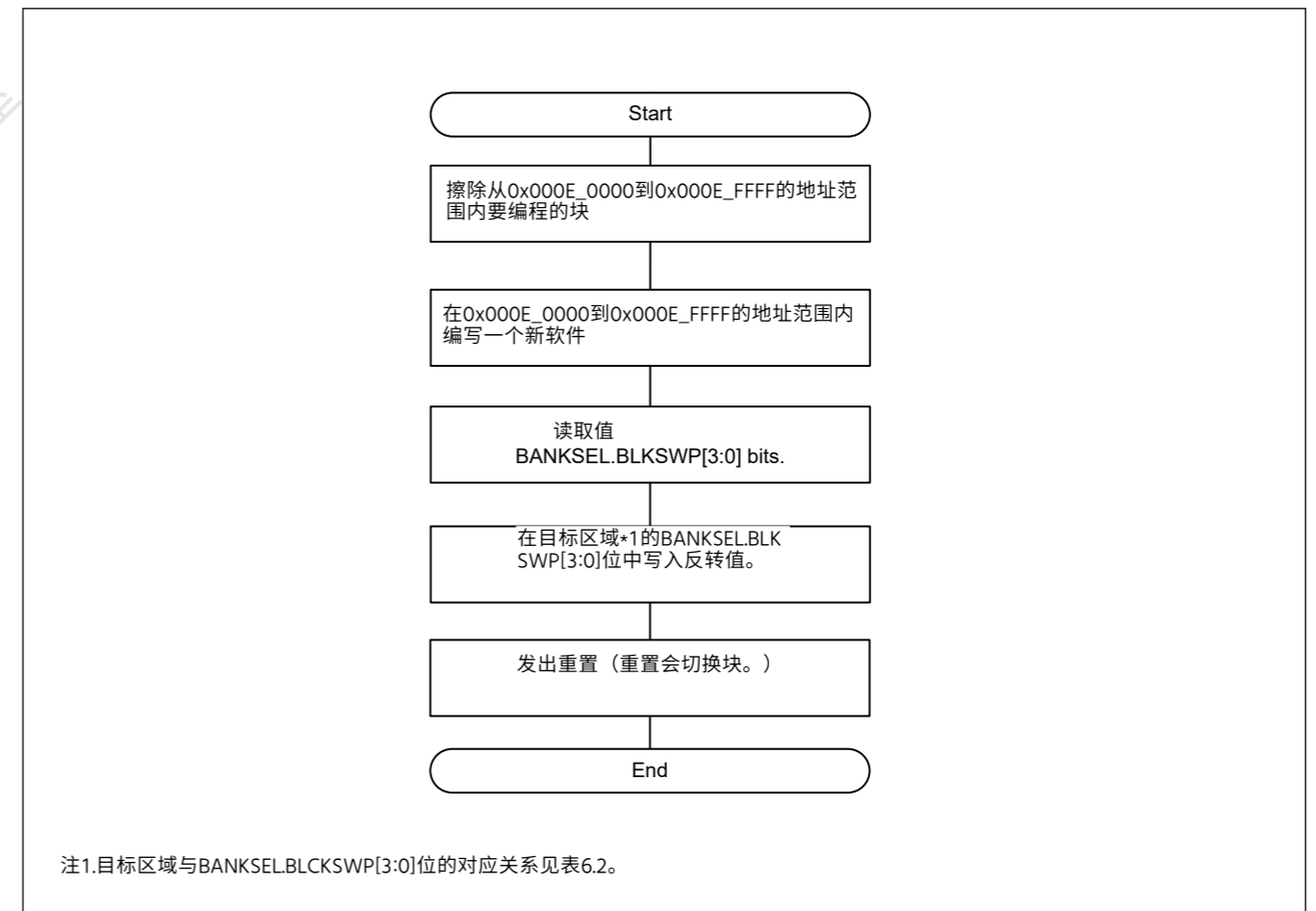


Figure 44.30 块交换选择流程示例 (适用于具有1MB代码闪存的产品)

44.12 Security Function

The flash sequencer supports the following security functions:

44.12 安全功能

闪存定序器支持以下安全功能：

- Security flag for startup area
- Permanent block protect setting
- Flash memory protection for TrustZone

### 44.12.1 Security Flag for Startup Area Select

The security flag (SAS.FSPR) for the startup area is located in the option-setting memory.

When the SAS.FSPR bit is 0, issuing the configuration set command to change the SAS.BTFLG bit causes the flash sequencer to be in the command-locked state. Also, when the SAS.FSPR bit is 0, it is invalid to write to the Startup Area Select bits SAS[1:0] in the FSUACR register. The SAS.FSPR bit enables protection.

### 44.12.2 Permanent Block Protect Setting

The permanent block protect setting is the clear protection for the block protection setting. User area cannot be permanently updated by the FACL command when the permanent block protect setting is enabled. See [section 44.11.1.3. Protection by Block Protect Setting](#) for more details.

The block protect setting and the permanent block protect setting have the write/clear protection against the configuration set command. The flash sequencer does not detect an error when the configuration set command is issued to the write/clear protected settings.

Figure 44.31 and Table 44.24 show the write/clear protection against the block protect setting (BPS[n]) and the permanent protect setting (PBPS[n]). Figure 44.32 and Table 44.25 show the write/clear protection against the block protect setting for secure (BPS\_SEC[n]) and permanent protect setting for secure (PBPS\_SEC[n]).

Effective permanent block protect setting (PBPS or PBPS\_SEC) depends on block protect select (BPS\_SEL). For details of permanent block protect setting (PBPS or PBPS\_SEC) and block protect select (BPS\_SEL), see [section 6, Option-Setting Memory](#).

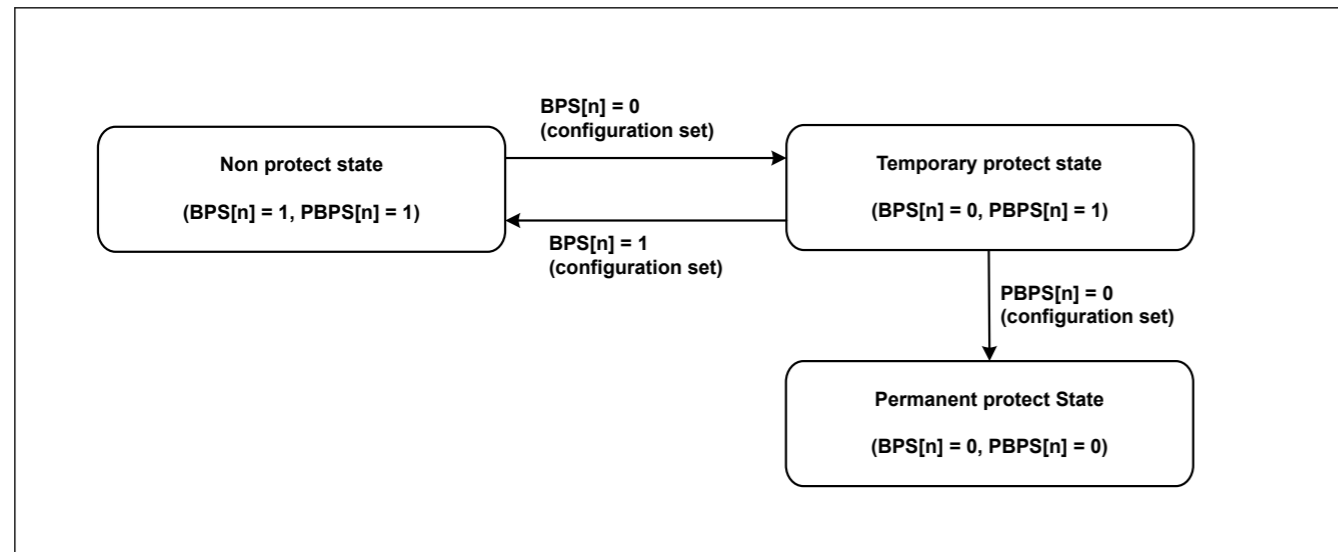


Figure 44.31 Status transition of flash sequencer by BPS[n] and PBPS[n]

Table 44.24 Write/clear protection of BPS[n] and PBPS[n]

| Current state |         | Updatable state by configuration set command |            |             |             |
|---------------|---------|--|------------|-------------|-------------|
| BPS[n]        | PBPS[n] | BPS[n] = 1                                   | BPS[n] = 0 | PBPS[n] = 1 | PBPS[n] = 0 |
| 1             | 1       | ✓  | ✓          | ✓           | X           |
| 1             | 0       | —  | —          | —           | —           |
| 0             | 1       | ✓  | ✓          | ✓           | ✓           |
| 0             | 0       | X  | ✓          | X           | ✓           |

Note:   
 • ✓ indicates updatable by configuration set command.   
 • X indicates not updatable by configuration set command (error does not occur).

- 启动区安全标志
- 永久封锁保护设置
- TrustZone的闪存保护

### 44.12.1 启动区域选择的安全标志

启动区域的安全标志(SAS.FSPR)位于选项设置内存中。

当SAS.FSPR位为0时，发出配置设置命令来更改SAS.BTFLG位会导致闪存定序器处于命令锁定状态。此外，当SAS.FSPR位为0时，写入FSUACR寄存器中的启动区域选择位SAS[1:0]无效。SAS.FSPR位启用保护。

### 44.12.2 永久块保护设置

永久块保护设置是对块保护设置的明确保护。启用永久块保护设置后，FACL命令无法永久更新用户区域。请参阅第44.11.1.3节。通过块保护设置进行保护以获取更多详细信息。

块保护设置和永久块保护设置具有针对配置集命令的写清除保护。向写清除保护设置发出配置设置命令时，闪存定序器不会检测到错误。

图44.31和表44.24显示了针对块保护设置(BPS[n])和永久保护设置(PBPS[n])的写清除保护。图44.32和表44.25显示了针对安全的块保护设置(BPS\_SEC[n])和安全的永久保护设置(PBPS\_SEC[n])的写清除保护。

有效的永久块保护设置 (PBPS或PBPS\_SEC) 取决于块保护选择 (BPS\_SEL)。有关永久块保护设置 (PBPS或PBPS\_SEC) 和块保护选择 (BPS\_SEL) 的详细信息，请参见第6节，选项设置存储器。

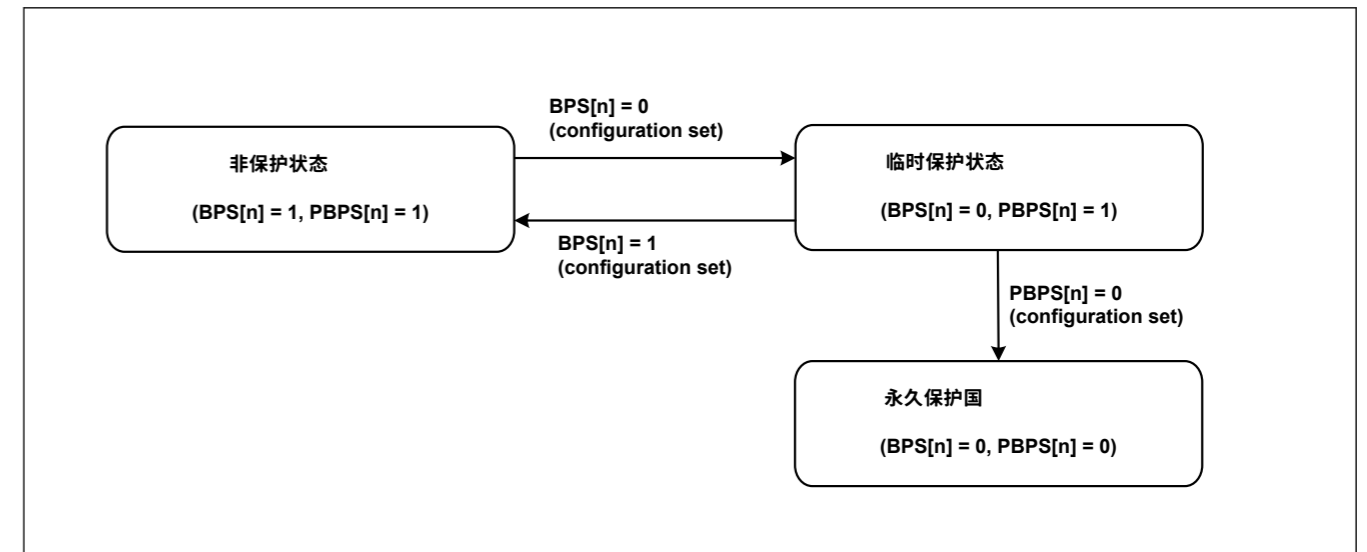


Figure 44.31 通过BPS[n]和PBPS[n]进行闪存定序器的状态转换

Table 44.24 BPS[n]和PBPS[n]的写清除保护

| 当前状态   |         | 可通过配置设置命令更新状态 |            |             |             |
|--------|---------|---------------|------------|-------------|-------------|
| BPS[n] | PBPS[n] | BPS[n] = 1    | BPS[n] = 0 | PBPS[n] = 1 | PBPS[n] = 0 |
| 1      | 1       | ✓             | ✓          | ✓           | X           |
| 1      | 0       | —             | —          | —           | —           |
| 0      | 1       | ✓             | ✓          | ✓           | ✓           |
| 0      | 0       | X             | ✓          | X           | ✓           |

Note:   
 • 表示可通过配置设置命令更新。   
 • X表示不能通过配置设置命令更新（不发生错误）。



• — indicates not reaching to this state.

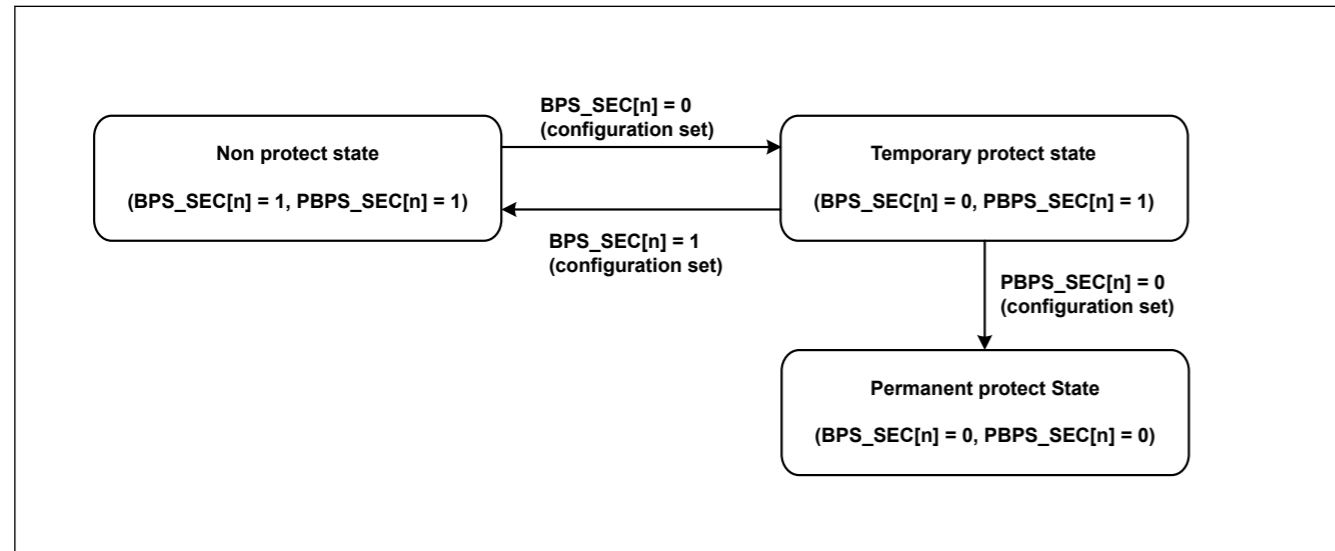


Figure 44.32 Status transition of flash sequencer by BPS\_SEC[n] and PBPS\_SEC[n]

Table 44.25 Write/clear protection of BPS\_SEC[n] and PBPS\_SEC[n]

| Current state |             | Updatable state by configuration set command |                |                 |                 |
|---------------|-------------|--|----------------|-----------------|-----------------|
| BPS_SEC[n]    | PBPS_SEC[n] | BPS_SEC[n] = 1                               | BPS_SEC[n] = 0 | PBPS_SEC[n] = 1 | PBPS_SEC[n] = 0 |
| 1             | 1           | ✓  | ✓              | ✓               | X               |
| 1             | 0           | —  | —              | —               | —               |
| 0             | 1           | ✓  | ✓              | ✓               | ✓               |
| 0             | 0           | X  | ✓              | X               | ✓               |

Note:   
 • ✓ indicates updatable by configuration set command.   
 • X indicates not updatable by configuration set command (error does not occur).   
 • — indicates not reaching to this state.

### 44.12.3 Flash Memory Protection for TrustZone

Information in this section focuses on the flash sequencer operation.

The flash memory provides the following types of protect function against non-secure access:

- Protection for flash memory area (P/E)
- Protection for flash memory area (read)
- Protection for registers
- Protection during FACI command operation
- Code flash P/E mode entry protection

#### 44.12.3.1 Protection for Flash Memory Area (P/E)

This function protects the secure region of the code flash and data flash from FACI commands of non-secure access. The condition of protection depends on the FACI command, the access attribution, and the memory boundary setting.

For details of secure region, see [section 46, Security Features](#).

See [Table 44.26](#) for information on protection of the flash memory area (P/E).

• —表示未达到此状态。

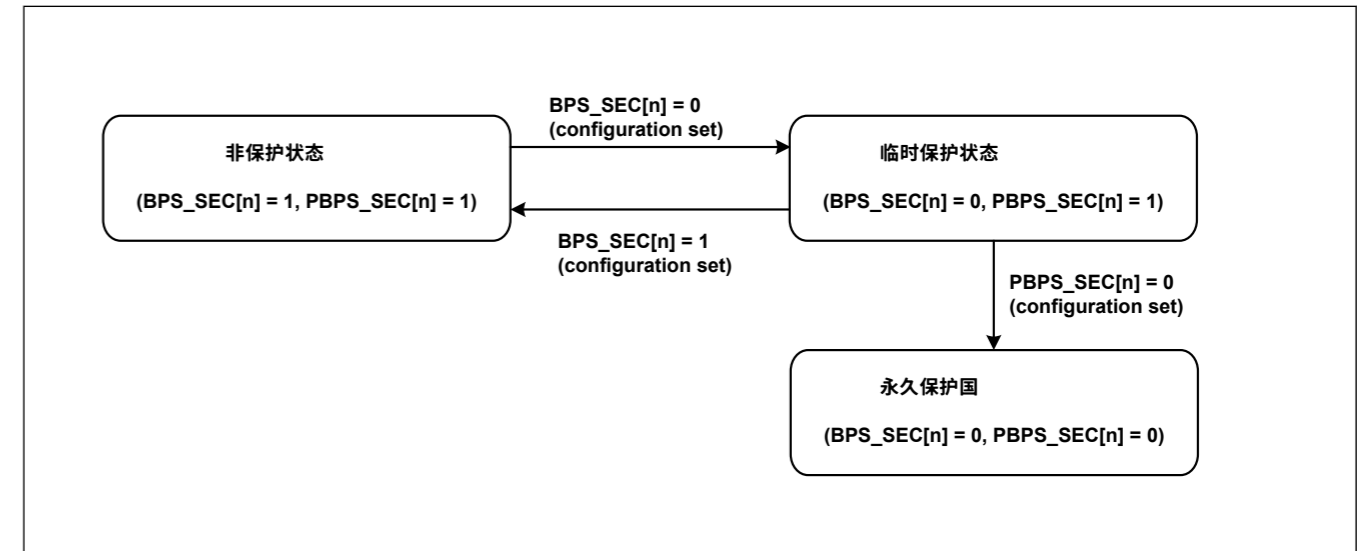


Figure 44.32 通过BPS\_SEC[n]和PBPS\_SEC[n]进行闪存定序器的状态转换

Table 44.25 BPS\_SEC[n]和PBPS\_SEC[n]的写清除保护

| 当前状态       |             | 可通过配置设置命令更新状态  |                |                 |                 |
|------------|-------------|----------------|----------------|-----------------|-----------------|
| BPS_SEC[n] | PBPS_SEC[n] | BPS_SEC[n] = 1 | BPS_SEC[n] = 0 | PBPS_SEC[n] = 1 | PBPS_SEC[n] = 0 |
| 1          | 1           | ✓              | ✓              | ✓               | X               |
| 1          | 0           | —              | —              | —               | —               |
| 0          | 1           | ✓              | ✓              | ✓               | ✓               |
| 0          | 0           | X              | ✓              | X               | ✓               |

Note:   
 • 表示可通过配置设置命令更新。   
 • X表示不能通过配置设置命令更新（不发生错误）。   
 • —表示未达到此状态。

### 44.12.3 TrustZone的闪存保护

本节中的信息侧重于闪存定序器的操作。

闪存提供以下类型的保护功能以防止非安全访问:

- 保护闪存区 (PE)
- 保护闪存区域 (读取)
- 寄存器保护
- FACI命令操作期间的保护
- CodeflashPE模式进入保护

#### 44.12.3.1 对闪存区域(PE)的保护

此功能保护代码闪存和数据闪存的安全区域免受非安全访问的FACI命令的影响。保护条件取决于FACI命令、访问属性和内存边界设置。

有关安全区域的详细信息，请参阅第46节，安全功能。

有关保护闪存区域(PE)的信息，请参见表44.26。

Table 44.26 Protection for the flash memory area (P/E)

| FACI command                  | Target area       |   | Issuing of FACI command by non-secure access | Issuing of FACI command by secure access |
|-------------------------------|-------------------|---|--|--|
| Program Block erase           | Code flash memory | User area (non-secure area)             | ✓  | ✓  |
|                               |                   | User area (secure area)                 | X  | ✓  |
|                               | Data flash memory | Data area (non-secure area)             | ✓  | ✓  |
|                               |                   | Data area (secure area)                 | X  | ✓  |
| Multi block erase Blank check | Data flash memory | Data area (non-secure area)             | ✓  | ✓  |
|                               |                   | Data area (secure area)                 | X  | ✓  |
| Configuration set             | Code flash memory | option-setting memory (non-secure area) | ✓  | ✓  |
|                               |                   | option-setting memory (secure area)     | X  | ✓  |

Note:   
 • ✓ indicates FACI command operation is not prohibited.   
 • X indicates FACI command operation is prohibited. Error occurs when the area is selected, and the FACI command is executed.

When the target area of FACI command is the user area of code flash, the flash sequencer compares the FSADDR register setting with the memory boundary setting of the code flash and determines whether the target area is in the secure region.

The memory boundary can be set to 0x0000\_0000 to 0x00FF\_8000 in 32 KB unit.

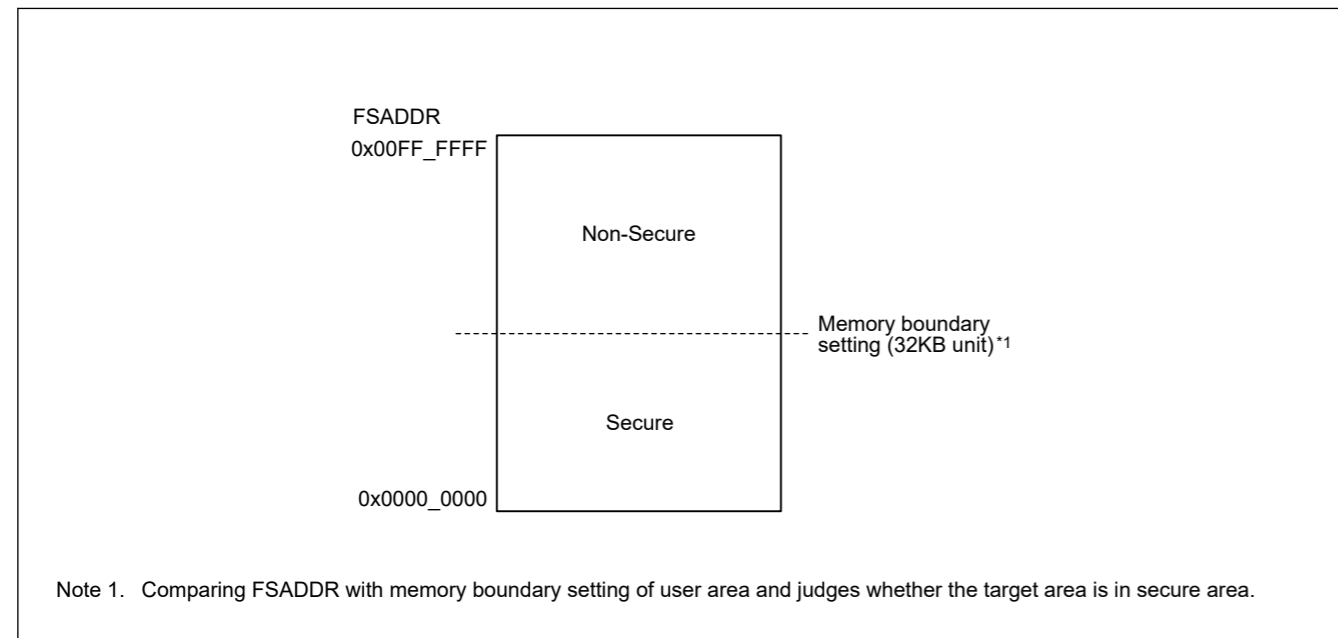


Figure 44.33 Secure/non-secure region in user area

When the target area of the issuing FACI command is the data area of data flash, the flash sequencer compares the FSADDR/FEADDR register setting with the memory boundary setting of the data flash and determines whether the target area is in secure region. The memory boundary can be set to 0x0800\_0000 to 0x0800\_FC00 in 1 KB unit. Figure 44.34 shows details of the non-secure/secure attribute of data area in the data flash.

Table 44.26 对闪存区域(PE)的保护

| FACI命令      | 目标区域 |   | 通过非安全访问发出FACI命令 | 通过安全访问发出FACI命令 |
|-------------|------|---|-----------------|----------------|
| Program 块擦除 | 代码闪存 | 用户区 (非安全区)                              | ✓               | ✓              |
|             |      | 用户区 (安全区)                               | X               | ✓              |
|             | 数据闪存 | 数据区 (非安全区)                              | ✓               | ✓              |
|             |      | 数据区 (安全区)                               | X               | ✓              |
| 多块擦除 空白支票   | 数据闪存 | 数据区 (非安全区)                              | ✓               | ✓              |
|             |      | 数据区 (安全区)                               | X               | ✓              |
| 配置集         | 代码闪存 | option-setting memory (non-secure area) | ✓               | ✓              |
|             |      | option-setting memory (secure area)     | X               | ✓              |

Note:   
 • 表示不禁止FACI命令操作。   
 • X表示禁止FACI命令操作。选择区域时发生错误，执行FACI命令。

当FACI命令的目标区域是代码闪存的用户区域时，闪存定序器将FSADDR寄存器设置与代码闪存的内存边界设置进行比较，并确定目标区域是否在安全区域中。

内存边界可以以32KB为单位设置为0x0000\_0000到0x00FF\_8000。

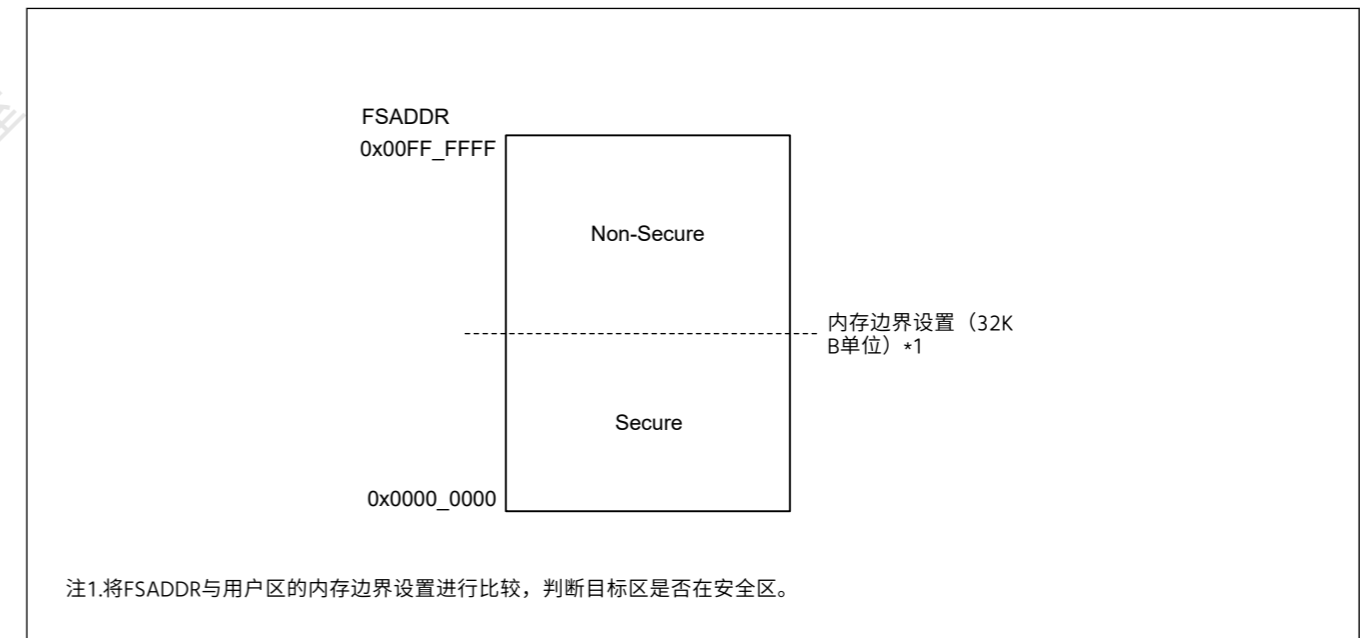
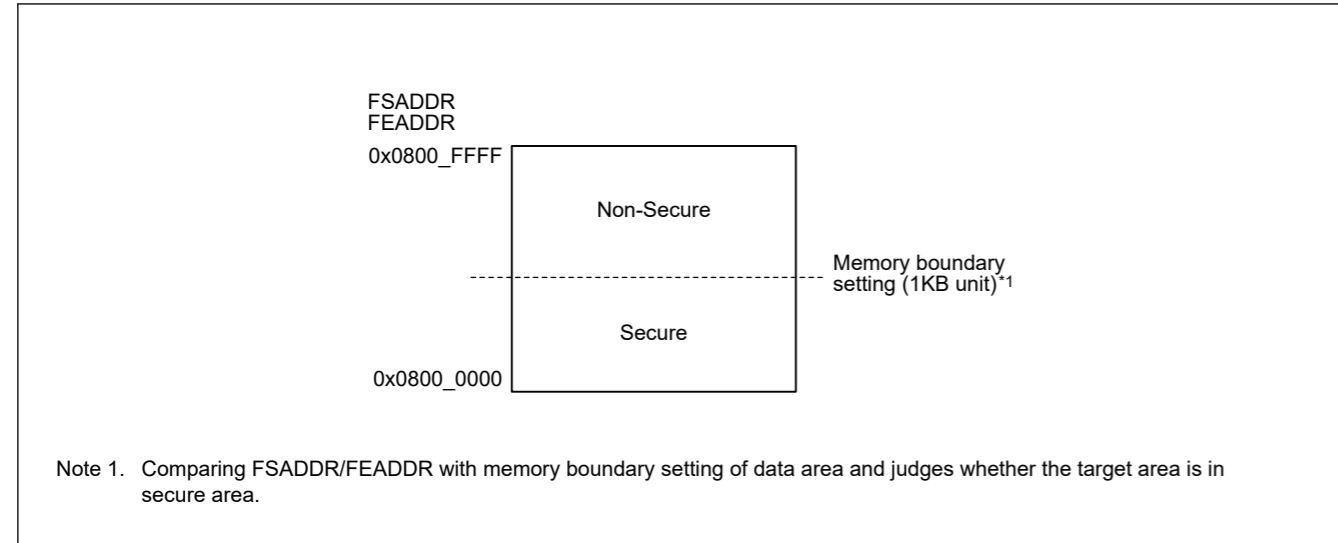


Figure 44.33 用户区域中的安全非安全区域

当发出FACI命令的目标区域是数据flash的数据区域时，flashsequencer比较FSADDR/FEADDR寄存器设置与数据闪存的内存边界设置并确定目标区域是否在安全区域中。内存边界可以以1KB为单位设置为0x0800\_0000到0x0800\_FC00。图44.34显示了数据闪存中数据区域的非安全安全属性的详细信息。



Note 1. Comparing FSADDR/FEADDR with memory boundary setting of data area and judges whether the target area is in secure area.

Figure 44.34 Secure/non-secure region in data area

See Figure 44.35 in the details of non-secure/secure region of option-setting memory. The flash sequencer judges that target area is secure region from the FSADDR register setting.

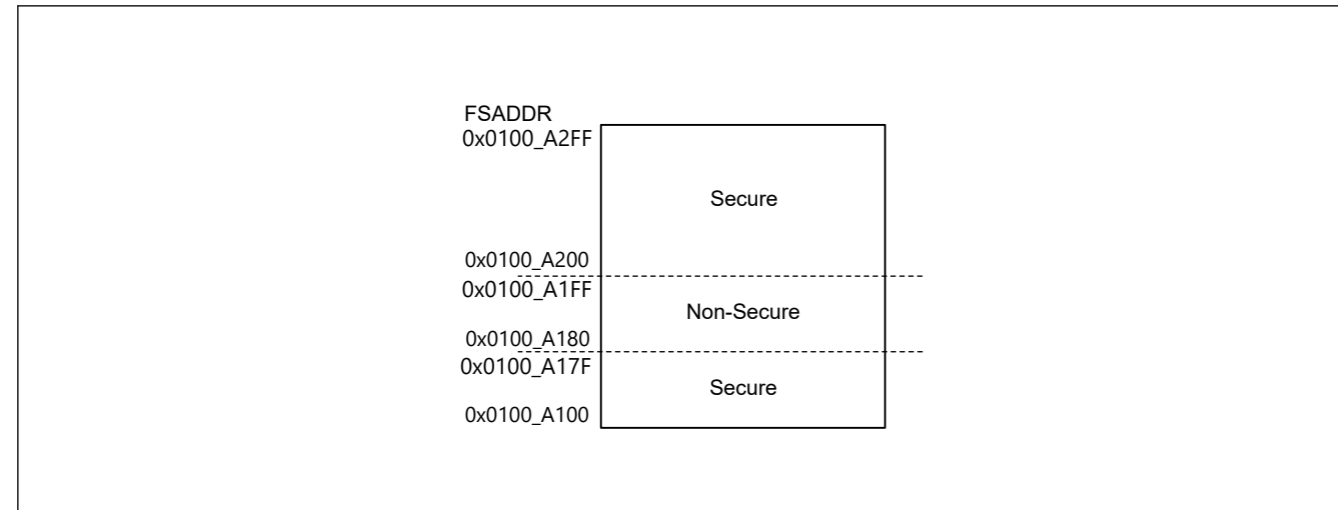


Figure 44.35 Secure/non-secure region in option-setting memory

### 44.12.3.2 Protection for Flash Memory Area (Read)

This function protects the secure region of code flash and data flash from non-secure bus access.

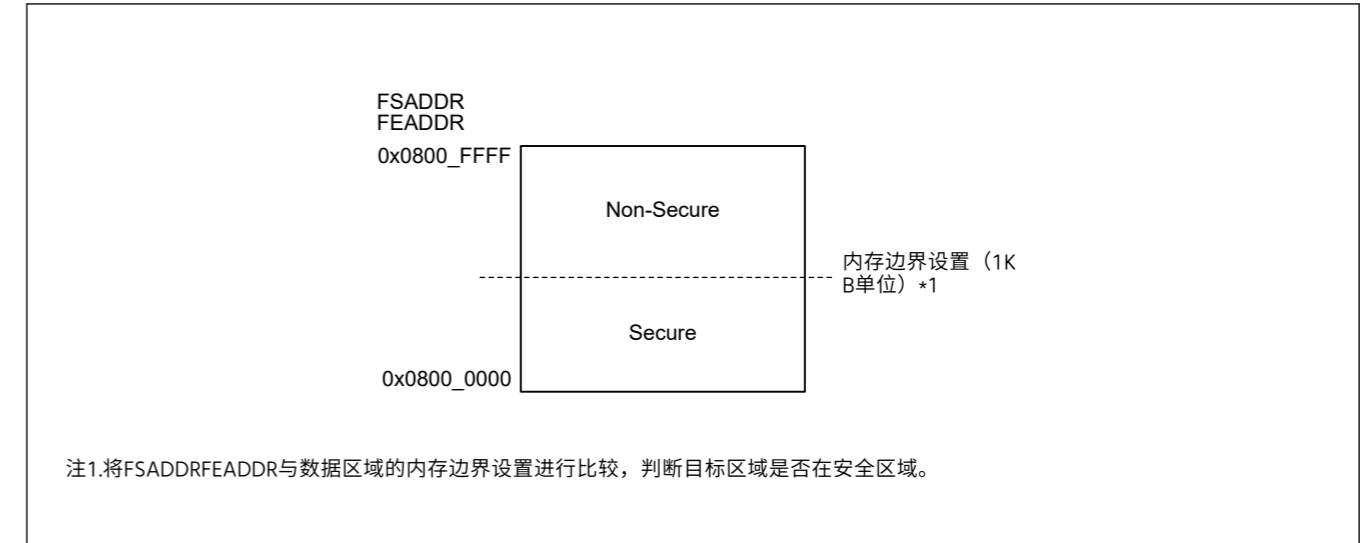
For details of secure region, see section 46, Security Features .

### 44.12.3.3 Protection for Register

The flash sequencer registers have write-access protection against non-secure access. Table 44.27 shows details of the protected registers of the flash sequencer.

Table 44.27 Protected registers of the flash sequencer for TrustZone (1 of 2)

| Protection target register | Security attribute setting                            | Notes   |
|----------------------------|---|---|
| FCKMHZ                     | Security attribution register setting (FSAR.FCKMHZSA) | See section 44.4.4. FSAR : Flash Security Attribution Register          |
| FMEPROT                    | Always secure   | See section 44.4.14. FMEPROT : Flash P/E Mode Entry Protection Register |



注1.将FSADDR/FEADDR与数据区域的内存边界设置进行比较,判断目标区域是否在安全区域。

Figure 44.34 数据区域中的安全非安全区域

有关选项设置内存的非安全安全区域的详细信息,请参见图44.35。闪存定序器根据FSADDR寄存器设置判断目标区域是安全区域。

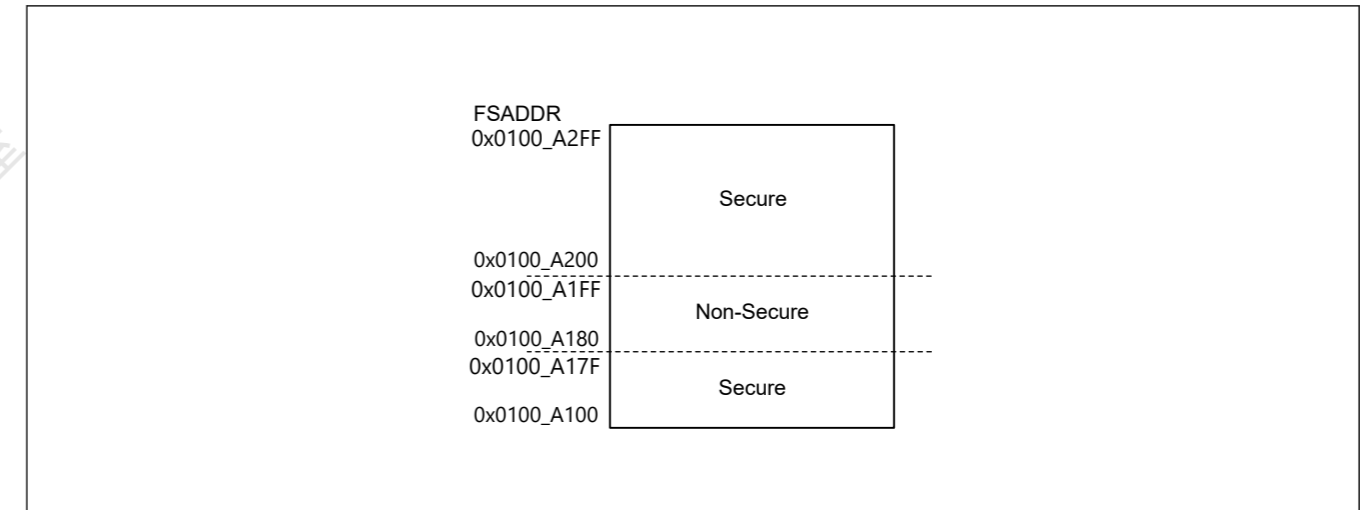


Figure 44.35 选项设置内存中的安全非安全区域

### 44.12.3.2 保护闪存区域 (读取)

该功能保护代码闪存和数据闪存的安全区域免受非安全总线访问。

有关安全区域的详细信息,请参阅第46节,安全功能。

### 44.12.3.3 注册保护

闪存定序器寄存器具有针对非安全访问的写访问保护。表44.27显示了闪存定序器的受保护寄存器的详细信息。

Table 44.27 TrustZone的闪存定序器的受保护寄存器 (1of2)

| 保护对象寄存器 | 安全属性设置                   | Notes                              |
|---------|--------------------------|------------------------------------|
| FCKMHZ  | 安全属性寄存器设置(FSAR.FCKMHZSA) | 请参见第44.4.4节。FSAR: 闪存安全归属登记         |
| FMEPROT | 始终安全                     | 请参见第44.4.14节。FMEPROT:闪存PE模式进入保护寄存器 |

Table 44.27 Protected registers of the flash sequencer for TrustZone (2 of 2)

| Protection target register  | Security attribute setting                      | Notes   |
|---|---|---|
| FBPROT1   | Always secure                                   | See section 44.4.16. FBPROT1 : Flash Block Protection for Secure Register |
| FSUACR  | Always secure                                   | See section 44.4.27. FSUACR : Flash Startup Area Control Register         |
| FACI command-issuing area and all registers of FACI (Base address is FACI) and FWEPROR register | During FACI command processing by secure access | See section 44.12.3.4. Protection during FACI Command Operation           |

44.12.3.4 Protection during FACI Command Operation

This function protects read/write access to the FACI command-issuing area, including all registers of FACI (Base address is FACI) and FWEPROR register by the non-secure access during the FACI command processing of the secure access. The protect condition includes the suspending period of the program, block erase, or multi block erase command by the P/E suspend command of the secure access. See Figure 44.36 and Table 44.28 for details of the protection during the FACI command operation.

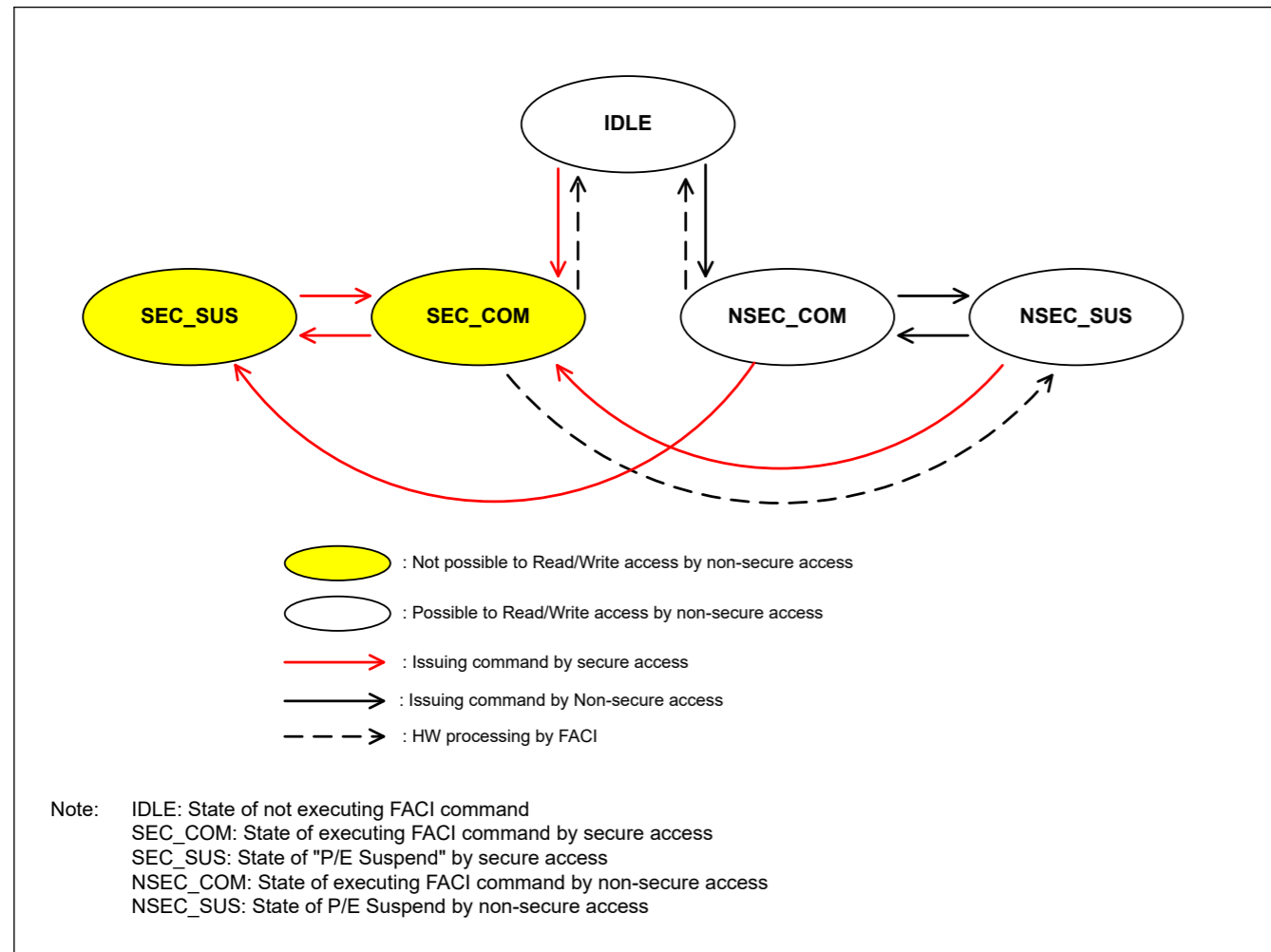


Figure 44.36 State of protection during FACI command operation

Table 44.27 TrustZone的闪存定序器的受保护寄存器 (2个中的2个)

| 保护对象寄存器                                     | 安全属性设置           | Notes                             |
|---|------------------|-----------------------------------|
| FBPROT1                                     | 始终安全             | 请参阅第44.4.16节。FBPROT1: 闪存安全寄存器的块保护 |
| FSUACR                                      | 始终安全             | 请参阅第44.4.27节。FSUACR: 闪存启动区控制寄存器   |
| FACI命令发布区和FACI的所有寄存器 (基地址为FACI) 和FWEPROR寄存器 | 通过安全访问处理FACI命令期间 | 请参见第44.12.3.4节。保护期间FACI命令操作       |

44.12.3.4 FACI指挥行动期间的保护

此功能保护对FACI命令发布区域的读写访问，包括FACI的所有寄存器（基地址为FACI）和FWEPROR在安全访问的FACI命令处理期间由非安全访问注册。保护条件包括程序的暂停周期、块擦除或由安全访问的PE暂停命令执行的多块擦除命令。FACI命令操作期间的保护细节见图44.36和表44.28。

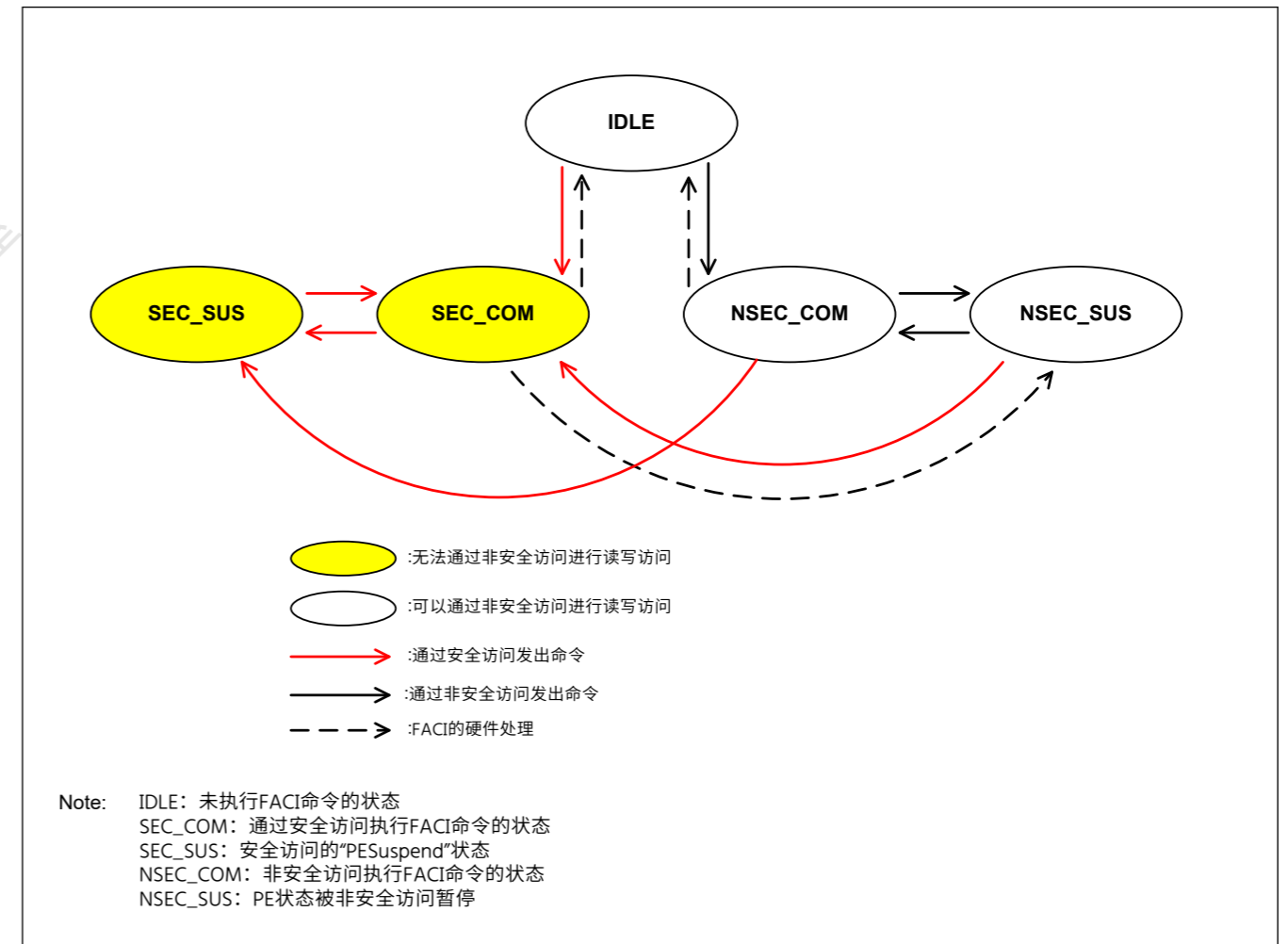


Figure 44.36 FACI指挥运行期间的保护状态



Table 44.28 Protection during FACL command operation

|                        | Flash sequencer is not operating |   | Program, Block erase, Multi block erase, Blank check, or Configuration set command processing |   | Command lock state |     | Forced stop command processing |     | While suspend Program, Block erase, or Multi block erase command |   | Program command processing while suspend Block erase or Multi block erase command by secure access |   | Program command processing while suspend Block erase or Multi block erase command by non-secure access |   | P/E resume command processing while suspend Program, Block erase, or Multi block erase command by secure access |   | P/E Resume command processing while suspend Program, Block erase, or Multi block erase command by non-secure access |  |
|------------------------|----------------------------------|---|---|---|--------------------|-----|--------------------------------|-----|--|---|--|---|--|---|---|---|---|--|
| FACL command attribute | —                                | S | NS  | S | NS                 | S   | NS                             | S   | NS   | S | NS   | S | NS   | S | NS  | S | NS  |  |
| FRDY bit               | 1                                | 0 | 0   | 1 | 1                  | 0   | 0                              | 1   | 1  | 0 | 0  | 0 | 0  | 1 | 1   | 0 | 0   |  |
| PRGSPD or ERSSPD bit   | 0                                | 0 | 0   | 0 | 0                  | 0   | 0                              | 1   | 1  | 1 | 1  | 1 | 1  | 0 | 0   | 0 | 0   |  |
| CMDLK bit              | 0                                | 0 | 0   | 1 | 1                  | 1/0 | 1/0                            | 1/0 | 1/0  | 0 | 0  | 0 | 0  | 0 | 0   | 0 | 0   |  |
| Non-secure access      | ✓                                | X | ✓   | ✓ | ✓                  | X   | ✓                              | X   | ✓  | X | ✓  | X | ✓  | X | ✓   | X | ✓   |  |

Note:

- S indicates the FACL command by the secure access.
- NS indicates the FACL command by the non-secure access.
- ✓ indicates read/write access is possible by the non-secure access.
- X indicates read/write access is not possible by the non-secure access. Write data is ignored and read data is always 0.

Note 1. The FACL command issued by the non-secure access is not allowed.

Code flash programming/erasure can be protected by the FMEPROT register of secure function. Therefore, it does not assume that secure function issues P/E suspend command during code flash programming/erasure of non-secure function.

Data flash programming/erasure of non-secure can be suspended by secure function. If secure function issues P/E suspend command during data flash programming/erasure of non-secure function, secure function should issue P/E resume command. When secure function issues P/E resume command, secure function should notify non-secure function that data flash programming/erasure is complete and return to non-secure function. See Figure 44.37 and Figure 44.38 in example of issuing P/E suspend of secure function during programming/erasure of non-secure function.

Table 44.28 FACL命令操作期间的保护

|                   | 闪存定序器未运行 |   | 编程、块擦除、多块擦除、空白检查或配置设置命令 processing |   | 命令锁定状态 |     | 强制停止指令处理 |     | 暂停编程、块擦除或多块擦除命令 |   | 块擦除或多块擦除命令由暂停时的程序命令处理 |   | 块擦除或多块擦除命令由暂停时的程序命令处理 |   | 暂停编程、块擦除或多块擦除命令 PE恢复命令处理 while |   | 通过非安全访问擦除命令 PE恢复命令处理 while |  |
|-------------------|----------|---|------------------------------------|---|--------|-----|----------|-----|-----------------|---|-----------------------|---|-----------------------|---|--------------------------------|---|----------------------------|--|
| FACL命令属性          | —        | S | NS                                 | S | NS     | S   | NS       | S   | NS              | S | NS                    | S | NS                    | S | NS                             | S | NS                         |  |
| FRDY bit          | 1        | 0 | 0                                  | 1 | 1      | 0   | 0        | 1   | 1               | 0 | 0                     | 0 | 0                     | 1 | 1                              | 0 | 0                          |  |
| PRGSPD或ERSSPD位    | 0        | 0 | 0                                  | 0 | 0      | 0   | 0        | 1   | 1               | 1 | 1                     | 1 | 1                     | 0 | 0                              | 0 | 0                          |  |
| CMDLK bit         | 0        | 0 | 0                                  | 1 | 1      | 1/0 | 1/0      | 1/0 | 1/0             | 0 | 0                     | 0 | 0                     | 0 | 0                              | 0 | 0                          |  |
| Non-secure access | ✓        | X | ✓                                  | ✓ | ✓      | X   | ✓        | X   | ✓               | X | ✓                     | X | ✓                     | X | ✓                              | X | ✓                          |  |

Note:

- S表示通过安全访问的FACL命令。
- NS通过非安全访问指示FACL命令。
- 表示非安全访问可以进行读写访问。
- X表示非安全访问无法进行读写访问。写入数据被忽略，读取数据始终为0。

注1.非安全访问发出的FACL命令是不允许的。

代码闪存编程擦除可以通过安全功能的FMEPROT寄存器进行保护。因此，不假设安全功能在非安全功能的代码闪存编程擦除期间发出PE挂起命令。

非安全的数据闪存编程擦除可以通过安全功能暂停。如果在非安全功能的数据闪存编程擦除期间安全功能发出PE暂停命令，安全功能应发出PE恢复命令。当安全功能发出PEresume命令时，安全功能应通知非安全功能数据闪存编程擦除完成并返回到非安全功能。在对非安全功能进行编程擦除时发出PE安全功能挂起的示例参见图44.37和图44.38。

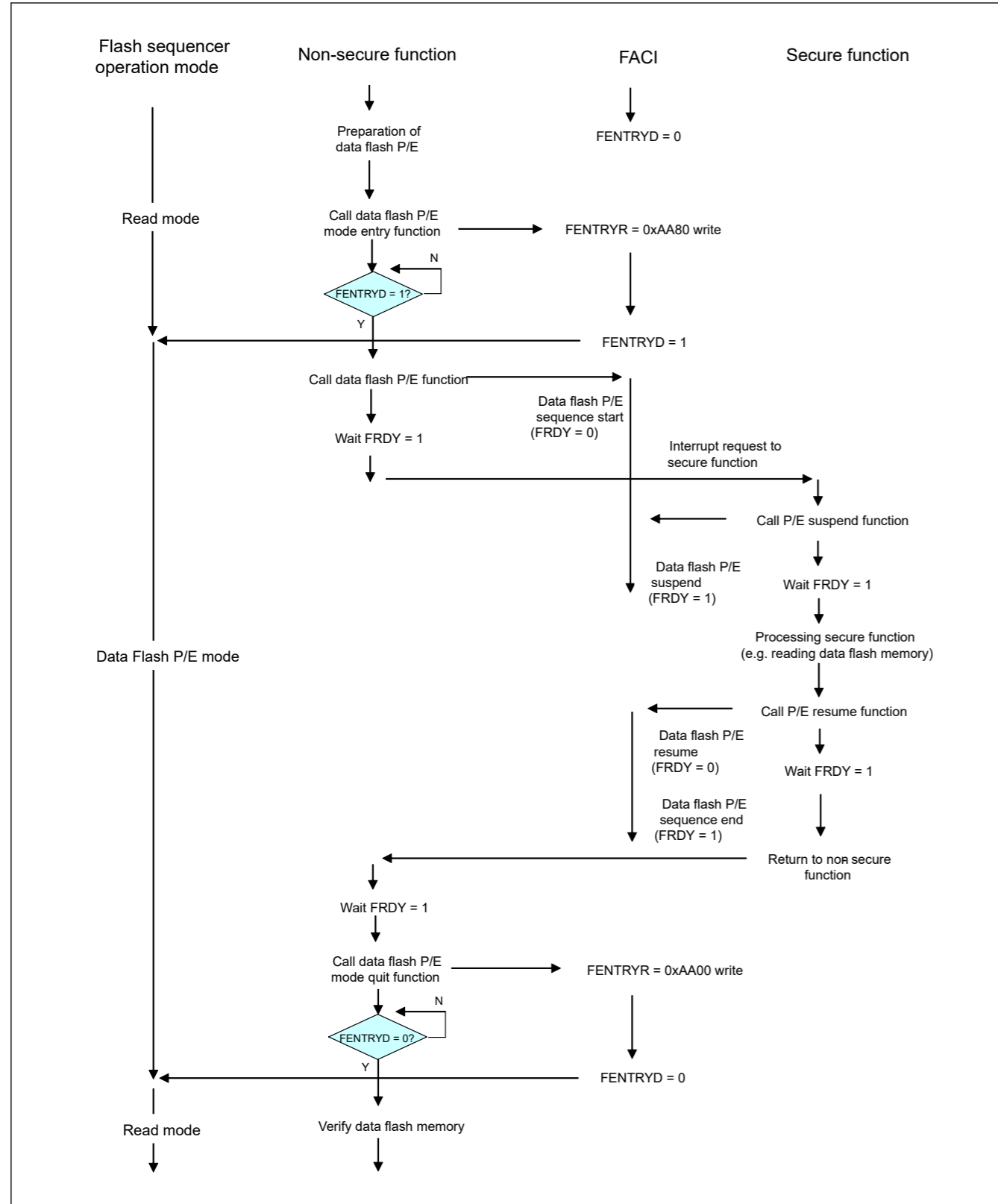


Figure 44.37 Data Flash P/E suspend of secure function Example (Check FRDY bit to detect P/E end)

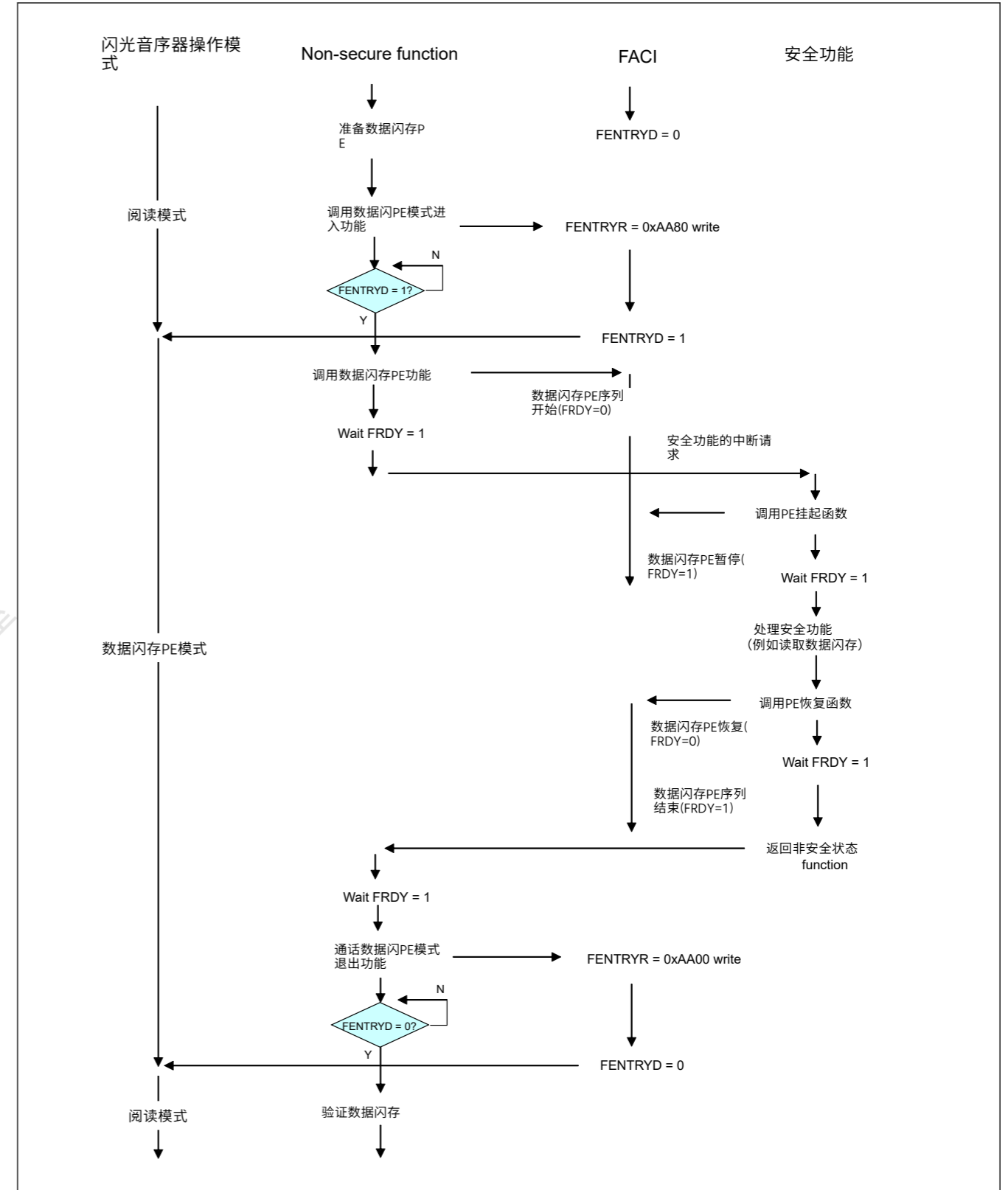


Figure 44.37 数据闪存PE安全功能暂停示例 (检查FRDY位以检测PE结束)

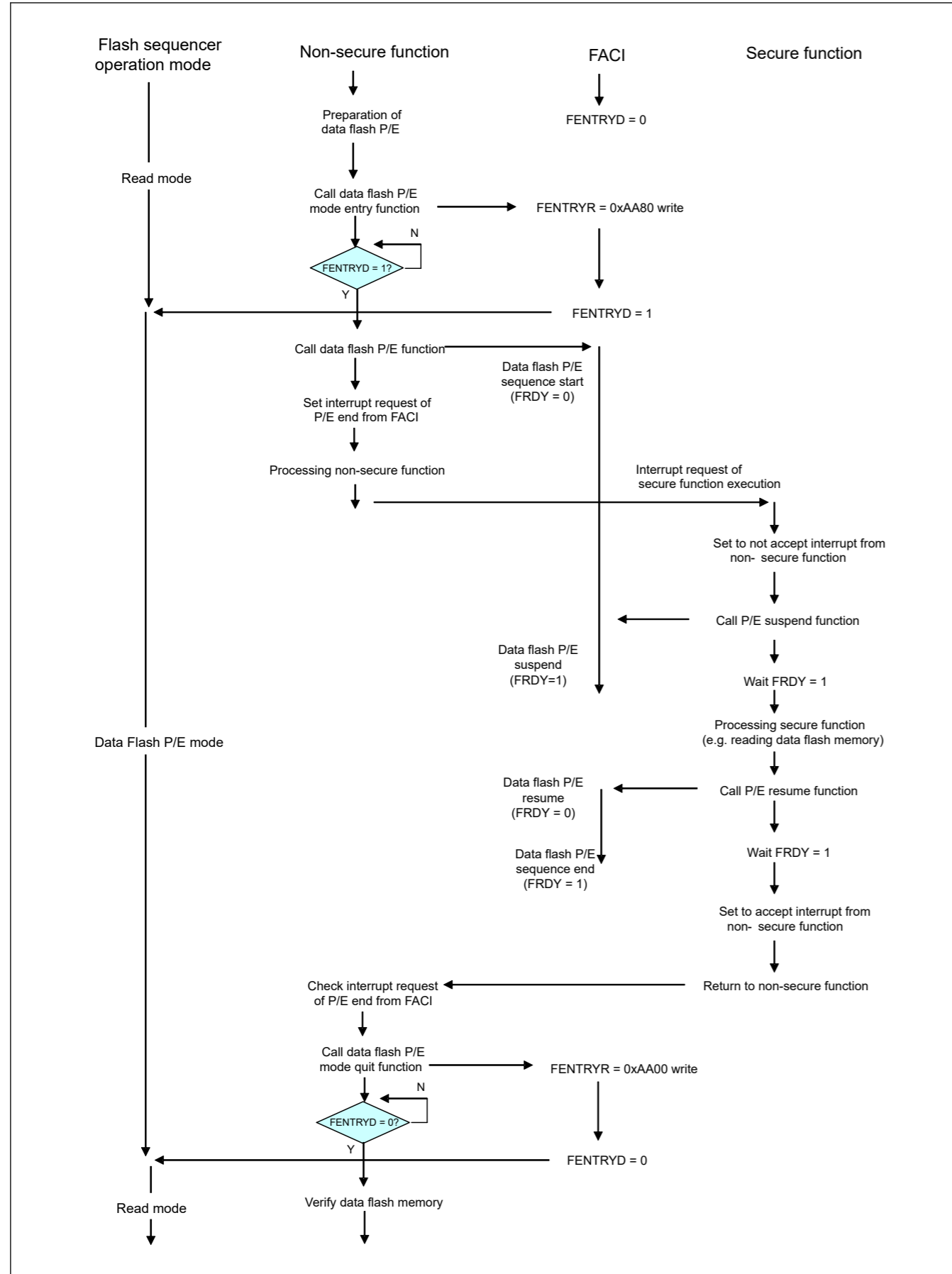


Figure 44.38 Data Flash P/E suspend of secure function Example (Check interrupt request to detect P/E end)

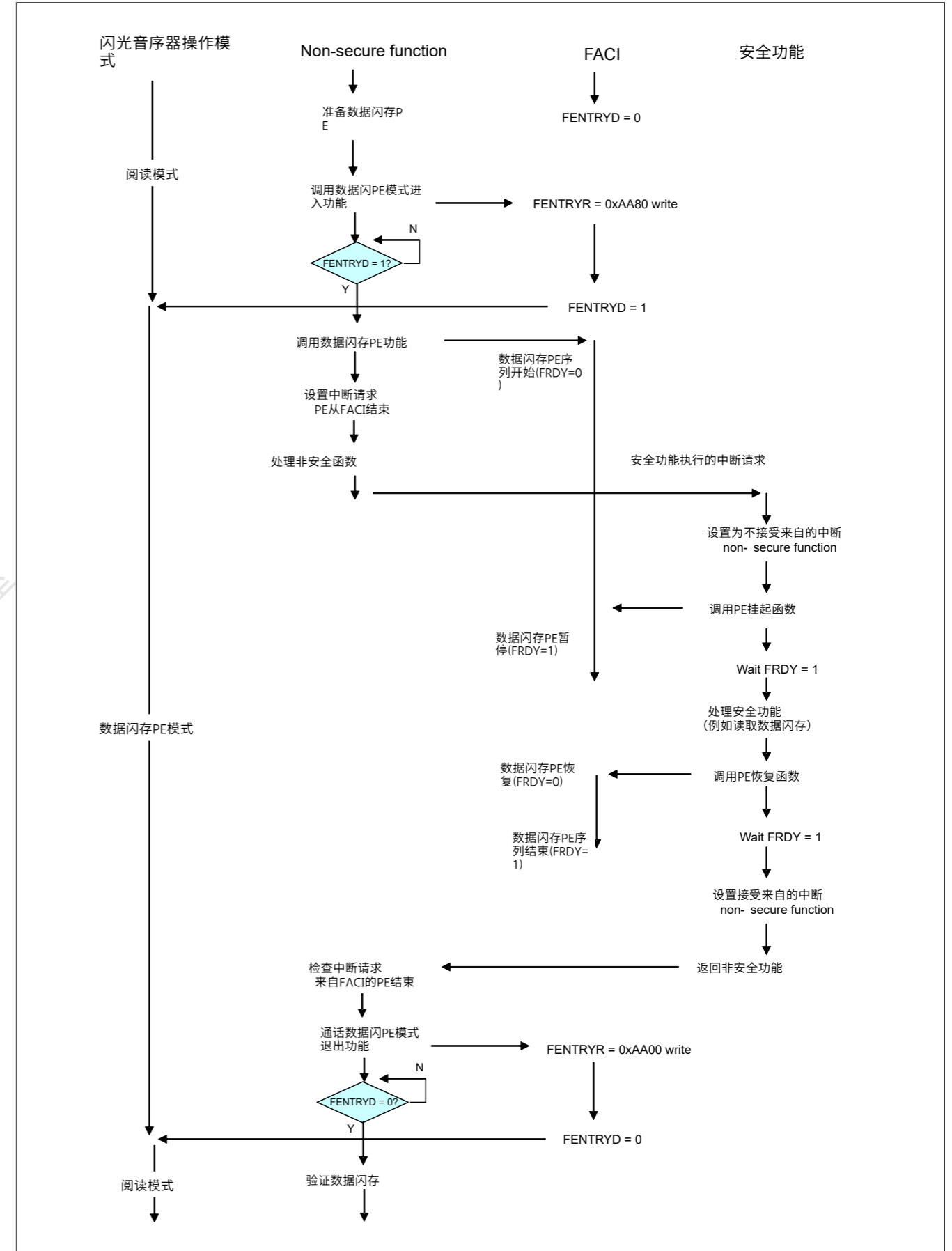


Figure 44.38 数据闪存PE安全功能暂停示例（检查中断请求以检测PE结束）

#### 44.12.3.5 Code Flash P/E Mode Entry Protection

The flash sequencer has protection function of code flash P/E by the FMEPROT register for the secure developer. Secure function can prevent disturbance of reading code flash memory by this protection function. See [section 44.4.14](#).

[FMEPROT : Flash P/E Mode Entry Protection Register](#).

For applications that do not require non-secure region programming/erasure other than from secure function, it is recommended to always disable non-secure function of code flash programming/erasure by enabling the protection function of FMEPROT register.

See [Figure 44.39](#) in details of the code flash P/E sequence example by non-secure function.

#### 44.12.3.5 CodeFlashPE模式进入保护

闪存定序器通过FMEPROT寄存器为安全开发人员提供代码闪存PE的保护功能。安全功能可以通过此保护功能防止读取代码闪存的干扰。请参阅第44.4.14节。FMEPROT：FlashPE模式进入保护寄存器。

对于除安全功能外不需要非安全区域编程擦除的应用，建议始终通过启用FMEPROT寄存器的保护功能来禁用代码闪存编程擦除的非安全功能。

有关非安全功能的代码闪存PE序列示例的详细信息，请参见图44.39。



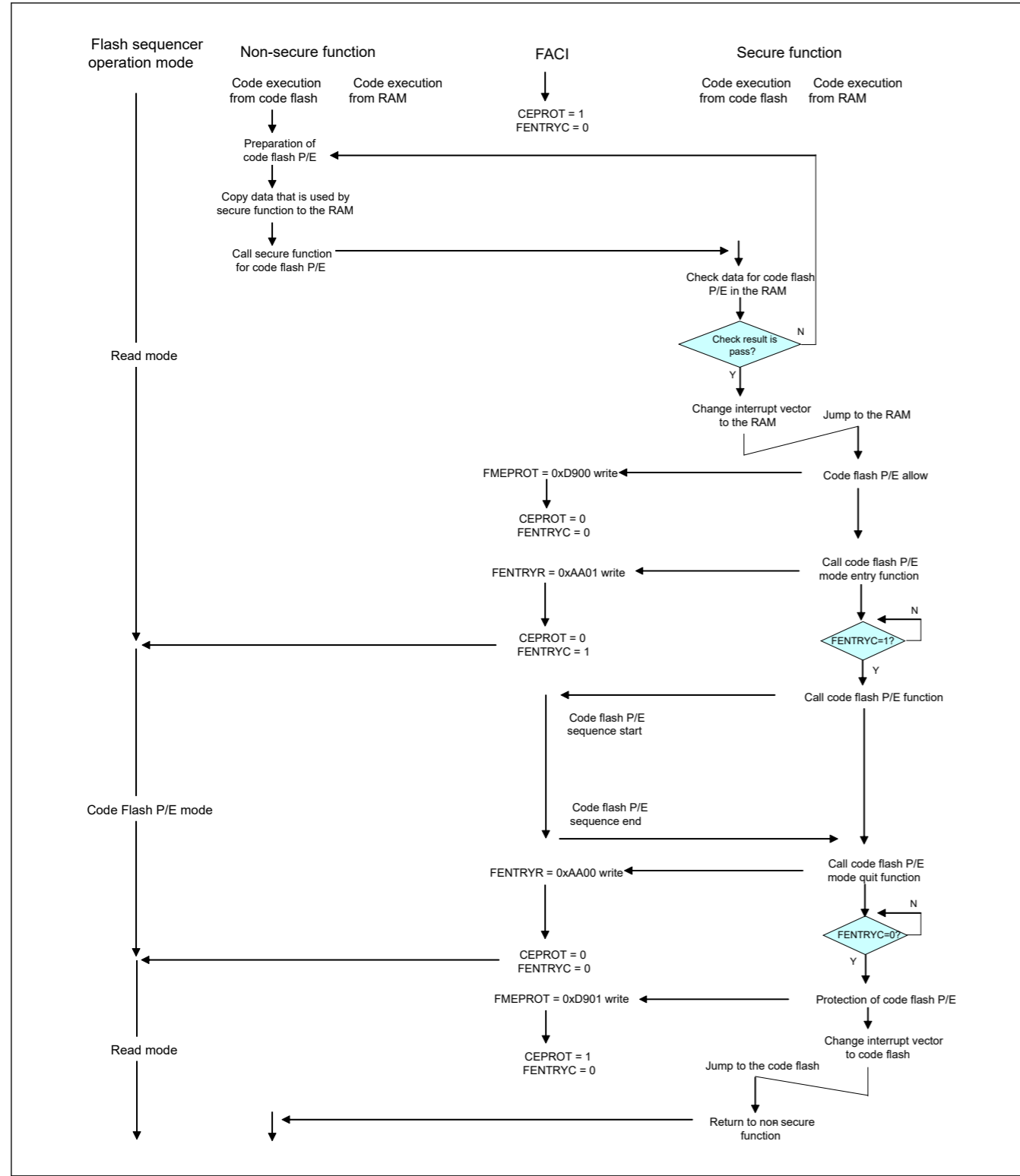


Figure 44.39 Code Flash P/E Sequence Example by non-secure function (Using secure function for code flash P/E)

44.13 Boot Mode

There are two serial programming modes; the boot mode (for the SCI interface) with SCI9 and the boot mode (for the USB interface) with USBFS. Table 44.29 lists the I/O pins used in boot mode. Table 44.30 lists the available communication interface used in the boot mode.

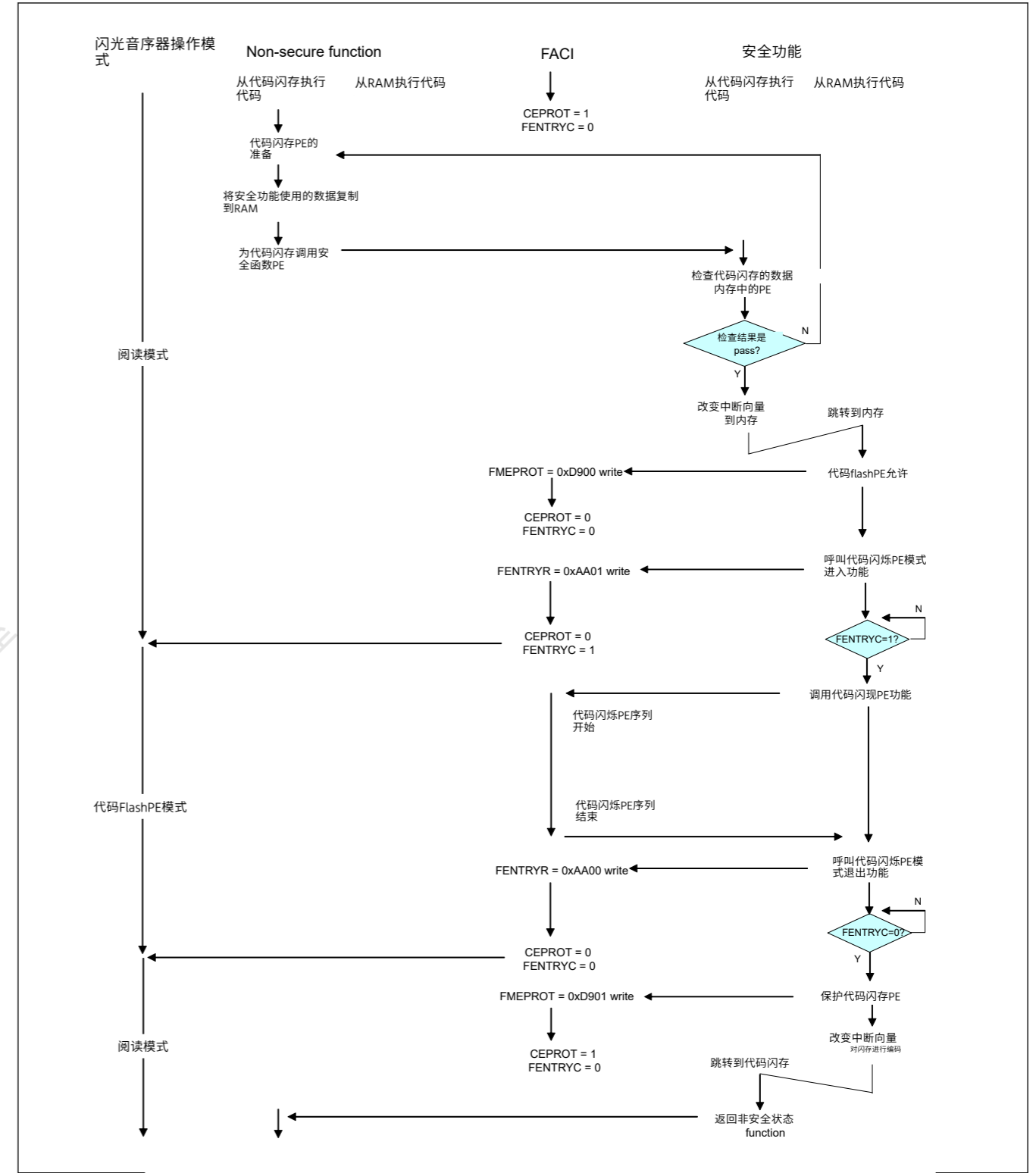


Figure 44.39 CodeFlashPESequenceExamplebynon-securefunction(UsingsecurefunctionforcodeflashPE)

44.13 引导模式

有两种串行编程模式；SCI9的引导模式（SCI接口）和USBFS的引导模式（USB接口）。表44.29列出了引导模式中使用的IO引脚。表44.30列出了启动模式中使用的可用通信接口。

Table 44.29 I/O Pins Used in Boot Mode

| Pin Name       | I/O    | Mode to be Used  | Use   |
|----------------|--------|--|---|
| MD             | Input  | Boot mode (for the SCI interface)<br>Boot mode (for the USB interface) | Selection of operating mode                             |
| P110/RXD9      | Input  | Boot mode (for the SCI interface)                                      | For host communication (to receive data through SCI)    |
| P109/TXD9      | Output |  | For host communication (to transmit data through SCI)   |
| USB_DP, USB_DM | I/O    | Boot mode (for the USB interface)                                      | Data input/output of USB                                |
| USB_VBUS       | Input  |  | Detection of connection and disconnection of USB cables |

Table 44.30 Available Communication Interface Used in Boot Mode

|  |                |                 |                 |
|--|----------------|-----------------|-----------------|
| Main clock oscillator or external clock is connected | Yes            | No              | No              |
| Sub clock oscillator is connected*1                  | Yes or No      | Yes             | No              |
| Available interface                                  | SCI or USB     | SCI or USB      | SCI             |
| Tool connection time*2                               | Up to 1 second | Up to 2 seconds | Up to 3 seconds |

Note 1. The drive capability of the sub clock oscillator is set to standard by SOMCR.SODRV bit. Note that if you use the crystal corresponding the low drive capability on your board, the crystal may not oscillate in the boot mode.

Note 2. See the boot firmware manual for the detail connection time.

#### 44.13.1 Boot Mode (for the SCI Interface)

In boot mode (for the SCI interface), the host sends control commands and data for programming, and the flash memory is programmed or erased accordingly. An on-chip SCI handles transfer between the host and this MCU in asynchronous mode. Tools for transmission of control commands and the data for programming must be prepared in the host.

When this MCU is activated in boot mode (for the SCI interface), the program on the dedicated area the MCU is executed. The boot program automatically adjusts the bit rate of the SCI and controls programming/erasure by receiving control commands from the host.

Figure 44.40 shows the system configuration for operations in boot mode (for the SCI interface).

Table 44.29 引导模式下使用的IO引脚

| 引脚名称           | I/O    | 使用模式                               | Use               |
|----------------|--------|------------------------------------|-------------------|
| MD             | Input  | Boot模式（用于SCI接口）<br>Boot模式（用于USB接口） | 操作模式的选择           |
| P110/RXD9      | Input  | 引导模式（用于SCI接口）                      | 用于主机通信（通过SCI接收数据） |
| P109/TXD9      | Output |                                    | 用于主机通信（通过SCI传输数据） |
| USB_DP, USB_DM | I/O    | 引导模式（用于USB接口）                      | USB数据输入输出         |
| USB_VBUS       | Input  |                                    | 检测USB电缆的连接和断开     |

Table 44.30 引导模式中使用的可用通信接口

|               |         |         |      |
|---------------|---------|---------|------|
| 连接主时钟振荡器或外部时钟 | Yes     | No      | No   |
| 副时钟振荡器已连接*1   | 是还是不是   | Yes     | No   |
| 可用接口          | SCI或USB | SCI或USB | SCI  |
| 工具连接时间*2      | 最多1秒    | 最多2秒    | 最多3秒 |

注1.副时钟振荡器的驱动能力由SOMCR.SODRV位设置为标准。请注意，如果您使用与板上低驱动能力相对应的晶体，则晶体可能不会在引导模式下振荡。

注2.详细连接时间请参见启动固件手册。

#### 44.13.1 引导模式（用于SCI接口）

在引导模式下（针对SCI接口），主机发送控制命令和数据进行编程，相应地对闪存进行编程或擦除。片上SCI以异步模式处理主机和该MCU之间的传输。主机中必须准备好用于传输控制命令和编程数据的工具。

当这个MCU在启动模式下被激活时（对于SCI接口），在MCU的专用区域上的程序被执行。引导程序通过接收来自主机的控制命令自动调整SCI的比特率并控制编程擦除。

图44.40显示了引导模式下操作的系统配置（对于SCI接口）。

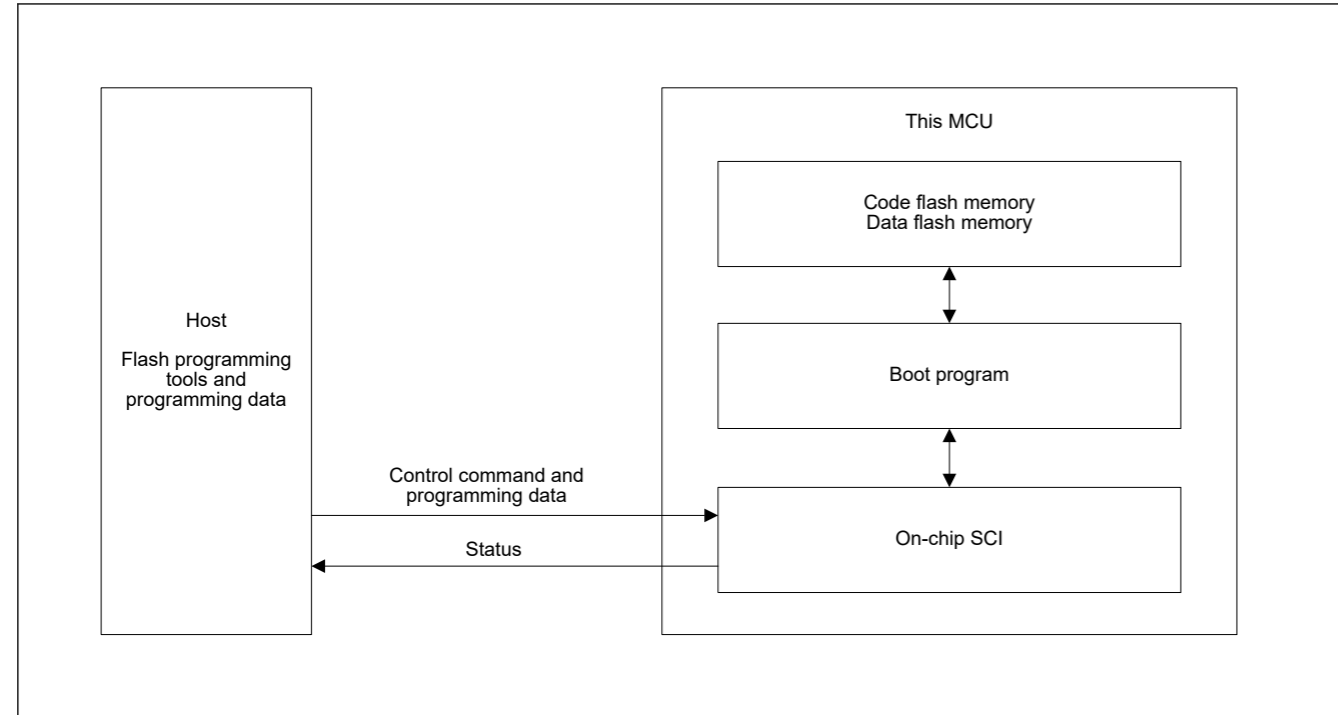


Figure 44.40 System Configuration for Operations in Boot Mode (for the SCI Interface)

44.13.2 Boot Mode (for the USB Interface)

In boot mode (with the USB interface), the flash memory can be programmed or erased by sending control commands and program data from the host. An on-chip USB is used for communications between the host and this MCU. The host requires tools for sending control commands and data for programming. Figure 44.41 shows the configuration of a system for use in boot mode (for the USB interface). The USB cable must be connected on reset release.

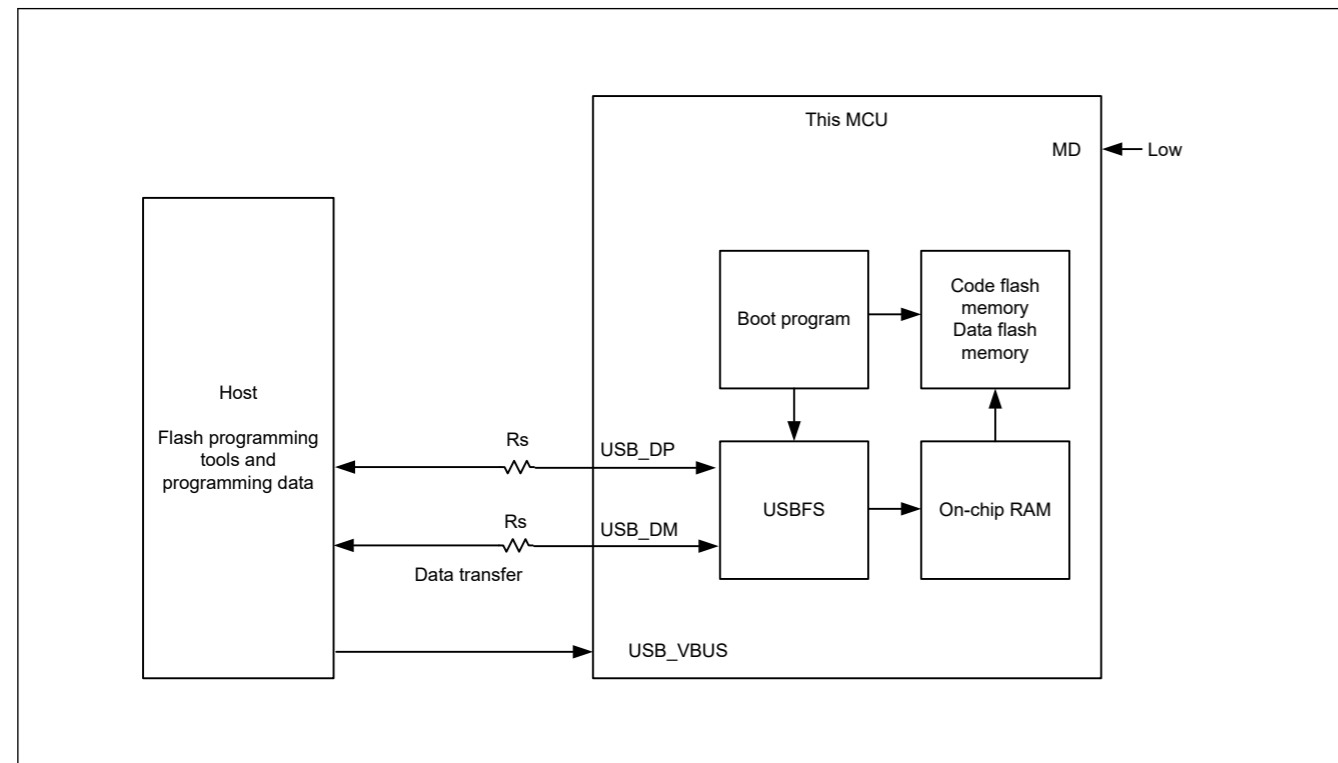


Figure 44.41 System Configuration in Boot Mode (for the USB Interface)

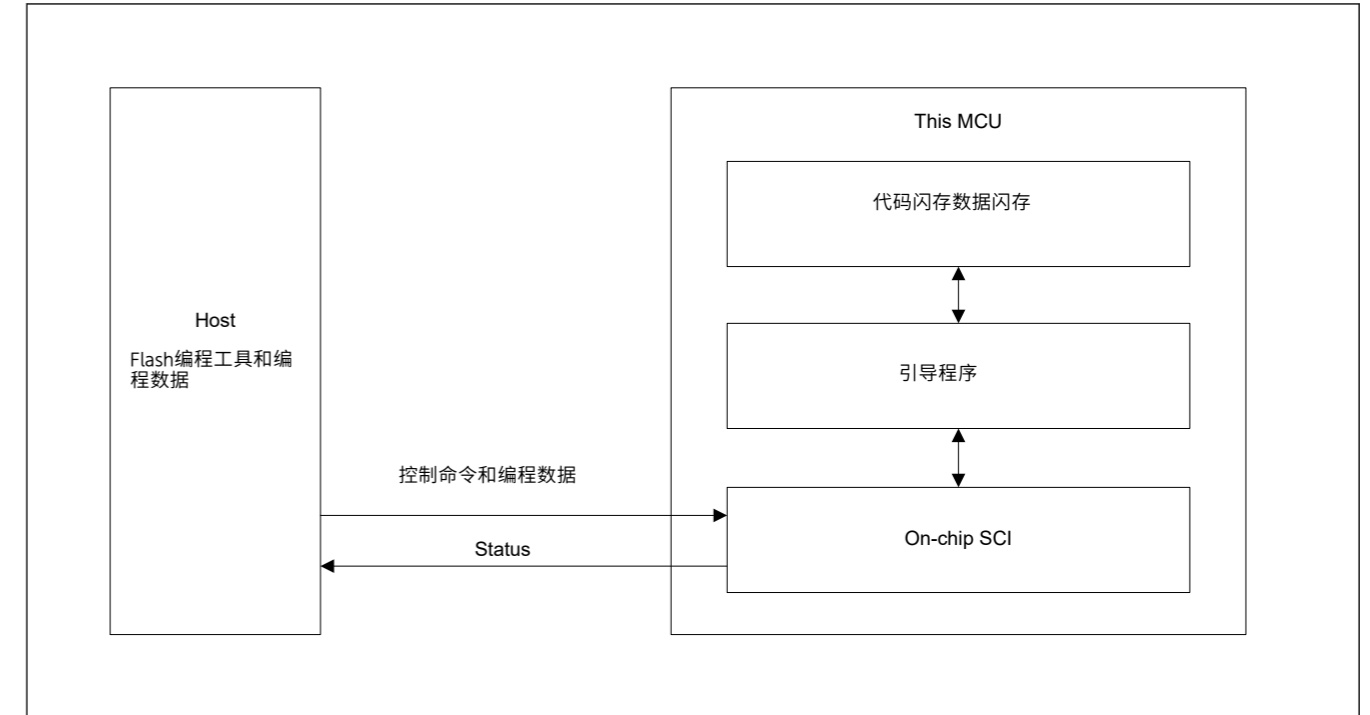


Figure 44.40 引导模式下操作的系统配置（用于SCI接口）

44.13.2 引导模式（用于USB接口）

在引导模式下（使用USB接口），可以通过从主机发送控制命令和编程数据来对闪存进行编程或擦除。片上USB用于主机和该MCU之间的通信。主机需要用于发送控制命令和编程数据的工具。图44.41显示了在引导模式下使用的系统配置（用于USB接口）。USB电缆必须在复位释放时连接。

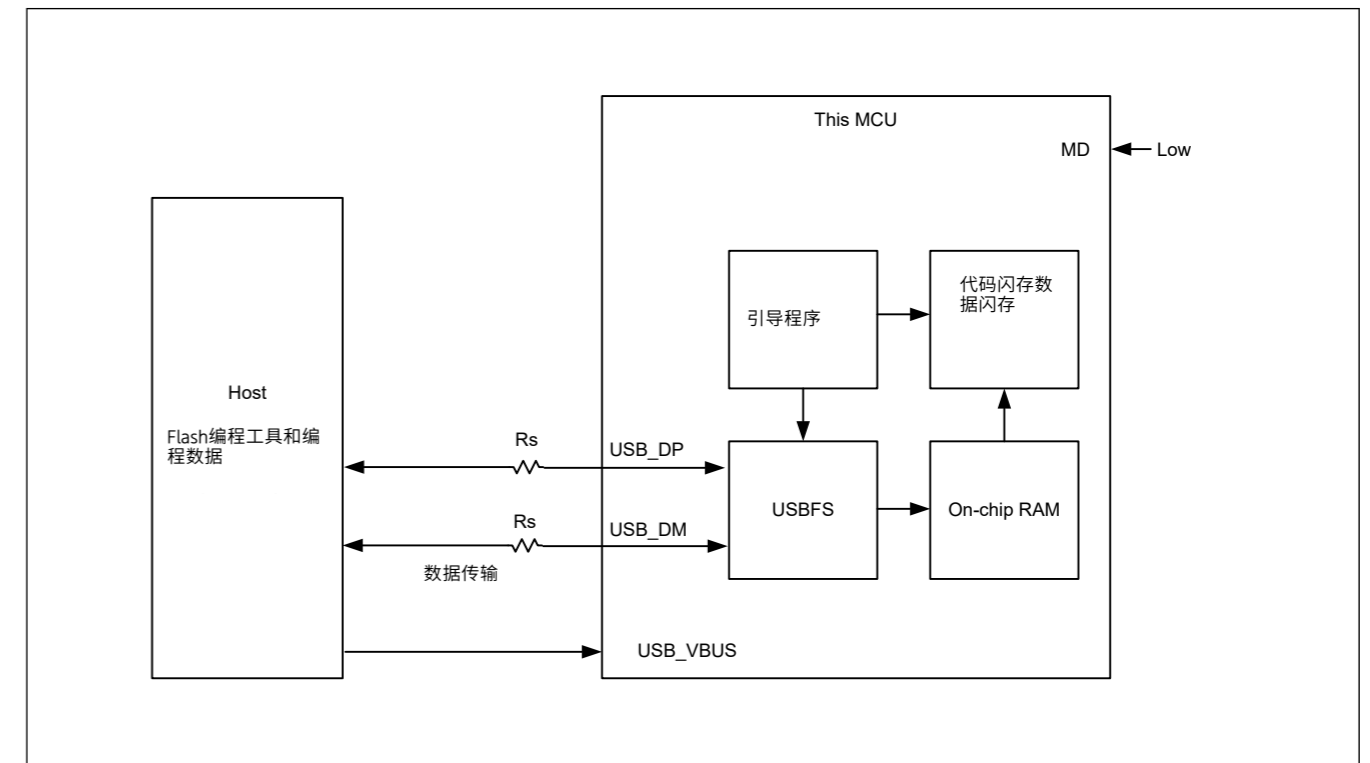


Figure 44.41 引导模式下的系统配置（用于USB接口）

### 44.14 Using the Serial Programmer for Rewriting

A serial programmer can be used to rewrite flash memory in boot mode.

#### (1) Serial Programming

This MCU is mounted on the system board at the time of serial programming. Providing a connector to the board enables rewriting of this MCU by the serial programmer to proceed.

#### 44.14.1 Environments for Serial Programming

The recommended environments for rewriting the flash memory of the MCU with data are described below.

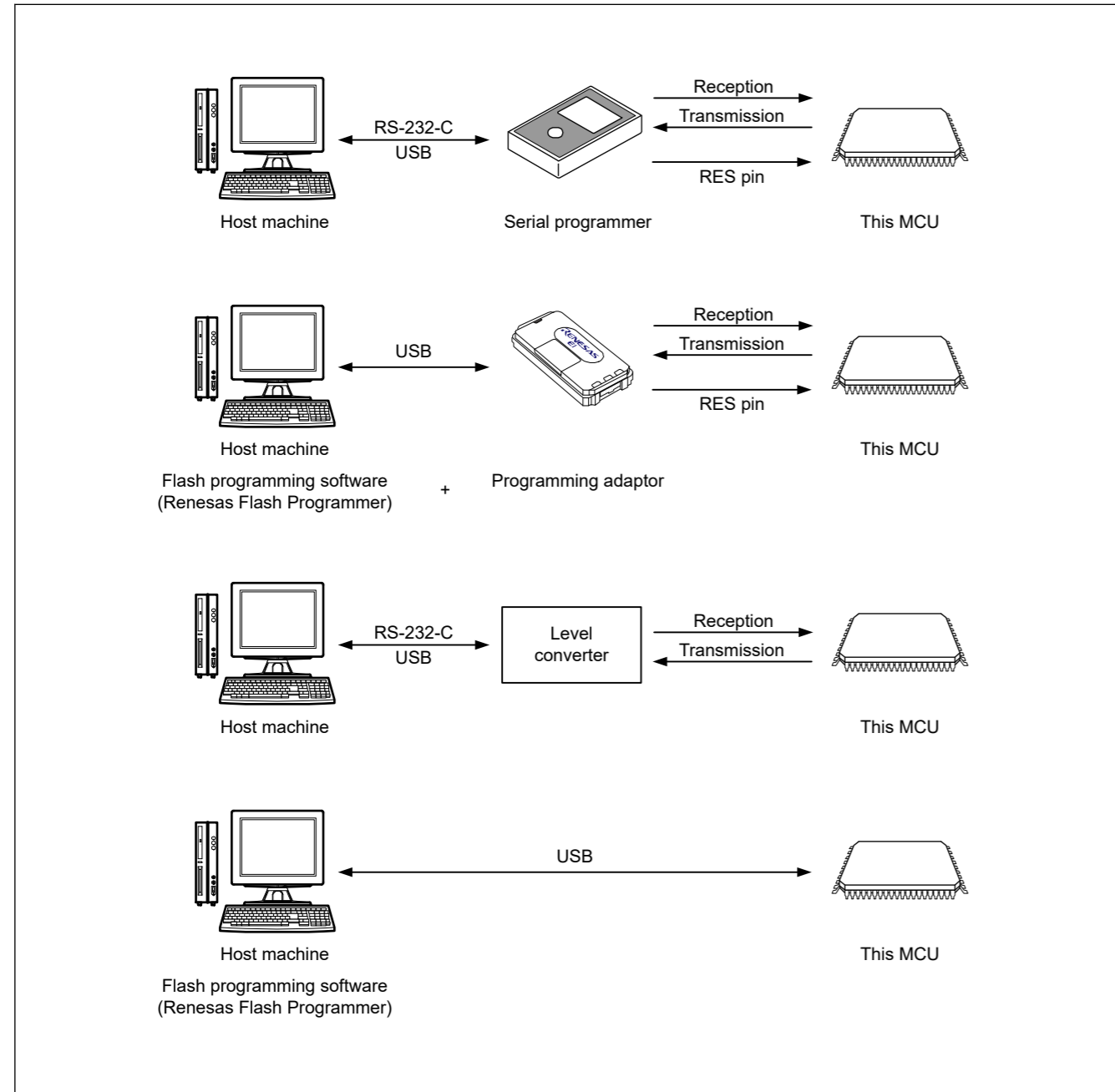


Figure 44.42 Environments for Rewriting the Flash Memory

### 44.14 使用串行编程器进行重写

串行编程器可用于在引导模式下重写闪存。

#### (1) 串行编程

该MCU在串行编程时安装在系统板上。为电路板提供连接器可以让串行编程器重写该MCU以继续进行。

#### 44.14.1 串行编程环境

使用数据重写MCU的闪存的推荐环境如下所述。

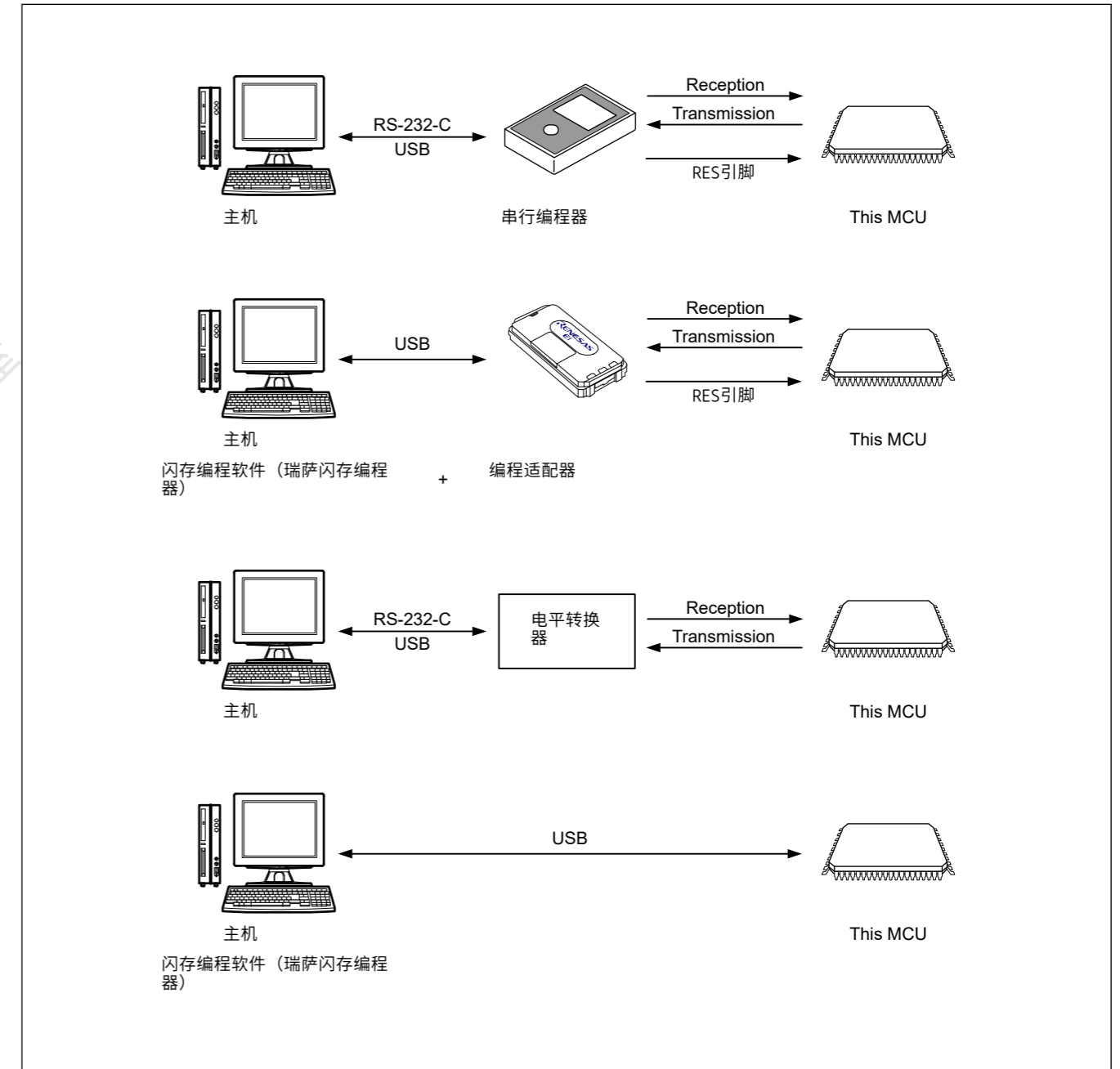


Figure 44.42 重写闪存的环境



## 44.15 Programming through Self-Programming

### 44.15.1 Overview

This MCU supports programming of the flash memory by the user program itself. The FACI commands can be used with user programs for writing to the flash memory. This allows upgrading of user programs and rewriting of constant data fields.

The program for rewriting must be transferred to the internal RAM or external memory in advance when the BGO is not available or when rewriting the option-setting memory.

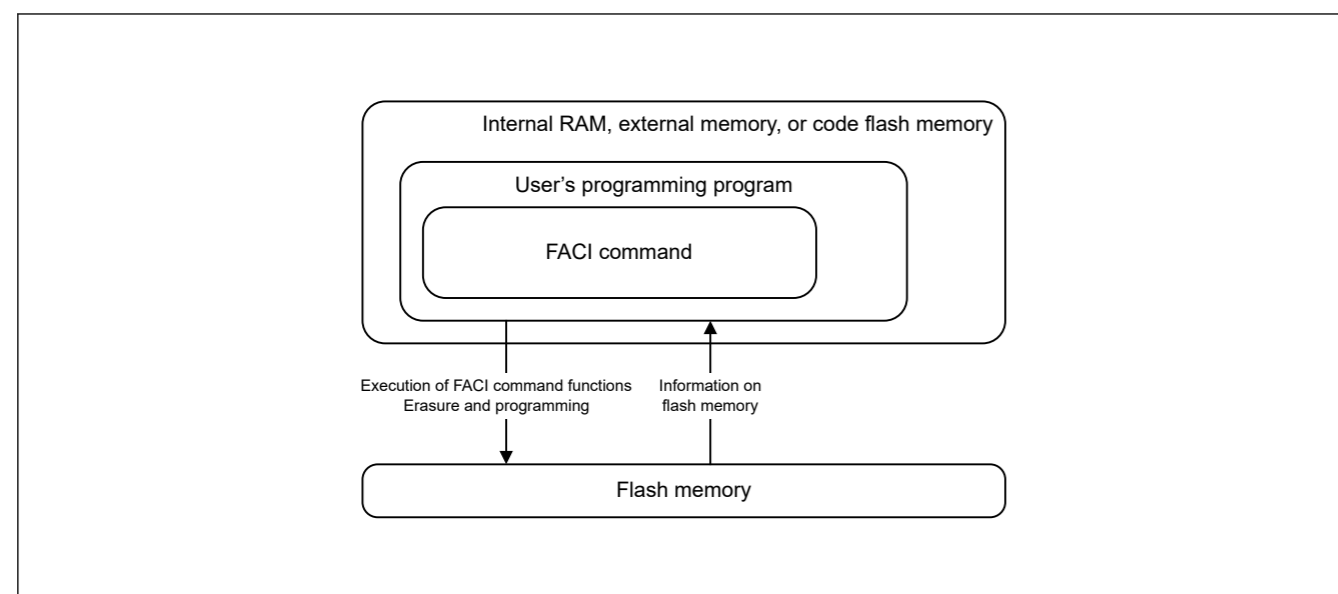


Figure 44.43 Schematic View of Self-Programming

For comprehensive information on the self-programming, refer to [section 44.9. FACI Commands](#)

### 44.15.2 Background Operation

The background operation (BGO) can be used to execute the flash rewrite routine on the code flash memory when the data flash memory.

Background operations can be used when the combination of the flash memory for rewriting and the flash memory for reading is any of those listed below.

Table 44.31 Conditions under which Background Operation is Usable

|        | Range for rewriting | Range for reading |
|--------|---------------------|-------------------|
| Common | Code flash memory   | Data flash memory |
|        | Data flash memory   | Code flash memory |

## 44.16 Reading Flash Memory

### 44.16.1 Reading Code Flash Memory

Special settings are not required to read code flash memory after release from the reset state. Data can simply be read out through access to addresses in the code flash memory.

When reading code flash memory that has been erased but not yet been programming again (i.e. that is in the non-programmed state), all bits are read as 1.

### 44.16.2 Reading Data Flash Memory

## 44.15 通过自编程进行编程

### 44.15.1 Overview

该MCU支持用户程序本身对闪存进行编程。FACI命令可与用户程序一起用于写入闪存。这允许升级用户程序和重写常量数据字段。

当BGO不可用或重写选项设置存储器时，必须将重写程序提前传送到内部RAM或外部存储器。

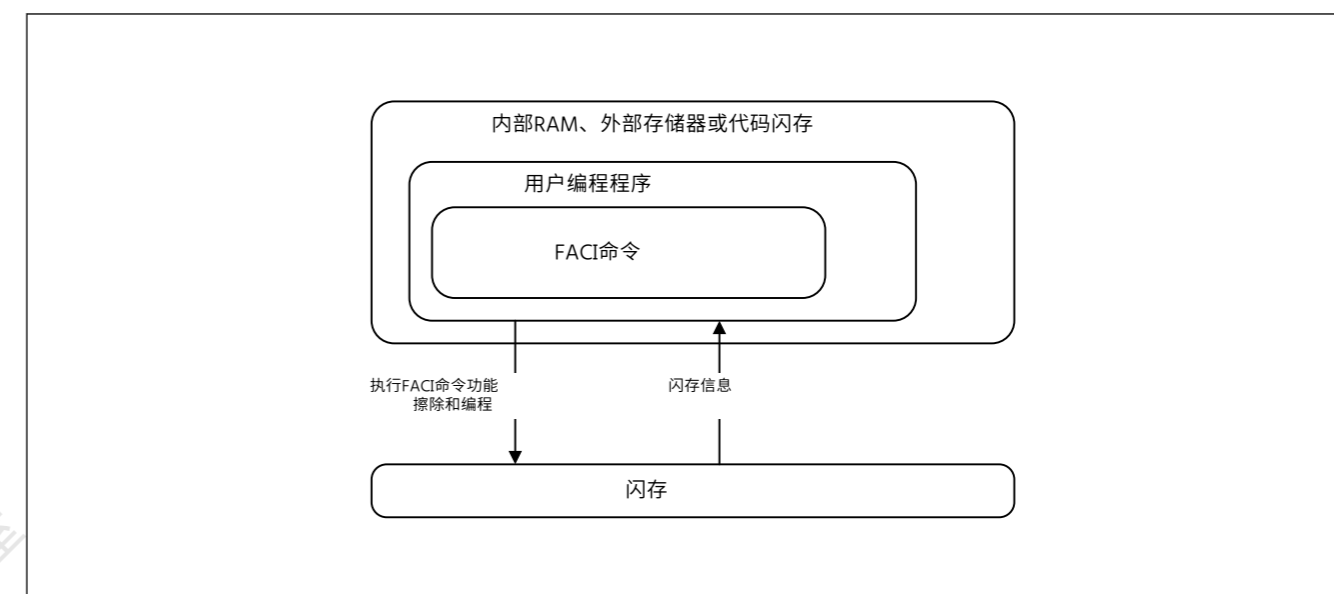


Figure 44.43 自编程示意图

有关自编程的全面信息，请参阅第44.9节。FACI命令

### 44.15.2 后台操作

后台操作（BGO）可用于在数据闪存时对代码闪存执行闪存重写程序。

当用于重写的闪存和用于读取的闪存的组合为下列任何一种时，可以使用后台操作。

Table 44.31 后台操作可用的条件

|        | 重写范围 | 读取范围 |
|--------|------|------|
| Common | 代码闪存 | 数据闪存 |
|        | 数据闪存 | 代码闪存 |

## 44.16 读取闪存

### 44.16.1 读码闪存

从复位状态释放后，读取代码闪存不需要特殊设置。可以通过访问代码闪存中的地址来简单地读取数据。

当读取已擦除但尚未再次编程的代码闪存时（即处于未编程状态），所有位都被读取为1。

### 44.16.2 读取数据闪存

Special settings are not required to read data flash memory after release from the reset state. Data can simply be read out through access to addresses in the data flash memory.

Values read from data flash memory that has been erased but not yet been programming again (i.e. that is in the non-programmed state) are undefined. Use blank checking when you need to confirm that an area is in the non-programmed state.

### 44.16.3 Access Cycle

When the CPU cache is hit, access is one cycle.

For the CPU cache is missed while CPU cache operation is enabled, or CPU cache is disabled. (This operation only guarantees the first read access of a wrapping burst in AHB protocol. Otherwise, access wait occurs until the CPU cache is filled.)

**Table 44.32 Code Flash Memory**

| Flash Cache Operation | FLWT Register Setting | Read cycle (ICLK) |
|-----------------------|-----------------------|-------------------|
| enable and hit        | —                     | 3                 |
| disable or miss       | 0x00                  | 3                 |
|                       | 0x01                  | 4                 |
|                       | 0x02                  | 5                 |
|                       | 0x03                  | 6                 |

**Table 44.33 Data Flash Memory**

| FCKMHZ Register Setting | Read (cycle)                                       |
|-------------------------|--|
| 0x00 to 0x09            | Min: 2 ICLK + 3 FCLK<br>Max: (n + 1) ICLK + 3 FCLK |
| 0x0A to 0x13            | Min: 2 ICLK + 4 FCLK<br>Max: (n + 1) ICLK + 4 FCLK |
| 0x14 to 0x1D            | Min: 2 ICLK + 5 FCLK<br>Max: (n + 1) ICLK + 5 FCLK |
| 0x1E to 0x27            | Min: 2 ICLK + 6 FCLK<br>Max: (n + 1) ICLK + 6 FCLK |
| 0x28 to 0x31            | Min: 2 ICLK + 7 FCLK<br>Max: (n + 1) ICLK + 7 FCLK |
| 0x32                    | Min: 2 ICLK + 8 FCLK<br>Max: (n + 1) ICLK + 8 FCLK |

Note: When the frequency ratio of ICLK : FCLK is n : 1

### 44.17 Usage Notes

#### (1) Reading Area Where Programming/Erase was Interrupted and Area Targeted for Suspension

The data stored in the area where programming or erasure has been suspended or the area where programming or erasure has been suspended by using the suspend command are undefined. To avoid faulty operation caused by reading undefined data, take care not to fetch instructions or read data from areas where programming or erasure was suspended and where programming or erasure was suspended by using the suspend command.

#### (2) Suspension During Programming/Erase

When processing of programming/erasure is stopped by issuing the P/E suspend command, the programming/erasure processing can be resumed by issuing the P/E resume command. If the flash sequencer enters the command-locked state for any reason and issues the forced stop command after the suspended processing is normally completed and the ERSSPD flag or PRGSPD flag is set to 1, the suspended processing cannot be resumed. In addition, the values in the area where the processing was suspended are not guaranteed. Erase that area

从复位状态释放后读取数据闪存不需要特殊设置。通过访问数据闪存中的地址可以简单地读取数据。

从已擦除但尚未再次编程（即处于未编程状态）的数据闪存中读取的值未定义。当您需确认某个区域处于非编程状态时，请使用空白检查。

### 44.16.3 访问周期

当CPU缓存被命中时，访问为一个周期。

启用CPU缓存操作或禁用CPU缓存时CPU缓存丢失。（此操作仅保证AHB协议中包装突发的第一次读取访问。否则，将等待访问，直到CPU缓存被填满。）

**Table 44.32 代码闪存**

| 闪存缓存操作 | FLWT寄存器设置 | 读周期(ICLK) |
|--------|-----------|-----------|
| 启用并点击  | —         | 3         |
| 禁用或错过  | 0x00      | 3         |
|        | 0x01      | 4         |
|        | 0x02      | 5         |
|        | 0x03      | 6         |

**Table 44.33 数据闪存**

| FCKMHZ寄存器设置  | Read (cycle)                                       |
|--------------|--|
| 0x00 to 0x09 | Min: 2 ICLK + 3 FCLK<br>Max: (n + 1) ICLK + 3 FCLK |
| 0x0A to 0x13 | Min: 2 ICLK + 4 FCLK<br>Max: (n + 1) ICLK + 4 FCLK |
| 0x14 to 0x1D | Min: 2 ICLK + 5 FCLK<br>Max: (n + 1) ICLK + 5 FCLK |
| 0x1E to 0x27 | Min: 2 ICLK + 6 FCLK<br>Max: (n + 1) ICLK + 6 FCLK |
| 0x28 to 0x31 | Min: 2 ICLK + 7 FCLK<br>Max: (n + 1) ICLK + 7 FCLK |
| 0x32         | Min: 2 ICLK + 8 FCLK<br>Max: (n + 1) ICLK + 8 FCLK |

Note: 当ICLK:FCLK的频率比为n:1时

### 44.17 使用说明

#### (1) 编程擦除被中断的阅读区域和暂停的目标区域

存储在已暂停编程或擦除的区域或已使用suspend命令暂停编程或擦除的区域中的数据是未定义的。为避免因读取未定义数据而导致错误操作，请注意不要从暂停编程或擦除的区域以及使用暂停命令暂停编程或擦除的区域获取指令或读取数据。

#### (2) 编程擦除期间的暂停

当通过发出PE暂停命令停止编程擦除处理时，可以通过发出PE恢复命令来恢复编程擦除处理。如果闪存定序器由于任何原因进入命令锁定状态并在挂起处理正常完成并且ERSSPD标志或PRGSPD标志设置为1后发出强制停止命令，则无法恢复挂起的处理。此外，不能保证处理暂停的区域中的值。擦除该区域

### (3) Prohibition of Additional Programming

Programming a given area of the code flash memory or data flash memory twice is not possible. To program the code flash memory or data flash memory where has been programmed, erase the target area. Programming can be added to the option-setting memory.

### (4) Resets During Programming/Erase, or Blank Checking

In the case of a reset due to the signal on the RES pin during programming/erase, or blank checking of the flash memory, wait for at least  $t_{RESW}$  (see section 47, Electrical Characteristics) of the reset input period once the operating voltage is within the range stipulated in the electrical characteristics, then release the device from the reset state.

### (5) Allocation of Vectors for Interrupts and Other Exceptions During Programming/Erase

Generation of an interrupt or other exception during programming/erase may lead to fetching of the vector from the code flash memory. Under conditions where BGO cannot be used, set the address of the vector to an address that is not in the code flash memory. Alternatively, make sure that no handling of interrupts or exceptions proceeds during programming/erase.

### (6) Items Prohibited During Programming/Erase, or Blank Checking

High voltage is applied to the flash memory during programming/erase, or blank checking. To prevent damage to the flash memory, do not perform the following operations.

- Have the operating voltage from the power supply go beyond the permitted range.
- Change the FWEPROR.FLWE[1:0]bits.
- Change the OPCCR.OPCM[2:0] and SOPCCR.SOPCM bits.
- Change the SCKDIVCR.FCK[2:0]bits.
- Change the SCKSCR.CKSEL[2:0]bits.
- Transition to the software standby mode, or deep software standby mode.

### (7) Programming/Erase in Low-Speed Modes and Subosc-Speed Mode

Do not programming/erase the flash memory when low-speed mode or subosc-speed mode is selected with the operating power control register (OPCCR or SOPCCR).

### (8) Emulator Connection

Renesas provides the emulator which supports both debugging using SWD or JTAG communication and serial programming using SCI communication. This emulator makes it easy to switch between debugging and serial programming.

Table 44.34 shows the pinout of 10 pin or 20 pin socket pinouts when using this emulator. The pinout of SWD and JTAG is ARM standard, and MD, TXD, RXD pins are added for the serial programming using SCI communication.

The serial programming interface must be used to program the TrustZone IDAU boundary register settings.

It is recommended to connect P300/SWCLK/TCK and P201/MD pins using wired OR circuit on the board to use both debugging and serial programming

Table 44.34 Pin assign for emulator (1 of 2)

| Pin No. | SWD                                 | JTAG                              | Serial Programming using SCI |
|---------|-------------------------------------|-----------------------------------|------------------------------|
| 1       | VCC                                 | VCC                               | VCC                          |
| 2       | P108/SWDIO                          | P108/TMS                          | NC                           |
| 4       | P300/SWCLK<br>Wired OR with P201/MD | P300/TCK<br>Wired OR with P201/MD | P201/MD                      |
| 6       | P109/SWO/TXD9                       | P109/TDO/TXD9                     | P109/TXD9                    |
| 8       | P110/RXD9                           | P110/TDI/RXD9                     | P110/RXD9                    |
| 9       | GNDdetect                           | GNDdetect                         | GNDdetect                    |
| 10      | nRESET                              | nRESET                            | nRESET                       |

### (3) 禁止额外编程

不能对代码闪存或数据闪存的给定区域进行两次编程。要对已编程的代码闪存或数据闪存进行编程，请擦除目标区域。可以将编程添加到选项设置存储器中。

### (4) 在编程擦除或空白检查期间复位

如果在编程擦除期间由于RES引脚上的信号而导致复位，或者闪存的空白检查，一旦工作电压达到在电气特性规定的范围内，然后将设备从复位状态释放。

### (5) 在编程擦除期间为中断和其他异常分配向量

在编程擦除期间产生中断或其他异常可能会导致从代码闪存中获取向量。在无法使用BGO的情况下，将向量的地址设置为不在代码闪存中的地址。或者，确保在编程擦除期间不处理中断或异常。

### (6) 编程擦除或空白检查期间禁止的项目

在编程擦除或空白检查期间向闪存施加高电压。为防止损坏闪存，请勿执行以下操作。

- 电源的工作电压是否超出允许范围。
- 改变FWEPROR.FLWE[1:0]位。
- 更改OPCCR.OPCM[2:0]和SOPCCR.SOPCM位。
- 更改SCKDIVCR.FCK[2:0]位。
- 更改SCKSCR.CKSEL[2:0]位。
- 转换到软件待机模式或深度软件待机模式。

### (7) 低速模式和Subosc-Speed模式下的编程擦除

当使用工作电源控制寄存器（OPCCR或SOPCCR）选择低速模式或subosc-speed模式时，不要对闪存进行编程擦除。

### (8) 仿真器连接

瑞萨电子提供的仿真器支持使用SWD或JTAG通信进行调试和使用SCI通信进行串行编程。该仿真器可以轻松地在调试和串行编程之间切换。

表44.34显示了使用该仿真器时10针或20针插座的引脚排列。SWD和JTAG的管脚是ARM标准，并增加了MD、TXD、RXD引脚用于使用SCI通信的串行编程。

必须使用串行编程接口对TrustZone IDAU边界寄存器设置进行编程。

建议使用板上的有线OR电路连接P300/SWCLK/TCK和P201/MD引脚，以同时使用调试和串行编程

Table 44.34 模拟器的引脚分配（2个中的1个）

| 针号 | SWD                      | JTAG                   | 使用SCI进行串行编程 |
|----|--------------------------|------------------------|-------------|
| 1  | VCC                      | VCC                    | VCC         |
| 2  | P108/SWDIO               | P108/TMS               | NC          |
| 4  | P300/SWCLK<br>有线或带P201MD | P300/TCK<br>有线或带P201MD | P201/MD     |
| 6  | P109/SWO/TXD9            | P109/TDO/TXD9          | P109/TXD9   |
| 8  | P110/RXD9                | P110/TDI/RXD9          | P110/RXD9   |
| 9  | GNDdetect                | GNDdetect              | GNDdetect   |
| 10 | nRESET                   | nRESET                 | nRESET      |

Table 44.34 Pin assign for emulator (2 of 2)

| Pin No.          | SWD           | JTAG          | Serial Programming using SCI |
|------------------|---------------|---------------|------------------------------|
| 12               | P214/TCLK     | P214/TCLK     | NC                           |
| 14               | P211/TDATA[0] | P211/TDATA[0] | NC                           |
| 16               | P210/TDATA[1] | P210/TDATA[1] | NC                           |
| 18               | P209/TDATA[2] | P209/TDATA[2] | NC                           |
| 20               | P209/TDATA[3] | P208/TDATA[3] | NC                           |
| 3, 5, 15, 17, 19 | GND           | GND           | GND                          |
| 7                | NC            | NC            | NC                           |
| 11, 13           | NC            | NC            | NC                           |

Table 44.34 仿真器的引脚分配 (2个中的2个)

| 针号               | SWD           | JTAG          | 使用SCI进行串行编程 |
|------------------|---------------|---------------|-------------|
| 12               | P214/TCLK     | P214/TCLK     | NC          |
| 14               | P211/TDATA[0] | P211/TDATA[0] | NC          |
| 16               | P210/TDATA[1] | P210/TDATA[1] | NC          |
| 18               | P209/TDATA[2] | P209/TDATA[2] | NC          |
| 20               | P209/TDATA[3] | P208/TDATA[3] | NC          |
| 3, 5, 15, 17, 19 | GND           | GND           | GND         |
| 7                | NC            | NC            | NC          |
| 11, 13           | NC            | NC            | NC          |



## 45. Internal Voltage Regulator

### 45.1 Overview

The MCU includes one internal voltage regulator:

- Linear regulator (LDO)

This regulator supplies voltage to all internal circuits and memory except for I/O, analog, USB, and battery backup power domains.

### 45.2 Operation

Table 45.1 lists the LDO mode pin settings, and Figure 45.1 shows the LDO mode settings. In LDO mode, the internal voltage is generated from VCC.

Table 45.1 LDO mode pin

| Pins      | Setting descriptions  |
|-----------|---|
| All VCC   | <ul style="list-style-type: none"> <li>• Connect each pin to the system power supply.</li> <li>• Connect each pin to VSS through a 0.1-<math>\mu</math>F multilayer ceramic capacitor. Place the capacitor close to the pin.</li> </ul> |
| VCL, VCL0 | Connect the each pin to VSS through a 0.1- $\mu$ F multilayer ceramic capacitor. Place the capacitor close to the pin.  |

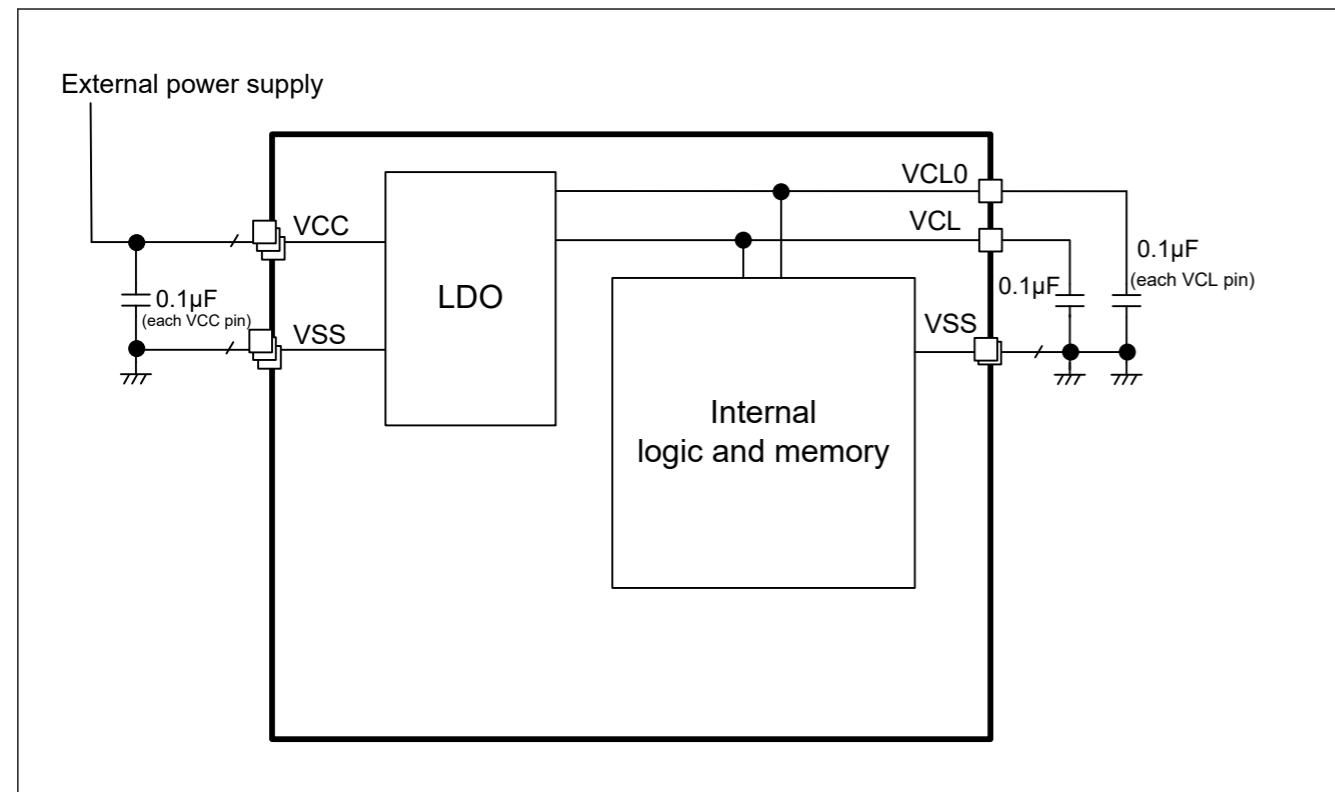


Figure 45.1 LDO mode settings

## 45. 内部稳压器

### 45.1 Overview

MCU包含一个内部稳压器：

- 线性稳压器 (LDO)

该稳压器为除IO、模拟、USB和电池备用电源域之外的所有内部电路和存储器提供电压。

### 45.2 Operation

表45.1列出了LDO模式引脚设置，图45.1显示了LDO模式设置。在LDO模式下，内部电压由VCC产生。

Table 45.1 LDO模式引脚

| Pins      | 设置说明  |
|-----------|---|
| All VCC   | <ul style="list-style-type: none"> <li>• 将每个引脚连接到系统电源。</li> <li>• 通过一个0.1<math>\mu</math>F多层陶瓷电容器将每个引脚连接到VSS。将电容器靠近引脚放置。</li> </ul> |
| VCL, VCL0 | 通过一个0.1 $\mu$ F多层陶瓷电容器将每个引脚连接到VSS。将电容器靠近引脚放置。   |

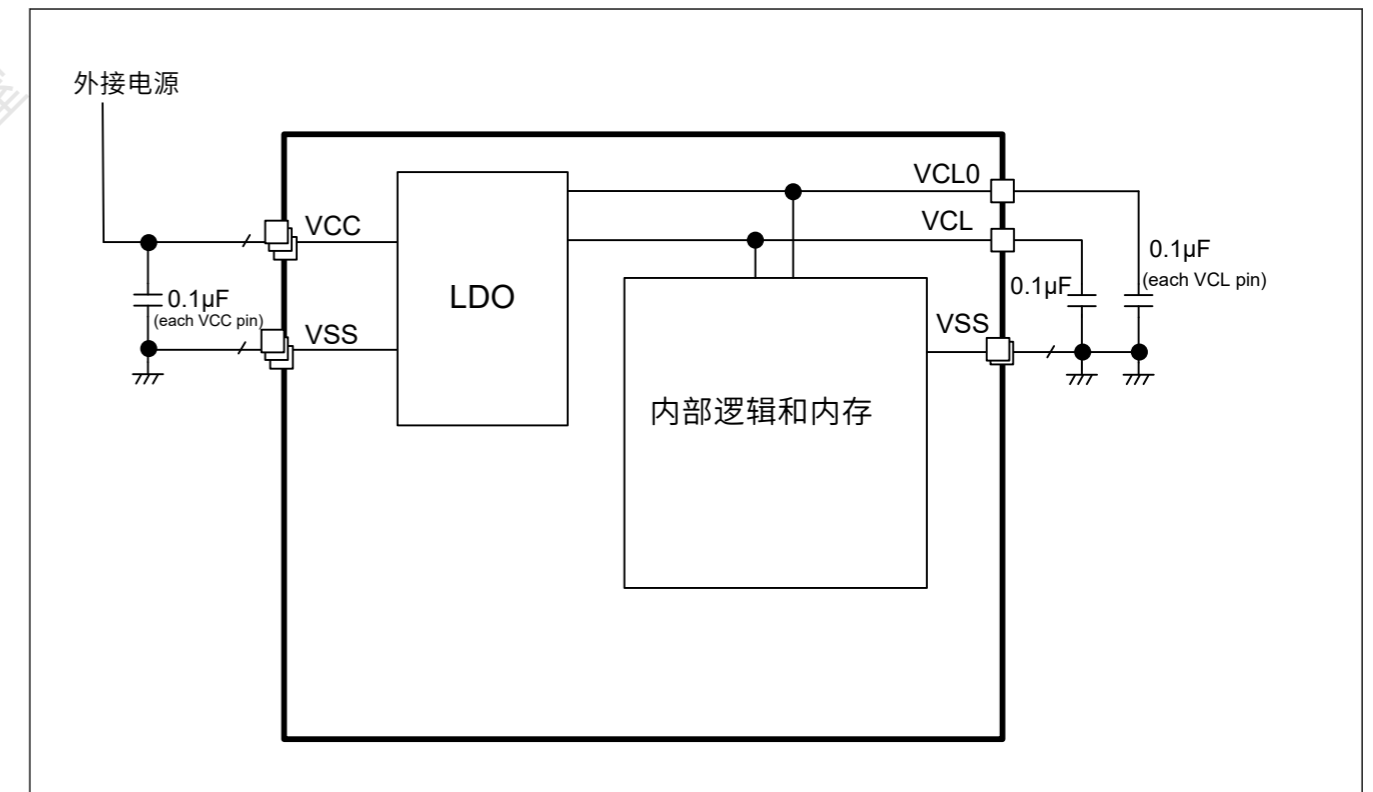


Figure 45.1 LDO模式设置

## 46. Security Features

### 46.1 Features

- ARMv8-M TrustZone security
  - Eight regions IDAU for memory space
    - Up to three regions for the code flash
    - Up to two regions for the data flash
    - Up to three regions for the SRAM
    - IDAU setting is common for the CPU, DMAC, and DTC
  - SAU is not implemented
  - Secure or Non-secure region for the Standby SRAM
  - Secure or Non-secure region for the VBATT backup registers
  - Individual Secure or Non-secure security attribution for each peripheral
  - Some peripherals support both Secure and Non-secure security attributions
- Device lifecycle management
- Three debug access levels
  - DBG2: The debugger connection is allowed, and no restriction to access memories and peripherals
  - DBG1: The debugger connection is allowed, and restricted to access only non-secure memory regions and peripherals
  - DBG0: The debugger connection is not allowed
- Key injection
- Cryptographic accelerator
  - See [section 36, Secure Cryptographic Engine \(SCE9\)](#)
- Secure pin multiplexing
  - All I/O port pins can be configured individually as secure or non-secure
  - Pin functions of SCI3, SPI0, IIC0, GPT321 and GPT165 can be configured as secure pin
  - See [section 19, I/O Ports](#)

### 46.2 Arm TrustZone Security

#### 46.2.1 Arm TrustZone Technology

Arm TrustZone technology divides the system and the application into Secure and Non-secure domains. Secure application can access both Secure and Non-secure memory and resources. Non-secure application can only access Non-secure memory and resources.

The system starts up in Secure state by default. The security state of CPU can be either Secure or Non-secure.

#### 46.2.2 Memory Security Attribution

The code flash, the data flash, and the SRAM are divided into Secure (S), Non-secure (NS) and Non-secure callable (NSC) regions. These memory security attributions are set into the nonvolatile memory by the serial programming command when the device lifecycle is SSD state. These memory security attributions are loaded into the IDAU and the memory controller before application execution. These memory security attributions cannot be updated by application but can be through the dedicated registers.

The code flash can be divided in up to three regions. The data flash can be divided in up to two regions. The SRAM can be divided in up to three regions. [Figure 46.1](#) shows the memory mapping. [Table 46.1](#) shows the size of memory region.

## 46. 安全功能

### 46.1 Features

- ARMv8-M TrustZone security
  - 八个区域IDAU用于存储空间
    - 代码闪存最多三个区域
    - 最多两个区域用于数据闪存
    - SRAM最多三个区域
    - IDAU设置对于CPU、DMAC和DTC是通用的
  - SAU未实施
  - 备用SRAM的安全或非安全区域
  - VBATT备份寄存器的安全或非安全区域
  - 每个外围设备的单独安全或非安全安全属性
  - 一些外围设备同时支持安全和非安全安全属性
- 设备生命周期管理
- 三个调试访问级别
  - DBG2: 允许调试器连接, 并且对访问内存和外设没有限制
  - DBG1: 允许调试器连接, 但仅限于访问非安全内存区域和外围设备
  - DBG0: 不允许调试器连接
- 密钥注入
- 密码加速器
  - 参见[第36节, 安全加密引擎\(SCE9\)](#)
- 安全引脚复用
  - 所有IO端口引脚都可以单独配置为安全或非安全
  - SCI3、SPI0、IIC0、GPT321和GPT165的引脚功能可配置为安全引脚
  - 参见[第19节, IO端口](#)

### 46.2 ArmTrustZone安全

#### 46.2.1 ArmTrustZone技术

ArmTrustZone技术将系统和应用程序划分为安全和非安全域。安全应用程序可以访问安全和非安全内存和资源。非安全应用程序只能访问非安全内存和资源。

系统默认以安全状态启动。CPU的安全状态可以是Secure或非-secure。

#### 46.2.2 内存安全归属

代码闪存、数据闪存和SRAM分为安全(S)、非安全(NS)和非安全可调用(NSC)区域。当设备生命周期为SSD状态时, 这些内存安全属性由串行编程命令设置到非易失性内存中。这些内存安全属性在应用程序执行之前被加载到IDAU和内存控制器中。这些内存安全属性不能由应用程序更新, 但可以通过专用寄存器来更新。

代码闪存最多可分为三个区域。数据闪存最多可分为两个区域。SRAM最多可分为三个区域。图46.1显示了内存映射。表46.1显示了内存区域的大小。

Note: It is prohibited to place Secure or Non-secure callable regions in a block swappable area because the secure application will be placed in the non-secure region after block swapping.

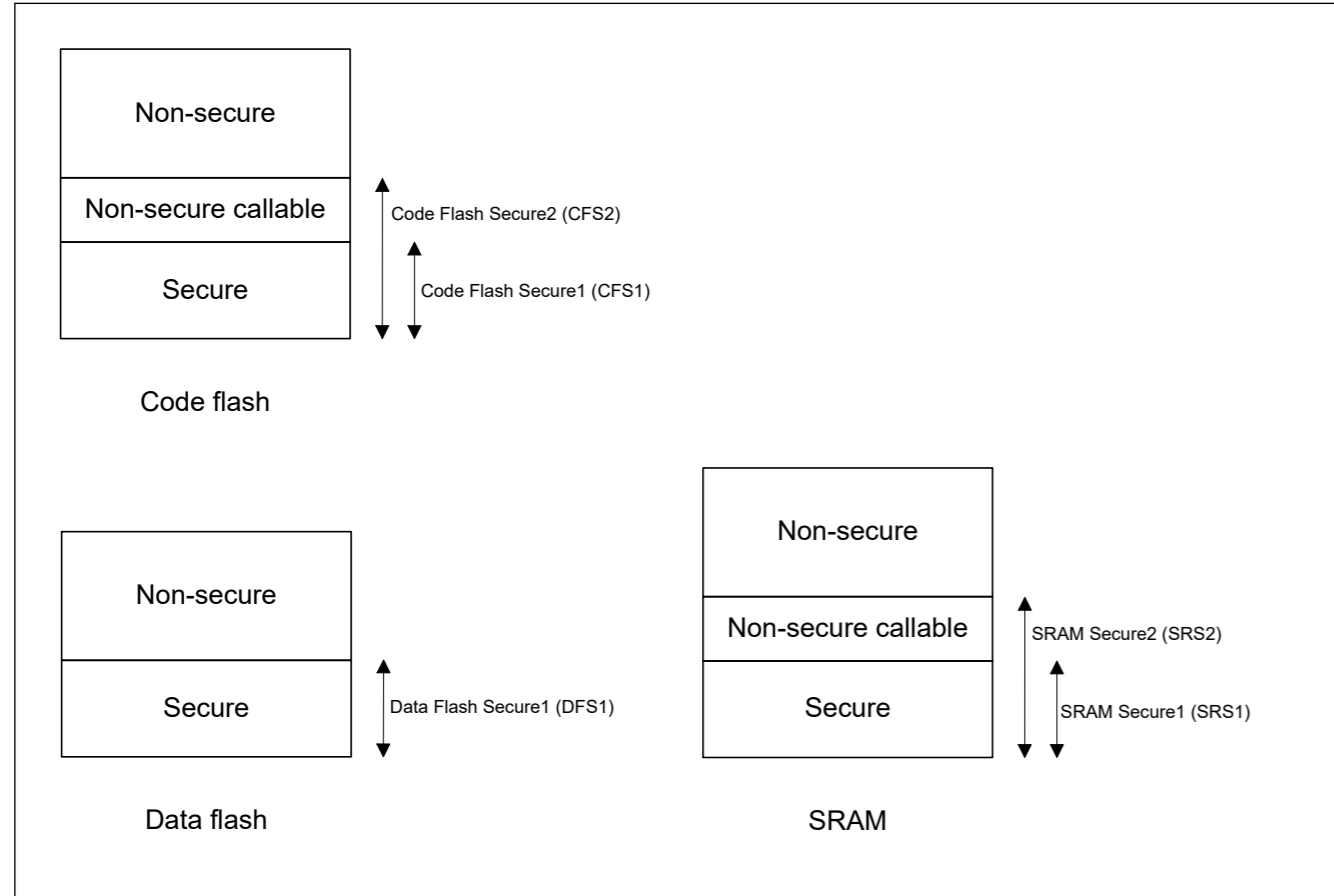


Figure 46.1 Memory mapping

Table 46.1 Memory Region Size

| Memory Region                  | Start Address             | Size                           |
|--------------------------------|---------------------------|--------------------------------|
| Code flash secure              | 0x0000_0000               | CFS1 × 1 KB                    |
| Code flash non-secure callable | CFS1 × 1 KB               | CFS2 × 32 KB - CFS1 × 1 KB     |
| Code flash non-secure          | CFS2 × 32 KB              | Code flash size - CFS2 × 32 KB |
| Data flash secure              | 0x0800_0000               | DFS1 × 1 KB                    |
| Data flash non-secure          | 0x0800_0000 + DFS1 × 1 KB | Data flash size - DFS1 × 1 KB  |
| SRAM secure                    | 0x2000_0000               | SRS1 × 1 KB                    |
| SRAM non-secure callable       | 0x2000_0000 + SRS1 × 1 KB | SRS2 × 8 KB - SRS1 × 1 KB      |
| SRAM non-secure                | 0x2000_0000 + SRS2 × 8 KB | SRAM size - SRS2 × 8 KB        |

The Standby SRAM is divided 8 regions. Security attribution can be set for each region, but both secure region and non-secure region must be contiguous. In other words, the Standby SRAM can have one contiguous secure region and one contiguous non-secure region. The Standby SRAM security attribution is set to the dedicated register by the secure application. See [section 43, Standby SRAM](#) for the details.

The VBATT backup register is divided 8 regions. Security attribution can be set for each region, but both secure region and non-secure region must be contiguous. In other words, the VBATT backup register can have one contiguous Secure region and one contiguous Non-secure region. The VBATT backup register security attribution is set to the dedicated register by the secure application. See [section 11, Battery Backup Function](#) for the details.

Table 46.2 shows the access permission of the memory.

Note: 禁止将安全或非安全可调用区域放置在块可交换区域中，因为安全应用程序将在块交换后放置在非安全区域中。

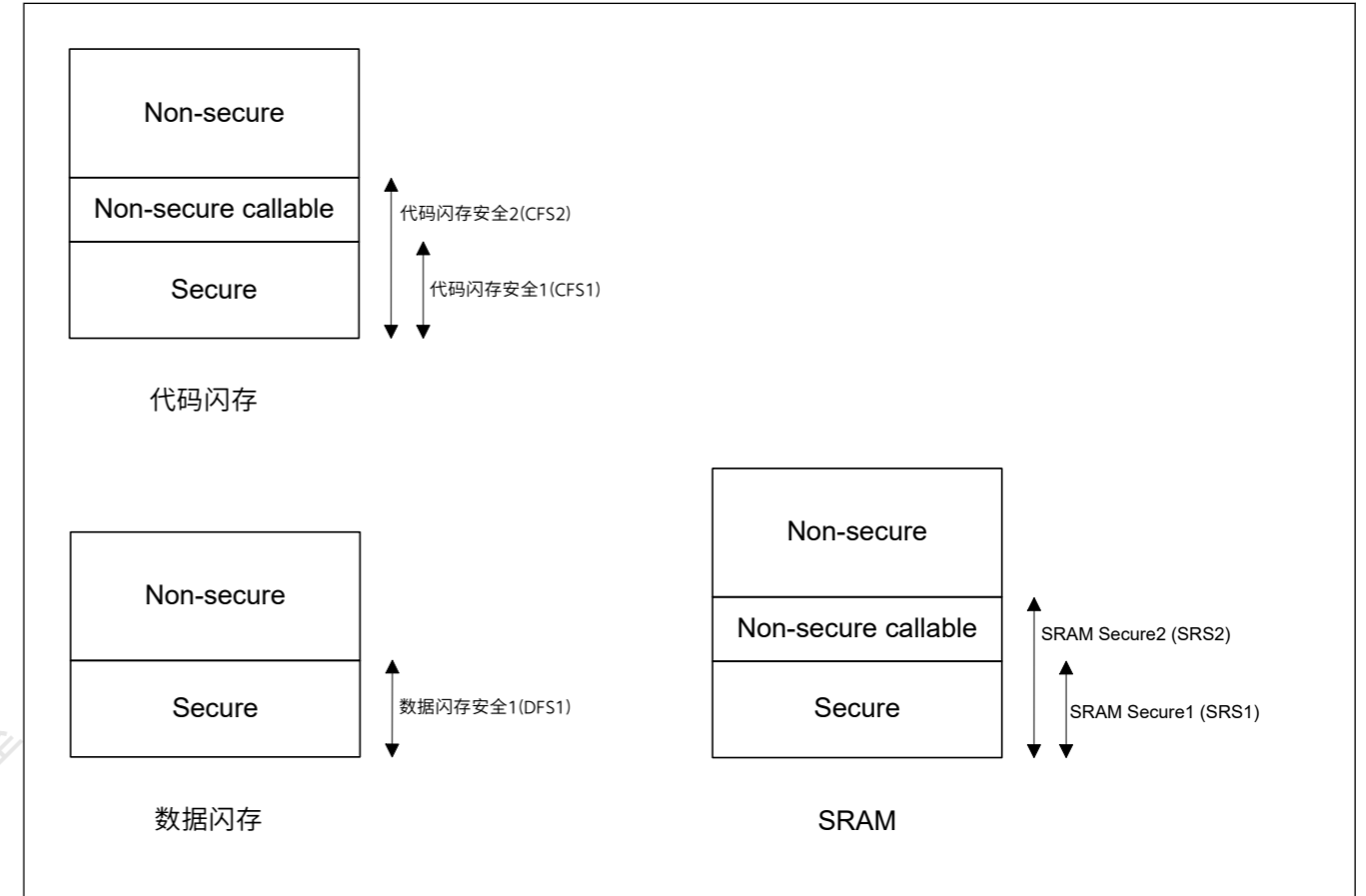


Figure 46.1 内存映射

Table 46.1 内存区域大小

| 记忆区        | 起始地址                      | Size                       |
|------------|---------------------------|----------------------------|
| 代码闪存安全     | 0x0000_0000               | CFS1 × 1 KB                |
| 代码闪存非安全可调用 | CFS1 × 1 KB               | CFS2 × 32 KB - CFS1 × 1 KB |
| 代码闪存不安全    | CFS2 × 32 KB              | 代码闪存大小 - CFS2 × 32 KB      |
| 数据闪存安全     | 0x0800_0000               | DFS1 × 1 KB                |
| 数据闪存不安全    | 0x0800_0000 + DFS1 × 1 KB | 数据闪存大小 - DFS1 × 1 KB       |
| SRAM安全     | 0x2000_0000               | SRS1 × 1 KB                |
| SRAM非安全可调用 | 0x2000_0000 + SRS1 × 1 KB | SRS2 × 8 KB - SRS1 × 1 KB  |
| SRAM非安全    | 0x2000_0000 + SRS2 × 8 KB | SRAM大小 - SRS2 × 8 KB       |

备用SRAM分为8个区域。可以为每个区域设置安全属性，但安全区域和非安全区域必须是连续的。换言之，Standby SRAM可以有一个连续的安全区域和一个连续的非安全区域。备用SRAM安全属性由安全应用程序设置到专用寄存器。有关详细信息，请参阅第43节，备用SRAM。

VBATT备份寄存器分为8个区域。可以为每个区域设置安全属性，但安全区域和非安全区域必须是连续的。换句话说，VBATT备份寄存器可以有一个连续的安全区域和一个连续的非安全区域。VBATT备份寄存器安全属性由安全应用程序设置为专用寄存器。有关详细信息，请参阅第11节，电池备份功能。

表46.2显示了内存的访问权限。

**Table 46.2 Access Permission of Memory**

| Memory   | Secure access | Non-secure access  |
|--|---------------|--|
| Code flash, Data flash, SRAM configured as Secure or Non-secure callable | allowed       | Write ignored / Read ignored<br>TrustZone Access error is generated  |
| Code flash, Data flash, SRAM configured as non-secure                    | allowed       | allowed  |
| Standby SRAM, VBATT backup register configured as Secure                 | allowed       | Write ignored / Read 0x00<br>TrustZone Access error is not generated |
| Standby SRAM, VBATT backup register configured as Non-secure             | allowed       | allowed  |

### 46.2.3 Peripheral Security Attribution

Each peripheral can be configured to be Secure or Non-secure.

Peripherals are divided into two types.

Type-1 peripherals has the one security attribution. Access to all registers is controlled by one security attribution. Type-1 peripheral security attribution is set to the PSARx (x = B to E) register by the secure application.

Type-2 peripherals has the security attribution for each register or for each bit. Access to each register or bit field is controlled according to these security attributions. Type-2 peripheral security attribution is set to the Security Attribution register in each module by the secure application. For the Security Attribution register, see sections in the user manual for each peripheral.

Table 46.3 shows the classification of peripheral type.

**Table 46.3 Peripheral Type Classification**

| Type              | Peripheral  |
|-------------------|---|
| Type-1            | SCI, SPI, USBFS, CAN, IIC, SCE9, DOC, SDHI, SSIE, CTSU, CRC, CAC, TSN, ADC12, DAC12, POEG, AGT, GPT, RTC, IWD, WDT  |
| Type-2            | System control (Resets, LVD, Clock Generation Circuit, Low Power Modes, Battery Backup Function), FLASH CACHE, SRAM controller, CPU CACHE, DMAC, DTC, ICU, MPU, BUS, Security setting, ELC, I/O ports |
| Always Non-secure | QSPI  |

Table 46.4 shows the access permission of type-1 peripherals. The access permission of type-2 peripherals is different by peripherals. See section Register Description of each peripherals.

**Table 46.4 The access permission of type-1 peripherals**

| Permission                          | Secure access | Non-secure access   |
|-------------------------------------|---------------|---|
| Peripheral configured as secure     | allowed       | Write ignored / Read ignored<br>TrustZone Access error is generated |
| Peripheral configured as non-secure | allowed       | allowed   |

### 46.2.4 Flash Sequencer Security Attribution

The flash sequencer is used to program or erase the flash.

The flash sequencer has the special security attribution. Table 46.5 shows the access permission of flash sequencer.

**Table 46.2 内存访问权限**

| Memory                     | 安全访问    | Non-secure access              |
|----------------------------|---------|--------------------------------|
| 代码闪存、数据闪存、SRAM配置为安全或非安全可调用 | allowed | 写被忽略读被忽略<br>生成TrustZone访问错误    |
| 代码闪存、数据闪存、配置为非安全的SRAM      | allowed | allowed                        |
| 备用SRAM、VBATT备份寄存器配置为安全     | allowed | 写入忽略读取0x00<br>未生成TrustZone访问错误 |
| 备用SRAM、VBATT备份寄存器配置为非安全    | allowed | allowed                        |

### 46.2.3 外围安全属性

每个外围设备都可以配置为安全或非安全。

外设分为两种。

Type-1外围设备具有唯一的安全属性。对所有寄存器的访问由一个安全属性控制。类型1外设安全属性由安全应用程序设置到PSARx (x=B到E) 寄存器。

Type-2外设对每个寄存器或每个位都有安全属性。根据这些安全属性控制对每个寄存器或位字段的访问。类型2外围安全属性由安全应用程序设置到每个模块中的安全属性寄存器。对于安全属性寄存器，请参阅每个外设的用户手册中的部分。

表46.3显示了外围类型的分类。

**Table 46.3 外设类型分类**

| Type              | Peripheral   |
|-------------------|--|
| Type-1            | SCI, SPI, USBFS, CAN, IIC, SCE9, DOC, SDHI, SSIE, CTSU, CRC, CAC, TSN, ADC12, DAC12, POEG, AGT, GPT, RTC, IWD, WDT |
| Type-2            | 系统控制 (复位、LVD、时钟生成电路、低功耗模式、电池备份功能)、FLASH CACHE、SRAM控制器、CPU CACHE、DMAC、DTC、ICU、MPU、BUS、安全设置、ELC、IO端口                 |
| Always Non-secure | QSPI   |

表46.4显示了type-1外设的访问权限。type-2外设的访问权限因外设而异。请参阅每个外设的寄存器描述部分。

**Table 46.4 type-1外设的访问权限**

| Permission | 安全访问    | Non-secure access           |
|------------|---------|-----------------------------|
| 外设配置为安全    | allowed | 写被忽略读被忽略<br>生成TrustZone访问错误 |
| 外设配置为非安全   | allowed | allowed                     |

### 46.2.4 FlashSequencer安全属性

闪存定序器用于对闪存进行编程或擦除。

闪存定序器具有特殊的安全属性。表46.5显示了flashsequencer的访问权限。



Table 46.5 Access Permissions of Flash Sequencer

|                                    | Secure access | Non-secure access   |
|------------------------------------|---------------|---|
| FACI command issuing area          | allowed       | When the FACI command is issued to the secure region of code flash, data flash and option-setting memory <ul style="list-style-type: none"> <li>Issued FACI command is invalid</li> <li>Flash sequencer error is generated</li> </ul> When the FACI command is issued to the non-secure region of code flash, data flash and option-setting memory <ul style="list-style-type: none"> <li>Issued FACI command is valid</li> </ul> |
| FBPROT1, FSUACR, FMEPROT registers | allowed       | Write ignored / Readable<br>TrustZone Access error is not generated   |
| FCKMHZ register                    | allowed       | Configured by Flash Security Attribution register<br>When configured as Secure, <ul style="list-style-type: none"> <li>Write ignored / Readable</li> <li>TrustZone Access error is not generated.</li> </ul> When configured as Non-secure <ul style="list-style-type: none"> <li>allowed</li> </ul>  |
| Other registers                    | allowed       | During programming/erasure or during suspend programming/erasure by secure application <ul style="list-style-type: none"> <li>Write ignored / Read 0x00</li> <li>TrustZone Access error is not generated</li> </ul> In other state <ul style="list-style-type: none"> <li>allowed</li> </ul>  |

### 46.2.5 Address Space Security Attribution

Table 46.6 shows the security attribution of the address space.

Table 46.6 Address Space Security Attribution

| Region                         | Attribution         |
|--------------------------------|---------------------|
| Code flash secure              | Secure              |
| Code flash non-secure callable | Non-secure callable |
| Code flash non-secure          | Non-secure          |
| Data flash secure              | Secure              |
| Data flash non-secure          | Non-Secure          |
| SRAM secure                    | Secure              |
| SRAM non-secure callable       | Non-secure callable |
| SRAM non-secure                | Non-secure          |
| Peripherals                    | Exempt              |
| External address space         | Exempt              |
| Other area                     | Exempt              |

Note: Exempt: No check will be done. All bus transactions are propagated.

### 46.2.6 TrustZone Access Error

Table 46.7 shows the behavior when TrustZone access error. The behavior varies depending on the master or slave area to be accessed.

Table 46.7 The Behavior When TrustZone Access Error (1 of 2)

| Area                         | CPU                            | DMAC/DTC  |
|------------------------------|--------------------------------|---|
| Code flash, Data flash, SRAM | Detect SecureFault exception*2 | <ul style="list-style-type: none"> <li>transfer does not start</li> <li>occur NMI or reset*1</li> <li>occur interrupt (DMA_TRANSERR)</li> </ul> |

Table 46.5 FlashSequencer的访问权限

|                                    | 安全访问    | Non-secure access   |
|------------------------------------|---------|---|
| FACI指令发布区                          | allowed | 当FACI命令被发送到代码闪存、数据闪存和选项设置存储器的安全区域时● <ul style="list-style-type: none"> <li>发出的FACI命令无效</li> <li>产生闪存定序器错误</li> </ul> 当FACI命令被发送到代码闪存、数据闪存和选项设置存储器的非安全区域时● <ul style="list-style-type: none"> <li>发出的FACI命令有效</li> </ul> |
| FBPROT1, FSUACR, FMEPROT registers | allowed | 写忽略可读<br>未生成TrustZone访问错误   |
| FCKMHZ register                    | allowed | 由Flash安全属性寄存器配置<br>当配置为安全时, ● <ul style="list-style-type: none"> <li>写忽略可读</li> <li>未生成TrustZone访问错误。</li> </ul> 当配置为非安全时●  |
| 其他寄存器                              | allowed | 在编程擦除期间或在安全应用程序的暂停编程擦除期间● <ul style="list-style-type: none"> <li>写入忽略读取0x00</li> <li>未生成TrustZone访问错误</li> </ul> 在其他状态●   |

### 46.2.5 地址空间安全属性

表46.6显示了地址空间的安全属性。

Table 46.6 地址空间安全属性

| Region                   | Attribution         |
|--------------------------|---------------------|
| 代码闪存安全                   | Secure              |
| 代码闪存非安全可调用               | Non-secure callable |
| 代码闪存不安全                  | Non-secure          |
| 数据闪存安全                   | Secure              |
| 数据闪存不安全                  | Non-Secure          |
| SRAM secure              | Secure              |
| SRAM non-secure callable | Non-secure callable |
| SRAM non-secure          | Non-secure          |
| Peripherals              | Exempt              |
| 外部地址空间                   | Exempt              |
| 其他区域                     | Exempt              |

Note: 豁免: 不会进行任何检查。传播所有总线事务。

### 46.2.6 TrustZone访问错误

表46.7显示了TrustZone访问错误时的行为。行为因要访问的主区域或从区域而异。

Table 46.7 TrustZone访问错误时的行为(1of2)

| Area           | CPU               | DMAC/DTC  |
|----------------|-------------------|---|
| 代码闪存、数据闪存、SRAM | 检测SecureFault异常*2 | <ul style="list-style-type: none"> <li>传输未开始</li> <li>发生NMI或复位*1</li> <li>发生中断(DMA_TRANSERR)</li> </ul> |

Table 46.7 The Behavior When TrustZone Access Error (2 of 2)

| Area       | CPU   | DMAC/DTC  |
|------------|---|---|
| Other area | <ul style="list-style-type: none"> <li>• Detect BusFault exception*2 *3</li> <li>• Occur NMI or reset*1*2 *3</li> </ul> | <ul style="list-style-type: none"> <li>• Stop transfer*4</li> <li>• Occur NMI or reset *1 *4</li> <li>• Occur interrupt (DMA_TRANSERR)*4</li> </ul> |

Note 1. NMI or reset is selected with TZFOAD.OAD bit.  
 Note 2. When TrustZone access error occurs by the debugger access, exception, NMI, or reset does not occurs.Only the error response is returned.  
 Note 3. These error behaviors does not occur for write access to the PHBIU or PLBIU address space which memory attribute is set to "Early Write Acknowledgment" by the ARM MPU.  
 Note 4. These error behaviors does not occur for write access from DMAC to the PHBIU or PLBIU address space when the bufferable write is enabled by DMBWR.BWE.

### 46.3 Device Lifecycle Management

Device lifecycle identifies the current phase of the device and controls the capabilities of the debug interface, the serial programming interface and Renesas test mode. Figure 46.2 is the illustration of the device lifecycle. Table 46.8 shows the lifecycle definition and capability in each lifecycle.

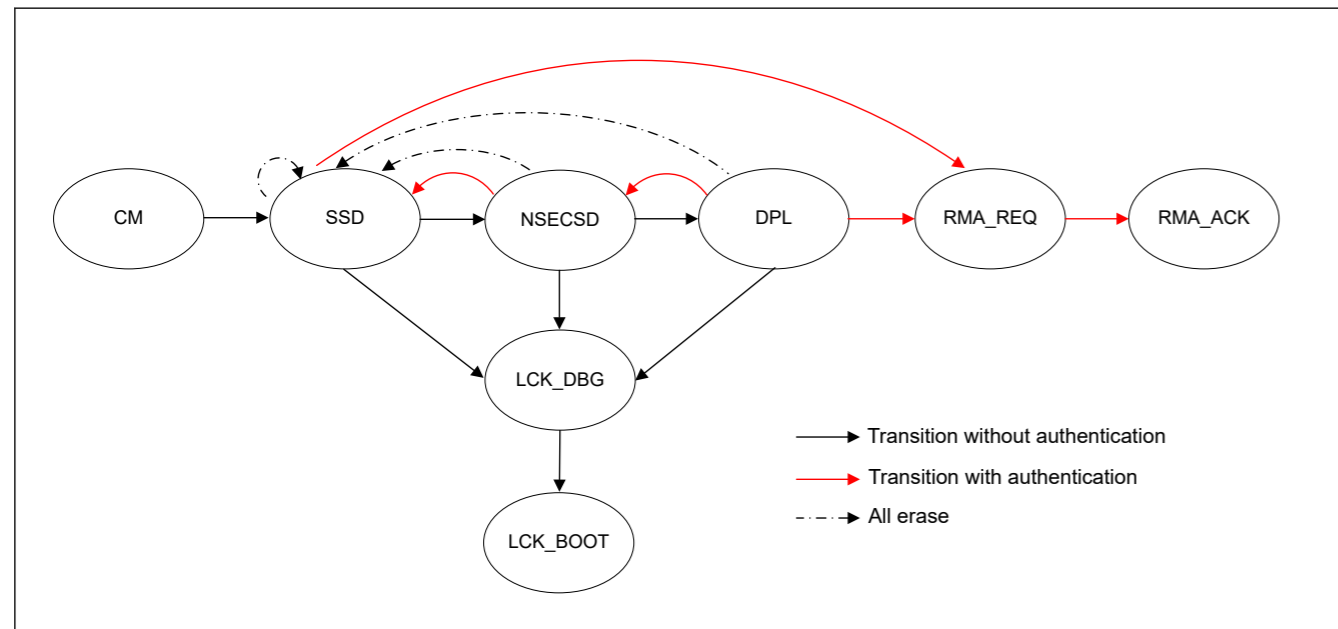


Figure 46.2 The illustration of the device lifecycle

Table 46.8 The lifecycle definition and the capability can be used in each lifecycle (1 of 2)

| Lifecycle | Definition   | Debug level | Serial programming   | Renesas test mode |
|-----------|--|-------------|--|-------------------|
| CM        | "Chip Manufacturing"<br>The device is in Renesas factory. The state when the customer received the device. | DBG2        | Available<br>cannot access code/data flash area                          | Not available     |
| SSD       | "Secure Software Development"<br>The secure part of application is being developed.                        | DBG2        | Available<br>can program/erase/read all code/data flash area             | Not available     |
| NSECSD    | "Non-SECure Software Development"<br>The non-secure part of application is being developed.                | DBG1        | Available<br>can program/erase/read only non-secure code/data flash area | Not available     |
| DPL       | "DePLoyed"<br>The device is in-field.  | DBG0        | Available<br>cannot access code/data flash area                          | Not available     |

Table 46.7 TrustZone访问错误时的行为(2of2)

| Area | CPU  | DMAC/DTC   |
|------|--|--|
| 其他区域 | <ul style="list-style-type: none"> <li>• 检测BusFault异常*2*3</li> <li>• 发生NMI或复位*1*2*3</li> </ul> | <ul style="list-style-type: none"> <li>• 停止传输*4</li> <li>• 发生NMI或复位*1*4</li> <li>• 发生中断(DMA_TRANSERR)*4</li> </ul> |

注1.通过TZFOAD.OAD位选择NMI或复位。  
 注2.当调试器访问发生TrustZone访问错误时，不会发生异常、NMI或复位。仅返回错误响应。  
 注3.对内存属性设置为“Early”的PHBIU或PLBIU地址空间的写访问不会发生这些错误行为ARMMPU的“写确认”。  
 注4.当DMBWR.BWE启用可缓冲写时，这些错误行为不会发生在从DMAC到PHBIU或PLBIU地址空间的写访问中。

### 46.3 设备生命周期管理

设备生命周期识别设备的当前阶段并控制调试接口、串行编程接口和瑞萨测试模式的功能。图46.2是设备生命周期的图示。表46.8显示了每个生命周期中的生命周期定义和能力。

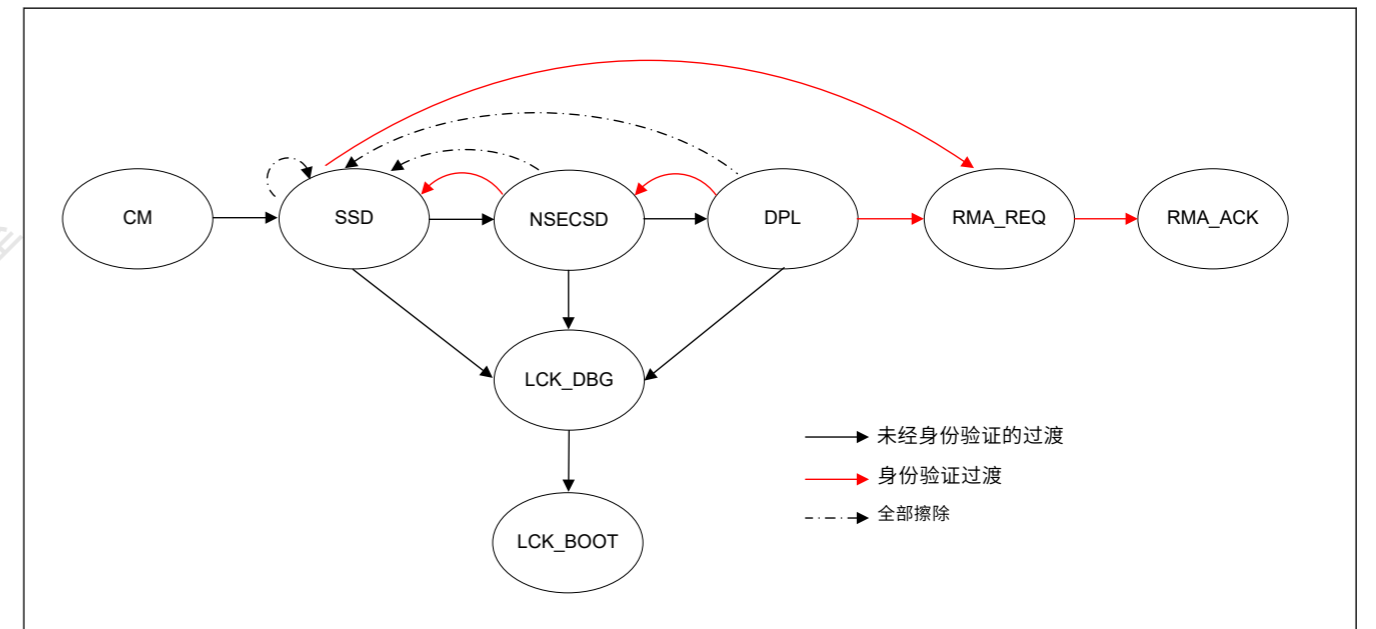


Figure 46.2 设备生命周期示意图

Table 46.8 生命周期定义和能力可以在每个生命周期中使用 (1of2)

| Lifecycle | Definition  | 调试级别 | 串行编程                             | 瑞萨测试模式 |
|-----------|---|------|----------------------------------|--------|
| CM        | "Chip Manufacturing"<br>该设备在瑞萨电子工厂。客户收到设备时的状态。        | DBG2 | Available<br>无法访问代码数据闪存区         | 无法使用   |
| SSD       | "Secure Software Development"<br>应用程序的安全部分正在开发中。      | DBG2 | Available<br>可以编程擦除读取所有代码数据闪存区域  | 无法使用   |
| NSECSD    | "Non-SECure Software Development"<br>应用程序的非安全部分正在开发中。 | DBG1 | Available<br>可以编程擦除只读非安全代码数据闪存区域 | 无法使用   |
| DPL       | "DePLoyed"<br>该设备在现场。                                 | DBG0 | Available<br>无法访问代码数据闪存区         | 无法使用   |

**Table 46.8 The lifecycle definition and the capability can be used in each lifecycle (2 of 2)**

| Lifecycle | Definition  | Debug level | Serial programming                              | Renesas test mode |
|-----------|---|-------------|---|-------------------|
| LCK_DBG   | "LoCKed DeBuG"<br>The debug interface is permanently disabled.  | DBG0        | Available<br>cannot access code/data flash area | Not available     |
| LCK_BOOT  | "LoCKed BOOT interface"<br>The debug interface and the serial programming interface are permanently disabled.           | DBG0        | Not available                                   | Not available     |
| RMA_REQ   | "Return Material Authorization REQuest"<br>Request for RMA. The customer must send the device to Renesas in this state. | DBG0        | Available<br>cannot access code/data flash area | Not available     |
| RMA_ACK   | "Return Material Authorization ACKnowledged"<br>Failure analysis in Renesas   | DBG2        | Available<br>cannot access code/data flash area | Available         |

### 46.3.1 Changing the Lifecycle State

Use the serial programming commands to change the device lifecycle state. See the boot firmware application note for the detail of command. The lifecycle cannot be updated by application but can read through the dedicated registers.

As shown in [Figure 46.2](#), there are three types lifecycle transition.

The first one is to change to lower debug access level or restrict the serial programming mode. This change can be done with no restriction.

**Note:** The debug interface is permanently disabled in LCK\_DBG. After changed to LCK\_DBG, the debug interface cannot be used forever.

**Note:** The debug interface and serial programming interface are permanently disabled in LCK\_BOOT. After changed to LCK\_BOOT, the debug interface and the serial programming interface cannot be used forever.

The second one is to change to higher debug access level or request for RMA. This change needs key authentication. The key length is 128 bits. The secure developer needs to inject two keys when the lifecycle is SSD state. One is "SECDBG\_KEY" which is used to authentication to change the lifecycle from NSECSD to SSD. Other one is "RMA\_KEY" which is used to authentication to change the lifecycle from SSD or DPL to RMA\_REQ. The non-secure developer needs to inject one key when the lifecycle is NSECSD state. This is "NONSECDBG\_KEY" which is used to authentication to change the lifecycle from DPL to NSECSD. See [section 46.4. Key Injection](#) for the detail of how to inject the key. The key authentication uses a challenge and response authentication or authentication using the unique ID. The authentication using the unique ID is available only transition to RMA\_REQ. The following is the process of how to calculate the response, challenge and response authentication, or the authentication code using unique ID.

Response = HMAC-SHA256 (KEY, 128bits challenge || fixed value (256bits))

Authentication code = HMAC-SHA256 (KEY, 128bits unique ID || fixed value (256 bits))

fixed value = 9e56dc41 cf0c9648 1b811141 f8f9ba1e 4dd77746 6d403593 17f46d64 fe64fdf6

**Note:** In case the key is not injected, these lifecycle changes cannot be done.

**Note:** In the lifecycle transition from NSECSD to SSD or from DPL to NSECSD, the contents on the flash memory are not erased.

**Note:** MCU does not respond after changing to higher debug access level or RMA\_REQ. If you continue to use the serial programming commands, need to re-enter the boot mode after a reset. See the boot firmware application note for the detail.

**Note:** In the lifecycle transition to RMA\_REQ, the contents on the flash memory except permanently locked block or setting or BPS\_SEL register are erased. The contents in the permanently locked block or register can be read by Renesas at failure analysis. Permanently locked block means the block which programming and erasure is disabled permanently by PBPS, PBPS\_SEC and BPS\_SEL register. Permanently locked register means SAS register which programming and erasure is disabled permanently by FSPR bit.

**Table 46.8 可以在每个生命周期中使用生命周期定义和能力 (2个中的2个)**

| Lifecycle | Definition                                   | 调试级别 | 串行编程                     | 瑞萨测试模式    |
|-----------|--|------|--------------------------|-----------|
| LCK_DBG   | "LoCKed DeBuG"<br>调试接口被永久禁用。                 | DBG0 | Available<br>无法访问代码数据闪存区 | 无法使用      |
| LCK_BOOT  | "LoCKed BOOT interface"<br>调试接口和串行编程接口被永久禁用。 | DBG0 | 无法使用                     | 无法使用      |
| RMA_REQ   | "退货授权请求"<br>请求RMA。客户必须在此状态下将设备发送给瑞萨电子。       | DBG0 | Available<br>无法访问代码数据闪存区 | 无法使用      |
| RMA_ACK   | "已确认退货授权"<br>瑞萨电子的故障分析                       | DBG2 | Available<br>无法访问代码数据闪存区 | Available |

### 46.3.1 更改生命周期状态

使用串行编程命令更改设备生命周期状态。有关命令的详细信息，请参见启动固件应用说明。生命周期不能由应用程序更新，但可以通过专用寄存器读取。

如图46.2所示，生命周期转换分为三种。

第一个是更改为降低调试访问级别或限制串行编程模式。这种改变可以不受限制地进行。

**Note:** 调试接口在LCK\_DBG中被永久禁用。改成LCK\_DBG后，调试接口就不能一直使用了。

**Note:** 调试接口和串行编程接口在LCK\_BOOT中永久禁用。改成之后LCK\_BOOT、调试接口和串行编程接口不能永远使用。

第二个是更改为更高的调试访问级别或请求RMA。此更改需要密钥身份验证。密钥长度为128位。当生命周期为SSD状态时，安全开发人员需要注入两个密钥。一种是"SECDBG\_KEY"，用于身份验证以将生命周期从NSECSD更改为SSD。另一种是"RMA\_KEY"，用于身份验证以将生命周期从SSD或DPL更改为RMA\_REQ。当生命周期为NSECSD状态时，非安全开发人员需要注入一个密钥。这是"NONSECDBG\_KEY"，用于身份验证以将生命周期从DPL更改为NSECSD。见第46.4节。KeyInjection有关如何注入密钥的详细信息。密钥身份验证使用质询和响应身份验证或使用唯一ID的身份验证。使用唯一ID的身份验证只能转换到RMA\_REQ。以下是如何计算响应、挑战和响应身份验证或使用唯一ID的身份验证码的过程。

响应=HMAC-SHA256(KEY 128bitschallengeFixedvalue(256bits))

认证码=HMAC-SHA256 (KEY, 128bits唯一ID固定值 (256bits) )

固定值=9e56dc41cf0c96481b811141f8f9ba1e4dd777466d40359317f46d64fe64fdf6

**Note:** 如果未注入密钥，则无法完成这些生命周期更改。

**Note:** 在从NSECSD到SSD或从DPL到NSECSD的生命周期转换中，闪存上的内容不会被擦除。

**Note:** 更改为更高的调试访问级别或RMA\_REQ后，MCU没有响应。如果继续使用串口编程命令，需要复位后重新进入开机模式。有关详细信息，请参阅启动固件应用说明。

**Note:** 在到RMA\_REQ的生命周期转换中，闪存上的内容除了永久锁定的块或设置或BPS\_SEL寄存器外被擦除。瑞萨在故障分析时可以读取永久锁定的块或寄存器中的内容。永久锁定块是指被PBPS、PBPS\_SEC和BPS\_SEL寄存器永久禁用编程和擦除的块。永久锁定寄存器是指通过FSPR位永久禁用编程和擦除的SAS寄存器。



The third one is all erase. This is done by an initialize command unless an initialize command itself is disabled. The lifecycle is back to SSD and the contents on the flash memory is erased. If there is permanently locked block or register, an initialize command does not execute. In case of the all bits of PBPS and PBPS\_SEC register are 1 and FSPR bit is 1, an initialize command is executable.

**Note:** The initialize command can be issued by everyone, so contents on the flash memory are easily erased. Developers who do not want this can invalidate the initialize command permanently by parameter setting command.

**Note:** MCU does not respond after executing the initialize command. If you continue to use the serial programming commands, need to re-enter the boot mode after a reset. See the boot firmware application note for the detail.

### 46.3.2 Debug access level

There are three debug access levels, and the debug access level changes according to the lifecycle state.

- DBG2: The debugger connection is allowed, and no restriction to access memories and peripherals
- DBG1: The debugger connection is allowed, and restricted to access only non-secure memory regions and peripherals
- DBG0: The debugger connection is not allowed

### 46.3.3 Serial Programming

Whether a serial programmer can be connected and the range of flash memory that can be accessed depends on the lifecycle state as shown in [Table 46.8](#). And the accepted serial programming command differs depending on the lifecycle state. See the boot firmware application note for the detail of command.

### 46.3.4 Lifecycle changing example

The following is a typical lifecycle changing example.

#### Secure developer

- Change the lifecycle from CM to SSD by using the serial programming command.
- Set the memory security attribution of the code flash, data flash and SRAM by using the serial programming command.
- Program the secure application by using the serial programming interface and debug the secure application. Debug is possible if the lifecycle is CM, but it is impossible to set the memory security attribution in CM state. If the memory security attribution is not set, all area of the code flash, data flash and SRAM is Secure.

**Note:** Need to configure the registers listed in [Table 46.10](#) as Non-secure only in NSECSD state. See [section 46.6.1. Restrictions on setting the security attribution](#) for details.

- Inject "SECDBG\_KEY" and "RMA\_KEY" by using the serial programming command (if need).
- Inject AES, RSA, ECC, HMAC keys listed in [Table 46.9](#) (if need).
- Disable the all erase by using the serial programming command (if need).
- Change the lifecycle from SSD to NSECSD by using the serial programming command.

#### Non-secure developer

- Program the Non-secure application by using the serial programming interface and debug the Non-secure application.
- Inject "NONSECDBG\_KEY" by using the serial programming command (if need).
- Inject AES, RSA, ECC, HMAC keys listed in [Table 46.9](#) (if need).
- Disable the all erase by using the serial programming command (if need).
- Change the lifecycle to DPL by using the serial programming command.

### 46.3.5 Failure analysis

If the customer requests the failure analysis to Renesas, it is necessary to send the device after changing the lifecycle to RMA\_REQ. If the lifecycle is not RMA\_REQ, Renesas can not do the failure analysis. Because RMA\_REQ is permanent state, it can not back to the another state after changing to RMA\_REQ. It is assumed to change to SSD or NSECSD and analyze before changing to RMA\_REQ.

第三个是全部擦除。这由初始化命令完成，除非初始化命令本身被禁用。生命周期回到SSD，闪存上的内容被擦除。如果存在永久锁定的块或寄存器，则不会执行初始化命令。如果PBPS和PBPS\_SEC寄存器的所有位为1，FSPR位为1，则可执行初始化命令。

**Note:** 每个人都可以发出初始化命令，因此闪存上的内容很容易被擦除。不希望这样的开发者可以通过参数设置命令使初始化命令永久无效。

**Note:** 执行初始化命令后MCU没有响应。如果继续使用串口编程命令，需要复位后重新进入开机模式。有关详细信息，请参阅启动固件应用说明。

### 46.3.2 调试访问级别

共有三个调试访问级别，调试访问级别根据生命周期状态而变化。

- DBG2: 允许调试器连接，不限制访问内存和外设
- DBG1: 允许调试器连接，但仅限于访问非安全内存区域和外围设备
- DBG0: 不允许调试器连接

### 46.3.3 串行编程

是否可以连接串行编程器以及可以访问的闪存范围取决于生命周期状态，如表46.8所示。并且接受的串行编程命令根据生命周期状态而有所不同。有关命令的详细信息，请参见启动固件应用说明。

### 46.3.4 生命周期更改示例

以下是一个典型的生命周期更改示例。

#### 安全开发人员

- 使用串行编程命令将生命周期从CM更改为SSD。
- 使用串行编程命令设置codeflash、dataflash和SRAM的内存安全属性。
- 使用串行编程接口对安全应用程序进行编程并调试安全应用程序。如果生命周期是CM，则可以调试，但无法在CM状态下设置内存安全属性。如果未设置内存安全属性，则代码闪存、数据闪存和SRAM的所有区域都是安全的。

**Note:** 仅在NSECSD状态下需要将表46.10中列出的寄存器配置为非安全。请参见第46.6.1节。[设置安全属性的限制以获取详细信息。](#)

- 使用串行编程命令（如果需要）注入"SECDBG\_KEY"和"RMA\_KEY"。
- 注入表46.9中列出的AES、RSA、ECC、HMAC密钥（如果需要）。
- 使用串行编程命令禁用全部擦除（如果需要）。
- 使用串行编程命令将生命周期从SSD更改为NSECSD。

#### Non-secure developer

- 使用串行编程接口对非安全应用程序进行编程并调试非安全应用程序。
- 使用串行编程命令（如果需要）注入"NONSECDBG\_KEY"。
- 注入表46.9中列出的AES、RSA、ECC、HMAC密钥（如果需要）。
- 使用串行编程命令禁用全部擦除（如果需要）。
- 使用串行编程命令将生命周期更改为DPL。

### 46.3.5 故障分析

如果客户要求对瑞萨进行故障分析，则需要将生命周期更改为RMA\_REQ后发送设备。如果生命周期不是RMA\_REQ，瑞萨将无法进行故障分析。因为RMA\_REQ是永久状态，所以在更改为RMA\_REQ后不能回到另一个状态。假设更改为SSD或NSECSD并在更改为RMA\_REQ之前进行分析。



Devices sent to Renesas will not be returned to customers. The device will be discarded.

Note: As described in the [section 46.3.1. Changing the Lifecycle State](#), RMA\_KEY is needed to change the lifecycle to RMA\_REQ. If the customer forgets the RMA\_KEY, Renesas can not do the failure analysis.

#### 46.4 Key Injection

There are three steps required to inject a user key into the MCU.

First, the customer needs to create the 128 bits installation key. This key is called User Factory Programming Key (UFPK) and used to encrypt a user key. The customer gets the key of the wrapped version (W-UFPK) through the Renesas Key Wrapping Service.

Second the customer encrypts the user key using UFPK as the AES key.

Last the customer sends W-UFPK and the encrypted user key to the MCU by using serial programming interface. The sent user key is decrypted, wrapped with the hardware unique key, and then stored in the nonvolatile memory.

[Figure 46.3](#) is the illustration of key injection. [Table 46.9](#) shows the keys that can be injected by serial programming interface.

User Key is also used for authentication during the life cycle transition.

发送给瑞萨的设备将不会退还给客户。该设备将被丢弃。

Note: 如第46.3.1节所述。更改LifecycleState，需要RMA\_KEY才能将生命周期更改为RMA\_REQ。如果客户忘记了RMA\_KEY，瑞萨将无法进行故障分析。

#### 46.4 密钥注入

将用户密钥注入MCU需要三个步骤。

首先，客户需要创建128位安装密钥。此密钥称为用户工厂编程密钥(UFPK)，用于加密用户密钥。客户通过RenesasKeyWrappingService获得打包版本(W-UFPK)的密钥。

其次，客户使用UFPK作为AES密钥对用户密钥进行加密。

最后客户通过串行编程接口将W-UFPK和加密的用户密钥发送给MCU。发送的用户密钥被解密，用硬件唯一密钥包装，然后存储在非易失性存储器中。

图46.3是密钥注入的示意图。表46.9显示了串行编程接口可以注入的密钥。

用户密钥还用于生命周期转换期间的身份验证。



**Table 46.9 The keys that can be injected by serial programming (2 of 2)**

|      |   |
|------|---|
| ECC  | ECC P192, ECC P224, ECC P256, ECC P384, ECC P512 (Public and Private) |
| HMAC | HMAC-SHA224, HMAC-SHA256  |

46.5 Register Description

46.5.1 PSARB : Peripheral Security Attribution Register B

Base address: PSCU = 0x400E\_0000  
Offset address: 0x04

|                    |          |          |          |          |          |    |         |         |    |          |    |    |          |         |         |    |
|--------------------|----------|----------|----------|----------|----------|----|---------|---------|----|----------|----|----|----------|---------|---------|----|
| Bit position:      | 31       | 30       | 29       | 28       | 27       | 26 | 25      | 24      | 23 | 22       | 21 | 20 | 19       | 18      | 17      | 16 |
| Bit field:         | PSAR B31 | PSAR B30 | PSAR B29 | PSAR B28 | PSAR B27 | —  | —       | —       | —  | PSAR B22 | —  | —  | PSAR B19 | —       | —       | —  |
| Value after reset: | 1        | 1        | 1        | 1        | 1        | 1  | 1       | 1       | 1  | 1        | 1  | 1  | 1        | 1       | 1       | 1  |
| Bit position:      | 15       | 14       | 13       | 12       | 11       | 10 | 9       | 8       | 7  | 6        | 5  | 4  | 3        | 2       | 1       | 0  |
| Bit field:         | —        | —        | —        | —        | PSAR B11 | —  | PSAR B9 | PSAR B8 | —  | PSAR B6  | —  | —  | —        | PSAR B2 | PSAR B1 | —  |
| Value after reset: | 1        | 1        | 1        | 1        | 1        | 1  | 1       | 1       | 1  | 1        | 1  | 1  | 1        | 1       | 1       | 1  |

| Bit   | Symbol  | Function  | R/W |
|-------|---------|---|-----|
| 0     | —       | This bit is read as 1. The write value should be 1.   | R/W |
| 1     | PSARB1  | CAN1 and the MSTPCRB.MSTPB1 bit security attribution<br>0: Secure<br>1: Non-secure          | R/W |
| 2     | PSARB2  | CAN0 and the MSTPCRB.MSTPB2 bit security attribution<br>0: Secure<br>1: Non-secure          | R/W |
| 3     | —       | This bit is read as 1. The write value should be 1.   | R/W |
| 5:4   | —       | These bits are read as 1. The write value should be 1.                                      | R/W |
| 6     | PSARB6  | QSPI and the MSTPCRB.MSTPB6 bit security attribution<br>This bit is read as 1 (non-secure). | R   |
| 7     | —       | This bit is read as 1. The write value should be 1.   | R/W |
| 8     | PSARB8  | IIC1 and the MSTPCRB.MSTPB8 bit security attribution<br>0: Secure<br>1: Non-secure          | R/W |
| 9     | PSARB9  | IIC0 and the MSTPCRB.MSTPB9 bit security attribution<br>0: Secure<br>1: Non-secure          | R/W |
| 10    | —       | This bit is read as 1. The write value should be 1.   | R/W |
| 11    | PSARB11 | USBFS and the MSTPCRB.MSTPB11 bit security attribution<br>0: Secure<br>1: Non-secure        | R/W |
| 12    | —       | This bit is read as 1. The write value should be 1.   | R/W |
| 14:13 | —       | These bits are read as 1. The write value should be 1.                                      | R/W |
| 15    | —       | This bit is read as 1. The write value should be 1.   | R/W |
| 16    | —       | This bit is read as 1. The write value should be 1.   | R/W |
| 17    | —       | This bit is read as 1. The write value should be 1.   | R/W |
| 18    | —       | This bit is read as 1. The write value should be 1.   | R/W |

**Table 46.9 可以通过串行编程注入的密钥(2of2)**

|      |   |
|------|---|
| ECC  | ECC P192, ECC P224, ECC P256, ECC P384, ECC P512 (Public and Private) |
| HMAC | HMAC-SHA224, HMAC-SHA256  |

46.5 注册说明

46.5.1 PSARB:外设安全属性寄存器B

Base address: PSCU = 0x400E\_0000  
Offset address: 0x04

|               |          |          |          |          |          |    |         |         |    |          |    |    |          |         |         |    |
|---------------|----------|----------|----------|----------|----------|----|---------|---------|----|----------|----|----|----------|---------|---------|----|
| Bit position: | 31       | 30       | 29       | 28       | 27       | 26 | 25      | 24      | 23 | 22       | 21 | 20 | 19       | 18      | 17      | 16 |
| Bit field:    | PSAR B31 | PSAR B30 | PSAR B29 | PSAR B28 | PSAR B27 | —  | —       | —       | —  | PSAR B22 | —  | —  | PSAR B19 | —       | —       | —  |
| 重置后的值:        | 1        | 1        | 1        | 1        | 1        | 1  | 1       | 1       | 1  | 1        | 1  | 1  | 1        | 1       | 1       | 1  |
| Bit position: | 15       | 14       | 13       | 12       | 11       | 10 | 9       | 8       | 7  | 6        | 5  | 4  | 3        | 2       | 1       | 0  |
| Bit field:    | —        | —        | —        | —        | PSAR B11 | —  | PSAR B9 | PSAR B8 | —  | PSAR B6  | —  | —  | —        | PSAR B2 | PSAR B1 | —  |
| 重置后的值:        | 1        | 1        | 1        | 1        | 1        | 1  | 1       | 1       | 1  | 1        | 1  | 1  | 1        | 1       | 1       | 1  |

| Bit   | Symbol  | Function   | R/W |
|-------|---------|--|-----|
| 0     | —       | 该位读取为1。写入值应为1。   | R/W |
| 1     | PSARB1  | CAN1和MSTPCRB.MSTPB1位安全属性<br>0: Secure<br>1: Non-secure   | R/W |
| 2     | PSARB2  | CAN0和MSTPCRB.MSTPB2位安全属性<br>0: Secure<br>1: Non-secure   | R/W |
| 3     | —       | 该位读取为1。写入值应为1。   | R/W |
| 5:4   | —       | 这些位被读取为1。写入值应为1。   | R/W |
| 6     | PSARB6  | QSPI和MSTPCRB.MSTPB6位安全属性<br>该位读为1（非安全）。                  | R   |
| 7     | —       | 该位读取为1。写入值应为1。   | R/W |
| 8     | PSARB8  | IIC1和MSTPCRB.MSTPB8位安全归属<br>0: Secure<br>1: Non-secure   | R/W |
| 9     | PSARB9  | IIC0和MSTPCRB.MSTPB9位安全归属<br>0: Secure<br>1: Non-secure   | R/W |
| 10    | —       | 该位读取为1。写入值应为1。   | R/W |
| 11    | PSARB11 | USBFS和MSTPCRB.MSTPB11位安全属性<br>0: Secure<br>1: Non-secure | R/W |
| 12    | —       | 该位读取为1。写入值应为1。   | R/W |
| 14:13 | —       | 这些位被读取为1。写入值应为1。   | R/W |
| 15    | —       | 该位读取为1。写入值应为1。   | R/W |
| 16    | —       | 该位读取为1。写入值应为1。   | R/W |
| 17    | —       | 该位读取为1。写入值应为1。   | R/W |
| 18    | —       | 该位读取为1。写入值应为1。   | R/W |

| Bit   | Symbol  | Function  | R/W |
|-------|---------|---|-----|
| 19    | PSARB19 | SPI0 and the MSTPCRB.MSTPB19 bit security attribution<br>0: Secure<br>1: Non-secure | R/W |
| 21:20 | —       | These bits are read as 1. The write value should be 1.                              | R/W |
| 22    | PSARB22 | SCI9 and the MSTPCRB.MSTPB22 bit security attribution<br>0: Secure<br>1: Non-secure | R/W |
| 23    | —       | These bits are read as 1. The write value should be 1.                              | R/W |
| 24    | —       | These bits are read as 1. The write value should be 1.                              | R/W |
| 25    | —       | These bits are read as 1. The write value should be 1.                              | R/W |
| 26    | —       | These bits are read as 1. The write value should be 1.                              | R/W |
| 27    | PSARB27 | SCI4 and the MSTPCRB.MSTPB27 bit security attribution<br>0: Secure<br>1: Non-secure | R/W |
| 28    | PSARB28 | SCI3 and the MSTPCRB.MSTPB28 bit security attribution<br>0: Secure<br>1: Non-secure | R/W |
| 29    | PSARB29 | SCI2 and the MSTPCRB.MSTPB29 bit security attribution<br>0: Secure<br>1: Non-secure | R/W |
| 30    | PSARB30 | SCI1 and the MSTPCRB.MSTPB30 bit security attribution<br>0: Secure<br>1: Non-secure | R/W |
| 31    | PSARB31 | SCI0 and the MSTPCRB.MSTPB31 bit security attribution<br>0: Secure<br>1: Non-secure | R/W |

Note: A bit undefined in this table is reserved bit. The reserved bit should be kept the initial value.

Note: Only secure access can write to this register. Both secure access and Non-secure read access are allowed but Non-secure write access is not allowed and TrustZone access error is not generated.

Note: This register is write-protected by PRCR register.

The PSARB specifies the security attribution for each module and the corresponding bit in Module Stop Control Register.

### 46.5.2 PSARC : Peripheral Security Attribution Register C

Base address: PSCU = 0x400E\_0000

Offset address: 0x08

|                    |          |    |          |          |    |    |    |         |    |    |    |    |         |    |         |         |
|--------------------|----------|----|----------|----------|----|----|----|---------|----|----|----|----|---------|----|---------|---------|
| Bit position:      | 31       | 30 | 29       | 28       | 27 | 26 | 25 | 24      | 23 | 22 | 21 | 20 | 19      | 18 | 17      | 16      |
| Bit field:         | PSAR C31 | —  | —        | —        | —  | —  | —  | —       | —  | —  | —  | —  | —       | —  | —       | —       |
| Value after reset: | 1        | 1  | 1        | 1        | 1  | 1  | 1  | 1       | 1  | 1  | 1  | 1  | 1       | 1  | 1       | 1       |
| Bit position:      | 15       | 14 | 13       | 12       | 11 | 10 | 9  | 8       | 7  | 6  | 5  | 4  | 3       | 2  | 1       | 0       |
| Bit field:         | —        | —  | PSAR C13 | PSAR C12 | —  | —  | —  | PSAR C8 | —  | —  | —  | —  | PSAR C3 | —  | PSAR C1 | PSAR C0 |
| Value after reset: | 1        | 1  | 1        | 1        | 1  | 1  | 1  | 1       | 1  | 1  | 1  | 1  | 1       | 1  | 1       | 1       |

| Bit | Symbol | Function  | R/W |
|-----|--------|---|-----|
| 0   | PSARC0 | CAC and the MSTPCRC.MSTPC0 bit security attribution<br>0: Secure<br>1: Non-secure | R/W |

| Bit   | Symbol  | Function  | R/W |
|-------|---------|---|-----|
| 19    | PSARB19 | SPI0和MSTPCRB.MSTPB19位安全归属<br>0: Secure<br>1: Non-secure | R/W |
| 21:20 | —       | 这些位被读取为1。写入值应为1。  | R/W |
| 22    | PSARB22 | SCI9和MSTPCRB.MSTPB22位安全归属<br>0: Secure<br>1: Non-secure | R/W |
| 23    | —       | 这些位被读取为1。写入值应为1。  | R/W |
| 24    | —       | 这些位被读取为1。写入值应为1。  | R/W |
| 25    | —       | 这些位被读取为1。写入值应为1。  | R/W |
| 26    | —       | 这些位被读取为1。写入值应为1。  | R/W |
| 27    | PSARB27 | SCI4和MSTPCRB.MSTPB27位安全归属<br>0: Secure<br>1: Non-secure | R/W |
| 28    | PSARB28 | SCI3和MSTPCRB.MSTPB28位安全归属<br>0: Secure<br>1: Non-secure | R/W |
| 29    | PSARB29 | SCI2和MSTPCRB.MSTPB29位安全归属<br>0: Secure<br>1: Non-secure | R/W |
| 30    | PSARB30 | SCI1和MSTPCRB.MSTPB30位安全归属<br>0: Secure<br>1: Non-secure | R/W |
| 31    | PSARB31 | SCI0和MSTPCRB.MSTPB31位安全归属<br>0: Secure<br>1: Non-secure | R/W |

Note: 该表中未定义的位是保留位。保留位应保持初始值。

Note: 只有安全访问才能写入该寄存器。允许安全访问和非安全读取访问，但不允许非安全写入访问，并且不会生成TrustZone访问错误。

Note: 该寄存器由PRCR寄存器写保护。

PSARB指定每个模块的安全属性以及模块停止控制寄存器中的相应位。

### 46.5.2 PSARC:外设安全属性寄存器C

Base address: PSCU = 0x400E\_0000

Offset address: 0x08

|               |          |    |          |          |    |    |    |         |    |    |    |    |         |    |         |         |
|---------------|----------|----|----------|----------|----|----|----|---------|----|----|----|----|---------|----|---------|---------|
| Bit position: | 31       | 30 | 29       | 28       | 27 | 26 | 25 | 24      | 23 | 22 | 21 | 20 | 19      | 18 | 17      | 16      |
| Bit field:    | PSAR C31 | —  | —        | —        | —  | —  | —  | —       | —  | —  | —  | —  | —       | —  | —       | —       |
| 重置后的值:        | 1        | 1  | 1        | 1        | 1  | 1  | 1  | 1       | 1  | 1  | 1  | 1  | 1       | 1  | 1       | 1       |
| Bit position: | 15       | 14 | 13       | 12       | 11 | 10 | 9  | 8       | 7  | 6  | 5  | 4  | 3       | 2  | 1       | 0       |
| Bit field:    | —        | —  | PSAR C13 | PSAR C12 | —  | —  | —  | PSAR C8 | —  | —  | —  | —  | PSAR C3 | —  | PSAR C1 | PSAR C0 |
| 重置后的值:        | 1        | 1  | 1        | 1        | 1  | 1  | 1  | 1       | 1  | 1  | 1  | 1  | 1       | 1  | 1       | 1       |

| Bit | Symbol | Function  | R/W |
|-----|--------|---|-----|
| 0   | PSARC0 | CAC和MSTPCRC.MSTPC0位安全属性<br>0: Secure<br>1: Non-secure | R/W |



| Bit   | Symbol  | Function   | R/W |
|-------|---------|--|-----|
| 1     | PSARC1  | CRC and the MSTPCRC.MSTPC1 bit security attribution<br>0: Secure<br>1: Non-secure    | R/W |
| 2     | —       | This bit is read as 1. The write value should be 1.                                  | R/W |
| 3     | PSARC3  | CTSU and the MSTPCRC.MSTPC3 bit security attribution<br>0: Secure<br>1: Non-secure   | R/W |
| 7:4   | —       | These bits are read as 1. The write value should be 1.                               | R/W |
| 8     | PSARC8  | SSIE0 and the MSTPCRC.MSTPC8 bit security attribution<br>0: Secure<br>1: Non-secure  | R/W |
| 11:9  | —       | These bits are read as 1. The write value should be 1.                               | R/W |
| 12    | PSARC12 | SDHI0 and the MSTPCRC.MSTPC12 bit security attribution<br>0: Secure<br>1: Non-secure | R/W |
| 13    | PSARC13 | DOC and the MSTPCRC.MSTPC13 bit security attribution<br>0: Secure<br>1: Non-secure   | R/W |
| 26:14 | —       | These bits are read as 1. The write value should be 1.                               | R/W |
| 27    | —       | These bits are read as 1. The write value should be 1.                               | R/W |
| 30:28 | —       | These bits are read as 1. The write value should be 1.                               | R/W |
| 31    | PSARC31 | SCE9 and the MSTPCRC.MSTPC31 bit security attribution<br>0: Secure<br>1: Non-secure  | R/W |

Note: Only secure access can write to this register. Both secure access and Non-secure read access are allowed but Non-secure write access is not allowed and TrustZone access error is not generated.

Note: This register is write-protected by PRCR register.

The PSARC specifies the security attribution for each module and the corresponding bit in Module Stop Control Register.

### 46.5.3 PSARD : Peripheral Security Attribution Register D

Base address: PSCU = 0x400E\_0000

Offset address: 0x0C

|                    |          |          |          |          |          |    |    |    |    |          |    |          |         |         |         |          |
|--------------------|----------|----------|----------|----------|----------|----|----|----|----|----------|----|----------|---------|---------|---------|----------|
| Bit position:      | 31       | 30       | 29       | 28       | 27       | 26 | 25 | 24 | 23 | 22       | 21 | 20       | 19      | 18      | 17      | 16       |
| Bit field:         | —        | —        | —        | —        | —        | —  | —  | —  | —  | PSAR D22 | —  | PSAR D20 | —       | —       | —       | PSAR D16 |
| Value after reset: | 1        | 1        | 1        | 1        | 1        | 1  | 1  | 1  | 1  | 1        | 1  | 1        | 1       | 1       | 1       | 1        |
| Bit position:      | 15       | 14       | 13       | 12       | 11       | 10 | 9  | 8  | 7  | 6        | 5  | 4        | 3       | 2       | 1       | 0        |
| Bit field:         | PSAR D15 | PSAR D14 | PSAR D13 | PSAR D12 | PSAR D11 | —  | —  | —  | —  | —        | —  | —        | PSAR D3 | PSAR D2 | PSAR D1 | PSAR D0  |
| Value after reset: | 1        | 1        | 1        | 1        | 1        | 1  | 1  | 1  | 1  | 1        | 1  | 1        | 1       | 1       | 1       | 1        |

| Bit | Symbol | Function   | R/W |
|-----|--------|--|-----|
| 0   | PSARD0 | AGT3 and the MSTPCRD.MSTPD0 bit security attribution<br>0: Secure<br>1: Non-secure | R/W |
| 1   | PSARD1 | AGT2 and the MSTPCRD.MSTPD1 bit security attribution<br>0: Secure<br>1: Non-secure | R/W |

| Bit   | Symbol  | Function   | R/W |
|-------|---------|--|-----|
| 1     | PSARC1  | CRC和MSTPCRC.MSTPC1位安全属性<br>0: Secure<br>1: Non-secure    | R/W |
| 2     | —       | 该位读取为1。写入值应为1。   | R/W |
| 3     | PSARC3  | CTSU和MSTPCRC.MSTPC3位安全属性<br>0: Secure<br>1: Non-secure   | R/W |
| 7:4   | —       | 这些位被读取为1。写入值应为1。   | R/W |
| 8     | PSARC8  | SSIE0和MSTPCRC.MSTPC8位安全属性<br>0: Secure<br>1: Non-secure  | R/W |
| 11:9  | —       | 这些位被读取为1。写入值应为1。   | R/W |
| 12    | PSARC12 | SDHI0和MSTPCRC.MSTPC12位安全属性<br>0: Secure<br>1: Non-secure | R/W |
| 13    | PSARC13 | DOC和MSTPCRC.MSTPC13位安全属性<br>0: Secure<br>1: Non-secure   | R/W |
| 26:14 | —       | 这些位被读取为1。写入值应为1。   | R/W |
| 27    | —       | 这些位被读取为1。写入值应为1。   | R/W |
| 30:28 | —       | 这些位被读取为1。写入值应为1。   | R/W |
| 31    | PSARC31 | SCE9和MSTPCRC.MSTPC31位安全属性<br>0: Secure<br>1: Non-secure  | R/W |

Note: 只有安全访问才能写入该寄存器。允许安全访问和非安全读取访问，但不允许非安全写入访问，并且不会生成TrustZone访问错误。

Note: 该寄存器由PRCR寄存器写保护。

PSARC指定每个模块的安全属性以及模块停止控制寄存器中的相应位。

### 46.5.3 PSARD:外围安全属性寄存器D

Base address: PSCU = 0x400E\_0000

Offset address: 0x0C

|               |          |          |          |          |          |    |    |    |    |          |    |          |         |         |         |          |
|---------------|----------|----------|----------|----------|----------|----|----|----|----|----------|----|----------|---------|---------|---------|----------|
| Bit position: | 31       | 30       | 29       | 28       | 27       | 26 | 25 | 24 | 23 | 22       | 21 | 20       | 19      | 18      | 17      | 16       |
| Bit field:    | —        | —        | —        | —        | —        | —  | —  | —  | —  | PSAR D22 | —  | PSAR D20 | —       | —       | —       | PSAR D16 |
| 重置后的值:        | 1        | 1        | 1        | 1        | 1        | 1  | 1  | 1  | 1  | 1        | 1  | 1        | 1       | 1       | 1       | 1        |
| Bit position: | 15       | 14       | 13       | 12       | 11       | 10 | 9  | 8  | 7  | 6        | 5  | 4        | 3       | 2       | 1       | 0        |
| Bit field:    | PSAR D15 | PSAR D14 | PSAR D13 | PSAR D12 | PSAR D11 | —  | —  | —  | —  | —        | —  | —        | PSAR D3 | PSAR D2 | PSAR D1 | PSAR D0  |
| 重置后的值:        | 1        | 1        | 1        | 1        | 1        | 1  | 1  | 1  | 1  | 1        | 1  | 1        | 1       | 1       | 1       | 1        |

| Bit | Symbol | Function   | R/W |
|-----|--------|--|-----|
| 0   | PSARD0 | AGT3和MSTPCRD.MSTPD0位安全归属<br>0: Secure<br>1: Non-secure | R/W |
| 1   | PSARD1 | AGT2和MSTPCRD.MSTPD1位安全归属<br>0: Secure<br>1: Non-secure | R/W |

| Bit   | Symbol  | Function  | R/W |
|-------|---------|---|-----|
| 2     | PSARD2  | AGT1 and the MSTPCRD.MSTPD2 bit security attribution<br>0: Secure<br>1: Non-secure          | R/W |
| 3     | PSARD3  | AGT0 and the MSTPCRD.MSTPD3 bit security attribution<br>0: Secure<br>1: Non-secure          | R/W |
| 10:4  | —       | These bits are read as 1. The write value should be 1.                                      | R/W |
| 11    | PSARD11 | POEG Group D and the MSTPCRD.MSTPD11 bit security attribution<br>0: Secure<br>1: Non-secure | R/W |
| 12    | PSARD12 | POEG Group C and the MSTPCRD.MSTPD12 bit security attribution<br>0: Secure<br>1: Non-secure | R/W |
| 13    | PSARD13 | POEG Group B and the MSTPCRD.MSTPD13 bit security attribution<br>0: Secure<br>1: Non-secure | R/W |
| 14    | PSARD14 | POEG Group A and the MSTPCRD.MSTPD14 bit security attribution<br>0: Secure<br>1: Non-secure | R/W |
| 15    | PSARD15 | ADC121 and the MSTPCRD.MSTPD15 bit security attribution<br>0: Secure<br>1: Non-secure       | R/W |
| 16    | PSARD16 | ADC120 and the MSTPCRD.MSTPD16 bit security attribution<br>0: Secure<br>1: Non-secure       | R/W |
| 19:17 | —       | These bits are read as 1. The write value should be 1.                                      | R/W |
| 20    | PSARD20 | DAC12 and the MSTPCRD.MSTPD20 bit security attribution<br>0: Secure<br>1: Non-secure        | R/W |
| 21    | —       | This bit is read as 1. The write value should be 1.   | R/W |
| 22    | PSARD22 | TSN and the MSTPCRD.MSTPD22 bit security attribution<br>0: Secure<br>1: Non-secure          | R/W |
| 31:23 | —       | These bits are read as 1. The write value should be 1.                                      | R/W |

Note: Only secure access can write to this register. Both secure access and Non-secure read access are allowed but Non-secure write access is not allowed and TrustZone access error is not generated.

Note: This register is write-protected by PRCR register.

The PSARD specifies the security attribution for each module and the corresponding bit in Module Stop Control Register.

#### 46.5.4 PSARE : Peripheral Security Attribution Register E

Base address: PSCU = 0x400E\_0000

Offset address: 0x10

| Bit position:      | 31       | 30       | 29       | 28       | 27       | 26       | 25       | 24       | 23 | 22 | 21 | 20 | 19 | 18 | 17      | 16      |         |
|--------------------|----------|----------|----------|----------|----------|----------|----------|----------|----|----|----|----|----|----|---------|---------|---------|
| Bit field:         | PSAR E31 | PSAR E30 | PSAR E29 | PSAR E28 | PSAR E27 | PSAR E26 | PSAR E25 | PSAR E24 | —  | —  | —  | —  | —  | —  | —       | —       |         |
| Value after reset: | 1        | 1        | 1        | 1        | 1        | 1        | 1        | 1        | 1  | 1  | 1  | 1  | 1  | 1  | 1       | 1       |         |
| Bit position:      | 15       | 14       | 13       | 12       | 11       | 10       | 9        | 8        | 7  | 6  | 5  | 4  | 3  | 2  | 1       | 0       |         |
| Bit field:         | PSAR E15 | PSAR E14 | —        | —        | —        | —        | —        | —        | —  | —  | —  | —  | —  | —  | PSAR E2 | PSAR E1 | PSAR E0 |
| Value after reset: | 1        | 1        | 1        | 1        | 1        | 1        | 1        | 1        | 1  | 1  | 1  | 1  | 1  | 1  | 1       | 1       |         |

| Bit   | Symbol  | Function  | R/W |
|-------|---------|---|-----|
| 2     | PSARD2  | AGT1和MSTPCRD.MSTPD2位安全归属<br>0: Secure<br>1: Non-secure        | R/W |
| 3     | PSARD3  | AGT0和MSTPCRD.MSTPD3位安全属性<br>0: Secure<br>1: Non-secure        | R/W |
| 10:4  | —       | 这些位被读取为1。写入值应为1。  | R/W |
| 11    | PSARD11 | POEGGroupD和MSTPCRD.MSTPD11位安全归属<br>0: Secure<br>1: Non-secure | R/W |
| 12    | PSARD12 | POEGGroupC和MSTPCRD.MSTPD12位安全归属<br>0: Secure<br>1: Non-secure | R/W |
| 13    | PSARD13 | POEGGroupB和MSTPCRD.MSTPD13位安全归属<br>0: Secure<br>1: Non-secure | R/W |
| 14    | PSARD14 | POEGGroupA和MSTPCRD.MSTPD14位安全归属<br>0: Secure<br>1: Non-secure | R/W |
| 15    | PSARD15 | ADC121和MSTPRD.MSTPD15位安全归属<br>0: Secure<br>1: Non-secure      | R/W |
| 16    | PSARD16 | ADC120和MSTPRD.MSTPD16位安全属性<br>0: Secure<br>1: Non-secure      | R/W |
| 19:17 | —       | 这些位被读取为1。写入值应为1。  | R/W |
| 20    | PSARD20 | DAC12和MSTPCRD.MSTPD20位安全归属<br>0: Secure<br>1: Non-secure      | R/W |
| 21    | —       | 该位读取为1。写入值应为1。  | R/W |
| 22    | PSARD22 | TSN和MSTPCRD.MSTPD22位安全属性<br>0: Secure<br>1: Non-secure        | R/W |
| 31:23 | —       | 这些位被读取为1。写入值应为1。  | R/W |

Note: 只有安全访问才能写入该寄存器。允许安全访问和非安全读取访问，但不允许非安全写入访问，并且不会生成TrustZone访问错误。

Note: 该寄存器由PRCR寄存器写保护。

PSARD指定每个模块的安全属性以及模块停止控制寄存器中的相应位。

#### 46.5.4 PSARE:外设安全属性寄存器E

Base address: PSCU = 0x400E\_0000

Offset address: 0x10

| Bit position: | 31       | 30       | 29       | 28       | 27       | 26       | 25       | 24       | 23 | 22 | 21 | 20 | 19 | 18 | 17      | 16      |         |
|---------------|----------|----------|----------|----------|----------|----------|----------|----------|----|----|----|----|----|----|---------|---------|---------|
| Bit field:    | PSAR E31 | PSAR E30 | PSAR E29 | PSAR E28 | PSAR E27 | PSAR E26 | PSAR E25 | PSAR E24 | —  | —  | —  | —  | —  | —  | —       | —       |         |
| 重置后的值:        | 1        | 1        | 1        | 1        | 1        | 1        | 1        | 1        | 1  | 1  | 1  | 1  | 1  | 1  | 1       | 1       |         |
| Bit position: | 15       | 14       | 13       | 12       | 11       | 10       | 9        | 8        | 7  | 6  | 5  | 4  | 3  | 2  | 1       | 0       |         |
| Bit field:    | PSAR E15 | PSAR E14 | —        | —        | —        | —        | —        | —        | —  | —  | —  | —  | —  | —  | PSAR E2 | PSAR E1 | PSAR E0 |
| 重置后的值:        | 1        | 1        | 1        | 1        | 1        | 1        | 1        | 1        | 1  | 1  | 1  | 1  | 1  | 1  | 1       | 1       |         |

| Bit   | Symbol  | Function   | R/W |
|-------|---------|--|-----|
| 0     | PSARE0  | WDT security attribution<br>0: Secure<br>1: Non-secure                                       | R/W |
| 1     | PSARE1  | IWDT security attribution<br>0: Secure<br>1: Non-secure                                      | R/W |
| 2     | PSARE2  | RTC security attribution<br>0: Secure<br>1: Non-secure                                       | R/W |
| 13:3  | —       | These bits are read as 1. The write value should be 1.                                       | R/W |
| 14    | PSARE14 | AGT5 and the MSTPCRE.MSTPE14 bit security attribution<br>0: Secure<br>1: Non-secure          | R/W |
| 15    | PSARE15 | AGT4 and the MSTPCRE.MSTPE15 bit security attribution<br>0: Secure<br>1: Non-secure          | R/W |
| 21:16 | —       | These bits are read as 1. The write value should be 1.                                       | R/W |
| 22    | —       | This bit is read as 1. The write value should be 1.  | R/W |
| 23    | —       | This bit is read as 1. The write value should be 1.  | R/W |
| 24    | PSARE24 | GPT7 and the MSTPCRE.MSTPE24 bit security attribution<br>0: Secure<br>1: Non-secure          | R/W |
| 25    | PSARE25 | GPT6 and the MSTPCRE.MSTPE25 bit security attribution<br>0: Secure<br>1: Non-secure          | R/W |
| 26    | PSARE26 | GPT5 and the MSTPCRE.MSTPE26 bit security attribution<br>0: Secure<br>1: Non-secure          | R/W |
| 27    | PSARE27 | GPT4 and the MSTPCRE.MSTPE27 bit security attribution<br>0: Secure<br>1: Non-secure          | R/W |
| 28    | PSARE28 | GPT3 and the MSTPCRE.MSTPE28 bit security attribution<br>0: Secure<br>1: Non-secure          | R/W |
| 29    | PSARE29 | GPT2 and the MSTPCRE.MSTPE29 bit security attribution<br>0: Secure<br>1: Non-secure          | R/W |
| 30    | PSARE30 | GPT1 and the MSTPCRE.MSTPE30 bit security attribution<br>0: Secure<br>1: Non-secure          | R/W |
| 31    | PSARE31 | GPT0, GPT_OPS and the MSTPCRE.MSTPE31 bit security attribution<br>0: Secure<br>1: Non-secure | R/W |

Note: Only secure access can write to this register. Both secure access and Non-secure read access are allowed but Non-secure write access is not allowed and TrustZone access error is not generated.

Note: This register is write-protected by PRCR register.

The PSARE specifies the security attribution for each module and the corresponding bit in Module Stop Control Register.

| Bit   | Symbol  | Function  | R/W |
|-------|---------|---|-----|
| 0     | PSARE0  | WDT安全归属<br>0: Secure<br>1: Non-secure                           | R/W |
| 1     | PSARE1  | IWDT安全归属<br>0: Secure<br>1: Non-secure                          | R/W |
| 2     | PSARE2  | RTC安全归属<br>0: Secure<br>1: Non-secure                           | R/W |
| 13:3  | —       | 这些位被读取为1。写入值应为1。  | R/W |
| 14    | PSARE14 | AGT5和MSTPCRE.MSTPE14位安全属性<br>0: Secure<br>1: Non-secure         | R/W |
| 15    | PSARE15 | AGT4和MSTPCRE.MSTPE15位安全属性<br>0: Secure<br>1: Non-secure         | R/W |
| 21:16 | —       | 这些位被读取为1。写入值应为1。  | R/W |
| 22    | —       | 该位读取为1。写入值应为1。  | R/W |
| 23    | —       | 该位读取为1。写入值应为1。  | R/W |
| 24    | PSARE24 | GPT7和MSTPCRE.MSTPE24位安全属性<br>0: Secure<br>1: Non-secure         | R/W |
| 25    | PSARE25 | GPT6和MSTPCRE.MSTPE25位安全属性<br>0: Secure<br>1: Non-secure         | R/W |
| 26    | PSARE26 | GPT5和MSTPCRE.MSTPE26位安全属性<br>0: Secure<br>1: Non-secure         | R/W |
| 27    | PSARE27 | GPT4和MSTPCRE.MSTPE27位安全属性<br>0: Secure<br>1: Non-secure         | R/W |
| 28    | PSARE28 | GPT3和MSTPCRE.MSTPE28位安全属性<br>0: Secure<br>1: Non-secure         | R/W |
| 29    | PSARE29 | GPT2和MSTPCRE.MSTPE29位安全属性<br>0: Secure<br>1: Non-secure         | R/W |
| 30    | PSARE30 | GPT1和MSTPCRE.MSTPE30位安全属性<br>0: Secure<br>1: Non-secure         | R/W |
| 31    | PSARE31 | GPT0、GPT_OPS和MSTPCRE.MSTPE31位安全属性<br>0: Secure<br>1: Non-secure | R/W |

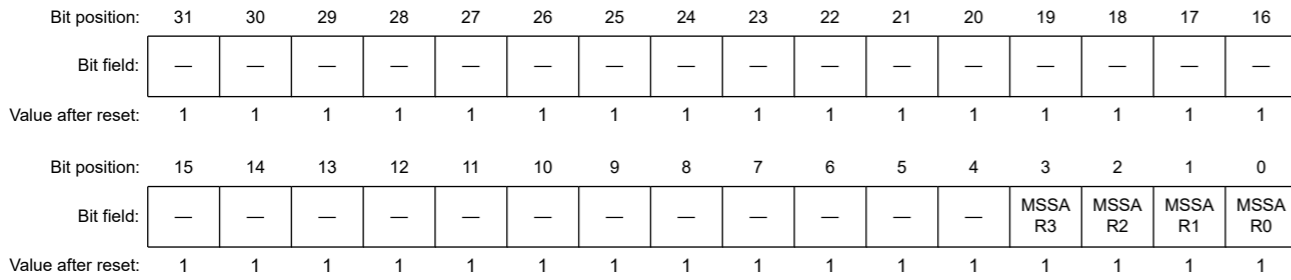
Note: 只有安全访问才能写入该寄存器。允许安全访问和非安全读取访问，但不允许非安全写入访问，并且不会生成TrustZone访问错误。

Note: 该寄存器由PRCR寄存器写保护。

PSARE指定每个模块的安全属性以及模块停止控制寄存器中的相应位。

### 46.5.5 MSSAR : Module Stop Security Attribution Register

Base address: PSCU = 0x400E\_0000  
Offset address: 0x14



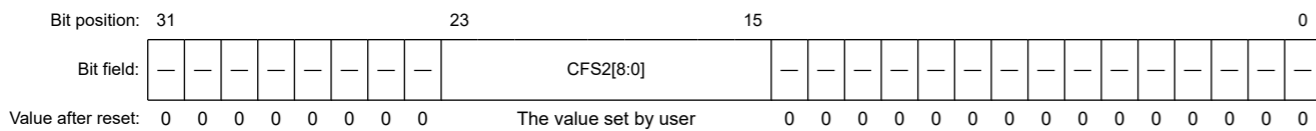
| Bit  | Symbol | Function   | R/W |
|------|--------|--|-----|
| 0    | MSSAR0 | The MSTPCRC.MSTPC14 bit security attribution<br>0: Secure<br>1: Non-secure | R/W |
| 1    | MSSAR1 | The MSTPCRA.MSTPA22 bit security attribution<br>0: Secure<br>1: Non-secure | R/W |
| 2    | MSSAR2 | The MSTPCRA.MSTPA7 bit security attribution<br>0: Secure<br>1: Non-secure  | R/W |
| 3    | MSSAR3 | The MSTPCRA.MSTPA0 bit security attribution<br>0: Secure<br>1: Non-secure  | R/W |
| 31:4 | —      | These bits are read as 1. The write value should be 1.                     | R/W |

Note: Only secure access can write to this register. Both secure access and Non-secure read access are allowed but Non-secure write access is not allowed and TrustZone access error is not generated.  
Note: This register is write-protected by PRCR register.

The MSSAR specifies the security attribution for the corresponding bit in Module Stop Control Register.

### 46.5.6 CFSAMONA : Code Flash Security Attribution Monitor Register A

Base address: PSCU = 0x400E\_0000  
Offset address: 0x18

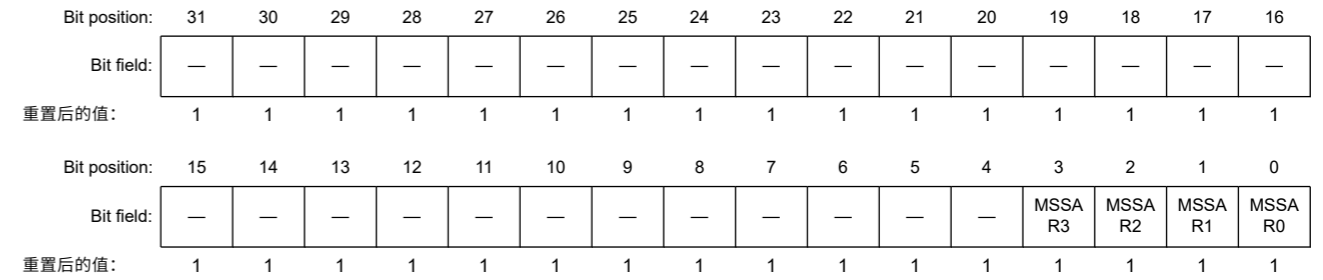


| Bit   | Symbol    | Function  | R/W |
|-------|-----------|---|-----|
| 14:0  | —         | These bits are read as 0.   | R   |
| 23:15 | CFS2[8:0] | Code Flash Secure area 2<br>Indicate the total area of secure region and non-secure callable region for code flash. | R   |
| 31:24 | —         | These bits are read as 0.   | R   |

Note: The CFSAMONA does not have security attribution.

### 46.5.5 MSSAR: 模块停止安全属性寄存器

Base address: PSCU = 0x400E\_0000  
Offset address: 0x14



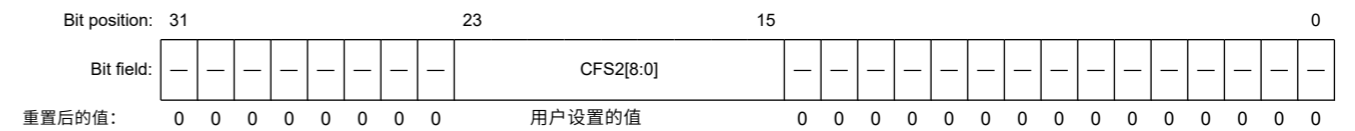
| Bit  | Symbol | Function   | R/W |
|------|--------|--|-----|
| 0    | MSSAR0 | MSTPCRC.MSTPC14位安全属性<br>0: Secure<br>1: Non-secure | R/W |
| 1    | MSSAR1 | MSTPCRA.MSTPA22位安全属性<br>0: Secure<br>1: Non-secure | R/W |
| 2    | MSSAR2 | MSTPCRA.MSTPA7位安全属性<br>0: Secure<br>1: Non-secure  | R/W |
| 3    | MSSAR3 | MSTPCRA.MSTPA0位安全属性<br>0: Secure<br>1: Non-secure  | R/W |
| 31:4 | —      | 这些位被读取为1。写入值应为1。                                   | R/W |

Note: 只有安全访问才能写入该寄存器。允许安全访问和非安全读取访问，但不允许非安全写入访问，并且不会生成TrustZone访问错误。  
Note: 该寄存器由PRCR寄存器写保护。

MSSAR指定模块停止控制寄存器中相应位的安全属性。

### 46.5.6 CFSAMONA: 代码闪存安全属性监控寄存器A

Base address: PSCU = 0x400E\_0000  
Offset address: 0x18



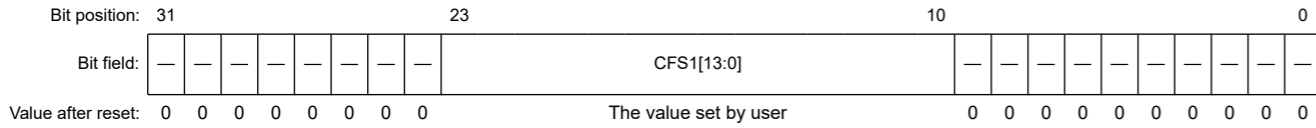
| Bit   | Symbol    | Function                                   | R/W |
|-------|-----------|--|-----|
| 14:0  | —         | 这些位读为0。                                    | R   |
| 23:15 | CFS2[8:0] | CodeFlash安全区2<br>指示代码闪存的安全区域和非安全可调用区域的总面积。 | R   |
| 31:24 | —         | 这些位读为0。                                    | R   |

Note: CFSAMONA没有安全属性。



### 46.5.7 CFSAMONB : Code Flash Security Attribution Monitor Register B

Base address: PSCU = 0x400E\_0000  
Offset address: 0x1C

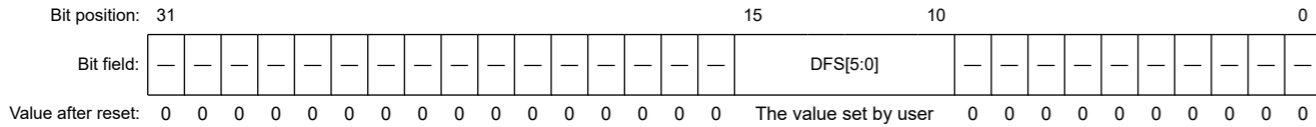


| Bit   | Symbol     | Function   | R/W |
|-------|------------|--|-----|
| 9:0   | —          | These bits are read as 0.  | R   |
| 23:10 | CFS1[13:0] | Code Flash Secure area 1<br>Indicate the area of secure region for code flash. | R   |
| 31:24 | —          | These bits are read as 0.  | R   |

Note: The CFSAMONB does not have security attribution.

### 46.5.8 DFSAMON : Data Flash Security Attribution Monitor Register

Base address: PSCU = 0x400E\_0000  
Offset address: 0x20

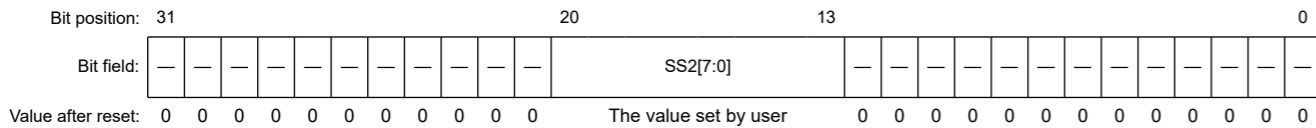


| Bit   | Symbol   | Function   | R/W |
|-------|----------|--|-----|
| 9:0   | —        | These bits are read as 0.  | R   |
| 15:10 | DFS[5:0] | Data flash Secure area<br>Indicate the area of Secure region for data flash. | R   |
| 31:16 | —        | These bits are read as 0.  | R   |

Note: The DFSAMON does not have security attribution.

### 46.5.9 SSAMONA : SRAM Security Attribution Monitor Register A

Base address: PSCU = 0x400E\_0000  
Offset address: 0x24

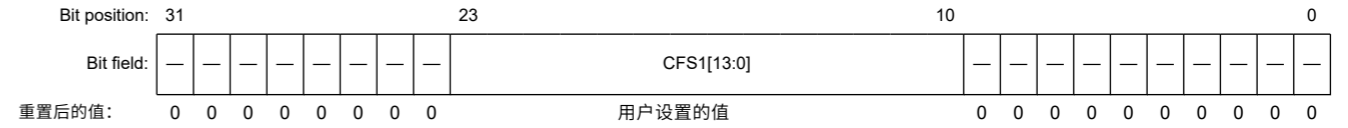


| Bit   | Symbol   | Function  | R/W |
|-------|----------|---|-----|
| 12:0  | —        | These bits are read as 0.   | R   |
| 20:13 | SS2[7:0] | SRAM Secure area 2<br>Indicate the total area of Secure region and non-secure callable region for SRAM. | R   |
| 31:21 | —        | These bits are read as 0.   | R   |

Note: The SSAMONA does not have security attribution.

### 46.5.7 CFSAMONB:代码闪存安全属性监控寄存器B

Base address: PSCU = 0x400E\_0000  
Offset address: 0x1C

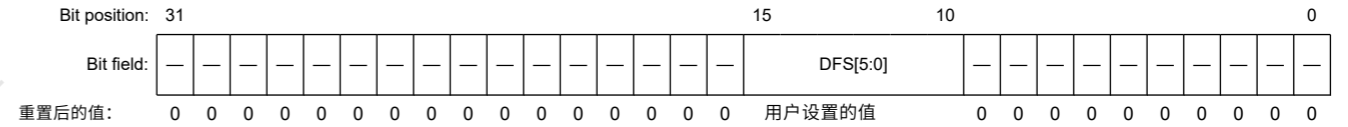


| Bit   | Symbol     | Function                        | R/W |
|-------|------------|---------------------------------|-----|
| 9:0   | —          | 这些位读为0。                         | R   |
| 23:10 | CFS1[13:0] | CodeFlash安全区1<br>指示代码闪存的安全区域区域。 | R   |
| 31:24 | —          | 这些位读为0。                         | R   |

Note: CFSAMONB没有安全属性。

### 46.5.8 DFSAMON:数据闪存安全属性监控寄存器

Base address: PSCU = 0x400E\_0000  
Offset address: 0x20

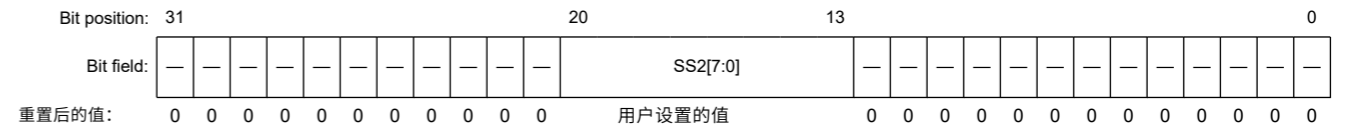


| Bit   | Symbol   | Function                  | R/W |
|-------|----------|---------------------------|-----|
| 9:0   | —        | 这些位读为0。                   | R   |
| 15:10 | DFS[5:0] | 数据闪存安全区<br>指示数据闪存的安全区域区域。 | R   |
| 31:16 | —        | 这些位读为0。                   | R   |

Note: DFSAMON没有安全属性。

### 46.5.9 SSAMONA:SRAM安全属性监控寄存器A

Base address: PSCU = 0x400E\_0000  
Offset address: 0x24

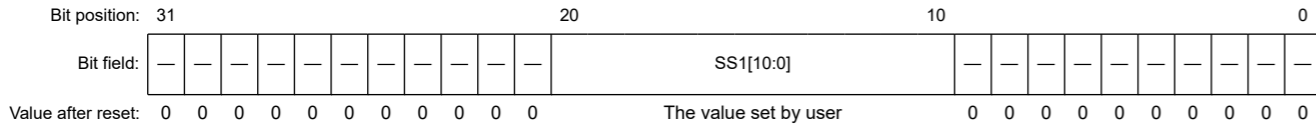


| Bit   | Symbol   | Function                               | R/W |
|-------|----------|--|-----|
| 12:0  | —        | 这些位读为0。                                | R   |
| 20:13 | SS2[7:0] | SRAM安全区域2<br>指示SRAM的安全区域和非安全可调用区域的总面积。 | R   |
| 31:21 | —        | 这些位读为0。                                | R   |

Note: SSAMONA没有安全属性。

46.5.10 SSAMONB : SRAM Security Attribution Monitor Register B

Base address: PSCU = 0x400E\_0000  
Offset address: 0x28

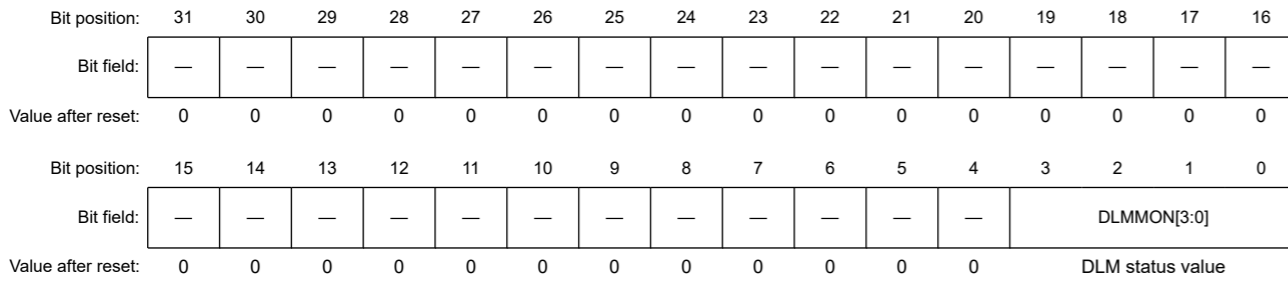


| Bit   | Symbol    | Function   | R/W |
|-------|-----------|--|-----|
| 9:0   | —         | These bits are read as 0.  | R   |
| 20:10 | SS1[10:0] | SRAM secure area 1<br>Indicate the area of secure region for SRAM. | R   |
| 31:21 | —         | These bits are read as 0.  | R   |

Note: The SSAMONB does not have security attribution.

46.5.11 DLMMON : Device Lifecycle Management State Monitor Register

Base address: PSCU = 0x400E\_0000  
Offset address: 0x2C

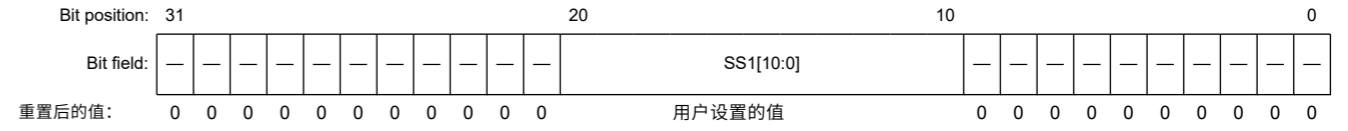


| Bit  | Symbol      | Function   | R/W |
|------|-------------|--|-----|
| 3:0  | DLMMON[3:0] | Device Lifecycle Management State Monitor<br>0x1: CM<br>0x2: SSD<br>0x3: NSECSD<br>0x4: DPL<br>0x5: LCK_DBG<br>0x6: LCK_BOOT<br>0x7: RMA_REQ<br>0x8: RMA_ACK<br>Others: Reserved | R   |
| 31:4 | —           | These bits are read as 0. The write value should be 0.   | R   |

Note: The DLMMON does not have security attribution.

46.5.10 SSAMONB:SRAM安全属性监控寄存器B

Base address: PSCU = 0x400E\_0000  
Offset address: 0x28

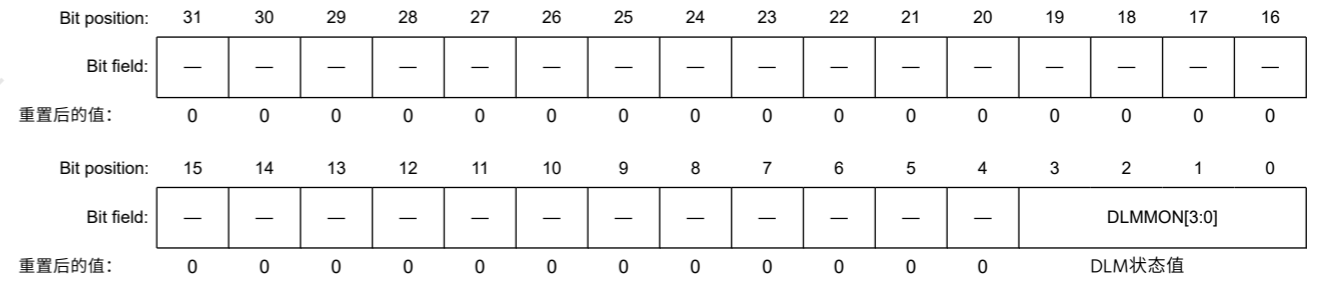


| Bit   | Symbol    | Function                   | R/W |
|-------|-----------|----------------------------|-----|
| 9:0   | —         | 这些位读为0。                    | R   |
| 20:10 | SS1[10:0] | SRAM安全区1<br>指示SRAM的安全区域区域。 | R   |
| 31:21 | —         | 这些位读为0。                    | R   |

Note: SSAMONB没有安全属性。

46.5.11 DLMMON:设备生命周期管理状态监视器寄存器

Base address: PSCU = 0x400E\_0000  
Offset address: 0x2C



| Bit  | Symbol      | Function   | R/W |
|------|-------------|--|-----|
| 3:0  | DLMMON[3:0] | 设备生命周期管理状态监视器<br>0x1: CM<br>0x2: SSD<br>0x3: NSECSD<br>0x4: DPL<br>0x5: LCK_DBG<br>0x6: LCK_BOOT<br>0x7: RMA_REQ<br>0x8: RMA_ACK<br>Others: Reserved | R   |
| 31:4 | —           | 这些位被读取为0。写入值应为0。   | R   |

Note: DLMMON没有安全属性。

## 46.5.12 TZFSAR : TrustZone Filter Security Attribution Register

Base address: CPSCU = 0x4000\_8000

Offset address: 0x180

|                    |    |    |    |    |    |    |    |    |    |    |    |    |    |    |    |            |
|--------------------|----|----|----|----|----|----|----|----|----|----|----|----|----|----|----|------------|
| Bit position:      | 31 | 30 | 29 | 28 | 27 | 26 | 25 | 24 | 23 | 22 | 21 | 20 | 19 | 18 | 17 | 16         |
| Bit field:         | —  | —  | —  | —  | —  | —  | —  | —  | —  | —  | —  | —  | —  | —  | —  | —          |
| Value after reset: | 1  | 1  | 1  | 1  | 1  | 1  | 1  | 1  | 1  | 1  | 1  | 1  | 1  | 1  | 1  | 1          |
| Bit position:      | 15 | 14 | 13 | 12 | 11 | 10 | 9  | 8  | 7  | 6  | 5  | 4  | 3  | 2  | 1  | 0          |
| Bit field:         | —  | —  | —  | —  | —  | —  | —  | —  | —  | —  | —  | —  | —  | —  | —  | TZFSA<br>0 |
| Value after reset: | 1  | 1  | 1  | 1  | 1  | 1  | 1  | 1  | 1  | 1  | 1  | 1  | 1  | 1  | 1  | 0          |

| Bit  | Symbol | Function  | R/W |
|------|--------|---|-----|
| 0    | TZFSA0 | Security attributes of registers for TrustZone Filter<br>0: Secure<br>1: Non-secure | R/W |
| 31:1 | —      | These bits are read as 1.   | R   |

Note: Only secure access can write to this register. Both secure access and Non-secure read access are allowed but Non-secure write access is not allowed and TrustZone access error is not generated.

Note: This register is write-protected by PRCR register.

**TZFSA0 bit (Security attributes of registers for TrustZone Filter)**

Security attributes of register for TZFOAD and TZFPT registers.

## 46.5.13 TZFOAD : TrustZone Filter Operation After Detection Register

Base address: TZF = 0x4000\_0E00

Offset address: 0x00

|                    |          |    |    |    |    |    |   |   |   |   |   |   |   |   |   |   |   |   |   |     |
|--------------------|----------|----|----|----|----|----|---|---|---|---|---|---|---|---|---|---|---|---|---|-----|
| Bit position:      | 15       | 14 | 13 | 12 | 11 | 10 | 9 | 8 | 7 | 6 | 5 | 4 | 3 | 2 | 1 | 0 |   |   |   |     |
| Bit field:         | KEY[7:0] |    |    |    |    |    |   |   |   |   |   | — | — | — | — | — | — | — | — | OAD |
| Value after reset: | 0        | 0  | 0  | 0  | 0  | 0  | 0 | 0 | 0 | 0 | 0 | 0 | 0 | 0 | 0 | 0 |   |   |   |     |

| Bit  | Symbol   | Function   | R/W |
|------|----------|--|-----|
| 0    | OAD      | Operation after detection<br>0: Non-maskable interrupt<br>1: Reset       | R/W |
| 7:1  | —        | These bits are read as 0. The write value should be 0.                   | R/W |
| 15:8 | KEY[7:0] | KeyCode<br>This bit is used to enable or disable writing of the OAD bit. | W   |

Note: If the security attribution is configured as secure:

- Secure access and Non-secure read access are allowed
- Non-secure write access is ignored, and TrustZone access error is not generated.

If the security attribution is configured as Non-secure:

- Secure and Non-secure access are allowed.

**OAD bit (Operation after detection)**

The OAD bit is specified to generate either reset or non-maskable interrupt when the access to the protect region is detected by the TrustZone Filter.

When the OAD bit is set, write 0xA5 in the KEY[7:0] bits at the same time.

## 46.5.12 TZFSAR:TrustZone过滤器安全属性寄存器

Base address: CPSCU = 0x4000\_8000

Offset address: 0x180

|               |    |    |    |    |    |    |    |    |    |    |    |    |    |    |    |            |
|---------------|----|----|----|----|----|----|----|----|----|----|----|----|----|----|----|------------|
| Bit position: | 31 | 30 | 29 | 28 | 27 | 26 | 25 | 24 | 23 | 22 | 21 | 20 | 19 | 18 | 17 | 16         |
| Bit field:    | —  | —  | —  | —  | —  | —  | —  | —  | —  | —  | —  | —  | —  | —  | —  | —          |
| 重置后的值:        | 1  | 1  | 1  | 1  | 1  | 1  | 1  | 1  | 1  | 1  | 1  | 1  | 1  | 1  | 1  | 1          |
| Bit position: | 15 | 14 | 13 | 12 | 11 | 10 | 9  | 8  | 7  | 6  | 5  | 4  | 3  | 2  | 1  | 0          |
| Bit field:    | —  | —  | —  | —  | —  | —  | —  | —  | —  | —  | —  | —  | —  | —  | —  | TZFSA<br>0 |
| 重置后的值:        | 1  | 1  | 1  | 1  | 1  | 1  | 1  | 1  | 1  | 1  | 1  | 1  | 1  | 1  | 1  | 0          |

| Bit  | Symbol | Function   | R/W |
|------|--------|--|-----|
| 0    | TZFSA0 | TrustZone过滤器寄存器的安全属性<br>0: Secure<br>1: Non-secure | R/W |
| 31:1 | —      | 这些位读为1。  | R   |

Note: 只有安全访问才能写入该寄存器。允许安全访问和非安全读取访问，但不允许非安全写入访问，并且不会生成TrustZone访问错误。

Note: 该寄存器由PRCR寄存器写保护。

**TZFSA0位 (TrustZone过滤器寄存器的安全属性)**

TZFOAD和TZFPT寄存器的寄存器安全属性。

## 46.5.13 TZFOAD: 检测寄存器后的TrustZone过滤器操作

Base address: TZF = 0x4000\_0E00

Offset address: 0x00

|               |          |    |    |    |    |    |   |   |   |   |   |   |   |   |   |   |   |   |   |     |
|---------------|----------|----|----|----|----|----|---|---|---|---|---|---|---|---|---|---|---|---|---|-----|
| Bit position: | 15       | 14 | 13 | 12 | 11 | 10 | 9 | 8 | 7 | 6 | 5 | 4 | 3 | 2 | 1 | 0 |   |   |   |     |
| Bit field:    | KEY[7:0] |    |    |    |    |    |   |   |   |   |   | — | — | — | — | — | — | — | — | OAD |
| 重置后的值:        | 0        | 0  | 0  | 0  | 0  | 0  | 0 | 0 | 0 | 0 | 0 | 0 | 0 | 0 | 0 | 0 |   |   |   |     |

| Bit  | Symbol   | Function                     | R/W |
|------|----------|------------------------------|-----|
| 0    | OAD      | 检测后操作<br>0: 不可屏蔽中断1: 复位      | R/W |
| 7:1  | —        | 这些位被读取为0。写入值应为0。             | R/W |
| 15:8 | KEY[7:0] | KeyCode<br>该位用于启用或禁用OAD位的写入。 | W   |

Note: 如果安全属性配置为安全: ●

- 允许安全访问和非安全读取访问
- 忽略非安全写入访问，不会生成TrustZone访问错误。

如果安全属性配置为非安全: ●

- 允许安全和非安全访问。

**OAD位 (检测后的操作)**

当TrustZone过滤器检测到对保护区域的访问时，OAD位被指定为产生复位或不可屏蔽中断。

当OAD位置位时，同时向KEY[7:0]位写入0xA5。

**KEY[7:0] bits (KeyCode)**

The KEY[7:0] bits are used to enable or disable writing of the OAD bit. When writing the OAD bit, write 0xA5 in the KEY[7:0] bits at the same time.

When the KEY[7:0] bits value except 0xA5 is written in, the OAD bit is not updated.

The KEY[7:0] bits are read always as 0x00.

**46.5.14 TZFPT : TrustZone Filter Protect Register**

Base address: TZF = 0x4000\_0E00

Offset address: 0x04

|                    |          |    |    |    |    |    |   |   |   |   |   |   |   |   |   |   |   |   |   |         |
|--------------------|----------|----|----|----|----|----|---|---|---|---|---|---|---|---|---|---|---|---|---|---------|
| Bit position:      | 15       | 14 | 13 | 12 | 11 | 10 | 9 | 8 | 7 | 6 | 5 | 4 | 3 | 2 | 1 | 0 |   |   |   |         |
| Bit field:         | KEY[7:0] |    |    |    |    |    |   |   |   |   |   | — | — | — | — | — | — | — | — | PROTECT |
| Value after reset: | 0        | 0  | 0  | 0  | 0  | 0  | 0 | 0 | 0 | 0 | 0 | 0 | 0 | 0 | 0 | 0 | 0 |   |   |         |

| Bit  | Symbol   | Function  | R/W |
|------|----------|---|-----|
| 0    | PROTECT  | Protection of register<br>0: All Bus TrustZone Filter register writing is protected. Read is possible.<br>1: All Bus TrustZone Filter register writing is possible. | R/W |
| 7:1  | —        | These bits are read as 0. The write value should be 0.  | R/W |
| 15:8 | KEY[7:0] | KeyCode<br>This bit is used to enable or disable writing of the PROTECT bit.  | W   |

Note: If the security attribution is configured as secure:

- Secure access and Non-secure read access are allowed
- Non-secure write access is ignored, and TrustZone access error is not generated.

If the security attribution is configured as Non-secure:

- Secure and Non-secure access are allowed.

**PROTECT bit (Protection of register)**

The PROTECT bit controls enable or disable writing to the corresponding registers to be protected. TZFOAD register is protected by PROTECT.

When the PROTECT bit is set, write 0xA5 in the KEY[7:0] bits at the same time.

**KEY[7:0] bits (KeyCode)**

The KEY[7:0] bits are used to enable or disable writing of the PROTECT bit. When writing the PROTECT bit, write 0xA5 in the KEY[7:0] bits at the same time.

When the KEY[7:0] bits value except 0xA5 is written in, the PROTECT bit is not updated.

The KEY[7:0] bits are read always as 0x00.

**46.6 Usage Notes****46.6.1 Restrictions on setting the security attribution**

To set the software breakpoint, the debugger need to re-program the flash. Table 46.10 shows the registers that the debugger sets to re-program the flash. If the security attribution of the register listed in Table 46.10 is configured as secure, the debugger can not set the software breakpoint in NSECSD state because the debugger can not change the register setting. Secure developer need to configure the registers listed in Table 46.10 as non-secure only in NSECSD state.

**Table 46.10 The registers that the debugger sets to re-program the flash**

| Function name            | Register name                                  |
|--------------------------|--|
| Clock Generation Circuit | SCKDIVCR, SCKCR, PLLCCR, PLLCR, HOCOCR, MOCOCR |
| Low-Power modes          | OPCCR, SOPCCR                                  |

**KEY[7:0] bits (KeyCode)**

KEY[7:0]位用于启用或禁用OAD位的写入。写入OAD位时，将0xA5写入KEY[7:0]位。

当KEY[7:0]位值除0xA5被写入时，OAD位不会更新。

KEY[7:0]位总是被读取为0x00。

**46.5.14 TZFPT:TrustZone过滤器保护寄存器**

Base address: TZF = 0x4000\_0E00

Offset address: 0x04

|               |          |    |    |    |    |    |   |   |   |   |   |   |   |   |   |   |   |   |   |    |
|---------------|----------|----|----|----|----|----|---|---|---|---|---|---|---|---|---|---|---|---|---|----|
| Bit position: | 15       | 14 | 13 | 12 | 11 | 10 | 9 | 8 | 7 | 6 | 5 | 4 | 3 | 2 | 1 | 0 |   |   |   |    |
| Bit field:    | KEY[7:0] |    |    |    |    |    |   |   |   |   |   | — | — | — | — | — | — | — | — | 保护 |
| 重置后的值:        | 0        | 0  | 0  | 0  | 0  | 0  | 0 | 0 | 0 | 0 | 0 | 0 | 0 | 0 | 0 | 0 |   |   |   |    |

| Bit  | Symbol   | Function   | R/W |
|------|----------|--|-----|
| 0    | PROTECT  | 注册保护<br>0: 所有总线TrustZone过滤器寄存器写入受到保护。读取是可能的。1: 所有总线TrustZone过滤器寄存器写入都是可能的。 | R/W |
| 7:1  | —        | 这些位被读取为0。写入值应为0。   | R/W |
| 15:8 | KEY[7:0] | KeyCode<br>该位用于启用或禁用PROTECT位的写入。   | W   |

Note: 如果安全属性配置为安全: ●

- 允许安全访问和非安全读取访问
- 忽略非安全写入访问，不会生成TrustZone访问错误。

如果安全属性配置为非安全: ●

- 允许安全和非安全访问。

**PROTECT位 (寄存器保护)**

PROTECT位控制启用或禁用对受保护的相应寄存器的写入。TZFOAD寄存器受PROTECT保护。

当PROTECT位置位时，同时向KEY[7:0]位写入0xA5。

**KEY[7:0] bits (KeyCode)**

KEY[7:0]位用于启用或禁用PROTECT位的写入。写入PROTECT位时，同时向KEY[7:0]位写入0xA5。

写入除0xA5以外的KEY[7:0]位值时，PROTECT位不更新。

KEY[7:0]位总是被读取为0x00。

**46.6 使用说明****46.6.1 设置安全属性的限制**

要设置软件断点，调试器需要重新编程闪存。表46.10显示了调试器为重新编程闪存而设置的寄存器。如果表46.10中列出的寄存器的安全属性配置为安全，则调试器无法在NSECSD状态下设置软件断点，因为调试器无法更改寄存器设置。仅在NSECSD状态下，安全开发人员需要将表46.10中列出的寄存器配置为非安全。

**Table 46.10 调试器设置的用于重新编程闪存的寄存器**

| 函数名称            | 注册名称   |
|-----------------|--|
| 时钟产生电路          | SCKDIVCR, SCKCR, PLLCCR, PLLCR, HOCOCR, MOCOCR |
| Low-Power modes | OPCCR, SOPCCR                                  |



### 46.6.2 SAU setting

After reset, all of address space is marked as Secure by SAU default setting. SAU\_CTRL register should be set to 0x2 to enable the IDAU security attribution. That is, after setting SAU\_CTRL register to 0x2, the address space security attribution becomes as shown in Table 46.6.

### 46.6.3 Non-secure exception during the setting of FACI registers

As shown in Table 46.5, the registers related to FACI are protected from non-secure access only during programming/erasure or during suspend programming/erasure. Outside of this state, the access from non-secure region is not protected. For example, when programming by the secure user, the non-secure user can rewrite the FSADDR if a non-secure exception occurs immediately after “Set the start address of the target block to the FSADDR register” flow in Figure 44.13. If the FACI command is issued after the non-secure exception processing is completed and the CPU state returns to the secure state, data will be programmed to an address not intended by the secure user.

To prevent such a things, secure user needs to set not to accept the non-secure exception during the following period.

- Set not to accept the non-secure exception before setting FWEPROR to 01h or setting FENTRYR to other than 0000h, that is before releasing the protection of FWEPROR or FENTRYR.
- Set to accept the non-secure exception after all write access to the FACI command-issuing area is completed.

### 46.6.4 FCU interrupt usage

It is recommended that secure users do not use the FCU interrupts, but rather use the register polling. Because non-secure users can program/erase the data flash without calling the secure gateway, if secure user uses FCU interrupts, the unintentional exception handling may be executed when data flash is programmed/erased by a non-secure user.

### 46.6.2 SAU设置

复位后，SAU默认设置将所有地址空间标记为安全。SAU\_CTRL寄存器应设置为0x2以启用IDAU安全属性。即设置SAU\_CTRL寄存器为0x2后，地址空间安全属性变为如表46.6所示。

### 46.6.3 FACI寄存器设置期间的非安全异常

如表46.5所示，与FACI相关的寄存器仅在编程擦除或挂起编程擦除期间受到保护，不会受到非安全访问。在此状态之外，来自非安全区域的访问不受保护。例如，当由安全用户编程时，如果在图44.13中的“将目标块的起始地址设置为FSADDR寄存器”流程之后立即发生非安全异常，则非安全用户可以重写FSADDR。如果在非安全异常处理完成后发出FACI命令并且CPU状态返回到安全状态，则数据将被编程到安全用户不打算使用的地址。

为了防止这样的事情发生，安全用户需要在接下来的时间段内设置不接受非安全异常。

- 在将FWEPROR设置为01h或将FENTRYR设置为0000h以外的值之前，即在解除对FWEPROR或FENTRYR的保护之前，设置不接受非安全例外。
- 设置为在对FACI命令发布区域的所有写访问完成后接受非安全异常。

### 46.6.4 FCU中断使用

建议安全用户不要使用FCU中断，而是使用寄存器轮询。由于非安全用户可以在不调用安全网关的情况下对数据闪存进行编程擦除，因此如果安全用户使用FCU中断，则在数据闪存被非安全用户编程擦除时可能会执行意外异常处理。

## 47. Electrical Characteristics

Supported peripheral functions and pins differ from one product name to another.

Unless otherwise specified, the electrical characteristics of the MCU are defined under the following conditions:

- $VCC = AVCC0 = VCC\_USB = VBATT = 2.7$  to  $3.6$  V
- $2.7 \leq VREFH0/VREFH \leq AVCC0$
- $VSS = AVSS0 = VREFL0/VREFL = VSS\_USB = 0$  V
- $T_a = T_{opr}$

Figure 47.1 shows the timing conditions.

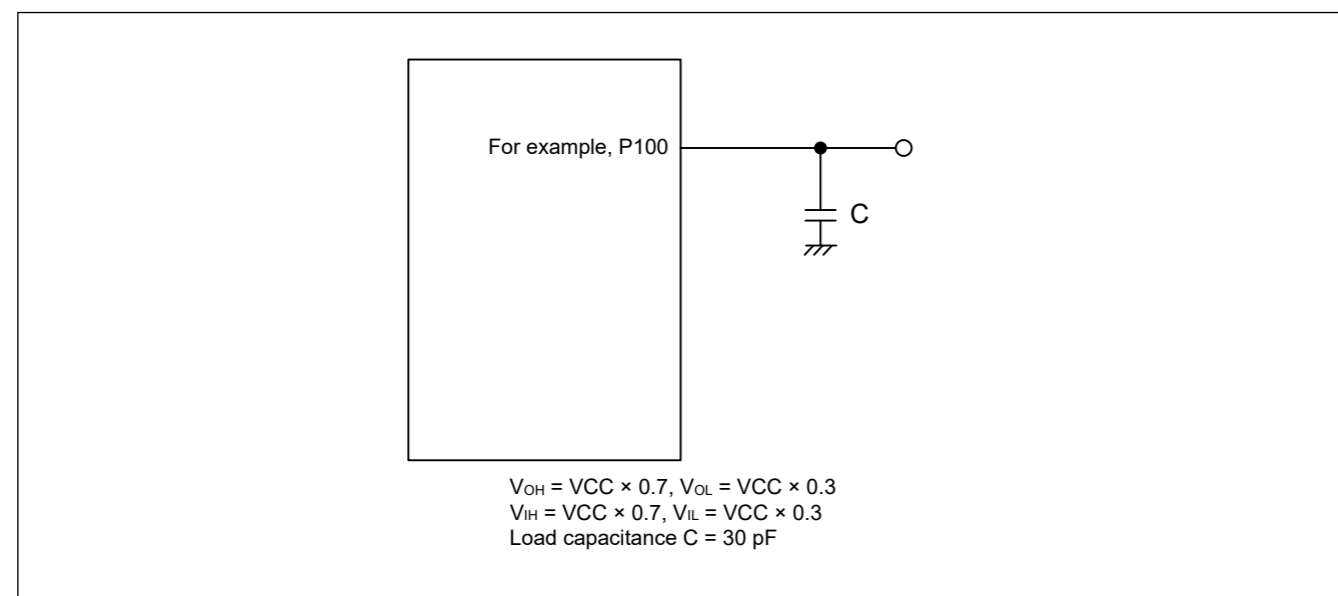


Figure 47.1 Input or output timing measurement conditions

The recommended measurement conditions for the timing specification of each peripheral provided are for the best peripheral operation. Make sure to adjust the driving abilities of each pin to meet your conditions.

### 47.1 Absolute Maximum Ratings

Table 47.1 Absolute maximum ratings

| Parameter  | Symbol                    | Value                          | Unit |
|--|---------------------------|--------------------------------|------|
| Power supply voltage   | VCC, VCC_USB <sup>2</sup> | -0.3 to +4.0                   | V    |
| VBATT power supply voltage                                   | VBATT                     | -0.3 to +4.0                   | V    |
| Input voltage (except for 5 V-tolerant ports <sup>*1</sup> ) | V <sub>in</sub>           | -0.3 to VCC + 0.3              | V    |
| Input voltage (5 V-tolerant ports <sup>*1</sup> )            | V <sub>in</sub>           | -0.3 to + VCC + 4.0 (max. 5.8) | V    |
| Reference power supply voltage                               | VREFH/VREFH0              | -0.3 to VCC + 0.3              | V    |
| Analog power supply voltage                                  | AVCC0 <sup>*2</sup>       | -0.3 to +4.0                   | V    |
| Analog input voltage   | V <sub>AN</sub>           | -0.3 to AVCC0 + 0.3            | V    |
| Operating temperature <sup>*3 *4</sup>                       | T <sub>opr</sub>          | -40 to +105                    | °C   |
| Storage temperature  | T <sub>stg</sub>          | -55 to +125                    | °C   |

Note 1. Ports P205, P206, P400, P401, P407 to P415, and P708 to P713 are 5 V tolerant.

Note 2. Connect AVCC0 and VCC\_USB to VCC.

Note 3. See section 47.2.1. Tj/Ta Definition.

Note 4. Contact a Renesas Electronics sales office for information on derating operation when Ta = +85°C to +105°C. Derating is the systematic reduction of load for improved reliability.

## 47. 电气特性

支持的外围功能和引脚因产品名称而异。

除非另有规定，MCU的电气特性在以下条件下定义：

- $VCC = AVCC0 = VCC\_USB = VBATT = 2.7$  to  $3.6$  V
- $2.7 \leq VREFH0/VREFH \leq AVCC0$
- $VSS = AVSS0 = VREFL0/VREFL = VSS\_USB = 0$  V
- $T_a = T_{opr}$

图47.1显示了时序条件。

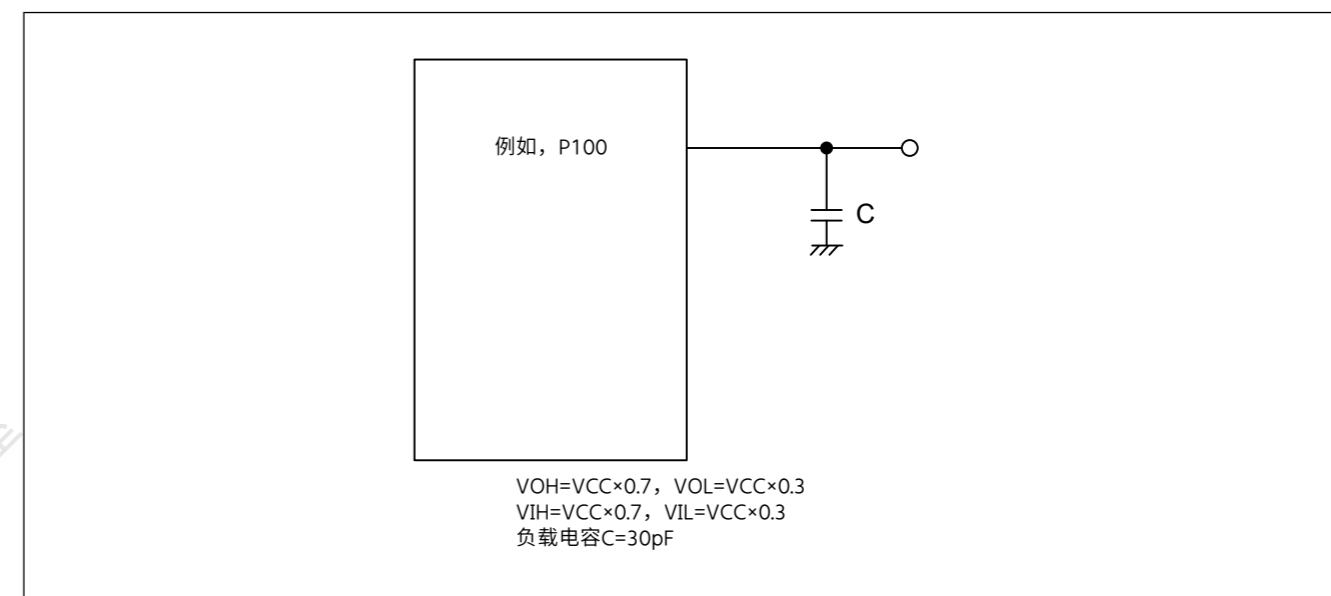


Figure 47.1 输入或输出定时测量条件

所提供的每个外设时序规范的推荐测量条件是为了实现最佳外设操作。确保调整每个引脚的驱动能力以满足您的条件。

### 47.1 绝对最大额定值

Table 47.1 绝对最大额定值

| Parameter         | Symbol                    | Value                          | Unit |
|-------------------|---------------------------|--------------------------------|------|
| 电源电压              | VCC, VCC_USB <sup>2</sup> | -0.3 to +4.0                   | V    |
| VBATT电源电压         | VBATT                     | -0.3 to +4.0                   | V    |
| 输入电压 (5V容限端口*1除外) | V <sub>in</sub>           | -0.3 to VCC + 0.3              | V    |
| 输入电压 (5V耐压端口*1)   | V <sub>in</sub>           | -0.3 to + VCC + 4.0 (max. 5.8) | V    |
| 参考电源电压            | VREFH/VREFH0              | -0.3 to VCC + 0.3              | V    |
| 模拟电源电压            | AVCC0 <sup>*2</sup>       | -0.3 to +4.0                   | V    |
| 模拟输入电压            | V <sub>AN</sub>           | -0.3 to AVCC0 + 0.3            | V    |
| 工作温度*3*4          | T <sub>opr</sub>          | -40 to +105                    | °C   |
| 贮存温度              | T <sub>stg</sub>          | -55 to +125                    | °C   |

注1. 端口P205、P206、P400、P401、P407至P415和P708至P713可承受5V电压。

注2. 将AVCC0和VCC\_USB连接到VCC。

注3: 见第47.2.1节。Tj/Ta定义。

注4. 有关在Ta=+85°C至+105°C时降额运行的信息，请联系瑞萨电子销售办事处。降额是系统地减少负载以提高可靠性。

**Caution:** Permanent damage to the MCU might result if absolute maximum ratings are exceeded.

**Table 47.2 Recommended operating conditions**

| Parameter                    | Symbol              | Value                | Min | Typ | Max | Unit |
|------------------------------|---------------------|----------------------|-----|-----|-----|------|
| Power supply voltages        | VCC                 | When USB is not used | 2.7 | —   | 3.6 | V    |
|                              |                     | When USB is used     | 3.0 | —   | 3.6 | V    |
|                              | VSS                 | —                    | 0   | —   | V   |      |
| USB power supply voltages    | VCC_USB             | —                    | VCC | —   | V   |      |
|                              | VSS_USB             | —                    | 0   | —   | V   |      |
| VBATT power supply voltage   | VBATT               | 1.8                  | —   | 3.6 | V   |      |
| Analog power supply voltages | AVCC0 <sup>*1</sup> | —                    | VCC | —   | V   |      |
|                              | AVSS0               | —                    | 0   | —   | V   |      |

Note 1. Connect AVCC0 to VCC. When the A/D converter and the D/A converter are not in use, do not leave the AVCC0, VREFH/VREFH0, AVSS0, and VREFL/VREFL0 pins open. Connect the AVCC0 and VREFH/VREFH0 pins to VCC, and the AVSS0 and VREFL/VREFL0 pins to VSS, respectively.

## 47.2 DC Characteristics

### 47.2.1 Tj/Ta Definition

**Table 47.3 DC characteristics**

Conditions: Products with operating temperature (T<sub>a</sub>) -40 to +105°C

| Parameter                        | Symbol         | Typ | Max | Unit | Test conditions  |
|----------------------------------|----------------|-----|-----|------|--|
| Permissible junction temperature | T <sub>j</sub> | —   | 125 | °C   | High-speed mode<br>Low-speed mode<br>Subosc-speed mode |

Note: Make sure that  $T_j = T_a + \theta_{ja} \times \text{total power consumption (W)}$ , where total power consumption =  $(VCC - V_{OH}) \times \Sigma I_{OH} + V_{OL} \times \Sigma I_{OL} + I_{CCmax} \times VCC$ .

### 47.2.2 I/O V<sub>IH</sub>, V<sub>IL</sub>

**Table 47.4 I/O V<sub>IH</sub>, V<sub>IL</sub> (1 of 2)**

| Parameter   | Symbol                  | Min  | Typ             | Max       | Unit                |           |
|---|-------------------------|--|-----------------|-----------|---------------------|-----------|
| Input voltage (except for Schmitt trigger input pins) | Peripheral function pin | EXTAL (external clock input), SPI (except RSPCK) | V <sub>IH</sub> | VCC × 0.8 | —                   | V         |
|   |                         |  | V <sub>IL</sub> | —         | —                   | VCC × 0.2 |
|   | IIC (SMBus)             | V <sub>IH</sub>                                  | 2.1             | —         | VCC + 3.6 (max 5.8) |           |
|   |                         | V <sub>IL</sub>                                  | —               | —         | 0.8                 |           |

**Caution:** 如果超过绝对最大额定值，可能会对MCU造成永久性损坏。

**Table 47.2 推荐工作条件**

| Parameter | Symbol              | Value   | Min | Typ | Max | Unit |
|-----------|---------------------|---------|-----|-----|-----|------|
| 电源电压      | VCC                 | 不使用USB时 | 2.7 | —   | 3.6 | V    |
|           |                     | 使用USB时  | 3.0 | —   | 3.6 | V    |
|           | VSS                 | —       | 0   | —   | V   |      |
| USB电源电压   | VCC_USB             | —       | VCC | —   | V   |      |
|           | VSS_USB             | —       | 0   | —   | V   |      |
| VBATT电源电压 | VBATT               | 1.8     | —   | 3.6 | V   |      |
| 模拟电源电压    | AVCC0 <sup>*1</sup> | —       | VCC | —   | V   |      |
|           | AVSS0               | —       | 0   | —   | V   |      |

注1.将AVCC0连接到VCC。不使用AD转换器和DA转换器时，不要离开AVCC0、VREFH/VREFH0、AVSS0和VREFL/VREFL0引脚打开。将AVCC0和VREFH/VREFH0引脚连接到VCC，以及AVSS0和VREFL/VREFL0引脚分别连接到VSS。

## 47.2 DC Characteristics

### 47.2.1 Tj/Ta Definition

**Table 47.3 DC characteristics**

条件：工作温度(T<sub>a</sub>)-40至+105°C的产品

| Parameter | Symbol         | Typ | Max | Unit | 测试条件   |
|-----------|----------------|-----|-----|------|--|
| 允许结温      | T <sub>j</sub> | —   | 125 | °C   | High-speed mode<br>Low-speed mode<br>Subosc-speed mode |

Note: 确保 $T_j = T_a + \theta_{ja} \times \text{总功耗(W)}$ ，其中总功耗= $(VCC - V_{OH}) \times \Sigma I_{OH} + V_{OL} \times \Sigma I_{OL} + I_{CCmax} \times VCC$ 。

### 47.2.2 I/O V<sub>IH</sub>, V<sub>IL</sub>

**Table 47.4 IOVIH VIL(1of2)**

| Parameter           | 符号最小值       | Typ                           | Max             | Unit      |                     |           |
|---------------------|-------------|-------------------------------|-----------------|-----------|---------------------|-----------|
| 输入电压 (施密特触发器输入引脚除外) | 外设功能引脚      | EXTAL (外部时钟输入), SPI (RSPCK除外) | V <sub>IH</sub> | VCC × 0.8 | —                   | V         |
|                     |             |                               | V <sub>IL</sub> | —         | —                   | VCC × 0.2 |
|                     | IIC (SMBus) | V <sub>IH</sub>               | 2.1             | —         | VCC + 3.6 (max 5.8) |           |
|                     |             | V <sub>IL</sub>               | —               | —         | 0.8                 |           |

Table 47.4 I/O V<sub>IH</sub>, V<sub>IL</sub> (2 of 2)

| Parameter                     |  |                         |  | Symbol                              | Min             | Typ                      | Max  | Unit |                         |
|-------------------------------|--|-------------------------|--|-------------------------------------|-----------------|--------------------------|--|------|-------------------------|
| Schmitt trigger input voltage | Peripheral function pin                    | IIC (except for SMBus)  |  | V <sub>IH</sub>                     | VCC × 0.7       | —                        | VCC + 3.6 (max 5.8)  | V    |                         |
|                               |  |                         |  | V <sub>IL</sub>                     | —               | —                        | VCC × 0.3  |      |                         |
|                               |  |                         |  | ΔV <sub>T</sub>                     | VCC × 0.05      | —                        | —  |      |                         |
|                               |  | 5 V-tolerant ports*1 *5 |  | V <sub>IH</sub>                     | VCC × 0.8       | —                        | VCC + 3.6 (max 5.8)  |      |                         |
|                               |  |                         |  | V <sub>IL</sub>                     | —               | —                        | VCC × 0.2  |      |                         |
|                               |  |                         |  | ΔV <sub>T</sub>                     | VCC × 0.05      | —                        | —  |      |                         |
|                               |  | RTCIC0, RTCIC1, RTCIC2  | When using the Battery Backup Function | When VBATT power supply is selected | V <sub>IH</sub> | V <sub>BATT</sub> × 0.8  | —  |      | V <sub>BATT</sub> + 0.3 |
|                               |  |                         |  |                                     | V <sub>IL</sub> | —                        | —  |      | V <sub>BATT</sub> × 0.2 |
|                               |  |                         |  |                                     | ΔV <sub>T</sub> | V <sub>BATT</sub> × 0.05 | —  |      | —                       |
|                               | When VCC power supply is selected          |                         |  | V <sub>IH</sub>                     | VCC × 0.8       | —                        | Higher voltage either VCC + 0.3 V or V <sub>BATT</sub> + 0.3 V |      |                         |
|                               |  |                         |  | V <sub>IL</sub>                     | —               | —                        | VCC × 0.2  |      |                         |
|                               |  |                         |  | ΔV <sub>T</sub>                     | VCC × 0.05      | —                        | —  |      |                         |
|                               | When not using the Battery Backup Function | V <sub>IH</sub>         | VCC × 0.8                              | —                                   | VCC + 0.3       |                          |  |      |                         |
|                               |  | V <sub>IL</sub>         | —                                      | —                                   | VCC × 0.2       |                          |  |      |                         |
|                               |  | ΔV <sub>T</sub>         | VCC × 0.05                             | —                                   | —               |                          |  |      |                         |
| Other input pins*2            |  | V <sub>IH</sub>         | VCC × 0.8                              | —                                   | —               |                          |  |      |                         |
|                               |  | V <sub>IL</sub>         | —                                      | —                                   | VCC × 0.2       |                          |  |      |                         |
|                               |  | ΔV <sub>T</sub>         | VCC × 0.05                             | —                                   | —               |                          |  |      |                         |
| Ports                         | 5 V-tolerant ports*3 *5                    |                         | V <sub>IH</sub>                        | VCC × 0.8                           | —               | VCC + 3.6 (max 5.8)      | V  |      |                         |
|                               |  |                         | V <sub>IL</sub>                        | —                                   | —               | VCC × 0.2                |  |      |                         |
|                               | Other input pins*4                         |                         | V <sub>IH</sub>                        | VCC × 0.8                           | —               | —                        |  |      |                         |
|                               |  |                         | V <sub>IL</sub>                        | —                                   | —               | VCC × 0.2                |  |      |                         |

Note 1. RES and peripheral function pins associated with Ports P205, P206, P400, P401, P407 to P415, and P708 to P713 (total 22 pins).  
 Note 2. All input pins except for the peripheral function pins already described in the table.  
 Note 3. Ports P205, P206, P400, P401, P407 to P415, and P708 to P713 (total 21 pins).  
 Note 4. All input pins except for the ports already described in the table.  
 Note 5. When VCC is less than 2.7 V, the input voltage of 5 V-tolerant ports should be less than 3.6 V, otherwise breakdown may occur because 5 V-tolerant ports are electrically controlled so as not to violate the break down voltage.

Table 47.4 IOVIH VIL(2of2)

| Parameter  |                         |                        |                 | 符号最小值                   |                  | Typ                 | Max                 | Unit                                     |                          |                     |                         |
|------------|-------------------------|------------------------|-----------------|-------------------------|------------------|---------------------|---------------------|--|--------------------------|---------------------|-------------------------|
| 施密特触发器输入电压 | 外设功能引脚                  | IIC (except for SMBus) |                 | V <sub>IH</sub>         | VCC × 0.7        | —                   | VCC + 3.6 (max 5.8) | V  |                          |                     |                         |
|            |                         |                        |                 | V <sub>IL</sub>         | —                | —                   | VCC × 0.3           |  |                          |                     |                         |
|            |                         |                        |                 | ΔV <sub>T</sub>         | VCC × 0.05       | —                   | —                   |  |                          |                     |                         |
|            |                         |                        |                 | 5 V-tolerant ports*1 *5 |                  | V <sub>IH</sub>     | VCC × 0.8           |  | —                        | VCC + 3.6 (max 5.8) |                         |
|            |                         |                        |                 |                         |                  | V <sub>IL</sub>     | —                   |  | —                        | VCC × 0.2           |                         |
|            |                         |                        |                 |                         |                  | ΔV <sub>T</sub>     | VCC × 0.05          |  | —                        | —                   |                         |
|            |                         |                        |                 | RTCIC0, RTCIC1, RTCIC2  | 使用备用电池时 Function | 选择VBATT电源时          | V <sub>IH</sub>     |  | V <sub>BATT</sub> × 0.8  | —                   | V <sub>BATT</sub> + 0.3 |
|            |                         |                        |                 |                         |                  |                     | V <sub>IL</sub>     |  | —                        | —                   | V <sub>BATT</sub> × 0.2 |
|            |                         |                        |                 |                         |                  |                     | ΔV <sub>T</sub>     |  | V <sub>BATT</sub> × 0.05 | —                   | —                       |
|            |                         | 选择VCC电源时               | V <sub>IH</sub> |                         |                  | VCC × 0.8           | —                   | 更高的电压 VCC+0.3V或 V <sub>BATT</sub> +0.3 V |                          |                     |                         |
|            |                         |                        | V <sub>IL</sub> |                         |                  | —                   | —                   | VCC × 0.2                                |                          |                     |                         |
|            |                         |                        | ΔV <sub>T</sub> |                         |                  | VCC × 0.05          | —                   | —  |                          |                     |                         |
|            |                         | 不使用备用电池时 Function      | V <sub>IH</sub> | VCC × 0.8               | —                | VCC + 0.3           |                     |  |                          |                     |                         |
|            |                         |                        | V <sub>IL</sub> | —                       | —                | VCC × 0.2           |                     |  |                          |                     |                         |
|            |                         |                        | ΔV <sub>T</sub> | VCC × 0.05              | —                | —                   |                     |  |                          |                     |                         |
| 其他输入引脚*2   |                         | V <sub>IH</sub>        | VCC × 0.8       | —                       | —                |                     |                     |  |                          |                     |                         |
|            |                         | V <sub>IL</sub>        | —               | —                       | VCC × 0.2        |                     |                     |  |                          |                     |                         |
|            |                         | ΔV <sub>T</sub>        | VCC × 0.05      | —                       | —                |                     |                     |  |                          |                     |                         |
| Ports      | 5 V-tolerant ports*3 *5 |                        | V <sub>IH</sub> | VCC × 0.8               | —                | VCC + 3.6 (max 5.8) | V                   |  |                          |                     |                         |
|            |                         |                        | V <sub>IL</sub> | —                       | —                | VCC × 0.2           |                     |  |                          |                     |                         |
|            | 其他输入引脚*4                |                        | V <sub>IH</sub> | VCC × 0.8               | —                | —                   |                     |  |                          |                     |                         |
|            |                         |                        | V <sub>IL</sub> | —                       | —                | VCC × 0.2           |                     |  |                          |                     |                         |

注1.与端口P205、P206、P400、P401、P407至P415和P708至P713相关的RES和外围功能引脚（共22个引脚）。  
 注2.除表中已描述的外围功能引脚外的所有输入引脚。  
 注3.端口P205、P206、P400、P401、P407~P415、P708~P713（共21针）。  
 注4.除表中已描述的端口外的所有输入引脚。  
 注5.当VCC小于2.7V时，5V容限端口的输入电压应小于3.6V，否则可能发生击穿，因为5V容限端口是电气控制的，以免违反击穿电压。



47.2.3 I/O  $I_{OH}$ ,  $I_{OL}$ Table 47.5 I/O  $I_{OH}$ ,  $I_{OL}$ 

| Parameter  |  | Symbol                | Min      | Typ | Max  | Unit |    |
|--|--|-----------------------|----------|-----|------|------|----|
| Permissible output current (average value per pin)         | Ports P000 to P009, P014, P015, P201                         | $I_{OH}$              | —        | —   | -2.0 | mA   |    |
|  |  | $I_{OL}$              | —        | —   | 2.0  | mA   |    |
|  | Ports P205, P206, P407 to P415, P708 to P713 (total 17 pins) | Low drive*1           | $I_{OH}$ | —   | —    | -2.0 | mA |
|  |  |                       | $I_{OL}$ | —   | —    | 2.0  | mA |
|  |  | Middle drive*2        | $I_{OH}$ | —   | —    | -4.0 | mA |
|  |  |                       | $I_{OL}$ | —   | —    | 4.0  | mA |
|  |  | High drive*3          | $I_{OH}$ | —   | —    | -20  | mA |
|  |  |                       | $I_{OL}$ | —   | —    | 20   | mA |
|  | Other output pins*4  | Low drive*1           | $I_{OH}$ | —   | —    | -2.0 | mA |
|  |  |                       | $I_{OL}$ | —   | —    | 2.0  | mA |
|  |  | Middle drive*2        | $I_{OH}$ | —   | —    | -4.0 | mA |
|  |  |                       | $I_{OL}$ | —   | —    | 4.0  | mA |
| High drive*3   |  | $I_{OH}$              | —        | —   | -16  | mA   |    |
|  |  | $I_{OL}$              | —        | —   | 16   | mA   |    |
| Permissible output current (max value per pin)             | Ports P000 to P009, P014, P015, P201                         | $I_{OH}$              | —        | —   | -4.0 | mA   |    |
|  |  | $I_{OL}$              | —        | —   | 4.0  | mA   |    |
|  | Ports P205, P206, P407 to P415, P708 to P713 (total 17 pins) | Low drive*1           | $I_{OH}$ | —   | —    | -4.0 | mA |
|  |  |                       | $I_{OL}$ | —   | —    | 4.0  | mA |
|  |  | Middle drive*2        | $I_{OH}$ | —   | —    | -8.0 | mA |
|  |  |                       | $I_{OL}$ | —   | —    | 8.0  | mA |
|  |  | High drive*3          | $I_{OH}$ | —   | —    | -40  | mA |
|  |  |                       | $I_{OL}$ | —   | —    | 40   | mA |
|  | Other output pins*4  | Low drive*1           | $I_{OH}$ | —   | —    | -4.0 | mA |
|  |  |                       | $I_{OL}$ | —   | —    | 4.0  | mA |
|  |  | Middle drive*2        | $I_{OH}$ | —   | —    | -8.0 | mA |
|  |  |                       | $I_{OL}$ | —   | —    | 8.0  | mA |
| High drive*3   |  | $I_{OH}$              | —        | —   | -32  | mA   |    |
|  |  | $I_{OL}$              | —        | —   | 32   | mA   |    |
| Permissible output current (maxvalue of total of all pins) | Maximum of all output pins                                   | $\Sigma I_{OH} (max)$ | —        | —   | -80  | mA   |    |
|  |  | $\Sigma I_{OL} (max)$ | —        | —   | 80   | mA   |    |

Note 1. This is the value when low driving ability is selected in the Port Drive Capability bit in the PmnPFS register. The selected driving ability is retained in Deep Software Standby mode.

Note 2. This is the value when middle driving ability is selected in the Port Drive Capability bit in the PmnPFS register. The selected driving ability is retained in Deep Software Standby mode.

Note 3. This is the value when high driving ability is selected in the Port Drive Capability bit in the PmnPFS register. The selected driving ability is retained in Deep Software Standby mode.

Note 4. Except for P200, which is an input port.

**Caution:** To protect the reliability of the MCU, the output current values should not exceed the values in this table. The average output current indicates the average value of current measured during 100  $\mu$ s.

## 47.2.3 我爱我哦

Table 47.5 我爱我哦

| Parameter           |  | Symbol                | 最小值      | 典型值 | 最大值  | 单位   |    |
|---------------------|--|-----------------------|----------|-----|------|------|----|
| 允许输出电流 (每个引脚的平均值)   | 端口P000至P009、P014、P015、P201               | $I_{OH}$              | —        | —   | -2.0 | mA   |    |
|                     |  | $I_{OL}$              | —        | —   | 2.0  | mA   |    |
|                     | 端口P205、P206、P407至P415、P708至P713 (共17个引脚) | 低驱动*1                 | $I_{OH}$ | —   | —    | -2.0 | mA |
|                     |  |                       | $I_{OL}$ | —   | —    | 2.0  | mA |
|                     |  | 中间驱动器*2               | $I_{OH}$ | —   | —    | -4.0 | mA |
|                     |  |                       | $I_{OL}$ | —   | —    | 4.0  | mA |
|                     |  | 高速驱动*3                | $I_{OH}$ | —   | —    | -20  | mA |
|                     |  |                       | $I_{OL}$ | —   | —    | 20   | mA |
|                     | 其他输出引脚*4                                 | 低驱动*1                 | $I_{OH}$ | —   | —    | -2.0 | mA |
|                     |  |                       | $I_{OL}$ | —   | —    | 2.0  | mA |
|                     |  | 中间驱动器*2               | $I_{OH}$ | —   | —    | -4.0 | mA |
|                     |  |                       | $I_{OL}$ | —   | —    | 4.0  | mA |
| 高速驱动*3              |  | $I_{OH}$              | —        | —   | -16  | mA   |    |
|                     |  | $I_{OL}$              | —        | —   | 16   | mA   |    |
| 允许输出电流 (每个引脚的最大值)   | 端口P000至P009、P014、P015、P201               | $I_{OH}$              | —        | —   | -4.0 | mA   |    |
|                     |  | $I_{OL}$              | —        | —   | 4.0  | mA   |    |
|                     | 端口P205、P206、P407至P415、P708至P713 (共17个引脚) | 低驱动*1                 | $I_{OH}$ | —   | —    | -4.0 | mA |
|                     |  |                       | $I_{OL}$ | —   | —    | 4.0  | mA |
|                     |  | 中间驱动器*2               | $I_{OH}$ | —   | —    | -8.0 | mA |
|                     |  |                       | $I_{OL}$ | —   | —    | 8.0  | mA |
|                     |  | 高速驱动*3                | $I_{OH}$ | —   | —    | -40  | mA |
|                     |  |                       | $I_{OL}$ | —   | —    | 40   | mA |
|                     | 其他输出引脚*4                                 | 低驱动*1                 | $I_{OH}$ | —   | —    | -4.0 | mA |
|                     |  |                       | $I_{OL}$ | —   | —    | 4.0  | mA |
|                     |  | 中间驱动器*2               | $I_{OH}$ | —   | —    | -8.0 | mA |
|                     |  |                       | $I_{OL}$ | —   | —    | 8.0  | mA |
| 高速驱动*3              |  | $I_{OH}$              | —        | —   | -32  | mA   |    |
|                     |  | $I_{OL}$              | —        | —   | 32   | mA   |    |
| 允许输出电流 (所有引脚总和的最大值) | 所有输出引脚的最大值                               | $\Sigma I_{OH} (max)$ | —        | —   | -80  | mA   |    |
|                     |  | $\Sigma I_{OL} (max)$ | —        | —   | 80   | mA   |    |

注1.这是在PmnPFS寄存器的端口驱动能力位中选择低驱动能力时的值。在深度软件待机模式下会保留所选的驱动能力。

注2.这是在PmnPFS寄存器的端口驱动能力位中选择中等驱动能力时的值。在深度软件待机模式下会保留所选的驱动能力。

注3.这是在PmnPFS寄存器的端口驱动能力位中选择高驱动能力时的值。在深度软件待机模式下会保留所选的驱动能力。

注4.P200除外，它是一个输入端口。

**Caution:** 为保护单片机的可靠性，输出电流值不应超过此表中的值。平均输出电流表示在100 $\mu$ s期间测量的电流平均值。

47.2.4 I/O  $V_{OH}$ ,  $V_{OL}$ , and Other CharacteristicsTable 47.6 I/O  $V_{OH}$ ,  $V_{OL}$ , and other characteristics

| Parameter                               |   | Symbol     | Min            | Typ | Max | Unit          | Test conditions  |
|---|---|------------|----------------|-----|-----|---------------|--|
| Output voltage                          | IIC   | $V_{OL}$   | —              | —   | 0.4 | V             | $I_{OL} = 3.0 \text{ mA}$  |
|   |   | $V_{OL}$   | —              | —   | 0.6 |               | $I_{OL} = 6.0 \text{ mA}$  |
|   | IIC*1   | $V_{OL}$   | —              | —   | 0.4 |               | $I_{OL} = 15.0 \text{ mA}$ (ICFER.FMPE = 1)  |
|   |   | $V_{OL}$   | —              | 0.4 | —   |               | $I_{OL} = 20.0 \text{ mA}$ (ICFER.FMPE = 1)  |
|   | Ports P205, P206, P407 to P415, P708 to P713 (total of 17 pins)*2 | $V_{OH}$   | $V_{CC} - 1.0$ | —   | —   |               | $I_{OH} = -20 \text{ mA}$<br>$V_{CC} = 3.3 \text{ V}$  |
|   |   | $V_{OL}$   | —              | —   | 1.0 |               | $I_{OL} = 20 \text{ mA}$<br>$V_{CC} = 3.3 \text{ V}$   |
|   | Other output pins   | $V_{OH}$   | $V_{CC} - 0.5$ | —   | —   |               | $I_{OH} = -1.0 \text{ mA}$   |
|   |   | $V_{OL}$   | —              | —   | 0.5 |               | $I_{OL} = 1.0 \text{ mA}$  |
| Input leakage current                   | RES   | $I_{in}$   | —              | —   | 5.0 | $\mu\text{A}$ | $V_{in} = 0 \text{ V}$<br>$V_{in} = 5.5 \text{ V}$   |
|   | Port P200   |            | —              | —   | 1.0 |               | $V_{in} = 0 \text{ V}$<br>$V_{in} = V_{CC}$  |
| Three-state leakage current (off state) | 5 V-tolerant ports  | $I_{TSIL}$ | —              | —   | 5.0 | $\mu\text{A}$ | $V_{in} = 0 \text{ V}$<br>$V_{in} = 5.5 \text{ V}$   |
|   | Other ports (except for port P200)                                |            | —              | —   | 1.0 |               | $V_{in} = 0 \text{ V}$<br>$V_{in} = V_{CC}$  |
| Input pull-up MOS current               | Ports P0 to P8  | $I_p$      | -300           | —   | -10 | $\mu\text{A}$ | $V_{CC} = 2.7 \text{ to } 3.6 \text{ V}$<br>$V_{in} = 0 \text{ V}$                                       |
| Input capacitance                       | USB_DP, USB_DM, and ports P014, P015, P400, P401, P511, P512      | $C_{in}$   | —              | —   | 16  | pF            | $V_{bias} = 0 \text{ V}$<br>$V_{amp} = 20 \text{ mV}$<br>$f = 1 \text{ MHz}$<br>$T_a = 25^\circ\text{C}$ |
|   | Other input pins  |            | —              | —   | 8   |               |  |

Note 1. SCL0\_A, SDA0\_A (total 2 pins).

Note 2. This is the value when high driving ability is selected in the Port Drive Capability bit in the PmnPFS register. The selected driving ability is retained in Deep Software Standby mode.

## 47.2.4 IOVOH VOL和其他特性

Table 47.6 IOVOH、VOL和其他特性

| Parameter    |  | 符号         | 最小值            | 典型值 | 最大单元测试条件          |  |
|--------------|--|------------|----------------|-----|-------------------|--|
| 输出电压         | IIC  | $V_{OL}$   | —              | —   | 0.4 V             |  |
|              |  | $V_{OL}$   | —              | —   | 0.6               |  |
|              | IIC*1  | $V_{OL}$   | —              | —   | 0.4               |  |
|              |  | $V_{OL}$   | —              | 0.4 | —                 |  |
|              | 端口P205、P206、P407至P415、P708至P713 (共17针) *2          | $V_{OH}$   | $V_{CC} - 1.0$ | —   | —                 | $I_{OH} = 20 \text{ mA}$<br>$V_{CC} = 3.3 \text{ V}$ |
|              |  | $V_{OL}$   | —              | —   | 1.0               | $I_{OL} = 20 \text{ mA}$<br>$V_{CC} = 3.3 \text{ V}$ |
|              | 其他输出引脚   | $V_{OH}$   | $V_{CC} - 0.5$ | —   | —                 | $I_{OH} = 1.0 \text{ mA}$                            |
|              |  | $V_{OL}$   | —              | —   | 0.5               | $I_{OL} = 1.0 \text{ mA}$                            |
| 输入漏电流        | RES  | $I_{in}$   | —              | —   | 5.0 $\mu\text{A}$ |  |
|              | Port P200  |            | —              | —   | 1.0               |  |
| 三态漏电流 (关闭状态) | 5 V-tolerant ports                                 | $I_{TSIL}$ | —              | —   | 5.0 $\mu\text{A}$ |  |
|              | 其他端口 (端口P200除外)                                    |            | —              | —   | 1.0               |  |
| 输入上拉MOS电流    | 端口P0至P8  | $I_p$      | -300           | —   | -10 $\mu\text{A}$ |  |
| 输入电容         | USB_DP、USB_DM和端口P014, P015, P400, P401, P511, P512 | $C_{in}$   | —              | —   | 16 pF             |  |
|              | 其他输入引脚   |            | —              | —   | 8                 |  |

Note 1. SCL0\_A, SDA0\_A (total 2 pins).

注2.这是在PmnPFS寄存器的端口驱动能力位中选择高驱动能力时的值。在深度软件待机模式下会保留所选的驱动能力。

47.2.5 Operating and Standby Current

Table 47.7 Operating and standby current (1 of 2)

| Parameter  |                            | Symbol   | Min  | Typ | Max     | Unit              | Test conditions   |   |
|--|----------------------------|--|--|-----|---------|-------------------|---|---|
| Supply current*1   | High-speed mode            | Maximum*2 *13  |  | —   | —       | 95                | ICLK = 100 MHz<br>PCLKA = 100 MHz<br>PCLKB = 50 MHz<br>PCLKC = 50 MHz<br>PCLKD = 100 MHz<br>FCLK = 50 MHz |   |
|  |                            | CoreMark®*5 *6 *12   |  | —   | 12      | —                 |   |   |
|  |                            | Normal mode  | All peripheral clocks enabled, while (1) code executing from flash*4 *12     |     | —       | 22                |   | — |
|  |                            |  | All peripheral clocks disabled, while (1) code executing from flash*5 *6 *12 |     | —       | 12                |   | — |
|  |                            | Sleep mode*5   |  | —   | 7*6 *12 | 47*7 *13          |   |   |
|  |                            | Increase during BGO operation                                | Data flash P/E   | —   | 6       | —                 |   |   |
|  | Code flash P/E             |  | —  | 8   | —       |                   |   |   |
|  | Low-speed mode*5 *10       |  | —  | 1.9 | —       | ICLK = 1 MHz      |   |   |
|  | Subosc-speed mode*5 *11    |  | —  | 1.7 | —       | ICLK = 32.768 kHz |   |   |
|  | Software Standby mode      |  | SNZCR.RXDREQEN = 1   | —   | —       | 34                | —   |   |
|  |                            |  | SNZCR.RXDREQEN = 0   | —   | 1.6     | —                 | —   |   |
|  | Deep Software Standby mode | Power supplied to Standby SRAM and USB resume detecting unit |  | —   | 16.9    | 131               | μA  | — |
|  |                            | Power not supplied to SRAM or USB resume detecting unit      | Power-on reset circuit low power function disabled                           | —   | 11.8    | 31                | —   | — |
|  |                            |  | Power-on reset circuit low power function enabled                            | —   | 4.8     | 21                | —   | — |
|  |                            | Increase when the RTC and AGT are operating                  | When the low-speed on-chip oscillator (LOCO) is in use                       |     | —       | 4.0               | —   | — |
| When a crystal oscillator for low clock loads is in use  |                            |  | —  | 1.2 | —       | —                 |   |   |
| When a crystal oscillator for standard clock loads is in use   |                            |  | —  | 1.5 | —       | —                 |   |   |
| RTC operating while VCC is off (with the battery backup function, only the RTC and sub-clock oscillator operate) |                            | When a crystal oscillator for low clock loads is in use      |  | —   | 0.9     | —                 | V <sub>BATT</sub> = 1.8 V, VCC = 0 V  |   |
|  |                            |  |  | —   | 1.3     | —                 | V <sub>BATT</sub> = 3.3 V, VCC = 0 V  |   |
|  |                            | When a crystal oscillator for standard clock loads is in use |  | —   | 1.0     | —                 | V <sub>BATT</sub> = 1.8 V, VCC = 0 V  |   |
|  |                            |  |  | —   | 1.7     | —                 | V <sub>BATT</sub> = 3.3 V, VCC = 0 V  |   |
| Inrush current on returning from deep software standby mode  |                            | Inrush current*8   | I <sub>RUSH</sub>  | —   | 160     | —                 | mA  |   |
|  |                            | Energy of inrush current*8                                   | E <sub>RUSH</sub>  | —   | 1.0     | —                 | μC  |   |

47.2.5 工作和待机电流

Table 47.7 工作和待机电流(1of2)

| Parameter                             |                         | Symbol              | Min                           | Typ | Max     | Unit              | 测试条件  |   |
|---------------------------------------|-------------------------|---------------------|-------------------------------|-----|---------|-------------------|---|---|
| 供电电流*1                                | High-speed mode         | Maximum*2 *13       |                               | —   | —       | 95                | ICLK = 100 MHz<br>PCLKA = 100 MHz<br>PCLKB = 50 MHz<br>PCLKC = 50 MHz<br>PCLKD = 100 MHz<br>FCLK = 50 MHz |   |
|                                       |                         | CoreMark®*5 *6 *12  |                               | —   | 12      | —                 |   |   |
|                                       |                         | 正常模式                | 启用所有外设时钟, 同时(1)从闪存执行代码*4*12   |     | —       | 22                |   | — |
|                                       |                         |                     | 禁用所有外设时钟, 同时(1)代码从闪存执行*5*6*12 |     | —       | 12                |   | — |
|                                       |                         | 睡眠模式*5              |                               | —   | 7*6 *12 | 47*7 *13          |   |   |
|                                       |                         | BGO运行期间增加           | 数据闪存PE                        | —   | 6       | —                 |   |   |
|                                       | 代码闪存PE                  |                     | —                             | 8   | —       |                   |   |   |
|                                       | Low-speed mode*5 *10    |                     | —                             | 1.9 | —       | ICLK = 1 MHz      |   |   |
|                                       | Subosc-speed mode*5 *11 |                     | —                             | 1.7 | —       | ICLK = 32.768 kHz |   |   |
|                                       | 软件待机模式                  |                     | SNZCR.RXDREQEN = 1            | —   | —       | 34                | —   |   |
|                                       |                         |                     | SNZCR.RXDREQEN = 0            | —   | 1.6     | —                 | —   |   |
|                                       | 深度软件待机模式                | 为备用SRAM和USB恢复检测单元供电 |                               | —   | 16.9    | 131               | μA  | — |
|                                       |                         | 未向SRAM或USB恢复检测单元供电  | 上电复位电路低功耗功能禁用                 | —   | 11.8    | 31                | —   | — |
|                                       |                         |                     | 上电复位电路低功耗功能启用                 | —   | 4.8     | 21                | —   | — |
|                                       |                         | RTC和AGT运行时增加        | 使用低速片上振荡器(LOCO)时              |     | —       | 4.0               | —   | — |
| 当使用用于低时钟负载的晶体振荡器时                     |                         |                     | —                             | 1.2 | —       | —                 |   |   |
| 当使用标准时钟负载的晶体振荡器时                      |                         |                     | —                             | 1.5 | —       | —                 |   |   |
| VCC关闭时RTC运行(具有电池备份功能, 只有RTC和副时钟振荡器运行) |                         | 当使用用于低时钟负载的晶体振荡器时   |                               | —   | 0.9     | —                 | V <sub>BATT</sub> = 1.8 V, VCC = 0 V  |   |
|                                       |                         |                     |                               | —   | 1.3     | —                 | V <sub>BATT</sub> = 3.3 V, VCC = 0 V  |   |
|                                       |                         | 当使用标准时钟负载的晶体振荡器时    |                               | —   | 1.0     | —                 | V <sub>BATT</sub> = 1.8 V, VCC = 0 V  |   |
|                                       |                         |                     |                               | —   | 1.7     | —                 | V <sub>BATT</sub> = 3.3 V, VCC = 0 V  |   |
| 从深度软件待机模式返回时的浪涌电流                     |                         | Inrush current*8    | I <sub>RUSH</sub>             | —   | 160     | —                 | mA  |   |
|                                       |                         | 浪涌电流能量*8            | E <sub>RUSH</sub>             | —   | 1.0     | —                 | μC  |   |

Table 47.7 Operating and standby current (2 of 2)

| Parameter                               | Symbol  | Min | Typ                | Max  | Unit | Test conditions    |                    |
|---|---|-----|--------------------|------|------|--------------------|--------------------|
| Analog power supply current             | During 12-bit A/D conversion                                | —   | 0.8                | 1.1  | mA   | —                  |                    |
|   |   |     | Temperature sensor | 0.1  |      |                    | 0.2                |
|   | During D/A conversion (per unit)                            | —   | 0.1                | 0.2  | mA   | Without AMP output |                    |
|   |   |     |                    |      |      | With AMP output    |                    |
|   | Waiting for A/D, D/A conversion (all units)                 | —   | 0.9                | 1.6  | mA   | —                  |                    |
|   | ADC12, DAC12 in standby modes (all units) <sup>9</sup>      | —   | 2                  | 8    |      |                    | μA                 |
| Reference power supply current (VREFH0) | During 12-bit A/D conversion (unit 0)                       | —   | 70                 | 120  | μA   | —                  |                    |
|   | Waiting for 12-bit A/D conversion (unit 0)                  | —   | 0.07               | 0.5  |      |                    |                    |
|   | ADC12 in standby modes (unit 0)                             | —   | 0.07               | 0.5  |      |                    |                    |
| Reference power supply current (VREFH)  | During 12-bit A/D conversion (unit 1)                       | —   | 70                 | 120  | μA   | —                  |                    |
|   | During D/A conversion (per unit)                            | —   | 0.1                | 0.4  |      |                    | Without AMP output |
|   |   |     |                    |      |      |                    | With AMP output    |
|   | Waiting for 12-bit A/D (unit 1), D/A (all units) conversion | —   | 0.07               | 0.8  |      |                    |                    |
|   | ADC12 unit 1 in standby modes                               | —   | 0.07               | 0.8  |      |                    |                    |
| USB operating current                   | Low speed   | —   | 3.5                | 6.5  | mA   | VCC_USB            |                    |
|   | Full speed  | —   | 4.0                | 10.0 |      | VCC_USB            |                    |

- Note 1. Supply current values are with all output pins unloaded and all input pull-up MOSs in the off state.  
 Note 2. Measured with clocks supplied to the peripheral functions. This does not include the BGO operation.  
 Note 3. I<sub>CC</sub> depends on f (ICLK) as follows.  
 I<sub>CC</sub> Max. = 0.53 × f + 42 (max. operation in high-speed mode)  
 I<sub>CC</sub> Typ. = 0.09 × f + 3.6 (normal operation in high-speed mode, all peripheral clocks disabled)  
 I<sub>CC</sub> Typ. = 0.2 × f + 1.7 (low-speed mode)  
 I<sub>CC</sub> Max. = 0.05 × f + 42 (sleep mode)  
 Note 4. This does not include the BGO operation.  
 Note 5. Supply of the clock signal to peripherals is stopped in this state. This does not include the BGO operation.  
 Note 6. FCLK, PCLKA, PCLKB, PCLKC, and PCLKD are set to divided by 64 (1.563 MHz).  
 Note 7. FCLK, PCLKA, PCLKB, PCLKC, and PCLKD are set to divided by 64 (3.125 MHz).  
 Note 8. Reference value  
 Note 9. When the MCU is in Software Standby mode or the MSTPCRD.MSTPD16 (12-Bit A/D Converter 0 Module Stop bit) and MSTPCRD.MSTPD15 (12-bit A/D converter 1 module stop bit) are in the module-stop state.  
 Note 10. FCLK, PCLKA, PCLKB, PCLKC, and PCLKD are set to divided by 64 (15.6 kHz).  
 Note 11. PCLKA, PCLKB, PCLKC, and PCLKD are set to divided by 64 (512 Hz). FCLK is the same frequency as that of ICLK.  
 Note 12. PLL output frequency = 100MHz.  
 Note 13. PLL output frequency = 200MHz.

Table 47.8 Coremark and normal mode current

| Parameter                   | Symbol  | Typ         | Unit   | Test conditions  |  |
|-----------------------------|---|-------------|--------|--|--|
| Supply Current <sup>1</sup> | Coremark <sup>2 3</sup>   | 119         | μA/MHz | ICLK = 100MHz<br>PCLKA = PCLKB = PCLKC = PCLKD = FCLK = 1.56 MHz |  |
|                             |   | Normal mode |        |  | 115  |
|                             |   |             |        |  | All peripheral clocks disabled, cache on, while (1) code executing from flash <sup>2 3</sup> |
|                             | All peripheral clocks disabled, cache off, while (1) code executing from flash <sup>2 3</sup> | 117         |        |  |  |

- Note 1. Supply current values are with all output pins unloaded and all input pull-up MOSs in the off state.  
 Note 2. Supply of the clock signal to peripherals is stopped in this state. This does not include the BGO operation.

Table 47.7 工作和待机电流(2of2)

| Parameter      | Symbol                     | Min | Typ                         | Max  | 单元 | 测试条件    |        |     |        |   |
|----------------|----------------------------|-----|-----------------------------|------|----|---------|--------|-----|--------|---|
| 模拟电源电流         | 在12位AD转换期间                 | —   | 0.8                         | 1.1  | mA | —       |        |     |        |   |
|                |                            |     | 温度感应器                       | 0.1  |    |         | 0.2    |     |        |   |
|                |                            |     | DA转换期间 (每单位)                | —    |    |         | 0.1    | 0.2 | 无AMP输出 |   |
|                |                            |     |                             |      |    |         |        |     | 带AMP输出 |   |
|                |                            |     | 等待AD、DA转换 (所有单位)            | —    |    |         | 0.9    | 1.6 | mA     | — |
|                |                            |     | ADC12、DAC12处于待机模式 (所有单元) *9 | —    |    |         | 2      | 8   |        |   |
| 参考电源电流(VREFH0) | 在12位AD转换期间 (单元0)           | —   | 70                          | 120  | μA | —       |        |     |        |   |
|                | 等待12位AD转换 (单元0)            | —   | 0.07                        | 0.5  |    |         |        |     |        |   |
|                | ADC12处于待机模式 (单元0)          | —   | 0.07                        | 0.5  |    |         |        |     |        |   |
| 参考电源电流(VREFH)  | 在12位AD转换期间 (单元1)           | —   | 70                          | 120  | μA | —       |        |     |        |   |
|                | DA转换期间 (每单位)               | —   | 0.1                         | 0.4  |    |         | 无AMP输出 |     |        |   |
|                |                            |     |                             |      |    |         | 带AMP输出 |     |        |   |
|                | 等待12位AD (单元1)、DA (所有单元) 转换 | —   | 0.07                        | 0.8  |    |         |        |     |        |   |
|                | ADC12单元1处于待机模式             | —   | 0.07                        | 0.8  |    |         |        |     |        |   |
| USB工作电流        | 低速                         | —   | 3.5                         | 6.5  | mA | VCC_USB |        |     |        |   |
|                | 全速                         | —   | 4.0                         | 10.0 |    | VCC_USB |        |     |        |   |

- 注1.电源电流值是在所有输出引脚空载且所有输入上拉MOS处于关闭状态时的值。  
 注2.使用提供给外设功能的时钟测量。这包括BGO操作。  
 注3.I<sub>CC</sub>取决于f(ICLK)，如下所示。  
 I<sub>CC</sub>最大。=0.53×f+42 (高速模式下的最大操作)  
 I<sub>CC</sub>典型。=0.09×f+3.6 (高速模式下正常运行，所有外设时钟禁用)  
 I<sub>CC</sub> Typ. = 0.2 × f + 1.7 (low-speed mode)  
 I<sub>CC</sub> Max. = 0.05 × f + 42 (sleep mode)  
 注4.这包括BGO操作。  
 注5.在此状态下停止向外围设备提供时钟信号。这包括BGO操作。  
 注6.FCLK、PCLKA、PCLKB、PCLKC和PCLKD设置为64分频(1.563MHz)。注7.FCLK、PCLKA、PCLKB、PCLKC和PCLKD设置为64分频(3.125MHz)。  
 注8.参考值  
 注9.当MCU处于软件待机模式或MSTPCRD.MSTPD16 (12位AD转换器0模块停止位) 和 MSTPCRD.MSTPD15 (12位AD转换器1模块停止位) 处于模块停止状态。  
 注10.FCLK、PCLKA、PCLKB、PCLKC和PCLKD设置为64分频 (15.6kHz)。  
 注11.PCLKA、PCLKB、PCLKC和PCLKD设置为除以64(512Hz)。FCLK与ICLK的频率相同。  
 注12.PLL输出频率=100MHz。注13.PLL输出频率=200MHz。

Table 47.8 Coremark和正常模式电流

| Parameter | Symbol                         | Typ  | Unit   | 测试条件   |                                |
|-----------|--------------------------------|------|--------|--|--------------------------------|
| 电源电流*1    | Coremark <sup>2 3</sup>        | 119  | μA/MHz | ICLK = 100MHz<br>PCLKA = PCLKB = PCLKC = PCLKD = FCLK = 1.56 MHz |                                |
|           |                                | 正常模式 |        |  | 115                            |
|           |                                |      |        |  | 所有外设时钟禁用，缓存打开，同时(1)代码从闪存执行*2*3 |
|           | 所有外设时钟禁用，缓存关闭，同时(1)代码从闪存执行*2*3 | 117  |        |  |                                |

- 注1.电源电流值是在所有输出引脚空载且所有输入上拉MOS处于关闭状态时的值。  
 注2.在此状态下停止向外围设备提供时钟信号。这包括BGO操作。



Note 3. PLL output frequency = 100MHz.

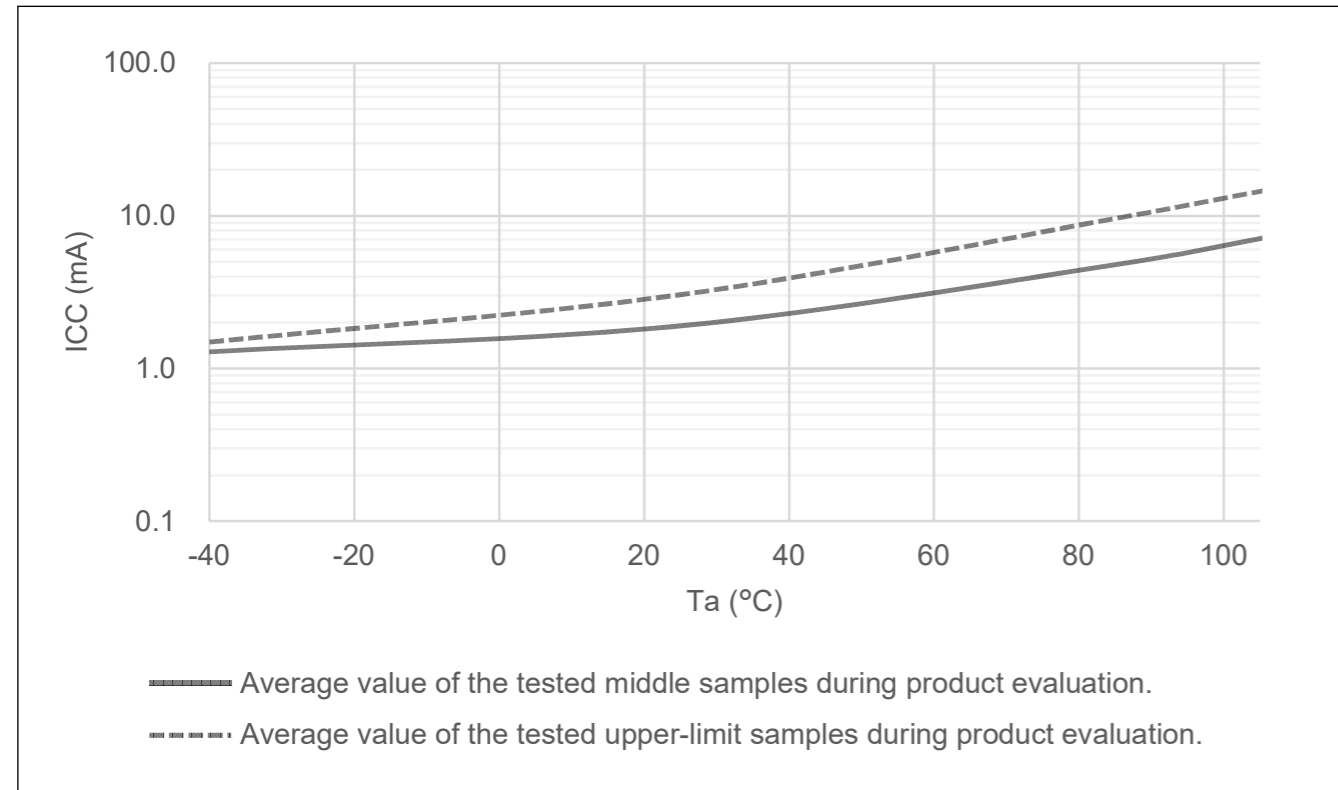


Figure 47.2 Temperature dependency in Software Standby mode (reference data)

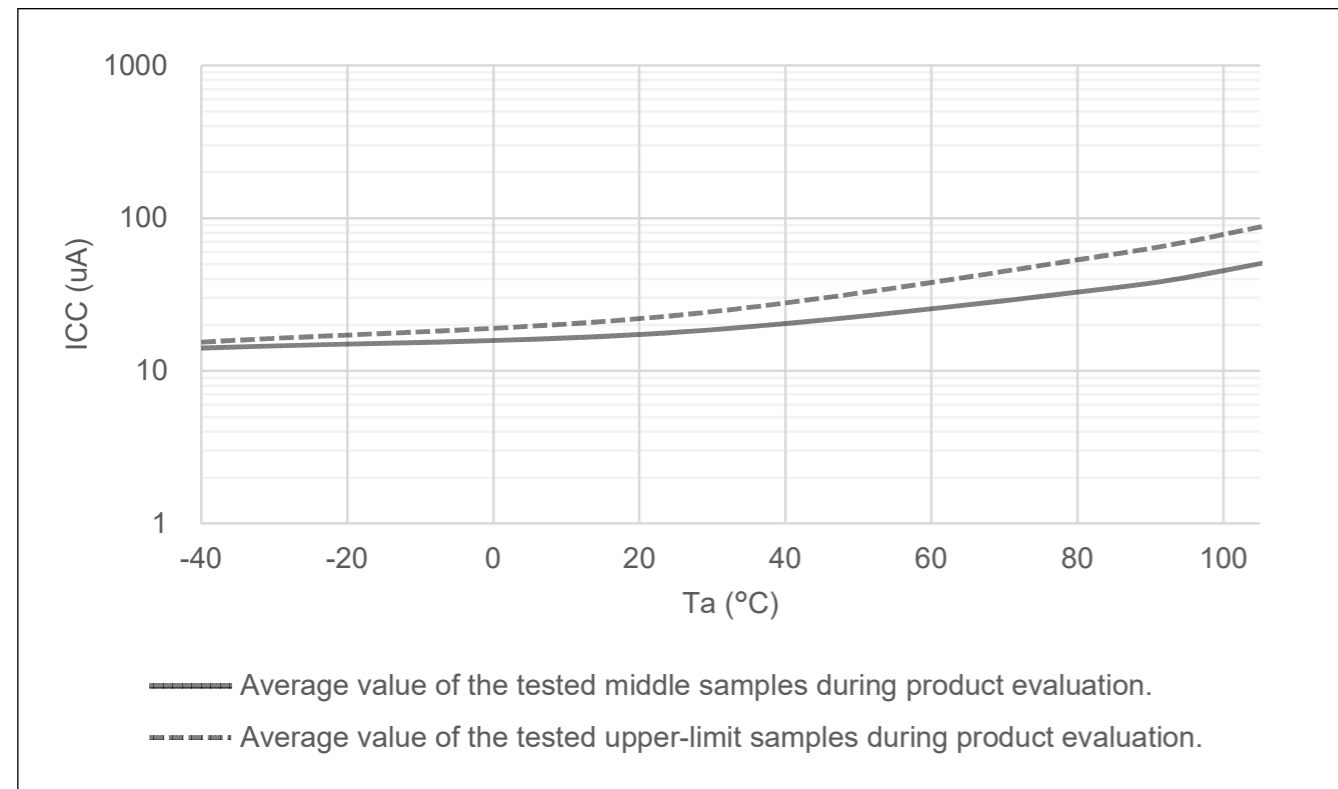


Figure 47.3 Temperature dependency in Deep Software Standby mode, power supplied to standby SRAM and USB resume detecting unit (reference data)

注3.PLL输出频率=100MHz。

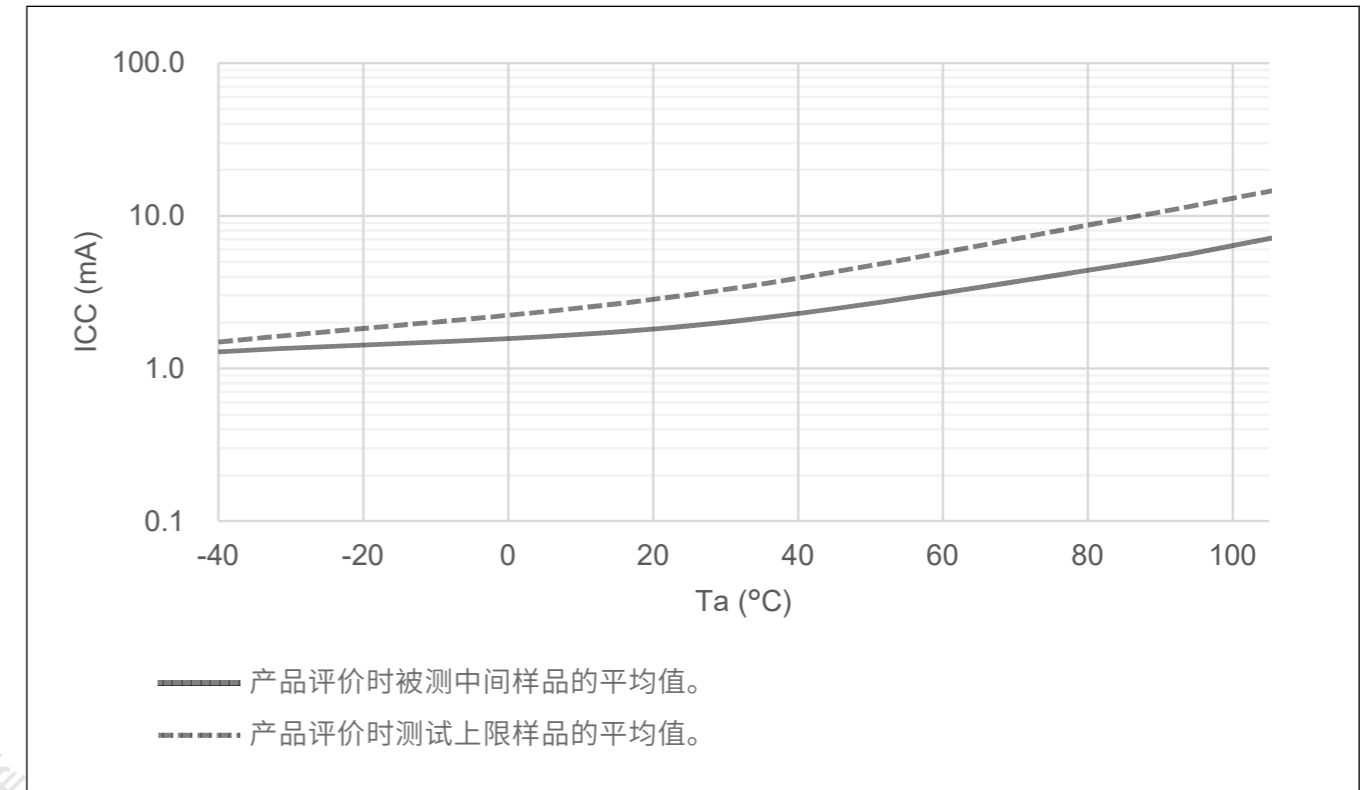


Figure 47.2 软件待机模式下的温度依赖性 (参考数据)

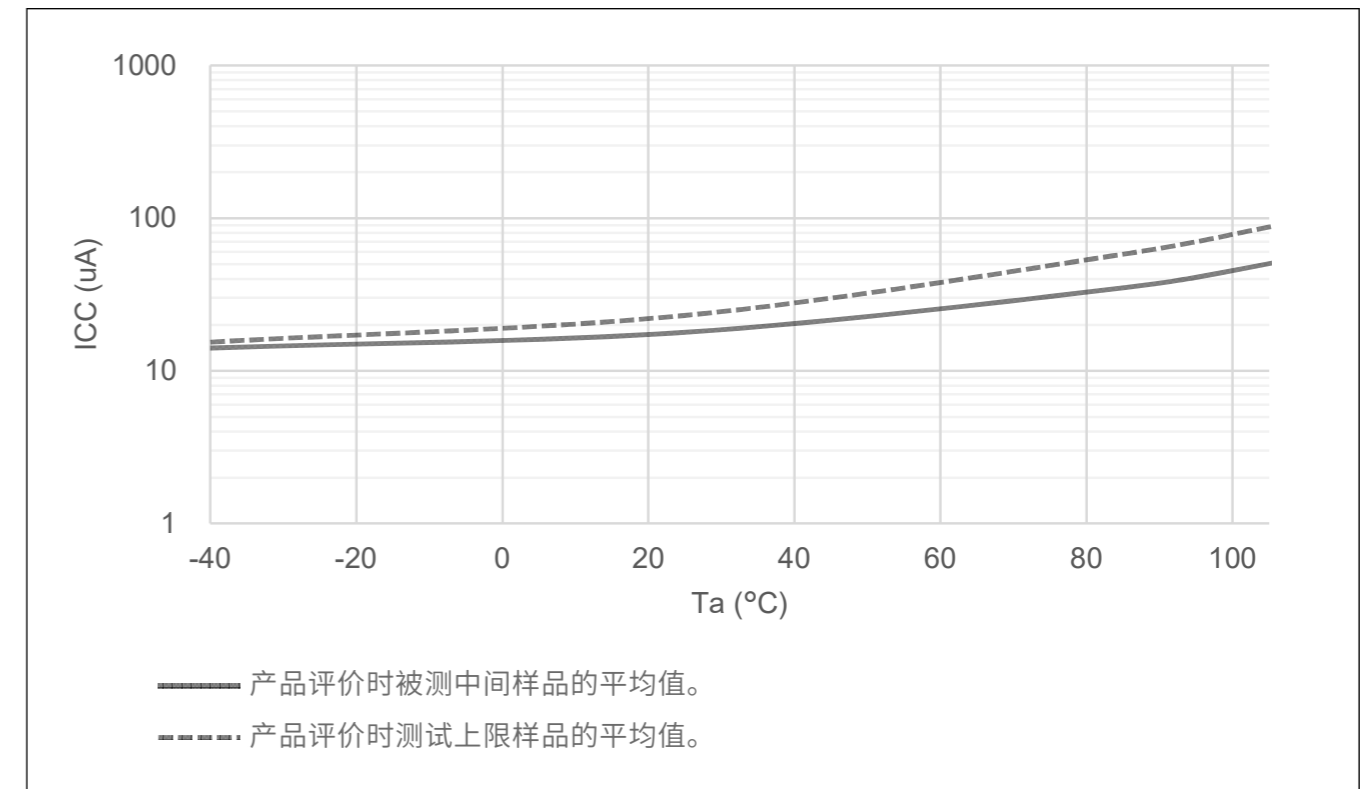


Figure 47.3 深度软件待机模式下的温度依赖性、为待机SRAM和USB恢复检测单元供电 (参考数据)

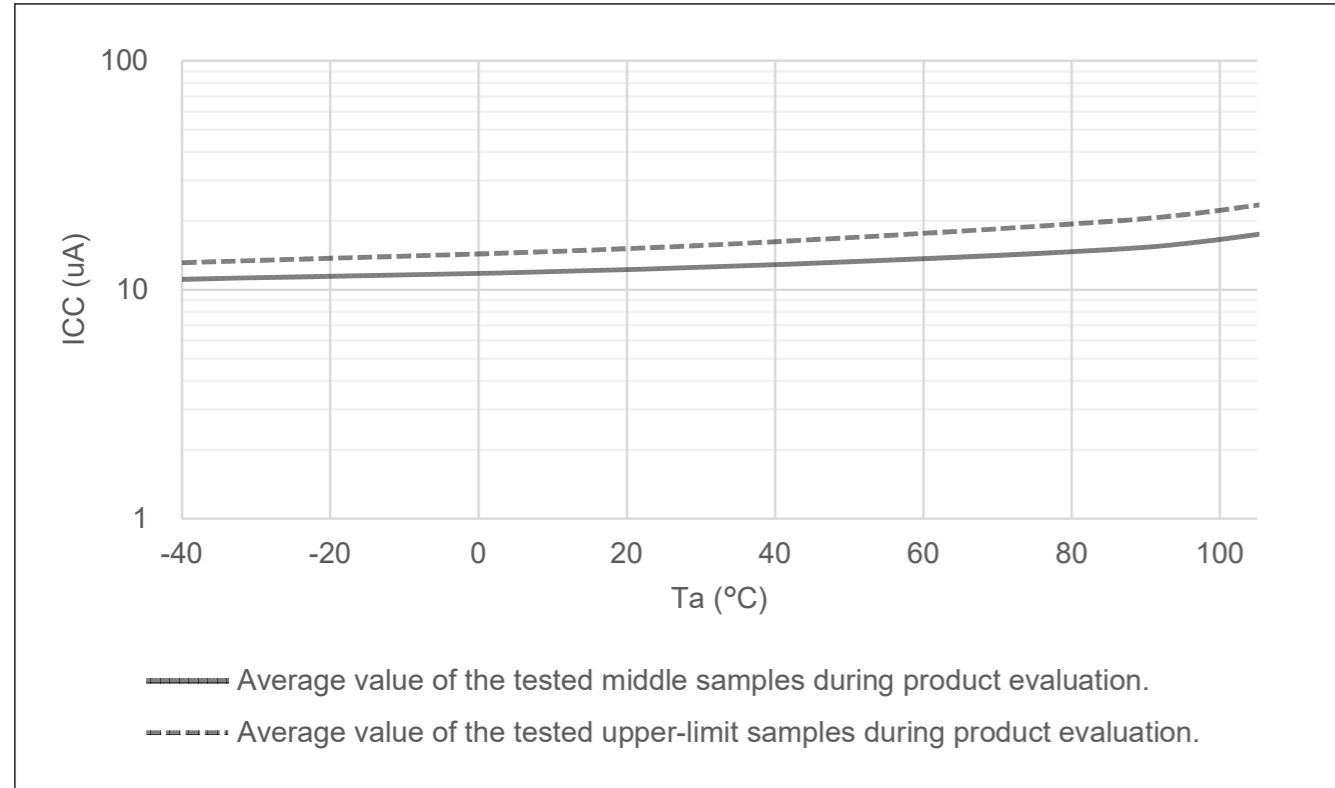


Figure 47.4 Temperature dependency in Deep Software Standby mode, power not supplied to SRAM or USB resume detecting unit, power-on reset circuit low power function disabled (reference data)

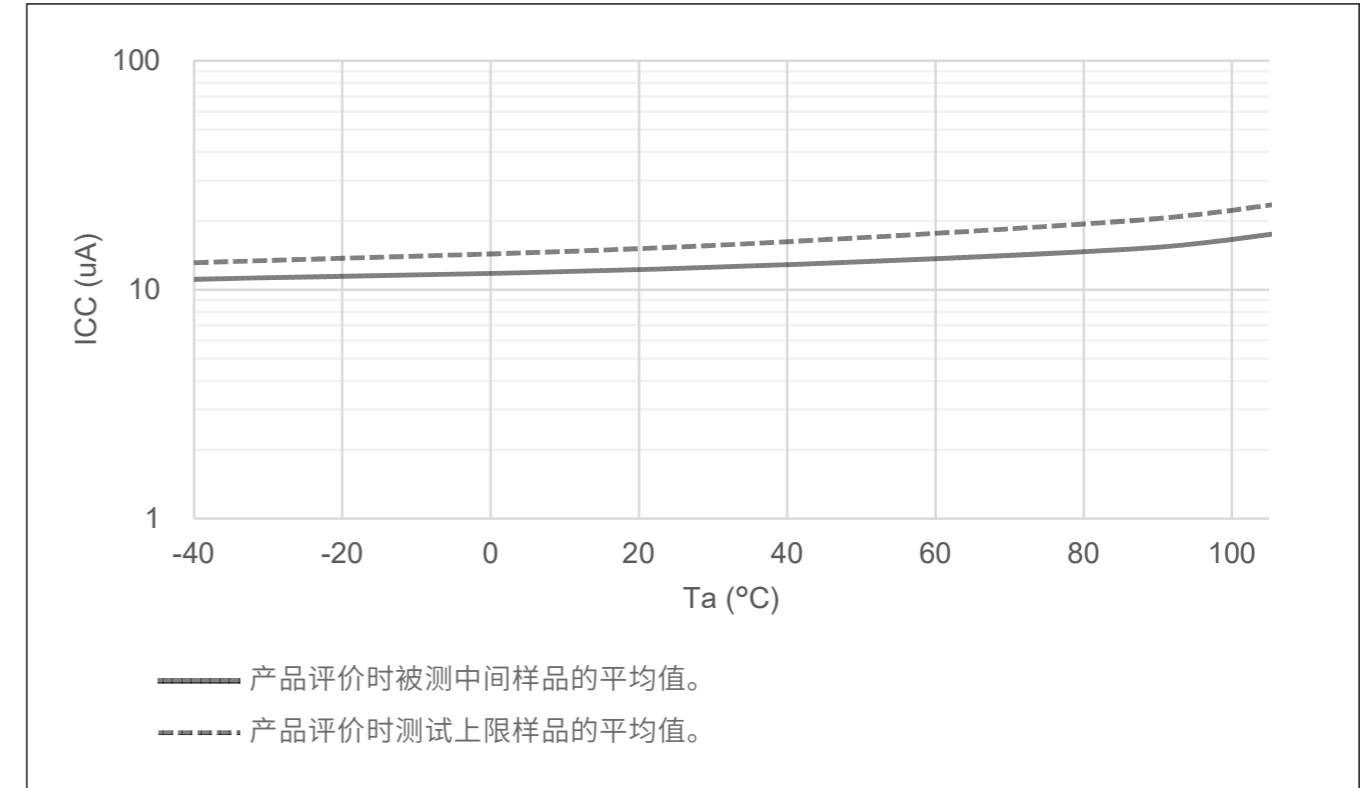


Figure 47.4 深度软件待机模式下的温度依赖性、未向SRAM或USB恢复检测单元供电、上电复位电路低功耗功能禁用（参考数据）

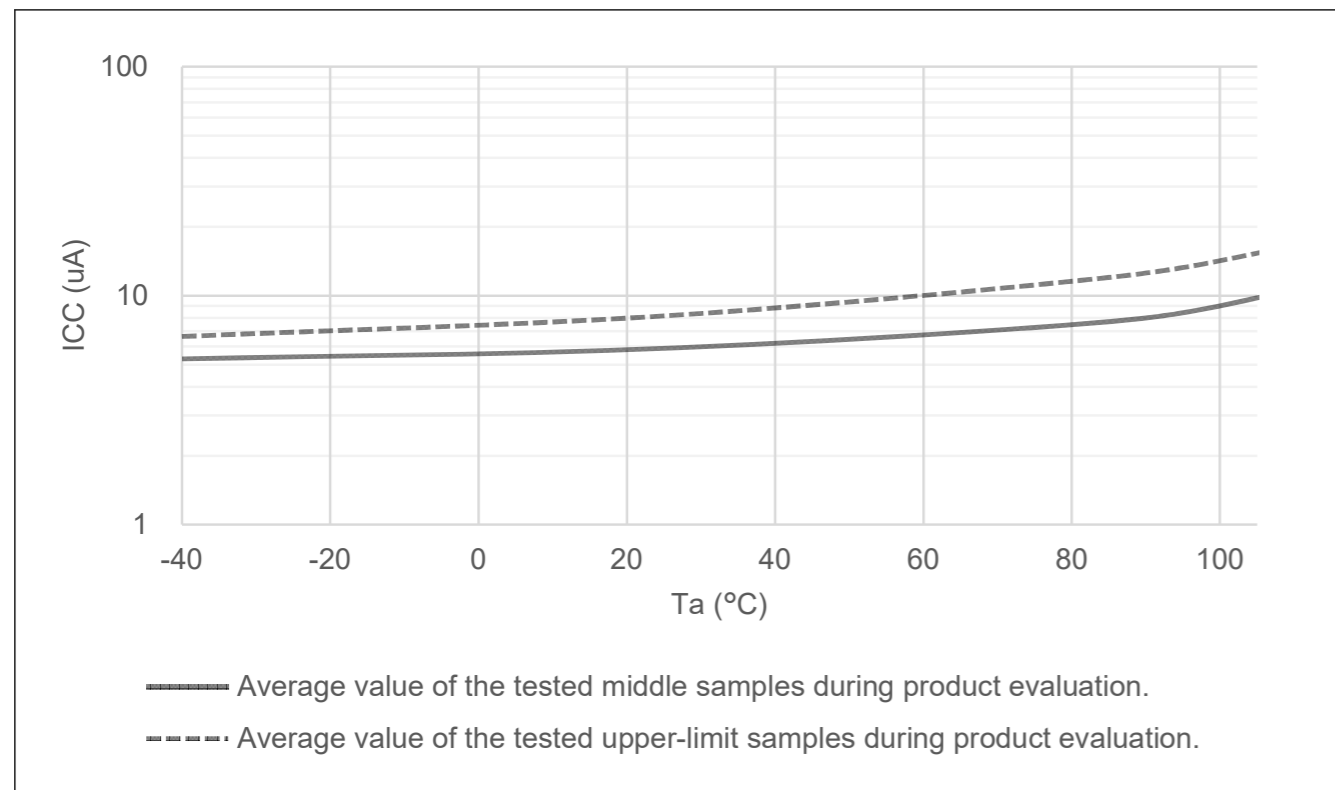


Figure 47.5 Temperature dependency in Deep Software Standby mode, power not supplied to SRAM or USB resume detecting unit, power-on reset circuit low power function enabled (reference data)

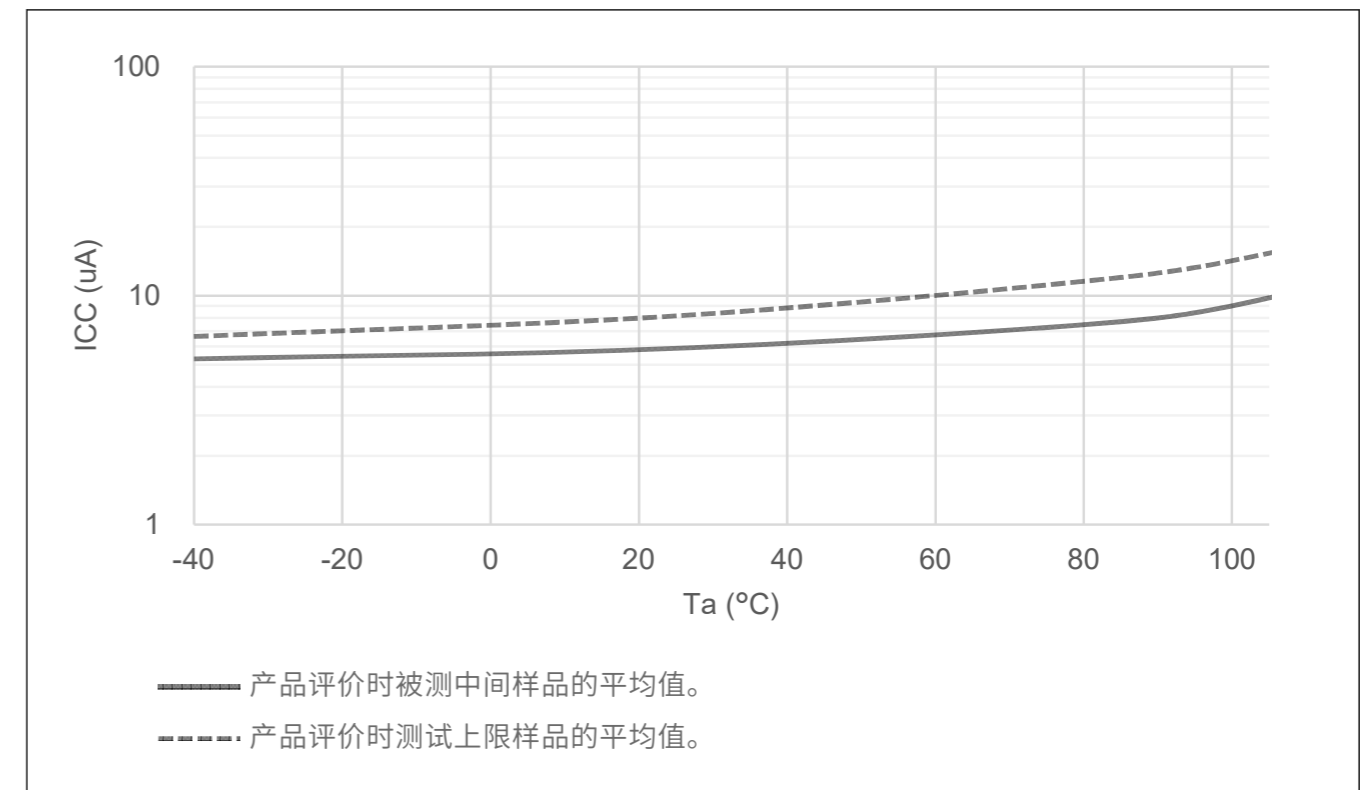


Figure 47.5 深度软件待机模式下的温度依赖性，未向SRAM供电或USB恢复检测单元，上电复位电路低功耗功能启用（参考数据）

### 47.2.6 VCC Rise and Fall Gradient and Ripple Frequency

**Table 47.9 Rise and fall gradient characteristics**

| Parameter              | Symbol                                      | Min    | Typ    | Max | Unit | Test conditions |   |
|------------------------|---|--------|--------|-----|------|-----------------|---|
| VCC rising gradient    | Voltage monitor 0 reset disabled at startup | SrVCC  | 0.0084 | —   | 20   | ms/V            | — |
|                        | Voltage monitor 0 reset enabled at startup  |        | 0.0084 | —   | —    |                 | — |
|                        | SCI/USB boot mode*1                         |        | 0.0084 | —   | 20   |                 | — |
| VCC falling gradient*2 | SfVCC                                       | 0.0084 | —      | —   | ms/V | —               |   |

Note 1. At boot mode, the reset from voltage monitor 0 is disabled regardless of the value of the OFS1.LVDAS bit.  
 Note 2. This applies when VBATT is used.

**Table 47.10 Rising and falling gradient and ripple frequency characteristics**

The ripple voltage must meet the allowable ripple frequency  $f_r(VCC)$  within the range between the VCC upper limit (3.6 V) and lower limit (2.7 V). When the VCC change exceeds  $VCC \pm 10\%$ , the allowable voltage change rising and falling gradient  $dt/dVCC$  must be met.

| Parameter  | Symbol     | Min | Typ | Max | Unit | Test conditions                                |
|--|------------|-----|-----|-----|------|--|
| Allowable ripple frequency                           | $f_r(VCC)$ | —   | —   | 10  | kHz  | Figure 47.6<br>$V_r(VCC) \leq VCC \times 0.2$  |
|  |            | —   | —   | 1   | MHz  | Figure 47.6<br>$V_r(VCC) \leq VCC \times 0.08$ |
|  |            | —   | —   | 10  | MHz  | Figure 47.6<br>$V_r(VCC) \leq VCC \times 0.06$ |
| Allowable voltage change rising and falling gradient | $dt/dVCC$  | 1.0 | —   | —   | ms/V | When VCC change exceeds $VCC \pm 10\%$         |

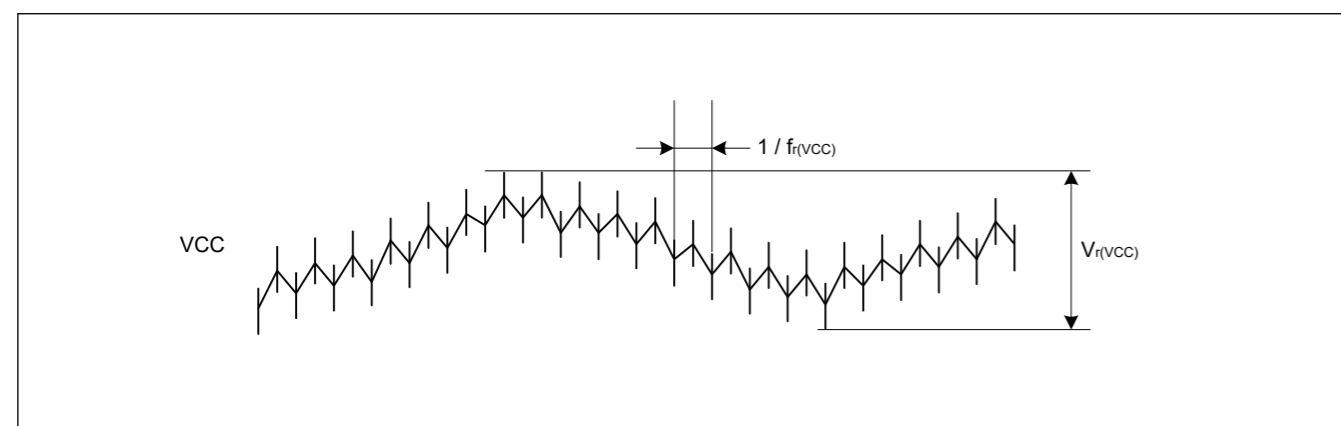


Figure 47.6 Ripple waveform

### 47.2.7 Thermal Characteristics

Maximum value of junction temperature ( $T_j$ ) must not exceed the value of “section 47.2.1.  $T_j/T_a$  Definition”.

$T_j$  is calculated by either of the following equations.

- $T_j = T_a + \theta_{ja} \times \text{Total power consumption}$
- $T_j = T_t + \Psi_{jt} \times \text{Total power consumption}$ 
  - $T_j$ : Junction Temperature (°C)
  - $T_a$ : Ambient Temperature (°C)
  - $T_t$ : Top Center Case Temperature (°C)
  - $\theta_{ja}$ : Thermal Resistance of “Junction”-to-“Ambient” (°C/W)

### 47.2.6 VCC上升和下降梯度和纹波频率

**Table 47.9 上升和下降梯度特性**

| Parameter | Symbol        | Min    | Typ    | Max | Unit | 测试条件 |   |
|-----------|---------------|--------|--------|-----|------|------|---|
| VCC上升梯度   | 启动时禁用电压监视器0复位 | SrVCC  | 0.0084 | —   | 20   | ms/V | — |
|           | 启动时启用电压监视器0复位 |        | 0.0084 | —   | —    |      | — |
|           | SCI/USB启动模式*1 |        | 0.0084 | —   | 20   |      | — |
| VCC下降梯度*2 | SfVCC         | 0.0084 | —      | —   | ms/V | —    |   |

注1.在引导模式下，无论OFS1.LVDAS位的值如何，都禁止从电压监视器0进行的复位。  
 注2.这适用于使用VBATT时。

**Table 47.10 上升下降梯度和纹波频率特性**

纹波电压必须在VCC上限(3.6V)和下限(2.7V)之间。当VCC变化超过 $VCC \pm 10\%$ 时，必须满足允许的电压变化上升和下降梯度 $dt/dVCC$ 。

| Parameter    | Symbol     | Min | Typ | Max | Unit | 测试条件   |
|--------------|------------|-----|-----|-----|------|--|
| 允许纹波频率       | $f_r(VCC)$ | —   | —   | 10  | kHz  | Figure 47.6<br>$V_r(VCC) \leq VCC \times 0.2$  |
|              |            | —   | —   | 1   | MHz  | Figure 47.6<br>$V_r(VCC) \leq VCC \times 0.08$ |
|              |            | —   | —   | 10  | MHz  | Figure 47.6<br>$V_r(VCC) \leq VCC \times 0.06$ |
| 允许电压变化上升下降梯度 | $dt/dVCC$  | 1.0 | —   | —   | ms/V | 当VCC变化超过 $VCC \pm 10\%$                        |

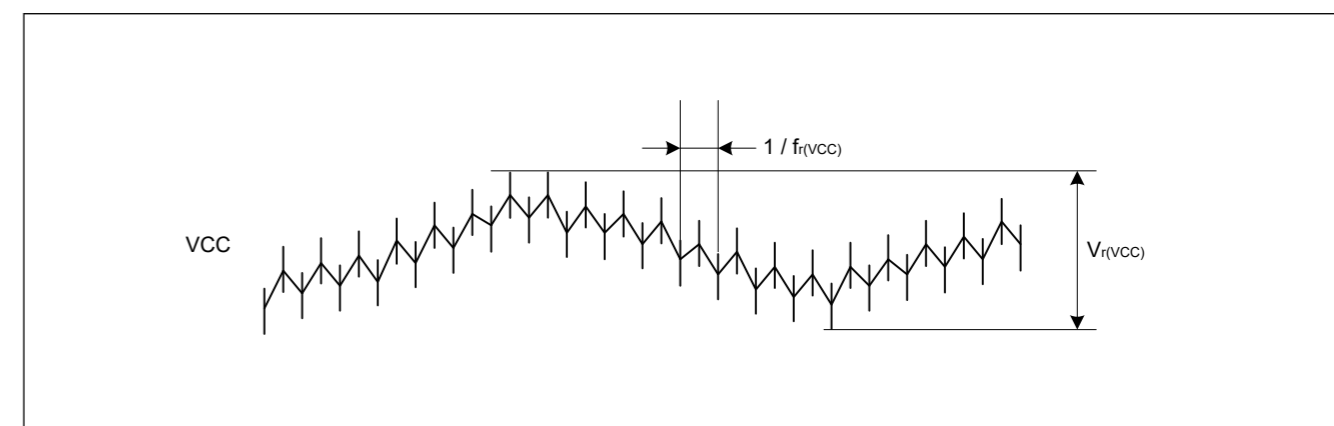


Figure 47.6 纹波波形

### 47.2.7 热特性

结温 ( $T_j$ ) 的最大值不得超过“第47.2.1节的值。 $T_j/T_a$ 定义”。

$T_j$ 通过以下任一公式计算。

- $T_j = T_a + \theta_{ja} \times \text{总功耗}$
- $T_j = T_t + \Psi_{jt} \times \text{总功耗}$ 
  - $T_j$ : 结温(°C)
  - $T_a$ : 环境温度 (°C)
  - $T_t$ : 顶部中心外壳温度(°C)
  - $\theta_{ja}$ : “结”到“环境”的热阻(°C/W)

- $\Psi_{jt}$ : Thermal Resistance of “Junction”-to-“Top Center Case” (°C/W)
- Total power consumption = Voltage × (Leakage current + Dynamic current)
- Leakage current of IO =  $\Sigma (I_{OL} \times V_{OL}) / \text{Voltage} + \Sigma (|I_{OH}| \times |V_{CC} - V_{OH}|) / \text{Voltage}$
- Dynamic current of IO =  $\Sigma IO (C_{in} + C_{load}) \times \text{IO switching frequency} \times \text{Voltage}$ 
  - $C_{in}$ : Input capacitance
  - $C_{load}$ : Output capacitance

Regarding  $\theta_{ja}$  and  $\Psi_{jt}$ , refer to Table 47.11.

**Table 47.11 Thermal Resistance**

| Parameter          | Package                     | Symbol        | Value*1 | Unit | Test conditions              |      |                              |
|--------------------|-----------------------------|---------------|---------|------|------------------------------|------|------------------------------|
| Thermal Resistance | 64-pin LQFP (PLQP0064KB-C)  | $\theta_{ja}$ | 38.0    | °C/W | JESD 51-2 and 51-7 compliant |      |                              |
|                    | 100-pin LQFP (PLQP0100KB-B) |               | 35.0    |      |                              |      |                              |
|                    | 144-pin LQFP (PLQP0144KA-B) |               | 33.0    |      |                              |      |                              |
|                    | 64-pin LQFP (PLQP0064KB-C)  | $\Psi_{jt}$   | 0.80    |      |                              | °C/W | JESD 51-2 and 51-7 compliant |
|                    | 100-pin LQFP (PLQP0100KB-B) |               | 0.76    |      |                              |      |                              |
|                    | 144-pin LQFP (PLQP0144KA-B) |               | 0.63    |      |                              |      |                              |

Note 1. The values are reference values when the 4-layer board is used. Thermal resistance depends on the number of layers or size of the board. For details, refer to the JEDEC standards.

#### 47.2.7.1 Calculation guide of $I_{CCmax}$

Table 47.12 shows the power consumption of each unit.

**Table 47.12 Power consumption of each unit (1 of 2)**

| Dynamic current/ Leakage current | MCU Domain | Category       | Item          | Frequency [MHz] | Current [uA/MHz] | Current*1 [mA] |
|----------------------------------|------------|----------------|---------------|-----------------|------------------|----------------|
| Leakage current                  | Analog     | LDO and Leak*2 | Ta = 75 °C*3  | —               | —                | 21.22          |
|                                  |            |                | Ta = 85 °C*3  | —               | —                | 25.22          |
|                                  |            |                | Ta = 95 °C*3  | —               | —                | 30.22          |
|                                  |            |                | Ta = 105 °C*3 | —               | —                | 37.42          |

- $\Psi_{jt}$ : “结”到“顶部中心外壳”的热阻(°CW)
- 总功耗=电压×(漏电流+动态电流)
- IO漏电流= $\Sigma(I_{OL} \times V_{OL})$ 电压+ $\Sigma(I_{OH} \times V_{CC} - V_{OH})$ 电压
- IO的动态电流= $\Sigma IO(C_{in} + C_{load}) \times \text{IO开关频率} \times \text{电压}$ 
  - Cin:输入电容
  - C负载:输出电容

关于 $\theta_{ja}$ 和 $\Psi_{jt}$ , 请参阅表47.11。

**Table 47.11 热阻**

| Parameter          | Package                     | Symbol        | Value*1 | Unit | 测试条件            |      |                 |
|--------------------|-----------------------------|---------------|---------|------|-----------------|------|-----------------|
| Thermal Resistance | 64-pin LQFP (PLQP0064KB-C)  | $\theta_{ja}$ | 38.0    | °C/W | 符合JESD51-2和51-7 |      |                 |
|                    | 100-pin LQFP (PLQP0100KB-B) |               | 35.0    |      |                 |      |                 |
|                    | 144-pin LQFP (PLQP0144KA-B) |               | 33.0    |      |                 |      |                 |
|                    | 64-pin LQFP (PLQP0064KB-C)  | $\Psi_{jt}$   | 0.80    |      |                 | °C/W | 符合JESD51-2和51-7 |
|                    | 100-pin LQFP (PLQP0100KB-B) |               | 0.76    |      |                 |      |                 |
|                    | 144-pin LQFP (PLQP0144KA-B) |               | 0.63    |      |                 |      |                 |

注1.数值为使用4层板时的参考值。热阻取决于板的层数或尺寸。有关详细信息, 请参阅JEDEC标准。

#### 47.2.7.1 ICCmax的计算指南

表47.12显示了每个单元的功耗。

**Table 47.12 每个单元的功耗 (2个中的1个)**

| 动态电流漏电流 | MCU Domain | Category | Item          | Frequency [MHz] | Current [uA/MHz] | Current*1 [mA] |
|---------|------------|----------|---------------|-----------------|------------------|----------------|
| 漏电流     | Analog     | LDO和泄漏*2 | Ta = 75 °C*3  | —               | —                | 21.22          |
|         |            |          | Ta = 85 °C*3  | —               | —                | 25.22          |
|         |            |          | Ta = 95 °C*3  | —               | —                | 30.22          |
|         |            |          | Ta = 105 °C*3 | —               | —                | 37.42          |



Table 47.12 Power consumption of each unit (2 of 2)

| Dynamic current/<br>Leakage current | MCU<br>Domain | Category                         | Item                        | Frequency<br>[MHz] | Current<br>[uA/MHz] | Current*1<br>[mA] |       |
|-------------------------------------|---------------|----------------------------------|-----------------------------|--------------------|---------------------|-------------------|-------|
| Dynamic current                     | CPU           | Operation with<br>Flash and SRAM | Coremark                    | 100                | 86.493              | 8.65              |       |
|                                     |               |                                  | Peripheral Unit             | Timer              | GPT16 (4ch)*4       | 100               | 3.548 |
|                                     |               |                                  |                             | GPT32 (4ch)*4      | 100                 | 3.946             | 0.39  |
|                                     |               |                                  |                             | POEG (4 Groups)    | 50                  | 1.378             | 0.07  |
|                                     |               |                                  |                             | AGT (6ch)*4        | 50                  | 10.095            | 0.50  |
|                                     |               |                                  |                             | RTC                | 50                  | 5.239             | 0.26  |
|                                     |               |                                  |                             | WDT                | 50                  | 0.722             | 0.04  |
|                                     |               |                                  |                             | IWDT               | 50                  | 0.267             | 0.01  |
|                                     |               |                                  | Communication<br>interfaces | USBFS              | 50                  | 8.788             | 0.44  |
|                                     |               |                                  |                             | SCI (6ch)*4        | 100                 | 18.077            | 1.81  |
|                                     |               |                                  |                             | IIC (2ch)*4        | 50                  | 3.014             | 0.15  |
|                                     |               |                                  |                             | CAN (2ch)*4        | 50                  | 3.843             | 0.19  |
|                                     |               |                                  |                             | SPI                | 100                 | 3.394             | 0.34  |
|                                     |               |                                  |                             | QSPI               | 100                 | 2.587             | 0.26  |
|                                     |               |                                  |                             | SSIE               | 50                  | 3.131             | 0.16  |
|                                     |               |                                  |                             | SDHI               | 50                  | 7.074             | 0.35  |
|                                     |               |                                  | Analog                      | ADC12 (2 Units)*4  | 100                 | 4.697             | 0.47  |
|                                     |               |                                  |                             | DAC12 (2ch)*4      | 100                 | 3.543             | 0.35  |
|                                     |               |                                  |                             | TSN                | 50                  | 0.166             | 0.01  |
|                                     |               |                                  | Human machine<br>interfaces | CTSU               | 50                  | 0.678             | 0.03  |
|                                     |               |                                  | Event link                  | ELC                | 50                  | 1.016             | 0.05  |
|                                     |               |                                  | Security                    | SCE9               | 100                 | 218.100           | 21.81 |
|                                     |               |                                  | Data processing             | CRC                | 100                 | 0.521             | 0.05  |
|                                     |               |                                  |                             | DOC                | 100                 | 0.358             | 0.04  |
|                                     |               |                                  | System                      | CAC                | 50                  | 0.909             | 0.05  |
|                                     |               |                                  | DMA                         | DMAC               | 100                 | 5.180             | 0.52  |
|                                     |               |                                  |                             | DTC                | 100                 | 3.792             | 0.38  |

Note 1. The values are guaranteed by design.

Note 2. LDO and Leak are internal voltage regulator's current and MCU's leakage current.

It is selected according to the temperature of Ta.

Note 3.  $\Delta(T_j - T_a) = 20^\circ\text{C}$  is considered to measure the current.

Note 4. To determine the current consumption per channel, group or unit, divide Current [mA] by the number of channels, groups or units.

Table 47.13 shows the outline of operation for each unit.

Table 47.13 Outline of operation for each unit (1 of 2)

| Peripheral | Outline of operation   |
|------------|--|
| GPT        | Operating modes is set to saw-wave PWM mode.<br>GPT is operating with PCLKD. |
| POEG       | Only clear module stop bit.  |
| AGT        | AGT is operating with PCLKB.   |
| RTC        | RTC is operating with LOCO.  |

Table 47.12 每个单元的功耗 (2个中的2个)

| 动态电流/漏电流 | MCU<br>Domain | Category       | Item     | Frequency<br>[MHz] | Current<br>[uA/MHz] | Current*1<br>[mA] |       |
|----------|---------------|----------------|----------|--------------------|---------------------|-------------------|-------|
| 动态电流     | CPU           | 操作与<br>闪存和SRAM | Coremark | 100                | 86.493              | 8.65              |       |
|          |               |                | 外围单元     | Timer              | GPT16 (4ch)*4       | 100               | 3.548 |
|          |               |                |          | GPT32 (4ch)*4      | 100                 | 3.946             | 0.39  |
|          |               |                |          | POEG (4 Groups)    | 50                  | 1.378             | 0.07  |
|          |               |                |          | AGT (6ch)*4        | 50                  | 10.095            | 0.50  |
|          |               |                |          | RTC                | 50                  | 5.239             | 0.26  |
|          |               |                |          | WDT                | 50                  | 0.722             | 0.04  |
|          |               |                |          | IWDT               | 50                  | 0.267             | 0.01  |
|          |               |                | 通讯接口     | USBFS              | 50                  | 8.788             | 0.44  |
|          |               |                |          | SCI (6ch)*4        | 100                 | 18.077            | 1.81  |
|          |               |                |          | IIC (2ch)*4        | 50                  | 3.014             | 0.15  |
|          |               |                |          | CAN (2ch)*4        | 50                  | 3.843             | 0.19  |
|          |               |                |          | SPI                | 100                 | 3.394             | 0.34  |
|          |               |                |          | QSPI               | 100                 | 2.587             | 0.26  |
|          |               |                |          | SSIE               | 50                  | 3.131             | 0.16  |
|          |               |                |          | SDHI               | 50                  | 7.074             | 0.35  |
|          |               |                | Analog   | ADC12 (2 Units)*4  | 100                 | 4.697             | 0.47  |
|          |               |                |          | DAC12 (2ch)*4      | 100                 | 3.543             | 0.35  |
|          |               |                |          | TSN                | 50                  | 0.166             | 0.01  |
|          |               |                | 人机界面     | CTSU               | 50                  | 0.678             | 0.03  |
|          |               |                | 活动链接     | ELC                | 50                  | 1.016             | 0.05  |
|          |               |                | Security | SCE9               | 100                 | 218.100           | 21.81 |
|          |               |                | 数据处理     | CRC                | 100                 | 0.521             | 0.05  |
|          |               |                |          | DOC                | 100                 | 0.358             | 0.04  |
|          |               |                | System   | CAC                | 50                  | 0.909             | 0.05  |
|          |               |                | DMA      | DMAC               | 100                 | 5.180             | 0.52  |
|          |               |                |          | DTC                | 100                 | 3.792             | 0.38  |

注1.数值由设计保证。

注2.LDO和Leak是内部稳压器的电流和MCU的漏电流。

根据Ta的温度选择。

注3.测量电流时考虑 $\Delta(T_j - T_a) = 20^\circ\text{C}$ 。

注4.要确定每个通道、组或单元的电流消耗，请将电流[mA]除以通道、组或单元的数量。

表47.13显示了每个单元的操作概要。

Table 47.13 每个单元的操作概要 (2个中的1个)

| Peripheral | 操作概要                              |
|------------|-----------------------------------|
| GPT        | 操作模式设置为锯齿波PWM模式。<br>GPT使用PCLKD运行。 |
| POEG       | 只清除模块停止位。                         |
| AGT        | AGT使用PCLKB运行。                     |
| RTC        | RTC与LOCO一起运行。                     |

Table 47.13 Outline of operation for each unit (2 of 2)

| Peripheral | Outline of operation  |
|------------|---|
| WDT        | WDT is operating with PCLKB.  |
| IWDT       | IWDT is operating with IWDTCLK.   |
| USBFS      | Transfer types is set to bulk transfer.<br>USBFS is operating using Full-speed transfer (12 Mbps).  |
| SCI        | SCI is transmitting data in clock synchronous mode.   |
| IIC        | Communication format is set to I2C-bus format.<br>IIC is transmitting data in master mode.  |
| CAN        | CAN is transmitting and receiving data in self-test mode 1.   |
| SPI        | SPI mode is set to SPI operation (4-wire method).<br>SPI master/slave mode is set to master mode.<br>SPI is transmitting 8-bit width data.                            |
| QSPI       | QSPI is issuing Fast Read Quad I/O Instruction.   |
| SSIE       | Communication mode is set to Master.<br>System word length is set to 32 bits.<br>Data word length is set to 20 bits.<br>SSIE is transmitting data using I2S format.   |
| SDHI       | Transfer bus mode is set to 4-bit wide bus mode.<br>SDHI is issuing CMD24 (single-block write).   |
| ADC12      | Resolution is set to 12-bit accuracy.<br>Data registers is set to A/D-converted value addition mode.<br>ADC12 is converting the analog input in continuous scan mode. |
| DAC12      | DAC12 is outputting the conversion result while updating the value of data register.  |
| TSN        | TSN is operating.   |
| CTSU       | CTSU is operating in self-capacitance single scan mode.   |
| ELC        | Only clear module stop bit.   |
| SCE9       | SCE9 is executing built-in self test.   |
| CRC        | CRC is generating CRC code using 32-bit CRC32-C polynomial.   |
| DOC        | DOC is operating in data addition mode.   |
| CAC        | Measurement target clocks is set to PCLKB.<br>Measurement reference clocks is set to PCLKB.<br>CAC is measuring the clock frequency accuracy.                         |
| DMAC       | Bit length of transfer data is set to 32 bits.<br>Transfer mode is set to block transfer mode.<br>DMAC is transferring data from SRAM0 to SRAM0.                      |
| DTC        | Bit length of transfer data is set to 32 bits.<br>Transfer mode is set to block transfer mode.<br>DTC is transferring data from SRAM0 to SRAM0.                       |

47.2.7.2 Example of  $T_j$  calculation

Assumption :

- Package 144-pin LQFP :  $\theta_{ja} = 33.0 \text{ } ^\circ\text{C/W}$
- $T_a = 100 \text{ } ^\circ\text{C}$
- $I_{CCmax} = 70 \text{ mA}$
- $V_{CC} = 3.5 \text{ V}$  ( $V_{CC} = AV_{CC} = V_{CC\_USB}$ )
- $I_{OH} = 1 \text{ mA}$ ,  $V_{OH} = V_{CC} - 0.5 \text{ V}$ , 12 Outputs
- $I_{OL} = 20 \text{ mA}$ ,  $V_{OL} = 1.0 \text{ V}$ , 8 Outputs
- $I_{OL} = 1 \text{ mA}$ ,  $V_{OL} = 0.5 \text{ V}$ , 12 Outputs

Table 47.13 每个单元的操作概要 (2个中的2个)

| Peripheral | 操作概要  |
|------------|---|
| WDT        | WDT使用PCLKB运行。   |
| IWDT       | IWDT使用IWDTCLK运行。  |
| USBFS      | 传输类型设置为批量传输。<br>USBFS使用全速传输(12Mbps)运行。                      |
| SCI        | SCI在时钟同步模式下传输数据。  |
| IIC        | 通信格式设置为I2C总线格式。<br>IIC在主机模式下传输数据。                           |
| CAN        | CAN在自检模式1中发送和接收数据。  |
| SPI        | SPI模式设置为SPI操作(4线方法)。<br>SPI主从模式设置为主模式。<br>SPI正在传输8位宽度的数据。   |
| QSPI       | QSPI正在发出快速读取四线IO指令。   |
| SSIE       | 通信模式设置为主。<br>系统字长设置为32位。<br>数据字长设置为20位。<br>SSIE使用I2S格式传输数据。 |
| SDHI       | 传输总线模式设置为4位宽总线模式。<br>SDHI正在发布CMD24(单块写入)。                   |
| ADC12      | 分辨率设置为12位精度。<br>数据寄存器设置为AD转换值加法模式。<br>ADC12在连续扫描模式下转换模拟输入。  |
| DAC12      | DAC12在更新数据寄存器值的同时输出转换结果。                                    |
| TSN        | TSN正在运行。  |
| CTSU       | CTSU在自电容单次扫描模式下运行。  |
| ELC        | 只清除模块停止位。   |
| SCE9       | SCE9正在执行内置自检。   |
| CRC        | CRC使用32位CRC32-C多项式生成CRC码。                                   |
| DOC        | DOC在数据添加模式下运行。  |
| CAC        | 测量目标时钟设置为PCLKB。<br>测量参考时钟设置为PCLKB。CAC正在测量时钟频率精度。            |
| DMAC       | 传输数据的位长设置为32位。<br>传输模式设置为块传输模式。<br>DMAC正在将数据从SRAM0传输到SRAM0。 |
| DTC        | 传输数据的位长设置为32位。<br>传输模式设置为块传输模式。<br>DTC正在将数据从SRAM0传输到SRAM0。  |

47.2.7.2  $T_j$ 计算示例

Assumption :

- Package 144-pin LQFP :  $\theta_{ja} = 33.0 \text{ } ^\circ\text{C/W}$
- $T_a = 100 \text{ } ^\circ\text{C}$
- ICC最大值=70mA
- $V_{CC} = 3.5 \text{ V}$  ( $V_{CC} = AV_{CC} = V_{CC\_USB}$ )
- $I_{OH}=1\text{mA}$ ,  $V_{OH}=V_{CC} - 0.5\text{V}$ , 12个输出
- $I_{OL}=20\text{mA}$ ,  $V_{OL}=1.0\text{V}$ , 8个输出
- $I_{OL}=1\text{mA}$ ,  $V_{OL}=0.5\text{V}$ , 12路输出

- $C_{in} = 8 \text{ pF}$ , 32 pins, Input frequency = 10 MHz
- $C_{load} = 30 \text{ pF}$ , 32 pins, Output frequency = 10 MHz

$$\begin{aligned} \text{Leakage current of IO} &= \Sigma (V_{OL} \times I_{OL}) / \text{Voltage} + \Sigma ((V_{CC} - V_{OH}) \times I_{OH}) / \text{Voltage} \\ &= (20 \text{ mA} \times 1 \text{ V}) \times 8 / 3.5 \text{ V} + (1 \text{ mA} \times 0.5 \text{ V}) \times 12 / 3.5 \text{ V} + ((V_{CC} - (V_{CC} - 0.5 \text{ V})) \times 1 \text{ mA}) \times 12 / 3.5 \text{ V} \\ &= 45.7 \text{ mA} + 1.71 \text{ mA} + 1.71 \text{ mA} \\ &= 49.1 \text{ mA} \end{aligned}$$

$$\begin{aligned} \text{Dynamic current of IO} &= \Sigma IO (C_{in} + C_{load}) \times \text{IO switching frequency} \times \text{Voltage} \\ &= ((8 \text{ pF} \times 32) \times 10 \text{ MHz} + (30 \text{ pF} \times 32) \times 10 \text{ MHz}) \times 3.5 \text{ V} \\ &= 42.6 \text{ mA} \end{aligned}$$

$$\begin{aligned} \text{Total power consumption} &= \text{Voltage} \times (\text{Leakage current} + \text{Dynamic current}) \\ &= (70 \text{ mA} \times 3.5 \text{ V}) + (49.1 \text{ mA} + 42.6 \text{ mA}) \times 3.5 \text{ V} \\ &= 566 \text{ mW} (0.566 \text{ W}) \end{aligned}$$

$$\begin{aligned} T_j &= T_a + \theta_{ja} \times \text{Total power consumption} \\ &= 100 \text{ }^\circ\text{C} + 33.0 \text{ }^\circ\text{C/W} \times 0.566 \text{ W} \\ &= 118.7 \text{ }^\circ\text{C} \end{aligned}$$

### 47.3 AC Characteristics

#### 47.3.1 Frequency

Table 47.14 Operation frequency value in high-speed mode

| Parameter           | Symbol  | Min             | Typ | Max | Unit |
|---------------------|---|-----------------|-----|-----|------|
| Operation frequency | System clock (ICLK) <sup>*2</sup>             | —               | —   | 100 | MHz  |
|                     | Peripheral module clock (PCLKA) <sup>*2</sup> | —               | —   | 100 |      |
|                     | Peripheral module clock (PCLKB) <sup>*2</sup> | —               | —   | 50  |      |
|                     | Peripheral module clock (PCLKC) <sup>*2</sup> | — <sup>*3</sup> | —   | 50  |      |
|                     | Peripheral module clock (PCLKD) <sup>*2</sup> | —               | —   | 100 |      |
|                     | Flash interface clock (FCLK) <sup>*2</sup>    | — <sup>*1</sup> | —   | 50  |      |

- Note 1. FCLK must run at a frequency of at least 4 MHz when programming or erasing the flash memory.  
 Note 2. See section 8, Clock Generation Circuit for the relationship between the ICLK, PCLKA, PCLKB, PCLKC, PCLKD, and FCLK frequencies.  
 Note 3. When the ADC12 is used, the PCLKC frequency must be at least 1 MHz.

Table 47.15 Operation frequency value in low-speed mode

| Parameter           | Symbol   | Min             | Typ | Max | Unit |
|---------------------|--|-----------------|-----|-----|------|
| Operation frequency | System clock (ICLK) <sup>*2</sup>                | —               | —   | 1   | MHz  |
|                     | Peripheral module clock (PCLKA) <sup>*2</sup>    | —               | —   | 1   |      |
|                     | Peripheral module clock (PCLKB) <sup>*2</sup>    | —               | —   | 1   |      |
|                     | Peripheral module clock (PCLKC) <sup>*2 *3</sup> | — <sup>*3</sup> | —   | 1   |      |
|                     | Peripheral module clock (PCLKD) <sup>*2</sup>    | —               | —   | 1   |      |
|                     | Flash interface clock (FCLK) <sup>*1 *2</sup>    | —               | —   | 1   |      |

- Note 1. Programming or erasing the flash memory is disabled in low-speed mode.  
 Note 2. See section 8, Clock Generation Circuit for the relationship between the ICLK, PCLKA, PCLKB, PCLKC, PCLKD, and FCLK frequencies.

- $C_{in}=8\text{pF}$ , 32引脚, 输入频率=10MHz
- $C_{\text{负载}}=30\text{pF}$ , 32引脚, 输出频率=10MHz

$$\begin{aligned} \text{IO的漏电流} &= \Sigma (\text{VOL} \times \text{IOL}) / \text{电压} + \Sigma ((\text{VCCVOH}) \times \text{IOH}) / \text{电压} \\ &= (20 \text{ mA} \times 1 \text{ V}) \times 8 / 3.5 \text{ V} + (1 \text{ mA} \times 0.5 \text{ V}) \times 12 / 3.5 \text{ V} + ((\text{VCC} - (\text{VCC} - 0.5 \text{ V})) \times 1 \text{ mA}) \times 12 / 3.5 \text{ V} \\ &= 45.7 \text{ mA} + 1.71 \text{ mA} + 1.71 \text{ mA} \\ &= 49.1 \text{ mA} \end{aligned}$$

$$\begin{aligned} \text{IO的动态电流} &= \Sigma \text{IO} (\text{Cin} + \text{Cload}) \times \text{IO开关频率} \times \text{电压} \\ &= ((8 \text{ pF} \times 32) \times 10 \text{ MHz} + (30 \text{ pF} \times 32) \times 10 \text{ MHz}) \times 3.5 \text{ V} \\ &= 42.6 \text{ mA} \end{aligned}$$

$$\begin{aligned} \text{总功耗} &= \text{电压} \times (\text{漏电流} + \text{动态电流}) \\ &= (70 \text{ mA} \times 3.5 \text{ V}) + (49.1 \text{ mA} + 42.6 \text{ mA}) \times 3.5 \text{ V} \\ &= 566 \text{ mW} (0.566 \text{ W}) \end{aligned}$$

$$\begin{aligned} T_j &= T_a + \theta_{ja} \times \text{总功耗} \\ &= 100 \text{ }^\circ\text{C} + 33.0 \text{ }^\circ\text{C/W} \times 0.566 \text{ W} \\ &= 118.7 \text{ }^\circ\text{C} \end{aligned}$$

### 47.3 交流特性

#### 47.3.1 Frequency

Table 47.14 高速模式下的运行频率值

| Parameter | Symbol          | Min             | Typ | Max | Unit |
|-----------|-----------------|-----------------|-----|-----|------|
| 运行频率      | 系统时钟 (ICLK)*2   | —               | —   | 100 | MHz  |
|           | 外围模块时钟(PCLKA)*2 | —               | —   | 100 |      |
|           | 外围模块时钟(PCLKB)*2 | —               | —   | 50  |      |
|           | 外围模块时钟(PCLKC)*2 | — <sup>*3</sup> | —   | 50  |      |
|           | 外围模块时钟(PCLKD)*2 | —               | —   | 100 |      |
|           | 闪存接口时钟(FCLK)*2  | — <sup>*1</sup> | —   | 50  |      |

- 注1.在对闪存进行编程或擦除时, FCLK必须以至少4MHz的频率运行。  
 注2.有关ICLK、PCLKA、PCLKB、PCLKC、PCLKD和FCLK频率之间的关系, 请参见第8节, 时钟生成电路。  
 注3.使用ADC12时, PCLKC频率必须至少为1MHz。

Table 47.15 低速模式下的运行频率值

| Parameter | Symbol              | Min             | Typ | Max | Unit |
|-----------|---------------------|-----------------|-----|-----|------|
| 运行频率      | 系统时钟(ICLK)*2        | —               | —   | 1   | MHz  |
|           | 外围模块时钟(PCLKA)*2     | —               | —   | 1   |      |
|           | 外围模块时钟(PCLKB)*2     | —               | —   | 1   |      |
|           | 外围模块时钟(PCLKC)*2*3   | — <sup>*3</sup> | —   | 1   |      |
|           | 外围模块时钟(PCLKD)*2     | —               | —   | 1   |      |
|           | Flash接口时钟(FCLK)*1*2 | —               | —   | 1   |      |

- 注1.在低速模式下禁止对闪存进行编程或擦除。  
 注2.有关ICLK、PCLKA、PCLKB、PCLKC、PCLKD和FCLK频率之间的关系, 请参见第8节, 时钟生成电路。

Note 3. When the ADC12 is used, the PCLKC frequency must be set to at least 1 MHz.

Table 47.16 Operation frequency value in Subosc-speed mode

| Parameter           | Symbol   | Min  | Typ  | Max  | Unit |     |
|---------------------|--|------|------|------|------|-----|
| Operation frequency | System clock (ICLK) <sup>*2</sup>                | f    | 29.4 | —    | 36.1 | kHz |
|                     | Peripheral module clock (PCLKA) <sup>*2</sup>    | —    | —    | 36.1 |      |     |
|                     | Peripheral module clock (PCLKB) <sup>*2</sup>    | —    | —    | 36.1 |      |     |
|                     | Peripheral module clock (PCLKC) <sup>*2 *3</sup> | —    | —    | 36.1 |      |     |
|                     | Peripheral module clock (PCLKD) <sup>*2</sup>    | —    | —    | 36.1 |      |     |
|                     | Flash interface clock (FCLK) <sup>*1 *2</sup>    | 29.4 | —    | 36.1 |      |     |

Note 1. Programming or erasing the flash memory is disabled in Subosc-speed mode.  
 Note 2. See section 8, Clock Generation Circuit for the relationship between the ICLK, PCLKA, PCLKB, PCLKC, PCLKD, and FCLK frequencies.  
 Note 3. The ADC12 cannot be used.

47.3.2 Clock Timing

Table 47.17 Clock timing except for sub-clock oscillator (1 of 2)

| Parameter  | Symbol                 | Min                 | Typ    | Max             | Unit   | Test conditions |  |
|--|------------------------|---------------------|--------|-----------------|--------|-----------------|--|
| EXTAL external clock input cycle time                                  | t <sub>EXcyc</sub>     | 41.66               | —      | —               | ns     | Figure 47.7     |  |
| EXTAL external clock input high pulse width                            | t <sub>EXH</sub>       | 15.83               | —      | —               | ns     |                 |  |
| EXTAL external clock input low pulse width                             | t <sub>EXL</sub>       | 15.83               | —      | —               | ns     |                 |  |
| EXTAL external clock rise time   | t <sub>EXr</sub>       | —                   | —      | 5.0             | ns     |                 |  |
| EXTAL external clock fall time   | t <sub>EXf</sub>       | —                   | —      | 5.0             | ns     |                 |  |
| Main clock oscillator frequency  | f <sub>MAIN</sub>      | 8                   | —      | 24              | MHz    | —               |  |
| Main clock oscillation stabilization wait time (crystal) <sup>*1</sup> | t <sub>MAINOSCWT</sub> | —                   | —      | — <sup>*1</sup> | ms     | Figure 47.8     |  |
| LOCO clock oscillation frequency                                       | f <sub>LOCO</sub>      | 29.4912             | 32.768 | 36.0448         | kHz    | —               |  |
| LOCO clock oscillation stabilization wait time                         | t <sub>LOCOWT</sub>    | —                   | —      | 60.4            | μs     | Figure 47.9     |  |
| ILOCO clock oscillation frequency                                      | f <sub>ILOCO</sub>     | 13.5                | 15     | 16.5            | kHz    | —               |  |
| MOCO clock oscillation frequency                                       | F <sub>MOCO</sub>      | 6.8                 | 8      | 9.2             | MHz    | —               |  |
| MOCO clock oscillation stabilization wait time                         | t <sub>MOCOWT</sub>    | —                   | —      | 15.0            | μs     | —               |  |
| HOCO clock oscillator oscillation frequency                            | Without FLL            | f <sub>HOCO16</sub> | 15.78  | 16              | 16.22  | MHz             | -20 ≤ Ta ≤ 105°C   |
|  |                        | f <sub>HOCO18</sub> | 17.75  | 18              | 18.25  |                 |  |
|  |                        | f <sub>HOCO20</sub> | 19.72  | 20              | 20.28  |                 |  |
|  |                        | f <sub>HOCO16</sub> | 15.71  | 16              | 16.29  |                 | -40 ≤ Ta ≤ -20°C   |
|  |                        | f <sub>HOCO18</sub> | 17.68  | 18              | 18.32  |                 |  |
|  |                        | f <sub>HOCO20</sub> | 19.64  | 20              | 20.36  |                 |  |
|  | With FLL               | f <sub>HOCO16</sub> | 15.960 | 16              | 16.040 | MHz             | -40 ≤ Ta ≤ 105°C<br>Sub-clock frequency accuracy is ±50 ppm. |
|  |                        | f <sub>HOCO18</sub> | 17.955 | 18              | 18.045 |                 |  |
|  |                        | f <sub>HOCO20</sub> | 19.950 | 20              | 20.050 |                 |  |
| HOCO clock oscillation stabilization wait time <sup>*2</sup>           | t <sub>HOCOWT</sub>    | —                   | —      | 64.7            | μs     | —               |  |
| HOCO period jitter   | —                      | —                   | ±85    | —               | ps     | —               |  |
| FLL stabilization wait time  | t <sub>FLLWT</sub>     | —                   | —      | 1.8             | ms     | —               |  |
| PLL clock frequency  | f <sub>PLL</sub>       | 100                 | —      | 200             | MHz    | —               |  |

注3.使用ADC12时，PCLKC频率必须设置为至少1MHz。

Table 47.16 Subosc-speed模式下的运行频率值

| Parameter | Symbol              | Min  | Typ  | Max  | Unit |     |
|-----------|---------------------|------|------|------|------|-----|
| 运行频率      | 系统时钟(ICLK)*2        | f    | 29.4 | —    | 36.1 | kHz |
|           | 外围模块时钟(PCLKA)*2     | —    | —    | 36.1 |      |     |
|           | 外围模块时钟(PCLKB)*2     | —    | —    | 36.1 |      |     |
|           | 外围模块时钟(PCLKC)*2*3   | —    | —    | 36.1 |      |     |
|           | 外围模块时钟(PCLKD)*2     | —    | —    | 36.1 |      |     |
|           | Flash接口时钟(FCLK)*1*2 | 29.4 | —    | 36.1 |      |     |

注1.在Subosc速度模式下，编程或擦除闪存被禁用。  
 注2.有关ICLK、PCLKA、PCLKB、PCLKC、PCLKD和FCLK频率之间的关系，请参见第8节，时钟生成电路。  
 注3.ADC12不能使用。

47.3.2 时钟时序

Table 47.17 除副时钟振荡器外的时钟时序 (2个中的1个)

| Parameter           | Symbol                 | Min                 | Typ    | Max             | Unit   | 测试条件        |                                     |
|---------------------|------------------------|---------------------|--------|-----------------|--------|-------------|-------------------------------------|
| EXTAL外部时钟输入周期时间     | t <sub>EXcyc</sub>     | 41.66               | —      | —               | ns     | Figure 47.7 |                                     |
| EXTAL外部时钟输入高脉冲宽度    | t <sub>EXH</sub>       | 15.83               | —      | —               | ns     |             |                                     |
| EXTAL外部时钟输入低脉冲宽度    | t <sub>EXL</sub>       | 15.83               | —      | —               | ns     |             |                                     |
| EXTAL外部时钟上升时间       | t <sub>EXr</sub>       | —                   | —      | 5.0             | ns     |             |                                     |
| EXTAL外部时钟下降时间       | t <sub>EXf</sub>       | —                   | —      | 5.0             | ns     |             |                                     |
| 主时钟振荡器频率            | f <sub>MAIN</sub>      | 8                   | —      | 24              | MHz    | —           |                                     |
| 主时钟振荡稳定等待时间 (晶体) *1 | t <sub>MAINOSCWT</sub> | —                   | —      | — <sup>*1</sup> | ms     | Figure 47.8 |                                     |
| LOCO时钟振荡频率          | f <sub>LOCO</sub>      | 29.4912             | 32.768 | 36.0448         | kHz    | —           |                                     |
| LOCO时钟振荡稳定等待时间      | t <sub>LOCOWT</sub>    | —                   | —      | 60.4            | μs     | Figure 47.9 |                                     |
| ILOCO时钟振荡频率         | f <sub>ILOCO</sub>     | 13.5                | 15     | 16.5            | kHz    | —           |                                     |
| MOCO时钟振荡频率          | F <sub>MOCO</sub>      | 6.8                 | 8      | 9.2             | MHz    | —           |                                     |
| MOCO时钟振荡稳定等待时间      | t <sub>MOCOWT</sub>    | —                   | —      | 15.0            | μs     | —           |                                     |
| HOCO时钟振荡器振荡频率       | Without FLL            | f <sub>HOCO16</sub> | 15.78  | 16              | 16.22  | MHz         | -20 ≤ Ta ≤ 105°C                    |
|                     |                        | f <sub>HOCO18</sub> | 17.75  | 18              | 18.25  |             |                                     |
|                     |                        | f <sub>HOCO20</sub> | 19.72  | 20              | 20.28  |             |                                     |
|                     |                        | f <sub>HOCO16</sub> | 15.71  | 16              | 16.29  |             | -40 ≤ Ta ≤ -20°C                    |
|                     |                        | f <sub>HOCO18</sub> | 17.68  | 18              | 18.32  |             |                                     |
|                     |                        | f <sub>HOCO20</sub> | 19.64  | 20              | 20.36  |             |                                     |
|                     | With FLL               | f <sub>HOCO16</sub> | 15.960 | 16              | 16.040 | MHz         | 40 ≤ Ta ≤ 105°C<br>副时钟频率精度为 ±50ppm。 |
|                     |                        | f <sub>HOCO18</sub> | 17.955 | 18              | 18.045 |             |                                     |
|                     |                        | f <sub>HOCO20</sub> | 19.950 | 20              | 20.050 |             |                                     |
| HOCO时钟振荡稳定等待时间*2    | t <sub>HOCOWT</sub>    | —                   | —      | 64.7            | μs     | —           |                                     |
| HOCO周期抖动            | —                      | —                   | ±85    | —               | ps     | —           |                                     |
| FLL稳定等待时间           | t <sub>FLLWT</sub>     | —                   | —      | 1.8             | ms     | —           |                                     |
| 锁相环时钟频率             | f <sub>PLL</sub>       | 100                 | —      | 200             | MHz    | —           |                                     |



Table 47.17 Clock timing except for sub-clock oscillator (2 of 2)

| Parameter  | Symbol                          | Min | Typ       | Max       | Unit    | Test conditions              |
|--|---------------------------------|-----|-----------|-----------|---------|------------------------------|
| PLL2 clock frequency                               | $f_{PLL2}$                      | 120 | —         | 240       | MHz     | —                            |
| PLL/PLL2 clock oscillation stabilization wait time | $t_{PLLWT}$                     | —   | —         | 174.9     | $\mu s$ | Figure 47.10                 |
| PLL/PLL2 period jitter                             | $f_{PLL}, f_{PLL2} \geq 120MHz$ | —   | —         | $\pm 100$ | ps      | —                            |
|  | $f_{PLL}, f_{PLL2} < 120MHz$    | —   | —         | $\pm 120$ | ps      | —                            |
| PLL/PLL2 long term jitter                          | —                               | —   | $\pm 300$ | —         | ps      | Term: 1 $\mu s$ , 10 $\mu s$ |

Note 1. When setting up the main clock oscillator, ask the oscillator manufacturer for an oscillation evaluation, and use the results as the recommended oscillation stabilization time. Set the MOSCWTCR register to a value equal to or greater than the recommended value. After changing the setting in the MOSCCR.MOSTP bit to start main clock operation, read the OSCSF.MOSCSF flag to confirm that it is 1, and then start using the main clock oscillator.

Note 2. This is the time from release from reset state until the HOCO oscillation frequency ( $f_{HOCO}$ ) reaches the range for guaranteed operation.

Table 47.18 Clock timing for the sub-clock oscillator

| Parameter                                     | Symbol         | Min | Typ    | Max | Unit | Test conditions |
|---|----------------|-----|--------|-----|------|-----------------|
| Sub-clock frequency                           | $f_{SUB}$      | —   | 32.768 | —   | kHz  | —               |
| Sub-clock oscillation stabilization wait time | $t_{SUBOSCWT}$ | —   | —      | —*1 | s    | Figure 47.11    |

Note 1. When setting up the sub-clock oscillator, ask the oscillator manufacturer for an oscillation evaluation and use the results as the recommended oscillation stabilization time. After changing the setting in the SOSCCR.SOSTP bit to start sub-clock operation, only start using the sub-clock oscillator after the sub-clock oscillation stabilization time elapses with an adequate margin. A value that is two times the value shown is recommended.

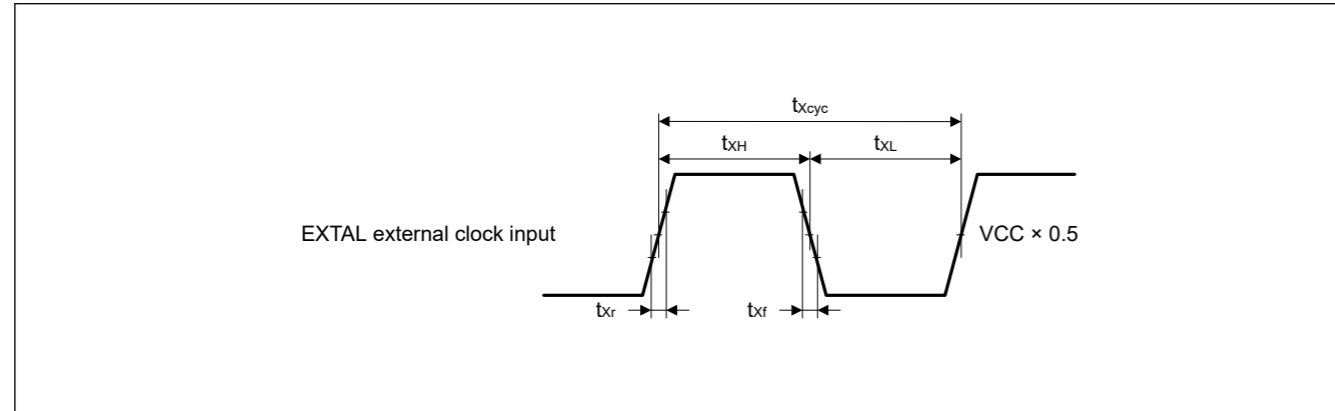


Figure 47.7 EXTAL external clock input timing

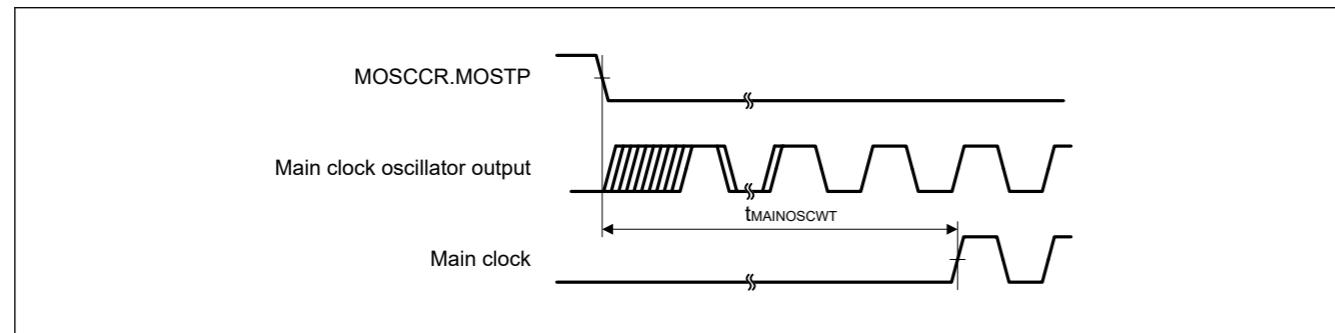


Figure 47.8 Main clock oscillation start timing

Table 47.17 除副时钟振荡器外的时钟时序 (2of2)

| Parameter         | Symbol                          | Min | Typ       | Max       | Unit    | 测试条件                         |
|-------------------|---------------------------------|-----|-----------|-----------|---------|------------------------------|
| PLL2时钟频率          | $f_{PLL2}$                      | 120 | —         | 240       | MHz     | —                            |
| PLLPLL2时钟振荡稳定等待时间 | $t_{PLLWT}$                     | —   | —         | 174.9     | $\mu s$ | Figure 47.10                 |
| PLLPLL2周期抖动       | $f_{PLL}, f_{PLL2} \geq 120MHz$ | —   | —         | $\pm 100$ | ps      | —                            |
|                   | $f_{PLL}, f_{PLL2} < 120MHz$    | —   | —         | $\pm 120$ | ps      | —                            |
| PLLPLL2长期抖动       | —                               | —   | $\pm 300$ | —         | ps      | Term: 1 $\mu s$ , 10 $\mu s$ |

注1.设置主时钟振荡器时，请咨询振荡器制造商索取振荡评估，并将结果作为推荐的振荡稳定时间。将MOSCWTCR寄存器设置为等于或大于推荐值的值。更改MOSCCR.MOSTP位的设置以启动主时钟操作后，读取OSCSF.MOSCSF标志以确认其为1，然后开始使用主时钟振荡器。

注2.这是从复位状态释放到HOCO振荡频率( $f_{HOCO}$ )达到保证工作范围的时间。

Table 47.18 副时钟振荡器的时钟时序

| Parameter           | Symbol         | Min | Typ    | Max | Unit | 测试条件         |
|---------------------|----------------|-----|--------|-----|------|--------------|
| Sub-clock frequency | $f_{SUB}$      | —   | 32.768 | —   | kHz  | —            |
| 副时钟振荡稳定等待时间         | $t_{SUBOSCWT}$ | —   | —      | —*1 | s    | Figure 47.11 |

注1.设置副时钟振荡器时，请咨询振荡器制造商进行振荡评估，并将结果作为推荐的振荡稳定时间。更改SOSCCR.SOSTP位的设置以启动副时钟操作后，只有在副时钟振荡稳定时间过去并留有足够余量后才开始使用副时钟振荡器。建议使用两倍于显示值的值。

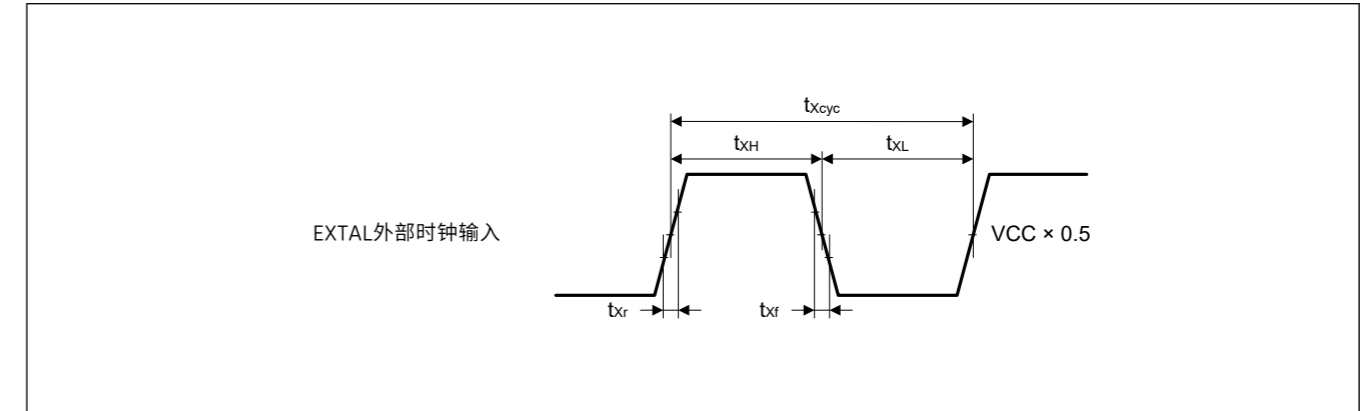


Figure 47.7 EXTAL外部时钟输入时序

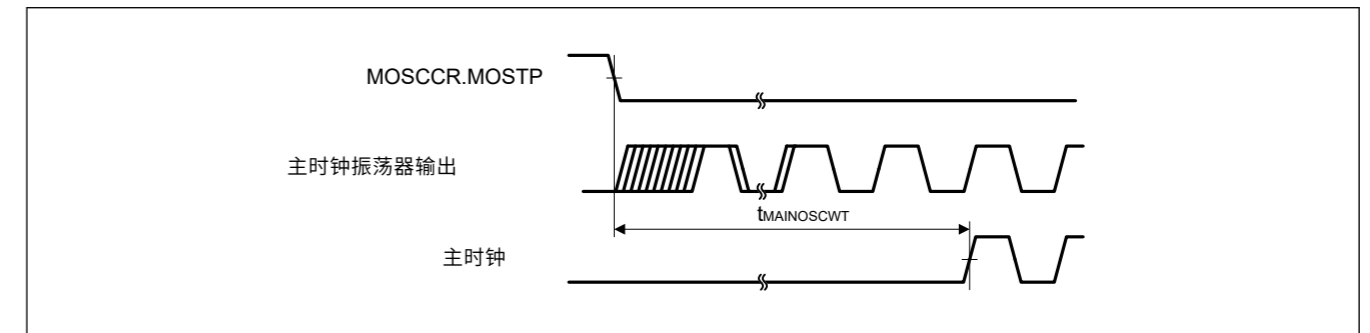


Figure 47.8 主时钟振荡开始时序

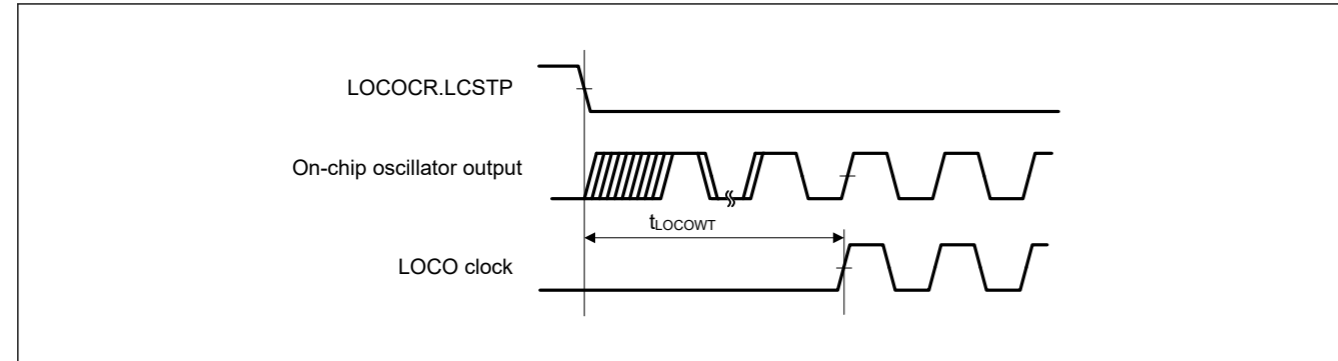


Figure 47.9 LOCO clock oscillation start timing

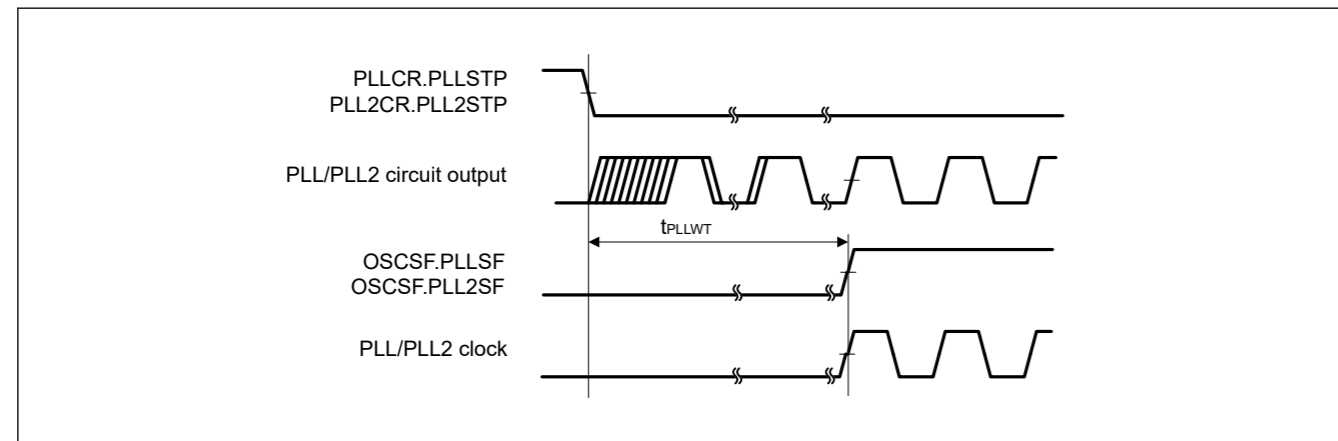


Figure 47.10 PLL/PLL2 clock oscillation start timing

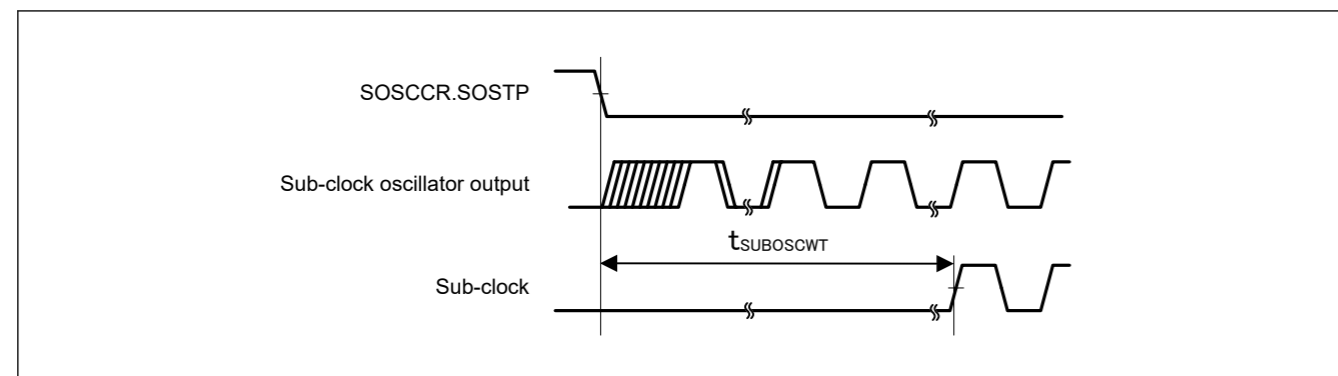


Figure 47.11 Sub-clock oscillation start timing

47.3.3 Reset Timing

Table 47.19 Reset timing (1 of 2)

| Parameter                        | Symbol                                   | Min         | Typ  | Max  | Unit    | Test conditions |
|----------------------------------|--|-------------|------|------|---------|-----------------|
| RES pulse width                  | Power-on                                 | $t_{RESWP}$ | 0.7  | —    | ms      | Figure 47.12    |
|                                  | Deep Software Standby mode               | $t_{RESWD}$ | 0.6  | —    | ms      | Figure 47.13    |
|                                  | Software Standby mode, Subosc-speed mode | $t_{RESWS}$ | 0.3  | —    | ms      |                 |
|                                  | All other                                | $t_{RESW}$  | 200  | —    | $\mu$ s |                 |
| Wait time after RES cancellation | $t_{RESWT}$                              | —           | 37.3 | 41.2 | $\mu$ s | Figure 47.12    |

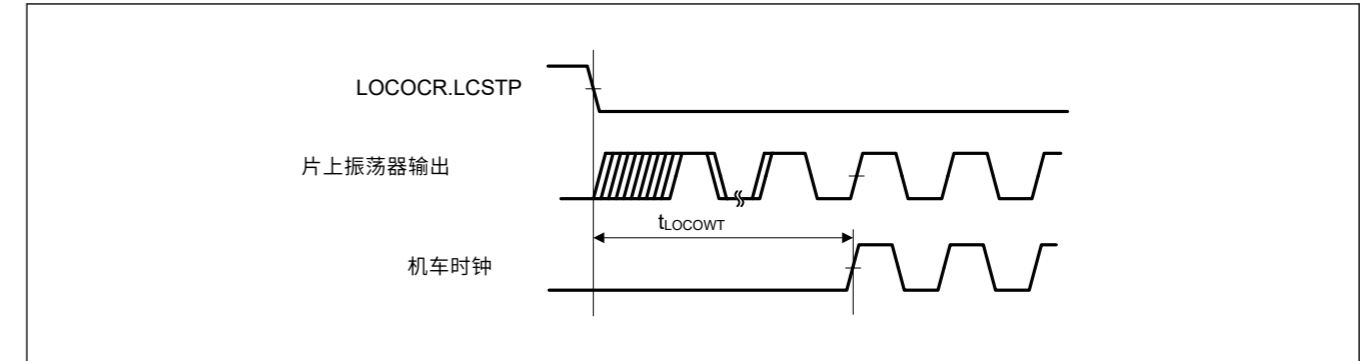


Figure 47.9 LOCO时钟振荡开始时序

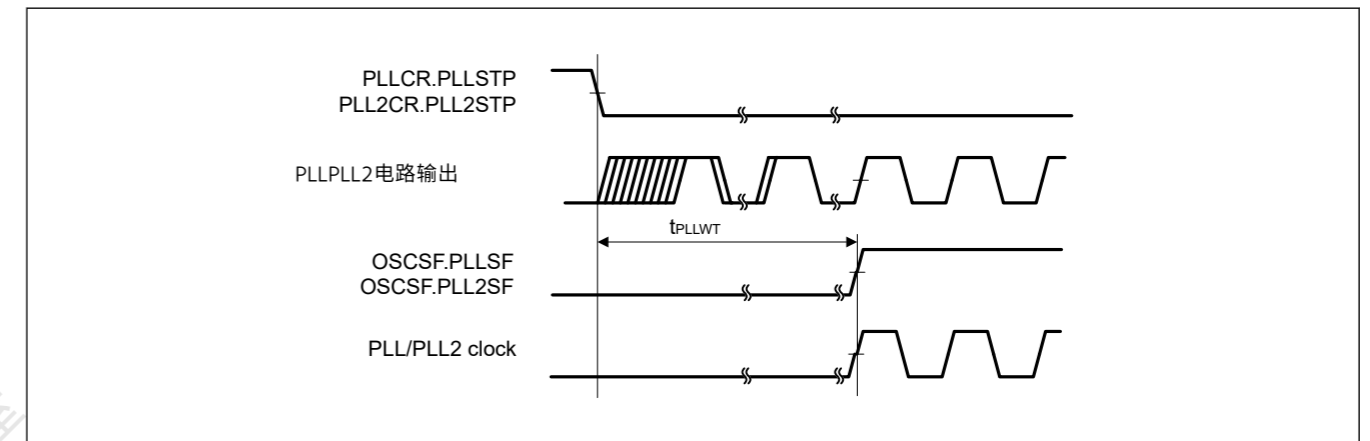


Figure 47.10 PLL/PLL2时钟振荡开始时序

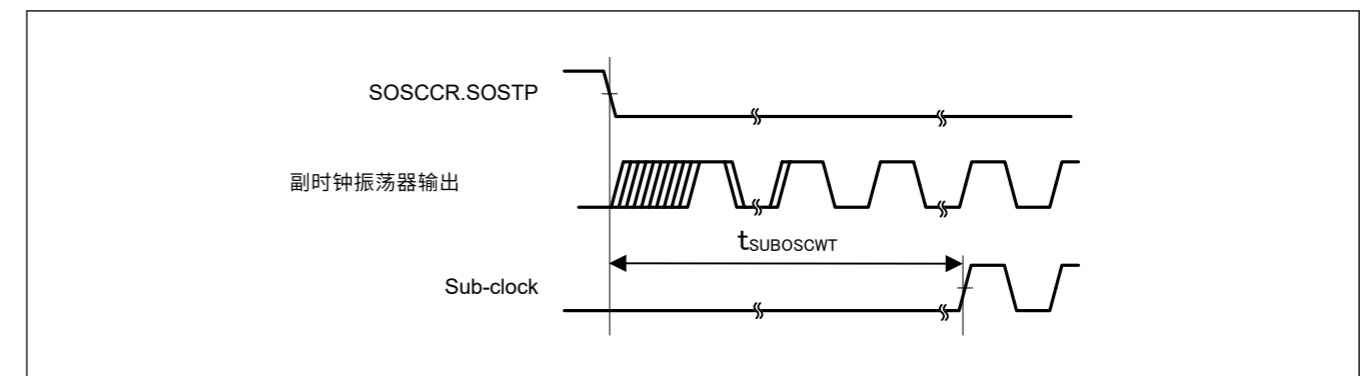


Figure 47.11 副时钟振荡开始时序

47.3.3 重置时间

Table 47.19 重置时间(1of2)

| Parameter   | 符号                 | 最小值         | 典型值  | Max  | 单元      | 测试条件         |
|-------------|--------------------|-------------|------|------|---------|--------------|
| RES脉冲宽度     | Power-on           | $t_{RESWP}$ | 0.7  | —    | ms      | Figure 47.12 |
|             | 深度软件待机模式           | $t_{RESWD}$ | 0.6  | —    | ms      | Figure 47.13 |
|             | 软件待机模式, Subosc速度模式 | $t_{RESWS}$ | 0.3  | —    | ms      |              |
|             | 所有其他               | $t_{RESW}$  | 200  | —    | $\mu$ s |              |
| RES取消后的等待时间 | $t_{RESWT}$        | —           | 37.3 | 41.2 | $\mu$ s | Figure 47.12 |

Table 47.19 Reset timing (2 of 2)

| Parameter   | Symbol             | Min | Typ | Max   | Unit | Test conditions |
|---|--------------------|-----|-----|-------|------|-----------------|
| Wait time after internal reset cancellation (IWDT reset, WDT reset, software reset, SRAM parity error reset, SRAM ECC error reset, bus master MPU error reset, TrustZone error reset, Cache parity error reset) | t <sub>RESW2</sub> | —   | 324 | 397.7 | μs   | —               |

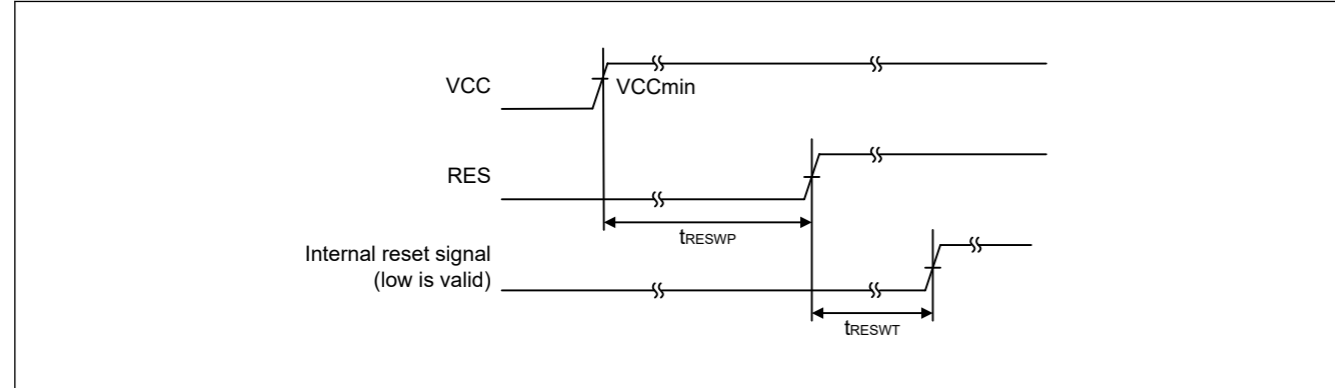


Figure 47.12 RES pin input timing under the condition that VCC exceeds V<sub>POR</sub> voltage threshold

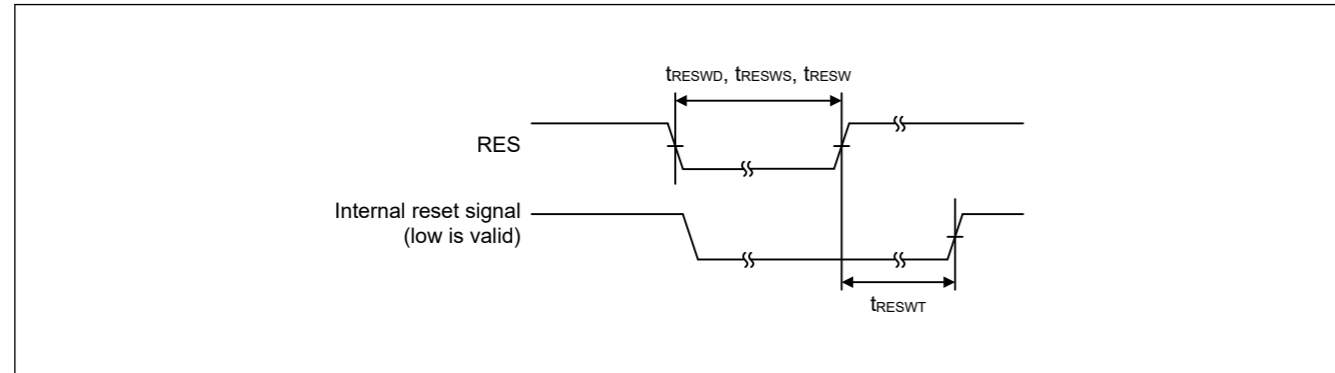


Figure 47.13 Reset input timing

47.3.4 Wakeup Timing

Table 47.20 Timing of recovery from low power modes (1 of 2)

| Parameter   | Symbol   | Min                               | Typ | Max | Unit | Test conditions |   |
|---|--|-----------------------------------|-----|-----|------|-----------------|---|
| Recovery time from Software Standby mode*1        | Crystal resonator connected to main clock oscillator<br>System clock source is main clock oscillator*2 | t <sub>SBYMC</sub> <sup>*13</sup> | —   | 2.1 | 2.4  | ms              | Figure 47.14<br>The division ratio of all oscillators is 1. |
|   | System clock source is PLL with main clock oscillator*3  | t <sub>SBYPC</sub> <sup>*13</sup> | —   | 2.2 | 2.6  | ms              |   |
| External clock input to main clock oscillator     | System clock source is main clock oscillator*4   | t <sub>SBYEX</sub> <sup>*13</sup> | —   | 45  | 125  | μs              |   |
|   | System clock source is PLL with main clock oscillator*5  | t <sub>SBYPE</sub> <sup>*13</sup> | —   | 170 | 255  | μs              |   |
| System clock source is sub-clock oscillator*6 *11 | t <sub>SBYSC</sub> <sup>*13</sup>  | —                                 | 0.7 | 0.8 | ms   |                 |   |
| System clock source is LOCO*7 *11                 | t <sub>SBYLO</sub> <sup>*13</sup>  | —                                 | 0.7 | 0.9 | ms   |                 |   |
| System clock source is HOCO clock oscillator*8    | t <sub>SBYHO</sub> <sup>*13</sup>  | —                                 | 55  | 130 | μs   |                 |   |
| System clock source is PLL with HOCO*9            | t <sub>SBYPH</sub> <sup>*13</sup>  | —                                 | 175 | 265 | μs   |                 |   |
| System clock source is MOCO clock oscillator*10   | t <sub>SBYMO</sub> <sup>*13</sup>  | —                                 | 35  | 65  | μs   |                 |   |

Table 47.19 重置时间 (2之2)

| Parameter  | 符号                 | 最小值 | 典型值 | Max   | 单元 | 测试条件 |
|--|--------------------|-----|-----|-------|----|------|
| 内部复位取消后的等待时间 (IWDT复位、WDT复位、软件复位、SRAM奇偶校验错误复位、SRAMECC错误复位、总线主控MPU错误复位、TrustZone错误复位、缓存奇偶校验错误复位) | t <sub>RESW2</sub> | —   | 324 | 397.7 | μs | —    |

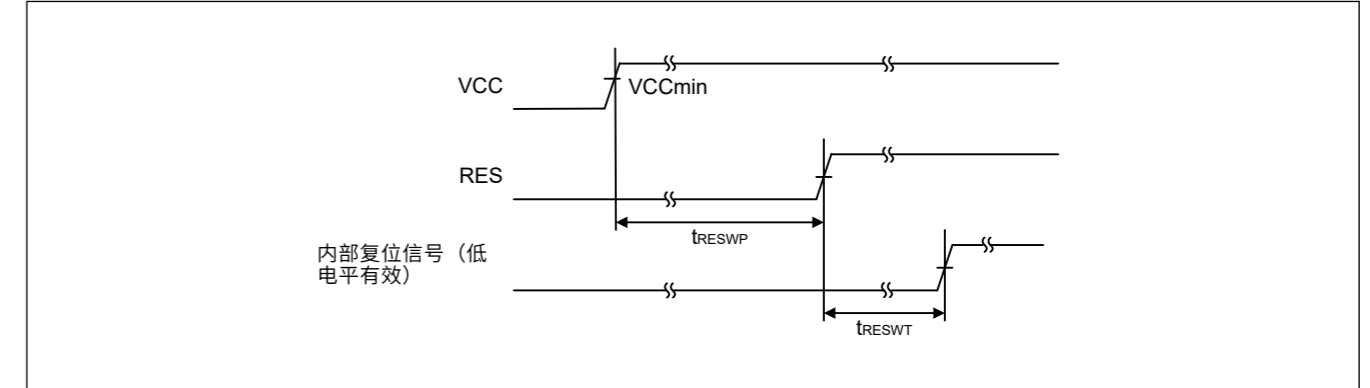


Figure 47.12 VCC超过V<sub>POR</sub>电压阈值条件下的RES引脚输入时序

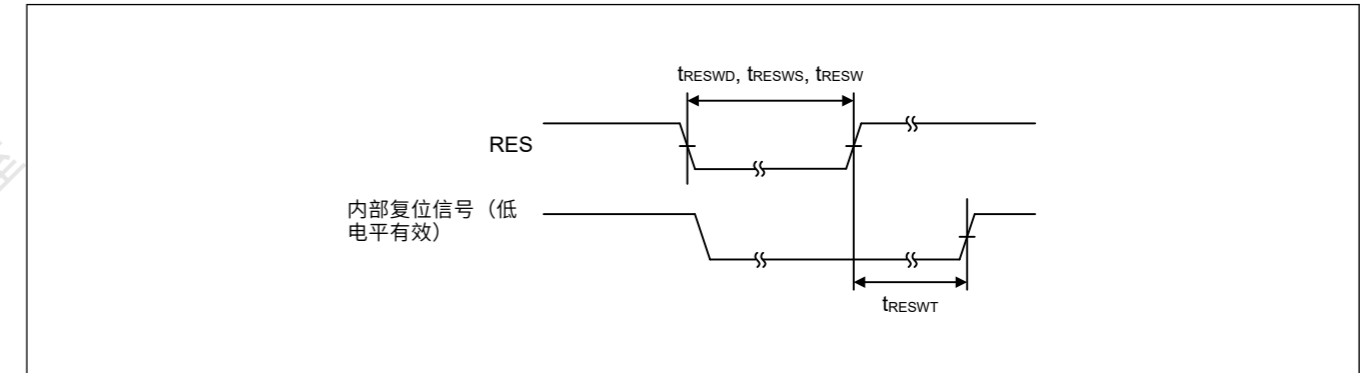


Figure 47.13 复位输入时序

47.3.4 唤醒时间

Table 47.20 从低功耗模式恢复的时间 (2个中的1个)

| Parameter          | Symbol                            | Min                               | Typ | Max | 单元  | 测试条件 |                              |
|--------------------|-----------------------------------|-----------------------------------|-----|-----|-----|------|------------------------------|
| 恢复时间从软件待机模式*1      | 连接到主时钟振荡器的晶体谐振器<br>系统时钟源为主时钟振荡器*2 | t <sub>SBYMC</sub> <sup>*13</sup> | —   | 2.1 | 2.4 | ms   | Figure 47.14<br>所有振荡器的分频比为1。 |
|                    | 系统时钟源为带主时钟振荡器的PLL*3               | t <sub>SBYPC</sub> <sup>*13</sup> | —   | 2.2 | 2.6 | ms   |                              |
| 主时钟振荡器的外部时钟输入      | 系统时钟源为主时钟振荡器*4                    | t <sub>SBYEX</sub> <sup>*13</sup> | —   | 45  | 125 | μs   |                              |
|                    | 系统时钟源为带主时钟振荡器的PLL*5               | t <sub>SBYPE</sub> <sup>*13</sup> | —   | 170 | 255 | μs   |                              |
| 系统时钟源为副时钟振荡器*6*11  | t <sub>SBYSC</sub> <sup>*13</sup> | —                                 | 0.7 | 0.8 | ms  |      |                              |
| 系统时钟源为LOCO*7*11    | t <sub>SBYLO</sub> <sup>*13</sup> | —                                 | 0.7 | 0.9 | ms  |      |                              |
| 系统时钟源为HOCO时钟振荡器*8  | t <sub>SBYHO</sub> <sup>*13</sup> | —                                 | 55  | 130 | μs  |      |                              |
| 系统时钟源是带有HOCO*9的PLL | t <sub>SBYPH</sub> <sup>*13</sup> | —                                 | 175 | 265 | μs  |      |                              |
| 系统时钟源为MOCO时钟振荡器*10 | t <sub>SBYMO</sub> <sup>*13</sup> | —                                 | 35  | 65  | μs  |      |                              |

Table 47.20 Timing of recovery from low power modes (2 of 2)

| Parameter  | Symbol  | Min               | Typ | Max               | Unit              | Test conditions |              |
|--|---|-------------------|-----|-------------------|-------------------|-----------------|--------------|
| Recovery time from Deep Software Standby mode              | DPSBYCR.DEEPCUT[1] = 0 and DPSWCR.WTSTS[5:0] = 0x0E       | t <sub>DSBY</sub> | —   | 0.38              | 0.54              | ms              | Figure 47.15 |
|  | DPSBYCR.DEEPCUT[1] = 1 and DPSWCR.WTSTS[5:0] = 0x19       | t <sub>DSBY</sub> | —   | 0.55              | 0.73              | ms              |              |
| Wait time after cancellation of Deep Software Standby mode | t <sub>DSBYWT</sub>                                       | 56                | —   | 57                | t <sub>cyc</sub>  |                 |              |
| Recovery time from Software Standby mode to Snooze mode    | High-speed mode when system clock source is HOCO (20 MHz) | t <sub>SNZ</sub>  | —   | 35 <sup>*12</sup> | 70 <sup>*12</sup> | μs              | Figure 47.16 |
|  | High-speed mode when system clock source is MOCO (8 MHz)  | t <sub>SNZ</sub>  | —   | 11 <sup>*12</sup> | 14 <sup>*12</sup> | μs              |              |

- Note 1. The recovery time is determined by the system clock source. When multiple oscillators are active, the recovery time can be determined with the following equation:  
Total recovery time = recovery time for an oscillator as the system clock source + the longest t<sub>SBYOSCWT</sub> in the active oscillators - t<sub>SBYOSCWT</sub> for the system clock + 2 LOCO cycles (when LOCO is operating) + Subosc is oscillating and MSTPC0 = 0 (CAC module stop)
- Note 2. When the frequency of the crystal is 24 MHz (Main Clock Oscillator Wait Control Register (MOSCWTCR) is set to 0x05) and the greatest value of the internal clock division setting is 1.
- Note 3. When the frequency of PLL is 200 MHz (Main Clock Oscillator Wait Control Register (MOSCWTCR) is set to 0x05) and the greatest value of the internal clock division setting is 4.
- Note 4. When the frequency of the external clock is 24 MHz (Main Clock Oscillator Wait Control Register (MOSCWTCR) is set to 0x00) and the greatest value of the internal clock division setting is 1.
- Note 5. When the frequency of PLL is 200 MHz (Main Clock Oscillator Wait Control Register (MOSCWTCR) is set to 0x00) and the greatest value of the internal clock division setting is 4.
- Note 6. The Sub-clock oscillator frequency is 32.768 KHz and the greatest value of the internal clock division setting is 1.
- Note 7. The LOCO frequency is 32.768 KHz and the greatest value of the internal clock division setting is 1.
- Note 8. The HOCO frequency is 20 MHz and the greatest value of the internal clock division setting is 1.
- Note 9. The PLL frequency is 200 MHz and the greatest value of the internal clock division setting is 4.
- Note 10. The MOCO frequency is 8 MHz and the greatest value of the internal clock division setting is 1.
- Note 11. In Subosc-speed mode, the sub-clock oscillator or LOCO continues oscillating in Software Standby mode.
- Note 12. When the SNZCR.RXDREQEN bit is set to 0, the following time is added as the power supply recovery time: 16 μs (typical), 48 μs (maximum).
- Note 13. The recovery time can be calculated with the equation of t<sub>SBYOSCWT</sub> + t<sub>SBYSEQ</sub>. And they can be determined with the following value and equation. For n, the greatest value is selected from among the internal clock division settings.

| Wakeup time        | TYP                         |   | MAX                         |   | Unit |
|--------------------|-----------------------------|---|-----------------------------|---|------|
|                    | t <sub>SBYOSCWT</sub>       | t <sub>SBYSEQ</sub>                                   | t <sub>SBYOSCWT</sub>       | t <sub>SBYSEQ</sub>                                   |      |
| t <sub>SBYMC</sub> | (MSTS[7:0]*32 + 3) / 0.262  | 35 + 18 / f <sub>CLK</sub> + 4n / f <sub>MAIN</sub>   | (MSTS[7:0]*32 + 14) / 0.236 | 62 + 18 / f <sub>CLK</sub> + 4n / f <sub>MAIN</sub>   | μs   |
| t <sub>SBYPC</sub> | (MSTS[7:0]*32 + 34) / 0.262 | 35 + 18 / f <sub>CLK</sub> + 4n / f <sub>PLL</sub>    | (MSTS[7:0]*32 + 45) / 0.236 | 62 + 18 / f <sub>CLK</sub> + 4n / f <sub>PLL</sub>    | μs   |
| t <sub>SBYEX</sub> | 10                          | 35 + 18 / f <sub>CLK</sub> + 4n / f <sub>EXMAIN</sub> | 62                          | 62 + 18 / f <sub>CLK</sub> + 4n / f <sub>EXMAIN</sub> | μs   |
| t <sub>SBYPE</sub> | 135                         | 35 + 18 / f <sub>CLK</sub> + 4n / f <sub>PLL</sub>    | 192                         | 62 + 18 / f <sub>CLK</sub> + 4n / f <sub>PLL</sub>    | μs   |
| t <sub>SBYSC</sub> | 0                           | 35 + 18 / f <sub>CLK</sub> + 4n / f <sub>SUB</sub>    | 0                           | 62 + 18 / f <sub>CLK</sub> + 4n / f <sub>SUB</sub>    | μs   |
| t <sub>SBYLO</sub> | 0                           | 35 + 18 / f <sub>CLK</sub> + 4n / f <sub>LOCO</sub>   | 0                           | 62 + 18 / f <sub>CLK</sub> + 4n / f <sub>LOCO</sub>   | μs   |
| t <sub>SBYHO</sub> | 20                          | 35 + 18 / f <sub>CLK</sub> + 4n / f <sub>HOCO</sub>   | 67                          | 62 + 18 / f <sub>CLK</sub> + 4n / f <sub>HOCO</sub>   | μs   |
| t <sub>SBYPH</sub> | 140                         | 35 + 18 / f <sub>CLK</sub> + 4n / f <sub>PLL</sub>    | 202                         | 62 + 18 / f <sub>CLK</sub> + 4n / f <sub>PLL</sub>    | μs   |
| t <sub>SBYMO</sub> | 0                           | 35 + 18 / f <sub>CLK</sub> + 4n / f <sub>MOCO</sub>   | 0                           | 62 + 18 / f <sub>CLK</sub> + 4n / f <sub>MOCO</sub>   | μs   |

Table 47.20 从低功耗模式恢复的时间 (2个中的2个)

| Parameter        | Symbol  | Min               | Typ | Max               | 单元测试条件            |    |              |
|------------------|---|-------------------|-----|-------------------|-------------------|----|--------------|
| 恢复时间从深度软件待机模式    | DPSBYCR.DEEPCUT[1] = 0 and DPSWCR.WTSTS[5:0] = 0x0E | t <sub>DSBY</sub> | —   | 0.38              | 0.54              | ms | Figure 47.15 |
|                  | DPSBYCR.DEEPCUT[1] = 1 and DPSWCR.WTSTS[5:0] = 0x19 | t <sub>DSBY</sub> | —   | 0.55              | 0.73              | ms |              |
| 取消深度软件待机模式后的等待时间 | t <sub>DSBYWT</sub>                                 | 56                | —   | 57                | t <sub>cyc</sub>  |    |              |
| 恢复时间从软件待机模式到贪睡模式 | 系统时钟源为高速模式 HOCO (20 MHz)                            | t <sub>SNZ</sub>  | —   | 35 <sup>*12</sup> | 70 <sup>*12</sup> | μs | Figure 47.16 |
|                  | 系统时钟源为高速模式 MOCO (8 MHz)                             | t <sub>SNZ</sub>  | —   | 11 <sup>*12</sup> | 14 <sup>*12</sup> | μs |              |

- 注1.恢复时间由系统时钟源决定。当多个振荡器处于活动状态时，恢复时间可以通过以下公式确定：总恢复时间=一个振荡器作为系统时钟源的恢复时间+系统时钟有效振荡器中的最长t<sub>SBYOSCWT</sub>t<sub>SBYOSCWT</sub>+2个LOCO周期（当LOCO正在运行）+Subosc正在振荡且MSTPC0=0（CAC模块停止）
- 注2.当晶振频率为24MHz（主时钟振荡器等待控制寄存器（MOSCWTCR）设置为0x05）且内部时钟分频设置的最大值为1时。
- 注3.当PLL的频率为200MHz（主时钟振荡器等待控制寄存器（MOSCWTCR）设置为0x05）且内部时钟分频设置的最大值为4时。
- 注4.当外部时钟频率为24MHz（主时钟振荡器等待控制寄存器（MOSCWTCR）设置为0x00）且内部时钟分频设置的最大值为1时。
- 注5.当PLL的频率为200MHz（主时钟振荡器等待控制寄存器（MOSCWTCR）设置为0x00）且内部时钟分频设置的最大值为4时。
- 注6.副时钟振荡器频率为32.768KHz，内部时钟分频设置的最大值为1。
- 注7.LOCO频率为32.768KHz，内部时钟分频设置的最大值为1。
- 注8.HOCO频率为20MHz，内部时钟分频设置最大值为1。注9.PLL频率为200MHz，内部时钟分频设置最大值为4。注10.MOCO频率为8MHz，内部时钟分频设置的最大值为1。
- 注11.在Subosc速度模式下，副时钟振荡器或LOCO在软件待机模式下继续振荡。
- 注12.当SNZCR.RXDREQEN位设置为0时，添加以下时间作为电源恢复时间：16μs（典型值）、48μs（最大值）。
- 注13.恢复时间可以用t<sub>SBYOSCWT</sub>+t<sub>SBYSEQ</sub>等式计算。它们可以用下面的值和方程来确定。对于n，从内部时钟分频设置中选择最大值。

| 唤醒时间典型值            | TYP                         |   | MAX                         |   | Unit |
|--------------------|-----------------------------|---|-----------------------------|---|------|
|                    | t <sub>SBYOSCWT</sub>       | t <sub>SBYSEQ</sub>                                   | t <sub>SBYOSCWT</sub>       | t <sub>SBYSEQ</sub>                                   |      |
| t <sub>SBYMC</sub> | (MSTS[7:0]*32 + 3) / 0.262  | 35 + 18 / f <sub>CLK</sub> + 4n / f <sub>MAIN</sub>   | (MSTS[7:0]*32 + 14) / 0.236 | 62 + 18 / f <sub>CLK</sub> + 4n / f <sub>MAIN</sub>   | μs   |
| t <sub>SBYPC</sub> | (MSTS[7:0]*32 + 34) / 0.262 | 35 + 18 / f <sub>CLK</sub> + 4n / f <sub>PLL</sub>    | (MSTS[7:0]*32 + 45) / 0.236 | 62 + 18 / f <sub>CLK</sub> + 4n / f <sub>PLL</sub>    | μs   |
| t <sub>SBYEX</sub> | 10                          | 35 + 18 / f <sub>CLK</sub> + 4n / f <sub>EXMAIN</sub> | 62                          | 62 + 18 / f <sub>CLK</sub> + 4n / f <sub>EXMAIN</sub> | μs   |
| t <sub>SBYPE</sub> | 135                         | 35 + 18 / f <sub>CLK</sub> + 4n / f <sub>PLL</sub>    | 192                         | 62 + 18 / f <sub>CLK</sub> + 4n / f <sub>PLL</sub>    | μs   |
| t <sub>SBYSC</sub> | 0                           | 35 + 18 / f <sub>CLK</sub> + 4n / f <sub>SUB</sub>    | 0                           | 62 + 18 / f <sub>CLK</sub> + 4n / f <sub>SUB</sub>    | μs   |
| t <sub>SBYLO</sub> | 0                           | 35 + 18 / f <sub>CLK</sub> + 4n / f <sub>LOCO</sub>   | 0                           | 62 + 18 / f <sub>CLK</sub> + 4n / f <sub>LOCO</sub>   | μs   |
| t <sub>SBYHO</sub> | 20                          | 35 + 18 / f <sub>CLK</sub> + 4n / f <sub>HOCO</sub>   | 67                          | 62 + 18 / f <sub>CLK</sub> + 4n / f <sub>HOCO</sub>   | μs   |
| t <sub>SBYPH</sub> | 140                         | 35 + 18 / f <sub>CLK</sub> + 4n / f <sub>PLL</sub>    | 202                         | 62 + 18 / f <sub>CLK</sub> + 4n / f <sub>PLL</sub>    | μs   |
| t <sub>SBYMO</sub> | 0                           | 35 + 18 / f <sub>CLK</sub> + 4n / f <sub>MOCO</sub>   | 0                           | 62 + 18 / f <sub>CLK</sub> + 4n / f <sub>MOCO</sub>   | μs   |



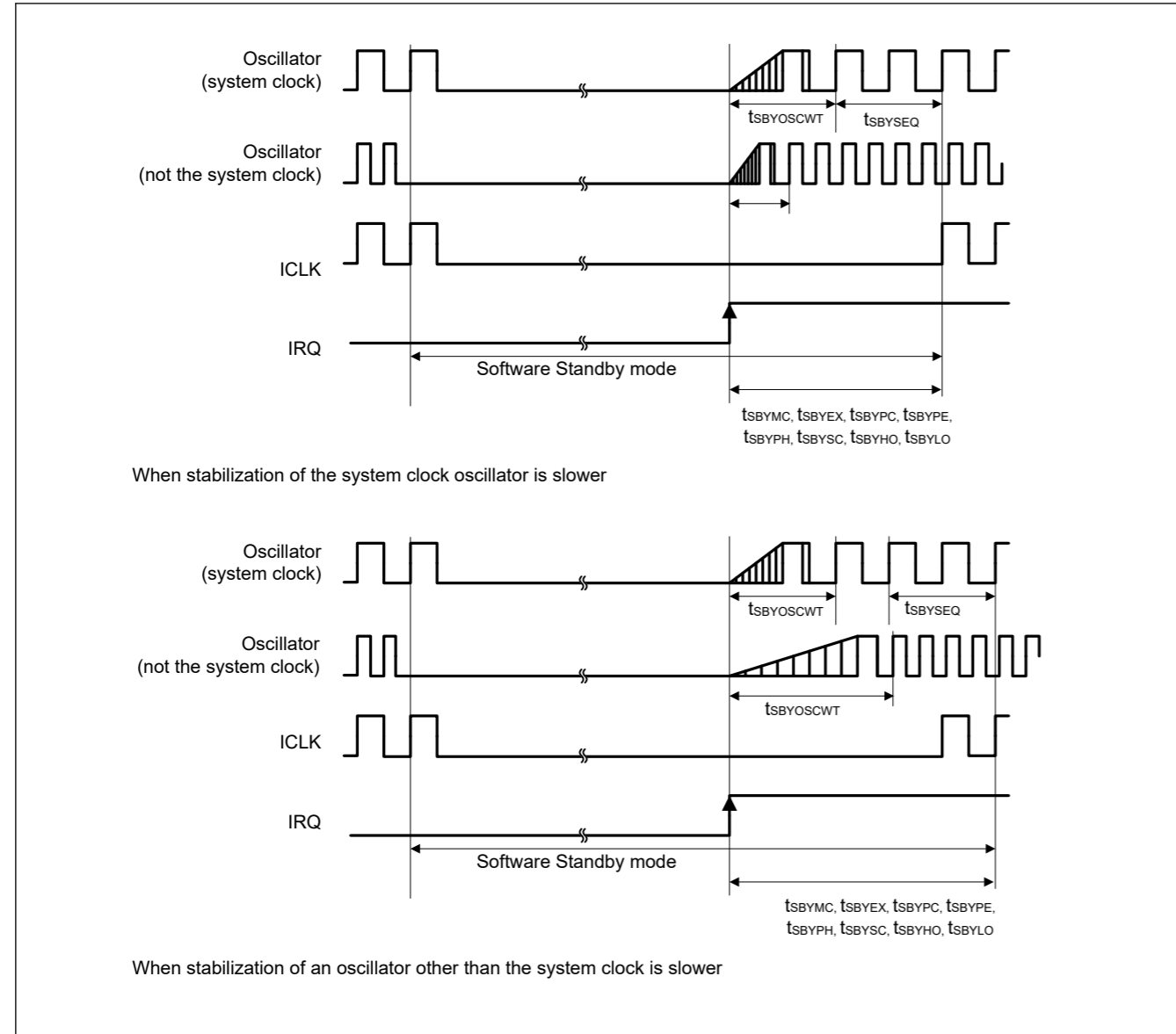


Figure 47.14 Software Standby mode cancellation timing

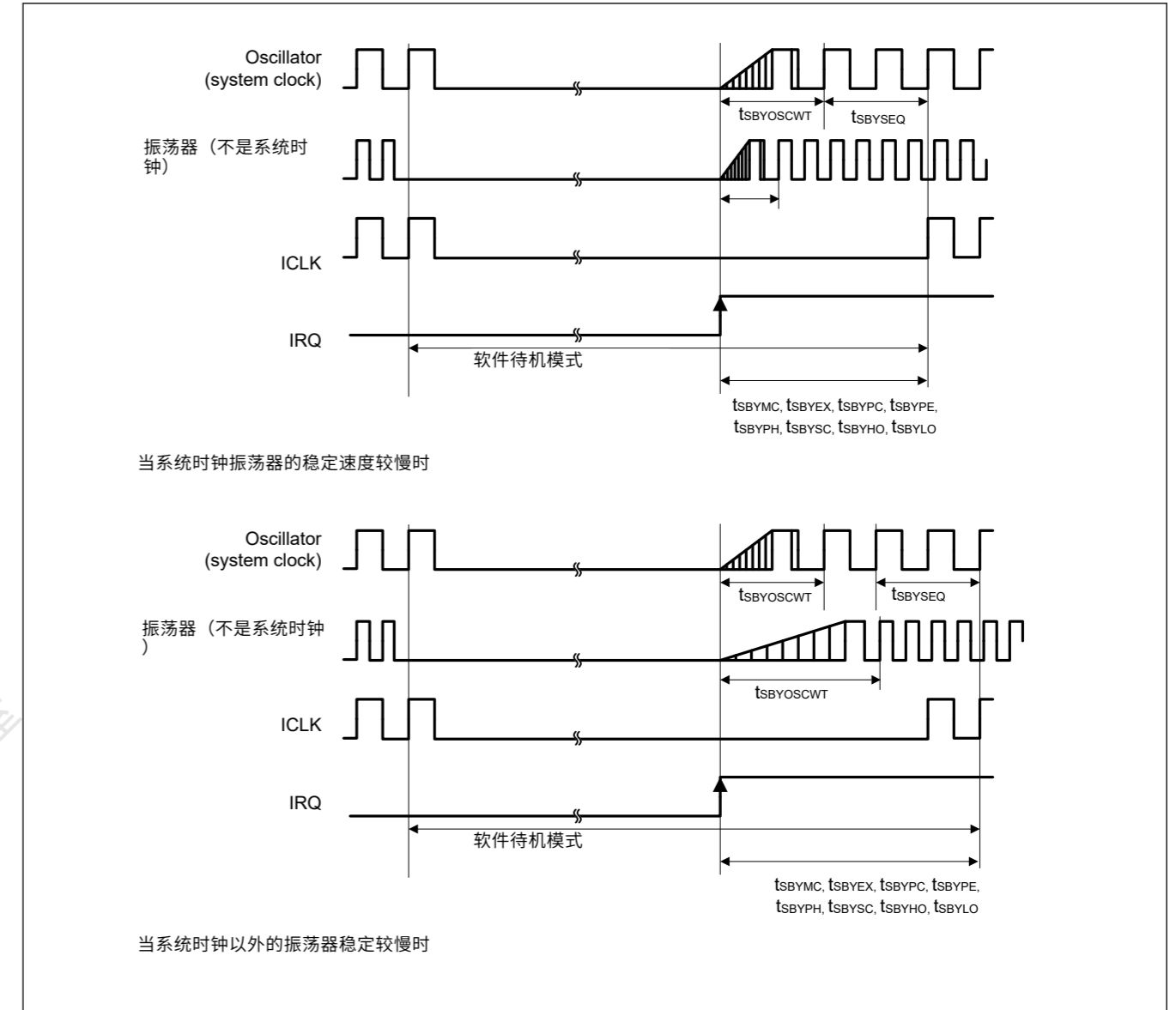


Figure 47.14 软件待机模式取消时序

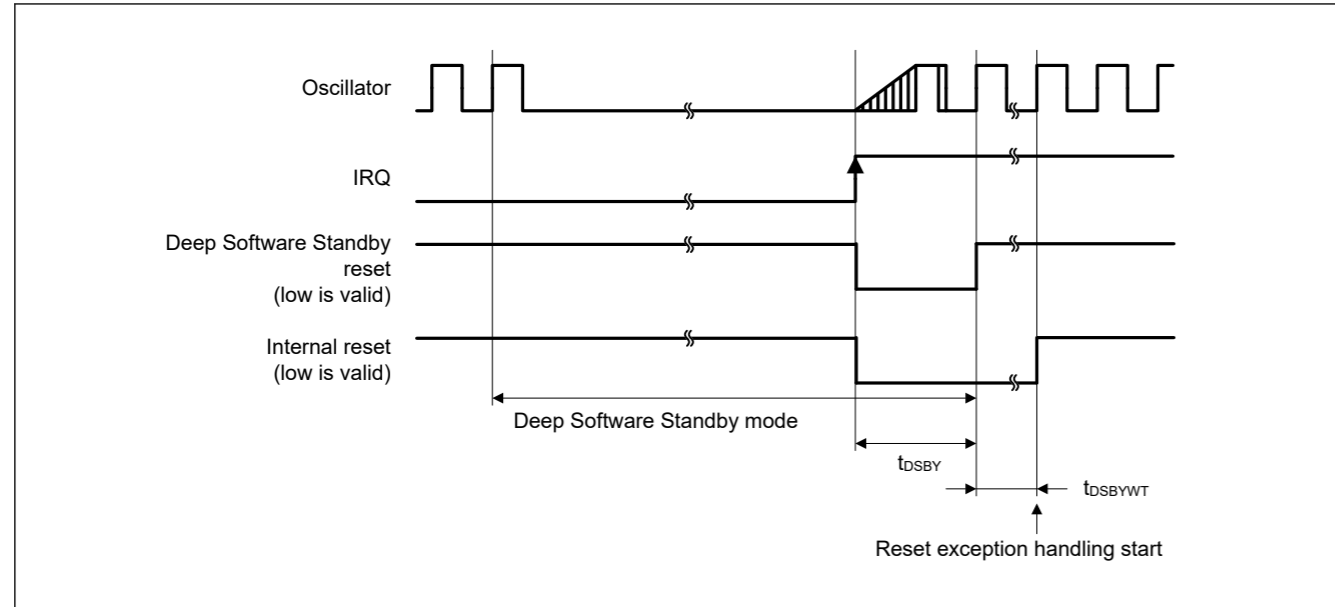


Figure 47.15 Deep Software Standby mode cancellation timing

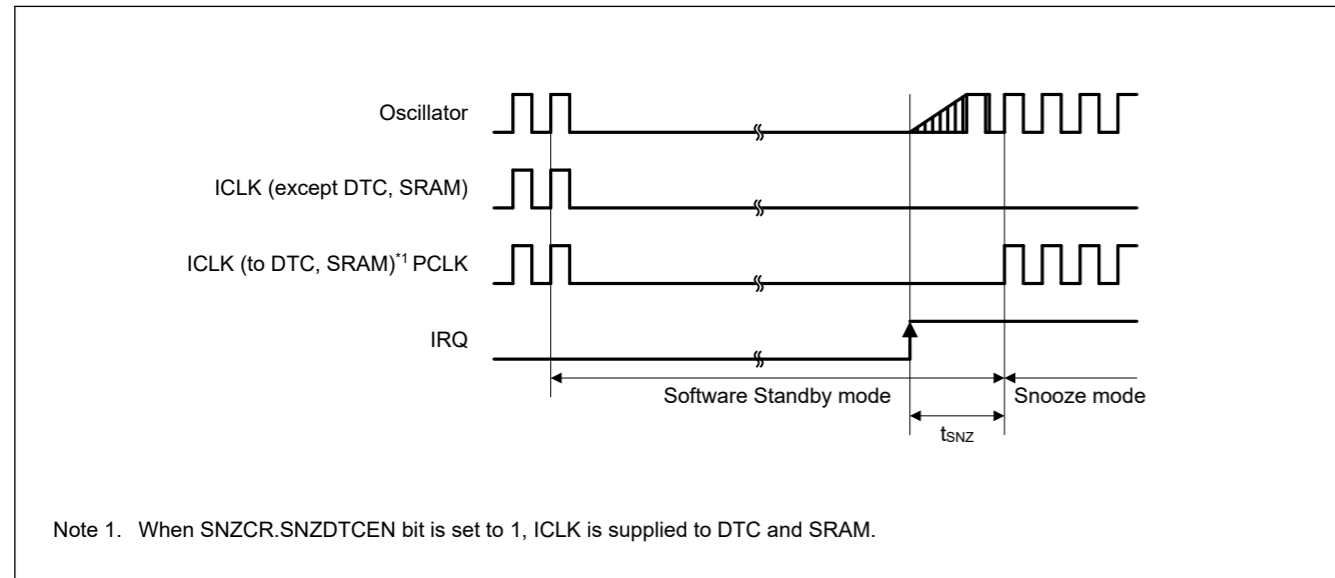


Figure 47.16 Recovery timing from Software Standby mode to Snooze mode

47.3.5 NMI and IRQ Noise Filter

Table 47.21 NMI and IRQ noise filter

| Parameter       | Symbol            | Min                                   | Typ | Max | Unit | Test conditions             |
|-----------------|-------------------|---------------------------------------|-----|-----|------|-----------------------------|
| NMI pulse width | t <sub>NMIW</sub> | 200                                   | —   | —   | ns   | NMI digital filter disabled |
|                 |                   | t <sub>Pcyc</sub> × 2 <sup>1</sup>    | —   | —   |      |                             |
|                 |                   | 200                                   | —   | —   |      | NMI digital filter enabled  |
|                 |                   | t <sub>NMICK</sub> × 3.5 <sup>2</sup> | —   | —   |      |                             |
| IRQ pulse width | t <sub>IRQW</sub> | 200                                   | —   | —   | ns   | IRQ digital filter disabled |
|                 |                   | t <sub>Pcyc</sub> × 2 <sup>1</sup>    | —   | —   |      |                             |
|                 |                   | 200                                   | —   | —   |      | IRQ digital filter enabled  |
|                 |                   | t <sub>IRQCK</sub> × 3.5 <sup>3</sup> | —   | —   |      |                             |

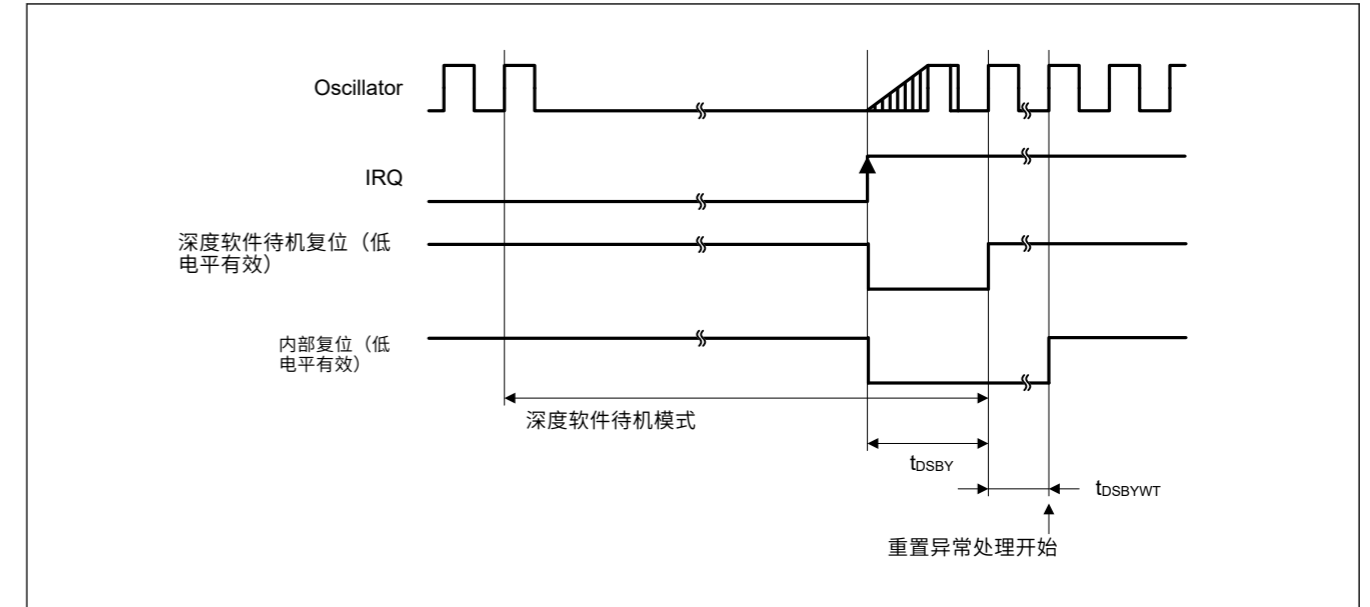


Figure 47.15 深度软件待机模式取消时序

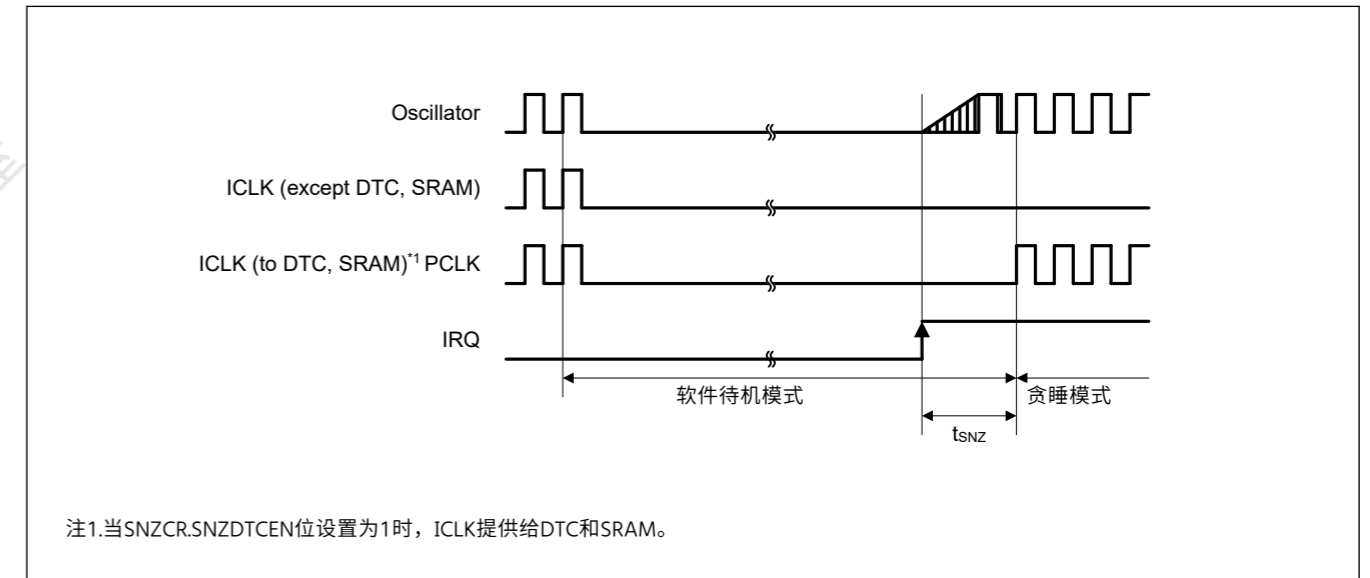


Figure 47.16 从软件待机模式到贪睡模式的恢复时间

47.3.5 NMI和IRQ噪声滤波器

Table 47.21 NMI和IRQ噪声滤波器

| Parameter | Symbol            | Min                                   | Typ | Max | Unit | 测试条件       |
|-----------|-------------------|---------------------------------------|-----|-----|------|------------|
| NMI脉冲宽度   | t <sub>NMIW</sub> | 200                                   | —   | —   | ns   | NMI数字滤波器禁用 |
|           |                   | t <sub>Pcyc</sub> × 2 <sup>1</sup>    | —   | —   |      |            |
|           |                   | 200                                   | —   | —   |      | 启用NMI数字滤波器 |
|           |                   | t <sub>NMICK</sub> × 3.5 <sup>2</sup> | —   | —   |      |            |
| IRQ脉冲宽度   | t <sub>IRQW</sub> | 200                                   | —   | —   | ns   | IRQ数字滤波器禁用 |
|           |                   | t <sub>Pcyc</sub> × 2 <sup>1</sup>    | —   | —   |      |            |
|           |                   | 200                                   | —   | —   |      | 启用IRQ数字滤波器 |
|           |                   | t <sub>IRQCK</sub> × 3.5 <sup>3</sup> | —   | —   |      |            |

Note: 200 ns minimum in Software Standby mode.  
 Note: If the clock source is switched, add 4 clock cycles of the switched source.  
 Note 1.  $t_{Pcyc}$  indicates the PCLKB cycle.  
 Note 2.  $t_{NMICK}$  indicates the cycle of the NMI digital filter sampling clock.  
 Note 3.  $t_{IRQCK}$  indicates the cycle of the IRQi digital filter sampling clock.

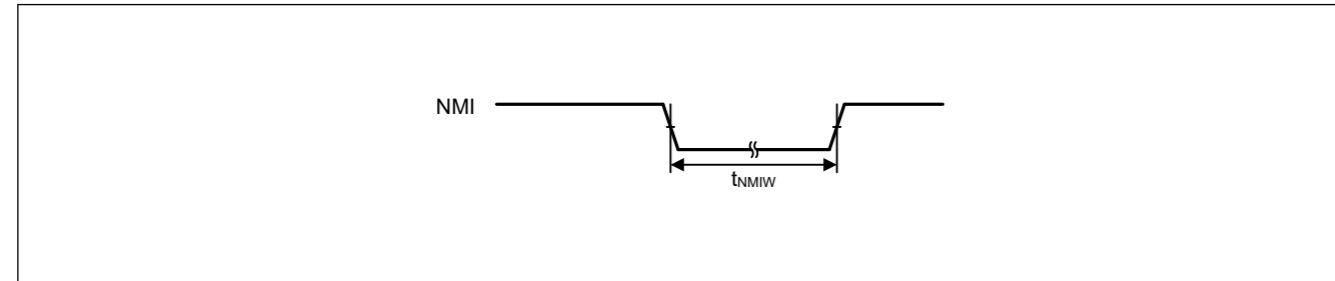


Figure 47.17 NMI interrupt input timing

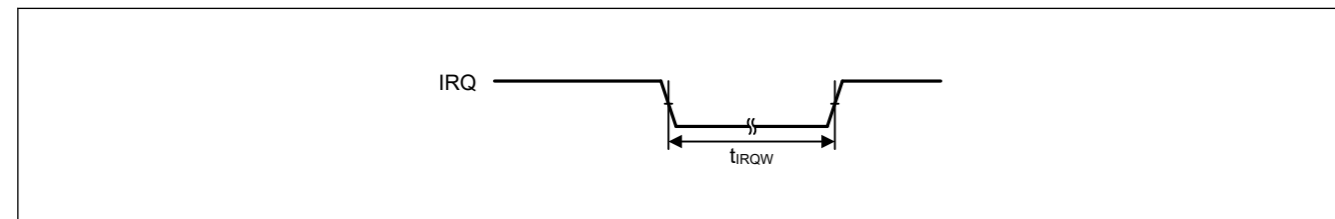


Figure 47.18 IRQ interrupt input timing

47.3.6 I/O Ports, POEG, GPT, AGT, and ADC12 Trigger Timing

Table 47.22 I/O ports, POEG, GPT, AGT, and ADC12 trigger timing

GPT32 Conditions:  
 High drive output is selected in the Port Drive Capability bit in the PmnPFS register.  
 AGT Conditions:  
 Middle drive output is selected in the Port Drive Capability bit in the PmnPFS register.

| Parameter  | Symbol                                       | Min                    | Max  | Unit | Test conditions          |              |
|--|--|------------------------|------|------|--------------------------|--------------|
| I/O ports  | Input data pulse width                       | $t_{PRW}$              | 1.5  | —    | $t_{Pcyc}$ Figure 47.19  |              |
| POEG   | POEG input trigger pulse width               | $t_{POEW}$             | 3    | —    | $t_{Pcyc}$ Figure 47.20  |              |
| GPT  | Input capture pulse width                    | Single edge            | 1.5  | —    | $t_{PDcyc}$ Figure 47.21 |              |
|  |  | Dual edge              | 2.5  | —    |                          |              |
|  | GTIOCxY output skew (x = 0 to 3, Y = A or B) | Middle drive buffer    | —    | 4    | ns                       | Figure 47.22 |
|  |  | High drive buffer      | —    | 4    |                          |              |
|  | GTIOCxY output skew (x = 4 to 7, Y = A or B) | Middle drive buffer    | —    | 4    |                          |              |
|  |  | High drive buffer      | —    | 4    |                          |              |
| GTIOCxY output skew (x = 0 to 7, Y = A or B)                         | Middle drive buffer                          | —                      | 6    |      |                          |              |
|  | High drive buffer                            | —                      | 6    |      |                          |              |
| OPS output skew<br>GTOUUP, GTOULO, GTOVUP,<br>GTOVLO, GTOWUP, GTOWLO | $t_{GTOSK}$                                  | —                      | 5    | ns   | Figure 47.23             |              |
| AGT  | AGTIO, AGTEE input cycle                     | $t_{ACYC}^{*2}$        | 100  | —    | ns                       | Figure 47.24 |
|  | AGTIO, AGTEE input high width, low width     | $t_{ACKWH}, t_{ACKWL}$ | 40   | —    |                          |              |
|  | AGTIO, AGTO, AGTOA, AGTOB output cycle       | $t_{ACYC2}$            | 62.5 | —    |                          |              |
| ADC12  | ADC12 trigger input pulse width              | $t_{TRGW}$             | 1.5  | —    | $t_{Pcyc}$ Figure 47.25  |              |

Note:  $t_{Pcyc}$ : PCLKB cycle,  $t_{PDcyc}$ : PCLKD cycle.  
 Note 1. This skew applies when the same driver I/O is used. If the I/O of the middle and high drivers is mixed, operation is not guaranteed.  
 Note 2. Constraints on input cycle:

Note: 软件待机模式下最少200ns。  
 Note: 如果时钟源切换, 则增加切换源的4个时钟周期。  
 注1.  $t_{Pcyc}$ 表示PCLKB周期。  
 注2.  $t_{NMICK}$ 表示NMI数字滤波器采样时钟的周期。注3.  $t_{IRQCK}$ 表示IRQi数字滤波器采样时钟的周期。

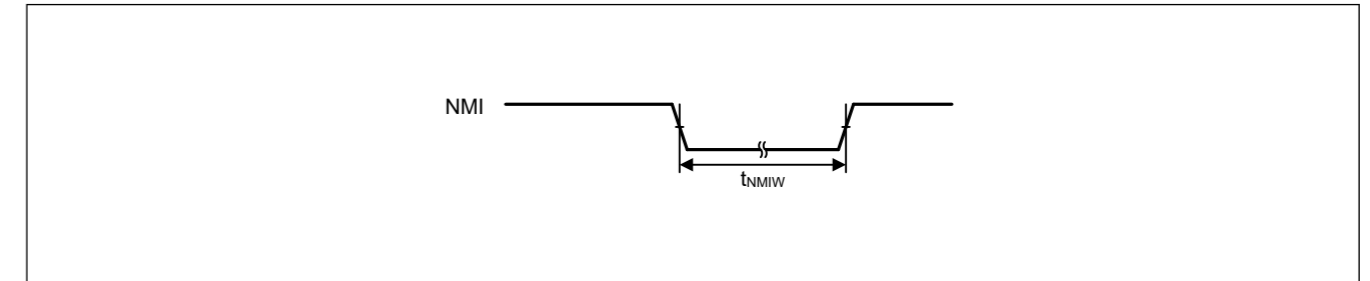


Figure 47.17 NMI中断输入时序

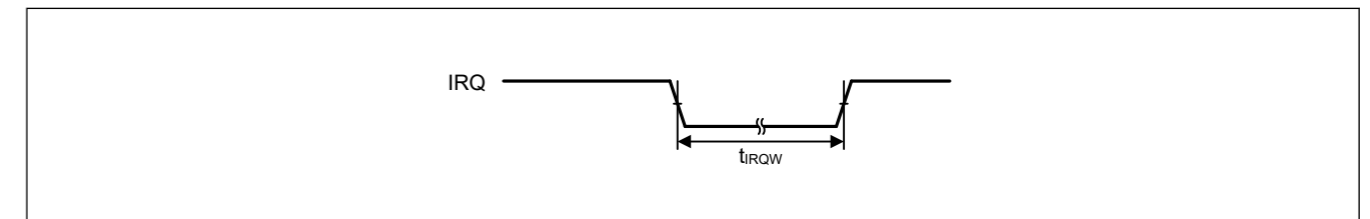


Figure 47.18 IRQ中断输入时序

47.3.6 IO端口、POEG、GPT、AGT和ADC12触发时序

Table 47.22 IO端口、POEG、GPT、AGT和ADC12触发时序

GPT32 Conditions:  
 在PmnPFS寄存器的端口驱动能力位中选择高驱动输出。  
 AGT Conditions:  
 在PmnPFS寄存器的端口驱动能力位中选择中间驱动输出。

| Parameter  | Symbol                     | Min                    | Max  | Unit | 测试条件                     |              |
|--|----------------------------|------------------------|------|------|--------------------------|--------------|
| I/O ports  | 输入数据脉冲宽度                   | $t_{PRW}$              | 1.5  | —    | $t_{Pcyc}$ Figure 47.19  |              |
| POEG   | POEG输入触发脉冲宽度               | $t_{POEW}$             | 3    | —    | $t_{Pcyc}$ Figure 47.20  |              |
| GPT  | 输入捕捉脉冲宽度                   | 单边                     | 1.5  | —    | $t_{PDcyc}$ Figure 47.21 |              |
|  |                            | 双刃                     | 2.5  | —    |                          |              |
| GPT  | GTIOCxY输出偏差 (x=0到3, Y=A或B) | 中间驱动缓冲器                | —    | 4    | ns                       | Figure 47.22 |
|  |                            | 高驱动缓冲器                 | —    | 4    |                          |              |
|  | GTIOCxY输出偏移 (x=4到7, Y=A或B) | 中间驱动缓冲器                | —    | 4    |                          |              |
|  |                            | 高驱动缓冲器                 | —    | 4    |                          |              |
| GTIOCxY输出偏移 (x=0到7, Y=A或B)                                   | 中间驱动缓冲器                    | —                      | 6    |      |                          |              |
|  | 高驱动缓冲器                     | —                      | 6    |      |                          |              |
| OPS输出偏差<br>GTOUUP, GTOULO, GTOVUP,<br>GTOVLO, GTOWUP, GTOWLO | $t_{GTOSK}$                | —                      | 5    | ns   | Figure 47.23             |              |
| AGT  | AGTIO、AGTEE输入周期            | $t_{ACYC}^{*2}$        | 100  | —    | ns                       | Figure 47.24 |
|  | AGTIO、AGTEE输入高宽、低宽         | $t_{ACKWH}, t_{ACKWL}$ | 40   | —    |                          |              |
|  | AGTIO、AGTO、AGTOA、AGTOB输出周期 | $t_{ACYC2}$            | 62.5 | —    |                          |              |
| ADC12  | ADC12触发输入脉冲宽度              | $t_{TRGW}$             | 1.5  | —    | $t_{Pcyc}$ Figure 47.25  |              |

Note:  $t_{Pcyc}$ : PCLKB cycle,  $t_{PDcyc}$ : PCLKD cycle.  
 注1. 当使用相同的驱动器IO时, 此偏差适用。如果中高驱动器的IO混合使用, 则无法保证运行。  
 注2. 输入周期的限制:

When not switching the source clock:  $t_{Pcyc} \times 2 < t_{ACYC}$  should be satisfied.  
 When switching the source clock:  $t_{Pcyc} \times 6 < t_{ACYC}$  should be satisfied.

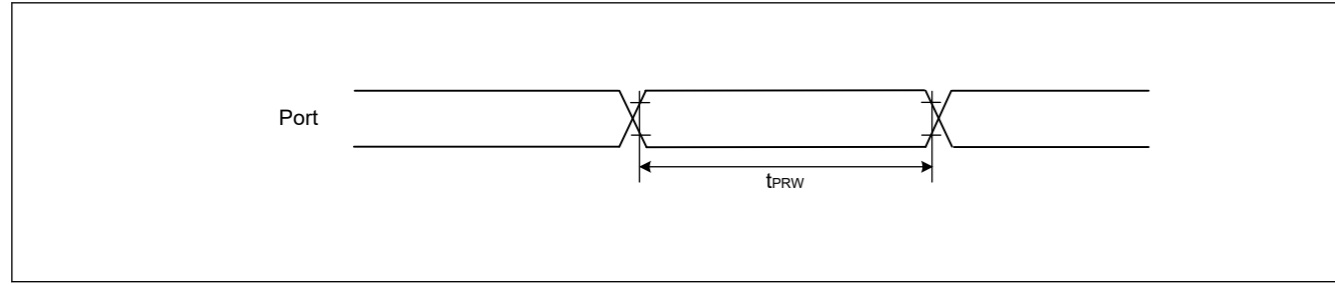


Figure 47.19 I/O ports input timing

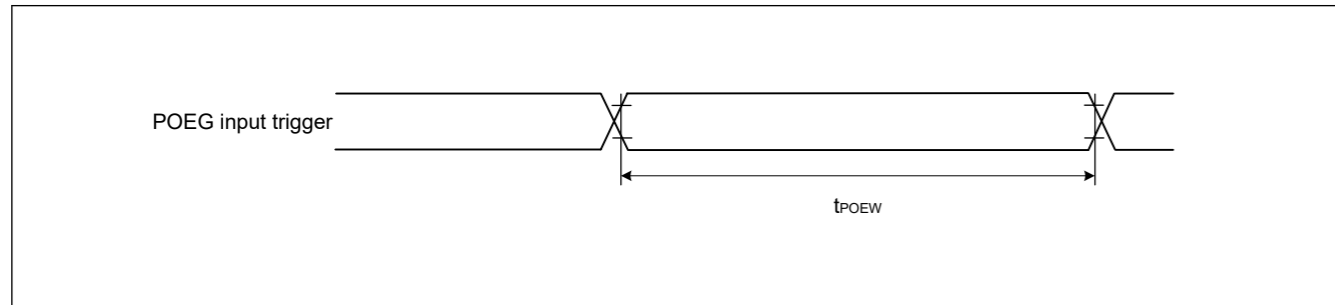


Figure 47.20 POEG input trigger timing

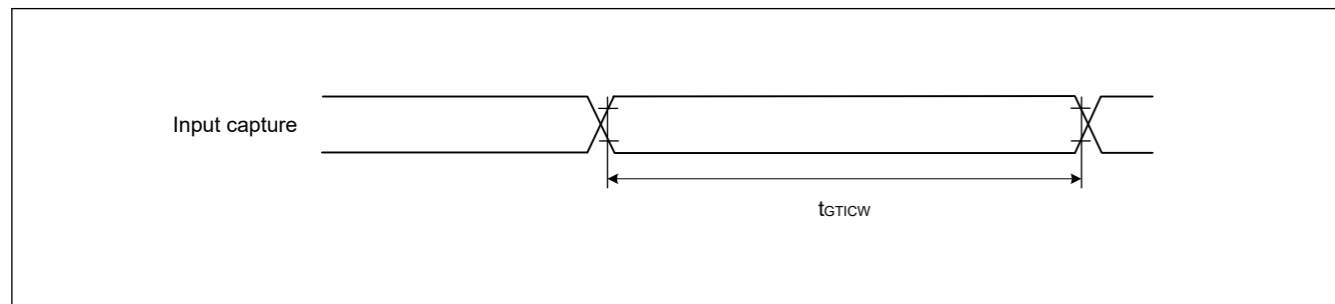


Figure 47.21 GPT input capture timing

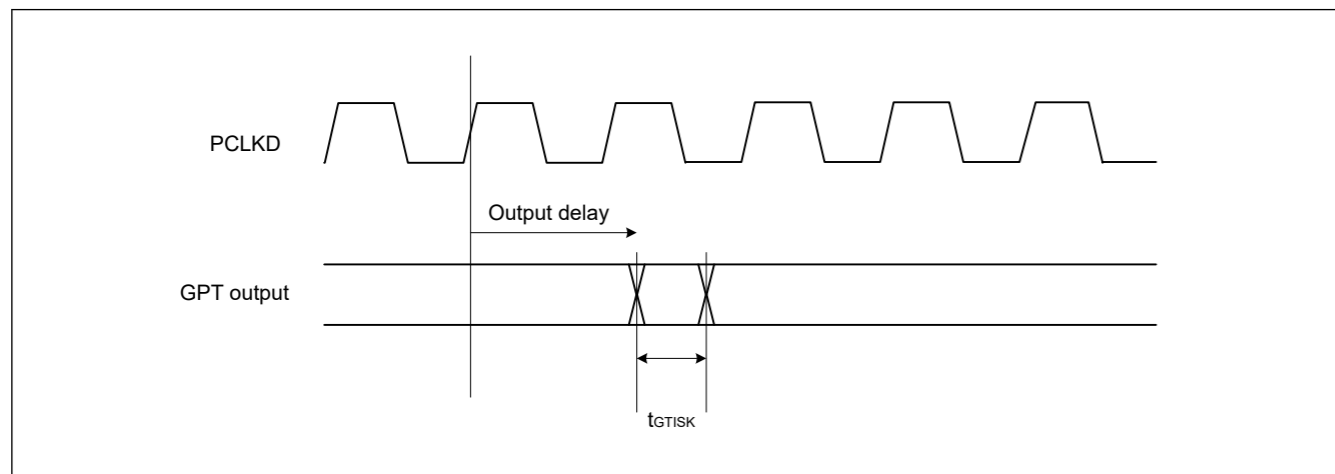


Figure 47.22 GPT output delay skew

不切换源时钟时:  $t_{Pcyc} \times 2 < t_{ACYC}$  应满足。  
 切换源时钟时:  $t_{Pcyc} \times 6 < t_{ACYC}$  应满足。

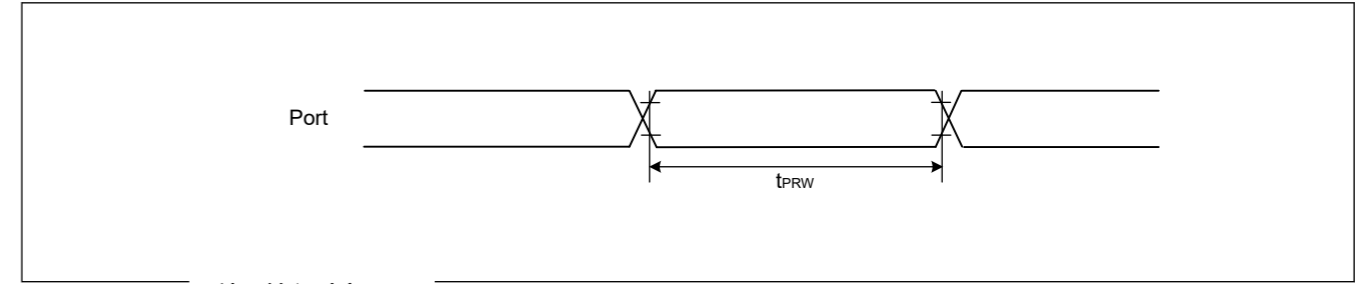


Figure 47.19 IO端口输入时序

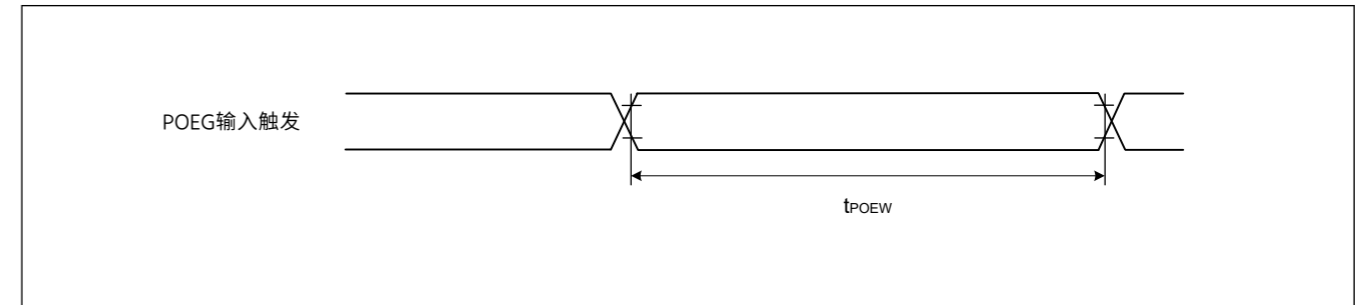


Figure 47.20 POEG输入触发时序

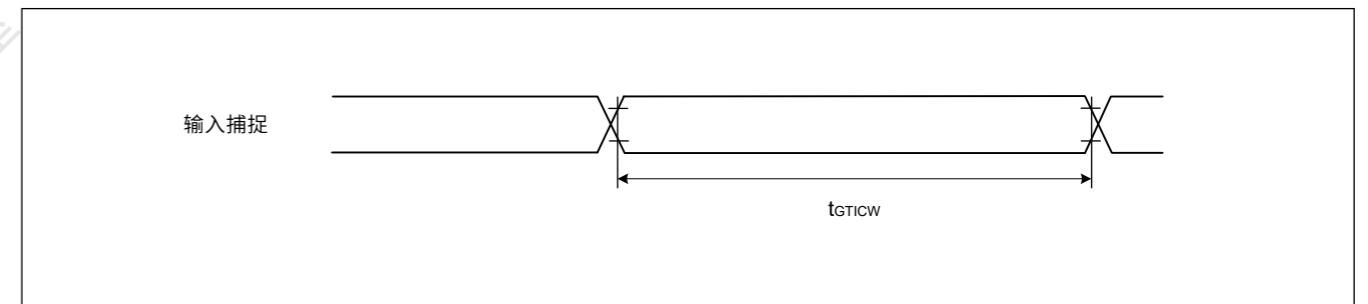


Figure 47.21 GPT输入捕捉时序

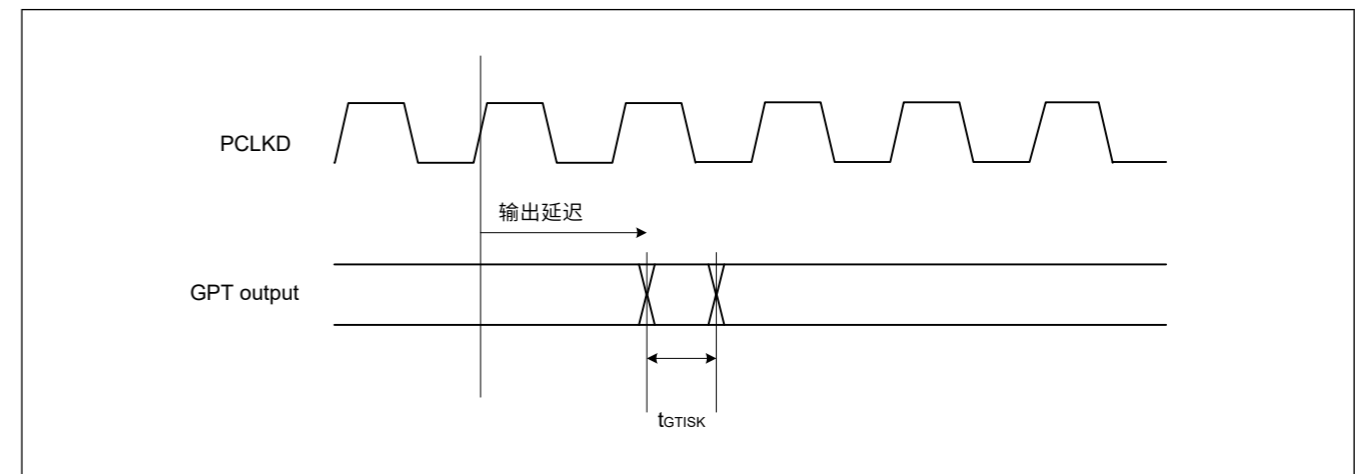


Figure 47.22 GPT输出延迟偏差



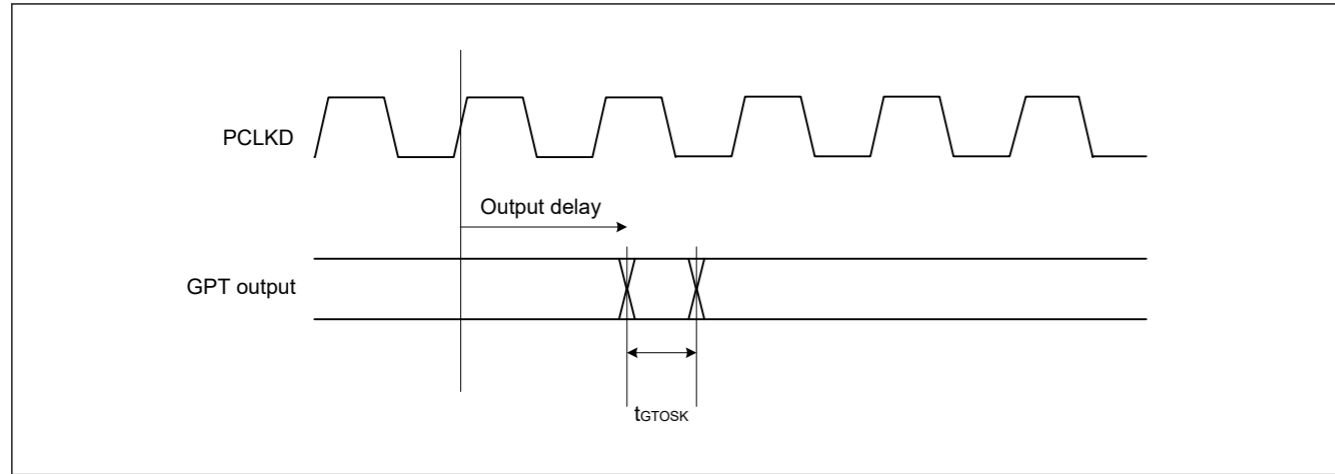


Figure 47.23 GPT output delay skew for OPS

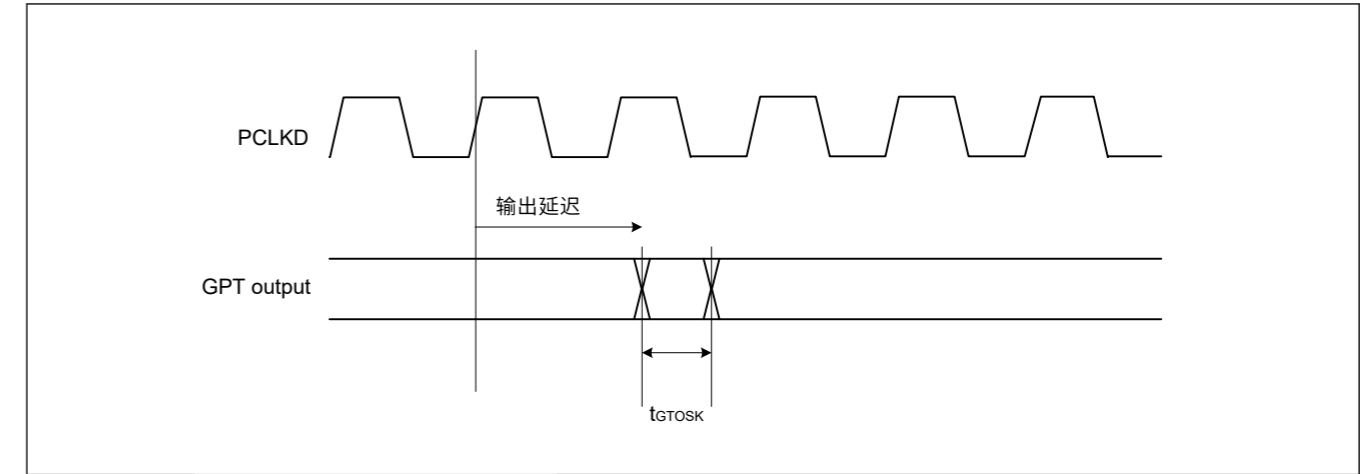


Figure 47.23 OPS的GPT输出延迟偏差

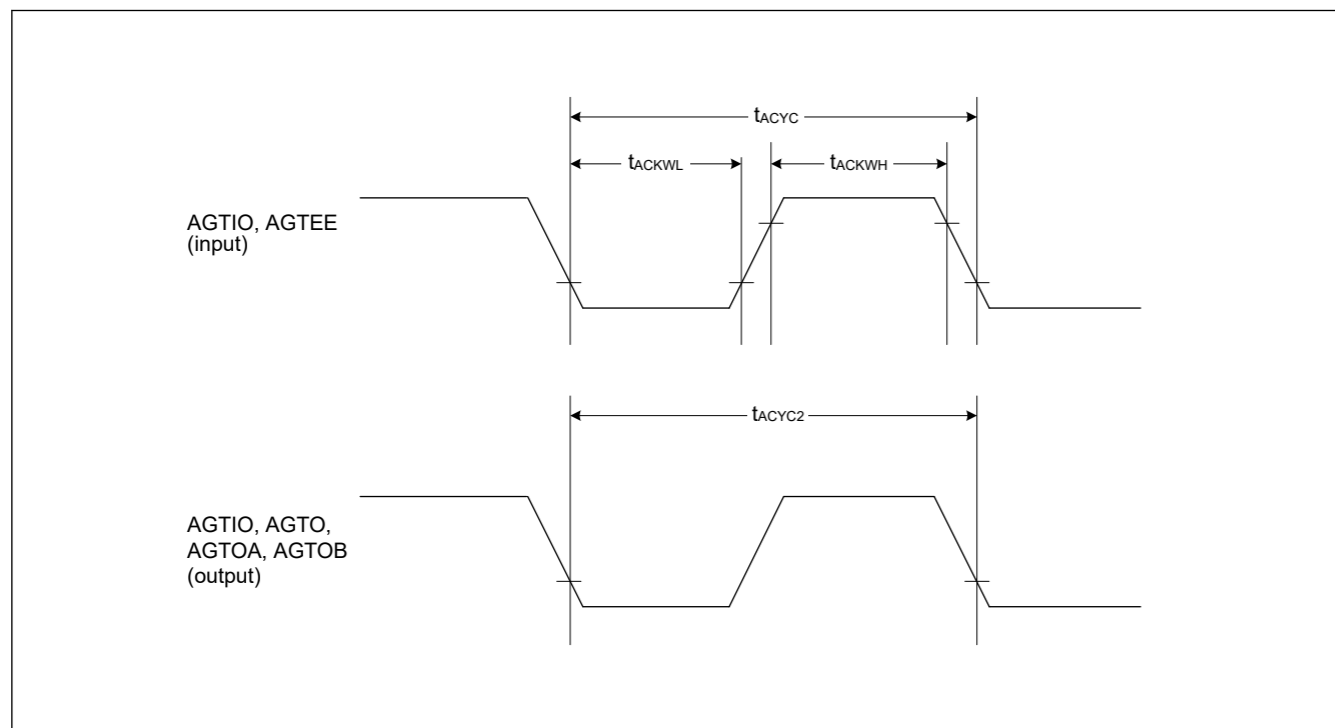


Figure 47.24 AGT input/output timing

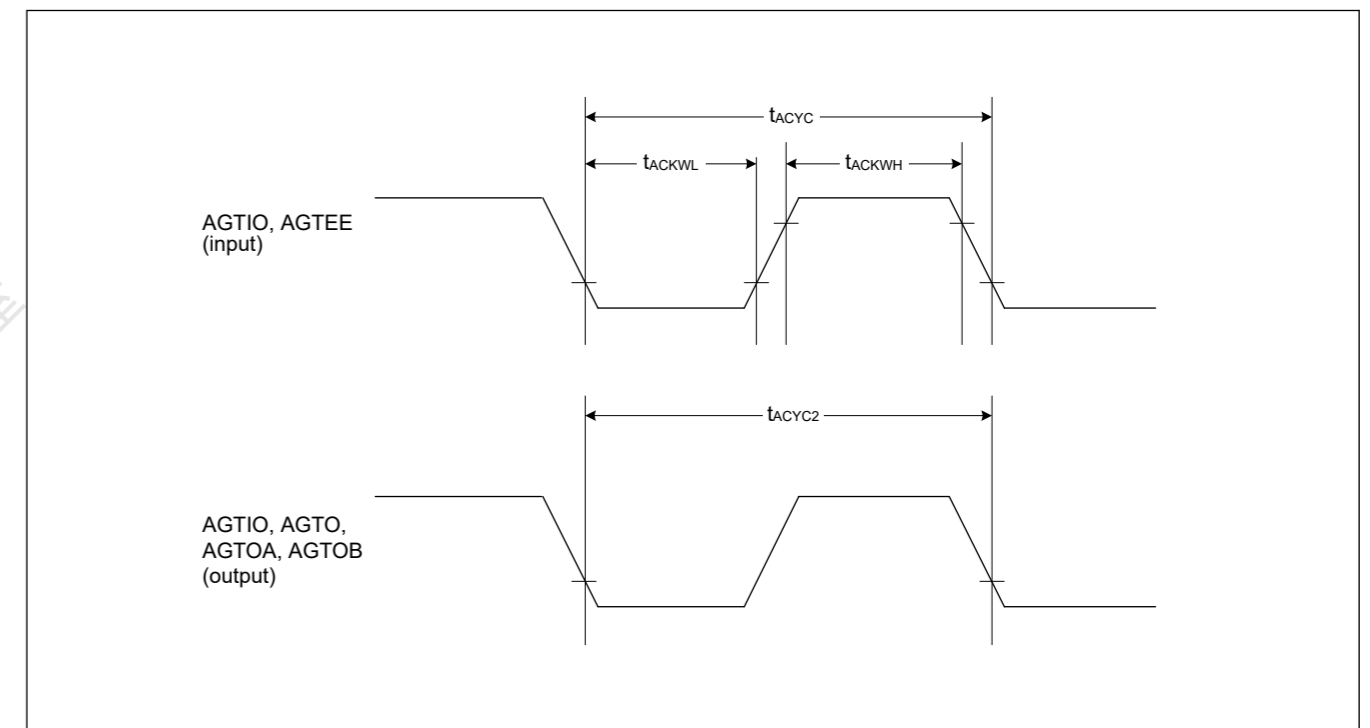


Figure 47.24 AGT input/output timing

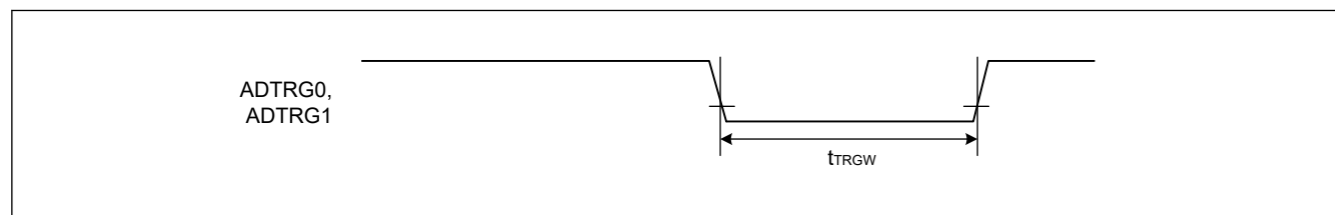


Figure 47.25 ADC12 trigger input timing

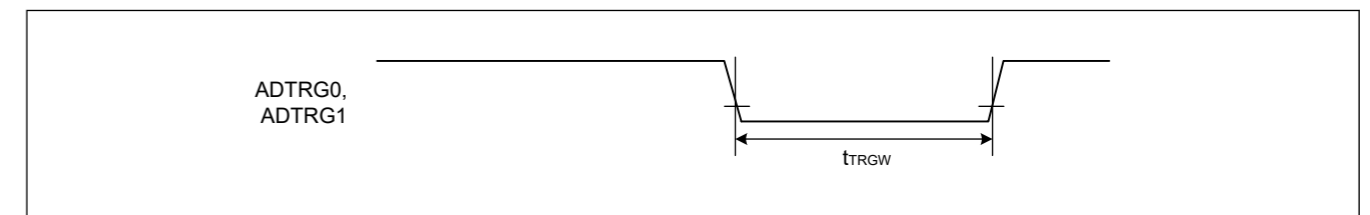


Figure 47.25 ADC12触发输入时序

47.3.7 CAC Timing

Table 47.23 CAC timing

| Parameter                       | Symbol  | Min          | Typ                                       | Max | Unit | Test conditions |
|---------------------------------|---|--------------|---|-----|------|-----------------|
| CAC<br>CACREF input pulse width | $t_{PBcyc} \leq t_{cac}^{*1}$<br>$t_{PBcyc} > t_{cac}^{*1}$ | $t_{CACREF}$ | $4.5 \times t_{cac} + 3 \times t_{PBcyc}$ | —   | —    | ns              |
|                                 |   |              | $5 \times t_{cac} + 6.5 \times t_{PBcyc}$ | —   | —    | ns              |

47.3.7 CAC时序

Table 47.23 CAC计时

| Parameter           | Symbol  | Min          | Typ                                       | Max | Unit | 测试条件 |
|---------------------|---|--------------|---|-----|------|------|
| CAC<br>CACREF输入脉冲宽度 | $t_{PBcyc} \leq t_{cac}^{*1}$<br>$t_{PBcyc} > t_{cac}^{*1}$ | $t_{CACREF}$ | $4.5 \times t_{cac} + 3 \times t_{PBcyc}$ | —   | —    | ns   |
|                     |   |              | $5 \times t_{cac} + 6.5 \times t_{PBcyc}$ | —   | —    | ns   |

Note:  $t_{PbCyc}$ : PCLKB cycle.  
 Note 1.  $t_{cac}$ : CAC count clock source cycle.

47.3.8 SCI Timing

Table 47.24 SCI timing (1)

Conditions: High drive output is selected in the Port Drive Capability bit in the PmnPFS register.

| Parameter                | Symbol     | Min  | Max   | Unit       | Test conditions         |
|--------------------------|------------|--|---|------------|-------------------------|
| SCI Input clock cycle    | $t_{Scyc}$ | Asynchronous                                   | 4   | —          | $t_{Pcyc}$ Figure 47.26 |
|                          |            | Clock synchronous                              | 6   | —          |                         |
| Input clock pulse width  | $t_{SCKW}$ | 0.4  | 0.6   | $t_{Scyc}$ |                         |
| Input clock rise time    | $t_{SCKr}$ | —  | 5   | ns         |                         |
| Input clock fall time    | $t_{SCKf}$ | —  | 5   | ns         |                         |
| Output clock cycle       | $t_{Scyc}$ | Asynchronous                                   | 6 (other than SCI1, SCI2)<br>8 (SCI1, SCI2) | —          | $t_{Pcyc}$              |
|                          |            | Clock synchronous                              | 4   | —          |                         |
| Output clock pulse width | $t_{SCKW}$ | 0.4  | 0.6   | $t_{Scyc}$ |                         |
| Output clock rise time   | $t_{SCKr}$ | —  | 5   | ns         |                         |
| Output clock fall time   | $t_{SCKf}$ | —  | 5   | ns         |                         |
| Transmit data delay      | $t_{TXD}$  | Clock synchronous master mode (internal clock) | —   | 5          | ns Figure 47.27         |
|                          |            | Clock synchronous slave mode (external clock)  | —   | 25         |                         |
| Receive data setup time  | $t_{RXS}$  | Clock synchronous master mode (internal clock) | 15  | —          | ns                      |
|                          |            | Clock synchronous slave mode (external clock)  | 5   | —          |                         |
| Receive data hold time   | $t_{RXH}$  | 5  | —   | ns         |                         |

Note:  $t_{Pcyc}$ : PCLKA cycle.

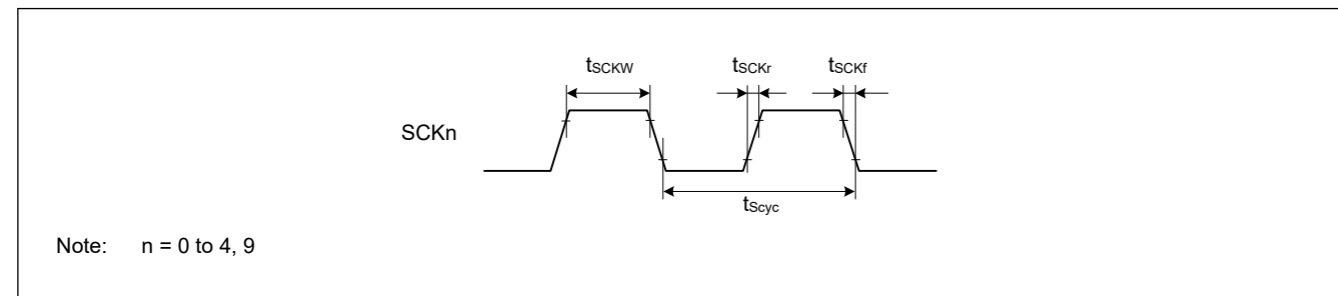


Figure 47.26 SCK clock input/output timing

Note:  $t_{PbCyc}$ : PCLKB cycle.  
 注1.  $t_{cac}$ : CAC计数时钟源周期。

47.3.8 SCI时序

Table 47.24 SCI时序 (1)

条件: 在PmnPFS寄存器的端口驱动能力位中选择高驱动输出。

| Parameter | 符号         | 最小值             | 最大单位  | 测试条件                    |                 |
|-----------|------------|-----------------|---|-------------------------|-----------------|
| SCI输入时钟周期 | $t_{Scyc}$ | Asynchronous    | 4   | $t_{Pcyc}$ Figure 47.26 |                 |
|           |            | 时钟同步            | 6   |                         |                 |
| 输入时钟脉冲宽度  | $t_{SCKW}$ | 0.4             | 0.6   | $t_{Scyc}$              |                 |
| 输入时钟上升时间  | $t_{SCKr}$ | —               | 5   | ns                      |                 |
| 输入时钟下降时间  | $t_{SCKf}$ | —               | 5   | ns                      |                 |
| 输出时钟周期    | $t_{Scyc}$ | Asynchronous    | 6 (other than SCI1, SCI2)<br>8 (SCI1, SCI2) | $t_{Pcyc}$              |                 |
|           |            | 时钟同步            | 4   |                         |                 |
| 输出时钟脉冲宽度  | $t_{SCKW}$ | 0.4             | 0.6   | $t_{Scyc}$              |                 |
| 输出时钟上升时间  | $t_{SCKr}$ | —               | 5   | ns                      |                 |
| 输出时钟下降时间  | $t_{SCKf}$ | —               | 5   | ns                      |                 |
| 传输数据延迟    | $t_{TXD}$  | 时钟同步主模式 (内部时钟)  | —   | 5                       | ns Figure 47.27 |
|           |            | 时钟同步从机模式 (外部时钟) | —   |                         |                 |
| 接收数据建立时间  | $t_{RXS}$  | 时钟同步主模式 (内部时钟)  | 15  | —                       | ns              |
|           |            | 时钟同步从机模式 (外部时钟) | 5   | —                       |                 |
| 接收数据保持时间  | $t_{RXH}$  | 5               | —   | ns                      |                 |

Note:  $t_{Pcyc}$ : PCLKA cycle.

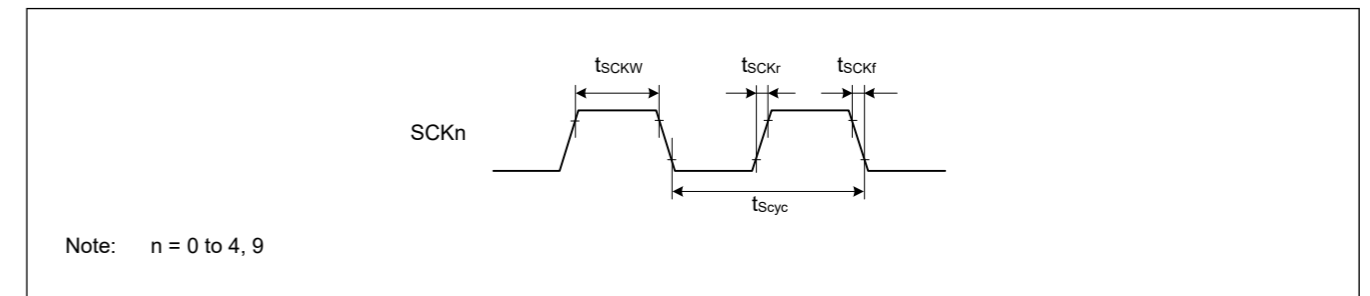
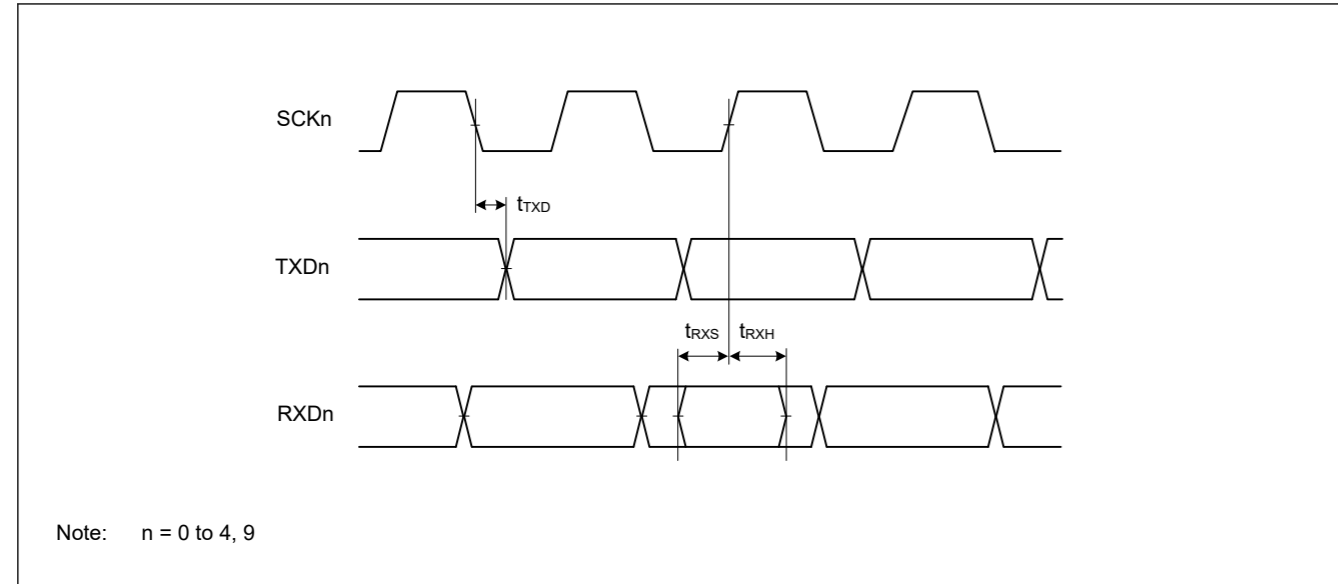


Figure 47.26 SCK时钟输入输出时序



Note: n = 0 to 4, 9

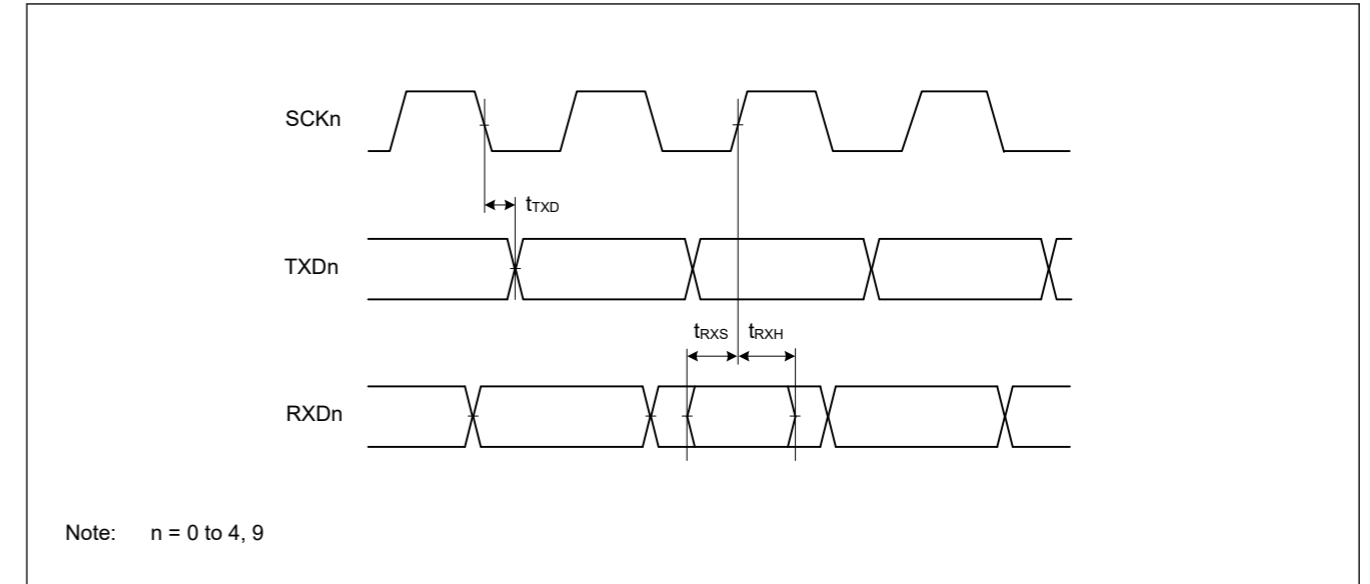
Figure 47.27 SCI input/output timing in clock synchronous mode

Table 47.25 SCI timing (2)

Conditions: High drive output is selected in the Port Drive Capability bit in the PmnPFS register.

| Parameter  | Symbol                          | Min                    | Max      | Unit                     | Test conditions |                              |              |
|------------|---------------------------------|------------------------|----------|--------------------------|-----------------|------------------------------|--------------|
| Simple SPI | SCK clock cycle output (master) | $t_{SPcyc}$            | 4        | 65536                    | $t_{Pcyc}$      | Figure 47.28                 |              |
|            | SCK clock cycle input (slave)   |                        | 6        | 65536                    |                 |                              |              |
|            | SCK clock high pulse width      | $t_{SPCKWH}$           | 0.4      | 0.6                      | $t_{SPcyc}$     | Figure 47.29 to Figure 47.32 |              |
|            | SCK clock low pulse width       | $t_{SPCKWL}$           | 0.4      | 0.6                      | $t_{SPcyc}$     |                              |              |
|            | SCK clock rise and fall time    | $t_{SPCKr}, t_{SPCKf}$ | —        | 5                        | ns              |                              |              |
|            | Data input setup time           | master                 | $t_{SU}$ | 15                       | —               |                              | ns           |
|            |                                 |                        | slave    |                          | 5               |                              | —            |
|            | Data input hold time            | $t_H$                  | 5        | —                        | ns              |                              |              |
|            | SS input setup time             | $t_{LEAD}$             | 1        | —                        | $t_{SPcyc}$     |                              |              |
|            | SS input hold time              | $t_{LAG}$              | 1        | —                        | $t_{SPcyc}$     |                              |              |
|            | Data output delay               | master                 | $t_{OD}$ | —                        | 5               |                              | ns           |
|            |                                 |                        | slave    |                          | —               |                              | 25           |
|            | Data output hold time           | $t_{OH}$               | -5       | —                        | ns              |                              |              |
|            | Data rise and fall time         | $t_{Dr}, t_{Df}$       | —        | 5                        | ns              |                              |              |
|            | SS input rise and fall time     | $t_{SSLr}, t_{SSLf}$   | —        | 5                        | ns              |                              |              |
|            | Slave access time               | $t_{SA}$               | —        | $3 \times t_{Pcyc} + 25$ | ns              |                              | Figure 47.32 |
|            | Slave output release time       | $t_{REL}$              | —        | $3 \times t_{Pcyc} + 25$ | ns              |                              |              |

Note:  $t_{Pcyc}$ : PCLKA cycle.



Note: n = 0 to 4, 9

Figure 47.27 时钟同步模式下的SCI输入输出时序

Table 47.25 SCI时序 (2)

条件: 在PmnPFS寄存器的端口驱动能力位中选择高驱动输出。

| Parameter | Symbol         | Min                    | Max      | Unit                     | 测试条件        |               |              |
|-----------|----------------|------------------------|----------|--------------------------|-------------|---------------|--------------|
| 简单的SPI    | SCK时钟周期输出 (主机) | $t_{SPcyc}$            | 4        | 65536                    | $t_{Pcyc}$  | Figure 47.28  |              |
|           | SCK时钟周期输入 (从机) |                        | 6        | 65536                    |             |               |              |
|           | SCK时钟高脉冲宽度     | $t_{SPCKWH}$           | 0.4      | 0.6                      | $t_{SPcyc}$ | 图47.29至图47.32 |              |
|           | SCK时钟低脉冲宽度     | $t_{SPCKWL}$           | 0.4      | 0.6                      | $t_{SPcyc}$ |               |              |
|           | SCK时钟上升和下降时间   | $t_{SPCKr}, t_{SPCKf}$ | —        | 5                        | ns          |               |              |
|           | 数据输入建立时间       | master                 | $t_{SU}$ | 15                       | —           |               | ns           |
|           |                |                        | slave    |                          | 5           |               | —            |
|           | 数据输入保持时间       | $t_H$                  | 5        | —                        | ns          |               |              |
|           | SS输入建立时间       | $t_{LEAD}$             | 1        | —                        | $t_{SPcyc}$ |               |              |
|           | SS输入保持时间       | $t_{LAG}$              | 1        | —                        | $t_{SPcyc}$ |               |              |
|           | 数据输出延迟         | master                 | $t_{OD}$ | —                        | 5           |               | ns           |
|           |                |                        | slave    |                          | —           |               | 25           |
|           | 数据输出保持时间       | $t_{OH}$               | -5       | —                        | ns          |               |              |
|           | 数据上升和下降时间      | $t_{Dr}, t_{Df}$       | —        | 5                        | ns          |               |              |
|           | SS输入上升和下降时间    | $t_{SSLr}, t_{SSLf}$   | —        | 5                        | ns          |               |              |
|           | 从站访问时间         | $t_{SA}$               | —        | $3 \times t_{Pcyc} + 25$ | ns          |               | Figure 47.32 |
|           | 从机输出释放时间       | $t_{REL}$              | —        | $3 \times t_{Pcyc} + 25$ | ns          |               |              |

Note:  $t_{Pcyc}$ : PCLKA cycle.

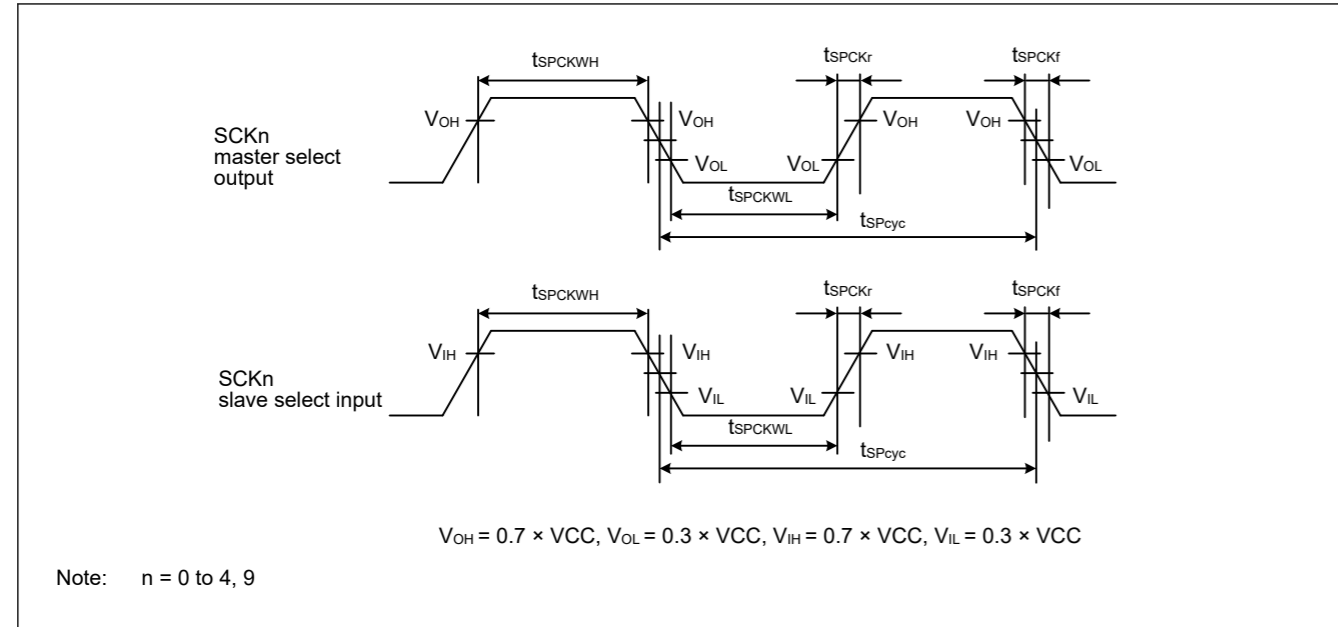


Figure 47.28 SCI simple SPI mode clock timing

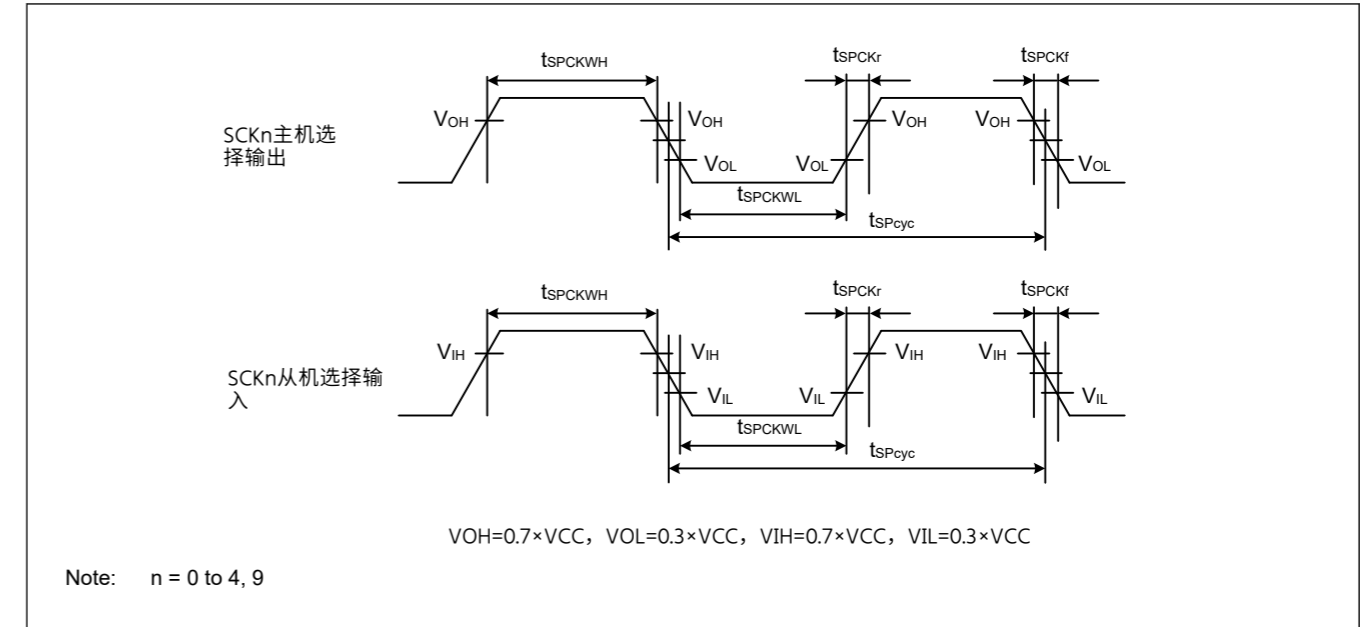


Figure 47.28 SCI简单SPI模式时钟时序

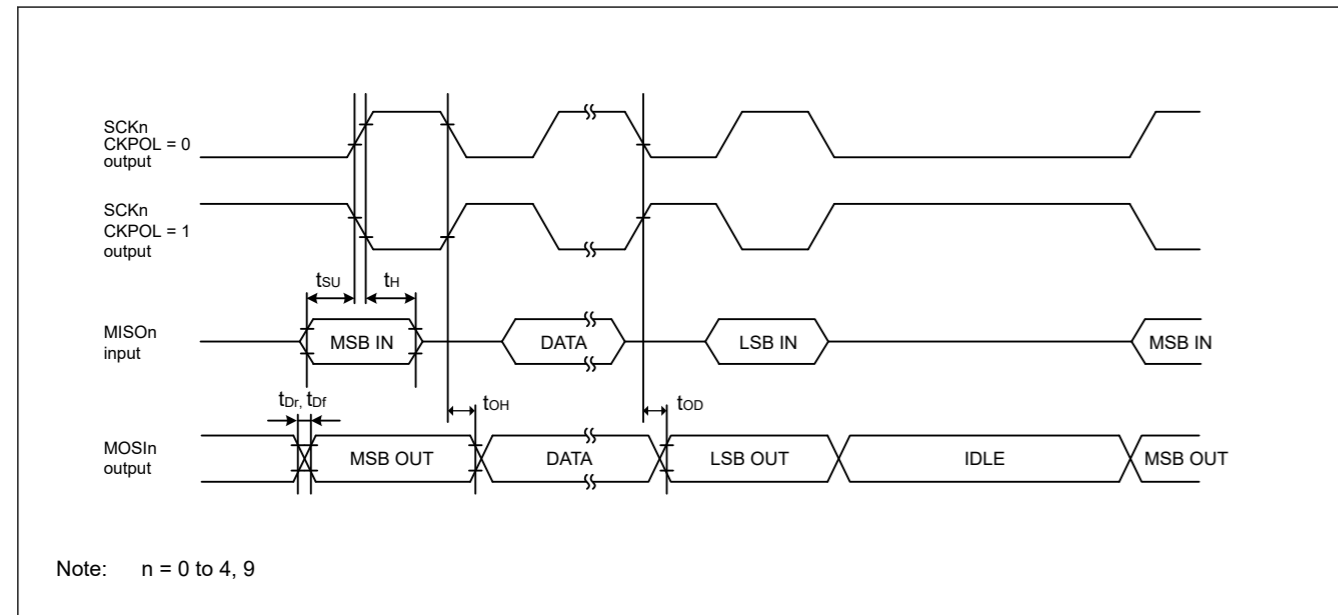


Figure 47.29 SCI simple SPI mode timing for master when CKPH = 1

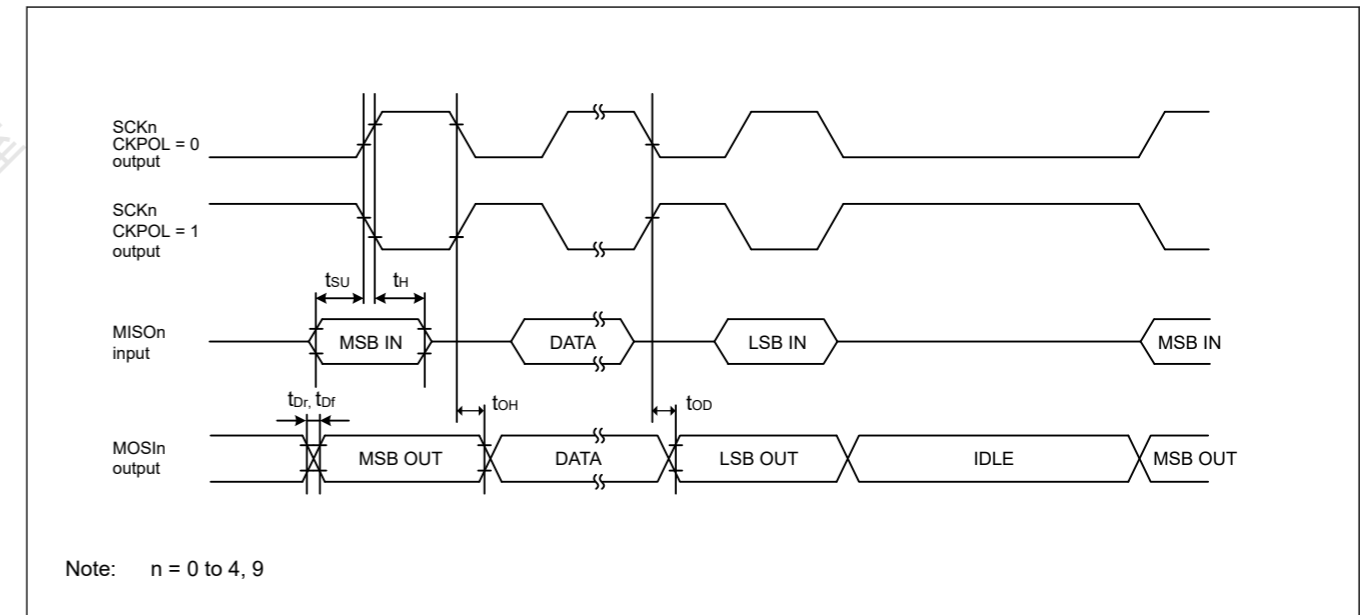


Figure 47.29 CKPH=1时主机的SCI简单SPI模式时序



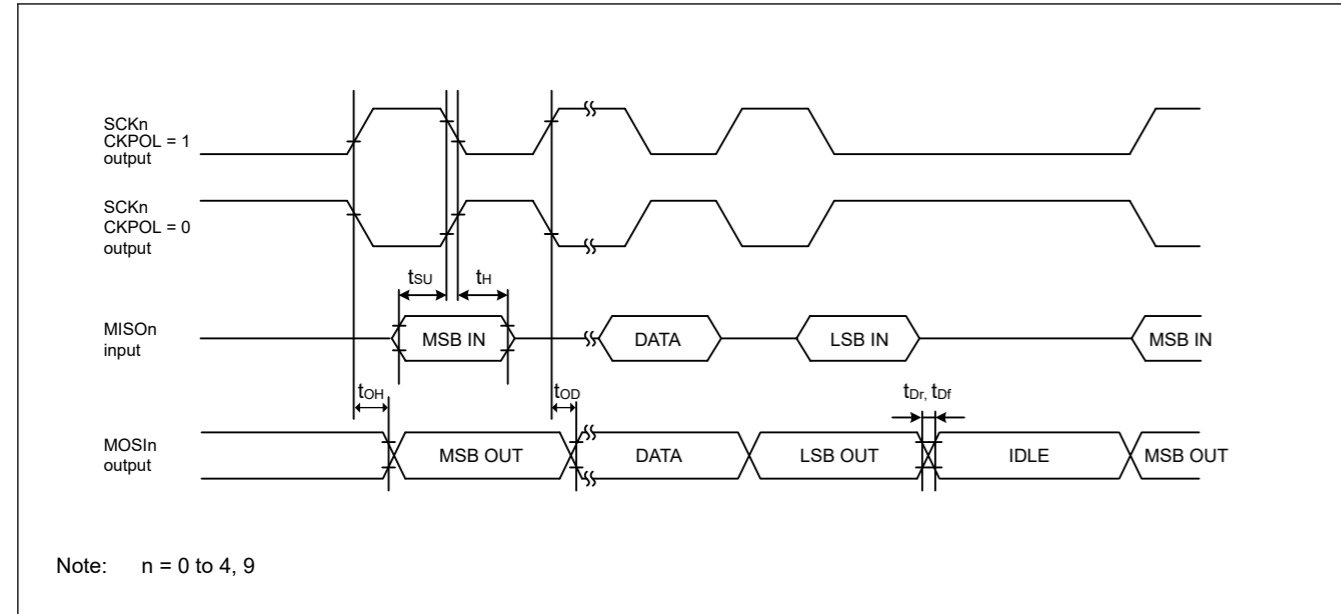


Figure 47.30 SCI simple SPI mode timing for master when CKPH = 0

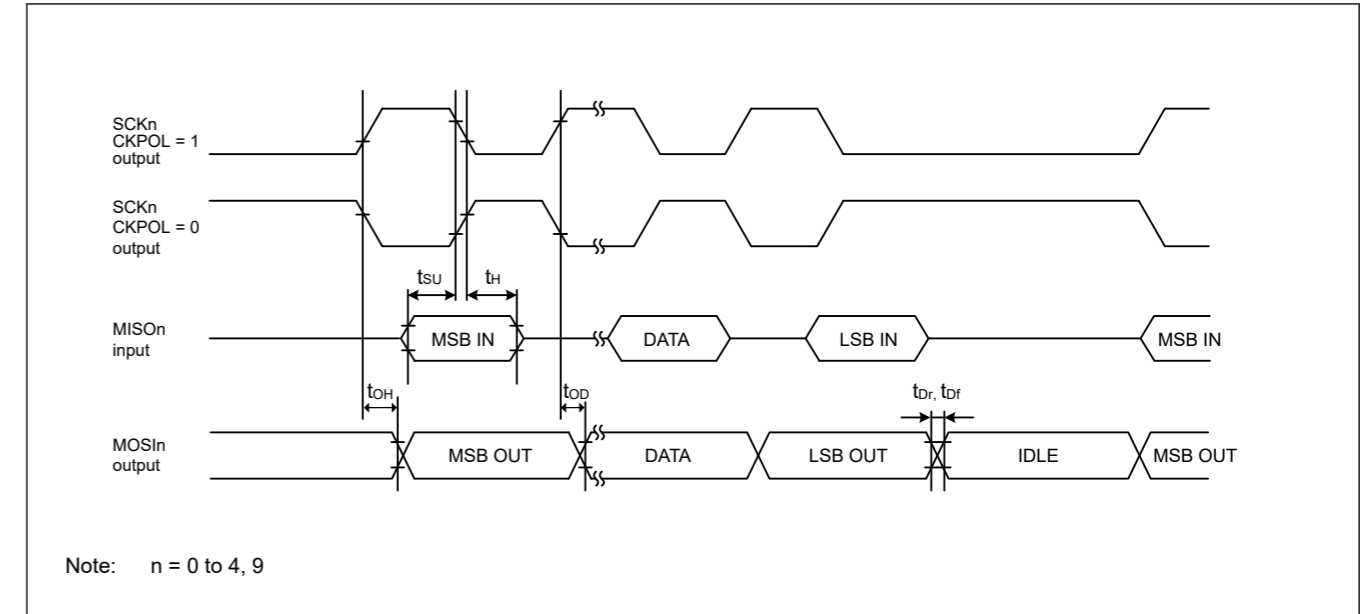


Figure 47.30 CKPH=0时主机的SCI简单SPI模式时序

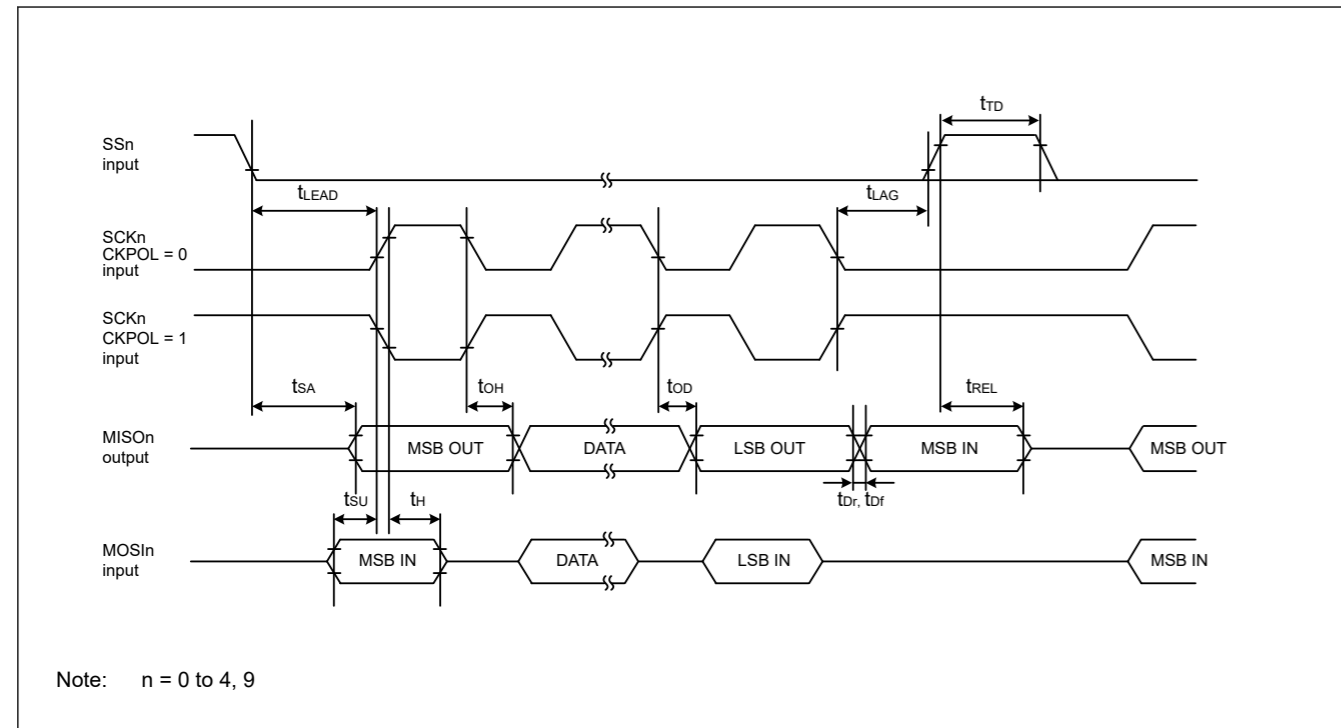


Figure 47.31 SCI simple SPI mode timing for slave when CKPH = 1

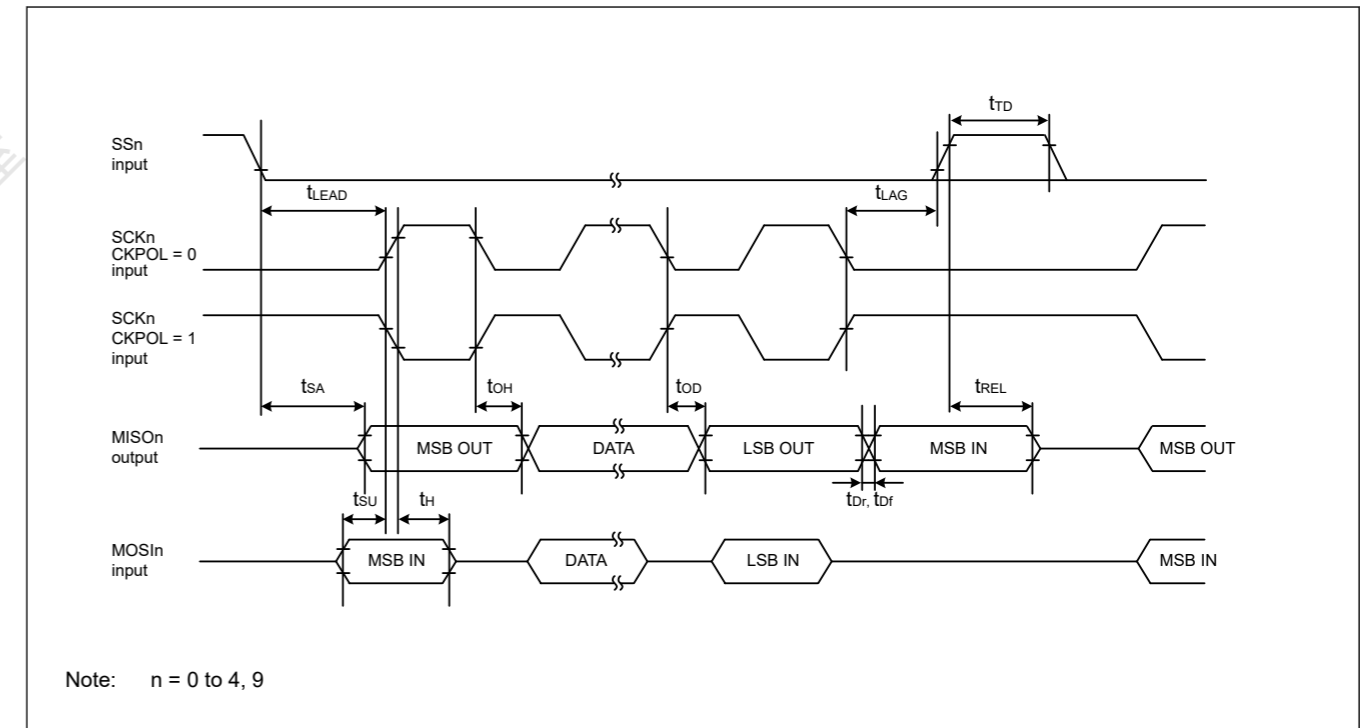
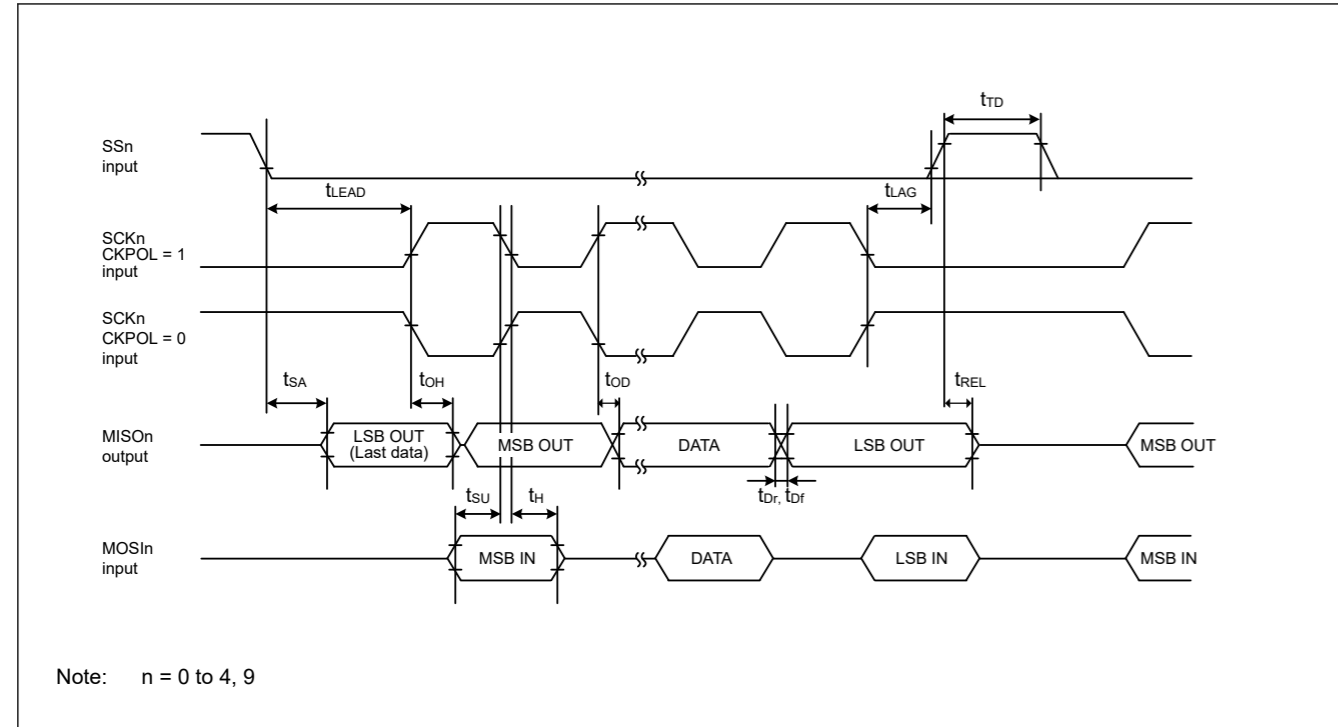


Figure 47.31 CKPH=1时从机的SCI简单SPI模式时序



Note: n = 0 to 4, 9

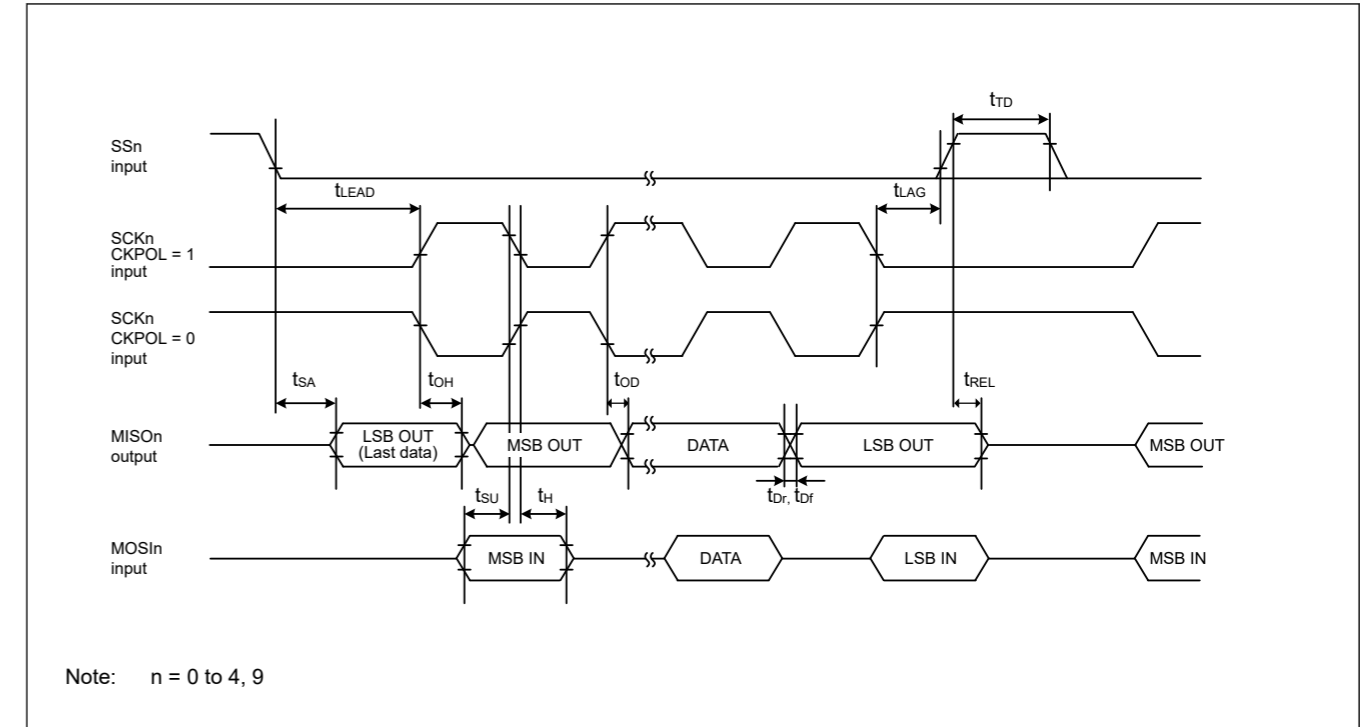
Figure 47.32 SCI simple SPI mode timing for slave when CKPH = 0

Table 47.26 SCI timing (3)

Conditions: Middle drive output is selected in the Port Drive Capability bit in the PmnPFS register.

| Parameter                  | Symbol                             | Min        | Max | Unit                  | Test conditions |              |
|----------------------------|------------------------------------|------------|-----|-----------------------|-----------------|--------------|
| Simple IIC (Standard mode) | SDA input rise time                | $t_{sr}$   | —   | 1000                  | ns              | Figure 47.33 |
|                            | SDA input fall time                | $t_{sf}$   | —   | 300                   | ns              |              |
|                            | SDA input spike pulse removal time | $t_{sp}$   | 0   | $4 \times t_{IICcyc}$ | ns              |              |
|                            | Data input setup time              | $t_{SDAS}$ | 250 | —                     | ns              |              |
|                            | Data input hold time               | $t_{SDAH}$ | 0   | —                     | ns              |              |
|                            | SCL, SDA capacitive load           | $C_b^{*1}$ | —   | 400                   | pF              |              |
| Simple IIC (Fast mode)     | SDA input rise time                | $t_{sr}$   | —   | 300                   | ns              | Figure 47.33 |
|                            | SDA input fall time                | $t_{sf}$   | —   | 300                   | ns              |              |
|                            | SDA input spike pulse removal time | $t_{sp}$   | 0   | $4 \times t_{IICcyc}$ | ns              |              |
|                            | Data input setup time              | $t_{SDAS}$ | 100 | —                     | ns              |              |
|                            | Data input hold time               | $t_{SDAH}$ | 0   | —                     | ns              |              |
|                            | SCL, SDA capacitive load           | $C_b^{*1}$ | —   | 400                   | pF              |              |

Note:  $t_{IICcyc}$ : IIC internal reference clock (IIC $\phi$ ) cycle.  
 Note 1.  $C_b$  indicates the total capacity of the bus line.



Note: n = 0 to 4, 9

Figure 47.32 CKPH=0时从机的SCI简单SPI模式时序

Table 47.26 SCI时序 (3)

条件: 在PmnPFS寄存器的端口驱动能力位中选择中间驱动输出。

| Parameter                  | Symbol                   | Min        | Max | Unit                  | 测试条件 |              |
|----------------------------|--------------------------|------------|-----|-----------------------|------|--------------|
| Simple IIC (Standard mode) | SDA输入上升时间                | $t_{sr}$   | —   | 1000                  | ns   | Figure 47.33 |
|                            | SDA输入下降时间                | $t_{sf}$   | —   | 300                   | ns   |              |
|                            | SDA输入尖峰脉冲去除时间            | $t_{sp}$   | 0   | $4 \times t_{IICcyc}$ | ns   |              |
|                            | 数据输入建立时间                 | $t_{SDAS}$ | 250 | —                     | ns   |              |
|                            | 数据输入保持时间                 | $t_{SDAH}$ | 0   | —                     | ns   |              |
|                            | SCL, SDA capacitive load | $C_b^{*1}$ | —   | 400                   | pF   |              |
| Simple IIC (Fast mode)     | SDA输入上升时间                | $t_{sr}$   | —   | 300                   | ns   | Figure 47.33 |
|                            | SDA输入下降时间                | $t_{sf}$   | —   | 300                   | ns   |              |
|                            | SDA输入尖峰脉冲去除时间            | $t_{sp}$   | 0   | $4 \times t_{IICcyc}$ | ns   |              |
|                            | 数据输入建立时间                 | $t_{SDAS}$ | 100 | —                     | ns   |              |
|                            | 数据输入保持时间                 | $t_{SDAH}$ | 0   | —                     | ns   |              |
|                            | SCL, SDA capacitive load | $C_b^{*1}$ | —   | 400                   | pF   |              |

Note:  $t_{IICcyc}$ : IIC内部参考时钟(IIC $\phi$ )周期。  
 注1.  $C_b$ 表示公交线路的总容量。

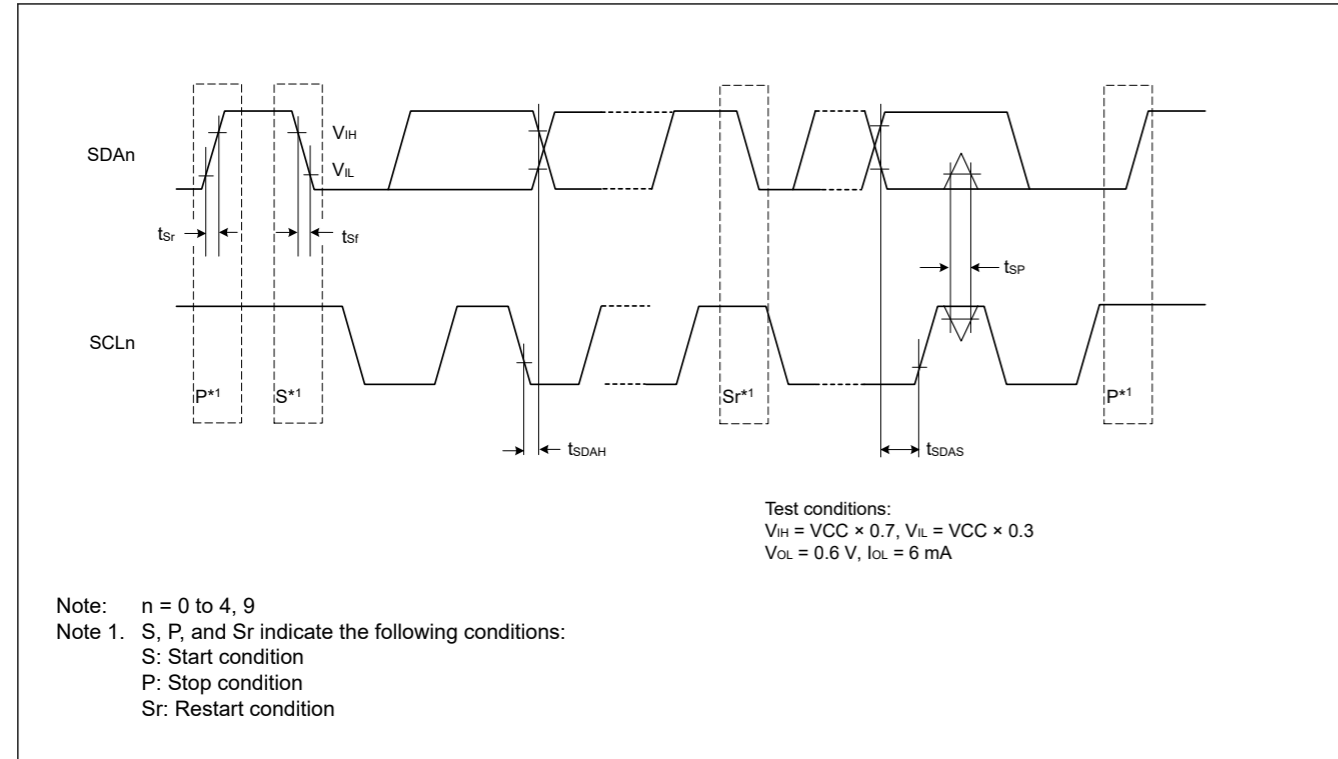


Figure 47.33 SCI simple IIC mode timing

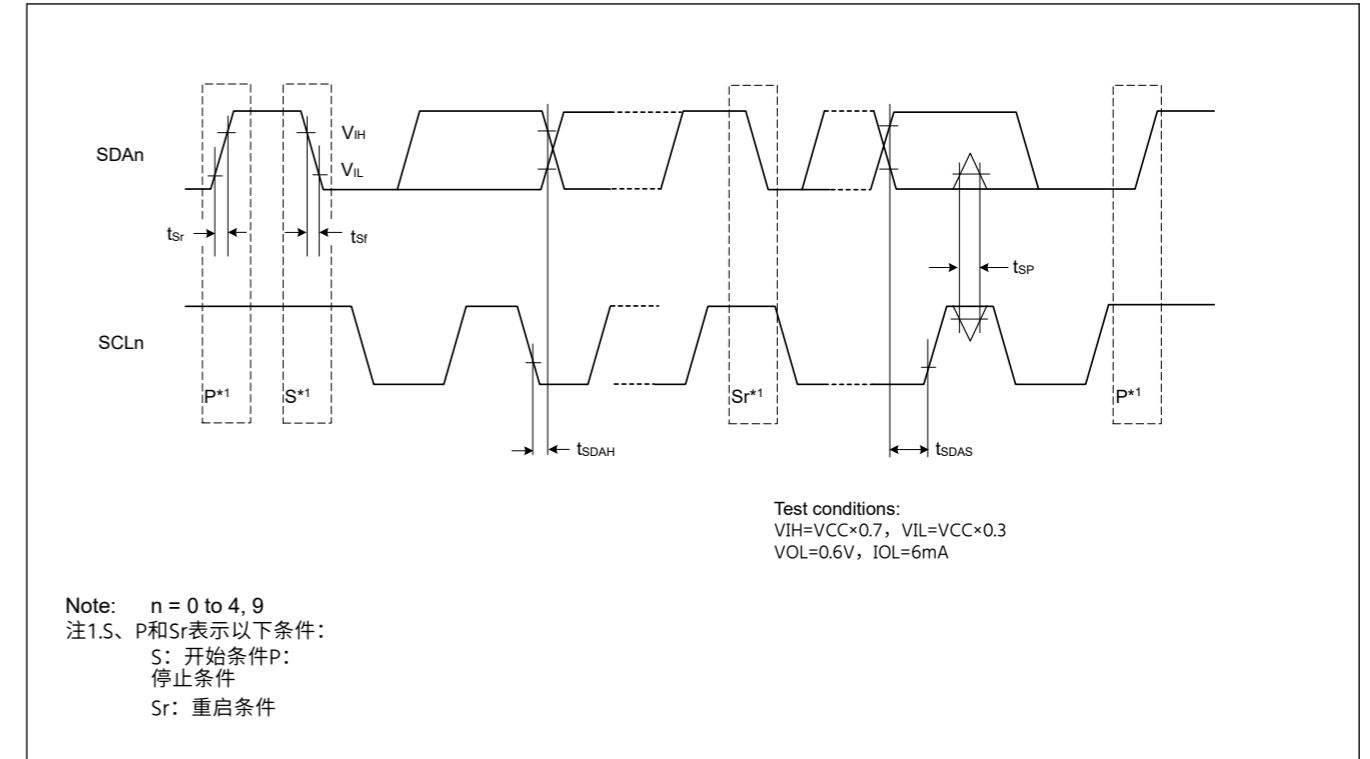


Figure 47.33 SCI简单IIC模式时序

47.3.9 SPI Timing

Table 47.27 SPI timing

Conditions: High drive output is selected in the Port Drive Capability bit in the PmnPFS register.

| Parameter                        | Symbol  | Min                    | Max   | Unit                                     | Test conditions |                               |                              |
|----------------------------------|---|------------------------|---|--|-----------------|-------------------------------|------------------------------|
| SPI RSPCK clock cycle            | Master  | $t_{SPcyc}$            | 2   | 4096                                     | $t_{Pcyc}$      | Figure 47.34                  |                              |
|                                  | Slave   |                        | 4   | 4096                                     |                 |                               |                              |
| RSPCK clock high pulse width     | Master  | $t_{SPCKWH}$           | $(t_{SPcyc} - t_{SPCKr} - t_{SPCKf}) / 2 - 3$ | —  | ns              |                               |                              |
|                                  | Slave   |                        | 0.4   | 0.6                                      | $t_{SPcyc}$     |                               |                              |
| RSPCK clock low pulse width      | Master  | $t_{SPCKWL}$           | $(t_{SPcyc} - t_{SPCKr} - t_{SPCKf}) / 2 - 3$ | —  | ns              |                               |                              |
|                                  | Slave   |                        | 0.4   | 0.6                                      | $t_{SPcyc}$     |                               |                              |
| RSPCK clock rise and fall time   | Master  | $t_{SPCKr}, t_{SPCKf}$ | —   | 5  | ns              |                               |                              |
|                                  | Slave   |                        | —   | 1  | $\mu s$         |                               |                              |
| Data input setup time            | Master  | $t_{SU}$               | 4   | —  | ns              |                               | Figure 47.35 to Figure 47.40 |
| Slave                            |   | 5                      | —   |  |                 |                               |                              |
| Data input hold time             | Master (PCLKA division ratio set to 1/2)                    | $t_{HF}$               | 0   | —  | ns              |                               |                              |
|                                  | Master (PCLKA division ratio set to a value other than 1/2) | $t_H$                  | $t_{Pcyc}$                                    | —  |                 |                               |                              |
|                                  | Slave   | $t_H$                  | 20  | —  |                 |                               |                              |
| SSL setup time                   | Master  | $t_{LEAD}$             | $N \times t_{SPcyc} - 10^{*1}$                | $N \times t_{SPcyc} + 100^{*1}$          | ns              |                               |                              |
|                                  | Slave   |                        | $4 \times t_{Pcyc}$                           | —  | ns              |                               |                              |
| SSL hold time                    | Master  | $t_{LAG}$              | $N \times t_{SPcyc} - 10^{*2}$                | $N \times t_{SPcyc} + 100^{*2}$          | ns              |                               |                              |
|                                  | Slave   |                        | $4 \times t_{Pcyc}$                           | —  | ns              |                               |                              |
| Data output delay                | Master  | $t_{OD1}$              | —   | 6.3                                      | ns              |                               |                              |
|                                  |   | $t_{OD2}$              | —   | 6.3                                      |                 |                               |                              |
|                                  | Slave   | $t_{OD}$               | —   | 20                                       |                 |                               |                              |
| Data output hold time            | Master  | $t_{OH}$               | 0   | —  | ns              |                               |                              |
|                                  | Slave   |                        | 0   | —  |                 |                               |                              |
| Successive transmission delay    | Master  | $t_{TD}$               | $t_{SPcyc} + 2 \times t_{Pcyc}$               | $8 \times t_{SPcyc} + 2 \times t_{Pcyc}$ | ns              |                               |                              |
|                                  | Slave   |                        | $4 \times t_{Pcyc}$                           |  |                 |                               |                              |
| MOSI and MISO rise and fall time | Output  | $t_{Dr}, t_{Df}$       | —   | 5  | ns              |                               |                              |
|                                  | Input   |                        | —   | 1  | $\mu s$         |                               |                              |
| SSL rise and fall time           | Output  | $t_{SSLr}, t_{SSLf}$   | —   | 5  | ns              |                               |                              |
|                                  | Input   |                        | —   | 1  | $\mu s$         |                               |                              |
| Slave access time                |   | $t_{SA}$               | —   | 25                                       | ns              | Figure 47.39 and Figure 47.40 |                              |
| Slave output release time        |   | $t_{REL}$              | —   | 25                                       |                 |                               |                              |

47.3.9 SPI时序

Table 47.27 SPI时序

条件：在PmnPFS寄存器的端口驱动能力位中选择高驱动输出。

| Parameter        | Symbol                 | Min                    | Max   | Unit                                     | 测试条件        |                      |               |
|------------------|------------------------|------------------------|---|--|-------------|----------------------|---------------|
| SPI RSPCK时钟周期    | Master                 | $t_{SPcyc}$            | 2   | 4096                                     | $t_{Pcyc}$  | Figure 47.34         |               |
|                  | Slave                  |                        | 4   | 4096                                     |             |                      |               |
| RSPCK时钟高脉冲宽度     | Master                 | $t_{SPCKWH}$           | $(t_{SPcyc} - t_{SPCKr} - t_{SPCKf}) / 2 - 3$ | —  | ns          |                      |               |
|                  | Slave                  |                        | 0.4   | 0.6                                      | $t_{SPcyc}$ |                      |               |
| RSPCK时钟低脉冲宽度     | Master                 | $t_{SPCKWL}$           | $(t_{SPcyc} - t_{SPCKr} - t_{SPCKf}) / 2 - 3$ | —  | ns          |                      |               |
|                  | Slave                  |                        | 0.4   | 0.6                                      | $t_{SPcyc}$ |                      |               |
| RSPCK时钟上升和下降时间   | Master                 | $t_{SPCKr}, t_{SPCKf}$ | —   | 5  | ns          |                      |               |
|                  | Slave                  |                        | —   | 1  | $\mu s$     |                      |               |
| 数据输入建立时间         | Master                 | $t_{SU}$               | 4   | —  | ns          |                      | 图47.35至图47.40 |
| Slave            |                        | 5                      | —   |  |             |                      |               |
| 数据输入保持时间         | 主控 (PCLKA分频比设置为12)     | $t_{HF}$               | 0   | —  | ns          |                      |               |
|                  | 主控 (PCLKA分频比设置为12以外的值) | $t_H$                  | $t_{Pcyc}$                                    | —  |             |                      |               |
|                  | Slave                  | $t_H$                  | 20  | —  |             |                      |               |
| SSL设置时间          | Master                 | $t_{LEAD}$             | $N \times t_{SPcyc} - 10^{*1}$                | $N \times t_{SPcyc} + 100^{*1}$          | ns          |                      |               |
|                  | Slave                  |                        | $4 \times t_{Pcyc}$                           | —  | ns          |                      |               |
| SSL保持时间          | Master                 | $t_{LAG}$              | $N \times t_{SPcyc} - 10^{*2}$                | $N \times t_{SPcyc} + 100^{*2}$          | ns          |                      |               |
|                  | Slave                  |                        | $4 \times t_{Pcyc}$                           | —  | ns          |                      |               |
| 数据输出延迟           | Master                 | $t_{OD1}$              | —   | 6.3                                      | ns          |                      |               |
|                  |                        | $t_{OD2}$              | —   | 6.3                                      |             |                      |               |
|                  | Slave                  | $t_{OD}$               | —   | 20                                       |             |                      |               |
| 数据输出保持时间         | Master                 | $t_{OH}$               | 0   | —  | ns          |                      |               |
|                  | Slave                  |                        | 0   | —  |             |                      |               |
| 连续传输延迟           | Master                 | $t_{TD}$               | $t_{SPcyc} + 2 \times t_{Pcyc}$               | $8 \times t_{SPcyc} + 2 \times t_{Pcyc}$ | ns          |                      |               |
|                  | Slave                  |                        | $4 \times t_{Pcyc}$                           |  |             |                      |               |
| MOSI和MISO上升和下降时间 | Output                 | $t_{Dr}, t_{Df}$       | —   | 5  | ns          |                      |               |
|                  | Input                  |                        | —   | 1  | $\mu s$     |                      |               |
| SSL上升和下降时间       | Output                 | $t_{SSLr}, t_{SSLf}$   | —   | 5  | ns          |                      |               |
|                  | Input                  |                        | —   | 1  | $\mu s$     |                      |               |
| 从站访问时间           |                        | $t_{SA}$               | —   | 25                                       | ns          | 图47.39和 Figure 47.40 |               |
| 从机输出释放时间         |                        | $t_{REL}$              | —   | 25                                       |             |                      |               |



Note:  $t_{Pcyc}$ : PCLKA cycle.

Note: Must use pins that have a letter appended to their name, for instance “\_A”, “\_B”, to indicate group membership. For the SPI interface, the AC portion of the electrical characteristics is measured for each group.

Note 1. N is set to an integer from 1 to 8 by the SPCKD register.

Note 2. N is set to an integer from 1 to 8 by the SSLND register.

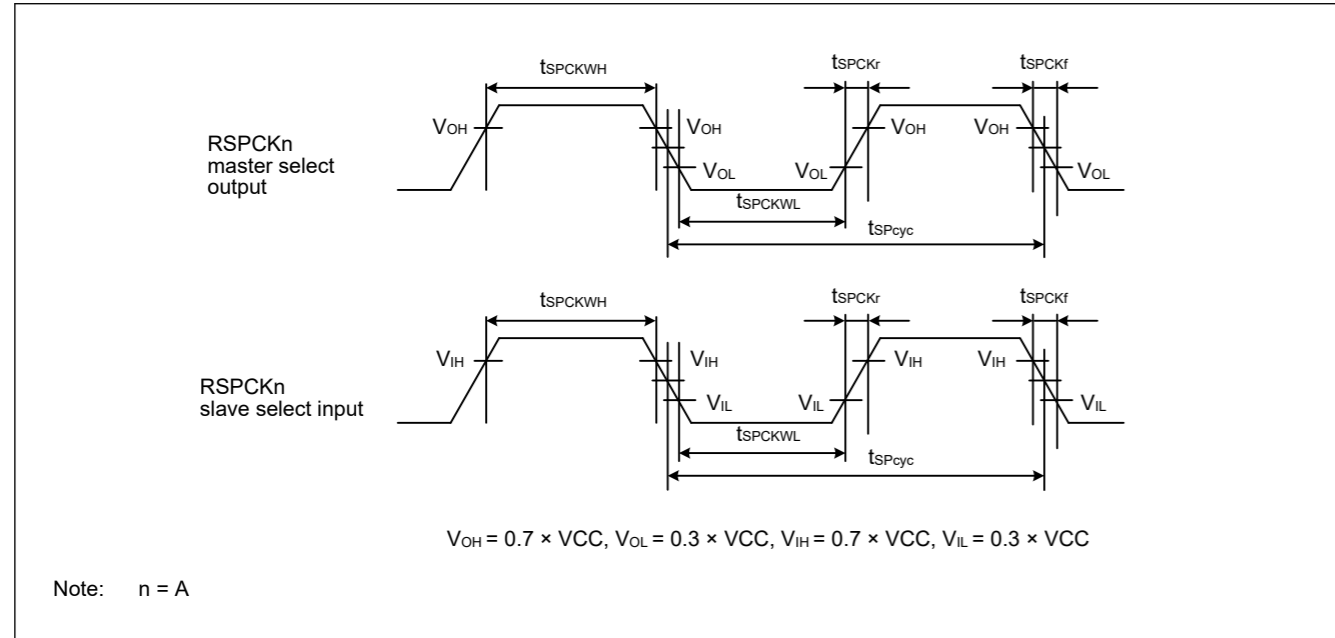


Figure 47.34 SPI clock timing

Note:  $t_{Pcyc}$ : PCLKA cycle.

Note: 必须使用名称后附有字母的引脚，例如“\_A”、“\_B”，以表示组成员身份。对于SPI接口，测量每组的电气特性的交流部分。

注1.N由SPCKD寄存器设置为1到8的整数。注2.N由SSLND寄存器

设置为1到8的整数。

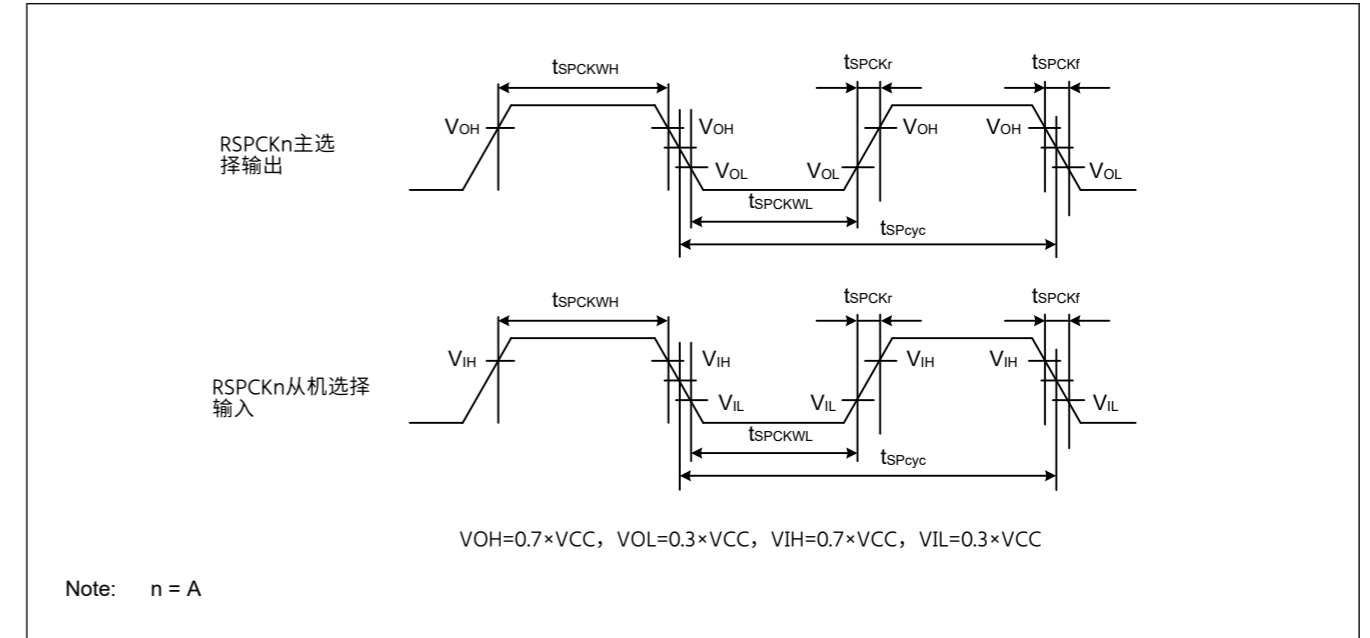


Figure 47.34 SPI时钟时序

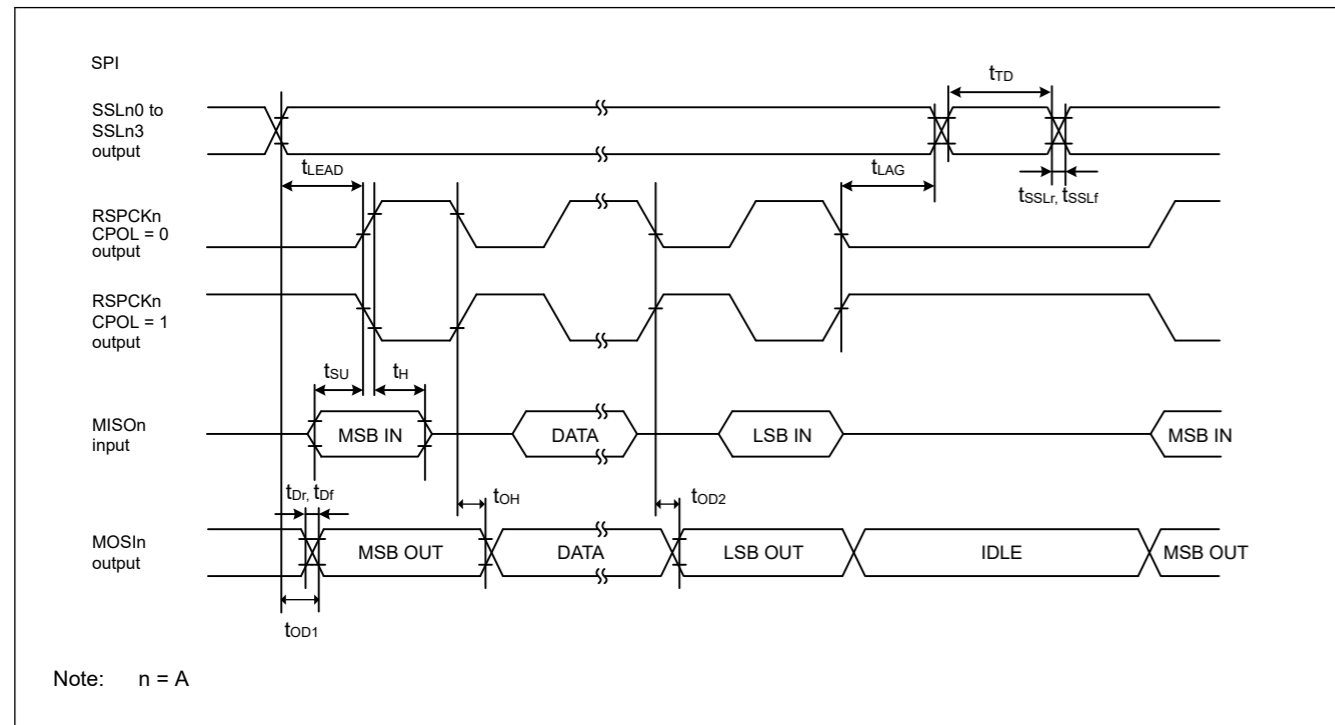


Figure 47.35 SPI timing for master when CPHA = 0

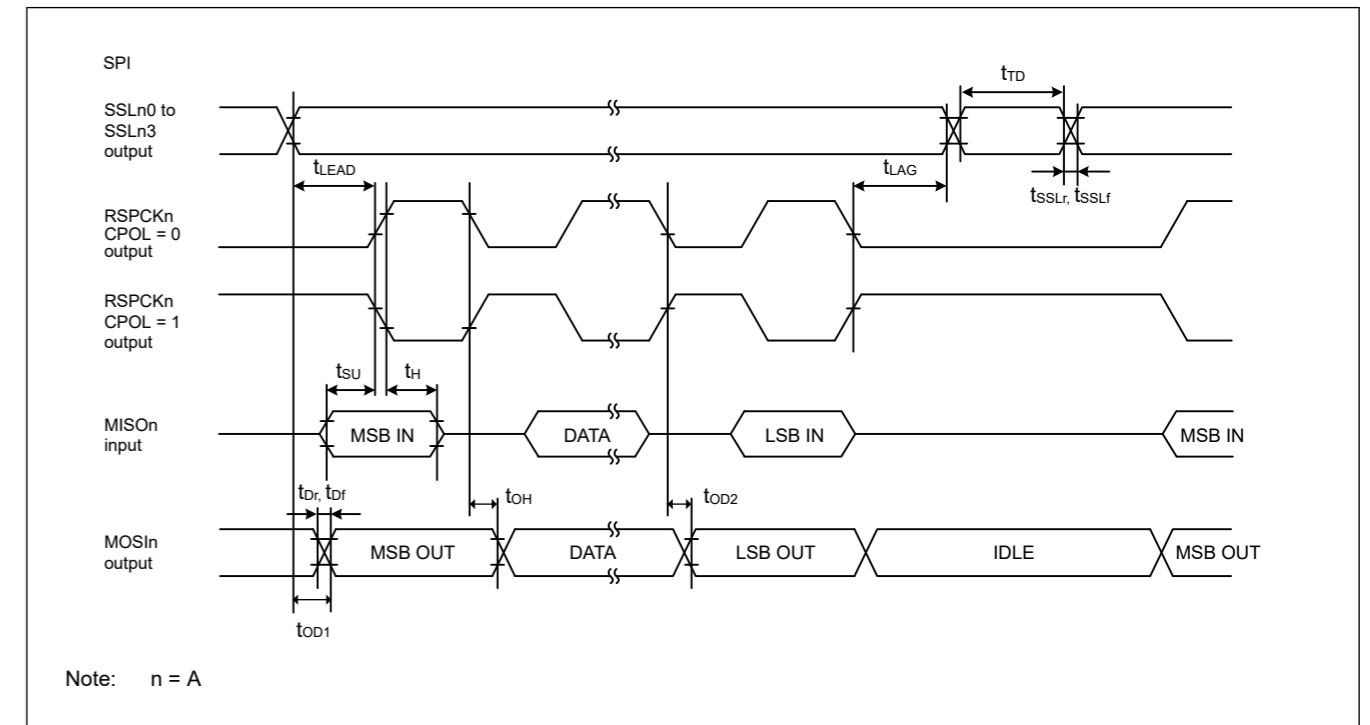


Figure 47.35 CPHA=0时主机的SPI时序

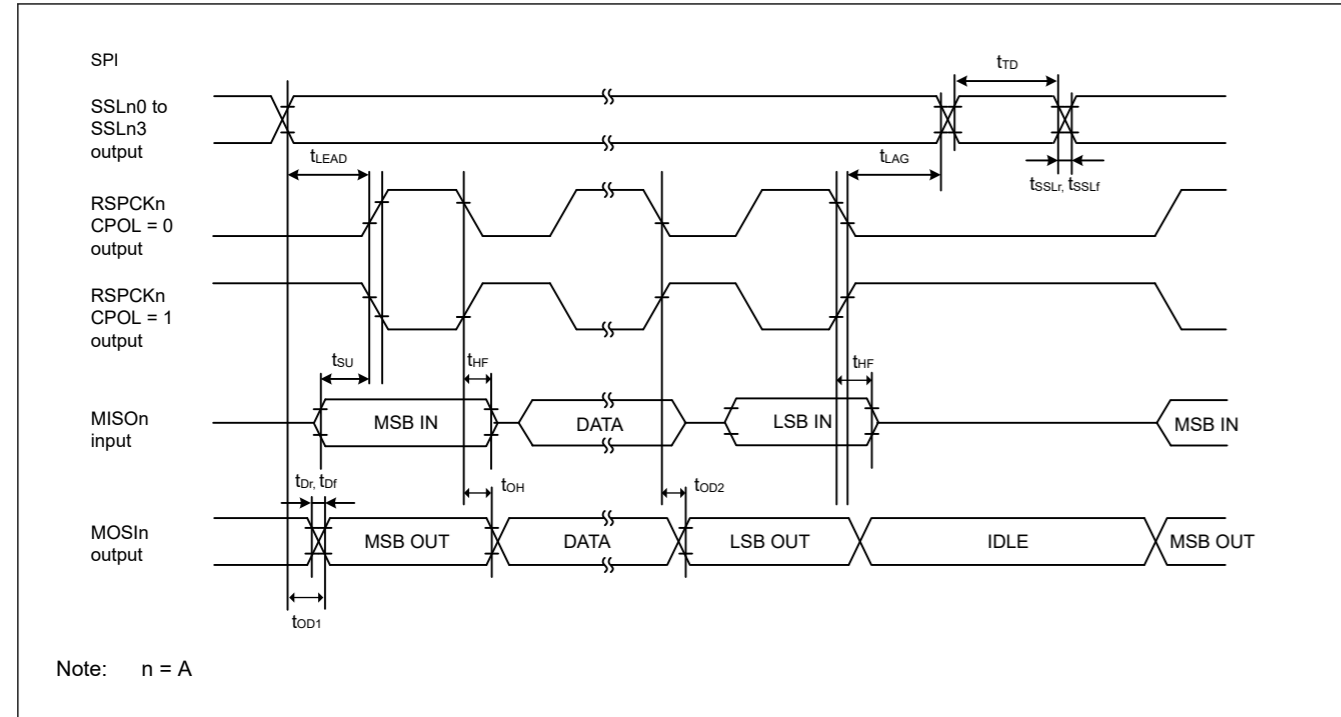


Figure 47.36 SPI timing for master when CPHA = 0 and the bit rate is set to PCLKA/2

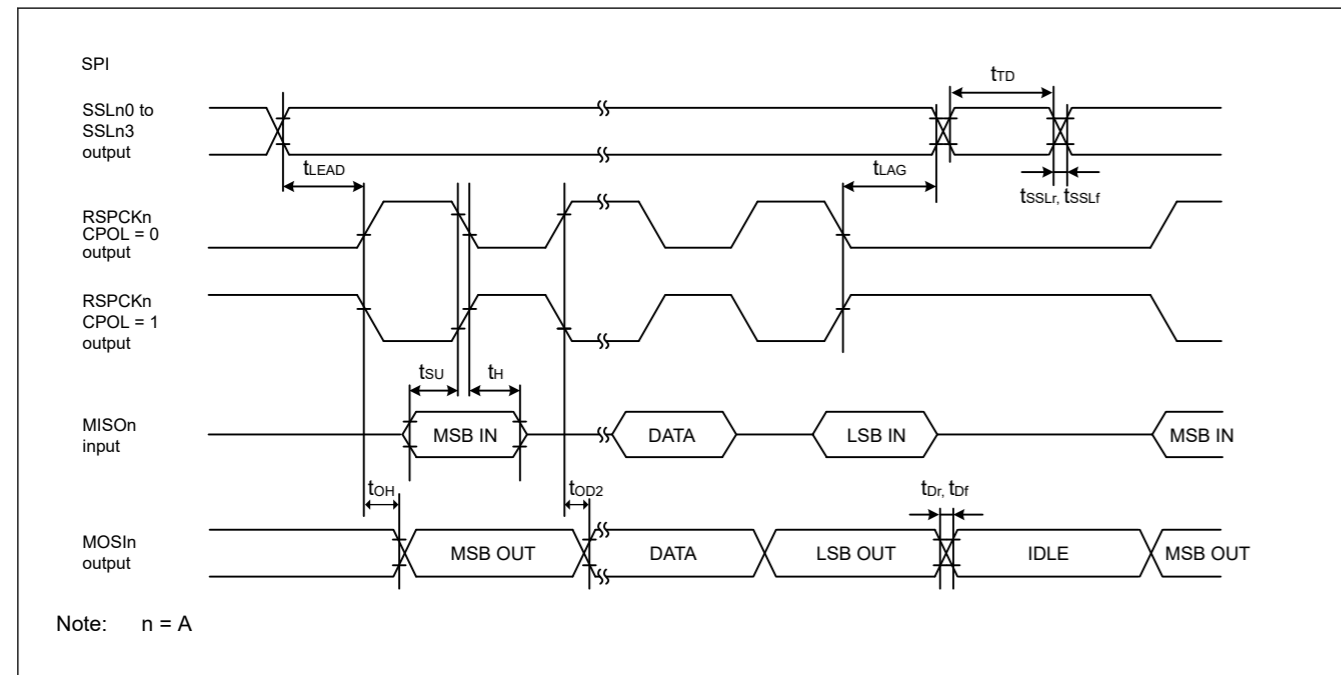


Figure 47.37 SPI timing for master when CPHA = 1

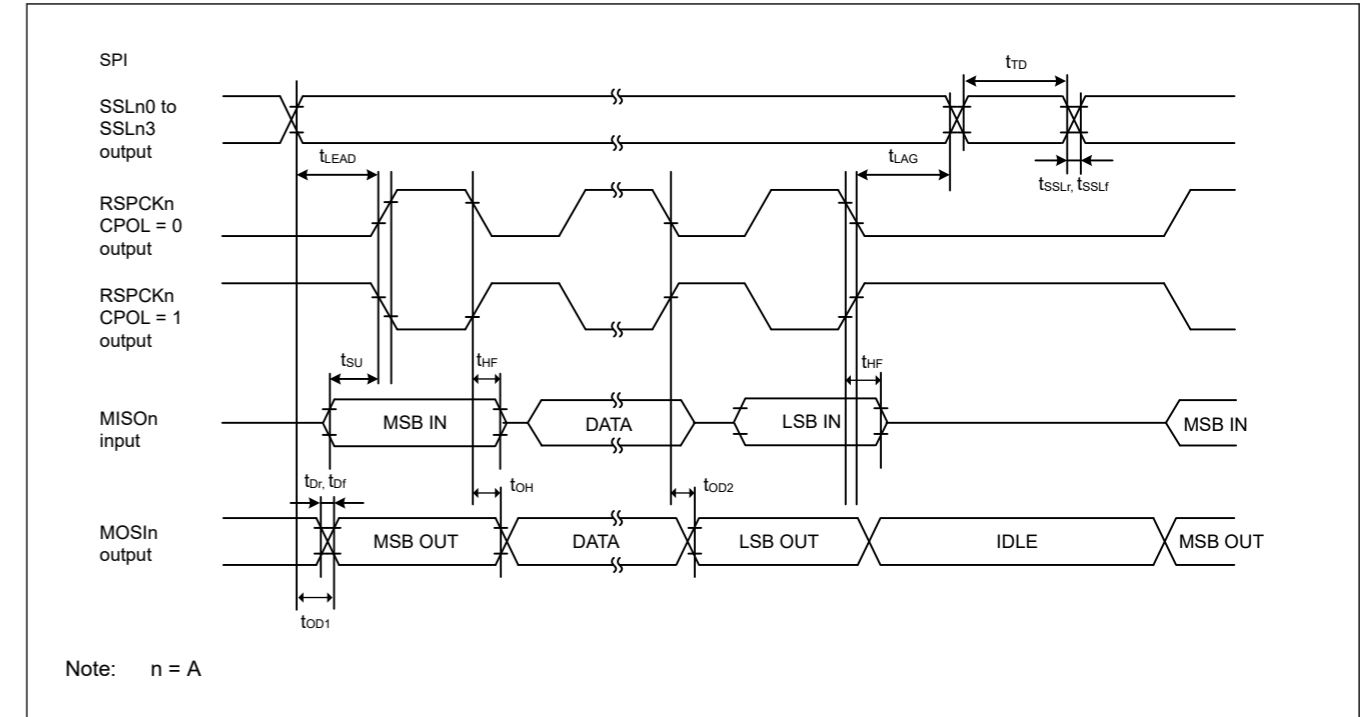


Figure 47.36 当CPHA=0且比特率设置为PCLKA/2时主设备的SPI时序

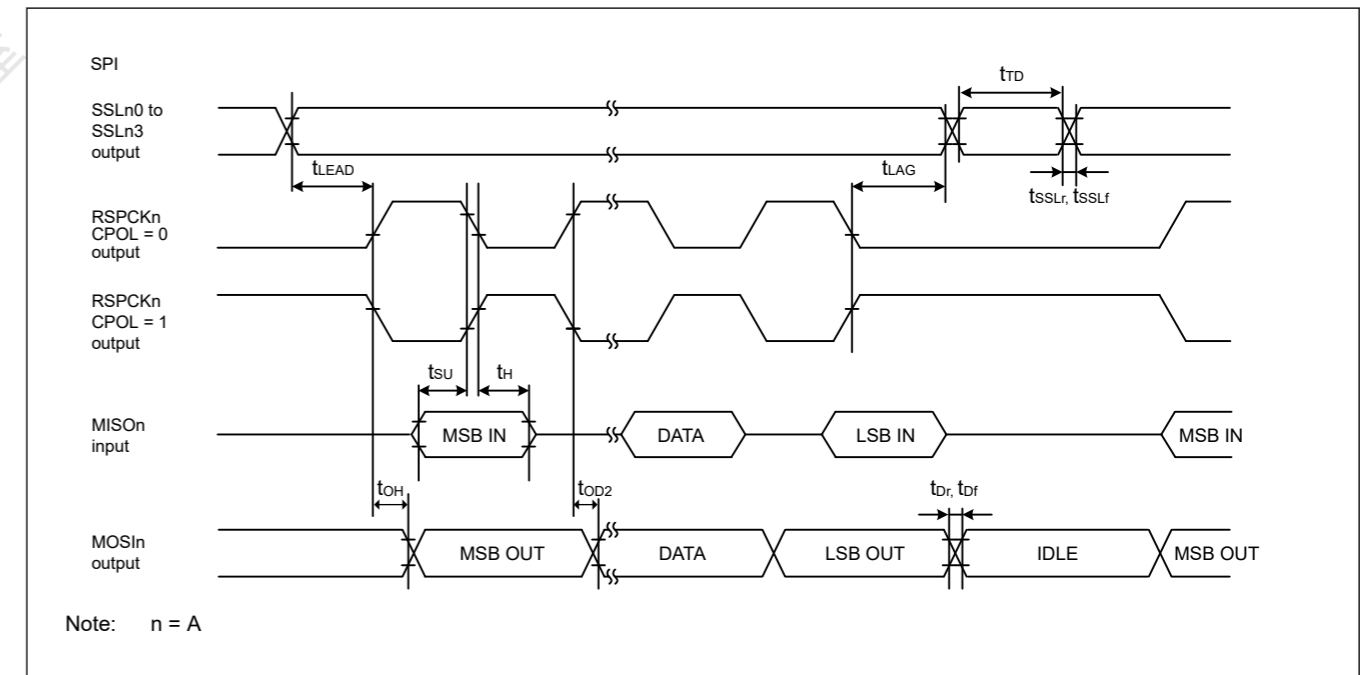


Figure 47.37 CPHA=1时主机的SPI时序

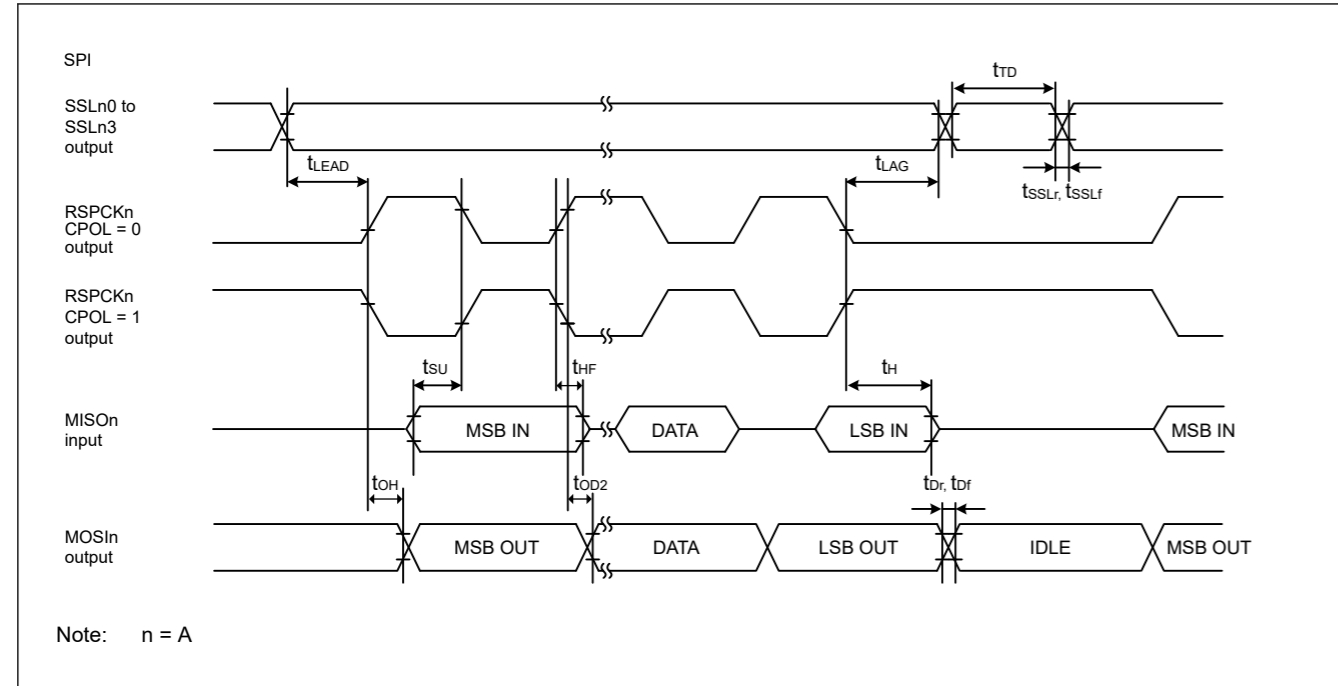


Figure 47.38 RSPi timing for master when CPHA = 1 and the bit rate is set to PCLKA/2

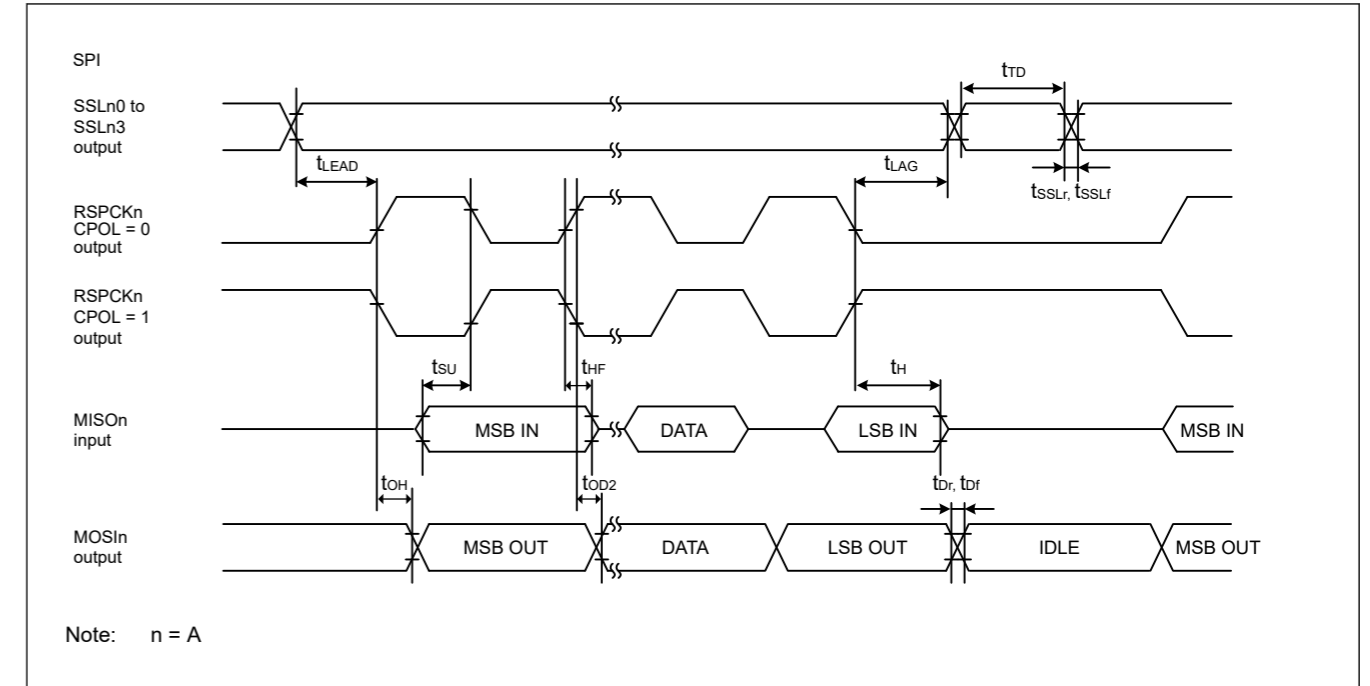


Figure 47.38 当CPHA=1且比特率设置为PCLKA/2时, 主机的RSPi时序

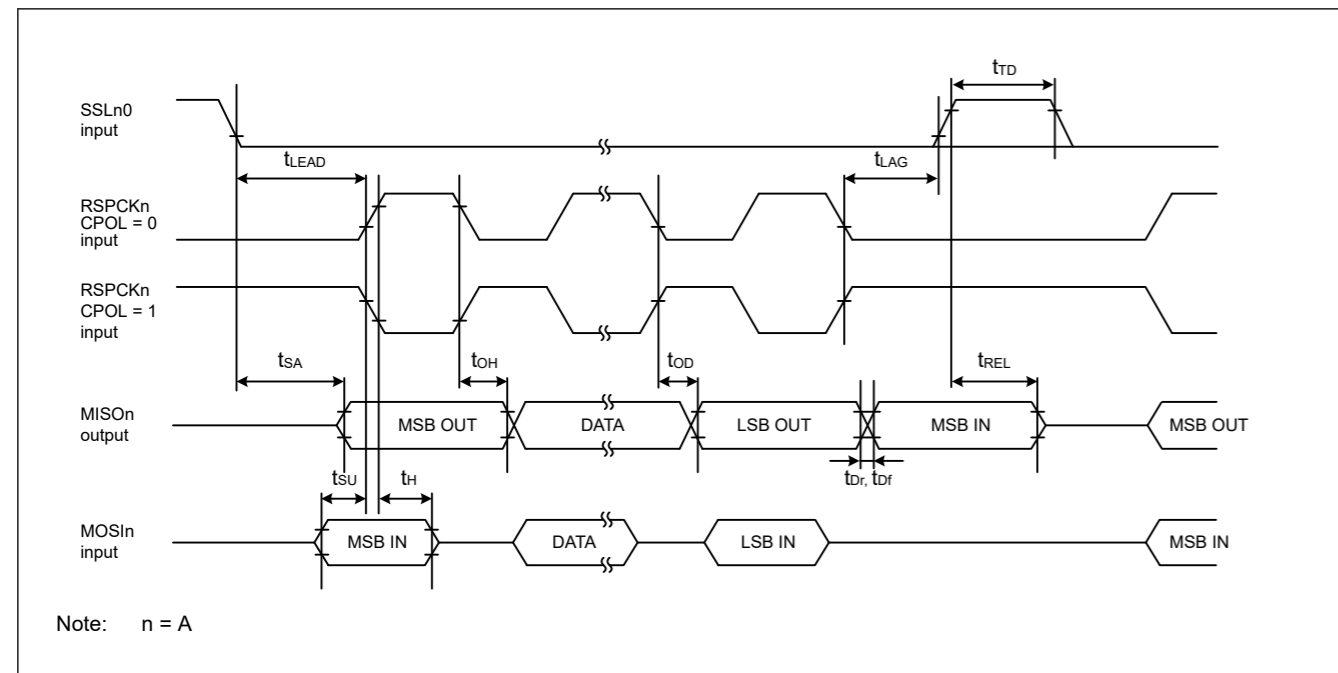


Figure 47.39 SPI timing for slave when CPHA = 0

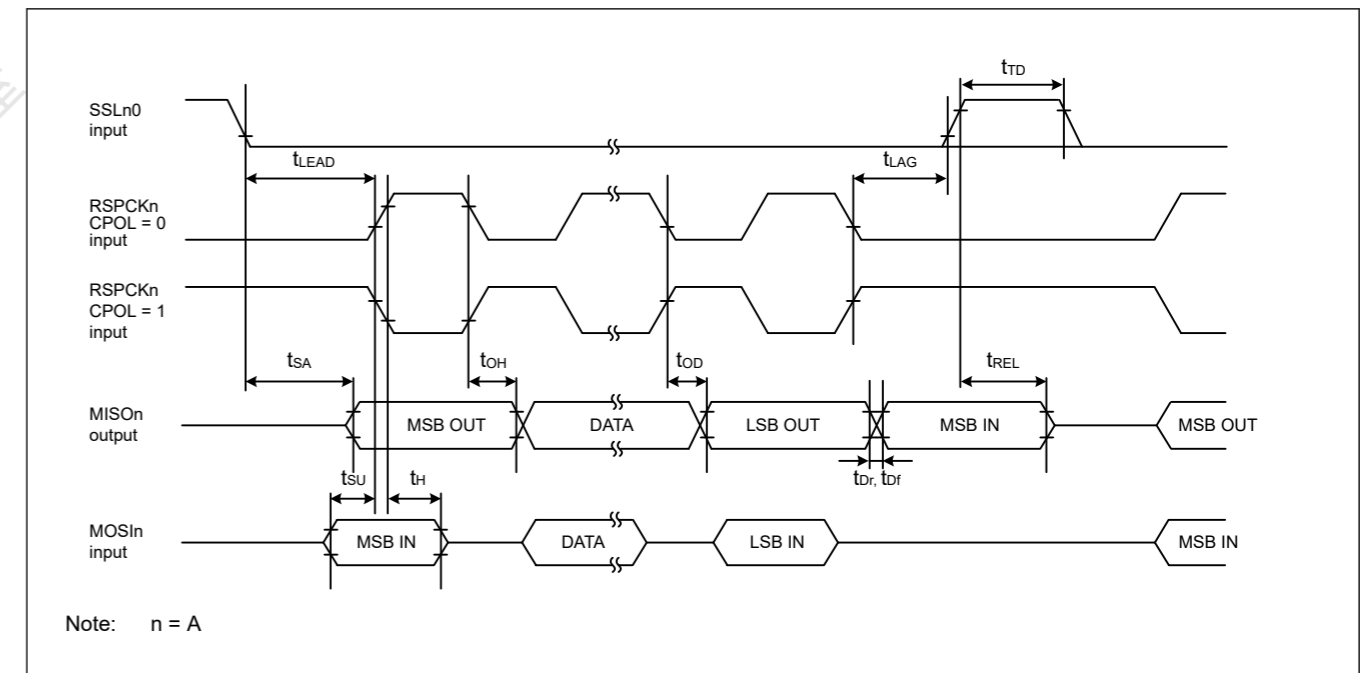


Figure 47.39 CPHA=0时从机的SPI时序

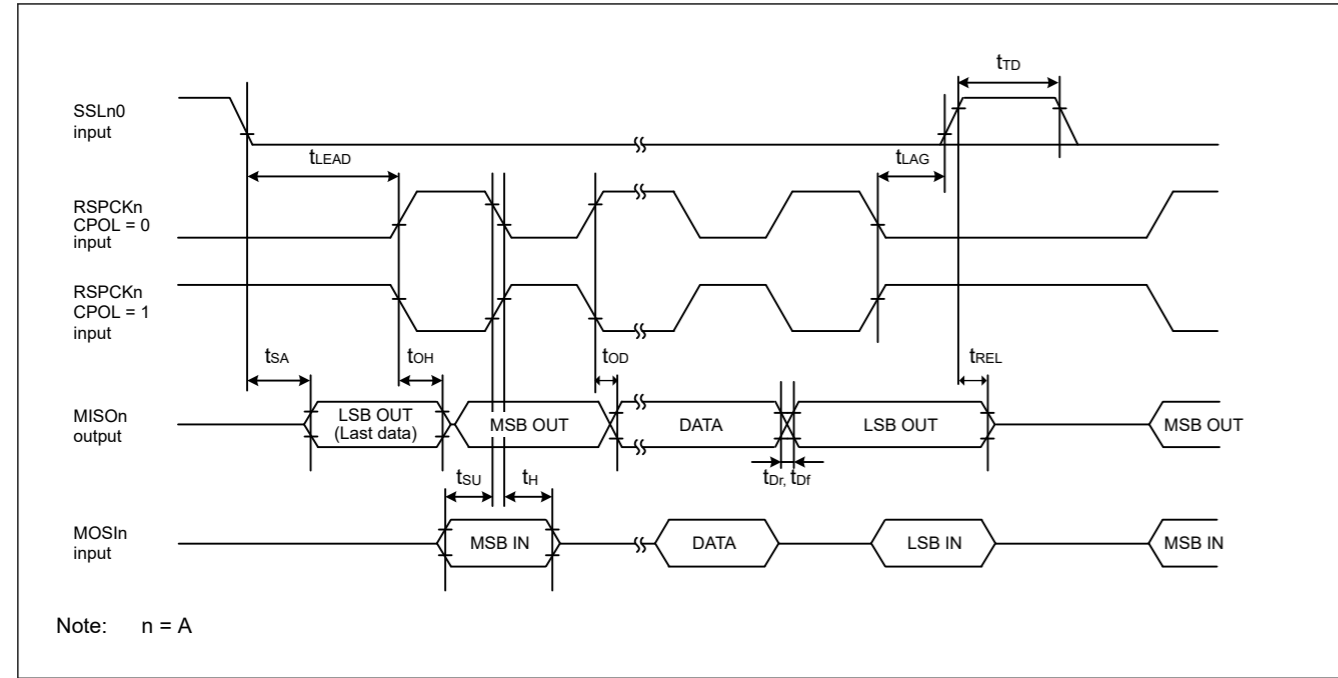


Figure 47.40 SPI timing for slave when CPHA = 1

47.3.10 QSPI Timing

Table 47.28 QSPI timing

Conditions: High drive output is selected in the Port Drive Capability bit in the PmnPFS register.

| Parameter | Symbol                        | Min         | Max                                   | Unit                                    | Test conditions |              |
|-----------|-------------------------------|-------------|---------------------------------------|---|-----------------|--------------|
| QSPI      | QSPCK clock cycle             | $t_{QScyc}$ | 2                                     | 48                                      | $t_{Pcyc}$      | Figure 47.41 |
|           | QSPCK clock high pulse width  | $t_{QSWH}$  | $t_{QScyc} \times 0.4$                | —                                       | ns              |              |
|           | QSPCK clock low pulse width   | $t_{QSWL}$  | $t_{QScyc} \times 0.4$                | —                                       | ns              |              |
| QSPI      | Data input setup time         | $t_{Su}$    | 10                                    | —                                       | ns              | Figure 47.42 |
|           | Data input hold time          | $t_{IH}$    | 0                                     | —                                       | ns              |              |
|           | QSSL setup time               | $t_{LEAD}$  | $(N + 0.5) \times t_{QScyc} - 5^{*1}$ | $(N + 0.5) \times t_{QScyc} + 100^{*1}$ | ns              |              |
|           | QSSL hold time                | $t_{LAG}$   | $(N + 0.5) \times t_{QScyc} - 5^{*2}$ | $(N + 0.5) \times t_{QScyc} + 100^{*2}$ | ns              |              |
|           | Data output delay             | $t_{OD}$    | —                                     | 4                                       | ns              |              |
|           | Data output hold time         | $t_{OH}$    | -3.3                                  | —                                       | ns              |              |
|           | Successive transmission delay | $t_{TD}$    | 1                                     | 16                                      | $t_{QScyc}$     |              |

Note:  $t_{Pcyc}$ : PCLKA cycle.  
 Note 1. N is set to 0 or 1 in SFMSLD.  
 Note 2. N is set to 0 or 1 in SFMSHD.

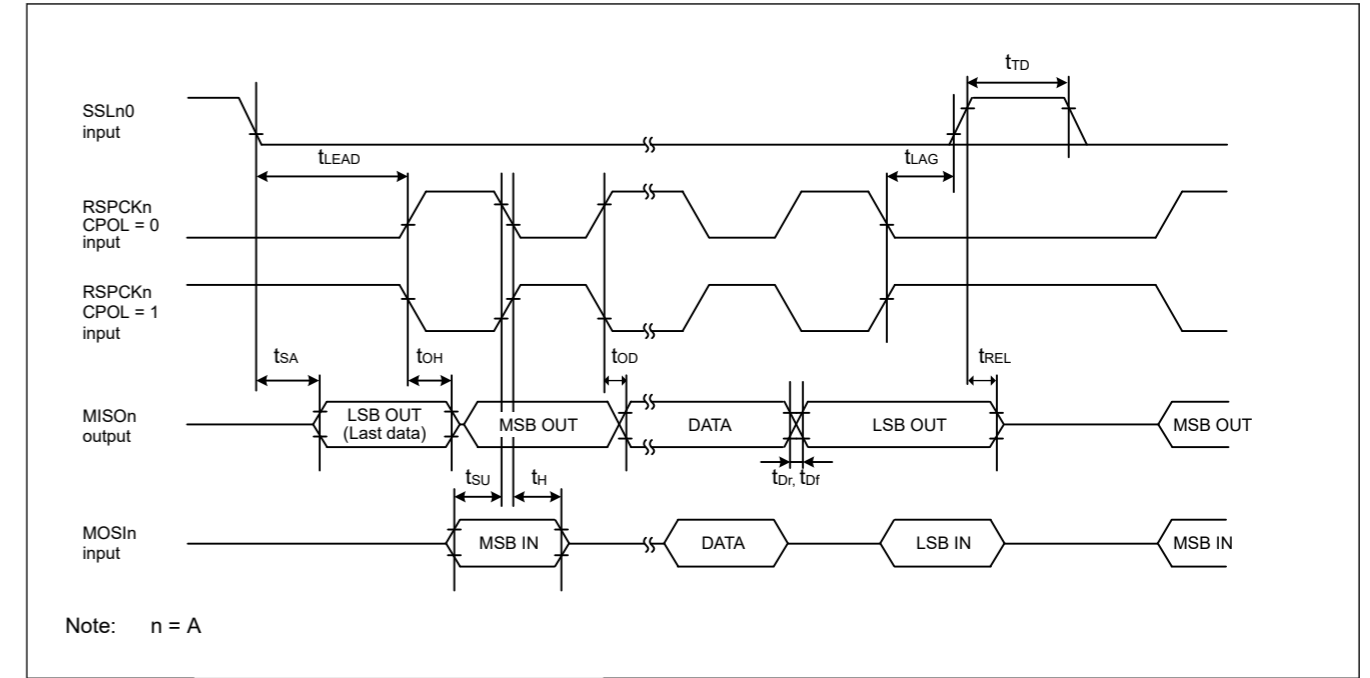


Figure 47.40 CPHA=1时从机的SPI时序

47.3.10 QSPI Timing

Table 47.28 QSPI timing

条件：在PmnPFS寄存器的端口驱动能力位中选择高驱动输出。

| Parameter | Symbol       | Min         | Max                                   | Unit                                    | 测试条件        |              |
|-----------|--------------|-------------|---------------------------------------|---|-------------|--------------|
| QSPI      | QSPCK时钟周期    | $t_{QScyc}$ | 2                                     | 48                                      | $t_{Pcyc}$  | Figure 47.41 |
|           | QSPCK时钟高脉冲宽度 | $t_{QSWH}$  | $t_{QScyc} \times 0.4$                | —                                       | ns          |              |
|           | QSPCK时钟低脉冲宽度 | $t_{QSWL}$  | $t_{QScyc} \times 0.4$                | —                                       | ns          |              |
| QSPI      | 数据输入建立时间     | $t_{Su}$    | 10                                    | —                                       | ns          | Figure 47.42 |
|           | 数据输入保持时间     | $t_{IH}$    | 0                                     | —                                       | ns          |              |
|           | QSSL设置时间     | $t_{LEAD}$  | $(N + 0.5) \times t_{QScyc} - 5^{*1}$ | $(N + 0.5) \times t_{QScyc} + 100^{*1}$ | ns          |              |
|           | QSSL保持时间     | $t_{LAG}$   | $(N + 0.5) \times t_{QScyc} - 5^{*2}$ | $(N + 0.5) \times t_{QScyc} + 100^{*2}$ | ns          |              |
|           | 数据输出延迟       | $t_{OD}$    | —                                     | 4                                       | ns          |              |
|           | 数据输出保持时间     | $t_{OH}$    | -3.3                                  | —                                       | ns          |              |
|           | 连续传输延迟       | $t_{TD}$    | 1                                     | 16                                      | $t_{QScyc}$ |              |

Note:  $t_{Pcyc}$ : PCLKA cycle.  
 注1.在SFMSLD中N设置为0或1。注2.在SFMSHD中N设置为0或1。



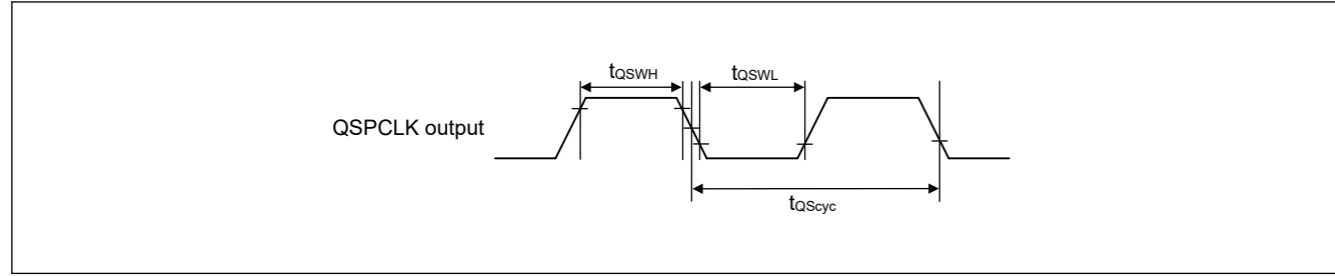


Figure 47.41 QSPI clock timing

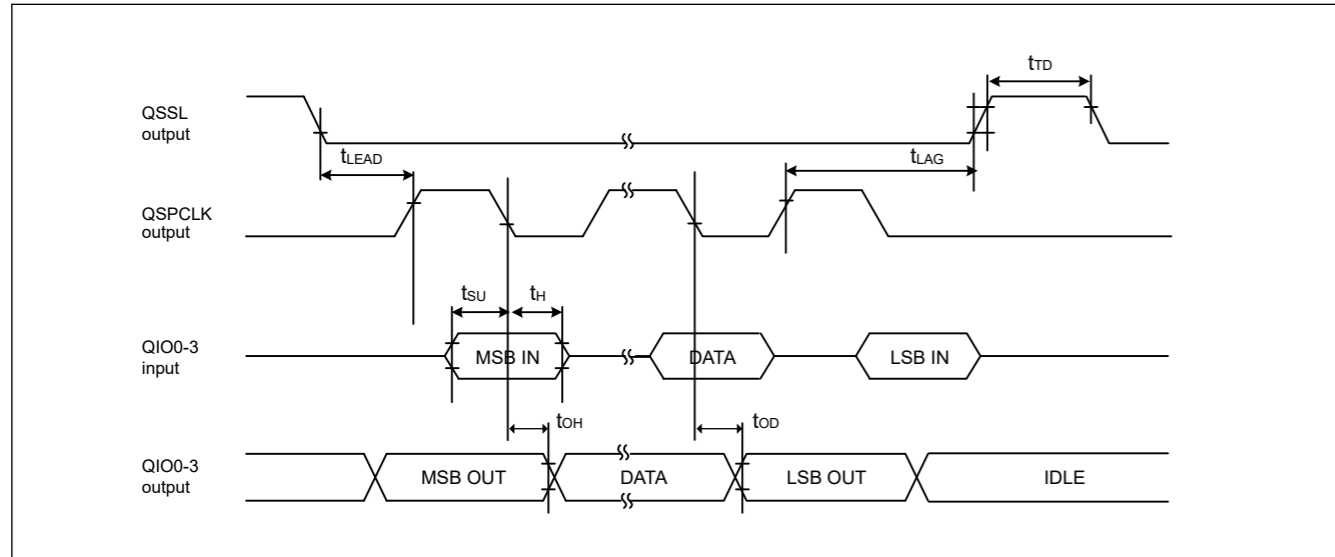


Figure 47.42 Transmit and receive timing

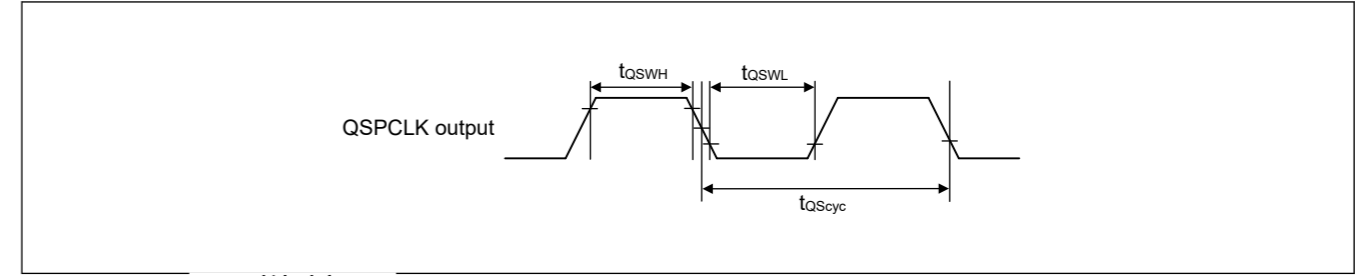


Figure 47.41 QSPI时钟时序

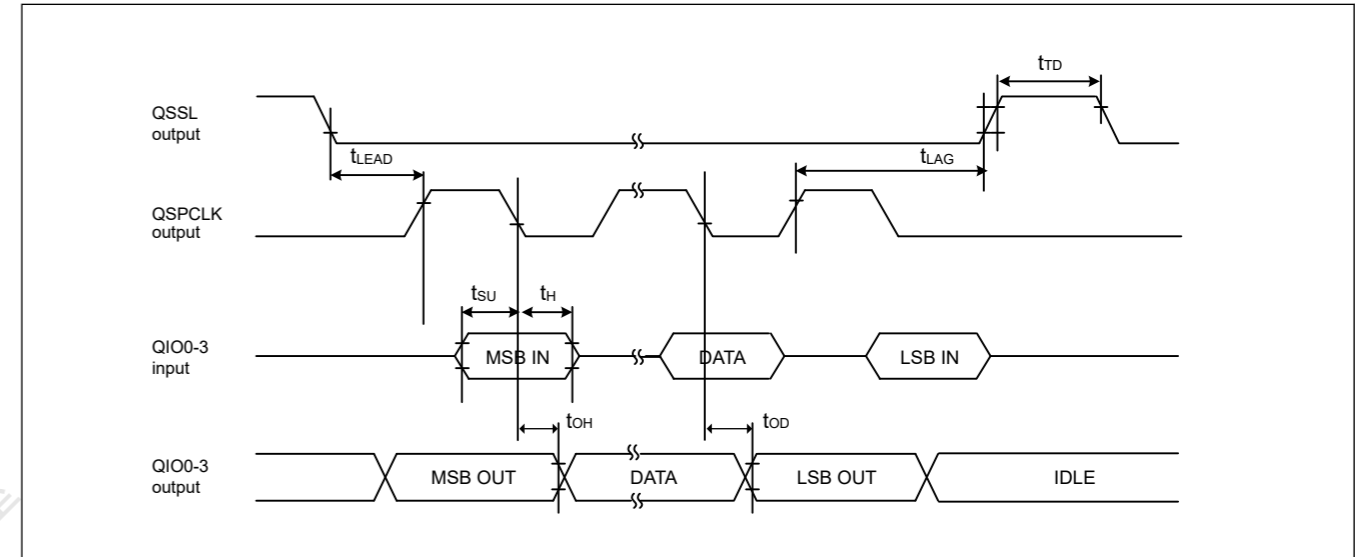


Figure 47.42 发送和接收时序

## 47.3.11 IIC Timing

Table 47.29 IIC timing (1) (1 of 2)

(1) Conditions: Middle drive output is selected in the Port Drive Capability bit in the PmnPFS register for the following pins: SDA0\_B, SCL0\_B, SDA1\_B, SCL1\_B.

(2) The following pins do not require setting: SCL0\_A, SDA0\_A, SCL1\_A, SDA1\_A.

(3) Use pins that have a letter appended to their names, for instance "\_A" or "\_B", to indicate group membership. For the IIC interface, the AC portion of the electrical characteristics is measured for each group.

| Parameter  | Symbol   | Min        | Max   | Unit                      | Test conditions |              |
|--|--|------------|---|---------------------------|-----------------|--------------|
| IIC<br>(Standard mode,<br>SMBus)<br>ICFER.FMPE = 0 | SCL input cycle time   | $t_{SCL}$  | $6 (12) \times t_{IICcyc} + 1300$                   | —                         | ns              | Figure 47.43 |
|  | SCL input high pulse width                                       | $t_{SCLH}$ | $3 (6) \times t_{IICcyc} + 300$                     | —                         | ns              |              |
|  | SCL input low pulse width  | $t_{SCLL}$ | $3 (6) \times t_{IICcyc} + 300$                     | —                         | ns              |              |
|  | SCL, SDA rise time   | $t_{Sr}$   | —   | 1000                      | ns              |              |
|  | SCL, SDA fall time   | $t_{Sf}$   | —   | 300                       | ns              |              |
|  | SCL, SDA input spike pulse removal time                          | $t_{SP}$   | 0   | $1 (4) \times t_{IICcyc}$ | ns              |              |
|  | SDA input bus free time when wakeup function is disabled         | $t_{BUF}$  | $3 (6) \times t_{IICcyc} + 300$                     | —                         | ns              |              |
|  | SDA input bus free time when wakeup function is enabled          | $t_{BUF}$  | $3 (6) \times t_{IICcyc} + 4 \times t_{Pcyc} + 300$ | —                         | ns              |              |
|  | START condition input hold time when wakeup function is disabled | $t_{STAH}$ | $t_{IICcyc} + 300$                                  | —                         | ns              |              |
|  | START condition input hold time when wakeup function is enabled  | $t_{STAH}$ | $1 (5) \times t_{IICcyc} + t_{Pcyc} + 300$          | —                         | ns              |              |
|  | Repeated START condition input setup time                        | $t_{STAS}$ | 1000  | —                         | ns              |              |
|  | STOP condition input setup time                                  | $t_{STOS}$ | 1000  | —                         | ns              |              |
|  | Data input setup time  | $t_{SDAS}$ | $t_{IICcyc} + 50$                                   | —                         | ns              |              |
|  | Data input hold time   | $t_{SDAH}$ | 0   | —                         | ns              |              |
|  | SCL, SDA capacitive load   | $C_b$      | —   | 400                       | pF              |              |

## 47.3.11 IIC Timing

Table 47.29 IIC时序(1)(1of2)

(1)条件：在PmnPFS寄存器的端口驱动能力位中为以下引脚选择中间驱动输出：SDA0\_B、SCL0\_B、SDA1\_B、SCL1\_B。(2)以下引脚不需要设置：SCL0\_A、SDA0\_A、SCL1\_A、SDA1\_A。(3)使用名称后附有字母的图钉，例如“A”或“B”，表示组成员身份。对于IIC接口，测量每组的电气特性的交流部分。

| Parameter  | Symbol                   | Min        | Max   | Unit                      | 测试条件 |              |
|--|--------------------------|------------|---|---------------------------|------|--------------|
| IIC<br>(Standard mode,<br>SMBus)<br>ICFER.FMPE = 0 | SCL输入周期时间                | $t_{SCL}$  | $6 (12) \times t_{IICcyc} + 1300$                   | —                         | ns   | Figure 47.43 |
|  | SCL输入高脉冲宽度               | $t_{SCLH}$ | $3 (6) \times t_{IICcyc} + 300$                     | —                         | ns   |              |
|  | SCL输入低脉冲宽度               | $t_{SCLL}$ | $3 (6) \times t_{IICcyc} + 300$                     | —                         | ns   |              |
|  | SCL、SDA上升时间              | $t_{Sr}$   | —   | 1000                      | ns   |              |
|  | SCL、SDA下降时间              | $t_{Sf}$   | —   | 300                       | ns   |              |
|  | SCL、SDA输入尖峰脉冲去除时间        | $t_{SP}$   | 0   | $1 (4) \times t_{IICcyc}$ | ns   |              |
|  | 禁用唤醒功能时的SDA输入总线空闲时间      | $t_{BUF}$  | $3 (6) \times t_{IICcyc} + 300$                     | —                         | ns   |              |
|  | 唤醒功能启用时SDA输入总线空闲时间       | $t_{BUF}$  | $3 (6) \times t_{IICcyc} + 4 \times t_{Pcyc} + 300$ | —                         | ns   |              |
|  | 禁用唤醒功能时的START条件输入保持时间    | $t_{STAH}$ | $t_{IICcyc} + 300$                                  | —                         | ns   |              |
|  | 启用唤醒功能时的START条件输入保持时间    | $t_{STAH}$ | $1 (5) \times t_{IICcyc} + t_{Pcyc} + 300$          | —                         | ns   |              |
|  | 重复启动条件输入建立时间             | $t_{STAS}$ | 1000  | —                         | ns   |              |
|  | STOP条件输入建立时间             | $t_{STOS}$ | 1000  | —                         | ns   |              |
|  | 数据输入建立时间                 | $t_{SDAS}$ | $t_{IICcyc} + 50$                                   | —                         | ns   |              |
|  | 数据输入保持时间                 | $t_{SDAH}$ | 0   | —                         | ns   |              |
|  | SCL, SDA capacitive load | $C_b$      | —   | 400                       | pF   |              |

**Table 47.29 IIC timing (1) (2 of 2)**

(1) Conditions: Middle drive output is selected in the Port Drive Capability bit in the PmnPFS register for the following pins: SDA0\_B, SCL0\_B, SDA1\_B, SCL1\_B.

(2) The following pins do not require setting: SCL0\_A, SDA0\_A, SCL1\_A, SDA1\_A.

(3) Use pins that have a letter appended to their names, for instance "\_A" or "\_B", to indicate group membership. For the IIC interface, the AC portion of the electrical characteristics is measured for each group.

| Parameter                | Symbol   | Min        | Max   | Unit                      | Test conditions |              |
|--------------------------|--|------------|---|---------------------------|-----------------|--------------|
| IIC (Fast mode)          | SCL input cycle time   | $t_{SCL}$  | $6 (12) \times t_{IICcyc} + 600$                        | —                         | ns              | Figure 47.43 |
|                          | SCL input high pulse width                                       | $t_{SCLH}$ | $3 (6) \times t_{IICcyc} + 300$                         | —                         | ns              |              |
|                          | SCL input low pulse width  | $t_{SCLL}$ | $3 (6) \times t_{IICcyc} + 300$                         | —                         | ns              |              |
|                          | SCL, SDA rise time   | $t_{Sr}$   | $20 \times (\text{external pullup voltage}/5.5V)^{1.1}$ | 300                       | ns              |              |
|                          | SCL, SDA fall time   | $t_{Sf}$   | $20 \times (\text{external pullup voltage}/5.5V)^{1.1}$ | 300                       | ns              |              |
|                          | SCL, SDA input spike pulse removal time                          | $t_{SP}$   | 0   | $1 (4) \times t_{IICcyc}$ | ns              |              |
|                          | SDA input bus free time when wakeup function is disabled         | $t_{BUF}$  | $3 (6) \times t_{IICcyc} + 300$                         | —                         | ns              |              |
|                          | SDA input bus free time when wakeup function is enabled          | $t_{BUF}$  | $3 (6) \times t_{IICcyc} + 4 \times t_{Pcyc} + 300$     | —                         | ns              |              |
|                          | START condition input hold time when wakeup function is disabled | $t_{STAH}$ | $t_{IICcyc} + 300$                                      | —                         | ns              |              |
|                          | START condition input hold time when wakeup function is enabled  | $t_{STAH}$ | $1 (5) \times t_{IICcyc} + t_{Pcyc} + 300$              | —                         | ns              |              |
|                          | Repeated START condition input setup time                        | $t_{STAS}$ | 300   | —                         | ns              |              |
|                          | STOP condition input setup time                                  | $t_{STOS}$ | 300   | —                         | ns              |              |
|                          | Data input setup time  | $t_{SDAS}$ | $t_{IICcyc} + 50$                                       | —                         | ns              |              |
|                          | Data input hold time   | $t_{SDAH}$ | 0   | —                         | ns              |              |
| SCL, SDA capacitive load | $C_b$  | —          | 400   | pF                        |                 |              |

Note:  $t_{IICcyc}$ : IIC internal reference clock (IIC $\phi$ ) cycle,  $t_{Pcyc}$ : PCLKB cycle.

Note: Values in parentheses apply when ICMR3.NF[1:0] is set to 11b while the digital filter is enabled with ICFER.NFE set to 1.

Note: Must use pins that have a letter appended to their name, for instance "\_A", "\_B", to indicate group membership. For the IIC interface, the AC portion of the electrical characteristics is measured for each group.

Note 1. Only supported for SCL0\_A, SDA0\_A, SCL1\_A, and SDA1\_A.

**Table 47.29 IIC时序(1)(2of2)**

(1)条件: 在PmnPFS寄存器的端口驱动能力位中为以下引脚选择中间驱动输出: SDA0\_B、SCL0\_B、SDA1\_B、SCL1\_B。(2)以下引脚不需要设置: SCL0\_A、SDA0\_A、SCL1\_A、SDA1\_A。(3)使用名称后附有字母的图钉, 例如"\_A"或"\_B", 表示组成员身份。对于IIC接口, 测量每组的电气特性的交流部分。

| Parameter                | Symbol                | Min        | Max   | Unit                      | 测试条件 |              |
|--------------------------|-----------------------|------------|---|---------------------------|------|--------------|
| IIC (Fast mode)          | SCL输入周期时间             | $t_{SCL}$  | $6 (12) \times t_{IICcyc} + 600$                        | —                         | ns   | Figure 47.43 |
|                          | SCL输入高脉冲宽度            | $t_{SCLH}$ | $3 (6) \times t_{IICcyc} + 300$                         | —                         | ns   |              |
|                          | SCL输入低脉冲宽度            | $t_{SCLL}$ | $3 (6) \times t_{IICcyc} + 300$                         | —                         | ns   |              |
|                          | SCL、SDA上升时间           | $t_{Sr}$   | $20 \times (\text{external pullup voltage}/5.5V)^{1.1}$ | 300                       | ns   |              |
|                          | SCL、SDA下降时间           | $t_{Sf}$   | $20 \times (\text{external pullup voltage}/5.5V)^{1.1}$ | 300                       | ns   |              |
|                          | SCL、SDA输入尖峰脉冲去除时间     | $t_{SP}$   | 0   | $1 (4) \times t_{IICcyc}$ | ns   |              |
|                          | 禁用唤醒功能时的SDA输入总线空闲时间   | $t_{BUF}$  | $3 (6) \times t_{IICcyc} + 300$                         | —                         | ns   |              |
|                          | 唤醒功能启用时SDA输入总线空闲时间    | $t_{BUF}$  | $3 (6) \times t_{IICcyc} + 4 \times t_{Pcyc} + 300$     | —                         | ns   |              |
|                          | 禁用唤醒功能时的START条件输入保持时间 | $t_{STAH}$ | $t_{IICcyc} + 300$                                      | —                         | ns   |              |
|                          | 启用唤醒功能时的START条件输入保持时间 | $t_{STAH}$ | $1 (5) \times t_{IICcyc} + t_{Pcyc} + 300$              | —                         | ns   |              |
|                          | 重复启动条件输入建立时间          | $t_{STAS}$ | 300   | —                         | ns   |              |
|                          | STOP条件输入建立时间          | $t_{STOS}$ | 300   | —                         | ns   |              |
|                          | 数据输入建立时间              | $t_{SDAS}$ | $t_{IICcyc} + 50$                                       | —                         | ns   |              |
|                          | 数据输入保持时间              | $t_{SDAH}$ | 0   | —                         | ns   |              |
| SCL, SDA capacitive load | $C_b$                 | —          | 400   | pF                        |      |              |

Note:  $t_{IICcyc}$ : IIC内部参考时钟(IIC $\phi$ )周期,  $t_{Pcyc}$ : PCLKB周期。

Note: 当ICMR3.NF[1:0]设置为11b且数字滤波器启用且ICFER.NFE设置为1时, 括号中的值适用。

Note: 必须使用名称后附有字母的引脚, 例如"\_A"、"\_B", 以表示组成员身份。对于IIC接口, 测量每组的电气特性的交流部分。

注1.仅支持SCL0\_A、SDA0\_A、SCL1\_A和SDA1\_A。

**Table 47.30 IIC timing (2)**

Setting of the SCL0\_A, SDA0\_A pins is not required with the Port Drive Capability bit in the PmnPFS register.

| Parameter                             | Symbol   | Min        | Max   | Unit                      | Test conditions    |
|---------------------------------------|--|------------|---|---------------------------|--------------------|
| IIC<br>(Fast-mode+)<br>ICFER.FMPE = 1 | SCL input cycle time   | $t_{SCL}$  | $6 (12) \times t_{IICcyc} + 240$                    | —                         | ns<br>Figure 47.43 |
|                                       | SCL input high pulse width                                       | $t_{SCLH}$ | $3 (6) \times t_{IICcyc} + 120$                     | —                         |                    |
|                                       | SCL input low pulse width  | $t_{SCLL}$ | $3 (6) \times t_{IICcyc} + 120$                     | —                         |                    |
|                                       | SCL, SDA rise time   | $t_{Sr}$   | —   | 120                       |                    |
|                                       | SCL, SDA fall time   | $t_{Sf}$   | $20 \times (\text{external pullup voltage} / 5.5V)$ | 120                       |                    |
|                                       | SCL, SDA input spike pulse removal time                          | $t_{SP}$   | 0   | $1 (4) \times t_{IICcyc}$ |                    |
|                                       | SDA input bus free time when wakeup function is disabled         | $t_{BUF}$  | $3 (6) \times t_{IICcyc} + 120$                     | —                         |                    |
|                                       | SDA input bus free time when wakeup function is enabled          | $t_{BUF}$  | $3 (6) \times t_{IICcyc} + 4 \times t_{Pcyc} + 120$ | —                         |                    |
|                                       | Start condition input hold time when wakeup function is disabled | $t_{STAH}$ | $t_{IICcyc} + 120$                                  | —                         |                    |
|                                       | START condition input hold time when wakeup function is enabled  | $t_{STAH}$ | $1 (5) \times t_{IICcyc} + t_{Pcyc} + 120$          | —                         |                    |
|                                       | Restart condition input setup time                               | $t_{STAS}$ | 120   | —                         |                    |
|                                       | Stop condition input setup time                                  | $t_{STOS}$ | 120   | —                         |                    |
|                                       | Data input setup time  | $t_{SDAS}$ | $t_{IICcyc} + 30$                                   | —                         |                    |
|                                       | Data input hold time   | $t_{SDAH}$ | 0   | —                         |                    |
| SCL, SDA capacitive load              | $C_b^{*1}$   | —          | 550   | pF                        |                    |

Note:  $t_{IICcyc}$ : IIC internal reference clock (IIC $\phi$ ) cycle,  $t_{Pcyc}$ : PCLKB cycle.

Note: Values in parentheses apply when ICMR3.NF[1:0] is set to 11b while the digital filter is enabled with ICFER.NFE set to 1.

Note 1.  $C_b$  indicates the total capacity of the bus line.**Table 47.30 IIC timing (2)**

PmnPFS寄存器中的端口驱动能力位不需要设置SCL0\_A、SDA0\_A引脚。

| Parameter                             | Symbol                | Min        | Max   | Unit                      | 测试条件               |
|---------------------------------------|-----------------------|------------|---|---------------------------|--------------------|
| IIC<br>(Fast-mode+)<br>ICFER.FMPE = 1 | SCL输入周期时间             | $t_{SCL}$  | $6 (12) \times t_{IICcyc} + 240$                    | —                         | ns<br>Figure 47.43 |
|                                       | SCL输入高脉冲宽度            | $t_{SCLH}$ | $3 (6) \times t_{IICcyc} + 120$                     | —                         |                    |
|                                       | SCL输入低脉冲宽度            | $t_{SCLL}$ | $3 (6) \times t_{IICcyc} + 120$                     | —                         |                    |
|                                       | SCL、SDA上升时间           | $t_{Sr}$   | —   | 120                       |                    |
|                                       | SCL、SDA下降时间           | $t_{Sf}$   | $20 \times (\text{external pullup voltage} / 5.5V)$ | 120                       |                    |
|                                       | SCL、SDA输入尖峰脉冲去除时间     | $t_{SP}$   | 0   | $1 (4) \times t_{IICcyc}$ |                    |
|                                       | 禁用唤醒功能时的SDA输入总线空闲时间   | $t_{BUF}$  | $3 (6) \times t_{IICcyc} + 120$                     | —                         |                    |
|                                       | 唤醒功能启用时SDA输入总线空闲时间    | $t_{BUF}$  | $3 (6) \times t_{IICcyc} + 4 \times t_{Pcyc} + 120$ | —                         |                    |
|                                       | 禁用唤醒功能时的启动条件输入保持时间    | $t_{STAH}$ | $t_{IICcyc} + 120$                                  | —                         |                    |
|                                       | 启用唤醒功能时的START条件输入保持时间 | $t_{STAH}$ | $1 (5) \times t_{IICcyc} + t_{Pcyc} + 120$          | —                         |                    |
|                                       | 重启条件输入建立时间            | $t_{STAS}$ | 120   | —                         |                    |
|                                       | 停止条件输入建立时间            | $t_{STOS}$ | 120   | —                         |                    |
|                                       | 数据输入建立时间              | $t_{SDAS}$ | $t_{IICcyc} + 30$                                   | —                         |                    |
|                                       | 数据输入保持时间              | $t_{SDAH}$ | 0   | —                         |                    |
| SCL, SDA capacitive load              | $C_b^{*1}$            | —          | 550   | pF                        |                    |

Note:  $t_{IICcyc}$ : IIC内部参考时钟(IIC $\phi$ )周期,  $t_{Pcyc}$ : PCLKB周期。

Note: 当ICMR3.NF[1:0]设置为11b且数字滤波器启用且ICFER.NFE设置为1时, 括号中的值适用。

注1.  $C_b$ 表示总线的总容量。



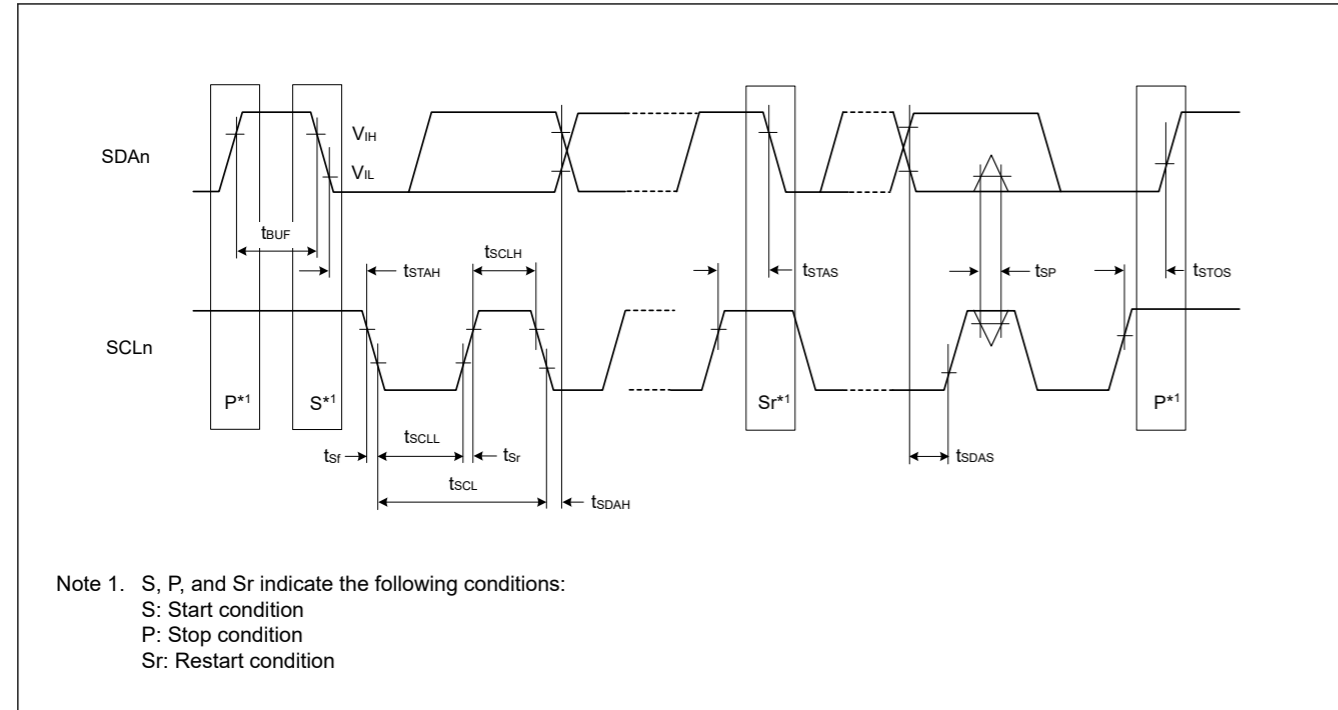


Figure 47.43 I<sup>2</sup>C bus interface input/output timing

47.3.12 SSIE Timing

Table 47.31 SSIE timing

(1) High drive output is selected with the Port Drive Capability bit in the PmnPFS register.  
 (2) Use pins that have a letter appended to their names, for instance “\_A” or “\_B” to indicate group membership. For the SSIE interface, the AC portion of the electrical characteristics is measured for each group.

| Parameter  | Symbol                    | Target specification |                 | Unit | Comments    |                            |                               |             |
|--|---------------------------|----------------------|-----------------|------|-------------|----------------------------|-------------------------------|-------------|
|  |                           | Min.                 | Max.            |      |             |                            |                               |             |
| SSIBCK0  | Cycle                     | Master               | $t_O$           | 80   | —           | ns                         | Figure 47.44                  |             |
|  |                           | Slave                | $t_I$           | 80   | —           |                            |                               |             |
|  | High level/ low level     | Master               | $t_{HC}/t_{LC}$ | 0.35 | —           |                            |                               | $t_O$       |
|  |                           | Slave                |                 | 0.35 | —           |                            |                               | $t_I$       |
|  | Rising time/ falling time | Master               | $t_{RC}/t_{FC}$ | —    | 0.15        |                            |                               | $t_O / t_I$ |
|  |                           | Slave                |                 | —    | 0.15        |                            |                               | $t_O / t_I$ |
| SSILRCK0/<br>SSIFS0,<br>SSITXD0,<br>SSIRXD0,<br>SSIDATA0 | Input set up time         | Master               | $t_{SR}$        | 12   | —           | ns                         | Figure 47.46,<br>Figure 47.47 |             |
|  |                           | Slave                |                 | 12   | —           |                            |                               |             |
|  | Input hold time           | Master               | $t_{HR}$        | 8    | —           |                            |                               |             |
|  |                           | Slave                |                 | 15   | —           |                            |                               |             |
|  | Output delay time         | Master               | $t_{DTR}$       | -10  | 5           |                            |                               | ns          |
| Slave  |                           |                      | 0               | 20   |             |                            |                               |             |
| Output delay time from SSILRCK0/ SSIFS0 change           | Slave                     | $t_{DTRW}$           | —               | 20   | ns          | Figure 47.48 <sup>*1</sup> |                               |             |
| GTIOC2A,<br>AUDIO_CLK                                    | Cycle                     | $t_{EXcyc}$          | 20              | —    | ns          | Figure 47.45               |                               |             |
|  | High level/ low level     | $t_{EXL}/t_{EXH}$    | 0.4             | 0.6  | $t_{EXcyc}$ |                            |                               |             |

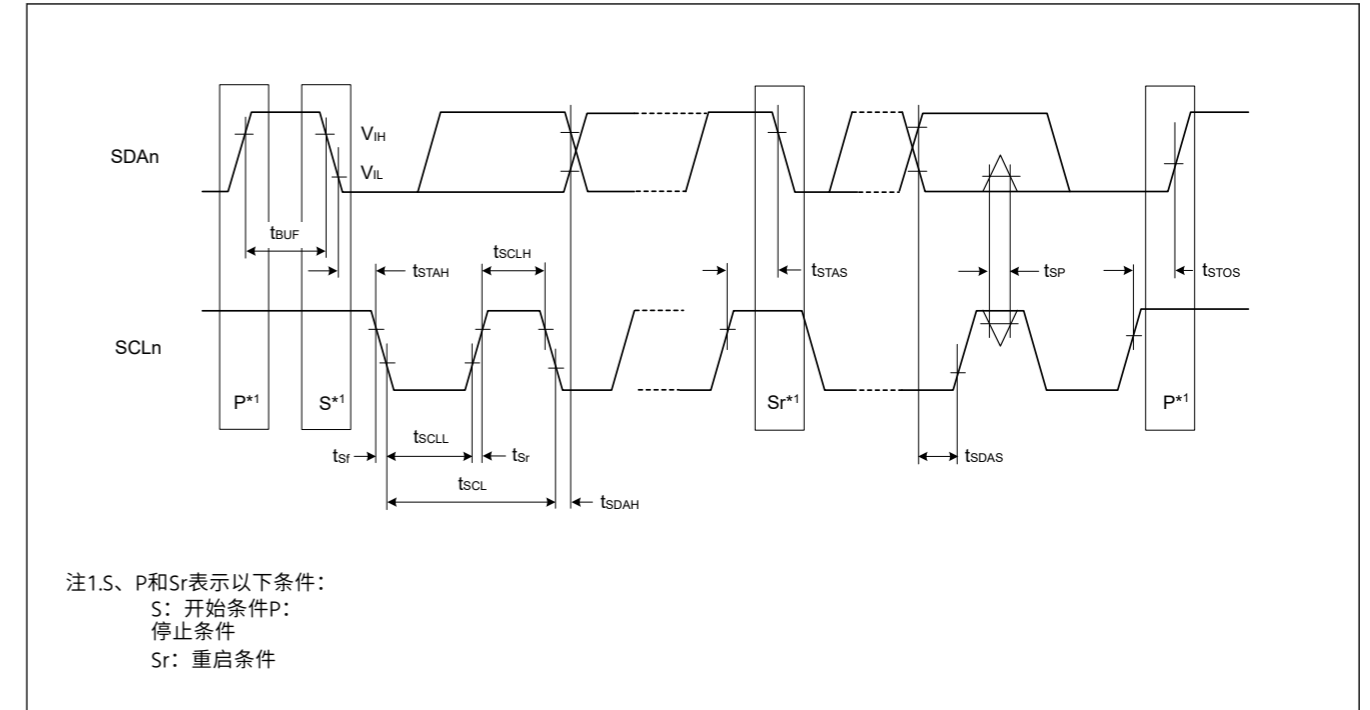


Figure 47.43 I<sup>2</sup>C总线接口输入输出时序

47.3.12 SSIE Timing

Table 47.31 SSIE timing

(1)通过PmnPFS寄存器中的端口驱动能力位选择高驱动输出。(2)使用名称后附有字母的引脚，例如“\_A”或“\_B”来表示组成员身份。对于SSIE接口，测量每组的电气特性的交流部分。

| Parameter  | Symbol   | 目标规格              |                 | Unit | Comments    |                            |                               |             |
|--|----------|-------------------|-----------------|------|-------------|----------------------------|-------------------------------|-------------|
|  |          | Min.              | Max.            |      |             |                            |                               |             |
| SSIBCK0  | Cycle    | Master            | $t_O$           | 80   | —           | ns                         | Figure 47.44                  |             |
|  |          | Slave             | $t_I$           | 80   | —           |                            |                               |             |
|  | 高电平低电平   | Master            | $t_{HC}/t_{LC}$ | 0.35 | —           |                            |                               | $t_O$       |
|  |          | Slave             |                 | 0.35 | —           |                            |                               | $t_I$       |
|  | 上升时间下降时间 | Master            | $t_{RC}/t_{FC}$ | —    | 0.15        |                            |                               | $t_O / t_I$ |
|  |          | Slave             |                 | —    | 0.15        |                            |                               | $t_O / t_I$ |
| SSILRCK0/<br>SSIFS0,<br>SSITXD0,<br>SSIRXD0,<br>SSIDATA0 | 输入建立时间   | Master            | $t_{SR}$        | 12   | —           | ns                         | Figure 47.46,<br>Figure 47.47 |             |
|  |          | Slave             |                 | 12   | —           |                            |                               |             |
|  | 输入保持时间   | Master            | $t_{HR}$        | 8    | —           |                            |                               |             |
|  |          | Slave             |                 | 15   | —           |                            |                               |             |
|  | 输出延迟时间   | Master            | $t_{DTR}$       | -10  | 5           |                            |                               | ns          |
| Slave  |          |                   | 0               | 20   |             |                            |                               |             |
| SSILRCK0的输出延迟时间 SSIFS0 change                            | Slave    | $t_{DTRW}$        | —               | 20   | ns          | Figure 47.48 <sup>*1</sup> |                               |             |
| GTIOC2A,<br>AUDIO_CLK                                    | Cycle    | $t_{EXcyc}$       | 20              | —    | ns          | Figure 47.45               |                               |             |
|  | 高电平低电平   | $t_{EXL}/t_{EXH}$ | 0.4             | 0.6  | $t_{EXcyc}$ |                            |                               |             |

Note 1. For slave-mode transmission, SSIE has a path, through which the signal input from the SSILRCK0/SSIFS0 pin is used to generate transmit data, and the transmit data is logically output to the SSITXD0 or SSIDATA0 pin.

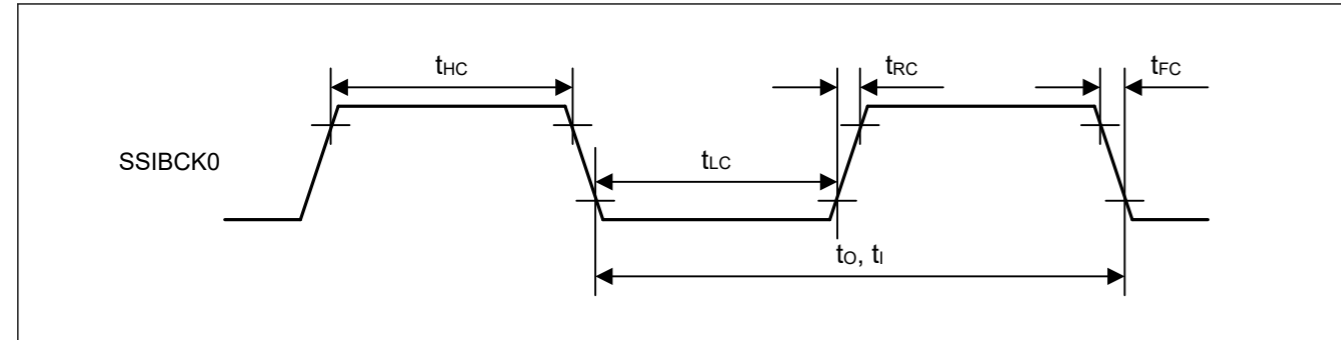


Figure 47.44 SSIE clock input/output timing

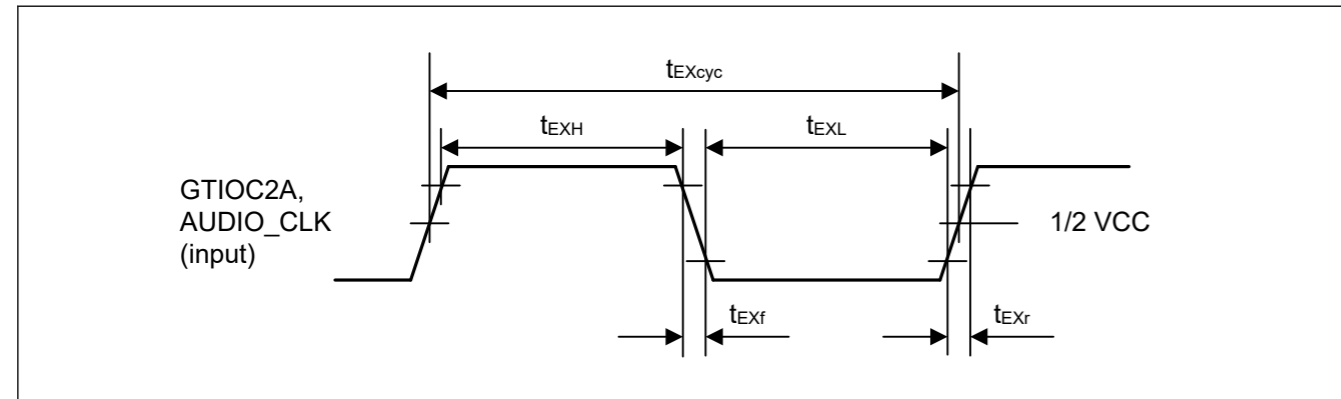


Figure 47.45 Clock input timing

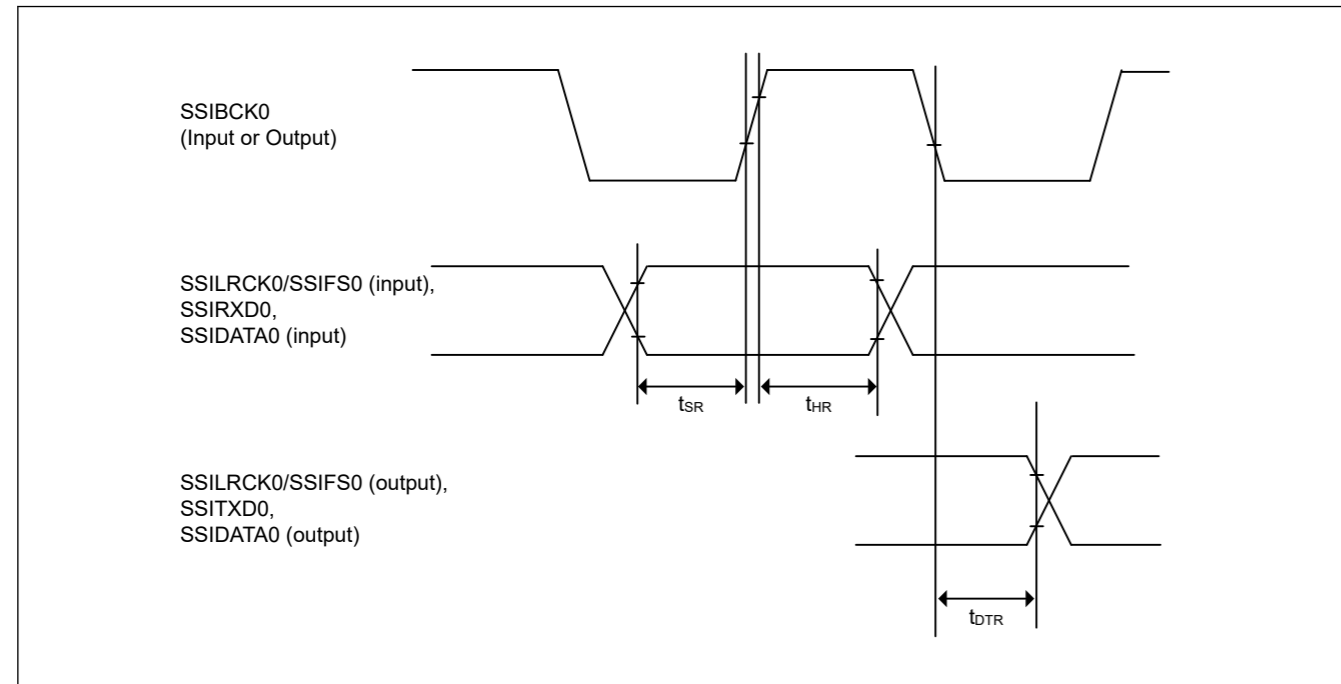


Figure 47.46 SSIE data transmit and receive timing when SSICR.BCKP = 0

注1.对于从模式传输, SSIE有一个路径, 通过该路径, 从SSILRCK0/SSIFS0引脚输入的信号用于生成发送数据, 发送数据逻辑输出到SSITXD0或SSIDATA0引脚。

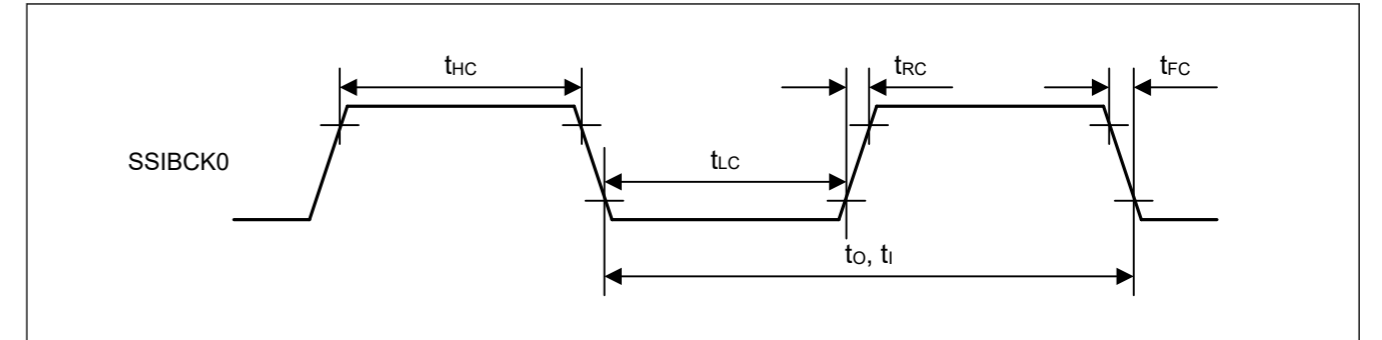


Figure 47.44 SSIE时钟输入输出时序

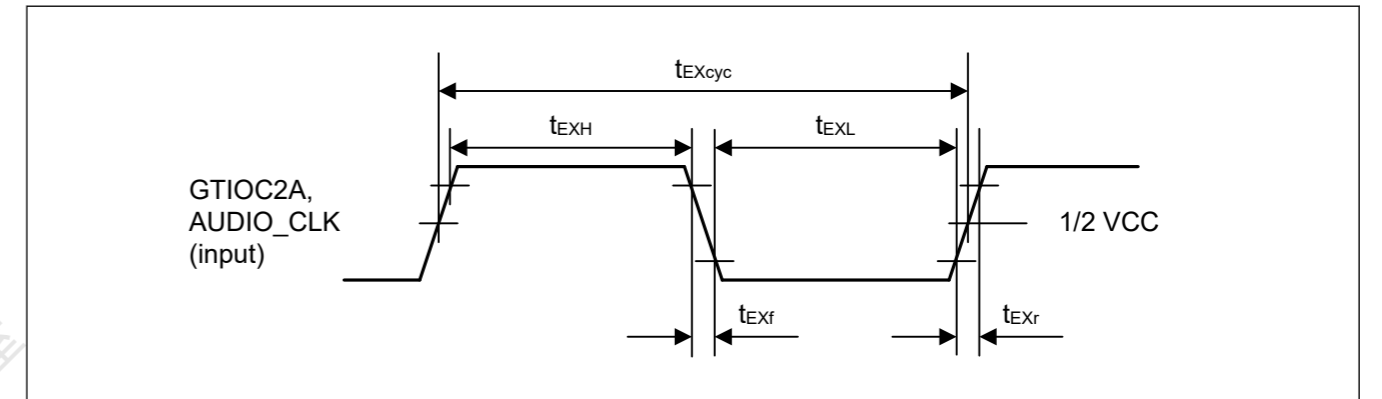


Figure 47.45 时钟输入时序

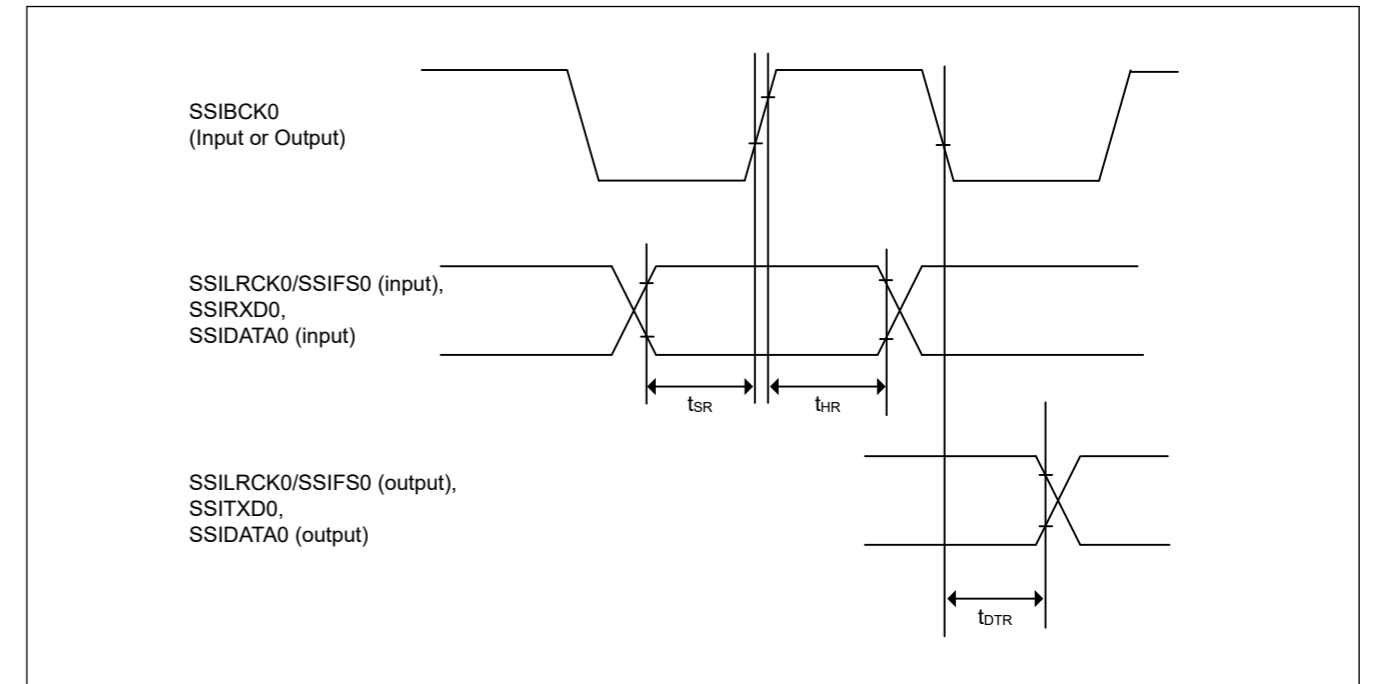


Figure 47.46 SSICR.BCKP=0时的SSIE数据发送和接收时序

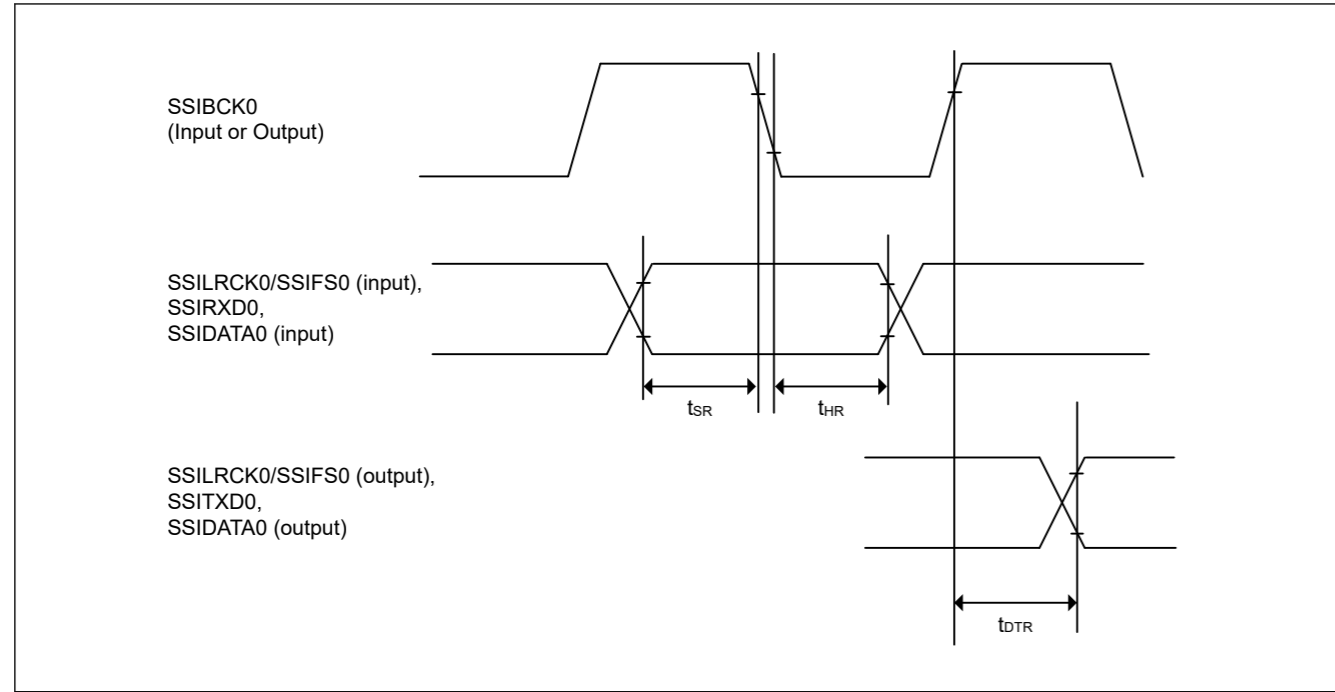


Figure 47.47 SSIE data transmit and receive timing when SSICR.BCKP = 1

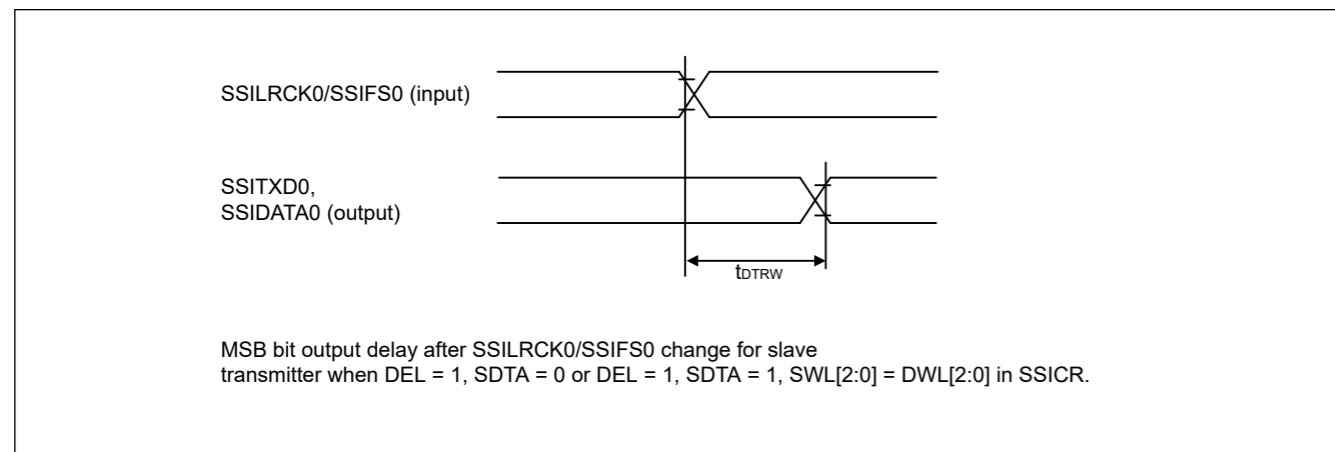


Figure 47.48 SSIE data output delay after SSILRCK0/SSIFS0 change

47.3.13 SD/MMC Host Interface Timing

Table 47.32 SD/MMC Host Interface signal timing

Conditions: High drive output is selected in the Port Drive Capability bit in the PmnPFS register. Clock duty ratio is 50%.

| Parameter                     | Symbol              | Min | Max | Unit | Test conditions |
|-------------------------------|---------------------|-----|-----|------|-----------------|
| SDCLK clock cycle             | T <sub>SDCYC</sub>  | 20  | —   | ns   | Figure 47.49    |
| SDCLK clock high pulse width  | T <sub>SDWH</sub>   | 6.5 | —   | ns   |                 |
| SDCLK clock low pulse width   | T <sub>SDWL</sub>   | 6.5 | —   | ns   |                 |
| SDCLK clock rise time         | T <sub>SDLH</sub>   | —   | 3   | ns   |                 |
| SDCLK clock fall time         | T <sub>SDHL</sub>   | —   | 3   | ns   |                 |
| SDCMD/SDDAT output data delay | T <sub>SDODLY</sub> | -7  | 4   | ns   |                 |
| SDCMD/SDDAT input data setup  | T <sub>SDIS</sub>   | 4.5 | —   | ns   |                 |
| SDCMD/SDDAT input data hold   | T <sub>SDIH</sub>   | 1.5 | —   | ns   |                 |

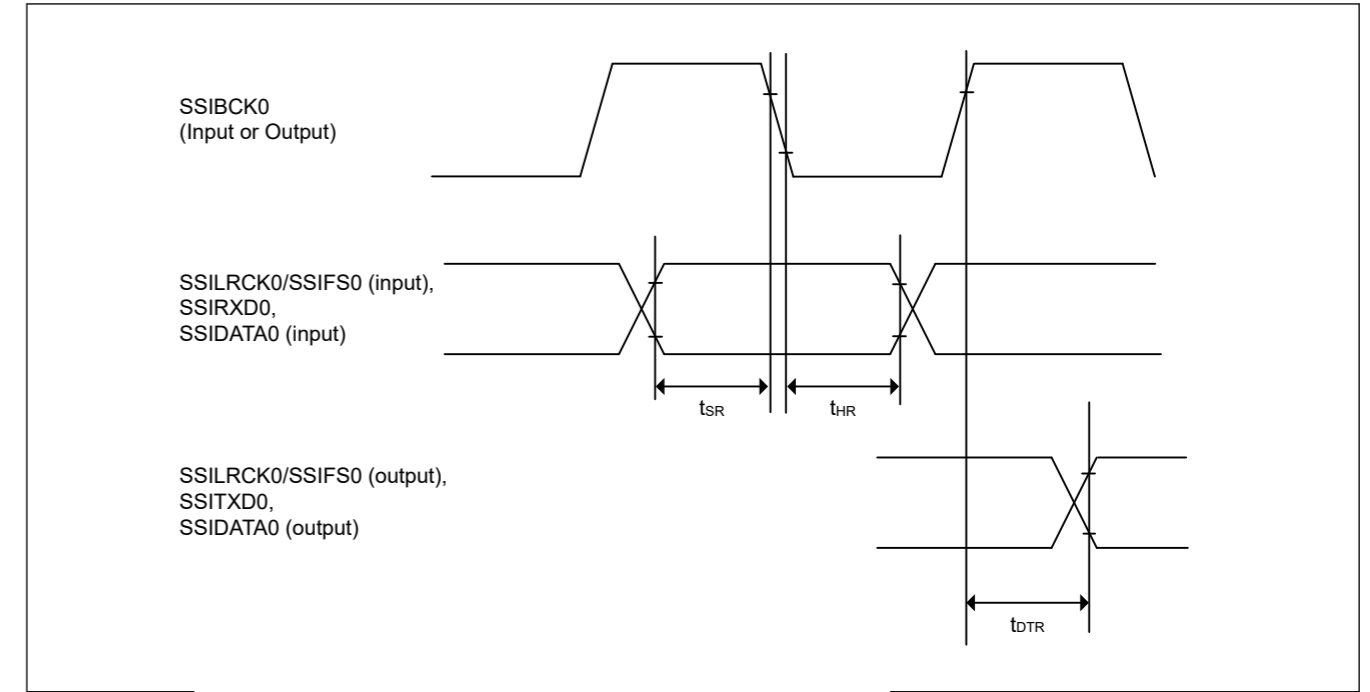


Figure 47.47 SSICR.BCKP=1时的SSIE数据发送和接收时序

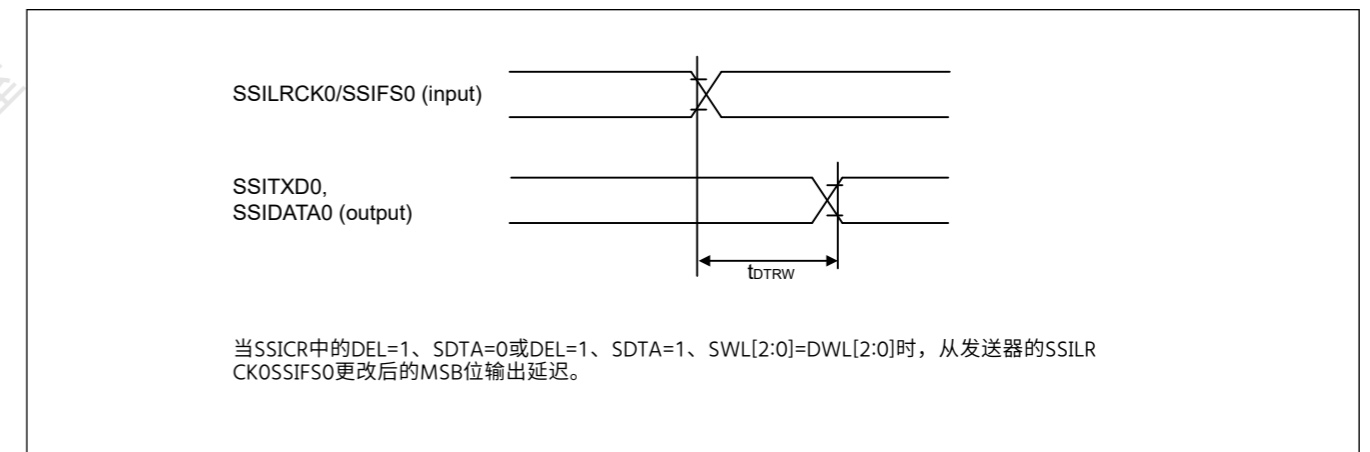


Figure 47.48 SSILRCKOSSIFS0更改后的SSIE数据输出延迟

47.3.13 SDMMC主机接口时序

Table 47.32 SDMMC主机接口信号时序

条件：在PmnPFS寄存器的端口驱动能力位中选择高驱动输出。时钟占空比为50%。

| Parameter         | Symbol              | Min | Max | Unit | 测试条件         |
|-------------------|---------------------|-----|-----|------|--------------|
| SDCLK 时钟周期        | T <sub>SDCYC</sub>  | 20  | —   | ns   | Figure 47.49 |
| SDCLK 时钟高脉冲宽度     | T <sub>SDWH</sub>   | 6.5 | —   | ns   |              |
| SDCLK 时钟低脉冲宽度     | T <sub>SDWL</sub>   | 6.5 | —   | ns   |              |
| SDCLK 时钟上升时间      | T <sub>SDLH</sub>   | —   | 3   | ns   |              |
| SDCLK 时钟下降时间      | T <sub>SDHL</sub>   | —   | 3   | ns   |              |
| SDCMD/SDDAT输出数据延迟 | T <sub>SDODLY</sub> | -7  | 4   | ns   |              |
| SDCMD/SDDAT输入数据设置 | T <sub>SDIS</sub>   | 4.5 | —   | ns   |              |
| SDCMD/SDDAT输入数据保持 | T <sub>SDIH</sub>   | 1.5 | —   | ns   |              |

Note: Must use pins that have a letter appended to their name, for instance “\_A”, “\_B”, to indicate group membership. For the SD/MMC Host interface, the AC portion of the electrical characteristics is measured for each group.

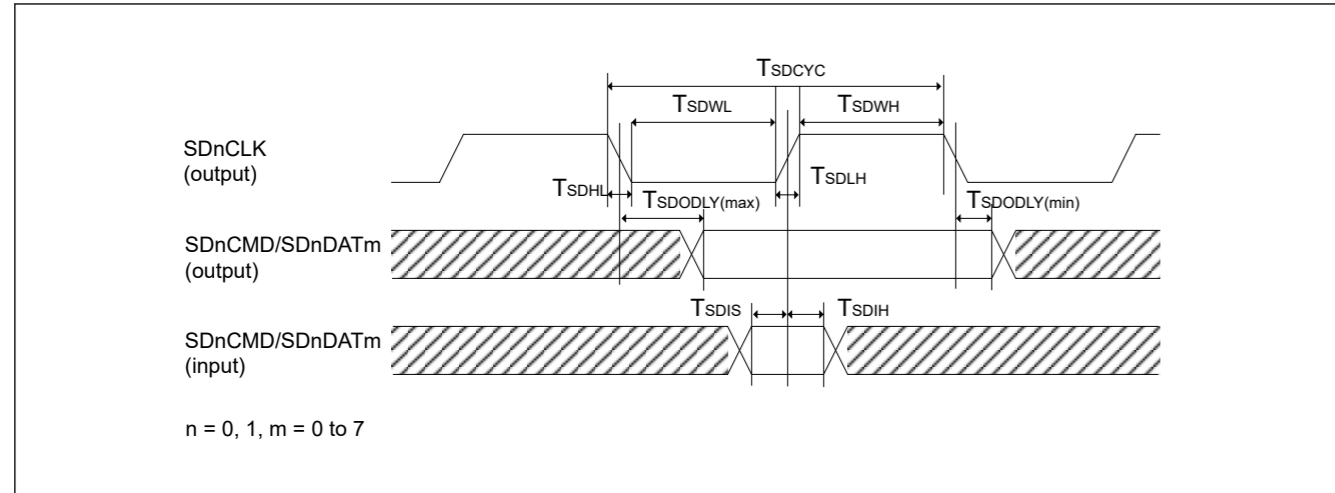


Figure 47.49 SD/MMC Host Interface signal timing

## 47.4 USB Characteristics

### 47.4.1 USBFS Timing

Table 47.33 USBFS low-speed characteristics for host only (USB\_DP and USB\_DM pin characteristics)

Conditions: VCC = AVCC0 = VCC\_USB = VBATT = 3.0 to 3.6V, 2.7 ≤ VREFH0/VREFH ≤ AVCC0, USBCLK = 48 MHz

| Parameter                             | Symbol   | Min              | Typ   | Max | Unit  | Test conditions                   |
|---------------------------------------|--|------------------|-------|-----|-------|-----------------------------------|
| Input characteristics                 | Input high voltage   | V <sub>IH</sub>  | 2.0   | —   | —     | V                                 |
|                                       | Input low voltage  | V <sub>IL</sub>  | —     | —   | 0.8   | V                                 |
|                                       | Differential input sensitivity                                 | V <sub>DI</sub>  | 0.2   | —   | —     | V                                 |
|                                       | Differential common-mode range                                 | V <sub>CM</sub>  | 0.8   | —   | 2.5   | V                                 |
| Output characteristics                | Output high voltage  | V <sub>OH</sub>  | 2.8   | —   | 3.6   | V                                 |
|                                       | Output low voltage   | V <sub>OL</sub>  | 0.0   | —   | 0.3   | V                                 |
|                                       | Cross-over voltage   | V <sub>CRS</sub> | 1.3   | —   | 2.0   | V                                 |
|                                       | Rise time  | t <sub>LR</sub>  | 75    | —   | 300   | ns                                |
|                                       | Fall time  | t <sub>LF</sub>  | 75    | —   | 300   | ns                                |
| Rise/fall time ratio                  | t <sub>LR</sub> / t <sub>LF</sub>                              | 80               | —     | 125 | %     | t <sub>LR</sub> / t <sub>LF</sub> |
| Pull-up and pull-down characteristics | USB_DP and USB_DM pull-down resistance in host controller mode | R <sub>pd</sub>  | 14.25 | —   | 24.80 | kΩ                                |

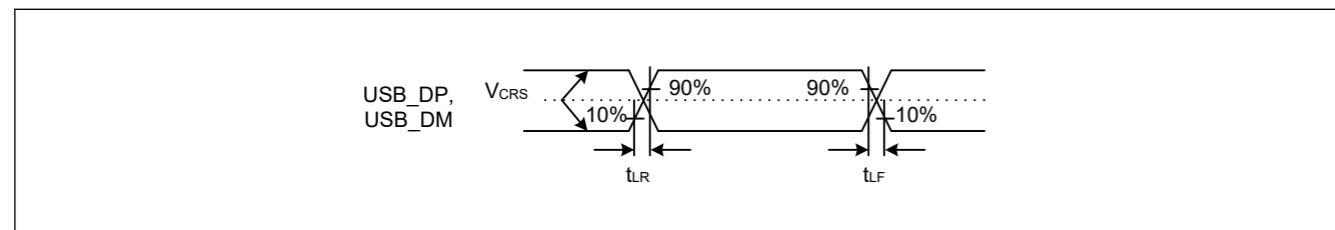


Figure 47.50 USB\_DP and USB\_DM output timing in low-speed mode

Note: 必须使用名称后附有字母的引脚，例如“\_A”、“\_B”，以表示组成员身份。对于SDMMC主机接口，对每组电气特性的交流部分进行测量。

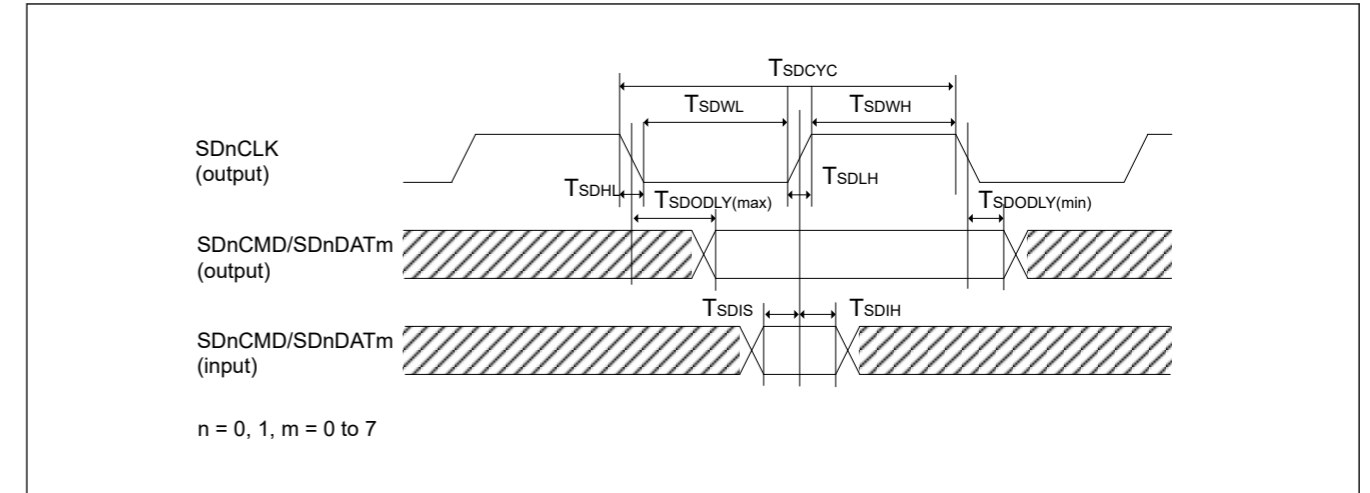


Figure 47.49 SDMMC主机接口信号时序

## 47.4 USB特性

### 47.4.1 USBFS Timing

Table 47.33 仅主机的USBFS低速特性 (USB\_DP和USB\_DM引脚特性)

Conditions: VCC = AVCC0 = VCC\_USB = VBATT = 3.0 to 3.6V, 2.7 ≤ VREFH0/VREFH ≤ AVCC0, USBCLK = 48 MHz

| Parameter | Symbol                            | Min              | Typ   | Max | Unit  | 测试条件                              |
|-----------|-----------------------------------|------------------|-------|-----|-------|-----------------------------------|
| 输入特性      | 输入高压                              | V <sub>IH</sub>  | 2.0   | —   | —     | V                                 |
|           | 输入低电压                             | V <sub>IL</sub>  | —     | —   | 0.8   | V                                 |
|           | 差分输入灵敏度                           | V <sub>DI</sub>  | 0.2   | —   | —     | V                                 |
|           | 差分共模范围                            | V <sub>CM</sub>  | 0.8   | —   | 2.5   | V                                 |
| 输出特性      | 输出高压                              | V <sub>OH</sub>  | 2.8   | —   | 3.6   | V                                 |
|           | 输出低电压                             | V <sub>OL</sub>  | 0.0   | —   | 0.3   | V                                 |
|           | Cross-over voltage                | V <sub>CRS</sub> | 1.3   | —   | 2.0   | V                                 |
|           | 上升时间                              | t <sub>LR</sub>  | 75    | —   | 300   | ns                                |
|           | 秋季时间                              | t <sub>LF</sub>  | 75    | —   | 300   | ns                                |
| 上升下降时间比   | t <sub>LR</sub> / t <sub>LF</sub> | 80               | —     | 125 | %     | t <sub>LR</sub> / t <sub>LF</sub> |
| 上拉和下拉特性   | 主机控制器模式下的USB_DP和USB_DM下拉电阻        | R <sub>pd</sub>  | 14.25 | —   | 24.80 | kΩ                                |

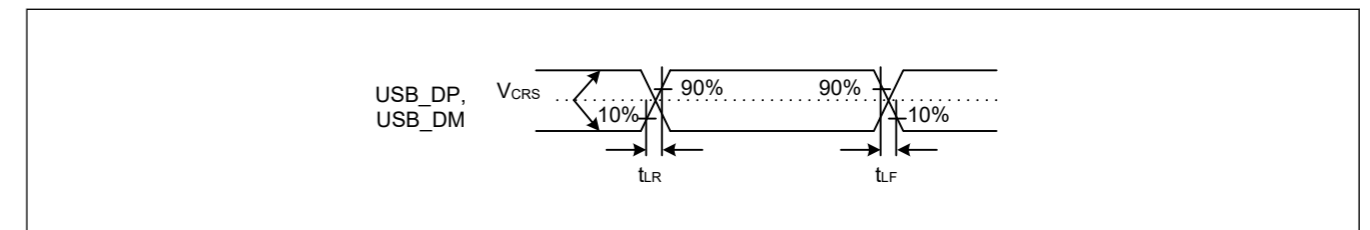


Figure 47.50 低速模式下的USB\_DP和USB\_DM输出时序



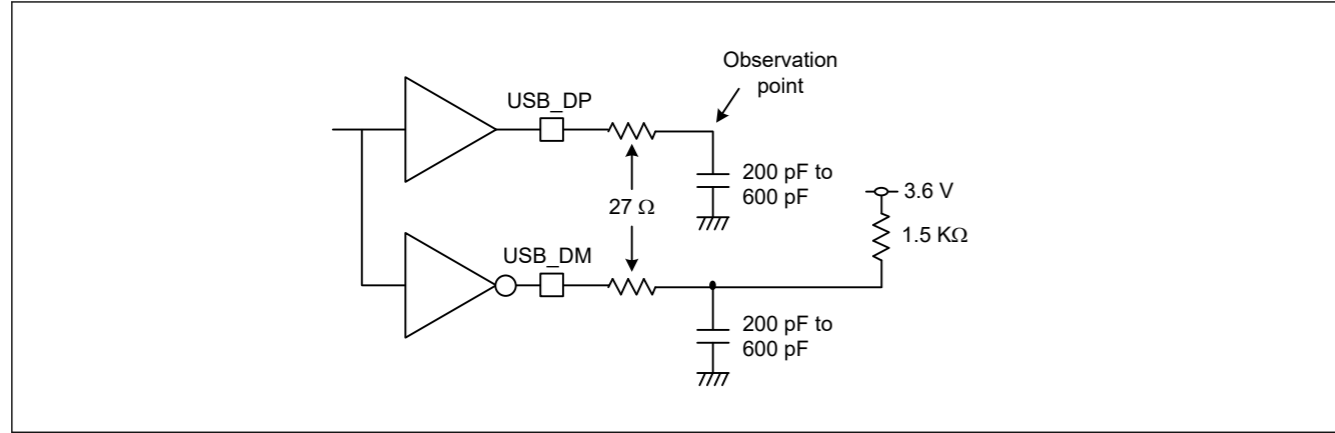


Figure 47.51 Test circuit in low-speed mode

Table 47.34 USBFS full-speed characteristics (USB\_DP and USB\_DM pin characteristics)

Conditions: VCC = AVCC0 = VCC\_USB = VBATT = 3.0 to 3.6 V, 2.7 ≤ VREFH0/VREFH ≤ AVCC0, USBCLK = 48 MHz

| Parameter                             | Symbol   | Min                               | Typ   | Max | Unit   | Test conditions |                                       |
|---------------------------------------|--|-----------------------------------|-------|-----|--------|-----------------|---------------------------------------|
| Input characteristics                 | Input high voltage   | V <sub>IH</sub>                   | 2.0   | —   | —      | V               |                                       |
|                                       | Input low voltage  | V <sub>IL</sub>                   | —     | —   | 0.8    | V               |                                       |
|                                       | Differential input sensitivity                                 | V <sub>DI</sub>                   | 0.2   | —   | —      | V               | USB_DP - USB_DM                       |
|                                       | Differential common-mode range                                 | V <sub>CM</sub>                   | 0.8   | —   | 2.5    | V               | —                                     |
| Output characteristics                | Output high voltage  | V <sub>OH</sub>                   | 2.8   | —   | 3.6    | V               | I <sub>OH</sub> = -200 μA             |
|                                       | Output low voltage   | V <sub>OL</sub>                   | 0.0   | —   | 0.3    | V               | I <sub>OL</sub> = 2 mA                |
|                                       | Cross-over voltage   | V <sub>CRS</sub>                  | 1.3   | —   | 2.0    | V               | Figure 47.52                          |
|                                       | Rise time  | t <sub>LR</sub>                   | 4     | —   | 20     | ns              | t <sub>FR</sub> / t <sub>FF</sub>     |
|                                       | Fall time  | t <sub>LF</sub>                   | 4     | —   | 20     | ns              |                                       |
|                                       | Rise/fall time ratio   | t <sub>LR</sub> / t <sub>LF</sub> | 90    | —   | 111.11 | %               | t <sub>FR</sub> / t <sub>FF</sub>     |
|                                       | Output resistance  | Z <sub>DRV</sub>                  | 28    | —   | 44     | Ω               | USBFS: R <sub>s</sub> = 27 Ω included |
| Pull-up and pull-down characteristics | DM pull-up resistance in device controller mode                | R <sub>pu</sub>                   | 0.900 | —   | 1.575  | kΩ              | During idle state                     |
|                                       |  | R <sub>pu</sub>                   | 1.425 | —   | 3.090  | kΩ              | During transmission and reception     |
|                                       | USB_DP and USB_DM pull-down resistance in host controller mode | R <sub>pd</sub>                   | 14.25 | —   | 24.80  | kΩ              | —                                     |

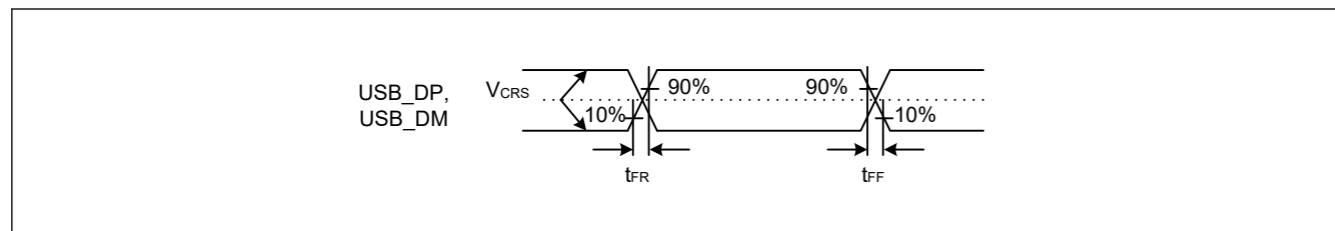


Figure 47.52 USB\_DP and USB\_DM output timing in full-speed mode

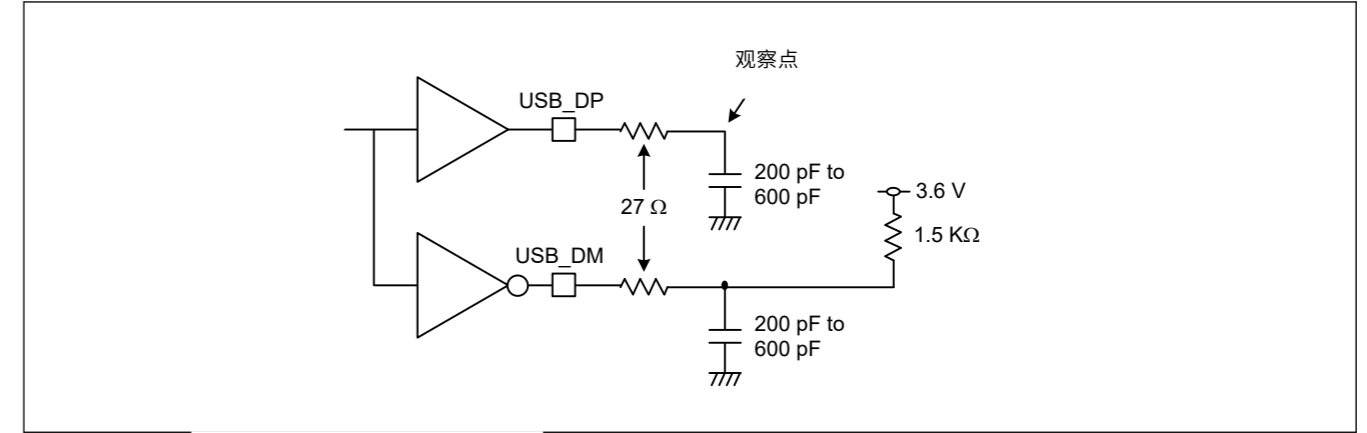


Figure 47.51 低速模式下的测试电路

Table 47.34 USBFS全速特性 (USB\_DP和USB\_DM引脚特性)

Conditions: VCC = AVCC0 = VCC\_USB = VBATT = 3.0 to 3.6 V, 2.7 ≤ VREFH0/VREFH ≤ AVCC0, USBCLK = 48 MHz

| Parameter | Symbol                     | Min                               | Typ   | Max | Unit   | 测试条件 |                                       |
|-----------|----------------------------|-----------------------------------|-------|-----|--------|------|---------------------------------------|
| 输入特性      | 输入高压                       | V <sub>IH</sub>                   | 2.0   | —   | —      | V    |                                       |
|           | 输入低电压                      | V <sub>IL</sub>                   | —     | —   | 0.8    | V    |                                       |
|           | 差分输入灵敏度                    | V <sub>DI</sub>                   | 0.2   | —   | —      | V    | USB_DP - USB_DM                       |
|           | 差分共模范围                     | V <sub>CM</sub>                   | 0.8   | —   | 2.5    | V    | —                                     |
| 输出特性      | 输出高压                       | V <sub>OH</sub>                   | 2.8   | —   | 3.6    | V    | I <sub>OH</sub> = -200 μA             |
|           | 输出低电压                      | V <sub>OL</sub>                   | 0.0   | —   | 0.3    | V    | I <sub>OL</sub> = 2毫安                 |
|           | Cross-over voltage         | V <sub>CRS</sub>                  | 1.3   | —   | 2.0    | V    | Figure 47.52                          |
|           | 上升时间                       | t <sub>LR</sub>                   | 4     | —   | 20     | ns   | t <sub>FR</sub> / t <sub>FF</sub>     |
|           | 秋季时间                       | t <sub>LF</sub>                   | 4     | —   | 20     | ns   |                                       |
|           | 上升下降时间比                    | t <sub>LR</sub> / t <sub>LF</sub> | 90    | —   | 111.11 | %    | t <sub>FR</sub> / t <sub>FF</sub>     |
|           | 输出电阻                       | Z <sub>DRV</sub>                  | 28    | —   | 44     | Ω    | USBFS: R <sub>s</sub> = 27 Ω included |
| 上拉和下拉特性   | 设备控制器模式下的DM上拉电阻            | R <sub>pu</sub>                   | 0.900 | —   | 1.575  | kΩ   | 空闲状态期间                                |
|           |                            | R <sub>pu</sub>                   | 1.425 | —   | 3.090  | kΩ   | 在发送和接收期间                              |
|           | 主机控制器模式下的USB_DP和USB_DM下拉电阻 | R <sub>pd</sub>                   | 14.25 | —   | 24.80  | kΩ   | —                                     |

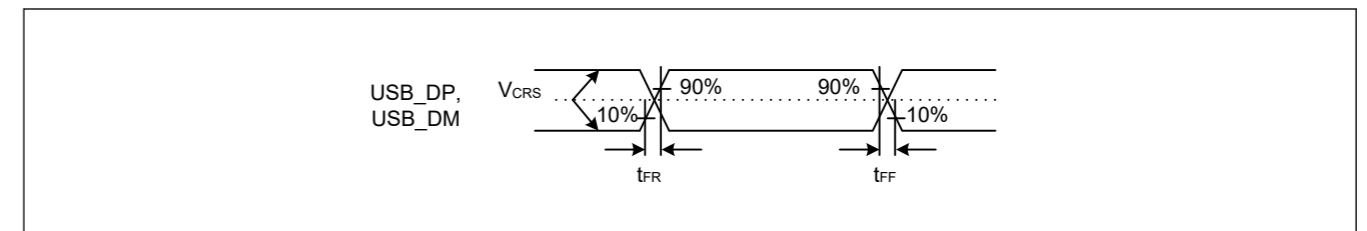


Figure 47.52 全速模式下的USB\_DP和USB\_DM输出时序

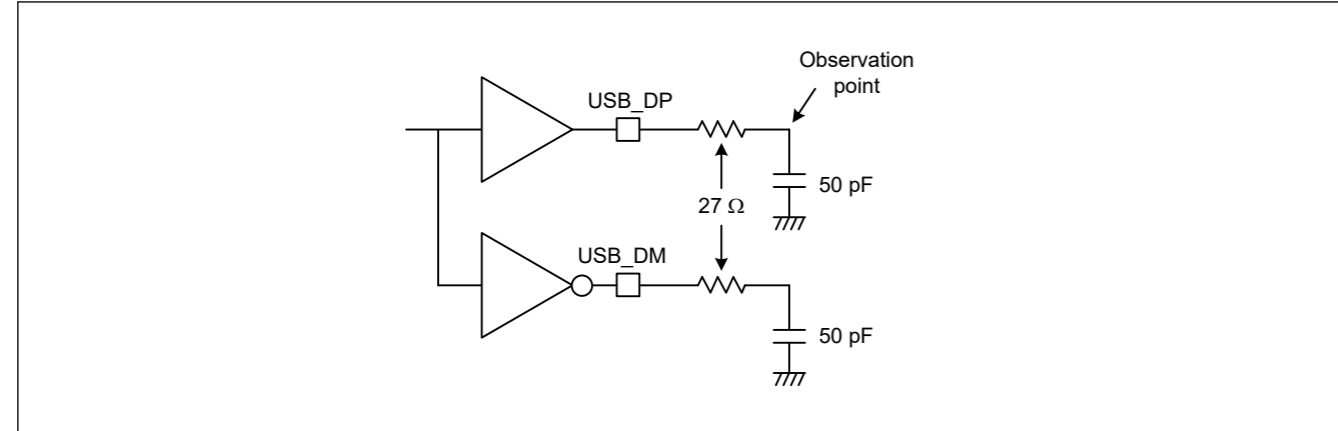


Figure 47.53 Test circuit in full-speed mode

Table 47.35 USBFS characteristics (USB\_DP and USB\_DM pin characteristics)

Conditions: VCC = AVCC0 = VCC\_USB = VBATT = 3.0 to 3.6 V, 2.7 ≤ VREFH0/VREFH ≤ AVCC0, USBCLK = 48 MHz

| Parameter                      | Symbol                 | Min                  | Typ  | Max | Unit | Test conditions |                         |
|--------------------------------|------------------------|----------------------|------|-----|------|-----------------|-------------------------|
| Battery Charging Specification | D+ sink current        | I <sub>DP_SINK</sub> | 25   | —   | 175  | μA              | —                       |
|                                | D- sink current        | I <sub>DM_SINK</sub> | 25   | —   | 175  | μA              | —                       |
|                                | DCD source current     | I <sub>DP_SRC</sub>  | 7    | —   | 13   | μA              | —                       |
|                                | Data detection voltage | V <sub>DAT_REF</sub> | 0.25 | —   | 0.4  | V               | —                       |
|                                | D+ source voltage      | V <sub>DP_SRC</sub>  | 0.5  | —   | 0.7  | V               | Outout current = 250 μA |
|                                | D- source voltage      | V <sub>DM_SRC</sub>  | 0.5  | —   | 0.7  | V               | Outout current = 250 μA |

47.5 ADC12 Characteristics

Table 47.36 A/D conversion characteristics for unit 0 (1 of 2)

Conditions: PCLKC = 1 to 50 MHz

| Parameter   | Min   | Typ   | Max                       | Unit | Test conditions |    |  |
|---|---|---|---------------------------|------|-----------------|----|--|
| Frequency   | 1   | —   | 50                        | MHz  | —               |    |  |
| Analog input capacitance                            | —   | —   | 30                        | pF   | —               |    |  |
| Quantization error                                  | —   | ±0.5  | —                         | LSB  | —               |    |  |
| Resolution  | —   | —   | 12                        | Bits | —               |    |  |
| High-precision high-speed channels (AN000 to AN005) | Conversion time*1 (operation at PCLKC = 50 MHz) | Permissible signal source impedance Max. = 1 kΩ | 0.52 (0.26) <sup>*2</sup> | —    | —               | μs | Sampling in 13 states  |
|   |   | Max. = 400 Ω                                    | 0.40 (0.14) <sup>*2</sup> | —    | —               | μs | Sampling in 7 states<br>VCC = AVCC0 = 3.0 to 3.6 V<br>3.0 V ≤ VREFH0 ≤ AVCC0 |
|   | Offset error                                    | —   | ±1.0                      | ±2.5 | LSB             | —  |  |
|   | Full-scale error                                | —   | ±1.0                      | ±2.5 | LSB             | —  |  |
|   | Absolute accuracy                               | —   | ±2.0                      | ±4.5 | LSB             | —  |  |
|   | DNL differential nonlinearity error             | —   | ±0.5                      | ±1.5 | LSB             | —  |  |
|   | INL integral nonlinearity error                 | —   | ±1.0                      | ±2.5 | LSB             | —  |  |

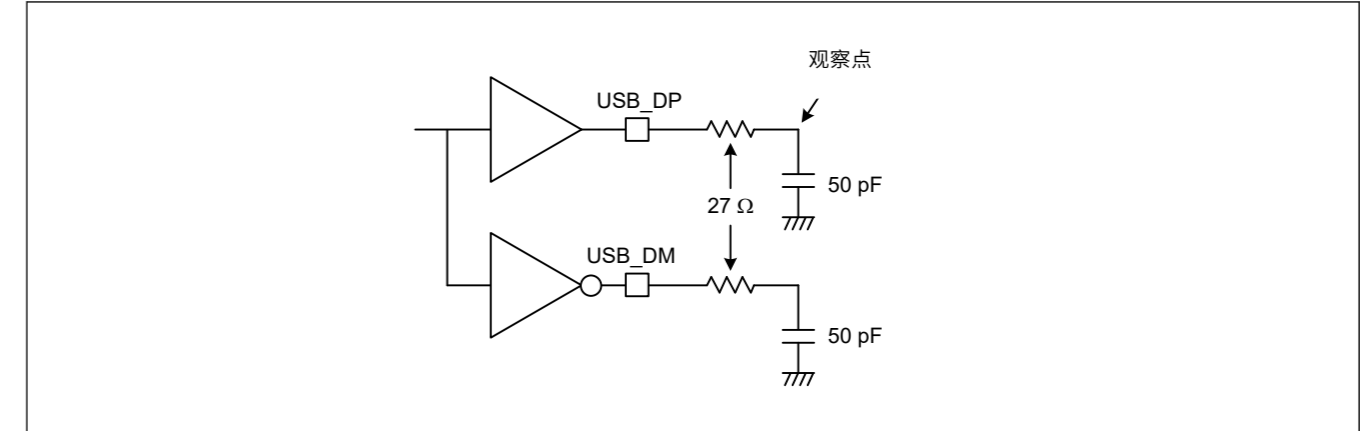


Figure 47.53 全速模式下的测试电路

Table 47.35 USBFS特性 (USB\_DP和USB\_DM引脚特性)

Conditions: VCC = AVCC0 = VCC\_USB = VBATT = 3.0 to 3.6 V, 2.7 ≤ VREFH0/VREFH ≤ AVCC0, USBCLK = 48 MHz

| Parameter          | Symbol            | Min                  | Typ  | Max | Unit | 测试条件 |                         |
|--------------------|-------------------|----------------------|------|-----|------|------|-------------------------|
| 电池充电 Specification | D+ 灌电流            | I <sub>DP_SINK</sub> | 25   | —   | 175  | μA   | —                       |
|                    | D- sink current   | I <sub>DM_SINK</sub> | 25   | —   | 175  | μA   | —                       |
|                    | DCD源电流            | I <sub>DP_SRC</sub>  | 7    | —   | 13   | μA   | —                       |
|                    | 数据检测电压            | V <sub>DAT_REF</sub> | 0.25 | —   | 0.4  | V    | —                       |
|                    | D+源电压             | V <sub>DP_SRC</sub>  | 0.5  | —   | 0.7  | V    | Outout current = 250 μA |
|                    | D- source voltage | V <sub>DM_SRC</sub>  | 0.5  | —   | 0.7  | V    | Outout current = 250 μA |

47.5 ADC12 Characteristics

Table 47.36 单元0(1of2)的AD转换特性

Conditions: PCLKC = 1 to 50 MHz

| Parameter              | Min                                  | Typ                | 最大单位                      | 测试条件 |     |    |  |
|------------------------|--------------------------------------|--------------------|---------------------------|------|-----|----|--|
| Frequency              | 1                                    | —                  | 50                        | MHz  | —   |    |  |
| 模拟输入电容                 | —                                    | —                  | 30                        | pF   | —   |    |  |
| 量化误差                   | —                                    | ±0.5               | —                         | LSB  | —   |    |  |
| Resolution             | —                                    | —                  | 12                        | Bits | —   |    |  |
| 高精度高速通道 (AN000 至AN005) | 转换时间*1 (operation at PCLKC = 50 MHz) | 允许的的信号源阻抗 Max.=1kΩ | 0.52 (0.26) <sup>*2</sup> | —    | —   | μs | 在13个州进行抽样                                      |
|                        |                                      | Max. = 400 Ω       | 0.40 (0.14) <sup>*2</sup> | —    | —   | μs | 在7种状态下采样VC C=AVCC0=3.0至3.6 V3.0V≤VREFH0≤AV CC0 |
|                        | 偏移误差                                 | —                  | ±1.0                      | ±2.5 | LSB | —  |  |
|                        | Full-scale error                     | —                  | ±1.0                      | ±2.5 | LSB | —  |  |
|                        | 绝对精度                                 | —                  | ±2.0                      | ±4.5 | LSB | —  |  |
|                        | DNL微分非线性误差                           | —                  | ±0.5                      | ±1.5 | LSB | —  |  |
|                        | INL积分非线性误差                           | —                  | ±1.0                      | ±2.5 | LSB | —  |  |

**Table 47.36 A/D conversion characteristics for unit 0 (2 of 2)**

Conditions: PCLKC = 1 to 50 MHz

| Parameter   | Min                       | Typ  | Max  | Unit | Test conditions                                 |
|---|---------------------------|------|------|------|---|
| High-precision normal-speed channels (AN006 to AN009, AN012, AN013) | 0.92 (0.66) <sup>*2</sup> | —    | —    | μs   | Sampling in 33 states                           |
| Conversion time <sup>*1</sup> (Operation at PCLKC = 50 MHz)         |                           |      |      |      | Permissible signal source impedance Max. = 1 kΩ |
| Offset error  | —                         | ±1.0 | ±2.5 | LSB  | —   |
| Full-scale error  | —                         | ±1.0 | ±2.5 | LSB  | —   |
| Absolute accuracy   | —                         | ±2.0 | ±4.5 | LSB  | —   |
| DNL differential nonlinearity error                                 | —                         | ±0.5 | ±1.5 | LSB  | —   |
| INL integral nonlinearity error                                     | —                         | ±1.0 | ±2.5 | LSB  | —   |

Note: These specification values apply when there is no access to the external memory during A/D conversion. If access occurs during A/D conversion, values might not fall within the indicated ranges.  
The use of PORT0 as digital outputs is not allowed when the 12-Bit A/D converter is used.  
The characteristics apply when AVCC0, AVSS0, VREFH0/VREFH, VREFL0, VREFL, and 12-bit A/D converter input voltage are stable.

Note: When both unit0 and unit1 are used, do not select the following analog input combinations at the same time except the interleave function. If selected, values might not fall within the indicated ranges.

- AN100 and AN000 or AN001 or AN002
- AN101 and AN000 or AN001 or AN002 or AN003
- AN102 and AN000 or AN001 or AN002 or AN003 or AN004

Note 1. The conversion time includes the sampling and comparison times. The number of sampling states is indicated for the test conditions.

Note 2. Values in parentheses indicate the sampling time.

**Table 47.37 A/D conversion characteristics for unit 1**

Conditions: PCLKC = 1 to 50 MHz

| Parameter   | Min   | Typ   | Max                       | Unit | Test conditions |     |   |
|---|---|---|---------------------------|------|-----------------|-----|---|
| Frequency   | 1   | —   | 50                        | MHz  | —               |     |   |
| Analog input capacitance                                | —   | —   | 30                        | pF   | —               |     |   |
| Quantization error                                      | —   | ±0.5  | —                         | LSB  | —               |     |   |
| Resolution  | —   | —   | 12                        | Bits | —               |     |   |
| High-precision high-speed channels (AN100 to AN102)     | Conversion time <sup>*1</sup> (Operation at PCLKC = 50 MHz) | Permissible signal source impedance Max. = 1 kΩ | 0.52 (0.26) <sup>*2</sup> | —    | —               | μs  | Sampling in 13 states   |
|   |   | Max. = 400 Ω                                    | 0.40 (0.14) <sup>*2</sup> | —    | —               | μs  | Sampling in 7 states<br>VCC = AVCC0 = 3.0 to 3.6 V<br>3.0 V ≤ VREFH ≤ AVCC0 |
|   | Offset error  | —   | ±1.0                      | ±2.5 | LSB             | —   |   |
|   | Full-scale error  | —   | ±1.0                      | ±2.5 | LSB             | —   |   |
|   | Absolute accuracy   | —   | ±2.0                      | ±4.5 | LSB             | —   |   |
|   | DNL differential nonlinearity error                         | —   | ±0.5                      | ±1.5 | LSB             | —   |   |
|   | INL integral nonlinearity error                             | —   | ±1.0                      | ±2.5 | LSB             | —   |   |
| Normal-precision normal-speed channels (AN116 to AN122) | Conversion time <sup>*1</sup> (Operation at PCLKC = 50 MHz) | Permissible signal source impedance Max. = 1 kΩ | 0.92 (0.66) <sup>*2</sup> | —    | —               | μs  | Sampling in 33 states   |
|   |   | Offset error                                    | —                         | ±1.0 | ±5.5            | LSB | —   |
|   | Full-scale error  | —   | ±1.0                      | ±5.5 | LSB             | —   |   |
|   | Absolute accuracy   | —   | ±2.0                      | ±7.5 | LSB             | —   |   |
|   | DNL differential nonlinearity error                         | —   | ±0.5                      | ±4.5 | LSB             | —   |   |
|   | INL integral nonlinearity error                             | —   | ±1.0                      | ±5.5 | LSB             | —   |   |

**Table 47.36 单元0(2of2)的AD转换特性**

Conditions: PCLKC = 1 to 50 MHz

| Parameter                            | Min                       | Typ  | 最大单位 | 测试条件               |
|--------------------------------------|---------------------------|------|------|--------------------|
| 高精度常速通道 (AN006至AN009、AN012、AN013)    | 0.92 (0.66) <sup>*2</sup> | —    | —    | μs 在33个州进行抽样       |
| 转换时间*1 (Operation at PCLKC = 50 MHz) |                           |      |      | 允许的的信号源阻抗 Max.=1kΩ |
| 偏移误差                                 | —                         | ±1.0 | ±2.5 | LSB                |
| Full-scale error                     | —                         | ±1.0 | ±2.5 | LSB                |
| 绝对精度                                 | —                         | ±2.0 | ±4.5 | LSB                |
| DNL微分非线性误差                           | —                         | ±0.5 | ±1.5 | LSB                |
| INL积分非线性误差                           | —                         | ±1.0 | ±2.5 | LSB                |

Note: 这些规格值适用于在AD转换期间无法访问外部存储器的情况。如果访问发生在D转换, 值可能不在指定范围内。  
使用12位AD转换器时, 不允许将PORT0用作数字输出。  
这些特性适用于AVCC0、AVSS0、VREFH0、VREFH、VREFL0、VREFL和12位AD转换器输入电压稳定时。

Note: 当同时使用unit0和unit1时, 除了交错功能外, 不要同时选择以下模拟输入组合。如果选中, 值可能不在指定范围内。●

- AN100和AN000或AN001或AN002
- AN101和AN000或AN001或AN002或AN003
- AN102和AN000或AN001或AN002或AN003或AN004

注1. 转换时间包括采样时间和比较时间。针对测试条件指示采样状态的数量。

注2: 括号内的数值表示采样时间。

**Table 47.37 单元1的AD转换特性**

Conditions: PCLKC = 1 to 50 MHz

| Parameter                | Min                                  | Typ                | 最大单位                      | 测试条件 |      |     |  |
|--------------------------|--------------------------------------|--------------------|---------------------------|------|------|-----|--|
| Frequency                | 1                                    | —                  | 50                        | MHz  |      |     |  |
| 模拟输入电容                   | —                                    | —                  | 30                        | pF   |      |     |  |
| 量化误差                     | —                                    | ±0.5               | —                         | LSB  |      |     |  |
| Resolution               | —                                    | —                  | 12                        | Bits |      |     |  |
| 高精度高速通道 (AN100至AN102)    | 转换时间*1 (Operation at PCLKC = 50 MHz) | 允许的的信号源阻抗 Max.=1kΩ | 0.52 (0.26) <sup>*2</sup> | —    | —    | μs  | 在13个州进行抽样  |
|                          |                                      | Max. = 400 Ω       | 0.40 (0.14) <sup>*2</sup> | —    | —    | μs  | 在7种状态下采样<br>VC C=AVCC0=3.0至3.6 V<br>3.0V≤VREFH≤AVCC0 |
|                          | 偏移误差                                 | —                  | ±1.0                      | ±2.5 | LSB  | —   |  |
|                          | Full-scale error                     | —                  | ±1.0                      | ±2.5 | LSB  | —   |  |
|                          | 绝对精度                                 | —                  | ±2.0                      | ±4.5 | LSB  | —   |  |
|                          | DNL微分非线性误差                           | —                  | ±0.5                      | ±1.5 | LSB  | —   |  |
|                          | INL积分非线性误差                           | —                  | ±1.0                      | ±2.5 | LSB  | —   |  |
| 正常精度正常速度通道 (AN116至AN122) | 转换时间*1 (Operation at PCLKC = 50 MHz) | 允许的的信号源阻抗 Max.=1kΩ | 0.92 (0.66) <sup>*2</sup> | —    | —    | μs  | 在33个州进行抽样  |
|                          |                                      | 偏移误差               | —                         | ±1.0 | ±5.5 | LSB | —  |
|                          | Full-scale error                     | —                  | ±1.0                      | ±5.5 | LSB  | —   |  |
|                          | 绝对精度                                 | —                  | ±2.0                      | ±7.5 | LSB  | —   |  |
|                          | DNL微分非线性误差                           | —                  | ±0.5                      | ±4.5 | LSB  | —   |  |
|                          | INL积分非线性误差                           | —                  | ±1.0                      | ±5.5 | LSB  | —   |  |

Note: These specification values apply when there is no access to the external memory during A/D conversion. If access occurs during A/D conversion, values might not fall within the indicated ranges.  
The use of PORT0 as digital outputs is not allowed when the 12-Bit A/D converter is used.  
The characteristics apply when AVCC0, AVSS0, VREFH0/VREFH, VREFL0, VREFL, and 12-bit A/D converter input voltage are stable.

Note: When both unit0 and unit1 are used, do not select the following analog input combinations at the same time except the interleave function. If selected, values might not fall within the indicated ranges.

- AN100 and AN000 or AN001 or AN002
- AN101 and AN000 or AN001 or AN002 or AN003
- AN102 and AN000 or AN001 or AN002 or AN003 or AN004

Note 1. The conversion time includes the sampling and comparison times. The number of sampling states is indicated for the test conditions.

Note 2. Values in parentheses indicate the sampling time.

**Table 47.38 A/D conversion characteristics for interleaving**

Conditions: PCLKC = 1 to 50 MHz

| Parameter   | Min   | Typ  | Max  | Unit | Test conditions |  |
|---|---|------|------|------|-----------------|--|
| Frequency   | 1   | —    | 50   | MHz  | —               |  |
| Analog input capacitance  | —   | —    | 30   | pF   | —               |  |
| Quantization error  | —   | ±0.5 | —    | LSB  | —               |  |
| Resolution  | —   | —    | 12   | Bits | —               |  |
| High-precision high-speed channels (AN000 & AN100, AN001 & AN101, AN002 & AN102)) | Conversion time*1 (operation at PCLKC = 50 MHz) | 0.22 | —    | —    | µs              | Sampling in 9 states<br>VCC = AVCC0 = 3.0 to 3.6 V<br>3.0 V ≤ VREFH0 ≤ AVCC0 |
|   | Offset error                                    | —    | ±1.0 | ±2.5 | LSB             | —  |
|   | Full-scale error                                | —    | ±1.0 | ±2.5 | LSB             | —  |
|   | Absolute accuracy                               | —    | ±2.0 | ±4.5 | LSB             | —  |
|   | DNL differential nonlinearity error             | —    | ±0.5 | ±3.5 | LSB             | —  |
|   | INL integral nonlinearity error                 | —    | ±1.0 | ±3.5 | LSB             | —  |

Note: These specification values apply when there is no access to the external memory during A/D conversion. If access occurs during A/D conversion, values might not fall within the indicated ranges.  
The use of PORT0 as digital outputs is not allowed when the 12-Bit A/D converter is used.  
The characteristics apply when AVCC0, AVSS0, VREFH0/VREFH, VREFL0, VREFL, and 12-bit A/D converter input voltage are stable.

Note 1. The conversion time includes the sampling and comparison times. The number of sampling states is indicated for the test conditions.

**Table 47.39 A/D internal reference voltage characteristics**

| Parameter                      | Min  | Typ  | Max  | Unit | Test conditions |
|--------------------------------|------|------|------|------|-----------------|
| A/D internal reference voltage | 1.13 | 1.18 | 1.23 | V    | —               |
| Sampling time                  | 4.15 | —    | —    | µs   | —               |

Note: 这些规格值适用于在AD转换期间无法访问外部存储器的情况。如果访问发生在D转换，值可能不在指定范围内。  
使用12位AD转换器时，不允许将PORT0用作数字输出。  
这些特性适用于AVCC0、AVSS0、VREFH0、VREFH、VREFL0、VREFL和12位AD转换器输入电压稳定时。

Note: 当同时使用unit0和unit1时，除了交错功能外，不要同时选择以下模拟输入组合。如果选中，值可能不在指定范围内。●

- AN100和AN000或AN001或AN002
- AN101和AN000或AN001或AN002或AN003
- AN102和AN000或AN001或AN002或AN003或AN004

注1. 转换时间包括采样时间和比较时间。针对测试条件指示采样状态的数量。

注2: 括号内的数值表示采样时间。

**Table 47.38 用于交织的AD转换特性**

Conditions: PCLKC = 1 to 50 MHz

| Parameter   | Min                                  | Typ  | 最大单位    | 测试条件     |  |
|---|--------------------------------------|------|---------|----------|--|
| Frequency   | 1                                    | —    | 50 MHz  | —        |  |
| 模拟输入电容  | —                                    | —    | 30 pF   | —        |  |
| 量化误差  | —                                    | ±0.5 | — LSB   | —        |  |
| Resolution  | —                                    | —    | 12 Bits | —        |  |
| High-precision high-speed channels (AN000 & AN100, AN001 & AN101, AN002 & AN102)) | 转换时间*1 (operation at PCLKC = 50 MHz) | 0.22 | —       | µs       | 在9个州进行抽样<br>VCC = AVCC0 = 3.0 to 3.6 V<br>3.0 V ≤ VREFH0 ≤ AVCC0 |
|   | 偏移误差                                 | —    | ±1.0    | ±2.5 LSB | —  |
|   | Full-scale error                     | —    | ±1.0    | ±2.5 LSB | —  |
|   | 绝对精度                                 | —    | ±2.0    | ±4.5 LSB | —  |
|   | DNL微分非线性误差                           | —    | ±0.5    | ±3.5 LSB | —  |
|   | INL积分非线性误差                           | —    | ±1.0    | ±3.5 LSB | —  |

Note: 这些规格值适用于在AD转换期间无法访问外部存储器的情况。如果访问发生在D转换，值可能不在指定范围内。  
使用12位AD转换器时，不允许将PORT0用作数字输出。  
这些特性适用于AVCC0、AVSS0、VREFH0、VREFH、VREFL0、VREFL和12位AD转换器输入电压稳定时。

注1. 转换时间包括采样时间和比较时间。针对测试条件指示采样状态的数量。

**Table 47.39 AD内部参考电压特性**

| Parameter | Min  | Typ  | Max  | Unit | 测试条件 |
|-----------|------|------|------|------|------|
| AD内部参考电压  | 1.13 | 1.18 | 1.23 | V    | —    |
| 采样时间      | 4.15 | —    | —    | µs   | —    |



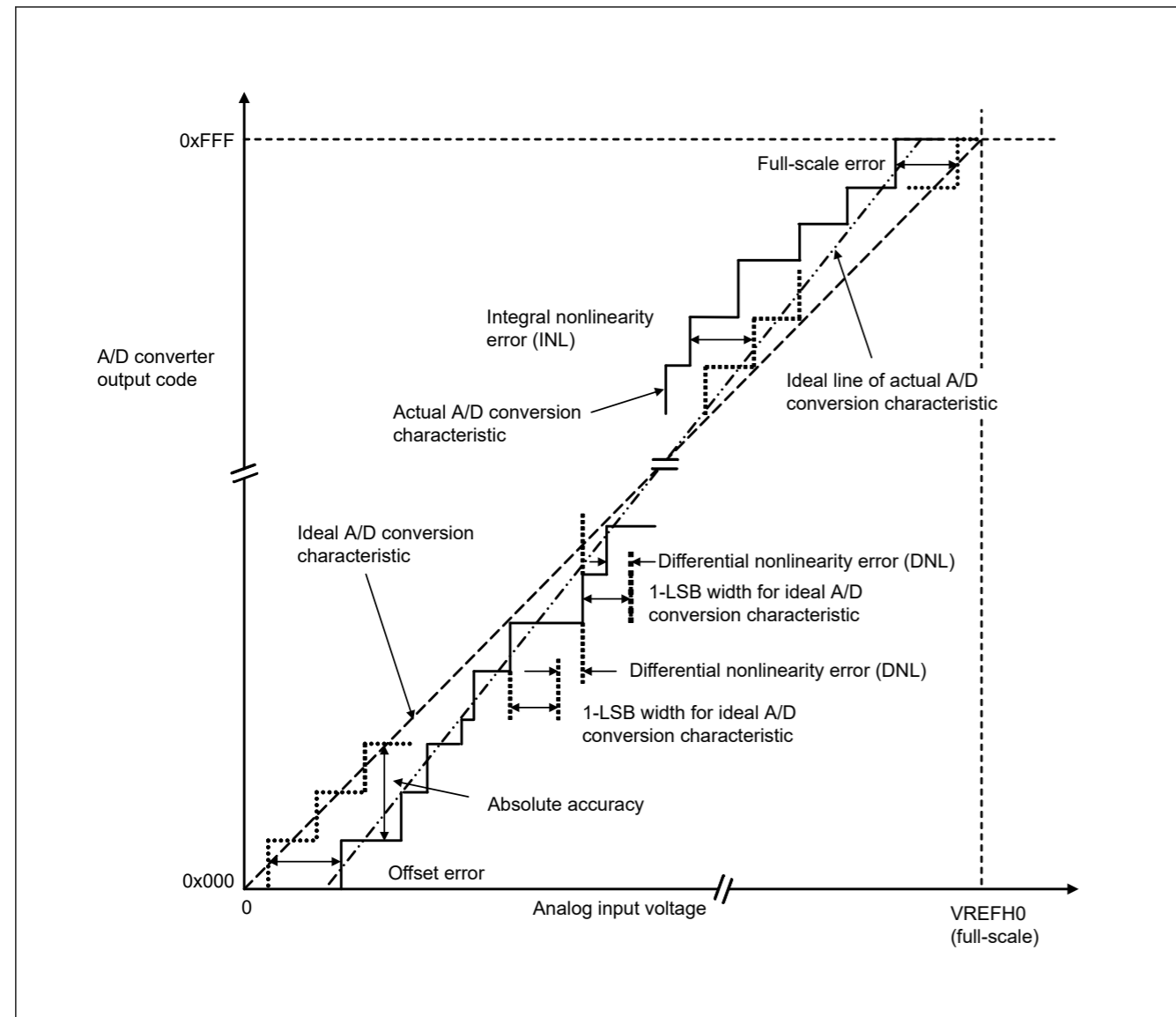


Figure 47.54 Illustration of ADC12 characteristic terms

#### Absolute accuracy

Absolute accuracy is the difference between output code based on the theoretical A/D conversion characteristics, and the actual A/D conversion result. When measuring absolute accuracy, the voltage at the midpoint of the width of the analog input voltage (1-LSB width), which can meet the expectation of outputting an equal code based on the theoretical A/D conversion characteristics, is used as an analog input voltage. For example, if 12-bit resolution is used and the reference voltage  $V_{REFH0} = 3.072\text{ V}$ , then the 1-LSB width becomes  $0.75\text{ mV}$ , and  $0\text{ mV}$ ,  $0.75\text{ mV}$ , and  $1.5\text{ mV}$  are used as the analog input voltages. If the analog input voltage is  $6\text{ mV}$ , an absolute accuracy of  $\pm 5\text{ LSB}$  means that the actual A/D conversion result is in the range of  $0x003$  to  $0x00D$ , though an output code of  $0x008$  can be expected from the theoretical A/D conversion characteristics.

#### Integral nonlinearity error (INL)

Integral nonlinearity error is the maximum deviation between the ideal line when the measured offset and full-scale errors are zeroed, and the actual output code.

#### Differential nonlinearity error (DNL)

Differential nonlinearity error is the difference between the 1-LSB width based on the ideal A/D conversion characteristics and the width of the actual output code.

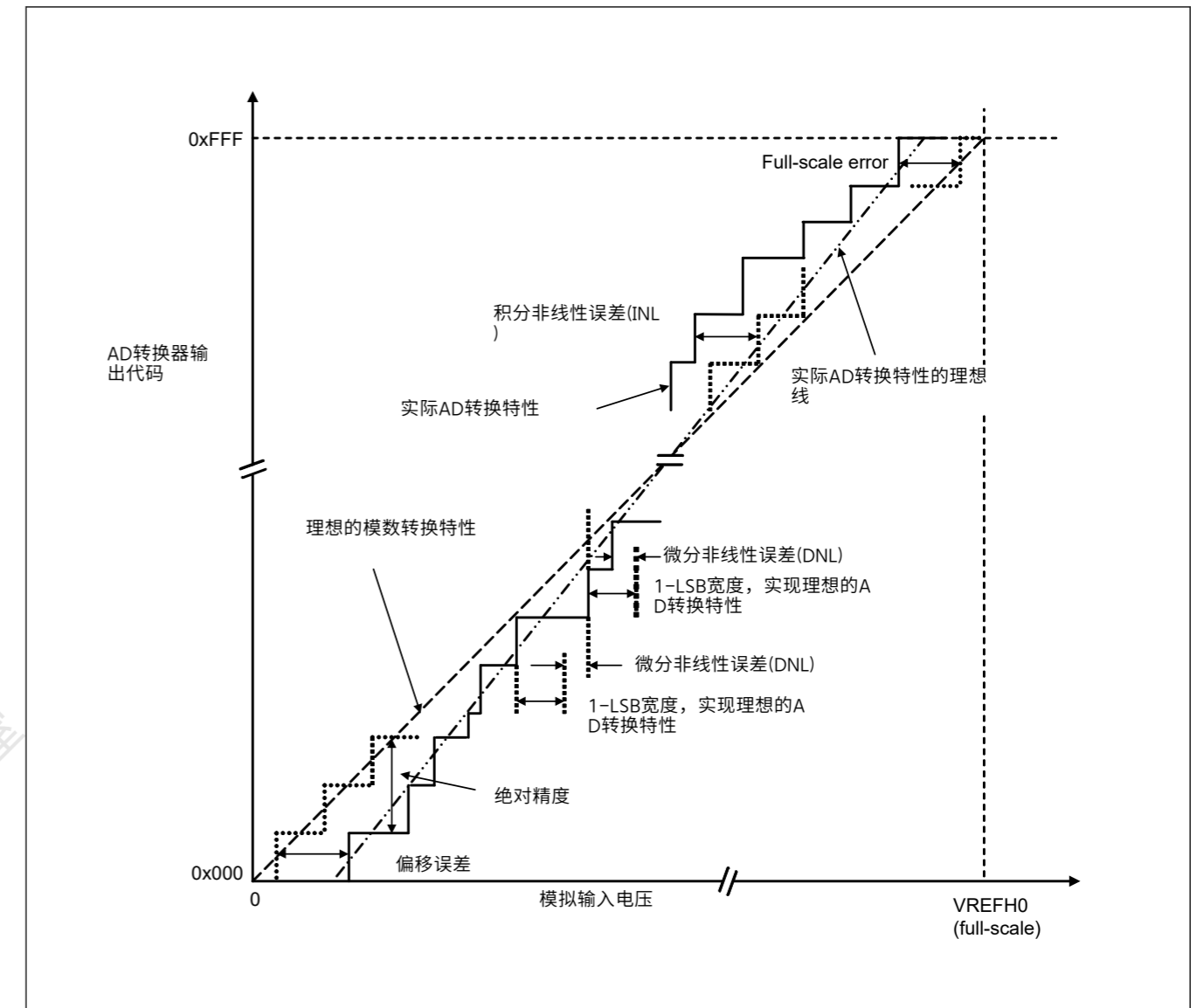


Figure 47.54 ADC12特征项说明

#### 绝对精度

绝对精度是基于理论AD转换特性的输出代码与实际AD转换结果之间的差异。测量绝对精度时，将模拟输入电压宽度（1-LSB宽度）的中点电压作为模拟输入电压，该电压可以满足基于理论模数转换特性输出等码的预期。例如，如果使用12位分辨率且参考电压 $V_{REFH0}=3.072\text{V}$ ，则1-LSB宽度变为 $0.75\text{mV}$ ，并且使用 $0\text{mV}$ 、 $0.75\text{mV}$ 和 $1.5\text{mV}$ 作为模拟输入电压。如果模拟输入电压为 $6\text{mV}$ ， $\pm 5\text{LSB}$ 的绝对精度意味着实际的AD转换结果在 $0x003$ 到 $0x00D$ 的范围内，尽管从理论上的AD转换特性可以预期输出代码为 $0x008$ 。

#### 积分非线性误差(INL)

积分非线性误差是测量的偏移和满量程误差为零时的理想线与实际输出代码之间的最大偏差。

#### 微分非线性误差(DNL)

微分非线性误差是基于理想AD转换特性的1-LSB宽度与实际输出码的宽度之差。

**Offset error**

Offset error is the difference between the transition point of the ideal first output code and the actual first output code.

**Full-scale error**

Full-scale error is the difference between the transition point of the ideal last output code and the actual last output code.

## 47.6 DAC12 Characteristics

Table 47.40 D/A conversion characteristics

| Parameter                | Min | Typ  | Max         | Unit | Test conditions                            |
|--------------------------|-----|------|-------------|------|--|
| Resolution               | —   | —    | 12          | Bits | —  |
| Without output amplifier |     |      |             |      |  |
| Absolute accuracy        | —   | —    | ±24         | LSB  | Resistive load 2 MΩ                        |
| INL                      | —   | ±2.0 | ±8.0        | LSB  | Resistive load 2 MΩ                        |
| DNL                      | —   | ±1.0 | ±2.0        | LSB  | —  |
| Output impedance         | —   | 8.5  | —           | kΩ   | —  |
| Conversion time          | —   | —    | 3           | μs   | Resistive load 2 MΩ, Capacitive load 20 pF |
| Output voltage range     | 0   | —    | VREFH       | V    | —  |
| With output amplifier    |     |      |             |      |  |
| INL                      | —   | ±2.0 | ±4.0        | LSB  | —  |
| DNL                      | —   | ±1.0 | ±2.0        | LSB  | —  |
| Conversion time          | —   | —    | 4.0         | μs   | —  |
| Resistive load           | 5   | —    | —           | kΩ   | —  |
| Capacitive load          | —   | —    | 50          | pF   | —  |
| Output voltage range     | 0.2 | —    | VREFH - 0.2 | V    | —  |

## 47.7 TSN Characteristics

Table 47.41 TSN characteristics

| Parameter                     | Symbol             | Min  | Typ   | Max | Unit  | Test conditions |
|-------------------------------|--------------------|------|-------|-----|-------|-----------------|
| Relative accuracy             | —                  | —    | ± 1.0 | —   | °C    | —               |
| Temperature slope             | —                  | —    | 4.0   | —   | mV/°C | —               |
| Output voltage (at 25 °C)     | —                  | —    | 1.24  | —   | V     | —               |
| Temperature sensor start time | t <sub>START</sub> | —    | —     | 30  | μs    | —               |
| Sampling time                 | —                  | 4.15 | —     | —   | μs    | —               |

## 47.8 OSC Stop Detect Characteristics

Table 47.42 Oscillation stop detection circuit characteristics

| Parameter      | Symbol          | Min | Typ | Max | Unit | Test conditions |
|----------------|-----------------|-----|-----|-----|------|-----------------|
| Detection time | t <sub>dr</sub> | —   | —   | 1   | ms   | Figure 47.55    |

**偏移误差**

偏移误差是理想的第一个输出代码的转换点与实际的第一个输出代码之间的差异。

**Full-scale error**

满量程误差是理想的最后输出代码的转换点与实际的最后输出代码之间的差异。

## 47.6 DAC12 Characteristics

Table 47.40 DA转换特性

| Parameter       | Min | Typ  | Max         | Unit | 测试条件              |
|-----------------|-----|------|-------------|------|-------------------|
| Resolution      | —   | —    | 12          | Bits | —                 |
| 无输出放大器          |     |      |             |      |                   |
| 绝对精度            | —   | —    | ±24         | LSB  | 阻性负载2MΩ           |
| INL             | —   | ±2.0 | ±8.0        | LSB  | 阻性负载2MΩ           |
| DNL             | —   | ±1.0 | ±2.0        | LSB  | —                 |
| 输出阻抗            | —   | 8.5  | —           | kΩ   | —                 |
| 转换时间            | —   | —    | 3           | μs   | 电阻负载2MΩ, 电容负载20pF |
| 输出电压范围          | 0   | —    | VREFH       | V    | —                 |
| 带输出放大器          |     |      |             |      |                   |
| INL             | —   | ±2.0 | ±4.0        | LSB  | —                 |
| DNL             | —   | ±1.0 | ±2.0        | LSB  | —                 |
| 转换时间            | —   | —    | 4.0         | μs   | —                 |
| 阻性负载            | 5   | —    | —           | kΩ   | —                 |
| Capacitive load | —   | —    | 50          | pF   | —                 |
| 输出电压范围          | 0.2 | —    | VREFH - 0.2 | V    | —                 |

## 47.7 TSN Characteristics

Table 47.41 TSN characteristics

| Parameter    | Symbol             | Min  | Typ   | Max | Unit  | 测试条件 |
|--------------|--------------------|------|-------|-----|-------|------|
| 相对精度         | —                  | —    | ± 1.0 | —   | °C    | —    |
| 温度斜率         | —                  | —    | 4.0   | —   | mV/°C | —    |
| 输出电压 (25°C时) | —                  | —    | 1.24  | —   | V     | —    |
| 温度传感器启动时间    | t <sub>START</sub> | —    | —     | 30  | μs    | —    |
| 采样时间         | —                  | 4.15 | —     | —   | μs    | —    |

## 47.8 OSC停止检测特性

Table 47.42 振荡停止检测电路特性

| Parameter | Symbol          | Min | Typ | Max | Unit | 测试条件         |
|-----------|-----------------|-----|-----|-----|------|--------------|
| 检测时间      | t <sub>dr</sub> | —   | —   | 1   | ms   | Figure 47.55 |

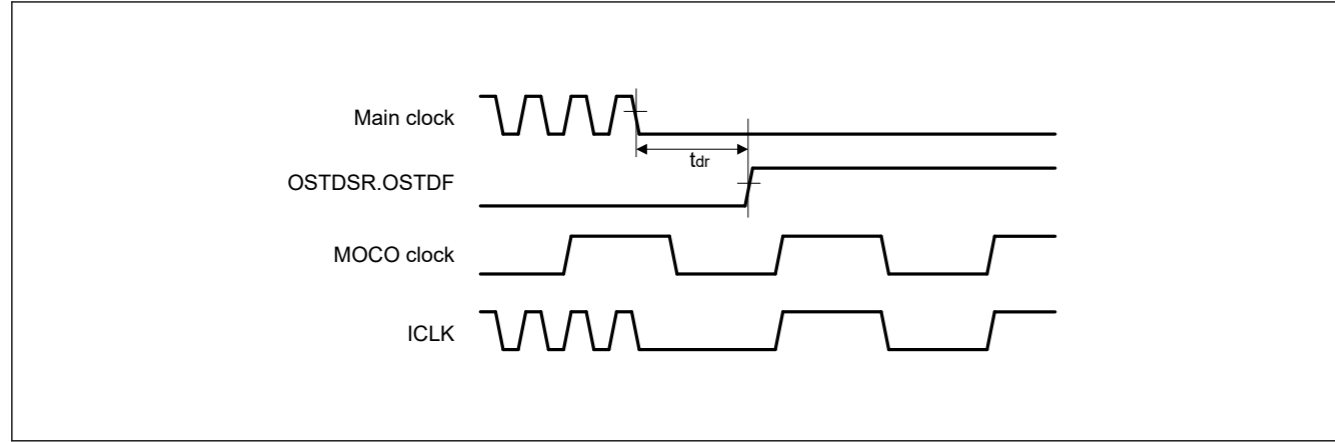


Figure 47.55 Oscillation stop detection timing

47.9 POR and LVD Characteristics

Table 47.43 Power-on reset circuit and voltage detection circuit characteristics (1)

| Parameter   | Symbol                           | Min                                | Typ              | Max  | Unit | Test conditions |                              |              |
|---|----------------------------------|------------------------------------|------------------|------|------|-----------------|------------------------------|--------------|
| Voltage detection level                                 | Power-on reset (POR)             | DPSBYCR.DEEPCUT[1:0] = 00b or 01b. | V <sub>POR</sub> | 2.5  | 2.6  | 2.7             | V                            | Figure 47.56 |
|   |                                  | DPSBYCR.DEEPCUT[1:0] = 11b.        | 1.8              | 2.25 | 2.7  |                 |                              |              |
|   | Voltage detection circuit (LVD0) | V <sub>det0_1</sub>                | 2.84             | 2.94 | 3.04 | ms              | Figure 47.57                 |              |
|   |                                  | V <sub>det0_2</sub>                | 2.77             | 2.87 | 2.97 |                 |                              |              |
|   |                                  | V <sub>det0_3</sub>                | 2.70             | 2.80 | 2.90 |                 |                              |              |
|   | Voltage detection circuit (LVD1) | V <sub>det1_1</sub>                | 2.89             | 2.99 | 3.09 | ms              | Figure 47.58                 |              |
|   |                                  | V <sub>det1_2</sub>                | 2.82             | 2.92 | 3.02 |                 |                              |              |
|   |                                  | V <sub>det1_3</sub>                | 2.75             | 2.85 | 2.95 |                 |                              |              |
|   | Voltage detection circuit (LVD2) | V <sub>det2_1</sub>                | 2.89             | 2.99 | 3.09 | ms              | Figure 47.59                 |              |
|   |                                  | V <sub>det2_2</sub>                | 2.82             | 2.92 | 3.02 |                 |                              |              |
|   |                                  | V <sub>det2_3</sub>                | 2.75             | 2.85 | 2.95 |                 |                              |              |
|   | Internal reset time              | Power-on reset time                | t <sub>POR</sub> | —    | 4.5  | —               | ms                           | Figure 47.56 |
| LVD0 reset time   |                                  | t <sub>LVD0</sub>                  | —                | 0.51 | —    | ms              | Figure 47.57                 |              |
| LVD1 reset time   |                                  | t <sub>LVD1</sub>                  | —                | 0.38 | —    | ms              | Figure 47.58                 |              |
| LVD2 reset time   |                                  | t <sub>LVD2</sub>                  | —                | 0.38 | —    | ms              | Figure 47.59                 |              |
| Minimum VCC down time*1                                 | t <sub>VOFF</sub>                | 200                                | —                | —    | —    | μs              | Figure 47.56, Figure 47.57   |              |
| Response delay  | t <sub>det</sub>                 | —                                  | —                | 200  | —    | μs              | Figure 47.57 to Figure 47.59 |              |
| LVD operation stabilization time (after LVD is enabled) | t <sub>d(E-A)</sub>              | —                                  | —                | 10   | —    | μs              | Figure 47.58, Figure 47.59   |              |
| Hysteresis width (LVD1 and LVD2)                        | V <sub>LVH</sub>                 | —                                  | 70               | —    | —    | mV              |                              |              |

Note 1. The minimum VCC down time indicates the time when VCC is below the minimum value of voltage detection levels V<sub>POR</sub>, V<sub>det0</sub>, V<sub>det1</sub>, and V<sub>det2</sub> for POR and LVD.

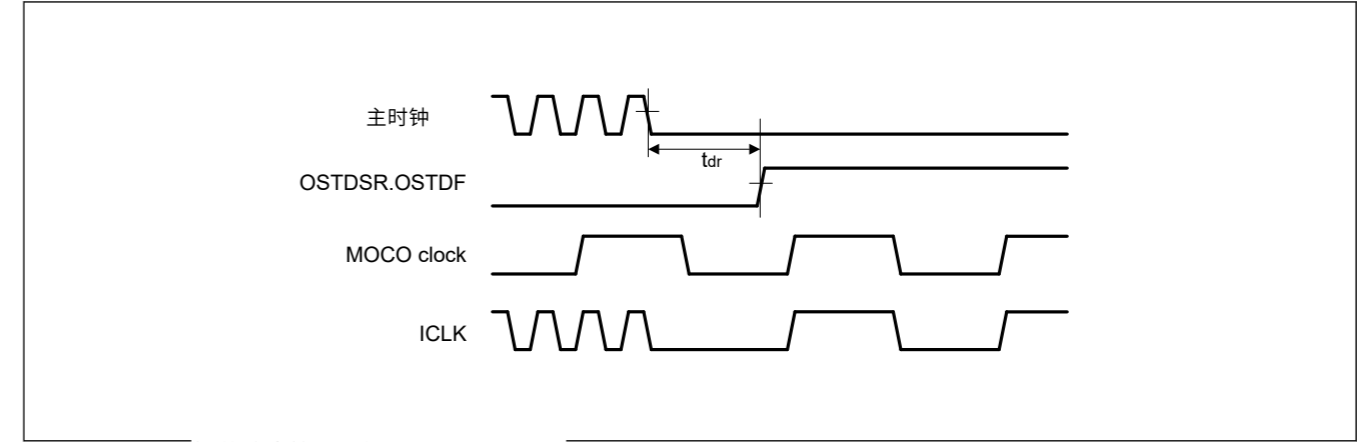


Figure 47.55 振荡停止检测时机

47.9 POR和LVD特性

Table 47.43 上电复位电路及电压检测电路特性 (一)

| Parameter          | Symbol               | Min                                | Typ              | Max  | Unit | 测试条件 |                            |              |
|--------------------|----------------------|------------------------------------|------------------|------|------|------|----------------------------|--------------|
| 电压检测电平             | Power-on reset (POR) | DPSBYCR.DEEPCUT[1:0] = 00b or 01b. | V <sub>POR</sub> | 2.5  | 2.6  | 2.7  | V                          | Figure 47.56 |
|                    |                      | DPSBYCR.DEEPCUT[1:0] = 11b.        | 1.8              | 2.25 | 2.7  |      |                            |              |
|                    | 电压检测电路 (LVD0)        | V <sub>det0_1</sub>                | 2.84             | 2.94 | 3.04 | ms   | Figure 47.57               |              |
|                    |                      | V <sub>det0_2</sub>                | 2.77             | 2.87 | 2.97 |      |                            |              |
|                    |                      | V <sub>det0_3</sub>                | 2.70             | 2.80 | 2.90 |      |                            |              |
|                    | 电压检测电路 (LVD1)        | V <sub>det1_1</sub>                | 2.89             | 2.99 | 3.09 | ms   | Figure 47.58               |              |
|                    |                      | V <sub>det1_2</sub>                | 2.82             | 2.92 | 3.02 |      |                            |              |
|                    |                      | V <sub>det1_3</sub>                | 2.75             | 2.85 | 2.95 |      |                            |              |
|                    | 电压检测电路 (LVD2)        | V <sub>det2_1</sub>                | 2.89             | 2.99 | 3.09 | ms   | Figure 47.59               |              |
|                    |                      | V <sub>det2_2</sub>                | 2.82             | 2.92 | 3.02 |      |                            |              |
|                    |                      | V <sub>det2_3</sub>                | 2.75             | 2.85 | 2.95 |      |                            |              |
|                    | 内部复位时间               | 上电复位时间                             | t <sub>POR</sub> | —    | 4.5  | —    | ms                         | Figure 47.56 |
| LVD0复位时间           |                      | t <sub>LVD0</sub>                  | —                | 0.51 | —    | ms   | Figure 47.57               |              |
| LVD1复位时间           |                      | t <sub>LVD1</sub>                  | —                | 0.38 | —    | ms   | Figure 47.58               |              |
| LVD2复位时间           |                      | t <sub>LVD2</sub>                  | —                | 0.38 | —    | ms   | Figure 47.59               |              |
| 最小VCC停机时间*1        | t <sub>VOFF</sub>    | 200                                | —                | —    | —    | μs   | Figure 47.56, Figure 47.57 |              |
| 响应延迟               | t <sub>det</sub>     | —                                  | —                | 200  | —    | μs   | 图47.57至 Figure 47.59       |              |
| LVD操作稳定时间 (启用LVD后) | t <sub>d(E-A)</sub>  | —                                  | —                | 10   | —    | μs   | Figure 47.58, Figure 47.59 |              |
| 迟滞宽度 (LVD1和LVD2)   | V <sub>LVH</sub>     | —                                  | 70               | —    | —    | mV   |                            |              |

注1.最小VCC停机时间是指VCC低于电压检测电平V<sub>POR</sub>、V<sub>det0</sub>、V<sub>det1</sub>和V<sub>det2</sub>用于POR和LVD。

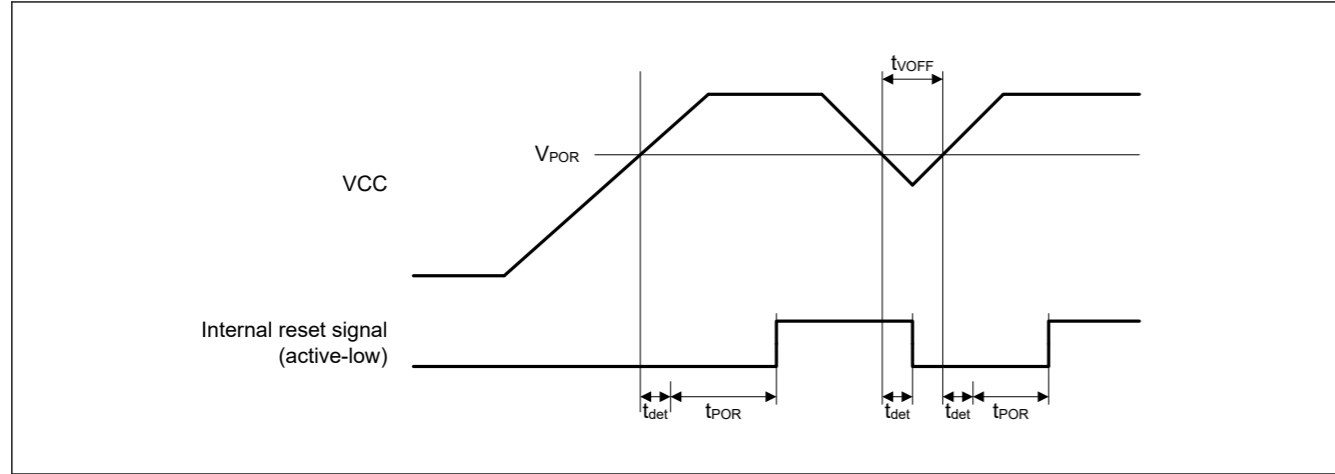


Figure 47.56 Power-on reset timing

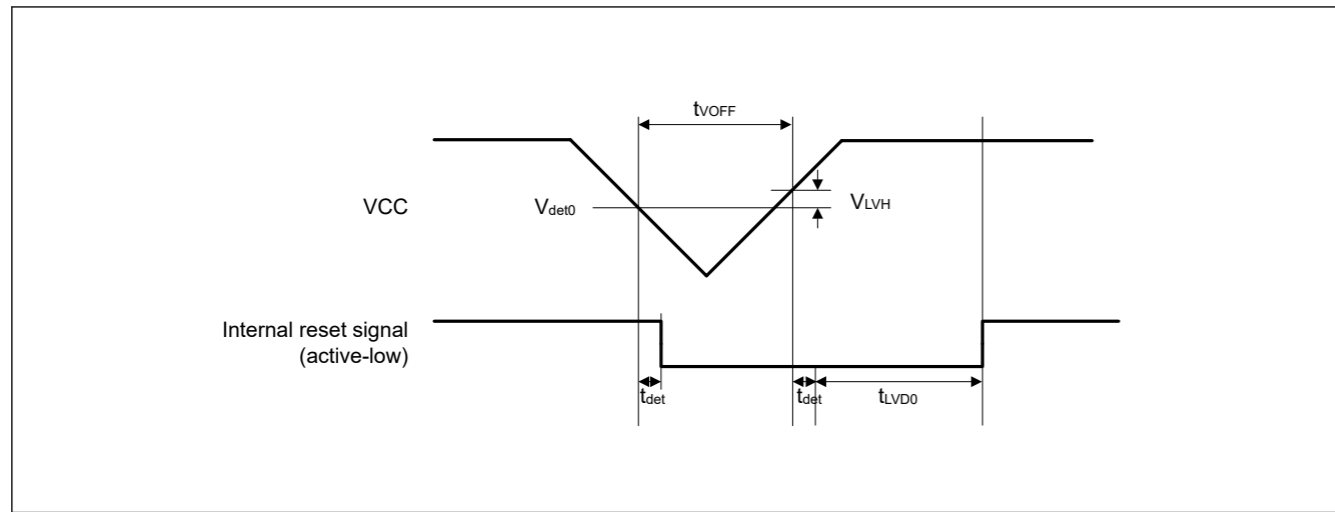


Figure 47.57 Voltage detection circuit timing ( $V_{det0}$ )

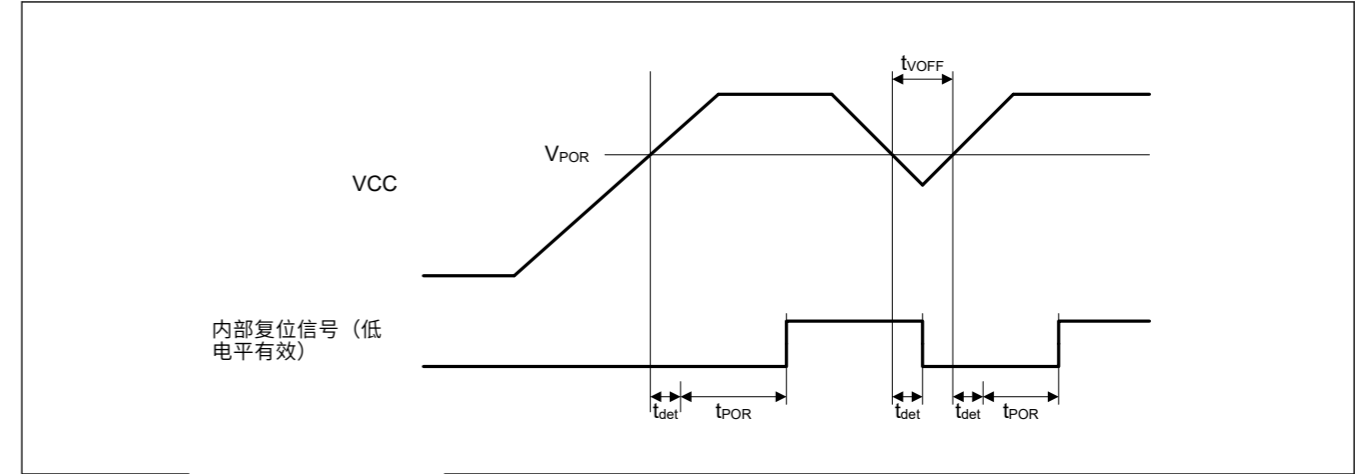


Figure 47.56 上电复位时序

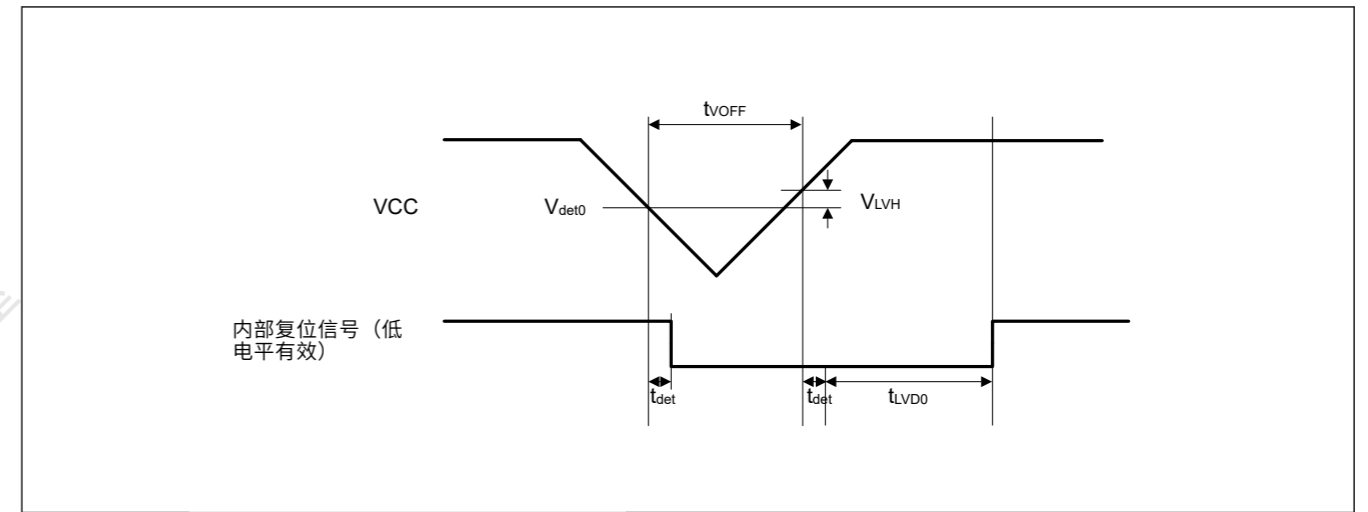


Figure 47.57 电压检测电路时序 ( $V_{det0}$ )



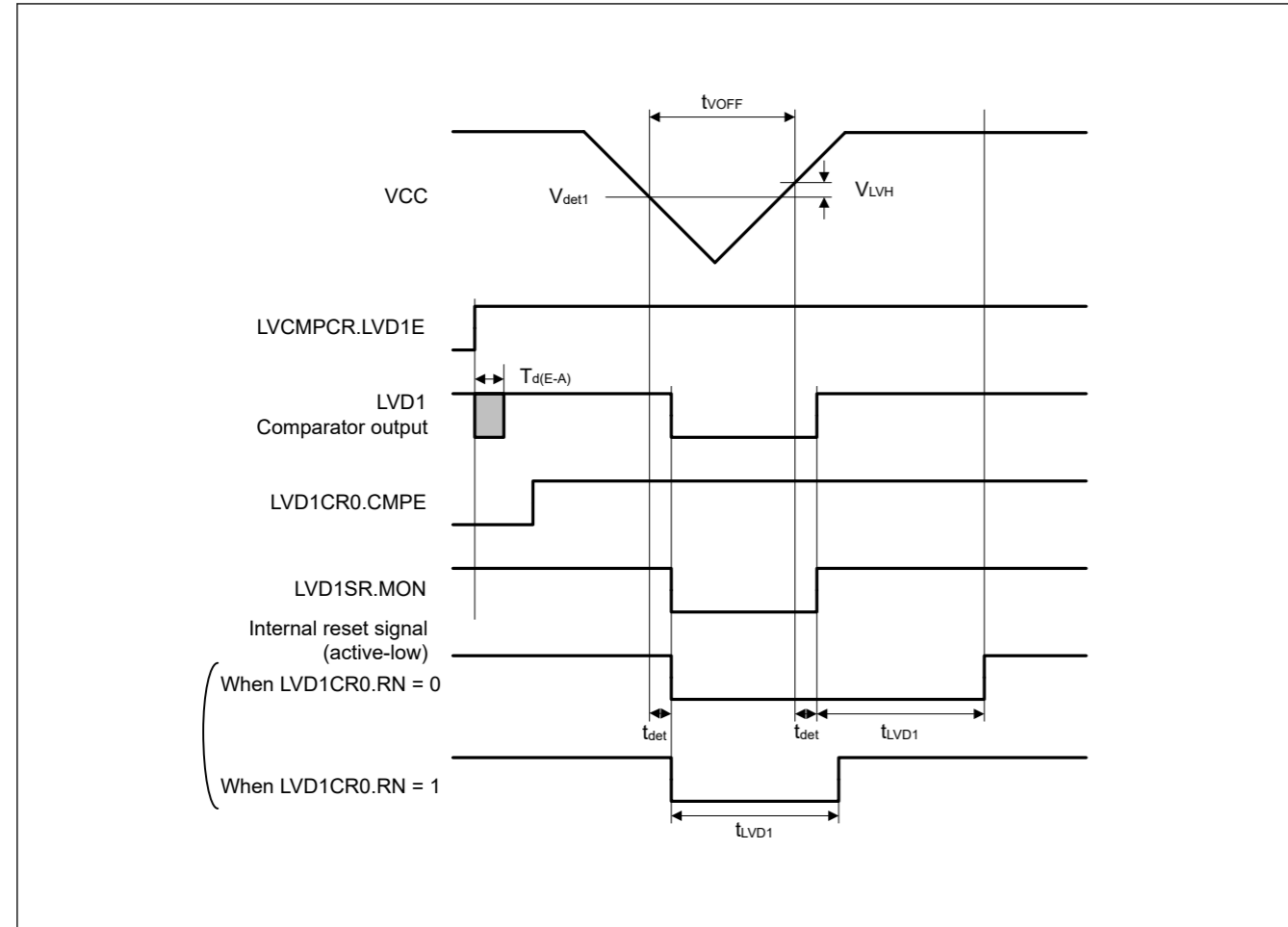


Figure 47.58 Voltage detection circuit timing ( $V_{det1}$ )

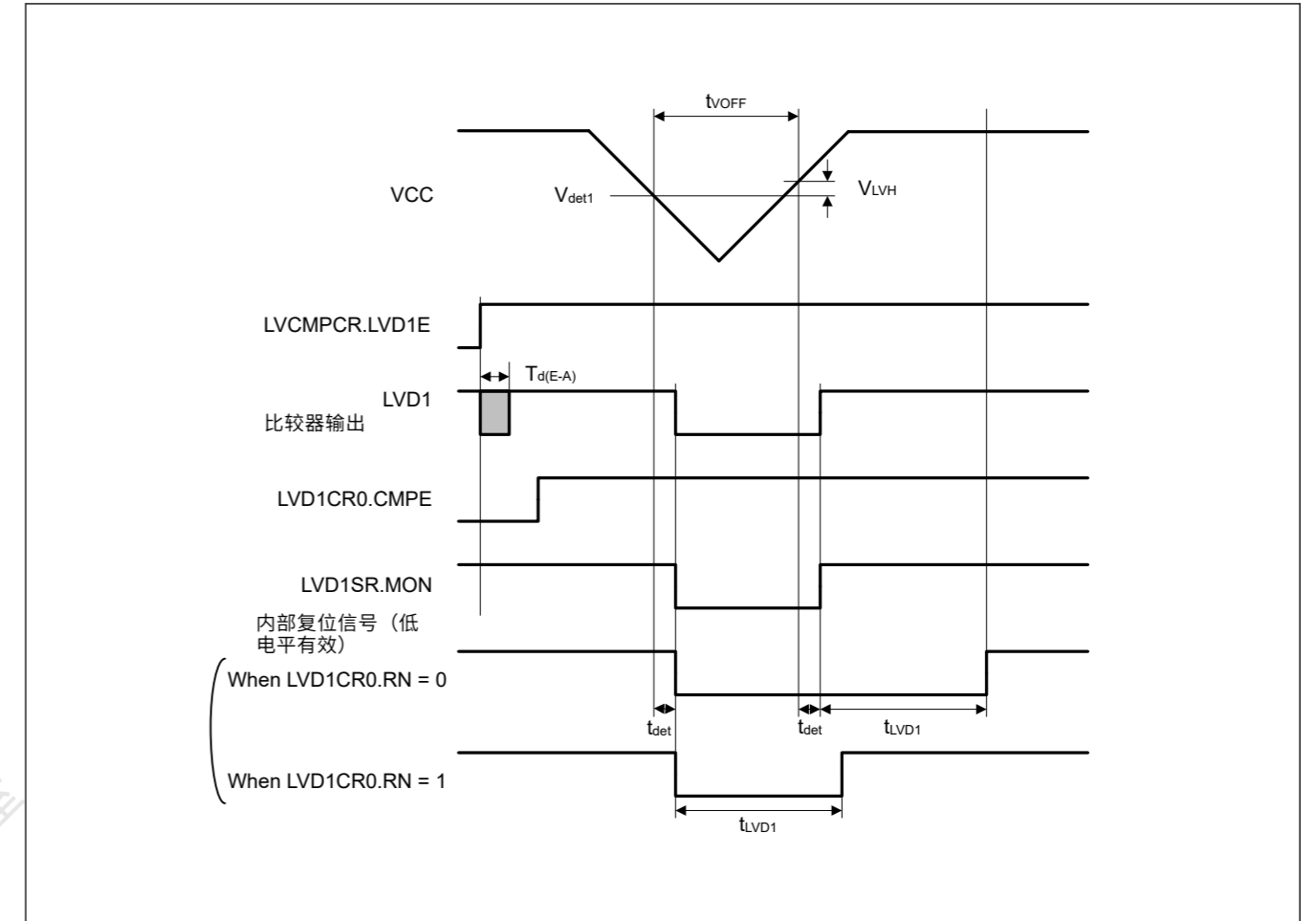


Figure 47.58 电压检测电路时序 ( $V_{det1}$ )

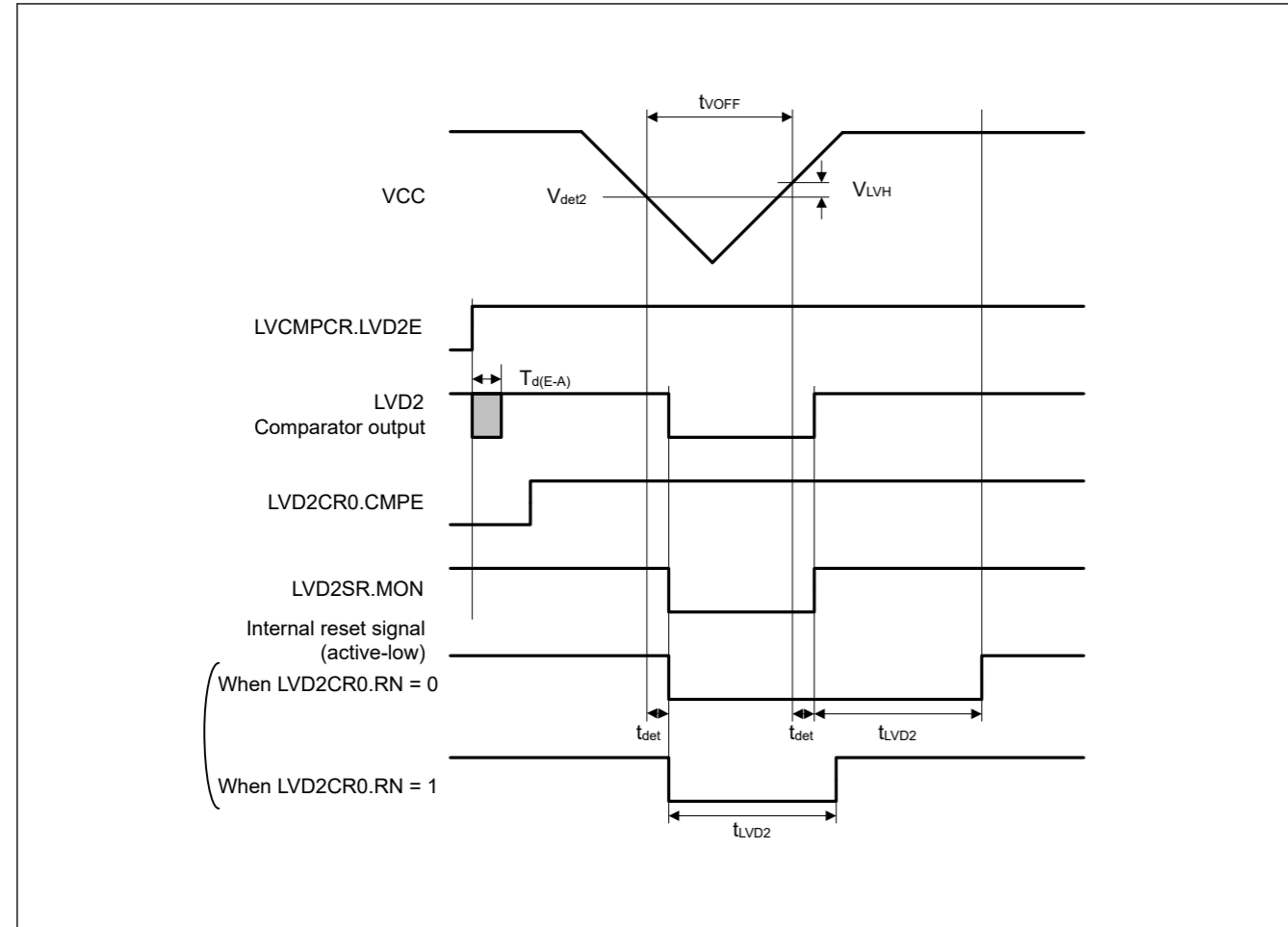


Figure 47.59 Voltage detection circuit timing (V<sub>det2</sub>)

47.10 VBATT Characteristics

Table 47.44 Battery backup function characteristics

Conditions: VCC = AVCC0 = VCC\_USB = 2.7 to 3.6 V, 2.7 ≤ VREFH0/VREFH ≤ AVCC0, VBATT = 1.8 to 3.6 V

| Parameter   | Symbol                | Min  | Typ  | Max  | Unit | Test conditions |
|---|-----------------------|------|------|------|------|-----------------|
| Voltage level for switching to battery backup   | V <sub>DETBATT</sub>  | 2.50 | 2.60 | 2.70 | V    | Figure 47.60    |
| Lower-limit VBATT voltage for power supply switching caused by VCC voltage drop                                 | V <sub>BATTSW</sub>   | 2.70 | —    | —    | V    |                 |
| VCC-off period for starting power supply switching  | t <sub>VOFFBATT</sub> | 200  | —    | —    | μs   |                 |
| VBATT low voltage detection level   | V <sub>battldet</sub> | 1.8  | 1.9  | 2.0  | V    | Figure 47.61    |
| Minimum VBATT down time   | t <sub>BATTOFF</sub>  | 200  | —    | —    | μs   |                 |
| Response delay  | t <sub>BATTdet</sub>  | —    | —    | 200  | μs   |                 |
| VBATT monitor operation stabilization time (after VBATTMNSLR.VBATTMNSSEL is changed to 1)                       | t <sub>d(E-A)</sub>   | —    | —    | 20   | μs   |                 |
| VBATT current increase (when VBATTMNSLR.VBATTMNSSEL is 1 compared to the case that VBATTMNSLR.VBATTMNSSEL is 0) | I <sub>BATTSEL</sub>  | —    | 140  | 350  | nA   |                 |

Note: The VCC-off period for starting power supply switching indicates the period in which VCC is below the minimum value of the voltage level for switching to battery backup (V<sub>DETBATT</sub>).

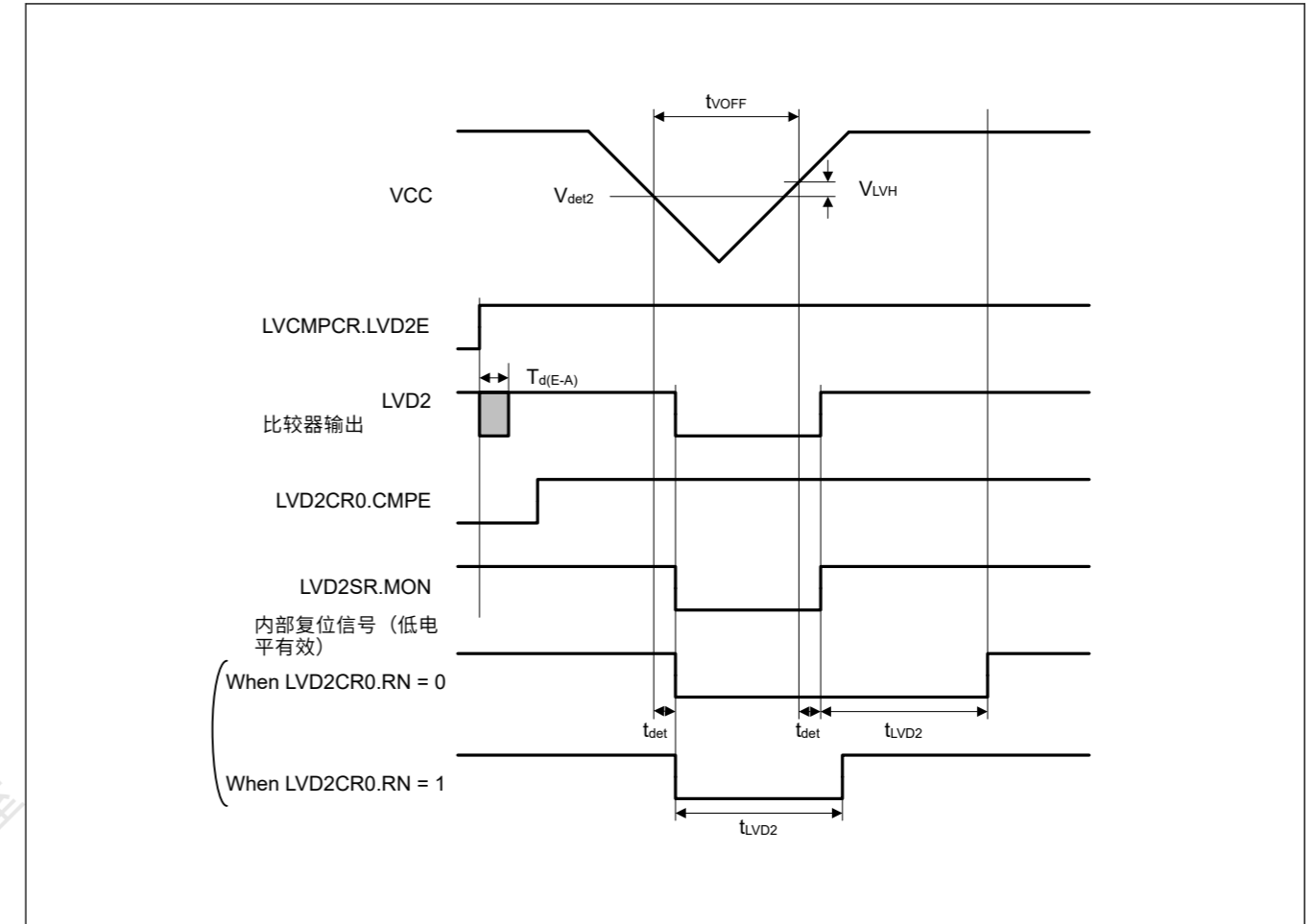


Figure 47.59 电压检测电路时序 (V<sub>det2</sub>)

47.10 VBATT Characteristics

Table 47.44 电池备份功能特点

Conditions: VCC = AVCC0 = VCC\_USB = 2.7 to 3.6 V, 2.7 ≤ VREFH0/VREFH ≤ AVCC0, VBATT = 1.8 to 3.6 V

| Parameter   | Symbol                | Min  | Typ  | Max  | Unit | 测试条件         |
|---|-----------------------|------|------|------|------|--------------|
| 切换到备用电池的电压电平  | V <sub>DETBATT</sub>  | 2.50 | 2.60 | 2.70 | V    | Figure 47.60 |
| VCC压降引起的电源切换下限VBATT电压   | V <sub>BATTSW</sub>   | 2.70 | —    | —    | V    |              |
| 启动电源切换的VCC-off周期  | t <sub>VOFFBATT</sub> | 200  | —    | —    | μs   |              |
| VBATT低电压检测电平  | V <sub>battldet</sub> | 1.8  | 1.9  | 2.0  | V    | Figure 47.61 |
| 最短VBATT停机时间   | t <sub>BATTOFF</sub>  | 200  | —    | —    | μs   |              |
| 响应延迟  | t <sub>BATTdet</sub>  | —    | —    | 200  | μs   |              |
| VBATT监视器运行稳定时间 (VBATTMNSLR.VBATTMNSSEL变为1后)                           | t <sub>d(E-A)</sub>   | —    | —    | 20   | μs   |              |
| VBATT电流增加 (当与VBATTMNSLR.VBATTMNSSEL为0的情况相比, VBATTMNSLR.VBATTMNSSEL为1) | I <sub>BATTSEL</sub>  | —    | 140  | 350  | nA   |              |

Note: 开始电源切换的VCC-off周期表示VCC低于切换到备用电池的电压电平最小值(V<sub>DETBATT</sub>)的周期。

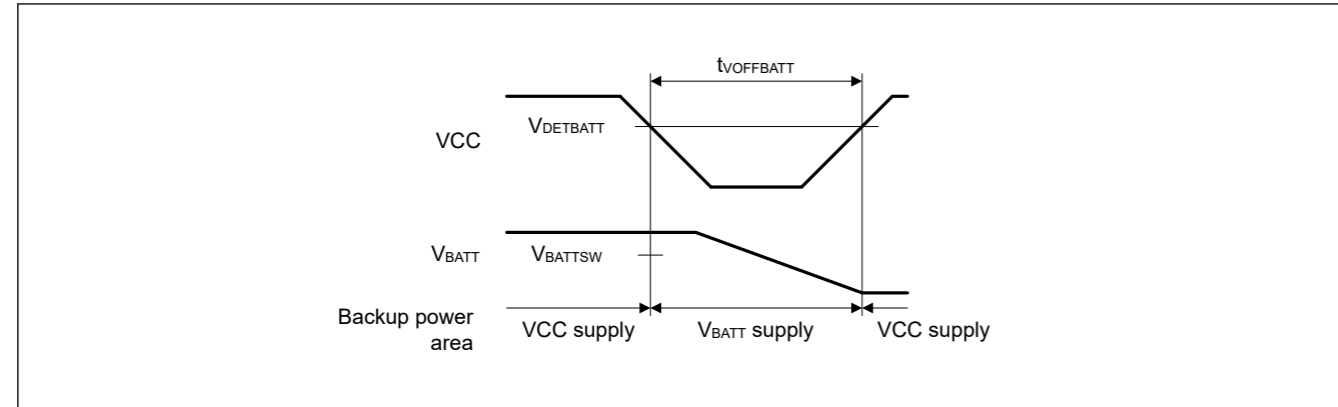


Figure 47.60 Battery backup function characteristics

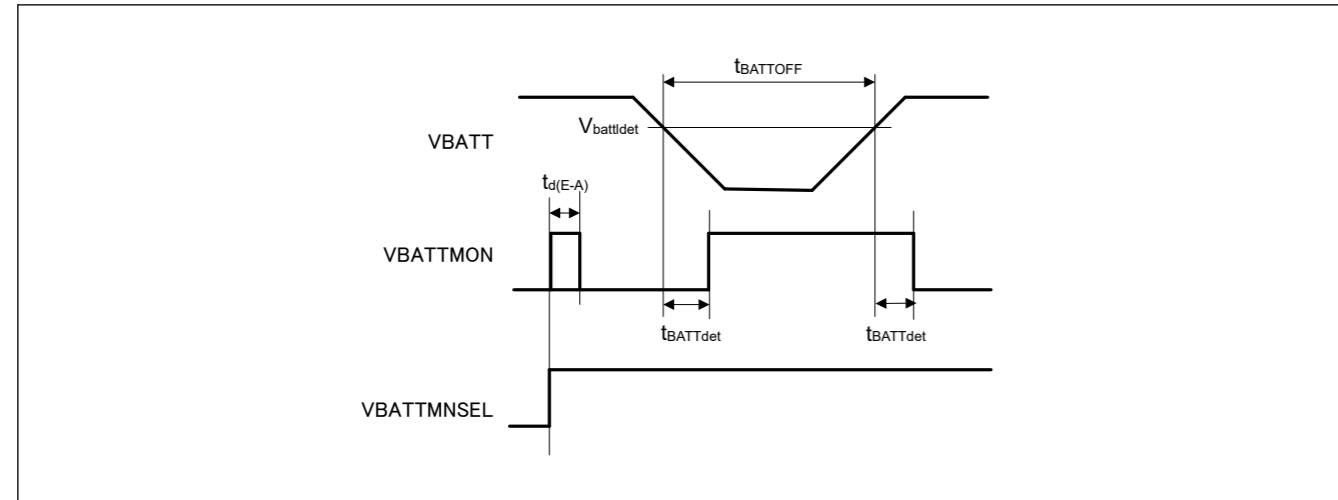


Figure 47.61 Battery backup function characteristics

47.11 CTSU Characteristics

Table 47.45 CTSU characteristics

| Parameter                                   | Symbol             | Min | Typ | Max | Unit | Test conditions                               |
|---|--------------------|-----|-----|-----|------|---|
| External capacitance connected to TSCAP pin | C <sub>tscap</sub> | 9   | 10  | 11  | nF   | —   |
| TS pin capacitive load                      | C <sub>base</sub>  | —   | —   | 50  | pF   | —   |
| Permissible output high current             | ΣI <sub>oH</sub>   | —   | —   | -40 | mA   | When the mutual capacitance method is applied |

47.12 Flash Memory Characteristics

47.12.1 Code Flash Memory Characteristics

Table 47.46 Code flash memory characteristics (1 of 2)

Conditions: Program or erase: FCLK = 4 to 50 MHz  
Read: FCLK ≤ 50 MHz

| Parameter  | Symbol   | FCLK = 4 MHz      |                  |      | 20 MHz ≤ FCLK ≤ 50 MHz |                  |      | Unit | Test conditions |
|--|----------|-------------------|------------------|------|------------------------|------------------|------|------|-----------------|
|  |          | Min               | Typ <sup>6</sup> | Max  | Min                    | Typ <sup>6</sup> | Max  |      |                 |
| Programming time<br>N <sub>PEC</sub> ≤ 100 times | 128-byte | t <sub>P128</sub> | —                | 0.75 | 13.2                   | —                | 0.34 | 6.0  | ms              |
|  | 8-KB     | t <sub>P8K</sub>  | —                | 49   | 176                    | —                | 22   | 80   | ms              |
|  | 32-KB    | t <sub>P32K</sub> | —                | 194  | 704                    | —                | 88   | 320  | ms              |

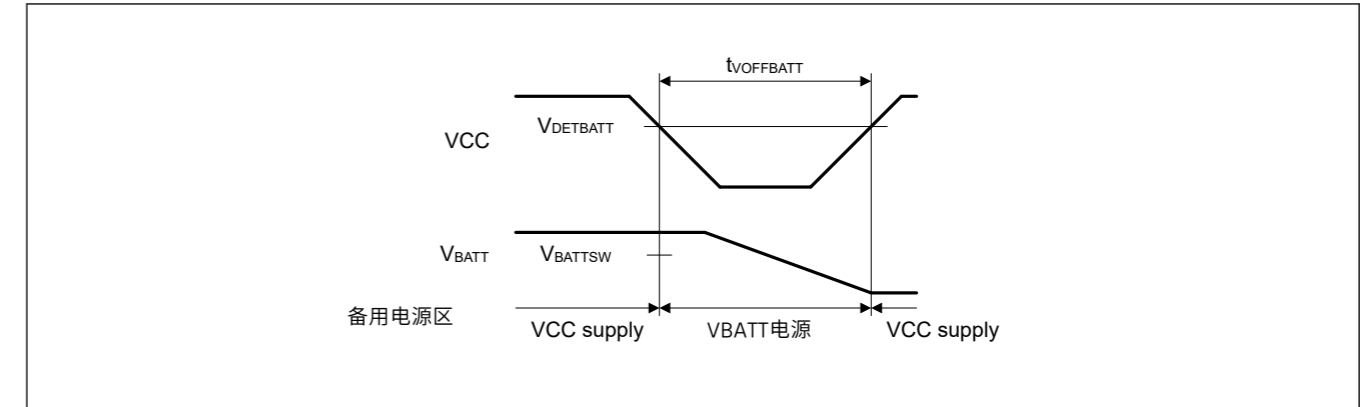


Figure 47.60 电池备份功能特点

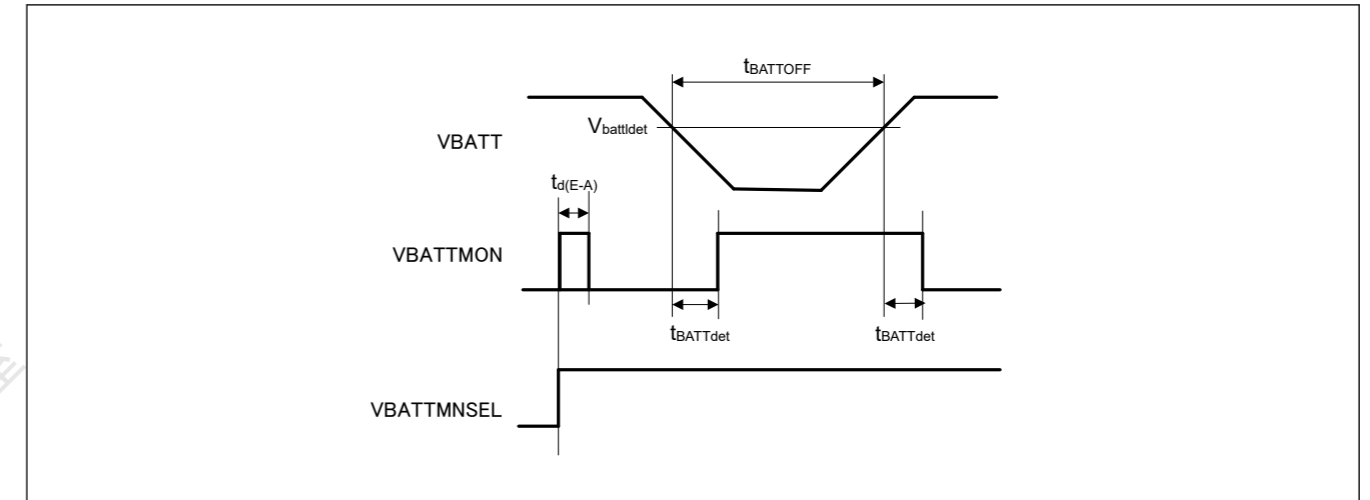


Figure 47.61 电池备份功能特点

47.11 CTSU Characteristics

Table 47.45 CTSU characteristics

| Parameter       | Symbol             | Min | Typ | Max | Unit | 测试条件    |
|-----------------|--------------------|-----|-----|-----|------|---------|
| 连接到TSCAP引脚的外部电容 | C <sub>tscap</sub> | 9   | 10  | 11  | nF   | —       |
| TS引脚容性负载        | C <sub>base</sub>  | —   | —   | 50  | pF   | —       |
| 允许输出大电流         | ΣI <sub>oH</sub>   | —   | —   | -40 | mA   | 应用互电容法时 |

47.12 闪存特性

47.12.1 代码闪存特性

Table 47.46 代码闪存特性(1of2)

条件: 编程或擦除: FCLK=4至50MHz  
Read: FCLK ≤ 50 MHz

| Parameter                      | Symbol   | FCLK = 4 MHz      |                  |      | 20 MHz ≤ FCLK ≤ 50 MHz |                  |      | Unit | 测试条件 |
|--------------------------------|----------|-------------------|------------------|------|------------------------|------------------|------|------|------|
|                                |          | Min               | Typ <sup>6</sup> | Max  | Min                    | Typ <sup>6</sup> | Max  |      |      |
| 编程时间N <sub>PEC</sub> ≤10<br>0次 | 128-byte | t <sub>P128</sub> | —                | 0.75 | 13.2                   | —                | 0.34 | 6.0  | ms   |
|                                | 8-KB     | t <sub>P8K</sub>  | —                | 49   | 176                    | —                | 22   | 80   | ms   |
|                                | 32-KB    | t <sub>P32K</sub> | —                | 194  | 704                    | —                | 88   | 320  | ms   |

Table 47.46 Code flash memory characteristics (2 of 2)

Conditions: Program or erase: FCLK = 4 to 50 MHz  
Read: FCLK ≤ 50 MHz

| Parameter   | Symbol             | FCLK = 4 MHz        |                  |      | 20 MHz ≤ FCLK ≤ 50 MHz |                  |      | Unit | Test conditions |
|---|--------------------|---------------------|------------------|------|------------------------|------------------|------|------|-----------------|
|   |                    | Min                 | Typ <sup>6</sup> | Max  | Min                    | Typ <sup>6</sup> | Max  |      |                 |
| Programming time<br>N <sub>PEC</sub> > 100 times                                | 128-byte           | t <sub>P128</sub>   | —                | 0.91 | 15.8                   | —                | 0.41 | 7.2  | ms              |
|   | 8-KB               | t <sub>P8K</sub>    | —                | 60   | 212                    | —                | 27   | 96   | ms              |
|   | 32-KB              | t <sub>P32K</sub>   | —                | 234  | 848                    | —                | 106  | 384  | ms              |
| Erasure time<br>N <sub>PEC</sub> ≤ 100 times                                    | 8-KB               | t <sub>E8K</sub>    | —                | 78   | 216                    | —                | 43   | 120  | ms              |
|   | 32-KB              | t <sub>E32K</sub>   | —                | 283  | 864                    | —                | 157  | 480  | ms              |
| Erasure time<br>N <sub>PEC</sub> > 100 times                                    | 8-KB               | t <sub>E8K</sub>    | —                | 94   | 260                    | —                | 52   | 144  | ms              |
|   | 32-KB              | t <sub>E32K</sub>   | —                | 341  | 1040                   | —                | 189  | 576  | ms              |
| Reprogramming/erase cycle <sup>*4</sup>   | N <sub>PEC</sub>   | 10000 <sup>*1</sup> | —                | —    | 10000 <sup>*1</sup>    | —                | —    | —    | Times           |
| Suspend delay during programming  | t <sub>SPD</sub>   | —                   | —                | 264  | —                      | —                | —    | 120  | μs              |
| Programming resume time   | t <sub>PRT</sub>   | —                   | —                | 110  | —                      | —                | —    | 50   | μs              |
| First suspend delay during erasure in suspend priority mode                     | t <sub>SESD1</sub> | —                   | —                | 216  | —                      | —                | —    | 120  | μs              |
| Second suspend delay during erasure in suspend priority mode                    | t <sub>SESD2</sub> | —                   | —                | 1.7  | —                      | —                | —    | 1.7  | ms              |
| Suspend delay during erasure in erasure priority mode                           | t <sub>SEED</sub>  | —                   | —                | 1.7  | —                      | —                | —    | 1.7  | ms              |
| First erasing resume time during erasure in suspend priority mode <sup>*5</sup> | t <sub>REST1</sub> | —                   | —                | 1.7  | —                      | —                | —    | 1.7  | ms              |
| Second erasing resume time during erasure in suspend priority mode              | t <sub>REST2</sub> | —                   | —                | 144  | —                      | —                | —    | 80   | μs              |
| Erasing resume time during erasure in erasure priority mode                     | t <sub>REET</sub>  | —                   | —                | 144  | —                      | —                | —    | 80   | μs              |
| Forced stop command   | t <sub>FD</sub>    | —                   | —                | 32   | —                      | —                | —    | 20   | μs              |
| Data hold time <sup>*2</sup>  | t <sub>DRP</sub>   | 10 <sup>*2</sup> *3 | —                | —    | 10 <sup>*2</sup> *3    | —                | —    | —    | Years           |

Note 1. This is the minimum number of times to guarantee all the characteristics after reprogramming. The guaranteed range is from 1 to the minimum value.

Note 2. This indicates the minimum value of the characteristic when reprogramming is performed within the specified range.

Note 3. This result is obtained from reliability testing.

Note 4. The reprogram/erase cycle is the number of erasures for each block. When the reprogram/erase cycle is n times (n = 10,000), erasing can be performed n times for each block. For example, when 128-byte programming is performed 64 times for different addresses in 8-KB blocks, and then the entire block is erased, the reprogram/erase cycle is counted as one. However, programming the same address several times as one erasure is not enabled. Overwriting is prohibited.

Note 5. Time for resumption includes time for reapplying the erasing pulse (up to one full pulse) that was cut off at the time of suspension.

Note 6. The reference value at VCC = 3.3V and room temperature.

Table 47.46 代码闪存特性(2of2)

条件: 编程或擦除: FCLK=4至50MHz  
Read: FCLK ≤ 50 MHz

| Parameter                               | Symbol             | FCLK = 4 MHz        |                  |      | 20 MHz ≤ FCLK ≤ 50 MHz |                  |      | Unit | 测试条件  |
|---|--------------------|---------------------|------------------|------|------------------------|------------------|------|------|-------|
|   |                    | Min                 | Typ <sup>6</sup> | Max  | Min                    | Typ <sup>6</sup> | Max  |      |       |
| 编程时间NPEC>100次                           | 128-byte           | t <sub>P128</sub>   | —                | 0.91 | 15.8                   | —                | 0.41 | 7.2  | ms    |
|   | 8-KB               | t <sub>P8K</sub>    | —                | 60   | 212                    | —                | 27   | 96   | ms    |
|   | 32-KB              | t <sub>P32K</sub>   | —                | 234  | 848                    | —                | 106  | 384  | ms    |
| 擦除时间<br>NPEC≤100次                       | 8-KB               | t <sub>E8K</sub>    | —                | 78   | 216                    | —                | 43   | 120  | ms    |
|   | 32-KB              | t <sub>E32K</sub>   | —                | 283  | 864                    | —                | 157  | 480  | ms    |
| 擦除时间<br>NPEC>100次                       | 8-KB               | t <sub>E8K</sub>    | —                | 94   | 260                    | —                | 52   | 144  | ms    |
|   | 32-KB              | t <sub>E32K</sub>   | —                | 341  | 1040                   | —                | 189  | 576  | ms    |
| Reprogramming/erase cycle <sup>*4</sup> | N <sub>PEC</sub>   | 10000 <sup>*1</sup> | —                | —    | 10000 <sup>*1</sup>    | —                | —    | —    | Times |
| 编程期间暂停延迟                                | t <sub>SPD</sub>   | —                   | —                | 264  | —                      | —                | —    | 120  | μs    |
| 编程恢复时间                                  | t <sub>PRT</sub>   | —                   | —                | 110  | —                      | —                | —    | 50   | μs    |
| 挂起优先模式下擦除期间的第一个挂起延迟                     | t <sub>SESD1</sub> | —                   | —                | 216  | —                      | —                | —    | 120  | μs    |
| 挂起优先模式下擦除期间的第二挂起延迟                      | t <sub>SESD2</sub> | —                   | —                | 1.7  | —                      | —                | —    | 1.7  | ms    |
| 擦除优先模式下擦除期间的挂起延迟                        | t <sub>SEED</sub>  | —                   | —                | 1.7  | —                      | —                | —    | 1.7  | ms    |
| 挂起优先模式擦除期间的第一次擦除恢复时间*5                  | t <sub>REST1</sub> | —                   | —                | 1.7  | —                      | —                | —    | 1.7  | ms    |
| 挂起优先模式擦除期间的第二次擦除恢复时间                    | t <sub>REST2</sub> | —                   | —                | 144  | —                      | —                | —    | 80   | μs    |
| 在擦除优先模式下擦除期间擦除恢复时间                      | t <sub>REET</sub>  | —                   | —                | 144  | —                      | —                | —    | 80   | μs    |
| 强制停止命令                                  | t <sub>FD</sub>    | —                   | —                | 32   | —                      | —                | —    | 20   | μs    |
| 数据保持时间*2                                | t <sub>DRP</sub>   | 10 <sup>*2</sup> *3 | —                | —    | 10 <sup>*2</sup> *3    | —                | —    | —    | Years |

注1.这是重新编程后保证所有特性的最少次数。保证范围是从1到最小值。

注2.这表示在指定范围内执行重新编程时特性的最小值。

注3: 此结果来自可靠性测试。

注4.重新编程擦除周期是每个块的擦除次数。当重新编程擦除周期为n次 (n=10 000) 时, 可以对每个块执行n次擦除。例如, 当对8KB块中的不同地址执行64次128字节编程, 然后擦除整个块时, 重新编程擦除周期计为1。但是, 不能将同一地址多次编程为一次擦除。禁止覆盖。

注5.恢复时间包括重新应用暂停时切断的擦除脉冲 (最多1个完整脉冲) 的时间。

注6.VCC=3.3V和室温下的参考值。



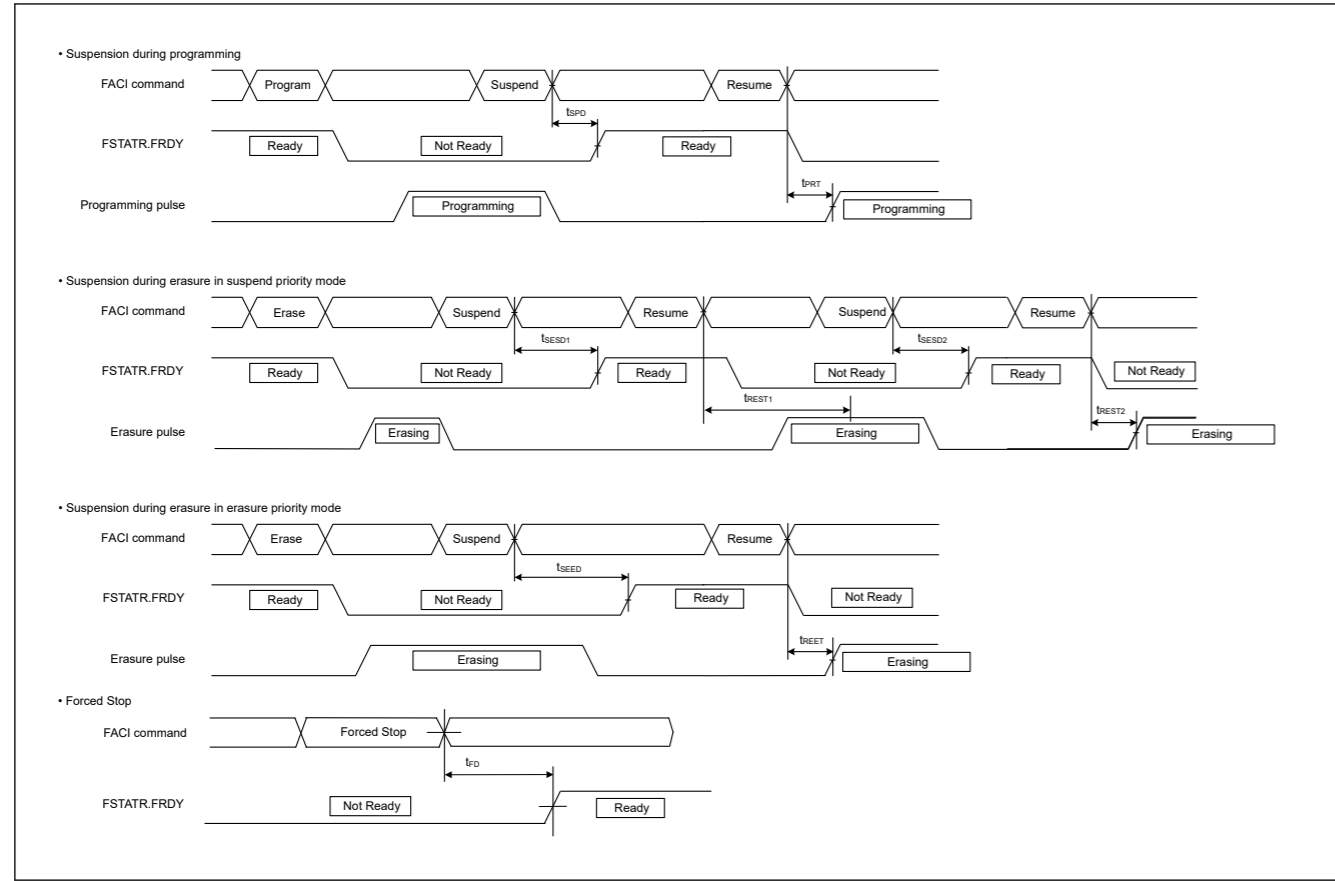


Figure 47.62 Suspension and forced stop timing for flash memory programming and erasure

47.12.2 Data Flash Memory Characteristics

Table 47.47 Data flash memory characteristics (1 of 2)

Conditions: Program or erase: FCLK = 4 to 50 MHz  
Read: FCLK ≤ 50 MHz

| Parameter   | Symbol            | FCLK = 4 MHz        |       |      | 20 MHz ≤ FCLK ≤ 50 MHz |       |      | Unit | Test conditions |
|---|-------------------|---------------------|-------|------|------------------------|-------|------|------|-----------------|
|   |                   | Min                 | Typ*6 | Max  | Min                    | Typ*6 | Max  |      |                 |
| Programming time  | 4-byte            | t <sub>DP4</sub>    | —     | 0.36 | 3.8                    | —     | 0.16 | 1.7  | ms              |
|   | 8-byte            | t <sub>DP8</sub>    | —     | 0.38 | 4.0                    | —     | 0.17 | 1.8  |                 |
|   | 16-byte           | t <sub>DP16</sub>   | —     | 0.42 | 4.5                    | —     | 0.19 | 2.0  |                 |
| Erasure time  | 64-byte           | t <sub>DE64</sub>   | —     | 3.1  | 18                     | —     | 1.7  | 10   | ms              |
|   | 128-byte          | t <sub>DE128</sub>  | —     | 4.7  | 27                     | —     | 2.6  | 15   |                 |
|   | 256-byte          | t <sub>DE256</sub>  | —     | 8.9  | 50                     | —     | 4.9  | 28   |                 |
| Blank check time  | 4-byte            | t <sub>DBC4</sub>   | —     | —    | 84                     | —     | —    | 30   | μs              |
| Reprogramming/erasure cycle*1                               | N <sub>DPEC</sub> | 125000*2            | —     | —    | 125000*2               | —     | —    | —    | —               |
| Suspend delay during programming                            | 4-byte            | t <sub>DSPD</sub>   | —     | —    | 264                    | —     | —    | 120  | μs              |
|   | 8-byte            |                     | —     | —    | 264                    | —     | —    | 120  |                 |
|   | 16-byte           |                     | —     | —    | 264                    | —     | —    | 120  |                 |
| Programming resume time                                     |                   | t <sub>DPRT</sub>   | —     | —    | 110                    | —     | —    | 50   | μs              |
| First suspend delay during erasure in suspend priority mode | 64-byte           | t <sub>DSESD1</sub> | —     | —    | 216                    | —     | —    | 120  | μs              |
|   | 128-byte          |                     | —     | —    | 216                    | —     | —    | 120  |                 |
|   | 256-byte          |                     | —     | —    | 216                    | —     | —    | 120  |                 |

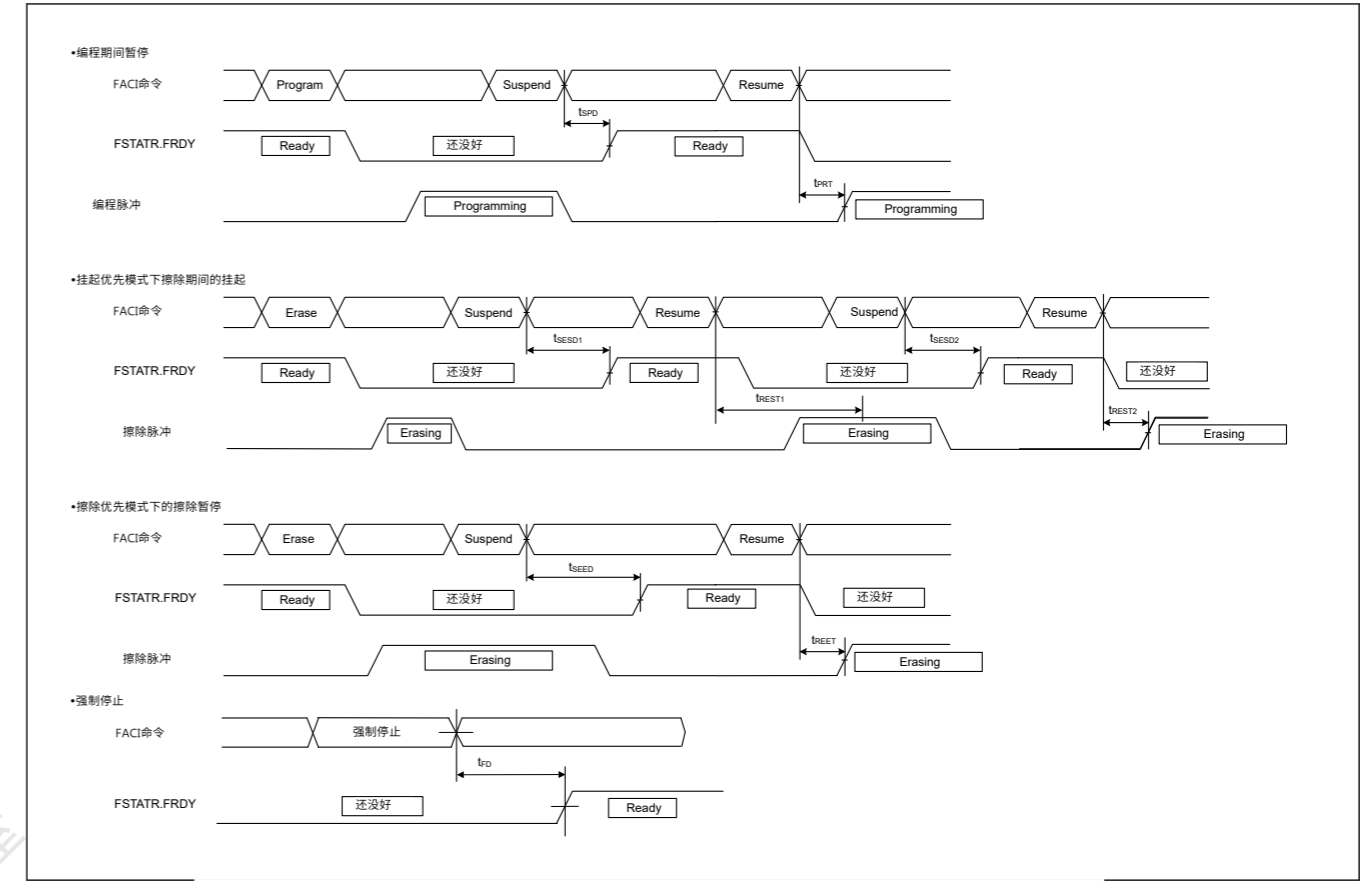


Figure 47.62 闪存编程和擦除的暂停和强制停止时序

47.12.2 数据闪存特性

Table 47.47 数据闪存特性(1of2)

条件: 编程或擦除: FCLK=4至50MHz  
Read: FCLK ≤ 50 MHz

| Parameter                     | Symbol            | FCLK = 4 MHz        |            |       | 20 MHz ≤ FCLK ≤ 50 MHz |     |       | Unit | 测试条件 |
|-------------------------------|-------------------|---------------------|------------|-------|------------------------|-----|-------|------|------|
|                               |                   | Min                 | 典型*6最大值最小值 | Typ*6 | Max                    | Min | Typ*6 |      |      |
| 编程时间                          | 4-byte            | t <sub>DP4</sub>    | —          | 0.36  | 3.8                    | —   | 0.16  | 1.7  | ms   |
|                               | 8-byte            | t <sub>DP8</sub>    | —          | 0.38  | 4.0                    | —   | 0.17  | 1.8  |      |
|                               | 16-byte           | t <sub>DP16</sub>   | —          | 0.42  | 4.5                    | —   | 0.19  | 2.0  |      |
| 擦除时间                          | 64-byte           | t <sub>DE64</sub>   | —          | 3.1   | 18                     | —   | 1.7   | 10   | ms   |
|                               | 128-byte          | t <sub>DE128</sub>  | —          | 4.7   | 27                     | —   | 2.6   | 15   |      |
|                               | 256-byte          | t <sub>DE256</sub>  | —          | 8.9   | 50                     | —   | 4.9   | 28   |      |
| 空白检查时间                        | 4-byte            | t <sub>DBC4</sub>   | —          | —     | 84                     | —   | —     | 30   | μs   |
| Reprogramming/erasure cycle*1 | N <sub>DPEC</sub> | 125000*2            | —          | —     | 125000*2               | —   | —     | —    | —    |
| 编程期间暂停延迟                      | 4-byte            | t <sub>DSPD</sub>   | —          | —     | 264                    | —   | —     | 120  | μs   |
|                               | 8-byte            |                     | —          | —     | 264                    | —   | —     | 120  |      |
|                               | 16-byte           |                     | —          | —     | 264                    | —   | —     | 120  |      |
| 编程恢复时间                        |                   | t <sub>DPRT</sub>   | —          | —     | 110                    | —   | —     | 50   | μs   |
| 挂起优先模式下擦除期间的第一个挂起延迟           | 64-byte           | t <sub>DSESD1</sub> | —          | —     | 216                    | —   | —     | 120  | μs   |
|                               | 128-byte          |                     | —          | —     | 216                    | —   | —     | 120  |      |
|                               | 256-byte          |                     | —          | —     | 216                    | —   | —     | 120  |      |

**Table 47.47 Data flash memory characteristics (2 of 2)**

Conditions: Program or erase: FCLK = 4 to 50 MHz  
Read: FCLK ≤ 50 MHz

| Parameter   | Symbol              | FCLK = 4 MHz        |       |     | 20 MHz ≤ FCLK ≤ 50 MHz |       |     | Unit | Test conditions |
|---|---------------------|---------------------|-------|-----|------------------------|-------|-----|------|-----------------|
|   |                     | Min                 | Typ*6 | Max | Min                    | Typ*6 | Max |      |                 |
| Second suspend delay during erasure in suspend priority mode        | 64-byte             | t <sub>DSESD2</sub> | —     | —   | 300                    | —     | —   | 300  | μs              |
|   | 128-byte            |                     | —     | —   | 390                    | —     | —   | 390  |                 |
|   | 256-byte            |                     | —     | —   | 570                    | —     | —   | 570  |                 |
| Suspend delay during erasing in erasure priority mode               | 64-byte             | t <sub>DSEED</sub>  | —     | —   | 300                    | —     | —   | 300  | μs              |
|   | 128-byte            |                     | —     | —   | 390                    | —     | —   | 390  |                 |
|   | 256-byte            |                     | —     | —   | 570                    | —     | —   | 570  |                 |
| First erasing resume time during erasure in suspend priority mode*5 | t <sub>DREST1</sub> | —                   | —     | 300 | —                      | —     | 300 | μs   |                 |
| Second erasing resume time during erasure in suspend priority mode  | t <sub>DREST2</sub> | —                   | —     | 126 | —                      | —     | 70  | μs   |                 |
| Erasing resume time during erasure in erasure priority mode         | t <sub>DREET</sub>  | —                   | —     | 126 | —                      | —     | 70  | μs   |                 |
| Forced stop command   | t <sub>FD</sub>     | —                   | —     | 32  | —                      | —     | 20  | μs   |                 |
| Data hold time*3  | t <sub>DRP</sub>    | 10*3*4              | —     | —   | 10*3*4                 | —     | —   | Year |                 |

Note 1. The reprogram/erase cycle is the number of erasures for each block. When the reprogram/erase cycle is n times (n = 125,000), erasing can be performed n times for each block. For example, when 4-byte programming is performed 16 times for different addresses in 64-byte blocks, and then the entire block is erased, the reprogram/erase cycle is counted as one. However, programming the same address several times as one erasure is not enabled. Overwriting is prohibited.

Note 2. This is the minimum number of times to guarantee all the characteristics after reprogramming. The guaranteed range is from 1 to the minimum value.

Note 3. This indicates the minimum value of the characteristic when reprogramming is performed within the specified range.

Note 4. This result is obtained from reliability testing.

Note 5. Time for resumption includes time for reapplying the erasing pulse (up to one full pulse) that was cut off at the time of suspension.

Note 6. The reference value at VCC = 3.3 V and room temperature.

### 47.12.3 Option Setting Memory Characteristics

**Table 47.48 Option setting memory characteristics**

Conditions: Program: FCLK = 4 to 50 MHz  
Read: FCLK ≤ 50 MHz

| Parameter  | Symbol           | FCLK = 4 MHz |       |     | 20 MHz ≤ FCLK ≤ 50 MHz |       |     | Unit  | Test conditions |
|--|------------------|--------------|-------|-----|------------------------|-------|-----|-------|-----------------|
|  |                  | Min          | Typ*4 | Max | Min                    | Typ*4 | Max |       |                 |
| Programming time<br>N <sub>OPC</sub> ≤ 100 times | t <sub>OP</sub>  | —            | 83    | 309 | —                      | 45    | 162 | ms    |                 |
| Programming time<br>N <sub>OPC</sub> > 100 times | t <sub>OP</sub>  | —            | 100   | 371 | —                      | 55    | 195 | ms    |                 |
| Reprogramming cycle                              | N <sub>OPC</sub> | 20000*1      | —     | —   | 20000*1                | —     | —   | Times |                 |
| Data hold time*2                                 | t <sub>DRP</sub> | 10*2*3       | —     | —   | 10*2*3                 | —     | —   | Years |                 |

Note 1. This is the minimum number of times to guarantee all the characteristics after reprogramming. The guaranteed range is from 1 to the minimum value.

Note 2. This indicates the minimum value of the characteristic when reprogramming is performed within the specified range.

Note 3. This result is obtained from reliability testing.

Note 4. The reference value at VCC = 3.3 V and room temperature.

### 47.13 Boundary Scan

**Table 47.47 数据闪存特性(2of2)**

条件: 编程或擦除: FCLK=4至50MHz  
Read: FCLK ≤ 50 MHz

| Parameter              | Symbol              | FCLK = 4 MHz        |            |     | 20 MHz ≤ FCLK ≤ 50 MHz |       |     | Unit | 测试条件 |
|------------------------|---------------------|---------------------|------------|-----|------------------------|-------|-----|------|------|
|                        |                     | Min                 | 典型*6最大值最小值 | Max | Min                    | Typ*6 | Max |      |      |
| 挂起优先模式下擦除期间的第二挂起延迟     | 64-byte             | t <sub>DSESD2</sub> | —          | —   | 300                    | —     | —   | 300  | μs   |
|                        | 128-byte            |                     | —          | —   | 390                    | —     | —   | 390  |      |
|                        | 256-byte            |                     | —          | —   | 570                    | —     | —   | 570  |      |
| 在擦除优先模式下擦除期间暂停延迟       | 64-byte             | t <sub>DSEED</sub>  | —          | —   | 300                    | —     | —   | 300  | μs   |
|                        | 128-byte            |                     | —          | —   | 390                    | —     | —   | 390  |      |
|                        | 256-byte            |                     | —          | —   | 570                    | —     | —   | 570  |      |
| 挂起优先模式擦除期间的第一次擦除恢复时间*5 | t <sub>DREST1</sub> | —                   | —          | 300 | —                      | —     | 300 | μs   |      |
| 挂起优先模式下擦除期间的第二次擦除恢复时间  | t <sub>DREST2</sub> | —                   | —          | 126 | —                      | —     | 70  | μs   |      |
| 在擦除优先模式下擦除期间擦除恢复时间     | t <sub>DREET</sub>  | —                   | —          | 126 | —                      | —     | 70  | μs   |      |
| 强制停止命令                 | t <sub>FD</sub>     | —                   | —          | 32  | —                      | —     | 20  | μs   |      |
| 数据保持时间*3               | t <sub>DRP</sub>    | 10*3*4              | —          | —   | 10*3*4                 | —     | —   | Year |      |

注1.重新编程擦除周期是每个块的擦除次数。当重新编程擦除周期为n次 (n=125 000) 时, 可以对每个块执行n次擦除。例如, 当对64字节块中的不同地址执行16次4字节编程, 然后擦除整个块时, 重新编程擦除周期计为1。但是, 不能将同一地址多次编程为一次擦除。禁止覆盖。

注2.这是重新编程后保证所有特性的最少次数。保证范围是从1到最小值。

注3.这表示在指定范围内执行重新编程时特性的最小值。

注4: 此结果来自可靠性测试。

注5.恢复时间包括重新应用暂停时切断的擦除脉冲 (最多1个完整脉冲) 的时间。

注6.VCC=3.3V和室温下的参考值。

### 47.12.3 选项设置内存特性

**Table 47.48 选项设置内存特性**

Conditions: Program: FCLK = 4 to 50 MHz  
Read: FCLK ≤ 50 MHz

| Parameter                  | Symbol           | FCLK = 4 MHz |       |     | 20 MHz ≤ FCLK ≤ 50 MHz |       |     | Unit  | 测试条件 |
|----------------------------|------------------|--------------|-------|-----|------------------------|-------|-----|-------|------|
|                            |                  | Min          | Typ*4 | Max | Min                    | Typ*4 | Max |       |      |
| 编程时间N <sub>OPC</sub> ≤100次 | t <sub>OP</sub>  | —            | 83    | 309 | —                      | 45    | 162 | ms    |      |
| 编程时间N <sub>OPC</sub> >100次 | t <sub>OP</sub>  | —            | 100   | 371 | —                      | 55    | 195 | ms    |      |
| 重编程周期                      | N <sub>OPC</sub> | 20000*1      | —     | —   | 20000*1                | —     | —   | Times |      |
| 数据保持时间*2                   | t <sub>DRP</sub> | 10*2*3       | —     | —   | 10*2*3                 | —     | —   | Years |      |

注1.这是重新编程后保证所有特性的最少次数。保证范围是从1到最小值。

注2.这表示在指定范围内执行重新编程时特性的最小值。

注3: 此结果来自可靠性测试。

注4.VCC=3.3V和室温下的参考值。

### 47.13 边界扫描

Table 47.49 Boundary scan characteristics

| Parameter                            | Symbol       | Min         | Typ | Max | Unit | Test conditions |
|--------------------------------------|--------------|-------------|-----|-----|------|-----------------|
| TCK clock cycle time                 | $t_{TCKcyc}$ | 100         | —   | —   | ns   | Figure 47.63    |
| TCK clock high pulse width           | $t_{TCKH}$   | 45          | —   | —   | ns   |                 |
| TCK clock low pulse width            | $t_{TCKL}$   | 45          | —   | —   | ns   |                 |
| TCK clock rise time                  | $t_{TCKr}$   | —           | —   | 5   | ns   |                 |
| TCK clock fall time                  | $t_{TCKf}$   | —           | —   | 5   | ns   |                 |
| TMS setup time                       | $t_{TMSS}$   | 20          | —   | —   | ns   | Figure 47.64    |
| TMS hold time                        | $t_{TMSH}$   | 20          | —   | —   | ns   |                 |
| TDI setup time                       | $t_{TDIS}$   | 20          | —   | —   | ns   |                 |
| TDI hold time                        | $t_{TDIH}$   | 20          | —   | —   | ns   |                 |
| TDO data delay                       | $t_{TDOD}$   | —           | —   | 40  | ns   | Figure 47.65    |
| Boundary scan circuit startup time*1 | $T_{BSSTUP}$ | $t_{RESWP}$ | —   | —   | —    |                 |

Note 1. Boundary scan does not function until the power-on reset becomes negative.

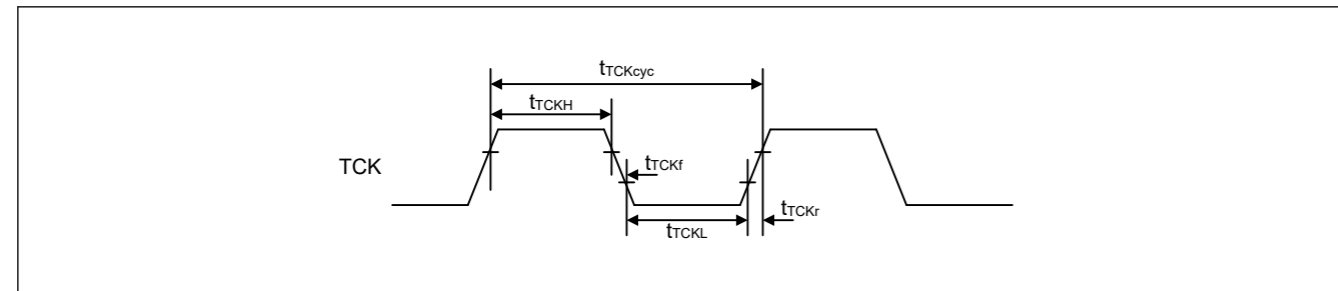


Figure 47.63 Boundary scan TCK timing

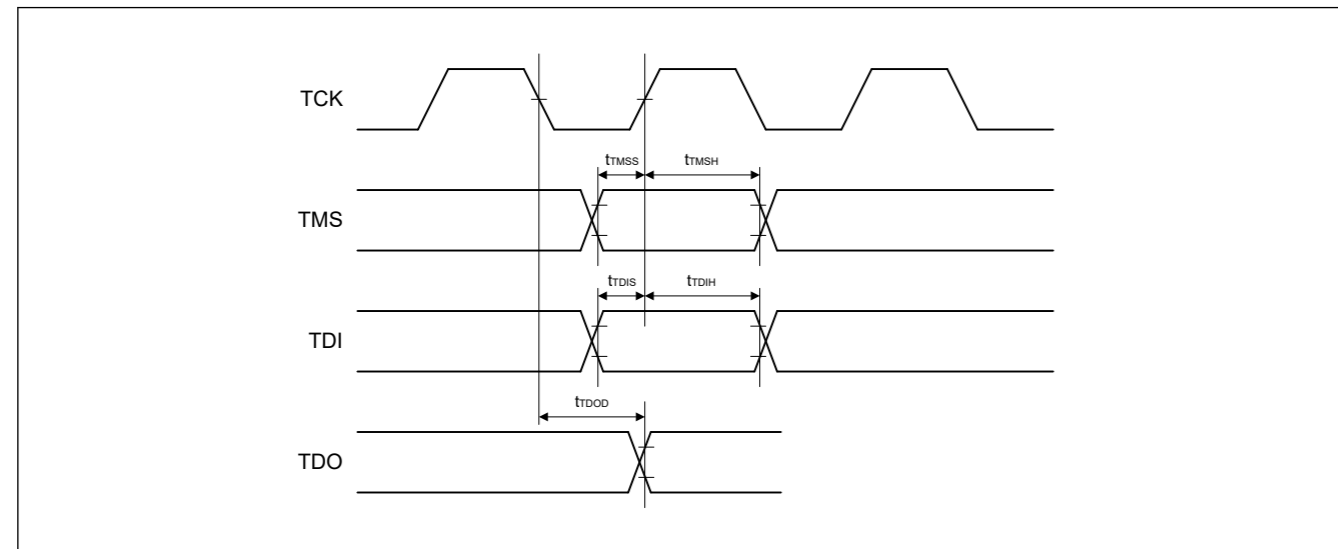


Figure 47.64 Boundary scan input/output timing

Table 47.49 边界扫描特性

| Parameter    | Symbol       | Min         | Typ | Max | Unit | 测试条件         |
|--------------|--------------|-------------|-----|-----|------|--------------|
| TCK时钟周期时间    | $t_{TCKcyc}$ | 100         | —   | —   | ns   | Figure 47.63 |
| TCK时钟高脉冲宽度   | $t_{TCKH}$   | 45          | —   | —   | ns   |              |
| TCK时钟低脉冲宽度   | $t_{TCKL}$   | 45          | —   | —   | ns   |              |
| TCK时钟上升时间    | $t_{TCKr}$   | —           | —   | 5   | ns   |              |
| TCK时钟下降时间    | $t_{TCKf}$   | —           | —   | 5   | ns   |              |
| TMS设置时间      | $t_{TMSS}$   | 20          | —   | —   | ns   | Figure 47.64 |
| TMS保持时间      | $t_{TMSH}$   | 20          | —   | —   | ns   |              |
| TDI建立时间      | $t_{TDIS}$   | 20          | —   | —   | ns   |              |
| TDI保持时间      | $t_{TDIH}$   | 20          | —   | —   | ns   |              |
| TDO数据延迟      | $t_{TDOD}$   | —           | —   | 40  | ns   | Figure 47.65 |
| 边界扫描电路启动时间*1 | $T_{BSSTUP}$ | $t_{RESWP}$ | —   | —   | —    |              |

注1.在上电复位变为负值之前，边界扫描不起作用。

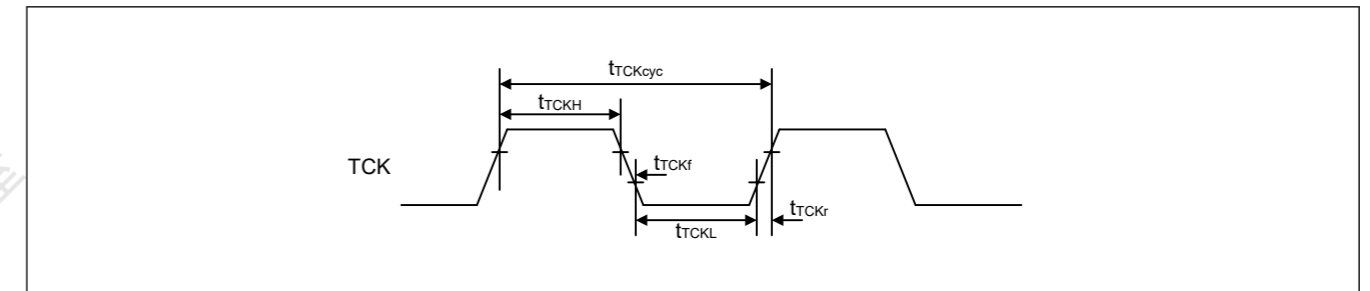


Figure 47.63 边界扫描TCK时序

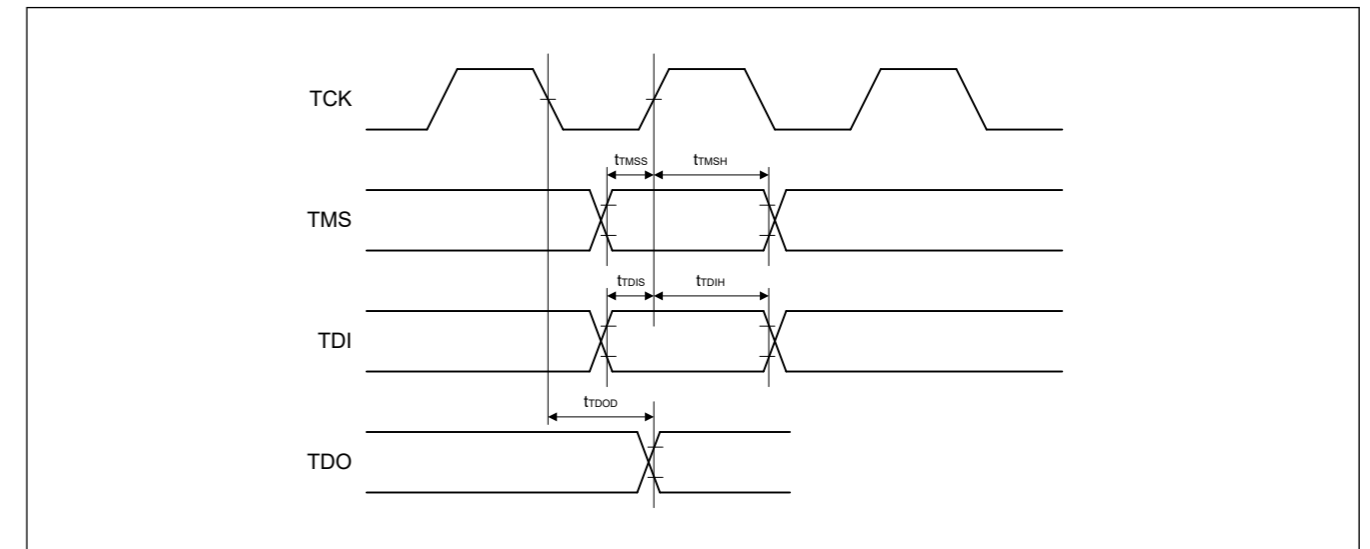


Figure 47.64 边界扫描输入输出时序

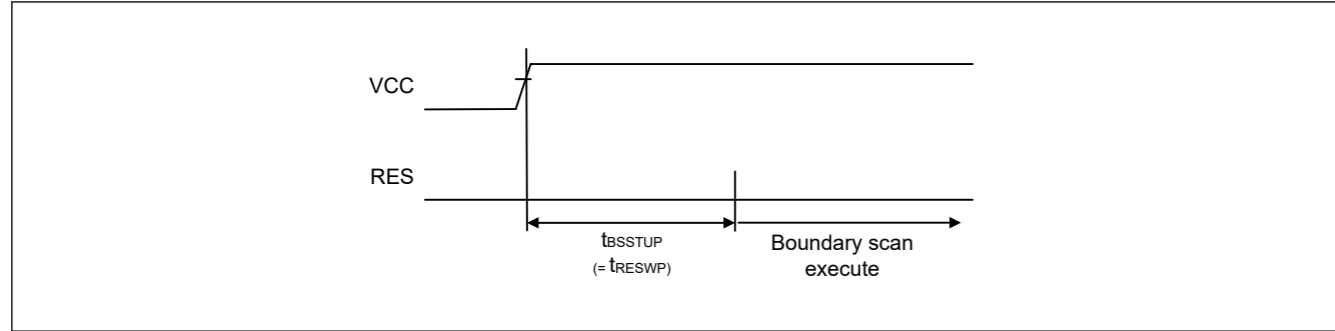


Figure 47.65 Boundary scan circuit startup timing

47.14 Joint European Test Action Group (JTAG)

Table 47.50 JTAG

| Parameter                  | Symbol       | Min | Typ | Max | Unit | Test conditions |
|----------------------------|--------------|-----|-----|-----|------|-----------------|
| TCK clock cycle time       | $t_{TCKcyc}$ | 40  | —   | —   | ns   | Figure 47.66    |
| TCK clock high pulse width | $t_{TCKH}$   | 15  | —   | —   | ns   |                 |
| TCK clock low pulse width  | $t_{TCKL}$   | 15  | —   | —   | ns   |                 |
| TCK clock rise time        | $t_{TCKr}$   | —   | —   | 5   | ns   |                 |
| TCK clock fall time        | $t_{TCKf}$   | —   | —   | 5   | ns   |                 |
| TMS setup time             | $t_{TMSS}$   | 8   | —   | —   | ns   | Figure 47.67    |
| TMS hold time              | $t_{TMSH}$   | 8   | —   | —   | ns   |                 |
| TDI setup time             | $t_{TDIS}$   | 8   | —   | —   | ns   |                 |
| TDI hold time              | $t_{TDIH}$   | 8   | —   | —   | ns   |                 |
| TDO data delay time        | $t_{TDOD}$   | —   | —   | 20  | ns   |                 |

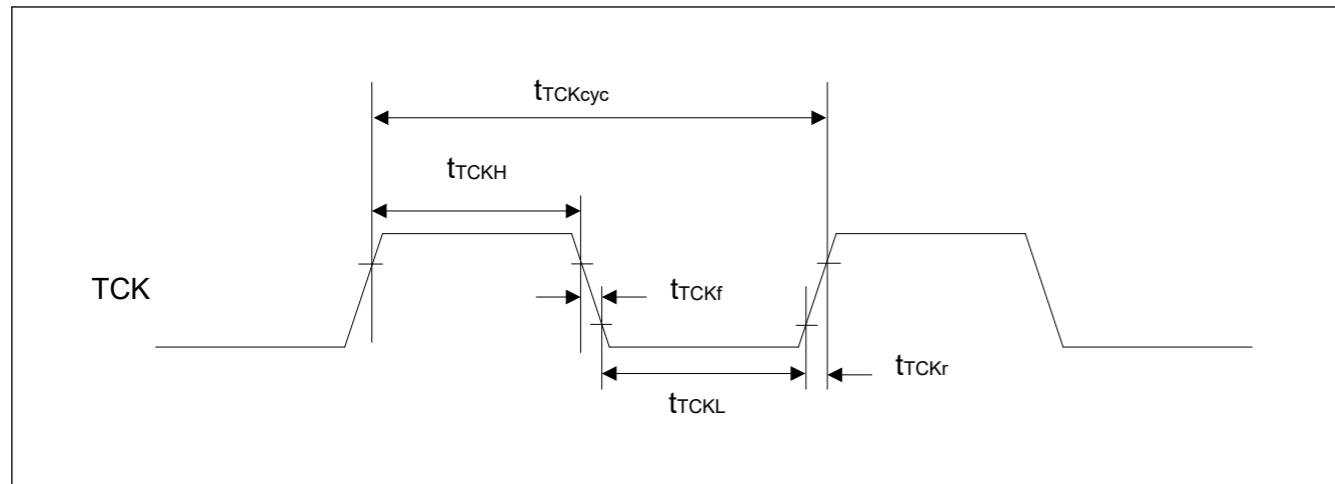


Figure 47.66 JTAG TCK timing

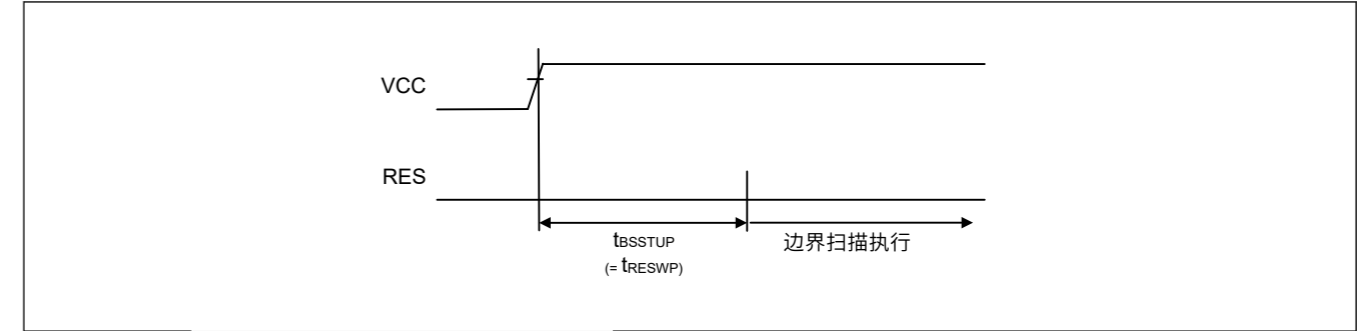


Figure 47.65 边界扫描电路启动时序

47.14 欧洲联合测试行动小组(JTAG)

Table 47.50 JTAG

| Parameter  | Symbol       | Min | Typ | Max | Unit | 测试条件         |
|------------|--------------|-----|-----|-----|------|--------------|
| TCK时钟周期时间  | $t_{TCKcyc}$ | 40  | —   | —   | ns   | Figure 47.66 |
| TCK时钟高脉冲宽度 | $t_{TCKH}$   | 15  | —   | —   | ns   |              |
| TCK时钟低脉冲宽度 | $t_{TCKL}$   | 15  | —   | —   | ns   |              |
| TCK时钟上升时间  | $t_{TCKr}$   | —   | —   | 5   | ns   |              |
| TCK时钟下降时间  | $t_{TCKf}$   | —   | —   | 5   | ns   |              |
| TMS设置时间    | $t_{TMSS}$   | 8   | —   | —   | ns   | Figure 47.67 |
| TMS保持时间    | $t_{TMSH}$   | 8   | —   | —   | ns   |              |
| TDI建立时间    | $t_{TDIS}$   | 8   | —   | —   | ns   |              |
| TDI保持时间    | $t_{TDIH}$   | 8   | —   | —   | ns   |              |
| TDO数据延迟时间  | $t_{TDOD}$   | —   | —   | 20  | ns   |              |

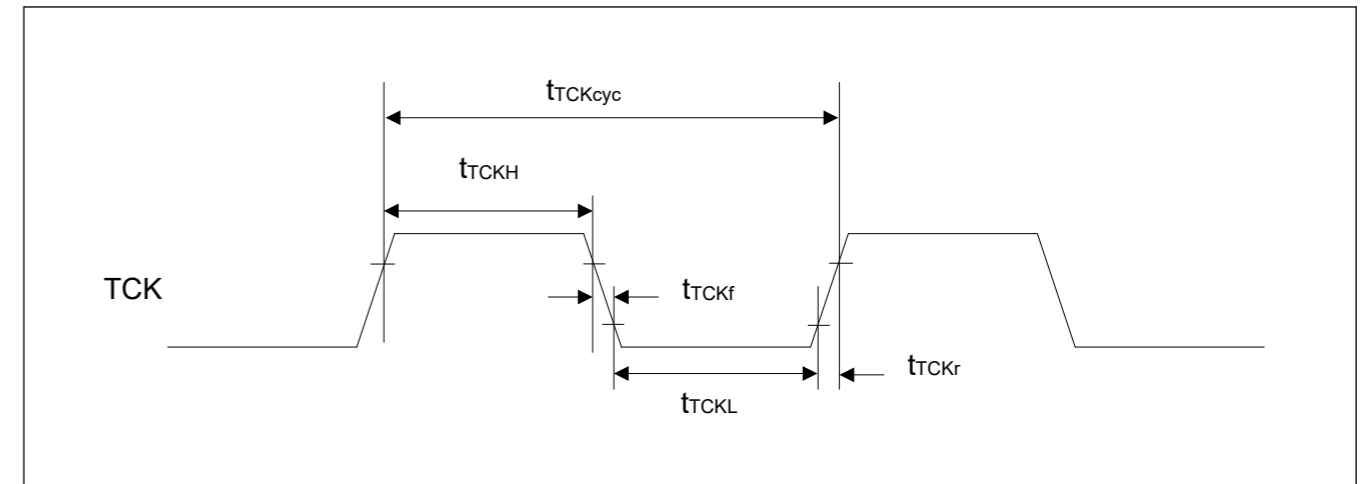


Figure 47.66 JTAG TCK timing



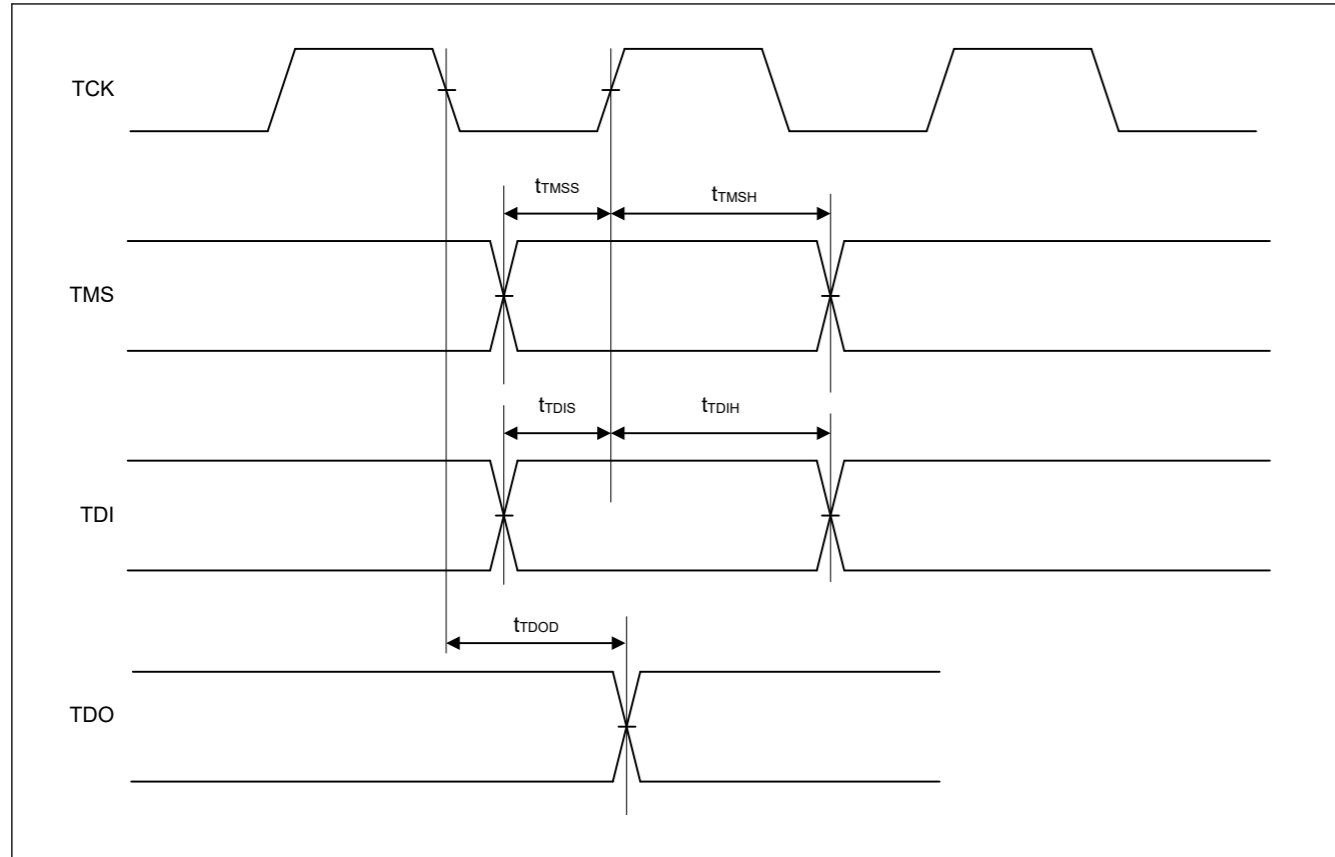


Figure 47.67 JTAG input/output timing

47.15 Serial Wire Debug (SWD)

Table 47.51 SWD

| Parameter                    | Symbol         | Min | Typ | Max | Unit | Test conditions |
|------------------------------|----------------|-----|-----|-----|------|-----------------|
| SWCLK clock cycle time       | $t_{SWCLKcyc}$ | 40  | —   | —   | ns   | Figure 47.68    |
| SWCLK clock high pulse width | $t_{SWCLKH}$   | 15  | —   | —   | ns   |                 |
| SWCLK clock low pulse width  | $t_{SWCLKL}$   | 15  | —   | —   | ns   |                 |
| SWCLK clock rise time        | $t_{SWCKr}$    | —   | —   | 5   | ns   |                 |
| SWCLK clock fall time        | $t_{SWCKf}$    | —   | —   | 5   | ns   |                 |
| SWDIO setup time             | $t_{SWDS}$     | 8   | —   | —   | ns   | Figure 47.69    |
| SWDIO hold time              | $t_{SWDH}$     | 8   | —   | —   | ns   |                 |
| SWDIO data delay time        | $t_{SWDD}$     | 2   | —   | 28  | ns   |                 |

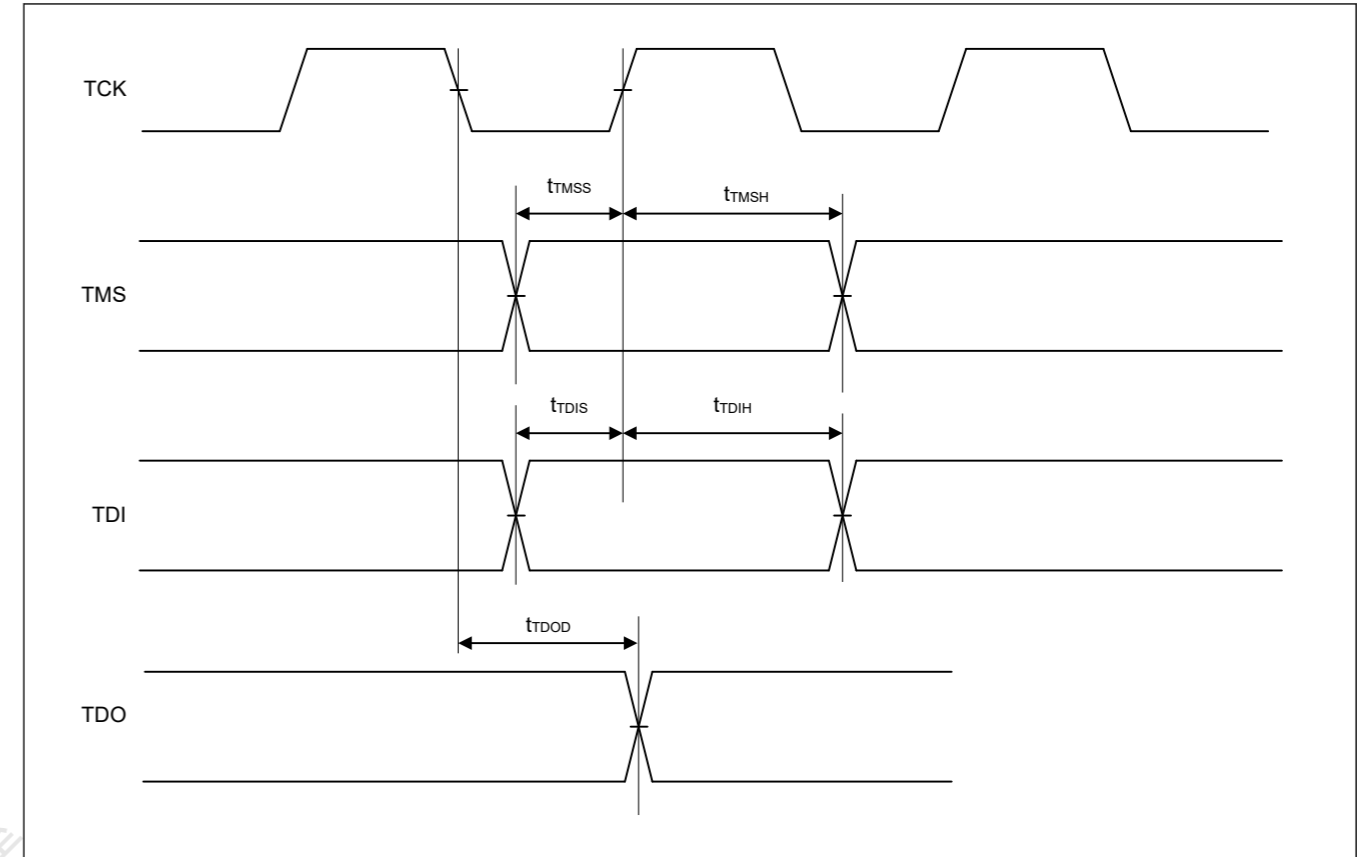


Figure 47.67 JTAG input/output timing

47.15 串行线调试(SWD)

Table 47.51 SWD

| Parameter    | Symbol         | Min | Typ | Max | Unit | 测试条件         |
|--------------|----------------|-----|-----|-----|------|--------------|
| SWCLK时钟周期时间  | $t_{SWCLKcyc}$ | 40  | —   | —   | ns   | Figure 47.68 |
| SWCLK时钟高脉冲宽度 | $t_{SWCLKH}$   | 15  | —   | —   | ns   |              |
| SWCLK时钟低脉冲宽度 | $t_{SWCLKL}$   | 15  | —   | —   | ns   |              |
| SWCLK时钟上升时间  | $t_{SWCKr}$    | —   | —   | 5   | ns   |              |
| SWCLK时钟下降时间  | $t_{SWCKf}$    | —   | —   | 5   | ns   |              |
| SWDIO设置时间    | $t_{SWDS}$     | 8   | —   | —   | ns   | Figure 47.69 |
| SWDIO保持时间    | $t_{SWDH}$     | 8   | —   | —   | ns   |              |
| SWDIO数据延迟时间  | $t_{SWDD}$     | 2   | —   | 28  | ns   |              |

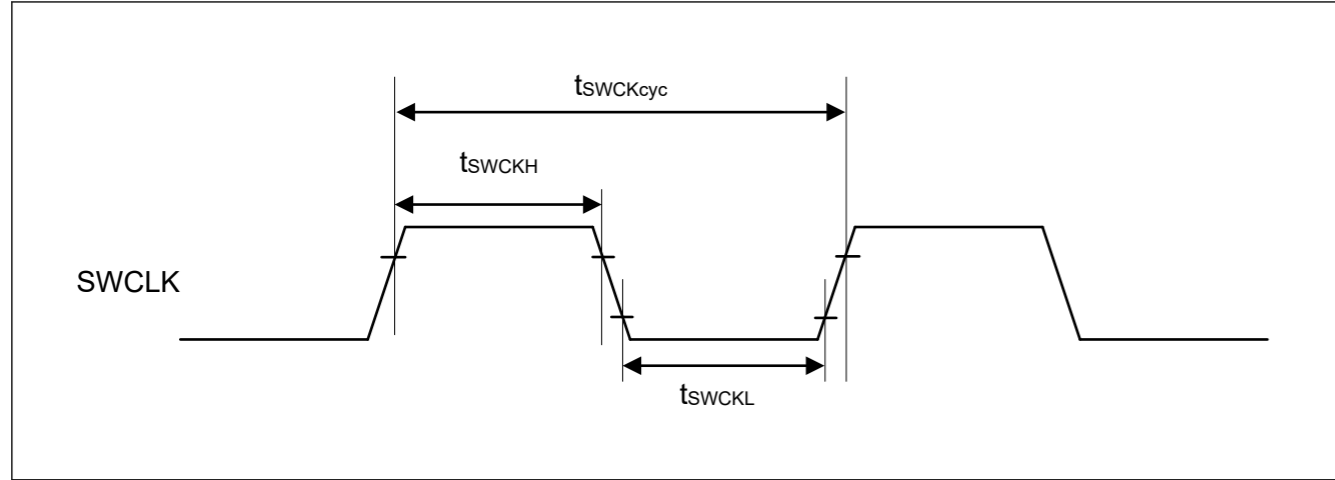


Figure 47.68 SWD SWCLK timing

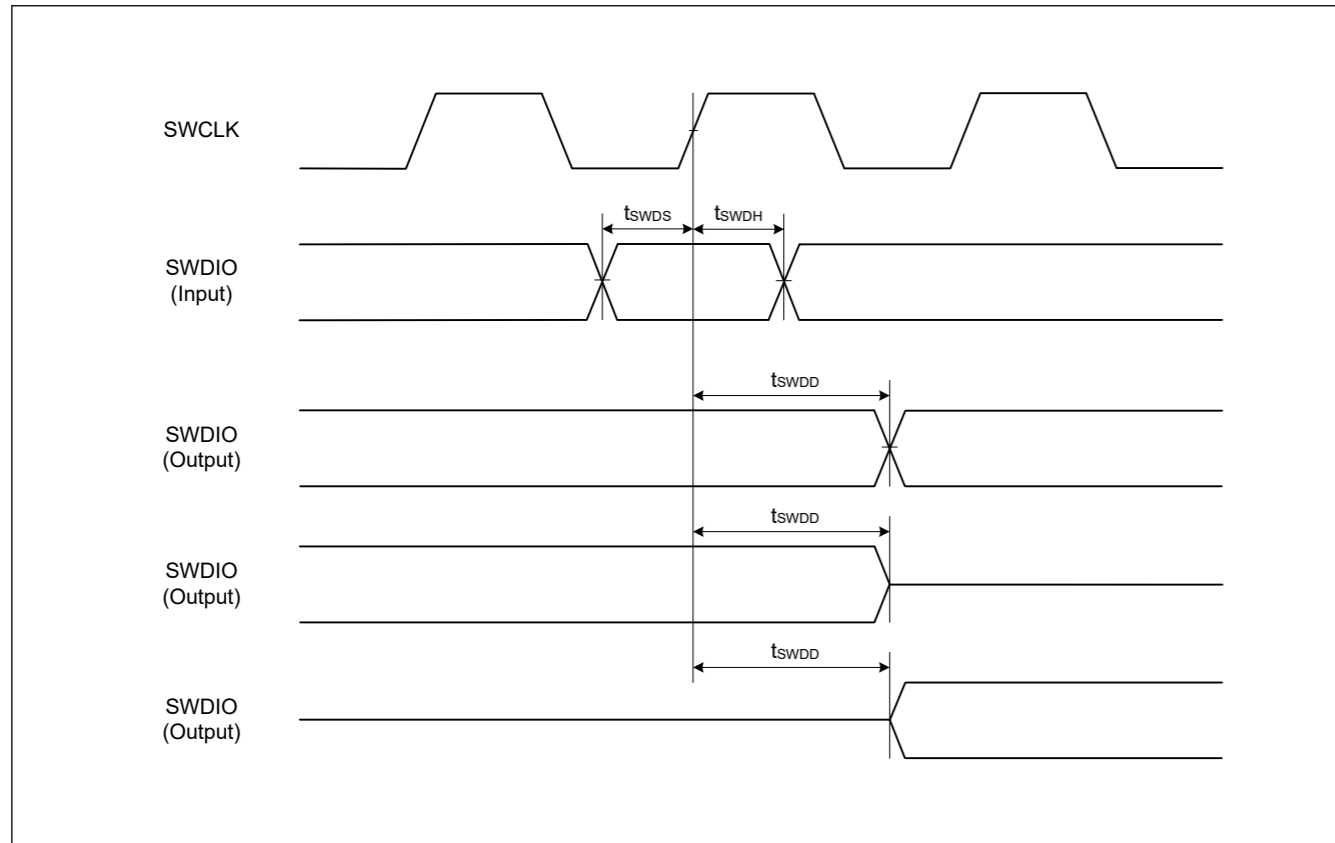


Figure 47.69 SWD input/output timing

47.16 Embedded Trace Macro Interface (ETM)

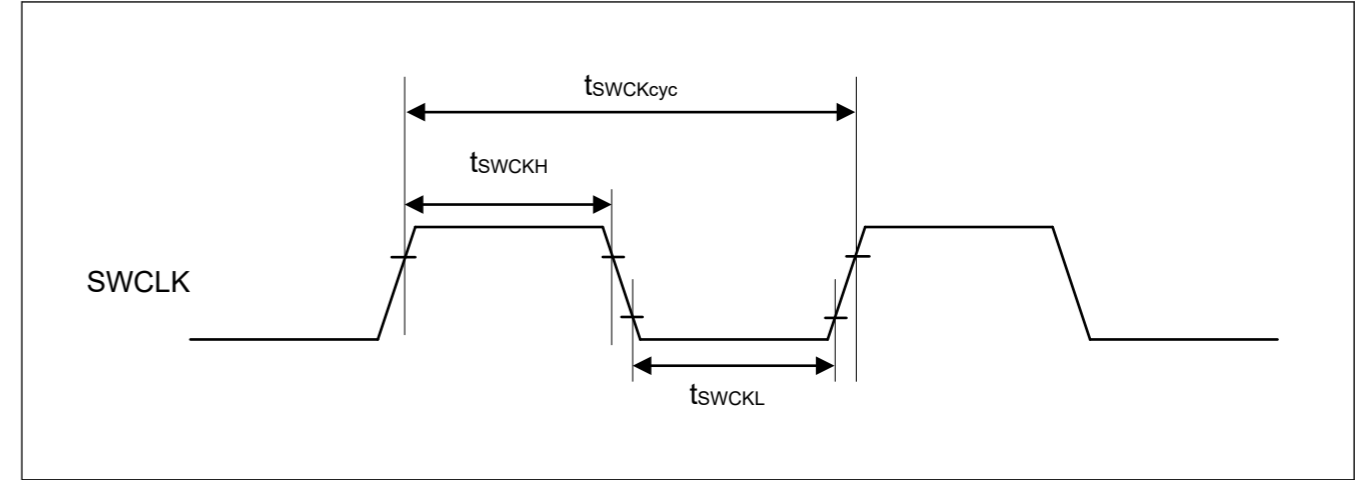


Figure 47.68 SWD SWCLK timing

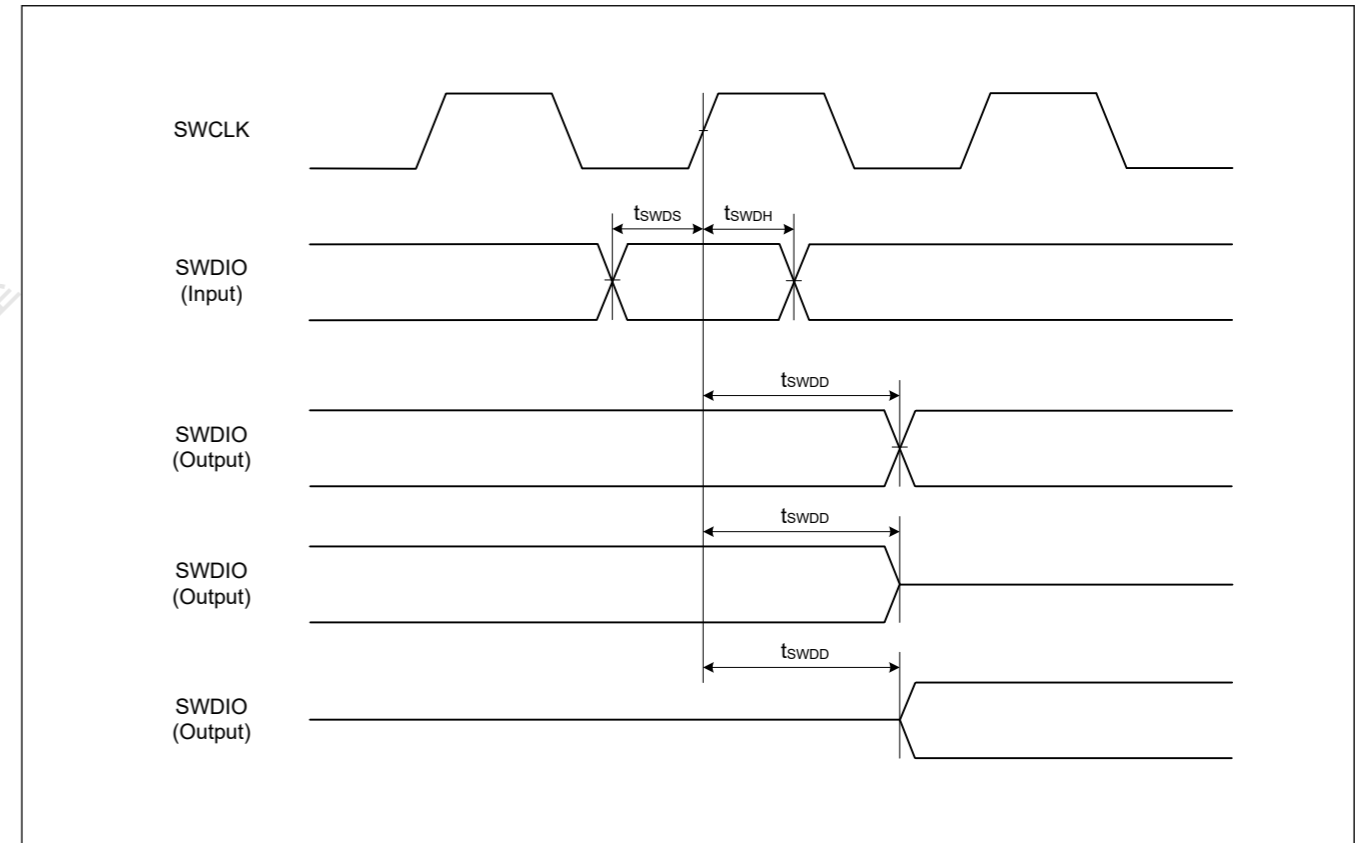


Figure 47.69 SWD input/output timing

47.16 嵌入式跟踪宏接口(ETM)

**Table 47.52 ETM**

Conditions: High speed high drive output is selected in the Port Drive Capability bit in the PmnPFS register.

| Parameter                    | Symbol        | Min | Typ | Max | Unit | Test conditions |
|------------------------------|---------------|-----|-----|-----|------|-----------------|
| TCLK clock cycle time        | $t_{TCLKcyc}$ | 40  | —   | —   | ns   | Figure 47.70    |
| TCLK clock high pulse width  | $t_{TCLKH}$   | 17  | —   | —   | ns   |                 |
| TCLK clock low pulse width   | $t_{TCLKL}$   | 17  | —   | —   | ns   |                 |
| TCLK clock rise time         | $t_{TCLKr}$   | —   | —   | 3   | ns   |                 |
| TCLK clock fall time         | $t_{TCLKf}$   | —   | —   | 3   | ns   |                 |
| TDATA[3:0] output setup time | $t_{TRDS}$    | 3.5 | —   | —   | ns   | Figure 47.71    |
| TDATA[3:0] output hold time  | $t_{TRDH}$    | 2.5 | —   | —   | ns   |                 |

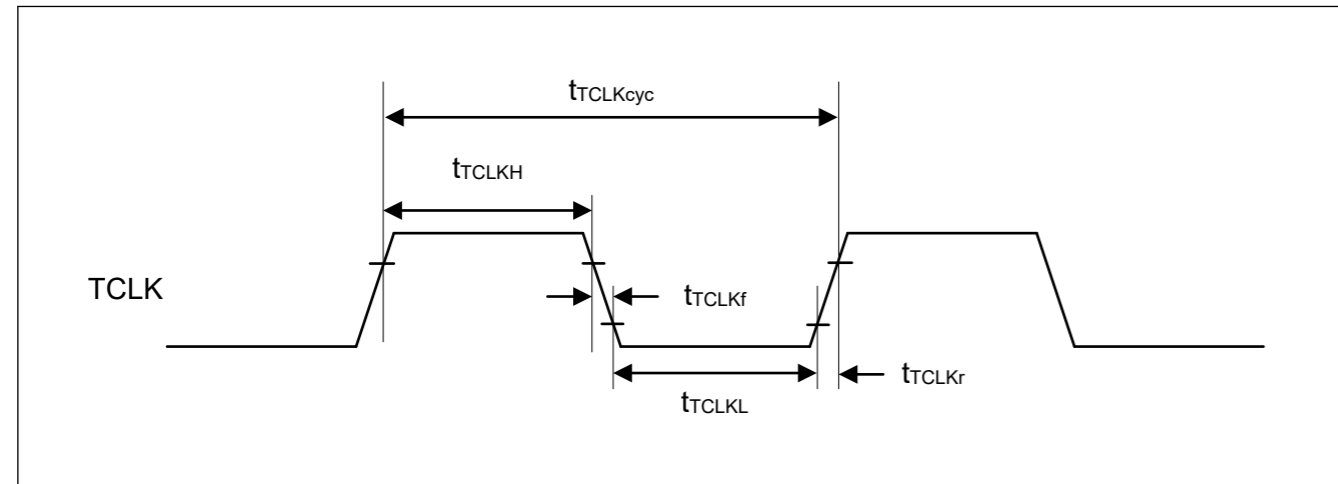


Figure 47.70 ETM TCLK timing

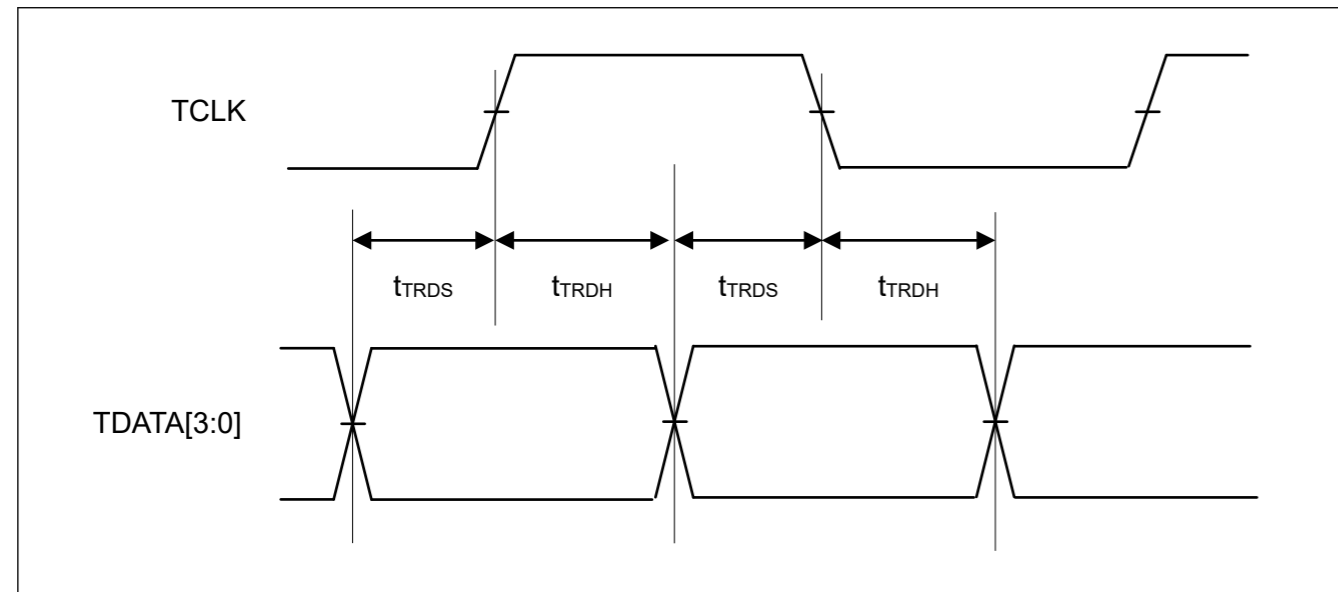


Figure 47.71 ETM output timing

**Table 47.52 ETM**

条件：在PmnPFS寄存器的端口驱动能力位中选择高速高驱动输出。

| Parameter        | Symbol        | Min | Typ | Max | Unit | 测试条件         |
|------------------|---------------|-----|-----|-----|------|--------------|
| TCLK时钟周期时间       | $t_{TCLKcyc}$ | 40  | —   | —   | ns   | Figure 47.70 |
| TCLK时钟高脉冲宽度      | $t_{TCLKH}$   | 17  | —   | —   | ns   |              |
| TCLK时钟低脉冲宽度      | $t_{TCLKL}$   | 17  | —   | —   | ns   |              |
| TCLK时钟上升时间       | $t_{TCLKr}$   | —   | —   | 3   | ns   |              |
| TCLK时钟下降时间       | $t_{TCLKf}$   | —   | —   | 3   | ns   |              |
| TDATA[3:0]输出建立时间 | $t_{TRDS}$    | 3.5 | —   | —   | ns   | Figure 47.71 |
| TDATA[3:0]输出保持时间 | $t_{TRDH}$    | 2.5 | —   | —   | ns   |              |

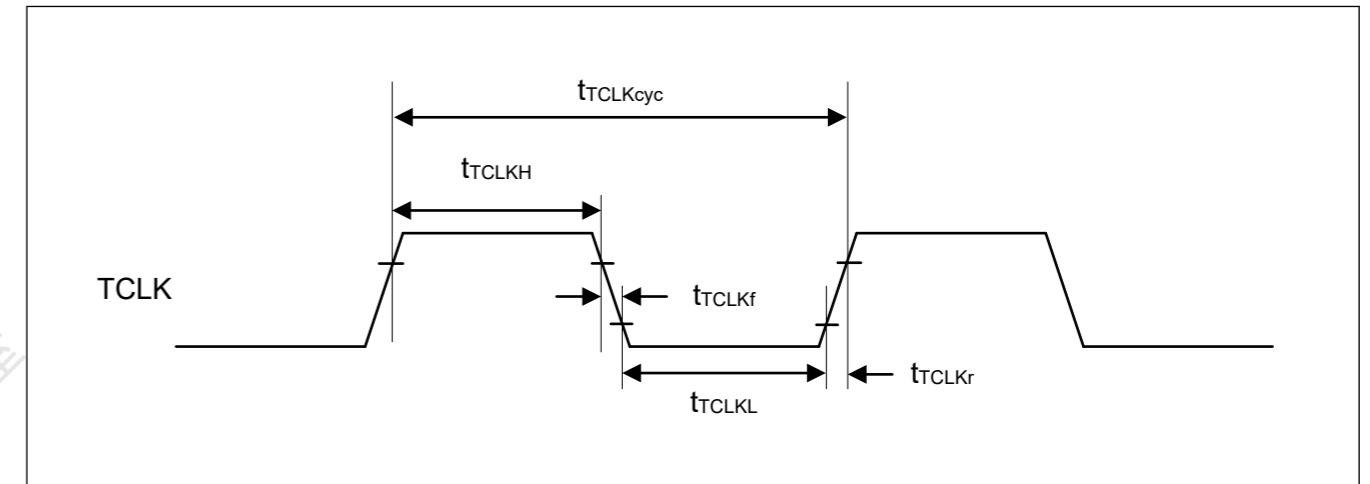


Figure 47.70 ETM TCLK timing

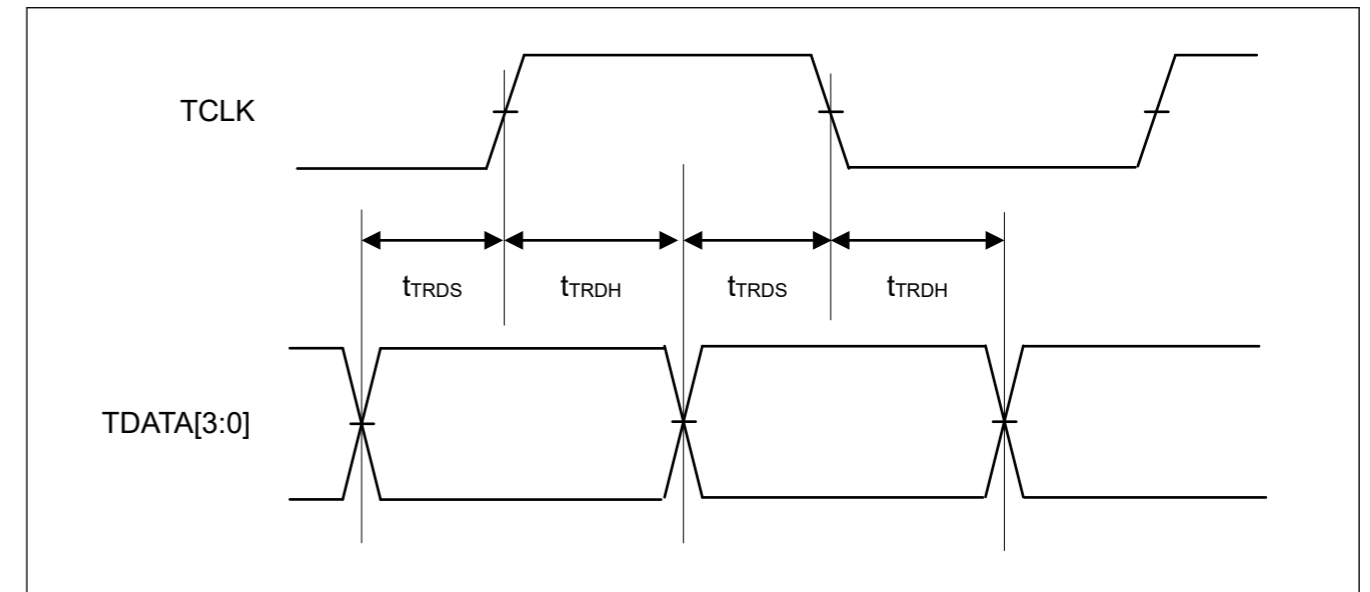


Figure 47.71 ETM输出时序

## Appendix 1. Port States in Each Processing Mode

| Function | Pin function                | Reset   | Software Standby mode                       | Deep Software Standby mode | After Deep Software Standby mode is canceled (return to startup mode) |                         |
|----------|-----------------------------|---------|---|----------------------------|---|-------------------------|
|          |                             |         |   |                            | IOKEEP = 0  | IOKEEP = 1 <sup>1</sup> |
| Mode     | MD                          | Pull-up | Keep-O                                      | Keep                       | Hi-Z  | Keep                    |
| JTAG     | TCK/TMS/TDI                 | Pull-up | Keep-O                                      | Keep                       | Hi-Z  | Keep                    |
|          | TDO                         | output  | Keep-O                                      | Keep                       | TDO output  | Keep                    |
| IRQ      | IRQx                        | Hi-Z    | Keep-O <sup>2</sup>                         | Keep                       | Hi-Z  | Keep                    |
|          | IRQx-DS                     | Hi-Z    | Keep-O <sup>2</sup>                         | Keep <sup>3</sup>          | Hi-Z  | Keep                    |
| AGT      | AGTIO <sub>n</sub>          | Hi-Z    | Keep-O <sup>2</sup>                         | Keep                       | Hi-Z  | Keep                    |
|          | AGTIO <sub>n</sub> (n=1,3)  | Hi-Z    | Keep-O <sup>2</sup>                         | Keep <sup>3</sup>          | Hi-Z  | Keep                    |
| SCI      | RXD0                        | Hi-Z    | Keep-O <sup>2</sup>                         | Keep                       | Hi-Z  | Keep                    |
| IIC      | SCLn/SDAn                   | Hi-Z    | Keep-O <sup>2</sup>                         | Keep                       | Hi-Z  | Keep                    |
| USBFS    | USB_OVRCURx                 | Hi-Z    | Keep-O <sup>2</sup>                         | Keep                       | Hi-Z  | Keep                    |
|          | USB_OVRCURx-DS/<br>USB_VBUS | Hi-Z    | Keep-O <sup>2</sup>                         | Keep <sup>3</sup>          | Hi-Z  | Keep                    |
|          | USB_DP/USB_DM               | Hi-Z    | Keep-O <sup>4</sup>                         | Keep <sup>3</sup>          | Hi-Z  | Keep                    |
| RTC      | RTCICx                      | Hi-Z    | Keep-O <sup>2</sup>                         | Keep <sup>3</sup>          | Hi-Z  | Keep                    |
|          | RTCOUT                      | Hi-Z    | [RTCOUT selected] RTCOUT output             | Keep                       | Hi-Z  | Keep                    |
| CLKOUT   | CLKOUT                      | Hi-Z    | [CLKOUT selected] CLKOUT output             | Keep                       | Hi-Z  | Keep                    |
| DAC      | DAn                         | Hi-Z    | [DAn output (DAOE = 1)] D/A output retained | Keep                       | Hi-Z  | Keep                    |
| Others   | —                           | Hi-Z    | Keep-O                                      | Keep                       | Hi-Z  | Keep                    |

Note: H: High-level  
L: Low-level  
Hi-Z: High-impedance  
Keep-O: Output pins retain their previous values. Input pins go to high-impedance.  
Keep: Pin states are retained during periods in Software Standby mode.

Note 1. Retains the I/O port state until the DPSBYCR.IOKEEP bit is cleared to 0.

Note 2. Input is enabled if the pin is specified as the Software Standby canceling source while it is used as an external interrupt pin.

Note 3. Input is enabled if the pin is specified as the Deep Software Standby canceling source.

Note 4. Input is enabled while the pin is used as an input pin.

## Appendix 1. 每种处理模式下的端口状态

| Function | 引脚功能                        | Reset   | 软件待机模式                          | 深度软件待机模式          | 取消深度软件待机模式后 (返回启动模式) |                         |
|----------|-----------------------------|---------|---------------------------------|-------------------|----------------------|-------------------------|
|          |                             |         |                                 |                   | IOKEEP = 0           | IOKEEP = 1 <sup>1</sup> |
| Mode     | MD                          | Pull-up | Keep-O                          | Keep              | Hi-Z                 | Keep                    |
| JTAG     | TCK/TMS/TDI                 | Pull-up | Keep-O                          | Keep              | Hi-Z                 | Keep                    |
|          | TDO                         | output  | Keep-O                          | Keep              | TDO输出                | Keep                    |
| IRQ      | IRQx                        | Hi-Z    | Keep-O <sup>2</sup>             | Keep              | Hi-Z                 | Keep                    |
|          | IRQx-DS                     | Hi-Z    | Keep-O <sup>2</sup>             | Keep <sup>3</sup> | Hi-Z                 | Keep                    |
| AGT      | AGTIO <sub>n</sub>          | Hi-Z    | Keep-O <sup>2</sup>             | Keep              | Hi-Z                 | Keep                    |
|          | AGTIO <sub>n</sub> (n=1,3)  | Hi-Z    | Keep-O <sup>2</sup>             | Keep <sup>3</sup> | Hi-Z                 | Keep                    |
| SCI      | RXD0                        | Hi-Z    | Keep-O <sup>2</sup>             | Keep              | Hi-Z                 | Keep                    |
| IIC      | SCLn/SDAn                   | Hi-Z    | Keep-O <sup>2</sup>             | Keep              | Hi-Z                 | Keep                    |
| USBFS    | USB_OVRCURx                 | Hi-Z    | Keep-O <sup>2</sup>             | Keep              | Hi-Z                 | Keep                    |
|          | USB_OVRCURx-DS/<br>USB_VBUS | Hi-Z    | Keep-O <sup>2</sup>             | Keep <sup>3</sup> | Hi-Z                 | Keep                    |
|          | USB_DP/USB_DM               | Hi-Z    | Keep-O <sup>4</sup>             | Keep <sup>3</sup> | Hi-Z                 | Keep                    |
| RTC      | RTCICx                      | Hi-Z    | Keep-O <sup>2</sup>             | Keep <sup>3</sup> | Hi-Z                 | Keep                    |
|          | RTCOUT                      | Hi-Z    | [RTCOUT selected] RTCOUT output | Keep              | Hi-Z                 | Keep                    |
| CLKOUT   | CLKOUT                      | Hi-Z    | [CLKOUT selected] CLKOUT output | Keep              | Hi-Z                 | Keep                    |
| DAC      | DAn                         | Hi-Z    | [DAn输出(DAOE=1)]DA输出保留           | Keep              | Hi-Z                 | Keep                    |
| Others   | —                           | Hi-Z    | Keep-O                          | Keep              | Hi-Z                 | Keep                    |

Note: H: High-level  
L: Low-level  
Hi-Z: High-impedance  
Keep-O: 输出引脚保留其先前的值。输入引脚变为高阻抗。  
保持: 在软件待机模式期间保持引脚状态。

注1. 保持IO端口状态直到DPSBYCR.IOKEEP位被清除为0。

注2. 如果引脚被指定为软件待机取消源, 同时它被用作外部中断引脚, 则输入被启用。

注3. 如果引脚被指定为深度软件待机取消源, 则启用输入。

注4. 当引脚用作输入引脚时, 输入被启用。



### Appendix 2. Package Dimensions

Information on the latest version of the package dimensions or mountings is displayed in "Packages" on the Renesas Electronics Corporation website.

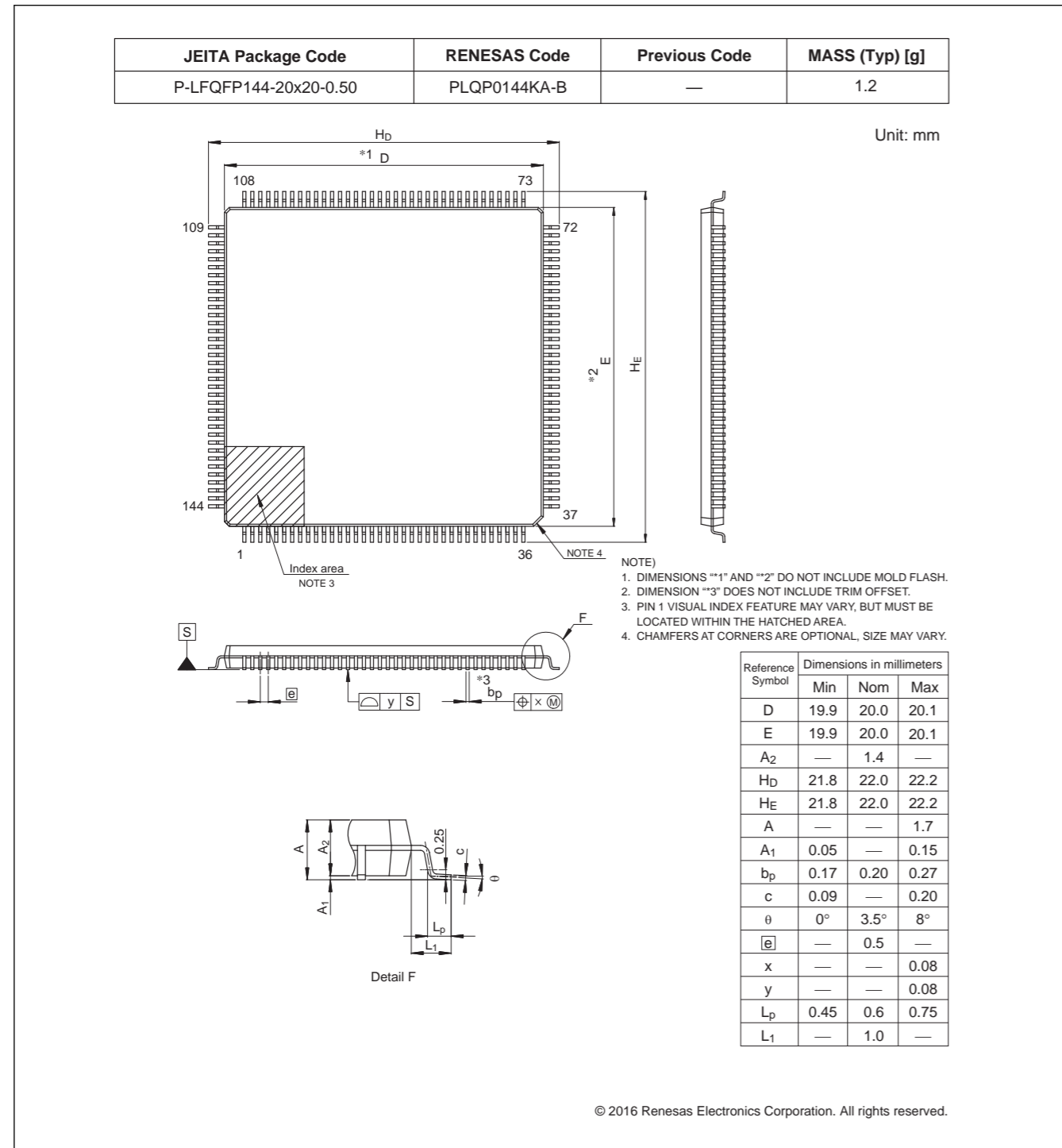


Figure 2.1 LQFP 144-pin

### Appendix 2. 包装尺寸

最新版本的封装尺寸或安装信息显示在瑞萨电子的“封装”中电子公司网站。

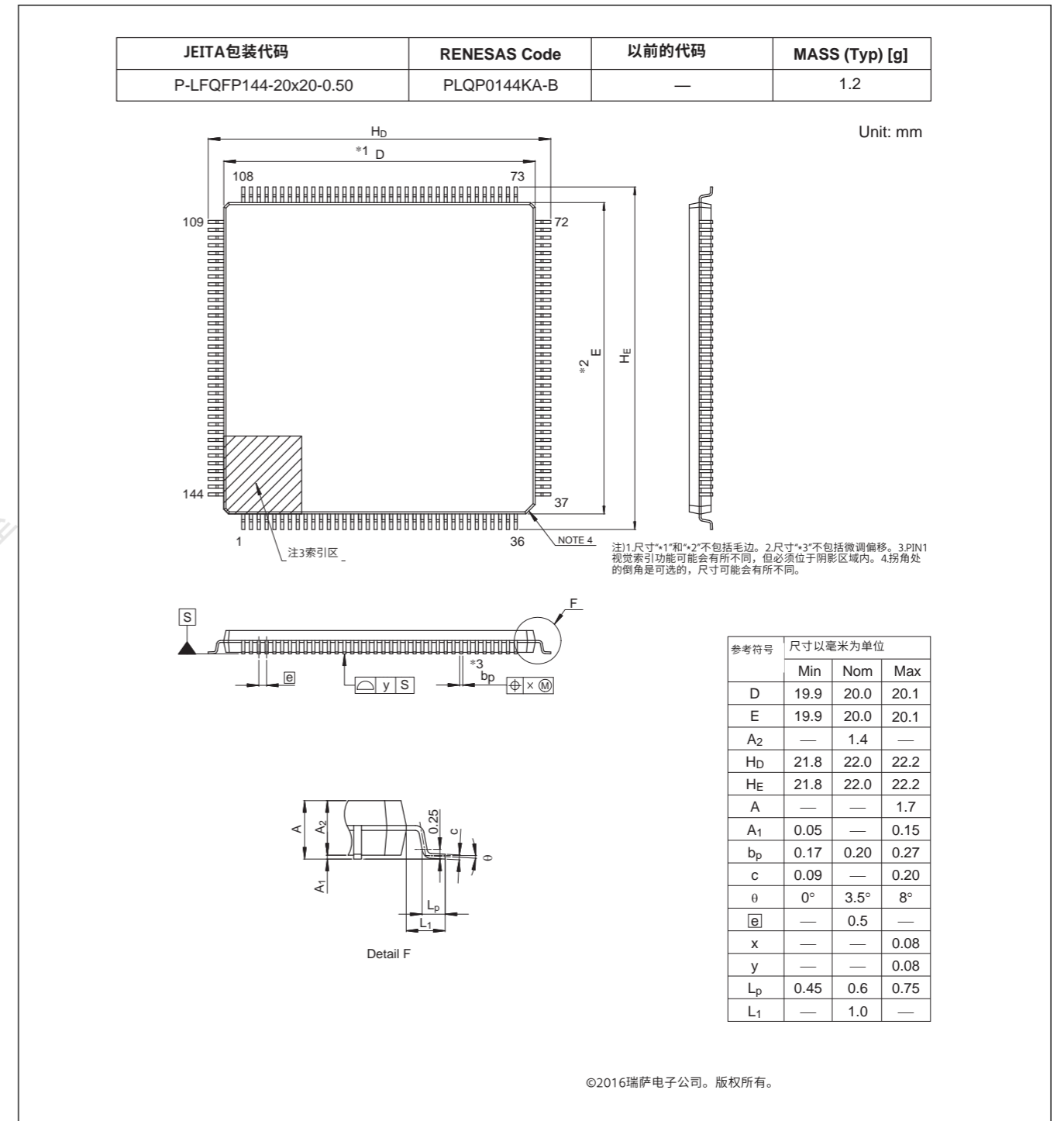


Figure 2.1 LQFP 144-pin

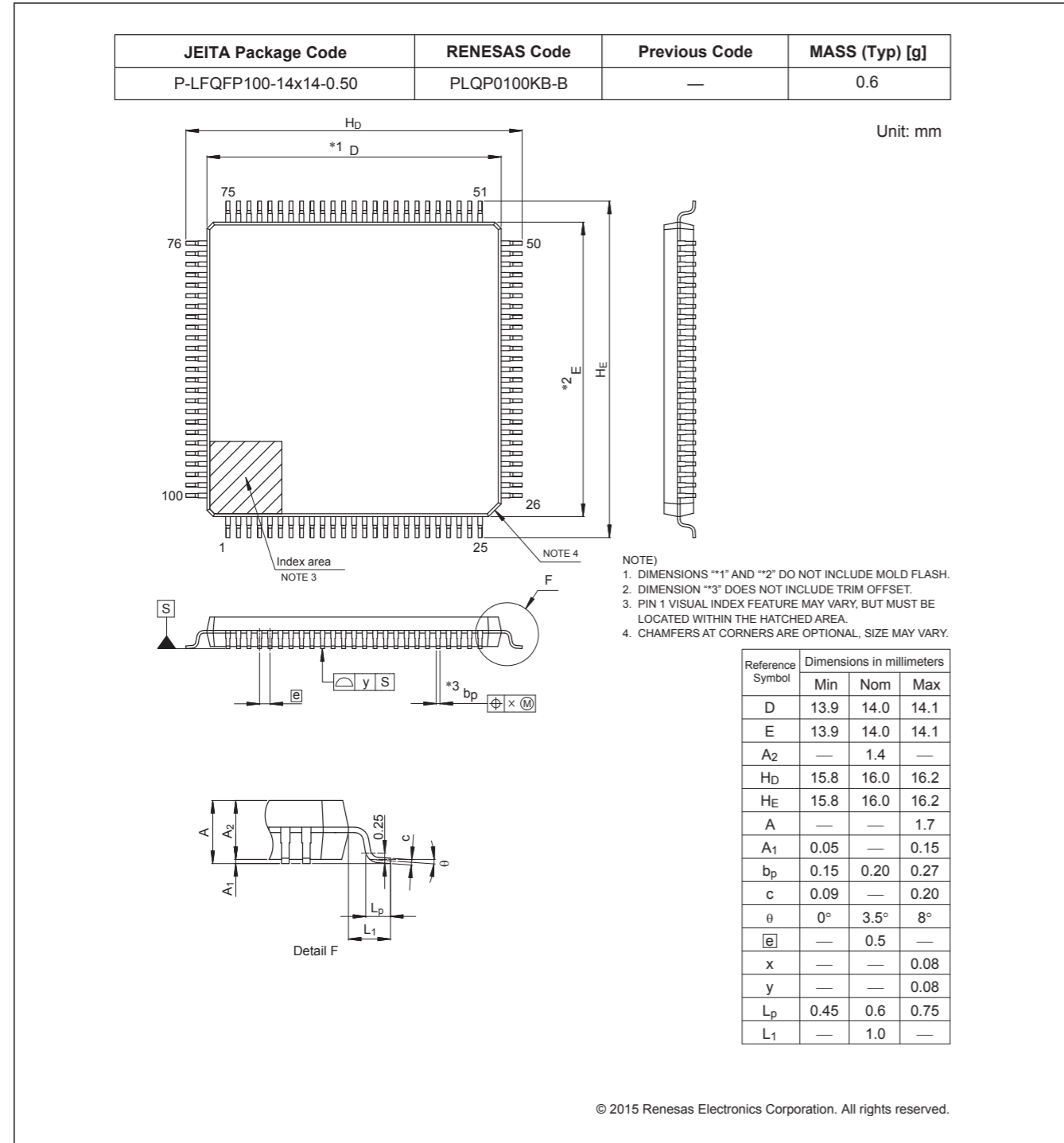


Figure 2.2 LQFP 100-pin

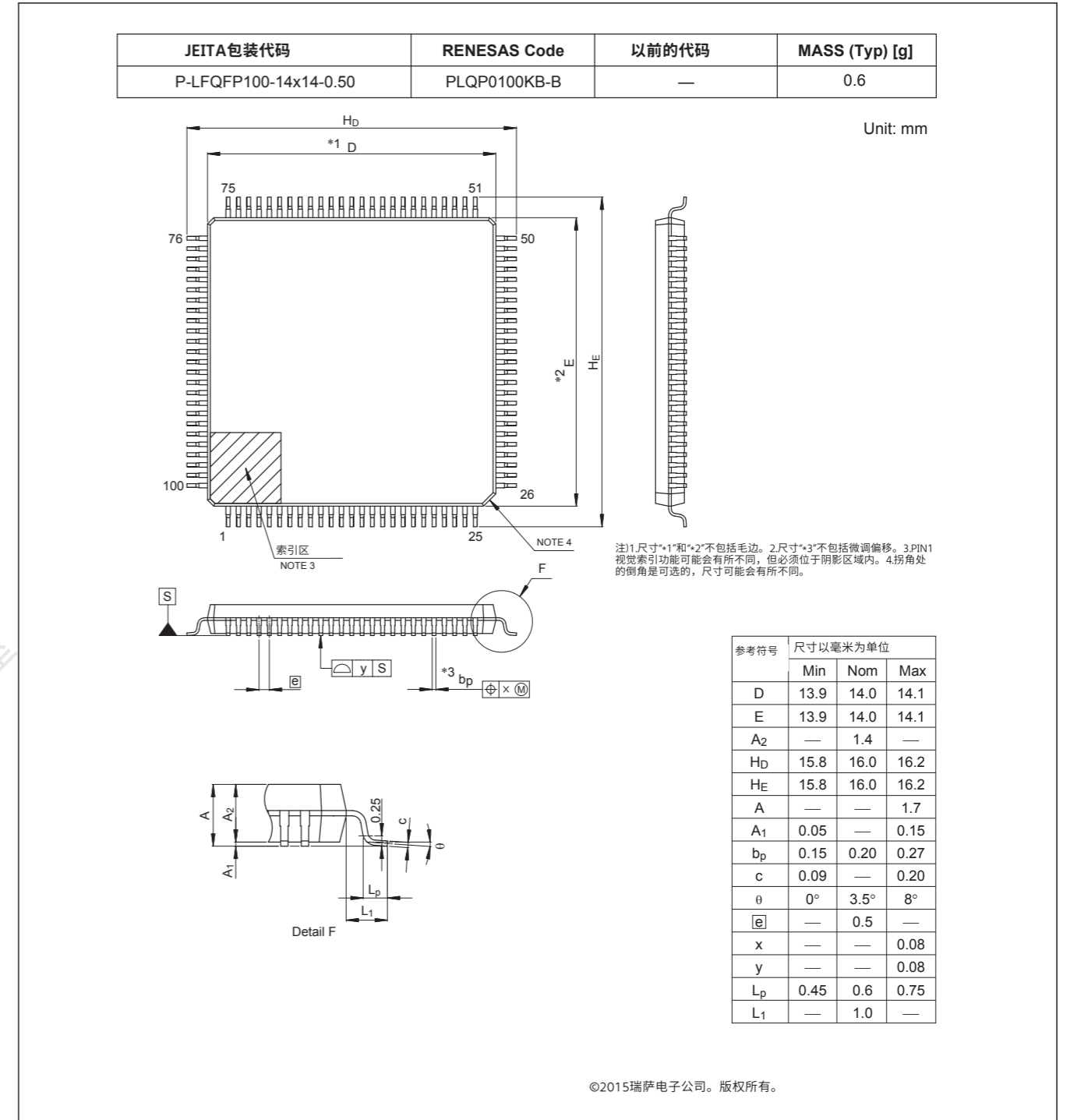


Figure 2.2 LQFP 100-pin

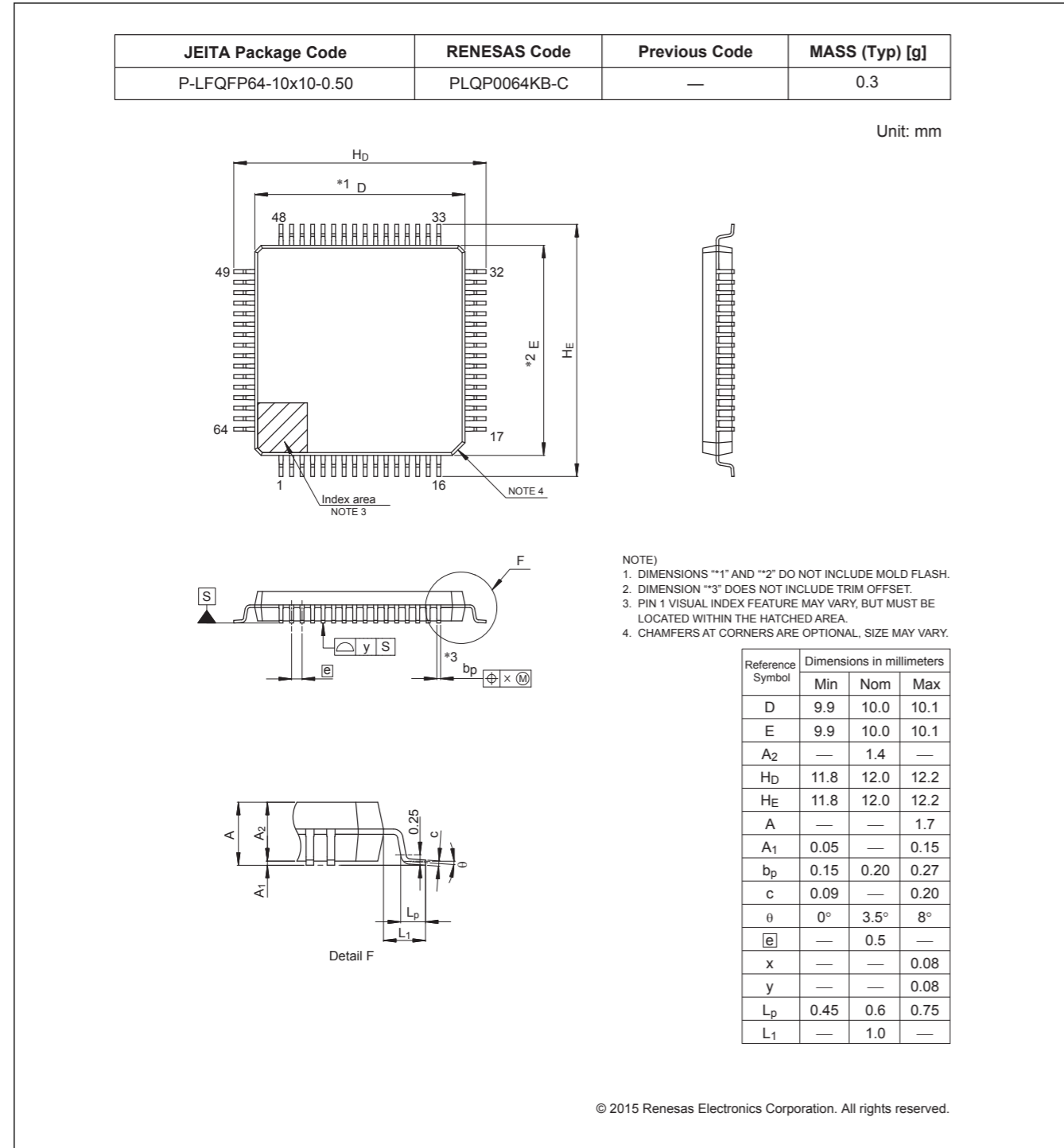


Figure 2.3 LQFP 64-pin

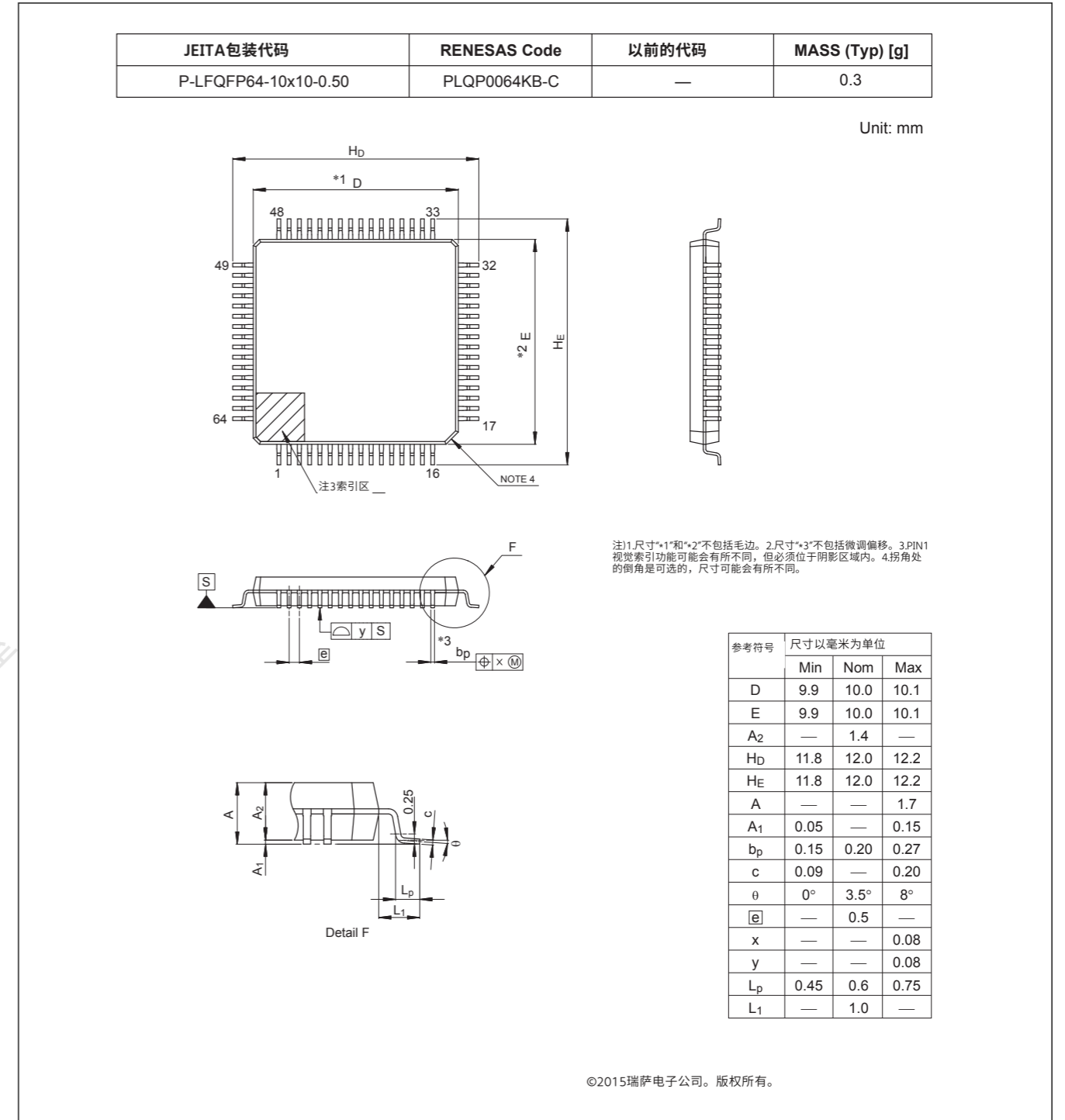


Figure 2.3 LQFP 64-pin

## Appendix 3. I/O Registers

This appendix describes I/O register address and access cycles by function.

### 3.1 Peripheral Base Addresses

This section provides the base addresses for peripherals described in this manual. Table 3.1 shows the name, description, and the base address of each peripheral.

**Table 3.1 Peripheral base address (1 of 3)**

| Name   | Description                                  | Base address |
|--------|--|--------------|
| RMPU   | Renesas Memory Protection Unit               | 0x4000_0000  |
| TZF    | TrustZone Filter                             | 0x4000_0E00  |
| SRAM   | SRAM Control                                 | 0x4000_2000  |
| BUS    | BUS Control                                  | 0x4000_3000  |
| DMAC0  | Direct memory access controller 0            | 0x4000_5000  |
| DMAC1  | Direct memory access controller 1            | 0x4000_5040  |
| DMAC2  | Direct memory access controller 2            | 0x4000_5080  |
| DMAC3  | Direct memory access controller 3            | 0x4000_50C0  |
| DMAC4  | Direct memory access controller 4            | 0x4000_5100  |
| DMAC5  | Direct memory access controller 5            | 0x4000_5140  |
| DMAC6  | Direct memory access controller 6            | 0x4000_5180  |
| DMAC7  | Direct memory access controller 7            | 0x4000_51C0  |
| DMA    | DMAC Module Activation                       | 0x4000_5200  |
| DTC    | Data Transfer Controller                     | 0x4000_5400  |
| ICU    | Interrupt Controller                         | 0x4000_6000  |
| CACHE  | CACHE  | 0x4000_7000  |
| CPSCU  | CPU System Security Control Unit             | 0x4000_8000  |
| DBG    | Debug Function                               | 0x400_1B000  |
| FCACHE | Flash Cache                                  | 0x400_1C100  |
| SYSC   | System Control                               | 0x4001_E000  |
| PORT0  | Port 0 Control Registers                     | 0x4008_0000  |
| PORT1  | Port 1 Control Registers                     | 0x4008_0020  |
| PORT2  | Port 2 Control Registers                     | 0x4008_0040  |
| PORT3  | Port 3 Control Registers                     | 0x4008_0060  |
| PORT4  | Port 4 Control Registers                     | 0x4008_0080  |
| PORT5  | Port 5 Control Registers                     | 0x4008_00A0  |
| PORT6  | Port 6 Control Registers                     | 0x4008_00C0  |
| PORT7  | Port 7 Control Registers                     | 0x4008_00E0  |
| PORT8  | Port 8 Control Registers                     | 0x4008_0100  |
| PFS    | Pmn Pin Function Control Register            | 0x4008_0800  |
| ELC    | Event Link Controller                        | 0x4008_2000  |
| RTC    | Realtime Clock                               | 0x4008_3000  |
| IWDT   | Independent Watchdog Timer                   | 0x4008_3200  |
| WDT    | Watchdog Timer                               | 0x4008_3400  |
| CAC    | Clock Frequency Accuracy Measurement Circuit | 0x4008_3600  |

## Appendix 3. I/O Registers

本附录按功能描述了IO寄存器地址和访问周期。

### 3.1 外设基地址

本节提供本手册中描述的外设的基地址。表3.1显示了每个外设的名称、描述和基地址。

**Table 3.1 外设基地址(1 of 3)**

| Name   | Description      | 基址          |
|--------|------------------|-------------|
| RMPU   | 瑞萨内存保护单元         | 0x4000_0000 |
| TZF    | TrustZone Filter | 0x4000_0E00 |
| SRAM   | SRAM Control     | 0x4000_2000 |
| BUS    | 总线控制             | 0x4000_3000 |
| DMAC0  | 直接内存访问控制器0       | 0x4000_5000 |
| DMAC1  | 直接内存访问控制器1       | 0x4000_5040 |
| DMAC2  | 直接内存访问控制器2       | 0x4000_5080 |
| DMAC3  | 直接内存访问控制器3       | 0x4000_50C0 |
| DMAC4  | 直接内存访问控制器4       | 0x4000_5100 |
| DMAC5  | 直接内存访问控制器5       | 0x4000_5140 |
| DMAC6  | 直接内存访问控制器6       | 0x4000_5180 |
| DMAC7  | 直接内存访问控制器7       | 0x4000_51C0 |
| DMA    | DMAC模块激活         | 0x4000_5200 |
| DTC    | 数据传输控制器          | 0x4000_5400 |
| ICU    | 中断控制器            | 0x4000_6000 |
| CACHE  | CACHE            | 0x4000_7000 |
| CPSCU  | CPU系统安全控制单元      | 0x4000_8000 |
| DBG    | 调试功能             | 0x400_1B000 |
| FCACHE | 闪存缓存             | 0x400_1C100 |
| SYSC   | 系统控制             | 0x4001_E000 |
| PORT0  | 端口0控制寄存器         | 0x4008_0000 |
| PORT1  | 端口1控制寄存器         | 0x4008_0020 |
| PORT2  | 端口2控制寄存器         | 0x4008_0040 |
| PORT3  | 端口3控制寄存器         | 0x4008_0060 |
| PORT4  | 端口4控制寄存器         | 0x4008_0080 |
| PORT5  | 端口5控制寄存器         | 0x4008_00A0 |
| PORT6  | 端口6控制寄存器         | 0x4008_00C0 |
| PORT7  | 端口7控制寄存器         | 0x4008_00E0 |
| PORT8  | 端口8控制寄存器         | 0x4008_0100 |
| PFS    | Pmn引脚功能控制寄存器     | 0x4008_0800 |
| ELC    | 事件链接控制器          | 0x4008_2000 |
| RTC    | 实时时钟             | 0x4008_3000 |
| IWDT   | 独立看门狗定时器         | 0x4008_3200 |
| WDT    | 看门狗定时器           | 0x4008_3400 |
| CAC    | 时钟频率精度测量电路       | 0x4008_3600 |



Table 3.1 Peripheral base address (2 of 3)

| Name    | Description                                    | Base address |
|---------|--|--------------|
| MSTP    | Module Stop Control A, B, C, D                 | 0x4008_4000  |
| POEG    | Port Output Enable Module for GPT              | 0x4008_A000  |
| USBFS   | USB 2.0 FS Module                              | 0x4009_0000  |
| SDHI0   | SD Host Interface 0                            | 0x4009_2000  |
| SSIE0   | Serial Sound Interface Enhanced (SSIE)         | 0x4009_D000  |
| IIC0    | Inter-Integrated Circuit 0                     | 0x4009_F000  |
| IIC0WU  | Inter-Integrated Circuit 0 Wake-up Unit        | 0x4009_F014  |
| IIC1    | Inter-Integrated Circuit 1                     | 0x4009_F100  |
| CAN0    | CAN0 Module                                    | 0x400A_8000  |
| CAN1    | CAN1 Module                                    | 0x400A_9000  |
| CTSU    | Capacitive Touch Sensing Unit                  | 0x400D_0000  |
| PSCU    | Peripheral Security Control Unit               | 0x400E_0000  |
| AGT0    | Low Power Asynchronous General purpose Timer 0 | 0x400E_8000  |
| AGT1    | Low Power Asynchronous General purpose Timer 1 | 0x400E_8100  |
| AGT2    | Low Power Asynchronous General purpose Timer 2 | 0x400E_8200  |
| AGT3    | Low Power Asynchronous General purpose Timer 3 | 0x400E_8300  |
| AGT4    | Low Power Asynchronous General purpose Timer 4 | 0x400E_8400  |
| AGT5    | Low Power Asynchronous General purpose Timer 5 | 0x400E_8500  |
| TSN     | Temperature Sensor                             | 0x400F_3000  |
| CRC     | CRC Calculator                                 | 0x4010_8000  |
| DOC     | Data Operation Circuit                         | 0x4010_9000  |
| SCI0    | Serial Communication Interface 0               | 0x4011_8000  |
| SCI1    | Serial Communication Interface 1               | 0x4011_8100  |
| SCI2    | Serial Communication Interface 2               | 0x4011_8200  |
| SCI3    | Serial Communication Interface 3               | 0x4011_8300  |
| SCI4    | Serial Communication Interface 4               | 0x4011_8400  |
| SCI9    | Serial Communication Interface 9               | 0x4011_8900  |
| SPI0    | Serial Peripheral Interface 0                  | 0x4011_A000  |
| SCE9    | Secure Cryptographic Engine                    | 0x4016_1000  |
| GPT320  | General PWM 32-Bit Timer 0                     | 0x4016_9000  |
| GPT321  | General PWM 32-Bit Timer 1                     | 0x4016_9100  |
| GPT322  | General PWM 32-Bit Timer 2                     | 0x4016_9200  |
| GPT323  | General PWM 32-Bit Timer 3                     | 0x4016_9300  |
| GPT164  | General PWM 16-Bit Timer 4                     | 0x4016_9400  |
| GPT165  | General PWM 16-Bit Timer 5                     | 0x4016_9500  |
| GPT166  | General PWM 16-Bit Timer 6                     | 0x4016_9600  |
| GPT167  | General PWM 16-Bit Timer 7                     | 0x4016_9700  |
| GPT_OPS | Output Phase Switching Controller              | 0x4016_9A00  |
| ADC120  | 12bit A/D Converter 0                          | 0x4017_0000  |
| ADC121  | 12bit A/D Converter 1                          | 0x4017_0200  |
| DAC12   | 12-bit D/A converter                           | 0x4017_1000  |

Table 3.1 外设基地址 (2个, 共3个)

| Name    | Description                | 基址          |
|---------|----------------------------|-------------|
| MSTP    | 模块停止控制A、B、C、D              | 0x4008_4000 |
| POEG    | GPT端口输出使能模块                | 0x4008_A000 |
| USBFS   | USB2.0FS模块                 | 0x4009_0000 |
| SDHI0   | SD主机接口0                    | 0x4009_2000 |
| SSIE0   | 串行声音接口增强(SSIE)             | 0x4009_D000 |
| IIC0    | Inter-Integrated Circuit 0 | 0x4009_F000 |
| IIC0WU  | 内部集成电路0唤醒单元                | 0x4009_F014 |
| IIC1    | Inter-Integrated Circuit 1 | 0x4009_F100 |
| CAN0    | CAN0 Module                | 0x400A_8000 |
| CAN1    | CAN1 Module                | 0x400A_9000 |
| CTSU    | 电容式触控感应单元                  | 0x400D_0000 |
| PSCU    | 外围安全控制单元                   | 0x400E_0000 |
| AGT0    | 低功耗异步通用定时器0                | 0x400E_8000 |
| AGT1    | 低功耗异步通用定时器1                | 0x400E_8100 |
| AGT2    | 低功耗异步通用定时器2                | 0x400E_8200 |
| AGT3    | 低功耗异步通用定时器3                | 0x400E_8300 |
| AGT4    | 低功耗异步通用定时器4                | 0x400E_8400 |
| AGT5    | 低功耗异步通用定时器5                | 0x400E_8500 |
| TSN     | 温度感应器                      | 0x400F_3000 |
| CRC     | CRC Calculator             | 0x4010_8000 |
| DOC     | 数据运算电路                     | 0x4010_9000 |
| SCI0    | 串行通讯接口0                    | 0x4011_8000 |
| SCI1    | 串行通讯接口1                    | 0x4011_8100 |
| SCI2    | 串行通讯接口2                    | 0x4011_8200 |
| SCI3    | 串行通讯接口3                    | 0x4011_8300 |
| SCI4    | 串行通讯接口4                    | 0x4011_8400 |
| SCI9    | 串行通讯接口9                    | 0x4011_8900 |
| SPI0    | 串行外设接口0                    | 0x4011_A000 |
| SCE9    | 安全加密引擎                     | 0x4016_1000 |
| GPT320  | 通用PWM32位定时器0               | 0x4016_9000 |
| GPT321  | 通用PWM32位定时器1               | 0x4016_9100 |
| GPT322  | 通用PWM32位定时器2               | 0x4016_9200 |
| GPT323  | 通用PWM32位定时器3               | 0x4016_9300 |
| GPT164  | 通用PWM16位定时器4               | 0x4016_9400 |
| GPT165  | 通用PWM16位定时器5               | 0x4016_9500 |
| GPT166  | 通用PWM16位定时器6               | 0x4016_9600 |
| GPT167  | 通用PWM16位定时器7               | 0x4016_9700 |
| GPT_OPS | 输出相位切换控制器                  | 0x4016_9A00 |
| ADC120  | 12bit A/D Converter 0      | 0x4017_0000 |
| ADC121  | 12bit A/D Converter 1      | 0x4017_0200 |
| DAC12   | 12-bit D/A converter       | 0x4017_1000 |

Table 3.1 Peripheral base address (3 of 3)

| Name | Description                         | Base address |
|------|-------------------------------------|--------------|
| FLAD | Data Flash                          | 0x407F_C000  |
| FACI | Flash Application Command Interface | 0x407F_E000  |
| QSPI | Quad-SPI                            | 0x6400_0000  |

Note: Name = Peripheral name  
 Description = Peripheral functionality  
 Base address = Lowest reserved address or address used by the peripheral

### 3.2 Access Cycles

This section provides access cycle information for the I/O registers described in this manual.

- Registers are grouped by associated module.
- The number of access cycles indicates the number of cycles based on the specified reference clock.
- In the internal I/O area, reserved addresses that are not allocated to registers must not be accessed, otherwise operations cannot be guaranteed.
- The number of I/O access cycles depends on bus cycles of the internal peripheral bus, divided clock synchronization cycles, and wait cycles of each module. Divided clock synchronization cycles differ depending on the frequency ratio between ICLK and PCLK.
- When the frequency of ICLK is equal to that of PCLK, the number of divided clock synchronization cycles is always constant.
- When the frequency of ICLK is greater than that of PCLK, at least 1 PCLK cycle is added to the number of divided clock synchronization cycles.
- The number of write access cycles indicates the number of cycles obtained by non-bufferable write access.

Note: This applies to the number of cycles when access from the CPU does not conflict with the instruction fetching to the external memory or bus access from other bus masters such as DTC or DMAC.

Table 3.2 Access cycles (1 of 3)

| Peripherals                                | Address     |             | Number of access cycles |       |                          |        | Cycle Unit | Related function   |
|--|-------------|-------------|-------------------------|-------|--------------------------|--------|------------|--|
|  |             |             | ICLK = PCLK             |       | ICLK > PCLK <sup>1</sup> |        |            |  |
|  |             |             | Read                    | Write | Read                     | Write  |            |  |
| RMPU, TZF, SRAM, BUS, DMACn, DMA, DTC, ICU | 0x4000_0000 | 0x4000_6FFF | 4                       | 3     | 4                        | 3      | ICLK       | Renesas Memory Protection Unit, TrustZone Filter, SRAM Control, BUS Control, Direct memory access controller n, DMAC Module Activation, DTC Control Register, Interrupt Controller |
| CACHE                                      | 0x4000_7000 | 0x4000_7FFF | 3                       | 5     | 3                        | 5      | ICLK       | CACHE  |
| CPSCU, DBG, FCACHE                         | 0x4000_8000 | 0x4001_CFFF | 4                       | 3     | 4                        | 3      | ICLK       | CPU System Security Control Unit, Debug Function, Flash Cache  |
| SYSC                                       | 0x4001_E000 | 0x4001_E3FF | 5                       | 4     | 5                        | 4      | ICLK       | System Control   |
| SYSC                                       | 0x4001_E400 | 0x4001_E5FF | 9                       | 8     | 5 to 8                   | 5 to 8 | PCLKB      | System Control   |
| PORTn, PFS                                 | 0x4008_0000 | 0x4008_0FFF | 5                       | 4     | 2 to 5                   | 2 to 4 | PCLKB      | Port n Control Registers, Pmn Pin Function Control Register  |

Table 3.1 外设基地址(3of3)

| Name | Description | 基址          |
|------|-------------|-------------|
| FLAD | 数据闪存        | 0x407F_C000 |
| FACI | Flash应用命令接口 | 0x407F_E000 |
| QSPI | Quad-SPI    | 0x6400_0000 |

Note: 名称=外设名称  
 描述=外围功能  
 基址=外设使用的最低保留地址或地址

### 3.2 访问周期

本节提供本手册中描述的IO寄存器的访问周期信息。

- 寄存器按相关模块分组。
- 访问周期数是指基于指定参考时钟的周期数。
- 在内部IO区，不能访问未分配给寄存器的保留地址，否则无法保证操作。
- IO访问周期数取决于内部外设总线的总线周期、分频时钟同步周期和每个模块的等待周期。分频时钟同步周期取决于ICLK和PCLK之间的频率比。
- 当ICLK的频率等于PCLK的频率时，分频的时钟同步周期数始终是恒定的。
- 当ICLK频率大于PCLK频率时，分频时钟同步周期数至少增加1个PCLK周期。
- 写访问周期数是指非缓冲写访问所获得的周期数。

Note: 这适用于当来自CPU的访问与从外部存储器获取指令或来自其他总线主控器（例如DTC或DMAC）的总线访问不冲突时的周期数。

Table 3.2 访问周期(1of3)

| Peripherals                                | Address     |             | 访问周期数       |       |                          |        | Cycle Unit | 相关功能   |
|--|-------------|-------------|-------------|-------|--------------------------|--------|------------|--|
|  |             |             | ICLK = PCLK |       | ICLK > PCLK <sup>1</sup> |        |            |  |
|  |             |             | Read        | Write | Read                     | Write  |            |  |
| RMPU, TZF, SRAM, BUS, DMACn, DMA, DTC, ICU | 0x4000_0000 | 0x4000_6FFF | 4           | 3     | 4                        | 3      | ICLK       | 瑞萨内存保护单元、TrustZone过滤器、SRAM控制、总线控制、直接内存访问控制器n、DMAC模块激活、DTC控制寄存器、中断控制器 |
| CACHE                                      | 0x4000_7000 | 0x4000_7FFF | 3           | 5     | 3                        | 5      | ICLK       | CACHE  |
| CPSCU, DBG, FCACHE                         | 0x4000_8000 | 0x4001_CFFF | 4           | 3     | 4                        | 3      | ICLK       | CPU系统安全控制单元，调试功能，闪存  |
| SYSC                                       | 0x4001_E000 | 0x4001_E3FF | 5           | 4     | 5                        | 4      | ICLK       | 系统控制   |
| SYSC                                       | 0x4001_E400 | 0x4001_E5FF | 9           | 8     | 5 to 8                   | 5 to 8 | PCLKB      | 系统控制   |
| PORTn, PFS                                 | 0x4008_0000 | 0x4008_0FFF | 5           | 4     | 2 to 5                   | 2 to 4 | PCLKB      | 端口n控制寄存器，Pmn引脚功能控制 Register  |

Table 3.2 Access cycles (2 of 3)

| Peripherals                | Address     |             | Number of access cycles |                     |                           |                      | Cycle Unit | Related function  |
|----------------------------|-------------|-------------|-------------------------|---------------------|---------------------------|----------------------|------------|---|
|                            |             |             | ICLK = PCLK             |                     | ICLK > PCLK <sup>*1</sup> |                      |            |   |
|                            | From        | To          | Read                    | Write               | Read                      | Write                |            |   |
| ELC, RTC, IWDI, WDT, CAC   | 0x4008_2000 | 0x4008_3FFF | 5                       | 4                   | 3 to 5                    | 2 to 4               | PCLKB      | Event Link Controller, Realtime Clock, Independent Watchdog Timer, Watchdog Timer, Clock Frequency Accuracy Measurement Circuit |
| MSTP                       | 0x4008_4000 | 0x4008_4FFF | 5                       | 4                   | 2 to 5                    | 2 to 4               | PCLKB      | Module Stop Control   |
| POEG                       | 0x4008_A000 | 0x4008_AFFF | 5                       | 4                   | 3 to 5                    | 2 to 4               | PCLKB      | Port Output Enable Module for GPT   |
| USBFS                      | 0x4009_0000 | 0x4009_3FFF | 6                       | 5                   | 3 to 6                    | 3 to 5               | PCLKB      | USB 2.0 FS Module   |
| USBFS                      | 0x4009_4000 | 0x4009_4FFF | 4                       | 3                   | 1 to 4                    | 1 to 3               | PCLKB      | USB 2.0 FS Module   |
| SDHI0, SSIE0, IICn, IIC0WU | 0x4009_2000 | 0x4009_FFFF | 5                       | 4                   | 2 to 5                    | 2 to 4               | PCLKB      | SD Host Interface 0, Serial Sound Interface Enhanced, Inter-Integrated Circuit n, Inter-Integrated Circuit 0 Wake-up Unit       |
| CANn                       | 0x400A_8000 | 0x400A_9FFF | 5                       | 4                   | 2 to 5                    | 2 to 4               | PCLKB      | CANn Module   |
| CTSU                       | 0x400D_0000 | 0x400D_FFFF | 4                       | 3                   | 1 to 4                    | 1 to 3               | PCLKB      | Capacitive Touch Sensing Unit   |
| PSCU                       | 0x400E_0000 | 0x400E_0FFF | 5                       | 4                   | 2 to 5                    | 2 to 4               | PCLKB      | Peripheral Security Control Unit  |
| AGTn                       | 0x400E_8000 | 0x400E_8FFF | 7                       | 4                   | 5 to 7                    | 2 to 4               | PCLKB      | Low Power Asynchronous General purpose Timer n  |
| TSN                        | 0x400F_3000 | 0x400F_3FFF | 5                       | 4                   | 2 to 5                    | 2 to 4               | PCLKB      | Temperature Sensor  |
| CRC, DOC                   | 0x4010_8000 | 0x4010_9FFF | 5                       | 4                   | 2 to 5                    | 2 to 4               | PCLKA      | CRC Calculator, Data Operation Circuit  |
| SCIn                       | 0x4011_8000 | 0x4011_8FFF | 5 <sup>*2</sup>         | 4 <sup>*2</sup>     | 2 to 5 <sup>*2</sup>      | 2 to 4 <sup>*2</sup> | PCLKA      | Serial Communication Interface n  |
| SPIIn                      | 0x4011_A000 | 0x4011_AFFF | 5 <sup>*3</sup>         | 4 <sup>*3</sup>     | 2 to 5 <sup>*3</sup>      | 2 to 4 <sup>*3</sup> | PCLKA      | Serial Peripheral Interface n   |
| SCE9                       | 0x4016_1000 | 0x4016_1FFF | 6                       | 4                   | 3 to 6                    | 2 to 4               | PCLKA      | Secure Cryptographic Engine   |
| GPT32n, GPT16n, GPT_OPS    | 0x4016_9000 | 0x4016_9FFF | 7                       | 4                   | 4 to 7                    | 2 to 4               | PCLKA      | General PWM 32-Bit Timer n, General PWM 16-Bit Timer n, Output Phase Switching Controller                                       |
| ADC12n, DAC12              | 0x4017_0000 | 0x4017_2FFF | 5                       | 4                   | 2 to 5                    | 2 to 4               | PCLKA      | 12bit A/D Converter n, 12-bit D/A converter   |
| QSPI                       | 0x6400_0000 | 0x6400_000F | 5                       | 14 to <sup>*4</sup> | 2 to 5                    | 14 to <sup>*4</sup>  | PCLKA      | Quad-SPI  |
| QSPI                       | 0x6400_0010 | 0x6400_0013 | 25 to <sup>*4</sup>     | 6 to <sup>*4</sup>  | 25 to <sup>*4</sup>       | 5 to <sup>*4</sup>   | PCLKA      | Quad-SPI  |
| QSPI                       | 0x6400_0014 | 0x6400_0037 | 5                       | 14 to <sup>*4</sup> | 2 to 5                    | 14 to <sup>*4</sup>  | PCLKA      | Quad-SPI  |
| QSPI                       | 0x6400_0804 | 0x6400_0807 | 4                       | 3                   | 1 to 4                    | 1 to 3               | PCLKA      | Quad-SPI  |

Table 3.2 访问周期 (2个, 共3个)

| Peripherals                | Address     |             | 访问周期数               |                     |                           |                      | Cycle Unit | 相关功能  |
|----------------------------|-------------|-------------|---------------------|---------------------|---------------------------|----------------------|------------|---|
|                            |             |             | ICLK = PCLK         |                     | ICLK > PCLK <sup>*1</sup> |                      |            |   |
|                            | From        | To          | Read                | Write               | Read                      | Write                |            |   |
| ELC, RTC, IWDI, WDT, CAC   | 0x4008_2000 | 0x4008_3FFF | 5                   | 4                   | 3 to 5                    | 2 to 4               | PCLKB      | 事件链接控制器, 实时时钟, 独立看门狗定时器, 看门狗定时器, 时钟频率 Accuracy 测量电路 |
| MSTP                       | 0x4008_4000 | 0x4008_4FFF | 5                   | 4                   | 2 to 5                    | 2 to 4               | PCLKB      | 模块停止控制  |
| POEG                       | 0x4008_A000 | 0x4008_AFFF | 5                   | 4                   | 3 to 5                    | 2 to 4               | PCLKB      | 端口输出使能 GPT模块  |
| USBFS                      | 0x4009_0000 | 0x4009_3FFF | 6                   | 5                   | 3 to 6                    | 3 to 5               | PCLKB      | USB2.0FS模块  |
| USBFS                      | 0x4009_4000 | 0x4009_4FFF | 4                   | 3                   | 1 to 4                    | 1 to 3               | PCLKB      | USB2.0FS模块  |
| SDHI0, SSIE0, IICn, IIC0WU | 0x4009_2000 | 0x4009_FFFF | 5                   | 4                   | 2 to 5                    | 2 to 4               | PCLKB      | SD主机接口0, 串行声音接口增强型, 国米集成电路n 内部集成电路0唤醒单元             |
| CANn                       | 0x400A_8000 | 0x400A_9FFF | 5                   | 4                   | 2 to 5                    | 2 to 4               | PCLKB      | CANn模块  |
| CTSU                       | 0x400D_0000 | 0x400D_FFFF | 4                   | 3                   | 1 to 4                    | 1 to 3               | PCLKB      | Capacitive Touch 传感单元                               |
| PSCU                       | 0x400E_0000 | 0x400E_0FFF | 5                   | 4                   | 2 to 5                    | 2 to 4               | PCLKB      | 外围安全控制单元  |
| AGTn                       | 0x400E_8000 | 0x400E_8FFF | 7                   | 4                   | 5 to 7                    | 2 to 4               | PCLKB      | 低电量 Asynchronous 一般用途 Timer n                       |
| TSN                        | 0x400F_3000 | 0x400F_3FFF | 5                   | 4                   | 2 to 5                    | 2 to 4               | PCLKB      | 温度感应器   |
| CRC, DOC                   | 0x4010_8000 | 0x4010_9FFF | 5                   | 4                   | 2 to 5                    | 2 to 4               | PCLKA      | CRC计算器, 数据运算电路                                      |
| SCIn                       | 0x4011_8000 | 0x4011_8FFF | 5 <sup>*2</sup>     | 4 <sup>*2</sup>     | 2 to 5 <sup>*2</sup>      | 2 to 4 <sup>*2</sup> | PCLKA      | 串行通信 Interface n                                    |
| SPIIn                      | 0x4011_A000 | 0x4011_AFFF | 5 <sup>*3</sup>     | 4 <sup>*3</sup>     | 2 to 5 <sup>*3</sup>      | 2 to 4 <sup>*3</sup> | PCLKA      | 串行外设 Interface n                                    |
| SCE9                       | 0x4016_1000 | 0x4016_1FFF | 6                   | 4                   | 3 to 6                    | 2 to 4               | PCLKA      | 安全密码学 Engine  |
| GPT32n, GPT16n, GPT_OPS    | 0x4016_9000 | 0x4016_9FFF | 7                   | 4                   | 4 to 7                    | 2 to 4               | PCLKA      | 通用PWM32位定时器n, 通用 PWM16位定时器n, 输出相位 开关控制器             |
| ADC12n, DAC12              | 0x4017_0000 | 0x4017_2FFF | 5                   | 4                   | 2 to 5                    | 2 to 4               | PCLKA      | 12bit A/D Converter n, 12-bit D/A converter         |
| QSPI                       | 0x6400_0000 | 0x6400_000F | 5                   | 14 to <sup>*4</sup> | 2 to 5                    | 14 to <sup>*4</sup>  | PCLKA      | Quad-SPI  |
| QSPI                       | 0x6400_0010 | 0x6400_0013 | 25 to <sup>*4</sup> | 6 to <sup>*4</sup>  | 25 to <sup>*4</sup>       | 5 to <sup>*4</sup>   | PCLKA      | Quad-SPI  |
| QSPI                       | 0x6400_0014 | 0x6400_0037 | 5                   | 14 to <sup>*4</sup> | 2 to 5                    | 14 to <sup>*4</sup>  | PCLKA      | Quad-SPI  |
| QSPI                       | 0x6400_0804 | 0x6400_0807 | 4                   | 3                   | 1 to 4                    | 1 to 3               | PCLKA      | Quad-SPI  |

Table 3.2 Access cycles (3 of 3)

| Peripherals | Address<br>From To |             | Number of access cycles |       |               |        | Cycle Unit | Related function                                |
|-------------|--------------------|-------------|-------------------------|-------|---------------|--------|------------|---|
|             |                    |             | ICLK = FCLK             |       | ICLK > FCLK*1 |        |            |   |
|             |                    |             | Read                    | Write | Read          | Write  |            |   |
| FLAD, FACI  | 0x407F_C000        | 0x407F_EFFF | 5                       | 4     | 2 to 5        | 2 to 4 | FCLK       | Data Flash, Flash Application Command Interface |

- Note 1. If the number of PCLK or FCLK cycles is non-integer (for example 1.5), the minimum value is without the decimal point, and the maximum value is rounded up to the decimal point. For example, 1.5 to 2. 5 is 1 to 3.
- Note 2. When accessing a 16-bit register (FTDRHL, FRDRHL, FCR, FDR, LSR, and CDR), access is 2 cycles more than the value shown in Table 3.2. When accessing an 8-bit register (including FTDRH, FTDRL, FRDRH, and FRDRL), the access cycles are as shown in Table 3.2.
- Note 3. When accessing the 32-bit register (SPDR), access is 2 cycles more than the value in Table 3.2. When accessing an 8-bit or 16-bit register (SPDR\_HA), the access cycles are as shown in Table 3.2.
- Note 4. The access cycles depend on the QSPI bus cycles.

Table 3.2 访问周期 (3个, 共3个)

| Peripherals | Address<br>From To |             | 访问周期数       |       |               |        | Cycle Unit | 相关功能          |
|-------------|--------------------|-------------|-------------|-------|---------------|--------|------------|---------------|
|             |                    |             | ICLK = FCLK |       | ICLK > FCLK*1 |        |            |               |
|             |                    |             | Read        | Write | Read          | Write  |            |               |
| FLAD, FACI  | 0x407F_C000        | 0x407F_EFFF | 5           | 4     | 2 to 5        | 2 to 4 | FCLK       | 数据闪存、闪存应用命令接口 |

- 注1.若PCLK或FCLK周期数为非整数（例如1.5），则最小值不带小数点，最大值四舍五入到小数点。例如，1.5到2。5是1到3。
- 注2.访问16位寄存器（FTDRHL、FRDRHL、FCR、FDR、LSR和CDR）时，访问时间比中所示的值多2个周期。访问8位寄存器（包括FTDRH、FTDRL、FRDRH和FRDRL）时，访问周期如下图所示：  
Table 3.2.
- 注3.访问32位寄存器(SPDR)时，访问比表3.2中的值多2个周期。访问8位或16位寄存器（SPDR\_HA）时，访问周期如表3.2所示。
- 注4.访问周期取决于QSPI总线周期。



## Revision History

**Revision 1.20 — December 2, 2020**

First edition, issued

## 修订记录

**1.20版——2020年12月2日**

第一版，已发行

RA生态工作室

RA生态工作室

---

RA4M3 Group User's Manual: Hardware

Publication Date: Rev.1.20 Dec 2, 2020

Published by: Renesas Electronics Corporation

---

---

RA4M3组用户手册：硬件

Publication Date: Rev.1.20 Dec 2, 2020

Published by: 瑞萨电子公司

---

32-Bit MCU  
RA4M3 Group

32-Bit MCU  
RA4M3 Group

RA生态工作室